

**HARMAN / KARDON**

**AVP-1**

***IMPORTANT:***

Unlike other Harman/Kardon models, technical inquiries and spare part orders for this unit should be addressed to a separate division we have set up in California. Please do *not* contact our New York office in this regard.

Your correspondence should be addressed as follows:

Audioaccess  
26046 Eden Landing Road, Suite 5  
Hayward, CA 94545

Fax: +510 293 0189  
Attn: Bob Popham

TABLE of CONTENTS

Safety Precautions *****	sect. 1
Schematic *****	sect. 2
Test Procedures *****	sect. 3
Mode Logic Tables *****	sect. 4
Front Panel *****	sect. 5
Rear Panel *****	sect. 6
Remote control *****	sect. 7
Parts List *****	sect. 8

**SECTION 1**

### Safety Precautions

The following listed are safety precautions that must be observed while service is being performed upon the MODEL-3

1. High voltage is present on printed circuit board. Caution should be observed while MODEL-3 is being serviced with power applied. Refer to IEC symbols on schematic [shock hazard].
2. Use exact replacement parts. Especially where parts are noted as "RISK OF FIRE OR SHOCK HAZARD."
3. Test for leakage currents prior to the return of unit to customer. (see sec. 3 for detail on test procedure)
4. CAUTION: FOR CONTINUED PROTECTION AGAINST RISK OF FIRE, REPLACE WITH SAME TYPE 375 mA, 250 VOLT FUSE.

**SECTION 2**

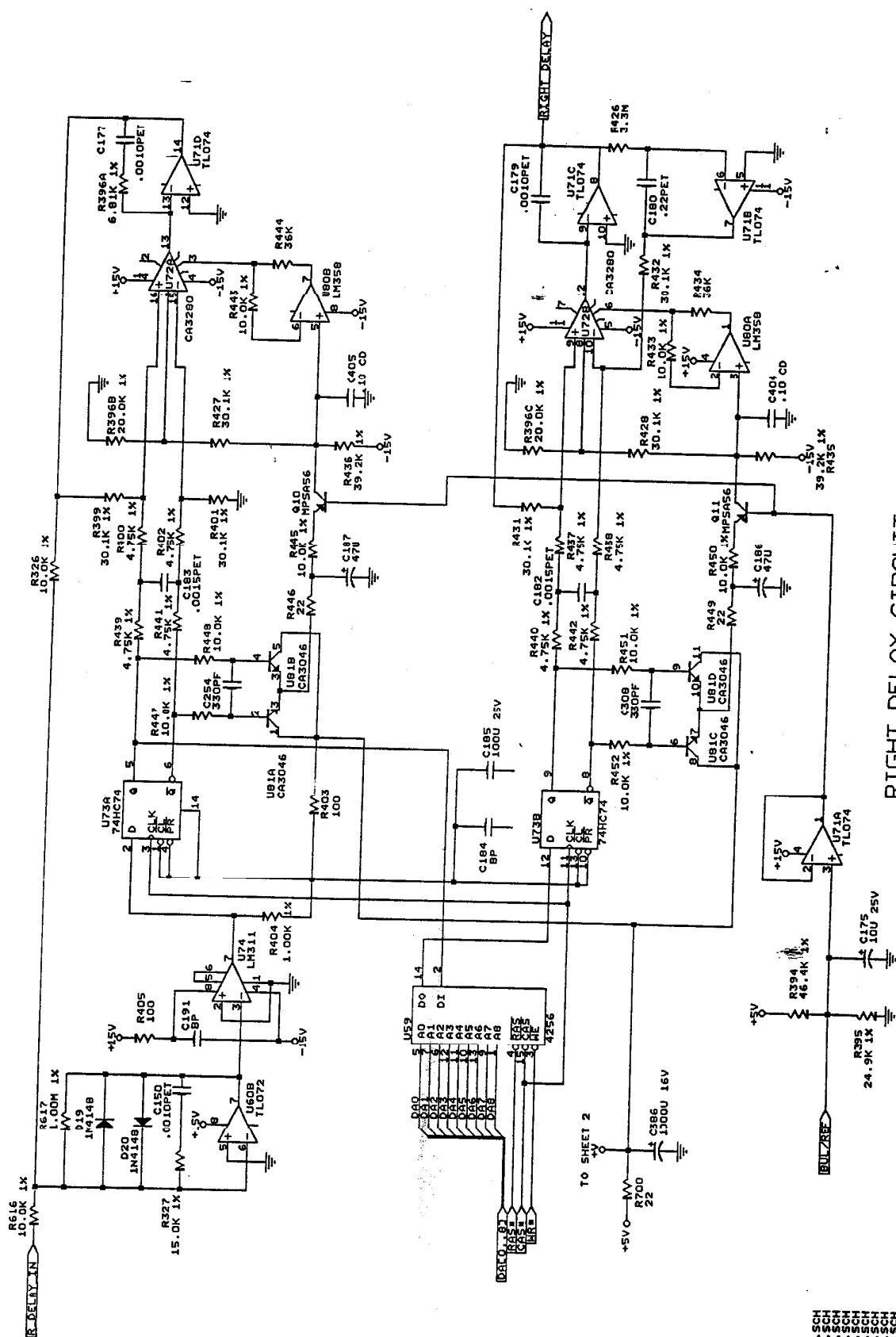

### RIGHT DELAY CIRCUIT

ILINK  
 INDL3D302.SCH  
 INDL3D303.SCH  
 INDL3D304.SCH  
 INDL3D305.SCH  
 INDL3D306.SCH  
 INDL3D307.SCH  
 INDL3D308.SCH  
 INDL3D309.SCH  
 INDL3D310.SCH  
 INDL3D311.SCH  
 INDL3D312.SCH  
 INDL3D313.SCH  
 INDL3D314.SCH  
 INDL3D315.SCH  
 INDL3D316.SCH  
 INDL3D317.SCH

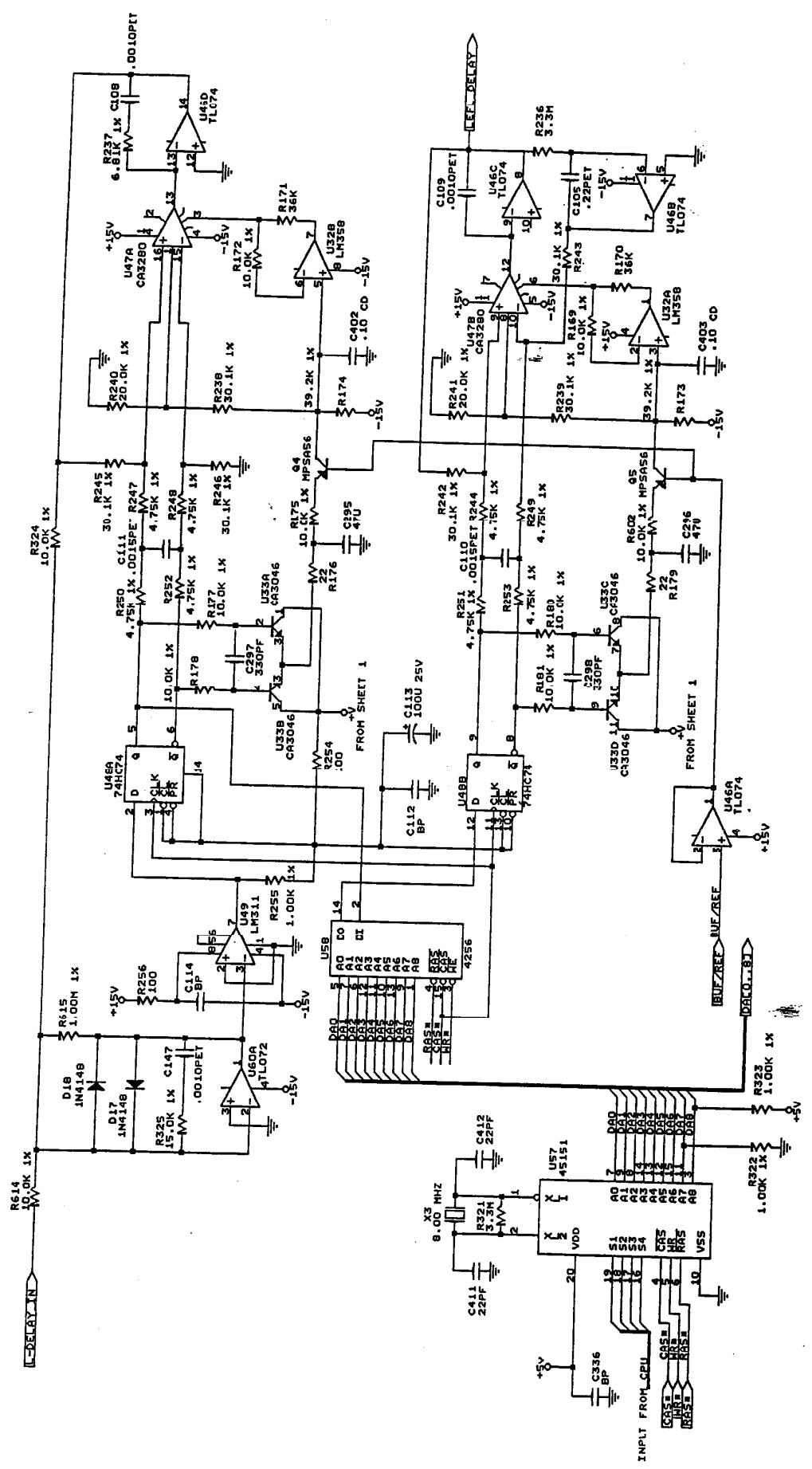

FOSGATE INC.	
Salt Lake City, Utah	
Title	LEFT DELAY
Size	Document Number
B	HDL30302.SCH
REV	03
Date:	November 11, 1992 Sheet 2 of 17



1HX1

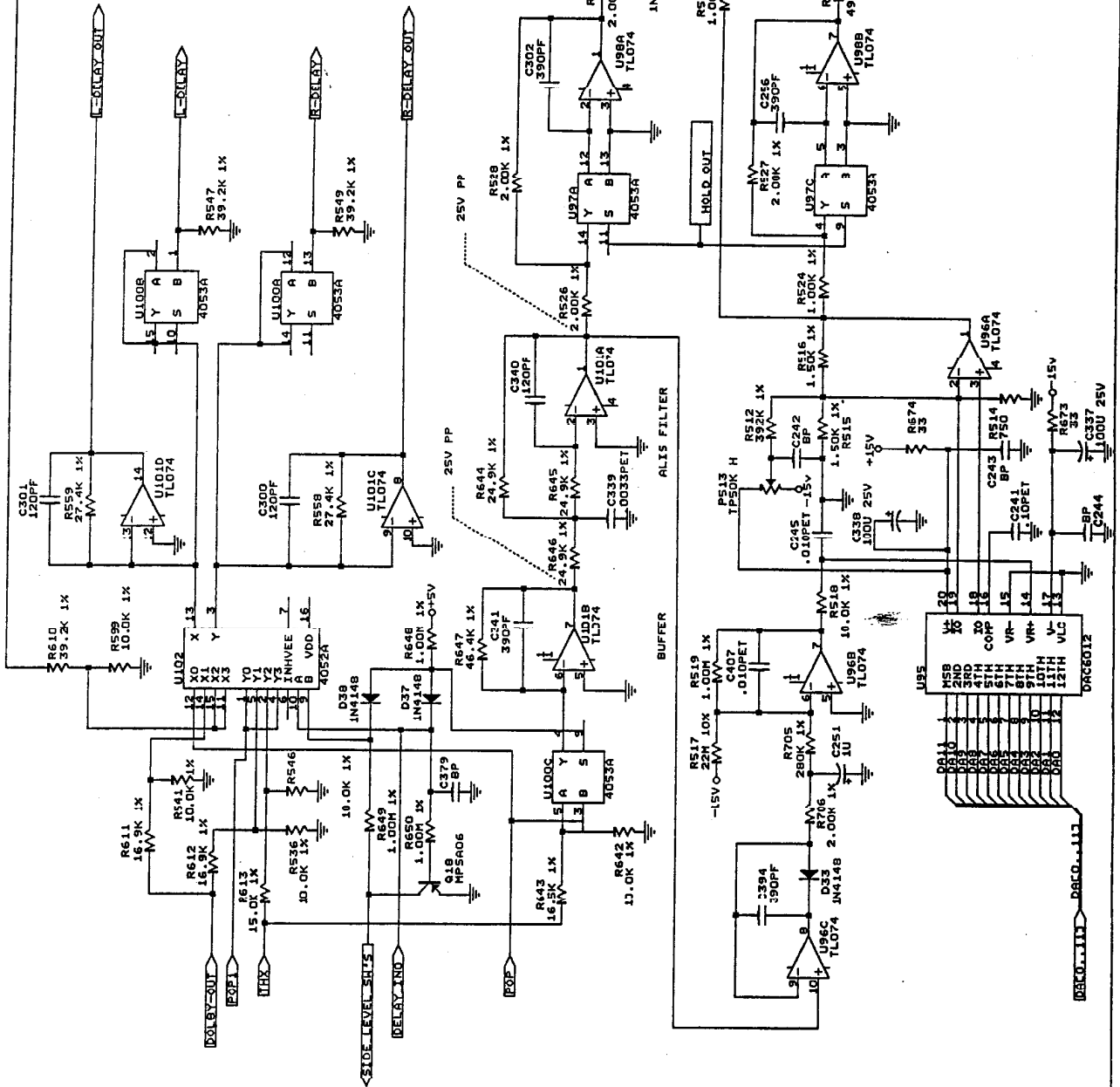

Title: FOSGATE INC. Salt Lake City, Utah.  
Size Document Number: PITCH SHIFTER  
B: HOL3D203.SCH  
Date: November 11, 1992 Sheet 3 of 17

REVISION HISTORY  
REV D2  
REV 17

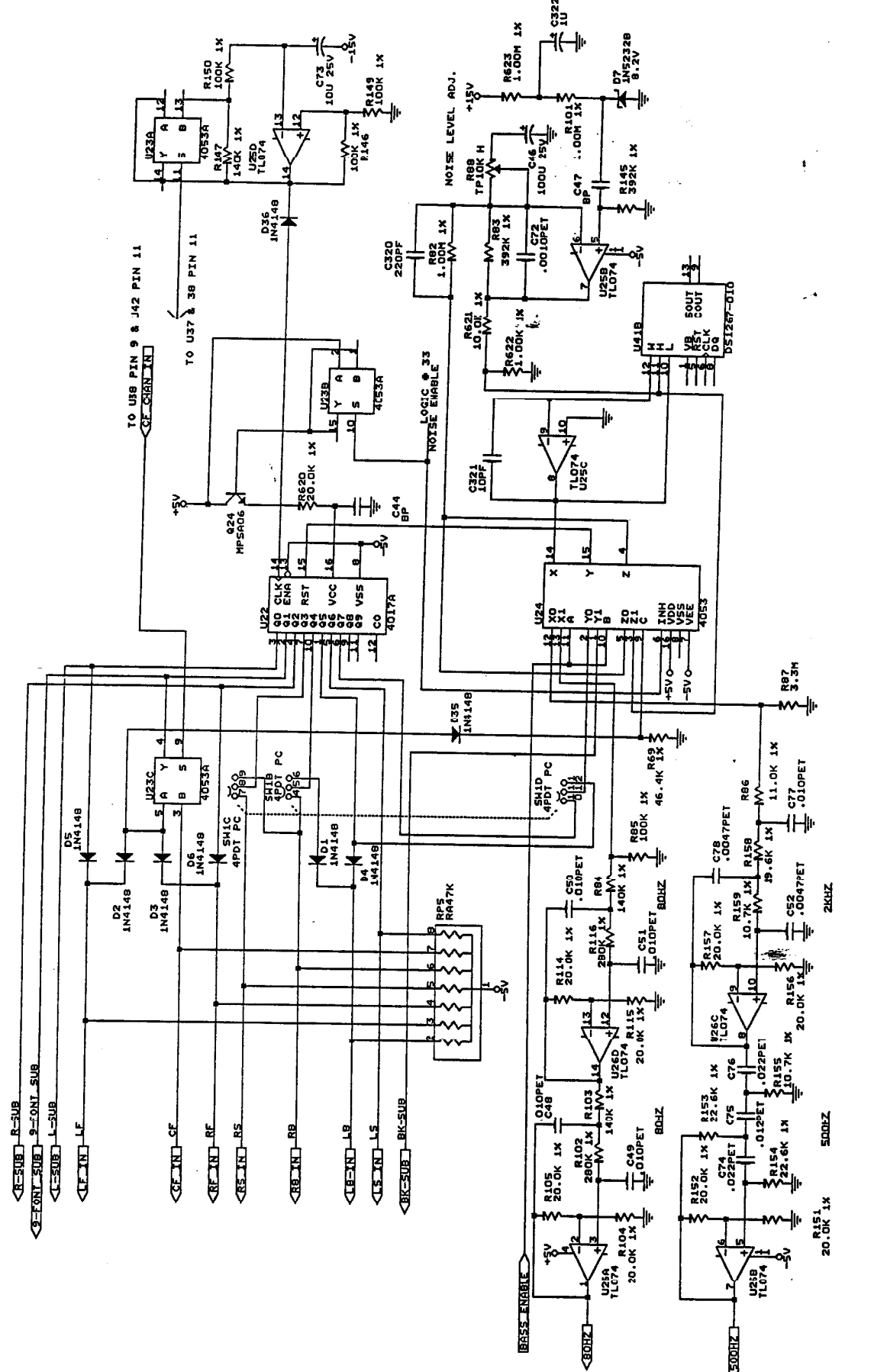

Title  
 Salt Lake City, Utah  
 CF-DELAY-SEQUENCER  
 Size Document Number  
 B MDL3304.SCH  
 Date: November 11, 1992  
 REV C3  
 4 of 17

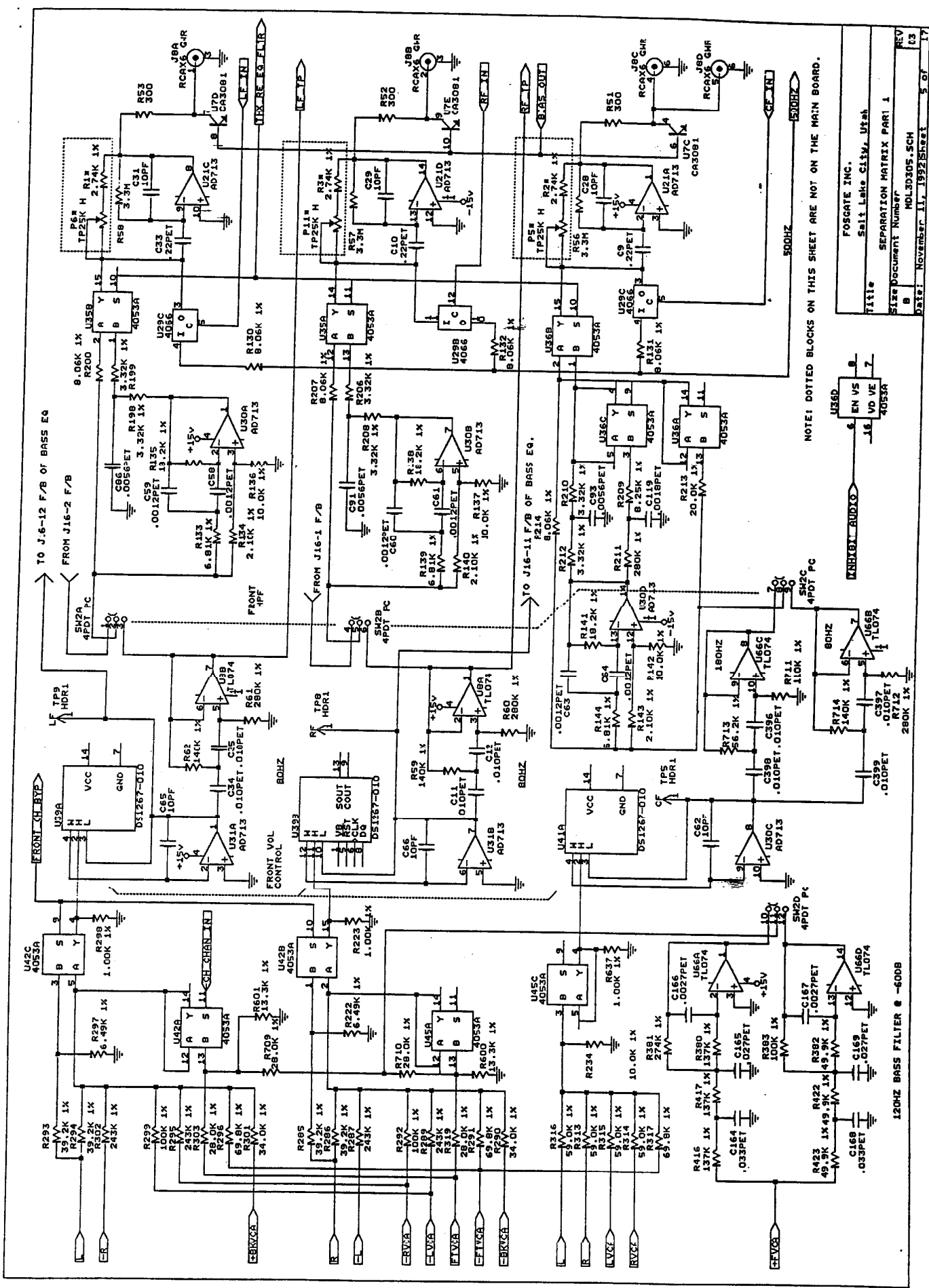

NOTE: DOTTED BLOCKS ON THIS SHEET ARE NOT ON THE MAIN BOARD.

Title		FOSGATE INC. Salt Lake City, Utah	
Size Document Number		SEPARATION MATRIX PART 1 MOL3D305.SCH	
Date		November 11, 1992 Sheet 5 of 17	

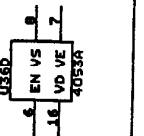

120HZ BASS FILTER # -600B

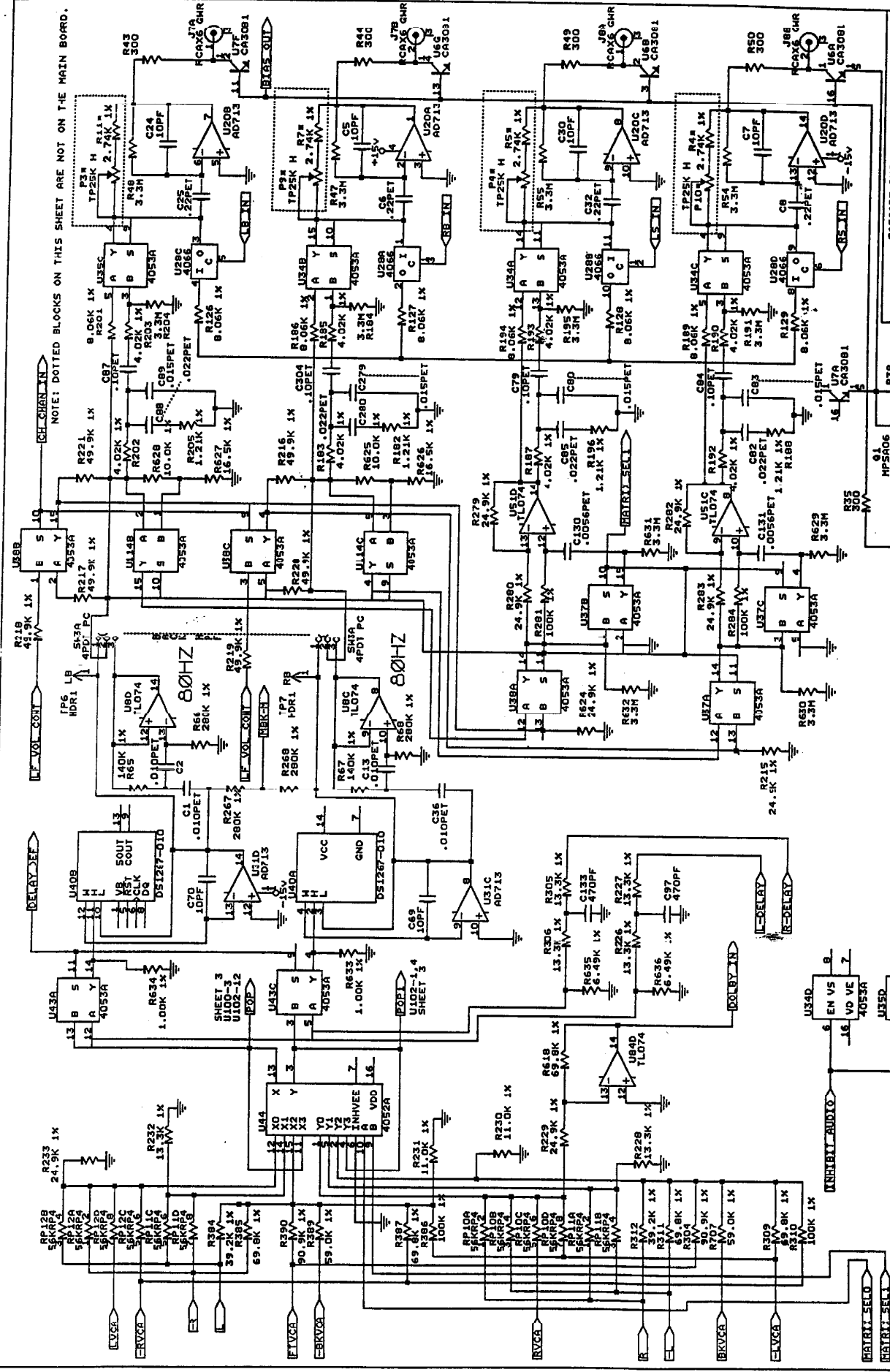

NOTE: DOTTED BLOCKS ON THIS SHEET ARE NOT ON THE MAIN BOARD.

FOSGATE INC.  
Salt Lake City, Utah  
Title  
SEPARATION MATRIX PART 2  
Size Document Number  
MOL30306.SCH  
REV  
13  
Date: November 12, 1992 Sheet 6 of 17

NOTE: DOTTED BLOCKS ON THIS SHEET ARE NOT ON THE MAIN BOARD.

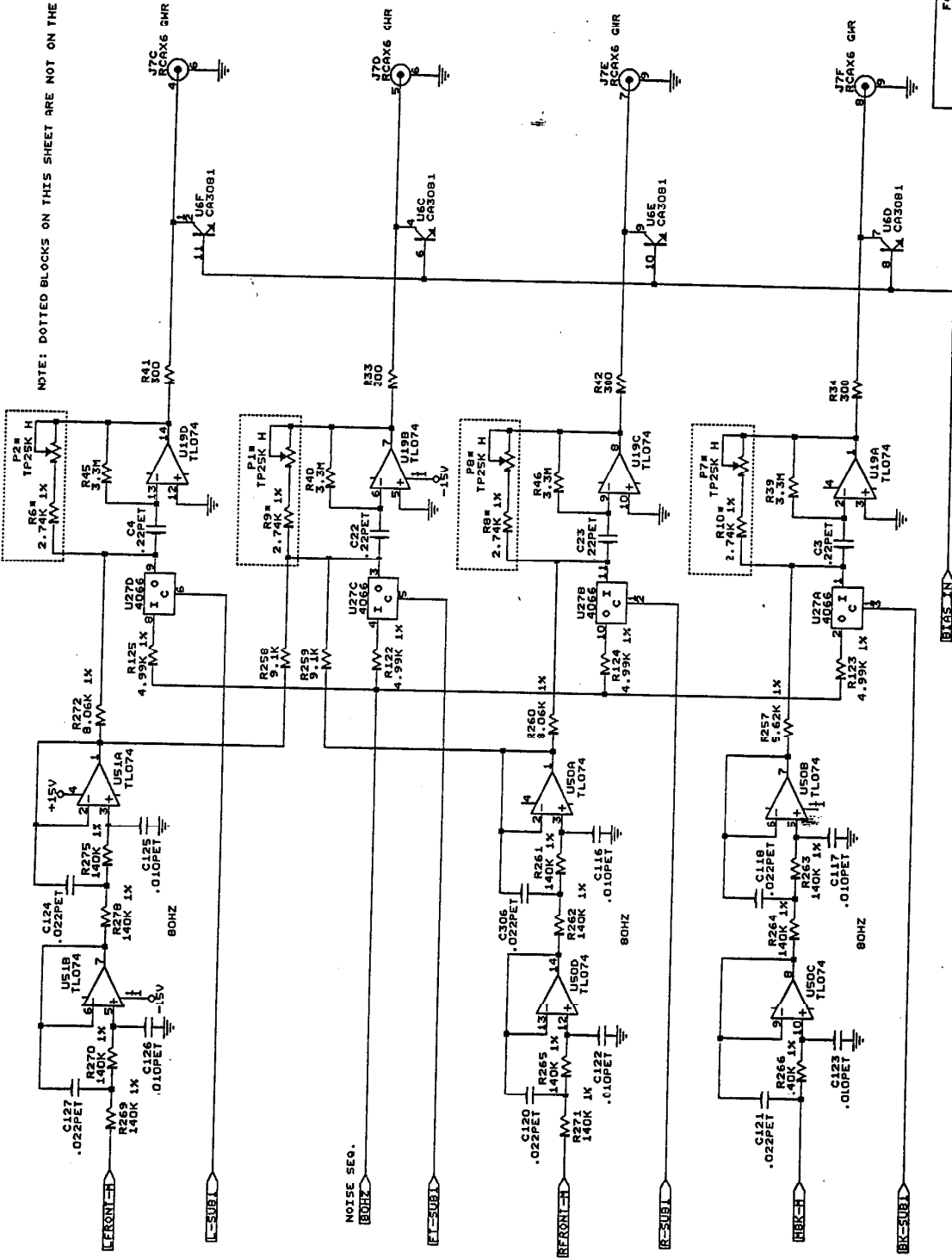

FOSGATE INC.	
Title	Salt Lake City, Utah
Size	SEPARATION MATRIX PART 3
Doc Number	MDL30307.SCH
Date	November 11, 1992
Sheet	7 of 17

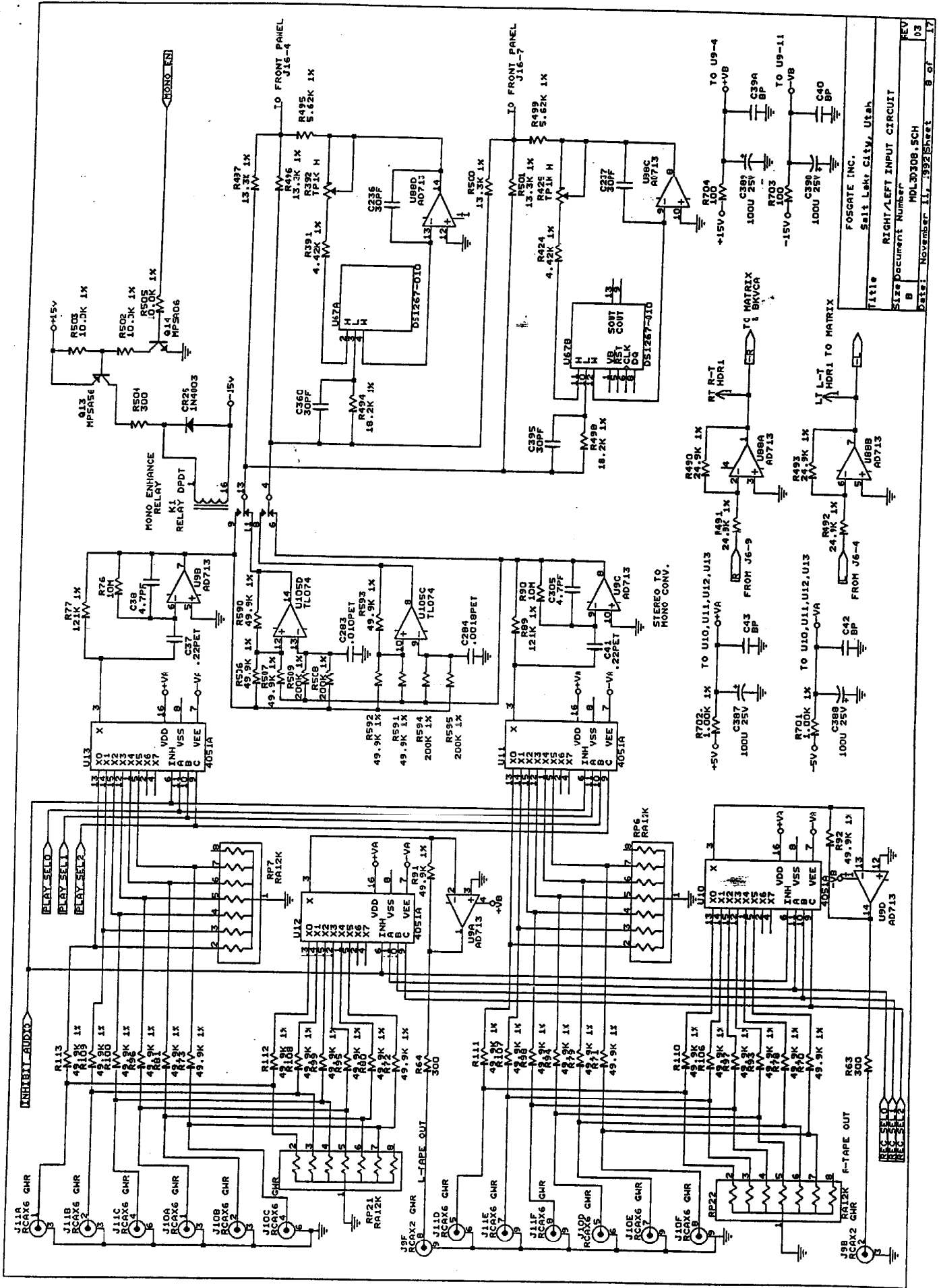

Title  
 Fosgate Inc.  
 Salt Lake City, Utah  
 Size Document Number  
 MDL3008.SCH  
 REV  
 03  
 Date: November 11, 1992 Sheet 8 of 17

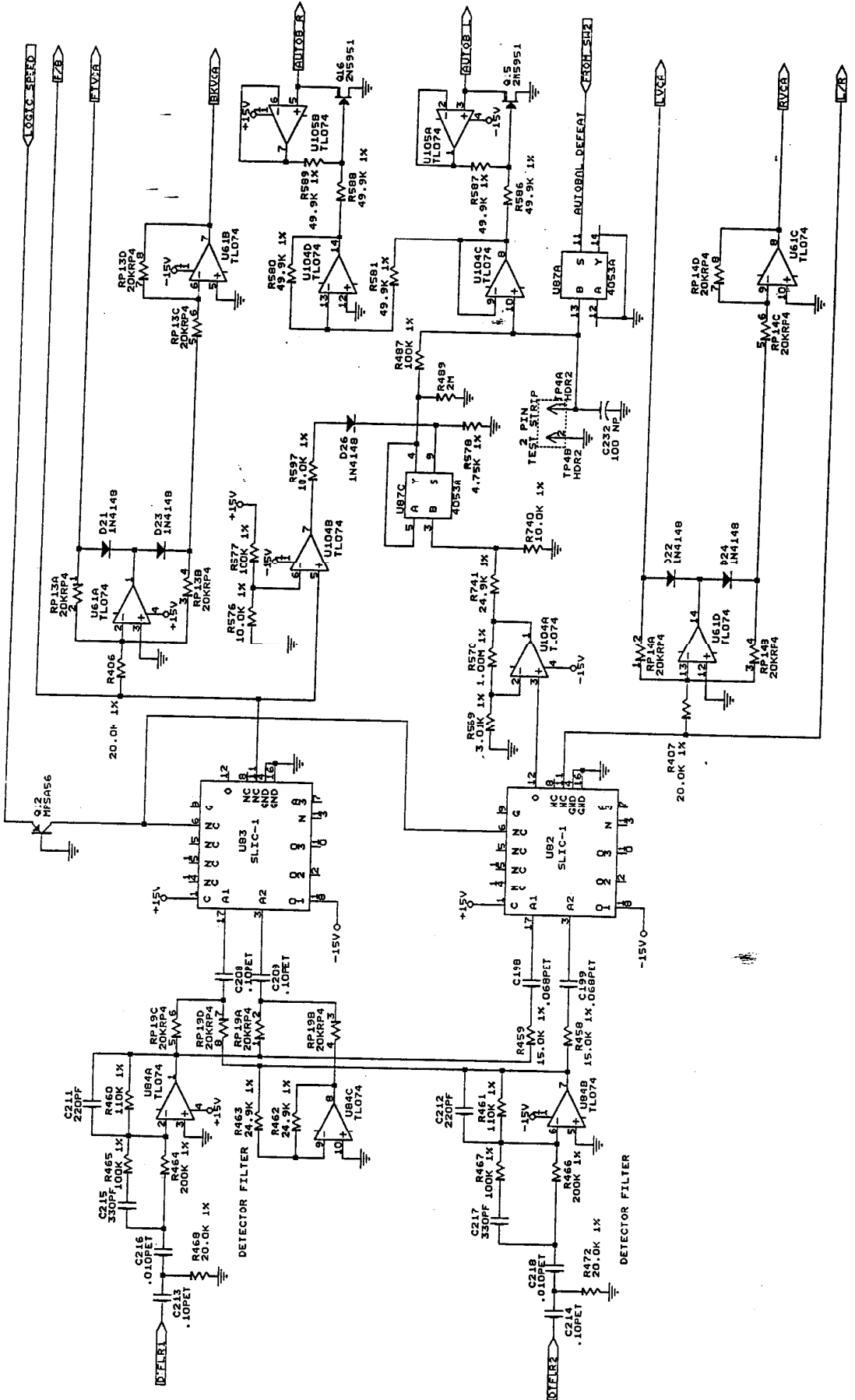

FOSGATE INC.  
 Salt Lake City, Utah  
 Title CONTROL VOLTAGE GENERATOR  
 Size Document Number HDL30309.SCH REV  
 B H 33  
 Date: November 11, 1992 Sheet 9 of 17

LEFT VCA

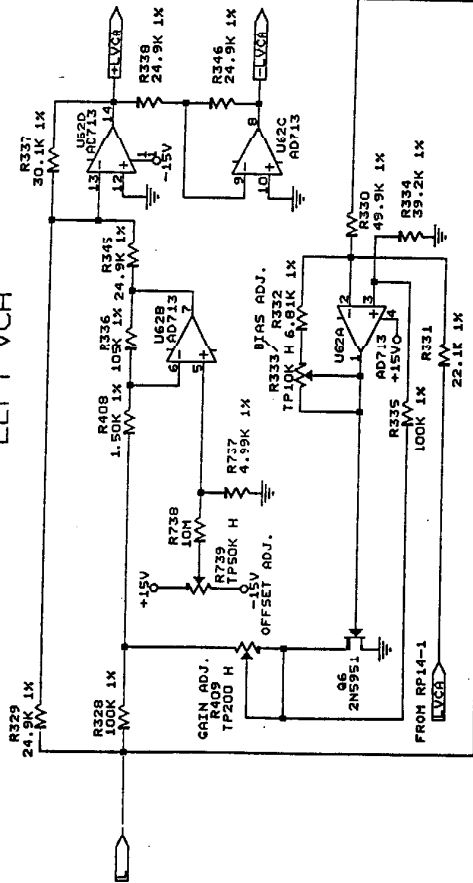

FRONT VCA

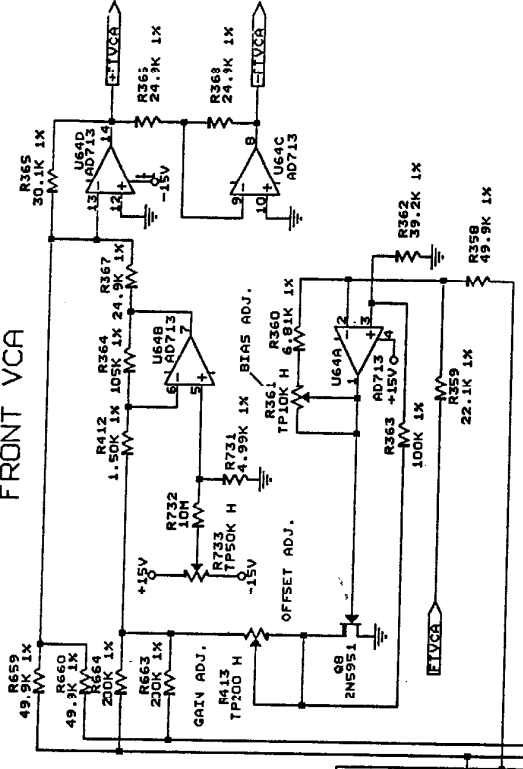

RIGHT VCA

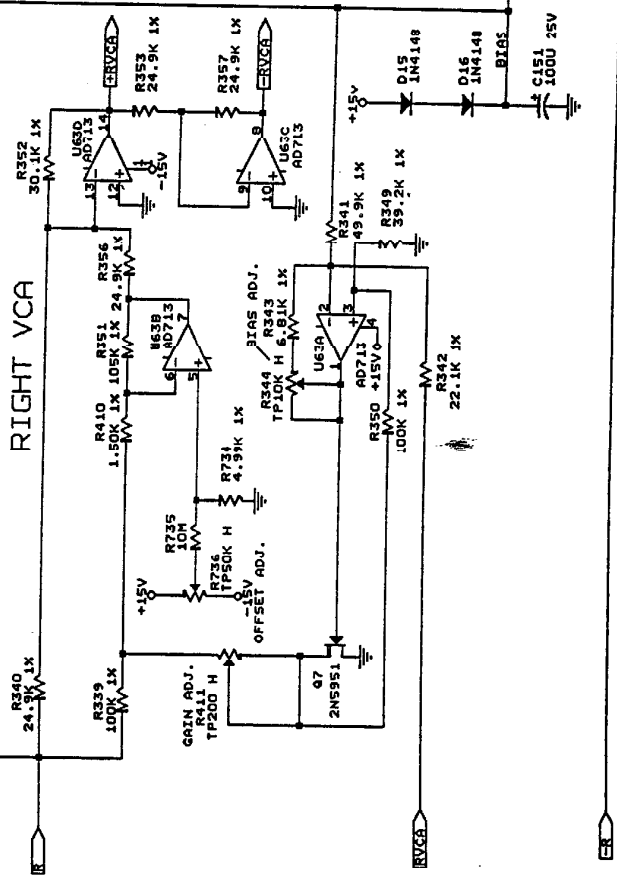

BACK VCA

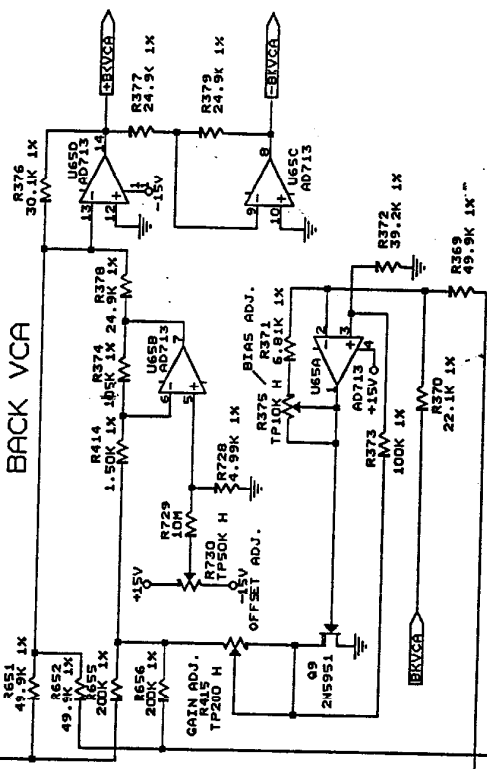

FOSGATE INC.	
Salt Lake City, Utah	
Title	VCA CIRCUITS
Size	MDL30310.SCH
Rev	B
Date	November 11, 1992
Sheet	10 of 17



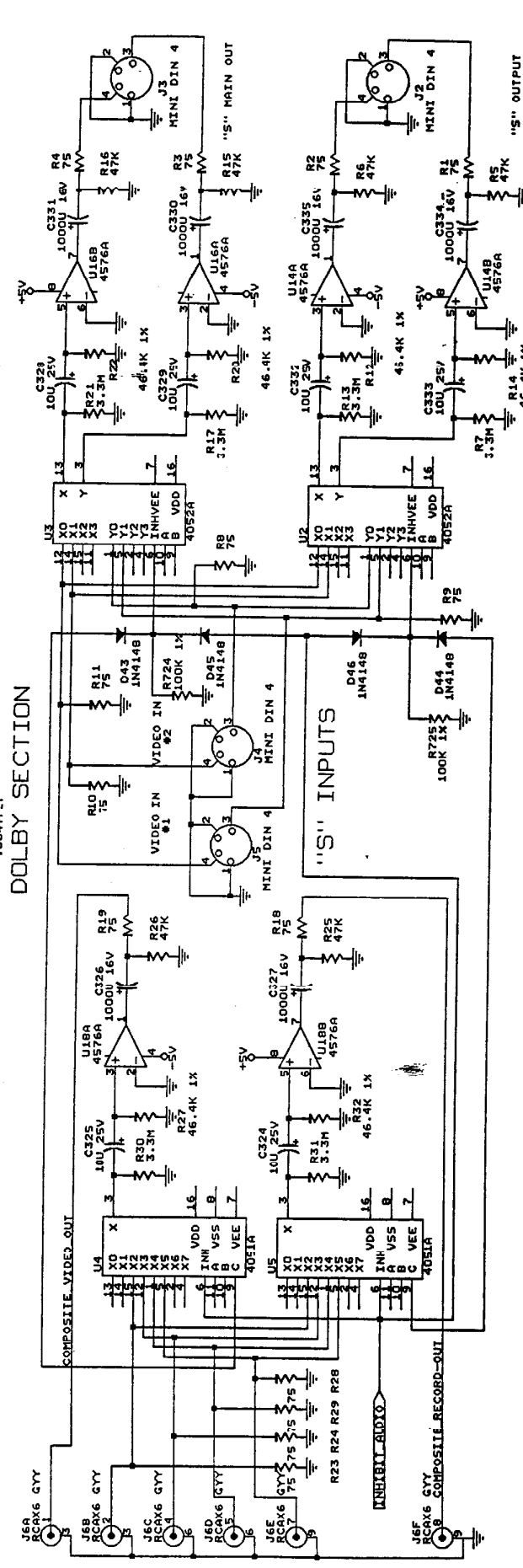
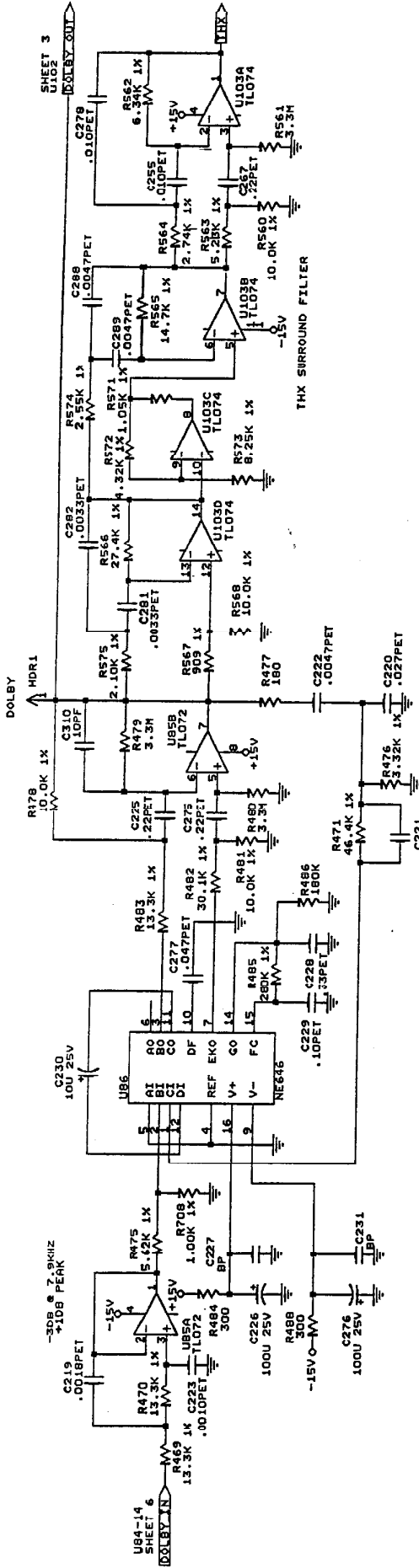

FOSCATE INC.  
Salt Lake City, Utah

VIDEO & DOLBY CIRCUITS

Size Document Number  
B MHL30311.5CH  
C3

Date: November 11, 1992 Sheet 11 of 17

⚠ FIRE RISK  
REPLACE WITH EQUIVALENT PARTS.

⚠ JUMPERS FOR 117V

CHASSIS GROUND

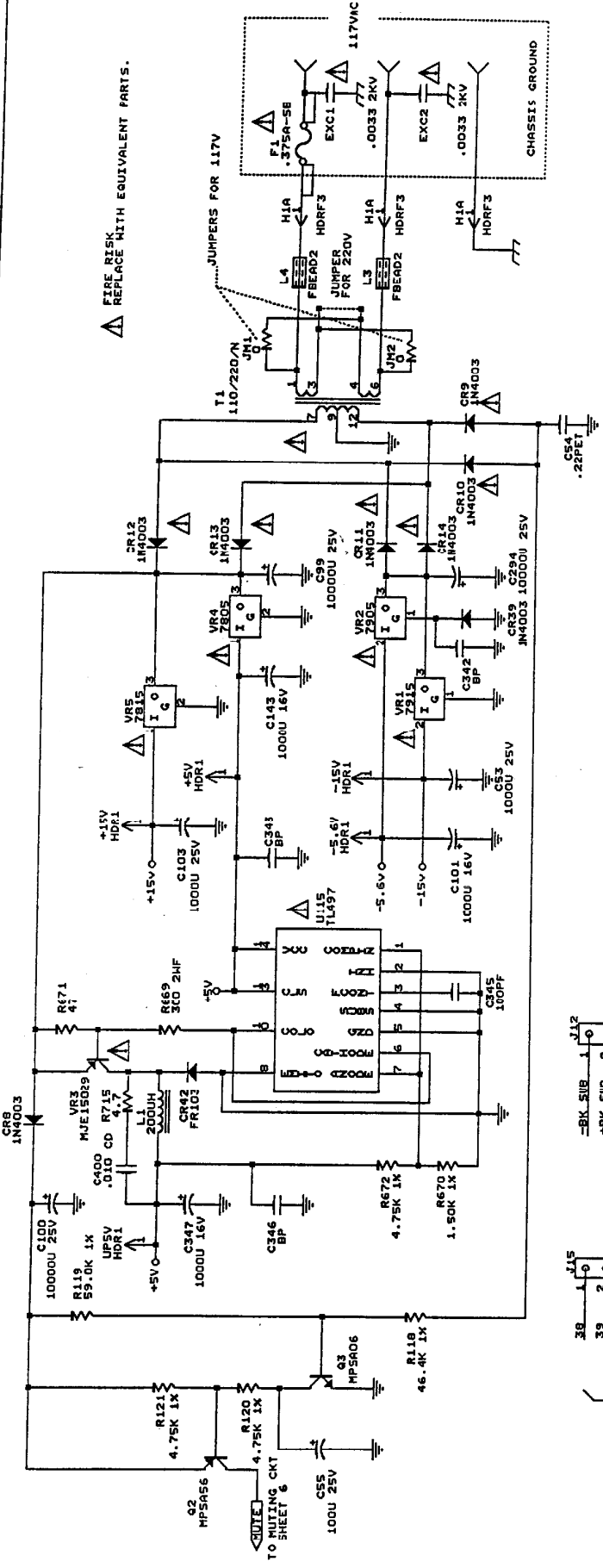

USE .047UF CONFORMAL COATED CERAMIC CAPACITORS AS NEEDED FOR BYPASS.  
NOISE = 4066 +/-5V SUPPLY.  
ALL OF AMPS +/-15V UNLESS MARKED OTHERWISE.  
UNMARKED DIODES ARE 1N4148 OR EQ.

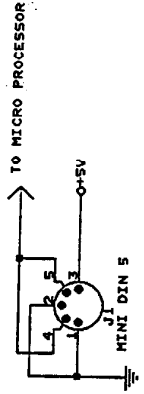

MICRO PROCESSOR LINES

38	1	0	T-BAN_22
39	2	0	T-BAN_22
40	3	0	T-BAN_22
41	4	0	T-BAN_22
42	5	0	T-BAN_22
43	6	0	T-BAN_22
44	7	0	T-BAN_22
45	8	0	T-BAN_22
46	9	0	T-BAN_22
47	10	0	T-BAN_22
48	11	0	T-BAN_22
49	12	0	T-BAN_22
50	13	0	T-BAN_22
51	14	0	T-BAN_22
52	15	0	T-BAN_22
53	16	0	T-BAN_22
54	17	0	T-BAN_22
55	18	0	T-BAN_22
56	19	0	T-BAN_22
57	20	0	T-BAN_22
58	21	0	T-BAN_22
59	22	0	T-BAN_22

RIGHT AUDIO CONN. LCD CONN.

1	0	T-BAN_16
2	0	T-BAN_16
3	0	T-BAN_16
4	0	T-BAN_16
5	0	T-BAN_16
6	0	T-BAN_16
7	0	T-BAN_16
8	0	T-BAN_16
9	0	T-BAN_16
10	0	T-BAN_16
11	0	T-BAN_16
12	0	T-BAN_16
13	0	T-BAN_16
14	0	T-BAN_16
15	0	T-BAN_16
16	0	T-BAN_16

BACK AUDIO CONN.

1	0	T-BAN_16
2	0	T-BAN_16
3	0	T-BAN_16
4	0	T-BAN_16
5	0	T-BAN_16
6	0	T-BAN_16
7	0	T-BAN_16
8	0	T-BAN_16
9	0	T-BAN_16
10	0	T-BAN_16
11	0	T-BAN_16
12	0	T-BAN_16
13	0	T-BAN_16
14	0	T-BAN_16
15	0	T-BAN_16
16	0	T-BAN_16

FOSGATE INC.  
Salt Lake City, Utah

POWER SUPPLY & CONNECTORS  
Size Document Number  
REV 03  
Date: November 11, 1992 Sheet 12 of 17

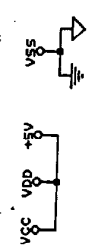
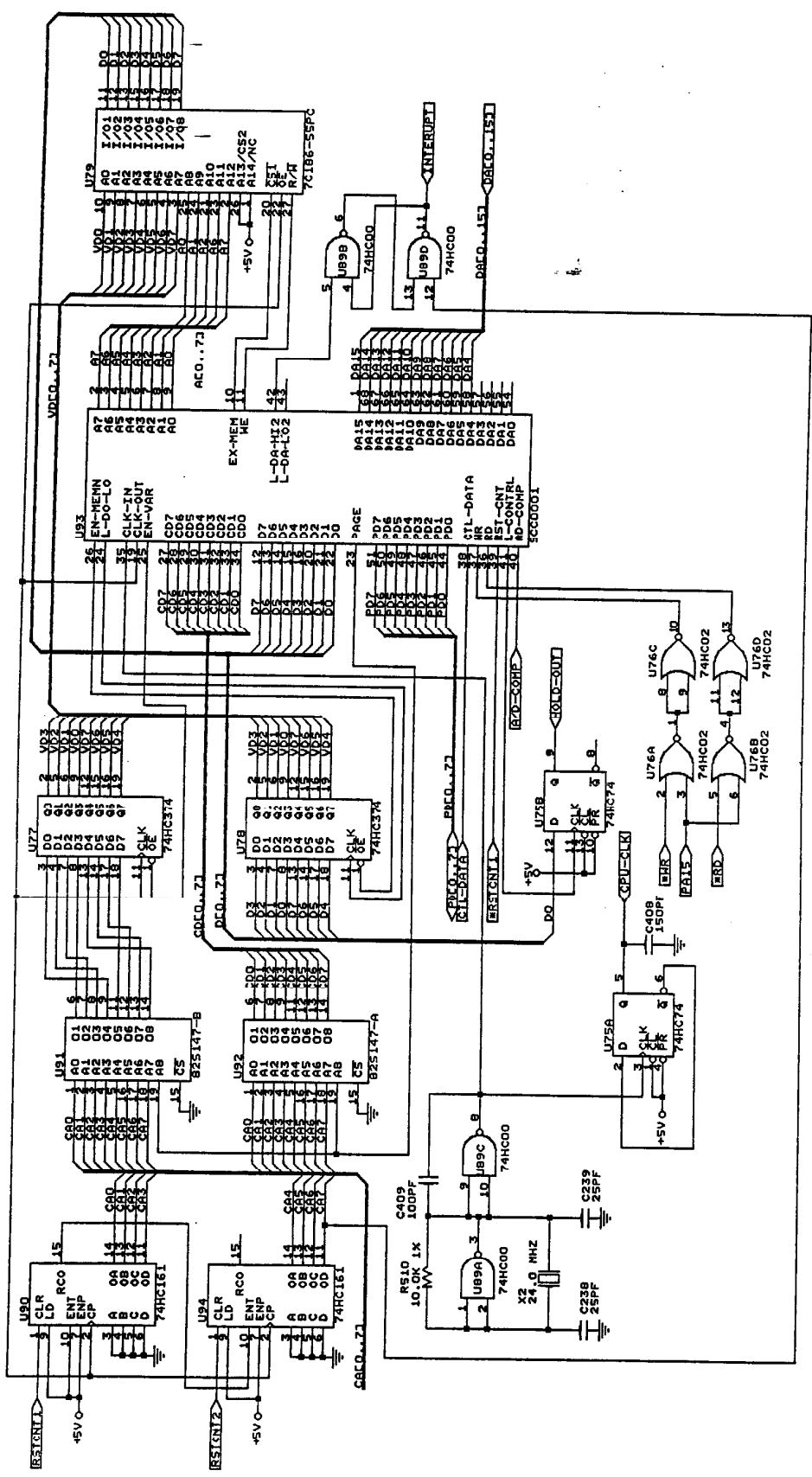

FOSGATE INC.	
Salt Lake City, UTAH	
Title	
DSV PROCESSOR	
Size	Document Number
B	HOL30313.SCH
REV	Date: November 11, 1992
03	Sheet 13 of 17

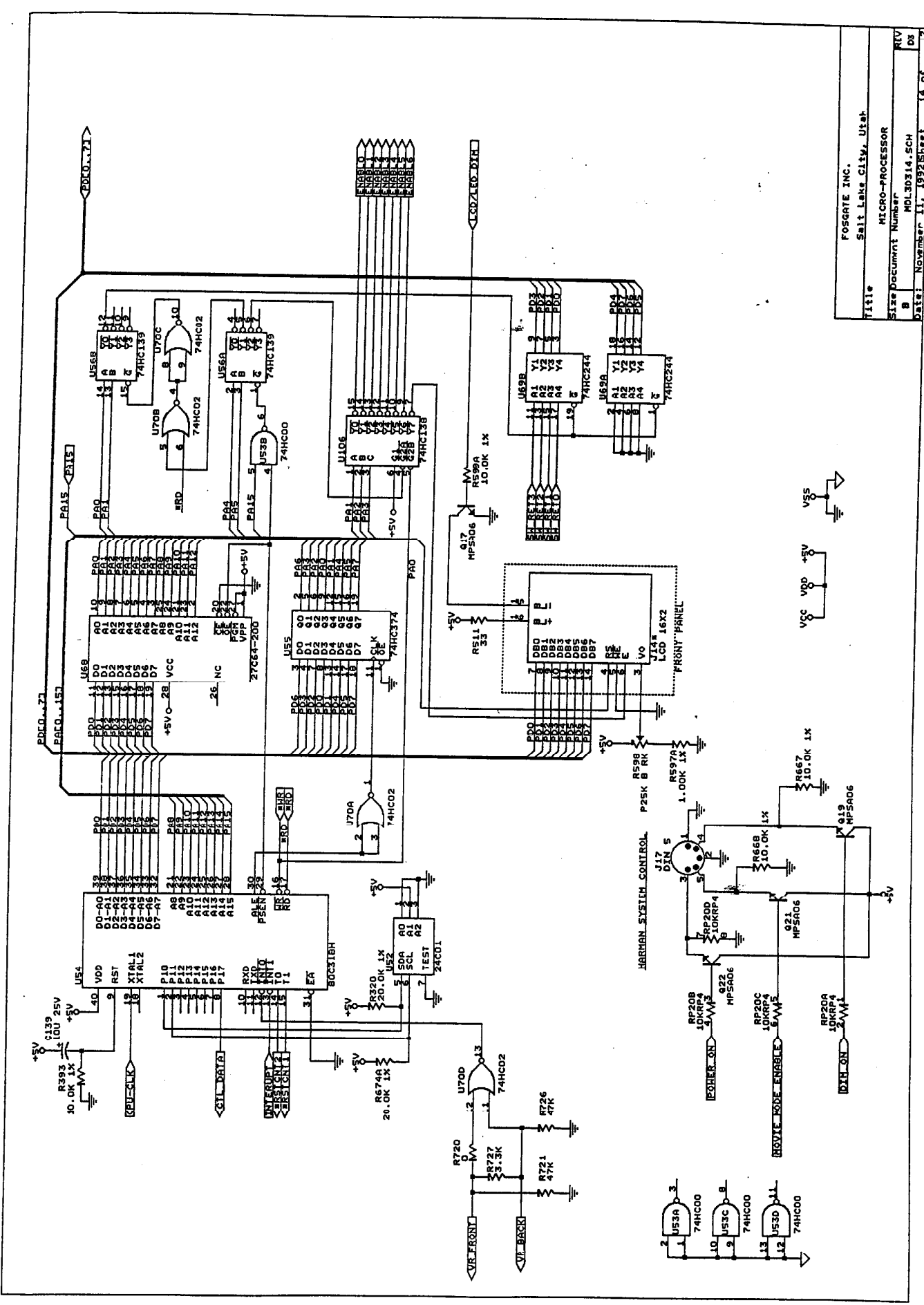

Title	FOSGATE INC. Salt Lake City, Utah
Size Document Number	MICRO-PROCESSOR B
Date	MDL30314.5CH 11, 1992 Sheet 14 of 17

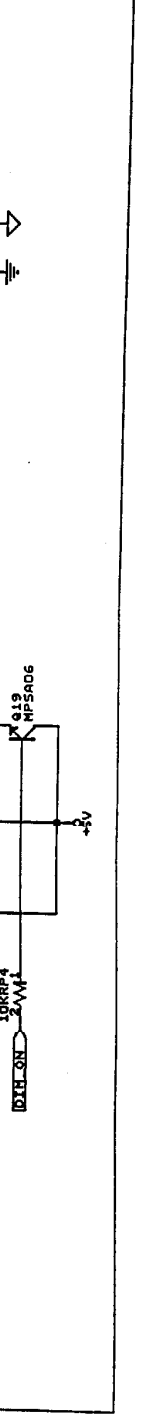

+5V  
 VCC  
 VDD  
 +5V  
 VSS

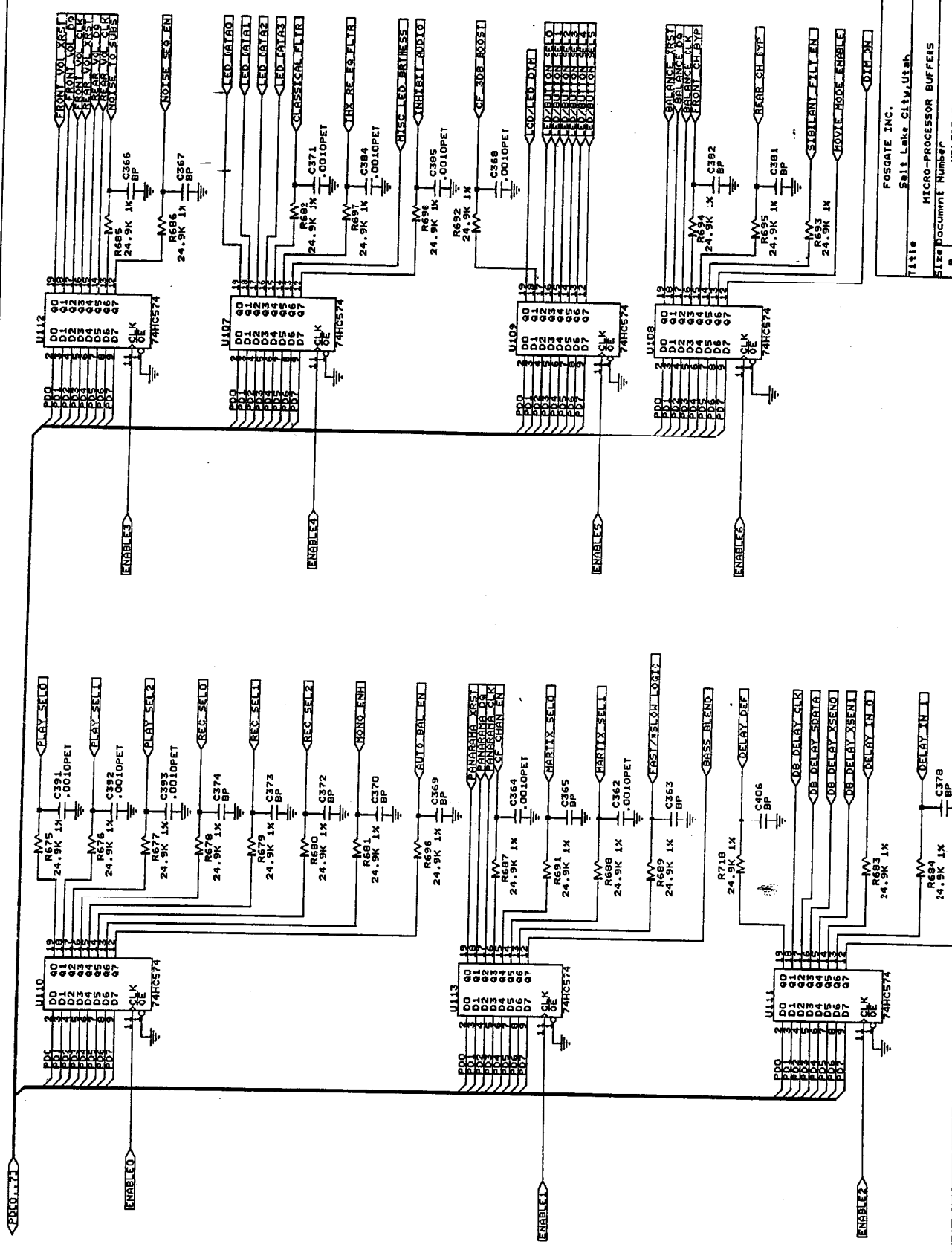

FOSGATE INC.

Salt Lake City, Utah

TITLE MICRO-PROCESSOR BUFFERS

Size Document Number HDL30315.SCH

Date: November 11, 1992 Sheet 15 of 17

REV  
D3

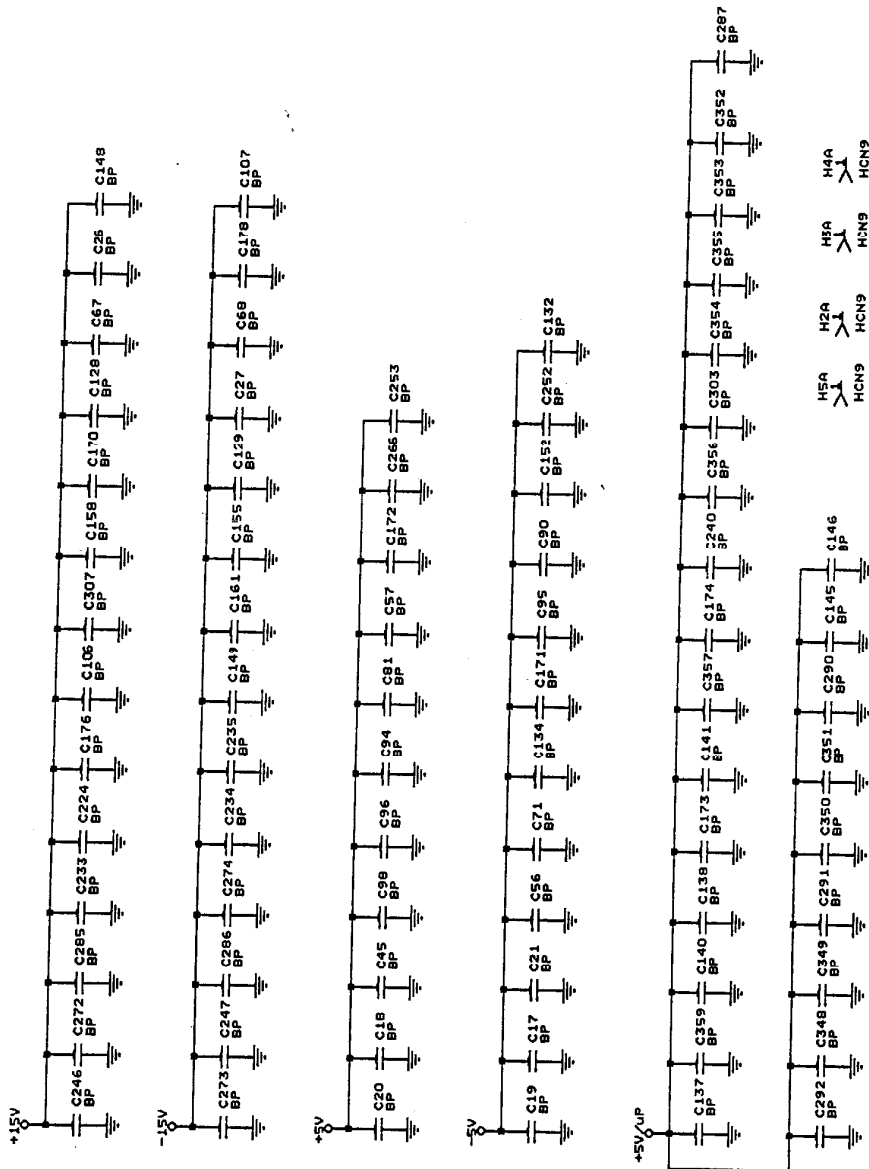

- .51 — .52 — .54 — .58 — .510 — .511 — .H51
- DIP85 DIP165 DIP205 DIP285 DIP405 PLCC685 MOL185
- .53 — .55 — .59
- DIP165 DIP205 DIP285
- .56 —
- DIP205
- .57 —
- DIP205

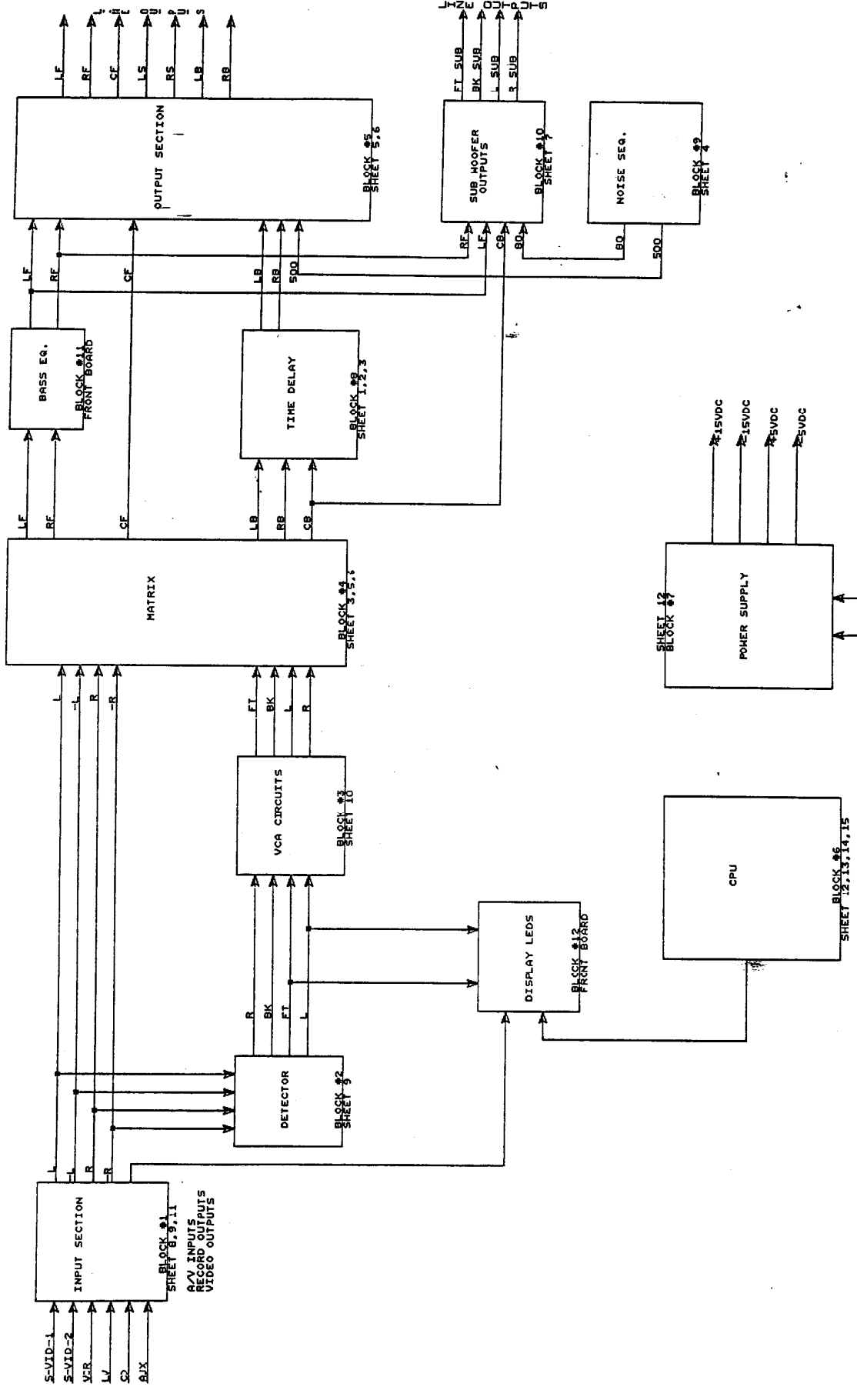

Title: FOSGATE INC.  
 Salt Lake City, Utah  
 BLOCK DIAGRAM  
 Size Document Number: B  
 MDL30517.5CH  
 REV: 03  
 Date: November 11, 1992 Sheet 17 of 17

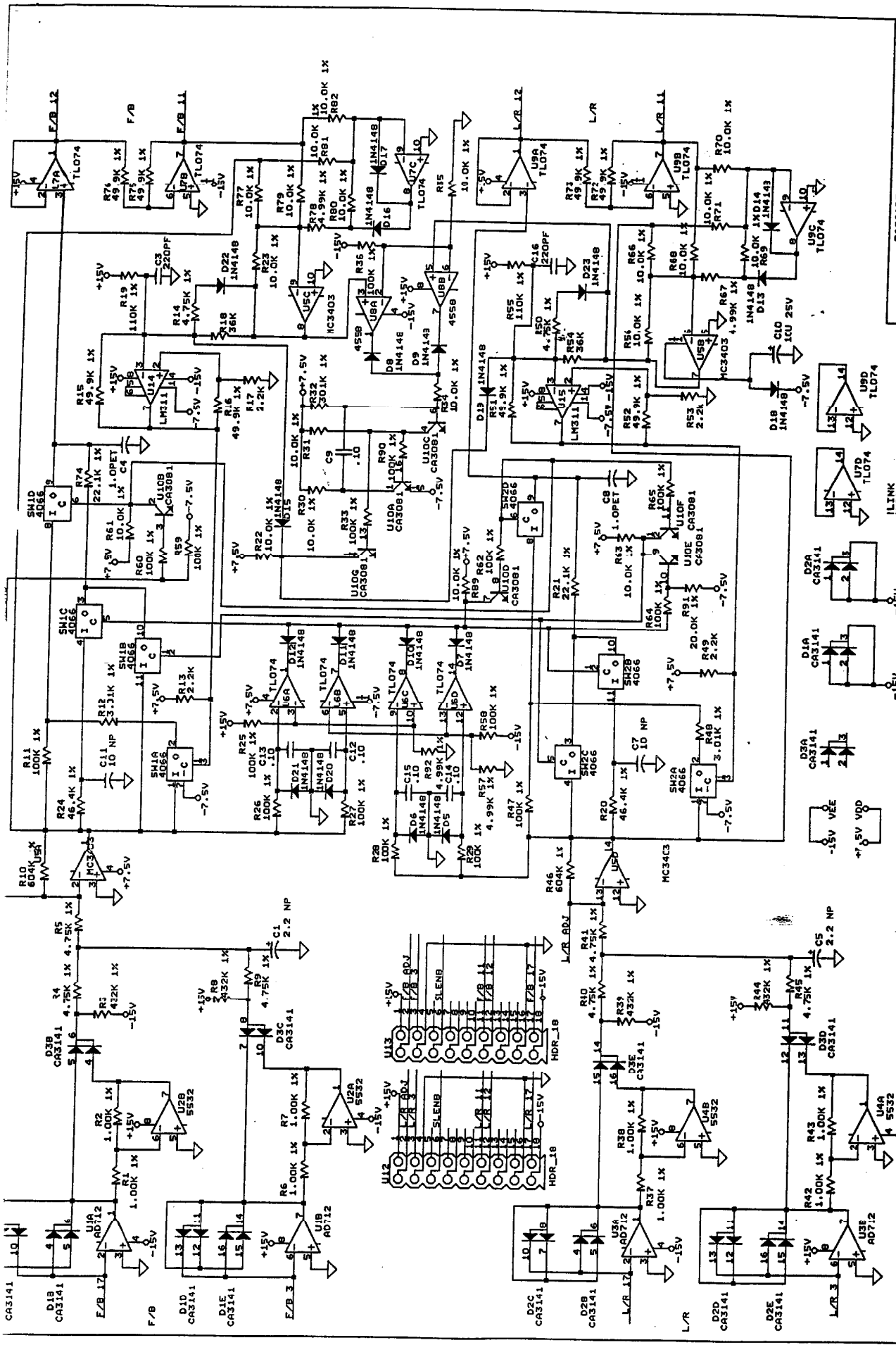

FOSGATE, INC.  
 Salt Lake City, Utah  
 Title: MODEL-3 CONTROL VOLTAGE GENERATOR  
 Size: Document Number MDS3BV81.SCH  
 REV 8  
 Date: June 1, 1992 ESK:ret 1 of 2

I LINK  
 IMDS3BV82.SCH



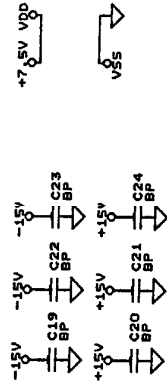
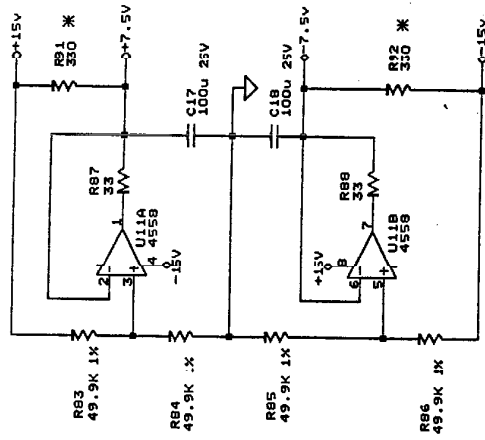

LAST USED REF. DES.

- C24
- D23
- S12
- S13
- U15

\* R81 AND R92 ARE INSTALLED ON SOLDER SIDE.

FOSGATE INC.	
Salt Lake City, Utah	
Title MODEL-3 CONTROL VOLTAGE GENERATOR	
Size	Document Number
B	MD382VB2.SCH
REV	B:
Date:	March 30, 1992 Sheet 2 of 2

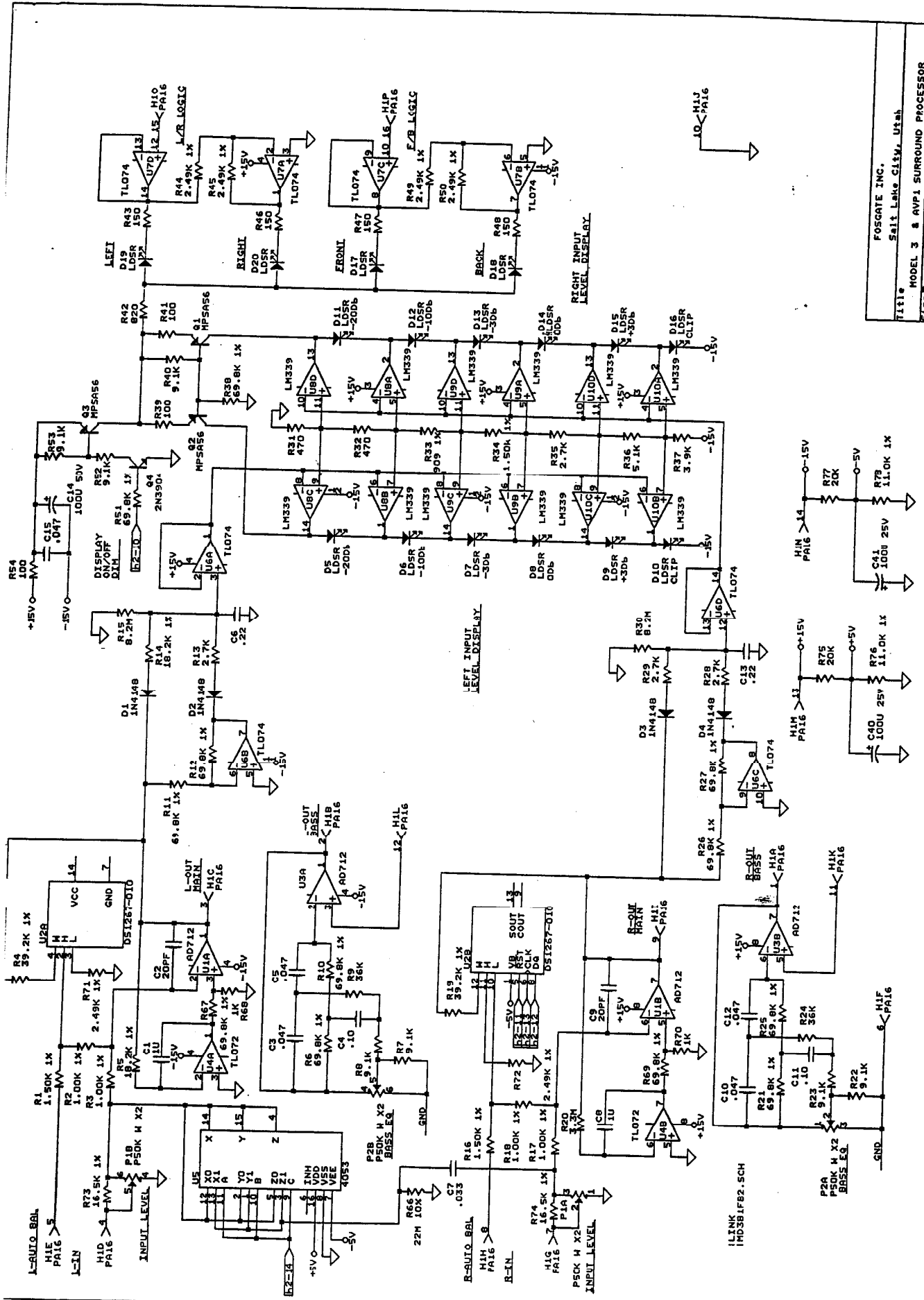

Title: FOSGATE INC.  
 Salt Lake City, Utah  
 Model 3 & AVPI SURROUND PROCESSOR  
 Size: Document Number: MDSB1FBI.SCH  
 Date: October 13, 1992 Sheet 1 of 2

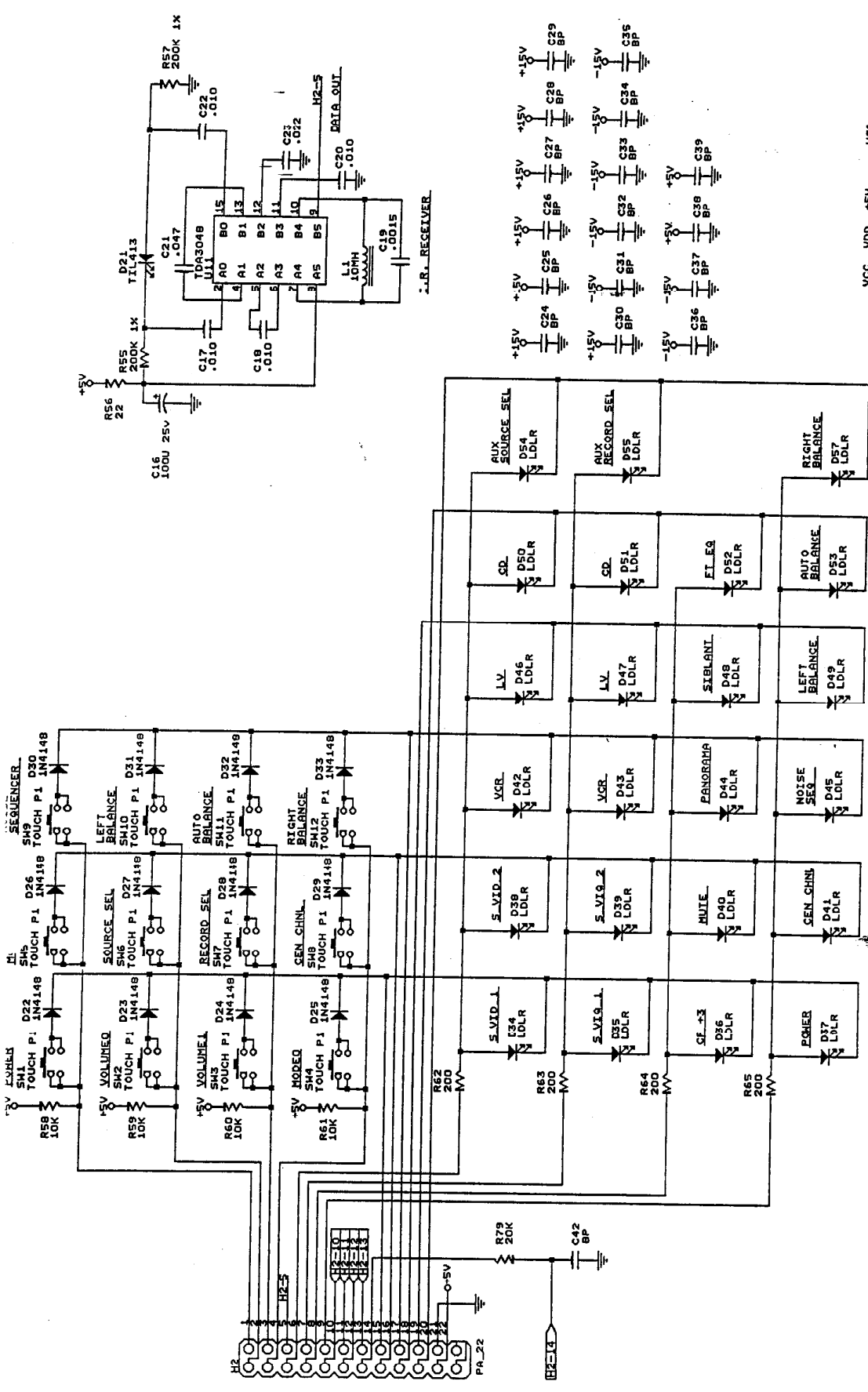

LAST REF.  
 D57  
 H2  
 L2  
 R79  
 SM12  
 T1  
 U11

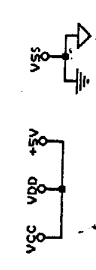
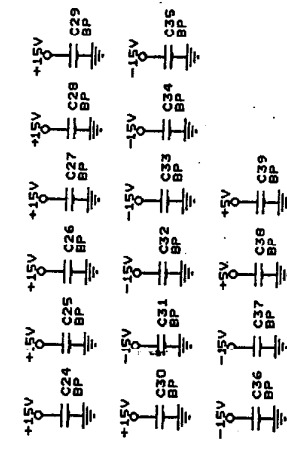
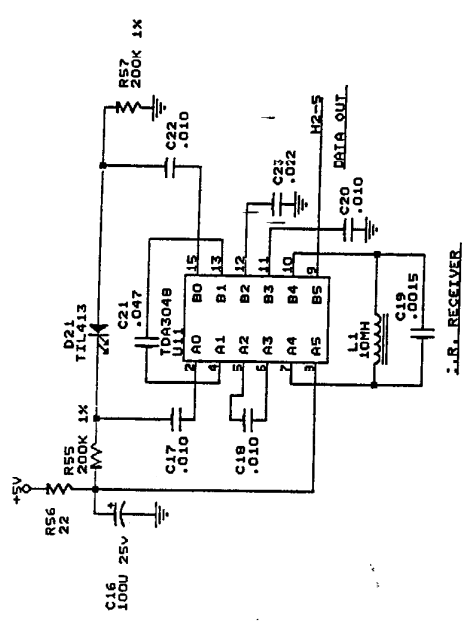

FOSGATE INC.  
 Salt Lake City, Utah  
 Title MODEL 3 & AVPI SURROUND PROCESSOR  
 Size Document Number B  
 H03B1F82.SCH  
 REV B1  
 Date: October 13, 1992 Sheet 2 of 2

SECTION 3

MODEL 3 TEST CHECKLIST

- \_\_\_ POWER SUPPLIES CHECK (digital 5v,5v,+15v,-15v,-5.6v)
- \_\_\_ L then R NULL SET
- \_\_\_ DETECT L/R and DETECT F/B SET
- \_\_\_ AUTO BALANCE SET AND CHECK
- \_\_\_ VCA BIAS SET and VCA GAIN SET
- \_\_\_ PITCH SHIFTER SET
- \_\_\_ OUTPUT LEVELS SET, VERIFY VOLUME CONTROL (to check 1267s, Front, left, right, backs, subs)
- \_\_\_ TIME DELAY AND THX OPERATION CHECK
- \_\_\_ DETECT SLOW LOGIC and PULSE WIDTH MODULATION CHECK
- \_\_\_ FREQUENCY RESPONSE CHECK (check sibilant and re-eq filters, and rear switches in appropriate channels)
- \_\_\_ NOISE SEQUENCER SET AND CHECK (check with and without CF, check subs)
- \_\_\_ REMOTE CONTROL FUNCTION CHECK (check panorama with left only signal, check CF switch and LED, mute switch and LED, centerboost switch and LED, Pan LED, sib LED, re eq LED)
- \_\_\_ REMOTE EXTERNAL CONTROL AND HARMON DIN CHECK (check on-off, THX, panel light.)
- \_\_\_ FRONT PANEL FUNCTIONS CHECK (check input balance, volume, and any LEDs not already checked, turn off unit and make sure signal turns off.)
- \_\_\_ AUDIO SWITCH OPERATION (INPUT AND RECORD)
- \_\_\_ COMPOSITE VIDEO SWITCH OPERATION (INPUT AND RECORD)
- \_\_\_ "S" VIDEO TEST
- \_\_\_ LISTEN TO OUTPUTS FOR NOISE (Check for Noise while in RE-EQ and Sibilant filters, all channels)
- \_\_\_ PAINT TRIMPOTS AND SIGN OFF

## DETAIL SET-UP PROCEDURES

### PRE-SETUP

1. Plug in unit and slowly turn up AC power while checking amp meter. Watch for too much current draw. Should draw about .3 amps.
2. Check power supply lines. +5 digital, +5, +15, -15, -5.6 volts DC.
3. Turn off bass EQ pot.
4. Turn up volume up to center of travel. (slow in shaft 90 degrees vertical.)
5. Turn up remote volume up full. (+15DB)
6. Turn mode to Rock mode and turn on center channel. Make sure time delay is set to 0.
7. Turn auto balance trim pots fully ccw.
8. Short tp4 pins together to turn off auto balance.

Detail Set-up (For nulling signals use at least 20mv sensitivity on scope. A ground wire on scope probe helps make signal readable)

(Signal)

(Direction)

(Left)

Null L & R trim pots

1. Null signal at U88 pin 1. Use L null trim pot (R425).
2. Null signal at U88 pin 7. Use R null trim pot (R392).

(L+R)

Set Detect Bal (pin 11 of U12 on CVG board)

3. Adjust R454 (L/R DET trim pot) to center signal.
4. Switch between L-R and L+R and center the DC offset between the two signals.

(Left)

5. Put probe on pin 11 of U13 on CVG board. Adjust R457 (F/B trim pot) and center signal to 0vd. Switch between Left and right signal and center the dc offset of the two signals.

(L+R)

Set auto balance

6. Put probe on pin 11 of U12. Turn up one of the auto balance trim pots until the signal just starts to move. Keep turning until the signal moves 10mv. Turn up the other trim pot until the signal moves in the opposite direction an equal amount. The signal should end up in the same dc offset as when you started.
7. Switch in the +4dc offset switch on your fixture and disconnect the short at TP4. The direction LEDs should show signal balance in about 4 to 6 seconds. Switch the offset switch in the opposite direction and reshort TP4 then unshort. Auto balance should balance the signal in about the same amount of time.

CVG board check

8. Check signal switches on U6 of CVG board. Check for the following.
  - A. pin 1 goes neg. in L-R only.
  - b. Pin 7 goes neg. in L+R only.
  - c. Pin 8 goes neg. in right only.
  - d. Pin 14 goes neg. in Left only.

### Slow logic check

9. SW1 pin 6 on CVG board. Logic goes low in chamber, orchestra, THX, Dolby, and mono enhance.

### Pulse width modulation check

10. Monitor pin 7 of U14 (CVG) while switching directions. The signal should start low and go momentarily hi then quickly low again.
11. Do the same at pin 7 of U15 CVG.

### Bias and Gain trim pot setting

(L+R)

12. Monitor pin 14 of U62. Null the Left bias trim pot.
13. Monitor pin 14 of U63. Null the Right bias trim pot.

(Left)

14. Monitor pin 14 of U64. Null the Front bias trim pot.
15. Monitor pin 14 of U65. Null the Back bias trim pot.
16. Use the below signal settings and matching test points and match and null the signals between the two test points.  
(it is easier and more accurate to use two probes and dual traces on the scope for this test.

<u>Signal Direction</u>	<u>Test Points</u>
Left	7,8
Right	6,9
Front	6,7
Back	8,9

(L-R)

### Set Bits Positive

17. Turn off Volume and put probe from the DB meter (set at -30dB) on pin 8 of U98. Slowly turn up volume until the DB meter goes to 0dB. (+or - .5dB)
18. Adjust R513 trim pot (just above U95) clock wise just until all of the bits go positive.

### Set output Levels

19. Set all output trim pots (accept sides) to the center of their travel. Turn sides down from center about 1/8th of a turn.

### Pitch shifter and delay circuit check

19. Put probes on back outputs and monitor sin waves while switching through modes. Sin waves should be the same size in all modes. You should see pitch shifter movement in THX Prologic and in Movie modes.
20. Put probe on pin 8 of U46 and add time delay in Rock mode. Sin wave should appear. Touch probe to U71 pin 8. Same wave should be there. Turn off time delay with remote.

### Signal Noise Generator set

21. Turn on noise generator and turn up noise level trim pot so you can see the channel switching in the level gauges.
22. Make sure each channel is turned on in turn with no skipping channels.
23. Turn off noise gen and turn off center front channel. Turn generator back on. Note switching goes from left front to left and right front (the same level) then to right then on around. The output level should be about the same amplitude.
24. Switch out the side channels (right switch on the back of the board. Make sure the side channels are skipped.

25. Set sequencer to bass and put back rca plugs in the front

- and back bass output jacks. Watch sequencer switch around the sub outputs. The levels should be about the same.
26. Set DB meter to -20dB range and put probe on pin 7 of U25. Adjust R88 (noise level trim pot) to show 0DB. (About .5vpp on the Scope)

#### Frequency Response check

27. Switch to RTA and monitor the below signals. L+R signal.
- a. Rock should have flat response.
  - b. In rock mode check front 80hz high pass crossover switch in cf and then right then left front. In cf the roll off will show flat signal. In the left and right front the normally flat signal will roll off at about 80 hz.
  - c. Switch to backs and switch in the back high pass switch. The low frequency will come through.
  - d. Check RE-EQ in cf. It should roll of the highs (about 8khz) slightly. Check in Left and Right fronts.
  - e. Check Sibilant in L and R front, sides and backs. It should roll off signal above about 4k in all channels.
  - f. Set signal to L back and then repeat in right back.
    1. Rock has flat response.
    2. Pop has -3dB drop from rock.
    3. Jazz is same as Pop
    4. Pro-logic has roll off above 4khz.
    5. Thx is about the same.
    6. Chamber rolls off below 250hz and above 2khz.
    7. Orchestra same as chamber but -3db lower level.
    8. 70mm movie rolls off at 8khz
    9. 35mm movie same.
    10. mono enhance has no signal.
    11. Stereo bypass has no signal.

#### Audio Input and record output check.

28. Unplug a left and right output cord and plug them into the record out jacks.
29. Switch through input channels and record output channels matching channels in turn. Make sure both input and record output show a signal processing and no bleed through from other channels.

#### Video inputs and output source check.

30. Input a source audio signal into the video inputs, VCR, LV, CD, AUX. Switch input select and record select to vcr and monitor with scope probe on .5v/d. Make sure video output source and record out shows signal at matching input signal.

#### "S" Video circuit test.

31. Connect video in on S-input video 1 (j5) and output on S-outputs Source (j3). Switch through input source. Video will turn on only in source select S-video-1. Switch input to Video 2. Video will turn on only in S-video-2.
32. Switch output to S-output Record jack (j2) and switch input back to video 1. Video will only play when record select is set to S-video-1. Switch input to video 2. Video will only play when record select in set to S-video-2.

#### Final Check



33. Input L+R signal.
34. Check all remote functions and LEDs not yet checked. including- cf switching. of boost, mute switch, sib and re-eq switch. Make sure all LEDs light.
35. Using Left signal change panorama on remote and watch for the change in direction LEDs and Panorama on LED in front panel.
36. Plug in the 5 pin din connector to J1 going to the remote sensor. Point remote control only at remote sensor to make sure the back sensor jack works.
37. Plug in the Harmon din LED circuit jig. With remote control turn off front panel lights and make sure led on jig lights. Switch mode to a time delay mode and make sure led on jig lights. Turn off unit and make sure red LED lights.
38. Check all front panel controls work including left and right side biasing and auto balance. Turn off unit and make sure the signal dies.
39. Listen to output for noise. (excessive popping, hums, static. Switch in RE-EQ and Sibilant filters to make sure they don't pop.
40. Paint trim pots and sign sheet.

## LEAKAGE TEST

All accessible parts are to be tested for leakage current and all parts accessible during user servicing are to be tested for shock current. The current from these parts measured to the grounded supply conductor individually as well as collectively where simultaneously accessible from one part, or group of parts, to another part or group of parts where simultaneously accessible. Parts are considered to be simultaneously accessible when they can be contacted by one or both hands of a person at the same time.

For the purpose of this measurement, one hand is considered to be able to simultaneously contact parts that are within a 4- by 8- inch (101.6- by 203.2-MM) rectangle. Parts that can be contacted simultaneously by a person having a reach of 6 Ft. (1.83M) are considered to be touchable by both hands.

Leakage or shock current refers to all currents, including capacitively coupled currents.

If leakage current is more than .5 ma at maximum rated voltage the unit will need to be repaired before it can be returned to the customer.

The meter that is actually used for the A measurement need only indicate the same numerical value for the particular measurement as the ideal instrument. The meter used need not have all the attributes of the ideal instrument.

## METER REQUIREMENTS

- A. The meter is to have an input impedance of 1500 ohms resistive shunted by a capacitance of .15uF.
- B. The meter is to indicate 1.11 times the average of the full-wave rectified composite waveform of voltage across the resistor or current through the resistor.
- C. Over a frequency range of 0-100khz the measurement circuitry is to have a frequency response (ratio of indicated to actual value of current) that is equal to the ratio of the impedance of A 1500 ohm resistor shunted by A .15 uF capacitor to 1500 ohms. At an indication of .5ma, the measurement is to have an error of not more than 5 percent at 60 HZ.
- D. Unless the meter is being used to measure current from one part of an appliance to another, the meter is to be connected between the accessible parts and the grounded supply conductor.

### LEAKAGE TEST

SEE FIG A FOR WIRING DIRECTIONS

- A. With switch S1 open, the Model 3 is to be connected to the measuring circuit. Immediately after connection, the current is to be measured using both positions of switch S2.
- B. Switch S1 is then to be closed energizing the Model 3; Immediately after closing the switch, the current is to be measured using both positions of S2.
- C. Current measurements of items A and B are to be repeated after thermal stabilization of Model 3 has been reached.

LEAKAGE CURRENT MEASUREMENT CIRCUITS

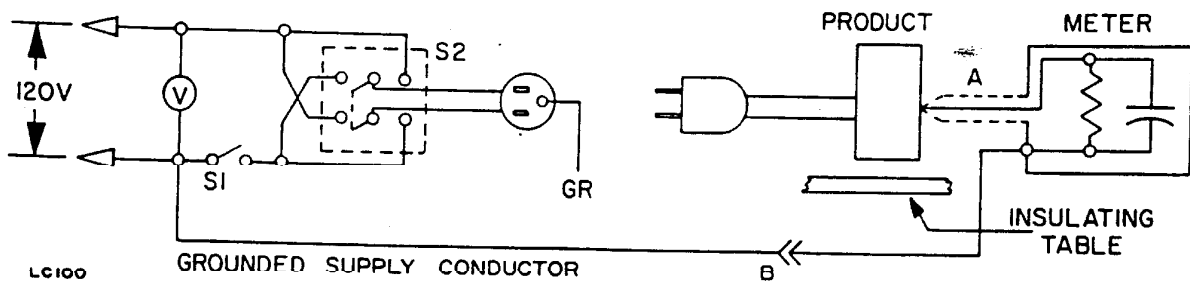

**SECTION 4**

Mode Logic

REGISTER 0 (ADDRESS 8020-H) U110

BIT 0 PLAY SEL.0  
BIT 1 PLAY SEL.1  
BIT 2 PLAY SEL.2  
BIT 3 RECORD SEL.0  
BIT 4 RECORD SEL.1  
BIT 5 RECORD SEL.2  
BIT 6 MONO ENHANCE  
BIT 7 AUTO BALANCE DEFEAT

IC PINOUTS FOR BITS

BIT 0=PIN 19  
BIT 1=PIN 18  
BIT 2=PIN 17  
BIT 3=PIN 16  
BIT 4=PIN 15  
BIT 5=PIN 14  
BIT 6=PIN 13  
BIT 7=PIN 12

REGISTER 1 (ADDRESS 8022-H) U113

BIT 0 PANORAMA XRST  
BIT 1 PANORAMA DQ  
BIT 2 PANORAMA CLK  
BIT 3 CENTER FRONT CHANNEL ENABLE  
BIT 4 MATRIX SEL.0  
BIT 5 MATRIX SEL.1  
BIT 6 FAST SLOW LOGIC  
BIT 7 OUTPUT MUTE

REGISTER 2 (ADDRESS 8024-H) U111

BIT 0 DELAY DEFEAT  
BIT 1 DELAY CLK  
BIT 2 DELAY SDATA  
BIT 3 DELAY XSENO  
BIT 4 DELAY XSENI  
BIT 5 DELAY IN 0  
BIT 6 DELAY IN 1  
BIT 7 POWER ON BUTTON

REGISTER 3 (ADDRESS 8026-H) U112

BIT 0 FRONT VOLUMN XRST  
BIT 1 FRONT VOLUMN DQ  
BIT 2 FRONT VOLUMN CLK  
BIT 3 REAR VOLUMN XRST  
BIT 4 REAR VOLUMN DQ  
BIT 5 REAR VOLUMN CLK  
BIT 6 NOISE TO SUBWOOFERS  
BIT 7 NOISE SEQUENCE ENABLE

REGISTER 4 (ADDRESS 8028-H) U107

BIT 0 LED DATA 0  
BIT 1 LED DATA 1  
BIT 2 LED DATA 2  
BIT 3 LED DATA 3  
BIT 4 CLASSICAL FILTER  
BIT 5 THX RE-EQ FILTER  
BIT 6 LED BRIGHTNESS  
BIT 7 INHIBIT AUDIO

REGISTER 5 (ADDRESS 802A-H) U109

BIT 0 LCD BACK LIGHT  
BIT 1 CENTER FRONT 3db BOOST  
BIT 2 LED, BUTTON SELECT 0  
BIT 3 LED, BUTTON SELECT 1  
BIT 4 LED, BUTTON SELECT 2  
BIT 5 LED, BUTTON SELECT 3  
BIT 6 LED, BUTTON SELECT 4  
BIT 7 LED, BUTTON SELECT 5

REGISTER 6 (ADDRESS 802C-H) U108

BIT 0 BALANCE XRST  
BIT 1 BALANCE DQ  
BIT 2 BALANCE CLK  
BIT 3 FRONT CHANNEL BYPASS  
BIT 4 REAR CHANNEL BYPASS  
BIT 5 SIBLANT FILTER ENABLE  
BIT 6 MOVIE MODE ENABLE  
BIT 7 DIM ON BUTTON

STEREO	MONO ENHANCE	ORCHESTRA	CHAMBER	35MM	70MM	PROLOGIC THX	PROLOGIC	JAZZ	POPULAR	ROCK	S-VID-1	S-VID-2	VCR	LV	CD	AUX	CF	POWER	CF+3DB								
										X	X		X														
											X	X															
													X	X													
										X	X		X														
											X	X															
													X	X													
X																											
																	X										
	X			X				X																			
X	X								X																		
X	X	X				X	X																				
								X	X																		
			X	X																							
						X	X																				
	X	X																									
																				X							
				X	X	X	X																				

REG.0 BIT0 PLAY SEL 0  
REG.0 BIT1 PLAY SEL 1  
REG.0 BIT2 PLAY SEL 2  
REG.0 BIT3 RECORD SEL 0  
REG.0 BIT4 RECORD SEL 1  
REG.0 BIT5 RECORD SEL 2  
REG.0 BIT6 MONO ENHANCE  
REG.1 BIT3 CF ENABLE  
REG.1 BIT4 MATRIX SEL 0  
REG.1 BIT5 MATRIX SEL 1  
REG.1 BIT6 FAST/SLO LOG  
REG.2 BIT0 DELAY DEF.  
REG.2 BIT5 DELAY IN 0  
REG.2 BIT6 DELAY IN 1  
REG.2 BIT7 POWER ON  
REG.4 BIT4 CLASCL FIL  
REG.4 BIT5 THX RE-EQ  
REG.5 BIT1 CF +3DB  
REG.6 BIT3 FRONT BYP  
REG.6 BIT4 REAR BYP  
REG.6 BIT5 SIB FILTER  
REG.6 BIT6 MOVIE MODE

**SECTION 5**



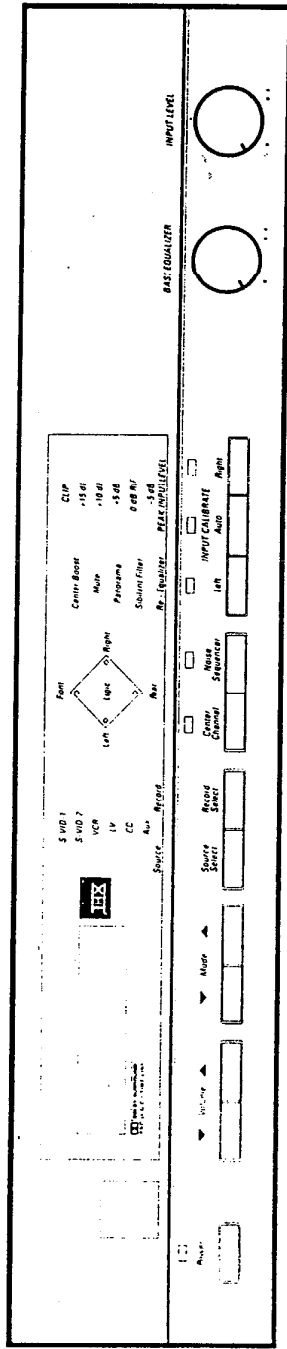

**PANORAMA**  
Panorama settings may be adjusted from -50 to +50 and will vary to taste depending on the individual recording. Panorama cannot be engaged in the Pro Logic or THX Cinema modes. Panorama settings cannot be stored because they are also program source dependant.

**Orchestra**  
**+0 Panorama -0**

The display system used on the front panel employs a combination of light emitting diodes (LED) and a liquid crystal (LCD).

**PRIMARY FUNCTIONS**

Surround operating modes, volume settings, audio delay time settings and panorama settings, are displayed on the liquid crystal panel. The selected surround operating mode is always displayed. Changes in volume (front or back channels) time delay settings, and panorama settings, are momentarily displayed (about ten seconds) on the second line of the liquid crystal display.

**INPUT CALIBRATE**

This function is performed automatically when the "Auto" button on the remote or the front panel is engaged. If a stereo audio source has a channel imbalance error

beyond the capability of Autobalance, then the left or right button may be engaged to restore proper channel balance. Under virtually all conditions the Autobalance circuit should be left engaged. Operating status is displayed by LED's on the front panel.

**INPUT LEVEL**

The input level control on the front panel is adjusted to never illuminate the red clip level LED.

**VOLUME**

The master volume setting has a range from -85 to +15 displayed on the liquid crystal display. These settings do not necessarily relate to dB equivalents. Normally, the output volume level is set to the 0 REF setting when playing reference "0 dB" level signals

from videocassettes or HiFi video cassettes. The channel output trim controls on the back of the are individually adjusted to achieve proper output levels with sufficient headroom and freedom from amplifier or speaker overload. The built-in Noise Sequencer is used to perform this function.

**DELAY TIME**

Delay settings can be adjusted from 15 to 30 ms in the Pro Logic or THX Cinema modes, up to 50 ms in the 35mm and 70mm movie modes and up to 85 ms in some music modes. Changes in audio signal delays settings are automatically retained in the memory

**Dolby Pro Logic**

Delay Time: 30ms

**SECONDARY FUNCTIONS**

These include: Center Channel Boost, Sibilant and Re-Equalization (RE-EQ) Filters, Mute, Source Record Select and Center Channel On/Off. The engagement of these functions is displayed by LEDs on the front panel or behind the front panel window.

**RE-EQ and Center Front Channel On functions may be selected in all music modes.**

RE-EQ is only selected automatically in the THX Cinema mode but it may be disengaged in the THX Cinema mode or engaged in other modes. The need of RE-EQ in non-THX modes is source dependant and cannot be stored.

**SECTION 6**

# INPUTS / OUTPUTS

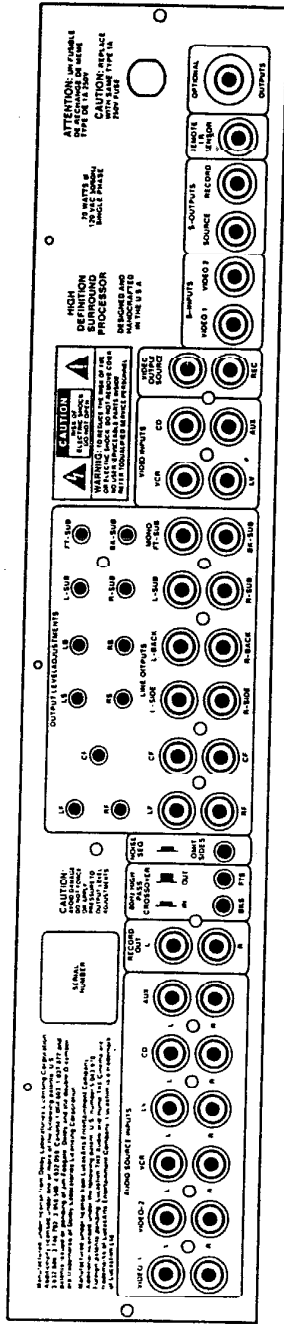

## S-OUTPUTS

The Source output feeds a video monitor or projector which accepts S-type video while the Record output feeds a VCR or second room location.

## AUDIO INPUTS

All input jacks are grouped to the left hand side of the rear panel as viewed from the backside of the AVPT. They are labeled Video 1 Video 2, VCR, LV, CD, and Aux, respectively. All six inputs accept input signals ranging in level from less than a tenth of a volt to over three volts in level.

## AUDIO OUTPUTS

This group of output jacks provides the appropriate signals to feed external amplifiers to power all of the main speakers (L, C, R), subwoofers (L, R, Mono and Surround Mono), and surround speakers (LS, RS, LB, RB). Individual output level trim controls are located directly above this group of jacks.

## VIDEO OUTPUTS

This pair of composite video outputs located to the right of video inputs provides an output to feed a video monitor or projector. The record (REC) output provides a separate feed for recording or a second room location. The video signal for the REC output is selected by the Record Select button on the front panel

## AUDIO RECORD OUTPUTS

This pair of output jacks located next to the audio input group, provides an output signal for a tape recorder or a second zone or room location.

## VIDEO INPUTS

This group of input jacks located to the right of the audio output jacks accepts composite video signals from VCRs, laser disc players, cable television tuners, or satellite television receivers, should be connect via these inputs.

## S-INPUTS

Video 1 and Video 2 accept S-type video signals from S-type VCRs laser disc players and satellite television receivers.

**SECTION 7**

# REMOTE CONTROL FUNCTIONS

## REAR (BACK) LEVEL

Raises or lowers the surround channel level.

## REF

Restores system front to back balance.

## PANORAMA

Widens or narrows the stereo stage. Panorama is not operative in Pro Logic or Home THX Cinema Mode. The CTR button below the PAN button turns off Panorama and restores the normal setting.

## SOURCE

Selects the desired A/V input.

## DELAY

Adjusts the Time Link setting from 15 to 30ms in Pro Logic and Home THX Cinema with additional options in music, 35mm, 75 mm modes.

## SURROUND PARAMETERS

Selects various modes for music and movies. See descriptions on page 6.

## SIB (Sibilant filter)

This filter reduces center channel dialog leakage in the surround channel.

## RE-EQ

This filter is automatically engaged in the Home THX Cinema mode. It can also be disengaged, if desired, in the Home THX Cinema mode or engaged in other surround modes.

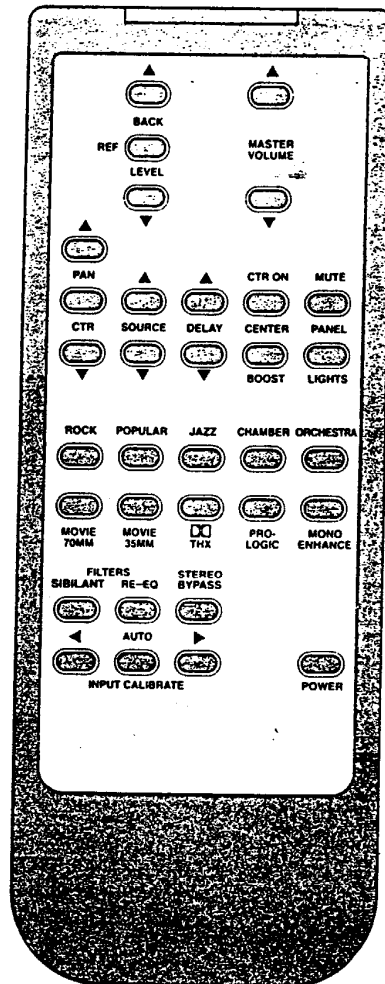

## MASTER VOLUME

These buttons raise or lower the total system volume. The reference volume level setting is shown as 0 dB Ref.

## CTR ON

This button turns the center channel on or off.

## MUTE

This button turns the audio output on or off.

## CTR BOOST

This button raises the center speaker level by 3 dB.

## PANEL DIM

This button dims the front panel LED display.

## BYPASS

This mode bypasses all processing except the electronic crossover (if used).

## POWER

This button turns the inputs/outputs on or off. Some digital section power supplies remain operative.

## INPUT CALIBRATE

The auto button selects the automatic balance circuit. The left/right buttons allow manual balance adjustment of input audio signals.

**SECTION 8**

MODEL 3 &amp; AVPL SURROUND PROCESSOR

Revised: October 13, 1992

MD3B1FB1.SCH

Revision: B1

Bill Of Materials

November 16, 1992

10:27:33

Quan Reference

Part

SYMAN

Description

Quan Reference	Part	SYMAN	Description
2	C1,C8	1U 60-0044-01	1.0 uF Capacitor +80%,-20% 50V Electrolytic
2	C2,C9	20PF 62-0014	20 pF Capacitor 5% 50V Ceramic Disc
6	C3,C5,C10,C12,C15,C21	.047 56-2028	0.047 uF Capacitor 10% 100V Polyester Film
2	C4,C11	.10 56-2035	0.10 uF Capacitor 10% 100V Polyester Film
2	C6,C13	.22 56-2038	0.22 uF Capacitor 10% 100V Polyester Film
1	C7	.033 56-2027	0.033 uF Capacitor 10% 100V Polyester Film
1	C14	100U 50V 60-0068	100.0 uF Capacitor +80%,-20% 50V Electrolytic
1	C16	100U 25v	
4	C17,C18,C20,C22	.010 56-2022	0.010 uF Capacitor 10% 100V Polyester Film
1	C19	.0015 56-2010	0.0015 uF Capacitor 10% 100V Polyester Film
1	C23	.022 56-2025	0.022 uF Capacitor 10% 100V Polyester Film
17	C24,C25,C26,C27,C28,C29, C30,C31,C32,C33,C34,C35, C36,C37,C38,C39,C42	BP 62-0067	0.047 uF Capacitor 20% 50V Axial Monolithic
2	C40,C41	100U 25V 60-0055	100.0 uF Capacitor +80%,-20% 25V Electrolytic
6	D1,D2,D3,D4,D22,D23,D24, D25,D26,D27,D28,D29,D30, D31,D32,D33	1N4148 70-0002	1N4148 Silicon Switching Diode, 75 Volts PIV
16	D5,D6,D7,D8,D9,D10,D11, D12,D13,D14,D15,D16,D17, D18,D19,D20	LDSR 70-2061	Red Light Emitting Diode, T1 Case
1	D21	TIL413 70-2028	Infrared diode
23	D34,D35,D36,D37,D38,D39, D40,D41,D42,D43,D44,D45, D46,D47,D48,D49,D50,D51, D52,D53,D54,D55,D57	LDLR 70-2059	Red Light Emitting Diode, T1.75 Case
1	H1	PA16 -----	16 Pin Pad, Not a part
1	H2	PA_22 -----	22 Pin Pad, Not a part
1	L1	10MH 26-0201	10 mH Torroid Choke
2	P1,P2	P50K W X2 40-2028	50 k "W" Pot, x2, Rack Leads
3	Q1,Q2,Q3	MPSA56 70-1025	MPSA06 NPN Gen. Purpose Transistor
1	Q4	2N3904 70-1004	2N3904 NPN Gen. Purp. Amplifier/Switching Transistor
2	R1,R16	1.50K 1% 52-0144-01	1.50 KOhm Resistor 1% 1/4 Watt Metal Film
4	R2,R3,R17,R18	1.00K 1% 52-0133-01	1.00 KOhm Resistor 1% 1/4 Watt Metal Film
	R4,R19	39.2K 1% 52-0079-01	39.2 KOhm Resistor 1% 1/4 Watt Metal Film
2	R5,R14	18.2K 1% 52-0093-01	18.2 KOhm Resistor 1% 1/4 Watt Metal Film
12	R6,R10,R11,R12,R21,R25, R26,R27,R38,R51,R67,R69	69.8K 1% 52-0012-01	69.6 KOhm Resistor 1% 1/4 Watt Metal Film
7	R7,R8,R22,R23,R40,R52, R53	9.1K 50-0223-01	9.1 KOhm Resistor 5% 1/4 Watt Carbon Film
2	R9,R24	36K 50-0238-01	36 KOhm Resistor 5% 1/4 Watt Carbon Film
4	R13,R28,R29,R35	2.7K 50-0210-01	2.7 KOhm Resistor 5% 1/4 Watt Carbon Film
2	R15,R30	8.2M 50-0297-01	8.2 MOhm Resistor 5% 1/4 Watt Carbon Film
1	R20	3.3M 50-0049-01	3.3 MOhm Resistor 5% 1/4 Watt Carbon Film
2	R31,R32	470 50-0006	470 Ohm Resistor 5% 1/4 Watt Carbon Film
1	R33	909 1% 52-0313-01	909 Ohm Resistor 1% 1/4 Watt Metal Film
1	R34	1.50k 1%	
1	R36	5.1K 50-0217-01	5.1 KOhm Resistor 5% 1/4 Watt Carbon Film
1	R37	3.9K 50-0214-01	3.9 KOhm Resistor 5% 1/4 Watt Carbon Film
3	R39,R41,R54	100 50-0003	100 Ohm Resistor 5% 1/4 Watt Carbon Film
1	R42	820 50-0009-01	820 Ohm Resistor 5% 1/4 Watt Carbon Film
4	R43,R46,R47,R48	150 50-0179-01	150 Ohm Resistor 5% 1/4 Watt Carbon Film

Quan	Reference	Part	SYMAN	Description
6	R44,R45,R49,R50,R71,R72	2.49K 1%	52-0141-01	2.49 KOhm Resistor 1% 1/4 Watt Metal Film
2	R55,R57	200K 1%	52-0276-01	200 KOhm Resistor 1% 1/4 Watt Metal Film
1	R56	22	50-0158-01	22 Ohm Resistor 5% 1/4 Watt Carbon Film
4	R58,R59,R60,R61	10K	50-0020	10 KOhm Resistor 5% 1/4 Watt Carbon Film
4	R62,R63,R64,R65	200	50-0004	200 Ohm Resistor 5% 1/4 Watt Carbon Film
1	R66	22M 10%	50-0308-01	22M MOhm Resistor 10% 1/4 Watt Carbon Film
2	R68,R70	1K	50-0012	1 KOhm Resistor 5% 1/4 Watt Carbon Film
2	R73,R74	16.5K 1%	52-0094-01	16.5 KOhm Resistor 1% 1/4 Watt Metal Film
3	R75,R77,R79	20K	50-0023	20 KOhm Resistor 5% 1/4 Watt Carbon Film
2	R76,R78	11.0K 1%	52-0105-01	11.0 KOhm Resistor 1% 1/4 Watt Metal Film
12	SW1,SW2,SW3,SW4,SW5,SW6, SW7,SW8,SW9,SW10,SW11, SW12	TOUCH P1		
2	U1,U3	AD712	72-4200	Dual High Speed Bifet Op-Amp
1	U2	DS1267-010	72-4106	Digital Volumn Control
1	U4	TL072	72-4020	Dual JFet-Input Op-Amp
1	U5	4053	72-0086	TRI 2 CH Analog Mix
2	U6,U7	TL074	72-4021	Quad JFet-Input Op-Amp
3	U8,U9,U10	LM339	72-4053	Quad Comparator
1	U11	TDA3048	72-4081	Infrared Remote Control Reciever



MODEL-3 CONTROL VOLTAGE GENERATOR

Revised: March 18, 1992

MD3B2VB1.SCH

Revision: B2

Bill Of Materials

November 16, 1992

10:19:21

Quan Reference

- Part

SYMAN

Description

Quan	Reference	Part	SYMAN	Description
2	C1,C5	2.2 NP	60-0043	2.2 uF Capacitor +80%,-20% 25V Elect., NP
2	C3,C16	220PF	62-0022	220 pF Capacitor 20% 50V Ceramic Disc
2	C4,C8	1.0PPT	62-1022	1.0 Box Cap., 10% 100V, 10mm Poly. Film
2	C7,C11	10 NP	60-0051-01	10.0 uF Capacitor +80%,-20% 16V Elect., NP
5	C9,C12,C13,C14,C15	.10	56-2035	0.10 uF Capacitor 10% 100V Polyester Film
1	C10	10U 25V	60-0050-01	10.0 uF Capacitor +80%,-20% 25V Electrolytic
2	C17,C18	100u 25V		
6	C19,C20,C21,C22,C23,C24	BP	62-0067	0.047 uF Capacitor 20% 50V Axial Monolithic
3	D1,D2,D3	CA3141	72-4122	High-voltage Diode Array
19	D5,D6,D7,D8,D9,D10,D11, D12,D13,D14,D15,D16,D17, D18,D19,D20,D21,D22,D23	1N4148	70-0002	1N4148 Silicon Switching Diode, 75 volts PIV
8	R1,R2,R6,R7,R37,R38,R42, R43	1.00K 1%	52-0133-01	1.00 KOhm Resistor 1% 1/4 Watt Metal Film
4	R3,R8,R39,R44	432K 1%	52-0244-01	432 KOhm Resistor 1% 1/4 Watt Metal Film
3	R4,R5,R9,R14,R40,R41,R45, R50	4.75K 1%	52-0166-01	4.75 KOhm Resistor 1% 1/4 Watt Metal Film
2	R10,R46	604K 1%	52-0230-01	604 KOhm Resistor 1% 1/4 Watt Metal Film
16	R11,R25,R26,R27,R28,R29, R33,R36,R47,R58,R59,R60, R62,R64,R65,R90	100K 1%	52-0305-01	100 KOhm Resistor 1% 1/4 Watt Metal Film
2	R12,R48	3.01K 1%	52-0125-01	3.01 KOhm Resistor 1% 1/4 Watt Metal Film
3	R13,R17,R49	2.2K	50-0208-01	2.2 KOhm Resistor 5% 1/4 Watt Carbon Film
12	R15,R16,R51,R52,R72,R73, R75,R76,R83,R84,R85,R86	49.9K 1%	52-0020-01	49.9 KOhm Resistor 1% 1/4 Watt Metal Film
2	R18,R54	36K	50-0238-01	36 KOhm Resistor 5% 1/4 Watt Carbon Film
2	R19,R55	110K 1%	52-0301-01	110 KOhm Resistor 1% 1/4 Watt Metal Film
2	R20,R24	46.4K 1%	52-0022-01	46.4 KOhm Resistor 1% 1/4 Watt Metal Film
2	R21,R74	22.1K 1%	52-0089-01	22.1 KOhm Resistor 1% 1/4 Watt Metal Film
20	R22,R23,R30,R31,R34,R35, R56,R61,R63,R66,R68,R69, R70,R71,R77,R79,R80,R81, R82,R89	10.0K 1%	52-0107	10.0 KOhm Resistor 1% 1/4 Watt Metal Film
1	R32	301K 1%	52-0259-01	301 KOhm Resistor 1% 1/4 Watt Metal Film
	R53	2.2k		
4	R57,R67,R78,R92	4.99K 1%	52-0165-01	4.99 KOhm Resistor 1% 1/4 Watt Metal Film
2	R87,R88	33	50-0162-01	33 Ohm Resistor 5% 1/4 Watt Carbon Film
1	R91	20.0K 1%	52-0091	20.0 KOhm Resistor 1% 1/4 Watt Metal Film
2	R91,R92	330	50-0005	330 Ohm Resistor 5% 1/4 Watt Carbon Film
2	SW1,SW2	4066	72-0037	CD4066, MC14066 Quad Bilateral Analog Switch
2	U1,U3	AD712	72-4200	Dual High Speed Bifet Op-Amp
2	U2,U4	5532	72-4023	5532 LOW NOISE Dual Op-Amp
1	U5	MC3403	72-4101	Quad Low Power OP Amp
3	U6,U7,U9	TL074	72-4021	Quad JFet-Input Op-Amp
2	U8,U11	4558	72-4024	4558 Wide Bandwidth Dual Op-Amp
1	U10	CA3081	72-4124	Common Emitter
2	U12,U13	HDR_18		
2	U14,U15	LM311	72-4027	LM311 Analog Voltage Comparator

DOD Software  
 MODEL-3/JBLSS/AVP1  
 MDL3D301.SCH  
 Bill Of Materials  
 Quan Reference

Revised: November 11, 1992  
 Revision: D3  
 November 12, 1992 12:47:46

Part	SYMAN	Description
13 +5V,TP5,UP5V,TP6,TP7,TP8, HDR1 TP9,+15V,-15V,-5.6V, DOLBY,L-T,R-T	32-1050	1 Pin Header
30 C1,C2,C11,C12,C13,C34, C35,C36,C48,C49,C50,C51, C77,C116,C117,C122,C123, C125,C126,C216,C218,C245, C255,C278,C283,C396,C397, C398,C399,C407	.010PET 62-1008-03	0.010 Box Cap., 10% 100V, 5mm Poly. Film
20 C3,C4,C6,C8,C9,C10,C22, C23,C25,C32,C33,C37,C41, C54,C105,C180,C225,C262, C267,C275	.22PET 62-1019	0.22 Box Cap., 10% 100V, 10mm Poly. Film
14 C5,C7,C24,C28,C29,C30, C31,C62,C65,C66,C69,C70, C310,C321	10PF 62-0013	10 pF Capacitor 5% 50V Ceramic Disc
19 C17,C18,C19,C20,C21,C26, C27,C39A,C40,C42,C43,C44, C45,C47,C56,C57,C67,C68, C71,C81,C90,C94,C95,C96, C98,C106,C107,C112,C114, C128,C129,C132,C134,C137, C138,C140,C141,C145,C146, C148,C149,C152,C155,C158, C161,C170,C171,C172,C173, C174,C176,C178,C184,C191, C224,C227,C231,C233,C234, C235,C240,C242,C243,C244, C246,C247,C252,C253,C266, C272,C273,C274,C285,C286, C287,C290,C291,C292,C303, C307,C336,C342,C343,C346, C348,C349,C350,C351,C352, C353,C354,C355,C356,C357, C359,C363,C365,C366,C367, C369,C370,C372,C373,C374, C378,C379,C381,C382,C406 C38,C305 C46,C55,C113,C151,C185, C226,C260,C264,C276,C337, C338,C387,C388,C389,C390	BP 62-0067	0.047 uF Capacitor 20% 50V Axial Monolithic
C52,C78,C221,C222,C288, C289	4.7PF 62-0011	4.7 pF Capacitor 5% 50V Ceramic Disc
C53,C103	100U 25V 60-0055	100.0 uF Capacitor +80%,-20% 25V Electrolytic
C58,C59,C60,C61,C63,C64	.0047PET 62-1006-03	0.0047 Box Cap., 10% 100V, 5mm Poly. Film
C72,C108,C109,C147,C150, C177,C179,C223,C362,C364, C368,C371,C384,C385,C391, C392,C393	1000U 25V 60-0070	1000.0 uF Capacitor +80%,-20% 25V Electrolytic
C73,C139,C175,C230,C324, C325,C328,C329,C332,C333	.0012PET 62-1051-03	0.0012 Box Cap., 10% 100V, 5mm Poly. Film
C74,C76,C82,C85,C88,C118,	.0010PET 62-1000-03	0.0010 Box Cap., 10% 100V, 5mm Poly. Film
	10U 25V 60-0050-01	10.0 uF Capacitor +80%,-20% 25V Electrolytic
	.022PET 62-1010-03	0.022 Box Cap., 10% 100V, 5mm Poly. Film

Quan	Reference	Part	SYMAN	Description
		C120,C121,C124,C127,C280, C306		
1		C75	.012PET 62-1063-03	0.012 Box Cap., 10% 100V, 5mm Poly. Film
10		C79,C84,C87,C208,C209, C213,C214,C229,C241,C304	.10PET 62-1017	0.10 Box Cap., 10% 100V, 10mm Poly. Film
4		C80,C83,C89,C279	.015PET 62-1009-03	0.015 Box Cap., 10% 100V, 5mm Poly. Film
5		C86,C91,C93,C130,C131	.0056PRT 62-1058-03	0.0056 Box Cap., 10% 100V, 5mm Poly. Film
2		C97,C133	470PF 62-0003	470 pF Capacitor 20% 50V Ceramic Disc
3		C99,C100,C294	10000U 25V 60-0071	10000.0uF Capacitor +80%,-20% 25V Electrolytic
10		C101,C143,C326,C327,C330, C331,C334,C335,C347,C386	1000U 16V 60-0064	1000.0 uF Capacitor +80%,-20% 16V Electrolytic
5		C110,C111,C182,C183,C258	.0015PET 62-1052-03	0.0015 Box Cap., 10% 100V, 5mm Poly. Film
3		C119,C219,C284	.0018PET 62-1002-03	0.0082 Box Cap., 10% 100V, 5mm Poly. Film
3		C164,C168,C257	.033PET 62-1012-03	0.033 Box Cap., 10% 100V, 5mm Poly. Film
3		C165,C169,C220	.027PET 62-1011-03	0.027 Box Cap., 10% 100V, 5mm Poly. Film
3		C166,C167,C401	.0027PET 62-1004-03	0.0027 Box Cap., 10% 100V, 5mm Poly. Film
4		C186,C187,C295,C296	47U 60-0054-01	47.0 uF Capacitor +80%,-20% 16V Electrolytic
2		C198,C199	.068PET 62-1015	0.068 Box Cap., 10% 100V, 10mm Poly. Film
3		C211,C212,C320	220PF 62-0022	220 pF Capacitor 20% 50V Ceramic Disc
6		C215,C217,C254,C297,C298, C308	330PF 62-0006	330 pF Capacitor 20% 50V Ceramic Disc
1		C228	.33PET 62-1020	0.33 Box Cap., 10% 100V, 10mm Poly. Film
1		C232	100 NP 60-0086	100.0 uF Capacitor +80%,-20% 16V Elect., NP
4		C236,C237,C360,C395	30PF 62-0029	30 pF Capacitor 5% 50V Ceramic Disc
2		C238,C239	25PF 62-0001	25 pF Capacitor 5% 50V Ceramic Disc
2		C251,C322	1U 60-0044-01	1.0 uF Capacitor +80%,-20% 50V Electrolytic
4		C256,C302,C341,C394	390PF 62-0024	390 pF Capacitor 20% 50V Ceramic Disc
1		C261	68PF 62-0018	68 pF Capacitor 50V Ceramic Disc
1		C277	.047PET 62-1013-03	0.047 Box Cap., 10% 100V, 5mm Poly. Film
3		C281,C282,C339	.0033PET 62-1005-03	0.0033 Box Cap., 10% 100V, 5mm Poly. Film
3		C300,C301,C340	120PF 62-0002	120 pF Capacitor 20% 50V Ceramic Disc
2		C345,C409	100PF 62-0020	100 pF Capacitor 20% 50V Ceramic Disc
1		C400	.010 CD 62-1027	0.010 uF Capacitor 12% 100V, 5mm Ceramic
4		C402,C403,C404,C405 C408	.10 CD 62-0030	0.10 uF Capacitor 12% 250V, 5mm Ceramic
4		C411,C412	150PF 62-0031	150 pF Capacitor 20% 50V Ceramic Disc
2		C411,C412	22PF 62-0015	22 pF Capacitor 5% 50V Ceramic Disc
9		CR8,CR9,CR10,CR11,CR12, CR13,CR14,CR25,CR39	1N4003 70-0007	1N4003 Silicon Rectifier
1		CR42	FR103 70-0080	FR103
9		D1,D2,D3,D4,D5,D6,D15, D16,D17,D18,D19,D20,D21, D22,D23,D24,D26,D31,D32, D33,D35,D36,D36A,D37,D38, D43,D44,D45,D46	1N4148 70-0002	1N4148 Silicon Switching Diode, 75 Volts PIV
1		D7	1N5232B 70-0153	1N5232B, Zener Diode, 5.6V
2		EXC1,EXC2	.0033 2KV 62-0035	0.0033 uF Capacitor, 20% 2KV Ceramic Disc
1		F1	.375A-SB 32-0112	Fuse .375 MH, SLO BLOW
1		H1	HDRF3 32-1052	3 Pin Z Header for Fosgate
4		H2,H3,H4,H5	HCN9 32-1166	9 Pin -- From 14 Pin Header Connector
1		HS1	MDL3HS 14-2548-B	Heatsink, PCB Mount, for Fosgate MDL3
1		J1	MINI DIN 5 32-0081	Mini 5 Pin DIN Jack, PCB Mount
4		J2,J3,J4,J5	MINI DIN 4 32-0082	Mini 4 Pin DIN Jack

Quan Reference	Part	SYMAN	Description
1	J6	RCAX6 GYY 32-0112-03	RCA X 6, PCB Mount Jack, Gold, Y/Y
4	J7,J8,J10,J11	RCAX6 GWR 32-0112-01	RCA X 6, PCB Mount Jack, Gold, W/R
1	J9	RCAX2 GWR 32-0111-01	RCA X 2, PCB Mount Jack, Gold, W/R
2	J12,J15	T+BAN_22 32-1159	22 Pin Ribbon Connector, PC Mount
2	J14,J16	T+BAN_16 32-1158	16 Pin Ribbon Connector, PC Mount
1	J17	DIN 5 32-0092	5 Pin DIN Jack
1	J14*	LCD 16X2 70-2167	16 X 2 LCD Array
3	JM1,JM2,R720	0 50-0050	0 Ohm Resistor 5% 1/4 Watt Carbon Film
1	K1	RELAY DPDT 72-5143	DPDT Relay Switch
1	L1	200UH 26-0206	200uH Torroid Choke
1	L2	10MH 26-0201	10 mH Torroid Choke
2	L3,L4	FBEAD2 26-0220	Ferrite Bead - 2 Hole
5	P513,R730,R733,R736,R739	TP50K H 42-0222	50 k Trim Pot, Horizontal Mount, 3/4 turn
11	P1*,P2*,P3*,P4*,P5*,P6*, P7*,P8*,P9*,P10*,P11*	TP25K H 40-0216	25 k Trim Pot, Horizontal Mount, 3/4 turn
7	Q1,Q3,Q14,Q17,Q18,Q19, Q21,Q22,Q24	MPSA06 70-1021	MPSA06 NPN Gen. Purpose Transistor
7	Q2,Q4,Q5,Q10,Q11,Q12,Q13	MPSA56 70-1025	MPSA06 NPN Gen. Purpose Transistor
6	Q6,Q7,Q8,Q9,Q15,Q16	2N5951 70-1070	2N5951 N-Channel JFET
14	R1,R2,R3,R4,R8,R9,R10, R11,R18,R19,R23,R24,R28, R29	75 50-0171-01	75 Ohm Resistor 5% 1/4 Watt Carbon Film
8	R5,R6,R15,R16,R25,R26, R721,R726	47K 50-0030	47 KOhm Resistor 5% 1/4 Watt Carbon Film
33	R7,R13,R17,R21,R30,R31, R39,R40,R45,R46,R47,R48, R54,R55,R56,R57,R58,R87, R184,R191,R195,R204,R236, R321,R426,R479,R480,R537, R561,R629,R630,R631,R632	3.3M 50-0049-01	3.3 MOhm Resistor 5% 1/4 Watt Carbon Film
13	R12,R14,R20,R22,R27,R32, R36,R38,R69,R118,R394, R471,R647	46.4K 1% 52-0022-01	46.4 KOhm Resistor 1% 1/4 Watt Metal Film
18	R33,R34,R35,R37,R41,R42, R43,R44,R49,R50,R51,R52, R53,R63,R64,R484,R488, R504	300 50-0186-01	300 Ohm Resistor 5% 1/4 Watt Carbon Film
9	R59,R62,R65,R67,R84,R103, R147,R261,R262,R263,R264, R265,R266,R269,R270,R271, R275,R278,R714	140K 1% 52-0291-01	140 KOhm Resistor 1% 1/4 Watt Metal Film
2	R60,R61,R66,R68,R102, R116,R211,R267,R268,R485, R705,R712	280K 1% 52-0262-01	280 KOhm Resistor 1% 1/4 Watt Metal Film
7	R70,R71,R72,R73,R78,R79, R80,R81,R91,R92,R93,R94, R95,R96,R97,R98,R99,R100, R106,R107,R108,R109,R110, R111,R112,R113,R216,R217, R218,R219,R220,R221,R330, R341,R358,R369,R382,R422, R423,R506,R507,R538,R540,	49.9K 1% 52-0020-01	49.9 KOhm Resistor 1% 1/4 Watt Metal Film

DOD Software  
 MODEL-3/JBLSS/AVP1  
 MDL3D301.SCH  
 Bill Of Materials

Revised: November 11, 1992

Revision: D3

November 12, 1992 12:47:46

Quan	Reference	Part	SYMAN	Description
	R580, R581, R586, R587, R588, R589, R590, R591, R592, R593, R651, R652, R659, R660			
6	R76, R90, R729, R732, R735, R738	10M	50-0060-01	10M MOhm Resistor 5% 1/4 Watt Carbon Film
2	R77, R89	121K 1%	52-0297-01	121 KOhm Resistor 1% 1/4 Watt Metal Film
10	R82, R101, R519, R570, R615, R617, R623, R648, R649, R650	1.00M 1%	52-0705-01	1.00 MOhm Resistor 1% 1/4 Watt Metal Film
3	R83, R145, R512	392K 1%	52-0248-01	392 KOhm Resistor 1% 1/4 Watt Metal Film
23	R85, R146, R149, R150, R281, R284, R292, R299, R310, R328, R335, R339, R350, R363, R373, R383, R386, R465, R467, R487, R577, R724, R775	100K 1%	52-0305-01	100 KOhm Resistor 1% 1/4 Watt Metal Film
3	R86, R230, R231	11.0K 1%	52-0105-01	11.0 KOhm Resistor 1% 1/4 Watt Metal Film
5	R88, R333, R344, R361, R375	TP10K H	42-0211	10 k Trim Pot, Horizontal Mount, 3/4 turn
20	R104, R105, R114, R115, R151, R152, R156, R157, R213, R240, R241, R320, R396B, R396C, R406, R407, R468, R472, R620, R674A	20.0K 1%	52-0091	20.0 KOhm Resistor 1% 1/4 Watt Metal Film
7	R119, R313, R314, R315, R316, R389, R707	59.0K 1%	52-0017-01	59.0 KOhm Resistor 1% 1/4 Watt Metal Film
20	R120, R121, R244, R247, R248, R249, R250, R251, R252, R253, R400, R402, R437, R438, R439, R440, R441, R442, R578, R672	4.75K 1%	52-0166-01	4.75 KOhm Resistor 1% 1/4 Watt Metal Film
9	R122, R123, R124, R125, R716, R728, R731, R734, R737	4.99K 1%	52-0165-01	4.99 KOhm Resistor 1% 1/4 Watt Metal Film
16	R126, R127, R128, R129, R130, R131, R132, R186, R189, R194, R200, R201, R207, R214, R260, R272	8.06K 1%	52-0111-01	8.06 KOhm Resistor 1% 1/4 Watt Metal Film
9	R133, R139, R144, R237, R332, R343, R360, R371, R396A	6.81K 1%	52-0157-01	6.81 KOhm Resistor 1% 1/4 Watt Metal Film
4	R134, R140, R143, R575	2.10K 1%	52-0184-01	2.10 KOhm Resistor 1% 1/4 Watt Metal Film
5	R135, R138, R141, R494, R498	18.2K 1%	52-0093-01	18.2 KOhm Resistor 1% 1/4 Watt Metal Film
10	R136, R137, R142, R169, R172, R175, R177, R178, R180, R181, R234, R324, R326, R393, R433, R443, R445, R447, R448, R450, R451, R452, R478, R481, R502, R503, R505, R510, R518, R532, R534, R536, R541, R546, R560, R568, R576, R597, R599, R599A, R602, R614, R616, R621, R625, R628, R642, R667, R668, R740	10.0K 1%	52-0107	10.0 KOhm Resistor 1% 1/4 Watt Metal Film
2	R153, R154	22.6K 1%	52-0088-01	22.6 KOhm Resistor 1% 1/4 Watt Metal Film
2	R155, R159	10.7K 1%	52-0061-01	10.7 KOhm Resistor 1% 1/4 Watt Metal Film
1	R158	19.6K 1%	52-0092-01	19.6 KOhm Resistor 1% 1/4 Watt Metal Film
1	R170, R171, R434, R444	36K	50-0238-01	36 KOhm Resistor 5% 1/4 Watt Carbon Film

Part	SYMAN	Description
17 R173,R174,R285,R286,R293, 39.2K 1%	52-0079-01	39.2 KOhm Resistor 1% 1/4 Watt Metal Film
R294,R312,R334,R349,R362, R372,R384,R435,R436,R547, R549,R610		
5 R176,R179,R446,R449,R700 22	50-0158-01	22 Ohm Resistor 5% 1/4 Watt Carbon Film
4 R182,R188,R196,R205 1.21K 1%	52-0202-01	1.21 KOhm Resistor 1% 1/4 Watt Metal Film
8 R183,R185,R187,R190,R192, 4.02K 1%	52-0121-01	4.02 KOhm Resistor 1% 1/4 Watt Metal Film
R193,R202,R203		
7 R198,R199,R206,R208,R210, 3.32K 1%	52-0174-01	3.32 KOhm Resistor 1% 1/4 Watt Metal Film
R212,R476		
2 R209,R573 8.25K 1%	52-0152-01	8.25 KOhm Resistor 1% 1/4 Watt Metal Film
57 R215,R229,R233,R279,R280, 24.9K 1%	52-0039-01	24.9 KOhm Resistor 1% 1/4 Watt Metal Film
R282,R283,R329,R338,R340, R345,R346,R353,R356,R357, R366,R367,R368,R377,R378, R379,R395,R462,R463,R490, R491,R492,R493,R624,R644, R645,R646,R675,R676,R677, R678,R679,R680,R681,R682, R683,R684,R685,R686,R687, R688,R689,R691,R692,R693, R694,R695,R696,R697,R698, R718,R741		
4 R222,R297,R635,R636 6.49K 1%	52-0114-01	6.49 KOhm Resistor 1% 1/4 Watt Metal Film
8 R223,R255,R298,R322,R323, 1.00K 1%	52-0133-01	1.00 KOhm Resistor 1% 1/4 Watt Metal Film
R404,R524,R525,R531,R533, R597A,R622,R633,R634, R637,R701,R702,R708		
5 R226,R227,R228,R232,R305, 13.3K 1%	52-0053-01	13.3 KOhm Resistor 1% 1/4 Watt Metal Film
R306,R469,R470,R483,R496, R497,R500,R501,R600,R601		
7 R238,R239,R242,R243,R245, 30.1K 1%	52-0083-01	30.1 KOhm Resistor 1% 1/4 Watt Metal Film
R246,R337,R352,R365,R376, R399,R401,R427,R428,R431, R432,R482		
R254,R256,R403,R405,R703, 100	50-0003	100 Ohm Resistor 5% 1/4 Watt Carbon Film
R704		
R257,R475,R495,R499 5.62K 1%	52-0161-01	5.62 KOhm Resistor 1% 1/4 Watt Metal Film
R258,R259 9.1K	50-0223-01	9.1 KOhm Resistor 5% 1/4 Watt Carbon Film
R287,R289,R295,R302 243K 1%	52-0268-01	243 KOhm Resistor 1% 1/4 Watt Metal Film
R290,R301 34.0K 1%	52-0081-01	34.0 KOhm Resistor 1% 1/4 Watt Metal Film
R291,R296,R309,R311,R317, 69.8K 1%	52-0012-01	69.6 KOhm Resistor 1% 1/4 Watt Metal Film
R385,R387,R618		
R303,R319,R709,R710 28.0K 1%	52-0035-01	28.0 KOhm Resistor 1% 1/4 Watt Metal Film
R304,R390 90.9K 1%	52-0066-01	90.9 KOhm Resistor 1% 1/4 Watt Metal Film
R325,R327,R458,R459,R613 15.0K 1%	52-0050-01	15.0 KOhm Resistor 1% 1/4 Watt Metal Film
R331,R342,R359,R370 22.1K 1%	52-0089-01	22.1 KOhm Resistor 1% 1/4 Watt Metal Film
R336,R351,R364,R374 105K 1%	52-0303-01	105 KOhm Resistor 1% 1/4 Watt Metal Film
R380,R416,R417 137K 1%	52-0292-01	137 KOhm Resistor 1% 1/4 Watt Metal Film
R381 274K 1%	52-0263-01	274 KOhm Resistor 1% 1/4 Watt Metal Film
R391,R424 4.42K 1%	52-0120-01	4.42 KOhm Resistor 1% 1/4 Watt Metal Film
R392,R425 TPlK H	42-0212	1 k Trim Pot, Horizontal Mount, 10mm

Part	SYMAN	Description
7 R408,R410,R412,R414,R515, R516,R670	1.50K 1% 52-0144-01	1.50 KOhm Resistor 1% 1/4 Watt Metal Film
4 R409,R411,R413,R415	TP200 H 42-0203	200 Trim Pot, Horizontal Mount
3 R460,R461,R711	110K 1% 52-0301-01	110 KOhm Resistor 1% 1/4 Watt Metal Film
10 R464,R466,R508,R509,R594, R595,R655,R656,R663,R664	200K 1% 52-0276-01	200 KOhm Resistor 1% 1/4 Watt Metal Film
1 R477	180 50-0181-01	180 Ohm Resistor 5% 1/4 Watt Carbon Film
1 R486	180K 50-0039-01	180 KOhm Resistor 5% 1/4 Watt Carbon Film
1 R489	2M 50-0046	2 MOhm Resistor 5% 1/4 Watt Carbon Film
3 R511,R673,R674	33 50-0162-01	33 Ohm Resistor 5% 1/4 Watt Carbon Film
1 R514	750 50-0008-01	750 Ohm Resistor 5% 1/4 Watt Carbon Film
1 R517	22M 10% 50-0308-01	22M MOhm Resistor 10% 1/4 Watt Carbon Film
7 R526,R527,R528,R529,R539, R706,R717	2.00K 1% 52-0186-01	2.00 KOhm Resistor 1% 1/4 Watt Metal Film
1 R530	499 1% 52-0338-01	499 Ohm Resistor 1% 1/4 Watt Metal Film
1 R558,R559,R566	27.4K 1% 52-0085-01	27.4 KOhm Resistor 1% 1/4 Watt Metal Film
1 R562	6.34K 1% 52-0159-01	6.34 KOhm Resistor 1% 1/4 Watt Metal Film
1 R563	5.23K 1% 52-0164-01	5.23 KOhm Resistor 1% 1/4 Watt Metal Film
1 R565	14.7K 1% 52-0098-01	14.7 KOhm Resistor 1% 1/4 Watt Metal Film
1 R567	909 1% 52-0313-01	909 Ohm Resistor 1% 1/4 Watt Metal Film
1 R569	3.01K 1% 52-0125-01	3.01 KOhm Resistor 1% 1/4 Watt Metal Film
1 R571	1.05K 1% 52-0207-01	1.05 KOhm Resistor 1% 1/4 Watt Metal Film
1 R572	4.32K 1% 52-0167-01	4.32 KOhm Resistor 1% 1/4 Watt Metal Film
1 R574	2.55K 1% 52-0140-01	2.55 KOhm Resistor 1% 1/4 Watt Metal Film
1 R598	P25K B RK 40-0271	25 k "B" Pot, w/shaft, Rack Style Leads
2 R611,R612	16.9K 1% 52-0048-01	16.9 KOhm Resistor 1% 1/4 Watt Metal Film
3 R626,R627,R643	16.5K 1% 52-0094-01	16.5 KOhm Resistor 1% 1/4 Watt Metal Film
1 R669	300 2WF 50-2186-01	300 Ohm Resistor 5% 2 Watt Flameproof
1 R671	47 50-0166-01	47 Ohm Resistor 5% 1/4 Watt Carbon Film
1 R713	56.2K 1% 52-0065-01	56.2 KOhm Resistor 1% 1/4 Watt Metal Film
1 R715	4.7 50-0141-01	4.7 Ohm Resistor 5% 1/4 Watt Carbon Film
1 R727	3.3K 50-0014	3.3 KOhm Resistor 5% 1/4 Watt Carbon Film
2 R1*,R2*,R3*,R4*,R5*,R6*, R7*,R8*,R9*,R10*,R11*, R564	2.74K 1% 52-0177-01	2.74 KOhm Resistor 1% 1/4 Watt Metal Film
1 RP5	RA47K 54-0380	47 KOhm 2%, 7 Element Resistor Bussed
4 RP6,RP7,RP21,RP22	RA12K 54-0382	12 KOhm 2%, 7 Element Resistor Bussed
3 RP10,RP11,RP12	56KRP4 54-0368	8 Pin SIP BX-563 56K
3 RP13,RP14,RP19	20KRP4 54-0369	20 kOhm 2%, 4 Element Resistor Discrete
1 RP20	10KRP4 54-0366	10 kOhm 2%, 4 Element Resistor Discrete
1 S1	DIP8S 70-3020	8 Pin Dip Socket
2 S2,S3	DIP16S 70-3022	16 Pin Dip Socket
4 S4,S5,S6,S7	DIP20S 70-3018	20 Pin Dip Socket
2 S8,S9	DIP28S 70-3161	28 Pin Dip Socket
1 S10	DIP40S 70-3162	40 Pin Dip Socket
1 S11	PLCC68S 70-3164	68 PLCC Socket
3 SW1,SW2,SW3	4PDT PC 44-0029	4PDT I/O Switch, PC Mount
1 T1	110/220/N 26-0055	110/220/N Transformer
1 TP4	HDR2 32-1069	2 Pin Header, 0.1" spacing, Cut from 5 Pin Hdr
1 U2,U3,U44,U102	4052A 72-0080	8 CH Analog Multiplex
1 U4,U5,U10,U11,U12,U13	4051A 72-0081	8 CH Analog Multiplex
1 U6,U7	CA3081 72-4124	Common Emitter

MODEL-3/JBLSS/AVP1

Revised: November 11, 1992

MDL3D301.SCH

Revision: D3

Bill Of Materials

November 12, 1992 12:47:46

Quan	Reference	Part	SYMAN	Description
17	U8,U19,U25,U26,U46,U50, U51,U61,U66,U71,U84,U96, U98,U101,U103,U104,U105	TL074	72-4021	Quad JFet-Input Op-Amp
10	U9,U20,U21,U30,U31,U62, U63,U64,U65,U88	AD713	72-4201	Precision Op-Amp
3	U14,U16,U18	4576A	72-4072	Video Amp
1	U22	4017A	72-0035	Decade Counter
13	U23,U34,U35,U36,U37,U38, U42,U43,U45,U87,U97,U100, U114	4053A	72-0086	TRI 2 CH Analog Mux
1	U24	4053	72-0086	TRI 2 CH Analog Mux
3	U27,U28,U29	4066	72-0037	CD4066, MC14066 Quad Bilateral Analog Switch
2	U32,U80	LM358	72-4031	LM358 Dual Low Power Operational Amplifier
2	U33,U81	CA3046	72-4121	Matched Transistor Pairs BPO
4	U39,U40,U41,U67 U47,U72	DS1267-010	72-4106	Digital Volumn Control
3	U48,U73,U75	CA3280	72-4123	Variable Gain Op-Amp
3	U49,U74,U99	74HC74	72-1092	74HC74 Dual D-Type Pos Edge Trig Flip-Flop
1	U52	LM311	72-4027	LM311 Analog Voltage Comparator
2	U53,U89	24C01	72-3075	256 X 8 Serial EEPROM
1	U54	74HC00	72-1090	Quadruple 2-Input Positive-Nand Gate
3	U55,U77,U78	80C31BH	72-3150	Microprocessor
1	U56	74HC374	72-1105	Octal D-Type Pos. Edge Triggered Flip-Flops
1	U57	74HC139	72-1100	Dual 2 Line to 4 Line Decoder/Demultiplexer
2	U58,U59	45151	72-4103	Dolby Timelink Controller
2	U60,U85	4256	72-3072	256K X 1 Dynamic Ram 250ns Access Time
1	U68	TL072	72-4020	Dual JFet-Input Op-Amp
1	U69	27C64-200	72-3067-20	CMOS 8K X 8 EPROM -200 ns
2	U70,U76	74HC244	72-1107	Octal Buffer-Line Driver W/3-State Outputs
1	U79	74HC02	72-1091	Quadruple 2-Input Positive-Nor Gate
2	U82,U83	7C186-55PC	72-3051	SRAM
1	U86	SLIC-1		
2	U90,U94	NE646	72-4005	NE646 Dolby-B Noise Reduction
1	U91	74HC161	72-1258	Synchronous 4-Bit Binary Counter
1	U92	82S147-B	72-3066-02	PROM
1	U93	82S147-A	72-3066-01	PROM
1	U95	SCC0001	72-3139	LSI SCC0001/Asic
1	U95	DAC6012	72-3080	DAC
1	U106	74HC138	72-1108	3 Line to 8 Line Decoder/Demultiplexer
1	U107,U108,U109,U110,U111, U112,U113	74HC574	72-1112	Octal D-Type Pos. Edge Triggered Flip-Flops
1	U115	TL497	72-4143	Switching Supply Controller
1	VR1	7915	70-4124	-15V Regulator, 1A, TO-220
1	VR2	7905	70-4011	7905 -5 Volt 1 Amp Voltage Regulator TO-220
1	VR3	MJE15029	70-1049	MJE15029 PNP High Volt. Transistor
1	VR4	7805	70-4014	7805 +5 Volt 1 Amp Voltage Regulator TO-220
1	VR5	7815	70-4123	+15V Regulator, 1A, TO-220
1	X2	24.0 MHZ	76-0325	24.00 MHZ Crystal
1	X3	8.00 MHZ	76-0100	8.00 MHZ Crystal