

# harman/kardon

## AVR145

### 5 X 40W 5.1 CHANNEL A/V RECEIVER

# SERVICE MANUAL



## CONTENTS

ESD WARNING.....	2	ELECTRICAL PARTS LIST....	12
LEAKAGE TESTING.....	3	SEMICONDUCTOR PINOUTS	48
BASIC SPECIFICATIONS.....	4	PCB DRAWINGS.....	119
TROUBLESHOOTING GUIDE.....	5	BLOCK DIAGRAM.....	126
PROCESSOR RESET.....	5	WIRING DIAGRAM.....	127
PACKAGE LIST AND PARTS.....	6	AMP BIAS ADJUSTMENT	128
DISASSEMBLY	7	SCHEMATIC DIAGRAMS.....	129
UNIT EXPLODED VIEW AND PARTS	11		

Released 2007  
Discontinued XXXX

Rev 0, 10/2007

harman/kardon, Inc.  
250 Crossways Park Dr.  
Woodbury, New York, 11797

## AVR145 ELECTROSTATICALLY SENSITIVE (ES) DEVICES

Some semiconductor (solid state) devices can be damaged easily by static electricity. Such components commonly are called Electrostatically Sensitive (ES) Devices. Examples of typical ES devices are integrated circuits and some field effect transistors and semiconductor "chip" components.

The following techniques should be used to help reduce the incidence of component damage caused by static electricity.



1. Immediately before handling any semiconductor component or semiconductor-equipped assembly, drain off any electrostatic charge on your body by touching a known earth ground. Alternatively, obtain and wear a commercially available discharging wrist strap device, which should be removed for potential shock reasons prior to applying power to the unit under test.
2. After removing an electrical assembly equipped with ES devices, place the assembly on a conductive surface such as aluminum foil, to prevent electrostatic charge build-up or exposure of the assembly.
3. Use only a grounded-tip soldering iron to solder or unsolder ES devices.
4. Use only an anti-static solder removal device. Some solder removal devices not classified as "anti-static" can generate electrical charges sufficient to damage ES devices.
5. Do not use freon-propelled chemicals. These can generate electrical change sufficient to damage ES devices.
6. Do not remove a replacement ES device from its protective package until immediately before you are ready to install it. (Most replacement ES devices are packaged with leads electrically shorted together by conductive foam, aluminum foil or comparable conductive material.)
7. Immediately before removing the protective material from the leads of a replacement ES device, touch the protective material to the chassis or circuit assembly into which the device will be installed.

**CAUTION** : Be sure no power is applied to the chassis or circuit, and observe all other safety precautions.

8. Minimize bodily motions when handling unpackaged replacement ES devices. (Otherwise harmless motion such as the brushing together of your clothes fabric or the lifting of your foot from a carpeted floor can generate static electricity sufficient to damage an ES devices.

## PRODUCT SAFETY NOTICE

Each precaution in this manual should be followed during servicing.

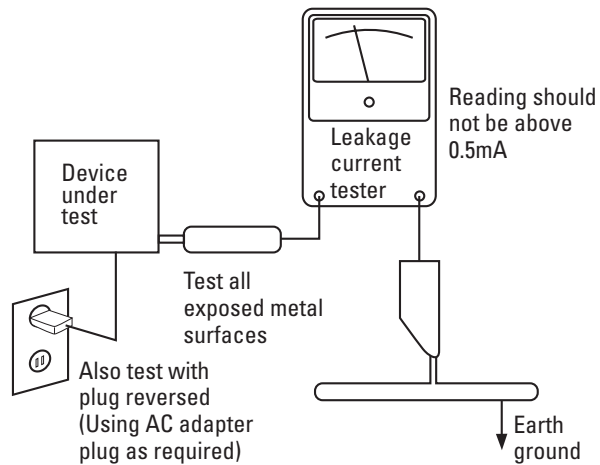
Components identified with the IEC symbol  in the parts list are special significance to safety. When replacing a component identified with , use only the replacement parts designated, or parts with the same ratings or resistance, wattage, or voltage that are designated in the parts list in this manual. Leakage-current or resistance measurements must be made to determine that exposed parts are acceptably insulated from the supply circuit before returning the product to the customer.

## SAFETY PRECAUTIONS

The following check should be performed for the continued protection of the customer and service technician.

### LEAKAGE CURRENT CHECK

Measure leakage current to a known earth ground (water pipe, conduit, etc.) by connecting a leakage current tester between the earth ground and all exposed metal parts of the appliance (input/output terminals, screwheads, metal overlays, control shaft, etc.). Plug the AC line cord of the appliance directly into a 120V AC 60Hz outlet and turn the AC power switch on. Any current measured must not exceed 0.5mA.



### AC Leakage Test

**ANY MEASUREMENTS NOT WITHIN THE LIMITS OUTLINED ABOVE ARE INDICATIVE OF A POTENTIAL SHOCK HAZARD AND MUST BE CORRECTED BEFORE RETURNING THE APPLIANCE TO THE CUSTOMER.**

# Technical Specifications AVR145/230

## Audio Section

Stereo Mode

Continuous Average Power (FTC)

50 Watts per channel, 20Hz–20kHz,  
@ < 0.07% THD, both channels driven into 8 ohms

5 Channel Surround Modes

Power Per Individual Channel

Front L&R channels:  
40 Watts per channel,  
@ < 0.07% THD, 20Hz–20kHz into 8 ohms

Center channel:  
40 Watts, @ < 0.07% THD, 20Hz–20kHz into 8 ohms

Surround channels:  
40 Watts per channel,  
@ < 0.07% THD, 20Hz–20kHz into 8 ohms

Input Sensitivity/Impedance

Linear (High Level) 200mV/47kohms

Signal-to-Noise Ratio (IHF-A) 100dB

Surround System Adjacent Channel Separation

Analog Decoding 40dB  
(Pro Logic, etc.)

Dolby Digital (AC-3) 55dB  
DTS 55dB

Frequency Response

@ 1W (+0dB, -3dB) 10Hz–130kHz

High Instantaneous

Current Capability (HCC) ±25 Amps

Transient Intermodulation

Distortion (TIM) Unmeasurable

Rise Time 16 µsec

Slew Rate 40V/µsec\*\*

## FM Tuner Section

Frequency Range	87.5–108MHz
Usable Sensitivity	IHF 1.3 µV/13.2dBf
Signal-to-Noise Ratio	Mono/Stereo: 70/68dB (DIN)
Distortion	Mono/Stereo: 0.2/0.3%
Stereo Separation	40dB @ 1kHz
Selectivity	±400kHz: 70dB
Image Rejection	80dB
IF Rejection	90dB

## AM Tuner Section

Frequency Range	522–1620kHz
Signal-to-Noise Ratio	45dB
Usable Sensitivity	Loop: 500µV
Distortion	1kHz, 50% Mod: 0.8%
Selectivity	±10kHz: 30dB

## Video Section

Video Format	PAL/NTSC
Input Level/Impedance	1Vp-p/75 ohms
Output Level/Impedance	1Vp-p/75 ohms
Video Frequency Response (Composite and S-Video)	10Hz–8MHz (-3dB)
Video Frequency Response (Component)	10Hz–100MHz (-3dB)

## General

Power Requirement	AC 220–240V/50Hz
Power Consumption	65W idle, 540W maximum (5 channels driven)

Dimensions (Max)

Width	440mm
Height	165mm
Depth	382mm
Weight	9.7 kg

Depth measurement includes knobs, buttons and terminal connections.

Height measurement includes feet and chassis.

All features and specifications are subject to change without notice.

Harman Kardon, The Bridge  and Logic 7 are registered trademarks of Harman International Industries, Incorporated.

 is a trademark of Harman International Industries, Inc.

\*Manufactured under license from Dolby Laboratories.

"Dolby," "Pro Logic" and the Double-D symbol are trademarks of Dolby Laboratories.

"DTS" and "DTS Neo:6" are registered trademarks of DTS,

Inc. "96/24" is a trademark of DTS, Inc.

SA-CD is a trademark of Sony Electronics, Inc.

Apple and iPod are registered trademarks of Apple Computer, Inc.

Cirrus is a registered trademark of Cirrus Logic Corp.

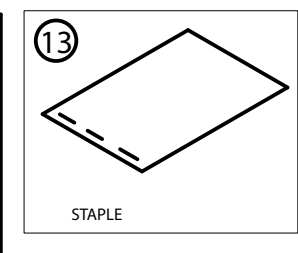
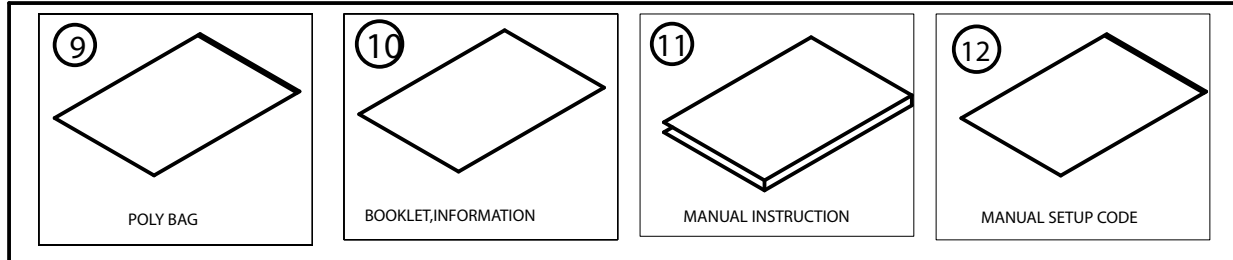
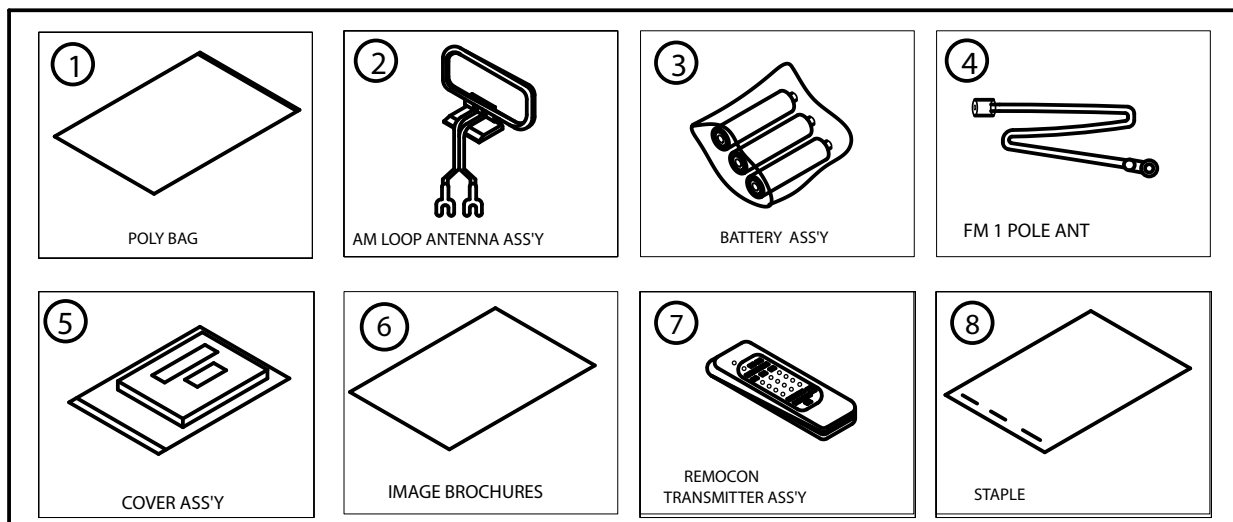
\*\*Without input anti slewing and output isolation networks.

# TROUBLESHOOTING GUIDE

SYMPTOM	CAUSE	SOLUTION
Unit does not function when Main Power Switch is pushed	<ul style="list-style-type: none"> <li>No AC Power</li> </ul>	<ul style="list-style-type: none"> <li>Make certain AC power cord is plugged into a live outlet</li> <li>Check to see whether outlet is switch-controlled</li> </ul>
Display lights, but no sound or picture	<ul style="list-style-type: none"> <li>Intermittent input connections</li> <li><b>Mute</b> is on</li> <li>Volume control is down</li> </ul>	<ul style="list-style-type: none"> <li>Make certain that all input and speaker connections are secure</li> <li>Press <b>Mute Button</b></li> <li>Turn up volume control</li> </ul>
No sound from any speaker; light around power switch is red	<ul style="list-style-type: none"> <li>Amplifier is in protection mode due to possible short</li> <li>Amplifier is in protection mode due to internal problems</li> </ul>	<ul style="list-style-type: none"> <li>Check speaker wire connections for shorts at receiver and speaker ends</li> <li>Contact your local Harman Kardon service center</li> </ul>
No sound from surround or center speakers	<ul style="list-style-type: none"> <li>Incorrect surround mode</li> <li>Input is monaural</li> <li>Incorrect configuration</li> <li>Stereo or Mono program material</li> </ul>	<ul style="list-style-type: none"> <li>Select a mode other than Stereo</li> <li>There is no surround information from mono sources</li> <li>Check speaker mode configuration</li> <li>The surround decoder may not create center- or rear-channel information from nonencoded programs</li> </ul>
Unit does not respond to remote commands	<ul style="list-style-type: none"> <li>Weak batteries in remote</li> <li>Wrong device selected</li> <li>Remote sensor is obscured</li> </ul>	<ul style="list-style-type: none"> <li>Change remote batteries</li> <li>Press the AVR selector</li> <li>Make certain front panel sensor is visible to remote or connect an optional remote sensor</li> </ul>
Intermittent buzzing in tuner	<ul style="list-style-type: none"> <li>Local interference</li> </ul>	<ul style="list-style-type: none"> <li>Move unit or antenna away from computers, fluorescent lights, motors or other electrical appliances</li> </ul>
Letters flash in the channel indicator display and digital audio stops	<ul style="list-style-type: none"> <li>Digital audio feed paused</li> </ul>	<ul style="list-style-type: none"> <li>Resume play for DVD</li> <li>Check that Digital Input is selected</li> </ul>

In addition to the items shown above, additional information on troubleshooting possible problems with your AVR 145, or installation-related issues, may be found in the list of "Frequently Asked Questions" which is located in the Product Support section of our Web site at [www.harmankardon.com](http://www.harmankardon.com).

### 1. Instruction manual ass'y - Accessories

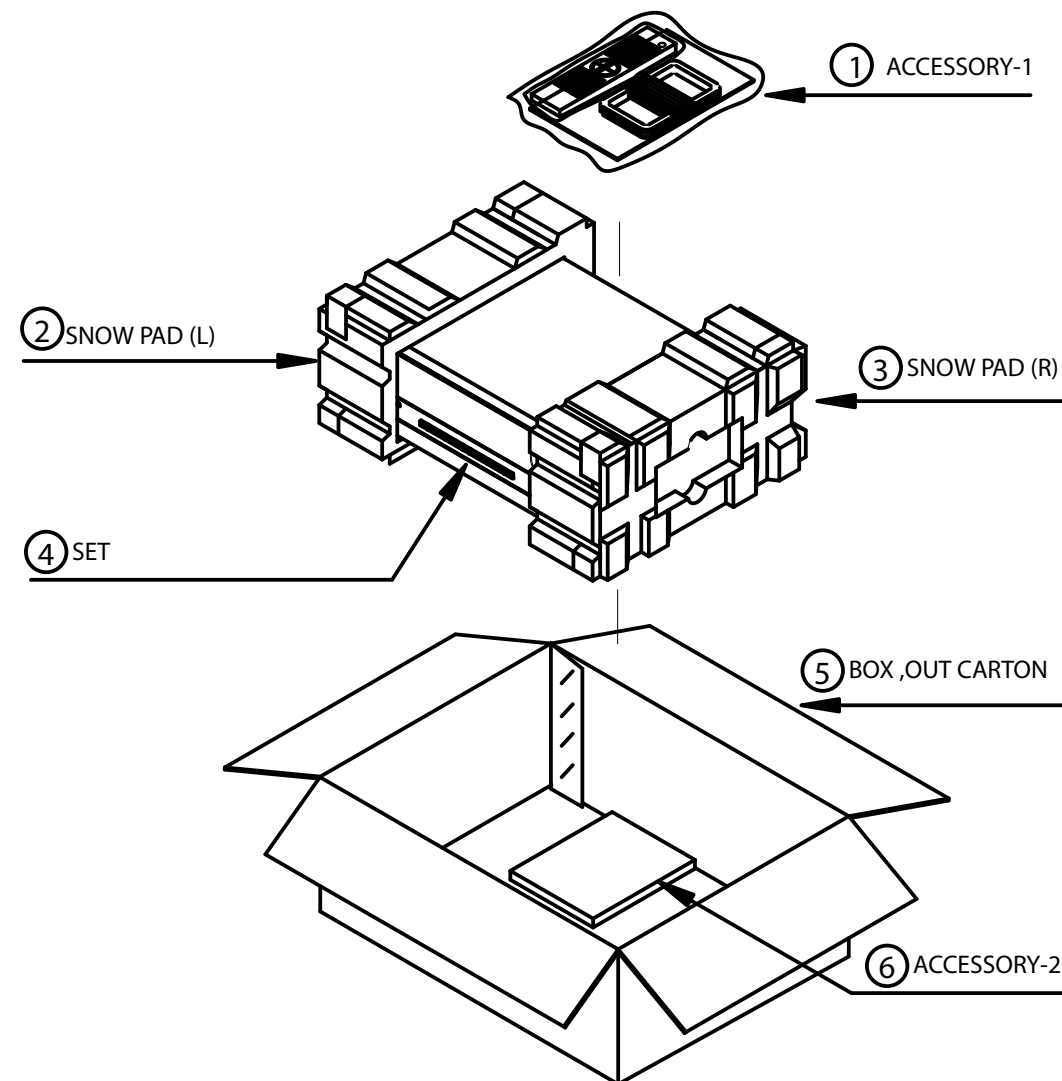


ACCESSORY-1			
NO	DESCRIPTION	PARTS NO.	Q.ty
1	POLY BAG	CPB1061Y	1
2	AM LOOP ANTENNA ASS'Y	CSA1A027Z	1
3	BATTERY	CABR03P3	3
4	FM 1 POL ANT	CSA1A018Z	1
5	COVER ASS'Y	CGRAVR130/230ZA	1
6	1 COVER A	CGR1A331M7H43	1
	2 COVER B	CGR1A332M7H43	1
	3 SHEET,FRONT COVER	CQE1A220Z	1
	4 PAD ,COVER	CPS1A676	1
	5 BAG ,POLY	CPB1A176Z	1
7	IMAGE BROCHURES	HQE1A273Z	1
7	REMOCON ASS'Y	CARTAVR145/230	1
8	STAPLE	CPL0905	3

ACCESSORY-2			
NO	DESCRIPTION	PARTS NO.	Q.ty
9	POLY BAG	CPB1061Y	1
10	BOOKLET, INFORMATION	CQE1A180Z	1
11	MANUAL, INSTRUCTION	CQX1A1135Y	1
12	MANUAL ,SETUP GUIDE	CQX1A1138X	1
13	STAPLE	CPL0905	3

### 2. Package Drawing

AVR145/230

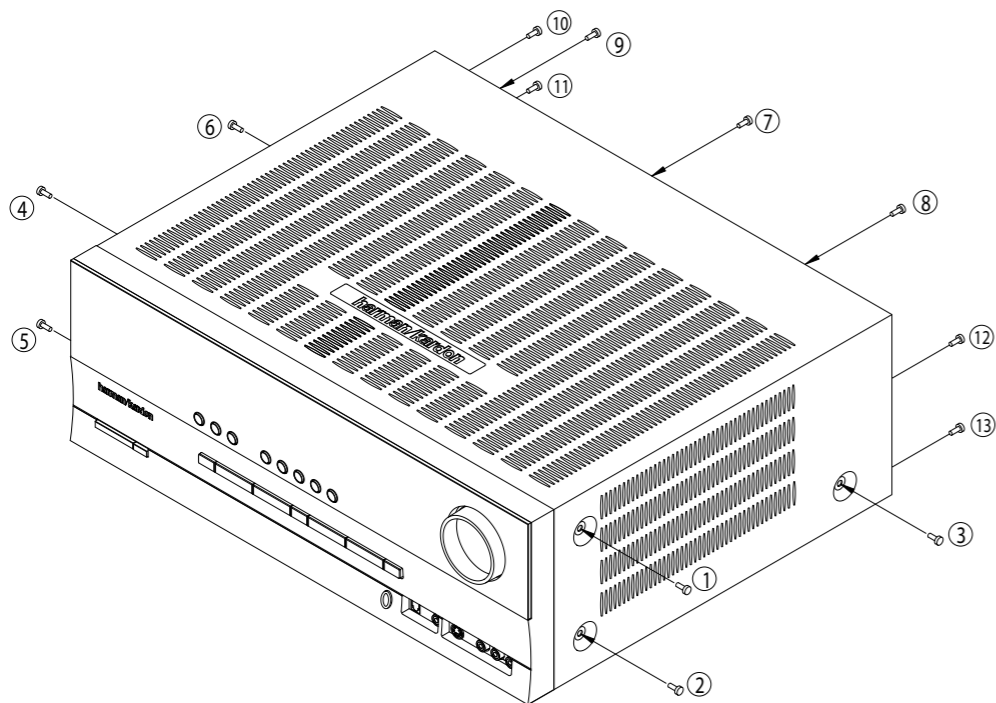


NO	DESCRIPTION	PARTS NO.	Q.ty
1	ACCESSORY-1	CQXAVR145/230	1
2	SNOW,PAD(L)	CPS4A564	1
3	SNOW,PAD(R)	CPS4A565	1
4	SET	AVR145/230SET	1
5	BOX,OUT CARTON	CPG1A820W	1
6	ACCESSORY-2	CQXAVR145/230	1

# DISASSEMBLY

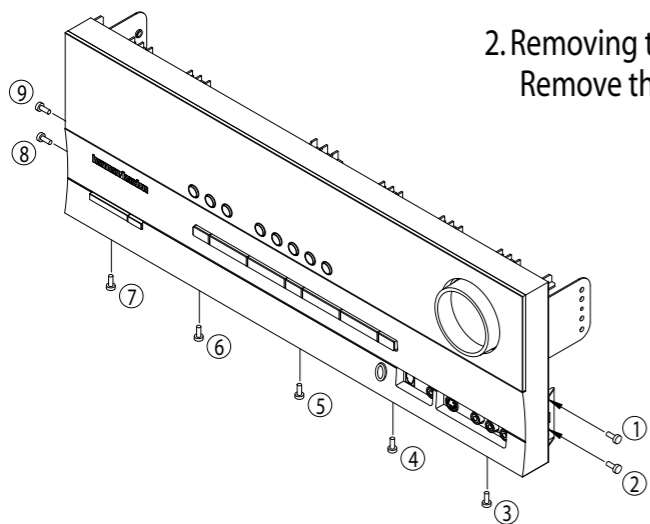
## 1. Removing the Top Cabinet Remove the Screws

① ~ ⑬



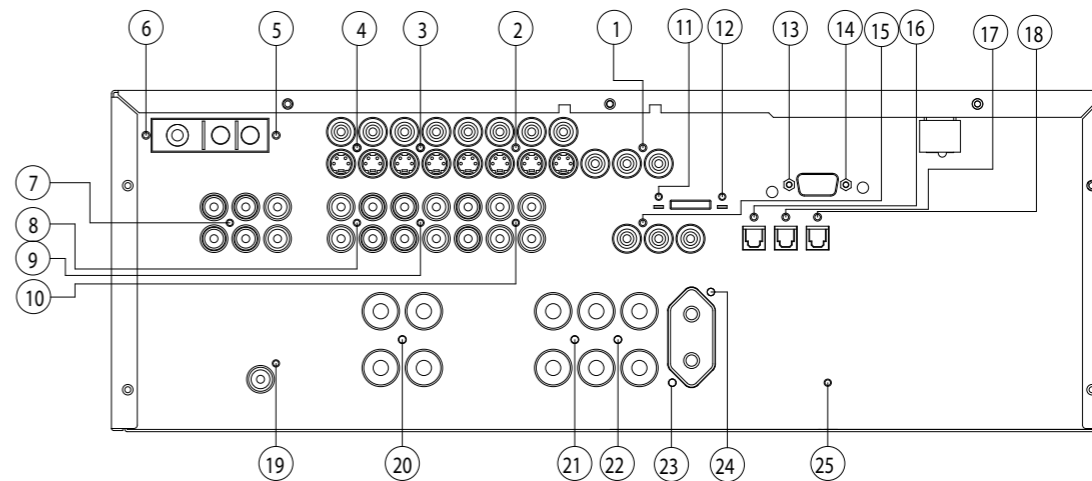
## 2. Removing the Front Panel Remove the Screws

① ~ ⑨



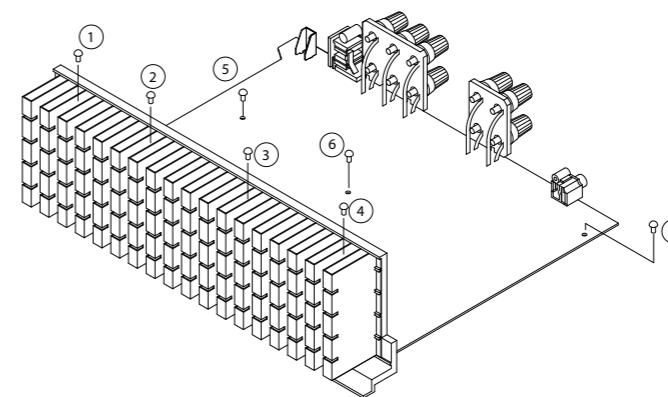
## 3. Removing the Rear Panel Remove the Screws

① ~ ⑲



## 4. Removing the Main PCB Remove the Screws

① ~ ⑦



# AVR145 DISASSEMBLY PROCEDURE

## 1 TOP-CABINET (21) REMOVAL

1. Remove 13 screws (S1,S7) and then remove the Top-cabinet.

## 2 FRONT PANEL ASS'Y REMOVAL

1. Remove the Top-cabinet, referring to the previous step 1.
2. Disconnect the card cable between connector (CN72-17p) on the FIP PCB (37-1) and connector (CN72) on the Input PCB (39-1).
3. Disconnect the lead wire (BN81-8P) on the FIP PCB (37-1) from connector (CN81) on the Trans PCB (40-4).
4. Disconnect the lead wire (BN22-6P) on the Phone PCB (37-5) from connector (CN22) on the Input PCB (39-1).
5. Disconnect the lead wire (BN18-5P) on the Phone PCB (37-5) from connector (CN18) on the Input PCB (39-1)
6. Disconnect the lead wire (BN10-4P) on the Volume PCB (37-6) from connector (CN10) on the Input PCB (39-1)
7. Disconnect the lead wire (BN41-6P) on the Volume PCB (37-6) from connector (CN41) on the Video PCB (41)
8. Remove 1 screw (S10) and then lead wire (JW82-1P,JW83-1P) on the Phone PCB (37-5).
9. Remove 1screw (S10) and then lead wire (JW84-1P) on the Volume PCB (37-3).
10. Remove 10 screws (S1) and then remove the Front Panel ASS'Y.

## 3 VOLUME PCB (37-6) REMOVAL

1. Remove the Top-cabinet, referring to the previous step 1.
2. Remove the Front Panel ASS'Y, referring to the previous step 2.
3. Pull out the Volume Knob ASS'Y.
4. Disconnect connector (CN84) on the Volume PCB (37-6) from the lead wire (BN84-5P) on the FIP PCB (37-1).
5. Remove 8 screws (S2,S14), and then remove the Volume PCB (37-6).

## 4 PHONE PCB (37-5) REMOVAL

1. Remove the Top-cabinet, referring to the previous step 1.
2. Remove the Front Panel ASS'Y, referring to the previous step 2.
- 3.. Disconnect connector (CN85)on the Phone PCB (37-5) from the lead wire (BN85-2P) on the FIP PCB (37-1).
4. Remove 2 screws (S2) and then remove the Phone PCB (37-5).

## 5 POWER LED PCB (37-3) REMOVAL

1. Remove the Top-cabinet, referring to the previous step 1.
2. Remove the Front Panel ASS'Y, referring to the previous step 2.
3. Disconnect connector (CN88) on the Power Led PCB (37-3) from the lead wire (BN88-4P) on the FIP PCB (37-1) .
4. Remove 2 screws (S2) and then remove the Power led PCB (37-3).

## 6 FIP PCB (37-1) REMOVAL

1. Remove the Top-cabinet, referring to the previous step 1.
2. Remove the Front Panel ASS'Y, referring to the previous step 2.
3. Disconnect the lead wire (BN84-5P) on the FIP PCB (37-1) from connector (CN84) on the Volume PCB (37-6).
4. Disconnect the lead wire (BN85-2P) on the FIP PCB (37-1) from connector (CN85) on the Phone PCB (37-5).
5. Disconnect the lead wire (BN88-4P) on the FIP PCB (37-1) from connector (CN88) on the Power Led PCB (37-3).
6. Disconnect the connector (CN89) on the FIP PCB (37-1) from lead wire (BN89-4P) on the Key PCB (37-2).
7. Remove 3 screws (S2) and then remove the Guide PCB (37-8) & the FIP PCB (37-1).

## 7 KEY PCB (37-2) REMOVAL

1. Remove the Top-cabinet, referring to the previous step 1.
2. Remove the Front Panel ASS'Y, referring to the previous step 2.
3. Remove the FIP PCB (37-1), referring to the previous step6.
4. Remove 10 screws (S2) and then remove the Key PCB (37-2).



## 8 TUNER MODULE (42) REMOVAL

1. Remove the Top-cabinet, referring to the previous step 1.
2. Disconnect the card cable between connector (CON1-13p) on the Tuner module (42) and connector (CN13) on Input PCB (39-1).
3. Remove 2 screws (S8) and then remove the Tuner Module (42).

## 9 VIDEO PCB (41) REMOVAL

1. Remove the Top-cabinet, referring to the previous step 1.
2. Disconnect the card cable between connector (BN14-13p) on the Video PCB (41) and connector (CN14) on the Input PCB (39-1).
3. Disconnect connector (CN43) on the Video PCB (41) from the lead wire (BN43-4P) on the Regulator PCB (A)(40-2).
4. Disconnect the card cable between connector (CN42) on the Video PCB (41) and connector (BN44-7p) on the I-Pod PCB (39-2).
5. Disconnect connector (CN41) on the Video PCB (41) from the lead wire (BN41-6P) on the Volume PCB (37-6).
6. Remove 6 screws (S8) and then remove the Video PCB (41).

## 10 I-POD PCB (39-2) REMOVAL

1. Remove the Top-cabinet, referring to the previous step 1.
2. Remove the Video PCB (41), referring to the previous step9
3. Disconnect connector (CN46) on the I-Pod PCB (39-2) from the lead wire (BN46-3P) on the Input PCB (39-1).
4. Disconnect the card cable between connector (BN19-9p) on the I-Pod PCB (39-2) and connector (CN19) on the Input PCB (39-1).
5. Disconnect the card cable between connector (BN44-7p) on the I-Pod PCB (39-2) and connector (CN42) on the Video PCB (41).
6. Disconnect the card cable between connector (CN47-7p) on the I-Pod PCB (39-2) and connector (CN47) on the RS232 PCB (37-7).
7. Remove 2 screws (S13) and then remove the I-Pod PCB (39-2).

## 11 RS232 PCB (37-7) REMOVAL

1. Remove the Top-cabinet, referring to the previous step 1.
2. Remove the Video PCB (41), referring to the previous step9
3. Disconnect the card cable between connector (CN47) on the RS232 PCB (37-7) and connector (CN47-7) on the RS232 PCB (37-7).
4. Remove 2 screws and then remove the RS232 PCB (37-7).

## 12 INPUT PCB (39-1) REMOVAL

1. Remove the Top-cabinet, referring to the previous step 1.
2. Remove the Tuner module (42), referring to the previous step8
3. Remove the Video PCB (41), referring to the previous step9
4. Disconnect connector (CN20) on the the Input PCB (39-1) from the lead wire (BN20-5P) on the Regulator PCB (B)(40-5).
5. Disconnect connector (CN22) on the Input PCB (39-1) from the lead wire (BN22-6P) on the Phone PCB (37-5).
6. Disconnect connector (CN18) on the Input PCB (39-1) from the lead wire (BN18-5P) on the Phone PCB (37-5)
7. Disconnect connector (CN10) on the Input PCB (39-1) from the lead wire (BN10-4P) on the Volume PCB (37-6).
8. Disconnect the card cable between connector (CN14) on the Input PCB (39-1) and connector (BN14-13p) on the Video PCB (41).
9. Disconnect the card cable between connector (CN19) on the Input PCB (39-1) and connector (BN19-9p) on the I-Pod PCB (39-2)
10. Disconnect the lead wire (BN46-3P) on the Input PCB (39-1) from connector (CN46) on the I-Pod PCB (39-2).
11. Disconnect the card cable between connector (CN12-21p) on the Input PCB (39-1) and connector (CN12-21p) on the main PCB (38-1)
12. Disconnect the card cable between connector (CN11-13p) on the Input PCB (39-1) and connector (CN11) on the main PCB (38-1)
13. Disconnect the card cable between connector (CN72) on the Input PCB (39-1) and connector (CN72-17p) on the FIP PCB (37-1)
14. Remove 11 screws (S8,S15) and then remove the Input PCB (39-1).

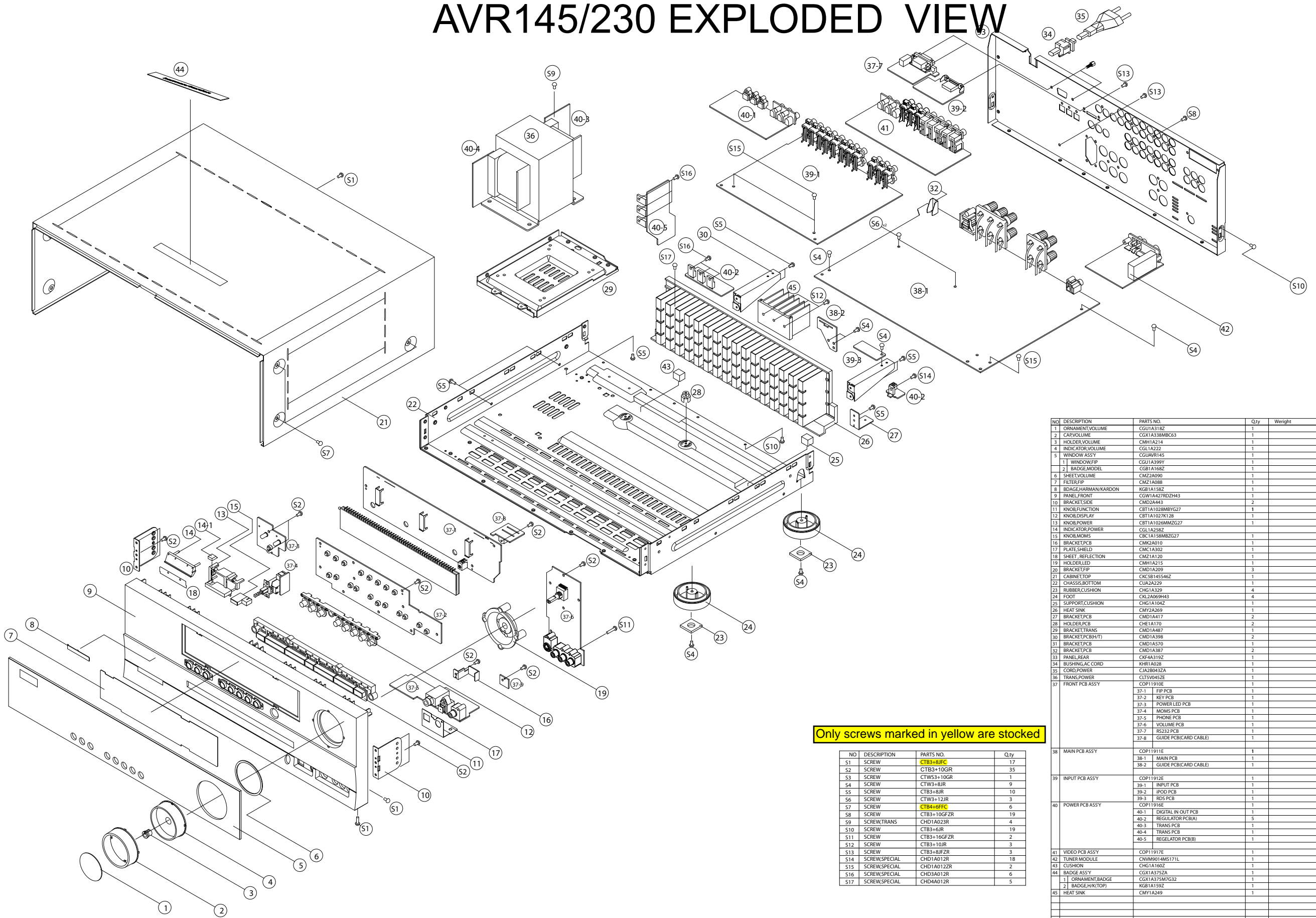
## 13 POWER TRANS (36) & POWER PCB ASS'Y(40) REMOVAL

1. Remove the Top-cabinet, referring to the previous step 1.
2. Disconnect lead wire of the Power Trans (36) from connector (CN91-3P) on the Main PCB (38-1)
3. Disconnect connector (CN19-3P,CN20-4P) on TRANS PCB (40-3) from the lead wire (BN19-3P,BN20-4P) on the Main PCB (38-1).
4. Disconnect the lead wire (BN96-8P) on the Power PCB (40-4) from connector (CN96) on the Regulator PCB (B)(40-5).
5. Disconnect the lead wire (BN99-8P) on the Power PCB (40-4) from connector (CN99) on the Regulator PCB (A)(40-2).
6. Disconnect connector (CN81) on the Trans PCB (40-4) from the lead wire (BN81-8P) on the FIP PCB (37-1).
7. Remove 4 Trans screws (S9) and then remove the Power Trans (36)& Power PCB ASS'Y(40) REMOVAL .

**14 MAIN PCB ASS'Y (38-1) REMOVAL**

1. Remove the Top-cabinet, referring to the previous step 1.
2. Remove the Tuner module (42), referring to the previous step8.
3. Remove the Video PCB (41) referring to the previous step9.
4. Remove the I-Pod PCB (39-2), referring to the previous step 10.
5. Remove the RS232 PCB (37-7), referring to the previous step 11.
6. Remove the Input PCB (39-1), referring to the previous step 12.
7. Remove the AC Cord(35) on the Main PCB (38-1)
8. Disconnect the lead wire (BN90-2P) on the Main PCB (38-1) from connector (CN86) on Moms PCB (37-4).
9. Disconnect connector (CN91-3P) on the Main PCB (38-1) from lead wire of the Power Trans (36)
10. Disconnect the lead wire (BN89-2P) on the Main PCB (38-1) from connector (CN89) on Regulator PCB (A)(40-2).
11. Disconnect the lead wire (BN19-3P,BN20-4P) on the Main PCB (38-1) from connector (CN19-3P,CN20-4P) on TRANS PCB (40-4).
12. Remove 11screws (S13-1EA, S4-2EA, S6-2EA, S8-6EA) and then remove the Main PCB ASS'Y (38-1).

# AVR145/230 EXPLODED VIEW



**Only screws marked in yellow are stocked**

NO	DESCRIPTION	PARTS NO.	Q.ty
S1	SCREW	CTB3+8JFPC	17
S2	SCREW	CTB3+10GR	35
S3	SCREW	CTW53+10GR	1
S4	SCREW	CTW3+8JR	9
S5	SCREW	CTB3+8JR	10
S6	SCREW	CTW3+12JR	3
S7	SCREW	CTB4+6FFC	6
S8	SCREW	CTB3+10GFZR	19
S9	SCREW,TRANS	CHD1A023R	4
S10	SCREW	CTB3+6JR	19
S11	SCREW	CTB3+16GFZR	2
S12	SCREW	CTB3+10JR	3
S13	SCREW	CTB3+8JFZR	3
S14	SCREW,SPECIAL	CHD1A012R	18
S15	SCREW,SPECIAL	CHD1A012ZR	2
S16	SCREW,SPECIAL	CHD3A012R	6
S17	SCREW,SPECIAL	CHD4A012R	5

NO	DESCRIPTION	PARTS NO.	Q.ty	Weight
1	ORNAMENT,VOLUME	CGU1A318Z	1	
2	CAP,VOLUME	CGX1A338MBC63	1	
3	HOLDER,VOLUME	CMH1A214	1	
4	INDICATOR,VOLUME	CGL1A222	1	
5	WINDOW ASSY	CGUAVR145	1	
1	WINDOW,FIP	CGU1A399Y	1	
2	BADGE,MODEL	CGB1A168Z	1	
6	SHEET,VOLUME	CMZ2A090	1	
7	FILTER,FIP	CMZ1A088	1	
8	BADGE,HARMAN/KARDON	KGB1A158Z	1	
9	PANEL,FRONT	CGW1A427RD2H43	1	
10	BRACKET,SIDE	CMZ2A443	2	
11	KNOB,FUNCTION	CBT1A1028MBYG27	1	
12	KNOB,DISPLAY	CBT1A1027K128	1	
13	KNOB,POWER	CBT1A1026MMZG27	1	
14	INDICATOR,POWER	CGL1A258Z	1	
15	KNOB,MOMS	CBCT1A158MBZG27	1	
16	BRACKET,PCB	CMK2A010	1	
17	PLATE,SHIELD	CMC1A302	1	
18	SHEET, REFLECTION	CMZ1A120	1	
19	HOLDER,LED	CMH1A215	1	
20	BRACKET,FIP	CMY1A209	3	
21	CABINET, TOP	CKC5B145546Z	1	
22	CHASSIS,BOTTOM	CUA2A229	1	
23	RUBBER,CUSHION	CHG1A329	4	
24	FOOT	CKL2A069H43	4	
25	SUPPORT,CUSHION	CHG1A104Z	1	
26	HEAT SINK	CMY2A269	1	
27	BRACKET,PCB	CMY1A417	2	
28	HOLDER,PCB	CHE1A170	2	
29	BRACKET,TRANS	CMY1A487	1	
30	BRACKET,PCB(H/T)	CMY1A398	2	
31	BRACKET,PCB	CMY1A570	1	
32	BRACKET,PCB	CMY1A387	2	
33	PANEL,REAR	CKF4A319Z	1	
34	BUSHING,AC CORD	KHR1A028	1	
35	CORD,POWER	CJA2B0432A	1	
36	TRANS,POWER	CLTSV045ZE	1	
37	FRONT PCB ASSY	COP11910E	1	
		37-1 FIP PCB	1	
		37-2 KEY PCB	1	
		37-3 POWER LED PCB	1	
		37-4 MOMS PCB	1	
		37-5 PHONE PCB	1	
		37-6 VOLUME PCB	1	
		37-7 RS232 PCB	1	
		37-8 GUIDE PCB(CARD CABLE)	1	
38	MAIN PCB ASSY	COP11911E	1	
		38-1 MAIN PCB	1	
		38-2 GUIDE PCB(CARD CABLE)	1	
39	INPUT PCB ASSY	COP11912E	1	
		39-1 INPUT PCB	1	
		39-2 IPOD PCB	1	
		39-3 RDS PCB	1	
40	POWER PCB ASSY	COP11916E	1	
		40-1 DIGITAL IN OUT PCB	1	
		40-2 REGULATOR PCB(A)	5	
		40-3 TRANS PCB	1	
		40-4 TRANS PCB	1	
		40-5 REGULATOR PCB(B)	1	
41	VIDEO PCB ASSY	COP11917E	1	
42	TUNER MODULE	CMW9014MS171L	1	
43	CUSHION	CMG1A160Z	1	
44	BADGE ASSY	CGX1A375ZA	1	
		1 ORNAMENT,BADGE	1	
		2 BADGE,H/K(TOP)	1	
45	HEAT SINK	CMY1A249	1	



<b>BOTTOM CHASSIS ASS'Y</b>				
<b>Ref. #</b>	<b>Part Number</b>	<b>Description</b>	<b>Value</b>	<b>Qty</b>
	CHE36-3	CLAMPER , WIRE	CLAMPER	1
	CHG1A104Z	CUSHION , RUBBER	CUSHION	1
	CHG1A160Z	CUSHION , RUBBER	CUSHION	1
	CHG1A360	CUSHION , FOOT	CUSHION	4
	CHS1A032	HEMELON TAPE	TAPE	5
	CJA2B043ZA	CORD , POWER(EUR)	QDR-7100CC	1
	CKF4A319Z	PANEL , REAR	PANEL	1
	CKL2A069H43	FOOT	FOOT	4
	CLZ9W003Z	FERRITE , RING	FERRITE RING	1
	CMD1A487	BRACKET , TRANS	BARCKET	1
	CNVM9014MS171L	MODULE , TUNER(EUR)	TUNER	1
	CQB1A173Y	LABEL, FUSE CAUTION	LABEL	1
	CTB3+10GFZR	SCREW	Not stocked	20
	CTB3+6FFZR	SCREW	Not stocked	3
	CTB3+6JR	SCREW	Not stocked	13
	CTB3+8JR	SCREW	Not stocked	7
	CTW3+12JR	SCREW	Not stocked	2
	CTW3+8JR	SCREW	Not stocked	8
	CUA2A229	CHASSIS , BOTTOM	CHASSIS	1
	KHR1A028	BUSHING , AC CORD	AC CORD	1
CB11	CWC1B2A13A100B	CABLE , CARD	CARD CABLE	1
CB12	CWC1C4A21B110B	CABLE , CARD	CARD CABLE	1
CB13	CWC1C4A13B080B	CABLE , CARD	CARD CABLE	1
CB14	CWC1B2A13A100B	CABLE , CARD	CARD CABLE	1
CB19	CWC1B2A09A240B	CABLE , CARD	CARD CABLE	1
CB42	CWC1B2A07A120B	CABLE, CARD (1mm PITCH, A-B TY	CARD CABLE	1
CB47	CWC1B2A07A060B	CABLE , CARD	CARD CABLE	1
F901	KBA2C4000TLEZ	FUSE(233TPYE,4A,250V)	LITTLE FUSE	1
T901	CLT5V045ZE	TRANS , POWER MAIN	MAIN TRANS	1
<b>FRONT PANEL ASSY</b>				
<b>Ref. #</b>	<b>Part Number</b>	<b>Description</b>	<b>Value</b>	<b>Qty</b>
	CGWAVR145/230	FRONT PANEL ASS'Y	ASS'Y	1
	CBC1A158MBZG27	KNOB , MOMS	KNOB	1
	CBT1A1026MMZG27	KNOB , POWER	KNOB	1
	CBT1A1027K128	KNOB , DISPLAY	KNOB	1
	CBT1A1028MBYG27	KNOB , FUNCTION	KNOB	1
	CGL1A258Z	INDICATOR , POWER	INDICATOR	1
	CGW1A427RDZH43	PANEL , FRONT	PANEL	1
	CHR301	CLAMPER	CLAMPER	12
	CMC1A302	PLATE , SHIELD	PLATE	1
	CMD2A443	BRACKET , SIDE	BRACKET	2
	CMH1A215	HOLDER , LED	HOLDER	1
	CMK2A010	BRACKET , PCB	BRACKET	1
	CMZ1A088	FILTER , FIP	FIP	1
	CMZ1A120	SHEET , REFLECTION	SHEET	1
	CTB3+10GR	SCREW	Not stocked	31
	CTB3+16GFZR	SCREW	Not stocked	2
	KGB1A158Z	BADGE , HARMAN/KARDON(FRONT)	BADGE	1
CB72	CWC1B2A17A230B	WAFER, CARD CABLE (1mm PITCH,	WAFER	1

FRONT PCB ASSY				
Ref. #	Part Number	Description	Value	Qty
	COP11910E	FRONT PCB ASS'Y(AVR145/230)	ASS'Y	1
C714	HCBS1H151KBT	CAP , CERAMIC	150UF 50V K	1
C716	CCEA1AH331T	CAP , ELECT	330UF 10V	1
C719	HCBS1H102KBT	CAP , CERAMIC	1000PF 50V K	1
C720	HCBS1H102KBT	CAP , CERAMIC	1000PF 50V K	1
C721	HCBS1H102KBT	CAP , CERAMIC	1000PF 50V K	1
C723	HCBS1H104ZFT	CAP , CERAMIC	0.1UF 50V Z	1
C728	HCBS1H104ZFT	CAP , CERAMIC	0.1UF 50V Z	1
C729	HCBS1H473ZFT	CAP , CERAMIC	0.047UF 50V Z	1
C731	CCEA1HH100T	CAP , ELECT	10UF 50V	1
C735	CCEA1CKS100T	CAP , ELECT	10UF 16V	1
C742	HCBS1H223ZFT	CAP , CERAMIC	0.02UF 50V Z	1
C793	HCBS1H104ZFT	CAP , CERAMIC	0.1UF 50V Z	1
C794	HCBS1C222MXT	CAP , CERAMIC	2200PF 16V	1
C795	HCBS1H102KBT	CAP , CERAMIC	1000PF 50V K	1
C796	HCBS1H102KBT	CAP , CERAMIC	1000PF 50V K	1
C805	HCBS1H223ZFT	CAP , CERAMIC	0.022UF 50V Z	1
C806	HCBS1H223ZFT	CAP , CERAMIC	0.022UF 50V Z	1
C807	HCBS1H104ZFT	CAP , CERAMIC	0.1UF 50V Z	1
C808	HCBS1H181KBT	CAP , CERAMIC	180PF 50V Z	1
C809	CCEA1AH471T	CAP , ELECT	470UF 10V	1
C812	HCBS1H104ZFT	CAP , CERAMIC	0.1UF 50V Z	1
C817	HCBS1H100JCT	CAP , CERAMIC	10PF 50V	1
C841	CCEA1HH100T	CAP , ELECT	10UF 50V	1
C842	CCEA1HH100T	CAP , ELECT	10UF 50V	1
C843	CCEA1HH100T	CAP , ELECT	10UF 50V	1
C850	HCBS1H471KBT	CAP , CERAMIC	470PF 50V	1
C851	HCBS1H471KBT	CAP , CERAMIC	470PF 50V	1
C852	HCBS1H104ZFT	CAP , CERAMIC	0.1UF 50V Z	1
C855	HCBS1H101KBT	CAP , CERAMIC	100PF 50V K	1
C856	HCBS1H101KBT	CAP , CERAMIC	100PF 50V K	1
C857	HCBS1H104ZFT	CAP , CERAMIC	0.1UF 50V Z	1
C862	HCBS1H101KBT	CAP , CERAMIC	100PF 50V K	1
C863	HCBS1H101KBT	CAP , CERAMIC	100PF 50V K	1
C866	CCEA1HKS100T	CAP , ELECT	10UF 50V SMALL	1
C867	CCEA1HKS100T	CAP , ELECT	10UF 50V SMALL	1
C868	CCEA1EKS470T	CAP , ELECT	47UF 25V	1
C869	CCEA1EKS470T	CAP , ELECT	47UF 25V	1
C870	HCBS1H681KBT	CAP , CERAMIC	680PF 50V K	1
C871	HCBS1H681KBT	CAP , CERAMIC	680PF 50V K	1
C872	CCEA1CH331T	CAP , ELECT	330UF 16V	1
C873	CCEA1CH331T	CAP , ELECT	330UF 16V	1
C874	HCBS1H101KBT	CAP , CERAMIC	100PF 50V K	1
C882	HCBS1H104ZFT	CAP , CERAMIC	0.1UF 50V Z	1
C889	HCBS1H104ZFT	CAP , CERAMIC	0.1UF 50V Z	1
C891	HCBS1H223ZFT	CAP , CERAMIC	0.023UF 50V Z	1
C892	HCBS1H223ZFT	CAP , CERAMIC	0.023UF 50V Z	1
C893	HCBS1H223ZFT	CAP , CERAMIC	0.023UF 50V Z	1
C894	CCEA1CKS100T	CAP , ELECT	10UF 16V	1

FRONT PCB ASSY				
Ref. #	Part Number	Description	Value	Qty
C896	HCBS1H223ZFT	CAP , CERAMIC	0.023UF 50V Z	1
C897	CCEA1AH471T	CAP , ELECT	470UF 10V	1
C901	HCBS1H390JT	CAP , CERAMIC	39PF 50V Z	1
C903	CCEA1HKS2R2T	CAP , ELECT	2.2UF 50V SMALL SIZE	1
C905	CCEA1HKS2R2T	CAP , ELECT	2.2UF 50V SMALL SIZE	1
C953	HCBS1H104ZFT	CAP , CERAMIC	0.1UF 50V Z	1
C954	HCBS1H104ZFT	CAP , CERAMIC	0.1UF 50V Z	1
C957	HCBS1H104ZFT	CAP , CERAMIC	0.1UF 50V Z	1
D730	CVD1SS133MT	DIODE	1SS133	1
D774	CVD1SS133MT	DIODE	1SS133	1
D778	HVD1N5819T	DIODE , SCHOTTKY	1N5819	1
D784	CVD1SS133MT	DIODE	1SS133	1
D785	CVD1SS133MT	DIODE	1SS133	1
L702	HLQ02C100KT	COIL , AXAIL	10uH	1
Q701	HVTKRC107MT	T.R	KRC107M	1
Q722	HVTKRA107MT	T.R	KRA107M	1
Q724	HVTKRC107MT	T.R	KRC107M	1
Q725	HVTKRC107MT	T.R	KRC107M	1
Q734	HVTKTC2874BT	T.R , MUTE	KTC2874B	1
Q735	HVTKTC2874BT	T.R , MUTE	KTC2874B	1
Q736	HVTKTC2874BT	T.R , MUTE	KTC2874B	1
Q737	HVTKTC2874BT	T.R , MUTE	KTC2874B	1
Q738	HVTKRC107MT	T.R	KRC107M	1
Q739	HVTKTA1271YT	T.R	KTA1271Y	1
R701	CRD20TJ103T	RES , CARBON	10K OHM 1/5W J	1
R704	CRD20TJ100T	RES , CARBON	10 OHM 1/5W J	1
R705	CRD20TJ820T	RES , CARBON	82 OHM 1/5W J	1
R706	CRD20TJ820T	RES , CARBON	82 OHM 1/5W J	1
R708	CRD20TJ820T	RES , CARBON	82 OHM 1/5W J	1
R709	CRD20TJ470T	RES , CARBON	47 OHM 1/5W J	1
R710	CRD20TJ470T	RES , CARBON	47 OHM 1/5W J	1
R711	CRD20TJ470T	RES , CARBON	47 OHM 1/5W J	1
R718	CRD20TJ222T	RES , CARBON	2.2K OHM 1/5W J	1
R737	CRD20TJ100T	RES , CARBON	10 OHM 1/5W J	1
R747	CRD20TJ103T	RES , CARBON	10K OHM 1/5W J	1
R753	CRD20TF1001T	RES , CARBON	1K 1/5W F	1
R754	CRD20TF1501T	RES , CARBON	1.5K 1/5W F	1
R755	CRD20TF1801T	RES , CARBON	1.8K 1/5W F	1
R756	CRD20TF2701T	RES , CARBON	2.7K 1/5W F	1
R757	CRD20TF3301T	RES , CARBON	3.3K 1/5W F	1
R758	CRD20TF5601T	RES , CARBON	5.6K 1/5W F	1
R759	CRD20TF1001T	RES , CARBON	1K 1/5W F	1
R760	CRD20TF1501T	RES , CARBON	1.5K 1/5W F	1
R761	CRD20TF1801T	RES , CARBON	1.8K 1/5W F	1
R762	CRD20TF2701T	RES , CARBON	2.7K 1/5W F	1
R763	CRD20TF3301T	RES , CARBON	3.3K 1/5WF	1
R764	CRD20TF5601T	RES , CARBON	5.6K 1/5W F	1
R765	CRD20TF7501T	RES , CARBON	7.5K 1/5W F	1
R766	CRD20TF1001T	RES , CARBON	1K 1/5W F	1
R767	CRD20TF1501T	RES , CARBON	1.5K 1/5W F	1

FRONT PCB ASSY				
Ref. #	Part Number	Description	Value	Qty
R768	CRD20TF1801T	RES , CARBON	1.8K 1/5W F	1
R769	CRD20TF2701T	RES , CARBON	2.7K 1/5W F	1
R781	CRD20TJ102T	RES , CARBON	1K OHM 1/5W J	1
R783	CRD20TJ102T	RES , CARBON	1K OHM 1/5W J	1
R784	CRD20TJ102T	RES , CARBON	1K OHM 1/5W J	1
R786	CRD20TJ152T	RES , CARBON	1.5K OHM 1/5W J	1
R787	CRD20TJ101T	RES , CARBON	100 OHM 1/5W J	1
R791	CRD20TJ822T	RES , CARBON	8.2K OHM 1/5W J	1
R805	CRD20TJ104T	RES , CARBON	100K OHM 1/5W J	1
R806	CRD20TJ472T	RES , CARBON	4.7K OHM 1/5W J	1
R824	CRD20TJ221T	RES , CARBON	220 OHM 1/5W J	1
R825	CRD20TJ681T	RES , CARBON	680 OHM 1/5W J	1
R828	CRD20TJ221T	RES , CARBON	220 OHM 1/5W J	1
R829	CRD20TJ681T	RES , CARBON	680 OHM 1/5W J	1
R864	CRD20TJ272T	RES , CARBON	2.7K OHM 1/5W J	1
R865	CRD20TJ101T	RES , CARBON	100 OHM 1/5W J	1
R866	CRD20TJ272T	RES , CARBON	2.7K OHM 1/5W J	1
R869	CRD20TJ750T	RES , CARBON	75 OHM 1/5W J	1
R871	CRD20TJ104T	RES , CARBON	100K OHM 1/5W J	1
R872	CRD20TJ104T	RES , CARBON	100K OHM 1/5W J	1
R873	CRD20TJ471T	RES , CARBON	470 OHM 1/5W J	1
R874	CRD20TJ471T	RES , CARBON	470 OHM 1/5W J	1
R875	CRD20TJ103T	RES , CARBON	10K OHM 1/5W J	1
R876	CRD20TJ750T	RES , CARBON	75 OHM 1/5W J	1
R877	CRD20TJ750T	RES , CARBON	75 OHM 1/5W J	1
R878	CRD20TJ750T	RES , CARBON	75 OHM 1/5W J	1
R892	CRD20TJ222T	RES , CARBON	2.2K OHM 1/5W J	1
R893	CRD20TJ333T	RES , CARBON	33K OHM 1/5W J	1
R895	CRD20TJ101T	RES , CARBON	100 OHM 1/5W J	1
R896	CRD20TJ101T	RES , CARBON	100 OHM 1/5W J	1
R897	CRD20TJ101T	RES , CARBON	100 OHM 1/5W J	1
R898	CRD20TJ101T	RES , CARBON	100 OHM 1/5W J	1
R899	CRD20TJ104T	RES , CARBON	100K OHM 1/5W J	1
R900	CRD20TJ104T	RES , CARBON	100K OHM 1/5W J	1
R901	CRD20TJ152T	RES , CARBON	1.5K OHM 1/5W J	1
R902	CRD20TJ152T	RES , CARBON	1.5K OHM 1/5W J	1
R903	CRD20TJ102T	RES , CARBON	1K OHM 1/5W J	1
R904	CRD20TJ102T	RES , CARBON	1K OHM 1/5W J	1
R905	CRD20TJ104T	RES , CARBON	100K OHM 1/5W J	1
R906	CRD20TJ104T	RES , CARBON	100K OHM 1/5W J	1
R907	CRD20TJ472T	RES , CARBON	4.7K OHM 1/5W J	1
R908	CRD20TJ472T	RES , CARBON	4.7K OHM 1/5W J	1
R909	CRD20TJ221T	RES , CARBON	220 OHM 1/5W J	1
R910	CRD20TJ221T	RES , CARBON	220 OHM 1/5W J	1
R911	CRD20TJ221T	RES , CARBON	220 OHM 1/5W J	1
R912	CRD20TJ221T	RES , CARBON	220 OHM 1/5W J	1
R913	CRD20TJ102T	RES , CARBON	1K OHM 1/5W J	1
R915	CRD20TJ473T	RES , CARBON	47K OHM 1/5W J	1
R918	CRD20TJ472T	RES , CARBON	4.7K OHM 1/5W J	1
R919	CRD20TJ472T	RES , CARBON	4.7K OHM 1/5W J	1



FRONT PCB ASSY				
Ref. #	Part Number	Description	Value	Qty
R956	CRD20TJ1R0T	RES , CARBON	1 OHM 1/5W J	1
S701	HST1A020ZT	SW , TACT	1A020	1
S702	HST1A020ZT	SW , TACT	1A020	1
S703	HST1A020ZT	SW , TACT	1A020	1
S704	HST1A020ZT	SW , TACT	1A020	1
S705	HST1A020ZT	SW , TACT	1A020	1
S706	HST1A020ZT	SW , TACT	1A020	1
S707	HST1A020ZT	SW , TACT	1A020	1
S708	HST1A020ZT	SW , TACT	1A020	1
S709	HST1A020ZT	SW , TACT	1A020	1
S710	HST1A020ZT	SW , TACT	1A020	1
S711	HST1A020ZT	SW , TACT	1A020	1
S712	HST1A020ZT	SW , TACT	1A020	1
S713	HST1A020ZT	SW , TACT	1A020	1
S714	HST1A020ZT	SW , TACT	1A020	1
S715	HST1A020ZT	SW , TACT	1A020	1
S716	HST1A020ZT	SW , TACT	1A020	1
S717	HST1A020ZT	SW , TACT	1A020	1
S718	HST1A020ZT	SW , TACT	1A020	1
S719	HST1A020ZT	SW , TACT	1A020	1
S720	HST1A020ZT	SW , TACT	1A020	1
	CMC3A111	PLATE , EARTH	PLATE	1
BK71	CMD1A209	BRACKET , FLT	BRACKET	1
BK72	CMD1A209	BRACKET , FLT	BRACKET	1
BK73	CMD1A209	BRACKET , FLT	BRACKET	1
BN10	CWZAVR230BN10	WIRE ASS'Y (SHIELD)	WIRE	1
BN18	CWZAVR125BN18	WIRE ASS'Y (SHIELD)	WIRE	1
BN22	CWZAVR145BN22	WIRE ASS'Y (SHIELD)	WIRE	1
BN41	CWZAVR130BN41	WIRE ASS'Y (SHIELD)	WIRE	1
BN81	CWB2C908200BM	WIRE ASS'Y	WIRE	1
BN84	CWB2B905080EN	WIRE ASS'Y	WIRE	1
BN85	CWB2B902100EW	WIRE ASS'Y ( ANGLE )	WIRE	1
BN88	CWB2B904100EN	WIRE ASS'Y	WIRE	1
BN89	CWB2B904100EN	WIRE ASS'Y	WIRE	1
CN47	CJP07GA117ZY	TEMP ITEM	WAFER	1
CN72	CJP17GA193ZY	WAFER, CARD CABLE (SMD)	WAFER	1
CN84	CJP05GB46ZY	WAFER	WAFER	1
CN85	CJP02GA19ZY	WAFER, 2PIN	WAFER	1
CN86	CJP02GA89ZM	WAFER	WAFER	1
CN88	CJP04GB46ZY	WAFER	WAFER	1
CN89	CJP04GB46ZY	WAFER	WAFER	1
D701	CVD52CSBBCEAB2	BLUE L.E.D	L.E.D	1
D703	CVD52CSBBCEAB2	BLUE L.E.D	L.E.D	1
D705	CVD52CSBBCEAB2	BLUE L.E.D	L.E.D	1
D723	CVD50BOBBWGA	L.E.D , 2 COLOR (ORG , BLUE)	L.E.D	1
D727	CVD50BOBBWGA	L.E.D , 2 COLOR (ORG , BLUE)	L.E.D	1
ET03	CMD1A569	BRACKET , PCB	BRACKET	1
FIP1	HFLHCA18ML03	F.I.P	FIP	1
IC73	HRVNJL34H380A	SENSOR , REMOTE	JRC	1
IC75	HVI74ACT04MTR	I.C , HEX INVERTER	FAIRCHILD	1

<b>FRONT PCB ASSY</b>				
<b>Ref. #</b>	<b>Part Number</b>	<b>Description</b>	<b>Value</b>	<b>Qty</b>
IC76	HVI74HCU04AFNG	I.C , INVERTER	TOSHIBA	1
IC86	HVINJM4556AL	I.C , HEADPHONE	JRC	1
IC97	HVIST202EBW	IC , RS232C TRANSCEIVER	ST	1
JK81	CJJ4M043Y	JACK , BOARD	BOARD JACK	1
JK82	HJSTORX177L	MODULE , OPTICAL(RX)	OPT JACK(RX)	1
JK83	CJJ2E026Z	JACK , HEADPHONE(SILVER PLATE)	JACK	1
JK85	CJJ9M003Z	JACK , S-VIDEO	JACK	1
JK86	CJJ4S023Y	JACK , BOARD	JACK	1
JK97	CJJ9W001Z	9P D-SUB FEMALE(RS-232C) SEMCO	JACK	1
JW82	CWE8202300RV	WIRE ASS'Y	WIRE	1
JW83	CWE8202150RV	WIRE ASS'Y	WIRE	1
JW84	CWE8202110RV	WIRE ASS'Y	WIRE	1
SW1	CSH1A008ZV	SW , PUSH (MOMS)	MOMS SWITCH	1
SW95	KST1A010Z	SW , TACT	SWITCH	1
SW98	HSH2B018Z	SW , PUSH	SWITCH	1
VR74	CSR2A037Z	ENCODER	ENCODER	1
<b>MAIN PCB ASSY</b>				
<b>Ref. #</b>	<b>Part Number</b>	<b>Description</b>	<b>Value</b>	<b>Qty</b>
	COP11911E	MAIN PCB ASS'Y(AVR145/230)	ASS'Y	1
	CHD3A012R	SCREW , SPECIAL	Not stocked	3
	CHS1A032	HEMELON TAPE	TAPE	1
C501	CCEA1HH100T	CAP , ELECT	10UF 50V	1
C502	CCEA1HH100T	CAP , ELECT	10UF 50V	1
C503	CCEA1HH100T	CAP , ELECT	10UF 50V	1
C504	CCEA1HH100T	CAP , ELECT	10UF 50V	1
C505	CCEA1HH100T	CAP , ELECT	10UF 50V	1
C506	CCKT1H331KB	CAP , CERAMIC	330PF 50V	1
C507	HCBS1H331KBT	CAP , CERAMIC	330PF 50V	1
C508	HCBS1H331KBT	CAP , CERAMIC	330PF 50V	1
C509	CCKT1H331KB	CAP , CERAMIC	330PF 50V	1
C510	HCBS1H331KBT	CAP , CERAMIC	330PF 50V	1
C561	CCEA1CH101T	CAP , ELECT	100UF 16V	1
C562	CCEA1CH101T	CAP , ELECT	100UF 16V	1
C563	CCEA1CH101T	CAP , ELECT	100UF 16V	1
C564	CCEA1CH101T	CAP , ELECT	100UF 16V	1
C565	CCEA1CH101T	CAP , ELECT	100UF 16V	1
C566	CCEA1CH101T	CAP , ELECT	100UF 16V	1
C567	CCEA1CH101T	CAP , ELECT	100UF 16V	1
C568	CCEA1CH101T	CAP , ELECT	100UF 16V	1
C569	CCEA1CH101T	CAP , ELECT	100UF 16V	1
C570	CCEA1CH101T	CAP , ELECT	100UF 16V	1
C571	HCBS1H681KBT	CAP , CERAMIC	680PF 50V	1
C572	HCBS1H681KBT	CAP , CERAMIC	680PF 50V	1
C573	HCBS1H681KBT	CAP , CERAMIC	680PF 50V	1
C574	HCBS1H681KBT	CAP , CERAMIC	680PF 50V	1
C575	HCBS1H681KBT	CAP , CERAMIC	680PF 50V	1
C601	CCCT1H120JC	CAP , CERAMIC	12PF 50V	1
C602	CCCT1H120JC	CAP , CERAMIC	12PF 50V	1

MAIN PCB ASSY				
Ref. #	Part Number	Description	Value	Qty
C603	CCCT1H120JC	CAP , CERAMIC	12PF 50V	1
C604	CCCT1H120JC	CAP , CERAMIC	12PF 50V	1
C605	CCCT1H120JC	CAP , CERAMIC	12PF 50V	1
C606	CCCT1H330JC	CAP , CERAMIC	33PF 50V	1
C607	CCCT1H330JC	CAP , CERAMIC	33PF 50V	1
C608	CCCT1H330JC	CAP , CERAMIC	33PF 50V	1
C609	CCCT1H330JC	CAP , CERAMIC	33PF 50V	1
C610	CCCT1H330JC	CAP , CERAMIC	33PF 50V	1
C681	CCEA1HH100T	CAP , ELECT	10UF 50V	1
C682	CCEA1HH100T	CAP , ELECT	10UF 50V	1
C683	CCEA1HH100T	CAP , ELECT	10UF 50V	1
C684	CCEA1HH100T	CAP , ELECT	10UF 50V	1
C685	CCEA1HH100T	CAP , ELECT	10UF 50V	1
C726	CKT1H221KB	CAP , CERAMIC	220PF 50V	1
C900	HCQ11H473JZT	CAP , MYLAR	0.047UF 50V	1
C901	HCQ11H473JZT	CAP , MYLAR	0.047UF 50V	1
C905	CCFT1H223ZF	CAP , CERAMIC	0.022UP 50V	1
C907	CCEA1CH101T	CAP , ELECT	100UF 16V	1
C908	CCFT1H223ZF	CAP , CERAMIC	0.022UP 50V	1
C910	HCQ11H473JZT	CAP , MYLAR	0.047UF 50V	1
C911	CCEA1CH471T	CAP , ELECT	470UF 16V	1
C912	CCEA1CH221T	CAP , ELECT	220UF 16V	1
C913	CCFT1H104ZF	CAP , SEMICONDUCTOR	0.1UF 50V ZF	1
C914	HCQ11H473JZT	CAP , MYLAR	0.047UF 50V J	1
C917	HCQ11H473JZT	CAP , MYLAR	0.047UF 50V J	1
C924	CCFT1H104ZF	CAP , SEMICONDUCTOR	0.1UF 50V ZF	1
C939	CCEA1HH4R7T	CAP , ELECT	4.7UF 50V	1
C940	CCEA1AH471T	CAP , ELECT	470UF 10V	1
C948	CCFT1H104ZF	CAP , SEMICONDUCTOR	0.1UF 50V ZF	1
C949	CCEA1HH220T	CAP , ELECT	22UF 50V	1
C971	HCQ11H562JZT	CAP , MYLAR	5600PF 50V	1
C972	HCQ11H562JZT	CAP , MYLAR	5600PF 50V	1
C973	HCQ11H562JZT	CAP , MYLAR	5600PF 50V	1
C980	HCQ11H562JZT	CAP , MYLAR	5600PF 50V	1
C981	HCQ11H562JZT	CAP , MYLAR	5600PF 50V	1
C990	HCQ11H473JZT	CAP , MYLAR	0.047UF 50V J	1
C991	CCEA1HH1R0T	CAP , ELECT	1UF 50V	1
C992	HCQ11H473JZT	CAP , MYLAR	0.047UF 50V J	1
C993	HCQ11H473JZT	CAP , MYLAR	0.047UF 50V J	1
C995	HCQ11H473JZT	CAP , MYLAR	0.047UF 50V J	1
C997	HCQ11H473JZT	CAP , MYLAR	0.047UF 50V J	1
C999	CCFT1H223ZF	CAP , CERAMIC	0.022UP 50V	1
D501	CVD1SS133MT	DIODE	1SS133	1
D502	CVD1SS133MT	DIODE	1SS133	1
D503	CVD1SS133MT	DIODE	1SS133	1
D504	CVD1SS133MT	DIODE	1SS133	1
D505	CVD1SS133MT	DIODE	1SS133	1
D581	CVD1SS133MT	DIODE	1SS133	1
D582	CVD1SS133MT	DIODE	1SS133	1
D583	CVD1SS133MT	DIODE	1SS133	1

MAIN PCB ASSY				
Ref. #	Part Number	Description	Value	Qty
D584	CVD1SS133MT	DIODE	1SS133	1
D585	CVD1SS133MT	DIODE	1SS133	1
D901	CVD1N4003SRT	RECT , DIODE	1N4003	1
D902	CVD1SS133MT	DIODE	1SS133	1
D911	CVD1SS133MT	DIODE	1SS133	1
D912	CVD1SS133MT	DIODE	1SS133	1
D914	CVD1SS133MT	DIODE	1SS133	1
D917	CVD1SS133MT	DIODE	1SS133	1
D953	CVD1SS133MT	DIODE	1SS133	1
D954	CVD1N4003SRT	RECT , DIODE	1N4003	1
D955	CVD1N4003SRT	RECT , DIODE	1N4003	1
D956	CVD1N4003SRT	RECT , DIODE	1N4003	1
D957	CVD1N4003SRT	RECT , DIODE	1N4003	1
D961	CVD1N4003ST	RECT , DIODE	1N4003	1
D962	CVD1N4003SRT	RECT , DIODE	1N4003	1
D963	CVD1N4003ST	RECT , DIODE	1N4003	1
D973	CVD1SS133MT	DIODE	1SS133	1
D974	CVD1SS133MT	DIODE	1SS133	1
D979	HVDMTZJ6.2BT	DIODE , ZENER	MTZJ6.2B	1
D980	CVD1SS133MT	DIODE	1SS133	1
ET90	HJT1A025	PALTE , EARTH	MET37-0002	1
ET91	HJT1A025	PALTE , EARTH	MET37-0002	1
F901	KJCF5S	HOLDER , FUSE	FUSE HOLDER	2
F902	KBA2D2500TLET	FUSE(SR-5, 2.5A, 250V)	SAVE FUSETECH	1
Q501	HVTKTA1268GRT	T.R	KTA1268GR	1
Q502	HVTKTA1268GRT	T.R	KTA1268GR	1
Q503	HVTKTA1268GRT	T.R	KTA1268GR	1
Q504	HVTKTA1268GRT	T.R	KTA1268GR	1
Q505	HVTKTA1268GRT	T.R	KTA1268GR	1
Q511	HVTKTC3200GRT	T.R	KTC3200GR	1
Q512	HVTKTC3200GRT	T.R	KTC3200GR	1
Q513	HVTKTC3200GRT	T.R	KTC3200GR	1
Q514	HVTKTC3200GRT	T.R	KTC3200GR	1
Q515	HVTKTC3200GRT	T.R	KTC3200GR	1
Q516	HVTKTC3200GRT	T.R	KTC3200GR	1
Q517	HVTKTC3200GRT	T.R	KTC3200GR	1
Q518	HVTKTC3200GRT	T.R	KTC3200GR	1
Q519	HVTKTC3200GRT	T.R	KTC3200GR	1
Q520	HVTKTC3200GRT	T.R	KTC3200GR	1
Q541	HVTKTC3198YT	T.R	KTC3198Y	1
Q542	HVTKTC3198YT	T.R	KTC3198Y	1
Q543	HVTKTC3198YT	T.R	KTC3198Y	1
Q544	HVTKTC3198YT	T.R	KTC3198Y	1
Q545	HVTKTC3198YT	T.R	KTC3198Y	1
Q556	HVTKTC3200GRT	T.R	KTC3200GR	1
Q557	HVTKTC3200GRT	T.R	KTC3200GR	1
Q558	HVTKTC3200GRT	T.R	KTC3200GR	1
Q559	HVTKTC3200GRT	T.R	KTC3200GR	1
Q560	HVTKTC3200GRT	T.R	KTC3200GR	1
Q561	HVTKTC3200GRT	T.R	KTC3200GR	1

MAIN PCB ASSY				
Ref. #	Part Number	Description	Value	Qty
Q562	HVTKTC3200GRT	T.R	KTC3200GR	1
Q563	HVTKTC3200GRT	T.R	KTC3200GR	1
Q564	HVTKTC3200GRT	T.R	KTC3200GR	1
Q565	HVTKTC3200GRT	T.R	KTC3200GR	1
Q601	HVTKTA1268GRT	T.R	KTA1268GR	1
Q602	HVTKTA1268GRT	T.R	KTA1268GR	1
Q603	HVTKTA1268GRT	T.R	KTA1268GR	1
Q604	HVTKTA1268GRT	T.R	KTA1268GR	1
Q605	HVTKTA1268GRT	T.R	KTA1268GR	1
Q681	HVTKSC2785YT	T.R	KSC2785Y	1
Q682	HVTKSC2785YT	T.R	KSC2785Y	1
Q683	HVTKSC2785YT	T.R	KSC2785Y	1
Q684	HVTKSC2785YT	T.R	KSC2785Y	1
Q685	HVTKSC2785YT	T.R	KSC2785Y	1
Q901	HVTKSC2785YT	T.R	KSC2785Y	1
Q938	HVTKRA107MT	T.R	KRA107M	1
Q939	HVTKRA107MT	T.R	KRA107M	1
Q942	HVTKSC2785YT	T.R	KSC2785Y	1
Q943	HVTKSC2785YT	T.R	KSC2785Y	1
Q951	HVTKRC107MT	T.R	KRC107M	1
Q952	HVTKRA107MT	T.R	KRA107M	1
Q960	HVTKRC107MT	T.R	KRC107M	1
Q961	HVTKTA1024YT	T.R	KTA1024YT	1
Q991	HVTKRC107MT	T.R	KRC107M	1
Q992	HVTKRA107MT	T.R	KRA107M	1
R501	CRD20TJ433T	RES , CARBON	43K OHM 1/5W J	1
R502	CRD20TJ433T	RES , CARBON	43K OHM 1/5W J	1
R503	CRD20TJ433T	RES , CARBON	43K OHM 1/5W J	1
R504	CRD20TJ433T	RES , CARBON	43K OHM 1/5W J	1
R505	CRD20TJ433T	RES , CARBON	43K OHM 1/5W J	1
R506	CRD20TJ333T	RES , CARBON	33K OHM 1/5W J	1
R507	CRD20TJ333T	RES , CARBON	33K OHM 1/5W J	1
R508	CRD20TJ333T	RES , CARBON	33K OHM 1/5W J	1
R509	CRD20TJ333T	RES , CARBON	33K OHM 1/5W J	1
R510	CRD20TJ333T	RES , CARBON	33K OHM 1/5W J	1
R511	CRD20TJ152T	RES , CARBON	1.5K OHM 1/5W J	1
R512	CRD20TJ152T	RES , CARBON	1.5K OHM 1/5W J	1
R513	CRD20TJ152T	RES , CARBON	1.5K OHM 1/5W J	1
R514	CRD20TJ152T	RES , CARBON	1.5K OHM 1/5W J	1
R515	CRD20TJ152T	RES , CARBON	1.5K OHM 1/5W J	1
R516	CRD20TJ152T	RES , CARBON	1.5K OHM 1/5W J	1
R517	CRD20TJ152T	RES , CARBON	1.5K OHM 1/5W J	1
R518	CRD20TJ152T	RES , CARBON	1.5K OHM 1/5W J	1
R519	CRD20TJ152T	RES , CARBON	1.5K OHM 1/5W J	1
R520	CRD20TJ152T	RES , CARBON	1.5K OHM 1/5W J	1
R521	CRD20TJ471T	RES , CARBON	470 OHM 1/5W J	1
R522	CRD20TJ471T	RES , CARBON	470 OHM 1/5W J	1
R523	CRD20TJ471T	RES , CARBON	470 OHM 1/5W J	1
R524	CRD20TJ471T	RES , CARBON	470 OHM 1/5W J	1
R525	CRD20TJ471T	RES , CARBON	470 OHM 1/5W J	1

MAIN PCB ASSY				
Ref. #	Part Number	Description	Value	Qty
R531	CRD20TJ221T	RES , CARBON	220 OHM 1/5W J	1
R532	CRD20TJ221T	RES , CARBON	220 OHM 1/5W J	1
R533	CRD20TJ221T	RES , CARBON	220 OHM 1/5W J	1
R534	CRD20TJ221T	RES , CARBON	220 OHM 1/5W J	1
R535	CRD20TJ221T	RES , CARBON	220 OHM 1/5W J	1
R536	CRD20TJ221T	RES , CARBON	220 OHM 1/5W J	1
R537	CRD20TJ221T	RES , CARBON	220 OHM 1/5W J	1
R538	CRD20TJ221T	RES , CARBON	220 OHM 1/5W J	1
R539	CRD20TJ221T	RES , CARBON	220 OHM 1/5W J	1
R540	CRD20TJ221T	RES , CARBON	220 OHM 1/5W J	1
R541	CRD20TJ271T	RES , CARBON	270 OHM 1/5W J	1
R542	CRD20TJ271T	RES , CARBON	270 OHM 1/5W J	1
R543	CRD20TJ271T	RES , CARBON	270 OHM 1/5W J	1
R544	CRD20TJ271T	RES , CARBON	270 OHM 1/5W J	1
R545	CRD20TJ271T	RES , CARBON	270 OHM 1/5W J	1
R556	CRD20TJ273T	RES , CARBON	27K OHM 1/5W J	1
R557	CRD20TJ273T	RES , CARBON	27K OHM 1/5W J	1
R558	CRD20TJ273T	RES , CARBON	27K OHM 1/5W J	1
R559	CRD20TJ273T	RES , CARBON	27K OHM 1/5W J	1
R560	CRD20TJ273T	RES , CARBON	27K OHM 1/5W J	1
R561	CRD20TJ182T	RES , CARBON	1.8K OHM 1/5W J	1
R562	CRD20TJ182T	RES , CARBON	1.8K OHM 1/5W J	1
R563	CRD20TJ182T	RES , CARBON	1.8K OHM 1/5W J	1
R564	CRD20TJ182T	RES , CARBON	1.8K OHM 1/5W J	1
R565	CRD20TJ182T	RES , CARBON	1.8K OHM 1/5W J	1
R566	CRD20TJ561T	RES , CARBON	560 OHM 1/5W J	1
R567	CRD20TJ561T	RES , CARBON	560 OHM 1/5W J	1
R568	CRD20TJ561T	RES , CARBON	560 OHM 1/5W J	1
R569	CRD20TJ561T	RES , CARBON	560 OHM 1/5W J	1
R570	CRD20TJ561T	RES , CARBON	560 OHM 1/5W J	1
R571	CRD20TJ561T	RES , CARBON	560 OHM 1/5W J	1
R572	CRD20TJ561T	RES , CARBON	560 OHM 1/5W J	1
R573	CRD20TJ561T	RES , CARBON	560 OHM 1/5W J	1
R574	CRD20TJ561T	RES , CARBON	560 OHM 1/5W J	1
R575	CRD20TJ561T	RES , CARBON	560 OHM 1/5W J	1
R576	CRD20TJ100T	RES , CARBON	10 OHM 1/5W J	1
R577	CRD20TJ100T	RES , CARBON	10 OHM 1/5W J	1
R578	CRD20TJ100T	RES , CARBON	10 OHM 1/5W J	1
R579	CRD20TJ100T	RES , CARBON	10 OHM 1/5W J	1
R580	CRD20TJ100T	RES , CARBON	10 OHM 1/5W J	1
R581	CRD20TJ561T	RES , CARBON	560 OHM 1/5W J	1
R582	CRD20TJ561T	RES , CARBON	560 OHM 1/5W J	1
R583	CRD20TJ561T	RES , CARBON	560 OHM 1/5W J	1
R584	CRD20TJ561T	RES , CARBON	560 OHM 1/5W J	1
R585	CRD20TJ561T	RES , CARBON	560 OHM 1/5W J	1
R586	CRD20TJ561T	RES , CARBON	560 OHM 1/5W J	1
R587	CRD20TJ561T	RES , CARBON	560 OHM 1/5W J	1
R588	CRD20TJ561T	RES , CARBON	560 OHM 1/5W J	1
R589	CRD20TJ561T	RES , CARBON	560 OHM 1/5W J	1
R590	CRD20TJ561T	RES , CARBON	560 OHM 1/5W J	1

MAIN PCB ASSY				
Ref. #	Part Number	Description	Value	Qty
R591	CRD20TJ561T	RES , CARBON	560 OHM 1/5W J	1
R592	CRD20TJ561T	RES , CARBON	560 OHM 1/5W J	1
R593	CRD20TJ561T	RES , CARBON	560 OHM 1/5W J	1
R594	CRD20TJ561T	RES , CARBON	560 OHM 1/5W J	1
R595	CRD20TJ561T	RES , CARBON	560 OHM 1/5W J	1
R596	CRD20TJ561T	RES , CARBON	560 OHM 1/5W J	1
R597	CRD20TJ561T	RES , CARBON	560 OHM 1/5W J	1
R598	CRD20TJ561T	RES , CARBON	560 OHM 1/5W J	1
R599	CRD20TJ561T	RES , CARBON	560 OHM 1/5W J	1
R600	CRD20TJ561T	RES , CARBON	560 OHM 1/5W J	1
R601	CRD20TJ223T	RES , CARBON	22K OHM 1/5W J	1
R602	CRD20TJ223T	RES , CARBON	22K OHM 1/5W J	1
R603	CRD20TJ223T	RES , CARBON	22K OHM 1/5W J	1
R604	CRD20TJ223T	RES , CARBON	22K OHM 1/5W J	1
R605	CRD20TJ223T	RES , CARBON	22K OHM 1/5W J	1
R606	CRD20TJ223T	RES , CARBON	22K OHM 1/5W J	1
R607	CRD20TJ223T	RES , CARBON	22K OHM 1/5W J	1
R608	CRD20TJ223T	RES , CARBON	22K OHM 1/5W J	1
R609	CRD20TJ223T	RES , CARBON	22K OHM 1/5W J	1
R610	CRD20TJ223T	RES , CARBON	22K OHM 1/5W J	1
R631	CRD25FJ180T	RES , CARBON	18 OHM 1/4W J	1
R632	CRD25FJ180T	RES , CARBON	18 OHM 1/4W J	1
R633	CRD25FJ180T	RES , CARBON	18 OHM 1/4W J	1
R634	CRD25FJ180T	RES , CARBON	18 OHM 1/4W J	1
R635	CRD25FJ180T	RES , CARBON	18 OHM 1/4W J	1
R636	CRD25FJ180T	RES , CARBON	18 OHM 1/4W J	1
R637	CRD25FJ180T	RES , CARBON	18 OHM 1/4W J	1
R638	CRD25FJ180T	RES , CARBON	18 OHM 1/4W J	1
R639	CRD25FJ180T	RES , CARBON	18 OHM 1/4W J	1
R640	CRD25FJ180T	RES , CARBON	18 OHM 1/4W J	1
R646	CRD25FJ3R3T	RES , CARBON	3.3 OHM 1/4W J	1
R647	CRD25FJ3R3T	RES , CARBON	3.3 OHM 1/4W J	1
R648	CRD25FJ3R3T	RES , CARBON	3.3 OHM 1/4W J	1
R649	CRD25FJ3R3T	RES , CARBON	3.3 OHM 1/4W J	1
R650	CRD25FJ3R3T	RES , CARBON	3.3 OHM 1/4W J	1
R651	CRD25FJ3R3T	RES , CARBON	3.3 OHM 1/4W J	1
R652	CRD25FJ3R3T	RES , CARBON	3.3 OHM 1/4W J	1
R653	CRD25FJ3R3T	RES , CARBON	3.3 OHM 1/4W J	1
R654	CRD25FJ3R3T	RES , CARBON	3.3 OHM 1/4W J	1
R655	CRD25FJ3R3T	RES , CARBON	3.3 OHM 1/4W J	1
R666	CRD25TJ470T	RES , CARBON	47 OHM 1/4W J	1
R667	CRD25TJ470T	RES , CARBON	47 OHM 1/4W J	1
R668	CRD25TJ470T	RES , CARBON	47 OHM 1/4W J	1
R669	CRD25TJ470T	RES , CARBON	47 OHM 1/4W J	1
R670	CRD25TJ470T	RES , CARBON	47 OHM 1/4W J	1
R671	CRD20TJ911T	RES , CARBON	910 OHM 1/5W J	1
R672	CRD20TJ911T	RES , CARBON	910 OHM 1/5W J	1
R673	CRD20TJ911T	RES , CARBON	910 OHM 1/5W J	1
R674	CRD20TJ911T	RES , CARBON	910 OHM 1/5W J	1
R675	CRD20TJ911T	RES , CARBON	910 OHM 1/5W J	1

MAIN PCB ASSY				
Ref. #	Part Number	Description	Value	Qty
R676	CRD20TJ182T	RES , CARBON	1.8K OHM 1/5W J	1
R677	CRD20TJ182T	RES , CARBON	1.8K OHM 1/5W J	1
R678	CRD20TJ182T	RES , CARBON	1.8K OHM 1/5W J	1
R679	CRD20TJ182T	RES , CARBON	1.8K OHM 1/5W J	1
R680	CRD20TJ182T	RES , CARBON	1.8K OHM 1/5W J	1
R681	CRD20TJ562T	RES , CARBON	5.6K OHM 1/5W J	1
R682	CRD20TJ562T	RES , CARBON	5.6K OHM 1/5W J	1
R683	CRD20TJ562T	RES , CARBON	5.6K OHM 1/5W J	1
R684	CRD20TJ562T	RES , CARBON	5.6K OHM 1/5W J	1
R685	CRD20TJ562T	RES , CARBON	5.6K OHM 1/5W J	1
R686	CRD20TJ103T	RES , CARBON	10K OHM 1/5W J	1
R687	CRD20TJ103T	RES , CARBON	10K OHM 1/5W J	1
R688	CRD20TJ103T	RES , CARBON	10K OHM 1/5W J	1
R689	CRD20TJ103T	RES , CARBON	10K OHM 1/5W J	1
R690	CRD20TJ103T	RES , CARBON	10K OHM 1/5W J	1
R696	CRD25TJ470T	RES , CARBON	47 OHM 1/4W J	1
R697	CRD25TJ470T	RES , CARBON	47 OHM 1/4W J	1
R698	CRD25TJ470T	RES , CARBON	47 OHM 1/4W J	1
R699	CRD25TJ470T	RES , CARBON	47 OHM 1/4W J	1
R700	CRD25TJ470T	RES , CARBON	47 OHM 1/4W J	1
R771	CRD20TJ750T	RES , CARBON	75 OHM 1/5W J	1
R772	CRD20TJ750T	RES , CARBON	75 OHM 1/5W J	1
R773	CRD20TJ750T	RES , CARBON	75 OHM 1/5W J	1
R774	CRD20TJ750T	RES , CARBON	75 OHM 1/5W J	1
R775	CRD20TJ750T	RES , CARBON	75 OHM 1/5W J	1
R781	CRD20TJ750T	RES , CARBON	75 OHM 1/5W J	1
R782	CRD20TJ750T	RES , CARBON	75 OHM 1/5W J	1
R783	CRD20TJ750T	RES , CARBON	75 OHM 1/5W J	1
R784	CRD20TJ750T	RES , CARBON	75 OHM 1/5W J	1
R785	CRD20TJ750T	RES , CARBON	75 OHM 1/5W J	1
R900	CRD20TJ103T	RES , CARBON	10K OHM 1/5W J	1
R901	CRD25TJ393T	RES , CARBON	39K OHM 1/4W J	1
R902	CRD25TJ393T	RES , CARBON	39K OHM 1/4W J	1
R903	CRD25TJ393T	RES , CARBON	39K OHM 1/4W J	1
R906	CRD25TJ393T	RES , CARBON	39K OHM 1/4W J	1
R907	CRD20TJ103T	RES , CARBON	10K OHM 1/5W J	1
R910	CRD20TJ105T	RES , CARBON	1M OHM 1/5W J	1
R911	CRD25TJ680T	RES , CARBON	68 OHM 1/4W J	1
R912	CRD20TJ332T	RES , CARBON	3.3K OHM 1/5W J	1
R917	CRD25TJ393T	RES , CARBON	39K OHM 1/4W J	1
R918	CRD25TJ393T	RES , CARBON	39K OHM 1/4W J	1
R919	CRD25TJ393T	RES , CARBON	39K OHM 1/4W J	1
R920	CRD25TJ393T	RES , CARBON	39K OHM 1/4W J	1
R932	CRD20TJ103T	RES , CARBON	10K OHM 1/5W J	1
R939	CRD20TJ472T	RES , CARBON	4.7K OHM 1/5W J	1
R940	CRD20TJ152T	RES , CARBON	1.5K OHM 1/5W J	1
R941	CRD20TJ223T	RES , CARBON	22K OHM 1/5W J	1
R942	CRD20TJ223T	RES , CARBON	22K OHM 1/5W J	1
R944	CRD25TJ223T	RES , CARBON	22K OHM 1/4W J	1
R946	CRD25TJ223T	RES , CARBON	22K OHM 1/4W J	1



MAIN PCB ASSY				
Ref. #	Part Number	Description	Value	Qty
R947	CRD20TJ223T	RES , CARBON	22K OHM 1/5W J	1
R948	CRD25TJ222T	RES , CARBON	2.2K OHM 1/5W J	1
R949	CRD20TJ822T	RES , CARBON	8.2K OHM 1/5W J	1
R955	CRD20TJ203T	RES , CARBON	20K OHM 1/5W J	1
R956	CRD20TJ394T	RES , CARBON	390K OHM 1/5W J	1
R957	CRD20TJ153T	RES , CARBON	15K OHM 1/5W J	1
R960	CRD20TJ332T	RES , CARBON	3.3K OHM 1/5W J	1
R961	CRD20TJ331T	RES , CARBON	330 OHM 1/5W J	1
R962	CRD20TJ273T	RES , CARBON	27K OHM 1/5W J	1
R963	CRD20TJ105T	RES , CARBON	1M OHM 1/5W J	1
R966	CRD20TJ472T	RES , CARBON	4.7K OHM 1/5W J	1
R980	CRD20TJ473T	RES , CARBON	47K OHM 1/5W J	1
R986	CRD20TJ102T	RES , CARBON	1K OHM 1/5W J	1
R987	CRD20TJ561T	RES , CARBON	560 OHM 1/5W J	1
R988	CRD20TJ562T	RES , CARBON	5.6K OHM 1/5W J	1
R989	CRD20TJ302T	RES , CARBON	3K OHM 1/5W J	1
R991	CRD20TJ822T	RES , CARBON	8.2K OHM 1/5W J	1
R992	CRD20TJ562T	RES , CARBON	5.6K OHM 1/5W J	1
R998	CRD20TJ103T	RES , CARBON	10K OHM 1/5W J	1
	CTW3+8JR	SCREW	Not stocked	2
BN19	CWB3FE03250UP	WIRE ASS'Y	WIRE	1
BN20	CWB3FC04280UP	WIRE ASS'Y	WIRE	1
BN82	CWB1C902050EN	WIRE ASS'Y	WIRE	1
BN83	CWB1C902050EN	WIRE ASS'Y	WIRE	1
BN84	CWB1C902050EN	WIRE ASS'Y	WIRE	1
BN85	CWB1C902050EN	WIRE ASS'Y	WIRE	1
BN86	CWB1C902050EN	WIRE ASS'Y	WIRE	1
BN89	CWB1C902250BM	WIRE ASS'Y	WIRE	1
BN90	CWB4F232550PU	WIRE ASS'Y	WIRE	1
BN98	HJP08GA130ZK	WAFER	WAFER	1
CN11	CJP13GA117ZY	WAFER , CARD CABLE	WAFER	1
CN12	CJP21GA115ZY	WAFER , CARD CABLE	WAFER	1
CN61	CJP02GA01ZY	WAFER, STRAIGHT, 2PIN	WAFER	1
CN62	CJP02GA01ZY	WAFER, STRAIGHT, 2PIN	WAFER	1
CN63	CJP02GA01ZY	WAFER, STRAIGHT, 2PIN	WAFER	1
CN64	CJP02GA01ZY	WAFER, STRAIGHT, 2PIN	WAFER	1
CN65	CJP02GA01ZY	WAFER, STRAIGHT, 2PIN	WAFER	1
CN91	CJP02GA89ZY	WAFER	WAFER	1
CN92	KJP02KA060ZY	WAFER	WAFER	1
C631	CCEA1JH101E	CAP , ELECT	100UF 63V	1
C632	CCEA1JH101E	CAP , ELECT	100UF 63V	1
C633	CCEA1JH101E	CAP , ELECT	100UF 63V	1
C634	CCEA1JH101E	CAP , ELECT	100UF 63V	1
C635	CCEA1JH101E	CAP , ELECT	100UF 63V	1
C636	CCEA1JH101E	CAP , ELECT	100UF 63V	1
C637	CCEA1JH101E	CAP , ELECT	100UF 63V	1
C638	CCEA1JH101E	CAP , ELECT	100UF 63V	1
C639	CCEA1JH101E	CAP , ELECT	100UF 63V	1
C640	CCEA1JH101E	CAP , ELECT	100UF 63V	1
C902	CCET50VKL4682NK	CAP , ELECT	6800UF/50V	1

MAIN PCB ASSY				
Ref. #	Part Number	Description	Value	Qty
C904	KCKDKS472ME	CAP , CERAMIC(X1/Y2/SC)	0.0047UF/2.5KV	1
C906	CCEA1EH102E	CAP , ELECT	1000UF 25V	1
C909	CCET50VKL4682NK	CAP , ELECT	6800UF/50V	1
C915	CCET50VKL4682NK	CAP , ELECT	6800UF/50V	1
C916	CCET50VKL4682NK	CAP , ELECT	6800UF/50V	1
ET01	CMD1A387	BRACKET , PCB	BRACKET	1
IC94	HVIMC7805C	I.C, REGULATOR	FAIRCHILD	1
IC97	HVIS-80842CNY-X	I.C RESET	SEIKO	1
JK90	CJJ4M040Z	JACK , BOARD (SW)	JACK	1
JK91	CJJ5R006Z	TERMINAL , SPEAKER	TERMINAL	1
JK92	CJJ5P020Z	TERMINAL , SPEAKER	TERMINAL	1
JW90	CWE8212120VV	WIRE , RED	WIRE	1
JW91	CWE8212180VV	WIRE ASS'Y	WIRE	1
JW92	CWEE212080VV	WIRE ASS'Y	WIRE	1
JW93	CWEP202110VV	WIRE	WIRE	1
L501	CLEY0R5KAK	COIL , SPEAKER	0.5UH	1
L502	CLEY0R5KAK	COIL , SPEAKER	0.5UH	1
L503	CLEY0R5KAK	COIL , SPEAKER	0.5UH	1
L504	CLEY0R5KAK	COIL , SPEAKER	0.5UH	1
L505	CLEY0R5KAK	COIL , SPEAKER	0.5UH	1
OL91	KJJ7A022Z	OUTLET , AC(EUR/1P)	A302D0061P	1
Q858	HVT2SA1360O	T.R	2SA1360O	1
Q871	HVT2SA1360O	T.R	2SA1360O	1
Q872	HVT2SA1360O	T.R	2SA1360O	1
Q874	HVT2SA1360O	T.R	2SA1360O	1
Q875	HVT2SA1360O	T.R	2SA1360O	1
Q881	HVT2SC3423O	T.R	2SC3423O	1
Q882	HVT2SC3423O	T.R	2SC3423O	1
Q883	HVT2SC3423O	T.R	2SC3423O	1
Q884	HVT2SC3423O	T.R	2SC3423O	1
Q885	HVT2SC3423O	T.R	2SC3423O	1
RY94	HSL1A008ZE	RELAY	SDT-S-112DMR	1
R656	CRF5EKR27HX2K	RES , CEMENT	0.27ohm X 2	1
R657	CRF5EKR27HX2K	RES , CEMENT	0.27ohm X 2	1
R658	CRF5EKR27HX2K	RES , CEMENT	0.27ohm X 2	1
R659	CRF5EKR27HX2K	RES , CEMENT	0.27ohm X 2	1
R660	CRF5EKR27HX2K	RES , CEMENT	0.27ohm X 2	1
R905	CRG1ANJ100H	RES , METAL OXIDE FILM	10 OHM 1W J	1
R990	CRG1ANJ100H	RES , METAL OXIDE FILM	10 OHM 1W J	1
R993	CRG1ANJ100H	RES , METAL OXIDE FILM	10 OHM 1W J	1
R995	CRG1ANJ100H	RES , METAL OXIDE FILM	10 OHM 1W J	1
R997	CRG1ANJ100H	RES , METAL OXIDE FILM	10 OHM 1W J	1
R999	CRG1ANJ100H	RES , METAL OXIDE FILM	10 OHM 1W J	1
TH91	KRTP42T7D330B	THERMAL SENSOR , POSISTOR	P42T7D330BW20	1
T902	CLT5J033YE	TRANS , SUB	TRANS	1
	<b>CMYAVR145</b>	<b>HEAR SINK ASS'Y</b>		<b>1</b>
	CHD1A012R	SCREW , SPECIAL	Not stocked	15
	CHD3A012R	SCREW , SPECIAL	Not stocked	4
	CMD1A398	BRACKET , PCB	AG-D9320	2

<b>CMYAVR145</b>		<b>HEAR SINK ASS'Y</b>		<b>1</b>
	CMD1A417	BRACKET , PCB	AG-D8900	2
	CMY1A249	HEAT SINK	HEAT SINK	1
	CMY2A269	HEAT SINK	HEAT SINK	1
	CTB3+10JR	SCREW	Not stocked	3
	CTB3+8JR	SCREW	Not stocked	6
Q652	HVT2SB1560-OKM	T.R , POWER	2SB1560	1
Q653	HVT2SB1560-OKM	T.R , POWER	2SB1560	1
Q654	HVT2SB1560-OKM	T.R , POWER	2SB1560	1
Q655	HVT2SB1560-OKM	T.R , POWER	2SB1560	1
Q657	HVT2SD2390-OKM	T.R , POWER	2SD2390	1
Q658	HVT2SD2390-OKM	T.R , POWER	2SD2390	1
Q659	HVT2SD2390-OKM	T.R , POWER	2SD2390	1
Q660	HVT2SD2390-OKM	T.R , POWER	2SD2390	1
Q661	HVT2SB1560-OKM	T.R , POWER	2SB1560	1
Q670	HVT2SD2390-OKM	T.R , POWER	2SD2390	1
<b>INPUT PCB ASSY</b>				
<b>Ref. #</b>	<b>Part Number</b>	<b>Description</b>	<b>Value</b>	<b>Qty</b>
	COP11912E	INPUT PCB ASS'Y(AVR145/230)	ASS'Y	1
C201	CCUS1H221JA	CAP , CHIP	220PF	1
C202	CCUS1H221JA	CAP , CHIP	220PF	1
C203	CCUS1H221JA	CAP , CHIP	220PF	1
C204	CCUS1H221JA	CAP , CHIP	220PF	1
C205	CCUS1H221JA	CAP , CHIP	220PF	1
C206	CCUS1H221JA	CAP , CHIP	220PF	1
C209	CCUS1H221JA	CAP , CHIP	220PF	1
C210	CCUS1H221JA	CAP , CHIP	220PF	1
C211	CCUS1H221JA	CAP , CHIP	220PF	1
C212	CCUS1H221JA	CAP , CHIP	220PF	1
C213	CCUS1H221JA	CAP , CHIP	220PF	1
C214	CCUS1H221JA	CAP , CHIP	220PF	1
C215	CCUS1H221JA	CAP , CHIP	220PF	1
C216	CCUS1H221JA	CAP , CHIP	220PF	1
C219	CCUS1H221JA	CAP , CHIP	220PF	1
C220	CCUS1H221JA	CAP , CHIP	220PF	1
C221	CCUS1H221JA	CAP , CHIP	220PF	1
C222	CCUS1H221JA	CAP , CHIP	220PF	1
C223	CCUS1H221JA	CAP , CHIP	220PF	1
C224	CCUS1H221JA	CAP , CHIP	220PF	1
C260	CCUS1H104KC	CAP , CHIP	0.1UF	1
C269	CCUS1A105KC	CAP , CHIP	1UF	1
C274	CCUS1A105KC	CAP , CHIP	1UF	1
C277	CCUS1H104KC	CAP , CHIP	0.1UF	1
C279	CCUS1H104KC	CAP , CHIP	0.1UF	1
C280	CCUS1H104KC	CAP , CHIP	0.1UF	1
C289	CCUS1H104KC	CAP , CHIP	0.1UF	1
C290	CCUS1H104KC	CAP , CHIP	0.1UF	1
C291	CCUS1H104KC	CAP , CHIP	0.1UF	1
C293	CCUS1H104KC	CAP , CHIP	0.1UF	1
C299	CCUS1H104KC	CAP , CHIP	0.1UF	1
C301	CCUS1H471JA	CAP , CHIP	470PF	1

INPUT PCB ASSY				
Ref. #	Part Number	Description	Value	Qty
C302	CCUS1H471JA	CAP , CHIP	470PF	1
C303	CCUS1H471JA	CAP , CHIP	470PF	1
C304	CCUS1H471JA	CAP , CHIP	470PF	1
C305	CCUS1H471JA	CAP , CHIP	470PF	1
C306	CCUS1H471JA	CAP , CHIP	470PF	1
C309	CCUS1H332KC	CAP , CHIP	3300PF	1
C310	CCUS1H332KC	CAP , CHIP	3300PF	1
C311	CCUS1H332KC	CAP , CHIP	3300PF	1
C312	CCUS1H332KC	CAP , CHIP	3300PF	1
C313	CCUS1H332KC	CAP , CHIP	3300PF	1
C314	CCUS1H332KC	CAP , CHIP	3300PF	1
C317	CCUS1H223KC	CAP , CHIP	0.022UF	1
C318	CCUS1H223KC	CAP , CHIP	0.022UF	1
C319	CCUS1H223KC	CAP , CHIP	0.022UF	1
C321	CCUS1H561JA	CAP , CHIP	560PF	1
C322	CCUS1H561JA	CAP , CHIP	560PF	1
C323	CCUS1H561JA	CAP , CHIP	560PF	1
C324	CCUS1H561JA	CAP , CHIP	560PF	1
C325	CCUS1H561JA	CAP , CHIP	560PF	1
C326	CCUS1H561JA	CAP , CHIP	560PF	1
C327	CCUS1H561JA	CAP , CHIP	560PF	1
C328	CCUS1H561JA	CAP , CHIP	560PF	1
C329	CCUS1H561JA	CAP , CHIP	560PF	1
C330	CCUS1H561JA	CAP , CHIP	560PF	1
C331	CCUS1H561JA	CAP , CHIP	560PF	1
C332	CCUS1H561JA	CAP , CHIP	560PF	1
C337	CCUS1H223KC	CAP , CHIP	0.022UF	1
C338	CCUS1H223KC	CAP , CHIP	0.022UF	1
C339	CCUS1H223KC	CAP , CHIP	0.022UF	1
C350	CCUS1H332KC	CAP , CHIP	3300PF	1
C351	CCUS1H332KC	CAP , CHIP	3300PF	1
C352	CCUS1H332KC	CAP , CHIP	3300PF	1
C353	CCUS1H332KC	CAP , CHIP	3300PF	1
C354	CCUS1H332KC	CAP , CHIP	3300PF	1
C355	CCUS1H332KC	CAP , CHIP	3300PF	1
C369	CCUS1H223KC	CAP , CHIP	0.022UF	1
C370	CCUS1H223KC	CAP , CHIP	0.022UF	1
C381	CCUS1H223KC	CAP , CHIP	0.022UF	1
C382	CCUS1H223KC	CAP , CHIP	0.022UF	1
C383	CCUS1H223KC	CAP , CHIP	0.022UF	1
C384	CCUS1H223KC	CAP , CHIP	0.022UF	1
C385	CCUS1H223KC	CAP , CHIP	0.022UF	1
C386	CCUS1H223KC	CAP , CHIP	0.022UF	1
C391	CCUS1H151JA	CAP , CHIP	150PF	1
C392	CCUS1H151JA	CAP , CHIP	150PF	1
C393	CCUS1H151JA	CAP , CHIP	150PF	1
C394	CCUS1H102KC	CAP , CHIP	1000PF	1
C395	CCUS1H151JA	CAP , CHIP	150PF	1
C396	CCUS1H151JA	CAP , CHIP	150PF	1
C400	CCUS1H104KC	CAP , CHIP	0.1UF	1

INPUT PCB ASSY				
Ref. #	Part Number	Description	Value	Qty
C401	CCUS1H104KC	CAP , CHIP	0.1UF	1
C402	CCUS1H471JA	CAP , CHIP	470PF	1
C403	CCUS1H471JA	CAP , CHIP	470PF	1
C410	CCUS1A105KC	CAP , CHIP	1UF	1
C411	CCUS1A105KC	CAP , CHIP	1UF	1
C412	CCUC1C225ZF	CAP , CHIP(2.2UF/16V/2012/Y5V)	2.2UF	1
C413	CCUC1C225ZF	CAP , CHIP(2.2UF/16V/2012/Y5V)	2.2UF	1
C416	CCUS1H473KC	CAP , CHIP	0.047UF	1
C420	CCUS1A105KC	CAP , CHIP	1UF	1
C421	CCUS1A105KC	CAP , CHIP	1UF	1
C422	CCUS1A105KC	CAP , CHIP	1UF	1
C423	CCUS1H220JA	CAP , CHIP	22PF	1
C424	CCUS1H220JA	CAP , CHIP	22PF	1
C425	CCUS1H223KC	CAP , CHIP	0.022UF	1
C426	CCUS1H223KC	CAP , CHIP	0.022UF	1
C427	CCUS1H223KC	CAP , CHIP	0.022UF	1
C432	HCEC1CRV2220T	CAP , ELEC (SMD)	22UF/16V	1
C435	CCUS1H070DA	CAP , CHIP	7PF	1
C436	CCUS1H120JA	CAP , CHIP 12PF/50V/COG/1608	12PF	1
C440	CCUS1H223KC	CAP , CHIP	0.022UF	1
C445	HCEC1CRV2220T	CAP , ELEC (SMD)	22UF/16V	1
C601	CCUS1H104KC	CAP , CHIP	0.1UF	1
C603	CCUS1H104KC	CAP , CHIP	0.1UF	1
C605	CCUS1H104KC	CAP , CHIP	0.1UF	1
C607	CCUS1H104KC	CAP , CHIP	0.1UF	1
C609	CCUS1H104KC	CAP , CHIP	0.1UF	1
C611	CCUS1H104KC	CAP , CHIP	0.1UF	1
C613	CCUS1H104KC	CAP , CHIP	0.1UF	1
C615	CCUS1H104KC	CAP , CHIP	0.1UF	1
C617	CCUS1H104KC	CAP , CHIP	0.1UF	1
C619	CCUS1H104KC	CAP , CHIP	0.1UF	1
C621	CCUS1H104KC	CAP , CHIP	0.1UF	1
C623	CCUS1H104KC	CAP , CHIP	0.1UF	1
C625	CCUS1H104KC	CAP , CHIP	0.1UF	1
C627	CCUS1H104KC	CAP , CHIP	0.1UF	1
C629	CCUS1H104KC	CAP , CHIP	0.1UF	1
C631	CCUS1H104KC	CAP , CHIP	0.1UF	1
C701	CCUS1H150JA	CHIP , CAP 15PF/50V/1608	15PF	1
C702	CCUS1H150JA	CHIP , CAP 15PF/50V/1608	15PF	1
C704	CCUS1H104KC	CAP , CHIP	0.1UF	1
C705	CCUS1H104KC	CAP , CHIP	0.1UF	1
C707	CCUS1H102KC	CAP , CHIP	1000PF	1
C708	CCUS1H104KC	CAP , CHIP	0.1UF	1
C709	CCUS1H102KC	CAP , CHIP	1000PF	1
C711	CCUS1H102KC	CAP , CHIP	1000PF	1
C712	CCUS1H223KC	CAP , CHIP	0.022UF	1
C713	CCUS1H390JA	CAP , CHIP	39PF	1
C714	CCUS1H390JA	CAP , CHIP	39PF	1
C718	CCUS1H104KC	CAP , CHIP	0.1UF	1
C719	CCUS1H104KC	CAP , CHIP	0.1UF	1

INPUT PCB ASSY				
Ref. #	Part Number	Description	Value	Qty
C722	CCUS1H104KC	CAP , CHIP	0.1UF	1
C723	CCUS1H473KC	CAP , CHIP	0.047UF	1
C725	CCUS1H104KC	CAP , CHIP	0.1UF	1
C727	CCUS1H104KC	CAP , CHIP	0.1UF	1
C729	CCUS1H104KC	CAP , CHIP	0.1UF	1
C731	CCUS1H104KC	CAP , CHIP	0.1UF	1
C733	CCUS1H104KC	CAP , CHIP	0.1UF	1
C734	CCUS1H102KC	CAP , CHIP	1000PF	1
C735	CCUS1H470JA	CAP , CHIP	0.047UF	1
C738	CCUS1A105KC	CAP , CHIP	1UF	1
C739	CCUS1H103KC	CAP , CHIP	0.01UF	1
C741	CCUS1H104KC	CAP , CHIP	0.1UF	1
C742	CCUS1H180JA	CHIP, CAP 18PF/50V/1608	18PF	1
C743	CCUS1H104KC	CAP , CHIP	0.1UF	1
C744	CCUS1H180JA	CHIP, CAP 18PF/50V/1608	18PF	1
C745	CCUS1H104KC	CAP , CHIP	0.1UF	1
C746	CCUS1H104KC	CAP , CHIP	0.1UF	1
C747	CCUS1H104KC	CAP , CHIP	0.1UF	1
C748	CCUS1H104KC	CAP , CHIP	0.1UF	1
C751	CCUS1H104KC	CAP , CHIP	0.1UF	1
C755	CCUS1H561JA	CAP , CHIP	560PF	1
C757	CCUS1H104KC	CAP , CHIP	0.1UF	1
C758	CCUS1H104KC	CAP , CHIP	0.1UF	1
C759	CCUS1H104KC	CAP , CHIP	0.1UF	1
C760	CCUS1H104KC	CAP , CHIP	0.1UF	1
C761	CCUS1H104KC	CAP , CHIP	0.1UF	1
C762	CCUS1H104KC	CAP , CHIP	0.1UF	1
C763	CCUS1H104KC	CAP , CHIP	0.1UF	1
C765	CCUS1H104KC	CAP , CHIP	0.1UF	1
C767	HCEC1CRV2100T	CAP , ELEC (SMD)	10UF / 16V	1
C768	CCUS1H104KC	CAP , CHIP	0.1UF	1
C769	CCUS1H104KC	CAP , CHIP	0.1UF	1
C770	CCUS1H104KC	CAP , CHIP	0.1UF	1
C771	CCUS1H104KC	CAP , CHIP	0.1UF	1
C772	CCUS1H104KC	CAP , CHIP	0.1UF	1
C773	CCUS1H104KC	CAP , CHIP	0.1UF	1
C774	HCEC1CRV2101T	CAP , ELEC (SMD)	100UF / 16V	1
D201	CVD1SS355T	CHIP , DIODE	1SS355T	1
D202	CVD1SS355T	CHIP , DIODE	1SS355T	1
D203	CVD1SS355T	CHIP , DIODE	1SS355T	1
D204	CVD1SS355T	CHIP , DIODE	1SS355T	1
D207	CVD1SS355T	CHIP , DIODE	1SS355T	1
D208	CVD1SS355T	CHIP , DIODE	1SS355T	1
D209	CVD1SS355T	CHIP , DIODE	1SS355T	1
D210	CVD1SS355T	CHIP , DIODE	1SS355T	1
D211	CVD1SS355T	CHIP , DIODE	1SS355T	1
D212	CVD1SS355T	CHIP , DIODE	1SS355T	1
D213	CVD1SS355T	CHIP , DIODE	1SS355T	1
D214	CVD1SS355T	CHIP , DIODE	1SS355T	1
D215	CVD1SS355T	CHIP , DIODE	1SS355T	1

INPUT PCB ASSY				
Ref. #	Part Number	Description	Value	Qty
D216	CVD1SS355T	CHIP , DIODE	1SS355T	1
D400	CVD1SS355T	CHIP , DIODE	1SS355T	1
D401	CVD1SS355T	CHIP , DIODE	1SS355T	1
IC20	CVINJW1197FC2	IC , SW(WITH VOLUME)	JRC	1
IC21	HVINJM2068MDTE1	I.C , OP AMP	JRC	1
IC22	HVINJM2068MDTE1	I.C , OP AMP	JRC	1
IC23	HVINJM2068MDTE1	I.C , OP AMP	JRC	1
IC25	HVINJM2068MDTE1	I.C , OP AMP	JRC	1
IC31	HVINJM2068MDTE1	I.C , OP AMP	JRC	1
IC32	HVINJM2068MDTE1	I.C , OP AMP	JRC	1
IC33	HVINJM2068MDTE1	I.C , OP AMP	JRC	1
IC41	HVINJM2068MDTE1	I.C , OP AMP	JRC	1
IC42	HVINJM2068MDTE1	I.C , OP AMP	JRC	1
IC43	HVINJM2137MTE1	I.C, OP AMP	JRC	1
IC72	HVI74HCU04AFNG	I.C , HEX INVERTER	TOSHIBA	1
IC73	HVIAK4589VQ-T	I.C , CODEC + DIR	ASAHI KASEI	1
IC74	HVILC72723M	IC , PLL (RDS)	SANYO	1
IC75	CVICS49510-CQ	I.C , DSP	CIRRUS LOGIC	1
IC76	HVIM29W800DT70N	I.C, 4M FLASH MEMORY	ST	1
IC77	HVI57V161610ET7	SDRAM 16M 7NS	HYNIX	1
IC78	HVINJM2391DL133	I.C , CHIP REGULATOR (+3.3V)	JRC	1
IC79	HVILM1117S-1V8	I.C , REGULATOR (1.8V)	HTC	1
IC88	HVILM1117S-3V3	I.C , REGULATOR (3.3V)	HTC	1
IC89	CVIM24C32WMN6TP	I.C , EEPROM (32 Kbit)	ST	1
IC90	CVIT5CC1	I.C , FLASH U-COM	TOSHIBA	1
IC91	HVI74ACT04MTR	I.C , HEX INVERTER	TOSHIBA	1
JK40	HJJ9L003Z	JACK , IPOD	IPOD JACK	1
L701	HLZ9Z014Z	CHIP , BEAD	HU-1H4516-600JT	1
L702	HLZ9Z014Z	CHIP , BEAD	HU-1H4516-600JT	1
L703	HLZ9Z014Z	CHIP , BEAD	HU-1H4516-600JT	1
L704	HLZ9R005Z	BEAD CHIP 60(1608 SIZE)	HH-1M1608-600	1
L705	HLZ9R005Z	BEAD CHIP 60(1608 SIZE)	HH-1M1608-600	1
Q402	HVTKRC102S	TR , CHIP	KRC102S	1
Q729	HVTKRC107S	TR , CHIP	KRC107S	1
Q730	HVTKRC107S	TR , CHIP	KRC107S	1
RN61	CRJ104DJ103T	RES , 4ARRAY (1608*4)	10K OHM/1608*4	1
RN62	CRJ104DJ103T	RES , 4ARRAY (1608*4)	10K OHM/1608*4	1
RN63	CRJ104DJ103T	RES , 4ARRAY (1608*4)	10K OHM/1608*4	1
RN64	CRJ104DJ101T	RES , 4ARRAY (1608*4)	100 OHM/1608*4	1
RN65	CRJ104DJ101T	RES , 4ARRAY (1608*4)	100 OHM/1608*4	1
RN66	CRJ104DJ101T	RES , 4ARRAY (1608*4)	100 OHM/1608*4	1
RN71	CRJ104DJ103T	RES , 4ARRAY (1608*4)	10K OHM/1608*4	1
RN72	CRJ104DJ103T	RES , 4ARRAY (1608*4)	10K OHM/1608*4	1
RN73	CRJ104DJ103T	RES , 4ARRAY (1608*4)	10K OHM/1608*4	1
RN74	CRJ104DJ330T	RES , 4ARRAY (1608*4)	33 OHM/1608*4	1
RN75	CRJ104DJ330T	RES , 4ARRAY (1608*4)	33 OHM/1608*4	1
RN76	CRJ104DJ330T	RES , 4ARRAY (1608*4)	33 OHM/1608*4	1
RN77	CRJ104DJ330T	RES , 4ARRAY (1608*4)	33 OHM/1608*4	1
RN78	CRJ104DJ330T	RES , 4ARRAY (1608*4)	33 OHM/1608*4	1
RN79	CRJ104DJ330T	RES , 4ARRAY (1608*4)	33 OHM/1608*4	1

INPUT PCB ASSY				
Ref. #	Part Number	Description	Value	Qty
RN80	CRJ104DJ330T	RES , 4ARRAY (1608*4)	33 OHM/1608*4	1
RN81	CRJ104DJ330T	RES , 4ARRAY (1608*4)	33 OHM/1608*4	1
RN82	CRJ104DJ330T	RES , 4ARRAY (1608*4)	33 OHM/1608*4	1
RN83	CRJ104DJ330T	RES , 4ARRAY (1608*4)	33 OHM/1608*4	1
RN84	CRJ104DJ330T	RES , 4ARRAY (1608*4)	33 OHM/1608*4	1
RN85	CRJ104DJ330T	RES , 4ARRAY (1608*4)	33 OHM/1608*4	1
RN86	CRJ104DJ103T	RES , 4ARRAY (1608*4)	10K OHM/1608*4	1
RN87	CRJ104DJ330T	RES , 4ARRAY (1608*4)	33 OHM/1608*4	1
RN88	CRJ104DJ103T	RES , 4ARRAY (1608*4)	10K OHM/1608*4	1
RN89	CRJ104DJ103T	RES , 4ARRAY (1608*4)	10K OHM/1608*4	1
RN90	CRJ104DJ330T	RES , 4ARRAY (1608*4)	33 OHM/1608*4	1
RN91	CRJ104DJ330T	RES , 4ARRAY (1608*4)	33 OHM/1608*4	1
RN92	CRJ104DJ101T	RES , 4ARRAY (1608*4)	100 OHM/1608*4	1
R201	CRJ10DJ101T	RES , CHIP	100 OHM	1
R202	CRJ10DJ101T	RES , CHIP	100 OHM	1
R203	CRJ10DJ101T	RES , CHIP	100 OHM	1
R204	CRJ10DJ101T	RES , CHIP	100 OHM	1
R205	CRJ10DJ101T	RES , CHIP	100 OHM	1
R206	CRJ10DJ101T	RES , CHIP	100 OHM	1
R209	CRJ10DJ101T	RES , CHIP	100 OHM	1
R210	CRJ10DJ101T	RES , CHIP	100 OHM	1
R211	CRJ10DJ101T	RES , CHIP	100 OHM	1
R212	CRJ10DJ101T	RES , CHIP	100 OHM	1
R213	CRJ10DJ101T	RES , CHIP	100 OHM	1
R214	CRJ10DJ101T	RES , CHIP	100 OHM	1
R215	CRJ10DJ101T	RES , CHIP	100 OHM	1
R216	CRJ10DJ101T	RES , CHIP	100 OHM	1
R219	CRJ10DJ101T	RES , CHIP	100 OHM	1
R220	CRJ10DJ101T	RES , CHIP	100 OHM	1
R221	CRJ10DJ101T	RES , CHIP	100 OHM	1
R222	CRJ10DJ101T	RES , CHIP	100 OHM	1
R223	CRJ10DJ101T	RES , CHIP	100 OHM	1
R224	CRJ10DJ272T	RES , CHIP	2.7K OHM	1
R227	CRJ10DJ474T	RES , CHIP	470K OHM	1
R228	CRJ10DJ474T	RES , CHIP	470K OHM	1
R229	CRJ10DJ474T	RES , CHIP	470K OHM	1
R230	CRJ10DJ474T	RES , CHIP	470K OHM	1
R231	CRJ10DJ474T	RES , CHIP	470K OHM	1
R232	CRJ10DJ474T	RES , CHIP	470K OHM	1
R235	CRJ10DJ474T	RES , CHIP	470K OHM	1
R236	CRJ10DJ474T	RES , CHIP	470K OHM	1
R237	CRJ10DJ474T	RES , CHIP	470K OHM	1
R238	CRJ10DJ474T	RES , CHIP	470K OHM	1
R239	CRJ10DJ474T	RES , CHIP	470K OHM	1
R240	CRJ10DJ474T	RES , CHIP	470K OHM	1
R241	CRJ10DJ474T	RES , CHIP	470K OHM	1
R242	CRJ10DJ474T	RES , CHIP	470K OHM	1
R245	CRJ10DJ474T	RES , CHIP	470K OHM	1
R246	CRJ10DJ474T	RES , CHIP	470K OHM	1
R247	CRJ10DJ474T	RES , CHIP	470K OHM	1



INPUT PCB ASSY				
Ref. #	Part Number	Description	Value	Qty
R248	CRJ10DJ474T	RES , CHIP	470K OHM	1
R249	CRJ10DJ474T	RES , CHIP	470K OHM	1
R250	CRJ10DJ103T	RES , CHIP	10K OHM	1
R253	CRJ10DJ4R7T	RES , CHIP	4.7 OHM	1
R254	CRJ10DJ4R7T	RES , CHIP	4.7 OHM	1
R255	CRJ10DJ4R7T	RES , CHIP	4.7 OHM	1
R256	CRJ10DJ4R7T	RES , CHIP	4.7 OHM	1
R257	CRJ10DJ4R7T	RES , CHIP	4.7 OHM	1
R259	CRJ10DJ4R7T	RES , CHIP	4.7 OHM	1
R260	CRJ10DJ4R7T	RES , CHIP	4.7 OHM	1
R261	CRJ10DJ184T	RES , CHIP	180K OHM	1
R262	CRJ10DJ184T	RES , CHIP	180K OHM	1
R263	CRJ10DJ184T	RES , CHIP	180K OHM	1
R264	CRJ10DJ184T	RES , CHIP	180K OHM	1
R265	CRJ10DJ184T	RES , CHIP	180K OHM	1
R266	CRJ10DJ184T	RES , CHIP	180K OHM	1
R271	CRJ10DJ102T	RES , CHIP	1K OHM	1
R272	CRJ10DJ102T	RES , CHIP	1K OHM	1
R273	CRJ10DJ102T	RES , CHIP	1K OHM	1
R274	CRJ10DJ102T	RES , CHIP	1K OHM	1
R275	CRJ10DJ102T	RES , CHIP	1K OHM	1
R276	CRJ10DJ102T	RES , CHIP	1K OHM	1
R281	CRJ10DJ512T	RES , CHIP	5.1K OHM	1
R282	CRJ10DJ512T	RES , CHIP	5.1K OHM	1
R283	CRJ10DJ512T	RES , CHIP	5.1K OHM	1
R284	CRJ10DJ912T	RES , CHIP	9.1K OHM/1608	1
R285	CRJ10DJ512T	RES , CHIP	5.1K OHM	1
R286	CRJ10DJ512T	RES , CHIP	5.1K OHM	1
R291	CRJ10DJ184T	RES , CHIP	180K OHM	1
R292	CRJ10DJ184T	RES , CHIP	180K OHM	1
R293	CRJ10DJ184T	RES , CHIP	180K OHM	1
R294	CRJ10DJ184T	RES , CHIP	180K OHM	1
R295	CRJ10DJ184T	RES , CHIP	180K OHM	1
R296	CRJ10DJ184T	RES , CHIP	180K OHM	1
R301	CRJ10DJ332T	RES , CHIP	3.3K OHM	1
R302	CRJ10DJ332T	RES , CHIP	3.3K OHM	1
R303	CRJ10DJ332T	RES , CHIP	3.3K OHM	1
R304	CRJ10DJ332T	RES , CHIP	3.3K OHM	1
R305	CRJ10DJ332T	RES , CHIP	3.3K OHM	1
R306	CRJ10DJ332T	RES , CHIP	3.3K OHM	1
R307	CRJ10DJ332T	RES , CHIP	3.3K OHM	1
R308	CRJ10DJ332T	RES , CHIP	3.3K OHM	1
R309	CRJ10DJ332T	RES , CHIP	3.3K OHM	1
R310	CRJ10DJ332T	RES , CHIP	3.3K OHM	1
R311	CRJ10DJ332T	RES , CHIP	3.3K OHM	1
R312	CRJ10DJ332T	RES , CHIP	3.3K OHM	1
R317	CRJ10DJ561T	RES , CHIP	560 OHM	1
R318	CRJ10DF3920T	RES. CHIP (392R 1%)	392 OHM	1
R321	CRJ10DJ512T	RES , CHIP	5.1K OHM	1
R322	CRJ10DJ122T	RES , CHIP	1.2K OHM	1

INPUT PCB ASSY				
Ref. #	Part Number	Description	Value	Qty
R323	CRJ10DJ122T	RES , CHIP	1.2K OHM	1
R324	CRJ10DJ512T	RES , CHIP	5.1K OHM	1
R325	CRJ10DJ512T	RES , CHIP	5.1K OHM	1
R326	CRJ10DJ122T	RES , CHIP	1.2K OHM	1
R327	CRJ10DJ122T	RES , CHIP	1.2K OHM	1
R328	CRJ10DJ103T	RES , CHIP	10K OHM	1
R329	CRJ10DJ512T	RES , CHIP	5.1K OHM	1
R330	CRJ10DJ122T	RES , CHIP	1.2K OHM	1
R331	CRJ10DJ122T	RES , CHIP	1.2K OHM	1
R332	CRJ10DJ512T	RES , CHIP	5.1K OHM	1
R341	CRJ10DJ122T	RES , CHIP	1.2K OHM	1
R344	CRJ10DJ122T	RES , CHIP	1.2K OHM	1
R345	CRJ10DJ122T	RES , CHIP	1.2K OHM	1
R348	CRJ10DJ122T	RES , CHIP	1.2K OHM	1
R349	CRJ10DJ122T	RES , CHIP	1.2K OHM	1
R352	CRJ10DJ122T	RES , CHIP	1.2K OHM	1
R361	CRJ10DJ104T	RES , CHIP	100K OHM	1
R362	CRJ10DJ104T	RES , CHIP	100K OHM	1
R363	CRJ10DJ104T	RES , CHIP	100K OHM	1
R364	CRJ10DJ104T	RES , CHIP	100K OHM	1
R365	CRJ10DJ104T	RES , CHIP	100K OHM	1
R366	CRJ10DJ104T	RES , CHIP	100K OHM	1
R371	CRJ10DJ512T	RES , CHIP	5.1K OHM	1
R372	CRJ10DJ512T	RES , CHIP	5.1K OHM	1
R373	CRJ10DJ512T	RES , CHIP	5.1K OHM	1
R374	CRJ10DJ103T	RES , CHIP	10K OHM	1
R375	CRJ10DJ512T	RES , CHIP	5.1K OHM	1
R376	CRJ10DJ512T	RES , CHIP	5.1K OHM	1
R381	CRJ10DJ561T	RES , CHIP	560 OHM	1
R382	CRJ10DJ561T	RES , CHIP	560 OHM	1
R383	CRJ10DJ561T	RES , CHIP	560 OHM	1
R384	CRJ10DJ561T	RES , CHIP	560 OHM	1
R385	CRJ10DJ561T	RES , CHIP	560 OHM	1
R386	CRJ10DJ561T	RES , CHIP	560 OHM	1
R389	CRJ10DJ184T	RES , CHIP	180K OHM	1
R390	CRJ10DJ184T	RES , CHIP	180K OHM	1
R391	CRJ10DF3920T	RES. CHIP (392R 1%)	392 OHM	1
R392	CRJ10DF3920T	RES. CHIP (392R 1%)	392 OHM	1
R393	CRJ10DF3920T	RES. CHIP (392R 1%)	392 OHM	1
R394	CRJ10DF3920T	RES. CHIP (392R 1%)	392 OHM	1
R395	CRJ10DF3920T	RES. CHIP (392R 1%)	392 OHM	1
R396	CRJ10DF3920T	RES. CHIP (392R 1%)	392 OHM	1
R400	CRJ10DJ4R7T	RES , CHIP	4.7 OHM	1
R401	CRJ10DJ4R7T	RES , CHIP	4.7 OHM	1
R402	CRJ10DF5493T	RES , CHIP 549KOHM/1608/1%	543K OHM 1%	1
R403	CRJ10DJ0R0T	RES , CHIP	0 OHM	1
R404	CRJ10DJ103T	RES , CHIP	10K OHM	1
R405	CRJ10DJ103T	RES , CHIP	10K OHM	1
R406	CRJ10DJ474T	RES , CHIP	470K OHM	1
R407	CRJ10DJ474T	RES , CHIP	470K OHM	1

INPUT PCB ASSY				
Ref. #	Part Number	Description	Value	Qty
R421	CRJ10DJ222T	RES , CHIP	2.2K OHM	1
R422	CRJ10DJ474T	RES , CHIP	470K OHM	1
R430	CRJ10DJ473T	RES , CHIP	47K OHM	1
R431	CRJ10DJ473T	RES , CHIP	47K OHM	1
R432	CRJ18AJ221T	RES , CHIP	220 OHM,2012 SIZE	1
R433	CRJ18AJ221T	RES , CHIP	220 OHM,2012 SIZE	1
R434	CRJ10DJ103T	RES , CHIP	10K OHM	1
R435	CRJ10DJ103T	RES , CHIP	10K OHM	1
R436	CRJ10DJ222T	RES , CHIP	2.2K OHM	1
R437	CRJ10DJ222T	RES , CHIP	2.2K OHM	1
R438	CRJ10DJ222T	RES , CHIP	2.2K OHM	1
R439	CRJ10DJ222T	RES , CHIP	2.2K OHM	1
R440	CRJ10DJ220T	RES , CHIP	2.2K OHM	1
R441	CRJ10DJ472T	RES , CHIP	4.7K OHM	1
R442	CRJ10DJ472T	RES , CHIP	4.7K OHM	1
R443	CRJ10DJ202T	RES , CHIP	2K OHM	1
R444	CCUS1H151JA	CAP , CHIP	150PF	1
R445	CRJ10DJ202T	RES , CHIP	2K OHM	1
R446	CRJ10DJ431T	RES , CHIP	430 OHM	1
R447	CRJ10DJ821T	RES , CHIP	820 OHM	1
R449	CRJ10DJ0R0T	RES , CHIP	0 OHM	1
R453	CRJ10DJ220T	RES , CHIP	22 OHM	1
R701	CRJ10DJ103T	RES , CHIP	10K OHM	1
R702	CRJ10DJ103T	RES , CHIP	10K OHM	1
R703	CRJ10DJ103T	RES , CHIP	10K OHM	1
R706	CRJ10DJ222T	RES , CHIP	2.2K OHM	1
R707	CRJ10DJ222T	RES , CHIP	2.2K OHM	1
R708	CRJ10DJ101T	RES , CHIP	100 OHM	1
R709	CRJ10DJ103T	RES , CHIP	10K OHM	1
R710	CRJ10DJ103T	RES , CHIP	10K OHM	1
R711	CRJ10DJ103T	RES , CHIP	10K OHM	1
R714	CRJ10DJ104T	RES , CHIP	100K OHM	1
R715	CRJ10DJ104T	RES , CHIP	100K OHM	1
R716	CRJ10DJ472T	RES , CHIP	4.7K OHM	1
R717	CRJ10DJ3R3T	RES , CHIP	3.3 OHM	1
R718	CRJ10DJ123T	RES , CHIP	12K OHM	1
R719	CRJ10DJ473T	RES , CHIP	47K OHM	1
R720	CRJ10DJ473T	RES , CHIP	47K OHM	1
R721	CRJ10DJ330T	RES , CHIP	33 OHM	1
R723	CRJ10DJ2R7T	RES , CHIP	2.7 OHM	1
R724	CRJ10DJ101T	RES , CHIP	100 OHM	1
R725	CRJ10DJ473T	RES , CHIP	47K OHM	1
R726	CRJ10DJ473T	RES , CHIP	47K OHM	1
R727	CRJ10DJ473T	RES , CHIP	47K OHM	1
R728	CRJ10DJ102T	RES , CHIP	1K OHM	1
R729	CRJ10DJ123T	RES , CHIP	12K OHM	1
R730	CRJ10DJ123T	RES , CHIP	12K OHM	1
R732	CRJ10DJ103T	RES , CHIP	10K OHM	1
R737	CRJ10DJ330T	RES , CHIP	33 OHM	1
R739	CRJ10DJ1R0T	RES , CHIP	1 OHM	1

INPUT PCB ASSY				
Ref. #	Part Number	Description	Value	Qty
R740	CRJ10DJ820T	RES , CHIP	820 OHM	1
R741	CRJ10DJ330T	RES , CHIP	33 OHM	1
R742	CRJ10DJ330T	RES , CHIP	33 OHM	1
R743	CRJ10DJ330T	RES , CHIP	33 OHM	1
R744	CRJ10DJ0R0T	RES , CHIP	0 OHM	1
R746	CRJ10DJ0R0T	RES , CHIP	0 OHM	1
R747	CRJ10DJ330T	RES , CHIP	33 OHM	1
R748	CRJ10DJ330T	RES , CHIP	33 OHM	1
R751	CRJ10DJ330T	RES , CHIP	33 OHM	1
R752	CRJ10DJ330T	RES , CHIP	33 OHM	1
R753	CRJ10DJ103T	RES , CHIP	10K OHM	1
R754	CRJ10DJ103T	RES , CHIP	10K OHM	1
R756	CRJ10DJ103T	RES , CHIP	10K OHM	1
R759	CRJ10DJ330T	RES , CHIP	33 OHM	1
R760	CRJ10DJ105T	RES , CHIP	1M OHM	1
R765	CRJ10DJ103T	RES , CHIP	10K OHM	1
R766	CRJ10DJ103T	RES , CHIP	10K OHM	1
R767	CRJ10DJ301T	RES , CHIP	300 OHM	1
R768	CRJ10DJ562T	RES , CHIP	5.6K OHM	1
R773	CRJ10DJ332T	RES , CHIP	3.3K OHM	1
R774	CRJ10DJ332T	RES , CHIP	3.3K OHM	1
R775	CRJ10DJ332T	RES , CHIP	3.3K OHM	1
R776	CRJ10DJ332T	RES , CHIP	3.3K OHM	1
R777	CRJ10DJ102T	RES , CHIP	1K OHM	1
R778	CRJ10DJ103T	RES , CHIP	10K OHM	1
R782	CRJ10DJ272T	RES , CHIP	2.7K OHM	1
R783	CRJ10DJ272T	RES , CHIP	2.7K OHM	1
R784	CRJ10DJ473T	RES , CHIP	47K OHM	1
R785	CRJ10DJ104T	RES , CHIP	100K OHM	1
R786	CRJ10DJ471T	RES , CHIP	470 OHM	1
R787	CRJ10DJ103T	RES , CHIP	10K OHM	1
R788	CRJ10DJ103T	RES , CHIP	10K OHM	1
R789	CRJ10DJ103T	RES , CHIP	10K OHM	1
R791	CRJ10DJ103T	RES , CHIP	10K OHM	1
R792	CRJ10DJ103T	RES , CHIP	10K OHM	1
R794	CRJ10DJ102T	RES , CHIP	1K OHM	1
R795	CRJ10DJ102T	RES , CHIP	1K OHM	1
R796	CRJ10DJ102T	RES , CHIP	1K OHM	1
X702	HOX27000E180S	CRYSTAL , CHIP(SMD)	27MHZ	1
C261	CCEA1EH470T	CAP , ELECT	47UF 25V	1
C262	CCEA1EH470T	CAP , ELECT	47UF 25V	1
C263	CCEA1EH470T	CAP , ELECT	47UF 25V	1
C264	CCEA1EH470T	CAP , ELECT	47UF 25V	1
C265	CCEA1EH470T	CAP , ELECT	47UF 25V	1
C266	CCEA1EH470T	CAP , ELECT	47UF 25V	1
C267	CCEA1EH470T	CAP , ELECT	47UF 25V	1
C268	CCEA1EH470T	CAP , ELECT	47UF 25V	1
C272	CCEA1HH100T	CAP , ELECT	10UF 50V	1
C273	CCEA1HH100T	CAP , ELECT	10UF 50V	1
C275	CCEA1HH100T	CAP , ELECT	10UF 50V	1

INPUT PCB ASSY				
Ref. #	Part Number	Description	Value	Qty
C276	CCEA1HH100T	CAP , ELECT	10UF 50V	1
C281	CCEA1HH100T	CAP , ELECT	10UF 50V	1
C282	CCEA1HH100T	CAP , ELECT	10UF 50V	1
C283	CCEA1HH100T	CAP , ELECT	10UF 50V	1
C284	CCEA1HH100T	CAP , ELECT	10UF 50V	1
C285	CCEA1HH100T	CAP , ELECT	10UF 50V	1
C286	CCEA1HH100T	CAP , ELECT	10UF 50V	1
C292	CCEA1CH101T	CAP , ELECT	100UF 16V	1
C294	CCEA1CH101T	CAP , ELECT	100UF 16V	1
C341	CCEA1HH100T	CAP , ELECT	10UF 50V	1
C342	CCEA1HH100T	CAP , ELECT	10UF 50V	1
C343	CCEA1HH100T	CAP , ELECT	10UF 50V	1
C344	CCEA1HH100T	CAP , ELECT	10UF 50V	1
C345	CCEA1HH100T	CAP , ELECT	10UF 50V	1
C346	CCEA1HH100T	CAP , ELECT	10UF 50V	1
C349	CCEA1CH101T	CAP , ELECT	100UF 16V	1
C358	CCEA1CH101T	CAP , ELECT	100UF 16V	1
C359	CCEA1CH101T	CAP , ELECT	100UF 16V	1
C360	CCEA1CH101T	CAP , ELECT	100UF 16V	1
C371	CCEA1HH100T	CAP , ELECT	10UF 50V	1
C372	CCEA1HH100T	CAP , ELECT	10UF 50V	1
C373	CCEA1HH100T	CAP , ELECT	10UF 50V	1
C374	CCEA1HH100T	CAP , ELECT	10UF 50V	1
C375	CCEA1HH100T	CAP , ELECT	10UF 50V	1
C376	CCEA1HH100T	CAP , ELECT	10UF 50V	1
C389	CCEA1HH100T	CAP , ELECT	10UF 50V	1
C390	CCEA1HH100T	CAP , ELECT	10UF 50V	1
C417	CCEA1CH471T	CAP , ELECT	470UF 16V	1
C430	CCEA1AH331T	CAP , ELECT	330UF 10V	1
C431	CCEA1CH221T	CAP , ELECT	220UF 16V	1
C433	CCEA1CH101T	CAP , ELECT	100UF 16V	1
C600	CCEA1CH101T	CAP , ELECT	100UF 16V	1
C602	CCEA1CH101T	CAP , ELECT	100UF 16V	1
C604	CCEA1CH101T	CAP , ELECT	100UF 16V	1
C606	CCEA1CH101T	CAP , ELECT	100UF 16V	1
C608	CCEA1CH101T	CAP , ELECT	100UF 16V	1
C610	CCEA1CH101T	CAP , ELECT	100UF 16V	1
C612	CCEA1CH101T	CAP , ELECT	100UF 16V	1
C614	CCEA1CH101T	CAP , ELECT	100UF 16V	1
C616	CCEA1CH101T	CAP , ELECT	100UF 16V	1
C618	CCEA1CH101T	CAP , ELECT	100UF 16V	1
C620	CCEA1CH101T	CAP , ELECT	100UF 16V	1
C622	CCEA1CH101T	CAP , ELECT	100UF 16V	1
C624	CCEA1CH101T	CAP , ELECT	100UF 16V	1
C626	CCEA1CH101T	CAP , ELECT	100UF 16V	1
C628	CCEA1CH101T	CAP , ELECT	100UF 16V	1
C630	CCEA1CH101T	CAP , ELECT	100UF 16V	1
C703	CCEA1CH101T	CAP , ELECT	100UF 16V	1
C706	CCEA1CH101T	CAP , ELECT	100UF 16V	1
C717	CCEA1CH101T	CAP , ELECT	100UF 16V	1

INPUT PCB ASSY				
Ref. #	Part Number	Description	Value	Qty
C720	CCEA1AH471T	CAP , ELECT	470UF 10V	1
C721	CCEA1AH471T	CAP , ELECT	470UF 10V	1
C724	CCEA1AH471T	CAP , ELECT	470UF 10V	1
C726	CCEA1CH101T	CAP , ELECT	100UF 16V	1
C728	CCEA1AH471T	CAP , ELECT	470UF 10V	1
C730	CCEA1CH101T	CAP , ELECT	100UF 16V	1
C736	CCEA1HH2R2T	CAP , ELECT	2.2UF 50V	1
C737	CCEA1CH101T	CAP , ELECT	100UF 16V	1
C740	CCEA1CH101T	CAP , ELECT	100UF 16V	1
C749	CCEA1CH101T	CAP , ELECT	100UF 16V	1
C764	CCEA0JH102T	CAP , ELECT	1000UF 6.3V	1
C766	CCEA0JH102T	CAP , ELECT	1000UF 6.3V	1
D221	CVD1N4003ST	RECT , DIODE	1N4003	1
D222	CVD1N4003ST	RECT , DIODE	1N4003	1
D402	CVD1N4003SRT	RECT , DIODE	1N4003	1
D703	CVD1N4003ST	RECT , DIODE	1N4003	1
D704	CVD1N4003SRT	RECT , DIODE	1N4003	1
IC87	HVIRE5VT28CATZ	IC , RESET	RICOH	1
Q301	HVTKTC2874BT	T.R , MUTE	KTC2874B	1
Q302	HVTKTC2874BT	T.R , MUTE	KTC2874B	1
Q303	HVTKTC2874BT	T.R , MUTE	KTC2874B	1
Q304	HVTKTC2874BT	T.R , MUTE	KTC2874B	1
Q305	HVTKTC2874BT	T.R , MUTE	KTC2874B	1
Q306	HVTKTC2874BT	T.R , MUTE	KTC2874B	1
Q311	HVTKTC2874BT	T.R , MUTE	KTC2874B	1
BN19	CJP09GA117ZY	WAFER	WAFER	1
BN44	CJP07GA117ZY	TEMP ITEM	WAFER	1
BN46	CWZAVR145BN46	WIRE ASS'Y (SHIELD)	WIRE	1
BN49	CWB2B905080EN	WIRE ASS'Y	WIRE	1
CN10	CJP04GB46ZY	WAFER	WAFER	1
CN11	CJP13GA117ZY	WAFER , CARD CABLE	WAFER	1
CN12	CJP21GA115ZY	WAFER , CARD CABLE	WAFER	1
CN13	CJP13GA115ZY	WAFER , CARD CABLE	WAFER	1
CN14	CJP13GA117ZY	WAFER , CARD CABLE	WAFER	1
CN17	KJP12GB142ZP	PIN HEADER	WAFER	1
CN18	CJP05GA19ZY	WAFER, STRAIGHT, 5PIN	WAFER	1
CN19	CJP09GA117ZY	WAFER	WAFER	1
CN20	CJP05GA01ZY	CON WAFER YMW025-05R	WAFER	1
CN22	CJP06GA19ZY	WAFER, STRAIGHT, 6PIN	WAFER	1
CN46	CJP03GB46ZY	WAFER , ANGLE , 3PIN	WAFER	1
CN47	CJP07GA117ZY	TEMP ITEM	WAFER	1
CN49	CJP05GA19ZY	WAFER, STRAIGHT, 5PIN	WAFER	1
CN72	CJP17GA117ZY	WAFER	WAFER	1
C732	CCEA0JKR3222E	CAP , ELECT	2200UF 6.3V	1
ET02	CMD1A570	BRACKET , PCB	BRACKET	1
IC36	HVIL7808CP	I.C , REGULATOR (+8V)	ST	1
IC37	HVINJM7908FA	I.C REGULATOR(-8V)	JRC	1
JK11	CJJ4R019W	TERMINAL , IN/OUT	TERMINAL	1
JK12	CJJ4P014W	JACK , IN/OUT	JACK	1
JK13	CJJ4R019W	TERMINAL , IN/OUT	TERMINAL	1

<b>INPUT PCB ASSY</b>				
<b>Ref. #</b>	<b>Part Number</b>	<b>Description</b>	<b>Value</b>	<b>Qty</b>
JK14	CJJ4P043W	JACK IN/OUT	JACK	1
X701	HOX24576E150TF	CRYSTAL	24.576MHz	1
X703	HOX04332E200C	CRYSTAL	4.332MHz	1
<b>POWER PCB ASSY</b>				
<b>Ref. #</b>	<b>Part Number</b>	<b>Description</b>	<b>Value</b>	<b>Qty</b>
	COP11916E	POWER PCB ASS'Y(AVR145/230)	ASS'Y	1
C104	HCBS1H103ZFT	CAP , CERAMIC	0.01UF 50V	1
C105	HCBS1H103ZFT	CAP , CERAMIC	0.01UF 50V	1
C106	CCFT1H104ZF	CAP , SEMICONDUCTOR	0.1UF 50V ZF	1
C107	HCBS1H103ZFT	CAP , CERAMIC	0.01UF 50V	1
C108	HCBS1H103ZFT	CAP , CERAMIC	0.01UF 50V	1
C109	CCFT1H104ZF	CAP , SEMICONDUCTOR	0.1UF 50V ZF	1
C117	CCEA1HH4R7T	CAP , ELECT	4.7UF 50V	1
C118	HCBS1H103ZFT	CAP , CERAMIC	0.01UF 50V	1
C119	CCEA1JH470TS	CAP , ELECT	63V/47UF/105°C	1
C120	CCEA1JH470TS	CAP , ELECT	63V/47UF/105°C	1
C121	HCBS1H103ZFT	CAP , CERAMIC	0.01UF 50V	1
C123	CCFT1H473ZF	CAP , CERAMIC	0.047UF 50V ZF	1
C125	CCFT1H473ZF	CAP , CERAMIC	0.047UF 50V ZF	1
C126	CCFT1H473ZF	CAP , CERAMIC	0.047UF 50V ZF	1
C131	CCEA1HH4R7T	CAP , ELECT	4.7UF 50V	1
C750	CCEA1CH101T	CAP , ELECT	100UF 16V	1
C751	CCEA1CH101T	CAP , ELECT	100UF 16V	1
C753	HCBS1H181KBT	CAP , CERAMIC	180PF 50V	1
C754	HCBS1H181KBT	CAP , CERAMIC	180PF 50V	1
C756	CCFT1H104ZF	CAP , SEMICONDUCTOR	0.1UF 50V ZF	1
C757	CCFT1H104ZF	CAP , SEMICONDUCTOR	0.1UF 50V ZF	1
C759	HCBS1H101KBT	CAP , CERAMIC	100PF 50V	1
C760	CCFT1H473ZF	CAP , CERAMIC	0.047UF 50V ZF	1
C761	CCEA1CH101T	CAP , ELECT	100UF 16V	1
C762	CCEA1CH101T	CAP , ELECT	100UF 16V	1
C763	CCFT1H104ZF	CAP , SEMICONDUCTOR	0.1UF 50V ZF	1
C851	CCEA1HH100T	CAP , ELECT	10UF 50V	1
C852	CCEA1HH100T	CAP , ELECT	10UF 50V	1
C853	CCEA1HH100T	CAP , ELECT	10UF 50V	1
C854	CCEA1HH100T	CAP , ELECT	10UF 50V	1
C855	CCEA1HH100T	CAP , ELECT	10UF 50V	1
C902	HCBS1H223ZFT	CAP , CERAMIC	0.022UF 50V	1
C903	HCBS1H223ZFT	CAP , CERAMIC	0.022UF 50V	1
C906	CCEA1CH101T	CAP , ELECT	100UF 16V	1
C907	CCEA1CH101T	CAP , ELECT	100UF 16V	1
C908	CCEA1CH101T	CAP , ELECT	100UF 16V	1
C910	CCEA1VH221T	CAP , ELECT	220UF 35V	1
C919	CCKT1H102KB	CAP , CERAMIC	1000PF 50V	1
C920	CCEA1HH470T	CAP , ELECT	47UF 50V	1
C921	HCQI1H104JZT	CAP , MYLAR	0.1UF 50V J	1
C922	HCQI1H104JZT	CAP , MYLAR	0.1UF 50V J	1
C923	HCQI1H104JZT	CAP , MYLAR	0.1UF 50V J	1
C924	HCQI1H104JZT	CAP , MYLAR	0.1UF 50V J	1

POWER PCB ASSY				
Ref. #	Part Number	Description	Value	Qty
C925	HCQI1H103JZT	CAP , MYLAR	0.01UF 50V J	1
C926	HCQI1H103JZT	CAP , MYLAR	0.01UF 50V J	1
C927	HCQI1H103JZT	CAP , MYLAR	0.01UF 50V J	1
C928	HCQI1H103JZT	CAP , MYLAR	0.01UF 50V J	1
C931	HCQI1H473JZT	CAP , MYLAR	0.047UF 50V J	1
C932	HCQI1H473JZT	CAP , MYLAR	0.047UF 50V J	1
C933	HCQI1H473JZT	CAP , MYLAR	0.047UF 50V J	1
C934	HCQI1H473JZT	CAP , MYLAR	0.047UF 50V J	1
C935	HCBS1H223ZFT	CAP , CERAMIC	0.022UF 50V	1
C936	HCBS1H223ZFT	CAP , CERAMIC	0.022UF 50V	1
C937	HCBS1H223ZFT	CAP , CERAMIC	0.022UF 50V	1
C938	CCEA1CH101T	CAP , ELECT	100UF 16V	1
C939	CCEA1EH101T	CAP , ELECT	100UF 25V	1
C940	CCEA1EH101T	CAP , ELECT	100UF 25V	1
D101	HVDMTZJ15BT	DIODE , ZENER	MTZJ15B 1/2W	1
D102	HVDMTZJ27BT	DIODE , ZENER	MTZJ27B 1/2W	1
D104	CVD1N4003ST	RECT , DIODE	1N4003	1
D105	CVD1N4003ST	RECT , DIODE	1N4003	1
D108	CVD1N4003ST	RECT , DIODE	1N4003	1
D109	HVDMTZJ12BT	DIODE , ZENER	MTZJ12B 1/2W	1
D111	HVDMTZJ12BT	DIODE , ZENER	MTZJ12B 1/2W	1
D112	CVD1N4003ST	RECT , DIODE	1N4003	1
D113	CVD1N4003ST	RECT , DIODE	1N4003	1
D114	CVD1N4003ST	RECT , DIODE	1N4003	1
D115	CVD1N4003ST	RECT , DIODE	1N4003	1
D116	CVD1N4003ST	RECT , DIODE	1N4003	1
D117	CVD1N4003ST	RECT , DIODE	1N4003	1
D118	CVD1N4003ST	RECT , DIODE	1N4003	1
D119	CVD1N4003ST	RECT , DIODE	1N4003	1
D120	CVD1N4003ST	RECT , DIODE	1N4003	1
D121	CVD1N4003ST	RECT , DIODE	1N4003	1
D124	CVD1N4003ST	RECT , DIODE	1N4003	1
D125	CVD1N4003ST	RECT , DIODE	1N4003	1
Q104	HVTKSC2316YT	T.R	KSC2316Y	1
Q911	HVTKTA1267YT	T.R	KTA1267Y	1
Q912	HVTKTC3198YT	T.R	KTC3198Y	1
Q913	HVTKTC3198YT	T.R	KTC3198Y	1
R101	CRD25FJ3R3T	RES , CARBON	3.3 OHM 1/4W J	1
R108	CRD20TJ4R7T	RES , CARBON	4.7 OHM 1/5W J	1
R109	CRD20TJ100T	RES , CARBON	10 OHM 1/5W J	1
R110	CRD20TJ4R7T	RES , CARBON	4.7 OHM 1/5W J	1
R112	CRD20TJ122T	RES , CARBON	1.2K OHM 1/5W J	1
R113	CRD20TJ473T	RES , CARBON	47K OHM 1/5W J	1
R120	CRD20TJ103T	RES , CARBON	10K OHM 1/5W J	1
R750	CRD20TJ103T	RES , CARBON	10K OHM 1/5W J	1
R751	CRD20TJ103T	RES , CARBON	10K OHM 1/5W J	1
R756	CRD20TJ750T	RES , CARBON	75 OHM 1/5W J	1
R757	CRD20TJ750T	RES , CARBON	75 OHM 1/5W J	1
R759	CRD20TJ100T	RES , CARBON	10 OHM 1/5W J	1
R760	CRD20TJ241T	RES , CARBON	240OHM 1/5W J	1



POWER PCB ASSY				
Ref. #	Part Number	Description	Value	Qty
R761	CRD20TJ750T	RES , CARBON	75 OHM 1/5W J	1
R764	CRD20TJ102T	RES , CARBON	1K OHM 1/5W J	1
R765	CRD20TJ104T	RES , CARBON	100K OHM 1/5W J	1
R766	CRD20TJ472T	RES , CARBON	4.7K OHM 1/5W J	1
R767	CRD20TJ472T	RES , CARBON	4.7K OHM 1/5W J	1
R768	CRD20TJ472T	RES , CARBON	4.7K OHM 1/5W J	1
R770	CRD20TJ104T	RES , CARBON	100K OHM 1/5W J	1
R771	CRD20TJ102T	RES , CARBON	1K OHM 1/5W J	1
R776	CRD20TJ104T	RES , CARBON	100K OHM 1/5W J	1
R874	CRD20TJ331T	RES , CARBON	330 OHM 1/5W J	1
R875	CRD20TJ331T	RES , CARBON	330 OHM 1/5W J	1
R876	CRD20TJ331T	RES , CARBON	330 OHM 1/5W J	1
R877	CRD20TJ331T	RES , CARBON	330 OHM 1/5W J	1
R878	CRD20TJ331T	RES , CARBON	330 OHM 1/5W J	1
R882	CRD20TJ122T	RES , CARBON	1.2K OHM 1/5W J	1
R883	CRD20TJ122T	RES , CARBON	1.2K OHM 1/5W J	1
R884	CRD20TJ122T	RES , CARBON	1.2K OHM 1/5W J	1
R885	CRD20TJ122T	RES , CARBON	1.2K OHM 1/5W J	1
R886	CRD20TJ122T	RES , CARBON	1.2K OHM 1/5W J	1
R912	CRD20TJ153T	RES , CARBON	15K OHM 1/5W J	1
R913	CRD20TJ153T	RES , CARBON	15K OHM 1/5W J	1
R917	CRD20TJ153T	RES , CARBON	15K OHM 1/5W J	1
R918	CRD20TJ153T	RES , CARBON	15K OHM 1/5W J	1
R919	CRD20TJ153T	RES , CARBON	15K OHM 1/5W J	1
R920	CRD20TJ153T	RES , CARBON	15K OHM 1/5W J	1
R921	CRD20TJ153T	RES , CARBON	15K OHM 1/5W J	1
R922	CRD20TJ153T	RES , CARBON	15K OHM 1/5W J	1
R923	CRD25TJ153T	RES , CARBON	15K OHM 1/4W J	1
R924	CRD20TJ153T	RES , CARBON	15K OHM 1/5W J	1
R925	CRD20TJ103T	RES , CARBON	10K OHM 1/5W J	1
R926	CRD25TJ103T	RES , CARBON	10K OHM 1/4W J	1
R927	CRD20TJ104T	RES , CARBON	100K OHM 1/5W J	1
R928	CRD20TJ333T	RES , CARBON	33K OHM 1/5W J	1
VR81	HVN1RA221B01T	RES , SEMI FIXED(220 OHM)	RH0615C100221	1
VR82	HVN1RA221B01T	RES , SEMI FIXED(220 OHM)	RH0615C100221	1
VR83	HVN1RA221B01T	RES , SEMI FIXED(220 OHM)	RH0615C100221	1
VR84	HVN1RA221B01T	RES , SEMI FIXED(220 OHM)	RH0615C100221	1
VR85	HVN1RA221B01T	RES , SEMI FIXED(220 OHM)	RH0615C100221	1
BN17	KJP12GB143ZP	DIP SOCKET	SOCKET	1
BN20	CWB1C905200BM	WIRE ASS'Y	WIRE	1
BN43	CWB1C904200BM	WIRE ASS'Y	WIRE	1
BN95	CWB1C903080EN	WIRE ASS'Y	WIRE	1
BN96	CWB1C909150BM	WIRE ASS'Y	WIRE	1
BN99	CWB1B908270EN	WIRE ASS'Y	WIRE	1
CN13	CJP05GA01ZY	CON WAFER YMW025-05R	WAFER	1
CN19	CJP03GA90ZY	WAFER	WAFER	1
CN20	CJP04GA90ZM	WAFER	WAFER	1
CN31	CJP02GA19ZY	WAFER, 2PIN	WAFER	1
CN32	CJP02GA19ZY	WAFER, 2PIN	WAFER	1
CN33	CJP02GA19ZY	WAFER, 2PIN	WAFER	1

<b>POWER PCB ASSY</b>				
<b>Ref. #</b>	<b>Part Number</b>	<b>Description</b>	<b>Value</b>	<b>Qty</b>
CN34	CJP02GA19ZY	WAFER, 2PIN	WAFER	1
CN35	CJP02GA19ZY	WAFER, 2PIN	WAFER	1
CN81	CJP08GA01ZY	WAFER, STRAIGHT, 8PIN	WAFER	1
CN89	CJP02GA01ZY	WAFER, STRAIGHT, 2PIN	WAFER	1
CN95	CJP03GA19ZY	WAFER, STRAIGHT, 3PIN	WAFER	1
CN96	CJP09GA01ZY	CON WAFER YMW025-09R	WAFER	1
CN98	HJP08GB131ZK	WAFER	WAFER	1
CN99	CJP08GA19ZY	WAFER, STRAIGHT, 8PIN	WAFER	1
C122	CCEA1JH101E	CAP , ELECT	100UF 63V	1
C124	CCEA1VH102E	CAP , ELECT	1000UF 35V	1
C128	CCEA1EH102E	CAP , ELECT	1000UF 25V	1
C129	CCEA1EH222E	CAP , ELECT	2200UF 25V	1
C912	CCEA0JKR3222E	CAP , ELECT	2200UF 6.3V	1
C929	CCEA1VH102E	CAP , ELECT	1000UF 35V	1
C930	CCEA1VH102E	CAP , ELECT	1000UF 35V	1
C941	CCEA1CH682E	CAP , ELECT	6800UF 16V	1
D991	CVDKBU804FMA	BRIDGE DIODE ASS'Y	ASS'Y	1
	CMY1A219	HEAT SINK (BRIDGE DIODE)	HEAT SINK	1
	CTB3+12JR	SCREW	Not stocked	1
	HVDKBU804F	DIODE , BRIDGE	KBU804F	1
D992	CVDKBU804FMA	BRIDGE DIODE ASS'Y	ASS'Y	1
	CMY1A219	HEAT SINK (BRIDGE DIODE)	HEAT SINK	1
	CTB3+12JR	SCREW	Not stocked	1
	HVDKBU804F	DIODE , BRIDGE	KBU804F	1
IC72	HVI74HCU04AFNG	I.C , INVERTER	TOSHIBA	1
IC89	HVIL7805CP	I.C, REGULATOR(+5V)	ST	1
IC90	HVIL7815CP	I.C, REGULATOR(+15V)	ST	1
IC91	HVIL7915CP	I.C, REGULATOR(-15V)	ST	1
IC93	HVIL7905CP	I.C, REGULATOR(-5V)	ST	1
IC94	HVIL7805CP	I.C, REGULATOR(+5V)	ST	1
IC95	HVIL7812CP	I.C , REGULATOR(+12V)	ST	1
JK74	HJSTOTX177L	MODULE , OPTICAL(TX)	OPT JACK(TX)	1
JK75	HJSTORX177L	MODULE , OPTICAL(RX)	OPT JACK(RX)	1
JK76	HJSTORX177L	MODULE , OPTICAL(RX)	OPT JACK(RX)	1
JK78	CJJ4S022Z	JACK , BOARD	JACK	1
Q851	HVTKTD600KGR	T.R , BIAS	KTD600KGR	1
Q852	HVTKTD600KGR	T.R , BIAS	KTD600KGR	1
Q853	HVTKTD600KGR	T.R , BIAS	KTD600KGR	1
Q854	HVTKTD600KGR	T.R , BIAS	KTD600KGR	1
Q855	HVTKTD600KGR	T.R , BIAS	KTD600KGR	1
R104	KRQ1AJR47H	RES , FUSE	0.47 OHM 1W J	1
R105	KRQ1AJR47H	RES , FUSE	0.47 OHM 1W J	1
R106	CRQ1AJR33H	RES , FUSE	0.33 OHM 1W J	1
R107	CRQ1AJR33H	RES , FUSE	0.33 OHM 1W J	1
R114	KRQ1AJR47H	RES , FUSE	0.47 OHM 1W J	1
R115	KRQ1AJR47H	RES , FUSE	0.47 OHM 1W J	1
R116	CRQ1AJR33H	RES , FUSE	0.33 OHM 1W J	1
R117	CRQ1AJR33H	RES , FUSE	0.33 OHM 1W J	1

VIDEO PCB ASSY				
Ref. #	Part Number	Description	Value	Qty
	COP11917E	VIDEO PCB ASS'Y(AVR145/230)	ASS'Y	1
C401	CCUS1H101JA	CAP , CHIP	100PF	1
C402	CCUS1H101JA	CAP , CHIP	100PF	1
C403	CCUS1H101JA	CAP , CHIP	100PF	1
C461	CCUS1H223KC	CAP , CHIP	0.022UF	1
C463	CCUS1H223KC	CAP , CHIP	0.022UF	1
C466	CCUS1H223KC	CAP , CHIP	0.022UF	1
C468	CCUS1H223KC	CAP , CHIP	0.022UF	1
C471	CCUS1H223KC	CAP , CHIP	0.022UF	1
C473	CCUS1H223KC	CAP , CHIP	0.022UF	1
C481	CCUS1H101JA	CAP , CHIP	100PF	1
C483	CCUS1H101JA	CAP , CHIP	100PF	1
C485	CCUS1H223KC	CAP , CHIP	0.022UF	1
C487	CCUS1H223KC	CAP , CHIP	0.022UF	1
C491	CCUS1H101JA	CAP , CHIP	100PF	1
C492	CCUS1H101JA	CAP , CHIP	100PF	1
C493	CCUS1H101JA	CAP , CHIP	100PF	1
C501	CCUS1H103KC	CAP , CHIP	0.01UF	1
C504	CCUS1H104KC	CAP , CHIP	0.1UF	1
C511	CCUS1H103KC	CAP , CHIP	0.01UF	1
C521	CCUS1H223KC	CAP , CHIP	0.022UF	1
C525	CCUS1H223KC	CAP , CHIP	0.022UF	1
C531	CCUS1H223KC	CAP , CHIP	0.022UF	1
C535	CCUS1H223KC	CAP , CHIP	0.022UF	1
C539	CCUS1H104KC	CAP , CHIP	0.1UF	1
C543	CCUS1H104KC	CAP , CHIP	0.1UF	1
C548	CCUS1H104KC	CAP , CHIP	0.1UF	1
C552	CCUS1H223KC	CAP , CHIP	0.022UF	1
C553	CCUS1H223KC	CAP , CHIP	0.022UF	1
C554	CCUS1H223KC	CAP , CHIP	0.022UF	1
C555	CCUS1H272KC	CAP , CHIP	2700PF	1
C559	CCUS1A105KC	CAP , CHIP	1UF	1
C601	CCUS1H220JA	CAP , CHIP	22PF	1
C603	CCUS1H220JA	CAP , CHIP	22PF	1
C605	CCUS1H220JA	CAP , CHIP	22PF	1
C611	CCUS1H220JA	CAP , CHIP	22PF	1
C613	CCUS1H220JA	CAP , CHIP	22PF	1
C615	CCUS1H220JA	CAP , CHIP	22PF	1
C621	CCUS1H220JA	CAP , CHIP	22PF	1
C623	CCUS1H220JA	CAP , CHIP	22PF	1
C625	CCUS1H220JA	CAP , CHIP	22PF	1
C672	CCUS1H104KC	CAP , CHIP	0.1UF	1
C677	CCUS1H473KC	CAP , CHIP	0.047UF	1
C701	CCUS1H270JA	CAP , CHIP	27PF	1
C702	CCUS1H270JA	CAP , CHIP	27PF	1
C703	CCUS1H330JA	CAP , CHIP	33PF	1
C704	CCUS1H330JA	CAP , CHIP	33PF	1
C705	CCUS1H181JA	CAP , CHIP	180PF	1
C717	CCUS1H220JA	CAP , CHIP	22PF	1
C721	CCUS1H560JA	CAP , CHIP	56PF	1

VIDEO PCB ASSY				
Ref. #	Part Number	Description	Value	Qty
C722	CCUS1H220JA	CAP , CHIP	22PF	1
C731	CCUS1H220JA	CAP , CHIP	22PF	1
C732	CCUS1H330JA	CAP , CHIP	33PF	1
C733	CCUS1H223KC	CAP , CHIP	0.022UF	1
C736	CCUS1H223KC	CAP , CHIP	0.022UF	1
C741	CCUS1H223KC	CAP , CHIP	0.022UF	1
D502	HVDRLS4148SR	DIODE, SWITCHING, SMD TYPE	RLS4148 TE-11	1
D505	HVDRLS4148SR	DIODE, SWITCHING, SMD TYPE	RLS4148 TE-11	1
D512	HVDRLS4148SR	DIODE, SWITCHING, SMD TYPE	RLS4148 TE-11	1
D514	HVDRLS4148SR	DIODE, SWITCHING, SMD TYPE	RLS4148 TE-11	1
D741	HVDRLS4148SR	DIODE, SWITCHING, SMD TYPE	RLS4148 TE-11	1
IC41	CVINJM2595MTE1	I.C , VIDEO S/W	JRC	1
IC42	CVINJM2595MTE1	I.C , VIDEO S/W	JRC	1
IC43	CVINJM2595MTE1	I.C , VIDEO S/W	JRC	1
IC48	HVIHCF4053M013T	I.C, ANALOG MULTIPLEXER	ST	1
IC51	HVIHCF4053M013T	I.C, ANALOG MULTIPLEXER	ST	1
IC52	HVIHCF4053M013T	I.C, ANALOG MULTIPLEXER	ST	1
IC53	CVINJM2587V	I.C, VIDEO S/W	JRC	1
IC54	HVIMM1511XNRE	IC, Y/C-MIX	MITSUMI	1
IC61	CVINJW1321FP1	I.C , VIDEO S/W	JRC	1
IC71	HVILC74763M	I.C , OSD	SANYO	1
IC72	HVI74ACT04MTR	I.C , HEX INVERTER	FARICHILD	1
L551	CRJ10DJ0R0T	RES , CHIP	0 OHM	1
Q505	HVTKRA107S	TR, CHIP	KRA107S	1
Q507	HVTKRC107S	TR , CHIP	KRC107S	1
Q512	HVTKRC107S	TR , CHIP	KRC107S	1
Q515	HVTKRA107S	TR, CHIP	KRA107S	1
Q516	HVTKRC107S	TR , CHIP	KRC107S	1
Q517	HVTKRC107S	TR , CHIP	KRC107S	1
Q518	HVTKRC107S	TR , CHIP	KRC107S	1
Q551	HVTKTD1304T	T.R , CHIP (MUTE)	KTD1304	1
Q552	HVTKRA104S	TR , CHIP	KRA104S	1
Q555	HVTKTD1304T	T.R , CHIP (MUTE)	KTD1304	1
Q556	HVTKRA104S	TR , CHIP	KRA104S	1
R401	CRJ10DJ750T	RES , CHIP	75 OHM	1
R402	CRJ10DJ750T	RES , CHIP	75 OHM	1
R403	CRJ10DJ750T	RES , CHIP	75 OHM	1
R404	CRJ10DJ332T	RES , CHIP	3300 OHM	1
R405	CRJ10DJ332T	RES , CHIP	3300 OHM	1
R411	CRJ10DJ750T	RES , CHIP	75 OHM	1
R412	CRJ10DJ750T	RES , CHIP	75 OHM	1
R413	CRJ10DJ750T	RES , CHIP	75 OHM	1
R421	CRJ10DJ750T	RES , CHIP	75 OHM	1
R422	CRJ10DJ750T	RES , CHIP	75 OHM	1
R423	CRJ10DJ750T	RES , CHIP	75 OHM	1
R451	CRJ10DJ750T	RES , CHIP	75 OHM	1
R452	CRJ10DJ750T	RES , CHIP	75 OHM	1
R453	CRJ10DJ750T	RES , CHIP	75 OHM	1
R461	CRJ10DJ102T	RES , CHIP	1K OHM	1
R466	CRJ10DJ102T	RES , CHIP	1K OHM	1

VIDEO PCB ASSY				
Ref. #	Part Number	Description	Value	Qty
R471	CRJ10DJ102T	RES , CHIP	1K OHM	1
R485	CRJ10DJ100T	RES , CHIP	10 OHM	1
R487	CRJ10DJ100T	RES , CHIP	10 OHM	1
R491	CRJ10DJ750T	RES , CHIP	75 OHM	1
R492	CRJ10DJ750T	RES , CHIP	75 OHM	1
R493	CRJ10DJ750T	RES , CHIP	75 OHM	1
R501	CRJ10DJ333T	RES , CHIP	33K OHM	1
R502	CRJ10DJ680T	RES , CHIP	68 OHM	1
R503	CRJ10DJ123T	RES , CHIP	12K OHM	1
R504	CRJ10DJ223T	RES , CHIP	22K OHM	1
R505	CRJ10DJ102T	RES , CHIP	1K OHM	1
R506	CRJ10DJ103T	RES , CHIP	10K OHM	1
R507	CRJ10DJ103T	RES , CHIP	10K OHM	1
R511	CRJ10DJ333T	RES , CHIP	33K OHM	1
R512	CRJ10DJ680T	RES , CHIP	68 OHM	1
R513	CRJ10DJ123T	RES , CHIP	12K OHM	1
R514	CRJ10DJ102T	RES , CHIP	1K OHM	1
R515	CRJ10DJ103T	RES , CHIP	10K OHM	1
R516	CRJ10DJ103T	RES , CHIP	10K OHM	1
R517	CRJ10DJ223T	RES , CHIP	22K OHM	1
R518	CRJ10DJ103T	RES , CHIP	10K OHM	1
R521	CRJ10DJ100T	RES , CHIP	10 OHM	1
R523	CRJ10DJ100T	RES , CHIP	10 OHM	1
R531	CRJ10DJ100T	RES , CHIP	10 OHM	1
R533	CRJ10DJ2R2T	RES , CHIP	2.2 OHM	1
R534	CRJ10DJ100T	RES , CHIP	10 OHM	1
R536	CRJ10DJ101T	RES , CHIP	100 OHM	1
R537	CRJ10DJ183T	RES , CHIP	18K OHM	1
R539	CRJ10DJ181T	RES , CHIP	180 OHM	1
R540	CRJ10DJ101T	RES , CHIP	100 OHM	1
R541	CRJ10DJ181T	RES , CHIP	180 OHM	1
R542	CRJ10DJ392T	RES , CHIP	3.9K OHM	1
R543	CRJ10DJ1R8T	RES , CHIP	1.8 OHM	1
R545	CRJ10DJ161T	RES , CHIP	160 OHM	1
R546	CRJ10DJ181T	RES , CHIP	180 OHM	1
R547	CRJ10DJ183T	RES , CHIP	18K OHM	1
R548	CRJ10DJ1R0T	RES , CHIP	1 OHM	1
R551	CRJ10DJ105T	RES , CHIP	1M OHM	1
R552	CRJ10DJ223T	RES , CHIP	22K OHM	1
R553	CRJ10DJ332T	RES , CHIP	3.3K OHM	1
R555	CRJ10DJ562T	RES , CHIP	5.6K OHM	1
R556	CRJ10DJ472T	RES , CHIP	4.7K OHM	1
R558	CRJ10DJ222T	RES , CHIP	2.2K OHM	1
R601	CRJ10DJ680T	RES , CHIP	68 OHM	1
R603	CRJ10DJ560T	RES , CHIP	56 OHM	1
R605	CRJ10DJ620T	RES , CHIP	62 OHM	1
R611	CRJ10DJ750T	RES , CHIP	75 OHM	1
R613	CRJ10DJ750T	RES , CHIP	75 OHM	1
R615	CRJ10DJ750T	RES , CHIP	75 OHM	1
R621	CRJ10DJ750T	RES , CHIP	75 OHM	1

VIDEO PCB ASSY				
Ref. #	Part Number	Description	Value	Qty
R623	CRJ10DJ750T	RES , CHIP	75 OHM	1
R625	CRJ10DJ750T	RES , CHIP	75 OHM	1
R674	CRJ10DJ102T	RES , CHIP	1K OHM	1
R675	CRJ10DJ102T	RES , CHIP	1K OHM	1
R701	CRJ10DJ0R0T	RES , CHIP	0 OHM	1
R705	CRJ10DJ102T	RES , CHIP	1K OHM	1
R706	CRJ10DJ102T	RES , CHIP	1K OHM	1
R707	CRJ10DJ102T	RES , CHIP	1K OHM	1
R711	CRJ10DJ104T	RES , CHIP	100K OHM	1
R712	CRJ10DJ103T	RES , CHIP	10K OHM	1
R713	CRJ10DJ223T	RES , CHIP	22K OHM	1
R714	CRJ10DJ202T	RES , CHIP	2K OHM	1
R715	CRJ10DJ822T	RES , CHIP	8.2K OHM	1
R716	CRJ10DJ103T	RES , CHIP	10K OHM	1
R717	CRJ10DJ271T	RES , CHIP	270 OHM	1
R721	CRJ10DJ222T	RES , CHIP	2.2 OHM	1
R724	CRJ10DJ393T	RES , CHIP	39J OHM	1
R725	CRJ10DJ152T	RES , CHIP	1.5K OHM	1
R726	CRJ10DJ682T	RES , CHIP	6.8K OHM	1
R727	CRJ10DJ102T	RES , CHIP	1K OHM	1
R728	CRJ10DJ102T	RES , CHIP	1K OHM	1
R735	CRJ10DJ102T	RES , CHIP	1K OHM	1
R737	CRJ10DJ104T	RES , CHIP	100K OHM	1
R742	CRJ10DJ102T	RES , CHIP	1K OHM	1
R743	CRJ10DJ102T	RES , CHIP	1K OHM	1
R744	CRJ10DJ102T	RES , CHIP	1K OHM	1
R745	CRJ10DJ102T	RES , CHIP	1K OHM 1/5W J	1
R746	CRJ10DJ103T	RES , CHIP	10K OHM 1/5W J	1
R747	CRJ10DJ332T	RES , CHIP	3.3K OHM 1/5W J	1
C411	CCEA1HH100T	CAP , ELECT	10UF 50V	1
C412	CCEA1HH100T	CAP , ELECT	10UF 50V	1
C413	CCEA1HH100T	CAP , ELECT	10UF 50V	1
C421	CCEA1HH100T	CAP , ELECT	10UF 50V	1
C422	CCEA1HH100T	CAP , ELECT	10UF 50V	1
C423	CCEA1HH100T	CAP , ELECT	10UF 50V	1
C451	CCEA1HH100T	CAP , ELECT	10UF 50V	1
C452	CCEA1HH100T	CAP , ELECT	10UF 50V	1
C453	CCEA1HH100T	CAP , ELECT	10UF 50V	1
C462	CCEA1CH101T	CAP , ELECT	100UF 16V	1
C464	CCEA1CH101T	CAP , ELECT	100UF 16V	1
C467	CCEA1CH101T	CAP , ELECT	100UF 16V	1
C469	CCEA1CH101T	CAP , ELECT	100UF 16V	1
C472	CCEA1CH101T	CAP , ELECT	100UF 16V	1
C474	CCEA1CH101T	CAP , ELECT	100UF 16V	1
C486	CCEA1CH101T	CAP , ELECT	100UF 16V	1
C488	CCEA1CH101T	CAP , ELECT	100UF 16V	1
C503	CCEA1HH100T	CAP , ELECT	10UF 50V	1
C505	CCEA1HH100T	CAP , ELECT	10UF 50V	1
C514	CCEA1HH100T	CAP , ELECT	10UF 50V	1
C515	CCEA1HH100T	CAP , ELECT	10UF 50V	1

VIDEO PCB ASSY				
Ref. #	Part Number	Description	Value	Qty
C522	CCEA1CH101T	CAP , ELECT	100UF 16V	1
C524	CCEA1CH101T	CAP , ELECT	100UF 16V	1
C532	CCEA1CH101T	CAP , ELECT	100UF 16V	1
C533	CCEA1CH101T	CAP , ELECT	100UF 16V	1
C534	CCEA1CH101T	CAP , ELECT	100UF 16V	1
C536	CCEA1AH471T	CAP , ELECT	470UF 10V	1
C537	CCEA1CH101T	CAP , ELECT	100UF 16V	1
C538	CCEA1CH101T	CAP , ELECT	100UF 16V	1
C544	CCEA1CH101T	CAP , ELECT	100UF 16V	1
C549	CCEA1CH101T	CAP , ELECT	100UF 16V	1
C602	CCEA0JH102T	CAP , ELECT	1000UF 6.3V	1
C604	CCEA0JH102T	CAP , ELECT	1000UF 6.3V	1
C606	CCEA0JH102T	CAP , ELECT	1000UF 6.3V	1
C612	CCEA1HH100T	CAP , ELECT	10UF 50V	1
C614	CCEA1HH100T	CAP , ELECT	10UF 50V	1
C616	CCEA1HH100T	CAP , ELECT	10UF 50V	1
C622	CCEA1HH100T	CAP , ELECT	10UF 50V	1
C624	CCEA1HH100T	CAP , ELECT	10UF 50V	1
C626	CCEA1HH100T	CAP , ELECT	10UF 50V	1
C671	CCEA1CH101T	CAP , ELECT	100UF 16V	1
C673	CCEA1HH100T	CAP , ELECT	10UF 50V	1
C676	CCEA1CH101T	CAP , ELECT	100UF 16V	1
C678	CCEA1CH101T	CAP , ELECT	100UF 16V	1
C708	CCEA1HHR47T	CAP , ELECT	0.47UF 50V	1
C711	CCEA1AH471T	CAP , ELECT	470UF 10V	1
C723	CCEA1HH0R1T	CAP , ELECT	0.1UF 50V	1
C725	HCQI1H682JZT	CAP , MYLAR	6800PF 50V J	1
C726	CCEA1HH1R0T	CAP , ELECT	1UF 50V	1
C734	CCEA1HH1R0T	CAP , ELECT	1UF 50V	1
C737	CCEA1CH101T	CAP , ELECT	100UF 16V	1
L731	KLQ5R6J405T	COIL, PEAKING(RADIAL)	5.6UH J 4X5	1
L736	HLQ02C101JT	COIL , AXAIL	100UH,J	1
Q501	HVTKSA733CYT	T.R	KSA733CY	1
Q504	HVTKTC2874BT	T.R , MUTE	KTC2874B	1
Q511	HVTKSA733CYT	T.R	KSA733CY	1
Q536	HVTKSA1175YT	T.R	KSA1175Y(DEAD)	1
Q712	HVTKSA1175YT	T.R	KSA1175Y(DEAD)	1
Q716	HVTKSC2785YT	T.R	KSC2785Y	1
BN14	CJP13GA117ZY	WAFER , CARD CABLE	WAFER	1
CN41	CJP06GA19ZY	WAFER, STRAIGHT, 6PIN	WAFER	1
CN42	CJP07GA117ZY	TEMP ITEM	WAFER	1
CN43	CJP04GA01ZY	WAFER, STRAIGHT, 4PIN	WAFER	1
C712	CCEA0JKR3222E	CAP , ELECT	2200UF 6.3V	1
IC62	HVIMC7809C	I.C , REGULATOR(+9V)	FAIRCHILD	1
JK40	CJJ9P003Z	JACK , (S-VIDEO + CVBS)	JACK	1
JK41	CJJ9R001Z	JACK , (S-VIDEO + CVBS)	JACK	1
JK62	CJJ4R045Z	JACK , BOARD	JACK	1
JK69	CJJ4S030Z	JACK , BOARD	JACK	1
X701	HOX17734E220C	CRYSTAL	17.734Mhz	1
X703	HOX14318E220C	CRYSTAL	14.318Mhz	1



# NJM2595

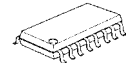
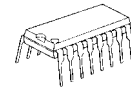
## 5-INPUT 3-OUTPUT VIDEO SWITCH

### ■ GENERAL DESCRIPTION

The **NJM2595** is a 5-input 3-output video switch. Its switches select one from five signals received from VTR,TV,DVD, TV-GAME and others.

The NJM2595 is designed for audio items, such as AV amplifier and others.

### ■ PACKAGE OUTLINE

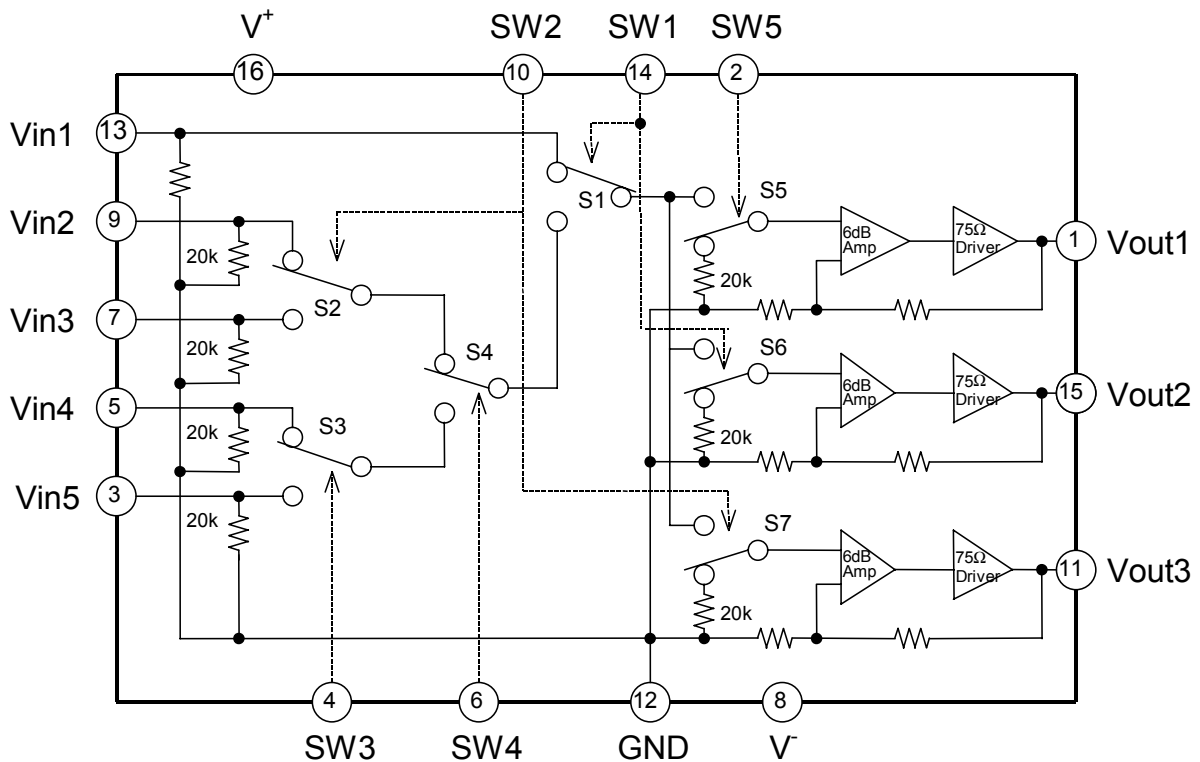


**NJM2595D NJM2595M**

### ■ FEATURES

- 5-input 3-output
- Operating Voltage  $\pm 4.0$  to  $\pm 6.5V$
- Operating current  $\pm 15mA$ typ. at  $V_{CC}=\pm 5V$
- Crosstalk  $-65dB$ typ.
- Internal 6dB Amplifier
- Internal 75Ω Driver
- Bipolar Technology
- Package Outline DIP16,DMP16

### ■ PIN CONFIGURATION and BLOCK DIAGRAM





# NJM2595

## ■ EQUIVALENT CIRCUIT

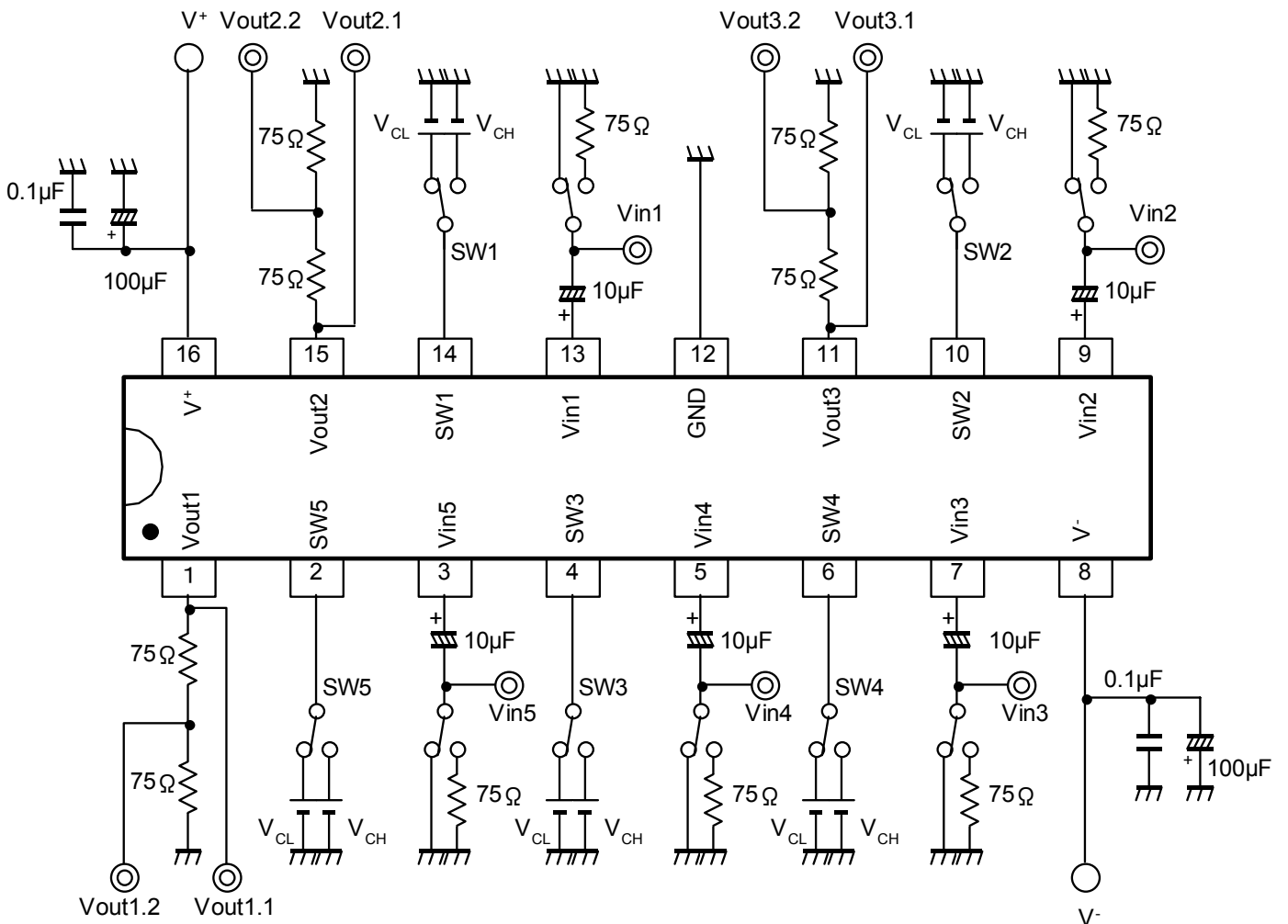
PIN No.	PIN NAME	INSIDE EQUIVALENT CIRCUIT	VOLTAGE
16	V <sup>+</sup>		5V
8	V <sup>-</sup>		-5V
12	GND		-
13 9 7 5 3	Vin1 Vin2 Vin3 Vin4 Vin5		0V
1 15 11	Vout1 Vout2 Vout3		0V
4 6 2	SW3 SW4 SW5		-

# NJM2595

## ■ EQUIVALENT CIRCUIT

PIN No.	PIN NAME	INSIDE EQUIVALENT CIRCUIT	VOLTAGE
14 10	SW1 SW2		-

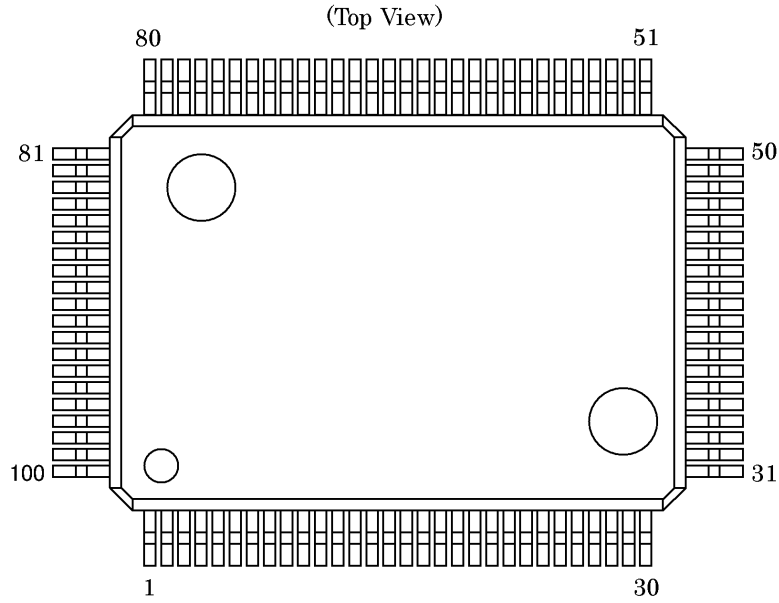
## ■ TEST CIRCUIT





■ PIN CONFIGURAITON

BEE-45919-000-00



No.	SYMBOL	No.	SYMBOL	No.	SYMBOL	No.	SYMBOL
1	ROUT	26	DCCAP_RS	51	DCR_IN	76	GND
2	COUT	27	L3IN	52	DCR_OUT	77	LSCIN
3	LSOUT	28	DCCAP_LS	53	GND	78	RSCIN
4	RSOUT	29	R3IN	54	DCL_IN	79	LBCIN
5	LBOUT	30	DCCAP_C	55	DCL_OUT	80	RBCIN
6	RBOUT	31	L4IN	56	GND	81	GND
7	SWOUT	32	DCCAP_R	57	REC_B1R	82	LAIN
8	GND	33	R4IN	58	REC_B1L	83	RAIN
9	FIL_BL2	34	DCCAP_L	59	REC_A4R	84	CAIN
10	FIL_BL1	35	L5IN	60	REC_A4L	85	LSAIN
11	FIL_TL	36	GND	61	REC_A3R	86	RSAIN
12	TCAP	37	R5IN	62	REC_A3L	87	LBAIN
13	FIL_BR2	38	GND	63	REC_A2R	88	RBAIN
14	FIL_BR1	39	L6IN	64	REC_A2L	89	SWAIN
15	FIL_TR	40	L9IN	65	REC_A1R	90	GND
16	V+	41	R6IN	66	REC_A1L	91	LBIN
17	ADR	42	R9IN	67	VDDOUT	92	RBIN
18	V-	43	L7IN	68	DATA	93	CBIN
19	L1IN	44	L10IN	69	CLOCK	94	LSBIN
20	DCCAP_SW	45	R7IN	70	LATCH	95	RSBIN
21	R1IN	46	R10IN	71	MUTE	96	LBBIN
22	DCCAP_RB	47	L8IN	72	FL+	97	RBBIN
23	L2IN	48	L11IN	73	FL-	98	SWBIN
24	DCCAP_LB	49	R8IN	74	FR+	99	GND
25	R2IN	50	R11IN	75	FR-	100	LOUT

**FUNCTIONAL DESCRIPTION**

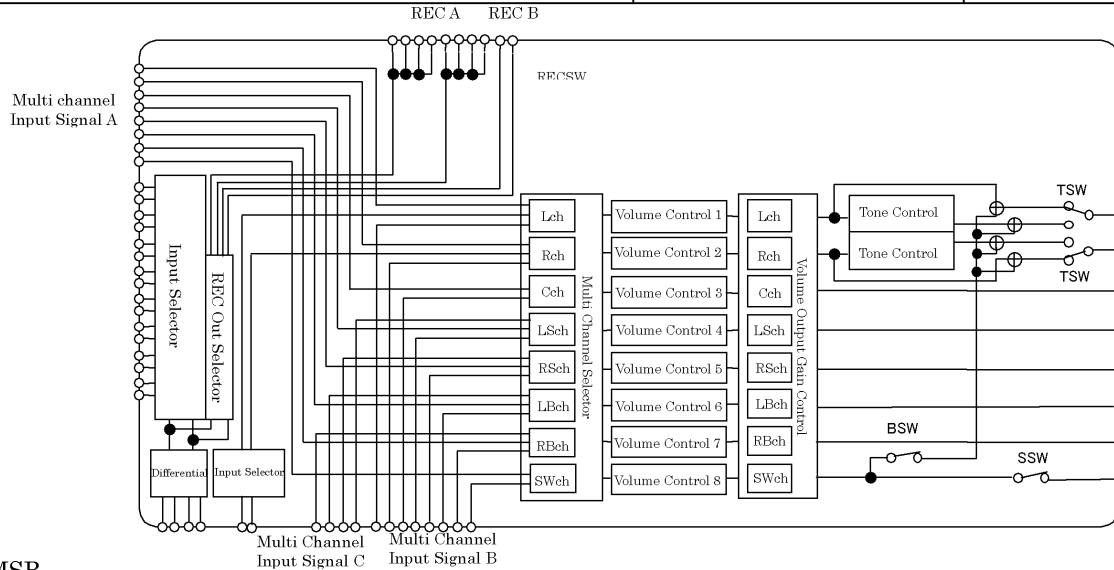
BGE-45919-000-00

(1) CONTROL DATA

NJW1197 control data is constructed with 16bits.

MSB LSB

D15	D14	D13	D12	D11	D10	D9	D8	D7	D6	D5	D4	D3	D2	D1	D0
Data								Select Address				Chip Address			



MSB LSB

D15	D14	D13	D12	D11	D10	D9	D8	D7	D6	D5	D4	D3	D2	D1	D0
L channel Volume Control								0	0	0	0	*	*	*	*
R channel Volume Control								0	0	0	1	*	*	*	*
C channel Volume Control								0	0	1	0	*	*	*	*
LS channel Volume Control								0	0	1	1	*	*	*	*
RS channel Volume Control								0	1	0	0	*	*	*	*
LB channel Volume Control								0	1	0	1	*	*	*	*
RB channel Volume Control								0	1	1	0	*	*	*	*
SW channel Volume Control								0	1	1	1	*	*	*	*
Input Selector Gain Control		Input Selector					SSW	1	0	0	0	*	*	*	*
TC/B	Tone Control Treble				TSW	BSW	*	1	0	0	1	*	*	*	*
BC/B	Tone Control Bass				*	*	*	1	0	1	0	*	*	*	*
REC B Selector				Input Selector			1	0	1	1	*	*	*	*	
SWch Volume Output Gain Control	REC B1	REC A4	REC A3	REC A2	REC A1	1	1	0	0	*	*	*	*		
L, Rch Volume Output Gain Control	Cch, Volume Output Gain Control			*	*	1	1	0	1	*	*	*	*		
LS, RSch Volume Output Gain Control	LB, RBch Volume Output Gain Control		SWch Selector		1	1	1	0	*	*	*	*			
L, Rch Selector	Cch Selector	LS, RSch Selector	LB, RBch Selector		1	1	1	1	*	*	*	*			

\*: Don't Care

\* Chip address is set by chip address select terminal (ADR) status.

Chip Address Select Terminal (ADR: 17pin)	Chip Address			
	D3	D2	D1	D0
Low	0	1	0	0
High	0	1	0	1

\* The mute function can be controlled externally. If the Mute control terminal (71pin) is switched to High, Multi-Channel outputs are muted immediately (hardware mute).

External mute control terminal (MUTE: 71pin)	Setting
Low	Mute cancellation
High	Mute

(2) INITIAL CONDITON

D15	D14	D13	D12	D11	D10	D9	D8	D7	D6	D5	D4	D3	D2	D1	D0
1	1	1	1	1	1	1	1	0	0	0	0	*	*	*	*
1	1	1	1	1	1	1	1	0	0	0	1	*	*	*	*
1	1	1	1	1	1	1	1	0	0	1	0	*	*	*	*
1	1	1	1	1	1	1	1	0	0	1	1	*	*	*	*
1	1	1	1	1	1	1	1	0	1	0	0	*	*	*	*
1	1	1	1	1	1	1	1	0	1	0	1	*	*	*	*
1	1	1	1	1	1	1	1	0	1	1	0	*	*	*	*
1	1	1	1	1	1	1	1	0	1	1	1	*	*	*	*
0	0	0	0	0	0	0	0	1	0	0	0	*	*	*	*
0	0	0	0	0	0	0	0	1	0	0	1	*	*	*	*
0	0	0	0	0	0	0	0	1	0	1	0	*	*	*	*
0	0	0	0	0	0	0	0	1	0	1	1	*	*	*	*
0	0	0	0	0	0	0	0	1	1	0	0	*	*	*	*
0	0	0	0	0	0	0	0	1	1	0	1	*	*	*	*
0	0	0	0	0	0	0	0	1	1	1	0	*	*	*	*
0	0	0	0	0	0	0	0	1	1	1	1	*	*	*	*

(3) DEFINITION OF RESISTOR

•Volume Control: 0dB to -100dB in 0.5dB/step.

D15	D14	D13	D12	D11	D10	D9	D8	D7	D6	D5	D4	D3	D2	D1	D0
L channel Volume Control								0	0	0	0	*	*	*	*
R channel Volume Control								0	0	0	1	*	*	*	*
C channel Volume Control								0	0	1	0	*	*	*	*
LS channel Volume Control								0	0	1	1	*	*	*	*
RS channel Volume Control								0	1	0	0	*	*	*	*
LB channel Volume Control								0	1	0	1	*	*	*	*
RB channel Volume Control								0	1	1	0	*	*	*	*
SW channel Volume Control								0	1	1	1	*	*	*	*

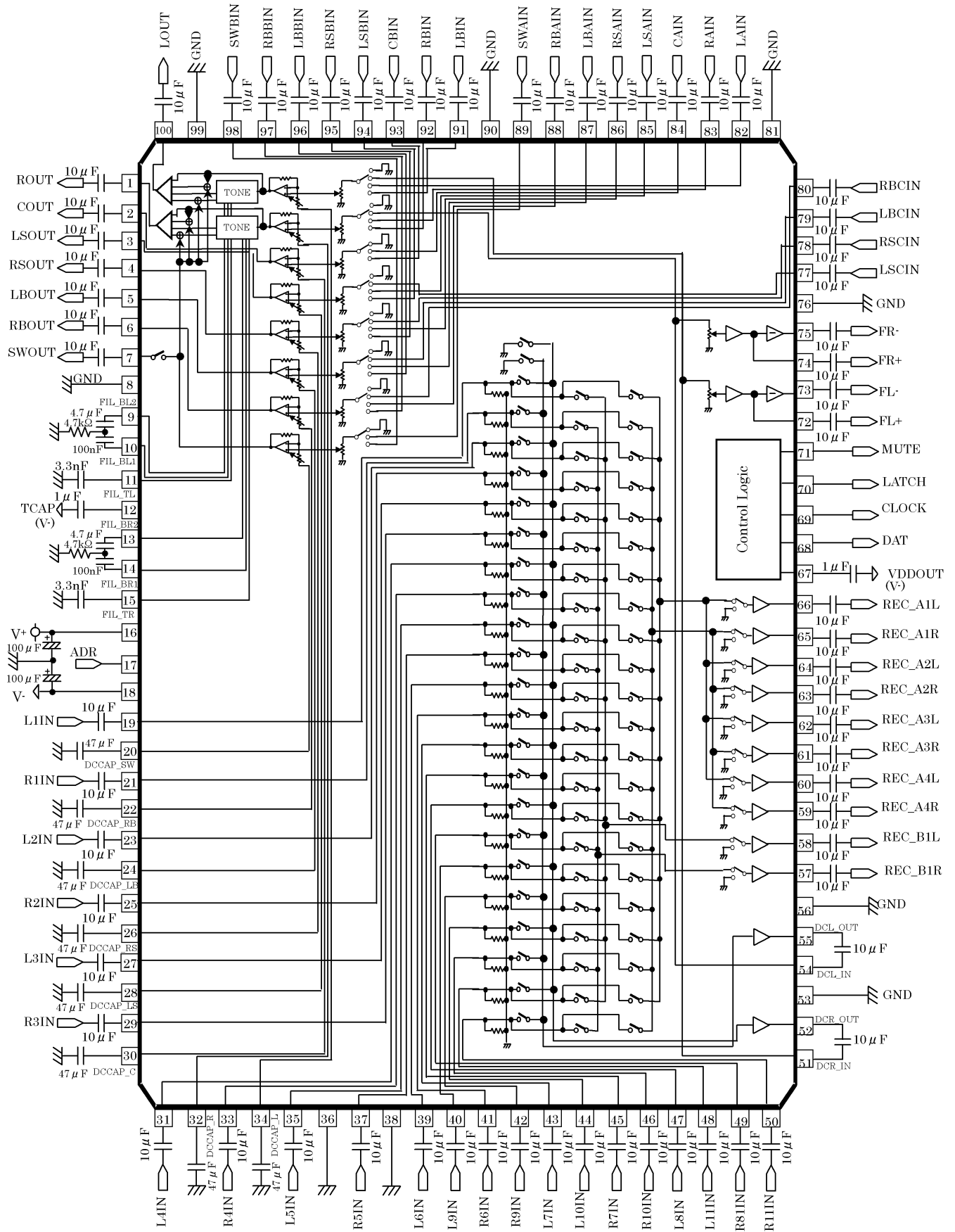
<Volume Control Data>

Data								Setting
D15	D14	D13	D12	D11	D10	D9	D8	
0	0	0	0	0	0	0	0	0dB
0	0	0	0	0	0	0	1	-0.5dB
0	0	0	0	0	0	1	0	-1dB
0	0	0	0	0	0	1	1	-1.5dB
0	0	0	0	0	1	0	0	-2dB
0	0	0	0	0	1	0	1	-2.5dB
0	0	0	0	0	1	1	0	-3dB
0	0	0	0	0	1	1	1	-3.5dB
0	0	0	0	1	0	0	0	-4dB
0	0	0	0	1	0	0	1	-4.5dB
0	0	0	0	1	0	1	0	-5dB
0	0	0	0	1	0	1	1	-5.5dB
0	0	0	0	1	1	0	0	-6dB
0	0	0	0	1	1	0	1	-6.5dB
0	0	0	0	1	1	1	0	-7dB
0	0	0	0	1	1	1	1	-7.5dB
0	0	0	1	0	0	0	0	-8dB
0	0	0	1	0	0	0	1	-8.5dB
0	0	0	1	0	0	1	0	-9dB
0	0	0	1	0	0	1	1	-9.5dB
0	0	0	1	0	1	0	0	-10dB
...								...
1	1	0	0	0	0	1	0	-97dB
1	1	0	0	0	0	1	1	-97.5dB
1	1	0	0	0	1	0	0	-98dB
1	1	0	0	0	1	0	1	-98.5dB
1	1	0	0	0	1	1	0	-99dB
1	1	0	0	0	1	1	1	-99.5dB
1	1	0	0	1	0	0	0	-100dB
1	1	1	1	1	1	1	1	MUTE(*)

(\*): Initial Setting

APPLICATION CIRCUIT

BHE-45919-000-00







# CS495xx Data Sheet

## FEATURES

- ❑ Powerful 32-bit Dual-core Audio DSP
- ❑ Multi-standard 32-bit Audio Decoding plus Post Processing, Dual-decode Capable
- ❑ Framework Applications Library
  - Dolby® Digital Pro Logic® IIx, Dolby® Digital EX, Dolby® Digital Headphone™, Dolby® Digital Virtual Speaker™
  - DTS-ES 96/24™, DTS-ES™ Discrete 6.1, DTS-ES™ Matrix 6.1, DTS® Digital Surround
  - MPEG-2 Multichannel
  - AAC™ Multichannel 5.1
  - MP3 - MPEG-1/2, Layer III
  - THX® Surround EX™, THX® Ultra2 Cinema™
  - DVD Audio/Video/SACD Multichannel Bass Management
- ❑ 10 Channels of 32-bit Serial Audio Input
- ❑ 16 Channels of 32-bit PCM Output
- ❑ Two Master/slave SPI or I<sup>2</sup>C Format Control Ports for Audio Subsystem Management
- ❑ Parallel Host Control & UART
- ❑ Customer Software Security Keys
- ❑ Large On-chip X, Y, and Program RAM & ROM
- ❑ SDRAM, SRAM, and FLASH Memory Support
- ❑ Dual 192-kHz SPDIF Transmitters

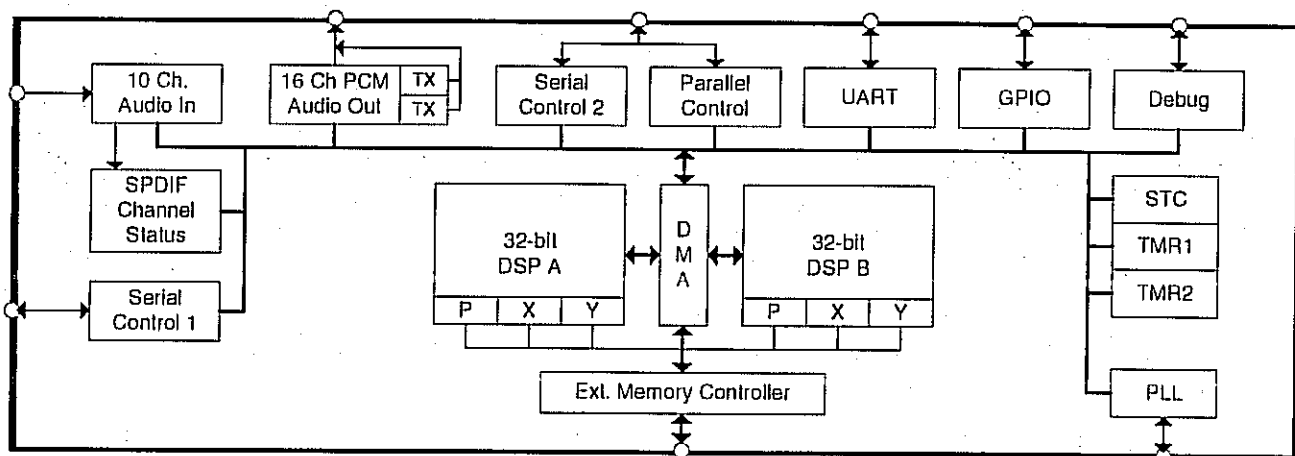
### 32-bit Audio Decoder DSP Family

The CS495xx DSP family integrates two programmable, 32-bit DSP cores and a DMA engine with a full set of audio peripherals. Feature-rich AVR designs can be easily developed using the Framework applications library, which includes both certified application programs and a modular programming environment for easy customization. The framework includes certified state-of-the-art audio decoders, virtualizers, surround simulators, and audio enhancement algorithms.

The CS495xx family was designed to reduce system costs and development time and to provide advanced features and flexibility for competitive system-level solutions. The difficult processing tasks of Dolby® Digital Surround EX™, AAC multichannel, DTS-ES 96/24, and THX Ultra2 Cinema can be accomplished without the expense of external logic or memory. Additionally, the CS495xx can meet the needs of dual-decode applications with twin DSP cores, and audio-I/O-intensive designs with support for up to 10 input and 16 output channels.

### Ordering Information

See page 33 for ordering information



Preliminary Product Information

This document contains information for a new product. Cirrus Logic reserves the right to modify this product without notice.



©Copyright 2005 Cirrus Logic, Inc.

NOV '05  
DS631PP4

**CS495xx Data Sheet**  
**32-bit Audio Decoder DSP Family**



Device	Firmware	Decoder	Mid-Processor	Post-Processor
<b>CS495002</b> -CQZ 90 MHz 1080 MOPS  -DQZ 80 MHz 960 MOPS	Firmware Pack	Dolby Digital DTS-ES DTS96/24 MPEG SGEN PCM (2Fs) AAC	PLIIx DTS Neo:6 Downmix Cirrus Original Surround	Tone Control Parametric EQ Bass Manager Delay
	Unbundled Code		Circle Surround (1Fs) Tru-Surround XT (1Fs)	Auto Speaker Setup (IRC1)
<b>CS495102</b> <i>(Superset of CS495002)</i> -CQZ 110 MHz 1320 MOPS  -DQZ 90 Mhz 1080 MOPS	Firmware Pack	Dolby Digital DTS-ES DTS96/24 DTS-ES96/24 MPEG SGEN PCM (2Fs) AAC	PLIIx DTS Neo:6 Downmix Cirrus Original Multichannel Surround	Tone Control Parametric EQ Bass Manager Delay
	Unbundled Code		Tru-Surround XT Circle Surround	Automatic Room EQ (IRC2) Dolby Headphone Dolby Headphone 2 Dolby Virtual Speaker Dolby Virtual Speaker 2
<b>CS495202</b> <i>(Superset of CS495102)</i> -CQZ 120 MHz 1440 MOPS  -DQZ 100 Mhz 1200 MOPS	Firmware Pack	Dolby Digital DTS-ES DTS96/24 DTS-ES96/24 MPEG SGEN PCM AAC	PLIIx DTS Neo:6 Downmix Cirrus Original Multichannel Surround	Tone Control 11-Band PEQ Bass Manager Delay THX Select THX Select2 THX Ultra2
	Unbundled Code		Tru-Surround XT Circle Surround	Automatic Room EQ (IRC2) Dolby Headphone Dolby Headphone 2 Dolby Virtual Speaker Dolby Virtual Speaker 2

**Table 1. Device and Firmware Selection Guide**



## 4. Hardware Functional Description

### 4.1 DSP Core

The CS495xx is a dual-core DSP with separate X- and Y-data memory spaces, and a separate P-code memory space. Each core is a high-performance, 32-bit, user-programmable, fixed-point DSP that is capable of performing two memory access control (MAC) operations per clock cycle. Each core has eight 72-bit accumulators, four X- and four Y-data registers, and 12 index registers.

Both DSP cores are coupled to a flexible DMA engine. The DMA engine can move data between peripherals such as the DAI and DAO, external memory, or any DSP core memory, all without the intervention of the DSP. The DMA engine offloads data move instructions from the DSP core, leaving more MIPS available for signal processing instructions.

The DSP obtains its functionality from application codes that are downloaded to the CS495xx and are provided through the Cirrus Logic Crystal Ware™ Software Licensing Program.

Both DSP cores are user-programmable in order to offer the customer the ability to implement unique post-processing algorithms. Additionally, users can choose to download standard audio decoder and post-processing modules which are available through the Cirrus Logic Crystal Ware™ Software Licensing Program.

The CS495xx is suitable for AVR/Outboard Decoder, DVD Audio/Video Player, and Digital Broadcast applications.

#### 4.1.1 DSP Memory

Each DSP core has its own on-chip data and program memory and does not require external memory for any of today's popular audio algorithms including Dolby Digital Surround EX, AAC Multichannel, DTS-ES 96/24, and THX Ultra2 Cinema.

The memory maps for the DSPs are as follows. All memory sizes are composed of 32-bit words.

Memory Type	DSP A	DSP B
X	16k SRAM, 32k ROM	8k SRAM, 8k ROM
Y	16k SRAM, 32k ROM	16k SRAM, 8k ROM
P	8k SRAM, 32k ROM	8k SRAM, 8k ROM

Table 2. DSP Memory Sizes

#### 4.1.2 DMA Controller

The powerful 12-channel DMA controller can move data between 8 on-chip resources. Each resource has its own arbiter: X-, Y-, and P-RAMs on DSP A; X-, Y-, P-RAMs on DSP B; external memory; and the peripheral bus. Modulo and linear addressing modes are supported, with flexible start address and increment controls. The service interval for each DMA channel as well as up to 6 interrupt events, is programmable.

## 4.2 On-chip DSP Peripherals

### 4.2.1 Digital Audio Input Port (DAI)

The 10-channel DAI port supports a wide variety of data input formats. The port is capable of accepting PCM or IEC61937. Up to 32-bit PCM and 16-bit compressed data input word lengths are supported. The port has two independent slave-only clock domains, each data input can be independently assigned to a clock domain. The sample rate of the input clock domains can be determined automatically by the DSP, eliminating the host from the task of monitoring the SPDIF receiver. A special channel status word function separates IEC channel status data from PCM data and places it into a separate data buffer for analysis by the DSP. A time-stamping feature allows the input data to be sample-rate converted via software.

### 4.2.2 Digital Audio Output Port (DAO)

There are two DAO ports, each port can output 8 channels of up to 32-bit PCM data. The port supports data rates from 32kHz to 192kHz. Each port can be configured as an independent clock domain in slave mode, or the ratio of the two clocks can be set to even multiples of each other in master mode. The two ports can be ganged together into a single clock domain. Each port has a 192kHz SPDIF transmitter that can be used instead of a PCM output.

### 4.2.3 Serial Control Port 1 & 2 (I<sup>2</sup>C or SPI)

There are two on-chip serial control ports that are capable of operating in master or slave mode in either I<sup>2</sup>C or SPI modes. Serial control port 2 shares pins with the parallel control port.

### 4.2.4 Parallel Control Port

The CS495xx parallel port can be used for either parallel control (Motorola<sup>®</sup>, Intel<sup>®</sup>, or multiplexed Intel modes). The parallel port pins are muxed with serial control port 2.

### 4.2.5 External Memory Interface

The external memory interface controller supports up to 128 Mbit of SDRAM, using a 16-bit data bus. The memory controller supports up to 1MB of SRAM and 1MB of FLASH memory in either 8-bit or 16-bit bus widths.

### 4.2.6 GPIO

The CS495xx has 42 GPIO pins multiplexed with other peripheral functions. Each GPIO can be configured as an output, an input, or an input with interrupt. Each input-pin interrupt can be configured as rising edge, falling edge, active-low, or active-high.

### 4.2.7 Channel Status Word (CSW)

The Channel Status Word peripheral extracts SPDIF IEC data and stores it in the CS495xx's internal memory for use by application code. The CSW operates in two modes: 1. extracting data from a DAI channel that is connected to a SPDIF receiver such as the Cirrus Logic CS8416 configured in IEC format mode (IEC data embedded in the I<sup>2</sup>S stream); or 2. capturing IEC data output from a SPDIF receiver on discrete data, clock, and frame clock pins. The CSW has two data input pins to capture two simultaneous synchronous data streams (U and C).

### 4.2.8 PLL-based Clock Generator

The PLL-based clock generator provides clock generation and system synchronization for the device. The low-jitter PLL generates integer multiples of a reference frequency which are used to clock the DSP core and peripherals. A second, dependent clock domain can be output on the DAO port for driving Delta-Sigma audio converters. The CS495xx is clocked from the external reference frequency until the



PLL is configured and locked, at which time the clocks can be switched. A built-in crystal oscillator circuit with dedicated, buffered output pin is provided to eliminate an external crystal oscillator.

### 4.3 DSP I/O Description

#### 4.3.1 Multiplexed Pins

The CS495xx incorporates a large amount of flexibility into a 144-pin package. The pins are internally multiplexed to serve multiple purposes. Some pins are designed to operate in one mode at power up, and serve a different purpose when the DSP is running. Other pins have functionality which can be controlled by the application running on the DSP. In order to better explain the behavior of the part, the pins which are multiplexed have been given multiple names. Each name is specific to the pin's operation in a particular mode.

#### 4.3.2 Termination Requirements

The CS495xx incorporates open-drain pins which must be pulled high for proper operation. PCP\_IRQ# and SCP\_IRQ# are always open drain which requires a pull-up for proper operation. The SCP\_SDA and SCP\_CLK lines are open drain in I<sup>2</sup>C communication mode.

The specific termination requirements may vary since the state of some of the GPIO pins will determine the communication mode at the rising edge of Reset. For the explicit termination requirements of each communication mode please see the *Typical Connection* diagrams in the *CS495xx Hardware User's Manual*.

Generally a 3.3 k $\Omega$  resistor is recommended for open-drain and mode-select pins. A 10 k $\Omega$  resistor is sufficient for all other unused inputs.

#### 4.3.3 Pads

The CS495xx has two different I/O voltage levels. All signal pins operate from the 3.3 V supply and are 5 V-tolerant.

### 4.4 Application Code Security

The external program code is encrypted by the programmer to protect any intellectual property it may contain. A secret, customer-specific key is used to encrypt the program code that is to be stored external to the device.



CS495xx Data Sheet  
32-bit Audio Decoder DSP Family

7. Package Pinout, 144-Pin QFP/LQFP

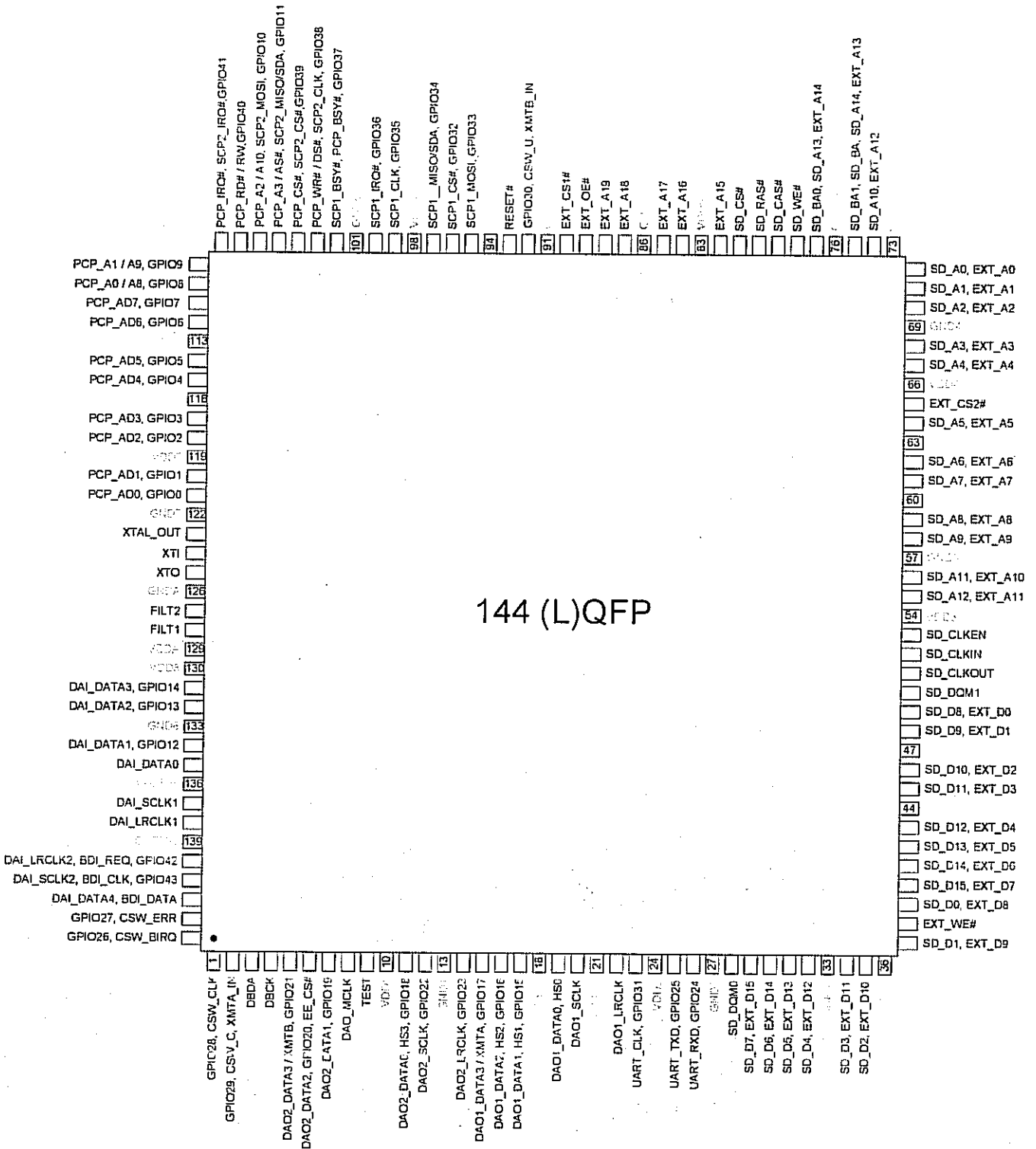


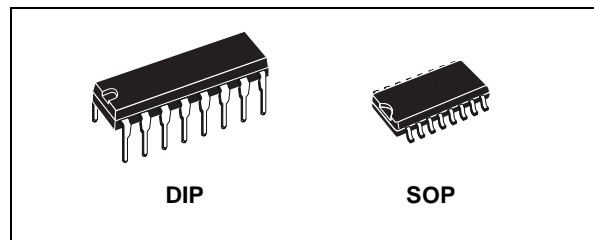
Figure 23. 144-Pin (L)QFP Package Pinout



# HCF4053B

## TRIPLE 2-CHANNEL ANALOG MULTIPLEXER/DEMULTIPLEXER

- LOW "ON" RESISTANCE : 125Ω (Typ.) OVER 15V p.p SIGNAL-INPUT RANGE FOR  $V_{DD} - V_{EE} = 15V$
- HIGH "OFF" RESISTANCE : CHANNEL LEAKAGE  $\pm 100pA$  (Typ.) at  $V_{DD} - V_{EE} = 18V$
- BINARY ADDRESS DECODING ON CHIP
- HIGH DEGREE OF LINEARITY :  $< 0.5\%$  DISTORTION TYP. at  $f_{IS} = 1KHz, V_{IS} = 5 V_{pp}, V_{DD} - V_{SS} \geq 10V, R_L = 10K\Omega$
- VERY LOW QUIESCENT POWER DISSIPATION UNDER ALL DIGITAL CONTROL INPUT AND SUPPLY CONDITIONS : 0.2  $\mu W$  (Typ.) at  $V_{DD} - V_{SS} = V_{DD} - V_{EE} = 10V$
- MATCHED SWITCH CHARACTERISTICS :  $R_{ON} = 5\Omega$  (Typ.) FOR  $V_{DD} - V_{EE} = 15V$
- WIDE RANGE OF DIGITAL AND ANALOG SIGNAL LEVELS : DIGITAL 3 to 20, ANALOG TO 20V p.p.
- QUIESCENT CURRENT SPECIF. UP TO 20V
- 5V, 10V AND 15V PARAMETRIC RATINGS
- INPUT LEAKAGE CURRENT  $I_I = 100nA$  (MAX) AT  $V_{DD} = 18V T_A = 25^\circ C$
- 100% TESTED FOR QUIESCENT CURRENT
- MEETS ALL REQUIREMENTS OF JEDEC JESD13B " STANDARD SPECIFICATIONS FOR DESCRIPTION OF B SERIES CMOS DEVICES"



### ORDER CODES

PACKAGE	TUBE	T & R
DIP	HCF4053BEY	
SOP	HCF4053BM1	HCF4053M013TR

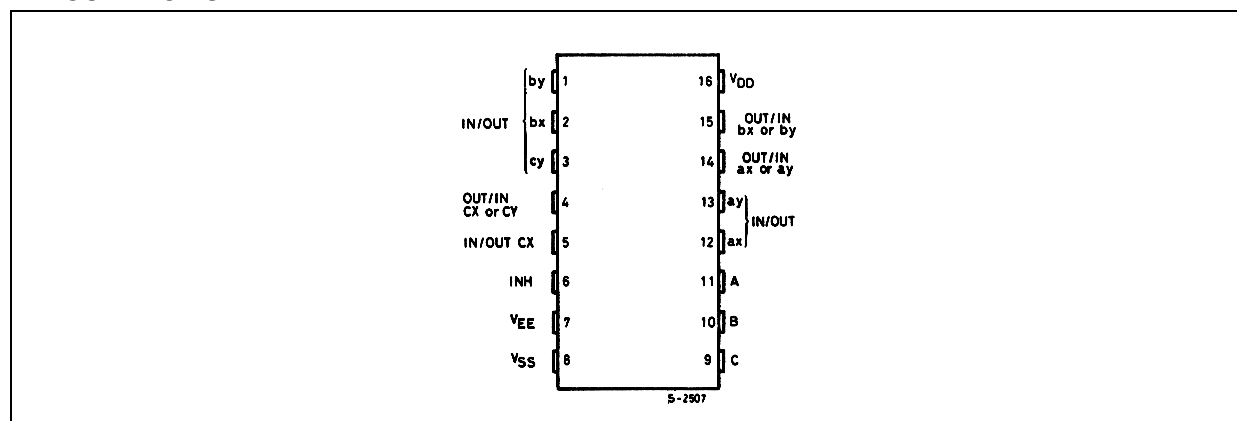
technology available in DIP and SOP packages. The HCF4053B analog multiplexer/demultiplexer is a digitally controlled analog switch having low ON impedance and very low OFF leakage current. This multiplexer circuit dissipate extremely low quiescent power over the full  $V_{DD} - V_{SS}$  and  $V_{DD} - V_{EE}$  supply voltage range, independent of the logic state of the control signals.

When a logic "1" is present at the inhibit input terminal all channel are off. This device is a triple 2-channel multiplexer having three separate digital control inputs, A, B, and C, and an inhibit input. Each control input selects one of a pair of channels which are connected in a single pole double-throw configuration.

### DESCRIPTION

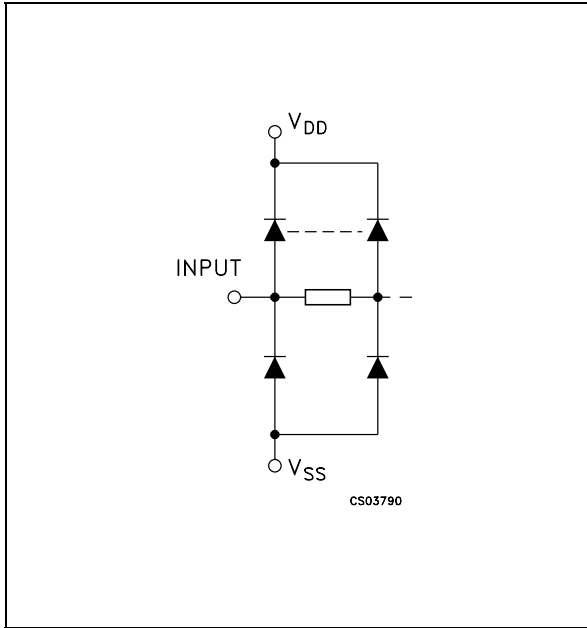
The HCF4053B is a monolithic integrated circuit fabricated in Metal Oxide Semiconductor

### PIN CONNECTION



# HCF4053B

## INPUT EQUIVALENT CIRCUIT



## PIN DESCRIPTION

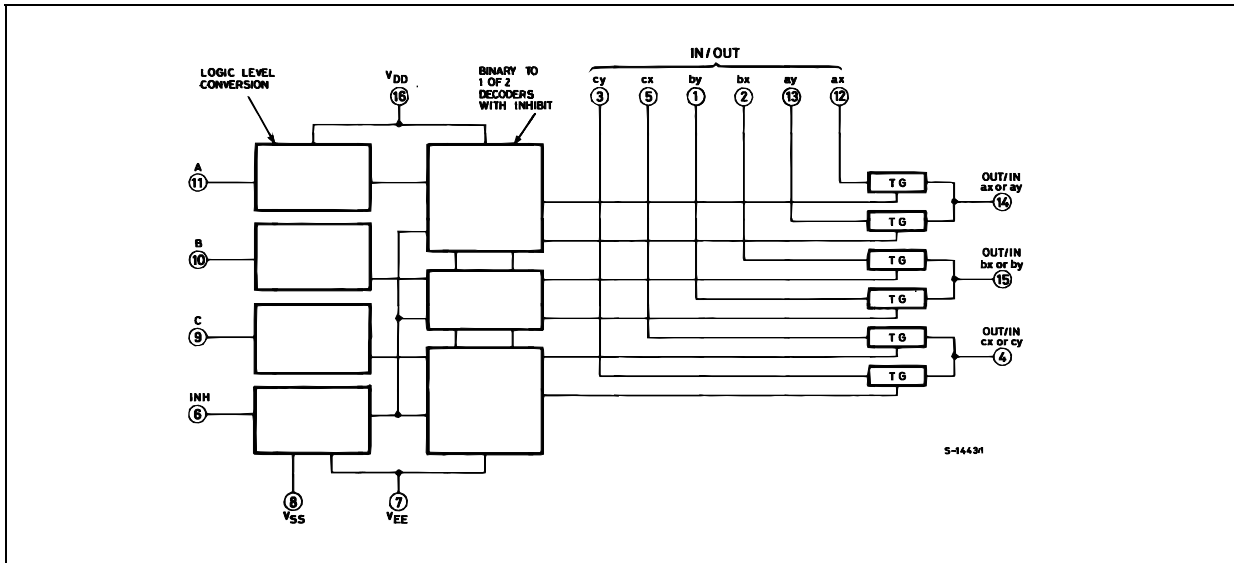
PIN No	SYMBOL	NAME AND FUNCTION
11, 10, 9	A, B, C	Binary Control Inputs
6	INH	Inhibit Inputs
12, 13, 2, 1, 5, 3	IN/OUT	$a_x, a_y, b_x, b_y, c_x, c_y$ Input/Output
14	OUT/IN	$a_x$ or $a_y$
15	OUT/IN	$b_x$ or $b_y$
4	OUT/IN	$c_x$ or $c_y$
7	$V_{EE}$	Supply Voltage
8	$V_{SS}$	Negative Supply Voltage
16	$V_{DD}$	Positive Supply Voltage

## TRUTH TABLE

INHIBIT	C or B or A	
0	0	$a_x$ or $b_x$ or $c_x$
0	1	$a_y$ or $b_y$ or $c_y$
1	X	NONE

X : Don't Care

## FUNCTIONAL DIAGRAM







# L7800 SERIES

## POSITIVE VOLTAGE REGULATORS

- OUTPUT CURRENT TO 1.5A
- OUTPUT VOLTAGES OF 5; 5.2; 6; 8; 8.5; 9; 10; 12; 15; 18; 24V
- THERMAL OVERLOAD PROTECTION
- SHORT CIRCUIT PROTECTION
- OUTPUT TRANSITION SOA PROTECTION

### DESCRIPTION

The L7800 series of three-terminal positive regulators is available in TO-220, TO-220FP, TO-220FM, TO-3 and D<sup>2</sup>PAK packages and several fixed output voltages, making it useful in a wide range of applications. These regulators can provide local on-card regulation, eliminating the distribution problems associated with single point regulation. Each type employs internal current limiting, thermal shut-down and safe area protection, making it essentially indestructible. If adequate heat sinking is provided, they can deliver over 1A output current. Although designed primarily as fixed voltage regulators, these devices can be used with external components to obtain adjustable voltage and currents.

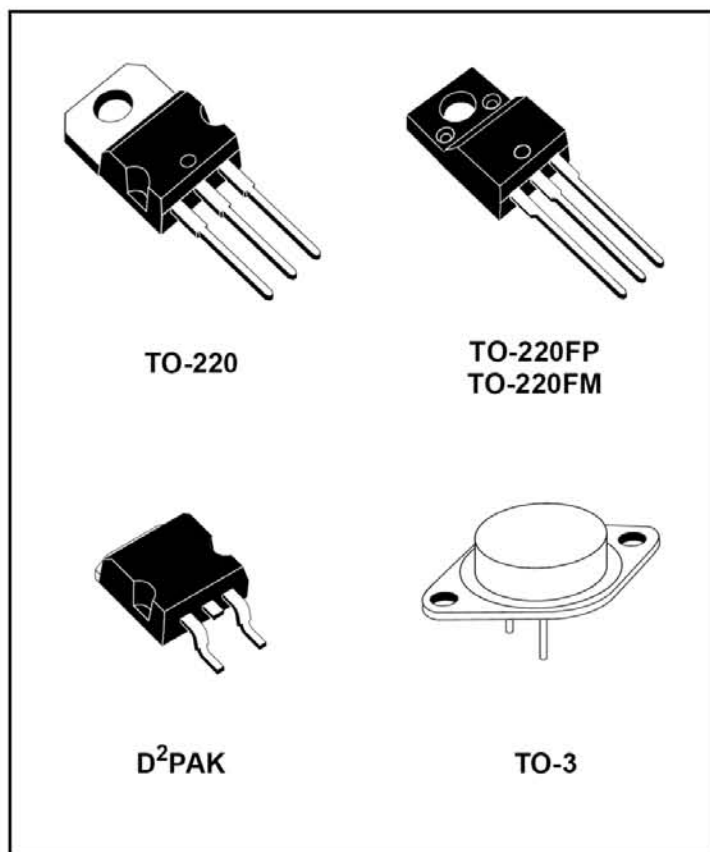
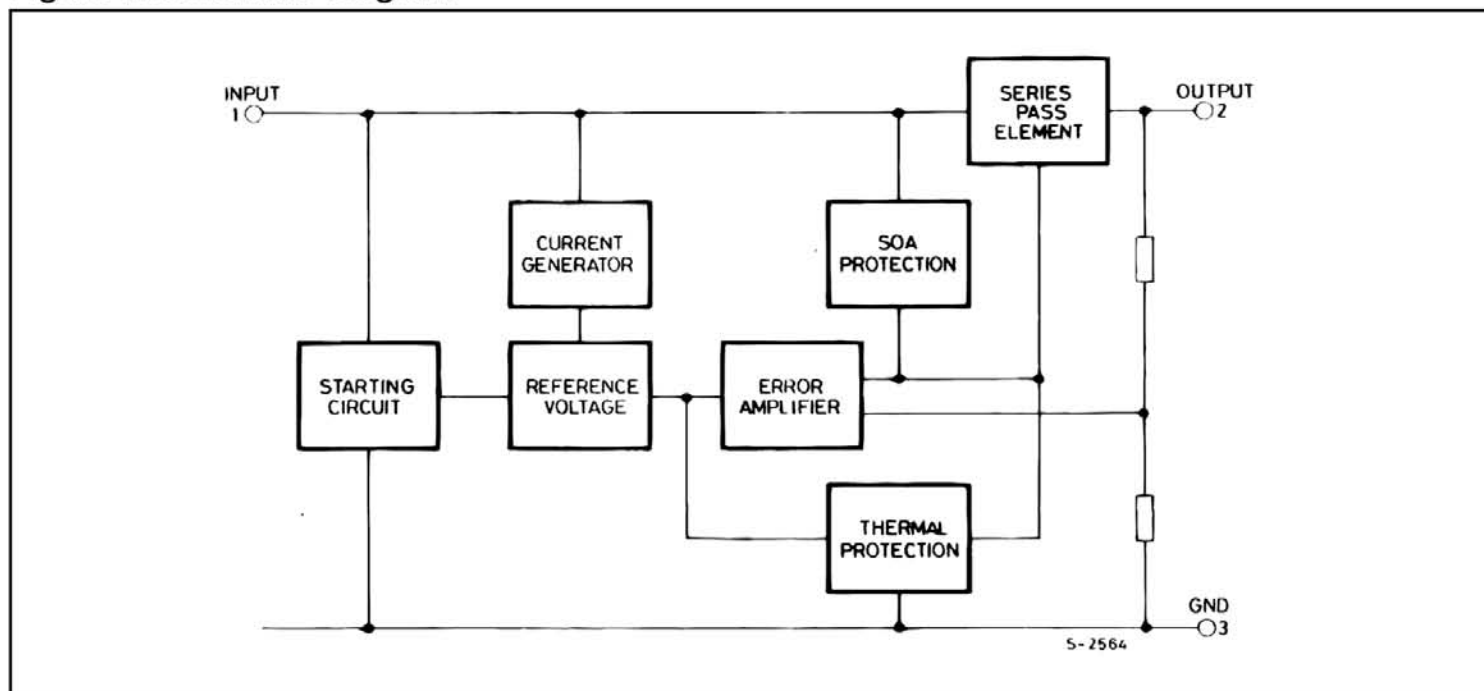


Figure 1: Schematic Diagram







# ANODE CONNECTION



	COM1	COM2	COM3	~	COM16	COM17	COM18
	1G	2G	3G	~	16G	17G	18G
SEGB 1	<input type="checkbox"/> (DIGITAL EX)	<input type="checkbox"/> (LOGIC 7)	1	1	1	B1	<input type="checkbox"/> (VID 1)
SEGB 2			2	2	2	B2	VID 1
SEGB 3			3	3	3	L	<input type="checkbox"/> (DVD 12)
SEGB 4			4	4	4	B3	DVD
SEGB 5			5	5	5	B4	1
SEGB 6	<input checked="" type="checkbox"/> DIGITAL	<input checked="" type="checkbox"/> LOGIC 7	6	6	6	B5	2
SEGB 7			7	7	7	C	<input type="checkbox"/> (VID 2)
SEGB 8			8	8	8	B6	VID 2
SEGB 9			9	9	9	B7	<input type="checkbox"/> (CD)
SEGB 10			10	10	10	B8	CD
SEGB 11	EX	<input type="checkbox"/> (VMax)	11	11	11	R	<input type="checkbox"/> (VID 3)
SEGB 12			12	12	12	B9	VID 3
SEGB 13			13	13	13	B10	<input type="checkbox"/> (FM AM)
SEGB 14			14	14	14	LFE	FM
SEGB 15			15	15	15	B11	AM
SEGB 16	<input type="checkbox"/> (PRO LOGIC)	VMax	16	16	16	B12	<input type="checkbox"/> (VID 4)
SEGB 17			17	17	17	SL	VID 4
SEGB 18			18	18	18	B13	<input type="checkbox"/> (TAPE)
SEGB 19			19	19	19	⊙	TAPE
SEGB 20			20	20	20	B14	<input type="checkbox"/> (VID 5)
SEGB 21	<input checked="" type="checkbox"/> PRO LOGIC	<input type="checkbox"/> (DSP)	21	21	21	B15	VID 5
SEGB 22			22	22	22	SR	<input type="checkbox"/> (88CH)
SEGB 23			23	23	23	B16	6
SEGB 24			24	24	24	B17	8
SEGB 25			25	25	25	B18	CH
SEGB 26	I	DSP	26	26	26	SBL	
SEGB 27			27	27	27	B19	
SEGB 28			28	28	28	—	
SEGB 29			29	29	29	B20	
SEGB 30			30	30	30	B21	
SEGB 31	<input type="checkbox"/> (3 STEREO)	<input type="checkbox"/> (57CH.)	31	31	31	SBR	
SEGB 32			32	32	32	B22	
SEGB 33			33	33	33		
SEGB 34			34	34	34		
SEGB 35			35	35	35		

	COM1	COM2	COM3	~	COM16	COM17	COM18
	1G	2G	3G	~	16G	17G	18G
SEGA 1	<input checked="" type="checkbox"/>	5	36	36	36		
SEGA 2			37	37	37		
SEGA 3			38	38	38		
SEGA 4			39	39	39		
SEGA 5			40	40	40		
SEGA 6	3	7	41	41	41		
SEGA 7			42	42	42		
SEGA 8			43	43	43		
SEGA 9			44	44	44		
SEGA 10			45	45	45		
SEGA 11	STEREO	CH. STEREO	46	46	46		
SEGA 12			47	47	47		
SEGA 13			48	48	48		
SEGA 14			49	49	49		
SEGA 15			50	50	50		
SEGA 16	<input type="checkbox"/> (HEADPHONE)	<input type="checkbox"/> (SURR.OFF)	51	51	51		
SEGA 17			52	52	52		
SEGA 18			53	53	53		
SEGA 19			54	54	54		
SEGA 20			55	55	55		
SEGA 21	<input checked="" type="checkbox"/> HEADPHONE	SURR. OFF	56	56	56		
SEGA 22			57	57	57		
SEGA 23			58	58	58		
SEGA 24			59	59	59		
SEGA 25			60	60	60		
SEGA 26	<input type="checkbox"/> (DTS,ES)		61	61	61		
SEGA 27			62	62	62		
SEGA 28			63	63	63		
SEGA 29			64	64	64		
SEGA 30			65	65	65		
SEGA 31	<input checked="" type="checkbox"/>		66	66	66		
SEGA 32			67	67	67		
SEGA 33			68	68	68		
SEGA 34			69	69	69		
SEGA 35	<input checked="" type="checkbox"/>		70	70	70		

MODEL : HCA-18LM03  
 ANODE CONNECTION  
 Rev. ① 20-Jan-2005

## CMOS 16-Bit Microcontrollers T5CC1

### 1. Outline and Features

T5CC1 is a high-speed 16-bit microcontroller designed for the control of various mid- to large-scale equipment.

T5CC1 comes in a 100-pin flat package.

Listed below are the features.

- (1) High-speed 16-bit CPU (900/L1 CPU)
  - Instruction mnemonics are upward-compatible with TLCS-90/900
  - General-purpose registers and register banks
  - 16 Mbytes of linear address space
  - 16-bit multiplication and division instructions; bit transfer and arithmetic instructions
  - Micro DMA: 4-channels (593 ns/2 bytes at 27 MHz)
- (2) Minimum instruction execution time: 148 ns (at 27 MHz)
- (3) Built-in RAM: 16 Kbytes  
Built-in ROM: 256 Kbytes Flash memory  
4 Kbytes mask ROM (used for booting)

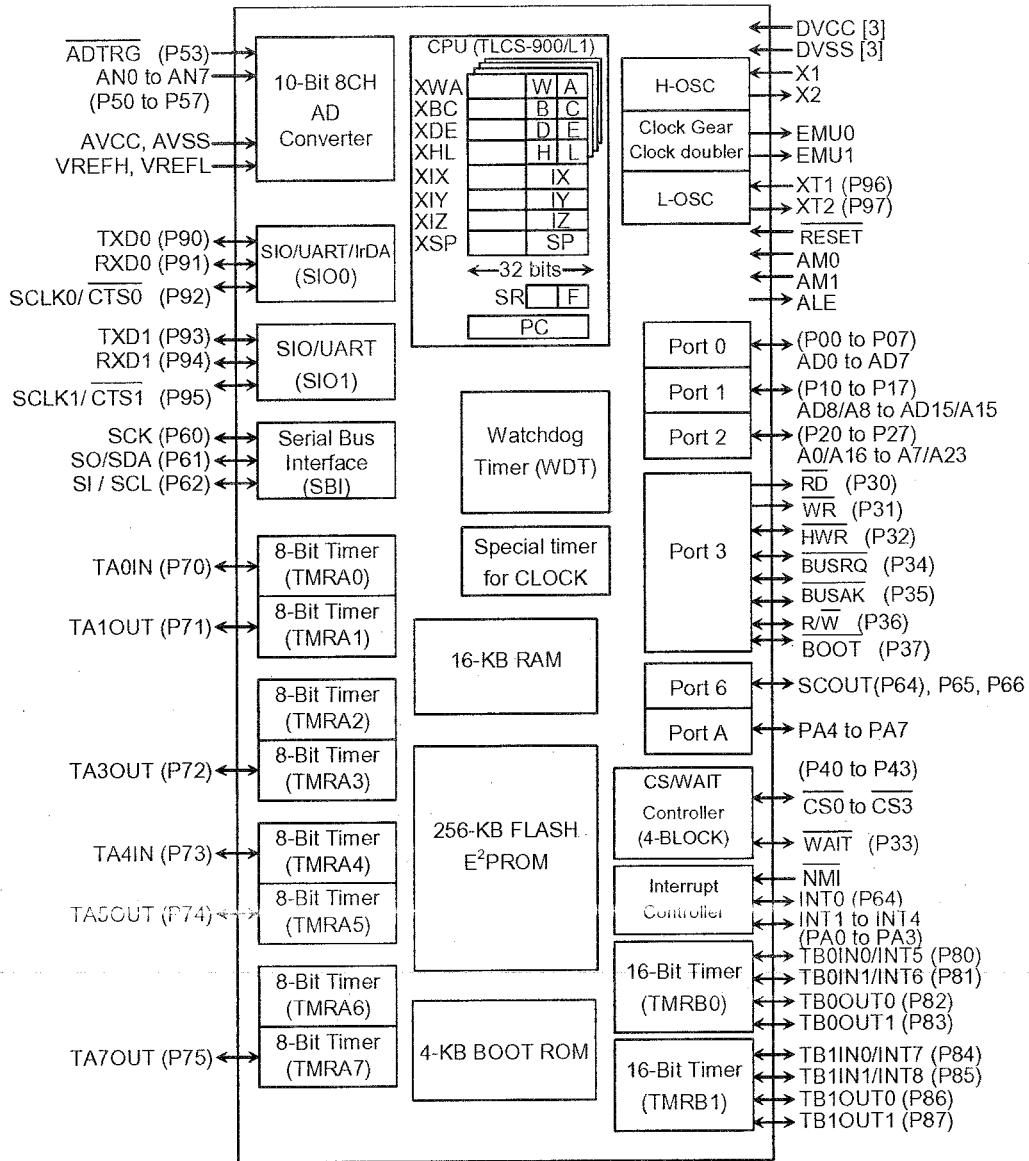
**TOSHIBA****T5CC1**

- (4) External memory expansion
  - Expandable up to 16 Mbytes (shared program/data area)
  - Can simultaneously support 8-/16-bit width external data bus
    - … Dynamic data bus sizing
- (5) 8-bit timers: 8 channels
- (6) 16-bit timer/event counter: 2 channels
- (7) General-purpose serial interface: 2 channels
  - UART/ Synchronous mode: 2 channels
  - IrDA ver1.0 (115.2 kbps) supported: 1 channel
- (8) Serial bus interface: 1 channel
  - I<sup>2</sup>C bus mode/clock synchronous Select mode
- (9) 10-bit AD converter (built-in sample hold circuit) : 8 channels
- (10) Watchdog timer
- (11) Special timer for clock
- (12) Chip Select/Wait controller: 4 channels
- (13) Interrupts: 45 interrupts
  - 9 CPU interrupts: Software interrupt instruction and illegal instruction
  - 26 internal interrupts: ]
  - 10 external interrupts: ] Seven selectable priority levels
- (14) Input/Output ports: 81 pins
- (15) Standby function
  - Three HALT modes: IDLE2 (programmable), IDLE1, STOP
- (16) Clock controller
  - Clock Gear function: Select a high-frequency clock ( $f_c$  to  $f_c/16$ )
  - Special timer for CLOCK ( $f_s = 32.768$  kHz)
- (17) Operating voltage
  - $V_{CC} = 2.7$  V to 3.6 V ( $f_c$  max = 27 MHz, flash memory read operation)
  - $V_{CC} = 3.0$  V to 3.6 V ( $f_c$  max = 27 MHz, flash memory erase/program operations)
- (18) Package
  - 100-pin LQFP: LQFP100-P-1414-0.50F

Note: This LSI does not build in Clock doubler (DFM.)

**TOSHIBA**

**T5CC1**



( ): Initial function after reset

Figure 1.1 T5CC1 Block Diagram

## 2. Pin Assignment and Pin Functions

The assignment of input/output pins for the T5CC1, their names and functions are as follows:

### 2.1 Pin Assignment Diagram

Figure 2.1.1 shows the pin assignment of the T5CC1.

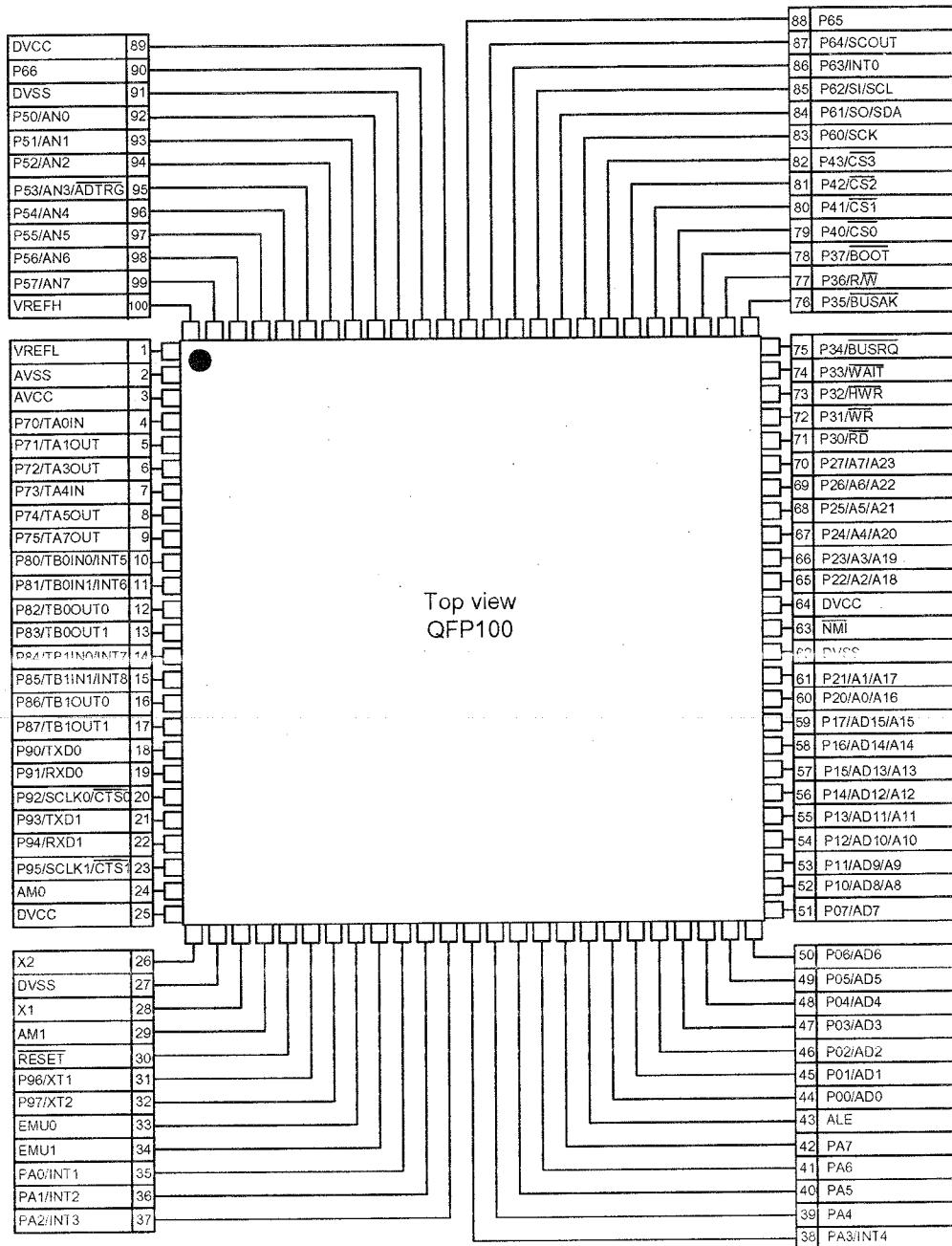


Figure 2.1.1 Pin assignment diagram (100-pin LQFP)



TOSHIBA

T5CC1

## 2.2 Pin Names and Functions

The names of the input/output pins and their functions are described below.

Table 2.2.1 Pin names and functions.

Table 2.2.1 Pin names and functions (1/3)

Pin Name	Number of Pins	I/O	Functions
P00~P07 AD0~AD7	8	I/O I/O	Port 0: I/O port that allows I/O to be selected at the bit level Address and data (lower): Bits 0 to 7 of address and data bus
P10~P17 AD8~AD15 A8~A15	8	I/O I/O Output	Port 1: I/O port that allows I/O to be selected at the bit level Address and data (upper): Bits 8 to 15 for address and data bus Address: Bits 8 to 15 of address bus
P20~P27 A0~A7 A16~A23	8	I/O Output Output	Port 2: I/O port that allows I/O to be selected at the bit level Address: Bits 0 to 7 of address bus Address: Bits 16 to 23 of address bus
P30 $\overline{RD}$	1	Output Output	Port 30: Output port Read: Strobe signal for reading external memory This port output RD signal also case of reading internal-area by setting P3 <P30> = 0 and P3FC <P30F> = 1.
P31 $\overline{WR}$	1	Output Output	Port 31: Output port Write: Strobe signal for writing data to pins AD0 to AD7
P32 $\overline{HWR}$	1	I/O Output	Port 32: I/O port (with pull-up resistor) High Write: Strobe signal for writing data to pins AD8 to AD15
P33 $\overline{WAIT}$	1	I/O Input	Port 33: I/O port (with pull-up resistor) Wait: Pin used to request CPU bus wait ((1+N) WAIT mode)
P34 BUSRQ	1	I/O Input	Port 34: I/O port (with pull-up resistor) Bus Request: Signal used to request Bus Release
P35 $\overline{BUSAk}$	1	I/O Output	Port 35: I/O port (with pull-up resistor) Bus Acknowledge: Signal used to acknowledge Bus Release
P36 R/W	1	I/O Output	Port 36: I/O port (with pull-up resistor) Read/Write: 1 represents Read or Dummy cycle; 0 represents Write cycle.
P37 BOOT	1	I/O Input	Port 36: I/O port (with pull-up resistor) This pin sets single boot mode. When released reset, Single boot mode is started at P37 = Low level.
P40 $\overline{CS0}$	1	I/O Output	Port 40: I/O port (with pull-up resistor) Chip Select 0: Outputs 0 when address is within specified address area
P41 $\overline{CS1}$	1	I/O Output	Port 41: I/O port (with pull-up resistor) Chip Select 1: Outputs 0 if address is within specified address area
P42 $\overline{CS2}$	1	I/O Output	Port 42: I/O port (with pull-up resistor) Chip Select 2: Outputs 0 if address is within specified address area
P43 $\overline{CS3}$	1	I/O Output	Port 43: I/O port (with pull-up resistor) Chip Select 3: Outputs 0 if address is within specified address area
P50~P57 AN0~AN7 ADTRG	8	Input Input Input	Port 5: Pin used to input port Analog input: Pin used to input to AD converter AD Trigger: Signal used to request start of AD converter (Shared with 53 pin)

TOSHIBA

T5CC1

Table 2.2.1 Pin names and functions (2/3)

Pin Name	Number of Pins	I/O	Functions
P60 SCK	1	I/O I/O	Port 60: I/O port Serial bus interface clock in SIO Mode
P61 SO SDA	1	I/O Output I/O	Port 61: I/O port Serial bus interface send data at SIO mode Serial bus interface send/recv data at I <sup>2</sup> C bus mode Open-drain output mode by programmable
P62 SI SCL	1	I/O Input I/O	Port 62: I/O port Serial bus interface receive data at SIO mode Serial bus interface clock I/O data at I <sup>2</sup> C bus mode Open-drain output mode by programmable
P63 INT0	1	I/O Input	Port 63: I/O port Interrupt Request Pin 0: Interrupt request pin with programmable level / rising edge / falling edge
P64 SCOUT	1	I/O Output	Port 64: I/O port System Clock Output: Outputs f <sub>FPH</sub> or fs clock.
P65	1	I/O	Port 65 I/O port
P66	1	I/O	Port 66 I/O port
P70 TA0IN	1	I/O Input	Port 70 I/O port 8-bit timer 0 input: Timer 0 input
P71 TA1OUT	1	I/O Output	Port 71 I/O port 8-bit timer 1 output: Timer 0 or Timer 1 output
P72 TA3OUT	1	I/O Output	Port 72 I/O port 8-bit 8-bit timer 3 output: Timer 2 or Timer 3 output
P73 TA4IN	1	I/O Input	Port 73: I/O port 8-bit timer 4 input: Timer 4 input
P74 TA5OUT	1	I/O Output	Port 74: I/O port 8-bit timer 5 output: Timer 4 or Timer 5 output
P75 TA7OUT	1	I/O Output	Port 75: I/O port 8-bit timer 7 output: Timer 6 or Timer 7 output
P80 TB0IN0 INT5	1	I/O Input Input	Port 80: I/O port 16-bit timer 0 input 0: 16-bit Timer 0 count / capture trigger input Interrupt Request Pin 5: Interrupt request pin with programmable rising edge / falling edge.
P81 TB0IN1 INT6	1	I/O Input Input	Port 81: I/O port 16-bit timer 0 input 1: 16-bit Timer 0 count / capture trigger input Interrupt Request Pin 6: Interrupt request on rising edge
P82 TB0OUT0	1	I/O Output	Port 82: I/O port 16-bit timer 0 output 0: 16-bit Timer 0 output
P83 TB0OUT1	1	I/O Output	Port 83: I/O port 16-bit timer 0 output 1: 16-bit Timer 0 output
P84 TB1IN0 INT7	1	I/O Input Input	Port 84: I/O port 16-bit timer 1 input 0: 16-bit Timer 1 count / capture trigger input Interrupt Request Pin 7: Interrupt request pin with programmable rising edge / falling edge.
P85 TB1IN1 INT8	1	I/O Input Input	Port 85: I/O port 16-bit timer 1 input 1: 16-bit Timer 1 count / capture trigger input Interrupt Request Pin 8: Interrupt request on rising edge
P86 TB1OUT0	1	I/O Output	Port 86: I/O port 16-bit timer 1 output 0: 16-bit Timer 1 output 16-bit
P87 TB1OUT1	1	I/O Output	Port 87: I/O port 16-bit timer 1 output 1: 16-bit Timer 1 output 16-bit

TOSHIBA

T5CC1

Table 2.2.1 Pin names and functions (3/3)

Pin Name	Number of Pins	I/O	Functions
P90 TXD0	1	I/O Output	Port 90: I/O port Serial Send Data 0 (programmable open-drain)
P91 RXD0	1	I/O Input	Port 91: I/O port Serial Receive Data 0
P92 SCLK0 <u>CTS0</u>	1	I/O I/O Input	Port 92: I/O port Serial Clock I/O 0 Serial Data Send Enable 0 (Clear to Send)
P93 TXD1	1	I/O Output	Port 93: I/O port Serial Send Data 1 (programmable open-drain)
P94 RXD1	1	I/O Input	Port 94: I/O port (with pull-up resistor) Serial Receive Data 1
P95 SCLK1 <u>CTS1</u>	1	I/O I/O Input	Port 95: I/O port (with pull-up resistor) Serial Clock I/O 1 Serial Data Send Enable 1 (Clear to Send)
P96 XT1	1	I/O Input	Port 96: I/O port (open-drain output) Low-frequency oscillator connection pin
P97 XT2	1	I/O Output	Port 97: I/O port (open-drain output) Low-frequency oscillator connection pin
PA0~PA3 INT1~INT4	4	I/O Input	Ports A0 to A3: I/O ports Interrupt Request Pins 1 to 4: Interrupt request pins with programmable rising edge / falling edge.
PA4~PA7 ALE	4 1	I/O Output	Ports A4 to A7: I/O ports Address Latch Enable Can be disabled to reduce noise.
<u>NMI</u>	1	Input	Non-Maskable Interrupt Request Pin: Interrupt request pin with programmable falling edge or both edge.
AM0~1	2	Input	Operation mode: Fixed to AM1 = 1, AM0 = 1
EMU0	1	Output	Open pin
EMU1	1	Output	Open pin
<u>RESET</u>	1	Input	Reset: initializes T5CC1. (With pull-up resistor)
VREFH	1	Input	Pin for reference voltage input to AD converter (H)
VREFL	1	Input	Pin for reference voltage input to AD converter (L)
AVCC	1		Power supply pin for AD converter
AVSS	1		GND pin for AD converter (0 V)
X1/X2	2	I/O	High-frequency oscillator connection pins
DVCC	3		Power supply pins (All DVCC pins should be connected with the power supply pin.)
DVSS	3		GND pins (0 V) (All DVSS pins should be connected with the power supply pin.)

Note: An external DMA controller cannot access the device's built-in memory or built-in I/O devices using the BUSRQ and BUSAK signal.

### 3. Operation

This following describes block by block the functions and operation of the T5CC1.

#### 3.1 CPU

The T5CC1 incorporates a high-performance 16-bit CPU (The 900/L1 CPU). For CPU operation, see the "TLCS-900/L1 CPU".

The following describe the unique function of the CPU used in the T5CC1; these functions are not covered in the TLCS-900/L1 CPU section.

##### 3.1.1 Reset

When resetting the T5CC1 microcontroller, ensure that the power supply voltage is within the operating voltage range, and that the internal high-frequency oscillator has stabilized. Then hold the  $\overline{\text{RESET}}$  input to low level for at least 10 system clocks (12 $\mu$ s at 27MHz).

Thus, when turn on the switch, be set to the power supply voltage is within the operating voltage range, and that the internal high-frequency oscillator has stabilized. Then hold the  $\overline{\text{RESET}}$  input to low level at least for 10 system clocks.

Clock gear is initialized 1/16 mode by reset operation. It means that the system clock mode  $f_{\text{SYS}}$  is set to  $f_c/32$  ( $= f_c/16 \times 1/2$ ).

When the reset is accept, the CPU:

- Sets as follows the program counter (PC) in accordance with the reset vector stored at address FFFF00H to FFFF02H:
  - PC<7:0> ← Value at FFFF00H address
  - PC<15:8> ← Value at FFFF01H address
  - PC<23:16> ← Value at FFFF02H address
- Sets the stack pointer (XSP) to 100H.
- Sets bits <IFF2:0> of the status register (SR) to 111 (Sets the interrupt level mark register to level 7).
- Sets the <MAX> bit of the status register to 1 (MAX mode).  
(Note: As this product does not support MIN mode, do not write a 0 to the <MAX>.)
- Clears bits <RFP2:0> of the status register to 000 (Sets the register bank to 0).

When reset is released, the CPU starts executing instructions in accordance with the program counter settings. CPU internal registers not mentioned above do not change when the reset is released.

When the reset is accepted, the CPU sets internal I/O, ports, and other pins as follows.

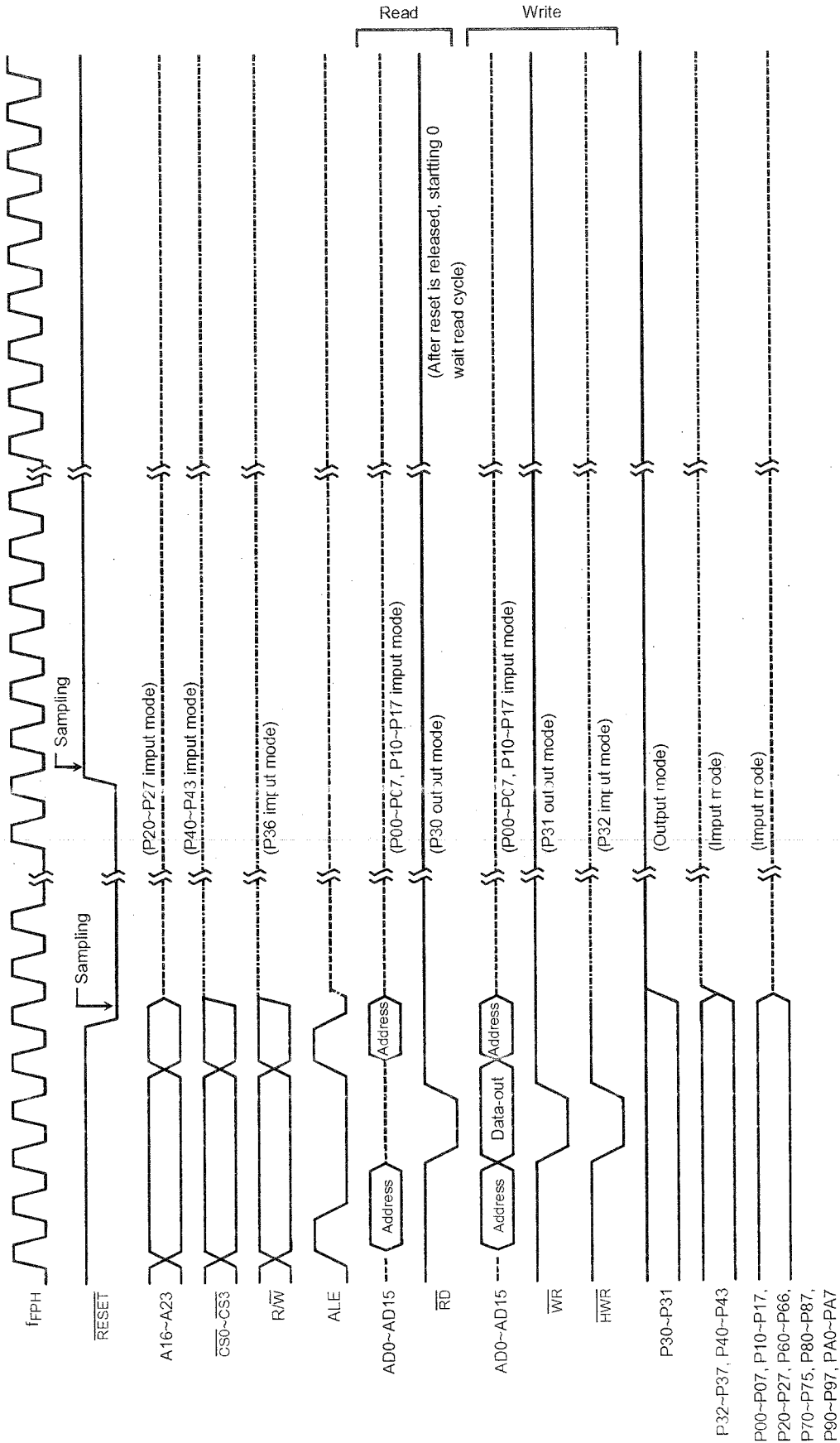
- Initializes the internal I/O registers.
- Sets the port pins, including the pins that also act as internal I/O, to general-purpose input or output port mode.
- Sets ALE pin to "High-Z"

Note: The CPU internal register (except to PC, SR, XSP) and internal RAM data do not change by resetting.

Figure 3.1.1 is a reset timing of the T5CC1.

**TOSHIBA**

T5CC1




### 3.1.2 Outline of Operation Modes

There are single-chip and single-boot modes. Which mode is selected depends on the device's pin state after a reset.

- Single-chip mode: The device normally operations in this mode. After a reset, the device starts executing the internal memory program.
- Single-boot mode: This mode is used to rewrite the internal flash memory by serial transfer (UART).  
After a reset, internal boot program starts up, executing an on-board rewrite program.

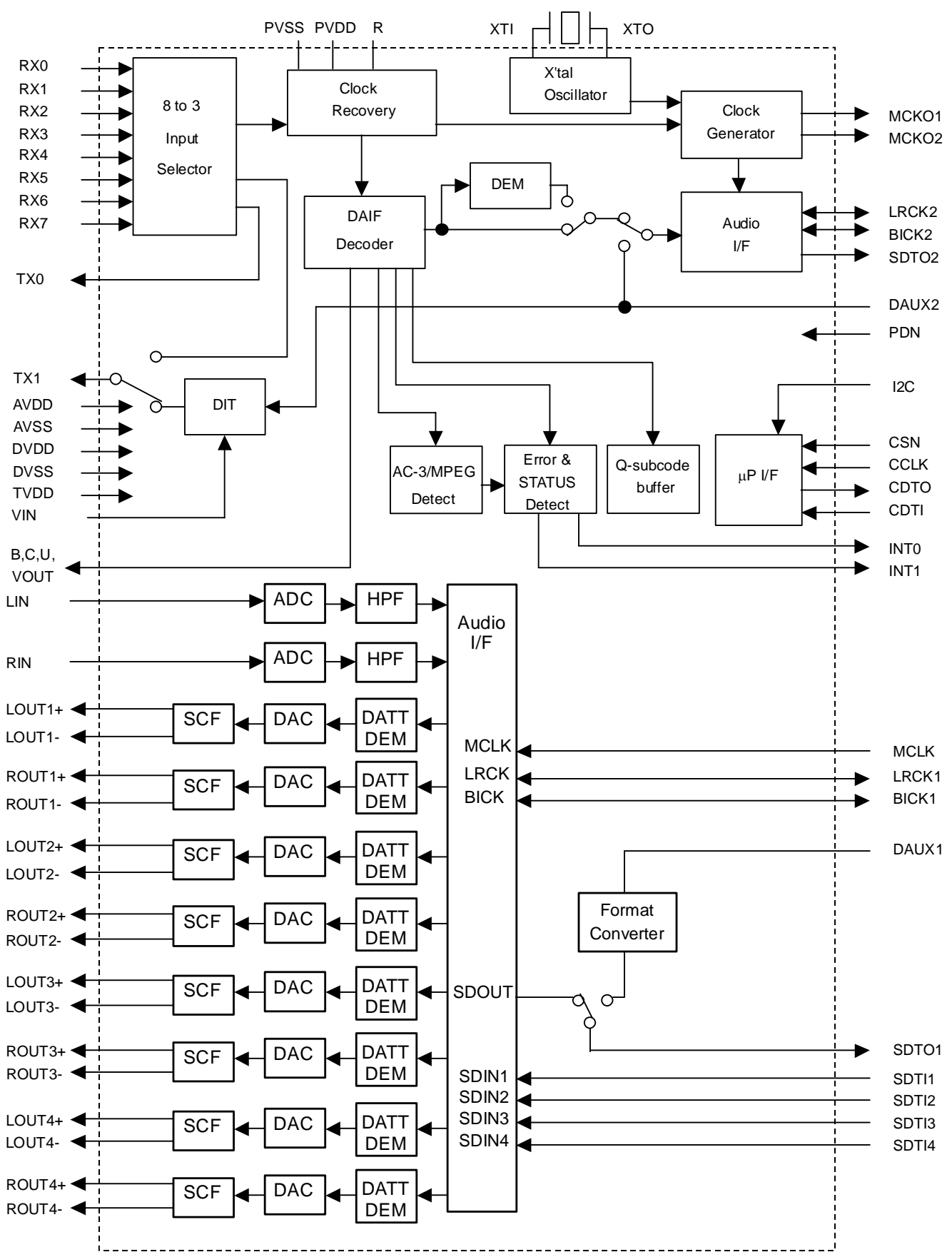
Table 3.1.1 Operation Mode Setup Table

Operation Mode	Mode Setup Input Pin			
	$\overline{\text{RESET}}$	$\overline{\text{BOOT}}$ (P37)	AM0	AM1
Single-chip mode		H	H	H
Single-boot mode		L		



# AK4589

## 2/8-Channel Audio CODEC with DIR



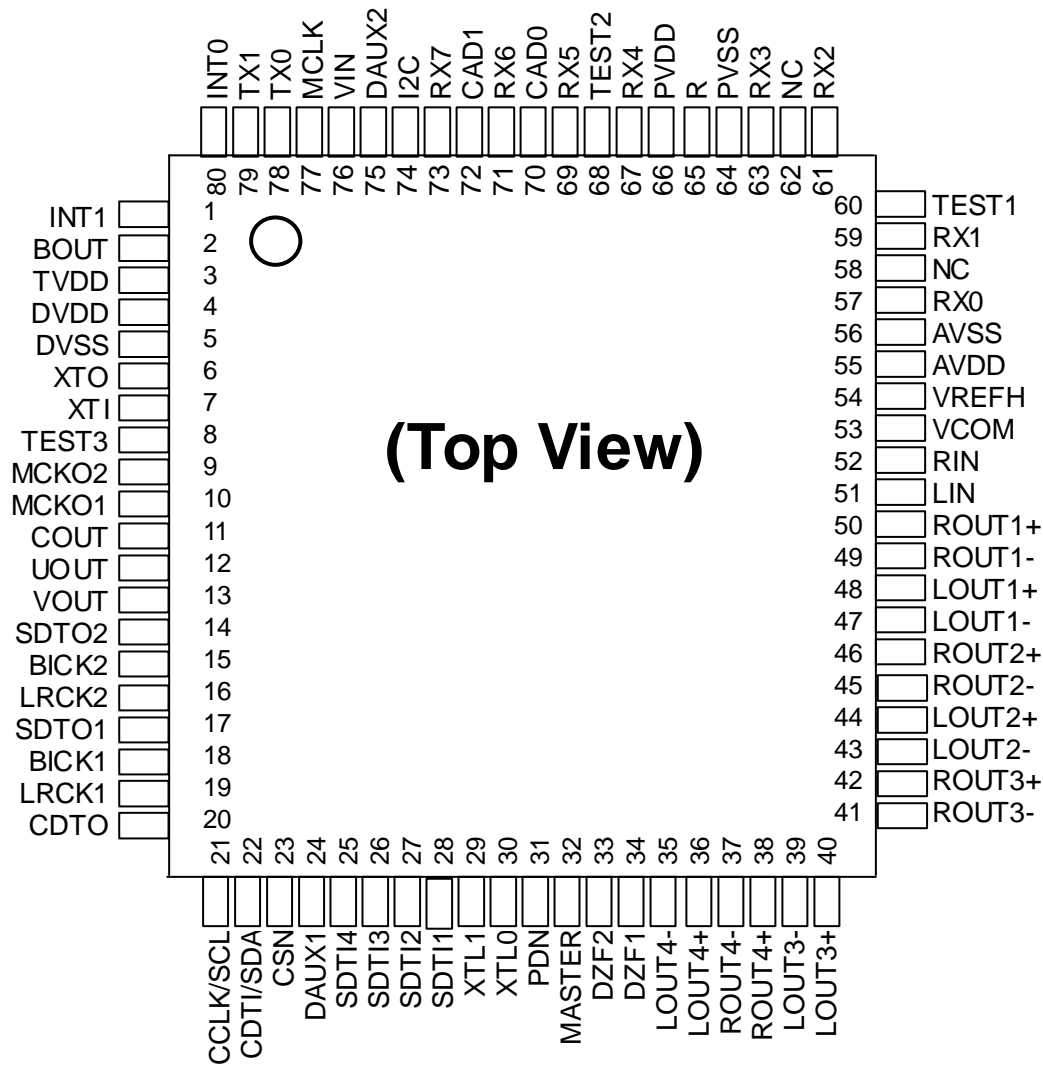
■ オーダリングガイド

AK4589VQ  
AKD4589

-10 ~ +70°C  
評価ボード

80pin LQFP(0.5mm pitch)

■ ピン配置





### ■ AK4588 との相違点

Functions	AK4588	AK4589
DAC 出力	シングルエンド	差動
DAC S/(N+D)	90dB	94dB
DAC S/N	106dB	114dB
DAC Output voltage	Typ 3.0Vpp	Typ $\pm 2.7$ Vpp
DAC AOUT	AOUT=0.6xVREFH	AOUT=0.54xVREFH
Load Resistance	5k ohm	2k ohm
Frequency Response 80kHz	$\pm 1.0$	+0/-0.6
アナログ出力ピン	#35, #37, #39, #41, #43, #45, #47, #49	#35 - #50
電源電圧	Min=4.5V, Max=5.5V	Min=4.75V, Max=5.25V

(注)AK4589 は内部に ADC/DAC 部レジスタ(AK4588 レジスタ互換)と DIR/DIT 部レジスタ(AK4588 レジスタ互換)の 2 つのレジスタをもちます。それぞれのレジスタはチップアドレスで指定します。

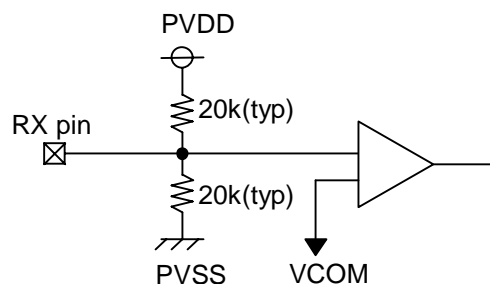
## ピン / 機能

No.	Pin Name	I/O	Function
1	INT1	O	Interrupt 1 Pin
2	BOUT	O	Block-Start Output Pin for Receiver Input “H” during first 40 flames.
3	TVDD	-	Output Buffer Power Supply Pin, 2.7V~5.25V
4	DVDD	-	Digital Power Supply Pin, 4.75V~5.25V
5	DVSS	-	Digital Ground Pin
6	XTO	O	X'tal Output Pin
7	XTI	I	X'tal Input Pin
8	TEST3	I	Test 3 Pin This pin should be connected to DVSS.
9	MCKO2	O	Master Clock Output 2 Pin
10	MCKO1	O	Master Clock Output 1 Pin
11	COUT	O	C-bit Output Pin for Receiver Input
12	UOUT	O	U-bit Output Pin for Receiver Input
13	VOUT	O	V-bit Output Pin for Receiver Input
14	SDTO2	O	Audio Serial Data Output Pin (DIR/DIT part)
15	BICK2	I/O	Audio Serial Data Clock Pin (DIR/DIT part)
16	LRCK2	I/O	Channel Clock Pin (DIR/DIT part)
17	SDTO1	O	Audio Serial Data Output Pin (ADC/DAC part)
18	BICK1	I/O	Audio Serial Data Clock Pin (ADC/DAC part)
19	LRCK1	I/O	Input Channel Clock Pin
20	CDTO	O	Control Data Output Pin in Serial Mode, I2C= “L”.
21	CCLK	I	Control Data Clock Pin in Serial Mode, I2C= “L”
	SCL	I	Control Data Clock Pin in Serial Mode, I2C= “H”
22	CDTI	I	Control Data Input Pin in Serial Mode, I2C= “L”.
	SDA	I/O	Control Data Pin in Serial Mode, I2C= “H”.
23	CSN	I	Chip Select Pin in Serial Mode, I2C= “L”.
		I	This pin should be connected to DVSS, I2C= “H”.
24	DAUX1	I	AUX Audio Serial Data Input Pin (ADC/DAC part)
25	SDTI4	I	DAC4 Audio Serial Data Input Pin
26	SDTI3	I	DAC3 Audio Serial Data Input Pin
27	SDTI2	I	DAC2 Audio Serial Data Input Pin
28	SDTI1	I	DAC1 Audio Serial Data Input Pin
29	XTL1	I	X'tal Frequency Select 0 Pin
30	XTL0	I	X'tal Frequency Select 1 Pin

No.	Pin Name	I/O	Function
31	PDN	I	Power-Down Mode Pin When “L”, the AK4589 is powered-down, all digital output pins go “L”, all registers are reset. When CAD1/0 pins are changed, the AK4589 should be reset by PDN pin.
32	MASTER	I	Master Mode Select Pin “H”: Master mode, “L”: Slave mode
33	DZF2	O	Zero Input Detect 2 Pin (Table 13) When the input data of the group 1 follow total 8192 LRCK cycles with “0” input data, this pin goes to “H”. And when RSTN bit is “0”, PWDAN bit is “0”, this pin goes to “H”. It always is in “L” when P/S pin is “H”.
	OVF	O	Analog Input Overflow Detect Pin This pin goes to “H” if the analog input of Lch or Rch overflows.
34	DZF1	O	Zero Input Detect 1 Pin (Table 13) When the input data of the group 1 follow total 8192 LRCK cycles with “0” input data, this pin goes to “H”. And when RSTN bit is “0”, PWDAN bit is “0”, this pin goes to “H”. Output is selected by setting DZFE pin when P/S pin is “H”.
35	LOUT4-	O	DAC4 Lch Negative Analog Output Pin
36	LOUT4+	O	DAC4 Lch Positive Analog Output Pin
37	ROUT4-	O	DAC4 Rch Negative Analog Output Pin
38	ROUT4+	O	DAC4 Rch Positive Analog Output Pin
39	LOUT3-	O	DAC3 Lch Negative Analog Output Pin
40	LOUT3+	O	DAC3 Lch Positive Analog Output Pin
41	ROUT3-	O	DAC3 Rch Negative Analog Output Pin
42	ROUT3+	O	DAC3 Rch Positive Analog Output Pin
43	LOUT2-	O	DAC2 Lch Negative Analog Output Pin
44	LOUT2+	O	DAC2 Lch Positive Analog Output Pin
45	ROUT2-	O	DAC2 Rch Negative Analog Output Pin
46	ROUT2+	O	DAC2 Rch Positive Analog Output Pin
47	LOUT1-	O	DAC1 Lch Negative Analog Output Pin
48	LOUT1+	O	DAC1 Lch Positive Analog Output Pin
49	ROUT1-	O	DAC1 Rch Negative Analog Output Pin
50	ROUT1+	O	DAC1 Rch Positive Analog Output Pin
51	LIN	I	Lch Analog Input Pin
52	RIN	I	Rch Analog Input Pin
53	VCOM	-	Common Voltage Output Pin 2.2μF capacitor should be connected to AVSS externally.
54	VREFH	-	Positive Voltage Reference Input Pin, AVDD

No.	Pin Name	I/O	Function
55	AVDD	-	Analog Power Supply Pin, 4.75V~5.25V
56	AVSS	-	Analog Ground Pin, 0V
57	RX0	I	Receiver Channel 0 Pin (Internal biased pin. Internally biased at PVDD/2)
58	NC	-	No Connect pin No internal bonding. This pin should be connected to PVSS.
59	RX1	I	Receiver Channel 1 Pin (Internal biased pin. Internally biased at PVDD/2)
60	TEST1	I	Test 1 Pin This pin should be connected to PVSS.
61	RX2	I	Receiver Channel 2 Pin (Internal biased pin. Internally biased at PVDD/2)
62	NC	-	No Connect pin No internal bonding. This pin should be connected to PVSS.
63	RX3	I	Receiver Channel 3 Pin (Internal biased pin. Internally biased at PVDD/2)
64	PVSS	-	PLL Ground pin
65	R	-	External Resistor Pin 12kΩ +/-1% resistor should be connected to PVSS externally.
66	PVDD	-	PLL Power supply Pin, 4.75V~5.25V
67	RX4	I	Receiver Channel 4 Pin (Internal biased pin. Internally biased at PVDD/2)
68	TEST2	I	Test 2 Pin This pin should be connected to PVSS.
69	RX5	I	Receiver Channel 5 Pin (Internal biased pin. Internally biased at PVDD/2)
70	CAD0	I	Chip Address 0 Pin (ADC/DAC part)
71	RX6	I	Receiver Channel 6 Pin (Internal biased pin. Internally biased at PVDD/2)
72	CAD1	I	Chip Address 1 Pin (ADC/DAC part)
73	RX7	I	Receiver Channel 7 Pin (Internal biased pin. Internally biased at PVDD/2)
74	I2C	I	Control Mode Select Pin. “L”: 4-wire Serial, “H”: I <sup>2</sup> C Bus
75	DAUX2	I	Auxiliary Audio Data Input Pin (DIR/DIT part)
76	VIN	I	V-bit Input Pin for Transmitter Output
77	MCLK	I	Master Clock Input Pin
78	TX0	O	Transmit Channel (Through Data) Output 0 Pin
79	TX1	O	Transmit Channel Output1 pin When DIT bit = “0”, Through Data. When DIT bit = “1”, DAUX2 Data.
80	INT0	O	Interrupt 0 Pin

Notes: 内部バイアスピピンとアナログ入力ピン(RX0-7, LIN, RIN)を除くすべての入力ピンはフローティングにしないで下さい。



Internal biased pin Circuit

### ■ 使用しないピンの処理について

使用しない入出力ピンは下記の設定を行い、適切に処理して下さい。

Classification	Pin Name	Setting
Analog	RX0-7, LOUT1-4, ROUT1-4, LIN, RIN	These pins should be open.
Digital	INT0-1, BOUT, XTO, MCKO1-2, COUT, UOUT, VOUT, SDTO1-2, CDTO, DZF1-2, TX1-0	These pins should be open.
	CSN, DAUX1-2, SDTI1-4, XTL0-1	These pins should be connected to DVSS.
	TEST1-3	These pins should be connected to PVSS.



# NJM7900

## 3-TERMINAL NEGATIVE VOLTAGE REGULATOR

### ■ GENERAL DESCRIPTION

The NJM7900 series of Monolithic 3-Terminal Negative Regulators is constructed using the New JRC Planar epitaxial process. These negative regulators are intended as complements to the popular NJM7800 series of positive voltage regulators, and they are available in the same voltage options from -5 to -24V. The 7900 series employ internal current-limiting, safe-area protection, and thermal shutdown, making the virtually indestructible.

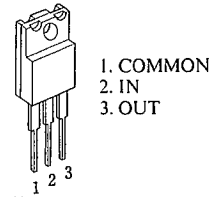
### ■ FEATURES

- Internal Short Circuit Current Limit
- Internal Thermal Overload Protection
- Excellent Ripple Rejection
- Guarantee'd 1.5A Output Current
- Package Outline
- Bipolar Technology

TO-220F

### ■ PACKAGE OUTLINE

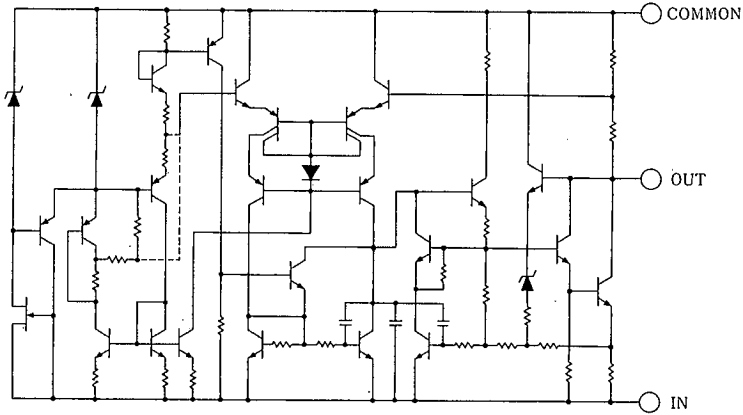
(TO-220F)



NJM7900FA

(note) The radiation fin is connected to Pin 2.

### ■ EQUIVALENT CIRCUIT



6



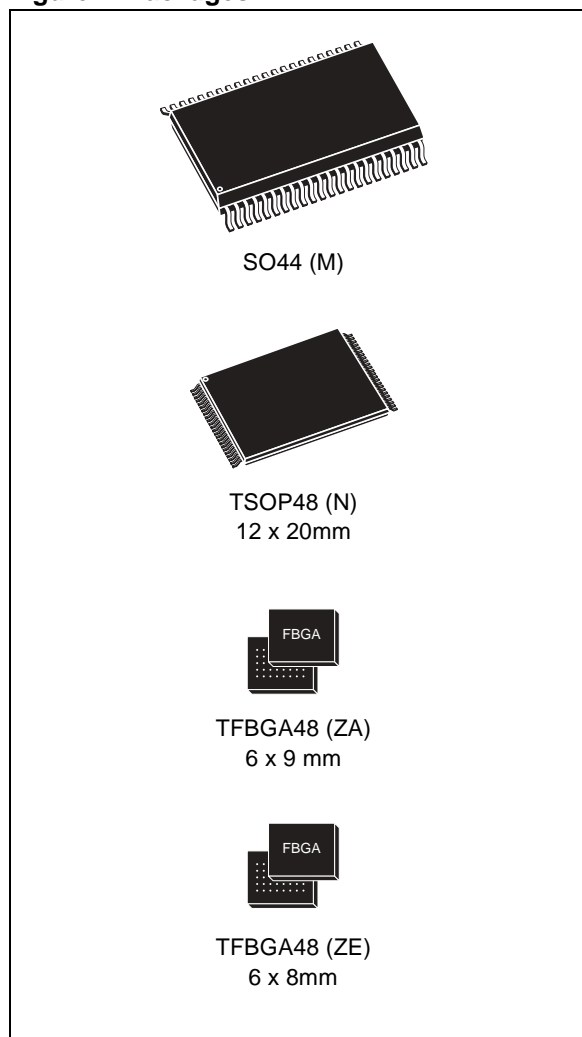
# M29W800DT M29W800DB

8 Mbit (1Mb x8 or 512Kb x16, Boot Block)  
3V Supply Flash Memory

## FEATURES SUMMARY

- SUPPLY VOLTAGE
  - $V_{CC} = 2.7V$  to  $3.6V$  for Program, Erase and Read
- ACCESS TIMES: 45, 70, 90ns
- PROGRAMMING TIME
  - $10\mu s$  per Byte/Word typical
- 19 MEMORY BLOCKS
  - 1 Boot Block (Top or Bottom Location)
  - 2 Parameter and 16 Main Blocks
- PROGRAM/ERASE CONTROLLER
  - Embedded Byte/Word Program algorithms
- ERASE SUSPEND and RESUME MODES
  - Read and Program another Block during Erase Suspend
- UNLOCK BYPASS PROGRAM COMMAND
  - Faster Production/Batch Programming
- TEMPORARY BLOCK UNPROTECTION MODE
- COMMON FLASH INTERFACE
  - 64 bit Security Code
- LOW POWER CONSUMPTION
  - Standby and Automatic Standby
- 100,000 PROGRAM/ERASE CYCLES per BLOCK
- ELECTRONIC SIGNATURE
  - Manufacturer Code: 0020h
  - Top Device Code M29W800DT: 22D7h
  - Bottom Device Code M29W800DB: 225Bh

Figure 1. Packages



**M29W800DT, M29W800DB**

**SUMMARY DESCRIPTION**

The M29W800D is a 8 Mbit (1Mb x8 or 512Kb x16) non-volatile memory that can be read, erased and reprogrammed. These operations can be performed using a single low voltage (2.7 to 3.6V) supply. On power-up the memory defaults to its Read mode where it can be read in the same way as a ROM or EPROM.

The memory is divided into blocks that can be erased independently so it is possible to preserve valid data while old data is erased. Each block can be protected independently to prevent accidental Program or Erase commands from modifying the memory. Program and Erase commands are written to the Command Interface of the memory. An on-chip Program/Erase Controller simplifies the process of programming or erasing the memory by taking care of all of the special operations that are required to update the memory contents.

The end of a program or erase operation can be detected and any error conditions identified. The

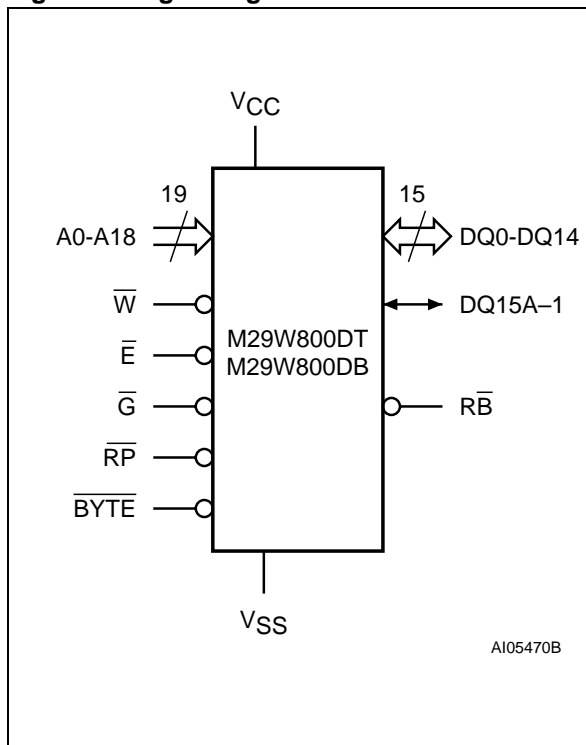
command set required to control the memory is consistent with JEDEC standards.

The blocks in the memory are asymmetrically arranged, see Figures 6 and 7, Block Addresses. The first or last 64 Kbytes have been divided into four additional blocks. The 16 Kbyte Boot Block can be used for small initialization code to start the microprocessor, the two 8 Kbyte Parameter Blocks can be used for parameter storage and the remaining 32K is a small Main Block where the application may be stored.

Chip Enable, Output Enable and Write Enable signals control the bus operation of the memory. They allow simple connection to most microprocessors, often without additional logic.

The memory is offered in SO44, TSOP48 (12 x 20mm), TFBGA48 6 x 9mm (0.8mm pitch) and TFBGA48 6 x 8mm (0.8mm pitch) packages. The memory is supplied with all the bits erased (set to '1').

**Figure 2. Logic Diagram**



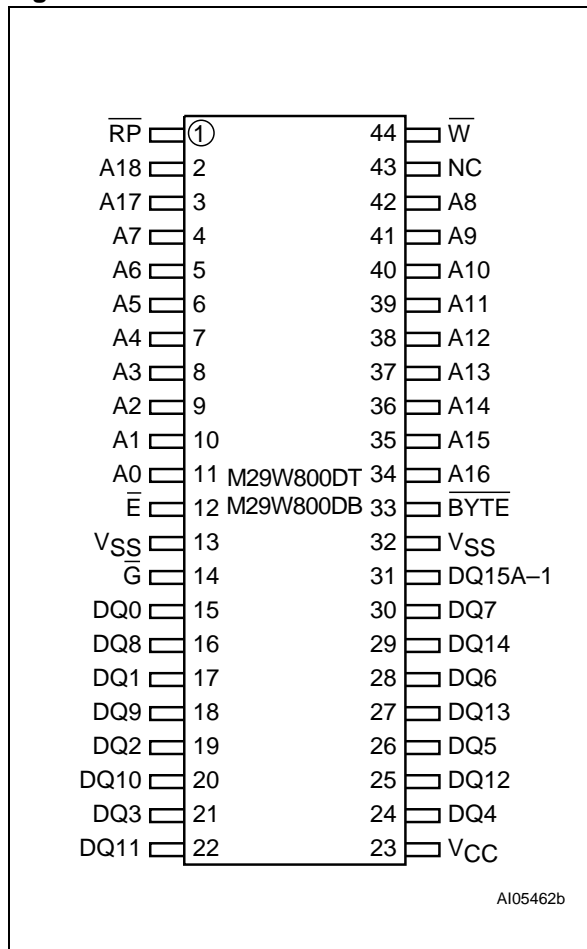
**Table 1. Signal Names**

A0-A18	Address Inputs
DQ0-DQ7	Data Inputs/Outputs
DQ8-DQ14	Data Inputs/Outputs
DQ15A-1	Data Input/Output or Address Input
$\bar{E}$	Chip Enable
$\bar{G}$	Output Enable
$\bar{W}$	Write Enable
$\bar{RP}$	Reset/Block Temporary Unprotect
$\bar{RB}$	Ready/Busy Output (not available on SO44 package)
$\bar{BYTE}$	Byte/Word Organization Select
Vcc	Supply Voltage
Vss	Ground
NC	Not Connected Internally

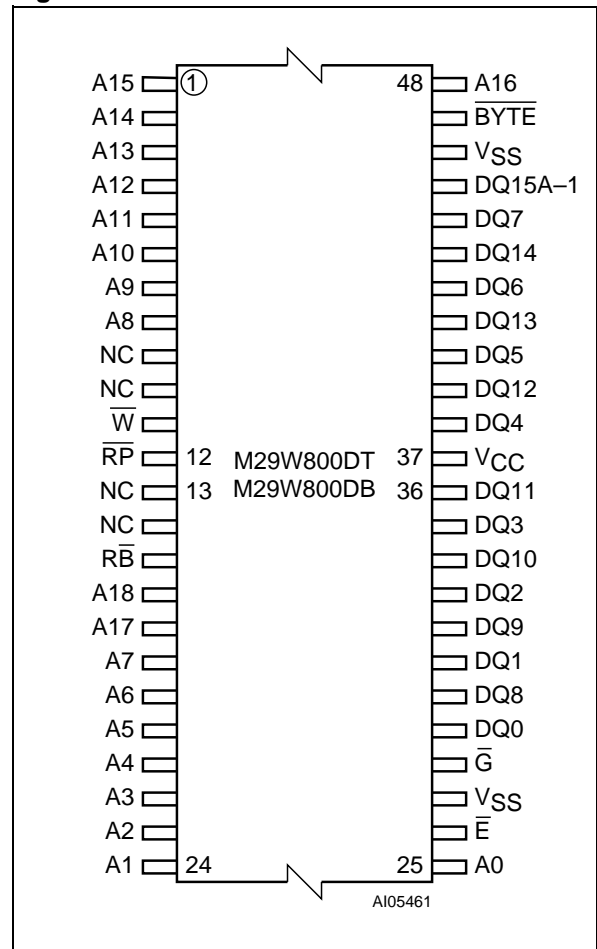


**M29W800DT, M29W800DB**

**Figure 3. SO Connections**

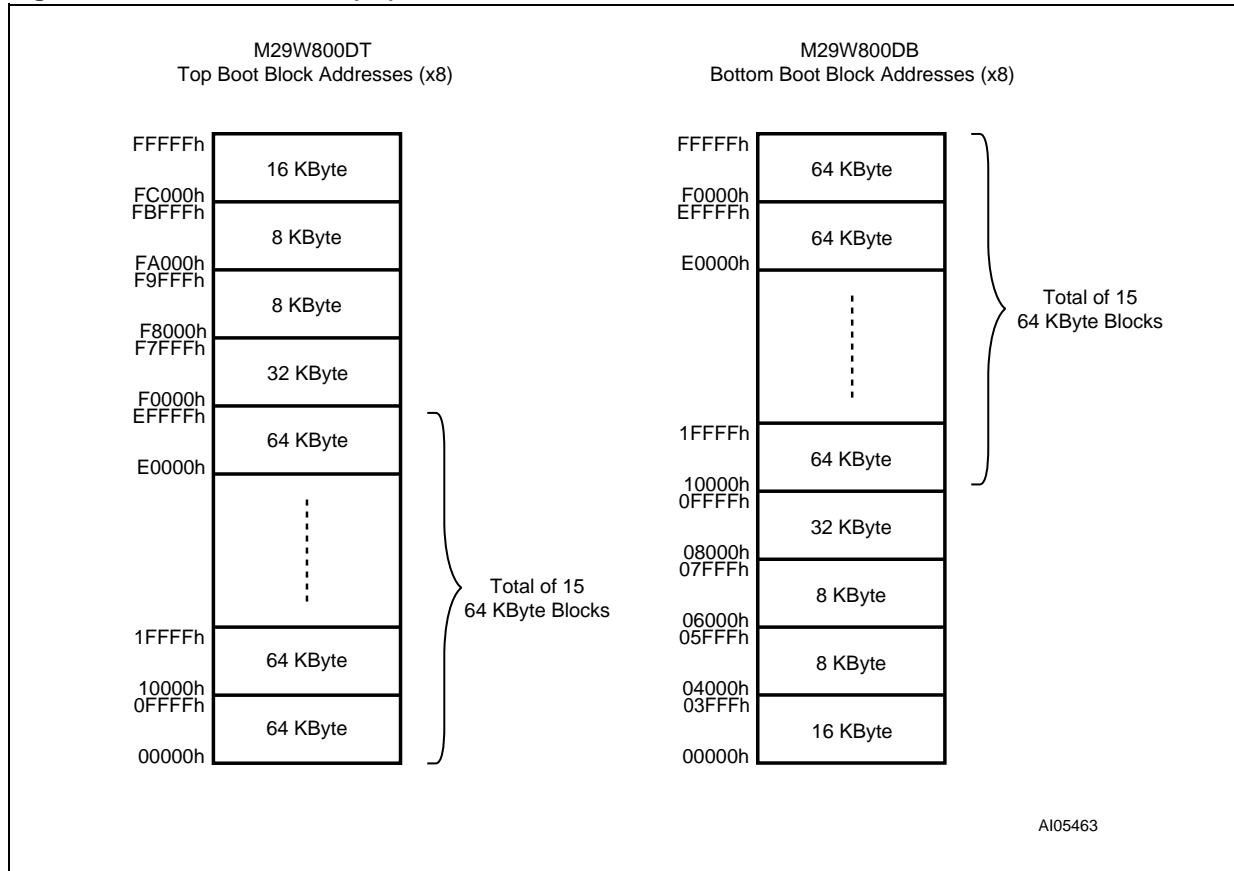


**Figure 4. TSOP Connections**



**M29W800DT, M29W800DB**

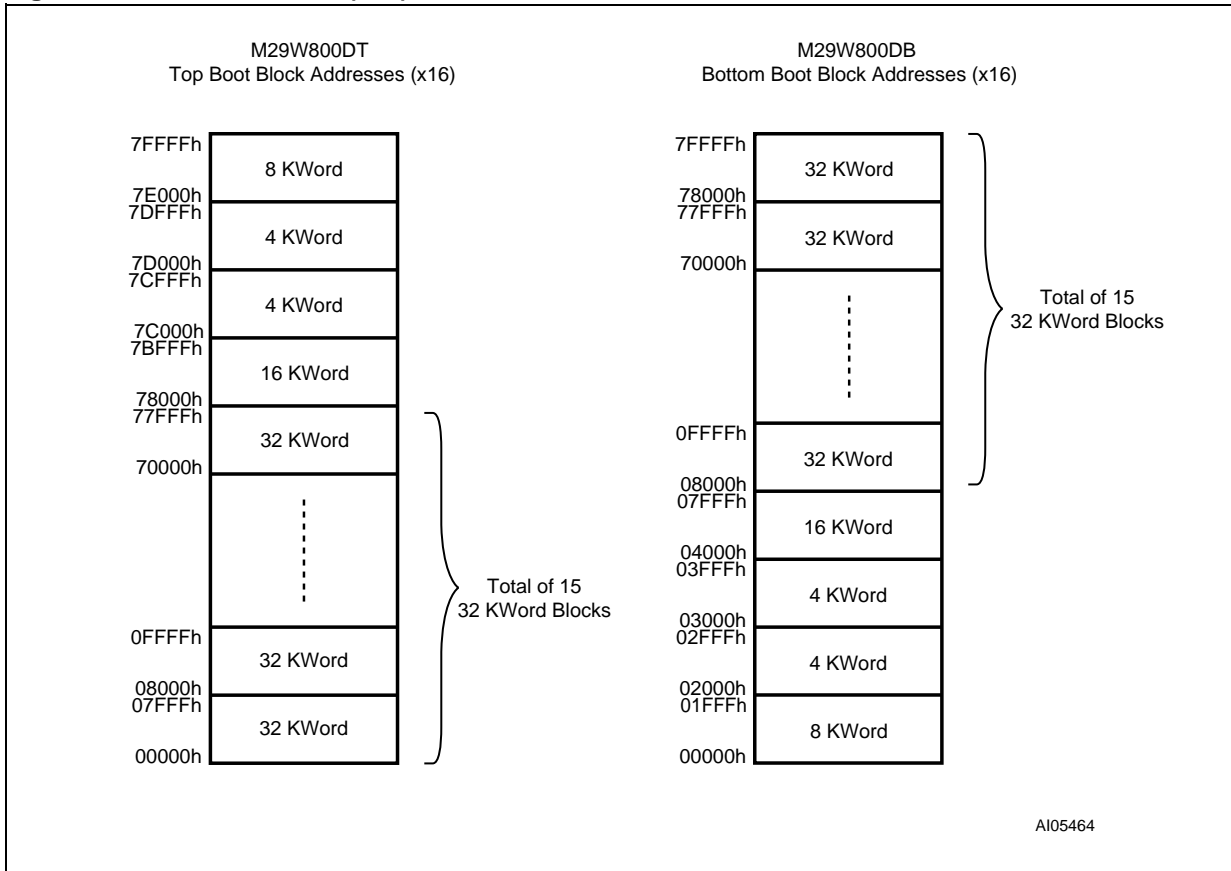
**Figure 6. Block Addresses (x8)**



Note: Also see [APPENDIX A.](#), Tables 21 and 22 for a full listing of the Block Addresses.

**M29W800DT, M29W800DB**

**Figure 7. Block Addresses (x16)**



Note: Also see APPENDIX A., Tables 21 and 22 for a full listing of the Block Addresses.

## M29W800DT, M29W800DB

### SIGNAL DESCRIPTIONS

See [Figure 2., Logic Diagram](#), and [Table 1., Signal Names](#), for a brief overview of the signals connected to this device.

**Address Inputs (A0-A18).** The Address Inputs select the cells in the memory array to access during Bus Read operations. During Bus Write operations they control the commands sent to the Command Interface of the internal state machine.

**Data Inputs/Outputs (DQ0-DQ7).** The Data Inputs/Outputs output the data stored at the selected address during a Bus Read operation. During Bus Write operations they represent the commands sent to the Command Interface of the internal state machine.

**Data Inputs/Outputs (DQ8-DQ14).** The Data Inputs/Outputs output the data stored at the selected address during a Bus Read operation when  $\overline{\text{BYTE}}$  is High,  $V_{IH}$ . When  $\overline{\text{BYTE}}$  is Low,  $V_{IL}$ , these pins are not used and are high impedance. During Bus Write operations the Command Register does not use these bits. When reading the Status Register these bits should be ignored.

**Data Input/Output or Address Input (DQ15A-1).** When  $\overline{\text{BYTE}}$  is High,  $V_{IH}$ , this pin behaves as a Data Input/Output pin (as DQ8-DQ14). When  $\overline{\text{BYTE}}$  is Low,  $V_{IL}$ , this pin behaves as an address pin; DQ15A-1 Low will select the LSB of the Word on the other addresses, DQ15A-1 High will select the MSB. Throughout the text consider references to the Data Input/Output to include this pin when  $\overline{\text{BYTE}}$  is High and references to the Address Inputs to include this pin when  $\overline{\text{BYTE}}$  is Low except when stated explicitly otherwise.

**Chip Enable (E).** The Chip Enable,  $\overline{\text{E}}$ , activates the memory, allowing Bus Read and Bus Write operations to be performed. When Chip Enable is High,  $V_{IH}$ , all other pins are ignored.

**Output Enable (G).** The Output Enable,  $\overline{\text{G}}$ , controls the Bus Read operation of the memory.

**Write Enable (W).** The Write Enable,  $\overline{\text{W}}$ , controls the Bus Write operation of the memory's Command Interface.

**Reset/Block Temporary Unprotect (RP).** The Reset/Block Temporary Unprotect pin can be used to apply a Hardware Reset to the memory or to temporarily unprotect all Blocks that have been protected.

A Hardware Reset is achieved by holding Reset/Block Temporary Unprotect Low,  $V_{IL}$ , for at least  $t_{PLPX}$ . After Reset/Block Temporary Unprotect goes High,  $V_{IH}$ , the memory will be ready for Bus Read and Bus Write operations after  $t_{PHEL}$  or

$t_{RHEL}$ , whichever occurs last. See the Ready/Busy Output section, [Table 15.](#) and [Figure 15., Reset/Block Temporary Unprotect AC Waveforms](#), for more details.

Holding  $\overline{\text{RP}}$  at  $V_{ID}$  will temporarily unprotect the protected Blocks in the memory. Program and Erase operations on all blocks will be possible. The transition from  $V_{IH}$  to  $V_{ID}$  must be slower than  $t_{PHPHH}$ .

**Ready/Busy Output (RB).** The Ready/Busy pin is an open-drain output that can be used to identify when the device is performing a Program or Erase operation. During Program or Erase operations Ready/Busy is Low,  $V_{OL}$ . Ready/Busy is high-impedance during Read mode, Auto Select mode and Erase Suspend mode.

After a Hardware Reset, Bus Read and Bus Write operations cannot begin until Ready/Busy becomes high-impedance. See [Table 15., Reset/Block Temporary Unprotect AC Characteristics](#) and [Figure 15., Reset/Block Temporary Unprotect AC Waveforms](#).

The use of an open-drain output allows the Ready/Busy pins from several memories to be connected to a single pull-up resistor. A Low will then indicate that one, or more, of the memories is busy.

**Byte/Word Organization Select (BYTE).** The Byte/Word Organization Select pin is used to switch between the 8-bit and 16-bit Bus modes of the memory. When Byte/Word Organization Select is Low,  $V_{IL}$ , the memory is in 8-bit mode, when it is High,  $V_{IH}$ , the memory is in 16-bit mode.

**V<sub>CC</sub> Supply Voltage.** The  $V_{CC}$  Supply Voltage supplies the power for all operations (Read, Program, Erase etc.).

The Command Interface is disabled when the  $V_{CC}$  Supply Voltage is less than the Lockout Voltage,  $V_{LKO}$ . This prevents Bus Write operations from accidentally damaging the data during power up, power down and power surges. If the Program/Erase Controller is programming or erasing during this time then the operation aborts and the memory contents being altered will be invalid.

A 0.1 $\mu\text{F}$  capacitor should be connected between the  $V_{CC}$  Supply Voltage pin and the  $V_{SS}$  Ground pin to decouple the current surges from the power supply. The PCB track widths must be sufficient to carry the currents required during program and erase operations,  $I_{CC3}$ .

**V<sub>SS</sub> Ground.** The  $V_{SS}$  Ground is the reference for all voltage measurements.

## M29W800DT, M29W800DB

### BUS OPERATIONS

There are five standard bus operations that control the device. These are Bus Read, Bus Write, Output Disable, Standby and Automatic Standby. See Tables 2 and 3, Bus Operations, for a summary. Typically glitches of less than 5ns on Chip Enable or Write Enable are ignored by the memory and do not affect bus operations.

**Bus Read.** Bus Read operations read from the memory cells, or specific registers in the Command Interface. A valid Bus Read operation involves setting the desired address on the Address Inputs, applying a Low signal,  $V_{IL}$ , to Chip Enable and Output Enable and keeping Write Enable High,  $V_{IH}$ . The Data Inputs/Outputs will output the value, see Figure 12., Read Mode AC Waveforms, and Table 12., Read AC Characteristics for details of when the output becomes valid.

**Bus Write.** Bus Write operations write to the Command Interface. A valid Bus Write operation begins by setting the desired address on the Address Inputs. The Address Inputs are latched by the Command Interface on the falling edge of Chip Enable or Write Enable, whichever occurs last. The Data Inputs/Outputs are latched by the Command Interface on the rising edge of Chip Enable or Write Enable, whichever occurs first. Output Enable must remain High,  $V_{IH}$ , during the whole Bus Write operation. See Figures 13 and 14, Write AC Waveforms, and Tables 13 and 14, Write AC Characteristics, for details of the timing requirements.

**Output Disable.** The Data Inputs/Outputs are in the high impedance state when Output Enable is High,  $V_{IH}$ .

**Standby.** When Chip Enable is High,  $V_{IH}$ , the memory enters Standby mode and the Data Inputs/Outputs pins are placed in the high-imped-

ance state. To reduce the Supply Current to the Standby Supply Current,  $I_{CC2}$ , Chip Enable should be held within  $V_{CC} \pm 0.2V$ . For the Standby current level see Table 11., DC Characteristics.

During program or erase operations the memory will continue to use the Program/Erase Supply Current,  $I_{CC3}$ , for Program or Erase operations until the operation completes.

**Automatic Standby.** If CMOS levels ( $V_{CC} \pm 0.2V$ ) are used to drive the bus and the bus is inactive for 150ns or more the memory enters Automatic Standby where the internal Supply Current is reduced to the Standby Supply Current,  $I_{CC2}$ . The Data Inputs/Outputs will still output data if a Bus Read operation is in progress.

**Special Bus Operations.** Additional bus operations can be performed to read the Electronic Signature and also to apply and remove Block Protection. These bus operations are intended for use by programming equipment and are not usually used in applications. They require  $V_{ID}$  to be applied to some pins.

**Electronic Signature.** The memory has two codes, the manufacturer code and the device code, that can be read to identify the memory. These codes can be read by applying the signals listed in Tables 2 and 3, Bus Operations.

**Block Protection and Blocks Unprotection.** Each block can be separately protected against accidental Program or Erase. Protected blocks can be unprotected to allow data to be changed.

There are two methods available for protecting and unprotecting the blocks, one for use on programming equipment and the other for in-system use. Block Protect and Chip Unprotect operations are described in APPENDIX C.

Table 2. Bus Operations,  $\overline{BYTE} = V_{IL}$

Operation	$\overline{E}$	$\overline{G}$	$\overline{W}$	Address Inputs DQ15A-1, A0-A18	Data Inputs/Outputs	
					DQ14-DQ8	DQ7-DQ0
Bus Read	$V_{IL}$	$V_{IL}$	$V_{IH}$	Cell Address	Hi-Z	Data Output
Bus Write	$V_{IL}$	$V_{IH}$	$V_{IL}$	Command Address	Hi-Z	Data Input
Output Disable	X	$V_{IH}$	$V_{IH}$	X	Hi-Z	Hi-Z
Standby	$V_{IH}$	X	X	X	Hi-Z	Hi-Z
Read Manufacturer Code	$V_{IL}$	$V_{IL}$	$V_{IH}$	A0 = $V_{IL}$ , A1 = $V_{IL}$ , A9 = $V_{ID}$ , Others $V_{IL}$ or $V_{IH}$	Hi-Z	20h
Read Device Code	$V_{IL}$	$V_{IL}$	$V_{IH}$	A0 = $V_{IH}$ , A1 = $V_{IL}$ , A9 = $V_{ID}$ , Others $V_{IL}$ or $V_{IH}$	Hi-Z	D7h (M29W800DT) 5Bh (M29W800DB)

Note: X =  $V_{IL}$  or  $V_{IH}$ .

**M29W800DT, M29W800DB****Table 3. Bus Operations,  $\overline{\text{BYTE}} = V_{IH}$** 

Operation	$\overline{\text{E}}$	$\overline{\text{G}}$	$\overline{\text{W}}$	Address Inputs A0-A18	Data Inputs/Outputs DQ15A-1, DQ14-DQ0
Bus Read	$V_{IL}$	$V_{IL}$	$V_{IH}$	Cell Address	Data Output
Bus Write	$V_{IL}$	$V_{IH}$	$V_{IL}$	Command Address	Data Input
Output Disable	X	$V_{IH}$	$V_{IH}$	X	Hi-Z
Standby	$V_{IH}$	X	X	X	Hi-Z
Read Manufacturer Code	$V_{IL}$	$V_{IL}$	$V_{IH}$	A0 = $V_{IL}$ , A1 = $V_{IL}$ , A9 = $V_{ID}$ , Others $V_{IL}$ or $V_{IH}$	0020h
Read Device Code	$V_{IL}$	$V_{IL}$	$V_{IH}$	A0 = $V_{IH}$ , A1 = $V_{IL}$ , A9 = $V_{ID}$ , Others $V_{IL}$ or $V_{IH}$	22D7h (M29W800DT) 225Bh (M29W800DB)

Note: X =  $V_{IL}$  or  $V_{IH}$ .

**COMMAND INTERFACE**

All Bus Write operations to the memory are interpreted by the Command Interface. Commands consist of one or more sequential Bus Write operations. Failure to observe a valid sequence of Bus Write operations will result in the memory returning to Read mode. The long command sequences are imposed to maximize data security.

The address used for the commands changes depending on whether the memory is in 16-bit or 8-bit mode. See either Table 4, or 5, depending on the configuration that is being used, for a summary of the commands.

**Read/Reset Command.** The Read/Reset command returns the memory to its Read mode where it behaves like a ROM or EPROM, unless otherwise stated. It also resets the errors in the Status Register. Either one or three Bus Write operations can be used to issue the Read/Reset command.

The Read/Reset Command can be issued, between Bus Write cycles before the start of a program or erase operation, to return the device to read mode. Once the program or erase operation has started the Read/Reset command is no longer accepted. The Read/Reset command will not abort an Erase operation when issued while in Erase Suspend.

**Auto Select Command.** The Auto Select command is used to read the Manufacturer Code, the Device Code and the Block Protection Status. Three consecutive Bus Write operations are required to issue the Auto Select command. Once the Auto Select command is issued the memory remains in Auto Select mode until a Read/Reset command is issued. Read CFI Query and Read/Reset commands are accepted in Auto Select mode, all other commands are ignored.

From the Auto Select mode the Manufacturer Code can be read using a Bus Read operation with A0 =  $V_{IL}$  and A1 =  $V_{IL}$ . The other address bits may be set to either  $V_{IL}$  or  $V_{IH}$ . The Manufacturer Code for STMicroelectronics is 0020h.

The Device Code can be read using a Bus Read operation with A0 =  $V_{IH}$  and A1 =  $V_{IL}$ . The other address bits may be set to either  $V_{IL}$  or  $V_{IH}$ . The Device Code for the M29W800DT is 22D7h and for the M29W800DB is 225Bh.

The Block Protection Status of each block can be read using a Bus Read operation with A0 =  $V_{IL}$ , A1 =  $V_{IH}$ , and A12-A18 specifying the address of the block. The other address bits may be set to either  $V_{IL}$  or  $V_{IH}$ . If the addressed block is protected then 01h is output on Data Inputs/Outputs DQ0-DQ7, otherwise 00h is output.

**Program Command.** The Program command can be used to program a value to one address in the memory array at a time. The command requires four Bus Write operations, the final write operation latches the address and data in the internal state machine and starts the Program/Erase Controller.

If the address falls in a protected block then the Program command is ignored, the data remains unchanged. The Status Register is never read and no error condition is given.

During the program operation the memory will ignore all commands. It is not possible to issue any command to abort or pause the operation. Typical program times are given in Table 6. Bus Read operations during the program operation will output the Status Register on the Data Inputs/Outputs. See the section on the Status Register for more details.

## M29W800DT, M29W800DB

After the program operation has completed the memory will return to the Read mode, unless an error has occurred. When an error occurs the memory will continue to output the Status Register. A Read/Reset command must be issued to reset the error condition and return to Read mode.

Note that the Program command cannot change a bit set at '0' back to '1'. One of the Erase Commands must be used to set all the bits in a block or in the whole memory from '0' to '1'.

**Unlock Bypass Command.** The Unlock Bypass command is used in conjunction with the Unlock Bypass Program command to program the memory. When the access time to the device is long (as with some EPROM programmers) considerable time saving can be made by using these commands. Three Bus Write operations are required to issue the Unlock Bypass command.

Once the Unlock Bypass command has been issued the memory will only accept the Unlock Bypass Program command and the Unlock Bypass Reset command. The memory can be read as if in Read mode.

**Unlock Bypass Program Command.** The Unlock Bypass Program command can be used to program one address in memory at a time. The command requires two Bus Write operations, the final write operation latches the address and data in the internal state machine and starts the Program/Erase Controller.

The Program operation using the Unlock Bypass Program command behaves identically to the Program operation using the Program command. A protected block cannot be programmed; the operation cannot be aborted and the Status Register is read. Errors must be reset using the Read/Reset command, which leaves the device in Unlock Bypass Mode. See the Program command for details on the behavior.

**Unlock Bypass Reset Command.** The Unlock Bypass Reset command can be used to return to Read/Reset mode from Unlock Bypass Mode. Two Bus Write operations are required to issue the Unlock Bypass Reset command. Read/Reset command does not exit from Unlock Bypass Mode.

**Chip Erase Command.** The Chip Erase command can be used to erase the entire chip. Six Bus Write operations are required to issue the Chip Erase Command and start the Program/Erase Controller.

If any blocks are protected then these are ignored and all the other blocks are erased. If all of the blocks are protected the Chip Erase operation appears to start but will terminate within about 100 $\mu$ s, leaving the data unchanged. No error condition is given when protected blocks are ignored.

During the erase operation the memory will ignore all commands. It is not possible to issue any command to abort the operation. Typical chip erase times are given in [Table 6](#). All Bus Read operations during the Chip Erase operation will output the Status Register on the Data Inputs/Outputs. See the section on the Status Register for more details.

After the Chip Erase operation has completed the memory will return to the Read Mode, unless an error has occurred. When an error occurs the memory will continue to output the Status Register. A Read/Reset command must be issued to reset the error condition and return to Read Mode.

The Chip Erase Command sets all of the bits in unprotected blocks of the memory to '1'. All previous data is lost.

**Block Erase Command.** The Block Erase command can be used to erase a list of one or more blocks. Six Bus Write operations are required to select the first block in the list. Each additional block in the list can be selected by repeating the sixth Bus Write operation using the address of the additional block. The Block Erase operation starts the Program/Erase Controller about 50 $\mu$ s after the last Bus Write operation. Once the Program/Erase Controller starts it is not possible to select any more blocks. Each additional block must therefore be selected within 50 $\mu$ s of the last block. The 50 $\mu$ s timer restarts when an additional block is selected. The Status Register can be read after the sixth Bus Write operation. See the Status Register for details on how to identify if the Program/Erase Controller has started the Block Erase operation.

If any selected blocks are protected then these are ignored and all the other selected blocks are erased. If all of the selected blocks are protected the Block Erase operation appears to start but will terminate within about 100 $\mu$ s, leaving the data unchanged. No error condition is given when protected blocks are ignored.

During the Block Erase operation the memory will ignore all commands except the Erase Suspend command. Typical block erase times are given in [Table 6](#). All Bus Read operations during the Block Erase operation will output the Status Register on the Data Inputs/Outputs. See the section on the Status Register for more details.

After the Block Erase operation has completed the memory will return to the Read Mode, unless an error has occurred. When an error occurs the memory will continue to output the Status Register. A Read/Reset command must be issued to reset the error condition and return to Read mode.

The Block Erase Command sets all of the bits in the unprotected selected blocks to '1'. All previous data in the selected blocks is lost.

## M29W800DT, M29W800DB

---

**Erase Suspend Command.** The Erase Suspend Command may be used to temporarily suspend a Block Erase operation and return the memory to Read mode. The command requires one Bus Write operation.

The Program/Erase Controller will suspend within the Erase Suspend Latency Time (refer to [Table 6](#), for value) of the Erase Suspend Command being issued. Once the Program/Erase Controller has stopped the memory will be set to Read mode and the Erase will be suspended. If the Erase Suspend command is issued during the period when the memory is waiting for an additional block (before the Program/Erase Controller starts) then the Erase is suspended immediately and will start immediately when the Erase Resume Command is issued. It is not possible to select any further blocks to erase after the Erase Resume.

During Erase Suspend it is possible to Read and Program cells in blocks that are not being erased; both Read and Program operations behave as normal on these blocks. If any attempt is made to program in a protected block or in the suspended block then the Program command is ignored and the data remains unchanged. The Status Register is not read and no error condition is given. Reading from blocks that are being erased will output the Status Register.

It is also possible to issue the Auto Select, Read CFI Query and Unlock Bypass commands during an Erase Suspend. The Read/Reset command must be issued to return the device to Read Array

mode before the Resume command will be accepted.

**Erase Resume Command.** The Erase Resume command must be used to restart the Program/Erase Controller from Erase Suspend. An erase can be suspended and resumed more than once.

**Read CFI Query Command.** The Read CFI Query Command is used to read data from the Common Flash Interface (CFI) Memory Area. This command is valid when the device is in the Read Array mode, or when the device is in Auto Select mode.

One Bus Write cycle is required to issue the Read CFI Query Command. Once the command is issued subsequent Bus Read operations read from the Common Flash Interface Memory Area.

The Read/Reset command must be issued to return the device to the previous mode (the Read Array mode or Auto Select mode). A second Read/Reset command would be needed if the device is to be put in the Read Array mode from Auto Select mode.

See [APPENDIX B.](#), [Tables 23, 24, 25, 26, 27](#) and [28](#) for details on the information contained in the Common Flash Interface (CFI) memory area.

**Block Protect and Chip Unprotect Commands.** Each block can be separately protected against accidental Program or Erase. The whole chip can be unprotected to allow the data inside the blocks to be changed.

Block Protect and Chip Unprotect operations are described in [APPENDIX C.](#)



**mitsumi**

Video Switch · 75Ω driver · Y/C mix MM1501

# Video Switch · 75Ω driver · Y/C mix Monolithic IC MM1501 Series

## Outline

This IC extends the series of ICs for video/audio signal switching, with a 2-input 1-output single video switch, video signal/chroma signal 75Ω driver, and Y/C mixing circuit in one small package (SOT-26).

## Features

- (1) Low power consumption achieved.
- (2) Low power supply voltage realized.
- (3) Frequency bandwidth   without 75Ω driver: 10MHz                      with 75Ω driver: 7MHz
- (4) Cross talk   70dB   When 4.43MHz
- (5) With SAG measures pin (75Ω driver and Y/C mix driver)

## Package

- SOT-26A (with 75Ω driver)
- SOT-26B (without 75Ω driver)

## Applications

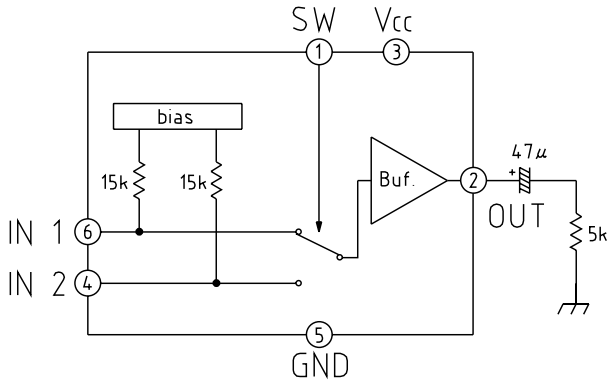
- (1) TV
- (2) VTR
- (3) Video camera
- (4) Digital still camera
- (5) Other visual equipment

## Line-up

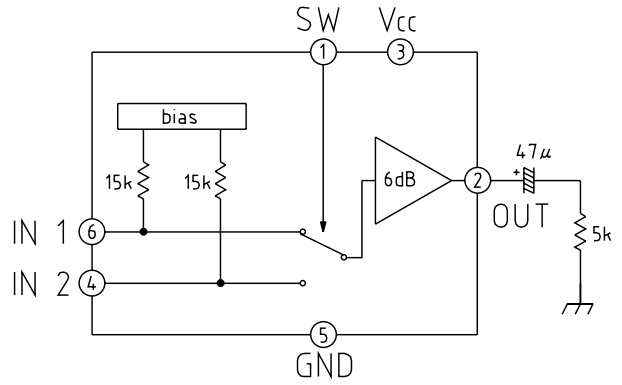
Functions	Model Name	Input	Output	Clamp	6dB amp	75Ω driver	SAG measures pin	Power supply voltage
Switch	MM1501	2	1	×	×	×	×	4.5~13.0V
	MM1502			×	○	×	×	4.5~13.0V
	MM1503			○	×	×	×	4.5~13.0V
	MM1504			○	○	×	×	4.5~13.0V
	MM1505			×	×	○	×	4.5~13.0V
	MM1506			×	○	○	×	4.5~13.0V
	MM1507			○	×	○	×	4.5~13.0V
	MM1508			○	○	○	×	4.5~13.0V
Driver	MM1509	1	1	×	○	○	○	4.5~13.0V
	MM1510			○	○	○	○	4.5~13.0V
Y/C mix	MM1511	1	1	○/×	×	×	×	4.5~13.0V
	MM1512			○/×	○	○	○	4.5~13.0V

**Block Diagram**

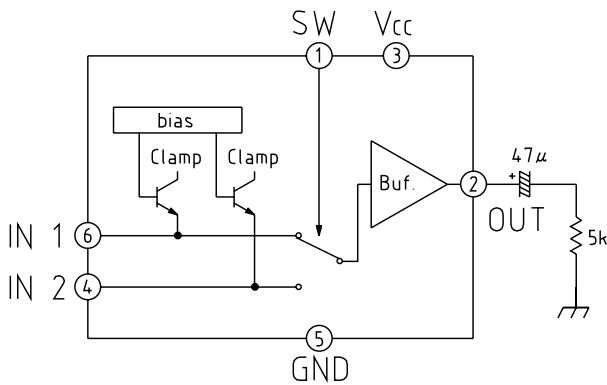
■ MM1501



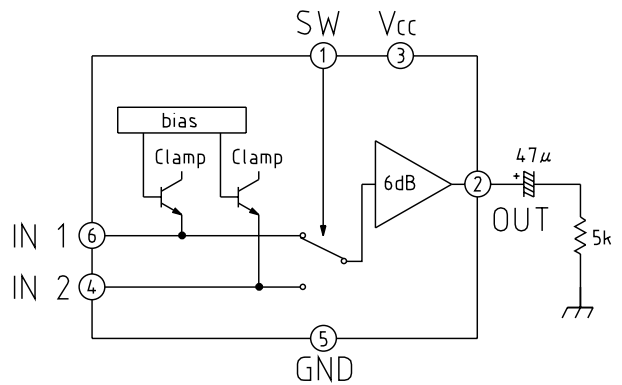
■ MM1502



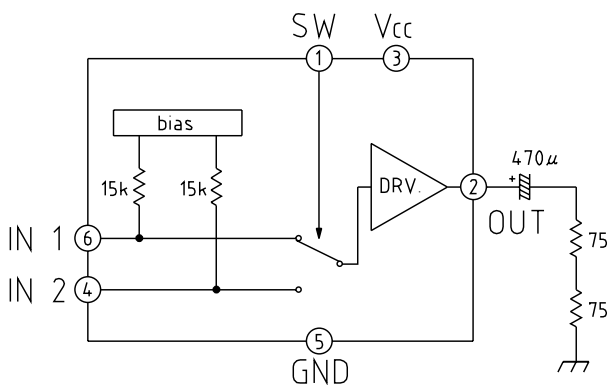
■ MM1503



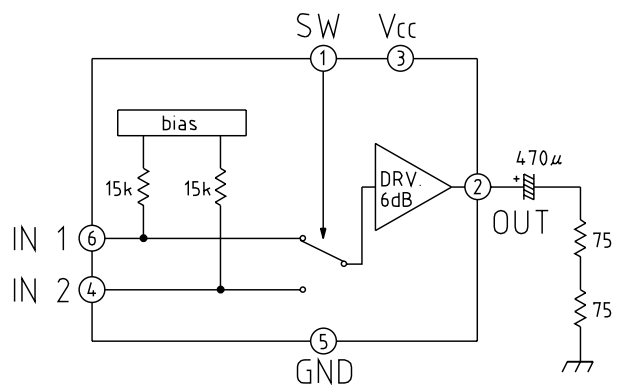
■ MM1504



■ MM1505



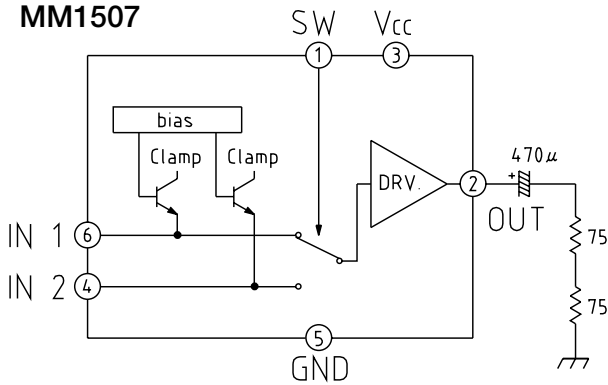
■ MM1506



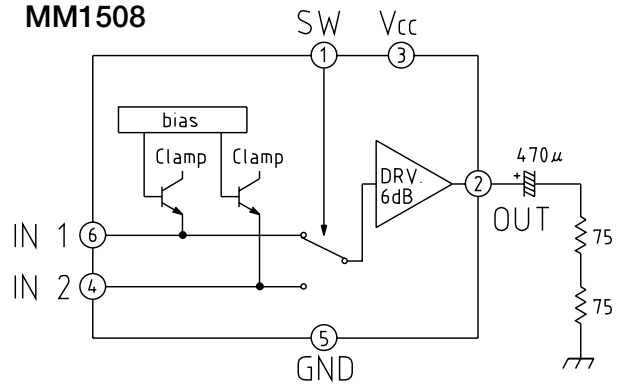
**mitsumi**

Video Switch · 75Ω driver · Y/C mix **MM1501**

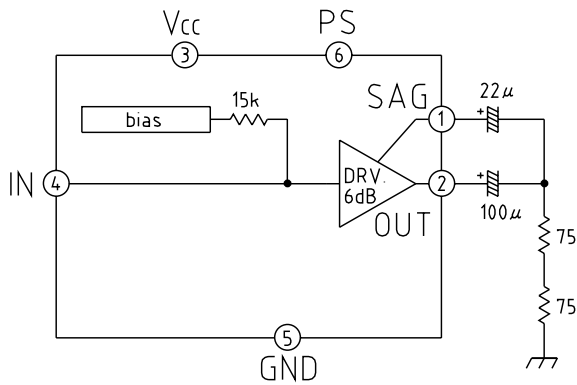
**MM1507**



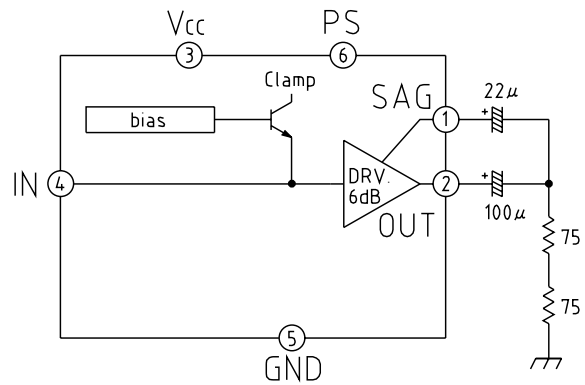
**MM1508**



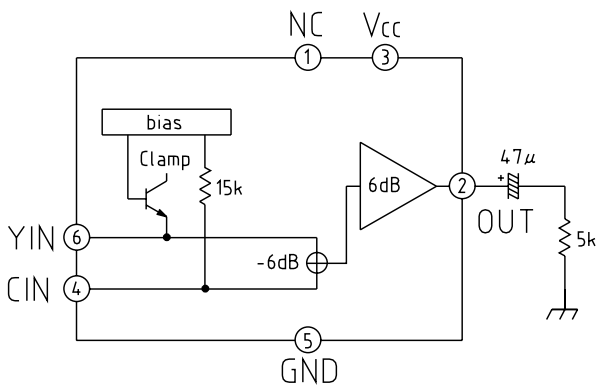
**MM1509**



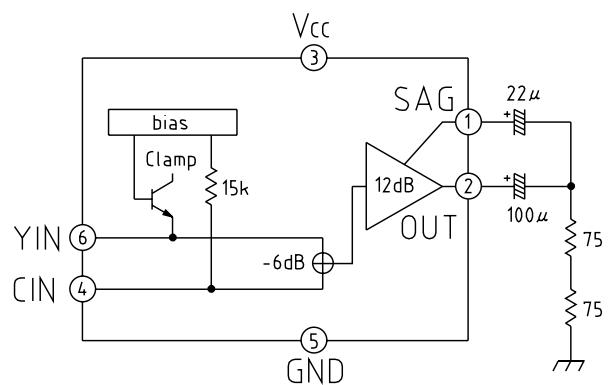
**MM1510**



**MM1511**



**MM1512**





# NJL31H/31V/32H/33H/34H000A

## INFRARED REMOTE CONTROL RECEIVER

### ■ GENERAL DESCRIPTION

The NJL30HV000A series are small and high performance receiving devices for infrared remote control system. They can operate under low and wide supply voltage (2.7V to 5.5V) with enhanced immunity against power saving light. The NJL30HV000A series have six kinds of package including seven types of metal case to meet the various applications.

### ■ FEATURES

1. Wide and low supply voltage 2.7V to 5.5V
2. Low supply current 0.43mA typ.  $V_{cc}=3.3V$
3. Six kinds of metal case type to meet the design of front panel.
4. Line-up for various center carrier frequencies.

### ■ APPLICATIONS

1. Home application such as Room light, Fan, etc.
2. AV instruments such as Audio, TV, DVD, STB etc.

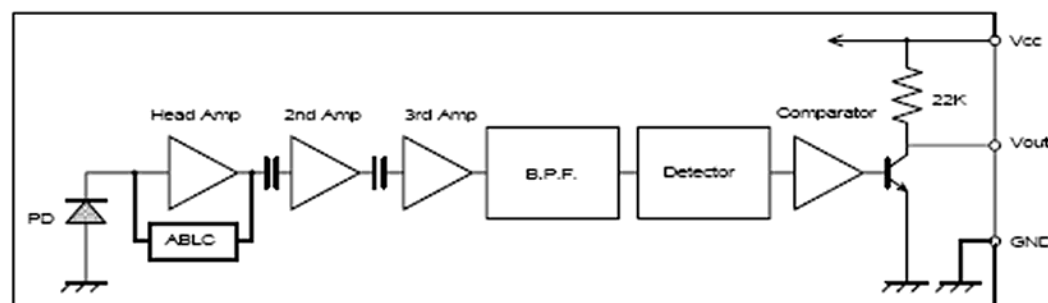
### ■ LINE-UP

View	Side
Height	6.3mm
Carrier Frequency	
$f_0=36$ kHz	NJL31V360A-M
36.7 kHz	NJL31V367A-M
38 kHz	NJL31V380A-M
40 kHz	NJL31V400A-M

View	Top				
Height	5.7mm	5.7mm	8mm	11mm	15mm
Carrier Frequency					
$f_0=36$ kHz	NJL31H360A-M	NJL31H360AF3-M	NJL32H360A	NJL33H360A	NJL34H360A
36.7 kHz	NJL31H367A-M	NJL31H367AF3-M	NJL32H367A	NJL33H367A	NJL34H367A
38 kHz	NJL31H380A-M	NJL31H380AF3-M	NJL32H380A	NJL33H380A	NJL34H380A
40 kHz	NJL31H400A-M	NJL31H400AF3-M	NJL32H400A	NJL33H400A	NJL34H400A

Regarding other frequency or packages, please contact to New JRC individually.

### ■ BLOCK DIAGRAM





KOREA ELECTRONICS CO.,LTD.

SEMICONDUCTOR  
TECHNICAL DATA

KTD600K

EPITAXIAL PLANAR NPN TRANSISTOR

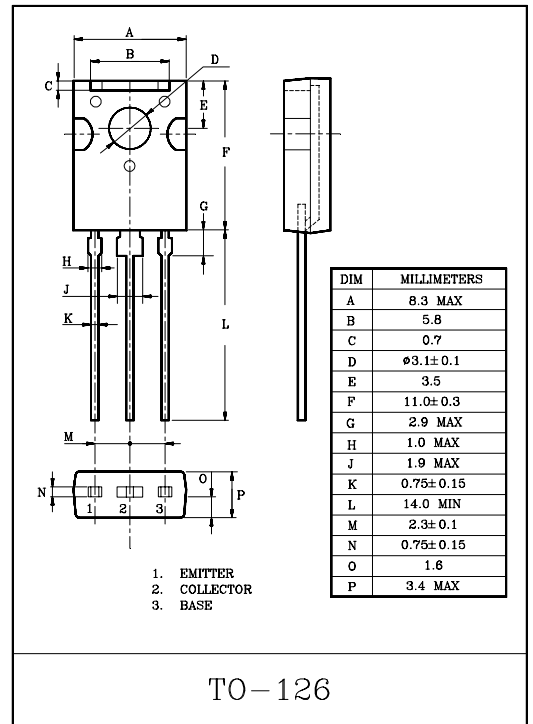
LOW FREQUENCY POWER AMP,  
MEDIUM SPEED SWITCHING APPLICATIONS

FEATURES

- High breakdown voltage  $V_{CE0}$  120V, high current 1A.
- Low saturation voltage and good linearity of  $h_{FE}$ .

MAXIMUM RATINGS ( $T_a=25^\circ\text{C}$ )

CHARACTERISTIC		SYMBOL	RATING	UNIT
Collector-Base Voltage		$V_{CBO}$	120	V
Collector-Emitter Voltage		$V_{CEO}$	120	V
Emitter-Base Voltage		$V_{EBO}$	5	V
Collector Current		$I_C$	1	A
		$I_{CP}$	2	
Collector Power Dissipation	$T_a=25^\circ\text{C}$	$P_C$	1.5	W
	$T_C=25^\circ\text{C}$		8	
Junction Temperature		$T_j$	150	$^\circ\text{C}$
Storage Temperature Range		$T_{stg}$	-55~150	$^\circ\text{C}$



ELECTRICAL CHARACTERISTICS ( $T_a=25^\circ\text{C}$ )

CHARACTERISTIC		SYMBOL	TEST CONDITION	MIN.	TYP.	MAX.	UNIT
Collector Cut of Current		$I_{CBO}$	$V_{CB}=50V, I_E=0$	-	-	1	$\mu\text{A}$
Emitter Cut of Current		$I_{EBO}$	$V_{EB}=4V, I_C=0$	-	-	1	$\mu\text{A}$
Collector-Base Breakdown Voltage		$V_{(BR)CBO}$	$I_C=10\mu\text{A}$	120	-	-	V
Collector-Emitter Breakdown Voltage		$V_{(BR)CEO}$	$I_C=1\text{mA}$	120	-	-	V
Emitter-Base Breakdown Voltage		$V_{(BR)EBO}$	$I_E=10\mu\text{A}$	5	-	-	V
DC Current Gain	$h_{FE(1)}$ Note		$V_{CE}=5V, I_C=50\text{mA}$	100	-	320	
	$h_{FE(2)}$		$V_{CE}=5V, I_C=500\text{mA}$	20	-	-	
Gain Bandwidth Product		$f_T$	$V_{CE}=10V, I_C=50\text{mA}$	-	130	-	MHz
Output Capacitance		$C_{ob}$	$V_{CB}=10V, f=1\text{MHz}$	-	20	-	pF
Collector-Emitter Saturation Voltage		$V_{CE(sat)}$	$I_C=500\text{mA}, I_B=50\text{mA}$	-	0.15	0.4	V
Base-Emitter Saturation Voltage		$V_{BE(sat)}$	$I_C=500\text{mA}, I_B=50\text{mA}$	-	0.85	1.2	V
Switching Time	Turn-on Time	$t_{on}$	<p style="text-align: center;"><math>V_{CB}=12V</math> <math>I_C=10I_{B1}=-10I_{B2}=500\text{mA}</math></p>	-	100	-	nS
	Turn-off Time	$t_{off}$		-	500	-	
	Storage Time	$t_{stg}$		-	700	-	

(Note) :  $h_{FE(1)}$  Classification Y:100~200, GR:160~320



www.fairchildsemi.com

# MC78XX/LM78XX/MC78XXA

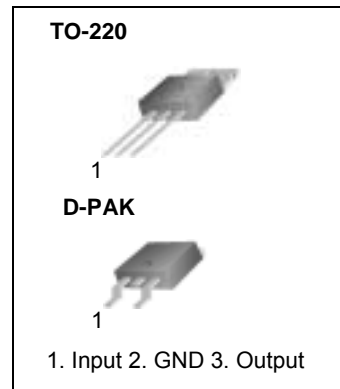
## 3-Terminal 1A Positive Voltage Regulator

### Features

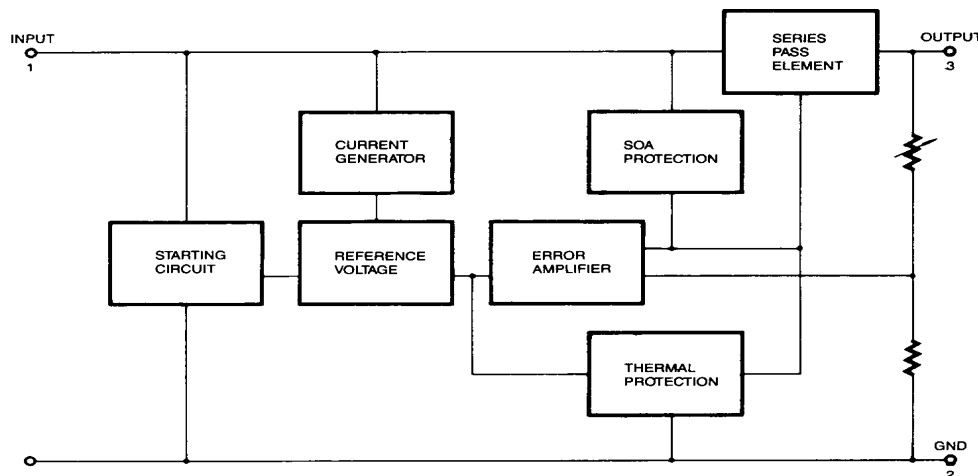
- Output Current up to 1A
- Output Voltages of 5, 6, 8, 9, 10, 12, 15, 18, 24V
- Thermal Overload Protection
- Short Circuit Protection
- Output Transistor Safe Operating Area Protection

### Description

The MC78XX/LM78XX/MC78XXA series of three terminal positive regulators are available in the TO-220/D-PAK package and with several fixed output voltages, making them useful in a wide range of applications. Each type employs internal current limiting, thermal shut down and safe operating area protection, making it essentially indestructible. If adequate heat sinking is provided, they can deliver over 1A output current. Although designed primarily as fixed voltage regulators, these devices can be used with external components to obtain adjustable voltages and currents.



### Internal Block Diagram





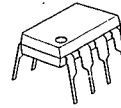
# NJM2068

## LOW-NOISE DUAL OPERATIONAL AMPLIFIER

### GENERAL DESCRIPTION

The NJM2068 is a high performance, low noise dual operational amplifier. This amplifier features popular pin-out, superior noise performance, and superior total harmonic distortion. This amplifier also features guaranteed noise performance with substantially higher gain-bandwidth product and slew rate which far exceeds that of the 4558 type amplifier. The specially designed low noise input transistors allow the NJM2068 to be used in very low noise signal processing applications such as audio preamplifiers and servo error amplifier.

### PACKAGE OUTLINE



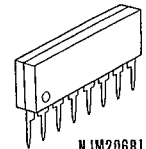
NJM2068D



NJM2068M



NJM2068V

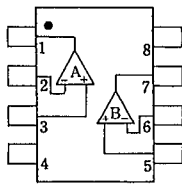


NJM2068L

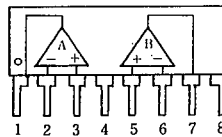
### FEATURES

- Operating Voltage (±4V ~ ±18V)
- Low Total Harmonic Distortion (0.001% typ.)
- Low Noise Voltage (FLAT+JISA, 0.56 μV typ.)
- High Slew Rate (6V/μs typ.)
- Unity Gain Bandwidth (27MHz @f=10kHz)
- Package Outline DIP8, DMP8, SIP8, SSOP8
- Bipolar Technology

### PIN CONFIGURATION



NJM2068D  
NJM2068M  
NJM2068V

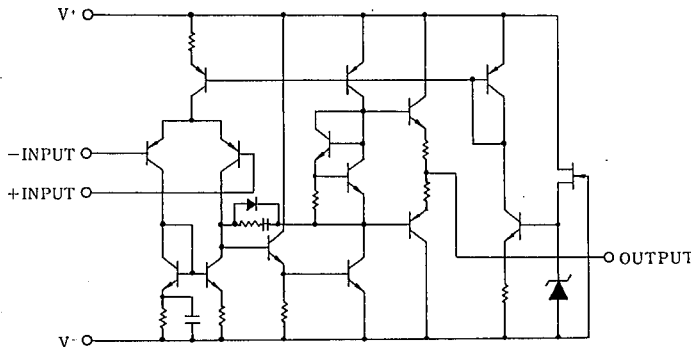


NJM2068L

#### PIN FUNCTION

1. A OUTPUT
2. A-INPUT
3. A+INPUT
4. V-
5. B+INPUT
6. B-INPUT
7. B OUTPUT
8. V+

### EQUIVALENT CIRCUIT (1/2 Shown)





# NJM4556A

## DUAL HIGH CURRENT OPERATIONAL AMPLIFIER

### ■ GENERAL DESCRIPTION

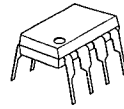
The NJM4556A integrated circuit is a high-gain, high output current dual operational amplifier capable of driving  $\pm 70\text{mA}$  into  $150\ \Omega$  loads ( $\pm 10.5\text{V}$  output voltage), and operating low supply voltage ( $V^+/V^- = \pm 2\text{V} \sim$ ).

The NJM4556A combines many of the features of the popular NJM4558 as well as having the capability of driving  $150\ \Omega$  loads. In addition, the wide band-width, low noise, high slew rate and low distortion of the NJM4556A make it ideal for many audio, telecommu- nications and instrumentation applications.

### ■ FEATURES

- Operating Voltage ( $\pm 2\text{V} \sim \pm 18\text{V}$ )
- High Output Current ( $I_o = 70\text{mA}$ )
- Slew Rate ( $3\text{V}/\mu\text{s}$  typ.)
- Gain Band Width Product ( $8\text{MHz}$  typ.)
- Package Outline DIP8, DMP8, SIP8, SSOP8
- Bipolar Technology

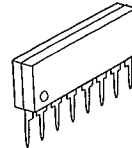
### ■ PACKAGE OUTLINE



NJM4556AD



NJM4556AM

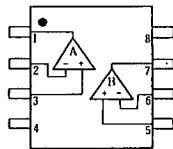


NJM4556AL

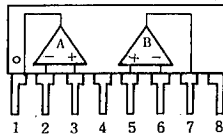


NJM4556AV

### ■ PIN CONFIGURATION



NJM4556AD.  
NJM4556AM  
NJM4556AV

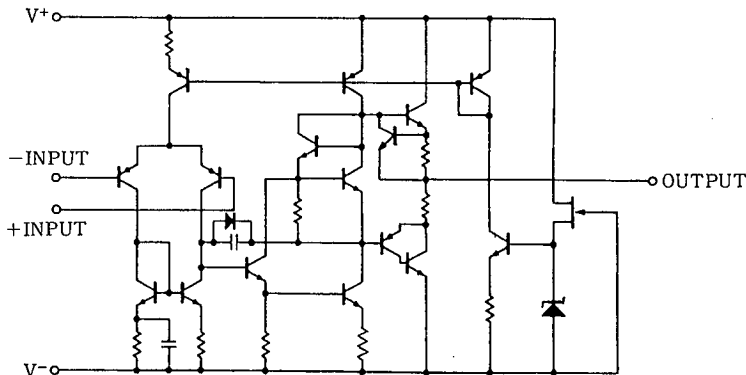


NJM4556AL

#### PIN FUNCTION

1. A OUTPUT
2. A- INPUT
3. A+ INPUT
4.  $V^-$
5. B+ INPUT
6. B- INPUT
7. B OUTPUT
8.  $V^+$

### ■ EQUIVALENT CIRCUIT (1/2 Shown)







# NJM7800

## 3-TERMINAL POSITIVE VOLTAGE REGULATOR

### ■ GENERAL DESCRIPTION

The NJM7800 series of monolithic 3-Terminal Positive Voltage Regulators is constructed using the New JRC Planar epitaxial process. These regulators employ internal current-limiting, thermal-shutdown and safe-area compensation making them essentially indestructible. If adequate heat sinking is provided, they can deliver over 1A output current. They are intended as fixed voltage regulators in a wide range of applications including local (on card) regulation for elimination of distribution problems associated with single point regulation. In addition to use as fixed voltage regulators, these devices can be used with external components to obtain adjustable output voltages and currents.

### ■ FEATURES

- Operating Voltage
- Internal Short Circuit Current Limit
- Internal Thermal Overload Protection
- Excellent Ripple Rejection
- Guarantee'd 1.5A Output Current
- Package Outline
- Bipolar Technology

TO-220F, TO-252

### ■ PACKAGE OUTLINE

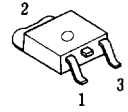
(TO-220F)



NJM7800FA

- 1. IN
- 2. GND
- 3. OUT

(TO-252)

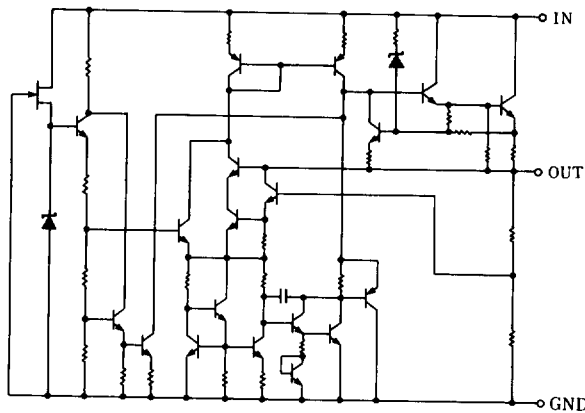


NJM7800LA

- 1. IN
- 2. GND
- 3. OUT

(note) The radiation fin is connected pin2.

### ■ EQUIVALENT CIRCUIT





# M24C64 M24C32

## 64Kbit and 32Kbit Serial I<sup>2</sup>C Bus EEPROM

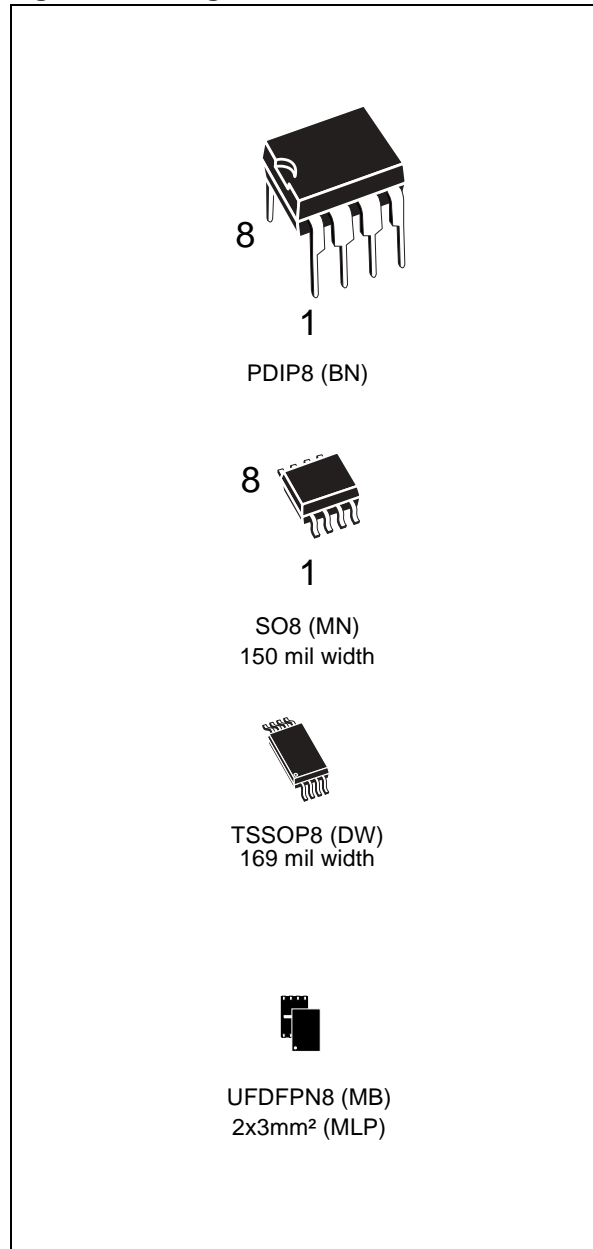
### FEATURES SUMMARY

- Two-Wire I<sup>2</sup>C Serial Interface  
Supports 400kHz Protocol
- Single Supply Voltage:
  - 4.5 to 5.5V for M24Cxx
  - 2.5 to 5.5V for M24Cxx-W
  - 1.8 to 5.5V for M24Cxx-R
- Write Control Input
- BYTE and PAGE WRITE (up to 32 Bytes)
- RANDOM and SEQUENTIAL READ Modes
- Self-Timed Programming Cycle
- Automatic Address Incrementing
- Enhanced ESD/Latch-Up Protection
- More than 1 Million Erase/Write Cycles
- More than 40-Year Data Retention

**Table 1. Product List**

Reference	Part Number
M24C64	M24C64
	M24C64-W
	M24C64-R
M24C32	M24C32
	M24C32-W
	M24C32-R

**Figure 1. Packages**

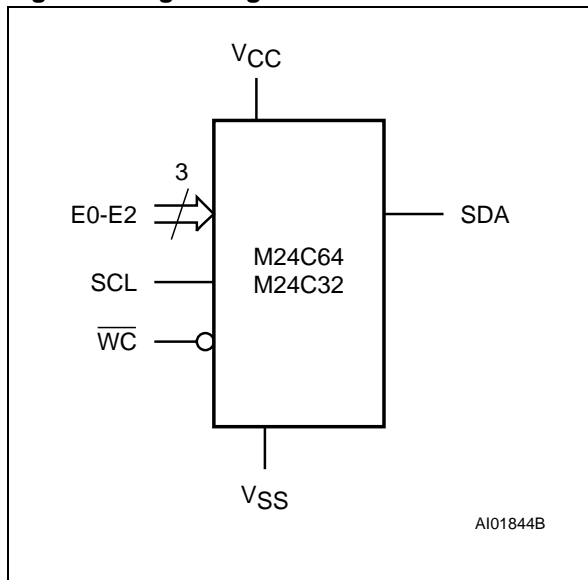


## M24C64, M24C32

### SUMMARY DESCRIPTION

These I<sup>2</sup>C-compatible electrically erasable programmable memory (EEPROM) devices are organized as 8192 x 8 bits (M24C64) and 4096 x 8 bits (M24C32).

Figure 2. Logic Diagram



I<sup>2</sup>C uses a two-wire serial interface, comprising a bi-directional data line and a clock line. The devices carry a built-in 4-bit Device Type Identifier code (1010) in accordance with the I<sup>2</sup>C bus definition.

The device behaves as a slave in the I<sup>2</sup>C protocol, with all memory operations synchronized by the serial clock. Read and Write operations are initiated by a Start condition, generated by the bus master. The Start condition is followed by a Device Select Code and Read/Write bit (RW) (as described in Table 3.), terminated by an acknowledge bit.

When writing data to the memory, the device inserts an acknowledge bit during the 9<sup>th</sup> bit time, following the bus master's 8-bit transmission. When data is read by the bus master, the bus master acknowledges the receipt of the data byte in the same way. Data transfers are terminated by a Stop condition after an Ack for Write, and after a NoAck for Read.

Table 2. Signal Names

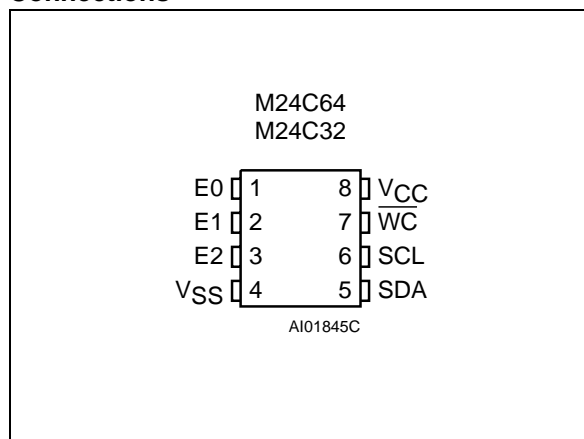
E0, E1, E2	Chip Enable
SDA	Serial Data
SCL	Serial Clock
WC	Write Control
VCC	Supply Voltage
VSS	Ground

#### Power On Reset: VCC Lock-Out Write Protect

In order to prevent data corruption and inadvertent Write operations during Power-up, a Power On Reset (POR) circuit is included. At Power-up, the internal reset is held active until VCC has reached the Power On Reset (POR) threshold voltage, and all operations are disabled – the device will not respond to any command. In the same way, when VCC drops from the operating voltage, below the Power On Reset (POR) threshold voltage, all operations are disabled and the device will not respond to any command.

A stable and valid VCC (as defined in Table 9. and Table 10.) must be applied before applying any logic signal.

Figure 3. DIP, SO, TSSOP and UDFPN Connections



Note: See PACKAGE MECHANICAL section for package dimensions, and how to identify pin-1.

**M24C64, M24C32**

**SIGNAL DESCRIPTION**

**Serial Clock (SCL).** This input signal is used to strobe all data in and out of the device. In applications where this signal is used by slave devices to synchronize the bus to a slower clock, the bus master must have an open drain output, and a pull-up resistor must be connected from Serial Clock (SCL) to  $V_{CC}$ . (Figure 4. indicates how the value of the pull-up resistor can be calculated). In most applications, though, this method of synchronization is not employed, and so the pull-up resistor is not necessary, provided that the bus master has a push-pull (rather than open drain) output.

**Serial Data (SDA).** This bi-directional signal is used to transfer data in or out of the device. It is an open drain output that may be wire-OR'ed with other open drain or open collector signals on the bus. A pull up resistor must be connected from Se-

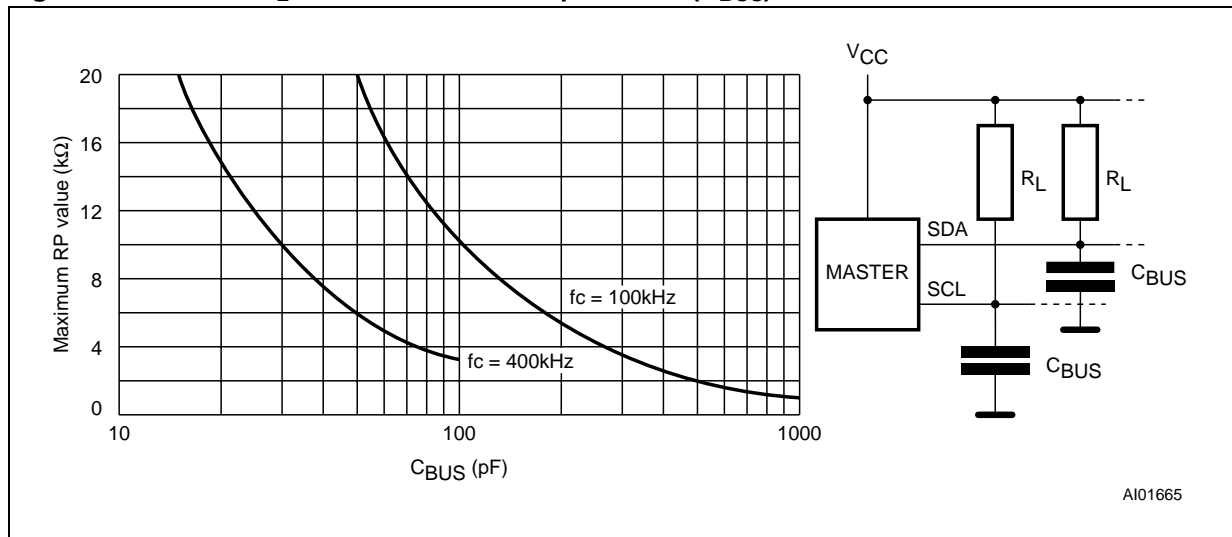
rial Data (SDA) to  $V_{CC}$ . (Figure 4. indicates how the value of the pull-up resistor can be calculated).

**Chip Enable (E0, E1, E2).** These input signals are used to set the value that is to be looked for on the three least significant bits (b3, b2, b1) of the 7-bit Device Select Code. These inputs must be tied to  $V_{CC}$  or  $V_{SS}$ , to establish the Device Select Code.

**Write Control ( $\overline{WC}$ ).** This input signal is useful for protecting the entire contents of the memory from inadvertent write operations. Write operations are disabled to the entire memory array when Write Control ( $\overline{WC}$ ) is driven High. When unconnected, the signal is internally read as  $V_{IL}$ , and Write operations are allowed.

When Write Control ( $\overline{WC}$ ) is driven High, Device Select and Address bytes are acknowledged, Data bytes are not acknowledged.

**Figure 4. Maximum  $R_L$  Value versus Bus Capacitance ( $C_{BUS}$ ) for an I<sup>2</sup>C Bus**

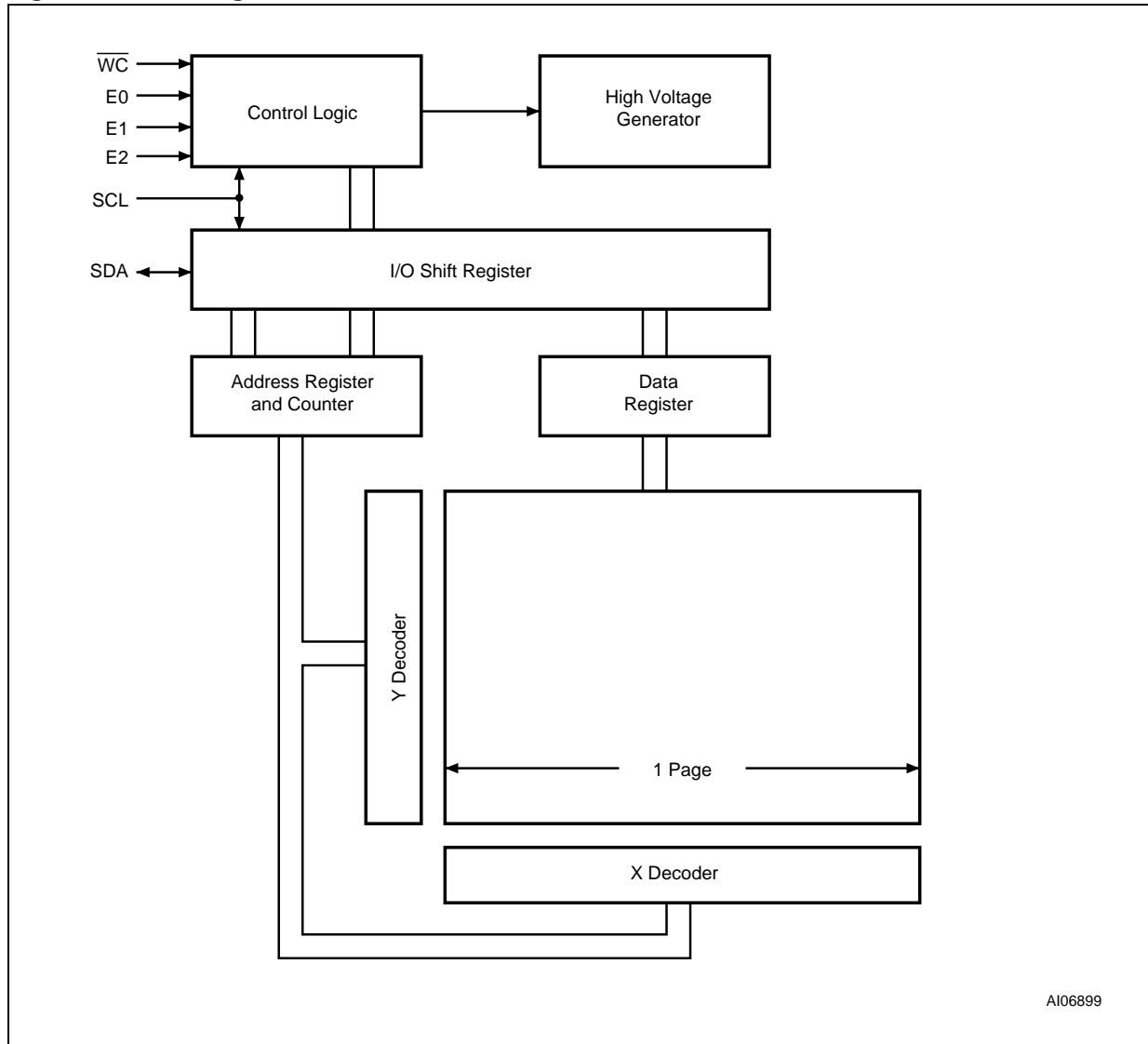


**M24C64, M24C32**

**MEMORY ORGANIZATION**

The memory is organized as shown in Figure 6..

**Figure 6. Block Diagram**



AI06899

## M24C64, M24C32

### DEVICE OPERATION

The device supports the I<sup>2</sup>C protocol. This is summarized in Figure 5.. Any device that sends data on to the bus is defined to be a transmitter, and any device that reads the data to be a receiver. The device that controls the data transfer is known as the bus master, and the other as the slave device. A data transfer can only be initiated by the bus master, which will also provide the serial clock for synchronization. The M24Cxx device is always a slave in all communication.

#### Start Condition

Start is identified by a falling edge of Serial Data (SDA) while Serial Clock (SCL) is stable in the High state. A Start condition must precede any data transfer command. The device continuously monitors (except during a Write cycle) Serial Data (SDA) and Serial Clock (SCL) for a Start condition, and will not respond unless one is given.

#### Stop Condition

Stop is identified by a rising edge of Serial Data (SDA) while Serial Clock (SCL) is stable and driven High. A Stop condition terminates communication between the device and the bus master. A Read command that is followed by NoAck can be followed by a Stop condition to force the device into the Stand-by mode. A Stop condition at the end of a Write command triggers the internal Write cycle.

#### Acknowledge Bit (ACK)

The acknowledge bit is used to indicate a successful byte transfer. The bus transmitter, whether it be bus master or slave device, releases Serial Data (SDA) after sending eight bits of data. During the 9<sup>th</sup> clock pulse period, the receiver pulls Serial

Data (SDA) Low to acknowledge the receipt of the eight data bits.

#### Data Input

During data input, the device samples Serial Data (SDA) on the rising edge of Serial Clock (SCL). For correct device operation, Serial Data (SDA) must be stable during the rising edge of Serial Clock (SCL), and the Serial Data (SDA) signal must change *only* when Serial Clock (SCL) is driven Low.

#### Memory Addressing

To start communication between the bus master and the slave device, the bus master must initiate a Start condition. Following this, the bus master sends the Device Select Code, shown in Table 3. (on Serial Data (SDA), most significant bit first).

The Device Select Code consists of a 4-bit Device Type Identifier, and a 3-bit Chip Enable "Address" (E2, E1, E0). To address the memory array, the 4-bit Device Type Identifier is 1010b.

Up to eight memory devices can be connected on a single I<sup>2</sup>C bus. Each one is given a unique 3-bit code on the Chip Enable (E0, E1, E2) inputs. When the Device Select Code is received, the device only responds if the Chip Enable Address is the same as the value on the Chip Enable (E0, E1, E2) inputs.

The 8<sup>th</sup> bit is the Read/Write bit ( $\overline{RW}$ ). This bit is set to 1 for Read and 0 for Write operations.

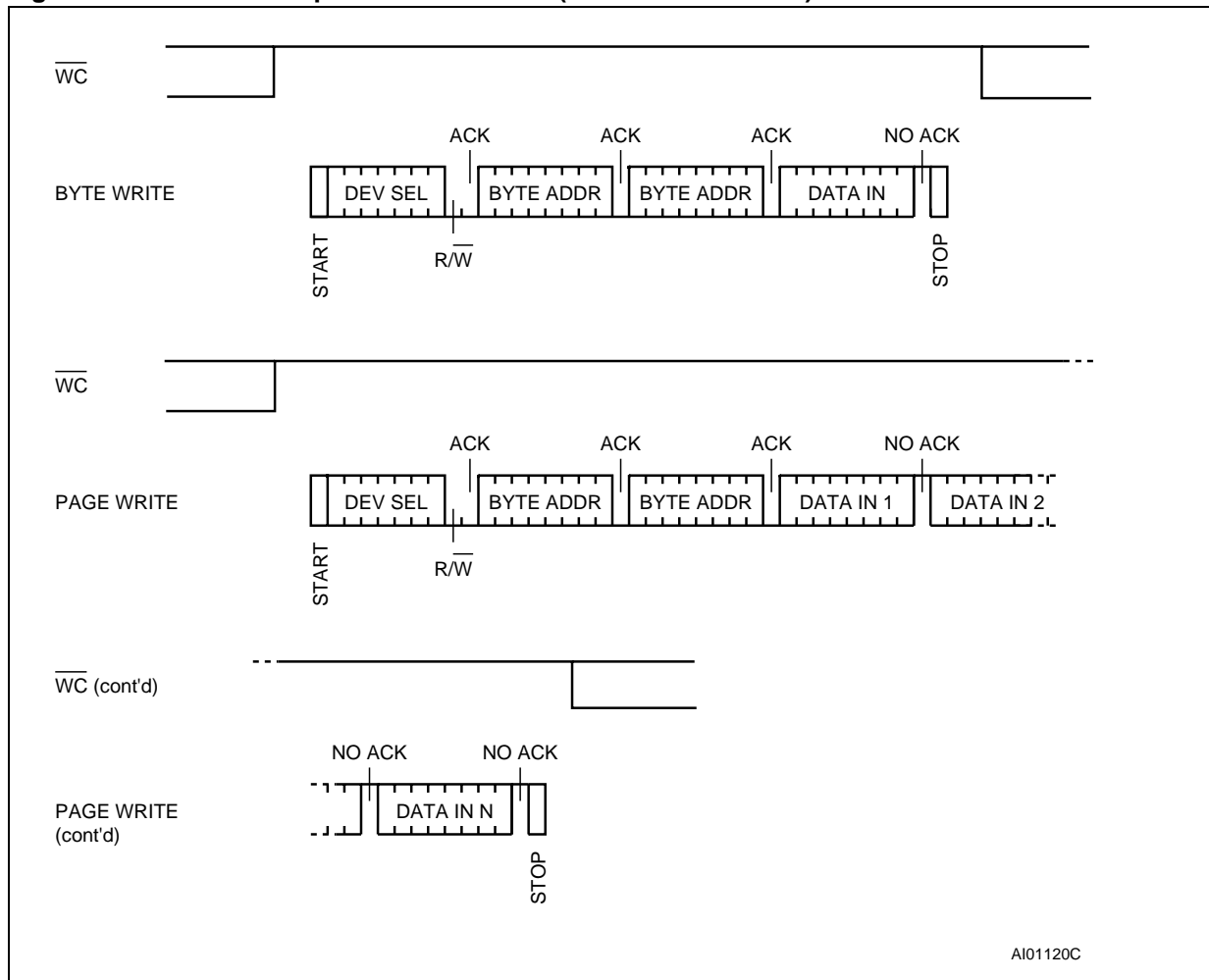
If a match occurs on the Device Select code, the corresponding device gives an acknowledgment on Serial Data (SDA) during the 9<sup>th</sup> bit time. If the device does not match the Device Select code, it deselected itself from the bus, and goes into Stand-by mode.

**Table 6. Operating Modes**

Mode	$\overline{RW}$ bit	$\overline{WC}$ <sup>1</sup>	Bytes	Initial Sequence
Current Address Read	1	X	1	START, Device Select, $\overline{RW} = 1$
Random Address Read	0	X	1	START, Device Select, $\overline{RW} = 0$ , Address
	1	X		reSTART, Device Select, $\overline{RW} = 1$
Sequential Read	1	X	≥ 1	Similar to Current or Random Address Read
Byte Write	0	V <sub>IL</sub>	1	START, Device Select, $\overline{RW} = 0$
Page Write	0	V <sub>IL</sub>	≤ 32	START, Device Select, $\overline{RW} = 0$

Note: 1. X = V<sub>IH</sub> or V<sub>IL</sub>.

## M24C64, M24C32

Figure 7. Write Mode Sequences with  $\overline{WC}=1$  (data write inhibited)

### Write Operations

Following a Start condition the bus master sends a Device Select Code with the Read/Write bit (RW) reset to 0. The device acknowledges this, as shown in Figure 8., and waits for two address bytes. The device responds to each address byte with an acknowledge bit, and then waits for the data byte.

Writing to the memory may be inhibited if Write Control ( $\overline{WC}$ ) is driven High. Any Write instruction with Write Control ( $\overline{WC}$ ) driven High (during a period of time from the Start condition until the end of the two address bytes) will not modify the memory contents, and the accompanying data bytes are *not* acknowledged, as shown in Figure 7..

Each data byte in the memory has a 16-bit (two byte wide) address. The Most Significant Byte (Table 4.) is sent first, followed by the Least Significant Byte (Table 5.). Bits b15 to b0 form the address of the byte in memory.

When the bus master generates a Stop condition immediately after the Ack bit (in the "10<sup>th</sup> bit" time

slot), either at the end of a Byte Write or a Page Write, the internal Write cycle is triggered. A Stop condition at any other time slot does not trigger the internal Write cycle.

After the Stop condition, the delay  $t_W$ , and the successful completion of a Write operation, the device's internal address counter is incremented automatically, to point to the next byte address after the last one that was modified.

During the internal Write cycle, Serial Data (SDA) is disabled internally, and the device does not respond to any requests.

### Byte Write

After the Device Select code and the address bytes, the bus master sends one data byte. If the addressed location is Write-protected, by Write Control ( $\overline{WC}$ ) being driven High, the device replies with NoAck, and the location is not modified. If, instead, the addressed location is not Write-protected, the device replies with Ack. The bus master terminates the transfer by generating a Stop condition, as shown in Figure 8..

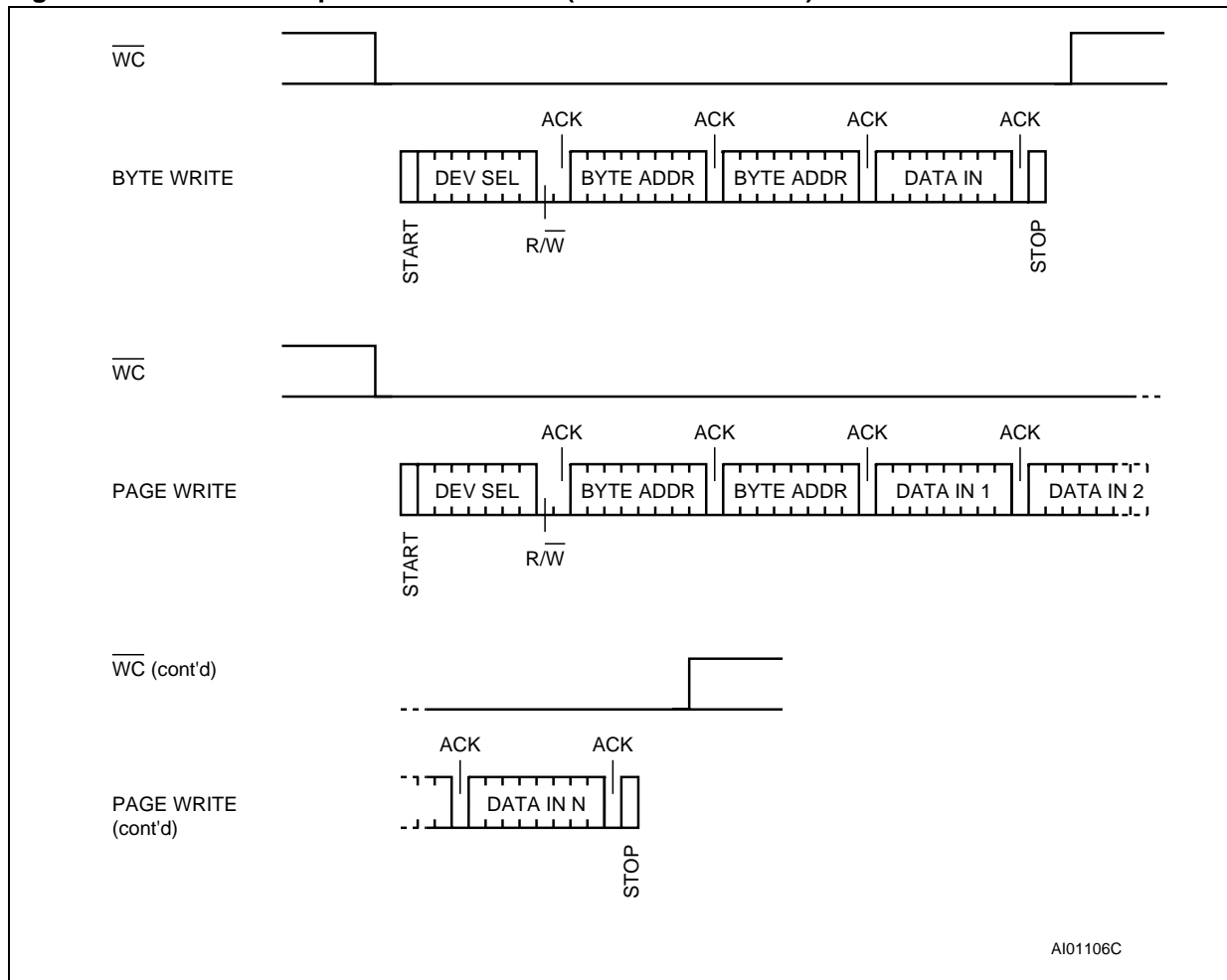
## M24C64, M24C32

### Page Write

The Page Write mode allows up to 32 bytes to be written in a single Write cycle, provided that they are all located in the same 'row' in the memory: that is, the most significant memory address bits (b12-b5 for M24C64, and b11-b5 for M24C32) are the same. If more bytes are sent than will fit up to the end of the row, a condition known as 'roll-over' occurs. This should be avoided, as data starts to become overwritten in an implementation dependent way.

The bus master sends from 1 to 32 bytes of data, each of which is acknowledged by the device if Write Control ( $\overline{WC}$ ) is Low. If Write Control ( $\overline{WC}$ ) is High, the contents of the addressed memory location are not modified, and each data byte is followed by a NoAck. After each byte is transferred, the internal byte address counter (the 5 least significant address bits only) is incremented. The transfer is terminated by the bus master generating a Stop condition.

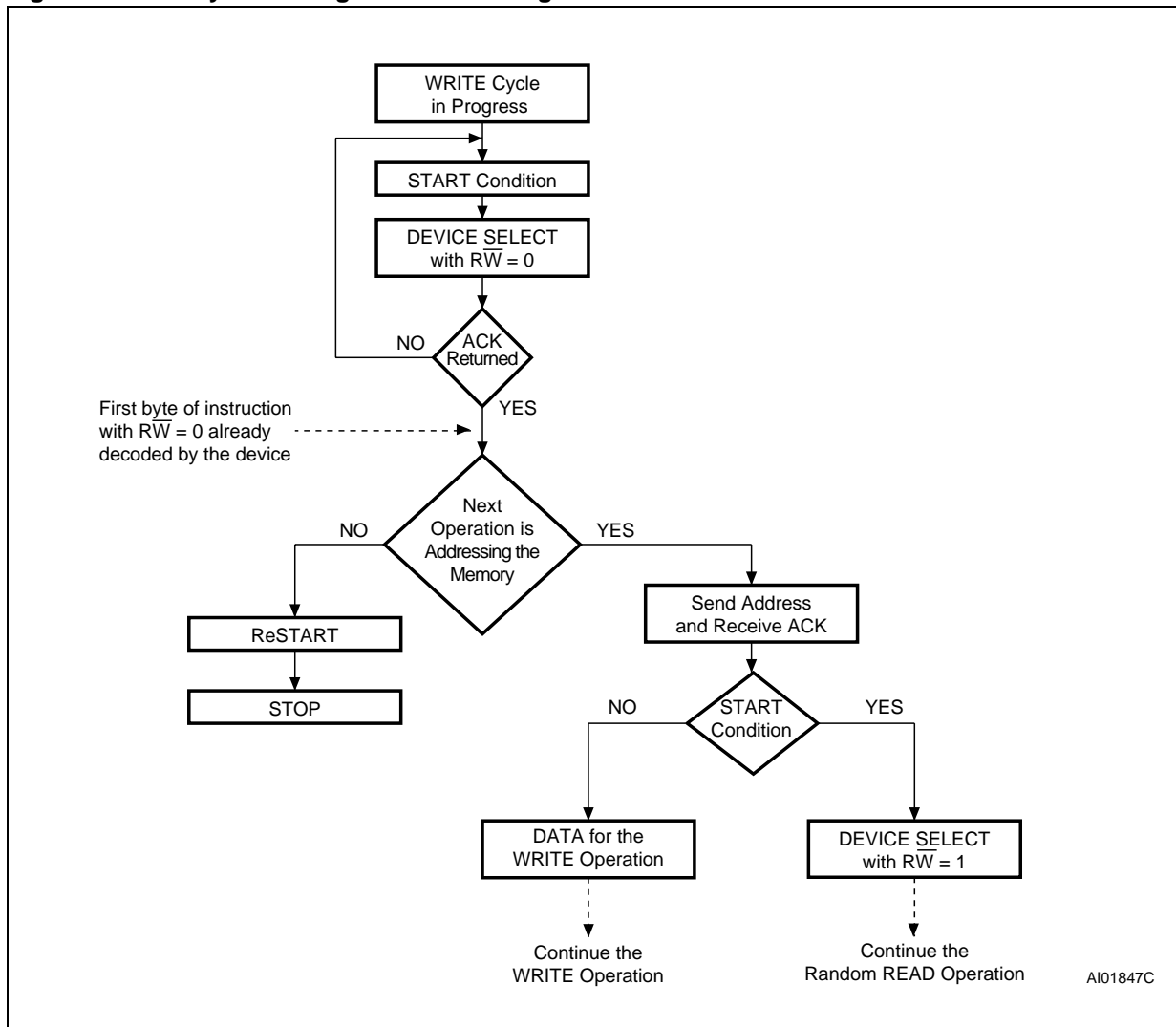
**Figure 8. Write Mode Sequences with  $\overline{WC}=0$  (data write enabled)**





## M24C64, M24C32

Figure 9. Write Cycle Polling Flowchart using ACK

**Minimizing System Delays by Polling On ACK**

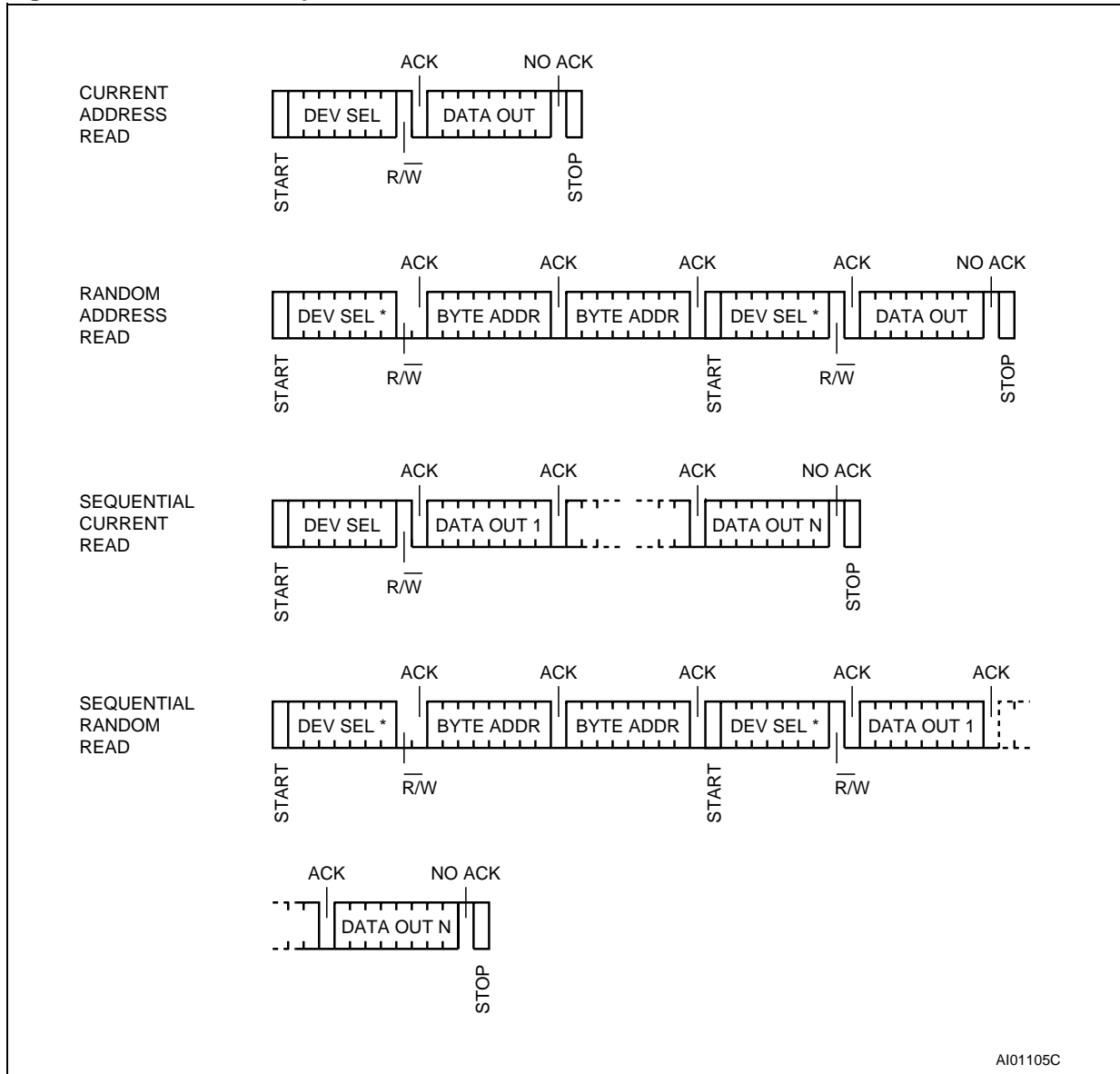
During the internal Write cycle, the device disconnects itself from the bus, and writes a copy of the data from its internal latches to the memory cells. The maximum Write time ( $t_w$ ) is shown in Table 16. and Table 17., but the typical time is shorter. To make use of this, a polling sequence can be used by the bus master.

The sequence, as shown in Figure 9., is:

- Initial condition: a Write cycle is in progress.
- Step 1: the bus master issues a Start condition followed by a Device Select Code (the first byte of the new instruction).
- Step 2: if the device is busy with the internal Write cycle, no Ack will be returned and the bus master goes back to Step 1. If the device has terminated the internal Write cycle, it responds with an Ack, indicating that the device is ready to receive the second part of the instruction (the first byte of this instruction having been sent during Step 1).

**M24C64, M24C32**

**Figure 10. Read Mode Sequences**



Note: 1. The seven most significant bits of the Device Select Code of a Random Read (in the 1<sup>st</sup> and 4<sup>th</sup> bytes) must be identical.

**Read Operations**

Read operations are performed independently of the state of the Write Control (WC) signal.

After the successful completion of a Read operation, the device's internal address counter is incremented by one, to point to the next byte address.

**Random Address Read**

A dummy Write is first performed to load the address into this address counter (as shown in Figure 10.) but *without* sending a Stop condition. Then, the bus master sends another Start condition, and repeats the Device Select Code, with the Read/Write bit (RW) set to 1. The device acknowledges this, and outputs the contents of the ad-

ressed byte. The bus master must *not* acknowledge the byte, and terminates the transfer with a Stop condition.

**Current Address Read**

For the Current Address Read operation, following a Start condition, the bus master only sends a Device Select Code with the Read/Write bit (RW) set to 1. The device acknowledges this, and outputs the byte addressed by the internal address counter. The counter is then incremented. The bus master terminates the transfer with a Stop condition, as shown in Figure 10., *without* acknowledging the byte.

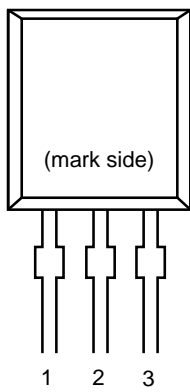
# LOW VOLTAGE DETECTOR

## R×5VT SERIES

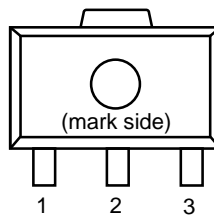
R×5VT

### PIN CONFIGURATION

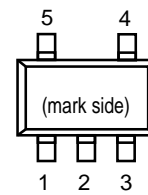
• TO-92



• SOT-89



• SOT-23-5



### PIN DESCRIPTION

• TO-92

Pin No.	Symbol
1	OUT
2	V <sub>DD</sub>
3	GND

• SOT-89

Pin No.	Symbol
1	OUT
2	V <sub>DD</sub>
3	GND

• SOT-23-5

Pin No.	Symbol
1	OUT
2	V <sub>DD</sub>
3	GND
4	NC
5	NC

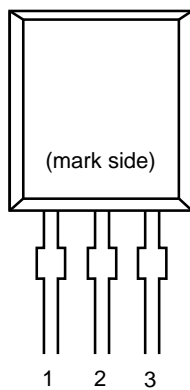
# VOLTAGE DETECTOR

## R×5VL SERIES

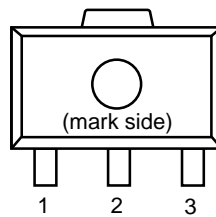
R×5VL

### PIN CONFIGURATION

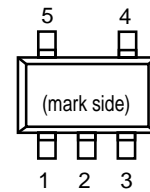
• TO-92



• SOT-89



• SOT-23-5



### PIN DESCRIPTION

• TO-92

Pin No	Symbol
1	OUT
2	VDD
3	GND

• SOT-89

Pin No	Symbol
1	OUT
2	VDD
3	GND

• SOT-23-5

Pin No	Symbol
1	OUT
2	VDD
3	GND
4	NC
5	NC

**TOSHIBA**

**TC74VHC157F/FN/FT**

TOSHIBA CMOS DIGITAL INTEGRATED CIRCUIT SILICON MONOLITHIC

**TC74VHC157F, TC74VHC157FN, TC74VHC157FT**

**QUAD 2-CHANNEL MULTIPLEXER**

The TC74VHC157 is an advanced high speed CMOS QUAD 2 - CHANNEL MULTIPLEXER fabricated with silicon gate C<sup>2</sup>MOS technology.

It achieves the high speed operation similar to equivalent Bipolar Schottky TTL while maintaining the CMOS low power dissipation.

It consists of four 2 - input digital multiplexers with common select and strobe inputs.

When the STROBE input is held "H" level, selection of data is inhibited and all the outputs become "L" level.

The SELECT decoding determines whether the A or B inputs get routed to their corresponding Y outputs.

An Input protection circuit ensures that 0 to 5.5V can be applied to the input pins without regard to the supply voltage. This device can be used to interface 5V to 3V systems and on two supply systems such as battery back up. This circuit prevents device destruction due to mismatched supply and input voltages.

**FEATURES :**

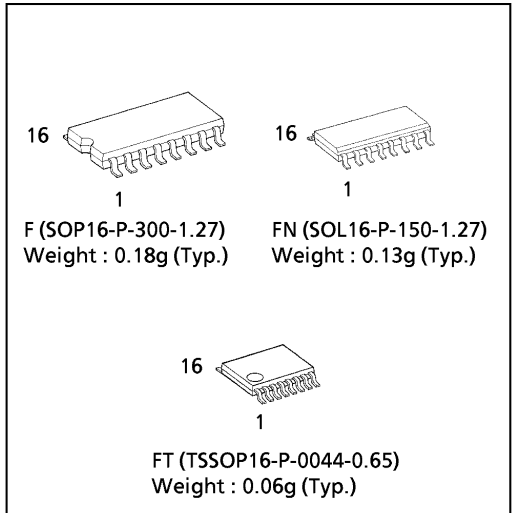
- High Speed..... $t_{pd} = 4.1ns(\text{typ.})$  at  $V_{CC} = 5V$
- Low Power Dissipation..... $I_{CC} = 4\mu A(\text{Max.})$  at  $T_a = 25^\circ C$
- High Noise Immunity..... $V_{NIH} = V_{NIL} = 28\% V_{CC} (\text{Min.})$
- Power Down Protection is provided on all inputs.
- Balanced Propagation Delays..... $t_{pLH} \approx t_{pHL}$
- Wide Operating Voltage Range..... $V_{CC} (\text{opr}) = 2V \sim 5.5V$
- Low Noise ..... $V_{OLP} = 0.8V (\text{Max.})$
- Pin and Function Compatible with 74ALS157

**TRUTH TABLE**

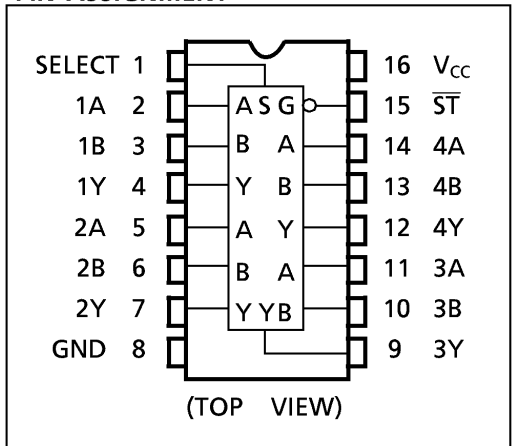
INPUTS				OUTPUT
$\overline{ST}$	SELECT	A	B	
H	X	X	X	L
L	L	L	X	L
L	L	H	X	H
L	H	X	L	L
L	H	X	H	H

X : Don't Care

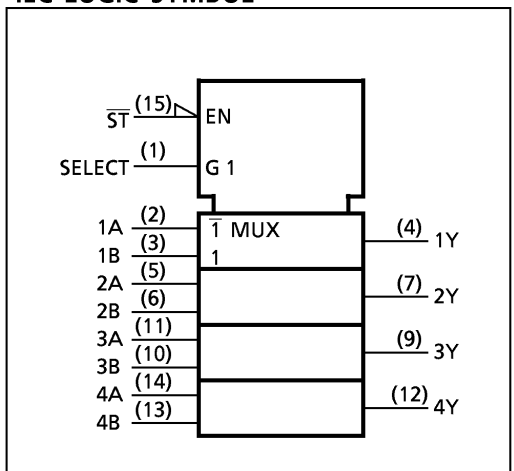
(Note) The JEDEC SOP (FN) is not available in Japan.



**PIN ASSIGNMENT**



**IEC LOGIC SYMBOL**

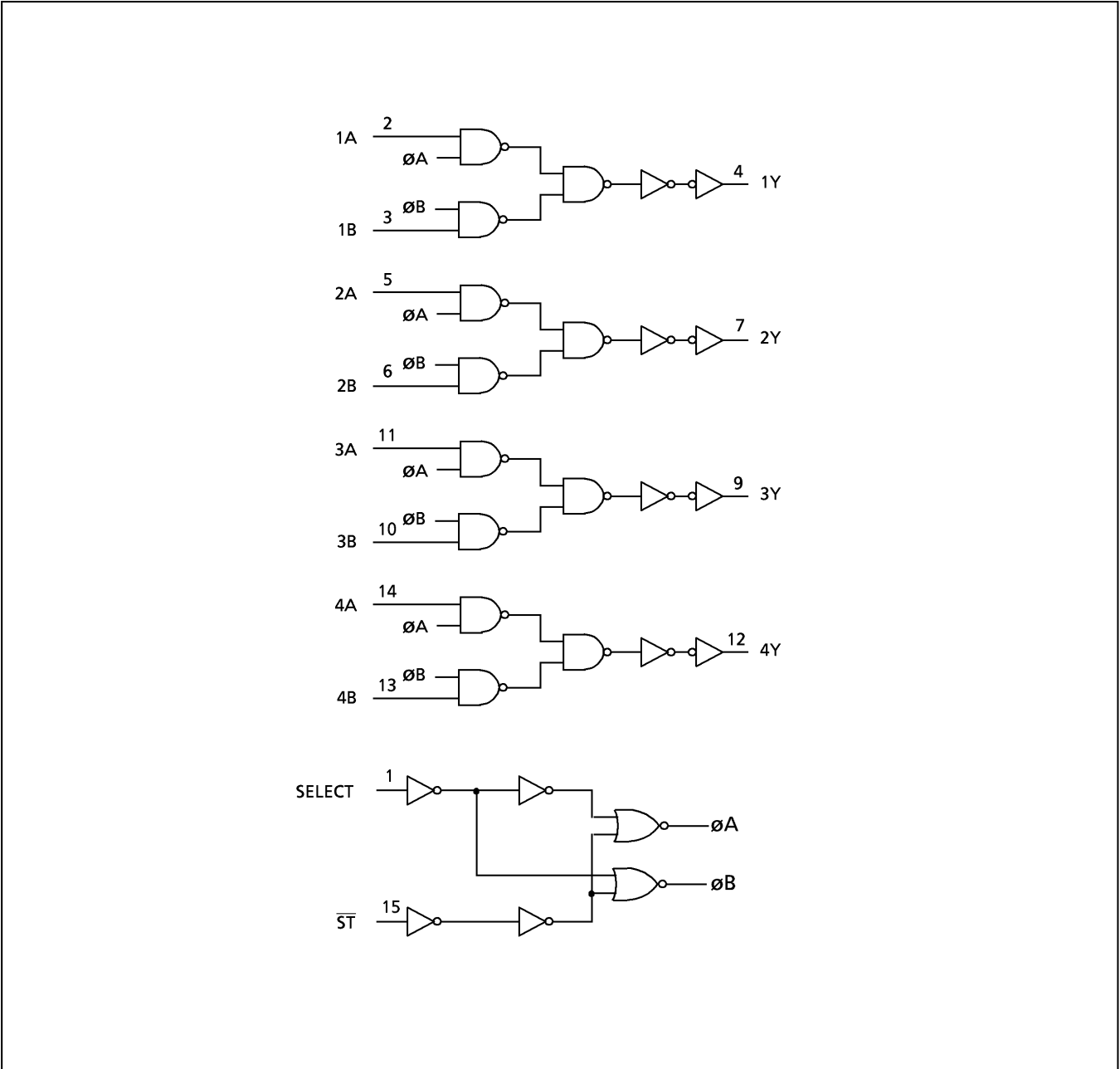


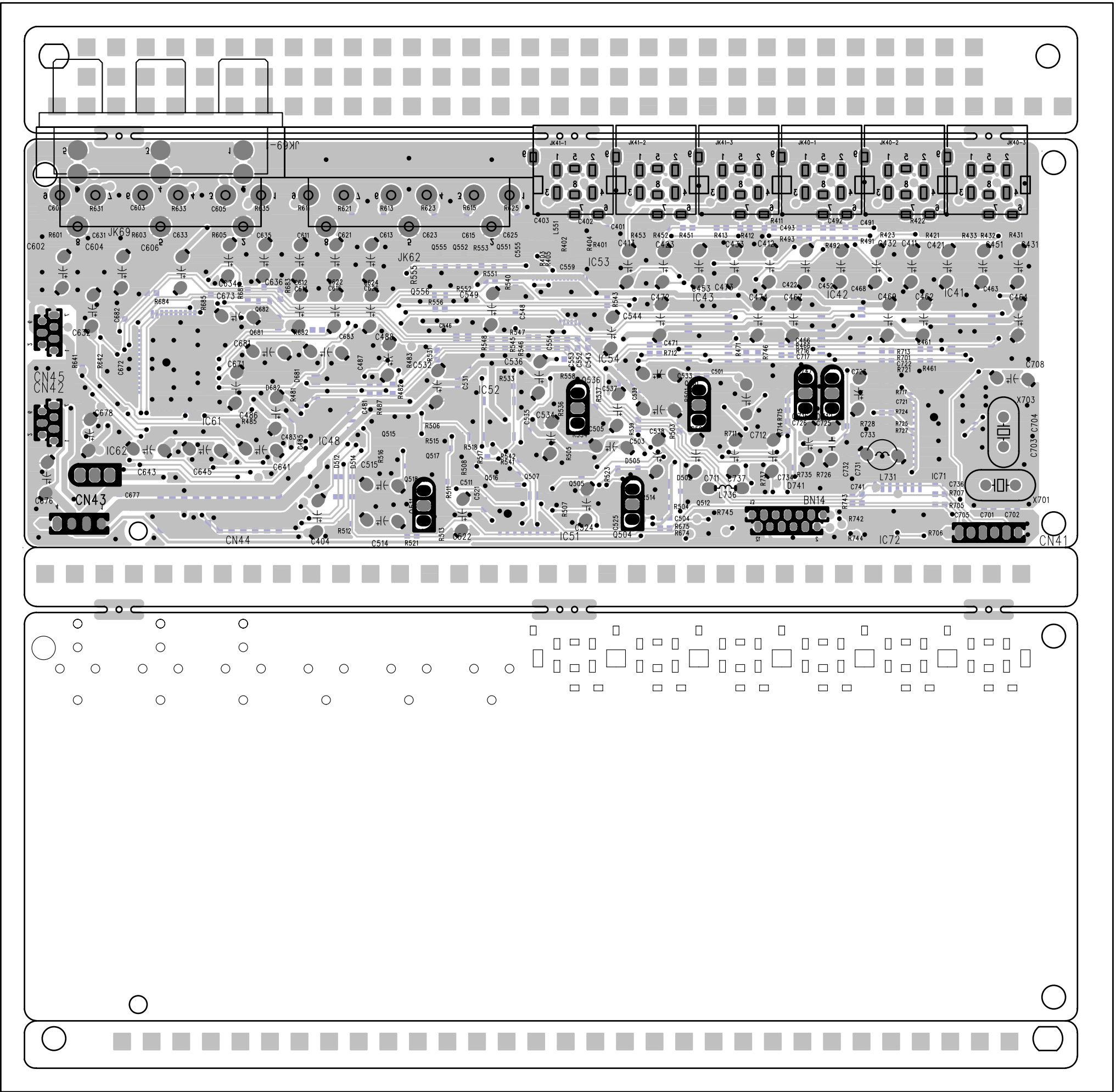
980910EBA2

**TOSHIBA**

**TC74VHC157F/FN/FT**

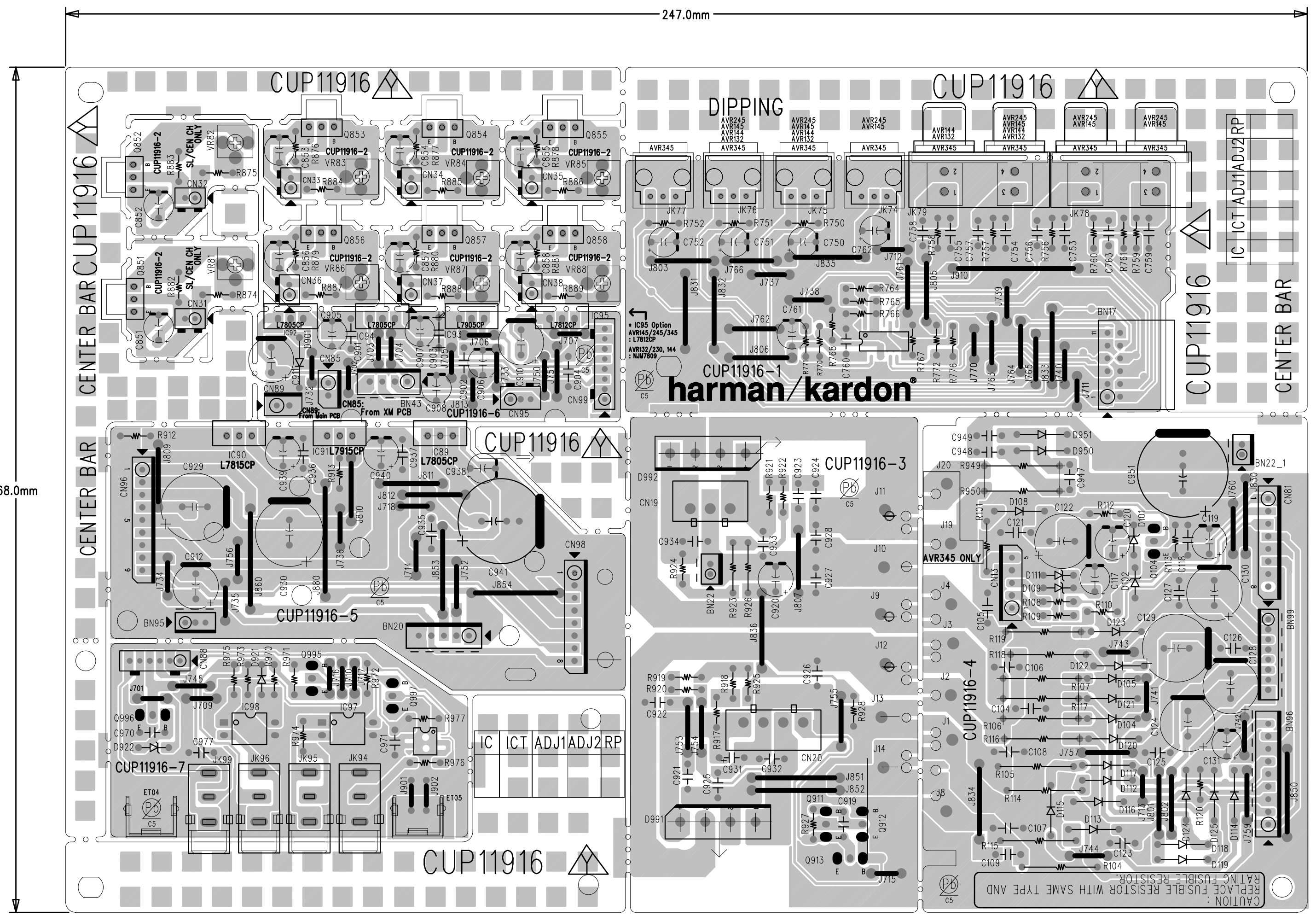
**SYSTEM DIAGRAM**





247.0mm

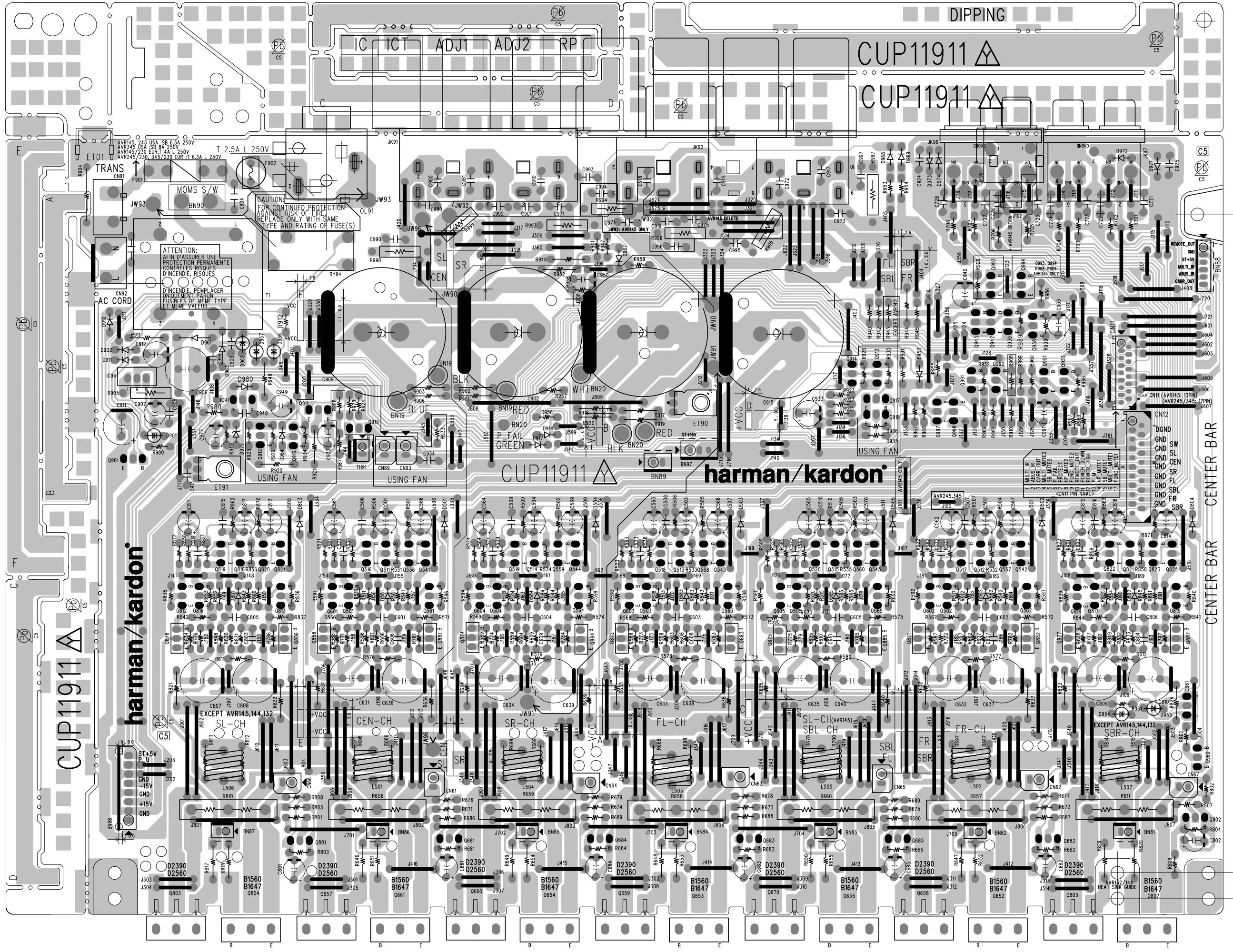
168.0mm

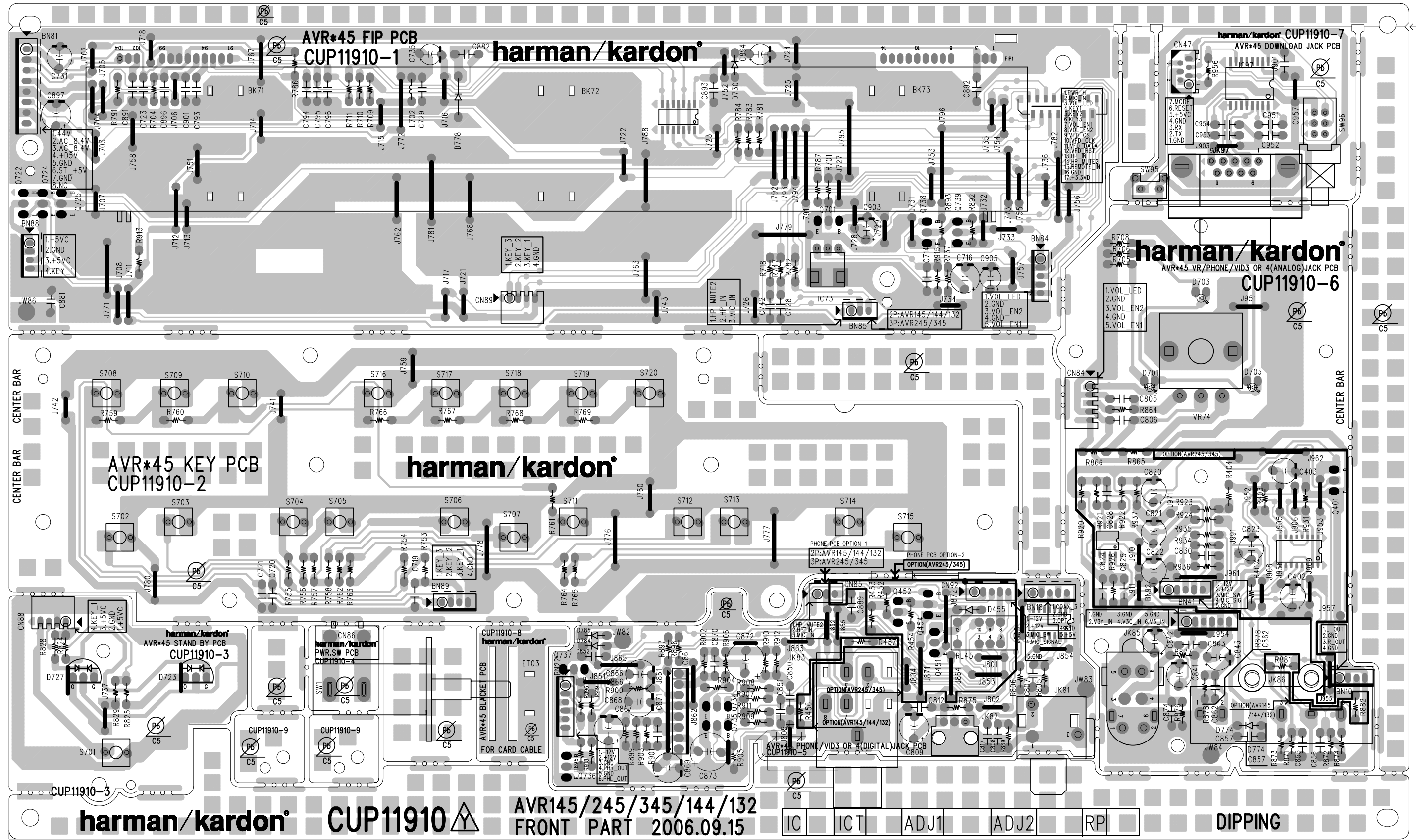


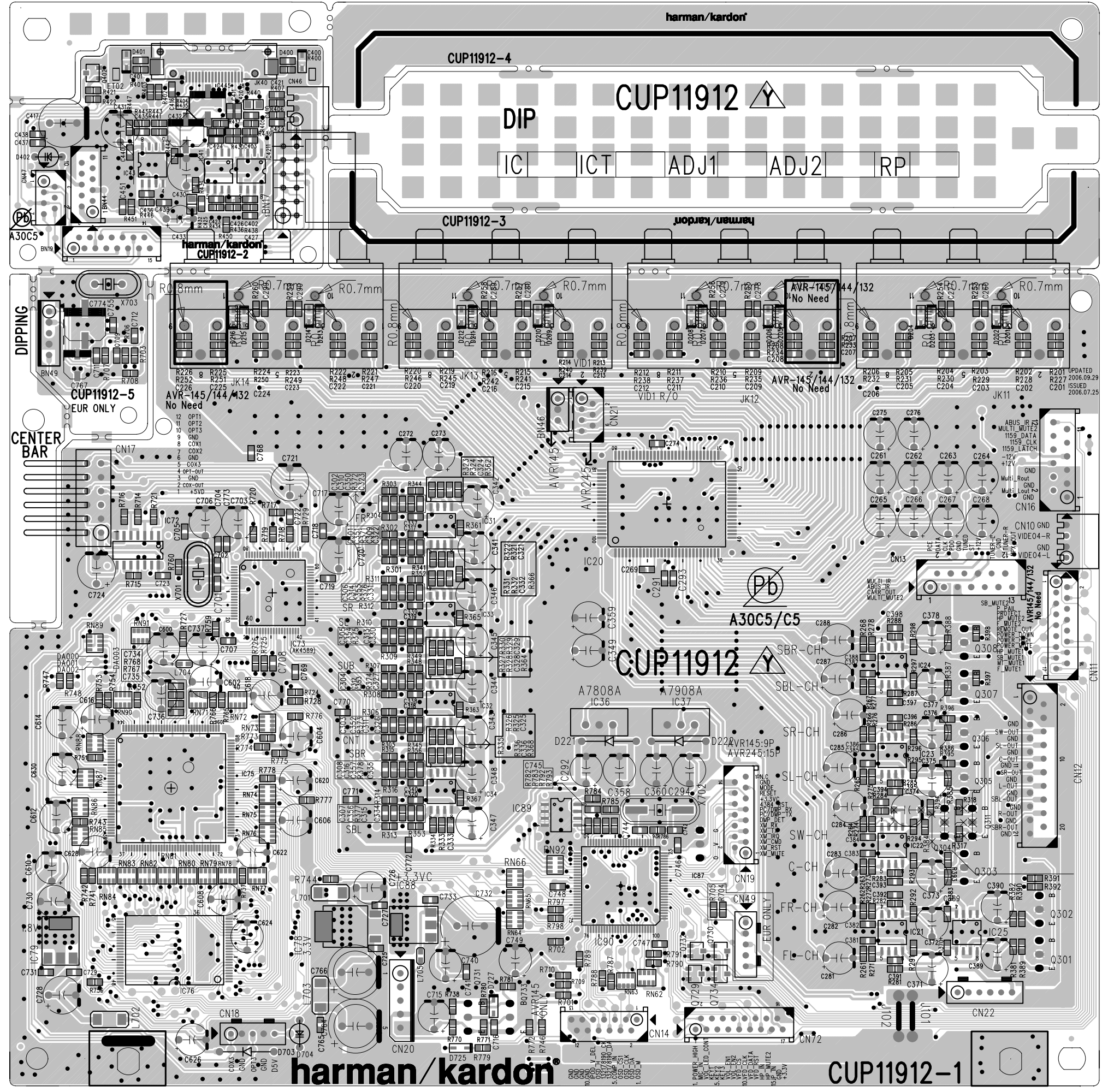
• IC95 Option  
 AVR145/245/345  
 : L7812CP  
 AVR132/230, 144  
 : N.M.7809

CAUTION:  
 REPLACE FUSIBLE RESISTOR WITH SAME TYPE AND  
 RATING FUSIBLE RESISTOR.



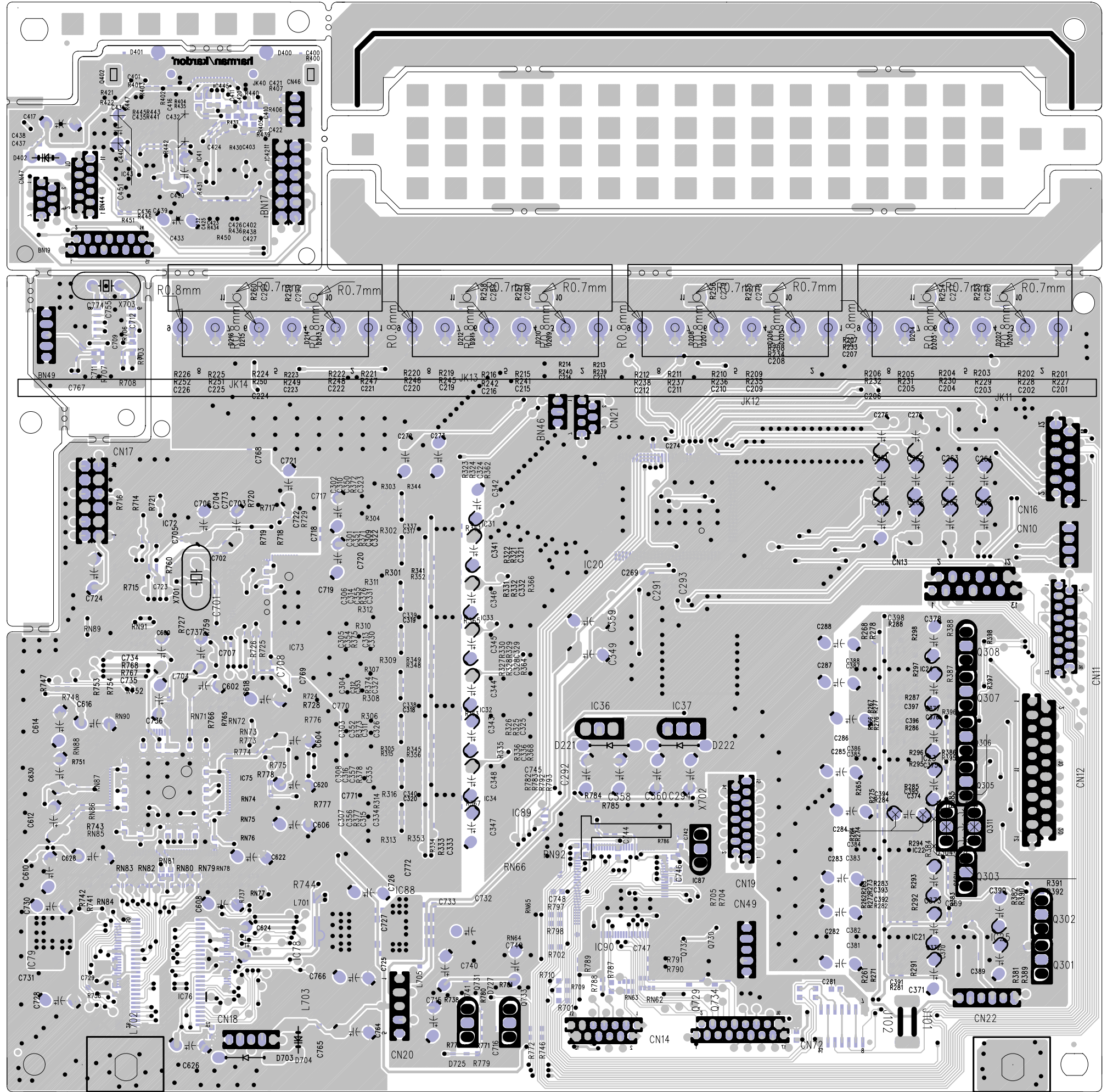






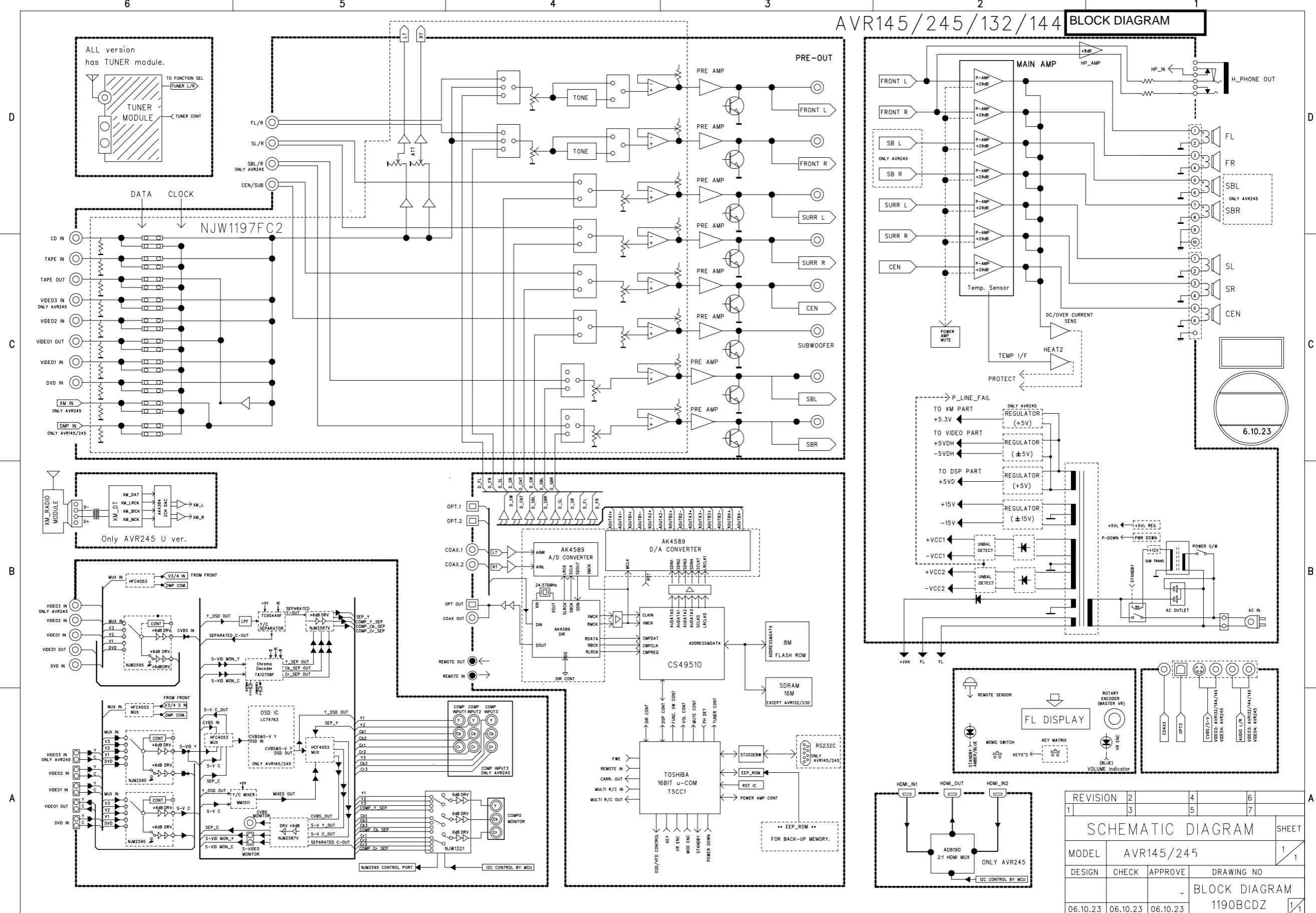
1.8mm  
1.7mm  
1.2mm

UPDATED  
2006.09.29  
ISSUED  
2006.07.25



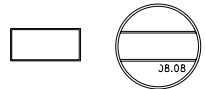
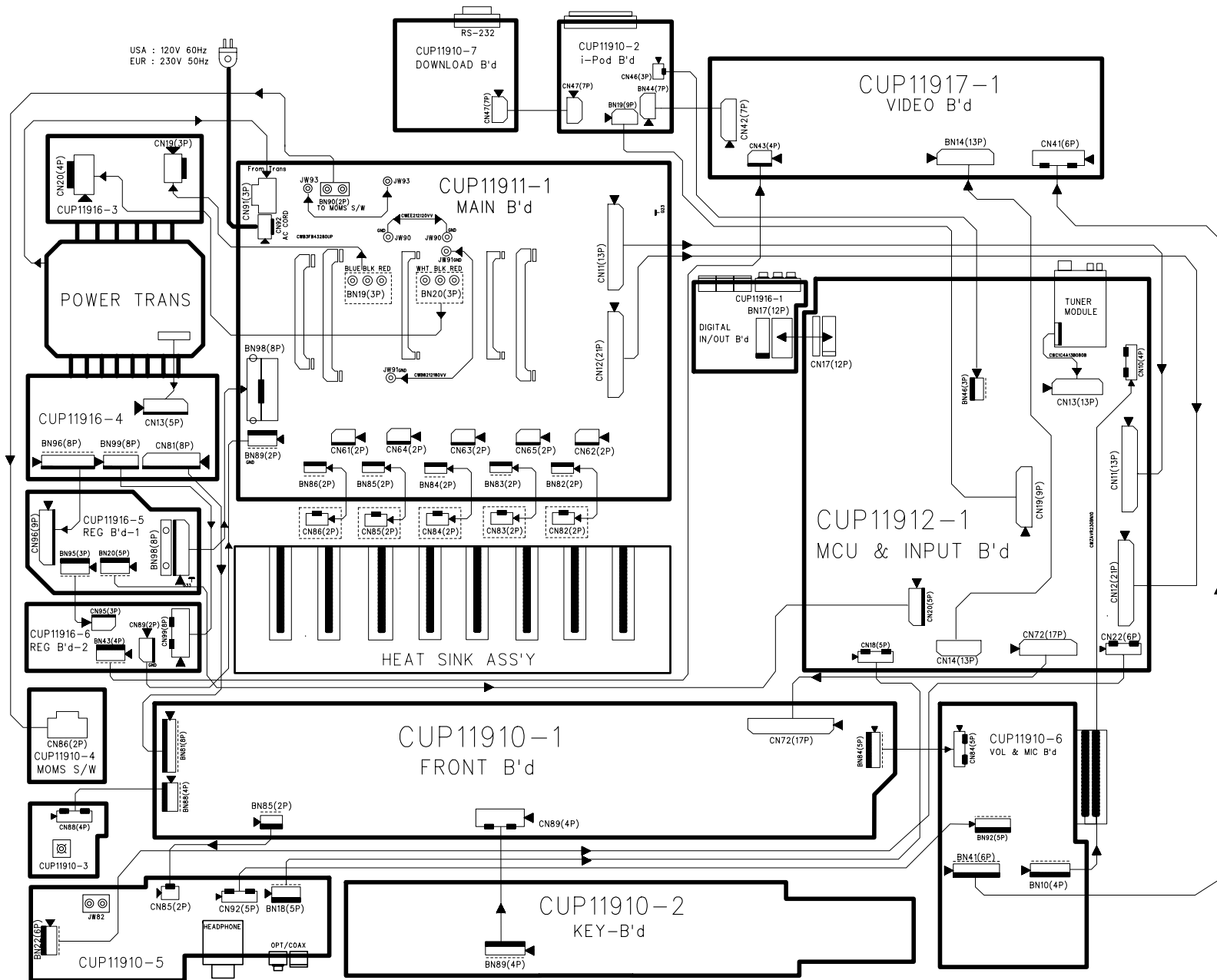


AVR145/245/132/144 BLOCK DIAGRAM



REVISION	2	4	6
	3	5	7
SCHEMATIC DIAGRAM SHEET			
MODEL	AVR145/245		
DESIGN	CHECK	APPROVE	DRAWING NO
06.10.23	06.10.23	06.10.23	BLOCK DIAGRAM 1190BCDZ

# AVR145 WIRING DIAGRAM



REVISION	2	4	6	
1	3	5	7	
SCHEMATIC DIAGRAM				SHEET
MODEL	AVR145			1 1
DESIGN	CHECK	APPROVE	DRAWING NO	
J.T.B	W.Y.Y	H.Y.L	WIRING DIAGRAM	
06.08.08	06.08.08	06.08.08	1190SCDZ	

## AMPLIFIER SECTION BIAS ADJUSTMENT

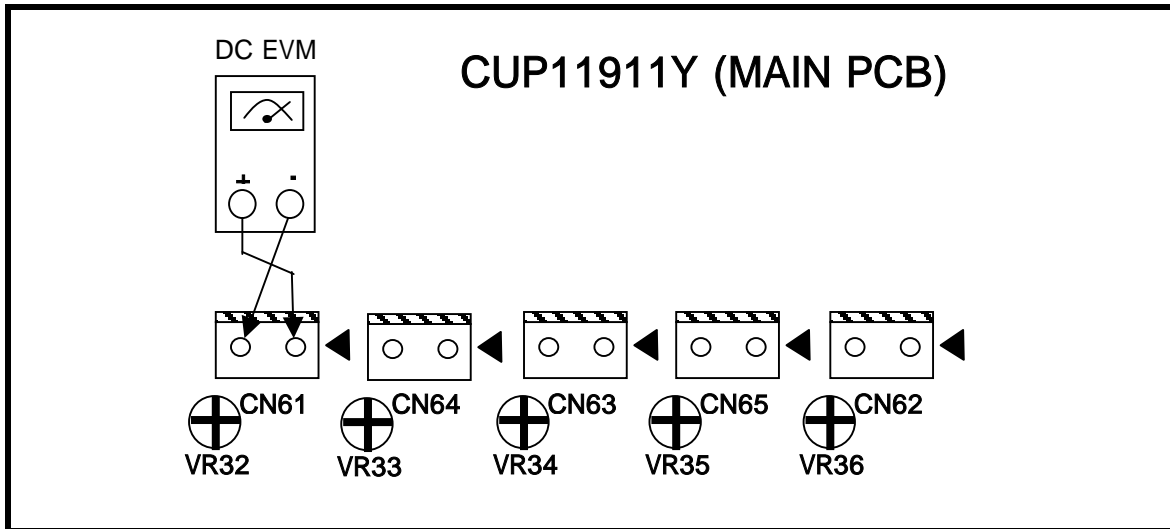
### Measurement condition

.No input signal or volume position is minimum.

### Standard value

.Ideal current = 48mA ( $\pm 5\%$ )

.Ideal DC Voltage = 25.92mV ( $\pm 5\%$ )



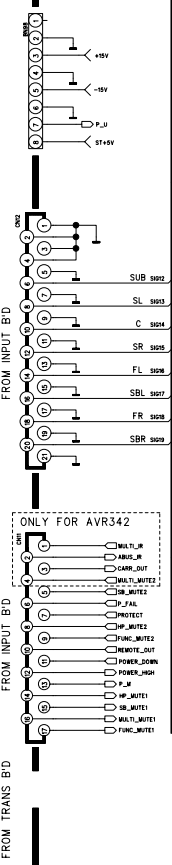
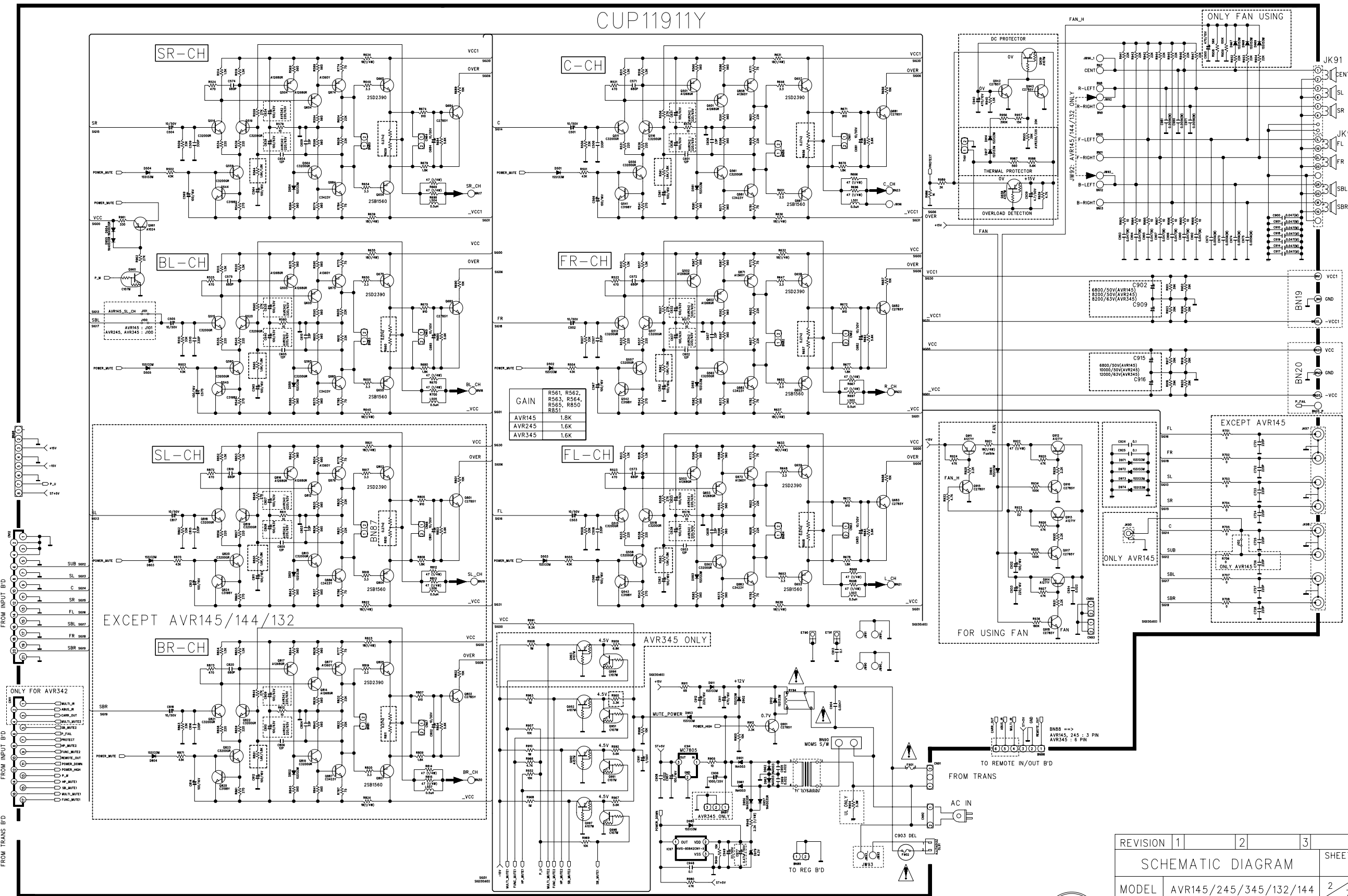
DC VOLTMETER ; Connect to

CN66(SL),CN61(CEN),CN64(SR),CN63(FL),CN65(SBL/SL(AVR132,144,145)),CN62(FR),CN67(SBR)

NO.	Channel	Adjust for	Adjustment
1	Front Left	25.92mV ( $\pm 5\%$ )	CN63
2	Front Right	25.92mV ( $\pm 5\%$ )	CN62
3	Center	25.92mV ( $\pm 5\%$ )	CN61
4	Surround Left	25.92mV ( $\pm 5\%$ )	CN65
5	Surround Right	25.92mV ( $\pm 5\%$ )	CN64



# CUP11911Y



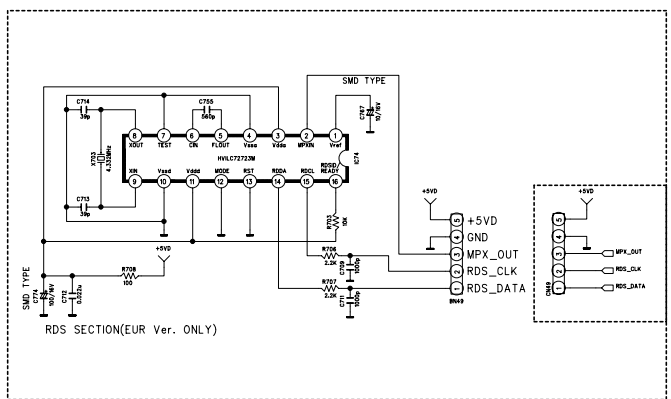
\*\* IMPORTANT SAFETY NOTICE.  
 IMPORTANT FOR SAFETY WHEN REPLACING ANY OF THESE COMPONENTS  
 USE ONLY MANUFACTURER'S SPECIFIED PARTS.  
 \*\* THE UNIT OF RESISTANCE IS OHM.  
 K=1000 OHM, M=1000 KOHM.  
 \*\* THE OHM OF CAPACITANCE IS MICROFARAD (UF)  
 UF = 10<sup>-6</sup> F  
 \*\* THIS SCHEMATIC DIAGRAM MAY MODIFIED AT ANY TIME WHILE THE  
 IMPROVEMENT OF PERFORMANCE

REVISION	1	2	3	SHEET
SCHEMATIC DIAGRAM				2
MODEL	AVR145/245/345/132/144			7
DESIGN	CHECK	APPROVE	DRAWING NO	
L.C.B	W.Y.Y	L.H.W	1911SCMY (MAIN)	
06.10.23	06.10.23	06.10.23		

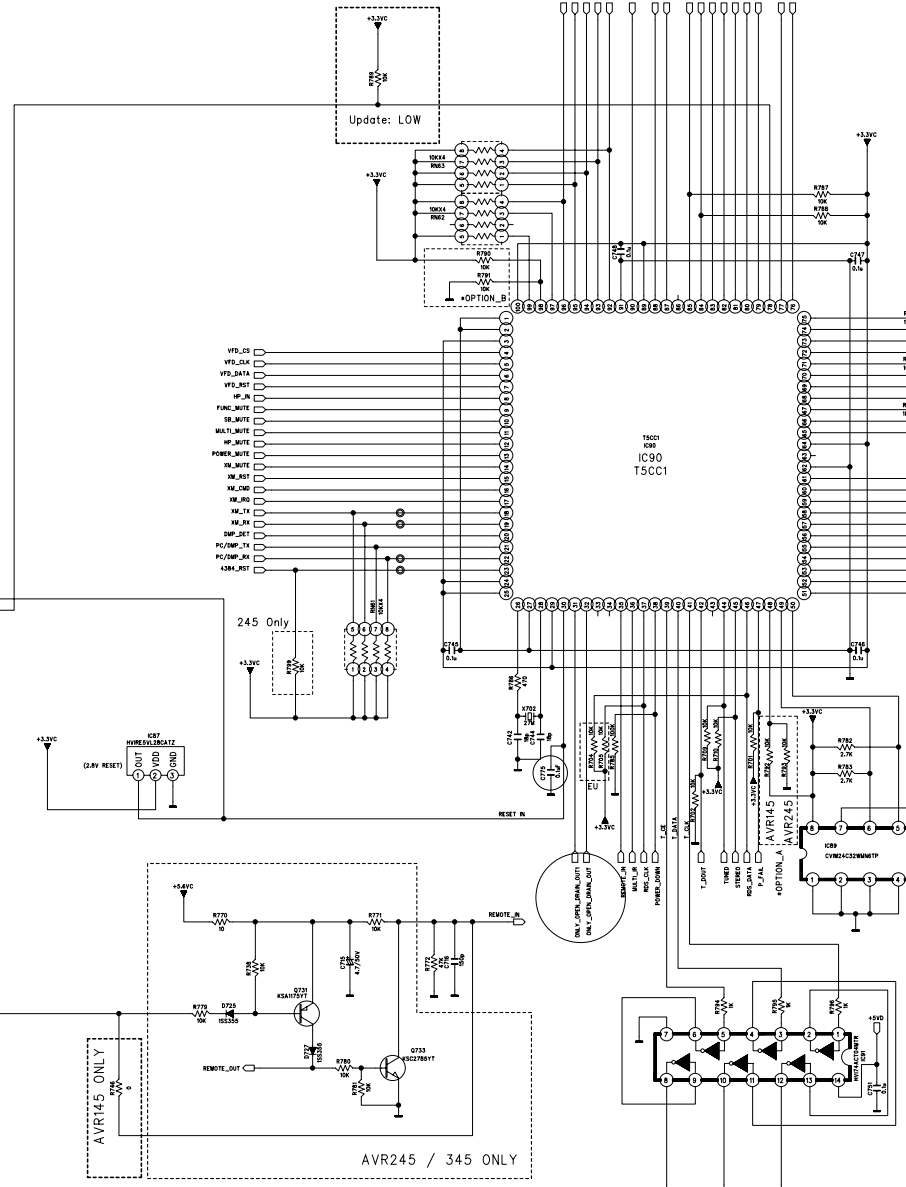
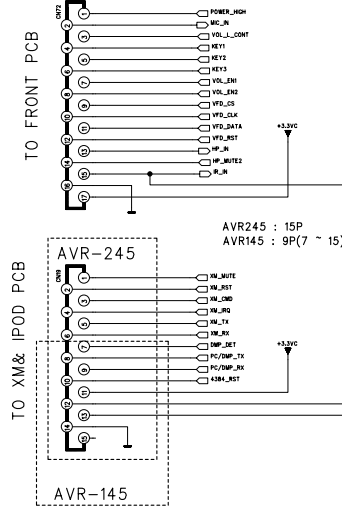
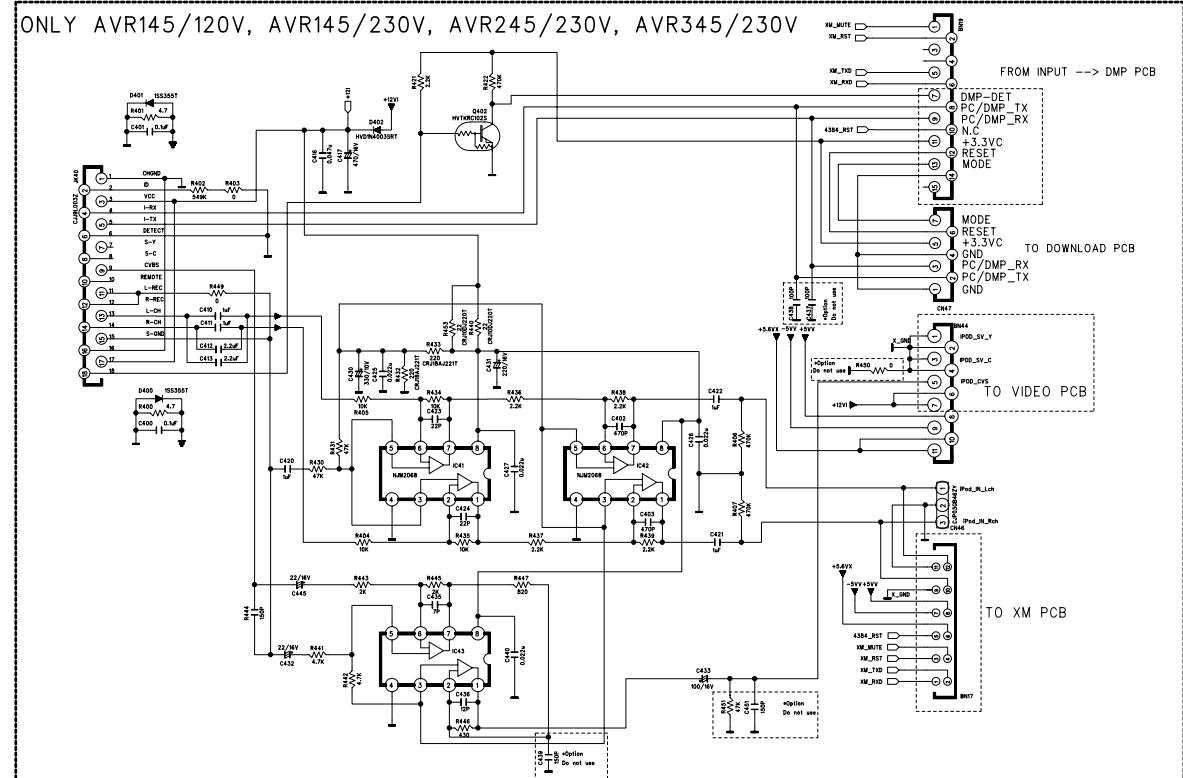
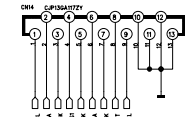


CUP11912Y

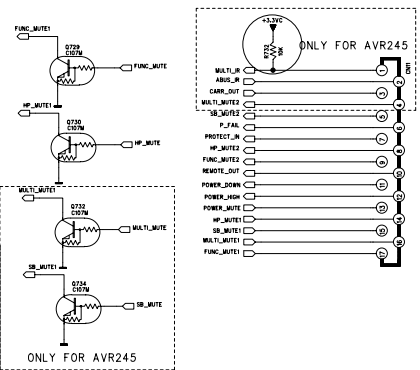
ONLY AVR145/120V, AVR145/230V, AVR245/230V, AVR345/230V



TO VIDEO PCB



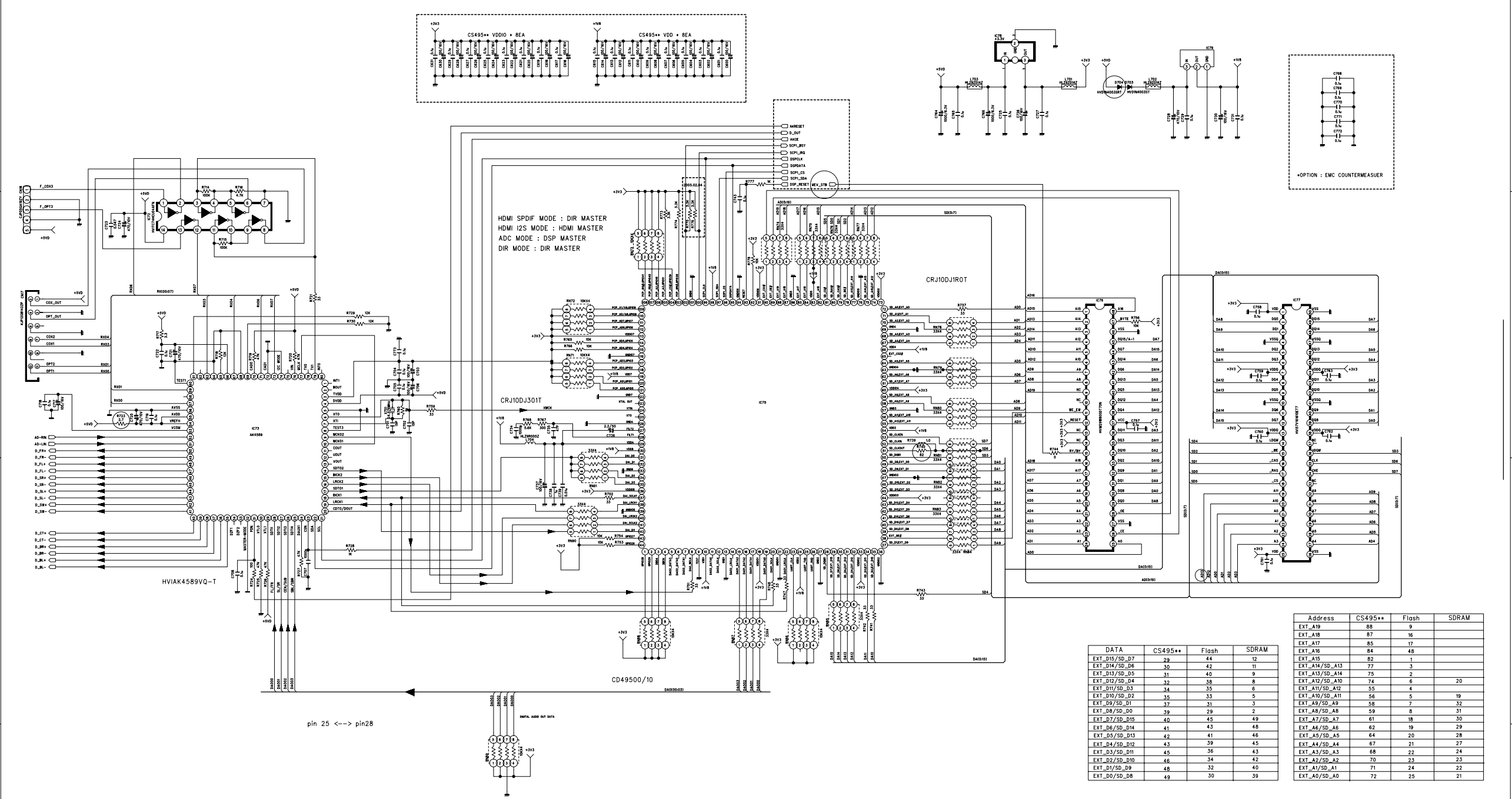
PULL\_UP  
GPIO : Input/Out Port(without pull\_up resistor)



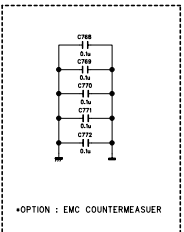
MODEL	OP_A(PIN48)	OP_B(PIN98)	OP_C(PIN52)
AVR145	HIGH(R792)	LOW(R791)	LOW(R712)
AVR245	LOW(R793)	LOW(R791)	LOW(R712)
AVR345	OPEN	LOW(R791)	NOT OPTION
AVR132	LOW(R793)	HIGH(R790)	LOW(R712)
AVR144	HIGH(R792)	HIGH(R790)	LOW(R712)
AVR145/230	HIGH(R792)	LOW(R791)	HIGH(R711)
AVR245/230	LOW(R793)	LOW(R791)	HIGH(R711)

REVISION	2	4	6
1	3	5	7
SCHEMATIC DIAGRAM			
MODEL	AVR145/245		
DESIGN	CHECK	APPROVE	DRAWING NO
M.S.K	W.Y.Y	H.W.L	1912SCMY
06.10.23	06.10.23	06.10.23	(INPUT)

CUP11912Y



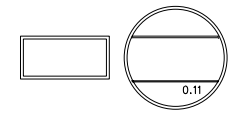
HDMI SPDIF MODE : DIR MASTER  
 HDMI I2S MODE : HDMI MASTER  
 ADC MODE : DSP MASTER  
 DIR MODE : DIR MASTER



DATA	CS495**	Flash	SDRAM
EXT_D15/SD_D7	28	44	12
EXT_D14/SD_D6	30	42	11
EXT_D13/SD_D5	31	40	9
EXT_D12/SD_D4	32	38	8
EXT_D11/SD_D3	34	35	6
EXT_D10/SD_D2	35	33	5
EXT_D9/SD_D1	37	31	3
EXT_D8/SD_D0	39	29	2
EXT_D7/SD_D15	40	45	49
EXT_D6/SD_D14	41	43	48
EXT_D5/SD_D13	42	41	46
EXT_D4/SD_D12	43	39	45
EXT_D3/SD_D11	45	36	43
EXT_D2/SD_D10	46	34	42
EXT_D1/SD_D9	48	32	40
EXT_D0/SD_D8	49	30	39

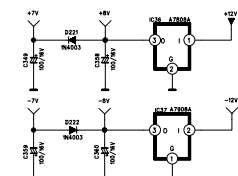
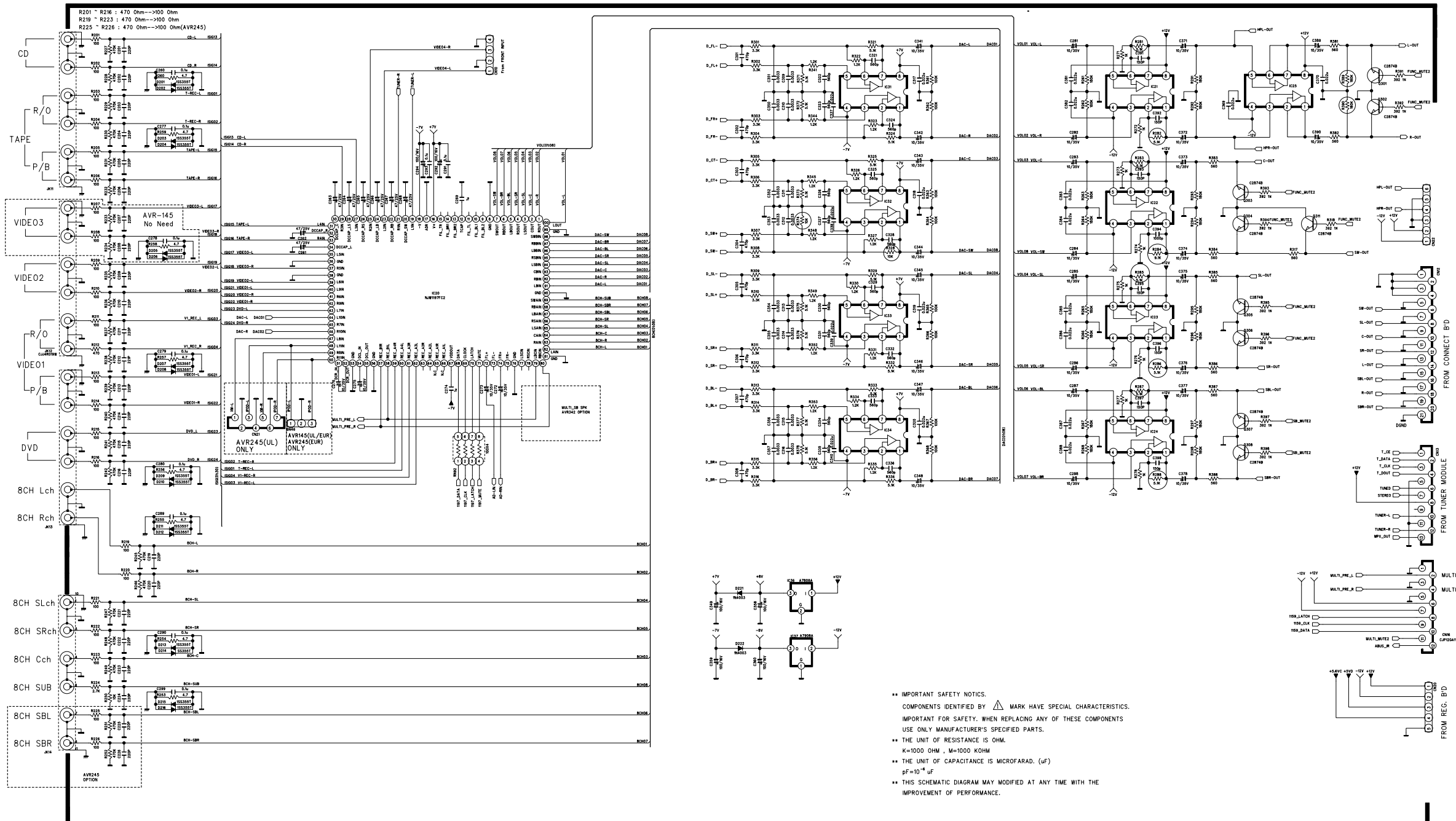
Address	CS495**	Flash	SDRAM
EXT_A19	88	9	
EXT_A18	87	16	
EXT_A17	85	17	
EXT_A16	84	48	
EXT_A15	82	1	
EXT_A14/SD_A13	77	3	
EXT_A13/SD_A14	75	2	
EXT_A12/SD_A10	74	6	20
EXT_A11/SD_A12	55	4	
EXT_A10/SD_A11	56	5	19
EXT_A9/SD_A9	58	7	32
EXT_A8/SD_A8	59	8	31
EXT_A7/SD_A7	61	18	30
EXT_A6/SD_A6	62	19	29
EXT_A5/SD_A5	64	20	28
EXT_A4/SD_A4	67	21	27
EXT_A3/SD_A3	68	22	24
EXT_A2/SD_A2	70	23	23
EXT_A1/SD_A1	71	24	22
EXT_A0/SD_A0	72	25	21

pin 25 <--> pin28



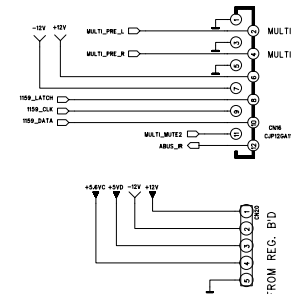
REVISION	2	4	6
1	3	5	7
SCHEMATIC DIAGRAM			
MODEL	AVR145/245		
DESIGN	CHECK	APPROVE	DRAWING NO
M.S.K	W.Y.Y	H.W.L	1912SCMY
06.10.11	06.10.11	06.10.11	(DSP)

# CUP11912Y

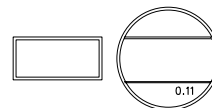


**IMPORTANT SAFETY NOTICES.**  
 COMPONENTS IDENTIFIED BY  $\Delta$  MARK HAVE SPECIAL CHARACTERISTICS.  
 IMPORTANT FOR SAFETY. WHEN REPLACING ANY OF THESE COMPONENTS  
 USE ONLY MANUFACTURER'S SPECIFIED PARTS.

- THE UNIT OF RESISTANCE IS OHM.  
 K=1000 OHM, M=1000 KOHM
- THE UNIT OF CAPACITANCE IS MICROFARAD. ( $\mu$ F)  
 $\mu$ F=10<sup>-6</sup> F
- THIS SCHEMATIC DIAGRAM MAY MODIFIED AT ANY TIME WITH THE  
 IMPROVEMENT OF PERFORMANCE.

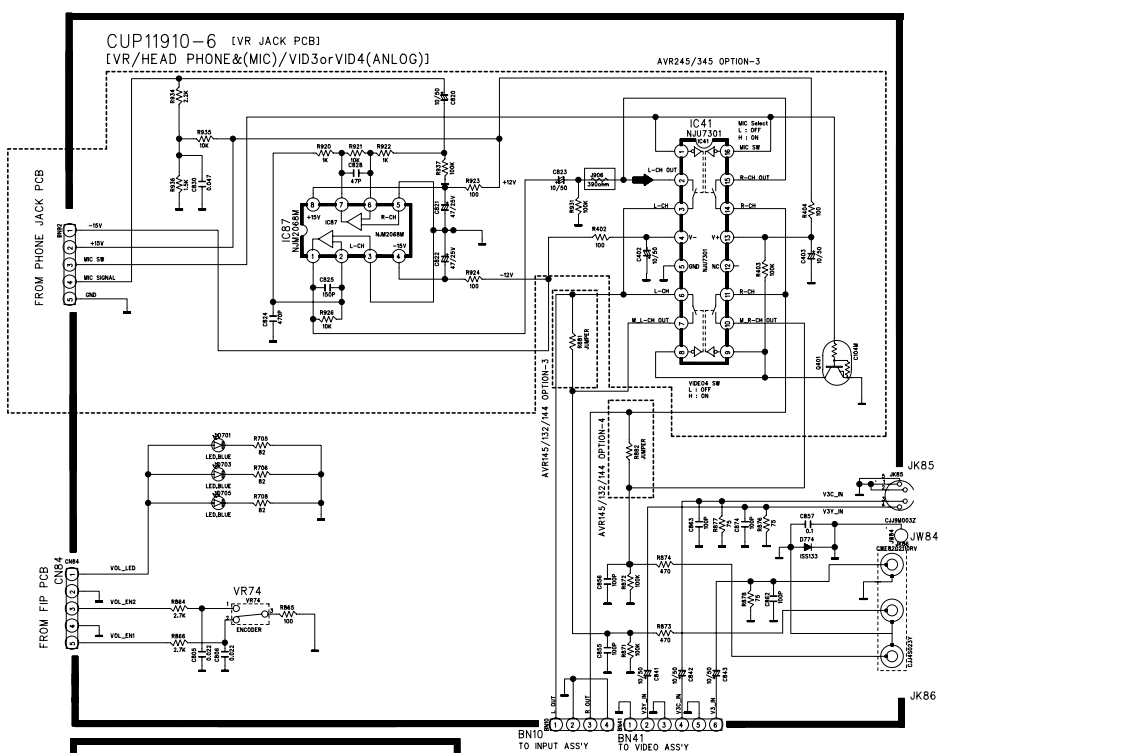
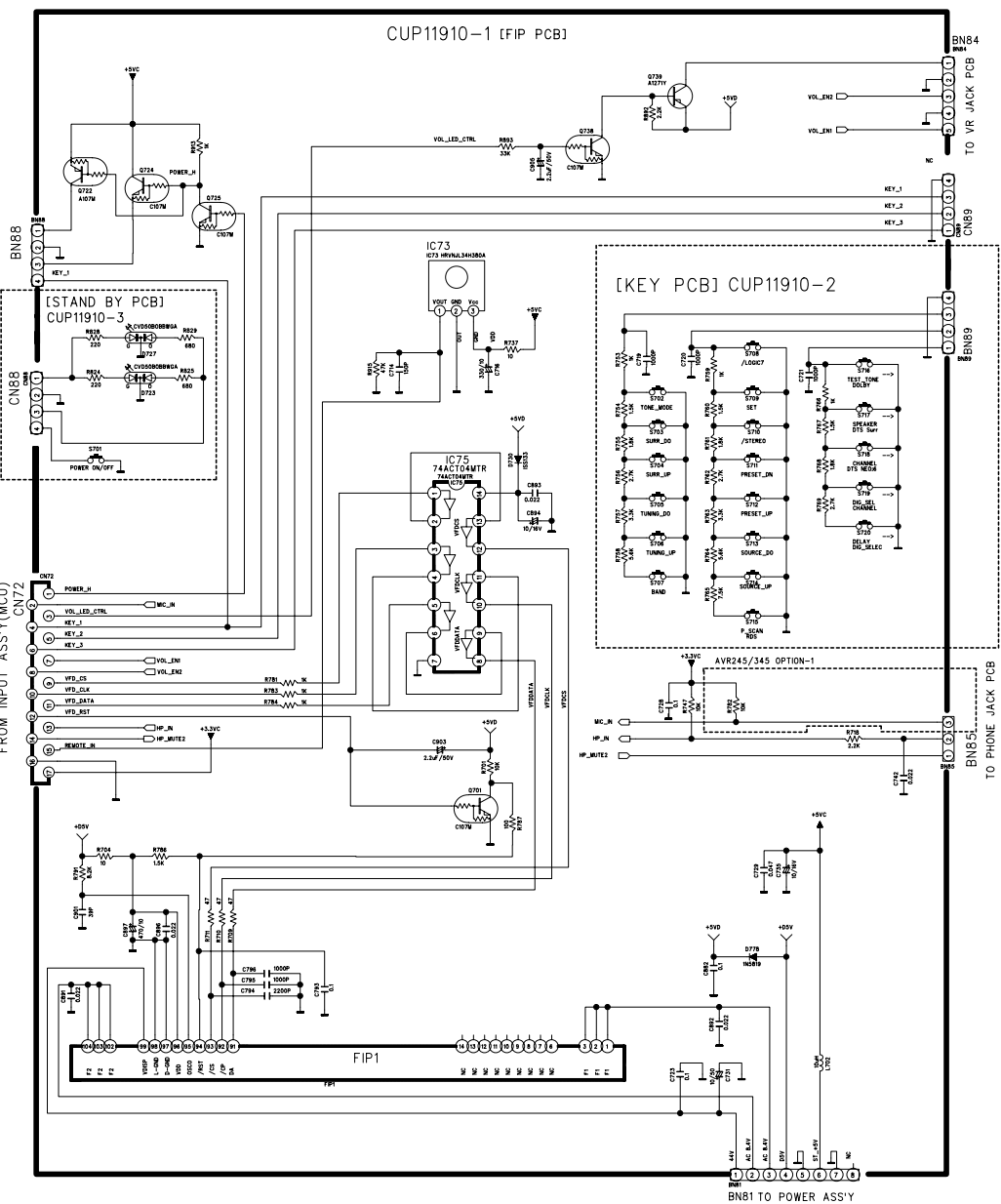
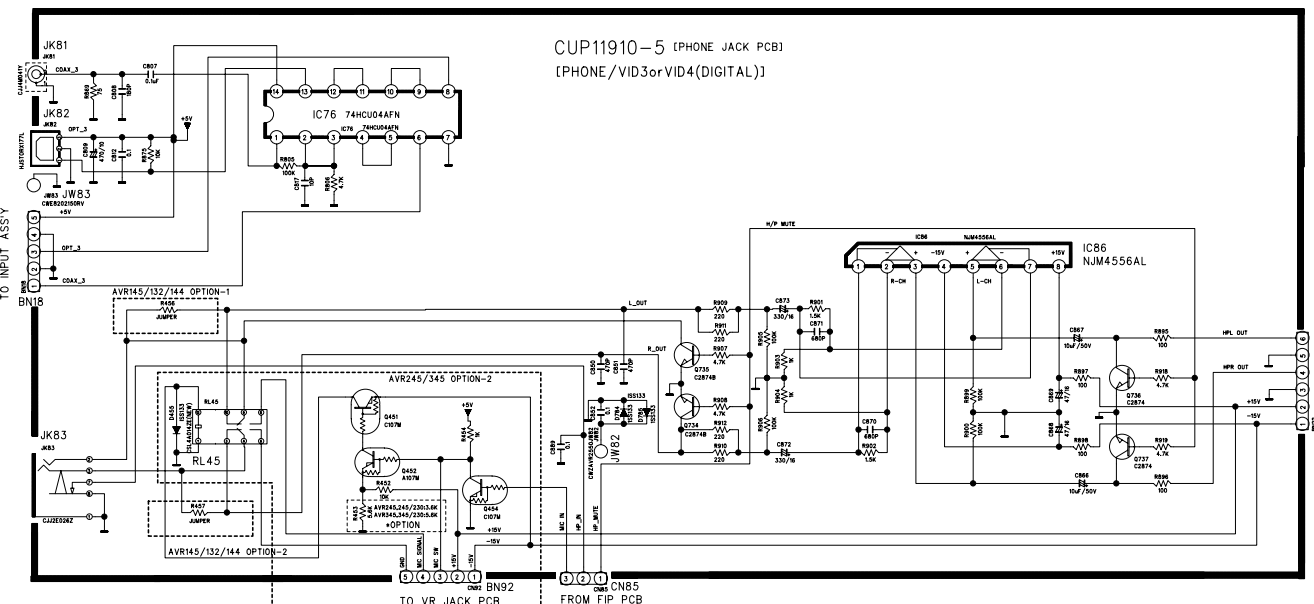
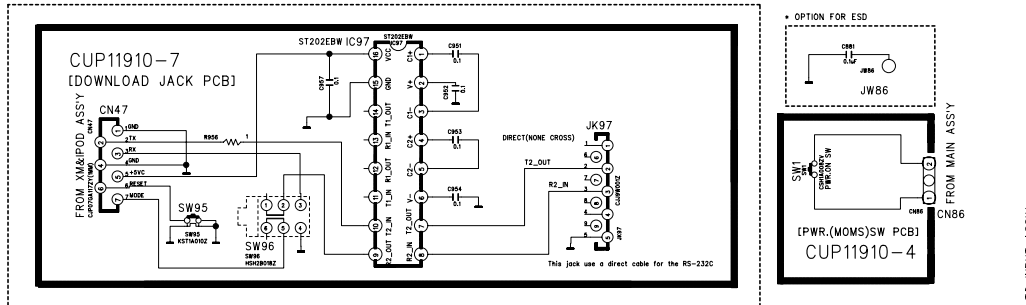


REVISION	2	4	6	
1	3	5	7	
SCHEMATIC DIAGRAM				SHEET
MODEL	AVR145/245			4/7
DESIGN	CHECK	APPROVE	DRAWING NO	
M.S.K	W.Y.Y	H.W.L	1912SCMY	
06.10.11	06.10.11	06.10.11	(INPUT)	



# CUP11910Y

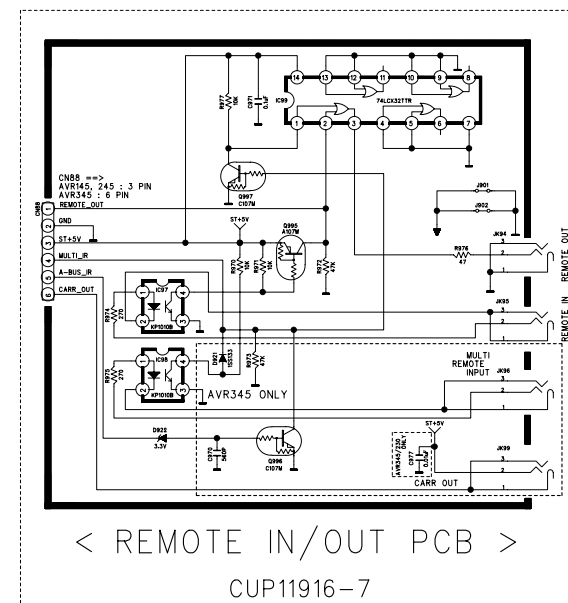
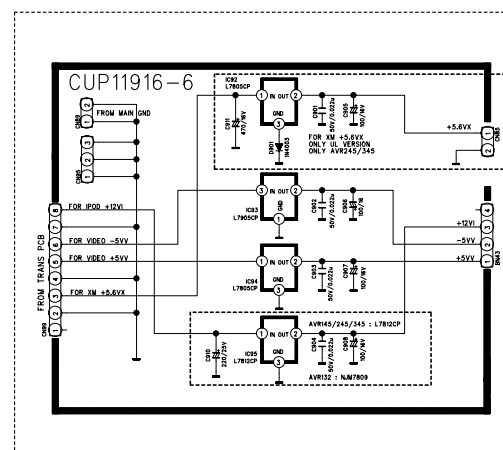
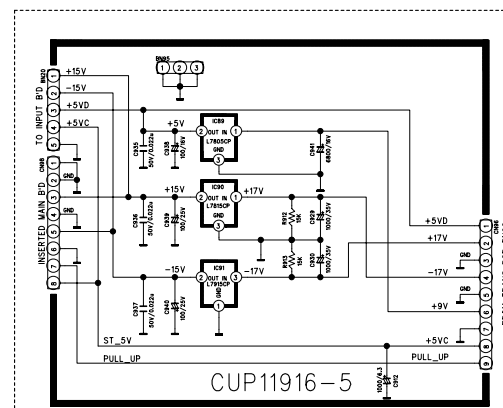
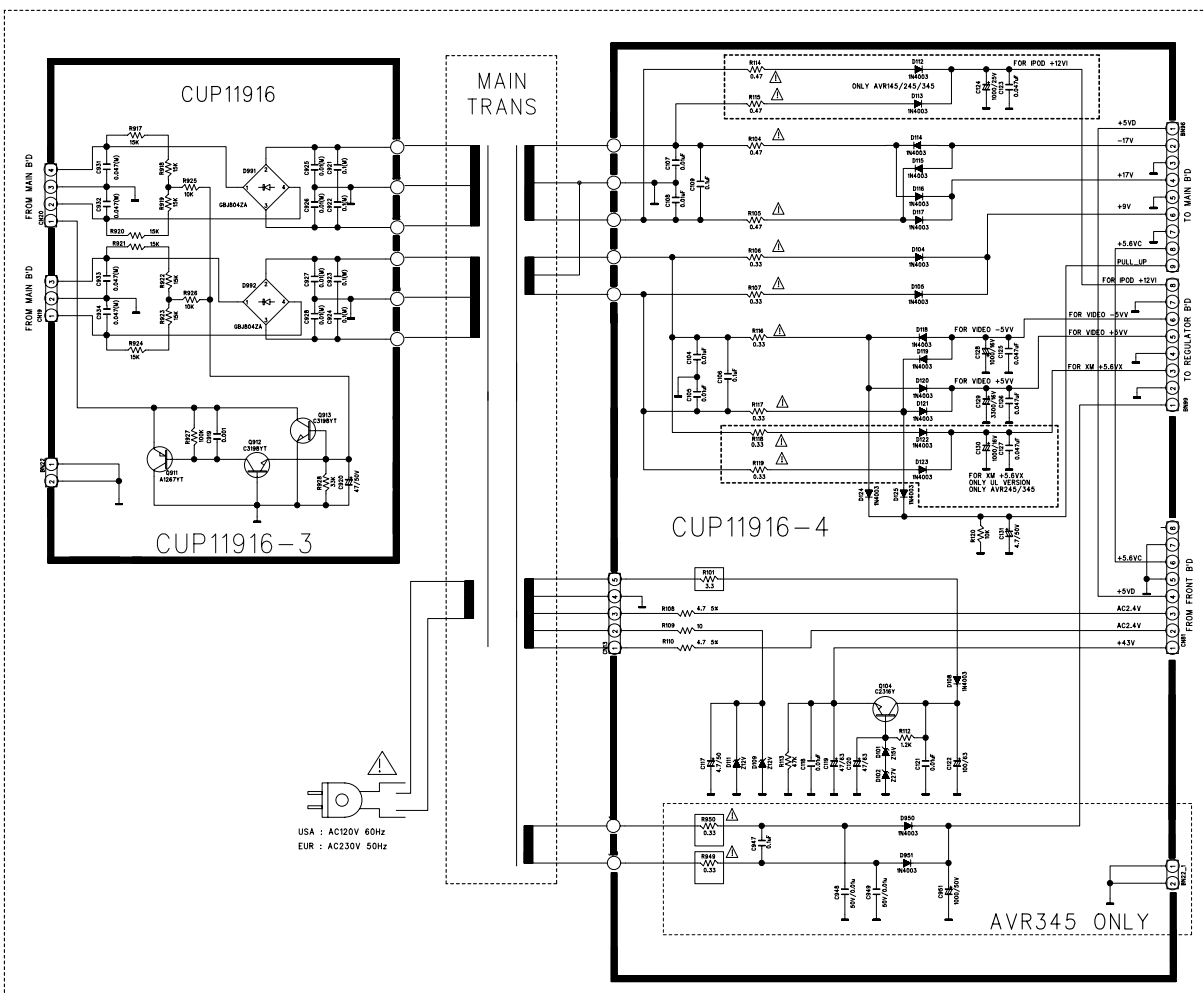
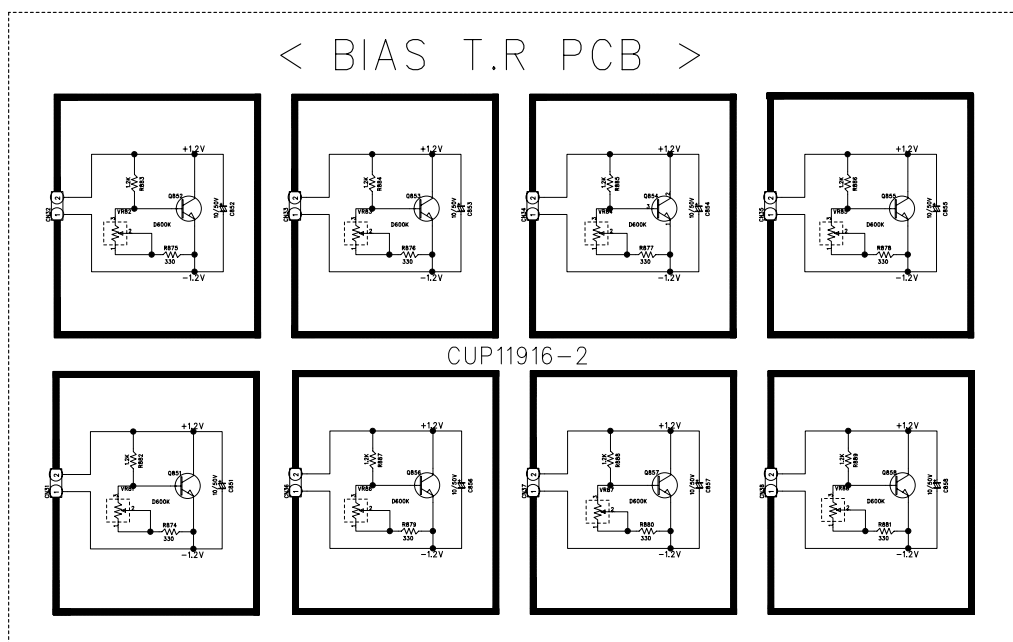
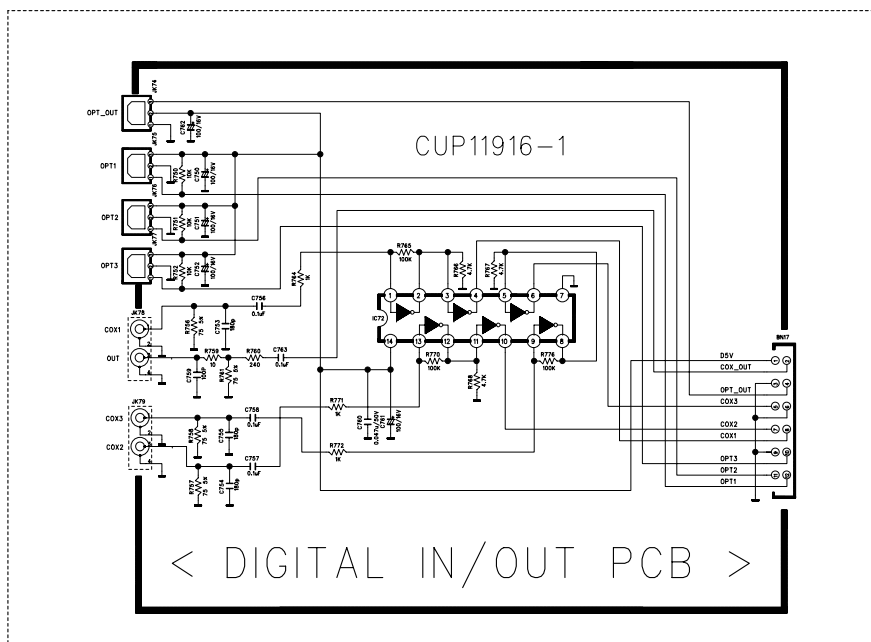
AVR145/245/345 OPTION-1



CUP11910-8 [BLACKET JACK PCB FOR CARD CABLE]  
 CUP11910-9 [BLACKET JACK PCB FOR PHONE JACK]

REVISION	2	4	6
	3	5	7
SCHEMATIC DIAGRAM			
MODEL	AVR145/245/345/132/144		
DESIGN	CHECK	APPROVE	DRAWING NO
S.H.Y	Y.W.Y	H.Y.L	CUP11910SCMY
06.10.23	06.10.23	06.10.23	

# CUP11916Y



USA : AC120V 60Hz  
 EUR : AC230V 50Hz

REVISION	2	4	6
1	3	5	7
SCHEMATIC DIAGRAM			
MODEL	AVR145/245/345/132/144		
DESIGN	CHECK	APPROVE	DRAWING NO
L.C.B	Y.W.Y	L.H.W	1916SCMY
06.10.23	06.10.23	06.10.23	(POWER)