

harman/kardon

AVR147

5 X 40W 5.1 CHANNEL A/V RECEIVER

SERVICE MANUAL



CONTENTS

ESD WARNING.....	2	DISASSEMBLY.....	32
LEAKAGE TESTING.....	3	UNIT EXPLODED VIEW.....	37
BASIC SPECIFICATIONS.....	4	EXPLODED VIEW PARTS LIST.....	38
PACKAGING.....	5	AMP BIAS ADJUSTMENT.....	39
FRONT PANEL CONTROLS.....	6	BLOCK DIAGRAM.....	40
REAR PANEL CONNECTIONS.....	8	PCB DRAWINGS.....	41
REMOTE CONTROL FUNCTIONS.....	10	ELECTRICAL PARTS LIST.....	52
CONNECTIONS/INSTALLATION.....	13	SEMICONDUCTOR PINOUTS.....	86
OPERATION.....	23	SCHEMATICS.....	181
TROUBLESHOOTING GUIDE.....	30	WIRING DIAGRAM.....	190
REMOTE & PROCESSOR RESETS.....	31		

harman/kardon, Inc.
250 Crossways Park Dr.
Woodbury, New York 11797

Released 2007
Discontinued XXXX

Rev0 6/2007

ELECTROSTATICALLY SENSITIVE (ES) DEVICES

Some semiconductor (solid state) devices can be damaged easily by static electricity. Such components commonly are called Electrostatically Sensitive (ES) Devices. Examples of typical ES devices are integrated circuits and some field effect transistors and semiconductor "chip" components.

The following techniques should be used to help reduce the incidence of component damage caused by static electricity.



1. Immediately before handling any semiconductor component or semiconductor-equipped assembly, drain off any electrostatic charge on your body by touching a known earth ground. Alternatively, obtain and wear a commercially available discharging wrist strap device, which should be removed for potential shock reasons prior to applying power to the unit under test.
2. After removing an electrical assembly equipped with ES devices, place the assembly on a conductive surface such as aluminum foil, to prevent electrostatic charge build-up or exposure of the assembly.
3. Use only a grounded-tip soldering iron to solder or unsolder ES devices.
4. Use only an anti-static solder removal device. Some solder removal devices not classified as "anti-static" can generate electrical charges sufficient to damage ES devices.
5. Do not use freon-propelled chemicals. These can generate electrical charge sufficient to damage ES devices.
6. Do not remove a replacement ES device from its protective package until immediately before you are ready to install it. (Most replacement ES devices are packaged with leads electrically shorted together by conductive foam, aluminum foil or comparable conductive material.)
7. Immediately before removing the protective material from the leads of a replacement ES device, touch the protective material to the chassis or circuit assembly into which the device will be installed.

CAUTION : Be sure no power is applied to the chassis or circuit, and observe all other safety precautions.

8. Minimize bodily motions when handling unpackaged replacement ES devices. (Otherwise harmless motion such as the brushing together of your clothes fabric or the lifting of your foot from a carpeted floor can generate static electricity sufficient to damage an ES devices.

PRODUCT SAFETY NOTICE

Each precaution in this manual should be followed during servicing.

Components identified with the IEC symbol  in the parts list are special significance to safety. When replacing a component identified with , use only the replacement parts designated, or parts with the same ratings or resistance, wattage, or voltage that are designated in the parts list in this manual. Leakage-current or resistance measurements must be made to determine that exposed parts are acceptably insulated from the supply circuit before returning the product to the customer.

SAFETY PRECAUTIONS

The following check should be performed for the continued protection of the customer and service technician.

LEAKAGE CURRENT CHECK

Measure leakage current to a known earth ground (water pipe, conduit, etc.) by connecting a leakage current tester between the earth ground and all exposed metal parts of the appliance (input/output terminals, screwheads, metal overlays, control shaft, etc.). Plug the AC line cord of the appliance directly into a 120V AC 60Hz outlet and turn the AC power switch on. Any current measured must not exceed 0.5mA.

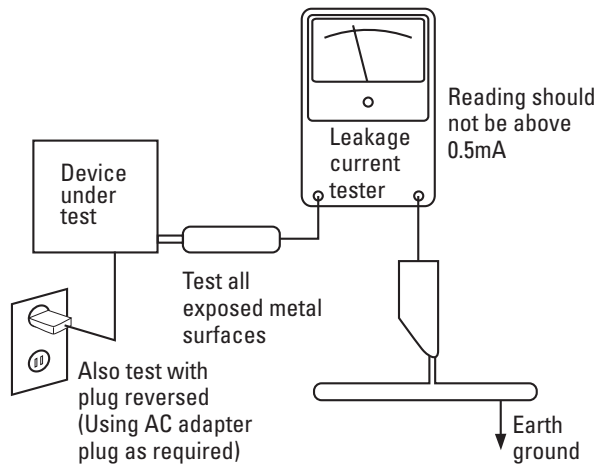

AC Leakage Test

ANY MEASUREMENTS NOT WITHIN THE LIMITS OUTLINED ABOVE ARE INDICATIVE OF A POTENTIAL SHOCK HAZARD AND MUST BE CORRECTED BEFORE RETURNING THE APPLIANCE TO THE CUSTOMER.

AVR 147 TECHNICAL SPECIFICATIONS

Audio Section

Stereo Mode	
Continuous Average Power (FTC)	
50 Watts per channel, 20Hz–20kHz, @ <0.07% THD, both channels driven into 8 ohms	
Five-Channel Surround Modes	
Power per Individual Channel	
Front L&R channels:	
40 Watts per channel @ <0.07% THD, 20Hz–20kHz into 8 ohms	
Center channel:	
40 Watts @ <0.07% THD, 20Hz–20kHz into 8 ohms	
Surround (L & R Side) channels:	
40 Watts per channel @ <0.07% THD, 20Hz–20kHz into 8 ohms	
Input Sensitivity/Impedance	
Linear (High-Level)	200mV/47k ohms
Signal-to-Noise Ratio (IHF-A)	100dB
Surround System Adjacent Channel Separation	
Pro Logic I/II	40dB
Dolby Digital (AC-3)	55dB
DTS	55dB
Frequency Response	
@ 1W (+0dB, -3dB)	10Hz – 130kHz
High Instantaneous	
Current Capability (HCC)	±25 Amps
Transient Intermodulation	
Distortion (TIM)	Unmeasurable
Slew Rate	40V/μsec

FM Tuner Section

Frequency Range	87.5–108.0MHz
Usable Sensitivity	IHF 1.3μV/13.2dBf
Signal-to-Noise Ratio	Mono/Stereo 70/68dB
Distortion	Mono/Stereo 0.2/0.3%
Stereo Separation	40dB @ 1kHz
Selectivity	±400kHz, 70dB
Image Rejection	80dB
IF Rejection	90dB

AM Tuner Section

Frequency Range	520–1720kHz
Signal-to-Noise Ratio	45dB
Usable Sensitivity	Loop 500μV
Distortion	1kHz, 50% Mod 0.8%
Selectivity	±10kHz, 30dB

Video Section

Television Format	NTSC
Input Level/Impedance	1Vp-p/75 ohms
Output Level/Impedance	1Vp-p/75 ohms
Video Frequency Response (Composite and S-Video)	10Hz–8MHz (-3dB)
Video Frequency Response (Component Video)	10Hz–100MHz (-3dB)
HDMI™	Switching

General

Power Requirement	AC 120V/60Hz	
Power Consumption	65W idle, 540W maximum (5 channels driven)	
Dimensions	(Product)	(Shipping)
	Width	17-5/16 inches (440mm) 22 inches (559mm)
	Height	6-1/2 inches (165mm) 10-1/2 inches (266mm)
	Depth	15 inches (382mm) 18-5/16 inches (465mm)
Weight	(Product)	(Shipping)
	21.3 lb (9.7kg)	26.2 lb (11.9kg)

Depth measurement includes knobs, buttons and terminal connections.

Height measurement includes feet and chassis.

All features and specifications are subject to change without notice.

Harman Kardon and Logic 7 are trademarks of Harman International Industries, Incorporated, registered in the United States and/or other countries. Designed to Entertain, **Bridge** and EzSet/EQ are trademarks of Harman International Industries, Incorporated.

Dolby, Pro Logic and the double-D symbol are trademarks of Dolby Laboratories.

Manufactured under license from Dolby Laboratories.

"DTS" and "DTS[ES Neo:6]" are registered trademarks of DTS, Inc. "96/24" is a trademark of DTS, Inc.

Cirrus Logic is a registered trademark of Cirrus Logic, Inc.

SACD is a trademark of Sony Corporation.

Apple, iTunes and iPod are trademarks of Apple Computer, Inc., registered in the U.S. and other countries.

Shuffle is a trademark of Apple Computer, Inc.

Blu-ray Disc is a trademark of the Blu-ray Disc Association.

HD-DVD is a trademark of the DVD Format/Logo Licensing Corporation (DVD FLLC).

TiVo is a registered trademark of TiVo Inc.

HDMI is a trademark of HDMI Licensing LLC.

XM and XM Ready are registered trademarks of XM Satellite Radio.

Audiovox is a registered trademark of Audiovox Corporation.

The Simplay HD logo and the Simplay, Simplay HD and Simplay Labs trademarks are owned by Silicon Image, Inc. and are used under license from Silicon Image, Inc. and/or Simplay Labs, LLC.

 The AVR 147 is Simplay HD™-verified for compatibility via the HDMI connection with other Simplay HD-verified products.

1. Instruction manual ass'y - Accessories

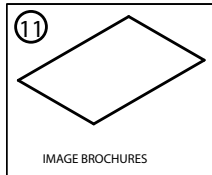
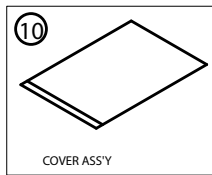
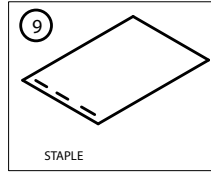
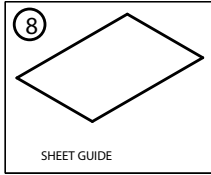
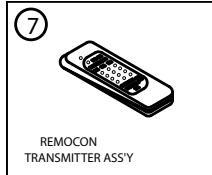
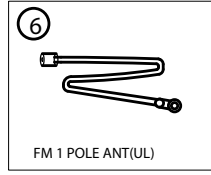
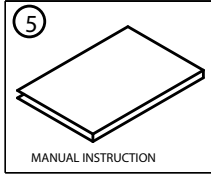
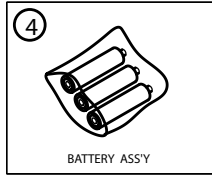
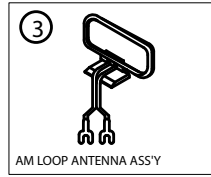
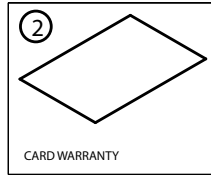
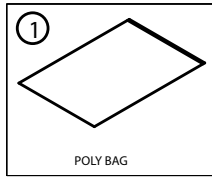

NO	DESCRIPTION	PARTS NO.	Q.ty
1	POLY BAG		1
2	CARD WARRANTY	CQE1A172X	1
3	AM LOOP ANTENNA	CSA1A027Z	1
4	BATTERY		3
5	INSTRUCTION MANUAL	SEE HK WEBSITE FOR PDF COPY	1
6	FM 1 POL ANT(UL)	CSA1A019Z	1
7	REMOCON TRANSMITTER ASS'Y	CARTAVR147	1
8	SHEET GUIDE(QUICK START GUIDE)	CQE1A329Y	1
9	STAPLE		3
10	DOOR KIT ASS'Y	CGRAVR130ZA	1
1	COVER A	CGR1A331M7H43	1
2	COVER B	CGR1A332M7H43	1
3	SHEET,FRONT COVER	CQE1A219Z	1
4	PAD,COVER	CPS1A676	1
5	BAG,POLY		1
11	IMAGE BROCHURES		1

2. Package Drawing

AVR147

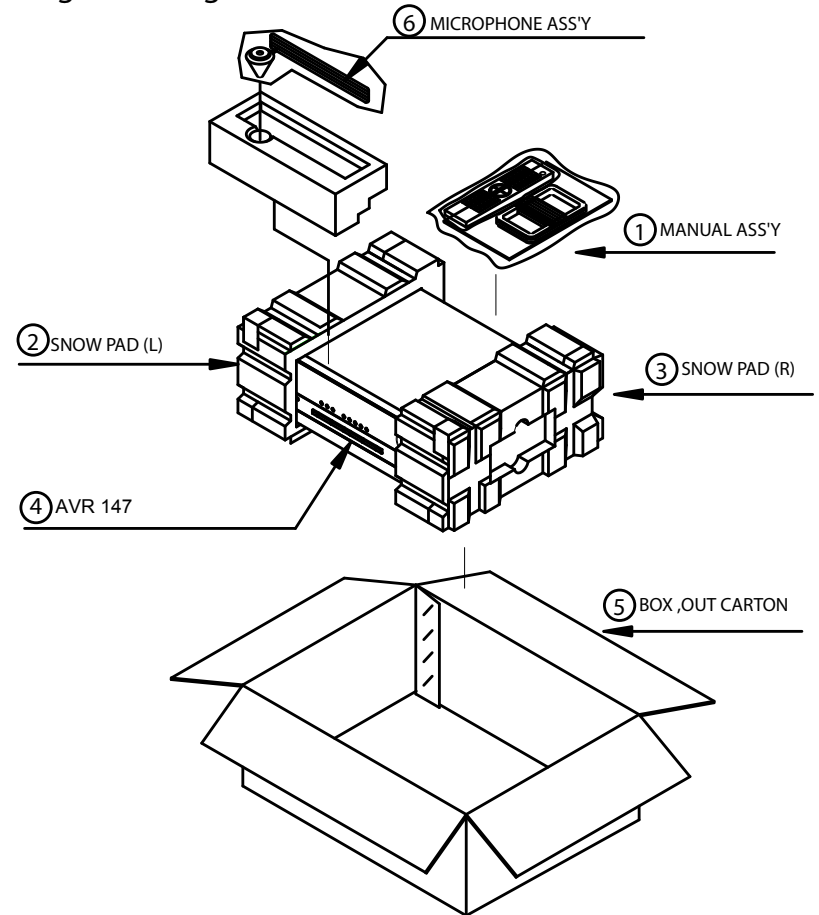

NO	DESCRIPTION	PARTS NO.	Q.ty
1	MANUAL ASS'Y		1
2	SNOW,PAD(L)	CPS4A564	1
3	SNOW,PAD(R)	CPS4A565	1
4	AVR 147	AVR 147	1
5	BOX,OUT CARTON	CPG1A822Y	1
6	MICROPHONE ASS'Y	CJXAVR340MICRO	1

FRONT-PANEL CONTROLS

Main Power Switch: This mechanical switch turns the power supply on or off. It is usually left pressed in (On position), and cannot be turned on using the remote control.

Standby/On Switch: This electrical switch turns the receiver on for playback, or leaves it in Standby mode for quick turn-on using this switch or the remote control.

Power Indicator: This LED has three possible modes. When main power is turned off, the LED is dark and the receiver won't respond to any button presses. When main power is turned on, but before the Standby/On Switch is used, the LED turns amber to indicate that the receiver is in Standby mode and ready to be turned on. When the receiver is turned on, the LED turns blue.

Source Select: Press this button to select a source device, which is a component where a playback signal originates, e.g., DVD, CD, cable TV, satellite or HDTV tuner.

Source Indicators: The name of the current source input lights up. The indicated input changes each time the Source Select button is pressed.

Volume Knob: Turn this knob to raise or lower the volume, which will be shown in decibels (dB) in the Message Display.

Message Display: Various messages appear in this two-line display in response to commands and changes in the incoming signal. When the on-screen display menu system (OSD) is in use, the message OSD ON will appear to remind you to check the video display.

Tuner Band: Press this button to select the tuner as the source, to switch between the AM and FM bands, or to select XM satellite radio.

Tuning: Press either side of this button to tune a radio station or XM channel.

Tuning Mode: This button toggles between manual (one frequency step at a time) and automatic (seeks frequencies with acceptable signal strength) tuning mode. It also toggles between stereo and mono modes when an FM station is tuned.

When XM Radio is in use, pressing this button repeatedly displays the channel name, category, artist and track title in the lower line of the Message Display. For traffic-and-weather channels, this button displays the city, channel name, local weather and local temperature.

Preset Stations: Press this button to select a preset radio station.

Headphone Jack/EzSet/EQ Microphone Input: Plug a 1/4" headphone plug into this jack for private listening.

This jack is also used to connect the supplied microphone before beginning the EzSet/EQ procedure described in the Initial Setup section. To begin EzSet/EQ, plug the supplied microphone into this jack, place the microphone at the listening position, and follow the directions given in the EzSet/EQ on-screen menu.

Surround Mode: Press this button to select a surround sound (e.g., multichannel) mode group. Choose from the Dolby modes, DTS modes, Logic 7 modes, DSP modes or Stereo modes.

Surround Select: After you have selected the desired surround mode group, press this button to select a specific mode.

Surround Mode Indicators: One or more of these icons may light up as you select different surround modes. The Message Display also indicates the surround mode.

Analog Audio, Video and Digital Audio Inputs: Connect a source component that will only be used temporarily, such as a camera or game console, to these jacks. Use only one type of audio and one type of video connection.

Speaker/Channel Input Indicators: The box icons indicate which speaker positions you have configured, and the size (frequency range) of each speaker. When a digital audio input is used, letters will light inside the boxes to indicate which channels are present in the incoming signal.

Navigation: These buttons are used together with the following five buttons to make selections.

Tone Mode: Press this button to access the tone controls (bass and treble). Use the ◀▶ Navigation Buttons to make your selections.

Speaker: Press this button to configure speaker sizes, that is, the low-frequency-range capability of each speaker.

Channel Level Adjust: Press this button to set the output level for each channel so that all speakers sound equally loud at the listening position.

Digital Input Select: Press this button to select the specific digital audio input (or analog audio input) you used for the current source.

Delay: Press this button to set delay times that compensate for placing the speakers at different distances from the listening position.

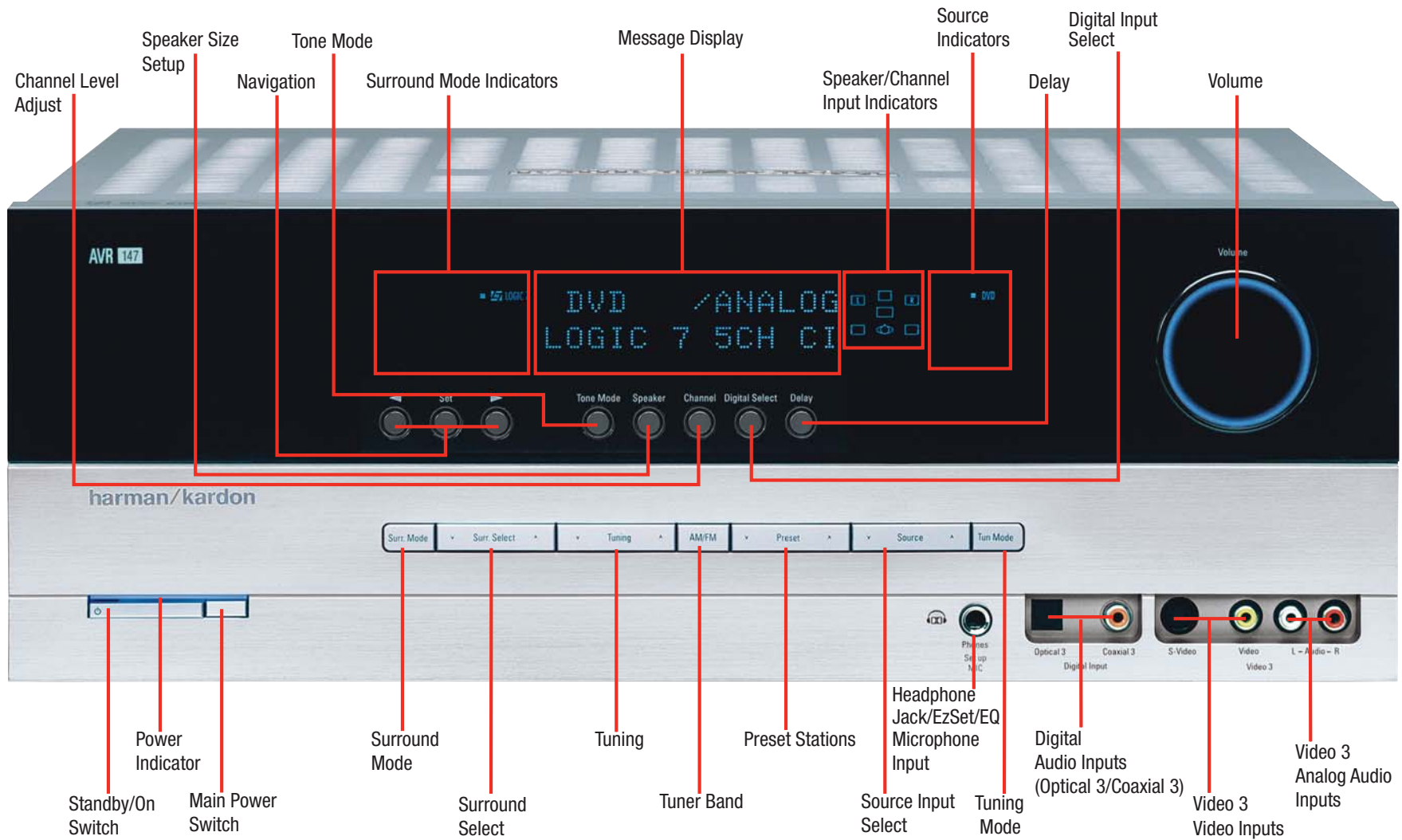

NOTE: To make it easier to follow the instructions throughout the manual that refer to this illustration, a copy of this page may be downloaded from the Product Support section at www.harmankardon.com.

REAR-PANEL CONNECTIONS

AM and FM Antenna Terminals: Connect the included AM and FM antennas to their respective terminals for radio reception.

XM Antenna Jack: Plug in an XM antenna module here. The XM antenna module is purchased separately, and should specify that it is for home use with an XM Ready® product. You will need to subscribe to the XM service, which is available separately, and activate the service for your antenna module. (XM service is not available in Alaska and Hawaii.)

Front, Center and Surround Speaker Outputs: Use two-conductor speaker wire to connect each set of terminals to the correct speaker. Remember to observe the correct polarity (positive and negative connections). Always connect the positive lead to the colored terminal on the receiver and the red terminal on the speaker. Connect the negative lead to the black terminal on both the receiver and the speaker. See the Connections section for more information on connecting your speakers.

Subwoofer Output: If you have a powered subwoofer with a line-level input, connect it to this jack.

Video 1, Video 2 and DVD Audio/Video Inputs: These jacks may be used to connect your video-capable source components (e.g., VCR, DVD player, cable TV box) to the receiver. Use only one type of video connection for each source. See the Connections section for more information on audio and video connection options for each source component.

Video 1 Audio/Video Outputs: These jacks may be used to connect your VCR or another recorder.

Composite and S-Video Monitor Outputs: If some of your sources use composite or S-video connections, connect one or both of these monitor outputs to the corresponding inputs on your television or video display to view them.

HDMI Inputs and Output: HDMI (High-Definition Multimedia Interface) is a newer type of connection for transmitting digital audio and video signals between devices. Although the AVR 147 is not capable of processing HDMI signals, if your video display is HDMI-capable, you may connect up to two HDMI sources here, and then connect the HDMI output to your video display for improved video performance. It is recommended that you disable the HDMI audio function of your video display, and make a separate digital audio connection from the source device to one of the AVR's coaxial or optical digital audio inputs to benefit from the AVR 147's multichannel audio processing.

The AVR 147 is Simplay HD-verified for compatibility via the HDMI connection with other Simplay HD-verified products.

NOTE: The AVR 147 will not convert other types of video to HDMI, and you will not be able to view the on-screen displays using the HDMI connection.

CD and Tape Audio Inputs: These jacks may be used to connect audio-only source components (e.g., CD player, tape deck). Do not connect a turntable to these jacks unless you are using it with a phono preamp.

Tape Outputs: These jacks may be used to connect a CDR or another audio-only recorder.

Coaxial and Optical Digital Audio Inputs: If your source has a compatible digital audio output, connect it to one of these jacks for improved audio performance. Use only one type of digital audio connection for each source.

Coaxial and Optical Digital Audio Outputs: If a source is also an audio recorder, you may connect a compatible digital audio output to the recorder's input for improved recording quality.

The Bridge/DMP Input: Connect the optional Harman Kardon  to this input for use with your iPod (not included). Make sure the receiver is turned off (in Standby mode) when connecting The Bridge.

6-Channel Inputs: Connect the multichannel analog audio outputs of a DVD-Audio, SACD™, Blu-ray Disc™ or HD-DVD™ player (or any other external decoder) to these jacks to enjoy these proprietary formats.

Component Video Inputs: If both your video source (e.g., DVD player or HDTV tuner) and your television or video display have analog component video (Y/Pb/Pr) capability, then you may connect the component video outputs of your source to one of the two component video inputs. Do not make any other video connections to that source.

Component Video Monitor Outputs: If you are using either of the Component Video Inputs and your television or video display is component-video-capable, you may connect these jacks to the corresponding inputs on your video display. You will also need to connect the composite and/or S-video monitor outputs to your video display if some of your sources use those types of video connections, and to view the AVR 147's on-screen displays.

RS-232 Serial Port: This specialized connector may be used with your personal computer in case Harman Kardon offers a software upgrade for the receiver at some time in the future.

RS-232 Mode: Leave this switch popped out in the Operate position unless the AVR 147 is being upgraded.

RS-232 Reset: This switch is only used during a software upgrade. A standard processor reset is performed by pressing and holding the front-panel Tone button.

Switched AC Accessory Outlet: You may plug the AC power cord of one source device into this outlet, and it will turn on whenever you turn on the receiver. Do not use a source that consumes more than 50 watts of power.

AC Power Cord: After you have made all other connections, plug the AC power cord into an unswitched outlet.

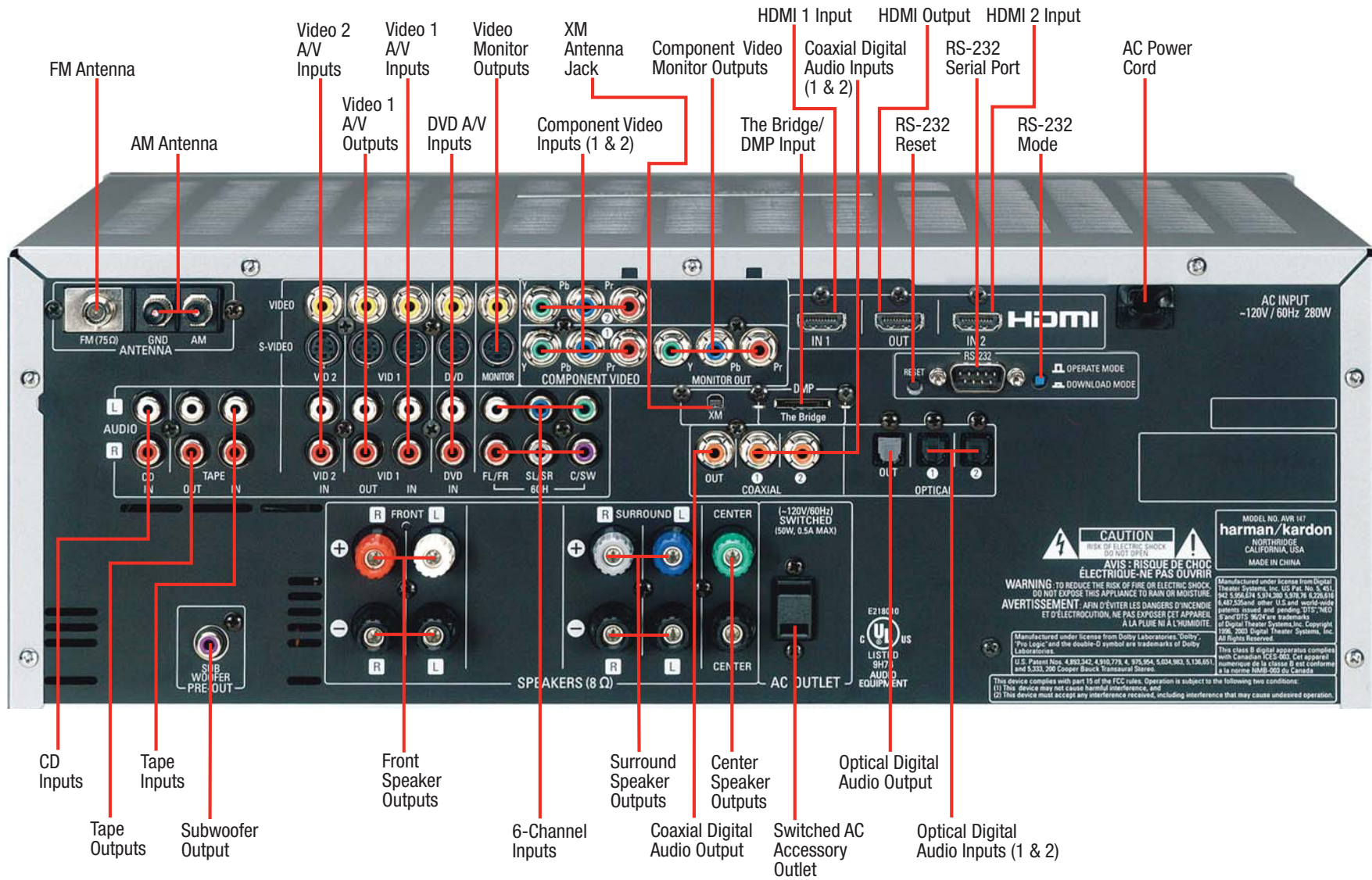

NOTE: To make it easier to follow the instructions throughout the manual that refer to this illustration, a copy of this page may be downloaded from the Product Support section at www.harmankardon.com.

REMOTE CONTROL FUNCTIONS

The AVR 147 remote is capable of controlling up to ten devices, including the AVR itself and an iPod docked in the optional The Bridge accessory. During the installation process, you may program the codes for each of your source components into the remote. Each time you wish to use the codes for any component, first press the Selector button for that component. This changes the button functions to the appropriate codes for that product.

NOTE: Several of the Input Selectors are shared between two devices. The selector button will light in red when the remote is in the device mode printed on the button, and it will light in green for the device mode printed above the button. To switch between the two device modes, press the selector *twice* quickly in succession. The selector will remain in the last-selected mode until the next time you press the selector twice quickly.

For example, the first time you press the DVD button, the button will light up in red, indicating that the remote is in DVD mode. If you press another selector, such as the VID3 selector, and then press the DVD button again, the DVD button will remain red, indicating the remote is still in DVD mode. Now press the DVD button twice quickly. At the first press the button will light red, indicating that the remote is in DVD mode. On the second press the button will turn green, indicating that the remote is now in CD mode. If you press a different selector and return to the DVD/CD Selector, you will observe that the remote is still in CD mode.

Each Input Selector has been preprogrammed to control certain types of components, with only the codes specific to each brand and model changing, depending on which product code is programmed. The device types programmed into each selector may not be changed.

DVD: Controls DVD players and recorders.

CD: Controls CD players and recorders.

Tape: Controls cassette decks.

Video 1: Controls VCRs, TiVo and DVRs.

Video 2: Controls cable and satellite television set-top boxes.

Video 3: Controls televisions and other video displays.

The Bridge/DMP: Controls an iPod docked in The Bridge.

HDMI 1 and 2: Each code set controls a source device (VCR/PVR, DVD player or cable/satellite set-top box) connected to one of these two inputs.

XM: Controls the AVR functions for XM Satellite Radio.

For example, if you have inserted a disc in your CD player and you would like to skip ahead three tracks, but you then find that the volume is too loud, you would follow this procedure:

1. Press the CD Input Selector to switch to the codes that control your CD player.
2. Press the Play Button (in the Transport Controls section) if the disc is not already playing.
3. Press the Skip Up Button three times to advance three tracks.

4. Press the AVR Button so that you can access the Volume Controls.

5. Press the Volume Down Button until the volume level is satisfactory.

Any given button may have different functions, depending on which component is being controlled. Some buttons are labeled with these functions. For example, the Sleep and DSP Surround Buttons are labeled for use as Channel Up/Down Buttons when controlling a television or cable box. See Table A8 in the appendix for listings of the different functions for each type of component.

IR Transmitter Lens: As buttons are pressed on the remote, infrared codes are emitted through this lens. Make sure it is pointing toward the component being operated.

Power On Button: Press this button to turn on the AVR or another device. The Master Power Switch on the AVR 147's front panel must first have been switched on.

Mute Button: Press this button to mute the AVR 147's speaker and headphones outputs temporarily. To end the muting, press this button or adjust the volume. Muting is also canceled when the receiver is turned off.

Program Indicator: This LED lights up or flashes in one of three colors as the remote is programmed with codes.

Power Off Button: Press this button to turn off the AVR 147 or another device.

AVR Selector: Press this button to switch the remote to the codes that operate the receiver.

Input Selectors: Press one of these buttons to select a source device, which is a component where a playback signal originates, e.g., DVD, CD, cable TV, satellite or HDTV tuner. This will also turn on the receiver and switch the remote's mode to operate the source device.

XM Radio Button: Press this button to select XM Satellite Radio as the source. You will need to have purchased and activated an XM antenna module, and you will also need to subscribe to the XM Radio service. Visit www.xmradio.com for more information.

AM/FM Button: Press this button to select the tuner as the source, or to switch between the AM and FM bands, or XM Radio.

6-Channel Input Selector: Press this button to select the 6-Channel Inputs as the audio source. The receiver will use the video input and remote control codes for the last-selected video source.

Test Tone: Press this button to activate the test tone for manual output-level calibration.

TV/Video: This button has no effect on the receiver, but is used to switch video inputs on some video source components.

Sleep Button: Press this button to activate the sleep timer, which shuts off the receiver after a programmed period of time of up to 90 minutes.

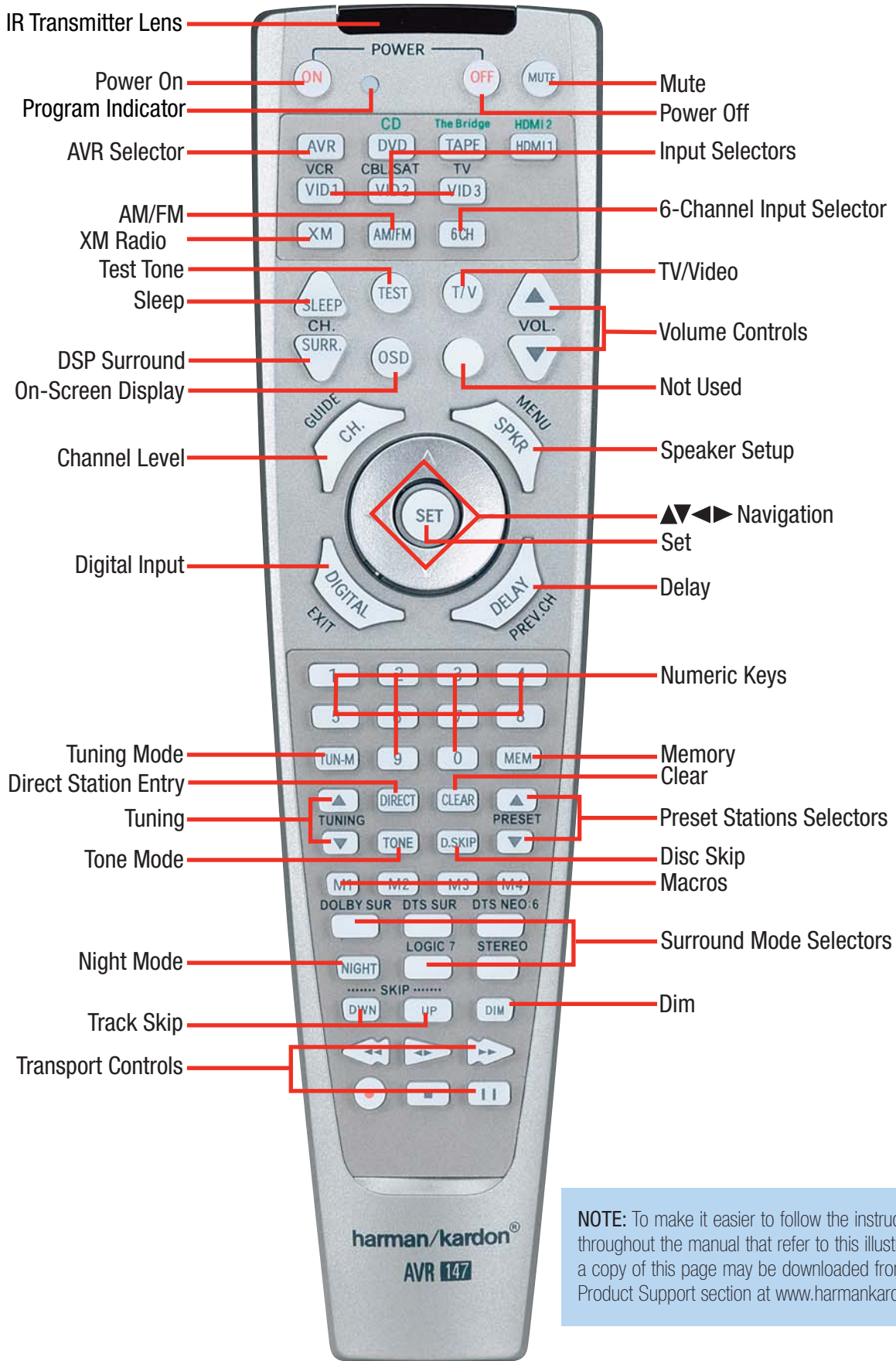

NOTE: To make it easier to follow the instructions throughout the manual that refer to this illustration, a copy of this page may be downloaded from the Product Support section at www.harmankardon.com.

REMOTE CONTROL FUNCTIONS

Volume Controls: Press these buttons to raise or lower the volume, which will be shown in decibels (dB) in the Message Display.

DSP Surround: Press this button to select a DSP surround mode (Hall 1, Hall 2, Theater).

On-Screen Display (OSD): Press this button to activate the on-screen menu system.

Channel Level: Press this button to set the output levels for each channel so that all speakers sound equally loud at the listening position. Usually this is done while playing an audio selection, such as a favorite CD, after you have calibrated the levels using EzSet/EQ, as described in the Initial Setup section.

Speaker Setup: Press this button to configure speaker sizes, that is, the frequency-range capability of each speaker. Usually this is done using the on-screen menu system, as described in the Initial Setup section.

Navigation ▲/▼/◀/▶ and Set Buttons: These buttons are used together to make selections within the on-screen menu system, or when accessing the functions of the four buttons surrounding this area of the remote – Channel Level, Speaker Setup, Digital Input or Delay.

Digital Input Select: Press this button to select the specific digital audio input (or analog audio input) you used for the current source.

Delay: Press this button to set delay times that compensate for placing the speakers at different distances from the listening position, or to resolve a "lip sync" issue that may be caused by digital video processing. This may also be done using the on-screen menu system, as described in the Initial Setup section.

Numeric Keys: Use these buttons to enter radio station frequencies or to select station presets. When the AM or FM band is in use, press the Direct button before entering the station frequency.

When listening to XM Radio, you may enter channel numbers without first pressing the Direct Button; however, to access the preset stations, you will need to use the Preset Stations Selectors. To access another bank of XM presets, press the Set Button repeatedly until PRESET SEARCH appears, then use the ▲/▼ Buttons to select the letter of the desired bank.

Tuning Mode: When listening to AM or FM radio, this button toggles between manual (one frequency step at a time) and automatic (seeks frequencies with acceptable signal strength) tuning mode. It also toggles between stereo and mono modes when an FM station is tuned.

When listening to XM Radio, press the Tuning Mode Button once to view the category name of the current channel. Additional presses will display the artist, song title and channel name.

Memory: After you have tuned a particular radio station, press this button, then the numeric keys, to save that station as a radio preset.

For XM Radio, the procedure for saving a preset is a little different. To save the current channel in one of the 40 available preset locations, press the Set Button repeatedly until PRESET SEARCH appears. Use

the ▲/▼ Buttons to select a letter (A through E) representing one of the five banks of preset memory slots. Then press the Memory button, followed by a Numeric Key (1 through 8) for the precise preset memory location you wish to save the channel in.

Tuning: Press these buttons to tune a radio station or XM Radio channel. For the AM and FM bands, and depending on whether the tuning mode has been set to manual or automatic, each press will either change one frequency step at a time, or seek the next frequency with acceptable signal strength.

Direct: Press this button before using the Numeric Keys to directly enter a radio station frequency (AM or FM bands only).

Clear: Press this button to clear a radio station frequency you have started to enter.

Preset Stations Selector: Press these buttons to select a preset radio station.

For XM Radio, first press the Set Button repeatedly until PRESET SEARCH appears and then use the ▲/▼ Buttons to select the letter of the desired bank of presets.

Tone Mode: Press this button to access the tone controls (bass and treble). Use the Navigation buttons to make your selections.

Disc Skip: This button has no effect on the receiver, but is used with some optical disc changers to skip to the next disc.

Macros: These buttons may be programmed to execute long command sequences with a single button press. They are useful for programming the command to turn on or off all of your components, or for accessing specialized functions for a different component than you are currently operating.

Surround Mode Selectors: Press any of these buttons to select a type of surround sound (e.g., multichannel) mode. Choose from the Dolby modes, DTS modes, Logic 7 modes or Stereo modes. Each press of a button will cycle to the next available variant of that mode. Not all modes or mode groups are available with all sources.

Night Mode: Press this button to activate Night mode with specially encoded Dolby Digital discs or broadcasts. Night mode compresses the audio so that louder passages are reduced in volume to avoid disturbing others, while dialogue remains intelligible.

Track Skip: These buttons have no effect on the receiver, but are used with many source components to change tracks or chapters.

Dim: Press this button to partially or fully dim the front-panel display.

Transport Controls: These buttons have no effect on the receiver, but are used to control many source components. By default, when the remote is operating the receiver, these buttons will control a DVD player.

CONNECTIONS

There are different types of audio and video connections used to connect the receiver to the speakers and video display, and to connect the source devices to the receiver. To make it easier to keep them all straight, the Consumer Electronics Association (CEA) has established a color-coding standard. Table 1 may be helpful to you as a reference while you set up your system.

Table 1— Connection Color Guide

Audio Connections	
	Left Right
Front (FL/FR)	[White] [Red]
Center (C)	[Green]
Surround (SL/SR)	[Blue] [Grey]
Subwoofer (SUB)	[Purple]
Digital Audio Connections	
Coaxial	[Orange]
Optical	Input [Black] Output [Grey]
Video Connections	
Component	Y [Green] Pb [Blue] Pr [Red]
Composite	[Yellow]
S-Video	[Circular Icon]
HDMI Connections (switching only)	
HDMI	[HDMI Connector]

Types of Connections

This section will briefly review different types of cables and connections that you may use to set up your system.

Speaker Connections

Speaker cables carry an amplified signal from the receiver's speaker terminals to each loudspeaker. Speaker cables generally contain two wire conductors, or leads, inside plastic insulation. The two conductors are usually differentiated in some way, by using different colors, or stripes, or even by adding a ridge to the insulation. Sometimes the actual wires are different, one being copper colored and the other silver.

The differentiation is important because each speaker must be connected to the receiver's speaker-output terminals using two wires, one positive (+) and one negative (-). This is called speaker polarity. It's important to maintain the proper polarity for all speakers in the system. If some speakers have their negative terminals connected to the receiver's positive terminals, performance can suffer, especially for the low frequencies.

Always connect the positive terminal on the loudspeaker, which is usually colored red, to the positive terminal on the receiver, which is colored as shown in the Connection Color Guide (Table 1). Similarly, always connect the black negative terminal on the speaker to the black negative terminal on the receiver.

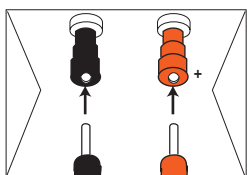

Figure 1 – Binding-Post Speaker Terminals With Banana Plugs

The AVR 147 uses binding-post speaker terminals that can accept banana plugs or bare-wire cables.

Banana plugs are simply plugged into the hole in the middle of the terminal cap. See Figure 1.

Bare wire cables are installed as follows (see Figure 2):

1. Unscrew the terminal cap until the pass-through hole in the collar is revealed.
2. Insert the bare end of the wire into the hole.
3. Screw the cap back into place until the wire is held snugly.

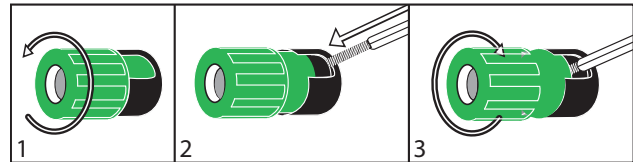

Figure 2 – Binding-Post Speaker Terminals With Bare Wires

Subwoofer

The subwoofer is a specialized type of loudspeaker that is usually connected in a different way. The subwoofer is used to play only the low frequencies (bass), which require much more power than the other speaker channels. In order to obtain the best results, most speaker manufacturers offer powered subwoofers, in which the speaker contains its own amplifier on board. Sometimes the subwoofer is connected to the receiver using the front left and right speaker outputs, and then the front left and right speakers are connected to terminals on the subwoofer. More often, a line-level (nonamplified) connection is made from the receiver's Subwoofer Output to a corresponding jack on the subwoofer, as shown in Figure 3.

Although the subwoofer output looks similar to the analog audio jacks used for the various components, it is filtered and only allows the low frequencies to pass. Don't connect this output to your other devices. Although doing so won't cause any harm, performance will suffer.



Figure 3 – Subwoofer

Connecting Source Devices to the AVR

The AVR 147 is designed to process audio and video input signals, playing back the audio and displaying the video on a television or monitor connected to the AVR. These signals originate in what are known as "source devices," including your DVD player, CD player, DVR (digital video recorder) or other recorder, tape deck, game console, cable or satellite television box or MP3 player. Although the tuner is built into the AVR, it also counts as a source, even though no external connections are needed, other than the FM and AM antennas.

Separate connections are required for the audio and video portions of the signal. The types of connections used depend upon what's available on the source device, and for video signals, the capabilities of your video display.

CONNECTIONS

Audio Connections

There are two formats for audio connections: digital and analog. Digital audio signals are of higher quality, and are required for listening to sources encoded with digital surround modes, such as Dolby Digital and DTS. There are two types of digital audio connections: coaxial and optical. Either type of digital audio connection may be used for each source device, but never both simultaneously for the same source. However, it's okay to make both analog and digital audio connections at the same time to the same source.

NOTE: Although HDMI cables are capable of carrying digital audio signals, the AVR 147 is not designed to process those signals. Therefore, if your source and video display are both HDMI-capable, use the HDMI connections for video only. Make a separate audio connection from the source device to the AVR 147, and turn the volume on your TV all the way off.

Digital Audio

Coaxial digital audio jacks are usually color-coded in orange. Although they look similar to analog jacks, they should not be confused, and you should not connect coaxial digital audio outputs to analog inputs or vice versa. See Figure 4.

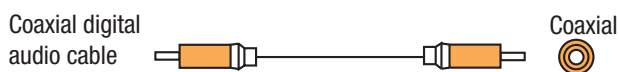

Figure 4 – Coaxial Digital Audio

Optical digital audio connectors are normally covered by a shutter to protect them from dust. The shutter opens as the cable is inserted. Input connectors are color-coded using a black shutter, while outputs use a gray shutter. See Figure 5.

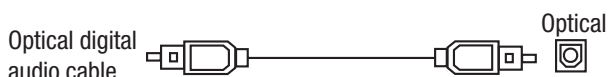

Figure 5 – Optical Digital Audio

Due to the nature of digital signals as binary bits, they aren't subject to signal degradation the way analog signals are. Therefore, the quality of coaxial and optical digital audio connections should be the same, although it is important to limit the length of the cable. Whichever type of connection you choose, Harman Kardon recommends that you always select the highest quality cables available within your budget.

Analog Audio

Analog connections require two cables, one for the left channel (white) and one for the right channel (red). These two cables are often attached to each other for most of their length. See Figure 6. Most sources that have digital audio jacks also have analog audio jacks, although some older types of sources, such as tape decks, have only analog jacks. For sources that are capable of both digital and analog audio, you may wish to make both connections. If you wish to record materials from DVDs or other copy-protected sources, you may only be able to do so using analog connections. Remember to comply with all copyright laws if you choose to make a copy for your own personal use.

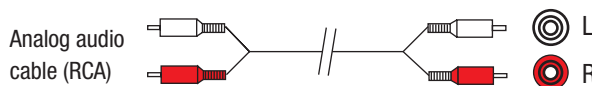

Figure 6 – Analog Audio

Multichannel analog connections are used with some high-definition sources where the copy-protected digital content is decoded inside the source. These types of connections are usually used with DVD-Audio, SACD, Blu-ray Disc, HD-DVD and other multichannel players. See Figure 7.

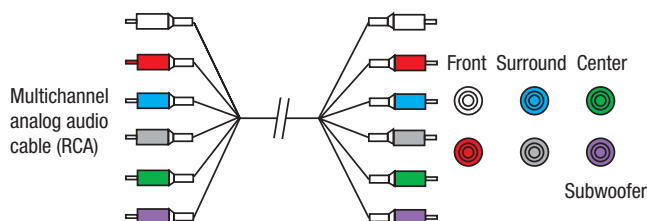

Figure 7 – Multichannel Analog Audio

Harman Kardon receivers also include a proprietary, dedicated audio connection called "The Bridge/DMP". If you own an iPod with a dock connector, you may purchase The Bridge separately and connect it to The Bridge/DMP port on the receiver. See Figure 8. Dock your iPod (not included) in The Bridge, and you may play your materials through your high-performance audio/video system. You may even use the AVR 147 remote to control the iPod, with navigation messages displayed on the front panel and on the screen of a video display connected to the AVR.



Figure 8 – The Bridge

Video Connections

Although some sources produce an audio signal only (e.g., CD player, tape deck), many sources output both audio and video signals (e.g., DVD player, cable television box, HDTV tuner, satellite box, VCR, DVR). In addition to the audio connection, you will need to connect one type of video connection for each of these sources (never more than one at the same time for any source).

Digital Video

The AVR 147 is equipped with two HDMI (High-Definition Multimedia Interface) inputs, and one output. HDMI is capable of carrying digital audio and video information using a single cable, thus delivering the highest possible quality picture and sound.

There are different versions of HDMI, depending on the capability of the source device and the type of signal it is capable of transmitting via the HDMI connection.

In addition, receivers and processors such as the AVR 147 may handle the incoming signal in several different ways, depending on their capability as well. The AVR 147 is only capable of switching the HDMI data. That is, the incoming audio and video data will be passed directly to your HDMI-capable video display, without the AVR 147 processing any

CONNECTIONS

of the data. Although this enables the AVR 147 to be compatible with virtually any HDMI-capable source device and video display, it requires a separate audio connection for each source since the AVR 147 doesn't have access to the audio data in the HDMI stream.

The AVR 147 is Simplay HD-verified for compatibility via the HDMI connection with other Simplay HD-verified products.

The AVR 147 will not convert analog video signals to the HDMI format, and the on-screen displays are not visible when using an HDMI source. Therefore, you will need to connect the composite or S-video monitor output to your video display (or both, depending on which video connections your sources use), to view the on-screen menus.

The physical HDMI connection is simple. The connector is shaped for easy plug-in (see Figure 9). If your video display has a DVI input, you may use an HDMI-to-DVI adapter (not included) to connect it to the AVR's HDMI Output.



Figure 9 – HDMI Connection

Analog Video

There are three types of analog video connections: composite video, S-video and component video.

Composite video is the basic connection most commonly available. The jack is usually color-coded yellow, and looks like an analog audio jack, although it is important never to confuse the two. Do not plug a composite video cable into an analog or coaxial digital audio jack, or vice versa. Both the chrominance (color) and luminance (intensity) components of the video signal are transmitted using a single cable. See Figure 10.



Figure 10 – Composite Video

S-video, or "separate" video, transmits the chrominance and luminance components using separate wires contained within a single cable. The plug on an S-video cable contains four metal pins, plus a plastic guide pin. Be careful to line up the plug correctly when you insert it into the jack on the receiver, source or video display. See Figure 11.



Figure 11 – S-Video

Component video separates the video signal into three components – one luminance ("Y") and two subsampled color signals ("Pb" and "Pr") – that are transmitted using three separate cables. The "Y" cable is color-coded green, the "Pb" cable is colored blue and the "Pr" cable is colored red. See Figure 12.

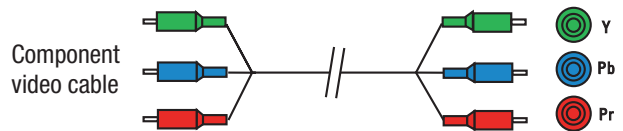

Figure 12 – Component Video

If it's available on your video display, HDMI is recommended as the best quality connection, followed by component video, S-video and then composite video.

NOTE: A composite or S-video connection to your TV is required to view the AVR's on-screen displays.

Antennas

The AVR 147 uses separate terminals for the included FM and AM antennas that provide proper reception for the tuner.

The FM antenna uses a 75-ohm F-connector. See Figure 13.



Figure 13 – FM Antenna

The AM loop antenna needs to be assembled. Then connect the two leads to the screw terminals on the receiver. See Figure 14.

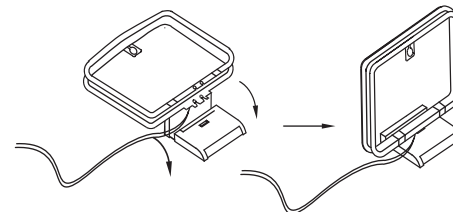

Figure 14 – AM Antenna

RS-232 Serial Port

The RS-232 serial port on the AVR 147 is used only for data. If Harman Kardon releases a software upgrade for the receiver's operating system at some time in the future, the upgrade may be downloaded to the AVR using this port. Complete instructions will be provided at that time.

INSTALLATION

You are now ready to connect your various components to your receiver. Before beginning, make sure that all components, including the AVR 147, are turned completely off and their power cords are unplugged. **Don't plug any of the power cords back in until you have finished making all of your connections.**

Remember that your receiver generates heat while it is on. Select a location that leaves several inches of space on all sides of the receiver. It is preferable to avoid completely enclosing the receiver inside a cabinet. It is also preferable to place components on separate shelves rather than stacking them directly on top of the receiver. Some surface finishes are delicate. Try to select a location with a sturdy surface finish.

Step One – Connect the Speakers

If you have not yet done so, place your speakers in the listening room as described in the Speaker Placement section above.

Connect the center, front left, front right, surround left and surround right loudspeakers to the corresponding speaker terminals on the AVR 147. See Figure 16. Remember to maintain the proper polarity by always connecting the positive and negative terminals on each speaker to the positive and negative terminals on the receiver. Use the Connection Color Guide on page 16 as a reference.

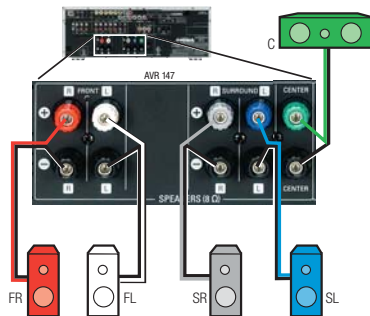

Figure 16 – Speaker Connections

Step Two – Connect the Subwoofer

Connect the Subwoofer Output on the AVR 147 to the line-level input on your subwoofer. See Figure 17. Consult the manufacturer's guide for the subwoofer for additional information.

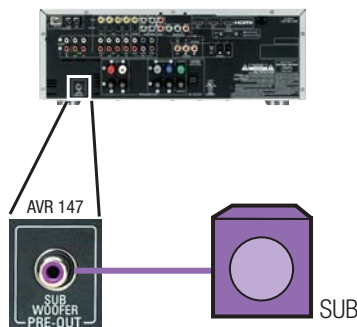

Figure 17 – Subwoofer Connection

Step Three – Connect the Antennas

Connect the FM and AM antennas to their terminals. See Figure 18.

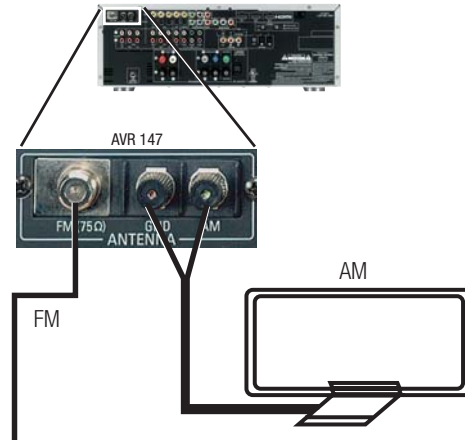

Figure 18 – Antenna Connections

Step Four – Connect the Source Components

Use the Table A4 worksheet in the Appendix to note which connections you will use for each of your source devices.

For each source, select a source input (Video 1, Video 2, Video 3, etc.). In Table 2 we recommend connecting certain types of sources to certain source inputs to make it easier to program and use the remote control.

Decide which audio connections you will use. If your source device has them, use *either* the coaxial digital or the optical digital audio connection. Referring to Table 2, we recommend you connect the DVD source to the Coaxial 1 input jack, and the source designated Video 2 to the Optical 2 input jack. If you are using the HDMI inputs for video switching, then we recommend using the Coaxial 2 digital audio connection for the source connected to the HDMI 1 input, and the Optical 2 digital audio connection for the source connected to the HDMI 2 input. However, you may make whatever connections are best for your system.

In addition to the digital audio connections, we recommend that you connect the analog audio connections for each source, as a backup to the digital connections for recording, or in the event that you use all six of the digital audio inputs for other devices. For sources that don't have digital audio outputs, you must use the analog audio connections.

For each video source, select one type of video connection. HDMI is preferred, but both your source device and your video display must have this type of video capability. If either device does not, then use component video, S-video or composite video.

Referring to Table 2, we recommend that you connect the DVD source to the Component Video 1 inputs, and any one source designated as Video 1, Video 2 or Video 3 to the Component Video 2 inputs. Any HDMI-capable source devices should be connected to one of the two HDMI inputs. All other source devices should be connected to component, the S- or composite video input for that source. However, you may make whatever video connections are best for your system.

INSTALLATION

NOTE: It's possible for a source to use none of the connections named for that source. For example, you might connect your DVD player to the Component Video 1 inputs and the Coax 1 digital audio input. However, we will refer to this source as "DVD"; and in Step Five of the Initial Setup section you will program the receiver so that these connections are assigned to the DVD source. When you select "DVD" as your source using the front panel or the remote, the correct connections for your DVD player will be used.

We recommend connecting your various sources using the connections shown in Table 2 below in order to simplify programming your receiver and remote control. However, you may connect any device to any source input.

Table 2 – Recommended Source Component Connections

Device Type	AVR 147 Source Input	Audio Connections	Video Connections
VCR, DVR, PVR, TiVo® or other audio/video recorder	Video 1	<ul style="list-style-type: none"> • Video 1 Analog (inputs and outputs) and • Any one available coaxial or optical digital audio input with corresponding coax or optical digital output 	<ul style="list-style-type: none"> • <i>One</i> of Component Video 2, Video 1 S-video or Video 1 composite video input • For recording, use Video 1 S-video or composite video output, and do not use component video connections at all
Cable TV, Satellite, HDTV or other device that delivers television programs	Video 2	<ul style="list-style-type: none"> • Video 2 Analog Inputs and • Optical 1 Input 	<ul style="list-style-type: none"> • <i>One</i> of Component Video 2, Video 2 S-video or Video 2 composite video input
TV, game console, camera or other audio/video device	Video 3 (front-panel jacks)	<ul style="list-style-type: none"> • Video 3 Analog Inputs and • <i>Either</i> Coax 3 or Optical 3 Input 	<ul style="list-style-type: none"> • <i>One</i> of Component Video 2, Video 3 S-video or Video 3 composite video input
DVD Audio/Video, SACD, HD-DVD, Blu-ray Disc	DVD	<ul style="list-style-type: none"> • DVD Analog Inputs • 6-Channel Inputs (optional) and • Coax 1 Input 	<ul style="list-style-type: none"> • Component Video 1 Input
CD player	CD	<ul style="list-style-type: none"> • CD Analog Inputs and • Any one available coaxial or optical digital audio input 	<ul style="list-style-type: none"> • Not required
CDR, MiniDisc, cassette	Tape	<ul style="list-style-type: none"> • Tape Analog (inputs and outputs) and • Any one available coaxial or optical digital audio input • Use corresponding coax or optical digital output 	<ul style="list-style-type: none"> • Not required

NOTE: The AVR 147 is equipped with a total of six digital audio inputs, four on the rear panel (Coaxial 1 and 2, Optical 1 and 2) and two on the front panel (Coaxial 3 and Optical 3), which may be assigned to any of the eight source inputs (DVD, Video 1 through 3, HDMI 1 and 2, CD and Tape). We recommend certain digital audio connections simply because, as reflected in Table A1 of the Appendix, those digital audio inputs are assigned to those sources by default at the factory. But any digital audio input may be reassigned to any source. Since you may not be using all eight source inputs, you may reassign a digital audio input that is recommended for a source you aren't using to another device. Table 2 is a guideline; you may need to make adjustments to fit your system.

Video 1 Source

Since this source includes audio and video recording output jacks, it is best suited to a video recorder, such as your VCR or DVR.

Referring to Table 2, connect your recorder to the Video 1 Analog Audio inputs and outputs **and** to any available coaxial or optical digital audio input (and corresponding digital audio output). See Figure 19. Use either the Video 1 S-video or composite video input and output if you wish to make recordings. If you don't plan on recording, you may use the Component Video 2 inputs.

INSTALLATION



Figure 19 – Video 1 AV Inputs and Outputs, and Digital Audio Inputs

Remember to connect the audio and video *output* jacks on your recorder to the Video 1 or digital audio *input* jacks on the AVR, and the audio and video *input* jacks on your recorder to the Video 1 or digital audio *output* jacks on the AVR.

NOTE: It isn't possible to make recordings using HDMI or component video connections. Keep this in mind as you connect other source devices that you may wish to make recordings from.

Video 2 Source

The Video 2 source is used only for playback. The AVR 147 remote control is programmed to operate many brands and models of cable and satellite television devices, and we recommend connecting your cable or satellite set-top box to this source.

Referring to Table 2, connect your set-top box to the Video 2 Analog Audio inputs **and** to the Optical 1 Digital Audio input. If possible, use the Component Video 2 inputs. Otherwise, connect the set-top box's S-video or composite video output to the matching Video 2 video input. See Figure 20.



Figure 20 – Video 2 AV, Digital Audio and Component Video Inputs

Video 3 Source

The Video 3 source is used only for playback. It is also generally reserved for components that are only temporarily connected to the receiver, such as cameras and game consoles, or for your TV to facilitate programming the remote. When not in use, you may place the supplied covers over the front-panel Video 3 jacks for a cleaner appearance. Simply snap the covers in place. When you wish to use the jacks, gently press on the left side of each cover to pivot it out for removal.

Referring to Table 2, connect your TV, camera or game console to the Video 3 Analog Audio inputs **and** to either the Coaxial 3 or Optical 3 digital audio input. See Figure 21. If possible, use the Component Video 2 inputs. Otherwise, connect the devices's S-video or composite video output to the matching Video 3 video input.



Figure 21 – Video 3 AV and Digital Audio Inputs

NOTE: If you receive your television programming using your TV with an antenna or direct cable connection, connect the TV's analog and optical digital audio outputs (if available) to the Video 3 Analog Audio inputs and to the Coax or Optical 3 Digital Audio input. Do not connect any video output on the television set to any video input on the receiver. See Step Five for information on connecting the receiver's video monitor outputs to the television.

DVD

The DVD source is used for a DVD player. If you have a more advanced multichannel device, such as a Blu-ray Disc or HD-DVD player, connect it to the DVD source.

Referring to Table 2, connect your DVD player to the DVD Analog Audio inputs **and** to the Coaxial 1 Digital Audio input. If possible, use the Component Video 1 inputs. Otherwise, connect the DVD player's S-video or composite video output to the matching DVD video input. See Figure 22.



Figure 22 – DVD AV, Digital Audio and Component Video Inputs

If your DVD player plays high-resolution audio discs such as SACD or DVD-Audio or when an HD-DVD or Blu-ray Disc player is used, connect the 6-channel analog audio outputs on the DVD player to the 6-channel analog audio inputs on the receiver in order to enjoy these discs to their fullest. See Figure 23.



Figure 23 – 6-Channel Analog Audio Inputs

HDMI 1 Source

The HDMI 1 source is used with a device that is capable of outputting digital video through an HDMI connection, such as a DVD, HD-DVD or Blu-ray Disc player or HDTV tuner. The HDMI 1 source is not used with any of the 2-channel analog audio or video inputs on the AVR 147.

Since the AVR 147 is not capable of processing either the audio or video signal transmitted via the HDMI connection, you will need to connect the source's coaxial digital audio output to the Coaxial 2 digital audio input on the AVR 147, or use the 6-/8-channel inputs. See Figure 24. You will also need to make sure your video display is HDMI-capable, and for many source devices, the display must be HDCP-compliant (High-Bandwidth Digital Content Protection) in order to display copy-protected materials.

INSTALLATION

The AVR 147 is Simplay HD-verified for compatibility via the HDMI connection with other Simplay HD-verified products.

If your source or video display is equipped with a DVI (Digital Video Interface) input, you may use an HDMI-to-DVI adapter (not included).



Figure 24 – HDMI 1 and Coaxial 2 Inputs

HDMI 2 Source

The HDMI 2 source is used with a second device that is capable of outputting digital video through an HDMI connection, such as a DVD, HD-DVD or Blu-ray Disc player. The HDMI 2 source is not used with any of the 2-channel analog audio or video inputs on the AVR 147.

Since the AVR 147 is not capable of processing either the audio or video signal transmitted via the HDMI connection, you will need to connect the source's optical digital audio output to the Optical 2 digital audio input on the AVR 147, or use the 6-/8-channel inputs. See Figure 25. You will also need to make sure your video display is HDMI-capable, and for many source devices, the display must be HDCP-compliant (High-Bandwidth Digital Content Protection) in order to display copy-protected materials.

If your source or video display is equipped with a DVI (Digital Video Interface) input, you may use an HDMI-to-DVI adapter (not included).



Figure 25 – HDMI 2 and Optical 2 Inputs

CD

The CD source is used for a strictly audio device, such as a CD player.

Referring to Table 2, connect your CD player to the CD Analog Audio inputs **and** to any available digital audio input. See Figure 26.



Figure 26 – CD Audio Inputs and Digital Audio Inputs

No video connections are needed.

Tape

The Tape source is used for audio-only recorders, such as a CDR, MiniDisc or cassette deck.

Referring to Table 2, connect your recorder to the Tape Analog Audio inputs and outputs, and to any available digital audio input (and corresponding digital audio output). See Figure 27.



Figure 27 – Tape Audio Inputs and Outputs, and Digital Audio Inputs and Outputs

Remember to connect the *output* jacks on your recorder to the Tape or digital audio *input* jacks on the AVR, and the *input* jacks on your recorder to the Tape or digital audio *output* jacks on the AVR.

No video connections are needed.



With Harman Kardon's optional The Bridge, you can enjoy audio, video or still images stored on your iPod (not included), use your AVR 147 remote control to operate the iPod, and even charge the iPod while it's docked in The Bridge.

Simply plug the proprietary cable from The Bridge into the special The Bridge/DMP connector on the rear of the AVR 147. See Figure 28. Refer to the owner's manual for The Bridge to select the appropriate insert to match your iPod.



Figure 28 – The Bridge/DMP Connector

Step Five – Connect the Video Display

Only video connections should be made between the receiver and your video display (TV), unless your TV is the source for your television programming (see Video 3 Source above).

You will need to make a video connection for each type of video used for your sources. In addition, even if you didn't use S-video or composite video for any of your sources, one of these video monitor connections is required to view the AVR 147's on-screen menus and displays.

First, determine what types of video your display is capable of handling. Remember that HDMI is preferred, followed by component video, S-video and then composite video. Ideally, this guided you in selecting the video connections for your sources.

Next, note which types of video connections you used for your source devices. Make sure you didn't use a better type of video connection for a source than your video display can handle. If so, you will need to disconnect the source and use a video connection that's compatible with your display.

If you used an HDMI video connection for any of your sources, then connect the HDMI Output on the AVR to an HDMI input on your video display. See Figure 29. As mentioned previously, you will need to make a separate digital audio connection from each source device to the AVR 147, and you will also need to consult the owner's guide for your television to learn the proper procedure for disabling or muting the audio.



Figure 29 – HDMI Output

If you used component video for any sources, connect the Component Video Monitor outputs on the receiver to one set of component video inputs on your display. See Figure 30. Make a note of how these inputs are labeled on the display.



Figure 30 – Component Video Monitor Outputs

INSTALLATION

If you used S-video for any sources, or if all of your sources used HDMI or component video, connect the S-video Monitor output on the receiver to an S-video input on your display. See Figure 31. Make a note of how the input is labeled.

If you used composite video for any sources, connect the composite video Monitor output on the receiver to a composite video input on the display. See Figure 31. Again, make a note of how this input is labeled on the display.



Figure 31 – S-Video and Composite Video Monitor Outputs

Consult the manual for your TV to make sure you understand how to select each video input. As you play different source devices that use different types of video connections, select the correct video input on your video display.

Step Six – Plug in AC Power

Having made all of your wiring connections, it is now time to plug each component's AC power cord into a working outlet.

You may plug one device into the AC Switched Accessory Outlet on the rear of the AVR 147. See Figure 32. Make sure this device draws no more than 50 watts. The device should have its mechanical or master power switch turned on, and it will power on any time the AVR 147 is turned on.



Figure 32 – Switched AC Accessory Outlet

Before plugging the AVR 147's AC Power Cord into an electrical outlet, make sure that the Master Power Switch on the front panel is popped out so that the word OFF appears on its top. Gently press the button to turn the switch off. This will prevent the possibility of damaging the AVR in case of a transient power surge.

Step Seven – Insert Batteries in Remote

The AVR 147 remote control uses three AAA batteries, which are included.

To remove the battery cover located on the back of the remote, firmly press the ridged depression and slide the cover toward the top of the remote.

Insert the batteries as shown in Figure 33, making sure to observe the correct polarity.

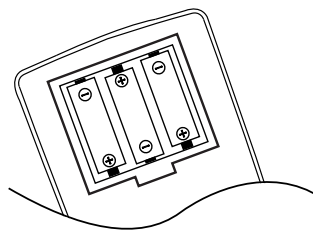

Figure 33 – Remote Battery Compartment

When using the remote, remember to point the lens toward the front panel of the AVR 147. Make sure no objects, such as furniture, are blocking the remote's path to the receiver. Bright lights, fluorescent lights and plasma video displays may interfere with the remote's functioning. The remote has a range of about 20 feet, depending on the lighting conditions. It may be used at an angle of up to 30 degrees to either side of the AVR.

If the remote seems to operate intermittently, or if pressing a button on the remote does not cause the AVR Selector or one of the Input Selectors to light up, then make sure the batteries have been inserted correctly, or replace all three batteries with fresh ones.

Step Eight – Program Sources Into the Remote

The AVR 147 remote not only is capable of controlling the receiver, but it may also be programmed to control many brands and models of VCRs, DVD players, CD players, cable boxes, satellite receivers, cassette decks and TVs, as well as an iPod docked in The Bridge.

It may help to think of the remote as a book with pages. Each page represents the button functions for a different device. In order to access the functions for a particular device, you first need to "turn to that page"; that is, switch the remote to that device mode. This is done by pressing the AVR Button to access the codes that control the receiver, or the Input Selector buttons to access the codes for the devices programmed into the remote.

You may have noticed that three of the Input Selectors look different from the others (see Figure 34). For the DVD/CD, TAPE/The Bridge and HDMI 1/HDMI 2 Selectors, there is a primary source, whose name is printed on the button, and a secondary source, whose name is printed in green above the button.

When the remote is in the device mode for the primary source, e.g. DVD, pressing the device selector will cause it to light up in red. When the remote is in the secondary source's device mode, the selector will light up in green when pressed.

To switch between the primary and secondary device modes, press the selector twice quickly in succession. The selector will retain this selection until the next time you toggle between the primary and secondary device modes. That is, if you press the DVD/CD Selector twice quickly so that the CD source is activated, then press another source selector, such as Video 1, the next time you press the DVD/CD Selector, the remote will return to the CD device mode.

The AVR 147's remote is factory-programmed to control an iPod docked in The Bridge and many Harman Kardon DVD and CD players.

INSTALLATION

If you have other source devices in your system, follow these steps to program the correct codes into the remote.

- Using the codes in Tables A9–A16 of the Appendix, look up the product type (e.g., DVD, cable TV box) and the brand name of your source. The number(s) listed are potential candidates for the correct code set for your particular device.
- Turn on your source device.
- This step places the remote in program mode, and varies slightly, depending on which Input Selector is being programmed. Refer to Figure 34.
 - DVD, Tape, Video 1, Video 2 and Video 3 Sources:** Press and hold the Input Selector until the Program Indicator LED starts to flash, then release it. Follow the directions in Step 4, below.
 - CD Source:** Press the DVD/CD Input Selector twice quickly so that it turns green, hold it until the Program LED starts to flash, then release. Follow the directions in Step 4, below.
 - HDMI 1 Source:** Press and hold the Input Selector until it turns red and the Program LED starts to flash, then release it. Next, press the Input Selector that corresponds to the device type you want to program into the HDMI 1 mode, i.e., DVD, VCR/PVR or CBL/SAT. Then follow the directions in Step 4, below.
 - HDMI 2 Source:** Press and release the Input Selector once, then quickly press the Input Selector again so that it turns green. Hold it until the Program LED starts to flash, then release it. Next, press the Input Selector that corresponds to the device type you want to program into the HDMI 2 mode, i.e., DVD, VCR/PVR or CBL/SAT. Then follow the directions in Step 4, below.



Figure 34 – Input Selectors

- Enter a code from Step 1 above.
 - If the device turns off, then press the Input Selector again to accept the code, which will flash. The remote will exit the Program mode.
 - If the device does not turn off, try entering another code. If you run out of codes, you may search through all of the codes in the remote's library for that product type by pressing the ▲ or ▼ button repeatedly until the device turns off. When the device turns off, enter the code by pressing the Input Selector, which will flash. The remote then exits Program mode.
- Once you have programmed a code, it's a good idea to try using some other functions to control the device. Sometimes manufacturers use the same Power code for several different models, while other codes will vary. You may wish to repeat this process until you've

programmed a satisfactory code set that operates most of the functions you frequently use.

- You may find out which code number you have programmed by pressing and holding the Input Selector to enter the Program mode. Then press the Set Button, and the Program Indicator LED will flash in the code sequence. One flash represents "1," two flashes for "2," and so forth. A series of many fast flashes represents "0." Record the codes programmed for each device in Table 3.

Table 3 – Remote Control Codes

Source Input	Product Type (circle one)	Remote Control Code
Video 1	VCR, PVR	
Video 2	Cable, Satellite	
Video 3	TV	
HDMI 1	VCR, PVR, DVD, Cable, Satellite	
HDMI 2	VCR, PVR, DVD, Cable, Satellite	
DVD	DVD	
CD	CD, CDR	
Tape	Cassette	

If you're unable to locate a code set that correctly operates your source device, it will not be possible to use the AVR remote to control that device. However, you may still connect the source to the AVR 147 and operate it using the device's original remote control. Alternatively, you may wish to consider purchasing Harman Kardon's optional TC 30 activity-based remote, which is programmed by accessing a large database of product codes on the Internet. The TC 30 is also capable of "learning" codes from your device's original remote.

Most of the button labels on the remote describe the button's function when used to control the AVR 147. However, the button may perform a very different function when used to control another device. Refer to the Remote Control Function List, Table A8 in the Appendix, for each button's functions with the various product types.

If you wish, you may program Macros, which are preprogrammed code sequences that execute many code commands with a single button press. You may also program "punch-through" codes, which allow the remote to operate the volume, channel or transport controls of another device without having to switch the remote's device mode. See pages 50 through 51 for instructions on these advanced programming functions.

NOTE: The AVR 147 remote is preprogrammed to operate the transport controls of Harman Kardon DVD players when the AVR or the Video 2 (cable/satellite) or Video 3 (TV) source is selected. You may change this punch-through programming at any time.

INSTALLATION

Step Nine – Turn On the AVR 147

Two steps are required the first time you turn on the AVR 147.

1. Gently press the Master Power Switch until the word OFF is no longer visible. The Power Indicator above the two power switches should light up in amber, indicating that the AVR is in Standby mode and is ready to be turned on. See Figure 35. Normally, you may leave the Master Power Switch in the ON position, even when the receiver is not being used.



Figure 35 – Power Switches

2. There are several ways in which the AVR 147 may be turned on from Standby mode.
 - a) Press the Standby/On Switch on the front panel. See Figure 35.
 - b) Press the Source Select Button on the front panel. See Figure 36.



Figure 36 – Source Select Button

- c) Using the remote, press any one of these buttons: AVR, DVD/CD, TAPE/The Bridge, HDMI 1/HDMI 2, VID1, VID2, VID3, XM, AM/FM or 6CH. See Figure 37.



Figure 37 – AVR and Input Selectors

NOTE: Any time you press one of the Input Selectors on the remote (i.e., DVD/CD, TAPE/The Bridge, HDMI 1/HDMI 2, VID1, VID2 or VID3), the remote will switch modes so that it will only transmit the codes programmed to operate that device. In order to control the receiver, you will need to press the AVR button to return the remote to AVR mode.

OPERATION

Now that you have installed your system components and completed at least a basic configuration of your receiver, you are ready to begin enjoying your home theater system.

Turning On the AVR 147

Gently press the Master Power Switch until the word OFF is no longer visible. The Power Indicator above the two power switches should light up in amber. This indicates that the AVR is in Standby mode and is ready to be turned on. Normally, you may leave the Master Power Switch in the ON position, even when the receiver is not being used. See Figure 55.



Figure 55 – Power Switches

There are several ways in which the AVR 147 may be turned on:

- Press the Standby/On Switch on the front panel. See Figure 55.
- Press the Source Select Button on the front panel. See Figure 56.



Figure 56 – Source Select Button

- Using the remote, press any one of these buttons: AVR, DVD/CD, TAPE/The Bridge, HDMI 1/HDMI 2, VID1, VID2, VID3, XM, AM/FM or 6CH. See Figure 57.



Figure 57 – AVR and Input Selectors

NOTE: Any time you press one of the remote's Input Selectors (i.e., DVD/CD, TAPE/The Bridge, HDMI 1/HDMI 2, VID1, VID2 or VID3), the remote will switch modes so that it will only transmit the codes programmed to operate that device. In order to control the receiver, you will need to press the AVR Button to return the remote to AVR mode.

To turn the receiver off, press either the Standby/On Switch on the front panel, or press the AVR Button and the OFF Button on the remote. Unless the receiver will not be used for an extended period of time (for example, if you will be on vacation), it is not necessary to turn off

the Master Power Switch. When the Master Power Switch is turned off, any settings you have programmed, including system configuration and preset radio stations, will be preserved for up to four weeks.

Sleep Timer

You may program the AVR to play for up to 90 minutes and then turn off automatically using the sleep timer.

Press the Sleep Button on the remote, and the time until turn-off will be displayed. See Figure 58. Each additional press of the Sleep Button will reduce the time until turn-off by 10 minutes, until the OFF setting is reached, which disables the sleep timer.



Figure 58 – Sleep Button

When the sleep timer has been set, the front-panel display will automatically dim to half-brightness. If you press any button on the remote or front panel, the display will return to full-brightness. The display will dim again several seconds after your last command.

If you press the Sleep Button after the timer has been set, the remaining time until turn-off will be displayed. You may press the Sleep Button to change the time until turn-off. Pressing and holding the Sleep Button will disable the sleep timer, and the SLEEP OFF message will appear.

Volume Control

The volume may be adjusted either by turning the knob on the front panel (clockwise to increase volume or counterclockwise to decrease volume), or by pressing the Volume Control Buttons on the remote. See Figure 59. The volume is displayed as a negative number of decibels (dB) below the 0dB reference point, and may be changed in 0.5dB increments.

Unlike the volume controls on some other products, 0dB is the maximum volume for the AVR 147. Although it's physically possible to turn the volume to a higher level, doing so may damage your hearing and your speakers. For certain more dynamic audio materials, even 0dB may be too high, allowing for damage to equipment.



Figure 59 – Volume Controls

The AVR 147 is designed to reproduce audio with a minimum amount of distortion, which may lead you to think that your hearing and the equipment can handle higher volumes. We urge caution with regard to volume levels.

OPERATION

Mute Function

To temporarily mute all speakers and the headphones, press the Mute Button on the remote. See Figure 60. Any recording in progress will not be affected. The MUTE message will flash in the display as a reminder. To restore normal audio, either press the Mute Button again, or adjust the volume. Turning off the AVR will also end muting.



Figure 60 – Mute Button

Tone Controls

You may boost or cut either the treble or the bass frequencies by up to 10dB.

Using the front-panel controls or the remote, press the Tone Mode Button once. See Figure 61. This will indicate whether the tone controls are in or out of the circuitry. If you wish to return the tone controls to 0, or "flat" response, press the ◀▶ Buttons (▲/▼ on the remote) until the TONE OUT message appears, which preserves any changes you have made to the bass or treble settings for later use. To reactivate your changes, the tone control must again be set to TONE IN.

With the TONE IN message displayed, press the Tone Mode Button repeatedly to access TREBLE MODE and BASS MODE. Use the ◀▶ Buttons (▲/▼ on the remote) to change the treble or bass settings, as desired. The display will return to normal a few seconds after your last command.



Figure 61 – Tone Button

You may alternatively adjust the tone controls using the full-OSD menu system. Press the OSD Button on the remote to view the Master Menu. The cursor will be pointing to the INPUT SETUP line; press the Set Button to display that menu and view the current tone settings. If you wish to make any changes to the TONE, BASS or TREBLE settings, use the arrow keys on the remote to move the cursor to the line you wish to change. Once you have changed the setting using the ◀▶ Buttons, simply move the cursor up or down to a different line; it isn't necessary to press the Set Button to enter the new setting. When you have finished, either wait until the display times out and disappears, press the OSD Button to clear the display, or move the cursor to the BACK TO MASTER MENU line if you wish to make other changes using the menu system.

NOTE: The AVR 147 does not have a conventional balance control. The EzSet/EQ process compensates for any characteristics of your room or speakers, and we recommend that you leave the settings as they are after EzSet/EQ has been run. However, you may manually adjust the levels of the left and right channels – decreasing one and increasing the other by the same amount – using the Channel Adjust submenu, as described on page 49. This achieves the same effect as a balance control.

Headphones

Plug the 1/4" plug on a pair of headphones into the headphone jack on the front of the receiver for private listening. See Figure 62. The first time you use the headphones, the DOLBY H:BP message will be displayed, indicating that Dolby Headphone surround processing is in the bypass mode, which delivers a conventional 2-channel signal to the headphones.



Figure 62 – Headphone Jack

Press the Surround Select Button on the front panel, or the Dolby Button on the remote, to switch to Dolby Headphone virtual surround processing, indicated by the DOLBY H:DH message. Dolby Headphone delivers an enhanced sound field that emulates a 5.1-channel speaker system. No other surround modes are available for the headphones.

Source Selection

Press the front-panel Source Select Button to scroll through the sources. The left side of the button scrolls down the list that appears in the display; the right side scrolls upward. For direct access to the tuner, press the Tuner Band Button, which switches to the last-used band and frequency. See Figure 63. For direct access to any source, press its Input Selector on the remote (see Figure 57).



Figure 63 – Source Select and Tuner Band Buttons

NOTE: The Bridge/DMP source has no icon in the Source Indicators display. When selected, the DMP indication will appear in the message display's upper line, and one of two messages will scroll on the right side to indicate whether The Bridge is unplugged or connected. If you have retitled this source, then only the new name will appear in the upper line.

For direct access to any source, press its Input Selector on the remote (see Figure 57). Since the AVR 147 allows for more source input devices than the remote has buttons for, some sources are required to share buttons. These are the DVD and CD sources, the Tape and The Bridge sources, and the HDMI 1 and HDMI 2 sources. The first press of any of these three Input Selectors will select the source whose name appears on the button (i.e., DVD, Tape or HDMI 1), as indicated by the

OPERATION

button lighting up in red. Press that Input Selector again quickly to select the source whose name appears above the button (i.e., CD, The Bridge or HDMI 2), and the selector will light in green to indicate that you have selected the source whose name is printed above the button.

The AVR 147 will switch to the audio and video inputs assigned to the source. If you set the BASS MGR setting in the Speaker X-over menu to INDEPENDENT, the AVR 147 will change the speaker size configuration to the one you programmed for the source. If you selected a surround mode for the source, the AVR 147 will switch to that mode.

The source name will appear in the upper line of the front-panel display. If you retitled the source, only the new title will appear. Otherwise, the audio input assigned to the source (analog or one of the digital audio inputs) will also appear. The surround mode will be displayed on the lower line. The same information will also appear on screen in the semi-OSD, unless you have set the semi-OSD to OFF in the System Setup menu, as described in the Advanced Functions section.

Audio Input Selection

The AVR 147 is programmed at the factory to use the analog audio inputs for each source (except for the DVD, Video 2, HDMI 1 and HDMI 2 sources; see Table 4). To assign a digital audio input to a source (if you have not done so using the Input Setup menu during Initial Setup), press the Digital Button on the remote or front panel. The current audio input selection will flash in the display, and you may press the ▲/▼ (or ◀/▶ on the front panel) Buttons to scroll through the audio inputs. When the desired input appears, press the Set Button to select it. See Figure 64.



Figure 64 – Digital Input Selection

If the Auto Poll feature is ON in the Input Setup menu, and if a digital audio input has been assigned to the source, the AVR 147 will first check the digital audio input for a signal. If a signal is present, the AVR 147 will select the digital audio input. If no signal is present, the AVR 147 will switch to the analog audio inputs for the source.

Video Input Selection

When a source is selected, the AVR 147 switches to a video input as follows:

Only signals originating at one of the two HDMI inputs will be available at the HDMI output. The AVR 147 will not transcode or convert any other types of video signals to the HDMI format. In addition, the AVR 147 cannot access the video data in the HDMI stream. The on-screen displays are not available via the HDMI output. To view the AVR's displays, connect the Composite or S-video Monitor Output to the corresponding input on your TV, and follow the manufacturer's instructions for selecting the correct video input on your TV.

The COMPONENT IN line of the Input Setup menu indicates which of the two component video inputs on the AVR 147 is assigned to each source. All of the sources listed in the left column of the Source Indicators

display on the front panel are assigned to the Component Video 2 inputs by default, and the sources listed in the right column default to the Component Video 1 sources. See Figure 65.

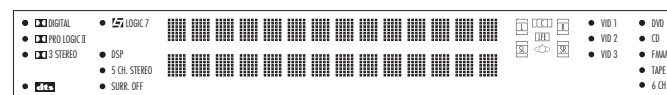

Figure 65 – Front-Panel Input Indicators

You may reassign either component video input to another source if it is physically connected to that input, but there is no option to disable the component video inputs for any source. If a signal is present at the component video input assigned to that source, it will be selected. If your device is not using component video, make sure that other devices connected to the component video inputs are turned off.

If no signal is present at the component video input, then the S-video or composite video input for the source will be selected. It is not possible to reassign the S-video or composite video inputs to other sources.

For audio-only sources, such as the tuner or CD inputs, when no component video signal is present, the last-used video source will be selected.

6-Channel Direct Inputs

If you wish to hear audio through the 6-Channel Direct Inputs together with video, then connect your multichannel player to both the 6-Channel Inputs and the Component Video 1 Inputs (the default for the 6-Channel Inputs), and the correct audio and video inputs will be selected when you select 6CH as your source. If your multichannel player uses S-video or composite video connections, first select the source you connected the video output to (e.g., DVD), and then select the 6CH source. See Figure 66.



Figure 66 – 6-Channel Input Selector

Example 1: You would like to connect a DVD-Audio player to the AVR 147. You plan on playing a variety of discs using this player, including conventional DVDs and even CDs as well as multichannel discs. When playing DVDs and CDs, it is preferable to use a digital audio connection to obtain the best sound quality and the benefit of any digital surround formats contained on the DVD. However, when playing DVD-Audio discs, you will need to use the 6-channel analog audio connections. In addition, some of these discs contain video materials. The player does not have an HDMI output.

We recommend that you connect this player as follows:

- a) Connect the player's coaxial digital audio output to the Coaxial 1 input on the AVR. This input is assigned by default to the DVD source.
- b) Connect the player's component video outputs to the Component Video 1 inputs on the AVR, which are assigned by default to the DVD source. If your video display doesn't have component video inputs,

OPERATION

then connect the player's composite or S-video output to the AVR's corresponding DVD video input.

- c) Connect the player's 6-channel analog audio outputs to the AVR's 6-Channel Inputs and assign the Component Video 1 inputs to this source using the Input Setup menu, as described in the Initial Setup section.
- d) Program the player's remote control codes into the DVD Input Selector. Note that not all commands will necessarily be available.

When you wish to view a DVD, simply select the DVD source.

When you wish to listen to a DVD-Audio disc and view the menus and other still images on the disc, first select DVD, and then the 6-Channel Inputs as the source.

Example 2: In this example, your multichannel disc player is equipped with an HDMI output. Connect it as follows:

- a) Connect the player's coaxial digital audio output to the Coaxial 2 input on the AVR. This input is assigned by default to the HDMI 1 source.
- b) Connect the player's HDMI output to the HDMI 1 source input, and make sure to connect the AVR's HDMI Output to your video display.
- c) Connect the player's 6-channel analog audio outputs to the AVR's 6-Channel Inputs and then select an unused component video input at the COMPONENT IN line to avoid inadvertently selecting the video signal from another device.
- d) Program the player's remote control codes into the HDMI 1 Input Selector.

When you wish to view a DVD, simply select the HDMI 1 source.

When you wish to play a multichannel disc, first select the HDMI 1 source to obtain the correct video signal, then select the 6-Channel Inputs to select the audio signal.

To select the 6-Channel Inputs as the source, use either the Source Selector on the front panel or press the 6CH Input Selector on the remote. See Figure 67.



Figure 67 – 6-Channel Input Selector

NOTE: The 6-Channel Inputs pass the incoming signals directly to the volume control, without digitizing or processing them. Therefore, you will need to configure bass management settings (i.e., speaker size, delay and output level) on your source device so that they match the settings you programmed using EzSet/EQ, which may be viewed using the Manual Setup menu (see the Advanced Functions section). Consult the owner's guide for your multichannel player for more information.

Using the Tuner

The AVR 147's built-in tuner may be selected in one of three ways (see Figure 68):

1. Press the Source Selector Button on the front panel repeatedly until the tuner is selected. The last-used band (AM or FM) will be active.
2. Press the Tuner Band Button (marked AM/FM). Press this button again to switch bands. This will also enable you to select XM Radio, which is described separately in the next section.
3. Press the Tuner Input Selector (marked AM/FM) on the remote. Press this button again to switch bands (AM, FM or XM).



Figure 68 – Tuner Input Selection

Radio stations may be selected in one of four ways (see Figure 69):

1. If you know the frequency number, enter it directly by first pressing the Direct Button on the remote, and then using the Numeric Keys.
2. After you have programmed Preset stations (see below), enter either the Preset number (1 through 30) using the remote, or use the Preset Stations Button (front-panel or remote) to scroll through the list of presets.
3. In Auto tuning mode, with each press of the Tuning Buttons (front-panel or remote) the AVR 147 will scan in the chosen direction until a station with acceptable signal strength is detected. Press the Tuning Button again to stop scanning.
4. In Manual tuning mode, with each press of the Tuning Buttons the AVR 147 will tune the next frequency increment (0.1MHz for FM, or 10kHz for AM) in the selected direction. Press and hold the Tuning Button for faster scanning.



Figure 69 – Tuning a Station

Press the Tuning Mode Button (TUN-M on the remote) to switch between Auto and Manual tuning modes. See Figure 70. When an FM station has been tuned, pressing the Tuning Mode Button will switch between stereo and mono tuning, which may improve reception of weaker stations.



Figure 70 – Tuning Mode

To store a station in one of the 30 presets (see Figure 71):

1. Tune the desired station.
2. Press the Memory Button on the remote.
3. Use the Numeric Keys to enter the desired preset number.



Figure 71 – Storing a Preset Station

XM Radio Operation

XM Radio is a satellite-delivered service that offers hundreds of program channels, as well as local traffic and weather information for select cities. The AVR 147 is “XM Ready,” which means that it is able to receive the XM service when an optional XM antenna module is connected and the service activated. As of this writing, the Audiovox® CNP 1000 “Connect and Play” module for home audio use and the XM Mini-Tuner and Home Dock (Models CNP-2000 and CNP-2000H) are compatible with the AVR 147. Additional modules may become available in the future. Modules produced for automotive, or “mobile,” use are not compatible with the AVR 147.

NOTE: To listen to XM Radio using the AVR 147, you will need to purchase an XM antenna module and subscription, and you will need to activate your module. (Note that XM service is not available in Alaska or Hawaii.) Visit the XM Radio Web site at www.xmradio.com for more information.

Plug the module into the XM Antenna Jack on the rear of the AVR 147. Place the antenna module so that it has a clear “view” through a south-facing window in order to obtain reception from the XM satellite.

Select XM Radio as the source in one of the following three ways (see Figure 72):

1. Press the Source Select Button on the front panel repeatedly until XM Radio is selected. XM will only appear in the Message Display.
2. Press the Tuner Band Button (front-panel or remote) repeatedly until XM Radio is selected.
3. Press the XM Radio Input Selector on the remote.



Figure 72 – XM Radio Source Selection

You should be able to tune in Channel 1, the Preview Channel, to confirm that your equipment is ready for activation. There are three ways to tune an XM Radio channel (see Figure 69):

1. Enter the channel number directly using the Numeric Keys on the remote. It is not necessary to press the Direct Button first.

2. Press the Tuning Buttons on the front panel or remote to scan through the channels. Auto tuning mode is not available.
3. The AVR 147 is capable of storing up to 40 XM Radio preset channels. The presets are divided into five banks, denoted by the letters A through E, with eight numeric presets per bank. After you have programmed preset stations (see below), you may select one by pressing the Set Button repeatedly until PRESET SEARCH appears, then use the ▲/▼ Buttons to change the bank (A through E). Use the Preset Buttons to scan through the eight numeric positions within a bank.

When you are able to hear Channel 1, you are ready to activate your module. If you don't hear Channel 1, make sure the module's plug is firmly seated in the XM Antenna jack, and that the module is near a south-facing window. Try unfolding the module and rotating it to obtain reception. You may need to purchase an extension cable, available on the XM Radio site, to ensure that the module is near the window.

Tune to Channel 0 for a display of your antenna module's Radio ID number, required for activation.

The current channel number and preset location will appear in the upper line of the Message Display, and the channel's name will appear in the lower line. Three signal-strength bars will appear to the right of the channel number and preset location. If you wish to display the category, current artist or song title, press the Tuning Mode Button repeatedly.

For traffic and weather channels, the current city's name will appear instead of the channel name, and pressing the Tuning Mode Button repeatedly will display the local weather and temperature.

Press the Set Button to search all channels. Press it again to search by category, using the ▲/▼ Buttons to change the category. Press the Set Button again to tune the lowest-numbered station available in that category, or without using the arrow keys, press the Set Button to change the preset bank, using the ▲/▼ Buttons to change the bank letter. Press the Set Button again to return to the all-channel search.

To store the current channel in one of the 40 preset locations:

1. Press the Set Button repeatedly until PRESET SEARCH appears, then use the ▲/▼ Buttons until the desired bank of presets (A through E) appears in the upper line of the message display.
2. Press the Memory Button, and a line will appear next to the preset bank letter.
3. Use the Numeric Keys to enter the preset location (1 through 8) you wish to store the channel in.

Recording

Two-channel analog and digital audio signals, as well as composite and S-video signals, are normally available at the appropriate recording outputs. Thus, to make a recording, you need only make sure to connect your audio or video recorder to the appropriate output jacks (as described in the Installation section), insert blank media and make sure the recorder is turned on and recording while the source is playing.

OPERATION

NOTES:

1. Analog audio signals are not converted to digital form, and digital audio signals are not converted to analog audio form. However, you may record a coaxial or optical digital audio source using either type of digital audio output.
2. Only PCM digital audio signals are available for recording. Proprietary formats such as Dolby Digital and DTS may not be recorded using the digital audio connections, although if the source is connected to the AVR using the analog audio connections, an analog recording may be made.
3. HDMI and Component video sources are not available for recording.
4. Please make certain that you are aware of any copyright restrictions on any material you record. Unauthorized duplication of copyrighted materials is prohibited by federal law.

Using

The Bridge is an optional dock that may be used with a compatible iPod (not included). When The Bridge is connected to its proprietary input on the AVR 147 and the iPod is docked, you may enjoy the audio, video and still-image materials on your iPod through your high-quality audio/video system, operate the iPod using the AVR remote or the AVR's front-panel controls, view navigation messages on the AVR's front panel or a connected video display, and charge the iPod.

Either press the front-panel Source Selector repeatedly until the message "DMP/The Bridge is CONNECTED" scrolls across the front-panel and semi-OSD displays, or press the DMP Button on the remote to select The Bridge as the input source.



(Left) Figure 73 – Using The Bridge (Remote)

(Above) Figure 74 – Using The Bridge (Front Panel)

Table 5 summarizes the controls available when The Bridge is in use; see also Figures 73 and 74.

Table 5 – Using The Bridge

iPod Function	Remote Control Key	Front-Panel Button
Play	Play (▶)	Tuner Mode
Pause	Pause ()	Tuner Mode
Menu	Menu (Spkr)	Tuner Band (AM/FM)
Select	Set	Set
Scroll Forward	Left Arrow (◀)	Preset Down
Scroll Reverse	Right Arrow (▶)	Preset Up
Forward Search/Next Track	Forward/Next (▶▶)	Tuning Up
Reverse Search/Previous Track	Reverse/Previous (◀◀)	Tuning Down

NOTE: For the Search function, press and hold the indicated button. Pressing the Previous Track Button once skips to the beginning of the current track. Press the Previous Track Button *twice* to skip to the beginning of the previous track.

It is possible to activate Repeat (one track or one album/playlist) and Shuffle (songs or albums) modes using the DMP SETTING menu (see Figure 54). This menu may also be used to turn on the Resume feature, which resumes play of the current track from the point it was interrupted, or to enable charging while the AVR is in Standby mode.

NOTE: The Resume setting disables the Remember Playback Position setting that you may set for audio and video files using later versions of iTunes. Resume affects all files on the iPod until you manually change the setting either in the DMP SETTING menu or using iTunes.

Access the DMP SETTING menu by pressing OSD to display the MASTER MENU. Press the Set Button to display the INPUT SETUP menu. When DMP/The Bridge is selected as the current source, you may scroll down to the GO TO DMP SETTING line and press the Set Button to display the DMP SETTING menu. See the Initial Setup section for more information on using the DMP SETTING menu.

NOTES ON VIDEO PLAYBACK:

- Before attempting to play videos stored on your iPod, check the Video Settings menu on the iPod and make sure that the TV Out setting is set to On. The TV Signal setting should be NTSC to match the capabilities of your video display. Set Widescreen to On or Off, depending on the aspect ratio of your video display. If your selection was playing and paused at the time you changed the TV Out setting, the iPod may require you to navigate its menu system and reselect the video for the new TV Out setting to take effect. Resuming play from the Now Playing function may not reflect the change to the TV Out setting. This is a function of the iPod, not the AVR 147.
- In Video mode, the iPod's menus will not be visible on your video display, although you may view them on the iPod's screen. You may operate the iPod using the AVR remote, as long as it is in The Bridge device mode.
- You may view the AVR's on-screen displays while The Bridge is in use, just as you would with any other video source.
- The MP4 and H.264 video formats often used for videos to be played on the iPod are intended for optimal performance on the iPod's small screen. Playback on larger displays may have different results.

Selecting a Surround Mode

Surround mode selection can be as simple or sophisticated as your individual system and tastes. Feel free to experiment with the many available surround modes on the AVR 147, and you may find a few that become your favorites for certain sources or program types. Although more detailed information on surround modes may be found in the Advanced Functions section, it is easy to select any of the modes available at a given time:

To select a surround mode using the front-panel controls, press the Surround Mode Button repeatedly until the desired group of modes is selected: Logic 7, Dolby, DTS, DSP or Stereo. Then press the Surround Select Button repeatedly to select the desired mode within the group. See Figure 75.



Figure 75 – Select a Surround Mode (Front Panel)

To select a surround mode using the remote control, locate the button dedicated to the desired group of modes: Logic 7, Dolby Sur, DTS Sur, DTS Neo:6, Surr (DSP) or Stereo. Press that button repeatedly to select the desired mode. See Figure 76.



Figure 76 – Select a Surround Mode (Remote)

To select a surround mode using the full-OSD menu system, press the OSD Button to display the Master Menu. Navigate to the SURROUND SELECT line and press the Set Button to view the Surround Select menu (see Figure 78). Each of the major surround mode groups is listed here. Select a group to access the MODE setting for selection of an individual mode. As explained in the Advanced Functions section, there are also some additional settings that may be made.

You are now ready to enjoy the best in home theater entertainment with your AVR 147. As you become more familiar with the receiver, you may wish to explore some of its advanced functions, which are described in the following section.

TROUBLESHOOTING GUIDE

SYMPTOM	CAUSE	SOLUTION
Unit does not function when Main Power Switch is pushed	<ul style="list-style-type: none"> • No AC Power 	<ul style="list-style-type: none"> • Make certain AC power cord is plugged into a live outlet • Check to see whether outlet is switch-controlled
Display lights, but no sound or picture	<ul style="list-style-type: none"> • Intermittent input connections • Mute is on • Volume control is down 	<ul style="list-style-type: none"> • Make certain that all input and speaker connections are secure • Press Mute Button • Turn up volume control
No sound from any speaker; light around power switch is red	<ul style="list-style-type: none"> • Amplifier is in protection mode due to possible short • Amplifier is in protection mode due to internal problems 	<ul style="list-style-type: none"> • Check speaker wire connections for shorts at receiver and speaker ends • Contact your local Harman Kardon service center
No sound from surround or center speakers	<ul style="list-style-type: none"> • Incorrect surround mode • Input is monaural • Incorrect configuration • Stereo or Mono program material 	<ul style="list-style-type: none"> • Select a mode other than Stereo • There is no surround information from mono sources • Check speaker mode configuration • The surround decoder may not create center- or rear-channel information from nonencoded programs
Unit does not respond to remote commands	<ul style="list-style-type: none"> • Weak batteries in remote • Wrong device selected • Remote sensor is obscured 	<ul style="list-style-type: none"> • Change remote batteries • Press the AVR selector • Make certain front-panel sensor is in line of sight of the remote or connect an optional remote sensor
Intermittent buzzing in tuner	<ul style="list-style-type: none"> • Local interference 	<ul style="list-style-type: none"> • Move unit or antenna away from computers, fluorescent lights, motors or other electrical appliances
Letters flash in the channel indicator display and digital audio stops	<ul style="list-style-type: none"> • Digital audio feed paused 	<ul style="list-style-type: none"> • Resume play for DVD • Check that Digital Input is selected
The XM Preview Channel (001) is silent	<ul style="list-style-type: none"> • XM antenna is not plugged in • XM antenna is not located in such a way as to enable reception 	<ul style="list-style-type: none"> • Make sure you are using a home audio XM antenna module designed for use with XM Ready home audio equipment, and that the module is plugged into the XM Radio Jack on the rear panel of the receiver. • The XM Antenna module needs to be placed with an unobstructed view of the southern sky, or within range of an XM terrestrial repeater. If necessary, purchase an extension cable from your XM Radio dealer.

In addition to the items shown above, additional information on troubleshooting possible problems with your AVR 147, or installation-related issues, may be found in the list of "Frequently Asked Questions" which is located in the Product Support section of our Web site at www.harmankardon.com.

Erasing Macros

It isn't possible to "edit" a command within a macro. However, you may erase the macro as follows:

1. Simultaneously press and hold the Mute Button and the Macro Button containing the macro until the LED flashes.
2. Press the Surround Button to erase the macro.

Resetting the Remote

To reset the remote to its factory defaults, simultaneously press and hold any Input Selector and the "0" Numeric Key. When the Program LED flashes in amber, enter the code "333". When the green LED goes out, the remote will have been fully reset.

Processor Reset

There may be instances when you wish to fully reset the AVR 147 to its factory defaults, or the unit may behave erratically after a power surge. To correct erratic behavior, first try turning the Master Power Switch off and unplugging the AC Power Cord for at least 3 minutes. Plug the cord back in and turn the receiver back on. If this doesn't help, try a system reset. NOTE: A system reset erases all user configurations, including speaker and level settings and tuner presets. After a reset, you will need to re-enter all of these settings. To reset the AVR 147, place the receiver in Standby mode (press the front-panel Standby/On Switch so that the Power Indicator turns amber). Then press and hold the front-panel Tone Mode Button for at least 5 seconds until the RESET message appears in the display. If the receiver still does not function correctly after a processor reset, contact an authorized Harman Kardon service center for assistance.

Service centers may be located by visiting our Web site at www.harmankardon.com.

Memory

If the AVR 147 is unplugged or experiences a power outage, it will retain user settings for up to four weeks.

1. Removing the Top Cabinet
Remove the Screws

① ~ ⑬

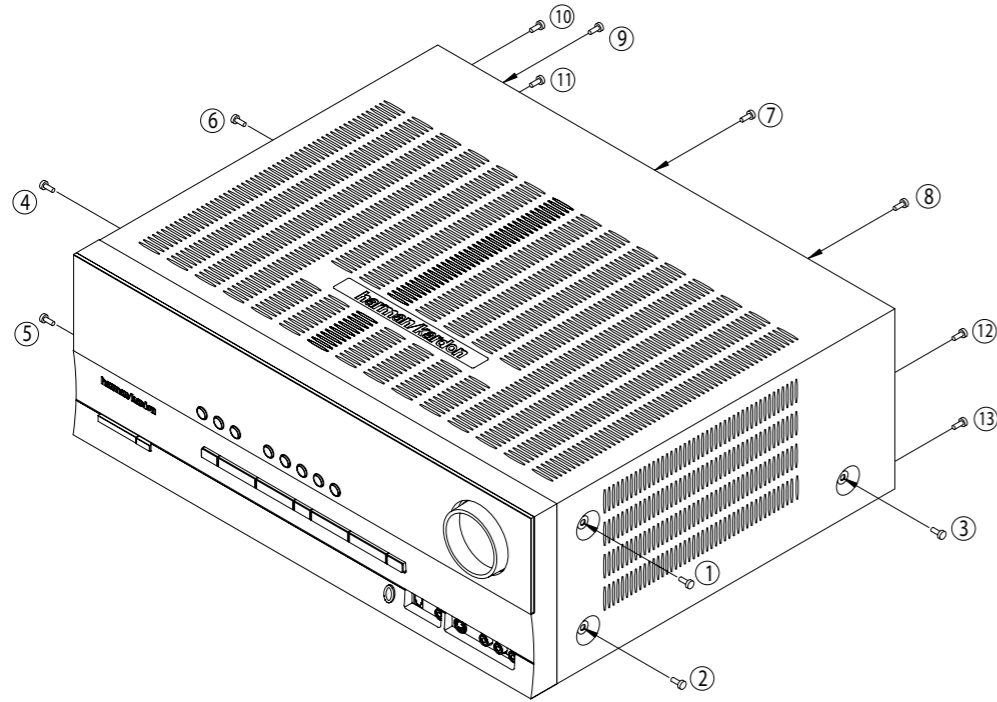

2. Removing the Front Panel
Remove the Screws

① ~ ⑨

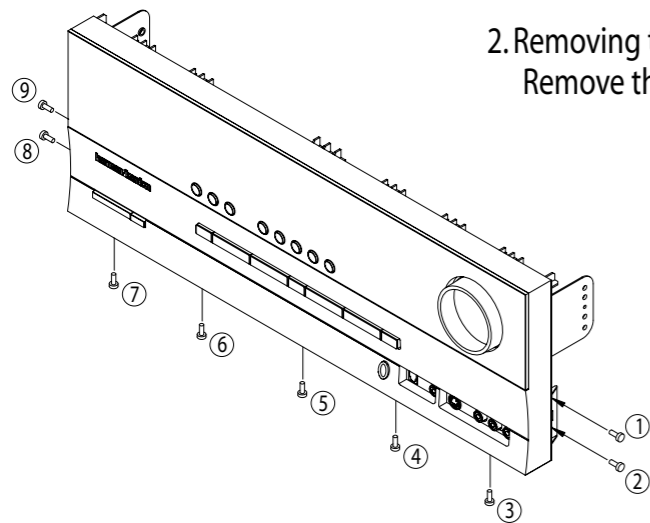

3. Removing the Rear Panel
Remove the Screws

① ~ ⑲

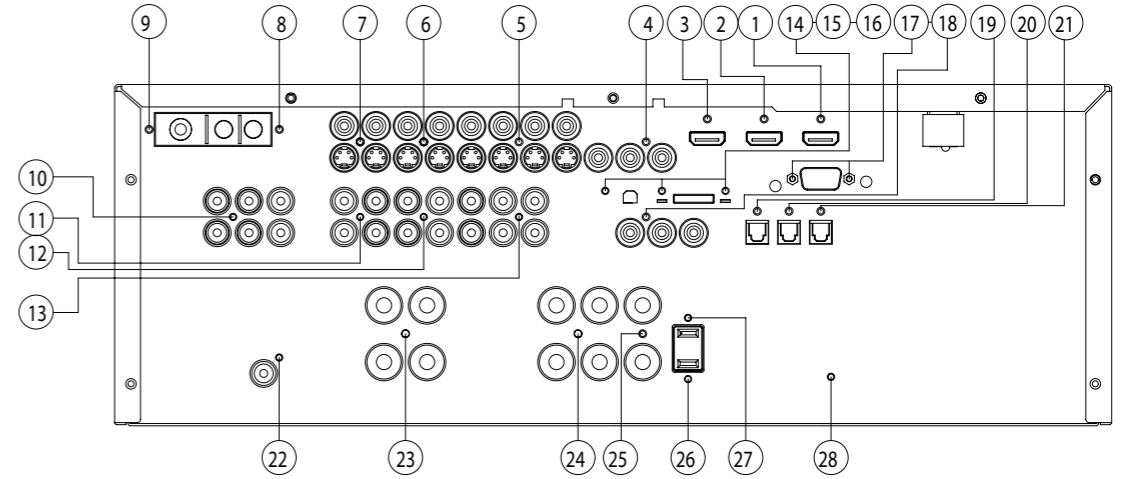

4. Removing the Main PCB
Remove the Screws

① ~ ⑦

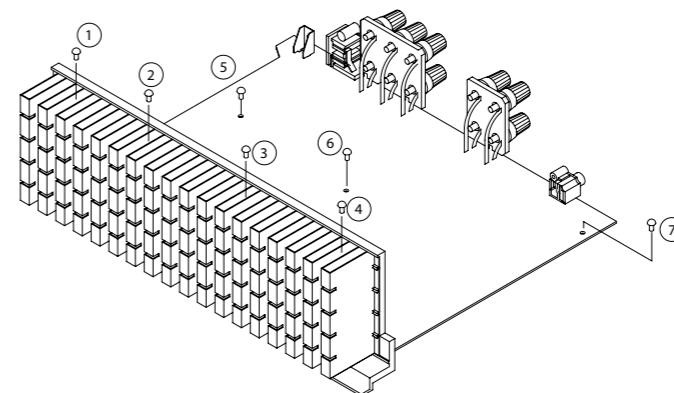

AVR147 DISASSEMBLY PROCEDURES

1 TOP-CABINET (21) REMOVAL

1. Remove 13 screws (S1,S7) and then remove the Top-cabinet.

2 FRONT PANEL ASS'Y REMOVAL

1. Remove the Top-cabinet, referring to the previous step 1.
2. Disconnect the card cable between connector (CN72-17p) on the Fip PCB (37-1) and connector (CN72) on the Input PCB (39-1).
3. Disconnect the lead wire (BN81-8P) on the Fip PCB (37-1) from connector (CN81) on the Trans PCB (40-4).
4. Disconnect the lead wire (BN22-6P) on the Phone PCB (37-5) from connector (CN22) on the Input PCB (39-1).
5. Disconnect the lead wire (BN18-5P) on the Phone PCB (37-5) from connector (CN18) on the Input PCB (39-1).
6. Disconnect the lead wire (BN10-4P) on the Volume PCB (37-6) from connector (CN10) on the Input PCB (39-1).
7. Disconnect the lead wire (BN51-2P) on the Volume PCB (37-6) from connector (CN51) on the Input PCB (39-1).
8. Disconnect the lead wire (BN41-6P) on the Volume PCB (37-6) from connector (CN41) on the Video PCB (41).
9. Disconnect the lead wire (BN90-2P) on the Main PCB (38-1) from connector (CN86) on the Moms PCB (37-4).
10. Remove 1 screw (S10) and then lead wire (JW82-1P,JW83-1P) on the Phone PCB (37-5).
11. Remove 1 screw (S10) and then lead wire (JW84-1P) on the Volume PCB (37-3).
12. Remove 10 screws (S1) and then remove the Front Panel ASS'Y.

3 Volume PCB (37-6) REMOVAL

1. Remove the Top-cabinet, referring to the previous step 1.
2. Remove the Front Panel ASS'Y, referring to the previous step 2.
3. Pull out the Volume Knob ASS'Y.
4. Disconnect connector (CN84) on the Volume PCB (37-6) from the lead wire (BN84-5P) on the Fip PCB (37-1).
5. Disconnect the lead wire (BN92-5P) on the Volume PCB (37-6) from connector (CN92) on the Phone PCB (37-5).
6. Remove 8 screws (S2,S14), and then remove the Volume PCB (37-6).

4 PHONE PCB (37-5) REMOVAL

1. Remove the Top-cabinet, referring to the previous step 1.
2. Remove the Front Panel ASS'Y, referring to the previous step 2.
3. Disconnect connector (CN85) on the Phone PCB (37-5) from the lead wire (BN85-3P) on the Fip PCB (37-1).
4. Disconnect the lead wire (BN92-5P) on the Volume PCB (37-6) from connector (CN92) on the Phone PCB (37-5).
5. Remove 2 screws (S2) and then remove the Phone PCB (37-5).

5 POWER LED PCB (37-3) REMOVAL

1. Remove the Top-cabinet, referring to the previous step 1.
2. Remove the Front Panel ASS'Y, referring to the previous step 2.
3. Disconnect connector (CN88) on the Power Led PCB (37-3) from the lead wire (BN88-4P) on the Fip PCB (37-1).
4. Remove 2 screws (S2) and then remove the Power led PCB (37-3).

6 FIP PCB (37-1) REMOVAL

1. Remove the Top-cabinet, referring to the previous step 1.
2. Remove the Front Panel ASS'Y, referring to the previous step 2.

3. Disconnect the lead wire (BN84-5P) on the Fip PCB (37-1) from connector (CN84) on the Volume PCB (37-6).
4. Disconnect the lead wire (BN85-3P) on the Fip PCB (37-1) from connector (CN85) on the Phone PCB (37-5).
5. Disconnect the lead wire (BN88-4P) on the Fip PCB (37-1) from connector (CN88) on the Power Led PCB (37-3).
6. Disconnect the connector (CN89) on the Fip PCB (37-1) from lead wire (BN89-4P) on the Key PCB (37-2).
7. Remove 3 screws (S2) and then remove the Guide PCB (37-8) & the Fip PCB (37-1).

7 KEY PCB (37-2) REMOVAL

1. Remove the Top-cabinet, referring to the previous step 1.
2. Remove the Front Panel ASS'Y, referring to the previous step 2.
3. Remove the Fip PCB (37-1), referring to the previous step 6.
4. Remove 10 screws (S2) and then remove the Key PCB (37-2).

8 TUNER MODULE (44) REMOVAL

1. Remove the Top-cabinet, referring to the previous step 1.
2. Disconnect the card cable between connector (CON1-13P) on the Tuner module (42) and connector (CN13) on the Input PCB (39-1).
3. Remove 2 screws (S8) and then remove the Tuner Module (43).

9 VIDEO PCB (41) REMOVAL

1. Remove the Top-cabinet, referring to the previous step 1.
2. Disconnect the card cable between connector (BN14-13P) on the Video PCB (41) and connector (CN14) on the Input PCB (39-1).
3. Disconnect connector (CN43) on the Video PCB (41) from the lead wire (BN43-3P) on the Regulator PCB (A)(40-2).
4. Disconnect the card cable between connector (CN42) on the Video PCB (41) and connector (BN44-7P) on the iPod PCB (39-2).
5. Disconnect connector (CN41) on the Video PCB (41) from the lead wire (BN41-6P) on the Volume PCB (37-6).
6. Remove 6 screws (S8) and then remove the Video PCB (41).

10 iPod PCB (39-2) REMOVAL

1. Remove the Top-cabinet, referring to the previous step 1.
2. Remove the Video PCB (41), referring to the previous step 9
3. Disconnect the card cable between connector (BN19-15P) on the the iPod PCB (39-2) and connector (CN19) on the Input PCB (39-1).
4. Disconnect the card cable between connector (BN44-7P) on the iPod PCB (39-2) and connector (CN42) on the Video PCB (41).
5. Disconnect the card cable between connector (CN47-7P) on the iPod PCB (39-2) and connector (CN47) on the RS232 PCB (37-7).
6. Disconnect the board to board connector between and connector (CN23) on the XM PCB (42) and connector (BN17-12P) on the iPod PCB (39-2).
7. Remove 2 screws (S13) and then remove the iPod PCB (39-2).

11 XM PCB (42) REMOVAL

1. Remove the Top-cabinet, referring to the previous step 1.
2. Remove the Video PCB (41), referring to the previous step 9.
3. Disconnect the card cable between connector (BN21-7P) on XM PCB (42) and connector (CN21) on the input PCB (39-1).
4. Disconnect the lead wire (BN85-2P) on the XM PCB (42) from connector (CN85) on the Regulator PCB (A)(40-2).

5. Disconnect the board to board connector between and connector (CN23) on the XM PCB (42) and connector (BN17-12P) on the iPod PCB (39-2).
6. Remove 1 screw (S15) and then remove the XM PCB (42).

12 HDMI PCB (47) REMOVAL

1. Remove the Top-cabinet, referring to the previous step 1.
2. Disconnect the card cable between connector (CN45-7P) on the HDMI PCB (47) and connector (CN45-7P) on the Video PCB (41).
3. Remove 3 screws (S15) and then remove the HDMI PCB (47).

13 RS232 PCB (37-7) REMOVAL

1. Remove the Top-cabinet, referring to the previous step 1.
2. Remove the Video PCB (41), referring to the previous step 9.
3. Disconnect the card cable between connector (CN47) on the RS232 PCB (37-7) and connector (CN47-7) on the iPod PCB (39-2).
4. Remove 2 screws and then remove the RS232 PCB (37-7).

14 INPUT PCB (39-1) REMOVAL

1. Remove the Top-cabinet, referring to the previous step 1.
2. Remove the Tuner module (43), referring to the previous step 8.
3. Remove the Video PCB (41), referring to the previous step 9.
4. Remove the iPod PCB (39-2), referring to the previous step 10.
5. Remove the XM PCB (42), referring to the previous step 11.
6. Remove the HDMI PCB (47), referring to the previous step 12.
7. Disconnect connector (CN20) on the the Input PCB (39-1) from the lead wire (BN20-5P) on the Regulator PCB (B)(40-5).
8. Disconnect connector (CN22) on the Input PCB (39-1) from the lead wire (BN22-6P) on the Phone PCB (37-5).
9. Disconnect connector (CN18) on the Input PCB (39-1) from the lead wire (BN18-5P) on the Phone PCB (37-5).
10. Disconnect connector (CN10) on the Input PCB (39-1) from the lead wire (BN10-4P) on the Volume PCB (37-6).
11. Disconnect the card cable between connector (CN12-21p) on the Input PCB (39-1) and connector (CN12-21p) on the main PCB (38-1)
12. Disconnect the card cable between connector (CN11-13p) on the Input PCB (39-1) and connector (CN11) on the main PCB (38-1)
13. Disconnect the card cable between connector (CN72) on the Input PCB (39-1) and connector (CN72-17p) on the Fip PCB (37-1)
14. Remove 11 screws (S8,S15) and then remove the Input PCB (39-1).

15 POWER TRANS (36) & POWER PCB ASS'Y(40) REMOVAL

1. Remove the Top-cabinet, referring to the previous step 1.
2. Disconnect lead wire of the Power Trans (36) from connector (CN91-3P) on the Main PCB (38-1)
3. Disconnect connector (CN19-3P,CN20-4P) on TRANS PCB (40-3) from the lead wire (BN19-3P,BN20-4P) on the in PCB (38-1).
4. Disconnect the lead wire (BN96-8P) on the Power PCB (40-4) from connector (CN96) on the Regulator PCB (B)(40-5).
5. Disconnect the lead wire (BN99-8P) on the Power PCB (40-4) from connector (CN99) on the Regulator PCB (A)(40-2).
6. Disconnect connector (CN81) on the Trans PCB (40-4) from the lead wire (BN81-8P) on the Fip PCB (37-1).
7. Remove 4 Trans screws (S9) and then remove the Power Trans (36) & Power PCB ASS'Y(40) REMOVAL .

16 MAIN PCB ASS'Y(38-1) REMOVAL

1. Remove the Top-cabinet, referring to the previous step 1.
2. Remove the Tuner module (43), referring to the previous step 8.
3. Remove the Video PCB (41) referring to the previous step 9.
4. Remove the iPod PCB (39-2), referring to the previous step 10.
5. Remove the XM PCB (42), referring to the previous step 11.
6. Remove the HDMI PCB (47), referring to the previous step 12.
7. Remove the RS232 PCB (37-7), referring to the previous step 13.
8. Remove the Input PCB (39-1), referring to the previous step 14.
9. Remove the AC Cord(35) on the Main PCB (38-1)
10. Disconnect the lead wire (BN90-2P) on the Main PCB (38-1) from connector (CN86) on Mems PCB (37-4).
11. Disconnect connector (CN91-3P) on the Main PCB (38-1) from lead wire of the Power Trans (36)
12. Disconnect the lead wire (BN89-2P) on the Main PCB (38-1) from connector (CN89) on Regulator PCB (A)(40-2).
13. Disconnect the lead wire (BN19-3P,BN20-4P) on the Main PCB (38-1) from connector (CN19-3P,CN20-4P) on TRANS PCB (40-3).
14. Remove 11screws (S13-1EA, S4-2EA, S6-2EA, S8-6EA) and then remove the Main PCB ASS'Y(38-1).

AVR147 EXPLODED VIEW

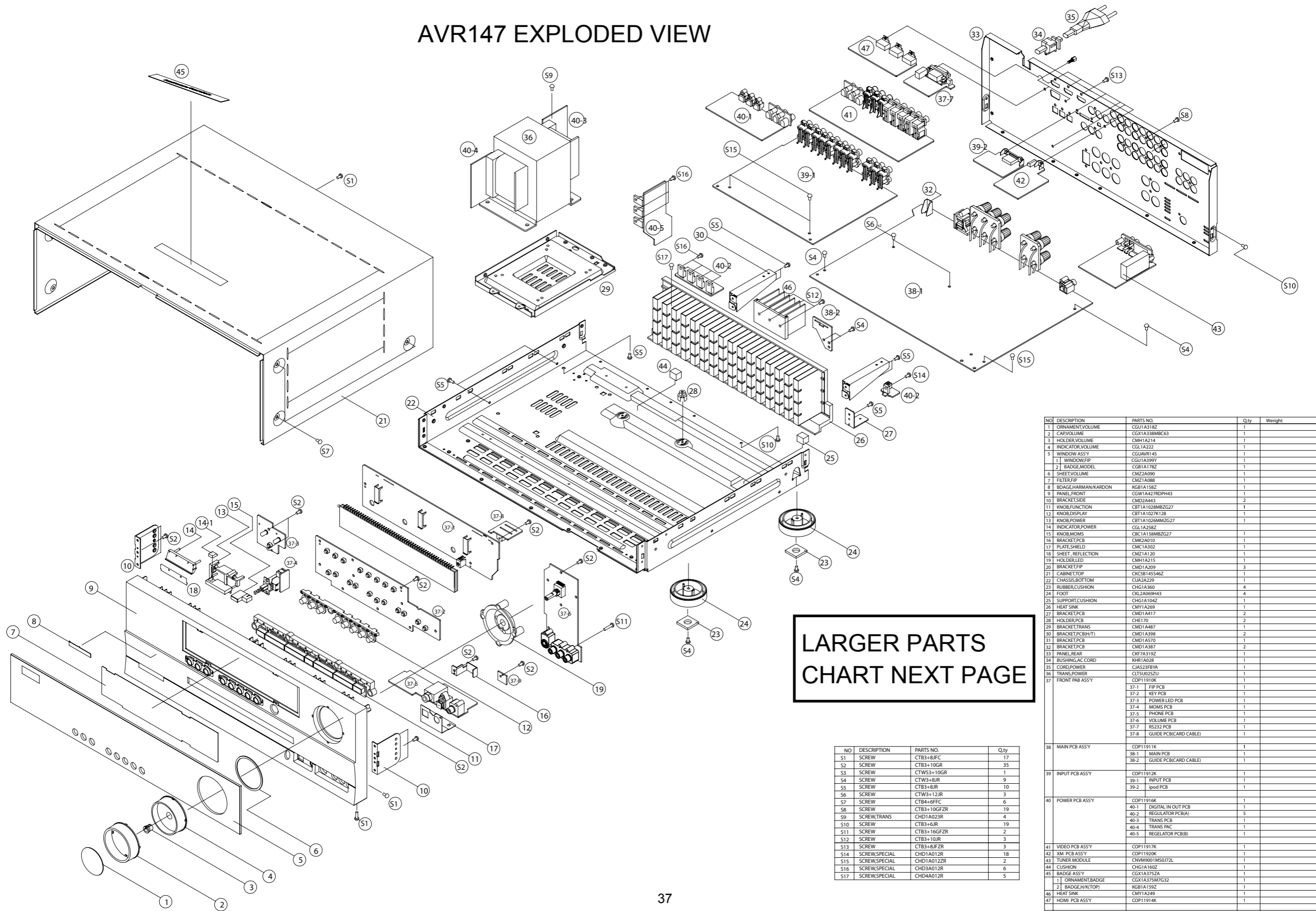

**LARGER PARTS
CHART NEXT PAGE**

NO	DESCRIPTION	PARTS NO.	Q.ty
S1	SCREW	CTB3+8JFC	17
S2	SCREW	CTB3+10GR	35
S3	SCREW	CTWS3+10GR	1
S4	SCREW	CTW3+8JR	9
S5	SCREW	CTB3+8JR	10
S6	SCREW	CTW3+12JR	3
S7	SCREW	CTB4+6FFC	6
S8	SCREW	CTB3+10GFZR	19
S9	SCREW,TRANS	CHD1A02ZR	4
S10	SCREW	CTB3+6JR	19
S11	SCREW	CTB3+16GFZR	2
S12	SCREW	CTB3+10JR	3
S13	SCREW	CTB3+8JFZR	3
S14	SCREW,SPECIAL	CHD1A012R	18
S15	SCREW,SPECIAL	CHD1A012ZR	2
S16	SCREW,SPECIAL	CHD3A012R	6
S17	SCREW,SPECIAL	CHD4A012R	5

NO	DESCRIPTION	PARTS NO.	Q.ty	Weight
1	ORNAMENT,VOLUME	CGU1A31BZ	1	
2	CAP,VOLUME	CGX1A338MBC63	1	
3	HOLDER,VOLUME	CMH1A214	1	
4	INDICATOR,VOLUME	CGL1A222	1	
5	WINDOW ASSY	CGUAVR145	1	
1	WINDOW,PIP	CGU1A399Y	1	
2	BADGE,MODEL	CGB1A178Z	1	
6	SHEET,VOLUME	CMZ2A090	1	
7	FILTER,PIP	CMZ1A088	1	
8	BRIDGE,HARMAN/KARDON	WGB1A158Z	1	
9	PANEL,FRONT	CGW1A427RDPH43	1	
10	BRACKET,SIDE	CMD2A443	2	
11	KNOB,FUNCTION	CBT1A1028MBZG27	1	
12	KNOB,DISPLAY	CBT1A1027K128	1	
13	KNOB,POWER	CBT1A1026MMZG27	1	
14	INDICATOR,POWER	CGL1A258Z	1	
15	KNOB,MOMS	CBT1A158MBZG27	1	
16	BRACKET,PCB	CMK2A010	1	
17	PLATE,SHIELD	CMC1A302	1	
18	SHEET, REFLECTION	CMZ1A120	1	
19	HOLDER,LED	CMH1A215	1	
20	BRACKET,PIP	CMD1A209	3	
21	CABINET, TOP	CKCSB145546Z	1	
22	CHASSIS,BOTTOM	CUA2A229	1	
23	RUBBER,CUSHION	CHG1A360	4	
24	FOOT	OKL2A069H43	4	
25	SUP,PORT,CUSHION	CHG1A104Z	1	
26	HEAT SINK	CMY1A269	1	
27	BRACKET,PCB	CMD1A417	2	
28	HOLDER,PCB	CHE1170	2	
29	BRACKET,TRANS	CMD1A487	1	
30	BRACKET,PCB(H/T)	CMD1A398	2	
31	BRACKET,PCB	CMD1A510	1	
32	BRACKET,PCB	CMD1A387	2	
33	PANEL,REAR	CKF7A319Z	1	
34	BUSHING,AC CORD	KHR1A028	1	
35	CORD,POWER	CJA523FBVA	1	
36	TRANS,POWER	CLTSU025ZU	1	
37	FRONT PAB ASSY	COP11910K	1	
		37-1 FIP PCB	1	
		37-2 KEY PCB	1	
		37-3 POWER LED PCB	1	
		37-4 MOMS PCB	1	
		37-5 PHONE PCB	1	
		37-6 VOLUME PCB	1	
		37-7 RS232 PCB	1	
		37-8 GUIDE PCB(CARD CABLE)	1	
38	MAIN PCB ASSY	COP11911K	1	
		38-1 MAIN PCB	17	
		38-2 GUIDE PCB(CARD CABLE)	1	
39	INPUT PCB ASSY	COP11912K	1	
		39-1 INPUT PCB	1	
		39-2 ipod PCB	1	
40	POWER PCB ASSY	COP11916K	1	
		40-1 DIGITAL IN OUT PCB	1	
		40-2 REGULATOR PCB(A)	5	
		40-3 TRANS PCB	1	
		40-4 TRANS PAC	1	
		40-5 REGLATOR PCB(B)	1	
41	VIDEO PCB ASSY	COP11917K	1	
42	XM PCB ASSY	COP11920K	1	
43	TUNER MODULE	CNVN9001MS0J72L	1	
44	CUSHION	CHG1A160Z	1	
45	BADGE ASSY	CGX1A375A	1	
		1 ORNAMENT/BADGE	1	
		2 BADGE,H/(TOP)	1	
46	HEAT SINK	CMY1A249	1	
47	HDMI PCB ASSY	COP11914K	1	

NO	DESCRIPTION	PART NO.	Qty
1	ORNAMENT,VOLUME	CGU1A318Z	1
2	CAP,VOLUME	CGX1A338MBC63	1
3	HOLDER,VOLUME	CMH1A214	1
4	INDICATOR,VOLUME	CGL1A222	1
5	WINDOW ASS'Y	CGUAVR145	1
	1 WINDOW,FIP	CGU1A399Y	1
	2 BADGE,MODEL	CGB1A178Z	1
6	SHEET,VOLUME	CMZ2A090	1
7	FILTER,FIP	CMZ1A088	1
8	BADGE,HARMAN/KARDON	KGB1A158Z	1
9	PANEL,FRONT	CGW1A427RDPH43	1
10	BRACKET,SIDE	CMD2A443	2
11	KNOB,FUNCTION	CBT1A1028MBZG27	1
12	KNOB,DISPLAY	CBT1A1027K128	1
13	KNOB,POWER	CBT1A1026MMZG27	1
14	INDICATOR,POWER	CGL1A258Z	
15	KNOB,MOMS	CBC1A158MBZG27	1
16	BRACKET,PCB	CMK2A010	1
17	PLATE,SHIELD	CMC1A302	1
18	SHEET , REFLECTION	CMZ1A120	1
19	HOLDER,LED	CMH1A215	1
20	BRACKET,FIP	CMD1A209	3
21	CABINET,TOP	CKC5B145S46Z	1
22	CHASSIS,BOTTOM	CUA2A229	1
23	RUBBER,CUSHION	CHG1A360	4
24	FOOT	CKL2A069H43	4
25	SUPPORT,CUSHION	CHG1A104Z	1
26	HEAT SINK	CMY1A269	1
27	BRACKET,PCB	CMD1A417	2
28	HOLDER,PCB	CHE170	2
29	BRACKET,TRANS	CMD1A487	1
30	BRACKET,PCB(H/T)	CMD1A398	2
31	BRACKET,PCB	CMD1A570	1
32	BRACKET,PCB	CMD1A387	2
33	PANEL,REAR	CKF7A319Z	1
34	BUSHING,AC CORD	KHR1A028	1
35	CORD,POWER	CJAS23FBYA	1
36	TRANS,POWER	CLTSU025ZU	1
37	FRONT PCB ASS'Y		1
	37-1 FIP PCB		1
	37-2 KEY PCB		1
	37-3 POWER LED PCB		1
	37-4 MOMS PCB		1
	37-5 PHONE PCB		1
	37-6 VOLUME PCB		1
	37-7 RS232 PCB		1
	37-8 GUIDE PCB(CARD CABLE)		1
38	MAIN PCB ASS'Y		1
	38-1 MAIN PCB		1
	38-2 GUIDE PCB(CARD CABLE)		1
39	INPUT PCB ASS'Y		1
	39-1 INPUT PCB		1
	39-2 ipod PCB		1
40	POWER PCB ASS'Y		1
	40-1 DIGITAL IN OUT PCB		1
	40-2 REGULATOR PCB(A)		5
	40-3 TRANS PCB		1
	40-4 TRANS PAC		1
	40-5 REGULATOR PCB(B)		1
41	VIDEO PCB ASS'Y		1
42	XM PCB ASS'Y		1
43	TUNER MODULE	CNVM9001MS0J72L	1
44	CUSHION	CHG1A160Z	1
45	BADGE ASS'Y	CGX1A375ZA	1
	1 ORNAMENT,BADGE	CGX1A375M7G32	1
	2 BADGE,H/K(TOP)	KGB1A159Z	1
46	HEAT SINK	CMY1A249	1
47	HDMI PCB ASS'Y		1

AMPLIFIER SECTION BIAS ADJUSTMENT

Measurement condition

.No input signal or volume position is minimum.

Standard value

.Ideal current = 48mA ($\pm 5\%$)

.Ideal DC Voltage = 25.92mV ($\pm 5\%$)

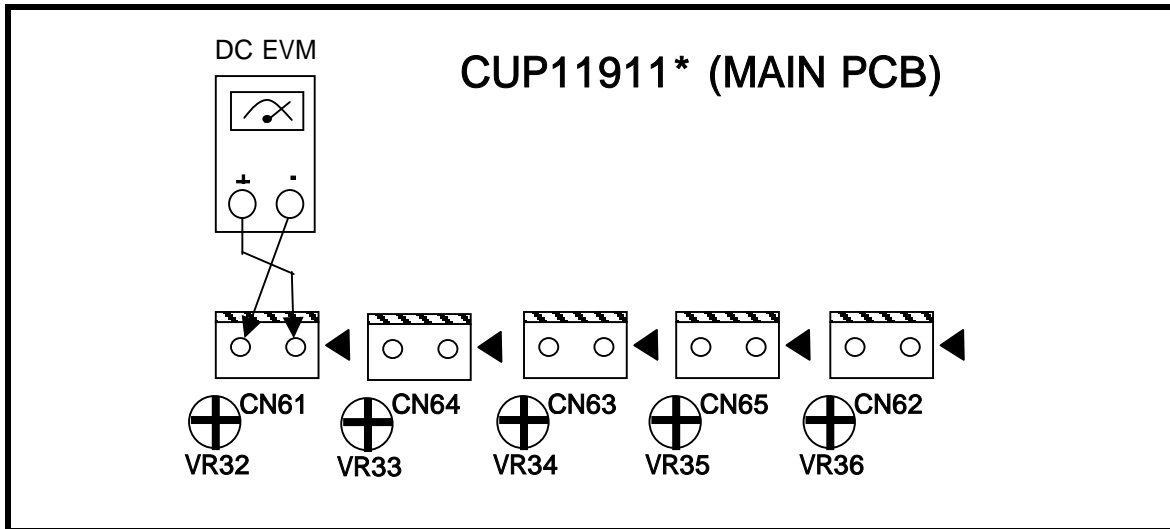

DC VOLTMETER ; Connect to

CN61(CEN),CN64(SR),CN63(FL),CN65(SBL/SL(AVR132,144,145,146,147)),CN62(FR)

NO.	Channel	Adjust for	Adjustment
1	Front Left	25.92mV ($\pm 5\%$)	CN63
2	Front Right	25.92mV ($\pm 5\%$)	CN62
3	Center	25.92mV ($\pm 5\%$)	CN61
4	Surround Left	25.92mV ($\pm 5\%$)	CN65
5	Surround Right	25.92mV ($\pm 5\%$)	CN64

AVR147 BLOCK DIAGRAM

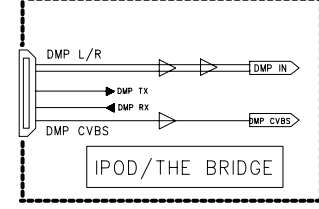
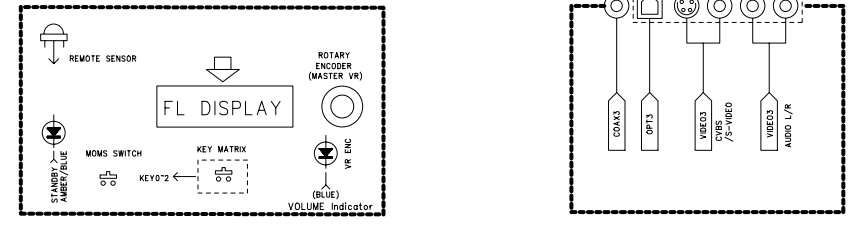
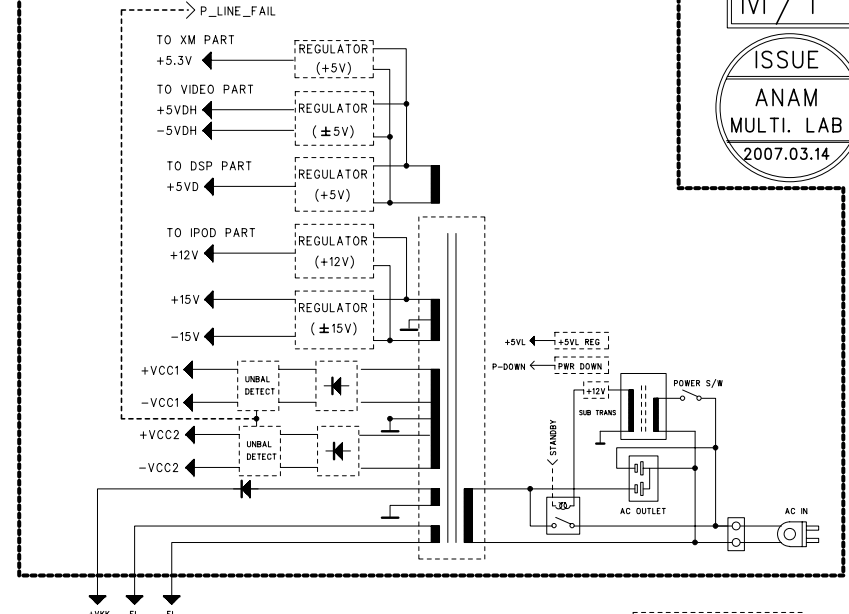
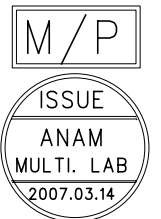
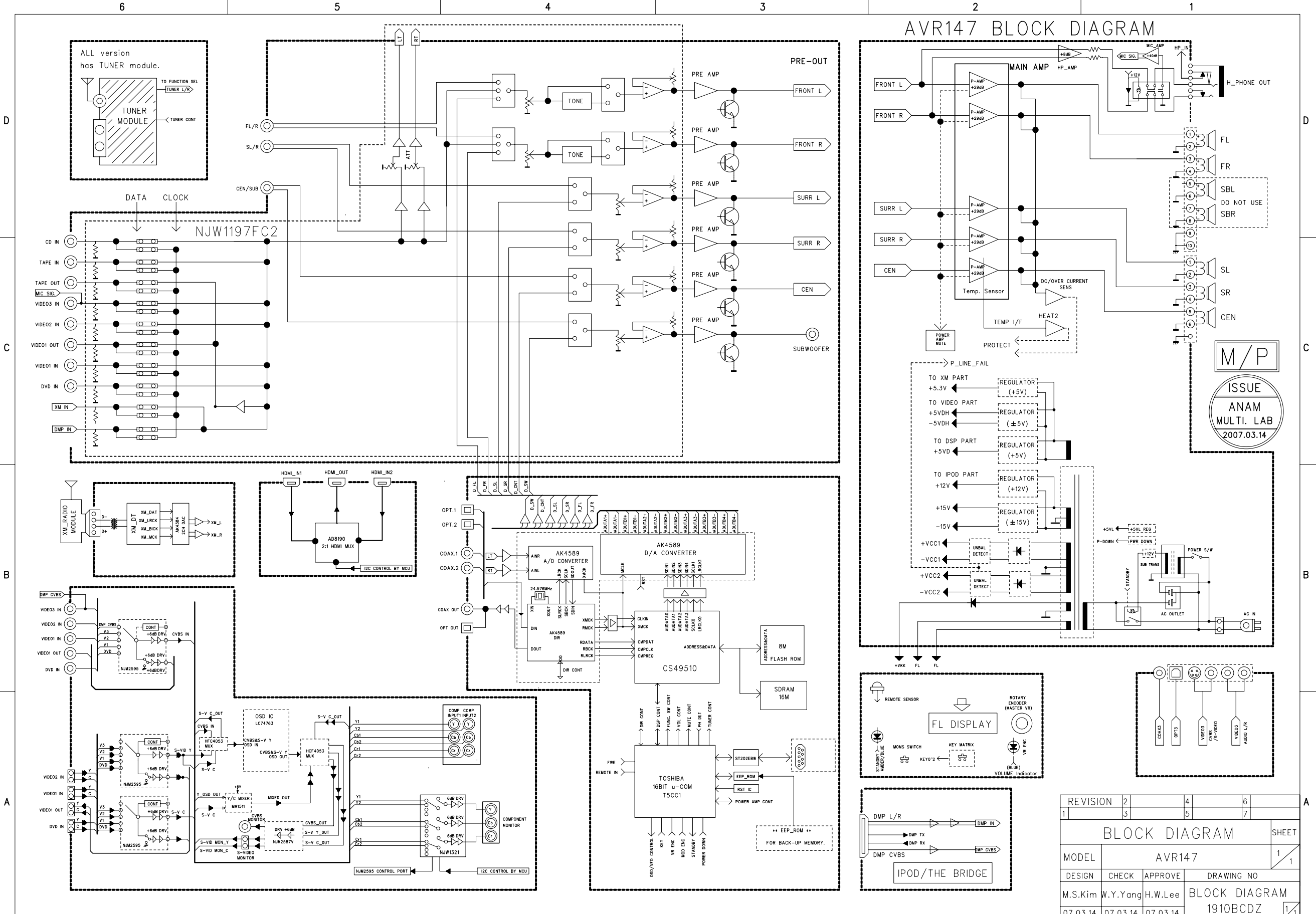

REVISION	2	4	6
1	3	5	7
BLOCK DIAGRAM			
MODEL	AVR147		
DESIGN	CHECK	APPROVE	DRAWING NO
M.S.Kim	W.Y.Yang	H.W.Lee	BLOCK DIAGRAM
07.03.14	07.03.14	07.03.14	1910BCDZ

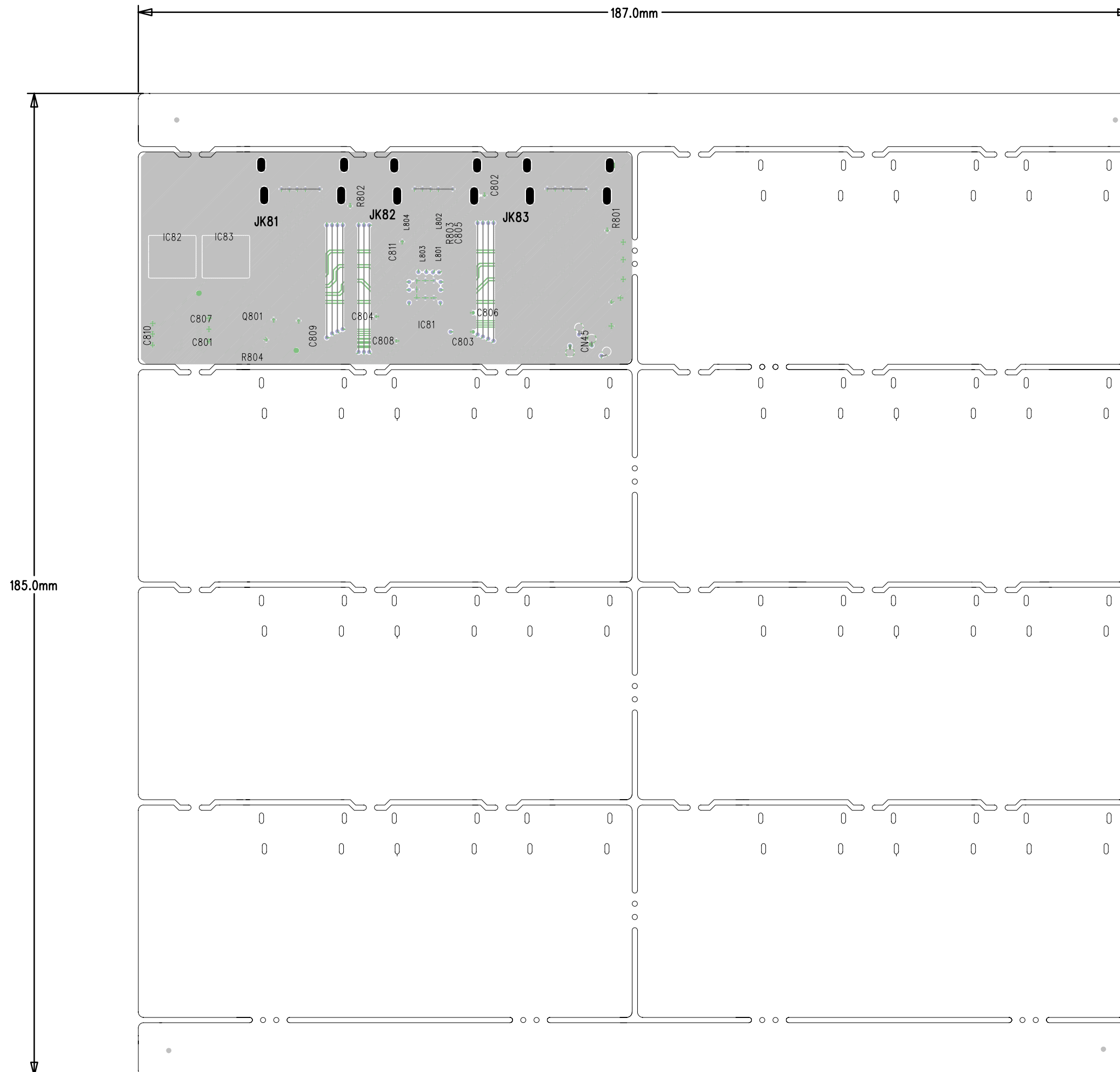

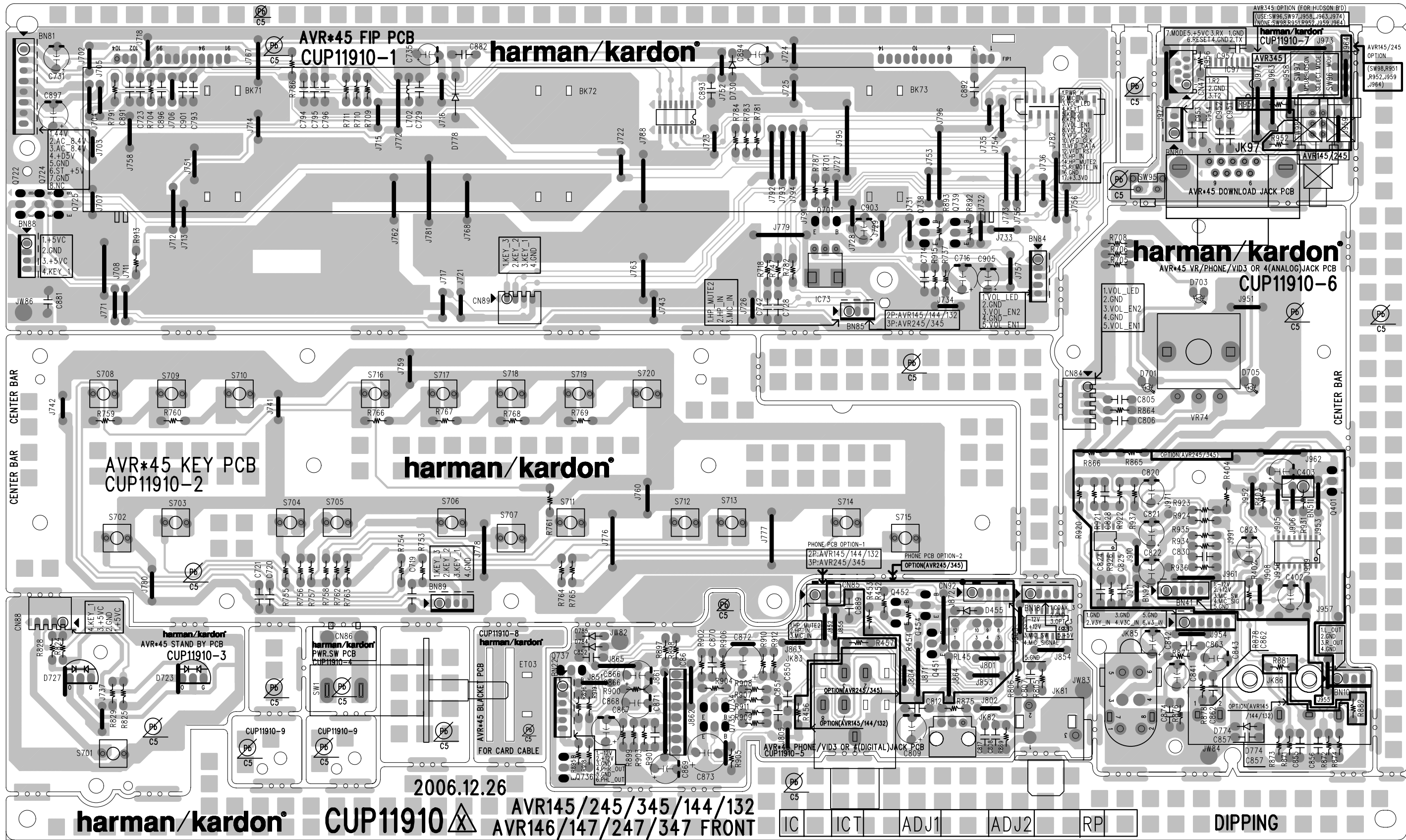



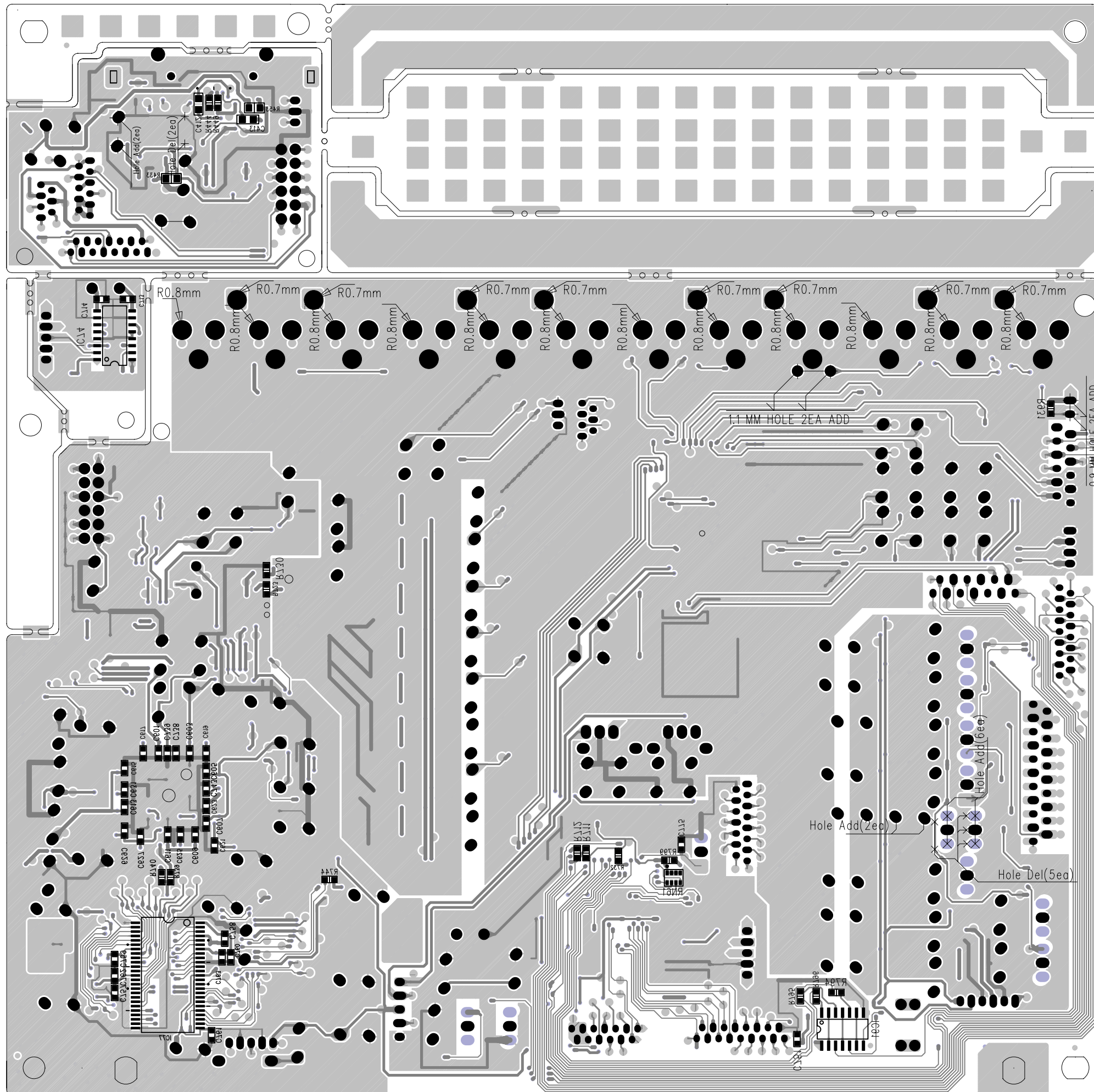

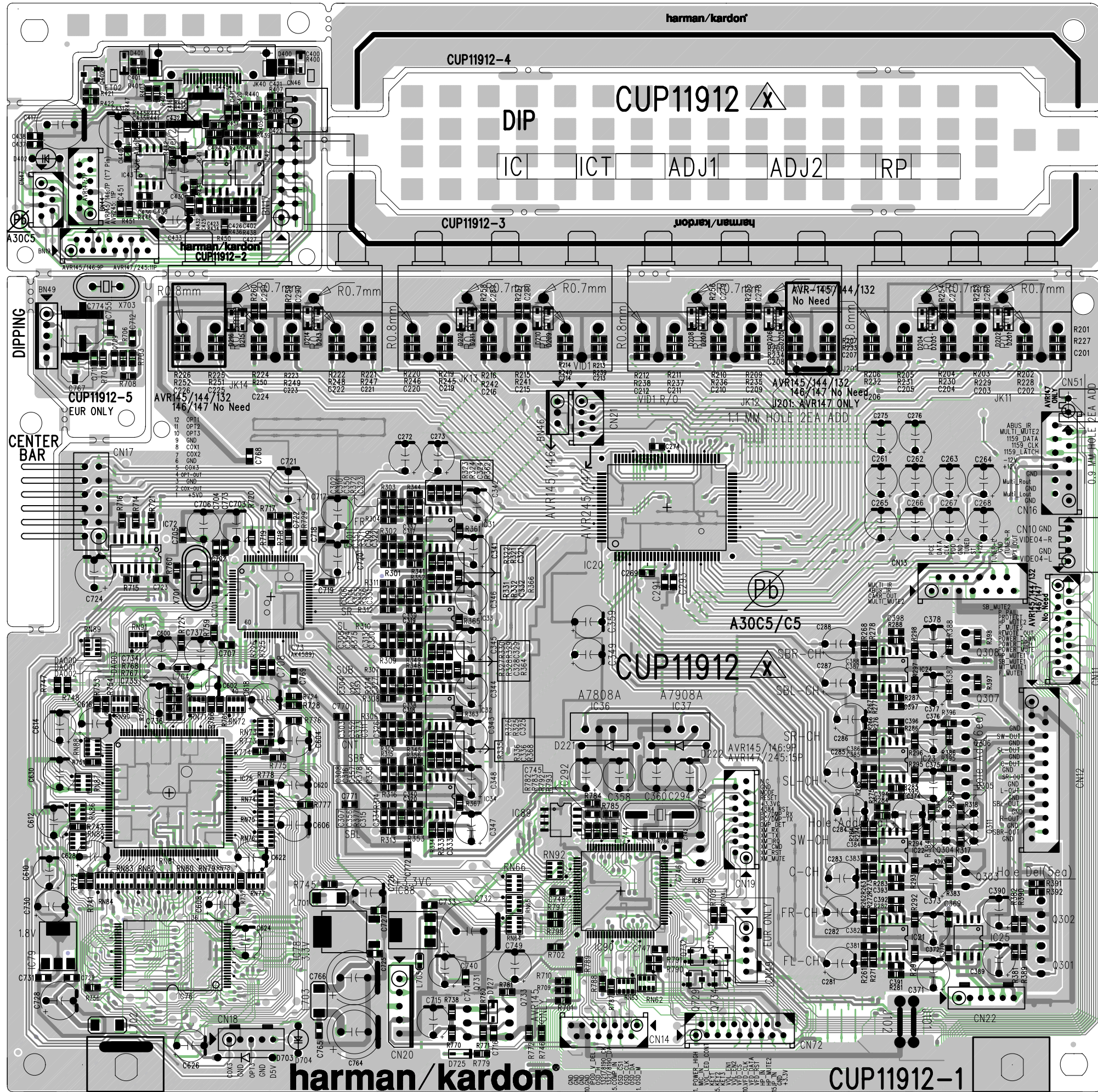

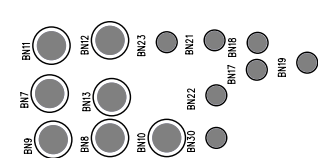
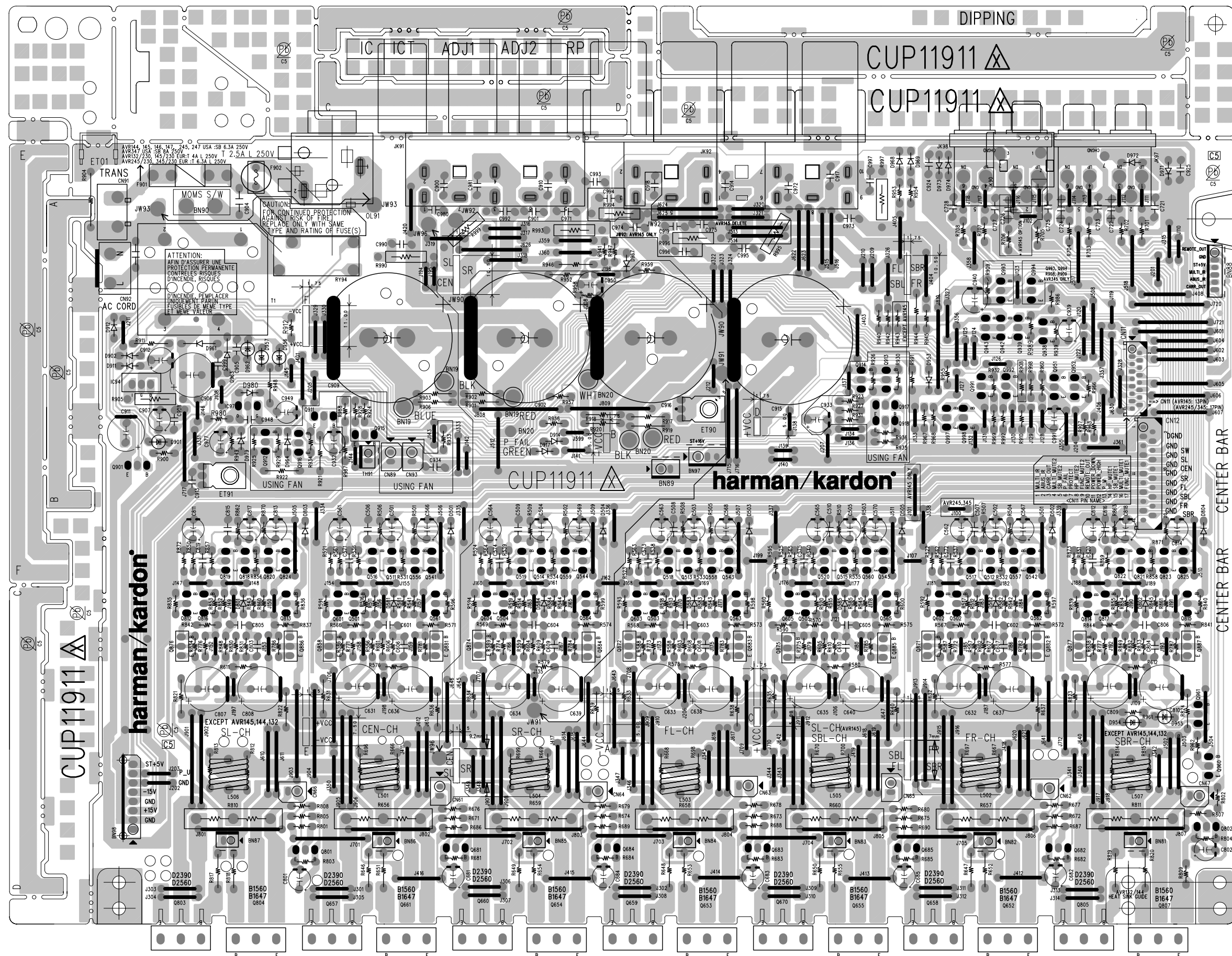

247.0mm

168.0mm

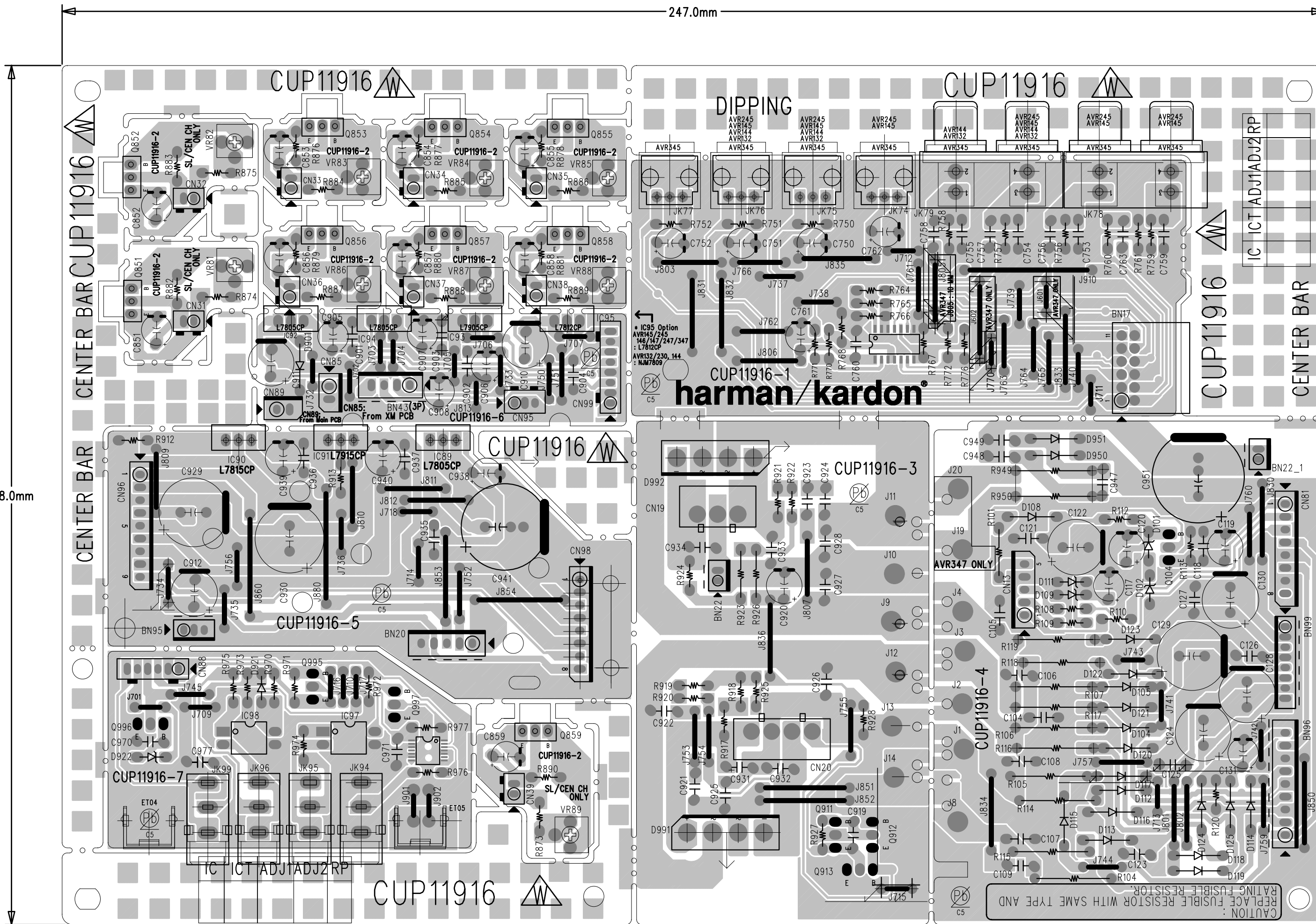

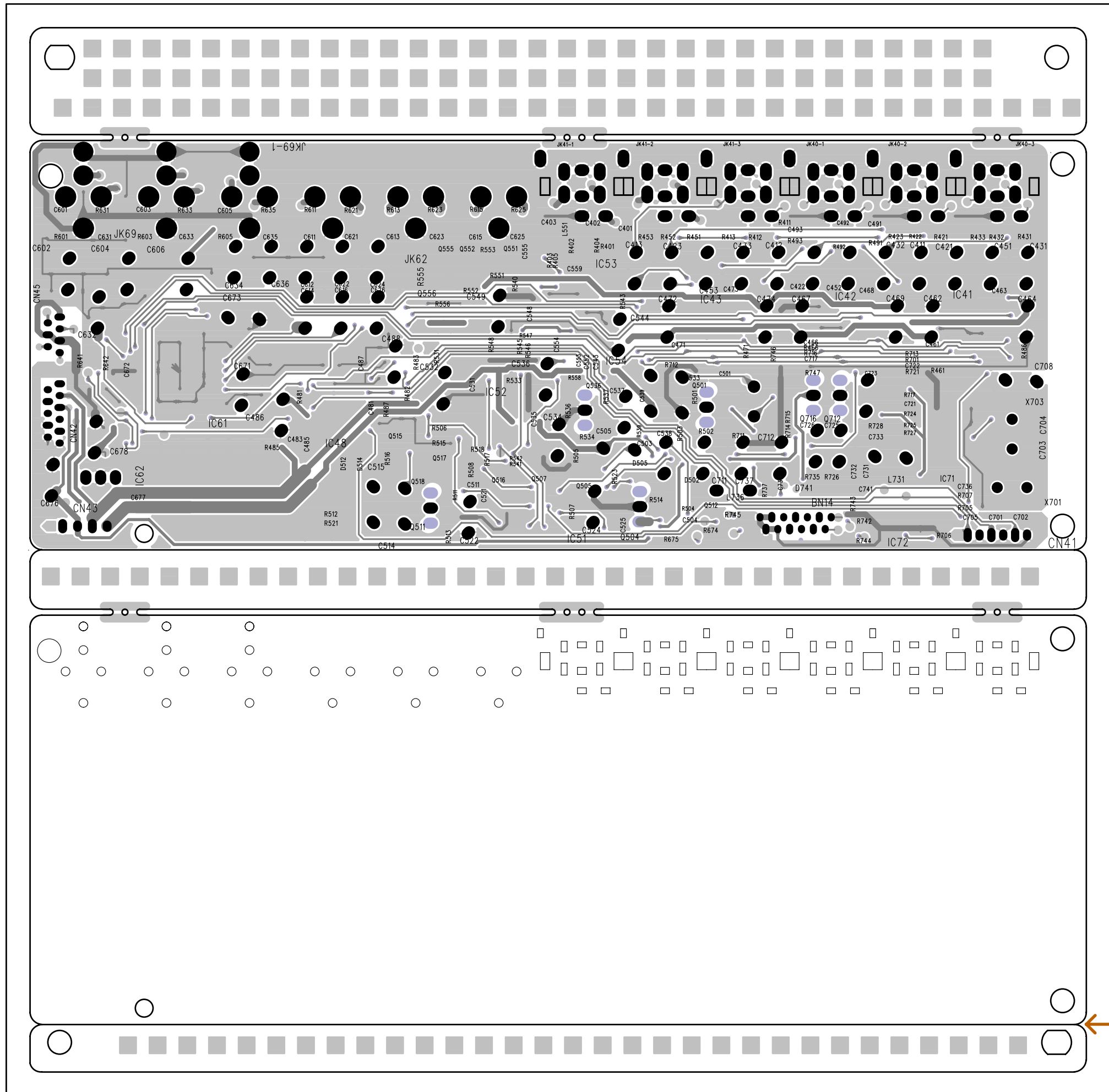

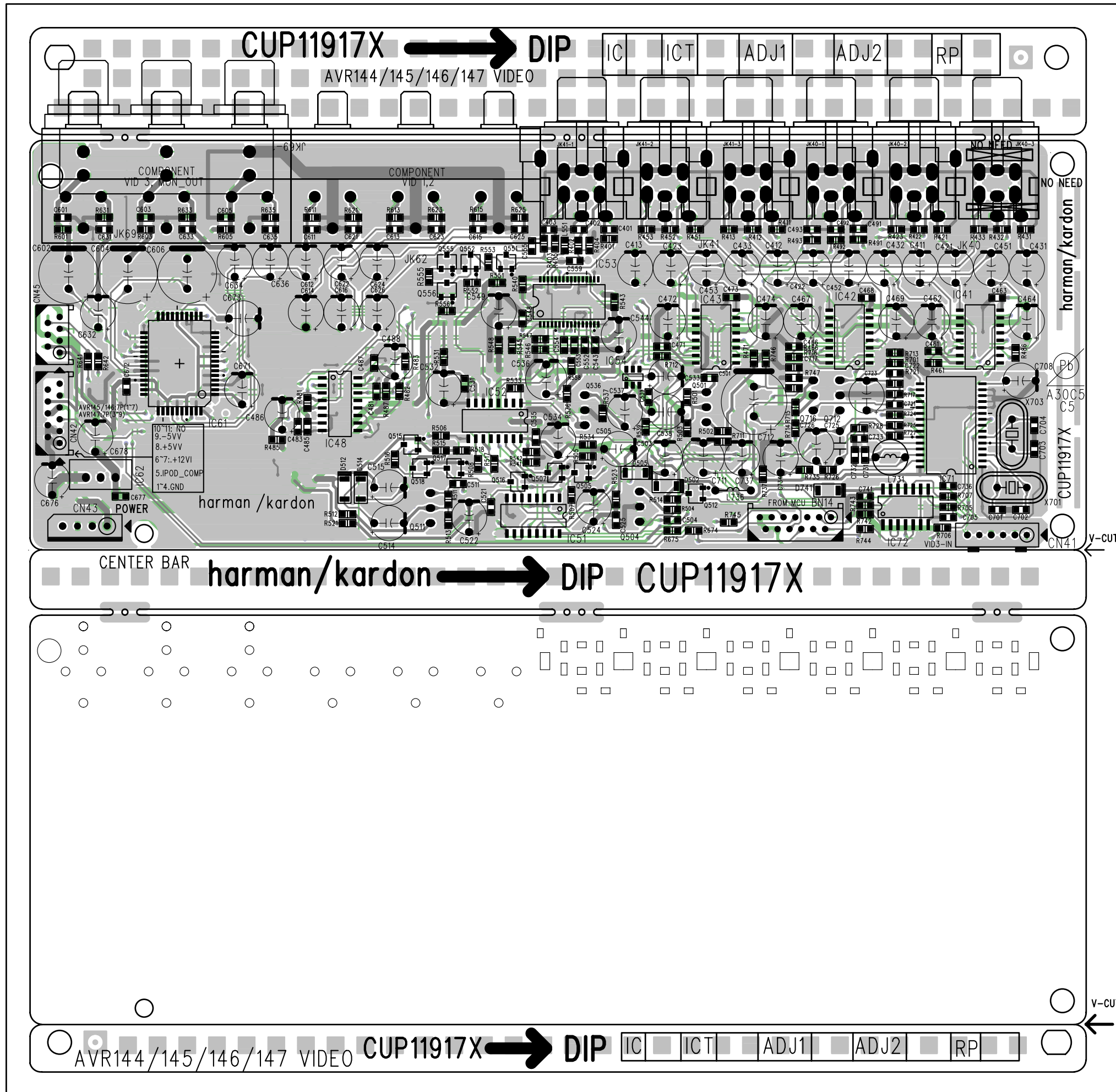

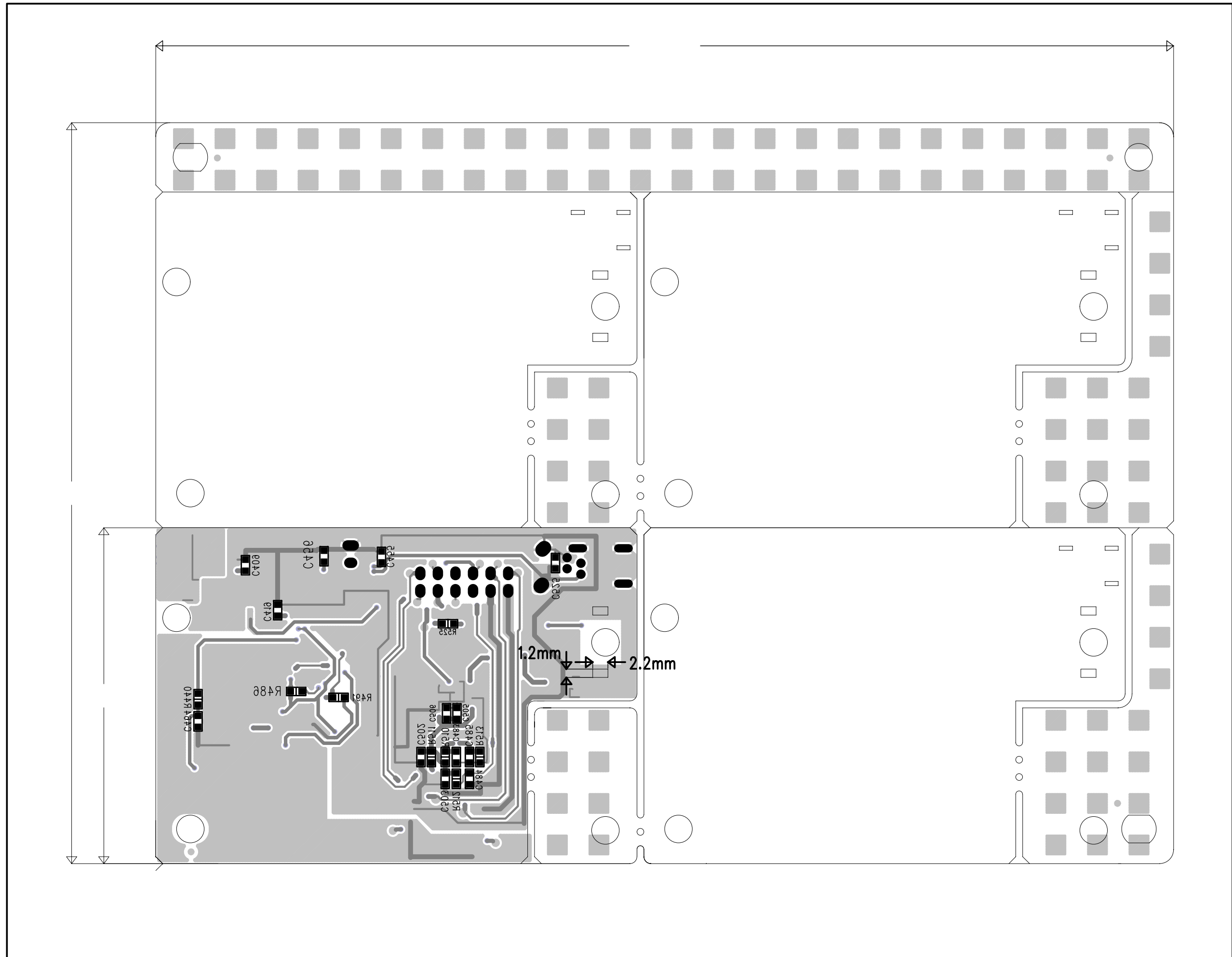

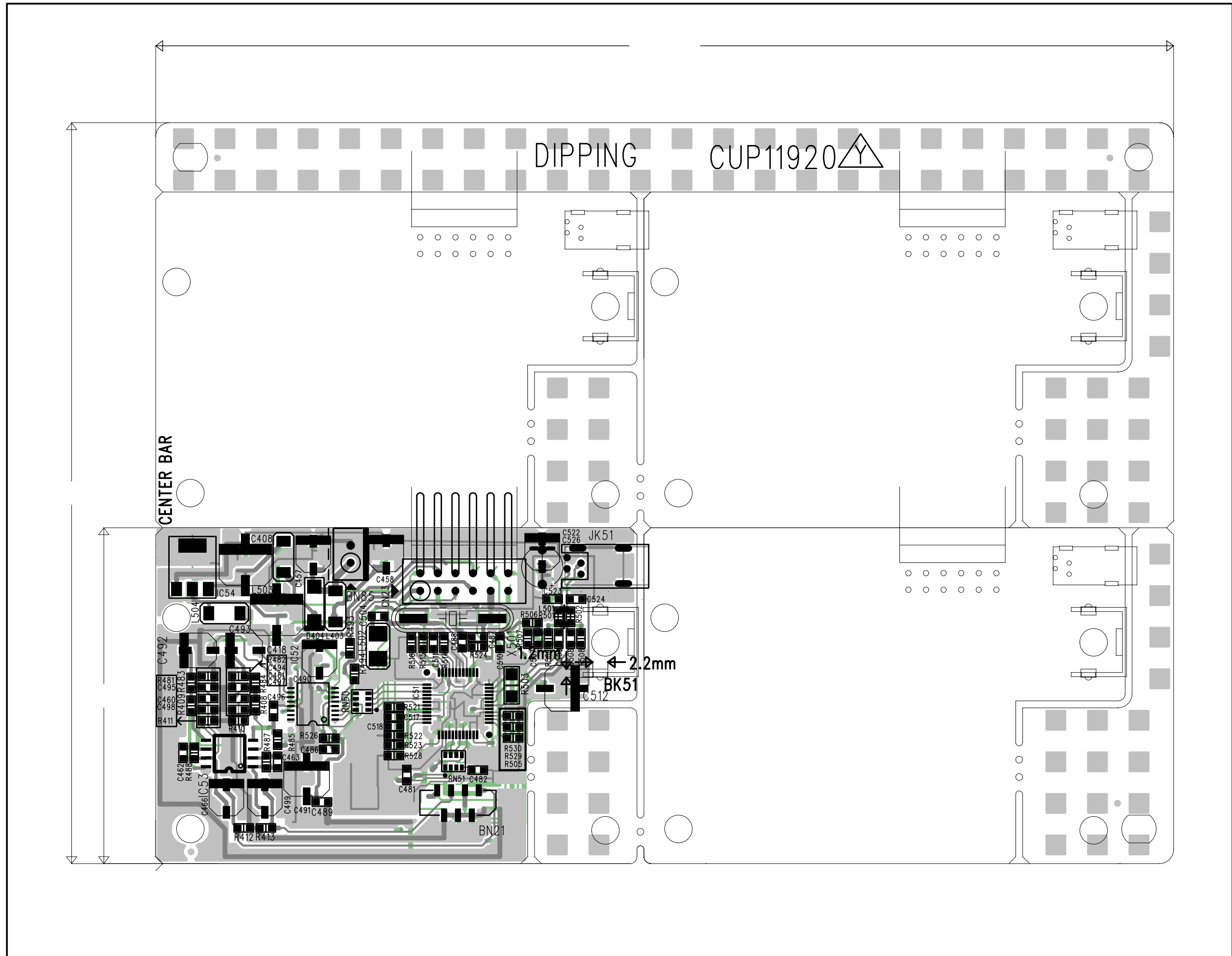

AVR147 Electrical Parts List					
Ref. Designator	Part Number	Description		Qty	
FRONT PCB ASSY		CUP11910-1			
<i>Capacitors</i>					
C714	HCBS1H151KBT	CAP , CERAMIC	150UF 50V K	1	EA
C716	CCEA1AH331T	CAP , ELECT	330UF 10V	1	EA
C723	HCBS1H104ZFT	CAP , CERAMIC	0.1UF 50V Z	1	EA
C728	HCBS1H104ZFT	CAP , CERAMIC	0.1UF 50V Z	1	EA
C729	HCBS1H473ZFT	CAP , CERAMIC	0.047UF 50V Z	1	EA
C731	CCEA1HH100T	CAP , ELECT	10UF 50V	1	EA
C735	CCEA1CKS100T	CAP , ELECT	10UF 16V	1	EA
C742	HCBS1H223ZFT	CAP , CERAMIC	0.02UF 50V Z	1	EA
C793	HCBS1H104ZFT	CAP , CERAMIC	0.1UF 50V Z	1	EA
C794	HCBS1C22MXT	CAP , CERAMIC	2200PF 16V	1	EA
C795	HCBS1H102KBT	CAP , CERAMIC	1000PF 50V K	1	EA
C796	HCBS1H102KBT	CAP , CERAMIC	1000PF 50V K	1	EA
C882	HCBS1H104ZFT	CAP , CERAMIC	0.1UF 50V Z	1	EA
C891	HCBS1H223ZFT	CAP , CERAMIC	0.023UF 50V Z	1	EA
C892	HCBS1H223ZFT	CAP , CERAMIC	0.023UF 50V Z	1	EA
C893	HCBS1H223ZFT	CAP , CERAMIC	0.023UF 50V Z	1	EA
C894	CCEA1CKS100T	CAP , ELECT	100UF 16V	1	EA
C896	HCBS1H223ZFT	CAP , CERAMIC	0.023UF 50V Z	1	EA
C897	CCEA1AH471T	CAP , ELECT	470UF 10V	1	EA
C901	HCBS1H390JT	CAP , CERAMIC	39PF 50V Z	1	EA
C903	CCEA1HKS2R2T	CAP , ELECT	2.2UF 50V	1	EA
C905	CCEA1HKS2R2T	CAP , ELECT	2.2UF 50V	1	EA
<i>Semiconductors</i>					
D455	CVD1SS133MT	DIODE	1SS133	1	EA
D730	CVD1SS133MT	DIODE	1SS133	1	EA
D778	HVD1N5819T	DIODE , SCHOTTKY	1N5819	1	EA
Q701	HVTKRC107MT	TRANSISTOR NPN	KRC107M	1	EA
Q722	HVTKRA107MT	TRANSISTOR PNP	KRA107M	1	EA
Q724	HVTKRC107MT	TRANSISTOR NPN	KRC107M	1	EA
Q725	HVTKRC107MT	TRANSISTOR NPN	KRC107M	1	EA
Q738	HVTKRC107MT	TRANSISTOR PNP	KRC107M	1	EA
Q739	HVTKTA1271YT	TRANSISTOR PNP	KTA1271Y	1	EA
IC73	HRVNJL34H380A	SENSOR , REMOTE	JRC	1	EA
IC75	HVI74ACT04MTR	I.C , HEX INVERTER	FAIRCHILD	1	EA
<i>Resistors</i>					
R701	CRD20TJ103T	RES , CARBON	10K OHM 1/5W J	1	EA
R704	CRD20TJ100T	RES , CARBON	10 OHM 1/5W J	1	EA
R709	CRD20TJ470T	RES , CARBON	47 OHM 1/5W J	1	EA
R710	CRD20TJ470T	RES , CARBON	47 OHM 1/5W J	1	EA
R711	CRD20TJ470T	RES , CARBON	47 OHM 1/5W J	1	EA
R718	CRD20TJ222T	RES , CARBON	2.2K OHM 1/5W J	1	EA
R737	CRD20TJ100T	RES , CARBON	10 OHM 1/5W J	1	EA
R747	CRD20TJ103T	RES , CARBON	10K OHM 1/5W J	1	EA
R781	CRD20TJ102T	RES , CARBON	1K OHM 1/5W J	1	EA
R782	CRD20TJ103T	RES , CARBON	10K OHM 1/5W J	1	EA
R783	CRD20TJ102T	RES , CARBON	1K OHM 1/5W J	1	EA
R784	CRD20TJ102T	RES , CARBON	1K OHM 1/5W J	1	EA
R786	CRD20TJ152T	RES , CARBON	1.5K OHM 1/5W J	1	EA
R787	CRD20TJ101T	RES , CARBON	100 OHM 1/5W J	1	EA
R791	CRD20TJ822T	RES , CARBON	8.2K OHM 1/5W J	1	EA
R892	CRD20TJ222T	RES , CARBON	2.2K OHM 1/5W J	1	EA
R893	CRD20TJ333T	RES , CARBON	33K OHM 1/5W J	1	EA
R895	CRD20TJ101T	RES , CARBON	100 OHM 1/5W J	1	EA

Ref. Designator	Part Number	Description		Qty	
FRONT PCB ASSY		CUP11910-1			
R920	CRD20TJ102T	RES , CARBON	1K OHM 1/5W J	1	EA
<i>Miscellaneous</i>					
L702	HLQ02C100KT	COIL , AXAIL	10uH	1	EA
BK71	CMD1A209	BRACKET , FLT	BRACKET	1	EA
BK72	CMD1A209	BRACKET , FLT	BRACKET	1	EA
BK73	CMD1A209	BRACKET , FLT	BRACKET	1	EA
BN81	CWB2C908200BM	WIRE ASS'Y	WIRE	1	EA
BN84	CWB2B905080EN	WIRE ASS'Y	WIRE	1	EA
BN85	CWB2B903100EW	WIRE ASS'Y	WIRE	1	EA
BN88	CWB2B904100EN	WIRE ASS'Y	WIRE	1	EA
CN72	CJP17GA193ZY	WAFER, CARD CABLE (SMD)	WAFER	1	EA
CN89	CJP04GB46ZY	WAFER	WAFER	1	EA
ET03	CMD1A569	BRACKET , PCB	BRACKET	1	EA
FIP1	HFLHCA18ML03	F.I.P	F.I.P	1	EA
RL45	CSL4A014ZE	RELAY (+12V)	HANDOUK	1	EA
PCB , FRONT STAND BY		CUP11910-3			
CN88	CJP04GB46ZY	WAFER	WAFER	1	EA
R824	CRD20TJ221T	RES , CARBON	220 OHM 1/5W J	1	EA
R825	CRD20TJ681T	RES , CARBON	680 OHM 1/5W J	1	EA
R828	CRD20TJ221T	RES , CARBON	220 OHM 1/5W J	1	EA
R829	CRD20TJ681T	RES , CARBON	680 OHM 1/5W J	1	EA
S701	HST1A020ZT	SW , TACT	1A020	1	EA
D723	CVD50BOBBWGA	L.E.D , 2 COLOR (ORG , BLUE)	L.E.D	1	EA
D727	CVD50BOBBWGA	L.E.D , 2 COLOR (ORG , BLUE)	L.E.D	1	EA
PCB , FRONT POWER (MOMS) SW		CUP11910-4			
CN86	CJP02GA89ZM	WAFER	WAFER	1	EA
SW1	CSH1A008ZV	SW , PUSH (MOMS)	MOMS SWITCH	1	EA
DOWNLOAD PCB		(CUP11910-7)			
CN47	CJP07GA117ZY	TEMP ITEM	WAFER	1	EA
IC97	HVIST202EBW	IC , RS232C TRANSCEIVER	ST	1	EA
SW95	KST1A010Z	SW , TACT	SWITCH	1	EA
SW98	HSH2B018Z	SW , PUSH	SWITCH	1	EA
R956	CRD20TJ1R0T	RES , CARBON	1 OHM 1/5W J	1	EA
C953	HCBS1H104ZFT	CAP , CERAMIC	0.1UF 50V Z	1	EA
C954	HCBS1H104ZFT	CAP , CERAMIC	0.1UF 50V Z	1	EA
C957	HCBS1H104ZFT	CAP , CERAMIC	0.1UF 50V Z	1	EA
R951	C3A206	WIRE , COPPER	SN95/PB5 , 0.6		
R952	C3A206	WIRE , COPPER	SN95/PB5 , 0.6		
JK97	CJJ9W001Z	9P D-SUB FEMALE(RS-232C) SEMCO	JACK	1	EA
PCB , FRONT PANEL KEY		CUP11910-2			
<i>Capacitors</i>					
C719	HCBS1H102KBT	CAP , CERAMIC	1000PF 50V K	1	EA
C720	HCBS1H102KBT	CAP , CERAMIC	1000PF 50V K	1	EA
C721	HCBS1H102KBT	CAP , CERAMIC	1000PF 50V K	1	EA
<i>Resistors</i>					
R753	CRD20TF1001T	RES , CARBON	1K /1/5W /F	1	EA
R754	CRD20TF1501T	RES , CARBON	1.5K /1/5W /F	1	EA

Ref. Designator	Part Number	Description		Qty	
PCB , FRONT PANEL KEY		CUP11910-2			
R755	CRD20TF1801T	RES , CARBON	1.8K /1/5W /F	1	EA
R756	CRD20TF2701T	RES , CARBON	2.7K /1/5W/F	1	EA
R757	CRD20TF3301T	RES , CARBON	3.3K /1/5W/F	1	EA
R758	CRD20TF5601T	RES , CARBON	5.6K/1/5W/F	1	EA
R759	CRD20TF1001T	RES , CARBON	1K /1/5W /F	1	EA
R760	CRD20TF1501T	RES , CARBON	1.5K /1/5W /F	1	EA
R761	CRD20TF1801T	RES , CARBON	1.8K /1/5W /F	1	EA
R762	CRD20TF2701T	RES , CARBON	2.7K /1/5W/F	1	EA
R763	CRD20TF3301T	RES , CARBON	3.3K /1/5W/F	1	EA
R764	CRD20TF5601T	RES , CARBON	5.6K/1/5W/F	1	EA
R765	CRD20TF7501T	RES , CARBON	7.5K/1/5W/F	1	EA
R766	CRD20TF1001T	RES , CARBON	1K /1/5W /F	1	EA
R767	CRD20TF1501T	RES , CARBON	1.5K /1/5W /F	1	EA
R768	CRD20TF1801T	RES , CARBON	1.8K /1/5W /F	1	EA
R769	CRD20TF2701T	RES , CARBON	2.7K /1/5W/F	1	EA
<i>Miscellaneous</i>					
S702	HST1A020ZT	SW , TACT	1A020	1	EA
S703	HST1A020ZT	SW , TACT	1A020	1	EA
S704	HST1A020ZT	SW , TACT	1A020	1	EA
S705	HST1A020ZT	SW , TACT	1A020	1	EA
S706	HST1A020ZT	SW , TACT	1A020	1	EA
S707	HST1A020ZT	SW , TACT	1A020	1	EA
S708	HST1A020ZT	SW , TACT	1A020	1	EA
S709	HST1A020ZT	SW , TACT	1A020	1	EA
S710	HST1A020ZT	SW , TACT	1A020	1	EA
S711	HST1A020ZT	SW , TACT	1A020	1	EA
S712	HST1A020ZT	SW , TACT	1A020	1	EA
S713	HST1A020ZT	SW , TACT	1A020	1	EA
S714	HST1A020ZT	SW , TACT	1A020	1	EA
S715	HST1A020ZT	SW , TACT	1A020	1	EA
S716	HST1A020ZT	SW , TACT	1A020	1	EA
S717	HST1A020ZT	SW , TACT	1A020	1	EA
S718	HST1A020ZT	SW , TACT	1A020	1	EA
S719	HST1A020ZT	SW , TACT	1A020	1	EA
S720	HST1A020ZT	SW , TACT	1A020	1	EA
BN89	CWB2B904100EN	WIRE ASS'Y	WIRE	1	EA
PCB , VR JACK		CUP11910-6			
<i>Capacitors</i>					
C805	HCBS1H223ZFT	CAP , CERAMIC	0.022UF 50V Z	1	EA
C806	HCBS1H223ZFT	CAP , CERAMIC	0.022UF 50V Z	1	EA
C820	CCEA1HH100T	CAP , ELECT	10UF 50V	1	EA
C821	CCEA1EH470T	CAP , ELECT	47UF 25V	1	EA
C822	CCEA1EH470T	CAP , ELECT	47UF 25V	1	EA
C823	CCEA1HH100T	CAP , ELECT	10UF 50V	1	EA
C824	HCBS1H471KBT	CAP , CERAMIC	470PF 50V	1	EA
C825	HCBS1H151KBT	CAP , CERAMIC	150PF 50V	1	EA
C828	HCBS1H470JT	CAP , CERAMIC	47PF 50V	1	EA
C830	HCBS1H473ZFT	CAP , CERAMIC	0.047F 50V	1	EA
C841	CCEA1HH100T	CAP , ELECT	10UF 50V	1	EA
C842	CCEA1HH100T	CAP , ELECT	10UF 50V	1	EA
C843	CCEA1HH100T	CAP , ELECT	10UF 50V	1	EA
C855	HCBS1H101KBT	CAP , CERAMIC	100PF 50V K	1	EA
C856	HCBS1H101KBT	CAP , CERAMIC	100PF 50V K	1	EA
C857	HCBS1H104ZFT	CAP , CERAMIC	0.1UF 50V Z	1	EA
C862	HCBS1H101KBT	CAP , CERAMIC	100PF 50V K	1	EA
C863	HCBS1H101KBT	CAP , CERAMIC	100PF 50V K	1	EA

Ref. Designator	Part Number	Description		Qty	
PCB , VR JACK		CUP11910-6			
C874	HCBS1H101KBT	CAP , CERAMIC	100PF 50V K	1	EA
<i>Semiconductors</i>					
IC87	HVINJM2068MDTE1	I.C , DUAL OP AMP	JRC	1	EA
D774	CVD1SS133MT	DIODE	1SS133	1	EA
D701	CVD52CSBBCEAB2	BLUE L.E.D	L.E.D	1	EA
D703	CVD52CSBBCEAB2	BLUE L.E.D	L.E.D	1	EA
D705	CVD52CSBBCEAB2	BLUE L.E.D	L.E.D	1	EA
<i>Resistors</i>					
R705	CRD20TJ820T	RES , CARBON	82 OHM 1/5W J	1	EA
R706	CRD20TJ820T	RES , CARBON	82 OHM 1/5W J	1	EA
R708	CRD20TJ820T	RES , CARBON	82 OHM 1/5W J	1	EA
R864	CRD20TJ272T	RES , CARBON	2.7K OHM 1/5W J	1	EA
R865	CRD20TJ101T	RES , CARBON	100 OHM 1/5W J	1	EA
R866	CRD20TJ272T	RES , CARBON	2.7K OHM 1/5W J	1	EA
R871	CRD20TJ104T	RES , CARBON	100K OHM 1/5W J	1	EA
R872	CRD20TJ104T	RES , CARBON	100K OHM 1/5W J	1	EA
R873	CRD20TJ471T	RES , CARBON	470 OHM 1/5W J	1	EA
R874	CRD20TJ471T	RES , CARBON	470 OHM 1/5W J	1	EA
R875	CRD20TJ103T	RES , CARBON	10K OHM 1/5W J	1	EA
R876	CRD20TJ750T	RES , CARBON	75 OHM 1/5W J	1	EA
R877	CRD20TJ750T	RES , CARBON	75 OHM 1/5W J	1	EA
R878	CRD20TJ750T	RES , CARBON	75 OHM 1/5W J	1	EA
R881	C3A206	WIRE , COPPER	SN95/PB5 , 0.6		
R882	C3A206	WIRE , COPPER	SN95/PB5 , 0.6		
R921	CRD20TJ103T	RES , CARBON	10K OHM 1/5W J	1	EA
R922	CRD20TJ102T	RES , CARBON	1K OHM 1/5W J	1	EA
R923	CRD20TJ101T	RES , CARBON	100 OHM 1/5W J	1	EA
R924	CRD20TJ101T	RES , CARBON	100 OHM 1/5W J	1	EA
R926	CRD20TJ103T	RES , CARBON	10K OHM 1/5W J	1	EA
R934	CRD20TJ222T	RES , CARBON	2.2K OHM 1/5W J	1	EA
R935	CRD20TJ103T	RES , CARBON	10K OHM 1/5W J	1	EA
R936	CRD20TJ152T	RES , CARBON	1.5K OHM 1/5W J	1	EA
R937	CRD20TJ104T	RES , CARBON	100K OHM 1/5W J	1	EA
<i>Miscellaneous</i>					
VR74	CSR2A037Z	ENCODER	ENCODER	1	EA
JK85	CJJ9M003Z	JACK , S-VIDEO	JACK	1	EA
JK86	CJJ4S023Y	JACK , BOARD	JACK	1	EA
JW84	CWE8202110RV	WIRE ASS'Y	WIRE	1	EA
CN84	CJP05GB46ZY	WAFER	WAFER	1	EA
BN51	CWZAVR147BN51	SHIELD WIRE ASS'Y	WIRE	1	EA
BN10	CWZAVR230BN10	WIRE ASS'Y (SHIELD)	WIRE	1	EA
BN41	CWZAVR130BN41	WIRE ASS'Y (SHIELD)	WIRE	1	EA
BN92	CWB2B905100EN	WIRE ASS'Y	WIRE	1	EA
PCB , PHONE JACK		CUP11910-5			
<i>Capacitors</i>					
C807	HCBS1H104ZFT	CAP , CERAMIC	0.1UF 50V Z	1	EA
C808	HCBS1H181KBT	CAP , CERAMIC	180PF 50V Z	1	EA
C809	CCEA1AH471T	CAP , ELECT	470UF 10V	1	EA
C812	HCBS1H104ZFT	CAP , CERAMIC	0.1UF 50V Z	1	EA
C817	HCBS1H100JCT	CAP , CERAMIC	10PF 50V	1	EA
C850	HCBS1H471KBT	CAP , CERAMIC	470PF 50V	1	EA
C851	HCBS1H471KBT	CAP , CERAMIC	470PF 50V	1	EA

Ref. Designator	Part Number	Description		Qty	
PCB , PHONE JACK		CUP11910-5			
C852	HCBS1H104ZFT	CAP , CERAMIC	0.1UF 50V Z	1	EA
C866	CCEA1HKS100T	CAP , ELECT	10UF 50V	1	EA
C867	CCEA1HKS100T	CAP , ELECT	10UF 50V	1	EA
C868	CCEA1EKS470T	CAP , ELECT	47UF 25V	1	EA
C869	CCEA1EKS470T	CAP , ELECT	47UF 25V	1	EA
C870	HCBS1H681KBT	CAP , CERAMIC	680PF 50V K	1	EA
C871	HCBS1H681KBT	CAP , CERAMIC	680PF 50V K	1	EA
C872	CCEA1CH331T	CAP , ELECT	330UF 16V	1	EA
C873	CCEA1CH331T	CAP , ELECT	330UF 16V	1	EA
C889	HCBS1H104ZFT	CAP , CERAMIC	0.1UF 50V Z	1	EA
<i>Semiconductors</i>					
D784	CVD1SS133MT	DIODE	1SS133	1	EA
D785	CVD1SS133MT	DIODE	1SS133	1	EA
IC76	HVI74HCU04AFNG	I.C , INVERTER	TOSHICA	1	EA
IC86	HVINJM4556AL	I.C , HEADPHONE, DUAL OP-AMP	JRC	1	EA
Q451	HVTKRC107MT	TRANSISTOR NPN	KRC107M	1	EA
Q452	HVTKRA107MT	TRANSISTOR PNP	KRA107M	1	EA
Q454	HVTKRC107MT	TRANSISTOR NPN	KRC107M	1	EA
Q734	HVTKTC2874BT	TRANSISTOR , MUTE NPN	KTC2874B	1	EA
Q735	HVTKTC2874BT	TRANSISTOR , MUTE NPN	KTC2874B	1	EA
Q736	HVTKTC2874BT	TRANSISTOR , MUTE NPN	KTC2874B	1	EA
Q737	HVTKTC2874BT	TRANSISTOR , MUTE NPN	KTC2874B	1	EA
<i>Resistors</i>					
R452	CRD20TJ103T	RES , CARBON	10K OHM 1/5W J	1	EA
R453	CRD20TJ362T	RES , CARBON	3.6K OHM 1/5W J	1	EA
R454	CRD20TJ102T	RES , CARBON	1K OHM 1/5W J	1	EA
R805	CRD20TJ104T	RES , CARBON	100K OHM 1/5W J	1	EA
R806	CRD20TJ472T	RES , CARBON	4.7K OHM 1/5W J	1	EA
R869	CRD20TJ750T	RES , CARBON	75 OHM 1/5W J	1	EA
R896	CRD20TJ101T	RES , CARBON	100 OHM 1/5W J	1	EA
R897	CRD20TJ101T	RES , CARBON	100 OHM 1/5W J	1	EA
R898	CRD20TJ101T	RES , CARBON	100 OHM 1/5W J	1	EA
R899	CRD20TJ104T	RES , CARBON	100K OHM 1/5W J	1	EA
R900	CRD20TJ104T	RES , CARBON	100K OHM 1/5W J	1	EA
R901	CRD20TJ152T	RES , CARBON	1.5K OHM 1/5W J	1	EA
R902	CRD20TJ152T	RES , CARBON	1.5K OHM 1/5W J	1	EA
R903	CRD20TJ102T	RES , CARBON	1K OHM 1/5W J	1	EA
R904	CRD20TJ102T	RES , CARBON	1K OHM 1/5W J	1	EA
R905	CRD20TJ104T	RES , CARBON	100K OHM 1/5W J	1	EA
R906	CRD20TJ104T	RES , CARBON	100K OHM 1/5W J	1	EA
R907	CRD20TJ472T	RES , CARBON	4.7K OHM 1/5W J	1	EA
R908	CRD20TJ472T	RES , CARBON	4.7K OHM 1/5W J	1	EA
R909	CRD20TJ221T	RES , CARBON	220 OHM 1/5W J	1	EA
R910	CRD20TJ221T	RES , CARBON	220 OHM 1/5W J	1	EA
R911	CRD20TJ221T	RES , CARBON	220 OHM 1/5W J	1	EA
R912	CRD20TJ221T	RES , CARBON	220 OHM 1/5W J	1	EA
R913	CRD20TJ102T	RES , CARBON	1K OHM 1/5W J	1	EA
R915	CRD20TJ473T	RES , CARBON	47K OHM 1/5W J	1	EA
R918	CRD20TJ472T	RES , CARBON	4.7K OHM 1/5W J	1	EA
R919	CRD20TJ472T	RES , CARBON	4.7K OHM 1/5W J	1	EA
<i>Miscellaneous</i>					
JK81	CJJ4M043Y	JACK , BOARD	JACK	1	EA
JK82	HJSTORX177L	MODULE , OPTICAL(RX)	OPT JACK(RX)	1	EA
JK83	CJJ2E026Z	JACK , HEADPHONE(SILVER PLATE)	JACK	1	EA
JW82	CWE8202300RV	WIRE ASS'Y	WIRE	1	EA

Ref. Designator	Part Number	Description		Qty	
PCB , PHONE JACK		CUP11910-5			
JW83	CWE8202150RV	WIRE ASS'Y	WIRE	1	EA
CN85	CJP03GA19ZY	WAFER, STRAIGHT, 3PIN	WAFER	1	EA
CN92	CJP05GA19ZY	WAFER, STRAIGHT, 5PIN	WAFER	1	EA
BN18	CWZAVR125BN18	WIRE ASS'Y (SHIELD)	WIRE	1	EA
BN22	CWZAVR145BN22	WIRE ASS'Y (SHIELD)	WIRE	1	EA
MAIN PCB/HEATSINK		(CUP11911)			
<i>Capacitors</i>					
C501	CCEA1HH100T	CAP , ELECT	10UF 50V	1	EA
C502	CCEA1HH100T	CAP , ELECT	10UF 50V	1	EA
C503	CCEA1HH100T	CAP , ELECT	10UF 50V	1	EA
C504	CCEA1HH100T	CAP , ELECT	10UF 50V	1	EA
C505	CCEA1HH100T	CAP , ELECT	10UF 50V	1	EA
C506	CCKT1H331KB	CAP , CERAMIC	330PF 50V	1	EA
C507	HCBS1H331KBT	CAP , CERAMIC	330PF 50V	1	EA
C508	HCBS1H331KBT	CAP , CERAMIC	330PF 50V	1	EA
C509	CCKT1H331KB	CAP , CERAMIC	330PF 50V	1	EA
C510	HCBS1H331KBT	CAP , CERAMIC	330PF 50V	1	EA
C561	CCEA1CH101T	CAP , ELECT	100UF 16V	1	EA
C562	CCEA1CH101T	CAP , ELECT	100UF 16V	1	EA
C563	CCEA1CH101T	CAP , ELECT	100UF 16V	1	EA
C564	CCEA1CH101T	CAP , ELECT	100UF 16V	1	EA
C565	CCEA1CH101T	CAP , ELECT	100UF 16V	1	EA
C566	CCEA1CH101T	CAP , ELECT	100UF 16V	1	EA
C567	CCEA1CH101T	CAP , ELECT	100UF 16V	1	EA
C568	CCEA1CH101T	CAP , ELECT	100UF 16V	1	EA
C569	CCEA1CH101T	CAP , ELECT	100UF 16V	1	EA
C570	CCEA1CH101T	CAP , ELECT	100UF 16V	1	EA
C571	HCBS1H681KBT	CAP , CERAMIC	680PF 50V	1	EA
C572	HCBS1H681KBT	CAP , CERAMIC	680PF 50V	1	EA
C573	HCBS1H681KBT	CAP , CERAMIC	680PF 50V	1	EA
C574	HCBS1H681KBT	CAP , CERAMIC	680PF 50V	1	EA
C575	HCBS1H681KBT	CAP , CERAMIC	680PF 50V	1	EA
C601	CCCT1H120JC	CAP , CERAMIC	12PF 50V	1	EA
C602	CCCT1H120JC	CAP , CERAMIC	12PF 50V	1	EA
C603	CCCT1H120JC	CAP , CERAMIC	12PF 50V	1	EA
C604	CCCT1H120JC	CAP , CERAMIC	12PF 50V	1	EA
C605	CCCT1H120JC	CAP , CERAMIC	12PF 50V	1	EA
C606	CCCT1H330JC	CAP , CERAMIC	33PF 50V	1	EA
C607	CCCT1H330JC	CAP , CERAMIC	33PF 50V	1	EA
C608	CCCT1H330JC	CAP , CERAMIC	33PF 50V	1	EA
C609	CCCT1H330JC	CAP , CERAMIC	33PF 50V	1	EA
C610	CCCT1H330JC	CAP , CERAMIC	33PF 50V	1	EA
C681	CCEA1HH100T	CAP , ELECT	10UF 50V	1	EA
C682	CCEA1HH100T	CAP , ELECT	10UF 50V	1	EA
C683	CCEA1HH100T	CAP , ELECT	10UF 50V	1	EA
C684	CCEA1HH100T	CAP , ELECT	10UF 50V	1	EA
C685	CCEA1HH100T	CAP , ELECT	10UF 50V	1	EA
C726	CCKT1H221KB	CAP , CERAMIC	220PF 50V	1	EA
C900	HCQI1H473JZT	CAP , MYLAR	0.047UF 50V	1	EA
C901	HCQI1H473JZT	CAP , MYLAR	0.047UF 50V	1	EA
C905	CCFT1H223ZF	CAP , CERAMIC	0.022UP 50V	1	EA
C907	CCEA1CH101T	CAP , ELECT	100UF 16V	1	EA
C908	CCFT1H223ZF	CAP , CERAMIC	0.022UP 50V	1	EA
C910	HCQI1H473JZT	CAP , MYLAR	0.047UF 50V	1	EA
C911	CCEA1CH471T	CAP , ELECT	470UF 16V	1	EA
C912	CCEA1CH221T	CAP , ELECT	220UF 16V	1	EA
C913	CCFT1H104ZF	CAP , SEMICONDUCTOR	0.1UF 50V ZF	1	EA
C914	HCQI1H473JZT	CAP , MYLAR	0.047UF 50V J	1	EA

Ref. Designator	Part Number	Description		Qty	
MAIN PCB/HEATSINK		(CUP11911)			
C917	HCQI1H473JZT	CAP , MYLAR	0.047UF 50V J	1	EA
C924	CCFT1H104ZF	CAP , SEMICONDUCTOR	0.1UF 50V ZF	1	EA
C939	CCEA1HH4R7T	CAP , ELECT	4.7UF 50V	1	EA
C940	CCEA1AH471T	CAP , ELECT	470UF 10V	1	EA
C948	CCFT1H104ZF	CAP , SEMICONDUCTOR	0.1UF 50V ZF	1	EA
C949	CCEA1HH220T	CAP , ELECT	22UF 50V	1	EA
C971	HCQI1H562JZT	CAP , MYLAR	5600PF 50V	1	EA
C972	HCQI1H562JZT	CAP , MYLAR	5600PF 50V	1	EA
C973	HCQI1H562JZT	CAP , MYLAR	5600PF 50V	1	EA
C980	HCQI1H562JZT	CAP , MYLAR	5600PF 50V	1	EA
C981	HCQI1H562JZT	CAP , MYLAR	5600PF 50V	1	EA
C990	HCQI1H473JZT	CAP , MYLAR	0.047UF 50V J	1	EA
C991	CCEA1HH1R0T	CAP , ELECT	1UF 50V	1	EA
C992	HCQI1H473JZT	CAP , MYLAR	0.047UF 50V J	1	EA
C993	HCQI1H473JZT	CAP , MYLAR	0.047UF 50V J	1	EA
C995	HCQI1H473JZT	CAP , MYLAR	0.047UF 50V J	1	EA
C997	HCQI1H473JZT	CAP , MYLAR	0.047UF 50V J	1	EA
C999	CCFT1H223ZF	CAP , CERAMIC	0.022UF 50V ZF	1	EA
C631	CCEA1JH101E	CAP , ELECT	100UF 63V	1	EA
C632	CCEA1JH101E	CAP , ELECT	100UF 63V	1	EA
C633	CCEA1JH101E	CAP , ELECT	100UF 63V	1	EA
C634	CCEA1JH101E	CAP , ELECT	100UF 63V	1	EA
C635	CCEA1JH101E	CAP , ELECT	100UF 63V	1	EA
C636	CCEA1JH101E	CAP , ELECT	100UF 63V	1	EA
C637	CCEA1JH101E	CAP , ELECT	100UF 63V	1	EA
C638	CCEA1JH101E	CAP , ELECT	100UF 63V	1	EA
C639	CCEA1JH101E	CAP , ELECT	100UF 63V	1	EA
C640	CCEA1JH101E	CAP , ELECT	100UF 63V	1	EA
C902	CCET50VKL4682NK	CAP , ELECT	6800UF/50V	1	EA
C904	KCKDKS472ME	CAP , CERAMIC(X1/Y2/SC)	0.0047UF/2.5KV	1	EA
C906	CCEA1EH102E	CAP , ELECT	1000UF 25V	1	EA
C909	CCET50VKL4682NK	CAP , ELECT	6800UF/50V	1	EA
C915	CCET50VKL4682NK	CAP , ELECT	6800UF/50V	1	EA
C916	CCET50VKL4682NK	CAP , ELECT	6800UF/50V	1	EA
<i>Semiconductors</i>					
D501	CVD1SS133MT	DIODE	1SS133	1	EA
D502	CVD1SS133MT	DIODE	1SS133	1	EA
D503	CVD1SS133MT	DIODE	1SS133	1	EA
D504	CVD1SS133MT	DIODE	1SS133	1	EA
D505	CVD1SS133MT	DIODE	1SS133	1	EA
D581	CVD1SS133MT	DIODE	1SS133	1	EA
D582	CVD1SS133MT	DIODE	1SS133	1	EA
D583	CVD1SS133MT	DIODE	1SS133	1	EA
D584	CVD1SS133MT	DIODE	1SS133	1	EA
D585	CVD1SS133MT	DIODE	1SS133	1	EA
D901	CVD1N4003SRT	RECT , DIODE	1N4003	1	EA
D902	CVD1SS133MT	DIODE	1SS133	1	EA
D911	CVD1SS133MT	DIODE	1SS133	1	EA
D912	CVD1SS133MT	DIODE	1SS133	1	EA
D914	CVD1SS133MT	DIODE	1SS133	1	EA
D917	CVD1SS133MT	DIODE	1SS133	1	EA
D953	CVD1SS133MT	DIODE	1SS133	1	EA
D954	CVD1N4003SRT	RECT , DIODE	1N4003	1	EA
D955	CVD1N4003SRT	RECT , DIODE	1N4003	1	EA
D956	CVD1N4003SRT	RECT , DIODE	1N4003	1	EA
D957	CVD1N4003SRT	RECT , DIODE	1N4003	1	EA
D961	CVD1N4003ST	RECT , DIODE	1N4003	1	EA
D962	CVD1N4003SRT	RECT , DIODE	1N4003	1	EA
D963	CVD1N4003ST	RECT , DIODE	1N4003	1	EA

Ref. Designator	Part Number	Description		Qty	
MAIN PCB/HEATSINK		(CUP11911)			
D973	CVD1SS133MT	DIODE	1SS133	1	EA
D974	CVD1SS133MT	DIODE	1SS133	1	EA
D979	HVDMTZJ6.2BT	DIODE , ZENER	MTZJ6.2B	1	EA
D980	CVD1SS133MT	DIODE	1SS133	1	EA
Q501	HVTKTA1268GRT	TRANSISTOR PNP	KTA1268GR	1	EA
Q502	HVTKTA1268GRT	TRANSISTOR PNP	KTA1268GR	1	EA
Q503	HVTKTA1268GRT	TRANSISTOR PNP	KTA1268GR	1	EA
Q504	HVTKTA1268GRT	TRANSISTOR PNP	KTA1268GR	1	EA
Q505	HVTKTA1268GRT	TRANSISTOR PNP	KTA1268GR	1	EA
Q511	HVTKTC3200GRT	TRANSISTOR NPN	KTC3200GR	1	EA
Q512	HVTKTC3200GRT	TRANSISTOR NPN	KTC3200GR	1	EA
Q513	HVTKTC3200GRT	TRANSISTOR NPN	KTC3200GR	1	EA
Q514	HVTKTC3200GRT	TRANSISTOR NPN	KTC3200GR	1	EA
Q515	HVTKTC3200GRT	TRANSISTOR NPN	KTC3200GR	1	EA
Q516	HVTKTC3200GRT	TRANSISTOR NPN	KTC3200GR	1	EA
Q517	HVTKTC3200GRT	TRANSISTOR NPN	KTC3200GR	1	EA
Q518	HVTKTC3200GRT	TRANSISTOR NPN	KTC3200GR	1	EA
Q519	HVTKTC3200GRT	TRANSISTOR NPN	KTC3200GR	1	EA
Q520	HVTKTC3200GRT	TRANSISTOR NPN	KTC3200GR	1	EA
Q541	HVTKTC3198YT	TRANSISTOR NPN	KTC3198Y	1	EA
Q542	HVTKTC3198YT	TRANSISTOR NPN	KTC3198Y	1	EA
Q543	HVTKTC3198YT	TRANSISTOR NPN	KTC3198Y	1	EA
Q544	HVTKTC3198YT	TRANSISTOR NPN	KTC3198Y	1	EA
Q545	HVTKTC3198YT	TRANSISTOR NPN	KTC3198Y	1	EA
Q556	HVTKTC3200GRT	TRANSISTOR NPN	KTC3200GR	1	EA
Q557	HVTKTC3200GRT	TRANSISTOR NPN	KTC3200GR	1	EA
Q558	HVTKTC3200GRT	TRANSISTOR NPN	KTC3200GR	1	EA
Q559	HVTKTC3200GRT	TRANSISTOR NPN	KTC3200GR	1	EA
Q560	HVTKTC3200GRT	TRANSISTOR NPN	KTC3200GR	1	EA
Q561	HVTKTC3200GRT	TRANSISTOR NPN	KTC3200GR	1	EA
Q562	HVTKTC3200GRT	TRANSISTOR NPN	KTC3200GR	1	EA
Q563	HVTKTC3200GRT	TRANSISTOR NPN	KTC3200GR	1	EA
Q564	HVTKTC3200GRT	TRANSISTOR NPN	KTC3200GR	1	EA
Q565	HVTKTC3200GRT	TRANSISTOR NPN	KTC3200GR	1	EA
Q601	HVTKTA1268GRT	TRANSISTOR PNP	KTA1268GR	1	EA
Q602	HVTKTA1268GRT	TRANSISTOR PNP	KTA1268GR	1	EA
Q603	HVTKTA1268GRT	TRANSISTOR PNP	KTA1268GR	1	EA
Q604	HVTKTA1268GRT	TRANSISTOR PNP	KTA1268GR	1	EA
Q605	HVTKTA1268GRT	TRANSISTOR PNP	KTA1268GR	1	EA
Q681	HVTKSC2785YT	TRANSISTOR NPN	KSC2785Y	1	EA
Q682	HVTKSC2785YT	TRANSISTOR NPN	KSC2785Y	1	EA
Q683	HVTKSC2785YT	TRANSISTOR NPN	KSC2785Y	1	EA
Q684	HVTKSC2785YT	TRANSISTOR NPN	KSC2785Y	1	EA
Q685	HVTKSC2785YT	TRANSISTOR NPN	KSC2785Y	1	EA
Q901	HVTKSC2785YT	TRANSISTOR NPN	KSC2785Y	1	EA
Q938	HVTKRA107MT	TRANSISTOR PNP	KRA107M	1	EA
Q939	HVTKRA107MT	TRANSISTOR PNP	KRA107M	1	EA
Q942	HVTKSC2785YT	TRANSISTOR NPN	KSC2785Y	1	EA
Q943	HVTKSC2785YT	TRANSISTOR NPN	KSC2785Y	1	EA
Q951	HVTKRC107MT	TRANSISTOR NPN	KRC107M	1	EA
Q952	HVTKRA107MT	TRANSISTOR PNP	KRA107M	1	EA
Q960	HVTKRC107MT	TRANSISTOR NPN	KRC107M	1	EA
Q961	HVTKTA1024YT	TRANSISTOR PNP	KTA1024YT	1	EA
Q991	HVTKRC107MT	TRANSISTOR NPN	KRC107M	1	EA
Q992	HVTKRA107MT	TRANSISTOR PNP	KRA107M	1	EA
Q858	HVT2SA1360O	TRANSISTOR PNP POWER	2SA1360O	1	EA
Q871	HVT2SA1360O	TRANSISTOR PNP POWER	2SA1360O	1	EA
Q872	HVT2SA1360O	TRANSISTOR PNP POWER	2SA1360O	1	EA
Q874	HVT2SA1360O	TRANSISTOR PNP POWER	2SA1360O	1	EA
Q875	HVT2SA1360O	TRANSISTOR PNP POWER	2SA1360O	1	EA
Q881	HVT2SC3423O	TRANSISTOR NPN POWER	2SC3423O	1	EA

Ref. Designator	Part Number	Description		Qty	
MAIN PCB/HEATSINK		(CUP11911)			
Q882	HVT2SC3423O	TRANSISTOR NPN POWER	2SC3423O	1	EA
Q883	HVT2SC3423O	TRANSISTOR NPN POWER	2SC3423O	1	EA
Q884	HVT2SC3423O	TRANSISTOR NPN POWER	2SC3423O	1	EA
Q885	HVT2SC3423O	TRANSISTOR NPN POWER	2SC3423O	1	EA
IC94	HVIMC7805C	I.C. REGULATOR(+5V)	FAIRCHILD	1	EA
IC97	HVIS-80842CNY-X	I.C. RESET	SEIKO	1	EA
<i>Resistors</i>					
R501	CRD20TJ433T	RES , CARBON	43K OHM 1/5W J	1	EA
R502	CRD20TJ433T	RES , CARBON	43K OHM 1/5W J	1	EA
R503	CRD20TJ433T	RES , CARBON	43K OHM 1/5W J	1	EA
R504	CRD20TJ433T	RES , CARBON	43K OHM 1/5W J	1	EA
R505	CRD20TJ433T	RES , CARBON	43K OHM 1/5W J	1	EA
R506	CRD20TJ333T	RES , CARBON	33K OHM 1/5W J	1	EA
R507	CRD20TJ333T	RES , CARBON	33K OHM 1/5W J	1	EA
R508	CRD20TJ333T	RES , CARBON	33K OHM 1/5W J	1	EA
R509	CRD20TJ333T	RES , CARBON	33K OHM 1/5W J	1	EA
R510	CRD20TJ333T	RES , CARBON	33K OHM 1/5W J	1	EA
R511	CRD20TJ152T	RES , CARBON	1.5K OHM 1/5W J	1	EA
R512	CRD20TJ152T	RES , CARBON	1.5K OHM 1/5W J	1	EA
R513	CRD20TJ152T	RES , CARBON	1.5K OHM 1/5W J	1	EA
R514	CRD20TJ152T	RES , CARBON	1.5K OHM 1/5W J	1	EA
R515	CRD20TJ152T	RES , CARBON	1.5K OHM 1/5W J	1	EA
R516	CRD20TJ152T	RES , CARBON	1.5K OHM 1/5W J	1	EA
R517	CRD20TJ152T	RES , CARBON	1.5K OHM 1/5W J	1	EA
R518	CRD20TJ152T	RES , CARBON	1.5K OHM 1/5W J	1	EA
R519	CRD20TJ152T	RES , CARBON	1.5K OHM 1/5W J	1	EA
R520	CRD20TJ152T	RES , CARBON	1.5K OHM 1/5W J	1	EA
R521	CRD20TJ471T	RES , CARBON	470 OHM 1/5W J	1	EA
R522	CRD20TJ471T	RES , CARBON	470 OHM 1/5W J	1	EA
R523	CRD20TJ471T	RES , CARBON	470 OHM 1/5W J	1	EA
R524	CRD20TJ471T	RES , CARBON	470 OHM 1/5W J	1	EA
R525	CRD20TJ471T	RES , CARBON	470 OHM 1/5W J	1	EA
R531	CRD20TJ221T	RES , CARBON	220 OHM 1/5W J	1	EA
R532	CRD20TJ221T	RES , CARBON	220 OHM 1/5W J	1	EA
R533	CRD20TJ221T	RES , CARBON	220 OHM 1/5W J	1	EA
R534	CRD20TJ221T	RES , CARBON	220 OHM 1/5W J	1	EA
R535	CRD20TJ221T	RES , CARBON	220 OHM 1/5W J	1	EA
R536	CRD20TJ221T	RES , CARBON	220 OHM 1/5W J	1	EA
R537	CRD20TJ221T	RES , CARBON	220 OHM 1/5W J	1	EA
R538	CRD20TJ221T	RES , CARBON	220 OHM 1/5W J	1	EA
R539	CRD20TJ221T	RES , CARBON	220 OHM 1/5W J	1	EA
R540	CRD20TJ221T	RES , CARBON	220 OHM 1/5W J	1	EA
R541	CRD20TJ271T	RES , CARBON	270 OHM 1/5W J	1	EA
R542	CRD20TJ271T	RES , CARBON	270 OHM 1/5W J	1	EA
R543	CRD20TJ271T	RES , CARBON	270 OHM 1/5W J	1	EA
R544	CRD20TJ271T	RES , CARBON	270 OHM 1/5W J	1	EA
R545	CRD20TJ271T	RES , CARBON	270 OHM 1/5W J	1	EA
R556	CRD20TJ273T	RES , CARBON	27K OHM 1/5W J	1	EA
R557	CRD20TJ273T	RES , CARBON	27K OHM 1/5W J	1	EA
R558	CRD20TJ273T	RES , CARBON	27K OHM 1/5W J	1	EA
R559	CRD20TJ273T	RES , CARBON	27K OHM 1/5W J	1	EA
R560	CRD20TJ273T	RES , CARBON	27K OHM 1/5W J	1	EA
R561	CRD20TJ182T	RES , CARBON	1.8K OHM 1/5W J	1	EA
R562	CRD20TJ182T	RES , CARBON	1.8K OHM 1/5W J	1	EA
R563	CRD20TJ182T	RES , CARBON	1.8K OHM 1/5W J	1	EA
R564	CRD20TJ182T	RES , CARBON	1.8K OHM 1/5W J	1	EA
R565	CRD20TJ182T	RES , CARBON	1.8K OHM 1/5W J	1	EA
R566	CRD20TJ561T	RES , CARBON	560 OHM 1/5W J	1	EA
R567	CRD20TJ561T	RES , CARBON	560 OHM 1/5W J	1	EA

Ref. Designator	Part Number	Description		Qty	
MAIN PCB/HEATSINK		(CUP11911)			
R568	CRD20TJ561T	RES , CARBON	560 OHM 1/5W J	1	EA
R569	CRD20TJ561T	RES , CARBON	560 OHM 1/5W J	1	EA
R570	CRD20TJ561T	RES , CARBON	560 OHM 1/5W J	1	EA
R571	CRD20TJ561T	RES , CARBON	560 OHM 1/5W J	1	EA
R572	CRD20TJ561T	RES , CARBON	560 OHM 1/5W J	1	EA
R573	CRD20TJ561T	RES , CARBON	560 OHM 1/5W J	1	EA
R574	CRD20TJ561T	RES , CARBON	560 OHM 1/5W J	1	EA
R575	CRD20TJ561T	RES , CARBON	560 OHM 1/5W J	1	EA
R576	CRD20TJ100T	RES , CARBON	10 OHM 1/5W J	1	EA
R577	CRD20TJ100T	RES , CARBON	10 OHM 1/5W J	1	EA
R578	CRD20TJ100T	RES , CARBON	10 OHM 1/5W J	1	EA
R579	CRD20TJ100T	RES , CARBON	10 OHM 1/5W J	1	EA
R580	CRD20TJ100T	RES , CARBON	10 OHM 1/5W J	1	EA
R581	CRD20TJ561T	RES , CARBON	560 OHM 1/5W J	1	EA
R582	CRD20TJ561T	RES , CARBON	560 OHM 1/5W J	1	EA
R583	CRD20TJ561T	RES , CARBON	560 OHM 1/5W J	1	EA
R584	CRD20TJ561T	RES , CARBON	560 OHM 1/5W J	1	EA
R585	CRD20TJ561T	RES , CARBON	560 OHM 1/5W J	1	EA
R586	CRD20TJ561T	RES , CARBON	560 OHM 1/5W J	1	EA
R587	CRD20TJ561T	RES , CARBON	560 OHM 1/5W J	1	EA
R588	CRD20TJ561T	RES , CARBON	560 OHM 1/5W J	1	EA
R589	CRD20TJ561T	RES , CARBON	560 OHM 1/5W J	1	EA
R590	CRD20TJ561T	RES , CARBON	560 OHM 1/5W J	1	EA
R591	CRD20TJ561T	RES , CARBON	560 OHM 1/5W J	1	EA
R592	CRD20TJ561T	RES , CARBON	560 OHM 1/5W J	1	EA
R593	CRD20TJ561T	RES , CARBON	560 OHM 1/5W J	1	EA
R594	CRD20TJ561T	RES , CARBON	560 OHM 1/5W J	1	EA
R595	CRD20TJ561T	RES , CARBON	560 OHM 1/5W J	1	EA
R596	CRD20TJ561T	RES , CARBON	560 OHM 1/5W J	1	EA
R597	CRD20TJ561T	RES , CARBON	560 OHM 1/5W J	1	EA
R598	CRD20TJ561T	RES , CARBON	560 OHM 1/5W J	1	EA
R599	CRD20TJ561T	RES , CARBON	560 OHM 1/5W J	1	EA
R600	CRD20TJ561T	RES , CARBON	560 OHM 1/5W J	1	EA
R601	CRD20TJ223T	RES , CARBON	22K OHM 1/5W J	1	EA
R602	CRD20TJ223T	RES , CARBON	22K OHM 1/5W J	1	EA
R603	CRD20TJ223T	RES , CARBON	22K OHM 1/5W J	1	EA
R604	CRD20TJ223T	RES , CARBON	22K OHM 1/5W J	1	EA
R605	CRD20TJ223T	RES , CARBON	22K OHM 1/5W J	1	EA
R606	CRD20TJ223T	RES , CARBON	22K OHM 1/5W J	1	EA
R607	CRD20TJ223T	RES , CARBON	22K OHM 1/5W J	1	EA
R608	CRD20TJ223T	RES , CARBON	22K OHM 1/5W J	1	EA
R609	CRD20TJ223T	RES , CARBON	22K OHM 1/5W J	1	EA
R610	CRD20TJ223T	RES , CARBON	22K OHM 1/5W J	1	EA
R631	CRD25FJ180T	RES , CARBON	18 OHM 1/4W	1	EA
R632	CRD25FJ180T	RES , CARBON	18 OHM 1/4W	1	EA
R633	CRD25FJ180T	RES , CARBON	18 OHM 1/4W	1	EA
R634	CRD25FJ180T	RES , CARBON	18 OHM 1/4W	1	EA
R635	CRD25FJ180T	RES , CARBON	18 OHM 1/4W	1	EA
R636	CRD25FJ180T	RES , CARBON	18 OHM 1/4W	1	EA
R637	CRD25FJ180T	RES , CARBON	18 OHM 1/4W	1	EA
R638	CRD25FJ180T	RES , CARBON	18 OHM 1/4W	1	EA
R639	CRD25FJ180T	RES , CARBON	18 OHM 1/4W	1	EA
R640	CRD25FJ180T	RES , CARBON	18 OHM 1/4W	1	EA
R646	CRD25FJ3R3T	RES , CARBON	3.3 OHM 1/4W J	1	EA
R647	CRD25FJ3R3T	RES , CARBON	3.3 OHM 1/4W J	1	EA
R648	CRD25FJ3R3T	RES , CARBON	3.3 OHM 1/4W J	1	EA
R649	CRD25FJ3R3T	RES , CARBON	3.3 OHM 1/4W J	1	EA
R650	CRD25FJ3R3T	RES , CARBON	3.3 OHM 1/4W J	1	EA
R651	CRD25FJ3R3T	RES , CARBON	3.3 OHM 1/4W J	1	EA
R652	CRD25FJ3R3T	RES , CARBON	3.3 OHM 1/4W J	1	EA
R653	CRD25FJ3R3T	RES , CARBON	3.3 OHM 1/4W J	1	EA

Ref. Designator	Part Number	Description		Qty	
MAIN PCB/HEATSINK		(CUP11911)			
R654	CRD25FJ3R3T	RES , CARBON	3.3 OHM 1/4W J	1	EA
R655	CRD25FJ3R3T	RES , CARBON	3.3 OHM 1/4W J	1	EA
R666	CRD25TJ470T	RES , CARBON	47 OHM 1/4W	1	EA
R667	CRD25TJ470T	RES , CARBON	47 OHM 1/4W	1	EA
R668	CRD25TJ470T	RES , CARBON	47 OHM 1/4W	1	EA
R669	CRD25TJ470T	RES , CARBON	47 OHM 1/4W	1	EA
R670	CRD25TJ470T	RES , CARBON	47 OHM 1/4W	1	EA
R671	CRD20TJ911T	RES , CARBON	910 OHM 1/5W J	1	EA
R672	CRD20TJ911T	RES , CARBON	910 OHM 1/5W J	1	EA
R673	CRD20TJ911T	RES , CARBON	910 OHM 1/5W J	1	EA
R674	CRD20TJ911T	RES , CARBON	910 OHM 1/5W J	1	EA
R675	CRD20TJ911T	RES , CARBON	910 OHM 1/5W J	1	EA
R676	CRD20TJ182T	RES , CARBON	1.8K OHM 1/5W J	1	EA
R677	CRD20TJ182T	RES , CARBON	1.8K OHM 1/5W J	1	EA
R678	CRD20TJ182T	RES , CARBON	1.8K OHM 1/5W J	1	EA
R679	CRD20TJ182T	RES , CARBON	1.8K OHM 1/5W J	1	EA
R680	CRD20TJ182T	RES , CARBON	1.8K OHM 1/5W J	1	EA
R681	CRD20TJ562T	RES , CARBON	5.6K OHM 1/5W J	1	EA
R682	CRD20TJ562T	RES , CARBON	5.6K OHM 1/5W J	1	EA
R683	CRD20TJ562T	RES , CARBON	5.6K OHM 1/5W J	1	EA
R684	CRD20TJ562T	RES , CARBON	5.6K OHM 1/5W J	1	EA
R685	CRD20TJ562T	RES , CARBON	5.6K OHM 1/5W J	1	EA
R686	CRD20TJ103T	RES , CARBON	10K OHM 1/5W J	1	EA
R687	CRD20TJ103T	RES , CARBON	10K OHM 1/5W J	1	EA
R688	CRD20TJ103T	RES , CARBON	10K OHM 1/5W J	1	EA
R689	CRD20TJ103T	RES , CARBON	10K OHM 1/5W J	1	EA
R690	CRD20TJ103T	RES , CARBON	10K OHM 1/5W J	1	EA
R696	CRD25TJ470T	RES , CARBON	47 OHM 1/4W	1	EA
R697	CRD25TJ470T	RES , CARBON	47 OHM 1/4W	1	EA
R698	CRD25TJ470T	RES , CARBON	47 OHM 1/4W	1	EA
R699	CRD25TJ470T	RES , CARBON	47 OHM 1/4W	1	EA
R700	CRD25TJ470T	RES , CARBON	47 OHM 1/4W	1	EA
R706	C3A206	WIRE , COPPER	SN95/PB5 , 0.6		
R771	CRD20TJ750T	RES , CARBON	75 OHM 1/5W J	1	EA
R772	CRD20TJ750T	RES , CARBON	75 OHM 1/5W J	1	EA
R773	CRD20TJ750T	RES , CARBON	75 OHM 1/5W J	1	EA
R774	CRD20TJ750T	RES , CARBON	75 OHM 1/5W J	1	EA
R775	CRD20TJ750T	RES , CARBON	75 OHM 1/5W J	1	EA
R781	CRD20TJ750T	RES , CARBON	75 OHM 1/5W J	1	EA
R782	CRD20TJ750T	RES , CARBON	75 OHM 1/5W J	1	EA
R783	CRD20TJ750T	RES , CARBON	75 OHM 1/5W J	1	EA
R784	CRD20TJ750T	RES , CARBON	75 OHM 1/5W J	1	EA
R785	CRD20TJ750T	RES , CARBON	75 OHM 1/5W J	1	EA
R900	CRD20TJ103T	RES , CARBON	10K OHM 1/5W J	1	EA
R901	CRD25TJ393T	RES , CARBON	39K OHM 1/4W	1	EA
R902	CRD25TJ393T	RES , CARBON	39K OHM 1/4W	1	EA
R903	CRD25TJ393T	RES , CARBON	39K OHM 1/4W	1	EA
R906	CRD25TJ393T	RES , CARBON	39K OHM 1/4W	1	EA
R907	CRD20TJ103T	RES , CARBON	10K OHM 1/5W J	1	EA
R910	CRD20TJ105T	RES , CARBON	1M OHM 1/5W J	1	EA
R911	CRD25TJ680T	RES , CARBON	68 OHM 1/4W J	1	EA
R912	CRD20TJ332T	RES , CARBON	3.3K OHM 1/5W J	1	EA
R917	CRD25TJ393T	RES , CARBON	39K OHM 1/4W	1	EA
R918	CRD25TJ393T	RES , CARBON	39K OHM 1/4W	1	EA
R919	CRD25TJ393T	RES , CARBON	39K OHM 1/4W	1	EA
R920	CRD25TJ393T	RES , CARBON	39K OHM 1/4W	1	EA
R932	CRD20TJ103T	RES , CARBON	10K OHM 1/5W J	1	EA
R939	CRD20TJ472T	RES , CARBON	4.7K OHM 1/5W J	1	EA
R940	CRD20TJ152T	RES , CARBON	1.5K OHM 1/5W J	1	EA
R941	CRD20TJ223T	RES , CARBON	22K OHM 1/5W J	1	EA
R942	CRD20TJ223T	RES , CARBON	22K OHM 1/5W J	1	EA

Ref. Designator	Part Number	Description		Qty	
MAIN PCB/HEATSINK		(CUP11911)			
R944	CRD25TJ223T	RES , CARBON	22K OHM 1/4W J	1	EA
R946	CRD25TJ223T	RES , CARBON	22K OHM 1/4W J	1	EA
R947	CRD20TJ223T	RES , CARBON	22K OHM 1/5W J	1	EA
R948	CRD25TJ222T	RES , CARBON	2.2K OHM 1/4W J	1	EA
R949	CRD20TJ822T	RES , CARBON	8.2K OHM 1/5W J	1	EA
R955	CRD20TJ203T	RES , CARBON	20K OHM 1/5W J	1	EA
R956	CRD20TJ394T	RES , CARBON	390K OHM 1/5W J	1	EA
R957	CRD20TJ153T	RES , CARBON	15K OHM 1/5W J	1	EA
R960	CRD20TJ332T	RES , CARBON	3.3K OHM 1/5W J	1	EA
R961	CRD20TJ331T	RES , CARBON	330 OHM 1/5W J	1	EA
R962	CRD20TJ273T	RES , CARBON	27K OHM 1/5W J	1	EA
R963	CRD20TJ105T	RES , CARBON	1M OHM 1/5W J	1	EA
R966	CRD20TJ472T	RES , CARBON	4.7K OHM 1/5W J	1	EA
R980	CRD20TJ473T	RES , CARBON	47K OHM 1/5W J	1	EA
R986	CRD20TJ102T	RES , CARBON	1K OHM 1/5W J	1	EA
R987	CRD20TJ561T	RES , CARBON	560 OHM 1/5W J	1	EA
R988	CRD20TJ562T	RES , CARBON	5.6K OHM 1/5W J	1	EA
R989	CRD20TJ302T	RES , CARBON	3K OHM 1/5W J	1	EA
R991	CRD20TJ822T	RES , CARBON	8.2K OHM 1/5W J	1	EA
R992	CRD20TJ562T	RES , CARBON	5.6K OHM 1/5W J	1	EA
R998	CRD20TJ103T	RES , CARBON	10K OHM 1/5W J	1	EA
R656	CRF5EKR27HX2K	RES , CEMENT	0.27ohm X 2	1	EA
R657	CRF5EKR27HX2K	RES , CEMENT	0.27ohm X 2	1	EA
R658	CRF5EKR27HX2K	RES , CEMENT	0.27ohm X 2	1	EA
R659	CRF5EKR27HX2K	RES , CEMENT	0.27ohm X 2	1	EA
R660	CRF5EKR27HX2K	RES , CEMENT	0.27ohm X 2	1	EA
R904	HRDERC12UGK335T	RES , CARBON	ERC12UGK 3.3M OHM	1	EA
R905	CRG1ANJ100H	RES , METAL OXIDE FILM	10 OHM 1W J	1	EA
R990	CRG1ANJ100H	RES , METAL OXIDE FILM	10 OHM 1W J	1	EA
R993	CRG1ANJ100H	RES , METAL OXIDE FILM	10 OHM 1W J	1	EA
R995	CRG1ANJ100H	RES , METAL OXIDE FILM	10 OHM 1W J	1	EA
R997	CRG1ANJ100H	RES , METAL OXIDE FILM	10 OHM 1W J	1	EA
R999	CRG1ANJ100H	RES , METAL OXIDE FILM	10 OHM 1W J	1	EA
<i>Miscellaneous</i>					
BN19	CWB3FE03250UP	WIRE ASS'Y	WIRE	1	EA
BN20	CWB3FC04280UP	WIRE ASS'Y	WIRE	1	EA
BN82	CWB1C902050EN	WIRE ASS'Y	WIRE	1	EA
BN83	CWB1C902050EN	WIRE ASS'Y	WIRE	1	EA
BN84	CWB1C902050EN	WIRE ASS'Y	WIRE	1	EA
BN85	CWB1C902050EN	WIRE ASS'Y	WIRE	1	EA
BN86	CWB1C902050EN	WIRE ASS'Y	WIRE	1	EA
BN89	CWB1C902250BM	WIRE ASS'Y	WIRE	1	EA
BN90	CWB4F232550PU	WIRE ASS'Y	WIRE	1	EA
BN98	HJP08GA130ZK	WAFER	WAFER	1	EA
CN11	CJP13GA117ZY	WAFER , CARD CABLE	WAFER	1	EA
CN12	CJP21GA115ZY	WAFER , CARD CABLE	WAFER	1	EA
CN61	CJP02GA01ZY	WAFER, STRAIGHT, 2PIN	WAFER	1	EA
CN62	CJP02GA01ZY	WAFER, STRAIGHT, 2PIN	WAFER	1	EA
CN63	CJP02GA01ZY	WAFER, STRAIGHT, 2PIN	WAFER	1	EA
CN64	CJP02GA01ZY	WAFER, STRAIGHT, 2PIN	WAFER	1	EA
CN65	CJP02GA01ZY	WAFER, STRAIGHT, 2PIN	WAFER	1	EA
CN91	CJP02GA89ZY	WAFER	WAFER	1	EA
CN92	KJP02KA060ZY	WAFER	WAFER	1	EA
ET90	HJT1A025	PLATE , EARTH	MET37-0002	1	EA
ET91	HJT1A025	PLATE , EARTH	MET37-0002	1	EA
	KJCF5S	HOLDER , FUSE	HOLDER	2	EA
F902	KBA2D2500TLET	FUSE(SR-5,2.5A,250V)	SAVE FUSETECH	1	EA
JK90	CJJ4M040Z	JACK , BOARD (SW)	JACK	1	EA
JK91	CJJ5R006Z	TERMINAL , SPEAKER	TERMINAL	1	EA

Ref. Designator	Part Number	Description		Qty	
MAIN PCB/HEATSINK		(CUP11911)			
JK92	CJJ5P020Z	TERMINAL , SPEAKER	TERMINAL	1	EA
JW90	CWE8212120VV	WIRE , RED	WIRE	1	EA
JW91	CWE8212180VV	WIRE ASS'Y	WIRE	1	EA
JW92	CWEE212080VV	WIRE ASS'Y	WIRE	1	EA
JW93	CWEP202110VV	WIRE	WIRE	1	EA
L501	CLEY0R5KAK	COIL , SPEAKER	0.5UH	1	EA
L502	CLEY0R5KAK	COIL , SPEAKER	0.5UH	1	EA
L503	CLEY0R5KAK	COIL , SPEAKER	0.5UH	1	EA
L504	CLEY0R5KAK	COIL , SPEAKER	0.5UH	1	EA
L505	CLEY0R5KAK	COIL , SPEAKER	0.5UH	1	EA
OL91	KJJ7A013Z	AC OUTLET , 1PIN USA	A202D0031P(1P)	1	EA
ET01	CMD1A387	BRACKET , PCB	BRACKET	1	EA
RY94	HSL1A008ZE	RELAY(+12VDC)	SDT-S-112DMR	1	EA
TH91	KRTP42T7D330B	THERMAL SENSOR , POSISTOR	P42T7D330BW20	1	EA
T902	CLT5J033ZU	TRANS , SUB	SR-68	1	EA
	CHD3A012R	SCREW , SPECIAL	ASS'Y	3	EA
	CTW3+8JR	SCREW	SCREW	2	EA
HEAT SINK ASS'Y		CMYAVR147			
	CHD1A012R	SCREW , SPECIAL	SCREW	15	EA
	CHD3A012R	SCREW , SPECIAL	SCREW	4	EA
	CMD1A398	BRACKET , PCB	BRACKET	2	EA
	CMD1A417	BRACKET , PCB	BRACKET	2	EA
	CMY1A249	HEAT SINK	HEAT SINK	1	EA
	CMY2A269	HEAT SINK	HEAT SINK	1	EA
	CTB3+10JR	SCREW	SCREW	3	EA
	CTB3+8JR	SCREW	SCREW	6	EA
Q652	HVT2SB1560-OKM	TRANSISTOR , POWER, PNP	2SB1560	1	EA
Q653	HVT2SB1560-OKM	TRANSISTOR , POWER, PNP	2SB1560	1	EA
Q654	HVT2SB1560-OKM	TRANSISTOR , POWER, PNP	2SB1560	1	EA
Q655	HVT2SB1560-OKM	TRANSISTOR , POWER, PNP	2SB1560	1	EA
Q657	HVT2SD2390-OKM	TRANSISTOR , POWER, NPN	2SD2390	1	EA
Q658	HVT2SD2390-OKM	TRANSISTOR , POWER, NPN	2SD2390	1	EA
Q659	HVT2SD2390-OKM	TRANSISTOR , POWER, NPN	2SD2390	1	EA
Q660	HVT2SD2390-OKM	TRANSISTOR , POWER, NPN	2SD2390	1	EA
Q661	HVT2SB1560-OKM	TRANSISTOR , POWER, PNP	2SB1560	1	EA
Q670	HVT2SD2390-OKM	TRANSISTOR , POWER, NPN	2SD2390	1	EA
PCB , POWER TRANS		CUP11916-3,4			
<i>Capacitors</i>					
C104	HCBS1H103ZFT	CAP , CERAMIC	0.01UF 50V	1	EA
C105	HCBS1H103ZFT	CAP , CERAMIC	0.01UF 50V	1	EA
C106	CCFT1H104ZF	CAP , SEMICONDUCTOR	0.1UF 50V ZF	1	EA
C107	HCBS1H103ZFT	CAP , CERAMIC	0.01UF 50V	1	EA
C108	HCBS1H103ZFT	CAP , CERAMIC	0.01UF 50V	1	EA
C109	CCFT1H104ZF	CAP , SEMICONDUCTOR	0.1UF 50V ZF	1	EA
C117	CCEA1HH4R7T	CAP , ELECT	4.7UF 50V	1	EA
C118	HCBS1H103ZFT	CAP , CERAMIC	0.01UF 50V	1	EA
C119	CCEA1JH470TS	CAP , ELECT	47UF 50V	1	EA
C120	CCEA1JH470TS	CAP , ELECT	47UF 50V	1	EA
C121	HCBS1H103ZFT	CAP , CERAMIC	0.01UF 50V	1	EA
C123	CCFT1H473ZF	CAP , CERAMIC	0.047UF 50V ZF	1	EA
C125	CCFT1H473ZF	CAP , CERAMIC	0.047UF 50V ZF	1	EA
C126	CCFT1H473ZF	CAP , CERAMIC	0.047UF 50V ZF	1	EA
C127	CCFT1H473ZF	CAP , CERAMIC	0.047UF 50V ZF	1	EA
C131	CCEA1HH4R7T	CAP , ELECT	4.7UF 50V	1	EA
C919	CCKT1H102KB	CAP , CERAMIC	1000PF 50V	1	EA
C920	CCEA1HH470T	CAP , ELECT	47UF 50V	1	EA

Ref. Designator	Part Number	Description		Qty	
PCB , POWER TRANS		CUP11916-3,4			
C921	HCQI1H104JZT	CAP , MYLAR	0.1UF 50V J	1	EA
C922	HCQI1H104JZT	CAP , MYLAR	0.1UF 50V J	1	EA
C923	HCQI1H104JZT	CAP , MYLAR	0.1UF 50V J	1	EA
C924	HCQI1H104JZT	CAP , MYLAR	0.1UF 50V J	1	EA
C925	HCQI1H103JZT	CAP , MYLAR	0.01UF 50V J	1	EA
C926	HCQI1H103JZT	CAP , MYLAR	0.01UF 50V J	1	EA
C927	HCQI1H103JZT	CAP , MYLAR	0.01UF 50V J	1	EA
C928	HCQI1H103JZT	CAP , MYLAR	0.01UF 50V J	1	EA
C931	HCQI1H473JZT	CAP , MYLAR	0.047UF 50V J	1	EA
C932	HCQI1H473JZT	CAP , MYLAR	0.047UF 50V J	1	EA
C933	HCQI1H473JZT	CAP , MYLAR	0.047UF 50V J	1	EA
C934	HCQI1H473JZT	CAP , MYLAR	0.047UF 50V J	1	EA
C122	CCEA1JH101E	CAP , ELECT	100UF 63V	1	EA
C124	CCEA1VH102E	CAP , ELECT	1000UF 35V	1	EA
C128	CCEA1EH102E	CAP , ELECT	1000UF 25V	1	EA
C129	CCEA1EH222E	CAP , ELECT	2200UF 25V	1	EA
C130	CCEA1EH102E	CAP , ELECT	1000UF 25V	1	EA
<i>Semiconductors</i>					
D101	HVDMTZJ15BT	DIODE , ZENER	MTZJ15B 1/2W	1	EA
D102	HVDMTZJ27BT	DIODE , ZENER	MTZJ27B 1/2W	1	EA
D104	CVD1N4003ST	RECT , DIODE	1N4003	1	EA
D105	CVD1N4003ST	RECT , DIODE	1N4003	1	EA
D108	CVD1N4003ST	RECT , DIODE	1N4003	1	EA
D109	HVDMTZJ12BT	DIODE , ZENER	MTZJ12B 1/2W	1	EA
D111	HVDMTZJ12BT	DIODE , ZENER	MTZJ12B 1/2W	1	EA
D112	CVD1N4003ST	RECT , DIODE	1N4003	1	EA
D113	CVD1N4003ST	RECT , DIODE	1N4003	1	EA
D114	CVD1N4003ST	RECT , DIODE	1N4003	1	EA
D115	CVD1N4003ST	RECT , DIODE	1N4003	1	EA
D116	CVD1N4003ST	RECT , DIODE	1N4003	1	EA
D117	CVD1N4003ST	RECT , DIODE	1N4003	1	EA
D118	CVD1N4003ST	RECT , DIODE	1N4003	1	EA
D119	CVD1N4003ST	RECT , DIODE	1N4003	1	EA
D120	CVD1N4003ST	RECT , DIODE	1N4003	1	EA
D121	CVD1N4003ST	RECT , DIODE	1N4003	1	EA
D122	CVD1N4003ST	RECT , DIODE	1N4003	1	EA
D123	CVD1N4003ST	RECT , DIODE	1N4003	1	EA
D124	CVD1N4003ST	RECT , DIODE	1N4003	1	EA
D125	CVD1N4003ST	RECT , DIODE	1N4003	1	EA
Q104	HVTKSC2316YT	TRANSISTOR NPN	KSC2316Y	1	EA
Q911	HVTKTA1267YT	TRANSISTOR PNP	KTA1267Y	1	EA
Q912	HVTKTC3198YT	TRANSISTOR NPN	KTC3198Y	1	EA
Q913	HVTKTC3198YT	TRANSISTOR NPN	KTC3198Y	1	EA
D991	CVDKBU804FMA	BRIDGE DIODE ASS'Y	ASS'Y	1	EA
D992	CVDKBU804FMA	BRIDGE DIODE ASS'Y	ASS'Y	1	EA
	HVDKBU804F	DIODE , BRIDGE	KBU804F	1	EA
	HVDKBU804F	DIODE , BRIDGE	KBU804F	1	EA
<i>Resistors</i>					
R101	CRD25FJ3R3T	RES , CARBON	3.3 OHM 1/4W J	1	EA
R108	CRD20TJ4R7T	RES , CARBON	4.7 OHM 1/5W J	1	EA
R109	CRD20TJ100T	RES , CARBON	10 OHM 1/5W J	1	EA
R110	CRD20TJ4R7T	RES , CARBON	4.7 OHM 1/5W J	1	EA
R112	CRD20TJ122T	RES , CARBON	1.2K OHM 1/5W J	1	EA
R113	CRD20TJ473T	RES , CARBON	47K OHM 1/5W J	1	EA
R120	CRD20TJ103T	RES , CARBON	10K OHM 1/5W J	1	EA
R912	CRD20TJ153T	RES , CARBON	15K OHM 1/5W J	1	EA
R913	CRD20TJ153T	RES , CARBON	15K OHM 1/5W J	1	EA

Ref. Designator	Part Number	Description		Qty	
PCB , POWER TRANS		CUP11916-3,4			
R917	CRD20TJ153T	RES , CARBON	15K OHM 1/5W J	1	EA
R918	CRD20TJ153T	RES , CARBON	15K OHM 1/5W J	1	EA
R919	CRD20TJ153T	RES , CARBON	15K OHM 1/5W J	1	EA
R920	CRD20TJ153T	RES , CARBON	15K OHM 1/5W J	1	EA
R921	CRD20TJ153T	RES , CARBON	15K OHM 1/5W J	1	EA
R922	CRD20TJ153T	RES , CARBON	15K OHM 1/5W J	1	EA
R923	CRD25TJ153T	RES , CARBON	15K OHM 1/4W J	1	EA
R924	CRD20TJ153T	RES , CARBON	15K OHM 1/5W J	1	EA
R925	CRD20TJ103T	RES , CARBON	10K OHM 1/5W J	1	EA
R926	CRD25TJ103T	RES , CARBON	10K OHM 1/4W J	1	EA
R927	CRD20TJ104T	RES , CARBON	100K OHM 1/5W J	1	EA
R928	CRD20TJ333T	RES , CARBON	33K OHM 1/5W J	1	EA
R104	KRQ1AJR47H	RES , FUSE	0.47 OHM 1W J	1	EA
R105	KRQ1AJR47H	RES , FUSE	0.47 OHM 1W J	1	EA
R106	CRQ1AJR33H	RES , FUSE	0.33 OHM 1W J	1	EA
R107	CRQ1AJR33H	RES , FUSE	0.33 OHM 1W J	1	EA
R114	KRQ1AJR47H	RES , FUSE	0.47 OHM 1W J	1	EA
R115	KRQ1AJR47H	RES , FUSE	0.47 OHM 1W J	1	EA
R116	CRQ1AJR33H	RES , FUSE	0.33 OHM 1W J	1	EA
R117	CRQ1AJR33H	RES , FUSE	0.33 OHM 1W J	1	EA
R118	CRQ1AJR33H	RES , FUSE	0.33 OHM 1W J	1	EA
R119	CRQ1AJR33H	RES , FUSE	0.33 OHM 1W J	1	EA
<i>Miscellaneous</i>					
BN43	CWB1C903200BM	WIRE ASS'Y	WIRE	1	EA
BN96	CWB1C909150BM	WIRE ASS'Y	WIRE	1	EA
BN99	CWB1B908270EN	WIRE ASS'Y	WIRE	1	EA
CN13	CJP05GA01ZY	CON WAFER YMW025-05R	WAFER	1	EA
CN19	CJP03GA90ZY	WAFER	WAFER	1	EA
CN20	CJP04GA90ZM	WAFER	WAFER	1	EA
CN81	CJP08GA01ZY	WAFER, STRAIGHT, 8PIN	WAFER	1	EA
	CMY1A219	HEAT SINK (BRIDGE DIODE)	HEAT SINK	1	EA
	CTB3+12JR	SCREW	SCREW	1	EA
	CMY1A219	HEAT SINK (BRIDGE DIODE)	HEAT SINK	1	EA
	CTB3+12JR	SCREW	SCREW	1	EA
PCB , DIGITAL IN/OUT		CUP11916-1			
BN17	KJP12GB143ZP	DIP SOCKET	DIP SOCKET	1	EA
C750	CCEA1CH101T	CAP , ELECT	100UF 16V	1	EA
C751	CCEA1CH101T	CAP , ELECT	100UF 16V	1	EA
C753	HCBS1H181KBT	CAP , CERAMIC	180PF 50V	1	EA
C754	HCBS1H181KBT	CAP , CERAMIC	180PF 50V	1	EA
C756	CCFT1H104ZF	CAP , SEMICONDUCTOR	0.1UF 50V ZF	1	EA
C757	CCFT1H104ZF	CAP , SEMICONDUCTOR	0.1UF 50V ZF	1	EA
C759	HCBS1H101KBT	CAP , CERAMIC	100PF 50V	1	EA
C760	CCFT1H473ZF	CAP , CERAMIC	0.047UF 50V ZF	1	EA
C761	CCEA1CH101T	CAP , ELECT	100UF 16V	1	EA
C762	CCEA1CH101T	CAP , ELECT	100UF 16V	1	EA
C763	CCFT1H104ZF	CAP , SEMICONDUCTOR	0.1UF 50V ZF	1	EA
IC72	HVI74HCU04AFNG	I.C , INVERTER	TOSHIBA	1	EA
R750	CRD20TJ103T	RES , CARBON	10K OHM 1/5W J	1	EA
R751	CRD20TJ103T	RES , CARBON	10K OHM 1/5W J	1	EA
R756	CRD20TJ750T	RES , CARBON	75 OHM 1/5W J	1	EA
R757	CRD20TJ750T	RES , CARBON	75 OHM 1/5W J	1	EA
R759	CRD20TJ100T	RES , CARBON	10 OHM 1/5W J	1	EA
R760	CRD20TJ241T	RES , CARBON	240OHM 1/5W J	1	EA
R761	CRD20TJ750T	RES , CARBON	75 OHM 1/5W J	1	EA
R764	CRD20TJ102T	RES , CARBON	1K OHM 1/5W J	1	EA
R765	CRD20TJ104T	RES , CARBON	100K OHM 1/5W J	1	EA

Ref. Designator	Part Number	Description		Qty	
PCB , DIGITAL IN/OUT		CUP11916-1			
R766	CRD20TJ472T	RES , CARBON	4.7K OHM 1/5W J	1	EA
R767	CRD20TJ472T	RES , CARBON	4.7K OHM 1/5W J	1	EA
R768	CRD20TJ472T	RES , CARBON	4.7K OHM 1/5W J	1	EA
R770	CRD20TJ104T	RES , CARBON	100K OHM 1/5W J	1	EA
R771	CRD20TJ102T	RES , CARBON	1K OHM 1/5W J	1	EA
R776	CRD20TJ104T	RES , CARBON	100K OHM 1/5W J	1	EA
JK74	HJSTOTX177L	MODULE , OPTICAL(TX)	OPT JACK(TX)	1	EA
JK75	HJSTORX177L	MODULE , OPTICAL(RX)	OPT JACK(RX)	1	EA
JK76	HJSTORX177L	MODULE , OPTICAL(RX)	OPT JACK(RX)	1	EA
JK78	CJJ4S022Z	JACK , BOARD	JACK	1	EA
PCB , BIAS TR		CUP11916-2			
C851	CCEA1HH100T	CAP , ELECT	10UF 50V	1	EA
C852	CCEA1HH100T	CAP , ELECT	10UF 50V	1	EA
C853	CCEA1HH100T	CAP , ELECT	10UF 50V	1	EA
C854	CCEA1HH100T	CAP , ELECT	10UF 50V	1	EA
C855	CCEA1HH100T	CAP , ELECT	10UF 50V	1	EA
CN31	CJP02GA19ZY	WAFER, 2PIN	WAFER	1	EA
CN32	CJP02GA19ZY	WAFER, 2PIN	WAFER	1	EA
CN33	CJP02GA19ZY	WAFER, 2PIN	WAFER	1	EA
CN34	CJP02GA19ZY	WAFER, 2PIN	WAFER	1	EA
CN35	CJP02GA19ZY	WAFER, 2PIN	WAFER	1	EA
Q851	HVTKTD600KGR	TRANSISTOR , BIAS, NPN	KTD600KGR	1	EA
Q852	HVTKTD600KGR	TRANSISTOR , BIAS, NPN	KTD600KGR	1	EA
Q853	HVTKTD600KGR	TRANSISTOR , BIAS, NPN	KTD600KGR	1	EA
Q854	HVTKTD600KGR	TRANSISTOR , BIAS, NPN	KTD600KGR	1	EA
Q855	HVTKTD600KGR	TRANSISTOR , BIAS, NPN	KTD600KGR	1	EA
R874	CRD20TJ331T	RES , CARBON	330 OHM 1/5W J	1	EA
R875	CRD20TJ331T	RES , CARBON	330 OHM 1/5W J	1	EA
R876	CRD20TJ331T	RES , CARBON	330 OHM 1/5W J	1	EA
R877	CRD20TJ331T	RES , CARBON	330 OHM 1/5W J	1	EA
R878	CRD20TJ331T	RES , CARBON	330 OHM 1/5W J	1	EA
R882	CRD20TJ122T	RES , CARBON	1.2K OHM 1/5W J	1	EA
R883	CRD20TJ122T	RES , CARBON	1.2K OHM 1/5W J	1	EA
R884	CRD20TJ122T	RES , CARBON	1.2K OHM 1/5W J	1	EA
R885	CRD20TJ122T	RES , CARBON	1.2K OHM 1/5W J	1	EA
R886	CRD20TJ122T	RES , CARBON	1.2K OHM 1/5W J	1	EA
VR81	HVN1RA221B01T	RES , SEMI FIXED(220 OHM)	RH0615C100221	1	EA
VR82	HVN1RA221B01T	RES , SEMI FIXED(220 OHM)	RH0615C100221	1	EA
VR83	HVN1RA221B01T	RES , SEMI FIXED(220 OHM)	RH0615C100221	1	EA
VR84	HVN1RA221B01T	RES , SEMI FIXED(220 OHM)	RH0615C100221	1	EA
VR85	HVN1RA221B01T	RES , SEMI FIXED(220 OHM)	RH0615C100221	1	EA
PCB , REGULATOR		CUP11916-5,6			
<i>Capacitors</i>					
C901	HCBS1H223ZFT	CAP , CERAMIC	0.022UF 50V	1	EA
C902	HCBS1H223ZFT	CAP , CERAMIC	0.022UF 50V	1	EA
C903	HCBS1H223ZFT	CAP , CERAMIC	0.022UF 50V	1	EA
C905	CCEA1CH101T	CAP , ELECT	100UF 16V	1	EA
C906	CCEA1CH101T	CAP , ELECT	100UF 16V	1	EA
C907	CCEA1CH101T	CAP , ELECT	100UF 16V	1	EA
C908	CCEA1CH101T	CAP , ELECT	100UF 16V	1	EA
C910	CCEA1VH221T	CAP , ELECT	220UF 35V	1	EA
C911	CCEA1EH471E	CAP , ELECT	470UF/25V	1	EA
C935	HCBS1H223ZFT	CAP , CERAMIC	0.022UF 50V	1	EA
C936	HCBS1H223ZFT	CAP , CERAMIC	0.022UF 50V	1	EA
C937	HCBS1H223ZFT	CAP , CERAMIC	0.022UF 50V	1	EA
C938	CCEA1CH101T	CAP , ELECT	100UF 16V	1	EA

Ref. Designator	Part Number	Description		Qty	
PCB , REGULATOR		CUP11916-5,6			
C939	CCEA1EH101T	CAP , ELECT	100UF 25V	1	EA
C940	CCEA1EH101T	CAP , ELECT	100UF 25V	1	EA
C912	CCEA0JKR3222E	CAP , ELECT	2200UF 6.3V	1	EA
C929	CCEA1VH102E	CAP , ELECT	1000UF 35V	1	EA
C930	CCEA1VH102E	CAP , ELECT	1000UF 35V	1	EA
C941	CCEA1CH682E	CAP , ELECT	6800UF 16V	1	EA
<i>Semiconductors</i>					
IC89	HVIL7805CP	I.C, REGULATOR(+5V)	ST	1	EA
IC90	HVIL7815CP	I.C, REGULATOR(+15V)	ST	1	EA
IC91	HVIL7915CP	I.C, REGULATOR(-15V)	ST	1	EA
IC92	HVIL7805CP	I.C, REGULATOR(+5V)	ST	1	EA
IC93	HVIL7905CP	I.C, REGULATOR(-5V)	ST	1	EA
IC94	HVIL7805CP	I.C, REGULATOR(+5V)	ST	1	EA
IC95	HVIL7812CP	I.C , REGULATOR(+12V)	ST	1	EA
D901	HVD1N5819T	DIODE , SCHOTTKY	1N5819	1	EA
<i>Miscellaneous</i>					
BN20	CWB1C905200BM	WIRE ASS'Y	WIRE	1	EA
BN95	CWB1C903080EN	WIRE ASS'Y	WIRE	1	EA
CN85	CJP02GA01ZY	WAFER, STRAIGHT, 2PIN	WAFER	1	EA
CN89	CJP02GA01ZY	WAFER, STRAIGHT, 2PIN	WAFER	1	EA
CN95	CJP03GA19ZY	WAFER, STRAIGHT, 3PIN	WAFER	1	EA
CN96	CJP09GA01ZY	CON WAFER YMW025-09R	WAFER	1	EA
CN98	HJP08GB131ZK	WAFER	WAFER	1	EA
CN99	CJP08GA19ZY	WAFER, STRAIGHT, 8PIN	WAFER	1	EA
PCB , INPUT		CUP11912-1			
<i>Capacitors</i>					
C201	CCUS1H221JA	CAP , CHIP	220PF	1	EA
C202	CCUS1H221JA	CAP , CHIP	220PF	1	EA
C203	CCUS1H221JA	CAP , CHIP	220PF	1	EA
C204	CCUS1H221JA	CAP , CHIP	220PF	1	EA
C205	CCUS1H221JA	CAP , CHIP	220PF	1	EA
C206	CCUS1H221JA	CAP , CHIP	220PF	1	EA
C209	CCUS1H221JA	CAP , CHIP	220PF	1	EA
C210	CCUS1H221JA	CAP , CHIP	220PF	1	EA
C211	CCUS1H221JA	CAP , CHIP	220PF	1	EA
C212	CCUS1H221JA	CAP , CHIP	220PF	1	EA
C213	CCUS1H221JA	CAP , CHIP	220PF	1	EA
C214	CCUS1H221JA	CAP , CHIP	220PF	1	EA
C215	CCUS1H221JA	CAP , CHIP	220PF	1	EA
C216	CCUS1H221JA	CAP , CHIP	220PF	1	EA
C219	CCUS1H221JA	CAP , CHIP	220PF	1	EA
C220	CCUS1H221JA	CAP , CHIP	220PF	1	EA
C221	CCUS1H221JA	CAP , CHIP	220PF	1	EA
C222	CCUS1H221JA	CAP , CHIP	220PF	1	EA
C223	CCUS1H221JA	CAP , CHIP	220PF	1	EA
C224	CCUS1H221JA	CAP , CHIP	220PF	1	EA
C260	CCUS1H104KC	CAP , CHIP	0.1UF	1	EA
C269	CCUS1A105KC	CAP , CHIP	1UF	1	EA
C274	CCUS1A105KC	CAP , CHIP	1UF	1	EA
C277	CCUS1H104KC	CAP , CHIP	0.1UF	1	EA
C279	CCUS1H104KC	CAP , CHIP	0.1UF	1	EA
C280	CCUS1H104KC	CAP , CHIP	0.1UF	1	EA
C289	CCUS1H104KC	CAP , CHIP	0.1UF	1	EA
C290	CCUS1H104KC	CAP , CHIP	0.1UF	1	EA

Ref. Designator	Part Number	Description		Qty	
PCB , INPUT		CUP11912-1			
C291	CCUS1H104KC	CAP , CHIP	0.1UF	1	EA
C293	CCUS1H104KC	CAP , CHIP	0.1UF	1	EA
C299	CCUS1H104KC	CAP , CHIP	0.1UF	1	EA
C301	CCUS1H471JA	CAP , CHIP	470PF	1	EA
C302	CCUS1H471JA	CAP , CHIP	470PF	1	EA
C303	CCUS1H471JA	CAP , CHIP	470PF	1	EA
C304	CCUS1H471JA	CAP , CHIP	470PF	1	EA
C305	CCUS1H471JA	CAP , CHIP	470PF	1	EA
C306	CCUS1H471JA	CAP , CHIP	470PF	1	EA
C309	CCUS1H332KC	CAP , CHIP	3300PF	1	EA
C310	CCUS1H332KC	CAP , CHIP	3300PF	1	EA
C311	CCUS1H332KC	CAP , CHIP	3300PF	1	EA
C312	CCUS1H332KC	CAP , CHIP	3300PF	1	EA
C313	CCUS1H332KC	CAP , CHIP	3300PF	1	EA
C314	CCUS1H332KC	CAP , CHIP	3300PF	1	EA
C317	CCUS1H223KC	CAP , CHIP	0.022UF	1	EA
C318	CCUS1H223KC	CAP , CHIP	0.022UF	1	EA
C319	CCUS1H223KC	CAP , CHIP	0.022UF	1	EA
C321	CCUS1H561JA	CAP , CHIP	560PF	1	EA
C322	CCUS1H561JA	CAP , CHIP	560PF	1	EA
C323	CCUS1H561JA	CAP , CHIP	560PF	1	EA
C324	CCUS1H561JA	CAP , CHIP	560PF	1	EA
C325	CCUS1H561JA	CAP , CHIP	560PF	1	EA
C326	CCUS1H561JA	CAP , CHIP	560PF	1	EA
C327	CCUS1H561JA	CAP , CHIP	560PF	1	EA
C328	CCUS1H561JA	CAP , CHIP	560PF	1	EA
C329	CCUS1H561JA	CAP , CHIP	560PF	1	EA
C330	CCUS1H561JA	CAP , CHIP	560PF	1	EA
C331	CCUS1H561JA	CAP , CHIP	560PF	1	EA
C332	CCUS1H561JA	CAP , CHIP	560PF	1	EA
C337	CCUS1H223KC	CAP , CHIP	0.022UF	1	EA
C338	CCUS1H223KC	CAP , CHIP	0.022UF	1	EA
C339	CCUS1H223KC	CAP , CHIP	0.022UF	1	EA
C350	CCUS1H332KC	CAP , CHIP	3300PF	1	EA
C351	CCUS1H332KC	CAP , CHIP	3300PF	1	EA
C352	CCUS1H332KC	CAP , CHIP	3300PF	1	EA
C353	CCUS1H332KC	CAP , CHIP	3300PF	1	EA
C354	CCUS1H332KC	CAP , CHIP	3300PF	1	EA
C355	CCUS1H332KC	CAP , CHIP	3300PF	1	EA
C369	CCUS1H223KC	CAP , CHIP	0.022UF	1	EA
C370	CCUS1H223KC	CAP , CHIP	0.022UF	1	EA
C381	CCUS1H223KC	CAP , CHIP	0.022UF	1	EA
C382	CCUS1H223KC	CAP , CHIP	0.022UF	1	EA
C383	CCUS1H223KC	CAP , CHIP	0.022UF	1	EA
C384	CCUS1H223KC	CAP , CHIP	0.022UF	1	EA
C385	CCUS1H223KC	CAP , CHIP	0.022UF	1	EA
C386	CCUS1H223KC	CAP , CHIP	0.022UF	1	EA
C391	CCUS1H151JA	CAP , CHIP	150PF	1	EA
C392	CCUS1H151JA	CAP , CHIP	150PF	1	EA
C393	CCUS1H151JA	CAP , CHIP	150PF	1	EA
C394	CCUS1H102KC	CAP , CHIP	1000PF	1	EA
C395	CCUS1H151JA	CAP , CHIP	150PF	1	EA
C396	CCUS1H151JA	CAP , CHIP	150PF	1	EA
C400	CCUS1H104KC	CAP , CHIP	0.1UF	1	EA
C401	CCUS1H104KC	CAP , CHIP	0.1UF	1	EA
C402	CCUS1H471JA	CAP , CHIP	470PF	1	EA
C403	CCUS1H471JA	CAP , CHIP	470PF	1	EA
C601	CCUS1H104KC	CAP , CHIP	0.1UF	1	EA
C603	CCUS1H104KC	CAP , CHIP	0.1UF	1	EA
C605	CCUS1H104KC	CAP , CHIP	0.1UF	1	EA
C607	CCUS1H104KC	CAP , CHIP	0.1UF	1	EA

Ref. Designator	Part Number	Description		Qty	
PCB , INPUT		CUP11912-1			
C609	CCUS1H104KC	CAP , CHIP	0.1UF	1	EA
C611	CCUS1H104KC	CAP , CHIP	0.1UF	1	EA
C613	CCUS1H104KC	CAP , CHIP	0.1UF	1	EA
C615	CCUS1H104KC	CAP , CHIP	0.1UF	1	EA
C617	CCUS1H104KC	CAP , CHIP	0.1UF	1	EA
C619	CCUS1H104KC	CAP , CHIP	0.1UF	1	EA
C621	CCUS1H104KC	CAP , CHIP	0.1UF	1	EA
C623	CCUS1H104KC	CAP , CHIP	0.1UF	1	EA
C625	CCUS1H104KC	CAP , CHIP	0.1UF	1	EA
C627	CCUS1H104KC	CAP , CHIP	0.1UF	1	EA
C629	CCUS1H104KC	CAP , CHIP	0.1UF	1	EA
C631	CCUS1H104KC	CAP , CHIP	0.1UF	1	EA
C701	CCUS1H150JA	CAP , CHIP	15PF	1	EA
C702	CCUS1H150JA	CAP , CHIP	15PF	1	EA
C704	CCUS1H104KC	CAP , CHIP	0.1UF	1	EA
C705	CCUS1H104KC	CAP , CHIP	0.1UF	1	EA
C707	CCUS1H102KC	CAP , CHIP	1000PF	1	EA
C708	CCUS1H104KC	CAP , CHIP	0.1UF	1	EA
C718	CCUS1H104KC	CAP , CHIP	0.1UF	1	EA
C719	CCUS1H104KC	CAP , CHIP	0.1UF	1	EA
C722	CCUS1H104KC	CAP , CHIP	0.1UF	1	EA
C723	CCUS1H473KC	CAP , CHIP	0.047UF	1	EA
C725	CCUS1H104KC	CAP , CHIP	0.1UF	1	EA
C727	CCUS1H104KC	CAP , CHIP	0.1UF	1	EA
C729	CCUS1H104KC	CAP , CHIP	0.1UF	1	EA
C731	CCUS1H104KC	CAP , CHIP	0.1UF	1	EA
C733	CCUS1H104KC	CAP , CHIP	0.1UF	1	EA
C734	CCUS1H102KC	CAP , CHIP	1000PF	1	EA
C735	CCUS1H470JA	CAP , CHIP	47PF	1	EA
C738	CCUS1A105KC	CAP , CHIP	1UF	1	EA
C739	CCUS1H103KC	CAP , CHIP	0.01UF	1	EA
C741	CCUS1H104KC	CAP , CHIP	0.1UF	1	EA
C742	CCUS1H180JA	CAP , CHIP	18PF	1	EA
C743	CCUS1H104KC	CAP , CHIP	0.1UF	1	EA
C744	CCUS1H180JA	CAP , CHIP	18PF	1	EA
C745	CCUS1H104KC	CAP , CHIP	0.1UF	1	EA
C746	CCUS1H104KC	CAP , CHIP	0.1UF	1	EA
C747	CCUS1H104KC	CAP , CHIP	0.1UF	1	EA
C748	CCUS1H104KC	CAP , CHIP	0.1UF	1	EA
C751	CCUS1H104KC	CAP , CHIP	0.1UF	1	EA
C757	CCUS1H104KC	CAP , CHIP	0.1UF	1	EA
C758	CCUS1H104KC	CAP , CHIP	0.1UF	1	EA
C759	CCUS1H104KC	CAP , CHIP	0.1UF	1	EA
C760	CCUS1H104KC	CAP , CHIP	0.1UF	1	EA
C761	CCUS1H104KC	CAP , CHIP	0.1UF	1	EA
C762	CCUS1H104KC	CAP , CHIP	0.1UF	1	EA
C763	CCUS1H104KC	CAP , CHIP	0.1UF	1	EA
C765	CCUS1H104KC	CAP , CHIP	0.1UF	1	EA
C768	CCUS1H104KC	CAP , CHIP	0.1UF	1	EA
C769	CCUS1H104KC	CAP , CHIP	0.1UF	1	EA
C770	CCUS1H104KC	CAP , CHIP	0.1UF	1	EA
C771	CCUS1H104KC	CAP , CHIP	0.1UF	1	EA
C772	CCUS1H104KC	CAP , CHIP	0.1UF	1	EA
C773	CCUS1H104KC	CAP , CHIP	0.1UF	1	EA
C261	CCEA1EH470T	CAP , ELECT	47UF 25V	1	EA
C262	CCEA1EH470T	CAP , ELECT	47UF 25V	1	EA
C263	CCEA1EH470T	CAP , ELECT	47UF 25V	1	EA
C264	CCEA1EH470T	CAP , ELECT	47UF 25V	1	EA
C265	CCEA1EH470T	CAP , ELECT	47UF 25V	1	EA
C266	CCEA1EH470T	CAP , ELECT	47UF 25V	1	EA
C267	CCEA1EH470T	CAP , ELECT	47UF 25V	1	EA

Ref. Designator	Part Number	Description		Qty	
PCB , INPUT		CUP11912-1			
C268	CCEA1EH470T	CAP , ELECT	47UF 25V	1	EA
C272	CCEA1HH100T	CAP , ELECT	10UF 50V	1	EA
C273	CCEA1HH100T	CAP , ELECT	10UF 50V	1	EA
C275	CCEA1HH100T	CAP , ELECT	10UF 50V	1	EA
C276	CCEA1HH100T	CAP , ELECT	10UF 50V	1	EA
C281	CCEA1HH100T	CAP , ELECT	10UF 50V	1	EA
C282	CCEA1HH100T	CAP , ELECT	10UF 50V	1	EA
C283	CCEA1HH100T	CAP , ELECT	10UF 50V	1	EA
C284	CCEA1HH100T	CAP , ELECT	10UF 50V	1	EA
C285	CCEA1HH100T	CAP , ELECT	10UF 50V	1	EA
C286	CCEA1HH100T	CAP , ELECT	10UF 50V	1	EA
C292	CCEA1CH101T	CAP , ELECT	100UF 16V	1	EA
C294	CCEA1CH101T	CAP , ELECT	100UF 16V	1	EA
C341	CCEA1HH100T	CAP , ELECT	10UF 50V	1	EA
C342	CCEA1HH100T	CAP , ELECT	10UF 50V	1	EA
C343	CCEA1HH100T	CAP , ELECT	10UF 50V	1	EA
C344	CCEA1HH100T	CAP , ELECT	10UF 50V	1	EA
C345	CCEA1HH100T	CAP , ELECT	10UF 50V	1	EA
C346	CCEA1HH100T	CAP , ELECT	10UF 50V	1	EA
C349	CCEA1CH101T	CAP , ELECT	100UF 16V	1	EA
C358	CCEA1CH101T	CAP , ELECT	100UF 16V	1	EA
C359	CCEA1CH101T	CAP , ELECT	100UF 16V	1	EA
C360	CCEA1CH101T	CAP , ELECT	100UF 16V	1	EA
C371	CCEA1HH100T	CAP , ELECT	10UF 50V	1	EA
C372	CCEA1HH100T	CAP , ELECT	10UF 50V	1	EA
C373	CCEA1HH100T	CAP , ELECT	10UF 50V	1	EA
C374	CCEA1HH100T	CAP , ELECT	10UF 50V	1	EA
C375	CCEA1HH100T	CAP , ELECT	10UF 50V	1	EA
C376	CCEA1HH100T	CAP , ELECT	10UF 50V	1	EA
C389	CCEA1HH100T	CAP , ELECT	10UF 50V	1	EA
C390	CCEA1HH100T	CAP , ELECT	10UF 50V	1	EA
C417	CCEA1CH471T	CAP , ELECT	470UF 16V	1	EA
C430	CCEA1AH331T	CAP , ELECT	330UF 10V	1	EA
C431	CCEA1CH221T	CAP , ELECT	220UF 16V	1	EA
C433	CCEA1CH101T	CAP , ELECT	100UF 16V	1	EA
C600	CCEA1CH101T	CAP , ELECT	100UF 16V	1	EA
C602	CCEA1CH101T	CAP , ELECT	100UF 16V	1	EA
C604	CCEA1CH101T	CAP , ELECT	100UF 16V	1	EA
C606	CCEA1CH101T	CAP , ELECT	100UF 16V	1	EA
C608	CCEA1CH101T	CAP , ELECT	100UF 16V	1	EA
C610	CCEA1CH101T	CAP , ELECT	100UF 16V	1	EA
C612	CCEA1CH101T	CAP , ELECT	100UF 16V	1	EA
C614	CCEA1CH101T	CAP , ELECT	100UF 16V	1	EA
C616	CCEA1CH101T	CAP , ELECT	100UF 16V	1	EA
C618	CCEA1CH101T	CAP , ELECT	100UF 16V	1	EA
C620	CCEA1CH101T	CAP , ELECT	100UF 16V	1	EA
C622	CCEA1CH101T	CAP , ELECT	100UF 16V	1	EA
C624	CCEA1CH101T	CAP , ELECT	100UF 16V	1	EA
C626	CCEA1CH101T	CAP , ELECT	100UF 16V	1	EA
C628	CCEA1CH101T	CAP , ELECT	100UF 16V	1	EA
C630	CCEA1CH101T	CAP , ELECT	100UF 16V	1	EA
C703	CCEA1CH101T	CAP , ELECT	100UF 16V	1	EA
C706	CCEA1CH101T	CAP , ELECT	100UF 16V	1	EA
C717	CCEA1CH101T	CAP , ELECT	100UF 16V	1	EA
C720	CCEA1AH471T	CAP , ELECT	470UF 10V	1	EA
C721	CCEA1AH471T	CAP , ELECT	470UF 10V	1	EA
C724	CCEA1AH471T	CAP , ELECT	470UF 10V	1	EA
C726	CCEA1CH101T	CAP , ELECT	100UF 16V	1	EA
C728	CCEA1AH471T	CAP , ELECT	470UF 10V	1	EA
C730	CCEA1CH101T	CAP , ELECT	100UF 16V	1	EA
C736	CCEA1HH2R2T	CAP , ELECT	2.2UF 50V	1	EA

Ref. Designator	Part Number	Description		Qty	
PCB , INPUT		CUP11912-1			
C737	CCEA1CH101T	CAP , ELECT	100UF 16V	1	EA
C740	CCEA1CH101T	CAP , ELECT	100UF 16V	1	EA
C749	CCEA1CH101T	CAP , ELECT	100UF 16V	1	EA
C764	CCEA0JH102T	CAP , ELECT	1000UF 6.3V	1	EA
C766	CCEA0JH102T	CAP , ELECT	1000UF 6.3V	1	EA
C732	CCEA0JKR3222E	CAP , ELECT	2200UF 6.3V	1	EA
<i>Semiconductors</i>					
D201	CVD1SS355T	CHIP , DIODE	1SS355T	1	EA
D202	CVD1SS355T	CHIP , DIODE	1SS355T	1	EA
D203	CVD1SS355T	CHIP , DIODE	1SS355T	1	EA
D204	CVD1SS355T	CHIP , DIODE	1SS355T	1	EA
D207	CVD1SS355T	CHIP , DIODE	1SS355T	1	EA
D208	CVD1SS355T	CHIP , DIODE	1SS355T	1	EA
D209	CVD1SS355T	CHIP , DIODE	1SS355T	1	EA
D210	CVD1SS355T	CHIP , DIODE	1SS355T	1	EA
D211	CVD1SS355T	CHIP , DIODE	1SS355T	1	EA
D212	CVD1SS355T	CHIP , DIODE	1SS355T	1	EA
D213	CVD1SS355T	CHIP , DIODE	1SS355T	1	EA
D214	CVD1SS355T	CHIP , DIODE	1SS355T	1	EA
D215	CVD1SS355T	CHIP , DIODE	1SS355T	1	EA
D216	CVD1SS355T	CHIP , DIODE	1SS355T	1	EA
IC20	CVINJW1197FC2	IC , SW(WITH VOLUME)	JRC	1	EA
IC21	HVINJM2068MDTE1	I.C , DUAL OP AMP	JRC	1	EA
IC22	HVINJM2068MDTE1	I.C , DUAL OP AMP	JRC	1	EA
IC23	HVINJM2068MDTE1	I.C , DUAL OP AMP	JRC	1	EA
IC25	HVINJM2068MDTE1	I.C , DUAL OP AMP	JRC	1	EA
IC31	HVINJM2068MDTE1	I.C , DUAL OP AMP	JRC	1	EA
IC32	HVINJM2068MDTE1	I.C , DUAL OP AMP	JRC	1	EA
IC33	HVINJM2068MDTE1	I.C , DUAL OP AMP	JRC	1	EA
IC72	HVI74HCU04AFNG	I.C , HEX INVERTER	TOSHIBA	1	EA
IC73	HVI4K4589VQ-T	I.C , CODEC + DIR	ASAHI KASEI	1	EA
IC75	CVICS49510-CQ	I.C , DSP	CIRRUS LOGIC	1	EA
IC76	CVIES29LV800ET70TG	IC , FLASH MEMORY (8Mbit)	EXCELSEMI	1	EA
IC77	HVI57V161610ET7	SDRAM 16M 7NS	HYNIX	1	EA
IC78	HVINJM2391DL133	I.C , CHIP REGULATOR (+3.3V)	JRC	1	EA
IC79	HVILM1117S-1V8	I.C , REGULATOR (1.8V)	HTC	1	EA
IC88	HVILM1117S-3V3	I.C , REGULATOR (3.3V)	HTC	1	EA
IC89	CVIM24C32WMMN6TP	I.C , EEPROM (32 Kbit)	ST	1	EA
IC90	CVIT5CC1	I.C , FLASH U-COM	TOSHIBA	1	EA
IC91	HVI74ACT04MTR	I.C , HEX	TOSHIBA	1	EA
Q729	HVTKRC107S	TRANSISTOR , CHIP NPN	KRC107S	1	EA
Q730	HVTKRC107S	TRANSISTOR , CHIP NPN	KRC107S	1	EA
D221	CVD1N4003ST	RECT , DIODE	1N4003	1	EA
D222	CVD1N4003ST	RECT , DIODE	1N4003	1	EA
D402	CVD1N4003SRT	RECT , DIODE	1N4003	1	EA
D703	CVD1N4003ST	RECT , DIODE	1N4003	1	EA
D704	CVD1N4003SRT	RECT , DIODE	1N4003	1	EA
IC87	HVIRE5VT28CATZ	IC , RESET	RICOH	1	EA
Q301	HVTKTC2874BT	TRANSISTOR , MUTE, NPN	KTC2874B	1	EA
Q302	HVTKTC2874BT	TRANSISTOR , MUTE, NPN	KTC2874B	1	EA
Q303	HVTKTC2874BT	TRANSISTOR , MUTE, NPN	KTC2874B	1	EA
Q304	HVTKTC2874BT	TRANSISTOR , MUTE, NPN	KTC2874B	1	EA
Q305	HVTKTC2874BT	TRANSISTOR , MUTE, NPN	KTC2874B	1	EA
Q306	HVTKTC2874BT	TRANSISTOR , MUTE, NPN	KTC2874B	1	EA
Q311	HVTKTC2874BT	TRANSISTOR , MUTE, NPN	KTC2874B	1	EA
IC36	HVIL7808CP	I.C , REGULATOR (+8V)	ST	1	EA
IC37	HVINJM7908FA	I.C , REGULATOR(-8V)	JRC	1	EA

Ref. Designator	Part Number	Description		Qty	
PCB , INPUT		CUP11912-1			
<i>Resistors</i>					
RN61	CRJ104DJ103T	RES , 4ARRAY (1608*4)	10K OHM/1608*4	1	EA
RN62	CRJ104DJ103T	RES , 4ARRAY (1608*4)	10K OHM/1608*4	1	EA
RN63	CRJ104DJ103T	RES , 4ARRAY (1608*4)	10K OHM/1608*4	1	EA
RN64	CRJ104DJ101T	RES , 4ARRAY (1608*4)	100 OHM/1608*4	1	EA
RN65	CRJ104DJ101T	RES , 4ARRAY (1608*4)	100 OHM/1608*4	1	EA
RN66	CRJ104DJ101T	RES , 4ARRAY (1608*4)	100 OHM/1608*4	1	EA
RN71	CRJ104DJ103T	RES , 4ARRAY (1608*4)	10K OHM/1608*4	1	EA
RN72	CRJ104DJ103T	RES , 4ARRAY (1608*4)	10K OHM/1608*4	1	EA
RN73	CRJ104DJ103T	RES , 4ARRAY (1608*4)	10K OHM/1608*4	1	EA
RN74	CRJ104DJ330T	RES , 4ARRAY (1608*4)	33 OHM/1608*4	1	EA
RN75	CRJ104DJ330T	RES , 4ARRAY (1608*4)	33 OHM/1608*4	1	EA
RN76	CRJ104DJ330T	RES , 4ARRAY (1608*4)	33 OHM/1608*4	1	EA
RN77	CRJ104DJ330T	RES , 4ARRAY (1608*4)	33 OHM/1608*4	1	EA
RN78	CRJ104DJ330T	RES , 4ARRAY (1608*4)	33 OHM/1608*4	1	EA
RN79	CRJ104DJ330T	RES , 4ARRAY (1608*4)	33 OHM/1608*4	1	EA
RN80	CRJ104DJ330T	RES , 4ARRAY (1608*4)	33 OHM/1608*4	1	EA
RN81	CRJ104DJ330T	RES , 4ARRAY (1608*4)	33 OHM/1608*4	1	EA
RN82	CRJ104DJ330T	RES , 4ARRAY (1608*4)	33 OHM/1608*4	1	EA
RN83	CRJ104DJ330T	RES , 4ARRAY (1608*4)	33 OHM/1608*4	1	EA
RN84	CRJ104DJ330T	RES , 4ARRAY (1608*4)	33 OHM/1608*4	1	EA
RN85	CRJ104DJ330T	RES , 4ARRAY (1608*4)	33 OHM/1608*4	1	EA
RN86	CRJ104DJ103T	RES , 4ARRAY (1608*4)	10K OHM/1608*4	1	EA
RN87	CRJ104DJ330T	RES , 4ARRAY (1608*4)	33 OHM/1608*4	1	EA
RN88	CRJ104DJ103T	RES , 4ARRAY (1608*4)	10K OHM/1608*4	1	EA
RN89	CRJ104DJ103T	RES , 4ARRAY (1608*4)	10K OHM/1608*4	1	EA
RN90	CRJ104DJ330T	RES , 4ARRAY (1608*4)	33 OHM/1608*4	1	EA
RN91	CRJ104DJ330T	RES , 4ARRAY (1608*4)	33 OHM/1608*4	1	EA
RN92	CRJ104DJ101T	RES , 4ARRAY (1608*4)	10K OHM/1608*4	1	EA
R201	CRJ10DJ101T	RES , CHIP	100 OHM	1	EA
R202	CRJ10DJ101T	RES , CHIP	100 OHM	1	EA
R203	CRJ10DJ101T	RES , CHIP	100 OHM	1	EA
R204	CRJ10DJ101T	RES , CHIP	100 OHM	1	EA
R205	CRJ10DJ101T	RES , CHIP	100 OHM	1	EA
R206	CRJ10DJ101T	RES , CHIP	100 OHM	1	EA
R209	CRJ10DJ101T	RES , CHIP	100 OHM	1	EA
R210	CRJ10DJ101T	RES , CHIP	100 OHM	1	EA
R211	CRJ10DJ101T	RES , CHIP	100 OHM	1	EA
R212	CRJ10DJ101T	RES , CHIP	100 OHM	1	EA
R213	CRJ10DJ101T	RES , CHIP	100 OHM	1	EA
R214	CRJ10DJ101T	RES , CHIP	100 OHM	1	EA
R215	CRJ10DJ101T	RES , CHIP	100 OHM	1	EA
R216	CRJ10DJ101T	RES , CHIP	100 OHM	1	EA
R219	CRJ10DJ101T	RES , CHIP	100 OHM	1	EA
R220	CRJ10DJ101T	RES , CHIP	100 OHM	1	EA
R221	CRJ10DJ101T	RES , CHIP	100 OHM	1	EA
R222	CRJ10DJ101T	RES , CHIP	100 OHM	1	EA
R223	CRJ10DJ101T	RES , CHIP	100 OHM	1	EA
R224	CRJ10DJ272T	RES , CHIP	2.7K OHM	1	EA
R227	CRJ10DJ474T	RES , CHIP	470K OHM	1	EA
R228	CRJ10DJ474T	RES , CHIP	470K OHM	1	EA
R229	CRJ10DJ474T	RES , CHIP	470K OHM	1	EA
R230	CRJ10DJ474T	RES , CHIP	470K OHM	1	EA
R231	CRJ10DJ474T	RES , CHIP	470K OHM	1	EA
R232	CRJ10DJ474T	RES , CHIP	470K OHM	1	EA
R235	CRJ10DJ474T	RES , CHIP	470K OHM	1	EA
R236	CRJ10DJ474T	RES , CHIP	470K OHM	1	EA
R237	CRJ10DJ474T	RES , CHIP	470K OHM	1	EA
R238	CRJ10DJ474T	RES , CHIP	470K OHM	1	EA
R239	CRJ10DJ474T	RES , CHIP	470K OHM	1	EA

Ref. Designator	Part Number	Description		Qty	
PCB , INPUT		CUP11912-1			
R240	CRJ10DJ474T	RES , CHIP	470K OHM	1	EA
R241	CRJ10DJ474T	RES , CHIP	470K OHM	1	EA
R242	CRJ10DJ474T	RES , CHIP	470K OHM	1	EA
R245	CRJ10DJ474T	RES , CHIP	470K OHM	1	EA
R246	CRJ10DJ474T	RES , CHIP	470K OHM	1	EA
R247	CRJ10DJ474T	RES , CHIP	470K OHM	1	EA
R248	CRJ10DJ474T	RES , CHIP	470K OHM	1	EA
R249	CRJ10DJ474T	RES , CHIP	470K OHM	1	EA
R250	CRJ10DJ103T	RES , CHIP	10K OHM	1	EA
R253	CRJ10DJ4R7T	RES , CHIP	4.7 OHM	1	EA
R254	CRJ10DJ4R7T	RES , CHIP	4.7 OHM	1	EA
R255	CRJ10DJ4R7T	RES , CHIP	4.7 OHM	1	EA
R256	CRJ10DJ4R7T	RES , CHIP	4.7 OHM	1	EA
R257	CRJ10DJ4R7T	RES , CHIP	4.7 OHM	1	EA
R259	CRJ10DJ4R7T	RES , CHIP	4.7 OHM	1	EA
R260	CRJ10DJ4R7T	RES , CHIP	4.7 OHM	1	EA
R261	CRJ10DJ184T	RES , CHIP	180K OHM	1	EA
R262	CRJ10DJ184T	RES , CHIP	180K OHM	1	EA
R263	CRJ10DJ184T	RES , CHIP	180K OHM	1	EA
R264	CRJ10DJ184T	RES , CHIP	180K OHM	1	EA
R265	CRJ10DJ184T	RES , CHIP	180K OHM	1	EA
R266	CRJ10DJ184T	RES , CHIP	180K OHM	1	EA
R271	CRJ10DJ102T	RES , CHIP	1K OHM	1	EA
R272	CRJ10DJ102T	RES , CHIP	1K OHM	1	EA
R273	CRJ10DJ102T	RES , CHIP	1K OHM	1	EA
R274	CRJ10DJ102T	RES , CHIP	1K OHM	1	EA
R275	CRJ10DJ102T	RES , CHIP	1K OHM	1	EA
R276	CRJ10DJ102T	RES , CHIP	1K OHM	1	EA
R281	CRJ10DJ512T	RES , CHIP	5.1K OHM	1	EA
R282	CRJ10DJ512T	RES , CHIP	5.1K OHM	1	EA
R283	CRJ10DJ512T	RES , CHIP	5.1K OHM	1	EA
R284	CRJ10DJ912T	RES , CHIP	9.1K OHM	1	EA
R285	CRJ10DJ512T	RES , CHIP	5.1K OHM	1	EA
R286	CRJ10DJ512T	RES , CHIP	5.1K OHM	1	EA
R291	CRJ10DJ184T	RES , CHIP	180K OHM	1	EA
R292	CRJ10DJ184T	RES , CHIP	180K OHM	1	EA
R293	CRJ10DJ184T	RES , CHIP	180K OHM	1	EA
R294	CRJ10DJ184T	RES , CHIP	180K OHM	1	EA
R295	CRJ10DJ184T	RES , CHIP	180K OHM	1	EA
R296	CRJ10DJ184T	RES , CHIP	180K OHM	1	EA
R301	CRJ10DJ332T	RES , CHIP	3.3K OHM	1	EA
R302	CRJ10DJ332T	RES , CHIP	3.3K OHM	1	EA
R303	CRJ10DJ332T	RES , CHIP	3.3K OHM	1	EA
R304	CRJ10DJ332T	RES , CHIP	3.3K OHM	1	EA
R305	CRJ10DJ332T	RES , CHIP	3.3K OHM	1	EA
R306	CRJ10DJ332T	RES , CHIP	3.3K OHM	1	EA
R307	CRJ10DJ332T	RES , CHIP	3.3K OHM	1	EA
R308	CRJ10DJ332T	RES , CHIP	3.3K OHM	1	EA
R309	CRJ10DJ332T	RES , CHIP	3.3K OHM	1	EA
R310	CRJ10DJ332T	RES , CHIP	3.3K OHM	1	EA
R311	CRJ10DJ332T	RES , CHIP	3.3K OHM	1	EA
R312	CRJ10DJ332T	RES , CHIP	3.3K OHM	1	EA
R317	CRJ10DJ561T	RES , CHIP	560 OHM	1	EA
R318	CRJ10DF3920T	RES. CHIP (392R 1%)	392 OHM	1	EA
R321	CRJ10DJ512T	RES , CHIP	5.1K OHM	1	EA
R322	CRJ10DJ122T	RES , CHIP	1.2K OHM	1	EA
R323	CRJ10DJ122T	RES , CHIP	1.2K OHM	1	EA
R324	CRJ10DJ512T	RES , CHIP	5.1K OHM	1	EA
R325	CRJ10DJ512T	RES , CHIP	5.1K OHM	1	EA
R326	CRJ10DJ122T	RES , CHIP	1.2K OHM	1	EA
R327	CRJ10DJ122T	RES , CHIP	1.2K OHM	1	EA

Ref. Designator	Part Number	Description		Qty	
PCB , INPUT		CUP11912-1			
R328	CRJ10DJ103T	RES , CHIP	10K OHM	1	EA
R329	CRJ10DJ512T	RES , CHIP	5.1K OHM	1	EA
R330	CRJ10DJ122T	RES , CHIP	1.2K OHM	1	EA
R331	CRJ10DJ122T	RES , CHIP	1.2K OHM	1	EA
R332	CRJ10DJ512T	RES , CHIP	5.1K OHM	1	EA
R341	CRJ10DJ122T	RES , CHIP	1.2K OHM	1	EA
R344	CRJ10DJ122T	RES , CHIP	1.2K OHM	1	EA
R345	CRJ10DJ122T	RES , CHIP	1.2K OHM	1	EA
R348	CRJ10DJ122T	RES , CHIP	1.2K OHM	1	EA
R349	CRJ10DJ122T	RES , CHIP	1.2K OHM	1	EA
R352	CRJ10DJ122T	RES , CHIP	1.2K OHM	1	EA
R361	CRJ10DJ104T	RES , CHIP	100K OHM	1	EA
R362	CRJ10DJ104T	RES , CHIP	100K OHM	1	EA
R363	CRJ10DJ104T	RES , CHIP	100K OHM	1	EA
R364	CRJ10DJ104T	RES , CHIP	100K OHM	1	EA
R365	CRJ10DJ104T	RES , CHIP	100K OHM	1	EA
R366	CRJ10DJ104T	RES , CHIP	100K OHM	1	EA
R371	CRJ10DJ512T	RES , CHIP	5.1K OHM	1	EA
R372	CRJ10DJ512T	RES , CHIP	5.1K OHM	1	EA
R373	CRJ10DJ512T	RES , CHIP	5.1K OHM	1	EA
R374	CRJ10DJ103T	RES , CHIP	10K OHM	1	EA
R375	CRJ10DJ512T	RES , CHIP	5.1K OHM	1	EA
R376	CRJ10DJ512T	RES , CHIP	5.1K OHM	1	EA
R381	CRJ10DJ561T	RES , CHIP	560 OHM	1	EA
R382	CRJ10DJ561T	RES , CHIP	560 OHM	1	EA
R383	CRJ10DJ561T	RES , CHIP	560 OHM	1	EA
R384	CRJ10DJ561T	RES , CHIP	560 OHM	1	EA
R385	CRJ10DJ561T	RES , CHIP	560 OHM	1	EA
R386	CRJ10DJ561T	RES , CHIP	560 OHM	1	EA
R389	CRJ10DJ184T	RES , CHIP	180K OHM	1	EA
R390	CRJ10DJ184T	RES , CHIP	180K OHM	1	EA
R391	CRJ10DF3920T	RES. CHIP (392R 1%)	392 OHM	1	EA
R392	CRJ10DF3920T	RES. CHIP (392R 1%)	392 OHM	1	EA
R393	CRJ10DF3920T	RES. CHIP (392R 1%)	392 OHM	1	EA
R394	CRJ10DF3920T	RES. CHIP (392R 1%)	392 OHM	1	EA
R395	CRJ10DF3920T	RES. CHIP (392R 1%)	392 OHM	1	EA
R396	CRJ10DF3920T	RES. CHIP (392R 1%)	392 OHM	1	EA
R701	CRJ10DJ103T	RES , CHIP	10K OHM	1	EA
R702	CRJ10DJ103T	RES , CHIP	10K OHM	1	EA
R709	CRJ10DJ103T	RES , CHIP	10K OHM	1	EA
R710	CRJ10DJ103T	RES , CHIP	10K OHM	1	EA
R712	CRJ10DJ103T	RES , CHIP	10K OHM	1	EA
R714	CRJ10DJ104T	RES , CHIP	100K OHM	1	EA
R715	CRJ10DJ104T	RES , CHIP	100K OHM	1	EA
R716	CRJ10DJ472T	RES , CHIP	4.7K OHM	1	EA
R717	CRJ10DJ3R3T	RES , CHIP	3.3 OHM	1	EA
R718	CRJ10DJ123T	RES , CHIP	12K OHM	1	EA
R719	CRJ10DJ473T	RES , CHIP	47K OHM	1	EA
R720	CRJ10DJ473T	RES , CHIP	47K OHM	1	EA
R721	CRJ10DJ330T	RES , CHIP	33 OHM	1	EA
R723	CRJ10DJ2R7T	RES , CHIP	2.7 OHM	1	EA
R724	CRJ10DJ101T	RES , CHIP	100 OHM	1	EA
R725	CRJ10DJ473T	RES , CHIP	47K OHM	1	EA
R726	CRJ10DJ473T	RES , CHIP	47K OHM	1	EA
R727	CRJ10DJ473T	RES , CHIP	47K OHM	1	EA
R728	CRJ10DJ102T	RES , CHIP	1K OHM	1	EA
R729	CRJ10DJ123T	RES , CHIP	12K OHM	1	EA
R730	CRJ10DJ123T	RES , CHIP	12K OHM	1	EA
R732	CRJ10DJ103T	RES , CHIP	10K OHM	1	EA
R737	CRJ10DJ330T	RES , CHIP	33 OHM	1	EA
R739	CRJ10DJ1R0T	RES , CHIP	1 OHM	1	EA

Ref. Designator	Part Number	Description		Qty	
PCB , INPUT		CUP11912-1			
R740	CRJ10DJ820T	RES , CHIP	820 OHM	1	EA
R741	CRJ10DJ330T	RES , CHIP	33 OHM	1	EA
R742	CRJ10DJ330T	RES , CHIP	33 OHM	1	EA
R743	CRJ10DJ330T	RES , CHIP	33 OHM	1	EA
R744	CRJ10DJ0R0T	RES , CHIP	0 OHM	1	EA
R746	CRJ10DJ0R0T	RES , CHIP	0 OHM	1	EA
R747	CRJ10DJ330T	RES , CHIP	33 OHM	1	EA
R748	CRJ10DJ330T	RES , CHIP	33 OHM	1	EA
R751	CRJ10DJ330T	RES , CHIP	33 OHM	1	EA
R752	CRJ10DJ330T	RES , CHIP	33 OHM	1	EA
R753	CRJ10DJ103T	RES , CHIP	10K OHM	1	EA
R754	CRJ10DJ103T	RES , CHIP	10K OHM	1	EA
R756	CRJ10DJ103T	RES , CHIP	10K OHM	1	EA
R759	CRJ10DJ330T	RES , CHIP	33 OHM	1	EA
R760	CRJ10DJ105T	RES , CHIP	1M OHM	1	EA
R765	CRJ10DJ103T	RES , CHIP	10K OHM	1	EA
R766	CRJ10DJ103T	RES , CHIP	10K OHM	1	EA
R767	CRJ10DJ301T	RES , CHIP	300 OHM	1	EA
R768	CRJ10DJ562T	RES , CHIP	5.6K OHM	1	EA
R773	CRJ10DJ332T	RES , CHIP	3.3K OHM	1	EA
R774	CRJ10DJ332T	RES , CHIP	3.3K OHM	1	EA
R775	CRJ10DJ332T	RES , CHIP	3.3K OHM	1	EA
R776	CRJ10DJ332T	RES , CHIP	3.3K OHM	1	EA
R777	CRJ10DJ102T	RES , CHIP	1K OHM	1	EA
R778	CRJ10DJ103T	RES , CHIP	10K OHM	1	EA
R782	CRJ10DJ272T	RES , CHIP	2.7K OHM	1	EA
R783	CRJ10DJ272T	RES , CHIP	2.7K OHM	1	EA
R784	CRJ10DJ473T	RES , CHIP	47K OHM	1	EA
R785	CRJ10DJ104T	RES , CHIP	100K OHM	1	EA
R786	CRJ10DJ471T	RES , CHIP	470 OHM	1	EA
R787	CRJ10DJ103T	RES , CHIP	10K OHM	1	EA
R788	CRJ10DJ103T	RES , CHIP	10K OHM	1	EA
R789	CRJ10DJ103T	RES , CHIP	10K OHM	1	EA
R791	CRJ10DJ103T	RES , CHIP	10K OHM	1	EA
R792	CRJ10DJ103T	RES , CHIP	10K OHM	1	EA
R794	CRJ10DJ102T	RES , CHIP	1K OHM	1	EA
R795	CRJ10DJ102T	RES , CHIP	1K OHM	1	EA
R796	CRJ10DJ102T	RES , CHIP	1K OHM	1	EA
R931	CRJ10DJ104T	RES , CHIP	100K OHM	1	EA
<i>Miscellaneous</i>					
X702	HOX27000E180S	CRYSTAL , CHIP(27MHZ,SMD)	27MHZ	1	EA
L701	HLZ9Z014Z	CHIP , BEAD	HU-1H4516-600JT	1	EA
L702	HLZ9Z014Z	CHIP , BEAD	HU-1H4516-600JT	1	EA
L703	HLZ9Z014Z	CHIP , BEAD	HU-1H4516-600JT	1	EA
L704	HLZ9R005Z	BEAD CHIP 60(1608 SIZE)	HH-1M1608-600	1	EA
L705	HLZ9R005Z	BEAD CHIP 60(1608 SIZE)	HH-1M1608-600	1	EA
CN10	CJP04GB46ZY	WAFER	WAFER	1	EA
CN11	CJP13GA117ZY	WAFER , CARD CABLE	WAFER	1	EA
CN12	CJP21GA115ZY	WAFER , CARD CABLE	WAFER	1	EA
CN13	CJP13GA115ZY	WAFER , CARD CABLE	WAFER	1	EA
CN14	CJP13GA117ZY	WAFER , CARD CABLE	WAFER	1	EA
CN17	KJP12GB142ZP	PIN HEADER	PIN HEADER	1	EA
CN18	CJP05GA19ZY	WAFER , STRAIGHT, 5PIN	WAFER	1	EA
CN19	CJP15GA117ZY	WAFER , CARD CABLE	WAFER	1	EA
CN20	CJP05GA01ZY	CON WAFER YMW025-05R	WAFER	1	EA
CN21	CJP07GA117ZY	TEMP ITEM	WAFER	1	EA
CN22	CJP06GA19ZY	WAFER , STRAIGHT, 6PIN	WAFER	1	EA
CN47	CJP07GA117ZY	TEMP ITEM	WAFER	1	EA
CN51	CJP02GB03ZY	WAFER	WAFER	1	EA

Ref. Designator	Part Number	Description		Qty	
PCB , INPUT		CUP11912-1			
CN72	CJP17GA117ZY	WAFER	WAFER	1	EA
ET02	CMD1A570	BRACKET , PCB	BARCKET	1	EA
JK11	CJJ4R019W	TERMINAL , IN/OUT	TERMINAL	1	EA
JK12	CJJ4P014W	JACK , IN/OUT	JACK	1	EA
JK13	CJJ4R019W	TERMINAL , IN/OUT	TERMINAL	1	EA
JK14	CJJ4P043W	JACK IN/OUT	JACK	1	EA
X701	HOX24576E150TF	CRYSTAL	24.576MHZ	1	EA
IPOD PCB(CUP11912-2)					
<i>Capacitors</i>					
C410	CCUS1A105KC	CAP , CHIP	1UF	1	EA
C411	CCUS1A105KC	CAP , CHIP	1UF	1	EA
C412	CCUC1C225ZF	CAP , CHIP	2.2UF	1	EA
C413	CCUC1C225ZF	CAP , CHIP	2.2UF	1	EA
C416	CCUS1H473KC	CAP , CHIP	0.047UF	1	EA
C420	CCUS1A105KC	CAP , CHIP	1UF	1	EA
C421	CCUS1A105KC	CAP , CHIP	1UF	1	EA
C422	CCUS1A105KC	CAP , CHIP	1UF	1	EA
C423	CCUS1H220JA	CAP , CHIP	22PF	1	EA
C424	CCUS1H220JA	CAP , CHIP	22PF	1	EA
C425	CCUS1H223KC	CAP , CHIP	0.022UF	1	EA
C426	CCUS1H223KC	CAP , CHIP	0.022UF	1	EA
C427	CCUS1H223KC	CAP , CHIP	0.022UF	1	EA
C432	HCEC1CRV2220T	CAP , ELEC (SMD)	22UF/16V	1	EA
C435	CCUS1H070DA	CAP , CHIP	7PF	1	EA
C436	CCUS1H120JA	CAP , CHIP	12PF	1	EA
C440	CCUS1H223KC	CAP , CHIP	0.022UF	1	EA
C445	HCEC1CRV2220T	CAP , ELEC (SMD)	22UF/16V	1	EA
R444	CCUS1H151JA	CAP , CHIP	150PF	1	EA
<i>Semiconductors</i>					
D400	CVD1SS355T	CHIP , DIODE	1SS355T	1	EA
D401	CVD1SS355T	CHIP , DIODE	1SS355T	1	EA
IC41	HVINJM2068MDTE1	I.C , DUAL OP AMP	JRC	1	EA
IC42	HVINJM2068MDTE1	I.C , DUAL OP AMP	JRC	1	EA
IC43	HVINJM2137MTE1	I.C , DUAL OP AMP	JRC	1	EA
Q402	HVTKRC102S	TRANSISTOR , PNP CHIP	KRC102S	1	EA
<i>Resistors</i>					
R400	CRJ10DJ4R7T	RES , CHIP	4.7 OHM	1	EA
R401	CRJ10DJ4R7T	RES , CHIP	4.7 OHM	1	EA
R402	CRJ10DF5493T	RES , CHIP	549K OHM	1	EA
R403	CRJ10DJ0R0T	RES , CHIP	0 OHM	1	EA
R404	CRJ10DJ103T	RES , CHIP	10K OHM	1	EA
R405	CRJ10DJ103T	RES , CHIP	10K OHM	1	EA
R406	CRJ10DJ474T	RES , CHIP	470K OHM	1	EA
R407	CRJ10DJ474T	RES , CHIP	470K OHM	1	EA
R421	CRJ10DJ222T	RES , CHIP	2.2K OHM	1	EA
R422	CRJ10DJ474T	RES , CHIP	470K OHM	1	EA
R430	CRJ10DJ473T	RES , CHIP	47K OHM	1	EA
R431	CRJ10DJ473T	RES , CHIP	47K OHM	1	EA
R432	CRJ18AJ221T	RES , CHIP	220 OHM	1	EA
R433	CRJ18AJ221T	RES , CHIP	220 OHM	1	EA
R434	CRJ10DJ103T	RES , CHIP	10K OHM	1	EA
R435	CRJ10DJ103T	RES , CHIP	10K OHM	1	EA
R436	CRJ10DJ222T	RES , CHIP	2.2K OHM	1	EA
R437	CRJ10DJ222T	RES , CHIP	2.2K OHM	1	EA

Ref. Designator	Part Number	Description		Qty	
IPOD PCB(CUP11912-2)					
R438	CRJ10DJ222T	RES , CHIP	2.2K OHM	1	EA
R439	CRJ10DJ222T	RES , CHIP	2.2K OHM	1	EA
R440	CRJ10DJ220T	RES , CHIP	2.2K OHM	1	EA
R441	CRJ10DJ472T	RES , CHIP	4.7K OHM	1	EA
R442	CRJ10DJ472T	RES , CHIP	4.7K OHM	1	EA
R443	CRJ10DJ202T	RES , CHIP	2K OHM	1	EA
R445	CRJ10DJ202T	RES , CHIP	2K OHM	1	EA
R446	CRJ10DJ431T	RES , CHIP	430 OHM	1	EA
R447	CRJ10DJ821T	RES , CHIP	820 OHM	1	EA
R449	CRJ10DJ0R0T	RES , CHIP	0 OHM	1	EA
R453	CRJ10DJ220T	RES , CHIP	22 OHM	1	EA
<i>Miscellaneous</i>					
JK40	HJJ9L003Z	JACK , IPOD	IPOD JACK	1	EA
BN17	KJP12GB142ZP	PIN HEADER	PIN HEADER	1	EA
BN19	CJP15GA117ZY	WAFER , CARD CABLE	WAFER	1	EA
BN44	CJP07GA117ZY	TEMP ITEM	WAFER	1	EA
XM PCB (CUP11920)					
<i>Capacitors</i>					
C408	HCEC1CRV2101T	CAP , ELEC (SMD)	100UF 16V	1	EA
C409	CCUS1H104KC	CAP , CHIP	0.1UF	1	EA
C418	HCEC1CRV2101T	CAP , ELEC (SMD)	100UF 16V	1	EA
C419	CCUS1H104KC	CAP , CHIP	0.1UF	1	EA
C455	CCUS1H104KC	CAP , CHIP	0.1UF	1	EA
C456	CCUS1H104KC	CAP , CHIP	0.1UF	1	EA
C457	HCEC1CRV2100T	CAP , ELEC (SMD)	10UF 16V	1	EA
C458	HCEC1CRV2100T	CAP , ELEC (SMD)	10UF 16V	1	EA
C460	CCUS1H102KC	CAP , CHIP	1000PF	1	EA
C461	CCUS1H102KC	CAP , CHIP	1000PF	1	EA
C462	CCUS1H271JA	CAP , CHIP	270PF	1	EA
C463	CCUS1H271JA	CAP , CHIP	270PF	1	EA
C464	CCUS1H223KC	CAP , CHIP	0.022UF	1	EA
C466	HCEC1VRV2100T	CAP , ELEC(SMD)	10UF 35V	1	EA
C481	CCUS1H102KC	CAP , CHIP	1000PF	1	EA
C482	CCUS1H102KC	CAP , CHIP	1000PF	1	EA
C483	CCUS1H102KC	CAP , CHIP	1000PF	1	EA
C484	CCUS1H104KC	CAP , CHIP	0.1UF	1	EA
C485	CCUS1H102KC	CAP , CHIP	1000PF	1	EA
C486	CCUS1H104KC	CAP , CHIP	0.1UF	1	EA
C487	CCUS1H180JA	CAP , CHIP	18PF	1	EA
C488	CCUS1H180JA	CAP , CHIP	18PF	1	EA
C489	CCUS1H104KC	CAP , CHIP	0.1UF	1	EA
C490	HCEC1CRV2100T	CAP , ELEC (SMD)	10UF 16V	1	EA
C491	HCEC1CRV2220T	CAP , ELEC (SMD)	22UF 16V	1	EA
C492	HCEC1VRV2100T	CAP , ELEC(SMD)	10UF 35V	1	EA
C493	HCEC1CRV2100T	CAP , ELEC (SMD)	10UF 16V	1	EA
C494	CCUS1H331JA	CAP , CHIP	330PF	1	EA
C495	CCUS1H331JA	CAP , CHIP	330PF	1	EA
C496	CCUS1H223KC	CAP , CHIP	0.022UF	1	EA
C497	CCUS1H122KC	CAP , CHIP	1200PF	1	EA
C498	CCUS1H122KC	CAP , CHIP	1200PF	1	EA
C499	HCEC1CRV2100T	CAP , ELEC (SMD)	10UF 16V	1	EA
C502	CCUS1H104KC	CAP , CHIP	0.1UF	1	EA
C503	CCUS1H104KC	CAP , CHIP	0.1UF	1	EA
C504	CCUS1H181JA	CAP , CHIP	180PF	1	EA
C505	CCUS1H104KC	CAP , CHIP	0.1UF	1	EA
C506	CCUS1H104KC	CAP , CHIP	0.1UF	1	EA

Ref. Designator	Part Number	Description		Qty	
XM PCB		(CUP11920)			
C507	CCUS1H104KC	CAP , CHIP	0.1UF	1	EA
C508	CCUS1H104KC	CAP , CHIP	0.1UF	1	EA
C509	CCUS1H104KC	CAP , CHIP	0.1UF	1	EA
C510	CCUS1H104KC	CAP , CHIP	0.1UF	1	EA
C511	CCUS1H104KC	CAP , CHIP	0.1UF	1	EA
C512	HCEC1CRV2220T	CAP , ELEC (SMD)	22UF 16V	1	EA
C517	CCUS1H104KC	CAP , CHIP	0.1UF	1	EA
C518	CCUS1H104KC	CAP , CHIP	0.1UF	1	EA
C525	CCUS1H104KC	CAP , CHIP	0.1UF	1	EA
C526	CCEA1CK5101T	CAP , ELECT	100UF 16V	1	EA
<i>Semiconductors</i>					
D404	HVDRB160L60TE25	DIODE , SCHOTTKY BARRIER	HU-1H4516-600JT	1	EA
IC51	CVIXMDTIC	I.C , XM	XM	1	EA
IC52	CVIK4384ET	I.C , ADC	ASAHI KASEI	1	EA
IC53	HVINJM2068MDTE1	I.C , DUAL OP AMP	JRC	1	EA
IC54	HVILM1117S-3V3	I.C , REGULATOR (3.3V)	HTC	1	EA
<i>Resistors</i>					
RN50	CRJ104DJ220T	RES , 4ARRAY (1608*4)	22 OHM/1608*4	1	EA
RN51	CRJ104DJ101T	RES , 4ARRAY (1608*4)	10K OHM/1608*4	1	EA
R408	CRJ10DJ102T	RES , CHIP	1K OHM	1	EA
R409	CRJ10DJ102T	RES , CHIP	1K OHM	1	EA
R410	CRJ10DJ332T	RES , CHIP	10K OHM	1	EA
R411	CRJ10DJ332T	RES , CHIP	10K OHM	1	EA
R412	CRJ10DJ104T	RES , CHIP	100K OHM	1	EA
R413	CRJ10DJ104T	RES , CHIP	100K OHM	1	EA
R440	CRJ10DJ101T	RES , CHIP	100 OHM	1	EA
R481	CRJ10DJ103T	RES , CHIP	10K OHM	1	EA
R482	CRJ10DJ103T	RES , CHIP	10K OHM	1	EA
R483	CRJ10DJ152T	RES , CHIP	1.5K OHM	1	EA
R484	CRJ10DJ152T	RES , CHIP	1.5K OHM	1	EA
R485	CRJ10DJ101T	RES , CHIP	100 OHM	1	EA
R486	CRJ10DJ103T	RES , CHIP	10K OHM	1	EA
R487	CRJ10DJ332T	RES , CHIP	18K OHM	1	EA
R488	CRJ10DJ332T	RES , CHIP	18K OHM	1	EA
R491	CRJ10DJ0R0T	RES , CHIP	0 OHM	1	EA
R494	CRJ10DJ0R0T	RES , CHIP	0 OHM	1	EA
R501	CRJ10DJ220T	RES , CHIP	22 OHM	1	EA
R502	CRJ10DJ220T	RES , CHIP	22 OHM	1	EA
R503	CRJ10CJ0R0T	RES. CHIP (1/10W OR)	0 OHM	1	EA
R505	CRJ10DJ223T	RES , CHIP	22K OHM	1	EA
R506	CRJ10DJ102T	RES , CHIP	1K OHM	1	EA
R507	CRJ10DJ102T	RES , CHIP	1K OHM	1	EA
R508	CRJ10DJ101T	RES , CHIP	100 OHM	1	EA
R509	CRJ10DJ101T	RES , CHIP	100 OHM	1	EA
R510	CRJ10DJ104T	RES , CHIP	100K OHM	1	EA
R511	CRJ10DJ104T	RES , CHIP	100K OHM	1	EA
R512	CRJ10DJ104T	RES , CHIP	100K OHM	1	EA
R513	CRJ10DJ104T	RES , CHIP	100K OHM	1	EA
R514	CRJ10DJ223T	RES , CHIP	22K OHM	1	EA
R515	CRJ10DJ223T	RES , CHIP	22K OHM	1	EA
R516	CRJ10DJ223T	RES , CHIP	22K OHM	1	EA
R521	CRJ10DJ223T	RES , CHIP	22K OHM	1	EA
R522	CRJ10DJ223T	RES , CHIP	22K OHM	1	EA
R523	CRJ10DJ223T	RES , CHIP	22K OHM	1	EA
R524	CRJ10DJ0R0T	RES , CHIP	0 OHM	1	EA
R525	CRJ10DJ105T	RES , CHIP	1M OHM	1	EA
R526	CRJ10DJ103T	RES , CHIP	10K OHM	1	EA

Ref. Designator	Part Number	Description		Qty	
XM PCB		(CUP11920)			
R528	CRJ10DJ223T	RES , CHIP	22K OHM	1	EA
R529	CRJ10DJ223T	RES , CHIP	22K OHM	1	EA
R530	CRJ10DJ223T	RES , CHIP	22K OHM	1	EA
<i>Miscellaneous</i>					
X501	COX45158E180S	X-TAL, 45.1584MHz (SMD)	45.1584MHz	1	EA
BK51	CMD1A569	BRACKET , PCB	BRACKET	1	EA
BN85	CWB1C902250BM	WIRE ASS'Y	WIRE	1	EA
CN23	KJP12GB143ZP	DIP SOCKET	DIP SOCKET	1	EA
JK51	CJJ9L006Z	JACK , XM	JACK	1	EA
L403	HLZ9Z014Z	CHIP , BEAD	HU-1H4516-600JT	1	EA
L502	CLQ06E2R7KRZ	INDUCTOR, CHIP	2.7UH	1	EA
L503	HLZ9Z014Z	CHIP , BEAD	HU-1H4516-600JT	1	EA
L504	HLZ9Z014Z	CHIP , BEAD	HU-1H4516-600JT	1	EA
BN21	CJP07GA193ZY	WAFER , CARD CABLE (SMD)	WAFER	1	EA
PCB , VIDEO		CUP11917			
<i>Capacitors</i>					
C401	CCUS1H101JA	CAP , CHIP	100PF	1	EA
C402	CCUS1H101JA	CAP , CHIP	100PF	1	EA
C403	CCUS1H101JA	CAP , CHIP	100PF	1	EA
C461	CCUS1H223KC	CAP , CHIP	0.022UF	1	EA
C463	CCUS1H223KC	CAP , CHIP	0.022UF	1	EA
C466	CCUS1H223KC	CAP , CHIP	0.022UF	1	EA
C468	CCUS1H223KC	CAP , CHIP	0.022UF	1	EA
C471	CCUS1H223KC	CAP , CHIP	0.022UF	1	EA
C473	CCUS1H223KC	CAP , CHIP	0.022UF	1	EA
C481	CCUS1H101JA	CAP , CHIP	100PF	1	EA
C483	CCUS1H101JA	CAP , CHIP	100PF	1	EA
C491	CCUS1H101JA	CAP , CHIP	100PF	1	EA
C492	CCUS1H101JA	CAP , CHIP	100PF	1	EA
C493	CCUS1H101JA	CAP , CHIP	100PF	1	EA
C501	CCUS1H103KC	CAP , CHIP	0.01UF	1	EA
C504	CCUS1H104KC	CAP , CHIP	0.1UF	1	EA
C511	CCUS1H103KC	CAP , CHIP	0.01UF	1	EA
C521	CCUS1H223KC	CAP , CHIP	0.022UF	1	EA
C525	CCUS1H223KC	CAP , CHIP	0.022UF	1	EA
C531	CCUS1H223KC	CAP , CHIP	0.022UF	1	EA
C535	CCUS1H223KC	CAP , CHIP	0.022UF	1	EA
C539	CCUS1H104KC	CAP , CHIP	0.1UF	1	EA
C543	CCUS1H104KC	CAP , CHIP	0.1UF	1	EA
C548	CCUS1H104KC	CAP , CHIP	0.1UF	1	EA
C552	CCUS1H223KC	CAP , CHIP	0.022UF	1	EA
C553	CCUS1H223KC	CAP , CHIP	0.022UF	1	EA
C554	CCUS1H223KC	CAP , CHIP	0.022UF	1	EA
C555	CCUS1H272KC	CAP , CHIP	2700PF	1	EA
C559	CCUS1A105KC	CAP , CHIP	1UF	1	EA
C601	CCUS1H220JA	CAP , CHIP	22PF	1	EA
C603	CCUS1H220JA	CAP , CHIP	22PF	1	EA
C605	CCUS1H220JA	CAP , CHIP	22PF	1	EA
C611	CCUS1H220JA	CAP , CHIP	22PF	1	EA
C613	CCUS1H220JA	CAP , CHIP	22PF	1	EA
C615	CCUS1H220JA	CAP , CHIP	22PF	1	EA
C621	CCUS1H220JA	CAP , CHIP	22PF	1	EA
C623	CCUS1H220JA	CAP , CHIP	22PF	1	EA
C625	CCUS1H220JA	CAP , CHIP	22PF	1	EA
C672	CCUS1H104KC	CAP , CHIP	0.1UF	1	EA
C677	CCUS1H473KC	CAP , CHIP	0.047UF	1	EA

Ref. Designator	Part Number	Description		Qty	
PCB , VIDEO		CUP11917			
C701	CCUS1H330JA	CAP , CHIP	33PF	1	EA
C702	CCUS1H330JA	CAP , CHIP	33PF	1	EA
C705	CCUS1H181JA	CAP , CHIP	180PF	1	EA
C717	CCUS1H220JA	CAP , CHIP	22PF	1	EA
C721	CCUS1H560JA	CAP , CHIP	56PF	1	EA
C722	CCUS1H220JA	CAP , CHIP	22PF	1	EA
C731	CCUS1H220JA	CAP , CHIP	22PF	1	EA
C732	CCUS1H330JA	CAP , CHIP	33PF	1	EA
C733	CCUS1H223KC	CAP , CHIP	0.022UF	1	EA
C736	CCUS1H223KC	CAP , CHIP	0.022UF	1	EA
C741	CCUS1H223KC	CAP , CHIP	0.022UF	1	EA
C411	CCEA1HH100T	CAP , ELECT	10UF 50V	1	EA
C412	CCEA1HH100T	CAP , ELECT	10UF 50V	1	EA
C413	CCEA1HH100T	CAP , ELECT	10UF 50V	1	EA
C421	CCEA1HH100T	CAP , ELECT	10UF 50V	1	EA
C422	CCEA1HH100T	CAP , ELECT	10UF 50V	1	EA
C423	CCEA1HH100T	CAP , ELECT	10UF 50V	1	EA
C451	CCEA1HH100T	CAP , ELECT	10UF 50V	1	EA
C452	CCEA1HH100T	CAP , ELECT	10UF 50V	1	EA
C453	CCEA1HH100T	CAP , ELECT	10UF 50V	1	EA
C462	CCEA1CH101T	CAP , ELECT	100UF 16V	1	EA
C464	CCEA1CH101T	CAP , ELECT	100UF 16V	1	EA
C467	CCEA1CH101T	CAP , ELECT	100UF 16V	1	EA
C469	CCEA1CH101T	CAP , ELECT	100UF 16V	1	EA
C472	CCEA1CH101T	CAP , ELECT	100UF 16V	1	EA
C474	CCEA1CH101T	CAP , ELECT	100UF 16V	1	EA
C503	CCEA1HH100T	CAP , ELECT	10UF 50V	1	EA
C505	CCEA1HH100T	CAP , ELECT	10UF 50V	1	EA
C514	CCEA1HH100T	CAP , ELECT	10UF 50V	1	EA
C515	CCEA1HH100T	CAP , ELECT	10UF 50V	1	EA
C522	CCEA1CH101T	CAP , ELECT	100UF 16V	1	EA
C524	CCEA1CH101T	CAP , ELECT	100UF 16V	1	EA
C532	CCEA1CH101T	CAP , ELECT	100UF 16V	1	EA
C533	CCEA1CH101T	CAP , ELECT	100UF 16V	1	EA
C534	CCEA1CH101T	CAP , ELECT	100UF 16V	1	EA
C536	CCEA1AH471T	CAP , ELECT	470UF 10V	1	EA
C537	CCEA1CH101T	CAP , ELECT	100UF 16V	1	EA
C538	CCEA1CH101T	CAP , ELECT	100UF 16V	1	EA
C544	CCEA1CH101T	CAP , ELECT	100UF 16V	1	EA
C549	CCEA1CH101T	CAP , ELECT	100UF 16V	1	EA
C602	CCEA0JH102T	CAP , ELECT	1000UF 6.3V	1	EA
C604	CCEA0JH102T	CAP , ELECT	1000UF 6.3V	1	EA
C606	CCEA0JH102T	CAP , ELECT	1000UF 6.3V	1	EA
C612	CCEA1HH100T	CAP , ELECT	10UF 50V	1	EA
C614	CCEA1HH100T	CAP , ELECT	10UF 50V	1	EA
C616	CCEA1HH100T	CAP , ELECT	10UF 50V	1	EA
C622	CCEA1HH100T	CAP , ELECT	10UF 50V	1	EA
C624	CCEA1HH100T	CAP , ELECT	10UF 50V	1	EA
C626	CCEA1HH100T	CAP , ELECT	10UF 50V	1	EA
C671	CCEA1CH101T	CAP , ELECT	100UF 16V	1	EA
C673	CCEA1HH100T	CAP , ELECT	10UF 50V	1	EA
C676	CCEA1CH101T	CAP , ELECT	100UF 16V	1	EA
C678	CCEA1CH101T	CAP , ELECT	100UF 16V	1	EA
C708	CCEA1HHR47T	CAP , ELECT	0.47UF 50V	1	EA
C711	CCEA1AH471T	CAP , ELECT	470UF 10V	1	EA
C723	CCEA1HH0R1T	CAP , ELECT	0.1UF 50V	1	EA
C725	HCQI1H682JZT	CAP , MYLAR	6800PF 50V J	1	EA
C726	CCEA1HH1R0T	CAP , ELECT	1UF 50V	1	EA
C734	CCEA1HH1R0T	CAP , ELECT	1UF 50V	1	EA
C737	CCEA1CH101T	CAP , ELECT	100UF 16V	1	EA
C712	CCEA0JKR3222E	CAP , ELECT	2200UF 6.3V	1	EA

Ref. Designator	Part Number	Description		Qty	
PCB , VIDEO		CUP11917			
<i>Semiconductors</i>					
D502	HVDRLS4148SR	DIODE, SWITCHING, SMD TYPE	RLS4148 TE-11	1	EA
D505	HVDRLS4148SR	DIODE, SWITCHING, SMD TYPE	RLS4148 TE-11	1	EA
D512	HVDRLS4148SR	DIODE, SWITCHING, SMD TYPE	RLS4148 TE-11	1	EA
D514	HVDRLS4148SR	DIODE, SWITCHING, SMD TYPE	RLS4148 TE-11	1	EA
D741	HVDRLS4148SR	DIODE, SWITCHING, SMD TYPE	RLS4148 TE-11	1	EA
IC41	CVINJM2595MTE1	I.C , VIDEO S/W	JRC	1	EA
IC42	CVINJM2595MTE1	I.C , VIDEO S/W	JRC	1	EA
IC43	CVINJM2595MTE1	I.C , VIDEO S/W	JRC	1	EA
IC51	HVIHCF4053M013T	I.C, ANALOG MULTIPLEXER	ST	1	EA
IC52	HVIHCF4053M013T	I.C, ANALOG MULTIPLEXER	ST	1	EA
IC53	CVINJM2587V	I.C , VIDEO AMP	JRC	1	EA
IC54	HVIMM1511XNRE	I.C, Y/C-MIX	MITSUMI	1	EA
IC61	CVINJW1321FP1	I.C , VIDEO S/W	JRC	1	EA
IC71	HVILC74763M	I.C , OSD	SANYO	1	EA
IC72	HVI74ACT04MTR	I.C , HEX INVERTER	FAIRCHILD	1	EA
Q505	HVTKRA107S	TRANSISTOR, CHIP PNP	KRA107S	1	EA
Q507	HVTKRC107S	TRANSISTOR, CHIP NPN	KRC107S	1	EA
Q512	HVTKRC107S	TRANSISTOR, CHIP NPN	KRC107S	1	EA
Q515	HVTKRA107S	TRANSISTOR, CHIP PNP	KRA107S	1	EA
Q516	HVTKRC107S	TRANSISTOR, CHIP NPN	KRC107S	1	EA
Q517	HVTKRC107S	TRANSISTOR, CHIP NPN	KRC107S	1	EA
Q518	HVTKRC107S	TRANSISTOR, CHIP NPN	KRC107S	1	EA
Q551	HVTKTD1304T	TRANSISTOR , CHIP (MUTE) NPN	KTD1304	1	EA
Q552	HVTKRA104S	TRANSISTOR, CHIP PNP	KRA104S	1	EA
Q555	HVTKTD1304T	TRANSISTOR , CHIP (MUTE) NPN	KTD1304	1	EA
Q556	HVTKRA104S	TRANSISTOR, CHIP PNP	KRA104S	1	EA
Q501	HVTKSA733CYT	TRANSISTOR PNP	KSA733CY	1	EA
Q504	HVTKTC2874BT	TRANSISTOR , MUTE NPN	KTC2874B	1	EA
Q511	HVTKSA733CYT	TRANSISTOR PNP	KSA733CY	1	EA
Q536	HVTKSA1175YT	TRANSISTOR PNP	KSA1175Y	1	EA
Q712	HVTKSA1175YT	TRANSISTOR PNP	KSA1175Y	1	EA
Q716	HVTKSC2785YT	TRANSISTOR NPN	KSC2785Y	1	EA
IC62	HVIMC7809C	I.C , REGULATOR(+9V)	FAIRCHILD	1	EA
<i>Resistors</i>					
R401	CRJ10DJ750T	RES , CHIP	75 OHM	1	EA
R402	CRJ10DJ750T	RES , CHIP	75 OHM	1	EA
R403	CRJ10DJ750T	RES , CHIP	75 OHM	1	EA
R404	CRJ10DJ332T	RES , CHIP	3300 OHM	1	EA
R405	CRJ10DJ332T	RES , CHIP	3300 OHM	1	EA
R411	CRJ10DJ750T	RES , CHIP	75 OHM	1	EA
R412	CRJ10DJ750T	RES , CHIP	75 OHM	1	EA
R413	CRJ10DJ750T	RES , CHIP	75 OHM	1	EA
R421	CRJ10DJ750T	RES , CHIP	75 OHM	1	EA
R422	CRJ10DJ750T	RES , CHIP	75 OHM	1	EA
R423	CRJ10DJ750T	RES , CHIP	75 OHM	1	EA
R451	CRJ10DJ750T	RES , CHIP	75 OHM	1	EA
R452	CRJ10DJ750T	RES , CHIP	75 OHM	1	EA
R453	CRJ10DJ750T	RES , CHIP	75 OHM	1	EA
R461	CRJ10DJ102T	RES , CHIP	1K OHM	1	EA
R466	CRJ10DJ102T	RES , CHIP	1K OHM	1	EA
R471	CRJ10DJ102T	RES , CHIP	1K OHM	1	EA
R481	CRJ10DJ0R0T	RES , CHIP	0 OHM	1	EA
R482	CRJ10DJ0R0T	RES , CHIP	0 OHM	1	EA
R483	CRJ10DJ0R0T	RES , CHIP	0 OHM	1	EA
R486	CRJ10DJ0R0T	RES , CHIP	0 OHM	1	EA
R491	CRJ10DJ750T	RES , CHIP	75 OHM	1	EA
R492	CRJ10DJ750T	RES , CHIP	75 OHM	1	EA

Ref. Designator	Part Number	Description		Qty	
PCB , VIDEO		CUP11917			
R493	CRJ10DJ750T	RES , CHIP	75 OHM	1	EA
R501	CRJ10DJ333T	RES , CHIP	33K OHM	1	EA
R502	CRJ10DJ680T	RES , CHIP	68 OHM	1	EA
R503	CRJ10DJ123T	RES , CHIP	12K OHM	1	EA
R504	CRJ10DJ223T	RES , CHIP	22K OHM	1	EA
R505	CRJ10DJ102T	RES , CHIP	1K OHM	1	EA
R506	CRJ10DJ103T	RES , CHIP	10K OHM	1	EA
R507	CRJ10DJ103T	RES , CHIP	10K OHM	1	EA
R511	CRJ10DJ333T	RES , CHIP	33K OHM	1	EA
R512	CRJ10DJ680T	RES , CHIP	68 OHM	1	EA
R513	CRJ10DJ123T	RES , CHIP	12K OHM	1	EA
R514	CRJ10DJ102T	RES , CHIP	1K OHM	1	EA
R515	CRJ10DJ103T	RES , CHIP	10K OHM	1	EA
R516	CRJ10DJ103T	RES , CHIP	10K OHM	1	EA
R517	CRJ10DJ223T	RES , CHIP	22K OHM	1	EA
R518	CRJ10DJ103T	RES , CHIP	10K OHM	1	EA
R521	CRJ10DJ100T	RES , CHIP	10 OHM	1	EA
R523	CRJ10DJ100T	RES , CHIP	10 OHM	1	EA
R531	CRJ10DJ100T	RES , CHIP	10 OHM	1	EA
R533	CRJ10DJ2R2T	RES , CHIP	2.2 OHM	1	EA
R534	CRJ10DJ100T	RES , CHIP	10 OHM	1	EA
R536	CRJ10DJ101T	RES , CHIP	100 OHM	1	EA
R537	CRJ10DJ183T	RES , CHIP	18K OHM	1	EA
R539	CRJ10DJ181T	RES , CHIP	180 OHM	1	EA
R540	CRJ10DJ101T	RES , CHIP	100 OHM	1	EA
R541	CRJ10DJ181T	RES , CHIP	180 OHM	1	EA
R542	CRJ10DJ392T	RES , CHIP	3.9K OHM	1	EA
R543	CRJ10DJ1R8T	RES , CHIP	1.8 OHM	1	EA
R545	CRJ10DJ161T	RES , CHIP	160 OHM	1	EA
R546	CRJ10DJ181T	RES , CHIP	180 OHM	1	EA
R547	CRJ10DJ183T	RES , CHIP	18K OHM	1	EA
R548	CRJ10DJ1R0T	RES , CHIP	1 OHM	1	EA
R551	CRJ10DJ105T	RES , CHIP	1M OHM	1	EA
R552	CRJ10DJ223T	RES , CHIP	22K OHM	1	EA
R553	CRJ10DJ332T	RES , CHIP	3.3K OHM	1	EA
R555	CRJ10DJ562T	RES , CHIP	5.6K OHM	1	EA
R556	CRJ10DJ472T	RES , CHIP	4.7K OHM	1	EA
R558	CRJ10DJ222T	RES , CHIP	2.2K OHM	1	EA
R601	CRJ10DJ680T	RES , CHIP	68 OHM	1	EA
R603	CRJ10DJ560T	RES , CHIP	56 OHM	1	EA
R605	CRJ10DJ620T	RES , CHIP	62 OHM	1	EA
R611	CRJ10DJ750T	RES , CHIP	75 OHM	1	EA
R613	CRJ10DJ750T	RES , CHIP	75 OHM	1	EA
R615	CRJ10DJ750T	RES , CHIP	75 OHM	1	EA
R621	CRJ10DJ750T	RES , CHIP	75 OHM	1	EA
R623	CRJ10DJ750T	RES , CHIP	75 OHM	1	EA
R625	CRJ10DJ750T	RES , CHIP	75 OHM	1	EA
R641	CRJ10DJ0R0T	RES , CHIP	0 OHM	1	EA
R642	CRJ10DJ0R0T	RES , CHIP	0 OHM	1	EA
R674	CRJ10DJ102T	RES , CHIP	1K OHM	1	EA
R675	CRJ10DJ102T	RES , CHIP	1K OHM	1	EA
R701	CRJ10DJ0R0T	RES , CHIP	0 OHM	1	EA
R705	CRJ10DJ102T	RES , CHIP	1K OHM	1	EA
R706	CRJ10DJ102T	RES , CHIP	1K OHM	1	EA
R707	CRJ10DJ102T	RES , CHIP	1K OHM	1	EA
R711	CRJ10DJ104T	RES , CHIP	100K OHM	1	EA
R712	CRJ10DJ103T	RES , CHIP	10K OHM	1	EA
R713	CRJ10DJ223T	RES , CHIP	22K OHM	1	EA
R714	CRJ10DJ202T	RES , CHIP	2K OHM	1	EA
R715	CRJ10DJ822T	RES , CHIP	8.2K OHM	1	EA
R716	CRJ10DJ103T	RES , CHIP	10K OHM	1	EA

Ref. Designator	Part Number	Description		Qty	
PCB , VIDEO		CUP11917			
R717	CRJ10DJ271T	RES , CHIP	270 OHM	1	EA
R721	CRJ10DJ222T	RES , CHIP	2.2 OHM	1	EA
R724	CRJ10DJ393T	RES , CHIP	39J OHM	1	EA
R725	CRJ10DJ152T	RES , CHIP	1.5K OHM	1	EA
R726	CRJ10DJ682T	RES , CHIP	6.8K OHM	1	EA
R727	CRJ10DJ102T	RES , CHIP	1K OHM	1	EA
R728	CRJ10DJ102T	RES , CHIP	1K OHM	1	EA
R735	CRJ10DJ102T	RES , CHIP	1K OHM	1	EA
R737	CRJ10DJ104T	RES , CHIP	100K OHM	1	EA
R742	CRJ10DJ102T	RES , CHIP	1K OHM	1	EA
R743	CRJ10DJ102T	RES , CHIP	1K OHM	1	EA
R744	CRJ10DJ102T	RES , CHIP	1K OHM	1	EA
R745	CRJ10DJ102T	RES , CHIP	1K OHM	1	EA
R746	CRJ10DJ103T	RES , CHIP	10K OHM	1	EA
R747	CRJ10DJ332T	RES , CHIP	3.3K OHM	1	EA
L551	CRJ10DJ0R0T	RES , CHIP	0 OHM	1	EA
<i>Miscellaneous</i>					
L731	KLQ5R6J405T	COIL, PEAKING(RADIAL)	5.6UH J 4X5	1	EA
L736	HLQ02C101JT	COIL , AXAIL	100UH,J	1	EA
BN14	CJP13GA117ZY	WAFER , CARD CABLE	WAFER	1	EA
CN41	CJP06GA19ZY	WAFER, STRAIGHT, 6PIN	WAFER	1	EA
CN42	CJP07GA117ZY	TEMP ITEM	WAFER	1	EA
CN43	CJP03GA01ZY	WAFER	WAFER	1	EA
CN45	CJP07GA117ZY	TEMP ITEM	WAFER	1	EA
JK40	CJJ9P003Z	JACK , (S-VIDEO + CVBS)	JACK	1	EA
JK41	CJJ9R001Z	JACK , (S-VIDEO + CVBS)	JACK	1	EA
JK62	CJJ4R045Z	JACK , BOARD	JACK	1	EA
JK69	CJJ4S030Z	JACK , BOARD	JACK	1	EA
X701	HOX14318E220C	CRYSTAL	14.318Mhz	1	EA
HDMI PCB		(CUP11914)			
CN45	CJP07GA193ZY	WAFER , CARD CABLE (SMD)	WAFER	1	EA
C801	HCEC1HRV21R0T	CAP , ELEC (SMD)	0.1UF	1	EA
C802	CCUS1H104KC	CAP , CHIP	0.1UF	1	EA
C803	CCUS1H104KC	CAP , CHIP	0.1UF	1	EA
C804	CCUS1H104KC	CAP , CHIP	0.1UF	1	EA
C805	CCUS1H104KC	CAP , CHIP	0.1UF	1	EA
C806	CCUS1H104KC	CAP , CHIP	0.1UF	1	EA
C807	CCUS1H104KC	CAP , CHIP	0.1UF	1	EA
C808	CCUS1H104KC	CAP , CHIP	0.1UF	1	EA
C809	HCEC1CRV2220T	CAP , ELEC (SMD)	22UF/16V	1	EA
C810	HCEC1CRV2220T	CAP , ELEC (SMD)	22UF/16V	1	EA
C811	CCUS1H104KC	CAP , CHIP	0.1UF	1	EA
IC81	CVIAD8190	I.C, HDMI S/W	ANALOG DEVICES	1	EA
IC82	HVILM1117S-5.0	IC REGULATOR/SOT-223(5V)	HTC	1	EA
IC83	HVILM1117S-3V3	I.C , REGULATOR (3.3V)	HTC	1	EA
JK81	HJJ9H003Z	JACK,HDMI(YKF45-7009)	JALCO	1	EA
JK82	HJJ9H003Z	JACK,HDMI(YKF45-7009)	JALCO	1	EA
JK83	HJJ9H003Z	JACK,HDMI(YKF45-7009)	JALCO	1	EA
L801	CLZ9R009Z	CHOKE COIL, CHIP (FOR HDMI)	CMM21T-900M-3H	1	EA
L802	CLZ9R009Z	CHOKE COIL, CHIP (FOR HDMI)	CMM21T-900M-3H	1	EA
L803	CLZ9R009Z	CHOKE COIL, CHIP (FOR HDMI)	CMM21T-900M-3H	1	EA
L804	CLZ9R009Z	CHOKE COIL, CHIP (FOR HDMI)	CMM21T-900M-3H	1	EA
Q801	HVTKRC107S	TRANSISTOR, CHIP NPN	KRC107S	1	EA
R801	CRJ10DJ102T	RES , CHIP	1K OHM	1	EA
R802	CRJ10DJ102T	RES , CHIP	1K OHM	1	EA
R803	CRJ10DJ103T	RES , CHIP	10K OHM	1	EA
R804	CRJ10DJ103T	RES , CHIP	10K OHM	1	EA

Ref. Designator	Part Number	Description	Qty	
AVR 147 TUNER MODULE	CNVM9001MS0J72L			

AKM

AK4384

106dB 192kHz 24-Bit 2ch $\Delta\Sigma$ DAC

GENERAL DESCRIPTION

The AK4384 offers the perfect mix for cost and performance based audio systems. Using AKM's multi bit architecture for its modulator the AK4384 delivers a wide dynamic range while preserving linearity for improved THD+N performance. The AK4384 integrates a combination of SCF and CTF filters increasing performance for systems with excessive clock jitter. The 24 Bit word length and 192kHz sampling rate make this part ideal for a wide range of applications including DVD-Audio. The AK4384 is offered in a space saving 16pin TSSOP package.

FEATURES

- Sampling Rate Ranging from 8kHz to 192kHz
- 128 times Oversampling (Normal Speed Mode)
- 64 times Oversampling (Double Speed Mode)
- 32 times Oversampling (Quad Speed Mode)
- 24-Bit 8 times FIR Digital Filter
- SCF with High Tolerance to Clock Jitter
- 2nd order Analog LPF
- Single Ended Output Buffer
- Digital de-emphasis for 32k, 44.1k and 48kHz sampling
- Soft mute
- Digital Attenuator (Linear 256 steps)
- I/F format: 24-Bit MSB justified, 24/20/16-Bit LSB justified or I^2S
- Master clock: 256fs, 384fs, 512fs, 768fs or 1152fs (Normal Speed Mode)
128fs, 192fs, 256fs or 384fs (Double Speed Mode)
128fs, 192fs (Quad Speed Mode)
- THD+N: -94dB
- Dynamic Range: 106dB
- Power supply: 4.5 to 5.5V
- Very Small Package: 16pin TSSOP (6.4mm x 5.0mm)

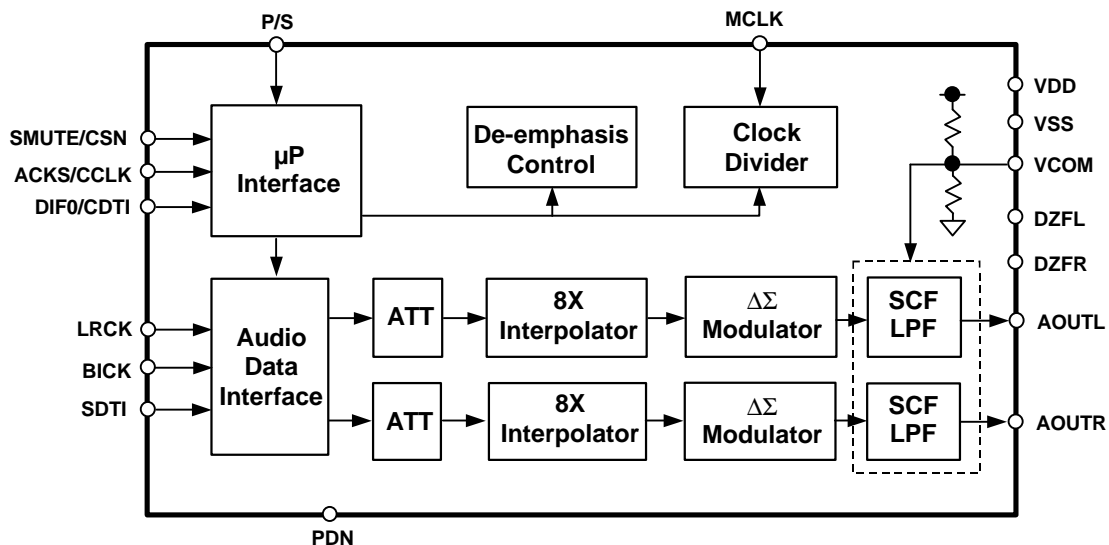

■ Ordering Guide

AK4384VT -40 ~ +85°C 16pin TSSOP (0.65mm pitch)
 AKD4384 Evaluation Board for AK4384

■ Pin Layout

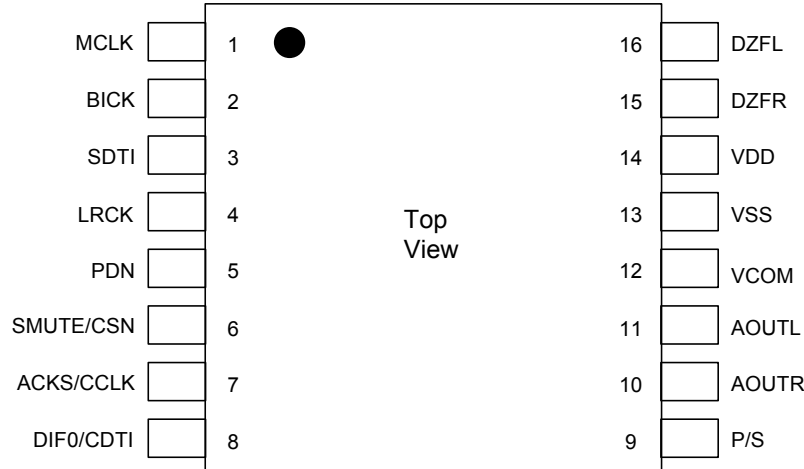

PIN/FUNCTION

No.	Pin Name	I/O	Function
1	MCLK	I	Master Clock Input Pin An external TTL clock should be input on this pin.
2	BICK	I	Audio Serial Data Clock Pin
3	SDTI	I	Audio Serial Data Input Pin
4	LRCK	I	L/R Clock Pin
5	PDN	I	Power-Down Mode Pin When at “L”, the AK4384 is in the power-down mode and is held in reset. The AK4384 should always be reset upon power-up.
6	SMUTE	I	Soft Mute Pin in parallel mode “H”: Enable, “L”: Disable
	CSN	I	Chip Select Pin in serial mode
7	ACKS	I	Auto Setting Mode Pin in parallel mode “L”: Manual Setting Mode, “H”: Auto Setting Mode
	CCLK	I	Control Data Clock Pin in serial mode
8	DIF0	I	Audio Data Interface Format Pin in parallel mode
	CDTI	I	Control Data Input Pin in serial mode
9	P/S	I	Parallel/Serial Select Pin (Internal pull-up pin) “L”: Serial control mode, “H”: Parallel control mode
10	AOUTR	O	Rch Analog Output Pin
11	AOUTL	O	Lch Analog Output Pin
12	VCOM	O	Common Voltage Pin, VDD/2 Normally connected to VSS with a 0.1μF ceramic capacitor in parallel with a 10μF electrolytic cap.
13	VSS	-	Ground Pin
14	VDD	-	Power Supply Pin
15	DZFR	O	Rch Data Zero Input Detect Pin
16	DZFL	O	Lch Data Zero Input Detect Pin

Note: All input pins except pull-up pin should not be left floating.

IC51 XM IC

PRELIMINARY (14 Aug 04)

User Spec - XM Digital Transceiver Integrated Circuit - Rev 3

1. Overview

The XM Digital Transceiver Integrated Circuit (XM/DT IC) provides a cost effective means for an electronics equipment manufacturer to be XM Satellite Radio compatible by multiplexing data and audio streams between the XM Receiver and User Interface Controller into a 2 wire time division duplex (TDD) high frequency serial link.

In a typical application, two XM/DT IC devices connect to each other via a differential link as depicted on Figure 1.1 below. In the 'Slave' unit ("XM/DT Digital Transceiver" (antenna)), the XM/DT IC interfaces directly to the XM Radio receiver chipset taking in a real-time PCM (I2S) audio stream along with data information. The XM/DT IC stores this data in internal RAM and then time division multiplexes the data on a 2-wire serial communication link. This link provides for the physical decoupling of the Slave and Master side of up 100 meters with software transparency

between the Master side processor and audio circuitry and the Slave side XM Satellite Radio receiver chip set.

In the Master unit ("XM/DT Ready Radio"), the XM/DT IC demultiplexes the received data, buffers it internally and reproduces it for consumption. The XM/DT IC is capable of simultaneously sending and receiving serial frames while multiplexing and de-multiplexing them in real time, formatting them and then routing them into the appropriate Slave or Master side interfaces.

The software interface between the user interface and the receiver is unaffected by the introduction of the XM/DT IC link pair.

An input pin on the XM/DT IC configures the part's functionality as either Master (user interface end) or Slave (XM Digital Transceiver end) allowing the same IC to be used at either end of the link.

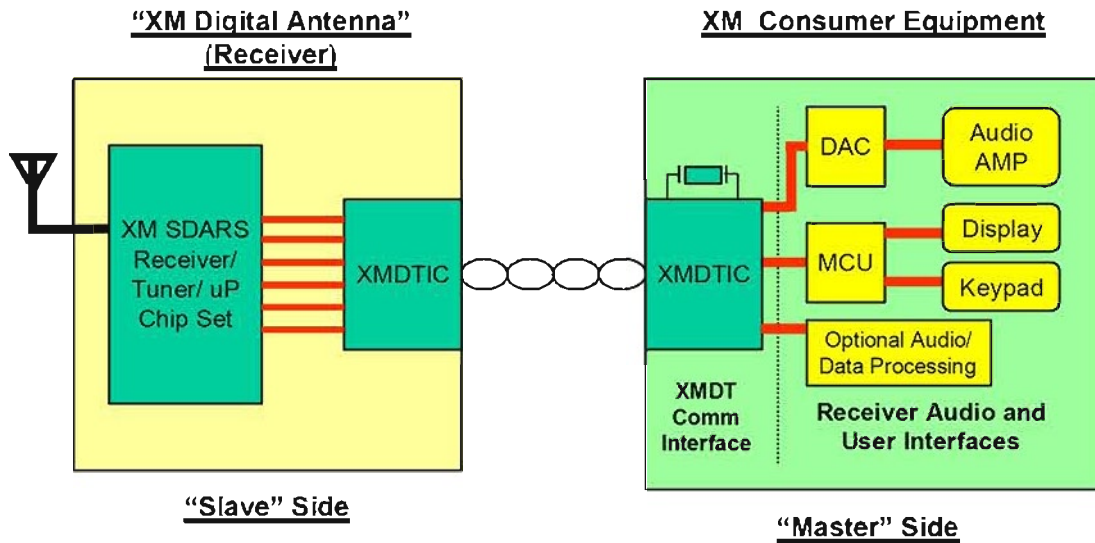

Figure 1.1 - Typical XM/DT Application

2. Functional Description

Figure 2.1 below shows a basic top level diagram showing each functional block in the XM/DT device.

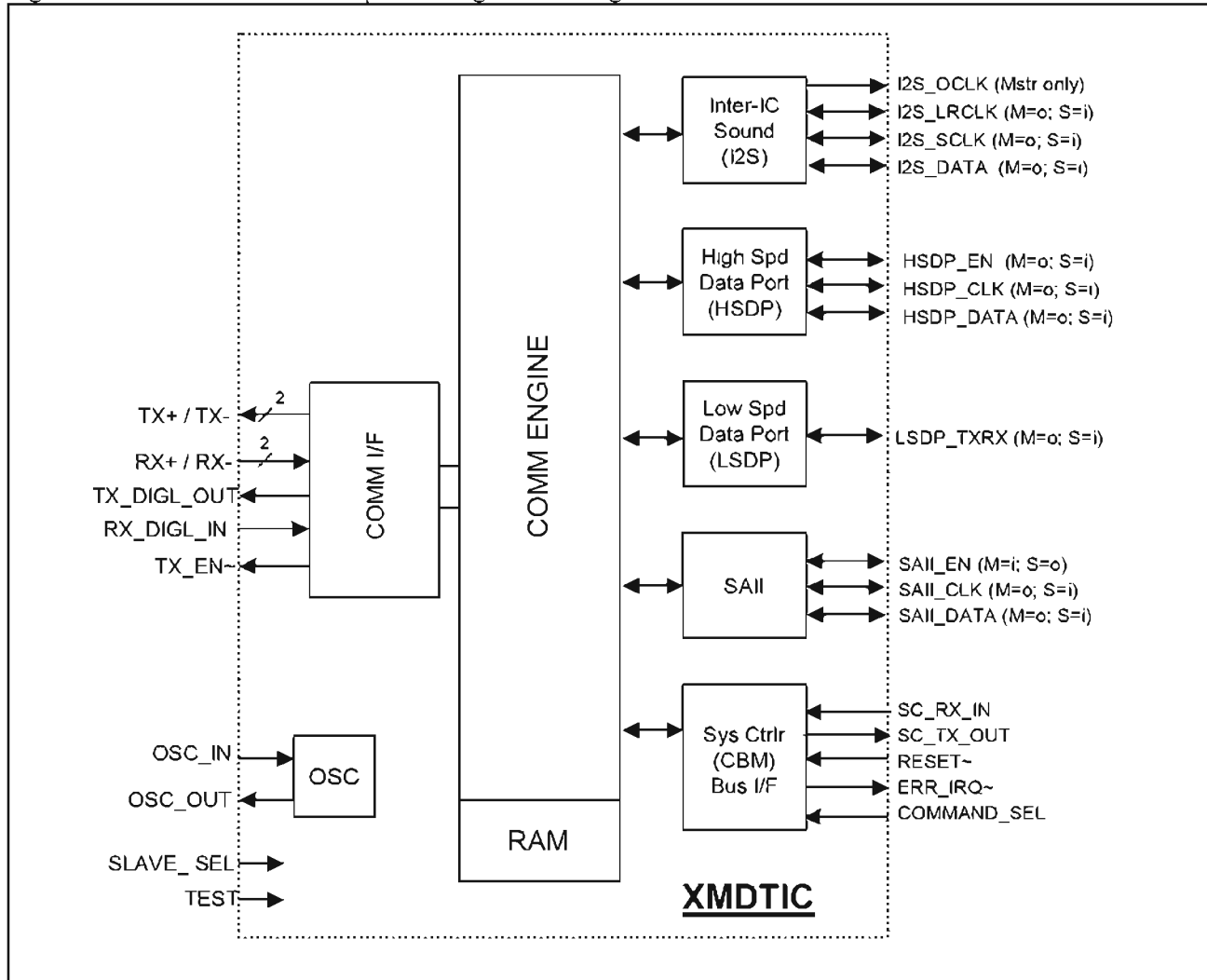

Figure 2.1 XM/DT Top Level Diagram

The XM/DT IC is broken into the following functional blocks:

SC I/F – System Controller Interface

The System Controller Interface transports the serial communication commands and data between the microprocessor in the user interface device and the microprocessor in the XM Digital Antenna. The commands and data transported follow typically follow the XM CBM (Common Bus Messaging) protocol.

The System Controller Interface functional block consists of a full duplex asynchronous serial interface. The SC I/F is used for both the software configuration of the XM/DT IC, monitoring of XM/DT link status, and transparent communications with the SC I/F at the other end of the communications link. The SC I/F block contains five signals, SC_RX_IN, SC_TX_OUT, COMMAND_SEL, ERR_IRQ#, and RESET#.

The SC_RX_IN and SC_TX_OUT connect the asynchronous serial communications to the respective microprocessors. The SC I/F

communicates at a default mode of 9600 baud, no parity, 8 data bits, and 1 stop bit. The baud rate can be changed using the XM/DT IC Command Mode. The Master and Slave baud rates must be set to the same rate by their respective microprocessors.

The COMMAND_SEL input allows configuration of the XM/DT IC and to retrieve feedback of the link status during normal operation. This signal is logic low for normal operation and logic high for Command/Stat Mode. Details of the operation of this signal are described in the Programming section of this specification.

The ERR_IRQ# output signal is active low when an error occurs on the link if interrupts are enabled via the Interrupt Mask register. Access to the Interrupt Mask register is gained via the Command Mode and the interrupt source identification is obtained via the Status Mode. Details of these modes are described in the Programming section of this specification.

The RESET# input signal is used to perform a complete asynchronous reset of the XM/DT IC. The RESET# signal is also used to place the XM/DT IC into Command Mode. Refer to the Programming section.

SAII – Synchronous Audio Input Interface

The SAI Interface functional block provides a synchronous interface with hardware flow control from the Master to the Slave devices.

In Master mode, the XM/DT IC receives SAI Data and SAI Clock from the SAI source in the "playback unit". The SAI Enable (SAI_EN) output signal is fed back to the SAI source to control the flow of input data based on the state of the SAI_EN signal at the Slave Device.

In Slave mode, the XM/DT IC sends SAI Data and SAI Clock to the Slave device SAI receiver, and receives the SAI_EN signal from the SAI receiver to control the flow of transmitted data.

The Master XM/DT IC adapts to the incoming SAI data rate.

LSDP – Low Speed Data Port

The LSDP functional block consists of a unidirectional asynchronous serial interface.

In Master mode, the LSDP transmits data out of the device. In Slave mode, the LSDP receives data into the device.

This interface operates in default mode at 115200, no parity, 8 data bits, and 1 stop bit.

HSDP – High Speed Data Port Interface

The HSDP Interface functional block provides a synchronous serial interface combined with a framing signal from the Slave XM/DT IC to the Master XM/DT IC.

The source of the HSDP is typically the XM receiver chipset. The HSDP data is typically received by the Host microprocessor. The HSDP signals include a serial data bitstream (HSDP_DA), a synchronous clock (HSDP_CLK), and a framing signal (HSDP_EN). The framing signal can be used as a gating mechanism for the clock or an interrupt source to indicate the beginning and end of the HSDP data burst.

In Slave mode, the HSDP Interface receives HSDP_DA, HSDP_CLK, and HSDP_EN from the HSDP source. In Master mode, the HSDP Interface transmits HSDP_DA, HSDP_CLK, and HSDP_EN.

I2S – Inter-IC Sound (I2S) digital audio Interface

The I2S functional block receives and transmits timing and frame sensitive data. The I2S interface is also referred to as the PCM interface.

In Slave mode, the XM/DT IC I2S Interface receives the I2S digital audio from the XM Receiver chipset. The XM/DT IC automatically adjusts to the incoming I2S data sampling rate.

In Master mode, the XM/DT IC I2S Interface generates all required signals to drive an I2S compatible audio DAC.

COMM2W – Two Wire Communications Interface

The COMM2W functional block enables communications between two XM/DT ICs. The COMM2W is differential Time-Division-Duplex Interface.

3. Physical Description

3.1 Device Pin-out

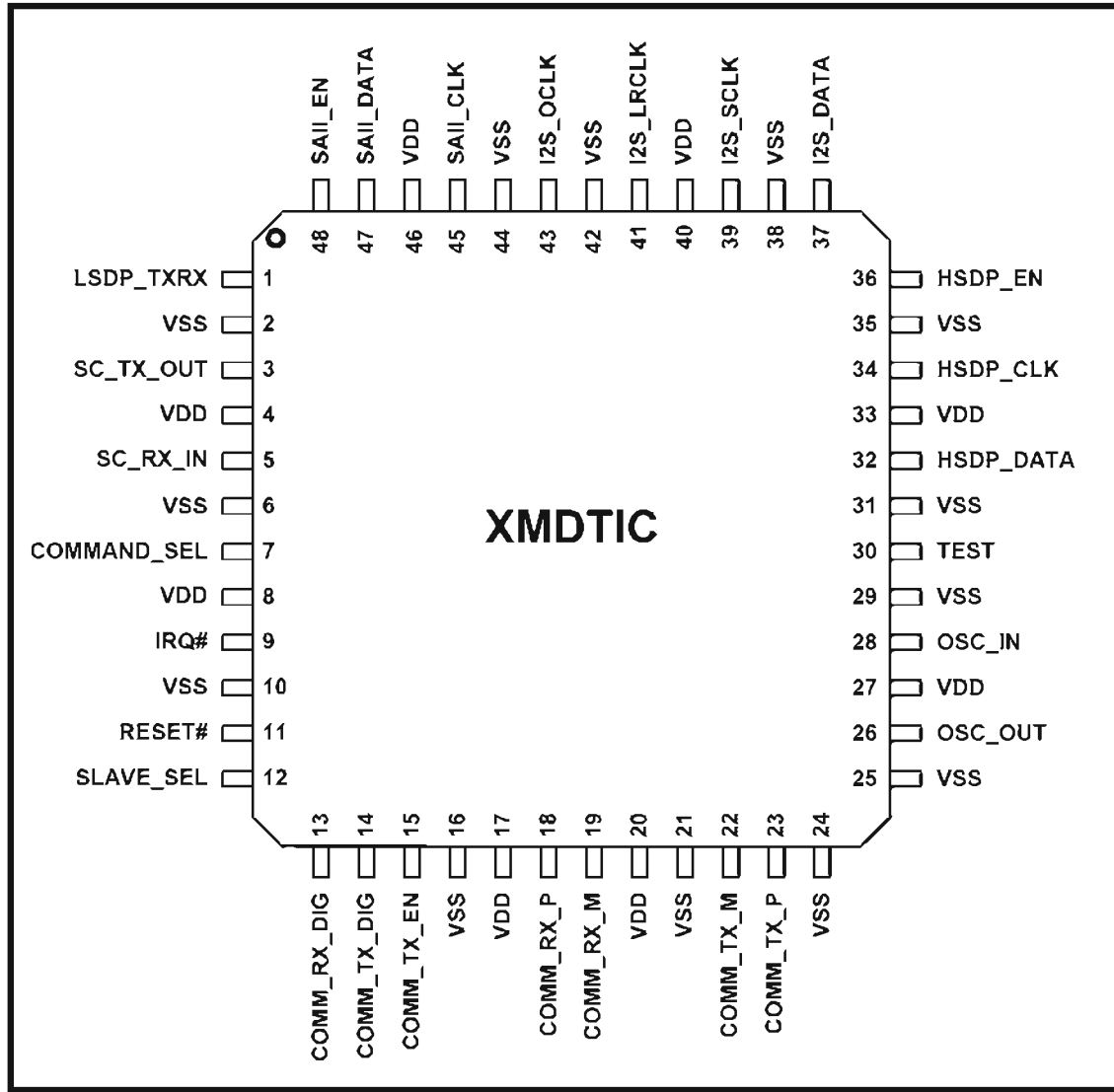

Figure 3.1 – Pin Connection (Top View)

3.2 Pin Descriptions

Table 3.2 Pin Descriptions

Pin #	Pin Name	Type	Function in Slave Mode	Function in Master Mode	Notes
1	LSDP_TXRX	S=In M=Out	Low Speed Data Port Output	Low Speed Data Port Input	LVTTTL S/T
3	SC_TX_OUT	S=Out M=Out	System Controller Bus (CBM) Transmit Data Out	System Controller Bus (CBM) Transmit Data Out	4mA, SLC
5	SC_RX_IN	S=In M=In	System Controller Bus (CBM) Receive Data In	System Controller Bus (CBM) Receive Data In	LVTTTL S/T
7	COMMAND_SEL	S=In M=In	Command Mode Select In (1= Command Mode, 0=Normal Mode)	Command Mode Select In (1= Command Mode, 0=Normal Mode)	LVTTTL S/T
9	IRQ#	S=Out M=Out	Interrupt Request Out (Active Low)	Interrupt Request Out (Active Low)	4mA Open Drain
11	RESET#	S=In M=In	Asynchronous Reset In, (Active Low)	Asynchronous Reset In, (Active Low)	LVTTTL S/T
12	SLAVE_SEL	S=In M=In	M/S Mode Select In (High = Slave Mode)	M/S Mode Select In (Low = Master Mode)	LVTTTL S/T
13	COMM_RX_DIG	S=In M=In	DT Comm Bus External Transceiver Receive Data In	DT Comm Bus External Transceiver Receive Data In	LVTTTL S/T
14	COMM_TX_DIG	Output	DT Comm Bus External Transceiver Transmit Data Out	DT Comm Bus External Transceiver Transmit Data Out	LVTTTL S/T
15	COMM_TX_EN	Output	DT Comm Bus External Transceiver Direction Out (1=Transmit, 0=Receive)	DT Comm Bus External Transceiver Direction Out (1=Transmit, 0=Receive)	LVTTTL S/T
18	COMM_RX_P	S=In M=In	DT Comm Bus Internal Receiver Differential Positive In	DT Comm Bus Internal Receiver Differential Positive In	LVDS in+
19	COMM_RX_M	S=In M=In	DT Comm Bus Internal Receiver Differential Negative In	DT Comm Bus Internal Receiver Differential Negative In	LVDS in-
22	COMM_TX_M	Output	DT Comm Bus Internal Transmitter Differential Negative Out	DT Comm Bus Internal Transmitter Differential Negative Out	LVDS out-
23	COMM_TX_P	Output	DT Comm Bus Internal Transmitter Differential Positive Out	DT Comm Bus Internal Transmitter Differential Positive Out	LVDS out+
26	OSC_OUT	Output	Crystal Output	Crystal Output	Crystal Buffer
28	OSC_IN	S=In M=In	Crystal Input	Crystal Input	Crystal Buffer
30	TEST	S=In M=In	Factory Test Mode Select (1=Test, 0= Normal Oper.)	Factory Test Mode Select (1=Test, 0= Normal Oper.)	LVTTTL S/T
32	HSDP_DATA	S=In M=Out	High Speed Data Port Data Input	High Speed Data Port Data Output	Out= 4mA, SLC In=LVTTTL S/T
34	HSDP_CLK	S=In M=Out	High Speed Data Port Clock Input	High Speed Data Port Clock Output	Out= 4mA, SLC In=LVTTTL S/T
36	HSDP_EN	S=Out M=In	High Speed Data Port Enable Output	High Speed Data Port Enable Input	Out= 4mA, SLC In=LVTTTL S/T
37	I2S_DATA	S=In M=Out	I2S Digital Port Data In	I2S Digital Audio Port Data Out	Out= 4mA, SLC In=LVTTTL S/T

Pin #	Pin Name	Type	Function in Slave Mode	Function in Master Mode	Notes
39	I2S_SCLK	S=In M=Out	I2S Digital Audio Port Bit Clock In	I2S Digital Audio Port Bit Clock Out	Out= 4mA, SLC In=LVTTL S/T
41	I2S_LRCLK	S=In M=Out	I2S Digital Audio Port Left/Right Clock In	I2S Digital Audio Port Left/Right Clock Out	Out= 4mA, SLC In=LVTTL S/T
43	I2S_OCLK	S=In M=Out	I2S Digital Audio Port Oversample Clock (not used - connect to Gnd???)	I2S Digital Audio Port Oversample Clock Out	Out= 4mA, SLC
45	SAII_CLK	S=Out M=In	SAII Port Clock Output	SAII Port Clock Input	Out= 4mA, SLC 3.3V S/T
47	SAII_DATA	S=Out M=In	SAII Port Data Output	SAII Port Data Input	Out= 4mA, SLC In=LVTTL S/T
48	SAII_REQ	S=In M=Out	SAII Port Request Input	SAII Port Request Output	Out= 4mA, SLC In=LVTTL S/T

Pin#	Pin Name	Type	Function in Slave Mode	Function in Master Mode	Notes
4, 8, 17, 20, 27, 33, 40, 46	VDD	PWR	+3.3V Supply Voltage	+3.3V Supply Voltage	
2, 6, 10, 16, 21, 24, 25, 29, 31, 25, 38, 42, 44	VSS	GND	Digital Ground	Digital Ground	

Notes: All Inputs are 3.3V LVTTL compatible; S/T = Schmitt Trigger inputs; SLC = Slew Rate Controller Output



ST202E ST232E

± 15KV ESD PROTECTED 5V RS-232 TRANSCEIVER

- ESD PROTECTION FOR RS-232 I/O PINS:
± 15 KV HUMAN BODY MODEL
- GUARANTEED 120 kbps DATA RATE
- GUARANTEED SLEW RATE RANGE 3 to 30V/μs
- OPERATE FROM A SINGLE 5V POWER SUPPLY

DESCRIPTION

The ST202E/ST232E are a 2 driver 2 receiver devices designed for RS-232 and V.28 communications in harsh environments. Each transmitter output and receiver input is protected against ± 15KV electrostatic discharge (ESD) shocks. The drivers meet all EIA/TIA-232E and CCITT V.28 specifications at data rates up to 120Kbps, when loaded in accordance with the EIA/TIA-232E specification.

The ST202E/232E use a single 5V supply voltage.

The ST232E operates with four 1μF capacitors,

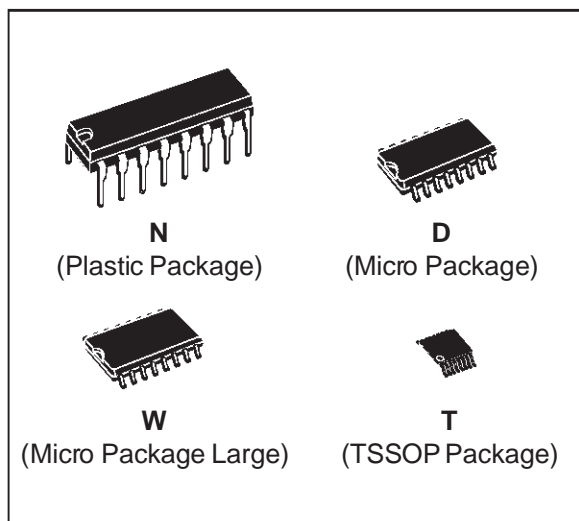

while the ST202E operates with four 0.1μF capacitors, further reducing cost and board space.

ORDER CODES

Type		Temperature Range	Package	Comments
ST202ECN	ST232ECN	0 to 70 °C	DIP-16	25 parts per tube / 40 tube per box
ST202EBN	ST232EBN	-40 to 85 °C	DIP-16	25 parts per tube / 40 tube per box
ST202ECD	ST232ECD	0 to 70 °C	SO-16 (Tube)	50 parts per tube / 20 tube per box
ST202EBD	ST232EBD	-40 to 85 °C	SO-16 (Tube)	50 parts per tube / 20 tube per box
ST202ECDR	ST232ECDR	0 to 70 °C	SO-16 (Tape & Reel)	2500 parts per reel
ST202EBDR	ST232EBDR	-40 to 85 °C	SO-16 (Tape & Reel)	2500 parts per reel
ST202ECW	ST232ECW	0 to 70 °C	SO-16 Large (Tube)	50 parts per tube / 20 tube per box
ST202EBW	ST232EBW	-40 to 85 °C	SO-16 Large (Tube)	50 parts per tube / 20 tube per box
ST202ECWR	ST232ECWR	0 to 70 °C	SO-16 Large (Tape & Reel)	1000 parts per reel
ST202EBWR	ST232EBWR	-40 to 85 °C	SO-16 Large (Tape & Reel)	1000 parts per reel
ST202ECTR	ST232ECTR	0 to 70 °C	TSSOP16 (Tape & Reel)	2500 parts per reel
ST202EBTR	ST232EBTR	-40 to 85 °C	TSSOP16 (Tape & Reel)	2500 parts per reel

ST202E/ST232E

PIN CONFIGURATION

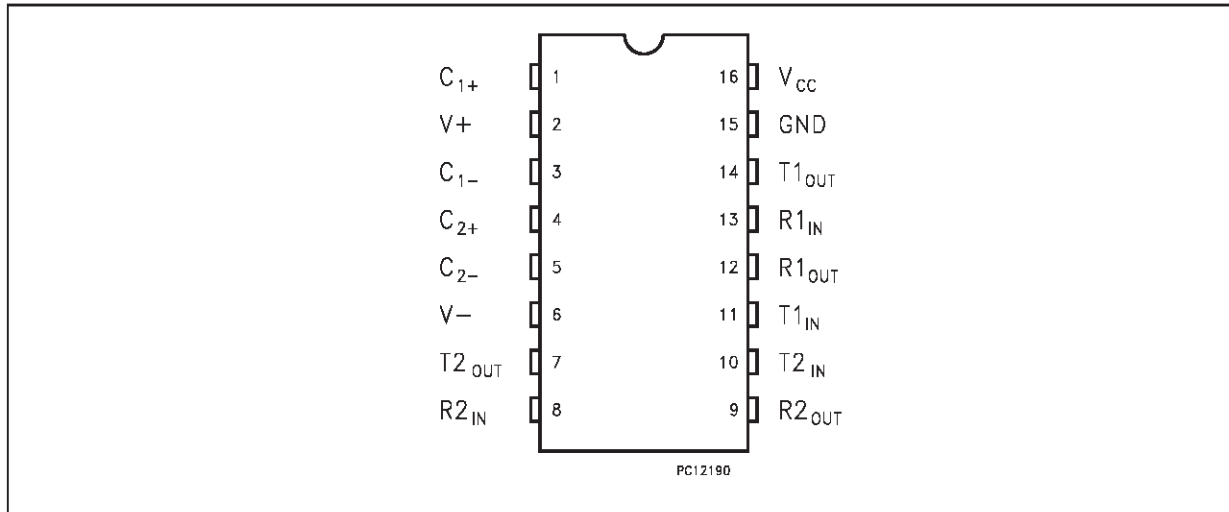

PIN DESCRIPTION

PIN No	SYMBOL	NAME AND FUNCTION
1	C ₁₊	Positive Terminal for the first Charge Pump Capacitor
2	V+	Doubled Voltage Terminal
3	C ₁₋	Negative Terminal for the first Charge Pump Capacitor
4	C ₂₊	Positive Terminal for the second Charge Pump Capacitor
5	C ₂₋	Negative Terminal for the second Charge Pump Capacitor
6	V-	Inverted Voltage Terminal
7	T ₂ OUT	Second Transmitter Output Voltage
8	R ₂ IN	Second Receiver Input Voltage
9	R ₂ OUT	Second Receiver Output Voltage
10	T ₂ IN	Second Transmitter Input Voltage
11	T ₁ IN	First Transmitter Input Voltage
12	R ₁ OUT	First Receiver Output Voltage
13	R ₁ IN	First Receiver Input Voltage
14	T ₁ OUT	First Transmitter Output Voltage
15	GND	Ground
16	V _{CC}	Supply Voltage



NJM2137

ULTRA WIDE BAND, HIGH SLEW RATE DUAL OPERATIONAL AMPLIFIER

■ GENERAL DESCRIPTION

The NJM2137 is an ultra wide band, high slew rate dual operational amplifier operated from low voltage ($\pm 1.35V$).

It can apply to active filter, high speed analog and digital signal processor, line driver, HDTV, industrial measurement equipment and others.

It can also apply to portable communication items because of low operating voltage and low operating current.

■ PACKAGE OUTLINE



NJM2137V



NJM2137M

■ FEATURES

- Operating Voltage ($\pm 1.35V \sim \pm 6V$)
- Ultra Wide Band (200MHz typ.)
- High Slew rate (45V/ μ s typ.)
- Low Operating Current (1.14mA typ.)
- Bipolar Technology
- Package Outline SSOP8, DMP8

■ PIN CONFIGURATION

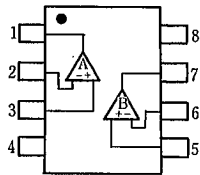

NJM2137M
NJM2137V

PIN FUNCTION

1. A OUTPUT
2. A -INPUT
3. A +INPUT
4. V^-
5. B +INPUT
6. B -INPUT
7. B OUTPUT
8. V^+

■ EQUIVALENT CIRCUIT (1/2 Shown)

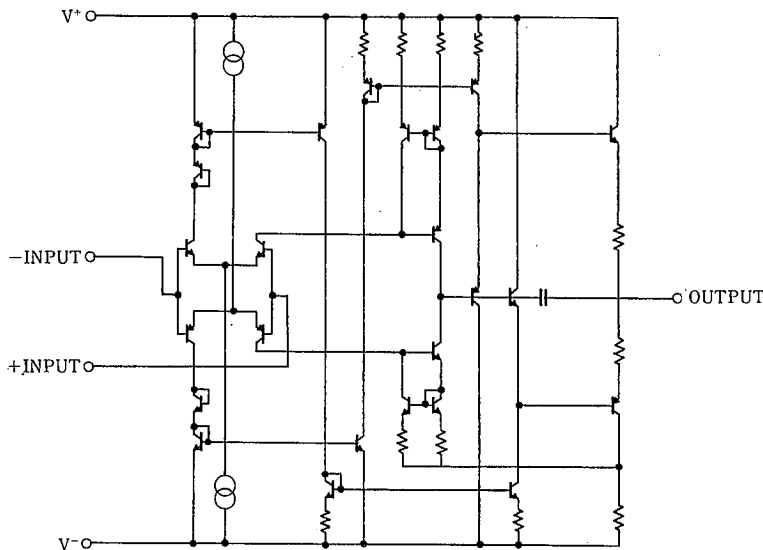

4



2:1 HDMI/DVI Switch with Equalization

AD8190

FEATURES

Two inputs, one output HDMI/DVI links

Enables HDMI 1.2a-compliant receiver

Four TMDS channels per link

Supports 250 Mbps to 1.65 Gbps data rates

Supports 25 MHz to 165 MHz pixel clocks

Equalized inputs for operation with long HDMI cables
(20 meters at 1080p)

Fully buffered unidirectional inputs/outputs

Globally switchable 50 Ω on-chip terminations

Pre-emphasized outputs

Low added jitter

Single-supply operation (3.3 V)

Four auxiliary channels per link

Bidirectional unbuffered inputs/outputs

Flexible supply operation (3.3 V to 5 V)

HDCP standard compatible

Allows switching of DDC bus and two additional signals

Output disable feature

Reduced power dissipation

Output termination removal

Two AD8190s support HDMI/DVI dual-link

Standards compliant: HDMI receiver, HDCP, DVI

Serial (I²C slave) control interface

56-lead, 8 mm x 8 mm, LFCSP, Pb-free package

APPLICATIONS

Multiple input displays

Projectors

A/V receivers

Set-top boxes

Advanced television (HDTV) sets

GENERAL DESCRIPTION

The AD8190 is an HDMI/DVI switch featuring equalized TMDS inputs and pre-emphasized TMDS outputs, ideal for systems with long cable runs. Outputs can be set to a high impedance state to reduce the power dissipation and/or allow the construction of larger arrays using the wire-OR technique.

The AD8190 is provided in a space saving, 56-lead, LFCSP, surface-mount, Pb-free, plastic package and is specified to operate over the -40°C to +85°C temperature range.

FUNCTIONAL BLOCK DIAGRAM

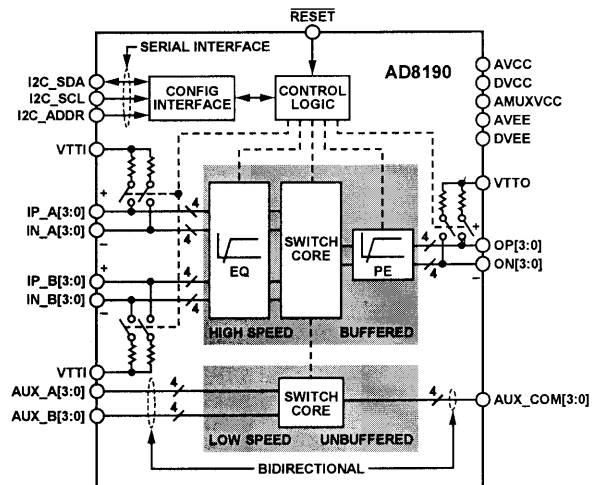

Figure 1.

TYPICAL APPLICATION

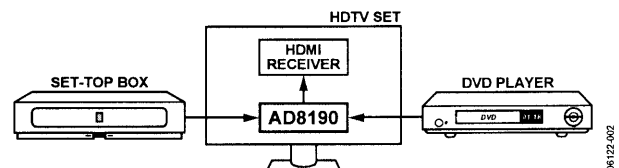

Figure 2. Typical AD8190 Application for HDTV Sets

PRODUCT HIGHLIGHTS

1. Supports data rates up to 1.65 Gbps, enabling UXGA (1600 × 1200) DVI resolutions and 1080p HDMI formats.
2. Input cable equalizer enables use of long cables at the input (more than 20 meters of 24 AWG cable at 1080p).
3. Auxiliary switch allows routing of the DDC bus and two additional single-ended signals for a single chip, fully HDMI 1.2a receive-compliant solution.

Rev. 0

Information furnished by Analog Devices is believed to be accurate and reliable. However, no responsibility is assumed by Analog Devices for its use, nor for any infringements of patents or other rights of third parties that may result from its use. Specifications subject to change without notice. No license is granted by implication or otherwise under any patent or patent rights of Analog Devices. Trademarks and registered trademarks are the property of their respective owners.

One Technology Way, P.O. Box 9106, Norwood, MA 02062-9106, U.S.A.
Tel: 781.329.4700 www.analog.com
Fax: 781.461.3113 ©2006 Analog Devices, Inc. All rights reserved.

AD8190

PIN CONFIGURATION AND FUNCTION DESCRIPTIONS

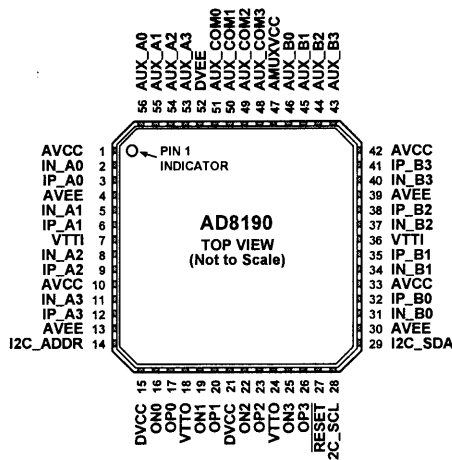

NOTES
 1. THE AD8190 LFCSP HAS AN EXPOSED PADDLE (ePAD) ON THE UNDERSIDE OF THE PACKAGE WHICH AIDS IN HEAT DISSIPATION. THE ePAD MUST BE ELECTRICALLY CONNECTED TO THE AVEE SUPPLY PLANE IN ORDER TO MEET THERMAL SPECIFICATIONS.

06122-003

Figure 3. Pin Configuration

Table 4. Pin Function Descriptions

Pin No.	Mnemonic	Type ¹	Description
1, 10, 33, 42	AVCC	Power	Positive Analog Supply. 3.3 V nominal.
2	IN_A0	HS I	High Speed Input Complement.
3	IP_A0	HS I	High Speed Input.
4, 13, 30, 39, ePAD	AVEE	Power	Negative Analog Supply. 0 V nominal.
5	IN_A1	HS I	High Speed Input Complement.
6	IP_A1	HS I	High Speed Input.
7, 36	VTTI	Power	Input Termination Supply. Nominally connected to AVCC.
8	IN_A2	HS I	High Speed Input Complement.
9	IP_A2	HS I	High Speed Input.
11	IN_A3	HS I	High Speed Input Complement.
12	IP_A3	HS I	High Speed Input.
14	I2C_ADDR	Control	I ² C Address LSB.
15, 21	DVCC	Power	Positive Digital Power Supply. 3.3 V nominal.
16	ON0	HS O	High Speed Output Complement.
17	OP0	HS O	High Speed Output.
18, 24	VTTO	Power	Output Termination Supply. Nominally connected to AVCC.
19	ON1	HS O	High Speed Output Complement.
20	OP1	HS O	High Speed Output.
22	ON2	HS O	High Speed Output Complement.
23	OP2	HS O	High Speed Output.
25	ON3	HS O	High Speed Output Complement.
26	OP3	HS O	High Speed Output.
27	RESET	Control	Configuration Registers Reset. This pin is normally pulled up to DVCC.
28	I2C_SCL	Control	I ² C Clock.
29	I2C_SDA	Control	I ² C Data.
31	IN_B0	HS I	High Speed Input Complement.
32	IP_B0	HS I	High Speed Input.

AD8190

Pin No.	Mnemonic	Type ¹	Description
34	IN_B1	HS I	High Speed Input Complement.
35	IP_B1	HS I	High Speed Input.
37	IN_B2	HS I	High Speed Input Complement.
38	IP_B2	HS I	High Speed Input.
40	IN_B3	HS I	High Speed Input Complement.
41	IP_B3	HS I	High Speed Input.
43	AUX_B3	LS I/O	Low Speed Input/Output.
44	AUX_B2	LS I/O	Low Speed Input/Output.
45	AUX_B1	LS I/O	Low Speed Input/Output.
46	AUX_B0	LS I/O	Low Speed Input/Output.
47	AMUXVCC	Power	Positive Auxiliary Switch Supply. 5 V typical.
48	AUX_COM3	LS I/O	Low Speed Common Input/Output.
49	AUX_COM2	LS I/O	Low Speed Common Input/Output.
50	AUX_COM1	LS I/O	Low Speed Common Input/Output.
51	AUX_COM0	LS I/O	Low Speed Common Input/Output.
52	DVEE	Power	Negative Digital and Auxiliary Switch Power Supply. 0 V nominal.
53	AUX_A3	LS I/O	Low Speed Input/Output.
54	AUX_A2	LS I/O	Low Speed Input/Output.
55	AUX_A1	LS I/O	Low Speed Input/Output.
56	AUX_A0	LS I/O	Low Speed Input/Output.

¹ HS = high speed, LS = low speed, I = input, O = output.

Ordering number : ※EN5039

CMOS IC

SANYO	No. ※5039	LC74763, 74763M
		On-Screen Display LSI

Preliminary

Overview

The LC74763 and LC74763M are on-screen display CMOS LSIs that superimpose text and low-level graphics onto a TV screen (video signal) under the control of a microcontroller. The display characters have a 12 by 18 dots structure, and 128 characters are provided.

Features

- Display structure: 12 lines by 24 characters (up to 288 characters)
- Maximum character display: Up to 288 characters
- Character configuration: 12 (W) by 18 (H) dots structure
- Number of characters: 128 characters (128 plus space 2 fonts)
- Character sizes: Three sizes (normal, double, and triple sizes)
- Display starting positions: 64 horizontal and 64 vertical locations
- Reverse video function: Characters can be inverted on a per character basis.
- Flashing types: Two types with periods of 0.5 and 1.0 second on a per character basis (duty fixed at 50%)
- Background color: One of eight colors (when internal synchronization used)
- External control input: Serial data input in 8-bit units
- Built-in horizontal/vertical sync separation circuit, AFC circuit, and synchronization detector
- Video output: Composite video signal output in NTSC, PAL, PAL-M, PAL-N, PAL60, NTSC4.43, or SECAM format

Package Dimensions

unit: mm

3196-DIP30SD

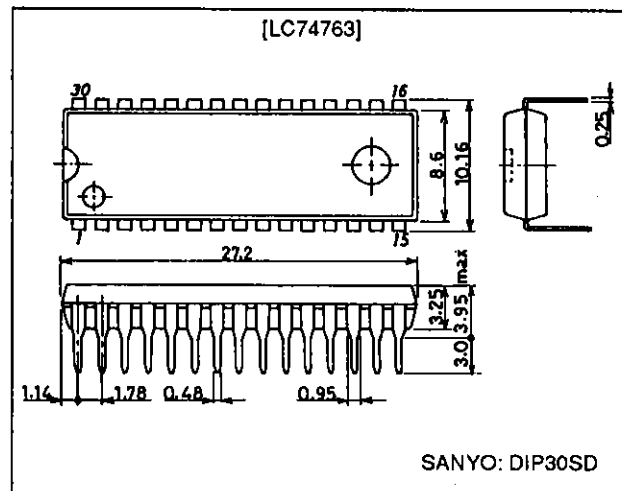

3216A-MFP30S

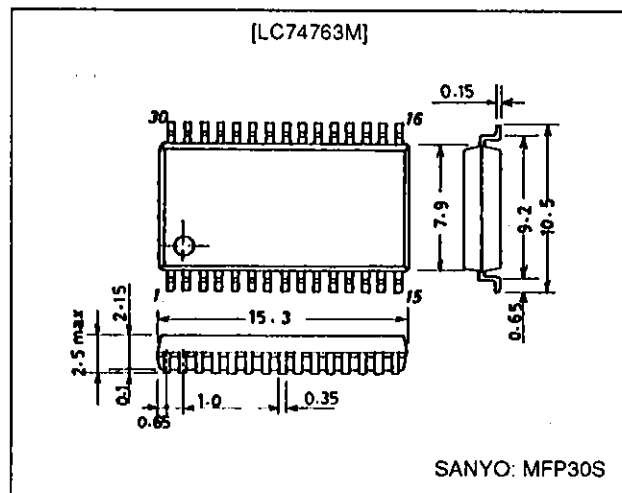

LC74763, 74763M

Pin Functions

Pin No.	Symbol	Function	Description
1	V _{SS}	Ground	Ground connection
2	Xtal _{IN1}	Crystal oscillator connection	Connection for the crystal and capacitor used to form the crystal oscillator that generates the internal synchronization signal. The oscillator can be selected with a command switch.
3	Xtal _{OUT1}		
4	HSYNC _{OUT}	Horizontal synchronization output	Outputs the horizontal synchronization signal (AFC). The output polarity can be selected (metal option). Also functions as general output port (command switch).
5	Xtal _{IN2}	Crystal oscillator connection	Connection for the crystal and capacitor used to form the crystal oscillator that generates the internal synchronization signal.
6	Xtal _{OUT2}		
7	VSYNC _{OUT}	Vertical synchronization output	Outputs the vertical synchronization signal. The output polarity can be selected (metal option). Also functions as general output port (command switch).
8	$\overline{\text{CS}}$	Enable input	Enables/disables serial data input. Serial data is enabled when this pin is low (hysteresis input). Pull-up resistor built in (metal option).
9	SIN	Data input	Serial data input (hysteresis input). Pull-up resistor built in (metal option).
10	SCLK	Clock input	Clock input for serial data input (hysteresis input). Pull-up resistor built in (metal option).
11	SECAM	SECAM mode switch input/output (command switch)	During input, switches between SECAM and other modes. During output, functions as general output port or internal V output (command switch). Low = other modes, high = SECAM mode
12	$\overline{525/625}$	525/625 switch input/output (command switch)	During input, switches between 525 scan lines and 625 scan lines. During output, functions as general output port or character data output (command switch). Low = 525 lines, high = 625 lines
13	$\overline{\text{NTSC/PAL}}$	NTSC/PAL switch input/output (command switch)	Switches the color mode between NTSC and PAL. During output, functions as general output port or frame data output (command switch). Low = NTSC, high = PAL
14	$\overline{3.58/4.43}$	3.58/4.43 switch input/output (command switch)	Switch FSC between 3.58 MHz and 4.43 MHz. During output, functions as general output port or halftone output (command switch). Low = 3.58, high = 4.43
15	RST	Reset input	System reset input pin, low is active (hysteresis input). Pull-up resistor built in (metal option).
16	CV _{OUT}	Video signal output	Composite video output
17	V _{DD2}	Power supply connection	Power supply connection for composite video signal level generation
18	CV _{IN}	Video signal input	Composite video input
19	CV _{CR}	Video signal input	SECAM chroma signal input
20	SYNC _{IN}	Sync separator circuit input	Built-in sync separator circuit video signal input
21	SEP _C	Sync separator circuit	Built-in sync separator circuit
22	V _{SS}	Ground	Ground connection
23	PD _{OUT}	Control voltage output	AFC control voltage output
24	AMP _{IN}	AFC filter connection	Filter connection
25	AMP _{OUT}		
26	FC	Control voltage input	AFC control voltage input
27	VCO _{IN}	LC oscillator connection	VCO LC oscillator circuit coil and capacitor connection
28	VCO _{OUT}		
29	SYNC _{DET}	External synchronization signal detection output	Outputs the exclusive NOR of the horizontal synchronization signal (AFC) and CSYNC (sync separator). The output polarity can be selected (metal option). Also functions as general output port (command switch).
30	V _{DD1}	Power supply connection	Power supply connection (+5 V: digital system power supply)

LC74763, 74763M

Pin Assignment

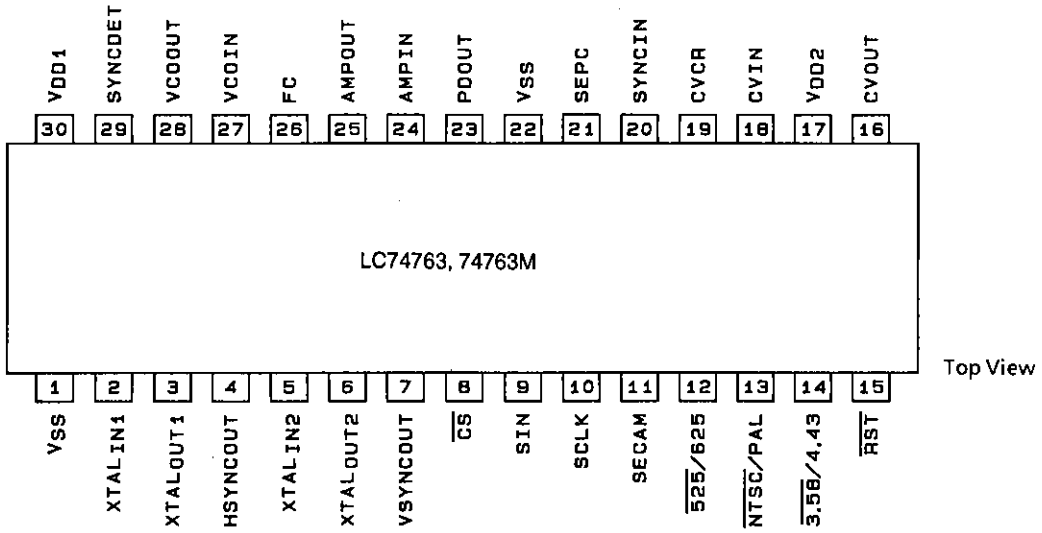

A03B19

Serial Data Input Timing

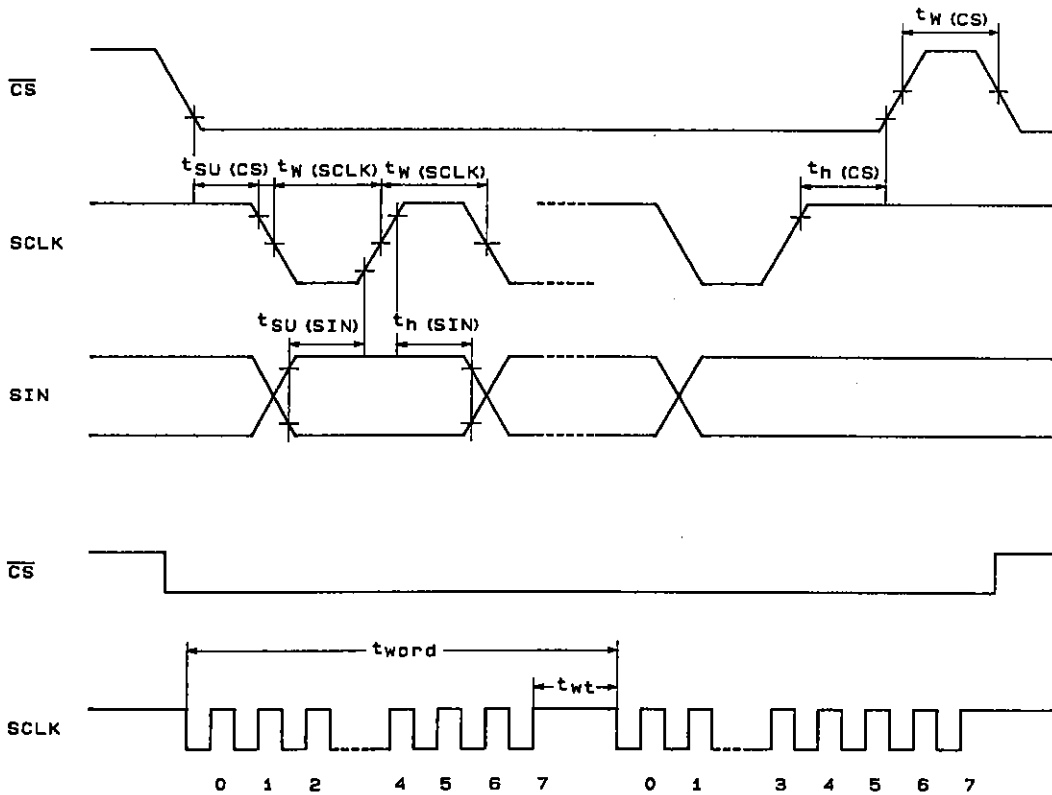

A03B19

LC74763, 74763M

System Block Diagram

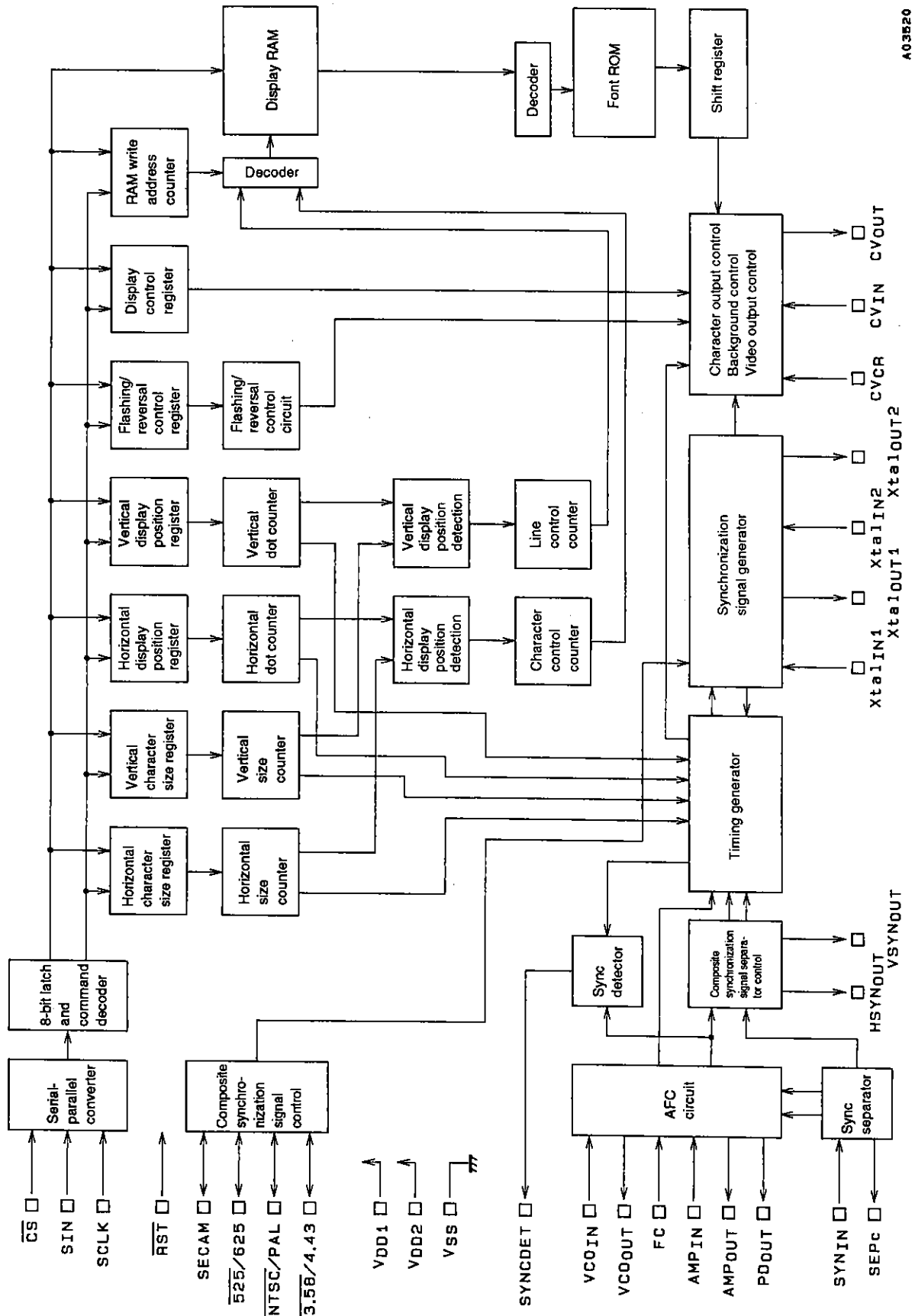

A03520



NJM2587

6CH VIDEO AMPLIFIER FOR DVD

■ GENERAL DESCRIPTION

The NJM2587 is a dual supply voltage 6ch Video Amplifier. It includes 6dB amplifier and 75Ω driver, Low Pass Filter.

The input corresponds to the composite signal, the Y/C signal, and the component signal.

The NJM2587 is suitable for the DVD player and DVD recorder corresponding to the progressive video signal.

■ PACKAGE OUTLINE

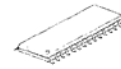

NJM2587V

■ FEATURES

- Operating Voltage ± 4.5 to ± 5.5 V
- 6dB amplifier
- Internal LPF
- Internal 75Ω Driver Circuit (2-system drive)
- Power Save Circuit
- Bipolar Technology
- Package Outline SSOP32

■ BLOCK DIAGRAM

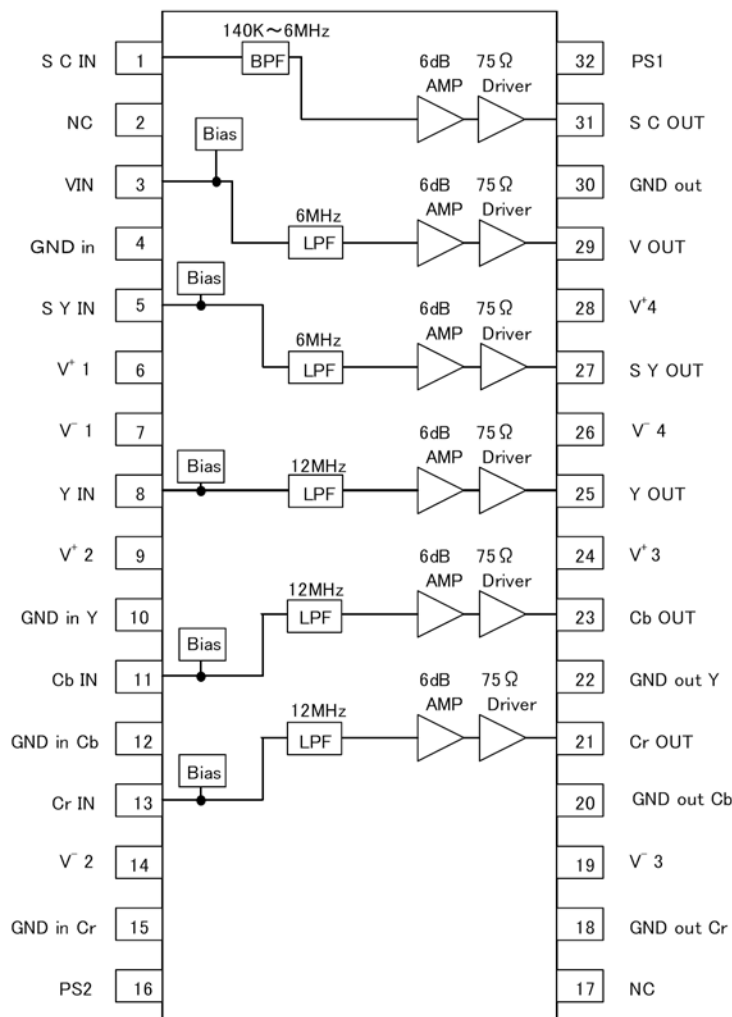



NJM2587

■ TERMINAL DESCRIPTION

No.	SYMBOL	EQUIVALENT CIRCUIT	VOLTAGE	NOTE
1	SCIN		-	
3 5 8 11 13	VIN SYIN YIN CbIN CrIN		0V	
4 10 12 15	GNDIN GNDINY GNDINCb GNDINCr		0V	
18 20 22 30	GNDOUTCr GNDOUTCb GNDOUTY GNDOUT		0V	



NJM2587

No.	SYMBOL	EQUIVALENT CIRCUIT	VOLTAGE	NOTE
25 27 29	YOUT SYOUT VOUT		-0.6V	
31	SCOUT		0.7V	
16 32	PS2 PS1		0V	
21 23	CrOUT CbOUT		-1.2V	



NJW1321

WIDE BAND VIDEO SWITCH WITH I²C BUS

■ GENERAL DESCRIPTION

The NJW1321 is a Wide Band Video Switch with I²C BUS.

The NJW1321 includes switch of 4-input 2-output and 6dB amplifier. It is suitable for RGB or Y, Pb, and Pr signal because frequency range is 100MHz.

The NJW1321 includes external logic control terminals and external logic discernment terminals.

The NJW1321 is suitable for PTV, DTV, PDP and other high quality AV systems.

■ PACKAGE OUTLINE



NJW1321FP1

■ FEATURES

- Operating Voltage +9.0V
- I²C BUS Interface
- 4-input 2-output 3-Circuits
- Wide frequency range 0dB at 100MHz typ.
-3dB at 300MHz typ.
- Internal 6dB amplifier (Selectable Bypass or 6dB)
- External logic discernment terminal
- External logic control terminal
- Selectable slave address
- Power Save Circuit
- Bi-CMOS Technology
- Package Outline QFP48

■ BLOCK DIAGRAM

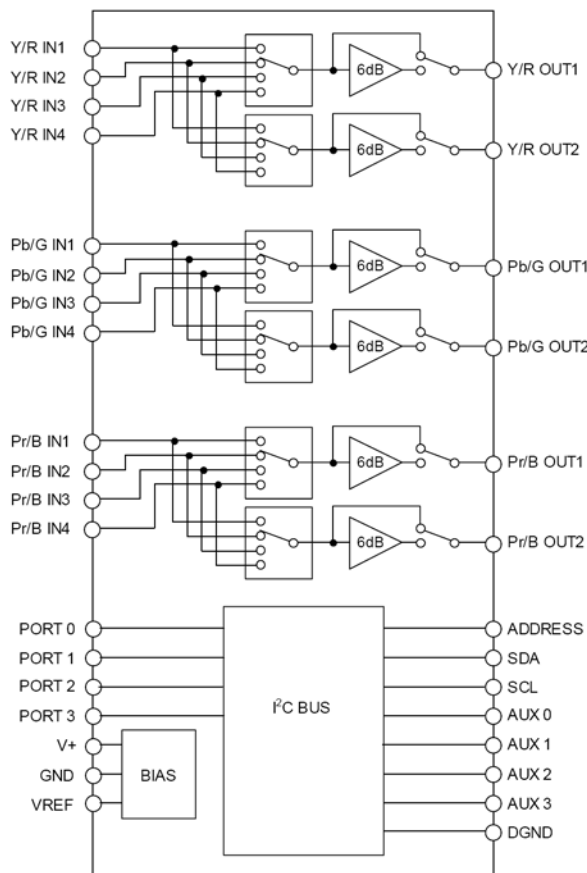

NJW1321

■ PIN CONFIGURATION

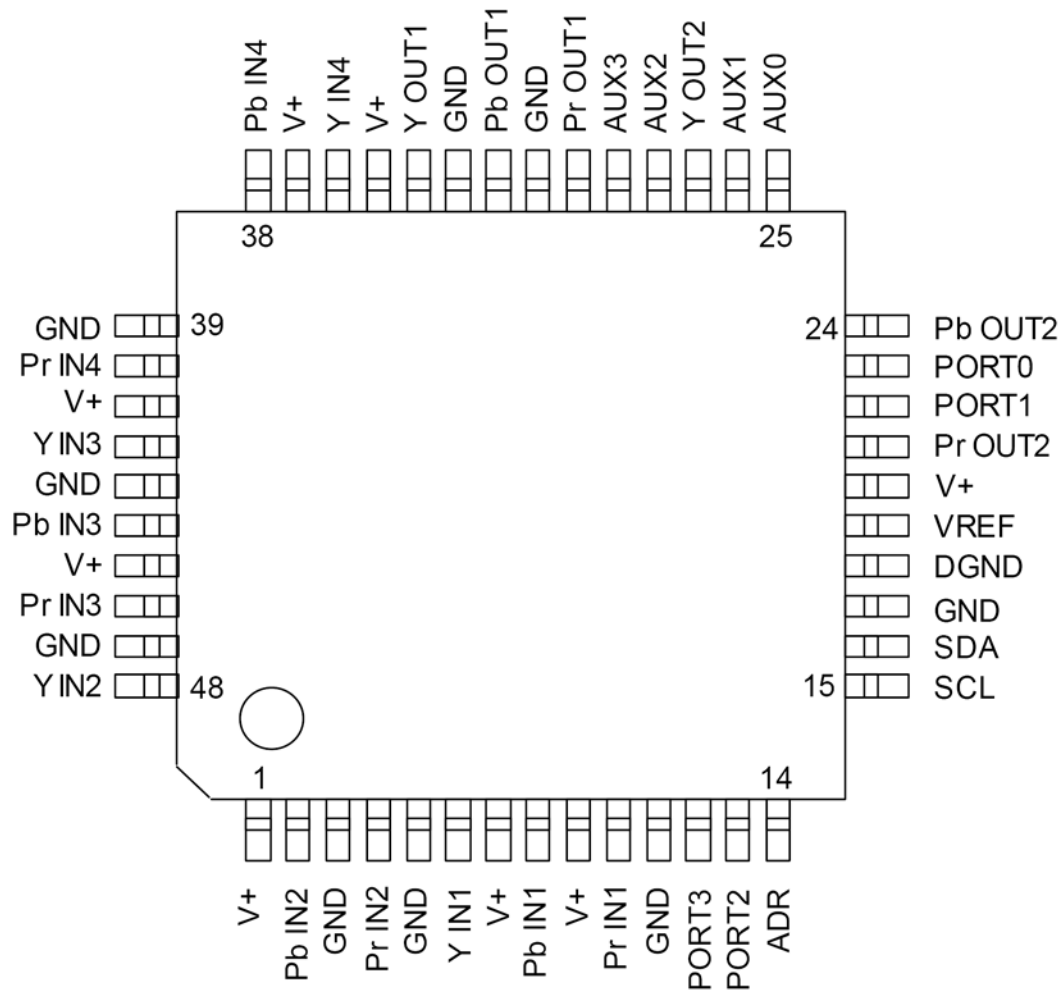

1. V+	13. PORT2	25. AUX0	37. V+
2. Pb IN2	14. ADR	26. AUX1	38. Pb IN4
3. GND	15. SCL	27. Y OUT2	39. GND
4. Pr IN2	16. SDA	28. AUX2	40. Pr IN4
5. GND	17. GND	29. AUX3	41. V+
6. Y IN1	18. DGND	30. Pr OUT1	42. Y IN3
7. V+	19. VREG	31. GND	43. GND
8. Pb IN1	20. V+	32. Pb OUT1	44. Pb IN3
9. V+	21. Pr OUT2	33. GND	45. V+
10. Pr IN1	22. PORT1	34. Y OUT1	46. Pr IN3
11. GND	23. PORT 0	35. V+	47. GND
12. PORT3	24. Pb OUT2	36. Y IN4	48. Y IN2

NJW1321

■EQUIVALENT CIRCUIT

PIN No.	NAME	FUNCTION	INSIDE EQUIVALENT CIRCUIT	VOLTAGE
6 8 10 48 2 4 42 44 46 36 38 40	Y IN1 Pb IN1 Pr IN1 Y IN2 Pb IN2 Pr IN2 Y IN3 Pb IN3 Pr IN3 Y IN4 Pb IN4 Pr IN4	Y,Pb,Pr Input RGB Input		4.4V
34 32 30 27 24 21	Y OUT1 Pb OUT1 Pr OUT1 Y OUT2 Pb OUT2 Pr OUT2	Y,Pb,Pr Output RGB Output		3.7V
23 22 13 12	PORT0 PORT1 PORT2 PORT3	Logic input terminal		-
25 26 28 29	AUX0 AUX1 AUX2 AUX3	Auxiliary 3 values voltage output terminal		0V 1.9V 5.0V

NJW1321

PIN No.	NAME	FUNCTION	INSIDE EQUIVALENT CIRCUIT	VOLTAGE
14	ADR	Slave address setting terminal		-
15 16	SCL SDA	I ² C clock terminal I ² C data terminal		-
19	VREF	Reference voltage terminal		4.8V
1 7 9 20 35 37 41 45	V+	Supply voltage terminal		-
3 5 11 17 31 33 39 43 47	GND	Ground terminal		-
18	DGND	Ground terminal		-

ES29LV800E

8Mbit(1M x 8/512K x 16)

CMOS 3.0 Volt-only, Boot Sector Flash Memory

GENERAL FEATURES

- **Single power supply operation**
 - 2.7V -3.6V for read, program and erase operations
- **Sector Structure**
 - 16Kbyte x 1, 8Kbyte x 2, 32Kbyte x 1 boot sectors
 - 64Kbyte x 15sectors
- **Top or Bottom boot block**
 - ES29LV800ET for Top boot block device
 - ES29LV800EB for Bottom boot block device
- **Package Options**
 - 48-pin TSOP
 - 48-ball FBGA (6 x 8 mm)
 - Pb-free packages
 - All Pb-free products are RoHS-Compliant
- **Low Vcc write inhibit**
- **Manufactured on 0.18um process technology**
- **Compatible with JEDEC standards**
 - Pinout and software compatible with single-power supply flash standard

DEVICE PERFORMANCE

- **Read access time**
 - 70ns / 90ns / 120ns
- **Program and erase time**
 - Program time : 6us/byte, 8us/word (typical)
 - Sector erase time : 0.7sec/sector (typical)
- **Power consumption (typical values)**
 - 200nA in standby or automatic sleep mode
 - 7mA active read current at 5 MHz
 - 15mA active write current during program or erase

- **Minimum 100,000 program/erase cycles per sector**
- **20 Year data retention at 125°C**

SOFTWARE FEATURES

- **Erase Suspend / Erase Resume**
- **Data# poll and toggle for Program/erase status**
- **Unlock Bypass program**
- **Autoselect mode**
- **Auto-sleep mode after $t_{ACC} + 30ns$**

HARDWARE FEATURES

- **Hardware reset input pin (RESET#)**
 - Provides a hardware reset to device
 - Any internal device operation is terminated and the device returns to read mode by the reset
- **Ready/Busy# output pin (RY/BY#)**
 - Provides a program or erase operational status about whether it is finished for read or still being progressed
- **Sector protection / unprotection (RESET# , A9)**
 - Hardware method of locking a sector to prevent any program or erase operation within that sector
 - Two methods are provided :
 - In-system method by RESET# pin
 - A9 high-voltage method for PROM programmers
- **Temporary Sector Unprotection (RESET#)**
 - Allows temporary unprotection of previously protected sectors to change data in-system

GENERAL PRODUCT DESCRIPTION

The ES29LV800 is a 8 megabit, 3.0 volt-only flash memory device, organized as 1M x 8 bits (Byte mode) or 512K x 16 bits (Word mode) which is configurable by BYTE#. Four boot sectors and fifteen main sectors are provided : 16Kbytes x 1, 8Kbytes x 2, 32Kbytes x 1 and 64Kbytes x 15. The device is manufactured with ESI's proprietary, high performance and highly reliable 0.18um CMOS flash technology. The device can be programmed or erased in-system with standard 3.0 Volt Vcc supply (2.7V-3.6V) and can also be programmed in standard EPROM programmers. The device offers minimum endurance of 100,000 program/erase cycles and more than 10 years of data retention.

The ES29LV800 offers access time as fast as 70ns or 90ns, allowing operation of high-speed microprocessors without wait states. Three separate control pins are provided to eliminate bus contention : chip enable (CE#), write enable (WE#) and output enable (OE#).

All program and erase operation are automatically and internally performed and controlled by embedded program/erase algorithms built in the device. The device automatically generates and times the necessary high-voltage pulses to be applied to the cells, performs the verification, and counts the number of sequences. Some status bits (DQ7, DQ6 and DQ5) read by data# polling or toggling between consecutive read cycles provide to the users the internal status of program/erase operation: whether it is successfully done or still being progressed.

The ES29LV800 is completely compatible with the JEDEC standard command set of single power supply Flash. Commands are written to the internal command register using standard write timings of microprocessor and data can be read out from the cell array in the device with the same way as used in other EPROM or flash devices.

PRODUCT SELECTOR GUIDE

Family Part Number	ES29LV800		
Voltage Range	2.7 ~ 3.6V		
Speed Option	70	90	120
Max Access Time (ns)	70	90	120
CE# Access (ns)	70	90	120
OE# Access (ns)	30	35	50

FUNCTION BLOCK DIAGRAM

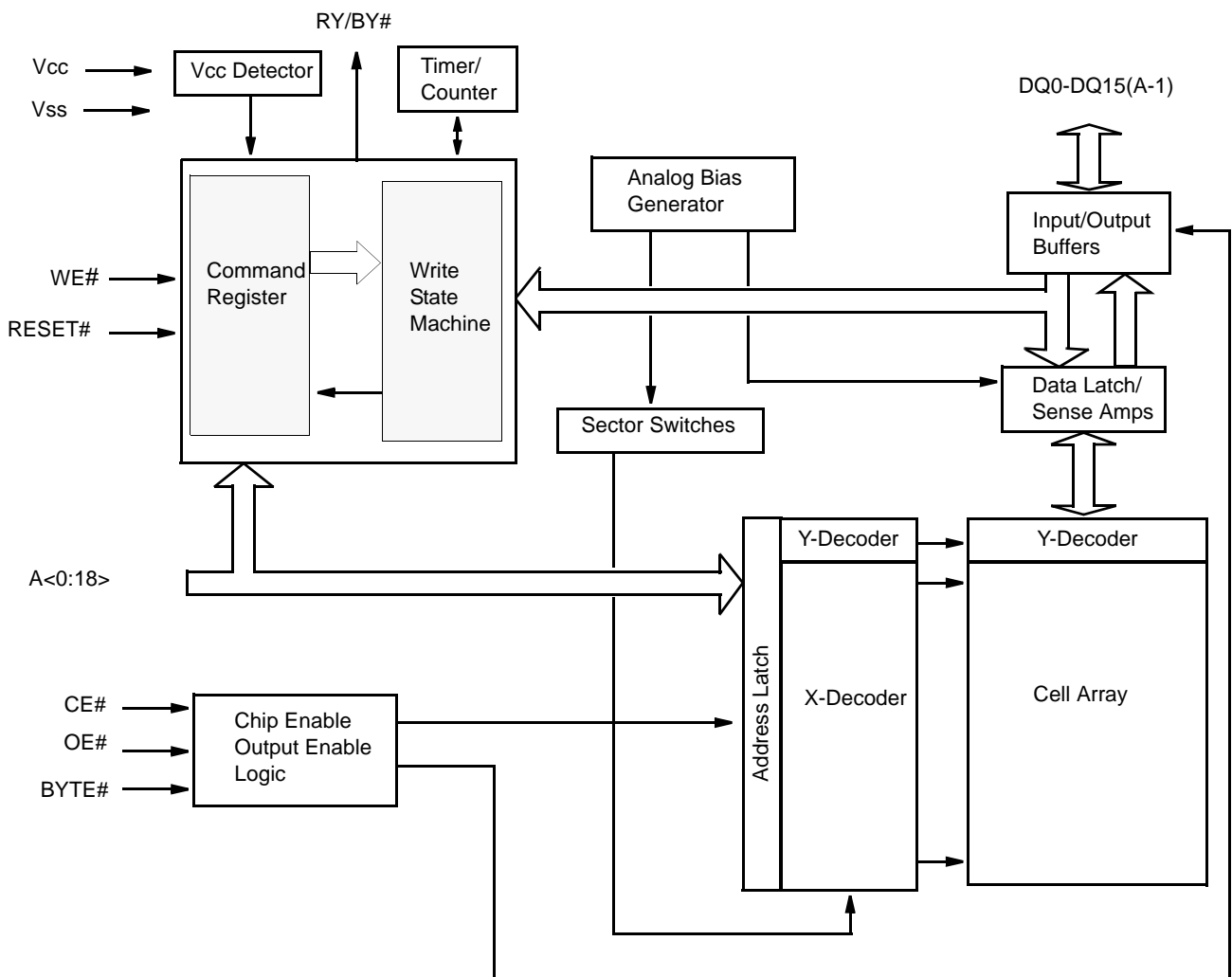

PIN DESCRIPTION

Pin	Description
A0-A18	19 Addresses
DQ0-DQ14	15 Data Inputs/Outputs
DQ15/A-1	DQ15 (Data Input/Output, Word Mode) A-1 (LSB Address Input, Byte Mode)
CE#	Chip Enable
OE#	Output Enable
WE#	Write Enable
RESET#	Hardware Reset Pin, Active Low
BYTE#	Selects 8-bit or 16-bit mode
RY/BY#	Ready/Busy Output
V _{cc}	3.0 volt-only single power supply (see Product Selector Guide for speed options and voltage supply tolerances)
V _{ss}	Device Ground
NC	Pin Not Connected Internally

LOGIC SYMBOL

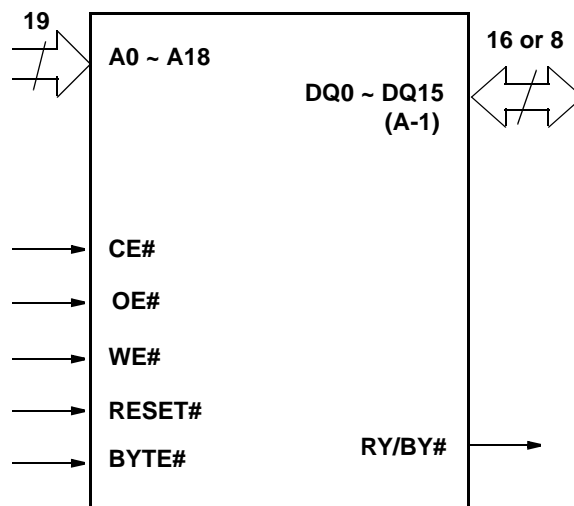

CONNECTION DIAGRAM

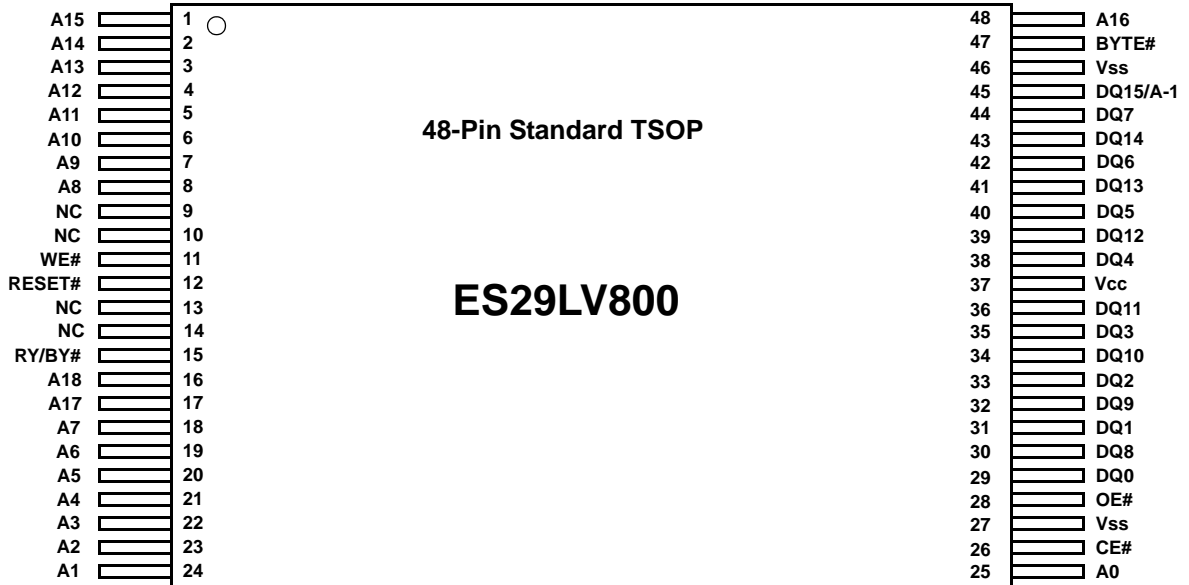

48-Ball FBGA (6 x 8 mm)
(Top View, Balls Facing Down)

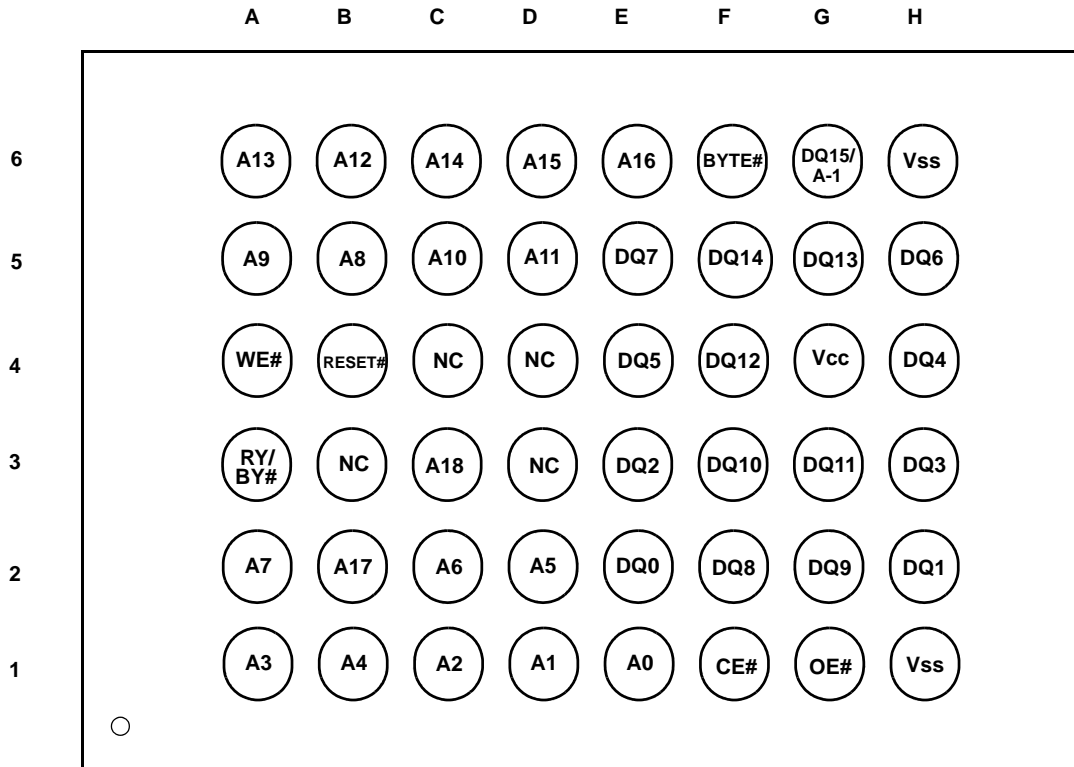



HY57V161610E

2 Banks x 512K x 16 Bit Synchronous DRAM

DESCRIPTION

THE Hynix HY57V161610E is a 16,777,216-bits CMOS Synchronous DRAM, ideally suited for the main memory and graphic applications which require large memory density and high bandwidth. HY57V161610E is organized as 2banks of 524,288x16.

HY57V161610E is offering fully synchronous operation referenced to a positive edge clock. All inputs and outputs are synchronized with the rising edge of the clock input. The data paths are internally pipelined to achieve very high bandwidth. All input and output voltage levels are compatible with LVTTTL.

Programmable options include the length of pipeline (Read latency of 1,2 or 3), the number of consecutive read or write cycles initiated by a single control command (Burst length of 1,2,4,8 or full page), and the burst count sequence(sequential or interleave). A burst of read or write cycles in progress can be terminated by a burst terminate command or can be interrupted and replaced by a new burst read or write command on any cycle. (This pipeline design is not restricted by a `2N` rule.)

FEATURES

- Single 3.0V to 3.6V power supply
- All device pins are compatible with LVTTTL interface
- JEDEC standard 400mil 50pin TSOP-II with 0.8mm of pin pitch
- All inputs and outputs referenced to positive edge of system clock
- Data mask function by UDQM/LDQM
- Internal two banks operation
- Auto refresh and self refresh
- 4096 refresh cycles / 64ms
- Programmable Burst Length and Burst Type
 - 1, 2, 4, 8 and Full Page for Sequence Burst
 - 1, 2, 4 and 8 for Interleave Burst
- Programmable $\overline{\text{CAS}}$ Latency ; 1, 2, 3 Clocks

ORDERING INFORMATION

Part No.	Clock Frequency	Organization	Interface	Package
HY57V161610ET-5	200MHz	2Banks x 512Kbits x 16	LVTTTL	400mil 50pin TSOP II
HY57V161610ET-55	183MHz			
HY57V161610ET-6	166MHz			
HY57V161610ET-7	143MHz			
HY57V161610ET-8	125MHz			
HY57V161610ET-10	100MHz			
HY57V161610ET-15	66MHz			

Note :

1. VDD(min) of HY57V161610ET-5/55 is 3.15V

This document is a general product description and is subject to change without notice. Hynix Semiconductor does not assume any responsibility for use of circuits described. No patent licenses are implied

Rev. 0.2 / Aug. 2003

1



HY57V161610E

PIN CONFIGURATION

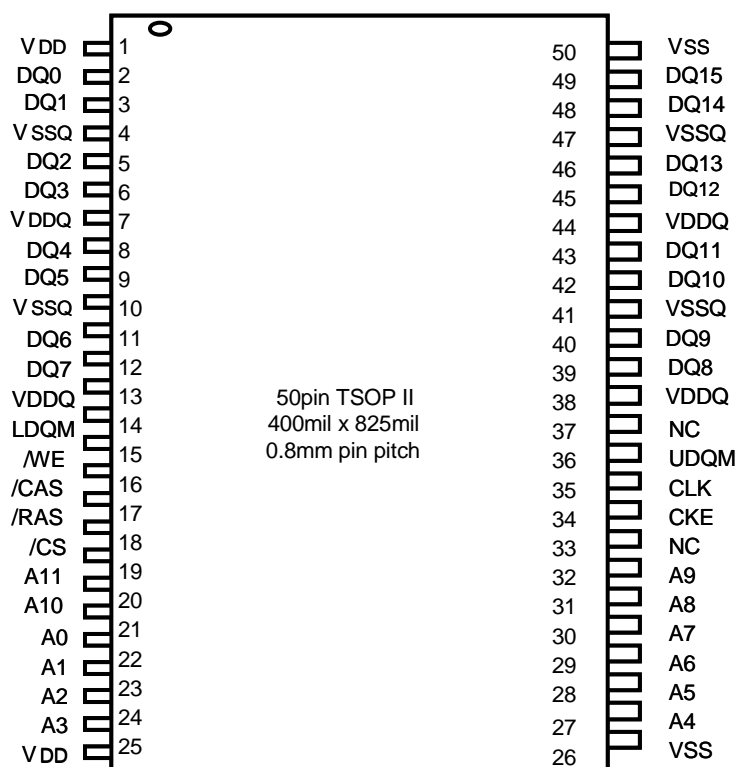

PIN DESCRIPTION

PIN	PIN NAME	DESCRIPTION
CLK	Clock	The system clock input. All other inputs are referenced to the SDRAM on the rising edge of CLK.
CKE	Clock Enable	Controls internal clock signal and when deactivated, the SDRAM will be one of the states among power down, suspend or self refresh.
$\overline{\text{CS}}$	Chip Select	Command input enable or mask except CLK, CKE and DQM
BA	Bank Address	Select either one of banks during both $\overline{\text{RAS}}$ and $\overline{\text{CAS}}$ activity.
A0 ~ A10	Address	Row Address : RA0 ~ RA10, Column Address : CA0 ~ CA7 Auto-precharge flag : A10
$\overline{\text{RAS}}$, $\overline{\text{CAS}}$, $\overline{\text{WE}}$	Row Address Strobe, Column Address Strobe, Write Enable	$\overline{\text{RAS}}$, $\overline{\text{CAS}}$ and $\overline{\text{WE}}$ define the operation. Refer function truth table for details
LDQM, UDQM	Data Input/Output Mask	DQM control output buffer in read mode and mask input data in write mode
DQ0 ~ DQ15	Data Input/Output	Multiplexed data input / output pin
VDD/VSS	Power Supply/Ground	Power supply for internal circuit and input buffer
VDDQ/VSSQ	Data Output Power/Ground	Power supply for DQ
NC	No Connection	No connection



HY57V161610E

FUNCTIONAL BLOCK DIAGRAM

1Mx16 Synchronous DRAM

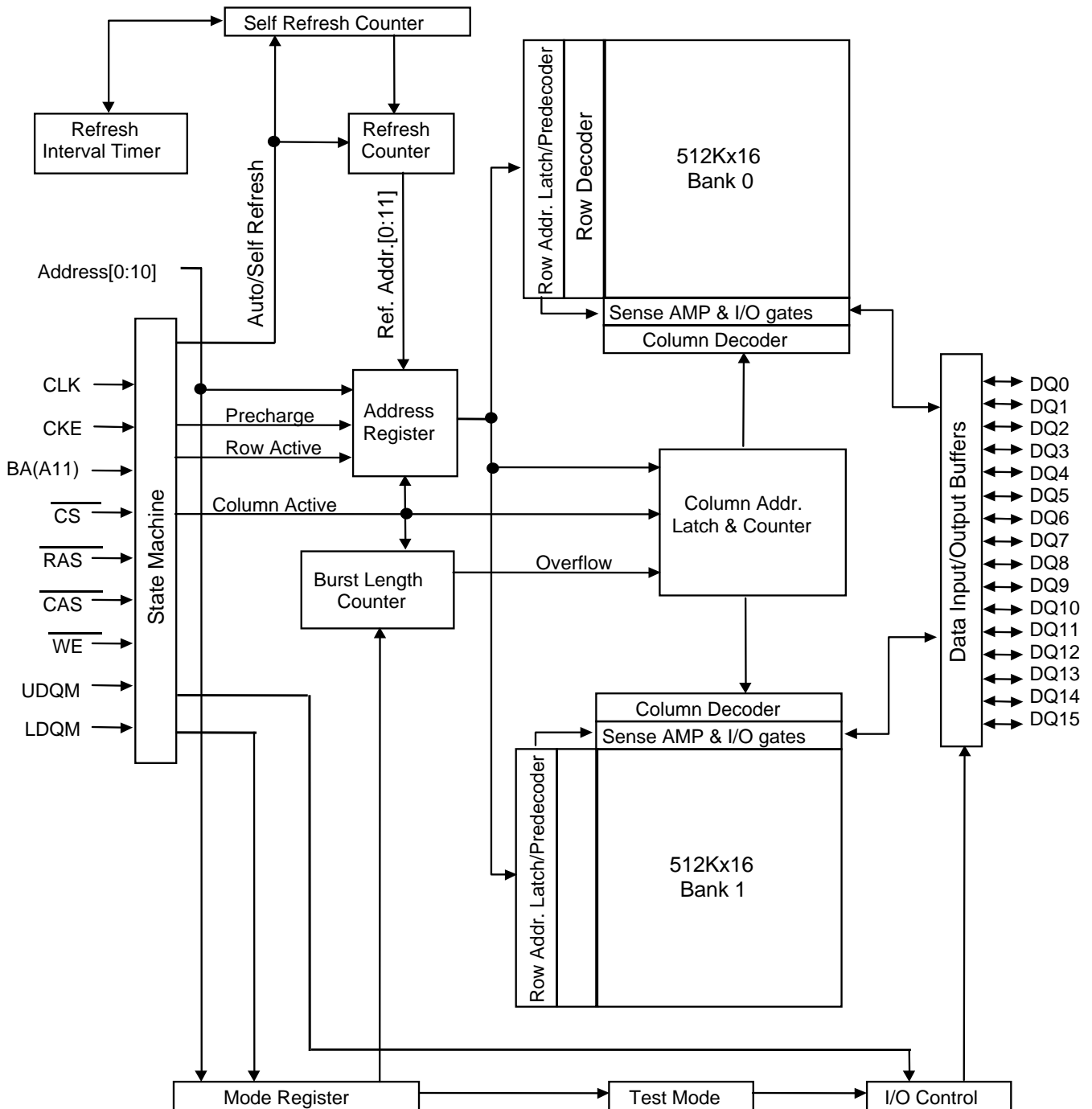



HY57V161610E

COMMAND TRUTH TABLE

Command	CKEn-1	CKEn	\overline{CS}	\overline{RAS}	\overline{CAS}	\overline{WE}	DQM	A0~A9	A10/AP	BA	Note	
Mode Register Set	H	X	L	L	L	L	X	OP code				
No Operation	H	X	H	X	X	X	X	X				
			L	H	H	H						
Bank Active	H	X	L	L	H	H	X	Row Address		V		
Read	H	X	L	H	L	H	X	Column Address	L	V		
Read with Auto precharge									H			
Write	H	X	L	H	L	L	X	Column Address	L	V		
Write with Auto precharge									H			
Precharge All Bank	H	X	L	L	H	L	X	X	H	X		
Precharge selected Bank									L	V		
Burst Stop	H	X	L	H	H	L	X	X				
U/LDQM	H	X					V	X				
Auto Refresh	H	H	L	L	L	H	X	X				
Burst-READ-Single-WRITE	H	X	L	L	L	L	X	A9 Pin High (Other Pins OP code)				
Self Refresh ¹	Entry	H	L	L	L	L	H	X	X			
	Exit	L	H	H	X	X	X	X				
Precharge power down	Entry	H	L	H	X	X	X	X	X			
				L	H	H	H					
	Exit	L	H	H	X	X	X	X				
				L	H	H	H					
Clock Suspend	Entry	H	L	H	X	X	X	X	X			
				L	V	V	V					
	Exit	L	H	X				X				

Note :

1. Exiting Self Refresh occurs by asynchronously bringing CKE from low to high.
2. X=Do not care, L=Low, H=High, BA=Bank Address, RA= Row Address, CA=Column Address, Opcode=Operand Code, NOP=No Operation.

Hex inverter**74HCU04****FEATURES**

- Output capability: standard
- I_{CC} category: SSI

GENERAL DESCRIPTION

The 74HCU04 is a high-speed Si-gate CMOS device and is pin compatible with low power Schottky TTL (LSTTL). It is specified in compliance with JEDEC standard no. 7A.

The 74HCU04 is a general purpose hex inverter. Each of the six inverters is a single stage

QUICK REFERENCE DATA

GND = 0 V; T_{amb} = 25 °C; t_r = t_f = 6 ns

SYMBOL	PARAMETER	CONDITIONS	TYP.	UNIT
t _{PHL} / t _{PLH}	propagation delay nA to nY	C _L = 15 pF; V _{CC} = 5 V	5	ns
C _I	input capacitance		3.5	pF
C _{PD}	power dissipation capacitance per inverter	note 1	10	pF

Note

1. C_{PD} is used to determine the dynamic power dissipation (P_D in μW):

$$P_D = C_{PD} \times V_{CC}^2 \times f_i + \sum (C_L \times V_{CC}^2 \times f_o) \text{ where:}$$

f_i = input frequency in MHz

f_o = output frequency in MHz

C_L = output load capacitance in pF

V_{CC} = supply voltage in V

∑ (C_L × V_{CC}² × f_o) = sum of outputs

ORDERING INFORMATION

See *"74HC/HCT/HCU/HCMOS Logic Package Information"*.

FUNCTION TABLE

INPUT	OUTPUT
nA	nY
L	H
H	L

Note

1. H = HIGH voltage level
L = LOW voltage level

Hex inverter

74HCU04

PIN DESCRIPTION

PIN NO.	SYMBOL	NAME AND FUNCTION
1, 3, 5, 9, 11, 13	1A to 6A	data inputs
2, 4, 6, 8, 10, 12	1Y to 6Y	data outputs
7	GND	ground (0 V)
14	V _{CC}	positive supply voltage

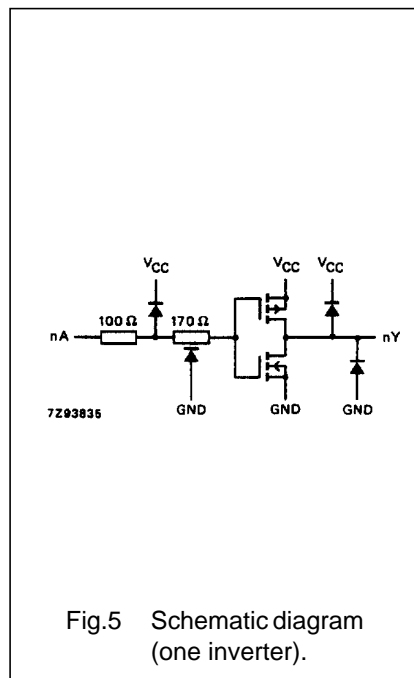
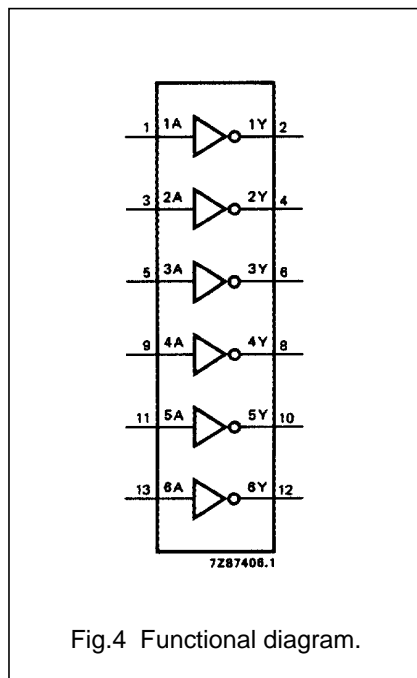
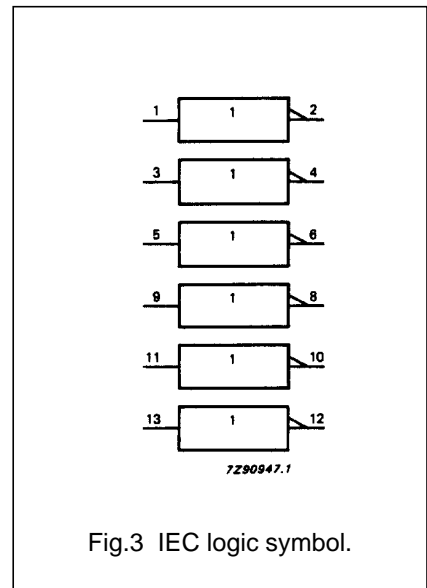
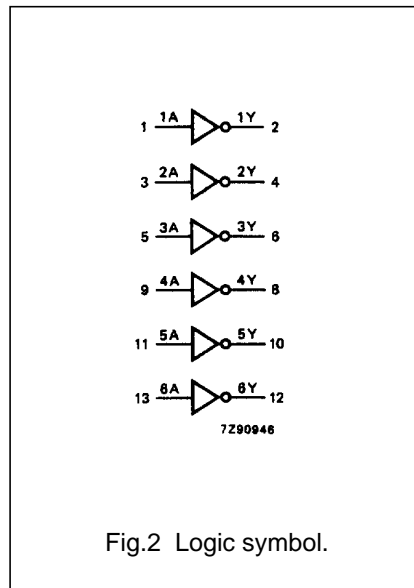
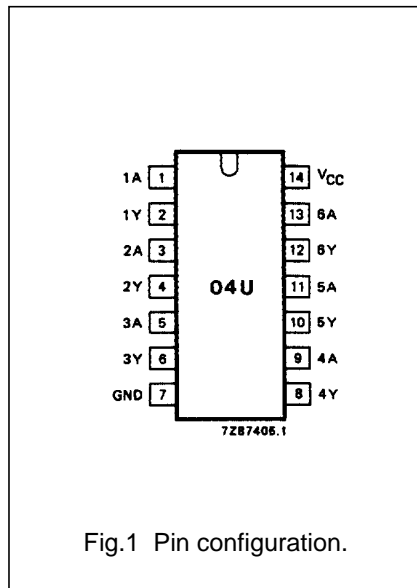



74ACT04

HEX INVERTER

- HIGH SPEED: $t_{PD} = 5.0ns$ (TYP.) at $V_{CC} = 5V$
- LOW POWER DISSIPATION:
 $I_{CC} = 2\mu A$ (MAX.) at $T_A=25^\circ C$
- COMPATIBLE WITH TTL OUTPUTS
 $V_{IH} = 2V$ (MIN.), $V_{IL} = 0.8V$ (MAX.)
- 50Ω TRANSMISSION LINE DRIVING CAPABILITY
- SYMMETRICAL OUTPUT IMPEDANCE:
 $|I_{OH}| = I_{OL} = 24mA$ (MIN)
- BALANCED PROPAGATION DELAYS:
 $t_{PLH} \approx t_{PHL}$
- OPERATING VOLTAGE RANGE:
 V_{CC} (OPR) = 4.5V to 5.5V
- PIN AND FUNCTION COMPATIBLE WITH 74 SERIES 04
- IMPROVED LATCH-UP IMMUNITY

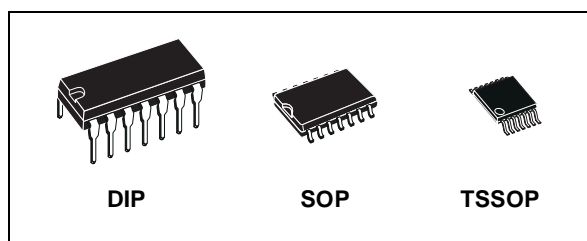

ORDER CODES

PACKAGE	TUBE	T & R
DIP	74ACT04B	
SOP	74ACT04M	74ACT04MTR
TSSOP		74ACT04TTR

DESCRIPTION

The 74ACT04 is an advanced high-speed CMOS HEX INVERTER fabricated with sub-micron silicon gate and double-layer metal wiring C²MOS technology.

The internal circuit is composed of 3 stages including buffer output, which enables high noise immunity and stable output.

The device is designed to interface directly High Speed CMOS systems with TTL, NMOS and CMOS output voltage levels.

All inputs and outputs are equipped with protection circuits against static discharge, giving them 2KV ESD immunity and transient excess voltage.

PIN CONNECTION AND IEC LOGIC SYMBOLS

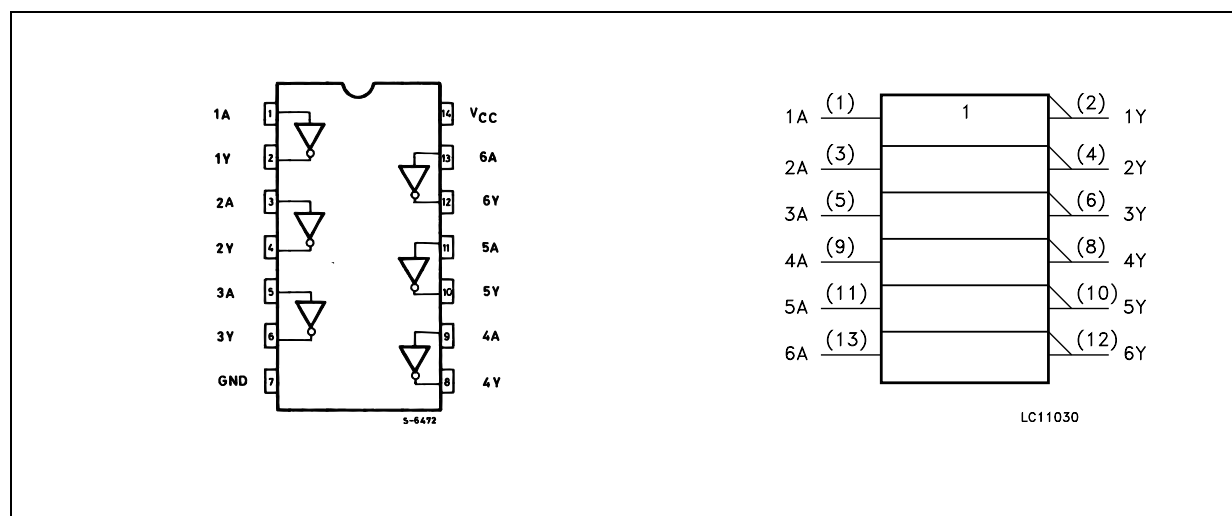



NJM2595

5-INPUT 3-OUTPUT VIDEO SWITCH

■ GENERAL DESCRIPTION

The **NJM2595** is a 5-input 3-output video switch. Its switches select one from five signals received from VTR,TV,DVD, TV-GAME and others.

The NJM2595 is designed for audio items, such as AV amplifier and others.

■ PACKAGE OUTLINE

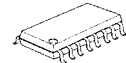
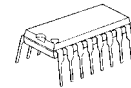

NJM2595D NJM2595M

■ FEATURES

- 5-input 3-output
- Operating Voltage ± 4.0 to $\pm 6.5V$
- Operating current $\pm 15mA$ typ. at $V_{CC} = \pm 5V$
- Crosstalk $-65dB$ typ.
- Internal 6dB Amplifier
- Internal 75Ω Driver
- Bipolar Technology
- Package Outline DIP16,DMP16

■ PIN CONFIGURATION and BLOCK DIAGRAM

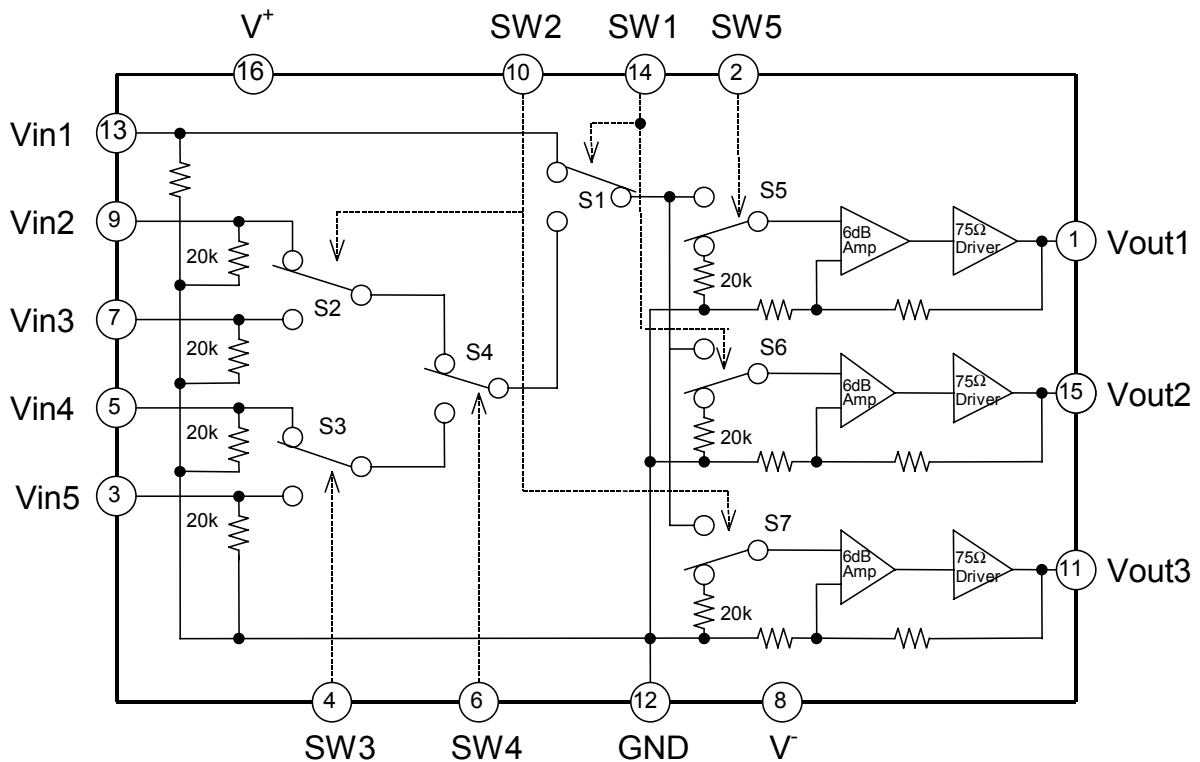

NJM2595

■ EQUIVALENT CIRCUIT

PIN No.	PIN NAME	INSIDE EQUIVALENT CIRCUIT	VOLTAGE
16	V ⁺		5V
8	V ⁻		-5V
12	GND		-
13 9 7 5 3	Vin1 Vin2 Vin3 Vin4 Vin5		0V
1 15 11	Vout1 Vout2 Vout3		0V
4 6 2	SW3 SW4 SW5		-

NJM2595

■ EQUIVALENT CIRCUIT

PIN No.	PIN NAME	INSIDE EQUIVALENT CIRCUIT	VOLTAGE
14 10	SW1 SW2		-

■ TEST CIRCUIT

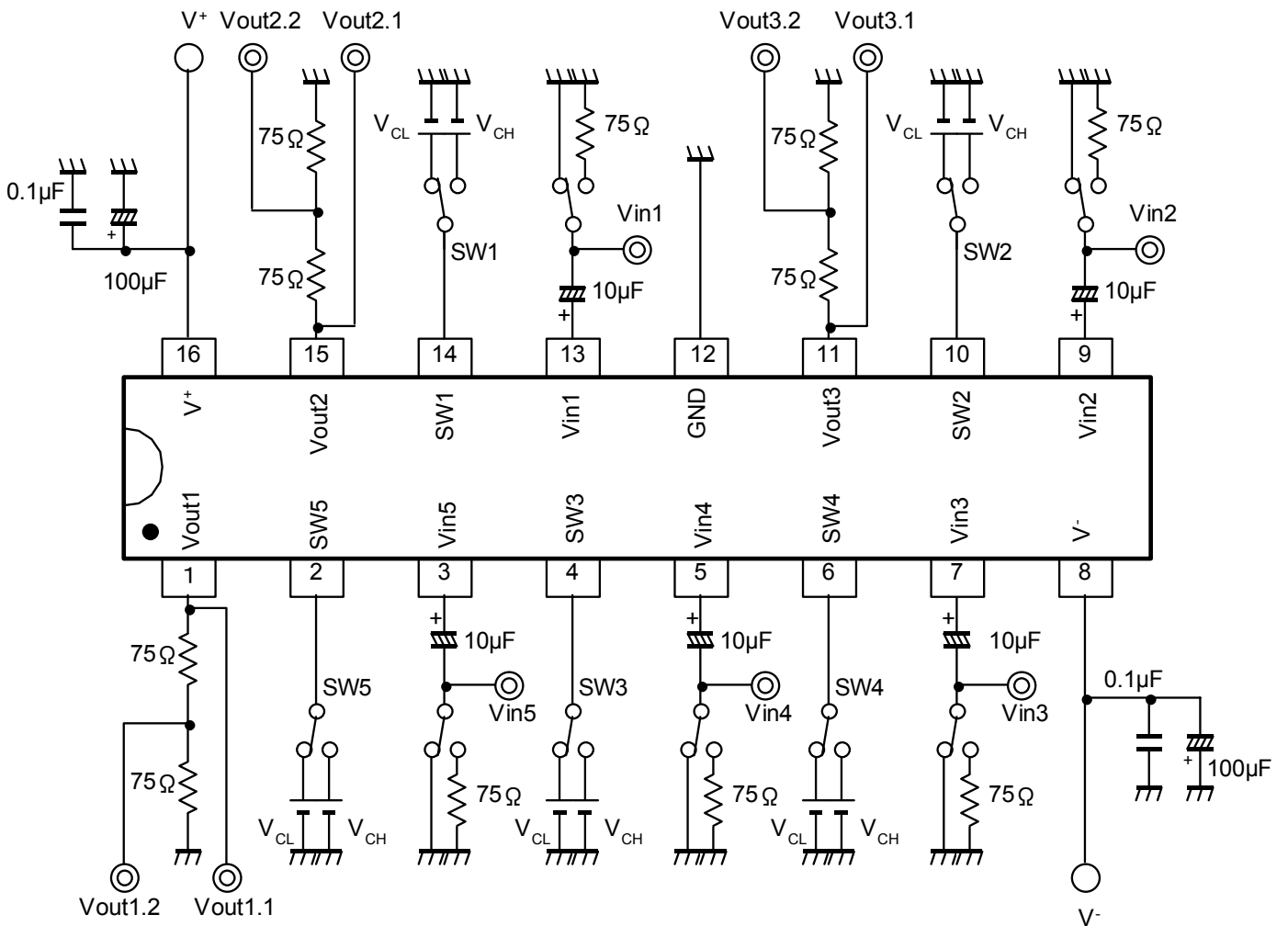

NJW1197FC2

[8-CHANNEL ELECTRONIC VOLUME WITH INPUT SELECTOR]

[STRUCTURE] Bi-CMOS
 [CATEGORIES] 3D Surround & Sound Enhancement
 [PACKAGE OUTLINE] QFP100-C2
 [SOLDERING METHOD] For this device, soldering method is recommended Reflow.
 [NOTE] -

BAE-45919-000-00

■ ABSOLUTE MAXIMUM RATINGS $T_a=25^\circ\text{C}$

Power Supply Voltage +8/-8 [V]	Operating Temperature Range -40 to +75 [°C]
Maximum Input Voltage V^+/V^- [V]	Storage Temperature Range -40 to +150 [°C]
Power Dissipation 1600 [mW] (Note)	

(Note) EIA/JEDEC STANDARD Test board (76.2 × 114.3 × 1.6mm, 2layer, FR-4) mounting.

■ BLOCK DIAGRAM

BDE-45919-000-00

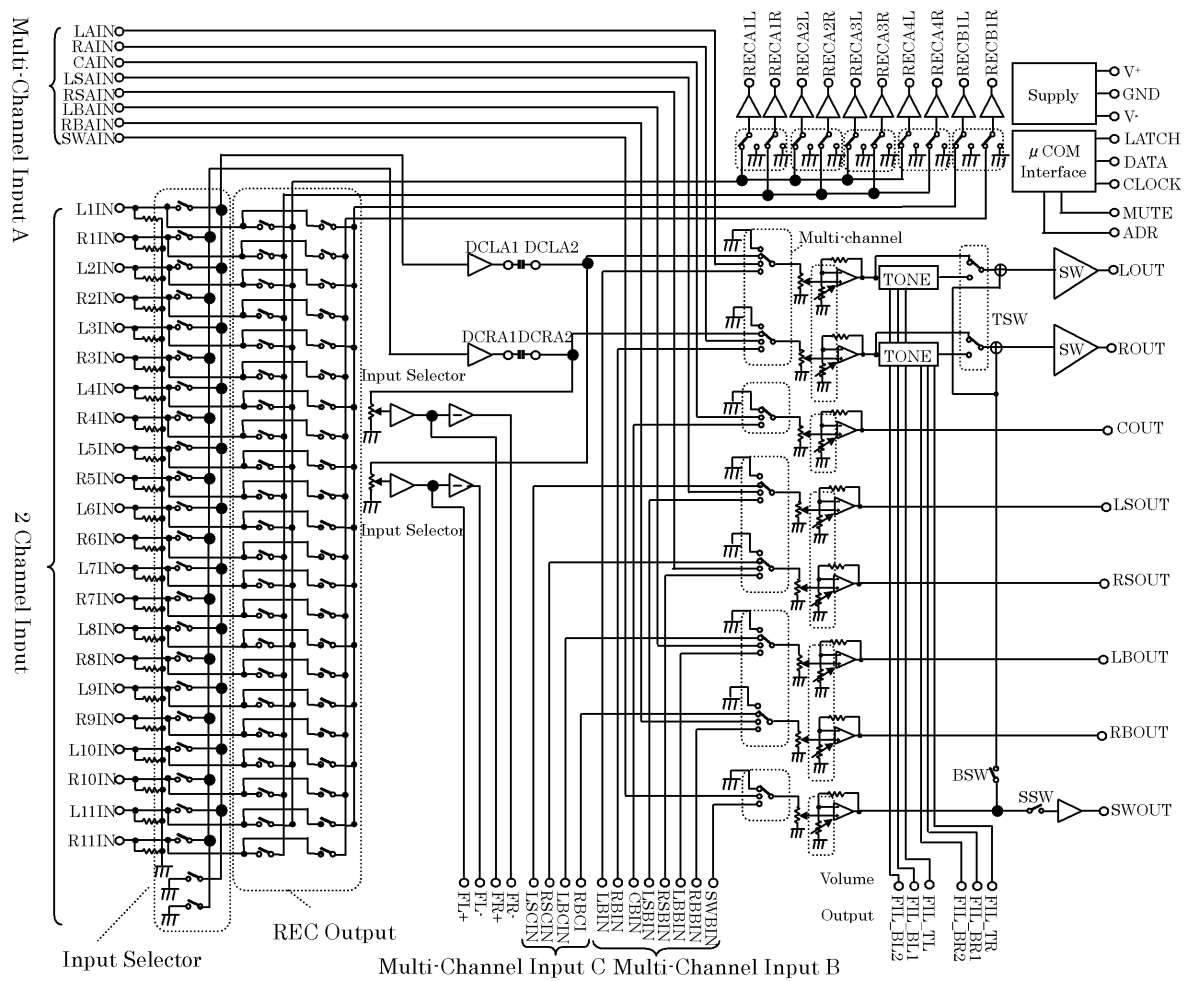

■ PIN CONFIGURAITON

BEE-45919-000-00

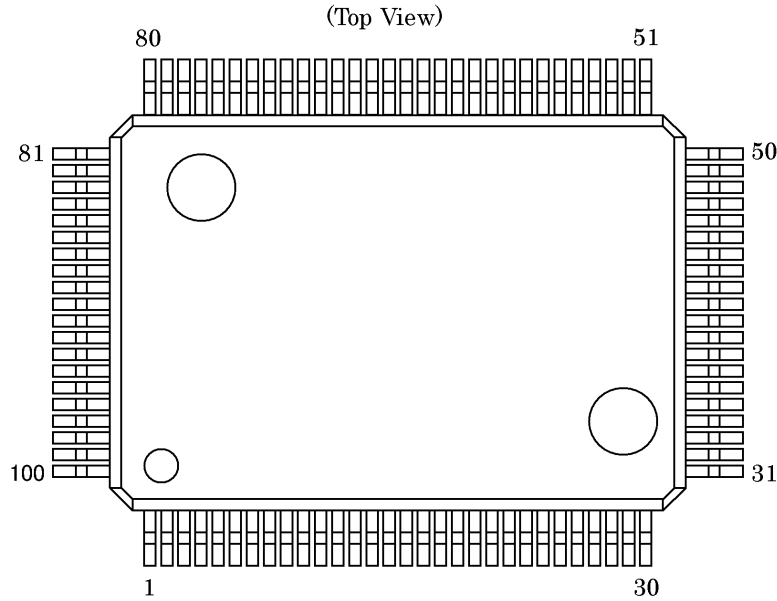

No.	SYMBOL	No.	SYMBOL	No.	SYMBOL	No.	SYMBOL
1	ROUT	26	DCCAP_RS	51	DCR_IN	76	GND
2	COUT	27	L3IN	52	DCR_OUT	77	LSCIN
3	LSOUT	28	DCCAP_LS	53	GND	78	RSCIN
4	RSOUT	29	R3IN	54	DCL_IN	79	LBCIN
5	LBOUT	30	DCCAP_C	55	DCL_OUT	80	RBCIN
6	RBOUT	31	L4IN	56	GND	81	GND
7	SWOUT	32	DCCAP_R	57	REC_B1R	82	LAIN
8	GND	33	R4IN	58	REC_B1L	83	RAIN
9	FIL_BL2	34	DCCAP_L	59	REC_A4R	84	CAIN
10	FIL_BL1	35	L5IN	60	REC_A4L	85	LSAIN
11	FIL_TL	36	GND	61	REC_A3R	86	RSAIN
12	TCAP	37	R5IN	62	REC_A3L	87	LBAIN
13	FIL_BR2	38	GND	63	REC_A2R	88	RBAIN
14	FIL_BR1	39	L6IN	64	REC_A2L	89	SWAIN
15	FIL_TR	40	L9IN	65	REC_A1R	90	GND
16	V ⁺	41	R6IN	66	REC_A1L	91	LBIN
17	ADR	42	R9IN	67	VDDOUT	92	RBIN
18	V ⁻	43	L7IN	68	DATA	93	CBIN
19	L1IN	44	L10IN	69	CLOCK	94	LSBIN
20	DCCAP_SW	45	R7IN	70	LATCH	95	RSBIN
21	R1IN	46	R10IN	71	MUTE	96	LBBIN
22	DCCAP_RB	47	L8IN	72	FL ⁺	97	RBBIN
23	L2IN	48	L11IN	73	FL ⁻	98	SWBIN
24	DCCAP_LB	49	R8IN	74	FR ⁺	99	GND
25	R2IN	50	R11IN	75	FR ⁻	100	LOUT

FUNCTIONAL DESCRIPTION

BGE-45919-000-00

(1) CONTROL DATA

NJW1197 control data is constructed with 16bits.

MSB LSB

D15	D14	D13	D12	D11	D10	D9	D8	D7	D6	D5	D4	D3	D2	D1	D0
Data								Select Address				Chip Address			

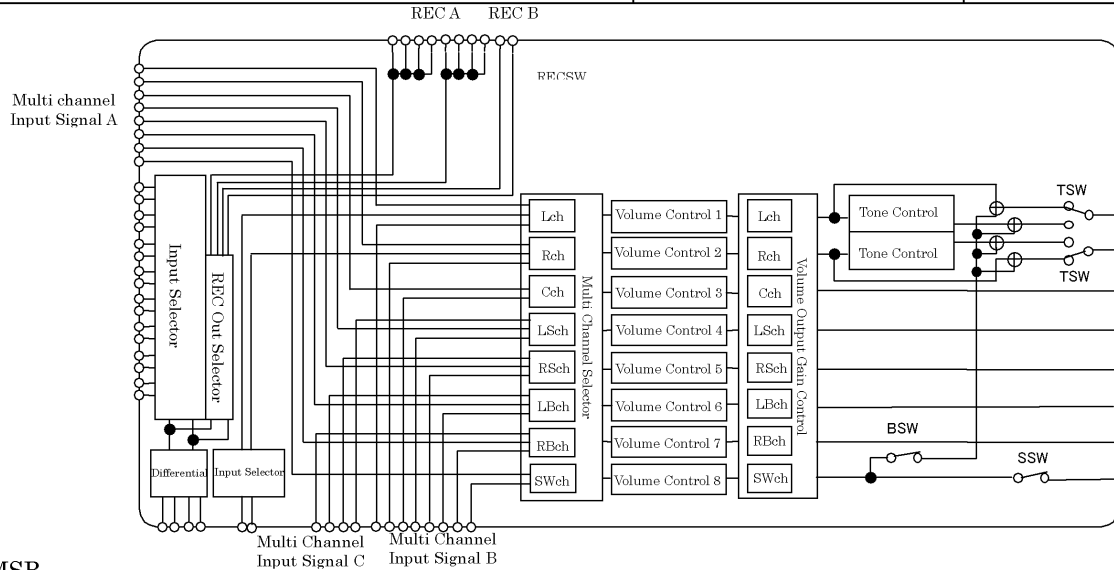

MSB LSB

D15	D14	D13	D12	D11	D10	D9	D8	D7	D6	D5	D4	D3	D2	D1	D0
L channel Volume Control								0	0	0	0	*	*	*	*
R channel Volume Control								0	0	0	1	*	*	*	*
C channel Volume Control								0	0	1	0	*	*	*	*
LS channel Volume Control								0	0	1	1	*	*	*	*
RS channel Volume Control								0	1	0	0	*	*	*	*
LB channel Volume Control								0	1	0	1	*	*	*	*
RB channel Volume Control								0	1	1	0	*	*	*	*
SW channel Volume Control								0	1	1	1	*	*	*	*
Input Selector Gain Control		Input Selector					SSW	1	0	0	0	*	*	*	*
TC/B	Tone Control Treble				TSW	BSW	*	1	0	0	1	*	*	*	*
BC/B	Tone Control Bass				*	*	*	1	0	1	0	*	*	*	*
REC B Selector				Input Selector				1	0	1	1	*	*	*	*
SWch Volume Output Gain Control		REC B1	REC A4	REC A3	REC A2	REC A1	1	1	0	0	*	*	*	*	
L, Rch Volume Output Gain Control		Cch, Volume Output Gain Control			*	*	1	1	0	1	*	*	*	*	
LS, RSch Volume Output Gain Control		LB, RBch Volume Output Gain Control		SWch Selector		1	1	1	0	*	*	*	*		
L, Rch Selector		Cch Selector		LS, RSch Selector		LB, RBch Selector		1	1	1	1	*	*	*	*

*: Don't Care

* Chip address is set by chip address select terminal (ADR) status.

Chip Address Select Terminal (ADR: 17pin)	Chip Address			
	D3	D2	D1	D0
Low	0	1	0	0
High	0	1	0	1

* The mute function can be controlled externally. If the Mute control terminal (71pin) is switched to High, Multi-Channel outputs are muted immediately (hardware mute).

External mute control terminal (MUTE: 71pin)	Setting
Low	Mute cancellation
High	Mute

(2) INITIAL CONDITON

D15	D14	D13	D12	D11	D10	D9	D8	D7	D6	D5	D4	D3	D2	D1	D0
1	1	1	1	1	1	1	1	0	0	0	0	*	*	*	*
1	1	1	1	1	1	1	1	0	0	0	1	*	*	*	*
1	1	1	1	1	1	1	1	0	0	1	0	*	*	*	*
1	1	1	1	1	1	1	1	0	0	1	1	*	*	*	*
1	1	1	1	1	1	1	1	0	1	0	0	*	*	*	*
1	1	1	1	1	1	1	1	0	1	0	1	*	*	*	*
1	1	1	1	1	1	1	1	0	1	1	0	*	*	*	*
1	1	1	1	1	1	1	1	0	1	1	1	*	*	*	*
0	0	0	0	0	0	0	0	1	0	0	0	*	*	*	*
0	0	0	0	0	0	0	0	1	0	0	1	*	*	*	*
0	0	0	0	0	0	0	0	1	0	1	0	*	*	*	*
0	0	0	0	0	0	0	0	1	0	1	1	*	*	*	*
0	0	0	0	0	0	0	0	1	1	0	0	*	*	*	*
0	0	0	0	0	0	0	0	1	1	0	1	*	*	*	*
0	0	0	0	0	0	0	0	1	1	1	0	*	*	*	*
0	0	0	0	0	0	0	0	1	1	1	1	*	*	*	*

(3) DEFINITION OF RESISTOR

•Volume Control: 0dB to -100dB in 0.5dB/step.

D15	D14	D13	D12	D11	D10	D9	D8	D7	D6	D5	D4	D3	D2	D1	D0
L channel Volume Control								0	0	0	0	*	*	*	*
R channel Volume Control								0	0	0	1	*	*	*	*
C channel Volume Control								0	0	1	0	*	*	*	*
LS channel Volume Control								0	0	1	1	*	*	*	*
RS channel Volume Control								0	1	0	0	*	*	*	*
LB channel Volume Control								0	1	0	1	*	*	*	*
RB channel Volume Control								0	1	1	0	*	*	*	*
SW channel Volume Control								0	1	1	1	*	*	*	*

<Volume Control Data>

Data								Setting
D15	D14	D13	D12	D11	D10	D9	D8	
0	0	0	0	0	0	0	0	0dB
0	0	0	0	0	0	0	1	-0.5dB
0	0	0	0	0	0	1	0	-1dB
0	0	0	0	0	0	1	1	-1.5dB
0	0	0	0	0	1	0	0	-2dB
0	0	0	0	0	1	0	1	-2.5dB
0	0	0	0	0	1	1	0	-3dB
0	0	0	0	0	1	1	1	-3.5dB
0	0	0	0	1	0	0	0	-4dB
0	0	0	0	1	0	0	1	-4.5dB
0	0	0	0	1	0	1	0	-5dB
0	0	0	0	1	0	1	1	-5.5dB
0	0	0	0	1	1	0	0	-6dB
0	0	0	0	1	1	0	1	-6.5dB
0	0	0	0	1	1	1	0	-7dB
0	0	0	0	1	1	1	1	-7.5dB
0	0	0	1	0	0	0	0	-8dB
0	0	0	1	0	0	0	1	-8.5dB
0	0	0	1	0	0	1	0	-9dB
0	0	0	1	0	0	1	1	-9.5dB
0	0	0	1	0	1	0	0	-10dB
...								...
1	1	0	0	0	0	1	0	-97dB
1	1	0	0	0	0	1	1	-97.5dB
1	1	0	0	0	1	0	0	-98dB
1	1	0	0	0	1	0	1	-98.5dB
1	1	0	0	0	1	1	0	-99dB
1	1	0	0	0	1	1	1	-99.5dB
1	1	0	0	1	0	0	0	-100dB
1	1	1	1	1	1	1	1	MUTE(*)

(*): Initial Setting

APPLICATION CIRCUIT

BHE-45919-000-00

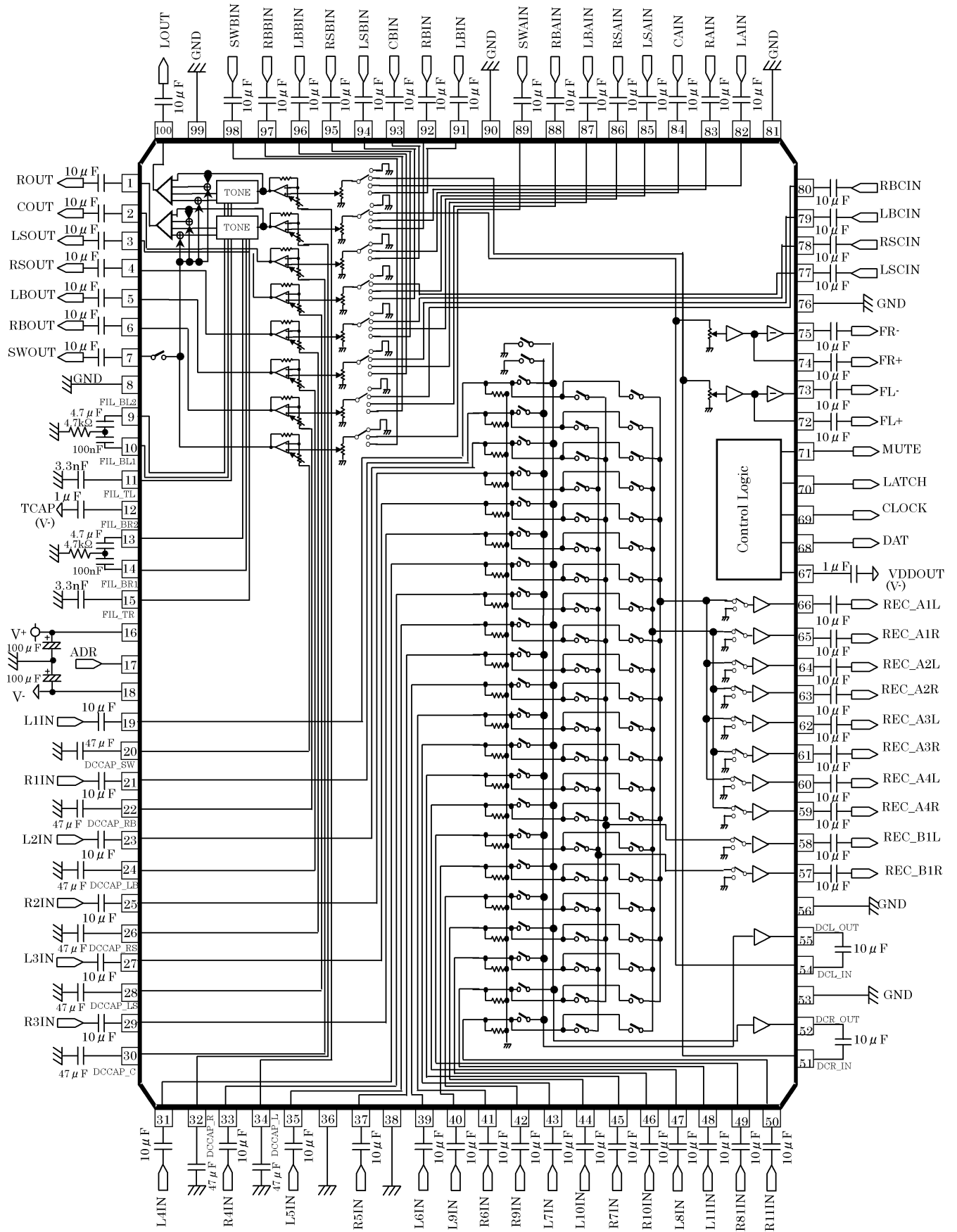



CS495xx Data Sheet

FEATURES

- Powerful 32-bit Dual-core Audio DSP
- Multi-standard 32-bit Audio Decoding plus Post Processing, Dual-decode Capable
- Framework Applications Library
 - Dolby® Digital Pro Logic® IIx, Dolby® Digital EX, Dolby® Digital Headphone™, Dolby® Digital Virtual Speaker™
 - DTS-ES 96/24™, DTS-ES™ Discrete 6.1, DTS-ES™ Matrix 6.1, DTS® Digital Surround
 - MPEG-2 Multichannel
 - AAC™ Multichannel 5.1
 - MP3 - MPEG-1/2, Layer III
 - THX® Surround EX™, THX® Ultra2 Cinema™
 - DVD Audio/Video/SACD Multichannel Bass Management
- 10 Channels of 32-bit Serial Audio Input
- 16 Channels of 32-bit PCM Output
- Two Master/slave SPI or I²C Format Control Ports for Audio Subsystem Management
- Parallel Host Control & UART
- Customer Software Security Keys
- Large On-chip X, Y, and Program RAM & ROM
- SDRAM, SRAM, and FLASH Memory Support
- Dual 192-kHz SPDIF Transmitters

32-bit Audio Decoder DSP Family

The CS495xx DSP family integrates two programmable, 32-bit DSP cores and a DMA engine with a full set of audio peripherals. Feature-rich AVR designs can be easily developed using the Framework applications library, which includes both certified application programs and a modular programming environment for easy customization. The framework includes certified state-of-the-art audio decoders, virtualizers, surround simulators, and audio enhancement algorithms.

The CS495xx family was designed to reduce system costs and development time and to provide advanced features and flexibility for competitive system-level solutions. The difficult processing tasks of Dolby® Digital Surround EX™, AAC multichannel, DTS-ES 96/24, and THX Ultra2 Cinema can be accomplished without the expense of external logic or memory. Additionally, the CS495xx can meet the needs of dual-decode applications with twin DSP cores, and audio-I/O-intensive designs with support for up to 10 input and 16 output channels.

Ordering Information

See page 33 for ordering information

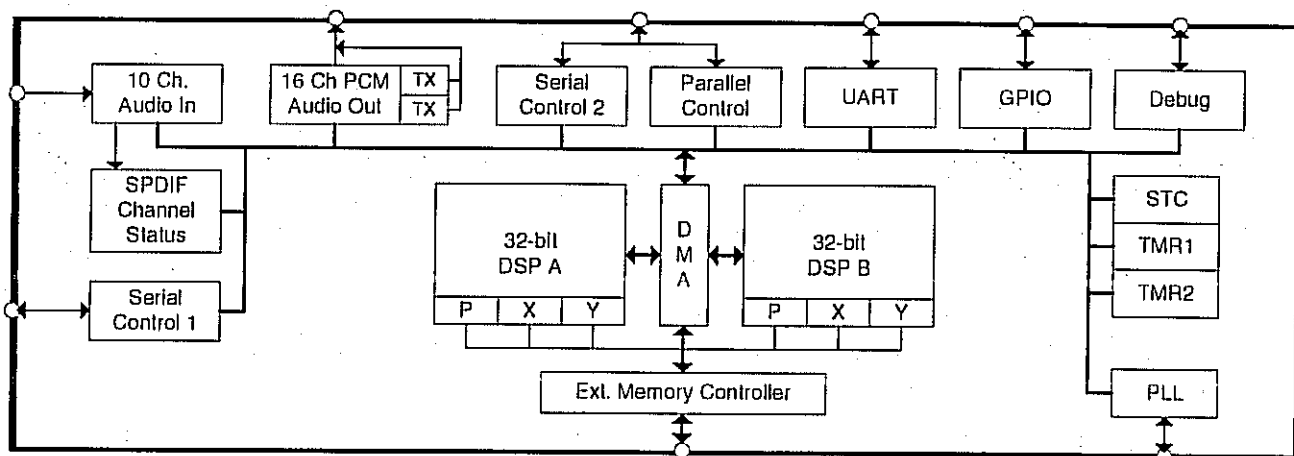

Preliminary Product Information

This document contains information for a new product.
Cirrus Logic reserves the right to modify this product without notice.

CIRRUS LOGIC
<http://www.cirrus.com>

©Copyright 2005 Cirrus Logic, Inc.

NOV '05
DS631PP4

CS495xx Data Sheet
32-bit Audio Decoder DSP Family



Device	Firmware	Decoder	Mid-Processor	Post-Processor
CS495002 -CQZ 90 MHz 1080 MOPS -DQZ 80 MHz 960 MOPS	Firmware Pack	Dolby Digital DTS-ES DTS96/24 MPEG SGEN PCM (2Fs) AAC	PLIIx DTS Neo:6 Downmix Cirrus Original Surround	Tone Control Parametric EQ Bass Manager Delay
	Unbundled Code		Circle Surround (1Fs) Tru-Surround XT (1Fs)	Auto Speaker Setup (IRC1)
CS495102 <i>(Superset of CS495002)</i> -CQZ 110 MHz 1320 MOPS -DQZ 90 MHz 1080 MOPS	Firmware Pack	Dolby Digital DTS-ES DTS96/24 DTS-ES96/24 MPEG SGEN PCM (2Fs) AAC	PLIIx DTS Neo:6 Downmix Cirrus Original Multichannel Surround	Tone Control Parametric EQ Bass Manager Delay
	Unbundled Code		Tru-Surround XT Circle Surround	Automatic Room EQ (IRC2) Dolby Headphone Dolby Headphone 2 Dolby Virtual Speaker Dolby Virtual Speaker 2
CS495202 <i>(Superset of CS495102)</i> -CQZ 120 MHz 1440 MOPS -DQZ 100 MHz 1200 MOPS	Firmware Pack	Dolby Digital DTS-ES DTS96/24 DTS-ES96/24 MPEG SGEN PCM AAC	PLIIx DTS Neo:6 Downmix Cirrus Original Multichannel Surround	Tone Control 11-Band PEQ Bass Manager Delay THX Select THX Select2 THX Ultra2
	Unbundled Code		Tru-Surround XT Circle Surround	Automatic Room EQ (IRC2) Dolby Headphone Dolby Headphone 2 Dolby Virtual Speaker Dolby Virtual Speaker 2

Table 1. Device and Firmware Selection Guide



4. Hardware Functional Description

4.1 DSP Core

The CS495xx is a dual-core DSP with separate X- and Y-data memory spaces, and a separate P-code memory space. Each core is a high-performance, 32-bit, user-programmable, fixed-point DSP that is capable of performing two memory access control (MAC) operations per clock cycle. Each core has eight 72-bit accumulators, four X- and four Y-data registers, and 12 index registers.

Both DSP cores are coupled to a flexible DMA engine. The DMA engine can move data between peripherals such as the DAI and DAO, external memory, or any DSP core memory, all without the intervention of the DSP. The DMA engine offloads data move instructions from the DSP core, leaving more MIPS available for signal processing instructions.

The DSP obtains its functionality from application codes that are downloaded to the CS495xx and are provided through the Cirrus Logic Crystal Ware™ Software Licensing Program.

Both DSP cores are user-programmable in order to offer the customer the ability to implement unique post-processing algorithms. Additionally, users can choose to download standard audio decoder and post-processing modules which are available through the Cirrus Logic Crystal Ware™ Software Licensing Program.

The CS495xx is suitable for AVR/Outboard Decoder, DVD Audio/Video Player, and Digital Broadcast applications.

4.1.1 DSP Memory

Each DSP core has its own on-chip data and program memory and does not require external memory for any of today's popular audio algorithms including Dolby Digital Surround EX, AAC Multichannel, DTS-ES 96/24, and THX Ultra2 Cinema.

The memory maps for the DSPs are as follows. All memory sizes are composed of 32-bit words.

Memory Type	DSP A	DSP B
X	16k SRAM, 32k ROM	8k SRAM, 8k ROM
Y	16k SRAM, 32k ROM	16k SRAM, 8k ROM
P	8k SRAM, 32k ROM	8k SRAM, 8k ROM

Table 2. DSP Memory Sizes

4.1.2 DMA Controller

The powerful 12-channel DMA controller can move data between 8 on-chip resources. Each resource has its own arbiter: X-, Y-, and P-RAMs on DSP A; X-, Y-, P-RAMs on DSP B; external memory; and the peripheral bus. Modulo and linear addressing modes are supported, with flexible start address and increment controls. The service interval for each DMA channel as well as up to 6 interrupt events, is programmable.

4.2 On-chip DSP Peripherals

4.2.1 Digital Audio Input Port (DAI)

The 10-channel DAI port supports a wide variety of data input formats. The port is capable of accepting PCM or IEC61937. Up to 32-bit PCM and 16-bit compressed data input word lengths are supported. The port has two independent slave-only clock domains, each data input can be independently assigned to a clock domain. The sample rate of the input clock domains can be determined automatically by the DSP, eliminating the host from the task of monitoring the SPDIF receiver. A special channel status word function separates IEC channel status data from PCM data and places it into a separate data buffer for analysis by the DSP. A time-stamping feature allows the input data to be sample-rate converted via software.

4.2.2 Digital Audio Output Port (DAO)

There are two DAO ports, each port can output 8 channels of up to 32-bit PCM data. The port supports data rates from 32kHz to 192kHz. Each port can be configured as an independent clock domain in slave mode, or the ratio of the two clocks can be set to even multiples of each other in master mode. The two ports can be ganged together into a single clock domain. Each port has a 192kHz SPDIF transmitter that can be used instead of a PCM output.

4.2.3 Serial Control Port 1 & 2 (I²C or SPI)

There are two on-chip serial control ports that are capable of operating in master or slave mode in either I²C or SPI modes. Serial control port 2 shares pins with the parallel control port.

4.2.4 Parallel Control Port

The CS495xx parallel port can be used for either parallel control (Motorola[®], Intel[®], or multiplexed Intel modes). The parallel port pins are muxed with serial control port 2.

4.2.5 External Memory Interface

The external memory interface controller supports up to 128 Mbit of SDRAM, using a 16-bit data bus. The memory controller supports up to 1MB of SRAM and 1MB of FLASH memory in either 8-bit or 16-bit bus widths.

4.2.6 GPIO

The CS495xx has 42 GPIO pins multiplexed with other peripheral functions. Each GPIO can be configured as an output, an input, or an input with interrupt. Each input-pin interrupt can be configured as rising edge, falling edge, active-low, or active-high.

4.2.7 Channel Status Word (CSW)

The Channel Status Word peripheral extracts SPDIF IEC data and stores it in the CS495xx's internal memory for use by application code. The CSW operates in two modes: 1. extracting data from a DAI channel that is connected to a SPDIF receiver such as the Cirrus Logic CS8416 configured in IEC format mode (IEC data embedded in the I²S stream); or 2. capturing IEC data output from a SPDIF receiver on discrete data, clock, and frame clock pins. The CSW has two data input pins to capture two simultaneous synchronous data streams (U and C).

4.2.8 PLL-based Clock Generator

The PLL-based clock generator provides clock generation and system synchronization for the device. The low-jitter PLL generates integer multiples of a reference frequency which are used to clock the DSP core and peripherals. A second, dependent clock domain can be output on the DAO port for driving Delta-Sigma audio converters. The CS495xx is clocked from the external reference frequency until the



PLL is configured and locked, at which time the clocks can be switched. A built-in crystal oscillator circuit with dedicated, buffered output pin is provided to eliminate an external crystal oscillator.

4.3 DSP I/O Description

4.3.1 Multiplexed Pins

The CS495xx incorporates a large amount of flexibility into a 144-pin package. The pins are internally multiplexed to serve multiple purposes. Some pins are designed to operate in one mode at power up, and serve a different purpose when the DSP is running. Other pins have functionality which can be controlled by the application running on the DSP. In order to better explain the behavior of the part, the pins which are multiplexed have been given multiple names. Each name is specific to the pin's operation in a particular mode.

4.3.2 Termination Requirements

The CS495xx incorporates open-drain pins which must be pulled high for proper operation. PCP_IRQ# and SCP_IRQ# are always open drain which requires a pull-up for proper operation. The SCP_SDA and SCP_CLK lines are open drain in I²C communication mode.

The specific termination requirements may vary since the state of some of the GPIO pins will determine the communication mode at the rising edge of Reset. For the explicit termination requirements of each communication mode please see the *Typical Connection* diagrams in the *CS495xx Hardware User's Manual*.

Generally a 3.3 k Ω resistor is recommended for open-drain and mode-select pins. A 10 k Ω resistor is sufficient for all other unused inputs.

4.3.3 Pads

The CS495xx has two different I/O voltage levels. All signal pins operate from the 3.3 V supply and are 5 V-tolerant.

4.4 Application Code Security

The external program code is encrypted by the programmer to protect any intellectual property it may contain. A secret, customer-specific key is used to encrypt the program code that is to be stored external to the device.

CS495xx Data Sheet
32-bit Audio Decoder DSP Family



7. Package Pinout, 144-Pin QFP/LQFP

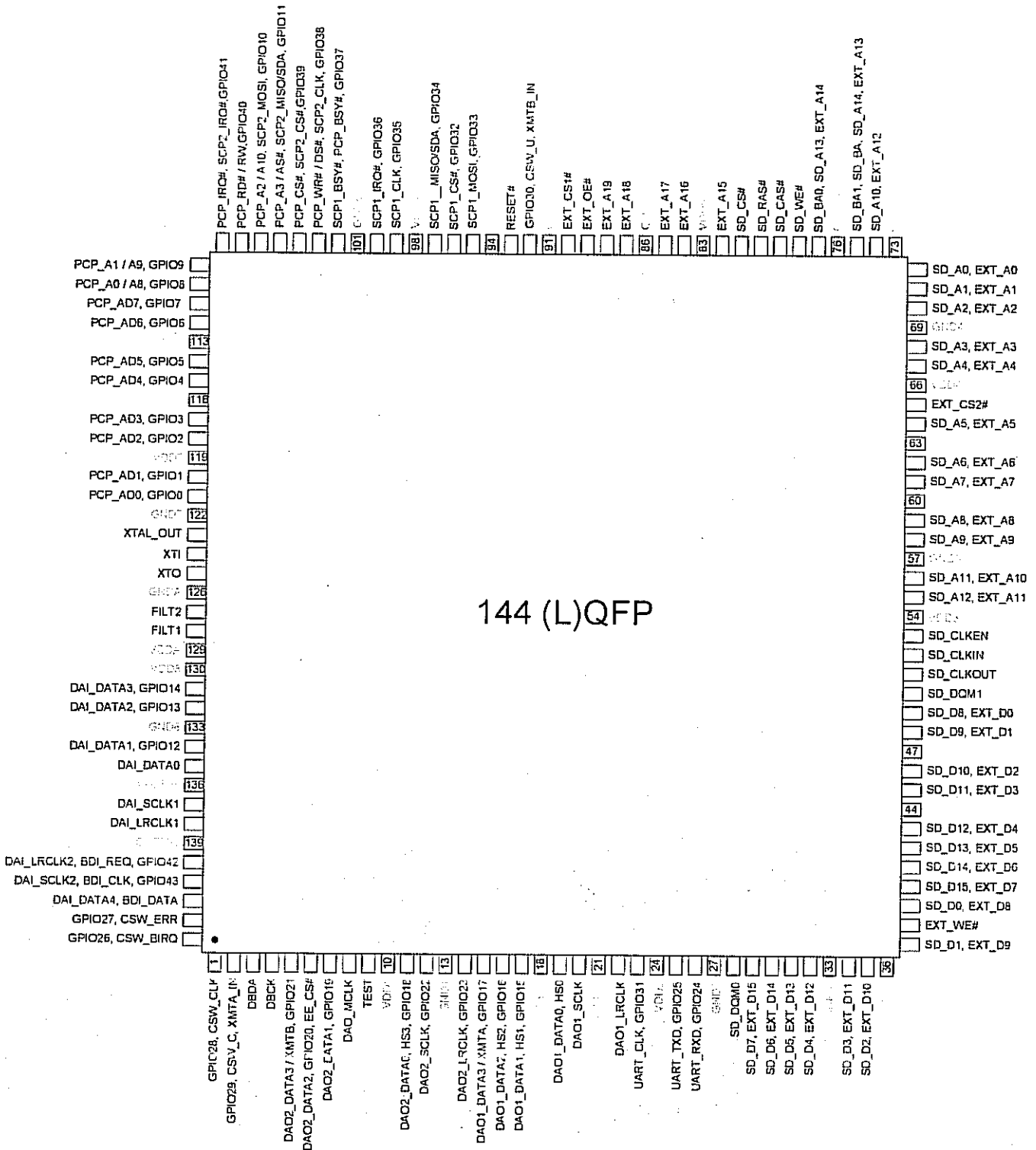

Figure 23. 144-Pin (L)QFP Package Pinout



HCF4053B

TRIPLE 2-CHANNEL ANALOG MULTIPLEXER/DEMULTIPLEXER

- LOW "ON" RESISTANCE : 125Ω (Typ.) OVER 15V p.p SIGNAL-INPUT RANGE FOR $V_{DD} - V_{EE} = 15V$
- HIGH "OFF" RESISTANCE : CHANNEL LEAKAGE $\pm 100pA$ (Typ.) at $V_{DD} - V_{EE} = 18V$
- BINARY ADDRESS DECODING ON CHIP
- HIGH DEGREE OF LINEARITY : < 0.5% DISTORTION TYP. at $f_{IS} = 1KHz, V_{IS} = 5 V_{pp}, V_{DD} - V_{SS} \geq 10V, R_L = 10K\Omega$
- VERY LOW QUIESCENT POWER DISSIPATION UNDER ALL DIGITAL CONTROL INPUT AND SUPPLY CONDITIONS : 0.2 μW (Typ.) at $V_{DD} - V_{SS} = V_{DD} - V_{EE} = 10V$
- MATCHED SWITCH CHARACTERISTICS : $R_{ON} = 5\Omega$ (Typ.) FOR $V_{DD} - V_{EE} = 15V$
- WIDE RANGE OF DIGITAL AND ANALOG SIGNAL LEVELS : DIGITAL 3 to 20, ANALOG TO 20V p.p.
- QUIESCENT CURRENT SPECIF. UP TO 20V
- 5V, 10V AND 15V PARAMETRIC RATINGS
- INPUT LEAKAGE CURRENT $I_I = 100nA$ (MAX) AT $V_{DD} = 18V T_A = 25^\circ C$
- 100% TESTED FOR QUIESCENT CURRENT
- MEETS ALL REQUIREMENTS OF JEDEC JESD13B " STANDARD SPECIFICATIONS FOR DESCRIPTION OF B SERIES CMOS DEVICES"

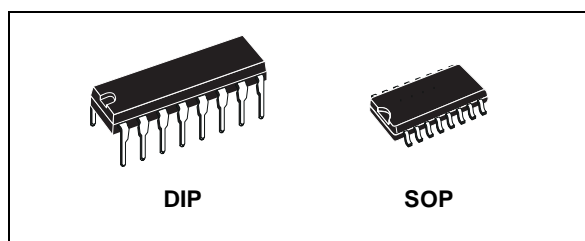

ORDER CODES

PACKAGE	TUBE	T & R
DIP	HCF4053BEY	
SOP	HCF4053BM1	HCF4053M013TR

technology available in DIP and SOP packages. The HCF4053B analog multiplexer/demultiplexer is a digitally controlled analog switch having low ON impedance and very low OFF leakage current. This multiplexer circuit dissipate extremely low quiescent power over the full $V_{DD} - V_{SS}$ and $V_{DD} - V_{EE}$ supply voltage range, independent of the logic state of the control signals.

When a logic "1" is present at the inhibit input terminal all channel are off. This device is a triple 2-channel multiplexer having three separate digital control inputs, A, B, and C, and an inhibit input. Each control input selects one of a pair of channels which are connected in a single pole double-throw configuration.

DESCRIPTION

The HCF4053B is a monolithic integrated circuit fabricated in Metal Oxide Semiconductor

PIN CONNECTION

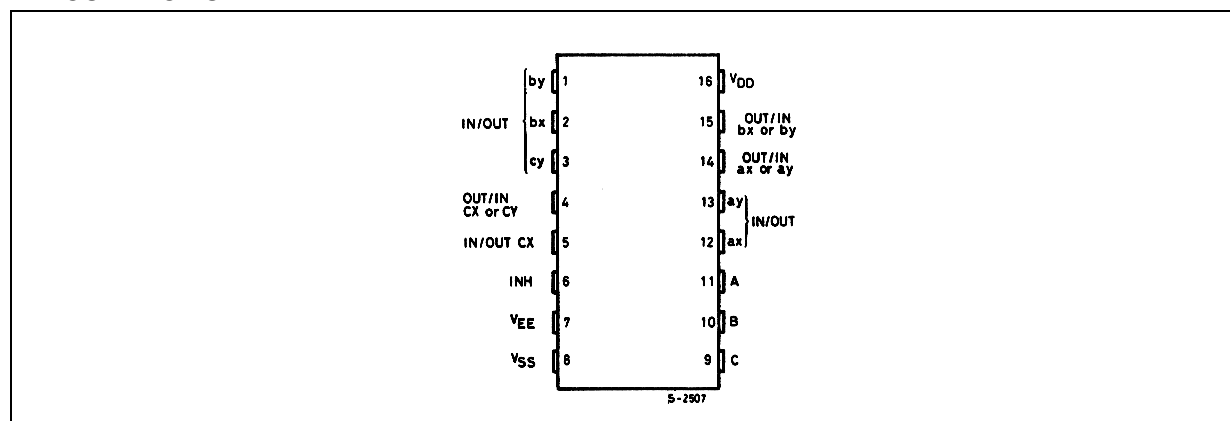

HCF4053B

INPUT EQUIVALENT CIRCUIT

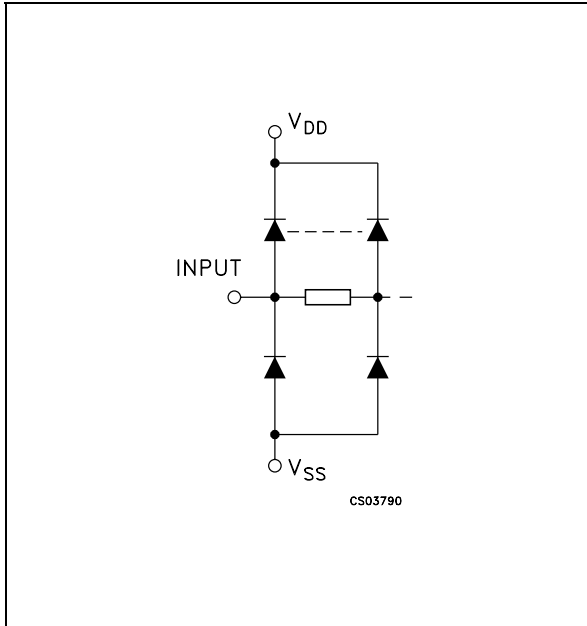

PIN DESCRIPTION

PIN No	SYMBOL	NAME AND FUNCTION
11, 10, 9	A, B, C	Binary Control Inputs
6	INH	Inhibit Inputs
12, 13, 2, 1, 5, 3	IN/OUT	ax,ay,bx,by,cx,cy Input/Output
14	OUT/IN	ax or ay
15	OUT/IN	bx or by
4	OUT/IN	cx or cy
7	V_{EE}	Supply Voltage
8	V_{SS}	Negative Supply Voltage
16	V_{DD}	Positive Supply Voltage

TRUTH TABLE

INHIBIT	C or B or A	
0	0	ax or bx or cx
0	1	ay or by or cy
1	X	NONE

X : Don't Care

FUNCTIONAL DIAGRAM

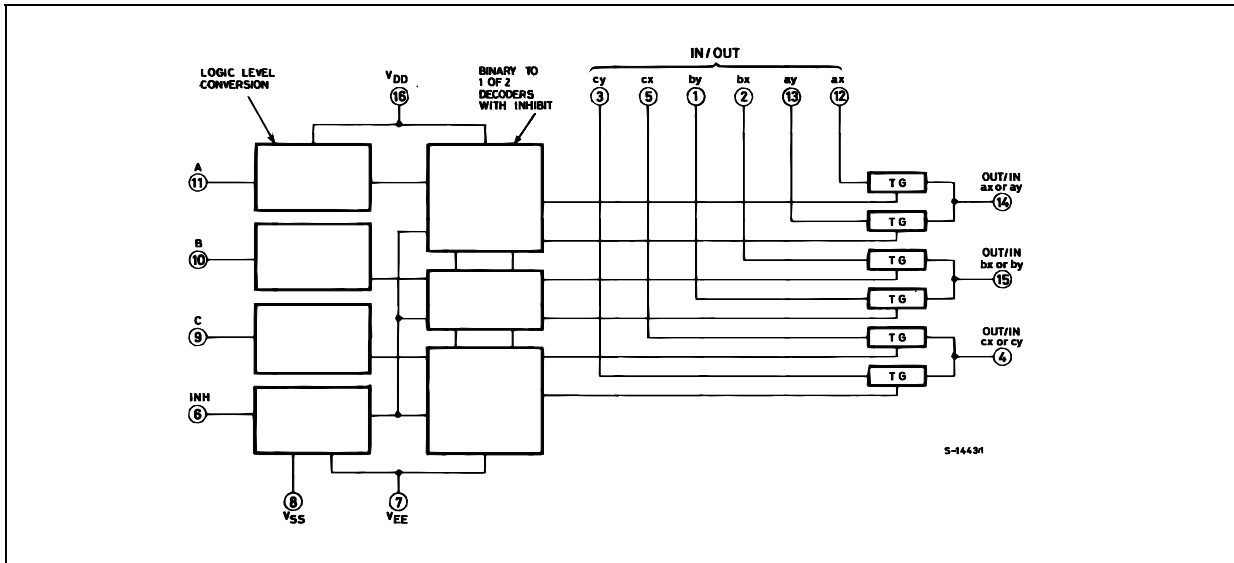

OUTER DIMENSIONS

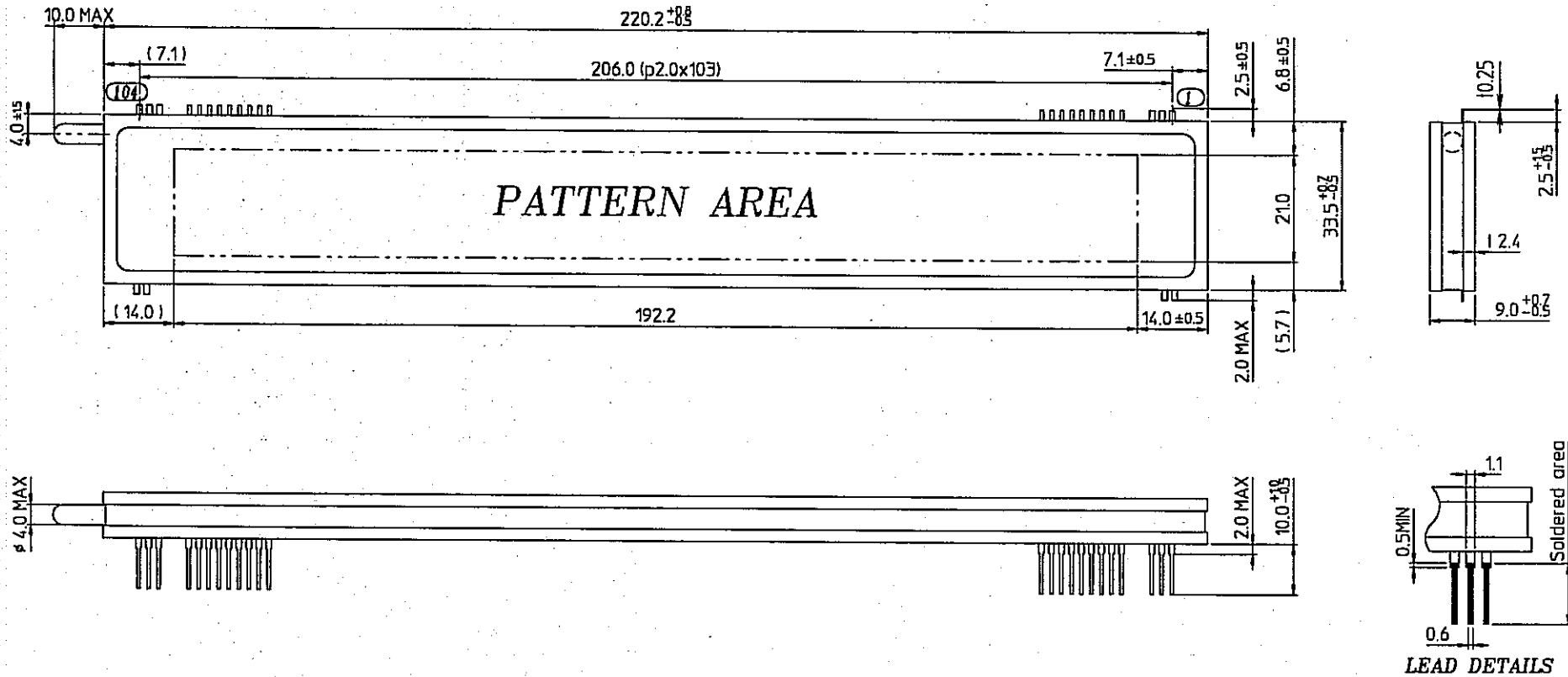

PIN CONNECTION

PIN NO.	104	103	102	101	100	99	98	97	96	95	94	93	92	91	90~15	14~6	5	4	3	2	1
CONNECTION	F2	F2	F2	NP	NP	V _{DISP}	L-GND	D-GND	V _{DD}	OSCO	/RST	/CS	/CP	DA	NP	NC	NP	NP	F1	F1	F1

***Notes**

- Fn : Filament Pin
- NP : No Pin
- NC : No Connection Pin

MODEL : HCA-18ML03
 OUTER DIMENSIONS
 Rev. ① 20-Jan-2005



GRID ASSIGNMENT

<p>1G</p> <input type="checkbox"/> DIGITAL EX <input type="checkbox"/> PRO LOGIC II <input type="checkbox"/> 3 STEREO <input type="checkbox"/> HEADPHONE <input type="checkbox"/>	<p>2G</p> <input type="checkbox"/> LOGIC 7 <input type="checkbox"/> VMAx <input type="checkbox"/> DSP <input type="checkbox"/> 57CH. STEREO <input type="checkbox"/> SURR. OFF	<p>3G</p> <p>4G</p> <p>5G</p> <p>6G</p> <p>7G</p> <p>8G</p> <p>9G</p> <p>10G</p> <p>11G</p> <p>12G</p> <p>13G</p> <p>14G</p> <p>15G</p> <p>16G</p>	<p>17G</p> <input type="checkbox"/> L <input type="checkbox"/> C <input type="checkbox"/> R <input type="checkbox"/> SL <input type="checkbox"/> LFE <input type="checkbox"/> SR <input type="checkbox"/> [SBL] — [SBR]	<p>18G</p> <input type="checkbox"/> VID 1 <input type="checkbox"/> DVD 12 <input type="checkbox"/> VID 2 <input type="checkbox"/> CD <input type="checkbox"/> VID 3 <input type="checkbox"/> FMAM <input type="checkbox"/> VID 4 <input type="checkbox"/> TAPE <input type="checkbox"/> VID 5 <input type="checkbox"/> 68CH
--	---	--	--	--

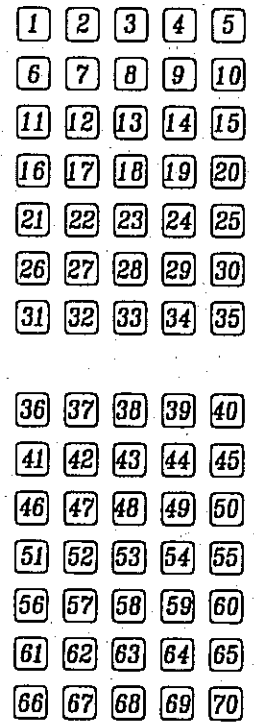

(3G-16G)

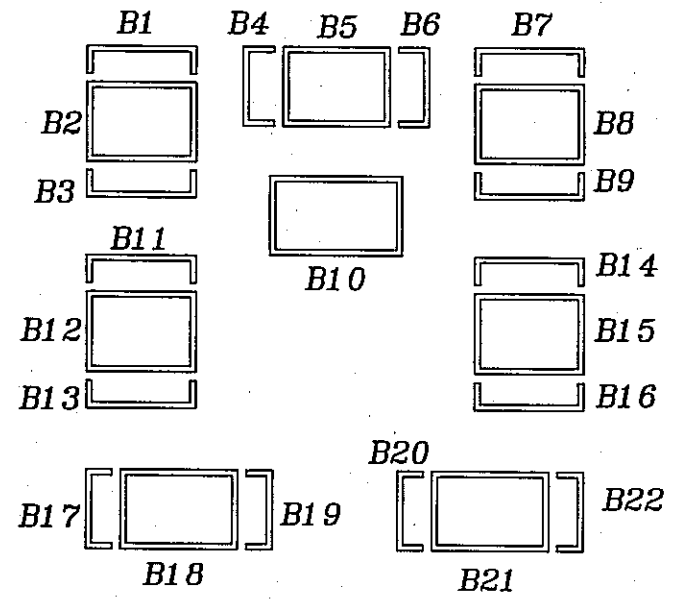

(17G)

MODEL : HCA-18ML03
 GRID ASSIGNMENT
 Rev. ① 20-Jan-2005

ANODE CONNECTION



	COM1	COM2	COM3	~	COM16	COM17	COM18		COM1	COM2	COM3	~	COM16	COM17	COM18
	1G	2G	3G	~	16G	17G	18G		1G	2G	3G	~	16G	17G	18G
SEGB 1	<input type="checkbox"/> (DIGITAL EX)	<input type="checkbox"/> (LOGIC 7)	1	1	1	B1	<input type="checkbox"/> (VID 1)	SEGA 1	<input checked="" type="checkbox"/>	5	36	36	36		
SEGB 2			2	2	2	B2	VID 1	SEGA 2			37	37	37		
SEGB 3			3	3	3	L	<input type="checkbox"/> (DVD 12)	SEGA 3			38	38	38		
SEGB 4			4	4	4	B3	DVD	SEGA 4			39	39	39		
SEGB 5			5	5	5	B4	1	SEGA 5			40	40	40		
SEGB 6	<input checked="" type="checkbox"/> DIGITAL	<input checked="" type="checkbox"/> LOGIC 7	6	6	6	B5	2	SEGA 6	3	7	41	41	41		
SEGB 7			7	7	7	C	<input type="checkbox"/> (VID 2)	SEGA 7			42	42	42		
SEGB 8			8	8	8	B6	VID 2	SEGA 8			43	43	43		
SEGB 9			9	9	9	B7	<input type="checkbox"/> (CD)	SEGA 9			44	44	44		
SEGB 10			10	10	10	B8	CD	SEGA 10			45	45	45		
SEGB 11	EX	<input type="checkbox"/> (VMAx)	11	11	11	R	<input type="checkbox"/> (VID 3)	SEGA 11	STEREO	CH. STEREO	46	46	46		
SEGB 12			12	12	12	B9	VID 3	SEGA 12			47	47	47		
SEGB 13			13	13	13	B10	<input type="checkbox"/> (FM AM)	SEGA 13			48	48	48		
SEGB 14			14	14	14	LFE	FM	SEGA 14			49	49	49		
SEGB 15			15	15	15	B11	AM	SEGA 15			50	50	50		
SEGB 16	<input type="checkbox"/> (PRO LOGIC)	VMAx	16	16	16	B12	<input type="checkbox"/> (VID 4)	SEGA 16	<input type="checkbox"/> (HEADPHONE)	<input type="checkbox"/> (SURR. OFF)	51	51	51		
SEGB 17			17	17	17	SL	VID 4	SEGA 17			52	52	52		
SEGB 18			18	18	18	B13	<input type="checkbox"/> (TAPE)	SEGA 18			53	53	53		
SEGB 19			19	19	19	Ⓞ	TAPE	SEGA 19			54	54	54		
SEGB 20			20	20	20	B14	<input type="checkbox"/> (VID 5)	SEGA 20			55	55	55		
SEGB 21	<input checked="" type="checkbox"/> PRO LOGIC	<input type="checkbox"/> (DSP)	21	21	21	B15	VID 5	SEGA 21	<input checked="" type="checkbox"/> HEADPHONE	SURR. OFF	56	56	56		
SEGB 22			22	22	22	SR	<input type="checkbox"/> (68CH)	SEGA 22			57	57	57		
SEGB 23			23	23	23	B16	6	SEGA 23			58	58	58		
SEGB 24			24	24	24	B17	8	SEGA 24			59	59	59		
SEGB 25			25	25	25	B18	CH	SEGA 25			60	60	60		
SEGB 26	I	DSP	26	26	26	SBL		SEGA 26	<input type="checkbox"/> (DTS, ES)		61	61	61		
SEGB 27			27	27	27	B19		SEGA 27			62	62	62		
SEGB 28			28	28	28	—		SEGA 28			63	63	63		
SEGB 29			29	29	29	B20		SEGA 29			64	64	64		
SEGB 30			30	30	30	B21		SEGA 30			65	65	65		
SEGB 31	<input type="checkbox"/> (3 STEREO)	<input type="checkbox"/> (57CH.)	31	31	31	SBR		SEGA 31	<input checked="" type="checkbox"/>		66	66	66		
SEGB 32			32	32	32	B22		SEGA 32			67	67	67		
SEGB 33			33	33	33			SEGA 33			68	68	68		
SEGB 34			34	34	34			SEGA 34			69	69	69		
SEGB 35			35	35	35			SEGA 35	<input checked="" type="checkbox"/>		70	70	70		

MODEL : HCA-18LM03
 ANODE CONNECTION
 Rev. ① 20-Jan-2005

CMOS 16-Bit Microcontrollers T5CC1

1. Outline and Features

T5CC1 is a high-speed 16-bit microcontroller designed for the control of various mid- to large-scale equipment.

T5CC1 comes in a 100-pin flat package.

Listed below are the features.

- (1) High-speed 16-bit CPU (900/L1 CPU)
 - Instruction mnemonics are upward-compatible with TLCS-90/900
 - General-purpose registers and register banks
 - 16 Mbytes of linear address space
 - 16-bit multiplication and division instructions; bit transfer and arithmetic instructions
 - Micro DMA: 4-channels (593 ns/2 bytes at 27 MHz)
- (2) Minimum instruction execution time: 148 ns (at 27 MHz)
- (3) Built-in RAM: 16 Kbytes
Built-in ROM: 256 Kbytes Flash memory
4 Kbytes mask ROM (used for booting)

- (4) External memory expansion
 - Expandable up to 16 Mbytes (shared program/data area)
 - Can simultaneously support 8-/16-bit width external data bus
 - … Dynamic data bus sizing
- (5) 8-bit timers: 8 channels
- (6) 16-bit timer/event counter: 2 channels
- (7) General-purpose serial interface: 2 channels
 - UART/ Synchronous mode: 2 channels
 - IrDA ver1.0 (115.2 kbps) supported: 1 channel
- (8) Serial bus interface: 1 channel
 - I²C bus mode/clock synchronous Select mode
- (9) 10-bit AD converter (built-in sample hold circuit) : 8 channels
- (10) Watchdog timer
- (11) Special timer for clock
- (12) Chip Select/Wait controller: 4 channels
- (13) Interrupts: 45 interrupts
 - 9 CPU interrupts: Software interrupt instruction and illegal instruction
 - 26 internal interrupts:]
 - 10 external interrupts:] Seven selectable priority levels
- (14) Input/Output ports: 81 pins
- (15) Standby function
 - Three HALT modes: IDLE2 (programmable), IDLE1, STOP
- (16) Clock controller
 - Clock Gear function: Select a high-frequency clock (f_c to $f_c/16$)
 - Special timer for CLOCK ($f_s = 32.768$ kHz)
- (17) Operating voltage
 - $V_{CC} = 2.7$ V to 3.6 V (f_c max = 27 MHz, flash memory read operation)
 - $V_{CC} = 3.0$ V to 3.6 V (f_c max = 27 MHz, flash memory erase/program operations)
- (18) Package
 - 100-pin LQFP: LQFP100-P-1414-0.50F

Note: This LSI does not build in Clock doubler (DFM.)

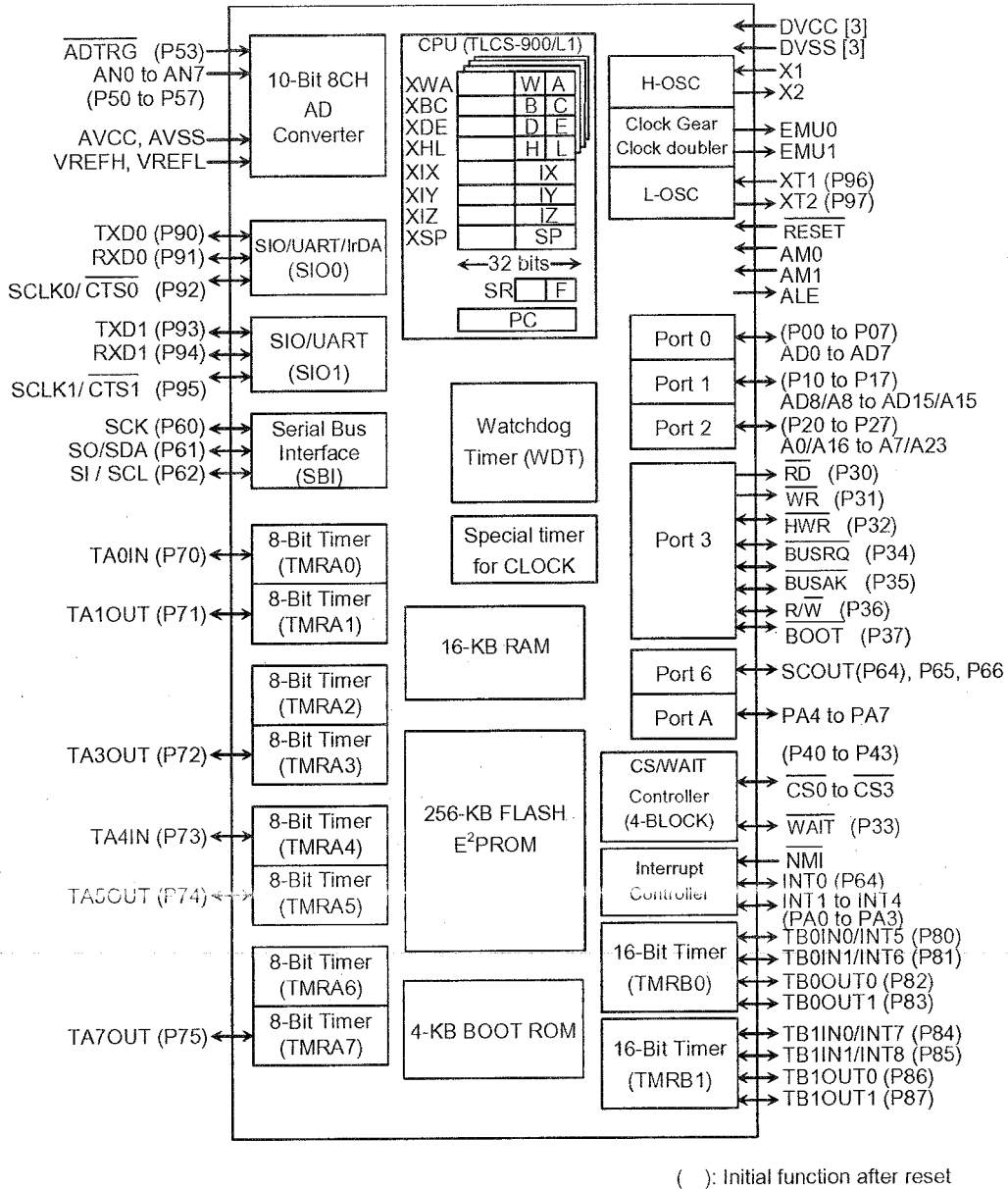

Figure 1.1 T5CC1 Block Diagram

2. Pin Assignment and Pin Functions

The assignment of input/output pins for the T5CC1, their names and functions are as follows:

2.1 Pin Assignment Diagram

Figure 2.1.1 shows the pin assignment of the T5CC1.

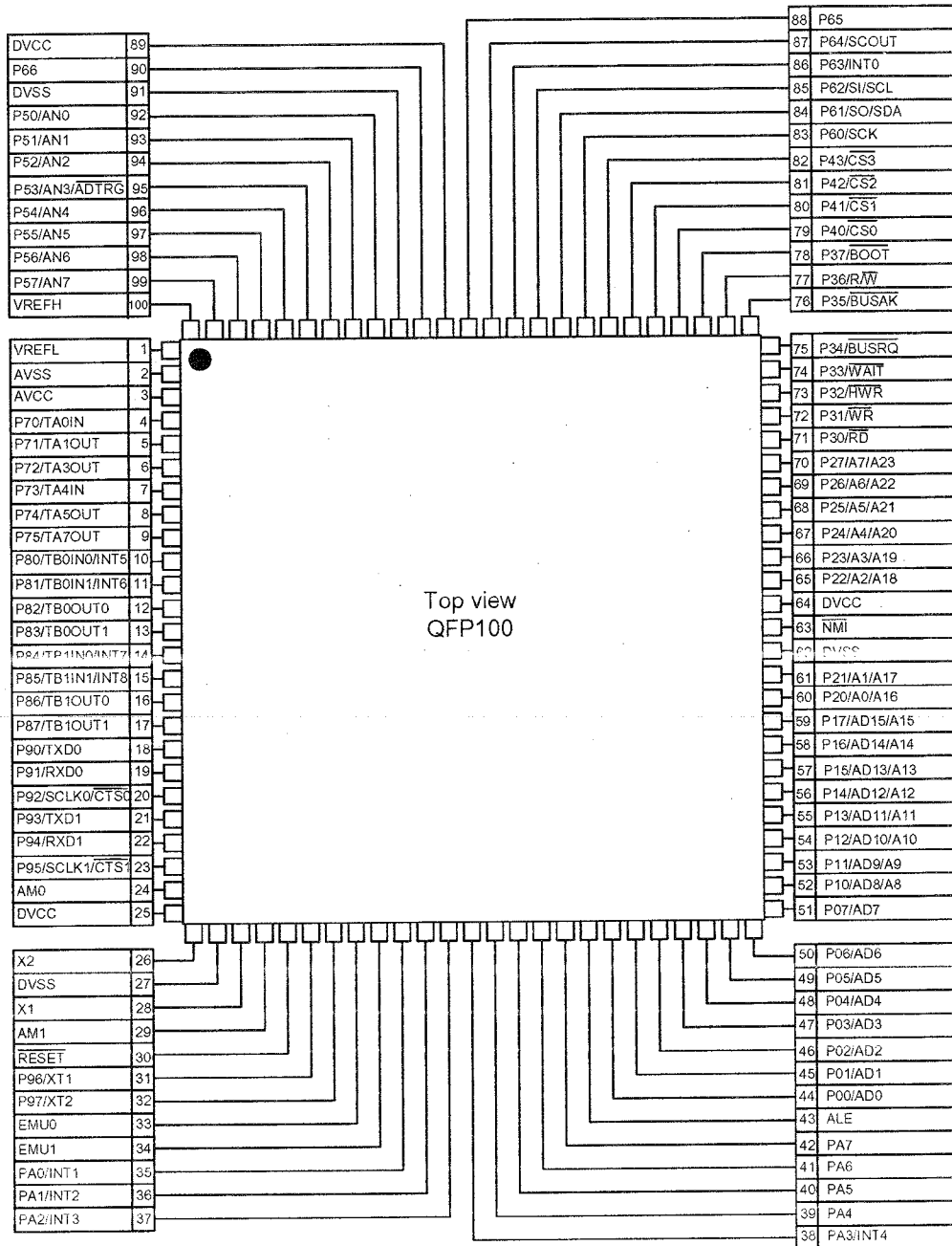

Figure 2.1.1 Pin assignment diagram (100-pin LQFP)

2.2 Pin Names and Functions

The names of the input/output pins and their functions are described below.

Table 2.2.1 Pin names and functions.

Table 2.2.1 Pin names and functions (1/3)

Pin Name	Number of Pins	I/O	Functions
P00~P07 AD0~AD7	8	I/O I/O	Port 0: I/O port that allows I/O to be selected at the bit level Address and data (lower): Bits 0 to 7 of address and data bus
P10~P17 AD8~AD15 A8~A15	8	I/O I/O Output	Port 1: I/O port that allows I/O to be selected at the bit level Address and data (upper): Bits 8 to 15 for address and data bus Address: Bits 8 to 15 of address bus
P20~P27 A0~A7 A16~A23	8	I/O Output Output	Port 2: I/O port that allows I/O to be selected at the bit level Address: Bits 0 to 7 of address bus Address: Bits 16 to 23 of address bus
P30 \overline{RD}	1	Output Output	Port 30: Output port Read: Strobe signal for reading external memory This port output RD signal also case of reading internal-area by setting P3 <P30> = 0 and P3FC <P30F> = 1.
P31 \overline{WR}	1	Output Output	Port 31: Output port Write: Strobe signal for writing data to pins AD0 to AD7
P32 \overline{HWR}	1	I/O Output	Port 32: I/O port (with pull-up resistor) High Write: Strobe signal for writing data to pins AD8 to AD15
P33 \overline{WAIT}	1	I/O Input	Port 33: I/O port (with pull-up resistor) Wait: Pin used to request CPU bus wait ((1+N) WAIT mode)
P34 BUSRQ	1	I/O Input	Port 34: I/O port (with pull-up resistor) Bus Request: Signal used to request Bus Release
P35 \overline{BUSAk}	1	I/O Output	Port 35: I/O port (with pull-up resistor) Bus Acknowledge: Signal used to acknowledge Bus Release
P36 $\overline{R/W}$	1	I/O Output	Port 36: I/O port (with pull-up resistor) Read/Write: 1 represents Read or Dummy cycle; 0 represents Write cycle.
P37 \overline{BOOT}	1	I/O Input	Port 36: I/O port (with pull-up resistor) This pin sets single boot mode. When released reset, Single boot mode is started at P37 = Low level.
P40 $\overline{CS0}$	1	I/O Output	Port 40: I/O port (with pull-up resistor) Chip Select 0: Outputs 0 when address is within specified address area
P41 $\overline{CS1}$	1	I/O Output	Port 41: I/O port (with pull-up resistor) Chip Select 1: Outputs 0 if address is within specified address area
P42 $\overline{CS2}$	1	I/O Output	Port 42: I/O port (with pull-up resistor) Chip Select 2: Outputs 0 if address is within specified address area
P43 $\overline{CS3}$	1	I/O Output	Port 43: I/O port (with pull-up resistor) Chip Select 3: Outputs 0 if address is within specified address area
P50~P57 AN0~AN7 \overline{ADTRG}	8	Input Input Input	Port 5: Pin used to input port Analog input: Pin used to input to AD converter AD Trigger: Signal used to request start of AD converter (Shared with 53 pin)

TOSHIBA

T5CC1

Table 2.2.1 Pin names and functions (2/3)

Pin Name	Number of Pins	I/O	Functions
P60 SCK	1	I/O I/O	Port 60: I/O port Serial bus interface clock in SIO Mode
P61 SO SDA	1	I/O Output I/O	Port 61: I/O port Serial bus interface send data at SIO mode Serial bus interface send/recv data at I ² C bus mode Open-drain output mode by programmable
P62 SI SCL	1	I/O Input I/O	Port 62: I/O port Serial bus interface receive data at SIO mode Serial bus interface clock I/O data at I ² C bus mode Open-drain output mode by programmable
P63 INT0	1	I/O Input	Port 63: I/O port Interrupt Request Pin 0: Interrupt request pin with programmable level / rising edge / falling edge
P64 SCOUT	1	I/O Output	Port 64: I/O port System Clock Output: Outputs f _{PPH} or fs clock.
P65	1	I/O	Port 65 I/O port
P66	1	I/O	Port 66 I/O port
P70 TA0IN	1	I/O Input	Port 70 I/O port 8-bit timer 0 input: Timer 0 input
P71 TA1OUT	1	I/O Output	Port 71 I/O port 8-bit timer 1 output: Timer 0 or Timer 1 output
P72 TA3OUT	1	I/O Output	Port 72 I/O port 8-bit 8-bit timer 3 output: Timer 2 or Timer 3 output
P73 TA4IN	1	I/O Input	Port 73: I/O port 8-bit timer 4 input: Timer 4 input
P74 TA5OUT	1	I/O Output	Port 74: I/O port 8-bit timer 5 output: Timer 4 or Timer 5 output
P75 TA7OUT	1	I/O Output	Port 75: I/O port 88-bit timer 7 output: Timer 6 or Timer 7 output
P80 TB0IN0 INT5	1	I/O Input Input	Port 80: I/O port 16-bit timer 0 input 0: 16-bit Timer 0 count / capture trigger input Interrupt Request Pin 5: Interrupt request pin with programmable rising edge / falling edge.
P81 TB0IN1 INT6	1	I/O Input Input	Port 81: I/O port 16-bit timer 0 input 1: 16-bit Timer 0 count / capture trigger input Interrupt Request Pin 6: Interrupt request on rising edge
P82 TB0OUT0	1	I/O Output	Port 82: I/O port 16-bit timer 0 output 0: 16-bit Timer 0 output
P83 TB0OUT1	1	I/O Output	Port 83: I/O port 16-bit timer 0 output 1: 16-bit Timer 0 output
P84 TB1IN0 INT7	1	I/O Input Input	Port 84: I/O port 16-bit timer 1 input 0: 16-bit Timer 1 count / capture trigger input Interrupt Request Pin 7: Interrupt request pin with programmable rising edge / falling edge.
P85 TB1IN1 INT8	1	I/O Input Input	Port 85: I/O port 16-bit timer 1 input 1: 16-bit Timer 1 count / capture trigger input Interrupt Request Pin 8: Interrupt request on rising edge
P86 TB1OUT0	1	I/O Output	Port 86: I/O port 16-bit timer 1 output 0: 16-bit Timer 1 output 16-bit
P87 TB1OUT1	1	I/O Output	Port 87: I/O port 16-bit timer 1 output 1: 16-bit Timer 1 output 16-bit 16-bit

Table 2.2.1 Pin names and functions (3/3)

Pin Name	Number of Pins	I/O	Functions
P90 TXD0	1	I/O Output	Port 90: I/O port Serial Send Data 0 (programmable open-drain)
P91 RXD0	1	I/O Input	Port 91: I/O port Serial Receive Data 0
P92 SCLK0 CTS0	1	I/O I/O Input	Port 92: I/O port Serial Clock I/O 0 Serial Data Send Enable 0 (Clear to Send)
P93 TXD1	1	I/O Output	Port 93: I/O port Serial Send Data 1 (programmable open-drain)
P94 RXD1	1	I/O Input	Port 94: I/O port (with pull-up resistor) Serial Receive Data 1
P95 SCLK1 CTS1	1	I/O I/O Input	Port 95: I/O port (with pull-up resistor) Serial Clock I/O 1 Serial Data Send Enable 1 (Clear to Send)
P96 XT1	1	I/O Input	Port 96: I/O port (open-drain output) Low-frequency oscillator connection pin
P97 XT2	1	I/O Output	Port 97: I/O port (open-drain output) Low-frequency oscillator connection pin
PA0~PA3 INT1~INT4	4	I/O Input	Ports A0 to A3: I/O ports Interrupt Request Pins 1 to 4: Interrupt request pins with programmable rising edge / falling edge.
PA4~PA7 ALE	4 1	I/O Output	Ports A4 to A7: I/O ports Address Latch Enable Can be disabled to reduce noise.
$\overline{\text{NMI}}$	1	Input	Non-Maskable Interrupt Request Pin: Interrupt request pin with programmable falling edge or both edge.
AM0~1	2	Input	Operation mode: Fixed to AM1 = 1, AM0 = 1
EMU0	1	Output	Open pin
EMU1	1	Output	Open pin
$\overline{\text{RESET}}$	1	Input	Reset: initializes T5CC1. (With pull-up resistor)
VREFH	1	Input	Pin for reference voltage input to AD converter (H)
VREFL	1	Input	Pin for reference voltage input to AD converter (L)
AVCC	1		Power supply pin for AD converter
AVSS	1		GND pin for AD converter (0 V)
X1/X2	2	I/O	High-frequency oscillator connection pins
DVCC	3		Power supply pins (All DVCC pins should be connected with the power supply pin.)
DVSS	3		GND pins (0 V) (All DVSS pins should be connected with the power supply pin.)

Note: An external DMA controller cannot access the device's built-in memory or built-in I/O devices using the $\overline{\text{BUSRQ}}$ and $\overline{\text{BUSAK}}$ signal.

3. Operation

This following describes block by block the functions and operation of the T5CC1.

3.1 CPU

The T5CC1 incorporates a high-performance 16-bit CPU (The 900/L1 CPU). For CPU operation, see the "TLCS-900/L1 CPU".

The following describe the unique function of the CPU used in the T5CC1; these functions are not covered in the TLCS-900/L1 CPU section.

3.1.1 Reset

When resetting the T5CC1 microcontroller, ensure that the power supply voltage is within the operating voltage range, and that the internal high-frequency oscillator has stabilized. Then hold the $\overline{\text{RESET}}$ input to low level for at least 10 system clocks (12 μ s at 27MHz).

Thus, when turn on the switch, be set to the power supply voltage is within the operating voltage range, and that the internal high-frequency oscillator has stabilized. Then hold the $\overline{\text{RESET}}$ input to low level at least for 10 system clocks.

Clock gear is initialized 1/16 mode by reset operation. It means that the system clock mode f_{SYS} is set to $f_c/32$ ($= f_c/16 \times 1/2$).

When the reset is accept, the CPU:

- Sets as follows the program counter (PC) in accordance with the reset vector stored at address FFFF00H to FFFF02H:
 - PC<7:0> ← Value at FFFF00H address
 - PC<15:8> ← Value at FFFF01H address
 - PC<23:16> ← Value at FFFF02H address
- Sets the stack pointer (XSP) to 100H.
- Sets bits <IFF2:0> of the status register (SR) to 111 (Sets the interrupt level mark register to level 7).
- Sets the <MAX> bit of the status register to 1 (MAX mode).
(Note: As this product does not support MIN mode, do not write a 0 to the <MAX>.)
- Clears bits <RFP2:0> of the status register to 000 (Sets the register bank to 0).

When reset is released, the CPU starts executing instructions in accordance with the program counter settings. CPU internal registers not mentioned above do not change when the reset is released.

When the reset is accepted, the CPU sets internal I/O. ports, and other pins as follows.

- Initializes the internal I/O registers.
- Sets the port pins, including the pins that also act as internal I/O. to general-purpose input or output port mode.
- Sets ALE pin to "High-Z"

Note: The CPU internal register (except to PC, SR, XSP) and internal RAM data do not change by resetting.

Figure 3.1.1 is a reset timing of the T5CC1.

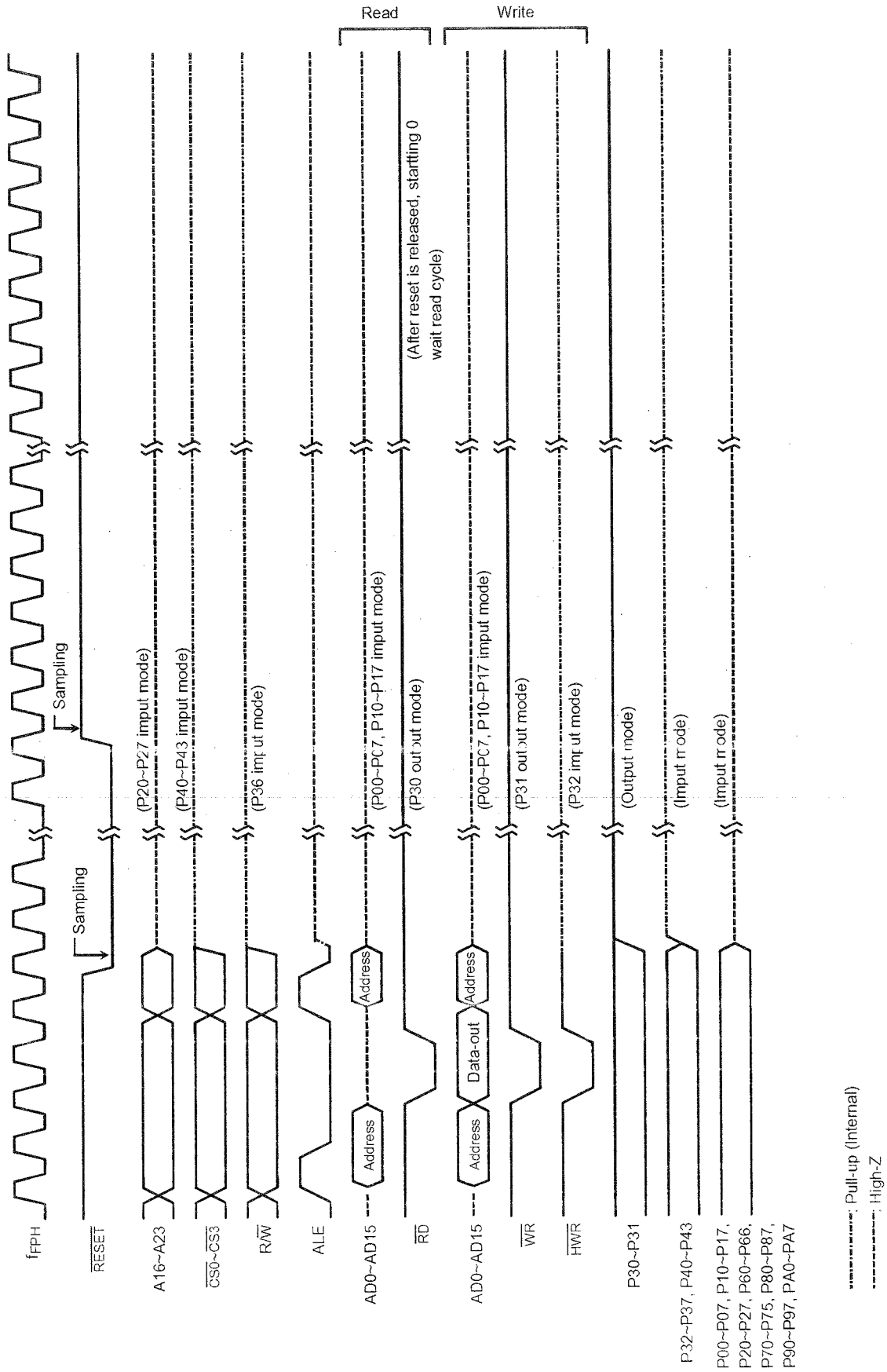



Figure 3.1.1 T5CC1 Reset Timing Example

3.1.2 Outline of Operation Modes

There are single-chip and single-boot modes. Which mode is selected depends on the device's pin state after a reset.

- Single-chip mode: The device normally operations in this mode. After a reset, the device starts executing the internal memory program.
- Single-boot mode: This mode is used to rewrite the internal flash memory by serial transfer (UART).
After a reset, internal boot program starts up, executing an on-board rewrite program.

Table 3.1.1 Operation Mode Setup Table

Operation Mode	Mode Setup Input Pin			
	$\overline{\text{RESET}}$	$\overline{\text{BOOT}}$ (P37)	AM0	AM1
Single-chip mode		H	H	H
Single-boot mode		L		



AK4589

2/8-Channel Audio CODEC with DIR

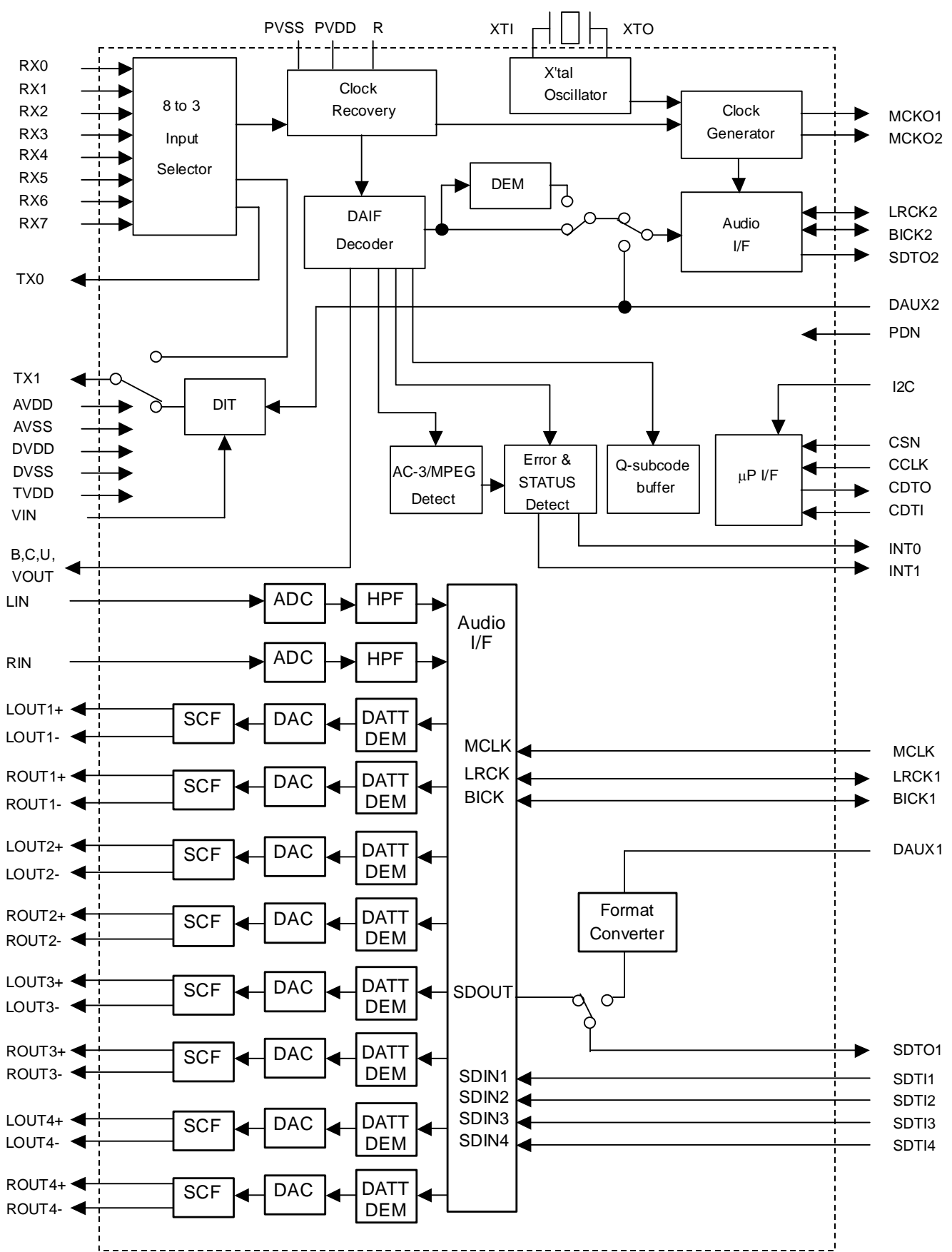

■ オーダリングガイド

AK4589VQ
AKD4589

-10 ~ +70°C
評価ボード

80pin LQFP(0.5mm pitch)

■ ピン配置

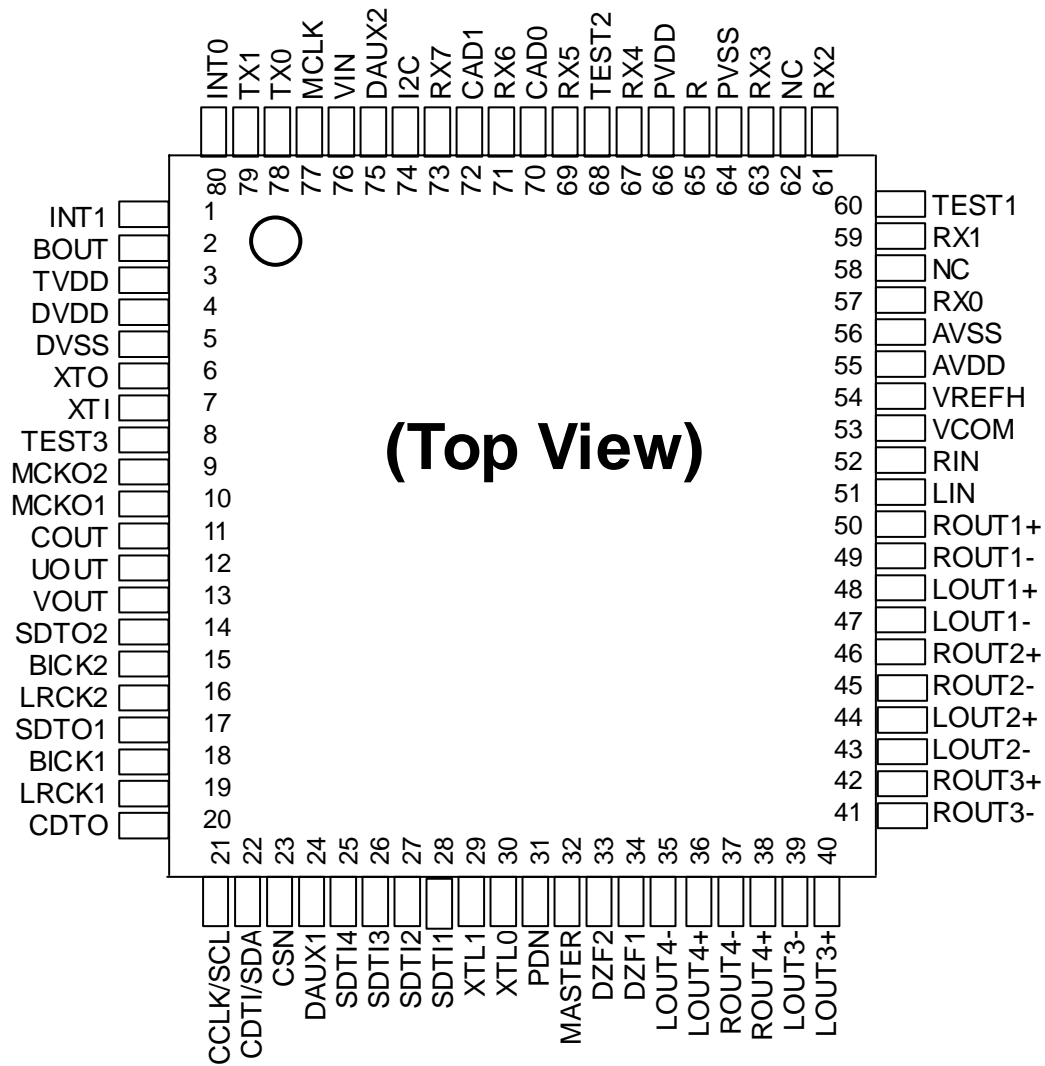

■ AK4588 との相違点

Functions	AK4588	AK4589
DAC 出力	シングルエンド	差動
DAC S/(N+D)	90dB	94dB
DAC S/N	106dB	114dB
DAC Output voltage	Typ 3.0Vpp	Typ ± 2.7 Vpp
DAC AOUT	AOUT=0.6xVREFH	AOUT=0.54xVREFH
Load Resistance	5k ohm	2k ohm
Frequency Response 80kHz	± 1.0	+0/-0.6
アナログ出力ピン	#35, #37, #39, #41, #43, #45, #47, #49	#35 - #50
電源電圧	Min=4.5V, Max=5.5V	Min=4.75V, Max=5.25V

(注)AK4589 は内部に ADC/DAC 部レジスタ(AK4588 レジスタ互換)と DIR/DIT 部レジスタ(AK4588 レジスタ互換)の 2 つのレジスタをもちます。それぞれのレジスタはチップアドレスで指定します。

ピン / 機能

No.	Pin Name	I/O	Function
1	INT1	O	Interrupt 1 Pin
2	BOUT	O	Block-Start Output Pin for Receiver Input “H” during first 40 flames.
3	TVDD	-	Output Buffer Power Supply Pin, 2.7V~5.25V
4	DVDD	-	Digital Power Supply Pin, 4.75V~5.25V
5	DVSS	-	Digital Ground Pin
6	XTO	O	X'tal Output Pin
7	XTI	I	X'tal Input Pin
8	TEST3	I	Test 3 Pin This pin should be connected to DVSS.
9	MCKO2	O	Master Clock Output 2 Pin
10	MCKO1	O	Master Clock Output 1 Pin
11	COUT	O	C-bit Output Pin for Receiver Input
12	UOUT	O	U-bit Output Pin for Receiver Input
13	VOUT	O	V-bit Output Pin for Receiver Input
14	SDTO2	O	Audio Serial Data Output Pin (DIR/DIT part)
15	BICK2	I/O	Audio Serial Data Clock Pin (DIR/DIT part)
16	LRCK2	I/O	Channel Clock Pin (DIR/DIT part)
17	SDTO1	O	Audio Serial Data Output Pin (ADC/DAC part)
18	BICK1	I/O	Audio Serial Data Clock Pin (ADC/DAC part)
19	LRCK1	I/O	Input Channel Clock Pin
20	CDTO	O	Control Data Output Pin in Serial Mode, I2C= “L”.
21	CCLK	I	Control Data Clock Pin in Serial Mode, I2C= “L”
	SCL	I	Control Data Clock Pin in Serial Mode, I2C= “H”
22	CDTI	I	Control Data Input Pin in Serial Mode, I2C= “L”.
	SDA	I/O	Control Data Pin in Serial Mode, I2C= “H”.
23	CSN	I	Chip Select Pin in Serial Mode, I2C= “L”.
		I	This pin should be connected to DVSS, I2C= “H”.
24	DAUX1	I	AUX Audio Serial Data Input Pin (ADC/DAC part)
25	SDTI4	I	DAC4 Audio Serial Data Input Pin
26	SDTI3	I	DAC3 Audio Serial Data Input Pin
27	SDTI2	I	DAC2 Audio Serial Data Input Pin
28	SDTI1	I	DAC1 Audio Serial Data Input Pin
29	XTL1	I	X'tal Frequency Select 0 Pin
30	XTL0	I	X'tal Frequency Select 1 Pin

No.	Pin Name	I/O	Function
31	PDN	I	Power-Down Mode Pin When “L”, the AK4589 is powered-down, all digital output pins go “L”, all registers are reset. When CAD1/0 pins are changed, the AK4589 should be reset by PDN pin.
32	MASTER	I	Master Mode Select Pin “H”: Master mode, “L”: Slave mode
33	DZF2	O	Zero Input Detect 2 Pin (Table 13) When the input data of the group 1 follow total 8192 LRCK cycles with “0” input data, this pin goes to “H”. And when RSTN bit is “0”, PWDAN bit is “0”, this pin goes to “H”. It always is in “L” when P/S pin is “H”.
	OVF	O	Analog Input Overflow Detect Pin This pin goes to “H” if the analog input of Lch or Rch overflows.
34	DZF1	O	Zero Input Detect 1 Pin (Table 13) When the input data of the group 1 follow total 8192 LRCK cycles with “0” input data, this pin goes to “H”. And when RSTN bit is “0”, PWDAN bit is “0”, this pin goes to “H”. Output is selected by setting DZFE pin when P/S pin is “H”.
35	LOUT4-	O	DAC4 Lch Negative Analog Output Pin
36	LOUT4+	O	DAC4 Lch Positive Analog Output Pin
37	ROUT4-	O	DAC4 Rch Negative Analog Output Pin
38	ROUT4+	O	DAC4 Rch Positive Analog Output Pin
39	LOUT3-	O	DAC3 Lch Negative Analog Output Pin
40	LOUT3+	O	DAC3 Lch Positive Analog Output Pin
41	ROUT3-	O	DAC3 Rch Negative Analog Output Pin
42	ROUT3+	O	DAC3 Rch Positive Analog Output Pin
43	LOUT2-	O	DAC2 Lch Negative Analog Output Pin
44	LOUT2+	O	DAC2 Lch Positive Analog Output Pin
45	ROUT2-	O	DAC2 Rch Negative Analog Output Pin
46	ROUT2+	O	DAC2 Rch Positive Analog Output Pin
47	LOUT1-	O	DAC1 Lch Negative Analog Output Pin
48	LOUT1+	O	DAC1 Lch Positive Analog Output Pin
49	ROUT1-	O	DAC1 Rch Negative Analog Output Pin
50	ROUT1+	O	DAC1 Rch Positive Analog Output Pin
51	LIN	I	Lch Analog Input Pin
52	RIN	I	Rch Analog Input Pin
53	VCOM	-	Common Voltage Output Pin 2.2μF capacitor should be connected to AVSS externally.
54	VREFH	-	Positive Voltage Reference Input Pin, AVDD

No.	Pin Name	I/O	Function
55	AVDD	-	Analog Power Supply Pin, 4.75V~5.25V
56	AVSS	-	Analog Ground Pin, 0V
57	RX0	I	Receiver Channel 0 Pin (Internal biased pin. Internally biased at PVDD/2)
58	NC	-	No Connect pin No internal bonding. This pin should be connected to PVSS.
59	RX1	I	Receiver Channel 1 Pin (Internal biased pin. Internally biased at PVDD/2)
60	TEST1	I	Test 1 Pin This pin should be connected to PVSS.
61	RX2	I	Receiver Channel 2 Pin (Internal biased pin. Internally biased at PVDD/2)
62	NC	-	No Connect pin No internal bonding. This pin should be connected to PVSS.
63	RX3	I	Receiver Channel 3 Pin (Internal biased pin. Internally biased at PVDD/2)
64	PVSS	-	PLL Ground pin
65	R	-	External Resistor Pin 12kΩ +/-1% resistor should be connected to PVSS externally.
66	PVDD	-	PLL Power supply Pin, 4.75V~5.25V
67	RX4	I	Receiver Channel 4 Pin (Internal biased pin. Internally biased at PVDD/2)
68	TEST2	I	Test 2 Pin This pin should be connected to PVSS.
69	RX5	I	Receiver Channel 5 Pin (Internal biased pin. Internally biased at PVDD/2)
70	CAD0	I	Chip Address 0 Pin (ADC/DAC part)
71	RX6	I	Receiver Channel 6 Pin (Internal biased pin. Internally biased at PVDD/2)
72	CAD1	I	Chip Address 1 Pin (ADC/DAC part)
73	RX7	I	Receiver Channel 7 Pin (Internal biased pin. Internally biased at PVDD/2)
74	I2C	I	Control Mode Select Pin. “L”: 4-wire Serial, “H”: I ² C Bus
75	DAUX2	I	Auxiliary Audio Data Input Pin (DIR/DIT part)
76	VIN	I	V-bit Input Pin for Transmitter Output
77	MCLK	I	Master Clock Input Pin
78	TX0	O	Transmit Channel (Through Data) Output 0 Pin
79	TX1	O	Transmit Channel Output 1 pin When DIT bit = “0”, Through Data. When DIT bit = “1”, DAUX2 Data.
80	INT0	O	Interrupt 0 Pin

Notes: 内部バイアスピピンとアナログ入力ピン(RX0-7, LIN, RIN)を除くすべての入力ピンはフローティングにしないで下さい。

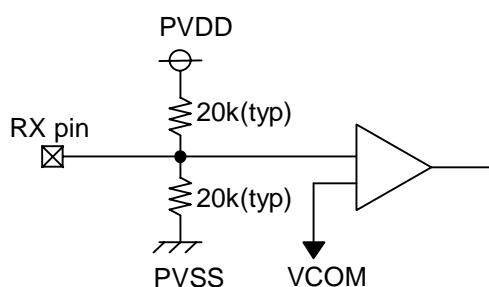

Internal biased pin Circuit

■ 使用しないピンの処理について

使用しない入出力ピンは下記の設定を行い、適切に処理して下さい。

Classification	Pin Name	Setting
Analog	RX0-7, LOUT1-4, ROUT1-4, LIN, RIN	These pins should be open.
Digital	INT0-1, BOUT, XTO, MCKO1-2, COUT, UOUT, VOUT, SDTO1-2, CDTO, DZF1-2, TX1-0	These pins should be open.
	CSN, DAUX1-2, SDTI1-4, XTL0-1	These pins should be connected to DVSS.
	TEST1-3	These pins should be connected to PVSS.

mitsumi

Video Switch · 75Ω driver · Y/C mix MM1501

Video Switch · 75Ω driver · Y/C mix Monolithic IC MM1501 Series

Outline

This IC extends the series of ICs for video/audio signal switching, with a 2-input 1-output single video switch, video signal/chroma signal 75Ω driver, and Y/C mixing circuit in one small package (SOT-26).

Features

- (1) Low power consumption achieved.
- (2) Low power supply voltage realized.
- (3) Frequency bandwidth without 75Ω driver: 10MHz with 75Ω driver: 7MHz
- (4) Cross talk 70dB When 4.43MHz
- (5) With SAG measures pin (75Ω driver and Y/C mix driver)

Package

- SOT-26A (with 75Ω driver)
- SOT-26B (without 75Ω driver)

Applications

- (1) TV
- (2) VTR
- (3) Video camera
- (4) Digital still camera
- (5) Other visual equipment

Line-up

Functions	Model Name	Input	Output	Clamp	6dB amp	75Ω driver	SAG measures pin	Power supply voltage
Switch	MM1501	2	1	×	×	×	×	4.5~13.0V
	MM1502			×	○	×	×	4.5~13.0V
	MM1503			○	×	×	×	4.5~13.0V
	MM1504			○	○	×	×	4.5~13.0V
	MM1505			×	×	○	×	4.5~13.0V
	MM1506			×	○	○	×	4.5~13.0V
	MM1507			○	×	○	×	4.5~13.0V
	MM1508			○	○	○	×	4.5~13.0V
Driver	MM1509	1	1	×	○	○	○	4.5~13.0V
	MM1510			○	○	○	○	4.5~13.0V
Y/C mix	MM1511	1	1	○/×	×	×	×	4.5~13.0V
	MM1512			○/×	○	○	○	4.5~13.0V

MITSUMI

Video Switch · 75Ω driver · Y/C mix MM1501

Block Diagram

MM1501

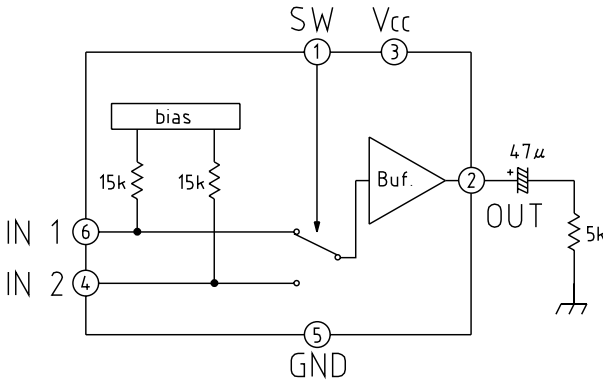

MM1502

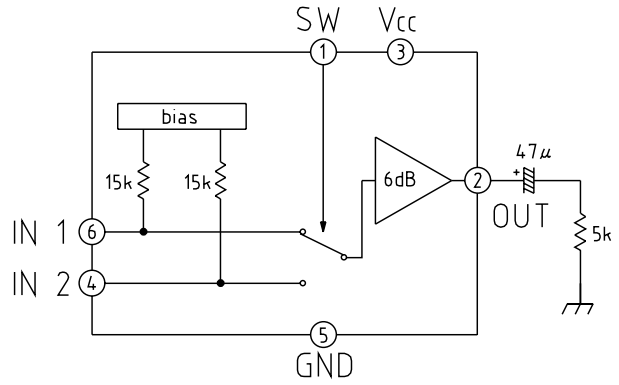

MM1503

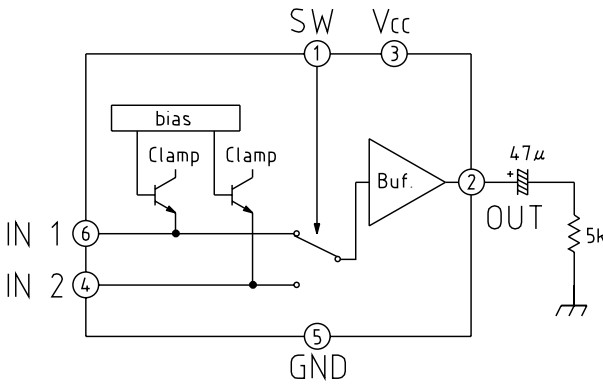

MM1504

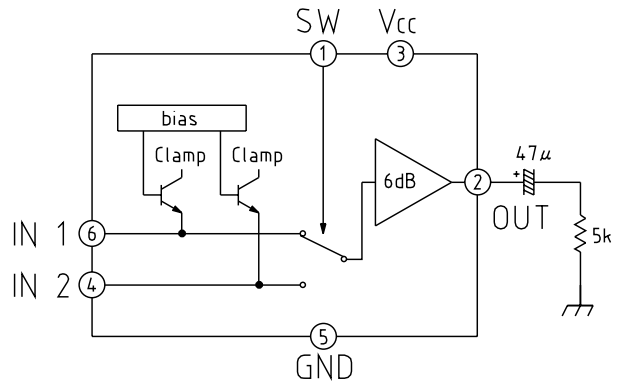

MM1505

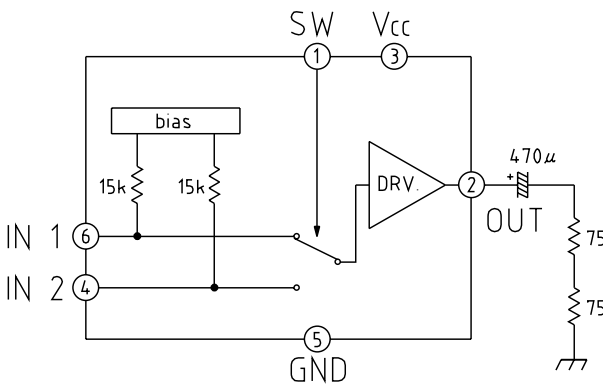

MM1506

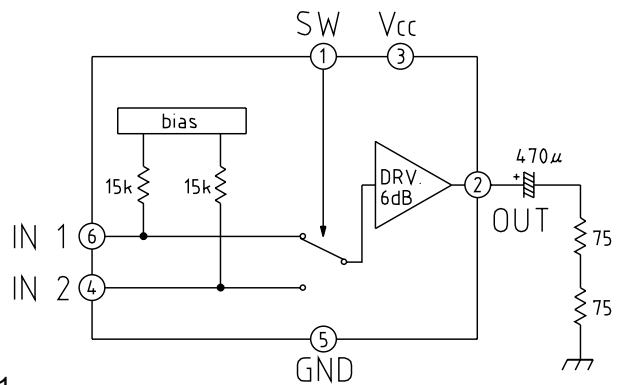

MITSUMI

Video Switch · 75Ω driver · Y/C mix MM1501

MM1507

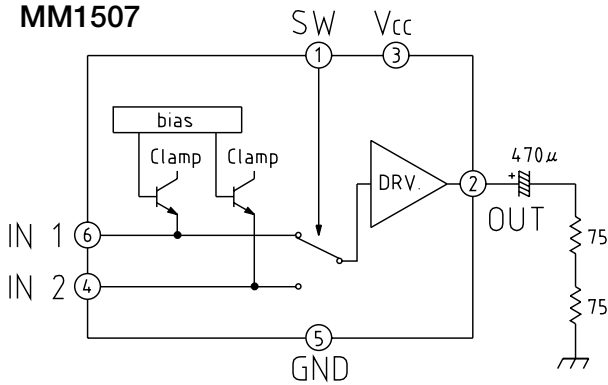

MM1508

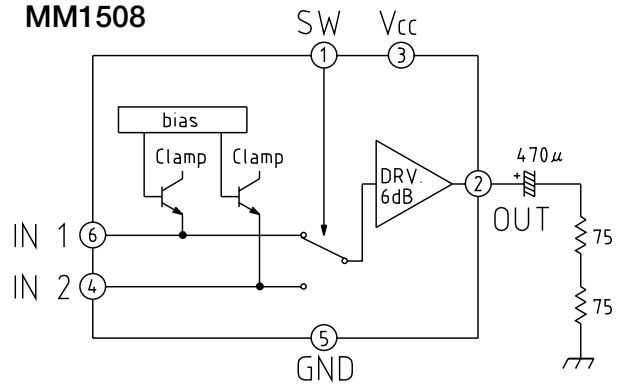

MM1509

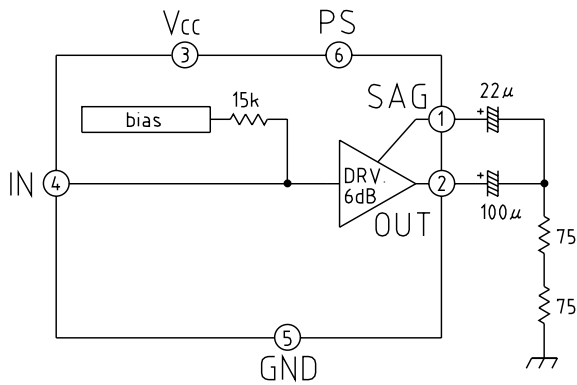

MM1510

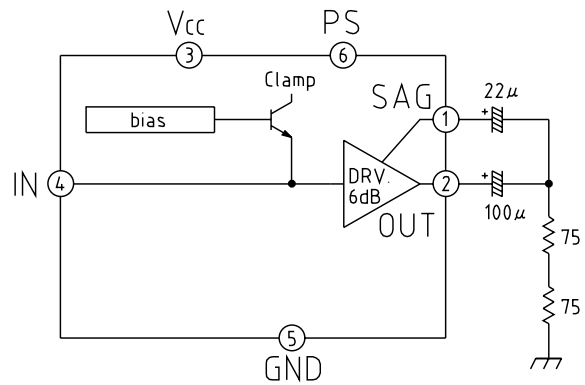

MM1511

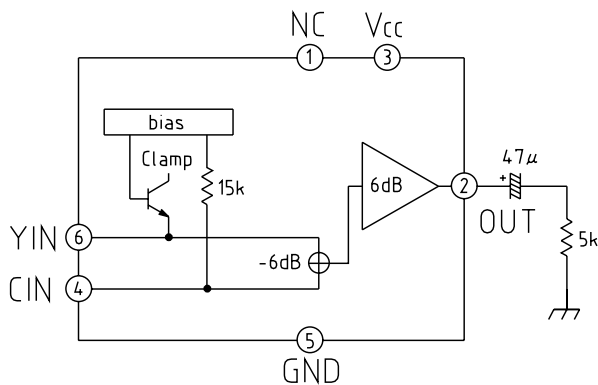

MM1512

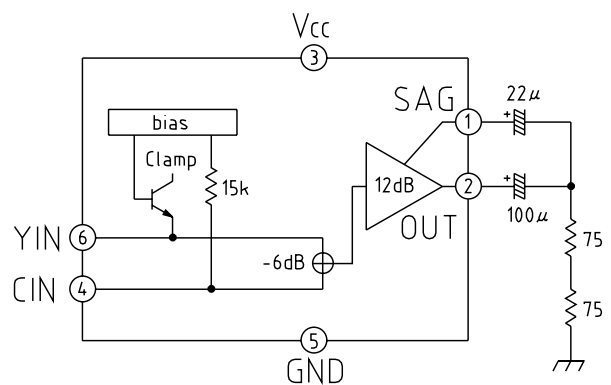



NJL31H/31V/32H/33H/34H000A

INFRARED REMOTE CONTROL RECEIVER

■ GENERAL DESCRIPTION

The NJL30HV000A series are small and high performance receiving devices for infrared remote control system. They can operate under low and wide supply voltage (2.7V to 5.5V) with enhanced immunity against power saving light. The NJL30HV000A series have six kinds of package including seven types of metal case to meet the various applications.

■ FEATURES

1. Wide and low supply voltage 2.7V to 5.5V
2. Low supply current 0.43mA typ. $V_{CC}=3.3V$
3. Six kinds of metal case type to meet the design of front panel.
4. Line-up for various center carrier frequencies.

■ APPLICATIONS

1. Home application such as Room light, Fan, etc.
2. AV instruments such as Audio, TV, DVD, STB etc.

■ LINE-UP

View	Side
Height	6.3mm
Carrier Frequency	
$f_0=36$ kHz	NJL31V360A-M
36.7 kHz	NJL31V367A-M
38 kHz	NJL31V380A-M
40 kHz	NJL31V400A-M

View	Top				
Height	5.7mm	5.7mm	8mm	11mm	15mm
Carrier Frequency					
$f_0=36$ kHz	NJL31H360A-M	NJL31H360AF3-M	NJL32H360A	NJL33H360A	NJL34H360A
36.7 kHz	NJL31H367A-M	NJL31H367AF3-M	NJL32H367A	NJL33H367A	NJL34H367A
38 kHz	NJL31H380A-M	NJL31H380AF3-M	NJL32H380A	NJL33H380A	NJL34H380A
40 kHz	NJL31H400A-M	NJL31H400AF3-M	NJL32H400A	NJL33H400A	NJL34H400A

Regarding other frequency or packages, please contact to New JRC individually.

■ BLOCK DIAGRAM

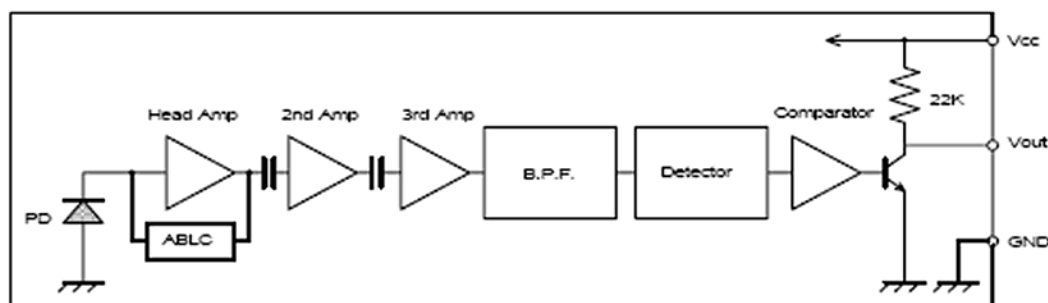



NJM2068

LOW-NOISE DUAL OPERATIONAL AMPLIFIER

GENERAL DESCRIPTION

The NJM2068 is a high performance, low noise dual operational amplifier. This amplifier features popular pin-out, superior noise performance, and superior total harmonic distortion. This amplifier also features guaranteed noise performance with substantially higher gain-bandwidth product and slew rate which far exceeds that of the 4558 type amplifier. The specially designed low noise input transistors allow the NJM2068 to be used in very low noise signal processing applications such as audio preamplifiers and servo error amplifier.

FEATURES

- Operating Voltage (±4V ~ ±18V)
- Low Total Harmonic Distortion (0.001% typ.)
- Low Noise Voltage (FLAT+JISA, 0.56 μV typ.)
- High Slew Rate (6V/μs typ.)
- Unity Gain Bandwidth (27MHz @f=10kHz)
- Package Outline DIP8, DMP8, SIP8, SSOP8
- Bipolar Technology

PACKAGE OUTLINE

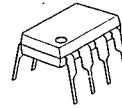

NJM2068D



NJM2068M



NJM2068V

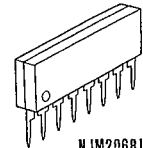

NJM2068L

PIN CONFIGURATION

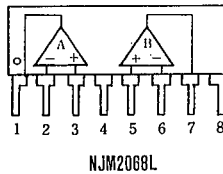
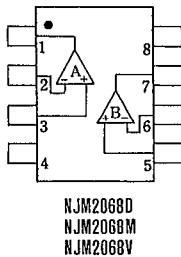

- PIN FUNCTION
1. A OUTPUT
 2. A-INPUT
 3. A+INPUT
 4. V-
 5. B+INPUT
 6. B-INPUT
 7. B OUTPUT
 8. V+

EQUIVALENT CIRCUIT (1/2 Shown)

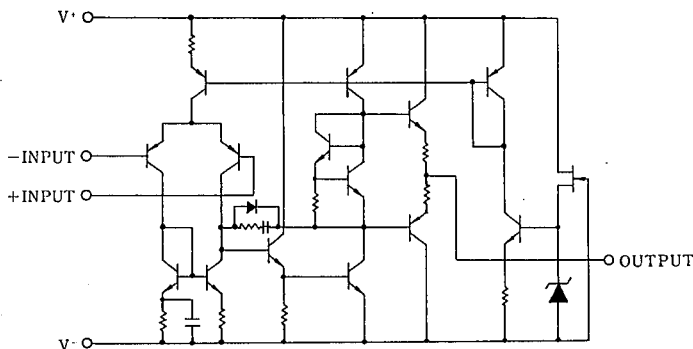



NJM4556A

DUAL HIGH CURRENT OPERATIONAL AMPLIFIER

■ GENERAL DESCRIPTION

The NJM4556A integrated circuit is a high-gain, high output current dual operational amplifier capable of driving $\pm 70\text{mA}$ into $150\ \Omega$ loads ($\pm 10.5\text{V}$ output voltage), and operating low supply voltage ($V^+/V^-=\pm 2\text{V}$).

The NJM4556A combines many of the features of the popular NJM4558 as well as having the capability of driving $150\ \Omega$ loads. In addition, the wide band-width, low noise, high slew rate and low distortion of the NJM4556A make it ideal for many audio, telecommunications and instrumentation applications.

■ FEATURES

- Operating Voltage ($\pm 2\text{V} \sim \pm 18\text{V}$)
- High Output Current ($I_o=70\text{mA}$)
- Slew Rate ($3\text{V}/\mu\text{s}$ typ.)
- Gain Band Width Product (8MHz typ.)
- Package Outline DIP8, DMP8, SIP8, SSOP8
- Bipolar Technology

■ PACKAGE OUTLINE

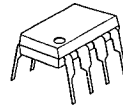

NJM4556AD



NJM4556AM

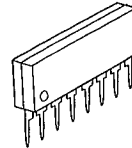

NJM4556AL

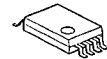

NJM4556AV

■ PIN CONFIGURATION

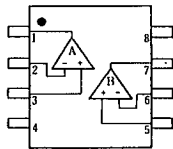

NJM4556AD
NJM4556AM
NJM4556AV

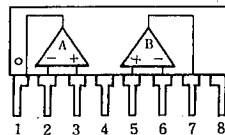

NJM4556AL

- PIN FUNCTION**
1. A OUTPUT
 2. A-INPUT
 3. A+INPUT
 4. V-
 5. B+INPUT
 6. B-INPUT
 7. B OUTPUT
 8. V+

■ EQUIVALENT CIRCUIT (1/2 Shown)

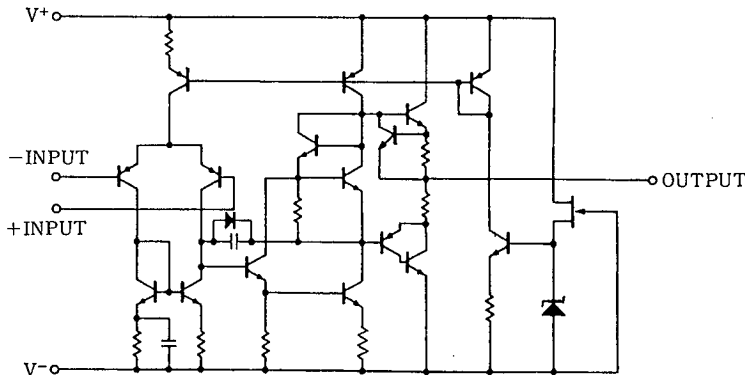



M24C64 M24C32

64Kbit and 32Kbit Serial I²C Bus EEPROM

FEATURES SUMMARY

- Two-Wire I²C Serial Interface
Supports 400kHz Protocol
- Single Supply Voltage:
 - 4.5 to 5.5V for M24Cxx
 - 2.5 to 5.5V for M24Cxx-W
 - 1.8 to 5.5V for M24Cxx-R
- Write Control Input
- BYTE and PAGE WRITE (up to 32 Bytes)
- RANDOM and SEQUENTIAL READ Modes
- Self-Timed Programming Cycle
- Automatic Address Incrementing
- Enhanced ESD/Latch-Up Protection
- More than 1 Million Erase/Write Cycles
- More than 40-Year Data Retention

Table 1. Product List

Reference	Part Number
M24C64	M24C64
	M24C64-W
	M24C64-R
M24C32	M24C32
	M24C32-W
	M24C32-R

Figure 1. Packages

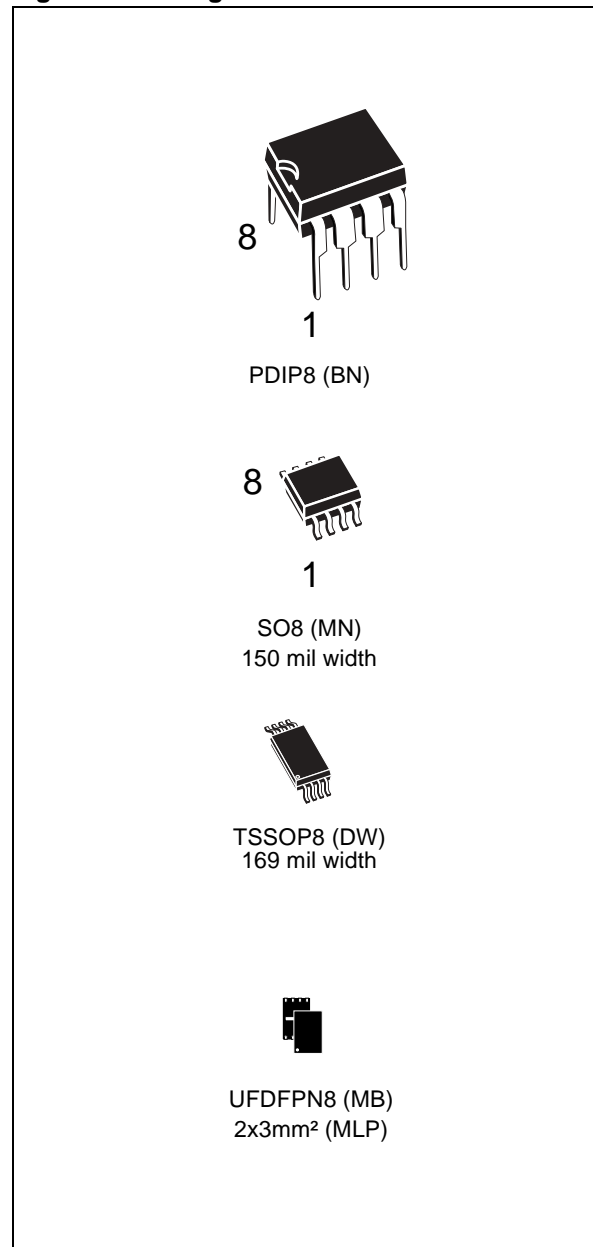

M24C64, M24C32

SUMMARY DESCRIPTION

These I²C-compatible electrically erasable programmable memory (EEPROM) devices are organized as 8192 x 8 bits (M24C64) and 4096 x 8 bits (M24C32).

Figure 2. Logic Diagram

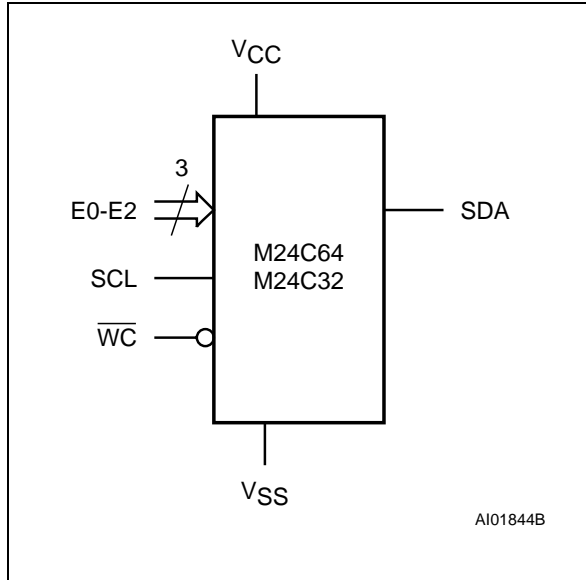

I²C uses a two-wire serial interface, comprising a bi-directional data line and a clock line. The devices carry a built-in 4-bit Device Type Identifier code (1010) in accordance with the I²C bus definition.

The device behaves as a slave in the I²C protocol, with all memory operations synchronized by the serial clock. Read and Write operations are initiated by a Start condition, generated by the bus master. The Start condition is followed by a Device Select Code and Read/Write bit (RW) (as described in Table 3.), terminated by an acknowledge bit.

When writing data to the memory, the device inserts an acknowledge bit during the 9th bit time, following the bus master's 8-bit transmission. When data is read by the bus master, the bus master acknowledges the receipt of the data byte in the same way. Data transfers are terminated by a Stop condition after an Ack for Write, and after a NoAck for Read.

Table 2. Signal Names

E0, E1, E2	Chip Enable
SDA	Serial Data
SCL	Serial Clock
\overline{WC}	Write Control
VCC	Supply Voltage
VSS	Ground

Power On Reset: VCC Lock-Out Write Protect

In order to prevent data corruption and inadvertent Write operations during Power-up, a Power On Reset (POR) circuit is included. At Power-up, the internal reset is held active until VCC has reached the Power On Reset (POR) threshold voltage, and all operations are disabled – the device will not respond to any command. In the same way, when VCC drops from the operating voltage, below the Power On Reset (POR) threshold voltage, all operations are disabled and the device will not respond to any command.

A stable and valid VCC (as defined in Table 9. and Table 10.) must be applied before applying any logic signal.

Figure 3. DIP, SO, TSSOP and UDFPN Connections

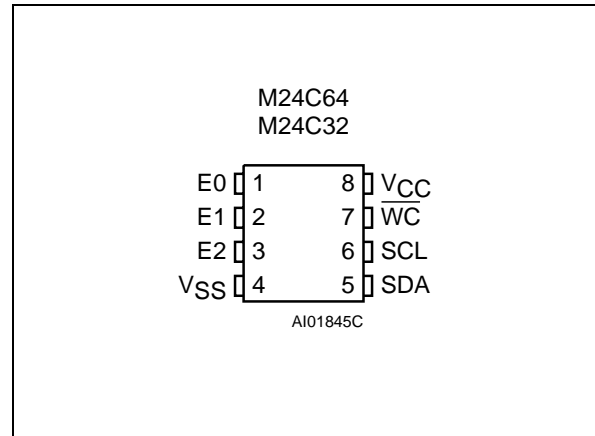

Note: See PACKAGE MECHANICAL section for package dimensions, and how to identify pin-1.

M24C64, M24C32

SIGNAL DESCRIPTION

Serial Clock (SCL). This input signal is used to strobe all data in and out of the device. In applications where this signal is used by slave devices to synchronize the bus to a slower clock, the bus master must have an open drain output, and a pull-up resistor must be connected from Serial Clock (SCL) to V_{CC} . (Figure 4. indicates how the value of the pull-up resistor can be calculated). In most applications, though, this method of synchronization is not employed, and so the pull-up resistor is not necessary, provided that the bus master has a push-pull (rather than open drain) output.

Serial Data (SDA). This bi-directional signal is used to transfer data in or out of the device. It is an open drain output that may be wire-OR'ed with other open drain or open collector signals on the bus. A pull up resistor must be connected from Se-

rial Data (SDA) to V_{CC} . (Figure 4. indicates how the value of the pull-up resistor can be calculated).

Chip Enable (E0, E1, E2). These input signals are used to set the value that is to be looked for on the three least significant bits (b3, b2, b1) of the 7-bit Device Select Code. These inputs must be tied to V_{CC} or V_{SS} , to establish the Device Select Code.

Write Control (\overline{WC}). This input signal is useful for protecting the entire contents of the memory from inadvertent write operations. Write operations are disabled to the entire memory array when Write Control (\overline{WC}) is driven High. When unconnected, the signal is internally read as V_{IL} , and Write operations are allowed.

When Write Control (\overline{WC}) is driven High, Device Select and Address bytes are acknowledged, Data bytes are not acknowledged.

Figure 4. Maximum R_L Value versus Bus Capacitance (C_{BUS}) for an I²C Bus

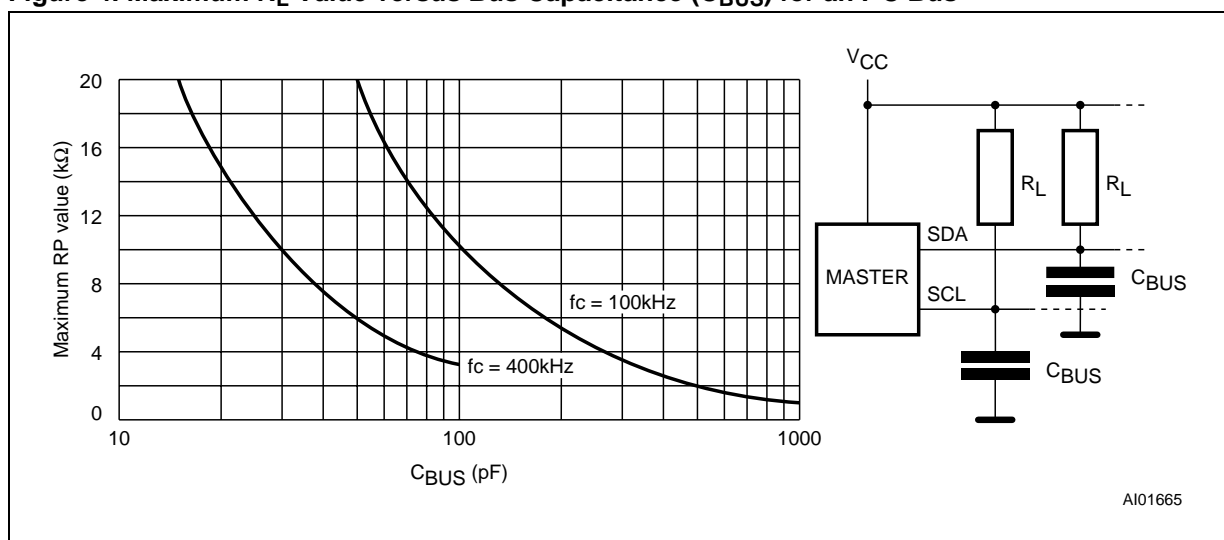

M24C64, M24C32

MEMORY ORGANIZATION

The memory is organized as shown in Figure 6..

Figure 6. Block Diagram

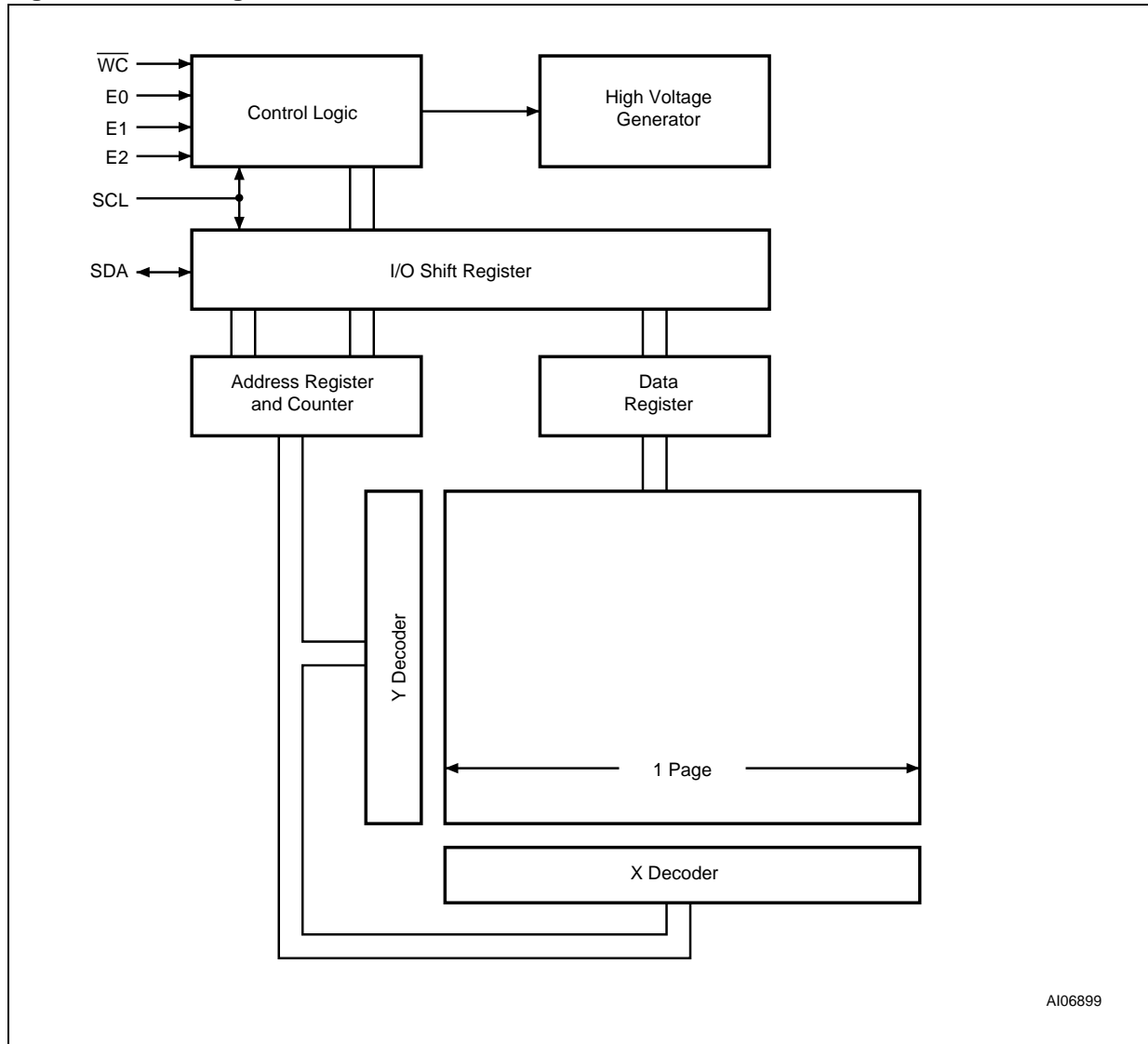

M24C64, M24C32

DEVICE OPERATION

The device supports the I²C protocol. This is summarized in Figure 5.. Any device that sends data on to the bus is defined to be a transmitter, and any device that reads the data to be a receiver. The device that controls the data transfer is known as the bus master, and the other as the slave device. A data transfer can only be initiated by the bus master, which will also provide the serial clock for synchronization. The M24Cxx device is always a slave in all communication.

Start Condition

Start is identified by a falling edge of Serial Data (SDA) while Serial Clock (SCL) is stable in the High state. A Start condition must precede any data transfer command. The device continuously monitors (except during a Write cycle) Serial Data (SDA) and Serial Clock (SCL) for a Start condition, and will not respond unless one is given.

Stop Condition

Stop is identified by a rising edge of Serial Data (SDA) while Serial Clock (SCL) is stable and driven High. A Stop condition terminates communication between the device and the bus master. A Read command that is followed by NoAck can be followed by a Stop condition to force the device into the Stand-by mode. A Stop condition at the end of a Write command triggers the internal Write cycle.

Acknowledge Bit (ACK)

The acknowledge bit is used to indicate a successful byte transfer. The bus transmitter, whether it be bus master or slave device, releases Serial Data (SDA) after sending eight bits of data. During the 9th clock pulse period, the receiver pulls Serial

Data (SDA) Low to acknowledge the receipt of the eight data bits.

Data Input

During data input, the device samples Serial Data (SDA) on the rising edge of Serial Clock (SCL). For correct device operation, Serial Data (SDA) must be stable during the rising edge of Serial Clock (SCL), and the Serial Data (SDA) signal must change *only* when Serial Clock (SCL) is driven Low.

Memory Addressing

To start communication between the bus master and the slave device, the bus master must initiate a Start condition. Following this, the bus master sends the Device Select Code, shown in Table 3. (on Serial Data (SDA), most significant bit first).

The Device Select Code consists of a 4-bit Device Type Identifier, and a 3-bit Chip Enable "Address" (E2, E1, E0). To address the memory array, the 4-bit Device Type Identifier is 1010b.

Up to eight memory devices can be connected on a single I²C bus. Each one is given a unique 3-bit code on the Chip Enable (E0, E1, E2) inputs. When the Device Select Code is received, the device only responds if the Chip Enable Address is the same as the value on the Chip Enable (E0, E1, E2) inputs.

The 8th bit is the Read/Write bit (\overline{RW}). This bit is set to 1 for Read and 0 for Write operations.

If a match occurs on the Device Select code, the corresponding device gives an acknowledgment on Serial Data (SDA) during the 9th bit time. If the device does not match the Device Select code, it deselected itself from the bus, and goes into Stand-by mode.

Table 6. Operating Modes

Mode	\overline{RW} bit	\overline{WC} ¹	Bytes	Initial Sequence
Current Address Read	1	X	1	START, Device Select, $\overline{RW} = 1$
Random Address Read	0	X	1	START, Device Select, $\overline{RW} = 0$, Address
	1	X		reSTART, Device Select, $\overline{RW} = 1$
Sequential Read	1	X	≥ 1	Similar to Current or Random Address Read
Byte Write	0	V _{IL}	1	START, Device Select, $\overline{RW} = 0$
Page Write	0	V _{IL}	≤ 32	START, Device Select, $\overline{RW} = 0$

Note: 1. X = V_{IH} or V_{IL}.

M24C64, M24C32

Figure 7. Write Mode Sequences with $\overline{WC}=1$ (data write inhibited)

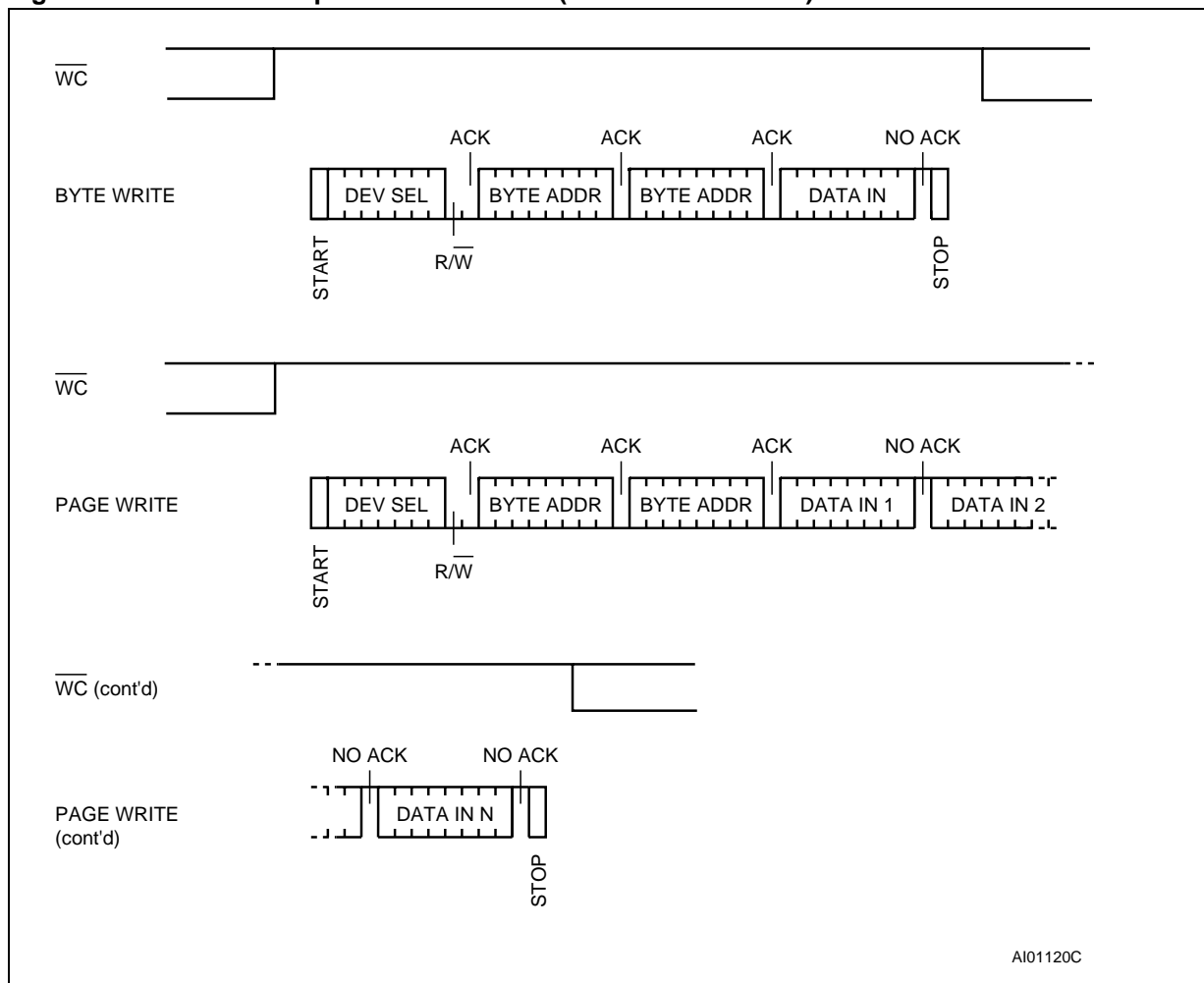

Write Operations

Following a Start condition the bus master sends a Device Select Code with the Read/Write bit ($\overline{R/W}$) reset to 0. The device acknowledges this, as shown in Figure 8., and waits for two address bytes. The device responds to each address byte with an acknowledge bit, and then waits for the data byte.

Writing to the memory may be inhibited if Write Control (\overline{WC}) is driven High. Any Write instruction with Write Control (\overline{WC}) driven High (during a period of time from the Start condition until the end of the two address bytes) will not modify the memory contents, and the accompanying data bytes are not acknowledged, as shown in Figure 7..

Each data byte in the memory has a 16-bit (two byte wide) address. The Most Significant Byte (Table 4.) is sent first, followed by the Least Significant Byte (Table 5.). Bits b15 to b0 form the address of the byte in memory.

When the bus master generates a Stop condition immediately after the Ack bit (in the "10th bit" time

slot), either at the end of a Byte Write or a Page Write, the internal Write cycle is triggered. A Stop condition at any other time slot does not trigger the internal Write cycle.

After the Stop condition, the delay t_W , and the successful completion of a Write operation, the device's internal address counter is incremented automatically, to point to the next byte address after the last one that was modified.

During the internal Write cycle, Serial Data (SDA) is disabled internally, and the device does not respond to any requests.

Byte Write

After the Device Select code and the address bytes, the bus master sends one data byte. If the addressed location is Write-protected, by Write Control (\overline{WC}) being driven High, the device replies with NoAck, and the location is not modified. If, instead, the addressed location is not Write-protected, the device replies with Ack. The bus master terminates the transfer by generating a Stop condition, as shown in Figure 8..

M24C64, M24C32

Page Write

The Page Write mode allows up to 32 bytes to be written in a single Write cycle, provided that they are all located in the same 'row' in the memory: that is, the most significant memory address bits (b12-b5 for M24C64, and b11-b5 for M24C32) are the same. If more bytes are sent than will fit up to the end of the row, a condition known as 'roll-over' occurs. This should be avoided, as data starts to become overwritten in an implementation dependent way.

The bus master sends from 1 to 32 bytes of data, each of which is acknowledged by the device if Write Control (\overline{WC}) is Low. If Write Control (\overline{WC}) is High, the contents of the addressed memory location are not modified, and each data byte is followed by a NoAck. After each byte is transferred, the internal byte address counter (the 5 least significant address bits only) is incremented. The transfer is terminated by the bus master generating a Stop condition.

Figure 8. Write Mode Sequences with $\overline{WC}=0$ (data write enabled)

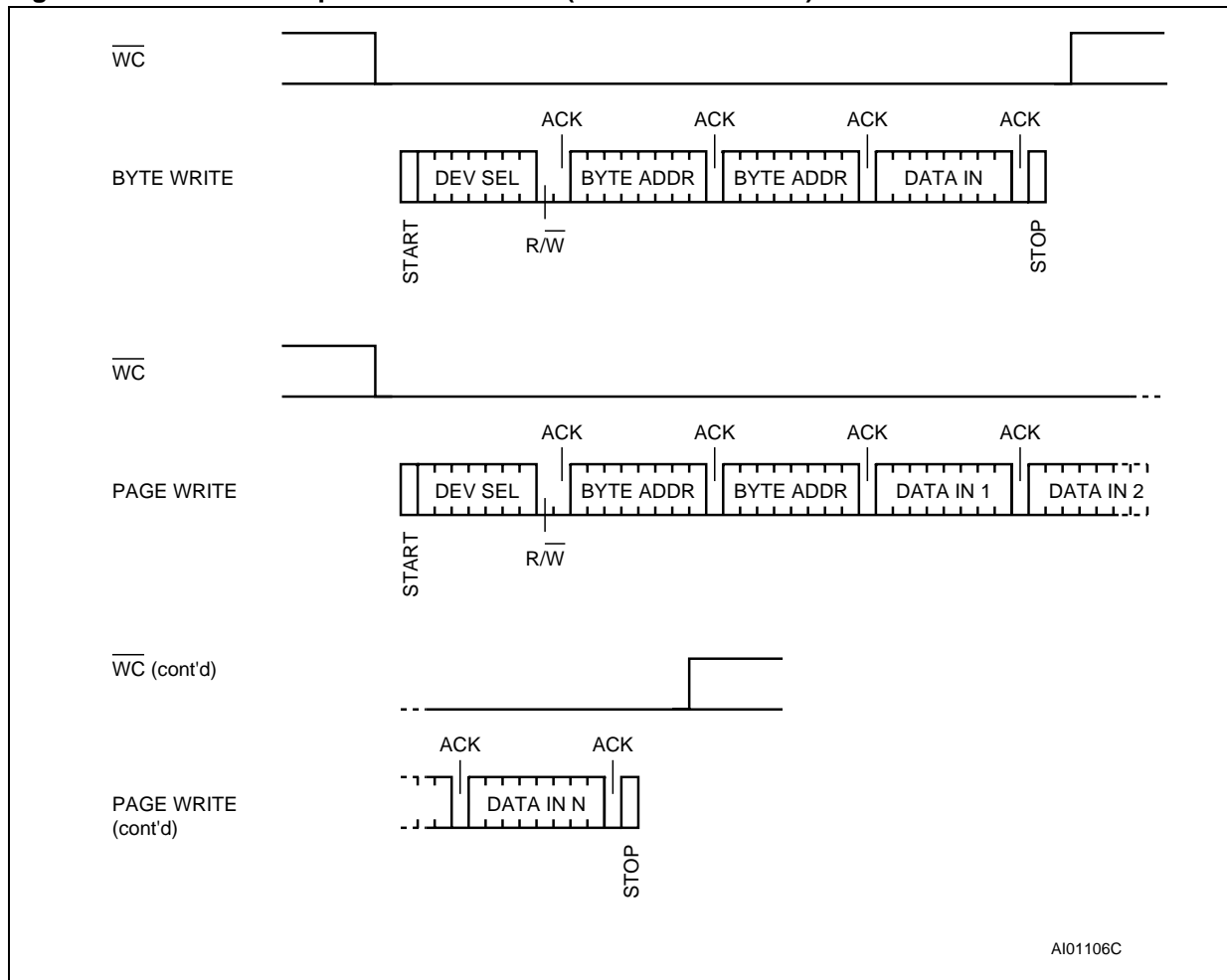

M24C64, M24C32

Figure 9. Write Cycle Polling Flowchart using ACK

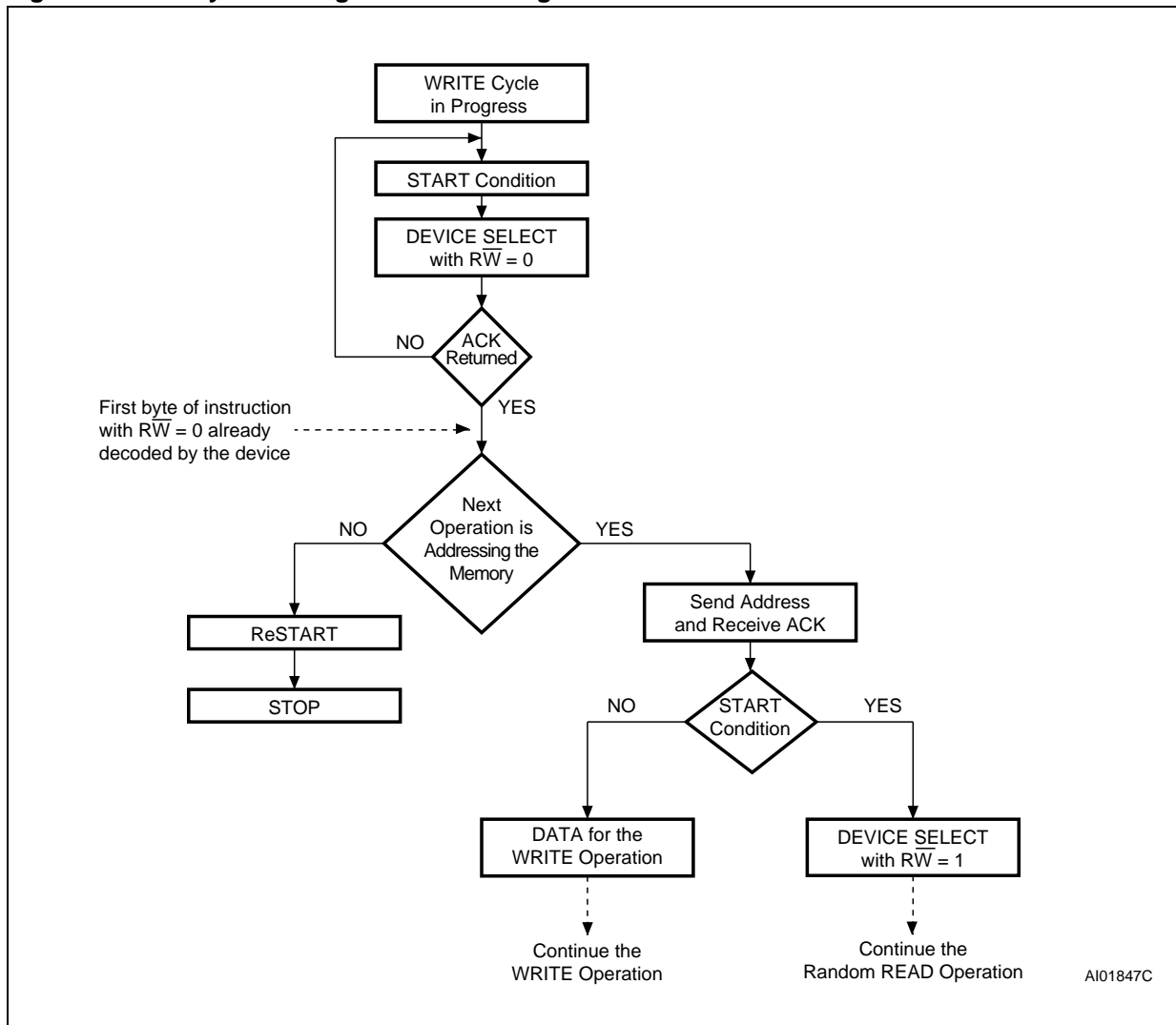

Minimizing System Delays by Polling On ACK

During the internal Write cycle, the device disconnects itself from the bus, and writes a copy of the data from its internal latches to the memory cells. The maximum Write time (t_w) is shown in Table 16. and Table 17., but the typical time is shorter. To make use of this, a polling sequence can be used by the bus master.

The sequence, as shown in Figure 9., is:

- Initial condition: a Write cycle is in progress.
- Step 1: the bus master issues a Start condition followed by a Device Select Code (the first byte of the new instruction).
- Step 2: if the device is busy with the internal Write cycle, no Ack will be returned and the bus master goes back to Step 1. If the device has terminated the internal Write cycle, it responds with an Ack, indicating that the device is ready to receive the second part of the instruction (the first byte of this instruction having been sent during Step 1).

M24C64, M24C32

Figure 10. Read Mode Sequences

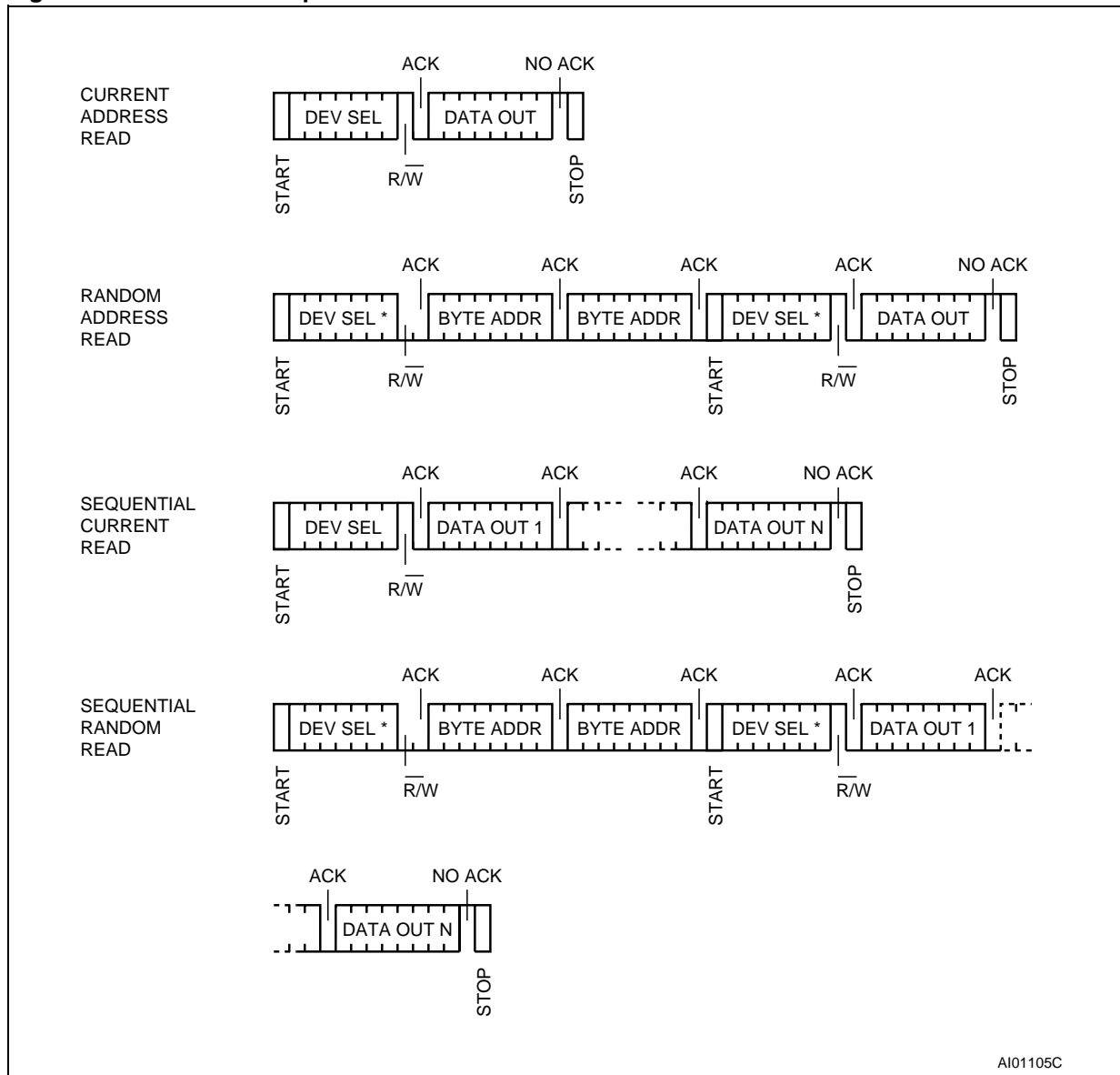

Note: 1. The seven most significant bits of the Device Select Code of a Random Read (in the 1st and 4th bytes) must be identical.

Read Operations

Read operations are performed independently of the state of the Write Control (WC) signal.

After the successful completion of a Read operation, the device's internal address counter is incremented by one, to point to the next byte address.

Random Address Read

A dummy Write is first performed to load the address into this address counter (as shown in Figure 10.) but *without* sending a Stop condition. Then, the bus master sends another Start condition, and repeats the Device Select Code, with the Read/Write bit (RW) set to 1. The device acknowledges this, and outputs the contents of the ad-

ressed byte. The bus master must *not* acknowledge the byte, and terminates the transfer with a Stop condition.

Current Address Read

For the Current Address Read operation, following a Start condition, the bus master only sends a Device Select Code with the Read/Write bit (RW) set to 1. The device acknowledges this, and outputs the byte addressed by the internal address counter. The counter is then incremented. The bus master terminates the transfer with a Stop condition, as shown in Figure 10., *without* acknowledging the byte.

LOW VOLTAGE DETECTOR

R×5VT SERIES

R×5VT

PIN CONFIGURATION

• TO-92

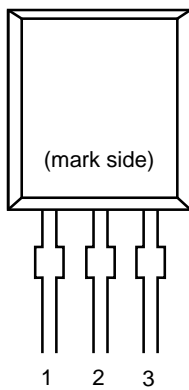

• SOT-89

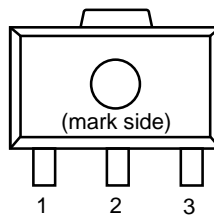

• SOT-23-5

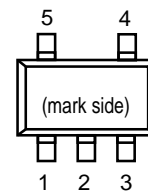

PIN DESCRIPTION

• TO-92

Pin No.	Symbol
1	OUT
2	V _{DD}
3	GND

• SOT-89

Pin No.	Symbol
1	OUT
2	V _{DD}
3	GND

• SOT-23-5

Pin No.	Symbol
1	OUT
2	V _{DD}
3	GND
4	NC
5	NC

VOLTAGE DETECTOR

R×5VL SERIES

R×5VL

PIN CONFIGURATION

• TO-92

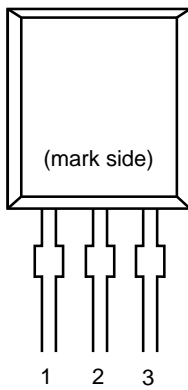

• SOT-89

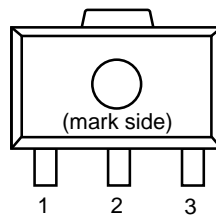

• SOT-23-5

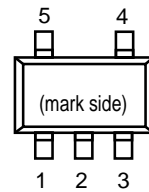

PIN DESCRIPTION

• TO-92

Pin No	Symbol
1	OUT
2	VDD
3	GND

• SOT-89

Pin No	Symbol
1	OUT
2	VDD
3	GND

• SOT-23-5

Pin No	Symbol
1	OUT
2	VDD
3	GND
4	NC
5	NC

1A LOWDROPOUT VOLTAGE REGULATOR (ADJUSTABLE & FIXED)

LM1117

FEATURES

- Output Current up to 1 A
- **Low Dropout Voltage (700mV at 1A Output Current)**
- Three Terminal Adjustable or Fixed 1.5V, 1.8V, 2.5V, 2.85V, 3.0V, 3.3V, 5.0V
- 2.85V Device for SCSI-II Active Terminator
- **0.04% Line Regulation, 0.1% Load Regulation**
- Very Low Quiescent Current
- Internal Current and Terminal Limit
- Logic-Controlled Electronics Shutdown
- Surface Mount Package SOT-223 & TO-263 (D2-Pack)
- 100% Thermal Limit Burn-In

APPLICATION

- Active SCSI Terminators
- Portable/Plan Top/Notebook Computers
- High Efficiency Linear Regulators
- SMPS Post Regulators
- Mother B/D Clock Supplies
- Disk Drives
- Battery Chargers

DESCRIPTION

The LM1117 is a low power positive-voltage regulator designed to meet 1A output current and comply with SCSI-II specifications with a fixed output voltage of 2.85V. This device is an excellent choice for use in battery-powered applications, as active terminators for the SCSI bus, and portable computers.

The LM1117 features very low quiescent current and very **low dropout voltage of 700mV at a full load** and lower as output current decreases. LM1117 is available as an adjustable or fixed 1.5V, 1.8V, 2.5V, 2.85V, 3.0V, 3.3V, and 5.0V output voltages.

The LM1117 is offered in a 3-pin surface mount package SOT-223 & TO-263. The output capacitor of 10µF or larger is needed for output stability of LM1117 as required by most of the other regulator circuits.

ABSOLUTE MAXIMUM RATINGS

CHARACTERISTIC	SYMBOL	MIN.	MAX.	UNIT
DC Input Voltage	V _{IN}		7	V
Lead Temperature (Soldering, 5 Seconds)	T _{SOL}		260	°C
Storage Temperature Range	T _{STG}	-65	150	°C
Operating Junction Temperature Range	T _{OPR}	0	125	°C

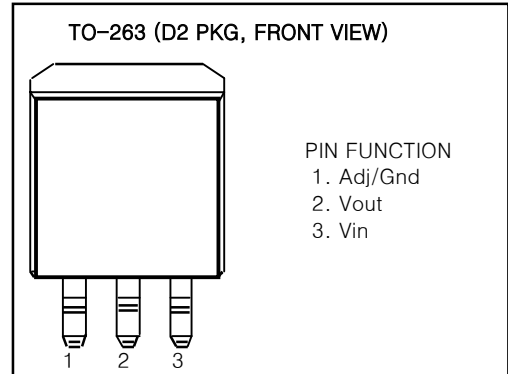
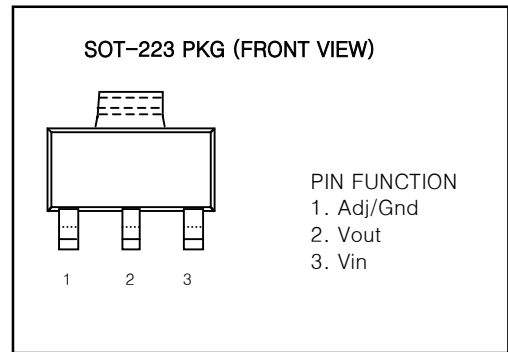







ORDERING INFORMATION

Device (Marking)	Package
LM1117S	SOT-223
LM1117S-XX	
LM1117T	TO-263 (D2)
LM1117T-XX	

(X=Output Voltage=1.5V, 1.8V, 2.5V, 2.85V, 3.0V, 3.3V, 5.0V, Adjustable=AD)

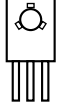
TRANSISTOR, REGULATOR IC BLOCK DIAGRAM

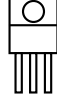
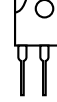
<p>TO-92M</p>  <p>1. Emitter 2. Collector 3. Base</p> <p>123</p> <p>KTC2874B KSC2785Y KRA107M KRC107M KRA104MT KRC104M KTA1267</p>	<p>TO-92</p>  <p>1. Emitter 2. Collector 3. Base</p> <p>123</p> <p>KTD1302T KTA1268GR KTC3200GR KTC3198Y KTA1271Y KSA1175YT</p>	<p>TO-220</p>  <p>1. GND 2. INPUT 3. OUTPUT</p> <p>123</p> <p>MCNJM7905 MC7915C NJM7908 L7905 L7915</p>	<p>TO-92L</p>  <p>1. Emitter 2. Collector 3. Base</p> <p>123</p> <p>KTA1024Y KSC2316Y</p>
<p>TO-126</p>  <p>1. Emitter 2. Collector 3. Base</p> <p>123</p> <p>2SA1360O 2SC3423O KTD600KG</p>	<p>TO-92</p>  <p>1. Emitter 2. Base 3. Collector</p> <p>123</p> <p>KSA733CYT</p>	<p>TO-220</p>  <p>1. INPUT 2. GND 3. OUTPUT</p> <p>123</p> <p>MC7815C MC7805C MC7809 L7805 NJM7824 L7815 L7808 NJM7812</p>	<p>TO-3P</p>  <p>1. Base 2. Collector 3. Emitter</p> <p>1 2 3</p> <p>2SB1560 2SB1559 2SD2390 2SD2389 2SA1360 2SB1647 2SD2560</p>

**NJM2391DL1-25 NJM2391DL1-33
LOW DROPOUT VOLTAGE REGULATOR**

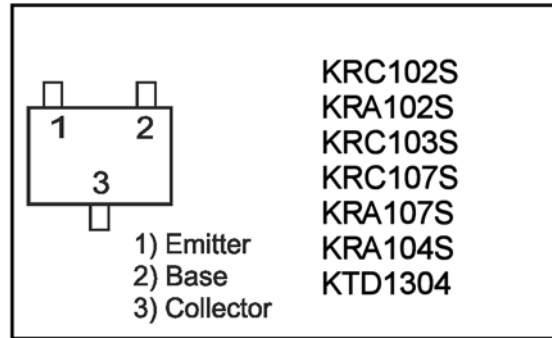
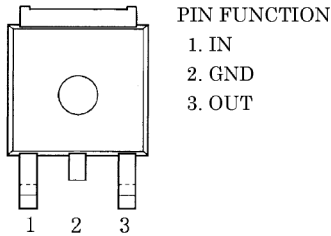

**N-CHANNEL MOS FET ARRAY
μPA672T**

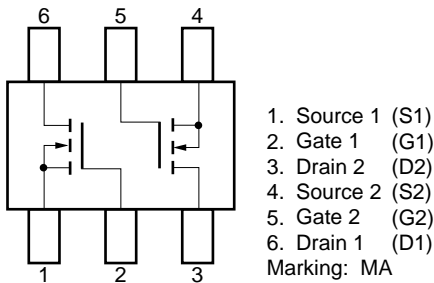

**PIN CONFIGURATION
SOT-23 Package
AD1580**

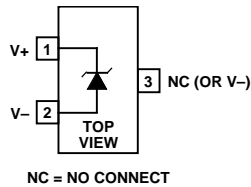

SOT-223 PKG (FRONT VIEW)

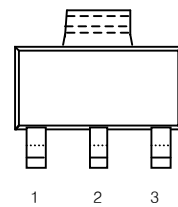

**LM1117
REGULATOR**

PIN FUNCTION
1. Adj/Gnd
2. Vout
3. Vin

TO-263 (D2 PKG, FRONT VIEW)

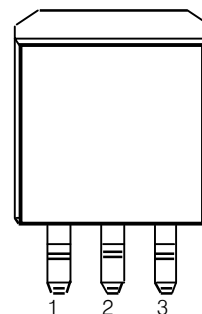

PIN FUNCTION
1. Adj/Gnd
2. Vout
3. Vin

KP1010 photocoupler

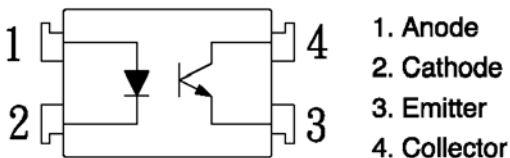

ULTRA-SMALL PACKAGE HIGH-PRECISION VOLTAGE DETECTOR

S-808xxC Series

Rev.3.2_00

■ Pin Configurations

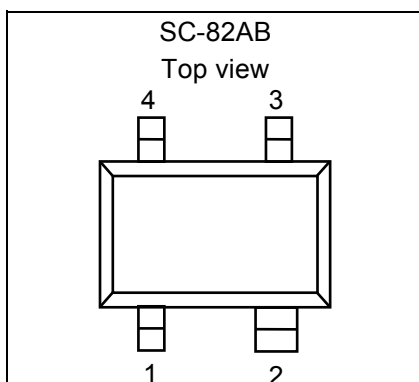

Figure 4

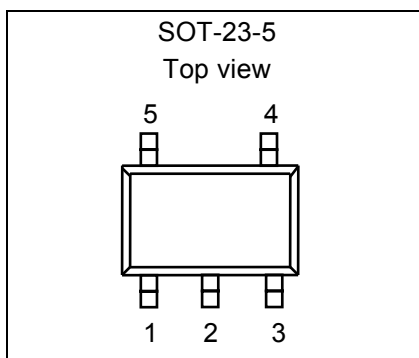

Figure 5

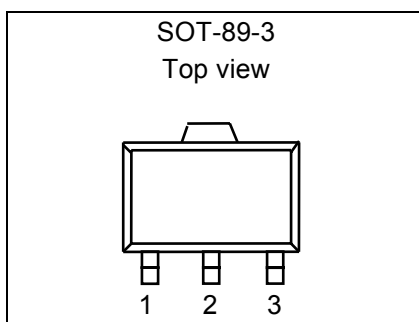

Figure 6

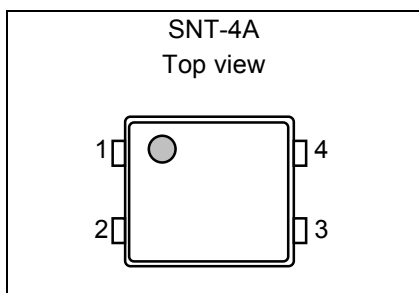

Figure 7

Table 7

Pin No.	Pin name	Pin description
1	OUT	Voltage detection output pin
2	VDD	Voltage input pin
3	NC*1	No connection
4	VSS	GND pin

*1. The NC pin is electrically open.
The NC pin can be connected to VDD or VSS.

Table 8

Pin No.	Pin name	Pin description
1	OUT	Voltage detection output pin
2	VDD	Voltage input pin
3	VSS	GND pin
4	NC*1	No connection
5	NC*1	No connection

*1. The NC pin is electrically open.
The NC pin can be connected to VDD or VSS.

Table 9

Pin No.	Pin name	Pin description
1	OUT	Voltage detection output pin
2	VDD	Voltage input pin
3	VSS	GND pin

Table10

Pin No.	Pin name	Pin description
1	OUT	Voltage detection output pin
2	VSS	GND pin
3	NC*1	No connection
4	VDD	Voltage input pin

*1. The NC pin is electrically open.
The NC pin can be connected to VDD or VSS.

ULTRA-SMALL PACKAGE HIGH-PRECISION VOLTAGE DETECTOR

S-808xxC Series

Rev.3.2_00

S-80842CNY

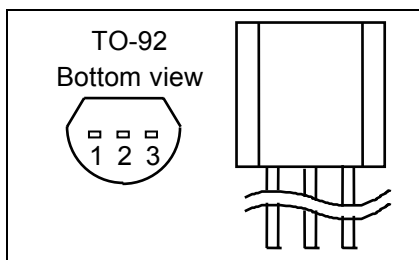

Figure 8

Table 11

Pin No.	Pin name	Pin description
1	OUT	Voltage detection output pin
2	VDD	Voltage input pin
3	VSS	GND pin

■ Absolute Maximum Ratings

1. Detection Voltage Typ. 1.4 V or Less Products

Table 12

(Ta=25°C unless otherwise specified)

Item	Symbol	Absolute maximum ratings	Unit
Power supply voltage	$V_{DD}-V_{SS}$	7	V
Output voltage	Nch open-drain output products	$V_{SS}-0.3$ to $V_{SS}+7$	
	CMOS output products	$V_{SS}-0.3$ to $V_{DD}+0.3$	
Output current	I_{OUT}	50	mA
Power dissipation	P_D	SC-82AB	150
		SNT-4A	140
Operating ambient temperature	T_{opr}	-40 to +85	°C
Storage temperature	T_{stg}	-40 to +125	

Caution The absolute maximum ratings are rated values exceeding which the product could suffer physical damage. These values must therefore not be exceeded under any conditions.

2. Detection Voltage Typ. 1.5 V or More Products

Table 13

(Ta=25°C unless otherwise specified)

Item	Symbol	Absolute maximum ratings	Unit
Power supply voltage	$V_{DD}-V_{SS}$	12	V
Output voltage	Nch open-drain output products	$V_{SS}-0.3$ to $V_{SS}+12$	
	CMOS output products	$V_{SS}-0.3$ to $V_{DD}+0.3$	
Output current	I_{OUT}	50	mA
Power dissipation	P_D	SC-82AB	150
		SOT-23-5	250
		SOT-89-3	500
		SNT-4A	140
		TO-92	400
Operating ambient temperature	T_{opr}	-40 to +85	°C
Storage temperature	T_{stg}	-40 to +125	

Caution The absolute maximum ratings are rated values exceeding which the product could suffer physical damage. These values must therefore not be exceeded under any conditions.

CUP11912X

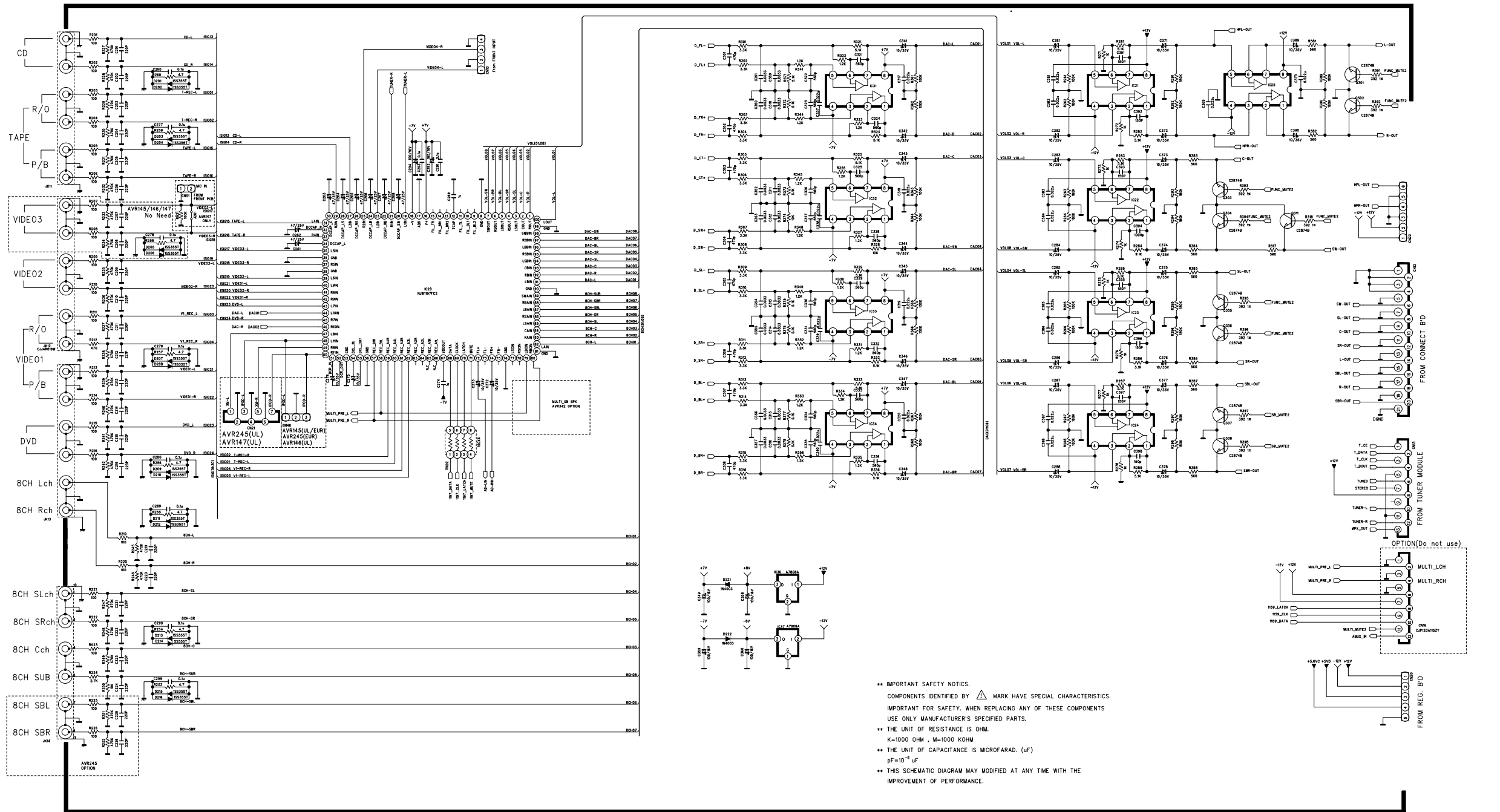

IMPORTANT SAFETY NOTICES.
 COMPONENTS IDENTIFIED BY Δ MARK HAVE SPECIAL CHARACTERISTICS.
 IMPORTANT FOR SAFETY. WHEN REPLACING ANY OF THESE COMPONENTS
 USE ONLY MANUFACTURER'S SPECIFIED PARTS.

THE UNIT OF RESISTANCE IS OHM.
 K=1000 OHM , M=1000 KOHM

THE UNIT OF CAPACITANCE IS MICROFARAD. (uF)
 pF=10⁻⁶ uF

THIS SCHEMATIC DIAGRAM MAY MODIFIED AT ANY TIME WITH THE
 IMPROVEMENT OF PERFORMANCE.

REVISION	2	4	6
1	3	5	7
SCHEMATIC DIAGRAM			
MODEL	AVR145/245/144/146/147		
DESIGN	CHECK	APPROVE	DRAWING NO
M.S.K	W.Y.Y	H.W.L	1912SCMX
07.01.04	07.01.04	07.01.04	(INPUT)

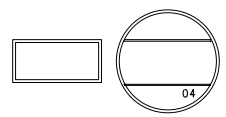

CUP11914Z

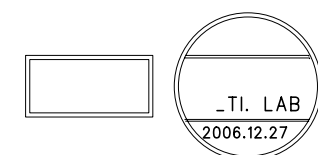
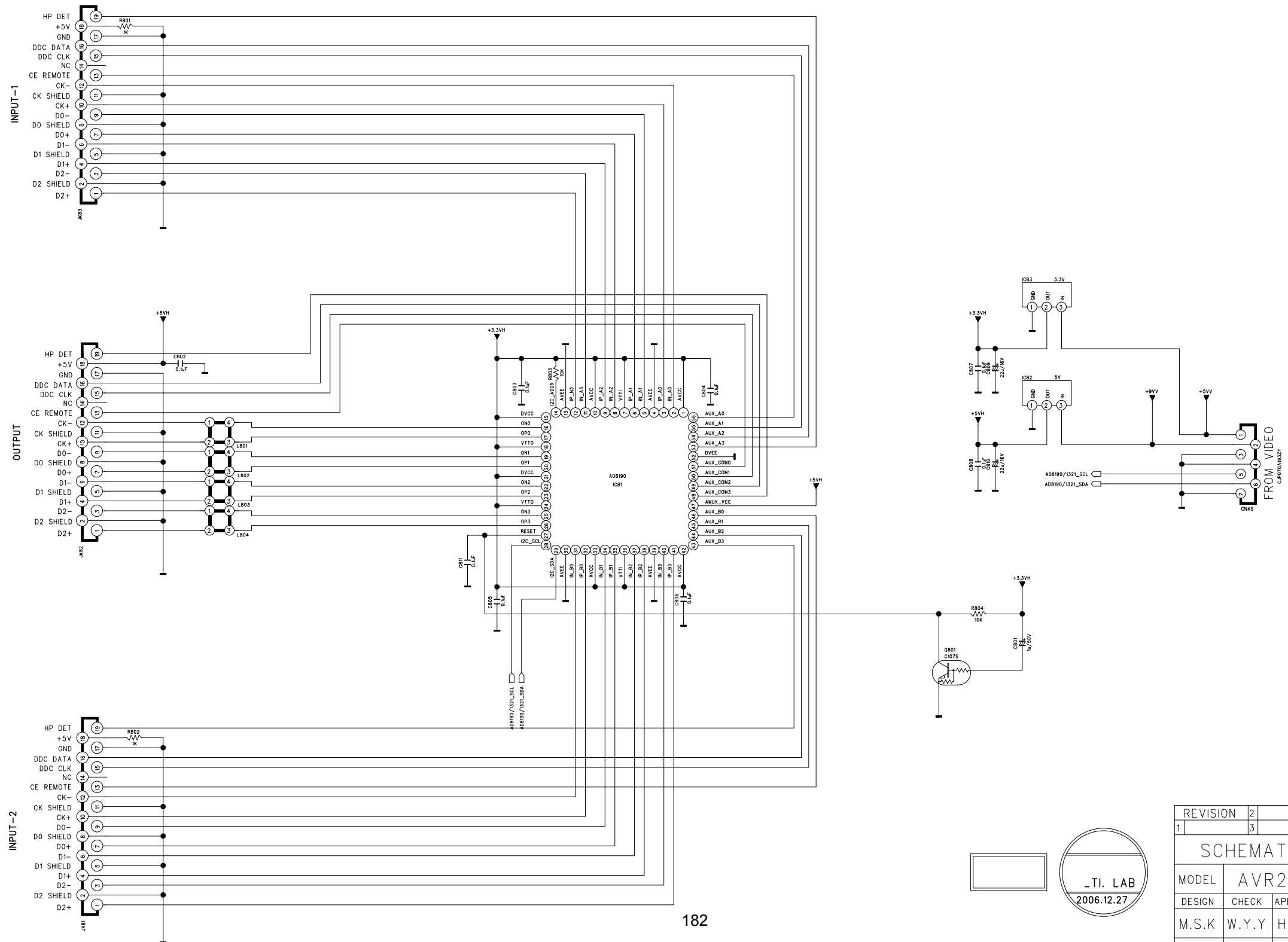

REVISION	2	4	6
1	3	5	7
SCHEMATIC DIAGRAM			
MODEL	AVR245/146/147		
DESIGN	CHECK	APPROVE	DRAWING NO
M.S.K	W.Y.Y	H.Y.L	1914SCMZ
06.12.27	06.12.27	06.12.27	(HDMI MUX)

CUP11912X

AVR145/245/146/147 PART (IPOD SECTION)

AVR145/245 PART RDS SECTION (EUR Ver. ONLY)

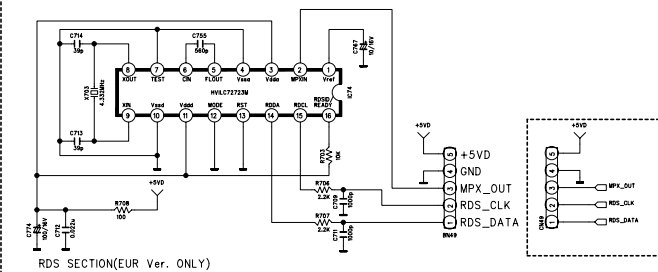

TO VIDEO PCB

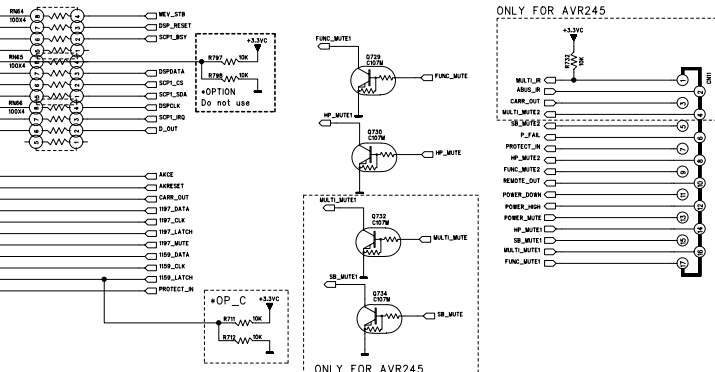
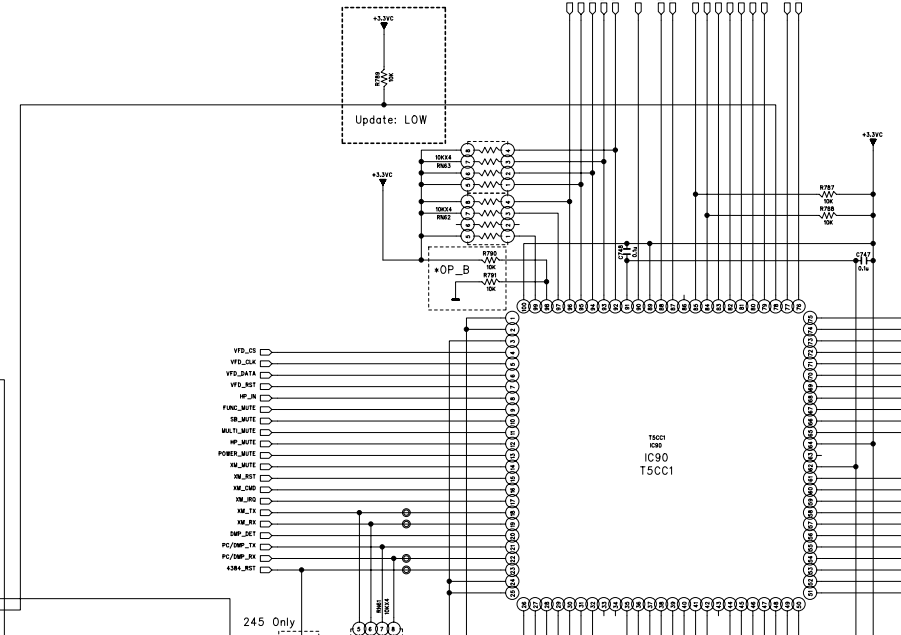
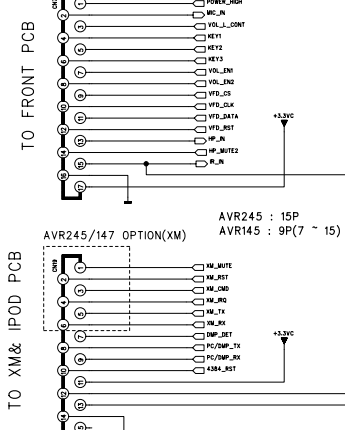
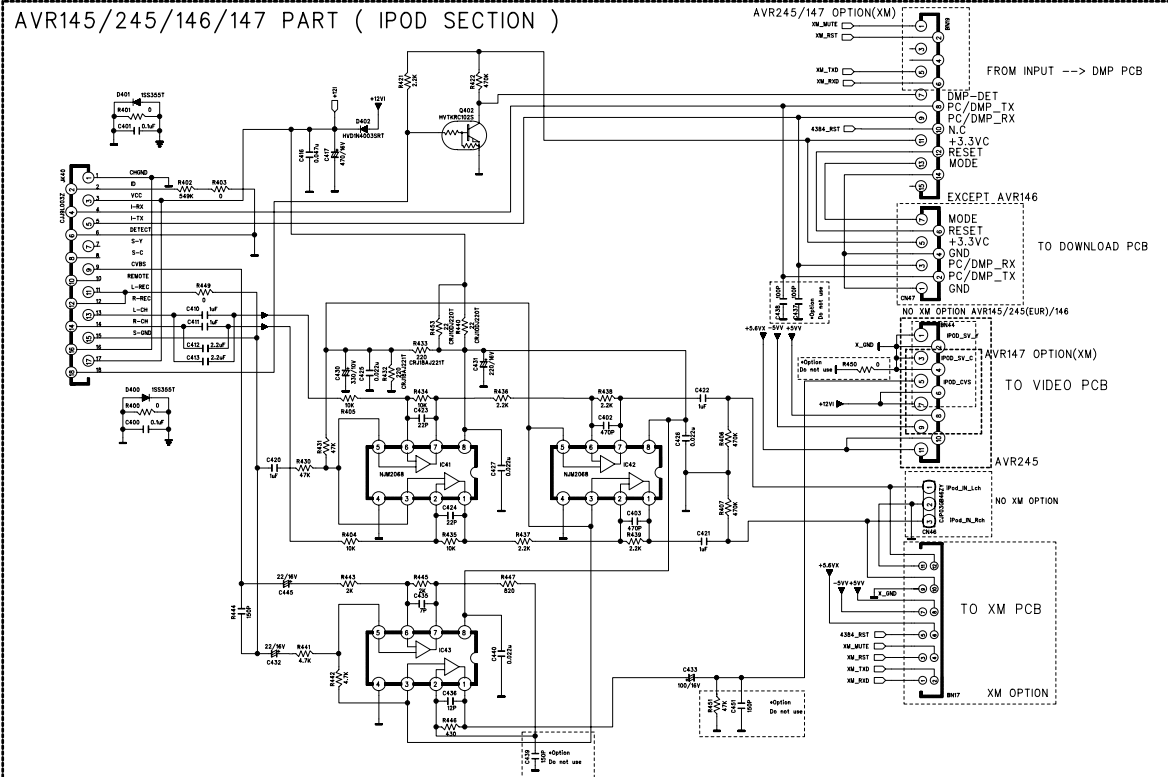
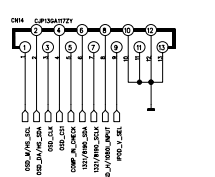

MODEL OPTION TABLE

MODEL	OP_A(PIN48)	OP_B(PIN98)	OP_C(PIN52)
AVR145/147	HIGH(R792)	LOW(R791)	LOW(R712)
AVR245	LOW(R793)	LOW(R791)	LOW(R712)
NONE	OPEN	LOW(R791)	NOT OPTION
AVR132	LOW(R793)	HIGH(R790)	LOW(R712)
AVR144/146	HIGH(R792)	HIGH(R790)	LOW(R712)
AVR145/230	HIGH(R792)	LOW(R791)	HIGH(R711)
AVR245/230	LOW(R793)	LOW(R791)	HIGH(R711)
AVR347	HIGH(R792)	LOW(R791)	NO OPTION
AVR247	LOW(R793)	LOW(R791)	NOT OPTION
AVR345/230	HIGH(R792)	HIGH(R790)	NOT OPTION

○: PULL_UP
GPIO : Input/Out Port(without pull_up resistor)

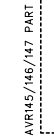
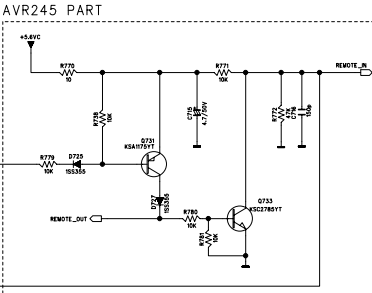

REVISION	2	4	6
1	3	5	7
SCHEMATIC DIAGRAM			
MODEL	AVR145/245/144/146/147		
DESIGN	CHECK	APPROVE	DRAWING NO
M.S.K	W.Y.Y	H.W.L	1912SCMX
07.01.04	07.01.04	07.01.04	(INPUT)

CUP11912X

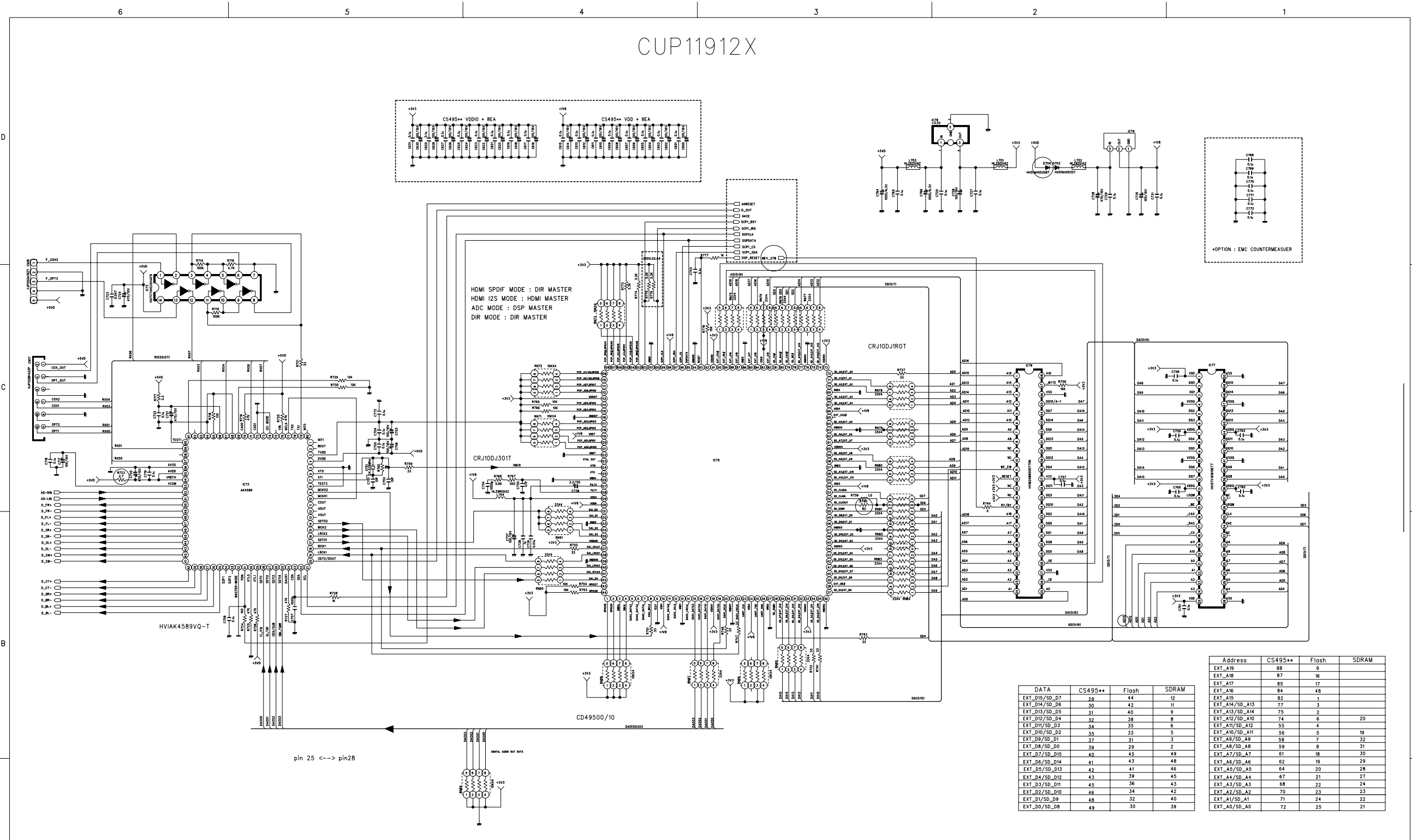

Address	CS495**	Flash	SDRAM
EXT_A19	88	9	
EXT_A18	87	16	
EXT_A17	85	17	
EXT_A16	84	48	
EXT_A15	82	1	
EXT_A14/SD_A13	77	3	
EXT_A13/SD_A14	75	2	
EXT_A12/SD_A10	74	6	20
EXT_A11/SD_A12	55	4	
EXT_A10/SD_A11	56	5	19
EXT_A9/SD_A9	58	7	32
EXT_A8/SD_A8	59	8	31
EXT_A7/SD_A7	61	18	30
EXT_A6/SD_A6	62	19	29
EXT_A5/SD_A5	64	20	28
EXT_A4/SD_A4	67	21	27
EXT_A3/SD_A3	68	22	24
EXT_A2/SD_A2	70	23	23
EXT_A1/SD_A1	71	24	22
EXT_A0/SD_A0	72	25	21

DATA	CS495**	Flash	SDRAM
EXT_D15/SD_D7	29	44	12
EXT_D14/SD_D6	30	42	11
EXT_D13/SD_D5	31	40	9
EXT_D12/SD_D4	32	38	8
EXT_D11/SD_D3	34	35	6
EXT_D10/SD_D2	35	33	5
EXT_D9/SD_D1	37	31	3
EXT_D8/SD_D0	39	29	2
EXT_D7/SD_D15	40	45	49
EXT_D6/SD_D14	41	43	48
EXT_D5/SD_D13	42	41	46
EXT_D4/SD_D12	43	39	45
EXT_D3/SD_D11	45	36	43
EXT_D2/SD_D10	46	34	42
EXT_D1/SD_D9	48	32	40
EXT_D0/SD_D8	49	30	39

REVISION	2	4	6
1	3	5	7
SCHEMATIC DIAGRAM			
MODEL	AVR145/245/144/146/147		
DESIGN	CHECK	APPROVE	DRAWING NO
M.S.K	W.Y.Y	H.W.L	1912SCMZ
07.01.04	07.01.04	07.01.04	(INPUT)



CUP11911X

SR-CH

C-CH

BL-CH

FR-CH

SL-CH

FL-CH

BR-CH

GAIN	R561, R562, R563, R564, R565, R850
AVR145/132/144 AVR146/147	1.8K
AVR245/345 AVR247/347	1.6K

EXCEPT AVR145/144/132/146/147

AVR345/347 ONLY

AVR245/345/247/347 PART

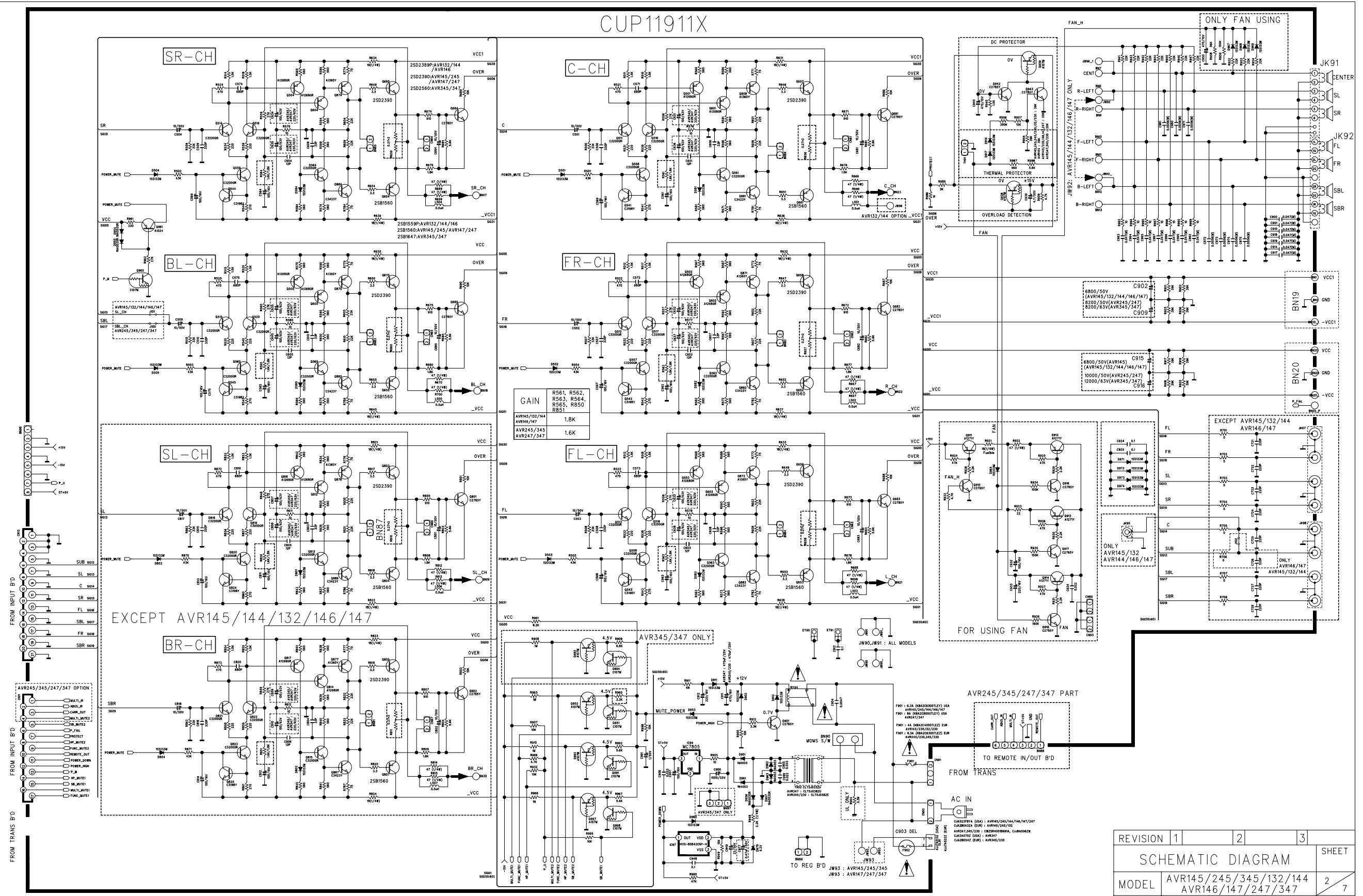

** IMPORTANT SAFETY NOTICE.
 IMPORTANT FOR SAFETY WHEN REPLACING ANY OF THESE COMPONENTS
 USE ONLY MANUFACTURER'S SPECIFIED PARTS.
 ** THE UNIT OF RESISTANCE IS OHM.
 ** K=1000 OHM, M=1000 KOHM.
 ** THE UNIT OF CAPACITANCE IS MICROFARAD (uF)
 ** uF = 10⁻⁶ F
 ** THIS SCHEMATIC DIAGRAM MAY MODIFIED AT ANY TIME WHILE THE
 IMPROVEMENT OF PERFORMANCE

REVISION	1	2	3	SHEET
SCHEMATIC DIAGRAM				2
MODEL	AVR145/245/345/132/144 AVR146/147/247/347			7
DESIGN	CHECK	APPROVE	DRAWING NO	
C.B.L	W.Y.Y	H.W.L	1911SCMX (MAIN)	
07.03.14	07.03.14	07.03.14		

CUP11911X

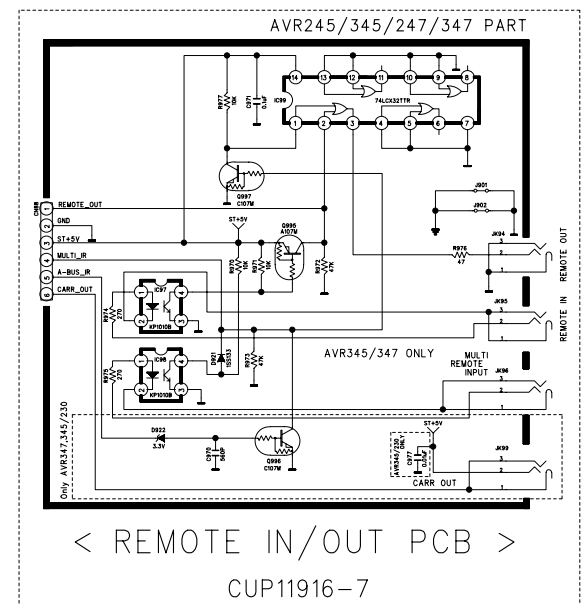
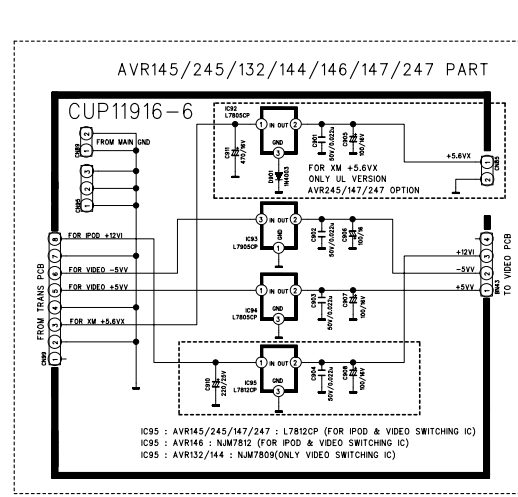
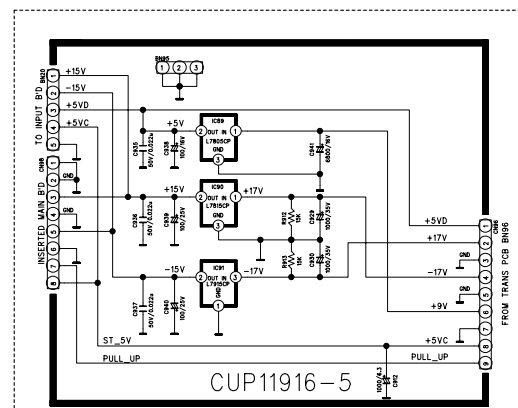
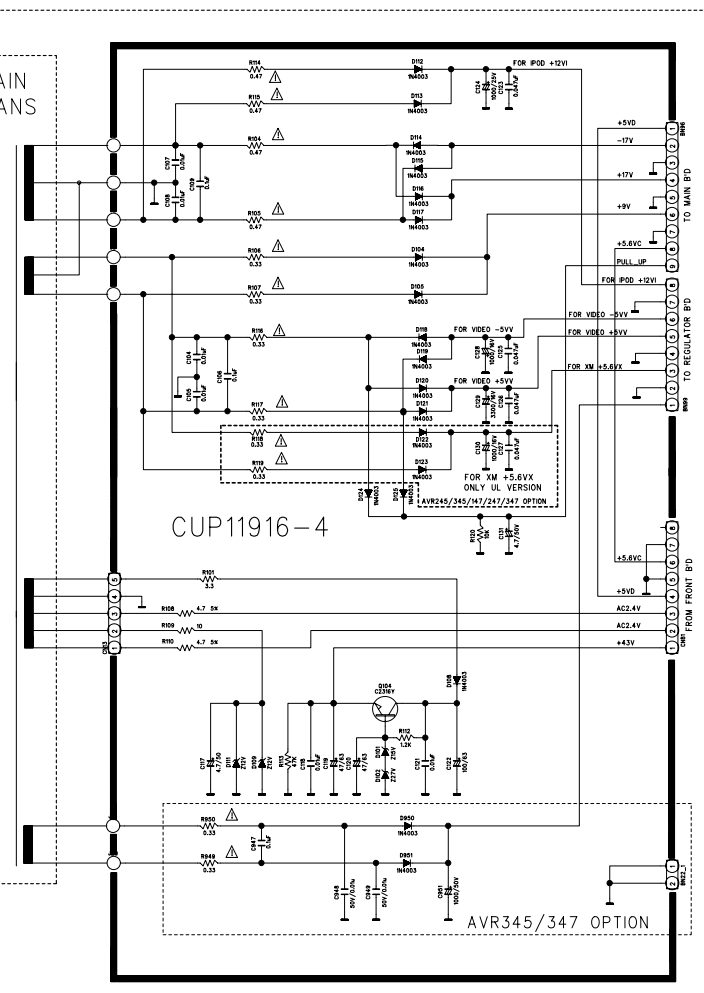
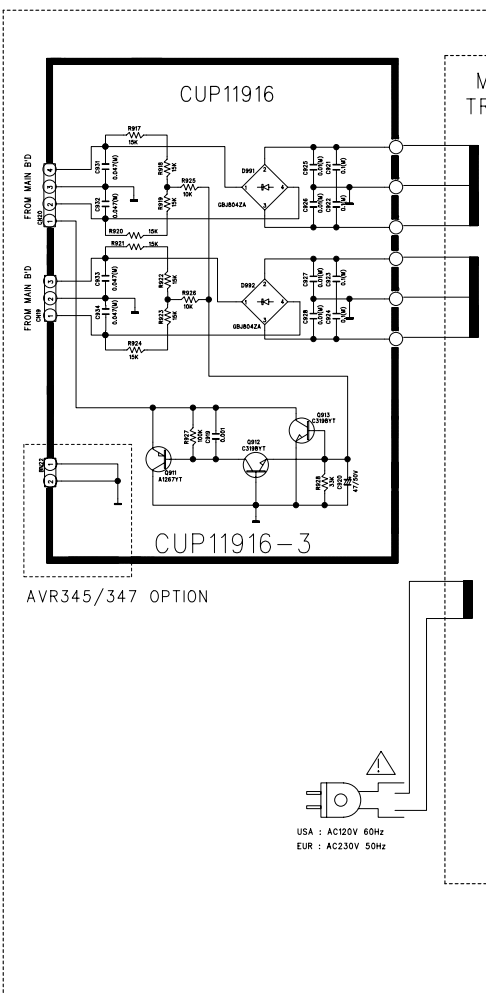
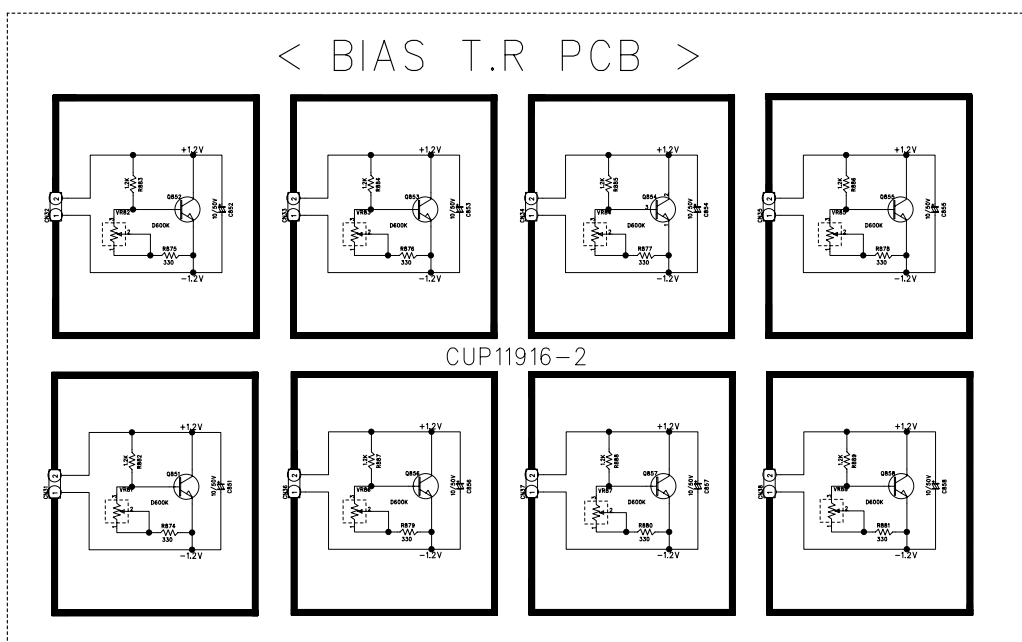
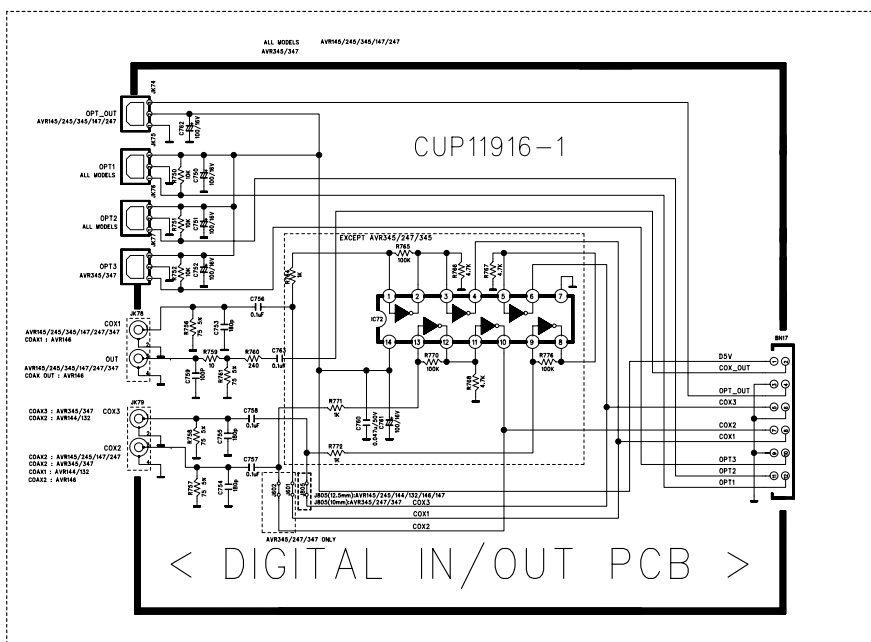

USA : AC120V 60Hz
EUR : AC230V 50Hz

REVISION	2	4	6
1	3	5	7
SCHEMATIC DIAGRAM			
MODEL	AVR145/245/345/132/144 AVR146/147/247/347		
DESIGN	CHECK	APPROVE	DRAWING NO
C.B.L	W.Y.Y	H.W.L	1916SCMX (POWER)
07.01.18	07.01.18	07.01.18	

CUP11920Y

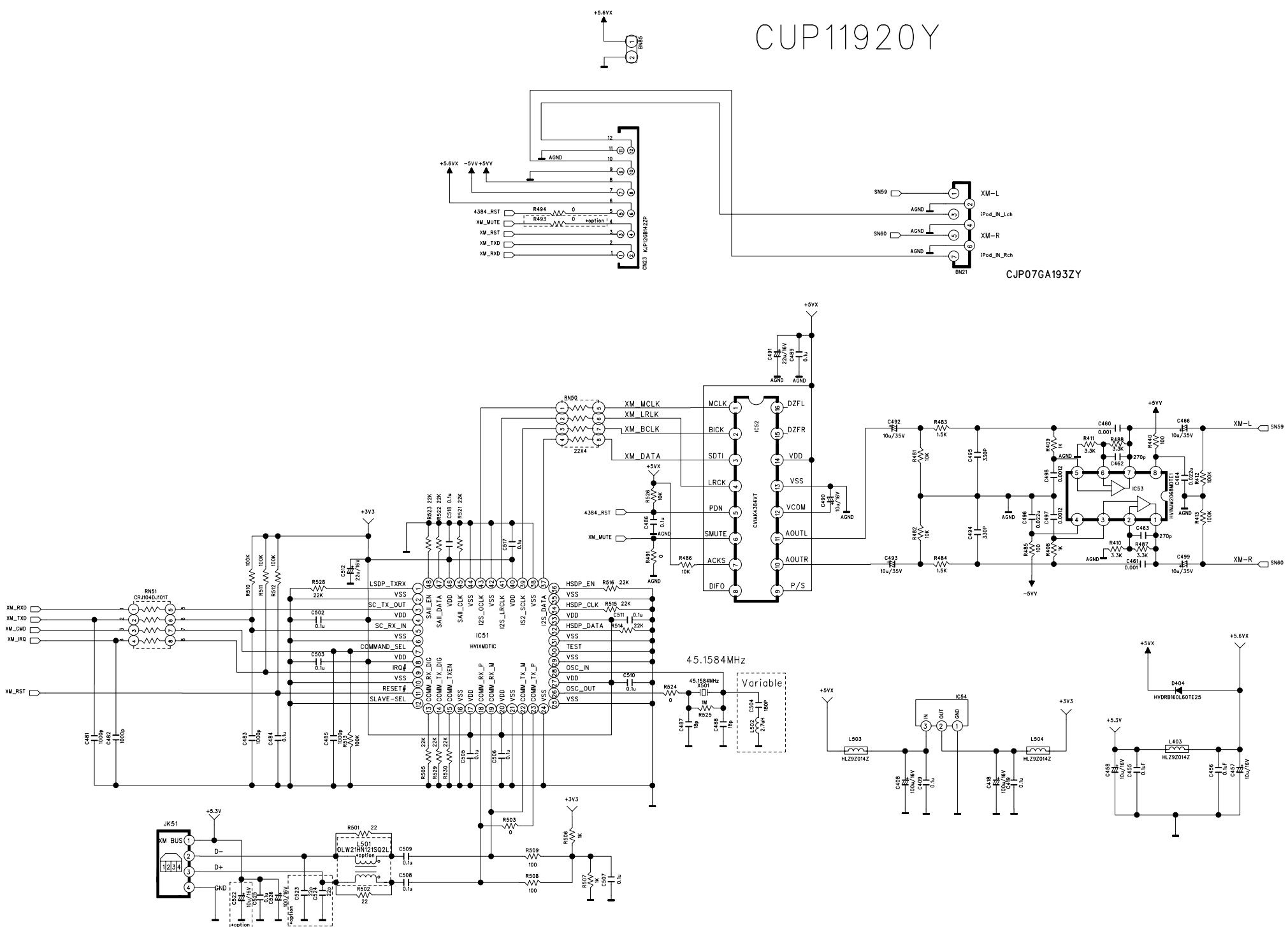

REVISION	2	4	6
1	3	5	7
SCHEMATIC DIAGRAM			
MODEL	AVR245/147 USA		SHEET 7/7
DESIGN	CHECK	APPROVE	DRAWING NO
M.S.K	W.Y.Y	H.Y.L	1920SCMY (XM)
07.01.18	07.01.18	07.01.18	1/1

AVR147 WIRING DIAGRAM

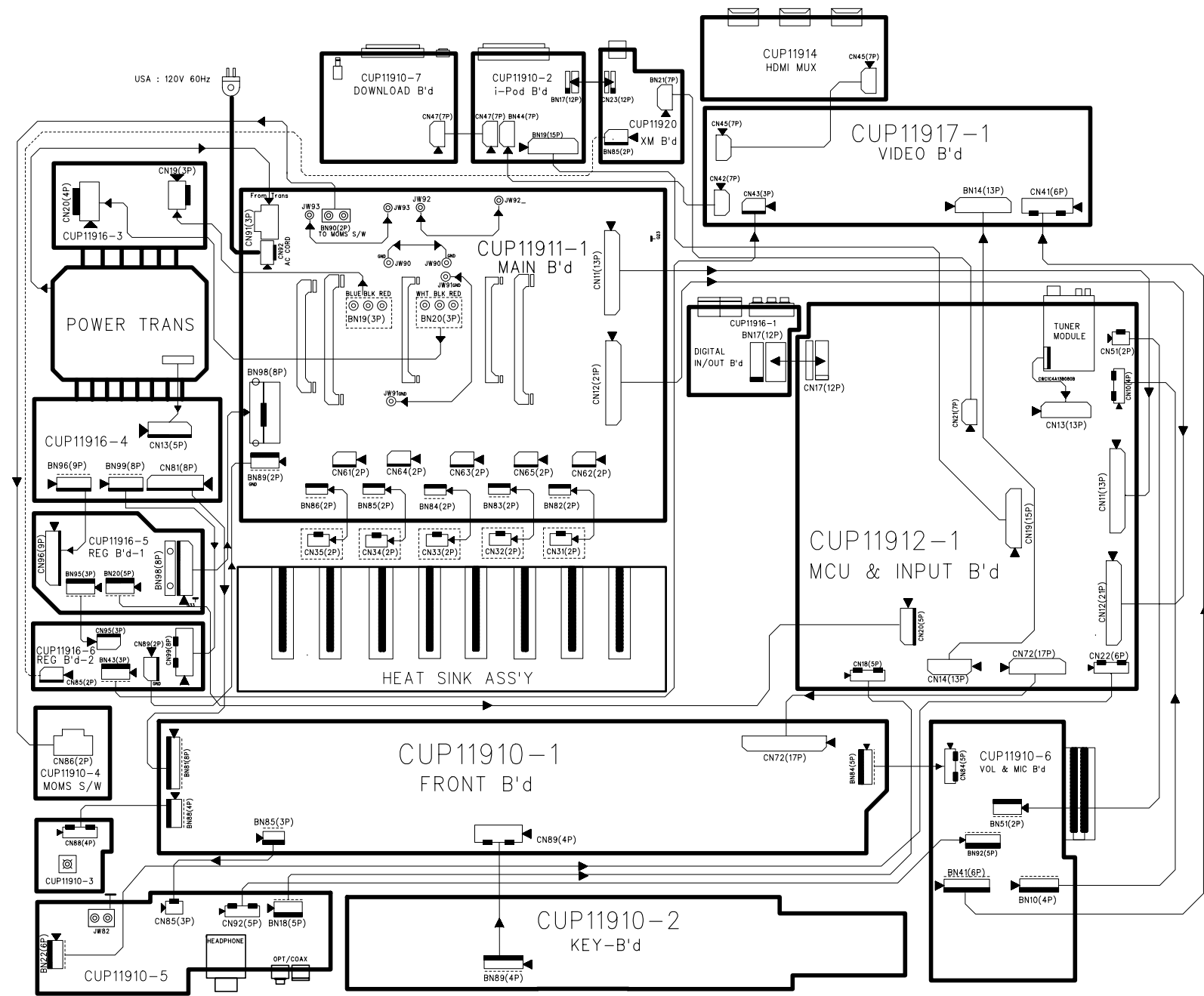

-14

REVISION	2	4	6	
1	3	5	7	
SCHEMATIC DIAGRAM				SHEET
MODEL	AVR147			1 1
DESIGN	CHECK	APPROVE	DRAWING NO	
J.T.B	W.Y.Y	H.W.L	WIRING DIAGRAM	
07.03.14	07.03.14	07.03.14	1190SCDZ	