

The Harman Kardon Model AVR20MKII AUDIO AND VIDEO RECEIVER

Technical Manual

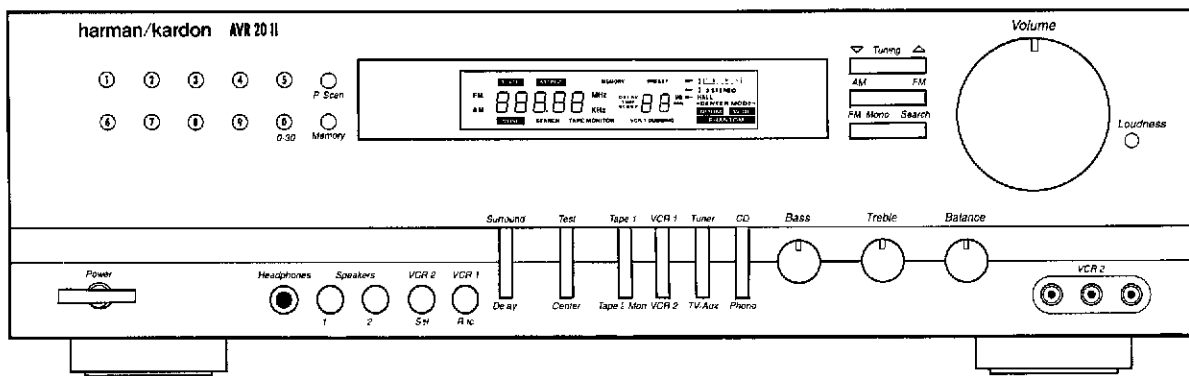

■ CONTENTS ■

SPECIFICATIONS	2	GENERAL UNIT	21
LEAKAGE TEST	4	PRINTED CIRCUIT BOARDS	22
BLOCK DIAGRAM	5	ELECTRICAL PARTS LIST	23
CONTROLS AND FUNCTIONS	6	IC FUNCTIONAL BLOCK DIAGRAM	28
DISASSEMBLY PROCEDURES	7	WIRING DIAGRAM	33
CIRCUIT DESCRIPTION	9	SCHEMATIC DIAGRAMS (I)	34
ALIGNMENT PROCEDURES	14	SCHEMATIC DIAGRAMS (II)	35
TROUBLESHOOTING	17	SCHEMATIC DIAGRAMS (III)	36
GENERAL UNIT PARTS LIST	20	SCHEMATIC DIAGRAMS (IV)	37

harman/kardon

Parts and Service Office
80 Crossways Park West, Woodbury, N.Y. 11797
1112-AVR20MKII G9604 1200 Printed in Korea

SPECIFICATIONS

FRONT AMP SECTION

	Nominal	Limit
RMS Output Power		
(STERE MODE), Input: CD	≥ 65 W	≥ 63 W
THD: 0.09%, 8 ohms		
Both Channel Driven (40 Hz - 10 kHz)		
(SURROUND MODE)	≥ 55 W	≥ 50 W
THD: 0.09%, 8 ohms, 1 kHz		
THD (40 Hz - 10 kHz) at 63 W, 8 ohms, Input: CD		
40 kHz	≤ 0.06%	≤ 0.09%
1 kHz	≤ 0.06%	≤ 0.09%
10 kHz	≤ 0.06%	≤ 0.09%
IM Distortion at 63 W, 8 ohms, Input: CD		
60:7000 Hz = 4:1	≤ 0.2%	≤ 0.3%
Input Sensitivity		
PHONO (MM)	2.5 mV	2.5 ± 0.4 mV
CD, AUX, VCR	150 mV	150 ± 30 mV
S/N Ratio Input Shorted at Volume Max. (WTD IHF-A)		
PHONO	≥ 74 dB	≥ 70 dB
CD, TAPE1,2	≥ 92 dB	≥ 90 dB
TV, VCR1,2	≥ 82 dB	≥ 80 dB
Phono Overload at 1 kHz, THD: 0.5%		
Phono Input → Tape Output	≥ 140 mV	≥ 130 mV
Phono Equalization (RIAA 30 Hz - 15 kHz)		
Tape Monitor Output	RIAA	RIAA ± 1.5 dB
Tone Control		
Bass: 100 Hz	+10 dB	+10 ± 2.0 dB
	-10 dB	-10 ± 2.0 dB
Treble: 10 kHz	+10 dB	+10 ± 2.0 dB
	-10 dB	-10 ± 2.0 dB
Loudness Contour at -40 dB		
100 Hz	+6 dB	+6 ± 2.0 dB
10 kHz	+3 dB	+3 ± 2.0 dB
Frequency Response (CD/AUX)		
20 Hz, 20 kHz	± 0.5 dB	± 1 dB
Channel Crosstalk Input Shorted		
1 kHz	≥ 60 dB	≥ 50 dB
10 kHz	≥ 50 dB	≥ 40 dB

CENTER AMP SECTION

	Nominal	Limit
RMS Output Power		
THD (0.3%, 8 ohms, 1 kHz)		
Only Center Channel Driven	≥ 55 W	≥ 50 W
S/N Ratio (Input Level: 350 mV)		
Input Shorted, IHF-A WTD	≥ 67 dB	≥ 65 dB
Frequency Response at -3 dB		
Normal	100 Hz - 20 kHz	150 Hz - 15 kHz
Wide	20 Hz - 20 kHz	50 Hz - 15 kHz

REAR AMP SECTION

	Nominal	Limit
RMS Output Power		
THD (0.7%, 8 ohms, 1 kHz)		
Only Rear Channel Driven	≥ 55 W	≥ 50 W
S/N Ratio (Input Shorted, IHF-A WTD)		
Delay: 20 ms, Input Level: 350 mV		
Dolby	≥ 60 dB	≥ 55 dB
Hall	≥ 60 dB	≥ 55 dB
Frequency Response at -3 dB		
8 ohms, Dolby Pro-Logic	80 Hz - 7 kHz	100 Hz - 6 kHz

VIDEO AMP SECTION

	Nominal	Limit
Input Sensitivity/Impedance		
VCR1, VCR2, VDP	1 V _{p-p} /75 Ω	± 1 dB
Output Level/Impedance		
VCR1, REC out, TV Monitor out	1 V _{p-p} /75 Ω	± 1 dB
Frequency Response at -3 dB	DC-10 MHz	5 - 6 MHz
Crosstalk at 1.0 MHz	≥ 45 dB	≥ 40 dB

FM SECTION

	Nominal	Limit
Tuning Cover Range		
USA/Canada: 75 kHz DIV.	87.5 - 107.9 MHz	
Europe: 40 kHz DIV.	87.5 - 108.0 MHz	
Usable Sensitivity (75 ohms Input)		
USA/Canada: 30 dB S/N	≤ 11.2 dbf	≤ 17.2 dbf
Europe: 26 dB S/N		
Image Rejection (at 106 MHz)		
USA/Canada	≥ 45 dB	≥ 35 dB
Europe	≥ 100 dB	≥ 90 dB
IF Rejection (at 90 MHz)	≥ 110 dB	≥ 100 dB
Full Limiting (at -3 dB)	≤ 12.2 dbf	≤ 15.2 dbf
50 dB Quieting Sensitivity (at 98.1 MHz, 100% MOD.)		
IHF Band Pass Filter		
Mono	≤ 17.2 dbf	≤ 23.2 dbf
Stereo: USA/Canada	≤ 40.2 dbf	≤ 43.3 dbf
Europe	≤ 45.3 dbf	≤ 48.3 dbf
Distortion (1 kHz, 100% MOD. at 98.1 MHz)		
IHF Band Pass Filter		
Mono	≤ 0.2%	≤ 0.5%
Stereo	≤ 0.4%	≤ 0.7%
S/N Ratio (1 mV Input, 100% MOD. at 98.1 MHz)		
IHF Band Pass Filter		
Mono	≥ 70 dB	≥ 65 dB
Stereo	≥ 65 dB	≥ 60 dB
Frequency Response (at +1 dB, -3 dB)		
	20 Hz - 15.5 kHz	30 Hz - 15 kHz
AM Rejection Ratio (100 uV - 20 mV Input)		
	≥ 60 dB	≥ 50 dB
Search Level (at 98.1 MHz)	31.2 dbf	31.2 ± 5 dbf
Automatic Stereo Threshold (at 98.1 MHz)		
	31.2 dbf	31.2 ± 5 dbf
Muting Threshold (at 98.1 MHz)	31.2 dbf	31.2 ± 5 dbf
Overload at 98.1 MHz		
(100% MOD. 100 mV RF Input)	≤ 0.2%	≤ 0.5%
Suprious Response (at 98.1 MHz)		
Antenna Input 3 uV	≥ 70 dB	≥ 60 dB
Capture Ratio at 40/60 dbf	≤ 2 dB	≤ 2.5 dB
Alternative Channel Selectivity (at 98.1 MHz ± 400 kHz)		
	≥ 65 dB	≥ 55 dB
Stereo Separation (at 98.1 MHz, 100% MOD., 1 mV Input)		
IHF Band Pass Filter		
100 Hz	≥ 40 dB	≥ 35 dB
1 kHz	≥ 45 dB	≥ 40 dB
10 kHz	≥ 35 dB	≥ 30 dB
Output Voltage (at 100% MOD., 1 kHz Input)		
Mono	500 mV	500 ± 150 mV
Stereo	450 mV	450 ± 150 mV

AM SECTION

	Nominal	Limit
Tuning Cover Range		
USA/Canada: 10 kHz Step	520 - 1710 kHz	
Europe: 9 kHz Step	522 - 11611 kHz	
Usable Sensitivity (400 Hz, 30% MOD., S/N 20 dB)		
	≤ 500 uV/m	≤ 1000 uV/m
Image Rejection (at 1400 kHz)	≥ 35 dB	≥ 30 dB
IF Rejection (at 600 kHz)	≥ 60 dB	≥ 50 dB
AGC Figure of Merit (From 100 mV/m at 1000 kHz)		
	≥ 50 dB	≥ 45 dB
Distortion (400 Hz, 30% MOD. 5 mV/m Input)		
	≤ 0.8%	≤ 1.5%
IF Bandwidth (6 dB Down, 350 uV/m)		
	6 kHz	4 - 11 kHz
Audio Response (5 mV/m Input 1 kHz 0 dB, 1000 kHz)		
at -6 dB	80 Hz - 2.3 kHz	100 Hz - 2 kHz
Selectivity (at 350 uV/m)		
± 10 kHz	≥ 35 dB	≥ 25 dB
S/N Ratio (1000 kHz, With Antenna Input 5 mV/m)		
	≥ 45 dB	≥ 40 dB

RF Overload (400 Hz 80% MOD, 100 mV/m Input)	$\leq 5\%$	$\leq 10\%$
Search Level (at 1000 kHz)	800 μ V	800 μ V \pm 6 dB
Output Voltage (400 Hz 30% MOD., 5 mV/m Input)	165 mV	165 \pm 40 mV
Whistle	$\leq 10\%$	$\leq 15\%$

GENERAL

Power Consumption;	
USA/Canada	180 W
Europe	500 W
Power Supplies;	
USA/Canada	AC 120 V, 60 Hz
Europe	AC 230 V, 50 Hz
Dimensions (W x H x D);	
inches	17 ^{3/8} x 6 ^{1/8} x 16 ^{1/2}
mm	440 x 155 x 420
Weight (lbs/kgs)	26.9/12.2

These specifications are service target specs.

Specifications and components are subject to change without notice.

Overall performance will be maintained or improved.

LEAKAGE TEST

Before returning the unit to the user, perform the following safety checks:

1. Inspect all lead dress to make certain that leads are not pinched or that hardware is not lodged between the chassis and other metallic parts in the unit.
2. Be sure that any protective devices such as nonmetallic control knobs, insulating fishpapers, cabinet backs, adjustment and compartment covers or shields, isolation resistor-capacity networks, mechanical insulators, etc. Which were removed for servicing are properly reinstalled.
3. Be sure that no shock hazard exists; check for leakage current using Simpson Model 229 Leakage Tester, standard equipment item No. 21641, RCA Model WT540A or use alternate method as follows: Plug the power cord directly into a 230-volt AC receptacle (do not use an Isolation Transformer for this test).

Using two clip leads, connect a 1500 Ohm, 10-watt resistor paralleled by a 0.15 μ F capacitor, in series with all exposed metal cabinet parts and a known earth ground, such as a water pipe or conduit. Use a VTVM or VOM with 1000 Ohms per volt, or higher sensitivity to measure the AC voltage drop across the resistor. (See Diagram.) Move the resistor connection to each exposed metal part having a return path to the chassis (antenna, metal cabinet, screw heads, knobs and control shafts, escutcheon, etc.) and measure the AC voltage drop across the resistor. (This test should be performed with the power switch in both the On and Off positions.)

A reading of 0.35 volt RMS or more is excessive and indicates a potential shock hazard which must be corrected before returning the unit to the owner.

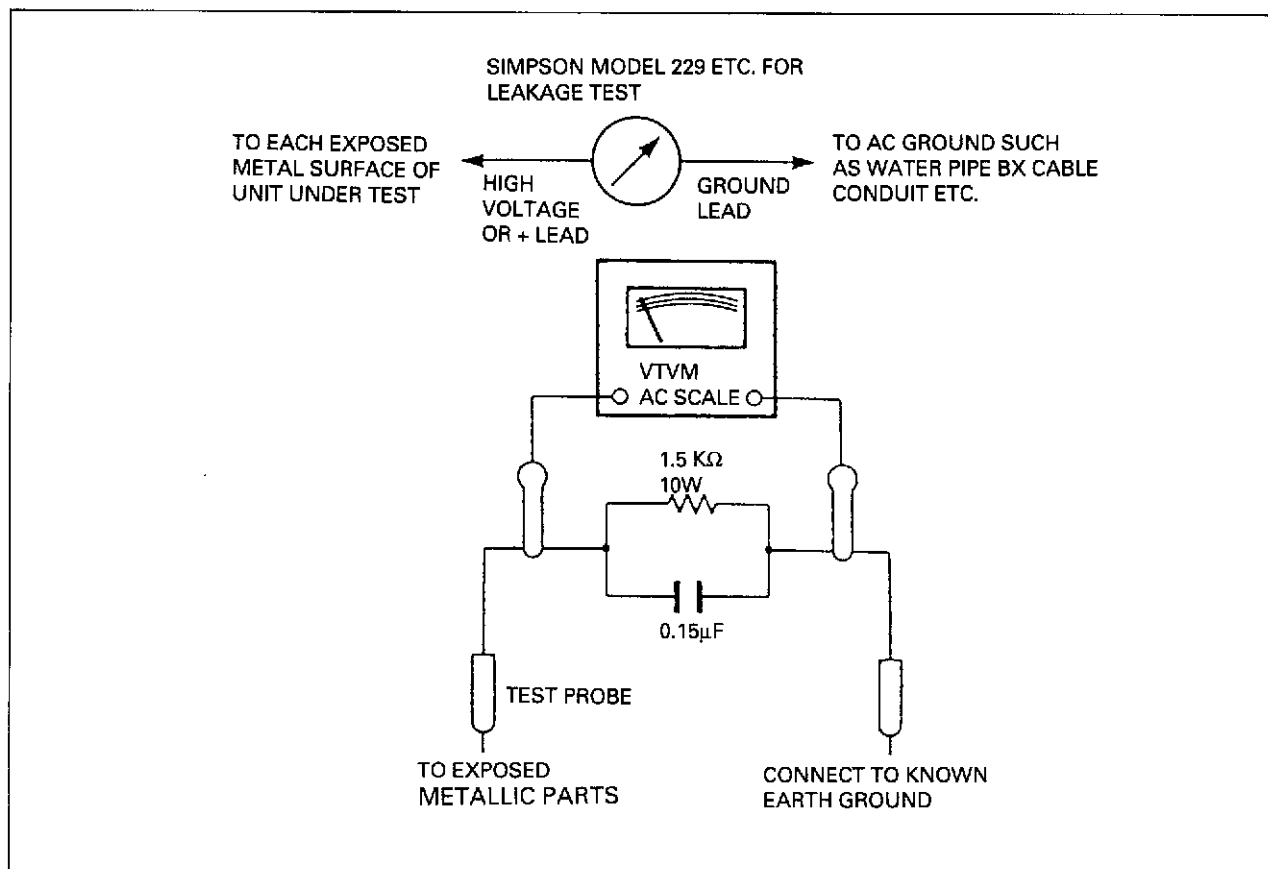

BLOCK DIAGRAM

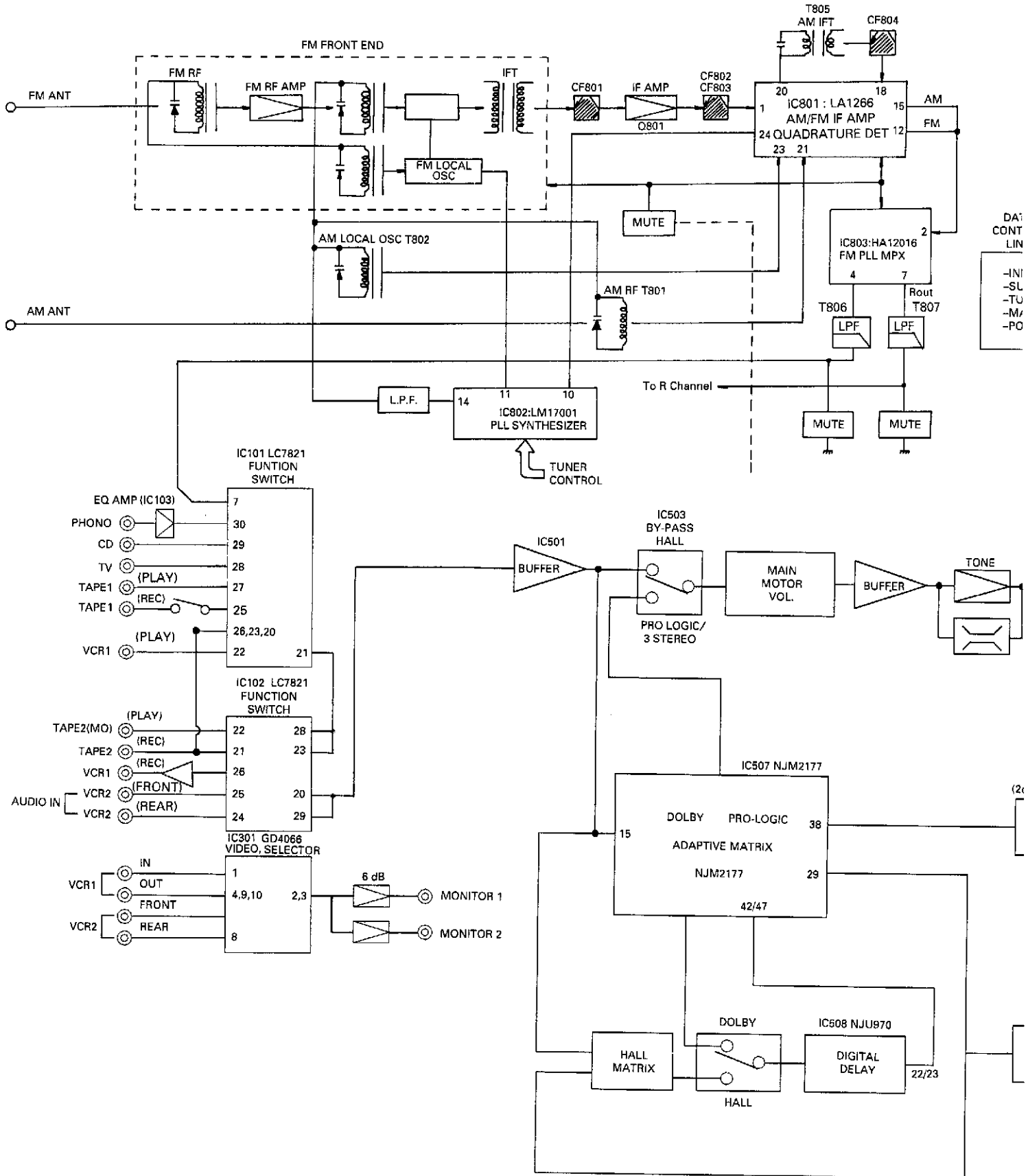

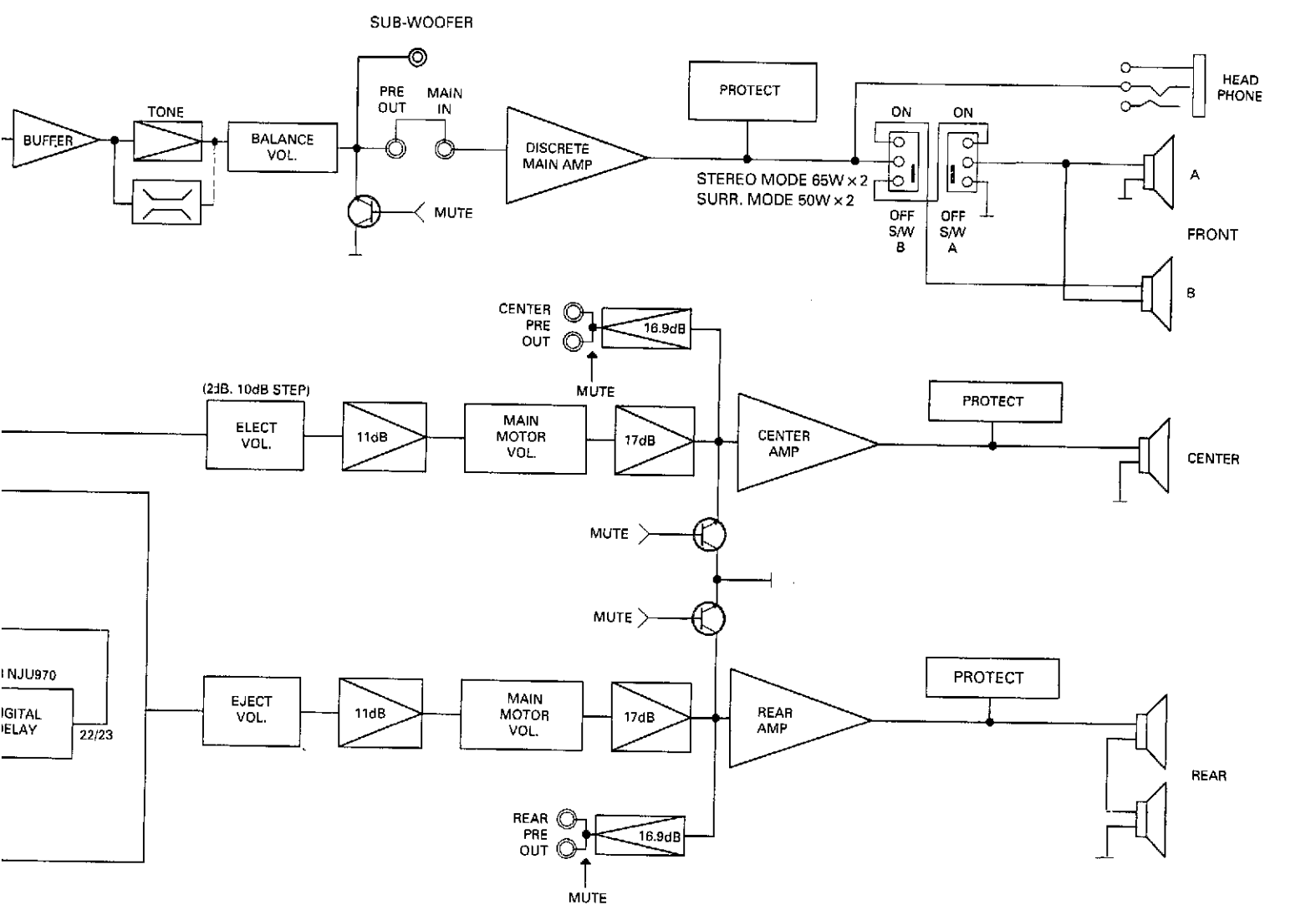
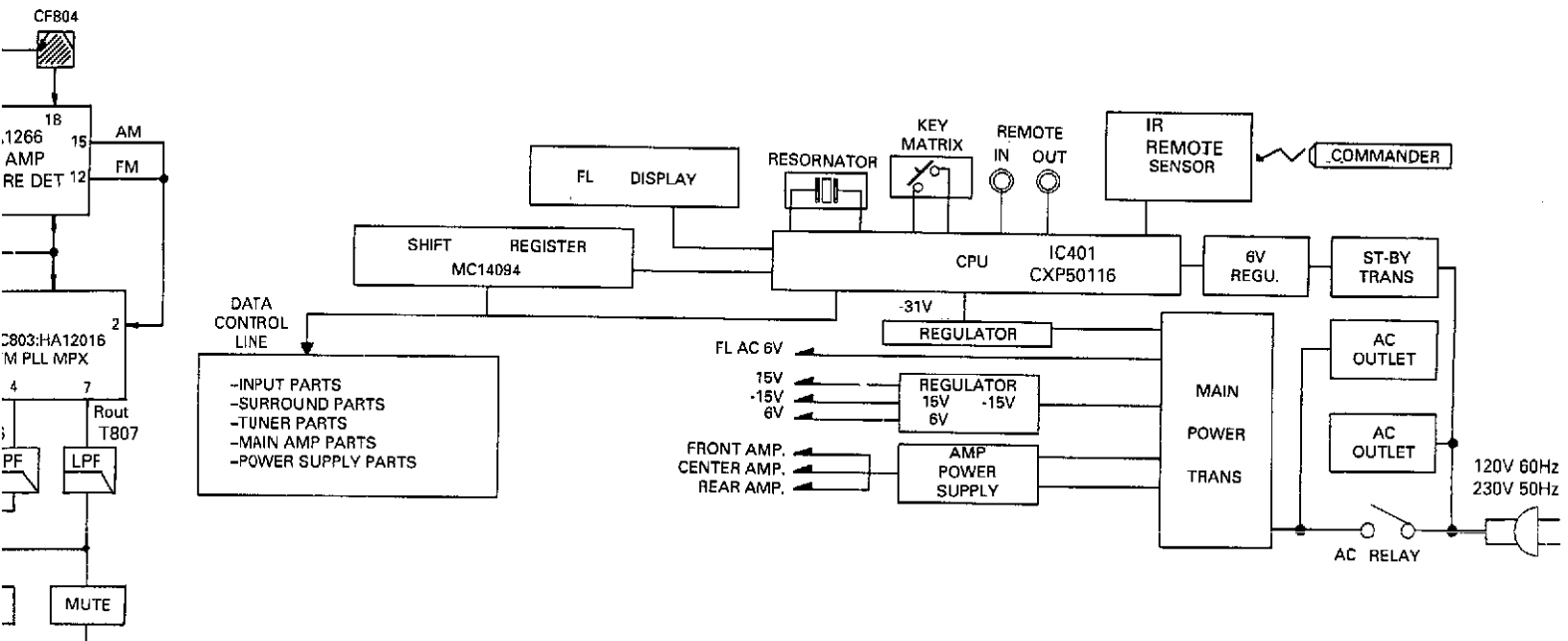

CONTROLS AND FUNCTIONS

17

11

14

25

13

15

16

12

24

23

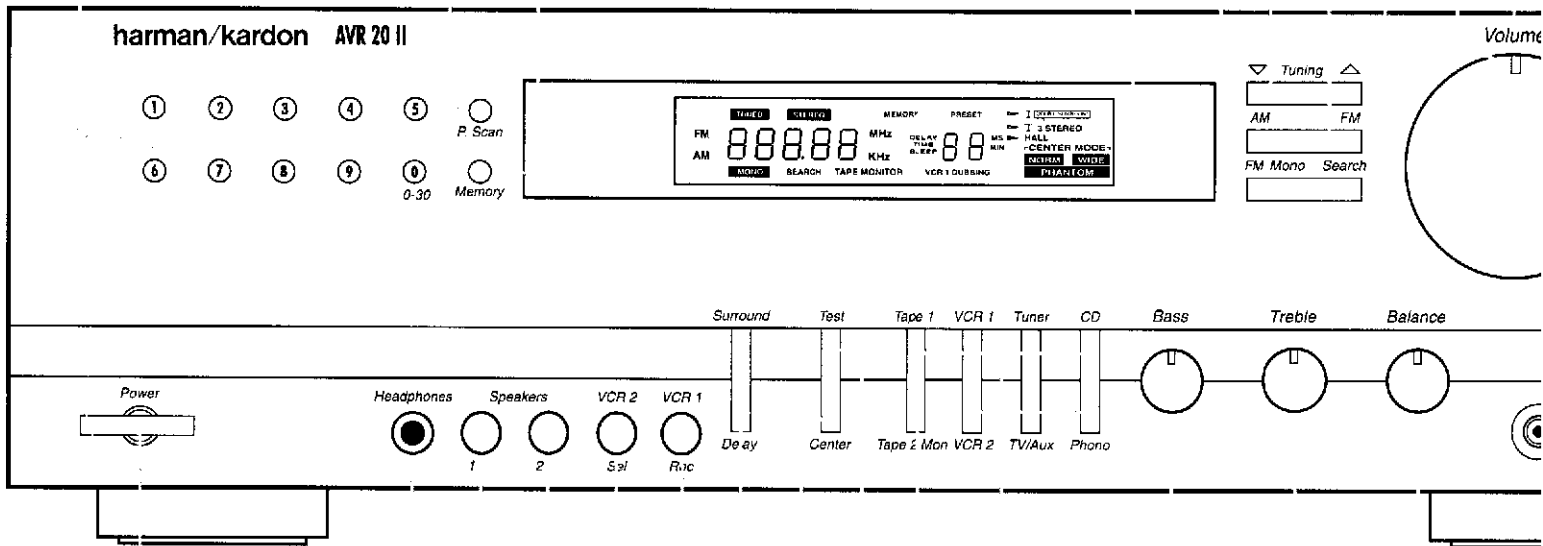

1

3

2

20

10

7

8

9

18

19

4

5

6

1. POWER BUTTON

Press this button to turn the power on. Press again to turn the power off. It can also be used as a system power button, if you connect the other components to the switched outlets.

NOTE: In POWER OFF state, the POWER Indicator will light up orange and power is partially supplied to the infrared remote control receiver and the memory circuitry.

2. 1/2 SPEAKER SWITCHES

These switches allow you to select various combinations of speakers as follows:

- To drive 1 pair of speakers, push only the speaker 1 switch in.
- To drive a second pair of speakers, push only the speaker 2 switch in.
- To drive both pairs of speakers, push both 1 and 2 switches in.

■ To use headphones for private listening or monitoring, leave both 1 and 2 switches pushed out.

NOTE: If both speaker switches are pushed in and only one set of speakers is connected to the receiver, no sound will be heard.

3. HEADPHONE JACK

Stereo headphones can be plugged into this jack for private listening. Headphone impedance should be between 8 and 2K ohms. Best results between 200 and 400 ohms.

4. BASS CONTROL

Modifies the low-frequency sound of the left and right channels as much as +/- 10dB. Set this control at a suitable position for your taste and room acoustics.

5. TREBLE CONTROL

Modifies the high-frequency sound of the left and right channels as much as +/- 10dB. Set this control at a suitable position for your taste and room acoustics.

6. BALANCE CONTROL

This control is used for balancing the relative sound volume of the left and right channel speakers. Clockwise rotation reduces the volume from the left speaker, counterclockwise rotation reduces the volume from the right speaker.

7. SURROUND-OFF MODE SELECTOR

Press this switch to select normal stereo mode.

8. DELAY TIME

Adjusts time delay rear channels, open surround mode is button on page 16

Adjusts the surround steps. For Dolby standard.

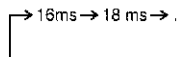

9. PRO LOGIC

Press this button f

10. 3 CHANNEL

The 3 channel mo when rear speake to provide a cente

13 15 16 12 24 23

22

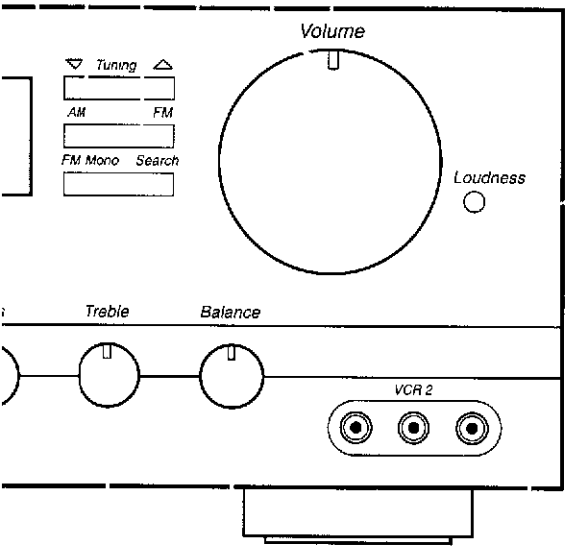

5

6

21

... sound of
as much as
at a suitable
room

8. DELAY TIME

Adjusts time delay between front and rear channels, operates only when the surround mode is on. (see Delay Time button on page 16).

Adjusts the surround delay time in steps. For Dolby Surround 20ms is standard.

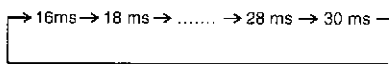

9. PRO LOGIC MODE

Press this button for Pro-Logic mode.

10. 3 CHANNEL MODE

The 3 channel mode can be used when rear speakers are not being used to provide a center (dialog) channel.

... normal

11. STADIUM/THEATER MODE

Switches for selecting desired surround mode; Stadium or Theater. See Surround Sound Effects on page 13.

12. CENTER MODE SELECTOR

This button operates only in DOLBY PRO-LOGIC and DOLBY 3 STEREO mode. The mode changes as below, when the button is pressed in succession.

DOLBY PRO-LOGIC MODE

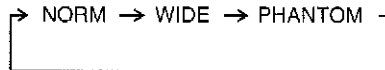

DOLBY 3 STEREO MODE

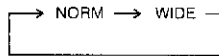

The display window shows each mode.

NORM: Select this mode if you use a small center speaker. The bass sound of the center channel is reproduced from the front speakers, because the small speaker cannot produce enough bass.

WIDE: Select this mode if you use a medium-to-large center speaker. The bass sound is reproduced from the center speaker.

PHANTOM: Select this mode if you don't use a center speaker. The center speaker's sound is reproduced from the front speakers.

13. TEST TONE BUTTON

This button operates only in DOLBY PRO-LOGIC and DOLBY 3 STEREO mode. When the button is pressed, 2 seconds of test tone is generated in all channels (Left, Center, Right, and Rear) in succession. The display window shows TEST Left, Center, Right, and Rear in succession (in DOLBY PRO-LOGIC mode) or Left Center or Right (in DOLBY 3 STEREO mode) in succession. Use this button to test speaker connections.

14. SOURCE/DIRECT BUTTON

This feature bypasses the tone control circuitry, resulting in flatter frequency response and wider bandwidth. When it is activated, "DIRECT" illuminates in the display.

15. PRESET SCAN BUTTON

Press this button to scan the preset station frequencies. The receiver stops at each preset location that contains a frequency for about 4 seconds, so you can hear a station. The preset location indicator blinks 4 times. Press this button again to stop scanning.

16. SEARCH SELECTOR

Press this button to select AUTO or MANUAL tuning.

■ In AUTO mode, scanning is automatically continued up or down until the next station is picked up by pressing the UP/DOWN tuning buttons. The display window shows 'AUTO'. Use this mode to quickly find strong AM or FM stations.

■ In MANUAL mode, the frequency is changed by a step with the UP/DOWN button. If you keep pressing the UP/DOWN tuning buttons, scanning is continued until the button is released.

NOTE: Tuning Intervals:

BAND	USA/CANADA
FM	50 KHz
AM	10 KHz

17. FM MODE BUTTON

Press this button to select stereo or mono mode.

■ **STEREO:** Provides stereophonic reception of an FM stereo broadcast. The display window shows 'FMST'.

■ **MONO:** The left and right channel signals detected from an FM stereo broadcast are mixed and reproduced through both channels. If you want to find a weak FM station, select this mode.

18. STATION MEMORY BUTTON

Use this button to store an AM or FM frequency. Press this button and select one of 30 preset locations to store the frequency with the STATION PRESET buttons while the memory indicator, 'MEMORY' blinks.

NOTE: When you store a frequency in a memory location that already contains a frequency, you replace the previous frequency. If your receiver is disconnected from AC power for more than about 10 days, it loses all stored frequencies.

19. UP/DOWN TUNING BUTTONS

Press the DOWN button (v) to tune in lower frequency stations, the UP button (^) to tune in higher frequency stations. If you press the DOWN button when the display is at the bottom of the frequency range, the display returns to the top of the range. If you press the UP button when the display is at the top of the frequency range, the display returns to the bottom of the range. When the receiver finds a strong frequency, the display window shows 'TUNED'.

20. FM/AM BAND SELECTOR

Press these buttons to select the FM or AM radio band. When you select the AM or FM radio band, the receiver displays the last frequency selected on that band.

21. STATION PRESET BUTTONS

Select one of 30 preset locations to recall the station stored in memory. The input function is automatically changed to TUNER when the button is pressed. When you select numbers from 10 through 29, you must select the second digit within about 2 seconds. To select preset 30, simply press "0".

22. TAPE 2 MONITOR BUTTON

Set TAPE 2 MONITOR to the "off" position when you want to hear the other input functions. Press this button to monitor the cassette deck connected to the TAPE 2 MON input jacks.

23. INPUT FUNCTION SELECTOR

Press the button to select the desired input function: VCR 1, VCR 2, VDP, TAPE 1, TV/Aux, Tuner, CD or Phono.

To dub from VCR 2 to VCR 1, press the VCR 2 button and then press the VCR 1 REC button.

For the input function of VCR 1 press the VCR 2 button and VCR1 DUBBING button. Set the recording VCR (VCR 1) to recording mode. Set the playback VCR (VCR 2) to play a tape.

Dubbing will start.

■ To hear another input source during video tape dubbing: Press the input function you want to hear, and play the input source.

NOTE: If you press the TEST TONE button during VCR 1 DUBBING, the audio signal is not recorded.

24. VCR 2 SELECTOR

Push in this button to select the VCR 2 jacks on the front, rather than the VCR 2 jacks on the rear.

25. VCR 2/CAMCORDER INPUT JACKS

VIDEO IN:

Connect to the VIDEO OUTPUT jack of a VCR (yellow jack).

AUDIO IN:

Connect to the AUDIO OUTPUT jacks of a VCR (red and white jacks).

26. LOUDNESS BUTTON

Press this button to compensate for the response of the human ear at low listening levels (known as the Fletcher-Munson hearing curve). The high and low frequencies are automatically boosted when this button is pushed in. In the OFF position, the frequency response is flat at all volume levels. This button does not work at high volume levels.

27. VOLUME CONTROL

Turn the VOLUME clockwise to increase the volume and counterclockwise to decrease it. The volume of the front, center, and rear channels is changed at the same time.

28. VOLUME LEVEL INDICATOR

This indicator moves in accordance with the volume level. The indicator blinks when the mute button on the remote commander is pressed.

29. DISPLAY WINDOW

This window shows the state of operation for easier control of the receiver. It also contains the IR Remote Sensor.

DISASSEMBLY PROCEDURES

REFER TO PAGE 21 and 33.

1 COVER TOP REMOVAL

Remove 8 screws (A) and then remove the Cover Top (51).

2 COVER BOTTOM REMOVAL

Remove 10 screws (B) and then remove the Cover Bottom (29).

3 FRONT PANEL ASSEMBLY REMOVAL

1. Remove the Cover Top (51), referring to the previous step 1.
2. Remove the flat cable from wafer (CP401) on the Volume P.C.Board (PCB9).
3. Disconnect (CP102) from the Volume P.C.Board (PCB6).
4. Disconnect (CNT602) from the Surround P.C.Board (PCB11).

5. Disconnect (CP701 and CP702) from the Input P.C.Board (PCB9).
6. Disconnect (CP703) from the Video P.C.Board (PCB2).
7. Remove 8 screws (C) and then remove the Front Panel Assembly (AA).

4 VOLUME P.C.Board (PCB9) REMOVAL

1. Remove the Cover Top (51), referring to the previous step 1.
2. Pull out the Volume Knob (1) with Volume LED P.C.Board (PCB8).
3. Disconnect (CP102 and CP503) from the Volume P.C.Board (PCB6).
4. Remove the Hex Nut from the Volume-motor to remove the Volume P.C.Board (PCB6).
5. Remove 3 screws (M) and then remove the Volume P.C.Board (PCB6).

5 SPEAKER SEL. P.C.Board (PCB7) REMOVAL

1. Remove the Cover Top (51), referring to the previous step [1](#).
2. Remove the Front Panel Assembly (AA), referring to the Previous step [3](#).
3. Remove 4 screws (D) and then remove the Sperkter Sel. P.C.Board (PCB7).

6 TONE P.C.Board (PCB5) REMOVAL

1. Remove the Cover Top(51), referring to the Previous step [1](#).
2. Remove the Front Panel Assembly (AA), referring to the previous step [3](#).
3. Pull the Bass, Treble, Balance Knobs (3).
4. Remove the Hex Nuts from the variable resistors (17, 18).
5. Remove 3 screws (E) and then Tone P.C.Board (PCB5).

7 FRONT P.C.Board (PCB4) REMOVAL

1. Remove the Cover Top (51), referring to the previous step [1](#).
2. Remove the Front Panel Assembly (AA), referring to the previous step [3](#).
3. Remove 9 screws (F) and then remove the Front P.C.Board (PCB4).

8 TUNER P.C.Board (PCB10) REMOVAL

1. Remove the Cover Top (51), referring to the previous step [1](#).
2. Remove 3 screws (G) and then remove the Tuner P.C.Board (PCB10).

9 SURROUND P.C.Board (PCB11) REMOVAL

1. Remove the Cover Top (51), referring to the previous step [1](#).
2. Disconnect (CNT602) from the Surround P.C.Board (PCB11).
3. Remove 2 screws (H) and then remove the Surround P.C.Board (PCB11).

10 VIDEO P.C.Board (PCB2) REMOVAL

1. Remove the Cover Top (51), referring to the previous step [1](#).
2. Remove the Surround P.C.Board (PCB11), referring to the previous step [9](#).
3. Disconnect (PC703, CP101 and CN301) from the Video P.C.Board (PCB2).
4. Disconnect (CP902) from the Sub-Woofer P.C.Board (PCB3).
5. Disconnect (CP301) from the Main P.C.Board (PCB1).
6. Remove 5 screws (I) and then remove the Video P.C.Board (PCB2).

11 SURROUND P.C.Board (PCB3) REMOVAL

1. Remove the Cover Top (51), referring to the previous step [1](#).
2. Disconnect (CP902 and CP110) from the Sub-Woofer P.C.Board (PCB3).
3. Remove 4 Screws (K) and then remove the Sub-Woofer P.C.Board (PCB3).

12 CHASSIS BACK REMOVAL

1. Remove the Cover Top (51), referring to the previous step [1](#).
2. Do Steps [2](#), [8](#), [9](#), [10](#) and [11](#).
3. Remove 15 screws (J) and then remove the Chassis Back (34).

13 MAIN P.C.Board (PCB1) REMOVAL

1. Remove the Cover Top (51), referring to the previous step [1](#).
2. Do Steps [2](#), [4](#), [8](#), [9](#) and [12](#).
3. Unsolder all leads of (Q116, Q112, Q115, Q123, Q126 and Q127) from copper track on the Input P.C.Board (PCB9).
4. Disconnect (CP103, CP109 and CP206) from the Main P.C.Board (PCB1).
5. Disconnect (CP110, CP701, CP702, CP204 and CP207) from the Input P.C.Board (PCB9).
6. Remove the flat cable from wafer (CP401) on the Input P.C.Board (PCB9).
7. Remove 5 screws (L) and then remove the Input P.C.Board (PCB9).

14 MAIN P.C.Board (PCB1) REMOVAL

1. Remove the Cover Top (51), referring to the previous step [1](#).
2. Do Steps [2](#), [8](#), [9](#), [10](#), [11](#) and [12](#).
3. Unsolder all leads of (Q216L/R, Q217L/R and Q213L/R) from copper track on the Main P.C.Board (PCB1).
4. Disconnect (CP201, CP202, CP203, CP204, CP206, CP207H and CP207T) from the Main P.C.Board (PCB1).
5. Remove 6 screws (N) and then remove the Main P.C.Board (PCB1).

CIRCUIT DESCRIPTION

CPU (4 bit CMOS MICROPROCESSOR : CXP50116-530Q)

1. Pin Description & Block Diagram

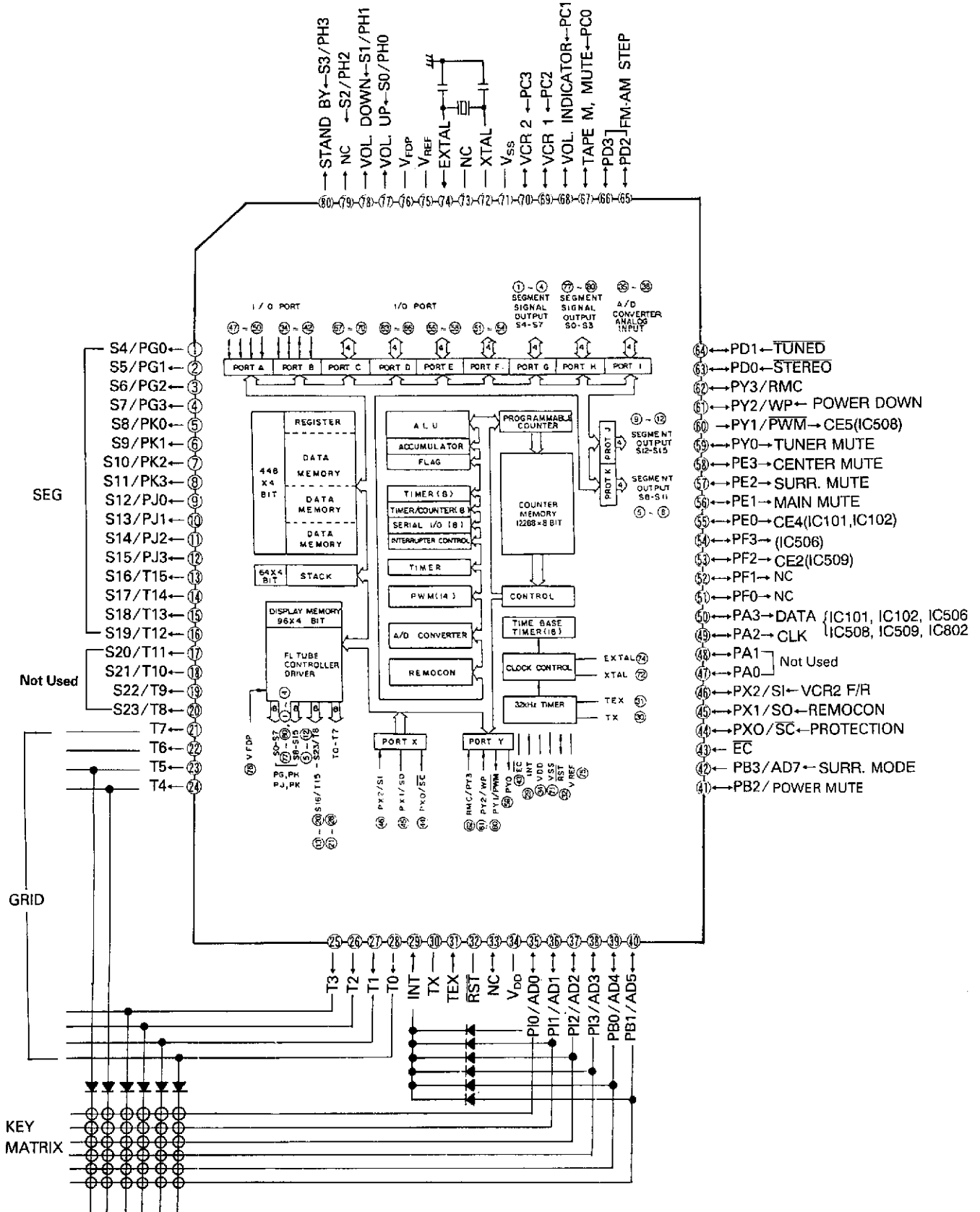

2. Input and Output Terminal Functions

Code	Function
S4/PG0-S19/T12	These are segment signal output pins of FL controller/driver.
S20/T1-S23/T8	Not used
T7-T 0	These are timing signal output pins of FL controller/driver and key scan pins.
INT	This is external interrupt dedicated pin.
TX, TEX	Not used
RST	This is the system reset of the device.
NC	No connection
V _{DD}	This is the power supply pin.
PI0/AD0-PB1/AD5	These are the key input pins.
PB2/AD6	This is the power mute output pin.
PB3/AD7	This is the channel mode control pin of surround mode.
EC	Not used.
PX0	This is the protection input pin.
PX1	This is the remote control input pin.
PX2	This is the VCR2 front and rar input control pin.
PA0	Not used.
PA1	Not used.
PA2-PA3	These are used to control the PLL IC, analog switching IC. Shift register IC, volume IC, delay IC. (CLK, DATA)
PF0	This is the FM mode colntrol pin.
PF1	This is used to control the PLL IC.
PF2	This is used to control the shift register IC.
PF3	This is used to control the volume IC.
PE0	This is used to control at analog switching IC.
PE1	This is the main mute output pin.
PE2	This is the surround mute output pin.
PE3	This is the center mute output pin.
PY0	This is the tuner mute output in.
PY1	This is used to control the delay IC.
PY2	This is the power down pin.
PY3	Not used.
PD0	This is the tuner stereo input pin.
PD1	This is the tuner tuned input pin.
PD2-PD3	These are used to control FM and AM step.
PC0	This is used to eliminate the noise of the PLL IC in the Tape 2 Monitor mode.
PC1	This is used to control volume indicator.
PC2	This is used to control VCR1
PC3	This is used to control VCR2
V _{SS}	This pin provides the ground potential.
XTAL, EXTAL	These pin serve for connecting a clock oscillator crystal.
NC	No connection.
V _{REF}	Not used.
V _{FDP}	This is the power supply pin of the FL controller.
PH0-PH1	These are used to control the motor volume.
PH2	Not used.
PH3	This is used to control stand-by mode.

3. Key Matrix

Pin No.	35	36	37	38	39	40
22	4	9	CD	O	5	PHONO
23	VCR1	VCR2	TV	T2M	T1	TUNER
24		VCR1 REC	SURR MODE	MEMORY		SCAN
25	▼	▲	FM MODE	AUTO MANUAL	FM	AM
26	2	6	3	2	7	8
27				POWER		
28	DELAY TIME		TEST TONE		CENTER MODE	

4. Digital Tuning System Description

Digital Turing System

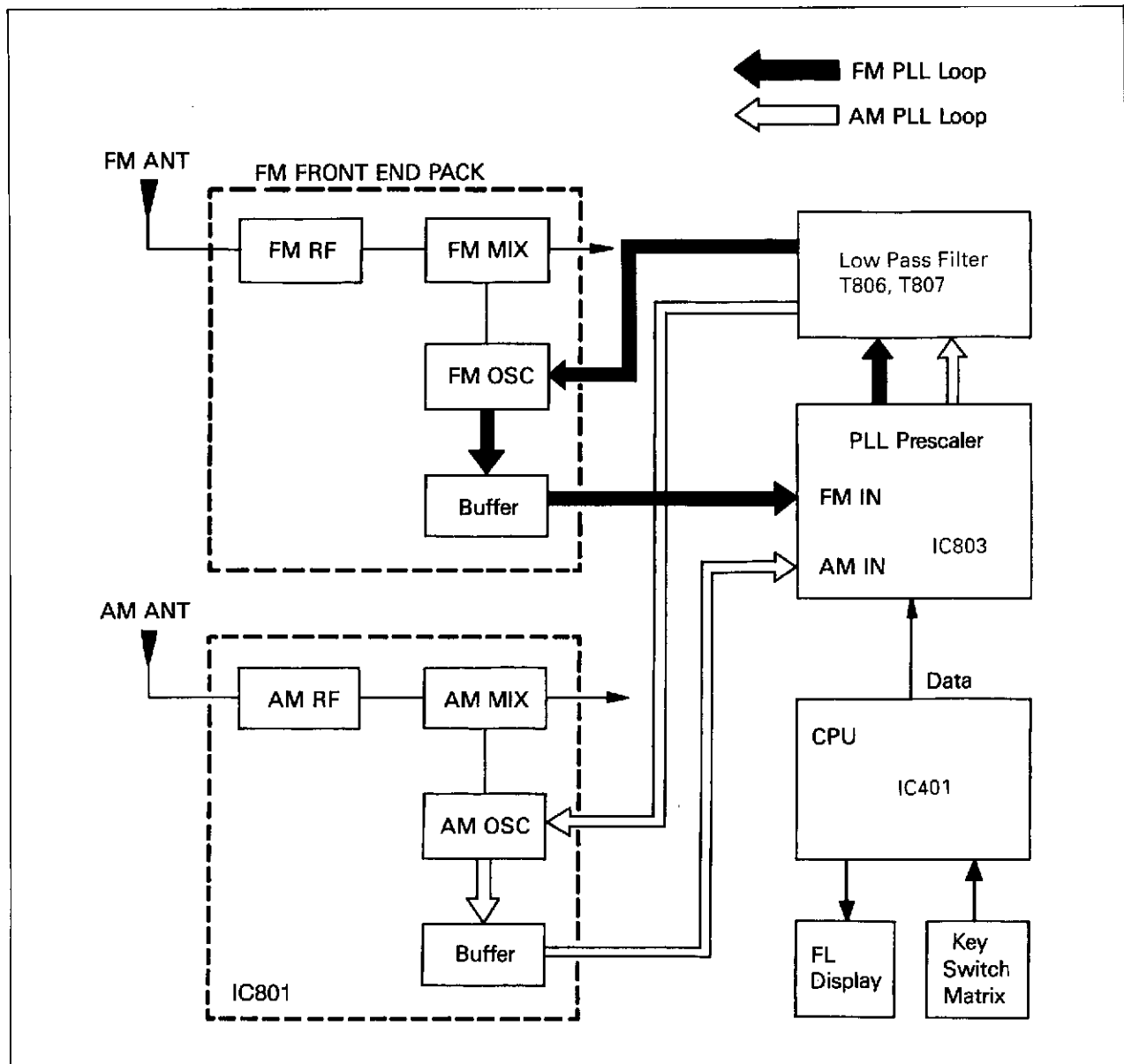

- Vco vs. FM Band Frequency Curve

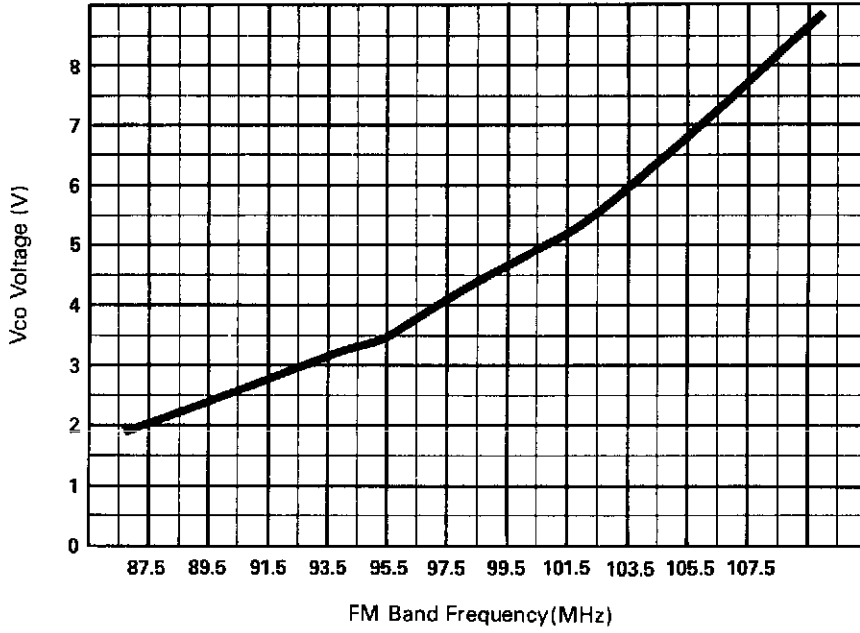

- Vco vs. AM Band Frequency Curve

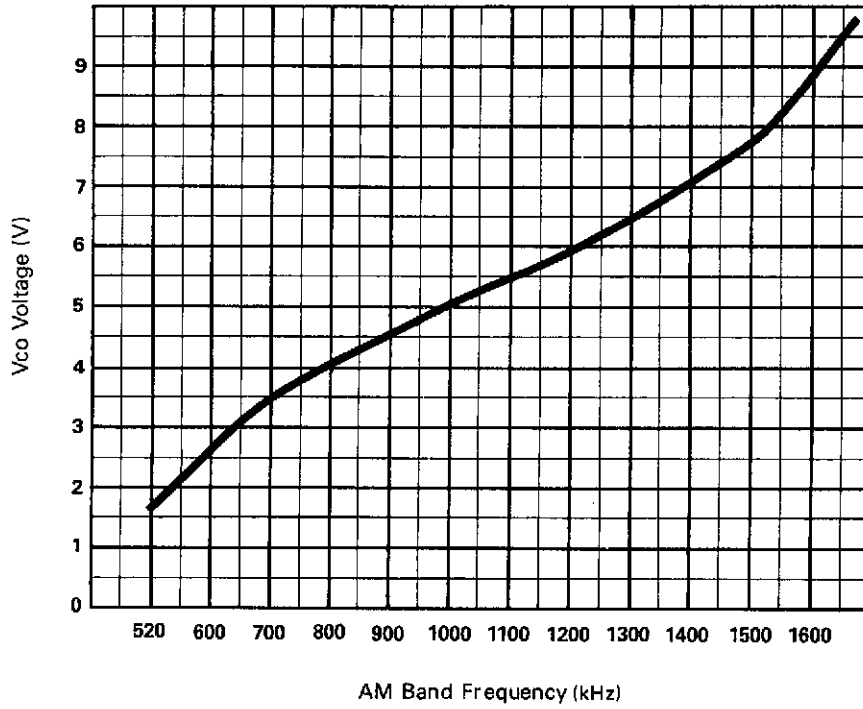

5. Protection Circuits

Speaker Protection Circuit

The CPU protects both this unit and the speakers when an abnormally high current flows in Q216 L/R and Q217 L/R due to excessive input drive, too low of a load impedance, or short of the speaker terminals. If current increase is excessive, the voltage across R245 L/R or R246 L/R turns on Q218 L/R, then Q219 turns on Q221.

It makes the protection port of the CPU to low state. Then the power is turned off.

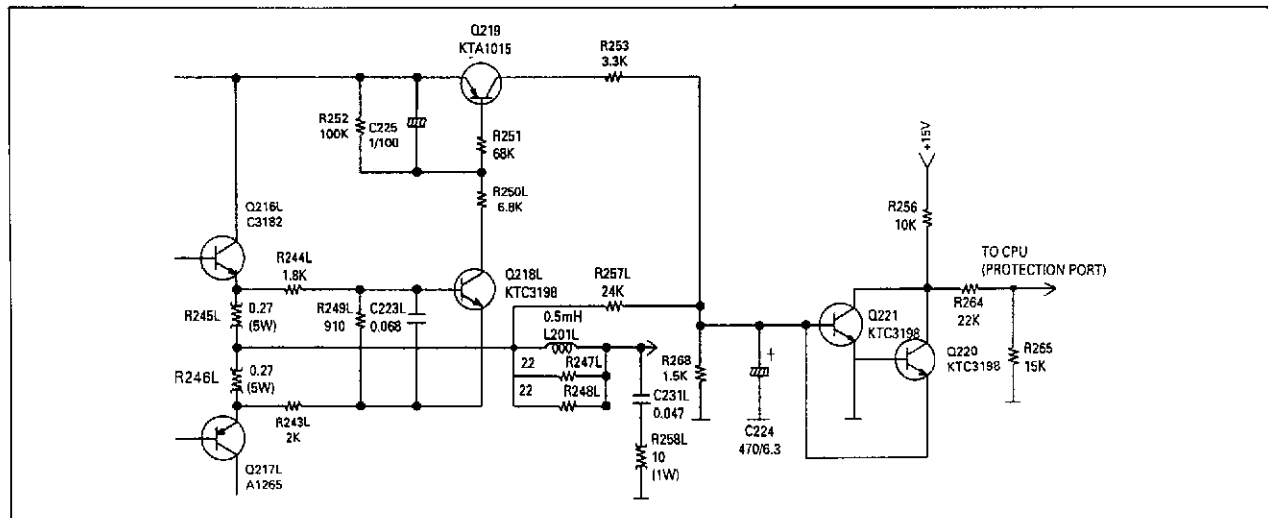

Thermal Protection Circuit

This receiver has a overload thermal protection circuits to guard against abnormal operation.

When the temperature of TRANS POSISTOR installed with the main transformer or H/SINK POSISTOR rises abnormally, the resistance of the posistor becomes larger and Q221 is turned on.

It makes the protection port of the CPU to low state. Then the power is turned off.

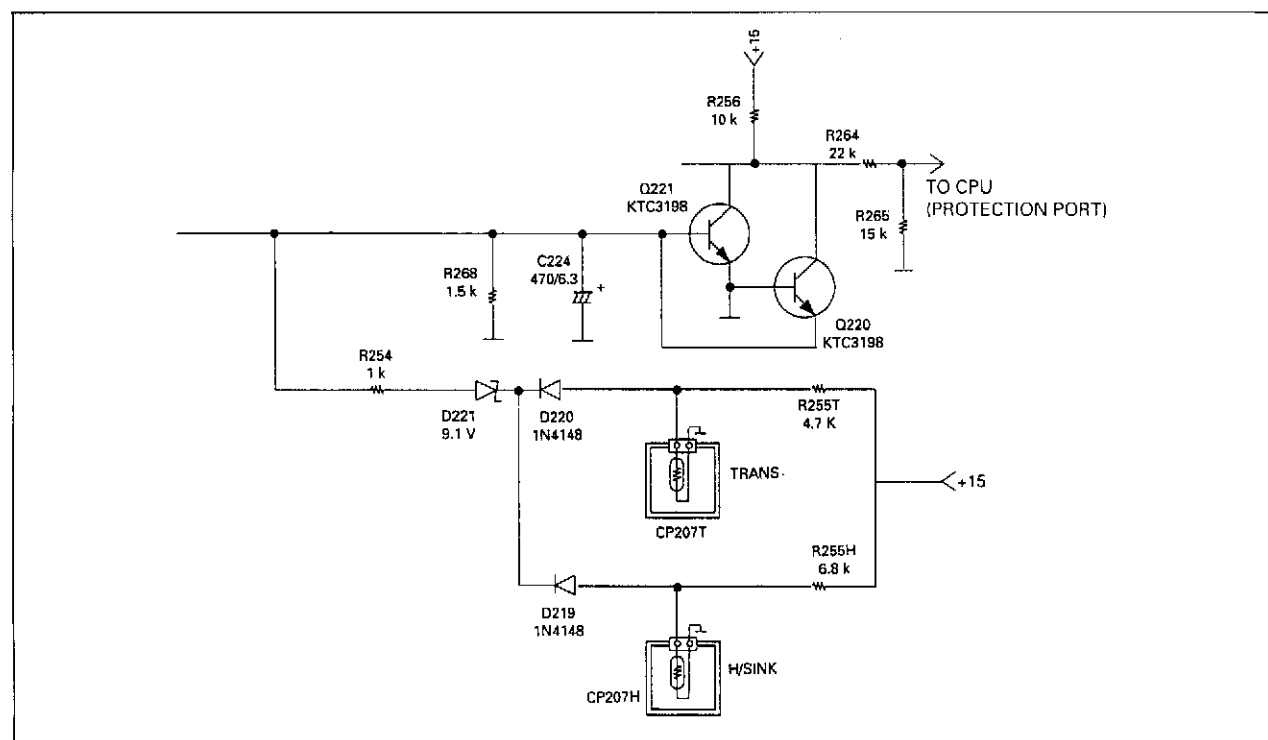

ALIGNMENT PROCEDURES

1. Equipment Required

- AM Standard Signal Generator (AM SSG)
- Oscilloscope
- AC Voltmeter
- FM Standard Signal Generator (FM SSG)
- Stereo Modulator
- Audio Generator
- Distortion Meter
- DC Voltmeter
- Frequency Counter

Note : Disconnect external FM antenna prior to alignment.

2. Alignment and Test Points (PCB10)

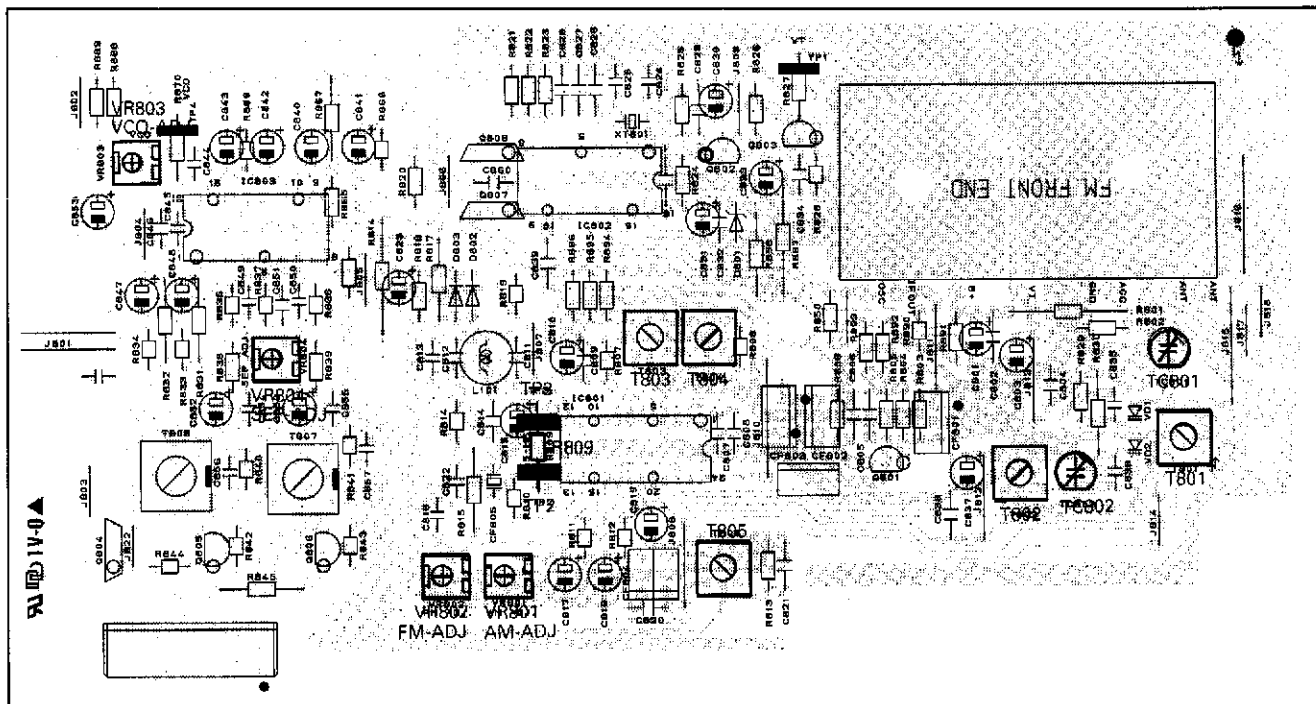

3. AM IF and RF Alignment

Preparation

1. Output of Signal Generator should not be higher than necessary to obtain an optimum output reading.
2. Signal Generator Modulation: 30%.
3. Switch: Press to AM.

Step	Signal Generator Frequency	Receiver Frequency on the Display	Equipment Connection	Adjustment Point	Adjust for
1	999 kHz (400 Hz, Mod.)	522 kHz	DC Voltmeter TP1	T802	1.2 V reading
		1611 kHz	DC Voltmeter TP1	TC802	8.5 V reading
2	594 kHz (400 Hz, Mod.)	594 kHz	AC voltmeter to TAPE OUT jack.	T801 (ANT Coil)	Maximum reading
3	1404 kHz (400 Hz, Mod.)	1404 kHz	AC voltmeter to TAPE OUT jack.	TC801 (ANT Trimmer)	Maximum reading

4	450 kHz (400 Hz, Mod.)	999 kHz	AC voltmeter to TAPE OUT jack.	T805 (IFT)	Maximum reading
5	999 kHz (400 Hz, Mod.)	999 kHz	Same as Step 1.	VR801	FL display 'TUNED' Indication on receiver with AM SSG Output level of 800 μ V/m

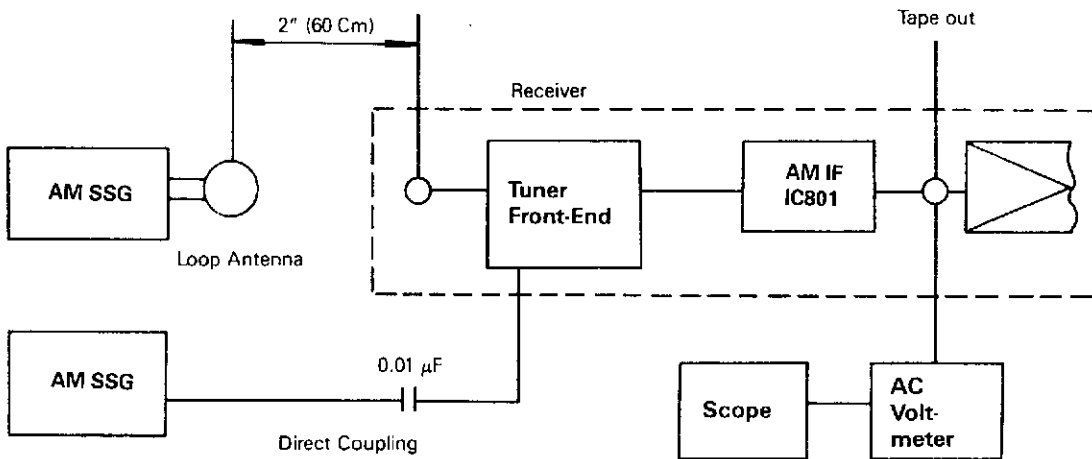

AM Alignment Connection

4. FM IF Alignment

Preparation

1. Signal Generator output should be no higher than necessary to obtain an optimum output reading.
2. Switch Press to FM.
3. Signal generator deviation : 40 kHz.

Step	Signal Generator Frequency	Receiver Frequency Display	Equipment Connection	Adjustment Point	Adjust for
1	98.0 MHz (1 kHz, Mod.)	98.0 MHz	DC Volt meter to R809 (PCB10)	T803	Zero reading on DC volt meter.
2	98.0 MHz (1 kHz, Mod.)	98.0 MHz	Distortion meter to TAPE OUT jack	T804	Minimum distortion
3	98.0 MHz (1 kHz, Mod.)	98.0 MHz	Same as Step 1	VR802	FL display 'TUNED' Indication on receiver with FM SSG output level of 10 μ V/m

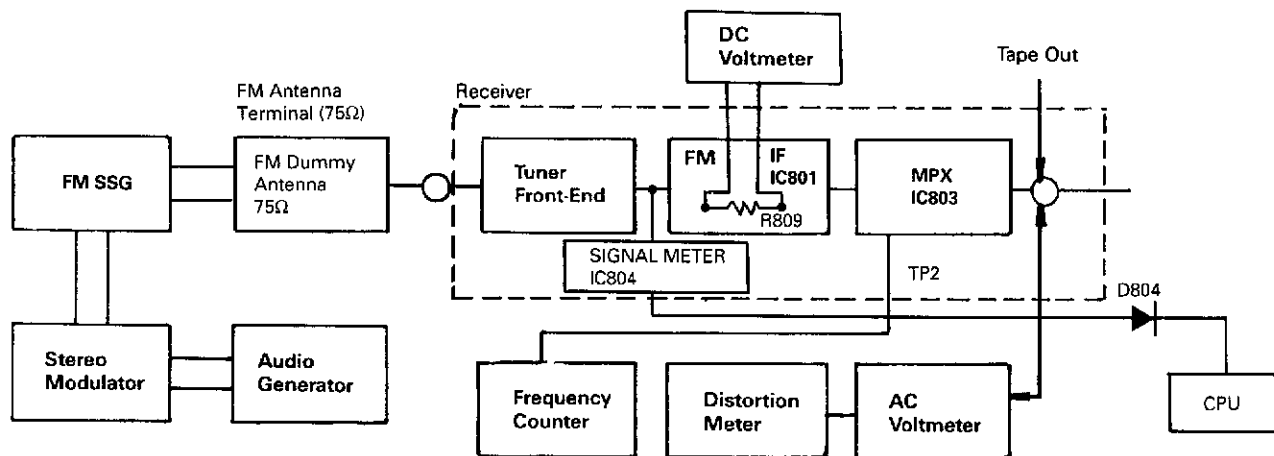

FM RF/IF and MPX Alignment Connection

5. MPX Alignment, SM Alignment Preparation

1. Switch : Press to FM.
2. Tuner for 98 MHz on band.
3. Signal Generator output level : 1000 μ V.
4. Deviation : 40 kHz, at 100% modulation of composite signal.
5. Connect Signal Generator to FM antenna terminal through FM dummy antenna (75 Ω).

Step	19 kHz Modulation Level	Signal Generator Frequency Setting	Equipment Connection	Adjustment Point	Adjust for
1	Pilot off	Carrier only	Frequency counter connect to TP2 (HOT) of PCB and ground	VR803	76 kHz
2	8% Mod.	Composite to channel 1kHz R	AC voltmeter to TAPE OUT jack of R channel	-	Adjust for about 450mV of audio output
3	8% Mod.	Composite to channel 1 kHz L	AC voltmeter to TAPE OUT jack of R channel	VR804	AC voltmeter reading should be at least 40 dB below.
4	8% Mod.	Composite to channel 1 kHz R	AC voltmeter to TAPE OUT jack of L channel	VR804	Same as Step 3.
5	8% Mod.	Composite to channel 1 kHz L or R	AC voltmeter to TAPE OUT jack Lor R channel	VR805	FL display 'SIG 60 dB' indication on receiver with FM SSG output lenel of 1000 μ V/m

If you could not obtain -40dB readings in Steps 3 and 4 (compared with Step 2), readjust VR804 until you obtain -40dB readings for both Steps 3 and 4. Nominal is -45 dB.

TROUBLESHOOTING

Symptom	Cause and Remedy
Receiver inoperative (FL indicator does not light)	<p>A) Faulty AC power cord. Replace.</p> <p>B) Defective the power switch. Replace.</p> <p>C) Broken wire in the power transformer. Replace the power transformer.</p> <p>D) Blown fuse. Replace the fuse.</p>
Fuse blows when power is turned on.	<p>A) Defective power transformer. Replace.</p> <p>B) Short on the primary or secondary of the transformer circuitry. Repair the trace.</p> <p>C) Damaged rectifier (D208 to D211) or damaged transistor (Q216 to Q217). Replace the defective component(s).</p> <p>D) Short circuit in the amplifier circuit. Replace the shorted component(s) in the amplifier circuit.</p>
Power indicator lights but no sound from both channels	<p>A) Speaker switch 1 or 2 defective. Replace the defective switch (es)</p> <p>B) Defect in transistor Q216 L/R, Q217 L/R on the Main Amp Board. Replace the defective component(s).</p>
Speaker A inoperative	<p>A) Speaker switch A defective. Replace</p>
Speaker B inoperative	<p>A) Speaker switch B defective. Replace.</p>
One channel does not work when Volume is at maximum with a test signal applied to the center terminal of Volume control VR5 of the dead channel	<p>A) Defect in transistor Q216 L/R, Q217 L/R on the Main Amp Board Locate and correct the defect.</p> <p>B) Break in copper foil of printed circuit board. Repair the circuit trace.</p> <p>C) Short in speaker output terminal. Repair or replace.</p>
Speaker works normally but headphones inoperative	<p>A) Headphone plug does not mate with jack. Replace the jack.</p> <p>B) Defective resistor R901, R902. Replace.</p>
PHONO input inoperative	<p>A) Poor contact in phono input jack. Repair or replace the jack.</p> <p>B) Defective phono switch or IC103. Replace.</p>
LOUDNESS has no effect	<p>A) Defective loudness switch. Replace.</p> <p>B) Defective resistor R601, R602, C601, C602. Replace the defective components(s).</p>
FM inoperative	<p>A) Defective front-end. (FE407-G60) Replace.</p> <p>B) Defective FM switch. Replace the switch</p>

Symptom	Cause and Remedy
FM inoperative	<p>C) Defective transistor Q801, Q805, Q806, IC801, IC803 Replace the defective transistor(s) or IC(s).</p> <p>D) Defective coil T803 or T804 Replace the coil(s).</p> <p>E) Defective lead-in. Repair or replace the lead-in.</p> <p>F) Ceramic filter CF801, CF802, CF803 defective. Replace the defective ceramic filter(s).</p> <p>G) Defective controller circuit component. Replace.</p>
Poor multiplex separation	<p>A) Improper adjustment. Readjust VR803 and VR804. (Refer to MPX Alignment.)</p> <p>B) IC803 defective. Replace.</p> <p>C) Variable resistor VR803 or VR804 defective. Replace the variable resistor(s).</p>
STEREO indicator does not light	<p>A) Defective indicator in FL. Replace.</p> <p>B) Improper adjustment of VR803 of tuner board. Make readjustment.</p> <p>C) Defective IC803 Replace the defective component.</p>
FM volume not sufficient	<p>A) If volume from both L and R channels is not loud enough : Front end Section defective. Faulty IC801, Coil T803, Defective C838 of tuner Board. If sound of one channel is not loud enough: Defective T806, T807</p>
FM Mono has no effect	<p>A) Defective FM MODE switch. Replace.</p>
AM inoperative	<p>A) Damaged IC801 of tuner board. Replace.</p> <p>B) Defective T801, T802, T805 or CF804 of tuner board. Replace the defective component(s).</p> <p>C) Resistor R829, R817 defective. Replace the defective component(s).</p> <p>D) Capacitor C836, C818, C813 defective. Replace the defective capacitor(s).</p> <p>E) Defective AM switch Replace.</p> <p>F) Defective varicap diode VD1, VD2 Replace varicap diods(s).</p> <p>G) Damaged AM loop antenna. Repair or replace.</p> <p>H) Defective controller circuit component. Replace.</p>
Bass control has no effect	<p>A) Variable resistor BASS defective. Replace.</p> <p>B) Defective R709L/R, R710L/R, C702 L/R, C708 L/R Replace the defective component(s).</p>

Symptom	Cause and Remedy
Treble control has no effect	A) Variable resistor TREBLE defective. B) Defective R711 L/R, R712 L/R, C709 L/R, C710L/R Replace the defective components(s).
Auto tune inoperative (UP/DOWN)	A) Poor contact in Up/Down key. Repair or replace. B) Defective IC401 Replace. C) Defective FL401. Replace. D) Defective tuner circuit component. Replace. E) In case of FM only, improper adjustment of FM front-end. Readjust.
Manual tune inoperative (UP/DOWN) (AM or FM)	A) Poor contact in Up/Down key. Replace. B) Defective IC401. Replace.
Memory setting (keys 1-10) inoperative	A) Poor contact in memory keys 1-10. Replace. B) Poor contact in memory set key. Replace. C) Defective IC401. Replace the defective component.
FL inoperative	A) FL defective. Replace. B) Defective IC401. Replace C) Defective X401. Replace.
Noise Volume control	A) Defective IC603. Replace. B) Defective capacitor C615 or C616. Replace the defective capacitor(s).
Remote Control Unit inoperative	A) Weak Battery. Replace. B) Defective. Replace. C) Defective IC401(CPU Board) or IC01. Replace.

GENERAL UNIT PARTS LIST

Ref. No.	Description	Mfr. Part No.	Q'ty	Version
CABINET AND CHASSIS				
1	Knob, Volume	048543059611	1	
2	Indicator, Volume	8555048610	1	
3	Knob, Rotary	048545124311	3	
4	Panel, Front	048501033612	1	
5	Window, Display	8553019710	1	
6	Filter	048555048511	1	
7	Button, Power	048545124011	1	
8	Button, Preset	048543059611	1	
9	Switch, Tact	4658003710	32	
10	Indicator, Power	8555048710	1	
11	Jack, Phone	4438005020	1	
12	Switch, Push	4626043610	2	
13	Shield, Fence, knob	6165147910	1	
14	Button, Speaker	048545124111	2	
15	Button, Function	048543059911	1	
16(SW433)	Switch, Push	4628054410	1	
17	Volume, Bass/Treble	3208049510	2	
18	Volume, Balance	3208052010	1	
19	Shield Fence	6165148410	1	
20	Jack, RCA, 3P, VCR	4438109710	1	
21	Button, Loud	048545124211	1	
22	Switch, Loud	4628059610	1	
23	Volume, Motor	3228019410	1	
24	Bracket, Volume	6505138410	1	
25	Button, Tuning	048543059711	2	
26	Foot	6033102510	2	USA/CANADA
(27)	Foot, Hot-stamping	046033102511	2	USA/CANADA
27	Foot, Hot-stamping	046033102511	4	EUROPE
28	Frame, Cover	6123205210	1	
29	Cover, Bottom	6122418120	1	
30	Bracket, PCB	6505111710	2	
31	Frame, Right	6122636410	1	
32	Jack, RCA, 4P	4438108110	1	
33	Terminal, Antenna	4408108210	1	
34	Chassis, Back	046102044251	1	EUROPE
(34)	Chassis, Back	046102044211	1	USA/CANADA
35	Jack, RCA, 6P	4438103210	1	
36	Frame, Center	6123205110	1	
37	Bracket, Jack	6505138510	1	
38	Terminal, Speaker, 4P	4408106410	1	
39	Jack, Multi	4438006510	2	
40	Jack, RCA, 2P	4438109310	2	
41	Jack, RCA, 1P	4438113810	1	
42	Bracket, Heatsink	6505135010	1	
43	Heatsink, Power	7502008510	1	
44	Heatsink, Regulator TR.	7505206220	1	
45	Heatsink, Regulator TR.	7505206120	2	
46	Bracket, PCB	6505134910	2	
47	Terminal, Speaker, 8P	4408105810	1	
49	Frame, Left	6121608930	1	
50	Chassis, Front	6122214510	1	
51	Cover, Top	046122022421	1	
52	Stopper, AC Cord	6518002320	1	EUROPE
(52)	Stopper, AC Cord	6518002310	1	USA/CANADA
53	Cord, AC Power	4408001430	1	EUROPE
(53)	Cord, AC Power	4408001410	1	USA/CANADA
54	System Ground	4408103710	1	
55	Jack, RCA, 4P	4438103410	2	
56	Heatsink, Regulator TR.	7505202410	4	
57	Jack, RCA, 4P	4438103110	1	
58	Jack, RCA, 6P	4438108010	1	
59	Terminal Speaker, 2P	4408108710	1	
60	Jack, RCA, 2P	4438111310	1	
HARDWARE KIT				
S1	Screw, #2BTC 3x8 (B)	8109230083	25	
S2	Screw, #1PT 3X10B	8119130103	18	
S3	Screw, #2BTC 3x8 (Y)	8109230081	7	
S4	Screw, #2WPTC 3x8 (B)	8159230081	38	
S5	Screw, #HEX MSPW 3x12	8099130121	12	
S6	Screw, WSAM 4X8B	8159440083	10	
S7	Screw, #2BTC 3x8 (B)	8109230083	18	
S8	Screw, Ground	8155000710	4	
MISCELLANEOUS				
TRANS	Power Transformer, 230V 50Hz	2828100257	1	EUROPE
(TRANS)	Power Transformer, 120V 60Hz	2828009981	1	USA/CANADA
	Ass'y Posistor	052438012202	2	
	Card Cable, 25P, 210mm	4118525215	1	

PRODUCT SAFETY NOTICE

Each precaution in this manual should be followed during servicing. Components identified with the IEC symbol Δ in the part list are of special significance to safety. When replacing a component identified with Δ , use only the replacement parts designated, or parts with the same ratings of resistance, wattage or voltage that are designated in the parts list in this manual. Leakage-current or resistance measurements must be made to determine that exposed parts are acceptably insulated from the supply circuit before returning the product to the customer.

GENERAL UNIT

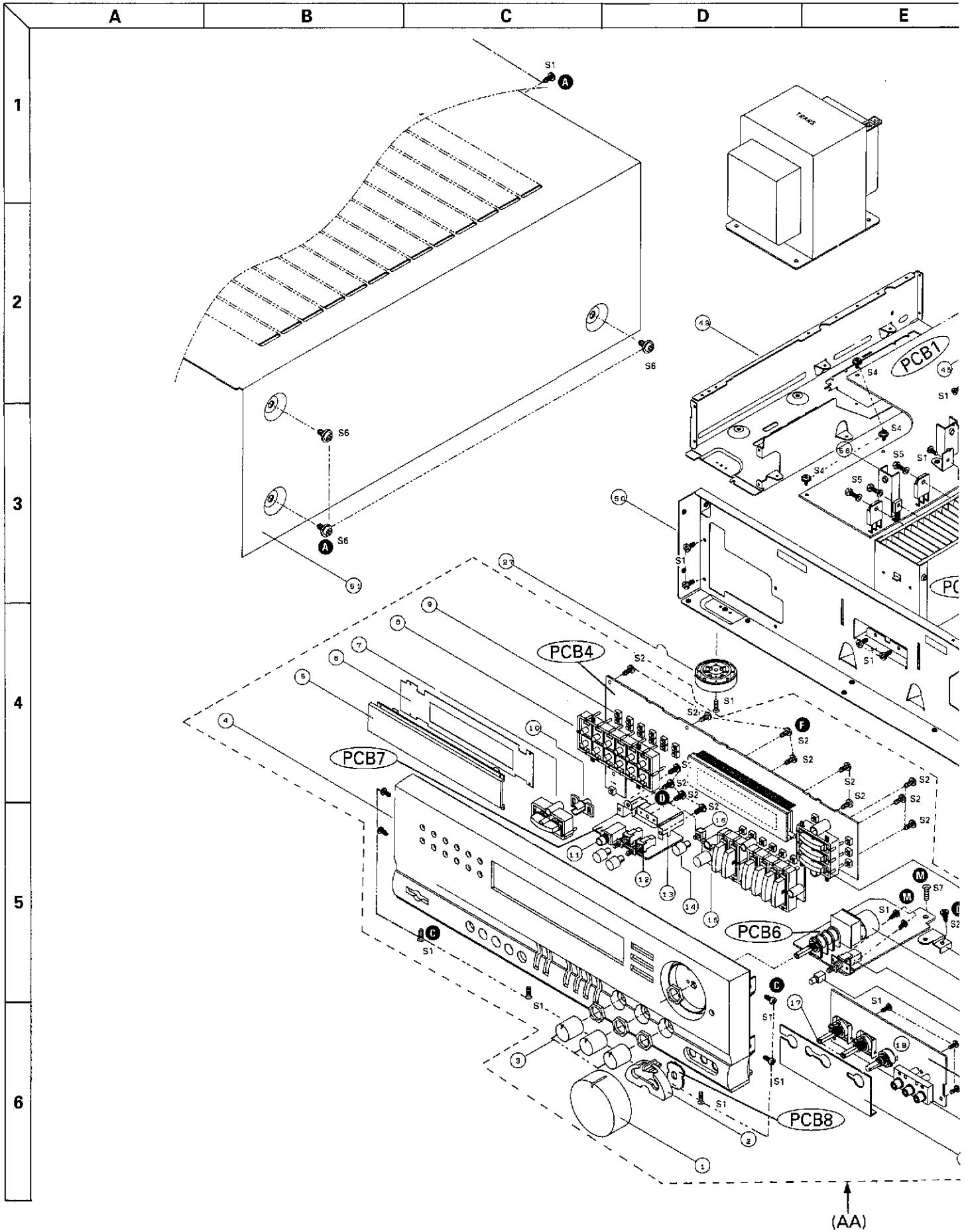

E

F

G

H

I

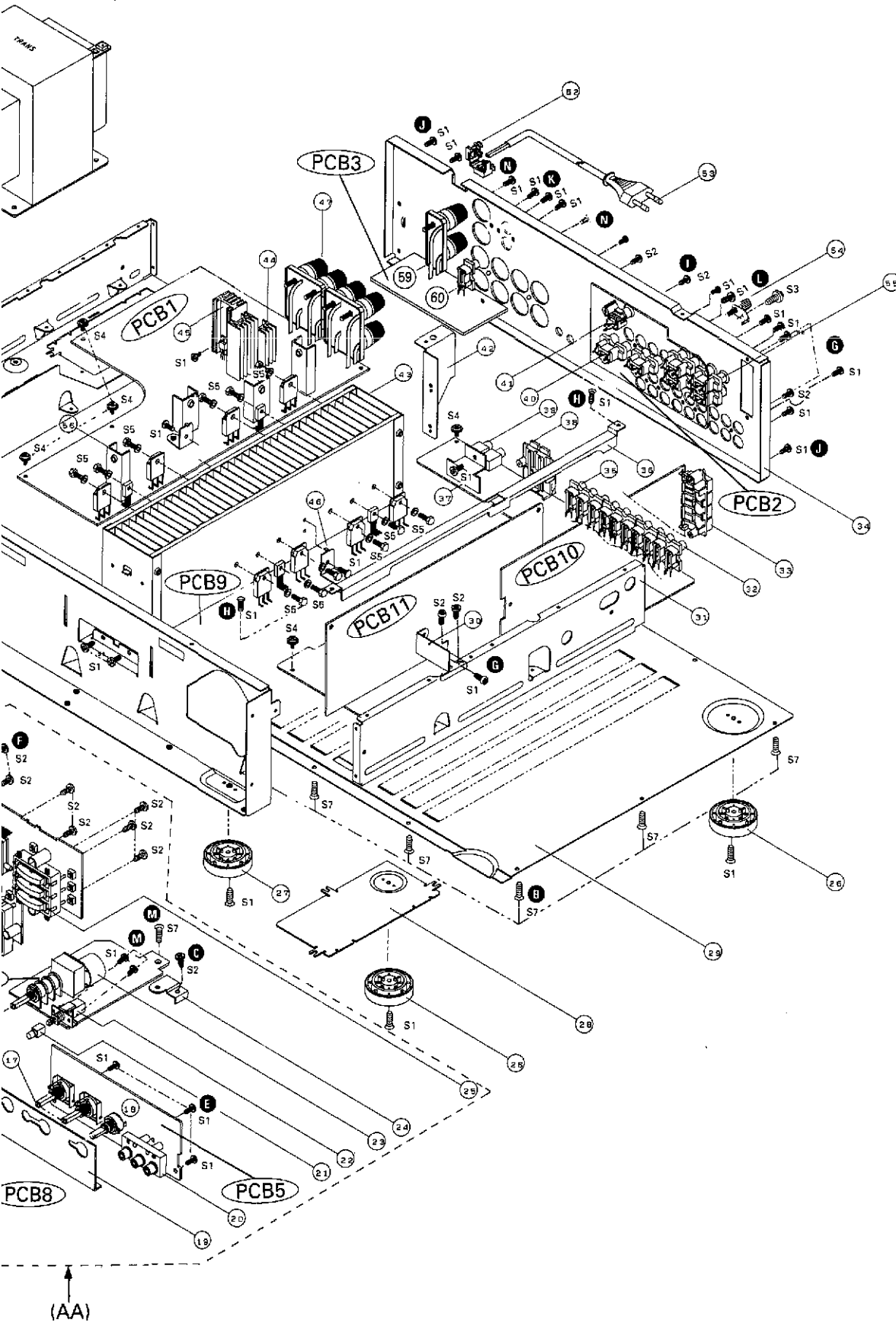

PRINTED CIRCUIT BOARDS

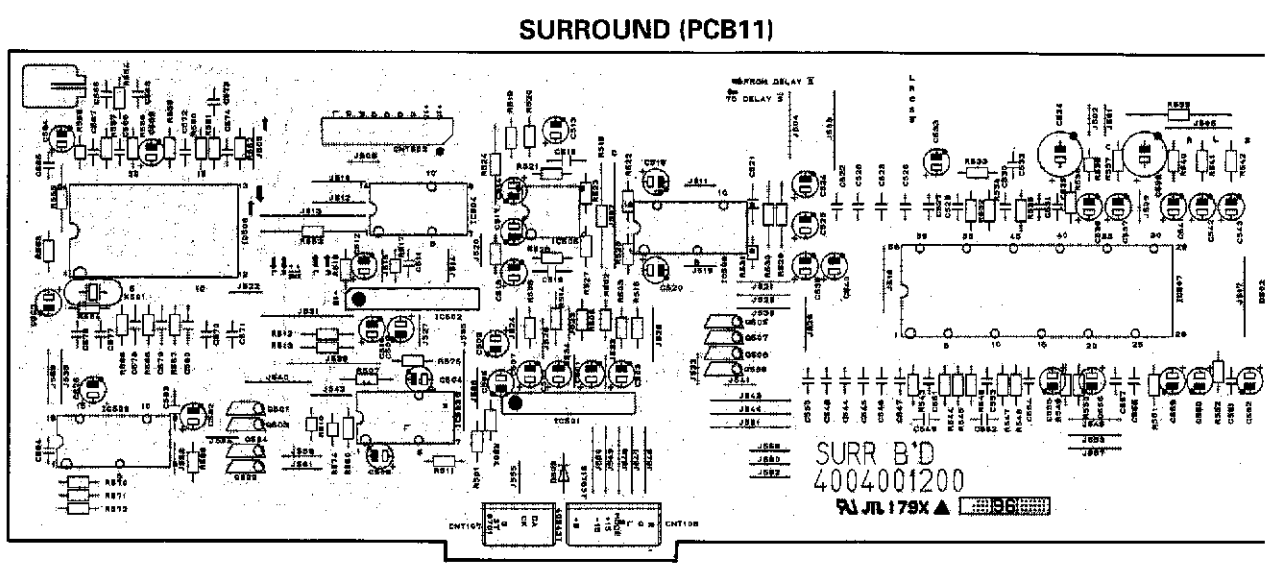
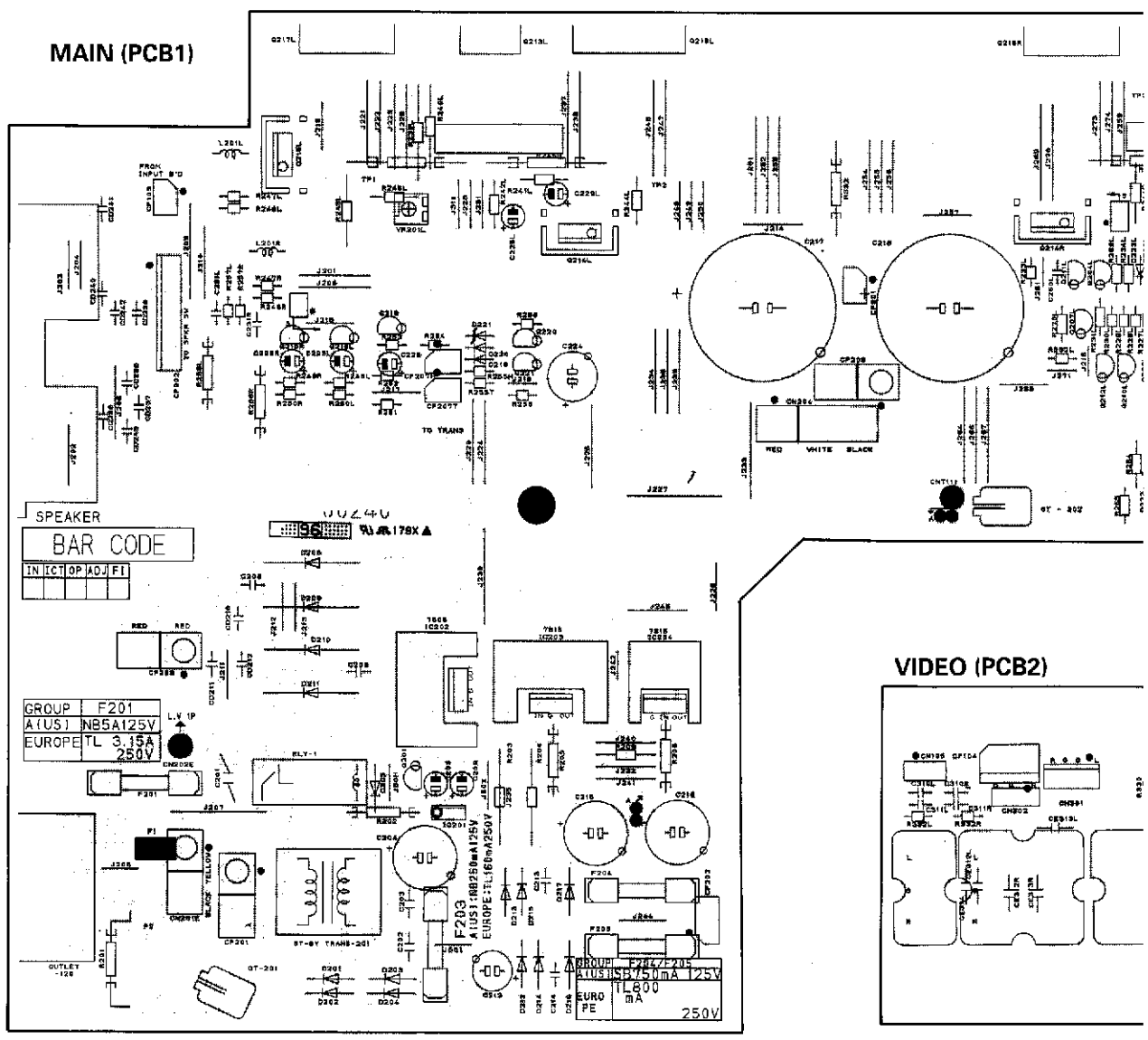

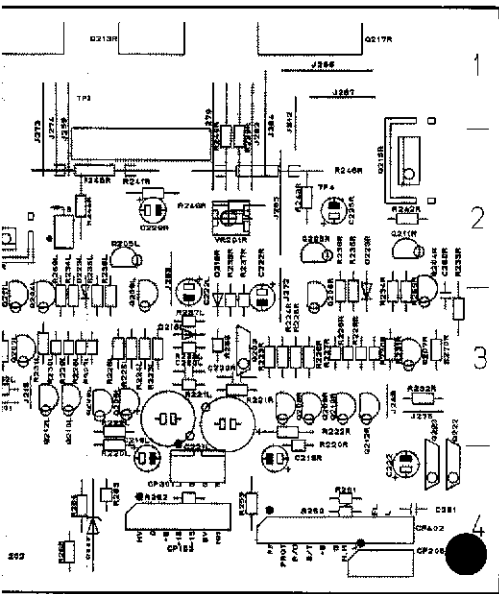

VOLUME (PCB6)

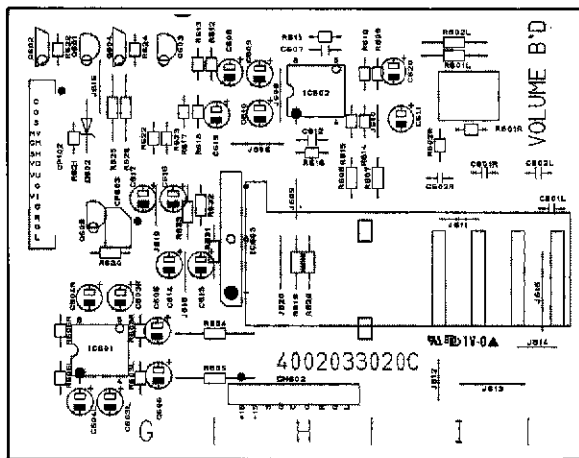

SPEAKER SEL. (PCB7)

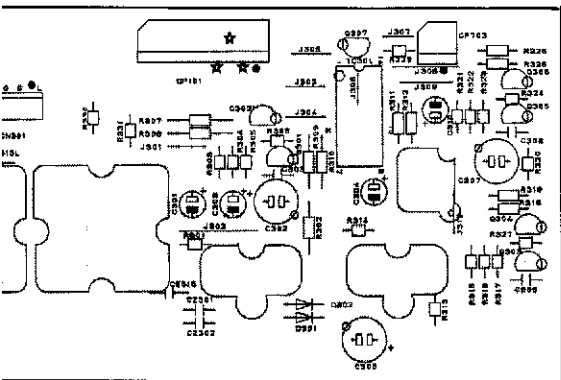
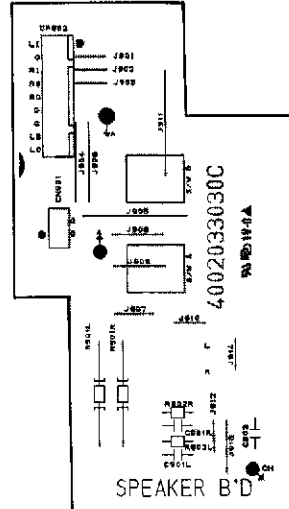

TONE (PCB5)

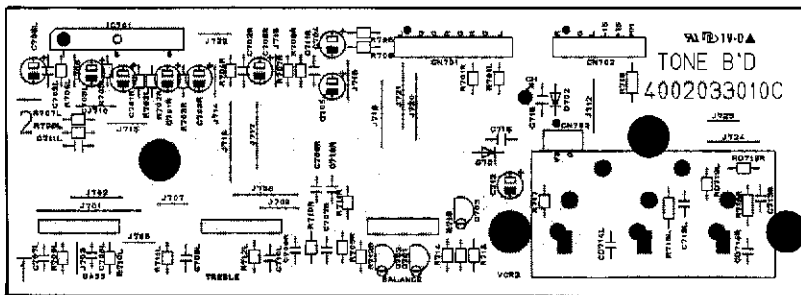

TUNER (PCB10)

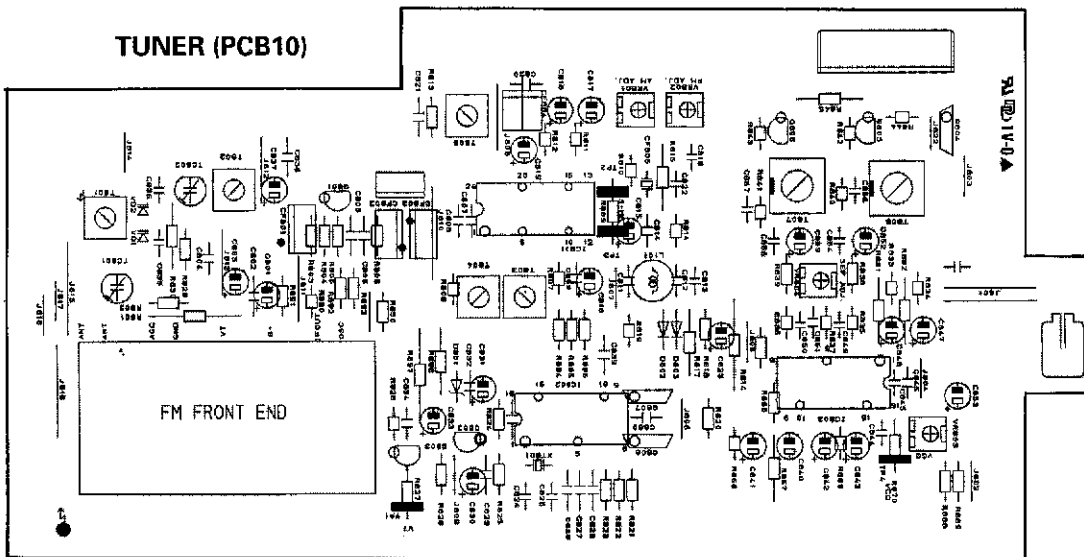

FRONT (PCB4)

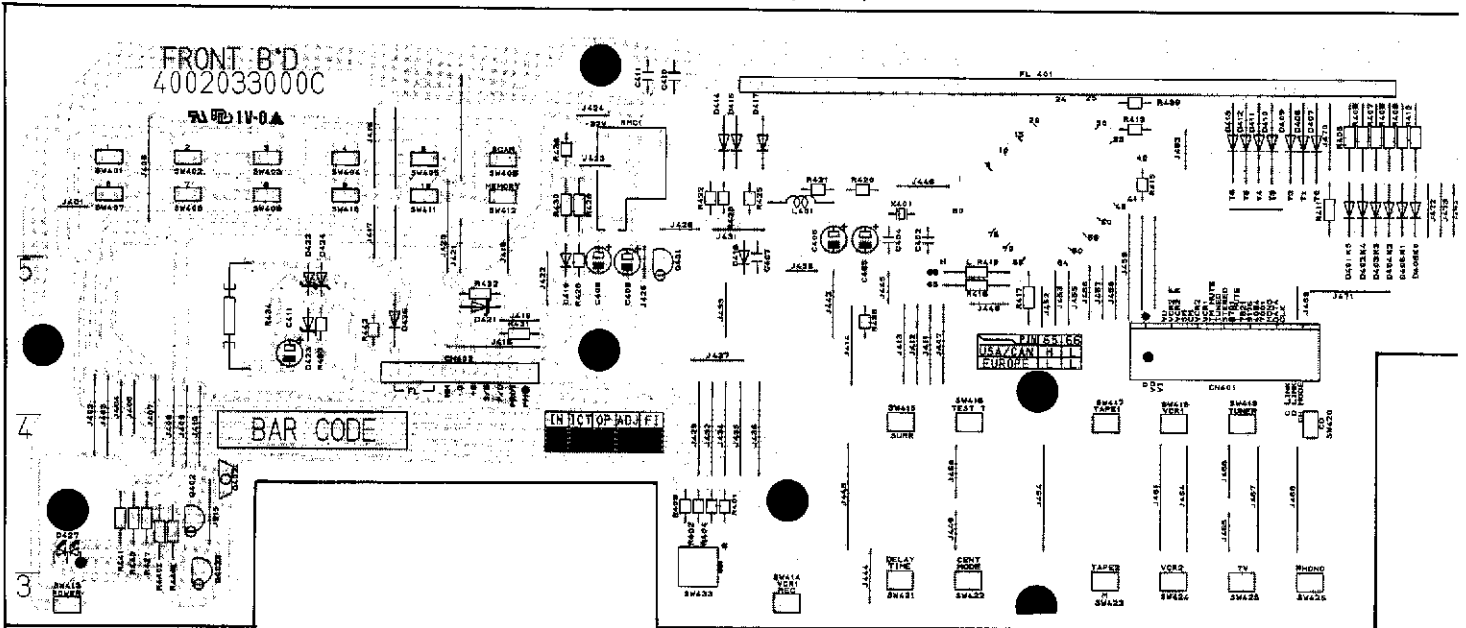

VOLUME LED (PCB8)

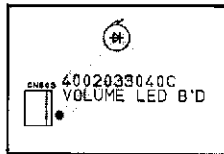

INPUT (PCB9)

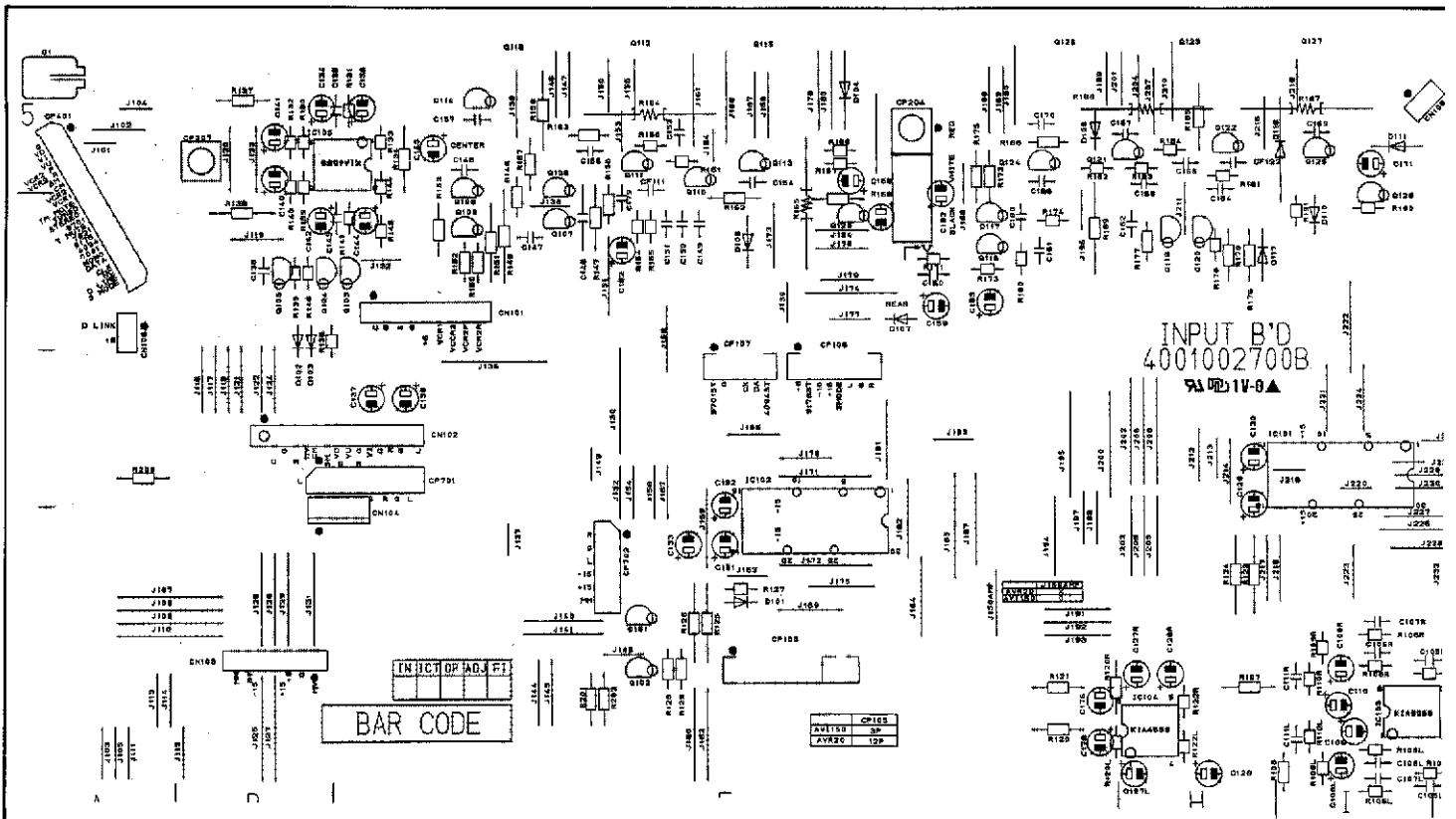

ELECTRICAL PARTS LIST

PRODUCT SAFETY NOTICE : Products marked with Δ have special characteristics important to safety. If you replace any of these components, read carefully the product safety notice in this manual.
 Don't degrade the safety of the product through improper servicing.
 Resistor/Capacitor tolerance - D : ($\pm 0.5\%$), J : ($\pm 5\%$), K : ($\pm 10\%$), M : ($\pm 20\%$), Z : +80, - 20%)

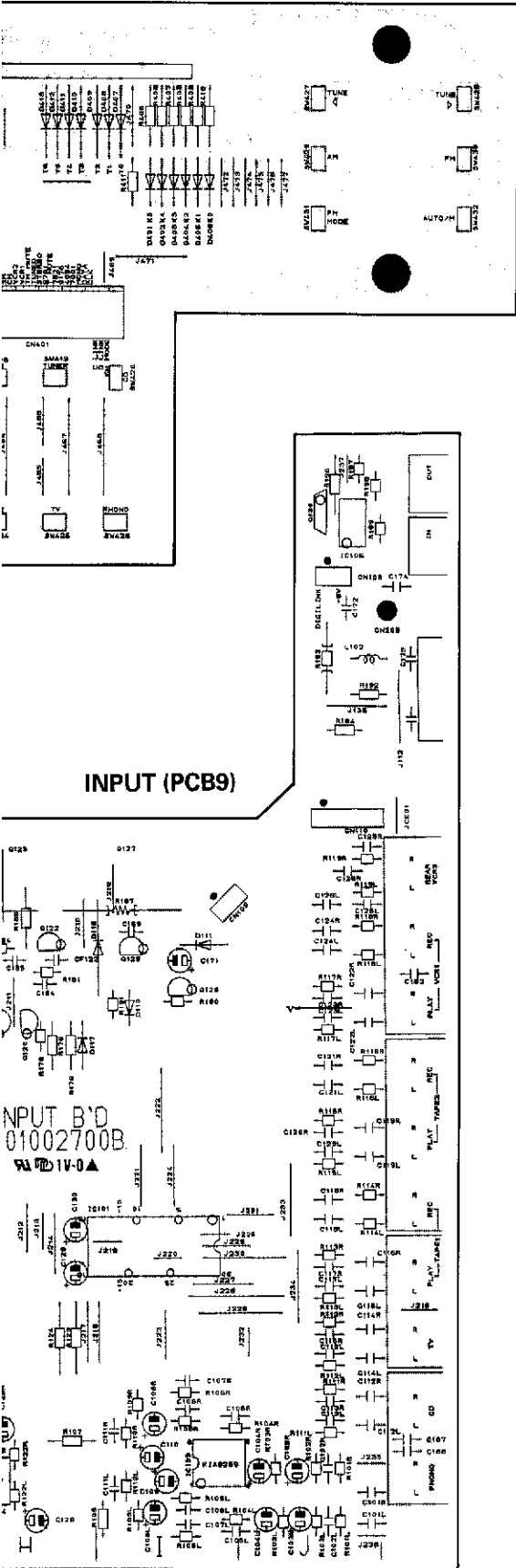

Ref. No.	Description	Mfr. Part No.	Q'ty	Version
PCB9 ASSEMBLY P.C. BOARD MAIN				
CAPACITORS				
C201	Ceramic Disc	0.0047 uF 400 V K	3548472340	1
C202/203	Mylar	0.047 uF 100 V J	3679473120	2
C204	Electrolytic SG	470 uF 16 V M	3479347139	1
C206	Electrolytic SG	22 uF 50 V M	3479322071	1
C208/209	Mylar	0.1 uF 250 V J	3679104257	2
C212	Ceramic Tubular	100 pF 35 V K	3519101935	1
C213/214	Mylar	0.047 uF 100 V J	3679473120	2
C215/216	Electric SG	1000 uF 35 V M	3409310268	2
C217/218	Electrolytic HM	8200 uF 63 V M	3419582235	2
C219L/R	Electrolytic SG	47 uF 25 V M	3479347041	2
C220L/R	Electrolytic SG	100 uF 50 V J	3479310171	2
C221L/R	Electrolytic SG	470 uF 10 V M	3479347121	2
C222	Electrolytic SG	10 uF 50 V M	3479310071	1
C222L/R	Electrolytic SG	1 uF 50 V M	3479310971	2
C223L/R	Mylar	0.068 uF 100 V J	3679683120	2
C224	Electrolytic SG	470 uF 10 V M	3479347121	1
C225	Electrolytic SA	10 uF 50 V M	3479310071	1
C225L/R	Electrolytic SG	10 uF 50 V M	3479310071	2
C229L/R	Electrolytic SG	4.7 uF 50 V M	3479347971	2
C231L/R	Mylar	0.047 uF 100 V J	3679473120	2
C260L/R	Ceramic Disc	5 pF 50 V D	3579509030	2
CD237-243	Ceramic Tubular	0.0047 uF 50 V K	3519472935	3 EUROPE
CD210-212	Mylar	0.1 uF 250 V J	3679104257	3 EUROPE
COILS				
L201L/R	Inductor, 0.5 uH		2648001010	2
CONNECTORS				
CN204	Lead Ass'y 3P 530mm		4358800353	1
CP103	Wafer 7P		4428505410	1
CP109	Wafer 2P		4428508210	1
CP201	Wafer 2P, LV		4428525780	1
CP202	Wafer 3P		4428505710	1
CP203	Wafer 2P, LV		4428525780	1
CP205	Wafer 4P		4428505610	1
CP206	Wafer 1P, LV		4428525660	1
CP207H	Wafer 2P		4428508210	1
CP207T	Wafer 2P		4428508210	1
CP301	Wafer, 4P		4428517710	1
CP402	Wafer 11P		4428510710	1
CP901	Wafer 2P		4428508210	1
CP902	Wafer 9P		4428518210	1
DIODES				
D201-205	1N4002, Rectifier		2258100135	5
D208-211	PX6A03, Rectifier		2058100138	4
D212-217	1N4002, Rectifier		2258100135	6
D218L/R	1N4148M, Switching		2058322101	2
D219/220	1N4148M, Switching		2058322101	2
D221	Zener, UZ 9.1 BSC		2258599107	1
D222	Zener, UZ 4.3 BSB		2258599102	1
D223L/R	1N4148M, Switching		2058322101	2
INTEGRATED CIRCUITS				
IC201/202	GL7806, Regulator		2168601110	2
IC203	GL7815, Regulator		2168602105	1
IC204	GL7915, Regulator		2168602114	1
TRANSISTORS				
Q112	2SC4137, Bias NPN		2008622110	1
Q115	2SC3854, NPN		2028416107	1
Q116	2SA1490, PNP		2028116104	1
Q123	2SC4137, Bias NPN		2008622110	1
Q126	2SC3854, NPN		2028416107	1
Q127	2SA1490, PNP		2028116104	1
Q201	KTC1815Y/BKTC3198Y, NPN		2208608104	1
Q203	DTC114YS, NPN		2208622106	1
Q204L/R	KTA970/KTA1268, PNP		2208206104	2
Q205L/R	KTA1015Y/BKTA1266Y, PNP		2208206105	2
Q206L/R	KTA970/KTA1268, PNP		2208206104	2
Q207L/R	KTC2240/BKTC3200, NPN		2208608108	2
Q208L/R	KTA970/KTA1268, PNP		2208206104	2
Q209L/R	KTA970/KTA1268, PNP		2208206104	2
Q210L/R	KTC2240/BKTC3200, NPN		2208608108	2

Ref. No.	Description	Mfr. Part No.	Q'ty	Version	Ref. No.	Description	Mfr. Part No.	Q'ty
Q211L/R	BKTA949/KTA1024, PNP	2208206102	2		PCB2 ASSEMBLY P.C. BOARD VIDEO			
Q212L/R	KTC2229/KTC3206, NPN	2208606107	2		CAPACITORS			
Q213L/R	2SC4137, Bias NPN	2008622110	2		C301	Electrolytic SG	33 uF 25 V M	3479333041 1
Q214L/R	2SC4983A, NPN	2026316100	2		C302	Electrolytic SG	470 uF 10 V M	3479347121 1
Q215L/R	2SA1859A, PNP	2028016100	2		C303	Ceramic Disc	470 pF 50V D	3579471130 1
Q216L/R	2SC3162N-O	2028307101	2		C304	Electrolytic SG	33 uF 25 V M	3479333041 1
Q217L/R	2SA1265N-O	2028007101	2		C305	Electrolytic SG	470 uF 10 V M	3479347121 1
Q218L/R	KTC1815Y/BKTC3198Y,NPN	2208606104	2		C306	Ceramic Tubular	1 pF 50 V K	3519010935 1
Q219	KTA1015Y/BKTA1266Y, PNP	2208206105	1		C307	Electrolytic SG	470 uF 10 V M	3479347121 1
Q220/221	KTC1815Y/BKTC3198Y,NPN	2208606104	2		C308	Ceramic Tubular	1 pF 50 V K	3519010935 1
Q222/223	DTC114YS, NPN	2208622106	2		C309	Electrolytic SG	100 uF 10 V M	3479310121 1
					C311	Ceramic Tubular	0.1 uF 50 V K	3519104935 1
					CZ301/302	Ceramic Disc	0.1 uF 50 V Z	3579104534 2
	RESISTORS					CONNECTORS		
R201	Carbon Film	3.3 Mohm 1/5 W J	3069335970	1		Lead Ass'y, 4P, 600mm		436204608331 1
R202	Metal Film	4.7 ohm 1 W J	3029479472	1		Lead Ass'y, 3P, 300mm		436103303331 1
R203/204	Metal Film	22 ohm 2 W J	3029220572	2	CN301	Wafer, 9P, Angle		4428513490 1
R205	Metal Film	10 ohm 1 W J	3029100472	1	CP101	Wafer 4P, Angle		4428513440 1
R206	Metal Film	4.7 ohm 1 W J	3029479472	1	CP104	Wafer 2P, Angle		4428513420 1
R209	Carbon Film	3.3 kohm 1/5 W J	3069332970	1	CP703			
R220L/R	Carbon Film	330 ohm 1/5 W J	3069331970	2		DIODES		
R221L/R	Carbon Film	33 kohm 1/5 W J	3069333970	2		1N4148M, Switching		2056322101 2
R222L/R	Carbon Film	1 kohm 1/5 W J	3069102970	2		INTEGRATED CIRCUIT		
R223L/R	Carbon Film	1.5 kohm 1/5 W J	3069152970	2	D301/302	GD4066, Switching		2138001101 1
R224L/R	Carbon Film	390 ohm 1/5 W J	3069391970	2		TRANSISTORS		
R225L/R	Carbon Film	1.5 kohm 1/5 W J	3069152970	2		Q301	KTA1015Y/BKTA1266Y, PNP	2208206105 1
R226L/R	Carbon Film	390 ohm 1/5 W J	3069391970	2		Q302	KTC1815Y/BKTC3198Y,NPN	2208606104 1
R227L/R	Carbon Film	560 ohm 1/5 W J	3069561970	2	IC301	KTA1015Y/BKTA1266Y, PNP	2208206105 1	
R228L/R	Carbon Film	560 ohm 1/5 W J	3069561970	2		Q303	KTC1815Y/BKTC3198Y,NPN	2208606104 1
R229L/R	Carbon Film	82 ohm 1/5 W J	3069820970	2		Q304	KTA1015Y/BKTA1266Y, PNP	2208206105 1
R230L/R	Carbon Film	560 ohm 1/5 W J	3069561970	2		Q305	KTC1815Y/BKTC3198Y,NPN	2208606104 1
R231L/R	Carbon Film	560 ohm 1/5 W J	3069561970	2		Q306	KTC1815Y/BKTC3198Y,NPN	2208606104 1
R232L/R	Carbon Film	22 kohm 1/5 W J	3069223970	2		Q307	FEET, 2SK117Y	2218207106 1
R233L/R	Carbon Film	22 kohm 1/5 W J	3069223970	2				
R234L/R	Carbon Film	82 ohm 1/5 W J	3069820970	2		RESISTORS		
R235L/R	Carbon Film	560 ohm 1/5 W J	3069561970	2		R301/302	Carbon Film	75 ohm 1/5 W J
R236L/R	Carbon Film	270 ohm 1/5 W J	3069271970	2		R303	Carbon Film	12 kohm 1/5 W J
R237L/R	Carbon Film	10 kohm 1/5 W J	3069103970	2		R304	Carbon Film	1.2 kohm 1/5 W J
R238L/R	Carbon Film	33 kohm 1/5 W J	3069333970	2		R305	Carbon Film	180 ohm 1/5 W J
R239L/R	Carbon Film	360 ohm 1/4 W J	3069361970	2		R306	Carbon Film	150 ohm 1/5 W J
R240L/R	Carbon Film	1.2 kohm 1/4 W J	3069122970	2		R307	Carbon Film	8.2 kohm 1/5 W J
R241L/R	Carbon Film	82 ohm 1/5 W J	3069820970	2		R308	Carbon Film	1.2 kohm 1/5 W J
R242L/R	Carbon Film	33 kohm 1/5 W J	3069333970	2		R309-312	Carbon Film	100 kohm 1/5 W J
R243L/R	Carbon Film	1.5 kohm 1/5 W J	3069152970	2		R313/314	Carbon Film	75 ohm 1/5 W J
R244L/R	Carbon Film	1.8 kohm 1/5 W J	3069182970	2		R315	Carbon Film	12 kohm 1/5 W J
R245L/R	Cement	0.27 ohm 5 W K	3059278782	2		R316	Carbon Film	1.2 kohm 1/5 W J
R246L/R	Cement	0.27 ohm 5 W K	3059278782	2		R317	Carbon Film	180 ohm 1/5 W J
R247L/R	Carbon Film	22 ohm 1/5 W J	3069220970	2		R318	Carbon Film	150 ohm 1/5 W J
R248L/R	Carbon Film	22 ohm 1/5 W J	3069220970	2		R319	Carbon Film	8.2 kohm 1/5 W J
R249L/R	Carbon Film	910 ohm 1/5 W J	3069911970	2		R320	Carbon Film	75 ohm 1/5 W J
R250L/R	Carbon Film	6.8 kohm 1/5 W J	3069682970	2		R321	Carbon Film	12 kohm 1/5 W J
R251	Carbon Film	68 kohm 1/5 W J	3069682970	2		R322	Carbon Film	1.2 kohm 1/5 W J
R252	Carbon Film	100 kohm 1/5 W J	3069104970	2		R323	Carbon Film	180 ohm 1/5 W J
R253	Carbon Film	3.3 kohm 1/5 W J	3069332970	2		R324	Carbon Film	1.2 kohm 1/5 W J
R254	Carbon Film	1 kohm 1/5 W J	3069102970	2		R325	Carbon Film	150 ohm 1/5 W J
R255T	Carbon Film	6.8 kohm 1/5 W J	3069682970	1		R326	Carbon Film	8.2 kohm 1/5 W J
R256	Carbon Film	10 kohm 1/5 W J	3069103970	1		R327	Carbon Film	1.2 kohm 1/5 W J
R257L/R	Carbon Film	24 kohm 1/5 W J	3069243970	2		R329	Carbon Film	1 Mohm 1/5 W J
R258L/R	Metal Film	10 ohm 1 W J	3029100472	2		R330/331	Carbon Film	470 ohm 1/5 W J
R259	Carbon Film	10 kohm 1/5 W J	3069103970	1				
R260	Carbon Film	10 kohm 1/5 W J	3069103970	1		MISCELLANEOUS		
R261	Carbon Film	10 kohm 1/5 W J	3069103970	1		40	Jack, RCA, 2P	4438109310 2
R262	Carbon Film	1 kohm 1/5 W J	3069102970	1		41	Jack, RCA, 1P	4438113810 1
R263	Carbon Film	2.4 kohm 1/5 W J	3069242970	1		55	Jack, RCA, 4P	4438103410 2
R264	Carbon Film	22 kohm 1/5 W J	3069223970	1				
R265	Carbon Film	15 kohm 1/5 W J	3069153970	1		PCB3 ASSEMBLY P.C. BOARD SUB-WOOFER		
R266	Carbon Film	150 kohm 1/5 W J	3069154970	1		C158	CAP, Mylar	0.047 uF 100 V J
R269L/R	Carbon Film	560 ohm 1/5 W J	3069561970	2		C174	CAP, Ceramic	0.047 uF 50 V K
R270L/R	Carbon Film	2.4 kohm 1/5 W J	3069242970	2		C312	CAP, Ceramic	0.047 uF 50 V K
						R169	RES, Carbon Film	10 ohm 1/5 W J
	FUSES					R170	RES, Carbon Film	10 ohm 1/4 W J
F201	5T 250 V, 3.15 A	5508302735	1	EUROPE		R195	RES, Carbon Film	24 kohm 1/5 W J
(F201)	NB 125 V, 5 A	5508203021	1	USA/CANADA		R333L/R	RES, Carbon Film	1 kohm 1/5 W J
F203	TL 250 V, 160 mA	5508301036	1	EUROPE		L101	Coil, Inductor, 0.5 uH	2648001010 1
(F203)	NB 125 V, 250 mA	5508201221	1	USA/CANADA		CP110	Connector, Wafer, 5P	4428506910 1
F204/205	TL 250 V, 800 mA	5508301934	2	EUROPE		CP302	Connector, Wafer, 3P	4428505710 1
(F204/205)	NB 125 V, 750 mA	5508101821	2	USA/CANADA		59	Terminal Speaker, 2P	4408108710 1
						60	Jack RCA, 2P	4438111310 1
	MISCELLANEOUS				PCB4 ASSEMBLY P.C. BOARD FRONT			
GT201/202	Ground Plate	4235007310	2			CAPACITORS		
RLY-1	Relay, SDT-SS-112DM	5528043000	1			C402	Ceramic CH	56 pF 50 V J
TRANS201	Transformer, Standby, 230V, 50Hz	2828090901	1	EUROPE		C404	Ceramic CH	56 pF 50 V J
(TRANS201)	Transformer, Standby, 120V, 60Hz	2828096001	1	USA/CANADA				
44	Heatsink, Regulator TR.	7505208220	1					
45	Heatsink, Regulator TR.	7505206120	2					
47	Terminal, Speaker, 8P	4408105810	1					
56	Heatsink, Regulator TR.	7505202410	4					

Ref. No.	Description	Mfr. Part No.	Q'ty	Version	Ref. No.	Description	Mfr. Part No.	Q'ty	Version
R817/818	Carbon Film	100 kohm 1/5 W J	3069104970	2	C544-546	Mylar	0.1 uF 83 V K	3679104297	3
R819	Carbon Film	47 kohm 1/5 W J	3069473970	1	C547/548	Mylar	0.22 uF 63 V K	3679224297	2
R820	Carbon Film	22 kohm 1/5 W J	3069223970	1	C549	Mylar	0.1 uF 63 V K	3679104297	1
R821-823	Carbon Film	1 kohm 1/5 W J	3069102970	3	C550	Mylar	0.047 uF 100 V J	3679473120	1
R824	Carbon Film	820 ohm 1/5 W J	3069821970	1	C551	Poly	680 pF 50 V J	3619681110	1
R825	Carbon Film	1.5 kohm 1/5 W J	3069152970	1	C552	Mylar	0.1 uF 63 V K	3679104297	1
R826	Carbon Film	10 kohm 1/5 W J	3069103970	1	C553	Poly	680 pF 50 V J	3619681110	1
R827	Carbon Film	1 kohm 1/5 W J	3069102970	1	C554	Mylar	0.047 uF 100 V J	3679473120	1
R828	Carbon Film	100 ohm 1/5 W J	3069101970	1	C555	Electrolytic SG	10 uF 35 V M	3479310061	1
R829/830	Carbon Film	100 kohm 1/5 W J	3069104970	2	C556	Electrolytic SG	1 uF 50 V M	3479310071	1
R831/832	Carbon Film	22 kohm 1/5 W J	3069223970	2	C557/558	Mylar	0.1 uF 83 V K	3679104297	2
R833/834	Carbon Film	2 kohm 1/5 W J	3069202970	2 EUROPE	C559	Electrolytic SG	1 uF 50 V M	3479310071	1
(R833/834)	Carbon Film	3.3 kohm 1/5 W J	3069332970	2 USA/CANADA	C560	Electrolytic SG	10 uF 35 V M	3479310061	1
R835/836	Carbon Film	47 kohm 1/5 W J	3069473970	2	C561	Mylar	0.0047 uF 100 V J	3679472120	1
R837	Carbon Film	3.9 kohm 1/5 W J	3069392970	1	C562	Electrolytic SG	22 uF 50 V M	3479322071	1
R838/839	Carbon Film	2.4 kohm 1/5 W J	3069242970	2 EUROPE	C563	Mylar	0.0056 uF 100 V J	3679562120	1
(R839/839)	Carbon Film	3.3 kohm 1/5 W J	3069332970	2 USA/CANADA	C564	Electrolytic SG	100 uF 10 V M	3479310121	1
R842/843	Carbon Film	1 kohm 1/5 W J	3069102970	2	C565	Ceramic Disc	0.1 uF 50 V Z	3579104534	1
R844/845	Carbon Film	3 kohm 1/5 W J	3069302970	2	C566	Mylar	0.0056 uF 100 V J	3679562120	1
R850	Carbon Film	470 ohm 1/5 W J	3069471970	1	C567	Ceramic Tubular	470 pF 50 V K	3518471935	1
R865	Carbon Film	10 kohm 1/5 W J	3069103970	1	C568	Mylar	0.1 uF 63 V K	3679104297	1
R867/868	Carbon Film	100 kohm 1/5 W J	3069104970	2	C569	Electrolytic SG	47 uF 25 V M	3479347041	1
R869	Carbon Film	1 kohm 1/5 W J	3069102970	1	C570/571	Mylar	0.047 uF 100 V J	3679473120	2
R870	Carbon Film	5.6 kohm 1/5 W J	3069562970	1	C572	Mylar	0.1 uF 63 V K	3679104297	1
R888/889	Carbon Film	270 ohm 1/5 W J	3069271970	2	C573	Mylar	0.0033 uF 100 V J	3679332120	1
R890/891	Carbon Film	220 ohm 1/5 W J	3069221970	2	C574	Ceramic Disc	470 pF 50 V K	3579471130	1
R892-898	Carbon Film	270 ohm 1/5 W J	3069271970	7	C578/577	Ceramic Disc	270 pF 50 V K	3579271130	2
					C578-580	Ceramic Tubular	100 pF 50 V K	3519101935	3
					C582	Electrolytic SG	47 uF 25 V M	3479347041	1
					C583	Ceramic Tubular	0.01 uF 50 V J	3519103935	1
					C584	Ceramic Tubular	100 pF 50 V K	3519101935	1
					C585	Electrolytic SG	100 uF 10 V M	3479310121	1
	COILS					CONNECTORS			
L801	Inductor, 20.8 mH	2648601430	1		CN106	Wafer, 8P		4428560080	1
T801	AM ANT	2608201120	1		CN107	Wafer, 6P		4428560060	1
T802	OSC, AM	2638201150	1		CNT602	Wafer, 9P		4426507010	1
T803	FM Quad DET (A)	2838501110	1						
T804	FM Quad DET (B)	2838501210	1						
T805	AM IFT, P-7SB	2848001250	1						
T806/807	MPX, 19k/38kHz	2858001050	2						
	SEMI FIXED RESISTORS					DIODES			
VR801	Semi, 20 k (B)	3248020343	1		D501-503	1N4148M, Switching		2058322101	3
VR802	Semi, 50 k (B)	3248050343	1						
VR803	Semi, 5 k (B)	3248050243	1						
VR804	Semi, 200 k (B)	3248020443	1						
	MISCELLANEOUS				IC501/502	KIA7559S/KIA4559S, OP AMP		2168206103	2
33	Terminal, Antenna	4408108210	1		IC503/504	LC4968		2138017108	2
FE1	FM Front-end, FE407-G60	3928801890	1 EUROPE		IC505	KIA7559P/KIA4559P, OP AMP		2168206104	1
(FE1)	FM Front-end, FE43-505H	3928101790	1 USA/CANADA		IC506	TC9176P		2138007124	1
XT801	Resonator, 7.2 MHz	3908101031	1		IC507	NJM2177L		2168020115	1
					IC508	NJU9701D		2168020114	1
					IC509	MC14094BCP		2138009115	1
	ASSEMBLY P.C. BOARD SURROUND					TRANSISTORS			
	CAPACITORS				Q501/502	KTA114Y/KRA107M, PNP		2238006103	2
C501	Electrolytic SG	10 uF 50 V M	3479310071	1	Q503/504	DTC114YS, NPN		2208622106	2
C502	Electrolytic SG	47 uF 25 V M	3479347041	1	Q505/506	KTA114Y/KRA107M, PNP		2238006103	2
C503-505	Electrolytic SG	10 uF 50 V M	3479310071	3	Q507/508	DTC114YS, NPN		2208622106	2
C506	Electrolytic SG	47 uF 25 V M	3479347041	1					
C507/508	Electrolytic SG	10 uF 50 V M	3479310071	2					
C509/510	Electrolytic SG	47 uF 25 V M	3479347041	2	R501	Carbon Film	100 ohm 1/5 W J	3069101970	1
C511	Ceramic Tubular	100 pF 50 V K	3519101935	1	R502/503	Carbon Film	100 kohm 1/5 W J	3069104970	2
C512	Electrolytic SG	1 uF 50 V M	3479310071	1	R504	Carbon Film	100 ohm 1/5 W J	3069101970	1
C513	Electrolytic SG	0.47 uF 50 V J	3479347871	1	R505-508	Carbon Film	100 kohm 1/5 W J	3069104970	4
C514	Electrolytic SG	47 uF 25 V M	3479347041	1	R510/511	Carbon Film	150 kohm 1/5 W J	3069154970	2
C515	Ceramic Tubular	680 pF 50 V K	3519681935	1	R512/513	Carbon Film	100 ohm 1/5 W J	3069101970	2
C516	Electrolytic SG	1 uF 50 V M	3479310071	1	R514/515	Carbon Film	22 kohm 1/5 W J	3069223970	2
C517	Electrolytic SG	47 uF 25 V M	3479347041	1	R516	Carbon Film	120 kohm 1/5 W J	3069124970	1
C518	Electrolytic SG	1 uF 50 V M	3479310071	1	R517	Carbon Film	10 kohm 1/5 W J	3069103970	1
C519	Ceramic Tubular	680 pF 50 V K	3519681935	1	R518	Carbon Film	100 kohm 1/5 W J	3069104970	1
C520	Electrolytic SG	1 uF 50 V M	3479310071	1	R519	Carbon Film	100 ohm 1/5 W J	3069101970	1
C521	Ceramic Tubular	100 pF 50 V K	3519101935	1	R520	Carbon Film	47 kohm 1/5 W J	3069473970	1
C522	Mylar	0.1 uF 63 V K	3679104297	1	R521	Carbon Film	3.6 kohm 1/5 W J	3069362970	1
C523	Mylar	0.022 uF 100 V J	3679223120	1	R522	Carbon Film	560 kohm 1/5 W J	3069564970	1
C524/525	Electrolytic SG	4.7 uF 50 V M	3479347971	2	R523	Carbon Film	1.8 kohm 1/5 W J	3069182970	1
C526-528	Mylar	0.22 uF 63 V K	3679224297	3	R524	Carbon Film	100 ohm 1/5 W J	3069101970	1
C529	Mylar	0.68 uF 63 V K	3679684297	1	R525	Carbon Film	47 kohm 1/5 W J	3069473970	1
C530	Poly	470 pF 50 V J	3619471110	1	R526	Carbon Film	4.7 kohm 1/5 W J	3069472970	1
C531	Mylar	0.047 uF 100 V J	3679473120	1	R527	Carbon Film	1.8 kohm 1/5 W J	3069182970	1
C532	Mylar	0.0022 uF 100 V J	3679222120	1	R528	Carbon Film	560 kohm 1/5 W J	3069564970	1
C533	Electrolytic SG	1 uF 50 V M	3479310071	1	R529-531	Carbon Film	1 kohm 1/5 W J	3069102970	3
C534	Electrolytic SG	220 uF 16 V M	3479322131	1	R532	Carbon Film	330 kohm 1/5 W J	3069334970	1
C535	Mylar	0.0056 uF 100 V J	3679562120	1	R533-535	Carbon Film	15 kohm 1/5 W J	3069153970	3
C536/537	Electrolytic SG	1 uF 50 V M	3479310071	2	R536-538	Carbon Film	100 kohm 1/5 W J	3069104970	3
C538	Electrolytic SG	220 uF 16 V M	3479322131	1	R539	Carbon Film	47 ohm 1/5 W J	3069470970	1
C539	Electrolytic SG	10 uF 50 V M	3479310071	1	R540/541	Carbon Film	100 kohm 1/5 W J	3069104970	2
C540	Electrolytic SG	0.22 uF 50 V K	3479322871	1	R542	Carbon Film	10 kohm 1/5 W J	3069103970	1
C541-543	Electrolytic SG	1 uF 50 V M	3479310071	2	R543	Carbon Film	7.5 kohm 1/5 W J	3069752970	1

Ref. No.	Description	Mfr. Part No.	Q'ty	Version	Ref. No.	Description	Mfr. Part No.	Q'ty	Version
R544	Carbon Film	47 kohm 1/5 W J	1		R559	Carbon Film	15 kohm 1/5 W J	1	
R545	Carbon Film	15 kohm 1/5 W J	1		R560	Carbon Film	22 ohm 1/5 W J	1	
R546	Carbon Film	7.5 kohm 1/5 W J	1		R561	Carbon Film	18 kohm 1/5 W J	1	
R547	Carbon Film	47 kohm 1/5 W J	1		R562	Carbon Film	15 kohm 1/5 W J	1	
R548	Carbon Film	15 kohm 1/5 W J	1		R563	Carbon Film	47 ohm 1/5 W J	1	
R549	Carbon Film	22 kohm 1/5 W J	1		R564	Carbon Film	1 Mohm 1/5 W J	1	
R550	Carbon Film	10 Mohm 1/5 W J	1		R665-567	Carbon Film	1 kohm 1/5 W J	3	
R551	Carbon Film	22 kohm 1/5 W J	1		R568	Carbon Film	470 ohm 1/5 W J	1	
R552	Carbon Film	100 kohm 1/5 W J	1		R570	Carbon Film	1 kohm 1/5 W J	1	
R553	Carbon Film	8.2 kohm 1/5 W J	1		R571/572	Carbon Film	1 kohm 1/5 W J	2	
R554	Carbon Film	7.5 kohm 1/5 W J	1		R573	Carbon Film	100 ohm 1/5 W J	1	
R555	Carbon Film	56 ohm 1/5 W J	1						
R556	Carbon Film	18 kohm 1/5 W J	1						
R557	Carbon Film	5.6 kohm 1/5 W J	1						
R558	Carbon Film	22 ohm 1/5 W J	1						
					MISCELLANEOUS				
					X501	Resonator, 2MHz		3938124001	1

IC FUNCTIONAL BLOCK DIAGRAM

FRONT-END : FE FTH3-505H (USA/CA)

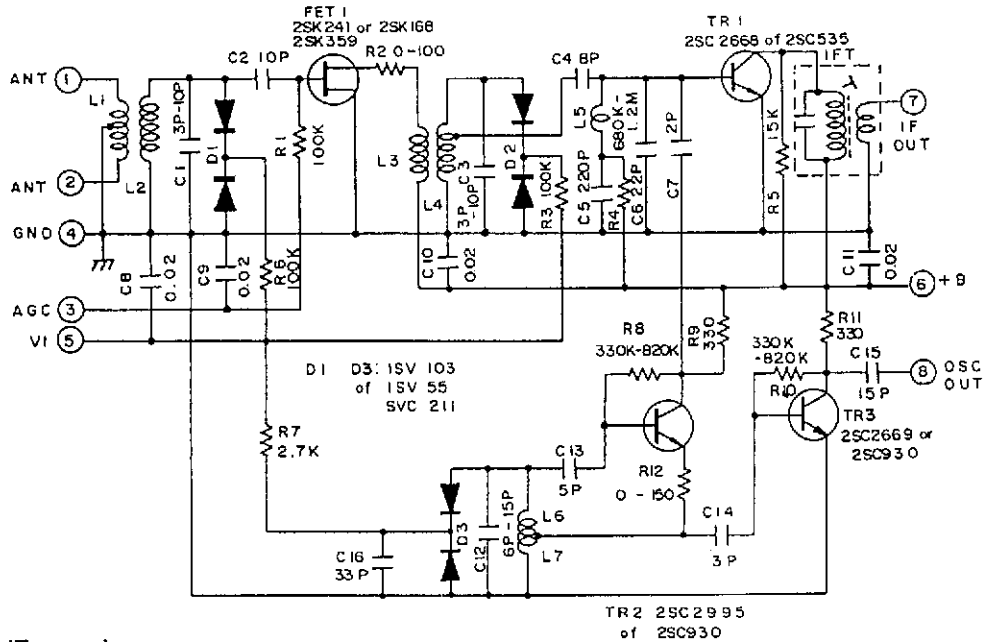

FE407-G60 (Europe)

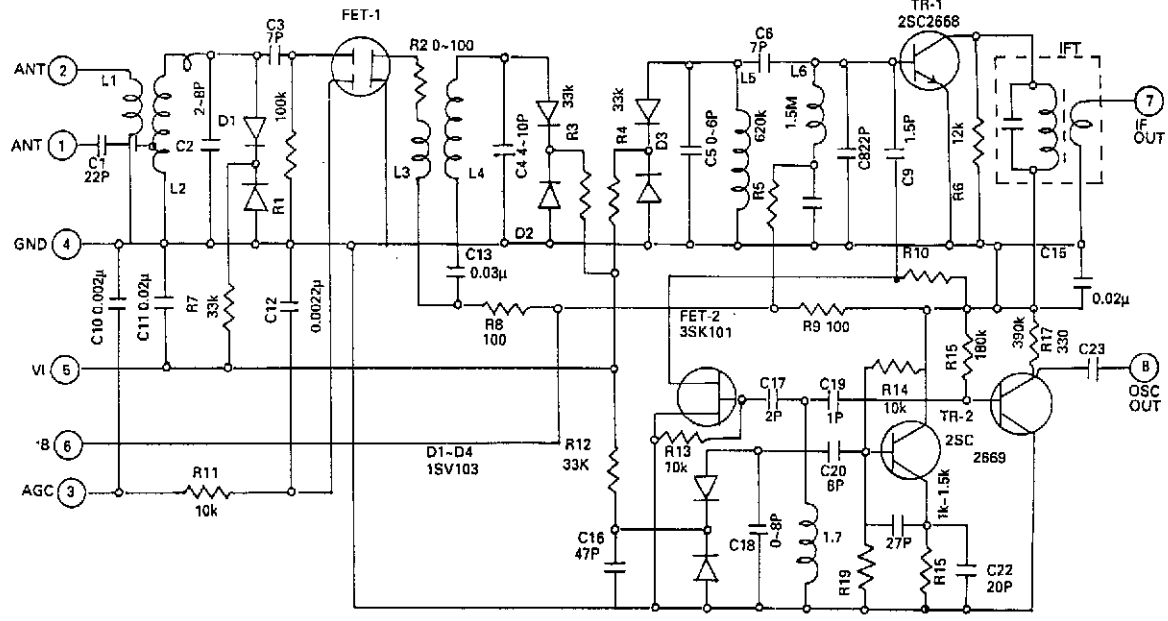

IC301 GD4066

CONNECTION DIAGRAM
DIP(TOP VIEW)

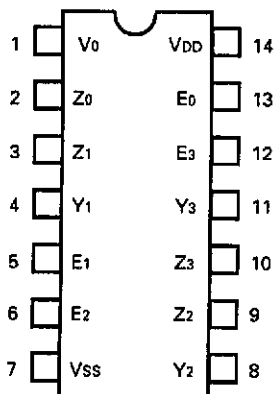

NOTE:
The SO Package has the same pinout (Connection Diagram) as the Dual-In-Line Package.

LOGIC SYMBOL

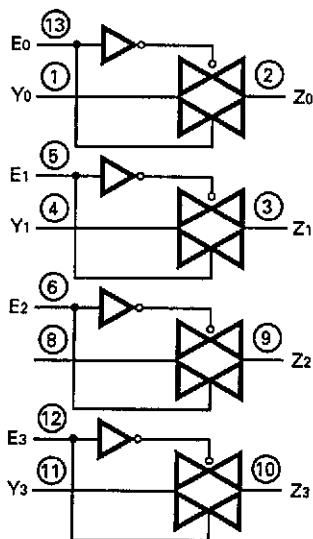

VDD - Pin 14
VSS - Pin 7
○ = Pin Numbers

LOGIC DIAGRAM (1/4 OF A 4066B)

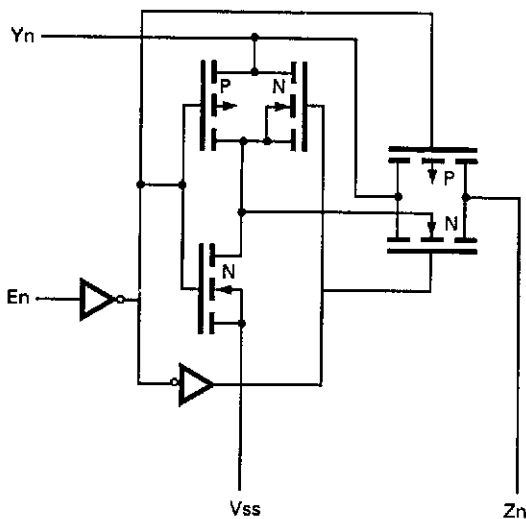

IC701, IC501, IC502 KIA75559/KIA4559S

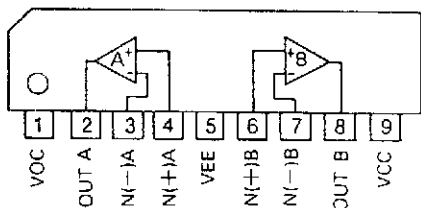

IC503, IC504 LC4966

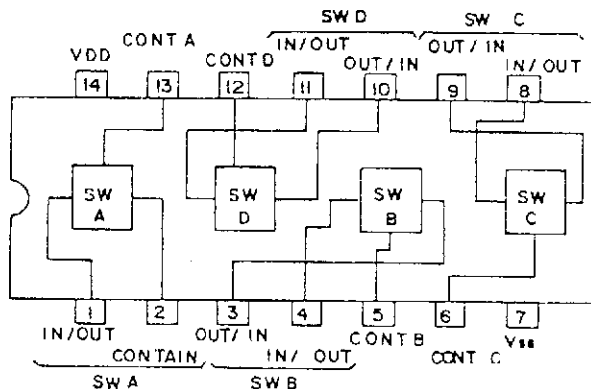

IC508 NJM9701D

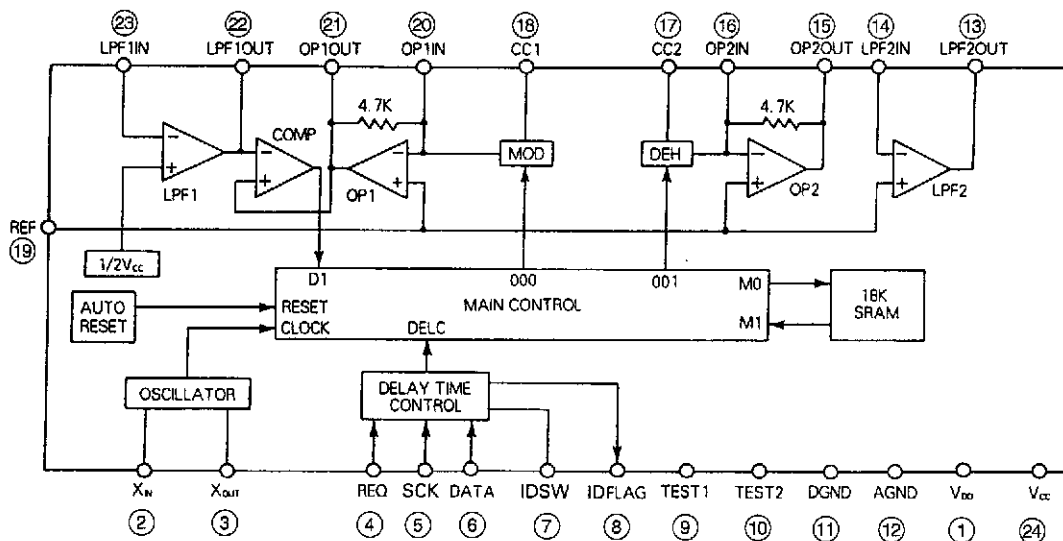

IC509 MC14094BCP

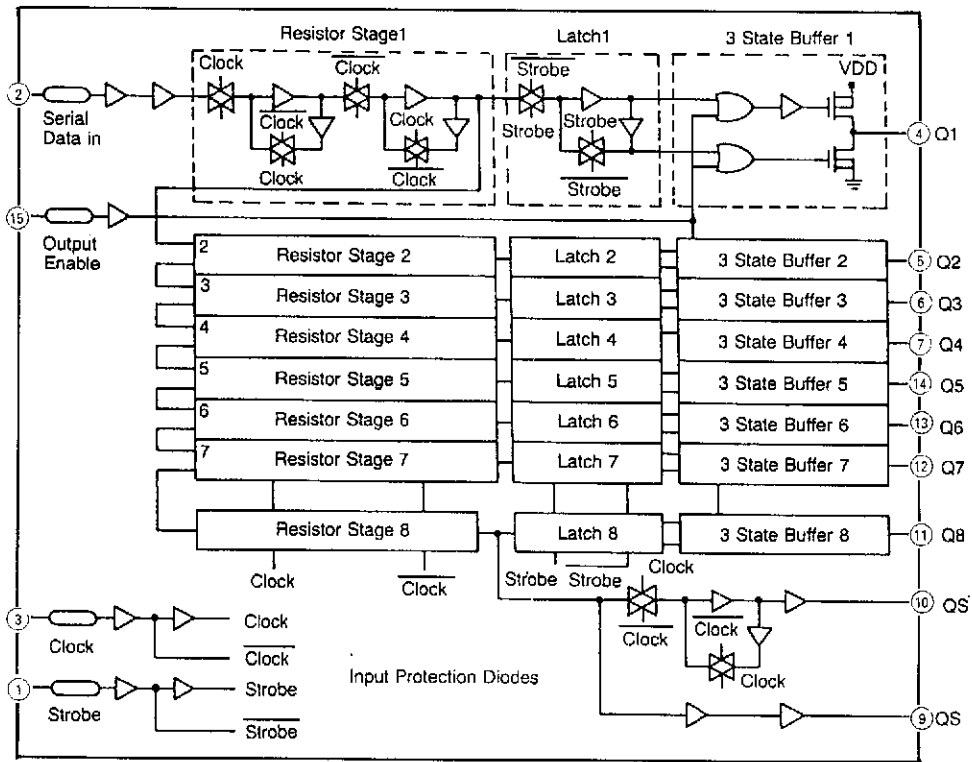

IC506 TC9176P

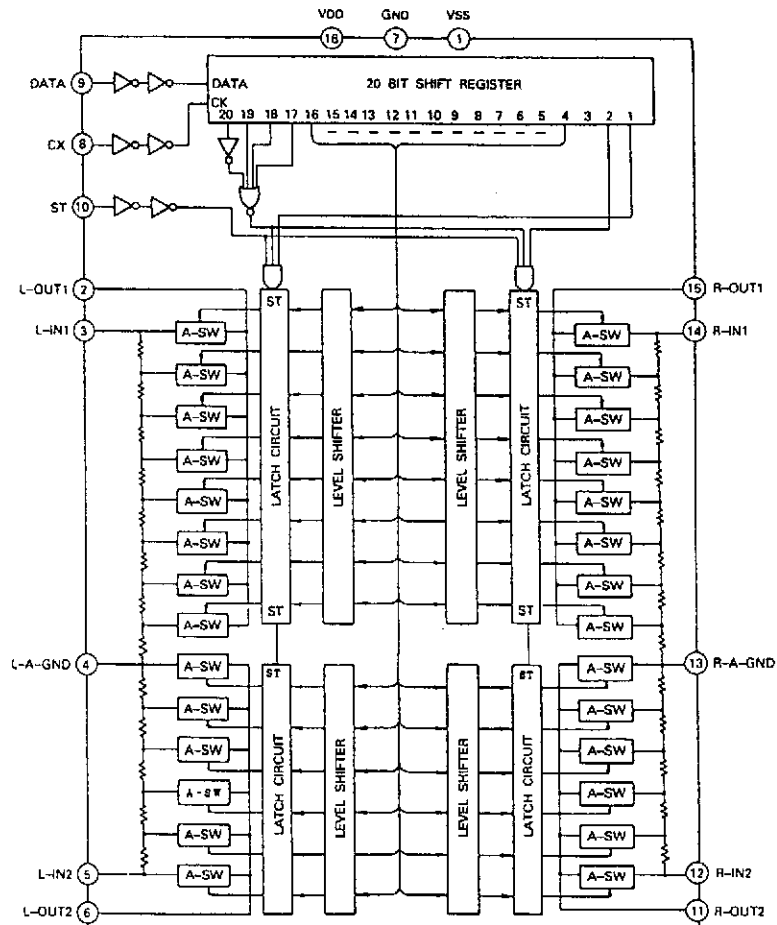

IC803 HA12016

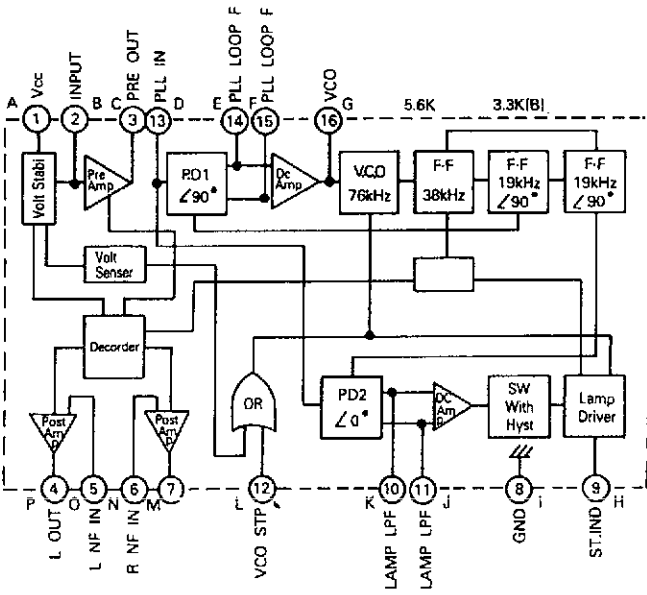

IC801 LA1266

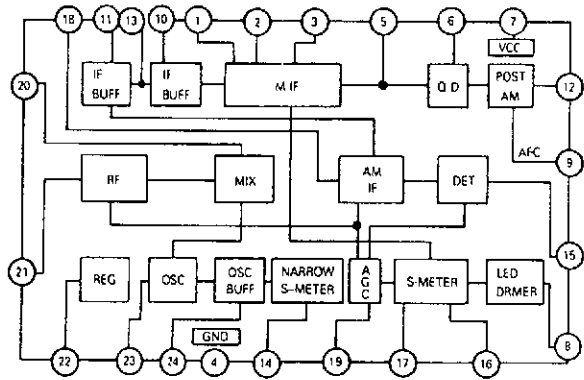

IC603 TA7291S

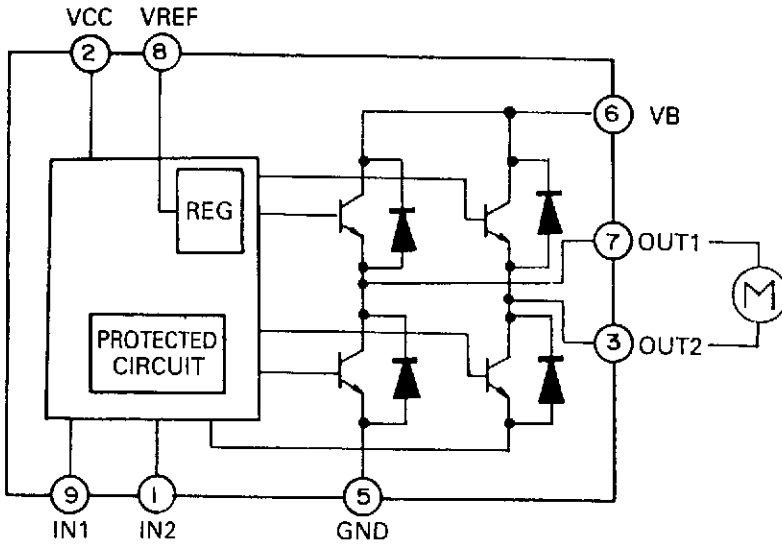

IC601, IC602, IC104, IC105
KIA 75559P/KIA 4559P
IC103 KIA 6259P

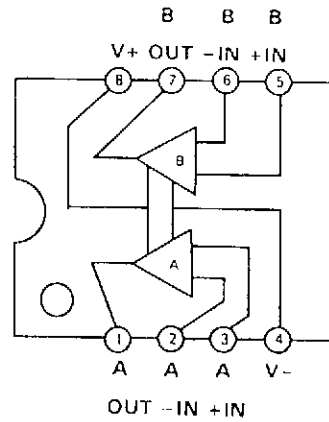

IC204 GL7915

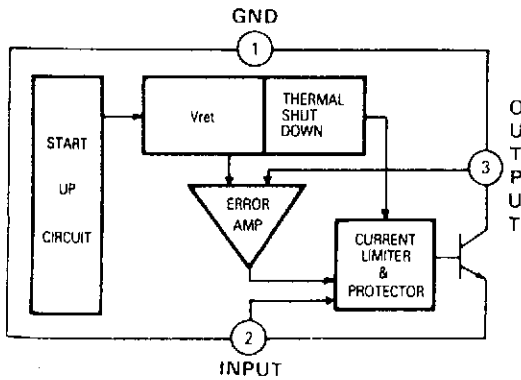

IC201, 202, IC203 GL7806, GL07815

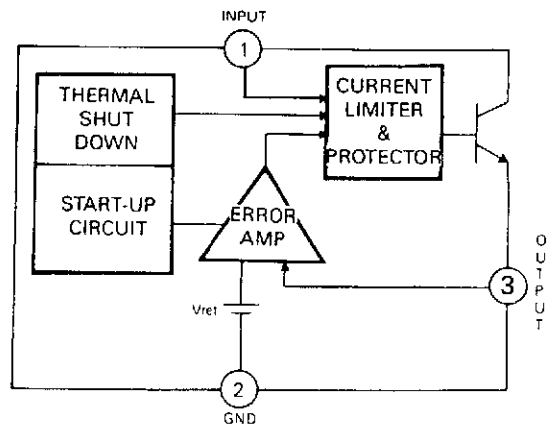

IC101, IC102 LC7821

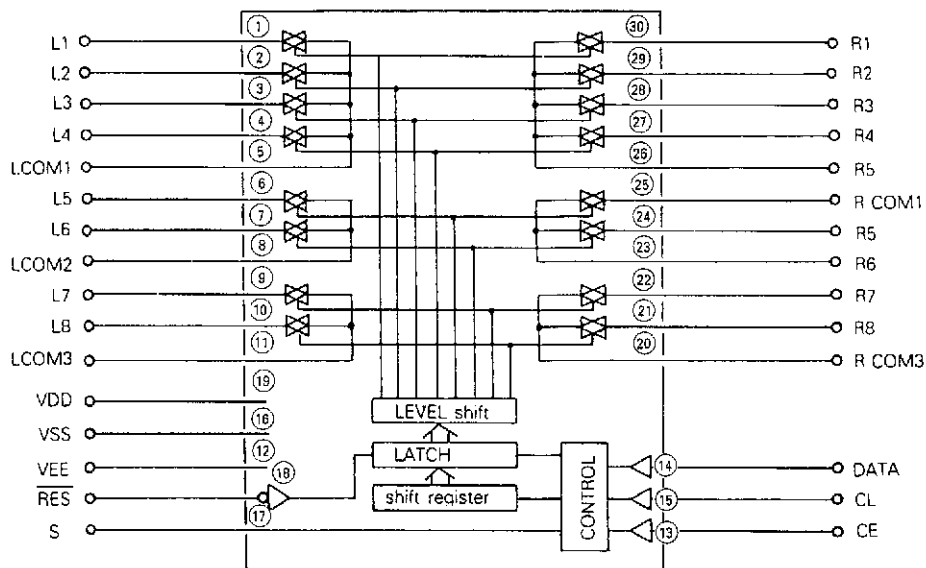

IC507 NJM2177L

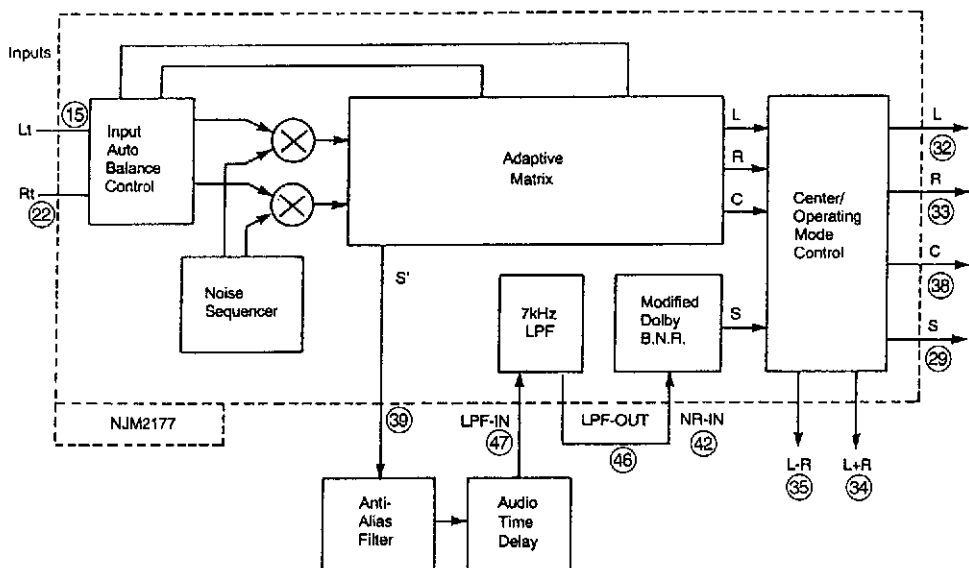

IC802 LM7001

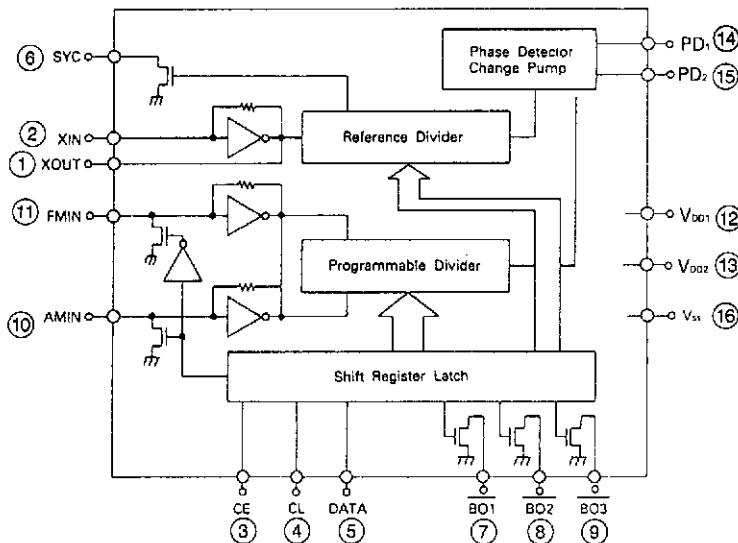

SCHEMATIC DIAGRAMS I

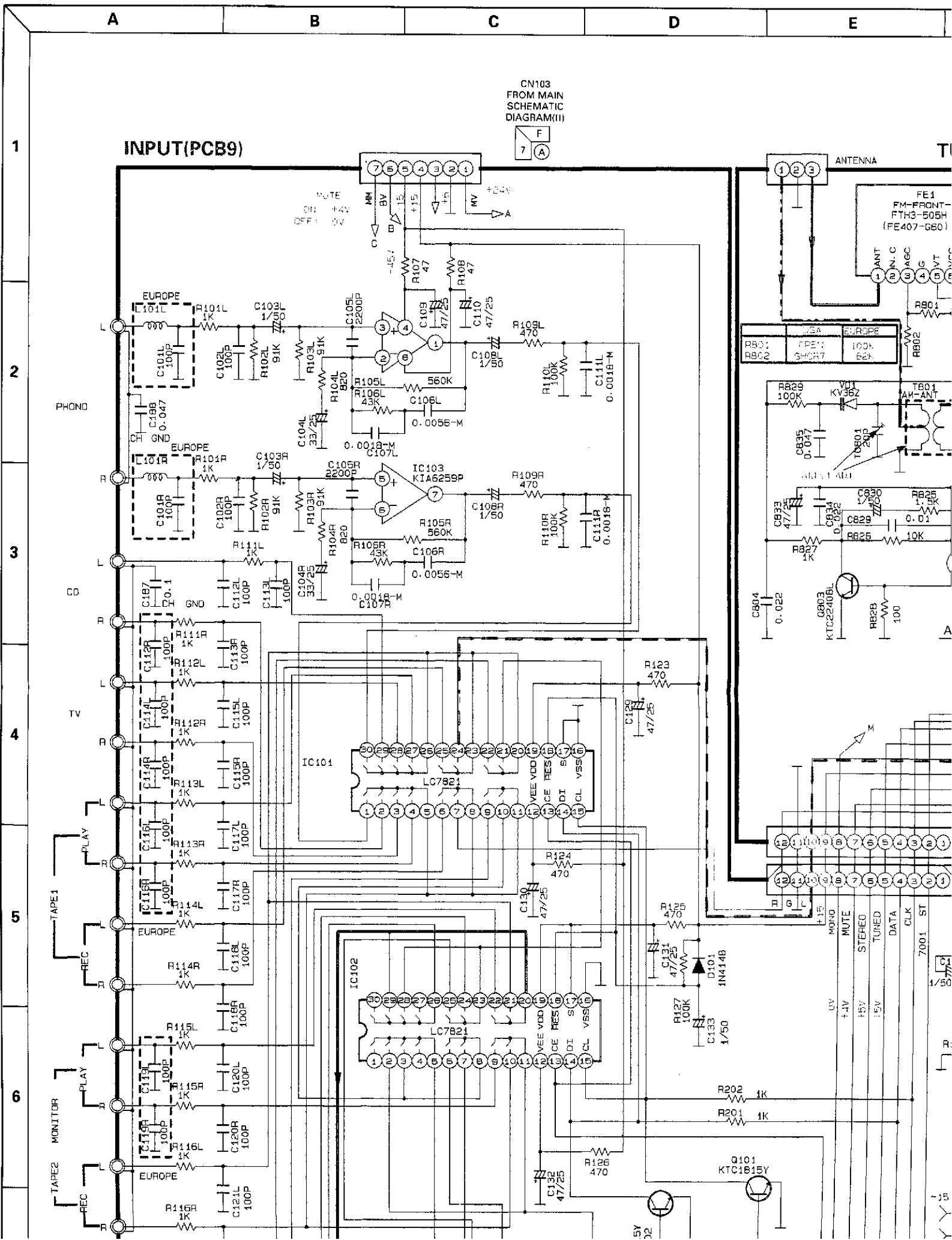

TUNER(PCB10)

-TUNER-
||: EUROPE
VOLTAGE: FM 98.1M
MARK

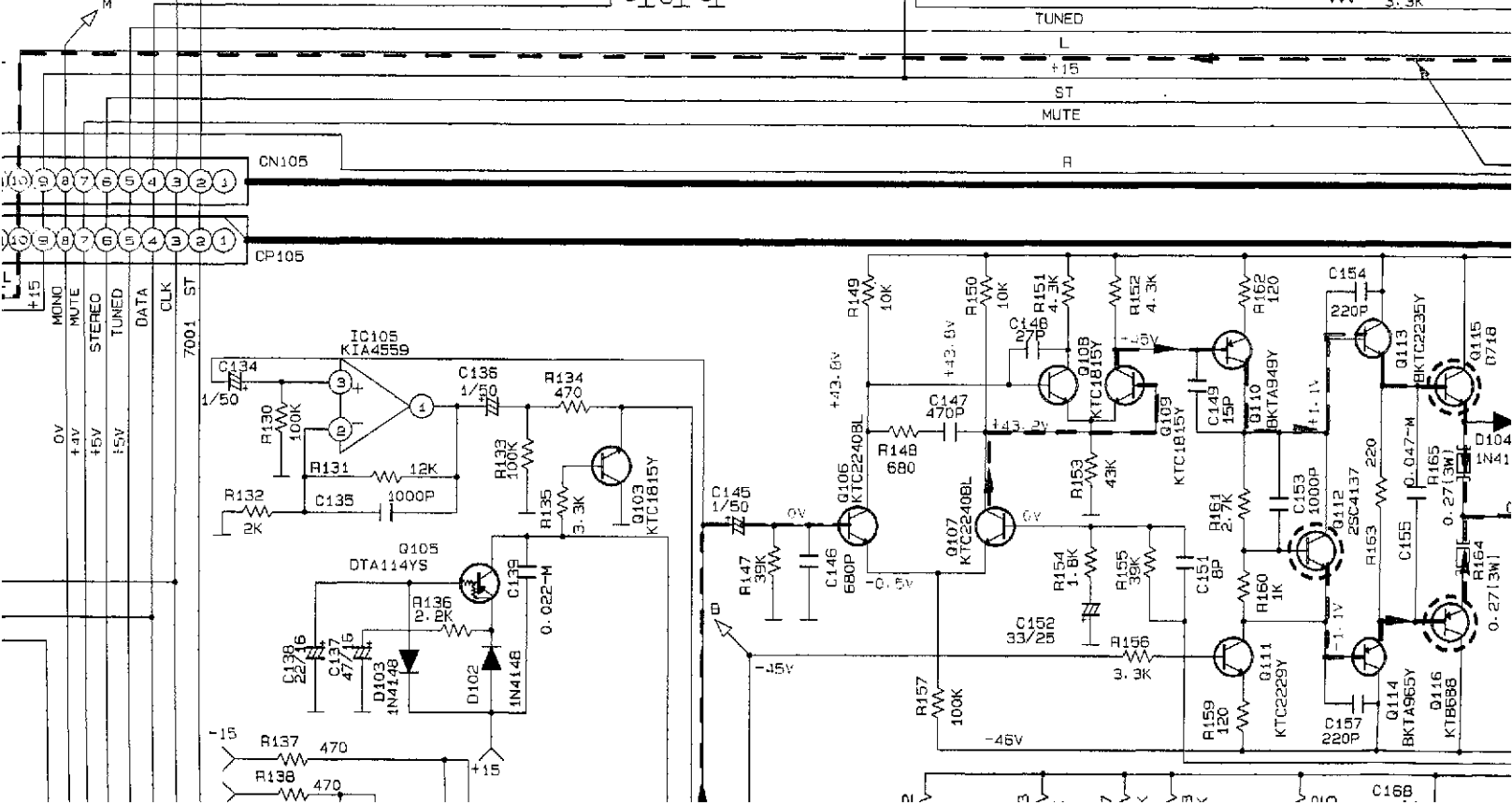
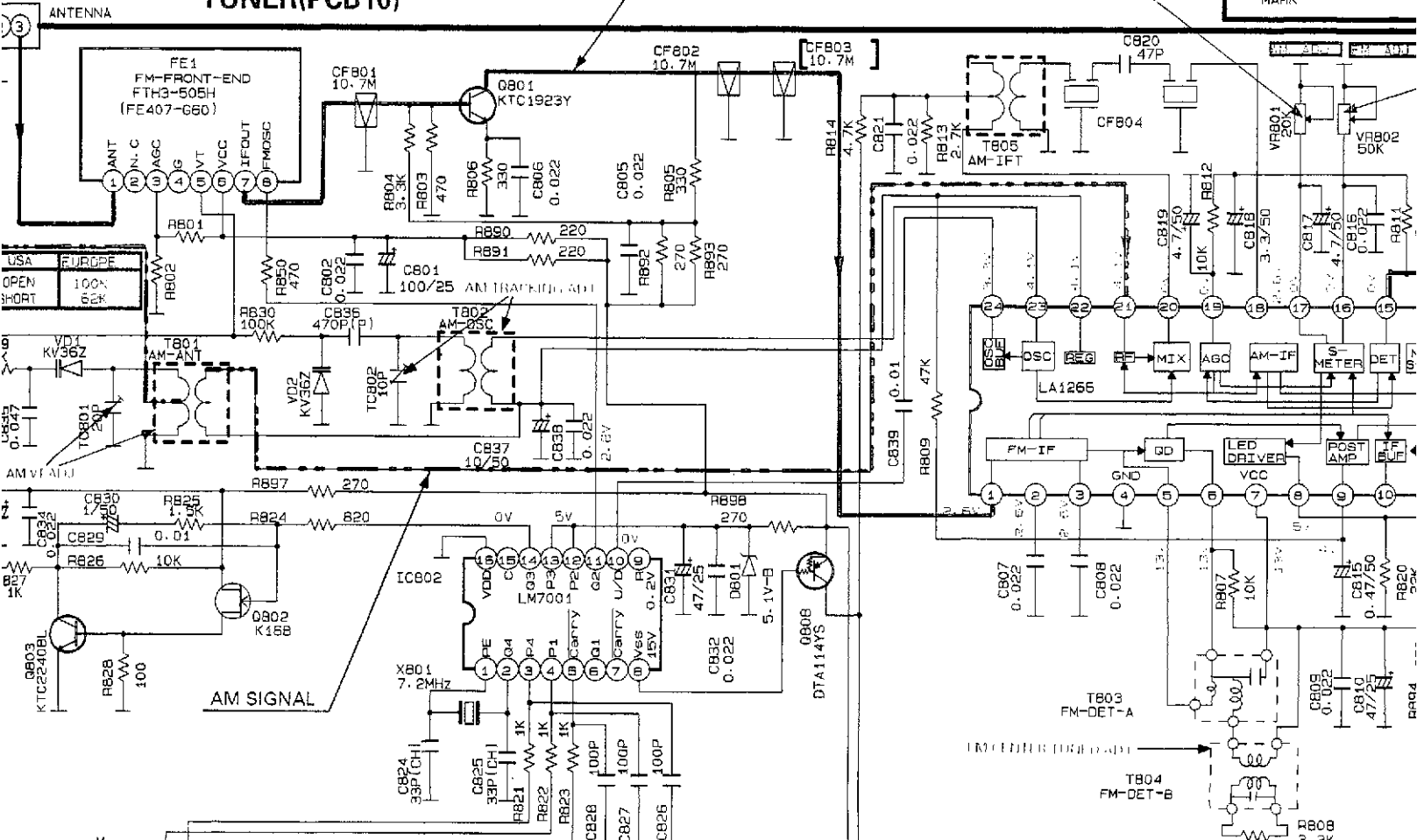

I J K L M

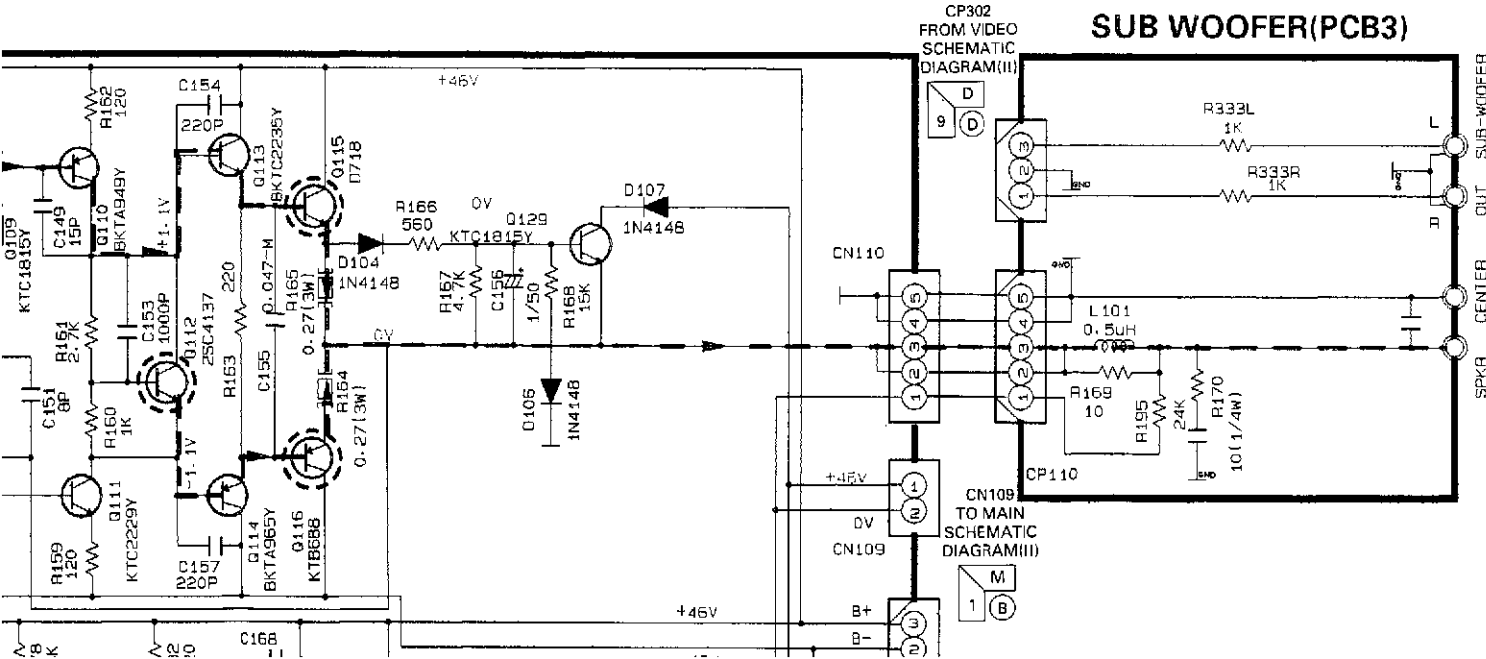
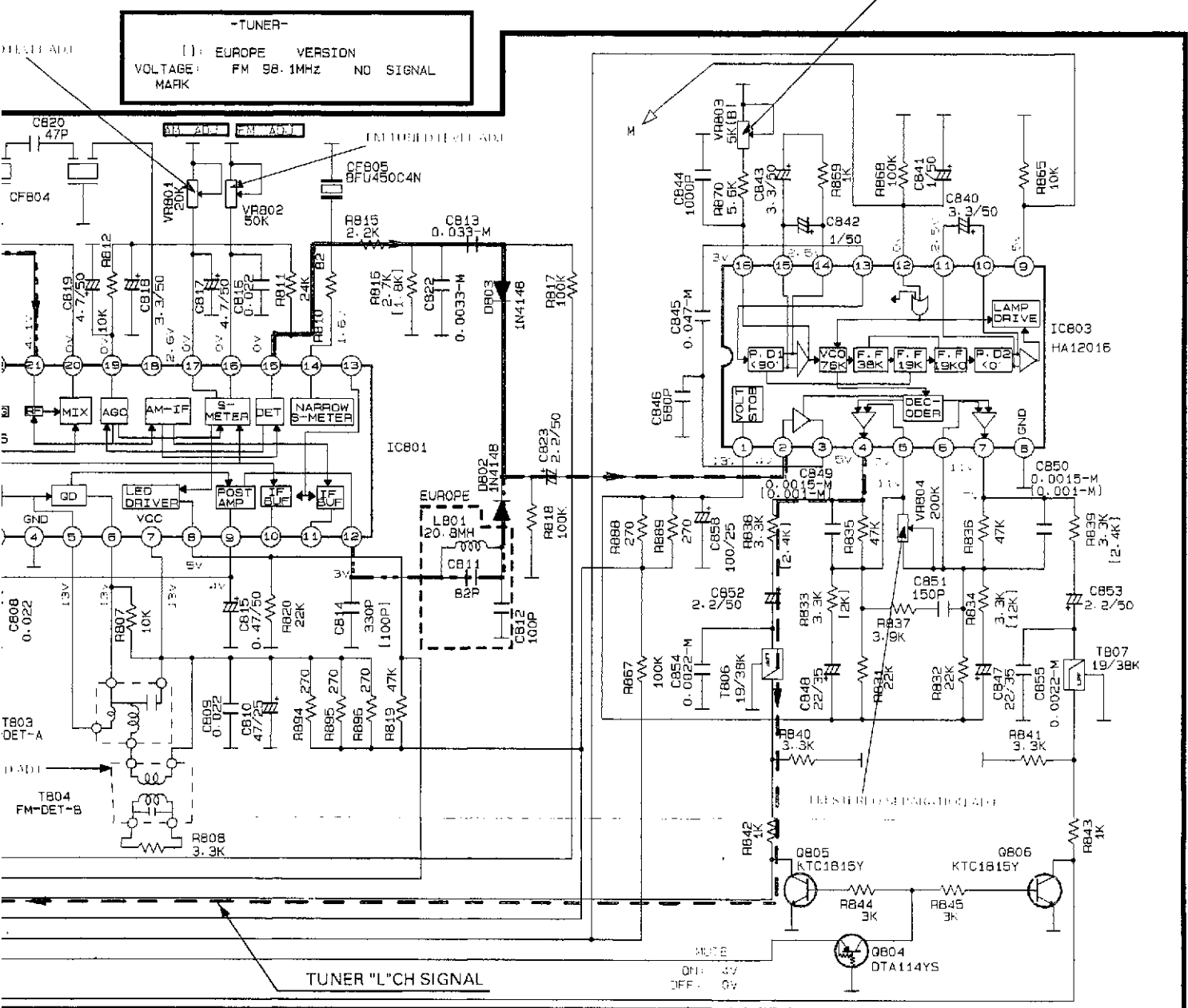

3
4
5
6
7
8
9

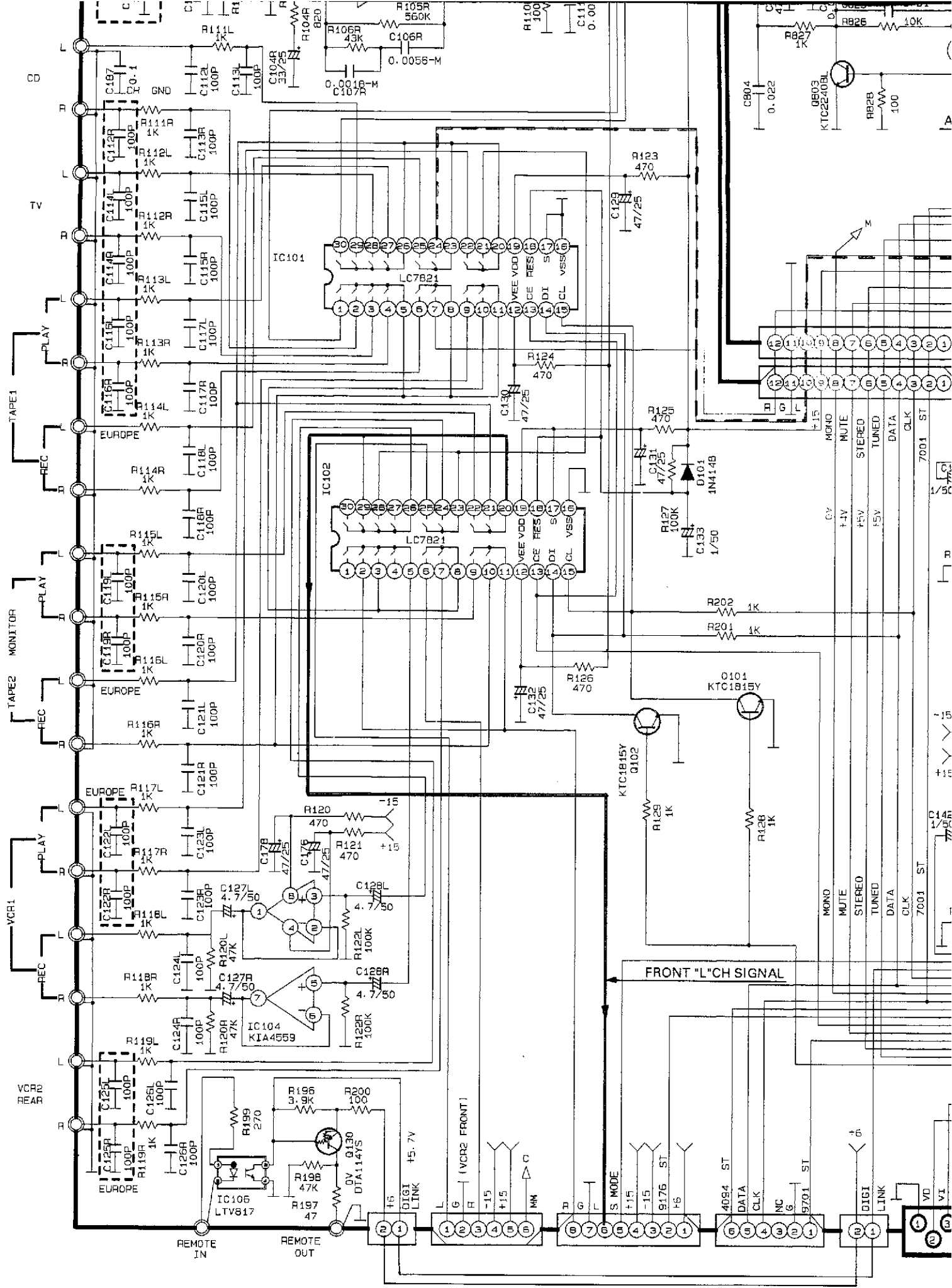

CN10B

CP702
FROM TONE
SCHEMATIC
DIAGRAM(II)

CP106
TO SURROUND
SCHEMATIC
DIAGRAM(III)

CP107
TO SURROUND
SCHEMATIC
DIAGRAM(III)

CN10B

1	E
L	

8	J
K	

7	I
J	

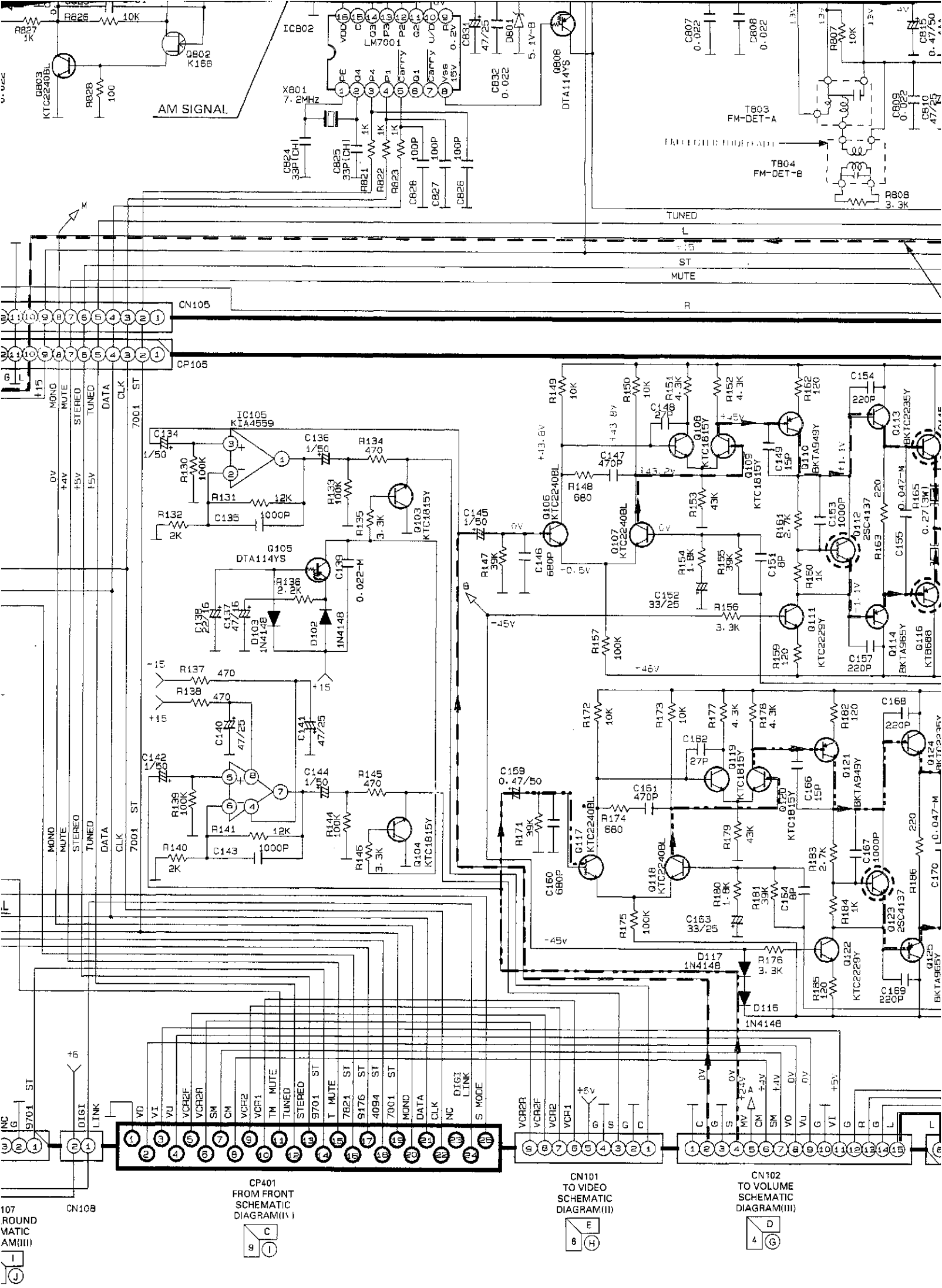

107
ROUND
MATIC
AM(III)

CP401
FROM FRONT
SCHEMATIC
DIAGRAM(II)

CN101
TO VIDEO
SCHEMATIC
DIAGRAM(III)

CN102
TO VOLUME
SCHEMATIC
DIAGRAM(III)



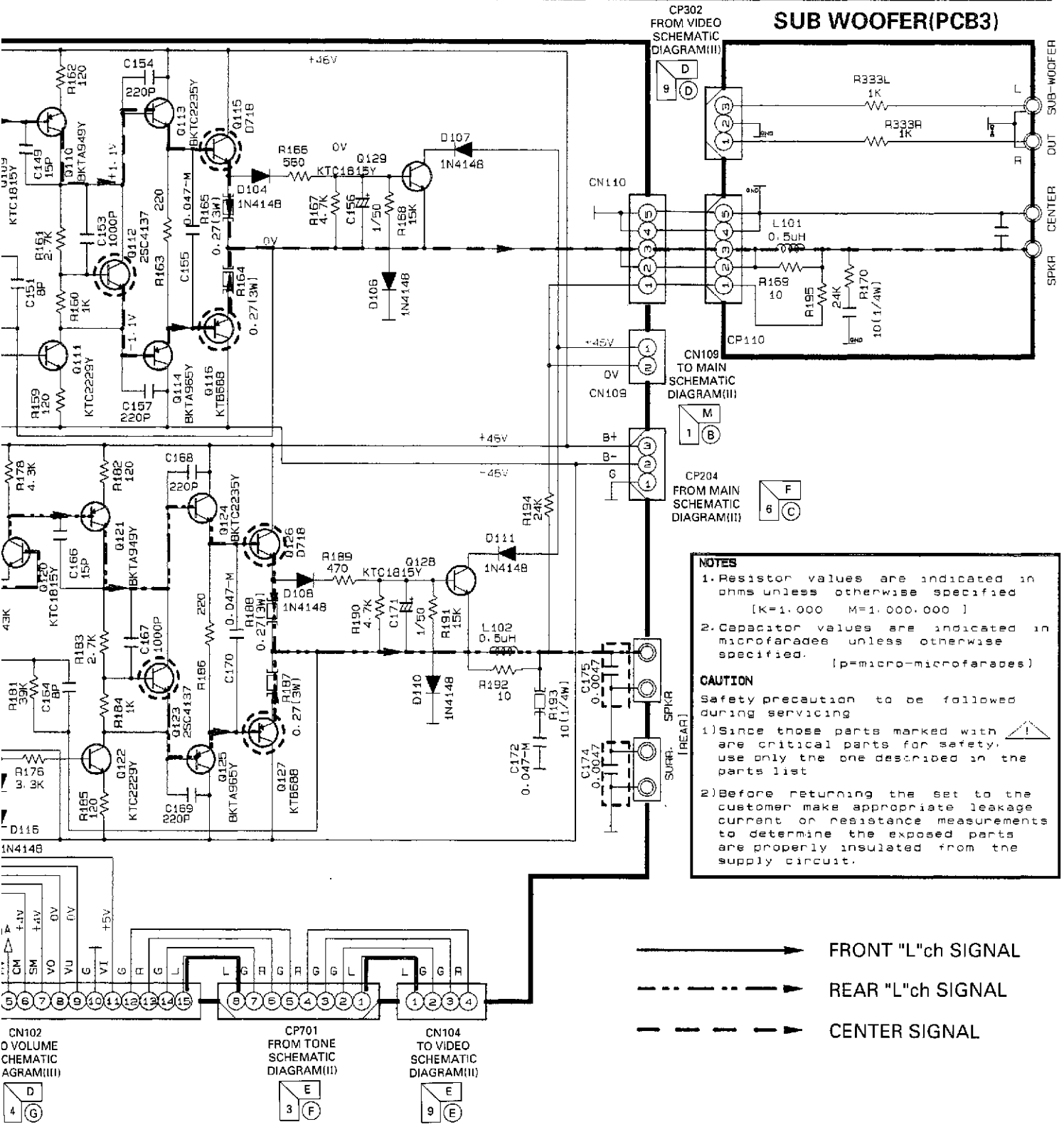
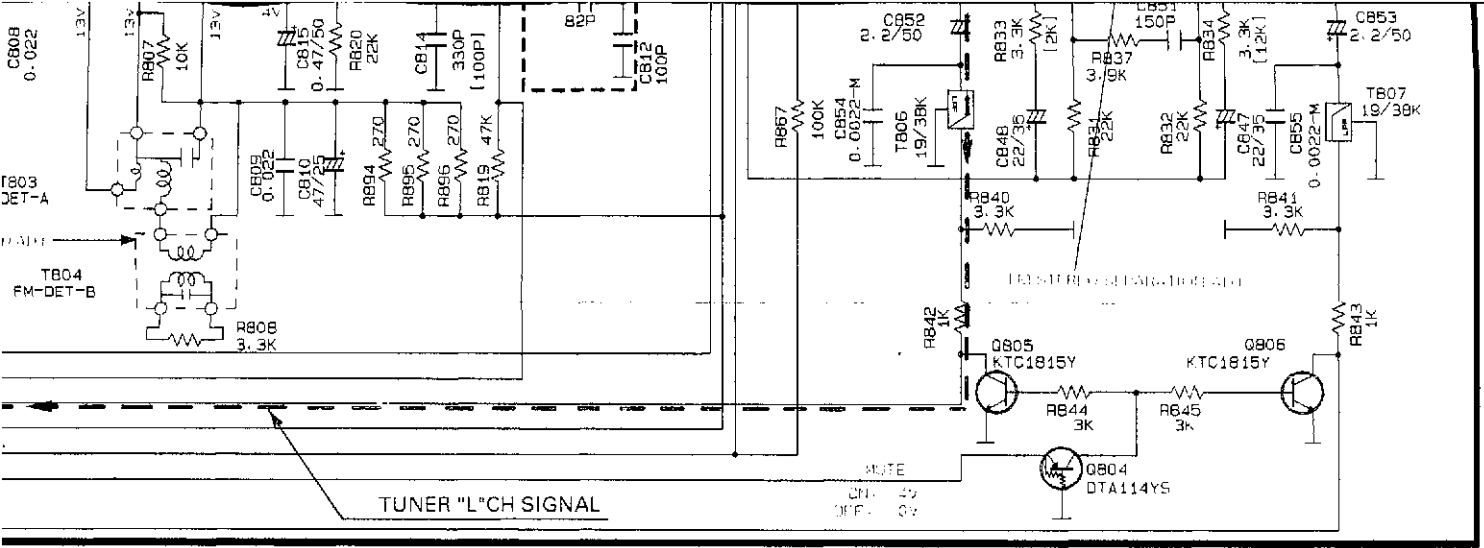

SCHEMATIC DIAGRAMS II

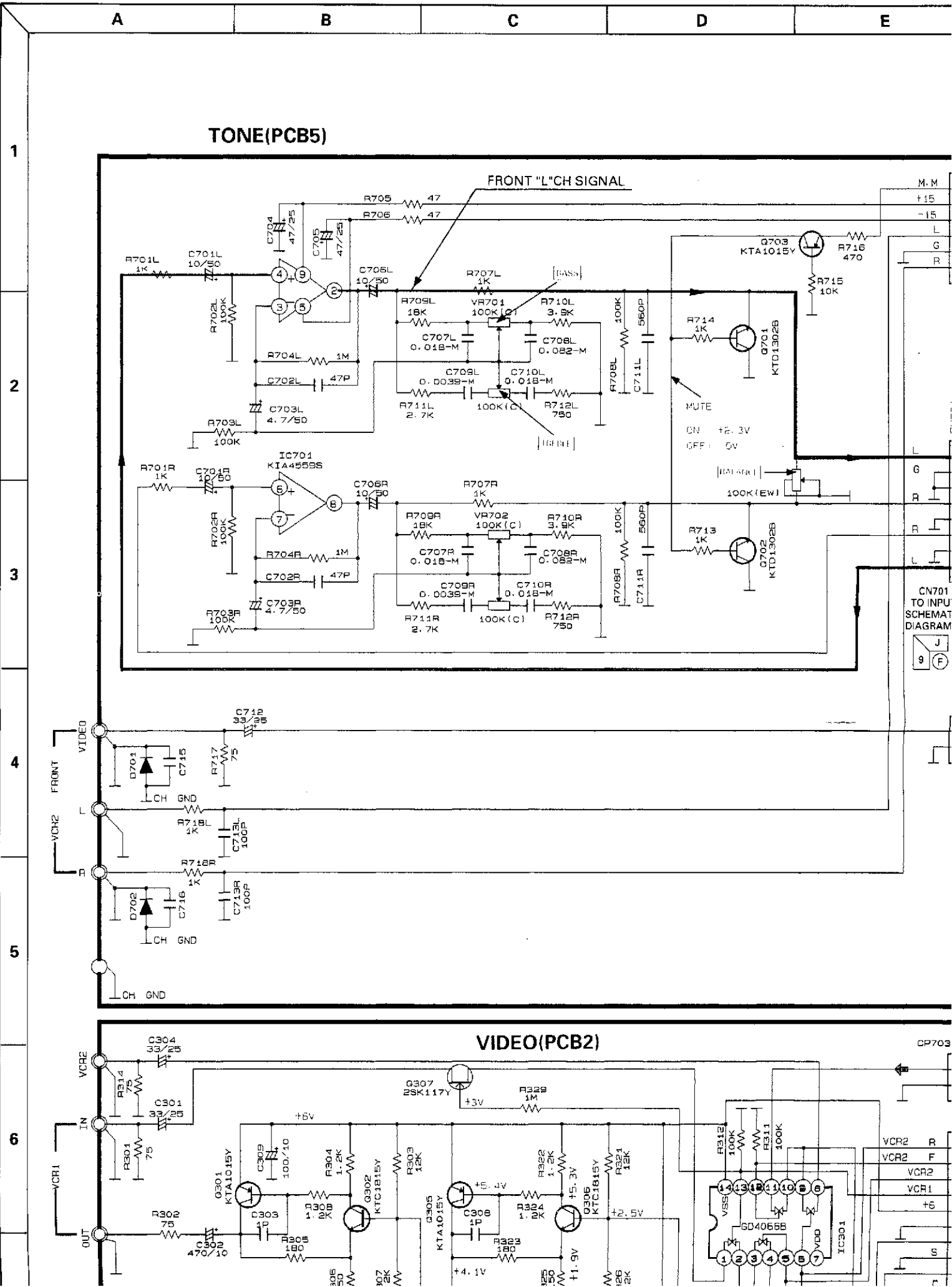

MAIN(PCB1)

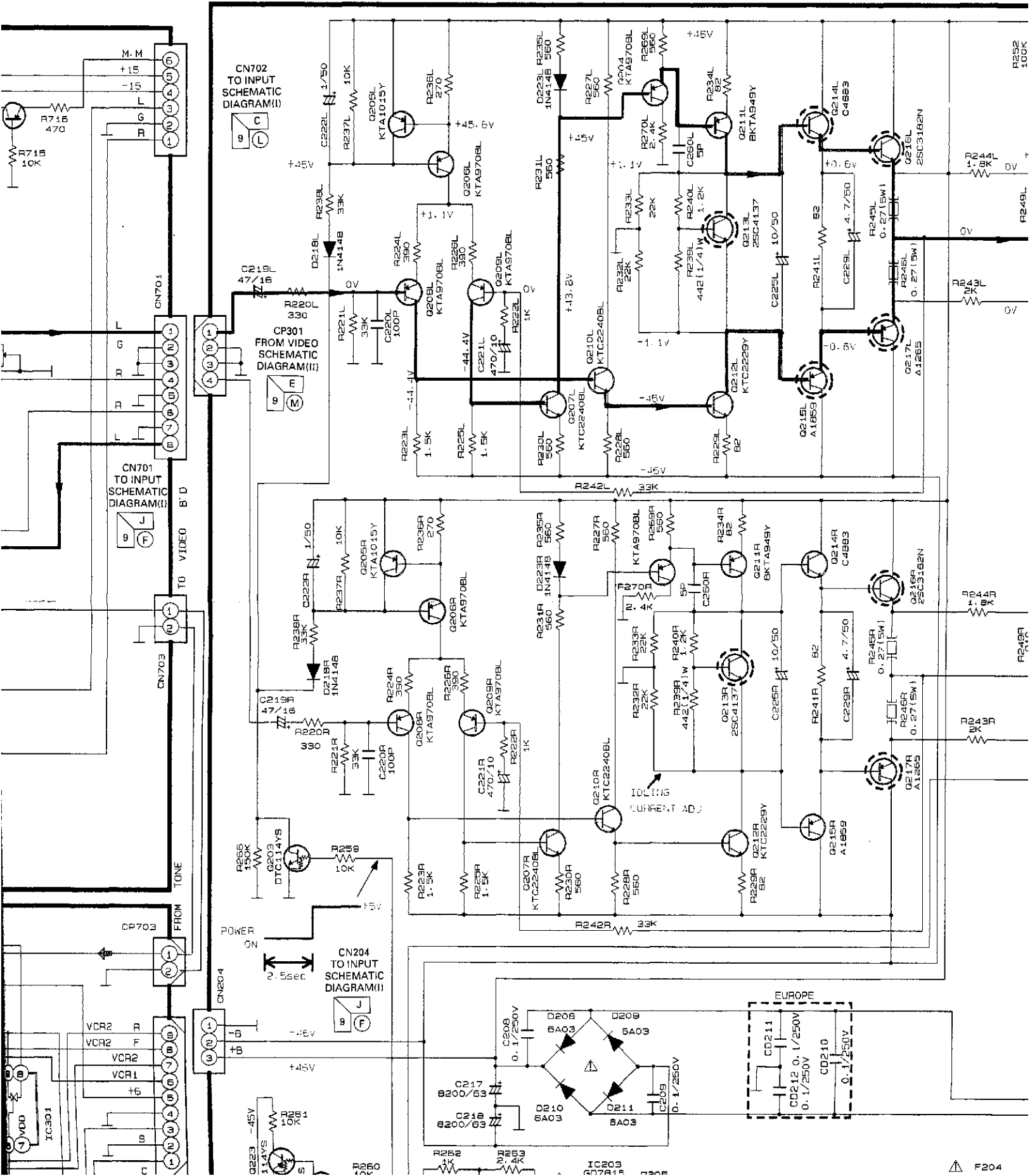

MAIN(PCB1)

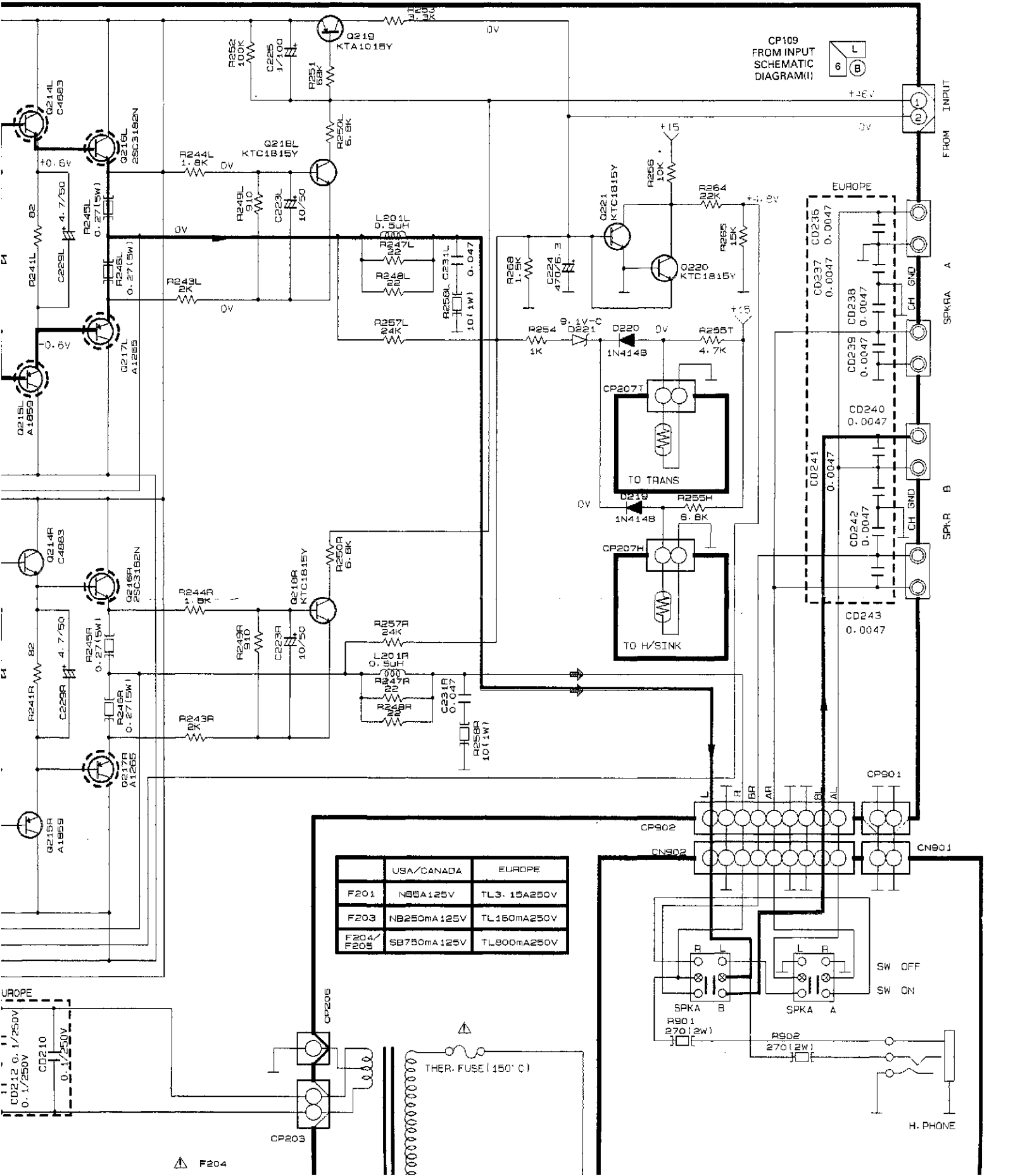

3
4
5
6
7
8
9

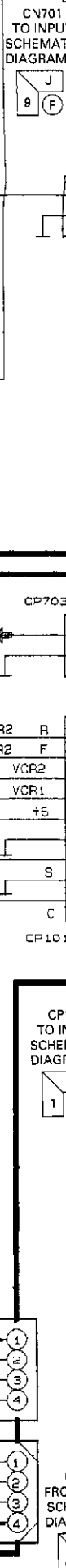
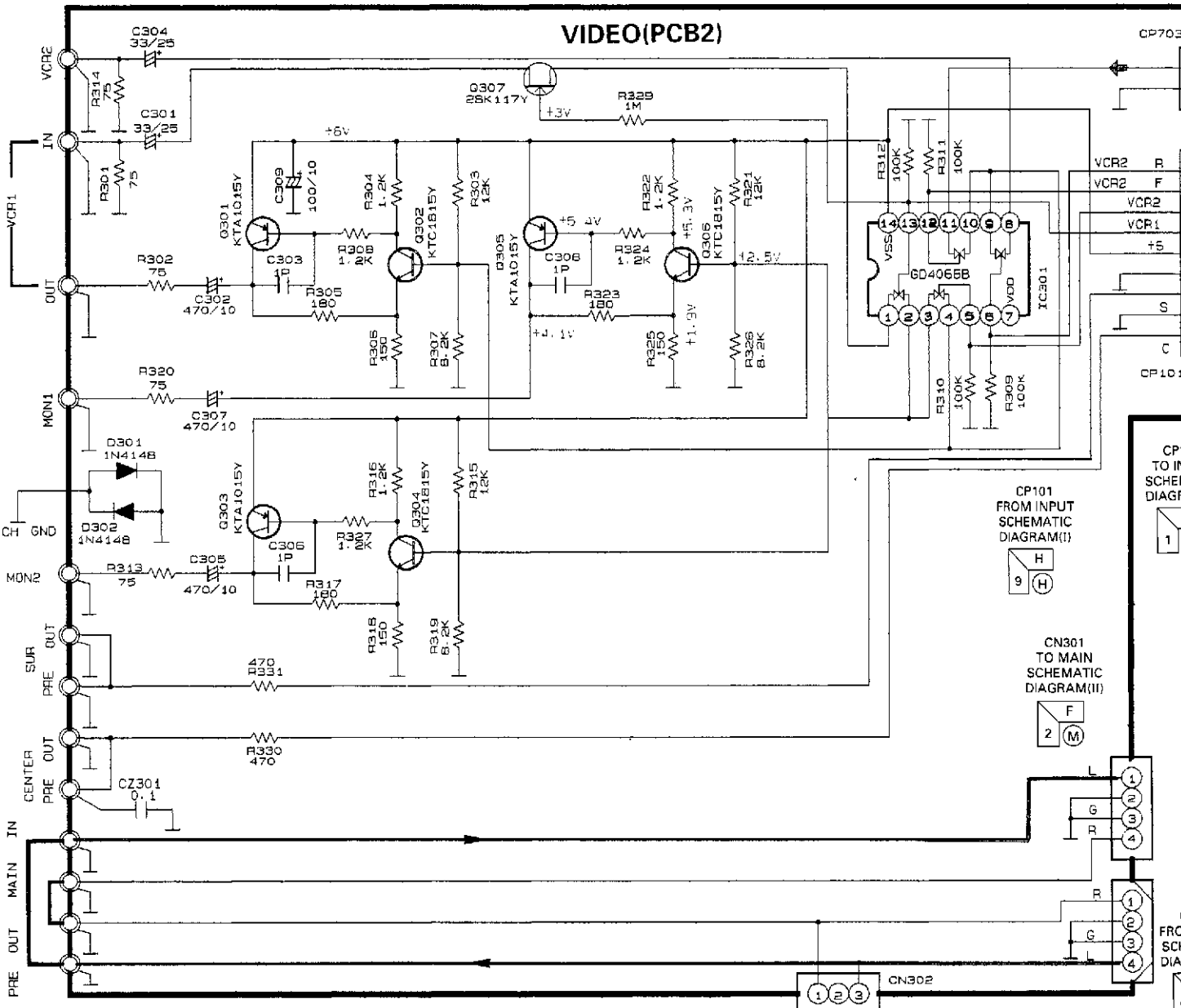
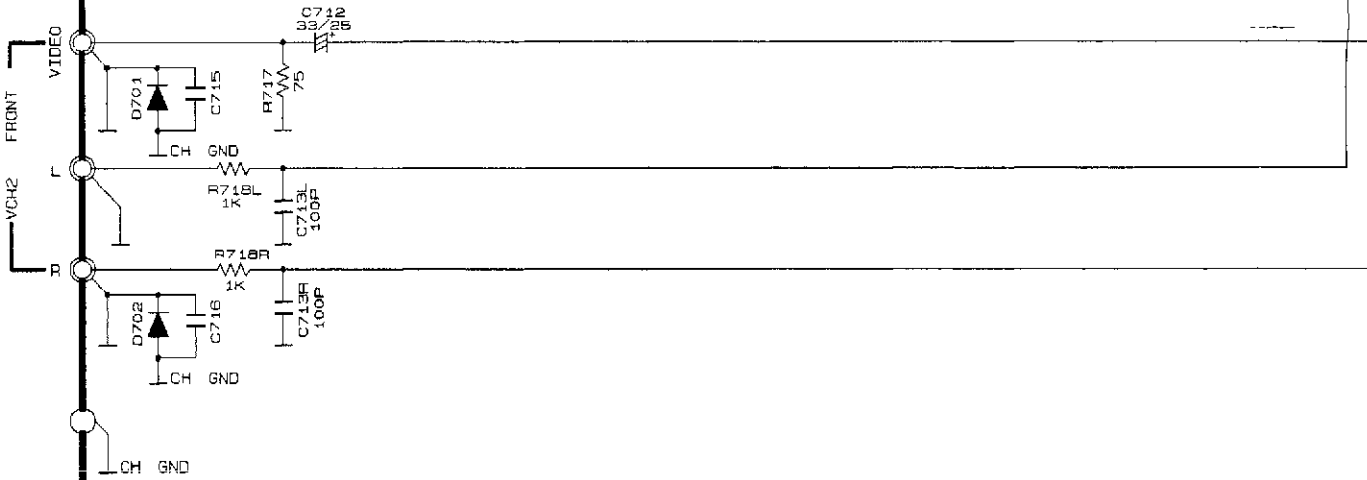
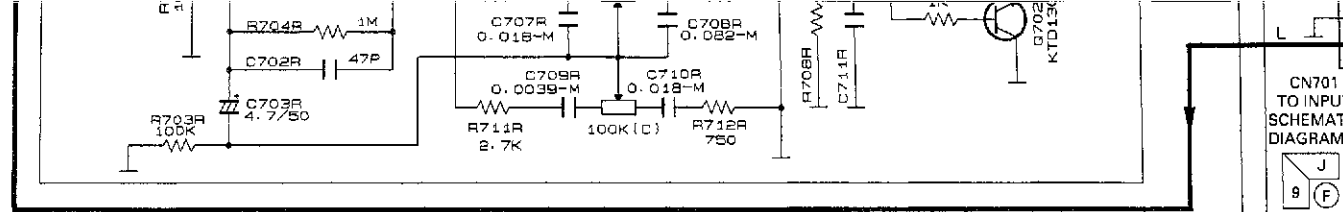

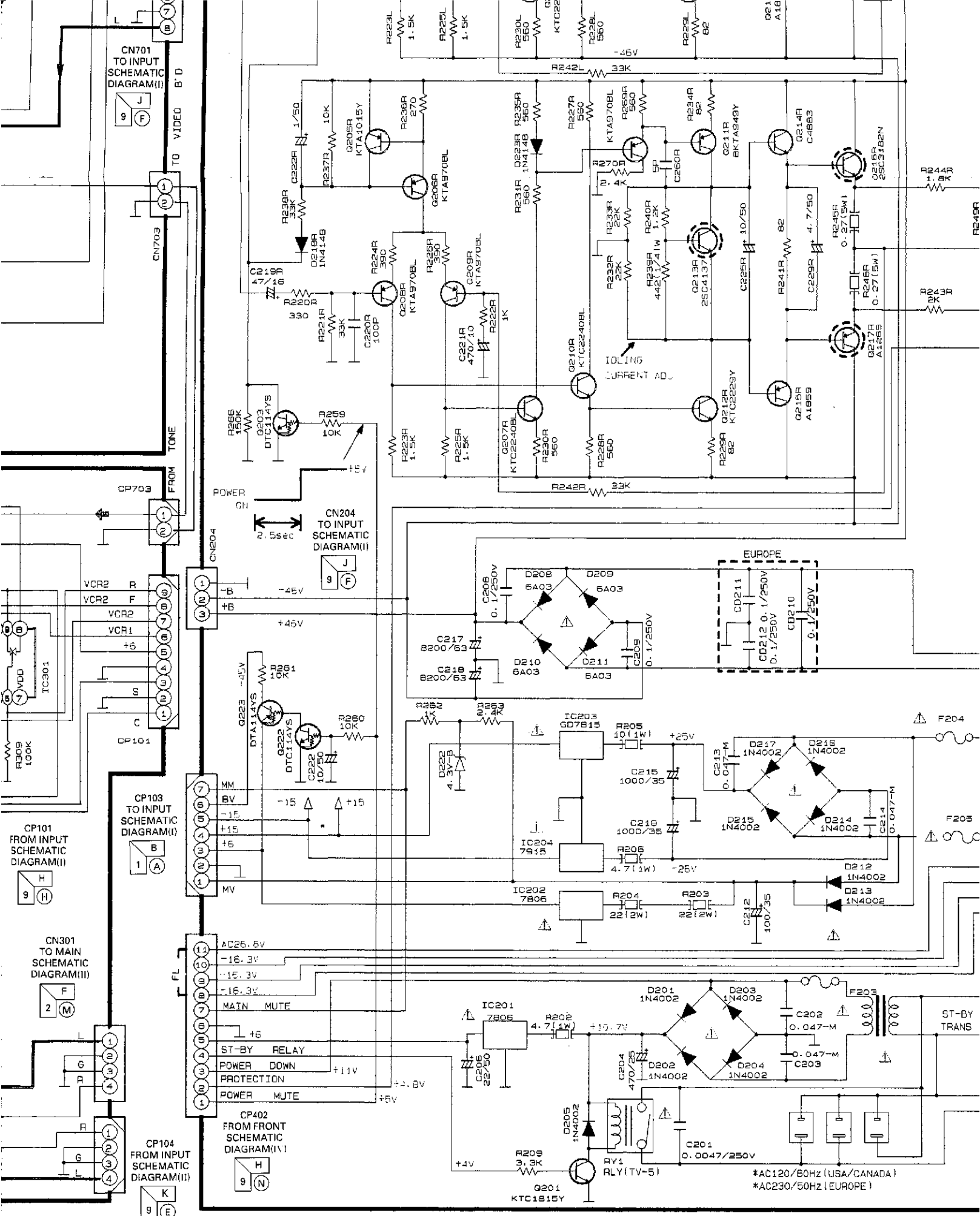

CN701
TO INPUT
SCHEMATIC
DIAGRAM(II)

CN703
TO VIDEO B'D

FROM TONE

CP703

POWER ON
2.5sec

CN204
TO INPUT
SCHEMATIC
DIAGRAM(II)

VCR2 R
VCR2 F
VCR2
VCR1
+6

CP101
FROM INPUT
SCHEMATIC
DIAGRAM(II)

CP103
TO INPUT
SCHEMATIC
DIAGRAM(II)

CP301
TO MAIN
SCHEMATIC
DIAGRAM(II)

FL
AC26.5V
-16.3V
-15.3V
-15.3V
MAIN MUTE
+6
ST-BY RELAY
POWER DOWN +11V
PROTECTION
POWER MUTE +5V

CP104
FROM INPUT
SCHEMATIC
DIAGRAM(II)

CP402
FROM FRONT
SCHEMATIC
DIAGRAM(IV)

EUROPE

D208 6A03
D209 6A03
D210 6A03
D211 6A03

C205 0.1/250V
C217 8200/63
C218 8200/63
C209 0.1/250V

C211 0.1/250V
C212 0.1/250V
C210 0.1/250V

D217 1N4002
D216 1N4002
D215 1N4002
D214 1N4002

C215 1000/35
C213 0.047-M
C216 1000/35
C214 0.047-M

D212 1N4002
D213 1N4002

IC202 7806
R204 22(2W)
R203 22(2W)
C212 100/35

IC203 GD7815
R205 10(1W)
+25V

D201 1N4002
D203 1N4002
D202 1N4002
D204 1N4002

C204 470/25
C202 0.047-M
C203 0.047-M

R202 4.7(1W)
+15.7V
R209 3.9K
C201 0.0047/250V

RY1 RLY(TV-5)

ST-BY TRANS

*AC120/60Hz (USA/CANADA)
*AC230/50Hz (EUROPE)

F204
F205

R223L 1.5K
R225L 1.5K
R230L 560
R228L 560
R229L 82
R21A16

R242R 33K
R247R 560
R248R 560
R249R 560
R244R 82
R245R 82
R246R 82
R243R 560
R241R 82
R240R 82
R239R 82
R238R 82
R237R 82
R236R 82
R235R 82
R234R 82
R233R 82
R232R 82
R231R 82
R230R 82
R229R 82
R228R 82
R227R 82
R226R 82
R225R 82
R224R 82
R223R 82
R222R 82
R221R 82
R220R 82
R219R 82
R218R 82
R217R 82
R216R 82
R215R 82
R214R 82
R213R 82
R212R 82
R211R 82
R210R 82
R209R 82
R208R 82
R207R 82
R206R 82
R205R 82
R204R 82
R203R 82
R202R 82
R201R 82

C225R 10/50
C224R 10/50
C223R 10/50
C222R 10/50
C221R 10/50
C220R 100P
C219R 10/50
C218R 10/50
C217R 8200/63
C216R 8200/63
C215R 1000/35
C214R 0.047-M
C213R 0.047-M
C212R 100/35
C211R 0.1/250V
C210R 0.1/250V
C209R 0.1/250V
C208R 0.1/250V
C207R 0.1/250V
C206R 0.1/250V
C205R 0.1/250V
C204R 470/25
C203R 0.047-M
C202R 0.047-M
C201R 0.0047/250V

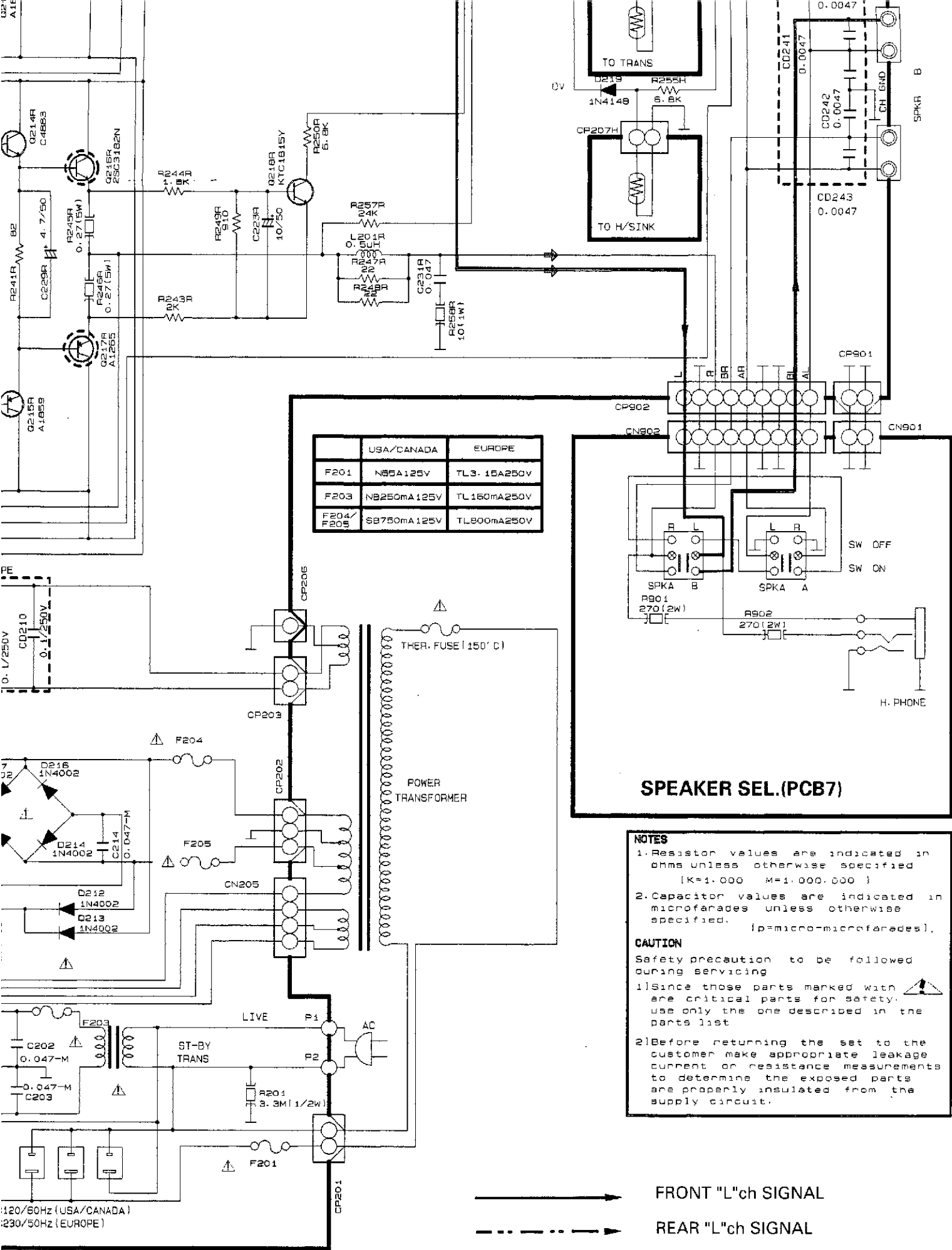

Q201R KTC1815Y
Q200R KT1A970BL
Q199R KT1A970BL
Q198R KT1A970BL
Q197R KT1A970BL
Q196R KT1A970BL
Q195R KT1A970BL
Q194R KT1A970BL
Q193R KT1A970BL
Q192R KT1A970BL
Q191R KT1A970BL
Q190R KT1A970BL
Q189R KT1A970BL
Q188R KT1A970BL
Q187R KT1A970BL
Q186R KT1A970BL
Q185R KT1A970BL
Q184R KT1A970BL
Q183R KT1A970BL
Q182R KT1A970BL
Q181R KT1A970BL
Q180R KT1A970BL
Q179R KT1A970BL
Q178R KT1A970BL
Q177R KT1A970BL
Q176R KT1A970BL
Q175R KT1A970BL
Q174R KT1A970BL
Q173R KT1A970BL
Q172R KT1A970BL
Q171R KT1A970BL
Q170R KT1A970BL
Q169R KT1A970BL
Q168R KT1A970BL
Q167R KT1A970BL
Q166R KT1A970BL
Q165R KT1A970BL
Q164R KT1A970BL
Q163R KT1A970BL
Q162R KT1A970BL
Q161R KT1A970BL
Q160R KT1A970BL
Q159R KT1A970BL
Q158R KT1A970BL
Q157R KT1A970BL
Q156R KT1A970BL
Q155R KT1A970BL
Q154R KT1A970BL
Q153R KT1A970BL
Q152R KT1A970BL
Q151R KT1A970BL
Q150R KT1A970BL
Q149R KT1A970BL
Q148R KT1A970BL
Q147R KT1A970BL
Q146R KT1A970BL
Q145R KT1A970BL
Q144R KT1A970BL
Q143R KT1A970BL
Q142R KT1A970BL
Q141R KT1A970BL
Q140R KT1A970BL
Q139R KT1A970BL
Q138R KT1A970BL
Q137R KT1A970BL
Q136R KT1A970BL
Q135R KT1A970BL
Q134R KT1A970BL
Q133R KT1A970BL
Q132R KT1A970BL
Q131R KT1A970BL
Q130R KT1A970BL
Q129R KT1A970BL
Q128R KT1A970BL
Q127R KT1A970BL
Q126R KT1A970BL
Q125R KT1A970BL
Q124R KT1A970BL
Q123R KT1A970BL
Q122R KT1A970BL
Q121R KT1A970BL
Q120R KT1A970BL
Q119R KT1A970BL
Q118R KT1A970BL
Q117R KT1A970BL
Q116R KT1A970BL
Q115R KT1A970BL
Q114R KT1A970BL
Q113R KT1A970BL
Q112R KT1A970BL
Q111R KT1A970BL
Q110R KT1A970BL
Q109R KT1A970BL
Q108R KT1A970BL
Q107R KT1A970BL
Q106R KT1A970BL
Q105R KT1A970BL
Q104R KT1A970BL
Q103R KT1A970BL
Q102R KT1A970BL
Q101R KT1A970BL
Q100R KT1A970BL
Q99R KT1A970BL
Q98R KT1A970BL
Q97R KT1A970BL
Q96R KT1A970BL
Q95R KT1A970BL
Q94R KT1A970BL
Q93R KT1A970BL
Q92R KT1A970BL
Q91R KT1A970BL
Q90R KT1A970BL
Q89R KT1A970BL
Q88R KT1A970BL
Q87R KT1A970BL
Q86R KT1A970BL
Q85R KT1A970BL
Q84R KT1A970BL
Q83R KT1A970BL
Q82R KT1A970BL
Q81R KT1A970BL
Q80R KT1A970BL
Q79R KT1A970BL
Q78R KT1A970BL
Q77R KT1A970BL
Q76R KT1A970BL
Q75R KT1A970BL
Q74R KT1A970BL
Q73R KT1A970BL
Q72R KT1A970BL
Q71R KT1A970BL
Q70R KT1A970BL
Q69R KT1A970BL
Q68R KT1A970BL
Q67R KT1A970BL
Q66R KT1A970BL
Q65R KT1A970BL
Q64R KT1A970BL
Q63R KT1A970BL
Q62R KT1A970BL
Q61R KT1A970BL
Q60R KT1A970BL
Q59R KT1A970BL
Q58R KT1A970BL
Q57R KT1A970BL
Q56R KT1A970BL
Q55R KT1A970BL
Q54R KT1A970BL
Q53R KT1A970BL
Q52R KT1A970BL
Q51R KT1A970BL
Q50R KT1A970BL
Q49R KT1A970BL
Q48R KT1A970BL
Q47R KT1A970BL
Q46R KT1A970BL
Q45R KT1A970BL
Q44R KT1A970BL
Q43R KT1A970BL
Q42R KT1A970BL
Q41R KT1A970BL
Q40R KT1A970BL
Q39R KT1A970BL
Q38R KT1A970BL
Q37R KT1A970BL
Q36R KT1A970BL
Q35R KT1A970BL
Q34R KT1A970BL
Q33R KT1A970BL
Q32R KT1A970BL
Q31R KT1A970BL
Q30R KT1A970BL
Q29R KT1A970BL
Q28R KT1A970BL
Q27R KT1A970BL
Q26R KT1A970BL
Q25R KT1A970BL
Q24R KT1A970BL
Q23R KT1A970BL
Q22R KT1A970BL
Q21R KT1A970BL
Q20R KT1A970BL
Q19R KT1A970BL
Q18R KT1A970BL
Q17R KT1A970BL
Q16R KT1A970BL
Q15R KT1A970BL
Q14R KT1A970BL
Q13R KT1A970BL
Q12R KT1A970BL
Q11R KT1A970BL
Q10R KT1A970BL
Q9R KT1A970BL
Q8R KT1A970BL
Q7R KT1A970BL
Q6R KT1A970BL
Q5R KT1A970BL
Q4R KT1A970BL
Q3R KT1A970BL
Q2R KT1A970BL
Q1R KT1A970BL



SPEAKER SEL.(PCB7)

NOTES
 1. Resistor values are indicated in ohms unless otherwise specified [K=1,000 M=1,000,000]
 2. Capacitor values are indicated in microfarads unless otherwise specified. [p=micro-microfarades].

CAUTION
 Safety precaution to be followed during servicing
 1) Since those parts marked with  are critical parts for safety, use only the one described in the parts list
 2) Before returning the set to the customer make appropriate leakage current or resistance measurements to determine the exposed parts are properly insulated from the supply circuit.

-  FRONT "L"ch SIGNAL
-  REAR "L"ch SIGNAL
-  CENTER SIGNAL

:120/60Hz (USA/CANADA)
 :230/50Hz (EUROPE)

SCHEMATIC DIAGRAMS III

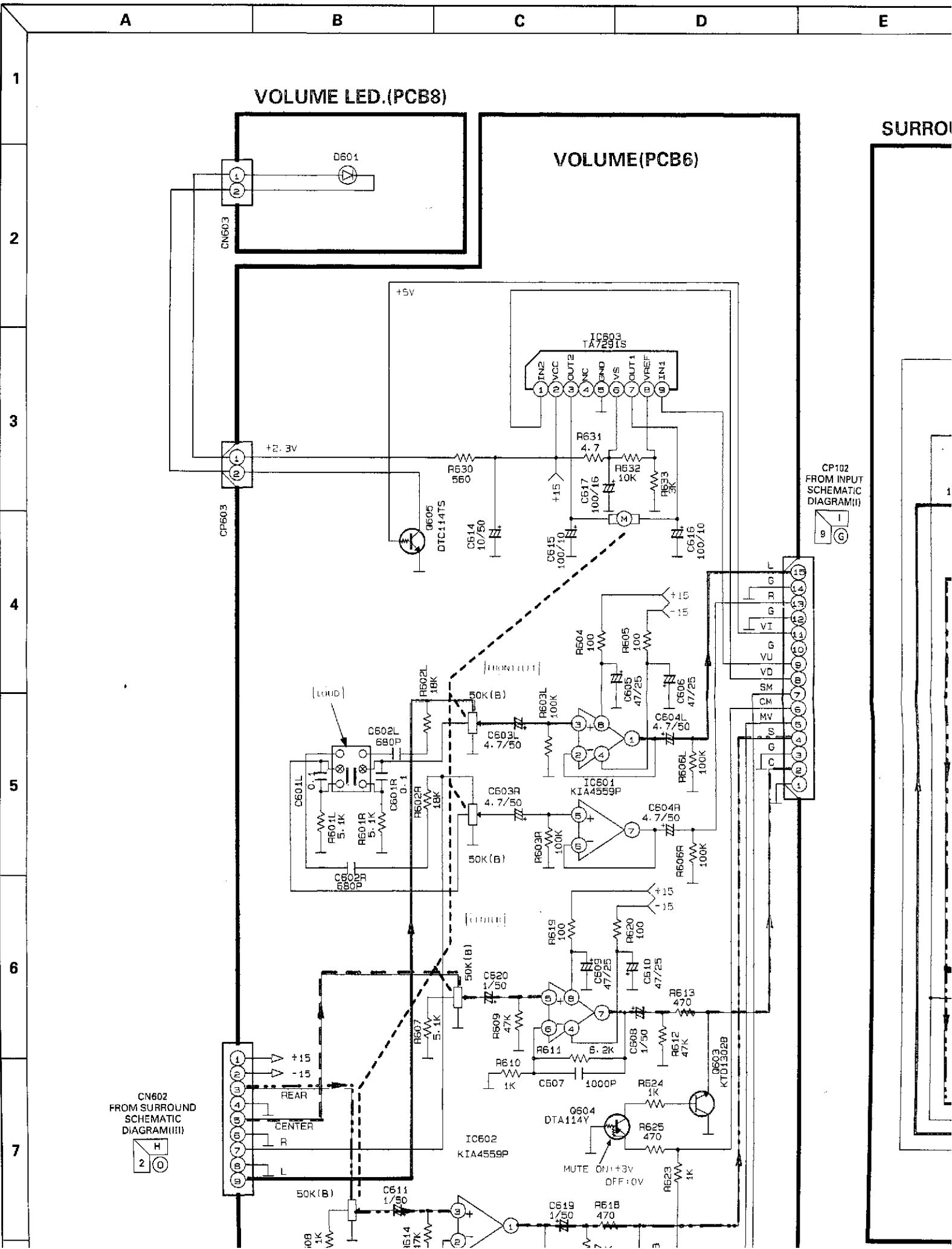

SURROUND(PCB11)

CP102
OM INPUT
SCHEMATIC
DIAGRAM(I)

9 G

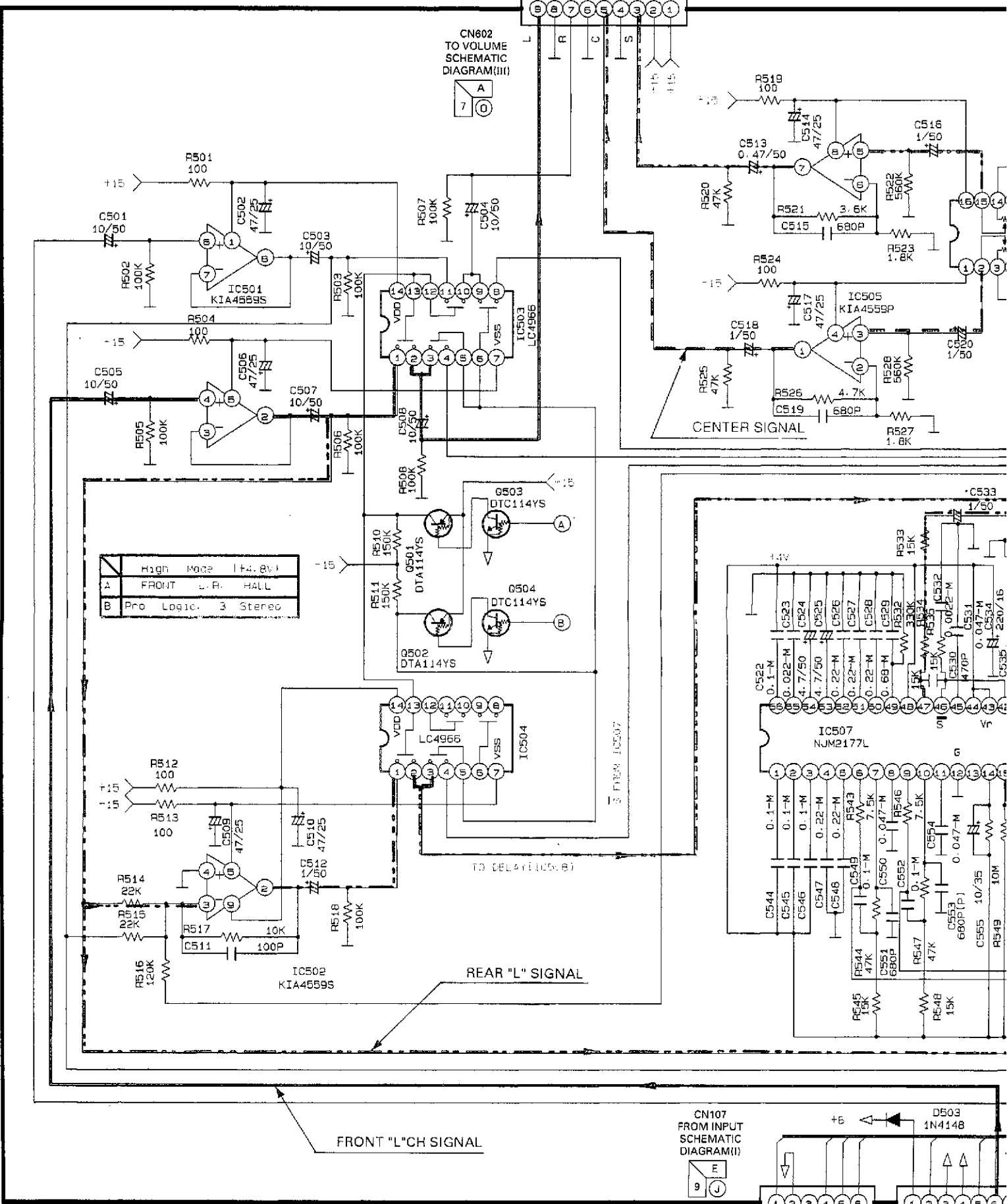

	High Mode	+4.8V
A	FRONT L.R.	HALL
B	Pro Logic	3 Stereo

CN602
TO VOLUME
SCHEMATIC
DIAGRAM(III)



CENTER SIGNAL

TO DELAY (IC503)

REAR "L" SIGNAL

FRONT "L" CH SIGNAL

CN107
FROM INPUT
SCHEMATIC
DIAGRAM(I)



E F G H I J

CN602
FROM SURROUND
SCHEMATIC
DIAGRAM(III)

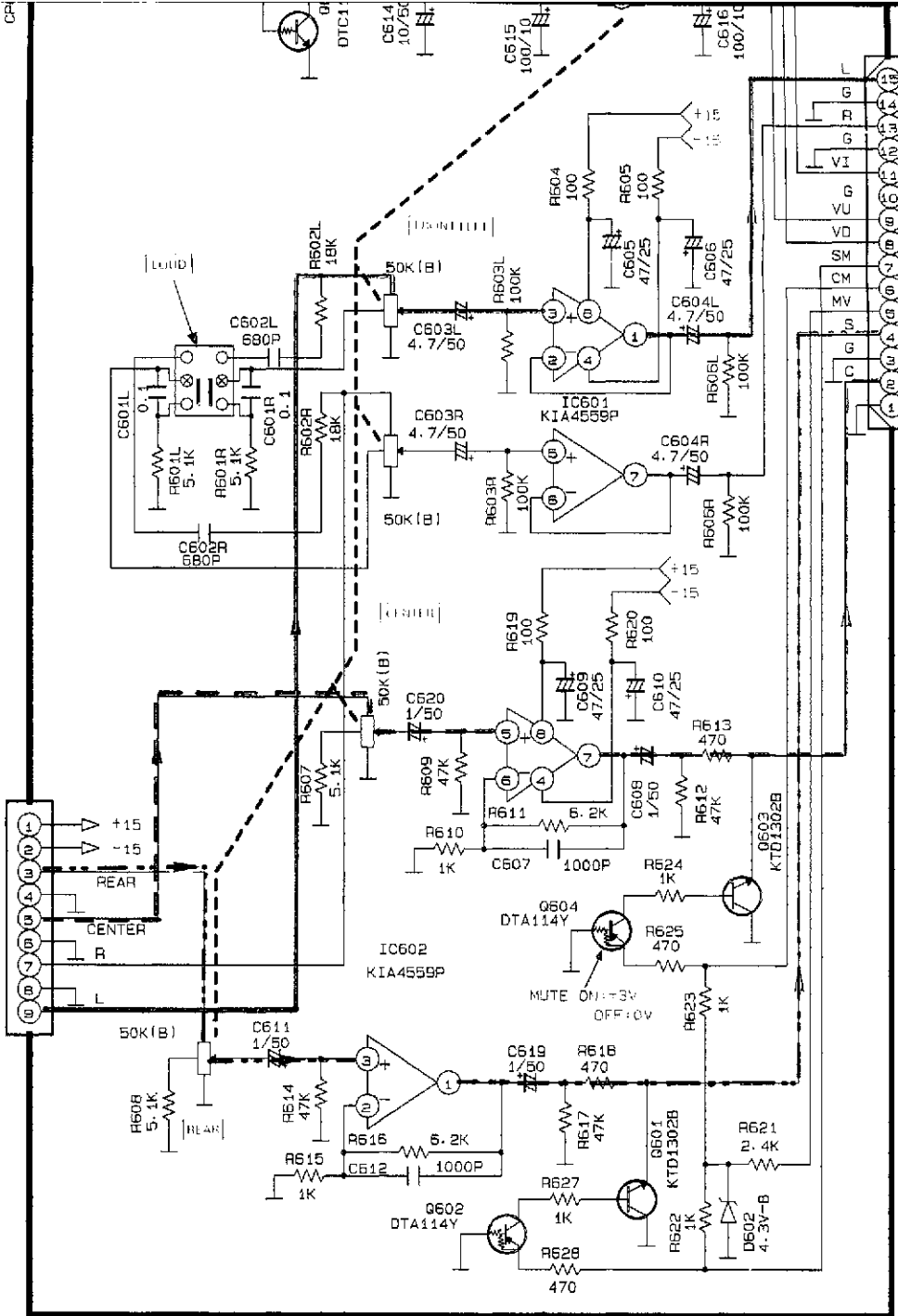

PIN CONNECTION OF TRANSISTORS, DIODES AND ICS.

<p>KTA949 KTA965 KTC2229 KTC2235</p>	<p>KTA970 KTA1015 KTC1923 KTC2240 KTC1815Y</p>	<p>DTA114YS DTC114YS DTC114TS</p>	<p>2SK168 2SK117</p>	<p>2SC4137</p>
<p>GL7806 GL7815</p>	<p>GL7915</p>	<p>LC4966</p>	<p>KIA4559P KIA6259P</p>	<p>TC9176 MC14094</p>

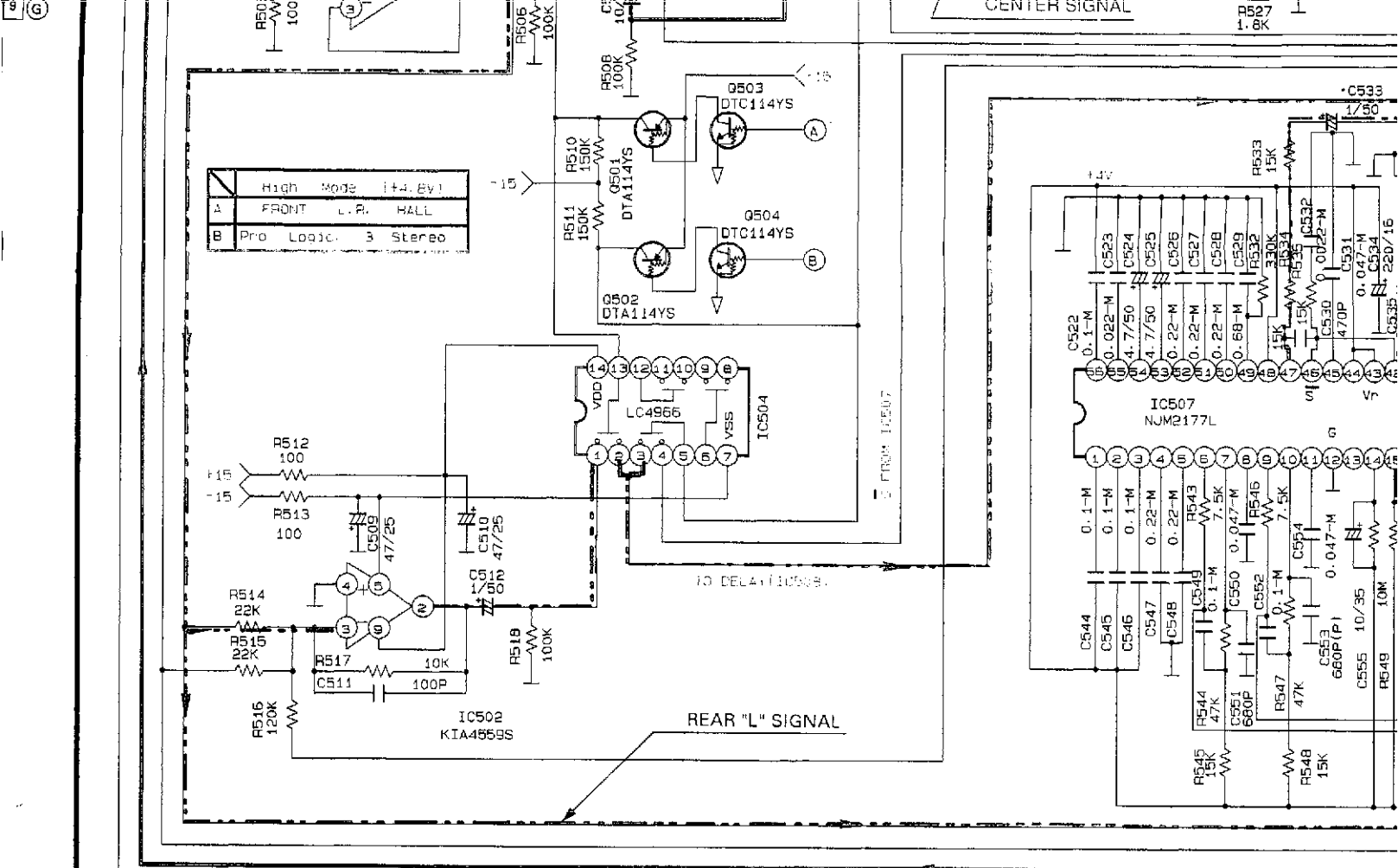

FRONT "L" CH SIGNAL

REAR "L" SIGNAL

CN107 FROM INPUT SCHEMATIC DIAGRAM (I)

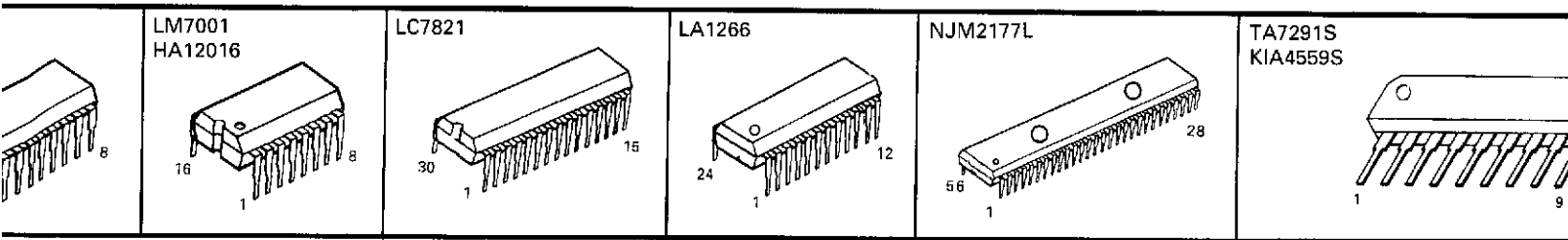
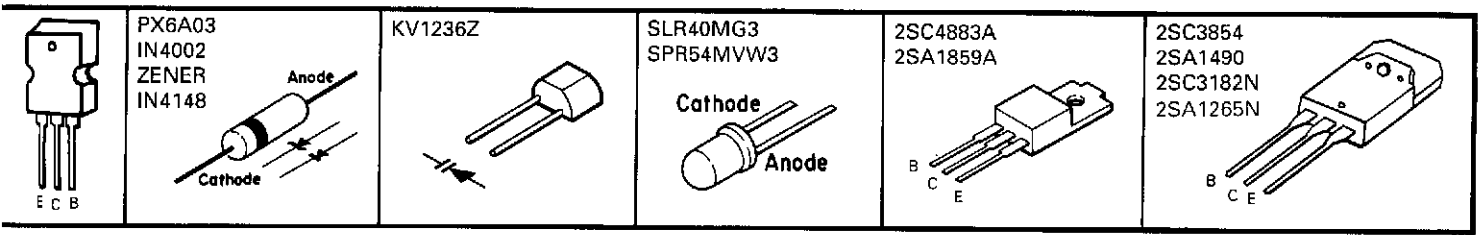
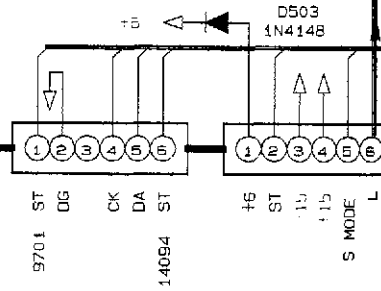

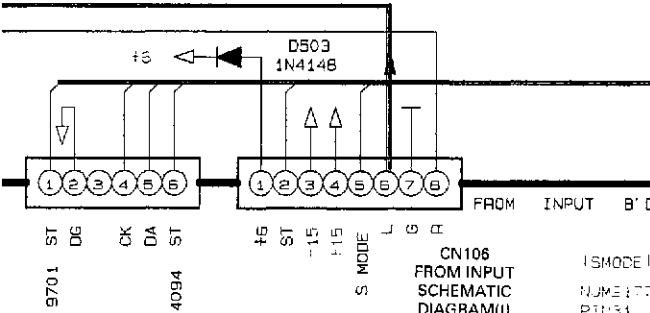
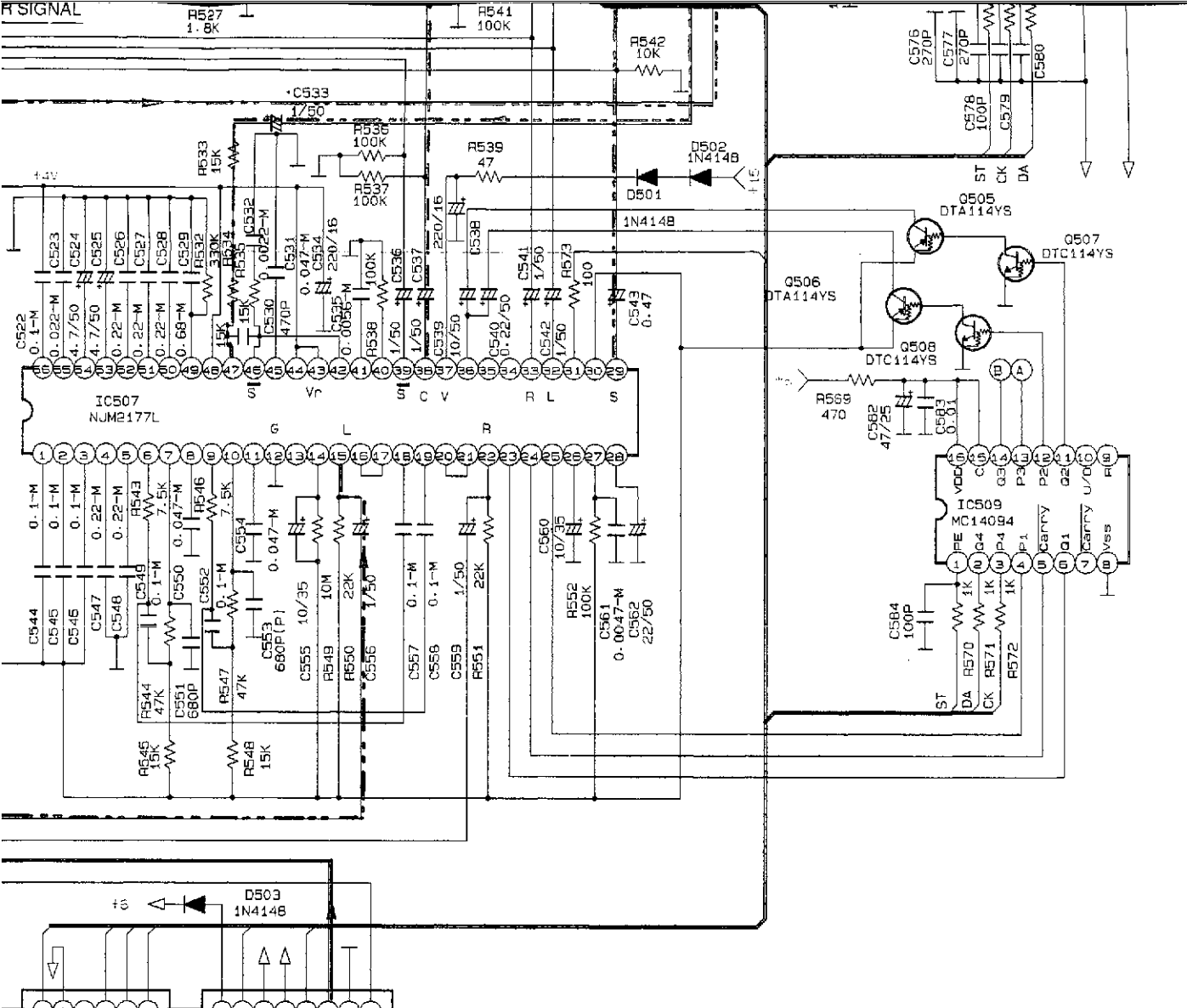

ISMODE1
 NAME:177
 PIN:31

PROLOGIC +5V
 BSTERED +12.6V
 HALL +5V
 OFF 0V

NOTES

1. Resistor values are indicated in ohms unless otherwise specified [K=1,000 M=1,000,000]
2. Capacitor values are indicated in microfarads unless otherwise specified. [p=micro-microfarads]

CAUTION

Safety precaution to be followed during servicing

- 1) Since those parts marked with are critical parts for safety, use only the one described in the parts list
- 2) Before returning the set to the customer make appropriate leakage current or resistance measurements to determine the exposed parts are properly insulated from the supply circuit.

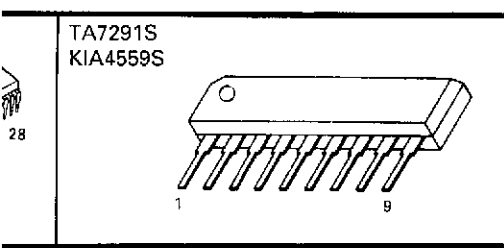
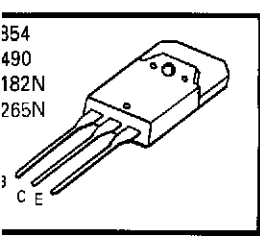

—————> FRONT "L"ch SIGNAL
 - - - - -> REAR "L"ch SIGNAL
 - · - · -> CENTER SIGNAL

SCHEMATIC DIAGRAM IV

FRONT(PCB4)

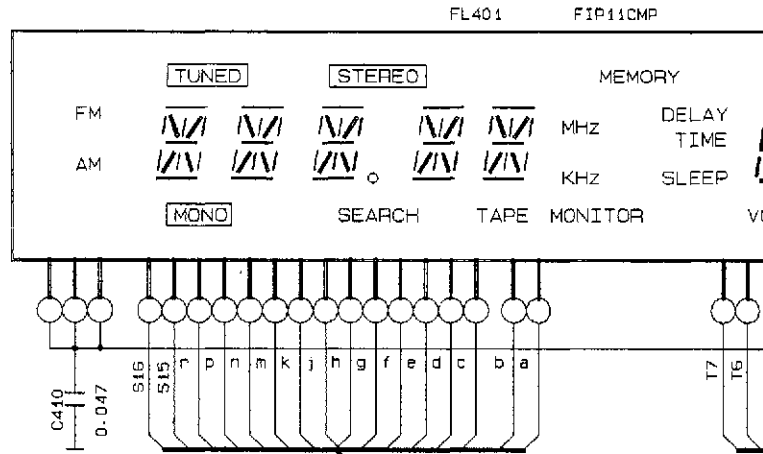

	PIN	
VERSION	55	66
USA/CAN	H	L
EUROPE	L	L

IC4C1
CXP50116

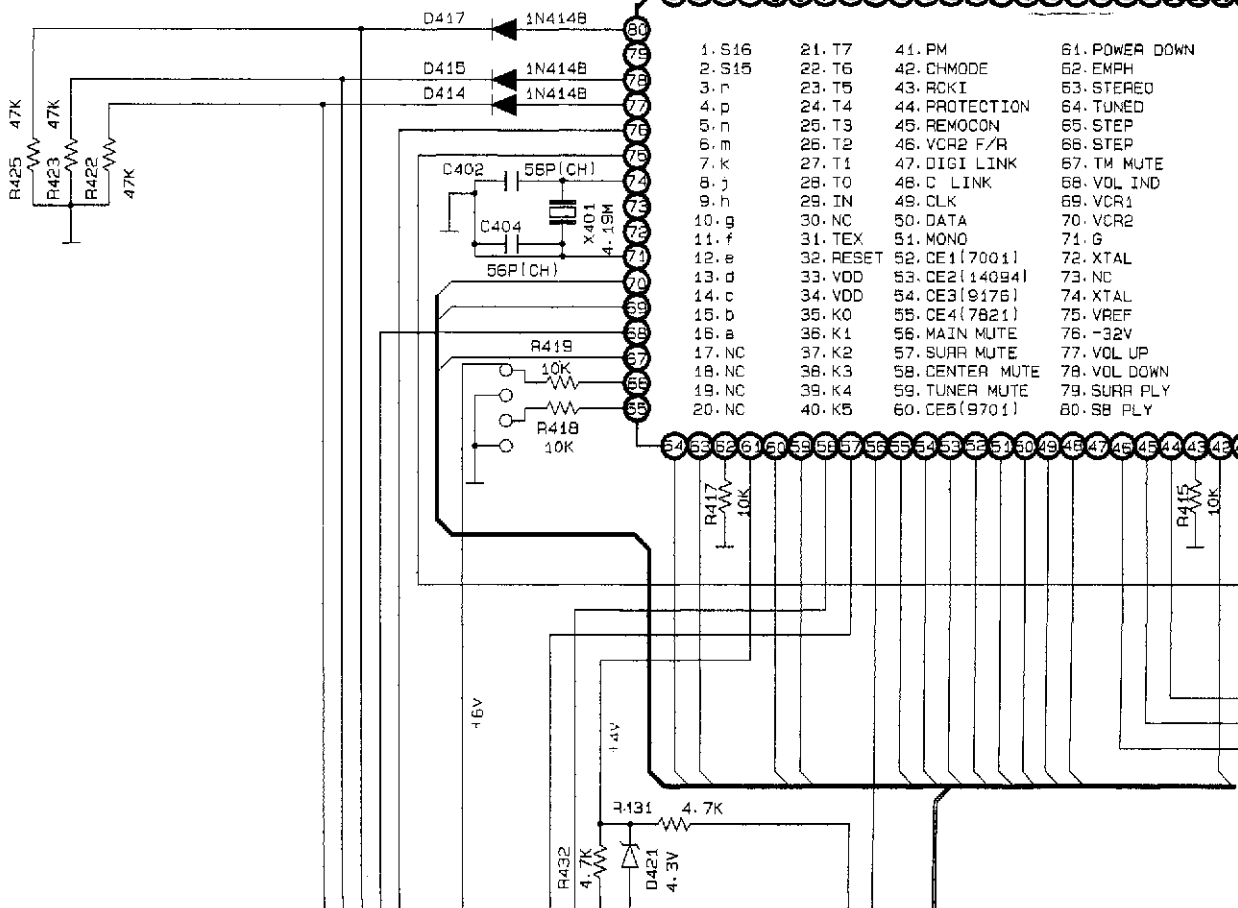

- 1. S16
- 2. S15
- 3. r
- 4. p
- 5. n
- 6. m
- 7. k
- 8. j
- 9. h
- 10. g
- 11. f
- 12. e
- 13. d
- 14. c
- 15. b
- 16. a
- 17. NC
- 18. NC
- 19. NC
- 20. NC
- 21. T7
- 22. T6
- 23. T5
- 24. T4
- 25. T3
- 26. T2
- 27. T1
- 28. T0
- 29. IN
- 30. NC
- 31. TEX
- 32. RESET
- 33. VDD
- 34. VDD
- 35. K0
- 36. K1
- 37. K2
- 38. K3
- 39. K4
- 40. K5
- 41. PM
- 42. CHMODE
- 43. ROCKI
- 44. PROTECTION
- 45. REMOCON
- 46. VCR2 F/R
- 47. DIGI LINK
- 48. C LINK
- 49. CLK
- 50. DATA
- 51. MONO
- 52. CE1(7001)
- 53. CE2(14094)
- 54. CE3(9176)
- 55. CE4(7821)
- 56. MAIN MUTE
- 57. SURR MUTE
- 58. CENTER MUTE
- 59. TUNER MUTE
- 60. CE5(9701)
- 61. POWER DOWN
- 62. EMPH
- 63. STEREO
- 64. TUNED
- 65. STEP
- 66. STEP
- 67. TM MUTE
- 68. VOL IND
- 69. VCR1
- 70. VCR2
- 71. G
- 72. XTAL
- 73. NC
- 74. XTAL
- 75. VREF
- 76. -32V
- 77. VOL UP
- 78. VOL DOWN
- 79. SURR PLY
- 80. SB PLY

E

F

G

H

I

FL401 FIP11CMP

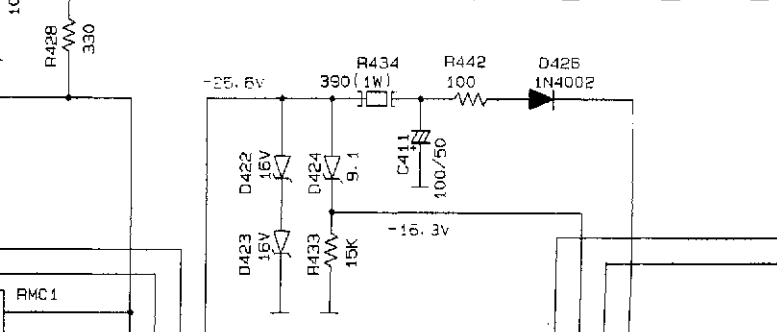
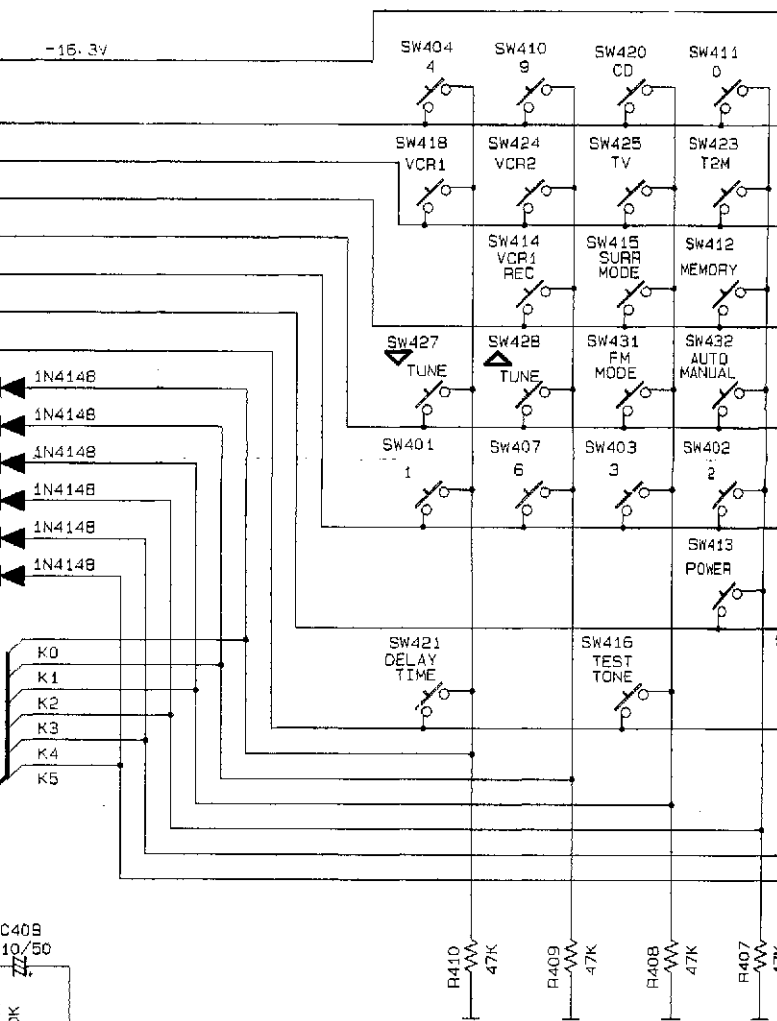
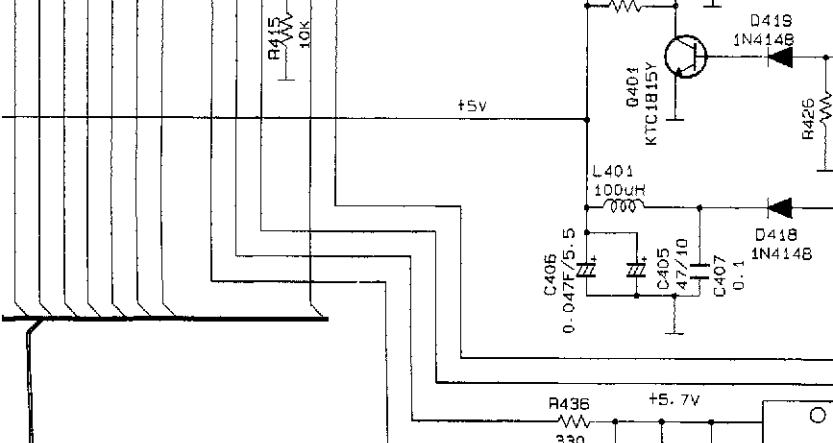
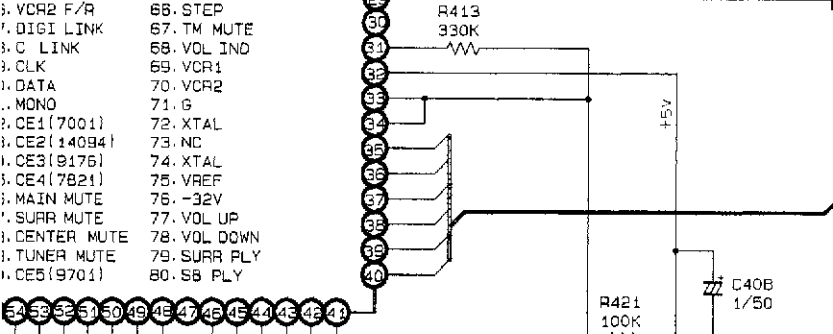
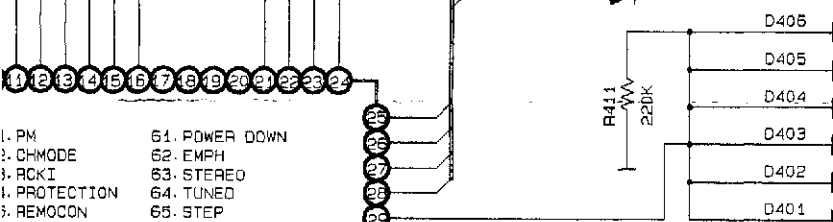
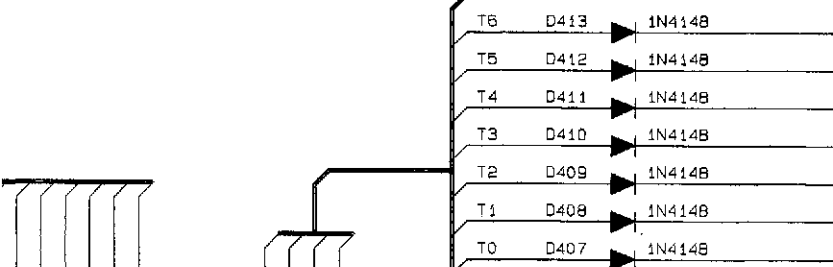
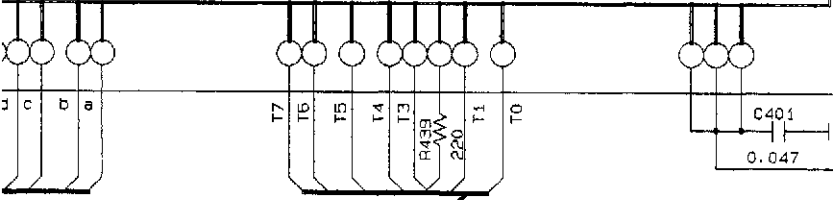

- 1. PM
- 2. CHMODE
- 3. RCKI
- 4. PROTECTION
- 5. REMOCON
- 6. VCR2 F/R
- 7. DIGI LINK
- 8. C LINK
- 9. CLK
- 10. DATA
- 11. MONO
- 12. CE1(7001)
- 13. CE2(140941)
- 14. CE3(9176)
- 15. CE4(7821)
- 16. MAIN MUTE
- 17. SURR MUTE
- 18. CENTER MUTE
- 19. TUNER MUTE
- 20. CE5(9701)
- 61. POWER DOWN
- 62. EMPH
- 63. STEREO
- 64. TUNED
- 65. STEP
- 66. STEP
- 67. TM MUTE
- 68. VOL IND
- 69. VCR1
- 70. VCR2
- 71. G
- 72. XTAL
- 73. NC
- 74. XTAL
- 75. VREF
- 76. -32V
- 77. VOL UP
- 78. VOL DOWN
- 79. SURR PLY
- 80. SB PLY

I

J

K

L

M

COMMANDER

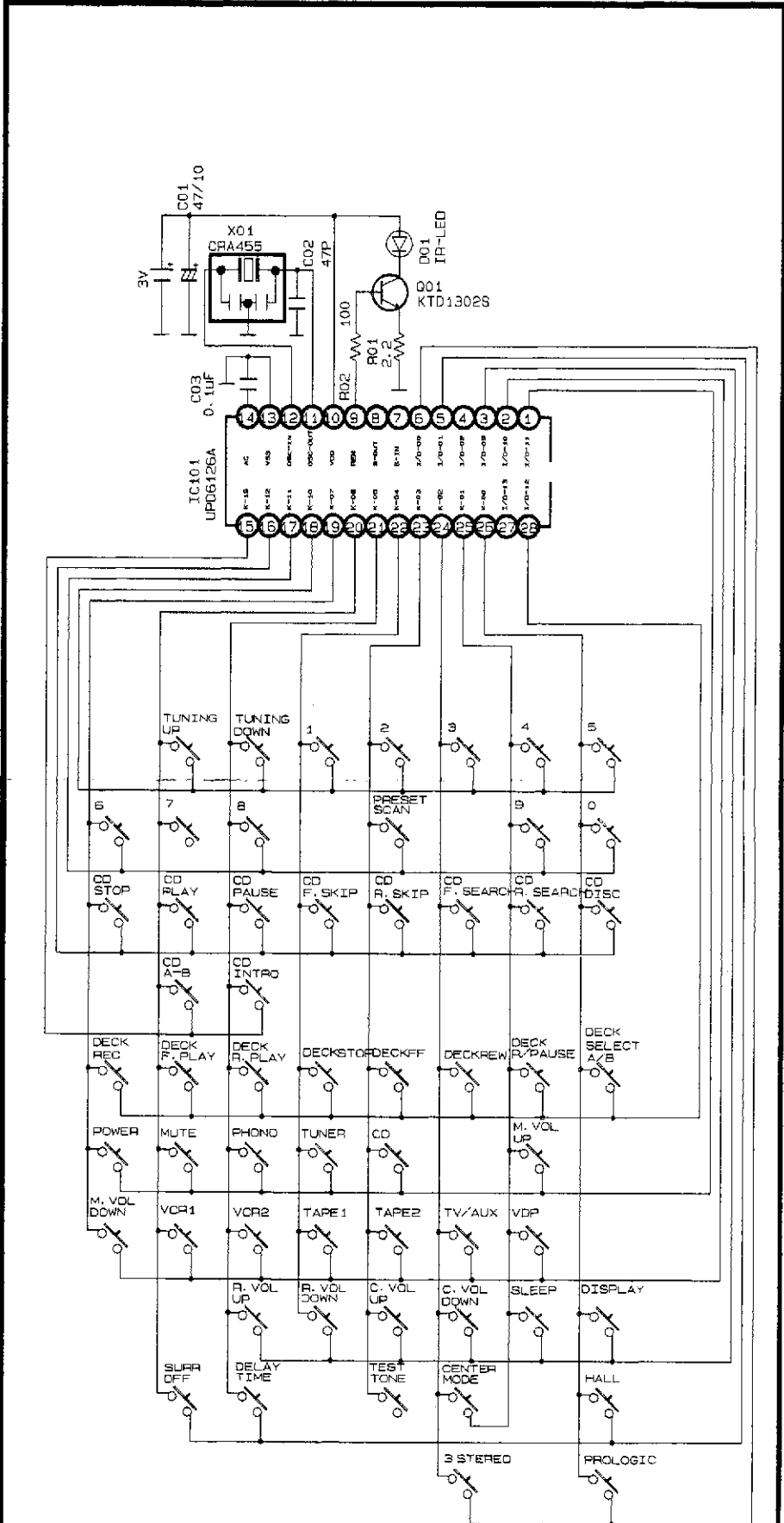
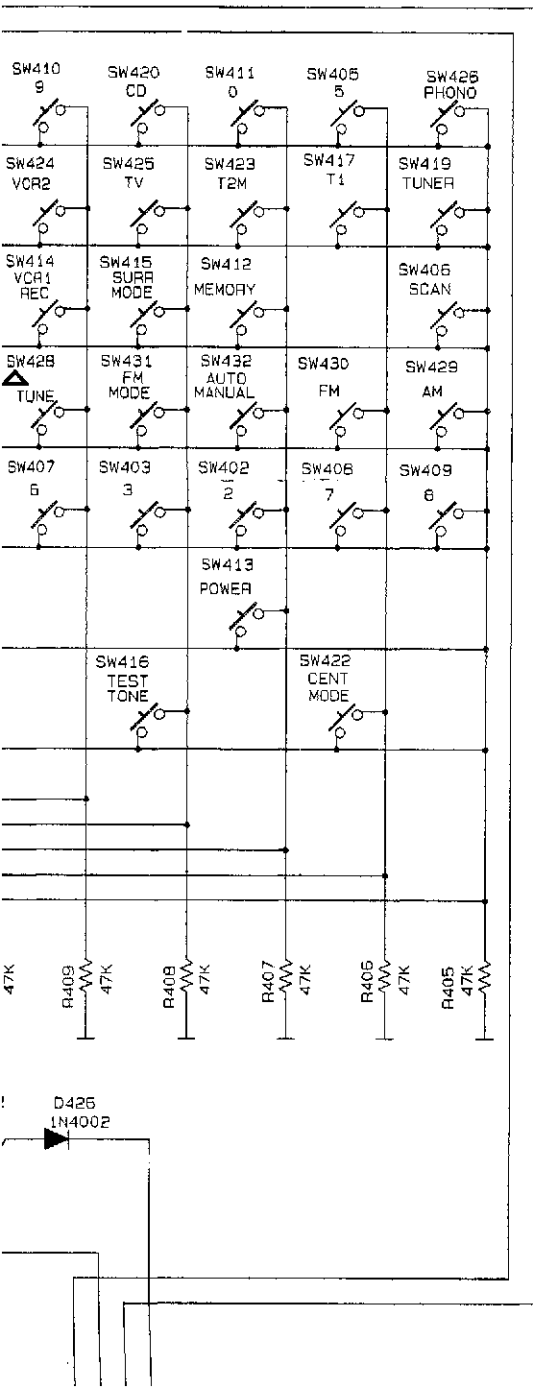

VERSION	PIN	
USA/CAN	65	66
EUROPE	L	L

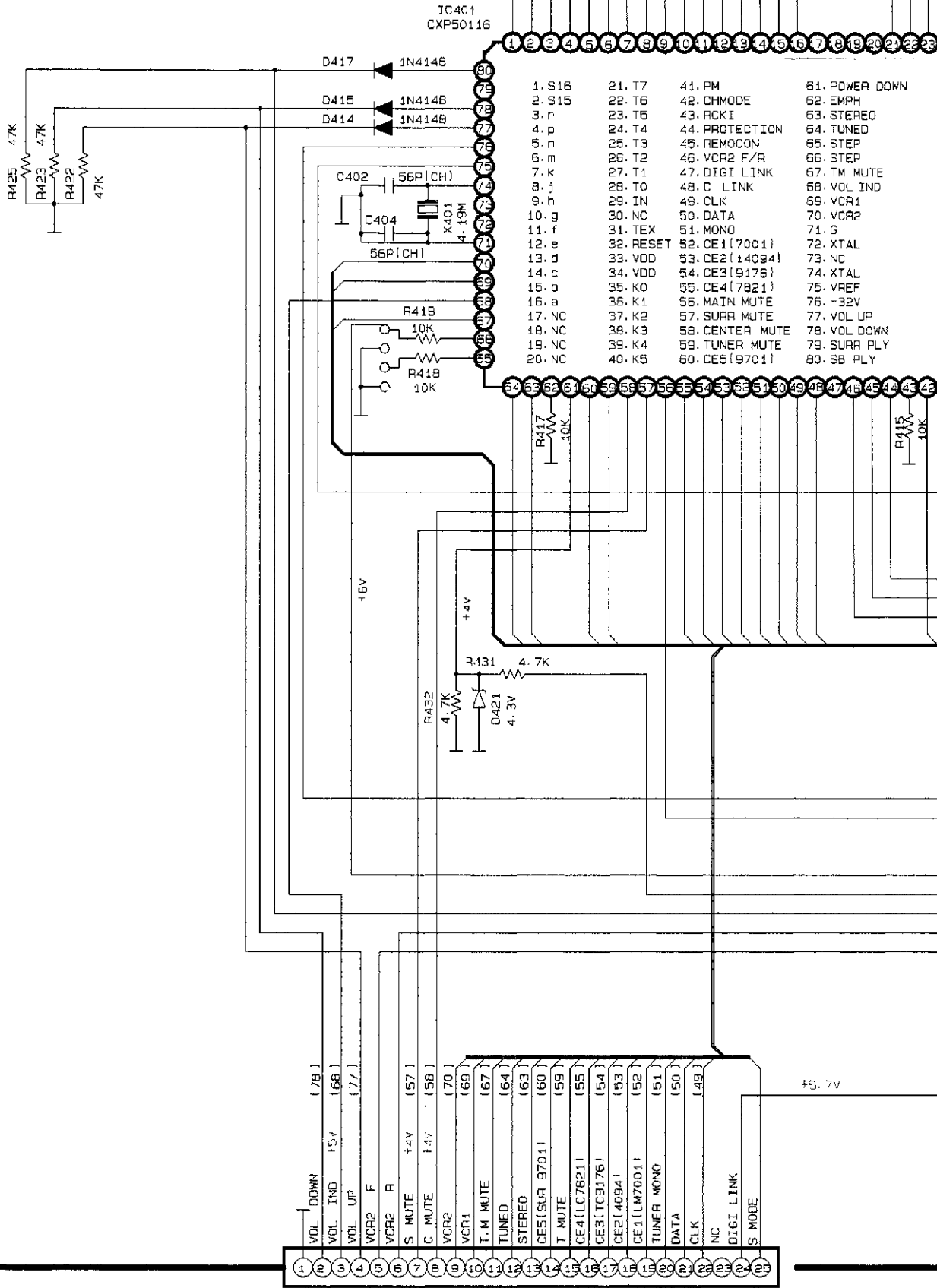

CN401
TO INPUT
SCHEMATIC
DIAGRAM(!)



3

4

5

6

7

8

9

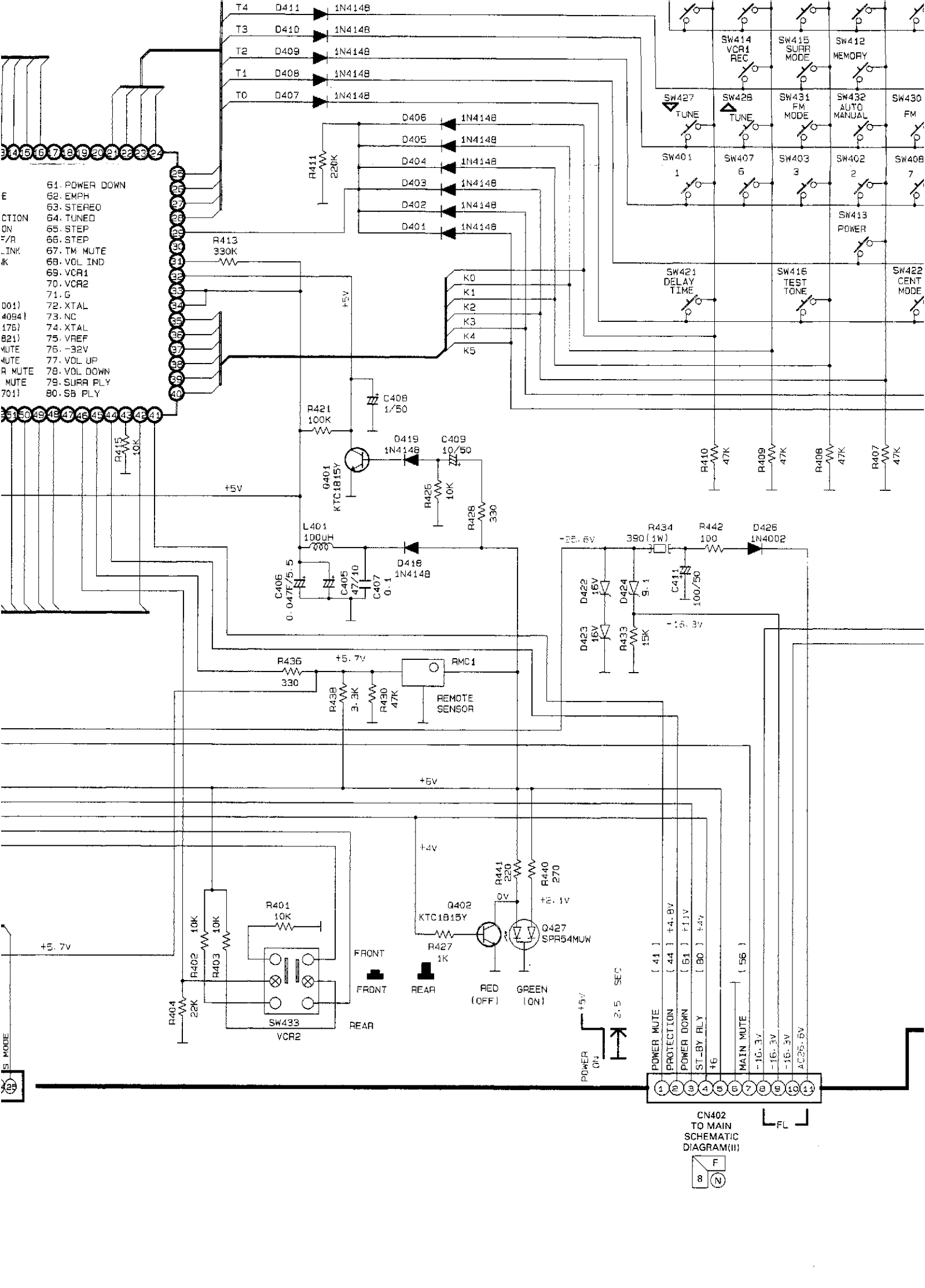

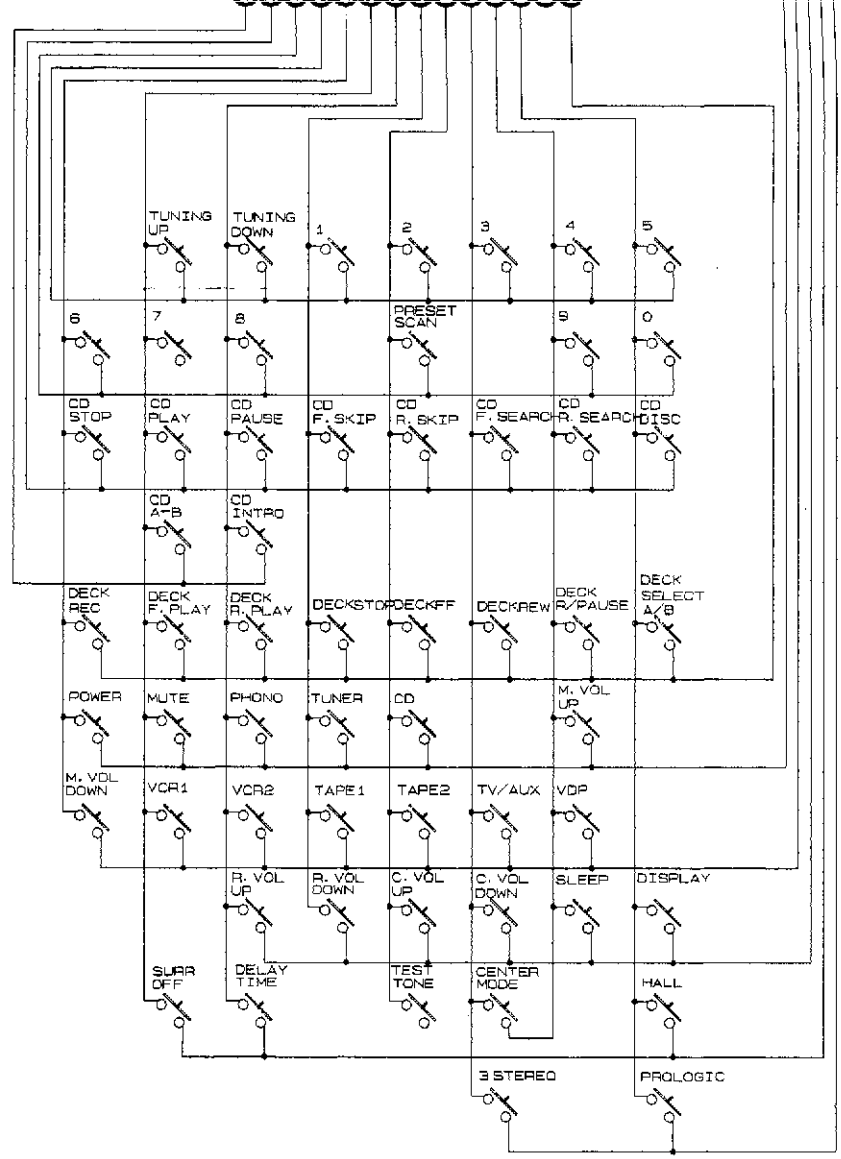
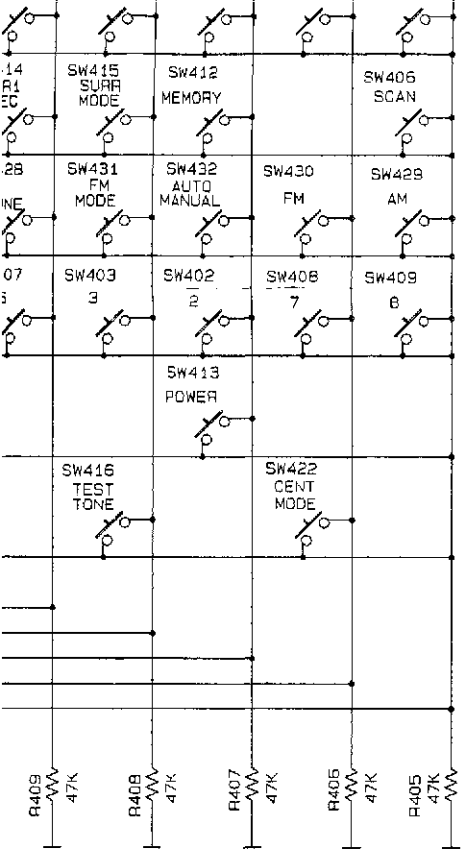

NOTES

1. Resistor values are indicated in ohms unless otherwise specified
(K=1,000 M=1,000,000)
2. Capacitor values are indicated in microfarads unless otherwise specified.
(p=micro-microfarads)

CAUTION

Safety precaution to be followed during servicing

- 1) Since those parts marked with are critical parts for safety, use only the one described in the parts list
- 2) Before returning the set to the customer make appropriate leakage current or resistance measurements to determine the exposed parts are properly insulated from the supply circuit.

WIRING DIAGRAM

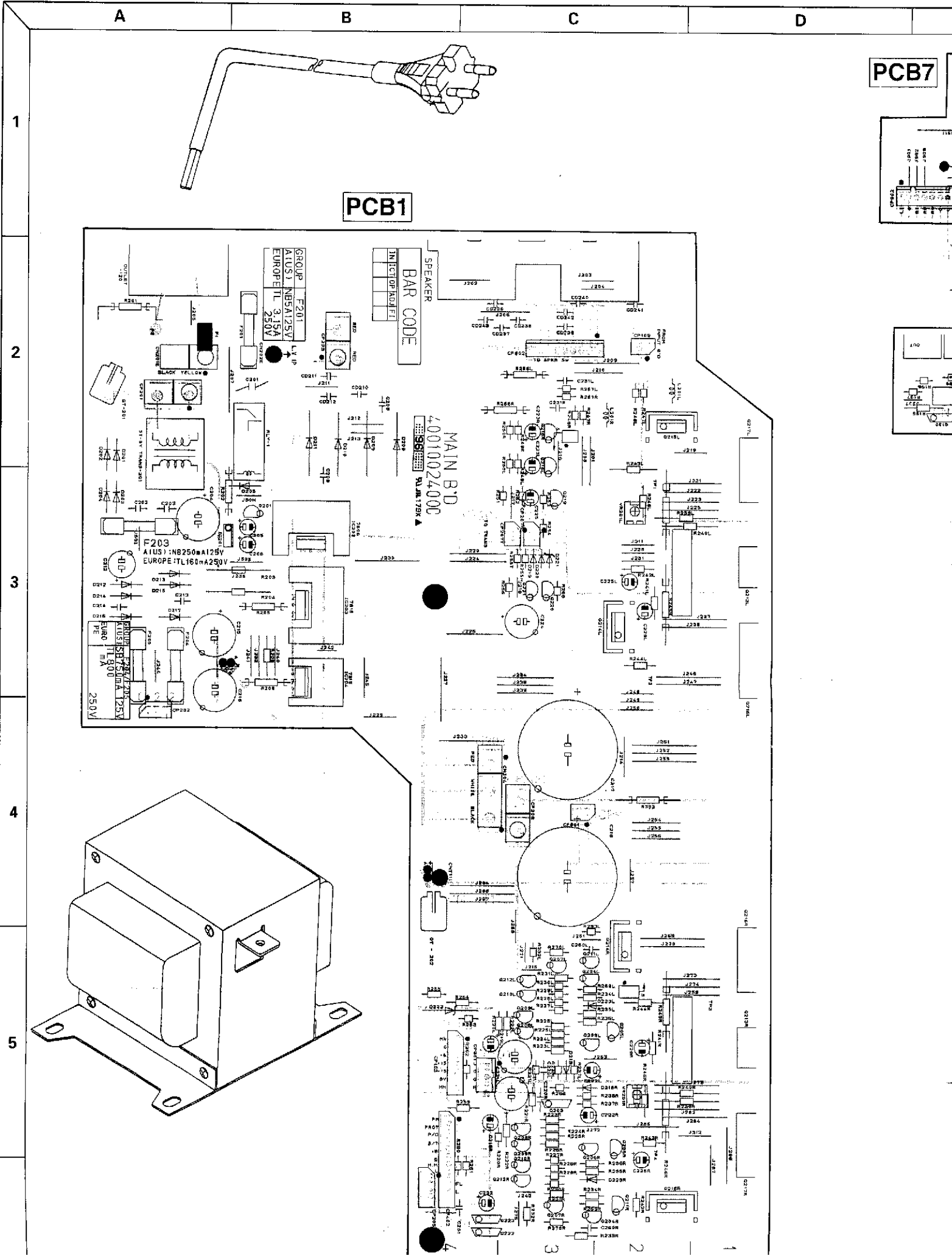

E

F

G

H

PCB7

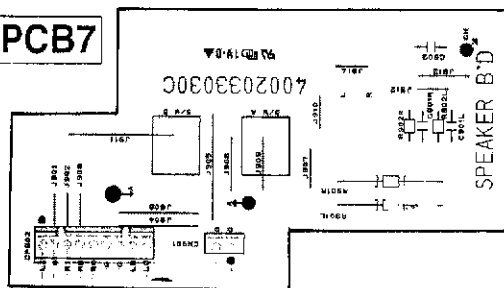

PCB3

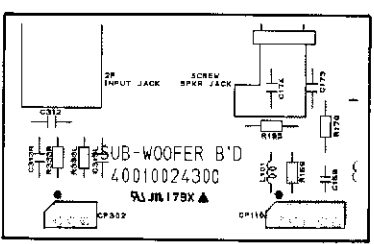

PCB9

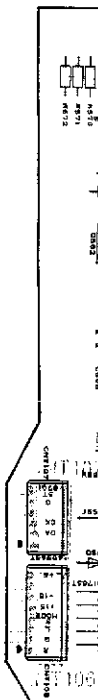
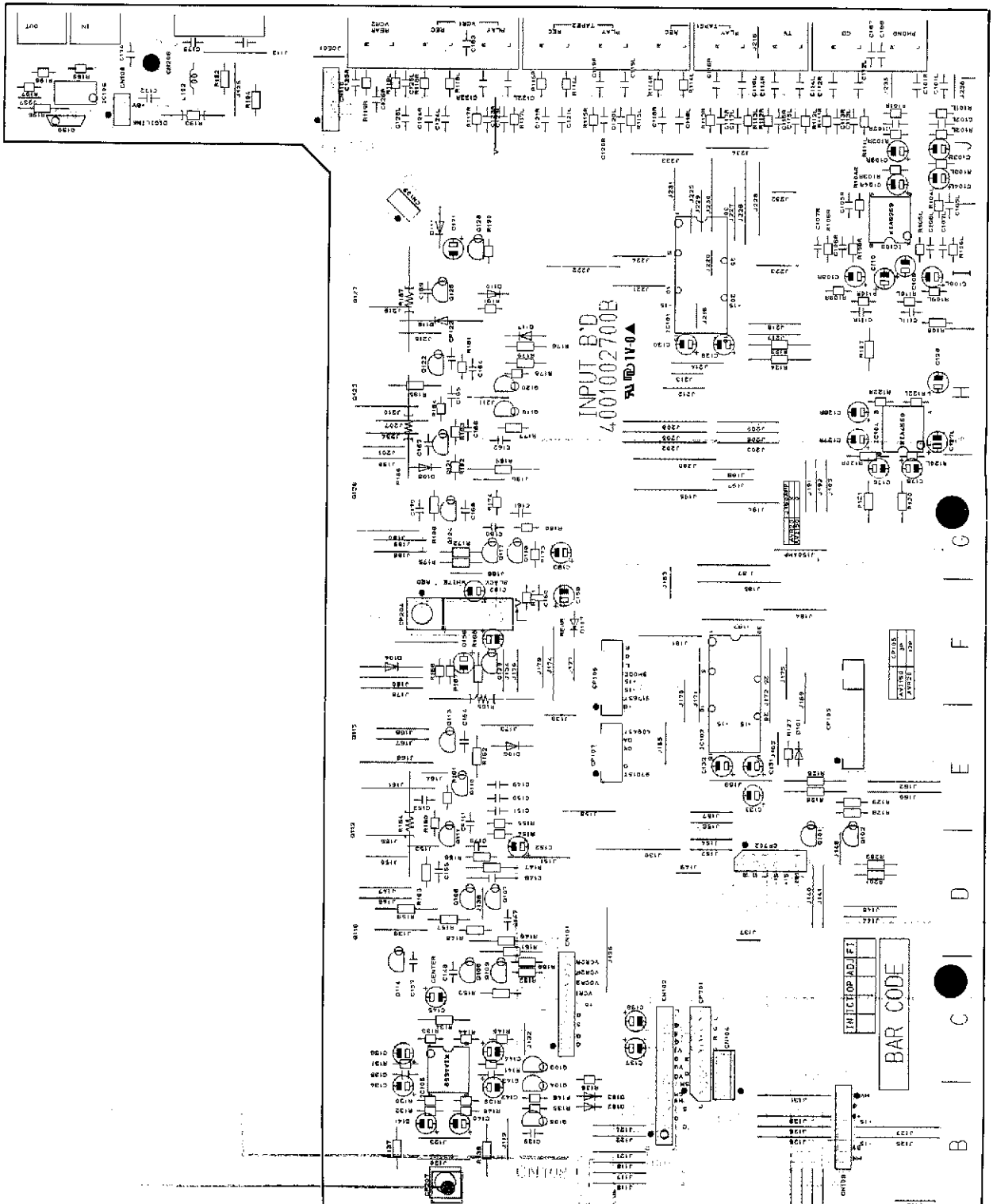

4001002700
REV. 1984

H

I

J

K

PCB2

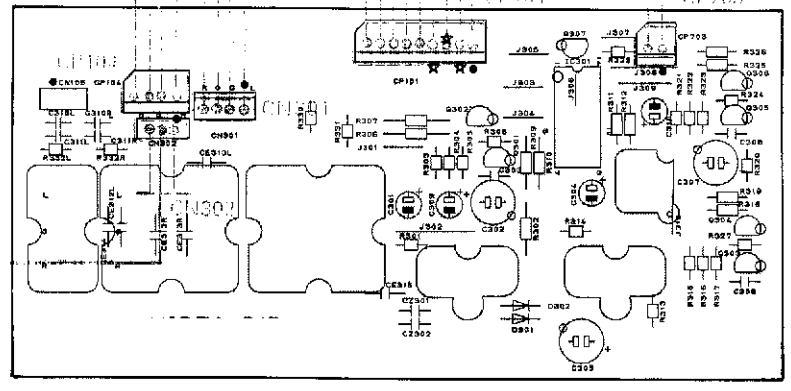

PCB11

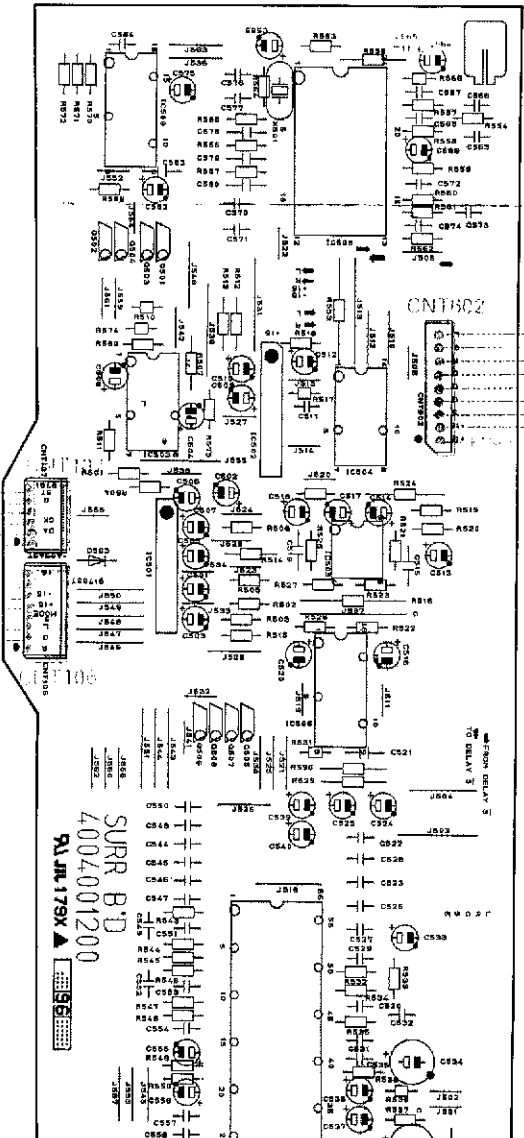

PCB10

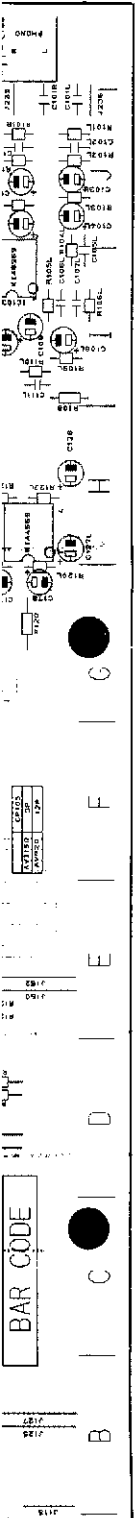
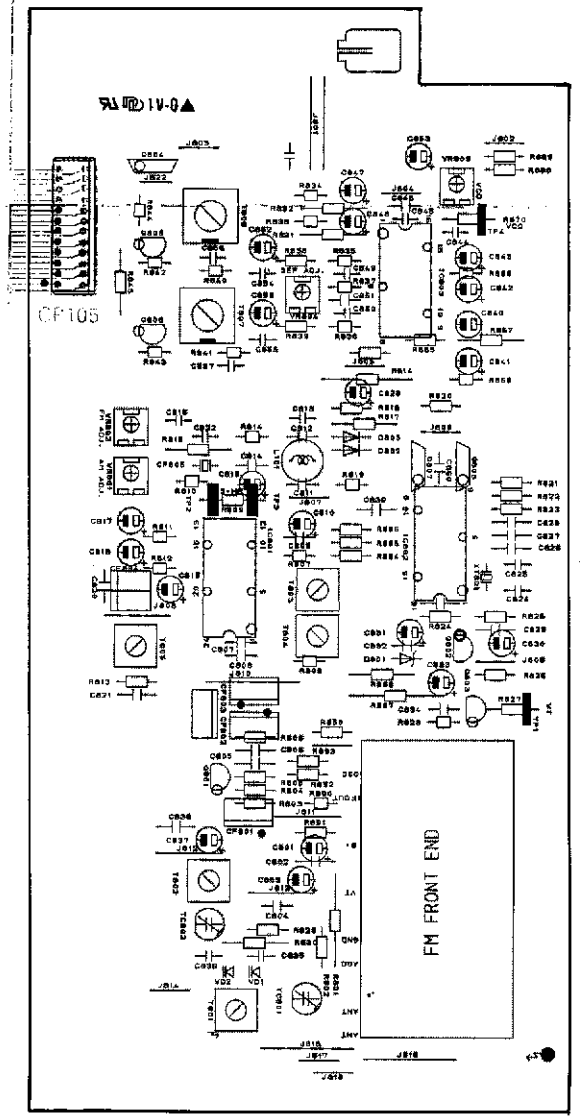

BAR CODE

SURR B'D
4004001200
PAL 179X

FM FRONT END

3
4
5
6
7
8

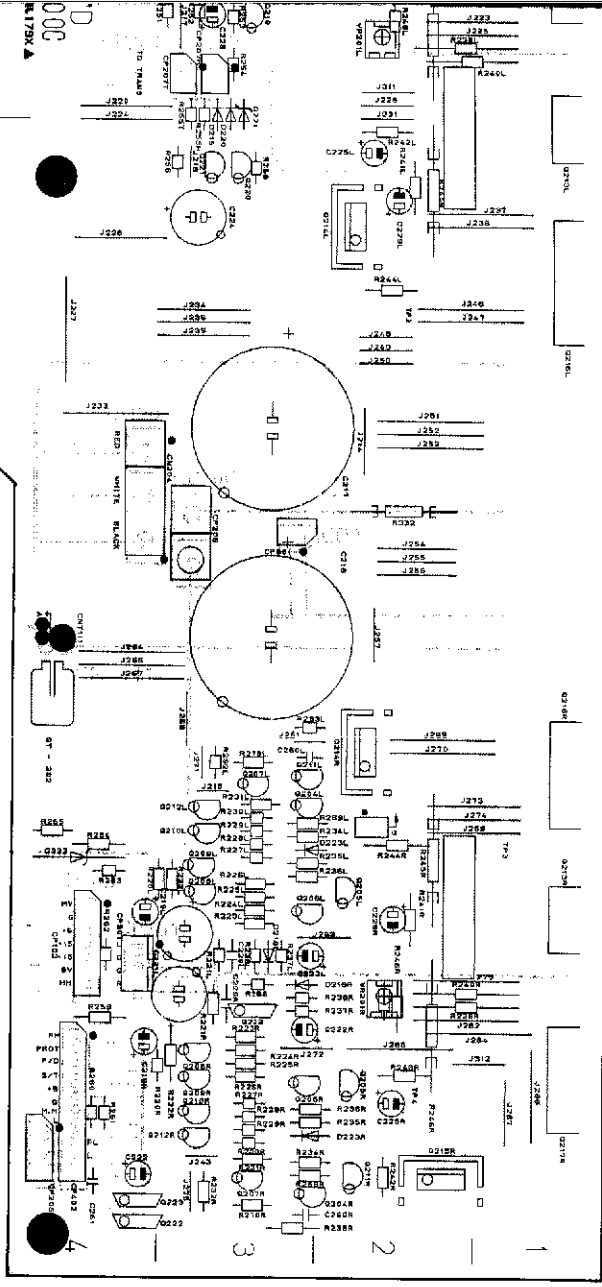
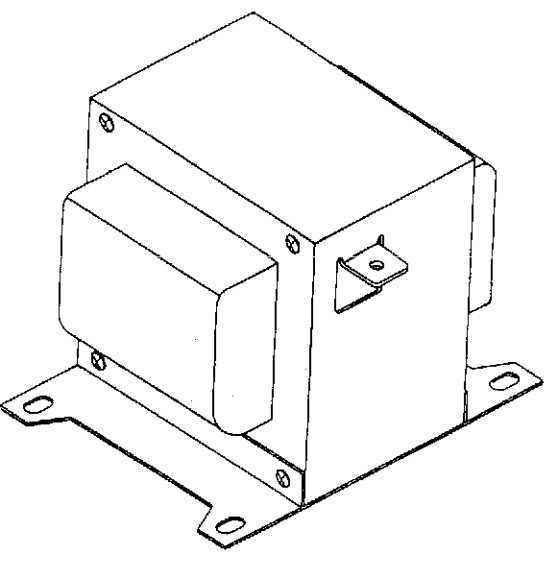
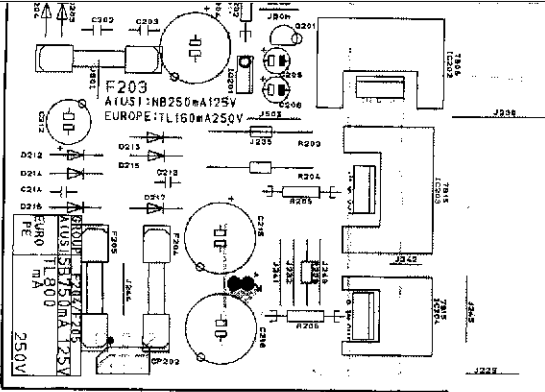

PCB4

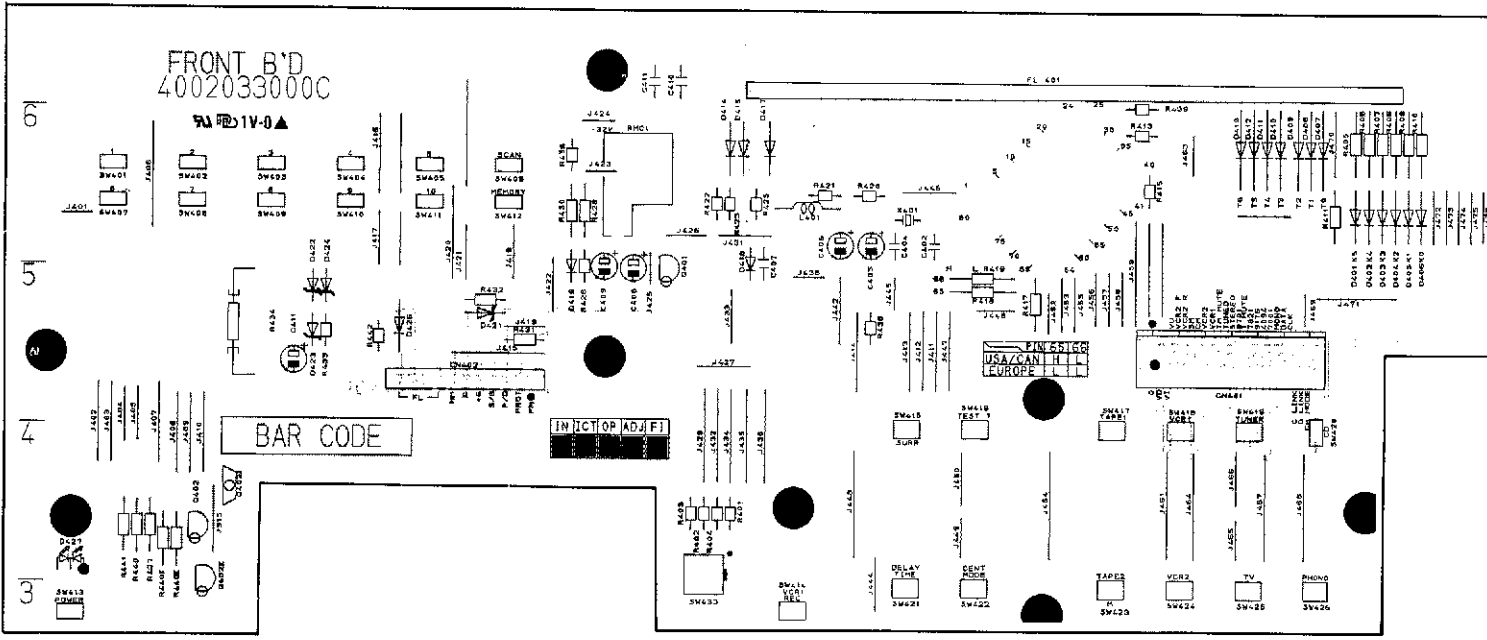

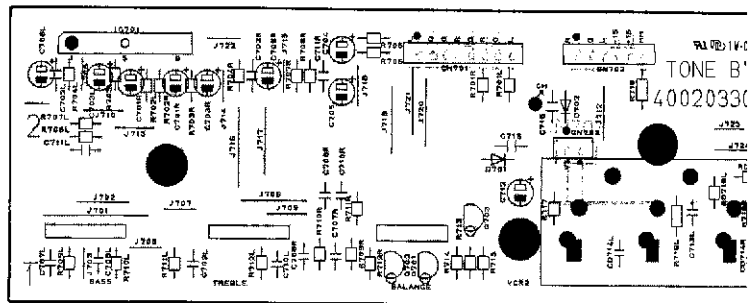
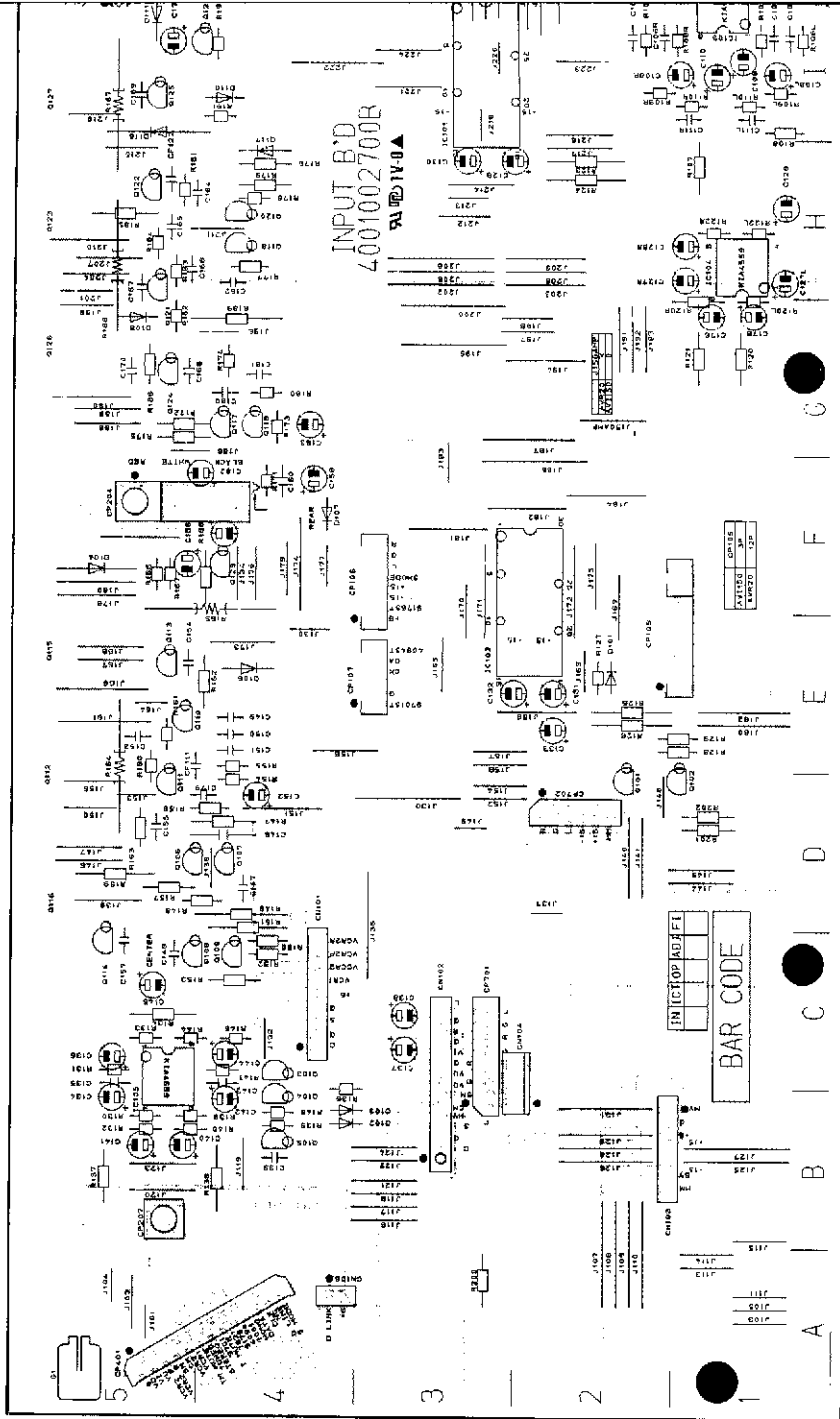
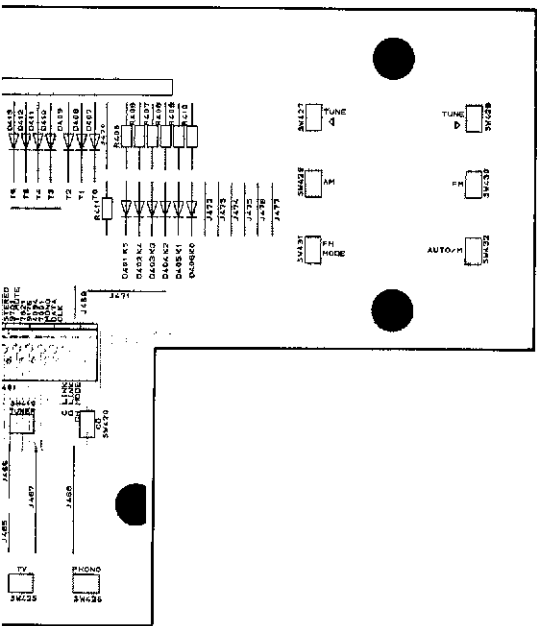

PCB5

TONE B
4002033



PCB11

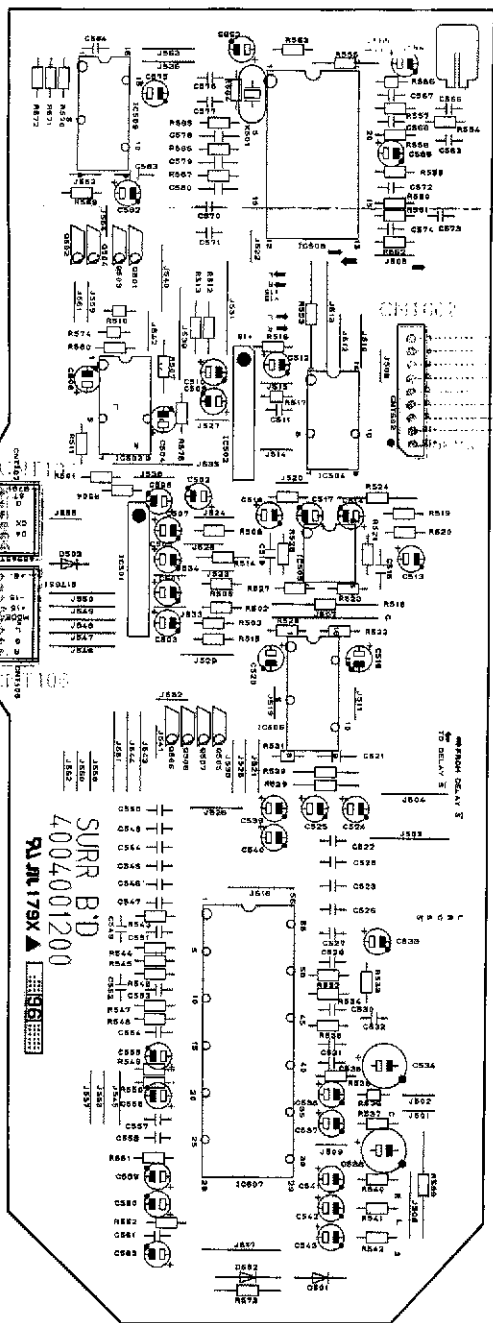

PCB10

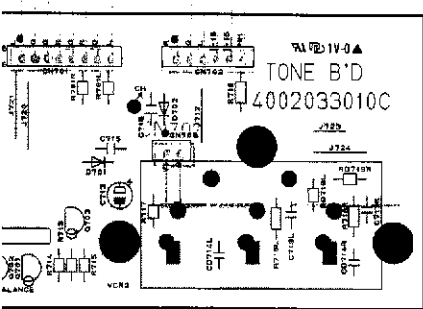
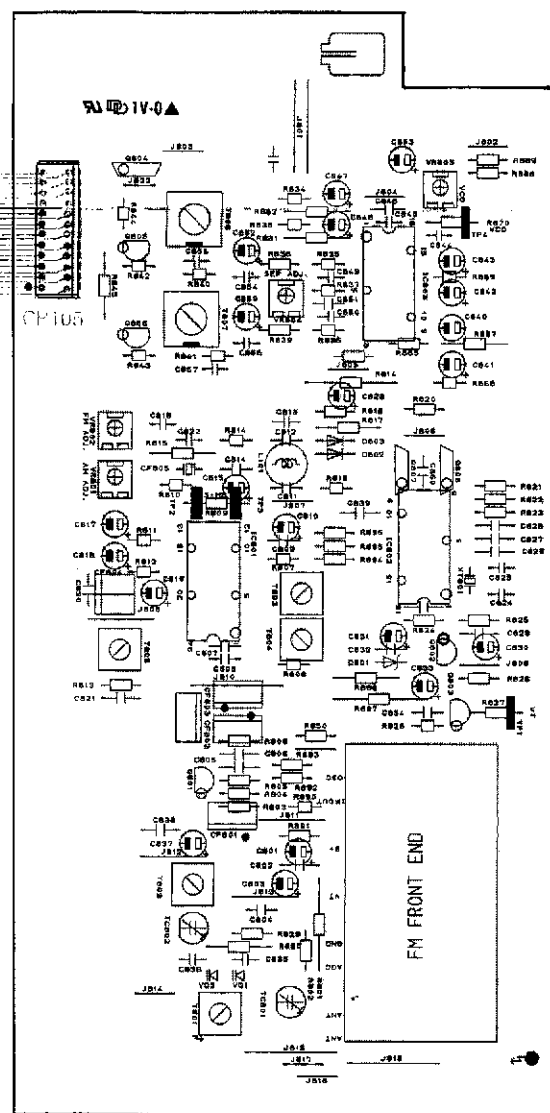

PCB8

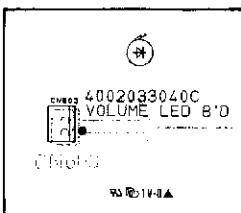

PCB6

