

harman/kardon

AVR240

7 X 50W 7.1 CHANNEL A/V RECEIVER

PRELIMINARY SERVICE MANUAL



CONTENTS

ESD WARNING.....	2	DISASSEMBLY.....	25
LEAKAGE TESTING.....	3	UNIT EXPLODED VIEW.....	26
BASIC SPECIFICATIONS.....	4	EXPLODED VIEW PARTS LIST.....	27
PACKAGING.....	5	AMP BIAS ADJUSTMENT.....	28
FRONT PANEL CONTROLS.....	6	TECH TIP HK2003-01.....	29
REAR PANEL CONNECTIONS.....	9	BLOCK DIAGRAM.....	30
REMOTE CONTROL FUNCTIONS.....	12	ELECTRICAL PARTS LIST.....	31
CONNECTIONS.....	16	PCB DRAWINGS.....	72
OPERATION.....	18	SEMICONDUCTOR PINOUTS.....	78
TROUBLESHOOTING GUIDE.....	24	SCHEMATICS.....	149
PROCESSOR RESET.....	24	WIRING DIAGRAM.....	156

harman/kardon, Inc.
 250 Crossways Park Dr.
 Woodbury, New York 11797

ELECTROSTATICALLY SENSITIVE (ES) DEVICES

Some semiconductor (solid state) devices can be damaged easily by static electricity. Such components commonly are called Electrostatically Sensitive (ES) Devices. Examples of typical ES devices are integrated circuits and some field effect transistors and semiconductor "chip" components.

The following techniques should be used to help reduce the incidence of component damage caused by static electricity.



1. Immediately before handling any semiconductor component or semiconductor-equipped assembly, drain off any electrostatic charge on your body by touching a known earth ground. Alternatively, obtain and wear a commercially available discharging wrist strap device, which should be removed for potential shock reasons prior to applying power to the unit under test.
2. After removing an electrical assembly equipped with ES devices, place the assembly on a conductive surface such as aluminum foil, to prevent electrostatic charge build-up or exposure of the assembly.
3. Use only a grounded-tip soldering iron to solder or unsolder ES devices.
4. Use only an anti-static solder removal device. Some solder removal devices not classified as "anti-static" can generate electrical charges sufficient to damage ES devices.
5. Do not use freon-propelled chemicals. These can generate electrical change sufficient to damage ES devices.
6. Do not remove a replacement ES device from its protective package until immediately before you are ready to install it. (Most replacement ES devices are packaged with leads electrically shorted together by conductive foam, aluminum foil or comparable conductive material.)
7. Immediately before removing the protective material from the leads of a replacement ES device, touch the protective material to the chassis or circuit assembly into which the device will be installed.

CAUTION : Be sure no power is applied to the chassis or circuit, and observe all other safety precautions.

8. Minimize bodily motions when handling unpackaged replacement ES devices. (Otherwise harmless motion such as the brushing together of your clothes fabric or the lifting of your foot from a carpeted floor can generate static electricity sufficient to damage an ES devices.

PRODUCT SAFETY NOTICE

Each precaution in this manual should be followed during servicing.

Components identified with the IEC symbol  in the parts list are special significance to safety. When replacing a component identified with , use only the replacement parts designated, or parts with the same ratings or resistance, wattage, or voltage that are designated in the parts list in this manual. Leakage-current or resistance measurements must be made to determine that exposed parts are acceptably insulated from the supply circuit before returning the product to the customer.

SAFETY PRECAUTIONS

The following check should be performed for the continued protection of the customer and service technician.

LEAKAGE CURRENT CHECK

Measure leakage current to a known earth ground (water pipe, conduit, etc.) by connecting a leakage current tester between the earth ground and all exposed metal parts of the appliance (input/output terminals, screwheads, metal overlays, control shaft, etc.). Plug the AC line cord of the appliance directly into a 120V AC 60Hz outlet and turn the AC power switch on. Any current measured must not exceed 0.5mA.

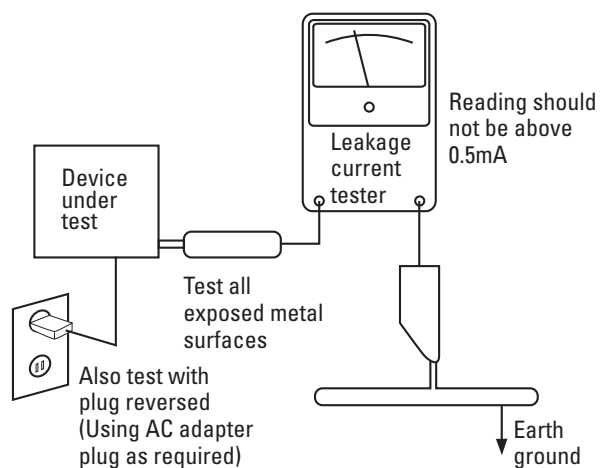

AC Leakage Test

ANY MEASUREMENTS NOT WITHIN THE LIMITS OUTLINED ABOVE ARE INDICATIVE OF A POTENTIAL SHOCK HAZARD AND MUST BE CORRECTED BEFORE RETURNING THE APPLIANCE TO THE CUSTOMER.

AVR 240 TECHNICAL SPECIFICATIONS

Audio Section

Stereo Mode	
Continuous Average Power (FTC)	
65 Watts per channel, 20Hz–20kHz, @ <0.07% THD, both channels driven into 8 ohms	
Six-Channel Surround Modes	
Power per Individual Channel	
Front L&R channels:	
50 Watts per channel @ <0.07% THD, 20Hz–20kHz into 8 ohms	
Center channel:	
50 Watts @ <0.07% THD, 20Hz–20kHz into 8 ohms	
Surround (L & R Side, Back) channels:	
50 Watts per channel @ <0.07% THD, 20Hz–20kHz into 8 ohms	
Input Sensitivity/Impedance	
Linear (High-Level)	200mV/47k ohms
Signal-to-Noise Ratio (IHF-A)	100dB
Surround System Adjacent Channel Separation	
Pro Logic	40dB
Dolby Digital	55dB
DTS	55dB
Frequency Response	
@ 1W (+0dB, –3dB)	10Hz – 130kHz
High Instantaneous Current Capability (HCC)	±35 Amps
Transient Intermodulation Distortion (TIM)	Unmeasurable
Slew Rate	40V/μsec

FM Tuner Section

Frequency Range	87.5–108.0MHz
Usable Sensitivity	IHF 1.3μV/13.2dB
Signal-to-Noise Ratio	Mono/Stereo 70/68dB
Distortion	Mono/Stereo 0.2/0.3%
Stereo Separation	40dB @ 1kHz
Selectivity	±400kHz, 70dB
Image Rejection	80dB
IF Rejection	90dB

AM Tuner Section

Frequency Range	520–1720kHz
Signal-to-Noise Ratio	45dB
Usable Sensitivity	Loop 500μV
Distortion	1kHz, 50% Mod 0.8%
Selectivity	±10kHz, 30dB

Video Section

Television Format	NTSC
Input Level/Impedance	1Vp-p/75 ohms
Output Level/Impedance	1Vp-p/75 ohms
Video Frequency Response (Composite and S-Video)	10Hz–8MHz (–3dB)
Video Frequency Response (Component Video)	10Hz–50MHz (–3dB)

General

Power Requirement	AC 120V/60Hz	
Power Consumption	65W idle, 540W maximum (6 channels driven)	
Dimensions	(Product)	(Shipping)
Width	17.3 inches (440mm)	21.5 inches (545mm)
Height	6.6 inches (168mm)	9.9 inches (251mm)
Depth	15 inches (382mm)	17.9 inches (455mm)
Weight	(Product) 24.4 lb (11.1kg)	(Shipping) 29.3 lb (13.3kg)

Depth measurement includes knobs, buttons and terminal connections.
Height measurement includes feet and chassis.
All features and specifications are subject to change without notice.

Harman Kardon, Harman International, Power for the Digital Revolution and Logic 7 are registered trademarks, and The Bridge and  are trademarks, of Harman International Industries, Incorporated.

*Manufactured under license from Dolby Laboratories. Dolby, Pro Logic and the double-D symbol are registered trademarks of Dolby Laboratories.

DTS, DTS Surround, DTS-ES, DTS 96/24 and DTS Neo:6 are registered trademarks of DTS, Inc.

VMAx is a registered trademark of Harman International Industries, Incorporated, and is an implementation of Cooper Bauck Transaural Stereo under patent license.

SACD is a trademark of Sony Electronics, Inc.

Apple and iPod are registered trademarks, and Shuffle is a trademark, of Apple Computer, Inc.

Please register your product on our Web site at www.harmankardon.com. Note: You'll need the product's serial number.
At the same time you can choose to be notified about our new products and/or special promotions.

1. Instruction manual ass'y - Accessories

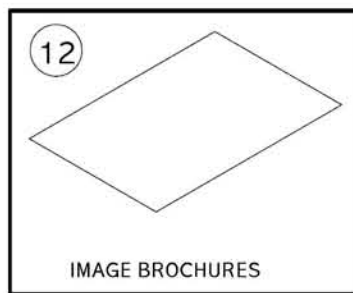
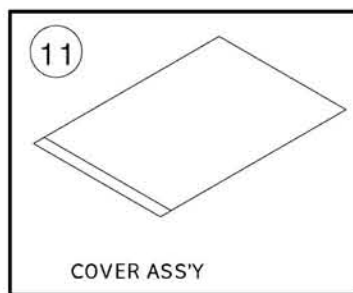
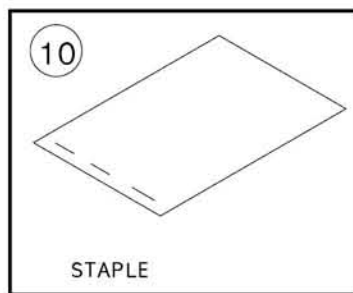
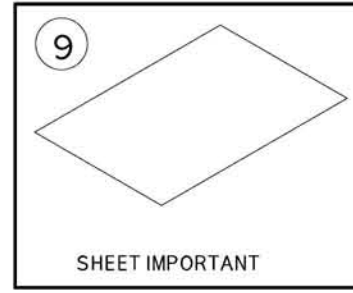
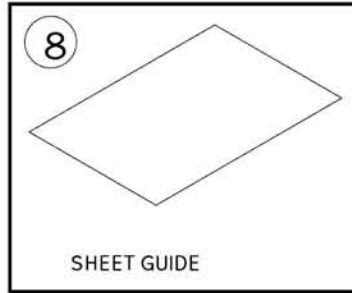
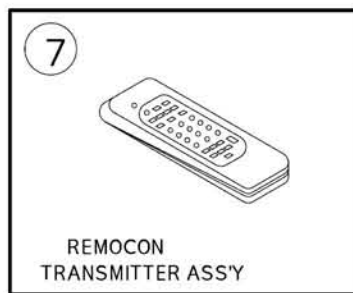
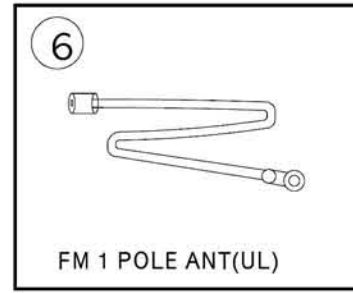
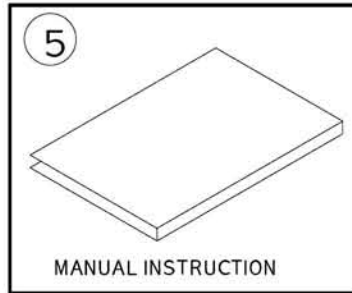
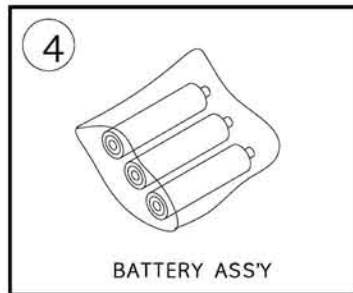
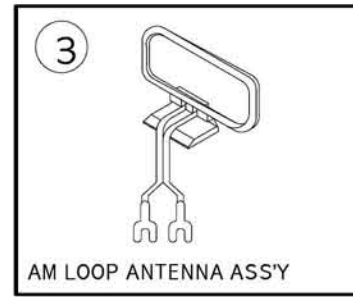
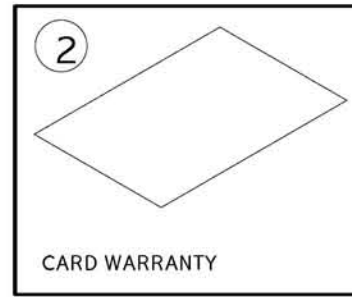
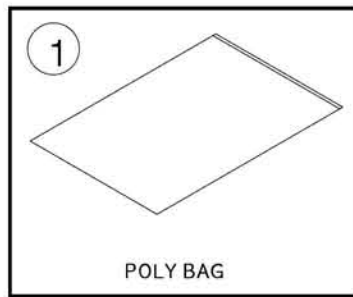

NO	DESCRIPTION	PARTS NO.	Q.ty
1	POLY BAG		1
2	CARD WARRANTY	CQE1A172X	1
3	AM LOOP ANTENNA ASS'Y	CSA1A027Z	1
4	BATTERY		3
5	OWNER'S MANUAL	CQX1A1026Z	1
6	FM 1 POL ANT(UL)	CSA1A019Z	1
7	REMOCON TRANSMITTER ASS'Y	RB30K00	1
8	SHEET GUIDE	CQE1A259Z	1
9	SHEET IMPORTANT	CQE1A169Z	1
10	STAPLE		3
11	COVER ASS'Y	CGRAVR130ZA	1
1	COVER A	CGR1A331M7H43	1
2	COVER B	CGR1A332M7H43	1
3	SHEET, FRONT COVER	CQE1A219Z	1
4	PAD,COVER	CPS1A676	1
5	BAG,POLY		1
12	IMAGE BROCHURES		1

2. Package Drawing

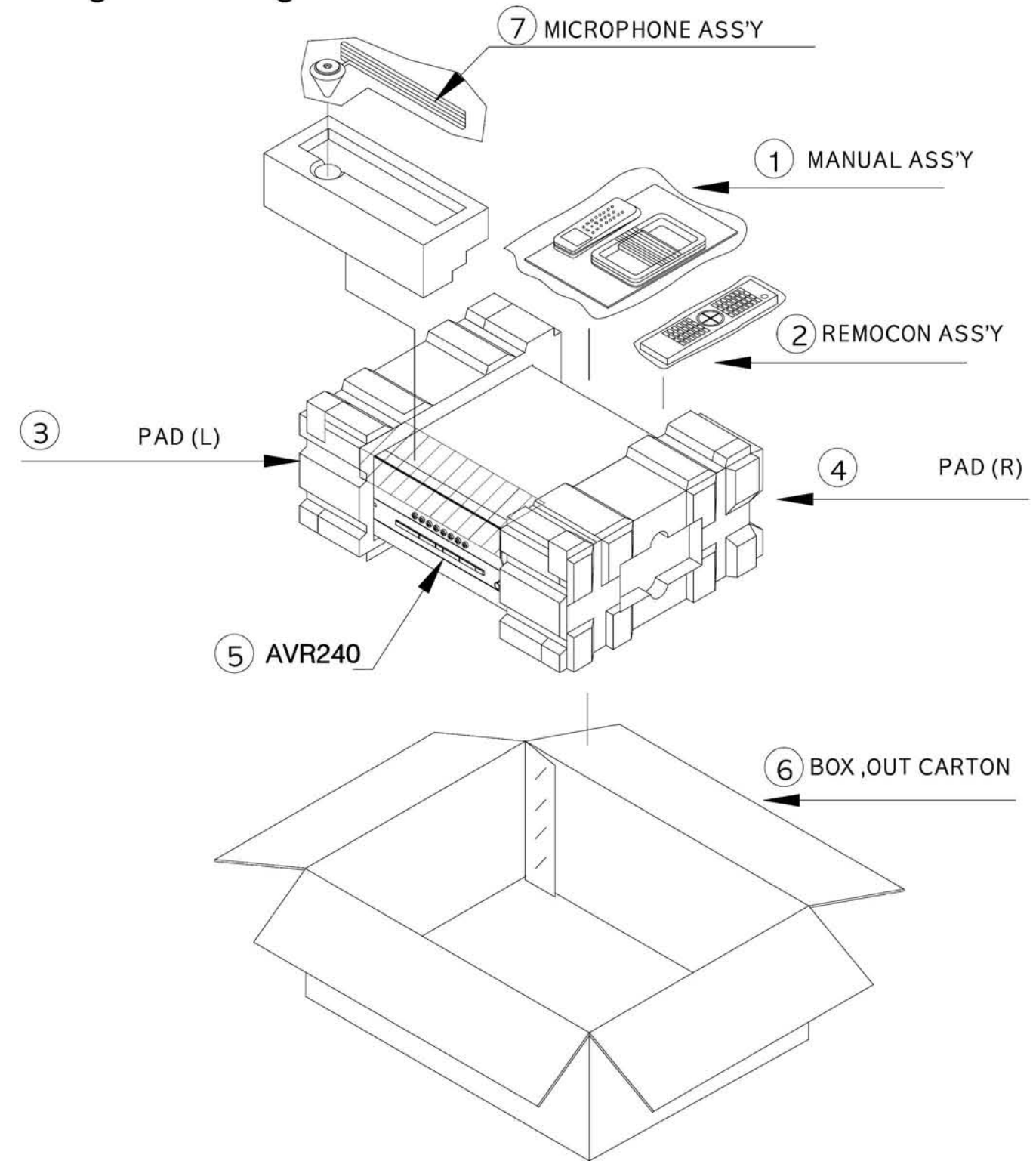

NO	DESCRIPTION	PART NO.	Qty
1	MANUAL ASS'Y		1
2	REMOCON ASS'Y	RB30K00	1
3	SNOW,PAD(L)	CPS5A564	1
4	SNOW,PAD(R)	CPS5A565	1
5	SET	AVR 240	1
6	OUTER CARTON	CPG1A797Y	1
7	MICROPHONE ASS'Y	CJXAVR335MICRO	1

FRONT - PANEL CONTROLS

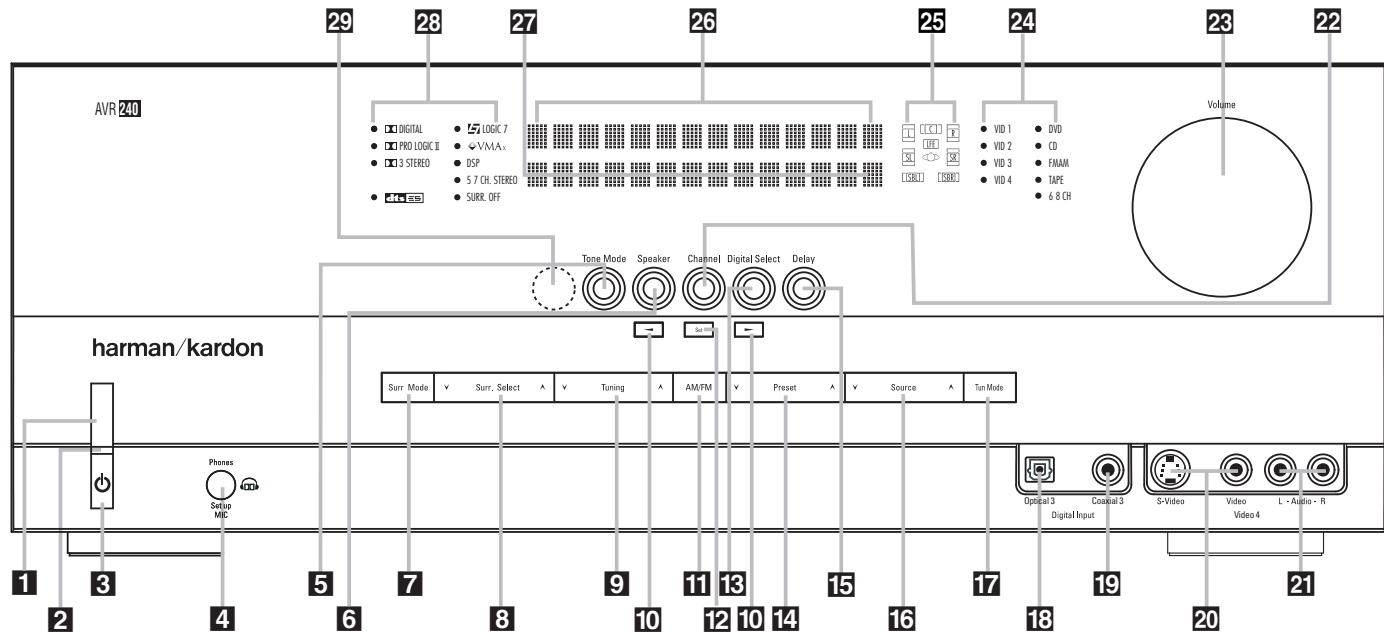

NOTE: To make it easier to follow the instructions that refer to this illustration, a larger copy may be downloaded from the Product Support section for this product at www.harmankardon.com.

- | | | |
|---|---|---|
| <p>1 Main Power Switch
 2 Power Indicator
 3 Standby/On Switch
 4 Headphone Jack
 5 Tone Mode
 6 Speaker Selector
 7 Surround Mode Group Selector
 8 Surround Mode Selector
 9 Tuning Selector
 10 ◀▶ Buttons</p> | <p>11 Tuner Band Selector
 12 Set Button
 13 Digital Input Selector
 14 Preset Station Selector
 15 Delay Adjust Selector
 16 Input Source Selector
 17 Tuner Mode Selector
 18 Optical 3 Digital Audio Input
 19 Coaxial 3 Digital Audio Input
 20 Video 4 Video Input Jacks</p> | <p>21 Video 4 Audio Input Jacks
 22 Channel Adjust Selector
 23 Volume Control
 24 Input Indicators
 25 Speaker/Channel Input Indicators
 26 Upper Display Line
 27 Lower Display Line
 28 Surround Mode Indicators
 29 Remote Sensor Window</p> |
|---|---|---|

1 Main Power Switch: Press this button to apply power to the AVR 240. When the switch is pressed in, the unit is in a Standby mode, as indicated by the amber **Power Indicator 2**. This button **MUST** be pressed in to operate the unit. To turn the unit off and prevent the use of the remote control, this switch should be pressed until it pops out from the front panel and the word "OFF" is seen at the top of the switch.

NOTE: This switch is normally left in the "ON" position.

2 Power Indicator: This LED lights amber when the unit is in the Standby mode to signal that the AVR is ready to be turned on. When the unit is in operation, the indicator is blue.

3 Standby/On Switch: When the **Main Power Switch 1** is "ON," press this button to turn on the AVR 240; press it again to turn the unit off. The **Power Indicator 2** turns blue when the unit is on.

4 Headphone Jack: This jack may be used to listen to the AVR 240's output through a pair of headphones. The speakers will automatically be turned off when the headphone jack is in use. When configuring your system using EzSet+, the calibration microphone should be plugged into this jack using the supplied adaptor that converts the small mini-plug at the end of the microphone's cord to a 1/4" plug.

5 Tone Mode: This button controls the tone mode settings, enabling adjustment of the bass and treble boost/cut. You may also use it to take the tone controls out of the signal path completely for "flat" response. The first press of the button displays a **TONE IN** message in the **Lower Display Line 27** and in the on-screen display. To take the controls out of the signal path, press either of the **Buttons 10** until the display reads **TONE OUT**.

To change the bass or treble settings, make sure that **TONE IN** appears in the **Lower Display Line 27** or press either of the **Buttons 10** until it does.

Press the **Tone Mode Button 5** until the desired option of **TREBLE MODE** or **BASS MODE** appears in the **Lower Display Line 27** and in the on-screen display and then press either of the **Buttons 10** to enter the desired boost or cut setting. Both treble and bass contours may be boosted or cut by up to + or -10dB in increments of 2dB. See pages 21 and 31 for more information on the tone controls.

NOTE: The AVR 240 is not equipped with a traditional Balance control. When listening to two-channel materials, if you wish to adjust the stereo image, you may use the **Channel Adjust Selector 22** to increase or decrease the level of the left front channel by up to + or -10dB, and then to decrease or increase the right front channel by the corresponding amount. However, when listening to surround materials and most two-channel materials, it is recommended that you leave these settings at the results obtained during the configuration process described on pages 19 through 30.

FRONT - PANEL CONTROLS

- 6 Speaker Selector:** Press this button to begin the process of configuring the unit to match the type of speakers used in your listening room. (See pages 26–28 for more information on speaker setup and configuration.)
- 7 Surround Mode Group Selector:** Press this button to select the top-level group of surround modes. Each press of the button will select the current or last used mode in each of the surround mode groups (e.g., Dolby, DTS, DTS Neo:6, Logic 7, DSP, Stereo). When the button is pressed so that the name of the surround mode group appears in the on-screen display and in the **Lower Display Line 27**, press the **Surround Mode Selector 8** to cycle through the individual modes available. For example, press this button to select Dolby modes, and then press the **Surround Mode Selector 8** to choose from the various Dolby mode options.
- 8 Surround Mode Selector:** Press this button to select from among the available surround mode options for the mode group selected. The specific modes will vary based on the number of speakers available, the mode group and if the input source is digital or analog. For example, press the **Surround Mode Group Selector 7** to select a main mode grouping such as Dolby or Logic 7, and then press this button to see the specific mode choices available. Note that the digital surround modes, such as Dolby Digital and DTS, may not be accessed unless that type of source signal is present, such as when a DVD movie or television signal programmed in Dolby Digital or DTS surround sound is playing. For more information on surround mode selection, see pages 23 and 32.
- 9 Tuning Selector:** Press the left side of the button to tune lower-frequency stations and the right side of the button to tune higher-frequency stations. When the tuner is in the Manual mode, each tap will increase or decrease the frequency by one increment. When the tuner receives a strong enough signal for adequate reception, **MANUAL TUNED** will appear in the on-screen display and the **Lower Display Line 27**. When the tuner is the Auto mode, press the button once, and the tuner will scan for a station with acceptable signal strength. When the next station with a strong signal is tuned the scan will stop and the on-screen display and **Lower Display Line 27** will indicate **AUTO TUNED**. When an FM Stereo station is tuned, the display will read **AUTO ST TUNED**.
- To switch back and forth between the Auto and Manual tuning modes, press the **Tuner Mode Selector 17**.

- 10 ◀▶ Buttons:** When configuring the AVR 240's settings, use these buttons to select from the available choices.
- 11 Tuner Band Selector:** Press this button to turn the AVR on and to select the Tuner as the input. Press it again to switch between the AM and FM frequency bands. (See page 37 for more information on the tuner.)
- 12 Set Button:** When making choices during the setup and configuration process, press this button to enter the desired setting into the AVR 240's memory.
- 13 Digital Input Selector:** Press this button to select one of the digital audio inputs or the analog audio input for any source. (See pages 32–37 for more information on digital audio.)
- 14 Preset Stations Selector:** Press this button to scroll up or down through the list of stations that have been entered into the preset memory. (See page 37 for more information on tuner presets.)
- 15 Delay Adjust Selector:** Press this button to begin the steps required to enter delay settings. (See pages 28–29 for more information on delay times.)
- 16 Input Source Selector:** Press this button to change the input by scrolling up or down through the list of **Input Indicators 24**.
- 17 Tuner Mode Selector:** Press this button to select Auto or Manual tuning. When the button is pressed so that the **AUTO** appears in the **Lower Display Line 27**, the tuner will search for the next station with an acceptable signal when the **Tuning Selector 9 21** is pressed. When the button is pressed so that **MANUAL** appears in the **Lower Display Line 27**, each press of the **Tuning Selector 9 21** will increase the frequency. This button may also be used to switch between Stereo and Mono modes for FM radio reception. When weak reception is encountered, press the button so that **MANUAL** appears in the **Lower Display Line 27** and on the on-screen display to switch to Mono reception. Press it again to switch back to Stereo mode. (See page 37 for more information on using the tuner.)
- 18 Optical 3 Digital Audio Input:** Connect the optical digital audio output of an audio or video product to this jack. When the input is not in use, the built-in shutter will close to avoid dust contamination that might degrade future performance.
- 19 Coaxial 3 Digital Audio Input:** This jack is used for connection to the output of portable audio devices, video game consoles or other products that have a coax digital audio jack.

- 20 Video 4 Video Input Jacks:** These jacks may be used for temporary connection to the composite or S-video output of video games, camcorders or other portable video products. You may make a connection to either jack at any time, but not to both simultaneously.
- 21 Video 4 Audio Input Jacks:** These audio jacks may be used for temporary connection to video games or portable audio/video products such as camcorders and portable audio players.
- 22 Channel Adjust Selector:** Press this button to begin the process of trimming the channel output levels using an external audio source. (For more information on output level trim adjustment, see page 38.)
- 23 Volume Control:** Turn this knob clockwise to increase the volume, counterclockwise to decrease the volume. If the AVR 240 is muted, adjusting the **Volume Control 23 38** will automatically release the unit from the silenced condition.

- 24 Input Indicators:** The current selected source will appear as one of these indicators. When the unit is turned on, the entire list of available modes will light briefly, and then revert to normal operation with only the active mode indicator illuminated.

NOTE: When **Bridge/DMP** has been selected as the input source, no **Input Indicator 24** will light. **DMP/THE BRIDGE IS CONNECTED** will scroll across the **Upper Display Line 26**, unless you have retitled the source name, in which case that name will appear. See page 20 for more information on input titling.

- 25 Speaker/Channel Input Indicators:** These indicators are multipurpose, indicating both the speaker type selected for each channel and the incoming data-signal configuration. The left, center, right, right surround and left surround speaker indicators are composed of three boxes, while the subwoofer is a single box. The center box lights when a "small" speaker is selected, and the two outer boxes light when "large" speakers are selected. When none of the boxes are lit for the center, surround or subwoofer channels, no speaker has been assigned that position. (See pages 26–28 for more information on configuring speakers.)

The letters inside each box display the active input channels. For standard analog sources, only the L and R will light, indicating a stereo input. For a digital source, the indicators will light to display the channels being received at the digital input. When the letters flash, the digital input has been interrupted. (See page 36 for more information on the Channel Indicators.)

- 26 Upper Display Line:** Depending on the unit's status, a variety of messages will appear here. In normal

FRONT - PANEL CONTROLS

operation, this line will show current input source and which analog or digital input is in use. When the tuner is the input, this line will identify the station as AM or FM and show the frequency and preset number, if any.

27 Lower Display Line: Depending on the unit's status, a variety of messages will appear here. In normal operation, the current surround mode will show here.

28 Surround Mode Indicators: The current selected surround mode will appear as one of these indicators. Note that when the unit is turned on, the entire list of available modes will light briefly, and then revert to normal operation with only the active mode indicator illuminated.

NOTE: When the Dolby Virtual Speaker or Dolby Headphone modes are in use, no **Surround Mode Indicator 28** will light. However, the surround mode name will scroll in the **Lower Display Line 27**.

29 Remote Sensor Window: The sensor behind this window receives infrared signals from the remote control. Aim the remote at this area and do not block or cover it.

REAR-PANEL CONNECTIONS

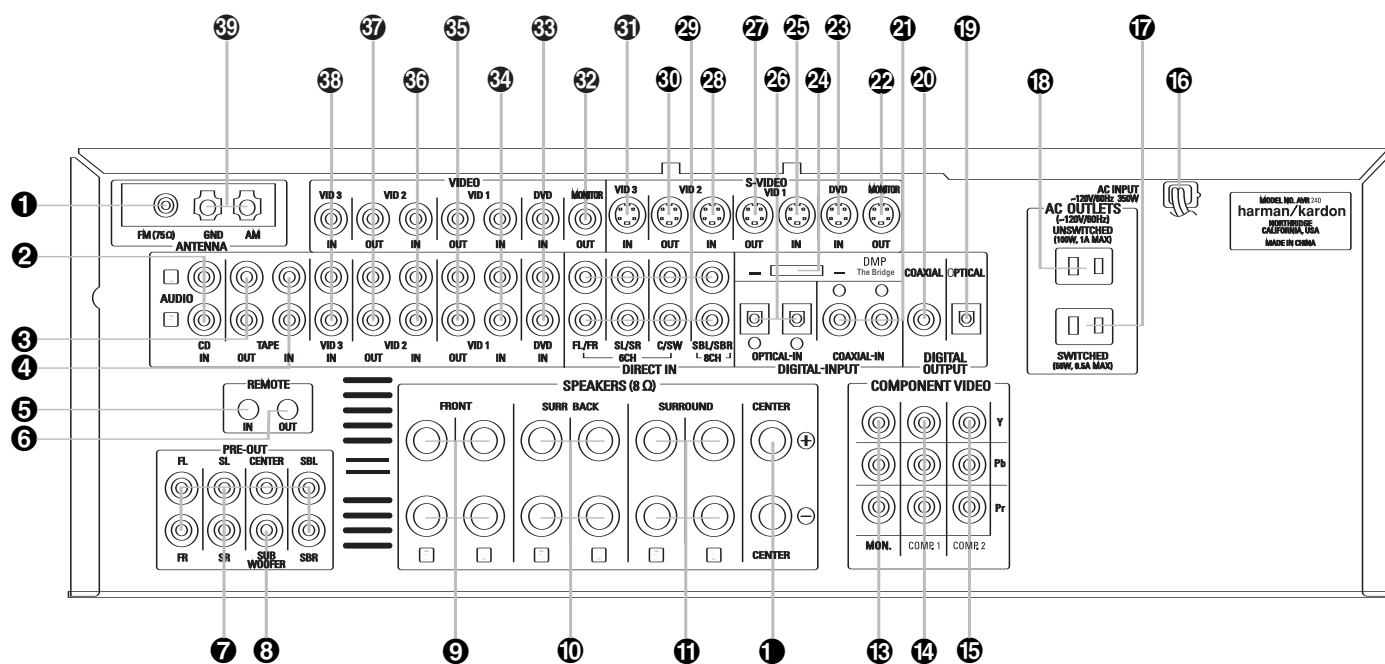

NOTE: To make it easier to follow the instructions that refer to this illustration, a larger copy may be downloaded from the Product Support section for this product at www.harmankardon.com.

- | | | |
|--|--|---|
| <ul style="list-style-type: none"> 1 FM Antenna Jack 2 CD Audio Inputs 3 Tape Outputs 4 Tape Inputs 5 Remote IR Input 6 Remote IR Output 7 Preamp Outputs 8 Subwoofer Output 9 Front Speaker Outputs 10 Surround Back Speaker Outputs 11 Surround Speaker Outputs 12 Center Speaker Outputs 13 Component Video Monitor Outputs 14 Component Video 1 Inputs | <ul style="list-style-type: none"> 15 Component Video 2 Inputs 16 AC Power Cord 17 Switched AC Accessory Outlet 18 Unswitched AC Accessory Outlet 19 Optical Digital Audio Output 20 Coaxial Digital Audio Output 21 Coaxial Digital Audio Inputs 22 S-Video Monitor Output 23 DVD S-Video Input 24 DMP Connector 25 Video 1 S-Video Input 26 Optical Digital Audio Inputs 27 Video 1 S-Video Output 28 Video 2 S-Video Input | <ul style="list-style-type: none"> 29 6/8-Channel Direct Inputs 30 Video 2 S-Video Output 31 Video 3 S-Video Input 32 Video Monitor Output 33 DVD Audio/Video Inputs 34 Video 1 Audio/Video Inputs 35 Video 1 Audio/Video Outputs 36 Video 2 Audio/Video Inputs 37 Video 2 Audio/Video Outputs 38 Video 3 Audio/Video Inputs 39 AM Antenna Terminals |
|--|--|---|

NOTE: To assist in making the correct connections for multichannel input, output and speaker connections, all connection jacks and terminals are color-coded in conformance with the CEA standards as follows:					
Front Left:	White	Center:	Green	Composite Video:	Yellow
Front Right:	Red	Surround Left:	Blue	Component Video "Y":	Green
		Surround Right:	Gray	Component Video "Pr":	Red
		Surround Back Left:	Brown	Component Video "Pb":	Blue
		Surround Back Right:	Tan		
		Subwoofer:	Purple		
		Coaxial Digital Audio:	Orange		

- 1 FM Antenna Jack:** Connect the supplied indoor (or an optional external) FM antenna to this terminal.
- 2 CD Audio Inputs:** Connect these jacks to the analog audio outputs of a compact disc player or CD changer.
- 3 Tape Outputs:** Connect these jacks to the RECORD/INPUT jacks of an audio recorder.
- 4 Tape Inputs:** Connect these jacks to the PLAY/OUT jacks of an audio recorder.
- 5 Remote IR Input:** If the AVR 240's front-panel IR sensor is blocked due to cabinet doors or other obstructions, an external IR sensor may be used. Connect the output of the sensor to this jack.

REAR-PANEL CONNECTIONS

6 Remote IR Output: This connection permits the IR sensor in the receiver to serve other remote controlled devices. Connect this jack to the "IR IN" jack on Harman Kardon (or other compatible) equipment.

7 Preamp Outputs: Connect these jacks to an optional, external power amplifier for applications where higher power is desired.

8 Subwoofer Output: Connect this jack to the line-level input of a powered subwoofer. If an external subwoofer amplifier is used, connect this jack to the subwoofer amplifier input.

9 Front Speaker Outputs: Connect these outputs to the matching + or – terminals on your left and right speakers. When making speaker connections always make certain to maintain correct polarity by connecting the color-coded (white for front left and red for front right) (+) terminals on the AVR 240 to the red (+) terminals on the speakers and the black (–) terminals on the AVR 240 to the black (–) terminals on the speakers. See page 15 for more information on speaker polarity.

10 Surround Back Speaker Outputs: These speaker terminals are normally used to power the surround back speakers in a 7.1-channel system. Connect these outputs to the matching + and – terminals on your surround back channel speaker. In conformance with the CEA color-code specification, the brown terminal is the positive, or "+," terminal that should be connected to the red (+) terminal on the left Surround Back speaker with older color-coding. The tan terminal is the positive, or "+," terminal that should be connected to the red (+) terminal on the right Surround Back speaker with older color-coding. Connect the black (–) terminals on the AVR to the matching black negative (–) terminals on the surround back speakers. (See page 15 for more information on speaker polarity.)

11 Surround Speaker Outputs: Connect these outputs to the matching + and – terminals on your surround channel speakers. In conformance with the CEA color-code specification, the blue terminal is the positive, or "+," terminal that should be connected to the red (+) terminal on the Surround Left speaker with older color-coding, while the gray terminal should be connected to the red (+) terminal on the Surround Right speaker with the older color-coding. Connect the black (–) terminal on the AVR to the matching black negative (–) terminals for each surround speaker. (See page 15 for more information on speaker polarity.)

1 Center Speaker Outputs: Connect these outputs to the matching + and – terminals on your center channel speaker. In conformance with the CEA color-code specification, the green terminal is the positive, or "+," terminal that should be connected to

the red (+) terminal on speakers with the older color-coding. Connect the black (–) terminal on the AVR to the black (–) terminal on your speaker. (See page 15 for more information on speaker polarity.)

13 Component Video Monitor Outputs: Connect these outputs to the component video inputs of a video projector or monitor. When a source connected to one of the **Component Video Inputs 14 15** is selected, the signal will be sent to these jacks.

14 Component Video 1 Inputs: Connect the Y/Pr/Pb component video outputs of a DVD player, HDTV set-top converter, satellite receiver or other video source device with component video outputs to these jacks.

15 Component Video 2 Inputs: Connect the Y/Pr/Pb component video outputs of a DVD player, HDTV set-top converter, satellite receiver or other video source device with component video outputs to these jacks.

See page 20 for information on assigning the **Component Video 1 and 2 Inputs 14 15** to the appropriate source inputs.

16 AC Power Cord: Connect the AC power cord to a non-switched AC wall outlet.

17 Switched AC Accessory Outlet: These outlets may be used to power any device you wish to have turned on when the AVR 240 is turned on.

18 Unswitched AC Accessory Outlet: This outlet may be used to power any AC device. The power will remain on at this outlet regardless of whether the AVR 240 is on or off.

NOTE: The total power consumption of all devices connected to the accessory outlets should not exceed 100 watts.

19 Optical Digital Audio Output: Connect this jack to the optical digital input connector on a CD-R/RW, MiniDisc or other digital recorder.

20 Coaxial Digital Audio Output: Connect this jack to the coaxial digital input of a CD-R/RW, MiniDisc or other digital recorder.

21 Coaxial Digital Audio Inputs: Connect the coax digital output from a DVD player, HDTV receiver, LD player or CD player to these jacks. The signal may be a Dolby Digital signal, DTS signal or a standard PCM digital source. Do not connect the RF digital output of an LD player to these jacks.

22 S-Video Monitor Output: If any of the input sources used in your system have S-video connections to the AVR, connect this jack to the S-video input on your television, projector or other video display.

23 DVD S-Video Input: Connect the S-video output of a DVD player or other video source to this jack.

24 Bridge Digital Media Player (DMP) Connector: With the AVR 240 turned off, connect the optional Harman Kardon Bridge to this connector. When the Digital Media Player source is selected, you may view iPod control and navigation messages on your video display (if one is connected to one of the **Video Monitor Outputs 22 23**), and in the **Upper and Lower Display Lines 26 27**. You may navigate the iPod and select tracks for playback using the **▲/▼/◀/▶ Buttons 14 15**, the **Set Button 16** and **Transport Controls 27** on your AVR remote. See page 37 for more information.

25 Video 1 S-Video Input: If the product connected to the **Video 1 Audio Inputs 34** has S-video capability, connect this jack to the PLAY/OUT S-video jack on that unit and then make certain that the **S-Video Monitor Output 22** is connected as described above.

26 Optical Digital Audio Inputs: Connect the optical digital output from a DVD player, HDTV receiver, LD player or CD player to these jacks. The signal may be a Dolby Digital signal, a DTS signal or a standard PCM digital source.

27 Video 1 S-Video Output: If the product connected to the **Video 1 Audio/Video Outputs 35** has S-video capability, connect this jack to the REC/IN S-video jack on that unit.

28 Video 2 S-Video Input: If the product connected to the **Video 2 Audio/Video Inputs 36** has S-video capability, connect this jack to the PLAY/OUT S-video jack on that unit and then make certain that the **S-Video Monitor Output 22** is connected as described above.

29 6/8-Channel Direct Inputs: These jacks are used for connection to source devices such as DVD-Audio or SACD™ players with discrete analog outputs. Depending on the source device in use, all eight jacks may be used, though in many cases only connections to the front left/right, center, surround left/right and LFE (subwoofer input) jacks will be used for standard 5.1 audio signals.

30 Video 2 S-Video Output: If the product connected to the **Video 2 Audio Outputs 37** has S-video capability, connect this jack to the REC/IN S-video jack on that unit.

31 Video 3 S-Video Input: If the product connected to the **Video 3 Audio Inputs 38** has S-video capability, connect this jack to the PLAY/OUT S-video jack on that unit and then make certain that the **S-Video Monitor Output 22** is connected as described above.

REAR-PANEL CONNECTIONS

32 Video Monitor Output: Connect this jack to the composite video input of a TV monitor or video projector to view the on-screen menus and the output of a standard video source.

33 DVD Audio/Video Inputs: Connect the composite video and L/R analog audio outputs of a DVD player or other video source to these jacks.

34 Video 1 Audio/Video Inputs: Connect the composite video and L/R analog audio PLAY/OUT jacks of a VCR or other video source to these jacks.

35 Video 1 Audio/Video Outputs: Connect the composite video and L/R analog audio REC/IN jacks of a VCR or other video recording device such as a DVD recorder or PVR to these jacks.

36 Video 2 Audio/Video Inputs: Connect the composite video and L/R analog audio PLAY/OUT jacks of a cable television box or other video source to these jacks.

37 Video 2 Audio/Video Outputs: Connect the composite video and L/R analog audio REC/IN jacks of a VCR or other video recording device such as a DVD recorder or PVR to these jacks.

38 Video 3 Audio/Video Inputs: Connect the composite video and L/R analog audio PLAY/OUT jacks of an HDTV tuner or other video source to these jacks.

39 AM Antenna Terminals: Connect the AM loop antenna supplied with the receiver to these terminals. If an external AM antenna is used, make connections to the **AM** and **GND** terminals in accordance with the instructions supplied with the antenna.

NOTE ON VIDEO CONNECTIONS: When connecting a video source product such as a VCR, DVD player, satellite receiver, cable set-top box, personal video recorder or video game to the AVR 240, you may use either a composite or S-video connection, but not both.

REMOTE CONTROL FUNCTIONS

- 1 Power Off Button
- 2 IR Transmitter Window
- 3 Program Indicator
- 4 Power On Button
- 5 Input Selectors
- 6 AVR Selector
- 7 AM/FM Tuner Select
- 8 Dim Button
- 9 Test Button
- 10 Sleep Button
- 11 DSP Surround Mode Selector
- 12 Night Mode
- 13 Channel Select Button
- 14 ▲/▼ Buttons
- 15 ◀/▶ Buttons
- 16 Set Button
- 17 Digital Select
- 18 Numeric Keys
- 19 Tuner Mode
- 20 Direct Button
- 21 Tuning Up/Down
- 22 OSD Button
- 23 Dolby Mode Selector
- 24 DTS Digital Mode Selector
- 25 Logic 7 Mode Select Button
- 26 Skip Up/Down Buttons
- 27 Transport Controls
- 28 Stereo Mode Select Button
- 29 DTS Neo:6 Mode Select
- 30 Macro Buttons
- 31 Disc Skip Button
- 32 Preset Up/Down
- 33 Clear Button
- 34 Memory Button
- 35 Delay/Prev. Ch.
- 36 Speaker Select
- 37 Spare Button
- 38 Volume Up/Down
- 39 TV/Video Selector
- 40 DMP [™]Bridge[®] Selector
- 41 6-Channel/8-Channel Direct Input
- 42 Mute

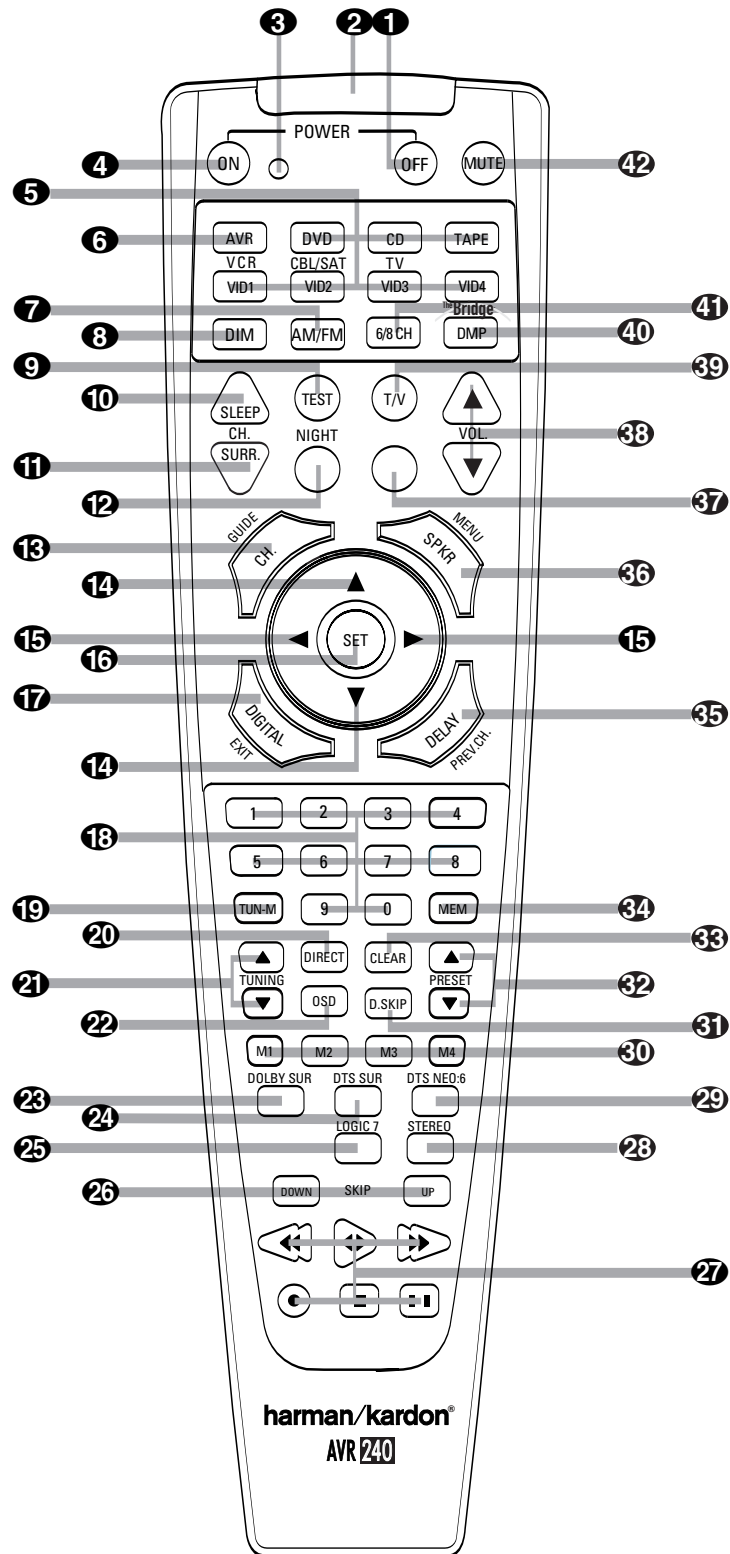

NOTES:

- The function names shown here are each button's feature when used with the AVR 240. Most buttons have additional functions when used with other devices. See pages 44–45 for a list of these functions.
- To make it easier to follow the instructions that refer to this illustration, a larger copy may be downloaded from the Product Support section for this product at www.harmankardon.com.

REMOTE CONTROL FUNCTIONS

IMPORTANT NOTE: The AVR 240's remote may be programmed to control up to seven devices, including the AVR 240. Before using the remote, it is important to remember to press the **Input Selector Button 5** that corresponds to the unit you wish to operate. In addition, the AVR 240's remote is shipped from the factory to operate the AVR 240 and most Harman Kardon CD or DVD players and cassette decks. The remote is also capable of operating a wide variety of other products using the control codes that are part of the remote. Before using the remote with other products, follow the instructions on page 41 to program the proper codes for the products in your system.

It is also important to remember that many of the buttons on the remote take on different functions, depending on the product selected using the Device Control Selectors. The descriptions shown here primarily detail the functions of the remote when it is used to operate the AVR 240. (See pages 42–45 for information about alternate functions for the remote's buttons.)

1 Power Off Button: Press this button to place the AVR 240 or a selected device in the Standby mode.

2 IR Transmitter Window: Point this window towards the AVR 240 when pressing buttons on the remote to make certain that infrared commands are properly received.

3 Program Indicator: This three-color indicator is used to guide you through the process of programming the remote. (See page 41 for information on programming the remote.)

4 Power On Button: Press this button to turn on the power to a device selected by pressing one of the **Input Selectors 5**.

5 Input Selectors: Pressing one of these buttons will perform three actions at the same time. First, if the AVR 240 is not turned on, this will power up the unit. Next, it will select the source shown on the button as the input to the AVR 240. Finally, it will change the remote control so that it controls the device selected. After pressing one of these buttons you must press the **AVR Selector Button 6** again to operate the AVR 240's functions with the remote.

6 AVR Selector: Pressing this button will switch the remote so that it will operate the AVR 240's functions. If the AVR 240 is in the Standby mode, it will also turn the AVR 240 on.

7 AM/FM Tuner Select: Press this button to select the AVR 240's tuner as the listening choice. Pressing this button when the tuner is already in use will select between the AM and FM bands.

8 Dim Button: Press this button to activate the Dimmer function, which reduces the brightness of the front panel display, or turns it off entirely. The first press of the button shows the default state, which is full brightness by indicating **VFD FULL** in the **Lower Display Line 27**. Press the button again within five seconds to reduce the brightness by 50%, as indicated by **VFD HALF** showing in the **Lower Display Line 27**. Press the button again within five seconds and the main display will go completely dark. Note that this setting is temporary, in that regardless of any changes, the display will always return to full brightness when the AVR is turned on. In addition, the **Power Indicator 2** will always remain at full brightness regardless of the setting. This is to remind you that the AVR is still turned on.

9 Test Button: Press this button to begin the sequence used to calibrate the AVR 240's output levels. (See pages 25, 29 and 38 for more information on calibrating the AVR 240.)

10 Sleep Button: Press this button to place the unit in the Sleep mode. After the time shown in the display, the AVR 240 will automatically go into the Standby mode. Each press of the button changes the time until turn-off in the following order:

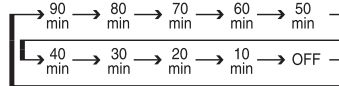

See page 31 for more information on the Sleep Function. This button is also used to change channels on your TV when the TV is selected.

11 DSP Surround Mode Selector: Press this button to cycle through the DSP, VMAX and Stereo surround modes such as Hall, Theater, VMAX Near and Far, and Surround Off. This button is also used to tune channels when the TV is selected using the device **Input Selector 5**.

12 Night Mode: Press this button to activate the Night mode. This mode is available in specially encoded digital sources, and it preserves dialogue (center channel) intelligibility at low volume levels.

13 Channel Select Button: This button is used to start the process of setting the AVR 240's output levels to an external source. Once this button is pressed, use the **▲/▼ Buttons 14** to select the channel being adjusted, then press the **Set Button 16**, followed by the **▲/▼ Buttons 14** again, to change the level setting. (See pages 29 and 38 for more information.) However, Harman Kardon recommends that you first perform the EzSet+ procedure, as described on pages 23 to 25.

14 ▲/▼ Buttons: These multipurpose buttons are used to change or scroll through items in the on-screen menus, make configuration settings such as digital inputs or delay timing, or to select surround modes. When changing a setting, first press the button for the function or setting to be changed (e.g., press the **DSP Surround Mode Selector 11** to select a sound field mode or the **Digital Select Button 17** to change a digital input) and then press one of these buttons to scroll through the list of options or to increase or decrease a setting. The sections in this manual describing the individual features and functions contain specific information on using these buttons for each application.

15 ◀▶ Buttons: These buttons are used to change the menu selection or setting during some of the setup procedures for the AVR 240.

16 Set Button: This button is used to enter settings into the AVR 240's memory. It is also used in the setup procedures for delay time, speaker configuration and channel output level adjustment.

17 Digital Select: Press this button to assign one of the digital inputs **18 19 21 26** to a source. (See pages 20 and 35 for more information on using digital inputs.)

18 Numeric Keys: These buttons serve as a 10-button numeric keypad to enter tuner preset positions. They are also used to select channel numbers when TV, Cable or SAT has been selected on the remote, or to select track numbers on a CD, DVD or LD player, depending on how the remote has been programmed.

19 Tuner Mode: Press this button when the tuner is in use to select between automatic tuning and manual tuning. When the button is pressed so that **MANUAL** appears in the **Lower Display Line 27**, pressing the **Tuning Buttons 9 21** will move the frequency up or down in single-step increments. When the FM band is in use, pressing this button when a station's signal is weak will change to monaural reception. (See page 37 for more information.)

20 Direct Button: Press this button when the tuner is in use to start the sequence for direct entry of a station's frequency. After pressing the button, simply press the proper **Numeric Keys 18** to select a station. (See page 37 for more information on the tuner.)

REMOTE CONTROL FUNCTIONS

21 Tuning Up/Down: When the tuner is in use, these buttons will tune up or down through the selected frequency band. If the **Tuner Mode Button 19 17** has been pressed so that **AUTO** appears in the on-screen display and **Lower Display Line 27**, pressing and holding either of the buttons for three seconds will cause the tuner to seek the next station with acceptable signal strength for quality reception. When **MANUAL** appears in the **Lower Display Line 27**, pressing these buttons will tune stations in single-step increments. (See page 37 for more information.)

22 OSD Button: Press this button to activate the On-Screen Display (OSD) system used to set up or adjust the AVR 240's parameters.

23 Dolby Mode Selector: This button is used to select from among the available Dolby Surround processing modes. Each press of this button will select one of the Dolby Pro Logic II or IIx, or Dolby Virtual Speaker modes or Dolby 3 Stereo. When a Dolby Digital-encoded source is in use, the Dolby Digital mode may also be selected. When the headphones are in use, this button selects from among the Dolby Headphone modes. (See pages 33–34 for the available Dolby surround mode options.)

24 DTS Digital Mode Selector: When a DTS-encoded digital source is selected, each press of this button will scroll through the available DTS modes. The specific choice of modes will vary according to whether or not the source material contains DTS-ES 6.1 Discrete encoding. When a DTS source is not in use, this button has no function. (See page 33 for the available DTS digital options.)

25 Logic 7 Mode Select Button: Press this button to select from among the available Logic 7 surround modes. (See page 33 for the available Logic 7 options.)

26 Skip Up/Down Buttons: These buttons do not have a direct function with the AVR 240, but when used with a compatibly programmed CD or DVD changer they will change to the previous disc in the changer or carousel.

27 Transport Controls: These buttons do not have any functions for the AVR 240, but they may be programmed for the forward/reverse play operation of a wide variety of CD or DVD players, and audio or video cassette recorders. When the DMP **Bridge** source is in use, these buttons may be used to operate some functions on a compatible iPod® if it is docked in The Bridge. See page 37 for more information on using **Bridge**.

When the remote is used to control the AVR, or the VID2 or VID3 device, by default these buttons are programmed to operate the DVD player. However, you may use the Transport Control Punch-Through feature described on page 43 to program these buttons to operate another device's transport controls when the AVR, VID2 or VID3 has been selected.

28 Stereo Mode Select Button: When the button is pressed so that **SURROUND OFF** appears in the **Lower Display Line 27**, with only the **Surr Off Surround Mode Indicator 28** lit, the AVR will operate in a bypass mode with true, fully analog, two-channel left/right stereo mode with no surround processing or bass management, unlike other modes where digital processing is used. When the button is pressed so that **SURROUND OFF** appears in the **Lower Display Line 27**, with both the **DSP** and **Surr Off Surround Mode Indicators 28** lit, you may enjoy a two-channel presentation of the sound along with the benefits of bass management. Depending on whether your system is configured for 5.1 or 6.1/7.1 channels, the next press of the button will cause either **5 CH STEREO** or **7 CH STEREO** to appear, and the stereo signal will be routed to all five (or seven) speaker channels. (See page 34 for more information on stereo playback modes.)

29 DTS Neo:6 Mode Select: Press this button to select a DTS Neo:6 mode. These modes take a two-channel stereo- or matrix surround-encoded source and create a full five-, six- or seven-channel sound field. (See page 33 for the DTS Neo:6 options.)

30 Macro Buttons: Press these buttons to store or recall a "Macro", which is a preprogrammed sequence of commands stored in the remote. (See page 41 for more information on storing and recalling macros.)

31 Disc Skip Button: This button has no direct function for the AVR 240 but is most often used to change to the next disc in a CD or DVD player when the remote is programmed for that type of device. (See page 42 for more information on using the remote with products other than the AVR 240.)

32 Preset Up/Down: When the tuner is in use, press these buttons to scroll through the stations programmed into the AVR 240's memory. When some source devices, such as CD players, VCRs and cassette decks, are selected using the device **Input Selectors 5**, these buttons may function as Chapter Step or Track Advance.

33 Clear Button: Press this button to clear incorrect entries when using the remote to directly enter a radio station's frequency.

34 Memory Button: Press this button to enter a radio station into the AVR 240's preset memory. First, tune the desired station, and then press this button. Two underline indicators will flash at the right side of the **Upper Display Line 26**, and within five seconds press the **Numeric Keys 18** for the preset number between 01 and 30 that you wish to assign to the station. (See page 37 for more information.)

35 Delay/Prev Ch.: Press this button to begin the process for setting the delay times used by the AVR 240 when processing surround sound. After pressing this button, the delay times are entered by pressing the **Set Button 16** and then using the **▲/▼ Buttons 14** to change the setting. Press the **Set Button 16** again to complete the process. (See page 22 for more information.) However, Harman Kardon recommends that you first perform the EzSet+ procedure, as described on pages 23–25.

36 Speaker Select: Press this button to begin the process of configuring the AVR 240's bass management system for use with the type of speakers used in your system. Once the button has been pressed, use the **▲/▼ Buttons 14** to select the channel you wish to set up. Press the **Set Button 16** and then select another channel to configure. When all adjustments have been completed, press the **Set Button 16** twice to exit the settings and return to normal operation. (See page 26 for more information.) However, Harman Kardon recommends that you first perform the EzSet+ procedure, as described on pages 23–25.

37 Spare Button: This button has no direct function for the AVR 240, but may be used by other devices.

38 Volume Up/Down: Press these buttons to raise or lower the system volume. By default, the **Volume Up/Down Buttons 38** are programmed at the factory to control the AVR 240's volume, no matter which source device has been selected (except TAPE). You may reprogram these buttons to control the volume of another device, such as your TV, using the Volume Control Punch-Through instructions found on page 43.

39 TV/Video Selector: This button does not have a direct function on the AVR 240, but when used with a compatible VCR, DVD or satellite receiver, pressing this button will switch between the output of the device and the external video input. Consult the owner's manual for your specific player or receiver for the details of how it implements this function.

REMOTE CONTROL FUNCTIONS

40 **The Bridge™ Digital Media Player (DMP) Selector:**

When Harman Kardon's **The Bridge™** (optional) is connected to **The Bridge™ Digital Media Player (DMP) Connector 29** and a compatible Apple® iPod® is docked in **The Bridge™**, pressing this selector will select the iPod as the audio source input device for the AVR 240. In addition, if a video display is connected to one of the **Video Monitor Outputs 22-23**, the iPod's messages will appear on screen, and in the **Upper and Lower Display Lines 26-27**. The **▲/▼/◀/▶ Buttons 14-15**, the **Set Button 16** and the **Transport Controls 27** may be used to navigate the iPod and to operate many functions. See page 37, and the manuals for The Bridge and your iPod for more information.

41 6-Channel/8-Channel Direct Input: Press this button to select the device connected to the **6/8-Channel Direct Inputs 29**. (See page 31 for more information.) When the device connected to the **6/8-Channel Direct Input 29** is also a video source, such as a DVD or DVD-Audio player with an onboard audio decoder, you must first select that video source by pressing one of the **Input Selectors 5**, then press this button to choose the device connected to the **6/8-Channel Direct Input 29** as the audio source. Note that if you desire, you may select any video source to be used in conjunction with the **6/8-Channel Direct Input 29** as the audio source.

42 Mute: Press this button to momentarily silence the AVR 240 or TV set being controlled, depending on which device has been selected. When the AVR 240 remote is being programmed to operate another device, this button is pressed with the **Input Selector Button 5** to begin the programming process. (See page 41 for more information on programming the remote.)

INSTALLATION AND CONNECTIONS

System Installation

After unpacking the unit, locating it in a place with adequate ventilation and placing it on a solid surface capable of supporting its weight, you will need to make the connections to your audio and video equipment.

IMPORTANT NOTE: For your personal safety and to avoid possible damage to your equipment and speakers, it is always a good practice to turn off and unplug the AVR and ALL source equipment from the AC output before making any audio or video system connections.

Audio Equipment Connections

We recommend that you use high-quality interconnect cables when making connections to source equipment and recorders to preserve the integrity of the signals.

1. Connect the analog outputs of a CD player to the **CD Audio Inputs 2**.

NOTE: When the CD player has both fixed and variable audio outputs, it is best to use the fixed output unless you find that the input to the receiver is so low that the sound is noisy, or so high that it is distorted.

2. Connect the analog Play/Out jacks of a cassette deck, MD, CD-R or other audio recorder to the **Tape Input Jacks 4**. Connect the analog Record/In jacks on the recorder to the **Tape Output Jacks 3** on the AVR 240.

3. Connect the output of any digital sources such as a CD or DVD changer or player, advanced video game, a digital satellite receiver, HDTV tuner or digital cable set-top box or the output of a compatible computer sound card to the **Optical and Coaxial Digital Audio Inputs 21, 25, 18, 19**. We recommend connecting the coaxial digital audio output of your DVD player to the **Coax 1 Digital Audio Input 19**, since that digital input is assigned to the DVD source by default. The Video 2/Cable/Sat source defaults to the **Optical 1 Digital Audio Input 25**. If your cable television set-top box or satellite receiver is equipped with an optical digital audio output, we recommend that you connect it to this input to obtain the benefits of higher-quality digital audio (such as PCM, Dolby Digital 2.0 or Dolby Digital 5.1 signals when broadcast by your cable or satellite provider).

4. Connect the **Coaxial or Optical Digital Audio Outputs 19, 20** on the rear panel of the AVR 240 to the matching digital input connections on a CD-R or MiniDisc or other digital recorder.

5. Assemble the AM Loop Antenna supplied with the unit so that the tabs at the bottom of the antenna loop snap into the holes in the base. Connect it to the **AM Antenna Terminals 39**.

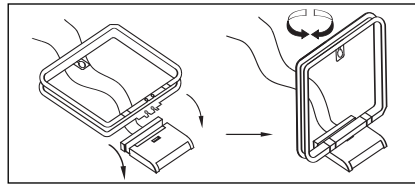

6. Connect the supplied FM antenna to the **FM (75-ohm) Connection 1**. The FM antenna may be an external roof antenna, an inside powered or wire-lead antenna or a connection from a cable TV system. If the antenna or connection uses 300-ohm twin-lead cable, you must use the 300-ohm-to-75-ohm adaptor supplied with the unit to make the connection.

7. With the AVR 240 turned off, connect the optional Harman Kardon **Bridge** to **Bridge**: **Digital Media Player (DMP) Connector 24**. Your compatible iPod® may be docked in **Bridge** when you wish to use it as an audio source device. Video materials stored on the iPod may not be viewed when The Bridge is in use.

8. Connect the front, center, surround and surround back speaker outputs **9, 10, 11, 1** to the respective speakers.

To ensure that all the audio signals are carried to your speakers without loss of clarity or resolution, we suggest that you use high-quality speaker cable. Many brands of cable are available and the choice of cable may be influenced by the distance between your speakers and the receiver, the type of speakers you use, personal preferences and other factors. Your dealer or installer is a valuable resource to consult in selecting the proper cable.

Regardless of the brand of cable selected, we recommend that you use a cable constructed of multi-strand copper with a gauge of 14 or smaller. Remember that in specifying cable, the lower the number, the thicker the cable.

Cable with a gauge of 16 may be used for short runs of less than 10 feet. We do not recommend that you use cables with an AWG equivalent of 18 or higher, due to the power loss and degradation in performance that will occur.

Cables that are run inside walls should have the appropriate markings to indicate listing with UL, CSA or other appropriate testing agency standards. Questions about running cables inside walls should be referred to your installer or a licensed electrician who is familiar with the NEC and/or the applicable local building codes in your area.

When connecting wires to the speakers, observe proper polarity. Note that the positive (+) terminal of each speaker connection may carry a specific color

code, as noted on page 8. However, many speakers still use a red terminal for the positive (+) connection. Connect the "negative" or "black" wire to the same terminal on both the receiver and the speaker.

NOTE: While most speaker manufacturers adhere to an industry convention of using black terminals for negative and red ones for positive, some may vary from this configuration. To ensure proper phase and optimal performance, consult the identification plate on your speaker or the speaker's manual to verify polarity. If you do not know the polarity of your speaker, ask your dealer for advice before proceeding, or consult the speaker's manufacturer.

We also recommend that the length of cable used to connect speaker pairs be identical. For example, use the same length piece of cable to connect the front-left and front-right or surround-left and surround-right speakers, even if the speakers are a different distance from the AVR 240.

9. Connections to a subwoofer are normally made via a line-level audio connection from the **Subwoofer Output 8** to the line-level input of a subwoofer with a built-in amplifier. When a passive subwoofer is used, the connection first goes to a power amplifier, which will be connected to one or more subwoofers. If you are using a powered subwoofer that does not have line-level input connections, follow the instructions furnished with the speaker for connection information.

10. If an external multichannel audio source with 5.1, 6.1 or 7.1 outputs such as an external digital processor/decoder, DVD-Audio or SACD player is used, connect the outputs of that device to the **6/8-Channel Direct Inputs 29**.

Video Equipment Connections

Video equipment is connected in the same manner as audio components. The use of high-quality interconnect cables is recommended to preserve signal quality.

1. Connect a VCR's, DVD recorder's, personal video recorder's or other video source's audio and video Play/Out jacks to the **Video 1 Audio/Video and/or S-Video Input Jacks 25, 34** on the rear panel. The Audio and Video Record/In jacks on the recorder should be connected to the **Video 1 Audio/Video and/or S-Video Output Jacks 27, 35** on the AVR 240. Although any video device may be connected to these jacks, we recommend connecting your video recorder so that you may take advantage of the fact that the remote control is preprogrammed with video recorder product codes for the Video 1 device.
2. Connect the analog audio and video outputs of a satellite receiver, cable TV converter, television set

INSTALLATION AND CONNECTIONS

or any other video source to the **Video 2 Audio/Video and S-Video Input Jacks 23/36**.

Although any video device may be connected to these jacks, we recommend connecting your cable TV converter or satellite receiver so that you may take advantage of the fact that the remote control is preprogrammed with the product codes of these device types for the Video 2 device.

3. Connect the analog audio and video outputs of a television or other video device to the **Video 3 Audio and Video Input Jacks 31/38** on the rear panel. Although any video or audio device may be connected to these jacks, we recommend connecting your television so that you may take advantage of the fact that the remote control is preprogrammed with TV product codes for the Video 3 device.

Important: If you are only using the television as a display device (i.e., if you receive your television programs through a cable box or satellite receiver), do not connect the television's outputs to the **Video 3 Audio and Video Input Jacks 31/38**, or to any other inputs on the AVR 240.

4. Connect the analog audio and video outputs of a DVD or laser disc player to the **DVD Audio/Video and S-Video Inputs 23/33**.

5. Connect the digital audio outputs of a DVD player, satellite receiver, cable box or HDTV converter to the appropriate **Optical** or **Coaxial Digital Inputs 21/26/18/19**. Remember that the DVD source defaults to the **Coaxial 1 Digital Input 19**, and the Video 2/Cable/Sat source defaults to the **Optical 1 Digital Audio Input 25**. All other sources default to their analog inputs, although any source may be assigned to any digital audio input on the receiver.

6. Connect the **Video and/or S-Video Monitor Output 22/32** jacks on the receiver to the composite or S-video input of your television monitor or video projector.

7. If both your video display monitor and at least one video source device, such as a DVD player or HDTV set-top box, is equipped with component video capability, then you may connect the component video outputs of the device to one of the two **Component Video Inputs 14/15**.

It is recommended that you connect a DVD player or a digital recorder to the **Component Video 1 Inputs 14**, as this input is assigned to the DVD, CD, Tuner and Tape sources by default. Thus, whenever any of these sources is selected, you may view the component video output of the device connected to the **Component Video 1 Inputs 14**, enabling you to view and listen to different sources.

Similarly, it is recommended that you connect any other audio/video device, such as a DVD-Audio or SACD player or HDTV set-top box, to the Video 1, Video 2 or Video 3 sources, or the 6-/8-channel direct inputs, as the **Component Video 2 Inputs 15** are assigned to the Video 1, Video 2, Video 3 and 6-/8-channel source audio inputs by default.

However, you may connect any component video source to either set of component video inputs, as they are assignable to any source. You will still need to connect either the analog or digital audio outputs, or the 6-/8-channel audio outputs, of your component video device to the analog audio inputs corresponding to the source (such as DVD or Video 2 for a cable converter box), or to any of the **Optical** or **Coaxial Digital Audio Inputs 21/26/18/19**.

8. If the component video inputs are used, connect the **Component Video Monitor Outputs 13** to the component video inputs of your TV, projector or display device.
9. If you have a camcorder, video game or other audio/video device that is connected to the AVR on a temporary rather than permanent basis, connect the audio, video and digital audio outputs of that device to the **Video 4 Inputs 18/19/20/21** on the front panel. A device connected here is selected as the Video 4 input, and the digital inputs must be assigned to the Video 4 input. (See page 20 for more information on input configuration.)

VIDEO CONNECTION NOTES:

- When the component video jacks are used, the on-screen menus are not visible and you must switch to the standard composite or S-video input on your TV to view them.
- The AVR 240 will accept either standard composite, S-video or Y/Pr/Pb component video signals. However, it will not convert any of these signals to a different format.
- When connecting a video source to the AVR 240, you may use either composite, component or S-video, but only one type of video may be connected for each device.
- When more than one video format is used, it is necessary to make a separate connection from the AVR to your video display for each format. For example, if both composite and component sources are connected to the AVR 240, both the **Composite** and **Component Video Monitor Outputs 13/32** must be connected to the appropriate inputs on your video display.

System and Power Connections

The AVR 240 is designed for flexible use with external control components.

Main Room Remote Control Extension

If the receiver is placed behind a solid or smoked glass cabinet door, the obstruction may prevent the remote sensor from receiving commands. In this event, an optional remote sensor may be used. Connect the output of the remote sensor to the **Remote IR Input 5** jack.

If other components are also prevented from receiving remote commands, only one sensor is needed. Simply use this unit's sensor or a remote eye by running a connection from the **Remote IR Output 6** jack to the Remote IR Input jack on Harman Kardon or other compatible equipment.

AC Power Connections

This unit is equipped with two accessory AC outlets. They may be used to power accessory devices, but they should not be used with high-current-draw equipment such as power amplifiers. The total power draw to each outlet may not exceed 100 watts.

The **Switched AC Accessory Outlet 17** will receive power only when the unit is on. This is recommended for devices that have no power switch or a mechanical power switch that may be left in the "ON" position.

NOTE: Many audio and video products go into a Standby mode when they are used with switched outlets, and cannot be fully turned on using the outlet alone without a remote control command.

The **Unswitched AC Accessory Outlet 18** will receive power as long as the unit is plugged into a powered AC outlet.

Once the **AC Power Cord 16** is connected, you are almost ready to enjoy the AVR 240's incredible power and fidelity!

OPERATION

Basic Operation

Once you have completed the initial setup and configuration of the AVR 240, it is simple to operate and enjoy. The following instructions will help you maximize the enjoyment of your new receiver:

Turning the AVR 240 On or Off

- When using the AVR 240 for the first time, you must first press the **Main Power Switch 1** on the front panel to turn the unit on. This places the unit in a Standby mode, as indicated by the amber color of the **Power Indicator 2**. Once the unit is in Standby, you may begin a listening session by pressing the **Standby/On Switch 3** on the front panel, or the **Power On Button 4** or **AVR Selector 6** on the remote. The **Power Indicator 2** will turn blue. This will turn the unit on and return it to the input source that was last used. The unit may also be turned on from Standby by pressing any of the **Input Selector Buttons 5 7** on the remote or the **Input Source Selector Button 16** on the front panel.

NOTE: After pressing one of the **Input Selector Buttons 5 7** to turn the unit on, press the **AVR Selector 6** to set the remote control to the AVR 240 functions.

To turn the unit off at the end of a listening session, simply press the **Standby/On Switch 3** on the front panel or the **Power Off Button 1** on the remote. Power will be shut off to any equipment plugged into the rear-panel **Switched AC Accessory Outlet 14** and the **Power Indicator 2** will turn amber.

When the remote is used to turn the unit "off" it is actually placing the system in a Standby mode, as indicated by the amber color of the **Power Indicator 2**.

- To program the AVR 240 for automatic turn-off, press the **Sleep Button 10** on the remote. Each press of the button will decrease the time before shut-down in the following sequence:

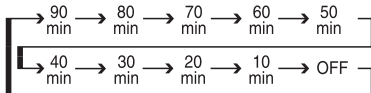

The sleep time will be displayed in the **Lower Display Line 27**. The front-panel display will dim to one-half brightness when the Sleep function is programmed. To view the current sleep time when the sleep function has been activated, press the **Sleep Button 10** once. The display will return to normal brightness, and the time until shutdown will appear in the **Lower Display Line 27**. After a few seconds, the message will disappear and the display will return to half-brightness.

When the programmed sleep time has elapsed, the unit will automatically turn off. To cancel the Sleep function, press and hold the **Sleep Button 10** as

the information display returns to normal brightness; continue to hold the button until the Sleep indicator numbers disappear and the words **SLEEP OFF** appear in the **Lower Display Line 27**.

When you will be away from home for an extended period of time it is always a good idea to completely turn the unit off with the front-panel **Main Power Switch 1**.

NOTE: All preset memories are lost if the unit is left turned off by using the **Main Power Switch 1** for more than four weeks.

Source Selection

- To select a source, press any of the **Input Selector Buttons 5 7 40 41** on the remote.
- The input source may also be changed by pressing the front-panel **Input Source Selector Button 16**. Each press of the button will move the input selection through the list of available inputs.
- As the input is changed, the AVR 240 will automatically switch to the digital input (if selected), component video input, surround mode, output levels and night mode status as well as any speaker configuration settings established by using the **INDEPENDENT** Bass Management setting, that were entered during the configuration process for that source.
- When the input source is changed, the new input name and the digital (or analog) audio input will appear in the **Upper Display Line 26**, and the current surround mode will appear in the **Lower Display Line 27**. The same messages will also appear momentarily in the on-screen display in the lower third of the screen (semi-OSD).
- When an audio source is selected, the last video input used remains routed to the **Video 1 Video** and **S-Video Outputs 27/35** and **Component Video, Composite Video** and **S-Video Monitor Outputs 13/24/32**. This permits you to simultaneously view and listen to different sources. This also allows you to choose a video source and then select the **6/8-Channel Direct Inputs 29** as the audio source.
- The front-panel **Video 4 Inputs 20/21**, **Optical 3 Digital Input 18** or the **Coaxial 3 Digital Input 19** may be used to connect a device such as a video game or camcorder to your home entertainment system on a temporary basis.
- When DMP **Bridge** is selected as the source and a compatible iPod is inserted in an optional Harman Kardon **Bridge** that is connected to

Bridge **DMP Connector 24** on the rear panel, navigation messages will appear on any video display connected to the AVR's **Video Monitor Outputs 23/32**. The remote control or front-panel controls may be used to navigate the iPod and access many of its functions. These messages will also appear in the front-panel display, and the iPod's battery may be charged. See the owner's guides for **Bridge** and your iPod for more information.

6-Channel/8-Channel Direct Input

- There are two input choices available for use with sources such as a DVD-Audio or SACD player that are connected to the **6/8-Channel Direct Inputs 29**. Select the appropriate input according to the way your system and source equipment are configured:
 - 6 CH DIRECT** should be used when the SBR and SBL inputs are NOT in use. It is assumed that the input source device has its own internal bass management system. This input passes the input from the source directly through to the volume control without any analog to digital conversion and it mutes the unused input jacks to prevent unwanted noise from interfering with system performance.
 - 8 CH DIRECT** should be used when an input is connected to all eight **8-Channel Direct Inputs 29**. It is assumed that the input source device has its own internal bass management system. This input passes the input from the source directly through to the volume control without any analog-to-digital conversion and it mutes the unused input jacks to prevent unwanted noise from interfering with system performance.

Volume Control

- Adjust the volume to a comfortable level using the front-panel **Volume Control 23** or remote **Volume Up/Down Buttons 38**.
- To temporarily silence all speaker outputs, press the **Mute Button 42**. This will interrupt the output to all speakers and the headphone jack, but it will not affect any recording or dubbing that may be in progress. When the system is muted, the word **MUTE** will flash in the **Upper Display Line 26**. Press the **Mute Button 42** again to return to normal operation.
- You may adjust the bass and treble tone controls at any point during a listening session by pressing the **Tone Mode Button 5** until **TONE IN** appears in the **Lower Display Line 27**. Press the **Tone Mode Button 5** again until either **TREBLE MODE** or **BASS MODE**

OPERATION

appears in the **Lower Display Line 5**, and then use the **◀▶ Buttons 10** to boost or cut the low or high frequencies by up to ± 10 dB, in 2dB steps, until the desired setting is achieved. You may also totally remove the tone controls from the circuit so that the output is "flat" at any time by pressing the **Tone Mode Button 5** and then pressing the **◀▶ Buttons 10** so that **TONE OUT** appears in the on-screen display and the **Lower Display Line 27**. The tone controls may also be adjusted using the **AUDIO SETUP** submenu as described on page 21.

- For private listening, plug the 1/4" stereo phone plug from a pair of stereo headphones into the front-panel **Headphone Jack 4**. When the headphone plug is connected, all speakers will be silenced and **DOLBY H:BP** will scroll once across the **Lower Display Line 27**, indicating that the headphone output is in the Bypass mode, and to confirm that no processing is being used. When the headphone plug is removed, the audio feed to the speakers will be restored.
- When the headphones are in use, you may take advantage of the Dolby Headphone modes to bring added spaciousness to headphone listening. Press the **Dolby Mode Select Button 23** or the **Surround Mode Group Selector 7** to cycle through the three Dolby Headphone modes and select the one that you prefer.

Surround Mode Selection

One of the important features of the AVR 240 is its ability to reproduce a full multichannel surround sound field from digital sources, analog matrix surround-encoded programs and standard stereo programs.

Selection of a surround mode is based on personal taste, as well as the type of program source material being used. For example, motion pictures or TV programs bearing the logo of one of the major surround-encoding processes, such as Dolby Surround or DTS Stereo, may be played in either the Dolby Digital, Dolby Pro Logic II or IIx Movie, DTS Neo:6 Cinema, or Logic 7 5.1 or 7.1 Cinema surround modes.

NOTE: Once a program has been encoded with matrix surround information, it retains the surround information as long as the program is broadcast in stereo. Thus, movies with surround sound may be decoded via any of the analog surround modes such as Dolby Pro Logic IIx Cinema, Logic 7 Cinema or DTS Neo:6 Cinema, when they are broadcast via conventional TV stations, cable, pay-TV and satellite transmission. In addition, a growing number of made-for-television programs, sports broadcasts, radio dramas and music CDs are also recorded in surround sound.

Even when a program is not listed as carrying intentional surround information, you may find that the Dolby Pro Logic IIx, Logic 7 Enhanced or DTS Neo:6, VMAx and the Hall or Theater modes often deliver enveloping surround presentations through the use of the natural information present in all stereo recordings.

Surround modes may be changed at any time by using either the front panel or remote control. Any changes made to the surround mode for that source will be retained in the AVR's menu, even after another source is selected, or if the AVR is placed in Standby mode. To select a new surround mode from the front panel, first press the **Surround Mode Group Selector Button 7** until the desired major surround mode group, such as Dolby, DTS or Logic 7, is selected. Next, press the **Surround Mode Selector Button 8** to choose the specific individual surround mode.

To select a surround mode using the remote, press the button for the major surround mode group that includes the mode you wish to choose from: **Dolby 23**, **DTS Surround 24**, **DTS Neo:6 29**, **Logic 7 25**, **Stereo 28** or **DSP Surround 11**. The first press of the button will show the current mode from that group. To cycle through the available modes in that group, press the button again until the desired mode appears in the **Lower Display Line 27**, the on-screen display and in the **Surround Mode Indicators 28**. As the surround mode changes, the appropriate **Surround Mode Indicator 28** will light to indicate the current mode. At times, it is possible that more than one indicator will light. This can occur when the DSP Surround Off mode has been selected, or when post-processing is being used with an input signal, such as when the Dolby Digital 2.0 plus Dolby Pro Logic IIx mode is used to create a 7-channel presentation of a two-channel signal.

The Dolby Digital, Dolby Digital EX and DTS 5.1, DTS-ES Matrix and DTS-ES Discrete modes may only be selected when a digital input is in use and a digital signal in that format is present. In addition, when a digital source is present, the AVR 240 will automatically select and switch to the correct mode, regardless of the mode that has been previously selected. For more information on selecting digital sources, see the Digital Audio Playback section.

The Dolby Pro Logic IIx modes are available only when the AVR 240 has been configured for 6.1/7.1 operation by setting the Surround Back speakers as either **LARGE** or **SMALL** as described on page 26. These modes provide a matrixed 6.1-channel presentation of analog sources. See page 26 for more information.

When the 6-channel/8-channel direct inputs are in use there is no surround processing, as these inputs take the analog output signals from an optional, exter-

nal DVD-Audio or SACD player, or another source device and carry them straight through to the volume control without any further digital processing.

To listen to a program in traditional two-channel stereo, using the front left and front right speakers only (plus the subwoofer, if installed and configured), press the **Stereo Button 28** until **SURROUND OFF** appears in the **Lower Display Line 27**, or press the **Surround Mode Group Selector 7** until the Stereo modes appear in the on-screen display and **Lower Display Line 27** and then press the **Surround Mode Select Button 8** until **SURROUND OFF** appears in the on-screen display and **Lower Display Line 27**.

When an analog audio source is in use, you may activate an analog bypass Surround Off mode, if you have removed the tone controls from the processing circuitry by pressing the **Tone Mode Button 5** and using the **◀▶ Buttons 10 15** until the **TONE OUT** message appears in the **Lower Display Line 27**.

Normally, the DSP icon will appear in the **Surround Mode Indicators 28**, and the message **SURROUND OFF** will appear in the lower line of the semi-OSD display. When the DSP icon appears, the incoming signal is digitized and any bass management settings are applied. This mode is recommended when your front speakers are not capable of reproducing the lower frequencies and are thus used with a subwoofer.

When the DSP icon is not lit in Surround Off mode with an analog audio input in use, the AVR is in analog bypass mode. The signal is being routed directly to the volume control, without entering the digital domain and without any bass management settings being applied. This mode is desirable when your left and right speakers are capable of reproducing low frequencies, and when you wish to hear the analog source material in its pure form.

Digital Audio Playback

Digital audio is a major advancement over older analog surround processing systems such as Dolby Pro Logic. It delivers five, six or seven discrete channels: left front, center, right front, left surround, right surround and optionally one or two surround back channels. Each channel reproduces full frequency range (20Hz to 20kHz) and offers dramatically improved dynamic range and significant improvements to signal-to-noise ratios. In addition, digital systems have the capability to deliver an additional channel that is specifically devoted to low-frequency information. This is the ".1" channel referred to when you see these systems described as "5.1," "6.1" or "7.1". The bass channel is separate from the other channels, but since it is intentionally bandwidth-limited, sound designers have given it that unique designation.

OPERATION

Dolby Digital

Dolby Digital is a standard part of DVD, and is available on specially encoded LD discs and satellite broadcasts and it is a part of the high-definition television (HDTV) system.

An optional, external RF demodulator is required to use the AVR 240 to listen to the Dolby Digital soundtracks available on laser discs. Connect the RF output of the LD player to the demodulator and then connect the digital output of the demodulator to the **Optical or Coaxial Inputs 18 19 21 26** of the AVR 240. No demodulator is required for use with DVD players or DTS-encoded laser discs.

DTS

DTS is another digital audio system that is capable of delivering 5.1 or 6.1 discrete or matrix sound field reproduction. Although both DTS and Dolby Digital are digital, they use different methods of encoding the signals, and thus they require different decoding circuits to convert the digital signals back to analog.

DTS-encoded soundtracks are available on select DVD and LD discs, as well as on special audio-only DTS discs. You may use any LD or CD player equipped with a digital output to play DTS-encoded discs with the AVR 240. All that is required is to connect the player's output to either an **Optical or Coaxial Input** on the rear panel **21 26** or front panel **18 19**.

In order to listen to DVDs encoded with DTS soundtracks, the DVD player must be compatible with the DTS signal as indicated by a DTS logo on the player's front panel. Early DVD players may not be able to play DTS-encoded DVDs. This does not indicate a problem with the AVR 240, as some players cannot pass the DTS signal through to the digital outputs. If you are in doubt as to the capability of your DVD player to handle DTS discs, consult the player's owner's manual.

IMPORTANT NOTE: Many DVD players have a default setting that does not pass through the DTS data, even though the machine is capable of doing so. If your DVD player has the "DTS Digital Out" logo but does not trigger DTS playback in the AVR 240, change the player's settings in the "Audio" or "Bitstream" configuration menu so that DTS playback is enabled. The method for doing this will vary with each player. In some cases, the proper menu choice will be "Original," while in others it will be "DTS." Consult the owner's manual for your player to find the specific information to find the proper setting.

Selecting a Digital Source

To utilize either digital mode, you must have properly connected a digital source to the AVR 240. Connect the digital outputs from DVD players, HDTV receivers, satellite systems or CD players to the **Optical or Coaxial Inputs 18 19 21 26**. In order to provide a backup signal and a source for analog stereo recording, the analog outputs provided on digital source equipment

should also be connected to their appropriate inputs on the AVR 240 rear panel (e.g., connect the analog stereo audio output from a DVD to the **DVD Audio Inputs 33** on the rear panel when you connect the source's digital outputs).

If you have not already configured an input for a digital source using the on-screen menus as shown on page 20, first select the input using the remote or front-panel controls as outlined in this manual. Next, select the digital source by pressing the **Digital Select Button 17 18** and then using the **▲/▼ Buttons 14** on the remote or the **◀▶ Selector Buttons 10** on the front panel to choose any of the **OPTICAL** or **COAXIAL** inputs, as they appear in the **Upper Display Line 26** or on-screen display. When the digital source is playing, the AVR 240 will automatically detect which type of digital data stream is being decoded and display that information in the **Upper Display Line 26**.

Digital Bitstream Indications

When a digital source is playing, the AVR 240 senses the type of bitstream data that is present. Using this information, the correct surround mode will automatically be selected. For example, DTS bitstreams will cause the unit to switch to DTS decoding, and Dolby Digital bitstreams will enable Dolby Digital decoding. When the unit senses PCM data from CDs or LDs, it will default to Logic 7 Music mode, although you may select any of the standard surround modes, such as Dolby Pro Logic II or Logic 7. Since the range of available surround modes is dependent on the type of digital data that is present, the AVR 240 uses a variety of indicators and messages to let you know what type of signal is present. These messages will appear shortly after an input or surround mode is changed, and they will remain in the **Lower Display Line 27** for about five seconds before that portion of the display returns to the normal surround mode indication.

Surround Mode Channel Indications

For Dolby Digital and DTS sources, a three-digit indication will appear, showing the number of channels present in the data. An example of this type of display is **3/2/.1**.

The first number indicates how many discrete front channel signals are present.

- A "3" tells you that separate front left, center and front right signals are available. This will be displayed for Dolby Digital 5.1 and DTS 5.1 programs.
- A "2" tells you that separate front left and right signals are available, but there is no discrete center channel signal. This will be displayed for Dolby Digital bitstreams that have stereo program material.
- A "1" tells you that there is only a mono channel available in the Dolby Digital bitstream.

The middle number indicates how many discrete surround channel signals are present.

- A "2" tells you that separate surround left and right signals are available. This will be displayed for Dolby Digital 5.1 and DTS 5.1 programs.
- A "1" tells you that there is only a single, surround-encoded surround channel. This will appear for Dolby Digital bitstreams that have matrix encoding.
- A "0" indicates that there is no surround channel information. This will be displayed for two-channel stereo programs.

The last number indicates whether there is a discrete low-frequency effects (LFE) channel. This is the ".1" in the common abbreviation of "5.1" sound and is a special channel that contains only bass frequencies.

- A "1" tells you that an LFE channel is present. This will be displayed for Dolby Digital 5.1 and DTS 5.1 programs, as available.
- A "0" indicates that there is no LFE channel information available. However, even when there is no dedicated LFE channel, low-frequency sound will be present at the subwoofer output when the speaker configuration is set to show the presence of a subwoofer.

The information in the right side of the display will tell you if the digital audio data contains a special flag signal that will automatically activate the appropriate 6.1 or 7.1 mode. This will be shown as **EX-ON** or **EX-OFF** for Dolby Digital bitstreams and **ES-ON** or **ES-OFF** for DTS bitstreams.

If the EX flag is off, and your receiver has been configured for 6.1/7.1 operation, you may manually turn on EX processing as appropriate by simply selecting the Dolby Digital EX surround mode as described on pages 21 and 32. When the ES flag is not present in a DTS bitstream, you may benefit from a 6.1-channel presentation by selecting the DTS+Neo:6 post-processing surround mode using the procedure described on pages 21 and 32. In that mode, the DTS Neo:6 algorithms will be used to derive the surround back channel from the DTS bitstream information.

When Dolby Digital 3/2/.1 or DTS 3/2/.1 signals are being played, the AVR will automatically switch to the proper surround mode, and no other processing may be selected, with these exceptions:

- When a Dolby Digital 2.0 signal is detected, you may choose to listen to it in its native form. To do so, scroll through the Dolby surround modes until the Stereo icon lights in the **Surround Mode Indicators 28** in addition to the Dolby Digital icon. Alternatively, you may engage surround post-processing by scrolling through the Dolby Pro Logic II and Ix modes, and the Dolby Pro Logic icon will light in addition to the Dolby Digital icon.

OPERATION

- As indicated above, when the EX flag is not present in a Dolby Digital bitstream, you may scroll through the Dolby surround modes to manually select Dolby Digital EX processing.
- When a DTS 5.1 signal is detected, you may listen to it as a two-channel presentation, a 5.1-channel presentation or a 6.1-channel presentation (if your AVR is configured for 6.1/7.1 operation). To hear a two-channel presentation, scroll through the DTS surround modes until the Stereo icon lights in the **Surround Mode Indicators 23** in addition to the DTS icon. Continue scrolling to engage DTS 5.1 processing or DTS+Neo:6 (6-channel) processing.
- If a DTS-ES 6.1 Discrete signal is present, you may choose a two-channel presentation, a 5.1-channel presentation or a 6.1-channel presentation (if your AVR has been configured for 6.1/7.1 operation). Scroll through the DTS surround modes until the Stereo icon lights in the **Surround Mode Indicators 23**, in addition to the DTS icon. Continue scrolling to engage DTS 5.1 processing or DTS-ES Discrete processing.

When a Dolby Digital signal with a 3/1/0 or 2/0/0 signal is detected you may select any of the Dolby surround modes.

See page 40 for information on setting a default surround mode.

It is always a good idea to check the readout for the channel data to make certain that it matches the audio logo information shown on the back of a DVD package. In some cases you will see indication for "2/0/0" even when the disc contains a full 5.1, or 3/2/1 signal. When this happens, check the audio output settings for your DVD player or the audio menu selections for the specific disc being played to make certain that the player is sending the correct signal to the AVR.

PCM Audio Playback

PCM is the abbreviation for Pulse Code Modulation, which is the type of digital signal used for standard CD playback and other non-Dolby Digital and non-DTS digital sources such as Mini-Disc. The digital circuits in the AVR 240 are capable of high-quality digital-to-analog decoding, and they may be connected directly to the digital audio output of your CD or LD player.

Connections may be made to either the rear-panel **Optical or Coaxial Inputs 21/26** or the front-panel **Digital Inputs 18/19**.

To listen to a PCM digital source, first select the input for the desired source (e.g., CD). Next press the **Digital Select Button 13/17** and then use the **▲/▼ Buttons 14** on the remote, or the **◀/▶ Selector Buttons 10** on the front panel, until the desired choice appears in the **Upper Display Line 26**.

During PCM playback, you may select any Surround mode except Dolby Digital or DTS.

When a PCM signal is detected, the **Lower Display Line 27** will briefly show a message with the letters PCM, in addition to a readout of the sampling frequency of the digital signal. In most cases this will be **48kHz**, though in the case of specially mastered, high-resolution audio discs you will see a **96kHz** indication.

Speaker/Channel Indicators

In addition to the bitstream indicators, the AVR 240 features a set of unique channel-input indicators that tell you how many channels of digital information are being received and/or whether the digital signal is interrupted. (See Figure 16.)

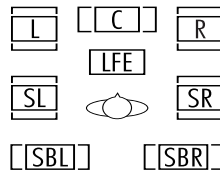

Figure 16

These indicators are the L/C/R/LFE/SL/SR/SBL/SBR letters that are inside the center boxes of the **Speaker/Channel Input Indicators 25** on the front panel. When a standard analog signal is in use, only the "L" and "R" indicators will light, as analog signals have only left and right channels.

Digital signals, however, may have two, five, six or seven channels, depending on the program material, the method of transmission and the way in which it was encoded. When a digital signal is playing, the letters in these indicators will light in response to the specific signal being received. It is important to note that although Dolby Digital, for example, is referred to as a "5.1" system, not all Dolby Digital DVDs or programs are encoded for 5.1. Thus, it is sometimes normal for a DVD with a Dolby Digital soundtrack to trigger only the "L" and "R" indicators.

NOTE: Many DVD discs are recorded with both "5.1" and "2.0" versions of the same soundtrack. When playing a DVD, always be certain to check the type of material on the disc. Most discs show this information in the form of a listing or icon on the back of the disc jacket. When a disc does offer multiple soundtrack choices, you may have to make some adjustments to your DVD player (usually with the "Audio Select" button or in a menu screen on the disc) to send a full 5.1 feed to the AVR 240. It is also possible for the type of signal feed to change during the course of a DVD playback. In some cases, the menu screens and previews of special material will only be recorded in 2.0 audio, while the main feature is available in 5.1 audio. The AVR 240 will automatically sense changes to the

bitstream and channel count and reflect them in these indicators.

The letters used by the **Speaker/Channel Input Indicators 25** also flash to indicate when a bitstream has been interrupted. This will happen when a digital input source is selected before the playback starts, or when a digital source such as a DVD is paused. The flashing indicators remind you that the playback has stopped due to the absence of a digital signal and not through any fault of the AVR 240. This is normal, and the digital playback will resume once the playback is started again.

Night Mode

A special feature of Dolby Digital is the Night mode, which enables specially encoded Dolby Digital input sources to be played back with full digital intelligibility while reducing the minimum peak level by 1/4 to 1/3. This prevents abruptly loud transitions from disturbing others, without reducing the impact of the digital source. The Night mode is available only when Dolby Digital signals with special data are being played.

The Night mode may be engaged when a Dolby Digital DVD is playing by pressing the **Night Mode Button 12** on the remote. Next, press the **▲/▼ Buttons 14** to select either the middle-range or full-compression versions of the Night mode. To turn the Night mode off, press the **▲/▼ Buttons 14** until the message in the lower third of the video display and in the **Lower Display Line 27** reads **D-RANGE OFF**.

The Night mode may also be selected to always be on at either level of compression using the options in the **DOLBY** menu. See page 22 for information on using the menus to set this option.

IMPORTANT NOTES ON DIGITAL PLAYBACK:

- When the digital playback source is stopped, or in a pause, fast-forward or chapter-search mode, the digital audio data will momentarily stop, the channel position letters inside the **Speaker/Channel Input Indicators 25** will flash. This is normal and does not indicate a problem with either the AVR 240 or the source machine. The AVR 240 will return to digital playback as soon as the data is available and when the machine is in a standard play mode.
- Although the AVR 240 will decode virtually all current DVD movies, CDs and HDTV sources, it is possible that some future digital sources may not be compatible with the AVR 240.
- Not all digitally encoded programs contain full 5.1- or 6.1-channel audio. Consult the program guide that accompanies the DVD or laser disc to determine which type of audio has been recorded on the disc. The AVR 240 will automatically sense the type

OPERATION

of digital surround encoding used and adjust to accommodate it.

- When some digital sources are playing, you may not be able to select some of the analog surround modes such as Dolby Pro Logic II or IIx, Dolby 3 Stereo, Hall, Theater or Logic 7.
- When a Dolby Digital or DTS source is playing, it is not possible to make an analog recording using the **Tape Outputs 3** and **Video 1 Audio Outputs 35**. However, the digital signals will be passed through to the **Digital Audio Outputs 19/20**.

Tuner Operation

The AVR 240's tuner is capable of tuning AM, FM and FM Stereo broadcast stations. Stations may be tuned manually, or they may be stored as favorite station presets and recalled from a 30-position memory.

Station Selection

1. Press the **AM/FM Tuner Select Button 7** on the remote to select the tuner as an input. The tuner may be selected from the front panel either by pressing the **Input Source Selector 16** until the tuner is active or by pressing the **Tuner Band Selector 11**.
2. Press the **AM/FM Tuner Select Button 7** or **Tuner Band Selector 11** again to switch between AM and FM so that the desired frequency band is selected.
3. Press the **Tuner Mode Button 17/19** to select manual or automatic tuning.

When the button is pressed so that **AUTO** appears in the **Lower Display Line 27** each press of the **Tuning Selectors 9/21** will put the tuner in a scan mode that seeks the next higher- or lower-frequency station with acceptable signal strength. An **AUTO ST TUNED** indication

will momentarily appear when the station stops at a stereo FM station, and an **AUTO TUNED** indication will momentarily appear when an AM or monaural FM station is tuned. Press the Tuning buttons again to scan to the next receivable station.

When the button is pressed so that **MANUAL** appears in the **Lower Display Line 27** each tap of the Selector will increase or decrease the frequency by one increment. When the tuner receives a strong-enough signal for adequate reception, **MANUAL TUNED** will appear in the **Lower Display Line 27**.

4. Stations may also be tuned directly in either the automatic or manual mode. To enter a station's frequency directly, first select the AM or FM band as desired by pressing the **AM/FM Tuner Select**

Button 7. Next, press the **Direct Button 20**. Within five seconds of seeing the **DIRECT IN** scroll in the **Upper Display Line 26**, enter the station frequency by pressing the **Numeric Keys 18**. If you press an incorrect button while entering a direct frequency, press the **Clear Button 43** to start over.

NOTE: When FM reception of a station is weak, audio quality will be increased by switching to Mono mode by pressing the **Tuner Mode Button 17/19** so that **MANUAL** appears momentarily in the **Lower Display Line 27** and goes out. This will also activate manual tuning mode.

Preset Tuning

Using the remote, up to 30 stations may be stored in the AVR 240's memory for easy recall using the front panel controls or the remote.

To enter a station into the memory, first tune the station using the steps outlined above. Then:

1. Press the **Memory Button 34** on the remote. Two underscore lines will appear at the far right side of the **Upper Display Line 26**.
2. Within five seconds, press the **Numeric Keys 18** corresponding to the location where you wish to store this station's frequency. Once entered, the preset number will appear in the **Upper Display Line 26**.
3. Repeat the process after tuning any additional stations to be preset.

Recalling Preset Stations

- To manually select a station previously entered in the preset memory, press the **Numeric Keys 18** that correspond to the desired station's memory location.
- To manually tune through the list of stored preset stations one by one, press the **Preset Stations Selector Buttons 14/30** on the front panel or remote.

Recording

In normal operation, the audio or video source selected for listening through the AVR 240 is sent to the record outputs. This means that any program you are watching or listening to may be recorded simply by placing machines connected to the **Tape Outputs 3** or **Video 1 Audio/Video** and **S-Video Outputs 27/35** in the Record mode.

When a digital audio recorder is connected to the **Digital Audio Outputs 19/20**, you are able to record the digital signal using a CD-R, MiniDisc or other digital recording system.

NOTES:

- The digital outputs are active only when a digital signal is present, and they do not convert an analog input to a digital signal, or change the format of the digital signal. In addition, the digital recorder must be compatible with the output signal. For example, the PCM digital input from a CD player may be recorded on a CD-R or MiniDisc, but Dolby Digital or DTS signals may not.
- Please make certain that you are aware of any copyright restrictions on any material you copy. Unauthorized duplication of copyrighted materials is prohibited by federal law.

Using The Bridge

When Harman Kardon's **The Bridge** (optional) is connected and a compatible iPod® is docked in The Bridge, press the **DMP The Bridge Selector Button 40** to choose the iPod as the input source. Pressing the **DMP The Bridge Selector Button 40** will also activate the AVR remote's control codes for the iPod, and you may also use the front-panel controls to operate the iPod. You may also select **DMP The Bridge** as the source from the front panel by repeatedly pressing the **Input Source Selector 16** until **DMP** appears in the **Upper Display Line 26**, although no **Input Indicator 24** will light.

When The Bridge is properly connected and a compatible iPod is properly docked, **DMP / THE BRIDGE IS CONNECTED** will scroll across the **Upper Display Line 26**. Once that message appears, use the remote or front-panel buttons to control the iPod. See the Function List Table on pages 44–45 for a listing of the remote control buttons that have been programmed to control the iPod. In brief, the **Reverse Search, Play** and **Forward Search Buttons 27** and the **▲/▼/◀/▶ Buttons 14/15** and **Set Button 16** may be used in a similar manner to the corresponding controls on the iPod. Additional buttons on the remote may also be used to navigate your iPod's albums and playlists. Complete details on operating an iPod using **The Bridge** and an AVR remote are furnished with **The Bridge**.

The front-panel controls may be used to access a limited number of iPod functions. Press the **Tuner Mode Button 17** to play or pause the current track. The **Tuning Selector 9** may be used to search reverse (left side of button) or forward (right side of button) through the tracks. Press the **Tuner Band Selector 11** to call up the iPod's menu. Press the **Preset Station Selectors 14** to scroll, and the **Set Button 12** to select. For complete information on using the AVR's remote or front-panel controls to operate an iPod, see the instructions packed with The Bridge.

OPERATION

Output Level Trim Adjustment

Normal output level adjustment for the AVR 240 is established using EzSet+, or the internal test tone, as outlined on pages 29–30. In some cases, however, it may be desirable to adjust the output levels using program material such as a test disc, or a selection you are familiar with.

To adjust the output levels using program material, first set the reference volume for the front left and front right channels using the **Volume Control** 23 38.

If you are using a disc with test signals or an external signal generator as the source from which to trim the output levels, you may use a handheld SPL meter to guide you to the correct SPL levels. Set the meter to the C-Weighting Slow scale, and adjust the volume until the meter reads 75dB.

Once the reference level has been set, press the **Channel Select Button** 13 and **FRONT LEVEL** will appear in the **Lower Display Line** 27 and semi-OSD. To change the level, first press the **Set Button** 16, and then use the **▲/▼ Buttons** 14 to raise or lower the level. DO NOT use the volume control, as this will alter the reference setting.

Once the change has been made, press the **Set Button** 16 and then press the **▲/▼ Buttons** 14 to select the next output channel location you wish to adjust. To adjust the subwoofer level, press the **▲/▼ Buttons** 14 until **WOOFER LEVEL** appears in the **Lower Display Line** 27 and on screen.

Repeat the procedure as needed until all channels requiring adjustment have been set. When all adjustments have been made and no further adjustments are made for five seconds, the AVR 240 will return to normal operation.

The channel output for any input may also be adjusted using the full-OSD on-screen menu system. First, set the volume to a comfortable listening level using the **Volume Control** 23 38. Then, press the **OSD Button** 22 to bring up the **MASTER MENU** (Figure 1). Press the **▼ Button** 14 until the on-screen ► cursor is next to the **MANUAL SETUP** line. Press the **Set Button** 16 to display the **MANUAL SETUP** submenu, and use the **▲/▼ Buttons** 14 to scroll to the **CHANNEL ADJUST** line. Press the **Set Button** 16 again to display the **CHANNEL ADJUST** submenu.

Once the menu appears on your video screen, first use the **▲/▼ Buttons** 14 to move the on-screen ► cursor so that it is next to the **TEST TONE** line. Press the **◀/▶ Buttons** 15 so that **OFF** appears. This will turn off the test tone and allow you

to use your external test disc or other source material as the reference. Then, use the **▲/▼ Buttons** 14 until the ► cursor is next to the **TEST TONE SEQ** line so that you may select between automatic and manual movement of the test tone from one channel to the next. When **AUTO** appears, the test tone will automatically circulate from one channel to the next, pausing momentarily at each channel. If you adjust the level of any channel, the test tone will remain paused at that channel until several seconds after your last adjustment before continuing to the next channel. When **MANUAL** appears, the test tone will remain paused at the last channel until you use the **▲/▼ Buttons** 14 to select another channel.

At each channel position, use the **◀/▶ Buttons** 15 to change the output level. Remember, the goal is to have the output level at each channel be equal when heard at the listening position.

If you wish to reset all the levels to their original factory default of 0dB offset, press the **▲/▼ Buttons** 14 so that the on-screen cursor is next to the **CHANNEL RESET** line and press the **◀/▶ Buttons** 15 so that the word **ON** appears. After the levels are reset, resume the procedure outlined above to reset the levels to the desired settings. When all adjustments are done, press the **▲/▼ Buttons** 14 to move the on-screen ► cursor so that it is next to **BACK TO MANUAL SETUP** and then press the **Set Button** 16 if you wish to go back to the manual setup menu to make other adjustments. If you have no other adjustments to make, press the **OSD Button** 22 to exit the menu system.

NOTE: The output levels may be separately trimmed for each digital and analog surround mode by selecting that mode and following the instructions shown above.

Memory Backup

This product is equipped with a memory backup system that preserves the system configuration information and tuner presets if the unit is accidentally unplugged or subjected to a power outage. This memory will last for approximately four weeks, after which time all information must be reentered.

TROUBLESHOOTING GUIDE

SYMPTOM	CAUSE	SOLUTION
Unit does not function when Main Power Switch is pushed	<ul style="list-style-type: none"> No AC Power 	<ul style="list-style-type: none"> Make certain AC power cord is plugged into a live outlet Check to see whether outlet is switch-controlled
Display lights, but no sound or picture	<ul style="list-style-type: none"> Intermittent input connections Mute is on Volume control is down 	<ul style="list-style-type: none"> Make certain that all input and speaker connections are secure Press Mute Button 42 Turn up volume control
No sound from any speaker; light around power switch is red	<ul style="list-style-type: none"> Amplifier is in protection mode due to possible short Amplifier is in protection mode due to internal problems 	<ul style="list-style-type: none"> Check speaker wire connections for shorts at receiver and speaker ends Contact your local Harman Kardon service center
No sound from surround or center speakers	<ul style="list-style-type: none"> Incorrect surround mode Input is monaural Incorrect configuration Stereo or Mono program material 	<ul style="list-style-type: none"> Select a mode other than Stereo There is no surround information from mono sources Check speaker mode configuration The surround decoder may not create center- or rear-channel information from nonencoded programs
Unit does not respond to remote commands	<ul style="list-style-type: none"> Weak batteries in remote Wrong device selected Remote sensor is obscured 	<ul style="list-style-type: none"> Change remote batteries Press the AVR selector Make certain front panel sensor is visible to remote or connect remote sensor
Intermittent buzzing in tuner	<ul style="list-style-type: none"> Local interference 	<ul style="list-style-type: none"> Move unit or antenna away from computers, fluorescent lights, motors or other electrical appliances
Letters flash in the channel indicator display and digital audio stops	<ul style="list-style-type: none"> Digital audio feed paused 	<ul style="list-style-type: none"> Resume play for DVD Check that Digital Input is selected

In addition to the items shown above, additional information on troubleshooting possible problems with your AVR 240, or installation-related issues, may be found in the list of "Frequently Asked Questions" which is located in the Product Support section of our Web site at www.harmankardon.com.

Processor Reset

In the rare case in which the unit's operation or the displays seem abnormal, the cause may involve the erratic operation of the system's memory or microprocessor.

To correct this problem, first unplug the unit from the AC wall outlet and wait at least three minutes. After the pause, reconnect the AC power cord and check the unit's operation. If the system still malfunctions, a system reset may clear the problem.

To clear the AVR 240's entire system memory including tuner presets, output level settings, delay times and speaker configuration data, first place the AVR in Standby Mode, and then press and hold the **Tone Mode Button 5** button for three seconds. The unit will turn on automatically.

NOTE: Resetting the processor will erase any configuration settings you have made for speakers, output levels, surround modes, digital input assignments as well as the tuner presets. The unit will be returned to the factory presets, and all settings for these items must be reentered.

If the system is still operating incorrectly, there may have been an electronic discharge or severe AC line interference that has corrupted the memory or microprocessor.

If these steps do not solve the problem, consult an authorized Harman Kardon service center.

DISASSEMBLY

1. Removing the Top Cabinet
Remove the Screws

①-⑬

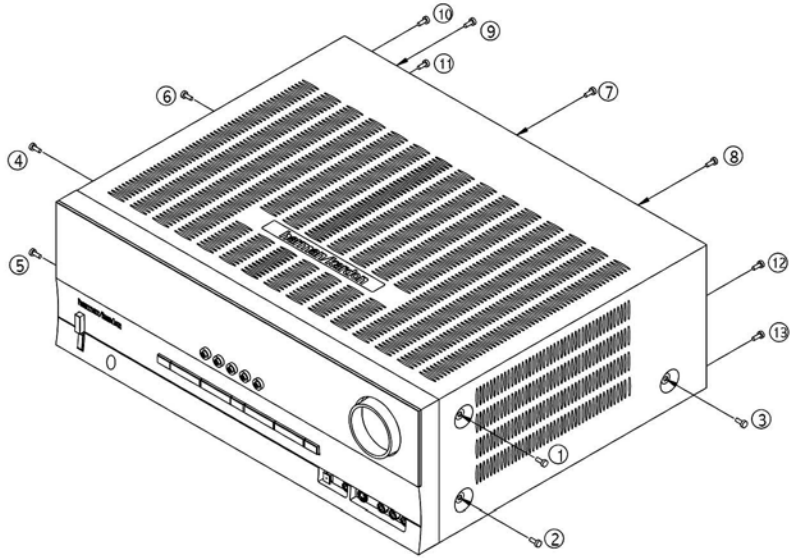

2. Removing the Front Panel
Remove the Screws

①-⑨

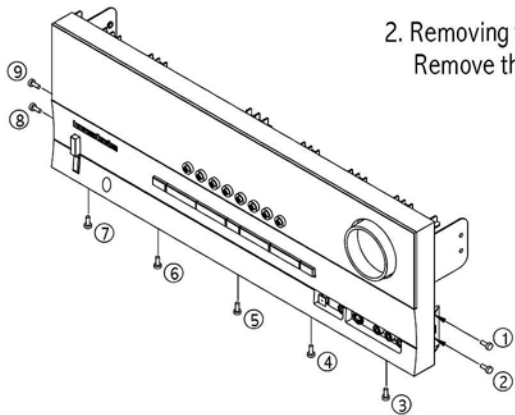

3. Removing the Rear Panel
Remove the Screws

①-③⑧

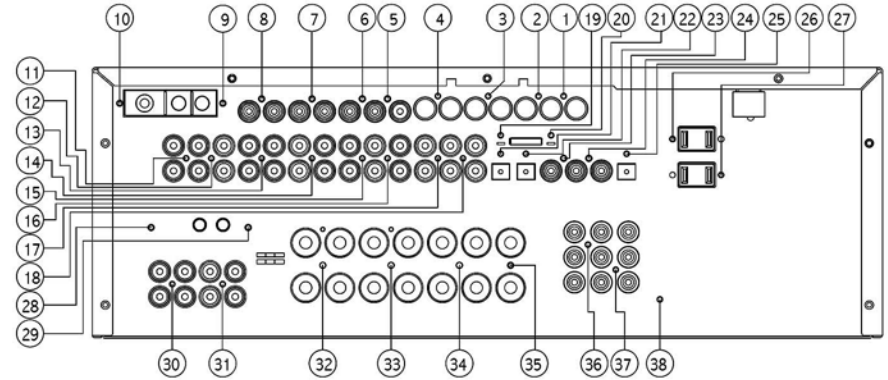

4. Removing the Main PCB
Remove the Screws

①-⑧

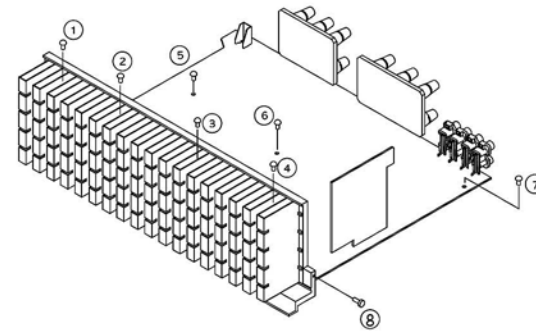

AVR240 EXPLODED VIEW

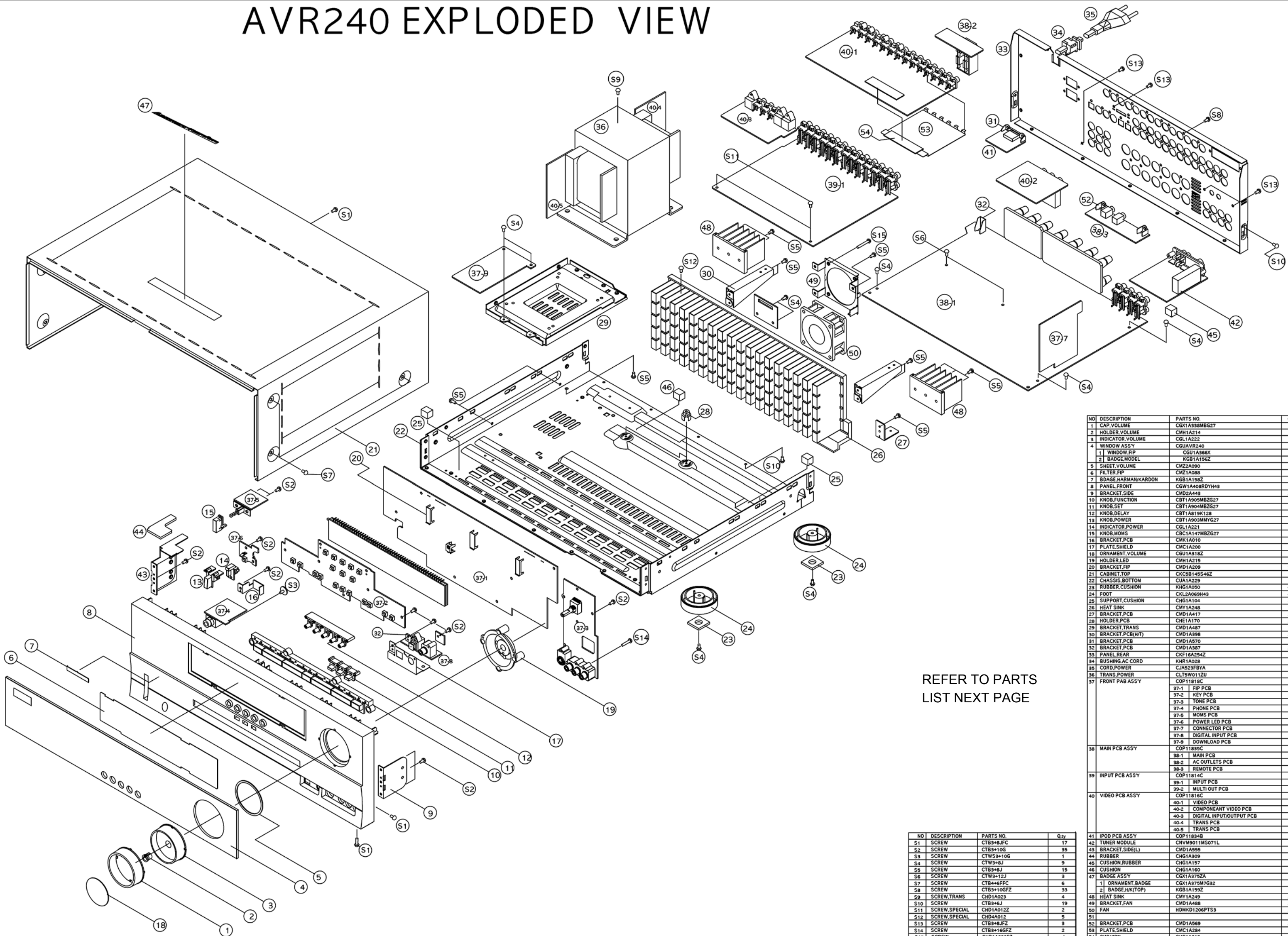

REFER TO PARTS LIST NEXT PAGE

NO	DESCRIPTION	PARTS NO.	Qty
1	CAP.VOLUME	CGX1A338MBG27	1
2	HOLDER.VOLUME	CMH1A214	1
3	INDICATOR.VOLUME	CGL1A232	1
4	WINDOW ASSY	CGU1A364X	1
1	WINDOW.FIP	CGU1A364X	1
2	BADGE.MODEL	KGB1A156Z	1
5	SHEET.VOLUME	CMZ2A090	1
6	FILTER.FIP	CMZ1A088	1
7	BDAGE.HARMAN/KARDON	KGB1A158Z	1
8	PANEL.FRONT	CGW1A408RDYH43	1
9	BRACKET.SIDE	CMZ2A443	2
10	KNOB.FUNCTION	CBT1A905MBZG27	1
11	KNOB.SET	CBT1A904MBZG27	1
12	KNOB.DELAY	CBT1A819K128	1
13	KNOB.POWER	CBT1A903MMYG27	1
14	INDICATOR.POWER	CGL1A221	1
15	KNOB.MOMS	CBT1A147MBZG27	1
16	BRACKET.PCB	CMK1A010	1
17	PLATE.SHIELD	CMC1A200	1
18	ORNAMENT.VOLUME	CGU1A318Z	1
19	HOLDER.LED	CMH1A215	1
20	BRACKET.FIP	CMZ1A209	3
21	CABINET.TOP	CHC5B145546Z	1
22	CHASSIS.BOTTOM	CU1A1A23	1
23	RUBBER.CUSHION	KHG1A050	4
24	FOOT	CKL2A069H43	4
25	SUPPORT.CUSHION	CHG1A104	2
26	HEAT.SINK	CMY1A248	1
27	BRACKET.PCB	CMZ1A417	2
28	HOLDER.PCB	CHZ1A170	2
29	BRACKET.TRANS	CMZ1A487	1
30	BRACKET.PCB(W/T)	CMZ1A398	2
31	BRACKET.PCB	CMZ1A570	1
32	BRACKET.PCB	CMZ1A387	1
33	PANEL.REAR	CKF16A254Z	1
34	BUSHING.AC CORD	KHR1A028	1
35	CORD.POWER	CJA523FBYA	1
36	TRANS.POWER	CLT5W012U	1
37	FRONT PAB ASSY	COP11818C	1
		37-1 FIP PCB	1
		37-2 KEY PCB	1
		37-3 TONE PCB	1
		37-4 PHONE PCB	1
		37-5 MOMS PCB	1
		37-6 POWER LED PCB	1
		37-7 CONNECTOR PCB	1
		37-8 DIGITAL INPUT PCB	1
		37-9 DOWNLOAD PCB	1
38	MAIN PCB ASSY	COP11835C	1
		38-1 MAIN PCB	1
		38-2 AC OUTLETS PCB	1
		38-3 REMOTE PCB	1
39	INPUT PCB ASSY	COP11814C	1
		39-1 INPUT PCB	1
		39-2 MULTI OUT PCB	1
40	VIDEO PCB ASSY	COP11816C	1
		40-1 VIDEO PCB	1
		40-2 COMPONEANT VIDEO PCB	1
		40-3 DIGITAL INPUT/OUTPUT PCB	1
		40-4 TRANS PCB	1
		40-5 TRANS PCB	1
41	IPOD PCB ASSY	COP11834B	1
42	TUNER MODULE	CMVM9011M5071L	1
43	BRACKET.SIDE(L)	CMZ1A555	1
44	RUBBER	CHG1A809	1
45	CUSHION.RUBBER	CHG1A157	1
46	CUSHION	CHG1A160	1
47	BADGE ASSY	CGX1A375ZA	1
		1 ORNAMENT.BADGE	6
		2 BADGE.HK(TOP)	1
48	HEAT.SINK	CMY1A249	2
49	BRACKET.FAN	CMZ1A488	2
50	FAN	HDMK1206PT53	2
51	SCREW	CTB3+8JFC	17
52	SCREW	CTB3+10G	35
53	SCREW	CTW53+10G	1
54	SCREW	CTW3+8J	9
55	SCREW	CTB3+6J	15
56	SCREW	CTW3+12J	3
57	SCREW	CTB4+6FFC	6
58	SCREW	CTB3+10GFZ	33
59	SCREW.TRANS	CHD1A023	4
S10	SCREW	CTB3+6J	19
S11	SCREW.SPECIAL	CHD1A012Z	2
S12	SCREW.SPECIAL	CHD4A01Z	9
S13	SCREW	CTB3+8JFZ	9
S14	SCREW	CTB3+16GFZ	2
S15	SCREW	CHD1A036FZ	4

AVR240

harman/kardon

NO	DESCRIPTION	PART NO.	Qty
1	CAP,VOLUME	CGX1A338MBG27	1
2	HOLDER,VOLUME	CMH1A214	1
3	INDICATOR,VOLUME	CGL1A222	1
4	WINDOW ASS'Y	CGUAVR240	1
	1 WINDOW,FIP	CGU1A366X	1
	2 BADGE,MODEL	KGB1A156Z	1
5	SHEET,VOLUME	CMZ2A090	1
6	FILTER,FIP	CMZ1A088	1
7	BDAGE,HARMAN/KARDON	KGB1A158Z	1
8	PANEL,FRONT	CGW1A408RDYH43	1
9	BRACKET,SIDE	CMD2A443	2
10	KNOB,FUNCTION	CBT1A905MBZG27	1
11	KNOB,SET	CBT1A904MBZG27	1
12	KNOB,DELAY	CBT1A819K128	1
13	KNOB,POWER	CBT1A903MMYG27	1
14	INDICATOR,POWER	CGL1A221	1
15	KNOB,MOMS	CBC1A147MBZG27	1
16	BRACKET,PCB	CMK1A010	1
17	PLATE,SHIELD	CMC1A200	1
18	ORNAMENT,VOLUME	CGU1A318Z	1
19	HOLDER,LED	CMH1A215	1
20	BRACKET,FIP	CMD1A209	3
21	CABINET, TOP	CKC5B145S46Z	1
22	CHASSIS,BOTTOM	CUA1A229	1
23	RUBBER,CUSHION	KHG1A050	4
24	FOOT	CKL2A069H43	4
25	SUPPORT,CUSHION	CHG1A104	2
26	HEAT SINK	CMY1A248	1
27	BRACKET,PCB	CMD1A417	2
28	HOLDER,PCB	CHE1A170	2
29	BRACKET,TRANS	CMD1A487	1
30	BRACKET,PCB(H/T)	CMD1A398	2
31	BRACKET,PCB	CMD1A570	1
32	BRACKET,PCB	CMD1A387	2
33	PANEL,REAR	CKF16A254Z	1
34	BUSHING,AC CORD	KHR1A028	1
35	CORD,POWER	CJA523FBYA	1
36	TRANS,POWER	CLT5W011ZU	1
37	FRONT PCB ASS'Y		1
	37-1 FIP PCB		1
	37-2 KEY PCB		1
	37-3 TONE PCB		1
	37-4 PHONE PCB		1
	37-5 MOMS PCB		1
	37-6 POWER LED PCB		1
	37-7 CONNECTOR PCB		1
	37-8 DIGITAL INPUT PCB		1
	37-9 DOWNLOAD PCB		1
38	MAIN PCB ASS'Y		1
	38-1 MAIN PCB		1
	38-2 AC OUTLETS PCB		1
	38-3 REMOTE PCB		1
39	INPUT PCB ASS'Y		1
	39-1 INPUT PCB		1
	39-2 MULTI OUT PCB		1
40	VIDEO PCB ASS'Y		1
	40-1 VIDEO PCB		1
	40-2 COMPONANT VIDEO PCB		1
	40-3 DIGITAL INPUT/OUTPUT PCB		1
	40-4 TRANS PCB		1
	40-5 TRANS PCB		1
41	IPOD PCB ASS'Y		1
42	TUNER MODULE	CNVM9011MS071L	1
43	BRACKET,SIDE(L)	CMD1A555	1
44	RUBBER	CHG1A309	1
45	CUSHION,RUBBER	CHG1A157	1
46	CUSHION	CHG1A160	1
47	BADGE ASS'Y	CGX1A375ZA	1
	1 ORNAMENT,BADGE	CGX1A375M7G32	1
	2 BADGE,H/K(TOP)	KGB1A159Z	1
48	HEAT SINK	CMY1A249	2
49	BRACKET,FAN	CMD1A488	2
50	FAN	HDMKD1206PTS3	2
51			
52	BRACKET,PCB	CMD1A569	2
53	PLATE,SHIELD	CMC1A284	1
54	CUSHION	CHG1A218	1

AMPLIFIER SECTION BIAS ADJUSTMENT

Measurement condition

. No input signal or volume position is minimum.

Standard value.

. Ideal current = 48mA (± 5%)

. Ideal DC Voltage = 25.92mV (± 5%)

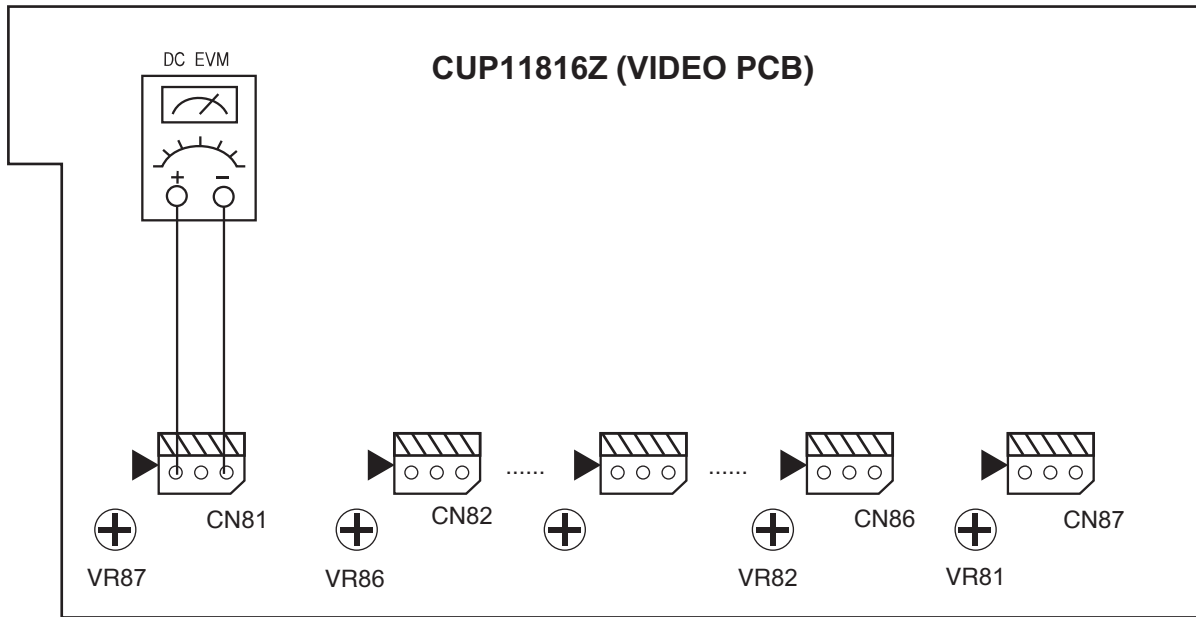

DC VOLTMETER.....Connect to CN81,CN82,CN83,CN84,CN85,CN86,CN87

NO.	Channel	Adjust for	Adjustment
1	Front Left	25.92mV (±5%)	VR83
2	Front Right	25.92mV (±5%)	VR84
3	Center	25.92mV (±5%)	VR85
4	Surround Left	25.92mV (±5%)	VR86
5	Surround Right	25.92mV (±5%)	VR87
6	Surround Back Left	25.92mV (±5%)	VR82
7	Surround Back Right	25.92mV (±5%)	VR81(ONLY AVR240/340)

harman/kardon**TECH TIPS****Troubleshooting tips and solutions to common service problems**

For models:

TIP# HKTT2003-01 Rev6

AVR7000/7200/7300/8000	AVR10
AVR100/200/300/500	DPR1001
AVR110/210/310/510	DPR1005
AVR120/220/320/520	DPR2005
AVR125/225/325/525	HK3370/3470/3375/3475
AVR130/230/330/430/630	HK3250
AVR135/235/335/435/635	
AVR140/240	

Subject: Backup Memory on AVR/DPR/HK series receivers**In the event of the complaint: “the receiver is losing its memory (any programmed system settings) when the unit is turned off, or after the unit is unplugged (briefly*)”:**

Check and replace:

Model	Designator	Location	Description	Part number
AVR10	C712 D709	Front PCB	0.047 Farad 5.5v capacitor and 1N4148 diode	#3439247315 #2058322101
AVR7000	C730	Front PCB	0.047 Farad 5.5v capacitor	# P10790-ND or # J3432147324X
AVR7200	C106	Front PCB	0.047 Farad 5.5v capacitor	# P10790-ND
AVR7300	C657	DSP PCB	0.047 Farad 5.5v capacitor	# H01-CEZXA0479MN-5
AVR8000	C726	Front PCB	0.047 Farad 5.5v capacitor	# 55230310NR or # P10790-ND
AVR100/200	C412	Front PCB	0.047 Farad 5.5v capacitor	# CEGT-B473J-0J0
AVR300	C906	Front PCB	0.1Farad 5.5v capacitor	# J4433210421X or # P10791-ND
AVR500	C906	Front PCB	0.1Farad 5.5v capacitor	# J4433210421X or # P10791-ND
AVR110/210/310/510 AVR120/220/320/520	C216	Front PCB	0.047 Farad 5.5v capacitor	# P10790-ND
AVR125/225	C734,C885	Front PCB	two 0.1F capacitors in parallel	# BCESOHD104
AVR325/525	C106	Front PCB	0.047 Farad 5.5v capacitor	# P10790-ND
AVR130/230/330	BAT1	Front PCB	3.6v Battery	# HABGP40BVH3A3H
AVR135/235/335	BAT1	Front PCB	3.6v Battery	# HGP15BNH3A3H
AVR140/240	BAT1	Front PCB	3.6v Battery	# HABGP40BVH3A3H
AVR430/630	C657	DSP PCB	0.047 Farad 5.5v capacitor	# CEZXA0479MN-5
AVR435/635	C557	DSP PCB	0.047 Farad 5.5v capacitor	# H03-CEZXA0479MN-0
DPR1001	BC601	Main PCB	0.1Farad 5.5v capacitor	# CEGT-B104J-0J0
DPR1005/2005	C437	Processor PCB	0.047 Farad 5.5v capacitor	# CEZXA0479MN-5
HK3370/3470	C301	Front PCB	0.1Farad 5.5v capacitor	# CEGT-B104J-0J0
HK3375/3475	C301	Front PCB	0.1Farad 5.5v capacitor	# CEGT-B104J-0J0
HK3250	C712 D709	Front PCB	0.047 Farad 5.5v capacitor and 1N4148 diode	#3439247315 #2058322101

* After approximately two weeks of being disconnected from AC supply, even a normally functioning receiver may lose any programmed settings and switch to default settings. (Four weeks for the DPR1005 & 2005)

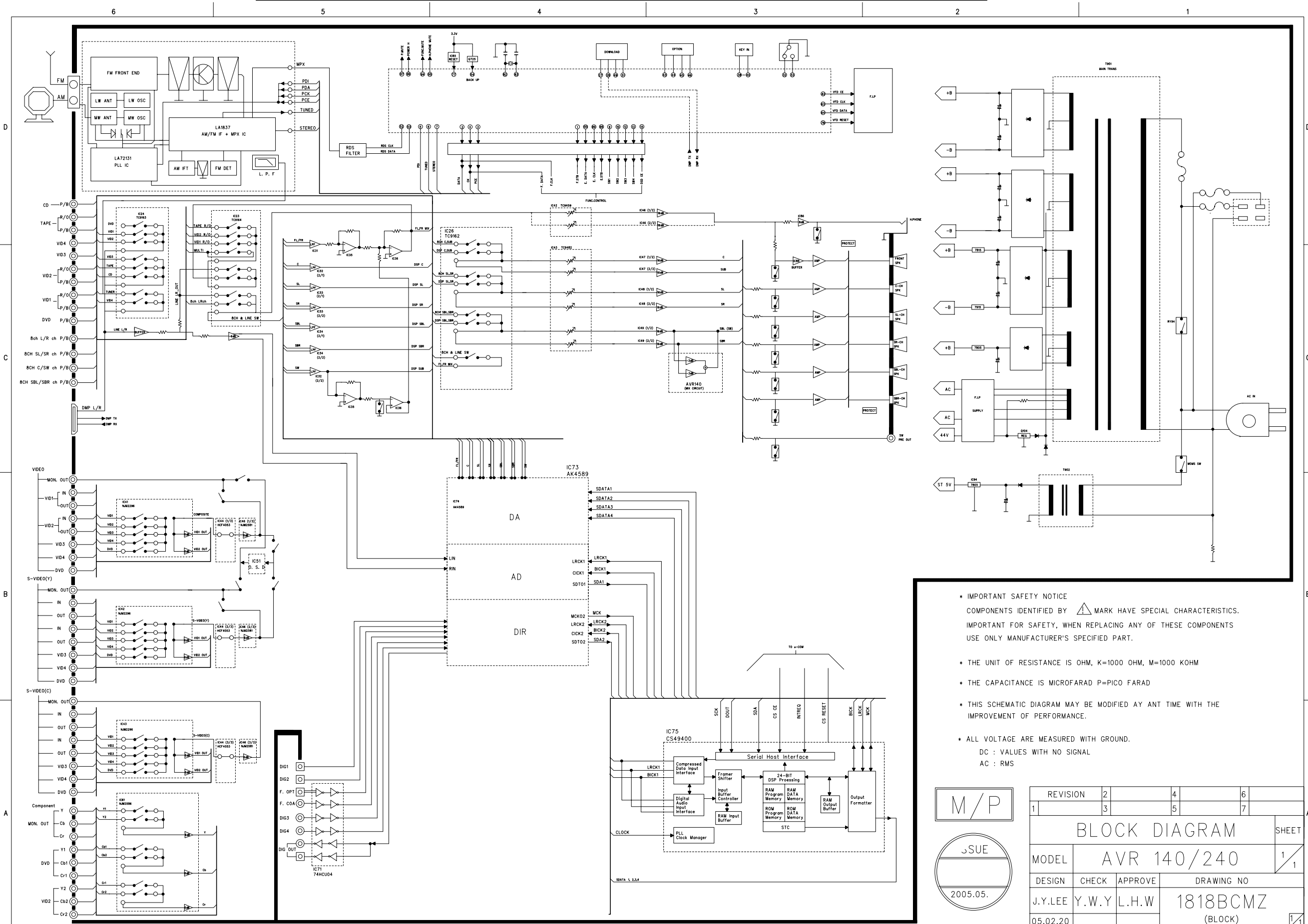

- * IMPORTANT SAFETY NOTICE
COMPONENTS IDENTIFIED BY MARK HAVE SPECIAL CHARACTERISTICS. IMPORTANT FOR SAFETY, WHEN REPLACING ANY OF THESE COMPONENTS USE ONLY MANUFACTURER'S SPECIFIED PART.
- * THE UNIT OF RESISTANCE IS OHM, K=1000 OHM, M=1000 KOHM
- * THE CAPACITANCE IS MICROFARAD P=PICO FARAD
- * THIS SCHEMATIC DIAGRAM MAY BE MODIFIED AT ANY TIME WITH THE IMPROVEMENT OF PERFORMANCE.
- * ALL VOLTAGE ARE MEASURED WITH GROUND.
DC : VALUES WITH NO SIGNAL
AC : RMS

M/P

JSUE
2005.05.

REVISION	2	4	6
1	3	5	7
BLOCK DIAGRAM			
MODEL	AVR 140/240		
DESIGN	CHECK	APPROVE	DRAWING NO
J.Y.LEE	Y.W.Y	L.H.W	1818BCMZ
05.02.20			(BLOCK)

AVR240 Electrical Parts List				
Ref. Designator	Part Number	Description		Qty
FRONT & INTERFACE PCB ASSY'S				
<i>Capacitors</i>				
C703	HCBS1H821KBT	CAP , CERAMIC	820PF 50V K	1
C704	CCEA1VH100T	CAP , ELECT	10UF 35V	1
C712	CCEA1HH1R0T	CAP , ELECT	1UF 50V	1
C713	HCBS1H223ZFT	CAP , CERAMIC	0.022UF 50V Z	1
C714	HCBS1H151KBT	CAP , CERAMIC	150PF 50V K	1
C715	CCEA1HH4R7T	CAP , ELECT	4.7UF 50V	1
C716	CCEA1CH331T	CAP , ELECT	330UF 16V	1
C719	HCBS1H181KBT	CAP , CERAMIC	180PF 50V K	1
C720	HCBS1H181KBT	CAP , CERAMIC	180PF 50V K	1
C721	HCBS1H181KBT	CAP , CERAMIC	180PF 50V K	1
C723	HCBS1H104ZFT	CAP , CERAMIC	0.1UF 50V Z	1
C725	HCBS1H473ZFT	CAP , CERAMIC	0.047UF 50V Z	1
C726	CCEA1CH101T	CAP , ELECT	100UF 16V	1
C728	HCBS1H104ZFT	CAP , CERAMIC	0.1UF 50V Z	1
C729	CCKT1H473ZF	CAP , CERAMIC	0.047UF 50V ZF	1
C730	CCFT1H104ZF	CAP , SEMICONDUCTOR	0.1UF 50V ZF	1
C731	CCEA1HH100T	CAP , ELECT	10UF 50V	1
C735	CCEA1CH101T	CAP , ELECT	100UF 16V	1
C736	HCBS1H223ZFT	CAP , CERAMIC	0.022UF 50V Z	1
C737	HCBS1H180JCT	CAP , CERAMIC	18PF 50V	1
C738	HCBS1H180JCT	CAP , CERAMIC	18PF 50V	1
C739	CCEA1AH221T	CAP , ELECT	220UF/10V	1
C740	CCEA1VH100T	CAP , ELECT	10UF 35V	1
C764	CCFT1H104ZF	CAP , SEMICONDUCTOR	0.1UF 50V ZF	1
C783	HCBS1H104ZFT	CAP , CERAMIC	0.1UF 50V Z	1
C793	HCBS1H104ZFT	CAP , CERAMIC	0.1UF 50V Z	1
C794	HCBS1H102KBT	CAP , CERAMIC	1000PF 50V B	1
C795	HCBS1H221KBT	CAP , CERAMIC	220PF 50V K	1
C796	HCBS1H101KBT	CAP , CERAMIC	100PF 50V K	1
C805	HCBS1H223ZFT	CAP , CERAMIC	0.022UF 50V Z	1
C806	HCBS1H223ZFT	CAP , CERAMIC	0.022UF 50V Z	1
C807	CCFT1H104ZF	CAP , SEMICONDUCTOR	0.1UF 50V ZF	1
C808	CCKT1H181KB	CAP , CERAMIC	180PF 50V KB	1
C809	CCEA1AH471T	CAP , ELECT	470UF 10V	1
C810	CCEA1CH101T	CAP , ELECT	100UF 16V	1
C811	CCEA1CH101T	CAP , ELECT	100UF 16V	1
C812	HCBS1H104ZFT	CAP , CERAMIC	0.1UF 50V Z	1
C813	CCEA1VH100T	CAP , ELECT	10UF 35V	1
C814	CCEA1VH100T	CAP , ELECT	10UF 35V	1
C817	HCBS1H100JCT	CAP , CERAMIC	10PF 50V J	1
C841	CCEA1VH100T	CAP , ELECT	10UF 35V	1
C842	CCEA1VH100T	CAP , ELECT	10UF 35V	1
C843	CCEA1VH100T	CAP , ELECT	10UF 35V	1
C855	HCBS1H101KBT	CAP , CERAMIC	100PF 50V K	1
C856	HCBS1H101KBT	CAP , CERAMIC	100PF 50V K	1
C857	HCBS1H104ZFT	CAP , CERAMIC	0.1UF 50V Z	1
C859	HCBS1H223ZFT	CAP , CERAMIC	0.022UF 50V Z	1
C860	HCBS1H223ZFT	CAP , CERAMIC	0.022UF 50V Z	1
C861	HCBS1H223ZFT	CAP , CERAMIC	0.022UF 50V Z	1
C862	HCBS1H101KBT	CAP , CERAMIC	100PF 50V K	1
C863	HCBS1H101KBT	CAP , CERAMIC	100PF 50V K	1
C874	HCBS1H101KBT	CAP , CERAMIC	100PF 50V K	1

Ref. Designator	Part Number	Description		Qty
FRONT & INTERFACE PCB ASSY'S				
C875	HCBS1H101KBT	CAP , CERAMIC	100PF 50V K	1
C876	HCBS1H101KBT	CAP , CERAMIC	100PF 50V K	1
C877	HCBS1H473ZFT	CAP , CERAMIC	0.047UF 50V Z	1
C878	HCBS1H473ZFT	CAP , CERAMIC	0.047UF 50V Z	1
C882	HCBS1H104ZFT	CAP , CERAMIC	0.1UF 50V Z	1
C886	CCEA0JH102T	CAP , ELECT	1000UF 6.3V	1
C891	HCBS1H223ZFT	CAP , CERAMIC	0.022UF 50V Z	1
C892	HCBS1H223ZFT	CAP , CERAMIC	0.022UF 50V Z	1
C893	HCBS1H223ZFT	CAP , CERAMIC	0.022UF 50V Z	1
C896	HCBS1H223ZFT	CAP , CERAMIC	0.022UF 50V Z	1
C897	CCEA1AH471T	CAP , ELECT	470UF 10V	1
C901	HCBS1H390JT	CAP , CERAMIC	39PF 50V J	1
C903	CCEA1HKS2R2T	CAP , ELECT	2.2UF 50V	1
C905	CCEA1HKS2R2T	CAP , ELECT	2.2UF 50V	1
<i>Semiconductors</i>				
D724	HVD1SS133MT	DIODE	1SS133	1
D725	HVD1SS133MT	DIODE	1SS133	1
D727	HVD1SS133MT	DIODE	1SS133	1
D728	HVD1SS133MT	DIODE	1SS133	1
D729	HVD1SS133MT	DIODE	1SS133	1
D730	HVD1SS133MT	DIODE	1SS133	1
D774	HVD1SS133MT	DIODE	1SS133	1
D778	KVD1N4003ST	DIODE	1N4003	1
D779	HVD1SS133MT	DIODE	1SS133	1
D780	HVD1SS133MT	DIODE	1SS133	1
D781	HVD1SS133MT	DIODE	1SS133	1
D782	KVD1N4003ST	DIODE	1N4003	1
D783	HVD1SS133MT	DIODE	1SS133	1
D786	HVD1SS133MT	DIODE	1SS133	1
D787	HVD1SS133MT	DIODE	1SS133	1
IC87	HVIRE5VL28CATZ	IC , RESET	RICOH	1
Q701	HVTKRC107MT	TRANSISTOR	KRC107M	1
Q705	HVTKRC107MT	TRANSISTOR	KRC107M	1
Q722	HVTKRA107MT	TRANSISTOR	KRA107M	1
Q724	HVTKRC107MT	TRANSISTOR	KRC107M	1
Q725	HVTKRC107MT	TRANSISTOR	KRC107M	1
Q726	HVTKRC107MT	TRANSISTOR	KRC107M	1
Q727	HVTKRC107MT	TRANSISTOR	KRC107M	1
Q728	HVTKRC107MT	TRANSISTOR	KRC107M	1
Q729	HVTKRC107MT	TRANSISTOR	KRC107M	1
Q731	KVTKSA1175YT	TRANSISTOR	KSA1175Y	1
Q733	HVTKSC2785YT	TRANSISTOR	KSC2785Y(DEAD)	1
Q738	HVTKRC107MT	TRANSISTOR	KRC107M	1
Q739	HVTKTA1271YT	TRANSISTOR	KTA1271Y	1
Q740	HVTKRC107MT	TRANSISTOR	KRC107M	1
Q743	HVTKRA107MT	TRANSISTOR	KRA107M	1
D701	CVD52CSBBCEAB2	BLUE L.E.D	L.E.D	1
D703	CVD52CSBBCEAB2	BLUE L.E.D	L.E.D	1
D705	CVD52CSBBCEAB2	BLUE L.E.D	L.E.D	1
D723	CVD50BOBBWGA	L.E.D , 2 COLOR (ORG , BLUE)	L.E.D	1
IC72	BVIMB90F482APFG	IC , FLASH U-COM	FUJITSU	1
IC73	HRVNJL34H380A	SENSOR , REMOTE	SENSOR	1
IC75	HVI74ACT04MTR	I.C , HEX	FAIRCHILD	1
IC76	HVI74HCU04AFNG	I.C , INVERTER	TOSHIBA	1
IC83	HVI74ACT04MTR	I.C , HEX	FAIRCHILD	1

AVR240

harman/kardon

Ref. Designator	Part Number	Description		Qty
FRONT & INTERFACE PCB ASSY'S				
IC84	HVI74ACT04MTR	I.C , HEX	FAIRCHILD	1
IC85	HVIRH5VT18C	I.C , RESET	RICOH	1
IC88	HVINJM2068MDTE1	I.C , OP AMP	JRC	1
<i>Resistors</i>				
R700	CRD20TJ102T	RES , CARBON	1K OHM 1/5W J	1
R701	CRD20TJ103T	RES , CARBON	10K OHM 1/5W J	1
R704	CRD20TJ100T	RES , CARBON	10 OHM 1/5W J	1
R705	CRD20TJ820T	RES , CARBON	82 OHM 1/5W J	1
R706	CRD20TJ820T	RES , CARBON	82 OHM 1/5W J	1
R708	CRD20TJ820T	RES , CARBON	82 OHM 1/5W J	1
R709	CRD20TJ470T	RES , CARBON	47 OHM 1/5W J	1
R710	CRD20TJ470T	RES , CARBON	47 OHM 1/5W J	1
R711	CRD20TJ470T	RES , CARBON	47 OHM 1/5W J	1
R712	CRD20TJ102T	RES , CARBON	1K OHM 1/5W J	1
R713	CRD20TJ102T	RES , CARBON	1K OHM 1/5W J	1
R714	CRD20TJ102T	RES , CARBON	1K OHM 1/5W J	1
R716	CRD20TJ102T	RES , CARBON	1K OHM 1/5W J	1
R718	CRD20TJ222T	RES , CARBON	2.2K OHM 1/5W J	1
R730	CRD20TJ112T	RES , CARBON	1.1K OHM 1/5W	1
R731	CRD20TJ223T	RES , CARBON	22K OHM 1/5W J	1
R732	CRD20TJ222T	RES , CARBON	2.2K OHM 1/5W J	1
R733	CRD20TJ272T	RES , CARBON	2.7K OHM 1/5W J	1
R734	CRD20TJ103T	RES , CARBON	10K OHM 1/5W J	1
R735	CRD20TJ103T	RES , CARBON	10K OHM 1/5W J	1
R736	CRD20TJ272T	RES , CARBON	2.7K OHM 1/5W J	1
R737	CRD20TJ100T	RES , CARBON	10 OHM 1/5W J	1
R738	CRD20TJ103T	RES , CARBON	10K OHM 1/5W J	1
R739	CRD20TJ103T	RES , CARBON	10K OHM 1/5W J	1
R740	CRD20TJ103T	RES , CARBON	10K OHM 1/5W J	1
R742	CRD20TJ103T	RES , CARBON	10K OHM 1/5W J	1
R743	CRD20TJ103T	RES , CARBON	10K OHM 1/5W J	1
R744	CRD20TF1002T	RES , CARBON	10K F 1/5W	1
R745	CRD20TF1002T	RES , CARBON	10K F 1/5W	1
R746	CRD20TF1002T	RES , CARBON	10K F 1/5W	1
R747	CRD20TJ103T	RES , CARBON	10K OHM 1/5W J	1
R750	CRD20TJ223T	RES , CARBON	22K OHM 1/5W J	1
R752	CRD20TJ223T	RES , CARBON	22K OHM 1/5W J	1
R753	CRD20TJ102T	RES , CARBON	1K OHM 1/5W J	1
R754	CRD20TJ152T	RES , CARBON	1.5K OHM 1/5W J	1
R755	CRD20TJ182T	RES , CARBON	1.8K OHM 1/5W J	1
R756	CRD20TJ272T	RES , CARBON	2.7K OHM 1/5W J	1
R757	CRD20TJ332T	RES , CARBON	3.3K OHM 1/5W J	1
R758	CRD20TJ562T	RES , CARBON	5.6K OHM 1/5W J	1
R759	CRD20TJ102T	RES , CARBON	1K OHM 1/5W J	1
R760	CRD20TJ152T	RES , CARBON	1.5K OHM 1/5W J	1
R761	CRD20TJ182T	RES , CARBON	1.8K OHM 1/5W J	1
R762	CRD20TJ272T	RES , CARBON	2.7K OHM 1/5W J	1
R763	CRD20TJ332T	RES , CARBON	3.3K OHM 1/5W J	1
R764	CRD20TJ562T	RES , CARBON	5.6K OHM 1/5W J	1
R765	CRD20TJ752T	RES , CARBON	7.5K OHM 1/5W J	1
R766	CRD20TJ102T	RES , CARBON	1K OHM 1/5W J	1
R767	CRD20TJ152T	RES , CARBON	1.5K OHM 1/5W J	1
R768	CRD20TJ182T	RES , CARBON	1.8K OHM 1/5W J	1
R769	CRD20TJ272T	RES , CARBON	2.7K OHM 1/5W J	1
R770	CRD20TJ100T	RES , CARBON	10 OHM 1/5W J	1

Ref. Designator	Part Number	Description		Qty
FRONT & INTERFACE PCB ASSY'S				
R771	CRD20TJ103T	RES , CARBON	10K OHM 1/5W J	1
R772	CRD20TJ103T	RES , CARBON	10K OHM 1/5W J	1
R773	CRD20TJ103T	RES , CARBON	10K OHM 1/5W J	1
R778	CRD20TJ1R0T	RES , CARBON	1 OHM 1/5W J	1
R779	CRD20TJ1R0T	RES , CARBON	1 OHM 1/5W J	1
R780	CRD20TJ100T	RES , CARBON	10 OHM 1/5W J	1
R781	CRD20TJ123T	RES , CARBON	12K OHM 1/5W J	1
R782	CRD20TJ103T	RES , CARBON	10K OHM 1/5W J	1
R786	CRD20TJ152T	RES , CARBON	1.5K OHM 1/5W J	1
R787	CRD20TJ101T	RES , CARBON	100 OHM 1/5W J	1
R789	CRD20TJ102T	RES , CARBON	1K OHM 1/5W J	1
R790	CRD20TJ105T	RES , CARBON	1M OHM 1/5W J	1
R791	CRD20TJ822T	RES , CARBON	8.2K OHM 1/5W J	1
R792	CRD20TJ102T	RES , CARBON	1K OHM 1/5W J	1
R805	CRD20TJ104T	RES , CARBON	100K OHM 1/5W J	1
R806	CRD20TJ472T	RES , CARBON	4.7K OHM 1/5W J	1
R810	CRD20TJ101T	RES , CARBON	100 OHM 1/5W J	1
R811	CRD20TJ101T	RES , CARBON	100 OHM 1/5W J	1
R813	CRD20TJ104T	RES , CARBON	100K OHM 1/5W J	1
R814	CRD20TJ104T	RES , CARBON	100K OHM 1/5W J	1
R820	CRD20TJ103T	RES , CARBON	10K OHM 1/5W J	1
R824	CRD20TJ221T	RES , CARBON	220 OHM 1/5W J	1
R825	CRD20TJ681T	RES , CARBON	680 OHM 1/5W J	1
R864	CRD20TJ272T	RES , CARBON	2.7K OHM 1/5W J	1
R865	CRD20TJ101T	RES , CARBON	100 OHM 1/5W J	1
R866	CRD20TJ272T	RES , CARBON	2.7K OHM 1/5W J	1
R869	CRD20TJ750T	RES , CARBON	75 OHM 1/5W J	1
R871	CRD20TJ104T	RES , CARBON	100K OHM 1/5W J	1
R872	CRD20TJ104T	RES , CARBON	100K OHM 1/5W J	1
R873	CRD20TJ471T	RES , CARBON	470 OHM 1/5W J	1
R874	CRD20TJ471T	RES , CARBON	470 OHM 1/5W J	1
R875	CRD20TJ103T	RES , CARBON	10K OHM 1/5W J	1
R876	CRD20TJ750T	RES , CARBON	75 OHM 1/5W J	1
R877	CRD20TJ750T	RES , CARBON	75 OHM 1/5W J	1
R878	CRD20TJ750T	RES , CARBON	75 OHM 1/5W J	1
R881	CRD20TJ103T	RES , CARBON	10K OHM 1/5W J	1
R882	CRD20TJ103T	RES , CARBON	10K OHM 1/5W J	1
R883	CRD20TJ103T	RES , CARBON	10K OHM 1/5W J	1
R884	CRD20TJ103T	RES , CARBON	10K OHM 1/5W J	1
R885	CRD20TJ103T	RES , CARBON	10K OHM 1/5W J	1
R886	CRD20TJ103T	RES , CARBON	10K OHM 1/5W J	1
R887	CRD20TJ103T	RES , CARBON	10K OHM 1/5W J	1
R888	CRD20TJ103T	RES , CARBON	10K OHM 1/5W J	1
R889	CRD20TJ103T	RES , CARBON	10K OHM 1/5W J	1
R890	CRD20TJ103T	RES , CARBON	10K OHM 1/5W J	1
R891	CRD20TJ103T	RES , CARBON	10K OHM 1/5W J	1
R892	CRD20TJ222T	RES , CARBON	2.2K OHM 1/5W J	1
R893	CRD20TJ333T	RES , CARBON	33K OHM 1/5W J	1
R913	CRD20TJ102T	RES , CARBON	1K OHM 1/5W J	1
R915	CRD20TJ473T	RES , CARBON	47K OHM 1/5W J	1
<i>Miscellaneous</i>				
FIP1	HFLHCA18ML03	F.I.P	SAMSUNG	1
L702	HLQ02C100KT	COIL , AXAIL	10UH	1
S701	HST1A020ZT	SW , TACT	1A020	1
S702	HST1A020ZT	SW , TACT	1A020	1

Ref. Designator	Part Number	Description		Qty
FRONT & INTERFACE PCB ASSY'S				
S703	HST1A020ZT	SW , TACT	1A020	1
S704	HST1A020ZT	SW , TACT	1A020	1
S705	HST1A020ZT	SW , TACT	1A020	1
S706	HST1A020ZT	SW , TACT	1A020	1
S707	HST1A020ZT	SW , TACT	1A020	1
S708	HST1A020ZT	SW , TACT	1A020	1
S709	HST1A020ZT	SW , TACT	1A020	1
S710	HST1A020ZT	SW , TACT	1A020	1
S711	HST1A020ZT	SW , TACT	1A020	1
S712	HST1A020ZT	SW , TACT	1A020	1
S713	HST1A020ZT	SW , TACT	1A020	1
S714	HST1A020ZT	SW , TACT	1A020	1
S715	HST1A020ZT	SW , TACT	1A020	1
S716	HST1A020ZT	SW , TACT	1A020	1
S717	HST1A020ZT	SW , TACT	1A020	1
S718	HST1A020ZT	SW , TACT	1A020	1
S719	HST1A020ZT	SW , TACT	1A020	1
S720	HST1A020ZT	SW , TACT	1A020	1
BAT1	HABGP40BVH3A3H	BATTERY , RECHARGEABLE	BATTERY	1
BK71	CMD1A209	BRACKET , FLT	BRACKET	1
BK72	CMD1A209	BRACKET , FLT	BRACKET	1
BK73	CMD1A387	BRACKET , PCB	BRACKET	1
BK74	CMD1A209	BRACKET , FLT	BRACKET	1
BN10	CWZAVR230BN10	WIRE ASS'Y (SHIELD)	WIRE	1
BN15	CWB2B908150EN	WIRE ASS'Y	WIRE	1
BN18	CWZAVR125BN18	WIRE ASS'Y (SHIELD)	WIRE	1
BN41	CWZAVR130BN41	WIRE ASS'Y (SHIELD)	WIRE	1
BN62	CWB2B904370EN	WIRE ASS'Y	WIRE	1
BN72	HJP32GA179ZJ	CONN,FFC 1M/M 32P STR,SMD_JST	CONNECTOR	1
BN80	CWB2B911420EW	WIRE ASS'Y	WIRE	1
BN81	CWB2B908250BM	WIRE , ASS'Y	WIRE	1
BN84	CWB2B905080EN	WIRE ASS'Y	WIRE	1
BN85	CWB2B903100EN	WIRE ASS'Y	WIRE	1
BN88	CWB2B904070EN	WIRE ASS'Y	WIRE	1
BN89	CWB2B905080EN	WIRE ASS'Y	WIRE	1
BN92	CWB2B905080EN	WIRE ASS'Y	WIRE	1
BN94	KJP13GB99ZM	CONNECTOR	CONNECTOR	1
BN95	KJP08GB99ZM	CONNECTOR , HOUSING	CONNECTOR	1
CN11	KJP08GA98ZM	WAFER	WAFER	1
CN12	KJP15GA98ZM	WAFER	WAFER	1
CN16	CJP06GA19ZY	WAFER, STRAIGHT, 6PIN	WAFER	1
CN79	CJP05GA19ZY	WAFER, STRAIGHT, 5PIN	WAFER	1
CN84	KJP05GB46ZM	WAFER	WAFER	1
CN86	KJP02GA89ZM	WAFER	WAFER	1
CN88	CJP04GA19ZY	WAFER, STRAIGHT, 4PIN	WAFER	1
CN89	CJP05GA19ZY	WAFER, STRAIGHT, 5PIN	WAFER	1
JK81	CJJ4M041Y	JACK , BOARD (COAX)	BOARD	1
JK82	HJSTORX177L	MODULE , OPTICAL(RX)	OPTICAL JACK	1
JK84	CJJ2E026Z	JACK , HEADPHONE(SILVER PLATE)	HEADPHONE JACK	1
JK85	CJJ9M003Z	JACK , S-VIDEO	S-VIDEO JACK	1
JK86	CJJ4S023Y	JACK , BOARD	BOARD	1
JW83	CWE8202150RV	WIRE ASS'Y	WIRE	1
JW84	CWE8202110RV	WIRE, ASS'Y	WIRE	1
JW85	CWE8202070AA	WIRE ASS'Y	WIRE	1
JW87	CWE8202110RV	WIRE, ASS'Y	WIRE	1
SW1	CSH1A008ZV	SW , PUSH (MOMS)	MOMS SWITCH	1
VR74	CSR2A037Z	ENCODER	ENCODER	1

Ref. Designator	Part Number	Description		Qty
FRONT & INTERFACE PCB ASSY'S				
X701	HOX05000E160C	CRYSTAL	5Mhz	1
	CTB3+10G	SCREW	SCREW	37
	CTB3+16GFZ	SCREW	SCREW	2
	CTWS3+10G	SCREW	SCREW	1
	KHR301	CLAMPER	CLAMPER	3
CB72	CWC1B2A32A260B	CABLE , CARD	CARD CABLE	1
	CGX1A338MBG27	CAP , VOLUME	VOLUME CAP	1
	CGX1A375ZA	BADGE ASS'Y	ASS'Y	1
	CGX1A375M7G32	ORNAMENT , BADGE	ORNAMENT	1
	KGB1A159Z	BADGE , HARMAN/KARDON(TOP)	BADGE	1
	CKC5B145S46Z	CABINET , TOP	CABINET	1
	BKC5C145S46	TOP CABINET	TOP CABINET	1
	CLZ9Z028Z	FERRITE CORE(21.2X6.4X12.7)	CORE(K5C T)	3
	CMH1A214	HOLDER , VOLUME	HOLDER	1
	CMZ2A090	SHEET,VOLUME	SHEET	1
	CTB3+8JFC	SCREW	SCREW	13
	CTB4+6FFC	SCREW	SCREW	6
INPUT PCB ASS'Y				
<i>Capacitors</i>				
C105	HCUS1H223KC	CAP , CHIP	0.022UF	1
C106	HCUS1H223KC	CAP , CHIP	0.022UF	1
C201	HCUS1H221JA	CAP , CHIP	220PF	1
C202	HCUS1H221JA	CAP , CHIP	220PF	1
C203	HCUS1H221JA	CAP , CHIP	220PF	1
C204	HCUS1H221JA	CAP , CHIP	220PF	1
C205	HCUS1H221JA	CAP , CHIP	220PF	1
C206	HCUS1H221JA	CAP , CHIP	220PF	1
C207	HCUS1H221JA	CAP , CHIP	220PF	1
C208	HCUS1H221JA	CAP , CHIP	220PF	1
C209	HCUS1H221JA	CAP , CHIP	220PF	1
C210	HCUS1H221JA	CAP , CHIP	220PF	1
C211	HCUS1H221JA	CAP , CHIP	220PF	1
C212	HCUS1H221JA	CAP , CHIP	220PF	1
C213	HCUS1H221JA	CAP , CHIP	220PF	1
C214	HCUS1H221JA	CAP , CHIP	220PF	1
C215	HCUS1H221JA	CAP , CHIP	220PF	1
C216	HCUS1H221JA	CAP , CHIP	220PF	1
C217	HCUS1H221JA	CAP , CHIP	220PF	1
C218	HCUS1H221JA	CAP , CHIP	220PF	1
C219	HCUS1H221JA	CAP , CHIP	220PF	1
C220	HCUS1H221JA	CAP , CHIP	220PF	1
C221	HCUS1H221JA	CAP , CHIP	220PF	1
C222	HCUS1H221JA	CAP , CHIP	220PF	1
C223	HCUS1H221JA	CAP , CHIP	220PF	1
C224	HCUS1H221JA	CAP , CHIP	220PF	1
C225	HCUS1H221JA	CAP , CHIP	220PF	1
C226	HCUS1H221JA	CAP , CHIP	220PF	1
C241	HCUS1H181JA	CAP , CHIP	180PF	1
C242	HCUS1H471JA	CAP , CHIP	470PF	1
C253	HCUS1H181JA	CAP , CHIP	180PF	1
C254	HCUS1H471JA	CAP , CHIP	470PF	1
C255	HCUS1H223KC	CAP , CHIP	0.022UF	1
C256	HCUS1H223KC	CAP , CHIP	0.022UF	1

AVR240

harman/kardon

Ref. Designator	Part Number	Description		Qty
INPUT PCB ASS'Y				
C270	HCUS1H181JA	CAP , CHIP	180PF	1
C271	HCUS1H471JA	CAP , CHIP	470PF	1
C291	HCUS1H104ZF	CAP , CHIP	0.1UF	1
C292	HCUS1H104ZF	CAP , CHIP	0.1UF	1
C293	HCUS1H104ZF	CAP , CHIP	0.1UF	1
C294	HCUS1H104ZF	CAP , CHIP	0.1UF	1
C295	HCUS1H104ZF	CAP , CHIP	0.1UF	1
C296	HCUS1H104ZF	CAP , CHIP	0.1UF	1
C297	HCUS1H104ZF	CAP , CHIP	0.1UF	1
C298	HCUS1H104ZF	CAP , CHIP	0.1UF	1
C309	HCUS1H332KC	CAP , CHIP	0.033UF	1
C310	HCUS1H332KC	CAP , CHIP	0.033UF	1
C311	HCUS1H332KC	CAP , CHIP	0.033UF	1
C312	HCUS1H332KC	CAP , CHIP	0.033UF	1
C313	HCUS1H332KC	CAP , CHIP	0.033UF	1
C314	HCUS1H332KC	CAP , CHIP	0.033UF	1
C315	HCUS1H332KC	CAP , CHIP	0.033UF	1
C316	HCUS1H332KC	CAP , CHIP	0.033UF	1
C317	HCUS1H223KC	CAP , CHIP	0.022UF	1
C318	HCUS1H223KC	CAP , CHIP	0.022UF	1
C319	HCUS1H223KC	CAP , CHIP	0.022UF	1
C320	HCUS1H223KC	CAP , CHIP	0.022UF	1
C321	HCUS1H561JA	CAP , CHIP	560PF	1
C322	HCUS1H561JA	CAP , CHIP	560PF	1
C323	HCUS1H561JA	CAP , CHIP	560PF	1
C324	HCUS1H561JA	CAP , CHIP	560PF	1
C325	HCUS1H561JA	CAP , CHIP	560PF	1
C326	HCUS1H561JA	CAP , CHIP	560PF	1
C327	HCUS1H561JA	CAP , CHIP	560PF	1
C328	HCUS1H561JA	CAP , CHIP	560PF	1
C329	HCUS1H561JA	CAP , CHIP	560PF	1
C330	HCUS1H561JA	CAP , CHIP	560PF	1
C331	HCUS1H561JA	CAP , CHIP	560PF	1
C332	HCUS1H561JA	CAP , CHIP	560PF	1
C333	HCUS1H561JA	CAP , CHIP	560PF	1
C334	HCUS1H561JA	CAP , CHIP	560PF	1
C335	HCUS1H561JA	CAP , CHIP	560PF	1
C336	HCUS1H561JA	CAP , CHIP	560PF	1
C337	HCUS1H223KC	CAP , CHIP	0.022UF	1
C338	HCUS1H223KC	CAP , CHIP	0.022UF	1
C339	HCUS1H223KC	CAP , CHIP	0.022UF	1
C340	HCUS1H223KC	CAP , CHIP	0.022UF	1
C350	HCUS1H332KC	CAP , CHIP	0.033UF	1
C351	HCUS1H332KC	CAP , CHIP	0.033UF	1
C352	HCUS1H332KC	CAP , CHIP	0.033UF	1
C353	HCUS1H332KC	CAP , CHIP	0.033UF	1
C354	HCUS1H332KC	CAP , CHIP	0.033UF	1
C355	HCUS1H332KC	CAP , CHIP	0.033UF	1
C356	HCUS1H332KC	CAP , CHIP	0.033UF	1
C357	HCUS1H332KC	CAP , CHIP	0.033UF	1
C371	HCUS1H221JA	CAP , CHIP	220PF	1
C372	HCUS1H221JA	CAP , CHIP	220PF	1
C373	HCUS1H221JA	CAP , CHIP	220PF	1
C374	HCUS1H221JA	CAP , CHIP	220PF	1
C375	HCUS1H223KC	CAP , CHIP	0.022UF	1
C376	HCUS1H223KC	CAP , CHIP	0.022UF	1
C378	HCUS1H223KC	CAP , CHIP	0.022UF	1

Ref. Designator	Part Number	Description		Qty
INPUT PCB ASS'Y				
C379	HCUS1H223KC	CAP , CHIP	0.022UF	1
C381	HCUS1H561JA	CAP , CHIP	560PF	1
C382	HCUS1H223KC	CAP , CHIP	0.022UF	1
C383	HCUS1H223KC	CAP , CHIP	0.022UF	1
C390	HCUS1H471JA	CAP , CHIP	470PF	1
C391	HCUS1H471JA	CAP , CHIP	470PF	1
C392	HCUS1H471JA	CAP , CHIP	470PF	1
C393	HCUS1H471JA	CAP , CHIP	470PF	1
C394	HCUS1H471JA	CAP , CHIP	470PF	1
C395	HCUS1H471JA	CAP , CHIP	470PF	1
C396	HCUS1H471JA	CAP , CHIP	470PF	1
C397	HCUS1H471JA	CAP , CHIP	470PF	1
C413	HCUS1H223KC	CAP , CHIP	0.022UF	1
C414	HCUS1H223KC	CAP , CHIP	0.022UF	1
C415	HCUS1H223KC	CAP , CHIP	0.022UF	1
C416	HCUS1H223KC	CAP , CHIP	0.022UF	1
C417	HCUS1H223KC	CAP , CHIP	0.022UF	1
C418	HCUS1H223KC	CAP , CHIP	0.022UF	1
C419	HCUS1H223KC	CAP , CHIP	0.022UF	1
C420	HCUS1H223KC	CAP , CHIP	0.022UF	1
C421	HCUS1H151JA	CAP , CHIP	150PF JA	1
C422	HCUS1H151JA	CAP , CHIP	150PF JA	1
C425	HCUS1H151JA	CAP , CHIP	150PF JA	1
C426	HCUS1H102KC	CAP , CHIP	1000PF	1
C427	HCUS1H151JA	CAP , CHIP	150PF JA	1
C428	HCUS1H151JA	CAP , CHIP	150PF JA	1
C429	HCUS1H151JA	CAP , CHIP	150PF JA	1
C430	HCUS1H151JA	CAP , CHIP	150PF JA	1
C471	HCUS1H181JA	CAP , CHIP	180PF	1
C472	HCUS1H181JA	CAP , CHIP	180PF	1
C473	HCUS1H181JA	CAP , CHIP	180PF	1
C474	HCUS1H181JA	CAP , CHIP	180PF	1
C701	HCUS1H330JA	CAP , CHIP	33PF	1
C702	HCUS1H330JA	CAP , CHIP	33PF	1
C704	HCUS1H104ZF	CAP , CHIP	0.1UF	1
C705	HCUS1H104ZF	CAP , CHIP	0.1UF	1
C707	HCUS1H102KC	CAP , CHIP	1000PF	1
C708	HCUS1H104ZF	CAP , CHIP	0.1UF	1
C718	HCUS1H104ZF	CAP , CHIP	0.1UF	1
C719	HCUS1H104ZF	CAP , CHIP	0.1UF	1
C722	HCUS1H104ZF	CAP , CHIP	0.1UF	1
C723	HCUS1H473ZF	CAP , CHIP	0.047UF	1
C725	HCUS1H104ZF	CAP , CHIP	0.1UF	1
C727	HCUS1H104ZF	CAP , CHIP	0.1UF	1
C729	HCUS1H104ZF	CAP , CHIP	0.1UF	1
C731	HCUS1H104ZF	CAP , CHIP	0.1UF	1
C733	HCUS1H104ZF	CAP , CHIP	0.1UF	1
C734	HCUS1H122KC	CAP , CHIP	1200PF	1
C735	HCUS1H680JA	CAP , CHIP	68PF	1
C738	HCUS1C105ZF	CAP , CHIP	1UF 16V	1
C739	HCUS1H103KC	CAP , CHIP	0.01UF	1
C740	HCUS1H104ZF	CAP , CHIP	0.1UF	1
C742	HCUS1H104ZF	CAP , CHIP	0.1UF	1
C743	HCUS1H104ZF	CAP , CHIP	0.1UF	1
C744	HCUS1H104ZF	CAP , CHIP	0.1UF	1
C745	HCUS1H104ZF	CAP , CHIP	0.1UF	1
C747	HCUS1H104ZF	CAP , CHIP	0.1UF	1

Ref. Designator	Part Number	Description		Qty
INPUT PCB ASS'Y				
C748	HCUS1H104ZF	CAP , CHIP	0.1UF	1
C750	HCUS1H104ZF	CAP , CHIP	0.1UF	1
C751	HCUS1H104ZF	CAP , CHIP	0.1UF	1
C752	HCUS1H104ZF	CAP , CHIP	0.1UF	1
C754	HCUS1H104ZF	CAP , CHIP	0.1UF	1
C756	HCUS1H104ZF	CAP , CHIP	0.1UF	1
C757	HCUS1H104ZF	CAP , CHIP	0.1UF	1
C758	HCUS1H104ZF	CAP , CHIP	0.1UF	1
C759	HCUS1H104ZF	CAP , CHIP	0.1UF	1
C760	HCUS1H104ZF	CAP , CHIP	0.1UF	1
C761	HCUS1H104ZF	CAP , CHIP	0.1UF	1
C762	HCUS1H104ZF	CAP , CHIP	0.1UF	1
C763	HCUS1H104ZF	CAP , CHIP	0.1UF	1
C765	HCUS1H104ZF	CAP , CHIP	0.1UF	1
C767	HCUS1H104ZF	CAP , CHIP	0.1UF	1
C768	HCUS1H104ZF	CAP , CHIP	0.1UF	1
C769	HCUS1H104ZF	CAP , CHIP	0.1UF	1
C770	HCUS1H104ZF	CAP , CHIP	0.1UF	1
C771	HCUS1H104ZF	CAP , CHIP	0.1UF	1
C772	HCUS1H104ZF	CAP , CHIP	0.1UF	1
C773	HCUS1H104ZF	CAP , CHIP	0.1UF	1
C103	CCEA1VH100T	CAP , ELECT	10UF 35V	1
C104	CCEA1VH100T	CAP , ELECT	10UF 35V	1
C237	CCEA1EH470T	CAP , ELECT	47UF 25V	1
C238	CCEA1EH470T	CAP , ELECT	47UF 25V	1
C239	CCEA1VH100T	CAP , ELECT	10UF 35V	1
C240	CCEA1VH100T	CAP , ELECT	10UF 35V	1
C251	CCEA1EH470T	CAP , ELECT	47UF 25V	1
C252	CCEA1EH470T	CAP , ELECT	47UF 25V	1
C261	CCEA1EH470T	CAP , ELECT	47UF 25V	1
C262	CCEA1EH470T	CAP , ELECT	47UF 25V	1
C263	CCEA1VH100T	CAP , ELECT	10UF 35V	1
C264	CCEA1VH100T	CAP , ELECT	10UF 35V	1
C265	CCEA1VH100T	CAP , ELECT	10UF 35V	1
C267	CCEA1VH100T	CAP , ELECT	10UF 35V	1
C268	CCEA1VH100T	CAP , ELECT	10UF 35V	1
C269	CCEA1VH100T	CAP , ELECT	10UF 35V	1
C341	CCEA1VH100T	CAP , ELECT	10UF 35V	1
C342	CCEA1VH100T	CAP , ELECT	10UF 35V	1
C343	CCEA1VH100T	CAP , ELECT	10UF 35V	1
C344	CCEA1VH100T	CAP , ELECT	10UF 35V	1
C345	CCEA1VH100T	CAP , ELECT	10UF 35V	1
C346	CCEA1VH100T	CAP , ELECT	10UF 35V	1
C347	CCEA1VH100T	CAP , ELECT	10UF 35V	1
C348	CCEA1VH100T	CAP , ELECT	10UF 35V	1
C349	CCEA1HH1R0T	CAP , ELECT	1UF 50V	1
C403	CCEA1VH100T	CAP , ELECT	10UF 35V	1
C404	CCEA1VH100T	CAP , ELECT	10UF 35V	1
C405	CCEA1VH100T	CAP , ELECT	10UF 35V	1
C406	CCEA1VH100T	CAP , ELECT	10UF 35V	1
C407	CCEA1VH100T	CAP , ELECT	10UF 35V	1
C408	CCEA1VH100T	CAP , ELECT	10UF 35V	1
C409	CCEA1VH100T	CAP , ELECT	10UF 35V	1
C410	CCEA1VH100T	CAP , ELECT	10UF 35V	1
C433	CCEA1EH470T	CAP , ELECT	47UF 25V	1
C434	CCEA1EH470T	CAP , ELECT	47UF 25V	1
C435	CCEA1EH470T	CAP , ELECT	47UF 25V	1

AVR240

harman/kardon

Ref. Designator	Part Number	Description		Qty
INPUT PCB ASS'Y				
C436	CCEA1EH470T	CAP , ELECT	47UF 25V	1
C437	CCEA1EH470T	CAP , ELECT	47UF 25V	1
C438	CCEA1EH470T	CAP , ELECT	47UF 25V	1
C439	CCEA1EH470T	CAP , ELECT	47UF 25V	1
C440	CCEA1EH470T	CAP , ELECT	47UF 25V	1
C453	CCEA1VH100T	CAP , ELECT	10UF 35V	1
C454	CCEA1VH100T	CAP , ELECT	10UF 35V	1
C455	CCEA1VH100T	CAP , ELECT	10UF 35V	1
C456	CCEA1VH100T	CAP , ELECT	10UF 35V	1
C457	CCEA1VH100T	CAP , ELECT	10UF 35V	1
C458	CCEA1VH100T	CAP , ELECT	10UF 35V	1
C459	CCEA1VH100T	CAP , ELECT	10UF 35V	1
C460	CCEA1VH100T	CAP , ELECT	10UF 35V	1
C703	CCEA1CH101T	CAP , ELECT	100UF 16V	1
C706	CCEA1CH101T	CAP , ELECT	100UF 16V	1
C717	CCEA1CH101T	CAP , ELECT	100UF 16V	1
C720	CCEA1AH471T	CAP , ELECT	470UF 10V	1
C721	CCEA1AH471T	CAP , ELECT	470UF 10V	1
C724	CCEA1AH471T	CAP , ELECT	470UF 10V	1
C726	CCEA1CH101T	CAP , ELECT	100UF 16V	1
C728	CCEA1AH471T	CAP , ELECT	470UF 10V	1
C730	CCEA1CH101T	CAP , ELECT	100UF 16V	1
C732	CCEA1CH101T	CAP , ELECT	100UF 16V	1
C736	CCEA1HH2R2T	CAP , ELECT	2.2UF 50V	1
C737	CCEA1CH101T	CAP , ELECT	100UF 16V	1
C741	CCEA1CH101T	CAP , ELECT	100UF 16V	1
C746	CCEA1CH101T	CAP , ELECT	100UF 16V	1
C749	CCEA1CH101T	CAP , ELECT	100UF 16V	1
C753	CCEA1CH101T	CAP , ELECT	100UF 16V	1
C755	CCEA1CH101T	CAP , ELECT	100UF 16V	1
C764	CCEA1AH471T	CAP , ELECT	470UF 10V	1
C766	CCEA0JH102T	CAP , ELECT	1000UF 6.3V	1
Semiconductors				
IC13	HVINJM2068MDTE1	I.C , OP AMP	JRC	1
IC23	HVITC9164CFG	I.C , FUNCTION SW	TOSHIBA	1
IC24	HVITC9163CFG	I.C , FUNCTION SW	TOSHIBA	1
IC25	HVINJM2068MDTE1	I.C , OP AMP	JRC	1
IC26	HVITC9162CFG	I.C , FUNCTION SW	TOSHIBA	1
IC31	HVINJM2068MDTE1	I.C , OP AMP	JRC	1
IC32	HVINJM2068MDTE1	I.C , OP AMP	JRC	1
IC33	HVINJM2068MDTE1	I.C , OP AMP	JRC	1
IC34	HVINJM2068MDTE1	I.C , OP AMP	JRC	1
IC35	HVINJM2068MDTE1	I.C , OP AMP	JRC	1
IC36	HVINJM2068MDTE1	I.C , OP AMP	JRC	1
IC37	HVINJM2068MDTE1	I.C , OP AMP	JRC	1
IC42	HVITC9459BFG	I.C , 2CH VOLUME	TOSHIBA	1
IC43	HVITC9482BFG	I.C , 6CH VOLUME	TOSHIBA	1
IC46	HVINJM2068MDTE1	I.C , OP AMP	JRC	1
IC47	HVINJM2068MDTE1	I.C , OP AMP	JRC	1
IC48	HVINJM2068MDTE1	I.C , OP AMP	JRC	1
IC49	HVINJM2068MDTE1	I.C , OP AMP	JRC	1
IC72	HVI74HCU04AFNG	I.C , INVERTER	TOSHIBA	1
IC73	HVIAK4589VQ-T	I.C , CODEC + DIR	ASAHI KASEI	1
IC74	HVI74LCX32TTR	I.C , OR-GATE	FAIRCHILD	1
IC75	HVICS49400-CQ	I.C , DECODER	CIRRUS LOGIC	1

Ref. Designator	Part Number	Description		Qty
INPUT PCB ASS'Y				
IC76	HVIM29W800DT70N	I.C, 8M FLASH MEMORY	ST	1
IC78	HVINJM2391DL133	I.C , CHIP REGULATOR (+3.3V)	JRC	1
IC79	HVINJM2391DL125	I.C , CHIP REGULATOR (+2.5V)	JRC	1
D201	HVD1SS133MT	DIODE	1SS133	1
D202	HVD1SS133MT	DIODE	1SS133	1
D203	HVD1SS133MT	DIODE	1SS133	1
D204	HVD1SS133MT	DIODE	1SS133	1
D205	HVD1SS133MT	DIODE	1SS133	1
D206	HVD1SS133MT	DIODE	1SS133	1
D207	HVD1SS133MT	DIODE	1SS133	1
D208	HVD1SS133MT	DIODE	1SS133	1
D209	HVD1SS133MT	DIODE	1SS133	1
D210	HVD1SS133MT	DIODE	1SS133	1
D211	HVD1SS133MT	DIODE	1SS133	1
D212	HVD1SS133MT	DIODE	1SS133	1
D213	HVD1SS133MT	DIODE	1SS133	1
D214	HVD1SS133MT	DIODE	1SS133	1
D215	HVD1SS133MT	DIODE	1SS133	1
D216	HVD1SS133MT	DIODE	1SS133	1
D701	KVD1N4003ST	DIODE	1N4003	1
Q201	HVTKTC2874BT	TRANSISTOR , MUTE	KTC2874B	1
Q202	HVTKTC2874BT	TRANSISTOR , MUTE	KTC2874B	1
Q203	HVTKTC2874BT	TRANSISTOR , MUTE	KTC2874B	1
Q204	HVTKRA107MT	TRANSISTOR	KRA107M	1
IC77	HVI57V161610ET7	SDRAM 16M 7NS	HYNIX	1
<i>Resistors</i>				
R701	CRJ10DJ0R0T	RES , CHIP	0 OHM	1
R107	CRJ10DJ101T	RES , CHIP	100 OHM	1
R108	CRJ10DJ101T	RES , CHIP	100 OHM	1
R317	CRJ10DJ101T	RES , CHIP	100 OHM	1
R318	CRJ10DJ101T	RES , CHIP	100 OHM	1
R319	CRJ10DJ101T	RES , CHIP	100 OHM	1
R320	CRJ10DJ101T	RES , CHIP	100 OHM	1
R337	CRJ10DJ101T	RES , CHIP	100 OHM	1
R338	CRJ10DJ101T	RES , CHIP	100 OHM	1
R339	CRJ10DJ101T	RES , CHIP	100 OHM	1
R340	CRJ10DJ101T	RES , CHIP	100 OHM	1
R381	CRJ10DJ101T	RES , CHIP	100 OHM	1
R382	CRJ10DJ101T	RES , CHIP	100 OHM	1
R383	CRJ10DJ101T	RES , CHIP	100 OHM	1
R384	CRJ10DJ101T	RES , CHIP	100 OHM	1
R385	CRJ10DJ101T	RES , CHIP	100 OHM	1
R386	CRJ10DJ101T	RES , CHIP	100 OHM	1
R397	CRJ10DJ101T	RES , CHIP	100 OHM	1
R398	CRJ10DJ101T	RES , CHIP	100 OHM	1
R433	CRJ10DJ101T	RES , CHIP	100 OHM	1
R434	CRJ10DJ101T	RES , CHIP	100 OHM	1
R435	CRJ10DJ101T	RES , CHIP	100 OHM	1
R436	CRJ10DJ101T	RES , CHIP	100 OHM	1
R437	CRJ10DJ101T	RES , CHIP	100 OHM	1
R438	CRJ10DJ101T	RES , CHIP	100 OHM	1
R439	CRJ10DJ101T	RES , CHIP	100 OHM	1
R440	CRJ10DJ101T	RES , CHIP	100 OHM	1
R702	CRJ10DJ101T	RES , CHIP	100 OHM	1
R703	CRJ10DJ101T	RES , CHIP	100 OHM	1

AVR240

harman/kardon

Ref. Designator	Part Number	Description		Qty
INPUT PCB ASS'Y				
R704	CRJ10DJ101T	RES , CHIP	100 OHM	1
R707	CRJ10DJ101T	RES , CHIP	100 OHM	1
R724	CRJ10DJ101T	RES , CHIP	100 OHM	1
R814	CRJ10DJ101T	RES , CHIP	100 OHM	1
R823	CRJ10DJ101T	RES , CHIP	100 OHM	1
R423	CRJ10DJ102T	RES , CHIP	1K OHM	1
R424	CRJ10DJ102T	RES , CHIP	1K OHM	1
R425	CRJ10DJ102T	RES , CHIP	1K OHM	1
R426	CRJ10DJ102T	RES , CHIP	1K OHM	1
R427	CRJ10DJ102T	RES , CHIP	1K OHM	1
R428	CRJ10DJ102T	RES , CHIP	1K OHM	1
R429	CRJ10DJ102T	RES , CHIP	1K OHM	1
R430	CRJ10DJ102T	RES , CHIP	1K OHM	1
R705	CRJ10DJ102T	RES , CHIP	1K OHM	1
R777	CRJ10DJ102T	RES , CHIP	1K OHM	1
R250	CRJ10DJ103T	RES , CHIP	10K OHM	1
R765	CRJ10DJ103T	RES , CHIP	10K OHM	1
R766	CRJ10DJ103T	RES , CHIP	10K OHM	1
R769	CRJ10DJ103T	RES , CHIP	10K OHM	1
R770	CRJ10DJ103T	RES , CHIP	10K OHM	1
R773	CRJ10DJ103T	RES , CHIP	10K OHM	1
R775	CRJ10DJ103T	RES , CHIP	10K OHM	1
R778	CRJ10DJ103T	RES , CHIP	10K OHM	1
R779	CRJ10DJ103T	RES , CHIP	10K OHM	1
R786	CRJ10DJ103T	RES , CHIP	10K OHM	1
R801	CRJ10DJ103T	RES , CHIP	10K OHM	1
R802	CRJ10DJ103T	RES , CHIP	10K OHM	1
R804	CRJ10DJ103T	RES , CHIP	10K OHM	1
R815	CRJ10DJ103T	RES , CHIP	10K OHM	1
R817	CRJ10DJ103T	RES , CHIP	10K OHM	1
R278	CRJ10DJ104T	RES , CHIP	100K OHM	1
R279	CRJ10DJ104T	RES , CHIP	100K OHM	1
R361	CRJ10DJ104T	RES , CHIP	100K OHM	1
R362	CRJ10DJ104T	RES , CHIP	100K OHM	1
R363	CRJ10DJ104T	RES , CHIP	100K OHM	1
R364	CRJ10DJ104T	RES , CHIP	100K OHM	1
R365	CRJ10DJ104T	RES , CHIP	100K OHM	1
R366	CRJ10DJ104T	RES , CHIP	100K OHM	1
R367	CRJ10DJ104T	RES , CHIP	100K OHM	1
R368	CRJ10DJ104T	RES , CHIP	100K OHM	1
R714	CRJ10DJ104T	RES , CHIP	100K OHM	1
R715	CRJ10DJ104T	RES , CHIP	100K OHM	1
R391	CRJ10DJ105T	RES , CHIP	1M OHM	1
R392	CRJ10DJ105T	RES , CHIP	1M OHM	1
R760	CRJ10DJ105T	RES , CHIP	1M OHM	1
R322	CRJ10DJ122T	RES , CHIP	1.2K OHM	1
R323	CRJ10DJ122T	RES , CHIP	1.2K OHM	1
R326	CRJ10DJ122T	RES , CHIP	1.2K OHM	1
R327	CRJ10DJ122T	RES , CHIP	1.2K OHM	1
R330	CRJ10DJ122T	RES , CHIP	1.2K OHM	1
R331	CRJ10DJ122T	RES , CHIP	1.2K OHM	1
R334	CRJ10DJ122T	RES , CHIP	1.2K OHM	1
R335	CRJ10DJ122T	RES , CHIP	1.2K OHM	1
R341	CRJ10DJ122T	RES , CHIP	1.2K OHM	1
R344	CRJ10DJ122T	RES , CHIP	1.2K OHM	1
R345	CRJ10DJ122T	RES , CHIP	1.2K OHM	1
R348	CRJ10DJ122T	RES , CHIP	1.2K OHM	1

AVR240

harman/kardon

Ref. Designator	Part Number	Description		Qty
INPUT PCB ASS'Y				
R349	CRJ10DJ122T	RES , CHIP	1.2K OHM	1
R352	CRJ10DJ122T	RES , CHIP	1.2K OHM	1
R353	CRJ10DJ122T	RES , CHIP	1.2K OHM	1
R356	CRJ10DJ122T	RES , CHIP	1.2K OHM	1
R328	CRJ10DJ123T	RES , CHIP	12K OHM	1
R484	CRJ10DJ123T	RES , CHIP	12K OHM	1
R718	CRJ10DJ123T	RES , CHIP	12K OHM	1
R105	CRJ10DJ151T	RES, CHIP	150 OHM	1
R106	CRJ10DJ151T	RES, CHIP	150 OHM	1
R767	CRJ10DJ152T	RES , CHIP	1.5K OHM	1
R768	CRJ10DJ152T	RES , CHIP	1.5K OHM	1
R394	CRJ10DJ153T	RES , CHIP	15K OHM	1
R395	CRJ10DJ153T	RES , CHIP	15K OHM	1
R759	CRJ10DJ181T	RES , CHIP	180 OHM	1
R268	CRJ10DJ184T	RES , CHIP	180K OHM	1
R269	CRJ10DJ184T	RES , CHIP	180K OHM	1
R285	CRJ10DJ184T	RES , CHIP	180K OHM	1
R286	CRJ10DJ184T	RES , CHIP	180K OHM	1
R287	CRJ10DJ184T	RES , CHIP	180K OHM	1
R288	CRJ10DJ184T	RES , CHIP	180K OHM	1
R289	CRJ10DJ184T	RES , CHIP	180K OHM	1
R290	CRJ10DJ184T	RES , CHIP	180K OHM	1
R403	CRJ10DJ184T	RES , CHIP	180K OHM	1
R404	CRJ10DJ184T	RES , CHIP	180K OHM	1
R405	CRJ10DJ184T	RES , CHIP	180K OHM	1
R406	CRJ10DJ184T	RES , CHIP	180K OHM	1
R407	CRJ10DJ184T	RES , CHIP	180K OHM	1
R408	CRJ10DJ184T	RES , CHIP	180K OHM	1
R409	CRJ10DJ184T	RES , CHIP	180K OHM	1
R410	CRJ10DJ184T	RES , CHIP	180K OHM	1
R453	CRJ10DJ184T	RES , CHIP	180K OHM	1
R454	CRJ10DJ184T	RES , CHIP	180K OHM	1
R455	CRJ10DJ184T	RES , CHIP	180K OHM	1
R456	CRJ10DJ184T	RES , CHIP	180K OHM	1
R457	CRJ10DJ184T	RES , CHIP	180K OHM	1
R458	CRJ10DJ184T	RES , CHIP	180K OHM	1
R459	CRJ10DJ184T	RES , CHIP	180K OHM	1
R460	CRJ10DJ184T	RES , CHIP	180K OHM	1
R822	CRJ10DJ220T	RES, CHIP	22 OHM	1
R224	CRJ10DJ272T	RES , CHIP	2.7K OHM	1
R471	CRJ10DJ272T	RES , CHIP	2.7K OHM	1
R472	CRJ10DJ272T	RES , CHIP	2.7K OHM	1
R473	CRJ10DJ272T	RES , CHIP	2.7K OHM	1
R474	CRJ10DJ272T	RES , CHIP	2.7K OHM	1
R723	CRJ10DJ2R7T	RES , CHIP	2.7 OHM	1
R721	CRJ10DJ330T	RES , CHIP	33 OHM	1
R728	CRJ10DJ330T	RES , CHIP	33 OHM	1
R771	CRJ10DJ330T	RES , CHIP	33 OHM	1
R772	CRJ10DJ330T	RES , CHIP	33 OHM	1
R774	CRJ10DJ330T	RES , CHIP	33 OHM	1
R803	CRJ10DJ330T	RES , CHIP	33 OHM	1
R809	CRJ10DJ330T	RES , CHIP	33 OHM	1
R810	CRJ10DJ330T	RES , CHIP	33 OHM	1
R824	CRJ10DJ330T	RES , CHIP	33 OHM	1
R283	CRJ10DJ331T	RES , CHIP	330 OHM	1
R284	CRJ10DJ331T	RES , CHIP	330 OHM	1

Ref. Designator	Part Number	Description		Qty
INPUT PCB ASS'Y				
R301	CRJ10DJ332T	RES , CHIP	3.3K OHM	1
R302	CRJ10DJ332T	RES , CHIP	3.3K OHM	1
R303	CRJ10DJ332T	RES , CHIP	3.3K OHM	1
R304	CRJ10DJ332T	RES , CHIP	3.3K OHM	1
R305	CRJ10DJ332T	RES , CHIP	3.3K OHM	1
R306	CRJ10DJ332T	RES , CHIP	3.3K OHM	1
R307	CRJ10DJ332T	RES , CHIP	3.3K OHM	1
R308	CRJ10DJ332T	RES , CHIP	3.3K OHM	1
R309	CRJ10DJ332T	RES , CHIP	3.3K OHM	1
R310	CRJ10DJ332T	RES , CHIP	3.3K OHM	1
R311	CRJ10DJ332T	RES , CHIP	3.3K OHM	1
R312	CRJ10DJ332T	RES , CHIP	3.3K OHM	1
R313	CRJ10DJ332T	RES , CHIP	3.3K OHM	1
R314	CRJ10DJ332T	RES , CHIP	3.3K OHM	1
R315	CRJ10DJ332T	RES , CHIP	3.3K OHM	1
R316	CRJ10DJ332T	RES , CHIP	3.3K OHM	1
R371	CRJ10DJ332T	RES , CHIP	3.3K OHM	1
R372	CRJ10DJ332T	RES , CHIP	3.3K OHM	1
R373	CRJ10DJ332T	RES , CHIP	3.3K OHM	1
R374	CRJ10DJ332T	RES , CHIP	3.3K OHM	1
R375	CRJ10DJ332T	RES , CHIP	3.3K OHM	1
R376	CRJ10DJ332T	RES , CHIP	3.3K OHM	1
R377	CRJ10DJ332T	RES , CHIP	3.3K OHM	1
R378	CRJ10DJ332T	RES , CHIP	3.3K OHM	1
R379	CRJ10DJ332T	RES , CHIP	3.3K OHM	1
R380	CRJ10DJ332T	RES , CHIP	3.3K OHM	1
R389	CRJ10DJ332T	RES , CHIP	3.3K OHM	1
R390	CRJ10DJ332T	RES , CHIP	3.3K OHM	1
R393	CRJ10DJ332T	RES , CHIP	3.3K OHM	1
R396	CRJ10DJ332T	RES , CHIP	3.3K OHM	1
R776	CRJ10DJ332T	RES , CHIP	3.3K OHM	1
R787	CRJ10DJ332T	RES , CHIP	3.3K OHM	1
R788	CRJ10DJ332T	RES , CHIP	3.3K OHM	1
R717	CRJ10DJ3R3T	RES , CHIP	3.3 OHM	1
R201	CRJ10DJ471T	RES , CHIP	470 OHM	1
R202	CRJ10DJ471T	RES , CHIP	470 OHM	1
R203	CRJ10DJ471T	RES , CHIP	470 OHM	1
R204	CRJ10DJ471T	RES , CHIP	470 OHM	1
R205	CRJ10DJ471T	RES , CHIP	470 OHM	1
R206	CRJ10DJ471T	RES , CHIP	470 OHM	1
R207	CRJ10DJ471T	RES , CHIP	470 OHM	1
R208	CRJ10DJ471T	RES , CHIP	470 OHM	1
R209	CRJ10DJ471T	RES , CHIP	470 OHM	1
R210	CRJ10DJ471T	RES , CHIP	470 OHM	1
R211	CRJ10DJ471T	RES , CHIP	470 OHM	1
R212	CRJ10DJ471T	RES , CHIP	470 OHM	1
R213	CRJ10DJ471T	RES , CHIP	470 OHM	1
R214	CRJ10DJ471T	RES , CHIP	470 OHM	1
R215	CRJ10DJ471T	RES , CHIP	470 OHM	1
R216	CRJ10DJ471T	RES , CHIP	470 OHM	1
R217	CRJ10DJ471T	RES , CHIP	470 OHM	1
R218	CRJ10DJ471T	RES , CHIP	470 OHM	1
R219	CRJ10DJ471T	RES , CHIP	470 OHM	1
R220	CRJ10DJ471T	RES , CHIP	470 OHM	1
R221	CRJ10DJ471T	RES , CHIP	470 OHM	1
R222	CRJ10DJ471T	RES , CHIP	470 OHM	1

AVR240

harman/kardon

Ref. Designator	Part Number	Description		Qty
INPUT PCB ASS'Y				
R223	CRJ10DJ471T	RES , CHIP	470 OHM	1
R225	CRJ10DJ471T	RES , CHIP	470 OHM	1
R226	CRJ10DJ471T	RES , CHIP	470 OHM	1
R265	CRJ10DJ471T	RES , CHIP	470 OHM	1
R267	CRJ10DJ471T	RES , CHIP	470 OHM	1
R273	CRJ10DJ471T	RES , CHIP	470 OHM	1
R274	CRJ10DJ471T	RES , CHIP	470 OHM	1
R270	CRJ10DJ472T	RES , CHIP	4.7K OHM	1
R271	CRJ10DJ472T	RES , CHIP	4.7K OHM	1
R272	CRJ10DJ472T	RES , CHIP	4.7K OHM	1
R275	CRJ10DJ472T	RES , CHIP	4.7K OHM	1
R276	CRJ10DJ472T	RES , CHIP	4.7K OHM	1
R277	CRJ10DJ472T	RES , CHIP	4.7K OHM	1
R291	CRJ10DJ472T	RES , CHIP	4.7K OHM	1
R292	CRJ10DJ472T	RES , CHIP	4.7K OHM	1
R293	CRJ10DJ472T	RES , CHIP	4.7K OHM	1
R716	CRJ10DJ472T	RES , CHIP	4.7K OHM	1
R719	CRJ10DJ473T	RES , CHIP	47K OHM	1
R720	CRJ10DJ473T	RES , CHIP	47K OHM	1
R725	CRJ10DJ473T	RES , CHIP	47K OHM	1
R726	CRJ10DJ473T	RES , CHIP	47K OHM	1
R727	CRJ10DJ473T	RES , CHIP	47K OHM	1
R227	CRJ10DJ474T	RES , CHIP	470K OHM	1
R228	CRJ10DJ474T	RES , CHIP	470K OHM	1
R229	CRJ10DJ474T	RES , CHIP	470K OHM	1
R230	CRJ10DJ474T	RES , CHIP	470K OHM	1
R231	CRJ10DJ474T	RES , CHIP	470K OHM	1
R232	CRJ10DJ474T	RES , CHIP	470K OHM	1
R233	CRJ10DJ474T	RES , CHIP	470K OHM	1
R234	CRJ10DJ474T	RES , CHIP	470K OHM	1
R235	CRJ10DJ474T	RES , CHIP	470K OHM	1
R236	CRJ10DJ474T	RES , CHIP	470K OHM	1
R237	CRJ10DJ474T	RES , CHIP	470K OHM	1
R238	CRJ10DJ474T	RES , CHIP	470K OHM	1
R239	CRJ10DJ474T	RES , CHIP	470K OHM	1
R240	CRJ10DJ474T	RES , CHIP	470K OHM	1
R241	CRJ10DJ474T	RES , CHIP	470K OHM	1
R242	CRJ10DJ474T	RES , CHIP	470K OHM	1
R243	CRJ10DJ474T	RES , CHIP	470K OHM	1
R244	CRJ10DJ474T	RES , CHIP	470K OHM	1
R245	CRJ10DJ474T	RES , CHIP	470K OHM	1
R246	CRJ10DJ474T	RES , CHIP	470K OHM	1
R247	CRJ10DJ474T	RES , CHIP	470K OHM	1
R248	CRJ10DJ474T	RES , CHIP	470K OHM	1
R249	CRJ10DJ474T	RES , CHIP	470K OHM	1
R251	CRJ10DJ474T	RES , CHIP	470K OHM	1
R252	CRJ10DJ474T	RES , CHIP	470K OHM	1
R491	CRJ10DJ4R7T	RES , CHIP	4.7 OHM	1
R492	CRJ10DJ4R7T	RES , CHIP	4.7 OHM	1
R493	CRJ10DJ4R7T	RES , CHIP	4.7 OHM	1
R494	CRJ10DJ4R7T	RES , CHIP	4.7 OHM	1
R495	CRJ10DJ4R7T	RES , CHIP	4.7 OHM	1
R496	CRJ10DJ4R7T	RES , CHIP	4.7 OHM	1
R497	CRJ10DJ4R7T	RES , CHIP	4.7 OHM	1
R498	CRJ10DJ4R7T	RES , CHIP	4.7 OHM	1
R321	CRJ10DJ512T	RES , CHIP	5.1K OHM	1

AVR240

harman/kardon

Ref. Designator	Part Number	Description		Qty
INPUT PCB ASS'Y				
R324	CRJ10DJ512T	RES , CHIP	5.1K OHM	1
R325	CRJ10DJ512T	RES , CHIP	5.1K OHM	1
R329	CRJ10DJ512T	RES , CHIP	5.1K OHM	1
R332	CRJ10DJ512T	RES , CHIP	5.1K OHM	1
R333	CRJ10DJ512T	RES , CHIP	5.1K OHM	1
R336	CRJ10DJ512T	RES , CHIP	5.1K OHM	1
R413	CRJ10DJ512T	RES , CHIP	5.1K OHM	1
R414	CRJ10DJ512T	RES , CHIP	5.1K OHM	1
R415	CRJ10DJ512T	RES , CHIP	5.1K OHM	1
R417	CRJ10DJ512T	RES , CHIP	5.1K OHM	1
R418	CRJ10DJ512T	RES , CHIP	5.1K OHM	1
R419	CRJ10DJ512T	RES , CHIP	5.1K OHM	1
R420	CRJ10DJ512T	RES , CHIP	5.1K OHM	1
R481	CRJ10DJ512T	RES , CHIP	5.1K OHM	1
R482	CRJ10DJ512T	RES , CHIP	5.1K OHM	1
R483	CRJ10DJ512T	RES , CHIP	5.1K OHM	1
R485	CRJ10DJ512T	RES , CHIP	5.1K OHM	1
R486	CRJ10DJ512T	RES , CHIP	5.1K OHM	1
R487	CRJ10DJ512T	RES , CHIP	5.1K OHM	1
R488	CRJ10DJ512T	RES , CHIP	5.1K OHM	1
R101	CRJ10DJ562T	RES , CHIP	5.6K OHM	1
R102	CRJ10DJ562T	RES , CHIP	5.6K OHM	1
R103	CRJ10DJ682T	RES , CHIP	6.8K OHM	1
R104	CRJ10DJ682T	RES , CHIP	6.8K OHM	1
R416	CRJ10DJ912T	RES , CHIP(1/10W) 9.1K OHM J	9.1K OHM	1
RN71	CRJ104DJ101T	RES, ARRAY, 100R (1608)	100 OHM/1608*4	1
RN72	CRJ104DJ101T	RES, ARRAY, 100R (1608)	100 OHM/1608*4	1
RN73	CRJ104DJ101T	RES, ARRAY, 100R (1608)	100 OHM/1608*4	1
RN74	CRJ104DJ101T	RES, ARRAY, 100R (1608)	100 OHM/1608*4	1
RN75	CRJ104DJ101T	RES, ARRAY, 100R (1608)	100 OHM/1608*4	1
RN76	CRJ104DJ101T	RES, ARRAY, 100R (1608)	100 OHM/1608*4	1
RN77	CRJ104DJ101T	RES, ARRAY, 100R (1608)	100 OHM/1608*4	1
RN78	CRJ104DJ101T	RES, ARRAY, 100R (1608)	100 OHM/1608*4	1
RN79	CRJ104DJ101T	RES, ARRAY, 100R (1608)	100 OHM/1608*4	1
RN80	CRJ104DJ330T	RES, 4ARRAY (1608*4)	33 OHM/1608*4	1
RN81	CRJ104DJ330T	RES, 4ARRAY (1608*4)	33 OHM/1608*4	1
RN82	CRJ104DJ330T	RES, 4ARRAY (1608*4)	33 OHM/1608*4	1
RN83	CRJ104DJ330T	RES, 4ARRAY (1608*4)	33 OHM/1608*4	1
RN84	CRJ104DJ332T	RES, ARRAY, 3.3K*4 (1608)	3.3K OHM/1608*4	1
RN86	CRJ104DJ103T	RES, ARRAY, 10K (1608)	10K OHM/1608*4	1
RN87	CRJ104DJ103T	RES, ARRAY, 10K (1608)	10K OHM/1608*4	1
RN88	CRJ104DJ103T	RES, ARRAY, 10K (1608)	10K OHM/1608*4	1
RN89	CRJ104DJ103T	RES, ARRAY, 10K (1608)	10K OHM/1608*4	1
RN90	CRJ104DJ103T	RES, ARRAY, 10K (1608)	10K OHM/1608*4	1
R780	CRG2ANJ470H	RES , METAL OXIDE FILM	47 OHM 2W J	1
R781	CRG2ANJ470H	RES , METAL OXIDE FILM	47 OHM 2W J	1
R782	CRG2ANJ330H	RES , METAL OXIDE FILM	33 OHM 2W J	1
<i>Miscellaneous</i>				
L701	HLZ9Z014Z	CHIP , BEAD	HU-1H4516-600JT	1
L702	HLZ9Z014Z	CHIP , BEAD	HU-1H4516-600JT	1
L703	HLZ9Z014Z	CHIP , BEAD	HU-1H4516-600JT	1
L704	HLZ9Z014Z	CHIP , BEAD	HU-1H4516-600JT	1
BN11	KJP08GB99ZM	CONNECTOR , HOUSING	CONNECTOR	1
BN12	KJP15GB99ZM	WAFER	WAFER	1

Ref. Designator	Part Number	Description		Qty
INPUT PCB ASS'Y				
BN42	CWZAVR140BN42	WIRE ASS'Y	WIRE	1
CN10	CJP04GB46ZY	WAFER	WAFER	1
CN13	CJP13GA115ZY	WAFER , CARD CABLE	WAFER	1
CN15	CJP13GA115ZY	WAFER , CARD CABLE	WAFER	1
CN17	KJP12GB142ZP	PIN HEADER	PIN HEADER	1
CN18	CJP05GA19ZY	WAFER, STRAIGHT, 5PIN	WAFER	1
CN19	CJP03GA19ZY	WAFER, STRAIGHT, 3PIN	WAFER	1
CN72	KJP32GA117ZG	WAFER , CARD CABLE	WAFER	1
CN97	CJP02GA19ZY	WAFER, 2PIN	WAFER	1
JK11	CJJ4R019W	TERMINAL , IN/OUT	TERMINAL JACK	1
JK12	CJJ4P014W	JACK , IN/OUT	JACK	1
JK13	CJJ4P014W	JACK , IN/OUT	JACK	1
JK14	CJJ4R019W	TERMINAL , IN/OUT	TERMINAL JACK	1
JK15	CJJ4R037W	JACK , BOARD	JACK	1
JW21	CWE7202090AA	WIRE ASS'Y	WIRE	1
X701	HOX12288E220CS	CRYSTAL	12.288MHZ 22PF	1
MAIN/VIDEO/BIAS/DIGITAL PCB ASS'Y SECTION 1				
<i>Capacitors</i>				
C107	CCKT1H103ZF	CAP , CERAMIC	0.01UF 50V ZF	1
C108	CCKT1H103ZF	CAP , CERAMIC	0.01UF 50V ZF	1
C109	CCFT1H104ZF	CAP , SEMICONDUCTOR	0.1UF 50V ZF	1
C110	CCFT1H104ZF	CAP , SEMICONDUCTOR	0.1UF 50V ZF	1
C111	CCKT1H103ZF	CAP , CERAMIC	0.01UF 50V ZF	1
C112	CCKT1H103ZF	CAP , CERAMIC	0.01UF 50V ZF	1
C117	CCEA1HH4R7T	CAP , ELECT	4.7UF 50V	1
C118	CCKT1H103ZF	CAP , CERAMIC	0.01UF 50V ZF	1
C119	CCEA1JH470TS	CAP , ELECT	63V/47UF/105°C	1
C120	CCEA1JH470TS	CAP , ELECT	63V/47UF/105°C	1
C121	CCKT1H103ZF	CAP , CERAMIC	0.01UF 50V ZF	1
C401	CCEA1VH100T	CAP , ELECT	10UF 35V	1
C402	CCKT1H101KB	CAP , CERAMIC	100PF 50V KB	1
C403	CCEA1VH100T	CAP , ELECT	10UF 35V	1
C404	CCKT1H101KB	CAP , CERAMIC	100PF 50V KB	1
C405	CCEA1VH100T	CAP , ELECT	10UF 35V	1
C406	CCEA1VH100T	CAP , ELECT	10UF 35V	1
C407	CCKT1H101KB	CAP , CERAMIC	100PF 50V KB	1
C408	CCEA1VH100T	CAP , ELECT	10UF 35V	1
C409	CCKT1H101KB	CAP , CERAMIC	100PF 50V KB	1
C410	CCKT1H101KB	CAP , CERAMIC	100PF 50V KB	1
C411	HCBS1H101KBT	CAP , CERAMIC	100PF 50V K	1
C412	HCBS1H101KBT	CAP , CERAMIC	100PF 50V K	1
C413	HCBS1H101KBT	CAP , CERAMIC	100PF 50V K	1
C414	HCBS1H101KBT	CAP , CERAMIC	100PF 50V K	1
C415	CCEA1VH100T	CAP , ELECT	10UF 35V	1
C416	CCEA1CH101T	CAP , ELECT	100UF 16V	1
C417	CCEA1CH101T	CAP , ELECT	100UF 16V	1
C418	HCBS1H223ZFT	CAP , CERAMIC	0.022UF 50V Z	1
C419	CCEA1VH100T	CAP , ELECT	10UF 35V	1
C420	HCBS1H223ZFT	CAP , CERAMIC	0.022UF 50V Z	1
C421	CCEA1CH101T	CAP , ELECT	100UF 16V	1
C422	HCBS1H223ZFT	CAP , CERAMIC	0.022UF 50V Z	1
C423	CCEA1CH101T	CAP , ELECT	100UF 16V	1
C424	CCEA1VH100T	CAP , ELECT	10UF 35V	1

AVR240

harman/kardon

Ref. Designator	Part Number	Description		Qty
MAIN/VIDEO/BIAS/DIGITAL PCB ASS'Y SECTION 1				
C425	CCEA1VH100T	CAP , ELECT	10UF 35V	1
C426	CCEA1VH100T	CAP , ELECT	10UF 35V	1
C427	HCBS1H223ZFT	CAP , CERAMIC	0.022UF 50V Z	1
C428	CCEA1CH101T	CAP , ELECT	100UF 16V	1
C429	HCBS1H223ZFT	CAP , CERAMIC	0.022UF 50V Z	1
C430	CCEA1CH101T	CAP , ELECT	100UF 16V	1
C431	CCEA1VH100T	CAP , ELECT	10UF 35V	1
C432	CCEA1VH100T	CAP , ELECT	10UF 35V	1
C436	HCBS1H223ZFT	CAP , CERAMIC	0.022UF 50V Z	1
C437	CCEA1CH101T	CAP , ELECT	100UF 16V	1
C438	HCBS1H223ZFT	CAP , CERAMIC	0.022UF 50V Z	1
C439	CCEA1CH101T	CAP , ELECT	100UF 16V	1
C442	HCBS1H103ZFT	CAP , CERAMIC	0.01UF 50V Z	1
C443	CCEA1VH100T	CAP , ELECT	10UF 35V	1
C444	CCEA1VH100T	CAP , ELECT	10UF 35V	1
C445	HCBS1H103ZFT	CAP , CERAMIC	0.01UF 50V Z	1
C446	CCEA1VH100T	CAP , ELECT	10UF 35V	1
C447	CCEA1VH100T	CAP , ELECT	10UF 35V	1
C448	HCBS1H223ZFT	CAP , CERAMIC	0.022UF 50V Z	1
C449	CCEA1CH101T	CAP , ELECT	100UF 16V	1
C450	HCBS1H223ZFT	CAP , CERAMIC	0.022UF 50V Z	1
C451	CCEA1CH101T	CAP , ELECT	100UF 16V	1
C452	HCBS1H223ZFT	CAP , CERAMIC	0.022UF 50V Z	1
C453	CCEA1CH101T	CAP , ELECT	100UF 16V	1
C454	HCBS1H223ZFT	CAP , CERAMIC	0.022UF 50V Z	1
C455	CCEA1CH101T	CAP , ELECT	100UF 16V	1
C456	HCBS1H104ZFT	CAP , CERAMIC	0.1UF 50V Z	1
C457	CCEA1CH101T	CAP , ELECT	100UF 16V	1
C458	CCEA1CH101T	CAP , ELECT	100UF 16V	1
C459	HCBS1H104ZFT	CAP , CERAMIC	0.1UF 50V Z	1
C460	HCBS1C272MXT	CAP , CERAMIC	2700PF 16V	1
C461	CCEA1CH101T	CAP , ELECT	100UF 16V	1
C462	CCEA1CH101T	CAP , ELECT	100UF 16V	1
C463	HCBS1H473ZFT	CAP , CERAMIC	0.047UF 50V Z	1
C501	HCBS1H330JT	CAP , CERAMIC	33PF 50V	1
C502	HCBS1H330JT	CAP , CERAMIC	33PF 50V	1
C503	HCBS1H181KBT	CAP , CERAMIC	180PF 50V K	1
C504	CCEA1HHR47T	CAP , ELECT	0.47UF 50V	1
C505	HCBS1H223ZFT	CAP , CERAMIC	0.022UF 50V Z	1
C506	CCEA1AH471T	CAP , ELECT	470UF 10V	1
C507	CCCT1H220JC	CAP , CERAMIC	22PF 50V JC	1
C508	CCCT1H270JC	CAP , CERAMIC	22PF 50V JC	1
C509	CCEA1HH1R0T	CAP , ELECT	1UF 50V	1
C510	CCEA1HH1R0T	CAP , ELECT	1UF 50V	1
C511	HCQI1H682JZT	CAP , MYLAR	6800PF 50V J	1
C512	CCEA1HH1R0T	CAP , ELECT	1UF 50V	1
C513	HCBS1H560JT	CAP , CERAMIC	56PF 50V J	1
C514	HCBS1H220JCT	CAP , CERAMIC	22PF 50V J	1
C515	CCEA1AH471T	CAP , ELECT	470UF 10V	1
C517	HCBS1H223ZFT	CAP , CERAMIC	0.022UF 50V Z	1
C518	HCBS1H223ZFT	CAP , CERAMIC	0.022UF 50V Z	1
C519	CCFT1H104ZF	CAP , SEMICONDUCTOR	0.1UF 50V ZF	1
C523	C3A206	WIRE , COPPER	SN95/PB5 , 0.6	0.018
C555	CCEA1AH471T	CAP , ELECT	470UF 10V	1
C556	CCEA1CH101T	CAP , ELECT	100UF 16V	1
C557	CCEA1CH101T	CAP , ELECT	100UF 16V	1

Ref. Designator	Part Number	Description		Qty
MAIN/VIDEO/BIAS/DIGITAL PCB ASS'Y SECTION 1				
C561	CCEA1CH101T	CAP , ELECT	100UF 16V	1
C568	HCBS1H104ZFT	CAP , CERAMIC	0.1UF 50V Z	1
C601	HCBS1H220JCT	CAP , CERAMIC	22PF 50V J	1
C602	HCBS1H220JCT	CAP , CERAMIC	22PF 50V J	1
C603	HCBS1H220JCT	CAP , CERAMIC	22PF 50V J	1
C604	HCBS1H220JCT	CAP , CERAMIC	22PF 50V J	1
C605	HCBS1H220JCT	CAP , CERAMIC	22PF 50V J	1
C606	HCBS1H220JCT	CAP , CERAMIC	22PF 50V J	1
C607	HCBS1H220JCT	CAP , CERAMIC	22PF 50V J	1
C608	HCBS1H220JCT	CAP , CERAMIC	22PF 50V J	1
C609	HCBS1H220JCT	CAP , CERAMIC	22PF 50V J	1
C610	HCBS1H223ZFT	CAP , CERAMIC	0.022UF 50V Z	1
C611	CCEA1CH101T	CAP , ELECT	100UF 16V	1
C612	HCBS1H223ZFT	CAP , CERAMIC	0.022UF 50V Z	1
C613	CCEA1CH101T	CAP , ELECT	100UF 16V	1
C701	CCEA1AH471T	CAP , ELECT	470UF 10V	1
C702	CCEA1AH471T	CAP , ELECT	470UF 10V	1
C703	CCKT1H181KB	CAP , CERAMIC	180PF 50V KB	1
C704	CCFT1H104ZF	CAP , SEMICONDUCTOR	0.1UF 50V ZF	1
C705	CCKT1H181KB	CAP , CERAMIC	180PF 50V KB	1
C706	HCBS1H104ZFT	CAP , CERAMIC	0.1UF 50V Z	1
C707	CCKT1H101KB	CAP , CERAMIC	100PF 50V KB	1
C708	CCEA1CH101T	CAP , ELECT	100UF 16V	1
C709	HCBS1H104ZFT	CAP , CERAMIC	0.1UF 50V Z	1
C711	CCEA1CH101T	CAP , ELECT	100UF 16V	1
C712	HCBS1H473ZFT	CAP , CERAMIC	0.047UF 50V Z	1
C820	CCEA1VH100T	CAP , ELECT	10UF 35V	1
C821	CCEA1EH470T	CAP , ELECT	47UF 25V	1
C822	CCEA1EH470T	CAP , ELECT	47UF 25V	1
C823	CCEA1VH100T	CAP , ELECT	10UF 35V	1
C824	HCBS1H471KBT	CAP , CERAMIC	470PF 50V	1
C825	HCBS1H151KBT	CAP , CERAMIC	150PF 50V K	1
C826	HCBS1H223ZFT	CAP , CERAMIC	0.022UF 50V Z	1
C827	HCBS1H223ZFT	CAP , CERAMIC	0.022UF 50V Z	1
C828	HCBS1H470JT	CAP , CERAMIC	47PF 50V J	1
C829	CCEA1VH100T	CAP , ELECT	10UF 35V	1
C830	HCBS1H473ZFT	CAP , CERAMIC	0.047UF 50V Z	1
C849	HCBS1H471KBT	CAP , CERAMIC	470PF 50V	1
C850	HCBS1H471KBT	CAP , CERAMIC	470PF 50V	1
C851	CCEA1HH100T	CAP , ELECT	10UF 50V	1
C852	CCEA1HH100T	CAP , ELECT	10UF 50V	1
C853	CCEA1HH100T	CAP , ELECT	10UF 50V	1
C854	CCEA1HH100T	CAP , ELECT	10UF 50V	1
C855	CCEA1HH100T	CAP , ELECT	10UF 50V	1
C856	CCEA1HH100T	CAP , ELECT	10UF 50V	1
C857	CCEA1HH100T	CAP , ELECT	10UF 50V	1
C866	CCEA1VH100T	CAP , ELECT	10UF 35V	1
C867	CCEA1VH100T	CAP , ELECT	10UF 35V	1
C868	CCEA1EH470T	CAP , ELECT	47UF 25V	1
C869	CCEA1EH470T	CAP , ELECT	47UF 25V	1
C870	HCBS1H681KBT	CAP , CERAMIC	680PF 50V	1
C871	HCBS1H681KBT	CAP , CERAMIC	680PF 50V	1
C872	CCEA1CH331T	CAP , ELECT	330UF 16V	1
C873	CCEA1CH331T	CAP , ELECT	330UF 16V	1
C921	HCQI1H104JZT	CAP , MYLAR	0.1UF 50V J	1
C922	HCQI1H104JZT	CAP , MYLAR	0.1UF 50V J	1

Ref. Designator	Part Number	Description		Qty
MAIN/VIDEO/BIAS/DIGITAL PCB ASS'Y SECTION 1				
C923	HCQI1H104JZT	CAP , MYLAR	0.1UF 50V J	1
C924	HCQI1H104JZT	CAP , MYLAR	0.1UF 50V J	1
C925	HCQI1H103JZT	CAP , MYLAR	0.01UF 50V J	1
C926	HCQI1H103JZT	CAP , MYLAR	0.01UF 50V J	1
C927	HCQI1H103JZT	CAP , MYLAR	0.01UF 50V J	1
C928	HCQI1H103JZT	CAP , MYLAR	0.01UF 50V J	1
C931	HCQI1H473JZT	CAP , MYLAR	0.047UF 50V J	1
C932	HCQI1H473JZT	CAP , MYLAR	0.047UF 50V J	1
C933	HCQI1H473JZT	CAP , MYLAR	0.047UF 50V J	1
C934	HCQI1H473JZT	CAP , MYLAR	0.047UF 50V J	1
C935	CCKT1H223ZF	CAP , CERAMIC	0.022UF 50V ZF	1
C936	CCKT1H223ZF	CAP , CERAMIC	0.022UF 50V ZF	1
C937	CCKT1H223ZF	CAP , CERAMIC	0.022UF 50V ZF	1
C938	CCEA1EH101T	CAP , ELECT	100UF 25V	1
C939	CCEA1EH101T	CAP , ELECT	100UF 25V	1
C940	CCEA1EH101T	CAP , ELECT	100UF 25V	1
C942	CCEA1HH2R2T	CAP , ELECT	2.2UF 50V	1
C953	HCBS1H104ZFT	CAP , CERAMIC	0.1UF 50V Z	1
C122	CCEA2AH101E	CAP , ELECT	100UF	1
C124	HCQE2E104KDE	CAP , LINE ACROSS	0.1UF	1
C520	CCEA0JKR3222E	CAP , ELECT	2200UF 6.3V	1
C929	CCEA1VH332F	CAP , ELECT (ANGLE)	3300UF 35V	1
C930	CCEA1VH222F	CAP,ELEC (ANGLE)	2200UF 35V	1
C941	CCEA1CKR3103E	CAP , ELECT	10000UF , 16V	1
<i>Semiconductors</i>				
D101	HVDMTZJ15BT	DIODE , ZENER	15V 1/2W	1
D102	HVDMTZJ27BT	DIODE , ZENER	27V 1/2W	1
D108	KVD1N4003ST	DIODE	1N4003	1
D109	HVDMTZJ12BT	DIODE , ZENER	12V 1/2W	1
D111	HVDMTZJ12BT	DIODE , ZENER	12V 1/2W	1
D401	HVD1SS133MT	DIODE	1SS133	1
D402	HVD1SS133MT	DIODE	1SS133	1
D403	HVD1SS133MT	DIODE	1SS133	1
D404	HVD1SS133MT	DIODE	1SS133	1
D405	HVD1SS133MT	DIODE	1SS133	1
D801	HVDMTZJ5.6BT	DIODE , ZENER	5.6V 1/2W	1
D802	HVDMTZJ5.6BT	DIODE , ZENER	5.6V 1/2W	1
D803	HVD1SS133MT	DIODE	1SS133	1
D904	KVD1N4003ST	DIODE	1N4003	1
D905	KVD1N4003ST	DIODE	1N4003	1
D906	KVD1N4003ST	DIODE	1N4003	1
D907	KVD1N4003ST	DIODE	1N4003	1
D915	HVD1SS133MT	DIODE	1SS133	1
D916	HVD1SS133MT	DIODE	1SS133	1
D917	HVDSB2100	DIODE , SCHOTTKY	SCHOTTKY	1
D918	HVDSB2100	DIODE , SCHOTTKY	SCHOTTKY	1
D952	HVD1SS133MT	DIODE	1SS133	1
D953	HVD1SS133MT	DIODE	1SS133	1
Q104	HVTKSC2316YT	TRANSISTOR	KSC2316Y	1
Q402	HVTKSA733CYT	TRANSISTOR	KSA733CY	1
Q403	HVTKRA107MT	TRANSISTOR	KRA107M	1
Q404	HVTKRC107MT	TRANSISTOR	KRC107M	1
Q405	HVTKSA733CYT	TRANSISTOR	KSA733CY	1
Q406	HVTKRA107MT	TRANSISTOR	KRA107M	1

Ref. Designator	Part Number	Description		Qty
MAIN/VIDEO/BIAS/DIGITAL PCB ASS'Y SECTION 1				
Q407	HVTKRC107MT	TRANSISTOR	KRC107M	1
Q408	HVTKRC107MT	TRANSISTOR	KRC107M	1
Q409	HVTKRA104MT	TRANSISTOR	KRA104M	1
Q410	HVTKTD1302T	TRANSISTOR	KTD1302	1
Q411	HVTKTD1302T	TRANSISTOR	KTD1302	1
Q412	HVTKRA104MT	TRANSISTOR	KRA104M	1
Q501	HVTKSC2785YT	TRANSISTOR	KSC2785Y(DEAD)	1
Q502	HVTKSA1175YT	TRANSISTOR	KSA1175Y(DEAD)	1
Q556	HVTKSA1175YT	TRANSISTOR	KSA1175Y(DEAD)	1
Q568	HVTKTC2874BT	TRANSISTOR , MUTE	KTC2874B	1
Q569	HVTKRC107MT	TRANSISTOR	KRC107M	1
Q734	HVTKTC2874BT	TRANSISTOR , MUTE	KTC2874B	1
Q735	HVTKTC2874BT	TRANSISTOR , MUTE	KTC2874B	1
Q736	HVTKTC2874BT	TRANSISTOR , MUTE	KTC2874B	1
Q737	HVTKTC2874BT	TRANSISTOR , MUTE	KTC2874B	1
Q738	HVTKRC107MT	TRANSISTOR	KRC107M	1
Q739	HVTKRA107MT	TRANSISTOR	KRA107M	1
Q740	HVTKRC107MT	TRANSISTOR	KRC107M	1
Q995	HVTKRA107MT	TRANSISTOR	KRA107M	1
D104	HVD1N5819T	DIODE , SCHOTTKY	1N5819	1
D105	HVD1N5819T	DIODE , SCHOTTKY	1N5819	1
D991	CVDKBU804FMA	BRIDGE DIODE ASS'Y	ASS'Y	1
	HVDKBU804F	DIODE , BRIDGE	BRIDGE DIODE	1
D992	CVDKBU804FMA	BRIDGE DIODE ASS'Y	ASS'Y	1
	HVDKBU804F	DIODE , BRIDGE	BRIDGE DIODE	1
IC41	HVINJM2296M	I.C , VIDEO SW	JRC	1
IC42	HVINJM2296M	I.C , VIDEO SW	JRC	1
IC43	HVINJM2296M	I.C , VIDEO SW	JRC	1
IC44	HVIHCF4053M013T	I.C	ST	1
IC45	HVIHCF4053M013T	I.C	ST	1
IC46	HVINJM2581MTE1	I.C	JRC	1
IC47	HVIMM1511XNRE	IC, Y/C-MIX	MITSUMI	1
IC48	CVIL7805CPNA	I.C ASS'Y	ASS'Y	1
	HVIL7805CP	I.C, REGULATOR	ST	1
IC49	CVIL7905CPNA	I.C ASS'Y	ASS'Y	1
	HVIL7905CP	I.C, REGULATOR	ST	1
IC51	HVILC74763M	I.C , OSD	SANYO	1
IC52	HVI74ACT04MTR	I.C , HEX	ST	1
IC61	HVINJM2586AMTE1	I.C , VIDEO SW	JRC	1
IC71	HVI74HCU04AFNG	I.C , INVERTER	TOSHIBA	1
IC86	HVINJM4556AL	I.C , HEADPHONE	JRC	1
IC87	HVINJM2068MDTE1	I.C , OP AMP	JRC	1
IC88	HVIHCF4053M013T	I.C	ST	1
IC91	HVIL7815CP	I.C, REGULATOR	ST	1
IC92	HVIL7915CP	I.C, REGULATOR	ST	1
IC93	HVIL7805CP	I.C, REGULATOR	ST	1
IC95	BVIKP1010B	IC, PHOTO COUPLER	COSMO	1
Q851	HVTKTD600KGR	TRANSISTOR , BIAS	KTD600KGR	1
Q852	HVTKTD600KGR	TRANSISTOR , BIAS	KTD600KGR	1
Q853	HVTKTD600KGR	TRANSISTOR , BIAS	KTD600KGR	1
Q854	HVTKTD600KGR	TRANSISTOR , BIAS	KTD600KGR	1
Q855	HVTKTD600KGR	TRANSISTOR , BIAS	KTD600KGR	1
Q856	HVTKTD600KGR	TRANSISTOR , BIAS	KTD600KGR	1
Q857	HVTKTD600KGR	TRANSISTOR , BIAS	KTD600KGR	1

AVR240

harman/kardon

Ref. Designator	Part Number	Description		Qty
MAIN/VIDEO/BIAS/DIGITAL PCB ASS'Y SECTION 1				
<i>Resistors</i>				
R101	KRD25FJ3R3T	RES , CARBON	3.3 OHM 1/4W J	1
R108	CRD20TJ4R7T	RES , CARBON	4.7 OHM 1/5W J	1
R109	CRD20TJ100T	RES , CARBON	10 OHM 1/5W J	1
R110	CRD20TJ4R7T	RES , CARBON	4.7 OHM 1/5W J	1
R112	CRD20TJ122T	RES , CARBON	1.2K OHM 1/5W J	1
R113	CRD20TJ473T	RES , CARBON	47K OHM 1/5W J	1
R401	CRD20TJ750T	RES , CARBON	75 OHM 1/5W J	1
R402	CRD20TJ750T	RES , CARBON	75 OHM 1/5W J	1
R403	CRD20TJ332T	RES , CARBON	3.3K OHM 1/5W J	1
R404	CRD20TJ750T	RES , CARBON	75 OHM 1/5W J	1
R405	CRD20TJ750T	RES , CARBON	75 OHM 1/5W J	1
R406	CRD20TJ332T	RES , CARBON	3.3K OHM 1/5W J	1
R407	CRD20TJ750T	RES , CARBON	75 OHM 1/5W J	1
R408	CRD20TJ750T	RES , CARBON	75 OHM 1/5W J	1
R409	CRD20TJ750T	RES , CARBON	75 OHM 1/5W J	1
R410	CRD20TJ332T	RES , CARBON	3.3K OHM 1/5W J	1
R411	CRD20TJ750T	RES , CARBON	75 OHM 1/5W J	1
R412	CRD20TJ750T	RES , CARBON	75 OHM 1/5W J	1
R413	CRD20TJ750T	RES , CARBON	75 OHM 1/5W J	1
R414	CRD20TJ332T	RES , CARBON	3.3K OHM 1/5W J	1
R415	CRD20TJ750T	RES , CARBON	75 OHM 1/5W J	1
R416	CRD20TJ332T	RES , CARBON	3.3K OHM 1/5W J	1
R417	CRD20TJ750T	RES , CARBON	75 OHM 1/5W J	1
R418	CRD20TJ750T	RES , CARBON	75 OHM 1/5W J	1
R419	CRD20TJ750T	RES , CARBON	75 OHM 1/5W J	1
R420	CRD20TJ332T	RES , CARBON	3.3K OHM 1/5W J	1
R421	CRD20TJ750T	RES , CARBON	75 OHM 1/5W J	1
R422	CRD20TJ332T	RES , CARBON	3.3K OHM 1/5W J	1
R423	CRD20TJ750T	RES , CARBON	75 OHM 1/5W J	1
R424	CRD20TJ750T	RES , CARBON	75 OHM 1/5W J	1
R425	CRD20TJ750T	RES , CARBON	75 OHM 1/5W J	1
R426	CRD20TJ332T	RES , CARBON	3.3K OHM 1/5W J	1
R427	CRD20TJ750T	RES , CARBON	75 OHM 1/5W J	1
R428	CRD20TJ332T	RES , CARBON	3.3K OHM 1/5W J	1
R430	CRD20TJ1R8T	RES , CARBON	1.8 OHM 1/5W J	1
R431	CRD20TJ102T	RES , CARBON	1K OHM 1/5W J	1
R432	CRD20TJ1R0T	RES , CARBON	1 OHM 1/5W J	1
R433	CRD20TJ102T	RES , CARBON	1K OHM 1/5W J	1
R434	CRD20TJ102T	RES , CARBON	1K OHM 1/5W J	1
R435	CRD20TJ102T	RES , CARBON	1K OHM 1/5W J	1
R436	CRD20TJ102T	RES , CARBON	1K OHM 1/5W J	1
R437	CRD20TJ102T	RES , CARBON	1K OHM 1/5W J	1
R438	CRD25TJ1R0T	RES , CARBON	1 OHM 1/4W J	1
R439	CRD20TJ750T	RES , CARBON	75 OHM 1/5W J	1
R440	CRD20TJ1R8T	RES , CARBON	1.8 OHM 1/5W J	1
R441	CRD20TJ102T	RES , CARBON	1K OHM 1/5W J	1
R442	CRD20TJ102T	RES , CARBON	1K OHM 1/5W J	1
R443	CRD20TJ102T	RES , CARBON	1K OHM 1/5W J	1
R444	CRD20TJ102T	RES , CARBON	1K OHM 1/5W J	1
R445	CRD20TJ1R0T	RES , CARBON	1 OHM 1/5W J	1
R446	CRD20TJ102T	RES , CARBON	1K OHM 1/5W J	1
R447	CRD20TJ750T	RES , CARBON	75 OHM 1/5W J	1
R448	CRD20TJ1R8T	RES , CARBON	1.8 OHM 1/5W J	1
R449	CRD20TJ102T	RES , CARBON	1K OHM 1/5W J	1

Ref. Designator	Part Number	Description		Qty
MAIN/VIDEO/BIAS/DIGITAL PCB ASS'Y SECTION 1				
R450	CRD20TJ102T	RES , CARBON	1K OHM 1/5W J	1
R451	CRD20TJ102T	RES , CARBON	1K OHM 1/5W J	1
R452	CRD20TJ102T	RES , CARBON	1K OHM 1/5W J	1
R453	CRD20TJ332T	RES , CARBON	3.3K OHM 1/5W J	1
R454	CRD20TJ562T	RES , CARBON	5.6K OHM 1/5W J	1
R455	CRD20TJ105T	RES , CARBON	1M OHM 1/5W J	1
R456	CRD20TJ680T	RES , CARBON	68 OHM 1/5W J	1
R457	CRD20TJ333T	RES , CARBON	33K OHM 1/5W J	1
R458	CRD20TJ123T	RES , CARBON	12K OHM 1/5W J	1
R459	CRD20TJ680T	RES , CARBON	68 OHM 1/5W J	1
R460	CRD20TJ333T	RES , CARBON	33K OHM 1/5W J	1
R461	CRD20TJ123T	RES , CARBON	12K OHM 1/5W J	1
R462	CRD20TJ102T	RES , CARBON	1K OHM 1/5W J	1
R463	CRD20TJ103T	RES , CARBON	10K OHM 1/5W J	1
R464	CRD20TJ103T	RES , CARBON	10K OHM 1/5W J	1
R465	CRD20TJ103T	RES , CARBON	10K OHM 1/5W J	1
R466	CRD20TJ103T	RES , CARBON	10K OHM 1/5W J	1
R467	CRD20TJ103T	RES , CARBON	10K OHM 1/5W J	1
R468	CRD20TJ100T	RES , CARBON	10 OHM 1/5W J	1
R469	CRD20TJ100T	RES , CARBON	10 OHM 1/5W J	1
R470	CRD20TJ100T	RES , CARBON	10 OHM 1/5W J	1
R471	CRD20TJ100T	RES , CARBON	10 OHM 1/5W J	1
R472	CRD20TJ151T	RES , CARBON	150 OHM 1/5W J	1
R473	CRD20TJ181T	RES , CARBON	180 OHM 1/5W J	1
R474	CRD20TJ1R8T	RES , CARBON	1.8 OHM 1/5W J	1
R475	CRD20TJ1R0T	RES , CARBON	1 OHM 1/5W J	1
R476	CRD25TJ101T	RES , CARBON	100 OHM 1/4W J	1
R477	CRD20TJ2R2T	RES , CARBON	2.2 OHM 1/5W J	1
R478	CRD20TJ223T	RES , CARBON	22K OHM 1/5W J	1
R479	CRD20TJ181T	RES , CARBON	180 OHM 1/5W J	1
R480	CRD20TJ223T	RES , CARBON	22K OHM 1/5W J	1
R481	CRD20TJ183T	RES , CARBON	18K OHM 1/5W J	1
R484	CRD20TJ104T	RES , CARBON	100K OHM 1/5W J	1
R485	CRD20TJ103T	RES , CARBON	10K OHM 1/5W J	1
R501	CRD20TJ102T	RES , CARBON	1K OHM 1/5W J	1
R502	CRD20TJ102T	RES , CARBON	1K OHM 1/5W J	1
R503	CRD20TJ102T	RES , CARBON	1K OHM 1/5W J	1
R504	CRD20TJ104T	RES , CARBON	100K OHM 1/5W J	1
R505	CRD20TJ102T	RES , CARBON	1K OHM 1/5W J	1
R506	CRD20TJ102T	RES , CARBON	1K OHM 1/5W J	1
R507	CRD20TJ102T	RES , CARBON	1K OHM 1/5W J	1
R508	CRD20TJ682T	RES , CARBON	6.8K OHM 1/5W J	1
R509	CRD20TJ152T	RES , CARBON	1.5K OHM 1/5W J	1
R510	CRD20TJ393T	RES , CARBON	39K OHM 1/5W	1
R511	CRD20TJ222T	RES , CARBON	2.2K OHM 1/5W J	1
R512	CRD20TJ102T	RES , CARBON	1K OHM 1/5W J	1
R513	CRD20TJ822T	RES , CARBON	8.2K OHM 1/5W J	1
R514	CRD20TJ103T	RES , CARBON	10K OHM 1/5W J	1
R516	CRD20TJ202T	RES , CARBON	2K OHM 1/5W J	1
R517	CRD20TJ273T	RES , CARBON	27K OHM 1/5W J	1
R555	CRD20TJ101T	RES , CARBON	100 OHM 1/5W J	1
R556	CRD20TJ183T	RES , CARBON	18K OHM 1/5W J	1
R558	CRD20TJ102T	RES , CARBON	1K OHM 1/5W J	1
R568	CRD20TJ223T	RES , CARBON	22K OHM 1/5W J	1
R569	CRD20TJ223T	RES , CARBON	22K OHM 1/5W J	1
R601	CRD20TJ750T	RES , CARBON	75 OHM 1/5W J	1

Ref. Designator	Part Number	Description		Qty
MAIN/VIDEO/BIAS/DIGITAL PCB ASS'Y SECTION 1				
R602	CRD20TJ750T	RES , CARBON	75 OHM 1/5W J	1
R603	CRD20TJ750T	RES , CARBON	75 OHM 1/5W J	1
R604	CRD20TJ750T	RES , CARBON	75 OHM 1/5W J	1
R605	CRD20TJ750T	RES , CARBON	75 OHM 1/5W J	1
R606	CRD20TJ750T	RES , CARBON	75 OHM 1/5W J	1
R607	CRD20TJ750T	RES , CARBON	75 OHM 1/5W J	1
R608	CRD20TJ750T	RES , CARBON	75 OHM 1/5W J	1
R609	CRD20TJ750T	RES , CARBON	75 OHM 1/5W J	1
R610	CRD20TJ4R7T	RES , CARBON	4.7 OHM 1/5W J	1
R611	CRD20TJ4R7T	RES , CARBON	4.7 OHM 1/5W J	1
R612	CRD20TJ472T	RES , CARBON	4.7K OHM 1/5W J	1
R701	CRD20TJ103T	RES , CARBON	10K OHM 1/5W J	1
R702	CRD20TJ1R0T	RES , CARBON	1 OHM 1/5W J	1
R703	CRD20TJ103T	RES , CARBON	10K OHM 1/5W J	1
R704	CRD20TJ1R0T	RES , CARBON	1 OHM 1/5W J	1
R705	CRD20TJ750T	RES , CARBON	75 OHM 1/5W J	1
R706	CRD20TJ750T	RES , CARBON	75 OHM 1/5W J	1
R707	CRD20TJ100T	RES , CARBON	10 OHM 1/5W J	1
R708	CRD20TJ241T	RES , CARBON	240OHM 1/5W J	1
R709	CRD20TJ750T	RES , CARBON	75 OHM 1/5W J	1
R710	CRD20TJ1R0T	RES , CARBON	1 OHM 1/5W J	1
R711	CRD20TJ1R0T	RES , CARBON	1 OHM 1/5W J	1
R713	CRD20TJ104T	RES , CARBON	100K OHM 1/5W J	1
R714	CRD20TJ104T	RES , CARBON	100K OHM 1/5W J	1
R715	CRD20TJ102T	RES , CARBON	1K OHM 1/5W J	1
R716	CRD20TJ102T	RES , CARBON	1K OHM 1/5W J	1
R717	CRD20TJ472T	RES , CARBON	4.7K OHM 1/5W J	1
R718	CRD20TJ472T	RES , CARBON	4.7K OHM 1/5W J	1
R719	CRD20TJ102T	RES , CARBON	1K OHM 1/5W J	1
R720	CRD20TJ102T	RES , CARBON	1K OHM 1/5W J	1
R874	CRD20TJ331T	RES , CARBON	330 OHM 1/5W J	1
R875	CRD20TJ331T	RES , CARBON	330 OHM 1/5W J	1
R876	CRD20TJ331T	RES , CARBON	330 OHM 1/5W J	1
R877	CRD20TJ331T	RES , CARBON	330 OHM 1/5W J	1
R878	CRD20TJ331T	RES , CARBON	330 OHM 1/5W J	1
R879	CRD20TJ331T	RES , CARBON	330 OHM 1/5W J	1
R880	CRD20TJ331T	RES , CARBON	330 OHM 1/5W J	1
R882	CRD20TJ122T	RES , CARBON	1.2K OHM 1/5W J	1
R883	CRD20TJ122T	RES , CARBON	1.2K OHM 1/5W J	1
R884	CRD20TJ122T	RES , CARBON	1.2K OHM 1/5W J	1
R885	CRD20TJ122T	RES , CARBON	1.2K OHM 1/5W J	1
R886	CRD20TJ122T	RES , CARBON	1.2K OHM 1/5W J	1
R887	CRD20TJ122T	RES , CARBON	1.2K OHM 1/5W J	1
R888	CRD20TJ122T	RES , CARBON	1.2K OHM 1/5W J	1
R895	CRD20TJ101T	RES , CARBON	100 OHM 1/5W J	1
R896	CRD20TJ101T	RES , CARBON	100 OHM 1/5W J	1
R897	CRD20TJ101T	RES , CARBON	100 OHM 1/5W J	1
R898	CRD20TJ101T	RES , CARBON	100 OHM 1/5W J	1
R899	CRD20TJ104T	RES , CARBON	100K OHM 1/5W J	1
R900	CRD20TJ104T	RES , CARBON	100K OHM 1/5W J	1
R901	CRD20TJ152T	RES , CARBON	1.5K OHM 1/5W J	1
R902	CRD20TJ152T	RES , CARBON	1.5K OHM 1/5W J	1
R903	CRD20TJ102T	RES , CARBON	1K OHM 1/5W J	1
R904	CRD20TJ102T	RES , CARBON	1K OHM 1/5W J	1
R905	CRD20TJ104T	RES , CARBON	100K OHM 1/5W J	1
R906	CRD20TJ104T	RES , CARBON	100K OHM 1/5W J	1

Ref. Designator	Part Number	Description		Qty
MAIN/VIDEO/BIAS/DIGITAL PCB ASS'Y SECTION 1				
R907	CRD20TJ562T	RES , CARBON	5.6K OHM 1/5W J	1
R908	CRD20TJ562T	RES , CARBON	5.6K OHM 1/5W J	1
R909	CRD20TJ221T	RES , CARBON	220 OHM 1/5W J	1
R910	CRD20TJ221T	RES , CARBON	220 OHM 1/5W J	1
R911	CRD20TJ221T	RES , CARBON	220 OHM 1/5W J	1
R912	CRD20TJ153T	RES , CARBON	15K OHM 1/5W J	1
R913	CRD20TJ153T	RES , CARBON	15K OHM 1/5W J	1
R914	CRD20TJ103T	RES , CARBON	10K OHM 1/5W J	1
R915	CRD20TJ221T	RES , CARBON	220 OHM 1/5W J	1
R918	CRD20TJ562T	RES , CARBON	5.6K OHM 1/5W J	1
R919	CRD20TJ562T	RES , CARBON	5.6K OHM 1/5W J	1
R920	CRD20TJ102T	RES , CARBON	1K OHM 1/5W J	1
R921	CRD20TJ103T	RES , CARBON	10K OHM 1/5W J	1
R922	CRD20TJ102T	RES , CARBON	1K OHM 1/5W J	1
R923	CRD20TJ101T	RES , CARBON	100 OHM 1/5W J	1
R924	CRD20TJ101T	RES , CARBON	100 OHM 1/5W J	1
R925	CRD20TJ680T	RES , CARBON	68 OHM 1/5W J	1
R926	CRD20TJ103T	RES , CARBON	10K OHM 1/5W J	1
R927	CRD20TJ102T	RES , CARBON	1K OHM 1/5W J	1
R928	CRD20TJ102T	RES , CARBON	1K OHM 1/5W J	1
R929	CRD20TJ562T	RES , CARBON	5.6K OHM 1/5W J	1
R930	CRD20TJ103T	RES , CARBON	10K OHM 1/5W J	1
R931	CRD20TJ104T	RES , CARBON	100K OHM 1/5W J	1
R932	CRD20TJ104T	RES , CARBON	100K OHM 1/5W J	1
R933	CRD20TJ103T	RES , CARBON	10K OHM 1/5W J	1
R934	CRD20TJ222T	RES , CARBON	2.2K OHM 1/5W J	1
R935	CRD20TJ103T	RES , CARBON	10K OHM 1/5W J	1
R936	CRD20TJ152T	RES , CARBON	1.5K OHM 1/5W J	1
R937	CRD20TJ104T	RES , CARBON	100K OHM 1/5W J	1
R952	CRD20TJ103T	RES , CARBON	10K OHM 1/5W J	1
R953	CRD20TJ103T	RES , CARBON	10K OHM 1/5W J	1
R954	CRD20TJ103T	RES , CARBON	10K OHM 1/5W J	1
R955	CRD20TJ271T	RES , CARBON	270 OHM 1/5W J	1
R957	CRD20TJ101T	RES , CARBON	100 OHM 1/5W J	1
R958	CRD20TJ471T	RES , CARBON	470 OHM 1/5W J	1
VR81	HVN1RA221B01T	RES , SEMI FIXED	220 OHM	1
VR82	HVN1RA221B01T	RES , SEMI FIXED	220 OHM	1
VR83	HVN1RA221B01T	RES , SEMI FIXED	220 OHM	1
VR84	HVN1RA221B01T	RES , SEMI FIXED	220 OHM	1
VR85	HVN1RA221B01T	RES , SEMI FIXED	220 OHM	1
VR86	HVN1RA221B01T	RES , SEMI FIXED	220 OHM	1
VR87	HVN1RA221B01T	RES , SEMI FIXED	220 OHM	1
R104	KRQ1AJR47H	RES , FUSE	0.47 OHM 1W J	1
R105	KRQ1AJR47H	RES , FUSE	0.47 OHM 1W J	1
R106	CRQ1AJR33H	RES , FUSE	0.33 OHM 1W J	1
R107	CRQ1AJR33H	RES , FUSE	0.33 OHM 1W J	1
<i>Miscellaneous</i>				
F903	KJCF5S	HOLDER , FUSE	HOLDER	2
F904	KJCF5S	HOLDER , FUSE	HOLDER	2
F905	KJCF5S	HOLDER , FUSE	HOLDER	2
F906	KJCF5S	HOLDER , FUSE	HOLDER	2
F907	KJCF5S	HOLDER , FUSE	HOLDER	2
L501	HLQ02C101JT	COIL , AXIAL	100UH,J	1
L502	KLQ5R6J405T	COIL , PEAKING(RADIAL)	5.6UH J 4X5	1
L503	KLQ220J405T	COIL , PEAKING(RADIAL)	22UH J 4X5	1

Ref. Designator	Part Number	Description		Qty
MAIN/VIDEO/BIAS/DIGITAL PCB ASS'Y SECTION 1				
	CMC1A284	PLATE , SHIELD	PLATE	1
BN14	CWB4F232450PU	WIRE ASS'Y	WIRE	1
BN16	CWZAVR140BN16	WIRE ASS'Y (SHIELD)	WIRE	1
BN17	KJP12GB143ZP	DIP SOCKET	SOCKET	1
BN19	CWZAVR335BN19	WIRE ASS'Y	WIRE	1
BN44	CWB2B904350EN	WIRE ASS'Y	WIRE	1
BN61	CWB2B903150EN	WIRE ASS'Y	WIRE	1
BN91	CWB4FE53130PU	WIRE ASS'Y	WIRE	1
BN96	CWB1C908150BM	WIRE ASS'Y	WIRE	1
BN97	CWB2B902200EN	WIRE ASS'Y	WIRE	1
CN13	CJP05GA01ZY	CON WAFER YMW025-05R	CONNECTOR	1
CN15	CJP08GA19ZY	WAFER, STRAIGHT, 8PIN	WAFER	1
CN19	KJP03GA90ZM	WAFER	WAFER	1
CN20	KJP04GA90ZM	WAFER	WAFER	1
CN21	KJP02GA89ZM	WAFER	WAFER	1
CN31	CJP02GB46ZY	WAFER, ANGLE, 2PIN	WAFER	1
CN32	CJP02GB46ZY	WAFER, ANGLE, 2PIN	WAFER	1
CN33	CJP02GB46ZY	WAFER, ANGLE, 2PIN	WAFER	1
CN34	CJP02GB46ZY	WAFER, ANGLE, 2PIN	WAFER	1
CN35	CJP02GB46ZY	WAFER, ANGLE, 2PIN	WAFER	1
CN36	CJP02GB46ZY	WAFER, ANGLE, 2PIN	WAFER	1
CN37	CJP02GB46ZY	WAFER, ANGLE, 2PIN	WAFER	1
CN41	CJP06GA19ZY	WAFER, STRAIGHT, 6PIN	WAFER	1
CN43	CJP13GA115ZY	WAFER , CARD CABLE	WAFER	1
CN61	CJP03GA19ZY	WAFER, STRAIGHT, 3PIN	WAFER	1
CN62	CJP04GA19ZY	WAFER, STRAIGHT, 4PIN	WAFER	1
CN81	CJP08GA01ZY	WAFER, STRAIGHT, 8PIN	WAFER	1
CN82	KJP06HA37ZM	WAFER	WAFER	1
CN84	KJP02KA060ZY	WAFER	WAFER	1
CN85	CJP03GA19ZY	WAFER, STRAIGHT, 3PIN	WAFER	1
CN88	CJP04GA19ZY	WAFER, STRAIGHT, 4PIN	WAFER	1
CN92	CJP05GA19ZY	WAFER, STRAIGHT, 5PIN	WAFER	1
CN96	CJP08GA01ZY	WAFER, STRAIGHT, 8PIN	WAFER	1
CN98	BJP08GB131ZK	WAFER	WAFER	1
CN98	HJP08GB131ZK	WAFER	WAFER	1
ET04	CMD1A569	BRACKET , PCB	BRACKET	1
ET05	CMD1A569	BRACKET , PCB	BRACKET	1
F901	KBA2D2500TLET	FUSE	2.5A	1
F902	KBA2D2500TLET	FUSE	2.5A	1
	CMY1A219	HEAT SINK (BRIDGE DIODE)	HEAT SINK	1
	CTB3+12J	SCREW	SCREW	1
	CMY1A218	HEAT SINK(TR)	HEAT SINK	1
	CTB3+8J	SCREW	SCREW	1
	CMY1A218	HEAT SINK(TR)	HEAT SINK	1
	CTB3+8J	SCREW	SCREW	1
JK41	CJJ9N001Z	JACK , S-VIDEO (2P/H)	JACK	1
JK42	CJJ9N001Z	JACK , S-VIDEO (2P/H)	JACK	1
JK43	CJJ9S001Z	JACK , S-VIDEO (3P/H)	JACK	1
JK48	CJJ4N043Z	JACK , BOARD	JACK	1
JK49	CJJ4N043Z	JACK , BOARD	JACK	1
JK50	CJJ4S010Z	JACK , BOARD	JACK	1
JK61	CJJ4L009Z	JACK 9P (RRR/BBB/GGG)	JACK	1
JK71	HJSTORX177L	MODULE , OPTICAL(RX)	OPTICAL JACK	1
JK72	HJSTORX177L	MODULE , OPTICAL(RX)	OPTICAL JACK	1
JK73	CJJ4S022Z	JACK , BOARD	JACK	1
JK74	HJSTOTX177L	MODULE , OPTICAL(TX)	OPTICAL JACK	1
JK94	CJJ2D008Z	JACK , STEREO	JACK	1

AVR240

harman/kardon

Ref. Designator	Part Number	Description		Qty
MAIN/VIDEO/BIAS/DIGITAL PCB ASS'Y SECTION 1				
JK95	CJJ2D008Z	JACK , STEREO	JACK	1
JW11	CWEP202110VV	WIRE	WIRE	1
OL91	KJJ7A015Z	OUTLET , AC(UL/2P/SEP)	OUTLET	1
RL81	HSL4A011ZE	RELAY	OMI-SS-212L	1
SW91	KST1A010Z	SW , TACT CN	SWITCH	1
X501	HOX14318E220C	CRYSTAL	14.318Mhz	1
IPOD PCB ASS'Y				
<i>Capacitors</i>				
C400	HCUS1H104ZF	CAP , CHIP	0.1UF	1
C401	HCUS1H104ZF	CAP , CHIP	0.1UF	1
C402	HCUS1H471JA	CAP , CHIP	470PF	1
C403	HCUS1H471JA	CAP , CHIP	470PF	1
C408	HCEC1CRV2100T	CAP , ELEC (SMD)	10UF / 16V	1
C409	HCEC1CRV2100T	CAP , ELEC (SMD)	10UF / 16V	1
C410	HCEC1HRV21R0T	CAP , ELEC (SMD)	1UF/50	1
C411	HCEC1HRV21R0T	CAP , ELEC (SMD)	1UF/50	1
C416	HCUS1H473ZF	CAP , CHIP	0.047UF	1
C421	HCUS1H471JA	CAP , CHIP	470PF	1
C422	HCUS1H471JA	CAP , CHIP	470PF	1
C423	HCUS1H223KC	CAP , CHIP	0.022UF	1
C424	HCUS1H223KC	CAP , CHIP	0.022UF	1
C417	CCEA1CH471T	CAP , ELECT	470UF 16V	1
<i>Semiconductors</i>				
D400	HVD1SS355T	DIODE , CHIP	1SS355	1
D401	HVD1SS355T	DIODE , CHIP	1SS355	1
IC41	HVITC9215AF	I.C	TOSHIBA	1
Q400	HVTKRC102S	TRANSISTOR , CHIP	KRC102S	1
Q402	HVTKRC102S	TRANSISTOR , CHIP	KRC102S	1
D402	KVD1N4003ST	DIODE	1N4003	1
<i>Resistors</i>				
R400	CRJ10DJ4R7T	RES , CHIP	4.7 OHM	1
R401	CRJ10DJ4R7T	RES , CHIP	4.7 OHM	1
R402	CRJ10DF5493T	RES , CHIP 549KOHM/1608/1%	549K OHM/1608/1%	1
R403	CRJ10DJ0R0T	RES , CHIP	0 OHM	1
R404	CRJ10DJ470T	RES , CHIP	47 OHM	1
R405	CRJ10DJ470T	RES , CHIP	47 OHM	1
R406	CRJ10DJ474T	RES , CHIP	470K OHM	1
R407	CRJ10DJ474T	RES , CHIP	470K OHM	1
R412	CRJ10DJ471T	RES , CHIP	470 OHM	1
R413	CRJ10DJ471T	RES , CHIP	470 OHM	1
R419	CRJ10DJ332T	RES , CHIP	3.3K OHM 1/5W J	1
R421	CRJ10DJ223T	RES , CHIP	22K OHM 1/5W J	1
R422	CRJ10DJ224T	RES , CHIP	220K OHM	1
<i>Miscellaneous</i>				
JK40	HJJ9L003Z	JACK , IPOD	IPOD JACK	1
CN42	CJP05GB46ZY	WAFER	WAFER	1
CN44	CJP04GB46ZY	WAFER	WAFER	1

Ref. Designator	Part Number	Description		Qty
IPOD PCB ASS'Y				
ET01	CMD1A570	BRACKET , PCB	BRACKET	1
R416	CLZ9Z068Z	COIL,CHOKE	CHOKE COIL	1
MAIN/VIDEO/BIAS/DIGITAL PCB ASS'Y SECTION 2				
<i>Capacitors</i>				
C501	CCEA1VH100T	CAP , ELECT	10UF 35V	1
C502	CCEA1VH100T	CAP , ELECT	10UF 35V	1
C503	CCEA1VH100T	CAP , ELECT	10UF 35V	1
C504	CCEA1VH100T	CAP , ELECT	10UF 35V	1
C505	CCEA1VH100T	CAP , ELECT	10UF 35V	1
C506	CCKT1H331KB	CAP , CERAMIC	330PF 50V KB	1
C507	CCKT1H331KB	CAP , CERAMIC	330PF 50V KB	1
C508	CCKT1H331KB	CAP , CERAMIC	330PF 50V KB	1
C509	CCKT1H331KB	CAP , CERAMIC	330PF 50V KB	1
C510	CCKT1H331KB	CAP , CERAMIC	330PF 50V KB	1
C561	HCEA1CH101T	CAP , ELECT	100UF 16V	1
C562	HCEA1CH101T	CAP , ELECT	100UF 16V	1
C564	HCEA1CH101T	CAP , ELECT	100UF 16V	1
C566	HCEA1CH101T	CAP , ELECT	100UF 16V	1
C567	HCEA1CH101T	CAP , ELECT	100UF 16V	1
C568	HCEA1CH101T	CAP , ELECT	100UF 16V	1
C569	HCEA1CH101T	CAP , ELECT	100UF 16V	1
C570	HCEA1CH101T	CAP , ELECT	100UF 16V	1
C571	HCBS1H681KBT	CAP , CERAMIC	680PF	1
C572	HCBS1H681KBT	CAP , CERAMIC	680PF	1
C573	HCBS1H681KBT	CAP , CERAMIC	680PF	1
C574	HCBS1H681KBT	CAP , CERAMIC	680PF	1
C575	HCBS1H681KBT	CAP , CERAMIC	680PF	1
C601	CCCT1H120JC	CAP , CERAMIC	12PF 50V JC	1
C602	CCCT1H120JC	CAP , CERAMIC	12PF 50V JC	1
C603	CCCT1H120JC	CAP , CERAMIC	12PF 50V JC	1
C604	CCCT1H120JC	CAP , CERAMIC	12PF 50V JC	1
C605	CCCT1H120JC	CAP , CERAMIC	12PF 50V JC	1
C606	CCCT1H330JC	CAP , CERAMIC	33PF 50V JC	1
C607	CCCT1H330JC	CAP , CERAMIC	33PF 50V JC	1
C608	CCCT1H330JC	CAP , CERAMIC	33PF 50V JC	1
C609	CCCT1H330JC	CAP , CERAMIC	33PF 50V JC	1
C610	CCCT1H330JC	CAP , CERAMIC	33PF 50V JC	1
C681	HCEA1HH100T	CAP , ELECT	10UF 50V	1
C682	HCEA1HH100T	CAP , ELECT	10UF 50V	1
C683	HCEA1HH100T	CAP , ELECT	10UF 50V	1
C684	HCEA1HH100T	CAP , ELECT	10UF 50V	1
C685	HCEA1HH100T	CAP , ELECT	10UF 50V	1
C721	CCKT1H221KB	CAP , CERAMIC	220PF 50V KB	1
C722	CCKT1H221KB	CAP , CERAMIC	220PF 50V KB	1
C723	CCKT1H221KB	CAP , CERAMIC	220PF 50V KB	1
C724	CCKT1H221KB	CAP , CERAMIC	220PF 50V KB	1
C725	CCKT1H221KB	CAP , CERAMIC	220PF 50V KB	1
C726	CCKT1H221KB	CAP , CERAMIC	220PF 50V KB	1
C727	CCKT1H221KB	CAP , CERAMIC	220PF 50V KB	1
C728	CCKT1H221KB	CAP , CERAMIC	220PF 50V KB	1
C801	HCEA1HH100T	CAP , ELECT	10UF 50V	1
C802	HCEA1HH100T	CAP , ELECT	10UF 50V	1
C803	CCCT1H330JC	CAP , CERAMIC	33PF 50V JC	1

Ref. Designator	Part Number	Description		Qty
MAIN/VIDEO/BIAS/DIGITAL PCB ASS'Y SECTION 2				
C804	CCCT1H330JC	CAP , CERAMIC	33PF 50V JC	1
C805	CCCT1H120JC	CAP , CERAMIC	12PF 50V JC	1
C806	CCCT1H120JC	CAP , CERAMIC	12PF 50V JC	1
C811	HCEA1CH101T	CAP , ELECT	100UF 16V	1
C812	HCEA1CH101T	CAP , ELECT	100UF 16V	1
C813	HCEA1CH101T	CAP , ELECT	100UF 16V	1
C814	HCEA1CH101T	CAP , ELECT	100UF 16V	1
C815	CCKT1H331KB	CAP , CERAMIC	330PF 50V KB	1
C816	CCKT1H331KB	CAP , CERAMIC	330PF 50V KB	1
C817	CCEA1VH100T	CAP , ELECT	10UF 35V	1
C818	CCEA1VKS100T	CAP , ELECT	10UF 35V	1
C819	HCBS1H681KBT	CAP , CERAMIC	680PF 50V	1
C820	HCBS1H681KBT	CAP , CERAMIC	680PF 50V	1
C900	HCQI1H473JZT	CAP , MYLAR	0.047UF 50V J	1
C901	HCQI1H473JZT	CAP , MYLAR	0.047UF 50V J	1
C905	CCKT1H223ZF	CAP , CERAMIC	0.022UF 50V ZF	1
C907	HCEA1CH101T	CAP , ELECT	100UF 16V	1
C908	CCKT1H223ZF	CAP , CERAMIC	0.022UF 50V ZF	1
C910	HCQI1H473JZT	CAP , MYLAR	0.047UF 50V J	1
C911	CCEA1CH471T	CAP , ELECT	470UF 16V	1
C912	CCEA1EH221T	CAP , ELECT	220UF 25V	1
C913	CCFT1H104ZF	CAP , SEMICONDUCTOR	0.1UF 50V ZF	1
C914	HCQI1H473JZT	CAP , MYLAR	0.047UF 50V J	1
C917	HCQI1H473JZT	CAP , MYLAR	0.047UF 50V J	1
C918	HCQI1H473JZT	CAP , MYLAR	0.047UF 50V J	1
C919	HCQI1H473JZT	CAP , MYLAR	0.047UF 50V J	1
C924	HCBS1H104ZFT	CAP , CERAMIC	0.1UF 50V Z	1
C925	HCBS1H104ZFT	CAP , CERAMIC	0.1UF 50V Z	1
C932	HCEA1CH101T	CAP , ELECT	100UF 16V	1
C933	CCEA1CH221T	CAP , ELECT	220UF 16V	1
C934	CCKT1H223ZF	CAP , CERAMIC	0.022UF 50V ZF	1
C939	CCEA1HH4R7T	CAP , ELECT	4.7UF 50V	1
C940	CCEA1AH471T	CAP , ELECT	470UF 10V	1
C950	HCEA1CH101T	CAP , ELECT	100UF 16V	1
C971	HCQI1H562JZT	CAP , MYLAR	5600PF 50V J	1
C972	HCQI1H562JZT	CAP , MYLAR	5600PF 50V J	1
C973	HCQI1H562JZT	CAP , MYLAR	5600PF 50V J	1
C974	HCQI1H562JZT	CAP , MYLAR	5600PF 50V J	1
C975	HCQI1H562JZT	CAP , MYLAR	5600PF 50V J	1
C980	HCQI1H562JZT	CAP , MYLAR	5600PF 50V J	1
C981	HCQI1H562JZT	CAP , MYLAR	5600PF 50V J	1
C990	HCQI1H473JZT	CAP , MYLAR	0.047UF 50V J	1
C991	CCEA1HH1R0T	CAP , ELECT	1UF 50V	1
C992	HCQI1H473JZT	CAP , MYLAR	0.047UF 50V J	1
C993	HCQI1H473JZT	CAP , MYLAR	0.047UF 50V J	1
C994	HCQI1H473JZT	CAP , MYLAR	0.047UF 50V J	1
C995	HCQI1H473JZT	CAP , MYLAR	0.047UF 50V J	1
C996	HCQI1H473JZT	CAP , MYLAR	0.047UF 50V J	1
C997	HCQI1H473JZT	CAP , MYLAR	0.047UF 50V J	1
C999	CCKT1H223ZF	CAP , CERAMIC	0.022UF 50V ZF	1
C563	HCEA1CH101T	CAP , ELECT	100UF 16V	1
C565	HCEA1CH101T	CAP , ELECT	100UF 16V	1
C631	CCEA1JH101E	CAP , ELECT	100UF 63V	1
C632	CCEA1JH101E	CAP , ELECT	100UF 63V	1
C633	CCEA1JH101E	CAP , ELECT	100UF 63V	1
C634	CCEA1JH101E	CAP , ELECT	100UF 63V	1
C635	CCEA1JH101E	CAP , ELECT	100UF 63V	1

Ref. Designator	Part Number	Description		Qty
MAIN/VIDEO/BIAS/DIGITAL PCB ASS'Y SECTION 2				
C636	CCEA1JH101E	CAP , ELECT	100UF 63V	1
C637	CCEA1JH101E	CAP , ELECT	100UF 63V	1
C638	CCEA1JH101E	CAP , ELECT	100UF 63V	1
C639	CCEA1JH101E	CAP , ELECT	100UF 63V	1
C640	CCEA1JH101E	CAP , ELECT	100UF 63V	1
C807	CCEA1JH101E	CAP , ELECT	100UF 63V	1
C808	CCEA1JH101E	CAP , ELECT	100UF 63V	1
C809	CCEA1JH101E	CAP , ELECT	100UF 63V	1
C810	CCEA1JH101E	CAP , ELECT	100UF 63V	1
C902	CCET50VKL4822NK	CAP , ELECT	8200UF/50V	1
C904	KCKDKS472ME	CAP , CERAMIC(X1/Y2/SC)	0.0047UF/2.5KV	1
C906	CCEA1EH102E	CAP , ELECT	1000UF 25V	1
C909	CCET50VKL4822NK	CAP , ELECT	8200UF/50V	1
C915	CCET50VKL4103NK	CAP , ELECT	10000UF/50V	1
C916	CCET50VKL4103NK	CAP , ELECT	10000UF/50V	1
<i>Semiconductors</i>				
D501	HVD1SS133MT	DIODE	1SS133	1
D502	HVD1SS133MT	DIODE	1SS133	1
D503	HVD1SS133MT	DIODE	1SS133	1
D504	HVD1SS133MT	DIODE	1SS133	1
D505	HVD1SS133MT	DIODE	1SS133	1
D581	HVD1SS133MT	DIODE	1SS133	1
D582	HVD1SS133MT	DIODE	1SS133	1
D583	HVD1SS133MT	DIODE	1SS133	1
D584	HVD1SS133MT	DIODE	1SS133	1
D585	HVD1SS133MT	DIODE	1SS133	1
D601	HVD1SS133MT	DIODE	1SS133	1
D801	HVD1SS133MT	DIODE	1SS133	1
D802	HVD1SS133MT	DIODE	1SS133	1
D803	HVD1SS133MT	DIODE	1SS133	1
D804	HVD1SS133MT	DIODE	1SS133	1
D901	KVD1N4003ST	DIODE	1N4003	1
D902	HVD1SS133MT	DIODE	1SS133	1
D911	HVD1SS133MT	DIODE	1SS133	1
D912	HVD1SS133MT	DIODE	1SS133	1
D914	HVD1SS133MT	DIODE	1SS133	1
D917	HVD1SS133MT	DIODE	1SS133	1
D953	HVD1SS133MT	DIODE	1SS133	1
D954	KVD1N4003SRT	DIODE TW	1N4003	1
D955	KVD1N4003SRT	DIODE TW	1N4003	1
D961	KVD1N4003ST	DIODE	1N4003	1
D962	KVD1N4003ST	DIODE	1N4003	1
D963	KVD1N4003ST	DIODE	1N4003	1
D964	HVD1SS133MT	DIODE	1SS133	1
D967	HVD1SS133MT	DIODE	1SS133	1
D968	HVD1SS133MT	DIODE	1SS133	1
D969	HVD1SS133MT	DIODE	1SS133	1
D971	HVD1SS133MT	DIODE	1SS133	1
D972	HVD1SS133MT	DIODE	1SS133	1
D973	HVD1SS133MT	DIODE	1SS133	1
D974	HVD1SS133MT	DIODE	1SS133	1
Q501	HVTKTA1268GRT	TRANSISTOR	KTA1268GR	1
Q502	HVTKTA1268GRT	TRANSISTOR	KTA1268GR	1
Q503	HVTKTA1268GRT	TRANSISTOR	KTA1268GR	1
Q504	HVTKTA1268GRT	TRANSISTOR	KTA1268GR	1

Ref. Designator	Part Number	Description		Qty
MAIN/VIDEO/BIAS/DIGITAL PCB ASS'Y SECTION 2				
Q505	HVTKTA1268GRT	TRANSISTOR	KTA1268GR	1
Q511	HVTKTC3200GRT	TRANSISTOR	KTC3200GR	1
Q512	HVTKTC3200GRT	TRANSISTOR	KTC3200GR	1
Q513	HVTKTC3200GRT	TRANSISTOR	KTC3200GR	1
Q514	HVTKTC3200GRT	TRANSISTOR	KTC3200GR	1
Q515	HVTKTC3200GRT	TRANSISTOR	KTC3200GR	1
Q516	HVTKTC3200GRT	TRANSISTOR	KTC3200GR	1
Q517	HVTKTC3200GRT	TRANSISTOR	KTC3200GR	1
Q518	HVTKTC3200GRT	TRANSISTOR	KTC3200GR	1
Q519	HVTKTC3200GRT	TRANSISTOR	KTC3200GR	1
Q520	HVTKTC3200GRT	TRANSISTOR	KTC3200GR	1
Q541	HVTKTC3198YT	TRANSISTOR	KTC3198Y	1
Q542	HVTKTC3198YT	TRANSISTOR	KTC3198Y	1
Q543	HVTKTC3198YT	TRANSISTOR	KTC3198Y	1
Q544	HVTKTC3198YT	TRANSISTOR	KTC3198Y	1
Q545	HVTKTC3198YT	TRANSISTOR	KTC3198Y	1
Q556	HVTKTC3200GRT	TRANSISTOR	KTC3200GR	1
Q557	HVTKTC3200GRT	TRANSISTOR	KTC3200GR	1
Q558	HVTKTC3200GRT	TRANSISTOR	KTC3200GR	1
Q559	HVTKTC3200GRT	TRANSISTOR	KTC3200GR	1
Q560	HVTKTC3200GRT	TRANSISTOR	KTC3200GR	1
Q561	HVTKTC3200GRT	TRANSISTOR	KTC3200GR	1
Q562	HVTKTC3200GRT	TRANSISTOR	KTC3200GR	1
Q563	HVTKTC3200GRT	TRANSISTOR	KTC3200GR	1
Q564	HVTKTC3200GRT	TRANSISTOR	KTC3200GR	1
Q565	HVTKTC3200GRT	TRANSISTOR	KTC3200GR	1
Q601	HVTKTA1268GRT	TRANSISTOR	KTA1268GR	1
Q602	HVTKTA1268GRT	TRANSISTOR	KTA1268GR	1
Q603	HVTKTA1268GRT	TRANSISTOR	KTA1268GR	1
Q604	HVTKTA1268GRT	TRANSISTOR	KTA1268GR	1
Q605	HVTKTA1268GRT	TRANSISTOR	KTA1268GR	1
Q681	KVTKSC2785YT	TRANSISTOR	KSC2785Y	1
Q682	KVTKSC2785YT	TRANSISTOR	KSC2785Y	1
Q683	KVTKSC2785YT	TRANSISTOR	KSC2785Y	1
Q684	KVTKSC2785YT	TRANSISTOR	KSC2785Y	1
Q685	KVTKSC2785YT	TRANSISTOR	KSC2785Y	1
Q701	HVTKTC2874BT	TRANSISTOR , MUTE	KTC2874B	1
Q702	HVTKTC2874BT	TRANSISTOR , MUTE	KTC2874B	1
Q703	HVTKTC2874BT	TRANSISTOR , MUTE	KTC2874B	1
Q704	HVTKTC2874BT	TRANSISTOR , MUTE	KTC2874B	1
Q705	HVTKTC2874BT	TRANSISTOR , MUTE	KTC2874B	1
Q706	HVTKTC2874BT	TRANSISTOR , MUTE	KTC2874B	1
Q707	HVTKTC2874BT	TRANSISTOR , MUTE	KTC2874B	1
Q708	HVTKTC2874BT	TRANSISTOR , MUTE	KTC2874B	1
Q801	KVTKSC2785YT	TRANSISTOR	KSC2785Y	1
Q802	KVTKSC2785YT	TRANSISTOR	KSC2785Y	1
Q812	HVTKTA1268GRT	TRANSISTOR	KTA1268GR	1
Q813	HVTKTC3200GRT	TRANSISTOR	KTC3200GR	1
Q814	HVTKTA1268GRT	TRANSISTOR	KTA1268GR	1
Q815	HVTKTC3200GRT	TRANSISTOR	KTC3200GR	1
Q816	HVTKTA1268GRT	TRANSISTOR	KTA1268GR	1
Q817	HVTKTA1268GRT	TRANSISTOR	KTA1268GR	1
Q818	HVTKTC3200GRT	TRANSISTOR	KTC3200GR	1
Q819	HVTKTC3200GRT	TRANSISTOR	KTC3200GR	1
Q820	HVTKTC3200GRT	TRANSISTOR	KTC3200GR	1
Q821	HVTKTC3200GRT	TRANSISTOR	KTC3200GR	1
Q822	HVTKTC3200GRT	TRANSISTOR	KTC3200GR	1

AVR240

harman/kardon

Ref. Designator	Part Number	Description		Qty
MAIN/VIDEO/BIAS/DIGITAL PCB ASS'Y SECTION 2				
Q823	HVTKTC3200GRT	TRANSISTOR	KTC3200GR	1
Q824	HVTKTC3198YT	TRANSISTOR	KTC3198Y	1
Q825	HVTKTC3198YT	TRANSISTOR	KTC3198Y	1
Q826	HVTKTC2874BT	TRANSISTOR , MUTE	KTC2874B	1
Q827	HVTKTC2874BT	TRANSISTOR , MUTE	KTC2874B	1
Q901	KVTKSC2785YT	TRANSISTOR	KSC2785Y	1
Q911	HVTKTA1271YT	TRANSISTOR	KTA1271Y	1
Q912	HVTKTA1271YT	TRANSISTOR	KTA1271Y	1
Q913	HVTKTA1271YT	TRANSISTOR	KTA1271Y	1
Q914	HVTKTA1271YT	TRANSISTOR	KTA1271Y	1
Q915	KVTKSC2785YT	TRANSISTOR	KSC2785Y	1
Q916	KVTKSC2785YT	TRANSISTOR	KSC2785Y	1
Q917	KVTKSC2785YT	TRANSISTOR	KSC2785Y	1
Q918	KVTKSC2785YT	TRANSISTOR	KSC2785Y	1
Q938	HVTKRA107MT	TRANSISTOR	KRA107M	1
Q939	HVTKRA107MT	TRANSISTOR	KRA107M	1
Q942	KVTKSC2785YT	TRANSISTOR	KSC2785Y	1
Q943	KVTKSC2785YT	TRANSISTOR	KSC2785Y	1
Q951	HVTKRC107MT	TRANSISTOR	KRC107M	1
Q952	HVTKRA107MT	TRANSISTOR	KRA107M	1
Q960	HVTKRC107MT	TRANSISTOR	KRC107M	1
Q961	HVTKTA1024YT	TRANSISTOR	KTA1024Y	1
Q969	HVTKTC2874BT	TRANSISTOR , MUTE	KTC2874B	1
Q970	HVTKTC2874BT	TRANSISTOR , MUTE	KTC2874B	1
Q971	HVTKTC2874BT	TRANSISTOR , MUTE	KTC2874B	1
Q972	HVTKTC2874BT	TRANSISTOR , MUTE	KTC2874B	1
Q973	HVTKTC2874BT	TRANSISTOR , MUTE	KTC2874B	1
Q991	HVTKRC107MT	TRANSISTOR	KRC107M	1
Q992	HVTKRA107MT	TRANSISTOR	KRA107M	1
Q652	HVT2SB1560-OKM	TRANSISTOR , POWER	2SB1560	1
Q653	HVT2SB1560-OKM	TRANSISTOR , POWER	2SB1560	1
Q654	HVT2SB1560-OKM	TRANSISTOR , POWER	2SB1560	1
Q655	HVT2SB1560-OKM	TRANSISTOR , POWER	2SB1560	1
Q657	HVT2SD2390-OKM	TRANSISTOR , POWER	2SD2390	1
Q658	HVT2SD2390-OKM	TRANSISTOR , POWER	2SD2390	1
Q659	HVT2SD2390-OKM	TRANSISTOR , POWER	2SD2390	1
Q660	HVT2SD2390-OKM	TRANSISTOR , POWER	2SD2390	1
Q661	HVT2SB1560-OKM	TRANSISTOR , POWER	2SB1560	1
Q670	HVT2SD2390-OKM	TRANSISTOR , POWER	2SD2390	1
Q803	HVT2SD2390-OKM	TRANSISTOR , POWER	2SD2390	1
Q804	HVT2SB1560-OKM	TRANSISTOR , POWER	2SB1560	1
Q805	HVT2SD2390-OKM	TRANSISTOR , POWER	2SD2390	1
Q807	HVT2SB1560-OKM	TRANSISTOR , POWER	2SB1560	1
Q858	HVT2SA1360O	TRANSISTOR	2SA1360O	1
Q871	HVT2SA1360O	TRANSISTOR	2SA1360O	1
Q872	HVT2SA1360O	TRANSISTOR	2SA1360O	1
Q874	HVT2SA1360O	TRANSISTOR	2SA1360O	1
Q875	HVT2SA1360O	TRANSISTOR	2SA1360O	1
Q876	HVT2SA1360O	TRANSISTOR	2SA1360O	1
Q877	HVT2SA1360O	TRANSISTOR	2SA1360O	1
Q881	HVT2SC3423O	TRANSISTOR	2SC3423O	1
Q882	HVT2SC3423O	TRANSISTOR	2SC3423O	1
Q883	HVT2SC3423O	TRANSISTOR	2SC3423O	1
Q884	HVT2SC3423O	TRANSISTOR	2SC3423O	1
Q885	HVT2SC3423O	TRANSISTOR	2SC3423O	1
Q886	HVT2SC3423O	TRANSISTOR	2SC3423O	1
Q887	HVT2SC3423O	TRANSISTOR	2SC3423O	1

AVR240

harman/kardon

Ref. Designator	Part Number	Description		Qty
MAIN/VIDEO/BIAS/DIGITAL PCB ASS'Y SECTION 2				
IC94	HVIMC7805C	I.C, REGULATOR	KA7805-ABTU	1
<i>Resistors</i>				
R501	CRD20TJ433T	RES , CARBON	43K OHM 1/5W J	1
R502	CRD20TJ433T	RES , CARBON	43K OHM 1/5W J	1
R503	CRD20TJ433T	RES , CARBON	43K OHM 1/5W J	1
R504	CRD20TJ433T	RES , CARBON	43K OHM 1/5W J	1
R505	CRD20TJ433T	RES , CARBON	43K OHM 1/5W J	1
R506	CRD20TJ333T	RES , CARBON	33K OHM 1/5W J	1
R507	CRD20TJ333T	RES , CARBON	33K OHM 1/5W J	1
R508	CRD20TJ333T	RES , CARBON	33K OHM 1/5W J	1
R509	CRD20TJ333T	RES , CARBON	33K OHM 1/5W J	1
R510	CRD20TJ333T	RES , CARBON	33K OHM 1/5W J	1
R511	CRD20TJ152T	RES , CARBON	1.5K OHM 1/5W J	1
R512	CRD20TJ152T	RES , CARBON	1.5K OHM 1/5W J	1
R513	CRD20TJ152T	RES , CARBON	1.5K OHM 1/5W J	1
R514	CRD20TJ152T	RES , CARBON	1.5K OHM 1/5W J	1
R515	CRD20TJ152T	RES , CARBON	1.5K OHM 1/5W J	1
R516	CRD20TJ152T	RES , CARBON	1.5K OHM 1/5W J	1
R517	CRD20TJ152T	RES , CARBON	1.5K OHM 1/5W J	1
R518	CRD20TJ152T	RES , CARBON	1.5K OHM 1/5W J	1
R519	CRD20TJ152T	RES , CARBON	1.5K OHM 1/5W J	1
R520	CRD20TJ152T	RES , CARBON	1.5K OHM 1/5W J	1
R521	CRD20TJ471T	RES , CARBON	470 OHM 1/5W J	1
R522	CRD20TJ471T	RES , CARBON	470 OHM 1/5W J	1
R523	CRD20TJ471T	RES , CARBON	470 OHM 1/5W J	1
R524	CRD20TJ471T	RES , CARBON	470 OHM 1/5W J	1
R525	CRD20TJ471T	RES , CARBON	470 OHM 1/5W J	1
R531	CRD20TJ221T	RES , CARBON	220 OHM 1/5W J	1
R532	CRD20TJ221T	RES , CARBON	220 OHM 1/5W J	1
R533	CRD20TJ221T	RES , CARBON	220 OHM 1/5W J	1
R534	CRD20TJ221T	RES , CARBON	220 OHM 1/5W J	1
R535	CRD20TJ221T	RES , CARBON	220 OHM 1/5W J	1
R536	CRD20TJ221T	RES , CARBON	220 OHM 1/5W J	1
R537	CRD20TJ221T	RES , CARBON	220 OHM 1/5W J	1
R538	CRD20TJ221T	RES , CARBON	220 OHM 1/5W J	1
R539	CRD20TJ221T	RES , CARBON	220 OHM 1/5W J	1
R540	CRD20TJ221T	RES , CARBON	220 OHM 1/5W J	1
R541	CRD20TJ271T	RES , CARBON	270 OHM 1/5W J	1
R542	CRD20TJ271T	RES , CARBON	270 OHM 1/5W J	1
R543	CRD20TJ271T	RES , CARBON	270 OHM 1/5W J	1
R544	CRD20TJ271T	RES , CARBON	270 OHM 1/5W J	1
R545	CRD20TJ271T	RES , CARBON	270 OHM 1/5W J	1
R556	CRD20TJ273T	RES , CARBON	27K OHM 1/5W J	1
R557	CRD20TJ273T	RES , CARBON	27K OHM 1/5W J	1
R558	CRD20TJ273T	RES , CARBON	27K OHM 1/5W J	1
R559	CRD20TJ273T	RES , CARBON	27K OHM 1/5W J	1
R560	CRD20TJ273T	RES , CARBON	27K OHM 1/5W J	1
R561	CRD20TJ162T	RES , CARBON	1.6K OHM 1/5W J	1
R562	CRD20TJ162T	RES , CARBON	1.6K OHM 1/5W J	1
R564	CRD20TJ162T	RES , CARBON	1.6K OHM 1/5W J	1
R566	CRD20TJ561T	RES , CARBON	560 OHM 1/5W J	1
R567	CRD20TJ561T	RES , CARBON	560 OHM 1/5W J	1
R568	CRD20TJ561T	RES , CARBON	560 OHM 1/5W J	1
R569	CRD20TJ561T	RES , CARBON	560 OHM 1/5W J	1
R570	CRD20TJ561T	RES , CARBON	560 OHM 1/5W J	1

Ref. Designator	Part Number	Description		Qty
MAIN/VIDEO/BIAS/DIGITAL PCB ASS'Y SECTION 2				
R571	CRD20TJ561T	RES , CARBON	560 OHM 1/5W J	1
R572	CRD20TJ561T	RES , CARBON	560 OHM 1/5W J	1
R573	CRD20TJ561T	RES , CARBON	560 OHM 1/5W J	1
R574	CRD20TJ561T	RES , CARBON	560 OHM 1/5W J	1
R575	CRD20TJ561T	RES , CARBON	560 OHM 1/5W J	1
R576	CRD20TJ100T	RES , CARBON	10 OHM 1/5W J	1
R577	CRD20TJ100T	RES , CARBON	10 OHM 1/5W J	1
R578	CRD20TJ100T	RES , CARBON	10 OHM 1/5W J	1
R579	CRD20TJ100T	RES , CARBON	10 OHM 1/5W J	1
R580	CRD20TJ100T	RES , CARBON	10 OHM 1/5W J	1
R581	CRD20TJ561T	RES , CARBON	560 OHM 1/5W J	1
R582	CRD20TJ561T	RES , CARBON	560 OHM 1/5W J	1
R583	CRD20TJ561T	RES , CARBON	560 OHM 1/5W J	1
R584	CRD20TJ561T	RES , CARBON	560 OHM 1/5W J	1
R585	CRD20TJ561T	RES , CARBON	560 OHM 1/5W J	1
R586	CRD20TJ561T	RES , CARBON	560 OHM 1/5W J	1
R587	CRD20TJ561T	RES , CARBON	560 OHM 1/5W J	1
R588	CRD20TJ561T	RES , CARBON	560 OHM 1/5W J	1
R589	CRD20TJ561T	RES , CARBON	560 OHM 1/5W J	1
R590	CRD20TJ561T	RES , CARBON	560 OHM 1/5W J	1
R591	CRD20TJ561T	RES , CARBON	560 OHM 1/5W J	1
R592	CRD20TJ561T	RES , CARBON	560 OHM 1/5W J	1
R593	CRD20TJ561T	RES , CARBON	560 OHM 1/5W J	1
R594	CRD20TJ561T	RES , CARBON	560 OHM 1/5W J	1
R595	CRD20TJ561T	RES , CARBON	560 OHM 1/5W J	1
R596	CRD20TJ561T	RES , CARBON	560 OHM 1/5W J	1
R597	CRD20TJ561T	RES , CARBON	560 OHM 1/5W J	1
R598	CRD20TJ561T	RES , CARBON	560 OHM 1/5W J	1
R599	CRD20TJ561T	RES , CARBON	560 OHM 1/5W J	1
R600	CRD20TJ561T	RES , CARBON	560 OHM 1/5W J	1
R601	CRD20TJ223T	RES , CARBON	22K OHM 1/5W J	1
R602	CRD20TJ223T	RES , CARBON	22K OHM 1/5W J	1
R603	CRD20TJ223T	RES , CARBON	22K OHM 1/5W J	1
R604	CRD20TJ223T	RES , CARBON	22K OHM 1/5W J	1
R605	CRD20TJ223T	RES , CARBON	22K OHM 1/5W J	1
R606	CRD20TJ223T	RES , CARBON	22K OHM 1/5W J	1
R607	CRD20TJ223T	RES , CARBON	22K OHM 1/5W J	1
R608	CRD20TJ223T	RES , CARBON	22K OHM 1/5W J	1
R609	CRD20TJ223T	RES , CARBON	22K OHM 1/5W J	1
R610	CRD20TJ223T	RES , CARBON	22K OHM 1/5W J	1
R611	CRD20TJ100T	RES , CARBON	10 OHM 1/5W J	1
R612	CRD20TJ100T	RES , CARBON	10 OHM 1/5W J	1
R631	KRD25FJ180T	RES , CARBON	18 OHM 1/4W	1
R632	KRD25FJ180T	RES , CARBON	18 OHM 1/4W	1
R633	KRD25FJ180T	RES , CARBON	18 OHM 1/4W	1
R634	KRD25FJ180T	RES , CARBON	18 OHM 1/4W	1
R635	KRD25FJ180T	RES , CARBON	18 OHM 1/4W	1
R636	KRD25FJ180T	RES , CARBON	18 OHM 1/4W	1
R637	KRD25FJ180T	RES , CARBON	18 OHM 1/4W	1
R638	KRD25FJ180T	RES , CARBON	18 OHM 1/4W	1
R639	KRD25FJ180T	RES , CARBON	18 OHM 1/4W	1
R640	KRD25FJ180T	RES , CARBON	18 OHM 1/4W	1
R646	KRD25FJ3R3T	RES , CARBON	3.3 OHM 1/4W	1
R647	KRD25FJ3R3T	RES , CARBON	3.3 OHM 1/4W	1
R648	KRD25FJ3R3T	RES , CARBON	3.3 OHM 1/4W	1
R649	KRD25FJ3R3T	RES , CARBON	3.3 OHM 1/4W	1
R650	KRD25FJ3R3T	RES , CARBON	3.3 OHM 1/4W	1

Ref. Designator	Part Number	Description		Qty
MAIN/VIDEO/BIAS/DIGITAL PCB ASS'Y SECTION 2				
R651	KRD25FJ3R3T	RES , CARBON	3.3 OHM 1/4W	1
R652	KRD25FJ3R3T	RES , CARBON	3.3 OHM 1/4W	1
R653	KRD25FJ3R3T	RES , CARBON	3.3 OHM 1/4W	1
R654	KRD25FJ3R3T	RES , CARBON	3.3 OHM 1/4W	1
R655	KRD25FJ3R3T	RES , CARBON	3.3 OHM 1/4W	1
R666	CRD25TJ470T	RES , CARBON	47 OHM 1/4W	1
R667	CRD25TJ470T	RES , CARBON	47 OHM 1/4W	1
R668	CRD25TJ470T	RES , CARBON	47 OHM 1/4W	1
R669	CRD25TJ470T	RES , CARBON	47 OHM 1/4W	1
R670	CRD25TJ470T	RES , CARBON	47 OHM 1/4W	1
R671	CRD20TJ911T	RES , CARBON	910 OHM 1/5W J	1
R672	CRD20TJ911T	RES , CARBON	910 OHM 1/5W J	1
R673	CRD20TJ911T	RES , CARBON	910 OHM 1/5W J	1
R674	CRD20TJ911T	RES , CARBON	910 OHM 1/5W J	1
R675	CRD20TJ911T	RES , CARBON	910 OHM 1/5W J	1
R676	CRD20TJ182T	RES , CARBON	1.8K OHM 1/5W J	1
R677	CRD20TJ182T	RES , CARBON	1.8K OHM 1/5W J	1
R678	CRD20TJ182T	RES , CARBON	1.8K OHM 1/5W J	1
R679	CRD20TJ182T	RES , CARBON	1.8K OHM 1/5W J	1
R680	CRD20TJ182T	RES , CARBON	1.8K OHM 1/5W J	1
R681	CRD20TJ562T	RES , CARBON	5.6K OHM 1/5W J	1
R682	CRD20TJ562T	RES , CARBON	5.6K OHM 1/5W J	1
R683	CRD20TJ562T	RES , CARBON	5.6K OHM 1/5W J	1
R684	CRD20TJ562T	RES , CARBON	5.6K OHM 1/5W J	1
R685	CRD20TJ562T	RES , CARBON	5.6K OHM 1/5W J	1
R686	CRD20TJ103T	RES , CARBON	10K OHM 1/5W J	1
R687	CRD20TJ103T	RES , CARBON	10K OHM 1/5W J	1
R688	CRD20TJ103T	RES , CARBON	10K OHM 1/5W J	1
R689	CRD20TJ103T	RES , CARBON	10K OHM 1/5W J	1
R690	CRD20TJ103T	RES , CARBON	10K OHM 1/5W J	1
R696	CRD25TJ470T	RES , CARBON	47 OHM 1/4W	1
R697	CRD25TJ470T	RES , CARBON	47 OHM 1/4W	1
R698	CRD25TJ470T	RES , CARBON	47 OHM 1/4W	1
R699	CRD25TJ470T	RES , CARBON	47 OHM 1/4W	1
R700	CRD25TJ470T	RES , CARBON	47 OHM 1/4W	1
R701	CRD20TJ821T	RES , CARBON	820 OHM 1/5W J	1
R702	CRD20TJ821T	RES , CARBON	820 OHM 1/5W J	1
R703	CRD20TJ821T	RES , CARBON	820 OHM 1/5W J	1
R704	CRD20TJ821T	RES , CARBON	820 OHM 1/5W J	1
R705	CRD20TJ821T	RES , CARBON	820 OHM 1/5W J	1
R706	CRD20TJ821T	RES , CARBON	820 OHM 1/5W J	1
R707	CRD20TJ821T	RES , CARBON	820 OHM 1/5W J	1
R708	CRD20TJ821T	RES , CARBON	820 OHM 1/5W J	1
R711	CRD20TJ472T	RES , CARBON	4.7K OHM 1/5W J	1
R712	CRD20TJ472T	RES , CARBON	4.7K OHM 1/5W J	1
R713	CRD20TJ472T	RES , CARBON	4.7K OHM 1/5W J	1
R714	CRD20TJ472T	RES , CARBON	4.7K OHM 1/5W J	1
R715	CRD20TJ472T	RES , CARBON	4.7K OHM 1/5W J	1
R716	CRD20TJ472T	RES , CARBON	4.7K OHM 1/5W J	1
R717	CRD20TJ472T	RES , CARBON	4.7K OHM 1/5W J	1
R718	CRD20TJ472T	RES , CARBON	4.7K OHM 1/5W J	1
R721	CRD20TJ104T	RES , CARBON	100K OHM 1/5W J	1
R722	CRD20TJ104T	RES , CARBON	100K OHM 1/5W J	1
R723	CRD20TJ104T	RES , CARBON	100K OHM 1/5W J	1
R724	CRD20TJ104T	RES , CARBON	100K OHM 1/5W J	1
R725	CRD20TJ104T	RES , CARBON	100K OHM 1/5W J	1
R726	CRD20TJ104T	RES , CARBON	100K OHM 1/5W J	1

Ref. Designator	Part Number	Description		Qty
MAIN/VIDEO/BIAS/DIGITAL PCB ASS'Y SECTION 2				
R727	CRD20TJ104T	RES , CARBON	100K OHM 1/5W J	1
R728	CRD20TJ104T	RES , CARBON	100K OHM 1/5W J	1
R771	CRD20TJ750T	RES , CARBON	75 OHM 1/5W J	1
R772	CRD20TJ750T	RES , CARBON	75 OHM 1/5W J	1
R773	CRD20TJ750T	RES , CARBON	75 OHM 1/5W J	1
R774	CRD20TJ750T	RES , CARBON	75 OHM 1/5W J	1
R775	CRD20TJ750T	RES , CARBON	75 OHM 1/5W J	1
R776	CRD20TJ750T	RES , CARBON	75 OHM 1/5W J	1
R777	CRD20TJ750T	RES , CARBON	75 OHM 1/5W J	1
R781	CRD20TJ750T	RES , CARBON	75 OHM 1/5W J	1
R782	CRD20TJ750T	RES , CARBON	75 OHM 1/5W J	1
R783	CRD20TJ750T	RES , CARBON	75 OHM 1/5W J	1
R784	CRD20TJ750T	RES , CARBON	75 OHM 1/5W J	1
R785	CRD20TJ750T	RES , CARBON	75 OHM 1/5W J	1
R786	CRD20TJ750T	RES , CARBON	75 OHM 1/5W J	1
R787	CRD20TJ750T	RES , CARBON	75 OHM 1/5W J	1
R801	CRD20TJ103T	RES , CARBON	10K OHM 1/5W J	1
R802	CRD20TJ103T	RES , CARBON	10K OHM 1/5W J	1
R803	CRD20TJ562T	RES , CARBON	5.6K OHM 1/5W J	1
R804	CRD20TJ562T	RES , CARBON	5.6K OHM 1/5W J	1
R805	CRD20TJ911T	RES , CARBON	910 OHM 1/5W J	1
R807	CRD20TJ911T	RES , CARBON	910 OHM 1/5W J	1
R808	CRD20TJ182T	RES , CARBON	1.8K OHM 1/5W J	1
R809	CRD20TJ182T	RES , CARBON	1.8K OHM 1/5W J	1
R812	CRD25TJ470T	RES , CARBON	47 OHM 1/4W	1
R813	CRD25TJ470T	RES , CARBON	47 OHM 1/4W	1
R814	CRD25TJ470T	RES , CARBON	47 OHM 1/4W	1
R815	CRD25TJ470T	RES , CARBON	47 OHM 1/4W	1
R817	KRD25FJ3R3T	RES , CARBON	3.3 OHM 1/4W	1
R818	KRD25FJ3R3T	RES , CARBON	3.3 OHM 1/4W	1
R819	KRD25FJ3R3T	RES , CARBON	3.3 OHM 1/4W	1
R820	KRD25FJ3R3T	RES , CARBON	3.3 OHM 1/4W	1
R821	KRD25FJ180T	RES , CARBON	18 OHM 1/4W	1
R822	KRD25FJ180T	RES , CARBON	18 OHM 1/4W	1
R823	KRD25FJ180T	RES , CARBON	18 OHM 1/4W	1
R824	KRD25FJ180T	RES , CARBON	18 OHM 1/4W	1
R830	CRD20TJ223T	RES , CARBON	22K OHM 1/5W J	1
R831	CRD20TJ223T	RES , CARBON	22K OHM 1/5W J	1
R832	CRD20TJ223T	RES , CARBON	22K OHM 1/5W J	1
R833	CRD20TJ223T	RES , CARBON	22K OHM 1/5W J	1
R834	CRD20TJ561T	RES , CARBON	560 OHM 1/5W J	1
R835	CRD20TJ561T	RES , CARBON	560 OHM 1/5W J	1
R836	CRD20TJ561T	RES , CARBON	560 OHM 1/5W J	1
R837	CRD20TJ561T	RES , CARBON	560 OHM 1/5W J	1
R838	CRD20TJ561T	RES , CARBON	560 OHM 1/5W J	1
R839	CRD20TJ561T	RES , CARBON	560 OHM 1/5W J	1
R840	CRD20TJ561T	RES , CARBON	560 OHM 1/5W J	1
R841	CRD20TJ561T	RES , CARBON	560 OHM 1/5W J	1
R842	CRD20TJ561T	RES , CARBON	560 OHM 1/5W J	1
R843	CRD20TJ561T	RES , CARBON	560 OHM 1/5W J	1
R844	CRD20TJ561T	RES , CARBON	560 OHM 1/5W J	1
R845	CRD20TJ561T	RES , CARBON	560 OHM 1/5W J	1
R848	CRD20TJ273T	RES , CARBON	27K OHM 1/5W J	1
R849	CRD20TJ273T	RES , CARBON	27K OHM 1/5W J	1
R850	CRD20TJ162T	RES , CARBON	1.6K OHM 1/5W J	1
R851	CRD20TJ162T	RES , CARBON	1.6K OHM 1/5W J	1
R852	CRD20TJ152T	RES , CARBON	1.5K OHM 1/5W J	1

Ref. Designator	Part Number	Description		Qty
MAIN/VIDEO/BIAS/DIGITAL PCB ASS'Y SECTION 2				
R853	CRD20TJ152T	RES , CARBON	1.5K OHM 1/5W J	1
R854	CRD20TJ152T	RES , CARBON	1.5K OHM 1/5W J	1
R855	CRD20TJ152T	RES , CARBON	1.5K OHM 1/5W J	1
R856	CRD20TJ221T	RES , CARBON	220 OHM 1/5W J	1
R857	CRD20TJ221T	RES , CARBON	220 OHM 1/5W J	1
R858	CRD20TJ221T	RES , CARBON	220 OHM 1/5W J	1
R859	CRD20TJ221T	RES , CARBON	220 OHM 1/5W J	1
R860	CRD20TJ271T	RES , CARBON	270 OHM 1/5W J	1
R861	CRD20TJ271T	RES , CARBON	270 OHM 1/5W J	1
R862	CRD20TJ333T	RES , CARBON	33K OHM 1/5W J	1
R863	CRD20TJ333T	RES , CARBON	33K OHM 1/5W J	1
R864	CRD20TJ331T	RES , CARBON	330 OHM 1/5W J	1
R865	CRD20TJ331T	RES , CARBON	330 OHM 1/5W J	1
R866	CRD20TJ472T	RES , CARBON	4.7K OHM 1/5W J	1
R867	CRD25TJ472T	RES , CARBON	4.7K OHM 1/4W J	1
R868	CRD20TJ473T	RES , CARBON	47K OHM 1/5W J	1
R869	CRD20TJ473T	RES , CARBON	47K OHM 1/5W J	1
R870	CRD20TJ433T	RES , CARBON	43K OHM 1/5W J	1
R871	CRD20TJ433T	RES , CARBON	43K OHM 1/5W J	1
R872	CRD20TJ471T	RES , CARBON	470 OHM 1/5W J	1
R873	CRD20TJ471T	RES , CARBON	470 OHM 1/5W J	1
R900	CRD20TJ103T	RES , CARBON	10K OHM 1/5W J	1
R901	CRD25TJ393T	RES , CARBON	39K OHM 1/4W J	1
R902	CRD25TJ393T	RES , CARBON	39K OHM 1/4W J	1
R903	CRD25TJ393T	RES , CARBON	39K OHM 1/4W J	1
R906	CRD25TJ393T	RES , CARBON	39K OHM 1/4W J	1
R910	CRD20TJ105T	RES , CARBON	1M OHM 1/5W J	1
R911	CRD25TJ680T	RES , CARBON	68 OHM 1/4W J	1
R917	CRD25TJ393T	RES , CARBON	39K OHM 1/4W J	1
R918	CRD25TJ393T	RES , CARBON	39K OHM 1/4W J	1
R919	CRD25TJ393T	RES , CARBON	39K OHM 1/4W J	1
R920	CRD25TJ393T	RES , CARBON	39K OHM 1/4W J	1
R921	KRD25FJ180T	RES , CARBON	18 OHM 1/4W	1
R922	CRD25TJ470T	RES , CARBON	47 OHM 1/4W J	1
R924	CRD20TJ473T	RES , CARBON	47K OHM 1/5W J	1
R925	CRD20TJ473T	RES , CARBON	47K OHM 1/5W J	1
R926	CRD20TJ473T	RES , CARBON	47K OHM 1/5W J	1
R927	CRD20TJ473T	RES , CARBON	47K OHM 1/5W J	1
R928	CRD20TJ222T	RES , CARBON	2.2K OHM 1/5W J	1
R929	CRD20TJ222T	RES , CARBON	2.2K OHM 1/5W J	1
R930	CRD20TJ222T	RES , CARBON	2.2K OHM 1/5W J	1
R931	CRD20TJ222T	RES , CARBON	2.2K OHM 1/5W J	1
R932	CRD20TJ103T	RES , CARBON	10K OHM 1/5W J	1
R933	CRD20TJ472T	RES , CARBON	4.7K OHM 1/5W J	1
R934	CRD20TJ104T	RES , CARBON	100K OHM 1/5W J	1
R935	CRD20TJ154T	RES , CARBON	150K OHM 1/5W J	1
R936	CRD20TJ184T	RES , CARBON	180K OHM 1/5W J	1
R939	CRD20TJ472T	RES , CARBON	4.7K OHM 1/5W J	1
R940	CRD20TJ152T	RES , CARBON	1.5K OHM 1/5W J	1
R941	CRD20TJ223T	RES , CARBON	22K OHM 1/5W J	1
R942	CRD20TJ223T	RES , CARBON	22K OHM 1/5W J	1
R943	CRD20TJ223T	RES , CARBON	22K OHM 1/5W J	1
R944	CRD25TJ223T	RES , CARBON	22K OHM 1/4W J	1
R945	CRD20TJ223T	RES , CARBON	22K OHM 1/5W J	1
R946	CRD25TJ223T	RES , CARBON	22K OHM 1/4W J	1
R947	CRD20TJ223T	RES , CARBON	22K OHM 1/5W J	1
R952	CRD20TJ223T	RES , CARBON	22K OHM 1/5W J	1

Ref. Designator	Part Number	Description		Qty
MAIN/VIDEO/BIAS/DIGITAL PCB ASS'Y SECTION 2				
R953	CRD20TJ223T	RES , CARBON	22K OHM 1/5W J	1
R954	CRD20TJ223T	RES , CARBON	22K OHM 1/5W J	1
R955	CRD20TJ203T	RES , CARBON	20K OHM 1/5W J	1
R956	CRD20TJ394T	RES , CARBON	390K OHM 1/5W J	1
R957	CRD20TJ153T	RES , CARBON	15K OHM 1/5W J	1
R958	CRD20TJ563T	RES , CARBON	56K OHM 1/5W J	1
R959	CRD20TJ223T	RES , CARBON	22K OHM 1/5W J	1
R960	CRD20TJ222T	RES , CARBON	2.2K OHM 1/5W J	1
R961	CRD20TJ331T	RES , CARBON	330 OHM 1/5W J	1
R962	CRD20TJ273T	RES , CARBON	27K OHM 1/5W J	1
R963	CRD20TJ105T	RES , CARBON	1M OHM 1/5W J	1
R966	CRD20TJ472T	RES , CARBON	4.7K OHM 1/5W J	1
R969	CRD20TJ472T	RES , CARBON	4.7K OHM 1/5W J	1
R970	CRD20TJ472T	RES , CARBON	4.7K OHM 1/5W J	1
R971	CRD20TJ472T	RES , CARBON	4.7K OHM 1/5W J	1
R972	CRD20TJ472T	RES , CARBON	4.7K OHM 1/5W J	1
R973	CRD20TJ472T	RES , CARBON	4.7K OHM 1/5W J	1
R974	CRD20TJ331T	RES , CARBON	330 OHM 1/5W J	1
R975	CRD20TJ331T	RES , CARBON	330 OHM 1/5W J	1
R976	CRD20TJ331T	RES , CARBON	330 OHM 1/5W J	1
R977	CRD20TJ331T	RES , CARBON	330 OHM 1/5W J	1
R978	CRD20TJ331T	RES , CARBON	330 OHM 1/5W J	1
R979	CRD20TJ473T	RES , CARBON	47K OHM 1/5W J	1
R980	CRD20TJ473T	RES , CARBON	47K OHM 1/5W J	1
R981	CRD20TJ473T	RES , CARBON	47K OHM 1/5W J	1
R982	CRD20TJ473T	RES , CARBON	47K OHM 1/5W J	1
R983	CRD20TJ473T	RES , CARBON	47K OHM 1/5W J	1
R986	CRD20TJ102T	RES , CARBON	1K OHM 1/5W J	1
R987	CRD20TJ561T	RES , CARBON	560 OHM 1/5W J	1
R988	CRD20TJ562T	RES , CARBON	5.6K OHM 1/5W J	1
R989	CRD20TJ1R0T	RES , CARBON	1 OHM 1/5W J	1
R991	CRD20TJ822T	RES , CARBON	8.2K OHM 1/5W J	1
R992	CRD20TJ562T	RES , CARBON	5.6K OHM 1/5W J	1
R998	CRD20TJ103T	RES , CARBON	10K OHM 1/5W J	1
R563	CRD20TJ162T	RES , CARBON	1.6K OHM 1/5W J	1
R565	CRD20TJ162T	RES , CARBON	1.6K OHM 1/5W J	1
R656	CRF5EKR27HX2K	RES , CEMENT	0.27ohm X 2	1
R657	CRF5EKR27HX2K	RES , CEMENT	0.27ohm X 2	1
R658	CRF5EKR27HX2K	RES , CEMENT	0.27ohm X 2	1
R659	CRF5EKR27HX2K	RES , CEMENT	0.27ohm X 2	1
R660	CRF5EKR27HX2K	RES , CEMENT	0.27ohm X 2	1
R810	CRF5EKR27HX2K	RES , CEMENT	0.27ohm X 2	1
R811	CRF5EKR27HX2K	RES , CEMENT	0.27ohm X 2	1
R904	HRDERC12UGK335T	RES , CARBON JP	3.3M OHM	1
R905	CRG1ANJ100H	RES , METAL OXIDE FILM	10 OHM	1
R923	CRD25TJ220T	RES , CARBON	22 OHM 1/4W J	1
R990	CRG1ANJ100H	RES , METAL OXIDE FILM	10 OHM	1
R993	CRG1ANJ100H	RES , METAL OXIDE FILM	10 OHM	1
R994	CRG1ANJ100H	RES , METAL OXIDE FILM	10 OHM	1
R995	CRG1ANJ100H	RES , METAL OXIDE FILM	10 OHM	1
R996	CRG1ANJ100H	RES , METAL OXIDE FILM	10 OHM	1
R997	CRG1ANJ100H	RES , METAL OXIDE FILM	10 OHM	1
R999	CRG1ANJ100H	RES , METAL OXIDE FILM	10 OHM	1
<i>Miscellaneous</i>				
	CMYAVR235	HEAT SINK ASS'Y	ASS'Y	1

Ref. Designator	Part Number	Description		Qty
MAIN/VIDEO/BIAS/DIGITAL PCB ASS'Y SECTION 2				
	CHD1A012	SCREW , TR	SCREW	21
	CHD1A036FZ	SCREW , SPECIAL	SCREW	4
	CHD3A012	SCREW , TR	SCREW	3
	CMD1A398	BRACKET , PCB	BRACKET	2
	CMD1A417	BRACKET , PCB	BRACKET	2
	CMD1A488	BRACKET , FAN	BRACKET	1
	CMY1A249	HEAT SINK	HEAT SINK	2
	CMY2A205	HEAT SINK,SUB	HEAT SINK	1
	CTB3+10J	SCREW	SCREW	6
	CTB3+8J	SCREW	SCREW	9
	HDMKD1206PTS3	MOTOR , FAN(60X60X25MM)	FAN	1
	CTW3+8J	SCREW	SCREW	3
BN19	CWB3FE03250UP	WIRE ASS'Y	WIRE	1
BN20	CWB3FB43280UP	WIRE ASS'Y	WIRE	1
BN79	CWZAVR230BN79	WIRE ASS'Y (SHIELD)	WIRE	1
BN81	CWB1C902050EN	WIRE ASS'Y	WIRE	1
BN82	CWB1C902050EN	WIRE ASS'Y	WIRE	1
BN83	CWB1C902050EN	WIRE ASS'Y	WIRE	1
BN84	CWB1C902050EN	WIRE ASS'Y	WIRE	1
BN85	CWB1C902050EN	WIRE ASS'Y	WIRE	1
BN86	CWB1C902050EN	WIRE ASS'Y	WIRE	1
BN87	CWB1C902050EN	WIRE ASS'Y	WIRE	1
BN88	CWB2B904070EN	WIRE ASS'Y	WIRE	1
BN98	BJP08GA130ZK	WAFER	WAFER	1
BN98	HJP08GA130ZK	WAFER	WAFER	1
CN61	KJP02GA01ZM	WAFER	WAFER	1
CN62	KJP02GA01ZM	WAFER	WAFER	1
CN63	KJP02GA01ZM	WAFER	WAFER	1
CN64	KJP02GA01ZM	WAFER	WAFER	1
CN65	KJP02GA01ZM	WAFER	WAFER	1
CN66	KJP02GA01ZM	WAFER	WAFER	1
CN67	KJP02GA01ZM	WAFER	WAFER	1
CN80	KJP11GA19ZM	WAFER	WAFER	1
CN89	KJP02GA01ZM	WAFER	WAFER	1
CN91	KJP03GA89ZM	WAFER	WAFER	1
CN94	KJP13GA98ZM	WAFER	WAFER	1
CN95	KJP08GA98ZM	WAFER	WAFER	1
ET01	CMD1A387	BRACKET , PCB	BRACKET	3
ET01	CNE75	PLATE , EARTH	PLATE	1
ET02	CMD1A387	BRACKET , PCB	BRACKET	3
ET03	CNE75	PLATE , EARTH	PLATE	1
JK91	CJJ5R006Z	TERMINAL , SPEAKER	SPEAKER TERMINAL	1
JK92	CJJ5Q012Z	TERMINAL , SPEAKER	SPEAKER TERMINAL	1
JK97	CJJ4P041W	JACK IN/OUT	JACK	1
JK98	CJJ4P042W	JACK IN/OUT	JACK	1
JW90	CWEE212120VV	WIRE ASS'Y	WIRE	1
JW91	CWE8212180VV	WIRE ASS'Y	WIRE	1
JW99	CWE8202150AA	WIRE ASS'Y	WIRE	1
L501	CLEY0R5KAK	COIL , SPEAKER	0.5UH K	1
L502	CLEY0R5KAK	COIL , SPEAKER	0.5UH K	1
L503	CLEY0R5KAK	COIL , SPEAKER	0.5UH K	1
L504	CLEY0R5KAK	COIL , SPEAKER	0.5UH K	1
L505	CLEY0R5KAK	COIL , SPEAKER	0.5UH K	1
L506	CLEY0R5KAK	COIL , SPEAKER	0.5UH K	1
L507	CLEY0R5KAK	COIL , SPEAKER	0.5UH K	1
RY94	HSL1A008ZE	RELAY	SDT-S-112DMR	1
TH91	KRTP42T7D330B	THERMAL SENSOR , POSISTOR	POSISTOR	1

AVR240

harman/kardon

Ref. Designator	Part Number	Description		Qty
MAIN/VIDEO/BIAS/DIGITAL PCB ASS'Y SECTION 2				
T902	CLT5J033ZU	TRANS , SUB	SUB TRANS	1
	CTB3+10GFZ	SCREW	SCREW	33
	CTB3+6J	SCREW	SCREW	13
	CTB3+8J	SCREW	SCREW	9
	CTB3+8JFZ	SCREW	SCREW	3
	CTW3+12J	SCREW	SCREW	3
	CTW3+8J	SCREW	SCREW	7
	CUA1A229	CHASSIS , BOTTOM	BOTTOM CHASSIS	1
	KHE36-3	CLAMPER , WIRE	CLAMPER	2
	KHG1A050	RUBBER , CUSHION	RUBBER	4
	KHG1A308	CUSHION, TRANS	CUSHION	1
	KHR1A028	BUSHING , AC CORD	BUSHING	1
	KHR301	CLAMPER	CLAMPER	13
CB13	CWC1C4A13B080B	CABLE , CARD	CARD CABLE	1
CB15	CWC1C4A13B100B	CABLE , CARD	CARD CABLE	1
F903	KBA2C8000TLUZ	FUSE	8A 250V	1
F904	KBA2C8000TLUZ	FUSE	8A 250V	1
F905	KBA2C6300TLUZ	FUSE	6.3A 250V	1
F906	KBA2C6300TLUZ	FUSE	6.3A 250V	1
F907	KBA2C6300TLUZ	FUSE	6.3A 250V	1
T901	CLT5W011ZU	TRANS , POWER	MAIN TRANS	1
MISCELLANEOUS/CHASSIS				
	CGL1A222	INDICATOR , VOLUME	INDICATOR	1
	CGUAVR240	WINDOW ASS'Y	ASS'Y	1
	CGU1A366X	WINDOW , FIP	FIP	1
	KGB1A156Z	BADGE , AVR240	BADGE	1
	CGU1A318Z	ORNAMENT , VOLUME	ORNAMENT	1
	CBC1A147MBZG27	KNOB , MOMS	KNOB	1
	CBT1A819K128	KNOB , DELAY	KNOB	1
	CBT1A903MMYG27	KNOB , POWER	KNOB	1
	CBT1A904MBZG27	KNOB , SET	KNOB	1
	CBT1A905MBZG27	KNOB , FUNCTION	KNOB	1
	CGL1A221	INDICATOR , POWER	INDICATOR	1
	CGW1A408YA	PANEL , FRONT	FRONT PANEL	1
	CGW1A408RDYH43	PANEL , FRONT	PANEL	1
	KGB1A158Z	BADGE , HARMAN/KARDON(FRONT)	BADGE	1
	CHG1A309	RUBBER	RUBBER	1
	CMC1A200	PLATE , SHIELD	PLATE	1
	CMC1A261	PLATE , EAETH	PLATE	1
	CMD1A555	BRACKET , SIDE (L)	BRACKET	1
	CMD2A443	BRACKET , SIDE	BRACKET	1
	CMH1A215	HOLDER , LED	HOLDER	1
	CMK1A010	BRACKET , PCB	BRACKET	1
	CMX1A148	INSULATOR , FUNCTION	INSULATOR	2
	CMX1A149	INSULATOR , SET	INSULATOR	2
	CMX1A170	INSULATOR , POWER	INSULATOR	1
	CMX1A173	INSULATOR , FUNCTION(L)	INSULATOR	2
	CMZ1A088	FILTER , FIP	FILTER	1
	CHD1A012Z	SCREW , SPECIAL	SCREW	2
	CHD1A023	SCREW , TRANS	SCREW	4
	CHD4A012	SCREW , TR	SCREW	5
	CHE170	HOLDER , PCB	HOLDER	2
	CHG1A104	CUSHION , EVA	CUSHION	1
	CHG1A157	CUSHION , RUBBER	CUSHION	1
	CHG1A160	RUBBER	RUBBER	1

AVR240

harman/kardon

Ref. Designator	Part Number	Description		Qty
MISCELLANEOUS/CHASSIS				
	CJA523FBYA	CORD , POWER	POWER CORD	1
	CKF16A254Z	PANEL , REAR	REAR PANEL	1
	CKL2A069H43	FOOT	FOOT	4
	CLZ9W003Z	FERRITE , RING	RING CORE	1
	CMD1A487	BRACKET , TRANS	BRACKET	1
	CNVM9011MS071L	MODULE , TUNER	TUNER	1

CAM350 PRO V 7.6 : Mon Sep 01 10:29:56 2003 - (Untitled)

MAIN BOARD 1 (AMP)

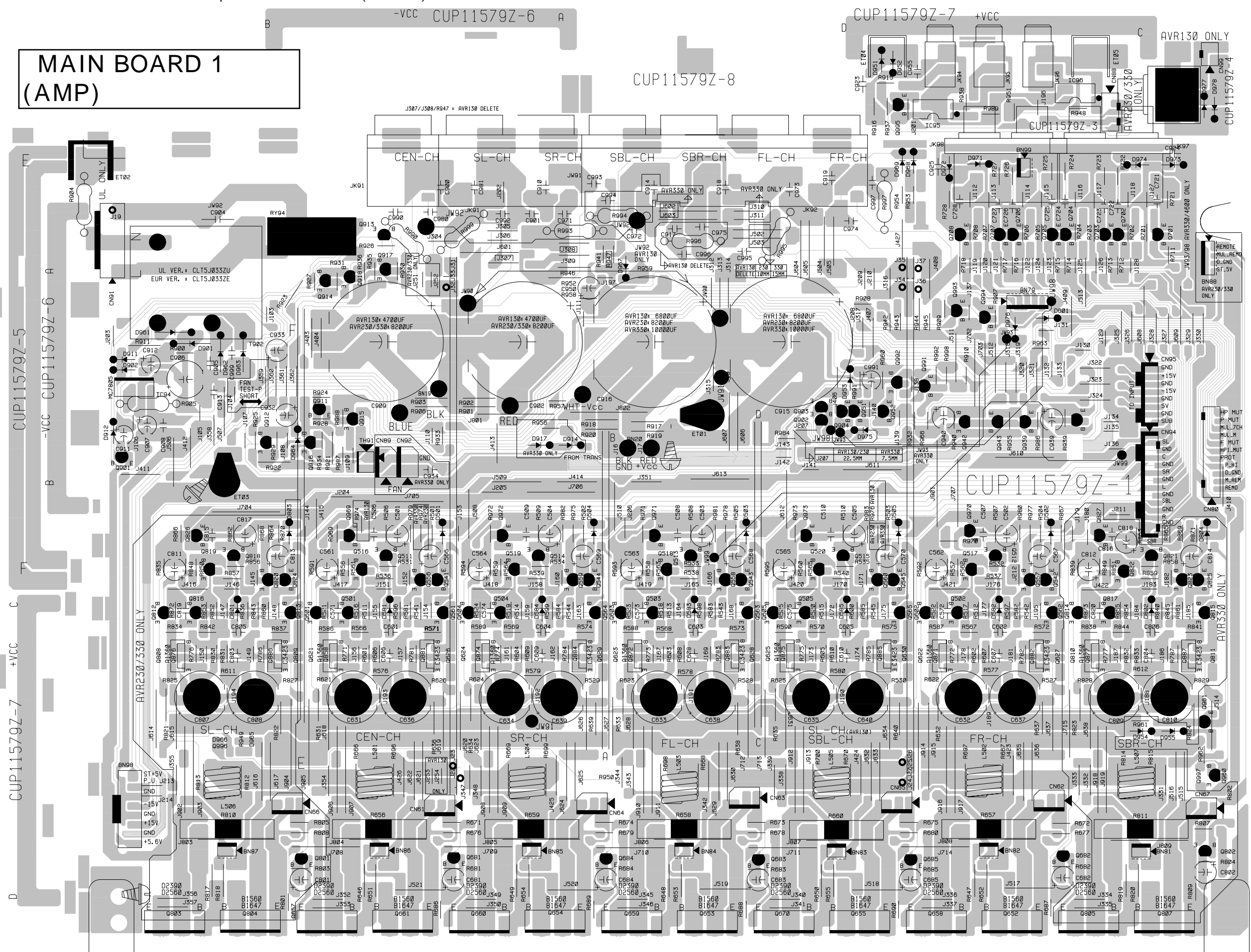

AVR240

harman/kardon

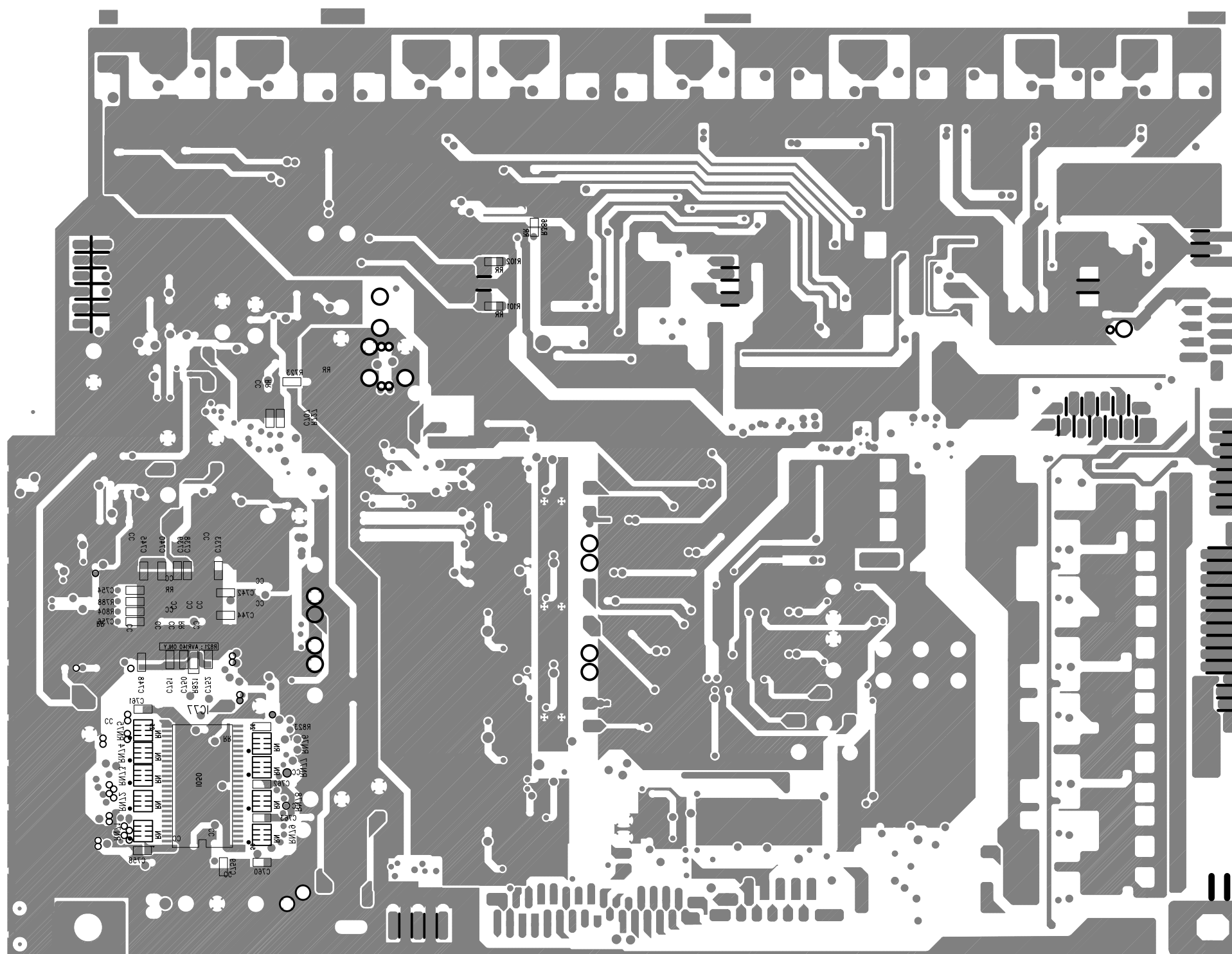

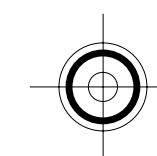
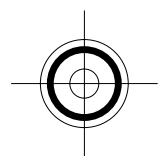
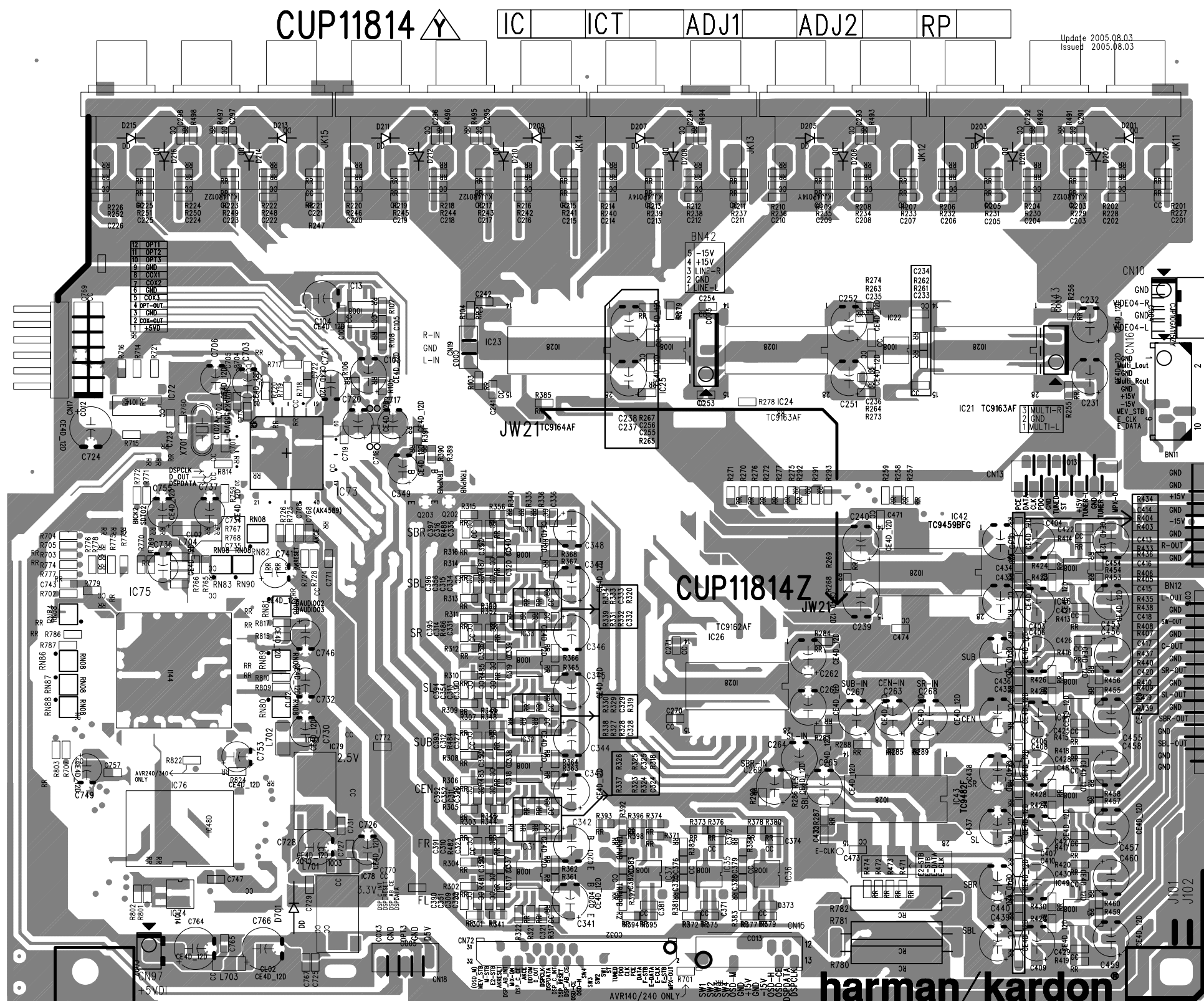
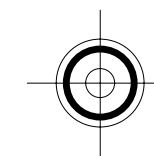
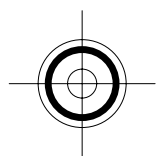

AVR240

harman/kardon

Modify : 2005.08.04

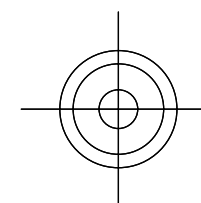
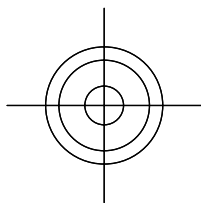

DIPPING

IC	ICT	ADJ1	ADJ2	RP

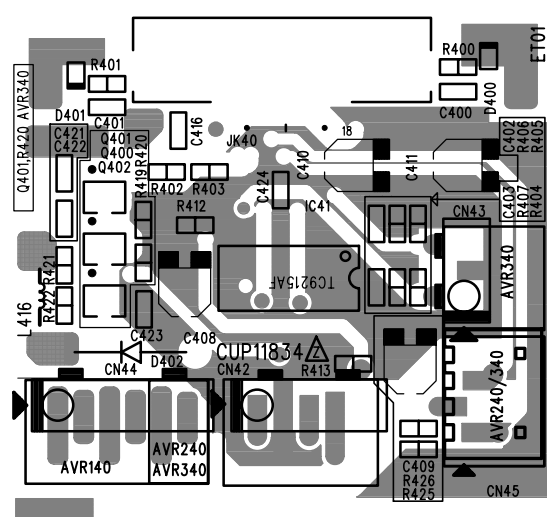

CUP11834

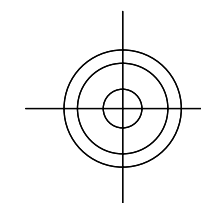
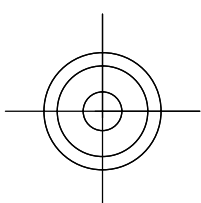

harman/kardon

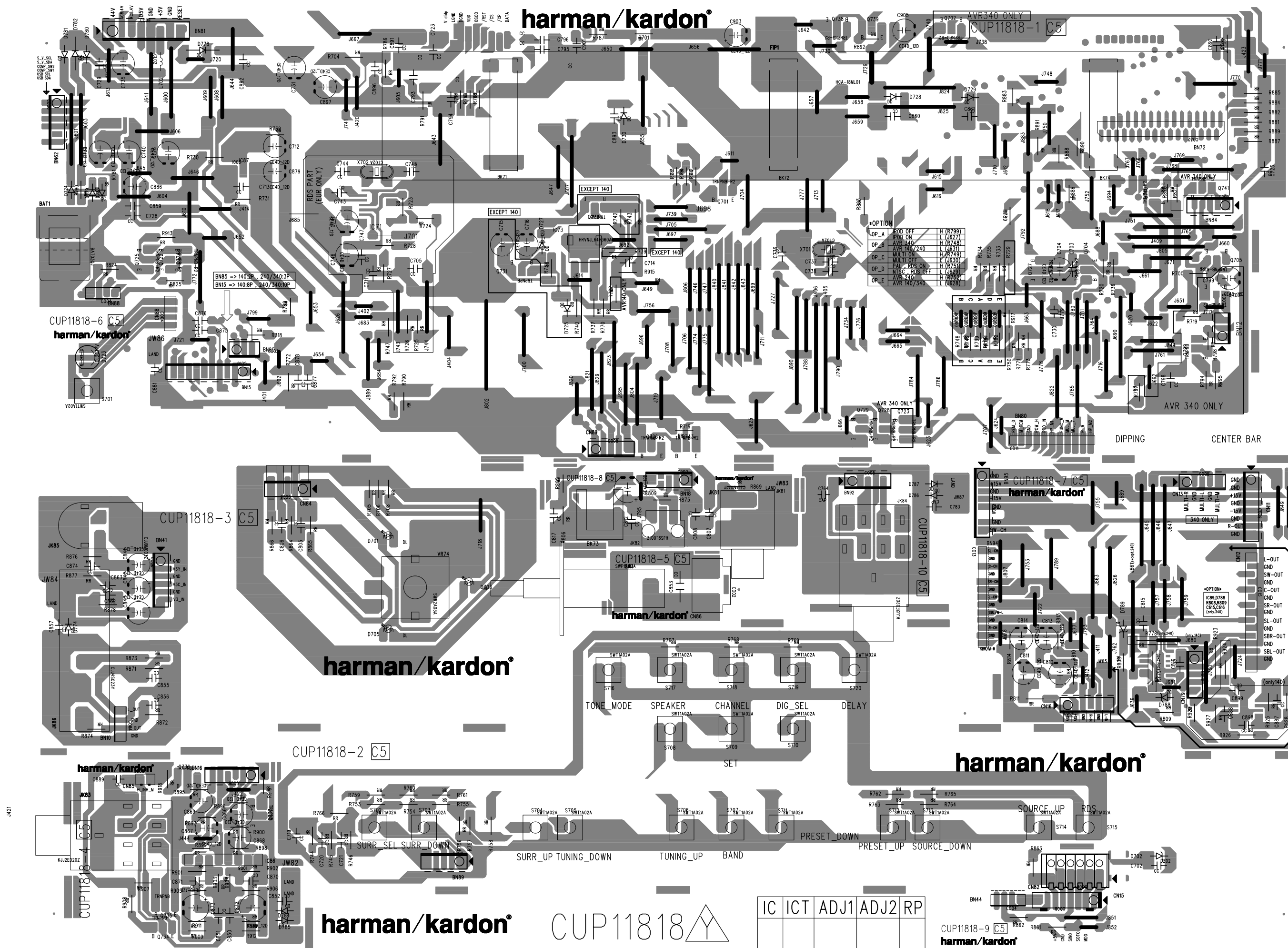

CUP11849

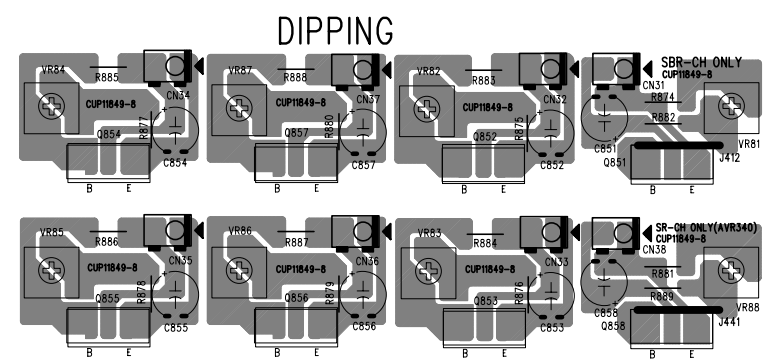

CUP11849

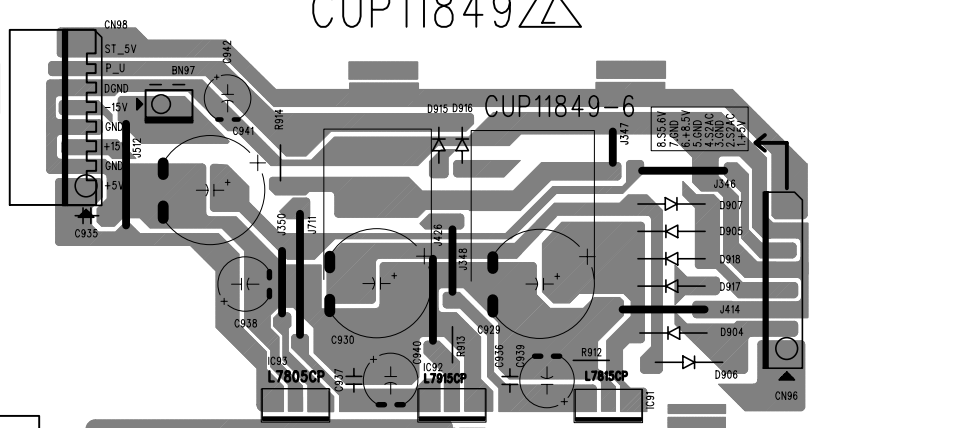

DIPPING

CUP11849

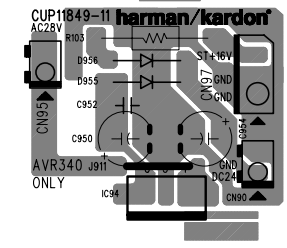

IC ICTADJ1ADJ2RP

CUP11849

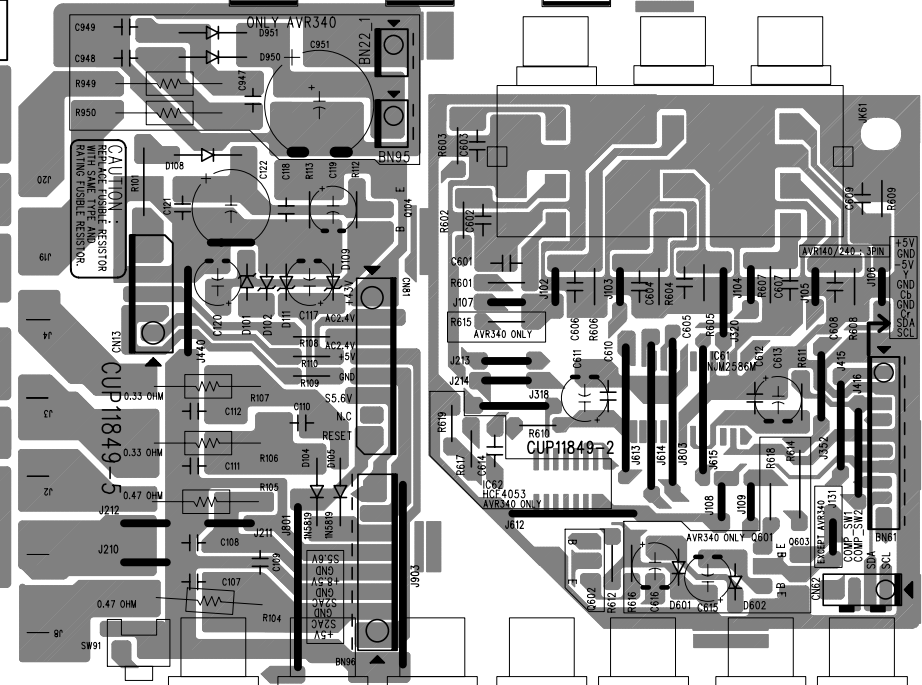
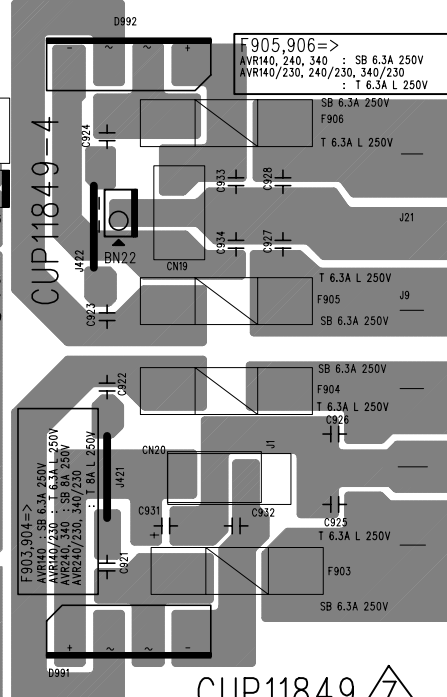
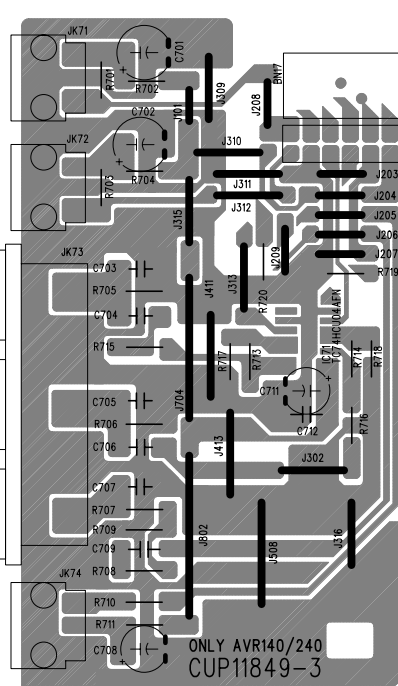

CUP11849

IC ICTADJ1ADJ2RP

harman/kardon CUP11849-9

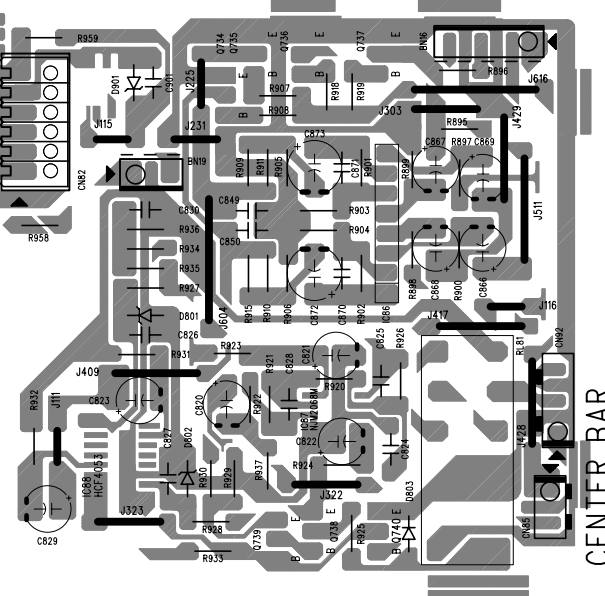

CENTER BAR

CAUTION: FOR CONTINUED PROTECTION PERMANENTE CONTRE LES RISQUES D'INCENDIE, RISQUES D'INCENDIE, RISQUES D'INCENDIE, REMPLACER LES FUSIBLES DE MEME TYPE ET MEME VALEUR.

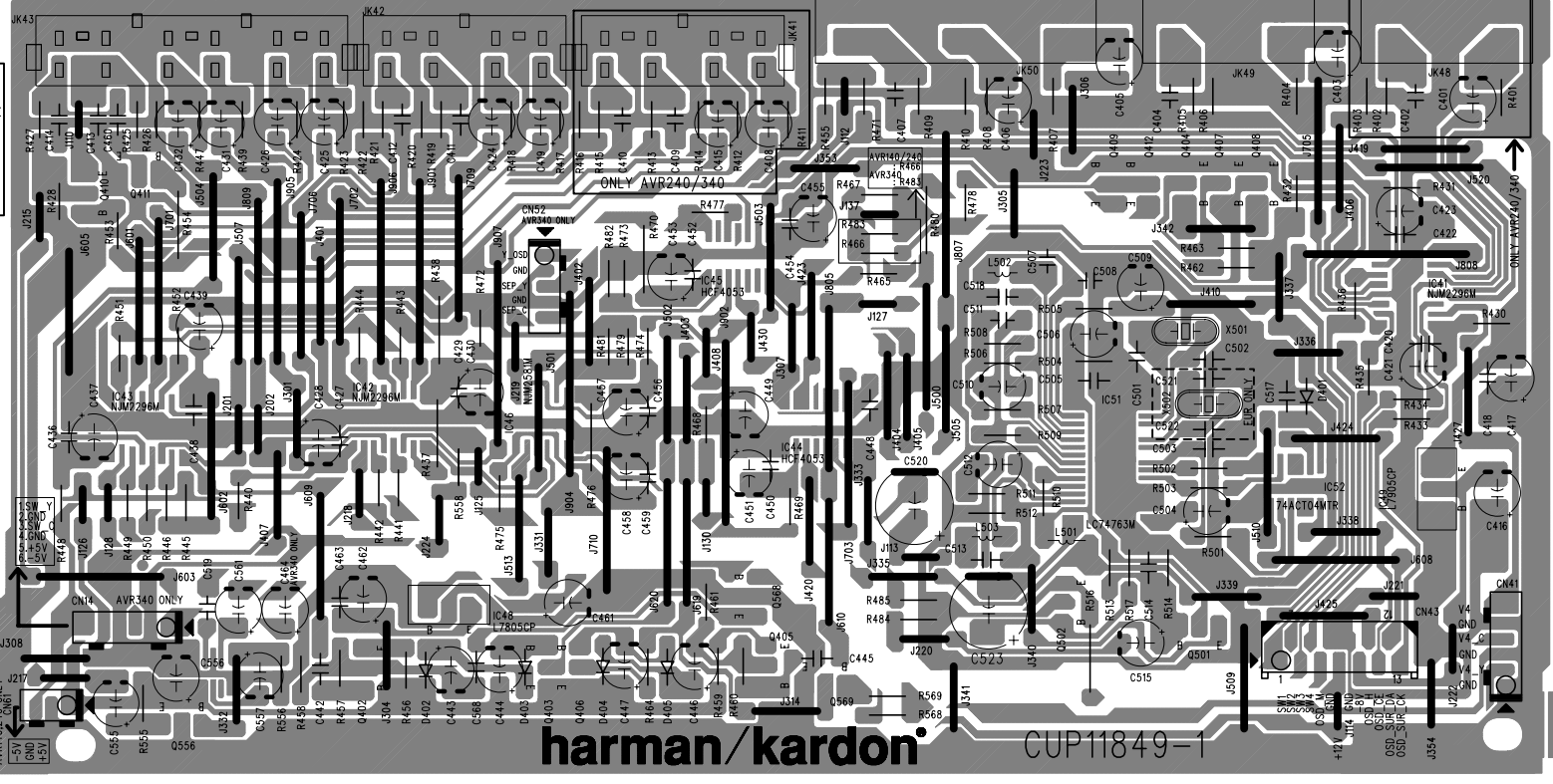
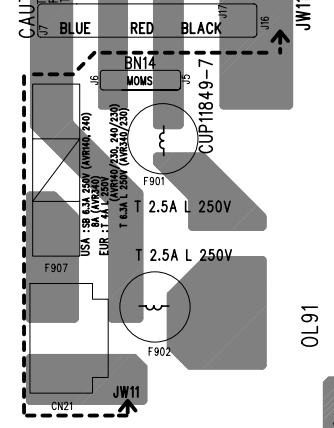

DIPPING

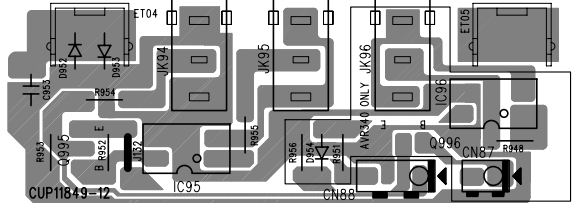

CENTER BAR

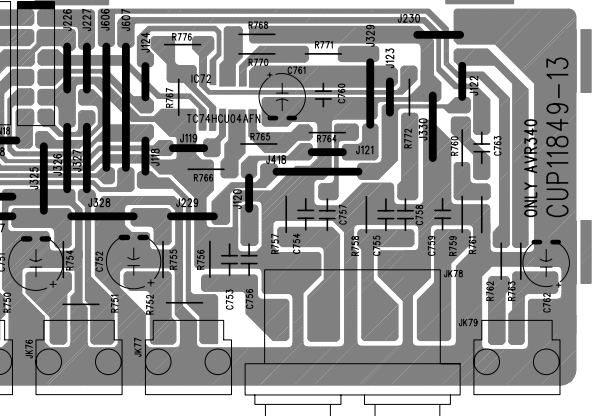

CUP11849

CUP11849

harman/kardon

CUP11849-1



November 1988
Revised November 1999

74AC04 • 74ACT04

Hex Inverter

74ACT04SC : IC52,75,83,84

General Description

The AC/ACT04 contains six inverters.

Features

- I_{CC} reduced by 50% on 74AC only
- Outputs source/sink 24 mA
- ACT04 has TTL-compatible inputs

Ordering Code:

Order Number	Package Number	Package Description
74AC04SC	M14A	14-Lead Small Outline Integrated Circuit (SOIC), JEDEC MS-120, 0.150" Narrow Body
74AC04SJ	M14D	14-Lead Small Outline Package (SOP), EIAJ TYPE II, 5.3mm Wide
74AC04MTC	MTC14	14-Lead Thin Shrink Small Outline Package (TSSOP), JEDEC MO-153, 4.4mm Wide
74AC04PC	N14A	14-Lead Plastic Dual-In-Line Package (PDIP), JEDEC MS-001, 0.300" Wide
74ACT04SC	M14A	14-Lead Small Outline Integrated Circuit (SOIC), JEDEC MS-120, 0.150" Narrow Body
74ACT04MTC	MTC14	14-Lead Thin Shrink Small Outline Package (TSSOP), JEDEC MO-153, 4.4mm Wide
74ACT04PC	N14A	14-Lead Plastic Dual-In-Line Package (PDIP), JEDEC MS-001, 0.300" Wide

Device also available in Tape and Reel. Specify by appending suffix letter "X" to the ordering code. (PC not available in Tape and Reel.)

Logic Symbol

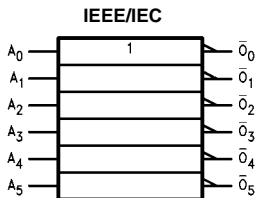

Connection Diagram

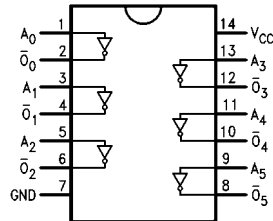

Pin Descriptions

Pin Names	Description
A_n	Inputs
\bar{O}_n	Outputs



M54HCU04

M74HCU04

HEX INVERTER (SINGLE STAGE)

- HIGH SPEED
 $t_{PD} = 5 \text{ ns}$ (TYP.) AT $V_{CC} = 5 \text{ V}$
- LOW POWER DISSIPATION
 $I_{CC} = 1 \mu\text{A}$ (MAX.) AT $T_A = 25 \text{ }^\circ\text{C}$
- HIGH NOISE IMMUNITY
 $V_{NIH} = V_{NIL} = 10\% V_{CC}$ (MIN.)
- OUTPUT DRIVE CAPABILITY
 10 LSTTL LOADS
- SYMMETRICAL OUTPUT IMPEDANCE
 $|I_{OH}| = I_{OL} = 4 \text{ mA}$ (MIN.)
- BALANCED PROPAGATION DELAYS
 $t_{PLH} = t_{PHL}$
- WIDE OPERATING VOLTAGE RANGE
 V_{CC} (OPR) = 2 V TO 6 V
- PIN AND FUNCTION COMPATIBLE WITH
 54/74LS04

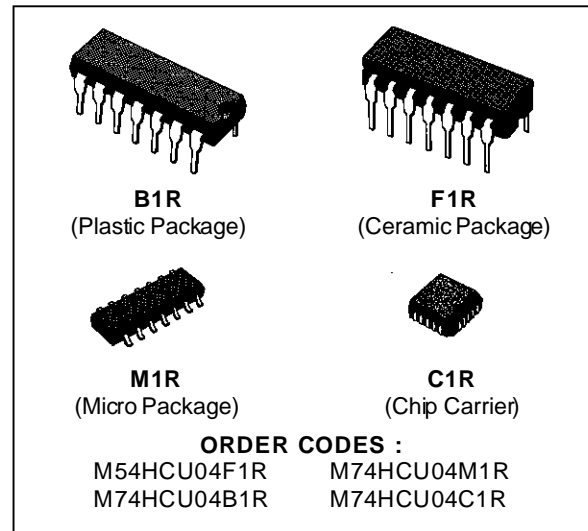

DESCRIPTION

The M54/74HCU04 is a high speed CMOS HEX INVERTER (SINGLE STAGE) fabricated in silicon gate C^2 MOS technology. It has the same high speed performance of LSTTL combined with true CMOS low power consumption.

As the intrnal circuit is composed of a single stage inverter, it can be used in crystal oscillator.

All inputs are equipped with circuits against static discharge and transient excess voltage.

INPUT AND OUTPUT EQUIVALENT CIRCUIT

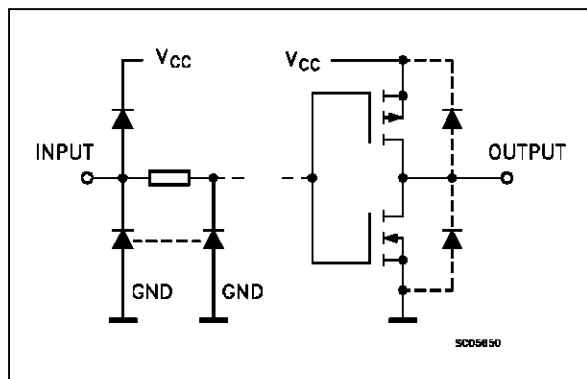

PIN CONNECTIONS (top view)

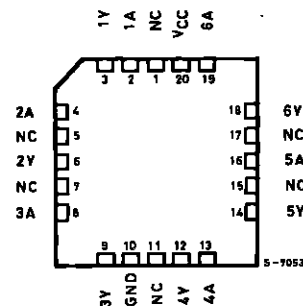
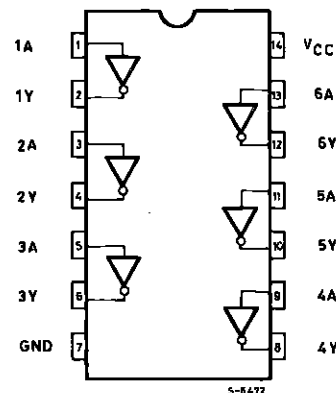

NC =
No Internal
Connection

■ PIN ASSIGNMENT (74HCU04AFN : IC71,72,76)

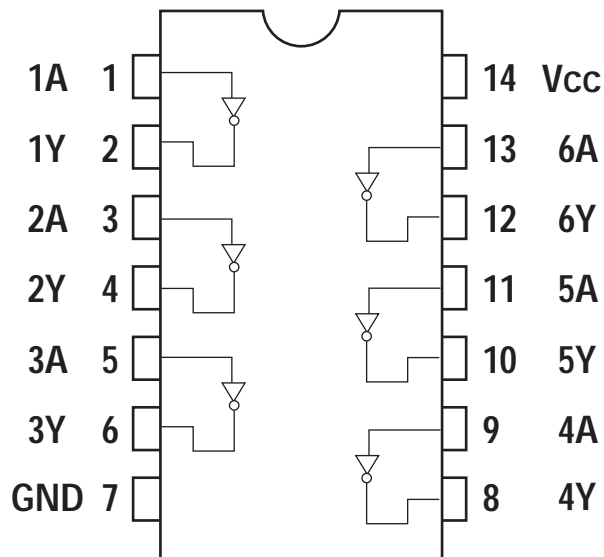

■ LOGIC SYMBOL

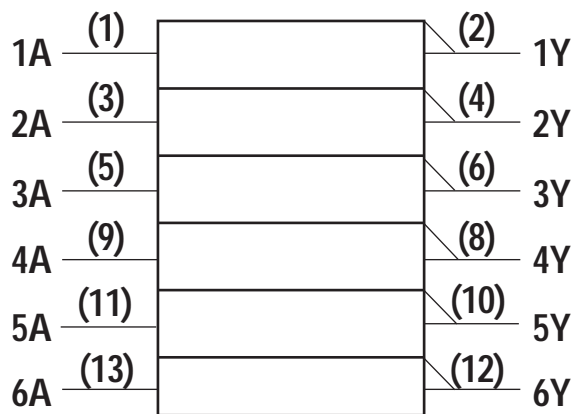

■ TRUTH TABLE

A	Y
L	H
H	L

mitsumi

Video Switch · 75Ω driver · Y/C mix MM1501

Video Switch · 75Ω driver · Y/C mix Monolithic IC MM1501 Series

Outline

This IC extends the series of ICs for video/audio signal switching, with a 2-input 1-output single video switch, video signal/chroma signal 75Ω driver, and Y/C mixing circuit in one small package (SOT-26).

Features

- (1) Low power consumption achieved.
- (2) Low power supply voltage realized.
- (3) Frequency bandwidth without 75Ω driver: 10MHz with 75Ω driver: 7MHz
- (4) Cross talk 70dB When 4.43MHz
- (5) With SAG measures pin (75Ω driver and Y/C mix driver)

Package

- SOT-26A (with 75Ω driver)
- SOT-26B (without 75Ω driver)

Applications

- (1) TV
- (2) VTR
- (3) Video camera
- (4) Digital still camera
- (5) Other visual equipment

Line-up

Functions	Model Name	Input	Output	Clamp	6dB amp	75Ω driver	SAG measures pin	Power supply voltage
Switch	MM1501	2	1	×	×	×	×	4.5~13.0V
	MM1502			×	○	×	×	4.5~13.0V
	MM1503			○	×	×	×	4.5~13.0V
	MM1504			○	○	×	×	4.5~13.0V
	MM1505			×	×	○	×	4.5~13.0V
	MM1506			×	○	○	×	4.5~13.0V
	MM1507			○	×	○	×	4.5~13.0V
	MM1508			○	○	○	×	4.5~13.0V
Driver	MM1509	1	1	×	○	○	○	4.5~13.0V
	MM1510			○	○	○	○	4.5~13.0V
Y/C mix	MM1511	1	1	○/×	×	×	×	4.5~13.0V
	MM1512			○/×	○	○	○	4.5~13.0V

MM1507

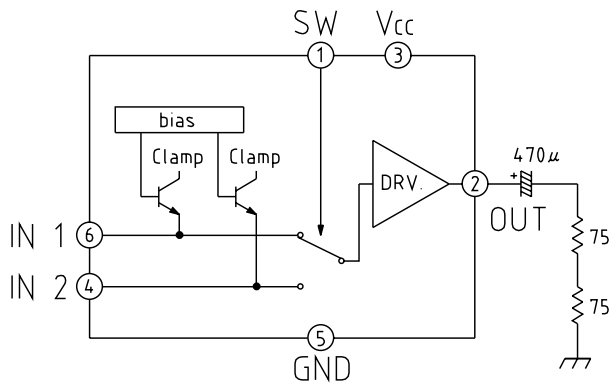

MM1508

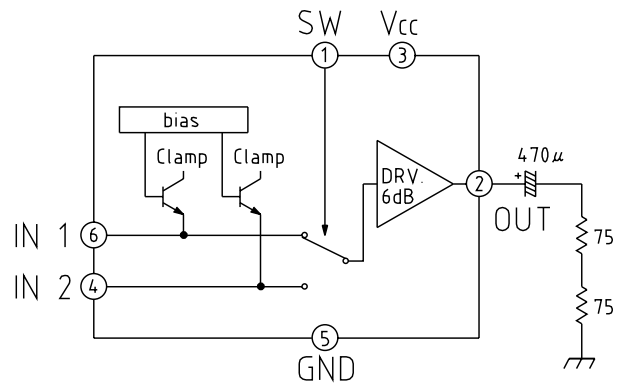

MM1509

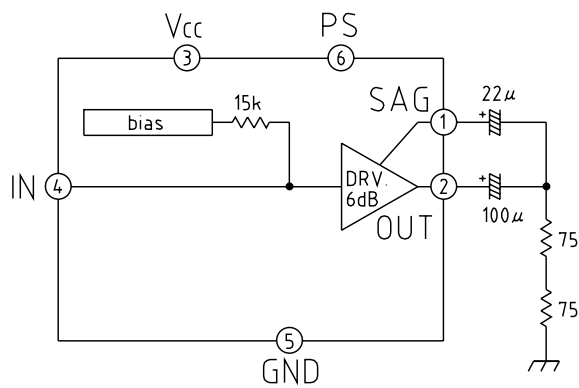

MM1510

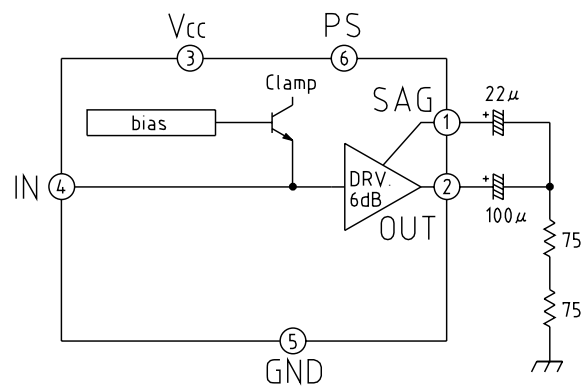

MM1511

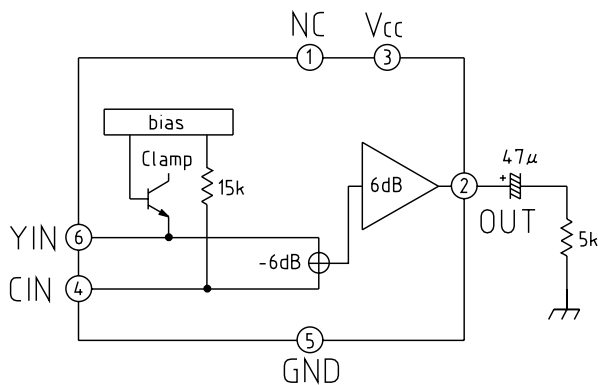

MM1512

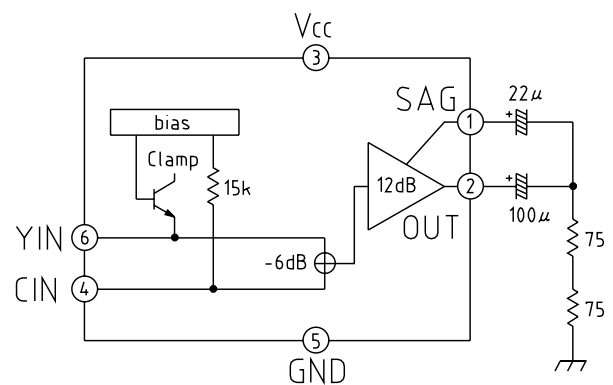

■ MM1509

Item	Symbol	Measurement conditions	Min.	Typ.	Max.	Unit
Consumption current	I _{CC1}	Refer to measurement procedures		6.3	8.2	mA
Current consumption for PS	I _{CC2}	Refer to measurement procedures		20	30	μA
PS input voltage L	V _{PSL}	Refer to measurement procedures			0.3	V
PS input voltage H	V _{PSH}	Refer to measurement procedures	1.8			V
Input pin voltage	V _{IN}	No-signal, no-load	1.75	1.95	2.15	V
Output pin voltage	V _{OUT}	No-signal, no-load		2.35		V
Voltage gain	G _V	Refer to measurement procedures	5.5	6.0	6.5	dB
Frequency characteristic	f _c	Refer to measurement procedures	-1	0	+1	dB
Differential gain	V _{CC=9V} DG	Refer to measurement procedures	-3	0	+3	%
Differential phase	V _{CC=9V} DP	Refer to measurement procedures	-3	0	+3	deg
Output dynamic range	V _D	Refer to measurement procedures	2.9	3.2		V
Input impedance	Z _i			15		kΩ

■ MM1510

Item	Symbol	Measurement conditions	Min.	Typ.	Max.	Unit
Consumption current	I _{CC1}	Refer to measurement procedures		6.4	8.3	mA
Current consumption for PS	I _{CC2}	Refer to measurement procedures		20	30	μA
PS input voltage L	V _{PSL}	Refer to measurement procedures			0.3	V
PS input voltage H	V _{PSH}	Refer to measurement procedures	1.8			V
Input pin voltage	V _{IN}	No-signal, no-load	1.15	1.35	1.55	V
Output pin voltage	V _{OUT}	No-signal, no-load		1.15		V
Voltage gain	G _V	Refer to measurement procedures	5.5	6.0	6.5	dB
Frequency characteristic	f _c	Refer to measurement procedures	-1	0	+1	dB
Differential gain	DG	Refer to measurement procedures	-3	0	+3	%
Differential phase	DP	Refer to measurement procedures	-3	0	+3	deg
Output dynamic range	V _D	Refer to measurement procedures	2.6	3.0		V

■ MM1511

Item	Symbol	Measurement conditions	Min.	Typ.	Max.	Unit
Consumption current	I _{CC}	Refer to measurement procedures		4.4	5.7	mA
Y input pin voltage	V _{YIN}	No-signal, no-load	2.00	2.20	2.40	V
C input pin voltage	V _{CIN}	No-signal, no-load	1.85	2.05	2.25	V
Output pin voltage	V _{OUT}	No-signal, no-load		1.15		V
Voltage gain	G _V	Refer to measurement procedures	-0.5	0	6.5	dB
Frequency characteristic	f _c	Refer to measurement procedures	-1	0	+0.5	dB
Differential gain	DG	Refer to measurement procedures	-3	0	+3	%
Differential phase	DP	Refer to measurement procedures	-3	0	+3	deg
Y output dynamic range	V _{DY}	Refer to measurement procedures	2.6	2.9		V
C output dynamic range	V _{DC}	Refer to measurement procedures	2.0			V
C input impedance	Z _i			15		kΩ
Output impedance	Z _o			25		Ω



HY57V161610ETP-I

2 Banks x 512K x 16 Bit Synchronous DRAM

DESCRIPTION

THE Hynix HY57V161610E is a 16,777,216-bits CMOS Synchronous DRAM, ideally suited for the main memory and graphic applications which require large memory density and high bandwidth. HY57V161610E is organized as 2banks of 524,288x16.

HY57V161610E is offering fully synchronous operation referenced to a positive edge clock. All inputs and outputs are synchronized with the rising edge of the clock input. The data paths are internally pipelined to achieve very high bandwidth. All input and output voltage levels are compatible with LVTTTL.

Programmable options include the length of pipeline (Read latency of 1,2 or 3), the number of consecutive read or write cycles initiated by a single control command (Burst length of 1,2,4,8 or full page), and the burst count sequence(sequential or interleave). A burst of read or write cycles in progress can be terminated by a burst terminate command or can be interrupted and replaced by a new burst read or write command on any cycle. (This pipeline design is not restricted by a '2N' rule.)

FEATURES

- Single 3.0V to 3.6V power supply
- All device pins are compatible with LVTTTL interface
- JEDEC standard 400mil 50pin TSOP-II with 0.8mm of pin pitch
- All inputs and outputs referenced to positive edge of system clock
- Data mask function by UDQM/LDQM
- Internal two banks operation
- Auto refresh and self refresh
- 4096 refresh cycles / 64ms
- Programmable Burst Length and Burst Type
 - 1, 2, 4, 8 and Full Page for Sequence Burst
 - 1, 2, 4 and 8 for Interleave Burst
- Programmable $\overline{\text{CAS}}$ Latency ; 1, 2, 3 Clocks
- Pb-free Package

ORDERING INFORMATION

Part No.	Clock Frequency	Organization	Interface	Package
HY57V161610ETP-5I	200MHz	2Banks x 512Kbits x 16	LVTTTL	400mil 50pin TSOP II (Pb free)
HY57V161610ETP-55I	183MHz			
HY57V161610ETP-6I	166MHz			
HY57V161610ETP-7I	143MHz			
HY57V161610ETP-8I	125MHz			
HY57V161610ETP-10I	100MHz			
HY57V161610ETP-15I	66MHz			

Note :

1. VDD(min) of HY57V161610ETP-5I/55I is 3.15V
2. Hynix supports lead free part for each speed grade with same specification.

This document is a general product description and is subject to change without notice. Hynix Semiconductor does not assume any responsibility for use of circuits described. No patent licenses are implied



HY57V161610ETP-I

PIN CONFIGURATION

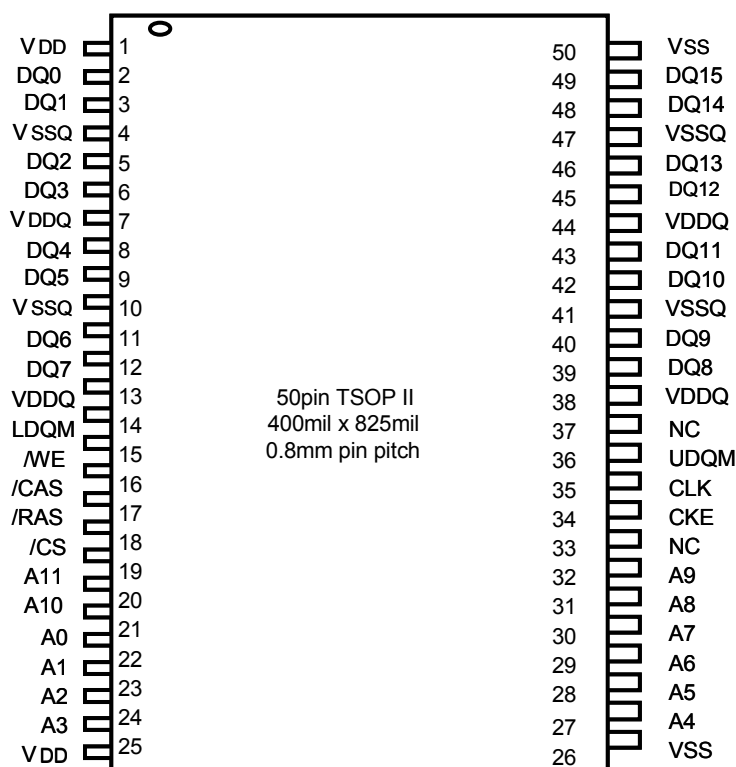

PIN DESCRIPTION

PIN	PIN NAME	DESCRIPTION
CLK	Clock	The system clock input. All other inputs are referenced to the SDRAM on the rising edge of CLK.
CKE	Clock Enable	Controls internal clock signal and when deactivated, the SDRAM will be one of the states among power down, suspend or self refresh.
$\overline{\text{CS}}$	Chip Select	Command input enable or mask except CLK, CKE and DQM
BA	Bank Address	Select either one of banks during both $\overline{\text{RAS}}$ and $\overline{\text{CAS}}$ activity.
A0 ~ A10	Address	Row Address : RA0 ~ RA10, Column Address : CA0 ~ CA7 Auto-precharge flag : A10
$\overline{\text{RAS}}$, $\overline{\text{CAS}}$, $\overline{\text{WE}}$	Row Address Strobe, Column Address Strobe, Write Enable	$\overline{\text{RAS}}$, $\overline{\text{CAS}}$ and $\overline{\text{WE}}$ define the operation. Refer function truth table for details
LDQM, UDQM	Data Input/Output Mask	DQM control output buffer in read mode and mask input data in write mode
DQ0 ~ DQ15	Data Input/Output	Multiplexed data input / output pin
VDD/VSS	Power Supply/Ground	Power supply for internal circuit and input buffer
VDDQ/VSSQ	Data Output Power/Ground	Power supply for DQ
NC	No Connection	No connection



HY57V161610ETP-I

FUNCTIONAL BLOCK DIAGRAM

1Mx16 Synchronous DRAM

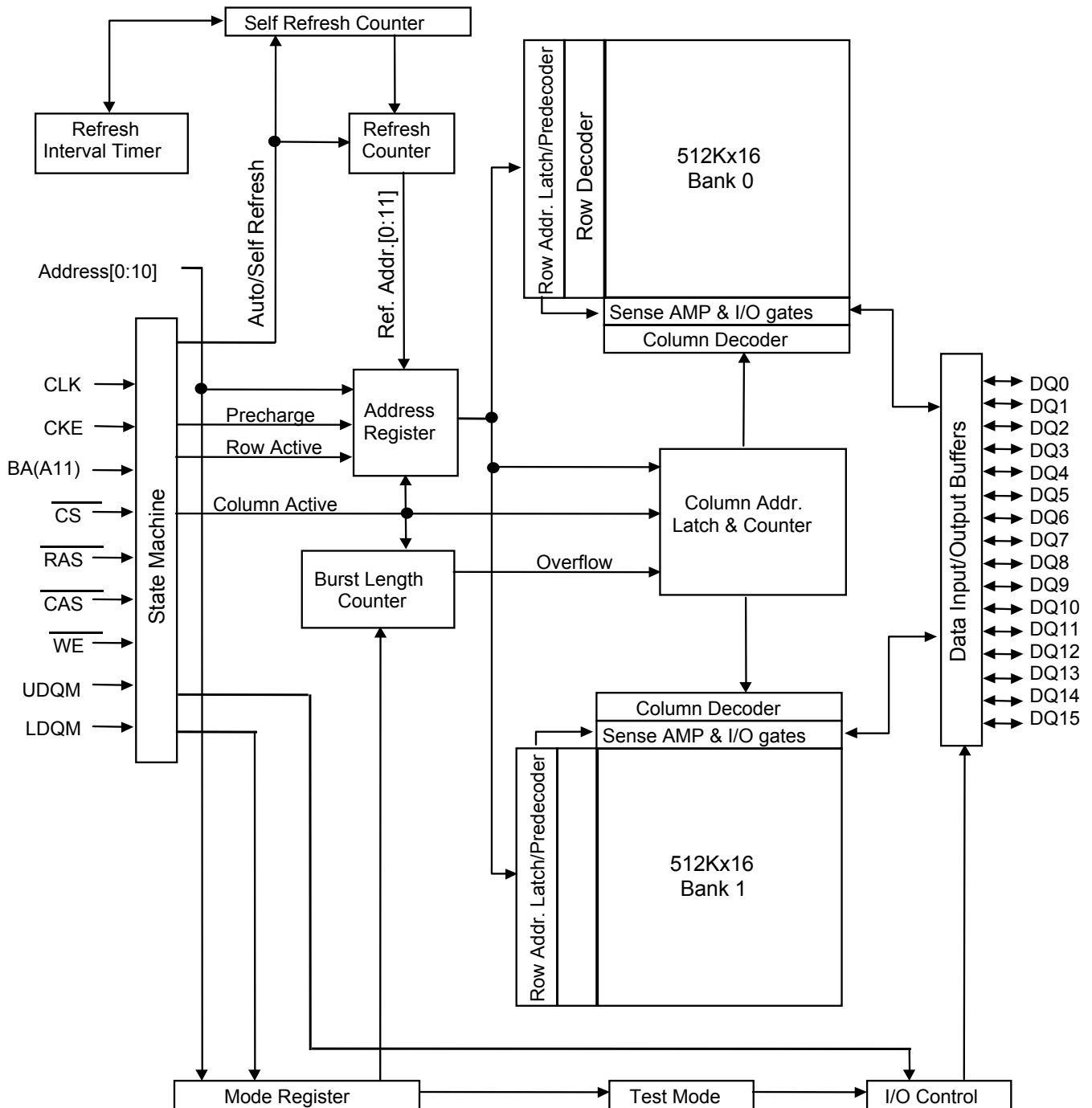



HY57V161610ETP-I

COMMAND TRUTH TABLE

Command	CKEn-1	CKEn	\overline{CS}	\overline{RAS}	\overline{CAS}	\overline{WE}	DQM	A0~A9	A10/AP	BA	Note	
Mode Register Set	H	X	L	L	L	L	X	OP code				
No Operation	H	X	H	X	X	X	X	X				
			L	H	H	H						
Bank Active	H	X	L	L	H	H	X	Row Address		V		
Read	H	X	L	H	L	H	X	Column Address	L	V		
Read with Auto precharge									H			
Write	H	X	L	H	L	L	X	Column Address	L	V		
Write with Auto precharge									H			
Precharge All Bank	H	X	L	L	H	L	X	X	H	X		
Precharge selected Bank									L	V		
Burst Stop	H	X	L	H	H	L	X	X				
U/LDQM	H	X					V	X				
Auto Refresh	H	H	L	L	L	H	X	X				
Burst-READ-Single-WRITE	H	X	L	L	L	L	X	A9 Pin High (Other Pins OP code)				
Self Refresh ¹	Entry	H	L	L	L	L	H	X	X			
	Exit	L	H	H	X	X	X	X				
Precharge power down	Entry	H	L	H	X	X	X	X	X			
				L	H	H	H					
	Exit	L	H	H	X	X	X	X				
				L	H	H	H					
Clock Suspend	Entry	H	L	H	X	X	X	X	X			
				L	V	V	V					
	Exit	L	H	X				X				

Note :

1. Exiting Self Refresh occurs by asynchronously bringing CKE from low to high.
2. X=Do not care, L=Low, H=High, BA=Bank Address, RA= Row Address, CA=Column Address, Opcode=Operand Code, NOP=No Operation.



March 1995
Revised February 2005

74LCX32

Low Voltage Quad 2-Input OR Gate with 5V Tolerant Inputs

General Description

The LCX32 contains four 2-input OR gates. The inputs tolerate voltages up to 7V allowing the interface of 5V systems to 3V systems.

The 74LCX32 is fabricated with advanced CMOS technology to achieve high speed operation while maintaining CMOS low power dissipation.

Features

- 5V tolerant inputs
- 2.3V–3.6V V_{CC} specifications provided
- 5.5 ns t_{PD} max ($V_{CC} = 3.3V$), 10 μA I_{CC} max
- Power down high impedance inputs and outputs
- ± 24 mA output drive ($V_{CC} = 3.0V$)
- Implements patented noise/EMI reduction circuitry
- Latch-up performance exceeds JEDEC 78 conditions
- ESD performance:
 - Human body model > 2000V
 - Machine model > 150V
- Leadless Pb-Free DQFN package

Ordering Code:

Order Number	Package Number	Package Description
74LCX32M	M14A	14-Lead Small Outline Integrated Circuit (SOIC), JEDEC MS-012, 0.150" Narrow
74LCX32MX_NL (Note 2)	M14A	Pb-Free 14-Lead Small Outline Integrated Circuit (SOIC), JEDEC MS-012, 0.150" Narrow
74LCX32SJ	M14D	Pb-Free 14-Lead Small Outline Package (SOP), EIAJ TYPE II, 5.3mm Wide
74LCX32BQX (Note 1)	MLP014A	Pb-Free 14-Terminal Depopulated Quad Very-Thin Flat Pack No Leads (DQFN), JEDEC MO-241, 2.5 x 3.0mm
74LCX32MTC	MTC14	14-Lead Thin Shrink Small Outline Package (TSSOP), JEDEC MO-153, 4.4mm Wide
74LCX32MTCX_NL (Note 2)	MTC14	Pb-Free 14-Lead Thin Shrink Small Outline Package (TSSOP), JEDEC MO-153, 4.4mm Wide

Devices also available in Tape and Reel. Specify by appending the suffix letter "X" to the ordering code.

Pb-Free package per JEDEC J-STD-020B.

Note 1: DQFN package available in Tape and Reel only.

Note 2: "_NL" indicates Pb-Free package (per JEDEC J-STD-020B). Device available in Tape and Reel only.

74LCX32 Low Voltage Quad 2-Input OR Gate with 5V Tolerant Inputs

74LCX32

Logic Symbol

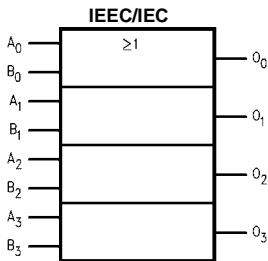

Pin Descriptions

Pin Names	Description
A _n , B _n	Inputs
O _n	Outputs

Connection Diagrams

Pin Assignments for SOIC, SOP, and TSSOP

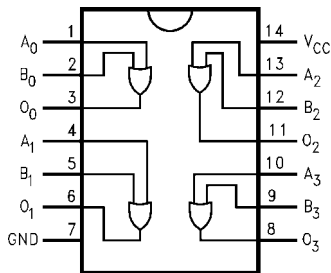

Pad Assignment for DQFN

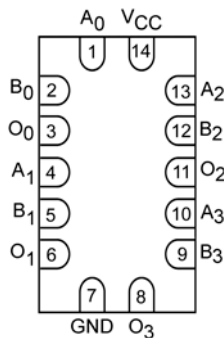

(Top View)

ASAHI KASEI

[AK4589]



AK4589

2/8-Channel Audio CODEC with DIR

GENERAL DESCRIPTION

The AK4589 is a single chip CODEC that includes two channels of ADC and eight channels of DAC. The ADC outputs 24bit data and the DAC accepts up to 24bit input data. The ADC has the Enhanced Dual Bit architecture with wide dynamic range. The DAC introduces the new developed Advanced Multi-Bit architecture, and achieves wider dynamic range and lower outband noise. The AK4589 has a dynamic range of 102dB for ADC, 114dB for DAC and is well suited for digital surround for home theater audio. The AK4589 also has the balance volume control corresponding to the Dolby Digital (AC-3) system.

The also has digital audio receiver (DIR) and transmitter (DIT) compatible with 192kHz, 24bits. The DIR has 8-channel input selector and can automatically detect a Non-PCM bit stream. The AK4589 provides a compatibility of hardware and software with the AK4588.

*Dolby Digital (AC-3) is a trademark of Dolby Laboratories.

FEATURES

□ ADC/DAC part

- 2ch 24bit ADC
 - 64x Oversampling
 - Sampling Rate up to 96kHz
 - Linear Phase Digital Anti-Alias Filter
 - Single-Ended Input
 - S/(N+D): 92dB
 - Dynamic Range, S/N: 102dB
 - Digital HPF for offset cancellation
 - Overflow flag
- 8ch 24bit DAC
 - 128x Oversampling
 - Sampling Rate up to 192kHz
 - 24bit 8 times Digital Filter
 - Differential Outputs
 - On-chip Switched-Capacitor Filter
 - S/(N+D): 94dB
 - Dynamic Range, S/N: 114dB
 - Individual channel digital volume with 128 levels and 0.5dB step
 - Soft mute
 - De-emphasis for 32kHz, 44.1kHz, 48kHz
 - Zero Detect Function
- High Jitter Tolerance
- Extenal Master Clock Input:
 - 256fs, 384fs, 512fs (fs=32kHz ~ 48kHz)
 - 128fs, 192fs, 256fs (fs=64kHz ~ 96kHz)
 - 128fs (fs=120kHz ~ 192kHz)

ASAHI KASEI

[AK4589]

 DIR/DIT Part

- AES3, IEC60958, S/PDIF, EIAJ CP1201 Compatible
- Low jitter Analog PLL
- PLL Lock Range : 32kHz to 192kHz
- Clock Source: PLL or X'tal
- 8-channel Receiver input
- 2-channel Transmission output (Through output or DIT)
- Auxiliary digital input
- De-emphasis for 32kHz, 44.1kHz, 48kHz and 96kHz
- Detection Functions
 - Non-PCM Bit Stream Detection
 - DTS-CD Bit Stream Detection
 - Sampling Frequency Detection
(32kHz, 44.1kHz, 48kHz, 88.2kHz, 96kHz, 176.4kHz, 192kHz)
 - Unlock & Parity Error Detection
 - Validity Flag Detection
- Up to 24bit Audio Data Format
- Audio I/F: Master or Slave Mode
- 40-bit Channel Status Buffer
- Burst Preamble bit Pc and Pd Buffer for Non-PCM bit stream
- Q-subcode Buffer for CD bit stream
- Serial μ P I/F
- Two Master Clock Outputs: 64fs/128fs/256fs/512fs

 TTL Level Digital I/F

- 4-wire Serial and I²C Bus μ P I/F for mode setting
- Operating Voltage: 4.75 to 5.25V with 5V tolerance
- Power Supply for output buffer: 2.7 to 5.25V
- 80pin LQFP Package (0.5mm pitch)
- AK4588 compatible w/o analog outputs

ASAHI KASEI

[AK4589]

■ Block Diagram

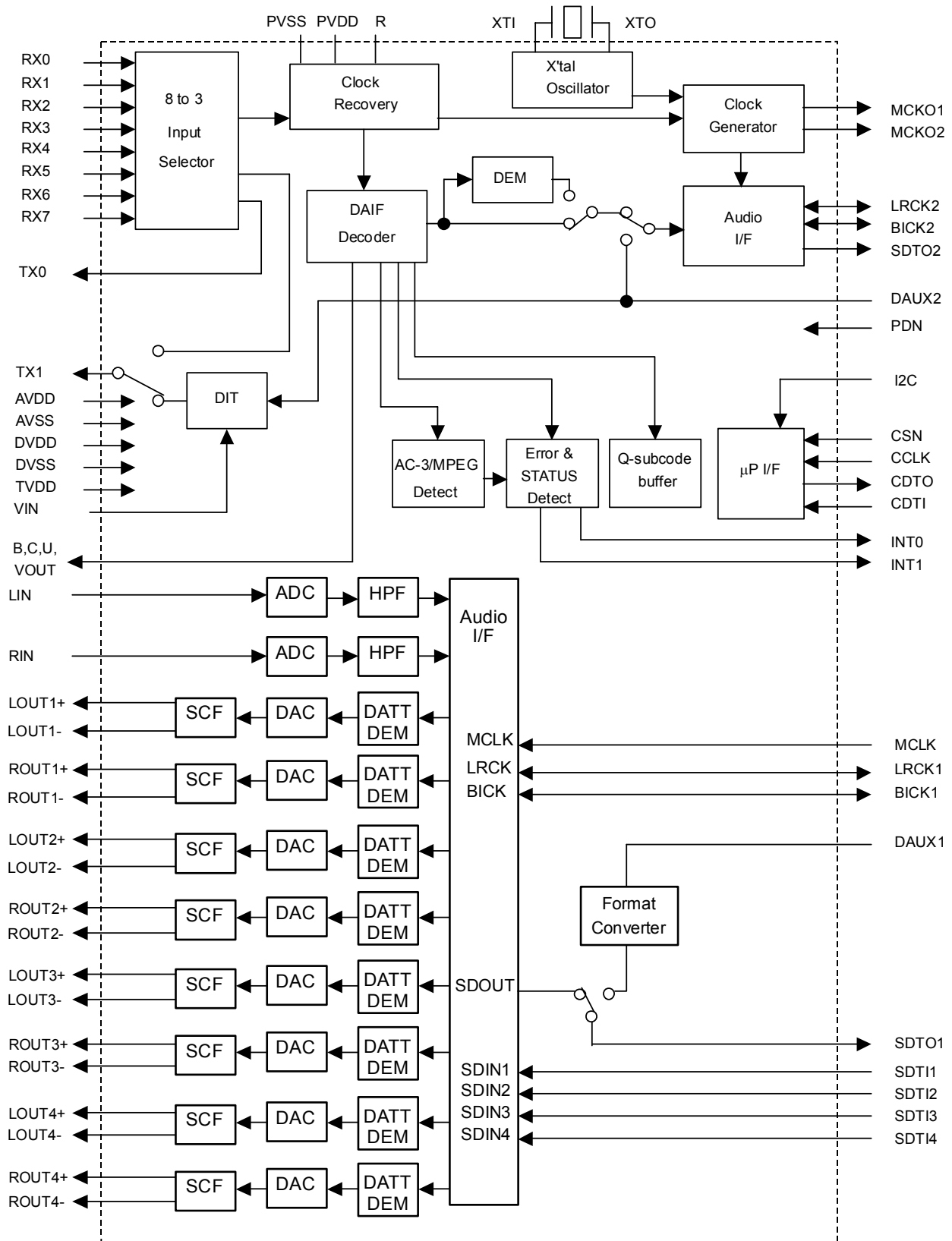

ASAHI KASEI

[AK4589]

■ Ordering Guide

AK4589VQ -10 ~ +70°C 80pin LQFP(0.5mm pitch)
 AKD4589 Evaluation Board for AK4589

■ Pin Layout

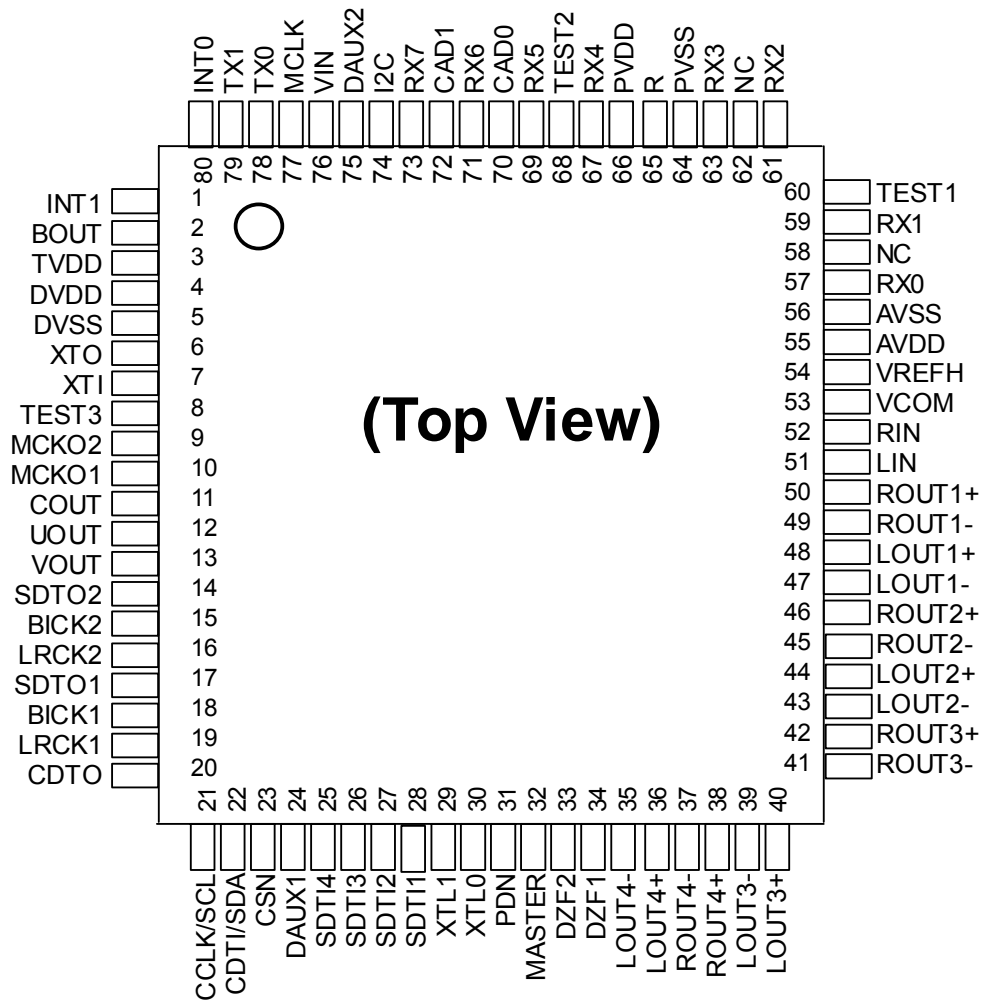

ASAHI KASEI

[AK4589]

PIN/FUNCTION			
No.	Pin Name	I/O	Function
1	INT1	O	Interrupt 1 Pin
2	BOUT	O	Block-Start Output Pin for Receiver Input "H" during first 40 flames.
3	TVDD	-	Output Buffer Power Supply Pin, 2.7V~5.25V
4	DVDD	-	Digital Power Supply Pin, 4.75V~5.25V
5	DVSS	-	Digital Ground Pin
6	XTO	O	X'tal Output Pin
7	XTI	I	X'tal Input Pin
8	TEST3	I	Test 3 Pin This pin should be connected to DVSS.
9	MCKO2	O	Master Clock Output 2 Pin
10	MCKO1	O	Master Clock Output 1 Pin
11	COOUT	O	C-bit Output Pin for Receiver Input
12	UOUT	O	U-bit Output Pin for Receiver Input
13	VOOUT	O	V-bit Output Pin for Receiver Input
14	SDTO2	O	Audio Serial Data Output Pin (DIR/DIT part)
15	BICK2	I/O	Audio Serial Data Clock Pin (DIR/DIT part)
16	LRCK2	I/O	Channel Clock Pin (DIR/DIT part)
17	SDTO1	O	Audio Serial Data Output Pin (ADC/DAC part)
18	BICK1	I/O	Audio Serial Data Clock Pin (ADC/DAC part)
19	LRCK1	I/O	Input Channel Clock Pin
20	CDTO	O	Control Data Output Pin in Serial Mode, I2C= "L".
21	CCLK	I	Control Data Clock Pin in Serial Mode, I2C= "L"
	SCL	I	Control Data Clock Pin in Serial Mode, I2C= "H"
22	CDTI	I	Control Data Input Pin in Serial Mode, I2C= "L".
	SDA	I/O	Control Data Pin in Serial Mode, I2C= "H".
23	CSN	I	Chip Select Pin in Serial Mode, I2C= "L".
		I	This pin should be connected to DVSS, I2C= "H".
24	DAUX1	I	AUX Audio Serial Data Input Pin (ADC/DAC part)
25	SDTI4	I	DAC4 Audio Serial Data Input Pin
26	SDTI3	I	DAC3 Audio Serial Data Input Pin
27	SDTI2	I	DAC2 Audio Serial Data Input Pin
28	SDTI1	I	DAC1 Audio Serial Data Input Pin
29	XTL1	I	X'tal Frequency Select 0 Pin
30	XTL0	I	X'tal Frequency Select 1 Pin

ASAHI KASEI

[AK4589]

No.	Pin Name	I/O	Function
31	PDN	I	Power-Down Mode Pin When "L", the AK4589 is powered-down, all digital output pins go "L", all registers are reset. When CAD1/0 pins are changed, the AK4589 should be reset by PDN pin.
32	MASTER	I	Master Mode Select Pin "H": Master mode, "L": Slave mode
33	DZF2	O	Zero Input Detect 2 Pin (Table 13) When the input data of the group 1 follow total 8192 LRCK cycles with "0" input data, this pin goes to "H". And when RSTN bit is "0", PWDAN bit is "0", this pin goes to "H". It always is in "L" when P/S pin is "H".
	OVF	O	Analog Input Overflow Detect Pin This pin goes to "H" if the analog input of Lch or Rch overflows.
34	DZF1	O	Zero Input Detect 1 Pin (Table 13) When the input data of the group 1 follow total 8192 LRCK cycles with "0" input data, this pin goes to "H". And when RSTN bit is "0", PWDAN bit is "0", this pin goes to "H". Output is selected by setting DZFE pin when P/S pin is "H".
35	LOUT4-	O	DAC4 Lch Negative Analog Output Pin
36	LOUT4+	O	DAC4 Lch Positive Analog Output Pin
37	ROUT4-	O	DAC4 Rch Negative Analog Output Pin
38	ROUT4+	O	DAC4 Rch Positive Analog Output Pin
39	LOUT3-	O	DAC3 Lch Negative Analog Output Pin
40	LOUT3+	O	DAC3 Lch Positive Analog Output Pin
41	ROUT3-	O	DAC3 Rch Negative Analog Output Pin
42	ROUT3+	O	DAC3 Rch Positive Analog Output Pin
43	LOUT2-	O	DAC2 Lch Negative Analog Output Pin
44	LOUT2+	O	DAC2 Lch Positive Analog Output Pin
45	ROUT2-	O	DAC2 Rch Negative Analog Output Pin
46	ROUT2+	O	DAC2 Rch Positive Analog Output Pin
47	LOUT1-	O	DAC1 Lch Negative Analog Output Pin
48	LOUT1+	O	DAC1 Lch Positive Analog Output Pin
49	ROUT1-	O	DAC1 Rch Negative Analog Output Pin
50	ROUT1+	O	DAC1 Rch Positive Analog Output Pin
51	LIN	I	Lch Analog Input Pin
52	RIN	I	Rch Analog Input Pin
53	VCOM	-	Common Voltage Output Pin 2.2μF capacitor should be connected to AVSS externally.
54	VREFH	-	Positive Voltage Reference Input Pin, AVDD

No.	Pin Name	I/O	Function
55	AVDD	-	Analog Power Supply Pin, 4.75V~5.25V
56	AVSS	-	Analog Ground Pin, 0V
57	RX0	I	Receiver Channel 0 Pin (Internal biased pin. Internally biased at PVDD/2)
58	NC	-	No Connect pin No internal bonding. This pin should be connected to PVSS.
59	RX1	I	Receiver Channel 1 Pin (Internal biased pin. Internally biased at PVDD/2)
60	TEST1	I	Test 1 Pin This pin should be connected to PVSS.
61	RX2	I	Receiver Channel 2 Pin (Internal biased pin. Internally biased at PVDD/2)
62	NC	-	No Connect pin No internal bonding. This pin should be connected to PVSS.
63	RX3	I	Receiver Channel 3 Pin (Internal biased pin. Internally biased at PVDD/2)
64	PVSS	-	PLL Ground pin
65	R	-	External Resistor Pin 12kΩ +/-1% resistor should be connected to PVSS externally.
66	PVDD	-	PLL Power supply Pin, 4.75V~5.25V
67	RX4	I	Receiver Channel 4 Pin (Internal biased pin. Internally biased at PVDD/2)
68	TEST2	I	Test 2 Pin This pin should be connected to PVSS.
69	RX5	I	Receiver Channel 5 Pin (Internal biased pin. Internally biased at PVDD/2)
70	CAD0	I	Chip Address 0 Pin (ADC/DAC part)
71	RX6	I	Receiver Channel 6 Pin (Internal biased pin. Internally biased at PVDD/2)
72	CAD1	I	Chip Address 1 Pin (ADC/DAC part)
73	RX7	I	Receiver Channel 7 Pin (Internal biased pin. Internally biased at PVDD/2)
74	I2C	I	Control Mode Select Pin. “L”: 4-wire Serial, “H”: I ² C Bus
75	DAUX2	I	Auxiliary Audio Data Input Pin (DIR/DIT part)
76	VIN	I	V-bit Input Pin for Transmitter Output
77	MCLK	I	Master Clock Input Pin
78	TX0	O	Transmit Channel (Through Data) Output 0 Pin
79	TX1	O	Transmit Channel Output1 pin When DIT bit = “0”, Through Data. When DIT bit = “1”, DAUX2 Data.
80	INT0	O	Interrupt 0 Pin

Note: All input pins except internal biased pins and Analog input pins (RX0-7, LIN, RIN) should not be left floating.

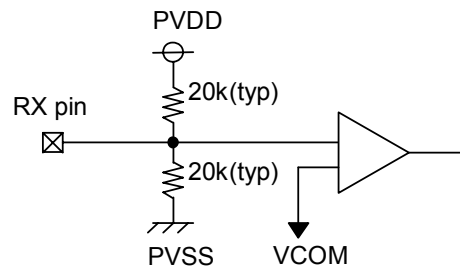

Internal biased pin Circuit

■ Handling of Unused Pin

The unused I/O pins should be processed appropriately as below.

Classification	Pin Name	Setting
Analog	RX0-7, LOUT1-4, ROUT1-4, LIN, RIN	These pins should be open.
Digital	INT0-1, BOUT, XTO, MCKO1-2, COUT, UOUT, VOUT, SDTO1-2, CDTO, DZF1-2, TX1-0	These pins should be open.
	CSN, DAUX1-2, SDTI1-4, XTLO-1	These pins should be connected to DVSS.
	TEST1-3	These pins should be connected to PVSS.



CS49400 Family DSP

Multi-Standard Audio Decoder

Features

- CS49300 Legacy Audio Decoder Support
- Dolby Digital EX™, Dolby Pro Logic II™
- DTS-ES 96/24™, DTS 96/24™, DTS-ES Discrete 6.1™, DTS-ES Matrix 6.1™, DTS Digital Surround™ and DTS Virtual 5.1™
- MPEG-2: AAC Multichannel 5.1
- MPEG Multichannel and Musicam
- MPEG-1/2, Layer III (MP3)
- DTS Neo:6™, LOGIC7®, SRS Circle Surround II™
- Cirrus Extra Surround™, Cirrus Original Surround 6.1 (C.O.S. 6.1)™
- THX Surround EX™, THX Ultra2 Cinema™
- 12-Channel Serial Audio Inputs
- Integrated 8K Byte Input Buffer
- Powerful 32-bit Audio DSP
- Customer Software Security Keys
- Large On-chip X, Y, and Program RAM
- Supports SDRAM, SRAM, FLASH memories
- 16-channel PCM output
- Dual S/PDIF Transmitters
- SPI Serial, and Motorola® and Intel® Parallel Host Control Interfaces
- GPIO support for all common sub-circuits

Description

The CS49400 Audio Decoder DSP is targeted as a market-specific consumer entertainment processor for AV Receivers and DVD Audio/Video Players. The device is constructed using an enhanced version of the CS49300 Family DSP audio decoder followed by a 32-bit programmable post-processor DSP, which gives the designer the ability to add product differentiation through the Cirrus Framework™ programming structure and Framework module library. Dolby Digital Pro Logic II, DTS Digital Surround, MPEG Multichannel, and Cirrus Original Surround 6.1 PCM Effects Processor (capable of generating such DSP audio modes as: Hall, Theater, Church) are included in the cost of the CS49400 Family DSP. Additional algorithms available through the Crystal Ware™ Software Licensing Program, give the designer the ability to further deliver end-product differentiation.

The CS49400 contains sufficient on-chip SRAM to support decoding all major audio decoding algorithms available today including: AAC Multichannel, DTS 96/24, DTS-ES 96/24. The CS49400 also supports a glueless SDRAM/SRAM for increased all-channel delays. The SRAM interface also supports connection to an external byte-wide EPROM for code storage or Flash memory thus allowing products to be field-upgradable as new audio algorithms are developed.

This chip, teamed with Crystal Ware™ certified decoder library, Cirrus digital interface products and mixed signal data converters, enables the conception and design of next generation digital entertainment products.

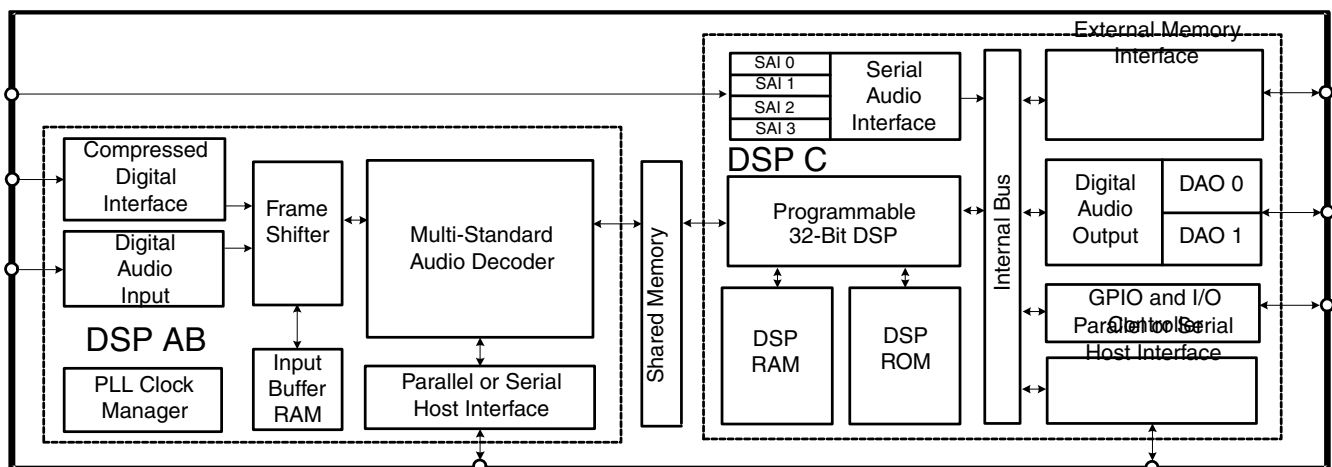

This document contains information for a new product.
Cirrus Logic reserves the right to modify this product without notice.



2. OVERVIEW

The CS49400 is a 24-bit fixed-point decoder DSP followed by a 32-bit fixed point programmable post-processor DSP. The decoder portion of the CS49400 is referred to as “DSPAB”. The post-processor DSP is referred to as “DSPC”. Both DSPAB and DSPC include their own dedicated peripherals such as serial and parallel control ports, and serial audio interfaces. DSPC also has an external memory interface which supports SRAM/SDRAM/EPROM.

All the decoding/processing algorithms listed below require delivery of PCM or IEC61937-packed compressed data via I2S or LJ formatted digital audio to the CS49400. Today the CS49400 will support all of the following decoding/processing standards:

- PCM Pass-Through/PCM Upsampler
- Dolby Digital™ (with Dolby Pro Logic™)
- Dolby Digital Pro Logic II™
- Dolby Digital EX™
- Dolby Digital EX Pro Logic II™
- MPEG-2, Advanced Audio Coding Algorithm (AAC)
- MPEG Multichannel
- MPEG Multichannel with Dolby Pro Logic II™
- MPEG-1/2, Layer III (MP3)
- DTS Digital Surround™
- DTS 96/24™ (Front-end Decoder)
- DTS Digital Surround™ with Dolby Pro Logic II™
- DTS-ES Extended Surround™ (DTS-ES Discrete 6.1 and DTS-ES Matrix 6.1)
- DTS-ES 96/24™ (Front-end Decoder)
- DTS Neo:6™
- LOGIC7®
- SRS Circle Surround™ II

- HDCD®

All of the above audio decoding/processing algorithms and the associated application notes (AN208 and their corresponding appendices) are available through the Crystal Ware™ Software Licensing Program. Please refer to AN208 for the latest listing of application codes for DSPAB.

DSPC is unique to DSPAB in the sense that the designer may choose to just load a standard or enhanced application code (.ULD file) from the Crystal Ware Software Library or if they have access to the Cirrus Framework DSPC Development Kit, they may choose to build their own application code from a variety of modules. A DSPC application code contains all of the necessary post-processing modules, such as Crossbar Mixer, Pro Logic Module, Bass Manager Module, and Audio Manager (Kernel). A module is just a single processing module, such as Tone Control, Parametric/Graphic EQ, or Dolby Pro Logic matrix decoder. DSPC on the CS49400 will support the following post-processing application codes and/or modules:

- Standard Post-Processor (includes the following modules all compiled into one .ULD file): Downmixer module, Dualzone module, Crossbar Mixer module, 7.1 Channel Bass Manager module, Audio Manager module (Volume Control, Trim Control and Channel Remap), and Delay module
- Advanced Post-Processor (includes the all of the standard post-processing modules plus the Tone Control module, Parametric EQ module, Re-EQ module in all compiled into one .ULD)
- Dolby Pro Logic™
- Dolby Pro Logic II™
- SRS Circle Surround II™
- DTS Neo:6™
- LOGIC7®
- THX® Surround EX™ 7.1 Channel Post-Processor



- THX[®] Ultra2 Cinema[™] 7.1 Channel Post-Processor
- Cirrus Extra Surround[™]
- Cirrus Original Multichannel Surround[™]
- Virtual Dolby Digital[™]/Virtual Dolby Digital Pro Logic II[™] Virtualizer Module
- VMaX VirtualTheater[™] Virtualizer Module
- HDCD[®] Multichannel Decoder
- DVD-Audio/Video and Multichannel SACD Bass Management
- DTS/DTS-ES 96/24[™] Back-End Decoder
- DTS/DTS-ES 96/24[™] Back-End Decoder with THX[®] Ultra2 Cinema[™]

All of the above audio post-processing applications codes and/or Cirrus Framework[™] modules and the associated application notes (AN209 and the associated appendices) are available through the Crystal Ware[™] Software Licensing Program. All standard or enhanced post-processing code modules are only available to customers who qualify for the Cirrus Framework[™] CS49400 Family DSPC Programming Kit. Please refer to AN209 for the latest listing of application codes and Cirrus Framework[™] modules available for DSPC.

2.1 DSPAB

DSPAB is an enhanced version of the CS49300. It was designed to have legacy code support for all decoder applications developed for the CS49300. It includes performance enhancements such as the ability to decode AAC without the need for external SRAM memory. DSPAB has a Digital Audio Input (DAI) and a Compressed Data Input (CDI) port for data delivery in either I²S or LJ format. DSPAB can be controlled serially using the SPI standard and can also be controlled via a Parallel host control port using the Motorola[®] or Intel[®] communication standards.

2.2 DSPC

DSPC is a 32-bit, general-purpose, fixed-point RAM-based processor which includes on-chip ROM tables. It has been designed with a generous amount of on-chip program and data RAM, and has all necessary peripherals required to support the latest standards in consumer entertainment products such as AV receivers and DVD-Audio/Video players.

DSPC has on-chip data and program RAM, and both external SDRAM and SRAM memory interfaces. These interfaces can be used to expand the data memory. DSPC also has its own 8-channel digital audio input for post-processing PCM from a Multichannel Super Audio CD (SACD) input or DVD-Audio/Video input, via high-performance A/Ds or from some other type of multichannel digital input, capable of delivering 4 stereo digital audio channels such as IEEE1394 (a.k.a. I-Link[®] or Firewire[®]). Data can be delivered to this port using the standard audio formats (I²S or LJ). DSPC can be controlled serially using the SPI standard or via Parallel host control port using the Motorola[®] or Intel[®] standard. DSPC has a Digital Audio output port that has eight stereo serial data outputs for a total of 16 channels. Data can be delivered from these outputs in serial I²S or LJ format. Two of these outputs (AUDAT3, AUDAT7) can be configured as a IEC60958-format S/PDIF transmitter.

This document focuses on the electrical features of the CS49400. The features are described from a hardware design perspective. It should be understood that not all of the features portrayed in this document are supported by all of the versions of application code available. The application code user's guides should be consulted to determine which hardware features are supported by the software.

Please note that a download of application software is required each time the part is powered up. This term should be interpreted as meaning the transfer of application code into the internal memory of the part



from either an external microcontroller or through one of the boot procedures listed in Section 8.

3. TYPICAL CONNECTION DIAGRAMS

Four typical connection diagrams have been presented to illustrate using the part with the different communication modes available. They are as follows:

Figure 27, "SPI Control with External Memory - 144 Pin Package" on page 38.

Figure 28, "Intel® Parallel Control Mode - 144 Pin Package" on page 39.

Figure 29, "Motorola® Parallel Control Mode - 144 Pin Package" on page 40.

The following should be noted when viewing the typical connection diagrams:

Note: The pins are grouped functionally in each of the typical connection diagrams. Please be aware that the CS49400 symbol may appear differently in each diagram.

The external memory interface is supported when a serial or parallel communication mode has been chosen.

3.1 Multiplexed Pins

The CS49400 incorporates a large amount of flexibility into a 144 pin package. The pins are internally multiplexed to serve multiple purposes. Some pins are designed to operate in one mode at power up, and serve a different purpose when the DSP is running. Other pins have functionality which can be controlled by the application running on the DSP. In order to better explain the behavior of the part, the pins which are multiplexed have been given multiple names. Each name is specific to the pin's operation in a particular mode.

In this document, pins will be referred to by their functionality. Section 12 "Pin Description" on page 86 describes each pin of the CS49400 and lists all of its names. Please refer to this section when exact pin numbers are in question.

3.2 Termination Requirements

The CS49400 incorporates open drain pins which must be pulled high for proper operation. $\overline{\text{FINTREQ}}$ and $\overline{\text{INTREQ}}$ are always open drains which requires a pull-up for proper operation.

Due to the internal, multiplexed design of the pins, certain signals may or may not require termination depending on the mode being used. If a parallel host communication mode is not being used, all parallel control pins must be terminated or driven as these pins will come up as high impedance inputs and will be prone to oscillation if they are left floating. The specific termination requirements may vary since the state of some of the GPIO pins will determine the communication mode at the rising edge of reset (please see Section 6 "Control" on page 41 for more information). For the explicit termination requirements of each communication mode please see the typical connection diagrams.

Generally a 3.3k Ohm resistor is recommended for open drain and mode select pins. A 10k Ohm resistor is sufficient for all other unused inputs.

3.3 Phase Locked Loop Filter

The internal phase locked loop (PLL) of the CS49400 requires an external filter. The topology of this filter is shown in the typical connection diagrams. The component values are shown below. Care should be taken when laying out the filter circuitry to minimize trace lengths and to avoid any high frequency signals. Any noise coupled onto the filter circuit will be directly coupled into the PLL, which could affect performance.

Reference Designator	Value
C1	2.2uF
C2	1200pF
C3	68pF
R1	3k Ohm

Table 1. PLL Filter Component Values



4. POWER

The CS49400 requires a 2.5V digital power supply for the core logic and 2.5V I/O and a 2.5V analog power supply for the internal PLL. For systems with external memory that runs on 3.3V, a 3.3V digital power supply is required on the VDDSD pins along with four digital grounds on VSSSD. There are seven digital power pins, VDD1 through VDD7, along with seven digital grounds, VSS1 through VSS7. There is one analog power pin, PLLVDD, and one analog ground, PLLVSS. The recommendations given below for decoupling and power conditioning of the CS49400 will help to ensure reliable performance.

4.1 Decoupling

It is necessary to decouple the power supply by placing capacitors directly between the power and ground of the CS49400. Each pair of power/ground pins (VDD1/VSS1, etc.) should have its own decoupling capacitors. The recommended procedure is to place both a 0.1 μ F and a 1 μ F capacitor as close as physically possible to each power pin. The 0.1 μ F capacitor should be closest to the part (typically 5mm or closer).

4.2 Analog Power Conditioning

In order to obtain the best performance from the CS49400's internal PLL, the analog power supply PLLVDD must be as noise-free as possible. A ferrite bead and two capacitors should be used to filter the VDD to generate PLLVDD. This power scheme is shown in the typical connection diagrams.

4.3 Ground

For two layer circuit boards, care should be taken to have sufficient ground between the DSP and parts in which it will be interfacing (DACs, ADCs, S/PDIF Receivers, microcontrollers, and especially external memory). Insufficient ground can degrade noise margins between devices resulting in data integrity problems.

4.4 Pads

The CS49400 has two different I/O voltage levels. All signal pins not associated with the External SRAM/SDRAM memory interface operate from the 2.5V supply and are 3.3V tolerant. The external SRAM/SDRAM memory interface operates at 3.3V only. However, if the external memory interface is not used VDDSD1-4 may be connected to 2.5V.



12.0 PIN DESCRIPTION

12.1 144-Pin LQFP Package Pin Layout

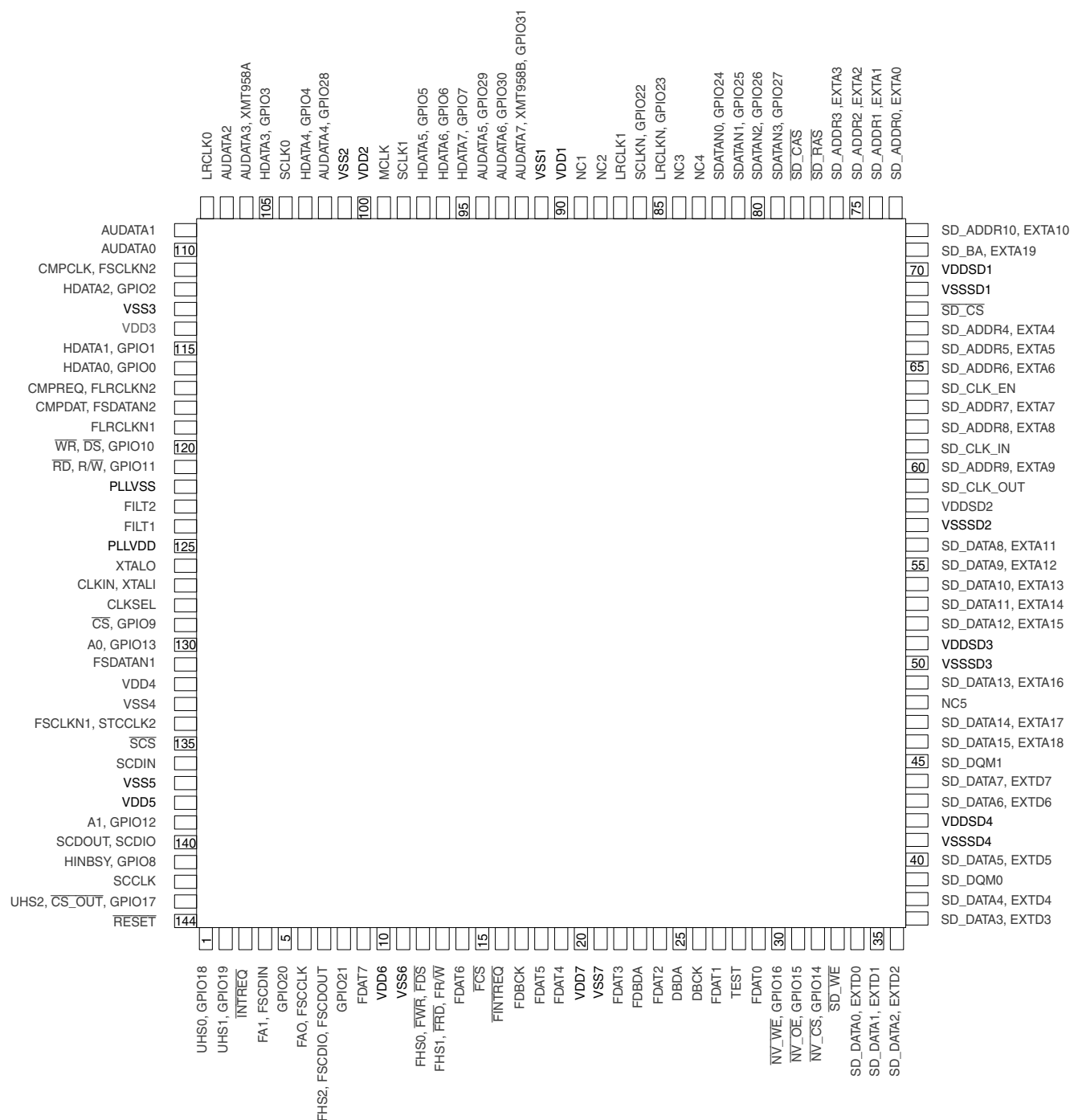

Figure 57. Pin Layout (144-Pin LQFP Package)



12.2 100-Pin LQFP Package Pin Layout

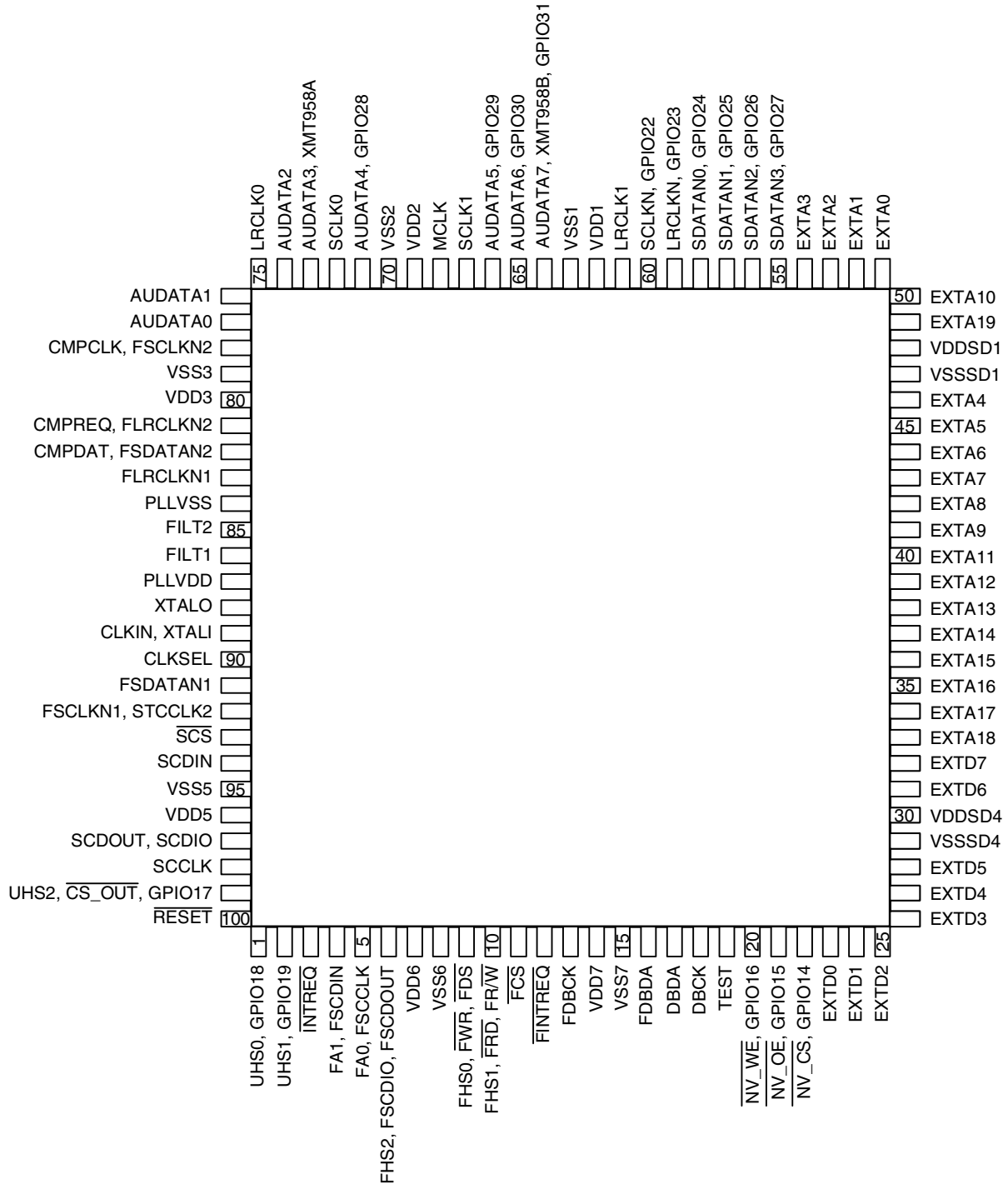

Figure 58. Pin Layout (100-Pin LQFP Package)



12.3 Pin Definitions

FILT1 — Phase-Locked Loop Filter

Connects to an external filter for the on-chip phase-locked loop.

FILT2 — Phase Locked Loop Filter

Connects to an external filter for the on-chip phase-locked loop.

CLKIN, XTALI — External Clock Input/Crystal Oscillator Input

CS49400 clock input. This pin accepts an external clock input signal that is used to drive the internal core logic. When in internal clock mode (CLKSEL == VSS), this input is connected to the internal PLL from which all internal clocks are derived. When in external clock mode (CLKSEL == VDD), this input is connected to the DSP clock. Alternatively, a 12.288 mHz crystal oscillator can be connected between XTALI and XTALO. *INPUT*

XTALO — Crystal Oscillator Output

Crystal oscillator output. *OUTPUT*

CLKSEL — DSP Clock Select

This pin selects the internal source clock. When CLKSEL is low, CLKIN is connected to the internal PLL from which all internal clocks are derived. When CLKSEL is high, the PLL is bypassed and the external clock directly drives all input logic. *INPUT*

FDAT7 — DSPAB Bidirectional Data Bus

FDAT6

FDAT5

FDAT4

FDAT3

FDAT2

FDAT1

FDAT0

In parallel host mode, these pins provide a bidirectional data bus to DSPAB. These pins have an internal pull-up.

BIDIRECTIONAL - Default: INPUT

FA0, FSCCLK — Host Parallel Address Bit Zero or Serial Control Port Clock

In parallel host mode, this pin serves as one of two address input pins used to select one of four parallel registers. In serial host mode, this pin serves as the serial control clock signal, specifically as the SPI clock input. *INPUT*



FA1, FSCDIN — Host Address Bit One or SPI Serial Control Data Input

In parallel host mode, this pin serves as one of two address input pins used to select one of four parallel registers. In SPI serial host mode, this pin serves as the data input. *INPUT*

FHS1, $\overline{\text{FRD}}$, $\overline{\text{FR/W}}$ — Mode Select Bit 1 or Host Parallel Output Enable or Host Parallel R/W

DSPAB control port mode select bit 1. This bit is one of 3 control port select bits that are sampled on the rising edge of $\overline{\text{RESET}}$ to determine the control port mode of DSPAB. In Intel parallel host mode, this pin serves as the active-low data bus enable input. In Motorola parallel host mode, this pin serves as the read-high/write-low control input signal. In serial host mode, this pin can serve as the external memory active-low data-enable output signal. *BIDIRECTIONAL - Default: INPUT*

FHS0, $\overline{\text{FWR}}$, $\overline{\text{FDS}}$ — Mode Select Bit 0 or Host Write Strobe or Host Data Strobe

DSPAB control port mode select bit 0. This bit is one of 3 control port select bits that are sampled on the rising edge of $\overline{\text{RESET}}$ to determine the control port mode of DSPAB. In Intel parallel host mode, this pin serves as the active-low data-write-input strobe. In Motorola parallel host mode, this pin serves as the active-low data-strobe-input signal. In serial host mode, this pin can serve as the external-memory active-low write-enable output signal. *BIDIRECTIONAL - Default: INPUT*

$\overline{\text{FCS}}$ — Host Parallel Chip Select, Host Serial SPI Chip Select

In parallel host mode, this pin serves as the active-low chip-select input signal. In serial host SPI mode, this pin is used as the active-low chip-select input signal. *INPUT*

FHS2, FSCDIO, FSCDOUT — Mode Select Bit 2 or Serial Control Port Data Input and Output, Parallel Port Type Select

DSPAB control port mode select bit 2. This bit is one of 3 control port select bits that are sampled on the rising edge of $\overline{\text{RESET}}$ to determine the control port mode of DSPAB. In SPI mode this pin serves as the data output pin. In parallel host mode, this pin is sampled at the rising edge of $\overline{\text{RESET}}$ to configure the parallel host mode as an Intel type bus or as a Motorola type bus. *BIDIRECTIONAL - Default: INPUT*

$\overline{\text{FINTREQ}}$ — Control Port Interrupt Request

Open-drain interrupt-request output. This pin is driven low to indicate that the DSP has outgoing control data that should be read by the host.
OPEN DRAIN I/O - Requires 3.3K Ohm Pull-Up

FSCLKN1, STCLK2 — PCM Audio Input Bit Clock

Digital-audio bit clock input. FSCLKN1 operates asynchronously from all other DSPAB clocks. In master mode, FSCLKN1 is derived from DSPAB's internal clock generator. The active edge of FSCLKN1 can be programmed by the DSP.
BIDIRECTIONAL - Default: INPUT

FLRCLKN1 — PCM Audio Input Sample Rate Clock



Digital-audio frame clock input. FLRCLKN1 typically is run at the sampling frequency. FLRCLKN1 operates asynchronously from all other DSPAB clocks. The polarity of FLRCLKN1 for a particular subframe can be programmed by the DSP.

BIDIRECTIONAL - Default: INPUT

FSDATAN1 — PCM Audio Data Input One

Digital-audio data input that can accept from one compressed line or 2 channels of PCM data. FSDATAN1 can be sampled with either edge of FSCLKN1, depending on how FSCLKN1 has been configured. *INPUT*

CMPCLK, FSCLKN2 — PCM Audio Input Bit Clock

Digital-audio bit clock input. FSCLKN2 operates asynchronously from all other DSPAB clocks. The active edge of FSCLKN2 can be programmed by the DSP.

BIDIRECTIONAL - Default: INPUT

CMPDAT, FSDATAN2 — PCM Audio Data Input Number Two

Digital-audio data input that can accept either one compressed line or 2 channels of PCM data. FSDATAN2 can be sampled with either edge of FSCLKN2, depending on how FSCLKN2 has been configured.

BIDIRECTIONAL - Default: INPUT

FDBCK — Reserved

This pin is reserved and should be pulled up with an external 3.3k resistor. *INPUT*

FDBDA — Reserved

This pin is reserved and should be pulled up with an external 3.3k resistor.

BIDIRECTIONAL - Default: INPUT

PLLVDV — PLL Supply Voltage

2.5 V PLL supply.

PLLVSS — PLL Ground Voltage

PLL ground.

$\overline{\text{RESET}}$ — Master Reset Input

Asynchronous active-low master reset input. Reset should be low at power-up to initialize the DSP and to guarantee that the device is not active during initial power-on stabilization periods. At the rising edge of reset the host interface mode of DSPAB is selected contingent on the state of the FHS0, FHS1, and FHS2 pins. At the rising edge of reset the host interface mode of DSPC is selected contingent on the state of the UHS0, UHS1, and UHS2 pins. If reset is low all bidirectional pins are high-Z inputs. *INPUT*

TEST — Reserved



This should be tied low for normal operation. *INPUT*

MCLK — Audio Master Clock

Bidirectional master audio clock. As an output, MCLK provides a low jitter oversampling clock. MCLK supports all standard oversampling frequencies. *BIDIRECTIONAL - Default: INPUT*

SCLK0 — Audio Output Bit Clock

Bidirectional digital-audio output bit clock for AUDATA0, AUDATA1, AUDATA2, and AUDATA3. As an output, SCLK0 can provide 32 Fs, 64 Fs, 128 Fs, 256 Fs, or 512 Fs frequencies and is synchronous to MCLK. As an input, SCLK0 is independent of MCLK.

BIDIRECTIONAL - Default: INPUT

SCLK1 — Audio Output Bit Clock

Bidirectional digital-audio output bit clock for AUDATA4, AUDATA5, AUDATA6, and AUDATA7. As an output, SCLK1 can provide 32 Fs, 64 Fs, 128 Fs, 256 Fs, or 512 Fs frequencies and is synchronous to MCLK. As an input, SCLK1 is independent of MCLK.

BIDIRECTIONAL - Default: INPUT

LRCLK0 — Audio Output Sample Rate Clock

Bidirectional digital-audio output frame clock for AUDATA0, AUDATA1, AUDATA2, and AUDATA3. As an output, LRCLK0 can provide all standard output sample rates up to 192 kHz and is synchronous to MCLK. As an input, LRCLK0 is independent of MCLK.

BIDIRECTIONAL - Default: INPUT

LRCLK1 — Audio Output Sample Rate Clock

Bidirectional digital-audio output frame clock for AUDATA4, AUDATA5, AUDATA6, and AUDATA7. As an output, LRCLK1 can provide all standard output sample rates up to 192 kHz and is synchronous to MCLK. As an input, LRCLK1 is independent of MCLK.

BIDIRECTIONAL - Default: INPUT

AUDATA0 — Digital Audio Output 0

PCM digital-audio data output. *OUTPUT*

AUDATA1 — Digital Audio Output 1

PCM digital-audio data output. *OUTPUT*

AUDATA2 — Digital Audio Output 2

PCM digital-audio data output. *OUTPUT*

AUDATA3, XMT958A — Digital Audio Output 3, S/PDIF Transmitter



CMOS level output that outputs a biphase-mark encoded (S/PDIF) IEC60958 signal or digital audio data which is capable of carrying two channels of PCM digital audio. *OUTPUT*

AUDATA4, GPIO28 — Digital Audio Output 4, General Purpose I/O

PCM digital-audio data output. This pin can act as a general-purpose input or output that can be individually configured and controlled by DSPC. *BIDIRECTIONAL - Default: OUTPUT*

AUDATA5, GPIO29 — Digital Audio Output 5, General Purpose I/O

PCM digital-audio data output. This pin can act as a general-purpose input or output that can be individually configured and controlled by DSPC. *BIDIRECTIONAL - Default: OUTPUT*

AUDATA6, GPIO30 — Digital Audio Output 6, General Purpose I/O

PCM digital-audio data output. This pin can act as a general-purpose input or output that can be individually configured and controlled by DSPC. *BIDIRECTIONAL - Default: OUTPUT*

AUDATA7, XMT958B, GPIO31 — Digital Audio Output 7, S/PDIF Transmitter, General Purpose I/O

CMOS level output that contains a biphase-mark encoded (S/PDIF) IEC60958 signal or digital audio data which is capable of carrying two channels of PCM digital audio. This pin can also act as a general-purpose input or output that can be individually configured and controlled by DSPC. *BIDIRECTIONAL - Default: OUTPUT*

DBCK — Debug Clock

Must be tied high to 3.3k ohm resistor. *INPUT*

DBDA — Debug Data

Must be tied high to 3.3k ohm resistor. *BIDIRECTIONAL - Default: INPUT*

SLCKN, GPIO22 — PCM Audio Input Bit Clock, General Purpose I/O

Digital-audio bit clock that is an input. SCLKN operates asynchronously from all other DSPAB clocks. The active edge of SCLKN can be programmed by the DSP. This pin can act as a general-purpose input or output that can be individually configured and controlled by DSPC. *BIDIRECTIONAL - Default: INPUT*

LRCLKN, GPIO23 — PCM Audio Input Sample Rate Clock, General Purpose I/O

Digital-audio frame clock input. LRCLKN operates asynchronously from all other DSPAB clocks. The polarity of LRCLKN for a particular subframe can be programmed by the DSP. This pin can act as a general-purpose input or output that can be individually configured and controlled by DSPC. *BIDIRECTIONAL - Default: INPUT*

SDATAN0, GPIO24 — PCM Audio Input Data, General Purpose I/O

Digital-audio PCM data input. This pin can act as a general-purpose input or output that can be individually configured and controlled by DSPC. *BIDIRECTIONAL - Default: INPUT*

SDATAN1, GPIO25 — PCM Audio Input Data, General Purpose I/O



Digital-audio PCM data input. This pin can act as a general-purpose input or output that can be individually configured and controlled by DSPC. *BIDIRECTIONAL - Default: INPUT*

SDATAN2, GPIO26 — PCM Audio Input Data, General Purpose I/O

Digital-audio PCM data input. This pin can act as a general-purpose input or output that can be individually configured and controlled by DSPC. *BIDIRECTIONAL - Default: INPUT*

SDATAN3, GPIO27 — PCM Audio Input Data, General Purpose I/O

Digital-audio PCM data input. This pin can act as a general-purpose input or output that can be individually configured and controlled by DSPC. *BIDIRECTIONAL - Default: INPUT*

SCS — Host Serial SPI Chip Select

SPI mode active-low chip-select input signal. *INPUT*

SCCLK — Serial Control Port Clock

This pin serves as the serial SPI clock input. *INPUT*

SCDIN — SPI Serial Control Data Input

In SPI mode this pin serves as the data input pin. *INPUT*

SCDOUT, SCDIO — Serial Control Port Data Input and Output

In SPI mode this pin serves as the data output pin. *BIDIRECTIONAL - Default: OUTPUT in SPI mode*

INTREQ — Control Port Interrupt Request

Open-drain interrupt-request output. This pin is driven low to indicate that DSPC has outgoing control data and should be serviced by the host.
OPEN DRAIN I/O - Requires 3.3K Ohm Pull-Up

**HDATA7, GPIO7 — DSPC Bidirectional Data Bus, General Purpose I/O****HDATA6, GPIO6****HDATA5, GPIO5****HDATA4, GPIO4****HDATA3, GPIO3****HDATA2, GPIO2****HDATA1, GPIO1****HDATA0, GPIO0**

In parallel host mode, these pins provide a bidirectional data bus. These pins can also act as general purpose input or output pins that can be individually configured and controlled by DSPC. These pins have an internal pull-up. *BIDIRECTIONAL - Default: INPUT*

A0, GPIO13 — Host Parallel Address Bit 0, General Purpose I/O

In parallel host mode, this pin serves as the LS Bit of a two bit address input used to select one of four parallel registers. This pin can act as a general-purpose input or output that can be individually configured and controlled by DSPC. *BIDIRECTIONAL - Default: INPUT*

A1, GPIO12 — Host Address Bit 1, General Purpose I/O

In parallel host mode, this pin serves as the MS Bit of a two bit address input used to select one of four parallel registers. This pin can act as a general-purpose input or output that can be individually configured and controlled by DSPC. *BIDIRECTIONAL - Default: INPUT*

 \overline{RD} , $\overline{R/W}$, GPIO11 — Host Parallel Output Enable, Host Parallel $\overline{R/W}$, General Purpose I/O

In Intel parallel host mode, this pin serves as the active-low data bus enable input. In Motorola parallel host mode, this pin serves as the read-high/write-low control input signal. This pin can act as a general-purpose input or output that can be individually configured and controlled by DSPC. This pin has an internal pull-up. *BIDIRECTIONAL - Default: INPUT*

 \overline{WR} , \overline{DS} , GPIO10 — Host Write Strobe, Host Data Strobe, General Purpose I/O

In Intel parallel host mode, this pin serves as the active-low data bus enable input. In Motorola parallel host mode, this pin serves as the read-high/write-low control input signal. In serial host mode, this pin can serve as a general purpose input or output bit. This pin can act as a general-purpose input or output that can be individually configured and controlled by DSPC. This pin has an internal pull-up.
BIDIRECTIONAL - Default: INPUT

 \overline{CS} , GPIO9 — Host Parallel Chip Select, General Purpose I/O

In parallel host mode, this pin serves as the active-low chip-select input signal. This pin can act as a general-purpose input or output that can be individually configured and controlled by DSPC. This pin has an internal pull-up. *BIDIRECTIONAL - Default: INPUT*



HINBSY, GPIO8 — Input Host Message Status, General Purpose I/O

This pin indicates that serial or parallel communication data written to the DSP has not been read yet. This pin can act as a general-purpose input or output that can be individually configured and controlled by DSPC. This pin has an internal pull-up. *BIDIRECTIONAL - Default: OUTPUT*

SD_DATA15, EXTA18 — SDRAM Data Bus, SRAM External Address Bus

SD_DATA14, EXTA17

SD_DATA13, EXTA16

SD_DATA12, EXTA15

SD_DATA11, EXTA14

SD_DATA10, EXTA13

SD_DATA9, EXTA12

SD_DATA8, EXTA11

SDRAM data bus 15:8. SRAM external address bus 18:11. *OUTPUT*

SD_DATA7, EXTD7 — SDRAM Data Bus, SRAM External Data Bus

SD_DATA6, EXTD6

SD_DATA5, EXTD5

SD_DATA4, EXTD4

SD_DATA3, EXTD3

SD_DATA2, EXTD2

SD_DATA1, EXTD1

SD_DATA0, EXTD0

SDRAM data bus 7:0. SRAM external data bus 7:0. *BIDIRECTIONAL - Default: INPUT*

SD_ADDR10, EXTA10 — SDRAM Address Bus, SRAM External Address Bus

SD_ADDR9, EXTA9

SD_ADDR8, EXTA8

SD_ADDR7, EXTA7

SD_ADDR6, EXTA6

SD_ADDR5, EXTA5

SD_ADDR4, EXTA4

SD_ADDR3, EXTA3

SD_ADDR2, EXTA2

SD_ADDR1, EXTA1

SD_ADDR0, EXTA0

SDRAM address bus 10:0. SRAM external address bus 10:0. *OUTPUT*



SD_CLK_OUT — SDRAM Clock Output

SDRAM clock output. *OUTPUT*

SD_CLK_IN — SDRAM Re-timing Clock Input

SDRAM re-timing clock input. *INPUT*

SD_CLK_EN — SDRAM Clock Enable

SDRAM clock enable. *OUTPUT*

SD_BA, EXTA19 — SDRAM Bank Address Select, SRAM External Address Bus

SDRAM bank address select. SRAM external address bus 19. *OUTPUT*

$\overline{\text{SD_CS}}$ — SDRAM Chip Select

SDRAM chip select. *OUTPUT*

$\overline{\text{SD_RAS}}$ — SDRAM Row Address Strobe

SDRAM row address strobe. *OUTPUT*

$\overline{\text{SD_CAS}}$ — SDRAM Column Address Strobe

SDRAM column address strobe. *OUTPUT*

$\overline{\text{SD_WE}}$ — SDRAM Write Enable

SDRAM write enable. *OUTPUT*

SD_DQM1 — SDRAM Data Mask 1

SDRAM data mask 1. *OUTPUT*

SD_DQM0 — SDRAM Data Mask 2

SDRAM data mask 0. *OUTPUT*

$\overline{\text{NV_CS}}$, GPIO14 — SRAM Chip Select, General Purpose I/O

SRAM/Flash chip select. This pin can act as a general-purpose input or output that can be individually configured and controlled by DSPC. *BIDIRECTIONAL - Default: OUTPUT*

$\overline{\text{NV_OE}}$, GPIO15 — SRAM Output Enable, General Purpose I/O

SRAM/Flash output enable. This pin can act as a general-purpose input or output that can be individually configured and controlled by DSPC. *BIDIRECTIONAL - Default: OUTPUT*

**NV_WE, GPIO16 — SRAM Write Enable, General Purpose I/O**

SRAM/Flash write enable. This pin can act as a general-purpose input or output that can be individually configured and controlled by DSPC. *BIDIRECTIONAL - Default: OUTPUT*

UHS2, CS_OUT, GPIO17 — Mode Select Bit 2, External Serial Memory Chip Select, General Purpose I/O

DSPC control port mode select bit 2. This pin is sampled at the rising edge of $\overline{\text{RESET}}$ and is one of three pins used to select the control port mode. In serial control port mode, this pin can serve as an output to provide the chip-select for a serial EEPROM. This pin can act as a general-purpose input or output that can be individually configured and controlled by DSPC. *BIDIRECTIONAL - Default: INPUT*

UHS0, GPIO18 — Mode Select Bit 0, General Purpose I/O

DSPC control port mode select bit 0. This pin is sampled at the rising edge of $\overline{\text{RESET}}$ and is one of three pins used to select the control port mode. This pin can act as a general-purpose input or output that can be individually configured and controlled by DSPC. *BIDIRECTIONAL - Default: INPUT*

UHS1, GPIO19 — Mode Select Bit 1, General Purpose I/O

DSPC control port mode select bit 1. This pin is sampled at the rising edge of $\overline{\text{RESET}}$ and is one of three pins used to select the control port mode. This pin can act as a general-purpose input or output that can be individually configured and controlled by DSPC. *BIDIRECTIONAL - Default: INPUT*

GPIO20 — General Purpose I/O

This pin can act as a general-purpose input or output that can be individually configured and controlled by DSPC. This pin has an internal pull-up. *BIDIRECTIONAL - Default: INPUT*

GPIO21 — General Purpose I/O

This pin can act as a general-purpose input or output that can be individually configured and controlled by DSPC. This pin has an internal pull-up. *BIDIRECTIONAL - Default: INPUT*

VDD[7:1] — 2.5V Supply Voltage

2.5V supply voltage.

VSS — 2.5V Ground

2.5V ground.



NC[5:1] — No Connect

Recommended tie to ground.

VDDSD[4:1] — 3.3V SDRAM/SRAM/EPROM Interface Supply

3.3V SDRAM/SRAM/EPROM supply.

VSSSD — 3.3V SDRAM/SRAM/EPROM Interface Ground

3.3V ground.

BLOCK DIAGRAM

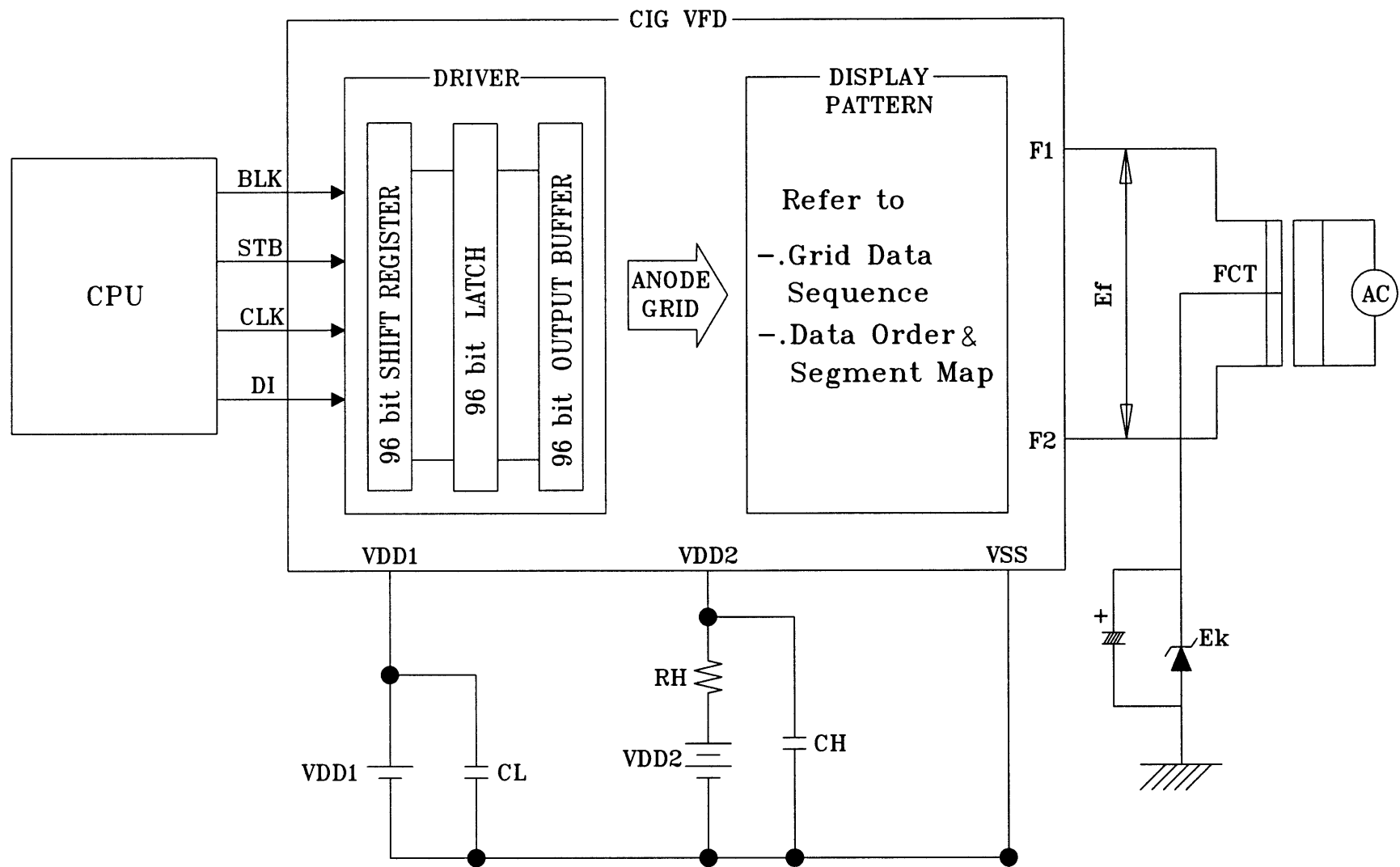

NOTE

RH: Current limit resistor for protecting IC.

CH,CL: Low pass filter for noise filtering.

RH: 22Ω, CH: 0.1 μF, CL: 0.1 μF

FCT: Filament is center-tab grounded.

MODEL : HCA-18ML01
 BLOCK DIAGRAM
 Rev. ① 20-Feb-2003

OUTER DIMENSIONS

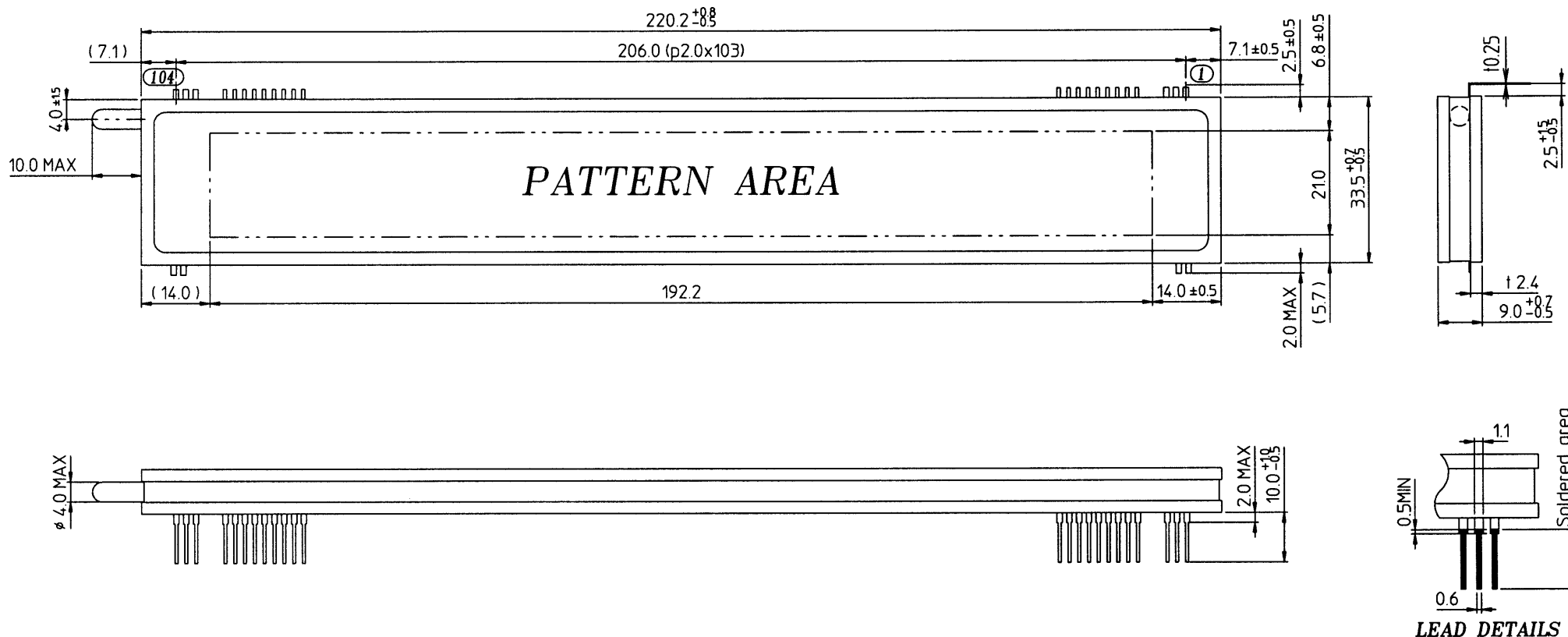

PIN CONNECTION

PIN NO.	104	103	102	101	100	99	98	97	96	95	94	93	92	91	90~15	14~6	5	4	3	2	1
CONNECTION	F2	F2	F2	NP	NP	VDD2	VSS	VSS	CLK	D0	DI	BLK	STB	VDD1	NP	NC	NP	NP	F1	F1	F1

***Notes**

Fn : Filament Pin

* D0(Serial data output) : Be left open if not used.

NP : No Pin

NC : No Connection Pin

MODEL : HCA-18ML01
 OUTER DIMENSIONS
 Rev. ① 20-Feb-2003



HCF4053B

TRIPLE 2-CHANNEL ANALOG MULTIPLEXER/DEMULTIPLEXER

- LOW "ON" RESISTANCE : 125Ω (Typ.)
OVER 15V p.p SIGNAL-INPUT RANGE FOR
 $V_{DD} - V_{EE} = 15V$
- HIGH "OFF" RESISTANCE : CHANNEL
LEAKAGE $\pm 100pA$ (Typ.) at $V_{DD} - V_{EE} = 18V$
- BINARY ADDRESS DECODING ON CHIP
- HIGH DEGREE OF LINEARITY : < 0.5%
DISTORTION TYP. at $f_{IS} = 1KHz$, $V_{IS} = 5 V_{pp}$,
 $V_{DD} - V_{SS} \geq 10V$, $R_L = 10K\Omega$
- VERY LOW QUIESCENT POWER
DISSIPATION UNDER ALL DIGITAL
CONTROL INPUT AND SUPPLY
CONDITIONS : 0.2 μW (Typ.)
at $V_{DD} - V_{SS} = V_{DD} - V_{EE} = 10V$
- MATCHED SWITCH CHARACTERISTICS :
 $R_{ON} = 5\Omega$ (Typ.) FOR $V_{DD} - V_{EE} = 15V$
- WIDE RANGE OF DIGITAL AND ANALOG
SIGNAL LEVELS : DIGITAL 3 to 20,
ANALOG TO 20V p.p.
- QUIESCENT CURRENT SPECIF. UP TO 20V
- 5V, 10V AND 15V PARAMETRIC RATINGS
- INPUT LEAKAGE CURRENT
 $I_l = 100nA$ (MAX) AT $V_{DD} = 18V$ $T_A = 25^\circ C$
- 100% TESTED FOR QUIESCENT CURRENT
- MEETS ALL REQUIREMENTS OF JEDEC
JESD13B " STANDARD SPECIFICATIONS
FOR DESCRIPTION OF B SERIES CMOS
DEVICES"

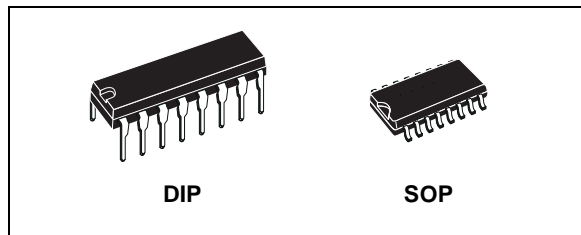

ORDER CODES

PACKAGE	TUBE	T & R
DIP	HCF4053BEY	
SOP	HCF4053BM1	HCF4053M013TR

technology available in DIP and SOP packages. The HCF4053B analog multiplexer/demultiplexer is a digitally controlled analog switch having low ON impedance and very low OFF leakage current. This multiplexer circuit dissipate extremely low quiescent power over the full $V_{DD} - V_{SS}$ and $V_{DD} - V_{EE}$ supply voltage range, independent of the logic state of the control signals. When a logic "1" is present at the inhibit input terminal all channel are off. This device is a triple 2-channel multiplexer having three separate digital control inputs, A, B, and C, and an inhibit input. Each control input selects one of a pair of channels which are connected in a single pole double-throw configuration.

DESCRIPTION

The HCF4053B is a monolithic integrated circuit fabricated in Metal Oxide Semiconductor

PIN CONNECTION

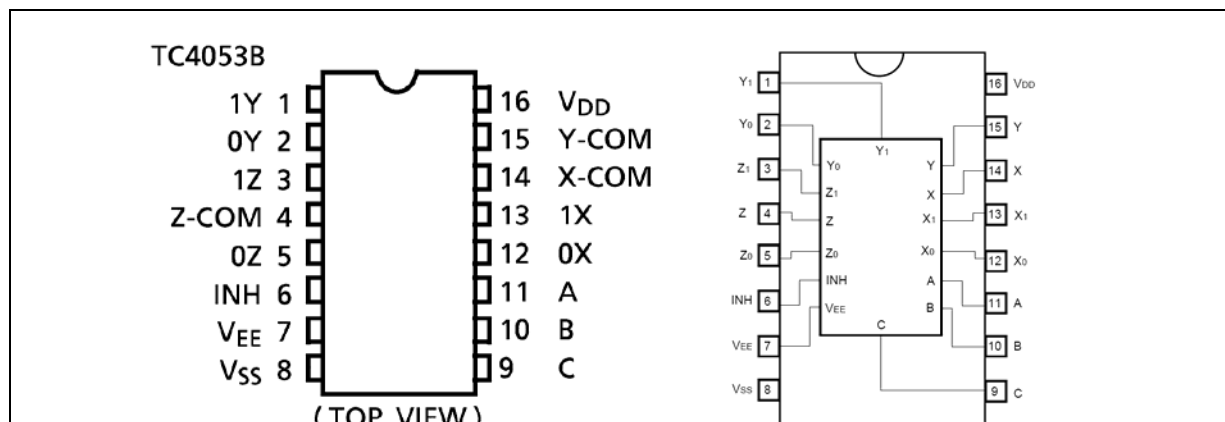

HCF4053B

INPUT EQUIVALENT CIRCUIT

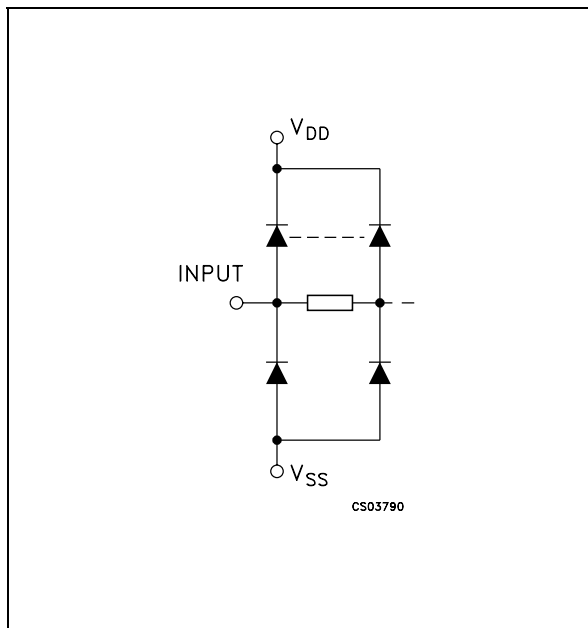

PIN DESCRIPTION

PIN No	SYMBOL	NAME AND FUNCTION
11, 10, 9	A, B, C	Binary Control Inputs
6	INH	Inhibit Inputs
12, 13, 2, 1, 5, 3	IN/OUT	ax,ay,bx,by,cx,cy Input/Output
14	OUT/IN	ax or ay
15	OUT/IN	bx or by
4	OUT/IN	cx or cy
7	V _{EE}	Supply Voltage
8	V _{SS}	Negative Supply Voltage
16	V _{DD}	Positive Supply Voltage

TRUTH TABLE

INHIBIT	C or B or A	
0	0	ax or bx or cx
0	1	ay or by or cy
1	X	NONE

X : Don't Care

FUNCTIONAL DIAGRAM

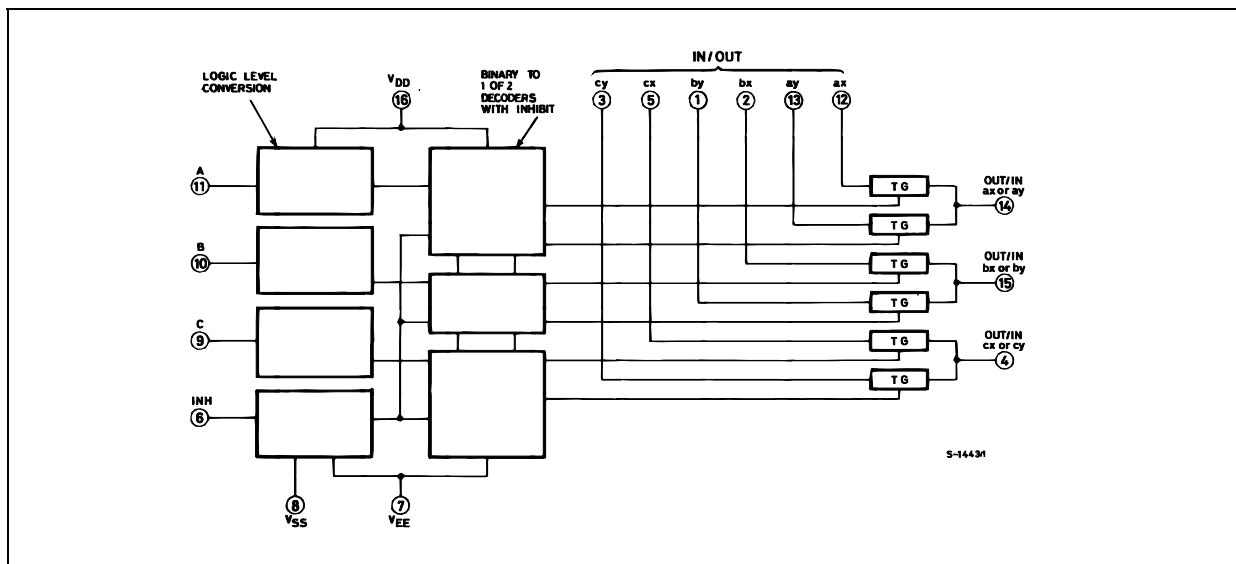

Ordering number : ※ EN5039

CMOS IC

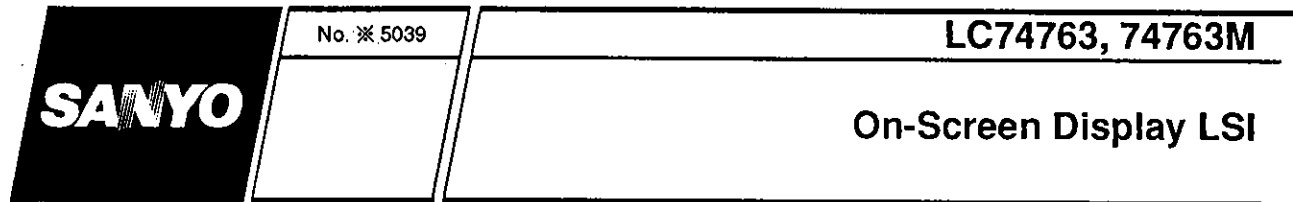

Preliminary

Overview

The LC74763 and LC74763M are on-screen display CMOS LSIs that superimpose text and low-level graphics onto a TV screen (video signal) under the control of a microcontroller. The display characters have a 12 by 18 dots structure, and 128 characters are provided.

Features

- Display structure: 12 lines by 24 characters (up to 288 characters)
- Maximum character display: Up to 288 characters
- Character configuration: 12 (W) by 18 (H) dots structure
- Number of characters: 128 characters (128 plus space 2 fonts)
- Character sizes: Three sizes (normal, double, and triple sizes)
- Display starting positions: 64 horizontal and 64 vertical locations
- Reverse video function: Characters can be inverted on a per character basis.
- Flashing types: Two types with periods of 0.5 and 1.0 second on a per character basis (duty fixed at 50%)
- Background color: One of eight colors (when internal synchronization used)
- External control input: Serial data input in 8-bit units
- Built-in horizontal/vertical sync separation circuit, AFC circuit, and synchronization detector
- Video output: Composite video signal output in NTSC, PAL, PAL-M, PAL-N, PAL60, NTSC4.43, or SECAM format

Package Dimensions

unit: mm

3196-DIP30SD

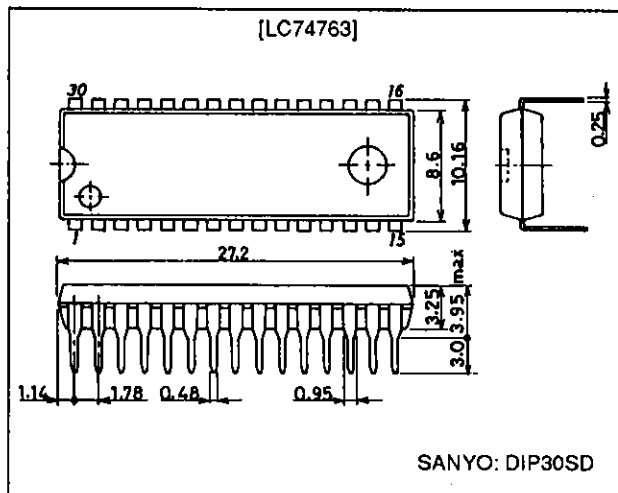

3216A-MFP30S

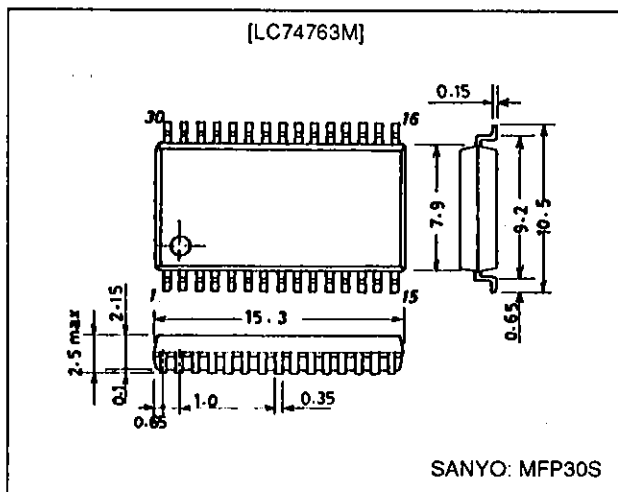

O.S.D IC (74763M)

Pin Functions (IC51)

Pin No.	Symbol	Function	Description
1	V _{SS}	Ground	Ground connection
2	Xtal _{IN1}	Crystal oscillator connection	Connection for the crystal and capacitor used to form the crystal oscillator that generates the internal synchronization signal. The oscillator can be selected with a command switch.
3	Xtal _{OUT1}		
4	HSYNC _{OUT}	Horizontal synchronization output	Outputs the horizontal synchronization signal (AFC). The output polarity can be selected (metal option). Also functions as general output port (command switch).
5	Xtal _{IN2}	Crystal oscillator connection	Connection for the crystal and capacitor used to form the crystal oscillator that generates the internal synchronization signal.
6	Xtal _{OUT2}		
7	VSYNC _{OUT}	Vertical synchronization output	Outputs the vertical synchronization signal. The output polarity can be selected (metal option). Also functions as general output port (command switch).
8	\overline{CS}	Enable input	Enables/disables serial data input. Serial data is enabled when this pin is low (hysteresis input). Pull-up resistor built in (metal option).
9	SIN	Data input	Serial data input (hysteresis input). Pull-up resistor built in (metal option).
10	SCLK	Clock input	Clock input for serial data input (hysteresis input). Pull-up resistor built in (metal option).
11	SECAM	SECAM mode switch input/output (command switch)	During input, switches between SECAM and other modes. During output, functions as general output port or internal V output (command switch). Low = other modes, high = SECAM mode
12	$\overline{525/625}$	525/625 switch input/output (command switch)	During input, switches between 525 scan lines and 625 scan lines. During output, functions as general output port or character data output (command switch). Low = 525 lines, high = 625 lines
13	$\overline{NTSC/PAL}$	NTSC/PAL switch input/output (command switch)	Switches the color mode between NTSC and PAL. During output, functions as general output port or frame data output (command switch). Low = NTSC, high = PAL
14	$\overline{3.58/4.43}$	3.58/4.43 switch input/output (command switch)	Switch FSC between 3.58 MHz and 4.43 MHz. During output, functions as general output port or halftone output (command switch). Low = 3.58, high = 4.43
15	\overline{RST}	Reset input	System reset input pin, low is active (hysteresis input). Pull-up resistor built in (metal option).
16	CV _{OUT}	Video signal output	Composite video output
17	V _{DD2}	Power supply connection	Power supply connection for composite video signal level generation
18	CV _{IN}	Video signal input	Composite video input
19	CV _{CR}	Video signal input	SECAM chroma signal input
20	SYNC _{IN}	Sync separator circuit input	Built-in sync separator circuit video signal input
21	SEP _C	Sync separator circuit	Built-in sync separator circuit
22	V _{SS}	Ground	Ground connection
23	PD _{OUT}	Control voltage output	AFC control voltage output
24	AMP _{IN}	AFC filter connection	Filter connection
25	AMP _{OUT}		
26	FC	Control voltage input	AFC control voltage input
27	VCO _{IN}	LC oscillator connection	VCO LC oscillator circuit coil and capacitor connection
28	VCO _{OUT}		
29	SYNC _{DET}	External synchronization signal detection output	Outputs the exclusive NOR of the horizontal synchronization signal (AFC) and CSYNC (sync separator). The output polarity can be selected (metal option). Also functions as general output port (command switch).
30	V _{DD1}	Power supply connection	Power supply connection (+5 V: digital system power supply)

LC74763, 74763M

Pin Assignment

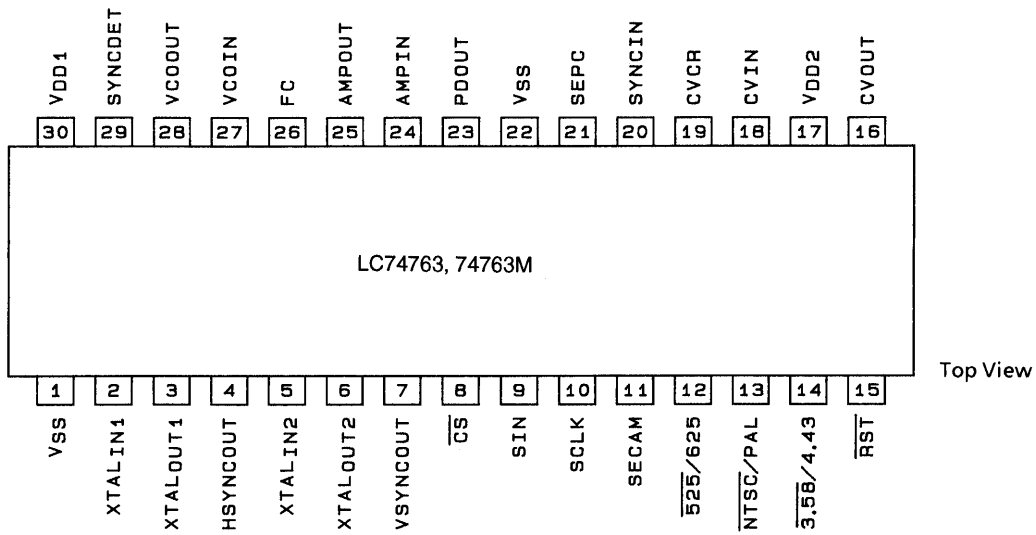

Top View

A03518

Top view

Serial Data Input Timing

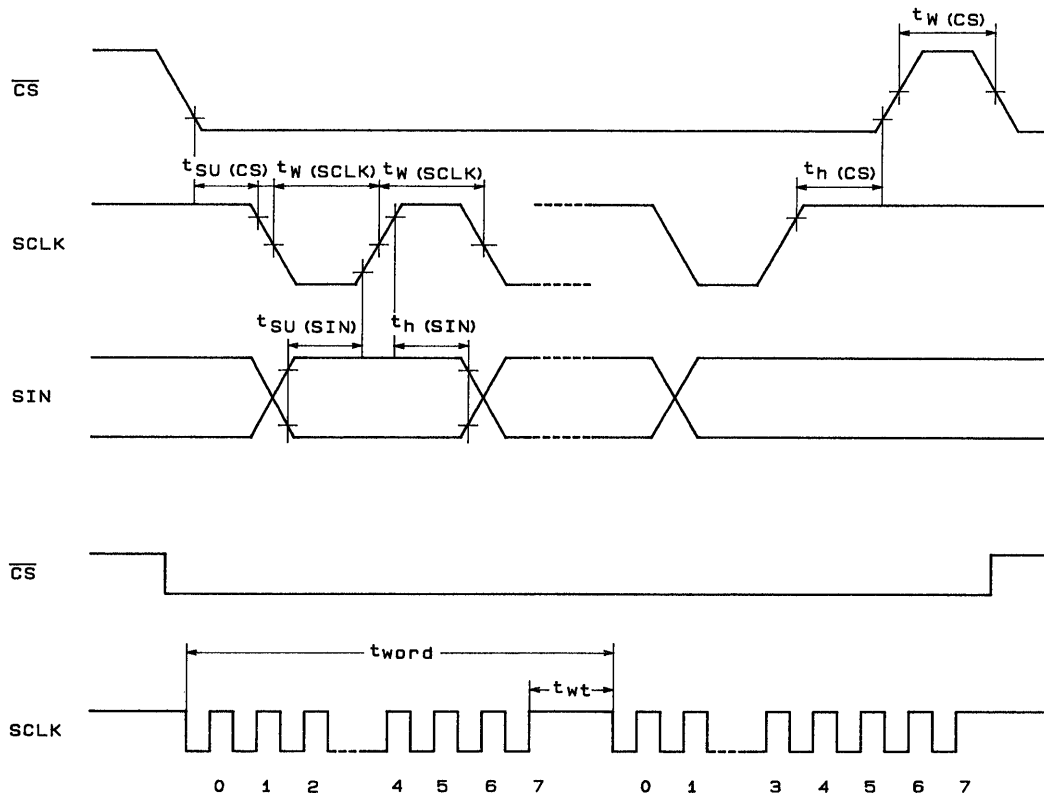

A03519

LC74763M BLOCK DIAGRAM

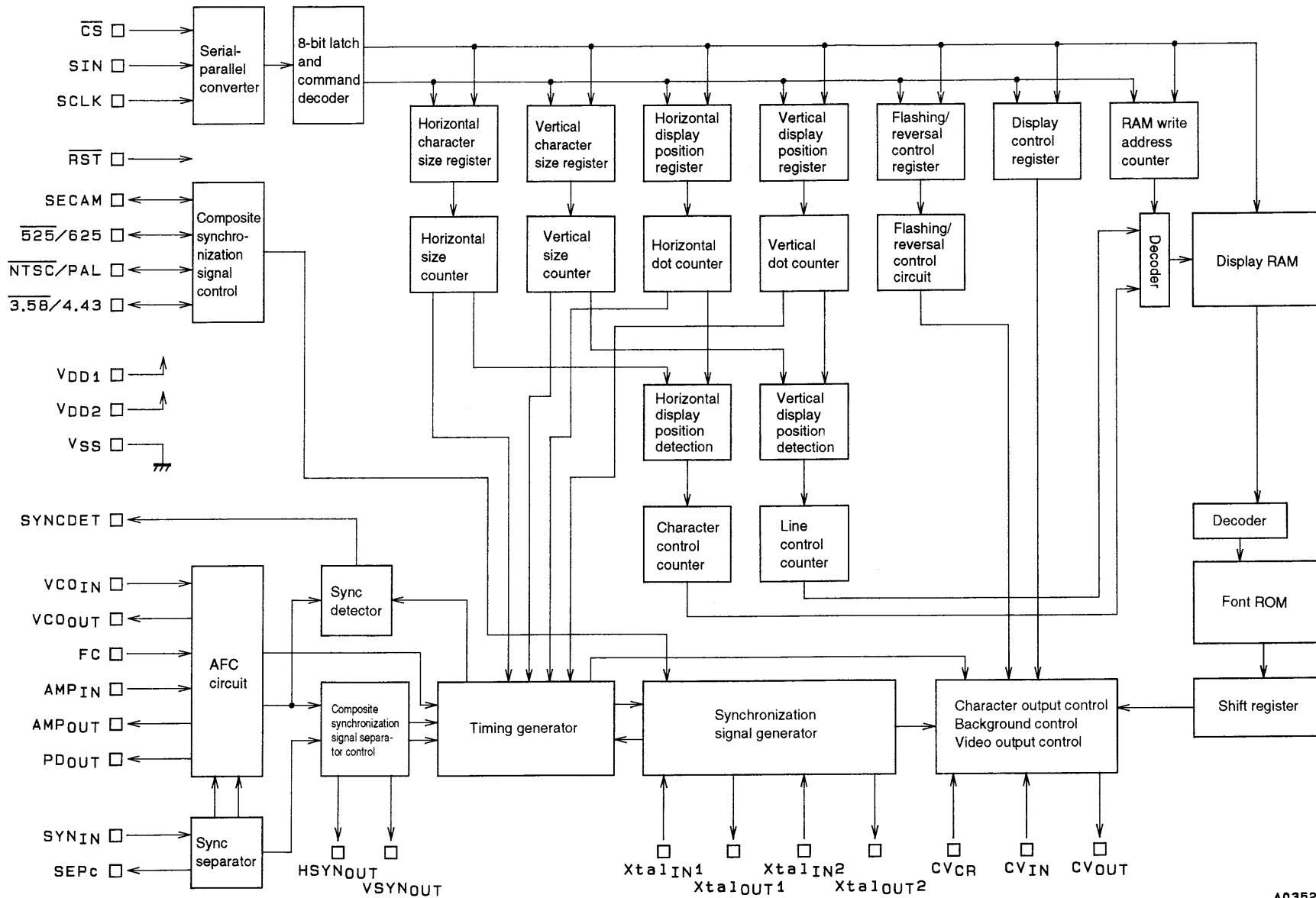

A03520

U-COM IC PIN ASSIGNMENT & DESCRIPTIONS

■ PIN ASSIGNMENT (IC72)

(TOP VIEW)

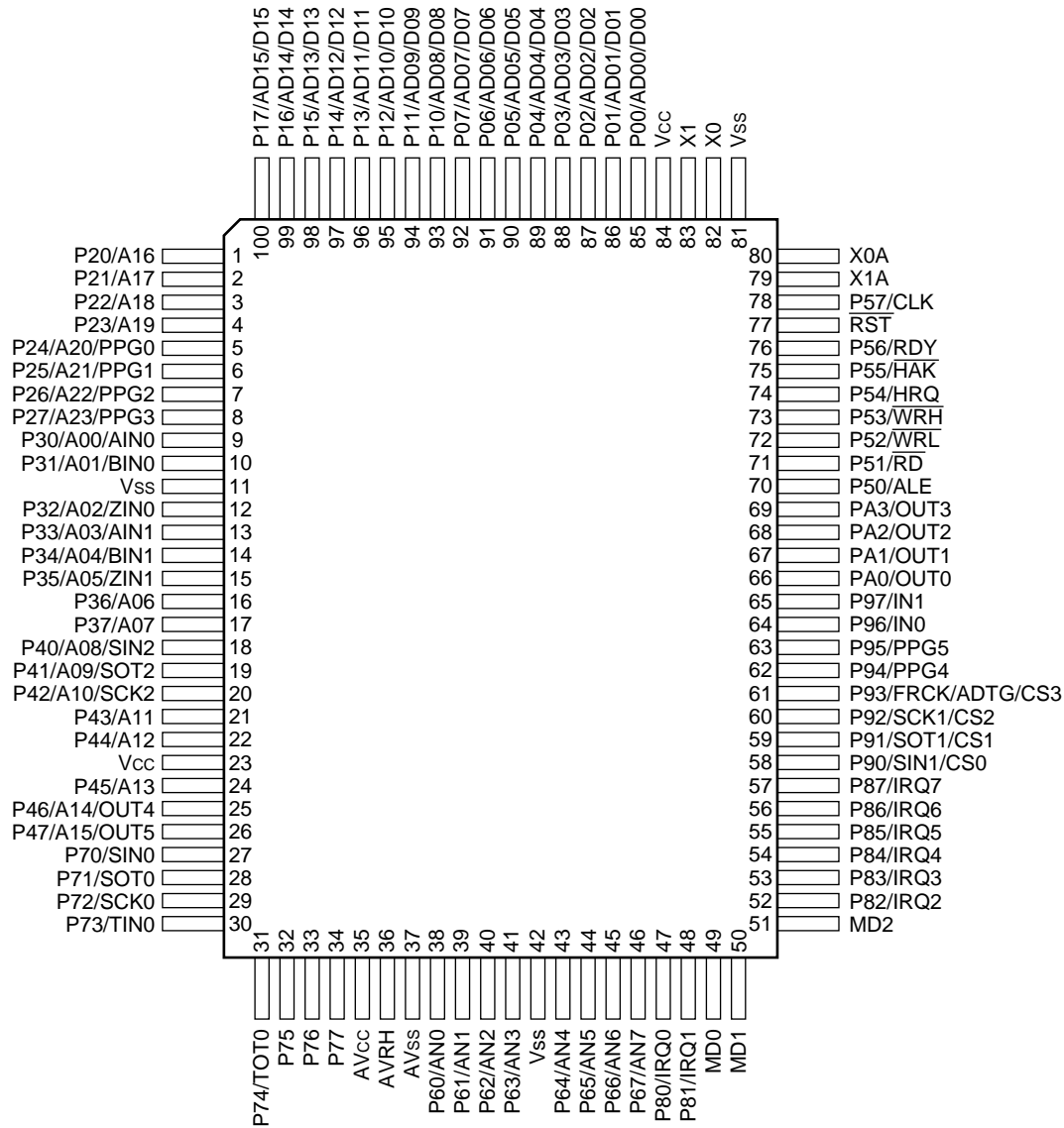

(FPT-100P-M06)

MB90482

■ PIN DESCRIPTIONS (IC72)

Pin No.		Pin name	Circuit type	Function
LQFP*1	QFP*2			
80	82	X0	A	Oscillator pin
81	83	X1	A	Oscillator pin
78	80	X0A	A	32 kHz oscillator pin
77	79	X1A	A	32 kHz oscillator pin
75	77	$\overline{\text{RST}}$	B	Reset input pin
83 to 90	85 to 92	P00 to P07	C (CMOS)	This is a general purpose I/O port. A setting in the pull-up resistance setting register (RDR0) can be used to apply pull-up resistance (RD00-RD07 = "1") . (Disabled when pin is set for output.)
		AD00 to AD07		In multiplex mode, these pins function as the external address/data bus low I/O pins.
		D00 to D07		In non-multiplex mode, these pins function as the external data bus low output pins.
91 to 98	93 to 100	P10 to P17	C (CMOS)	This is a general purpose I/O port. A setting in the pull-up resistance setting register (RDR1) can be used to apply pull-up resistance (RD10-RD17 = "1") . (Disabled when pin is set for output.)
		AD08 to AD15		In multiplex mode, these pins function as the external address/data bus high I/O pins.
		D08 to D15		In non-multiplex mode, these pins function as the external data bus high output pins.
99, 100, 1,2	1 to 4	P20 to P23	E (CMOS/H)	This is a general purpose I/O port. When the bits of external address output control register (HACR) are set to "1" in external bus mode, these pins function as general purpose I/O ports.
		A16 to A19		When the bits of external address output control register (HACR) are set to "0" in multiplex mode, these pins function as address high output pins (A16-A19).
		A16 to A19		When the bits of external address output control register (HACR) are set to "0" in non-multiplex mode, these pins function as address high output pins (A16-A19).
3 to 6	5 to 8	P24 to P27	E (CMOS/H)	This is a general purpose I/O port. When the bits of external address output control register (HACR) are set to "1" in external bus mode, these pins function as general purpose I/O ports.
		A20 to A23		When the bits of external address output control register (HACR) are set to "0" in multiplex mode, these pins function as address high output pins (A20-A23).
		A20 to A23		When the bits of external address output control register (HACR) are set to "0" in non-multiplex mode, these pins function as address high output pins (A20-A23).
		PPG0 to PPG3		PPG timer output pins.

(Continued)

MB90482

Pin No.		Pin name	Circuit type	Function
LQFP*1	QFP*2			
7	9	P30	E (CMOS/H)	This is a general purpose I/O port.
		A00		In non-multiplex mode, this pin functions as an external address pin.
		AIN0		8/16-bit up/down timer input pin (channel 0) .
8	10	P31	E (CMOS/H)	This is a general purpose I/O port.
		A01		In non-multiplex mode, this pin functions as an external address pin.
		BIN0		8/16-bit up/down counter input pin (channel0) .
10	12	P32	E (CMOS/H)	This is a general purpose I/O port.
		A02		In non-multiplex mode, this pin functions as an external address pin.
		ZIN0		8/16-bit up/down counter input pin (channel 0)
11	13	P33	E (CMOS/H)	This is a general purpose I/O port.
		A03		In non-multiplex mode, this pin functions as an external address pin.
		AIN1		8/16-bit up/down counter input pin (channel 1) .
12	14	P34	E (CMOS/H)	This is a general purpose I/O port.
		A04		In non-multiplex mode, this pin functions as an external address pin.
		BIN1		8/16-bit up/down counter input pin (channel 1) .
13	15	P35	E (CMOS/H)	This is a general purpose I/O port.
		A05		In non-multiplex mode, this pin functions as an external address pin.
		ZIN1		8/16-bit up/down counter input pin (channel 1)
14 15	16 17	P36, P37 A06, A07	D*3 (CMOS)	This is a general purpose I/O port. In non-multiplex mode, this pin functions as an external address pin.
16	18	P40	G (CMOS/H)	This is a general purpose I/O port.
		A08		In non-multiplex mode, this pin functions as an external address pin.
		SIN2		Simple serial I/O input pin.
17	19	P41	F (CMOS)	This is a general purpose I/O port.
		A09		In non-multiplex mode, this pin functions as an external address pin.
		SOT2		Simple serial I/O output pin.
18	20	P42	G (CMOS/H)	This is a general purpose I/O port.
		A10		In non-multiplex mode, this pin functions as an external address pin.
		SCK2		Simple serial I/O clock input/output pin.

(Continued)

MB90482

Pin No.		Pin name	Circuit type	Function
LQFP*1	QFP*2			
19 20	21 22	P43, P44	F (CMOS)	This is a general purpose I/O port.
		A11, A12		In non-multiplex mode, this pin functions as an external address pin.
22	24	P45	F*4 (CMOS)	This is a general purpose I/O port.
		A13		In non-multiplex mode, this pin functions as an external address pin.
23 24	25 26	P46, P47	F (CMOS)	This is a general purpose I/O port.
		A14, A15		In non-multiplex mode, this pin functions as an external address pin.
		OUT4/OUT5		Output compare event output pins.
68	70	P50	D (CMOS)	This is a general purpose I/O port. In external bus mode, this pin functions as the ALE pin.
		ALE		In external bus mode, this pin functions as the address load enable (ALE) signal pin.
69	71	P51	D (CMOS)	This is a general purpose I/O port. In external bus mode, this pin functions as the \overline{RD} pin.
		\overline{RD}		In external bus mode, this pin functions as the read strobe output (\overline{RD}) signal pin.
70	72	P52	D (CMOS)	This is a general purpose I/O port. In external bus mode, when the WRE pin in the EPCR register is set to "1", this pin functions as the \overline{WRL} pin.
		\overline{WRL}		In external bus mode, this pin functions as the lower data write strobe output (\overline{WRL}) pin. When the WRE bit in the EPCR register is set to "0", this pin functions as a general purpose I/O port.
71	73	P53	D (CMOS)	This is a general purpose I/O port. In external bus mode with 16-bit bus width, when the WRE bit in the EPCR register is set to "1", this pin functions as the \overline{WRH} pin.
		\overline{WRH}		In external bus mode with 16-bit bus width, this pin functions as the upper data write strobe output (\overline{WRH}) pin. When the WRE bit in the EPCR register is set to "0", this pin functions as a general purpose I/O port.
72	74	P54	D (CMOS)	This is a general purpose I/O port. In external bus mode, when the HDE bit in the EPCR register is set to "1", this pin functions as the HRQ pin.
		HRQ		In external bus mode, this pin functions as the hold request input (HRQ) pin. When the HDE bit in the EPCR register is set to "0", this pin functions as a general purpose I/O port.
73	75	P55	D (CMOS)	This is a general purpose I/O port. In external bus mode, when the HDE bit in the EPCR register is set to "1", this pin functions as the \overline{HAK} pin.
		\overline{HAK}		In external bus mode, this pin functions as the hold acknowledge (\overline{HAK}) pin. When the HDE bit in the EPCR register is set to "0", this pin functions as a general purpose I/O port.

(Continued)

MB90482

Pin No.		Pin name	Circuit type	Function
LQFP*1	QFP*2			
74	76	P56	D (CMOS)	This is a general purpose I/O port. In external bus mode, when the RYE bit in the EPCR register is set to "1", this pin functions as the RDY pin.
		RDY		In external bus mode, this pin functions as the external ready (RDY) input pin. When the RYE bit in the EPCR register is set to "0", this pin functions as a general purpose I/O port.
76	78	P57	D (CMOS)	This is a general purpose I/O port. In external bus mode, when the CKE bit in the EPCR register is set to "1", this pin functions as the CLK pin.
		CLK		In external bus mode, this pin functions as the machine cycle clock (CLK) output pin. When the CKE bit in the EPCR register is set to "0", this pin functions as a general purpose I/O port.
36 to 39	38 to 41	P60 to P63	H (CMOS)	These are general purpose I/O ports.
		AN0 to AN3		These are the analog input pins.
41 to 44	43 to 46	P64 to P67	H (CMOS)	These are general purpose I/O ports.
		AN4 to AN7		These are the analog input pins.
25	27	P70	G (CMOS/H)	This is a general purpose I/O port.
		SIN0		This is the UART data input pin.
26	28	P71	F (CMOS)	This is a general purpose I/O port.
		SOT0		This is the UART data output pin.
27	29	P72	G (CMOS/H)	This is a general purpose I/O port.
		SCK0		This is the UART clock I/O pin.
28	30	P73	G (CMOS/H)	This is a general purpose I/O port.
		TIN0		This is the 16-bit reload timer event input pin.
29	31	P74	F (CMOS)	This is a general purpose I/O port.
		TOT0		This is the 16-bit reload timer output pin.
30	32	P75	F*4 (CMOS)	This is a general purpose I/O port.
31	33	P76	F*5 (CMOS)	This is a general purpose I/O port.
32	34	P77	F*5 (CMOS)	This is a general purpose I/O port.
45, 46	47, 48	P80, P81	E (CMOS/H)	These are general purpose I/O ports.
		IRQ0, IRQ1		External interrupt input pins.
50 to 55	52 to 57	P82 to P87	E (CMOS/H)	These are general purpose I/O ports.
		IRQ2 to IRQ7		External interrupt input pins.

(Continued)

MB90482

(Continued)

Pin No.		Pin name	Circuit type	Function
LQFP*1	QFP*2			
56	58	P90	E (CMOS/H)	This is a general purpose I/O port.
		SIN1		Simple serial I/O data input pin.
		CS0		Chip select 0.
57	59	P91	D (CMOS)	This is a general purpose I/O port.
		SOT1		Simple serial I/O data output pin.
		CS1		Chip select 1.
58	60	P92	E (CMOS/H)	This is a general purpose I/O port.
		SCK1		Simple serial I/O data input/output pin.
		CS2		Chip select 2.
59	61	P93	E (CMOS/H)	This is a general purpose I/O port.
		FRCK		When the free run timer is in use, this pin functions as the external clock input pin.
		ADTG		When the A/D converter is in use, this pin functions as the external trigger input pin.
		CS3		Chip select 3.
60	62	P94	D (CMOS)	This is a general purpose I/O port.
		PPG4		PPG timer output pin.
61	63	P95	D (CMOS)	This is a general purpose I/O port.
		PPG5		PPG timer output pin.
62	64	P96	E (CMOS/H)	This is a general purpose I/O port.
		IN0		Input capture channel 0 trigger input pin.
63	65	P97	E (CMOS/H)	This is a general purpose I/O port.
		IN1		Input capture channel 1 trigger input pin.
64 to 67	66 to 69	PA0 to PA3	D (CMOS)	These are general purpose I/O ports.
		OUT0 to OUT3		Output compare event output pins.
33	35	AV _{cc}	—	A/D converter power supply pin.
34	36	AV _{RH}	—	A/D converter external reference voltage supply pin.
35	37	AV _{ss}	—	A/D converter power supply pin.
47 to 49	49 to 51	MD0 to MD2	J (CMOS/H)	Operating mode selection input pins.
21, 82	23, 84	V _{cc}	—	3.3 V ± 0.3 V power supply pins (V _{cc3}) .
9, 40, 79	11, 42, 81	V _{ss}	—	Power supply input pins (GND) .

*1 : LQFP : FPT-100P-M05

*2 : QFP : FPT-100P-M06

*3 : The circuit type of MB90V480 is E (CMOS/H).

*4 : The circuit type of MB90V480 is G (CMOS/H).

*5 : The circuit type of MB90V480 is I (NMOS/H)

NJM2068M (OP - AMP)



NJM2068

LOW-NOISE DUAL OPERATIONAL AMPLIFIER

■ **GENERAL DESCRIPTION**

The NJM2068 is a high performance, low noise dual operational amplifier. This amplifier features popular pin-out, superior noise performance, and superior total harmonic distortion. This amplifier also features guaranteed noise performance with substantially higher gain-bandwidth product and slew rate which far exceeds that of the 4558 type amplifier. The specially designed low noise input transistors allow the NJM2068 to be used in very low noise signal processing applications such as audio preamplifiers and servo error amplifier.

■ **PACKAGE OUTLINE**

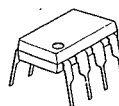

NJM2068D



NJM2068M



NJM2068V

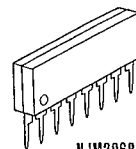

NJM2068L

■ **FEATURES**

- Operating Voltage (±4V ~ ±18V)
- Low Total Harmonic Distortion (0.001% typ.)
- Low Noise Voltage (FLAT+JISA, 0.56 μV typ.)
- High Slew Rate (6V/μs typ.)
- Unity Gain Bandwidth (27MHz @f=10kHz)
- Package Outline DIP8, DMP8, SIP8, SSOP8
- Bipolar Technology

■ **PIN CONFIGURATION**

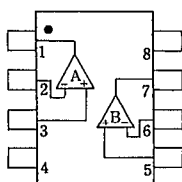

NJM2068D
NJM2068M
NJM2068V

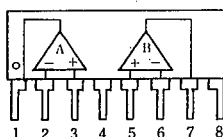

NJM2068L

PIN FUNCTION

1. A OUTPUT
2. A-INPUT
3. A+INPUT
4. V-
5. B+INPUT
6. B-INPUT
7. B OUTPUT
8. V+

■ **EQUIVALENT CIRCUIT (1/2 Shown)**

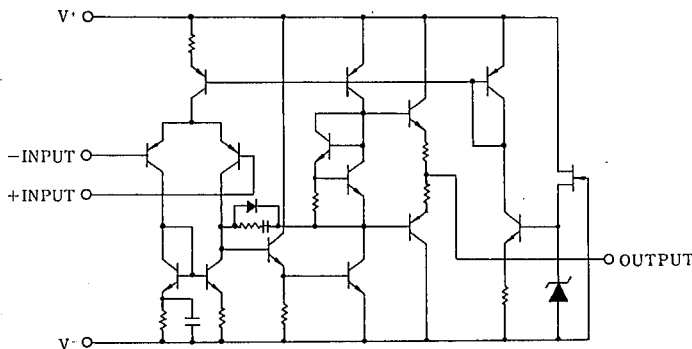

NJM2296

5-INPUT 3-OUTPUT VIDEO SW

■GENERAL DESCRIPTION

The NJM2296 is a 5-input 3-output video switch.

Its switches select one from five signals received from VTR, TV, TV GAME and others.

This IC is designed for audio items, such as AV amplifier and receivers, and others

■PACKAGE OUTLINE

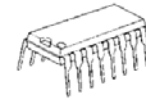

NJM2296D

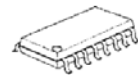

NJM2296M

■FEATURES

- 5-input 3-output
- Operating Voltage ± 4.0 to $\pm 6.5V$
- Operating Current $\pm 31mA$ typ. at $V_{CC}=\pm 5V$
- Crosstalk $-65dB$ typ.
- Internal 6dB Amplifier
- Internal 75Ω Driver
- Bipolar Technology
- Package Outline DIP16,DMP16

■BLOCK DIAGRAM

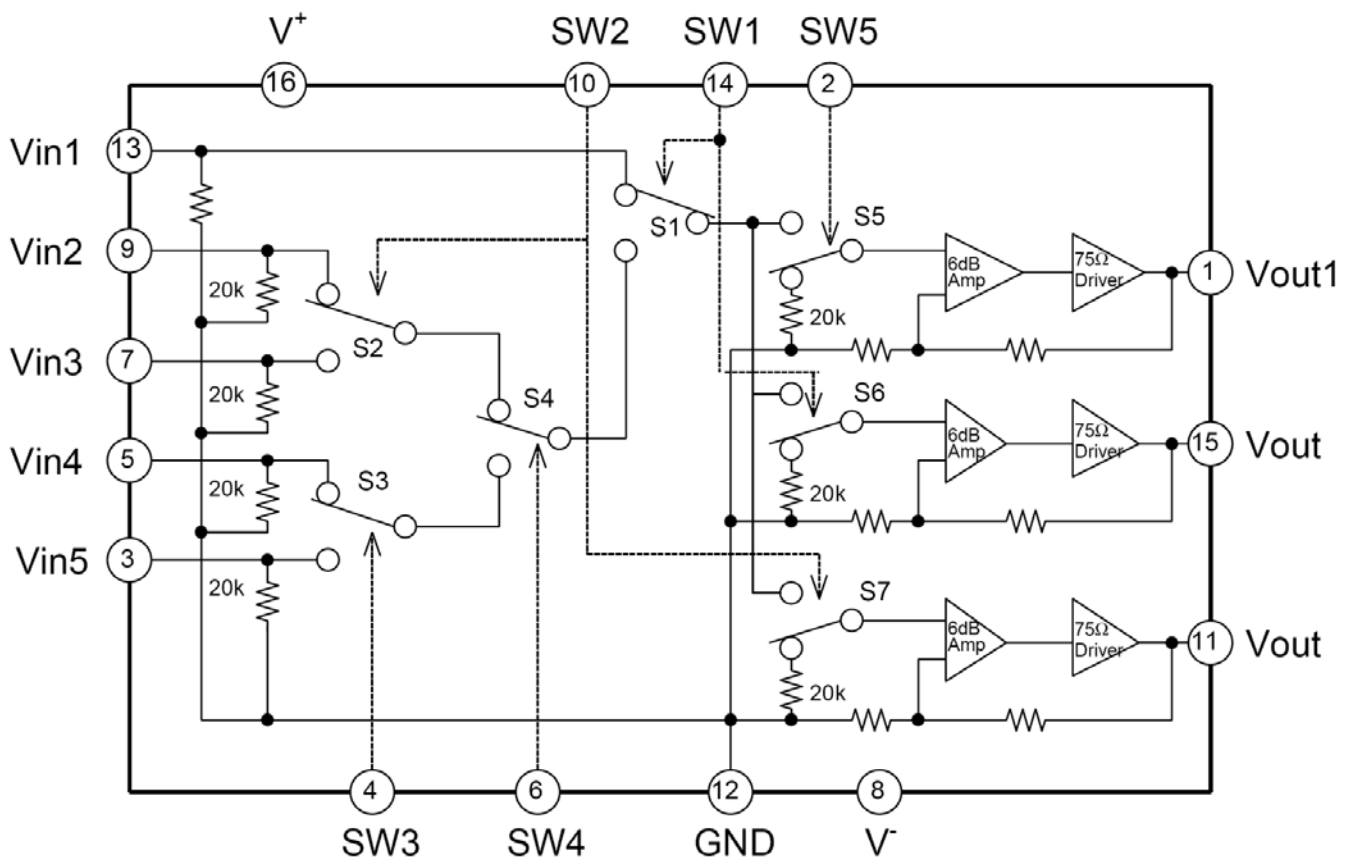



NJM2581

DUAL SUPPLY WIDE BAND 3ch VIDEO AMPLIFIER

GENERAL DESCRIPTION

The **NJM2581** is a dual supply voltage wide band 3ch video amplifier. It is suitable for Y, Pb, and Pr signal because frequency range is 50MHz.

The **NJM2581** is suitable for Set Top Box, AV amplifier, and other high quality AV systems.

PACKAGE OUTLINE

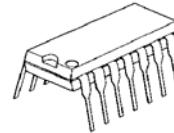

NJM2581D

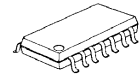

NJM2581M

FEATURES

- Operating Voltage ± 4.5 to $\pm 5.5V$
- Wide frequency range 50MHz at 0dB typ.
- Internal 6dB Amplifier
- Internal 75Ω Driver Circuit (2-system drive)
- Power Save Circuit
- Bipolar Technology
- Package Outline DIP14, DMP14

BLOCK DIAGRAM

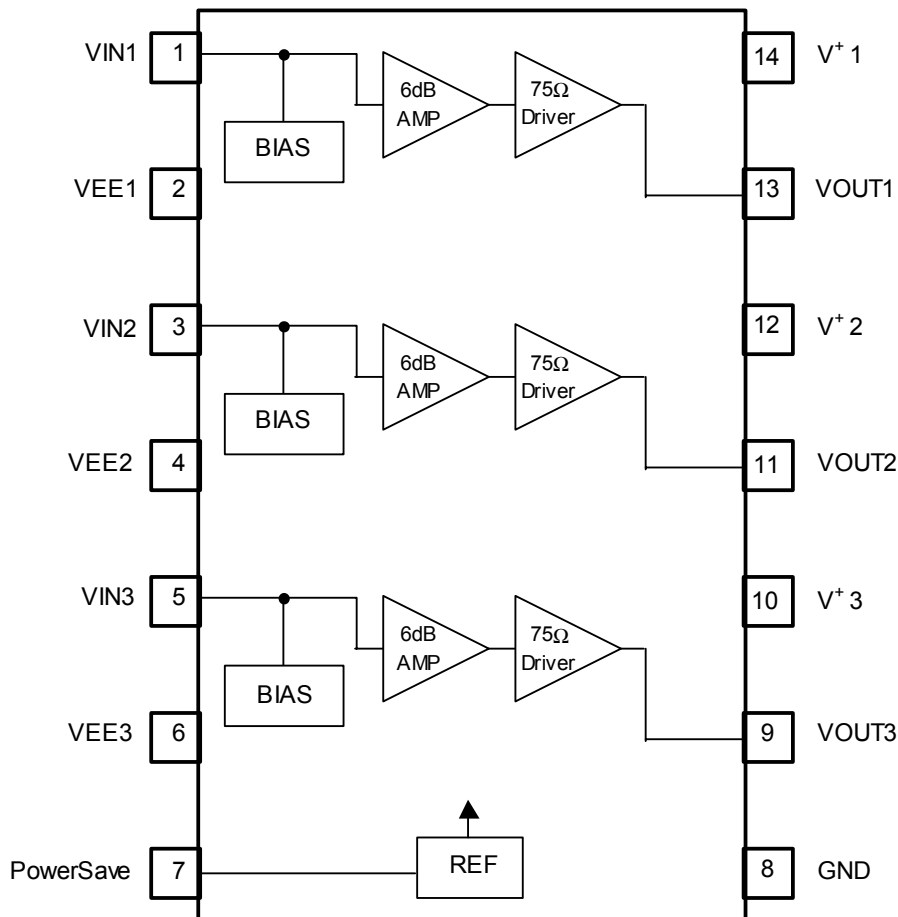

NJM2581

■ EQUIVALENT CIRCUIT

PIN No.	PIN NAME	FUNCTION	INSIDE EQUIVALENT CIRCUIT
1 3 5	VIN1 VIN2 VIN3	Input	
13 11 9	VOUT1 VOUT2 VOUT3	Output	
7	PowerSave	Power Save	
14 12 10	V ⁺ 1 V ⁺ 2 V ⁺ 3	V+	_____
2 4 6	VEE1 VEE2 VEE3	V-	_____
8	GND	GND	_____



IC86

NJM4556A

DUAL HIGH CURRENT OPERATIONAL AMPLIFIER

■ GENERAL DESCRIPTION

The NJM4556A integrated circuit is a high-gain, high output current dual operational amplifier capable of driving $\pm 70\text{mA}$ into $150\ \Omega$ loads ($\pm 10.5\text{V}$ output voltage), and operating low supply voltage ($V^+/V^- = \pm 2\text{V} \sim$).

The NJM4556A combines many of the fetures of the popular NJM4558 as well as having the capability of driving $150\ \Omega$ loads. In addition, the wide band-width, low noise, high slew rate and low distortion of the NJM4556A make it ideal for many audio, telecommuncations and instrumentation applications.

■ FEATURES

- Operating Voltage ($\pm 2\text{V} \sim \pm 18\text{V}$)
- High Output Current ($I_o = 70\text{mA}$)
- Slew Rate ($3\text{V}/\mu\text{s}$ typ.)
- Gain Band Width Product (8MHz typ.)
- Package Outline DIP8, DMP8, SIP8, SSOP8
- Bipolar Technology

■ PACKAGE OUTLINE

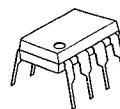

NJM4556AD



NJM4556AM

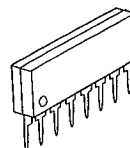

NJM4556AL



NJM4556AV

■ PIN CONFIGURATION

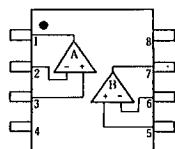

NJM4556AD
NJM4556AM
NJM4556AV

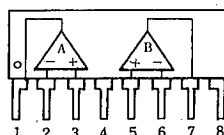

NJM4556AL

PIN FUNCTION

1. A OUTPUT
2. A-INPUT
3. A+INPUT
4. V-
5. B+INPUT
6. B-INPUT
7. B OUTPUT
8. V+

■ EQUIVALENT CIRCUIT (1/2 Shown)

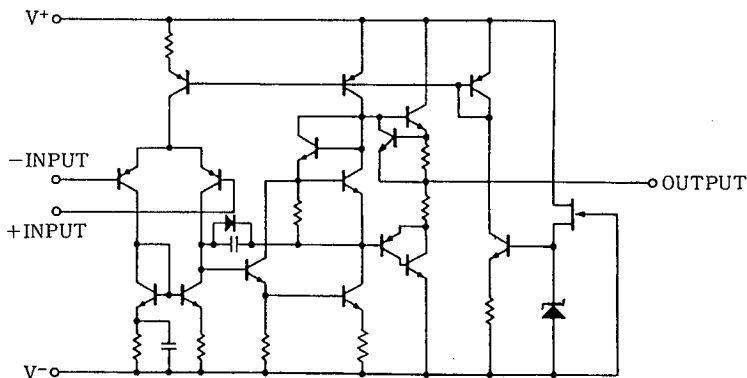

PIN CONFIGURATION

IC87 RE5VL28CATZ
IC85 RH5VT18C

IC , RESET
I.C , RESET

• TO-92

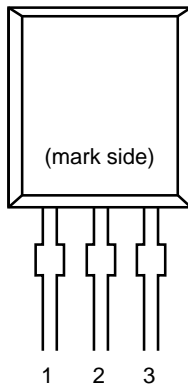

• SOT-89

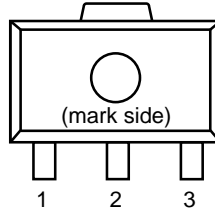

• SOT-23-5

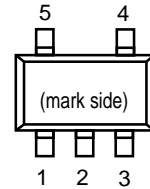

PIN DESCRIPTION

• TO-92

Pin No	Symbol
1	OUT
2	VDD
3	GND

• SOT-89

Pin No	Symbol
1	OUT
2	VDD
3	GND

• SOT-23-5

Pin No	Symbol
1	OUT
2	VDD
3	GND
4	NC
5	NC

BLOCK DIAGRAMS

• Nch Open Drain Output (R5VLxA)

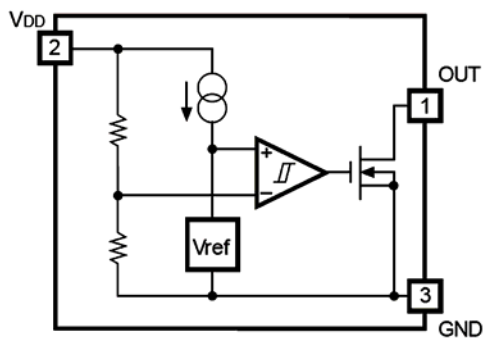

• CMOS Output (R5VLxC)

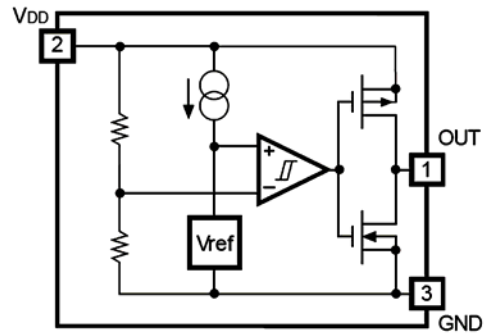

TC9162AF (FUNCTION/INPUT :

■ BLOCK DIAGRAM

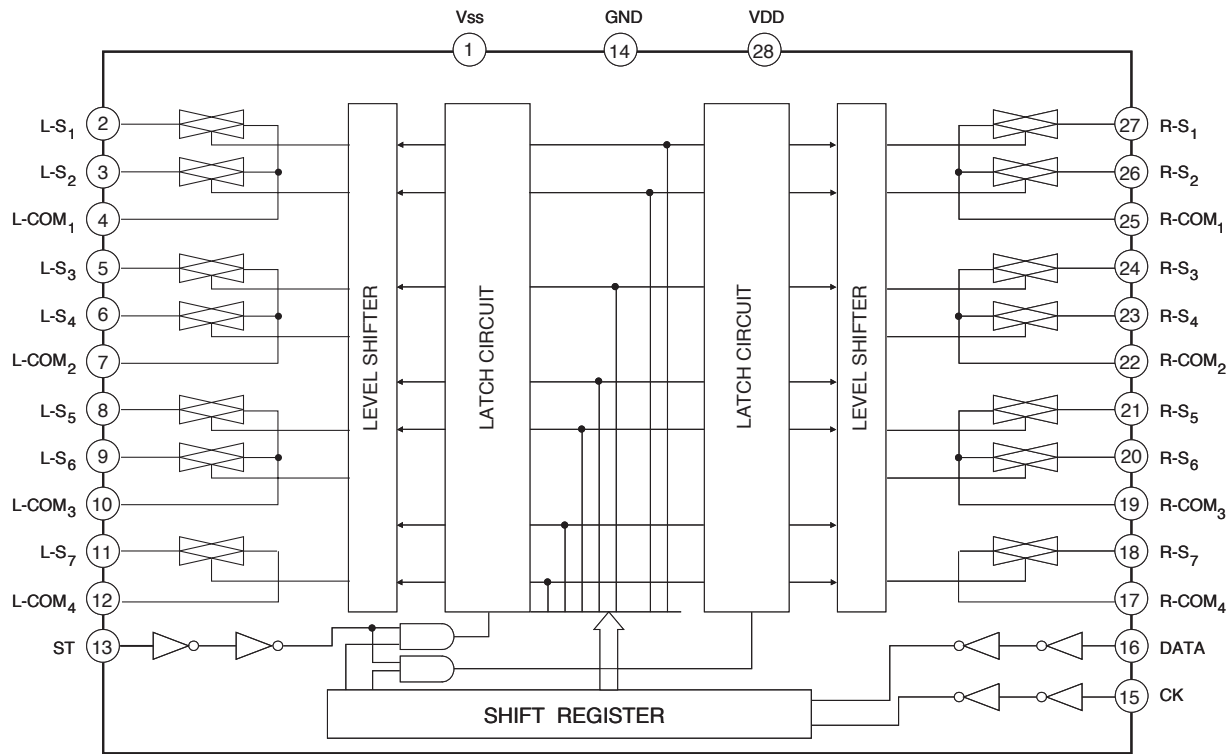

TC9164AF (FUNCTION/INPUT) : IC23

■ BLOCK DIAGRAM

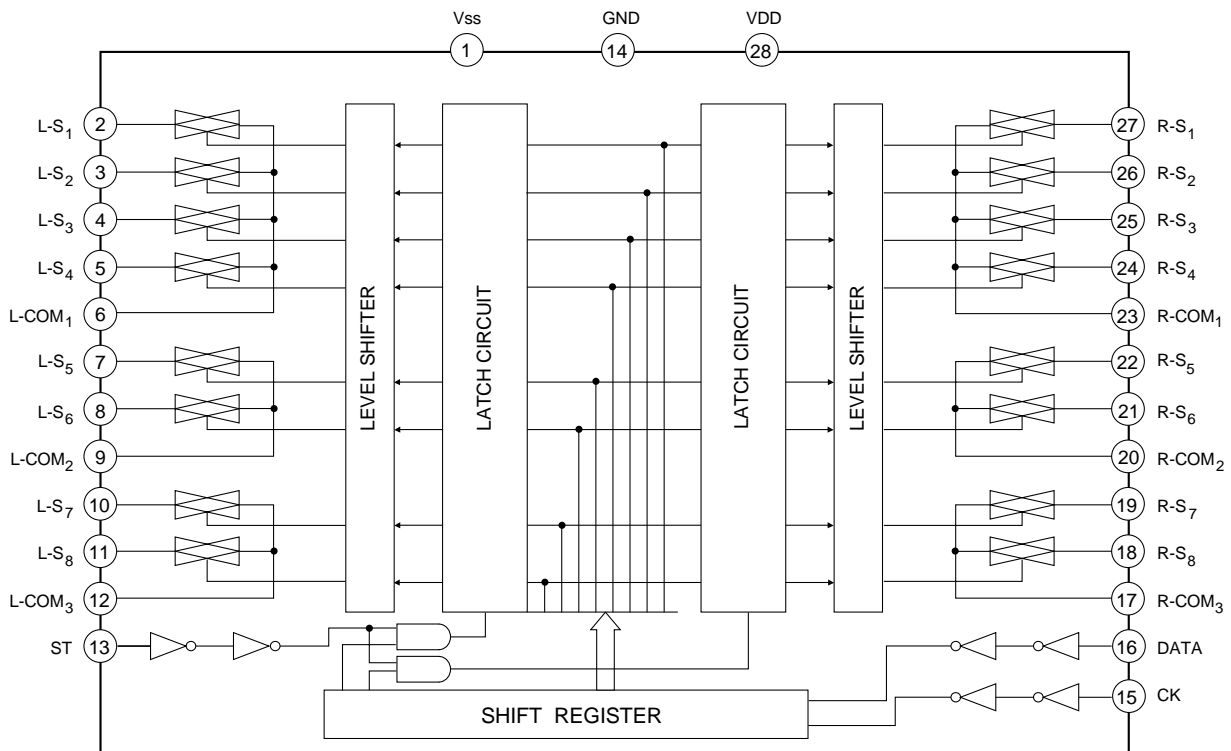

TC9163AF (FUNCTION/INPUT) : IC24

■ BLOCK DIAGRAM

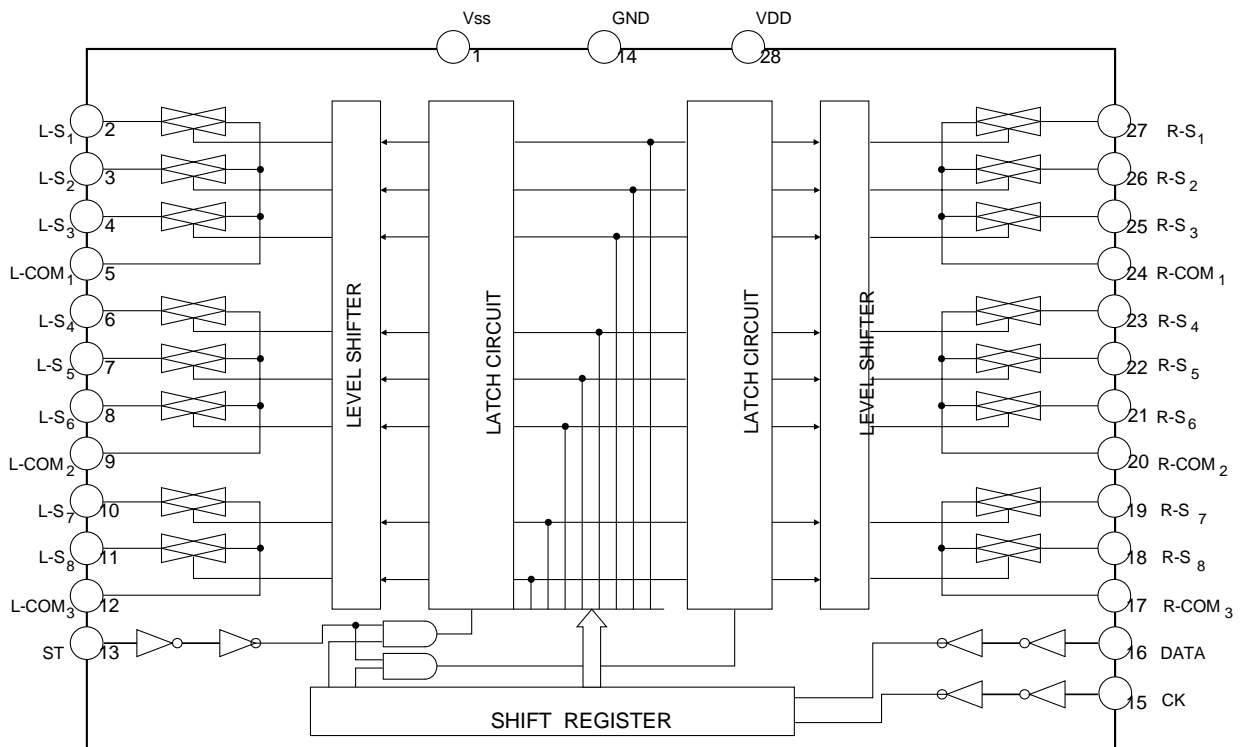

TOSHIBA**TC9214,15AP/AF**

TOSHIBA CMOS DIGITAL INTEGRATED CIRCUIT SILICON MONOLITHIC

TC9214AP, TC9214AF, TC9215AP, TC9215AF**HIGH VOLTAGE ANALOG SWITCH**

TC9214AP/AF, TC9215AP/AF are Analog Switch for high voltage audio application.

FEATURES

- Analog Switch Circuit Formation
TC9214AP, TC9214AF : 5 circuits
TC9215AP, TC9215AF : 6 circuits
- Dual Power Supply of (+) and (-) can be used.
- Including Level Shift Circuit, this IC can be operated by (+) power supply only under dual power supply operating.
- Setting Low Input-threshold-voltage in control signal input terminal. 5V CPU application can control this IC directly.
- Package : DIP-16 PIN
SOP-16 PIN

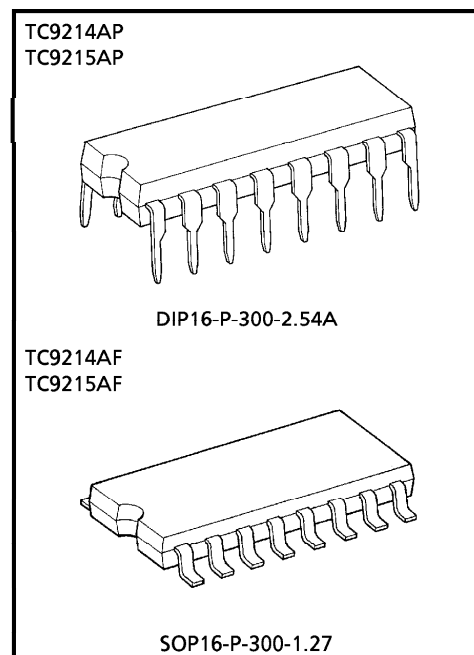

Weight
DIP16-P-300-2.54A : 1.0g (Typ.)
SOP16-P-300-1.27 : 0.16g (Typ.)

PIN CONNECTION (TOP VIEW)

TC9214AP, TC9214AF

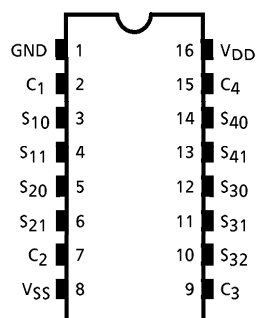

TC9215AP, TC9215AF

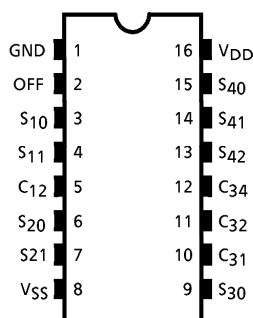

980508EBA2

TOSHIBA

TC9214,15AP/AF

BLOCK DIAGRAM

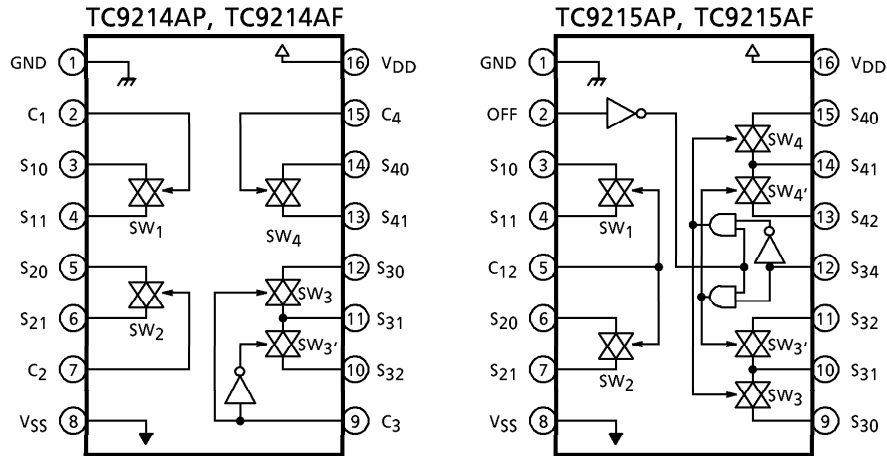

PIN FUNCTION

1. TC9214AP, TC9214AF

PIN No.	SYMBOL	PIN NAME	FUNCTION	NOTE																		
1	GND	Ground Terminal	Dual power supplying : + B →V _{DD} 0V →GND - B →V _{SS}	—																		
8	V _{SS}	(-) Power Supply Terminal																				
16	V _{DD}	(+) Power Supply Terminal																				
2	C ₁	Switch (1) Control Terminal	SWITCH CONNECTION TRUTH TABLE <table border="1" style="margin-left: 20px;"> <tr> <td>C₁, C₂, C₄</td> <td colspan="2">SW₁, SW₂, SW₃</td> </tr> <tr> <td>H</td> <td colspan="2">ON</td> </tr> <tr> <td>L</td> <td colspan="2">OFF</td> </tr> </table> <table border="1" style="margin-left: 20px;"> <tr> <td>C₃</td> <td>S₃₀-S₃₁</td> <td>S₃₁-S₃₂</td> </tr> <tr> <td>H</td> <td>ON</td> <td>OFF</td> </tr> <tr> <td>L</td> <td>OFF</td> <td>ON</td> </tr> </table>	C ₁ , C ₂ , C ₄	SW ₁ , SW ₂ , SW ₃		H	ON		L	OFF		C ₃	S ₃₀ -S ₃₁	S ₃₁ -S ₃₂	H	ON	OFF	L	OFF	ON	—
C ₁ , C ₂ , C ₄	SW ₁ , SW ₂ , SW ₃																					
H	ON																					
L	OFF																					
C ₃	S ₃₀ -S ₃₁	S ₃₁ -S ₃₂																				
H	ON	OFF																				
L	OFF	ON																				
3	S ₁₀	Switch (1) Input/Output Terminal																				
4	S ₁₁																					
5	S ₂₀	Switch (2) Input/Output Terminal																				
6	S ₂₁																					
7	C ₂	Switch (2) Control Terminal																				
9	C ₃	Switch (3) Control Terminal																				
10	S ₃₂	Switch (3) Input/Output Terminal																				
11	S ₃₁																					
12	S ₃₀																					
13	S ₄₁	Switch (4) Input/Output Terminal																				
14	S ₄₀																					
15	C ₄		Switch (4) Control Terminal																			

TOSHIBA**TC9214,15AP/AF**

2. TC9215AP, TC9215AF

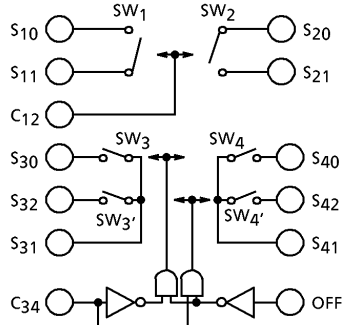
PIN No.	SYMBOL	PIN NAME	FUNCTION	NOTE																						
1	GND	Ground Terminal	Dual power supplying : + B →V _{DD} 0V →GND - B →V _{SS}	—																						
8	V _{SS}	(-) Power Supply Terminal																								
16	V _{DD}	(+) Power Supply Terminal			Single power supplying: + B →V _{DD} 0V →GND, V _{SS}																					
2	OFF	Switch (3), (4) OFF Input Terminal	SWITCH CONNECTION 	—																						
3	S ₁₀	Switch (1) Input / Output Terminal																								
4	S ₁₁																									
5	C ₁₂	Switch (1), (2) Control Terminal																								
6	S ₂₀	Switch (2) Input / Output Terminal																								
7	S ₂₁																									
9	S ₃₀	Switch (3) Input / Output Terminal																								
10	S ₃₁																									
11	S ₃₂																									
12	C ₃₄	Switch (3), (4) Control Terminal																								
13	S ₄₂	Switch (4) Input / Output Terminal			TRUTH TABLE <table border="1" data-bbox="726 1052 1189 1182"> <thead> <tr> <th>C₁₂</th> <th>SW₁, SW₂</th> </tr> </thead> <tbody> <tr> <td>H</td> <td>ON</td> </tr> <tr> <td>L</td> <td>OFF</td> </tr> </tbody> </table> <table border="1" data-bbox="726 1220 1284 1377"> <thead> <tr> <th>OFF</th> <th>C₃₄</th> <th>S₃₀-S₃₁ S₄₀-S₄₁</th> <th>S₃₁-S₃₂ S₄₁-S₄₂</th> </tr> </thead> <tbody> <tr> <td rowspan="2">L</td> <td>L</td> <td>ON</td> <td>OFF</td> </tr> <tr> <td>H</td> <td>OFF</td> <td>ON</td> </tr> <tr> <td>H</td> <td>※</td> <td>OFF</td> <td>OFF</td> </tr> </tbody> </table>	C ₁₂	SW ₁ , SW ₂	H	ON	L	OFF	OFF	C ₃₄	S ₃₀ -S ₃₁ S ₄₀ -S ₄₁	S ₃₁ -S ₃₂ S ₄₁ -S ₄₂	L	L	ON	OFF	H	OFF	ON	H	※	OFF	OFF
C ₁₂	SW ₁ , SW ₂																									
H	ON																									
L	OFF																									
OFF	C ₃₄	S ₃₀ -S ₃₁ S ₄₀ -S ₄₁			S ₃₁ -S ₃₂ S ₄₁ -S ₄₂																					
L	L	ON	OFF																							
	H	OFF	ON																							
H	※	OFF	OFF																							
14	S ₄₁																									
15	S ₄₀																									

(※ H or L)

TOSHIBA

ELECTRONIC VOLUME CONTROL IC(IC42)

TC9459N/F

BLOCK DIAGRAM (TC9459F)

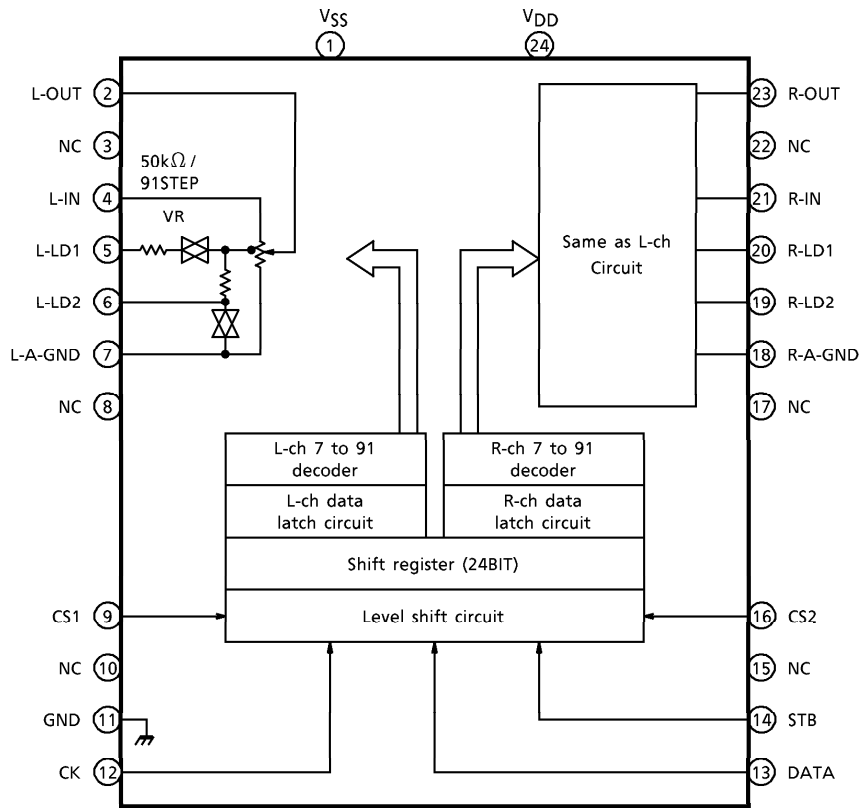

TOSHIBA**TC9459N/F****PIN DESCRIPTION**

Numeral in () means the pin No. of TC9459F.

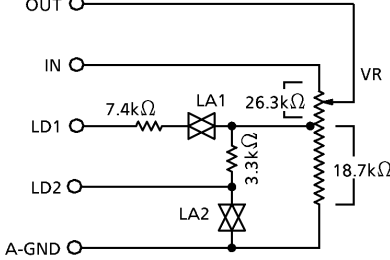
PIN No.	SYMBOL	PIN NAME	FUNCTION	REMARK										
1 (1)	V _{SS}	Negative power supply pin	When using dual power supplies $V_{DD} = 6.0 \sim 17V$ $GND = 0V$ $V_{SS} = -6.0 \sim -17V$ When using a single power supply $V_{DD} = 6.0 \sim 18V$ $GND = V_{SS} = 0V$	—										
28 (24)	V _{DD}	Positive power supply pin												
13 (11)	GND	Digital GND pin												
3 (2)	L-OUT	Volume output pin	• Volume circuit 	—										
26 (23)	R-OUT													
5 (4)	L-IN	Volume input pin												
24 (21)	R-IN													
6 (5)	L-LD1	Loudness tap output pin			<table border="1" data-bbox="933 1086 1236 1220"> <tr> <td></td> <td>LA1</td> <td>LA2</td> </tr> <tr> <td>LOUDNESS "ON"</td> <td>ON</td> <td>OFF</td> </tr> <tr> <td>LOUDNESS "OFF"</td> <td>OFF</td> <td>ON</td> </tr> </table>		LA1	LA2	LOUDNESS "ON"	ON	OFF	LOUDNESS "OFF"	OFF	ON
	LA1					LA2								
LOUDNESS "ON"	ON					OFF								
LOUDNESS "OFF"	OFF					ON								
23 (20)	R-LD1													
7 (6)	L-LD2													
22 (19)	R-LD2													
8 (7)	L-A-GND	Analog GND pin												
21 (18)	R-A-GND													
10 (9)	CS1	Chip select input pin	Up to 4 chips on the same bus can be used by switching over chip select code.	—										
19 (16)	CS2													
14 (12)	CK	Clock input pin	Data transfer clock input	Low threshold value input pin										
15 (13)	DATA	Data input pin	Volume setup serial data input											
16 (14)	STB	Strobe input pin	Data write strobe input											
2 (3)	NC	No connection	—	—										
27 (22)														
4														
25														
9 (8)														
20 (17)														
11														
18														
12 (10)														
17 (15)														

TOSHIBA

TC9482BNG/BFG

TOSHIBA CMOS DIGITAL INTEGRATED CIRCUIT SILICON MONOLITHIC

TC948BNG, TC9482BFG

SYSTEM ELECTRONIC VOLUME CONTROL

The TC9482BNG and TC9482BFG are six-channel electronic volume control ICs developed for Hi-Fi audio equipment. Since all six channels can be individually controlled, the devices are optimum for audio equipment with multiple outputs.

FEATURES

- Sound volume can be controlled in 97 steps from 0 to -95dB or up to an infinite level in 1dB increments.
- Incorporating six channels of volume control circuits, the device allows independent volume control.
- Can operate with a single or dual power supplies.
- Can control up to 4 chips on the same bus by using chip select input.
- Built-in interface for 3-V microcomputers.
- Thanks to its polysilicon resistor, the device allows you to configure a low-distortion, high-performance volume control system.
- Two packages supported: 28-pin shrink DIP and 28-pin flat package.

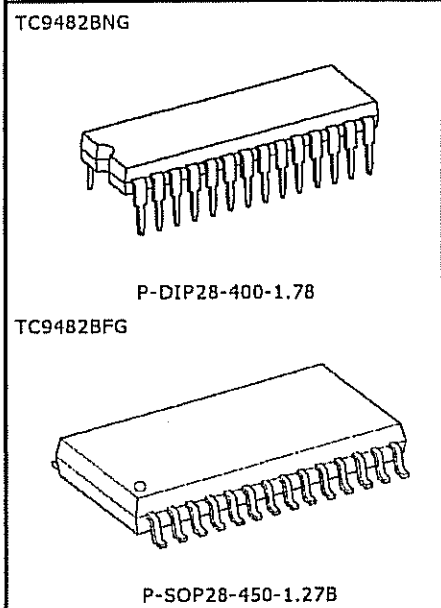

Weight
P-SDIP28-400-1.78 : 2.2 g (Typ.)
P-SOP28-450-1.27B : 0.8 g (Typ.)

TOSHIBA

TC9482BNG/BFG

PIN CONNECTIONS

V _{SS}	1	28	V _{DD}
NC	2	27	TEST
L-OUTA	3	26	R-OUTA
L-INA	4	25	R-INA
L-A-GNDA	5	24	R-A-GNDA
L-OUTB	6	23	R-OUTB
L-INB	7	22	R-INB
L-A-GNDB	8	21	R-A-GNDB
L-OUTC	9	20	R-OUTC
L-INC	10	19	R-INC
L-A-GNDC	11	18	R-A-GNDC
CS1	12	17	CS2
GND	13	16	STB
CK	14	15	DATA

BLOCK DIAGRAM

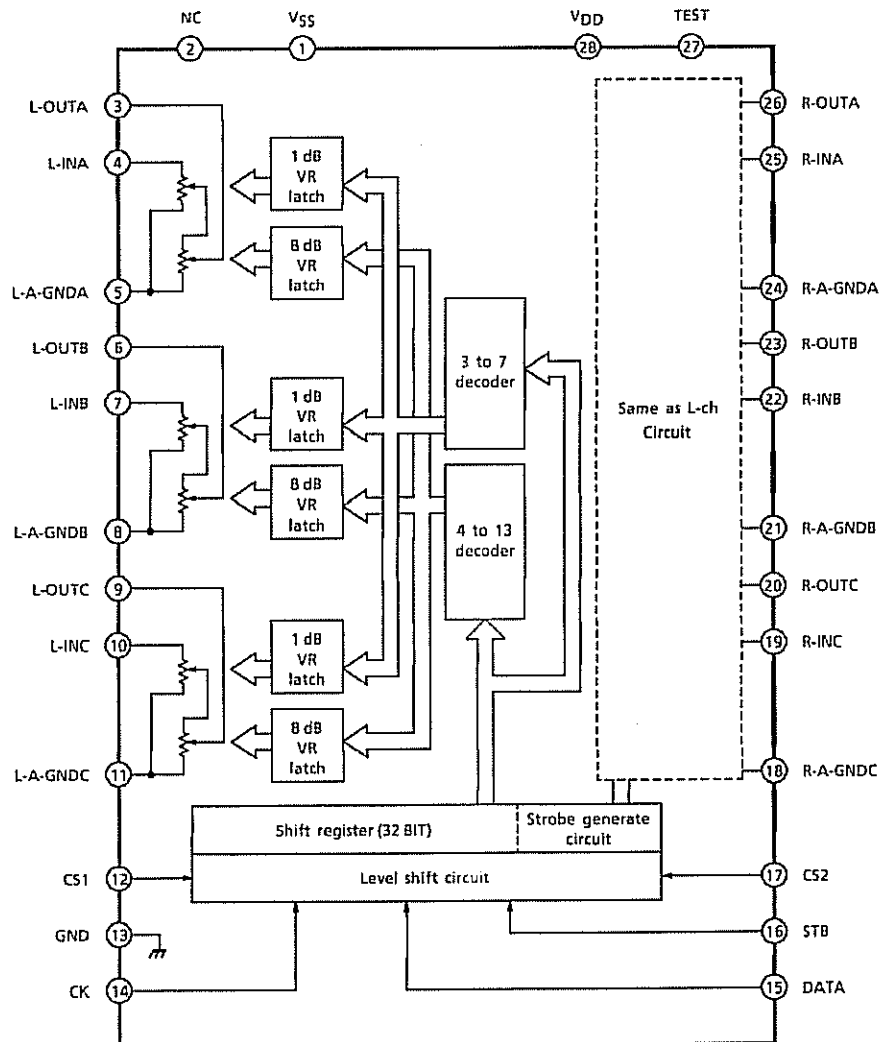

TOSHIBA

TC9482BNG/BFG

PIN DESCRIPTION

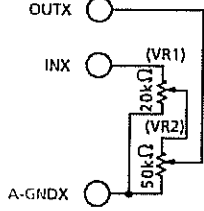
PIN No.	SYMBOL	PIN NAME	FUNCTION	REMARK
1	V _{SS}	Negative power supply pin	<ul style="list-style-type: none"> Power Supply Pins 	—
28	V _{DD}	Positive power supply pin		
3	L-OUTA	Volume output pin	<ul style="list-style-type: none"> Volume circuit 	—
26	R-OUTA			
6	L-OUTB			
22	R-OUTB			
9	L-OUTC			
19	R-OUTC			
4	L-INA	Volume input pin		—
25	R-INA			
7	L-INB			
22	R-INB			
10	L-INC			
19	R-INC			
5	L-A-GNDA	Analog GND pin		—
24	R-A-GNDA			
8	L-A-GNDB			
21	R-A-GNDB			
11	L-A-GNDC			
18	R-A-GNDC			
12	CS1	Chip select input pin	Up to 4 chips on the same bus can be used by switching over chip select code.	—
17	CS2			
14	CK	Clock input pin	Inputs clock for serial data transfer.	Low threshold value input pin
15	DATA	Data input pin	Inputs control data for setting volume.	
16	STB	Strobe input pin	Inputs strobe for writing data.	
13	GND	Digital GND pin	Digital ground pin	—
27	TEST	Test Pin	Normally connect to V _{DD} pin.	—
2	NC	No connection	—	—



M29W800DT M29W800DB

8 Mbit (1Mb x8 or 512Kb x16, Boot Block)
3V Supply Flash Memory

FEATURES SUMMARY

- **SUPPLY VOLTAGE**
 - $V_{CC} = 2.7V$ to $3.6V$ for Program, Erase and Read
- **ACCESS TIME: 70, 90ns**
- **PROGRAMMING TIME**
 - $10\mu s$ per Byte/Word typical
- **19 MEMORY BLOCKS**
 - 1 Boot Block (Top or Bottom Location)
 - 2 Parameter and 16 Main Blocks
- **PROGRAM/ERASE CONTROLLER**
 - Embedded Byte/Word Program algorithms
- **ERASE SUSPEND and RESUME MODES**
 - Read and Program another Block during Erase Suspend
- **UNLOCK BYPASS PROGRAM COMMAND**
 - Faster Production/Batch Programming
- **TEMPORARY BLOCK UNPROTECTION MODE**
- **COMMON FLASH INTERFACE**
 - 64 bit Security Code
- **LOW POWER CONSUMPTION**
 - Standby and Automatic Standby
- **100,000 PROGRAM/ERASE CYCLES per BLOCK**
- **ELECTRONIC SIGNATURE**
 - Manufacturer Code: 0020h
 - Top Device Code M29W800DT: 22D7h
 - Bottom Device Code M29W800DB: 225Bh

Figure 1. Packages

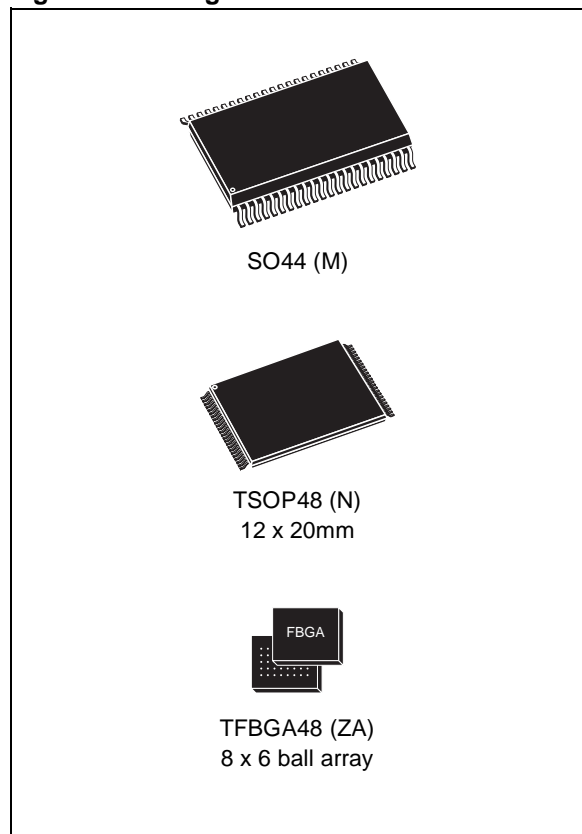

M29W800DT, M29W800DB

Figure 3. SO Connections

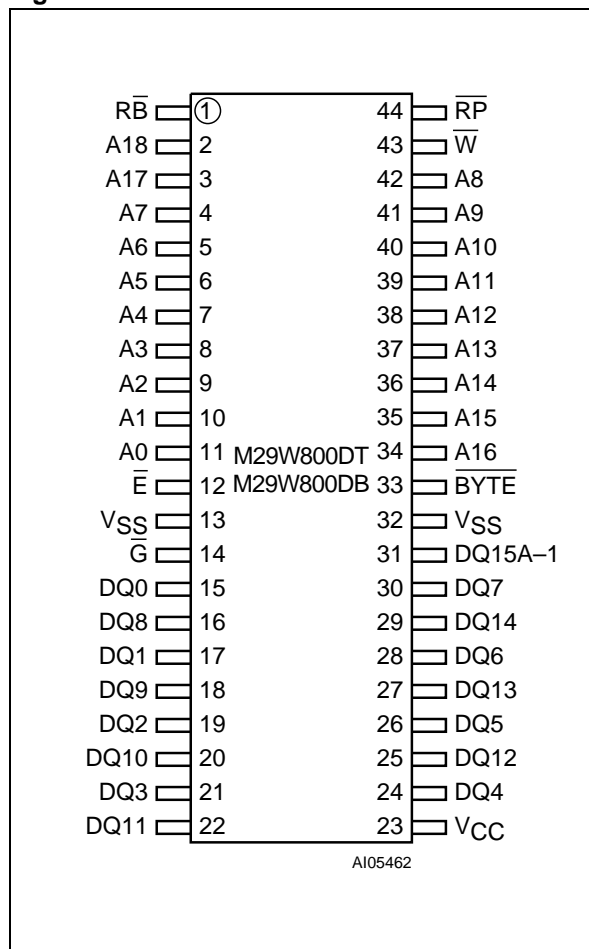
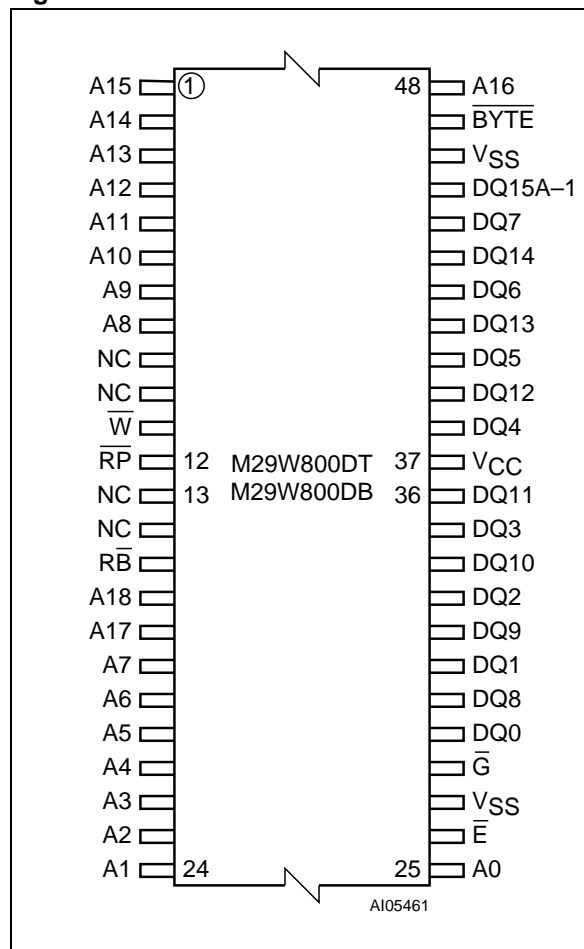

Figure 4. TSOP Connections



NJM2586AM [WIDE BAND 3-INPUT 1-OUTPUT 3-CIRCUIT VIDEO AMPLIFIER]

[STRUCTURE] Bipolar
[CATEGORIES] TV-Video
[PACKAGE OUTLINE] DMP-24
[SOLDERING METHOD] For this device, soldering method is recommended Reflow.
[NOTE] -

■ **ABSOLUTE MAXIMUM RATINGS** $T_a=25^\circ\text{C}$

BAE-38461-000-01

Supply Voltage	± 6.0 [V]	Operating Temperature Range	-40 to +85 [°C]
Power Dissipation	500 [mW]	Storage Temperature Range	-40 to +125 [°C]

■ **BLOCK DIAGRAM**

BDE-33546-000-00

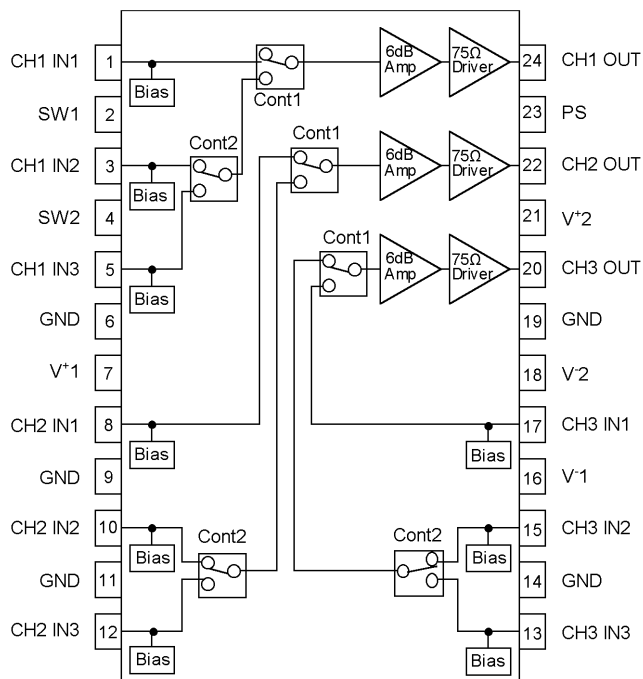





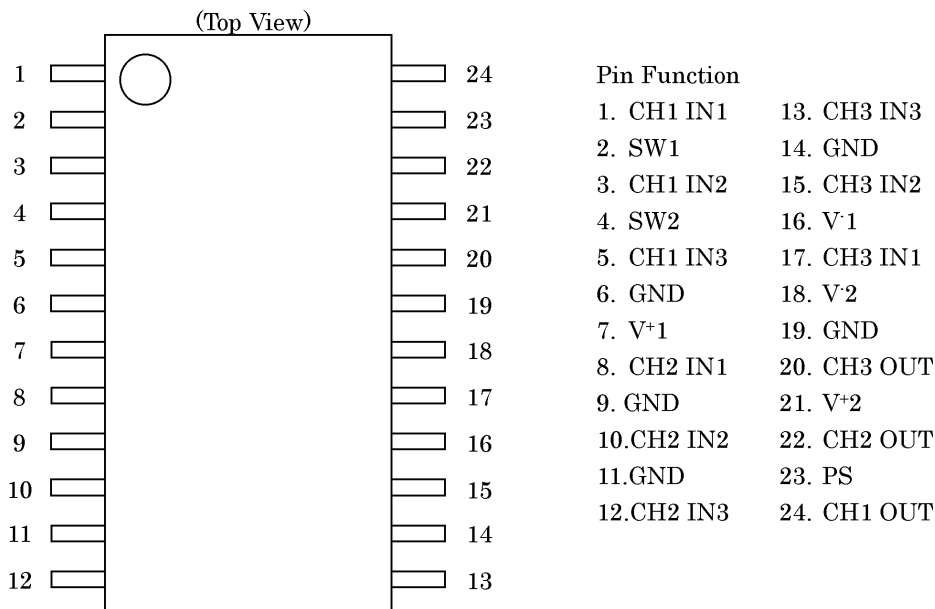



■ **PIN CONFIGURATION**

BEE-33546-000-01



TRANSISTOR, REGULATOR IC BLOCK DIAGRAM

<p>TO-92M</p>  <p>1. Emitter 2. Collector 3. Base</p> <p>123</p> <p>KTC2874B KSC2785Y KRA107M KRC107M KRA104MT</p>	<p>TO-92</p>  <p>1. Emitter 2. Collector 3. Base</p> <p>123</p> <p>KTD1302T KTA1268GR KTC3200GR KTC3198Y KTA1271Y KSA1175YT</p>	<p>TO-220</p>  <p>1. GND 2. INPUT 3. OUTPUT</p> <p>123</p> <p>MCNJM7905 MC7915C</p>	<p>TO-92L</p>  <p>1. Emitter 2. Collector 3. Base</p> <p>123</p> <p>KTA1024Y KSC2316Y</p>
<p>TO-126</p>  <p>1. Emitter 2. Collector 3. Base</p> <p>123</p> <p>2SA1360O 2SC3423O KTD600KG</p>	<p>TO-92</p>  <p>1. Emitter 2. Base 3. Collector</p> <p>123</p> <p>KSA733CYT</p>	<p>TO-220</p>  <p>1. INPUT 2. GND 3. OUTPUT</p> <p>123</p> <p>MC7815C MC7805C</p>	<p>TO-3P</p>  <p>1. Base 2. Collector 3. Emitter</p> <p>1 2 3</p> <p>2SB1560 2SD2390</p>

NJM2391DL1-25 NJM2391DL1-33
LOW DROPOUT VOLTAGE REGULATOR

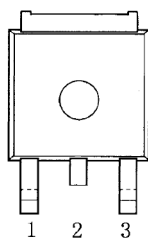

PIN FUNCTION
1. IN
2. GND
3. OUT

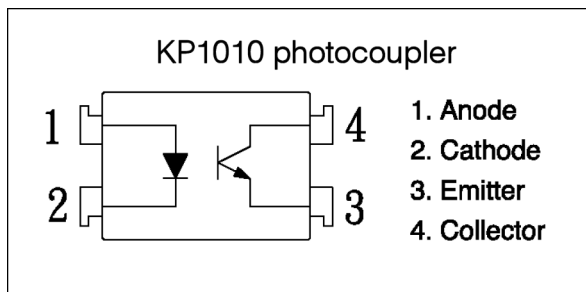
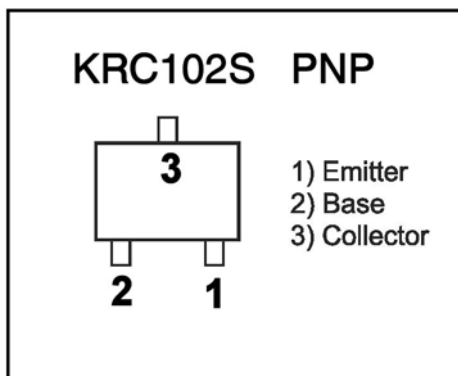

6

5

4

3

2

1

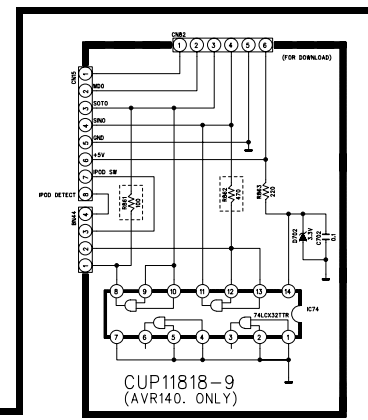
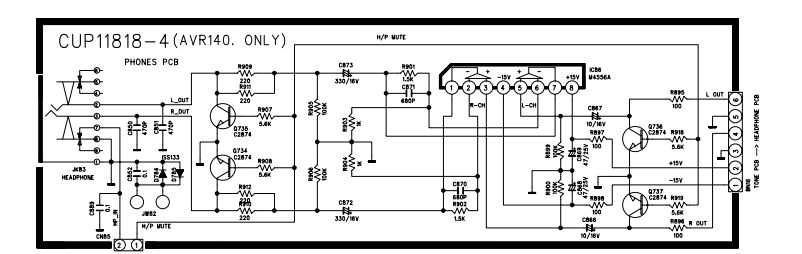
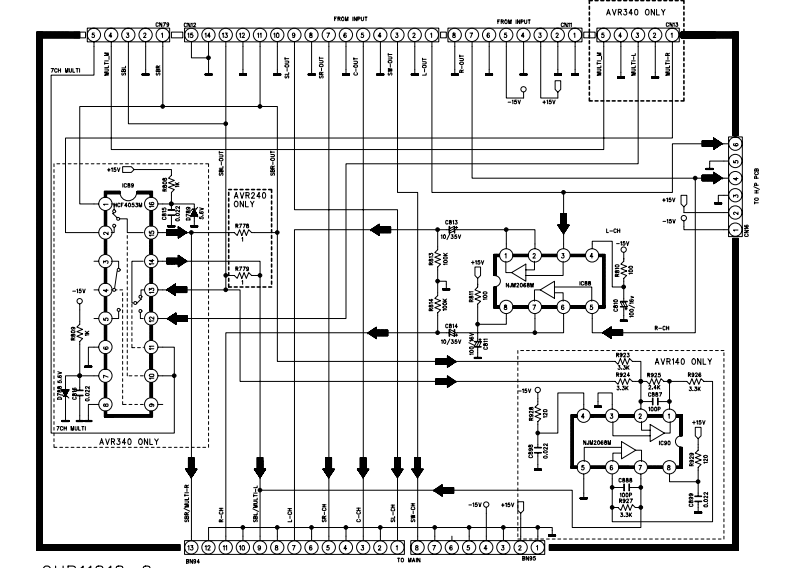
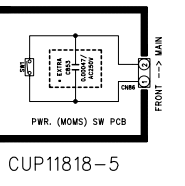
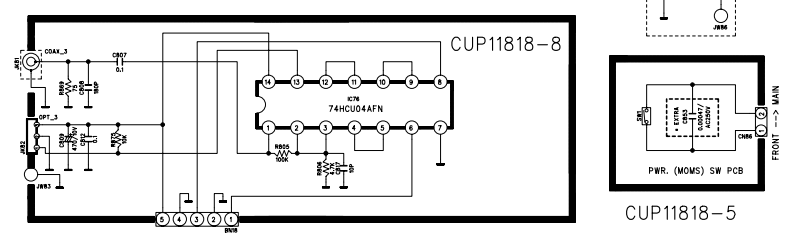
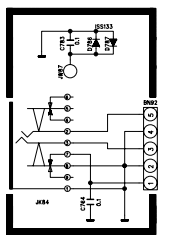
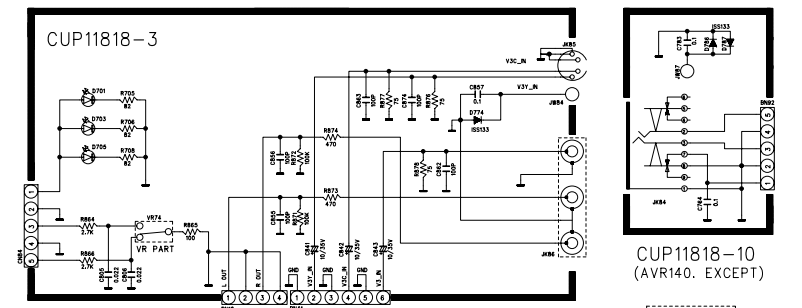
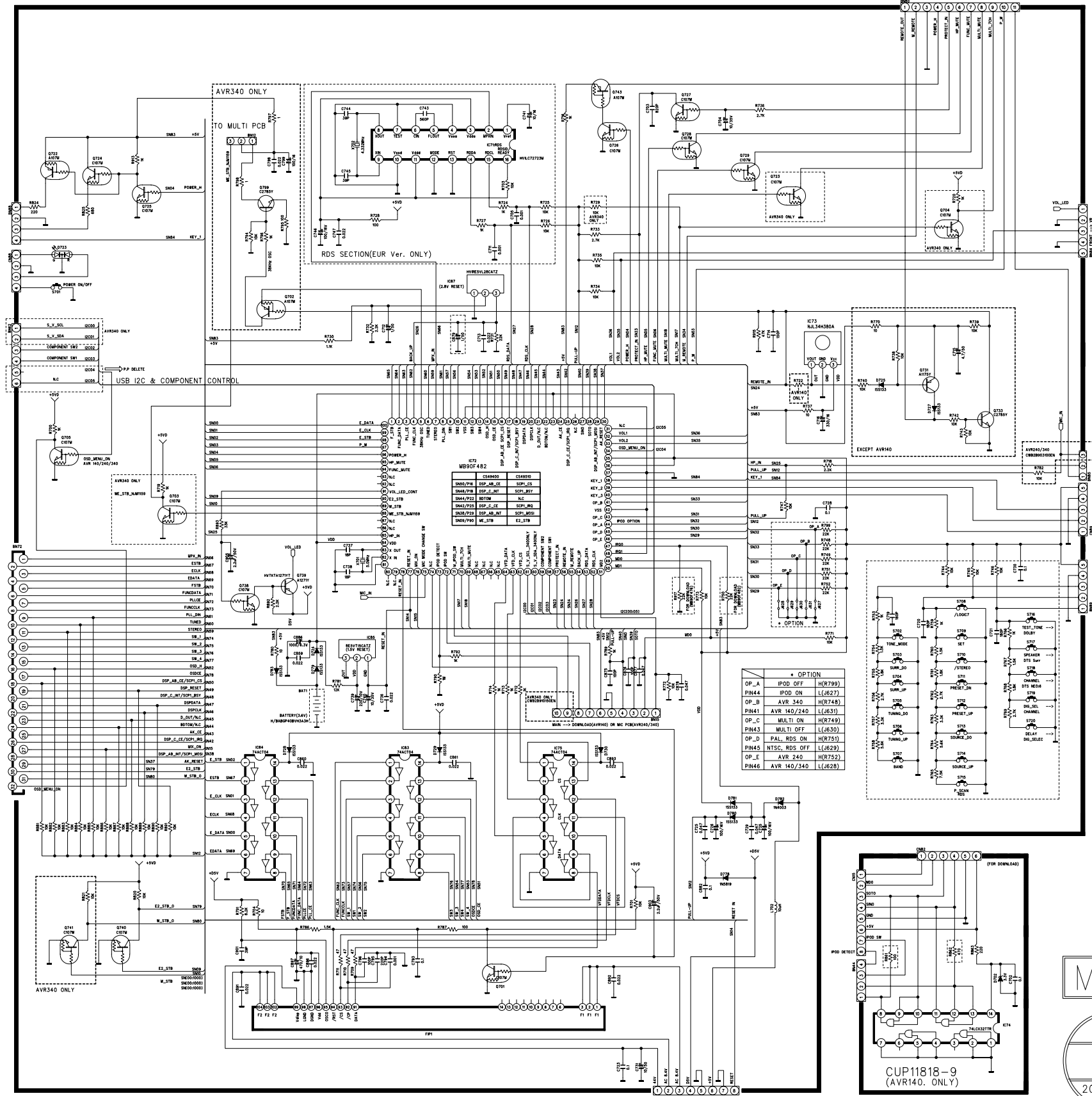

M/P

JSUE
2005.06.0

REVISION	2	4	6
1	3	5	7
SCHEMATIC DIAGRAM			
MODEL	AVR140/240/340		
DESIGN	CHECK	APPROVE	DRAWING NO
C.H.C	Y.W.Y	LEE H W	1818SCMZ
05.06.23			(FRONT)

6 5 4 3 2 1

< BIAS T.R PCB >

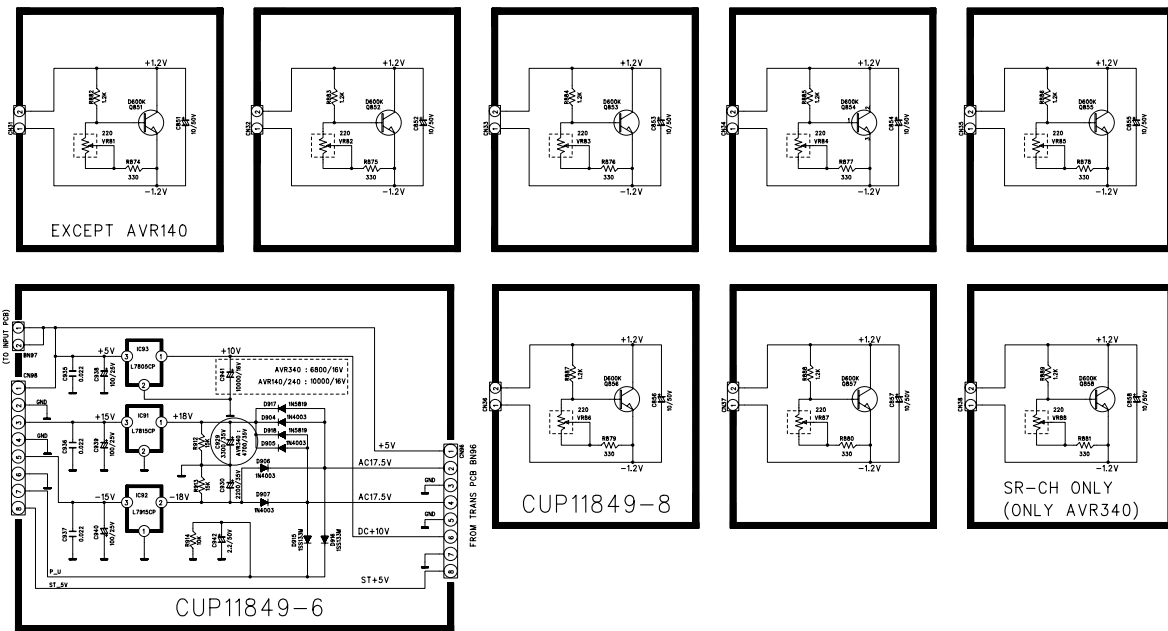

< POWER TRANS & OUTLET PCB >

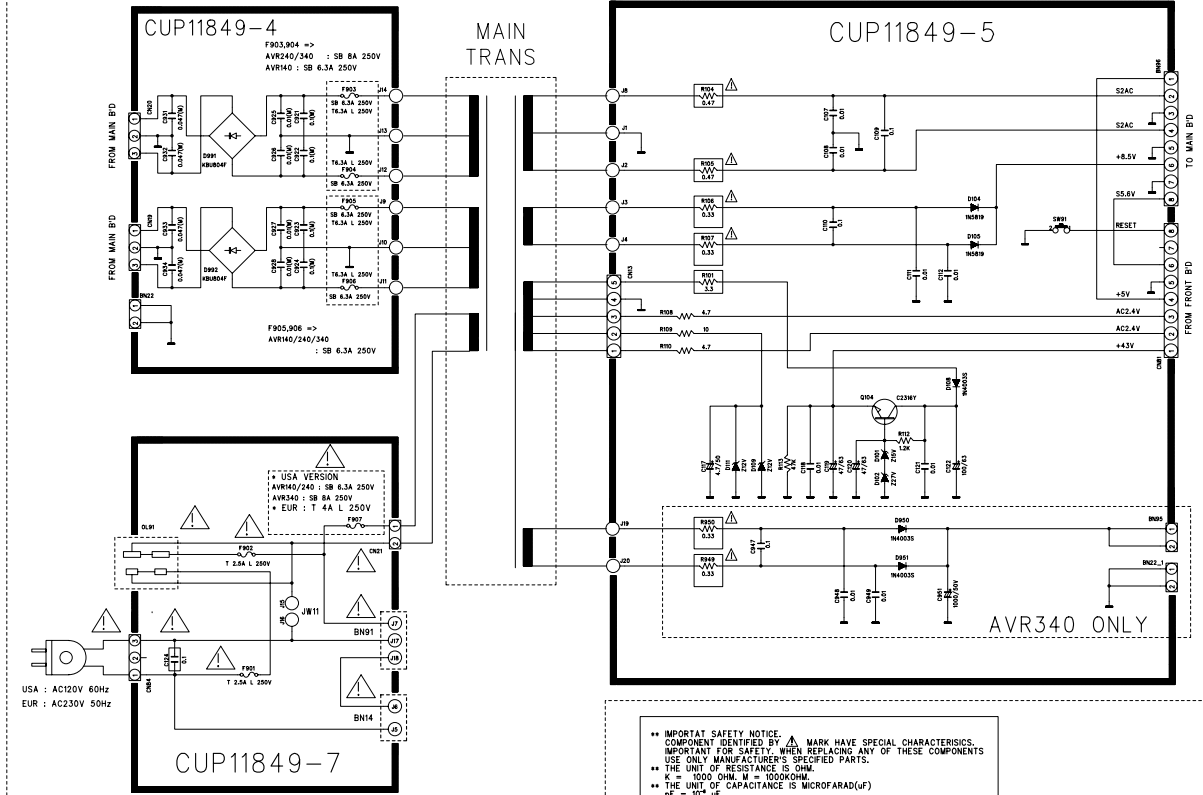

*** IMPORTANT SAFETY NOTICE: COMPONENT IDENTIFIED BY MARK HAVE SPECIAL CHARACTERISTICS. IMPORTANT FOR SAFETY WHEN REPLACING ANY OF THESE COMPONENTS USE ONLY MANUFACTURER'S SPECIFIED PARTS.
 ** THE UNIT OF RESISTANCE IS OHM.
 * K = 1000 OHM, M = 10000 OHM.
 ** THE UNIT OF CAPACITANCE IS MICROFARAD(μF)
 ** THIS SCHEMATIC DIAGRAM MAY MODIFIED AT ANY TIME WITH THE IMPROVEMENT OF PERFORMANCE.

< MIC & HP PCB >

AVR240, 340 ONLY

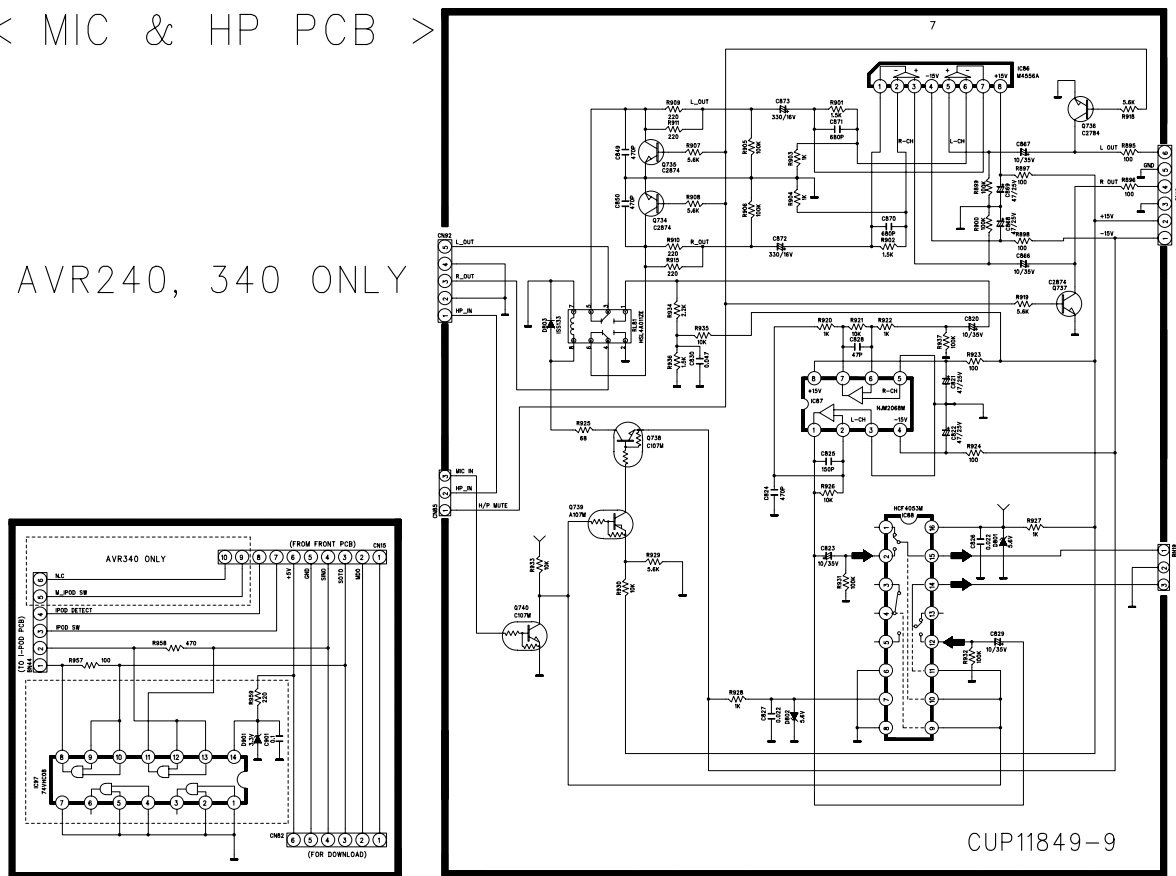

< +24V REGULATOR PCB >

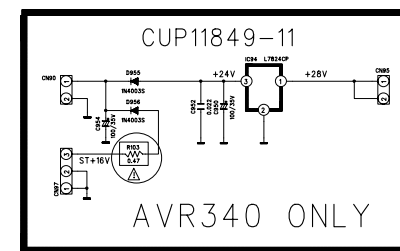

< REMOTE IN/OUT PCB >

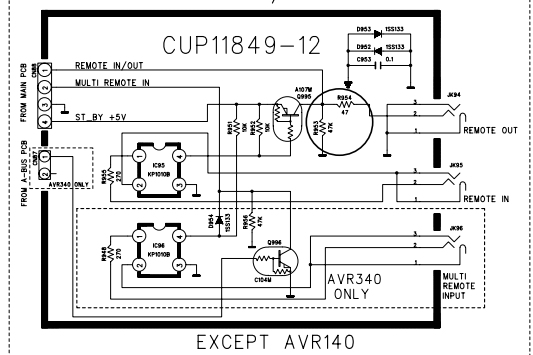

M/P



REVISION	2	4	6	
1	3	5	7	
SCHEMATIC DIAGRAM				SHEET
MODEL	AVR240, AVR340			7
DESIGN	CHECK	APPROVE	DRAWING NO	
LEE C B	Y.W.Y	L.H.W	1849SCMZ	
05.02.03	(BIAS&MIC&POWER TRANS)			2

AVR240

harman/kardon

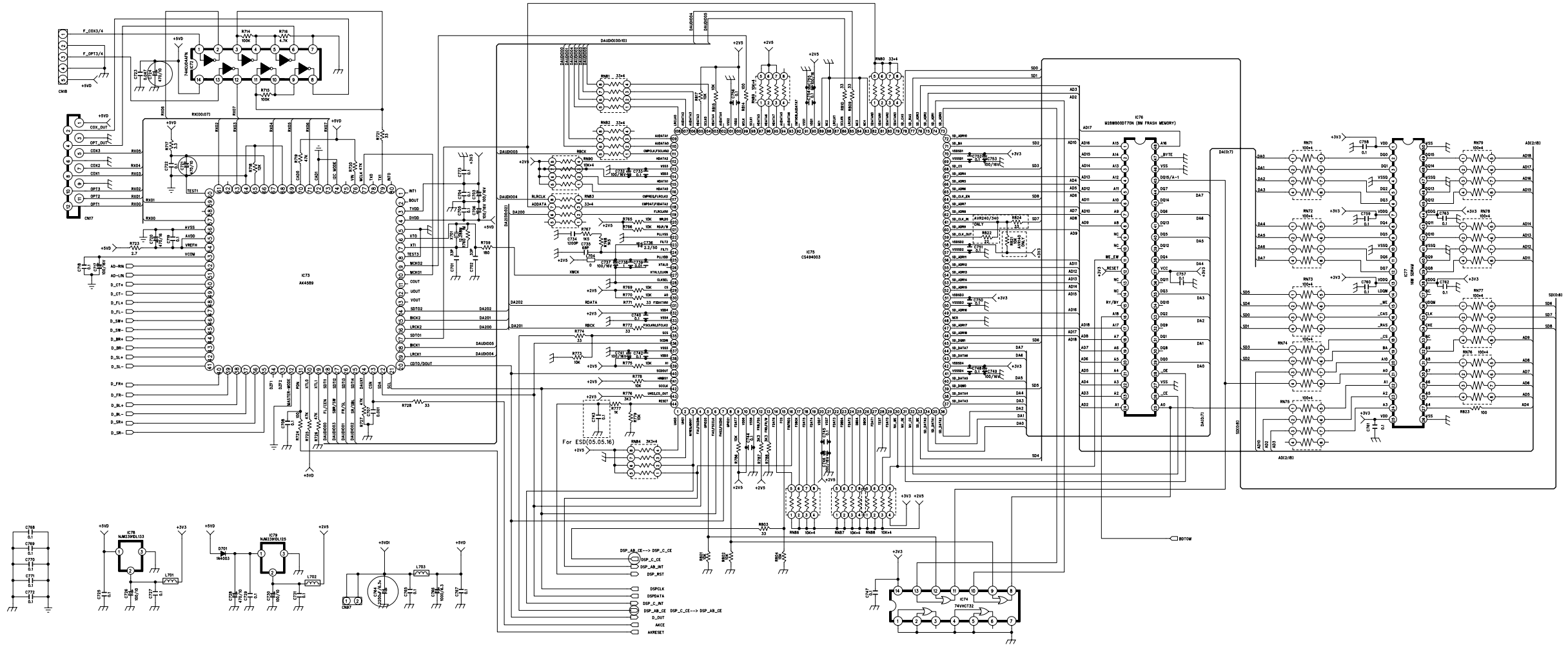

CUP11814-1

M/P

SSUE
2005.05.0

REVISION	2	4	6
1	3	5	7
SCHMATIC DIAGRAM			
MODEL	AVR140/240		
DESIGN	CHECK	APPROVE	DRAWING NO
Y.W.Y	Y.W.Y	L.H.W	1814SCMZ

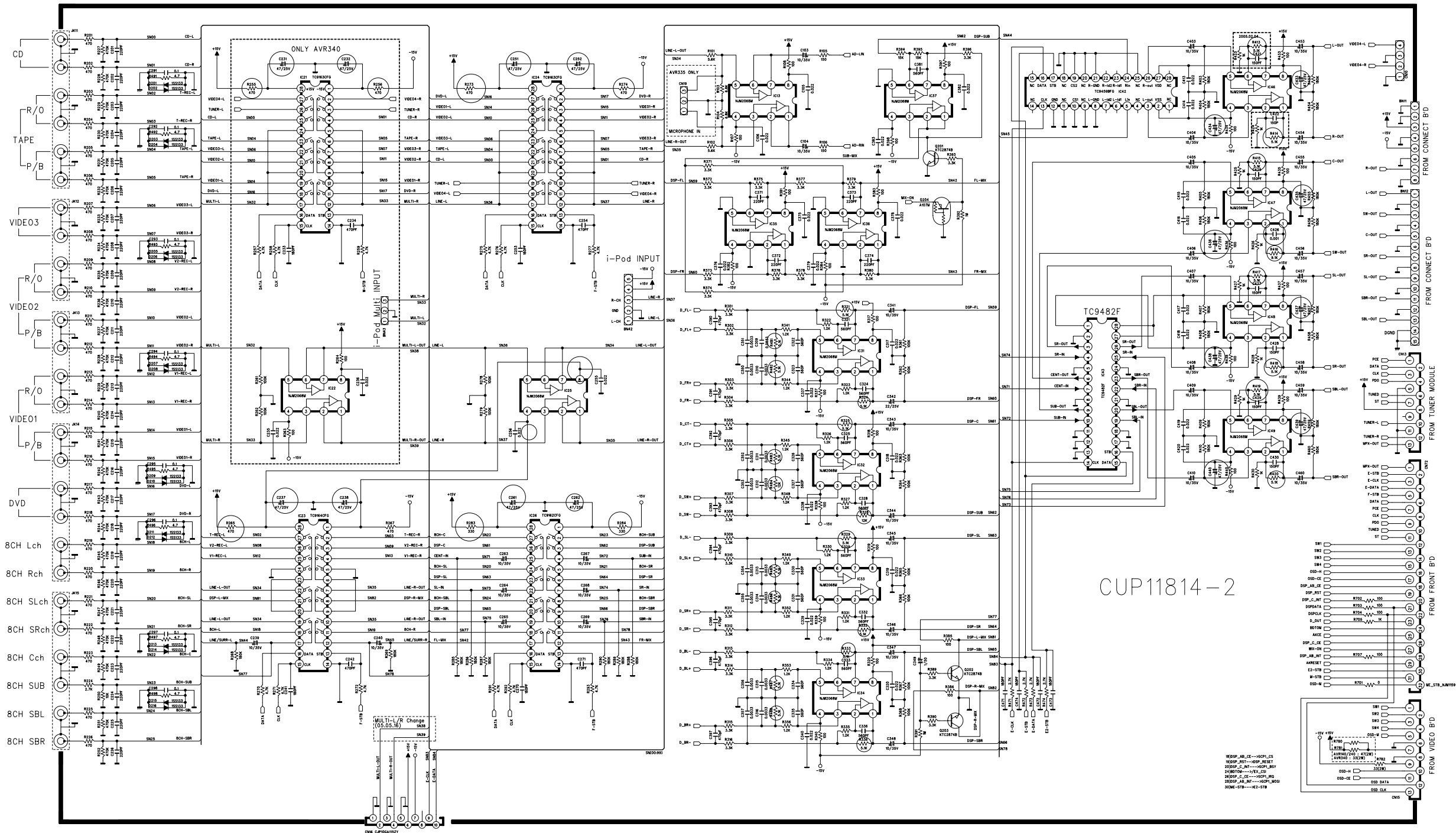

•• IMPORTANT SAFETY NOTICES.
 COMPONENTS IDENTIFIED BY Δ MARK HAVE SPECIAL CHARACTERISTICS.
 IMPORTANT FOR SAFETY. WHEN REPLACING ANY OF THESE COMPONENTS
 USE ONLY MANUFACTURER'S SPECIFIED PARTS.
 •• THE UNIT OF RESISTANCE IS OHM.
 K=1000 OHM, M=1000 KOHM
 •• THE UNIT OF CAPACITANCE IS MICROFARAD. (μ F)
 pF=10⁻¹² uF
 •• THIS SCHEMATIC DIAGRAM MAY MODIFIED AT ANY TIME WITH THE
 IMPROVEMENT OF PERFORMANCE.

M/P

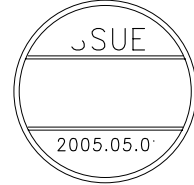

REVISION	2	4	6
1	3	5	7
SCHEMATIC DIAGRAM			SHEET
MODEL	AVR140/240/340		3/6
DESIGN	CHECK	APPROVE	DRAWING NO
K.M.S	Y.W.Y	L.H.W	1814SCEZ
04.02.20			(INPUT) 1/2

AVR240

harman/kardon

CUP11834Z

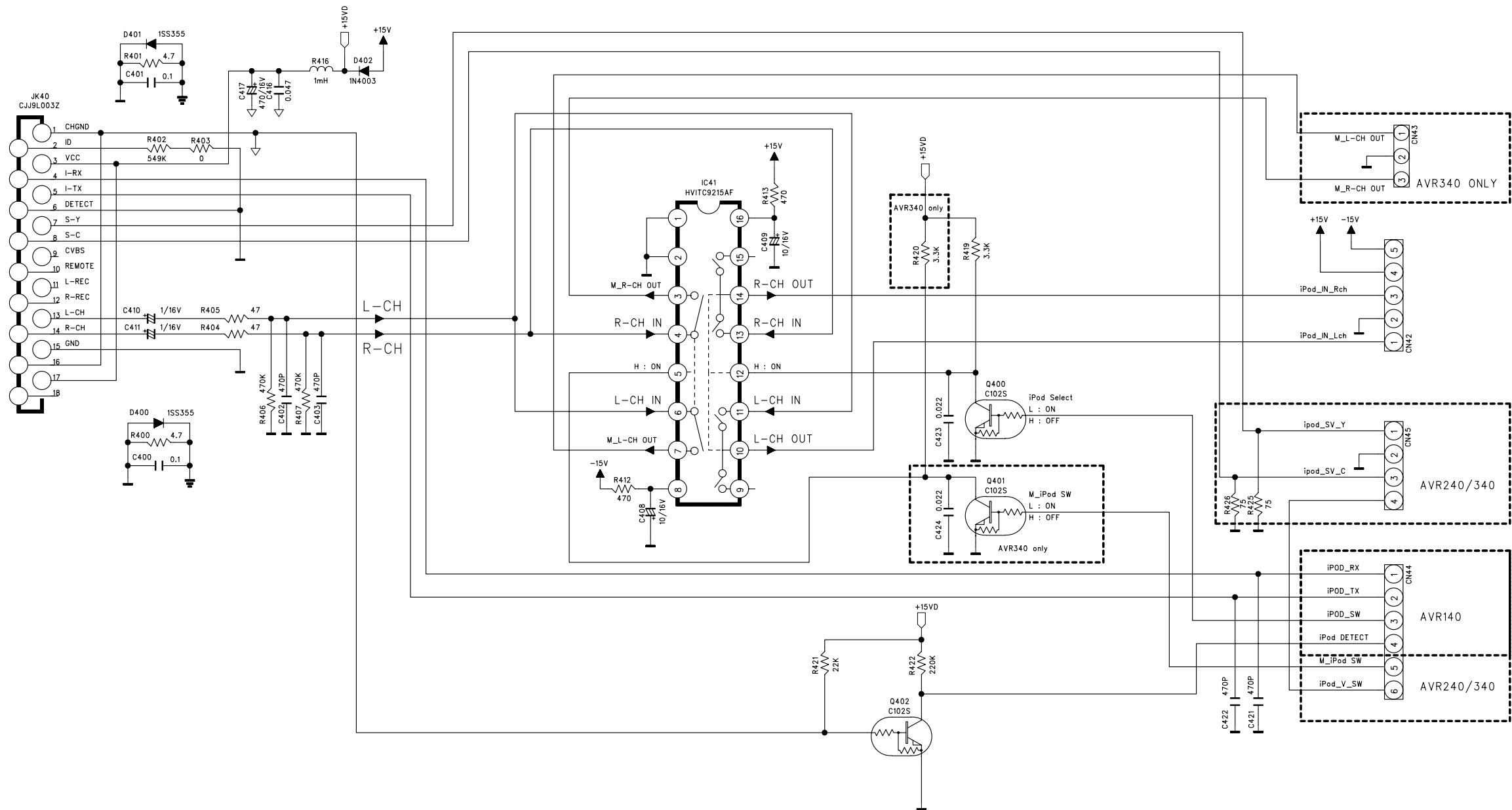

REVISION	2	4	6	
1	3	5	7	
SCHEMATIC DIAGRAM				SHEET
MODEL	AVR140/240/340			2/4
DESIGN	CHECK	APPROVE	DRAWING NO	
L.J.Y	L.B.C	L.H.W	1834SCMZ	
05.06.28	05.07.29	05.07.29	(DMP)	

CUP11835

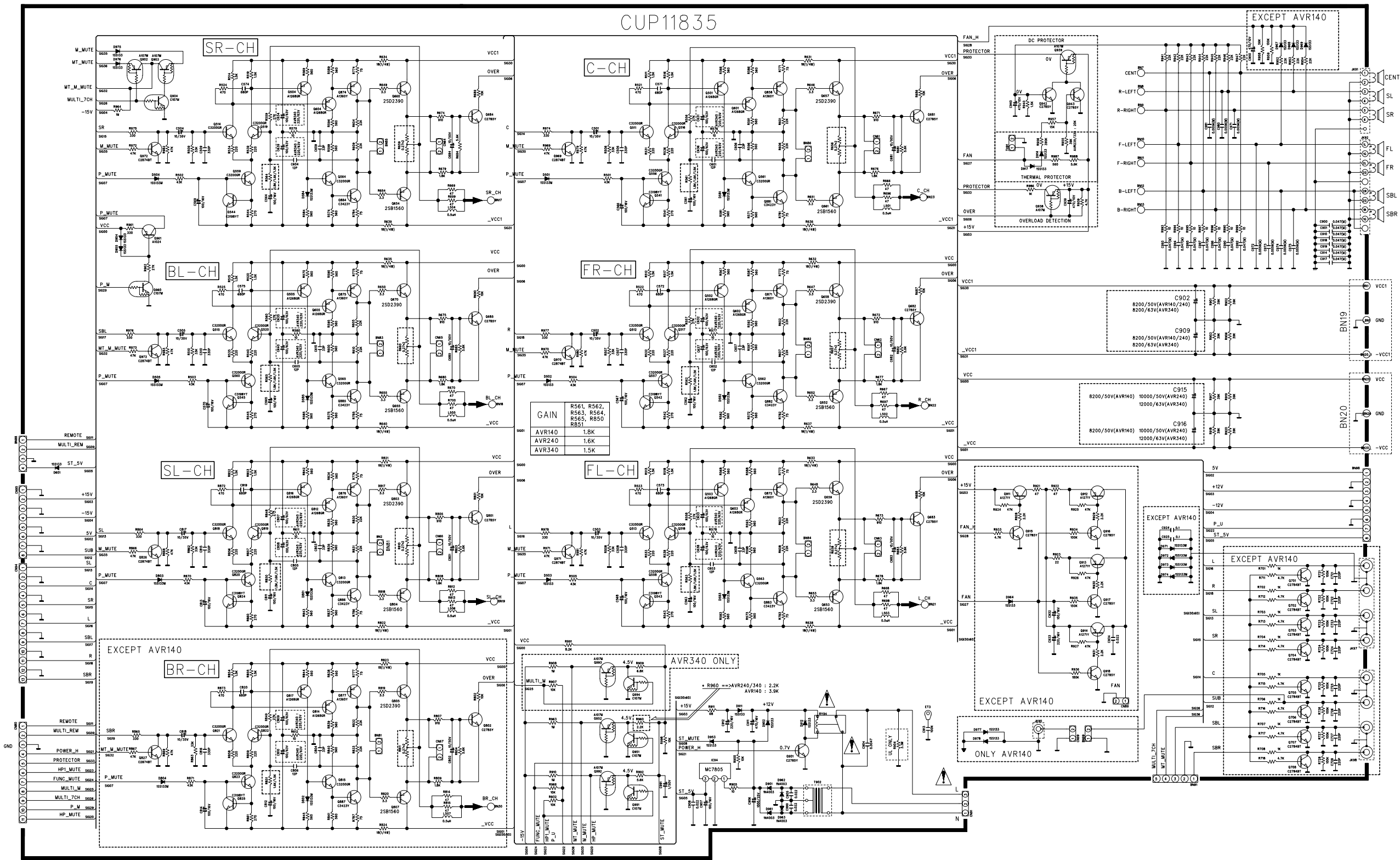

GAIN	R561, R562, R563, R564, R565
AVR140	1.8K
AVR240	1.6K
AVR340	1.5K

AVR340 ONLY
 R960 = AVR240/340 : 2.2K
 AVR140 : 3.9K

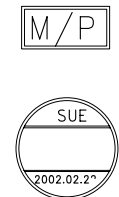

REVISION	1	2	3	SHEET
SCHEMATIC DIAGRAM				2
MODEL	AVR140, AVR240, AVR340			6
DESIGN	CHECK	APPROVE	DRAWING NO	
L.C.B	Y.W.Y	L.H.W	1835SCMZ (MAIN)	
04.02.24				

•• IMPORTANT SAFETY NOTICE.
 IMPORTANT FOR SAFETY WHEN REPLACING ANY OF THESE COMPONENTS
 USE ONLY MANUFACTURER'S SPECIFIED PARTS.
 •• THE UNIT OF RESISTANCE IS OHM.
 K=1000 OHM, M=1000 KOHM.
 •• THE UNIT OF CAPACITANCE IS MICROFARAD (uF)
 pF = 10⁻⁶ uF
 •• THIS SCHEMATIC DIAGRAM MAY BE MODIFIED AT ANY TIME WITH THE
 IMPROVEMENT OF PERFORMANCE

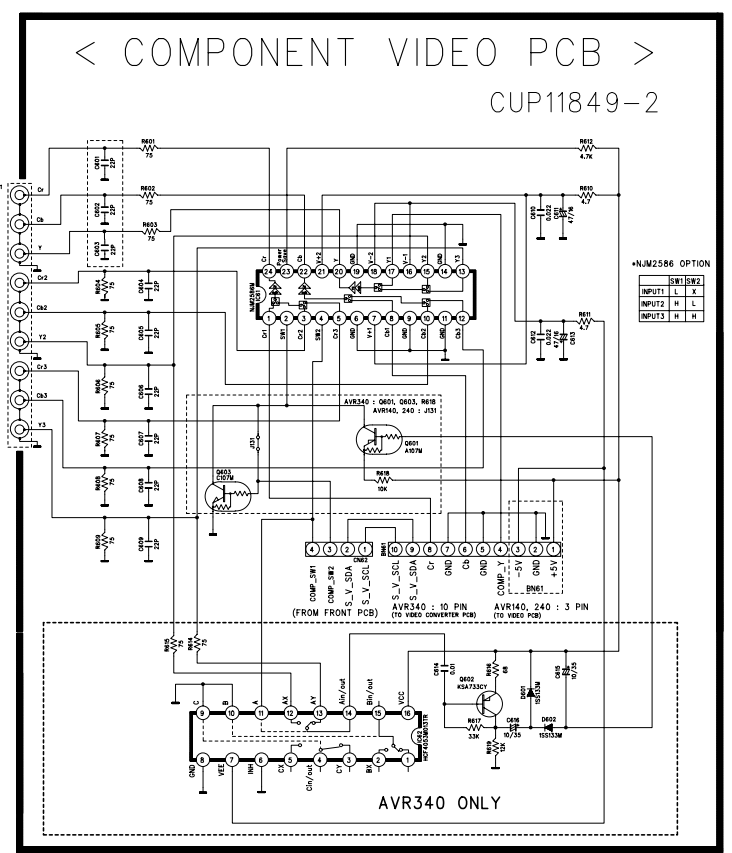
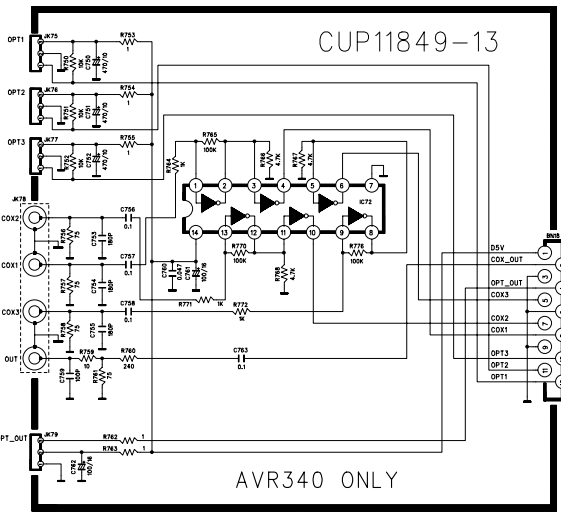
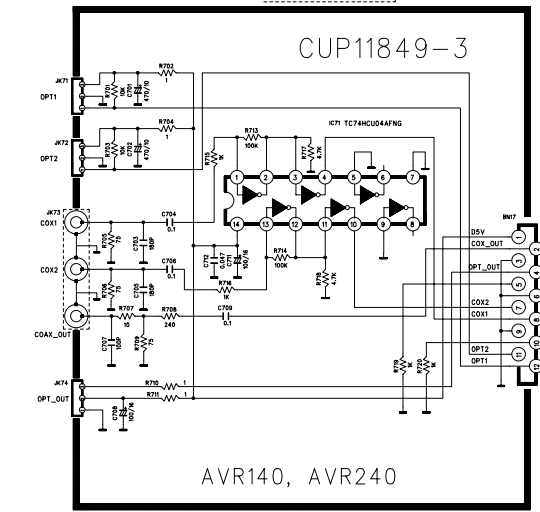
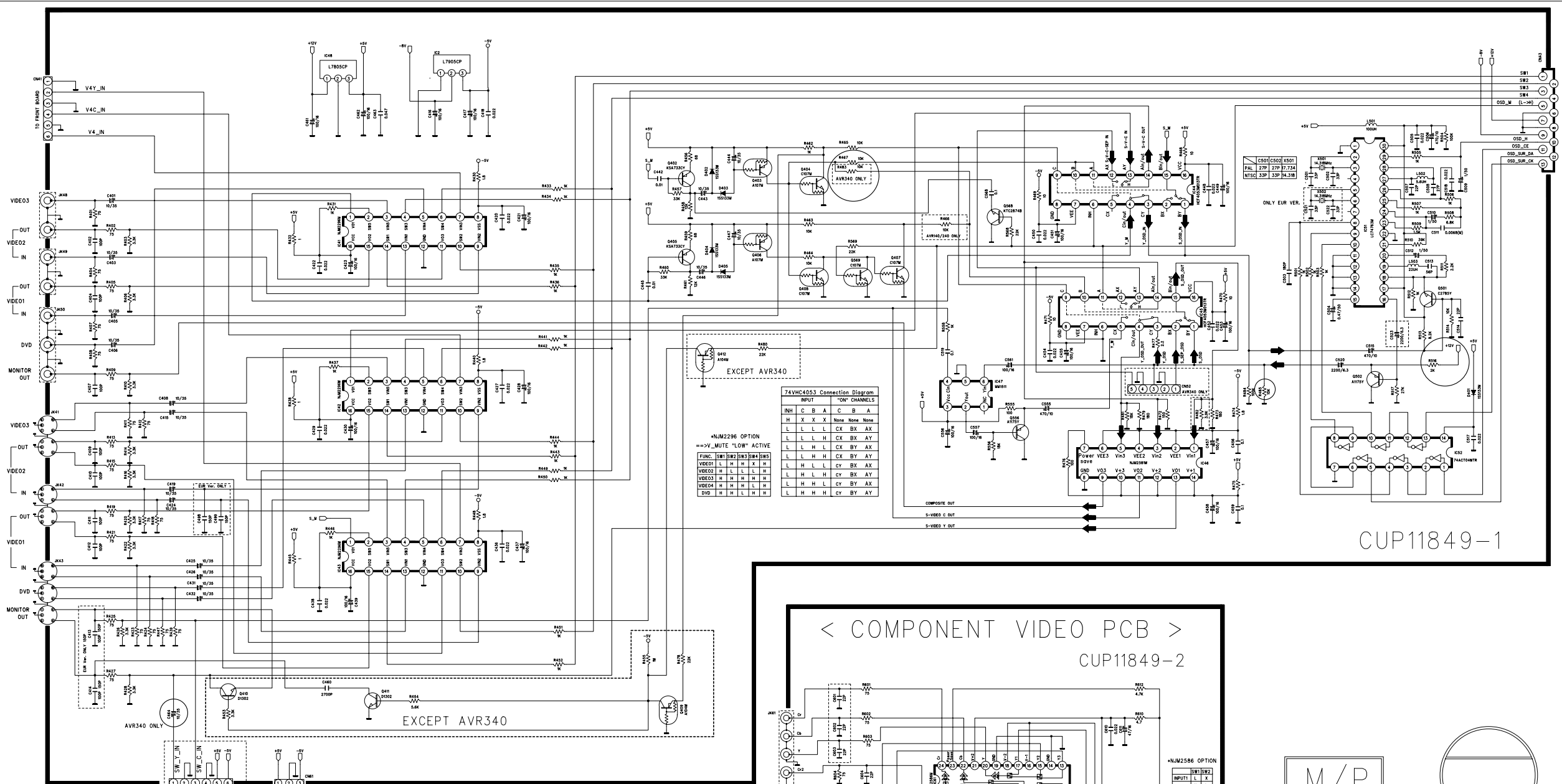

REVISION	2	4	6
1	3	5	7
SCHEMATIC DIAGRAM			
MODEL			AVR240, AVR340
DESIGN	CHECK	APPROVE	DRAWING NO
LEE C B	Y.W.Y	L.H.W	1849SCMZ (VIDEO)
.02.01			

SHEET 6/8

AVR240/340 WIRING DIAGRAM

USA : 120V 60Hz
EUR : 230V 50Hz

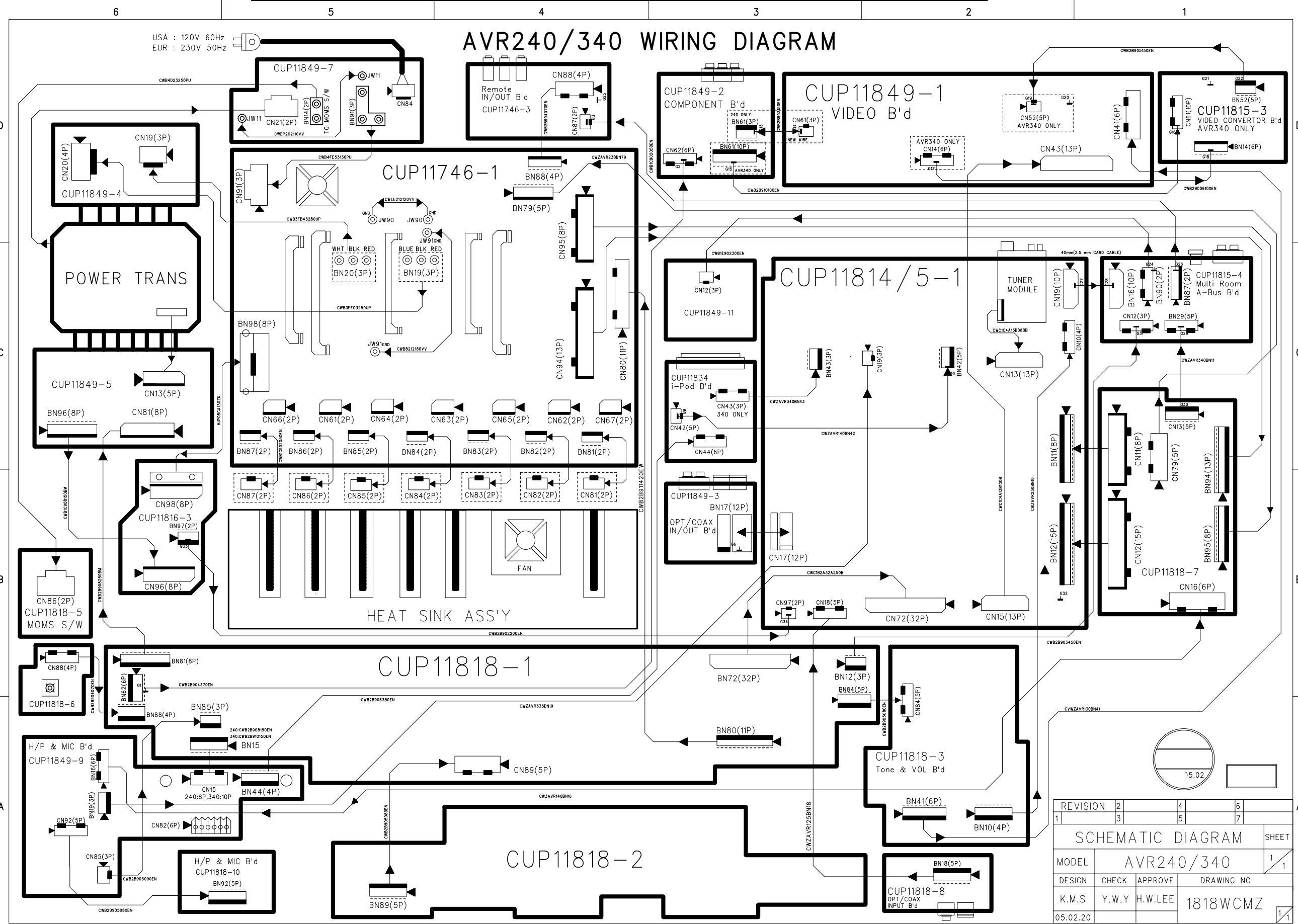

REVISION	2	4	6
	3	5	7
SCHEMATIC DIAGRAM			
MODEL	AVR240/340		
DESIGN	CHECK	APPROVE	DRAWING NO
K.M.S	Y.W.Y	H.W.LEE	1818WCMZ
05.02.20			