

# AVR 2500 Audio/Video Receiver

## SERVICE MANUAL

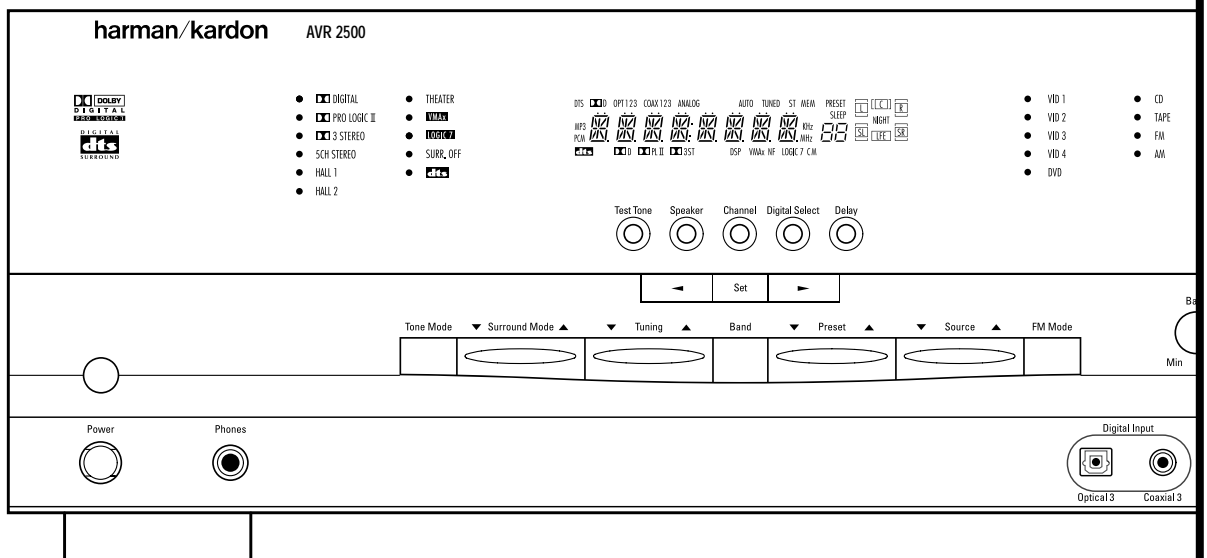

**harman/kardon®**

Power for the Digital Revolution.™

# Technical Specifications

## Audio Section

Stereo Mode

Continuous Average Power (FTC)

50 Watts per channel, @ < 0.07% THD, 20Hz – 20kHz,  
both channels driven into 8 ohms

Five-Channel Surround Modes

Power Per Individual Channel

Front L&R channels:

40 Watts per channel

@ < 0.07% THD, 20Hz–20kHz into 8 ohms

Center channel:

40 Watts @ < 0.07% THD, 20Hz–20kHz into 8 ohms

Surround channels:

40 Watts per channel

@ < 0.07% THD, 20Hz–20kHz into 8 ohms

Input Sensitivity/Impedance

Linear (High-Level) 200mV/47k ohms

Signal-to-Noise Ratio (IHF-A) 95dB

Surround System Adjacent Channel Separation

Pro Logic II 45dB

Dolby Digital (AC-3) 55dB

DTS 55dB

Frequency Response

@ 1W (+0dB, –3dB) 10Hz–100kHz

High Instantaneous

Current Capability (HCC) ±25 Amps

Transient Intermodulation

Distortion (TIM) Unmeasurable

Slew Rate 40V/μsec

## FM Tuner Section

Frequency Range	87.5–108.0MHz
Usable Sensitivity	IHF 1.3μV/13.2dB
Signal-to-Noise Ratio	Mono/Stereo 70dB/68dB
Distortion	Mono/Stereo 0.2%/0.3%
Stereo Separation	40dB @ 1kHz
Selectivity	±400kHz, 70dB
Image Rejection	80dB
IF Rejection	90dB

## AM Tuner Section

Frequency Range	520–1710kHz
Signal-to-Noise Ratio	45dB
Usable Sensitivity	Loop 500μV
Distortion	1kHz, 50% Mod 0.8%
Selectivity	±10kHz, 30dB

## Video Section

Television Format	pal
Input Level/Impedance	1Vp-p/75 ohms
Output Level/Impedance	1Vp-p/75 ohms
Video Frequency Response	10Hz–8MHz (–3dB)

## General

Power Requirement	AC 230V/50Hz
Power Consumption	W idle, W maximum (2 channels driven)

Dimensions

Width	17.3 inches (440mm)
Height	6.5 inches (165mm)
Depth	17.1 inches (435mm)

Weight 31 lb (14.1kg)

Depth measurement includes knobs, buttons and terminal connections.

Height measurement includes feet and chassis.

All features and specifications are subject to change without notice.

Harman Kardon is a registered trademark, and Power for the Digital Revolution is a trademark, of Harman Kardon, Inc.

\*Manufactured under license from Dolby Laboratories.

Dolby, Pro Logic II, AC-3 and the Double-D symbol are trademarks of Dolby Laboratories. Confidential Unpublished Works. ©1992–1999 Dolby Laboratories, Inc. All rights reserved.

DTS and DTS Surround are registered trademarks of Digital Theater Systems, Inc.

UltraStereo is a trademark of UltraStereo Corp.

VMaX is a registered trademark of Harman International Industries, Inc., and is an implementation of Cooper Bauck Transaural Stereo under patent license.

Logic 7 is a registered trademark of Lexicon, Inc., a Harman International Company.

Crystal is a registered trademark of Cirrus Logic Corp.

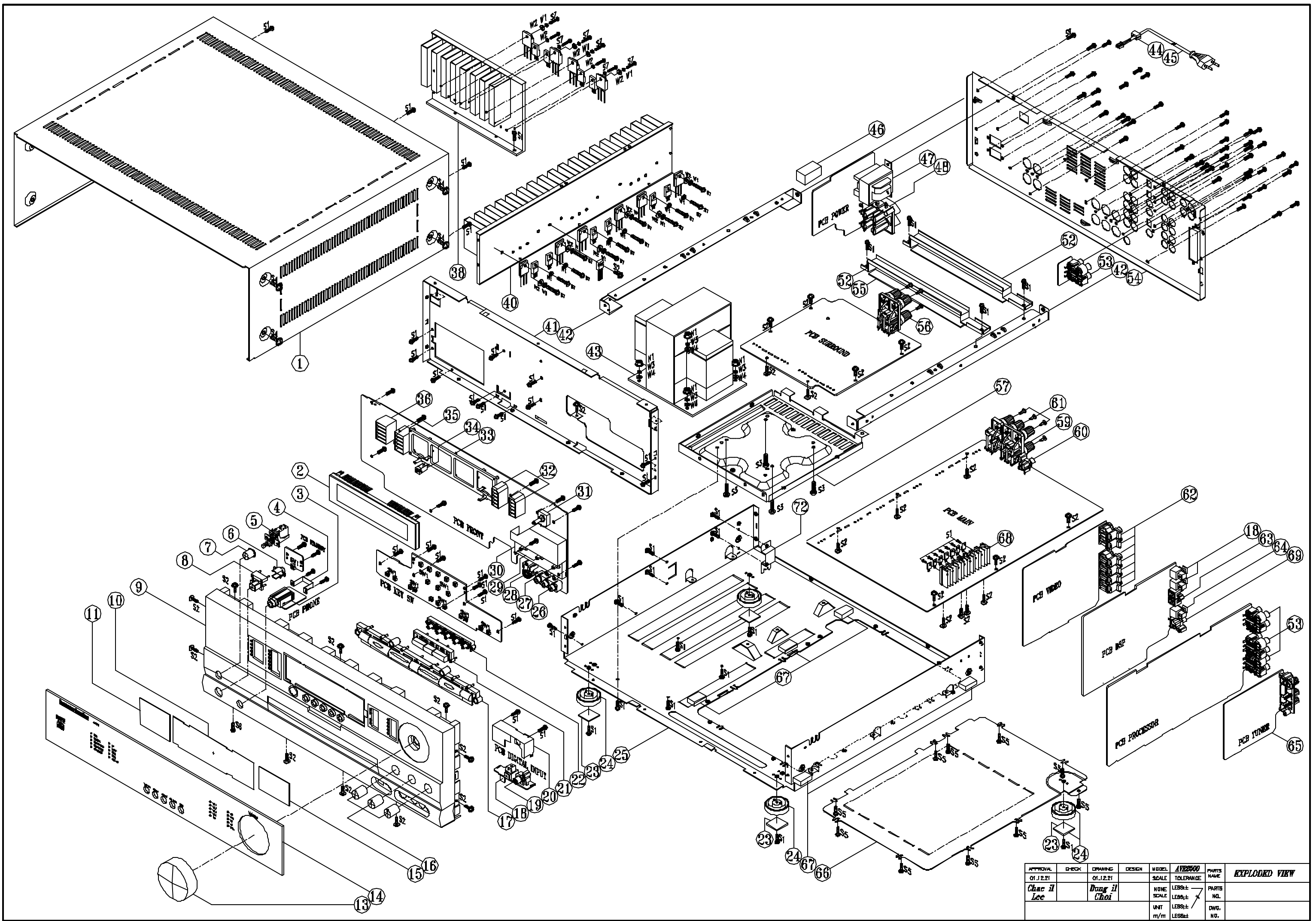

APPROVAL	CHECK	DRAWING	DESIGN	MODEL	AV28600	PARTS NAME	EXPLODED VIEW
01.12.21		01.12.21		SCALE	TOLERANCE	PARTS	
Chac il		Dong il		NONE	LESB±	NL	
Lec		Choi		SCALE	LESB±	DWG.	
				UNIT	LESB±	NO.	
				m/m	LESB±		

# AVR2500 EXPLODED VIEW PART LIST

NO.	Part #	QTY	Description
1	55178030XX	1	AC PUN COVER TOP
2	55155740XX	1	DISPLAY HMA-10MM22
3	55058400XX	1	CONN-PLUG 6.35 ST HORIZ EST-16313 BK 0 0
4	55124350XX	1	AC PUN BRACKET HEADPHONE
5	55178020NR	1	SW PUSH POWER SWITCH 6.0A 250.0V 100MEDIUM IT 2P
6	55178020XX	1	AC MLD BUTTON INDICATOR STAND-BY
7	55177810XX	1	AC DEC BUTTON POWER
8	55177820XX	1	AC DEC BUTTON STANDBY
9	55242850XX	1	AC DEC CABINET PANEL FRONT AVR2500
10	55177830XX	1	AC DEC CRYSTAL FILTER DISPLAY
11	55101540XX	1	AC NON-METAL DIFFUSER 0.2T 62.5*41 WH
12	BLANK		
13	55177740XX	1	AC DEC KNOB MAIN HPS 04H
14	55242860XX	1	AC DEC CRYSTAL DISPLAY AVR2500
15	55177890XX	1	AC NON-METAL DIFFUSER 0.2T 58.8*41 WH
16	55177750XX	3	AC DEC KNOB TONE
17	55177790XX	1	AC DEC BUTTON 7 KEY
18	55125440XX	3	D-LEN TOTX178B RD RND CL
19	55175240XX	1	CON PHONE SCKT RCA 1P V/END JED10003MG
20	55182550XX	1	AC PUN SHIELD DIGITAL ET
21	55177760XX	1	AC DEC BUTTON 3 KEY
22	55177780XX	1	AC DEC BUTTON 5 KEY
23	55174760XX	4	AC FOOT RUBBER ROUND 3.0MM 23.0MM JS 60 Y DA
24	55178110XX	4	AC FOOT ASSY ROUND 12.5MM 50MM
25	55178070XX	1	AC CPL CABINET CHASSIS MAIN SECC 1.0T
26	55113740XX	1	CON PHONE SCKT RCA-307 3 PINS
27	55179910DD	2	FR-ROT 100K0 OHM NON-LINEAR RK14K12400BQ 0 0
28	55113840XX	1	CON DIN SCKT SOCKET CONNECTOR SVHS EST-5408M
29	55179920DD	1	FR-ROT 100K0 OHM NON-LINEAR RK14K12400BR 0 0
30	55177570XX	1	AC PUN SHIELD FENCE TONE
31	55154900NR	1	SWPRT EC18B242D4A5 0V 00000A TOT 3P 0 0
32	55178040XX	2	AC PLASTIC MOLD REFRACTOR E WH
33	55244320XX	1	AC MLD HOLDER FL-GUIDE HPS 04-H
34	55155850NR	1	IC-REMOTE RM883B-FSIP-A3 RECEIVER 38KHZ
35	55101520XX	1	AC PLASTIC MOLD REFRACTOR A WH
36	55178850XX	1	AC PLASTIC MOLD REFRACTOR F WH
37	BLANK		
38	55244260XX	1	AC METAL HEATSINK SURROUND
39	BLANK		
40	55244280XX	1	AC METAL HEATSINK MAIN
41	55178250XX	1	AC CPL CABINET CHASSIS FRONT SECC 1.0T
42	55178170XX	2	AC PUN BRACKET FRAME-GUIDE SECC TT.0
43	55201720NR	1	TF-LAN POWER-TRANSFORMER 230V
44	55125180XX	1	AC MLD CLAMP AC CORD
45	55188800XX	1	WIRE-MICRON 0.75MM2 1830MM BK CORD POWER CE
46	55178400XX	1	AC BUFFER CUSHION (A) EVA
47	55155890NR	1	TF-LAN POWER-TRANSFORMER 230V
48	55246750NR	1	CONN-SPE AC OUTLET 2P 220V
49	BLANK		
50	BLANK		
51	BLANK		
52	55244240XX	2	AC PUN BRACKET PCB
53	55178330XX	4	CON PHONE SCKT RCA 4P JM4104RS GND
54	55242880XX	1	AC CPL REAR PANEL AVR2500
55	55178300XX	3	AC BUFFER CUSHION-BRKT EVA
56	55191390XX	1	CONN-SPE TERMINAL SPKR 4P SHD410376P
57	55178090XX	1	AC PUN COVER TRANS BOTTOM TT.0
58	BLANK		
59	55101400XX		CONN-SPE TERMINAL SPKR 6P
60	55191370XX	1	CON PHONE SCKT RCA 1P JACK JED10003XN
61	55201080XX	10	AC PLASTIC KNOB CORK SH08N79080 BK
62	55148520XX	6	CON DIN SCKT MIX SOCKET RCA-1184P15
63	55191000XX	1	CON PHONE SCKT RCA 2P V/ENDCAP JW-1502SN 00
64	55125440NR	1	D-LEN TOTX178B RD RND CL
65	55227740XX	1	AC NSA ASY KST-M114MW1-8D TU MODULE
66	55178050XX	1	AC PUN COVER BOTTOM SECC TT.0
67	55125220XX	11	AC BUFFER PCB
68	55178400XX	1	AC METAL HEATSINK REG 118*20*50H
69	55175850XX	1	CON PHONE SCKT RCA 1P V/END JED10003MN
70	BLANK		
71	BLANK		
72	55202430XX	1	AC PUN BRACKET PROTECT
73	BLANK		
XX	55178840XX	1	AC SPRING PLATE SPRING GND C5212 0.2T
XX	55148840NR	1	FERR FERRIT MAGNET RING34 34.5X21X12 K-150
XX		1	
S1	55127070XX	50	SCREW-ST 3MM 10MM
S2	55127120XX	34	SCREW-ST 3MM 8MM
S3	55308240XX	4	SCREW-SPEC 4MM 10MM
S4	55127080XX	8	SCREW-ST 4MM 8MM
S5	55127280XX	10	SCREW-ST 3MM 6MM
S6	55164800XX	1	SCREW 3MM 8MM
S7	55178320XX	15	SCREW-ST 3MM 12MM
S9	55156460XX	45	SCREW-SPEC 3MM 10MM
N1	55308350XX	4	NUT-HEXAGON 4.0MM 5.0MM CIRCULAR EXTERNAL 53
V1	55127300XX	10	WASHER-SPRING 3
V2	55127310XX	10	WASHER-FLAT 3
V3	55168800XX	4	WASHER-SPRING 4
V4	55131750XX	4	WASHER-FLAT 4
	20952870XX	2	AC PRI LABEL QC CHECK DRKD1217(20X13MM)
	55149150XX	2	AC PRI LABEL RISK CORW1211
	55174780XX	1	AC PRI LABEL DATE
	55242820XX	1	AC PRI LABEL SERIAL AVR2500
	55242850XX	1	AC PRI LABEL BARCODE AVR2500
	55178620XX	1	AC PRI LABEL "PLEASE REMOVE..."

**AVR 2500,3500,4500,5500 matrix**

	<b>AVR 2500</b>	<b>AVR 3500</b>	<b>AVR 4500</b>	<b>AVR 5500</b>
Remote Control	55242980	55242990	55262320/55178550	55262330/55178550
Power Transformer 230V	55201720	55201720	55274640	55163910
St-By Transformer 230V	55155650	55155650	55155650	55155650
uPC Main, IC201 (on front board)	55267250	55267250	55285950	55285950
uPC SUB IC128			55285930	55285930
Key SW PCB asm	55243610	55245880	55315730	55315700
Key SW stby PCB asm	55243610-1	55245880-1	55315730-1	55315700-1
Headphone PCB asm	55243610-2	55245880-2	55315730-2	55315700-2
Remote in/out PCB asm	55243610-3	55245880-3	55315730-2	55315700-3
Front PCB asm	55246230	55245850	55261830	55261820
Main PCB asm	55246120	55245840	55261860	55261840
Video PCB asm	55243640	55245890	55261900	55261890
DSP PCB asm	55243670	55245900	55261880	55261870
Digital 3 input PCB asm	55243670-1	55245900-1	55261880-1	55261870-1
Processor PCB asm	55243540	55245860	55196680	55182700
Tuner PCB asm	5522774A	5522774A	55317330	55317330
Surround PCB asm	55271240	55245870	55261930	55261940
St-by PCB asm	55271240-1	55245870-1	55261930-1	55261940-1
Component PCB asm				
Input PCB asm			55261920	55261910

PART NO : 55246080

TITEL : AC MECH BOM AVR2500 OEM

Pos	Tocom#	Pkg	M/B	St	Qty	Unit	SName
0050	55170390		B	so	25	PCE	CABLE-FIX WIRE-TIE MELLERMAI NYLON6 0 0
0060	55227740		B	ud	1	PCE	AC MSA ASY KST-M1114MW1-60 TU MODULE AVR2500
0070	55242850		M	SO	1	PCE	AC DEC CABINET PANEL FRONT
0080	55177740		M	SO	1	PCE	AC DEC KNOB MAIN HIPS 94H
0090	55177750		M	SO	3	PCE	AC DEC KNOB TONE HIPS
0100	55177760		M	SO	1	PCE	AC DEC BUTTON 3 KEY HIPS 9
0110	55177780		M	SO	1	PCE	AC DEC BUTTON 5 KEY
0120	55177790		M	SO	1	PCE	AC DEC BUTTON 7 KEY
0130	55242880		B	ud	1	PCE	AC DEC CRYSTAL DISPLAY AVR2500
0150	55177800		B	ud	1	PCE	AC DEC CRYSTAL FILTER DISPLAY
0160	55191560		B	so	1	PCE	AC NON-METAL DIFFUSER 0.2T 62.5*41 WH
0170	55177990		B	so	1	PCE	AC NON-METAL DIFFUSER 0.2T 59.6*41 WH
0180	55175250	NR	B	so	1	PCE	SWIPUSH PUSH POWER SWITCH 5.0A 250.0V 100MIOHM 1T 2P
0190	55273340	NR	B	so	1	PCE	WIRECONASY UNIQUE 2P 500MM UL1617 PVC DOUBLE INSULATED 22
0200	55177810		M	SO	1	PCE	AC DEC BUTTON POWER HIPS DVD10
0210	55177820		M	SO	1	PCE	AC DEC BUTTON STANDBY
0220	55178020		M	SO	1	PCE	AC MLD BUTTON INDICATOR STAND-BY AVR520
0230	55124350		B	so	1	PCE	AC PUN BRACKET HEADPHONE RT2280/RT2250(PAV5007/5005)
0250	55178050		B	ud	1	PCE	AC PUN COVER TOP AVR520 --
0260	55178070		B	po	0	PCE	AC CPL CABINET CHASSIS MAIN SECC 1.0T AVR520
0260	5517807A		B	so	1	PCE	AC CPL CABINET CHASSIS MAIN SECC 1.0T AVR520
0270	55178080		B	ud	1	PCE	AC PUN COVER BOTTOM SECC T1.0 AVR45UL --
0271	55127280		B	so	10	PCE	SCREW-ST 3MM 6MM JIS B 1122 25 0 0
0280	55178090		B	po	0	PCE	AC PUN COVER TRANS BOTTOM T1.0 AVR45UL --
0280	5517809A		B	so	1	PCE	AC PUN COVER TRANS BOTTOM SECC 1.0T AVR520 --
0300	55178110		M	SO	4	PCE	AC FOOT ASSY ROUND 12.5MM 50MM NOT DEFINED Y DIA
0301	55174760		B	so	4	PCE	AC FOOT RUBBER ROUND 3.0MM 25.0MM JIS 60 Y DIA
0310	55178170		B	ud	2	PCE	AC PUN BRACKET FRAME-GUIDE SECC T1.0
0320	55244240		B	so	2	PCE	AC PUN BRACKET PCB AVR120US
0340	55178300		B	ud	3	PCE	AC BUFFER CUSHION-BRK'T EVA
0350	55178250		B	ud	1	PCE	AC CPL CABINET CHASSIS FRONT SECC 1.0T AVR520
0370	55244250		B	so	1	PCE	AC METAL HEATSINK MAIN AVR310 --
0380	55244260		B	so	1	PCE	AC METAL HEATSINK SURROUND --
0400	55127300		B	so	15	PCE	WASHER-SPR 3.0MM 5.0MM 1.0MM Y 53 0 I4
0410	55127310		B	so	10	PCE	WASHER 3.3MM 8.0MM 0.5MM Y 53 0 A4
0420	55201720	NR	B	so	1	PCE	TF-LAM POWER-TRANSFORMER 230V
0430	55188980		B	ud	1	PCE	WIRE-MCRDM 1830MM BK CORD POWER CE
0440	55168690		B	so	4	PCE	AC SPRING WASHER RT2250(PAV5005)
0450	55131730		B	so	4	PCE	WASHER 4.8MM 12MM 1.0MM -- 53 0 I5
0460	55242860		B	so	1	PCE	AC CPL REAR PANEL AVR2500
0470	55125180		B	so	1	PCE	AC MLD CLAMP AC CORD RT2280/RT2250(PAV5007/PAV5005)
0480	55125220		B	so	11	PCE	AC BUFFER PCB
0490	55178400		B	ud	1	PCE	AC BUFFER CUSHION (A) EVA
0500	55127070		B	so	59	PCE	SCREW-ST 3MM 10MM JIS B 1122 25 0 0
0510	55127120		B	so	34	PCE	SCREW-ST 3MM 8MM JIS B 1122 53 0 0
0511	55164800		B	so	1	PCE	SCREW 3MM 8MM DIN963 00 2182 B7
0520	55178320		B	so	15	PCE	SCREW-ST 3MM 12MM JIS B 1122 53 0 A4
0530	55255900		B	so	4	PCE	SCREW-ST 4MM 10MM SAM 53 0 A4
0540	55135460		B	so	45	PCE	SCREW-SPEC 3MM 10MM JIS 27 0 0
0550	55127090		B	so	8	PCE	SCREW-ST 4MM 8MM JIS B 1122 25 0 0
0560	55149150		B	so	2	PCE	AC PRI LABEL RISK CDRW1211
0570	55174780		B	so	1	PCE	AC PRI LABEL DATE
0580	55242920		B	ud	1	PCE	AC PRI LABEL SERIAL AVR2500
0590	20253760		B	so	0	KG	SOLDER BAR 63SN/37PB BAR
0600	20290240		B	so	0	KG	SOLDER ALPHA RELIA. II 60/40 SOLDER WIRE 1.27 MM
0610	55060660		B	so	0	L	SOLDER-FLUX GW9810A-5
0620	20457000		B	so	0	KG	MAT-ING DOW CORNING 176 CATALYST

0630	20289760		B	so	0	L	DILUTION THINNER 4520 100% ALCOHOL
0640	20289870		B	so	0	KG	GLUE CEMENDINE 575
0650	20190880		B	so	0	KG	WAX ZOPHAR 1340 120 82C YE 0.906
0660	20290210		B	so	0	KG	SOLDER RELIACORE II 60/40 SOLDER WIRE 0.63 MM
0670	20289720		B	so	0	KG	GLUE THREE BOND 1401C
0680	20289590		B	so	0	KG	GLUE HOT MELT TEX YEAR 705
0690	20290110		B	so	0	KG	LUBRICANT HYCHEM/TC 609
0700	55178410		B	ud	4	PCE	AC BUFFER CUSHION
0710	55191520		M	SO	1	PCE	AC PLASTIC MOLD REFRACTOR A WH
0720	55178940		M	SO	1	PCE	AC PLASTIC MOLD REFRACTOR E WH
0730	55244320		M	SO	1	PCE	AC MLD HOLDER FL-GUIDE HIPS 94HB AVR120
0740	55178930		M	SO	1	PCE	AC PLASTIC MOLD REFRACTOR F WH
0750	55261080		B	so	10	PCE	AC PLASTIC KNOB CORK SH08M790B0 BK
0760	55262430		B	so	1	PCE	AC PUN BRACKET PROTECT
0770	55215950		B	ud	4	PCE	SHRINK-PREF 30.0MM
0780	55178960		B	so	1	PCE	AC SPRING PLATE SPRING GND C5212 0.2T AVR520
0790	20372500		B	so	5	PCE	WASHER 3.0MM 7.9MM 0.8MM N/A 00 0 0
0800	20932870		B	so	2	PCE	AC PRI LABEL QC CHECK CRKD1217(20 X 13MM)
0810	20564850		B	so	0.2	M	TAPE-ADH ADHESIVE TAPE ANCHOR 303 0.2MM 12.0MM BK
0850	20634190		B	so	1	PCE	FELT BK 30.0MM X 25.0MM 0.8MM 0MM 0 0
0860	55148840	NR	B	so	1	PCE	FCORE FERRIT MAGNET RING34 34.5X21X12 K-150

PART NO : 55243670

TITEL : AC EMBD IMA DSP BD AVR120US

Pos	Tocom#	Pkg	M/B	St	Qty	Unit	SName
0020	55243680		M	SO	1	PCE	AC ESABD IAU DSP BD AVR120US
0050	55182550		B	ud	1	PCE	AC PUN SHIELD DIGITAL ET
C112	20252560	30	B	so	1	PCE	CE 220U0F +20% 6.3V 85C
C148	20269180	AM	B	so	1	PCE	CE 1MI0F +20% 6.3V 85C
C149	20269180	AM	B	so	1	PCE	CE 1MI0F +20% 6.3V 85C
C150	20269180	AM	B	so	1	PCE	CE 1MI0F +20% 6.3V 85C
CN05	55175860	NR	B	so	1	PCE	WIRECONASY UNIQUE 5P 480MM UL1007 PVC DISCRETE 26 1
COIL1	55176540	NR	B	so	1	PCE	TFPULSE TRANSFORMER 110UH FP-110 FERRIT MAGNET
CP01	55124690		B	so	1	PCE	CONN 1.25MM 21 FE R WH GF120-21S-LS 2794 A6
CP02	55125030		B	so	1	PCE	CONN 2.0MM 11 MA R NAT MOLEX 35237-1110 0 0
CP03	55174650		B	so	1	PCE	CONN 2.0MM 16 MA R NAT SOCKET MOLEX 35237-1610 0 0
CP04	55123390		B	so	1	PCE	CONN 2.0MM 5 MA R NAT LW2003P05 0 0
JAC1	55125430	NR	B	so	1	PCE	D-LEM TORX178B RD RND CL
JAC2	55125430	NR	B	so	1	PCE	D-LEM TORX178B RD RND CL
JAC3	55191600		B	so	1	PCE	CON PHONO SCKT RCA 2P W/GND CAP JW-1502SN OO
JAC4	55125440	NR	B	so	1	PCE	D-LEM TOTX178B RD RND CL
JAC5	55175950		B	so	1	PCE	CON PHONO SCKT RCA 1P W/GND JE010003MN
JAC6	55125430	NR	B	so	1	PCE	D-LEM TORX178B RD RND CL
JAC7	55175240		B	so	1	PCE	CON PHONO SCKT RCA 1P W/GND JE010003MG
OSC1	55179490	65	B	ud	1	PCE	FILQZOSC 12M288 HZ +30 PPM -30 PPM
W001	55180120	NR	M	SO	1	PCE	WIRECONASY UNIQUE 1P 100MM UL1007 PVC DISCRETE 18 1

PART NO : 55243680

TITEL : AC ESABD IAU DSP BD AVR120US

Pos	Tocom#	Pkg	M/B	St	Qty	Unit	SName
0022	5524476D		B	so	1	PCE	AC PCB DSP BD 144*184XT AVR120US -
C020	55179400	70	B	so	1	PCE	CPM 68N0F +5% 63.0V
C031	20268840	30	B	so	1	PCE	CE 1U0F +20% 50.0V 85C
C032	20268840	30	B	so	1	PCE	CE 1U0F +20% 50.0V 85C
C056	20268850	30	B	so	1	PCE	CE 2U2F +20% 50.0V 85C
C068	55246790	39	B	so	1	PCE	CE 10U0F +20% 16.0V 85C
C069	55246790	39	B	so	1	PCE	CE 10U0F +20% 16.0V 85C
C070	55246790	39	B	so	1	PCE	CE 10U0F +20% 16.0V 85C
C071	55246790	39	B	so	1	PCE	CE 10U0F +20% 16.0V 85C
C080	55246790	39	B	so	1	PCE	CE 10U0F +20% 16.0V 85C
C081	55246790	39	B	so	1	PCE	CE 10U0F +20% 16.0V 85C
C082	55246790	39	B	so	1	PCE	CE 10U0F +20% 16.0V 85C
C083	55246790	39	B	so	1	PCE	CE 10U0F +20% 16.0V 85C
C092	55246790	39	B	so	1	PCE	CE 10U0F +20% 16.0V 85C
C093	55246790	39	B	so	1	PCE	CE 10U0F +20% 16.0V 85C
C094	55246790	39	B	so	1	PCE	CE 10U0F +20% 16.0V 85C
C095	55246790	39	B	so	1	PCE	CE 10U0F +20% 16.0V 85C
C110	55246790	39	B	so	1	PCE	CE 10U0F +20% 16.0V 85C
C111	55246790	39	B	so	1	PCE	CE 10U0F +20% 16.0V 85C
C114	20268840	30	B	so	1	PCE	CE 1U0F +20% 50.0V 85C
C115	20268840	30	B	so	1	PCE	CE 1U0F +20% 50.0V 85C
C116	20268840	30	B	so	1	PCE	CE 1U0F +20% 50.0V 85C
C117	20268840	30	B	so	1	PCE	CE 1U0F +20% 50.0V 85C
C118	20268840	30	B	so	1	PCE	CE 1U0F +20% 50.0V 85C
C119	20268840	30	B	so	1	PCE	CE 1U0F +20% 50.0V 85C
C146	55246790	39	B	so	1	PCE	CE 10U0F +20% 16.0V 85C
C151	20269020	30	B	so	1	PCE	CE 100U0F +20% 16.0V 85C
C152	20269020	30	B	so	1	PCE	CE 100U0F +20% 16.0V 85C
C155	55246790	39	B	so	1	PCE	CE 10U0F +20% 16.0V 85C
C156	55246790	39	B	so	1	PCE	CE 10U0F +20% 16.0V 85C



C157	55246790	39	B	so	1	PCE	CE 10U0F +20% 16.0V 85C
C158	55246790	39	B	so	1	PCE	CE 10U0F +20% 16.0V 85C
C159	55246790	39	B	so	1	PCE	CE 10U0F +20% 16.0V 85C
C160	55246790	39	B	so	1	PCE	CE 10U0F +20% 16.0V 85C
C164	20267830	30	B	so	1	PCE	CE 47U0F +20% 16.0V 85C
C165	20267830	30	B	so	1	PCE	CE 47U0F +20% 16.0V 85C
C167	20267830	30	B	so	1	PCE	CE 47U0F +20% 16.0V 85C
C168	20267830	30	B	so	1	PCE	CE 47U0F +20% 16.0V 85C

PART NO : 55243690

TITEL : AC ESABD SMD -T DSP BD AVR120US

Pos	Tocom#	Pkg	M/B	St	Qty	Unit	SName
BD05	55126570	50	B	so	1	PCE	FBEAD SURFACE MT 2500OHM CHIP FERRITE BEAD U
BD16	55126570	50	B	so	1	PCE	FBEAD SURFACE MT 2500OHM CHIP FERRITE BEAD U
BD18	55126570	50	B	so	1	PCE	FBEAD SURFACE MT 2500OHM CHIP FERRITE BEAD U
BD61	55126570	50	B	so	1	PCE	FBEAD SURFACE MT 2500OHM CHIP FERRITE BEAD U
C003	11059340	91	B	so	1	PCE	CCCFMIN 10N0F +10% -10% 50.0V X7R
C004	11059340	91	B	so	1	PCE	CCCFMIN 10N0F +10% -10% 50.0V X7R
C010	60441080	91	B	so	1	PCE	CCCFMIN 22P0F +5% -5% 50.0V NP0
C011	11059340	91	B	so	1	PCE	CCCFMIN 10N0F +10% -10% 50.0V X7R
C019	20267290	91	B	so	1	PCE	CCCFMIN 100N0F +80% -20% 50.0V Y5V
C021	40435180	91	B	so	1	PCE	CCCFMIN 47P0F +5% -5% 50.0V NP0
C024	40435180	91	B	so	1	PCE	CCCFMIN 47P0F +5% -5% 50.0V NP0
C025	40435180	91	B	so	1	PCE	CCCFMIN 47P0F +5% -5% 50.0V NP0
C057	20267320	91	B	so	1	PCE	CCCFMIN 220N0F +80% -20% 50.0V Y5V
C060	20471950	91	B	so	1	PCE	RMGCFMIN 1K0 OHM +5% 100MI0W
C062	11058640	91	B	so	1	PCE	CCCFMIN 27P0F +5% -5% 50.0V NP0
C067	40435180	91	B	so	1	PCE	CCCFMIN 47P0F +5% -5% 50.0V NP0
C072	30939230	91	B	so	1	PCE	CCCFMIN 2N7F +10% -10% 50.0V X7R
C073	30939230	91	B	so	1	PCE	CCCFMIN 2N7F +10% -10% 50.0V X7R
C074	11058710	91	B	so	1	PCE	CCCFMIN 560P0F +5% -5% 50.0V NP0
C075	30939230	91	B	so	1	PCE	CCCFMIN 2N7F +10% -10% 50.0V X7R
C076	30939230	91	B	so	1	PCE	CCCFMIN 2N7F +10% -10% 50.0V X7R
C077	11058710	91	B	so	1	PCE	CCCFMIN 560P0F +5% -5% 50.0V NP0
C078	11058710	91	B	so	1	PCE	CCCFMIN 560P0F +5% -5% 50.0V NP0
C079	11058710	91	B	so	1	PCE	CCCFMIN 560P0F +5% -5% 50.0V NP0
C084	30939230	91	B	so	1	PCE	CCCFMIN 2N7F +10% -10% 50.0V X7R
C085	30939230	91	B	so	1	PCE	CCCFMIN 2N7F +10% -10% 50.0V X7R
C086	11058710	91	B	so	1	PCE	CCCFMIN 560P0F +5% -5% 50.0V NP0
C087	30939230	91	B	so	1	PCE	CCCFMIN 2N7F +10% -10% 50.0V X7R
C088	30939230	91	B	so	1	PCE	CCCFMIN 2N7F +10% -10% 50.0V X7R
C089	11058710	91	B	so	1	PCE	CCCFMIN 560P0F +5% -5% 50.0V NP0
C090	11058710	91	B	so	1	PCE	CCCFMIN 560P0F +5% -5% 50.0V NP0
C091	11058710	91	B	so	1	PCE	CCCFMIN 560P0F +5% -5% 50.0V NP0
C096	30939230	91	B	so	1	PCE	CCCFMIN 2N7F +10% -10% 50.0V X7R
C097	30939230	91	B	so	1	PCE	CCCFMIN 2N7F +10% -10% 50.0V X7R
C098	11058710	91	B	so	1	PCE	CCCFMIN 560P0F +5% -5% 50.0V NP0
C099	20469340	91	B	so	1	PCE	CCCFMIN 4N7F +10% -10% 50.0V X7R
C100	20469340	91	B	so	1	PCE	CCCFMIN 4N7F +10% -10% 50.0V X7R
C101	11059320	91	B	so	1	PCE	CCCFMIN 1N0F +10% -10% 50.0V X7R
C102	11058710	91	B	so	1	PCE	CCCFMIN 560P0F +5% -5% 50.0V NP0
C103	11059320	91	B	so	1	PCE	CCCFMIN 1N0F +10% -10% 50.0V X7R
C104	11059330	91	B	so	1	PCE	CCCFMIN 2N2F +10% -10% 50.0V X7R
C105	11059330	91	B	so	1	PCE	CCCFMIN 2N2F +10% -10% 50.0V X7R
C106	11058670	91	B	so	1	PCE	CCCFMIN 100P0F +5% -5% 50.0V NP0
C107	11058670	91	B	so	1	PCE	CCCFMIN 100P0F +5% -5% 50.0V NP0
C108	11058670	91	B	so	1	PCE	CCCFMIN 100P0F +5% -5% 50.0V NP0
C109	11058670	91	B	so	1	PCE	CCCFMIN 100P0F +5% -5% 50.0V NP0
C120	20267290	91	B	so	1	PCE	CCCFMIN 100N0F +80% -20% 50.0V Y5V
C121	20267290	91	B	so	1	PCE	CCCFMIN 100N0F +80% -20% 50.0V Y5V

C122	20267290	91	B	so	1	PCE	CCCFMIN 100N0F +80% -20% 50.0V Y5V
C136	20267290	91	B	so	1	PCE	CCCFMIN 100N0F +80% -20% 50.0V Y5V
C163	70434200	91	B	so	1	PCE	RMGCFMIN 100R0 OHM +5% 100MI0W
C178	20267290	91	B	so	1	PCE	CCCFMIN 100N0F +80% -20% 50.0V Y5V
D003	20496510	91	B	so	1	PCE	D-SLP 1SS355 35.0V 225MI0A
D004	20496510	91	B	so	1	PCE	D-SLP 1SS355 35.0V 225MI0A
D008	20496510	91	B	so	1	PCE	D-SLP 1SS355 35.0V 225MI0A
IC01	55180060	00	B	so	1	PCE	IC-SPECFUNC NJU6324M SOP8 CMOS-CRYSTAL
IC04	55172540	CQ	B	so	0	PCE	IC-EPROM AT27LV020A-90JC
IC04	55179570	NR	B	so	1	PCE	IC-EPROM AT27LV020A-12JC
IC05	55125380	NR	B	so	1	PCE	IC-LOWFREQ CS493263-CL DSP
IC06	55179580	NR	B	so	1	PCE	IC-CONV CS4391-KS D/A
IC07	55179580	NR	B	so	1	PCE	IC-CONV CS4391-KS D/A
IC08	55179580	NR	B	so	1	PCE	IC-CONV CS4391-KS D/A
IC09	55204160	NR	B	so	1	PCE	IC-CONV CS5360-KS A/D
IC10	55133310	NR	B	so	1	PCE	IC-LOGIC M74HCU04M1R INVERTER HCT
IC11	55133310	NR	B	so	1	PCE	IC-LOGIC M74HCU04M1R INVERTER HCT
IC12	55133310	NR	B	so	1	PCE	IC-LOGIC M74HCU04M1R INVERTER HCT
IC13	55179260	NR	B	so	1	PCE	IC-LOGIC DUAL 4-INPUT MP 74VHC153MX SOL16 FLIP/FLOP F
IC14	55179590	NR	B	so	1	PCE	IC-LOWFREQ CS8414-CS DSP
IC15	20718660	65	B	so	1	PCE	IC-LOGIC BU4094BF SHIFT REGISTER CMOS
IC16	55087180	65	B	so	1	PCE	IC-LOGIC BU4051BCF MULTIPLEXER HCT
IC17	55179270	NR	B	so	1	PCE	IC-LOGIC QUAD 2-INPUT MP 74VHC157MX SOL16 FLIP/FLOP F
IC18	55125420	CP	B	so	1	PCE	IC-LOGIC 74VHC244MX INVERTER CMOS
IC19	55125420	CP	B	so	1	PCE	IC-LOGIC 74VHC244MX INVERTER CMOS
IC20	55142610	64	B	so	1	PCE	IC-OPERAMP NJM2068M DUAL OP
IC21	55142610	64	B	so	1	PCE	IC-OPERAMP NJM2068M DUAL OP
IC22	55142610	64	B	so	1	PCE	IC-OPERAMP NJM2068M DUAL OP
IC24	55142610	64	B	so	1	PCE	IC-OPERAMP NJM2068M DUAL OP
IC25	55142610	64	B	so	1	PCE	IC-OPERAMP NJM2068M DUAL OP
J001	14036730	91	B	so	1	PCE	LF-SMD 470N0H +20%
J002	80440510	91	B	so	1	PCE	RMGCFMIN 0 OHM +0% 100MI0W
J003	80440510	91	B	so	1	PCE	RMGCFMIN 0 OHM +0% 100MI0W
L001	14040520	91	B	so	1	PCE	LF-SMD 33U0H +10%
L002	14040520	91	B	so	1	PCE	LF-SMD 33U0H +10%
L003	14040520	91	B	so	1	PCE	LF-SMD 33U0H +10%
L004	14040520	91	B	so	1	PCE	LF-SMD 33U0H +10%
R003	11066480	91	B	so	1	PCE	RMGCFMIN 47K0 OHM +5% 100MI0W
R004	11066480	91	B	so	1	PCE	RMGCFMIN 47K0 OHM +5% 100MI0W
R005	50886550	91	B	so	1	PCE	RMGCFMIN 560R0 OHM +5% 100MI0W
R006	50886550	91	B	so	1	PCE	RMGCFMIN 560R0 OHM +5% 100MI0W
R007	80440390	91	B	so	1	PCE	RMGCFMIN 2K2 OHM +5% 100MI0W
R008	11066480	91	B	so	1	PCE	RMGCFMIN 47K0 OHM +5% 100MI0W
R009	80440390	91	B	so	1	PCE	RMGCFMIN 2K2 OHM +5% 100MI0W
R010	11066480	91	B	so	1	PCE	RMGCFMIN 47K0 OHM +5% 100MI0W
R011	80440400	91	B	so	1	PCE	RMGCFMIN 5K6 OHM +5% 100MI0W
R012	30944250	91	B	so	1	PCE	RMGCFMIN 10R0 OHM +5% 100MI0W
R013	90574400	91	B	so	1	PCE	RMGCFMIN 470R0 OHM +5% 100MI0W
R014	70434200	91	B	so	1	PCE	RMGCFMIN 100R0 OHM +5% 100MI0W
R015	20471930	91	B	so	1	PCE	RMGCFMIN 510R0 OHM +5% 100MI0W
R016	70434230	91	B	so	1	PCE	RMGCFMIN 1K2 OHM +5% 100MI0W
R017	70434230	91	B	so	1	PCE	RMGCFMIN 1K2 OHM +5% 100MI0W
R018	50886550	91	B	so	1	PCE	RMGCFMIN 560R0 OHM +5% 100MI0W
R019	50886550	91	B	so	1	PCE	RMGCFMIN 560R0 OHM +5% 100MI0W
R020	11066390	91	B	so	1	PCE	RMGCFMIN 75R0 OHM +5% 100MI0W
R022	11066480	91	B	so	1	PCE	RMGCFMIN 47K0 OHM +5% 100MI0W
R023	90574400	91	B	so	1	PCE	RMGCFMIN 470R0 OHM +5% 100MI0W
R027	80440390	91	B	so	1	PCE	RMGCFMIN 2K2 OHM +5% 100MI0W
R028	11066480	91	B	so	1	PCE	RMGCFMIN 47K0 OHM +5% 100MI0W
R031	80440400	91	B	so	1	PCE	RMGCFMIN 5K6 OHM +5% 100MI0W
R036	80440400	91	B	so	1	PCE	RMGCFMIN 5K6 OHM +5% 100MI0W

R037	80440390	91	B	so	1	PCE	RMGCFMIN 2K2 OHM +5% 100MI0W
R038	11066480	91	B	so	1	PCE	RMGCFMIN 47K0 OHM +5% 100MI0W
R039	50886630	91	B	so	1	PCE	RMGCFMIN 100K0 OHM +5% 100MI0W
R040	50886630	91	B	so	1	PCE	RMGCFMIN 100K0 OHM +5% 100MI0W
R041	20471950	91	B	so	1	PCE	RMGCFMIN 1K0 OHM +5% 100MI0W
R042	20471950	91	B	so	1	PCE	RMGCFMIN 1K0 OHM +5% 100MI0W
R044	80440400	91	B	so	1	PCE	RMGCFMIN 5K6 OHM +5% 100MI0W
R045	80440400	91	B	so	1	PCE	RMGCFMIN 5K6 OHM +5% 100MI0W
R046	50886610	91	B	so	1	PCE	RMGCFMIN 10K0 OHM +5% 100MI0W
R047	50886610	91	B	so	1	PCE	RMGCFMIN 10K0 OHM +5% 100MI0W
R048	50886600	91	B	so	1	PCE	RMGCFMIN 5K1 OHM +5% 100MI0W
R049	90574400	91	B	so	1	PCE	RMGCFMIN 470R0 OHM +5% 100MI0W
R050	50886600	91	B	so	1	PCE	RMGCFMIN 5K1 OHM +5% 100MI0W
R051	50886610	91	B	so	1	PCE	RMGCFMIN 10K0 OHM +5% 100MI0W
R052	50886610	91	B	so	1	PCE	RMGCFMIN 10K0 OHM +5% 100MI0W
R053	80440400	91	B	so	1	PCE	RMGCFMIN 5K6 OHM +5% 100MI0W
R054	70434230	91	B	so	1	PCE	RMGCFMIN 1K2 OHM +5% 100MI0W
R055	70434230	91	B	so	1	PCE	RMGCFMIN 1K2 OHM +5% 100MI0W
R056	80440400	91	B	so	1	PCE	RMGCFMIN 5K6 OHM +5% 100MI0W
R057	70434230	91	B	so	1	PCE	RMGCFMIN 1K2 OHM +5% 100MI0W
R058	70434230	91	B	so	1	PCE	RMGCFMIN 1K2 OHM +5% 100MI0W
R059	50886550	91	B	so	1	PCE	RMGCFMIN 560R0 OHM +5% 100MI0W
R060	50886550	91	B	so	1	PCE	RMGCFMIN 560R0 OHM +5% 100MI0W
R061	50886610	91	B	so	1	PCE	RMGCFMIN 10K0 OHM +5% 100MI0W
R062	50886610	91	B	so	1	PCE	RMGCFMIN 10K0 OHM +5% 100MI0W
R063	50886610	91	B	so	1	PCE	RMGCFMIN 10K0 OHM +5% 100MI0W
R064	50886610	91	B	so	1	PCE	RMGCFMIN 10K0 OHM +5% 100MI0W
R071	20471950	91	B	so	1	PCE	RMGCFMIN 1K0 OHM +5% 100MI0W
R072	40438290	91	B	so	1	PCE	RMGCFMIN 1K5 OHM +5% 100MI0W
R073	80440400	91	B	so	1	PCE	RMGCFMIN 5K6 OHM +5% 100MI0W
R074	80440400	91	B	so	1	PCE	RMGCFMIN 5K6 OHM +5% 100MI0W
R075	50886630	91	B	so	1	PCE	RMGCFMIN 100K0 OHM +5% 100MI0W
R076	50886610	91	B	so	1	PCE	RMGCFMIN 10K0 OHM +5% 100MI0W
R078	50886610	91	B	so	1	PCE	RMGCFMIN 10K0 OHM +5% 100MI0W
R080	30944310	91	B	so	1	PCE	RMGCFMIN 4K7 OHM +5% 100MI0W
R081	50886610	91	B	so	1	PCE	RMGCFMIN 10K0 OHM +5% 100MI0W
R082	50886610	91	B	so	1	PCE	RMGCFMIN 10K0 OHM +5% 100MI0W
R083	50886610	91	B	so	1	PCE	RMGCFMIN 10K0 OHM +5% 100MI0W
R084	50886610	91	B	so	1	PCE	RMGCFMIN 10K0 OHM +5% 100MI0W
R085	50886610	91	B	so	1	PCE	RMGCFMIN 10K0 OHM +5% 100MI0W
R086	50886610	91	B	so	1	PCE	RMGCFMIN 10K0 OHM +5% 100MI0W
R087	50886610	91	B	so	1	PCE	RMGCFMIN 10K0 OHM +5% 100MI0W
R088	50886610	91	B	so	1	PCE	RMGCFMIN 10K0 OHM +5% 100MI0W
R089	50886630	91	B	so	1	PCE	RMGCFMIN 100K0 OHM +5% 100MI0W
R091	80440370	91	B	so	1	PCE	RMGCFMIN 150R0 OHM +5% 100MI0W
R092	80440370	91	B	so	1	PCE	RMGCFMIN 150R0 OHM +5% 100MI0W
R093	50886610	91	B	so	1	PCE	RMGCFMIN 10K0 OHM +5% 100MI0W
R094	50886610	91	B	so	1	PCE	RMGCFMIN 10K0 OHM +5% 100MI0W
R095	50886610	91	B	so	1	PCE	RMGCFMIN 10K0 OHM +5% 100MI0W
R096	50886610	91	B	so	1	PCE	RMGCFMIN 10K0 OHM +5% 100MI0W
R097	50886610	91	B	so	1	PCE	RMGCFMIN 10K0 OHM +5% 100MI0W
R098	50886610	91	B	so	1	PCE	RMGCFMIN 10K0 OHM +5% 100MI0W
R099	80440370	91	B	so	1	PCE	RMGCFMIN 150R0 OHM +5% 100MI0W
R100	80440370	91	B	so	1	PCE	RMGCFMIN 150R0 OHM +5% 100MI0W
R101	30944330	91	B	so	1	PCE	RMGCFMIN 20K0 OHM +5% 100MI0W
R102	30944330	91	B	so	1	PCE	RMGCFMIN 20K0 OHM +5% 100MI0W
R105	50886630	91	B	so	1	PCE	RMGCFMIN 100K0 OHM +5% 100MI0W
R106	50886630	91	B	so	1	PCE	RMGCFMIN 100K0 OHM +5% 100MI0W
R107	30944310	91	B	so	1	PCE	RMGCFMIN 4K7 OHM +5% 100MI0W
R108	30944310	91	B	so	1	PCE	RMGCFMIN 4K7 OHM +5% 100MI0W
R109	50886610	91	B	so	1	PCE	RMGCFMIN 10K0 OHM +5% 100MI0W

R111	50886610	91	B	so	1	PCE	RMGCFMIN 10K0 OHM +5% 100MI0W
R112	30944310	91	B	so	1	PCE	RMGCFMIN 4K7 OHM +5% 100MI0W
R113	50886610	91	B	so	1	PCE	RMGCFMIN 10K0 OHM +5% 100MI0W
R114	50886610	91	B	so	1	PCE	RMGCFMIN 10K0 OHM +5% 100MI0W
R115	20471950	91	B	so	1	PCE	RMGCFMIN 1K0 OHM +5% 100MI0W
R116	20267290	91	B	so	1	PCE	CCCFMIN 100N0F +80% -20% 50.0V Y5V
R117	50886610	91	B	so	1	PCE	RMGCFMIN 10K0 OHM +5% 100MI0W
R119	30944310	91	B	so	1	PCE	RMGCFMIN 4K7 OHM +5% 100MI0W
R120	30944310	91	B	so	1	PCE	RMGCFMIN 4K7 OHM +5% 100MI0W
R124	20472020	91	B	so	1	PCE	RMGCFMIN 180K0 OHM +5% 100MI0W
R125	20472020	91	B	so	1	PCE	RMGCFMIN 180K0 OHM +5% 100MI0W
R126	50886600	91	B	so	1	PCE	RMGCFMIN 5K1 OHM +5% 100MI0W
R127	50886600	91	B	so	1	PCE	RMGCFMIN 5K1 OHM +5% 100MI0W
R128	50886600	91	B	so	1	PCE	RMGCFMIN 5K1 OHM +5% 100MI0W
R129	50886600	91	B	so	1	PCE	RMGCFMIN 5K1 OHM +5% 100MI0W
R130	80440400	91	B	so	1	PCE	RMGCFMIN 5K6 OHM +5% 100MI0W
R131	70434230	91	B	so	1	PCE	RMGCFMIN 1K2 OHM +5% 100MI0W
R132	70434230	91	B	so	1	PCE	RMGCFMIN 1K2 OHM +5% 100MI0W
R133	80440400	91	B	so	1	PCE	RMGCFMIN 5K6 OHM +5% 100MI0W
R134	70434230	91	B	so	1	PCE	RMGCFMIN 1K2 OHM +5% 100MI0W
R135	70434230	91	B	so	1	PCE	RMGCFMIN 1K2 OHM +5% 100MI0W
R136	50886550	91	B	so	1	PCE	RMGCFMIN 560R0 OHM +5% 100MI0W
R137	50886550	91	B	so	1	PCE	RMGCFMIN 560R0 OHM +5% 100MI0W
R138	80440400	91	B	so	1	PCE	RMGCFMIN 5K6 OHM +5% 100MI0W
R139	80440400	91	B	so	1	PCE	RMGCFMIN 5K6 OHM +5% 100MI0W
R141	11066480	91	B	so	1	PCE	RMGCFMIN 47K0 OHM +5% 100MI0W
R143	80440400	91	B	so	1	PCE	RMGCFMIN 5K6 OHM +5% 100MI0W
R144	80440400	91	B	so	1	PCE	RMGCFMIN 5K6 OHM +5% 100MI0W
R145	80440400	91	B	so	1	PCE	RMGCFMIN 5K6 OHM +5% 100MI0W
R146	80440400	91	B	so	1	PCE	RMGCFMIN 5K6 OHM +5% 100MI0W
R147	80440400	91	B	so	1	PCE	RMGCFMIN 5K6 OHM +5% 100MI0W
R148	70434230	91	B	so	1	PCE	RMGCFMIN 1K2 OHM +5% 100MI0W
R149	70434230	91	B	so	1	PCE	RMGCFMIN 1K2 OHM +5% 100MI0W
R151	70434200	91	B	so	1	PCE	RMGCFMIN 100R0 OHM +5% 100MI0W
R152	70434200	91	B	so	1	PCE	RMGCFMIN 100R0 OHM +5% 100MI0W
R160	20471950	91	B	so	1	PCE	RMGCFMIN 1K0 OHM +5% 100MI0W
R162	30944250	91	B	so	1	PCE	RMGCFMIN 10R0 OHM +5% 100MI0W
R163	30944250	91	B	so	1	PCE	RMGCFMIN 10R0 OHM +5% 100MI0W
R170	20471950	91	B	so	1	PCE	RMGCFMIN 1K0 OHM +5% 100MI0W

PART NO : 55243710

TITEL : AC ESABD SMD -B DSP BD AVR120US

Pos	Tocom#	Pkg	M/B	St	Qty	Unit	SName
BD01	55126570	50	B	so	1	PCE	FBEAD SURFACE MT 2500OHM CHIP FERRITE BEAD U
BD02	55126570	50	B	so	1	PCE	FBEAD SURFACE MT 2500OHM CHIP FERRITE BEAD U
BD04	55126570	50	B	so	1	PCE	FBEAD SURFACE MT 2500OHM CHIP FERRITE BEAD U
BD10	55126570	50	B	so	1	PCE	FBEAD SURFACE MT 2500OHM CHIP FERRITE BEAD U
BD11	55126570	50	B	so	1	PCE	FBEAD SURFACE MT 2500OHM CHIP FERRITE BEAD U
BD12	55126570	50	B	so	1	PCE	FBEAD SURFACE MT 2500OHM CHIP FERRITE BEAD U
BD15	55126590	50	B	so	1	PCE	FBEAD SURFACE MT 120OHM CHIP FERRITE BEAD
BD23	55126570	50	B	so	1	PCE	FBEAD SURFACE MT 2500OHM CHIP FERRITE BEAD U
BD25	55126570	50	B	so	1	PCE	FBEAD SURFACE MT 2500OHM CHIP FERRITE BEAD U
BD26	55126570	50	B	so	1	PCE	FBEAD SURFACE MT 2500OHM CHIP FERRITE BEAD U
BD27	55126570	50	B	so	1	PCE	FBEAD SURFACE MT 2500OHM CHIP FERRITE BEAD U
BD28	55126570	50	B	so	1	PCE	FBEAD SURFACE MT 2500OHM CHIP FERRITE BEAD U
BD29	55126570	50	B	so	1	PCE	FBEAD SURFACE MT 2500OHM CHIP FERRITE BEAD U
BD30	55126570	50	B	so	1	PCE	FBEAD SURFACE MT 2500OHM CHIP FERRITE BEAD U
BD31	55126570	50	B	so	1	PCE	FBEAD SURFACE MT 2500OHM CHIP FERRITE BEAD U
BD32	55126570	50	B	so	1	PCE	FBEAD SURFACE MT 2500OHM CHIP FERRITE BEAD U



C166	20267290	91	B	so	1	PCE	CCCFMIN 100NOF +80% -20% 50.0V Y5V
C169	20468970	91	B	so	1	PCE	CCCFMIN 330POF +5% -5% 50.0V NP0
C170	20267290	91	B	so	1	PCE	CCCFMIN 100NOF +80% -20% 50.0V Y5V
C171	20267290	91	B	so	1	PCE	CCCFMIN 100NOF +80% -20% 50.0V Y5V
C172	20267290	91	B	so	1	PCE	CCCFMIN 100NOF +80% -20% 50.0V Y5V
C174	40435180	91	B	so	1	PCE	CCCFMIN 47POF +5% -5% 50.0V NP0
C175	40435180	91	B	so	1	PCE	CCCFMIN 47POF +5% -5% 50.0V NP0
C176	40435180	91	B	so	1	PCE	CCCFMIN 47POF +5% -5% 50.0V NP0
D009	20496510	91	B	so	1	PCE	D-SLP 1SS355 35.0V 225MI0A
IC02	55170220	CP	B	so	1	PCE	IC-LOGIC F/F 74VHC574MX FLIP/FLOP HCMOS
IC03	55170220	CP	B	so	1	PCE	IC-LOGIC F/F 74VHC574MX FLIP/FLOP HCMOS
R001	11066390	91	B	so	1	PCE	RMGCFMIN 75R0 OHM +5% 100MI0W
R002	11066390	91	B	so	1	PCE	RMGCFMIN 75R0 OHM +5% 100MI0W
R043	15112590	91	B	so	1	PCE	RMGCFMIN 3R3 OHM +5% 100MI0W
R090	15112590	91	B	so	1	PCE	RMGCFMIN 3R3 OHM +5% 100MI0W
R150	10355190	91	B	so	1	PCE	RMGCFMIN 2R2 OHM +5% 100MI0W

PART NO : 55246230

TITEL : AC EMBD IMA FRONT BD AVR2500

Pos	Tocom#	Pkg	M/B	St	Qty	Unit	SName
0020	55246310		M	SO	1	PCE	AC ESABD IAU FRONT BD AVR2500
0050	70436540	16	B	so	1	PCE	D-SLP 1N4148 100.0V 150E-3A
C203	20267830	30	B	so	1	PCE	CE 47U0F +20% 16.0V 85C
C210	20268880	30	B	so	1	PCE	CE 10U0F +20% 50.0V 85C
C216	55134360	0	B	so	1	PCE	CM 47MI0F +80% -20% 5.5V 70C
CN201	55175770	NR	B	po	1	PCE	WIRECONASY UNIQUE 7P 450MM UL2791 SHIELD 24 1
CN202	55175780	NR	B	po	1	PCE	WIRECONASY UNIQUE 3P 620MM UL2791 SHIELD 24 1
CN203	55175810	NR	B	so	1	PCE	WIRECONASY UNIQUE 9P 400MM UL1007 PVC DISCRETE 26 1
CN204	55175790	NR	B	so	1	PCE	WIRECONASY UNIQUE 4P 100MM UL1007 PVC DISCRETE 26 1
CN205	55175840	NR	B	so	1	PCE	WIRECONASY UNIQUE 4P 360MM UL1533 SHIELD 28 1
CN206	55175830	NR	B	so	1	PCE	WIRECONASY UNIQUE 10P 220MM UL1533 SHIELD 28 1
CN207	55244430	NR	B	so	1	PCE	FFC-JUMPER 21X 1.25MM 380MM
CN208	55179520	NR	B	so	1	PCE	FFC-JUMPER 27X 1.25MM 500MM
CN209	55175850	NR	B	so	1	PCE	WIRECONASY UNIQUE 8P 500MM UL1533 SHIELD 28 1
CN210	55175880	NR	B	so	1	PCE	WIRECONASY UNIQUE 2P 100MM UL1007 PVC DISCRETE 26 1
CP201	55179450		B	ud	1	PCE	CONN 1.25MM 27 FE R WH GF120-27S-LS 2794 A6
CP202	55124690		B	so	1	PCE	CONN 1.25MM 21 FE R WH GF120-21S-LS 2794 A6
CP203	55123340		B	so	1	PCE	CONN 2.0MM 8 MA ST NAT LW2002P08 0 0
CP204	55123320		B	so	1	PCE	CONN 2.0MM 5 MA ST NAT LW2002P05 0 0
D201	55179290	NR	B	so	1	PCE	D-LEM LTL-1CHGEC P-GN RND CL
D202	55179290	NR	B	so	1	PCE	D-LEM LTL-1CHGEC P-GN RND CL
D203	55179290	NR	B	so	1	PCE	D-LEM LTL-1CHGEC P-GN RND CL
D204	55179290	NR	B	so	1	PCE	D-LEM LTL-1CHGEC P-GN RND CL
D205	55179290	NR	B	so	1	PCE	D-LEM LTL-1CHGEC P-GN RND CL
D206	55179290	NR	B	so	1	PCE	D-LEM LTL-1CHGEC P-GN RND CL
D207	55179290	NR	B	so	1	PCE	D-LEM LTL-1CHGEC P-GN RND CL
D208	55179290	NR	B	so	1	PCE	D-LEM LTL-1CHGEC P-GN RND CL
D210	55179290	NR	B	so	1	PCE	D-LEM LTL-1CHGEC P-GN RND CL
D211	55179290	NR	B	so	1	PCE	D-LEM LTL-1CHGEC P-GN RND CL
D212	55179290	NR	B	so	1	PCE	D-LEM LTL-1CHGEC P-GN RND CL
D213	55179290	NR	B	so	1	PCE	D-LEM LTL-1CHGEC P-GN RND CL
D214	55179290	NR	B	so	1	PCE	D-LEM LTL-1CHGEC P-GN RND CL
D217	55179290	NR	B	so	1	PCE	D-LEM LTL-1CHGEC P-GN RND CL
D218	55179290	NR	B	so	1	PCE	D-LEM LTL-1CHGEC P-GN RND CL
D219	55179290	NR	B	so	1	PCE	D-LEM LTL-1CHGEC P-GN RND CL
D220	55179290	NR	B	so	1	PCE	D-LEM LTL-1CHGEC P-GN RND CL
D221	55179290	NR	B	so	1	PCE	D-LEM LTL-1CHGEC P-GN RND CL
D222	55179290	NR	B	so	1	PCE	D-LEM LTL-1CHGEC P-GN RND CL
D223	55179290	NR	B	so	1	PCE	D-LEM LTL-1CHGEC P-GN RND CL
D224	55179290	NR	B	so	1	PCE	D-LEM LTL-1CHGEC P-GN RND CL
D225	55179290	NR	B	so	1	PCE	D-LEM LTL-1CHGEC P-GN RND CL
D227	55179290	NR	B	so	1	PCE	D-LEM LTL-1CHGEC P-GN RND CL
D228	55179290	NR	B	so	1	PCE	D-LEM LTL-1CHGEC P-GN RND CL
D229	55179290	NR	B	so	1	PCE	D-LEM LTL-1CHGEC P-GN RND CL
D230	55179290	NR	B	so	1	PCE	D-LEM LTL-1CHGEC P-GN RND CL
D231	55179290	NR	B	so	1	PCE	D-LEM LTL-1CHGEC P-GN RND CL
D233	55179290	NR	B	so	1	PCE	D-LEM LTL-1CHGEC P-GN RND CL
D234	55179290	NR	B	so	1	PCE	D-LEM LTL-1CHGEC P-GN RND CL
D235	55179290	NR	B	so	1	PCE	D-LEM LTL-1CHGEC P-GN RND CL
D236	55179290	NR	B	so	1	PCE	D-LEM LTL-1CHGEC P-GN RND CL
D237	55179290	NR	B	so	1	PCE	D-LEM LTL-1CHGEC P-GN RND CL
D238	55179290	NR	B	so	1	PCE	D-LEM LTL-1CHGEC P-GN RND CL
D239	55179290	NR	B	so	1	PCE	D-LEM LTL-1CHGEC P-GN RND CL
D240	55179290	NR	B	so	1	PCE	D-LEM LTL-1CHGEC P-GN RND CL
D241	55179290	NR	B	so	1	PCE	D-LEM LTL-1CHGEC P-GN RND CL
D243	55179290	NR	B	so	1	PCE	D-LEM LTL-1CHGEC P-GN RND CL
D244	55179290	NR	B	so	1	PCE	D-LEM LTL-1CHGEC P-GN RND CL

D245	55179290	NR	B	so	1	PCE	D-LEM LTL-1CHGEC P-GN RND CL
D246	55179290	NR	B	so	1	PCE	D-LEM LTL-1CHGEC P-GN RND CL
D247	55179290	NR	B	so	1	PCE	D-LEM LTL-1CHGEC P-GN RND CL
D260	55179290	NR	B	so	1	PCE	D-LEM LTL-1CHGEC P-GN RND CL
D271	55179290	NR	B	so	1	PCE	D-LEM LTL-1CHGEC P-GN RND CL
D272	55179290	NR	B	so	1	PCE	D-LEM LTL-1CHGEC P-GN RND CL
D273	55179290	NR	B	so	1	PCE	D-LEM LTL-1CHGEC P-GN RND CL
FL201	55155740	NR	B	so	1	PCE	DISPLAY HNA-10MM22
FN201	55177570		B	ud	1	PCE	AC PUN SHIELD FENCE TONE
IC201	55267250	NR	B	so	1	PCE	IC-MICROCONT CXP82860-351Q AVR2500/3500
IC205	55142240	NR	B	so	1	PCE	IC-OPERAMP NJM2068DD DUAL OP
JA201	55113740		B	so	1	PCE	CON PHONO SCKT RCA-307 3 PINS
JA202	55113960		B	so	1	PCE	CON DIN SCKT SOCKET CONNECTOR SVHS EST-S408J
L201	55179380	16	B	ud	1	PCE	LF 4U7H +10% 1.7 OHM 190.0A
L202	55179380	16	B	ud	1	PCE	LF 4U7H +10% 1.7 OHM 190.0A
RM201	55155930	NR	B	so	1	PCE	IC-REMOTE RPM6938-RSIP-A3 RECEIVER 38KHZ
VR201	55134900	NR	B	so	1	PCE	SWIROT EC16B24204A5 5V 500U0A 10T 3P 0 0
VR202	55179920	0	B	ud	1	PCE	PR-ROT 100K0 OHM NON-LINEAR RK14K12400BR 0 0
VR203	55179920	0	B	ud	1	PCE	PR-ROT 100K0 OHM NON-LINEAR RK14K12400BR 0 0
VR204	55179910	0	B	ud	1	PCE	PR-ROT 100K0 OHM NON-LINEAR RK14K12400BQ 0 0
W201	55180140	NR	B	so	1	PCE	WIRECONASY UNIQUE 1P 200MM UL1007 PVC DISCRETE 18 1
X201	55179650	NR	B	ud	1	PCE	CRESONATOR 10M0 HZ 25.0 OHM 0F

PART NO : 55246310

TITEL : AC ESABD IAU FRONT BD AVR2500

Pos	Tocom#	Pkg	M/B	St	Qty	Unit	SName
0020	55246350		M	SO	1	PCE	AC ESABD SMD FRONT BD AVR2500
0021	55155690		B	ud	1	PCE	AC PCB FRONT AVR120 SINGLE LAYER
C201	20267830	30	B	so	1	PCE	CE 47U0F +20% 16.0V 85C
C202	20267830	30	B	so	1	PCE	CE 47U0F +20% 16.0V 85C
C204	20269010	30	B	so	1	PCE	CE 47U0F +20% 50.0V 85C
C214	20267830	30	B	so	1	PCE	CE 47U0F +20% 16.0V 85C
C215	20267830	30	B	so	1	PCE	CE 47U0F +20% 16.0V 85C
C219	20269010	30	B	so	1	PCE	CE 47U0F +20% 50.0V 85C
C220	20268880	30	B	so	1	PCE	CE 10U0F +20% 50.0V 85C
C232	20267830	30	B	so	1	PCE	CE 47U0F +20% 16.0V 85C
C233	20267830	30	B	so	1	PCE	CE 47U0F +20% 16.0V 85C
C234	20268950	30	B	so	1	PCE	CE 100N0F +20% 50.0V 85C
C235	10364820	71	B	so	1	PCE	CPF 47N0F +10% 100.0V
C236	10364820	71	B	so	1	PCE	CPF 47N0F +10% 100.0V
CL201	15002130	30	B	so	1	PCE	CE 10U0F +20% 16.0V 85C
CL202	30936230	71	B	so	1	PCE	CC 100P0F +5% -5% 50.0V NP0
CL203	80434590	71	B	so	1	PCE	CC 22P0F +5% -5% 50.0V NP0
CL204	15002130	30	B	so	1	PCE	CE 10U0F +20% 16.0V 85C
CL205	15002130	30	B	so	1	PCE	CE 10U0F +20% 16.0V 85C
CL206	55179370	70	B	so	1	PCE	CPM 18N0F +5% 100.0V
CL207	55179410	70	B	so	1	PCE	CPM 82N0F +5% 100.0V
CL208	55179390	70	B	so	1	PCE	CPM 3N3F +5% 100.0V
CL209	55179370	70	B	so	1	PCE	CPM 18N0F +5% 100.0V
CR201	15002130	30	B	so	1	PCE	CE 10U0F +20% 16.0V 85C
CR202	30936230	71	B	so	1	PCE	CC 100P0F +5% -5% 50.0V NP0
CR203	80434590	71	B	so	1	PCE	CC 22P0F +5% -5% 50.0V NP0
CR204	15002130	30	B	so	1	PCE	CE 10U0F +20% 16.0V 85C
CR205	15002130	30	B	so	1	PCE	CE 10U0F +20% 16.0V 85C
CR206	55179370	70	B	so	1	PCE	CPM 18N0F +5% 100.0V
CR207	55179410	70	B	so	1	PCE	CPM 82N0F +5% 100.0V
CR208	55179390	70	B	so	1	PCE	CPM 3N3F +5% 100.0V
CR209	55179370	70	B	so	1	PCE	CPM 18N0F +5% 100.0V
Q222	55133210	56	B	so	1	PCE	TR-SLPLF DTC114YSA N 100MIOA



Q222	55179230	56	B	so	0	PCE	TR-SLPSWA KRC107M N
Q223	55133210	56	B	so	1	PCE	TR-SLPLF DTC114YSA N 100MI0A
Q223	55179230	56	B	so	0	PCE	TR-SLPSWA KRC107M N
Q224	55133210	56	B	so	1	PCE	TR-SLPLF DTC114YSA N 100MI0A
Q224	55179230	56	B	so	0	PCE	TR-SLPSWA KRC107M N
Q225	55133210	56	B	so	1	PCE	TR-SLPLF DTC114YSA N 100MI0A
Q225	55179230	56	B	so	0	PCE	TR-SLPSWA KRC107M N
Q226	55133210	56	B	so	1	PCE	TR-SLPLF DTC114YSA N 100MI0A
Q227	55142670	56	B	so	1	PCE	TR-SLPLF MPSA06 N 500MI0A
Q235	55133210	56	B	so	1	PCE	TR-SLPLF DTC114YSA N 100MI0A
Q235	55179230	56	B	so	0	PCE	TR-SLPSWA KRC107M N

PART NO : 55246350

TITEL : AC ESABD SMD FRONT BD AVR2500

Pos	Tocom#	Pkg	M/B	St	Qty	Unit	SName
C205	20267290	91	B	so	1	PCE	CCCFMIN 100NOF +80% -20% 50.0V Y5V
C206	50882360	91	B	so	1	PCE	CCCFMIN 33POF +5% -5% 50.0V NPO
C208	50882360	91	B	so	1	PCE	CCCFMIN 33POF +5% -5% 50.0V NPO
C209	20267290	91	B	so	1	PCE	CCCFMIN 100NOF +80% -20% 50.0V Y5V
C211	15070900	91	B	so	1	PCE	CCCFMIN 820POF +10% -10% 50.0V NPO
C212	15070900	91	B	so	1	PCE	CCCFMIN 820POF +10% -10% 50.0V NPO
C213	20267290	91	B	so	1	PCE	CCCFMIN 100NOF +80% -20% 50.0V Y5V
C217	20267290	91	B	so	1	PCE	CCCFMIN 100NOF +80% -20% 50.0V Y5V
C218	20267290	91	B	so	1	PCE	CCCFMIN 100NOF +80% -20% 50.0V Y5V
C228	11058670	91	B	so	1	PCE	CCCFMIN 100POF +5% -5% 50.0V NPO
C229	11058670	91	B	so	1	PCE	CCCFMIN 100POF +5% -5% 50.0V NPO
C230	11058670	91	B	so	1	PCE	CCCFMIN 100POF +5% -5% 50.0V NPO
C237	20267290	91	B	so	1	PCE	CCCFMIN 100NOF +80% -20% 50.0V Y5V
C238	20267290	91	B	so	1	PCE	CCCFMIN 100NOF +80% -20% 50.0V Y5V
C239	20267290	91	B	so	1	PCE	CCCFMIN 100NOF +80% -20% 50.0V Y5V
C240	20267290	91	B	so	1	PCE	CCCFMIN 100NOF +80% -20% 50.0V Y5V
C241	20267290	91	B	so	1	PCE	CCCFMIN 100NOF +80% -20% 50.0V Y5V
C242	20267290	91	B	so	1	PCE	CCCFMIN 100NOF +80% -20% 50.0V Y5V
C244	20267290	91	B	so	1	PCE	CCCFMIN 100NOF +80% -20% 50.0V Y5V
C245	20267290	91	B	so	1	PCE	CCCFMIN 100NOF +80% -20% 50.0V Y5V
C246	11058670	91	B	so	1	PCE	CCCFMIN 100POF +5% -5% 50.0V NPO
C247	11058670	91	B	so	1	PCE	CCCFMIN 100POF +5% -5% 50.0V NPO
C248	11058670	91	B	so	1	PCE	CCCFMIN 100POF +5% -5% 50.0V NPO
CL211	11058670	91	B	so	1	PCE	CCCFMIN 100POF +5% -5% 50.0V NPO
CR211	11058670	91	B	so	1	PCE	CCCFMIN 100POF +5% -5% 50.0V NPO
D248	20496510	NR	B	so	1	PCE	D-SLP 1SS355 35.0V 225MI0A
D249	20496510	NR	B	so	1	PCE	D-SLP 1SS355 35.0V 225MI0A
D250	20496510	NR	B	so	1	PCE	D-SLP 1SS355 35.0V 225MI0A
D251	20496510	NR	B	so	1	PCE	D-SLP 1SS355 35.0V 225MI0A
D253	20496510	NR	B	so	1	PCE	D-SLP 1SS355 35.0V 225MI0A
D254	20496510	NR	B	so	1	PCE	D-SLP 1SS355 35.0V 225MI0A
D255	20496510	NR	B	so	1	PCE	D-SLP 1SS355 35.0V 225MI0A
D261	20496510	NR	B	so	1	PCE	D-SLP 1SS355 35.0V 225MI0A
D262	20496510	NR	B	so	1	PCE	D-SLP 1SS355 35.0V 225MI0A
IC202	20718660	65	B	so	1	PCE	IC-LOGIC BU4094BF SHIFT REGISTER CMOS
IC203	20718660	65	B	so	1	PCE	IC-LOGIC BU4094BF SHIFT REGISTER CMOS
IC204	20718660	65	B	so	1	PCE	IC-LOGIC BU4094BF SHIFT REGISTER CMOS
J173	80440510	91	B	so	1	PCE	RMGCFMIN 0 OHM +0% 100MI0W
J201	80440510	91	B	so	1	PCE	RMGCFMIN 0 OHM +0% 100MI0W
J210	80440510	91	B	so	1	PCE	RMGCFMIN 0 OHM +0% 100MI0W
J211	80440510	91	B	so	1	PCE	RMGCFMIN 0 OHM +0% 100MI0W
J212	80440510	91	B	so	1	PCE	RMGCFMIN 0 OHM +0% 100MI0W
J213	80440510	91	B	so	1	PCE	RMGCFMIN 0 OHM +0% 100MI0W
J214	80440510	91	B	so	1	PCE	RMGCFMIN 0 OHM +0% 100MI0W

J215	80440510	91	B	so	1	PCE	RMGCFMIN 0 OHM +0% 100MI0W
J222	80440510	91	B	so	1	PCE	RMGCFMIN 0 OHM +0% 100MI0W
J237	80440510	91	B	so	1	PCE	RMGCFMIN 0 OHM +0% 100MI0W
J243	80440510	91	B	so	1	PCE	RMGCFMIN 0 OHM +0% 100MI0W
J244	80440510	91	B	so	1	PCE	RMGCFMIN 0 OHM +0% 100MI0W
J245	80440510	91	B	so	1	PCE	RMGCFMIN 0 OHM +0% 100MI0W
J246	80440510	91	B	so	1	PCE	RMGCFMIN 0 OHM +0% 100MI0W
J247	80440510	91	B	so	1	PCE	RMGCFMIN 0 OHM +0% 100MI0W
J248	80440510	91	B	so	1	PCE	RMGCFMIN 0 OHM +0% 100MI0W
J288	80440510	91	B	so	1	PCE	RMGCFMIN 0 OHM +0% 100MI0W
J294	80440510	91	B	so	1	PCE	RMGCFMIN 0 OHM +0% 100MI0W
J997	80440510	91	B	so	1	PCE	RMGCFMIN 0 OHM +0% 100MI0W
J998	80440510	91	B	so	1	PCE	RMGCFMIN 0 OHM +0% 100MI0W
J999	80440510	91	B	so	1	PCE	RMGCFMIN 0 OHM +0% 100MI0W
Q201	55050920	92	B	so	0	PCE	TR-SSD KRC111S N 10K0 OHM
Q201	55133330	92	B	so	1	PCE	TR-SSD DTC114TKA N 10K0 OHM
Q202	55050920	92	B	so	0	PCE	TR-SSD KRC111S N 10K0 OHM
Q202	55133330	92	B	so	1	PCE	TR-SSD DTC114TKA N 10K0 OHM
Q203	55050920	92	B	so	0	PCE	TR-SSD KRC111S N 10K0 OHM
Q203	55133330	92	B	so	1	PCE	TR-SSD DTC114TKA N 10K0 OHM
Q204	55050920	92	B	so	0	PCE	TR-SSD KRC111S N 10K0 OHM
Q204	55133330	92	B	so	1	PCE	TR-SSD DTC114TKA N 10K0 OHM
Q205	55050920	92	B	so	0	PCE	TR-SSD KRC111S N 10K0 OHM
Q205	55133330	92	B	so	1	PCE	TR-SSD DTC114TKA N 10K0 OHM
Q207	55050920	92	B	so	0	PCE	TR-SSD KRC111S N 10K0 OHM
Q207	55133330	92	B	so	1	PCE	TR-SSD DTC114TKA N 10K0 OHM
Q208	55050920	92	B	so	0	PCE	TR-SSD KRC111S N 10K0 OHM
Q208	55133330	92	B	so	1	PCE	TR-SSD DTC114TKA N 10K0 OHM
Q209	55050920	92	B	so	0	PCE	TR-SSD KRC111S N 10K0 OHM
Q209	55133330	92	B	so	1	PCE	TR-SSD DTC114TKA N 10K0 OHM
Q210	55050920	92	B	so	0	PCE	TR-SSD KRC111S N 10K0 OHM
Q210	55133330	92	B	so	1	PCE	TR-SSD DTC114TKA N 10K0 OHM
Q211	55050920	92	B	so	0	PCE	TR-SSD KRC111S N 10K0 OHM
Q211	55133330	92	B	so	1	PCE	TR-SSD DTC114TKA N 10K0 OHM
Q212	55050920	92	B	so	0	PCE	TR-SSD KRC111S N 10K0 OHM
Q212	55133330	92	B	so	1	PCE	TR-SSD DTC114TKA N 10K0 OHM
Q213	55050920	92	B	so	0	PCE	TR-SSD KRC111S N 10K0 OHM
Q213	55133330	92	B	so	1	PCE	TR-SSD DTC114TKA N 10K0 OHM
Q214	55050920	92	B	so	0	PCE	TR-SSD KRC111S N 10K0 OHM
Q214	55133330	92	B	so	1	PCE	TR-SSD DTC114TKA N 10K0 OHM
Q215	55050920	92	B	so	0	PCE	TR-SSD KRC111S N 10K0 OHM
Q215	55133330	92	B	so	1	PCE	TR-SSD DTC114TKA N 10K0 OHM
Q217	55050920	92	B	so	0	PCE	TR-SSD KRC111S N 10K0 OHM
Q217	55133330	92	B	so	1	PCE	TR-SSD DTC114TKA N 10K0 OHM
Q218	55050920	92	B	so	0	PCE	TR-SSD KRC111S N 10K0 OHM
Q218	55133330	92	B	so	1	PCE	TR-SSD DTC114TKA N 10K0 OHM
Q219	55050920	92	B	so	0	PCE	TR-SSD KRC111S N 10K0 OHM
Q219	55133330	92	B	so	1	PCE	TR-SSD DTC114TKA N 10K0 OHM
Q220	55050920	92	B	so	0	PCE	TR-SSD KRC111S N 10K0 OHM
Q220	55133330	92	B	so	1	PCE	TR-SSD DTC114TKA N 10K0 OHM
Q221	55050920	92	B	so	0	PCE	TR-SSD KRC111S N 10K0 OHM
Q221	55133330	92	B	so	1	PCE	TR-SSD DTC114TKA N 10K0 OHM
Q236	55051260	92	B	so	0	PCE	TR-SSD KRA107S P 10K0 OHM 47K0 OHM
Q236	55133190	92	B	so	1	PCE	TR-SSD DTA114YKA P 10K0 OHM 47K0 OHM
Q237	55051240	92	B	so	0	PCE	TR-SSD KRC107S N 10K0 OHM 47K0 OHM
Q237	55133180	92	B	so	1	PCE	TR-SSD DTC114YKA N 10K0 OHM 47K0 OHM
Q238	55050920	92	B	so	0	PCE	TR-SSD KRC111S N 10K0 OHM
Q238	55133330	92	B	so	1	PCE	TR-SSD DTC114TKA N 10K0 OHM
R205	60444350	91	B	so	1	PCE	RMGCFMIN 47R0 OHM +5% 100MI0W
R206	60444350	91	B	so	1	PCE	RMGCFMIN 47R0 OHM +5% 100MI0W
R207	60444350	91	B	so	1	PCE	RMGCFMIN 47R0 OHM +5% 100MI0W



R284	20471950	91	B	so	1	PCE	RMGCFMIN 1K0 OHM +5% 100MI0W
R285	20471950	91	B	so	1	PCE	RMGCFMIN 1K0 OHM +5% 100MI0W
R286	50886610	91	B	so	1	PCE	RMGCFMIN 10K0 OHM +5% 100MI0W
R287	11066500	91	B	so	1	PCE	RMGCFMIN 68K0 OHM +5% 100MI0W
R288	11066500	91	B	so	1	PCE	RMGCFMIN 68K0 OHM +5% 100MI0W
R289	11066480	91	B	so	1	PCE	RMGCFMIN 47K0 OHM +5% 100MI0W
R290	30944310	91	B	so	1	PCE	RMGCFMIN 4K7 OHM +5% 100MI0W
R291	30944250	91	B	so	1	PCE	RMGCFMIN 10R0 OHM +5% 100MI0W
R292	50886630	91	B	so	1	PCE	RMGCFMIN 100K0 OHM +5% 100MI0W
R293	11066460	91	B	so	1	PCE	RMGCFMIN 8K2 OHM +5% 100MI0W
R294	50886610	91	B	so	1	PCE	RMGCFMIN 10K0 OHM +5% 100MI0W
R295	20471950	91	B	so	1	PCE	RMGCFMIN 1K0 OHM +5% 100MI0W
R296	20471950	91	B	so	1	PCE	RMGCFMIN 1K0 OHM +5% 100MI0W
R297	20471950	91	B	so	1	PCE	RMGCFMIN 1K0 OHM +5% 100MI0W
R298	30944310	91	B	so	1	PCE	RMGCFMIN 4K7 OHM +5% 100MI0W
R299	30944310	91	B	so	1	PCE	RMGCFMIN 4K7 OHM +5% 100MI0W
R300	30944310	91	B	so	1	PCE	RMGCFMIN 4K7 OHM +5% 100MI0W
R302	60444350	91	B	so	1	PCE	RMGCFMIN 47R0 OHM +5% 100MI0W
R361	20471920	91	B	so	1	PCE	RMGCFMIN 220R0 OHM +5% 100MI0W
R362	20471920	91	B	so	1	PCE	RMGCFMIN 220R0 OHM +5% 100MI0W
R365	60444350	91	B	so	1	PCE	RMGCFMIN 47R0 OHM +5% 100MI0W
R366	20471950	91	B	so	1	PCE	RMGCFMIN 1K0 OHM +5% 100MI0W
RL201	20471950	91	B	so	1	PCE	RMGCFMIN 1K0 OHM +5% 100MI0W
RL202	50886630	91	B	so	1	PCE	RMGCFMIN 100K0 OHM +5% 100MI0W
RL203	50886670	91	B	so	1	PCE	RMGCFMIN 1M0 OHM +5% 100MI0W
RL204	11066480	91	B	so	1	PCE	RMGCFMIN 47K0 OHM +5% 100MI0W
RL205	90574400	91	B	so	1	PCE	RMGCFMIN 470R0 OHM +5% 100MI0W
RL206	50886630	91	B	so	1	PCE	RMGCFMIN 100K0 OHM +5% 100MI0W
RL207	20471940	91	B	so	1	PCE	RMGCFMIN 680R0 OHM +5% 100MI0W
RL208	60444390	91	B	so	1	PCE	RMGCFMIN 3K9 OHM +5% 100MI0W
RL209	60444400	91	B	so	1	PCE	RMGCFMIN 22K0 OHM +5% 100MI0W
RL210	80440390	91	B	so	1	PCE	RMGCFMIN 2K2 OHM +5% 100MI0W
RP388	50886630	91	B	so	1	PCE	RMGCFMIN 100K0 OHM +5% 100MI0W
RR201	20471950	91	B	so	1	PCE	RMGCFMIN 1K0 OHM +5% 100MI0W
RR202	50886630	91	B	so	1	PCE	RMGCFMIN 100K0 OHM +5% 100MI0W
RR203	50886670	91	B	so	1	PCE	RMGCFMIN 1M0 OHM +5% 100MI0W
RR204	11066480	91	B	so	1	PCE	RMGCFMIN 47K0 OHM +5% 100MI0W
RR205	90574400	91	B	so	1	PCE	RMGCFMIN 470R0 OHM +5% 100MI0W
RR206	50886630	91	B	so	1	PCE	RMGCFMIN 100K0 OHM +5% 100MI0W
RR207	20471940	91	B	so	1	PCE	RMGCFMIN 680R0 OHM +5% 100MI0W
RR208	60444390	91	B	so	1	PCE	RMGCFMIN 3K9 OHM +5% 100MI0W
RR209	60444400	91	B	so	1	PCE	RMGCFMIN 22K0 OHM +5% 100MI0W
RR210	80440390	91	B	so	1	PCE	RMGCFMIN 2K2 OHM +5% 100MI0W

PART NO : 55243610

TITEL : AC EMBD IMA AVR120US KEY BD

Pos	Tocom#	Pkg	M/B	St	Qty	Unit	SName
0020	55243620		M	SO	1	PCE	AC ESABD IAU KEY BD AVR120US
CN401	55175800	NR	B	so	1	PCE	WIRECONASY UNIQUE 8P 100MM UL1007 PVC DISCRETE 26 1
CN402	55175820	NR	B	so	1	PCE	WIRECONASY UNIQUE 5P 100MM UL1007 PVC DISCRETE 26 1
CN403	55175870	NR	B	so	1	PCE	WIRECONASY UNIQUE 3P 600MM UL2547 28 1
CN404	55175930	NR	B	so	1	PCE	WIRECONASY UNIQUE 7P 100MM UL2547 28 1
CP403	55090070		B	so	1	PCE	CONN 2.0MM 2 MA ST NAT LW2002P0200T 0 0
CP404	55123310		B	so	1	PCE	CONN 2.0MM 4 MA ST NAT LW2002P04 0 0
CP405	55123310		B	so	1	PCE	CONN 2.0MM 4 MA ST NAT LW2002P04 0 0
D401	55179330	NR	B	so	1	PCE	D-LEM RED/GREEN 5 RD RND CL
HP401	55088400		B	so	1	PCE	CONN-PHJAC 6.35 ST HORZ EST-J6313 BK 0 0
JA401	55176330		B	so	1	PCE	CONN PHONO SCKT RCA 4P JW4104RS GND
L401	55168840	16	B	so	1	PCE	LF 47U0H +10% 5.8 OHM 70MI0A
L402	55168840	16	B	so	1	PCE	LF 47U0H +10% 5.8 OHM 70MI0A
W401	55180140	NR	M	SO	1	PCE	WIRECONASY UNIQUE 1P 200MM UL1007 PVC DISCRETE 18 1

PART NO : 55243620

TITEL : AC ESABD IAU KEY BD AVR120US

Pos	Tocom#	Pkg	M/B	St	Qty	Unit	SName
0021	55179530		B	ud	1	PCE	AC PCB KEY BD 247*163 AVR520 DUAL LAYERS
Q403	55133220	56	B	so	0	PCE	TR-SLPLF DTAl14YSA P 100MI0A
Q403	55179220	56	B	so	1	PCE	TR-SLPSWA KRA107M P
SW401	55145270	KX	B	so	1	PCE	SWITACT VERTICAL TACTILE F/B 50MI0A 12.0V 500MI0OHM 15
SW402	55145270	KX	B	so	1	PCE	SWITACT VERTICAL TACTILE F/B 50MI0A 12.0V 500MI0OHM 15
SW403	55145270	KX	B	so	1	PCE	SWITACT VERTICAL TACTILE F/B 50MI0A 12.0V 500MI0OHM 15
SW404	55145270	KX	B	so	1	PCE	SWITACT VERTICAL TACTILE F/B 50MI0A 12.0V 500MI0OHM 15
SW405	55145270	KX	B	so	1	PCE	SWITACT VERTICAL TACTILE F/B 50MI0A 12.0V 500MI0OHM 15
SW406	55145270	KX	B	so	1	PCE	SWITACT VERTICAL TACTILE F/B 50MI0A 12.0V 500MI0OHM 15
SW407	55145270	KX	B	so	1	PCE	SWITACT VERTICAL TACTILE F/B 50MI0A 12.0V 500MI0OHM 15
SW408	55145270	KX	B	so	1	PCE	SWITACT VERTICAL TACTILE F/B 50MI0A 12.0V 500MI0OHM 15
SW409	55145270	KX	B	so	1	PCE	SWITACT VERTICAL TACTILE F/B 50MI0A 12.0V 500MI0OHM 15
SW410	55145270	KX	B	so	1	PCE	SWITACT VERTICAL TACTILE F/B 50MI0A 12.0V 500MI0OHM 15
SW411	55145270	KX	B	so	1	PCE	SWITACT VERTICAL TACTILE F/B 50MI0A 12.0V 500MI0OHM 15
SW412	55145270	KX	B	so	1	PCE	SWITACT VERTICAL TACTILE F/B 50MI0A 12.0V 500MI0OHM 15
SW413	55145270	KX	B	so	1	PCE	SWITACT VERTICAL TACTILE F/B 50MI0A 12.0V 500MI0OHM 15
SW414	55145270	KX	B	so	1	PCE	SWITACT VERTICAL TACTILE F/B 50MI0A 12.0V 500MI0OHM 15
SW415	55145270	KX	B	so	1	PCE	SWITACT VERTICAL TACTILE F/B 50MI0A 12.0V 500MI0OHM 15
SW416	55145270	KX	B	so	1	PCE	SWITACT VERTICAL TACTILE F/B 50MI0A 12.0V 500MI0OHM 15
SW417	55145270	KX	B	so	1	PCE	SWITACT VERTICAL TACTILE F/B 50MI0A 12.0V 500MI0OHM 15
SW418	55145270	KX	B	so	1	PCE	SWITACT VERTICAL TACTILE F/B 50MI0A 12.0V 500MI0OHM 15
SW419	55145270	KX	B	so	1	PCE	SWITACT VERTICAL TACTILE F/B 50MI0A 12.0V 500MI0OHM 15
SW420	55145270	KX	B	so	1	PCE	SWITACT VERTICAL TACTILE F/B 50MI0A 12.0V 500MI0OHM 15

PART NO : 55243630

TITEL : AC ESABD SMD KEY BD AVR120US

Pos	Tocom#	Pkg	M/B	St	Qty	Unit	SName
C401	30939240	91	B	so	1	PCE	CCCFMIN 22N0F +10% -10% 50.0V X7R
C402	30939240	91	B	so	1	PCE	CCCFMIN 22N0F +10% -10% 50.0V X7R
C403	11059330	91	B	so	1	PCE	CCCFMIN 2N2F +10% -10% 50.0V X7R
C404	11059330	91	B	so	1	PCE	CCCFMIN 2N2F +10% -10% 50.0V X7R
C405	20267290	91	B	so	1	PCE	CCCFMIN 100N0F +80% -20% 50.0V Y5V
C406	20267290	91	B	so	1	PCE	CCCFMIN 100N0F +80% -20% 50.0V Y5V
C409	11058670	91	B	so	1	PCE	CCCFMIN 100P0F +5% -5% 50.0V NP0

C410	11058670	91	B	so	1	PCE	CCCFMIN 100POF +5% -5% 50.0V NPO
C411	11058670	91	B	so	1	PCE	CCCFMIN 100POF +5% -5% 50.0V NPO
C412	11058670	91	B	so	1	PCE	CCCFMIN 100POF +5% -5% 50.0V NPO
C413	11058670	91	B	so	1	PCE	CCCFMIN 100POF +5% -5% 50.0V NPO
C414	11058670	91	B	so	1	PCE	CCCFMIN 100POF +5% -5% 50.0V NPO
C415	20267290	91	B	so	1	PCE	CCCFMIN 100NOF +80% -20% 50.0V Y5V
C416	20267290	91	B	so	1	PCE	CCCFMIN 100NOF +80% -20% 50.0V Y5V
D404	20496510	91	B	so	1	PCE	D-SLP 1SS355 35.0V 225MIOA
D405	20496510	91	B	so	1	PCE	D-SLP 1SS355 35.0V 225MIOA
D406	20496510	91	B	so	1	PCE	D-SLP 1SS355 35.0V 225MIOA
J407	80440510	91	B	so	1	PCE	RMGCFMIN 0 OHM +0% 100MIOW
J408	80440510	91	B	so	1	PCE	RMGCFMIN 0 OHM +0% 100MIOW
Q401	55051240	92	B	so	0	PCE	TR-SSD KRC107S N 10K0 OHM 47K0 OHM
Q401	55133180	92	B	so	1	PCE	TR-SSD DTC114YKA N 10K0 OHM 47K0 OHM
R401	50886610	91	B	so	1	PCE	RMGCFMIN 10K0 OHM +5% 100MIOW
R402	20471950	91	B	so	1	PCE	RMGCFMIN 1K0 OHM +5% 100MIOW
R403	70434230	91	B	so	1	PCE	RMGCFMIN 1K2 OHM +5% 100MIOW
R404	40438290	91	B	so	1	PCE	RMGCFMIN 1K5 OHM +5% 100MIOW
R405	80440390	91	B	so	1	PCE	RMGCFMIN 2K2 OHM +5% 100MIOW
R406	50886590	91	B	so	1	PCE	RMGCFMIN 2K7 OHM +5% 100MIOW
R407	11066440	91	B	so	1	PCE	RMGCFMIN 3K3 OHM +5% 100MIOW
R408	80440400	91	B	so	1	PCE	RMGCFMIN 5K6 OHM +5% 100MIOW
R409	11066460	91	B	so	1	PCE	RMGCFMIN 8K2 OHM +5% 100MIOW
R410	90574430	91	B	so	1	PCE	RMGCFMIN 18K0 OHM +5% 100MIOW
R411	50886610	91	B	so	1	PCE	RMGCFMIN 10K0 OHM +5% 100MIOW
R412	20471950	91	B	so	1	PCE	RMGCFMIN 1K0 OHM +5% 100MIOW
R413	70434230	91	B	so	1	PCE	RMGCFMIN 1K2 OHM +5% 100MIOW
R414	40438290	91	B	so	1	PCE	RMGCFMIN 1K5 OHM +5% 100MIOW
R415	80440390	91	B	so	1	PCE	RMGCFMIN 2K2 OHM +5% 100MIOW
R416	50886590	91	B	so	1	PCE	RMGCFMIN 2K7 OHM +5% 100MIOW
R417	11066440	91	B	so	1	PCE	RMGCFMIN 3K3 OHM +5% 100MIOW
R418	80440400	91	B	so	1	PCE	RMGCFMIN 5K6 OHM +5% 100MIOW
R419	11066460	91	B	so	1	PCE	RMGCFMIN 8K2 OHM +5% 100MIOW
R420	90574430	91	B	so	1	PCE	RMGCFMIN 18K0 OHM +5% 100MIOW
R421	60444370	91	B	so	1	PCE	RMGCFMIN 180R0 OHM +5% 100MIOW
R422	60444370	91	B	so	1	PCE	RMGCFMIN 180R0 OHM +5% 100MIOW
R423	20471940	91	B	so	1	PCE	RMGCFMIN 680R0 OHM +5% 100MIOW
R424	20471940	91	B	so	1	PCE	RMGCFMIN 680R0 OHM +5% 100MIOW
R427	90574400	91	B	so	1	PCE	RMGCFMIN 470R0 OHM +5% 100MIOW
R428	90574400	91	B	so	1	PCE	RMGCFMIN 470R0 OHM +5% 100MIOW
R433	60444350	91	B	so	1	PCE	RMGCFMIN 47R0 OHM +5% 100MIOW
R434	60444380	91	B	so	1	PCE	RMGCFMIN 270R0 OHM +5% 100MIOW
R435	50886610	91	B	so	1	PCE	RMGCFMIN 10K0 OHM +5% 100MIOW
R436	11066480	91	B	so	1	PCE	RMGCFMIN 47K0 OHM +5% 100MIOW

PART NO : 55246120

TITEL : AC EMBD IMA MAIN BD AVR2500

Pos	Tocom#	Pkg	M/B	St	Qty	Unit	SName
0020	55246280		M	SO	1	PCE	AC ESABD IAU MAIN BD AVR2500
0050	55176400		B	ud	1	PCE	AC METAL HEATSINK REG 118*20*50H AVR520 --
C421	13076940	AM	B	so	1	PCE	CE 470U0F +20% 63.0V 85C
C422	13076940	AM	B	so	1	PCE	CE 470U0F +20% 63.0V 85C
C423	13076940	AM	B	so	1	PCE	CE 470U0F +20% 63.0V 85C
C424	13076940	AM	B	so	1	PCE	CE 470U0F +20% 63.0V 85C
C481	55126170	DD	B	so	1	PCE	CE 6MI8F +20% 63.0V 85C
C482	55126170	DD	B	so	1	PCE	CE 6MI8F +20% 63.0V 85C
C485	40433130	30	B	so	1	PCE	CE 2MI2F +20% 35.0V 85C
C486	40433130	30	B	so	1	PCE	CE 2MI2F +20% 35.0V 85C
C487	55126160	NR	B	so	1	PCE	CE 6MI8F +20% 16.0V 85C
C488	13039870	AM	B	so	1	PCE	CE 2MI2F +20% 16.0V 85C
C511	13076940	AM	B	so	1	PCE	CE 470U0F +20% 63.0V 85C
C512	13076940	AM	B	so	1	PCE	CE 470U0F +20% 63.0V 85C
CN401	55171550		B	so	1	PCE	CON 3.96MM PITCH MOLEX 35313-0310
CN402	55146610		B	so	1	PCE	CONN 2.5MM 6 MA ST NAT 0 0
CN403	55146570		B	so	1	PCE	CONN 2.5MM 3 MA ST NAT 0 0
CN407	55123350		B	so	1	PCE	CONN 2.0MM 9 MA ST NAT LW2002P09 0 0
CN408	55125010		B	so	1	PCE	CONN 2.0MM 15 MA R NAT MOLEX 35336-1510 0 0
CN409	55125010		B	so	1	PCE	CONN 2.0MM 15 MA R NAT MOLEX 35336-1510 0 0
CN410	55125010		B	so	1	PCE	CONN 2.0MM 15 MA R NAT MOLEX 35336-1510 0 0
CN411	55125010		B	so	1	PCE	CONN 2.0MM 15 MA R NAT MOLEX 35336-1510 0 0
CN412	55205630		B	so	1	PCE	CONN 2.0MM 16 MA ST NAT MOLEX 35336-1610 0 0
CN413	55124960		B	so	1	PCE	CONN 2.0MM 11 MA R NAT MOLEX 35336-1110 0 0
CN414	55179440		B	so	1	PCE	CONN 1.25MM 27 FE ST WH GF120-27S-TS 2794 A4
CN415	55205630		B	so	1	PCE	CONN 2.0MM 16 MA ST NAT MOLEX 35336-1610 0 0
CN416	55123330		B	so	1	PCE	CONN 2.0MM 6 MA ST NAT LW2002P06 0 0
CN417	55146570		B	so	1	PCE	CONN 2.5MM 3 MA ST NAT 0 0
CP404	55175910	NR	B	ud	1	PCE	WIRECONASY UNIQUE 12P 390MM UL1533 SHIELD 28 1
CP406	55199410	NR	B	ud	1	PCE	WIRECONASY UNIQUE 14P 520MM UL1533 SHIELD 28 1
CW407	55164160	NR	B	so	1	PCE	WIRECONASY UNIQUE 12P 130MM UL1007 PVC DISCRETE 26 1
D481	55179280	NR	B	ud	1	PCE	D-BRDLC BRIDGE BU8-04F FRONTIER
D482	55179300	NR	B	ud	1	PCE	D-BRDLC BRIDGE W2-04F FRONTIER
D568	55041640	NR	B	so	1	PCE	D-SRSHC 1N5402 200.0V 3.0A
D569	55041640	NR	B	so	1	PCE	D-SRSHC 1N5402 200.0V 3.0A
D570	55041640	NR	B	so	1	PCE	D-SRSHC 1N5402 200.0V 3.0A
D571	55041640	NR	B	so	1	PCE	D-SRSHC 1N5402 200.0V 3.0A
FU481	20828790	NR	B	so	1	PCE	FUSULSLWBL 2.0 A 250.0 V
FU482	20828790	NR	B	so	1	PCE	FUSULSLWBL 2.0 A 250.0 V
FU483	20828790	NR	B	so	1	PCE	FUSULSLWBL 2.0 A 250.0 V
FU484	20828790	NR	B	so	1	PCE	FUSULSLWBL 2.0 A 250.0 V
G011	55135980	NR	B	so	1	PCE	TERMLUG GND
IC481	20832440	NR	B	so	1	PCE	IC-REGPOSFXD KIA7815API NORMAL
IC482	55124020	NR	B	so	1	PCE	IC-REGNEGFXD KIA7915PI NORMAL
IC483	55125450	NR	B	so	1	PCE	IC-REGPOSFXD BA033T NORMAL
IC484	55123960	NR	B	so	1	PCE	IC-REGPOSFXD KIA7805API NORMAL
IC485	55123960	NR	B	so	1	PCE	IC-REGPOSFXD KIA7805API NORMAL
IC486	55123990	NR	B	so	1	PCE	IC-REGNEGFXD KIA7905PI NORMAL
IC487	55179240	NR	B	so	1	PCE	IC-REGULADJ KA337 TO-220
JK401	55191370		B	so	1	PCE	CON PHONO SCKT RCA 1P JACK JE010003XN
JP401	55191400	NR	B	so	1	PCE	CONN-SPE TERMINAL SPKR 6P SH0611705P FE 19MM 6 BK 0 C
L401	55179560	NR	M	SO	1	PCE	LFA 1MM 10MM 5 LEFT
L402	55179560	NR	M	SO	1	PCE	LFA 1MM 10MM 5 LEFT
L501	55179560	NR	M	SO	1	PCE	LFA 1MM 10MM 5 LEFT
P551	55179640	NR	B	so	1	PCE	POS 100R0 OHM 16.0V
Q425	55133270	NR	B	so	1	PCE	TR-SHPLF 2SC4137 N 100MIOA 20V
Q426	55133270	NR	B	so	1	PCE	TR-SHPLF 2SC4137 N 100MIOA 20V

Q437	55127360	NR	B	so	1	PCE	TR-SHPLF 2SD2390 DARLINGTON N 10.0A
Q438	55127360	NR	B	so	1	PCE	TR-SHPLF 2SD2390 DARLINGTON N 10.0A
Q439	55127370	NR	B	so	1	PCE	TR-SHPLF 2SB1560 DARLINGTON P 10.0A
Q440	55127370	NR	B	so	1	PCE	TR-SHPLF 2SB1560 DARLINGTON P 10.0A
Q513	55133270	NR	B	so	1	PCE	TR-SHPLF 2SC4137 N 100MIOA 20V
Q519	55127360	NR	B	so	1	PCE	TR-SHPLF 2SD2390 DARLINGTON N 10.0A
Q520	55127370	NR	B	so	1	PCE	TR-SHPLF 2SB1560 DARLINGTON P 10.0A
R471	55179340	NR	B	ud	1	PCE	RW 220MIO OHM +5% 5.0W 600PPM/'C -600PPM/'C
R472	55179340	NR	B	ud	1	PCE	RW 220MIO OHM +5% 5.0W 600PPM/'C -600PPM/'C
R475	60442550	16	B	so	1	PCE	RMOF 10R0 OHM +5% 1.0W
R476	60442550	16	B	so	1	PCE	RMOF 10R0 OHM +5% 1.0W
R481	15022710	6	B	so	1	PCE	RMOF 10R0 OHM +5% 2.0W
R482	15022710	6	B	so	1	PCE	RMOF 10R0 OHM +5% 2.0W
R483	15022710	6	B	so	1	PCE	RMOF 10R0 OHM +5% 2.0W
R484	80442780	0	B	so	1	PCE	RMOF 4R7 OHM +5% 2.0W
R485	80442780	0	B	so	1	PCE	RMOF 4R7 OHM +5% 2.0W
R486	80442780	0	B	so	1	PCE	RMOF 4R7 OHM +5% 2.0W
R487	40440550	0	B	so	1	PCE	RMOF 3R3 OHM +5% 2.0W
R536	55179340	NR	B	ud	1	PCE	RW 220MIO OHM +5% 5.0W 600PPM/'C -600PPM/'C
R538	60442550	16	B	so	1	PCE	RMOF 10R0 OHM +5% 1.0W
VR401	55244060	0	B	ud	1	PCE	PR 220R0 OHM +30% 100MIOW
VR402	55244060	0	B	ud	1	PCE	PR 220R0 OHM +30% 100MIOW
VR501	55244060	0	B	ud	1	PCE	PR 220R0 OHM +30% 100MIOW
W002	55097370		M	SO	1	PCE	WCL 180-05-05 UL1007 HOOK-UP 18 180MM BK 5 5 2033884C
W003	55097370		M	SO	1	PCE	WCL 180-05-05 UL1007 HOOK-UP 18 180MM BK 5 5 2033884C
W401	55244370	NR	B	ud	1	PCE	WIRECONASY UNIQUE 1P 250MM UL1007 PVC DISCRETE 18 1
WA401	55146560		B	so	1	PCE	CONN 2.5MM 2 MA ST NAT 0 0
WA402	55146560		B	so	1	PCE	CONN 2.5MM 2 MA ST NAT 0 0
WA403	55146560		B	so	1	PCE	CONN 2.5MM 2 MA ST NAT 0 0

PART NO : 55246280

TITEL : AC ESABD IAU MAIN BD AVR2500

Pos	Tocom#	Pkg	M/B	St	Qty	Unit	SName
0020	55155710		B	ud	1	PCE	AC PCB MAIN AVR120 SINGLE LAYER
C111	20936650	16	B	so	1	PCE	CC 100P0F +10% -10% 50.0V Y5P
C112	20936650	16	B	so	1	PCE	CC 100P0F +10% -10% 50.0V Y5P
C113	20936650	16	B	so	1	PCE	CC 100P0F +10% -10% 50.0V Y5P
C114	20936650	16	B	so	1	PCE	CC 100P0F +10% -10% 50.0V Y5P
C115	20936650	16	B	so	1	PCE	CC 100P0F +10% -10% 50.0V Y5P
C116	20936650	16	B	so	1	PCE	CC 100P0F +10% -10% 50.0V Y5P
C401	20268880	30	B	so	1	PCE	CE 10U0F +20% 50.0V 85C
C402	20268880	30	B	so	1	PCE	CE 10U0F +20% 50.0V 85C
C403	11055300	71	B	so	1	PCE	CC 68P0F +5% -5% 50.0V NP0
C404	11055300	71	B	so	1	PCE	CC 68P0F +5% -5% 50.0V NP0
C405	20269070	30	B	so	1	PCE	CE 100U0F +20% 25.0V 85C
C406	20269070	30	B	so	1	PCE	CE 100U0F +20% 25.0V 85C
C407	20269080	30	B	so	1	PCE	CE 220U0F +20% 10.0V 85C
C408	20269080	30	B	so	1	PCE	CE 220U0F +20% 10.0V 85C
C409	30936070	71	B	so	1	PCE	CC 12P0F +5% -5% 50.0V NP0
C410	30936070	71	B	so	1	PCE	CC 12P0F +5% -5% 50.0V NP0
C411	60439150	71	B	so	1	PCE	CC 33P0F +5% -5% 50.0V NP0
C412	60439150	71	B	so	1	PCE	CC 33P0F +5% -5% 50.0V NP0
C413	20268880	30	B	so	1	PCE	CE 10U0F +20% 50.0V 85C
C414	20268880	30	B	so	1	PCE	CE 10U0F +20% 50.0V 85C
C417	55180340	70	B	so	1	PCE	CPM 100N0F +10% 63.0V
C418	55180340	70	B	so	1	PCE	CPM 100N0F +10% 63.0V
C419	55180340	70	B	so	1	PCE	CPM 100N0F +10% 63.0V
C420	55180340	70	B	so	1	PCE	CPM 100N0F +10% 63.0V
C425	11055530	71	B	so	1	PCE	CC 1N5F +10% -10% 50.0V Y5P
C426	11055530	71	B	so	1	PCE	CC 1N5F +10% -10% 50.0V Y5P



C431	10364820	71	B	so	1	PCE	CPF 47N0F +10% 100.0V
C432	10364820	71	B	so	1	PCE	CPF 47N0F +10% 100.0V
C433	10364820	71	B	so	1	PCE	CPF 47N0F +10% 100.0V
C443	20250040	16	B	so	1	PCE	CC 220P0F +10% -10% 50.0V Y5P
C444	20250040	16	B	so	1	PCE	CC 220P0F +10% -10% 50.0V Y5P
C446	20246470	71	B	so	1	PCE	CC 100N0F +80% -20% 25.0V Z5V
C483	20416690	70	B	so	1	PCE	CPM 100N0F +20% 250.0V
C484	10364820	71	B	so	1	PCE	CPF 47N0F +10% 100.0V
C489	20268880	30	B	so	1	PCE	CE 10U0F +20% 50.0V 85C
C490	20268880	30	B	so	1	PCE	CE 10U0F +20% 50.0V 85C
C492	20268880	30	B	so	1	PCE	CE 10U0F +20% 50.0V 85C
C494	20268880	30	B	so	1	PCE	CE 10U0F +20% 50.0V 85C
C496	20268880	30	B	so	1	PCE	CE 10U0F +20% 50.0V 85C
C497	20268880	30	B	so	1	PCE	CE 10U0F +20% 50.0V 85C
C498	20268880	30	B	so	1	PCE	CE 10U0F +20% 50.0V 85C
C501	20268880	30	B	so	1	PCE	CE 10U0F +20% 50.0V 85C
C502	11055300	71	B	so	1	PCE	CC 68P0F +5% -5% 50.0V NP0
C503	20269070	30	B	so	1	PCE	CE 100U0F +20% 25.0V 85C
C504	20269080	30	B	so	1	PCE	CE 220U0F +20% 10.0V 85C
C505	30936070	71	B	so	1	PCE	CC 12P0F +5% -5% 50.0V NP0
C506	60439150	71	B	so	1	PCE	CC 33P0F +5% -5% 50.0V NP0
C507	20268880	30	B	so	1	PCE	CE 10U0F +20% 50.0V 85C
C509	55180340	70	B	so	1	PCE	CPM 100N0F +10% 63.0V
C510	55180340	70	B	so	1	PCE	CPM 100N0F +10% 63.0V
C513	11055530	71	B	so	1	PCE	CC 1N5F +10% -10% 50.0V Y5P
C551	55179400	70	B	so	1	PCE	CPM 68N0F +5% 63.0V
C552	55179400	70	B	so	1	PCE	CPM 68N0F +5% 63.0V
C553	55179400	70	B	so	1	PCE	CPM 68N0F +5% 63.0V
C554	20252670	30	B	so	1	PCE	CE 47U0F +20% 10.0V 85C
C555	70428520	71	B	so	1	PCE	CC 10N0F +10% -10% 50.0V Y5P
C556	70428520	71	B	so	1	PCE	CC 10N0F +10% -10% 50.0V Y5P
C564	20416690	70	B	so	1	PCE	CPM 100N0F +20% 250.0V
C565	20416690	70	B	so	1	PCE	CPM 100N0F +20% 250.0V
C566	10364820	71	B	so	1	PCE	CPF 47N0F +10% 100.0V
C567	10364820	71	B	so	1	PCE	CPF 47N0F +10% 100.0V
C568	15002130	30	B	so	1	PCE	CE 10U0F +20% 16.0V 85C
C569	40433580	71	B	so	1	PCE	CC 680P0F +10% -10% 50.0V Y5P
C570	40433580	71	B	so	1	PCE	CC 680P0F +10% -10% 50.0V Y5P
C571	40433580	71	B	so	1	PCE	CC 680P0F +10% -10% 50.0V Y5P
C576	20936650	16	B	so	1	PCE	CC 100P0F +10% -10% 50.0V Y5P
C577	20936650	16	B	so	1	PCE	CC 100P0F +10% -10% 50.0V Y5P
C590	20267830	30	B	so	1	PCE	CE 47U0F +20% 16.0V 85C
D401	70436540	16	B	so	1	PCE	D-SLP 1N4148 100.0V 150E-3A
D402	70436540	16	B	so	1	PCE	D-SLP 1N4148 100.0V 150E-3A
D403	70436540	16	B	so	1	PCE	D-SLP 1N4148 100.0V 150E-3A
D404	70436540	16	B	so	1	PCE	D-SLP 1N4148 100.0V 150E-3A
D405	70436540	16	B	so	1	PCE	D-SLP 1N4148 100.0V 150E-3A
D406	70436540	16	B	so	1	PCE	D-SLP 1N4148 100.0V 150E-3A
D501	70436540	16	B	so	1	PCE	D-SLP 1N4148 100.0V 150E-3A
D502	70436540	16	B	so	1	PCE	D-SLP 1N4148 100.0V 150E-3A
D551	70436540	16	B	so	1	PCE	D-SLP 1N4148 100.0V 150E-3A
D552	70436540	16	B	so	1	PCE	D-SLP 1N4148 100.0V 150E-3A
D553	70436540	16	B	so	1	PCE	D-SLP 1N4148 100.0V 150E-3A
D554	70436540	16	B	so	1	PCE	D-SLP 1N4148 100.0V 150E-3A
D555	70436540	16	B	so	1	PCE	D-SLP 1N4148 100.0V 150E-3A
D556	70436540	16	B	so	1	PCE	D-SLP 1N4148 100.0V 150E-3A
D566	70436540	16	B	so	1	PCE	D-SLP 1N4148 100.0V 150E-3A
D567	70436540	16	B	so	1	PCE	D-SLP 1N4148 100.0V 150E-3A
D572	20421210	16	B	so	1	PCE	D-ZENER 1N5242B 12.0V 500MI0W
FH401	55170330	CM	B	so	1	PCE	TERMFUSEHLDR FUSE-HOLDER
FH402	55170330	CM	B	so	1	PCE	TERMFUSEHLDR FUSE-HOLDER

FH403	55170330	CM	B	so	1	PCE	TERMFUSEHLDR FUSE-HOLDER
FH404	55170330	CM	B	so	1	PCE	TERMFUSEHLDR FUSE-HOLDER
FH405	55170330	CM	B	so	1	PCE	TERMFUSEHLDR FUSE-HOLDER
FH406	55170330	CM	B	so	1	PCE	TERMFUSEHLDR FUSE-HOLDER
FH407	55170330	CM	B	so	1	PCE	TERMFUSEHLDR FUSE-HOLDER
FH408	55170330	CM	B	so	1	PCE	TERMFUSEHLDR FUSE-HOLDER
Q401	20556600	56	B	so	1	PCE	TR-SHPLF KTC3200BL N 100MIOA 120V
Q402	20556600	56	B	so	1	PCE	TR-SHPLF KTC3200BL N 100MIOA 120V
Q403	20556600	56	B	so	1	PCE	TR-SHPLF KTC3200BL N 100MIOA 120V
Q404	20556600	56	B	so	1	PCE	TR-SHPLF KTC3200BL N 100MIOA 120V
Q405	20556600	56	B	so	1	PCE	TR-SHPLF KTC3200BL N 100MIOA 120V
Q406	20556600	56	B	so	1	PCE	TR-SHPLF KTC3200BL N 100MIOA 120V
Q407	20508080	56	B	so	1	PCE	TR-SLPLF KTC3198BL N 150MIOA
Q408	20508080	56	B	so	1	PCE	TR-SLPLF KTC3198BL N 150MIOA
Q411	20647850	56	B	so	1	PCE	TR-SHPLF KTA1268BL P 100MIOA 120V
Q412	20647850	56	B	so	1	PCE	TR-SHPLF KTA1268BL P 100MIOA 120V
Q413	20647850	56	B	so	1	PCE	TR-SHPLF KTA1268BL P 100MIOA 120V
Q414	20647850	56	B	so	1	PCE	TR-SHPLF KTA1268BL P 100MIOA 120V
Q415	20556600	56	B	so	1	PCE	TR-SHPLF KTC3200BL N 100MIOA 120V
Q416	20556600	56	B	so	1	PCE	TR-SHPLF KTC3200BL N 100MIOA 120V
Q417	55133260	56	B	so	1	PCE	TR-SLPLF KTA1024 Y P 50MIOA -150V
Q418	55133260	56	B	so	1	PCE	TR-SLPLF KTA1024 Y P 50MIOA -150V
Q419	55133240	56	B	so	1	PCE	TR-SLPLF KTC3206 Y N 50MIOA 150V
Q420	55133240	56	B	so	1	PCE	TR-SLPLF KTC3206 Y N 50MIOA 150V
Q501	20556600	56	B	so	1	PCE	TR-SHPLF KTC3200BL N 100MIOA 120V
Q502	20556600	56	B	so	1	PCE	TR-SHPLF KTC3200BL N 100MIOA 120V
Q503	20556600	56	B	so	1	PCE	TR-SHPLF KTC3200BL N 100MIOA 120V
Q504	20508080	56	B	so	1	PCE	TR-SLPLF KTC3198BL N 150MIOA
Q506	20647850	56	B	so	1	PCE	TR-SHPLF KTA1268BL P 100MIOA 120V
Q507	20647850	56	B	so	1	PCE	TR-SHPLF KTA1268BL P 100MIOA 120V
Q508	20556600	56	B	so	1	PCE	TR-SHPLF KTC3200BL N 100MIOA 120V
Q509	55133260	56	B	so	1	PCE	TR-SLPLF KTA1024 Y P 50MIOA -150V
Q510	55133240	56	B	so	1	PCE	TR-SLPLF KTC3206 Y N 50MIOA 150V
Q551	20556600	56	B	so	1	PCE	TR-SHPLF KTC3200BL N 100MIOA 120V
Q552	20556600	56	B	so	1	PCE	TR-SHPLF KTC3200BL N 100MIOA 120V
Q553	20556600	56	B	so	1	PCE	TR-SHPLF KTC3200BL N 100MIOA 120V
Q554	20508080	56	B	so	1	PCE	TR-SLPLF KTC3198BL N 150MIOA
Q555	20508080	56	B	so	1	PCE	TR-SLPLF KTC3198BL N 150MIOA
Q556	20508080	56	B	so	1	PCE	TR-SLPLF KTC3198BL N 150MIOA
Q557	20508210	56	B	so	1	PCE	TR-SLPLF KTA1266 Y P 150MIOA
Q558	55133260	56	B	so	1	PCE	TR-SLPLF KTA1024 Y P 50MIOA -150V
Q559	55133210	56	B	so	0	PCE	TR-SLPLF DTC114YSA N 100MIOA
Q559	55179230	56	B	so	1	PCE	TR-SLPSWA KRC107M N
Q561	20647850	56	B	so	1	PCE	TR-SHPLF KTA1268BL P 100MIOA 120V
Q562	55133290	56	B	so	1	PCE	TR-SLPLF KTD1302 B N 300MIOA 20V
Q563	55133290	56	B	so	1	PCE	TR-SLPLF KTD1302 B N 300MIOA 20V
R401	60441550	16	B	so	1	PCE	RCF 330R0 OHM +5% 250MIOW
R402	60441550	16	B	so	1	PCE	RCF 330R0 OHM +5% 250MIOW
R403	80437030	16	B	so	1	PCE	RCF 27K0 OHM +5% 250MIOW
R404	80437030	16	B	so	1	PCE	RCF 27K0 OHM +5% 250MIOW
R405	40435630	16	B	so	1	PCE	RCF 1K5 OHM +5% 250MIOW
R406	40435630	16	B	so	1	PCE	RCF 1K5 OHM +5% 250MIOW
R407	40435630	16	B	so	1	PCE	RCF 1K5 OHM +5% 250MIOW
R408	40435630	16	B	so	1	PCE	RCF 1K5 OHM +5% 250MIOW
R409	20469450	16	B	so	1	PCE	RCF 220R0 OHM +5% 250MIOW
R410	20469450	16	B	so	1	PCE	RCF 220R0 OHM +5% 250MIOW
R411	20469450	16	B	so	1	PCE	RCF 220R0 OHM +5% 250MIOW
R412	20469450	16	B	so	1	PCE	RCF 220R0 OHM +5% 250MIOW
R413	11059610	16	B	so	1	PCE	RCF 270R0 OHM +5% 250MIOW
R414	11059610	16	B	so	1	PCE	RCF 270R0 OHM +5% 250MIOW
R415	20469510	16	B	so	1	PCE	RCF 43K0 OHM +5% 250MIOW

R416	20469510	16	B	so	1	PCE	RCF 43K0 OHM +5% 250MIOW
R417	80437030	16	B	so	1	PCE	RCF 27K0 OHM +5% 250MIOW
R418	80437030	16	B	so	1	PCE	RCF 27K0 OHM +5% 250MIOW
R419	80437010	16	B	so	1	PCE	RCF 1K8 OHM +5% 250MIOW
R420	80437010	16	B	so	1	PCE	RCF 1K8 OHM +5% 250MIOW
R421	60441560	16	B	so	1	PCE	RCF 560R0 OHM +5% 250MIOW
R422	60441560	16	B	so	1	PCE	RCF 560R0 OHM +5% 250MIOW
R423	60441560	16	B	so	1	PCE	RCF 560R0 OHM +5% 250MIOW
R424	60441560	16	B	so	1	PCE	RCF 560R0 OHM +5% 250MIOW
R425	60441560	16	B	so	1	PCE	RCF 560R0 OHM +5% 250MIOW
R426	60441560	16	B	so	1	PCE	RCF 560R0 OHM +5% 250MIOW
R427	60441560	16	B	so	1	PCE	RCF 560R0 OHM +5% 250MIOW
R428	60441560	16	B	so	1	PCE	RCF 560R0 OHM +5% 250MIOW
R429	60441560	16	B	so	1	PCE	RCF 560R0 OHM +5% 250MIOW
R430	60441560	16	B	so	1	PCE	RCF 560R0 OHM +5% 250MIOW
R431	60441560	16	B	so	1	PCE	RCF 560R0 OHM +5% 250MIOW
R432	60441560	16	B	so	1	PCE	RCF 560R0 OHM +5% 250MIOW
R433	11059590	16	B	so	1	PCE	RCF 82R0 OHM +5% 250MIOW
R434	11059590	16	B	so	1	PCE	RCF 82R0 OHM +5% 250MIOW
R435	11059590	16	B	so	1	PCE	RCF 82R0 OHM +5% 250MIOW
R436	11059590	16	B	so	1	PCE	RCF 82R0 OHM +5% 250MIOW
R437	60441580	16	B	so	1	PCE	RCF 22K0 OHM +5% 250MIOW
R438	60441580	16	B	so	1	PCE	RCF 22K0 OHM +5% 250MIOW
R439	60441580	16	B	so	1	PCE	RCF 22K0 OHM +5% 250MIOW
R440	60441580	16	B	so	1	PCE	RCF 22K0 OHM +5% 250MIOW
R445	30939360	16	B	so	1	PCE	RCF 10R0 OHM +5% 250MIOW
R446	30939360	16	B	so	1	PCE	RCF 10R0 OHM +5% 250MIOW
R447	30939360	16	B	so	1	PCE	RCF 10R0 OHM +5% 250MIOW
R448	30939360	16	B	so	1	PCE	RCF 10R0 OHM +5% 250MIOW
R449	80437000	16	B	so	1	PCE	RCF 1K2 OHM +5% 250MIOW
R450	80437000	16	B	so	1	PCE	RCF 1K2 OHM +5% 250MIOW
R451	60441550	16	B	so	1	PCE	RCF 330R0 OHM +5% 250MIOW
R452	60441550	16	B	so	1	PCE	RCF 330R0 OHM +5% 250MIOW
R453	70434970	16	B	so	1	PCE	RCF 3R3 OHM +5% 250MIOW
R454	70434970	16	B	so	1	PCE	RCF 3R3 OHM +5% 250MIOW
R455	70434970	16	B	so	1	PCE	RCF 3R3 OHM +5% 250MIOW
R456	70434970	16	B	so	1	PCE	RCF 3R3 OHM +5% 250MIOW
R473	30939360	16	B	so	1	PCE	RCF 10R0 OHM +5% 250MIOW
R474	30939360	16	B	so	1	PCE	RCF 10R0 OHM +5% 250MIOW
R477	30939360	16	B	so	1	PCE	RCF 10R0 OHM +5% 250MIOW
R478	30939360	16	B	so	1	PCE	RCF 10R0 OHM +5% 250MIOW
R489	20469450	16	B	so	1	PCE	RCF 220R0 OHM +5% 250MIOW
R490	11059630	16	B	so	1	PCE	RCF 680R0 OHM +5% 250MIOW
R501	60441550	16	B	so	1	PCE	RCF 330R0 OHM +5% 250MIOW
R502	80437030	16	B	so	1	PCE	RCF 27K0 OHM +5% 250MIOW
R503	40435630	16	B	so	1	PCE	RCF 1K5 OHM +5% 250MIOW
R504	40435630	16	B	so	1	PCE	RCF 1K5 OHM +5% 250MIOW
R505	20469450	16	B	so	1	PCE	RCF 220R0 OHM +5% 250MIOW
R506	20469450	16	B	so	1	PCE	RCF 220R0 OHM +5% 250MIOW
R507	11059610	16	B	so	1	PCE	RCF 270R0 OHM +5% 250MIOW
R508	20469510	16	B	so	1	PCE	RCF 43K0 OHM +5% 250MIOW
R509	80437030	16	B	so	1	PCE	RCF 27K0 OHM +5% 250MIOW
R510	80437010	16	B	so	1	PCE	RCF 1K8 OHM +5% 250MIOW
R511	60441560	16	B	so	1	PCE	RCF 560R0 OHM +5% 250MIOW
R512	60441560	16	B	so	1	PCE	RCF 560R0 OHM +5% 250MIOW
R513	60441560	16	B	so	1	PCE	RCF 560R0 OHM +5% 250MIOW
R514	60441560	16	B	so	1	PCE	RCF 560R0 OHM +5% 250MIOW
R515	60441560	16	B	so	1	PCE	RCF 560R0 OHM +5% 250MIOW
R516	60441560	16	B	so	1	PCE	RCF 560R0 OHM +5% 250MIOW
R517	11059590	16	B	so	1	PCE	RCF 82R0 OHM +5% 250MIOW
R518	11059590	16	B	so	1	PCE	RCF 82R0 OHM +5% 250MIOW

R519	60441580	16	B	so	1	PCE	RCF 22K0 OHM +5% 250MIOW
R520	60441580	16	B	so	1	PCE	RCF 22K0 OHM +5% 250MIOW
R523	30939360	16	B	so	1	PCE	RCF 10R0 OHM +5% 250MIOW
R524	30939360	16	B	so	1	PCE	RCF 10R0 OHM +5% 250MIOW
R525	11059640	16	B	so	1	PCE	RCF 1K0 OHM +5% 250MIOW
R526	60441550	16	B	so	1	PCE	RCF 330R0 OHM +5% 250MIOW
R527	70434970	16	B	so	1	PCE	RCF 3R3 OHM +5% 250MIOW
R528	70434970	16	B	so	1	PCE	RCF 3R3 OHM +5% 250MIOW
R537	30939360	16	B	so	1	PCE	RCF 10R0 OHM +5% 250MIOW
R539	30939360	16	B	so	1	PCE	RCF 10R0 OHM +5% 250MIOW
R551	40435630	16	B	so	1	PCE	RCF 1K5 OHM +5% 250MIOW
R552	40435630	16	B	so	1	PCE	RCF 1K5 OHM +5% 250MIOW
R553	50883010	16	B	so	1	PCE	RCF 15K0 OHM +5% 250MIOW
R554	50883010	16	B	so	1	PCE	RCF 15K0 OHM +5% 250MIOW
R555	60441580	16	B	so	1	PCE	RCF 22K0 OHM +5% 250MIOW
R556	60441580	16	B	so	1	PCE	RCF 22K0 OHM +5% 250MIOW
R557	40435630	16	B	so	1	PCE	RCF 1K5 OHM +5% 250MIOW
R558	50883010	16	B	so	1	PCE	RCF 15K0 OHM +5% 250MIOW
R559	60441580	16	B	so	1	PCE	RCF 22K0 OHM +5% 250MIOW
R561	70430570	16	B	so	1	PCE	RCF 8K2 OHM +5% 250MIOW
R562	11059710	16	B	so	1	PCE	RCF 56K0 OHM +5% 250MIOW
R563	11059710	16	B	so	1	PCE	RCF 56K0 OHM +5% 250MIOW
R564	11059710	16	B	so	1	PCE	RCF 56K0 OHM +5% 250MIOW
R565	90571120	16	B	so	1	PCE	RCF 12K0 OHM +5% 250MIOW
R566	50882950	16	B	so	1	PCE	RCF 100R0 OHM +5% 250MIOW
R567	30939480	16	B	so	1	PCE	RCF 10K0 OHM +5% 250MIOW
R568	30939480	16	B	so	1	PCE	RCF 10K0 OHM +5% 250MIOW
R569	30939480	16	B	so	1	PCE	RCF 10K0 OHM +5% 250MIOW
R570	11059610	16	B	so	1	PCE	RCF 270R0 OHM +5% 250MIOW
R571	80437030	16	B	so	1	PCE	RCF 27K0 OHM +5% 250MIOW
R585	40435630	16	B	so	1	PCE	RCF 1K5 OHM +5% 250MIOW
R586	40435630	16	B	so	1	PCE	RCF 1K5 OHM +5% 250MIOW
R587	90571130	16	B	so	1	PCE	RCF 39K0 OHM +5% 250MIOW
R588	90571130	16	B	so	1	PCE	RCF 39K0 OHM +5% 250MIOW
R589	40435630	16	B	so	1	PCE	RCF 1K5 OHM +5% 250MIOW
R590	90571130	16	B	so	1	PCE	RCF 39K0 OHM +5% 250MIOW
R591	30939480	16	B	so	1	PCE	RCF 10K0 OHM +5% 250MIOW
R592	90571130	16	B	so	1	PCE	RCF 39K0 OHM +5% 250MIOW
R593	50882970	16	B	so	1	PCE	RCF 470R0 OHM +5% 250MIOW
R594	50882970	16	B	so	1	PCE	RCF 470R0 OHM +5% 250MIOW
R595	50882970	16	B	so	1	PCE	RCF 470R0 OHM +5% 250MIOW
R612	70430510	16	B	so	1	PCE	RCF 47R0 OHM +5% 250MIOW
R613	50883000	16	B	so	1	PCE	RCF 3K3 OHM +5% 250MIOW
R614	50883000	16	B	so	1	PCE	RCF 3K3 OHM +5% 250MIOW

PART NO : 55246090

TITEL : AC BOM PKG AVR2500

Pos	Tocom#	Pkg	M/B	St	Qty	Unit	SName
0050	55127490		B	so	1	PCE	ANTENNA WIRE ANTENNA LOOP CT01-AM 0 0
0060	55242980		B	so	1	PCE	AC MSA ASY RMC CONTROLER AVR2500
0070	55020220	NR	B	po	3	PCE	BATNCALK 1.5V AAA 1.15 AH
0080	55243010		B	ud	1	PCE	AC CARTON AVR2500
0090	55178720		B	ud	1	PCE	AC PRI LABEL CARD-POST
0100	55178740		B	ud	1	PCE	AC PRI LABEL CARD-WARRANTY PAPE
0110	55178610		B	ud	2	PCE	AC CPL ENDCAP CUSHION POLY 0.024
0120	55127450		B	so	1	PCE	ANTENNA WIRE 75 CT02-FM 0 0
0130	55178620		B	so	1	PCE	AC PRI LABEL "PLEASE" AVR520
0140	55242950		B	ud	3	PCE	AC PRI LABEL BARCODE AVR2500
0150	55178770		B	so	1	PCE	AC PRI LABEL SAFETY LEAF
0160	55164890		B	so	1	PCE	AC CPL BAG POLY PE T0.05 500MM X 300MM
0170	55170660		B	ud	1	PCE	AC SHEET EPE DVD5 920MM X 1000MM
0180	55243030		B	ud	1	PCE	AC BOOK INSTR AVR2500
0190	20676090		B	so	1	PCE	AC CPL BAG PE 230MM X 120MM
0200	20194780		B	so	1	PCE	CABLE-FIX CABLE-TIE THE FITMOS PLASTIC 0 0
0210	20357210		B	so	1	M	TAPE-ADH ROLL 3M #373 0.06MM 50MM WH T
0220	55244740		B	so	1	M	TAPE-ADH ROLL 3M# 0.1MM 6MM --
0230	55297830		B	ud	1	PCE	AC PRI LEAFLET HANGTAG AVR2500

PART NO : 55243540

TITEL : AC EMBD IMA AVR120US PROCESS BD

Pos	Tocom#	Pkg	M/B	St	Qty	Unit	SName
0020	55243550		M	SO	1	PCE	AC ESABD IAU AVR120US PROCESS BD
CN408	55125070		B	so	1	PCE	CONN 2.0MM 15 MA R NAT MOLEX 35237-1510 0 0
CN409	55125070		B	so	1	PCE	CONN 2.0MM 15 MA R NAT MOLEX 35237-1510 0 0
CN410	55125070		B	so	1	PCE	CONN 2.0MM 15 MA R NAT MOLEX 35237-1510 0 0
CN411	55125070		B	so	1	PCE	CONN 2.0MM 15 MA R NAT MOLEX 35237-1510 0 0
CP205	55123310		B	so	1	PCE	CONN 2.0MM 4 MA ST NAT LW2002P04 0 0
CP206	55090050		B	so	1	PCE	CONN 2.0MM 10 MA ST NAT LW2002P10 0 0
CP403	55090080		B	so	1	PCE	CONN 2.0MM 3 MA ST NAT LW2002P03 0 0
CP404	55090060		B	so	1	PCE	CONN 2.0MM 7 MA ST NAT LW2002P07 0 0
CP405	55090100		B	so	1	PCE	CONN 2.0MM 12 MA ST NAT LW2002P12 0 0
CP412	55202850	NR	B	so	1	PCE	WIRECONASY UNIQUE 2P 120MM UL2791 SHIELD 26 1
CP413	55202850	NR	B	so	1	PCE	WIRECONASY UNIQUE 2P 120MM UL2791 SHIELD 26 1
CP414	55202850	NR	B	so	1	PCE	WIRECONASY UNIQUE 2P 120MM UL2791 SHIELD 26 1
CP415	55202850	NR	B	so	1	PCE	WIRECONASY UNIQUE 2P 120MM UL2791 SHIELD 26 1
IC701	55142750	NR	B	so	1	PCE	IC-SWITCH TC9273N-007 DIP28 ANALOG SWITCH
JK701	55176330		B	so	1	PCE	CON PHONO SCKT RCA 4P JW4104RS GND
JK702	55176330		B	so	1	PCE	CON PHONO SCKT RCA 4P JW4104RS GND
JK703	55176330		B	so	1	PCE	CON PHONO SCKT RCA 4P JW4104RS GND

PART NO : 55243550

TITEL : AC ESABD IAU AVR120US PROCESS BD

Pos	Tocom#	Pkg	M/B	St	Qty	Unit	SName
0020	55243560		M	SO	1	PCE	AC ESABD SMD AVR120US PROCESS BD
0021	5518695A		B	so	1	PCE	AC PCB PROCESS BD 330*16 AVR120US -
C709	10121000	39	B	so	1	PCE	CE 10U0F +20% 16.0V 85C
C710	20342060	39	B	so	1	PCE	CE 47U0F +20% 16.0V 85C
C711	10121000	39	B	so	1	PCE	CE 10U0F +20% 16.0V 85C
C714	10121000	39	B	so	1	PCE	CE 10U0F +20% 16.0V 85C
C715	20342060	39	B	so	1	PCE	CE 47U0F +20% 16.0V 85C
C716	10121000	39	B	so	1	PCE	CE 10U0F +20% 16.0V 85C
C723	10121000	39	B	so	1	PCE	CE 10U0F +20% 16.0V 85C
C724	20342060	39	B	so	1	PCE	CE 47U0F +20% 16.0V 85C
C725	10121000	39	B	so	1	PCE	CE 10U0F +20% 16.0V 85C
C728	10121000	39	B	so	1	PCE	CE 10U0F +20% 16.0V 85C
C729	20342060	39	B	so	1	PCE	CE 47U0F +20% 16.0V 85C
C730	10121000	39	B	so	1	PCE	CE 10U0F +20% 16.0V 85C
C764	20342060	39	B	so	1	PCE	CE 47U0F +20% 16.0V 85C
C765	20342060	39	B	so	1	PCE	CE 47U0F +20% 16.0V 85C
C768	20342060	39	B	so	1	PCE	CE 47U0F +20% 16.0V 85C
C769	20342060	39	B	so	1	PCE	CE 47U0F +20% 16.0V 85C
C770	20342060	39	B	so	1	PCE	CE 47U0F +20% 16.0V 85C
C771	20342060	39	B	so	1	PCE	CE 47U0F +20% 16.0V 85C
C773	20342060	39	B	so	1	PCE	CE 47U0F +20% 16.0V 85C
C774	20342060	39	B	so	1	PCE	CE 47U0F +20% 16.0V 85C
C782	10121000	39	B	so	1	PCE	CE 10U0F +20% 16.0V 85C
C783	20342060	39	B	so	1	PCE	CE 47U0F +20% 16.0V 85C
C784	10121000	39	B	so	1	PCE	CE 10U0F +20% 16.0V 85C
C787	10121000	39	B	so	1	PCE	CE 10U0F +20% 16.0V 85C
C788	20342060	39	B	so	1	PCE	CE 47U0F +20% 16.0V 85C
C789	10121000	39	B	so	1	PCE	CE 10U0F +20% 16.0V 85C
C792	10121000	39	B	so	1	PCE	CE 10U0F +20% 16.0V 85C
C795	20342060	39	B	so	1	PCE	CE 47U0F +20% 16.0V 85C
C796	10121000	39	B	so	1	PCE	CE 10U0F +20% 16.0V 85C
C797	20342060	39	B	so	1	PCE	CE 47U0F +20% 16.0V 85C
C798	20342060	39	B	so	1	PCE	CE 47U0F +20% 16.0V 85C



Q731	55133340	56	B	so	1	PCE	TR-SLPLF DTC114TS N 600MIOA
Q732	55112030	56	B	so	1	PCE	TR-M FET RA/TAD 2SK117Y N 300MIOW 14MIOA

PART NO : 55243560

TITEL : AC ESABD SMD AVR120US PROCESS BD

Pos	Tocom#	Pkg	M/B	St	Qty	Unit	SName
C701	11058670	91	B	so	1	PCE	CCCFMIN 100POF +5% -5% 50.0V NP0
C702	11058670	91	B	so	1	PCE	CCCFMIN 100POF +5% -5% 50.0V NP0
C703	11058670	91	B	so	1	PCE	CCCFMIN 100POF +5% -5% 50.0V NP0
C704	11058670	91	B	so	1	PCE	CCCFMIN 100POF +5% -5% 50.0V NP0
C705	11058670	91	B	so	1	PCE	CCCFMIN 100POF +5% -5% 50.0V NP0
C706	11058670	91	B	so	1	PCE	CCCFMIN 100POF +5% -5% 50.0V NP0
C707	11058670	91	B	so	1	PCE	CCCFMIN 100POF +5% -5% 50.0V NP0
C708	11058670	91	B	so	1	PCE	CCCFMIN 100POF +5% -5% 50.0V NP0
C712	11058670	91	B	so	1	PCE	CCCFMIN 100POF +5% -5% 50.0V NP0
C713	11058670	91	B	so	1	PCE	CCCFMIN 100POF +5% -5% 50.0V NP0
C717	11058670	91	B	so	1	PCE	CCCFMIN 100POF +5% -5% 50.0V NP0
C718	11058670	91	B	so	1	PCE	CCCFMIN 100POF +5% -5% 50.0V NP0
C719	11058670	91	B	so	1	PCE	CCCFMIN 100POF +5% -5% 50.0V NP0
C720	11058670	91	B	so	1	PCE	CCCFMIN 100POF +5% -5% 50.0V NP0
C721	11058670	91	B	so	1	PCE	CCCFMIN 100POF +5% -5% 50.0V NP0
C722	11058670	91	B	so	1	PCE	CCCFMIN 100POF +5% -5% 50.0V NP0
C726	11058670	91	B	so	1	PCE	CCCFMIN 100POF +5% -5% 50.0V NP0
C727	11058670	91	B	so	1	PCE	CCCFMIN 100POF +5% -5% 50.0V NP0
C731	11058670	91	B	so	1	PCE	CCCFMIN 100POF +5% -5% 50.0V NP0
C732	11058670	91	B	so	1	PCE	CCCFMIN 100POF +5% -5% 50.0V NP0
C733	11058670	91	B	so	1	PCE	CCCFMIN 100POF +5% -5% 50.0V NP0
C734	11058670	91	B	so	1	PCE	CCCFMIN 100POF +5% -5% 50.0V NP0
C735	11058670	91	B	so	1	PCE	CCCFMIN 100POF +5% -5% 50.0V NP0
C736	11058670	91	B	so	1	PCE	CCCFMIN 100POF +5% -5% 50.0V NP0
C737	11058670	91	B	so	1	PCE	CCCFMIN 100POF +5% -5% 50.0V NP0
C738	11058670	91	B	so	1	PCE	CCCFMIN 100POF +5% -5% 50.0V NP0
C739	11058670	91	B	so	1	PCE	CCCFMIN 100POF +5% -5% 50.0V NP0
C740	11058670	91	B	so	1	PCE	CCCFMIN 100POF +5% -5% 50.0V NP0
C763	11058670	91	B	so	1	PCE	CCCFMIN 100POF +5% -5% 50.0V NP0
C767	11058670	91	B	so	1	PCE	CCCFMIN 100POF +5% -5% 50.0V NP0
C772	11058670	91	B	so	1	PCE	CCCFMIN 100POF +5% -5% 50.0V NP0
C775	11058670	91	B	so	1	PCE	CCCFMIN 100POF +5% -5% 50.0V NP0
C793	11059330	91	B	so	1	PCE	CCCFMIN 2N2F +10% -10% 50.0V X7R
C794	11059330	91	B	so	1	PCE	CCCFMIN 2N2F +10% -10% 50.0V X7R
C812	50882360	91	B	so	1	PCE	CCCFMIN 33P0F +5% -5% 50.0V NP0
C817	50882360	91	B	so	1	PCE	CCCFMIN 33P0F +5% -5% 50.0V NP0
C820	11058670	91	B	so	1	PCE	CCCFMIN 100POF +5% -5% 50.0V NP0
C824	11058670	91	B	so	1	PCE	CCCFMIN 100POF +5% -5% 50.0V NP0
C828	11058670	91	B	so	1	PCE	CCCFMIN 100POF +5% -5% 50.0V NP0
C830	50882360	91	B	so	1	PCE	CCCFMIN 33P0F +5% -5% 50.0V NP0
C833	11058670	91	B	so	1	PCE	CCCFMIN 100POF +5% -5% 50.0V NP0
C835	50882360	91	B	so	1	PCE	CCCFMIN 33P0F +5% -5% 50.0V NP0
C838	11058670	91	B	so	1	PCE	CCCFMIN 100POF +5% -5% 50.0V NP0
C840	50882360	91	B	so	1	PCE	CCCFMIN 33P0F +5% -5% 50.0V NP0
C843	11058670	91	B	so	1	PCE	CCCFMIN 100POF +5% -5% 50.0V NP0
C845	50882360	91	B	so	1	PCE	CCCFMIN 33P0F +5% -5% 50.0V NP0
C848	11058670	91	B	so	1	PCE	CCCFMIN 100POF +5% -5% 50.0V NP0
C850	11059330	91	B	so	1	PCE	CCCFMIN 2N2F +10% -10% 50.0V X7R
C853	11058670	91	B	so	1	PCE	CCCFMIN 100POF +5% -5% 50.0V NP0
C855	50882360	91	B	so	1	PCE	CCCFMIN 33P0F +5% -5% 50.0V NP0
C858	80436820	91	B	so	1	PCE	CCCFMIN 680POF +10% -10% 50.0V X7R
C860	80436820	91	B	so	1	PCE	CCCFMIN 680POF +10% -10% 50.0V X7R
C863	80436820	91	B	so	1	PCE	CCCFMIN 680POF +10% -10% 50.0V X7R



C865	80436820	91	B	so	1	PCE	CCCFMIN 680POF +10% -10% 50.0V X7R
IC704	55142710	NR	B	so	1	PCE	IC-SWITCH KIC9162AF ANALOG SWITCH
IC705	55142680	NR	B	so	1	PCE	IC-SWITCH KIC9163AF ANALOG SWITCH
IC706	55179480	NR	B	so	1	PCE	IC-LOWFREQ TC9482F SOP28 TONE/VOL/BAL/MUTE
IC707	55142610	NR	B	so	1	PCE	IC-OPERAMP NJM2068M DUAL OP
IC708	55142610	NR	B	so	1	PCE	IC-OPERAMP NJM2068M DUAL OP
IC709	55142610	NR	B	so	1	PCE	IC-OPERAMP NJM2068M DUAL OP
IC713	55142610	NR	B	so	1	PCE	IC-OPERAMP NJM2068M DUAL OP
IC714	55142610	NR	B	so	1	PCE	IC-OPERAMP NJM2068M DUAL OP
IC715	55142610	NR	B	so	1	PCE	IC-OPERAMP NJM2068M DUAL OP
IC716	55142610	NR	B	so	1	PCE	IC-OPERAMP NJM2068M DUAL OP
IC717	55142610	NR	B	so	1	PCE	IC-OPERAMP NJM2068M DUAL OP
IC718	55142610	NR	B	so	1	PCE	IC-OPERAMP NJM2068M DUAL OP
IC719	55164460	NR	B	so	1	PCE	IC-OPERAMP NJM4556AM DUAL OP
IC720	55142610	NR	B	so	1	PCE	IC-OPERAMP NJM2068M DUAL OP
IC721	55142610	NR	B	so	1	PCE	IC-OPERAMP NJM2068M DUAL OP
IC722	55142610	NR	B	so	1	PCE	IC-OPERAMP NJM2068M DUAL OP
J933	80440510	91	B	so	1	PCE	RMGCFMIN 0 OHM +0% 100MI0W
J934	80440510	91	B	so	1	PCE	RMGCFMIN 0 OHM +0% 100MI0W
J935	80440510	91	B	so	1	PCE	RMGCFMIN 0 OHM +0% 100MI0W
J936	80440510	91	B	so	1	PCE	RMGCFMIN 0 OHM +0% 100MI0W
J937	80440510	91	B	so	1	PCE	RMGCFMIN 0 OHM +0% 100MI0W
J938	80440510	91	B	so	1	PCE	RMGCFMIN 0 OHM +0% 100MI0W
J939	80440510	91	B	so	1	PCE	RMGCFMIN 0 OHM +0% 100MI0W
J940	80440510	91	B	so	1	PCE	RMGCFMIN 0 OHM +0% 100MI0W
J941	80440510	91	B	so	1	PCE	RMGCFMIN 0 OHM +0% 100MI0W
J942	80440510	91	B	so	1	PCE	RMGCFMIN 0 OHM +0% 100MI0W
J943	80440510	91	B	so	1	PCE	RMGCFMIN 0 OHM +0% 100MI0W
J944	80440510	91	B	so	1	PCE	RMGCFMIN 0 OHM +0% 100MI0W
J945	80440510	91	B	so	1	PCE	RMGCFMIN 0 OHM +0% 100MI0W
J946	80440510	91	B	so	1	PCE	RMGCFMIN 0 OHM +0% 100MI0W
J947	80440510	91	B	so	1	PCE	RMGCFMIN 0 OHM +0% 100MI0W
J948	80440510	91	B	so	1	PCE	RMGCFMIN 0 OHM +0% 100MI0W
J949	80440510	91	B	so	1	PCE	RMGCFMIN 0 OHM +0% 100MI0W
J950	80440510	91	B	so	1	PCE	RMGCFMIN 0 OHM +0% 100MI0W
J951	80440510	91	B	so	1	PCE	RMGCFMIN 0 OHM +0% 100MI0W
J952	80440510	91	B	so	1	PCE	RMGCFMIN 0 OHM +0% 100MI0W
J953	80440510	91	B	so	1	PCE	RMGCFMIN 0 OHM +0% 100MI0W
J954	80440510	91	B	so	1	PCE	RMGCFMIN 0 OHM +0% 100MI0W
J955	80440510	91	B	so	1	PCE	RMGCFMIN 0 OHM +0% 100MI0W
J956	80440510	91	B	so	1	PCE	RMGCFMIN 0 OHM +0% 100MI0W
J957	80440510	91	B	so	1	PCE	RMGCFMIN 0 OHM +0% 100MI0W
J959	80440510	91	B	so	1	PCE	RMGCFMIN 0 OHM +0% 100MI0W
J960	80440510	91	B	so	1	PCE	RMGCFMIN 0 OHM +0% 100MI0W
J961	80440510	91	B	so	1	PCE	RMGCFMIN 0 OHM +0% 100MI0W
J962	80440510	91	B	so	1	PCE	RMGCFMIN 0 OHM +0% 100MI0W
J963	80440510	91	B	so	1	PCE	RMGCFMIN 0 OHM +0% 100MI0W
J964	80440510	91	B	so	1	PCE	RMGCFMIN 0 OHM +0% 100MI0W
J965	80440510	91	B	so	1	PCE	RMGCFMIN 0 OHM +0% 100MI0W
J966	80440510	91	B	so	1	PCE	RMGCFMIN 0 OHM +0% 100MI0W
J967	80440510	91	B	so	1	PCE	RMGCFMIN 0 OHM +0% 100MI0W
J970	80440510	91	B	so	1	PCE	RMGCFMIN 0 OHM +0% 100MI0W
Q706	55133190	92	B	so	1	PCE	TR-SSD DTA114YKA P 10K0 OHM 47K0 OHM
Q715	55133190	92	B	so	1	PCE	TR-SSD DTA114YKA P 10K0 OHM 47K0 OHM
Q718	55133190	92	B	so	1	PCE	TR-SSD DTA114YKA P 10K0 OHM 47K0 OHM
Q721	55133190	92	B	so	1	PCE	TR-SSD DTA114YKA P 10K0 OHM 47K0 OHM
Q724	55133190	92	B	so	1	PCE	TR-SSD DTA114YKA P 10K0 OHM 47K0 OHM
Q725	55133190	92	B	so	1	PCE	TR-SSD DTA114YKA P 10K0 OHM 47K0 OHM
Q733	55133190	92	B	so	1	PCE	TR-SSD DTA114YKA P 10K0 OHM 47K0 OHM
Q734	55133180	92	B	so	1	PCE	TR-SSD DTC114YKA N 10K0 OHM 47K0 OHM
Q735	55133190	92	B	so	1	PCE	TR-SSD DTA114YKA P 10K0 OHM 47K0 OHM

Q736	55133190	92	B	so	1	PCE	TR-SSD DTAl14YKA P 10K0 OHM 47K0 OHM
R701	90574400	91	B	so	1	PCE	RMGCFMIN 470R0 OHM +5% 100MI0W
R702	40438350	91	B	so	1	PCE	RMGCFMIN 470K0 OHM +5% 100MI0W
R703	90574400	91	B	so	1	PCE	RMGCFMIN 470R0 OHM +5% 100MI0W
R704	40438350	91	B	so	1	PCE	RMGCFMIN 470K0 OHM +5% 100MI0W
R705	90574400	91	B	so	1	PCE	RMGCFMIN 470R0 OHM +5% 100MI0W
R706	40438350	91	B	so	1	PCE	RMGCFMIN 470K0 OHM +5% 100MI0W
R707	90574400	91	B	so	1	PCE	RMGCFMIN 470R0 OHM +5% 100MI0W
R708	40438350	91	B	so	1	PCE	RMGCFMIN 470K0 OHM +5% 100MI0W
R709	70434200	91	B	so	1	PCE	RMGCFMIN 100R0 OHM +5% 100MI0W
R710	90574400	91	B	so	1	PCE	RMGCFMIN 470R0 OHM +5% 100MI0W
R711	20472020	91	B	so	1	PCE	RMGCFMIN 180K0 OHM +5% 100MI0W
R712	50886630	91	B	so	1	PCE	RMGCFMIN 100K0 OHM +5% 100MI0W
R713	20471950	91	B	so	1	PCE	RMGCFMIN 1K0 OHM +5% 100MI0W
R714	90574400	91	B	so	1	PCE	RMGCFMIN 470R0 OHM +5% 100MI0W
R715	20472020	91	B	so	1	PCE	RMGCFMIN 180K0 OHM +5% 100MI0W
R716	50886630	91	B	so	1	PCE	RMGCFMIN 100K0 OHM +5% 100MI0W
R717	20471950	91	B	so	1	PCE	RMGCFMIN 1K0 OHM +5% 100MI0W
R718	70434200	91	B	so	1	PCE	RMGCFMIN 100R0 OHM +5% 100MI0W
R719	80440390	91	B	so	1	PCE	RMGCFMIN 2K2 OHM +5% 100MI0W
R720	80440390	91	B	so	1	PCE	RMGCFMIN 2K2 OHM +5% 100MI0W
R721	90574400	91	B	so	1	PCE	RMGCFMIN 470R0 OHM +5% 100MI0W
R722	40438350	91	B	so	1	PCE	RMGCFMIN 470K0 OHM +5% 100MI0W
R723	90574400	91	B	so	1	PCE	RMGCFMIN 470R0 OHM +5% 100MI0W
R724	40438350	91	B	so	1	PCE	RMGCFMIN 470K0 OHM +5% 100MI0W
R725	80440390	91	B	so	1	PCE	RMGCFMIN 2K2 OHM +5% 100MI0W
R726	80440390	91	B	so	1	PCE	RMGCFMIN 2K2 OHM +5% 100MI0W
R727	70434200	91	B	so	1	PCE	RMGCFMIN 100R0 OHM +5% 100MI0W
R728	90574400	91	B	so	1	PCE	RMGCFMIN 470R0 OHM +5% 100MI0W
R729	20472020	91	B	so	1	PCE	RMGCFMIN 180K0 OHM +5% 100MI0W
R730	50886630	91	B	so	1	PCE	RMGCFMIN 100K0 OHM +5% 100MI0W
R731	20471950	91	B	so	1	PCE	RMGCFMIN 1K0 OHM +5% 100MI0W
R732	90574400	91	B	so	1	PCE	RMGCFMIN 470R0 OHM +5% 100MI0W
R733	20472020	91	B	so	1	PCE	RMGCFMIN 180K0 OHM +5% 100MI0W
R734	50886630	91	B	so	1	PCE	RMGCFMIN 100K0 OHM +5% 100MI0W
R735	20471950	91	B	so	1	PCE	RMGCFMIN 1K0 OHM +5% 100MI0W
R736	70434200	91	B	so	1	PCE	RMGCFMIN 100R0 OHM +5% 100MI0W
R737	90574400	91	B	so	1	PCE	RMGCFMIN 470R0 OHM +5% 100MI0W
R738	40438350	91	B	so	1	PCE	RMGCFMIN 470K0 OHM +5% 100MI0W
R739	90574400	91	B	so	1	PCE	RMGCFMIN 470R0 OHM +5% 100MI0W
R740	40438350	91	B	so	1	PCE	RMGCFMIN 470K0 OHM +5% 100MI0W
R741	90574400	91	B	so	1	PCE	RMGCFMIN 470R0 OHM +5% 100MI0W
R742	40438350	91	B	so	1	PCE	RMGCFMIN 470K0 OHM +5% 100MI0W
R743	90574400	91	B	so	1	PCE	RMGCFMIN 470R0 OHM +5% 100MI0W
R744	40438350	91	B	so	1	PCE	RMGCFMIN 470K0 OHM +5% 100MI0W
R768	20471950	91	B	so	1	PCE	RMGCFMIN 1K0 OHM +5% 100MI0W
R769	20471950	91	B	so	1	PCE	RMGCFMIN 1K0 OHM +5% 100MI0W
R781	70434200	91	B	so	1	PCE	RMGCFMIN 100R0 OHM +5% 100MI0W
R782	70434200	91	B	so	1	PCE	RMGCFMIN 100R0 OHM +5% 100MI0W
R783	20471950	91	B	so	1	PCE	RMGCFMIN 1K0 OHM +5% 100MI0W
R784	20471950	91	B	so	1	PCE	RMGCFMIN 1K0 OHM +5% 100MI0W
R785	20471950	91	B	so	1	PCE	RMGCFMIN 1K0 OHM +5% 100MI0W
R796	20471950	91	B	so	1	PCE	RMGCFMIN 1K0 OHM +5% 100MI0W
R797	20471950	91	B	so	1	PCE	RMGCFMIN 1K0 OHM +5% 100MI0W
R798	20471950	91	B	so	1	PCE	RMGCFMIN 1K0 OHM +5% 100MI0W
R799	70434200	91	B	so	1	PCE	RMGCFMIN 100R0 OHM +5% 100MI0W
R800	70434200	91	B	so	1	PCE	RMGCFMIN 100R0 OHM +5% 100MI0W
R801	70434200	91	B	so	1	PCE	RMGCFMIN 100R0 OHM +5% 100MI0W
R802	70434200	91	B	so	1	PCE	RMGCFMIN 100R0 OHM +5% 100MI0W
R803	20471950	91	B	so	1	PCE	RMGCFMIN 1K0 OHM +5% 100MI0W
R804	20471950	91	B	so	1	PCE	RMGCFMIN 1K0 OHM +5% 100MI0W

R805	20471950	91	B	so	1	PCE	RMGCFMIN 1K0 OHM +5% 100MI0W
R806	70434200	91	B	so	1	PCE	RMGCFMIN 100R0 OHM +5% 100MI0W
R807	70434200	91	B	so	1	PCE	RMGCFMIN 100R0 OHM +5% 100MI0W
R808	20471950	91	B	so	1	PCE	RMGCFMIN 1K0 OHM +5% 100MI0W
R809	20471950	91	B	so	1	PCE	RMGCFMIN 1K0 OHM +5% 100MI0W
R810	20471950	91	B	so	1	PCE	RMGCFMIN 1K0 OHM +5% 100MI0W
R811	70434200	91	B	so	1	PCE	RMGCFMIN 100R0 OHM +5% 100MI0W
R812	90574400	91	B	so	1	PCE	RMGCFMIN 470R0 OHM +5% 100MI0W
R813	20472020	91	B	so	1	PCE	RMGCFMIN 180K0 OHM +5% 100MI0W
R814	20472020	91	B	so	1	PCE	RMGCFMIN 180K0 OHM +5% 100MI0W
R815	20471950	91	B	so	1	PCE	RMGCFMIN 1K0 OHM +5% 100MI0W
R816	90574400	91	B	so	1	PCE	RMGCFMIN 470R0 OHM +5% 100MI0W
R817	20472020	91	B	so	1	PCE	RMGCFMIN 180K0 OHM +5% 100MI0W
R818	20472020	91	B	so	1	PCE	RMGCFMIN 180K0 OHM +5% 100MI0W
R819	20471950	91	B	so	1	PCE	RMGCFMIN 1K0 OHM +5% 100MI0W
R820	70434200	91	B	so	1	PCE	RMGCFMIN 100R0 OHM +5% 100MI0W
R821	80440390	91	B	so	1	PCE	RMGCFMIN 2K2 OHM +5% 100MI0W
R822	80440390	91	B	so	1	PCE	RMGCFMIN 2K2 OHM +5% 100MI0W
R823	30944340	91	B	so	1	PCE	RMGCFMIN 27K0 OHM +5% 100MI0W
R830	11066480	91	B	so	1	PCE	RMGCFMIN 47K0 OHM +5% 100MI0W
R831	90574400	91	B	so	1	PCE	RMGCFMIN 470R0 OHM +5% 100MI0W
R832	50886630	91	B	so	1	PCE	RMGCFMIN 100K0 OHM +5% 100MI0W
R833	80440390	91	B	so	1	PCE	RMGCFMIN 2K2 OHM +5% 100MI0W
R834	80440400	91	B	so	1	PCE	RMGCFMIN 5K6 OHM +5% 100MI0W
R835	50886630	91	B	so	1	PCE	RMGCFMIN 100K0 OHM +5% 100MI0W
R836	70434200	91	B	so	1	PCE	RMGCFMIN 100R0 OHM +5% 100MI0W
R837	70434200	91	B	so	1	PCE	RMGCFMIN 100R0 OHM +5% 100MI0W
R838	80440480	91	B	so	1	PCE	RMGCFMIN 3M3 OHM +5% 100MI0W
R839	70434200	91	B	so	1	PCE	RMGCFMIN 100R0 OHM +5% 100MI0W
R840	70434200	91	B	so	1	PCE	RMGCFMIN 100R0 OHM +5% 100MI0W
R841	50886630	91	B	so	1	PCE	RMGCFMIN 100K0 OHM +5% 100MI0W
R842	20471990	91	B	so	1	PCE	RMGCFMIN 12K0 OHM +5% 100MI0W
R843	20471990	91	B	so	1	PCE	RMGCFMIN 12K0 OHM +5% 100MI0W
R844	20471990	91	B	so	1	PCE	RMGCFMIN 12K0 OHM +5% 100MI0W
R845	11066440	91	B	so	1	PCE	RMGCFMIN 3K3 OHM +5% 100MI0W
R846	11066440	91	B	so	1	PCE	RMGCFMIN 3K3 OHM +5% 100MI0W
R847	50886630	91	B	so	1	PCE	RMGCFMIN 100K0 OHM +5% 100MI0W
R848	20471990	91	B	so	1	PCE	RMGCFMIN 12K0 OHM +5% 100MI0W
R849	20471990	91	B	so	1	PCE	RMGCFMIN 12K0 OHM +5% 100MI0W
R850	20471990	91	B	so	1	PCE	RMGCFMIN 12K0 OHM +5% 100MI0W
R851	11066440	91	B	so	1	PCE	RMGCFMIN 3K3 OHM +5% 100MI0W
R852	11066440	91	B	so	1	PCE	RMGCFMIN 3K3 OHM +5% 100MI0W
R853	50886630	91	B	so	1	PCE	RMGCFMIN 100K0 OHM +5% 100MI0W
R854	80440390	91	B	so	1	PCE	RMGCFMIN 2K2 OHM +5% 100MI0W
R855	80440390	91	B	so	1	PCE	RMGCFMIN 2K2 OHM +5% 100MI0W
R856	80440390	91	B	so	1	PCE	RMGCFMIN 2K2 OHM +5% 100MI0W
R857	80440390	91	B	so	1	PCE	RMGCFMIN 2K2 OHM +5% 100MI0W
R858	80440390	91	B	so	1	PCE	RMGCFMIN 2K2 OHM +5% 100MI0W
R859	80440390	91	B	so	1	PCE	RMGCFMIN 2K2 OHM +5% 100MI0W
R860	90574430	91	B	so	1	PCE	RMGCFMIN 18K0 OHM +5% 100MI0W
R861	90574430	91	B	so	1	PCE	RMGCFMIN 18K0 OHM +5% 100MI0W
R862	90574430	91	B	so	1	PCE	RMGCFMIN 18K0 OHM +5% 100MI0W
R863	90574430	91	B	so	1	PCE	RMGCFMIN 18K0 OHM +5% 100MI0W
R864	20471920	91	B	so	1	PCE	RMGCFMIN 220R0 OHM +5% 100MI0W
R865	80440390	91	B	so	1	PCE	RMGCFMIN 2K2 OHM +5% 100MI0W
R866	80440390	91	B	so	1	PCE	RMGCFMIN 2K2 OHM +5% 100MI0W
R867	70434200	91	B	so	1	PCE	RMGCFMIN 100R0 OHM +5% 100MI0W
R868	70434200	91	B	so	1	PCE	RMGCFMIN 100R0 OHM +5% 100MI0W
R869	70434200	91	B	so	1	PCE	RMGCFMIN 100R0 OHM +5% 100MI0W
R870	70434200	91	B	so	1	PCE	RMGCFMIN 100R0 OHM +5% 100MI0W
R871	70434200	91	B	so	1	PCE	RMGCFMIN 100R0 OHM +5% 100MI0W

R872	70434200	91	B	so	1	PCE	RMGCFMIN	100R0	OHM +5%	100MI0W
R873	70434200	91	B	so	1	PCE	RMGCFMIN	100R0	OHM +5%	100MI0W
R874	70434200	91	B	so	1	PCE	RMGCFMIN	100R0	OHM +5%	100MI0W
R875	70434200	91	B	so	1	PCE	RMGCFMIN	100R0	OHM +5%	100MI0W
R876	70434200	91	B	so	1	PCE	RMGCFMIN	100R0	OHM +5%	100MI0W
R878	70434200	91	B	so	1	PCE	RMGCFMIN	100R0	OHM +5%	100MI0W
R879	70434200	91	B	so	1	PCE	RMGCFMIN	100R0	OHM +5%	100MI0W
R880	70434200	91	B	so	1	PCE	RMGCFMIN	100R0	OHM +5%	100MI0W
R881	70434200	91	B	so	1	PCE	RMGCFMIN	100R0	OHM +5%	100MI0W
R882	90574400	91	B	so	1	PCE	RMGCFMIN	470R0	OHM +5%	100MI0W
R883	20472020	91	B	so	1	PCE	RMGCFMIN	180K0	OHM +5%	100MI0W
R884	50886630	91	B	so	1	PCE	RMGCFMIN	100K0	OHM +5%	100MI0W
R885	90574400	91	B	so	1	PCE	RMGCFMIN	470R0	OHM +5%	100MI0W
R886	20472020	91	B	so	1	PCE	RMGCFMIN	180K0	OHM +5%	100MI0W
R887	50886630	91	B	so	1	PCE	RMGCFMIN	100K0	OHM +5%	100MI0W
R888	90574400	91	B	so	1	PCE	RMGCFMIN	470R0	OHM +5%	100MI0W
R889	20472020	91	B	so	1	PCE	RMGCFMIN	180K0	OHM +5%	100MI0W
R890	20471950	91	B	so	1	PCE	RMGCFMIN	1K0	OHM +5%	100MI0W
R891	80440400	91	B	so	1	PCE	RMGCFMIN	5K6	OHM +5%	100MI0W
R892	50886630	91	B	so	1	PCE	RMGCFMIN	100K0	OHM +5%	100MI0W
R893	90574400	91	B	so	1	PCE	RMGCFMIN	470R0	OHM +5%	100MI0W
R894	20472020	91	B	so	1	PCE	RMGCFMIN	180K0	OHM +5%	100MI0W
R895	20471950	91	B	so	1	PCE	RMGCFMIN	1K0	OHM +5%	100MI0W
R896	80440400	91	B	so	1	PCE	RMGCFMIN	5K6	OHM +5%	100MI0W
R897	50886630	91	B	so	1	PCE	RMGCFMIN	100K0	OHM +5%	100MI0W
R898	90574400	91	B	so	1	PCE	RMGCFMIN	470R0	OHM +5%	100MI0W
R899	50886630	91	B	so	1	PCE	RMGCFMIN	100K0	OHM +5%	100MI0W
R901	80440400	91	B	so	1	PCE	RMGCFMIN	5K6	OHM +5%	100MI0W
R902	50886630	91	B	so	1	PCE	RMGCFMIN	100K0	OHM +5%	100MI0W
R903	20471950	91	B	so	1	PCE	RMGCFMIN	1K0	OHM +5%	100MI0W
R904	90574400	91	B	so	1	PCE	RMGCFMIN	470R0	OHM +5%	100MI0W
R905	50886630	91	B	so	1	PCE	RMGCFMIN	100K0	OHM +5%	100MI0W
R907	80440400	91	B	so	1	PCE	RMGCFMIN	5K6	OHM +5%	100MI0W
R908	50886630	91	B	so	1	PCE	RMGCFMIN	100K0	OHM +5%	100MI0W
R909	20471950	91	B	so	1	PCE	RMGCFMIN	1K0	OHM +5%	100MI0W
R910	90574400	91	B	so	1	PCE	RMGCFMIN	470R0	OHM +5%	100MI0W
R911	50886630	91	B	so	1	PCE	RMGCFMIN	100K0	OHM +5%	100MI0W
R912	20471950	91	B	so	1	PCE	RMGCFMIN	1K0	OHM +5%	100MI0W
R913	80440400	91	B	so	1	PCE	RMGCFMIN	5K6	OHM +5%	100MI0W
R914	50886630	91	B	so	1	PCE	RMGCFMIN	100K0	OHM +5%	100MI0W
R915	20471950	91	B	so	1	PCE	RMGCFMIN	1K0	OHM +5%	100MI0W
R916	90574400	91	B	so	1	PCE	RMGCFMIN	470R0	OHM +5%	100MI0W
R917	50886630	91	B	so	1	PCE	RMGCFMIN	100K0	OHM +5%	100MI0W
R918	20471950	91	B	so	1	PCE	RMGCFMIN	1K0	OHM +5%	100MI0W
R919	50886610	91	B	so	1	PCE	RMGCFMIN	10K0	OHM +5%	100MI0W
R920	50886630	91	B	so	1	PCE	RMGCFMIN	100K0	OHM +5%	100MI0W
R921	20471950	91	B	so	1	PCE	RMGCFMIN	1K0	OHM +5%	100MI0W
R922	90574400	91	B	so	1	PCE	RMGCFMIN	470R0	OHM +5%	100MI0W
R923	50886630	91	B	so	1	PCE	RMGCFMIN	100K0	OHM +5%	100MI0W
R924	20471950	91	B	so	1	PCE	RMGCFMIN	1K0	OHM +5%	100MI0W
R925	80440400	91	B	so	1	PCE	RMGCFMIN	5K6	OHM +5%	100MI0W
R926	50886630	91	B	so	1	PCE	RMGCFMIN	100K0	OHM +5%	100MI0W
R927	20471950	91	B	so	1	PCE	RMGCFMIN	1K0	OHM +5%	100MI0W
R928	90574400	91	B	so	1	PCE	RMGCFMIN	470R0	OHM +5%	100MI0W
R929	50886630	91	B	so	1	PCE	RMGCFMIN	100K0	OHM +5%	100MI0W
R930	20471950	91	B	so	1	PCE	RMGCFMIN	1K0	OHM +5%	100MI0W
R931	40438290	91	B	so	1	PCE	RMGCFMIN	1K5	OHM +5%	100MI0W
R932	50886630	91	B	so	1	PCE	RMGCFMIN	100K0	OHM +5%	100MI0W
R933	20471920	91	B	so	1	PCE	RMGCFMIN	220R0	OHM +5%	100MI0W
R934	90574400	91	B	so	1	PCE	RMGCFMIN	470R0	OHM +5%	100MI0W
R935	30944340	91	B	so	1	PCE	RMGCFMIN	27K0	OHM +5%	100MI0W

R936	50886630	91	B	so	1	PCE	RMGCFMIN 100K0 OHM +5% 100MI0W
R937	20471950	91	B	so	1	PCE	RMGCFMIN 1K0 OHM +5% 100MI0W
R938	40438290	91	B	so	1	PCE	RMGCFMIN 1K5 OHM +5% 100MI0W
R939	50886630	91	B	so	1	PCE	RMGCFMIN 100K0 OHM +5% 100MI0W
R940	20471920	91	B	so	1	PCE	RMGCFMIN 220R0 OHM +5% 100MI0W
R942	90574400	91	B	so	1	PCE	RMGCFMIN 470R0 OHM +5% 100MI0W
R943	20472020	91	B	so	1	PCE	RMGCFMIN 180K0 OHM +5% 100MI0W
R944	50886630	91	B	so	1	PCE	RMGCFMIN 100K0 OHM +5% 100MI0W
R945	90574400	91	B	so	1	PCE	RMGCFMIN 470R0 OHM +5% 100MI0W
R946	20472020	91	B	so	1	PCE	RMGCFMIN 180K0 OHM +5% 100MI0W
R947	50886630	91	B	so	1	PCE	RMGCFMIN 100K0 OHM +5% 100MI0W
R948	30944340	91	B	so	1	PCE	RMGCFMIN 27K0 OHM +5% 100MI0W
R949	20471920	91	B	so	1	PCE	RMGCFMIN 220R0 OHM +5% 100MI0W
R950	90574400	91	B	so	1	PCE	RMGCFMIN 470R0 OHM +5% 100MI0W
R951	20471950	91	B	so	1	PCE	RMGCFMIN 1K0 OHM +5% 100MI0W
R952	20471950	91	B	so	1	PCE	RMGCFMIN 1K0 OHM +5% 100MI0W
R953	50886630	91	B	so	1	PCE	RMGCFMIN 100K0 OHM +5% 100MI0W
R954	80440400	91	B	so	1	PCE	RMGCFMIN 5K6 OHM +5% 100MI0W
R955	50886630	91	B	so	1	PCE	RMGCFMIN 100K0 OHM +5% 100MI0W
R956	90574430	91	B	so	1	PCE	RMGCFMIN 18K0 OHM +5% 100MI0W
R957	20471950	91	B	so	1	PCE	RMGCFMIN 1K0 OHM +5% 100MI0W
R958	20471950	91	B	so	1	PCE	RMGCFMIN 1K0 OHM +5% 100MI0W
R963	50886550	91	B	so	1	PCE	RMGCFMIN 560R0 OHM +5% 100MI0W
R964	50886550	91	B	so	1	PCE	RMGCFMIN 560R0 OHM +5% 100MI0W
R965	90574400	91	B	so	1	PCE	RMGCFMIN 470R0 OHM +5% 100MI0W
R966	90574400	91	B	so	1	PCE	RMGCFMIN 470R0 OHM +5% 100MI0W
R967	30944340	91	B	so	1	PCE	RMGCFMIN 27K0 OHM +5% 100MI0W
R968	30944340	91	B	so	1	PCE	RMGCFMIN 27K0 OHM +5% 100MI0W
R969	90574430	91	B	so	1	PCE	RMGCFMIN 18K0 OHM +5% 100MI0W
R970	90574430	91	B	so	1	PCE	RMGCFMIN 18K0 OHM +5% 100MI0W
R971	90574430	91	B	so	1	PCE	RMGCFMIN 18K0 OHM +5% 100MI0W

PART NO : 55271240

TITEL : AC EMBD IMA SURROUND BD AVR2500

Pos	Tocom#	Pkg	M/B	St	Qty	Unit	SName
0020	55271250		M	SO	1	PCE	AC ESABD IAU SURROUND BD AVR2500
0050	55249990		B	ud	1	PCE	AC METAL HEATSINK 16X7.5X30 AVR120 --
0060	55127070		B	so	1	PCE	SCREW-ST 3MM 10MM JIS B 1122 25 0 0
0070	55210560		B	so	1	PCE	AC PRI LABEL PCB AVR120/220
AC981	55246750	NR	B	so	1	PCE	CONN-SPE AC OUTLET 2P 220V FE 19MM 2 BK 0 0
C621	13073530	AM	B	so	1	PCE	CE 470U0F +20% 50.0V 85C
C622	13073530	AM	B	so	1	PCE	CE 470U0F +20% 50.0V 85C
C623	13073530	AM	B	so	1	PCE	CE 470U0F +20% 50.0V 85C
C624	13073530	AM	B	so	1	PCE	CE 470U0F +20% 50.0V 85C
C691	55244040	NR	B	ud	1	PCE	CE 4MI7F +20% 50.0V 85C
C692	55244040	NR	B	ud	1	PCE	CE 4MI7F +20% 50.0V 85C
C982	55095470	NR	B	so	1	PCE	CC 4N7F +20% -20% 250.0V Y5V
C984	13073530	AM	B	so	1	PCE	CE 470U0F +20% 50.0V 85C
C989	13073530	AM	B	so	1	PCE	CE 470U0F +20% 50.0V 85C
C990	13073530	AM	B	so	1	PCE	CE 470U0F +20% 50.0V 85C
CA81	55095460	NR	B	so	1	PCE	CPPMX 100NOF +20% -20%
CN606	55244420	NR	B	so	1	PCE	WIRECONASY UNIQUE 3P 864MM UL1007 PVC DISCRETE 26 1
D691	55125540	NR	B	ud	1	PCE	D-BRDLC BU6-04F
D981	20415060	16	B	so	1	PCE	D-SR 1N4004 400.0V 1.0A
D982	20415060	16	B	so	1	PCE	D-SR 1N4004 400.0V 1.0A
D983	20415060	16	B	so	1	PCE	D-SR 1N4004 400.0V 1.0A
D984	20415060	16	B	so	1	PCE	D-SR 1N4004 400.0V 1.0A
D985	20415060	16	B	so	1	PCE	D-SR 1N4004 400.0V 1.0A
D986	20415060	16	B	so	1	PCE	D-SR 1N4004 400.0V 1.0A
D989	20415060	16	B	so	1	PCE	D-SR 1N4004 400.0V 1.0A
D990	20415060	16	B	so	1	PCE	D-SR 1N4004 400.0V 1.0A
FU981	20828800	NR	B	so	1	PCE	FUSVDETIMELG 3.15 A 250.0 V 5X20
H012	55180170	NR	M	SO	1	PCE	WIRECONASY UNIQUE 1P 200MM UL1007 PVC DISCRETE 18 1
H020	55180170	NR	M	SO	1	PCE	WIRECONASY UNIQUE 1P 200MM UL1007 PVC DISCRETE 18 1
IC981	55123960	NR	B	so	1	PCE	IC-REGPOSFXD KIA7805API NORMAL
JK601	55191390	NR	B	so	1	PCE	CONN-SPE TERMINAL SPKR 4P SH0410376P FE 19MM 4 BK 0
L601	55179560	NR	M	SO	1	PCE	LFA 1MM 10MM 5 LEFT
L602	55179560	NR	M	SO	1	PCE	LFA 1MM 10MM 5 LEFT
Q625	55133270	NR	B	so	1	PCE	TR-SHPLF 2SC4137 N 100MIOA 20V
Q626	55133270	NR	B	so	1	PCE	TR-SHPLF 2SC4137 N 100MIOA 20V
Q637	55127360	NR	B	so	1	PCE	TR-SHPLF 2SD2390 DARLINGTON N 10.0A
Q638	55127360	NR	B	so	1	PCE	TR-SHPLF 2SD2390 DARLINGTON N 10.0A
Q639	55127370	NR	B	so	1	PCE	TR-SHPLF 2SB1560 DARLINGTON P 10.0A
Q640	55127370	NR	B	so	1	PCE	TR-SHPLF 2SB1560 DARLINGTON P 10.0A
R671	55179340	NR	B	ud	1	PCE	RW 220MIO OHM +5% 5.0W 600PPM/'C -600PPM/'C
R672	55179340	NR	B	ud	1	PCE	RW 220MIO OHM +5% 5.0W 600PPM/'C -600PPM/'C
R675	60442550	16	B	so	1	PCE	RMOF 10R0 OHM +5% 1.0W
R676	60442550	16	B	so	1	PCE	RMOF 10R0 OHM +5% 1.0W
RL981	55091500	NR	B	so	1	PCE	RELAYPWR 12.0V 270.0OHM 10.0A 250.0V
RL981	55127440	NR	B	ud	0	PCE	RELAYPWR 12.0V 1K1OHM 10.0A
T981	55155650	NR	B	so	1	PCE	TF-LAM POWER-TRANSFORMER 230V
VR601	55244060	0	B	ud	1	PCE	PR 220R0 OHM +30% 100MIOW
VR602	55244060	0	B	ud	1	PCE	PR 220R0 OHM +30% 100MIOW
WA601	55146560		B	so	1	PCE	CONN 2.5MM 2 MA ST NAT 0 0
WA602	55146560		B	so	1	PCE	CONN 2.5MM 2 MA ST NAT 0 0
WA603	55171550		B	so	1	PCE	CON 3.96MM PITCH MOLEX 35313-0310
WA625	55123310		B	so	1	PCE	CONN 2.0MM 4 MA ST NAT LW2002P04 0 0
WA981	5504884A		B	so	1	PCE	CON 3.96MM PITCH HEADER 2 POS
WA983	55123510		B	so	1	PCE	CON 3.96MM PITCH HEADER 2 POS MOLEX 35328-0210
WA985	55123510		B	so	1	PCE	CON 3.96MM PITCH HEADER 2 POS MOLEX 35328-0210
WA986	55146620		B	so	1	PCE	CONN 2.5MM 7 MA ST NAT 0 0

PART NO : 55271250

TITEL : AC ESABD IAU SURROUND BD AVR2500

Pos	Tocom#	Pkg	M/B	St	Qty	Unit	SName
020	55270340		B	ud	1	PCE	AC PCB SURR AVR2500 SINGLE LAYER
C601	20268880	30	B	so	1	PCE	CE 10U0F +20% 50.0V 85C
C602	20268880	30	B	so	1	PCE	CE 10U0F +20% 50.0V 85C
C603	11055300	71	B	so	1	PCE	CC 68P0F +5% -5% 50.0V NP0
C604	11055300	71	B	so	1	PCE	CC 68P0F +5% -5% 50.0V NP0
C605	20269070	30	B	so	1	PCE	CE 100U0F +20% 25.0V 85C
C606	20269070	30	B	so	1	PCE	CE 100U0F +20% 25.0V 85C
C607	20269080	30	B	so	1	PCE	CE 220U0F +20% 10.0V 85C
C608	20269080	30	B	so	1	PCE	CE 220U0F +20% 10.0V 85C
C609	30936070	71	B	so	1	PCE	CC 12P0F +5% -5% 50.0V NP0
C610	30936070	71	B	so	1	PCE	CC 12P0F +5% -5% 50.0V NP0
C611	60439150	71	B	so	1	PCE	CC 33P0F +5% -5% 50.0V NP0
C612	60439150	71	B	so	1	PCE	CC 33P0F +5% -5% 50.0V NP0
C613	20268880	30	B	so	1	PCE	CE 10U0F +20% 50.0V 85C
C614	20268880	30	B	so	1	PCE	CE 10U0F +20% 50.0V 85C
C617	55180340	71	B	so	1	PCE	CPM 100N0F +10% 63.0V
C618	55180340	71	B	so	1	PCE	CPM 100N0F +10% 63.0V
C619	55180340	71	B	so	1	PCE	CPM 100N0F +10% 63.0V
C620	55180340	71	B	so	1	PCE	CPM 100N0F +10% 63.0V
C625	11055530	71	B	so	1	PCE	CC 1N5F +10% -10% 50.0V Y5P
C626	11055530	71	B	so	1	PCE	CC 1N5F +10% -10% 50.0V Y5P
C629	40433580	71	B	so	1	PCE	CC 680P0F +10% -10% 50.0V Y5P
C630	40433580	71	B	so	1	PCE	CC 680P0F +10% -10% 50.0V Y5P
C681	55179400	71	B	so	1	PCE	CPM 68N0F +5% 63.0V
C682	55179400	71	B	so	1	PCE	CPM 68N0F +5% 63.0V
C693	55095430	71	B	so	1	PCE	CPM 100N0F +10% 250.0V
C694	55095430	71	B	so	1	PCE	CPM 100N0F +10% 250.0V
C695	55095430	71	B	so	1	PCE	CPM 100N0F +10% 250.0V
C696	15002130	30	B	so	1	PCE	CE 10U0F +20% 16.0V 85C
C971	20268840	30	B	so	1	PCE	CE 1U0F +20% 50.0V 85C
C983	70428520	71	B	so	1	PCE	CC 10N0F +10% -10% 50.0V Y5P
C985	20495030	16	B	so	1	PCE	CC 100N0F +10% -10% 25.0V Y5P
C986	20268840	30	B	so	1	PCE	CE 1U0F +20% 50.0V 85C
C987	20268880	30	B	so	1	PCE	CE 10U0F +20% 50.0V 85C
C988	20495030	16	B	so	1	PCE	CC 100N0F +10% -10% 25.0V Y5P
C991	20269010	30	B	so	1	PCE	CE 47U0F +20% 50.0V 85C
C992	13039350	30	B	so	1	PCE	CE 100U0F +20% 35.0V 85C
C993	20495030	16	B	so	1	PCE	CC 100N0F +10% -10% 25.0V Y5P
C994	20495030	16	B	so	1	PCE	CC 100N0F +10% -10% 25.0V Y5P
C995	20495030	16	B	so	1	PCE	CC 100N0F +10% -10% 25.0V Y5P
C997	70428520	71	B	so	1	PCE	CC 10N0F +10% -10% 50.0V Y5P
C998	70428520	71	B	so	1	PCE	CC 10N0F +10% -10% 50.0V Y5P
C999	70428520	71	B	so	1	PCE	CC 10N0F +10% -10% 50.0V Y5P
D601	70436540	16	B	so	1	PCE	D-SLP 1N4148 100.0V 150E-3A
D602	70436540	16	B	so	1	PCE	D-SLP 1N4148 100.0V 150E-3A
D603	70436540	16	B	so	1	PCE	D-SLP 1N4148 100.0V 150E-3A
D604	70436540	16	B	so	1	PCE	D-SLP 1N4148 100.0V 150E-3A
D681	70436540	16	B	so	1	PCE	D-SLP 1N4148 100.0V 150E-3A
D682	70436540	16	B	so	1	PCE	D-SLP 1N4148 100.0V 150E-3A
D683	70436540	16	B	so	1	PCE	D-SLP 1N4148 100.0V 150E-3A
D684	70436540	16	B	so	1	PCE	D-SLP 1N4148 100.0V 150E-3A
D685	70436540	16	B	so	1	PCE	D-SLP 1N4148 100.0V 150E-3A
D987	70436540	16	B	so	1	PCE	D-SLP 1N4148 100.0V 150E-3A
D988	70436540	16	B	so	1	PCE	D-SLP 1N4148 100.0V 150E-3A
D991	20475340	16	B	so	1	PCE	D-ZENER BZX55B30 30V 500MIOW
D992	70436540	16	B	so	1	PCE	D-SLP 1N4148 100.0V 150E-3A

D994	20873880	16	B	so	1	PCE	D-ZENER 1N5236B 7.5V 500MIOW
D996	20526960	16	B	so	1	PCE	D-ZENER 1N5231B 5.1V 500MIOW
FH981	55170330	CM	B	so	1	PCE	TERMFUSEHLDR FUSE-HOLDER
FH982	55170330	CM	B	so	1	PCE	TERMFUSEHLDR FUSE-HOLDER
Q601	20556600	56	B	so	1	PCE	TR-SHPLF KTC3200BL N 100MIOA 120V
Q602	20556600	56	B	so	1	PCE	TR-SHPLF KTC3200BL N 100MIOA 120V
Q603	20556600	56	B	so	1	PCE	TR-SHPLF KTC3200BL N 100MIOA 120V
Q604	20556600	56	B	so	1	PCE	TR-SHPLF KTC3200BL N 100MIOA 120V
Q605	20556600	56	B	so	1	PCE	TR-SHPLF KTC3200BL N 100MIOA 120V
Q606	20556600	56	B	so	1	PCE	TR-SHPLF KTC3200BL N 100MIOA 120V
Q607	20508080	56	B	so	1	PCE	TR-SLPLF KTC3198BL N 150MIOA
Q608	20508080	56	B	so	1	PCE	TR-SLPLF KTC3198BL N 150MIOA
Q611	20647850	56	B	so	1	PCE	TR-SHPLF KTA1268BL P 100MIOA 120V
Q612	20647850	56	B	so	1	PCE	TR-SHPLF KTA1268BL P 100MIOA 120V
Q613	20647850	56	B	so	1	PCE	TR-SHPLF KTA1268BL P 100MIOA 120V
Q614	20647850	56	B	so	1	PCE	TR-SHPLF KTA1268BL P 100MIOA 120V
Q615	20556600	56	B	so	1	PCE	TR-SHPLF KTC3200BL N 100MIOA 120V
Q616	20556600	56	B	so	1	PCE	TR-SHPLF KTC3200BL N 100MIOA 120V
Q617	55133260	56	B	so	1	PCE	TR-SLPLF KTA1024 Y P 50MIOA -150V
Q618	55133260	56	B	so	1	PCE	TR-SLPLF KTA1024 Y P 50MIOA -150V
Q619	55133240	56	B	so	1	PCE	TR-SLPLF KTC3206 Y N 50MIOA 150V
Q620	55133240	56	B	so	1	PCE	TR-SLPLF KTC3206 Y N 50MIOA 150V
Q681	20556600	56	B	so	1	PCE	TR-SHPLF KTC3200BL N 100MIOA 120V
Q682	20556600	56	B	so	1	PCE	TR-SHPLF KTC3200BL N 100MIOA 120V
Q683	20647850	56	B	so	1	PCE	TR-SHPLF KTA1268BL P 100MIOA 120V
Q981	20647850	56	B	so	1	PCE	TR-SHPLF KTA1268BL P 100MIOA 120V
Q982	55142670	56	B	so	1	PCE	TR-SLPLF MPSA06 N 500MIOA
R601	60441550	16	B	so	1	PCE	RCF 330R0 OHM +5% 250MIOW
R602	60441550	16	B	so	1	PCE	RCF 330R0 OHM +5% 250MIOW
R603	80437030	16	B	so	1	PCE	RCF 27K0 OHM +5% 250MIOW
R604	80437030	16	B	so	1	PCE	RCF 27K0 OHM +5% 250MIOW
R605	40435630	16	B	so	1	PCE	RCF 1K5 OHM +5% 250MIOW
R606	40435630	16	B	so	1	PCE	RCF 1K5 OHM +5% 250MIOW
R607	40435630	16	B	so	1	PCE	RCF 1K5 OHM +5% 250MIOW
R608	40435630	16	B	so	1	PCE	RCF 1K5 OHM +5% 250MIOW
R609	20469450	16	B	so	1	PCE	RCF 220R0 OHM +5% 250MIOW
R610	20469450	16	B	so	1	PCE	RCF 220R0 OHM +5% 250MIOW
R611	20469450	16	B	so	1	PCE	RCF 220R0 OHM +5% 250MIOW
R612	20469450	16	B	so	1	PCE	RCF 220R0 OHM +5% 250MIOW
R613	11059610	16	B	so	1	PCE	RCF 270R0 OHM +5% 250MIOW
R614	11059610	16	B	so	1	PCE	RCF 270R0 OHM +5% 250MIOW
R615	20469510	16	B	so	1	PCE	RCF 43K0 OHM +5% 250MIOW
R616	20469510	16	B	so	1	PCE	RCF 43K0 OHM +5% 250MIOW
R617	80437030	16	B	so	1	PCE	RCF 27K0 OHM +5% 250MIOW
R618	80437030	16	B	so	1	PCE	RCF 27K0 OHM +5% 250MIOW
R619	80437010	16	B	so	1	PCE	RCF 1K8 OHM +5% 250MIOW
R620	80437010	16	B	so	1	PCE	RCF 1K8 OHM +5% 250MIOW
R621	60441560	16	B	so	1	PCE	RCF 560R0 OHM +5% 250MIOW
R622	60441560	16	B	so	1	PCE	RCF 560R0 OHM +5% 250MIOW
R623	60441560	16	B	so	1	PCE	RCF 560R0 OHM +5% 250MIOW
R624	60441560	16	B	so	1	PCE	RCF 560R0 OHM +5% 250MIOW
R625	60441560	16	B	so	1	PCE	RCF 560R0 OHM +5% 250MIOW
R626	60441560	16	B	so	1	PCE	RCF 560R0 OHM +5% 250MIOW
R627	60441560	16	B	so	1	PCE	RCF 560R0 OHM +5% 250MIOW
R628	60441560	16	B	so	1	PCE	RCF 560R0 OHM +5% 250MIOW
R629	60441560	16	B	so	1	PCE	RCF 560R0 OHM +5% 250MIOW
R630	60441560	16	B	so	1	PCE	RCF 560R0 OHM +5% 250MIOW
R631	60441560	16	B	so	1	PCE	RCF 560R0 OHM +5% 250MIOW
R632	60441560	16	B	so	1	PCE	RCF 560R0 OHM +5% 250MIOW
R633	11059590	16	B	so	1	PCE	RCF 82R0 OHM +5% 250MIOW
R634	11059590	16	B	so	1	PCE	RCF 82R0 OHM +5% 250MIOW



R635	11059590	16	B	so	1	PCE	RCF 82R0 OHM +5% 250MI0W
R636	11059590	16	B	so	1	PCE	RCF 82R0 OHM +5% 250MI0W
R637	60441580	16	B	so	1	PCE	RCF 22K0 OHM +5% 250MI0W
R638	60441580	16	B	so	1	PCE	RCF 22K0 OHM +5% 250MI0W
R639	60441580	16	B	so	1	PCE	RCF 22K0 OHM +5% 250MI0W
R640	60441580	16	B	so	1	PCE	RCF 22K0 OHM +5% 250MI0W
R641	70434970	16	B	so	1	PCE	RCF 3R3 OHM +5% 250MI0W
R642	70434970	16	B	so	1	PCE	RCF 3R3 OHM +5% 250MI0W
R643	70434970	16	B	so	1	PCE	RCF 3R3 OHM +5% 250MI0W
R644	70434970	16	B	so	1	PCE	RCF 3R3 OHM +5% 250MI0W
R645	30939360	16	B	so	1	PCE	RCF 10R0 OHM +5% 250MI0W
R646	30939360	16	B	so	1	PCE	RCF 10R0 OHM +5% 250MI0W
R647	30939360	16	B	so	1	PCE	RCF 10R0 OHM +5% 250MI0W
R648	30939360	16	B	so	1	PCE	RCF 10R0 OHM +5% 250MI0W
R649	80437000	16	B	so	1	PCE	RCF 1K2 OHM +5% 250MI0W
R650	80437000	16	B	so	1	PCE	RCF 1K2 OHM +5% 250MI0W
R651	60441550	16	B	so	1	PCE	RCF 330R0 OHM +5% 250MI0W
R652	60441550	16	B	so	1	PCE	RCF 330R0 OHM +5% 250MI0W
R673	30939360	16	B	so	1	PCE	RCF 10R0 OHM +5% 250MI0W
R674	30939360	16	B	so	1	PCE	RCF 10R0 OHM +5% 250MI0W
R677	30939360	16	B	so	1	PCE	RCF 10R0 OHM +5% 250MI0W
R678	30939360	16	B	so	1	PCE	RCF 10R0 OHM +5% 250MI0W
R679	50882970	16	B	so	1	PCE	RCF 470R0 OHM +5% 250MI0W
R680	50882970	16	B	so	1	PCE	RCF 470R0 OHM +5% 250MI0W
R681	40435630	16	B	so	1	PCE	RCF 1K5 OHM +5% 250MI0W
R682	40435630	16	B	so	1	PCE	RCF 1K5 OHM +5% 250MI0W
R683	50883010	16	B	so	1	PCE	RCF 15K0 OHM +5% 250MI0W
R684	50883010	16	B	so	1	PCE	RCF 15K0 OHM +5% 250MI0W
R685	60441580	16	B	so	1	PCE	RCF 22K0 OHM +5% 250MI0W
R686	60441580	16	B	so	1	PCE	RCF 22K0 OHM +5% 250MI0W
R687	40435630	16	B	so	1	PCE	RCF 1K5 OHM +5% 250MI0W
R688	40435630	16	B	so	1	PCE	RCF 1K5 OHM +5% 250MI0W
R689	90571130	16	B	so	1	PCE	RCF 39K0 OHM +5% 250MI0W
R690	90571130	16	B	so	1	PCE	RCF 39K0 OHM +5% 250MI0W
R691	30939480	16	B	so	1	PCE	RCF 10K0 OHM +5% 250MI0W
R692	90571130	16	B	so	1	PCE	RCF 39K0 OHM +5% 250MI0W
R971	30939480	16	B	so	1	PCE	RCF 10K0 OHM +5% 250MI0W
R972	30939510	16	B	so	1	PCE	RCF 100K0 OHM +5% 250MI0W
R981	20472530	16	B	so	1	PCE	RCF 4R7 OHM +5% 250MI0W
R982	20469460	16	B	so	1	PCE	RCF 2K2 OHM +5% 250MI0W
R983	11059640	16	B	so	1	PCE	RCF 1K0 OHM +5% 250MI0W
R984	11059670	16	B	so	1	PCE	RCF 2K7 OHM +5% 250MI0W
R985	30939380	16	B	so	1	PCE	RCF 22R0 OHM +5% 250MI0W
R986	20469460	16	B	so	1	PCE	RCF 2K2 OHM +5% 250MI0W
R987	60441560	16	B	so	1	PCE	RCF 560R0 OHM +5% 250MI0W
R988	11067570	16	B	so	1	PCE	RCF 1R0 OHM +5% 250MI0W
R989	11067570	16	B	so	1	PCE	RCF 1R0 OHM +5% 250MI0W
R993	70430560	16	B	so	1	PCE	RCF 5K6 OHM +5% 250MI0W

PART NO : 55243640

TITEL : AC EMBD IMA AVR120US VIDEO BD

Pos	Tocom#	Pkg	M/B	St	Qty	Unit	SName
0020	55243650		M	SO	1	PCE	AC ESABD IAU VIDEO BD AVR120US
CP601	55174650		B	so	1	PCE	CONN 2.0MM 16 MA R NAT SOCKET MOLEX 35237-1610 0 0
CP602	55123340		B	so	1	PCE	CONN 2.0MM 8 MA ST NAT LW2002P08 0 0
JA601	55164770		B	ud	1	PCE	CON PHONO SCKT Y+BK RCA+S
JA602	55164770		B	ud	1	PCE	CON PHONO SCKT Y+BK RCA+S
JA604	55164770		B	ud	1	PCE	CON PHONO SCKT Y+BK RCA+S
JA605	55164770		B	ud	1	PCE	CON PHONO SCKT Y+BK RCA+S
JA606	55164770		B	ud	1	PCE	CON PHONO SCKT Y+BK RCA+S
JA607	55164770		B	ud	1	PCE	CON PHONO SCKT Y+BK RCA+S

PART NO : 55243650

TITEL : AC ESABD IAU VIDEO BD AVR120US

Pos	Tocom#	Pkg	M/B	St	Qty	Unit	SName
0020	55243660		M	SO	1	PCE	AC ESABD SMD VIDEO BD AVR120US
0021	55244750		B	so	1	PCE	AC PCB VIDEO BD 163*163 AVR120US -
C601	20268880	30	B	so	1	PCE	CE 10U0F +20% 50.0V 85C
C602	20268880	30	B	so	1	PCE	CE 10U0F +20% 50.0V 85C
C603	20268880	30	B	so	1	PCE	CE 10U0F +20% 50.0V 85C
C604	20268880	30	B	so	1	PCE	CE 10U0F +20% 50.0V 85C
C605	20252670	30	B	so	1	PCE	CE 470U0F +20% 10.0V 85C
C606	20252670	30	B	so	1	PCE	CE 470U0F +20% 10.0V 85C
C613	20268880	30	B	so	1	PCE	CE 10U0F +20% 50.0V 85C
C614	20268880	30	B	so	1	PCE	CE 10U0F +20% 50.0V 85C
C615	20252670	30	B	so	1	PCE	CE 470U0F +20% 10.0V 85C
C616	20268880	30	B	so	1	PCE	CE 10U0F +20% 50.0V 85C
C617	20268880	30	B	so	1	PCE	CE 10U0F +20% 50.0V 85C
C618	20252670	30	B	so	1	PCE	CE 470U0F +20% 10.0V 85C
C621	20268880	30	B	so	1	PCE	CE 10U0F +20% 50.0V 85C
C622	20268880	30	B	so	1	PCE	CE 10U0F +20% 50.0V 85C
C623	20268880	30	B	so	1	PCE	CE 10U0F +20% 50.0V 85C
C624	20268880	30	B	so	1	PCE	CE 10U0F +20% 50.0V 85C
C625	20252670	30	B	so	1	PCE	CE 470U0F +20% 10.0V 85C
C626	20268880	30	B	so	1	PCE	CE 10U0F +20% 50.0V 85C
C627	20252670	30	B	so	1	PCE	CE 470U0F +20% 10.0V 85C
C628	20268880	30	B	so	1	PCE	CE 10U0F +20% 50.0V 85C
C647	20252670	30	B	so	1	PCE	CE 470U0F +20% 10.0V 85C
C650	20252670	30	B	so	1	PCE	CE 470U0F +20% 10.0V 85C
C651	20252670	30	B	so	1	PCE	CE 470U0F +20% 10.0V 85C
C652	20252670	30	B	so	1	PCE	CE 470U0F +20% 10.0V 85C
C653	20252670	30	B	so	1	PCE	CE 470U0F +20% 10.0V 85C
C664	20252670	30	B	so	1	PCE	CE 470U0F +20% 10.0V 85C
C665	20252670	30	B	so	1	PCE	CE 470U0F +20% 10.0V 85C
C699	20267830	30	B	so	1	PCE	CE 47U0F +20% 16.0V 85C
CC601	20268880	30	B	so	1	PCE	CE 10U0F +20% 50.0V 85C
CC603	20268880	30	B	so	1	PCE	CE 10U0F +20% 50.0V 85C
CC606	20268880	30	B	so	1	PCE	CE 10U0F +20% 50.0V 85C
CF601	20268880	30	B	so	1	PCE	CE 10U0F +20% 50.0V 85C
CF602	20268880	30	B	so	1	PCE	CE 10U0F +20% 50.0V 85C
CF604	20268880	30	B	so	1	PCE	CE 10U0F +20% 50.0V 85C
CF605	20268880	30	B	so	1	PCE	CE 10U0F +20% 50.0V 85C
CF611	20268880	30	B	so	1	PCE	CE 10U0F +20% 50.0V 85C
CF612	20268880	30	B	so	1	PCE	CE 10U0F +20% 50.0V 85C
CS607	20268880	30	B	so	1	PCE	CE 10U0F +20% 50.0V 85C

PART NO : 55243660

TITEL : AC ESABD SMD VIDEO BD AVR120US

Pos	Tocom#	Pkg	M/B	St	Qty	Unit	SName
C608	11058670	91	B	so	1	PCE	CCCFMIN 100P0F +5% -5% 50.0V NP0
C609	11058670	91	B	so	1	PCE	CCCFMIN 100P0F +5% -5% 50.0V NP0
C611	11058670	91	B	so	1	PCE	CCCFMIN 100P0F +5% -5% 50.0V NP0
C612	11058670	91	B	so	1	PCE	CCCFMIN 100P0F +5% -5% 50.0V NP0
C619	11058670	91	B	so	1	PCE	CCCFMIN 100P0F +5% -5% 50.0V NP0
C620	11058670	91	B	so	1	PCE	CCCFMIN 100P0F +5% -5% 50.0V NP0
C637	11058670	91	B	so	1	PCE	CCCFMIN 100P0F +5% -5% 50.0V NP0
C638	11058670	91	B	so	1	PCE	CCCFMIN 100P0F +5% -5% 50.0V NP0
C640	11058670	91	B	so	1	PCE	CCCFMIN 100P0F +5% -5% 50.0V NP0
C641	11058670	91	B	so	1	PCE	CCCFMIN 100P0F +5% -5% 50.0V NP0
C642	11058670	91	B	so	1	PCE	CCCFMIN 100P0F +5% -5% 50.0V NP0
C657	20267290	91	B	so	1	PCE	CCCFMIN 100N0F +80% -20% 50.0V Y5V
C696	11058670	91	B	so	1	PCE	CCCFMIN 100P0F +5% -5% 50.0V NP0
CC602	20267290	91	B	so	1	PCE	CCCFMIN 100N0F +80% -20% 50.0V Y5V
CC604	20267290	91	B	so	1	PCE	CCCFMIN 100N0F +80% -20% 50.0V Y5V
CC607	20267290	91	B	so	1	PCE	CCCFMIN 100N0F +80% -20% 50.0V Y5V
CC609	20267290	91	B	so	1	PCE	CCCFMIN 100N0F +80% -20% 50.0V Y5V
CF603	20267290	91	B	so	1	PCE	CCCFMIN 100N0F +80% -20% 50.0V Y5V
CF606	20267290	91	B	so	1	PCE	CCCFMIN 100N0F +80% -20% 50.0V Y5V
CF613	20267290	91	B	so	1	PCE	CCCFMIN 100N0F +80% -20% 50.0V Y5V
IC601	55125370	64	B	so	1	PCE	IC-SWITCH NJM2296 SOP16 VIDEO
IC602	55125370	64	B	so	1	PCE	IC-SWITCH NJM2296 SOP16 VIDEO
IC603	55125370	64	B	so	1	PCE	IC-SWITCH NJM2296 SOP16 VIDEO
IC619	20718660	65	B	so	1	PCE	IC-LOGIC BU4094BF SHIFT REGISTER CMOS
J036	80440510	91	B	so	1	PCE	RMGCFMIN 0 OHM +0% 100MI0W
J039	80440510	91	B	so	1	PCE	RMGCFMIN 0 OHM +0% 100MI0W
J040	80440510	91	B	so	1	PCE	RMGCFMIN 0 OHM +0% 100MI0W
J041	80440510	91	B	so	1	PCE	RMGCFMIN 0 OHM +0% 100MI0W
J048	80440510	91	B	so	1	PCE	RMGCFMIN 0 OHM +0% 100MI0W
J052	80440510	91	B	so	1	PCE	RMGCFMIN 0 OHM +0% 100MI0W
R617	20471950	91	B	so	1	PCE	RMGCFMIN 1K0 OHM +5% 100MI0W
R619	20471950	91	B	so	1	PCE	RMGCFMIN 1K0 OHM +5% 100MI0W
R621	50886610	91	B	so	1	PCE	RMGCFMIN 10K0 OHM +5% 100MI0W
R622	50886610	91	B	so	1	PCE	RMGCFMIN 10K0 OHM +5% 100MI0W
R623	50886610	91	B	so	1	PCE	RMGCFMIN 10K0 OHM +5% 100MI0W
R624	50886610	91	B	so	1	PCE	RMGCFMIN 10K0 OHM +5% 100MI0W
R625	50886610	91	B	so	1	PCE	RMGCFMIN 10K0 OHM +5% 100MI0W
R626	50886610	91	B	so	1	PCE	RMGCFMIN 10K0 OHM +5% 100MI0W
R627	50886610	91	B	so	1	PCE	RMGCFMIN 10K0 OHM +5% 100MI0W
R628	50886610	91	B	so	1	PCE	RMGCFMIN 10K0 OHM +5% 100MI0W
R629	50886610	91	B	so	1	PCE	RMGCFMIN 10K0 OHM +5% 100MI0W
R632	11066390	91	B	so	1	PCE	RMGCFMIN 75R0 OHM +5% 100MI0W
R633	11066390	91	B	so	1	PCE	RMGCFMIN 75R0 OHM +5% 100MI0W
R674	20471950	91	B	so	1	PCE	RMGCFMIN 1K0 OHM +5% 100MI0W
R699	20471990	91	B	so	1	PCE	RMGCFMIN 12K0 OHM +5% 100MI0W
RC601	30944250	91	B	so	1	PCE	RMGCFMIN 10R0 OHM +5% 100MI0W
RC602	11066390	91	B	so	1	PCE	RMGCFMIN 75R0 OHM +5% 100MI0W
RC603	30944250	91	B	so	1	PCE	RMGCFMIN 10R0 OHM +5% 100MI0W
RC604	11066390	91	B	so	1	PCE	RMGCFMIN 75R0 OHM +5% 100MI0W
RC606	11066390	91	B	so	1	PCE	RMGCFMIN 75R0 OHM +5% 100MI0W
RC607	11066390	91	B	so	1	PCE	RMGCFMIN 75R0 OHM +5% 100MI0W
RC608	30944250	91	B	so	1	PCE	RMGCFMIN 10R0 OHM +5% 100MI0W
RC609	30944250	91	B	so	1	PCE	RMGCFMIN 10R0 OHM +5% 100MI0W
RC610	11066390	91	B	so	1	PCE	RMGCFMIN 75R0 OHM +5% 100MI0W
RC612	11066390	91	B	so	1	PCE	RMGCFMIN 75R0 OHM +5% 100MI0W
RC614	11066390	91	B	so	1	PCE	RMGCFMIN 75R0 OHM +5% 100MI0W
RF602	30944250	91	B	so	1	PCE	RMGCFMIN 10R0 OHM +5% 100MI0W

RF604	30944250	91	B	so	1	PCE	RMGCFMIN 10R0 OHM +5% 100MI0W
RF612	30944250	91	B	so	1	PCE	RMGCFMIN 10R0 OHM +5% 100MI0W
RF615	11066390	91	B	so	1	PCE	RMGCFMIN 75R0 OHM +5% 100MI0W
RF616	11066390	91	B	so	1	PCE	RMGCFMIN 75R0 OHM +5% 100MI0W
RF617	11066390	91	B	so	1	PCE	RMGCFMIN 75R0 OHM +5% 100MI0W
RS602	11066390	91	B	so	1	PCE	RMGCFMIN 75R0 OHM +5% 100MI0W
RS603	11066390	91	B	so	1	PCE	RMGCFMIN 75R0 OHM +5% 100MI0W
RS605	11066390	91	B	so	1	PCE	RMGCFMIN 75R0 OHM +5% 100MI0W
RS606	11066390	91	B	so	1	PCE	RMGCFMIN 75R0 OHM +5% 100MI0W
RS608	11066390	91	B	so	1	PCE	RMGCFMIN 75R0 OHM +5% 100MI0W
RS609	11066390	91	B	so	1	PCE	RMGCFMIN 75R0 OHM +5% 100MI0W
RS611	11066390	91	B	so	1	PCE	RMGCFMIN 75R0 OHM +5% 100MI0W
RS612	11066390	91	B	so	1	PCE	RMGCFMIN 75R0 OHM +5% 100MI0W
RS620	11066390	91	B	so	1	PCE	RMGCFMIN 75R0 OHM +5% 100MI0W
RS621	11066390	91	B	so	1	PCE	RMGCFMIN 75R0 OHM +5% 100MI0W
RS622	11066390	91	B	so	1	PCE	RMGCFMIN 75R0 OHM +5% 100MI0W
RS623	11066390	91	B	so	1	PCE	RMGCFMIN 75R0 OHM +5% 100MI0W



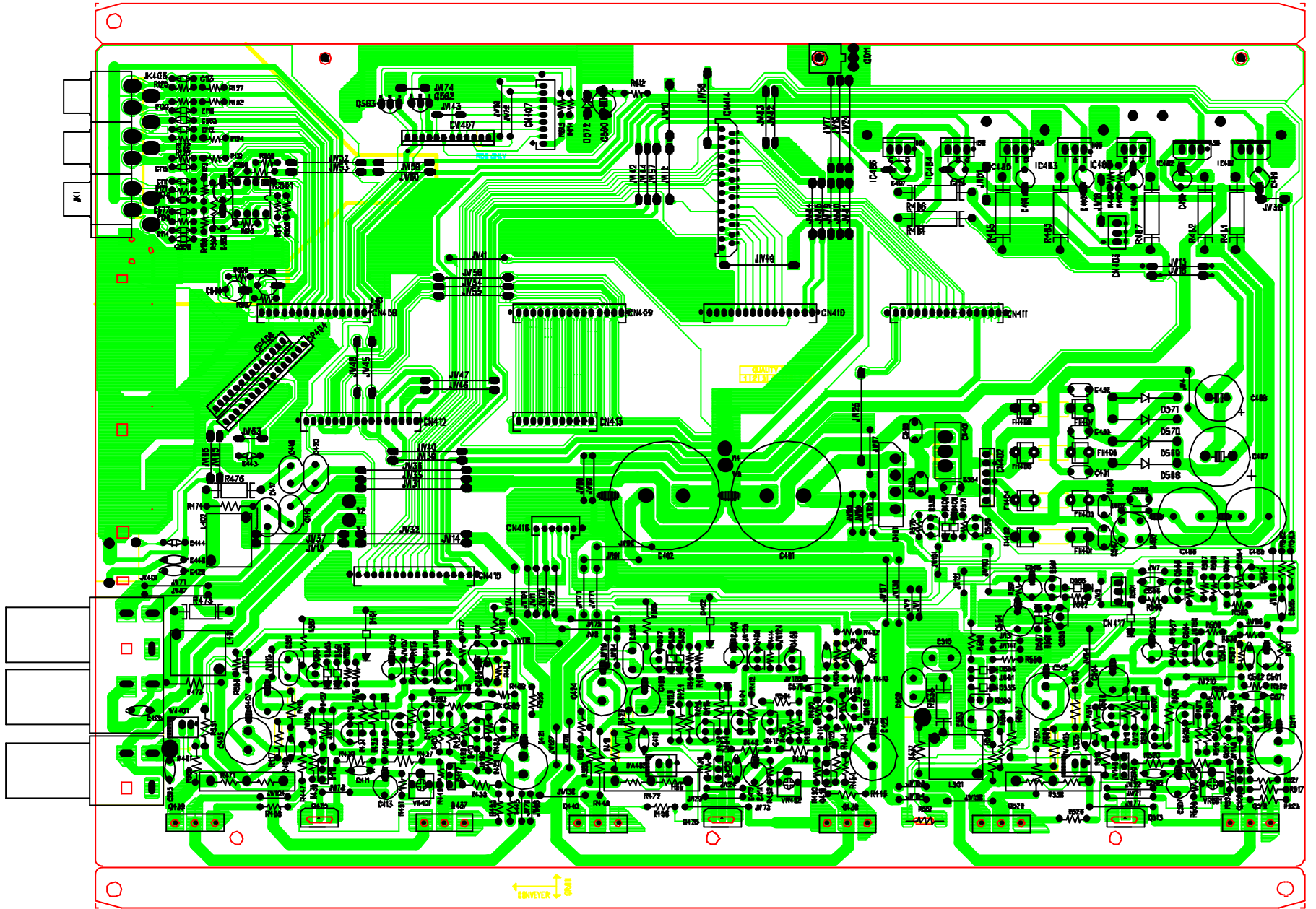

← INVEYER → OBIT

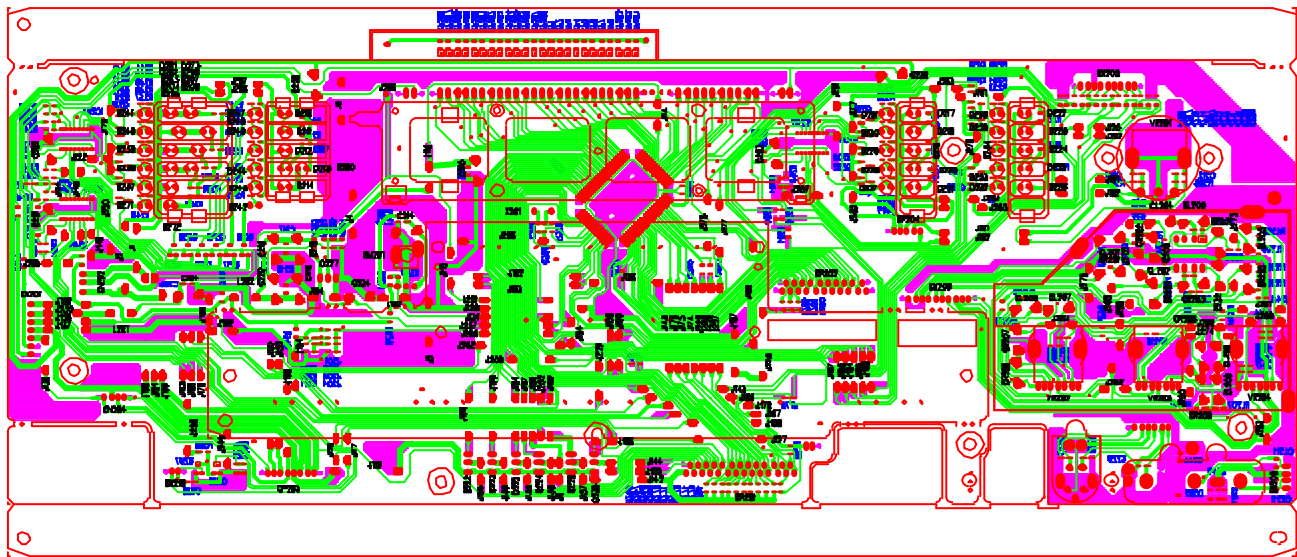

# SCHEMATIC DIAGRAM

## AVR2500/3500 DSP B'D

REVISION RECORD			
LTR	ECO NO.	APPROVER	DATE

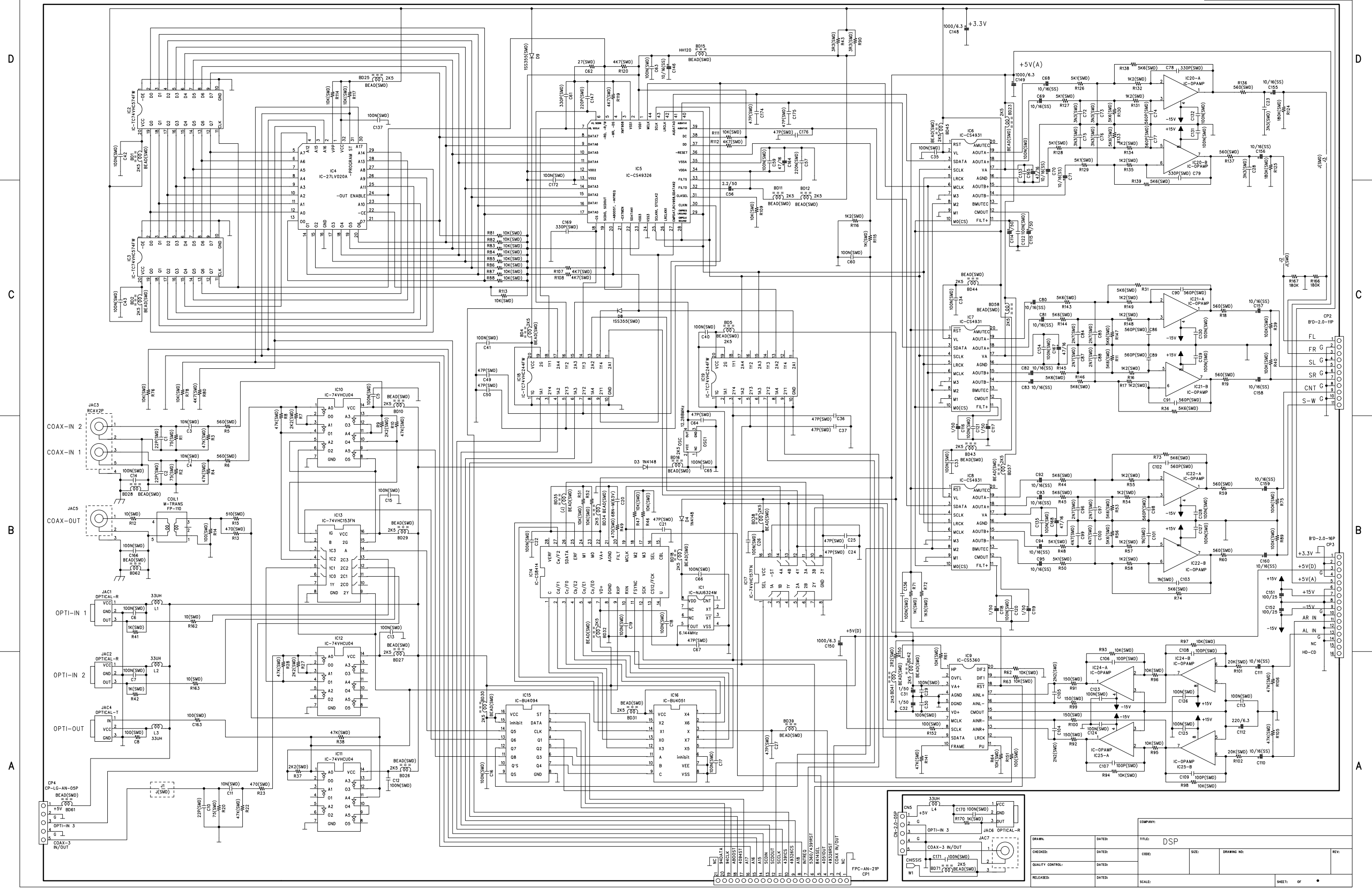

DRAWN:		DATE:		TITLE: DSP	
CHECKED:		DATE:		CODE:	
QUALITY CONTROL:		DATE:		DRAWING NO.:	
RELEASED:		DATE:		SCALE:	

A  
B  
C  
D

A  
B  
C  
D



# AVR2500/3500 FRONT SCHEMATIC DIAGRAM

REVISION RECORD			
LTR	ECO NO:	APPROVED:	DATE:

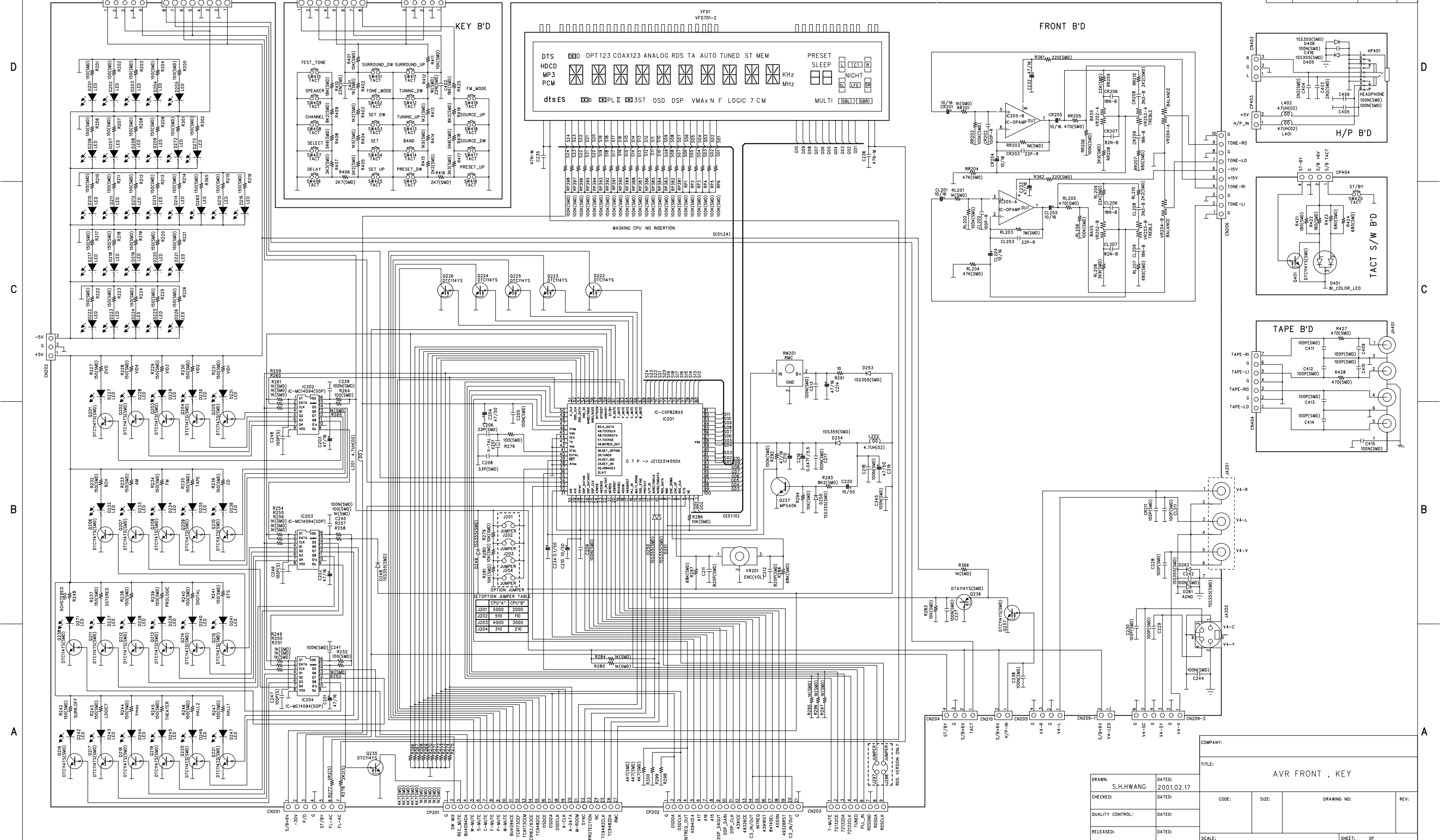

OPTIONAL JUMPER TABLE

J201	CPU'A	CPU'B
J201	5000	2000
J202	510	110
J203	4000	3000
J204	310	210

DRAWN: S.H.HWANG		DATED: 2001.02.17	
CHECKED:	DATED:	CODE:	SIZE:
QUALITY CONTROL:	DATED:	DRAWING NO:	REV:
RELEASED:	DATED:	SCALE:	SHEET: OF

# AVR 2500/3500 MAIN AMP SCHEMATIC DIAGRAM

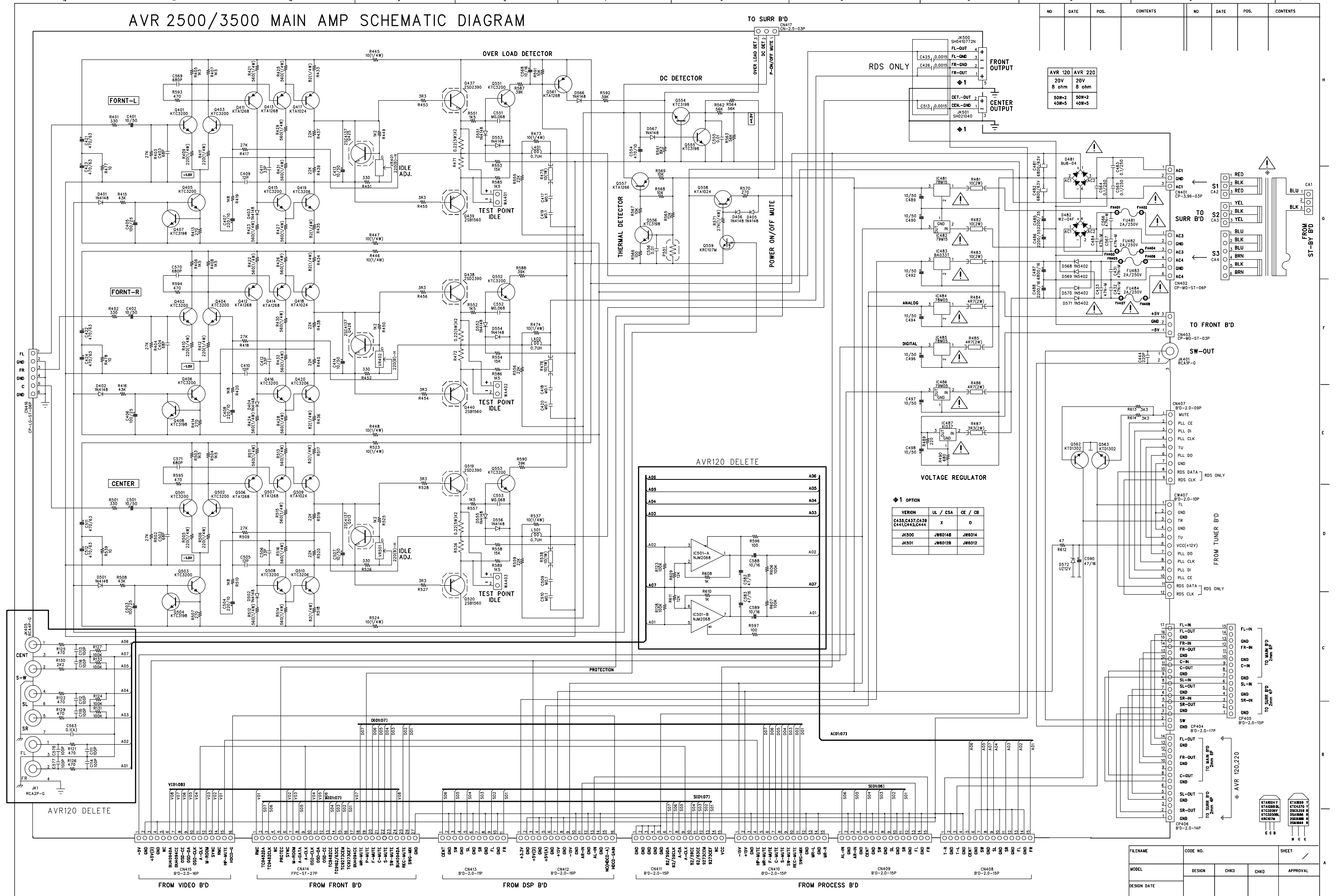

NO	DATE	POS.	CONTENTS

AVR 120	AVR 220
20V 8 ohm	20V 8 ohm
50W-2 40W-5	50W-2 40W-5

◆ 1 OPTION

VERSION	UL / CSA	CE / CB
C435,C437,C439 C441,C443,C444	X	0
JK500	JW6014B	JW6014
JK501	JW6012B	JW6012

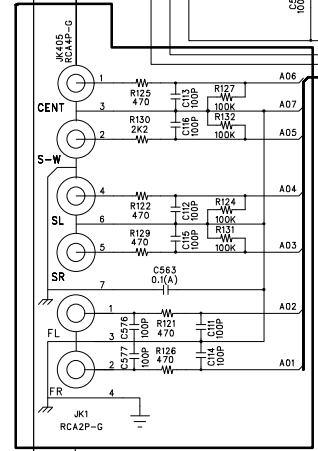
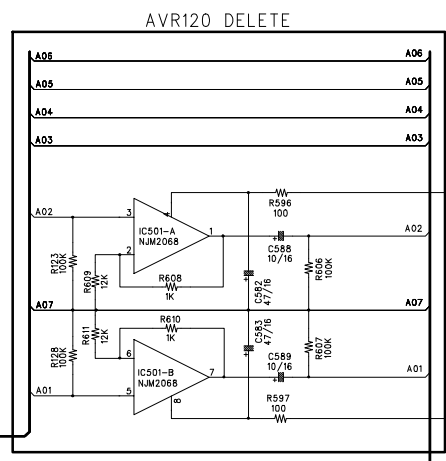

FILENAME	CODE NO.	SHEET

AVR 2500/3500

# SCHEMATIC DIAGRAM

FROM TAPE B'D CP404 CP205  
CP-LG-ST-07P CP-LG-ST-04P

## MP

REVISION RECORD			
LTR	ECO NO:	APPROVED:	DATE:

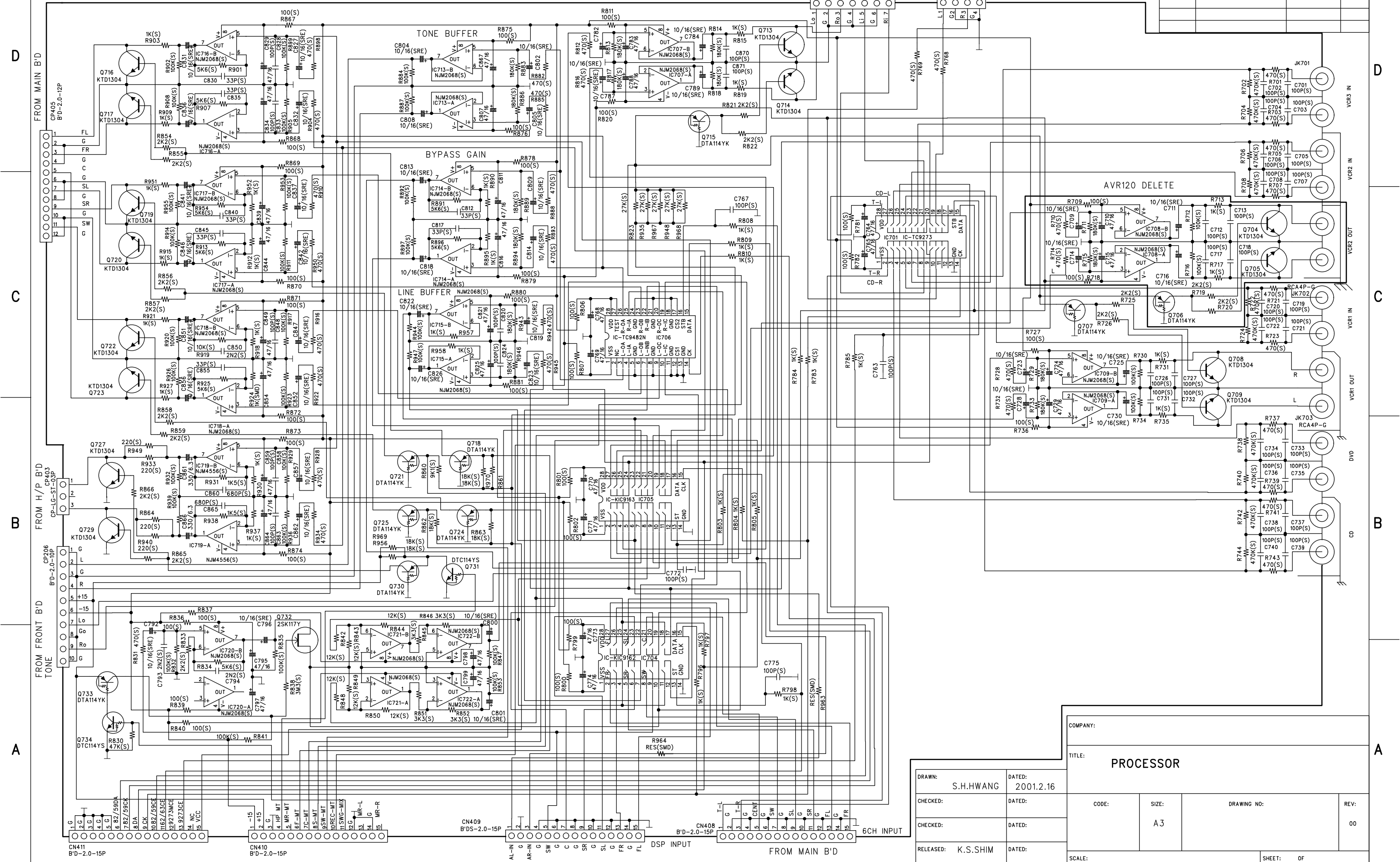

COMPANY:

TITLE: **PROCESSOR**

DRAWN: S.H.HWANG	DATED: 2001.2.16	CODE:	SIZE: A3	DRAWING NO:	REV: 00
CHECKED:	DATED:				
CHECKED:	DATED:				
RELEASED: K.S.SHIM	DATED:				

SCALE: SHEET: OF

# AVR2500/3500 SURROUND AMP SCHEMATIC DIAGRAM

## REAR AMP ASS'Y

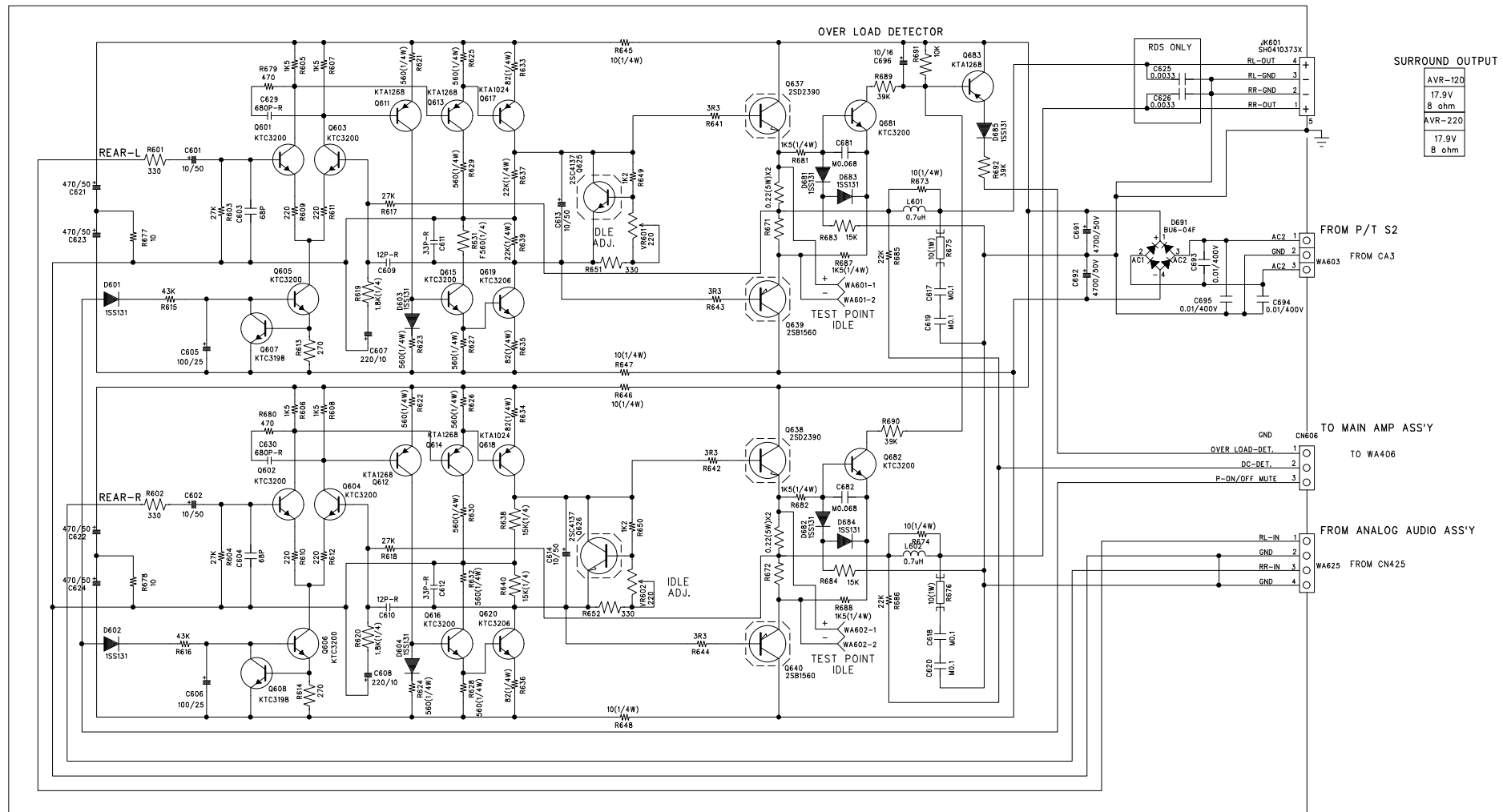

## SUB POWER SUPPLY ASS'Y

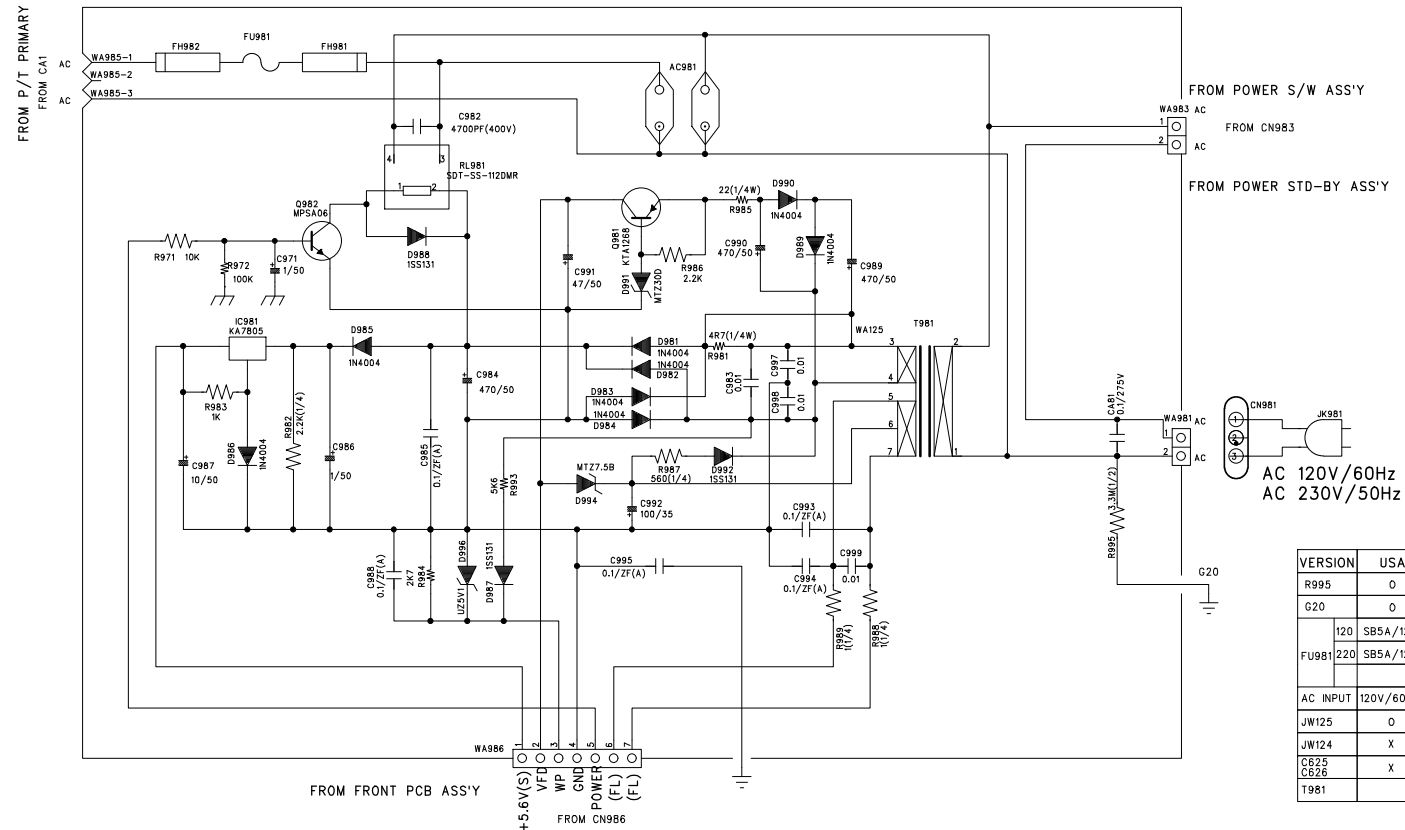

VERSION	USA	EU
R995	0	X
G20	0	X
FU981	120 SB5A/125V	T3.15A/250V
	220 SB5A/125V	T3.15A/250V
AC INPUT	120V/60Hz	230V/50Hz
JW125	0	X
JW124	X	0
C625	X	0
C626	X	0
T981		

CONFIDENTIAL/CONTROL COPY				
FILENAME	CODE NO.	SHEET		
SURROUND		/		
MODEL	DESIGN	CHKD	CHKD	APPROVAL
DESIGN DATE	01.04.15.			

REVISION RECORD			
LTR	ECO NO:	APPROVED:	DATE:

# AVR2500 VIDEO SCHEMATIC DIAGRAM

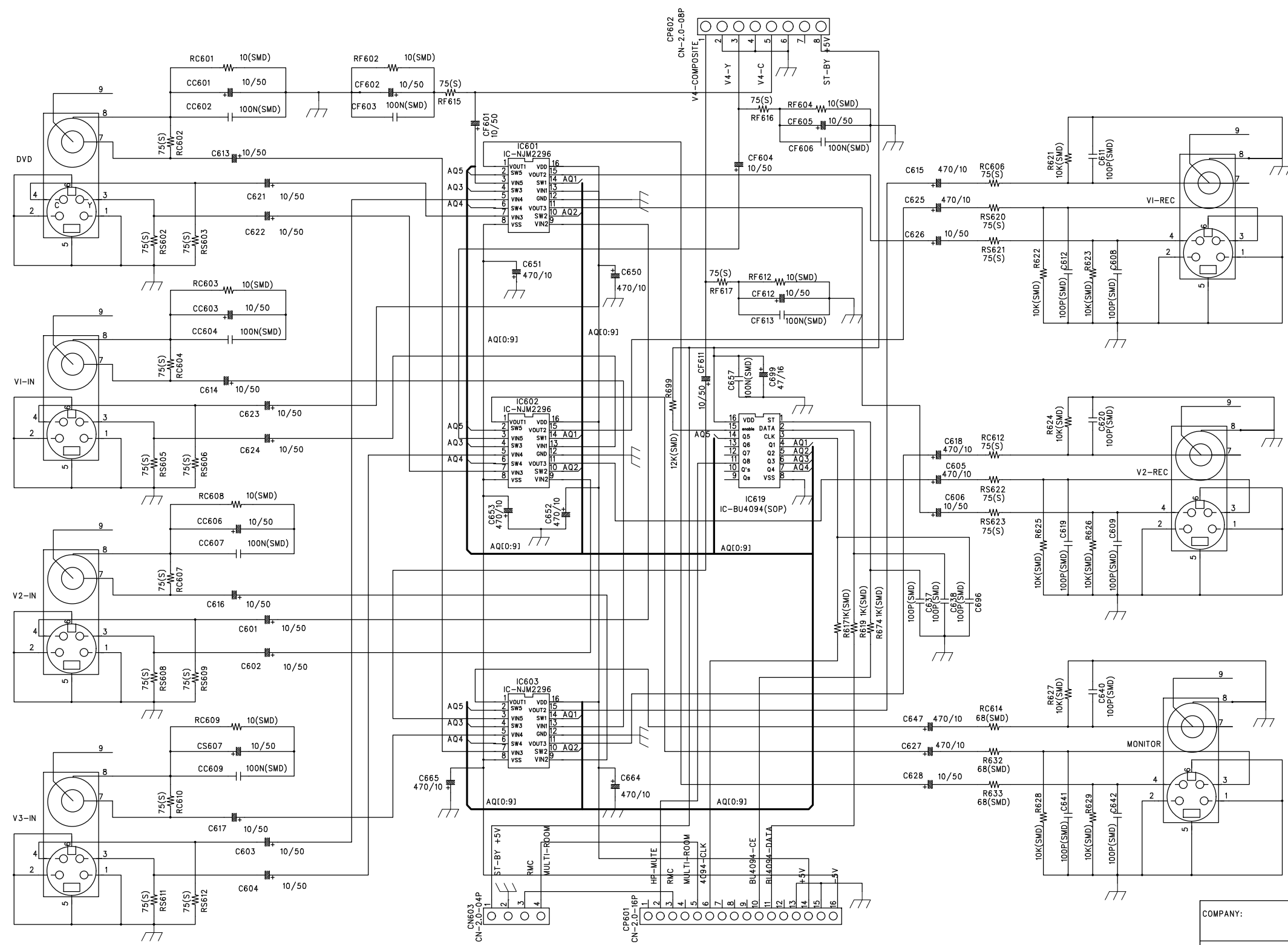

D

D

C

C

B

B

A

A

COMPANY:			
TITLE:			
DRAWN:	DATED:	CODE:	SIZE:
CHECKED:	DATED:	DRAWING NO:	
QUALITY CONTROL:	DATED:	REV:	
RELEASED:	DATED:	SCALE:	SHEET: OF

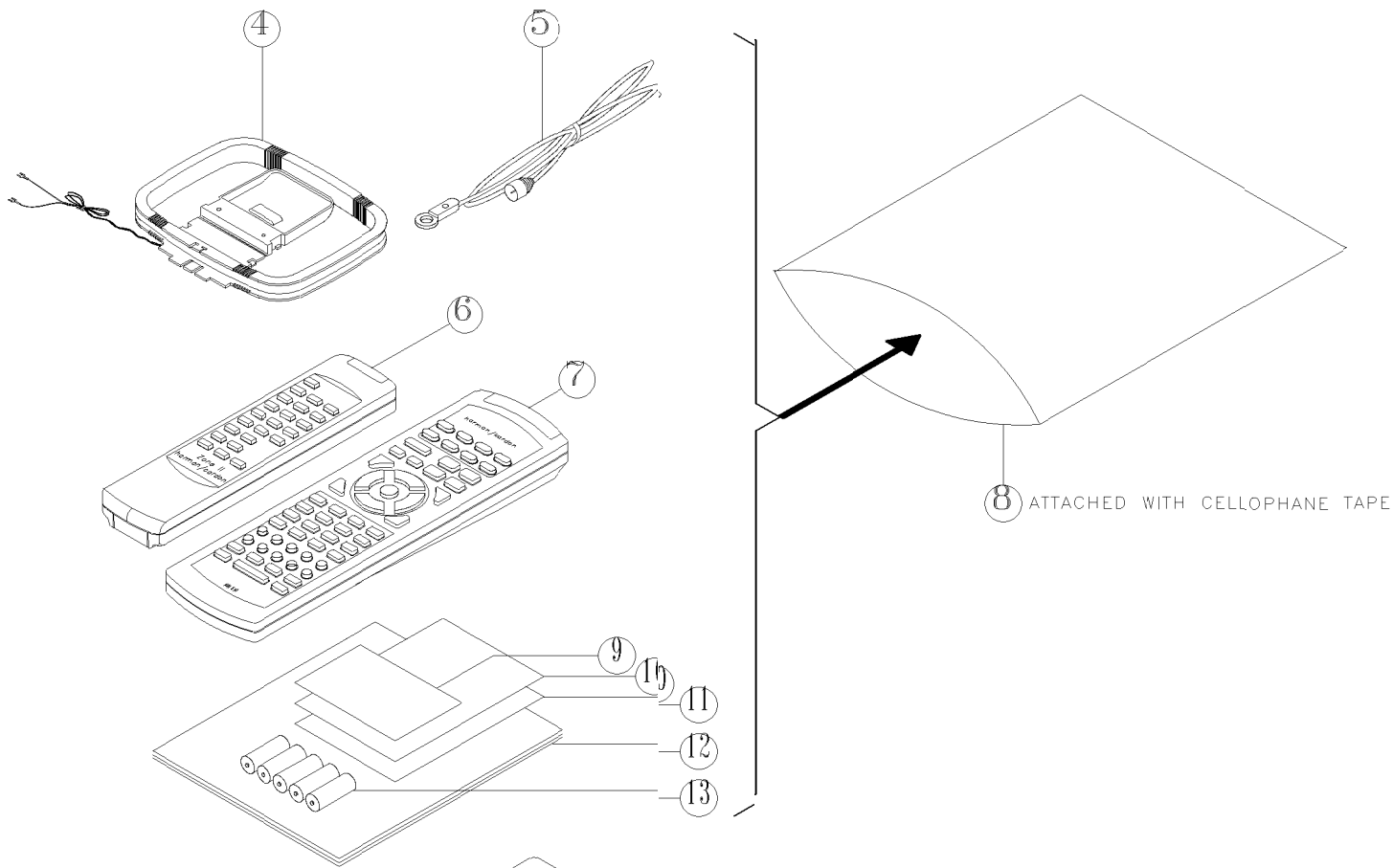

8 ATTACHED WITH CELLOPHANE TAPE

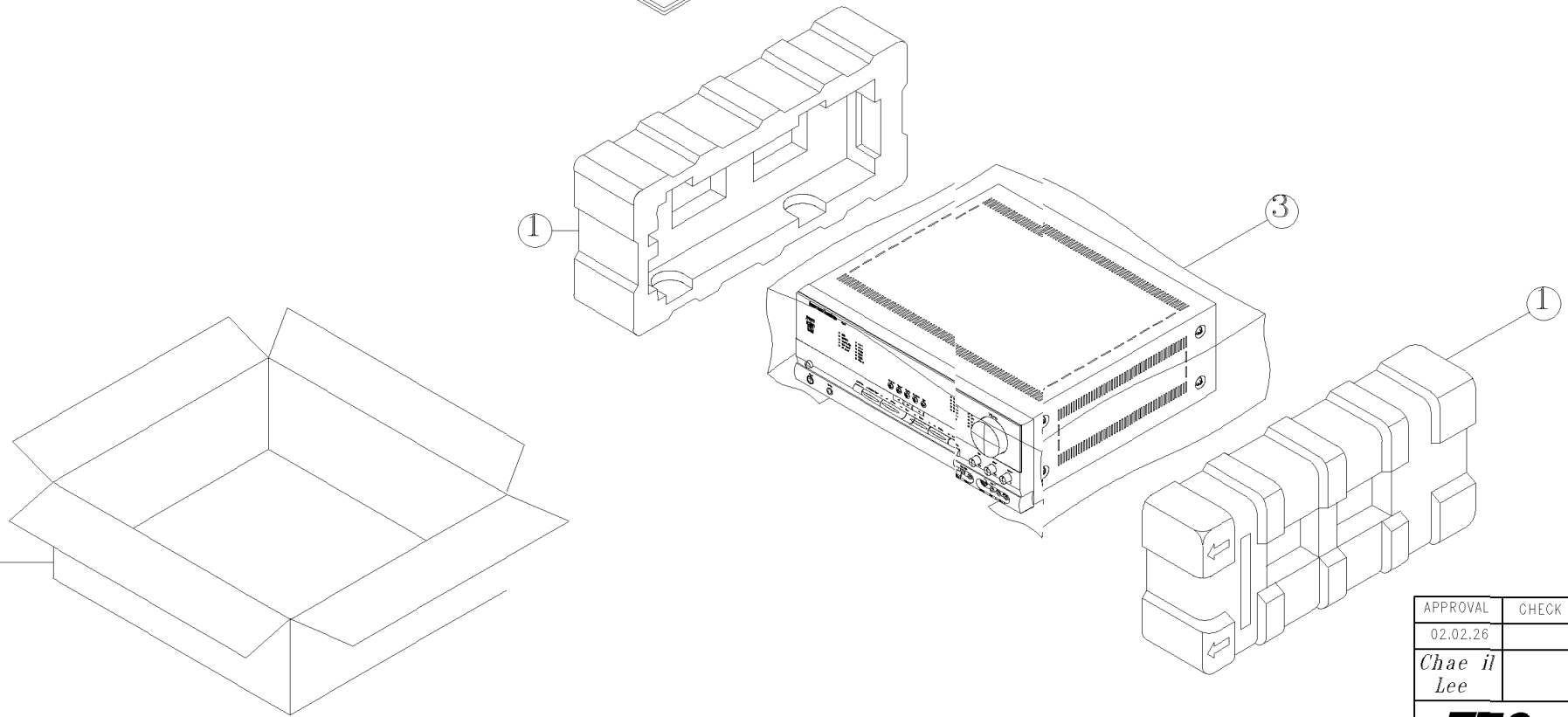

NO.	PARTS NO.	DESCRIPTION	AVR	AVR	AVR	AVR	AVR	AVR	AVR	AVR
			520US	320US	220US	120US	5500EU	4500EU	3500EU	2500EU
1	55178610XX	CUSHION POLY	2	2	2	2	2	2	2	2
2	55178580XX	BOX CARTON AVR 520 US	1							
	55198680XX	BOX CARTON AVR 320 US		1						
	55244340XX	BOX CARTON AVR 220 US			1					
	55244330XX	BOX CARTON AVR 120 US				1				
	55247310XX	BOX CARTON AVR 5500 EU					1			
	55247300XX	BOX CARTON AVR 4500 EU						1		
	55243020XX	BOX CARTON AVR 3500 EU							1	
3	55243010XX	BOX CARTON AVR 2500 EU								1
	55170660XX	SHEET PE 0.5t	1	1	1	1	1	1	1	1
	55127490XX	AM ANTENNA LOOP	1	1	1	1	1	1	1	1
	55127460XX	FM ANTENNA 75 EU					1	1	1	1
	55127450XX	FM ANTENNA 75 US	1	1	1	1				
	55178560XX	ASS'Y REMOCON ZONE II	1	1				1	1	
	7	55178540XX	ASS'Y REMOCON AVR 520 US	1						
55194410XX		ASS'Y REMOCON AVR 320 US		1						
55244360XX		ASS'Y REMOCON AVR 220 US			1					
55244350XX		ASS'Y REMOCON AVR 120 US				1				
55262330XX		ASS'Y REMOCON AVR 5500 EU					1			
55262320XX		ASS'Y REMOCON AVR 4500 EU						1		
55242980XX		ASS'Y REMOCON AVR 3500 EU							1	
8	55242980XX	ASS'Y REMOCON AVR 2500 EU								1
	55164890XX	POLY BAG PE 0.05t	1	1	1	1	1	1	1	1
	55178720XX	CARD POST PAPER	1	1	1	1				
	55178740XX	CADR WARRANTY PAPER	1	1	1	1	1	1	1	1
	55178770XX	SAFETY LEAFLET PAPER	1	1	1	1	1	1	1	1
	55180380XX	MANUAL AVR 520 US	1							
	12	55198680XX	MANUAL AVR 320 US		1					
55244450XX		MANUAL AVR 220 US			1					
55244440XX		MANUAL AVR 120 US				1				
55247330XX		MANUAL AVR 5500 EU					1			
55247320XX		MANUAL AVR 4500 EU						1		
55243040XX		MANUAL AVR 3500 EU							1	
55243030XX		MANUAL AVR 2500 EU								1
13	55020220NR	BATTERY 1.5V AAA	3	3	5	5	3	3	5	5
	55178380XX	LABEL BARCODE AVR 520 US	2							
	55198670XX	LABEL BARCODE AVR 320 US		2						
	55244410XX	LABEL BARCODE AVR 220 US			2					
	55244380XX	LABEL BARCODE AVR 120 US				2				
	55247280XX	LABEL BARCODE 5500 EU					2			
	55247280XX	LABEL BARCODE 4500 EU						2		
55242960XX	LABEL BARCODE 3500 EU							2		
55242960XX	LABEL BARCODE 2500 EU								2	

APPROVAL	CHECK	DRAWING	DESIGN	MODEL	SCALE	TOLERANCE	PARTS NAME	
02.02.26		02.02.26		N		LESS; ±	PACKING DRAWING	
Chae il Lee		Dong il Choi		S		LESS; ±	MODEL NO.	
TTC TOTAL TECHNOLOGY							UNIT	AVR 520/320/220/120 US AVR 5500/4500/3500/2500 EU