

# The Harman Kardon Model AVR30

## AUDIO AND VIDEO RECEIVER

Manual 188B

# Technical Manual

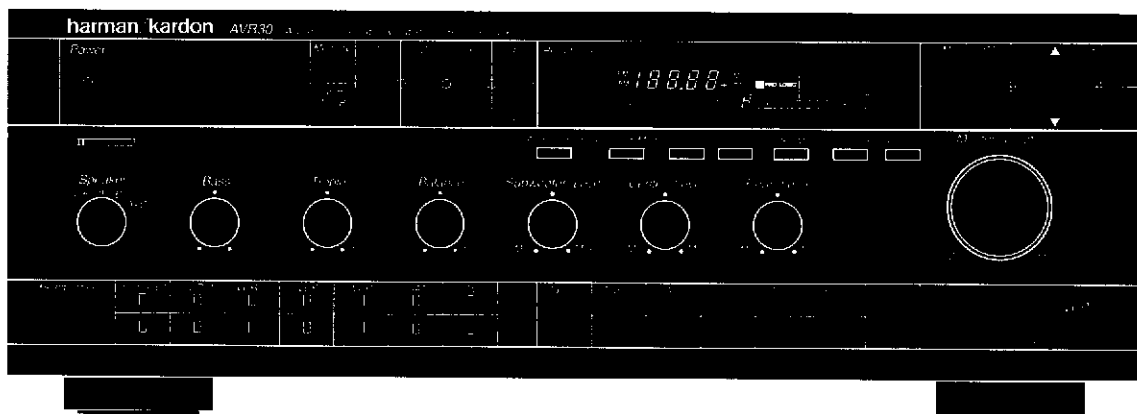

This manual is to be applied to the North America area model Black version with serial number S235-05761 and above, and Asia, Singapore and international models.

The following marks found in the parts list of this manual identify the models as follows.

- BK** : North America area model Black version
- WB** : Asia model Black version
- SB** : Singapore model Black version
- IB** : International model Black version

### CONTENTS

SPECIFICATIONS .....	2	BLOCK DIAGRAM .....	7
PRECAUTIONS .....	2	GENERAL UNIT PARTS LIST .....	8
LEAKAGE TEST .....	3	GENERAL UNIT .....	8
POWER CORD REPLACEMENT .....	3	P. C. BOARDS .....	10
DISASSEMBLY PROCEDURES .....	4	ELECTRICAL PARTS LIST .....	15
CONTROLS AND FUNCTIONS .....	5	IC BLOCK DIAGRAMS .....	31
ALIGNMENT PROCEDURES .....	6	SCHEMATIC DIAGRAMS .....	36
CIRCUIT DESCRIPTION .....	6	WIRING DIAGRAM .....	48

**harman/kardon**

Parts and Service Office  
240 Crossways Park West, Woodbury, N.Y. 11797  
1112-0330B152 G9402 1500 Printed in Japan

## SPECIFICATIONS

	Nominal	Limit	
<b>● FM SECTION</b>			
Tuning Range	87.5 – 108.0 MHz		
50dB Quieting Sensitivity (at 98MHz)			
Mono	17.0 dBf $\leq$ 24.0 dBf		BK
	17.0 dBf $\leq$ 32.0 dBf		WB SB
	26.0 dBf $\leq$ 32.0 dBf		IB
Stereo	40.0 dBf $\leq$ 45.0 dBf		BK
	40.0 dBf $\leq$ 54.0 dBf		WB SB
	50.0 dBf $\leq$ 54.0 dBf		IB
Usable Sensitivity, Mono (at 98 MHz)			
	14.0 dBf $\leq$ 20.0 dBf		BK
	14.0 dBf $\leq$ 22.0 dBf		WB SB
	16.0 dBf $\leq$ 22.0 dBf		IB
Image Ratio	45.0 dB $\geq$ 40.0 dB		
IF Rejection	105.0 dB $\geq$ 80.0 dB		
Capture Ratio (at 65 dBf)	1.5 dB		
Alternate Channel Selectivity	50.0 dB $\geq$ 40.0 dB		
AM Rejection (at 45 dBf)	60.0 dB $\geq$ 45.0 dB		
Signal to Noise (at 65 dBf)			
Mono	80.5 dB $\geq$ 76.0 dB		BK
	80.5 dB $\geq$ 70.0 dB		WB SB
	75.0 dB $\geq$ 70.0 dB		IB
Stereo	73.0 dB $\geq$ 68.0 dB		BK
	73.0 dB $\geq$ 62.0 dB		WB SB
	66.0 dB $\geq$ 62.0 dB		IB
Stereo Separation (at 65 dBf, 1kHz)			
	54.0 dB $\geq$ 42.0 dB		BK
	54.0 dB $\geq$ 35.0 dB		WB SB
	42.0 dB $\geq$ 35.0 dB		IB
Total Harmonic Distortion (at 65 dBf, 1kHz)			
Mono	0.2% $\leq$ 0.4%		
Stereo	0.2% $\leq$ 0.5%		
<b>● AM SECTION</b>			
Tuning Range	530 – 1710 kHz		BK
	531 – 1602 kHz		WB SB IB
20dB S/N Sensitivity			
External Antenna	18.0 $\mu$ V $\leq$ 30.0 $\mu$ V		
Selectivity (at $\pm$ 20 kHz)	50.0 dB		
Signal to Noise Ratio	52.0 dB $\geq$ 47.0 dB		
Image Rejection (at 1000 kHz)	39.0 dB $\geq$ 30.0 dB		
IF Rejection	63.0 dB $\geq$ 50.0 dB		
<b>● AUDIO SECTION</b>			
Usable Sensitivity (at 60W output)			
CD	125.0 mV 135 mV $\pm$ 25mV / 27k $\Omega$		
Phono	2.47 mV 2.5 mV $\pm$ 0.2mV / 47k $\Omega$		

	Nominal	Limit	
Signal to Noise Ratio			
CD	80.0 dB $\geq$ 75.0 dB		
Phono	77.5 dB $\geq$ 73.0 dB		
Channel Separation			
CD	60.5 dB $\geq$ 45.0 dB		
Phono	64.0 dB $\geq$ 45.0 dB		
IM Distortion Ratio	0.039% $\leq$ 0.1%		
RMS Output Power			
6 $\Omega$ , 20 Hz – 20 kHz, THD 0.09% (Front, Left Center Right)	66.6 W $\geq$ 50 W		BK
	66.6 W $\geq$ 45 W		WB SB
	68.0 W $\geq$ 50 W		BK
4 $\Omega$ , 20 Hz – 20 kHz, THD 0.7% (Rear, Left Right)	27.3 W $\geq$ 20 W		
High-Instantaneous Current Capability (HCC)	42.0 A $\geq$ 30.0 A		
Damping Factor	44.0 $\geq$ 35.0		
Tone Control Characteristics			
Bass (at 50Hz)			
Boost	11 dB $\pm$ 2 dB		
Cut	11 dB $\pm$ 2 dB		
Treble (at 10 kHz)			
Boost	11 dB $\pm$ 2 dB		
Cut	11 dB $\pm$ 2 dB		
Loudness Control (at 50 Hz)	10 dB $\pm$ 2 dB		
DC output Voltage			
L channel	12.5 mV $\pm$ 60mV		
R channel	3.5 mV $\pm$ 60mV		
RIAA Equalization (at Tape Out) (20 Hz / 20 kHz)	0.5 dB $\pm$ 1 dB		
Frequency Response (at -3 dB Down)			
	0.4 Hz – 220 kHz $<$ 1 Hz – $\geq$ 150 kHz		BK WB SB
	0.4 Hz – 185 kHz $<$ 1 Hz – $\geq$ 150 kHz		IB
Rise Time	1.6 $\mu$ sec. $\leq$ 3 $\mu$ sec.		
Phono Over Load	130 mV $\geq$ 100 mV		
Subwoofer Output (at 6 $\Omega$ )	2.0 V / 10 k $\Omega$		
● DIMENSIONS	17-3/8" x 6-3/8" x 16-1/4"		
(W x H x D)	(443 x 162 x 412 mm)		
● WEIGHT	30.0 lbs. / 13.6 kg		
● POWER SUPPLY	AC 120V, 60Hz		BK
	AC 230V/240V, 50Hz/60Hz		WB SB IB
● POWER CONSUMPTION	236 W		BK
	260 W		WB SB IB

These specifications are service target specs.

Specifications and components are subject to change without notice. Overall performance will be maintained or improved.

## PRECAUTIONS

Lithium Battery warning notice; Please revise as follows:

## Safety Instructions for Lithium Batteries.

Lithium batteries contain inflammable materials such as lithium, organic solvent and other chemical. Incorrect handling of lithium batteries may result in HEAT GENERATION, EXPLOSION or FIRE which may lead to personal injuries. To prevent accidents, strict observance of the following precautions is essential.

## 1. Do not stack the batteries.

When the positive and minus terminals of the batteries touch each other or other metal surfaces, large currents will flow resulting in heat generation, explosions or fire. To prevent short circuits, be sure to use the correct packing material for storage and shipment. Should a fire occur, do not use water to extinguish. Chemical reaction between lithium and water may accelerate the chemical reaction and the fire. Use dry sand for extinguishing the fire.

## 2. Do not dispose the batteries in fire.

Disposing batteries in fire, is very dangerous because an explosion or violent flames will occur.

## 3. Do not heat the batteries or solder directly to the batteries.

When heat in excess of 100 °C (212 °F) is applied, the resin at the sealing sections, separator and other areas becomes damaged.

Internal short circuits or leakage of electrolyte may cause explosion or fire.

## 4. Do not recharge the batteries.

Recharging may result in gas generation inside the battery and cause swelling, explosion or fire.

## 5. Do not disassemble the batteries.

Internal gas is irritating to the throat. Exposed lithium may generate heat and fire.

## 6. Do not apply pressure to or deform the batteries.

When pressure is applied to the batteries, electrolyte may leak or internal short circuit may occur. As result there can be heat generation, leading to explosion or fire.

## 7. Do not mix different types of batteries.

Mixing different types of batteries or new with old batteries can cause some batteries to overcharge, resulting in swelling or explosion.

## 8. Observe proper polarity.

Improper assembly of the batteries into the product may result in short-circuit conditions causing heat generation, explosion or fire.

## LEAKAGE TEST (FOR SERVICE ENGINEERS IN THE U.S.A.)

Before returning the unit to the user, perform the following safety checks:

1. Inspect all lead dress to make certain that leads are not pinched or that hardware is not lodged between the chassis and other metal parts in the unit.
2. Be sure that any protective devices such as nonmetallic control knobs, insulating fishpapers, cabinet backs, adjustment and compartment covers or shields, isolation resistor-capacity networks, mechanical insulators, etc. which were removed for servicing are properly reinstalled.
3. Be sure that no shock hazard exists; check for leakage current using Simpson Model 229 Leakage Tester, standard equipment item No. 21641, RCA Model WT540A or use alternate method as follows: Plug the power cord directly into a 120-volt AC receptacle (do not use an Isolation Transformer for this test). Using two clip leads, connect a 1500 Ohm, 10-watt resistor paralleled by a 0.15  $\mu$ F capacitor, in series with all exposed metal cabinet parts and a known earth ground, such as a water pipe or conduit. Use a VTVM or VOM with 1000 Ohms per volt, or higher sensitivity to measure the AC voltage drop across the resistor. (See Diagram.) Move the resistor connection to each exposed metal part having a return path to the chassis (antenna, metal, cabinet, screw heads, knobs and control shafts, escutcheon, etc.) and measure the AC voltage drop across the resistor. (This test should be performed with the power switch in both the On and Off positions.)

A reading of 0.35 volt RMS or more is excessive and indicates a potential shock hazard which must be corrected before returning the unit to the owner.

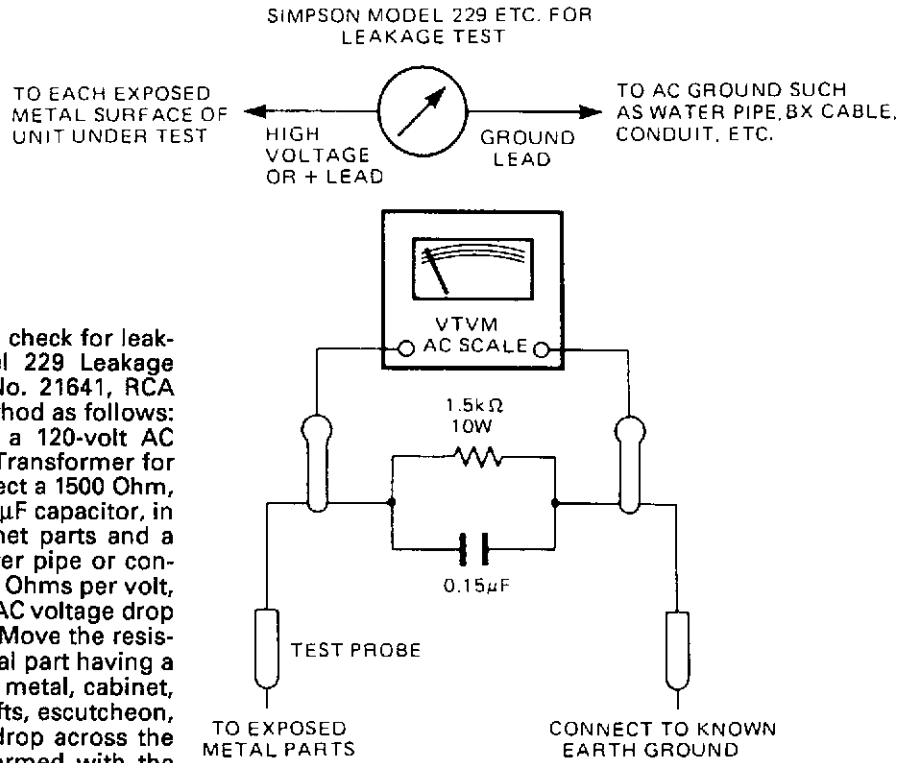

## POWER CORD REPLACEMENT (FOR SERVICE ENGINEERS OTHER THAN NORTH AMERICA)

In order to prevent fire or shock hazard when replacing the power cord, follow the procedure below to replace the parts with the standard supply parts.

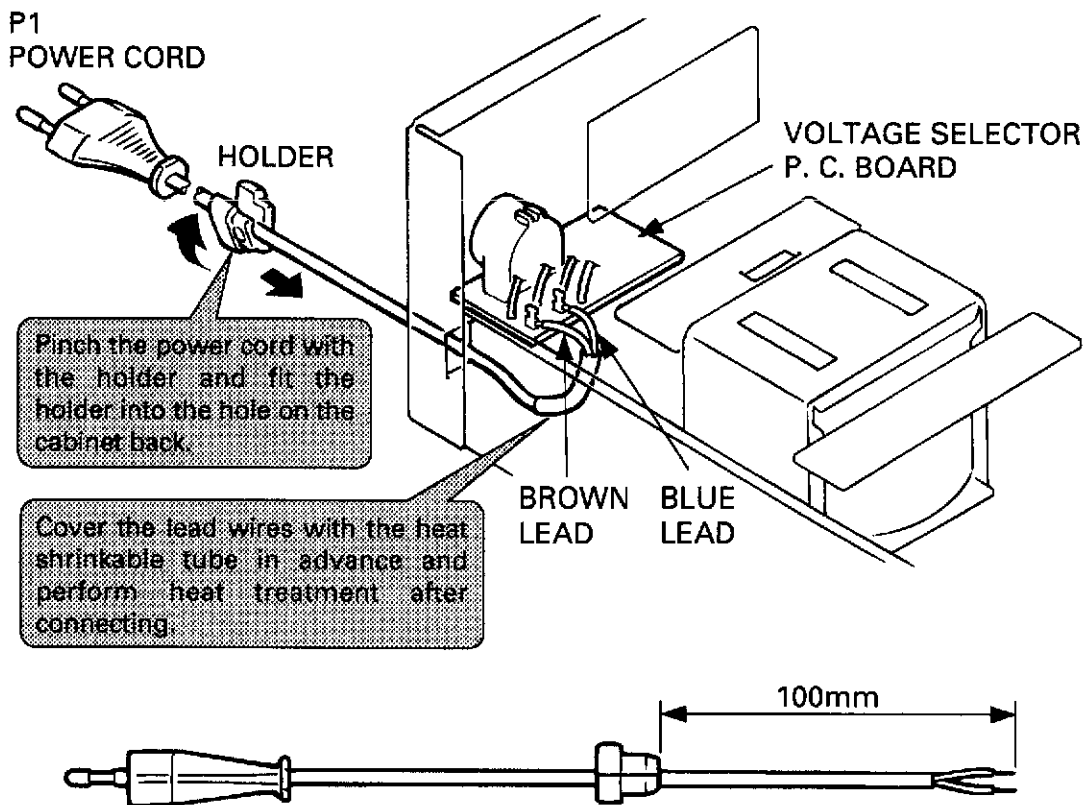

**DISASSEMBLY PROCEDURES (REFER TO PAGES 8,9 AND 48)****1 CABINET TOP REMOVAL**

Remove 10 screws (A) and then remove the Cabinet Top (131).

**2 FRONT PANEL ASS'Y (AA) REMOVAL**

1. Remove the Cabinet Top (131), referring to the previous step **1**.
2. Disconnect the connector (LCN506) from connector (CN506) on the Master VR P. C. Board (PCB-3).
3. Pull out the Master Volume knob (150).
4. Disconnect the lead wire (JL704) from connector (CN351) on the Tuner P. C. Board (PCB-9).
5. Disconnect the lead wire (JL703) from connector (CN4) on the Power Supply P. C. Board (PCB-10).
6. Disconnect the lead wire (JL701) from connector (CN701) on the Power Switch P. C. Board (PCB-13).
7. Disconnect the lead wire (W-151) from connector (CN151) on the Video Function P. C. Board (PCB-6).
8. Disconnect the lead wire (W-152) from connector (CN901) on the Video/On Screen P. C. Board (PCB-24).
9. Pull out the Speakers, Bass, Treble, Balance, Subwoofer Level, Center Level and Rear Level knobs (152).
10. Remove 7 screws (B) and then remove the Front Panel Ass'y (AA).

**3 TUNER P. C. BOARD (PCB-9) REMOVAL**

1. Remove the Cabinet Top (131), referring to the previous step **1**.
2. Remove 10 screws (C), 2 revets (Q) and then remove the Metal Fitting (185) and Metal Fitting (186).
3. Disconnect the lead wires (JL704, JL301 and LCN22) from connectors (CN351, CN301 and CN22) on the Tuner P. C. Board (PCB-9).
4. Remove 3 screws (D) and then the Tuner P. C. Board (PCB-9). **BK**
4. Remove 4 screws (D) and then the Tuner P. C. Board (PCB-9). **WB SB IB**

**4 AUDIO FUNCTION P. C. BOARD (PCB-5) REMOVAL**

1. Remove the Tuner P. C. Board (PCB-9), referring to the previous step **3**.
2. Pull up the Function Connector P. C. Board (PCB-29).
3. Disconnect the lead wire (W-602) from connector (CN602) on the Audio Function P. C. Board (PCB-5).
4. Disconnect the lead wire (W-601) from connector (CN712) on the Main Amp. P. C. Board (PCB-20).
5. Remove 4 screws (E) and then remove the Audio Function P. C. Board (PCB-5).

**5 VIDEO FUNCTION P. C. BOARD (PCB-6) AND DISPLAY P. C. BOARD (PCB-23) REMOVAL**

1. Remove the Audio Function P. C. Board (PCB-5), referring to the previous step **4**.
2. Pull up the Function Connector P. C. Board (PCB-29).
3. Disconnect the lead wire (W-151) from connector (CN151) on the Video Function P. C. Board (PCB-6).
4. Remove 4 screws (F), and then disconnect the connector (CN155) from connector (CN710) on the Main Amp. P. C. Board (PCB-20).
5. Disconnect the connectors (CN801 and CN802) from connectors (CN715 and CN711) on the Main Amp. P. C. Board (PCB-20), and then remove the Video Function P. C. Board (PCB-6) and Display P. C. Board (PCB-23).

**6 VIDEO/ON SCREEN P. C. BOARD (PCB-24) REMOVAL**

1. Remove the Cabinet Top (131), referring to the previous step **1**.
2. Disconnect the lead wire (W-152) from connector (CN901) on the Video/On Screen P. C. Board (PCB-24).
3. Remove 4 screws (G) and screw (C) and then the Video/On Screen P. C. Board (PCB-24).

**7 FRONT CHASSIS (171) REMOVAL**

1. Remove the Cabinet Top (131), referring to the previous step **1**.
2. Remove the Front Panel Ass'y (AA), referring to the previous step **2**.
3. Remove 18 screws (H) and then remove the Front Chassis (171) with the Master VR, Rear VR, Tone, Front SP Select, Power Switch, Power LED, Headphones P. C. Board (PCB-3, PCB-2, PCB-1, PCB-16, PCB-13, PCB-14, PCB-19).
4. Remove 1 hexagon nut (I) and then remove the Master VR P. C. Board (PCB-3).
5. Remove 1 hexagon nut (J) and then remove the Rear VR P. C. Board (PCB-2).
6. Remove 5 hexagon nuts (K) and then remove the Tone P. C. Board (PCB-1).
7. Remove 1 hexagon nut (L) and then remove the Front Speaker Select P. C. Board (PCB-16).

**8 MAIN AMP P. C. BOARD (PCB-20) REMOVAL**

1. Remove the Video Function P. C. Board (PCB-6), referring to the previous step **5**.
2. Remove the Video/On Screen P. C. Board (PCB-24), referring to the previous step **6**.
3. Remove 4 screws (M) and then the Main Connector P. C. Board (PCB-28).
4. Disconnect the lead wire (JL703) from connector (CN4) on the Power Supply P. C. Board (PCB-10).
5. Disconnect the lead wires (JL402 and JL509) from connectors (CN1491 and CN1490) on the Line Out 2 P. C. Board (PCB-27).
6. Remove 4 screws (N) and then the Rear/Center Speaker P. C. Board (PCB-18) and Line Out 2 P. C. Board (PCB-27).
7. Remove 10 screws (O) and then the Main Amp. P. C. Board (PCB-20).

**9 POWER SUPPLY P. C. BOARD (PCB-10) REMOVAL**

1. Remove the Cabinet Top (131), referring to the previous step **1**.
2. Remove 4 screws (M) and then remove the Main Connector P. C. Board (PCB-28).
3. Disconnect the lead wire (JL703) from connector (CN4) on the Power Supply P. C. Board (PCB-10).
4. Remove 5 screws (P) and then remove the Power Supply P. C. Board (PCB-10).

# CONTROLS AND FUNCTIONS

## Bass

Turn to increase or decrease the proportion of low frequency sound.

## Treble

Turn to increase or decrease the proportion of high frequency sound.

## Center

Press to select the desired center mode (NORMAL, PHANTOM, or WIDE).

## Speaker

Turn to select either of two sets of speakers, or both, or neither (headphone output only).

## Power

Press to turn the unit on (Green Indicator) and off (Orange Indicator) (for use with remote control)

## Shift A-B

Allows you to access 16 pre-selected stations using the 8 preset buttons.

## Audio Direct

Press this button to bypass all surround sound processing.

## Surround

Press this button to select the desired surround mode (MOVIE, HALL, THEATER, etc.).

## Memory

Press to set a new preset station in memory.

## Preset Buttons

Press to access pre-selected stations.

## Effect Level + / -

Press these buttons to adjust the "liveness" of the Digital Signal Processor.

## Delay

Press Pro Lo

## FI

Pre or

## Te

Pr the for ad

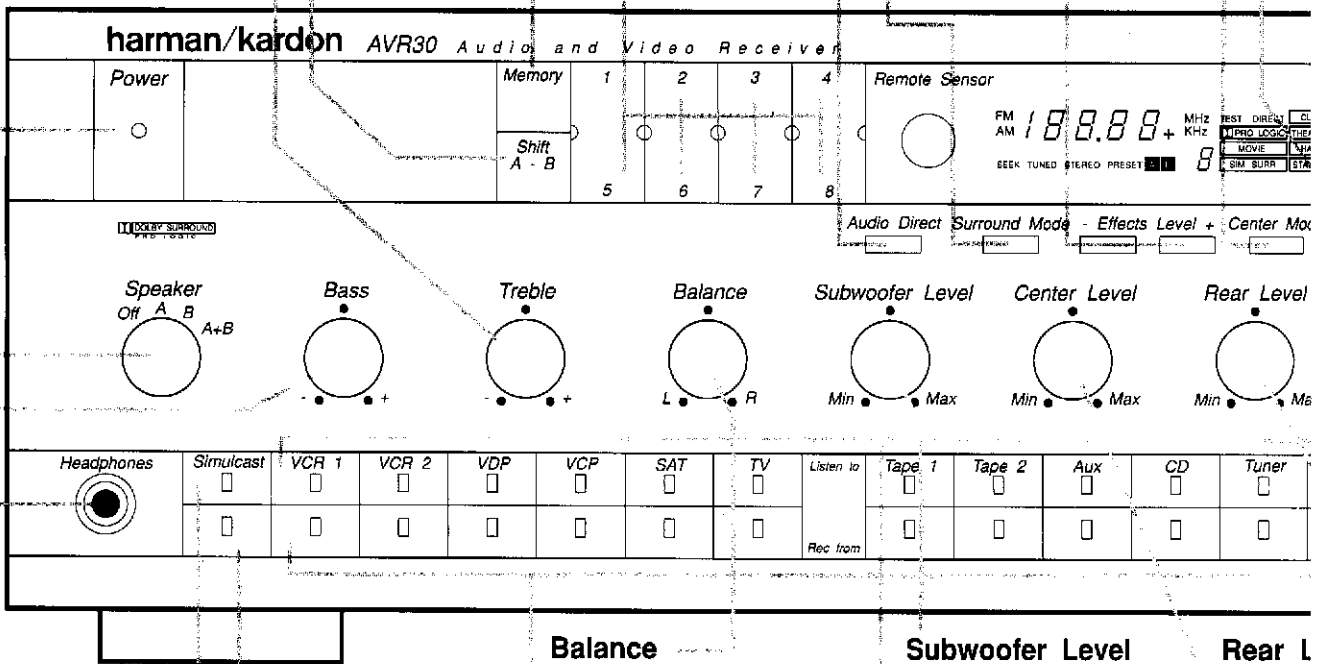

## Headphone Jack

Plug in headphones if desired (with Speaker switch in "Off" position, output is supplied only to headphones).

## Simulcast "Rec From"

Press to record from a video source combining the audio from a different source.

## Simulcast "Listen To"

Press to view a video source while listening to separate audio source.

## Balance

Turn to adjust relative output level of left and right speakers.

## "Record From" Selector

Press desired key to choose source for recording.

## Subwoofer Level

Turn to increase or decrease the subwoofer output level relative to the front speakers connected to the AVR30.

## "Listen To" Selector

Press desired key to choose listening source.

## Rear L

Turn to increase or decrease relative to front speaker

## Center L

Turn to increase or decrease center speaker

Manufactured under license from Dolby Laboratories Licensing Corporation. Additionally licensed under one or more of the following patents: U.S. numbers 3,632,886, 3,746,792 and 3,959,590; Canadian numbers 1,004,603 and 1,037,877. "Dolby" and the double-D symbol **DD** are trademarks of Dolby Laboratories Licensing Corporation.

\*Dolby Prologic Surround is a trademark of DOLBY LABORATORIES LICENSING CORPORATION.

USING THE ON SCREEN MENU SYSTEM

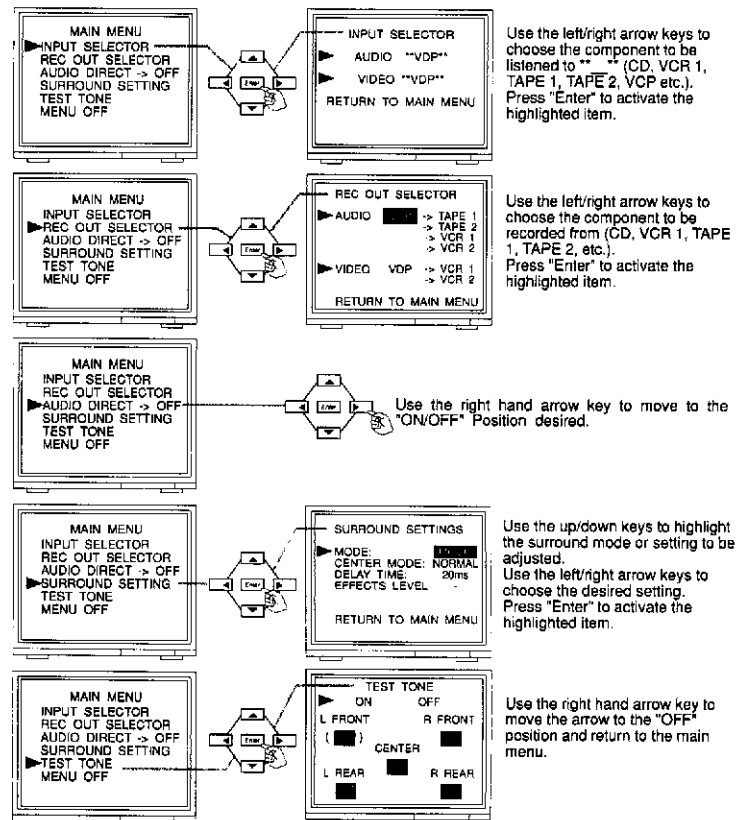

Use the left/right arrow keys to choose the component to be listened to (CD, VCR 1, TAPE 1, TAPE 2, VCR etc.). Press "Enter" to activate the highlighted item.

Use the left/right arrow keys to choose the component to be recorded from (CD, VCR 1, TAPE 1, TAPE 2, etc.). Press "Enter" to activate the highlighted item.

Use the right hand arrow key to move to the "ON/OFF" Position desired.

Use the up/down keys to highlight the surround mode or setting to be adjusted. Use the left/right arrow keys to choose the desired setting. Press "Enter" to activate the highlighted item.

Use the right hand arrow key to move the arrow to the "OFF" position and return to the main menu.

REMOTE CONTROL

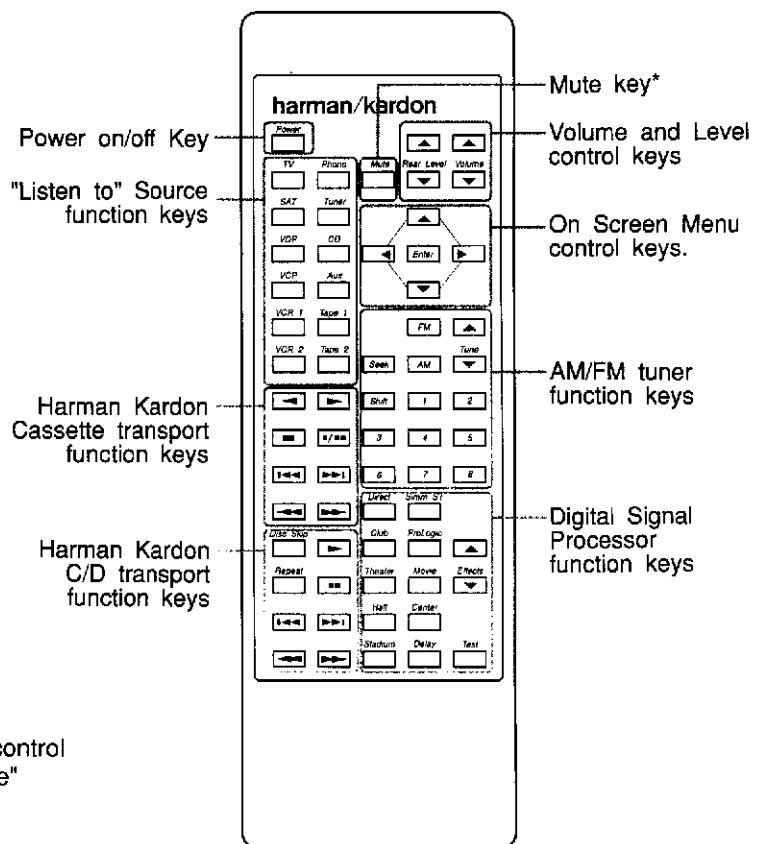

**\*Note:** The AVR30 volume control LED will flash when the "mute" function is on.

**Delay**  
Press to select the appropriate Dolby Pro Logic delay time (15, 20, or 30ms).

**Volume**  
Turn to raise or lower system output volume.

**FM/AM**  
Press to select AM or FM reception.

**Tuning**  
Press ▲ to tune to stations with higher frequencies; press ▼ for lower frequencies.

**Test Tone**  
Press to turn on the test tone used for Speaker level adjustment.

**Seek-Stereo**  
Press to select Seek tuning in stereo, or manual tuning in mono.

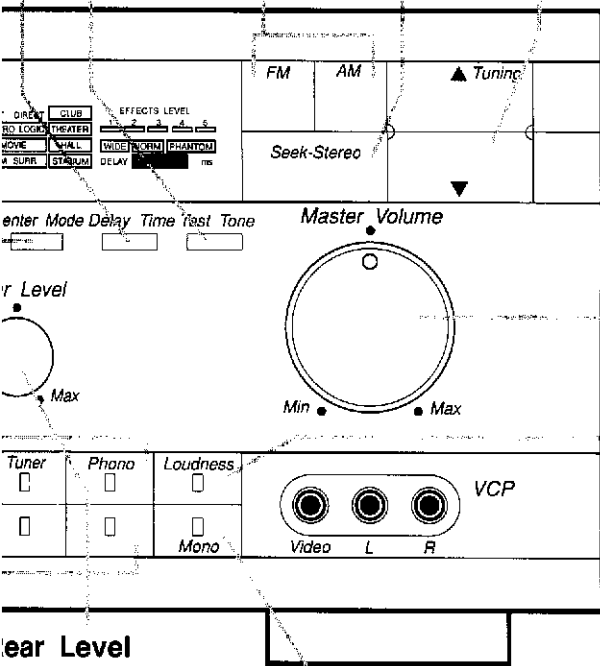

**Rear Level**  
Turn to increase or decrease the rear speaker level relative to the front speakers connected to the AVR30.

**Mono**  
Press to hear input from any source in mono.

**Center Level**  
Turn to increase or decrease the center speaker level relative to the front speakers connected to the AVR30.

**Loudness**  
Press to improve sound quality when listening to your system at low volume.

**ALIGNMENT PROCEDURES (REFER TO PAGES 11,12,39,40,42 AND 46)**

**Conditions :** • Set the Master Volume control to minimum.

- Set the Speaker switches to A position.
- Set the Function switch to tuner position.
- Make the adjustment at a room temperature of 77°F (25°C).
- After the Power switch is pushed on, wait for 30 minutes before measuring to be sure of the most stable operation.

**■ IDLING CURRENT ADJUSTMENT**

Step	Terminals to be connected	Adjustment	For
1	Connect the Digital Volt Meter to TP401	VR401 (Front L ch)	32 mV± 2mV
	Connect the Digital Volt Meter to JP1423, JP1424	VR1401 (Rear L ch)	6 mV± 2mV
	Connect the Digital Volt Meter to TP402	VR402 (Front R ch)	32 mV± 2mV
	Connect the Digital Volt Meter to JP1412, JP1415	VR1402 (Rear R ch)	6 mV± 2mV
	Connect the Digital Volt Meter to TP1501	VR1501 (Front Center)	32 mV± 2mV

**■ DC BALANCE CONFIRMATION**

Step	Terminal to be connected	For
1	Connect the Digital Volt Meter to Rear Speaker Terminal.	0 ± 60mV

**■ AM ADJUSTMENT**

**Conditions :** • Set the AM mode by pressing the "AM" button.

- Standard modulation of the AM Signal Generator is 400Hz at 30%.
- Set the Seek-Stereo switch to off position.

Step	Alignment	Terminals to be connected	Measurement Frequency	Station Display	Adjustment	For
1	IF	• Connect the AM Test Loop Antenna cable into the output jack of AM Signal Generator. (80dBµV input signal) Place AM Test Loop Antenna close enough to couple signal into the AM Loop Antenna.	1400 kHz *1404 kHz	1400 kHz *1404 kHz	T251	Maximum output level and symmetrical curve on scope.
2	Tracking		1400 kHz *1404 kHz	1400 kHz *1404 kHz		
3		600 kHz *603 kHz	600 kHz *603 kHz	CB251(C)	Maximum output	
4		• Connect the VTVM and oscilloscope to the Connector (CN301).	Repeat step 2 and 3 for optimum sensitivity			

\*International models

**■ FM ADJUSTMENT**

**Conditions :** • Set the FM mode by pressing the "FM" button.

- Set the Seek-Stereo switch to off position.

<b>FM Signal Generator</b>	1kHz, 100% modulation *1kHz, 40kHz modulation
<b>Stereo Modulator</b>	L+R=45.5%, L-R=45.5%, 19kHz=9% *L+R=22.5%, L-R=22.5%, 19kHz=8%

Step	Alignment	Terminals to be connected	Measurement Frequency	Station Display	Adjustment	For
1	Discriminator	• Connect the FM Signal Generator to FM 300Ω BAL Antenna terminals through the 300Ω balanced dummy. [1mV (65dBf) input signal] • Connect the Digital Volt Meter to TP201 and TP202.	97.9MHz	97.9MHz	T201(A)	Adjust T201(A) so that adjustment value is less than ±30mV.
2			97.9MHz	97.9MHz	T201(B)	Minimum Distortion
3			Repeat step 1 and 2 for optimum sensitivity			
4	Muting level	• Connect the Oscilloscope and Distortion meter to the Connector (CN301).	97.9MHz	97.9MHz	VR251	Adjust VR251 so that the waveform is muted at 30 dBf input.
5	Separation	• Connect the Stereo Modulator to FM Signal Generator. Connect the FM Signal Generator to FM 300Ω BAL Antenna terminals through the 300Ω balanced dummy. [1mV (65dBf) input signal] • Connect the VTVM and Oscilloscope to the Connector (CN301).	97.9MHz	97.9MHz	VR301	Adjust so that the left (or right) channel output becomes minimum when only the right (or left) channel of the Stereo Modulator is modulated.

# CIRCUIT DESCRIPTION

## 1. SURROUND CIRCUIT

This model incorporates a surround processor circuit that provides 6 types of the surround sound. Fig. 1-1 is a block diagram of the surround processor circuit.

The microprocessor transfers the data to the parameter control (Bit clock, Word clock, Serial data) to operate the circuits in each mode.

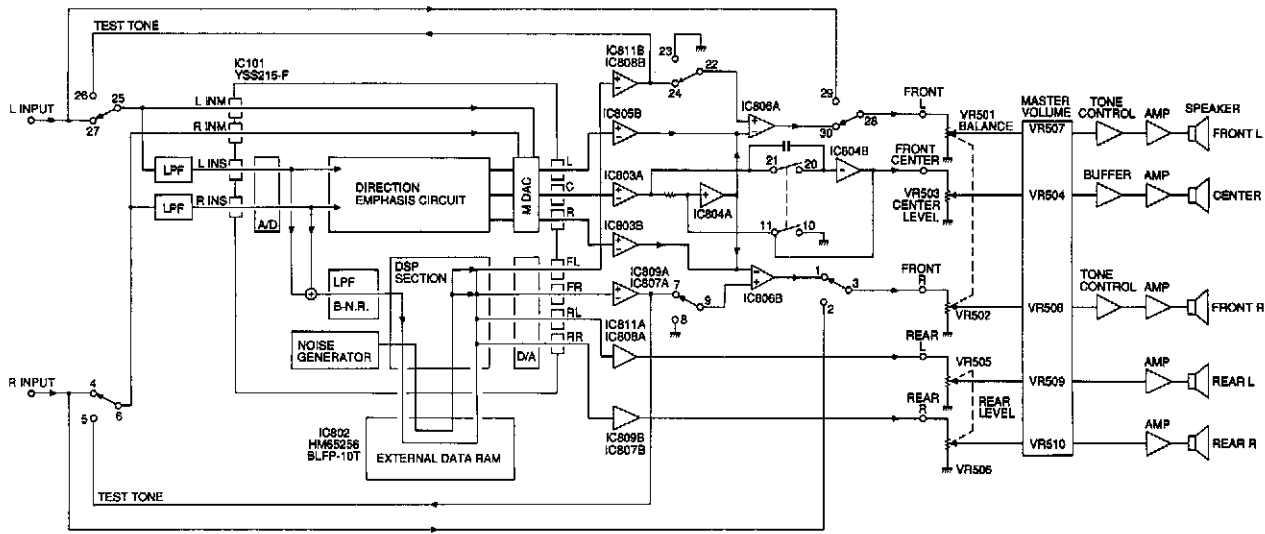

(Block diagram of the surround processor circuit.)

Fig. 1-1

### (1) Off

Set to this mode to listen to ordinary stereo sound. The rear L/R and center outputs will be muted.

### (3) Movie, Simulated Surround, Club, Theater, Hall, Stadium

The Movie mode provides the feeling of presence you get from a 35-mm movie in a movie theater.

The Simulated Surround mode gives sound impact to monaural TV programs and movies, the Club mode provides the atmosphere of a small club seating about 300 people, the Theater mode gives a listener the feeling as if he (she) were in a theater seating 1200 people, and the Hall mode gives an effect of presence in a 5000-seat concert hall.

The Stadium mode gives an atmosphere of a stadium accommodating 20,000 people.

All the connections of the circuits are the same in these modes. IC801, controlled by the microprocessor, processes the audio signals to produce various sound effects and creates surround components to use them as signals to drive the rear speakers.

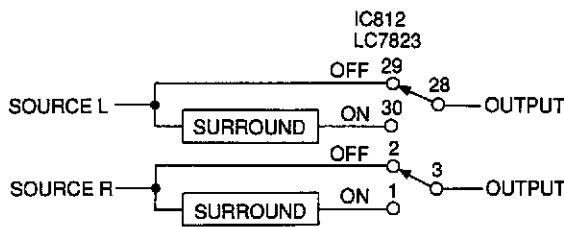
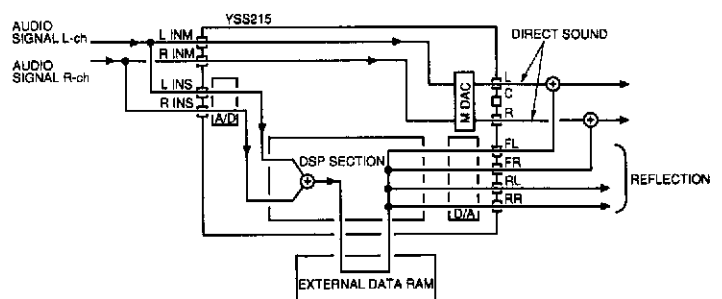

Fig. 1-2

### (2) Dolby pro logic

IC801 (YSS215-F) is a Dolby pro logic decoder IC. When an audio signal recorded using the Dolby pro logic system is sent to this IC, the left, right, center and surround components are separated. The surround signal component is delayed by the digital delay circuit by 15-30 mS and is sent to the modified B-type decoder IC801 where noise reduction processing is performed.



(Flow of signals within the system in the simulated surround mode.)

Fig. 1-4

Processing in YSS215-F creates the Hall, Live and Simulated Surround effects.

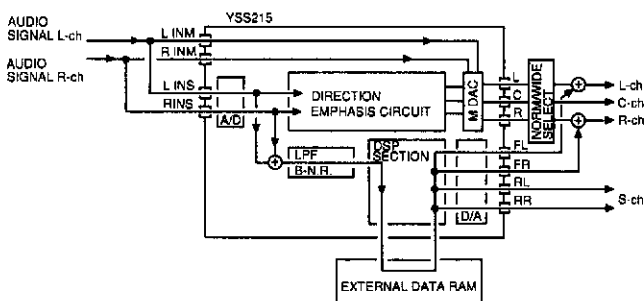
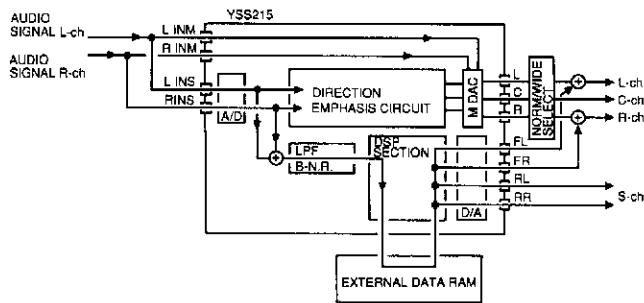

Fig. 1-3



## 2. DOLBY PRO LOGIC CIRCUIT

Dolby Pro Logic is a sound effect system for movies developed by the Dolby Laboratories Licensing Corp. Fig. 2 shows the configuration of the Dolby decoder.



< Flow of signals within the system in the Dolby pro logic mode.

Fig. 2

The active decoder circuit is a professional decoder system as used in theaters. It resolves the sound into the right, left, center and surround components correctly and also uses a center speaker to solve the problem that the picture and sound do not coincide. The direction enhancer included in the decoder improves the sound separation to 25-40 dB to achieve more dynamic presence.

With Dolby pro logic, three center modes depend on the use of a center speaker as follows.

<b>NORMAL</b>	: Bass frequencies are sent only to the Left and Right Front channels. Select this mode when the Center Speaker is smaller than the Left and Right speakers.
<b>WIDE</b>	: Bass frequencies are sent to the Left, Center and Right speakers. Select this mode when the Center speaker is approximately the same size as the Left and Right speakers.
<b>PHANTOM</b>	: Center channel information is sent to the Left and Right speakers. Select this mode when you do not have a center channel speaker.

## 3. TEST TONE GENERATOR

The test tone generator generates a test tone (noise) to check the balance of sound output from each speaker in the Dolby pro logic mode. (This circuit is produced under license of the Dolby Laboratories Licensing Corp.) The noise generator signals shown in the table below are applied to the LINM and RINM pins of IC801.

The test tone is sent to the loudspeakers at 1 second intervals in the following sequence: Left, Center, Right, Rear (both rear channels).

CHANNEL \ INPUT	LINM	RINM	Reference
L	0dB	OFF	—
R	OFF	0dB	—
CENTER	-3dB	-3dB	FORWARD
SURROUND	-3dB	-3dB	REVERS

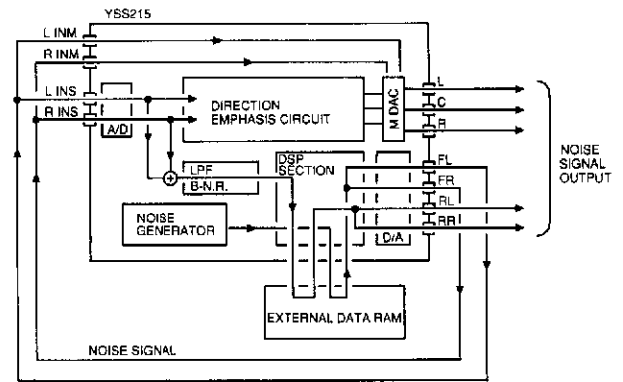

< Flow of noise signals within the system.

Fig. 3

## 4. DSP (DIGITAL SURROUND PROCESSOR) CIRCUIT

IC801 (YSS215-E) is a DSP IC that creates various surround effects through digital processing. It incorporates A/D and D/A converters for digital processing and also uses LPFs to prevent aliasing signals during conversion which could degrade sound quality. Fig. 4 is a block diagram of the DSP circuit.

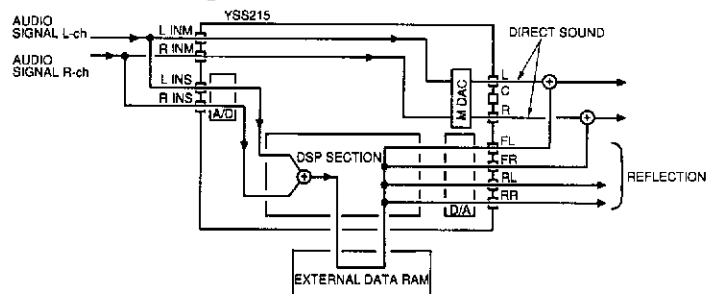

< Flow of signals within the system in the simulated surround mode.

Fig. 4

**BLOCK DIAGRAM**  
**GENERAL UNIT**

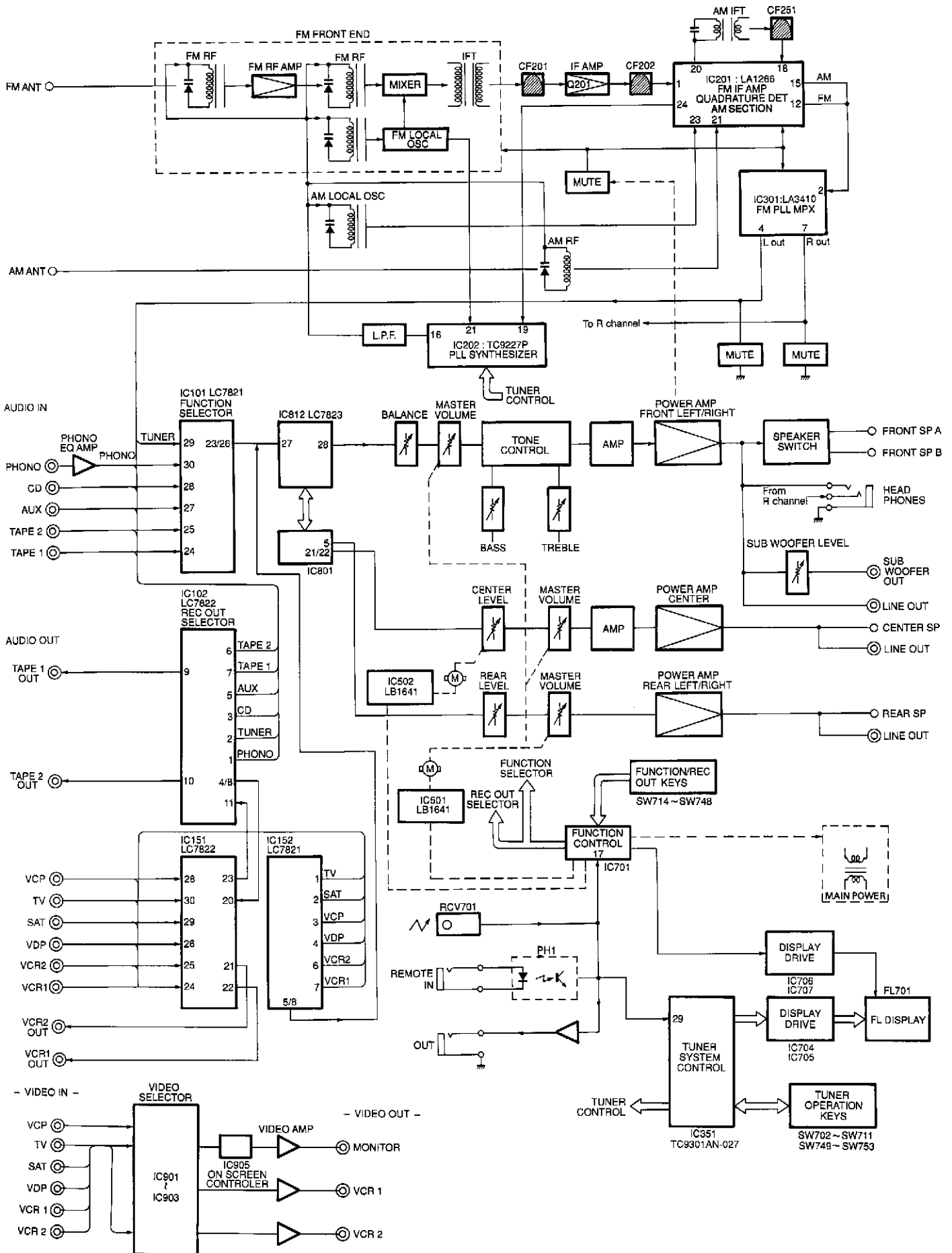

**GENERAL UNIT PARTS LIST**

Ref. No.	Part No.	Description	Ref. No.	Part No.	Description
AA	A442-AVR30B	FRONT PANEL ASS'Y	188	2219-8388	METAL FITTG, MAIN VR PCB
AB	A424-AVR30A	CABINET BOTTOM ASS'Y <b>BK</b>	189	2219-8389	METAL FITTG, REMOTE (IN/OUT PCB) <b>BK</b>
AC	A424-AVR30B	CABINET BACK ASS'Y, REAR <b>BK</b>	189	2219-8390	METAL FITTG, REMOTE (IN/OUT PCB) (x2) <b>WB SB IB</b>
AC	A424-AVR30D	CABINET BACK ASS'Y, REAR <b>WB</b>	191	2222-7318	HEAT SINK, MAIN
AC	A424-AVR30F	CABINET BACK ASS'Y, REAR <b>SB</b>	192	2222-7319	HEAT SINK, SUB
AD	A662-AVR30C	PUSH BUTTON ASS'Y, TV	193	2222-7319	HEAT SINK, POWER SUPPLY
AE	A662-AVR30D	PUSH BUTTON ASS'Y, LOUDNESS	195	2224-7135	INSULATOR, PLATE
Q22	2224-7140	INSULATOR, TRANS <b>WB SB IB</b>	196	2224-7137	INSULATOR, TOP COVER
Q41	1756-R01TL312	LABEL, T3.15A/T3.15AL 250V <b>WB SB IB</b>	198	2240-364	HOLDER, AC CORD
Q42	1756-R01TL402	LABEL, T4A/T4AL 250V (x4) <b>WB SB IB</b>	199	2240-7373	HOLDER, POWER SW PCB
Q43	1756-R01TL632	LABEL, T6.3A/T6.3A L250V (x4) <b>WB SB IB</b>	200	2240-7400	HOLDER, POWER PCB
Q45	1756-R01TL402	LABEL, T4A/T4AL 250V (x2) <b>WB SB IB</b>	201	2240-R0101	HOLDER, WIRING (x22)
122	1756-21912	LABEL, FTZ DBP NO. <b>IB</b>	202	2240-R0101	HOLDER, WIRING (x2)
123	1756-23601	LABEL, BATTERY CAUTION <b>IB</b>	203	2240-R0101	HOLDER, WIRING (x4)
127	1751-01018	LABEL <b>BK</b>	206	2360-7066	BOSS, SPE, POWER PCB BOTTOM
128	1756-05910	LABEL, FUSE CAUTION <b>BK WB SB</b>	208	2459-3004511	RIVET, PLASTIC (x2)
131	1414-17101	CABINET TOP	210	2651-2101736	SPRING, POWER BUTTON
132	1424-29901	CABINET BOTTOM, CENTER	211	2651-110519	SPRING, VR
133	1424-36501	CABINET BACK, REAR <b>BK</b>	215	2401-0373	WASHER METAL, MAIN/REAR (x5)
133	1424-36502	CABINET BACK, REAR <b>WB</b>	218	2112-11771	SPONGE, TOP COVER, DSP PCB (x2)
133	1424-36503	CABINET BACK, REAR <b>SB IB</b>	220	2134-11411	ADHESI SHEET, VOLUME
134	1424-36801	CABINET BACK, TRANS (BOTTOM LEFT)	221	2327-R0130062	SCREW, BND+ (3x6mm) (x2)
135	1424-36901	CABINET BACK, TUNER PCB (BOTTOM RIGHT)	223	2347-R0126082	SCREW, BND T+ (2.6x8mm) (x23)
138	1319-05001	LEG (x4)	225	2347-R0130062	SCREW, BND T+ (3x6mm) (x2)
140	1442-28902	FRONT PANEL	226	2347-R0130062	SCREW, BND T+ (3x6mm) (x12)
141	1442-24702	PANEL, DUMMY	227	2347-R0130062	SCREW, BND T+ (3x6mm) (x19)
145	1511-19805	PANEL, FL FILTER	228	2347-R0130062	SCREW, BND T+ (3x6mm) (x14) <b>BK WB SB</b>
146	1532-17504	WINDOW, FRONT (REMOTE SENSOR)	228	2347-R0130062	SCREW, BND T+ (3x6mm) (x15) <b>IB</b>
150	1630-04602	ROTARY KNOB, VOLUME	229	2347-R0130062	SCREW, BND T+ (3x6mm) (x13)
152	1632-20702	ROTARY KNOB, SP, BASS, TRE, BAL, SUB VR (x7)	230	2347-R0130062	SCREW, BND T+ (3x6mm) (x9)
154	1662-36301	PUSH BUTTON, AUDIO, SURR, EFFECT, CENTER DELAY, TEST (x7)	231	2347-R0130062	SCREW, BND T+ (3x6mm) (x5)
155	1662-58605	PUSH BUTTON, PRESET 1/5	232	2347-R0130122	SCREW, BND T+ (3x12mm)
156	1662-58606	PUSH BUTTON, PRESET 2/6	233	2347-R0130084	SCREW, BND T+ (3x8mm) (x14) <b>BK WB SB</b>
157	1662-58607	PUSH BUTTON, PRESET 3/7	233	2347-R0130084	SCREW, BND T+ (3x8mm) (x13) <b>IB</b>
158	1662-58608	PUSH BUTTON, PRESET 4/8	234	2347-R0130084	SCREW, BND T+ (3x8mm) (x24) <b>BK WB SB</b>
159	1662-58902	PUSH BUTTON, TUNING UP/DOWN	234	2347-R0130084	SCREW, BND T+ (3x8mm) (x25) <b>IB</b>
160	1662-59004	PUSH BUTTON, MEMORY, SHIFT A-B	236	2347-R0140082	SCREW, BND T+ (4x8mm) (x4)
161	1662-62402	PUSH BUTTON, FM/AM SEEK-STEREO	237	2347-R0140064	SCREW, BND T+ (4x6mm) (x8)
162	1662-62502	PUSH BUTTON, POWER	240	2557-301029	SCREW, B SPW+ (3x10mm) (x3)
163	1662-62705	PUSH BUTTON, FUNCTION (TV)	241	2557-301029	SCREW, B SPW+ (3x10mm) (x6)
164	1662-62706	PUSH BUTTON, FUNCTION (LOUDNESS)	242	2557-301429	SCREW, B SPW+ (3x14mm) (x5)
167	1732-07901	INDICATOR, POWER	259	2240-7372	HOLDER, FL DISPLAY
168	1732-08101	INDICATOR, FUNCTION (x14)	260	2240-7375	HOLDER, FRONT PCB
169	1732-08101	INDICATOR, FUNCTION (x14)	265	2224-7134	INSULATOR, Q423-426 (x4)
171	2211-7326	CHASSIS, FRONT	266	2224-7134	INSULATOR, Q1512, 1513 (x2)
173	2218-89	BRACKET, FIX, H/P LEFT SPRING	267	2224-7134	INSULATOR, Q1423-1426 (x4)
174	2218-R0130	BRACKET, FIX, WIRING (x3)	342	2216-7202	SHIELD PLATE
178	2219-7945	METAL FITTG, GND	343	2216-7204	SHIELD PLATE
179	2219-8350	METAL FITTG, REAR AMP PCB	344	2216-7205	SHIELD PLATE
180	2219-8378	METAL FITTG, HEADPHONES	345	2216-7206	SHIELD PLATE
181	2219-8379	METAL FITTG, HEAT SINK REAR SIDE	627	2440-62	NUT, SPE
182	2219-8380	METAL FITTG, HEAT SINK FRONT SIDE	998	4214-168	TERMINAL, GND
183	2219-8379	METAL FITTG, CONNECTOR PCB (x2)	△ P1	4161-09901192	CORD W/PLUG, AC CORD <b>BK</b>
184	2219-8381	METAL FITTG, HEAT SINK GUIDE (x2)	△ P1	4161-09801192	CORD W/PLUG, AC CORD <b>WB SB IB</b>
185	2219-8382	METAL FITTG, PHONO PCB TOP	△ T1	5584-T2001	XFORMER, MAIN POWER <b>BK</b>
186	2219-8383	METAL FITTG, VIDEO PCB	△ T1	5584-T2002	XFORMER, MAIN POWER <b>WB SB IB</b>
187	2219-8387	METAL FITTG, REAR AMP PCB (L)			

A

B

C

D

E

# GENERAL UNIT (1/2)

## EXPLODED VIEW FRONT PANEL ASSY

1

2

3

4

5

6

7

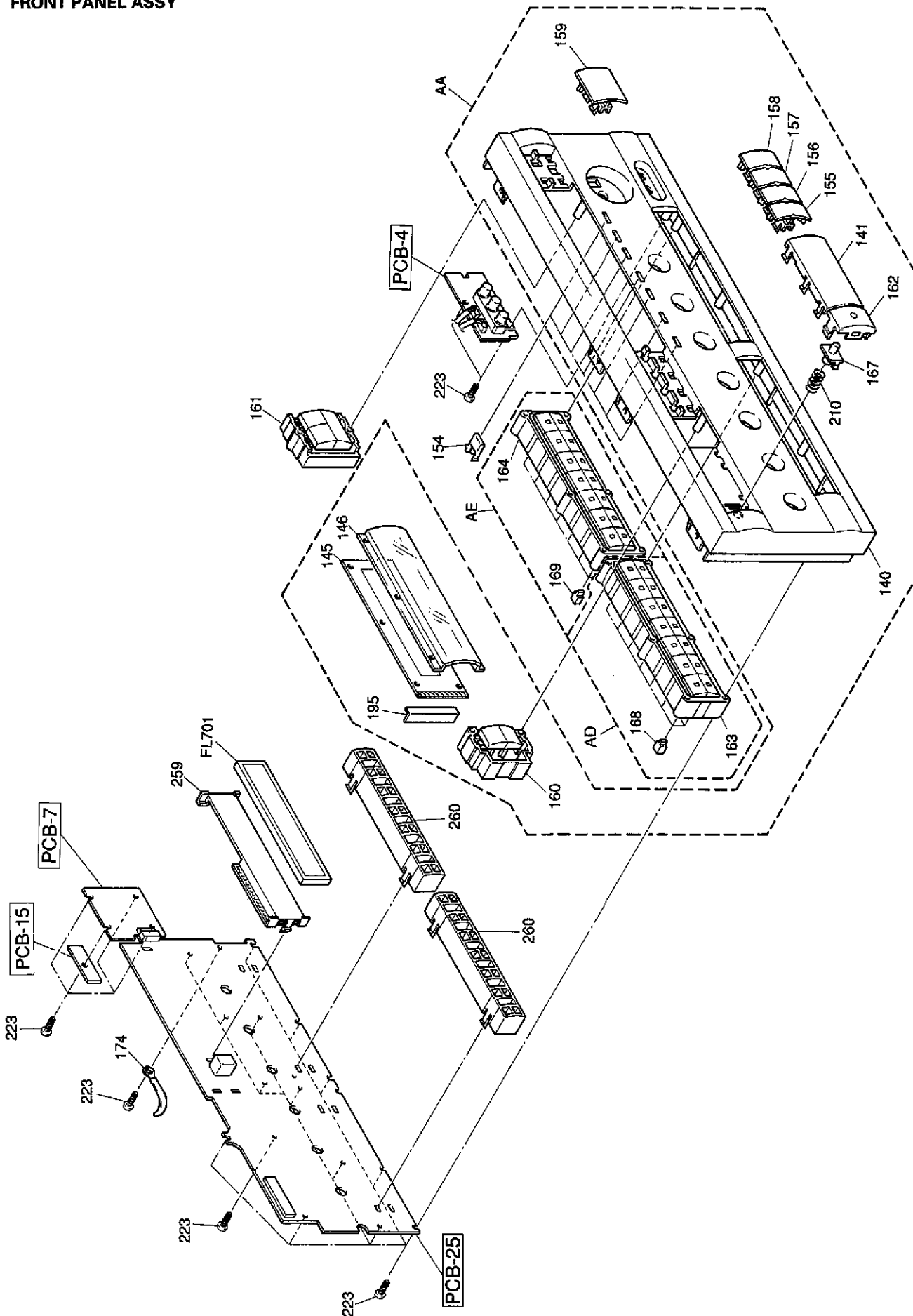

**GENERAL UNIT (2/2)**

**EXPLODED VIEW  
CHASSIS**

1  
2  
3  
4  
5  
6  
7

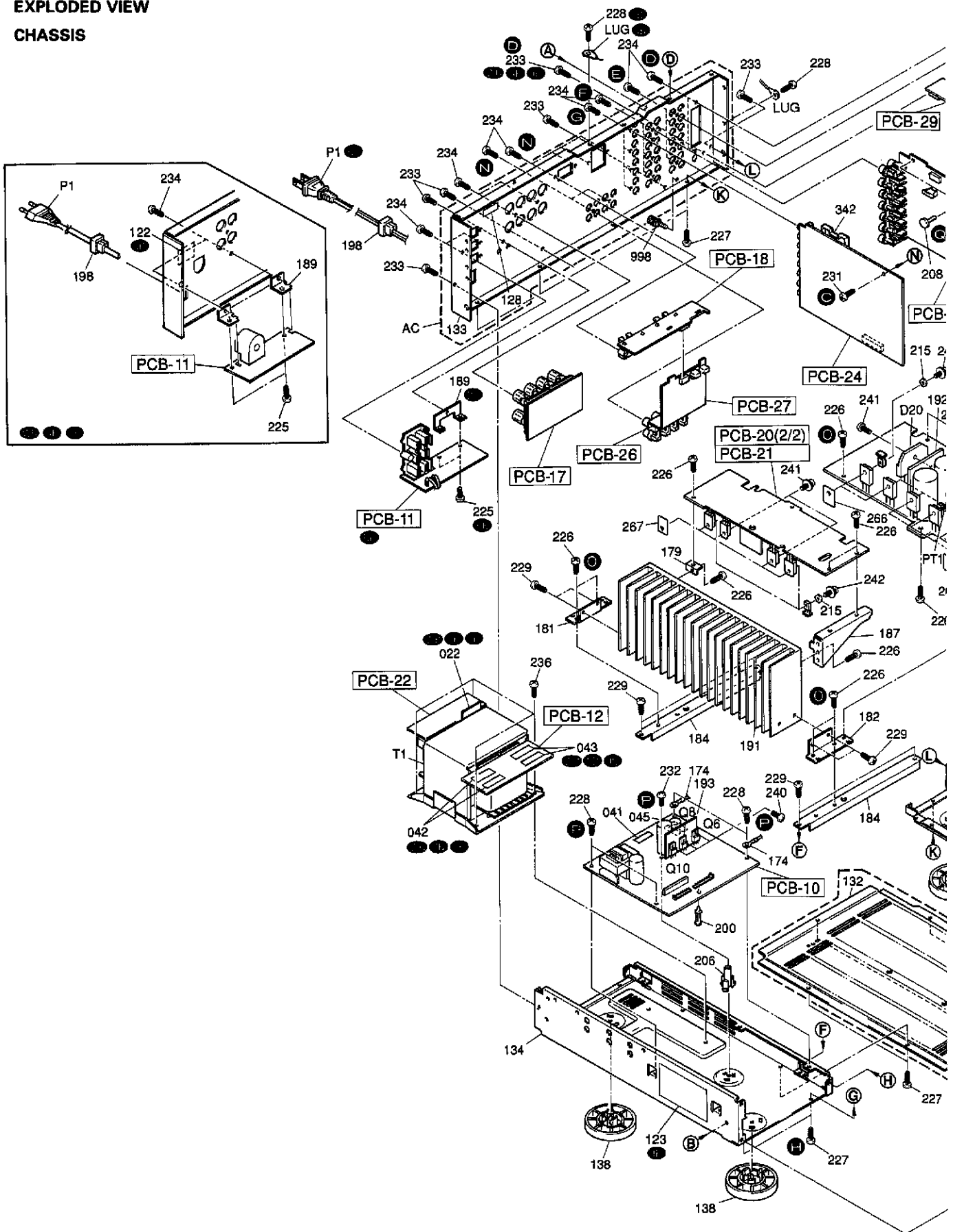

F

G

H

I

J

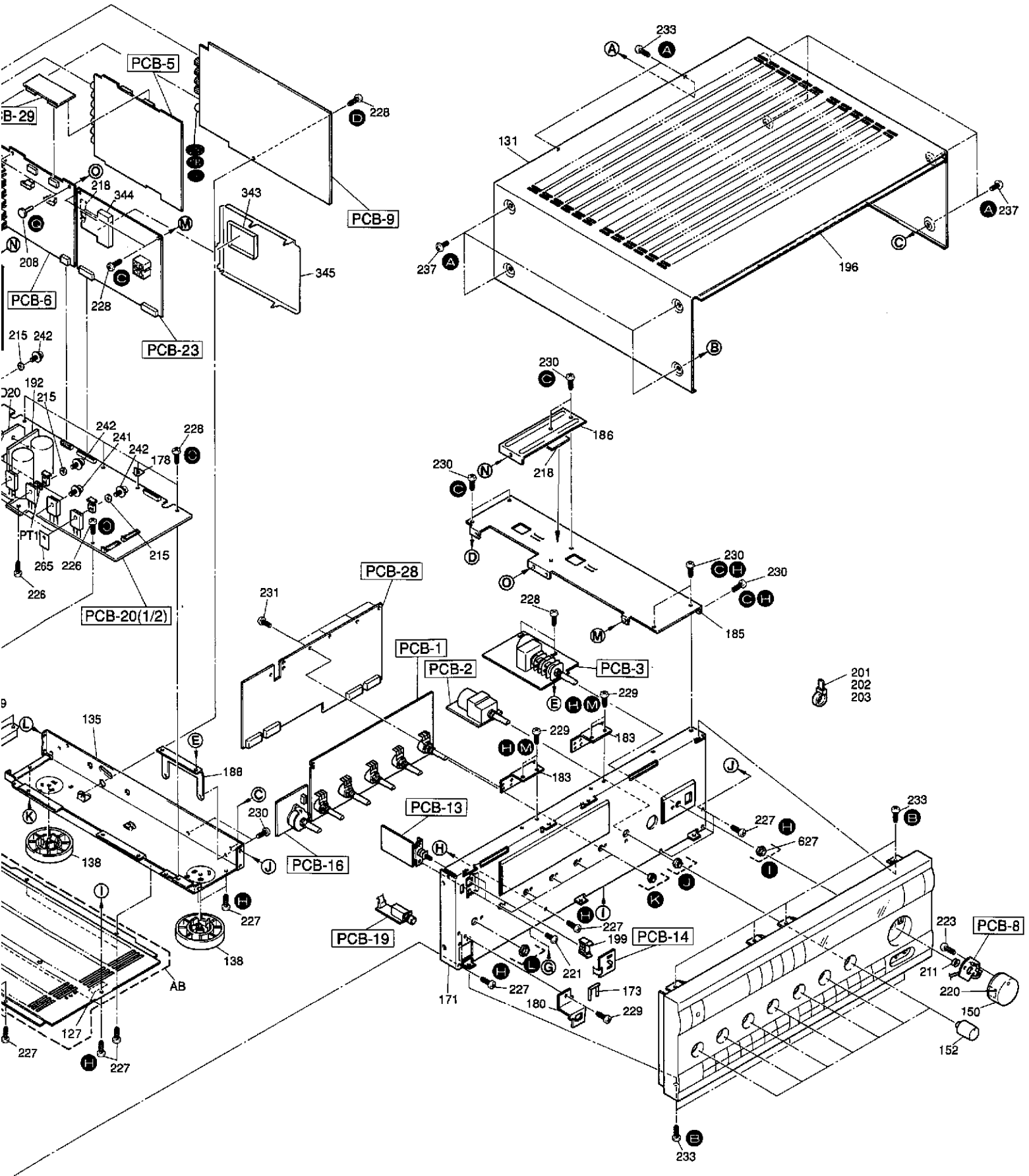

A B C D E

P. C. BOARDS (1)

PCB-6 Video Func P. C. Board

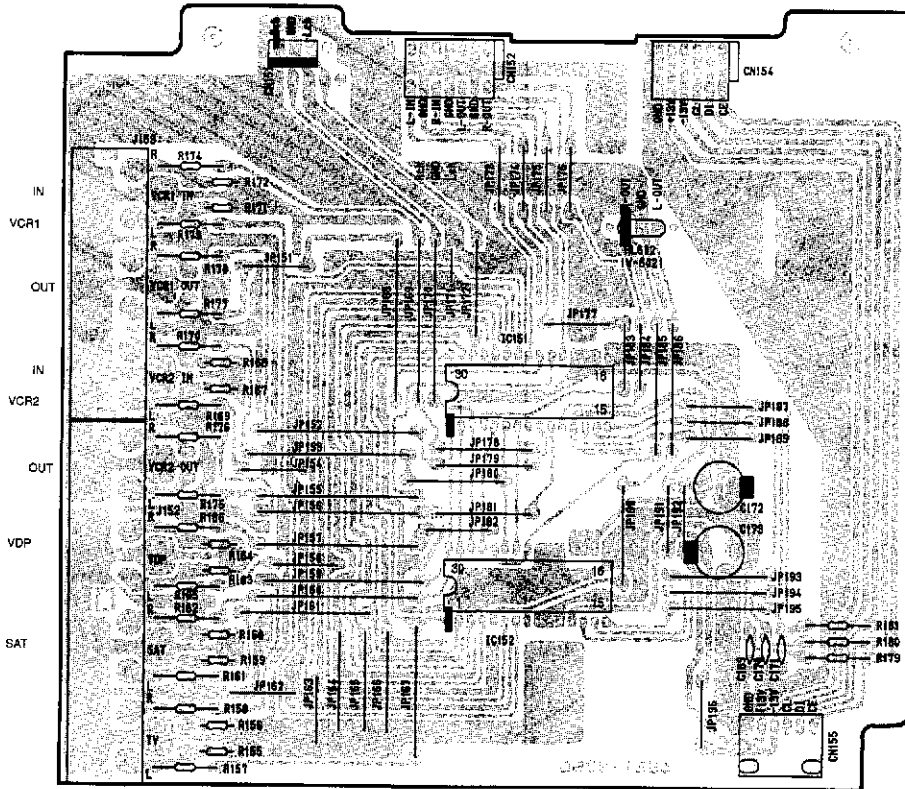

PCB-5 Audio Func P

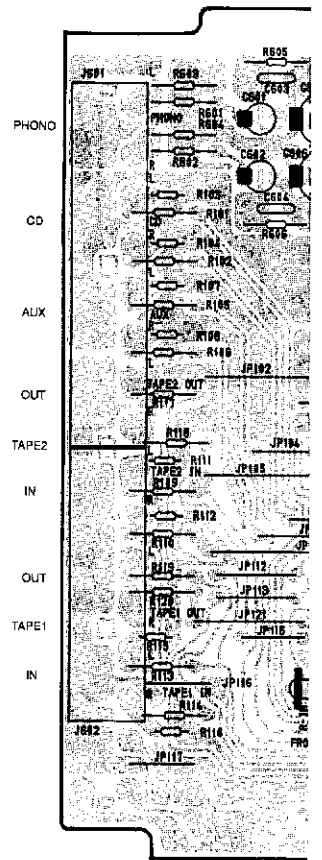

PCB-2

Rear VR P. C. Board

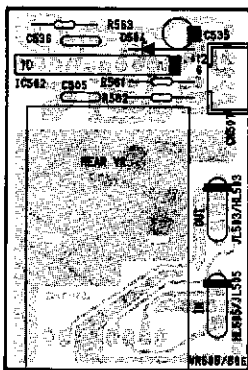

PCB-1 Tone P. C. Board

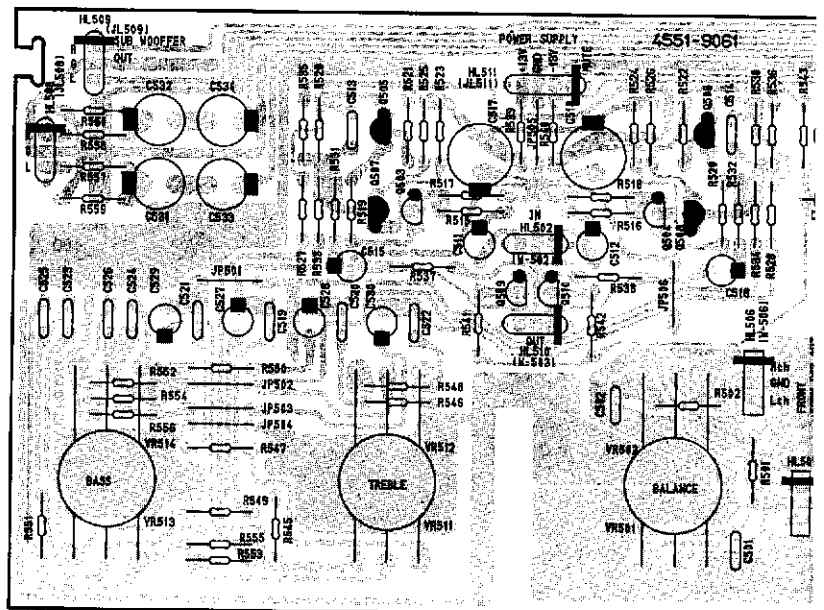

PCB-8

VR LED P. C. Board

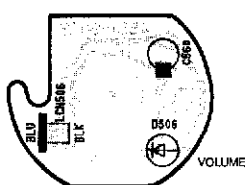

BASS TREBLE BALANCE

1

2

3

4

5

6

7

PCB-5 Audio Func P. C. Board

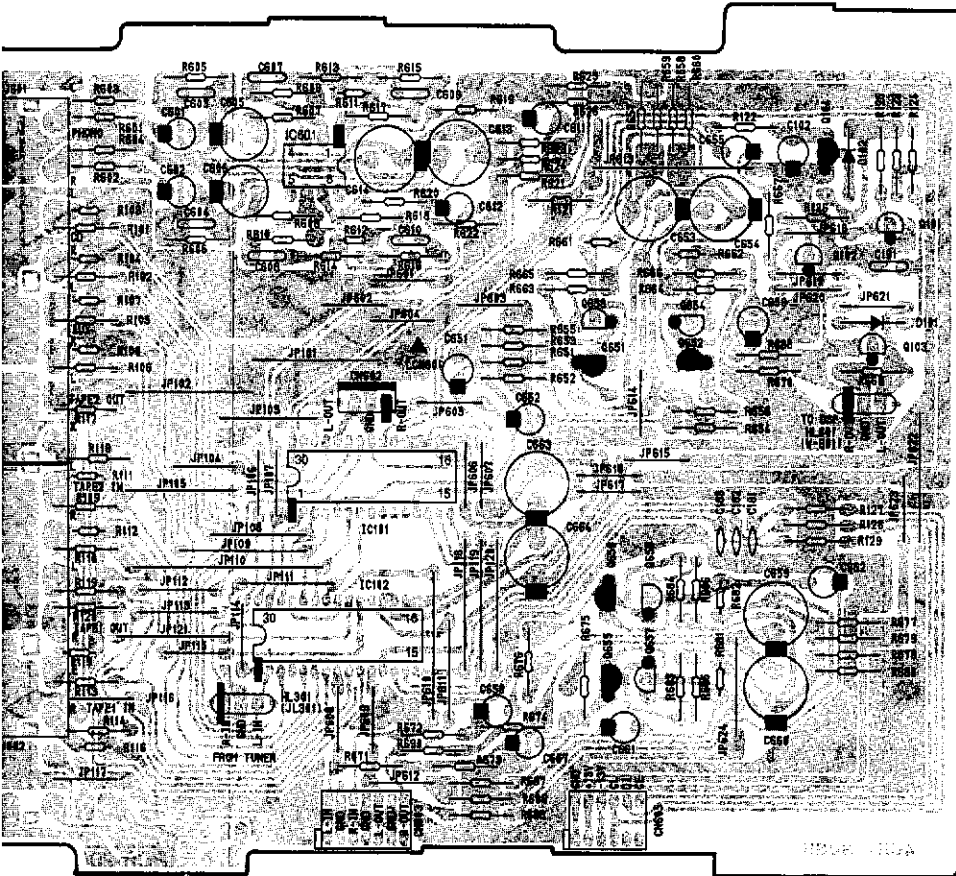

PCB-4

Front Pin Jack P. C. Board

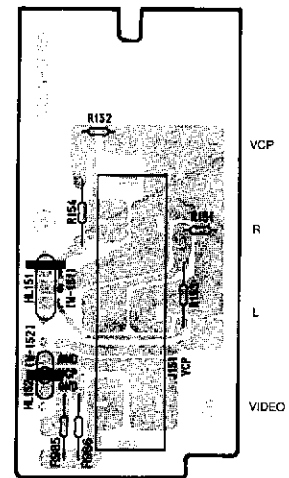

PCB-7 Tuner SW P. C. Board

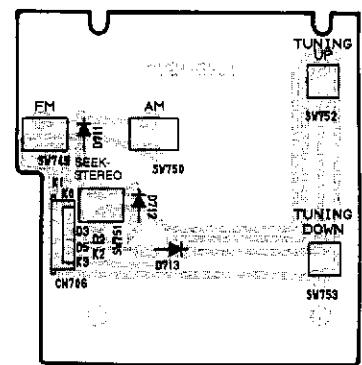

PCB-3 Master VR P. C. Board

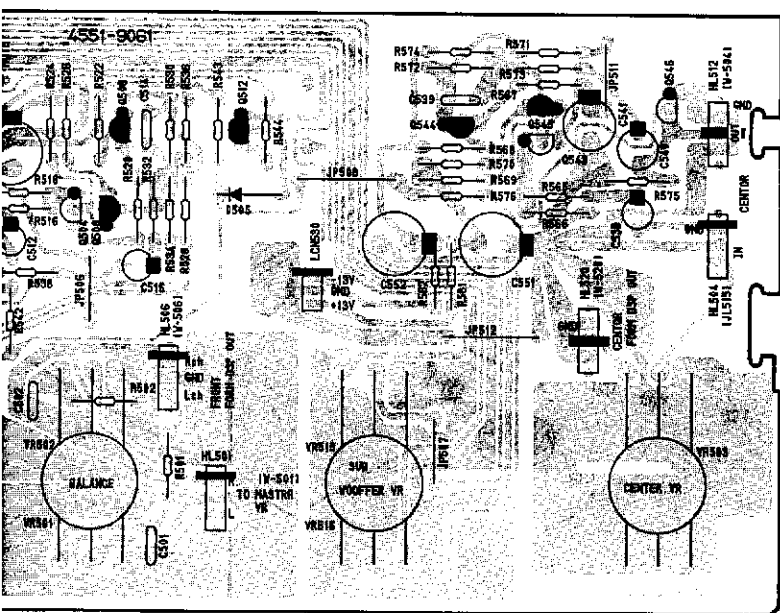
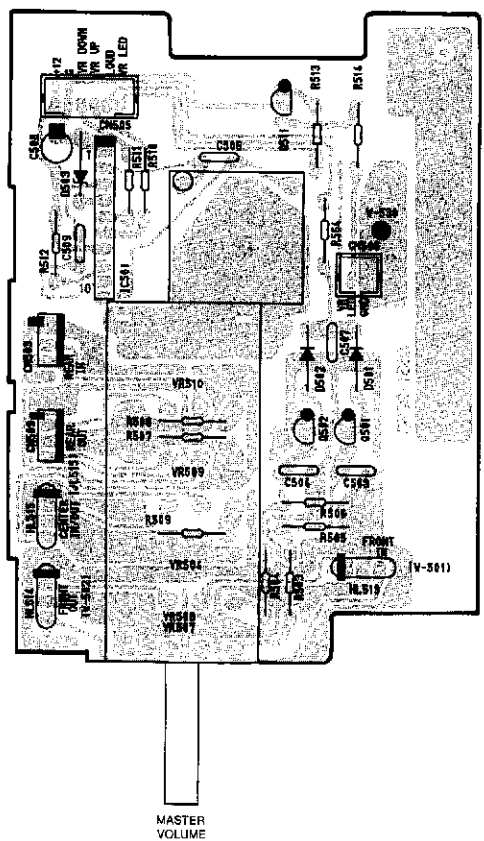

BALANCE

SUB WOOFER LEVEL

CENTER LEVEL

MASTER VOLUME



A

B

C

D

E

# P. C. BOARDS (2)

**PCB-9** Tuner P. C. Board

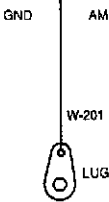
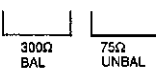
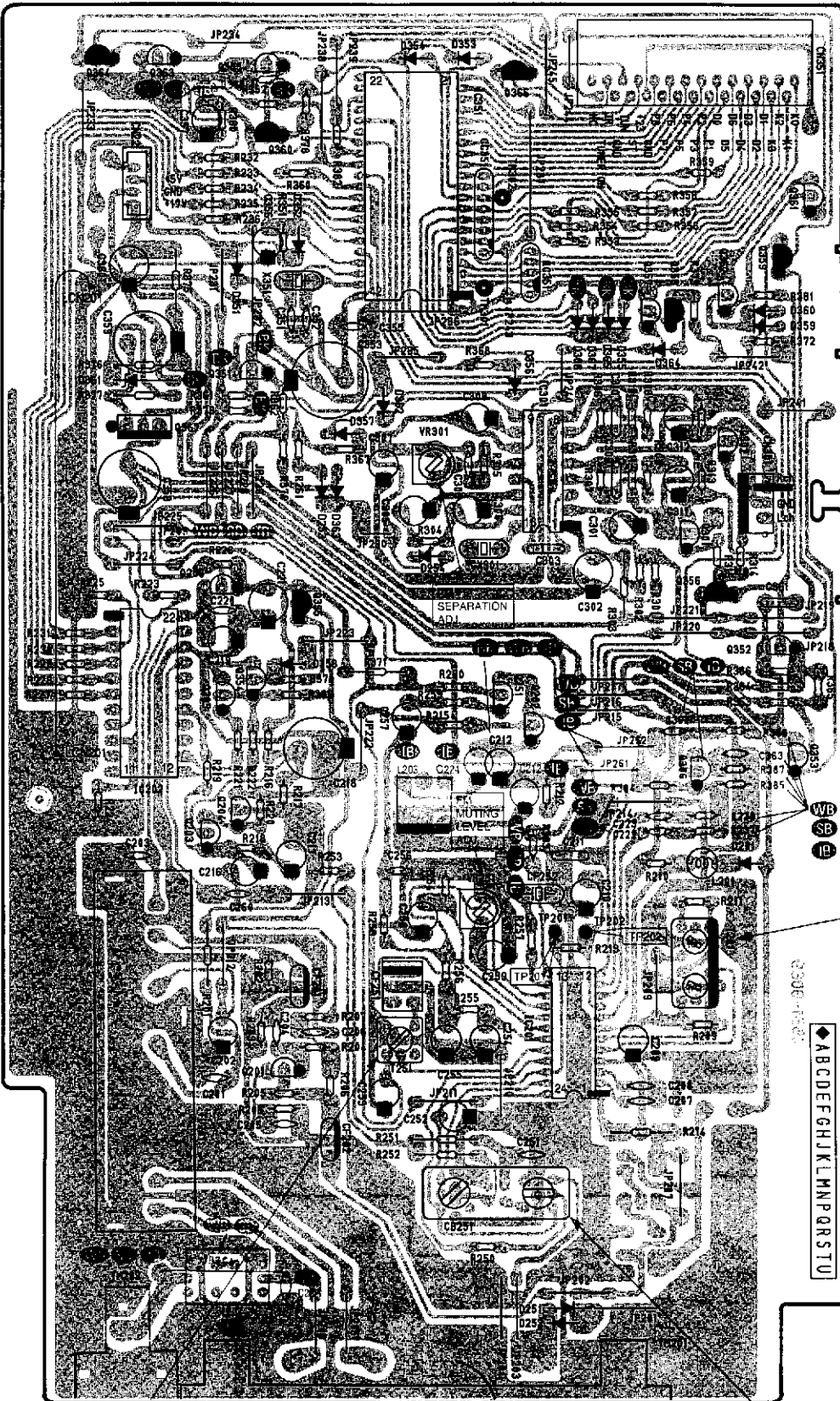

**PCB-11** AC Out

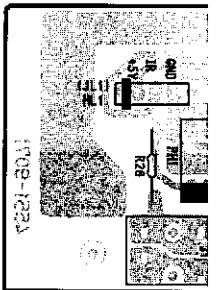

**PCB-11** AC Out/Vol Sele F

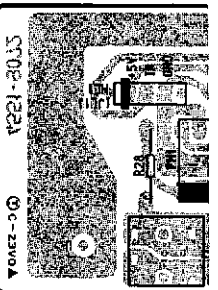

**PCB-10** Power

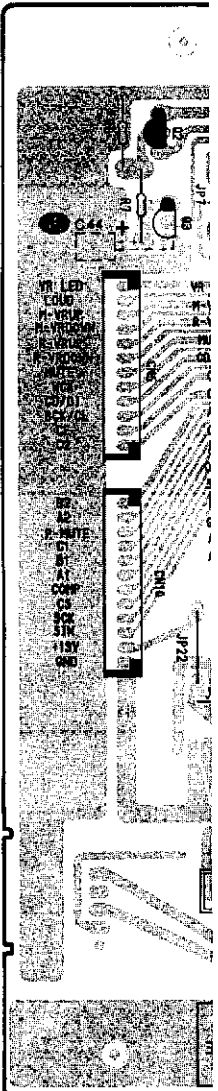

1

2

3

4

5

6

7

FM DISCRIMINATOR ADJ.

◆ ABCDEFGHJKLMNPQRSTU

AM TRACKING ADJ.

W-201

LUG

F

G

H

I

J

AC Out/Vol Sele P.C. Board BK

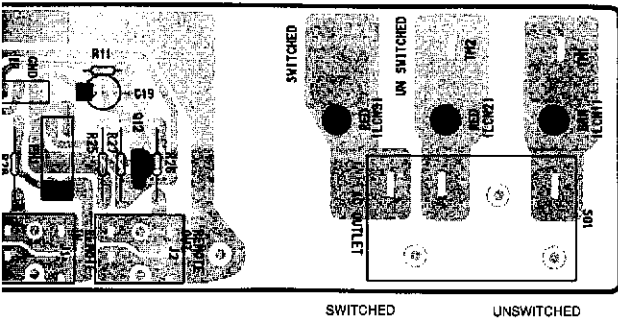

PCB-14

Power LED P. C. Board

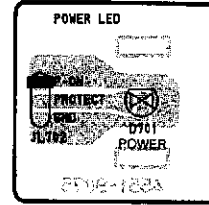

Sele P.C. Board WB SB IB

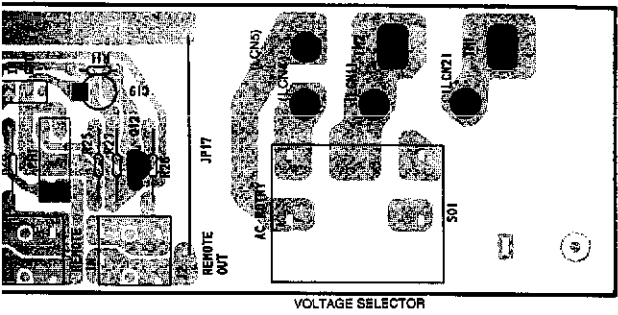

PCB-13

Power Switch P. C. Board

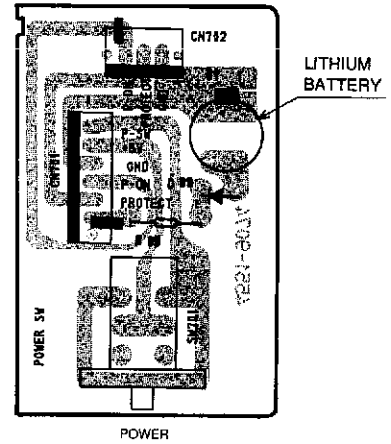

Power Supply P. C. Board

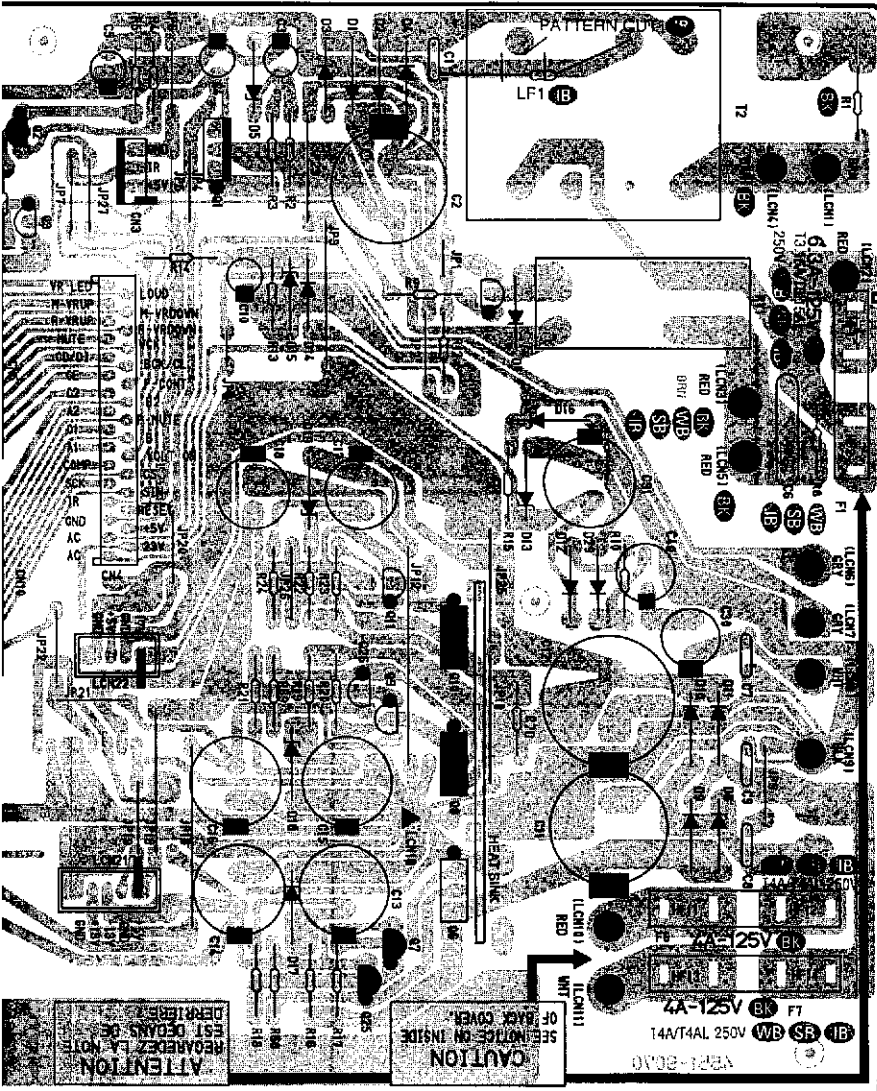

PCB-12

Power Supply 2 P. C. Board BK

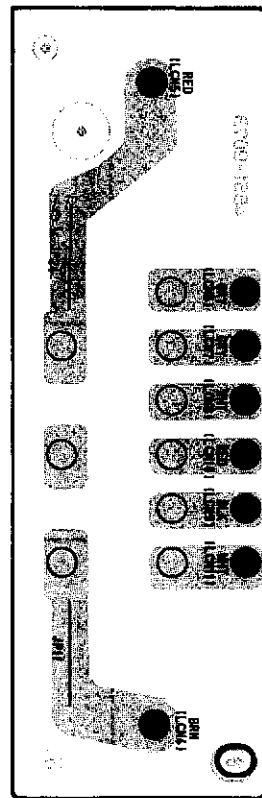

PCB-12

Power Supply 2 P. C. Board WB SB IB

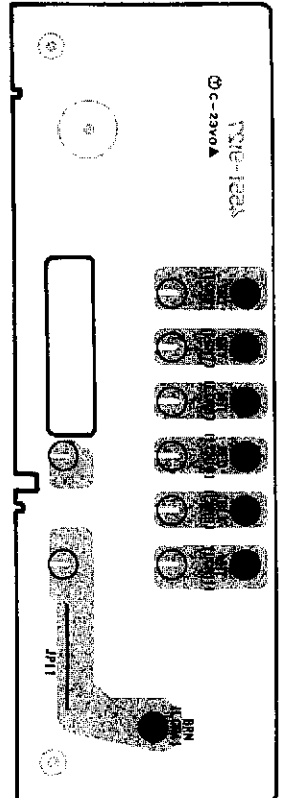

A B C D E

P. C. BOARDS (3)

1

Main L-ch Bias  
P.C. Board

Main R-ch Bias  
P.C. Board



2

PCB-20 (1/2) Main Amp P. C. Board

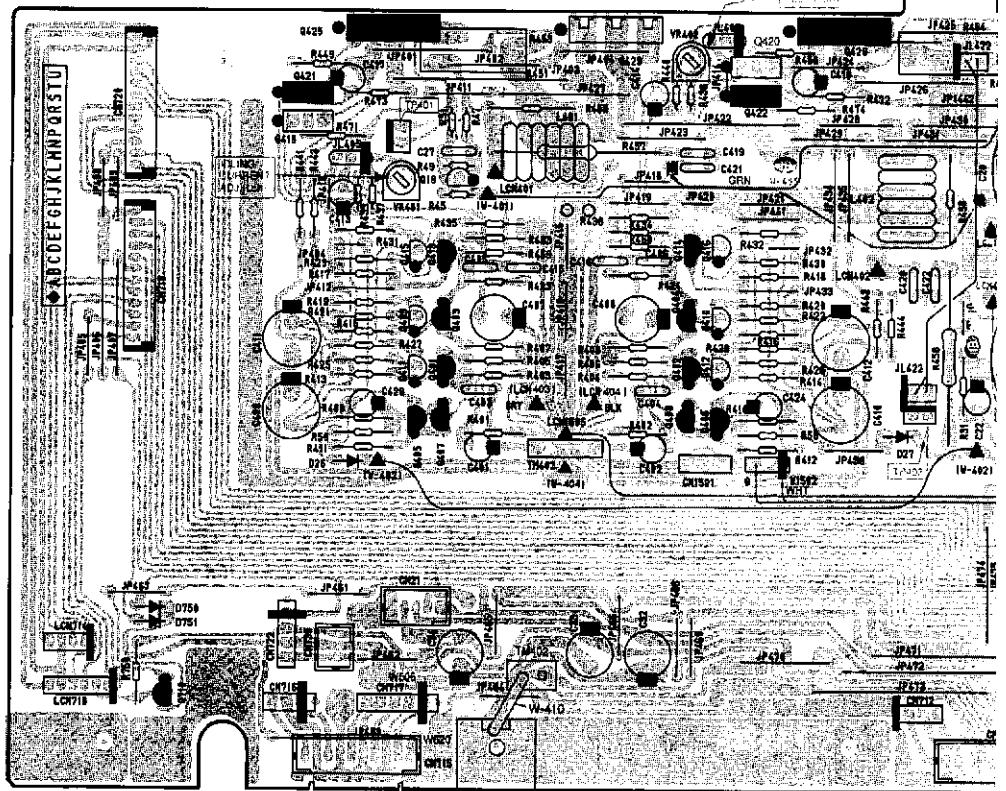

3

4

5

PCB-16 Front SP Select P. C. Board

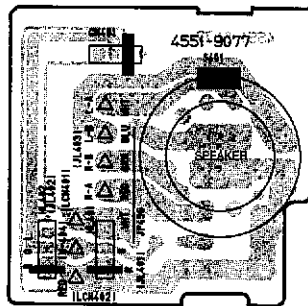

PCB-22 Power Supply 3 P.C. Board

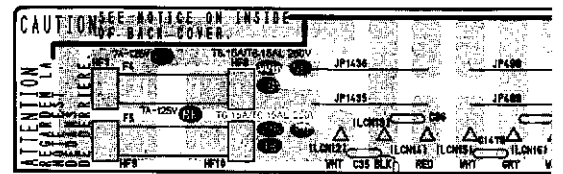

PCB-19

Headphones P. C. Board

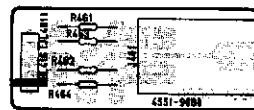

Rear L Bias  
P.C. Board



6

PCB-17 Front SP P. C. Board

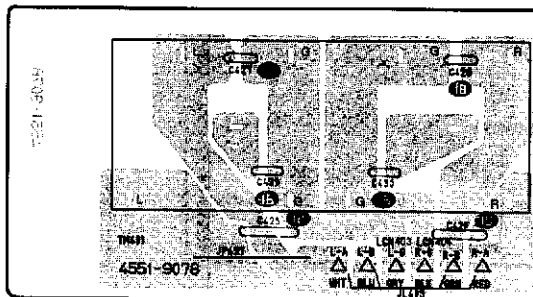

SPEAKER SYSTEM B

SPEAKER SYSTEM A

PCB-20 (2/2)  
PCB-21

Rear Amp P

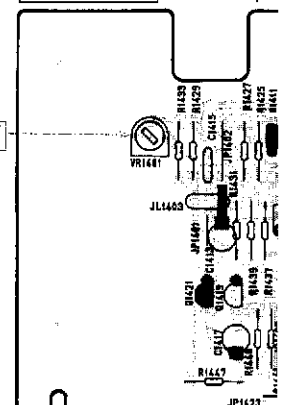

7

E

F

G

H

Main R-ch Bias P.C. Board



Center Bias P.C. Board

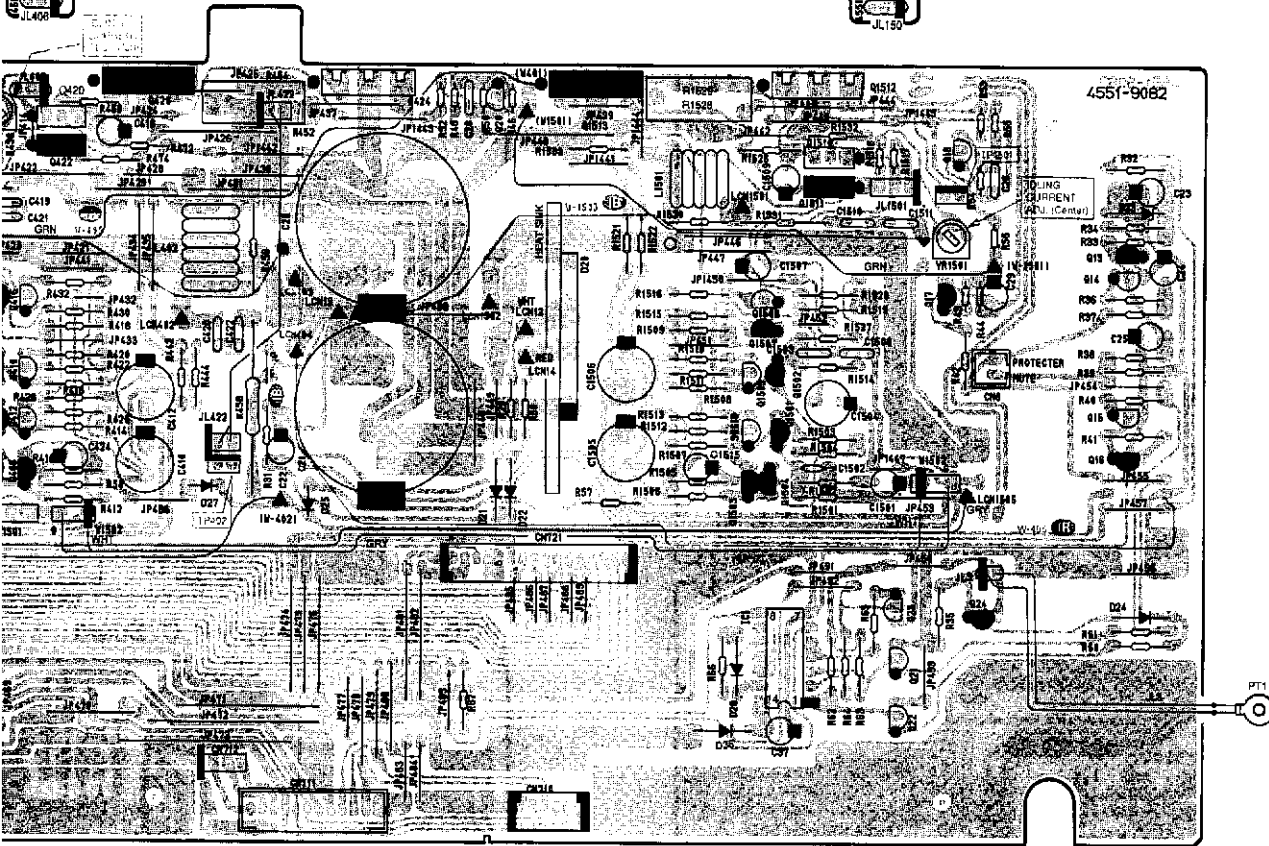

3 P.C. Board

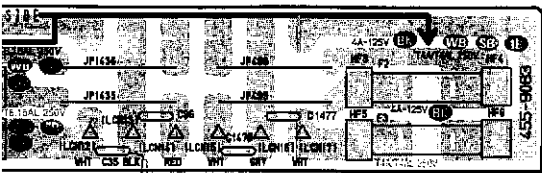

PCB-18 Rear, Center SP P. C. Board

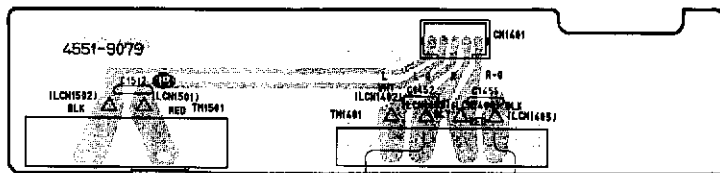

Rear L Bias P.C. Board



Rear R Bias P.C. Board



PCB-20 (2/2) PCB-21 Rear Amp P. C. Board

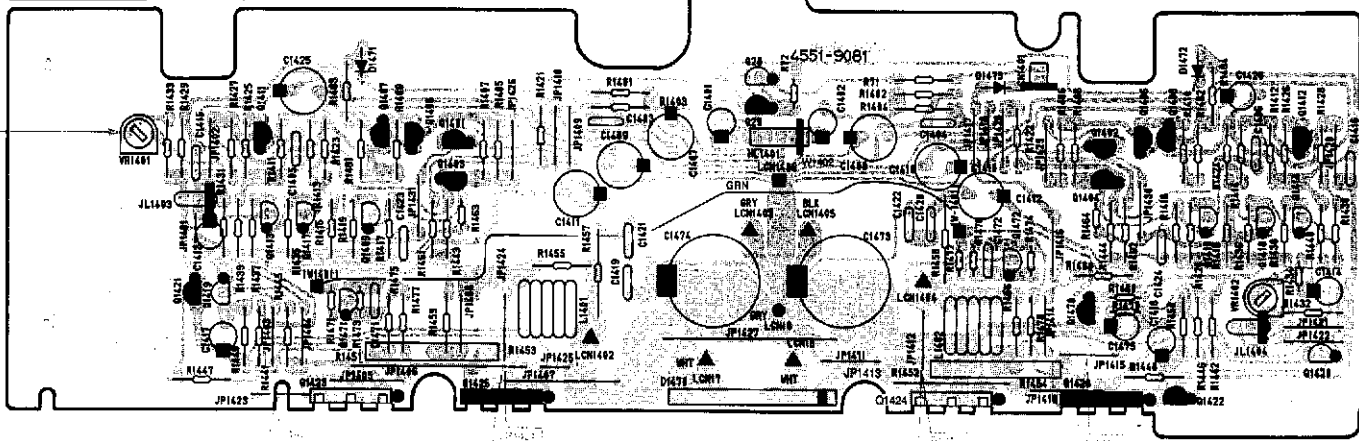

P. C. BOARDS (4)

PCB-28 Main Connector P. C. Board

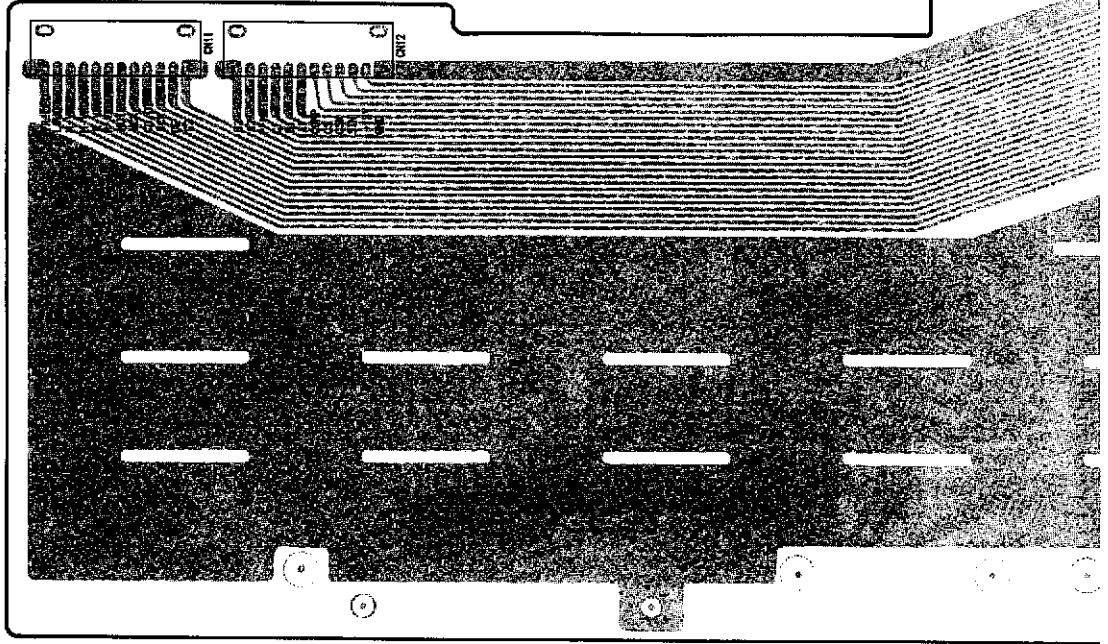

PCB-25 Front P. C. Board

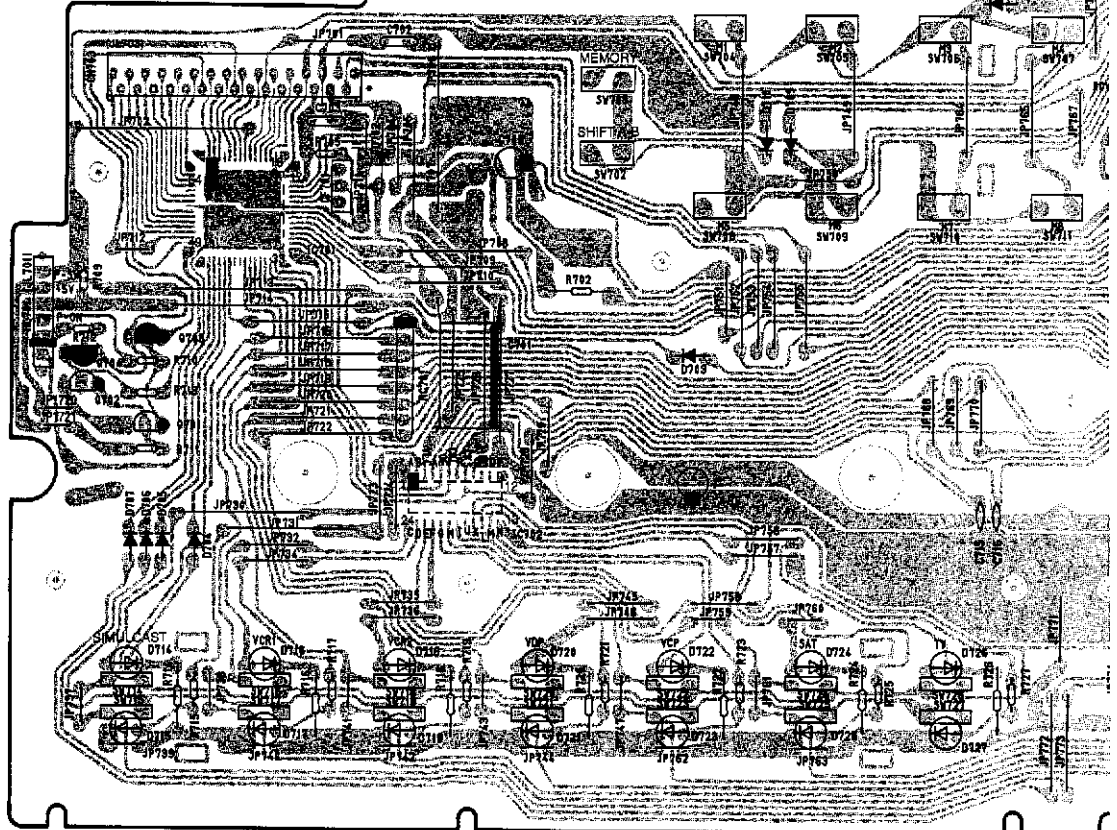

**PCB-26**

Line Out 1  
(Pin Jack)

P. C. Board

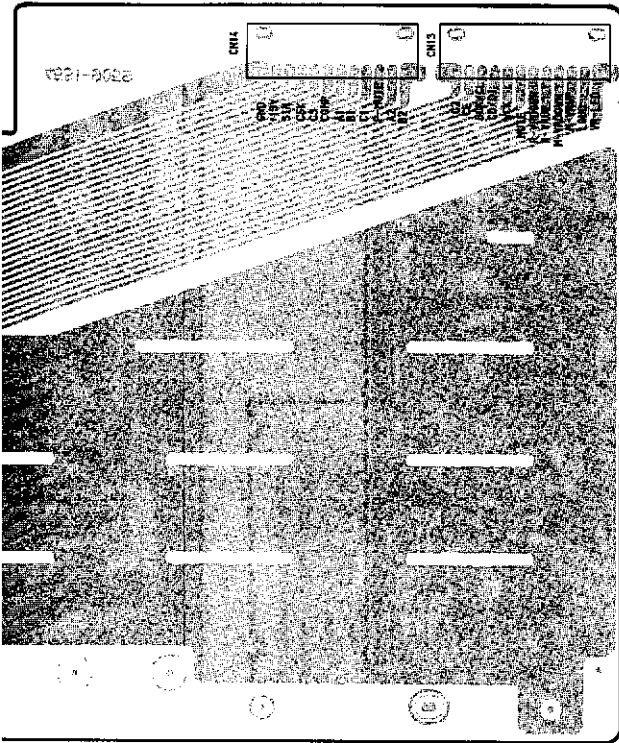

**PCB-27** Line Out 2 P. C. Board

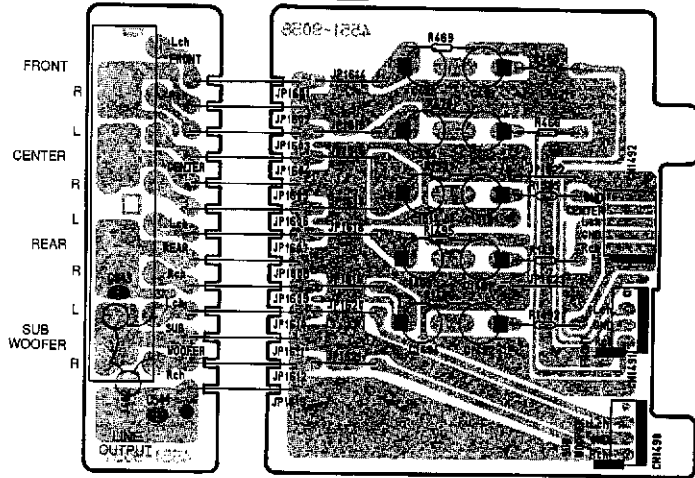

**PCB-29** Func Connector P.C. Board

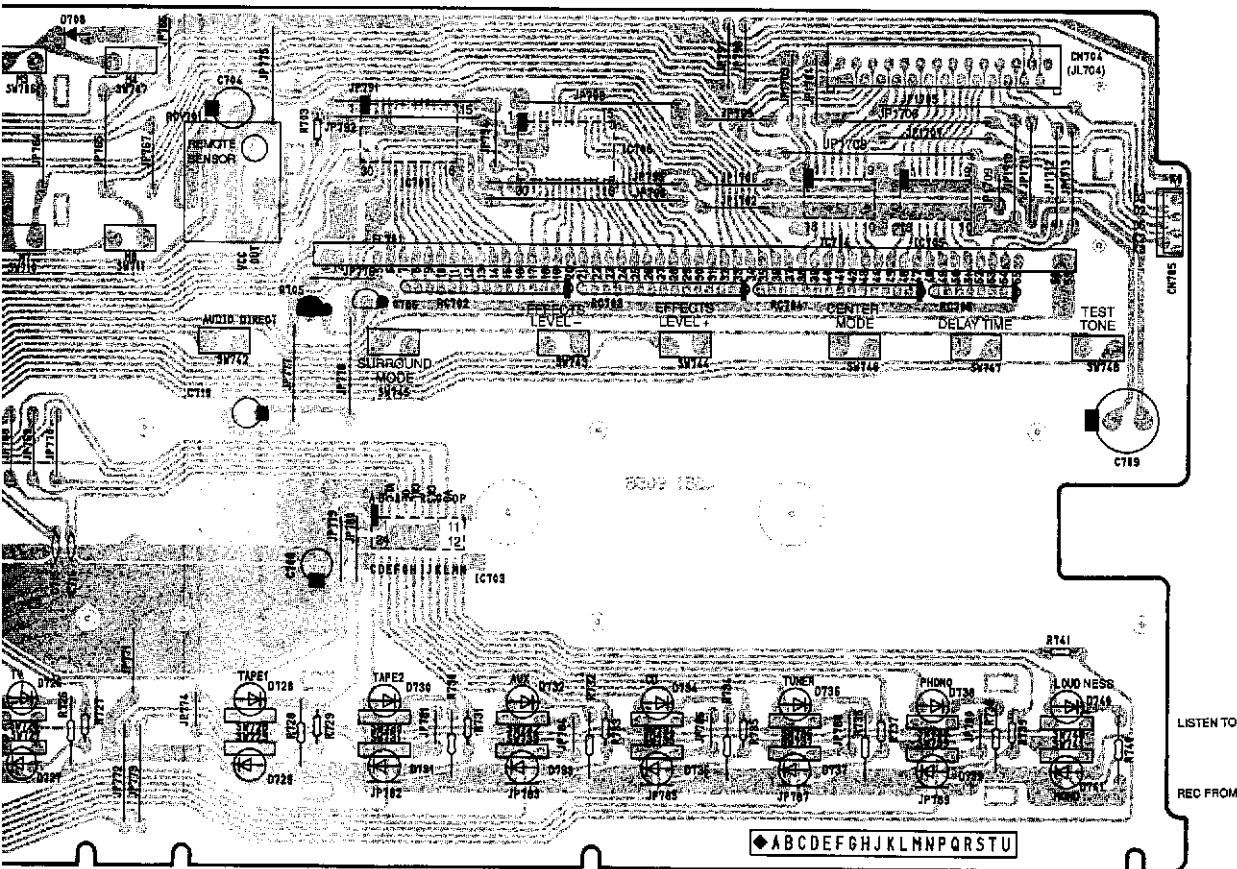
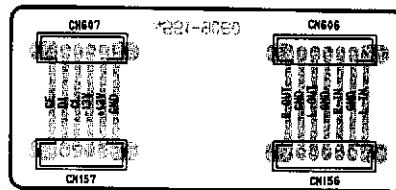

A

B

C

D

E

P. C. BOARDS (5)

PCB-23 DSP P. C. Board (Parts Side)

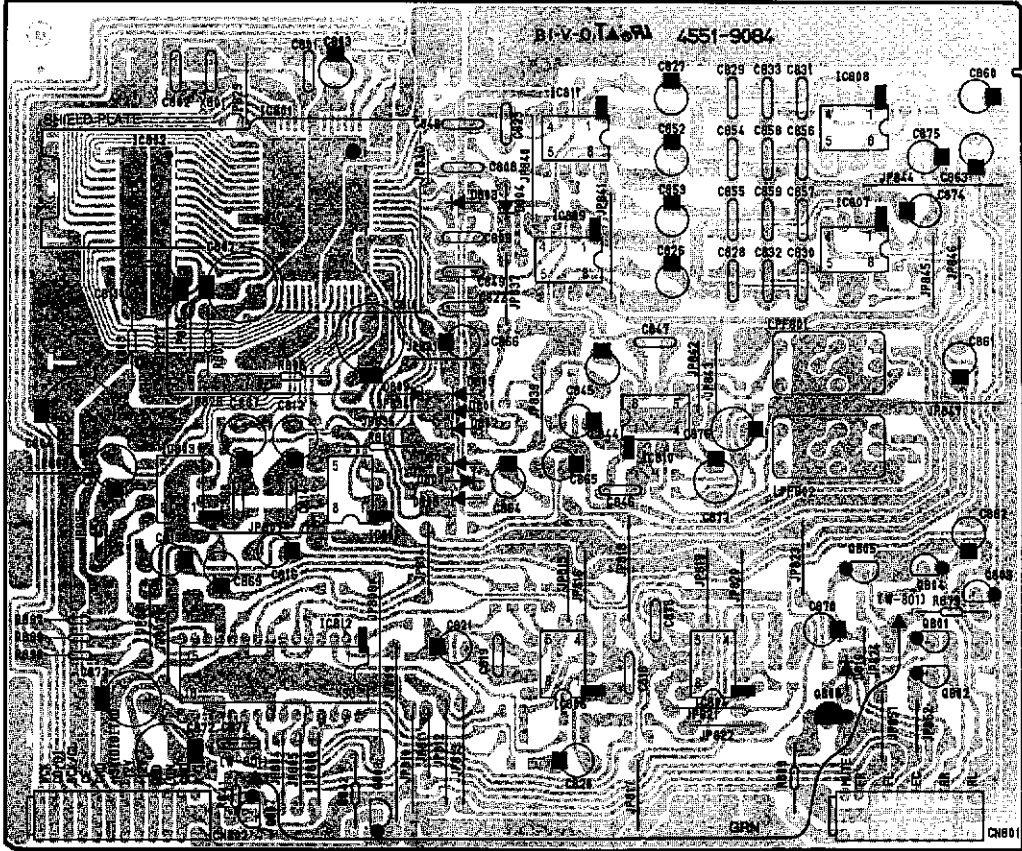

(Pattern Side)

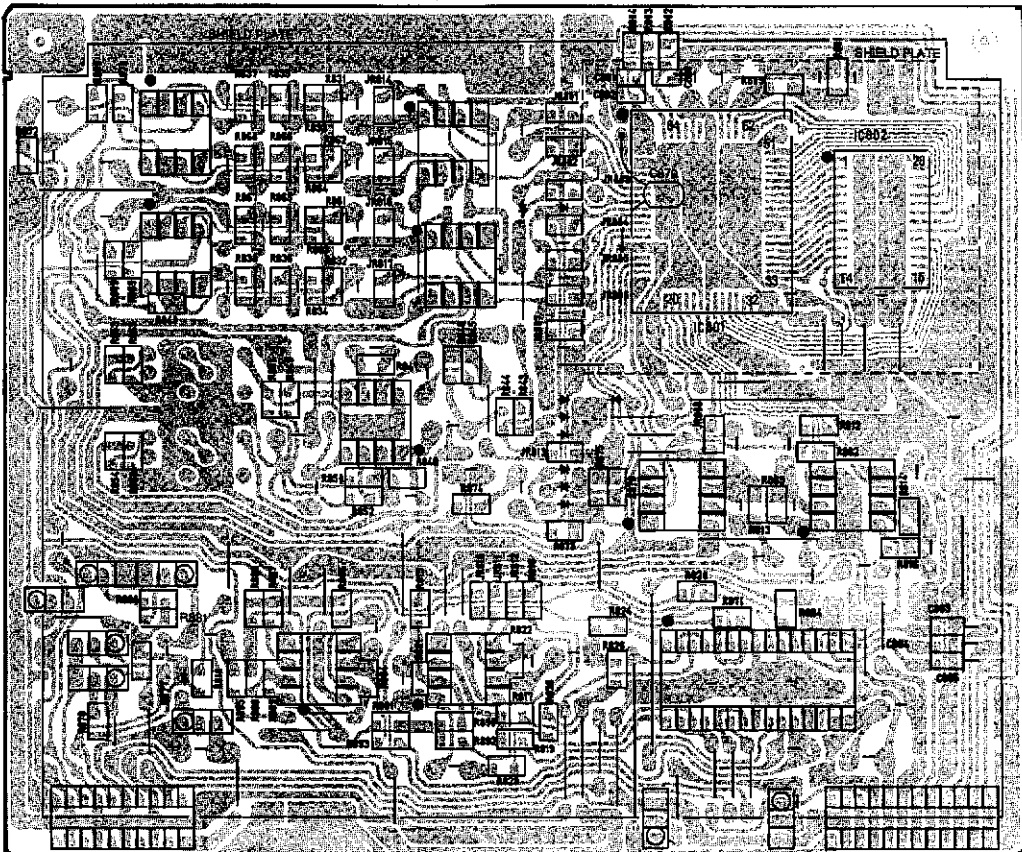

E

F

G

H

I

PCB-24 Video/On Screen P. C. Board (Parts Side)

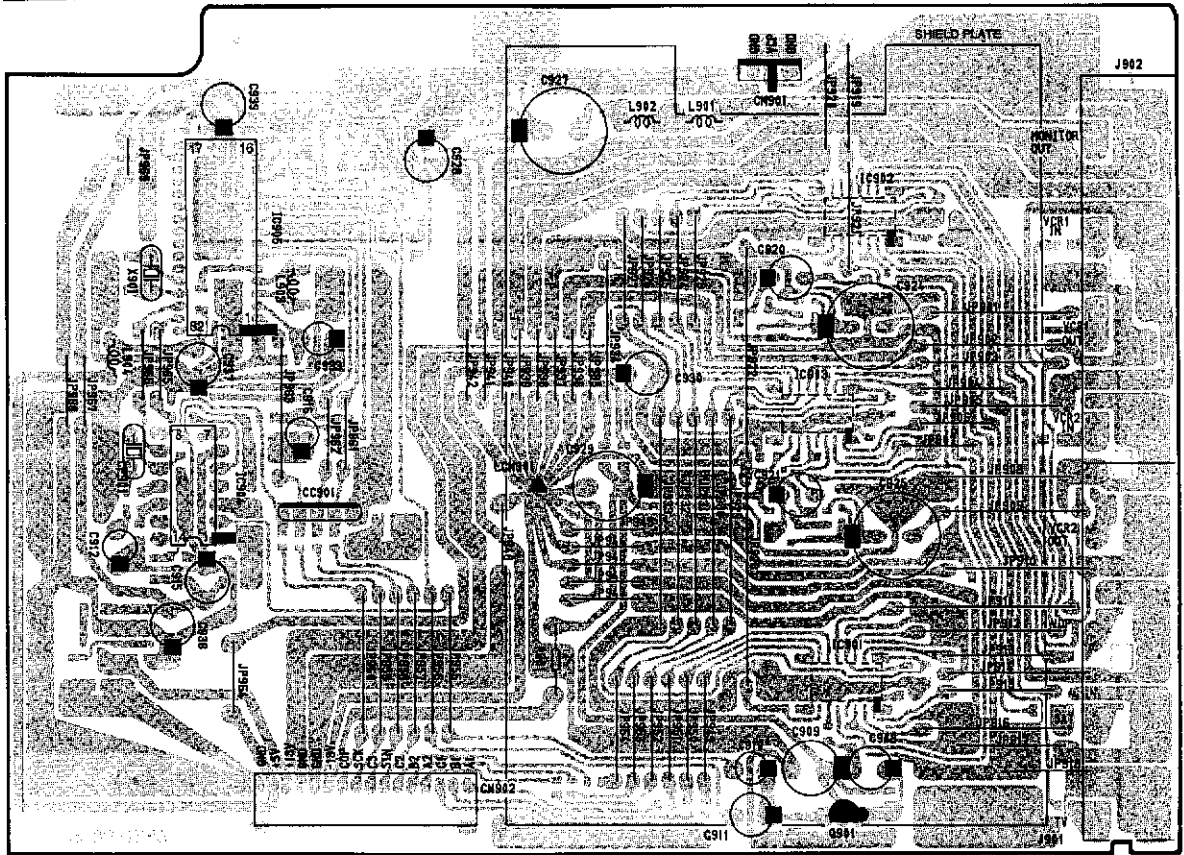

(Pattern Side)

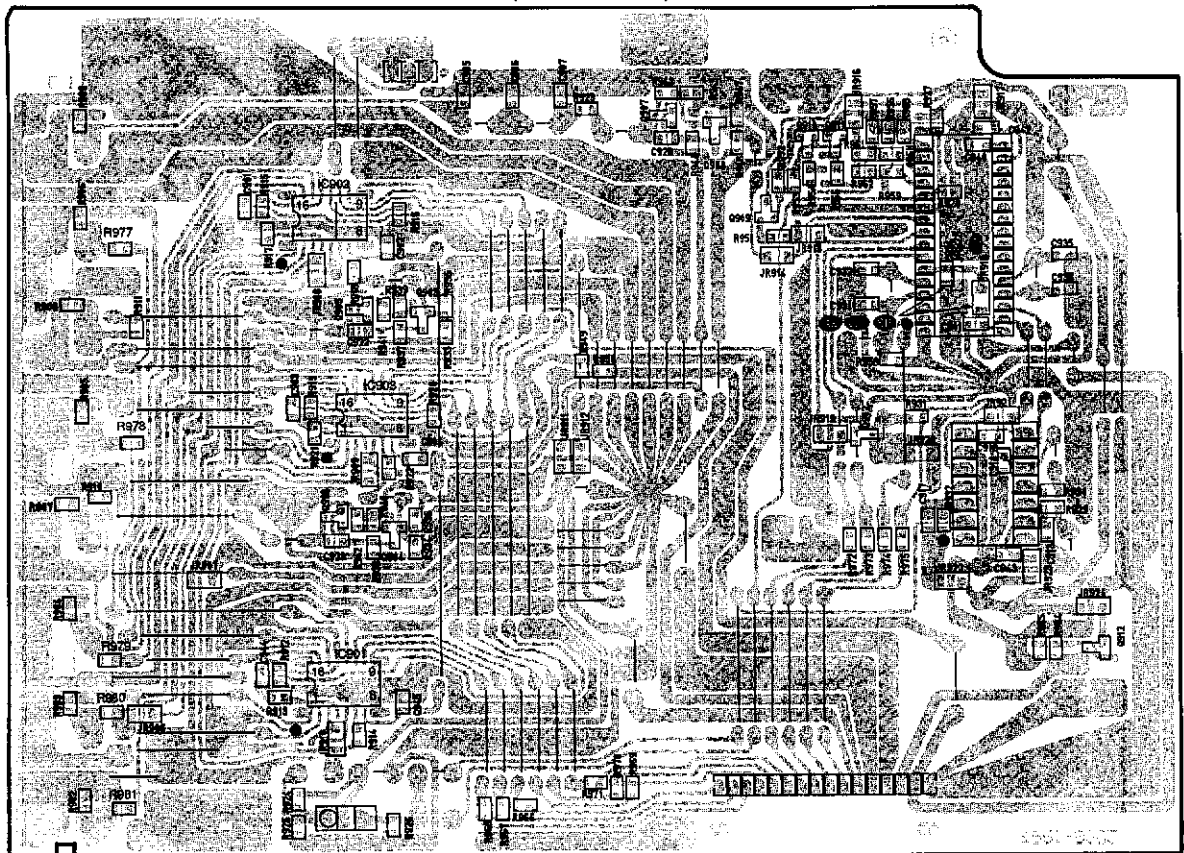



## ELECTRICAL PARTS LIST

Ser. No.	Ref. No.	Part No.	Description	Ser. No.	Ref. No.	Part No.	Description
<b>PCB-1 TONE P.C. BOARD</b>							
<b>CAPACITORS</b>							
685	C501	5359-1015851	CAP,PPP 100P	700	R552	5130-R030J154	RES,CBN 1/2P 150K
685	C502	5359-1015851	CAP,PPP 100P	698	R553	5130-R030J473	RES,CBN 1/2P 47K
669	C511	5345-226C041	CAP,MINI ELE 22 $\mu$ /16V	698	R554	5130-R030J473	RES,CBN 1/2P 47K
669	C512	5345-226C041	CAP,MINI ELE 22 $\mu$ /16V	694	R555	5130-R030J272	RES,CBN 1/2P 2.7K
673	C513	5353-020933	CAP,MCA 2P	694	R556	5130-R030J272	RES,CBN 1/2P 2.7K
673	C514	5353-020933	CAP,MCA 2P	695	R557	5130-R030J822	RES,CBN 1/2P 8.2K
672	C515	5345-476D041	CAP,MINI ELE 47 $\mu$ /25V	695	R558	5130-R030J822	RES,CBN 1/2P 8.2K
672	C516	5345-476D041	CAP,MINI ELE 47 $\mu$ /25V	692	R559	5130-R030J122	RES,CBN 1/2P 1.2K
671	C517	5345-337C041	CAP,MINI ELE 330 $\mu$ /16V	692	R560	5130-R030J122	RES,CBN 1/2P 1.2K
671	C518	5345-337C041	CAP,MINI ELE 330 $\mu$ /16V	690	R565	5130-R030J331	RES,CBN 1/2P 330
684	C519	5354-682J1HM	CAP,MYL 6800P	707	R566	5130-R030J683	RES,CBN 1/2P 68K
884	C520	5354-682J1HM	CAP,MYL 6800P	687	R567	5130-R030J101	RES,CBN 1/2P 100
683	C521	5354-393J1HM	CAP,MYL .039 $\mu$	691	R568	5130-R030J102	RES,CBN 1/2P 1K
683	C522	5354-393J1HM	CAP,MYL .039 $\mu$	691	R569	5130-R030J102	RES,CBN 1/2P 1K
682	C523	5354-273J1HM	CAP,MYL .027 $\mu$	686	R570	5130-R030J820	RES,CBN 1/2P 82
682	C524	5354-273J1HM	CAP,MYL .027 $\mu$	691	R571	5130-R030J102	RES,CBN 1/2P 1K
681	C525	5352-S110J154	CAP,MTL .15 $\mu$	690	R572	5130-R030J103	RES,CBN 1/2P 10K
681	C526	5352-S110J154	CAP,MTL .15 $\mu$	690	R573	5130-R030J331	RES,CBN 1/2P 330
668	C527	5345-225F041	CAP,MINI ELE 2.2 $\mu$ /50V	693	R574	5130-R030J222	RES,CBN 1/2P 2.2K
668	C528	5345-225F041	CAP,MINI ELE 2.2 $\mu$ /50V	698	R575	5130-R030J473	RES,CBN 1/2P 47K
669	C529	5345-226C041	CAP,MINI ELE 22 $\mu$ /16V	703	R576	5130-R030J105	RES,CBN 1/2P 1M
669	C530	5345-226C041	CAP,MINI ELE 22 $\mu$ /16V	688	R581	5130-R030J121	RES,CBN 1/2P 120
667	C531	5345-107D041	CAP,MINI ELE 100 $\mu$ /25V	688	R582	5130-R030J121	RES,CBN 1/2P 120
667	C532	5345-107D041	CAP,MINI ELE 100 $\mu$ /25V	<b>TRANSISTORS</b>			
667	C533	5345-107D041	CAP,MINI ELE 100 $\mu$ /25V	653	Q503	5613-2320L(F)	XISTOR,NPN R
667	C534	5345-107D041	CAP,MINI ELE 100 $\mu$ /25V	653	Q504	5613-2320L(F)	XISTOR,NPN R
669	C538	5345-226C041	CAP,MINI ELE 22 $\mu$ /16V	651	Q505	5611-999L(F)	XISTOR,PNP R
673	C539	5353-020933	CAP,MCA 2P	651	Q506	5611-999L(F)	XISTOR,PNP R
672	C540	5345-476D041	CAP,MINI ELE 47 $\mu$ /25V	651	Q507	5611-999L(F)	XISTOR,PNP R
670	C541	5345-227B041	CAP,MINI ELE 220 $\mu$ /10V	651	Q508	5611-999L(F)	XISTOR,PNP R
666	C551	5345-107D041	CAP,MINI ELE 100 $\mu$ /25V	654	Q509	5616-2SK364BL	FET,N-CH
666	C552	5345-107D041	CAP,MINI ELE 100 $\mu$ /25V	654	Q510	5616-2SK364BL	FET,N-CH
<b>RESISTORS</b>							
702	R501	5130-R030J331	RES,CBN 1/2P 330	652	Q512	5611-999L(F)	XISTOR,PNP R
702	R502	5130-R030J331	RES,CBN 1/2P 330	653	Q543	5613-2320L(F)	XISTOR,NPN R
690	R515	5130-R030J331	RES,CBN 1/2P 330	651	Q544	5611-999L(F)	XISTOR,PNP R
690	R516	5130-R030J331	RES,CBN 1/2P 330	651	Q545	5611-999L(F)	XISTOR,PNP R
707	R517	5130-R030J683	RES,CBN 1/2P 68K	654	Q546	5616-2SK364BL	FET,N-CH
707	R518	5130-R030J683	RES,CBN 1/2P 68K	<b>DIODE</b>			
687	R519	5130-R030J101	RES,CBN 1/2P 100	655	D505	5631-1S2473	DIODE,DET
687	R520	5130-R030J101	RES,CBN 1/2P 100	<b>CONTROLS</b>			
691	R521	5130-R030J102	RES,CBN 1/2P 1K	658	VR501/502	5113-S0906503	RES,V CBN 16 50K, BALANCE
691	R522	5130-R030J102	RES,CBN 1/2P 1K	660	VR503	5113-S1901503	RES,V CBN 16 50K, CENTER LEVEL
691	R523	5130-R030J102	RES,CBN 1/2P 1K	662	VR511/512	5113-S0905503	RES,V CBN 16 50K, TREBLE
691	R524	5130-R030J102	RES,CBN 1/2P 1K	664	VR513/514	5113-S0904104	RES,V CBN 16 100K, BASS
686	R525	5130-R030J820	RES,CBN 1/2P 82	656	VR515/516	5113-S1902502	RES,V CBN 16 5K, SUB WOOFER LEVEL
686	R526	5130-R030J820	RES,CBN 1/2P 82	<b>MISCELLANEOUS</b>			
690	R527	5130-R030J331	RES,CBN 1/2P 330	898	△ JL508	4242-R0503600	JUMPER LEAD
690	R528	5130-R030J331	RES,CBN 1/2P 330	899	△ JL509	4242-R0503601	JUMPER LEAD
701	R529	5130-R030J274	RES,CBN 1/2P 270K	896	△ JL511	4242-R0504301	JUMPER LEAD
701	R530	5130-R030J274	RES,CBN 1/2P 270K	937	△ LCN530	4163-S0203251	CONNECTOR W/W
690	R531	5130-R030J331	RES,CBN 1/2P 330	248		2240-Z031	HOLDER, HL501, 502, 506, 510, 512, 520
690	R532	5130-R030J331	RES,CBN 1/2P 330	249		2240-Z032	HOLDER, HL504, 508, 509
689	R533	5130-R030J221	RES,CBN 1/2P 220	257		2240-Z042	HOLDER, HL511
689	R534	5130-R030J221	RES,CBN 1/2P 220	<b>PCB-2 REAR VOLUME P.C. BOARD</b>			
693	R535	5130-R030J222	RES,CBN 1/2P 2.2K	<b>CAPACITORS</b>			
693	R536	5130-R030J222	RES,CBN 1/2P 2.2K	644	C505	5352-S110J104	CAP,MTL .1 $\mu$
698	R537	5130-R030J473	RES,CBN 1/2P 47K	643	C535	5345-106F041	CAP,MINI ELE 10 $\mu$ /50V
698	R538	5130-R030J473	RES,CBN 1/2P 47K	645	C536	5359-S010J103	CAP,PPP .01 $\mu$
688	R539	5130-R030J121	RES,CBN 1/2P 120	<b>RESISTORS</b>			
688	R540	5130-R030J121	RES,CBN 1/2P 120	646	R561	5130-R030J102	RES,CBN 1/2P 1K
703	R541	5130-R030J105	RES,CBN 1/2P 1M	646	R562	5130-R030J102	RES,CBN 1/2P 1K
703	R542	5130-R030J105	RES,CBN 1/2P 1M	647	R563	5130-R030J100	RES,CBN 1/2P 10
699	R543	5130-R030J104	RES,CBN 1/2P 100K	<b>INTEGRATED CIRCUIT</b>			
696	R544	5130-R030J103	RES,CBN 1/2P 10K	639	IC502	5653-LB1641	IC,LINEAR
692	R545	5130-R030J122	RES,CBN 1/2P 1.2K	<b>DIODE</b>			
692	R546	5130-R030J122	RES,CBN 1/2P 1.2K	640	D504	5635-HZ562	DIODE,ZENER
690	R547	5130-R030J331	RES,CBN 1/2P 330				
690	R548	5130-R030J331	RES,CBN 1/2P 330				
697	R549	5130-R030J153	RES,CBN 1/2P 15K				
697	R550	5130-R030J153	RES,CBN 1/2P 15K				
700	R551	5130-R030J154	RES,CBN 1/2P 150K				

Ser. No.	Ref. No.	Part No.	Description
<b>CONTROLS</b>			
641	VR505/506	6161-00901	VR BLOCK 50K, REAR LEVEL
<b>MISCELLANEOUS</b>			
885	CN507	4443-0401140	CONNECTOR
895	△ JL503	4242-R0503121	JUMPER LEAD
895	△ JL505	4242-R0503121	JUMPER LEAD
250		2240-Z032	HOLDER, HL503, 505

**PCB-3 MASTER VOLUME P.C. BOARD**

<b>CAPACITORS</b>			
629	C503	5352-S110J823	CAP,MTL .082μ
629	C504	5352-S110J823	CAP,MTL .082μ
631	C506	5352-S110J104	CAP,MTL .1μ
631	C507	5352-S110J104	CAP,MTL .1μ
628	C508	5345-106F041	CAP,MINI ELE 10μ/50V
630	C509	5359-S010J103	CAP,PPP .01μ
<b>RESISTORS</b>			
634	R503	5130-R030J472	RES,CBN 1/2P 4.7K
634	R504	5130-R030J472	RES,CBN 1/2P 4.7K
635	R505	5130-R030J273	RES,CBN 1/2P 27K
635	R506	5130-R030J273	RES,CBN 1/2P 27K
634	R507	5130-R030J472	RES,CBN 1/2P 4.7K
634	R508	5130-R030J472	RES,CBN 1/2P 4.7K
634	R509	5130-R030J472	RES,CBN 1/2P 4.7K
633	R510	5130-R030J102	RES,CBN 1/2P 1K
633	R511	5130-R030J102	RES,CBN 1/2P 1K
632	R512	5130-R030J100	RES,CBN 1/2P 10
633	R513	5130-R030J102	RES,CBN 1/2P 1K
637	R514	5130-R030J221	RES,CBN 1/2P 220
636	R564	5130-R030J105	RES,CBN 1/2P 1M

**INTEGRATED CIRCUIT**

621	IC501	5653-LB1641	IC,LINEAR
-----	-------	-------------	-----------

**TRANSISTORS**

622	Q501	5616-2SK366BL	FET,N-CH
622	Q502	5616-2SK366BL	FET,N-CH
623	Q511	5613-2603(F)	XISTOR,NPN R

**DIODES**

624	D501	5631-1S2473	DIODE,DET
624	D502	5631-1S2473	DIODE,DET
625	D503	5635-HZ5B2	DIODE,ZENER

**CONTROLS**

626	VR504/507/ 508/509/ 510	6161-00801	VR BLOCK 100K, MASTER VOLUME
-----	-------------------------------	------------	------------------------------

**MISCELLANEOUS**

882	CN503	4443-030185	CONNECTOR
883	CN505	4443-0601140	CONNECTOR
884	CN506	4443-0201140	CONNECTOR
882	CN509	4443-030185	CONNECTOR
894	△ JL515	4242-R0503201	JUMPER LEAD
251		2240-Z032	HOLDER, HL515
252		2240-Z031	HOLDER, HL513, 514

**PCB-4 FRONT PIN JACK P.C. BOARD**

<b>RESISTORS</b>			
738	R151	5130-R010J104	RES,CBN 1/6P 100K
738	R152	5130-R010J104	RES,CBN 1/6P 100K
740	R153	5130-R030J102	RES,CBN 1/2P 1K
740	R154	5130-R030J102	RES,CBN 1/2P 1K
739	R985	5130-R030J750	RES,CBN 1/2P 75
736	R986	5130-R030J470	RES,CBN 1/2P 47
<b>MISCELLANEOUS</b>			
938	△ J151	4489-04201003	3 PIN JACK,MLT, VIDEO, VCP
258		2240-Z031	HOLDER, HL151, 152

**PCB-5 AUDIO FUNCTION P.C. BOARD**

<b>CAPACITORS</b>			
717	C101	5354-104593	CAP,MYL .1μ
716	C102	5345-105F041	CAP,MINI ELE 1μ/50V
726	C181	5361-R02BK221	CAP,CER 220P
726	C182	5361-R02BK221	CAP,CER 220P
726	C183	5361-R02BK221	CAP,CER 220P
744	C601	5345-106F041	CAP,MINI ELE 10μ/50V
744	C602	5345-106F041	CAP,MINI ELE 10μ/50V
748	C603	5359-1215851	CAP,PPP 120P <b>BK WB SB</b>
748	C603	5359-3915851	CAP,PPP 390P <b>IB</b>
748	C604	5359-1215851	CAP,PPP 120P <b>BK WB SB</b>
748	C604	5359-3915851	CAP,PPP 390P <b>IB</b>
746	C605	5345-227B041	CAP,MINI ELE 220μ/10V
746	C606	5345-227B041	CAP,MINI ELE 220μ/10V
749	C607	5359-5625851	CAP,PPP 5600P
749	C608	5359-5625851	CAP,PPP 5600P
750	C609	5359-2025851	CAP,PPP 2000P
750	C610	5359-2025851	CAP,PPP 2000P
744	C611	5345-106F041	CAP,MINI ELE 10μ/50V
744	C612	5345-106F041	CAP,MINI ELE 10μ/50V
747	C613	5345-337C041	CAP,MINI ELE 330μ/16V
747	C614	5345-337C041	CAP,MINI ELE 330μ/16V
744	C651	5345-106F041	CAP,MINI ELE 10μ/50V
744	C652	5345-106F041	CAP,MINI ELE 10μ/50V
747	C653	5345-337C041	CAP,MINI ELE 330μ/16V
747	C654	5345-337C041	CAP,MINI ELE 330μ/16V
768	C655	5345-476D041	CAP,MINI ELE 47μ/25V
768	C656	5345-476D041	CAP,MINI ELE 47μ/25V
744	C657	5345-106F041	CAP,MINI ELE 10μ/50V
744	C658	5345-106F041	CAP,MINI ELE 10μ/50V
747	C659	5345-337C041	CAP,MINI ELE 330μ/16V
747	C660	5345-337C041	CAP,MINI ELE 330μ/16V
744	C661	5345-106F041	CAP,MINI ELE 10μ/50V
744	C662	5345-106F041	CAP,MINI ELE 10μ/50V
745	C663	5345-107D041	CAP,MINI ELE 100μ/25V
745	C664	5345-107D041	CAP,MINI ELE 100μ/25V
<b>RESISTORS</b>			
719	R101	5130-R030J102	RES,CBN 1/2P 1K
719	R102	5130-R030J102	RES,CBN 1/2P 1K
718	R103	5130-R010J104	RES,CBN 1/6P 100K
718	R104	5130-R010J104	RES,CBN 1/6P 100K
719	R105	5130-R030J102	RES,CBN 1/2P 1K
719	R106	5130-R030J102	RES,CBN 1/2P 1K
718	R107	5130-R010J104	RES,CBN 1/6P 100K
718	R108	5130-R010J104	RES,CBN 1/6P 100K
719	R109	5130-R030J102	RES,CBN 1/2P 1K
719	R110	5130-R030J102	RES,CBN 1/2P 1K
718	R111	5130-R010J104	RES,CBN 1/6P 100K
718	R112	5130-R010J104	RES,CBN 1/6P 100K
719	R113	5130-R030J102	RES,CBN 1/2P 1K
719	R114	5130-R030J102	RES,CBN 1/2P 1K
718	R115	5130-R010J104	RES,CBN 1/6P 100K
718	R116	5130-R010J104	RES,CBN 1/6P 100K
719	R117	5130-R030J102	RES,CBN 1/2P 1K
719	R118	5130-R030J102	RES,CBN 1/2P 1K
719	R119	5130-R030J102	RES,CBN 1/2P 1K
719	R120	5130-R030J102	RES,CBN 1/2P 1K
721	R121	5130-R030J104	RES,CBN 1/2P 100K
722	R122	5130-R030J223	RES,CBN 1/2P 22K
723	R123	5130-R030J474	RES,CBN 1/2P 470K
724	R124	5130-R030J105	RES,CBN 1/2P 1M
724	R125	5130-R030J105	RES,CBN 1/2P 1M
724	R126	5130-R030J105	RES,CBN 1/2P 1M
720	R127	5130-R030J102	RES,CBN 1/2P 1K
720	R128	5130-R030J102	RES,CBN 1/2P 1K
720	R129	5130-R030J102	RES,CBN 1/2P 1K
755	R601	5130-R030J471	RES,CBN 1/2P 470 <b>BK WB SB</b>
769	R601	5130-R030J122	RES,CBN 1/2P 1.2K <b>IB</b>
755	R602	5130-R030J471	RES,CBN 1/2P 470 <b>BK WB SB</b>
769	R602	5130-R030J122	RES,CBN 1/2P 1.2K <b>IB</b>
756	R603	5130-R030J823	RES,CBN 1/2P 82K
756	R604	5130-R030J823	RES,CBN 1/2P 82K
757	R605	5130-R030J124	RES,CBN 1/2P 120K
757	R606	5130-R030J124	RES,CBN 1/2P 120K
758	R607	5130-R030J102	RES,CBN 1/2P 1K

Ser. No.	Ref. No.	Part No.	Description
758	R608	5130-R030J102	RES,CBN 1/2P 1K
759	R609	5130-R030J564	RES,CBN 1/2P 560K
759	R610	5130-R030J564	RES,CBN 1/2P 560K
751	R611	5130-R010J105	RES,CBN 1/6P 1M
751	R612	5130-R010J105	RES,CBN 1/6P 1M
760	R613	5130-R030J222	RES,CBN 1/2P 2.2K
760	R614	5130-R030J222	RES,CBN 1/2P 2.2K
761	R615	5130-R030J393	RES,CBN 1/2P 39K
761	R616	5130-R030J393	RES,CBN 1/2P 39K
753	R617	5130-R030J102	RES,CBN 1/2P 1K
753	R618	5130-R030J102	RES,CBN 1/2P 1K
753	R619	5130-R030J102	RES,CBN 1/2P 1K
753	R620	5130-R030J102	RES,CBN 1/2P 1K
766	R621	5130-R030J333	RES,CBN 1/2P 33K
766	R622	5130-R030J333	RES,CBN 1/2P 33K
763	R623	5130-R030J391	RES,CBN 1/2P 390
763	R624	5130-R030J391	RES,CBN 1/2P 390
763	R625	5130-R030J391	RES,CBN 1/2P 390
763	R626	5130-R030J391	RES,CBN 1/2P 390
762	R651	5130-R030J224	RES,CBN 1/2P 220K
762	R652	5130-R030J224	RES,CBN 1/2P 220K
754	R653	5130-R030J104	RES,CBN 1/2P 100K
754	R654	5130-R030J104	RES,CBN 1/2P 100K
755	R655	5130-R030J471	RES,CBN 1/2P 470
755	R656	5130-R030J471	RES,CBN 1/2P 470
764	R657	5130-R030J221	RES,CBN 1/2P 220
764	R658	5130-R030J221	RES,CBN 1/2P 220
764	R659	5130-R030J221	RES,CBN 1/2P 220
764	R660	5130-R030J221	RES,CBN 1/2P 220
752	R661	5130-R010J222	RES,CBN 1/6P 2.2K
752	R662	5130-R010J222	RES,CBN 1/6P 2.2K
753	R663	5130-R030J102	RES,CBN 1/2P 1K
753	R664	5130-R030J102	RES,CBN 1/2P 1K
765	R665	5130-R030J101	RES,CBN 1/2P 100
765	R666	5130-R030J101	RES,CBN 1/2P 100
755	R667	5130-R030J471	RES,CBN 1/2P 470
755	R668	5130-R030J471	RES,CBN 1/2P 470
754	R669	5130-R030J104	RES,CBN 1/2P 100K
754	R670	5130-R030J104	RES,CBN 1/2P 100K
755	R671	5130-R030J471	RES,CBN 1/2P 470
755	R672	5130-R030J471	RES,CBN 1/2P 470
762	R673	5130-R030J224	RES,CBN 1/2P 220K
762	R674	5130-R030J224	RES,CBN 1/2P 220K
754	R675	5130-R030J104	RES,CBN 1/2P 100K
754	R676	5130-R030J104	RES,CBN 1/2P 100K
764	R677	5130-R030J221	RES,CBN 1/2P 220
764	R678	5130-R030J221	RES,CBN 1/2P 220
764	R679	5130-R030J221	RES,CBN 1/2P 220
764	R680	5130-R030J221	RES,CBN 1/2P 220
752	R681	5130-R010J222	RES,CBN 1/6P 2.2K
752	R682	5130-R010J222	RES,CBN 1/6P 2.2K
753	R683	5130-R030J102	RES,CBN 1/2P 1K
753	R684	5130-R030J102	RES,CBN 1/2P 1K
765	R685	5130-R030J101	RES,CBN 1/2P 100
765	R686	5130-R030J101	RES,CBN 1/2P 100
755	R687	5130-R030J471	RES,CBN 1/2P 470
755	R688	5130-R030J471	RES,CBN 1/2P 470
754	R689	5130-R030J104	RES,CBN 1/2P 100K
754	R690	5130-R030J104	RES,CBN 1/2P 100K

**INTEGRATED CIRCUITS**

711	IC101	5654-LC7821	IC,DIGITAL
712	IC102	5654-LC7822	IC,DIGITAL
741	IC601	5653-BA15218	IC,LINEAR

**TRANSISTORS**

713	Q101	5616-2SK364BL	FET,N-CH
713	Q102	5616-2SK364BL	FET,N-CH
713	Q103	5616-2SK364BL	FET,N-CH
714	Q104	5611-999L(F)	XISTOR,PNP R
742	Q651	5611-999(F)	XISTOR,PNP R
742	Q652	5611-999(F)	XISTOR,PNP R
743	Q653	5613-2603(F)	XISTOR,NPN R
743	Q654	5613-2603(F)	XISTOR,NPN R
742	Q655	5611-999(F)	XISTOR,PNP R
742	Q656	5611-999(F)	XISTOR,PNP R
743	Q657	5613-2603(F)	XISTOR,NPN R
743	Q658	5613-2603(F)	XISTOR,NPN R

Ser. No.	Ref. No.	Part No.	Description
<b>DIODES</b>			
715	D101	5631-1S2473	DIODE,DET
715	D102	5631-1S2473	DIODE,DET
<b>MISCELLANEOUS</b>			
770	CN602	4443-030185	CONNECTOR
887	CN603	4443-01701007	CONNECTOR
888	CN605	4443-01701006	CONNECTOR
942	△ J601	4489-04301008	8 PIN JACK,MLT, PHONO
941	△ J602	4489-04302006	6 PIN JACK,MLT, CD, AUX, TAPE2 OUT TAPE2 IN, TAPE1 OUT, TAPE1 IN
892	△ JL301	4242-R0503181	JUMPER LEAD
767	△ LCN601	4163-0135039	CONNECTOR W/W
247		2240-Z031	HOLDER, HL601
255		2240-Z032	HOLDER, HL301

**PCB-6 VIDEO FUNCTION P.C. BOARD****CAPACITORS**

737	C169	5361-R02BK221	CAP,CER 220P
737	C170	5361-R02BK221	CAP,CER 220P
737	C171	5361-R02BK221	CAP,CER 220P
732	C172	5345-107D041	CAP,MINI ELE 100µ25V
732	C173	5345-107D041	CAP,MINI ELE 100µ25V

**RESISTORS**

733	R155	5130-R010J104	RES,CBN 1/6P 100K
733	R156	5130-R010J104	RES,CBN 1/6P 100K
734	R157	5130-R030J102	RES,CBN 1/2P 1K
734	R158	5130-R030J102	RES,CBN 1/2P 1K
733	R159	5130-R010J104	RES,CBN 1/6P 100K
733	R160	5130-R010J104	RES,CBN 1/6P 100K
734	R161	5130-R030J102	RES,CBN 1/2P 1K
734	R162	5130-R030J102	RES,CBN 1/2P 1K
733	R163	5130-R010J104	RES,CBN 1/6P 100K
733	R164	5130-R010J104	RES,CBN 1/6P 100K
734	R165	5130-R030J102	RES,CBN 1/2P 1K
734	R166	5130-R030J102	RES,CBN 1/2P 1K
733	R167	5130-R010J104	RES,CBN 1/6P 100K
733	R168	5130-R010J104	RES,CBN 1/6P 100K
734	R169	5130-R030J102	RES,CBN 1/2P 1K
733	R170	5130-R030J102	RES,CBN 1/2P 1K
733	R171	5130-R010J104	RES,CBN 1/6P 100K
733	R172	5130-R010J104	RES,CBN 1/6P 100K
734	R173	5130-R030J102	RES,CBN 1/2P 1K
734	R174	5130-R030J102	RES,CBN 1/2P 1K
734	R175	5130-R030J102	RES,CBN 1/2P 1K
734	R176	5130-R030J102	RES,CBN 1/2P 1K
734	R177	5130-R030J102	RES,CBN 1/2P 1K
734	R178	5130-R030J102	RES,CBN 1/2P 1K
735	R179	5130-R030J102	RES,CBN 1/2P 1K
735	R180	5130-R030J102	RES,CBN 1/2P 1K
735	R181	5130-R030J102	RES,CBN 1/2P 1K

**INTEGRATED CIRCUITS**

730	IC151	5654-LC7822	IC,DIGITAL
731	IC152	5654-LC7821	IC,DIGITAL

**MISCELLANEOUS**

876	CN151	4443-030185	CONNECTOR
877	CN152	4443-01701007	CONNECTOR
879	CN154	4443-01701006	CONNECTOR
878	CN155	4443-08001006	CONNECTOR
940	△ J152	4489-04301008	8 PIN JACK,MLT, TV, SAT, VDP VCR2 OUT
939	△ J153	4489-04302006	6 PIN JACK,MLT, VCR2 IN, VCR1 OUT, VCR1 IN
259		2240-Z031	HOLDER, HL602

**PCB-7 TUNER SWITCH P.C. BOARD****DIODES**

771	D711	5631-1SS133	DIODE,DET
771	D712	5631-1SS133	DIODE,DET
771	D713	5631-1SS133	DIODE,DET

Ser. No.	Ref. No.	Part No.	Description
<b>MISCELLANEOUS</b>			
889	CN706	443-07801008	CONNECTOR
948	SW749	4437-01301	SWITCH,PU-TC, FM
948	SW750	4437-01301	SWITCH,PU-TC, AM
948	SW751	4437-01301	SWITCH,PU-TC, SEEK-STEREO
949	SW752	4437-00704	SWITCH,PU-TC, UP
949	SW753	4437-00704	SWITCH,PU-TC, DOWN

**PCB-8 VOLUME LED P.C. BOARD**

<b>CAPACITOR</b>			
706	C560	5345-106F041	CAP,MINI ELE 10μ/50V
<b>DIODE</b>			
704	D506	5637-S2410E1	LED, VOLUME
<b>MISCELLANEOUS</b>			
705	△ LCN506	4163-01524002	CONNECTOR W/W

**PCB-9 TUNER P.C. BOARD**

<b>CAPACITORS</b>			
334	C201	5361-R02FZ223	CAP,CER .022μ
339	C202	5345-476D041	CAP,MINI ELE 47μ/25V
335	C203	5361-150J917	CAP,CER 15P
338	C204	5361-R02FZ103	CAP,CER .01μ
334	C205	5361-R02FZ223	CAP,CER .022μ
334	C206	5361-R02FZ223	CAP,CER .022μ
334	C207	5361-R02FZ223	CAP,CER .022μ
334	C208	5361-R02FZ223	CAP,CER .022μ
340	C209	5345-106F041	CAP,MINI ELE 10μ/50V
341	C210	5345-105F041	CAP,MINI ELE 1μ/50V
336	C211	5359-1015851	CAP,PPP 100P
342	C212	5345-226C041	CAP,MINI ELE 22μ/16V
304	C213	5361-220J917	CAP,CER 22P <b>IB</b>
343	C216	5345-S19FM224	CAP,MINI ELE 22μ/50V
344	C217	5345-S19FM684	CAP,MINI ELE .68μ/50V
345	C218	5345-227C041	CAP,MINI ELE 220μ/16V
346	C219	5345-476C041	CAP,MINI ELE 47μ/16V
334	C220	5361-R02FZ223	CAP,CER .022μ
347	C221	5345-476D041	CAP,MINI ELE 47μ/25V
029B	C222	5361-R02FZ223	CAP,CER .022μ <b>WB SB IB</b>
029B	C223	5361-R02FZ223	CAP,CER .022μ <b>WB SB IB</b>
342	C224	5345-226C041	CAP,MINI ELE 22μ/16V <b>IB</b>
370	C251	5361-R02FZ223	CAP,CER .022μ
372	C252	5345-106F041	CAP,MINI ELE 10μ/50V
372	C253	5345-106F041	CAP,MINI ELE 10μ/50V
376	C254	5345-475F041	CAP,MINI ELE 4.7μ/50V
376	C255	5345-475F041	CAP,MINI ELE 4.7μ/50V
371	C256	5361-472M919	CAP,CER 4700P
374	C257	5345-224F041	CAP,MINI ELE 22μ/50V
373	C258	5345-105F041	CAP,MINI ELE 1μ/50V
374	C259	5345-224F041	CAP,MINI ELE 22μ/50V <b>BK</b>
027B	C259	5345-104F041	CAP,MINI ELE 1μ/50V <b>WB SB IB</b>
370	C260	5361-R02FZ223	CAP,CER .022μ
393	C301	5345-226C041	CAP,MINI ELE 22μ/16V
392	C302	5345-476C041	CAP,MINI ELE 47μ/16V
389	C303	5354-473K1HM	CAP,MYL .047μ
394	C304	5345-224F041	CAP,MINI ELE 22μ/50V
395	C305	5345-474F041	CAP,MINI ELE 47μ/50V
388	C306	5361-101K918	CAP,CER 100P
391	C307	5345-106F041	CAP,MINI ELE 10μ/50V
396	C308	5345-225F041	CAP,MINI ELE 2.2μ/50V
390	C309	5359-4715851	CAP,PPP 470P <b>BK</b>
028B	C309	5359-2715851	CAP,PPP 270P <b>WB SB IB</b>
390	C310	5359-4715851	CAP,PPP 470P <b>BK</b>
028B	C310	5359-2715851	CAP,PPP 270P <b>WB SB IB</b>
396	C311	5345-225F041	CAP,MINI ELE 2.2μ/50V
396	C312	5345-225F041	CAP,MINI ELE 2.2μ/50V
419	C351	5361-R02CJ300	CAP,CER 30P
419	C352	5361-R02CJ300	CAP,CER 30P
422	C353	5345-228A041	CAP,MINI ELE 2200μ/6.3V
418	C355	5361-R02FZ223	CAP,CER .022μ
421	C356	5345-225F041	CAP,MINI ELE 2.2μ/50V
420	C357	5345-105F041	CAP,MINI ELE 1μ/50V
423	C358	5345-107C041	CAP,MINI ELE 100μ/16V
423	C359	5345-107C041	CAP,MINI ELE 100μ/16V

Ser. No.	Ref. No.	Part No.	Description
431	C360	5345-476D041	CAP,MINI ELE 47μ/25V
438	C361	5352-S110J104	CAP,MTL .1μ
029B	C362	5361-R02FZ223	CAP,CER .022μ <b>WB SB IB</b>
029B	C363	5361-R02FZ223	CAP,CER .022μ <b>WB SB IB</b>
<b>RESISTORS</b>			
361	R201	5130-R030J102	RES,CBN 1/2P 1K
349	R202	5130-R010J391	RES,CBN 1/6P 390
349	R203	5130-R010J391	RES,CBN 1/6P 390
350	R204	5130-R010J154	RES,CBN 1/6P 150K
351	R205	5130-R010J101	RES,CBN 1/6P 100
349	R206	5130-R010J391	RES,CBN 1/6P 390
348	R207	5130-R010J102	RES,CBN 1/6P 1K
351	R208	5130-R010J101	RES,CBN 1/6P 100
352	R209	5130-R010J103	RES,CBN 1/6P 10K
353	R210	5130-R010J472	RES,CBN 1/6P 4.7K
354	R211	5130-R010J332	RES,CBN 1/6P 3.3K
353	R212	5130-R010J472	RES,CBN 1/6P 4.7K <b>BK WB SB</b>
305	R212	5130-R010J222	RES,CBN 1/6P 2.2K <b>IB</b>
360	R213	5130-R010J153	RES,CBN 1/6P 15K <b>BK</b>
030B	R213	5130-R010J273	RES,CBN 1/6P 27K <b>WB SB IB</b>
362	R214	5130-R030J221	RES,CBN 1/2P 220
355	R215	5130-R010J105	RES,CBN 1/6P 1M
356	R216	5130-R010J102	RES,CBN 1/6P 1K
352	R217	5130-R010J103	RES,CBN 1/6P 10K
357	R218	5130-R010J222	RES,CBN 1/6P 2.2K
352	R219	5130-R010J103	RES,CBN 1/6P 10K
358	R220	5130-R010J473	RES,CBN 1/6P 47K
352	R221	5130-R010J103	RES,CBN 1/6P 10K
352	R222	5130-R010J103	RES,CBN 1/6P 10K
348	R223	5130-R010J102	RES,CBN 1/6P 1K
359	R224	5130-R010J104	RES,CBN 1/6P 100K
354	R225	5130-R010J332	RES,CBN 1/6P 3.3K
348	R226	5130-R010J102	RES,CBN 1/6P 1K
357	R227	5130-R010J222	RES,CBN 1/6P 2.2K
357	R228	5130-R010J222	RES,CBN 1/6P 2.2K
357	R229	5130-R010J222	RES,CBN 1/6P 2.2K
357	R230	5130-R010J222	RES,CBN 1/6P 2.2K
353	R231	5130-R010J472	RES,CBN 1/6P 4.7K
357	R232	5130-R010J222	RES,CBN 1/6P 2.2K
357	R233	5130-R010J222	RES,CBN 1/6P 2.2K
357	R234	5130-R010J222	RES,CBN 1/6P 2.2K
357	R235	5130-R010J222	RES,CBN 1/6P 2.2K
353	R236	5130-R010J472	RES,CBN 1/6P 4.7K
034B	R237	5130-R010J472	RES,CBN 1/6P 4.7K <b>WB SB IB</b>
037B	R238	5130-R010J104	RES,CBN 1/6P 100K <b>WB SB IB</b>
377	R250	5130-R010J101	RES,CBN 1/6P 100
381	R251	5130-R030J334	RES,CBN 1/2P 330K
380	R252	5130-R030J104	RES,CBN 1/2P 100K
385	R253	5130-R010J102	RES,CBN 1/6P 1K
384	R254	5130-R010J223	RES,CBN 1/6P 22K
378	R255	5130-R010J103	RES,CBN 1/6P 10K
378	R256	5130-R010J103	RES,CBN 1/6P 10K
383	R257	5130-R010J820	RES,CBN 1/6P 82
385	R258	5130-R010J102	RES,CBN 1/6P 1K
382	R259	5130-R010J153	RES,CBN 1/6P 15K
379	R260	5130-R010J105	RES,CBN 1/6P 1M
378	R261	5130-R010J103	RES,CBN 1/6P 10K
400	R301	5130-R010J563	RES,CBN 1/6P 56K
399	R302	5130-R010J104	RES,CBN 1/6P 100K <b>WB SB IB</b>
403	△ R303	5102-1005116	RES,FUSE 10
402	R304	5130-R010J102	RES,CBN 1/6P 1K
398	R305	5130-R010J103	RES,CBN 1/6P 10K
397	R306	5130-R010J154	RES,CBN 1/6P 150K <b>BK</b>
031B	R306	5130-R010J184	RES,CBN 1/6P 180K <b>WB SB IB</b>
397	R307	5130-R010J154	RES,CBN 1/6P 150K <b>BK</b>
031B	R307	5130-R010J184	RES,CBN 1/6P 180K <b>WB SB IB</b>
401	R308	5130-R010J182	RES,CBN 1/6P 1.8K
401	R309	5130-R010J182	RES,CBN 1/6P 1.8K
399	R310	5130-R010J104	RES,CBN 1/6P 100K <b>BK</b>
032B	R310	5130-R010J154	RES,CBN 1/6P 150K <b>WB SB IB</b>
399	R311	5130-R010J104	RES,CBN 1/6P 100K <b>BK</b>
032B	R311	5130-R010J154	RES,CBN 1/6P 150K <b>WB SB IB</b>
398	R312	5130-R010J103	RES,CBN 1/6P 10K
398	R313	5130-R010J103	RES,CBN 1/6P 10K
398	R314	5130-R010J103	RES,CBN 1/6P 10K
398	R315	5130-R010J103	RES,CBN 1/6P 10K
429	R351	5130-R010J104	RES,CBN 1/6P 100K

Ser. No.	Ref. No.	Part No.	Description
429	R352	5130-R010J104	RES,CBN 1/6P 100K BK
433	R353	5130-R010J102	RES,CBN 1/6P 1K
433	R354	5130-R010J102	RES,CBN 1/6P 1K
433	R355	5130-R010J102	RES,CBN 1/6P 1K
433	R356	5130-R010J102	RES,CBN 1/6P 1K
433	R357	5130-R010J102	RES,CBN 1/6P 1K
433	R358	5130-R010J102	RES,CBN 1/6P 1K
433	R359	5130-R010J102	RES,CBN 1/6P 1K
429	R360	5130-R010J104	RES,CBN 1/6P 100K
426	R361	5130-R010J472	RES,CBN 1/6P 4.7K BK
426	R362	5130-R010J472	RES,CBN 1/6P 4.7K BK
430	R363	5130-R010J223	RES,CBN 1/6P 22K
425	R364	5130-R010J103	RES,CBN 1/6P 10K
430	R365	5130-R010J223	RES,CBN 1/6P 22K
428	R366	5130-R010J473	RES,CBN 1/6P 47K
425	R367	5130-R010J103	RES,CBN 1/6P 10K
425	R368	5130-R010J103	RES,CBN 1/6P 10K
432	R369	5130-R010J273	RES,CBN 1/6P 27K
432	R370	5130-R010J273	RES,CBN 1/6P 27K
436	R371	5130-R030J681	RES,CBN 1/2P 680
426	R372	5130-R010J472	RES,CBN 1/6P 4.7K
426	R373	5130-R010J472	RES,CBN 1/6P 4.7K
433	R374	5130-R010J102	RES,CBN 1/6P 1K
435	▲ R375	5102-4R75116	RES,FUSE 4.7
434	R376	5130-R030J102	RES,CBN 1/2P 1K
434	R377	5130-R030J102	RES,CBN 1/2P 1K
429	R378	5130-R010J104	RES,CBN 1/6P 100K
425	R379	5130-R010J103	RES,CBN 1/6P 10K
427	R380	5130-R010J332	RES,CBN 1/6P 3.3K
430	R381	5130-R010J223	RES,CBN 1/6P 22K
433	R382	5130-R010J102	RES,CBN 1/6P 1K
035B	R383	5130-R010J103	RES,CBN 1/6P 10K WB SB IB
037B	R384	5130-R010J104	RES,CBN 1/6P 100K WB SB IB
038B	R385	5130-R010J154	RES,CBN 1/6P 150K WB SB IB
034B	R386	5130-R010J472	RES,CBN 1/6P 4.7K WB SB IB
033B	R387	5130-R010J102	RES,CBN 1/6P 1K WB SB IB
036B	R388	5130-R010J473	RES,CBN 1/6P 47K WB SB IB

**INTEGRATED CIRCUITS**

322	IC201	5653-LA1266	IC,LINEAR
323	IC202	5654-TC9227P	IC,DIGITAL
386	IC301	5653-LA3410	IC,LINEAR
407	IC351	5654-T9301-27	IC,DIGITAL

**TRANSISTORS**

324	Q201	5613-2058(N)	XISTOR,NPN R
325	Q202	5616-2SK364BL	FET,N-CH
326	Q203	5613-2240(BL)	XISTOR,NPN R
327	Q204	5613-1740S(R)	XISTOR,NPN R
328	Q205	5613-C124ES	XISTOR,NPN R
327	Q206	5613-1740S(R)	XISTOR,NPN R
325	Q251	5616-2SK364BL	FET,N-CH
387	Q301	5614-1450(T)	XISTOR,NPN A
387	Q302	5614-1450(T)	XISTOR,NPN A
408	Q351	5613-C124ES	XISTOR,NPN R BK
327	Q352	5613-1740S(R)	XISTOR,NPN R
408	Q353	5613-C124ES	XISTOR,NPN R
408	Q354	5613-C124ES	XISTOR,NPN R
409	Q355	5611-A124ES	XISTOR,PNP R
409	Q356	5611-A124ES	XISTOR,PNP R
408	Q357	5613-C124ES	XISTOR,NPN R
409	Q358	5611-A124ES	XISTOR,PNP R
409	Q359	5611-A124ES	XISTOR,PNP R
410	Q360	5611-933S(R)	XISTOR,PNP R
408	Q361	5613-C124ES	XISTOR,NPN R
408	Q362	5613-C124ES	XISTOR,NPN R
408	Q363	5613-C124ES	XISTOR,NPN R
409	Q364	5611-A124ES	XISTOR,PNP R
408	Q365	5613-C124ES	XISTOR,NPN R
409	Q366	5611-A124ES	XISTOR,PNP R
411	Q367	5614-1266(P)	XISTOR,NPN A
026B	Q386	5613-1740S(R)	XISTOR,NPN R WB SB IB

**DIODES**

329	D201	5631-1SS133	DIODE,DET
365	D251	5631-1SS133	DIODE,DET
365	D252	5631-1SS133	DIODE,DET
365	D253	5631-1SS133	DIODE,DET

Ser. No.	Ref. No.	Part No.	Description
365	D254	5631-1SS133	DIODE,DET
415	D351	5631-1SS133	DIODE,DET
415	D352	5631-1SS133	DIODE,DET
412	D353	5631-1SS133	DIODE,DET
412	D354	5631-1SS133	DIODE,DET
412	D355	5631-1SS133	DIODE,DET BK
415	D356	5631-1SS133	DIODE,DET
415	D357	5631-1SS133	DIODE,DET
415	D358	5631-1SS133	DIODE,DET
413	D359	5631-1SS133	DIODE,DET
413	D360	5631-1SS133	DIODE,DET
414	D361	5635-HZ12B2L	DIODE,ZENER
415	D362	5631-1SS133	DIODE,DET
415	D363	5631-1SS133	DIODE,DET
415	D364	5631-1SS133	DIODE,DET
412	D365	5631-1SS133	DIODE,DET BK
412	D366	5631-1SS133	DIODE,DET BK
412	D367	5631-1SS133	DIODE,DET

**COILS**

332	L201	5995-2R2J69	COIL W/CORE
302	L202	5214-78	LC COMPOSITE IB
303	L203	5214-86	LC COMPOSITE IB

**TRANSFORMERS**

331	T201	5572-10201	DISCRI 7
369	T251	5552-00712	IFT,AM 7

**CONTROLS**

366	VR251	5101-S0801503	RES,SEMI FIX 50K, MUTING LEVEL
404	VR301	5101-S0801104	RES,SEMI FIX 100K, SEPARATION

**MISCELLANEOUS**

364	CB251	6111-02402	RF BLOCK
424	CC351	5213-S0307221	C COMPOSITE, 220P×7
330	CF201	5671-0101A113	FILTER,CER S BK
025B	CF201	5671-7142A	FILTER,CER S WB SB IB
330	CF202	5671-0101A113	FILTER,CER S BK WB SB
284	CF202	5671-7142A	FILTER,CER S IB
368	CF251	5671-0159	FILTER,CER S
367	CF252	5671-7137C	FILTER,CER S
613	CN22	4443-0401140	CONNECTOR
886	CN301	4443-030185	CONNECTOR
880	CN351	4443-05401027	CONNECTOR
416	CX301	5693-CSB456F1	OSC,CER
405	LCN201	4163-0109040	CONNECTOR W/W
406	LUG	4211-4	LUG
437	RC351	5212-473J0403	R COMPOSITE, 47K, ±5% ×4
943	▲ TM201	4214-164	TERMINAL, EXT ANT
024B	▲ TM202	4214-167	TERMINAL WB SB IB
440	TM301	4214-132	TERMINAL
440	TM302	4214-132	TERMINAL
333	TP201	4214-132	TERMINAL
333	TP202	4214-132	TERMINAL
321	▲ TU201	6114-00701	FM TUNER BK WB SB
321	▲ TU201	6114-00601	FM TUNER IB
417	X351	5691-00720027	XTAL,OSC

**PCB-10 POWER SUPPLY P.C BOARD**

**CAPACITORS**

822	C1	5352-S181K104	CAP,MTL .1μ
832	C2	5345-228D041	CAP,MINI ELE 2200μ/25V
825	C3	5345-107B041	CAP,MINI ELE 100μ/10V
825	C4	5345-107B041	CAP,MINI ELE 100μ/10V
825	C5	5345-107B041	CAP,MINI ELE 100μ/10V
859	▲ C6	5352-S010M103	CAP,MTL .01μ BK
859B	C6	5352-1030958	CAP,MTL .01μ WB SB IB
822	C7	5352-S181K104	CAP,MTL .1μ BK WB SB
822	C7	5352-S080K104	CAP,MTL .1μ IB
822	C8	5352-S181K104	CAP,MTL .1μ BK WB SB
822	C8	5352-S060K104	CAP,MTL .1μ IB
822	C9	5352-S181K104	CAP,MTL .1μ BK WB SB
822	C9	5352-S060K104	CAP,MTL .1μ IB
823	C10	5345-106F041	CAP,MINI ELE 10μ/50V
832	C11	5345-228D041	CAP,MINI ELE 2200μ/25V
833	C12	5345-338D041	CAP,MINI ELE 3300μ/25V
826	C13	5345-227D041	CAP,MINI ELE 220μ/25V

Ser. No.	Ref. No.	Part No.	Description
829	C14	5345-477C041	CAP,MINI ELE 470μ/16V
826	C15	5345-227D041	CAP,MINI ELE 220μ/25V
829	C16	5345-477C041	CAP,MINI ELE 470μ/16V
827	C17	5345-227C041	CAP,MINI ELE 220μ/16V
828	C18	5345-477B041	CAP,MINI ELE 470μ/10V
824	C30	5345-476F041	CAP,MINI ELE 47μ/50V
830	C31	5345-477E041	CAP,MINI ELE 470μ/35V
824	C40	5345-476F041	CAP,MINI ELE 47μ/50V
993	C44	5345-105F041	CAP,MINI ELE 1μ/50V (IB)

**RESISTORS**

841	△ R1	5130-R030J335	RES,CBN 1/2P 3.3M (BK)
838	R2	5130-R030J152	RES,CBN 1/2P 1.5K
834	R3	5130-R030J101	RES,CBN 1/2P 100
837	R4	5130-R030J102	RES,CBN 1/2P 1K
839	R5	5130-R030J103	RES,CBN 1/2P 10K
839	R6	5130-R030J103	RES,CBN 1/2P 10K
837	R7	5130-R030J102	RES,CBN 1/2P 1K
841B	R8	5130-R030J335	RES,CBN 1/2P 3.3M (WB) (SB) (IB)
837	R9	5130-R030J102	RES,CBN 1/2P 1K
834	R10	5130-R030J101	RES,CBN 1/2P 100
837	R12	5130-R030J102	RES,CBN 1/2P 1K
611	R13	5130-R030J562	RES,CBN 1/2P 5.6K
839	R14	5130-R030J103	RES,CBN 1/2P 10K
840	R15	5130-R030J223	RES,CBN 1/2P 22K
838	R16	5130-R030J152	RES,CBN 1/2P 1.5K
835	R17	5130-R030J391	RES,CBN 1/2P 390
834	R18	5130-R030J101	RES,CBN 1/2P 100
838	R19	5130-R030J152	RES,CBN 1/2P 1.5K
835	R20	5130-R030J391	RES,CBN 1/2P 390
834	R21	5130-R030J101	RES,CBN 1/2P 100
838	R22	5130-R030J152	RES,CBN 1/2P 1.5K
835	R23	5130-R030J391	RES,CBN 1/2P 390
834	R24	5130-R030J101	RES,CBN 1/2P 100
610	R68	5130-R030J2R2	RES,CBN 1/2P 2.2
610	R69	5130-R030J2R2	RES,CBN 1/2P 2.2
728	△ R70	5102-4R75116	RES,FUSE 4.7

**TRANSISTORS**

813	Q1	5614-1266(P)	XISTOR,NPN A
808	Q2	5611-933S(R)	XISTOR,PNP R
810	Q3	5613-1740S(R)	XISTOR,NPN R
812	Q4	5613-2603(F)	XISTOR,NPN R
813	Q6	5614-1266(P)	XISTOR,NPN A
807	Q7	5611-1115(F)	XISTOR,PNP R
809	Q8	5612-941(P)	XISTOR,PNP A
812	Q9	5613-2603(F)	XISTOR,NPN R
809	Q10	5612-941(P)	XISTOR,PNP A
812	Q11	5613-2603(F)	XISTOR,NPN R
811	Q25	5611-933S(R)	XISTOR,PNP R
810	Q26	5613-1740S(R)	XISTOR,NPN R

**DIODES**

814	△ D1	5632-S5566B	DIODE,RECT
814	△ D2	5632-S5566B	DIODE,RECT
814	△ D3	5632-S5566B	DIODE,RECT
814	△ D4	5632-S5566B	DIODE,RECT
816	D5	5635-HZ7A1	DIODE,ZENER
814	D7	5632-S5566B	DIODE,RECT
814	△ D8	5632-S5566B	DIODE,RECT
814	△ D9	5632-S5566B	DIODE,RECT
814	△ D10	5632-S5566B	DIODE,RECT
814	△ D11	5632-S5566B	DIODE,RECT
814	D12	5632-S5566B	DIODE,RECT
818	D13	5635-HZ24-1L	DIODE,ZENER
815	D14	5631-1S2473	DIODE,DET
821	D15	5635-RD5R1EB2	DIODE,ZENER
819	D16	5635-HZ5B1	DIODE,ZENER
820	D17	5635-HZ12C1	DIODE,ZENER
820	D18	5635-HZ12C1	DIODE,ZENER
816	D19	5635-HZ7A1	DIODE,ZENER
814	△ D29	5632-S5566B	DIODE,RECT

**TRANSFORMERS**

851	△ T2	5584-001479	XFORMER, SUB POWER (BK)
851B	△ T2	5584-T1101	XFORMER, SUB POWER (WB) (SB) (IB)

Ser. No.	Ref. No.	Part No.	Description
<b>MISCELLANEOUS</b>			
883	CN3	4443-030185	CONNECTOR
882	CN4	4443-05501031	CONNECTOR
861	CN5	4443-08101012	CONNECTOR
861	CN10	4443-08101012	CONNECTOR
856	△ F1	5732-632031	FUSE, 6.3A 125V (BK)
856B	△ F1	5732-01601312	FUSE, T315A/T3.15AL 250V (WB) (SB) (IB)
727	△ F6	5732-01501402	FUSE, 4A 125V (BK)
727B	△ F6	5732-01601402	FUSE, T4A/T4AL 250V (WB) (SB) (IB)
727	△ F7	5732-01501402	FUSE, 4A 125V (BK)
727B	△ F7	5732-01601402	FUSE, T4A/T4AL 250V (WB) (SB) (IB)
855	△ HF1	4472-04501	HOLDER,FUSE
855	△ HF2	4472-04501	HOLDER,FUSE
855	△ HF11	4472-04501	HOLDER,FUSE
855	△ HF12	4472-04501	HOLDER,FUSE
855	△ HF13	4472-04501	HOLDER,FUSE
855	△ HF14	4472-04501	HOLDER,FUSE
912	△ LCN1	4163-S5101250	CONNECTOR W/W
913	△ LCN2	4163-S5201250	CONNECTOR W/W
913	△ LCN3	4163-S5201250	CONNECTOR W/W (BK)
912B	△ LCN3	4163-S5101250	CONNECTOR W/W (WB) (SB) (IB)
914	△ LCN4	4163-S5101200	CONNECTOR W/W (BK)
300	△ LCN4	4163-S4901200	CONNECTOR W/W (WB) (SB) (IB)
915	△ LCN5	4163-S5201400	CONNECTOR W/W (BK)
039B	△ LCN5	4163-S5001200	CONNECTOR W/W (WB) (SB) (IB)
916	△ LCN6	4163-0122026	CONNECTOR W/W
916	△ LCN7	4163-0122026	CONNECTOR W/W
919	△ LCN8	4163-0122027	CONNECTOR W/W
918	△ LCN9	4163-0122024	CONNECTOR W/W
917	△ LCN10	4163-0125025	CONNECTOR W/W
817	△ LCN11	4163-0125027	CONNECTOR W/W
911	△ LCN18	4163-D135020	CONNECTOR W/W
908	△ LCN21	4163-S0205351	CONNECTOR W/W
906	△ LCN22	4163-S0204401	CONNECTOR W/W
729	△ LF1	5732-02001381	FUSE (IB)
854	△ RY1	4331-01301	RELAY,DC (BK)
854B	△ RY1	4331-02601	RELAY,DC (WB) (SB) (IB)

**PCB-11 AC OUT/VOL SELE P.C. BOARD**

<b>CAPACITOR</b>			
849	C19	5345-226C041	CAP,MINI ELE 22μ/16V
<b>RESISTORS</b>			
844	R11	5130-R010J101	RES,CBN 1/6P 100
848	R25	5130-R030J473	RES,CBN 1/2P 47K
845	R26	5130-R030J470	RES,CBN 1/2P 47
847	R27	5130-R030J392	RES,CBN 1/2P 3.9K
846	R28	5130-R030J271	RES,CBN 1/2P 270
<b>TRANSISTOR</b>			
842	Q12	5611-A143ES	XISTOR,PNP R

**MISCELLANEOUS**

935	J1	4451-00184	JACK,1P, REMOTE IN
935	J2	4451-00184	JACK,1P, REMOTE OUT
891	△ JL1	4242-R0503401	JUMPER LEAD
843	PH1	5624-PC817	PHOTO COUPLR
850	△ S01	4474-04302	SOCKET, AC OUTLET (BK)
040B	△ S01	4411-00501102	SWITCH, ROTARY, VOLTAGE SELECTOR (WB) (SB) (IB)
853	TM1	4214-122	TERMINAL
853	TM2	4214-122	TERMINAL
246		2240-Z032	HOLDER, HL1

**PCB-13 POWER SWITCH P.C. BOARD**

<b>RESISTOR</b>			
709	R99	5130-R030J222	RES,CBN 1/2P 2.2K
<b>DIODE</b>			
710	D99	5631-1SS133	DIODE,DET
<b>MISCELLANEOUS</b>			
708	△ BT1	4199-004	LITHIUM BATTERY
866	CN701	4443-060185	CONNECTOR
865	CN702	4443-030185	CONNECTOR
947	SW701	4431-S2701102	SWITCH,PUSH, POWER

Ser. No.	Ref. No.	Part No.	Description
<b>PCB-14 POWER LED P.C. BOARD</b>			
<b>DIODE</b>			
860	D701	5637-GL3ED8	LED, POWER
<b>MISCELLANEOUS</b>			
900	▲ JL702	4242-R0203161	JUMPER LEAD

<b>PCB-16 FRONT SPEAKER SELECTOR P.C. BOARD</b>			
<b>MISCELLANEOUS</b>			
881	CN401	4443-030185	CONNECTOR
893	▲ JL401	4242-R0503101	JUMPER LEAD
904	▲ JL402	4242-R0503601	JUMPER LEAD
901	▲ JL403	4242-044505	JUMPER LEAD
931	▲ LCN403	4163-0160026	CONNECTOR W/W <b>BK WB SB</b>
931	▲ LCN403	4163-0180026	CONNECTOR W/W <b>IB</b>
930	▲ LCN404	4163-0160024	CONNECTOR W/W <b>BK WB SB</b>
930	▲ LCN404	4163-0180024	CONNECTOR W/W <b>IB</b>
950	S401	4411-00305103	SWITCH, ROTRY, SPEAKER
253		2240-Z032	HOLDER, HL401, 402 <b>IB</b>

<b>PCB-17 FRONT SPEAKER P.C. BOARD</b>			
<b>CAPACITORS</b>			
612	C425	5359-S010K151	CAP,PPP 150P <b>IB</b>
612	C426	5359-S010K151	CAP,PPP 150P <b>IB</b>
612	C427	5359-S010K151	CAP,PPP 150P <b>IB</b>
612	C428	5359-S010K151	CAP,PPP 150P <b>IB</b>
553	C429	5359-S010J102	CAP,PPP 1000P <b>IB</b>
553	C430	5359-S010J102	CAP,PPP 1000P <b>IB</b>
<b>MISCELLANEOUS</b>			
946	▲ TM401	4214-235	TERMINAL, SPEAKER <b>BK WB</b>
946C	▲ TM401	4214-238	TERMINAL, SPEAKER <b>SB IB</b>

<b>PCB-18 REAR/CENTER SPEAKER P.C. BOARD</b>			
<b>CAPACITORS</b>			
988	C1451	5359-S010K331	CAP,PPP 330P <b>IB</b>
988	C1452	5359-S010K331	CAP,PPP 330P <b>IB</b>
988	C1453	5359-S010K331	CAP,PPP 330P <b>IB</b>
988	C1454	5359-S010K331	CAP,PPP 330P <b>IB</b>
987	C1512	5359-S010K151	CAP,PPP 150P <b>IB</b>
<b>MISCELLANEOUS</b>			
890	CN1401	4443-01801005	CONNECTOR
990	LUG	4211-4	LUG <b>IB</b>
944	▲ TM1401	4214-244	TERMINAL, REAR SPEAKER
945	▲ TM1501	4214-243	TERMINAL, CENTER SPEAKER

<b>PCB-19 HEADPHONES P.C. BOARD</b>			
<b>RESISTORS</b>			
591	R461	5130-R030J102	RES,CBN 1/2P 1K
591	R462	5130-R030J102	RES,CBN 1/2P 1K
591	R463	5130-R030J102	RES,CBN 1/2P 1K
591	R464	5130-R030J102	RES,CBN 1/2P 1K
<b>MISCELLANEOUS</b>			
936	▲ J401	4451-51501	JACK,1P, HEADPHONES
245		2240-Z032	HOLDER, HL416

<b>PCB-20 MAIN AMP P.C. BOARD</b>			
<b>CAPACITORS</b>			
786	C20	5341-S07FM822	CAP,ELE 8200µ50V <b>BK</b>
786B	C20	5341-S18FM109	CAP,ELE 10000µ50V <b>WB SB IB</b>
786	C21	5341-S07FM822	CAP,ELE 8200µ50V <b>BK</b>
786B	C21	5341-S18FM109	CAP,ELE 10000µ50V <b>WB SB IB</b>
790	C22	5345-335F041	CAP,MINI ELE 3.3µ50V
790	C23	5345-335F041	CAP,MINI ELE 3.3µ50V
787	C24	5345-105F041	CAP,MINI ELE 1µ50V
789	C25	5345-107B041	CAP,MINI ELE 100µ/10V
805	C26	5354-683J1HM	CAP,MYL .068µ
805	C27	5354-683J1HM	CAP,MYL .068µ
805	C28	5354-683J1HM	CAP,MYL .068µ

Ser. No.	Ref. No.	Part No.	Description
788	C29	5345-105J0962	CAP,MINI ELE 1µ/100V
806	C32	5345-107C041	CAP,MINI ELE 100µ/16V
806	C33	5345-107C041	CAP,MINI ELE 100µ/16V
806	C34	5345-107C041	CAP,MINI ELE 100µ/16V
609	C37	5345-106F041	CAP,MINI ELE 10µ/50V
553	C41	5359-S010J102	CAP,PPP 1000P <b>IB</b>
573	C401	5345-476B041	CAP,MINI ELE 47µ/10V
573	C402	5345-476B041	CAP,MINI ELE 47µ/10V
579	C403	5359-6805851	CAP,PPP 68P
579	C404	5359-6805851	CAP,PPP 68P
580	C405	5353-030933	CAP,MCA 3P <b>BK WB SB</b>
580	C405	5353-020933	CAP,MCA 2P <b>IB</b>
580	C406	5353-030933	CAP,MCA 3P <b>BK WB SB</b>
580	C406	5353-020933	CAP,MCA 2P <b>IB</b>
574	C407	5345-477A041	CAP,MINI ELE 470µ/6.3V
574	C408	5345-477A041	CAP,MINI ELE 470µ/6.3V
575	C409	5345-227F041	CAP,MINI ELE 220µ/50V
575	C410	5345-227F041	CAP,MINI ELE 220µ/50V
575	C411	5345-227F041	CAP,MINI ELE 220µ/50V
615	C412	5345-227F041	CAP,MINI ELE 220µ/50V
576	C413	5345-106F041	CAP,MINI ELE 10µ/50V
576	C414	5345-106F041	CAP,MINI ELE 10µ/50V
581	C415	5359-1015851	CAP,PPP 100P
581	C416	5359-1015851	CAP,PPP 100P
577	C417	5345-475D041	CAP,MINI ELE 4.7µ/25V
577	C418	5345-475D041	CAP,MINI ELE 4.7µ/25V
582	C419	5352-S110J104	CAP,MTL .1µ
582	C420	5352-S110J104	CAP,MTL .1µ
582	C421	5352-S110J104	CAP,MTL .1µ
582	C422	5352-S110J104	CAP,MTL .1µ
617	C423	5345-105F041	CAP,MINI ELE 1µ/50V
617	C424	5345-105F041	CAP,MINI ELE 1µ/50V
456	C1401	5345-476B041	CAP,MINI ELE 47µ/10V
456	C1402	5345-476B041	CAP,MINI ELE 47µ/10V
462	C1403	5359-6805851	CAP,PPP 68P
462	C1404	5359-6805851	CAP,PPP 68P
463	C1405	5353-010933	CAP,MCA 1P
463	C1406	5353-010933	CAP,MCA 1P
457	C1407	5345-477A041	CAP,MINI ELE 470µ/6.3V
457	C1408	5345-477A041	CAP,MINI ELE 470µ/6.3V
458	C1409	5345-S25EM477	CAP,MINI ELE 470µ/35V
458	C1410	5345-S25EM477	CAP,MINI ELE 470µ/35V
458	C1411	5345-S25EM477	CAP,MINI ELE 470µ/35V
458	C1412	5345-S25EM477	CAP,MINI ELE 470µ/35V
459	C1413	5345-106F041	CAP,MINI ELE 10µ/50V
459	C1414	5345-106F041	CAP,MINI ELE 10µ/50V
464	C1415	5359-1015851	CAP,PPP 100P
464	C1416	5359-1015851	CAP,PPP 100P
460	C1417	5345-475D041	CAP,MINI ELE 4.7µ/25V
460	C1418	5345-475D041	CAP,MINI ELE 4.7µ/25V
466	C1419	5352-S110J104	CAP,MTL .1µ
466	C1420	5352-S110J104	CAP,MTL .1µ
466	C1421	5352-S110J104	CAP,MTL .1µ
466	C1422	5352-S110J104	CAP,MTL .1µ
494	C1423	5359-S010K221	CAP,PPP 220P
494	C1424	5359-S010K221	CAP,PPP 220P
618	C1425	5345-106F041	CAP,MINI ELE 10µ/50V
618	C1426	5345-106F041	CAP,MINI ELE 10µ/50V
465	C1471	5354-683J1HM	CAP,MYL .068µ
465	C1472	5354-683J1HM	CAP,MYL .068µ
455	▲ C1473	5345-338E0962	CAP,MINI ELE 3300µ/35V
455	▲ C1474	5345-338E0962	CAP,MINI ELE 3300µ/35V
461	C1475	5345-105F041	CAP,MINI ELE 1µ/50V
513	C1501	5345-476B041	CAP,MINI ELE 47µ/10V
519	C1502	5359-6805851	CAP,PPP 68P
520	C1503	5353-030933	CAP,MCA 3P
514	C1504	5345-477A041	CAP,MINI ELE 470µ/6.3V
515	C1505	5345-227F041	CAP,MINI ELE 220µ/50V
515	C1506	5345-227F041	CAP,MINI ELE 220µ/50V
516	C1507	5345-106F041	CAP,MINI ELE 10µ/50V
521	C1508	5359-1015851	CAP,PPP 100P
517	C1509	5345-475D041	CAP,MINI ELE 4.7µ/25V
523	C1510	5352-S110J104	CAP,MTL .1µ
523	C1511	5352-S110J104	CAP,MTL .1µ
617	C1515	5345-105F041	CAP,MINI ELE 1µ/50V

<b>RESISTORS</b>			
792	R29	5130-R030J471	RES,CBN 1/2P 470

Ser. No.	Ref. No.	Part No.	Description	Ser. No.	Ref. No.	Part No.	Description
792	R30	5130-R030J471	RES,CBN 1/2P 470	604	R439	5130-R010J271	RES,CBN 1/6P 270
798	R31	5130-R030J392	RES,CBN 1/2P 3.9K	604	R440	5130-R010J271	RES,CBN 1/6P 270
797	R32	5130-R030J332	RES,CBN 1/2P 3.3K	603	△ R441	5102-1005116	RES,FUSE 10
804	R33	5130-R030J104	RES,CBN 1/2P 100K	603	△ R442	5102-1005116	RES,FUSE 10
799	R34	5130-R030J472	RES,CBN 1/2P 4.7K	603	△ R443	5102-1005116	RES,FUSE 10
802	R35	5130-R030J333	RES,CBN 1/2P 33K	603	△ R444	5102-1005116	RES,FUSE 10
799	R36	5130-R030J472	RES,CBN 1/2P 4.7K	585	△ R449	5102-8205116	RES,FUSE 82
799	R37	5130-R030J472	RES,CBN 1/2P 4.7K	585	△ R450	5102-8205116	RES,FUSE 82
803	R38	5130-R030J683	RES,CBN 1/2P 68K	600	R451	5273-R27672	RES,CEM 3P .27
614	R39	5130-R030J393	RES,CBN 1/2P 39K	600	R452	5273-R27672	RES,CEM 3P .27
619	R40	5130-R030J103	RES,CBN 1/2P 10K	600	R453	5273-R27672	RES,CEM 3P .27
796	R41	5130-R030J222	RES,CBN 1/2P 2.2K	600	R454	5273-R27672	RES,CEM 3P .27
606	R42	5130-R030J472	RES,CBN 1/2P 4.7K	586	R455	5171-1R0583	RES,MTL 1P 1
607	R43	5130-R010J683	RES,CBN 1/6P 68K	586	R456	5171-1R0583	RES,MTL 1P 1
608	R44	5130-R010J104	RES,CBN 1/6P 100K	599	R457	5175-100581	RES,MTL 3P 10
800	R45	5130-R010J682	RES,CBN 1/6P 6.8K	599	R458	5175-100581	RES,MTL 3P 10
800	R46	5130-R010J682	RES,CBN 1/6P 6.8K	596	R459	5130-R030J333	RES,CBN 1/2P 33K
795	R47	5130-R010J162	RES,CBN 1/6P 1.6K	596	R460	5130-R030J333	RES,CBN 1/2P 33K
795	R48	5130-R010J162	RES,CBN 1/6P 1.6K	605	△ R471	5102-2R25116	RES,FUSE 2.2
791	R49	5130-R010J331	RES,CBN 1/6P 330	605	△ R472	5102-2R25116	RES,FUSE 2.2
791	R50	5130-R010J331	RES,CBN 1/6P 330	605	△ R473	5102-2R25116	RES,FUSE 2.2
794	R51	5130-R010J152	RES,CBN 1/6P 1.5K	605	△ R474	5102-2R25116	RES,FUSE 2.2
794	R52	5130-R010J152	RES,CBN 1/6P 1.5K	804	R750	5130-R030J104	RES,CBN 1/2P 100K
795	R53	5130-R010J162	RES,CBN 1/6P 1.6K	547	R1401	5130-R030J683	RES,CBN 1/2P 68K
791	R54	5130-R010J331	RES,CBN 1/6P 330	547	R1402	5130-R030J683	RES,CBN 1/2P 68K
794	R55	5130-R010J152	RES,CBN 1/6P 1.5K	475	R1403	5130-R030J331	RES,CBN 1/2P 330
800	R56	5130-R010J682	RES,CBN 1/6P 6.8K	475	R1404	5130-R030J331	RES,CBN 1/2P 330
802	R57	5130-R030J333	RES,CBN 1/2P 33K	471	R1405	5130-R030J150	RES,CBN 1/2P 15
802	R58	5130-R030J333	RES,CBN 1/2P 33K	471	R1406	5130-R030J150	RES,CBN 1/2P 15
802	R59	5130-R030J333	RES,CBN 1/2P 33K	471	R1407	5130-R030J150	RES,CBN 1/2P 15
799	R60	5130-R030J472	RES,CBN 1/2P 4.7K	471	R1408	5130-R030J150	RES,CBN 1/2P 15
803	R61	5130-R030J683	RES,CBN 1/2P 68K	474	R1409	5130-R030J271	RES,CBN 1/2P 270
804	R62	5130-R030J104	RES,CBN 1/2P 100K	474	R1410	5130-R030J271	RES,CBN 1/2P 270
804	R63	5130-R030J104	RES,CBN 1/2P 100K	476	R1411	5130-R030J561	RES,CBN 1/2P 560
804	R64	5130-R030J104	RES,CBN 1/2P 100K	476	R1412	5130-R030J561	RES,CBN 1/2P 560
801	R65	5130-R030J103	RES,CBN 1/2P 10K	476	R1413	5130-R030J561	RES,CBN 1/2P 560
793	R66	5130-R030J102	RES,CBN 1/2P 1K	476	R1414	5130-R030J561	RES,CBN 1/2P 560
793	R67	5130-R030J102	RES,CBN 1/2P 1K	480	R1415	5130-R030J152	RES,CBN 1/2P 1.5K
492	R71	5130-R030J103	RES,CBN 1/2P 10K	480	R1416	5130-R030J152	RES,CBN 1/2P 1.5K
497	R72	5130-R010J222	RES,CBN 1/6P 2.2K	480	R1417	5130-R030J152	RES,CBN 1/2P 1.5K
596	R401	5130-R030J333	RES,CBN 1/2P 33K	480	R1418	5130-R030J152	RES,CBN 1/2P 1.5K
596	R402	5130-R030J333	RES,CBN 1/2P 33K	476	R1419	5130-R030J561	RES,CBN 1/2P 560
588	R403	5130-R030J331	RES,CBN 1/2P 330	476	R1420	5130-R030J561	RES,CBN 1/2P 560
588	R404	5130-R030J331	RES,CBN 1/2P 330	473	R1421	5130-R030J102	RES,CBN 1/2P 1K
589	R405	5130-R030J391	RES,CBN 1/2P 390	473	R1422	5130-R030J102	RES,CBN 1/2P 1K
589	R406	5130-R030J391	RES,CBN 1/2P 390	476	R1423	5130-R030J561	RES,CBN 1/2P 560
589	R407	5130-R030J391	RES,CBN 1/2P 390	476	R1424	5130-R030J561	RES,CBN 1/2P 560
589	R408	5130-R030J391	RES,CBN 1/2P 390	468	△ R1425	5102-5605116	RES,FUSE 56
594	R409	5130-R030J103	RES,CBN 1/2P 10K	468	△ R1426	5102-5605116	RES,FUSE 56
594	R410	5130-R030J103	RES,CBN 1/2P 10K	483	R1427	5130-R030J223	RES,CBN 1/2P 22K
587	R411	5130-R030J271	RES,CBN 1/2P 270	483	R1428	5130-R030J223	RES,CBN 1/2P 22K
587	R412	5130-R030J271	RES,CBN 1/2P 270	483	R1429	5130-R030J223	RES,CBN 1/2P 22K
593	R413	5130-R030J152	RES,CBN 1/2P 1.5K	483	R1430	5130-R030J223	RES,CBN 1/2P 22K
593	R414	5130-R030J152	RES,CBN 1/2P 1.5K	479	R1431	5130-R030J122	RES,CBN 1/2P 1.2K
593	R415	5130-R030J152	RES,CBN 1/2P 1.5K	479	R1432	5130-R030J122	RES,CBN 1/2P 1.2K
593	R416	5130-R030J152	RES,CBN 1/2P 1.5K	557	R1433	5130-R030J271	RES,CBN 1/2P 270
590	R417	5130-R030J561	RES,CBN 1/2P 560	556	R1434	5130-R010J271	RES,CBN 1/6P 270
590	R418	5130-R030J561	RES,CBN 1/2P 560	476	R1435	5130-R030J561	RES,CBN 1/2P 560
583	△ R419	5102-5615116	RES,FUSE 560	476	R1436	5130-R030J561	RES,CBN 1/2P 560
583	△ R420	5102-5615116	RES,FUSE 560	468	△ R1437	5102-5605116	RES,FUSE 56
583	△ R421	5102-5615116	RES,FUSE 560	468	△ R1438	5102-5605116	RES,FUSE 56
583	△ R422	5102-5615116	RES,FUSE 560	469	△ R1439	5102-8205116	RES,FUSE 82
597	R423	5130-R030J122	RES,CBN 1/2P 1.2K	469	△ R1440	5102-8205116	RES,FUSE 82
597	R424	5130-R030J122	RES,CBN 1/2P 1.2K	469	△ R1441	5102-8205116	RES,FUSE 82
583	△ R425	5102-5615116	RES,FUSE 560	469	△ R1442	5102-8205116	RES,FUSE 82
583	△ R426	5102-5615116	RES,FUSE 560	482	R1443	5130-R030J103	RES,CBN 1/2P 10K
583	△ R427	5102-5615116	RES,FUSE 560	482	R1444	5130-R030J103	RES,CBN 1/2P 10K
583	△ R428	5102-5615116	RES,FUSE 560	467	△ R1445	5102-4R75713	RES,FUSE 4.7
584	△ R429	5102-5605116	RES,FUSE 56	467	△ R1446	5102-4R75713	RES,FUSE 4.7
584	△ R430	5102-5605116	RES,FUSE 56	467	△ R1447	5102-4R75713	RES,FUSE 4.7
584	△ R431	5102-5605116	RES,FUSE 56	467	△ R1448	5102-4R75713	RES,FUSE 4.7
584	△ R432	5102-5605116	RES,FUSE 56	472	R1449	5130-R030J820	RES,CBN 1/2P 82
595	R433	5130-R030J223	RES,CBN 1/2P 22K	472	R1450	5130-R030J820	RES,CBN 1/2P 82
595	R434	5130-R030J223	RES,CBN 1/2P 22K	490	R1451	5275-S040JR27	RES,CEM 5P .27
595	R435	5130-R030J223	RES,CBN 1/2P 22K	490	R1452	5275-S040JR27	RES,CEM 5P .27
595	R436	5130-R030J223	RES,CBN 1/2P 22K	490	R1453	5275-S040JR27	RES,CEM 5P .27
592	R437	5130-R010J122	RES,CBN 1/6P 1.2K	490	R1454	5275-S040JR27	RES,CEM 5P .27
592	R438	5130-R010J122	RES,CBN 1/6P 1.2K	470	R1455	5130-R030J100	RES,CBN 1/2P 10



Ser. No.	Ref. No.	Part No.	Description	Ser. No.	Ref. No.	Part No.	Description
470	R1456	5130-R030J100	RES,CBN 1/2P 10	561	Q407	5611-872(E)	XISTOR,PNP R
489	R1457	5171-100583	RES,MTL 1P 10	561	Q408	5611-872(E)	XISTOR,PNP R
489	R1458	5171-100583	RES,MTL 1P 10	565	Q409	5613-2240(BL)	XISTOR,NPN R
485	R1459	5130-R030J683	RES,CBN 1/2P 68K	565	Q410	5613-2240(BL)	XISTOR,NPN R
485	R1460	5130-R030J683	RES,CBN 1/2P 68K	565	Q411	5613-2240(BL)	XISTOR,NPN R
546	R1461	5130-R030J222	RES,CBN 1/2P 2.2K	565	Q412	5613-2240(BL)	XISTOR,NPN R
546	R1462	5130-R030J222	RES,CBN 1/2P 2.2K	563	Q413	5612-646A(C)	XISTOR,PNP A
493	R1463	5130-R010J221	RES,CBN 1/6P 220	563	Q414	5612-646A(C)	XISTOR,PNP A
493	R1464	5130-R010J221	RES,CBN 1/6P 220	567	Q415	5614-666A(C)	XISTOR,NPN A
481	R1471	5130-R010J472	RES,CBN 1/6P 4.7K	567	Q416	5614-666A(C)	XISTOR,NPN A
481	R1472	5130-R010J472	RES,CBN 1/6P 4.7K	566	Q417	5613-3423(Y)	XISTOR,NPN R
558	R1473	5130-R010J331	RES,CBN 1/6P 330	578	Q418	5613-3423(Y)	XISTOR,NPN R
558	R1474	5130-R010J331	RES,CBN 1/6P 330	568	Q419	5613-3298(Y)	XISTOR,NPN R
477	R1475	5130-R030J681	RES,CBN 1/2P 680	568	Q420	5613-3298(Y)	XISTOR,NPN R
559	R1476	5130-R010J681	RES,CBN 1/6P 680	564	Q421	5611-1306(Y)	XISTOR,PNP R
478	R1477	5130-R030J821	RES,CBN 1/2P 820	564	Q422	5611-1306(Y)	XISTOR,PNP R
478	R1478	5130-R030J821	RES,CBN 1/2P 820	571	Q423	5613-3182(O)	XISTOR,NPN R
487	R1479	5130-R010J104	RES,CBN 1/6P 100K	571	Q424	5613-3182(O)	XISTOR,NPN R
486	R1480	5130-R010J683	RES,CBN 1/6P 68K	569	Q425	5611-1265(O)	XISTOR,PNP R
482	R1481	5130-R030J103	RES,CBN 1/2P 10K	569	Q426	5611-1265(O)	XISTOR,PNP R
482	R1482	5130-R030J103	RES,CBN 1/2P 10K	776	Q710	5611-A124ES	XISTOR,PNP R
484	R1483	5130-R030J333	RES,CBN 1/2P 33K	441	Q1401	5611-970(BL)	XISTOR,PNP R
484	R1484	5130-R030J333	RES,CBN 1/2P 33K	441	Q1402	5611-970(BL)	XISTOR,PNP R
548	R1501	5130-R030J333	RES,CBN 1/2P 33K	441	Q1403	5611-970(BL)	XISTOR,PNP R
530	R1502	5130-R030J331	RES,CBN 1/2P 330	441	Q1404	5611-970(BL)	XISTOR,PNP R
549	R1503	5130-R030J391	RES,CBN 1/2P 390	442	Q1405	5611-1115(F)	XISTOR,PNP R
549	R1504	5130-R030J391	RES,CBN 1/2P 390	442	Q1406	5611-1115(F)	XISTOR,PNP R
535	R1505	5130-R030J103	RES,CBN 1/2P 10K	442	Q1407	5611-1115(F)	XISTOR,PNP R
529	R1506	5130-R030J271	RES,CBN 1/2P 270	442	Q1408	5611-1115(F)	XISTOR,PNP R
534	R1507	5130-R030J152	RES,CBN 1/2P 1.5K	445	Q1409	5613-2240(BL)	XISTOR,NPN R
534	R1508	5130-R030J152	RES,CBN 1/2P 1.5K	445	Q1410	5613-2240(BL)	XISTOR,NPN R
531	R1509	5130-R030J561	RES,CBN 1/2P 560	443	Q1411	5612-646A(C)	XISTOR,PNP A
537	△ R1510	5102-5615116	RES,FUSE 560	443	Q1412	5612-646A(C)	XISTOR,PNP A
537	△ R1511	5102-5615116	RES,FUSE 560	447	Q1413	5614-666A(C)	XISTOR,NPN A
537	△ R1512	5102-5615116	RES,FUSE 560	447	Q1414	5614-666A(C)	XISTOR,NPN A
537	△ R1513	5102-5615116	RES,FUSE 560	446	Q1415	5613-3423(Y)	XISTOR,NPN R
532	R1514	5130-R030J122	RES,CBN 1/2P 1.2K	446	Q1416	5613-3423(Y)	XISTOR,NPN R
525	△ R1515	5102-5605116	RES,FUSE 56	445	Q1417	5613-2240(BL)	XISTOR,NPN R
525	△ R1516	5102-5605116	RES,FUSE 56	445	Q1418	5613-2240(BL)	XISTOR,NPN R
533	R1517	5130-R010J122	RES,CBN 1/6P 1.2K	448	Q1419	5613-2235(Y)	XISTOR,NPN R
543	R1518	5130-R010J271	RES,CBN 1/6P 270	448	Q1420	5613-2235(Y)	XISTOR,NPN R
536	R1519	5130-R030J223	RES,CBN 1/2P 22K	444	Q1421	5611-965(Y)	XISTOR,PNP R
536	R1520	5130-R030J223	RES,CBN 1/2P 22K	444	Q1422	5611-965(Y)	XISTOR,PNP R
524	△ R1521	5102-1005116	RES,FUSE 10	451	Q1423	5613-3180(O)	XISTOR,NPN R
524	△ R1522	5102-1005116	RES,FUSE 10	451	Q1424	5613-3180(O)	XISTOR,NPN R
526	△ R1526	5102-8205116	RES,FUSE 82	449	Q1425	5611-1263(O)	XISTOR,PNP R
550	R1527	5130-R030J333	RES,CBN 1/2P 33K	449	Q1426	5611-1263(O)	XISTOR,PNP R
540	R1528	5273-R27872	RES,CEM 3P .27	554	Q1470	5611-970(BL)	XISTOR,PNP R
540	R1529	5273-R27872	RES,CEM 3P .27	445	Q1471	5613-2240(BL)	XISTOR,NPN R
527	R1530	5130-R030J100	RES,CBN 1/2P 10	445	Q1472	5613-2240(BL)	XISTOR,NPN R
539	R1531	5171-100583	RES,MTL 1P 10	501	Q1501	5611-872(E)	XISTOR,PNP R
544	△ R1532	5102-2R25116	RES,FUSE 2.2	501	Q1502	5611-872(E)	XISTOR,PNP R
544	△ R1533	5102-2R25116	RES,FUSE 2.2	502	Q1503	5611-1115(F)	XISTOR,PNP R
		<b>INTEGRATED CIRCUIT</b>		501	Q1504	5611-872(E)	XISTOR,PNP R
772	IC1	5654-TC4069BP	IC,DIGITAL	505	Q1505	5613-2240(BL)	XISTOR,NPN R
		<b>TRANSISTORS</b>		505	Q1506	5613-2240(BL)	XISTOR,NPN R
773	Q13	5611-1309A(R)	XISTOR,PNP R	503	Q1507	5612-646A(C)	XISTOR,PNP A
777	Q14	5613-3311A(R)	XISTOR,NPN R	507	Q1508	5614-666A(C)	XISTOR,NPN A
779	Q15	5613-2320L(F)	XISTOR,NPN R	506	Q1509	5613-3423(Y)	XISTOR,NPN R
774	Q16	5611-970(BL)	XISTOR,PNP R	508	Q1510	5613-3298(Y)	XISTOR,NPN R
775	Q17	5611-872(E)	XISTOR,PNP R	504	Q1511	5611-1306(Y)	XISTOR,PNP R
778	Q18	5613-2240(BL)	XISTOR,NPN R	511	Q1512	5613-3182(O)	XISTOR,NPN R
778	Q19	5613-2240(BL)	XISTOR,NPN R	509	Q1513	5611-1265(O)	XISTOR,PNP R
778	Q20	5613-2240(BL)	XISTOR,NPN R			<b>DIODES</b>	
779	Q21	5613-2320L(F)	XISTOR,NPN R	780	△ D20	5685-D5SB20	SILICON,BRIG
777	Q22	5613-3311A(R)	XISTOR,NPN R	781	D21	5636-1S2471	DIODE,SWITCH
779	Q23	5613-2320L(F)	XISTOR,NPN R	781	D22	5636-1S2471	DIODE,SWITCH
773	Q24	5611-1309A(R)	XISTOR,PNP R	784	D23	5635-HZ6B1L	DIODE,ZENER
500	Q28	5613-2320L(F)	XISTOR,NPN R	781	D24	5636-1S2471	DIODE,SWITCH
499	Q29	5611-1309A(R)	XISTOR,PNP R	782	D25	5631-1SS133	DIODE,DET
561	Q401	5611-872(E)	XISTOR,PNP R	782	D26	5631-1SS133	DIODE,DET
561	Q402	5611-872(E)	XISTOR,PNP R	782	D27	5631-1SS133	DIODE,DET
561	Q403	5611-872(E)	XISTOR,PNP R	783	D28	5631-1S2473	DIODE,DET
561	Q404	5611-872(E)	XISTOR,PNP R	782	D750	5631-1SS133	DIODE,DET
562	Q405	5611-1115(F)	XISTOR,PNP R	782	D751	5631-1SS133	DIODE,DET
562	Q406	5611-1115(F)	XISTOR,PNP R	454	△ D1470	5685-RBV-602	SILICON,BRIG

Ser. No.	Ref. No.	Part No.	Description
555	D1471	5631-1SS133	DIODE,DET
555	D1472	5631-1SS133	DIODE,DET
453	D1473	5631-1SS133	DIODE,DET

**COILS**

601	L401	5991-7125	SPRING COIL
601	L402	5991-7125	SPRING COIL
491	L1401	5991-7165	SPRING COIL
491	L1402	5991-7165	SPRING COIL
541	L1501	5991-7165	SPRING COIL

**CONTROLS**

598	VR401	5101-S0801501	RES,SEMI FIX 500, IDLING
598	VR402	5101-S0801501	RES,SEMI FIX 500, IDLING
488	VR1401	5101-S0801501	RES,SEMI FIX 500, IDLING
488	VR1402	5101-S0801501	RES,SEMI FIX 500, IDLING
538	VR1501	5101-S0801501	RES,SEMI FIX 500, IDLING

**MISCELLANEOUS**

870	CN8	4443-0201140	CONNECTOR
864	CN21	4443-0501140	CONNECTOR
872	CN710	4443-08101006	CONNECTOR
874	CN711	4443-01801012	CONNECTOR
867	CN712	4443-030185	CONNECTOR
875	CN715	4443-01801010	CONNECTOR
867	CN716	4443-030185	CONNECTOR
869	CN717	4443-050185	CONNECTOR
871	CN719	4443-08101012	CONNECTOR
871	CN720	4443-08101012	CONNECTOR
873	CN721	4443-08101016	CONNECTOR
868	CN722	4443-040185	CONNECTOR
620	CN730	4443-0301140	CONNECTOR
867	CN1501	4443-030185	CONNECTOR
934	△ JL3	4132-R0202161	CORD,2C
902	△ JL405	4242-R0103800	JUMPER LEAD
902	△ JL406	4242-R0103800	JUMPER LEAD
545	△ JL422	4132-R0100800	CORD,2C
903	△ JL1403	4242-R0103101	JUMPER LEAD
903	△ JL1404	4242-R0103101	JUMPER LEAD
902	△ JL1501	4242-R0103800	JUMPER LEAD
897	△ LCN12	4163-0155027	CONNECTOR W/W <b>BK WB SB</b>
897	△ LCN12	4163-0140027	CONNECTOR W/W <b>IB</b>
923	△ LCN13	4163-0150024	CONNECTOR W/W <b>BK WB SB</b>
923	△ LCN13	4163-0140024	CONNECTOR W/W <b>IB</b>
922	△ LCN14	4163-0155025	CONNECTOR W/W <b>BK WB SB</b>
922	△ LCN14	4163-0140025	CONNECTOR W/W <b>IB</b>
920	△ LCN15	4163-0130027	CONNECTOR W/W <b>BK WB SB</b>
920	△ LCN15	4163-0155027	CONNECTOR W/W <b>IB</b>
921	△ LCN16	4163-0130026	CONNECTOR W/W <b>BK WB SB</b>
921	△ LCN16	4163-0155026	CONNECTOR W/W <b>IB</b>
905	△ LCN17	4163-0130025	CONNECTOR W/W <b>BK WB SB</b>
905	△ LCN17	4163-0155025	CONNECTOR W/W <b>IB</b>
929	△ LCN401	4163-0145027	CONNECTOR W/W <b>BK WB SB</b>
929	△ LCN401	4163-0170027	CONNECTOR W/W <b>IB</b>
928	△ LCN402	4163-0145025	CONNECTOR W/W <b>BK WB SB</b>
928	△ LCN402	4163-0170025	CONNECTOR W/W <b>IB</b>
909	△ LCN714	4163-S0204101	CONNECTOR W/W
910	△ LCN718	4163-S0206161	CONNECTOR W/W
907	△ LCN1401	4163-S0202141	CONNECTOR W/W
927	△ LCN1402	4163-0135027	CONNECTOR W/W <b>BK WB SB</b>
927	△ LCN1402	4163-0130027	CONNECTOR W/W <b>IB</b>
926	△ LCN1403	4163-0135026	CONNECTOR W/W <b>BK WB SB</b>
926	△ LCN1403	4163-0130026	CONNECTOR W/W <b>IB</b>
925	△ LCN1404	4163-0135025	CONNECTOR W/W <b>BK WB SB</b>
925	△ LCN1404	4163-0130025	CONNECTOR W/W <b>IB</b>
924	△ LCN1405	4163-0135024	CONNECTOR W/W <b>BK WB SB</b>
924	△ LCN1405	4163-0130024	CONNECTOR W/W <b>IB</b>
498	△ LCN1406	4163-0125039	CONNECTOR W/W
933	△ LCN1501	4163-0180025	CONNECTOR W/W <b>BK WB SB</b>
933	△ LCN1501	4163-0180025	CONNECTOR W/W <b>IB</b>
932	△ LCN1502	4163-0180024	CONNECTOR W/W <b>BK WB SB</b>
932	△ LCN1502	4163-0180024	CONNECTOR W/W <b>IB</b>
552	△ LCN1505	4163-0122024	CONNECTOR W/W
560	PT1	5192-010BD471	POSISTOR
616	TM402	4214-11022	TERMINAL
852	TM403	4214-11032	TERMINAL
602	TP401	4443-027114	CONNECTOR
602	TP402	4443-027114	CONNECTOR

Ser. No.	Ref. No.	Part No.	Description
542	TP1501	4443-027114	CONNECTOR
551		4211-4	LUG <b>IB</b>
254		2240-Z031	HOLDER, HL1401

**PCB-21 REAR AMP P.C. BOARD**

**CAPACITORS**

456	C1401	5345-476B041	CAP,MINI ELE 47μ/10V
456	C1402	5345-476B041	CAP,MINI ELE 47μ/10V
462	C1403	5359-6805851	CAP,PPP 68P
462	C1404	5359-6805851	CAP,PPP 68P
463	C1405	5353-010933	CAP,MCA 1P
463	C1406	5353-010933	CAP,MCA 1P
457	C1407	5345-477A041	CAP,MINI ELE 470μ/6.3V
457	C1408	5345-477A041	CAP,MINI ELE 470μ/6.3V
458	C1409	5345-S25EM477	CAP,MINI ELE 470μ/35V
458	C1410	5345-S25EM477	CAP,MINI ELE 470μ/35V
458	C1411	5345-S25EM477	CAP,MINI ELE 470μ/35V
458	C1412	5345-S25EM477	CAP,MINI ELE 470μ/35V
459	C1413	5345-106F041	CAP,MINI ELE 10μ/50V
459	C1414	5345-106F041	CAP,MINI ELE 10μ/50V
464	C1415	5359-1015851	CAP,PPP 100P
464	C1416	5359-1015851	CAP,PPP 100P
460	C1417	5345-475D041	CAP,MINI ELE 4.7U/25V
460	C1418	5345-475D041	CAP,MINI ELE 4.7U/25V
466	C1419	5352-S110J104	CAP,MTL .1μ
466	C1420	5352-S110J104	CAP,MTL .1μ
466	C1421	5352-S110J104	CAP,MTL .1μ
466	C1422	5352-S110J104	CAP,MTL .1μ
494	C1423	5359-S010K221	CAP,PPP 220P
494	C1424	5359-S010K221	CAP,PPP 220P
618	C1425	5345-106F041	CAP,MINI ELE 10μ/50V
618	C1426	5345-106F041	CAP,MINI ELE 10μ/50V
465	C1471	5354-683J1HM	CAP,MYL .068μ
465	C1472	5354-683J1HM	CAP,MYL .068μ
455	△ C1473	5345-338E0962	CAP,MINI ELE 3300μ/35V
455	△ C1474	5345-338E0962	CAP,MINI ELE 3300μ/35V
461	C1475	5345-105F041	CAP,MINI ELE 1μ/50V

**RESISTORS**

492	R71	5130-R030J103	RES,CBN 1/2P 10K
497	R72	5130-R010J222	RES,CBN 1/6P 2.2K
547	R1401	5130-R030J683	RES,CBN 1/2P 68K
547	R1402	5130-R030J683	RES,CBN 1/2P 68K
475	R1403	5130-R030J331	RES,CBN 1/2P 330
475	R1404	5130-R030J331	RES,CBN 1/2P 330
471	R1405	5130-R030J150	RES,CBN 1/2P 15
471	R1406	5130-R030J150	RES,CBN 1/2P 15
471	R1407	5130-R030J150	RES,CBN 1/2P 15
471	R1408	5130-R030J150	RES,CBN 1/2P 15
474	R1409	5130-R030J271	RES,CBN 1/2P 270
474	R1410	5130-R030J271	RES,CBN 1/2P 270
476	R1411	5130-R030J561	RES,CBN 1/2P 560
476	R1412	5130-R030J561	RES,CBN 1/2P 560
476	R1413	5130-R030J561	RES,CBN 1/2P 560
476	R1414	5130-R030J561	RES,CBN 1/2P 560
480	R1415	5130-R030J152	RES,CBN 1/2P 1.5K
480	R1416	5130-R030J152	RES,CBN 1/2P 1.5K
480	R1417	5130-R030J152	RES,CBN 1/2P 1.5K
480	R1418	5130-R030J152	RES,CBN 1/2P 1.5K
476	R1419	5130-R030J561	RES,CBN 1/2P 560
476	R1420	5130-R030J561	RES,CBN 1/2P 560
473	R1421	5130-R030J102	RES,CBN 1/2P 1K
473	R1422	5130-R030J102	RES,CBN 1/2P 1K
476	R1423	5130-R030J561	RES,CBN 1/2P 560
476	R1424	5130-R030J561	RES,CBN 1/2P 560
468	△ R1425	5102-5605116	RES,FUSE 56
468	△ R1426	5102-5605116	RES,FUSE 56
483	R1427	5130-R030J223	RES,CBN 1/2P 22K
483	R1428	5130-R030J223	RES,CBN 1/2P 22K
483	R1429	5130-R030J223	RES,CBN 1/2P 22K
483	R1430	5130-R030J223	RES,CBN 1/2P 22K
479	R1431	5130-R030J122	RES,CBN 1/2P 1.2K
479	R1432	5130-R030J122	RES,CBN 1/2P 1.2K
557	R1433	5130-R030J271	RES,CBN 1/2P 270
556	R1434	5130-R010J271	RES,CBN 1/6P 270
476	R1435	5130-R030J561	RES,CBN 1/2P 560
476	R1436	5130-R030J561	RES,CBN 1/2P 560

Ser. No.	Ref. No.	Part No.	Description
468	△ R1437	5102-5605116	RES,FUSE 56
468	△ R1438	5102-5605116	RES,FUSE 56
469	△ R1439	5102-8205116	RES,FUSE 82
469	△ R1440	5102-8205116	RES,FUSE 82
469	△ R1441	5102-8205116	RES,FUSE 82
469	△ R1442	5102-8205116	RES,FUSE 82
482	R1443	5130-R030J103	RES,CBN 1/2P 10K
482	R1444	5130-R030J103	RES,CBN 1/2P 10K
467	△ R1445	5102-4R75713	RES,FUSE 4.7
467	△ R1446	5102-4R75713	RES,FUSE 4.7
467	△ R1447	5102-4R75713	RES,FUSE 4.7
467	△ R1448	5102-4R75713	RES,FUSE 4.7
472	R1449	5130-R030J820	RES,CBN 1/2P 82
472	R1450	5130-R030J820	RES,CBN 1/2P 82
490	R1451	5275-S040JR27	RES,CEM 5P .27
490	R1452	5275-S040JR27	RES,CEM 5P .27
490	R1453	5275-S040JR27	RES,CEM 5P .27
490	R1454	5275-S040JR27	RES,CEM 5P .27
470	R1455	5130-R030J100	RES,CBN 1/2P 10
470	R1456	5130-R030J100	RES,CBN 1/2P 10
489	R1457	5171-100583	RES,MTL 1P 10
489	R1458	5171-100583	RES,MTL 1P 10
485	R1459	5130-R030J68K	RES,CBN 1/2P 68K
485	R1460	5130-R030J68K	RES,CBN 1/2P 68K
546	R1461	5130-R030J222	RES,CBN 1/2P 2.2K
546	R1462	5130-R030J222	RES,CBN 1/2P 2.2K
493	R1463	5130-R010J221	RES,CBN 1/6P 220
493	R1464	5130-R010J221	RES,CBN 1/6P 220
481	R1471	5130-R010J472	RES,CBN 1/6P 4.7K
481	R1472	5130-R010J472	RES,CBN 1/6P 4.7K
558	R1473	5130-R010J331	RES,CBN 1/6P 330
558	R1474	5130-R010J331	RES,CBN 1/6P 330
477	R1475	5130-R030J681	RES,CBN 1/2P 680
559	R1476	5130-R010J681	RES,CBN 1/6P 680
478	R1477	5130-R030J821	RES,CBN 1/2P 820
478	R1478	5130-R030J821	RES,CBN 1/2P 820
487	R1479	5130-R010J104	RES,CBN 1/6P 100K
486	R1480	5130-R010J68K	RES,CBN 1/6P 68K
482	R1481	5130-R030J103	RES,CBN 1/2P 10K
482	R1482	5130-R030J103	RES,CBN 1/2P 10K
484	R1483	5130-R030J333	RES,CBN 1/2P 33K
484	R1484	5130-R030J333	RES,CBN 1/2P 33K

**TRANSISTORS**

500	Q28	5613-2320L(F)	XISTOR,NPN R
499	Q29	5611-1309A(R)	XISTOR,PNP R
441	Q1401	5611-970(BL)	XISTOR,PNP R
441	Q1402	5611-970(BL)	XISTOR,PNP R
441	Q1403	5611-970(BL)	XISTOR,PNP R
441	Q1404	5611-970(BL)	XISTOR,PNP R
442	Q1405	5611-1115(F)	XISTOR,PNP R
442	Q1406	5611-1115(F)	XISTOR,PNP R
442	Q1407	5611-1115(F)	XISTOR,PNP R
442	Q1408	5611-1115(F)	XISTOR,PNP R
445	Q1409	5613-2240(BL)	XISTOR,NPN R
445	Q1410	5613-2240(BL)	XISTOR,NPN R
443	Q1411	5612-646A(C)	XISTOR,PNP A
443	Q1412	5612-646A(C)	XISTOR,PNP A
447	Q1413	5614-666A(C)	XISTOR,NPN A
447	Q1414	5614-666A(C)	XISTOR,NPN A
446	Q1415	5613-3423(Y)	XISTOR,NPN R
446	Q1416	5613-3423(Y)	XISTOR,NPN R
445	Q1417	5613-2240(BL)	XISTOR,NPN R
445	Q1418	5613-2240(BL)	XISTOR,NPN R
448	Q1419	5613-2235(Y)	XISTOR,NPN R
448	Q1420	5613-2235(Y)	XISTOR,NPN R
444	Q1421	5611-965(Y)	XISTOR,PNP R
444	Q1422	5611-965(Y)	XISTOR,PNP R
451	Q1423	5613-3180(O)	XISTOR,NPN R
451	Q1424	5613-3180(O)	XISTOR,NPN R
449	Q1425	5611-1263(O)	XISTOR,PNP R
449	Q1426	5611-1263(O)	XISTOR,PNP R
554	Q1470	5611-970(BL)	XISTOR,PNP R
445	Q1471	5613-2240(BL)	XISTOR,NPN R
445	Q1472	5613-2240(BL)	XISTOR,NPN R

**DIODES**

454	△ D1470	5685-RBV-602	SILICON,BRIG
-----	---------	--------------	--------------

Ser. No.	Ref. No.	Part No.	Description
555	D1471	5631-1SS133	DIODE,DET
555	D1472	5631-1SS133	DIODE,DET
453	D1473	5631-1SS133	DIODE,DET
<b>COILS</b>			
491	L1401	5991-7165	SPRING COIL
491	L1402	5991-7165	SPRING COIL
<b>CONTROLS</b>			
488	VR1401	5101-S0801501	RES,SEMI FIX 500, IDLING
488	VR1402	5101-S0801501	RES,SEMI FIX 500, IDLING
<b>MISCELLANEOUS</b>			
903	△ JL1403	4242-R0103101	JUMPER LEAD
903	△ JL1404	4242-R0103101	JUMPER LEAD
920	△ LCN15	4163-0130027	CONNECTOR W/W
920	△ LCN15	4163-0155027	CONNECTOR W/W
921	△ LCN16	4163-0130026	CONNECTOR W/W
921	△ LCN16	4163-0155026	CONNECTOR W/W
905	△ LCN17	4163-0130025	CONNECTOR W/W
905	△ LCN17	4163-0155025	CONNECTOR W/W
907	△ LCN1401	4163-S0202141	CONNECTOR W/W
927	△ LCN1402	4163-0135027	CONNECTOR W/W
927	△ LCN1402	4163-0130027	CONNECTOR W/W
926	△ LCN1403	4163-0135026	CONNECTOR W/W
926	△ LCN1403	4163-0130026	CONNECTOR W/W
925	△ LCN1404	4163-0135025	CONNECTOR W/W
925	△ LCN1404	4163-0130025	CONNECTOR W/W
924	△ LCN1405	4163-0135024	CONNECTOR W/W
924	△ LCN1405	4163-0130024	CONNECTOR W/W
498	△ LCN1406	4163-0125039	CONNECTOR W/W
254		2240-Z031	HOLDER, HL1401

**PCB 22 POWER SUPPLY 3 P.C. BOARD**

**CAPACITORS**

785	C35	5352-S181K104	CAP,MTL .1μ
785	C35	5352-S060K104	CAP,MTL .1μ
785	C36	5352-S181K104	CAP,MTL .1μ
785	C36	5352-S060K104	CAP,MTL .1μ
785	C1476	5352-S181K104	CAP,MTL .1μ
785	C1476	5352-S060K104	CAP,MTL .1μ
785	C1477	5352-S181K104	CAP,MTL .1μ
785	C1477	5352-S060K104	CAP,MTL .1μ

**MISCELLANEOUS**

858	△ F2	5732-01501402	FUSE, 4A 125V
858B	△ F2	5732-01601402	FUSE, 7A/7AAL 250V
858	△ F3	5732-01501402	FUSE, 4A 125V
858B	△ F3	5732-01601402	FUSE, 7A/7AAL 250V
831	△ F4	5732-702031	FUSE, 7A 125V
831B	△ F4	5732-01601632	FUSE, 7A/7AAL 250V
831	△ F5	5732-702031	FUSE, 7A 125V
831B	△ F5	5732-01601632	FUSE, 7A/7AAL 250V
857	△ HF3	4472-04501	HOLDER,FUSE
857	△ HF4	4472-04501	HOLDER,FUSE
857	△ HF5	4472-04501	HOLDER,FUSE
857	△ HF6	4472-04501	HOLDER,FUSE
857	△ HF7	4472-04501	HOLDER,FUSE
857	△ HF8	4472-04501	HOLDER,FUSE
857	△ HF9	4472-04501	HOLDER,FUSE
857	△ HF10	4472-04501	HOLDER,FUSE

**PCB 23 DISPLAY P.C. BOARD**

**CAPACITORS**

119	C801	5361-R02BK101	CAP,CER 100P
119	C802	5361-R02BK101	CAP,CER 100P
112	C803	5345-106F041	CAP,MINI ELE 10μ/50V
115	C804	5345-477A041	CAP,MINI ELE 470μ/6.3V
115	C807	5345-477A041	CAP,MINI ELE 470μ/6.3V
121	C808	5361-R02BK332	CAP,CER 3300P
121	C809	5361-R02BK332	CAP,CER 3300P
115	C810	5345-477A041	CAP,MINI ELE 470μ/6.3V
116	C811	5345-107C041	CAP,MINI ELE 100μ/16V
117	C812	5345-476C041	CAP,MINI ELE 47μ/16V
117	C813	5345-476C041	CAP,MINI ELE 47μ/16V
122	C814	5361-R02BK331	CAP,CER 330P



Ser. No.	Ref. No.	Part No.	Description
105	IC806	5653-UPC4570C	IC,LINEAR
105	IC807	5653-UPC4570C	IC,LINEAR
105	IC808	5653-UPC4570C	IC,LINEAR
104	IC809	5652-TA75072P	IC,MONO
105	IC810	5653-UPC4570C	IC,LINEAR
104	IC811	5652-TA75072P	IC,MONO
106	IC812	5654-LC7823	IC,DIGITAL

**TRANSISTORS**

107	Q801	5616-2SK366BL	FET,N-CH
107	Q802	5616-2SK366BL	FET,N-CH
107	Q803	5616-2SK366BL	FET,N-CH
107	Q804	5616-2SK366BL	FET,N-CH
107	Q805	5616-2SK366BL	FET,N-CH
108	Q806	5611-999L(F)	XISTDR,PNP R
107	Q807	5616-2SK366BL	FET,N-CH
107	Q808	5616-2SK366BL	FET,N-CH

**DIODES**

109	D801	5631-1SS133	DIODE,DET
109	D802	5631-1SS133	DIODE,DET
109	D803	5631-1SS133	DIODE,DET
109	D804	5631-1SS133	DIODE,DET
109	D805	5631-1SS133	DIODE,DET
109	D806	5631-1SS133	DIODE,DET
109	D807	5631-1SS133	DIODE,DET
109	D808	5631-1SS133	DIODE,DET
109	D809	5631-1SS133	DIODE,DET
109	D810	5631-1SS133	DIODE,DET



**MISCELLANEOUS**

157	CN801	4443-01701010	CONNECTOR
158	CN802	4443-01701012	CONNECTOR
146	JR801	5134-S040J0R0	JUMPER LEAD
146	JR802	5134-S040J0R0	JUMPER LEAD
146	JR803	5134-S040J0R0	JUMPER LEAD
146	JR804	5134-S040J0R0	JUMPER LEAD
146	JR805	5134-S040J0R0	JUMPER LEAD
146	JR806	5134-S040J0R0	JUMPER LEAD
146	JR807	5134-S040J0R0	JUMPER LEAD
146	JR808	5134-S040J0R0	JUMPER LEAD
146	JR809	5134-S040J0R0	JUMPER LEAD
146	JR810	5134-S040J0R0	JUMPER LEAD
146	JR811	5134-S040J0R0	JUMPER LEAD
146	JR812	5134-S040J0R0	JUMPER LEAD
146	JR813	5134-S040J0R0	JUMPER LEAD
146	JR814	5134-S040J0R0	JUMPER LEAD
146	JR815	5134-S040J0R0	JUMPER LEAD
146	JR816	5134-S040J0R0	JUMPER LEAD
146	JR817	5134-S040J0R0	JUMPER LEAD
111	LPF801	5214-14301	LC COMPOSITE
111	LPF802	5214-14301	LC COMPOSITE
110	X801	5691-S1002113	XTAL,OSC, 11.2896MHz

**PCB-24 VIDEO/ON SCREEN P.C. BOARD**

**CAPACITORS**

168	C901	5361-S140Z103	CAP,CER .01μ
168	C902	5361-S140Z103	CAP,CER .01μ
168	C903	5361-S140Z103	CAP,CER .01μ
168	C904	5361-S140Z103	CAP,CER .01μ
169	C905	5361-S130K331	CAP,CER 330P
170	C906	5361-S130K681	CAP,CER 680P
169	C907	5361-S130K331	CAP,CER 330P
185	C908	5345-R01BM107	CAP,MINI ELE 100μ/10V
186	C909	5345-R01CM107	CAP,MINI ELE 100μ/16V
182	C910	5345-R01FM105	CAP,MINI ELE 1μ/50V
186	C911	5345-R01CM107	CAP,MINI ELE 100μ/16V
182	C912	5345-R01FM105	CAP,MINI ELE 1μ/50V
168	C913	5361-S140Z103	CAP,CER .01μ
171	C914	5361-S130K821	CAP,CER 820P
184	C915	5345-476A041	CAP,MINI ELE 47μ/6.3V
183	C916	5345-R01FM225	CAP,MINI ELE 2.2μ/50V
177	C917	5361-S140Z473	CAP,CER .047μ
176	C918	5361-S140Z223	CAP,CER .022μ
185	C920	5345-R01BM107	CAP,MINI ELE 100μ/10V
185	C921	5345-R01BM107	CAP,MINI ELE 100μ/10V
172	C922	5361-R05CC050	CAP,CER 5P

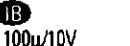
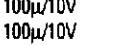
Ser. No.	Ref. No.	Part No.	Description
172	C923	5361-R05CC050	CAP,CER 5P
188	C924	5345-R01BM108	CAP,MINI ELE 1000μ/10V
188	C925	5345-R01BM108	CAP,MINI ELE 1000μ/10V
172	C926	5361-R05CC050	CAP,CER 5P
188	C927	5345-R01BM108	CAP,MINI ELE 1000μ/10V
185	C928	5345-R01BM107	CAP,MINI ELE 100μ/10V
187	C929	5345-R01CM227	CAP,MINI ELE 220μ/16V
186	C930	5345-R01CM107	CAP,MINI ELE 100μ/16V
175	C931	5361-R05CJ560	CAP,CER 56P
174	C932	5361-R05CJ270	CAP,CER 27P
182	C933	5345-R01FM105	CAP,MINI ELE 1μ/50V
168	C934	5361-S140Z103	CAP,CER .01μ 
173	C935	5361-R05CD070	CAP,CER 7P 
173B	C935	5361-R05CJ150	CAP,CER 15P 
173	C936	5361-R05CD070	CAP,CER 7P 
173B	C936	5361-R05CJ150	CAP,CER 15P 
185	C937	5345-R01BM107	CAP,MINI ELE 100μ/10V
185	C938	5345-R01BM107	CAP,MINI ELE 100μ/10V
185	C939	5345-R01BM107	CAP,MINI ELE 100μ/10V
168	C940	5361-S140Z103	CAP,CER .01μ
168	C941	5361-S140Z103	CAP,CER .01μ
168	C942	5361-S140Z103	CAP,CER .01μ
168	C943	5361-S140Z103	CAP,CER .01μ
168	C944	5361-S140Z103	CAP,CER .01μ
168	C945	5361-S140Z103	CAP,CER .01μ

**RESISTORS**

219	 R901	5102-4R75116	RES,FUSE 4.7
191	R902	5234-R010J750	RES,CBN 1/10P 75
191	R903	5234-R010J750	RES,CBN 1/10P 75
191	R904	5234-R010J750	RES,CBN 1/10P 75
191	R905	5234-R010J750	RES,CBN 1/10P 75
191	R906	5234-R010J750	RES,CBN 1/10P 75
208	R907	5234-R010J103	RES,CBN 1/10P 10K
208	R908	5234-R010J103	RES,CBN 1/10P 10K
208	R909	5234-R010J103	RES,CBN 1/10P 10K
191	R910	5234-R010J750	RES,CBN 1/10P 75
191	R911	5234-R010J750	RES,CBN 1/10P 75
191	R912	5234-R010J750	RES,CBN 1/10P 75
191	R913	5234-R010J750	RES,CBN 1/10P 75
211	R914	5234-R010J104	RES,CBN 1/10P 100K
191	R915	5234-R010J750	RES,CBN 1/10P 75
191	R916	5234-R010J750	RES,CBN 1/10P 75
191	R917	5234-R010J750	RES,CBN 1/10P 75
211	R918	5234-R010J104	RES,CBN 1/10P 100K
191	R919	5234-R010J750	RES,CBN 1/10P 75
191	R920	5234-R010J750	RES,CBN 1/10P 75
191	R921	5234-R010J750	RES,CBN 1/10P 75
211	R922	5234-R010J104	RES,CBN 1/10P 100K
191	R923	5234-R010J750	RES,CBN 1/10P 75
209	R924	5234-R010J153	RES,CBN 1/10P 15K
207	R925	5234-R010J822	RES,CBN 1/10P 8.2K
193	R926	5234-R010J221	RES,CBN 1/10P 220
203	R927	5234-R010J362	RES,CBN 1/10P 3.6K
200	R928	5234-R010J222	RES,CBN 1/10P 2.2K
204	R929	5234-R010J392	RES,CBN 1/10P 3.9K
195	R930	5234-R010J561	RES,CBN 1/10P 560
210	R931	5234-R010J223	RES,CBN 1/10P 22K
212	R932	5234-R010J154	RES,CBN 1/10P 150K
209	R933	5234-R010J153	RES,CBN 1/10P 15K
209	R934	5234-R010J153	RES,CBN 1/10P 15K
207	R935	5234-R010J822	RES,CBN 1/10P 8.2K
207	R936	5234-R010J822	RES,CBN 1/10P 8.2K
196	R937	5234-R010J681	RES,CBN 1/10P 680
196	R938	5234-R010J681	RES,CBN 1/10P 680
192	R939	5234-R010J201	RES,CBN 1/10P 200
192	R940	5234-R010J201	RES,CBN 1/10P 200
193	R941	5234-R010J221	RES,CBN 1/10P 220
193	R942	5234-R010J221	RES,CBN 1/10P 220
196	R944	5234-R010J681	RES,CBN 1/10P 680
194	R945	5234-R010J181	RES,CBN 1/10P 180
209	R946	5234-R010J153	RES,CBN 1/10P 15K
206	R947	5234-R010J682	RES,CBN 1/10P 6.8K
205	R949	5234-R010J472	RES,CBN 1/10P 4.7K
206	R950	5234-R010J682	RES,CBN 1/10P 6.8K
211	R951	5234-R010J104	RES,CBN 1/10P 100K
208	R952	5234-R010J103	RES,CBN 1/10P 10K

Ser. No.	Ref. No.	Part No.	Description
210	R953	5234-R010J223	RES,CBN 1/10P 22K
196	R954	5234-R010J681	RES,CBN 1/10P 680
206	R955	5234-R010J682	RES,CBN 1/10P 6.8K
197	R956	5234-R010J821	RES,CBN 1/10P 820
205	R957	5234-R010J472	RES,CBN 1/10P 4.7K
214	R958	5234-R010J105	RES,CBN 1/10P 1M
202	R959	5234-R010J332	RES,CBN 1/10P 3.3K
202	R960	5234-R010J332	RES,CBN 1/10P 3.3K
201	R961	5234-R010J272	RES,CBN 1/10P 2.7K
202	R962	5234-R010J332	RES,CBN 1/10P 3.3K
209	R963	5234-R010J153	RES,CBN 1/10P 15K
199	R964	5234-R010J132	RES,CBN 1/10P 1.3K
198	R965	5234-R010J102	RES,CBN 1/10P 1K
205	R966	5234-R010J472	RES,CBN 1/10P 4.7K
205	R967	5234-R010J472	RES,CBN 1/10P 4.7K
205	R968	5234-R010J472	RES,CBN 1/10P 4.7K
205	R969	5234-R010J472	RES,CBN 1/10P 4.7K
205	R970	5234-R010J472	RES,CBN 1/10P 4.7K
205	R971	5234-R010J472	RES,CBN 1/10P 4.7K
198	R972	5234-R010J102	RES,CBN 1/10P 1K
198	R973	5234-R010J102	RES,CBN 1/10P 1K
198	R974	5234-R010J102	RES,CBN 1/10P 1K
198	R975	5234-R010J102	RES,CBN 1/10P 1K
213	R977	5234-R010J470	RES,CBN 1/10P 47
213	R978	5234-R010J470	RES,CBN 1/10P 47
213	R979	5234-R010J470	RES,CBN 1/10P 47
213	R980	5234-R010J470	RES,CBN 1/10P 47
213	R981	5234-R010J470	RES,CBN 1/10P 47

**INTEGRATED CIRCUITS**

163	IC901	5654-TC4051BF	IC,DIGITAL
163	IC902	5654-TC4051BF	IC,DIGITAL
163	IC903	5654-TC4051BF	IC,DIGITAL
162	IC904	5653-LA7217	IC,LINEAR
161	IC905	5653-M458-001	IC,LINEAR

**TRANSISTORS**

164	Q901	5611-1115(F)	XISTOR,PNP R
165	Q902	5611-1235(F)	XISTOR,PNP R
165	Q903	5611-1235(F)	XISTOR,PNP R
165	Q904	5611-1235(F)	XISTOR,PNP R
166	Q905	5613-3052(F)	XISTOR,NPN R
166	Q906	5613-3052(F)	XISTOR,NPN R
166	Q907	5613-3052(F)	XISTOR,NPN R
165	Q908	5611-1235(F)	XISTOR,PNP R
166	Q909	5613-3052(F)	XISTOR,NPN R
166	Q910	5613-3052(F)	XISTOR,NPN R
166	Q911	5613-3052(F)	XISTOR,NPN R
166	Q912	5613-3052(F)	XISTOR,NPN R

**COILS**

224	L901	5995-1R8J107	COIL W/CORE
224	L902	5995-1R8J107	COIL W/CORE
225	L903	5995-120J107	COIL W/CORE
226	L904	5995-101J107	COIL W/CORE

**MISCELLANEOUS**

180	CC901	5213-221K0401	C COMPOSITE, 220Px4
221	CF901	5693-CSB500F9	OSC,CER, 500kHz
232	CN901	4443-030185	CONNECTOR
233	CN902	4443-08001016	CONNECTOR
231	▲ J901	4489-04401004	4 PIN JACK,MLT, TV VIDED, SAT, VDP, VCR2 OUT
231	▲ J902	4489-04401004	4 PIN JACK,MLT, VCR2 IN, VCR1 OUT, VCR1 IN, MONITOR OUT

217	JR906	5134-S040J0R0	JUMPER LEAD
217	JR907	5134-S040J0R0	JUMPER LEAD
217	JR908	5134-S040J0R0	JUMPER LEAD
217	JR909	5134-S040J0R0	JUMPER LEAD
217	JR910	5134-S040J0R0	JUMPER LEAD
217	JR911	5134-S040J0R0	JUMPER LEAD
217	JR912	5134-S040J0R0	JUMPER LEAD
217	JR914	5134-S040J0R0	JUMPER LEAD
217	JR915	5134-S040J0R0	JUMPER LEAD
217	JR916	5134-S040J0R0	JUMPER LEAD
217	JR917	5134-S040J0R0	JUMPER LEAD
217	JR918	5134-S040J0R0	JUMPER LEAD
217	JR919	5134-S040J0R0	JUMPER LEAD

Ser. No.	Ref. No.	Part No.	Description
217	JR920	5134-S040J0R0	JUMPER LEAD
217	JR921	5134-S040J0R0	JUMPER LEAD
217	JR922	5134-S040J0R0	JUMPER LEAD
217	JR923	5134-S040J0R0	JUMPER LEAD
217	JR924	5134-S040J0R0	JUMPER LEAD
021B	JR925	5234-R010J000	JUMPER LEAD <sup>IB</sup>
229	LCN901	4163-0125039	CONNECTOR W/W
222	X901	5691-S1003143	XTAL,OSC 14.318MHz <sup>BK WB SB</sup>
222B	X901	5691-S1005183	XTAL,OSC 17.734475MHz <sup>IB</sup>

**PCB-25 FRONT P.C. BOARD**

**CAPACITORS**

121	C701	5345-108C041	CAP,MINI ELE 1000µ/16V
124	C702	5359-S010J103	CAP,PPP .01µ
124	C703	5359-S010J103	CAP,PPP .01µ
120	C704	5345-476C043	CAP,MINI ELE 47µ/16V
122	C705	5345-106F041	CAP,MINI ELE 10µ/50V
123	C707	5345-107B041	CAP,MINI ELE 100µ/10V
123	C708	5345-107B041	CAP,MINI ELE 100µ/10V
122	C709	5345-106F041	CAP,MINI ELE 10µ/50V
122	C710	5345-106F041	CAP,MINI ELE 10µ/50V
126	C715	5361-R02BK102	CAP,CER 1000P
126	C716	5361-R02BK102	CAP,CER 1000P

**RESISTORS**

131	R702	5130-R030J101	RES,CBN 1/2P 100
139	R703	5130-R010J153	RES,CBN 1/6P 15K
138	R705	5130-R010J124	RES,CBN 1/6P 120K
137	R709	5130-R010J103	RES,CBN 1/6P 10K
140	R710	5130-R010J221	RES,CBN 1/6P 220
137	R711	5130-R010J103	RES,CBN 1/6P 10K
134	R712	5130-R010J271	RES,CBN 1/6P 270
136	R713	5130-R010J102	RES,CBN 1/6P 1K
141	R714	5130-R030J271	RES,CBN 1/2P 270
134	R715	5130-R010J271	RES,CBN 1/6P 270
132	R716	5130-R030J221	RES,CBN 1/2P 220
134	R717	5130-R010J271	RES,CBN 1/6P 270
132	R718	5130-R030J221	RES,CBN 1/2P 220
134	R719	5130-R010J271	RES,CBN 1/6P 270
132	R720	5130-R030J221	RES,CBN 1/2P 220
134	R721	5130-R010J271	RES,CBN 1/6P 270
132	R722	5130-R030J221	RES,CBN 1/2P 220
134	R723	5130-R010J271	RES,CBN 1/6P 270
132	R724	5130-R030J221	RES,CBN 1/2P 220
134	R725	5130-R010J271	RES,CBN 1/6P 270
132	R726	5130-R030J221	RES,CBN 1/2P 220
134	R727	5130-R010J271	RES,CBN 1/6P 270
132	R728	5130-R030J221	RES,CBN 1/2P 220
134	R729	5130-R010J271	RES,CBN 1/6P 270
132	R730	5130-R030J221	RES,CBN 1/2P 220
134	R731	5130-R010J271	RES,CBN 1/6P 270
132	R732	5130-R030J221	RES,CBN 1/2P 220
135	R733	5130-R010J271	RES,CBN 1/6P 270
132	R734	5130-R030J221	RES,CBN 1/2P 220
135	R735	5130-R010J271	RES,CBN 1/6P 270
133	R736	5130-R030J221	RES,CBN 1/2P 220
135	R737	5130-R010J271	RES,CBN 1/6P 270
133	R738	5130-R030J221	RES,CBN 1/2P 220
135	R739	5130-R010J271	RES,CBN 1/6P 270
141	R740	5130-R030J271	RES,CBN 1/2P 270
135	R741	5130-R010J271	RES,CBN 1/6P 270

**INTEGRATED CIRCUITS**

102	IC701	5654-M38002-1	IC,DIGITAL
103	IC702	5654-M66310FP	IC,DIGITAL
103	IC703	5654-M66310FP	IC,DIGITAL
104	IC704	5654-TD62784F	IC,DIGITAL
104	IC705	5654-TD62784F	IC,DIGITAL
105	IC706	5654-TB2104F	IC,DIGITAL
105	IC707	5654-TB2104F	IC,DIGITAL

**TRANSISTORS**

107	Q701	5613-C114ES	XISTDR,NPN R
107	Q702	5613-C114ES	XISTDR,NPN R
106	Q703	5611-A114ES	XISTDR,PNP R
106	Q704	5611-A114ES	XISTDR,PNP R
106	Q705	5611-A114ES	XISTDR,PNP R

Ser. No.	Ref. No.	Part No.	Description
107	D706	5613-C114ES	XISTOR,NPN R
<b>DIODES</b>			
111	D702	5632-S5566B	DIODE,RECT
110	D703	5631-1SS133	DIODE,DET
110	D704	5631-1SS133	DIODE,DET
110	D705	5631-1SS133	DIODE,DET
110	D706	5631-1SS133	DIODE,DET
110	D707	5631-1SS133	DIODE,DET
110	D708	5631-1SS133	DIODE,DET
110	D709	5631-1SS133	DIODE,DET
110	D710	5631-1SS133	DIODE,DET
117	D714	5637-S2810A1	LED, SIMULCAST
117	D715	5637-S2810A1	LED, SIMULCAST
115	D716	5637-S2410E1	LED, VCR1
113	D717	5637-S2210S1	LED, VCR1
115	D718	5637-S2410E1	LED, VCR2
113	D719	5637-S2210S1	LED, VCR2
115	D720	5637-S2410E1	LED, VDP
113	D721	5637-S2210S1	LED, VDP
115	D722	5637-S2410E1	LED, VCP
113	D723	5637-S2210S1	LED, VCP
115	D724	5637-S2410E1	LED, SAT
113	D725	5637-S2210S1	LED, SAT
115	D726	5637-S2410E1	LED, TV
113	D727	5637-S2210S1	LED, TV
116	D728	5637-S2410E1	LED, TAPE1
114	D729	5637-S2210S1	LED, TAPE1
116	D730	5637-S2410E1	LED, TAPE2
114	D731	5637-S2210S1	LED, TAPE2
116	D732	5637-S2410E1	LED, AUX
114	D733	5637-S2210S1	LED, AUX
116	D734	5637-S2410E1	LED, CD
114	D735	5637-S2210S1	LED, CD
116	D736	5637-S2410E1	LED, TUNER
114	D737	5637-S2210S1	LED, TUNER
116	D738	5637-S2410E1	LED, PHONO
114	D739	5637-S2210S1	LED, PHONO
117	D740	5637-S2810A1	LED, LOUDNESS
117	D741	5637-S2810A1	LED, MONO
<b>MISCELLANEOUS</b>			
153	CF701	5693-CST5MGW	OSC,CER
172	CN703	4443-05401031	CONNECTOR
171	CN704	4443-05401027	CONNECTOR
173	CN705	4443-07901008	CONNECTOR
152	FL701	5722-060	TUBE DISPLAY
155	JL701	4242-R0506161	JUMPER LEAD
157	JL703	4242-S0331181	JUMPER LEAD
156	JL704	4242-S0327251	JUMPER LEAD
142	RC701	5212-S0307103	R COMPOSITE, 10Kx7
143	RC702	5212-473J1403	R COMPOSITE, 47Kx14
143	RC703	5212-473J1403	R COMPOSITE, 47Kx14
143	RC704	5212-473J1403	R COMPOSITE, 47Kx14
144	RC705	5212-473J0703	R COMPOSITE, 47Kx7
150	△ RCV701	6143-00802	RECEIV BLOCK, REMOTE SENSOR
148	SW702	4437-01301	SWITCH,PU-TC, SHIFT A-B
148	SW703	4437-01301	SWITCH,PU-TC, MEMORY
147	SW704	4437-00704	SWITCH,PU-TC, M1
147	SW705	4437-00704	SWITCH,PU-TC, M2
147	SW706	4437-00704	SWITCH,PU-TC, M3
147	SW707	4437-00704	SWITCH,PU-TC, M4
147	SW708	4437-00704	SWITCH,PU-TC, M5
147	SW709	4437-00704	SWITCH,PU-TC, M6
147	SW710	4437-00704	SWITCH,PU-TC, M7
147	SW711	4437-00704	SWITCH,PU-TC, M8
146	SW714	4437-00901	SWITCH,PU-TC, SIMULCAST
146	SW715	4437-00901	SWITCH,PU-TC, SIMULCAST
146	SW716	4437-00901	SWITCH,PU-TC, VCR1
146	SW717	4437-00901	SWITCH,PU-TC, VCR1
146	SW718	4437-00901	SWITCH,PU-TC, VCR2
146	SW719	4437-00901	SWITCH,PU-TC, VCR2
146	SW720	4437-00901	SWITCH,PU-TC, VDP
146	SW721	4437-00901	SWITCH,PU-TC, VDP
146	SW722	4437-00901	SWITCH,PU-TC, VCP
146	SW723	4437-00901	SWITCH,PU-TC, VCP
146	SW724	4437-00901	SWITCH,PU-TC, SAT
146	SW725	4437-00901	SWITCH,PU-TC, SAT

Ser. No.	Ref. No.	Part No.	Description
146	SW726	4437-00901	SWITCH,PU-TC, TV
146	SW727	4437-00901	SWITCH,PU-TC, TV
146	SW728	4437-00901	SWITCH,PU-TC, TAPE1
146	SW729	4437-00901	SWITCH,PU-TC, TAPE1
146	SW730	4437-00901	SWITCH,PU-TC, TAPE2
146	SW731	4437-00901	SWITCH,PU-TC, TAPE2
146	SW732	4437-00901	SWITCH,PU-TC, AUX
146	SW733	4437-00901	SWITCH,PU-TC, AUX
146	SW734	4437-00901	SWITCH,PU-TC, CD
146	SW735	4437-00901	SWITCH,PU-TC, CD
146	SW736	4437-00901	SWITCH,PU-TC, TUNER
146	SW737	4437-00901	SWITCH,PU-TC, TUNER
146	SW738	4437-00901	SWITCH,PU-TC, PHONO
146	SW739	4437-00901	SWITCH,PU-TC, PHONO
146	SW740	4437-00901	SWITCH,PU-TC, LOUDNESS
146	SW741	4437-00901	SWITCH,PU-TC, MONO
147	SW742	4437-00704	SWITCH,PU-TC, AUDIO DIRECT
147	SW743	4437-00704	SWITCH,PU-TC, EFFECTS LEVEL -
147	SW744	4437-00704	SWITCH,PU-TC, EFFECTS LEVEL +
147	SW745	4437-00704	SWITCH,PU-TC, SURROUND MODE
147	SW746	4437-00704	SWITCH,PU-TC, CENTER MODE
147	SW747	4437-00704	SWITCH,PU-TC, DELAY TIME
147	SW748	4437-00704	SWITCH,PU-TC, TEST TONE
158		2240-2062	HOLDER, HL701

**PCB-26 LINE OUT 1 P.C. BOARD**

<b>CAPACITORS</b>			
021B	C543	5359-S010K151	CAP,PPP 150P 16
021B	C544	5359-S010K151	CAP,PPP 150P 16
<b>MISCELLANEOUS</b>			
177	△ J402	4489-04301008	PIN JACK, MLT, SUB WOOFER

**PCB-27 LINE OUT 2 P.C. BOARD**

<b>CAPACITORS</b>			
180	C431	5345-107D041	CAP,MINI ELE 100μ25V
180	C432	5345-107D041	CAP,MINI ELE 100μ25V
180	C433	5345-107D041	CAP,MINI ELE 100μ25V
180	C434	5345-107D041	CAP,MINI ELE 100μ25V
180	C1491	5345-107D041	CAP,MINI ELE 100μ25V
180	C1492	5345-107D041	CAP,MINI ELE 100μ25V
180	C1493	5345-107D041	CAP,MINI ELE 100μ25V
180	C1494	5345-107D041	CAP,MINI ELE 100μ25V
180	C1513	5345-107D041	CAP,MINI ELE 100μ25V
180	C1514	5345-107D041	CAP,MINI ELE 100μ25V
<b>RESISTORS</b>			
182	R465	5130-R030J822	RES,CBN 1/2P 8.2K
182	R466	5130-R030J822	RES,CBN 1/2P 8.2K
181	R469	5130-R030J122	RES,CBN 1/2P 1.2K
181	R470	5130-R030J122	RES,CBN 1/2P 1.2K
182	R1491	5130-R030J822	RES,CBN 1/2P 8.2K
182	R1492	5130-R030J822	RES,CBN 1/2P 8.2K
181	R1495	5130-R030J122	RES,CBN 1/2P 1.2K
181	R1496	5130-R030J122	RES,CBN 1/2P 1.2K
182	R1535	5130-R030J822	RES,CBN 1/2P 8.2K
181	R1537	5130-R030J122	RES,CBN 1/2P 1.2K
<b>MISCELLANEOUS</b>			
168	CN1490	4443-030185	CONNECTOR
168	CN1491	4443-030185	CONNECTOR
169	CN1492	4443-01701005	CONNECTOR

**PCB-28 MAIN CONNECTOR P.C. BOARD**

<b>MISCELLANEOUS</b>			
166	CN11	4443-08001012	CONNECTOR
166	CN12	4443-08001012	CONNECTOR
166	CN13	4443-08001012	CONNECTOR
166	CN14	4443-08001012	CONNECTOR

**PCB-29 FUNCTION CONNECTOR P.C. BOARD**

<b>MISCELLANEOUS</b>			
162	CN156	4443-01801007	CONNECTOR

Ser. No.	Ref. No.	Part No.	Description
163	CN157	4443-01801006	CONNECTOR
162	CN606	4443-01801007	CONNECTOR
163	CN607	4443-01801006	CONNECTOR

**CHASSIS MISCELLANEOUS**

**CAPACITOR**

850	C42	5352-S060K104	CAP,MTL .1U <b>IB</b>
-----	-----	---------------	-----------------------

**MISCELLANEOUS**

836		LCN30	4163-0112020	CONNECTOR W/W <b>IB</b>
991		LUG	4211-039	LUG, C42 <b>IB</b>
996		P1	4161-09901192	CORD W/PLUG, AC CORD 120V/60Hz <b>BK</b>
996B		P1	4161-09901192	CORD W/PLUG, AC CORD 230/240V 50Hz <b>WB SB IB</b>
965		PCB-12	4551-9073	POWER SUPPLY 2 P.C. BOARD <b>BK</b>
965B		PCB-12	4551-9127	POWER SUPPLY 2 P.C. BOARD <b>WB SB IB</b>
968		PCB-15	4551-9076	P.C. BOARD
995		T1	5584-T2001	XFORMER, MAIN POWER <b>BK</b>
995B		T1	5584-T2002	XFORMER, MAIN POWER <b>WB SB IB</b>

**PACKING PARTS LIST**

021		1111-0370J152	OWNER GUIDE, VOLT SELECT ADDENDUM <b>WB SB</b>
023		1756-03101	LABEL, (W)LABEL (x2) <b>WB</b>
023		1756-03132	LABEL, (S)LABEL (x2) <b>SB</b>
023		1756-03108	LABEL, (I)LABEL (x2) <b>IB</b>
111		1221-31902	CARTON BOX
112		1222-7395	CUSHION, (L)
113		1222-7396	CUSHION, (R)
116		1223-R0425055	SOFT SHEET, FRONT PANEL
117		1241-R0123351	POLYETHY BAG, IB
118		1241-R0165751	POLYETHY BAG, SET
119		1111-0750J152	OWNER GUIDE, IB <b>BK WB SB</b>
119		1111-0760J152	OWNER GUIDE, IB <b>IB</b>
120		1113-02501	OWNER CARD, REPLY CARD <b>BK</b>
121		1116-03801	GUARANT CARD, WARRANTY CARD <b>BK</b>
122		1119-05302	ATTACH SHEET, SAFETY GUARDS <b>BK</b>
123		1119-04501	ATTACH SHEET, SERVICE GUIDE <b>BK</b>
275		4161-08201102	CORD W/PLUG, REMOTE (x2)
276		6142-07501	CONT BLOCK, REMOTE CONTROL
277		4191-0355	BATTERY, DRY
278		5911-278	ANT COIL, BC, AM
279		1397-6	T FEEDER ANT, FM

**ABBREVIATIONS IN PARTS LIST**

**CAPACITORS**

CAP, MINI ELE	: Electrolytic
CAP, CER	: Ceramic
CAP, PPP	: Polypropylene
CAP, MYL	: Mylar
CAP, MCA	: Mica
470μ	: 470μF
6800P	: 6800pF
.047μ	: 0.047μF

**RESISTORS**

RES, CBN	1/6P	: Carbon 1/6W
	2.2K	: 2.2kΩ
	220	: 220Ω
RES, FUSE		: Fuse
RES, CEM	5P	: Cement 5W
RES, MTL	1P	: Metal 1W

**TRANSISTORS**

XISTOR	: Transistor
FET	: Field Effect Transistor

**CONTROLS**

RES, V CBN	: Variable Carbon Resistor
RES, SEMI FIX	: Semi - fixed Resistors

**NOTE:**

SAFETY RELATED COMPONENT. USE ONLY EXACT REPLACEMENT PART AS SPECIFIED.



IC BLOCK DIAGRAMS

IC101, IC152 : LC7821  
FUNCTION SELECTOR

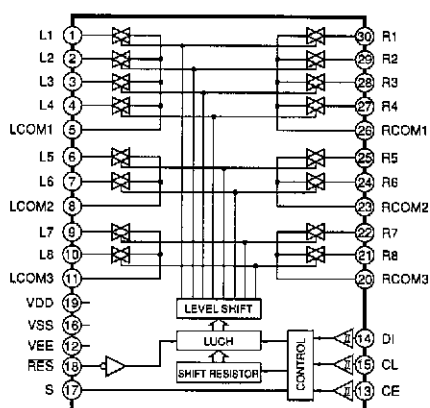

IC102 IC151 : LC7822  
FUNCTION SELECTOR

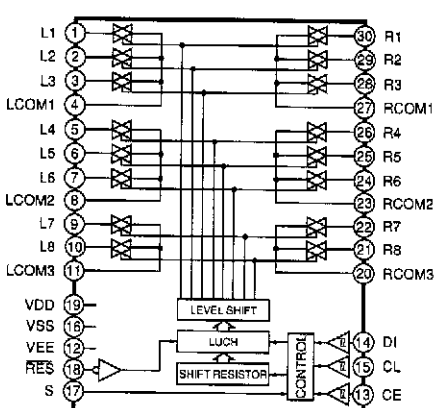

IC201 : LA1266  
FM/AM IF AMP, AM MIXER, FM DET.

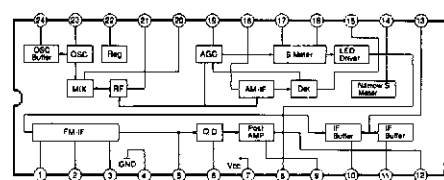

IC301 : LA3410  
FM MPX

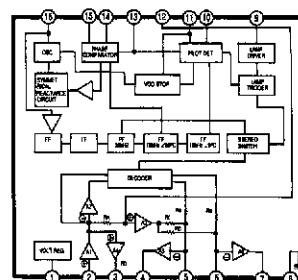

IC351 : TC9301AN-027  
TUNER SYSTEM CONTROL

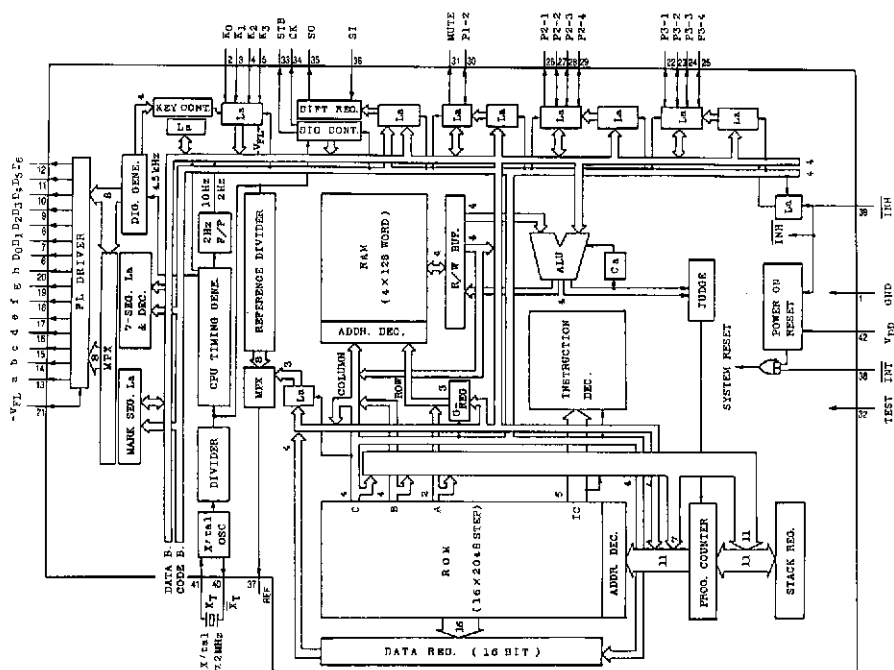

IC351 : TERMINAL FUNCTIONS

NO.	Port name	I/O	Functions	NO.	Port name	I/O	Functions	NO.	Port name	I/O	Functions
1	GND		GND pin	17	e	O	Segment output	31	MUTE	O	1-bit muting signal output port
2	K0	I	4-bit key input port	18	f	O	Segment output	32	TEST	I	Test mode control input terminal
3	K1	I	4-bit key input port	19	g	O	Segment output	33	STB	O	Serial interface (strobe pulse output)
4	K2	I	4-bit key input port	20	h	O	Segment output	34	CK	O	Serial interface (serial clock output)
5	K3	I	4-bit key input port	21	-VFL	I	Negative power terminal (4-bit key input port, digit output, segment output)	35	SO	O	Serial interface (serial data output)
6	D0	O	Digit output					36	SI	I	Serial interface (serial data input)
7	D1	O	Digit output					37	REF	O	Reference frequency signal output terminal
8	D2	O	Digit output	22	P3-1	I/O	4-bit I/O port (3)	38	INT	I	Initialize input (system reset signal input terminal)
9	D3	O	Digit output	23	P3-2	I/O	4-bit I/O port (3)	39	INH	I	Inhibit input (select signal input port of radio mode)
10	D4	O	Digit output	24	P3-3	I/O	4-bit I/O port (3)	40	XT		Connect quartz oscillator
11	D5	O	Digit output	25	P3-4	I/O	4-bit I/O port (3)	41	XT		Connect quartz oscillator
12	D6	O	Digit output	26	P2-1	I/O	4-bit I/O port (2)	42	VDD	I	Power supply terminal
13	a	O	Segment output	27	P2-2	I/O	4-bit I/O port (2)				
14	b	O	Segment output	28	P2-3	I/O	4-bit I/O port (2)				
15	c	O	Segment output	29	P2-4	I/O	4-bit I/O port (2)				
16	d	O	Segment output	30	P1-2	I/O	1-bit I/O port (1)				

**IC202 : TC9227P  
PLL SYNTHESIZER**

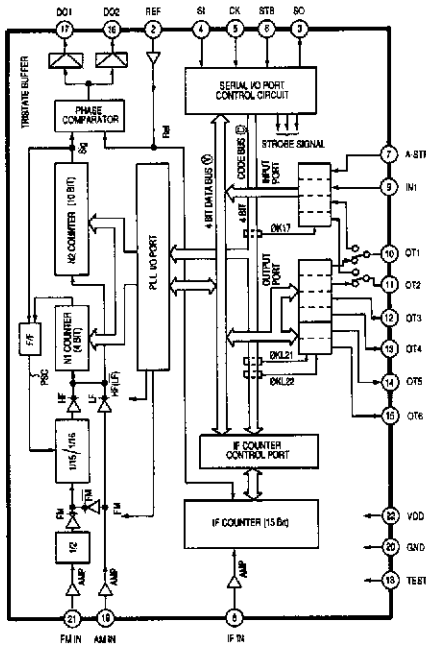

**IC202 : TERMINAL FUNCTIONS**

NO.	Port name	I/O	Functions	NO.	Port name	I/O	Functions
1	NC		Not connected	12	DT3	O	Output port
2	REF	I	Reference frequency input	13	DT4	O	Output port
3	SD	O	Serial I/O port (serial output)	14	DT5	O	Output port
4	SI	I	Serial I/O port (serial input)	15	DT6	O	Output port
5	CK	I	Serial I/O port (clock signal input)	16	DO2	O	Phase comparator output
6	STB	I	Serial I/O port (strobe signal input)	17	DO1	O	Phase comparator output
7	A-STP	I	Autostop signal input	18	TEST	I	Test mode control input
8	IFIN	I	IF signal input of IF counter detected autostop	19	AMIN	I	AM local oscillator (programmable counter input)
9	IN1	I	Input port	20	GND		GND pin
10	OT1	O	Output port	21	FMIN	I	FM local oscillator (prescaler input)
11	OT2	O	Output port	22	VDD	I	5V ± 10% power supply terminal

**IC501 : LB1641  
MOTOR CONTROL**

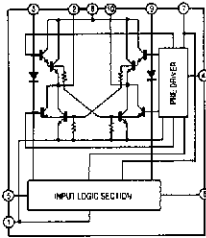

**IC702, IC703 : M66310FP  
LED DRIVER**

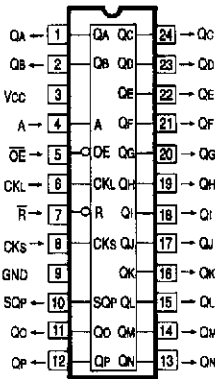

**IC704, IC705 : TD62784F  
FL DRIVER**

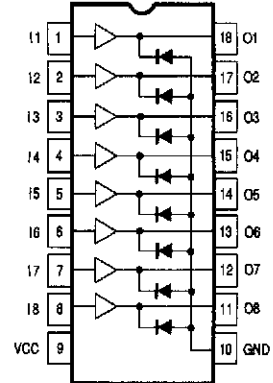

**IC701 : M38002M2-114FP  
MICRO COMPUTER**

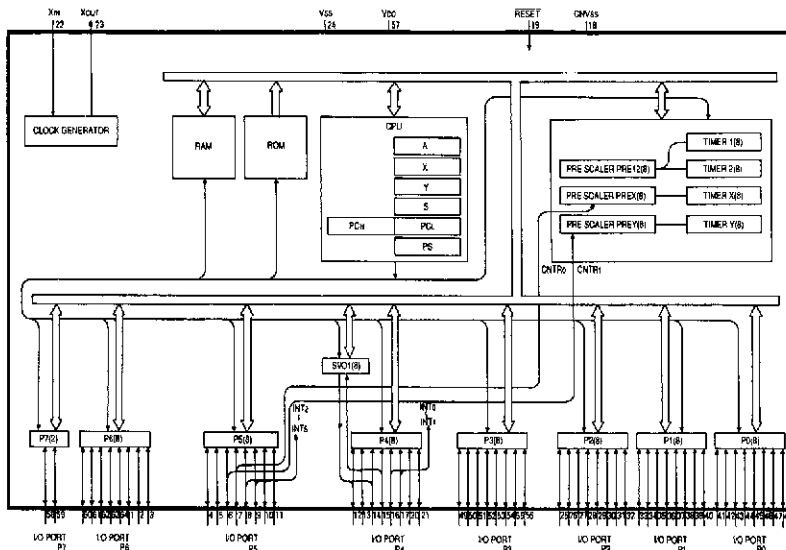

IC701 : TERMINAL FUNCTIONS

NO.	Port name	Functions	NO.	Port name	Functions	NO.	Port name	Functions
1	P62	I/O port P6	23	X out	Clock output	45	P03	I/O port P0
2	P61	I/O port P6	24	Vss	Power supply input	46	P02	I/O port P0
3	P60	I/O port P6	25	P27	I/O port P2	47	P01	I/O port P0
4	P57	I/O port P5	26	P26	I/O port P2	48	P00	I/O port P0
5	P56	I/O port P5	27	P25	I/O port P2	49	P37	I/O port P3
6	P55/CNTR1	I/O port P5	28	P24	I/O port P2	50	P36	I/O port P3
7	P54/CNTR0	I/O port P5	29	P23	I/O port P2	51	P35	I/O port P3
8	P53/INT5	I/O port P5	30	P22	I/O port P2	52	P34	I/O port P3
9	P52/INT4	I/O port P5	31	P21	I/O port P2	53	P33	I/O port P3
10	P51/INT3	I/O port P5	32	P20	I/O port P2	54	P32	I/O port P3
11	P50/INT2	I/O port P5	33	P17	I/O port P1	55	P31	I/O port P3
12	P47/SRDY	I/O port P4	34	P16	I/O port P1	56	P30	I/O port P3
13	P46/SCLK	I/O port P4	35	P15	I/O port P1	57	Vcc	Power supply input
14	P45/TxD	I/O port P4	38	P14	I/O port P1	58	P71	I/O port P7
15	P44/RxD	I/O port P4	37	P13	I/O port P1	59	P70	I/O port P7
16	P43/INT1	I/O port P4	38	P12	I/O port P1	60	P67	I/O port P6
17	P42/INT0	I/O port P4	39	P11	I/O port P1	61	P66	I/O port P6
18	CN Vss	CN Vss	40	P10	I/O port P1	62	P65	I/O port P6
19	RESET	Reset input	41	P07	I/O port P0	63	P64	I/O port P6
20	P41	I/O port P4	42	P06	I/O port P0	64	P63	I/O port P6
21	P40	I/O port P4	43	P05	I/O port P0			
22	X IN	Clock input	44	P04	I/O port P0			

IC801 : YSS215-F  
DOLBY PRO LOGIC SURROUND DECODER

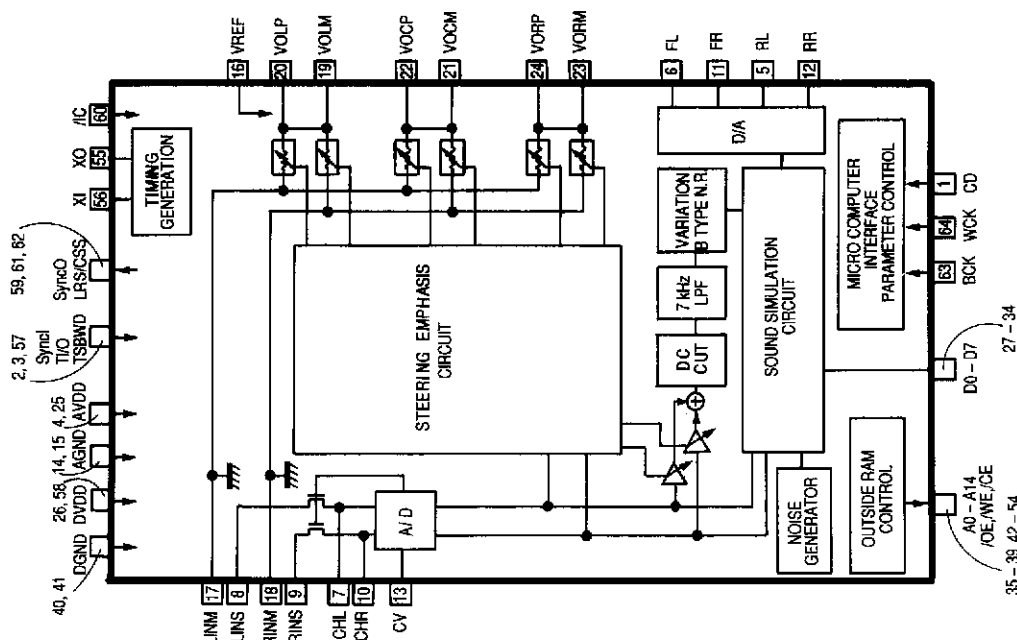

IC801 : TERMINAL FUNCTIONS

NO.	Port name	I/O	Functions	NO.	Port name	I/O	Functions	NO.	Port name	I/O	Functions
1	CD	Ic	Serial data of parallel meter data input	22	VOCP	AO	C channel Ope-amplifier	44	A7	O	External delay RAM Address terminal
2	TSBWD	Ic	+5V	23	VORM	AO	R channel Ope-amplifier	45	A12	O	External delay RAM Address terminal
3	TI/O	Ic	+5V	24	VORP	AO	R channel Ope-amplifier	46	A14	O	External delay RAM Address terminal
4	AVDD	A-	+5V power supply (A/D, D/A section)	25	AVDD	A-	+5V power supply (Multi-planning DAC section)	47	/WE	O	External delay Write enable terminal
5	RL	AO	RL channel D/A output	26	DVDD	-	+5V power supply (Digital section)	48	A13	O	External delay Address terminal
6	FL	AO	FL channel D/A output	27	D7	I/Ot	External delay RAM Data terminal	49	A8	O	External delay Address terminal
7	CHL	A-	LINS input	28	D6	I/Ot	External delay RAM Data terminal	50	A9	O	External delay Address terminal
8	LINS	AI	L channel A/D input	29	D5	I/Ot	External delay RAM Data terminal	51	A11	O	External delay Address terminal
9	RINS	AI	R channel A/D input	30	D4	I/Ot	External delay RAM Data terminal	52	/OE	O	External delay Output enable terminal
10	CHR	A-	RINS input	31	D3	I/Ot	External delay RAM Data terminal	53	A10	O	External delay Address terminal
11	FR	AO	FR channel D/A output	32	D2	I/Ot	External delay RAM Data terminal	54	/CE	O	External delay Chip enable terminal
12	RR	AO	RR channel D/A output	33	D1	I/Ot	External delay RAM Data terminal	55	XO	O	Crystal oscillator connection terminal
13	CV	AO	A/D, center voltage of multi-planning DAC	34	D0	I/Ot	External delay RAM Data terminal	56	XI	I	Crystal oscillator connection (11.2896 MHz)
14	AGND	A-	Ground (A/D, D/A section)	35	A0	O	External delay RAM Address terminal	57	Sync I	It	+5V
15	AGND	A-	Ground (Multi-planning DAC section)	36	A1	O	External delay RAM Address terminal	58	DVDD	-	+5V power supply (Digital section)
16	VREF	AI	Reference voltage input of multi-planning DAC	37	A2	O	External delay RAM Address terminal	59	Sync O	O	Non connection
17	LINM	AI	L channel Multi-planning DAC input	38	A3	O	External delay RAM Address terminal	60	/ICs	Ics	Initial clear terminal
18	RINM	AI	R channel Multi-planning DAC input	39	A4	O	External delay RAM Address terminal	61	LRS	O	Non connection
19	VOLM	AO	L channel Ope-amplifier	40	DGND	-	Ground (Digital section)	62	/CSS	O	Non connection
20	VOLP	AO	L channel Ope-amplifier	41	DGND	-	Ground (Digital section)	63	BCK	Ics	Bit clock of parallel meter data input
21	VOCM	AO	C channel Ope-amplifier	42	A5	O	External delay RAM Address terminal	64	WCK	Ics	Word clock of parallel meter data input
				43	A6	O	External delay RAM Address terminal				

**IC706, IC707 : TB2104F  
FL DRIVER**

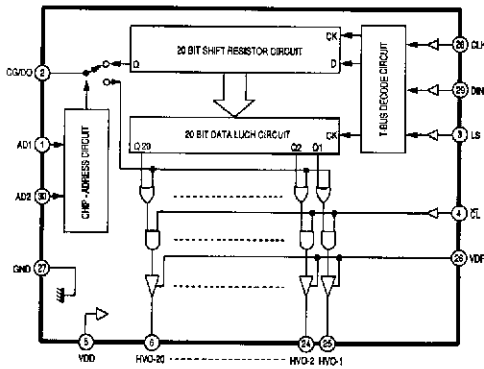

**IC803, IC805, IC809 IC811  
: TA75072P  
IC804, IC806, IC807, IC808,  
IC810 : μPC4570C  
PRE-AMP**

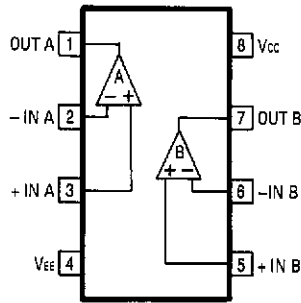

**IC812 : LC7823  
SELECTOR**

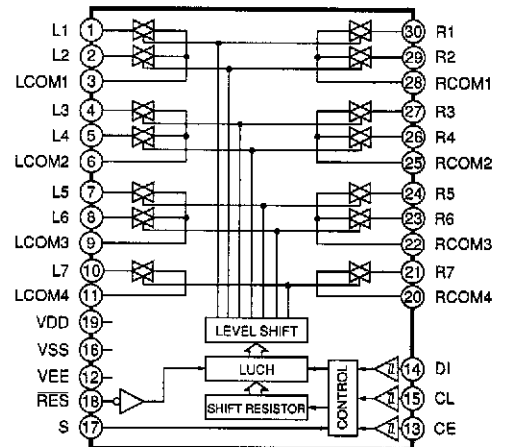

**IC802 : HM65256BLFP-10T  
DIGITAL DELAY TIME REGISTER**

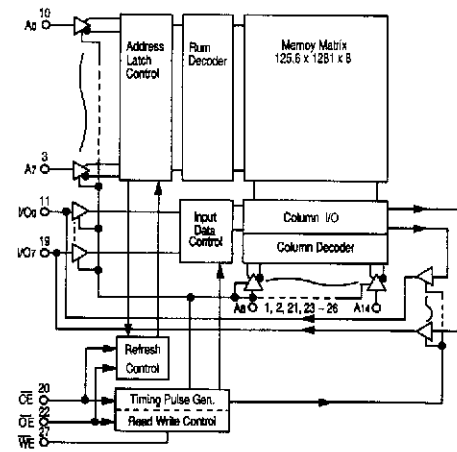

**IC802 : TERMINAL FUNCTIONS**

NO.	Port name	I/O	Functions
1	A14	I	Address input
2	A12	I	Address input
3	A7	I	Address input
4	A6	I	Address input
5	A5	I	Address input
6	A4	I	Address input
7	A3	I	Address input
8	A2	I	Address input
9	A1	I	Address input
10	A0	I	Address input
11	I/O <sub>0</sub>	I/O	Data input/output
12	I/O <sub>1</sub>	I/O	Data input/output
13	I/O <sub>2</sub>	I/O	Data input/output
14	Vss	-	GND

NO.	Port name	I/O	Functions
15	I/O <sub>3</sub>	I/O	Data input/output
16	I/O <sub>4</sub>	I/O	Data input/output
17	I/O <sub>5</sub>	I/O	Data input/output
18	I/O <sub>6</sub>	I/O	Data input/output
19	I/O <sub>7</sub>	I/O	Data input/output
20	CE	I	Chip enable input
21	A10	I	Address input
22	OE	I	Output enable input
23	A11	I	Address input
24	A9	I	Address input
25	A8	I	Address input
26	A13	I	Address input
27	WE	I	Write enable input
28	Vcc	-	Power

**FUNCTION**

CE	DE	WE	I/O TERMINAL	MODE
L	L	H	Low Z	Read
L	x	L	High Z	Write
L	H	H	High Z	-
H	L	x	High Z	Refresh
H	H	x	High Z	Standby

**IC904 : LA7217  
SYNC SEP, VER/HORI. SEP**

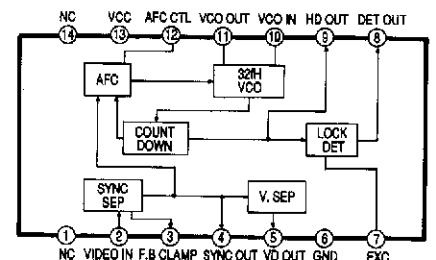

**IC905 : M50458-001SP  
ON SCREEN CONTROL**

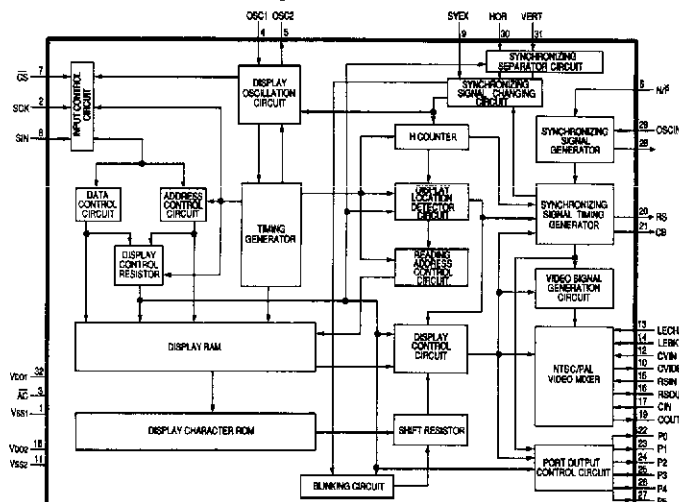

**IC901 : TC4051BF  
VIDEO SELECTOR**

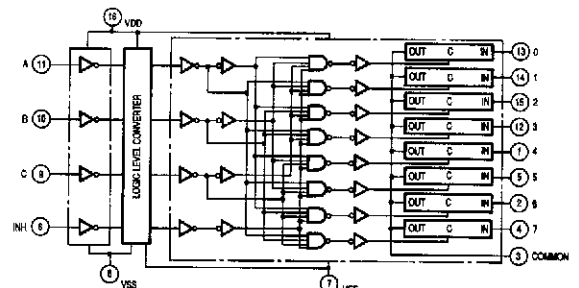

**IC905 : TERMINAL FUNCTIONS**

NO.	Port name	I/O	Functions
1	Vss1	-	GND terminal
2	SCK	I	Serial clock input
3	AC	I	Auto clear input
4	OSC1	I	Oscillator circuit external terminal
5	OSC2	O	Oscillator circuit external terminal
6	N/P	I	NTSC/PAL changing input
7	CS	I	Chip select input
8	SIN	I	Serial data input
9	SYEX	I	Synchronizing signal changing input
10	CVIDEO	O	Composite video signal output
11	Vss2	-	GND terminal

NO.	Port name	I/O	Functions
12	CVIN	I	Composite video signal input
13	LECHA	I	Character level input
14	LEBK	I	Blanking level input
15	RSIN	I	Video signal input
16	RSOUT	O	Video signal output
17	CIN	I	Chroma signal input
18	VDD2	-	Power supply terminal
19	CSOUT	O	Chroma signal output
20	RS	O	Carrier color signal output
21	CB	O	Color burst signal output
22	PG	O	Output port P0

NO.	Port name	I/O	Functions
23	P1	O	Output port P1
24	P2	O	Output port P2
25	P3	O	Output port P3
26	P4	O	Output port P4
27	P5	O	Output port P5
28	OSCOU	O	Synchronizing signal oscillator circuit
29	OSCI	I	Synchronizing signal oscillator circuit
30	HOR	I	Horizontal sync. signal input
31	VERT	I	Vertical sync. signal input
32	VDD1	-	Power supply terminal

FL701

DISPLAY PIN CONNECTION

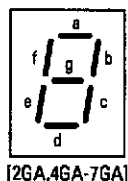
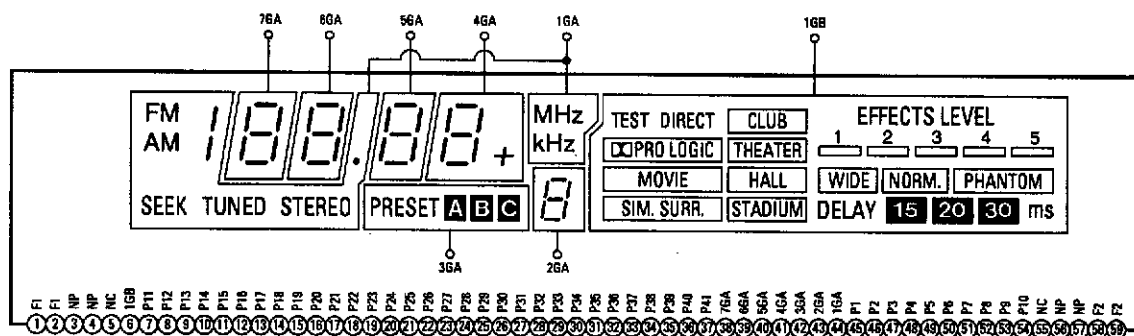

[2GA,4GA-7GA]

ANODE CONNECTION

	7GA	6GA	5GA	4GA	3GA	2GA	1GA	1GB		7GA	6GA	5GA	4GA	3GA	2GA	1GA	1GB
P1	a	a	a	a	A	a	FM. MHz	-	P22	-	-	-	-	-	-	-	(MOVIE)
P2	b	b	b	b	B	b		-	P23	-	-	-	-	-	-	-	(PRO LOGIC)
P3	c	c	c	c	C	c	-	-	P24	-	-	-	-	-	-	-	PRO LOGIC
P4	d	d	d	d	-	d	AM kHz	-	P25	-	-	-	-	-	-	-	(WIDE)
P5	e	e	e	e	-	e	-	-	P26	-	-	-	-	-	-	-	WIDE
P6	f	f	f	f	-	f	-	-	P27	-	-	-	-	-	-	-	(NORM.)
P7	g	g	g	g	-	g	-	-	P28	-	-	-	-	-	-	-	NORM.
P8	-	-	-	+	PRESET	-	SEEK	-	P29	-	-	-	-	-	-	-	(PHANTOM)
P9	-	-	-	-	-	-	STEREO	-	P30	-	-	-	-	-	-	-	PHANTOM
P10	-	-	-	-	-	-	TUNED	-	P31	-	-	-	-	-	-	-	TEST
P11	-	-	-	-	-	-	-	STADIUM	P32	-	-	-	-	-	-	-	DELAY ms
P12	-	-	-	-	-	-	-	(STADIUM)	P33	-	-	-	-	-	-	-	DIRECT
P13	-	-	-	-	-	-	-	HALL	P34	-	-	-	-	-	-	-	15
P14	-	-	-	-	-	-	-	(HALL)	P35	-	-	-	-	-	-	-	20
P15	-	-	-	-	-	-	-	THEATER	P36	-	-	-	-	-	-	-	30
P16	-	-	-	-	-	-	-	(THEATER)	P37	-	-	-	-	-	-	-	EFFECTS LEVEL
P17	-	-	-	-	-	-	-	CLUB		1 2 3 4 5							
P18	-	-	-	-	-	-	-	(CLUB)	P38	-	-	-	-	-	-	-	(2)
P19	-	-	-	-	-	-	-	SIM. SURR.	P39	-	-	-	-	-	-	-	(3)
P20	-	-	-	-	-	-	-	(SIM.SURR.)	P40	-	-	-	-	-	-	-	(4)
P21	-	-	-	-	-	-	-	MOVIE	P41	-	-	-	-	-	-	-	(5)

A B C D E

**SCHEMATIC DIAGRAM (1)**  
(FM TUNER PACK SECTION)

● For North America area model **BK WB SB**

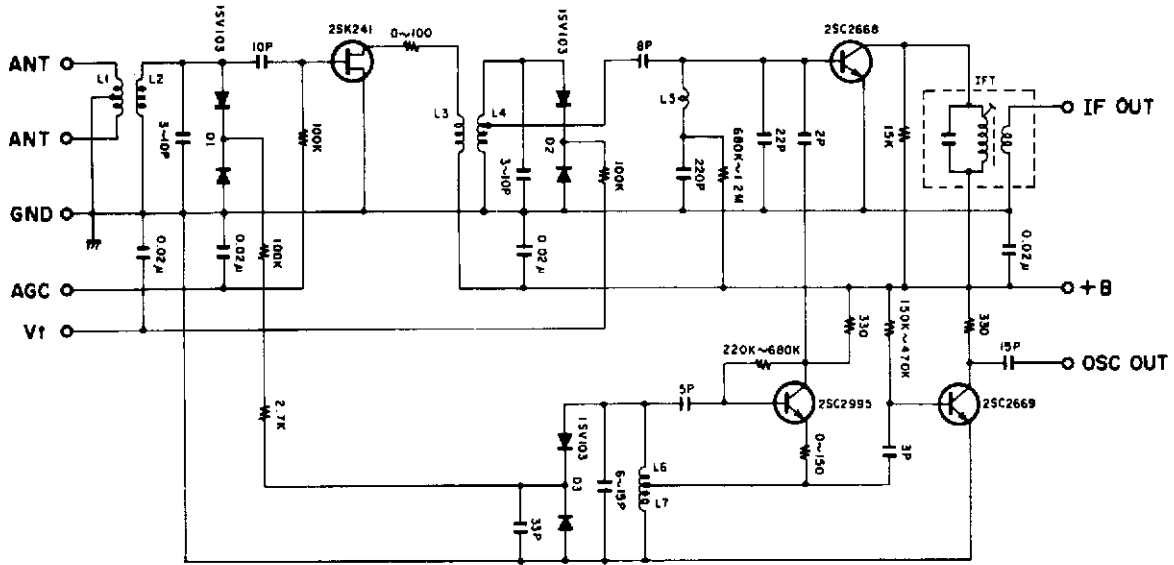

● For International model **IB**

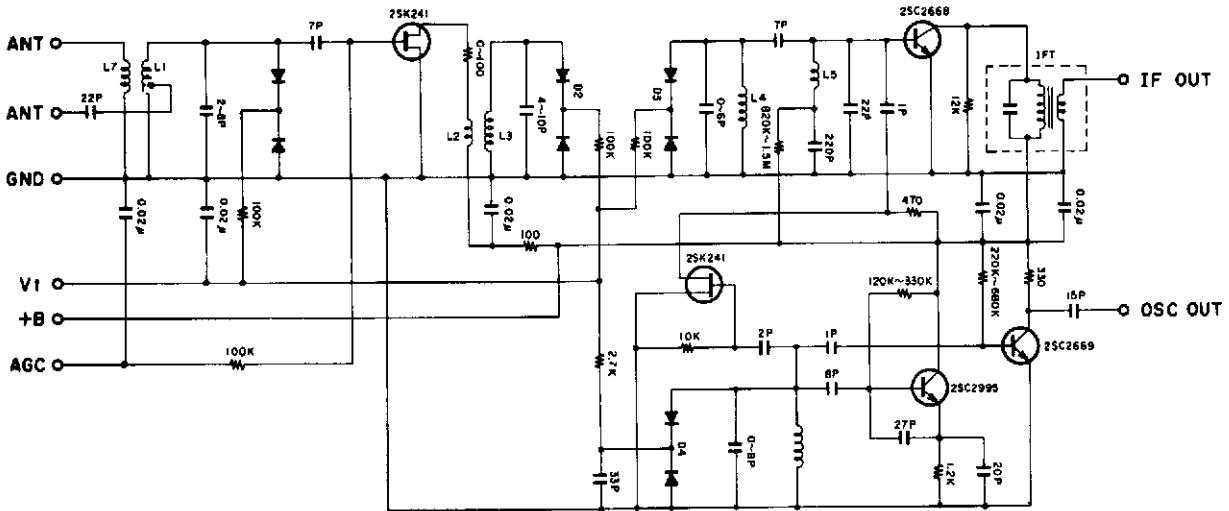

**NOTE:** Front End parts not available.  
Schematic diagram supplied for  
reference only.

A

B

C

D

E

# SCHEMATIC DIAGRAM (2) AUDIO FUNCTION

## PCB-5 AUDIO FUNCTION

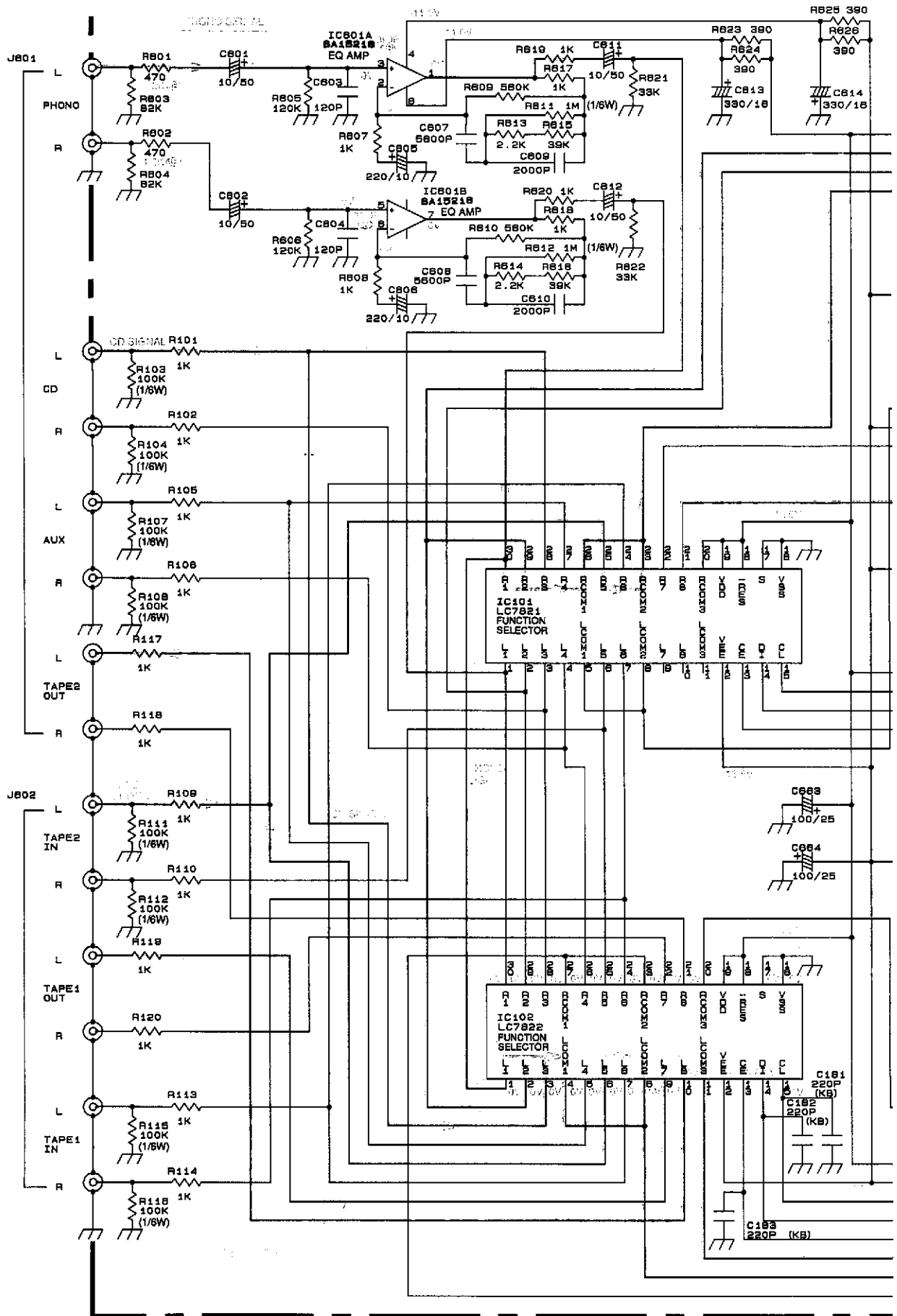

1

2

3

4

5

6

7

F G H I J

NOTE:

1. FUNCTION SWITCHES ARE SHOWN IN PHONO POSITION.
2. ALL RESISTANCES VALUES ARE IN  $\Omega$ .  
K $\Omega$ =1000 $\Omega$ , M $\Omega$ =1000K $\Omega$ .
3. THE WATTAGE OF RESISTORS IS 1/2W UNLESS OTHERWISE NOTED.

4. ALL CAPACITANCES VALUES ARE IN  $\mu\text{F}$  UNLESS OTHERWISE NOTED. P= $\mu\text{F}$
5. ...V:DC VOLTAGE AT NO SIGNAL UNLESS OTHERWISE NOTED.
6. SAFETY REQUIREMENTS COMPONENTS IN ACCORDANCE WITH PRESENT SAFETY REGULATIONS. THESE COMPONENTS MUST ONLY BE REPLACED BY ORIGINAL PARTS.

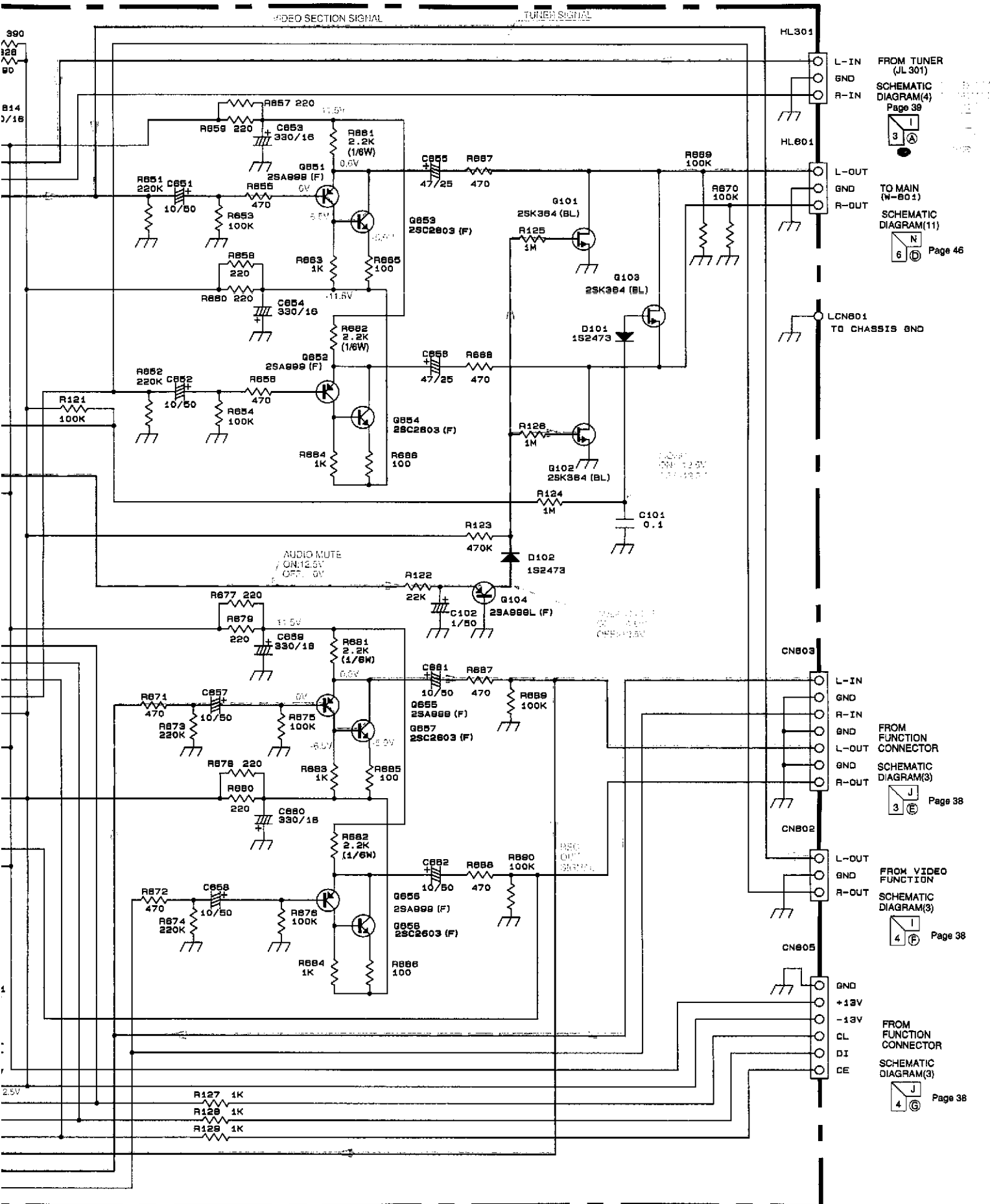



**SCHEMATIC DIAGRAM (3) FRONT PIN JACK/VIDEO FUNCTION**

Page 43  
SCHEMATIC  
DIAGRAM(8)

1  
2  
3  
4  
5  
6  
7

A B C D E

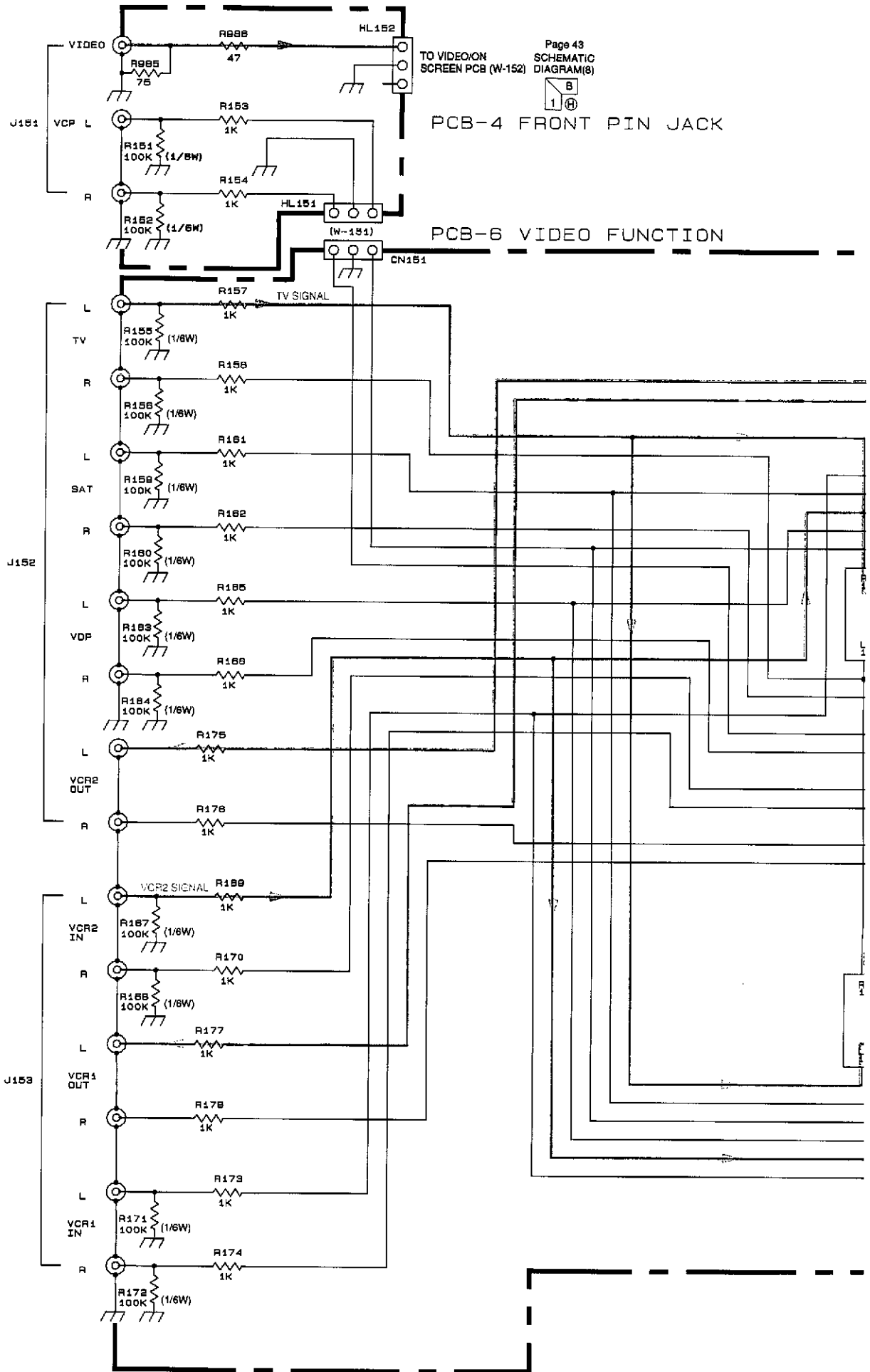

TO VIDEO/ON  
SCREEN PCB (W-152)

PCB-4 FRONT PIN JACK

PCB-6 VIDEO FUNCTION

- NOTE:**
1. FUNCTION SWITCHES ARE SHOWN IN PHONO POSITION.
  2. ALL RESISTANCES VALUES ARE IN  $\Omega$ .  
 $K\Omega=1000\Omega$ ,  $M\Omega=1000K\Omega$ .
  3. THE WATTAGE OF RESISTORS IS 1/2W UNLESS OTHERWISE NOTED.
  4. ALL CAPACITANCES VALUES ARE IN  $\mu F$  UNLESS OTHERWISE NOTED.  $P=\mu\mu F$
  5. ... V:DC VOLTAGE AT NO SIGNAL UNLESS OTHERWISE NOTED.
  6.  SAFETY REQUIREMENTS COMPONENTS IN ACCORDANCE WITH PRESENT SAFETY REGULATIONS. THESE COMPONENTS MUST ONLY BE REPLACED BY ORIGINAL PARTS.

**PCB-29  
FUNCTION CONNECTOR**

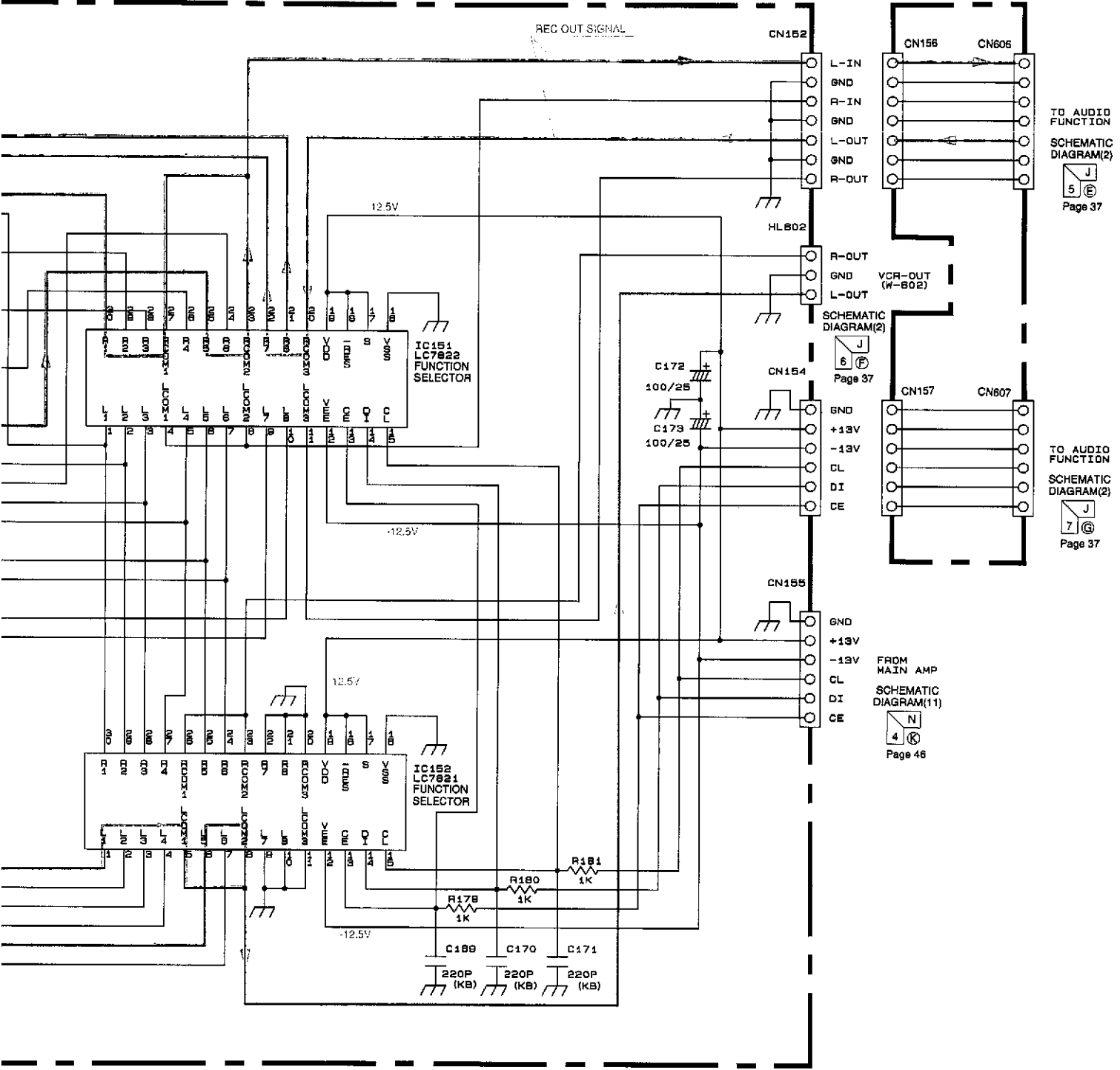

# SCHEMATIC DIAGRAM (4) TUNER

• For North America area model **BK**

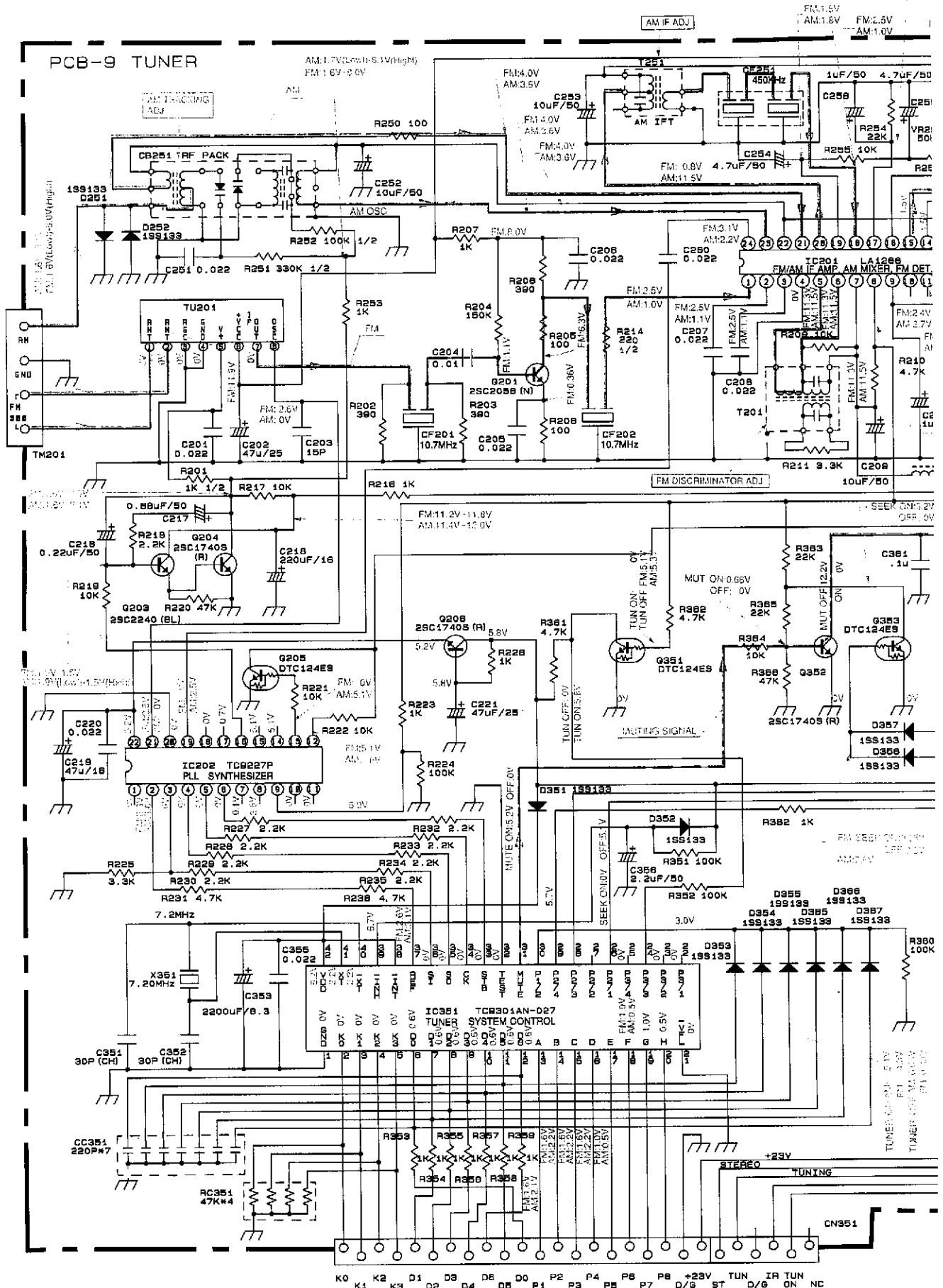

SCHEMATIC DIAGRAM(12)



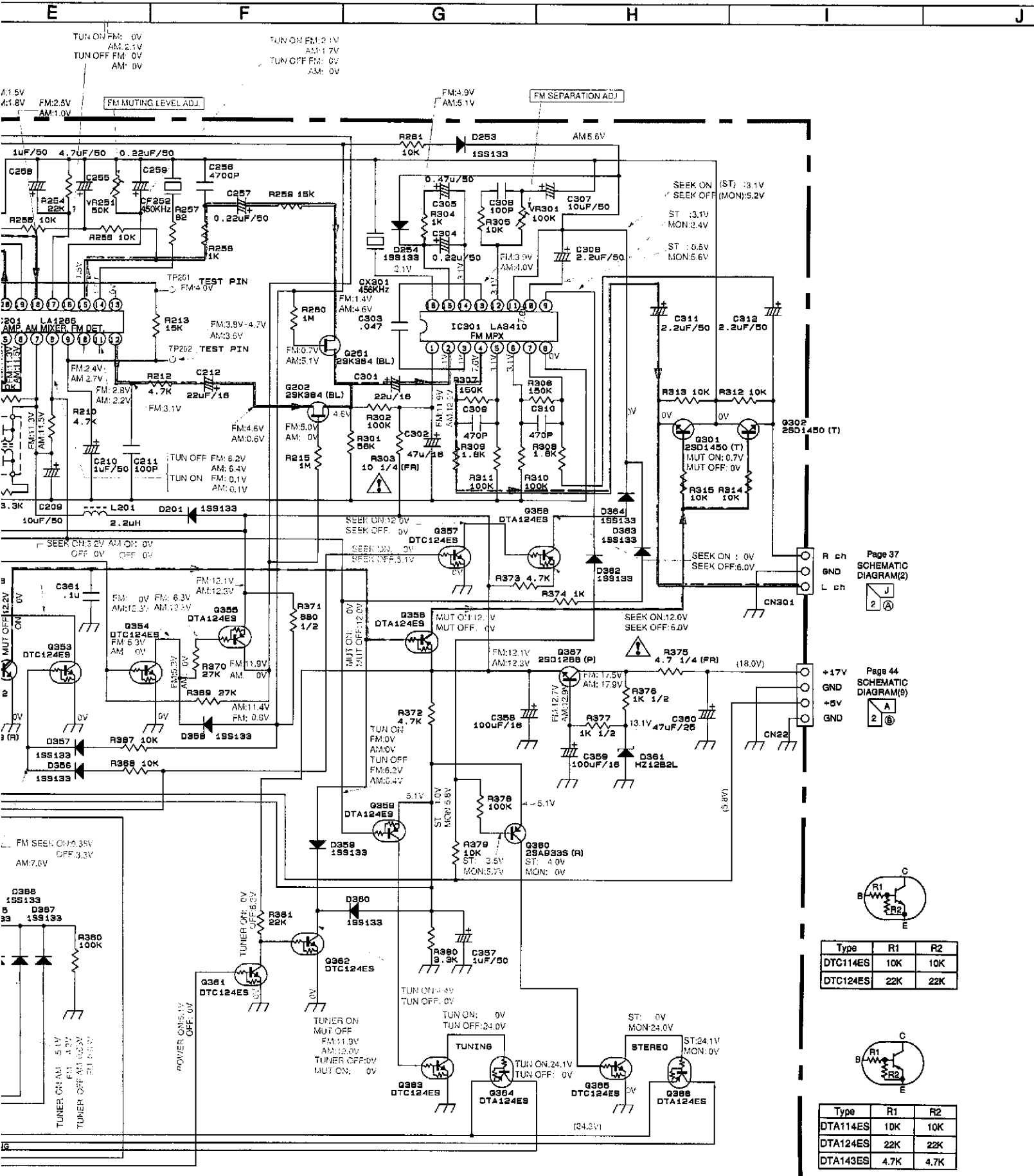

Page 37  
SCHEMATIC  
DIAGRAM(2)

Page 44  
SCHEMATIC  
DIAGRAM(9)

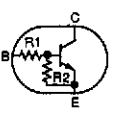

Type	R1	R2
DTC114ES	10K	10K
DTC124ES	22K	22K

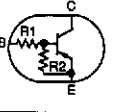

Type	R1	R2
DTA114ES	10K	10K
DTA124ES	22K	22K
DTA143ES	4.7K	4.7K

- NOTE:
1. FUNCTION SWITCHES ARE SHOWN IN PHONO POSITION.
  2. ALL RESISTANCES VALUES ARE IN Ω.
  3. THE WATTAGE OF RESISTORS IS 1/8W UNLESS OTHERWISE NOTED.
  4. ALL CAPACITANCES VALUES ARE IN μF UNLESS OTHERWISE NOTED. P=μμF
  5. ...V:DC VOLTAGE AT NO SIGNAL UNLESS OTHERWISE NOTED.
  6. SAFETY REQUIREMENTS COMPONENTS IN ACCORDANCE WITH PRESENT SAFETY REGULATIONS. THESE COMPONENTS MUST ONLY BE REPLACED BY ORIGINAL PARTS.

# SCHEMATIC DIAGRAM (5) TUNER

• For Asia, Singapore and International models **WB SB IB**

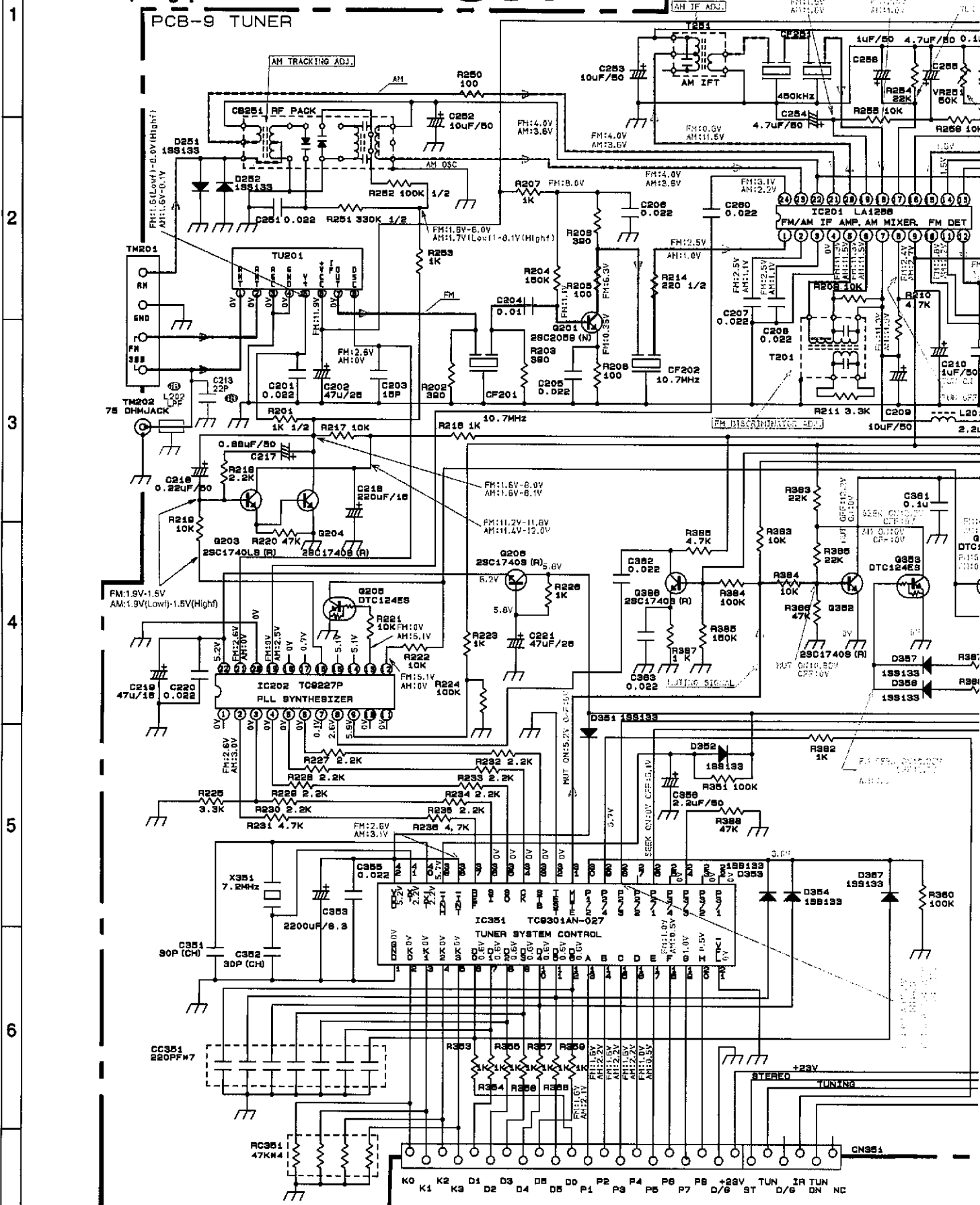

SCHEMATIC DIAGRAM(12)



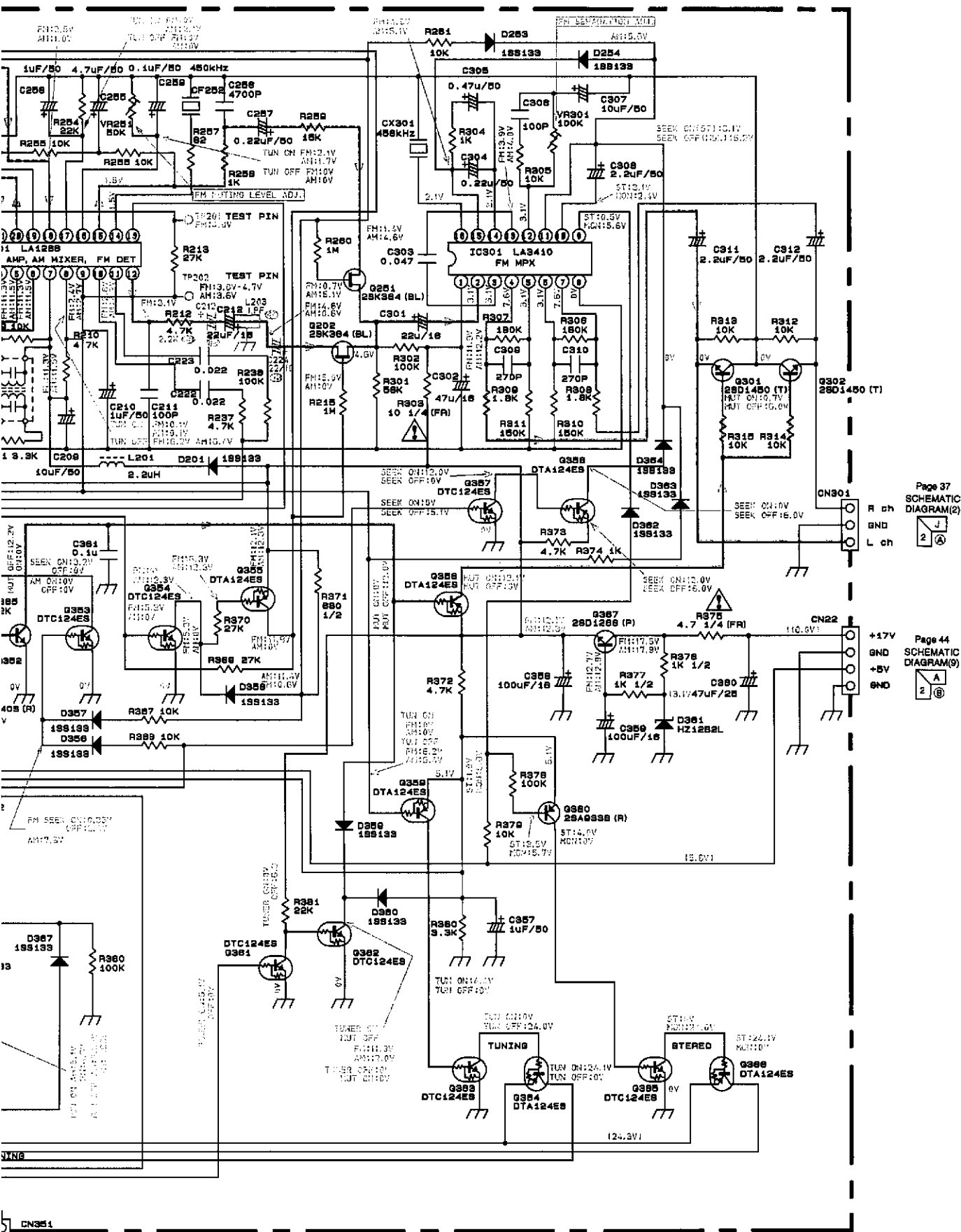

Page 37  
SCHEMATIC  
DIAGRAM(2)

Page 44  
SCHEMATIC  
DIAGRAM(9)

- NOTE:
1. FUNCTION SWITCHES ARE SHOWN IN PHONO POSITION.
  2. ALL RESISTANCE VALUES ARE IN  $\Omega$ .  
 $K\Omega=1000\Omega$ ,  $M\Omega=1000K\Omega$ .
  3. THE WATTAGE OF RESISTORS IS 1/2W UNLESS OTHERWISE NOTED.
  4. ALL CAPACITANCE VALUES ARE IN  $\mu F$  UNLESS OTHERWISE NOTED.  $P=\mu\mu F$
  5. ... V:DC VOLTAGE AT NO SIGNAL UNLESS OTHERWISE NOTED.
  6. SAFETY REQUIREMENTS COMPONENTS IN ACCORDANCE WITH PRESENT SAFETY REGULATIONS. THESE COMPONENTS MUST ONLY BE REPLACED BY ORIGINAL PARTS.

# SCHEMATIC DIAGRAM (6) TONE/REAR VOLUME/MASTER VOLUME

Page 46  
SCHEMATIC  
DIAGRAM(11)

Page 46  
SCHEMATIC  
DIAGRAM(11)

Page 46  
SCHEMATIC  
DIAGRAM(11)

Page 46  
SCHEMATIC  
DIAGRAM(11)

Page 46  
SCHEMATIC  
DIAGRAM(11)

## PCB-1 TONE

## (JL508) SUB WOOFER OUT

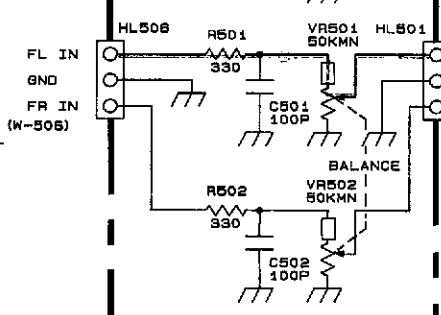
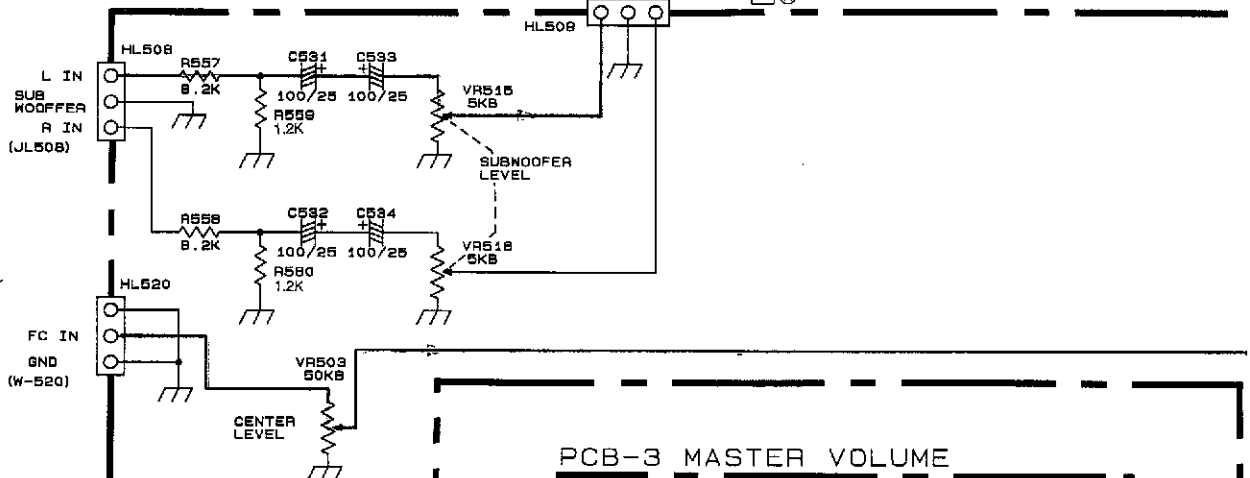

## PCB-3 MASTER VOLUME

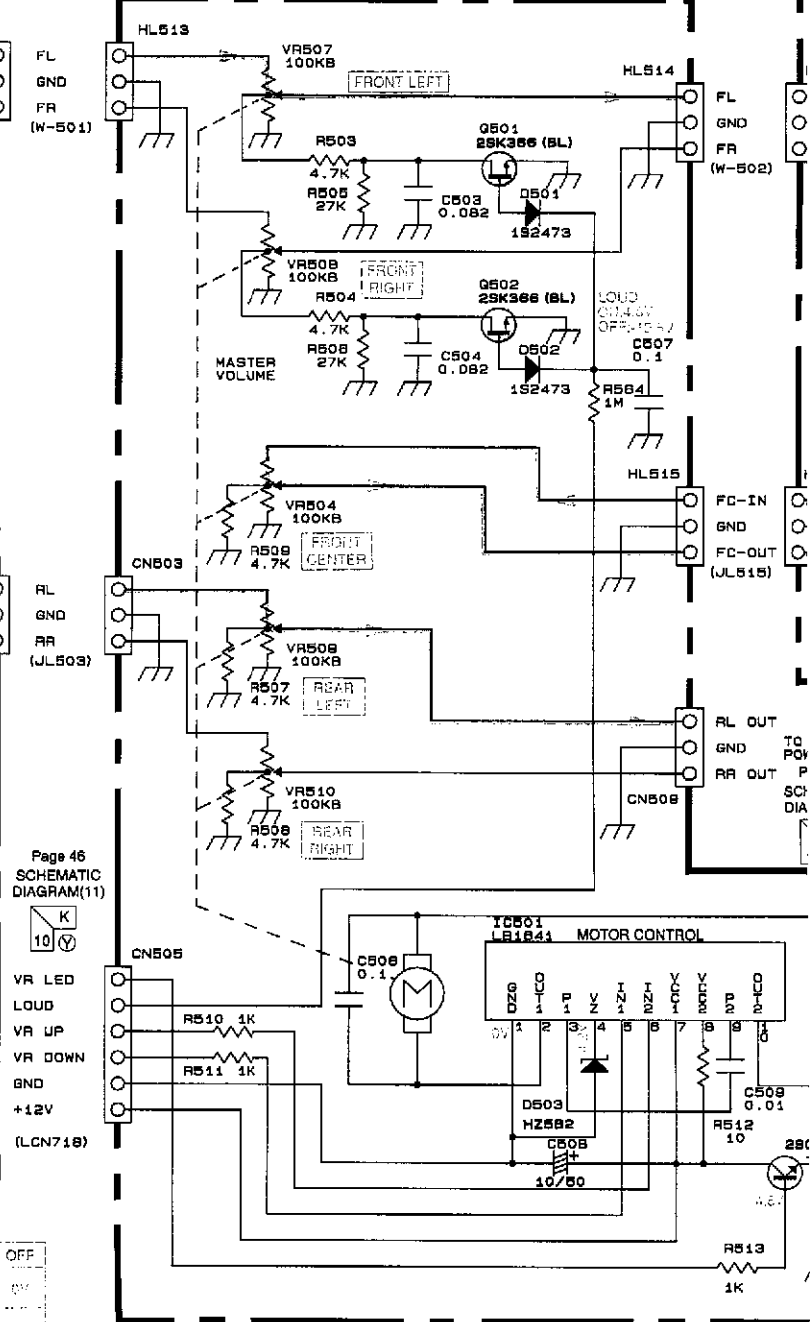

## PCB-2 REAR VOLUME

IC502			IC501				
pin	UP	DOWN	OFF	pin	UP	DOWN	OFF
①	4.5V	0V	0V	⑤	4.5V	0V	0V
②	0V	4.5V	0V	⑥	0V	4.5V	0V
③	3.0V	0V	0V	⑦	4.5V	3.0V	0V
④	0V	3.0V	0V	⑧	3.0V	0V	0V

Page 46  
SCHEMATIC  
DIAGRAM(11)

Page 46  
SCHEMATIC  
DIAGRAM(11)

## IC501 MOTOR CONTROL

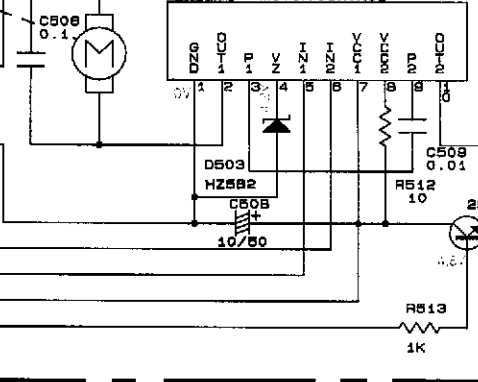

Page 46  
SCHEMATIC  
DIAGRAM(11)

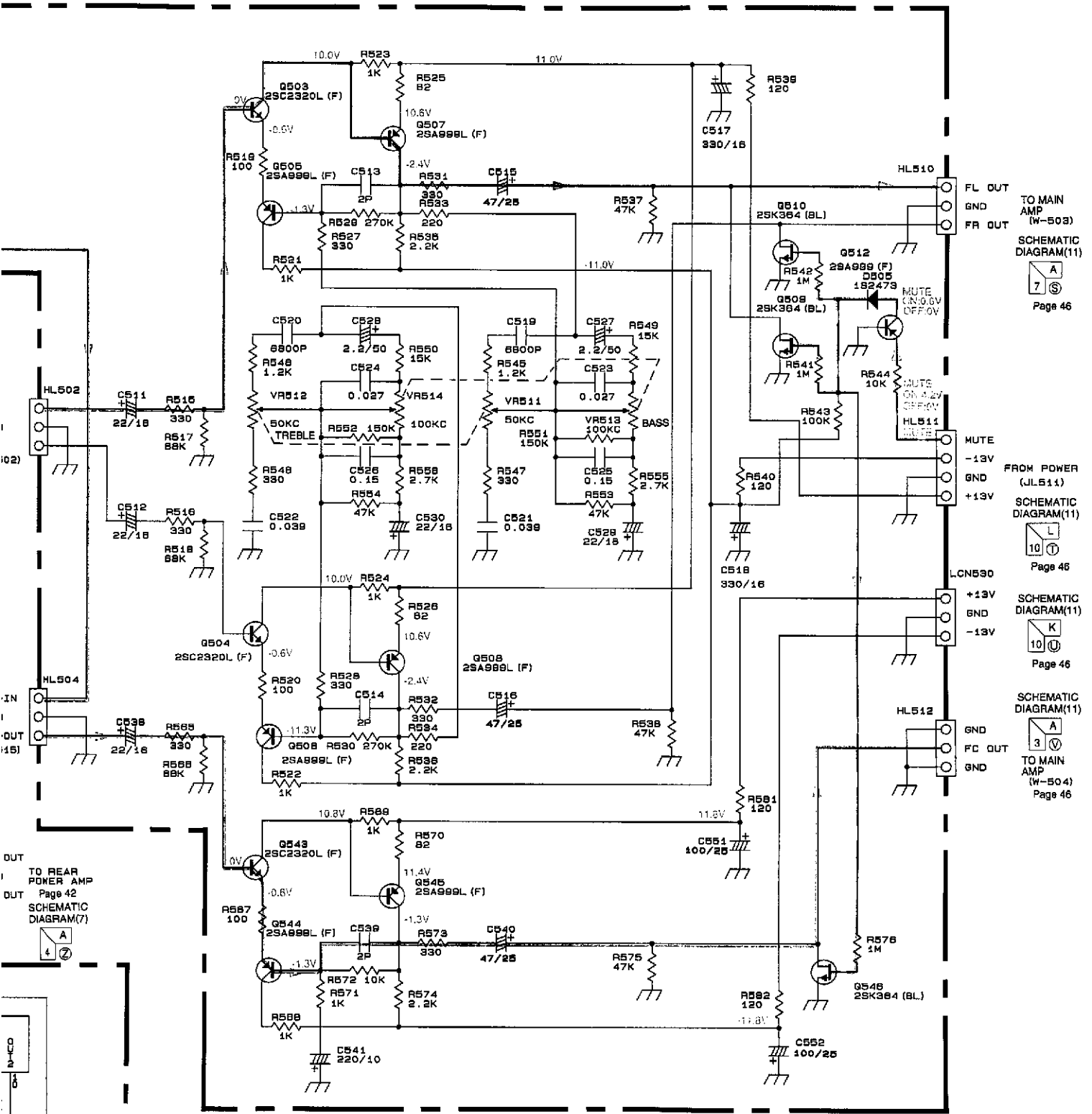

TO MAIN AMP (W-503)  
SCHEMATIC DIAGRAM(11)  
A  
7  
Page 46

FROM POWER (JL511)  
SCHEMATIC DIAGRAM(11)  
L  
10  
Page 46

SCHEMATIC DIAGRAM(11)  
K  
10  
Page 46

SCHEMATIC DIAGRAM(11)  
A  
3  
TO MAIN AMP (W-504)  
Page 46

PCB-8 VOLUME LED

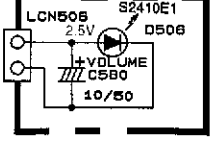
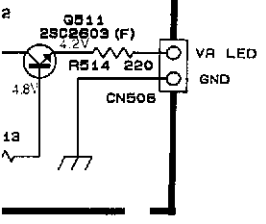

NOTE:

1. FUNCTION SWITCHES ARE SHOWN IN PHONO POSITION.
2. ALL RESISTANCES VALUES ARE IN Ω.  
KΩ=1000Ω, MΩ=1000KΩ.
3. THE WATTAGE OF RESISTORS IS 1/2W UNLESS OTHERWISE NOTED.
4. ALL CAPACITANCES VALUES ARE IN μF UNLESS OTHERWISE NOTED. P=μμF
5. ...V:DC VOLTAGE AT NO SIGNAL UNLESS OTHERWISE NOTED.
6. SAFETY REQUIREMENTS COMPONENTS IN ACCORDANCE WITH PRESENT SAFETY REGULATIONS. THESE COMPONENTS MUST ONLY BE REPLACED BY ORIGINAL PARTS.



SCHEMATIC DIAGRAM (7) REAR AMP

PCB-21 REAR AMP

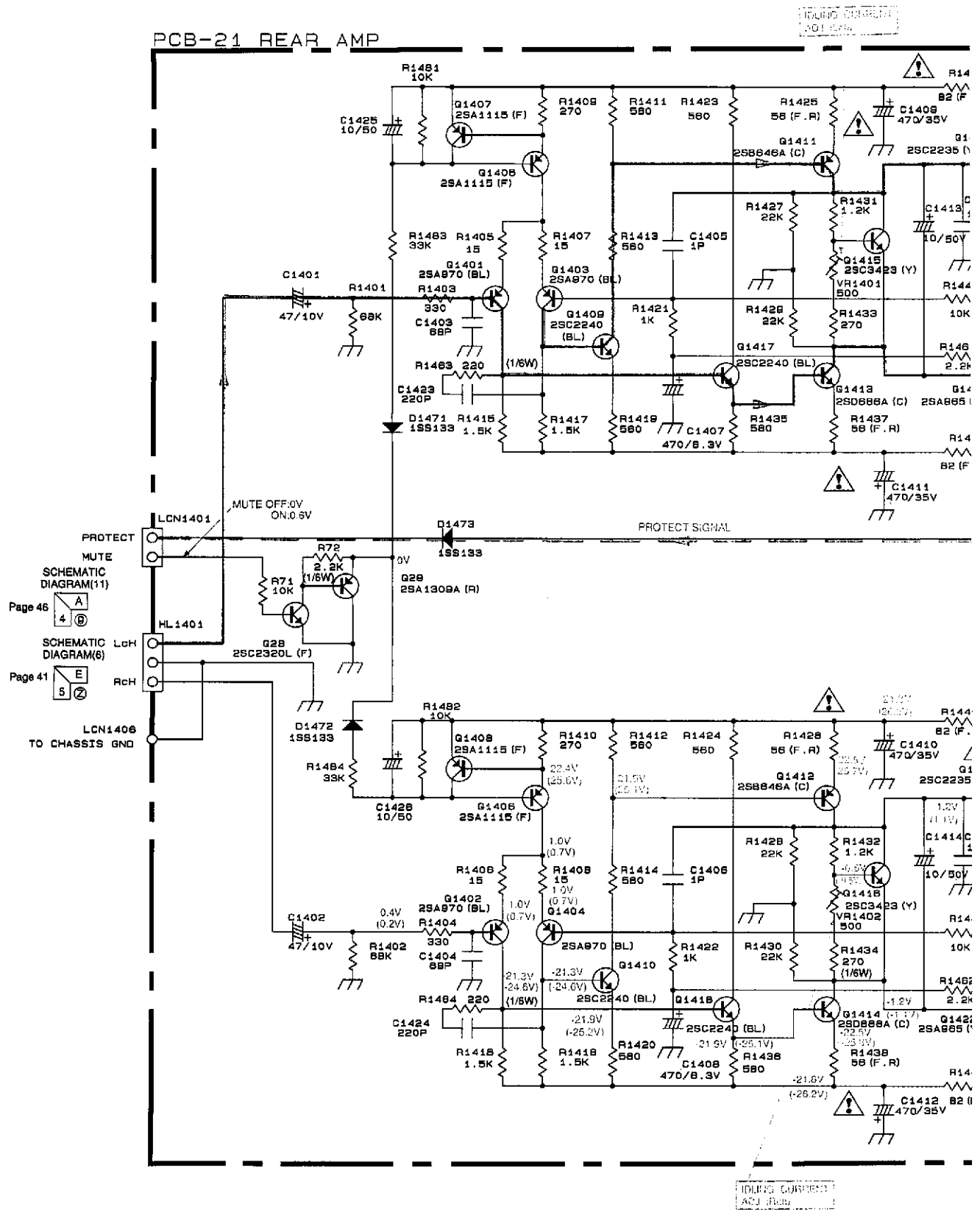

SCHEMATIC DIAGRAM(11)  
 Page 46  
 4  
 SCHEMATIC DIAGRAM(6)  
 Page 41  
 5  
 LCN1406 TO CHASSIS GND

ROUND CAPACITOR  
 50% TOL.

INDICATED CAPACITOR  
 ACU. BUS

- NOTE:
1. FUNCTION SWITCHES ARE SHOWN IN PHONO POSITION,
  2. ALL RESISTANCES VALUES ARE IN  $\Omega$ .  
K $\Omega$ =1000 $\Omega$ , M $\Omega$ =1000K $\Omega$ .
  3. THE WATTAGE OF RESISTORS IS 1/2W UNLESS OTHERWISE NOTED.
  4. ALL CAPACITANCES VALUES ARE IN  $\mu$ F UNLESS OTHERWISE NOTED. P= $\mu$ F
  5. ... V:DC VOLTAGE AT NO SIGNAL UNLESS OTHERWISE NOTED.
  6. (... V):FOR  $\text{Ⓢ}$   $\text{Ⓟ}$  and  $\text{Ⓡ}$
- ⚠** SAFETY REQUIREMENTS COMPONENTS IN ACCORDANCE WITH PRESENT SAFETY REGULATIONS. THESE COMPONENTS MUST ONLY BE REPLACED BY ORIGINAL PARTS.

IRRENT

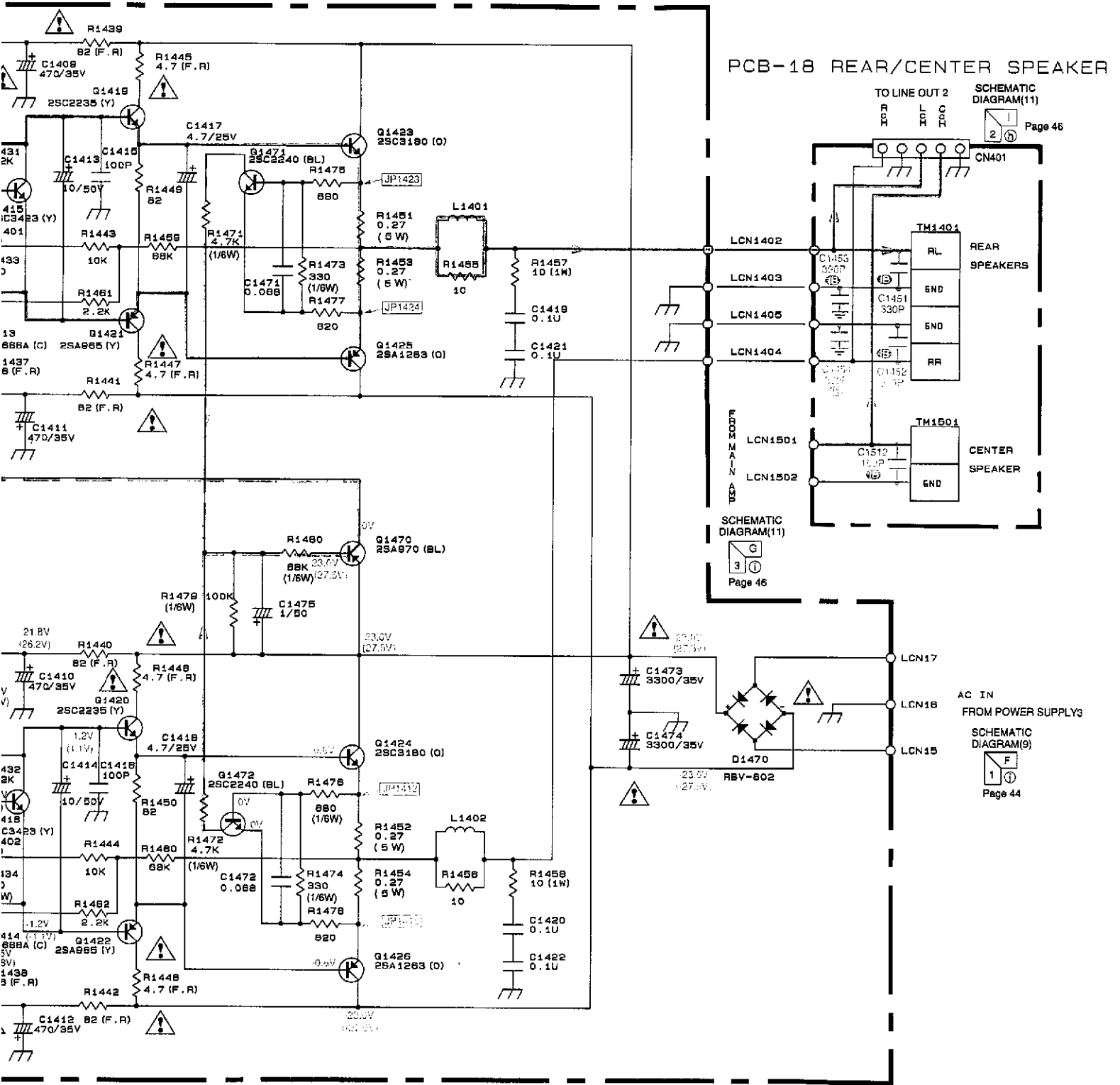

PCB-18 REAR/CENTER SPEAKER

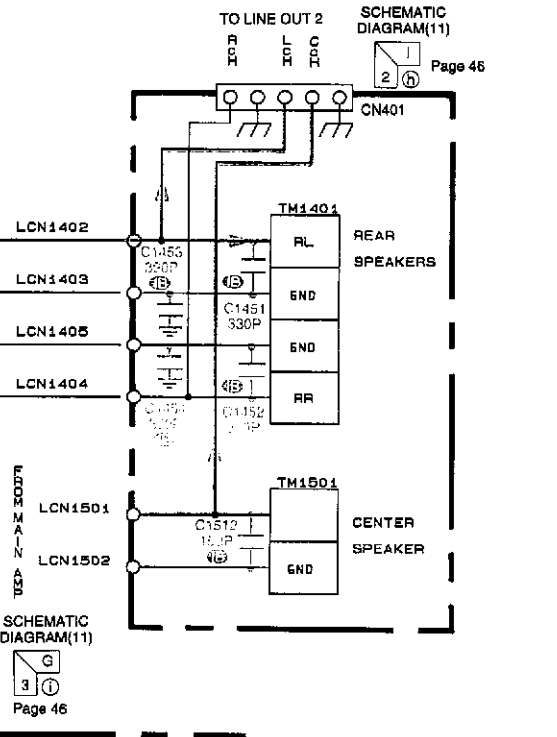

AC IN FROM POWER SUPPLY3

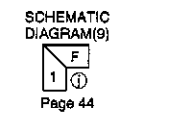

SCHMATIC DIAGRAM(9)  
1 ①  
Page 44

SCHMATIC DIAGRAM(11)  
2 ①  
Page 46

SCHMATIC DIAGRAM(11)  
3 ①  
Page 46

# SCHEMATIC DIAGRAM (8) VIDEO ON SCREEN

PCB-24  
VIDEO/ON SCREEN

Page 38  
SCHEMATIC  
DIAGRAM(8)

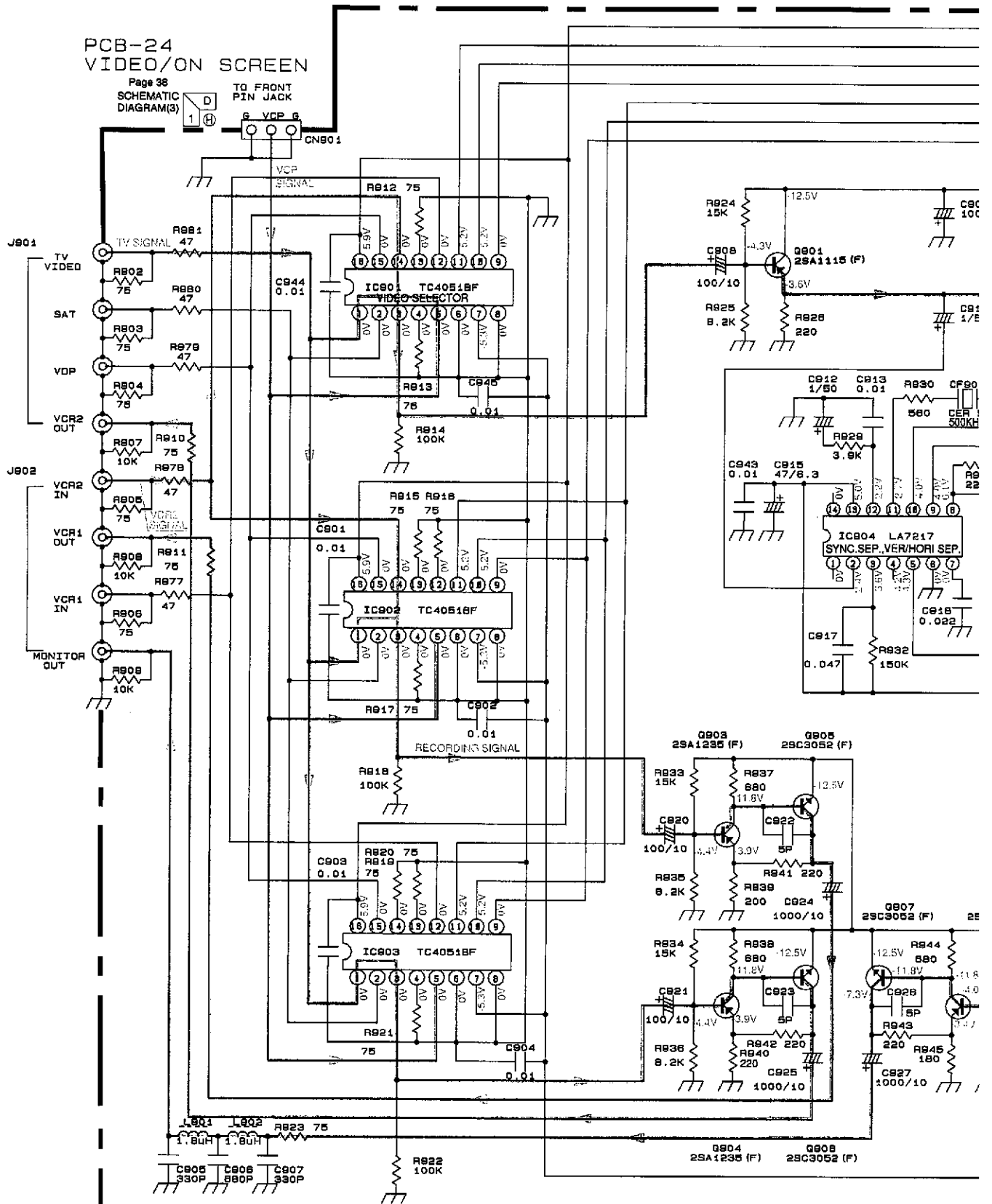

- NOTE:  
 1. FUNCTION SWITCH  
 2. ALL RESISTANCES  
 KΩ=1000Ω, MΩ=100  
 3. THE WATTAGE OF I

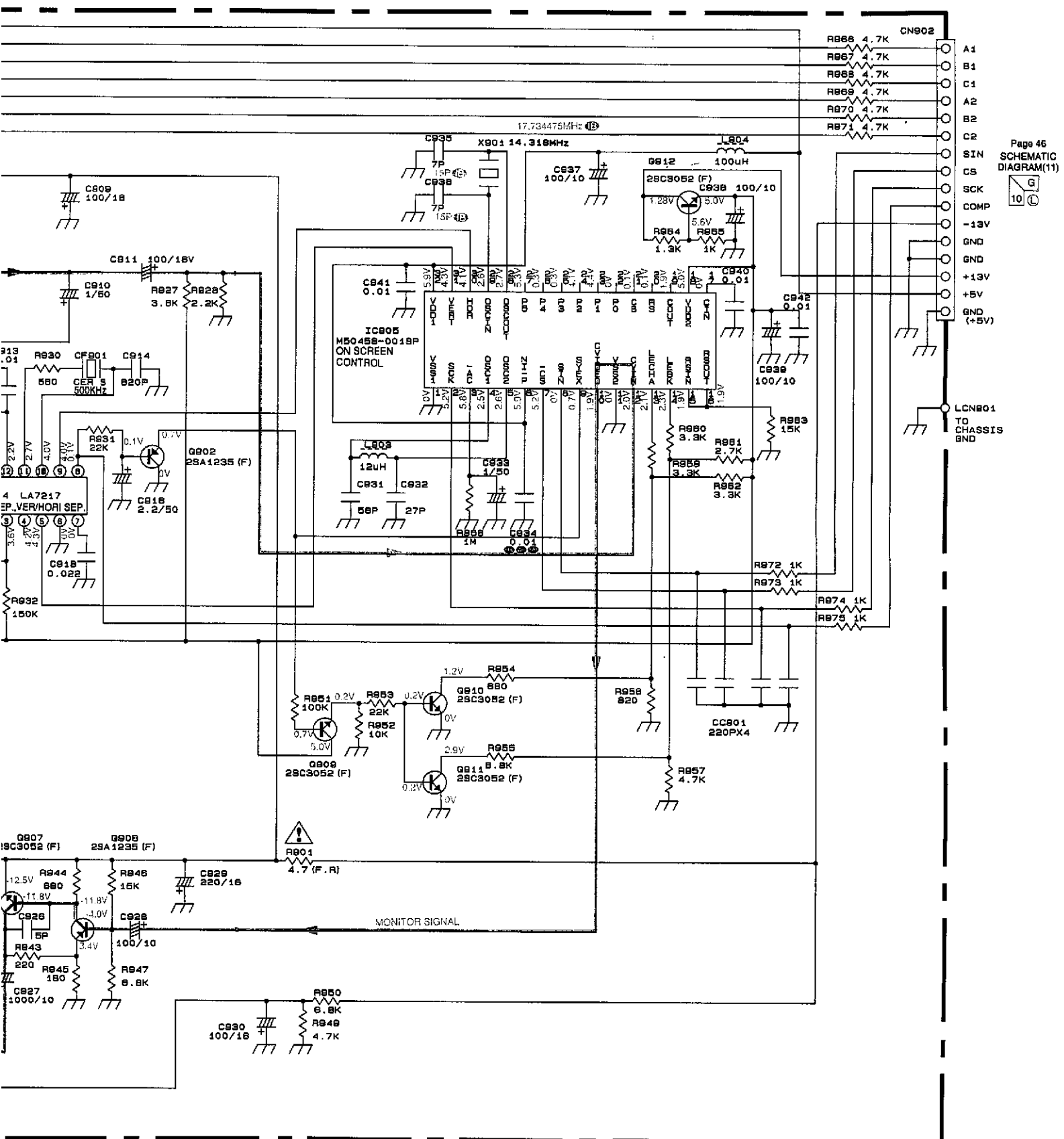

Page 46  
SCHEMATIC  
DIAGRAM(11)

JUNCTION SWITCHES ARE SHOWN IN PHONO POSITION.  
ALL RESISTANCES VALUES ARE IN  $\Omega$ .  
 $\Omega=1000\Omega$ ,  $M\Omega=1000K\Omega$ .  
THE WATTAGE OF RESISTORS IS 1/10W UNLESS OTHERWISE NOTED.

4. ALL CAPACITANCES VALUES ARE IN  $\mu F$  UNLESS OTHERWISE NOTED.  $P=\mu\mu F$
5. ...V:DC VOLTAGE AT NO SIGNAL UNLESS OTHERWISE NOTED.
6. SAFETY REQUIREMENTS COMPONENTS IN ACCORDANCE WITH PRESENT SAFETY REGULATIONS. THESE COMPONENTS MUST ONLY BE REPLACED BY ORIGINAL PARTS.

# SCHEMATIC DIAGRAM (9) POWER SUPPLY/MAIN CONNECTOR

Page 46  
SCHEMATIC  
DIAGRAM(11)

Page 41  
SCHEMATIC  
DIAGRAM

## PCB-10 POWER SUPPLY

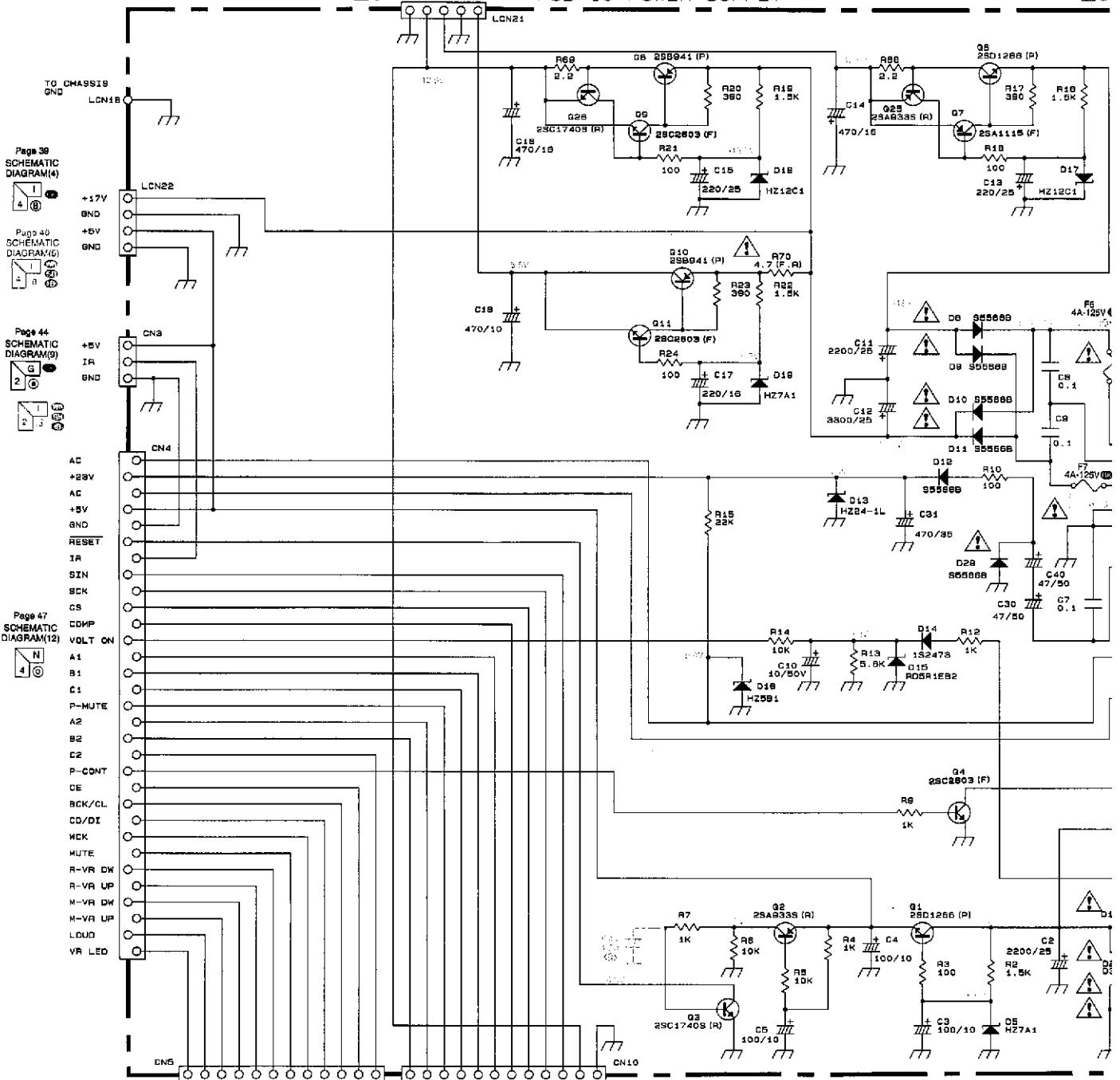

Page 39  
SCHEMATIC  
DIAGRAM(4)

Page 40  
SCHEMATIC  
DIAGRAM(6)

Page 44  
SCHEMATIC  
DIAGRAM(8)

Page 47  
SCHEMATIC  
DIAGRAM(12)

Page 46  
SCHEMATIC  
DIAGRAM(11)

Page 46  
SCHEMATIC  
DIAGRAM(11)

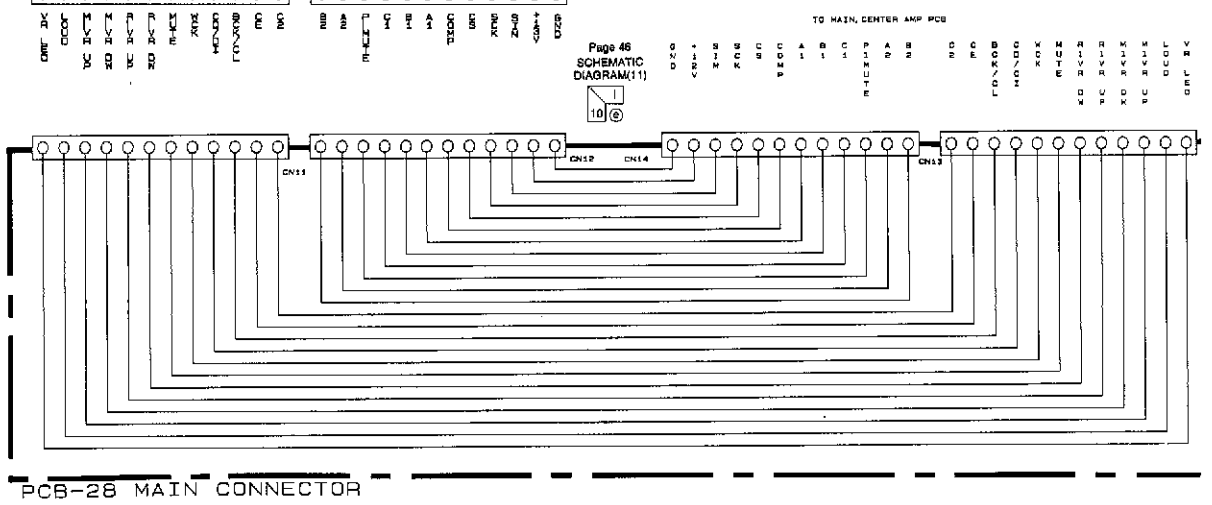

## PCB-28 MAIN CONNECTOR

Page 45  
SCHEMATIC  
DIAGRAM(11)

Page 42  
SCHEMATIC  
DIAGRAM(7)

### PCB-22 POWER SUPPLY 3

### PCB-11 AC OUT/VOL SELE

Page 44  
SCHEMATIC  
DIAGRAM(9)

### PCB-12 POWER SUPPLY 2

### PCB-12 POWER SUPPLY 2

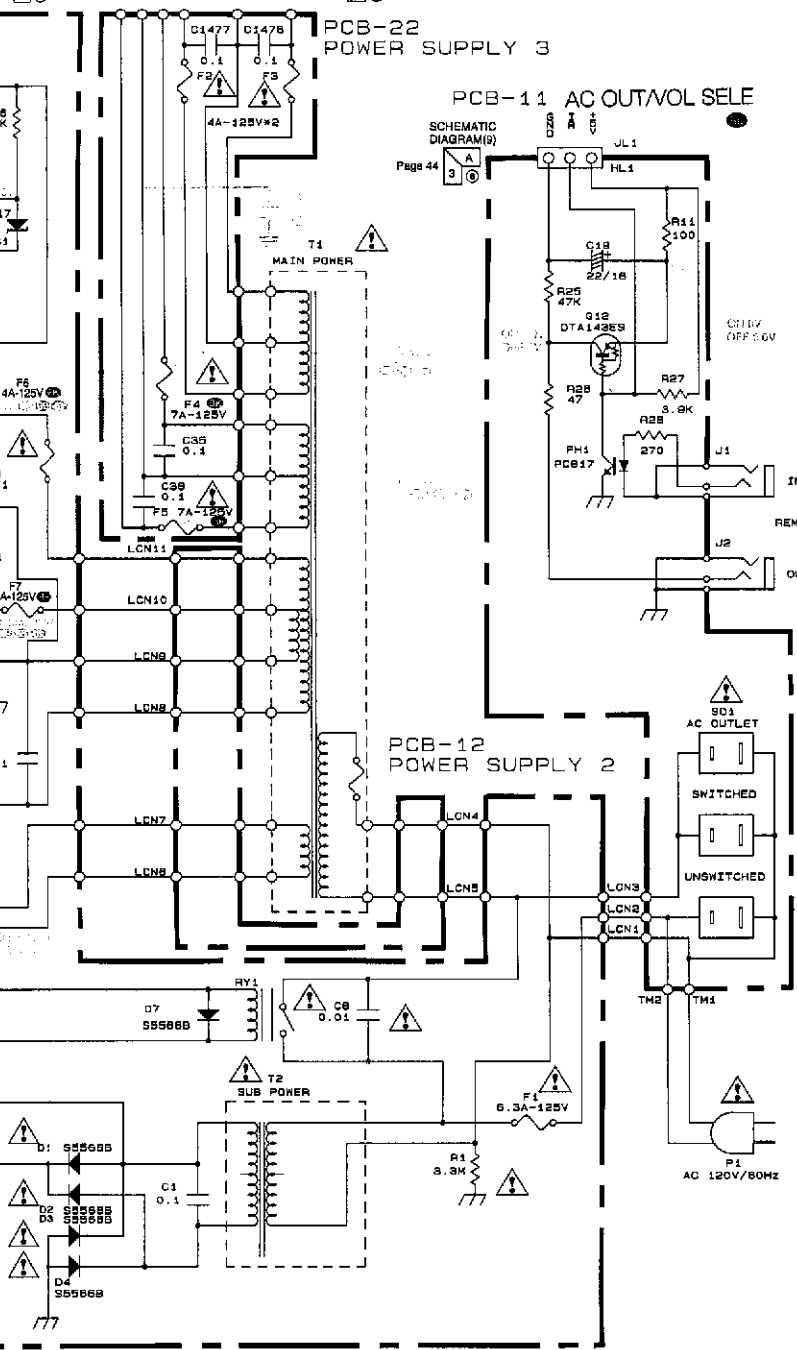

Page 46  
SCHEMATIC  
DIAGRAM(11)

**NOTE:**

1. FUNCTION SWITCHES ARE SHOWN IN PHONO POSITION.
2. ALL RESISTANCES VALUES ARE IN Ω.  
KΩ=1000Ω, MΩ=1000KΩ.
3. THE WATTAGE OF RESISTORS IS 1/2W UNLESS OTHERWISE NOTED.
4. ALL CAPACITANCES VALUES ARE IN μF UNLESS OTHERWISE NOTED. P=μF
5. ...V-DC VOLTAGE AT NO SIGNAL UNLESS OTHERWISE NOTED.
6. SAFETY REQUIREMENTS COMPONENTS IN ACCORDANCE WITH PRESENT SAFETY REGULATIONS. THESE COMPONENTS MUST ONLY BE REPLACED BY ORIGINAL PARTS.

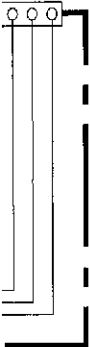

# SCHEMATIC DIAGRAM (10) DISPLAY

PCB-23 DISPLAY

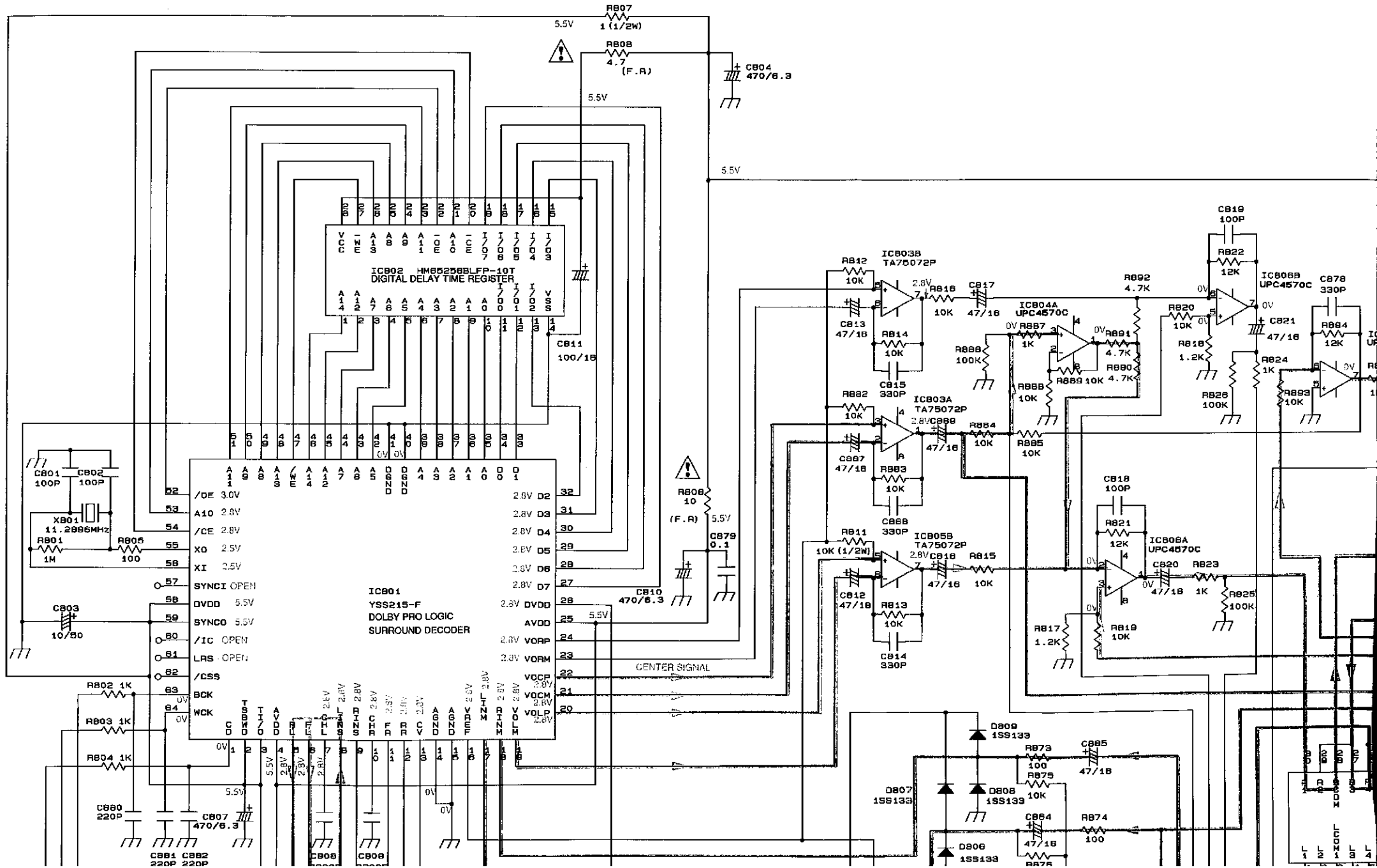

H I J K L M N

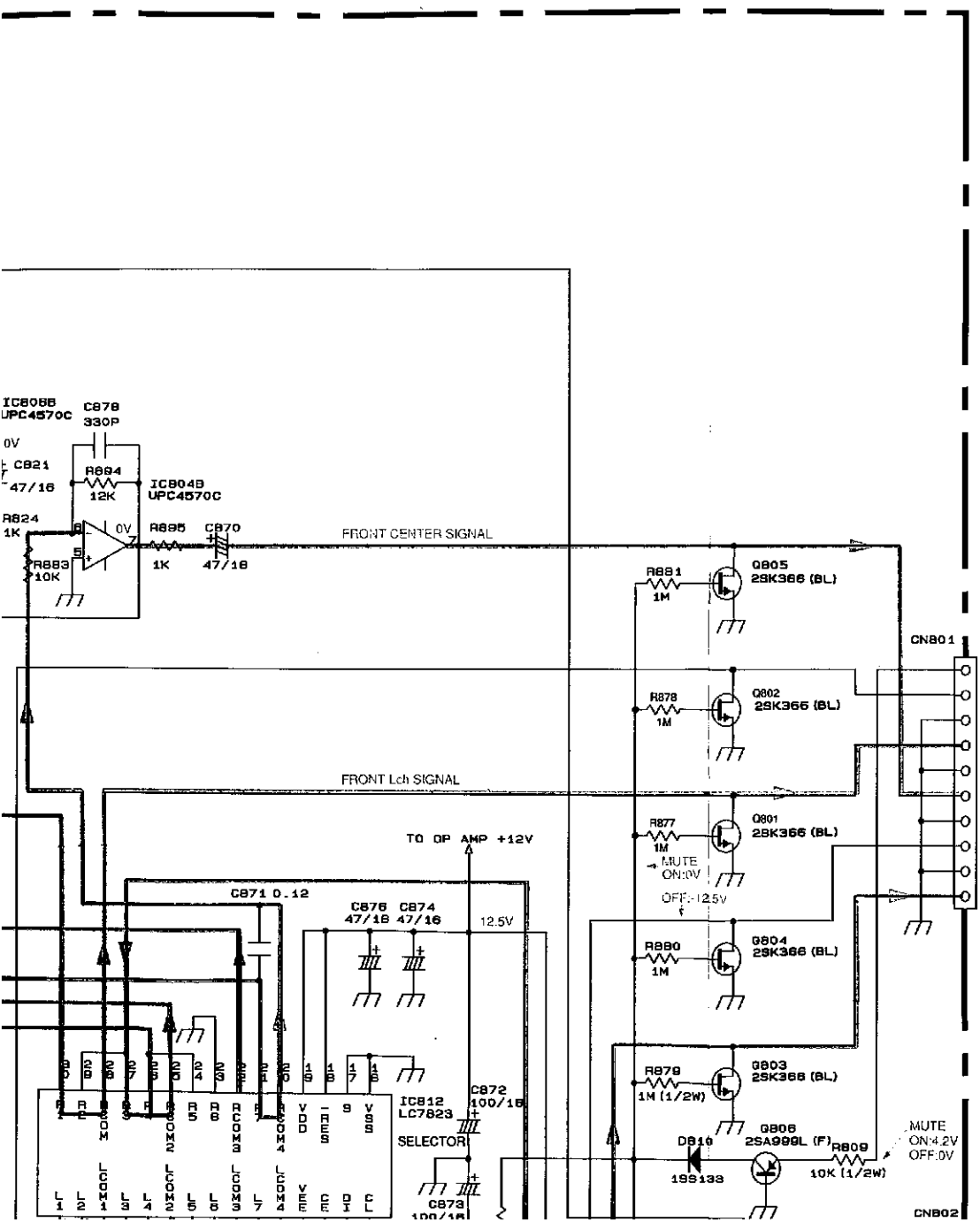

- NOTE:
1. FUNCTION SWITCHES ARE SHOWN IN PHONO POSITION.
  2. ALL RESISTANCES VALUES ARE IN  $\Omega$ .  
K $\Omega$ =1000 $\Omega$ , M $\Omega$ =1000K $\Omega$ .
  3. THE WATTAGE OF RESISTORS IS 1/4W UNLESS OTHERWISE NOTED.
  4. ALL CAPACITANCES VALUES ARE IN  $\mu$ F UNLESS OTHERWISE NOTED. P= $\mu$ F
  5. . . V:DC VOLTAGE AT NO SIGNAL UNLESS OTHERWISE NOTED.
  6. SAFETY REQUIREMENTS COMPONENTS IN ACCORDANCE WITH PRESENT SAFETY REGULATIONS. THESE COMPONENTS MUST ONLY BE REPLACED BY ORIGINAL PARTS.

### INFRARED REMOTE CONTROL SCHEMATIC DIAGRAM

Page 46  
SCHEMATIC  
DIAGRAM(11)

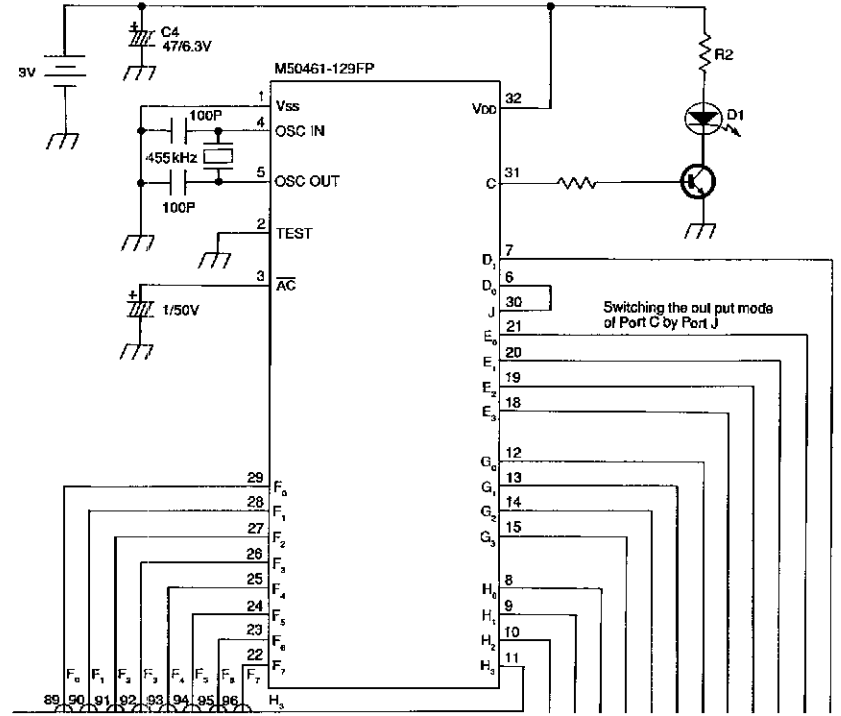



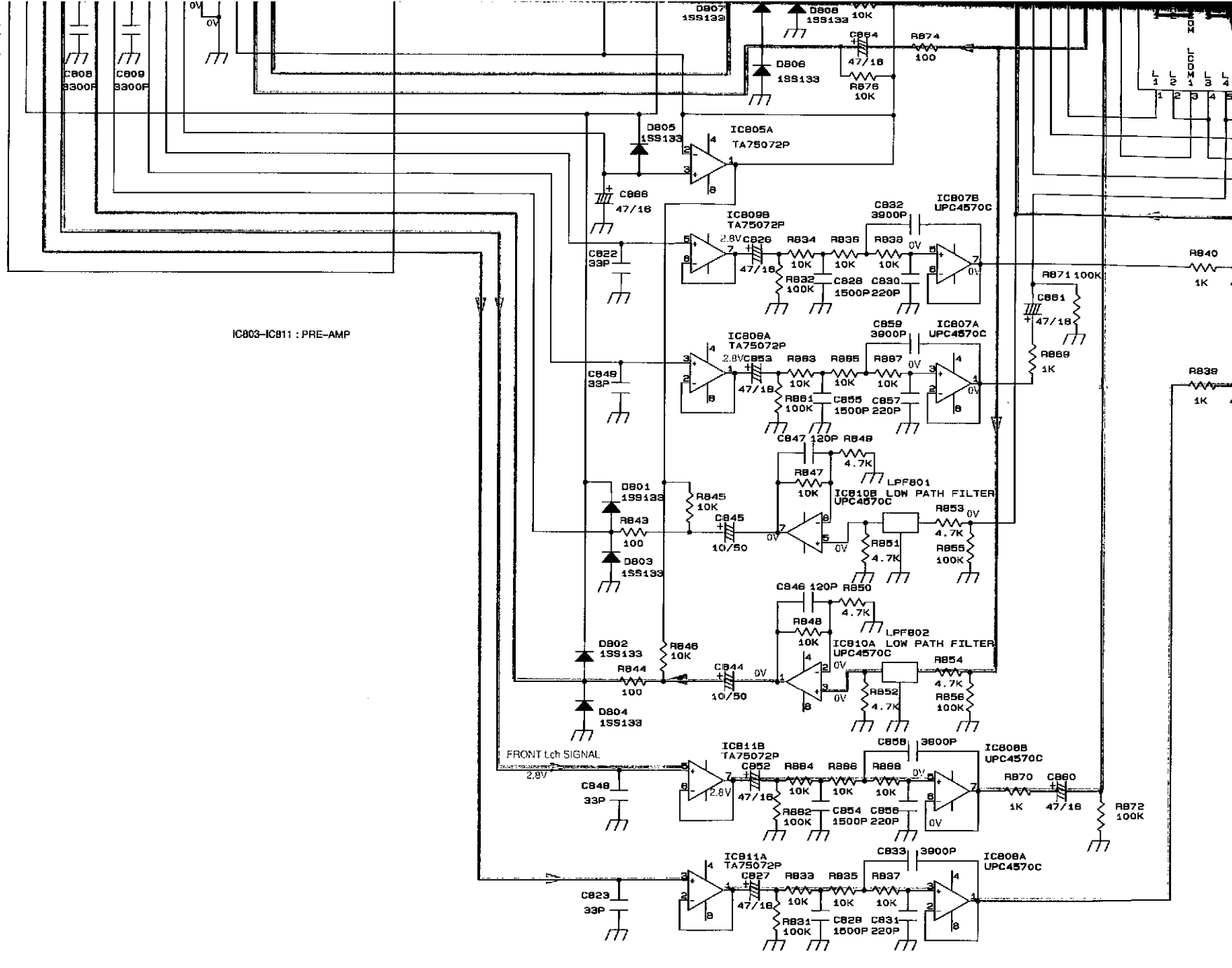
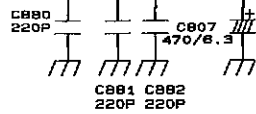

IC803-IC811 : PRE-AMP

FRONT Lch SIGNAL  
2.8V

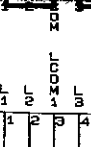

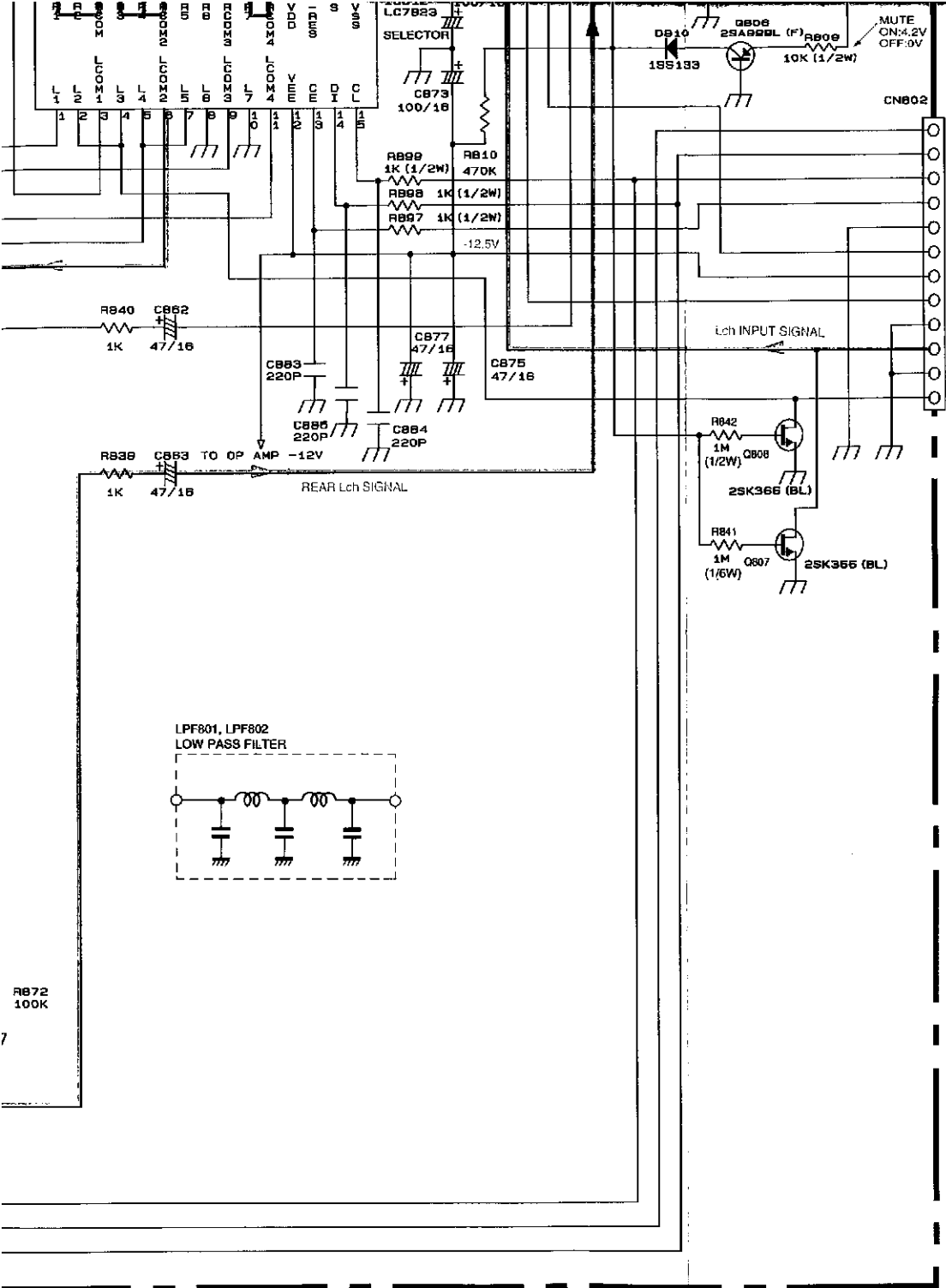

WCK  
CD/DI  
BCK/CL  
CE  
GND  
+5V (DIGITAL)  
-12  
+12  
GND  
L-IN  
GND  
R-IN

Page 46  
SCHEMATIC  
DIAGRAM(11)

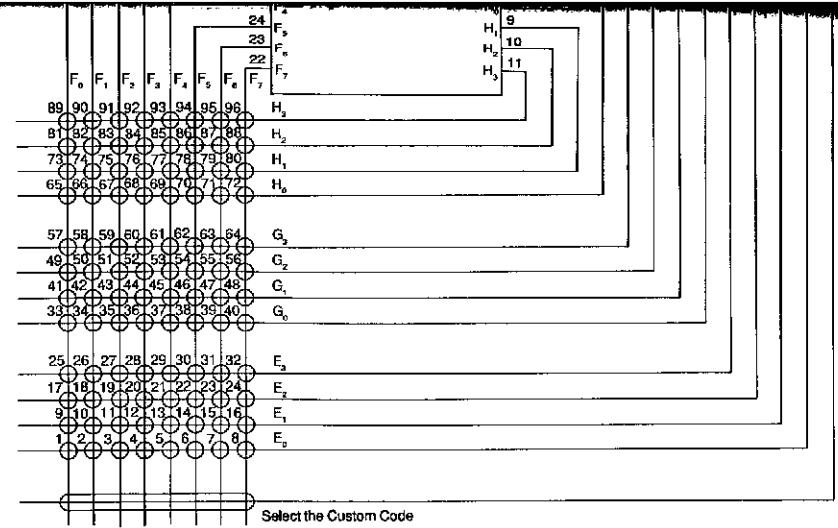

NO.	CATEGORY	KEY NAME	NO.	CATEGORY	KEY NAME
1	AMP	POWER	49	ON SCREEN	▲
2	AMP	TAPE 1	50	ON SCREEN	▼
3	AMP	TAPE 2	51	ON SCREEN	▶
4	AMP	AUX	52	ON SCREEN	◀
5	AMP	CD	53	ON SCREEN	■
6	AMP	TUNER	54	CD	REPEAT
7	AMP	PHONO	55	CD	DISK SKIP
8	AMP	VCR 1	56	CD	F. SEARCH
9	AMP	VCR 2	57	CD	R. SEARCH
10	AMP	VDP	58	CD	PLAY
11	AMP	VCP	59	CD	PAUSE
12	AMP	SAT	60	CD	F. SKIP
13	AMP	TV	61	CD	R. SKIP
14	AMP	LISTEN SIM	62	CASS. DECK	A-REC PAUSE
15	AMP	VR UP	63	CASS. DECK	A-STOP
16	AMP	VR DOWN	64	CASS. DECK	A-FF
17	AMP	R VR UP	65	CASS. DECK	A-REW
18	AMP	R VR DOWN	66	CASS. DECK	A-PLAY. F
19	AMP	AUDIO MUTE	67	CASS. DECK	A-PLAY. R
20	AMP	LOUDNESS	68	CASS. DECK	A-FWD. SKIP
21	AMP	MONO	69	CASS. DECK	A-REV. SKIP
22	TUNER	SHIFT(A/B)	70	AMP	A/V 1
23	TUNER	MEMO 1	71	AMP	A/V 2
24	TUNER	MEMO 2	72	AMP	VIDEO
25	TUNER	MEMO 3	73	AMP	SOURCE
26	TUNER	MEMO 4	74	AMP	C VR UP
27	TUNER	MEMO 5	75	AMP	C VR DOWN
28	TUNER	MEMO 6	76	SURROUND	SURR. MODE. +
29	TUNER	MEMO 7	77	SURROUND	SURR. MODE. -
30	TUNER	MEMO 8	78	SURROUND	A
31	TUNER	FM	79	SURROUND	B
32	TUNER	AM	80	SURROUND	C
33	TUNER	SEEK	81	SURROUND	D
34	TUNER	TUNING UP	82	SURROUND	E
35	TUNER	TUNING DOWN	83	SURROUND	F
36	SURROUND	AUDIODIRECT	84	SURROUND	G
37	SURROUND	PROLOGIC	85	CD	STOP
38	SURROUND	MOVIE	86	CD	A-B
39	SURROUND	SIM.SURR.	87	CD	PROGRAM
40	SURROUND	CLUB	88	CD	CLEAR
41	SURROUND	THEATER	89	CD	TIME
42	SURROUND	HALL	90	CD	DISPLAY
43	SURROUND	STADIUM	91	CD	RANDDM
44	SURROUND	EFF.LEVEL +	92	CD	DISK #1
45	SURROUND	EFF.LEVEL -	93	CD	DISK #2
46	SURROUND	CENTERMODE	94	CD	DISK #3
47	SURROUND	DELAY TIME	95	CD	DISK #4
48	SURROUND	TEST TONE	96	CD	DISK #5

# SCHEMATIC DIAGRAM (11) MAIN AMP/LINE OUT/HEADPHONES/FRONT SPEAKER SELECT

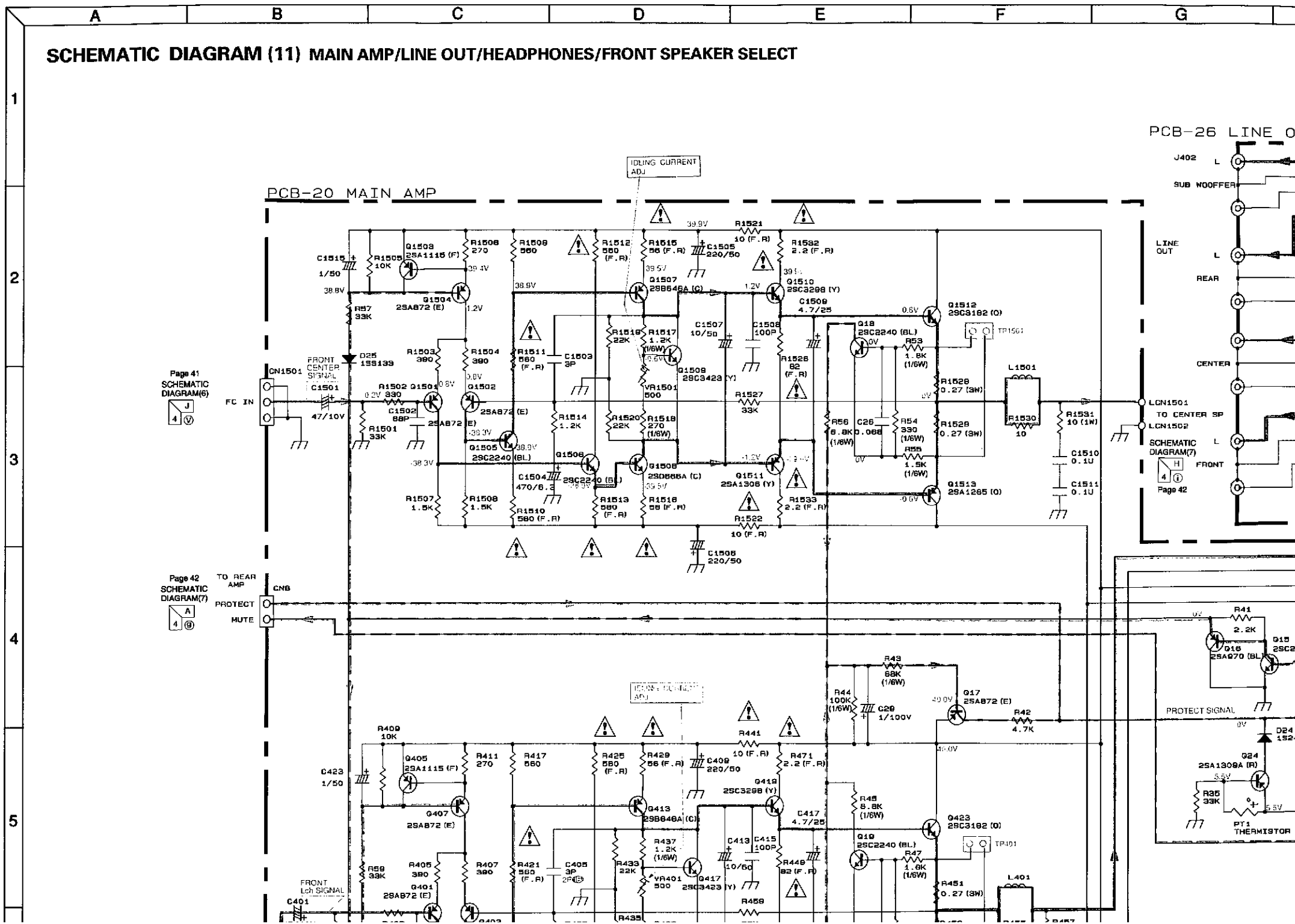

Page 41  
SCHEMATIC  
DIAGRAM(6)

Page 42  
SCHEMATIC  
DIAGRAM(7)

PCB-26 LINE OUT

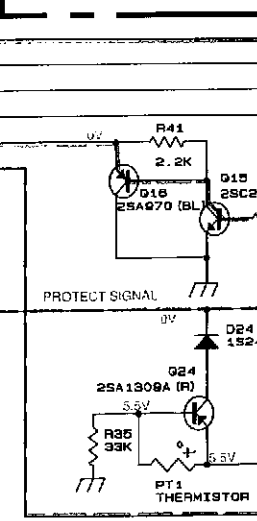
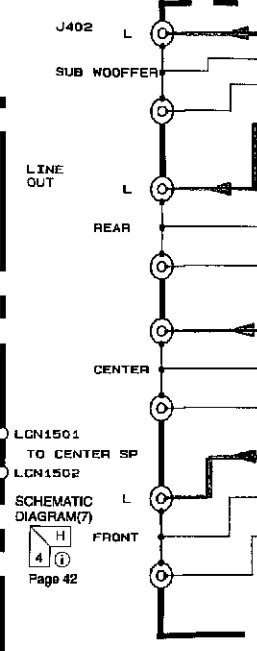

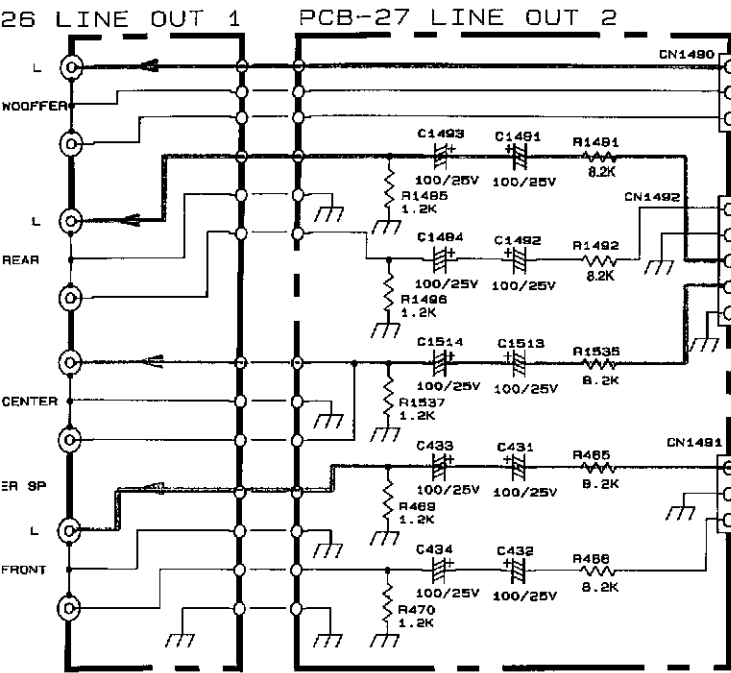

PCB-19 HEADPHONES

FROM TONE SCHEMATIC DIAGRAM(6)

Page 41

FROM REAR/CENTER SP SCHEMATIC DIAGRAM(7)

Page 42

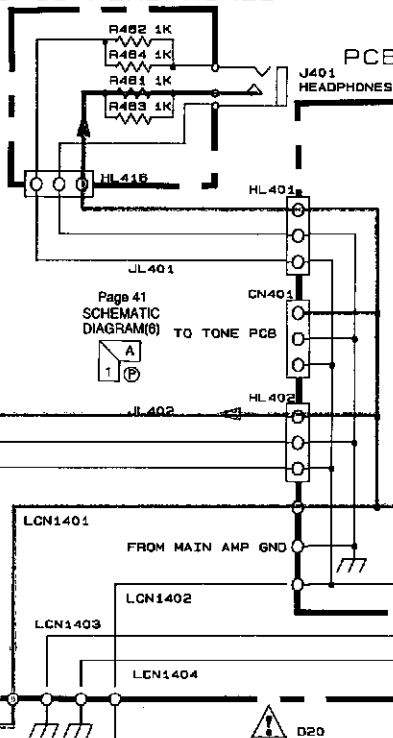

PCB-16 FRONT SPEAKER SELECT

PCB-17 FRONT SPEAKER

S401 SPEAKER

OFF

OFF

OFF

OFF

OFF

OFF

OFF

OFF

OFF

OFF

OFF

OFF

OFF

OFF

OFF

OFF

OFF

OFF

OFF

OFF

OFF

OFF

OFF

OFF

OFF

OFF

OFF

OFF

OFF

OFF

OFF

OFF

OFF

OFF

OFF

OFF

OFF

OFF

OFF

OFF

OFF

OFF

OFF

OFF

OFF

OFF

OFF

OFF

OFF

OFF

OFF

OFF

OFF

OFF

OFF

OFF

OFF

OFF

OFF

OFF

OFF

OFF

OFF

OFF

OFF

OFF

OFF

OFF

OFF

OFF

OFF

OFF

OFF

OFF

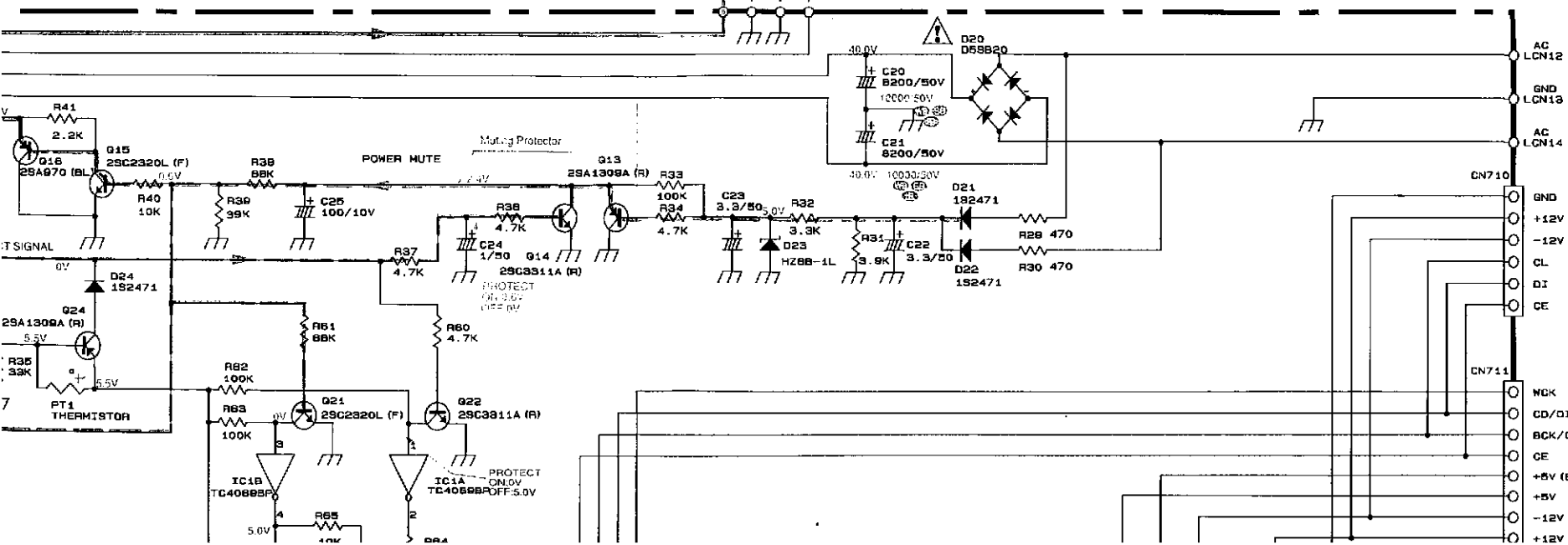

Page 44 SCHEMATIC DIAGRAM(9)

Page 38 SCHEMATIC DIAGRAM(3)

Page 45 SCHEMATIC DIAGRAM(10)

FROM POWER SUPPLY 3

TO VIDEO FUNCTION

TO DISPLAY

6

7

8

9

10

Page 41  
SCHEMATIC  
DIAGRAM(S)  
J  
2

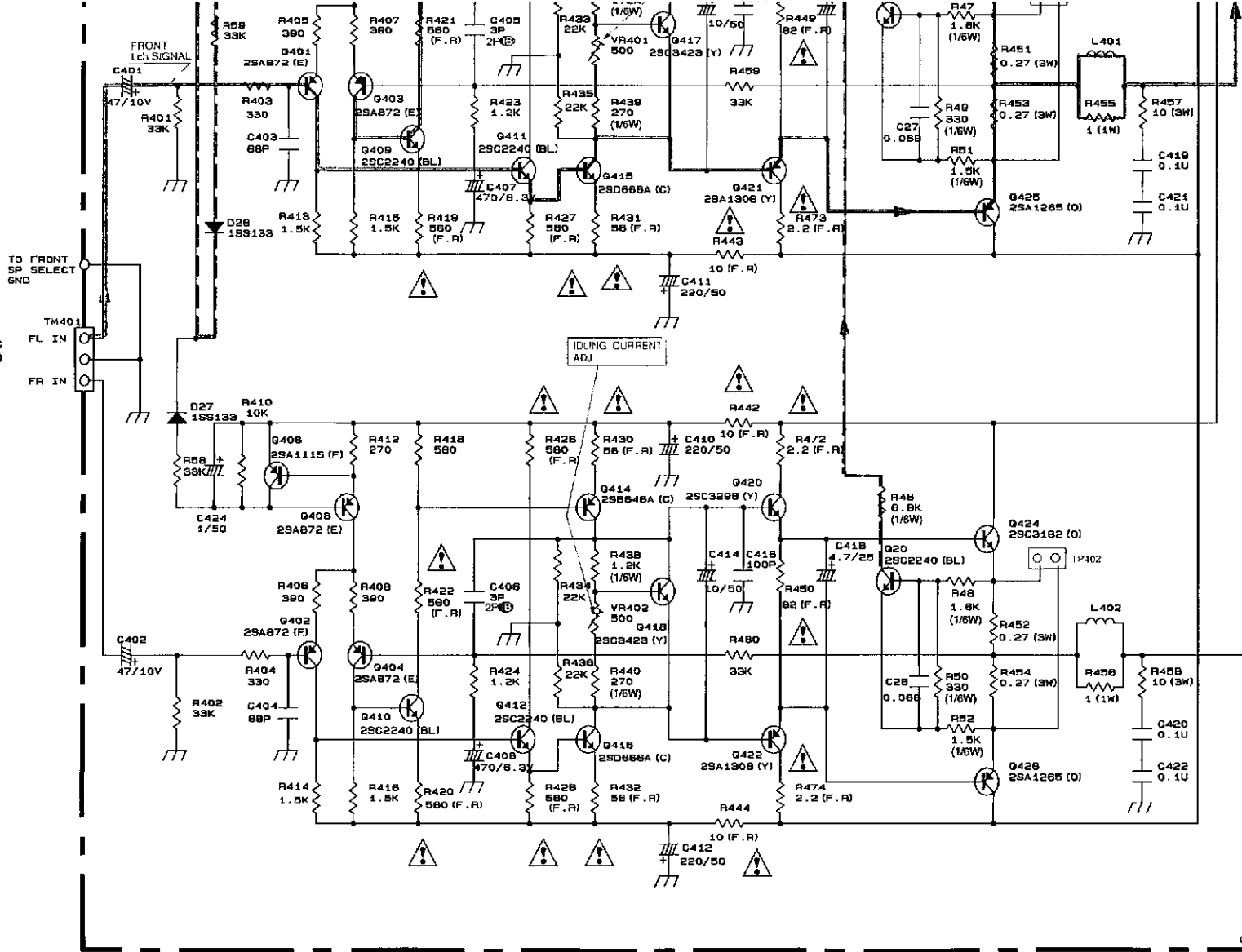

- NOTE:
1. FUNCTION SWITCHES ARE SHOWN IN PHONO POSITION.
  2. ALL RESISTANCES VALUES ARE IN  $\Omega$ .  
 $K\Omega=1000\Omega$ ,  $M\Omega=1000K\Omega$ .
  3. THE WATTAGE OF RESISTORS IS 1/2W UNLESS OTHERWISE NOTED.
  4. ALL CAPACITANCES VALUES ARE IN  $\mu F$  UNLESS OTHERWISE NOTED.  $P=\mu\mu F$
  5. ...V:DC VOLTAGE AT NO SIGNAL UNLESS OTHERWISE NOTED.
  6. SAFETY REQUIREMENTS COMPONENTS IN ACCORDANCE WITH PRESENT SAFETY REGULATIONS. THESE COMPONENTS MUST ONLY BE REPLACED BY ORIGINAL PARTS.

A B C D E F G H I J K L M N O P Q R S T U V W X Y Z 1-100

TO VIDEO/ON SCRE

SCHEMATIC  
DIAGRAM(S)  
J  
2  
Page 43

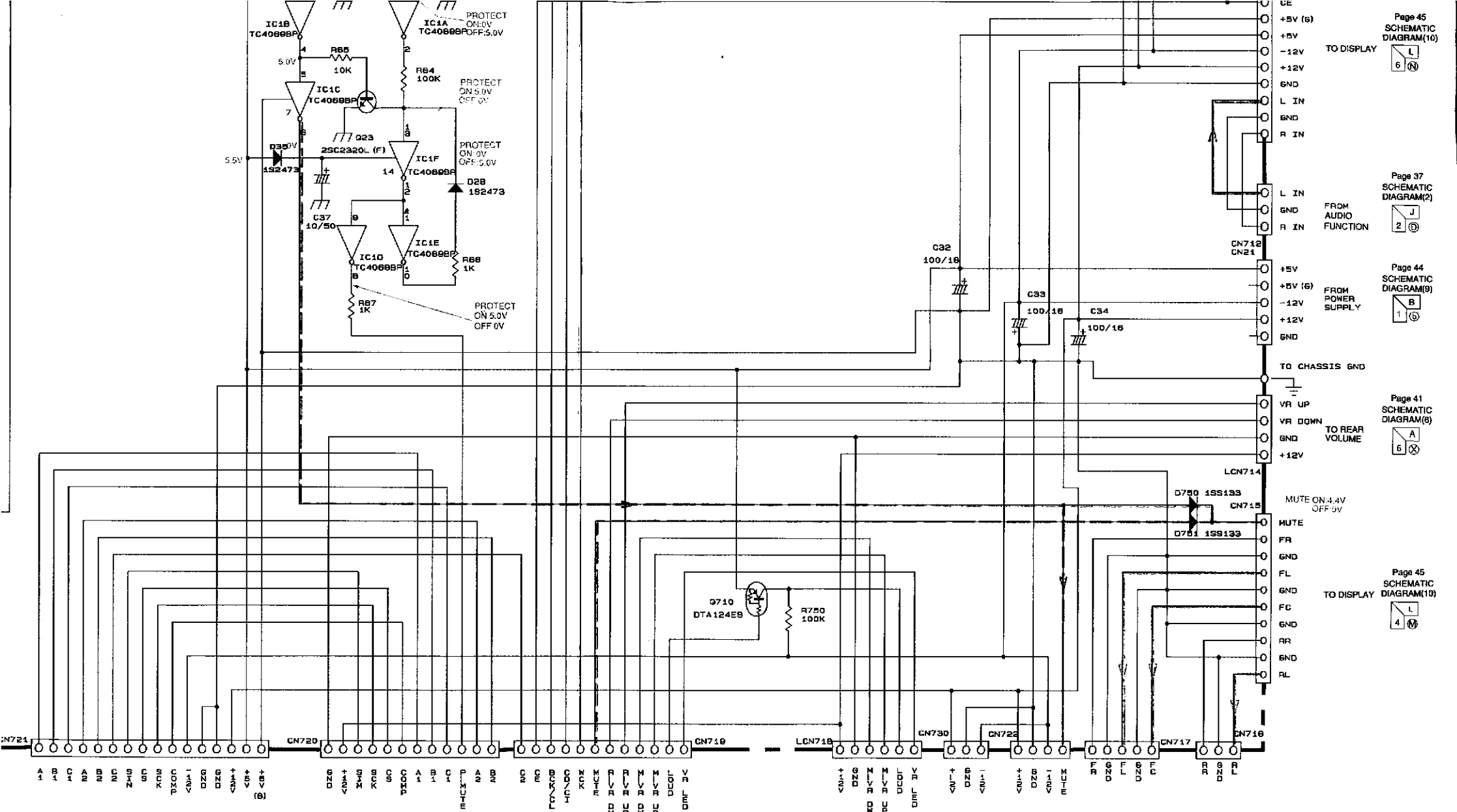

Page 45  
SCHEMATIC  
DIAGRAM(10)

Page 37  
SCHEMATIC  
DIAGRAM(2)

Page 44  
SCHEMATIC  
DIAGRAM(9)

Page 41  
SCHEMATIC  
DIAGRAM(8)

Page 45  
SCHEMATIC  
DIAGRAM(10)

TO VIDEO/ON SCREEN

SCHEMATIC  
DIAGRAM(8)



Page 43

FROM MAIN CONNECTOR

SCHEMATIC  
DIAGRAM(9)



Page 44

FROM MAIN CONNECTOR

SCHEMATIC  
DIAGRAM(9)



Page 44

TO MASTER  
VOLUME

SCHEMATIC  
DIAGRAM(6)



Page 41

TO TONE

SCHEMATIC  
DIAGRAM(6)



Page 41

TO TONE

SCHEMATIC  
DIAGRAM(6)



Page 41

FROM TONE

SCHEMATIC  
DIAGRAM(6)



Page 41

FROM REAR VOLUME

SCHEMATIC  
DIAGRAM(6)



Page 41

**SCHEMATIC DIAGRAM (12) POWER SWITCH/FRONT PANEL/TUNER SWITCH**

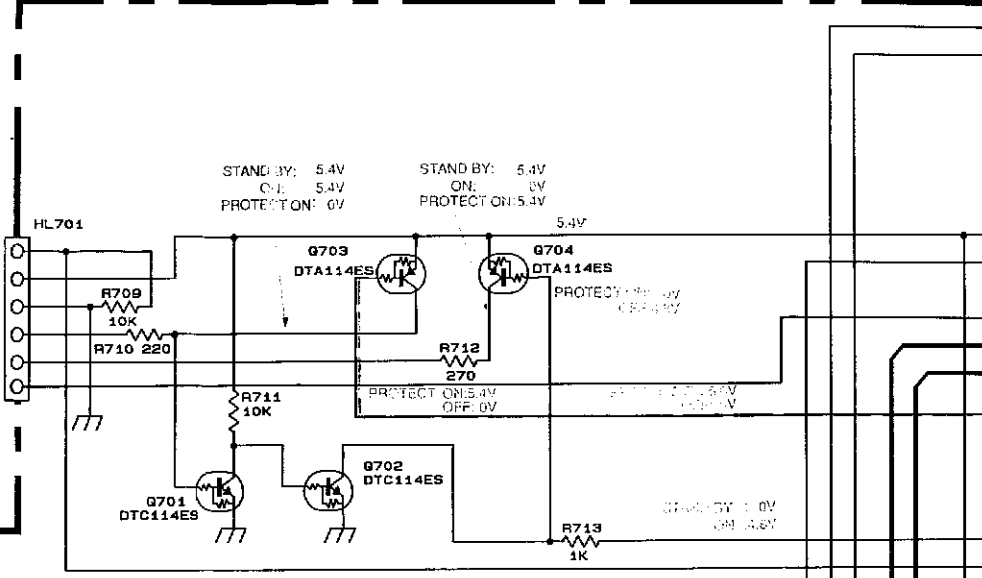
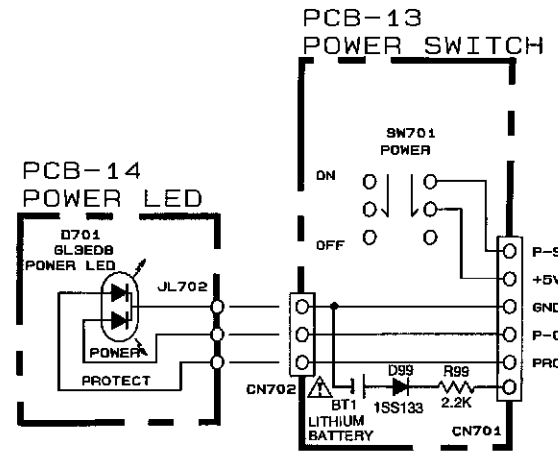

PCB-25 FRONT

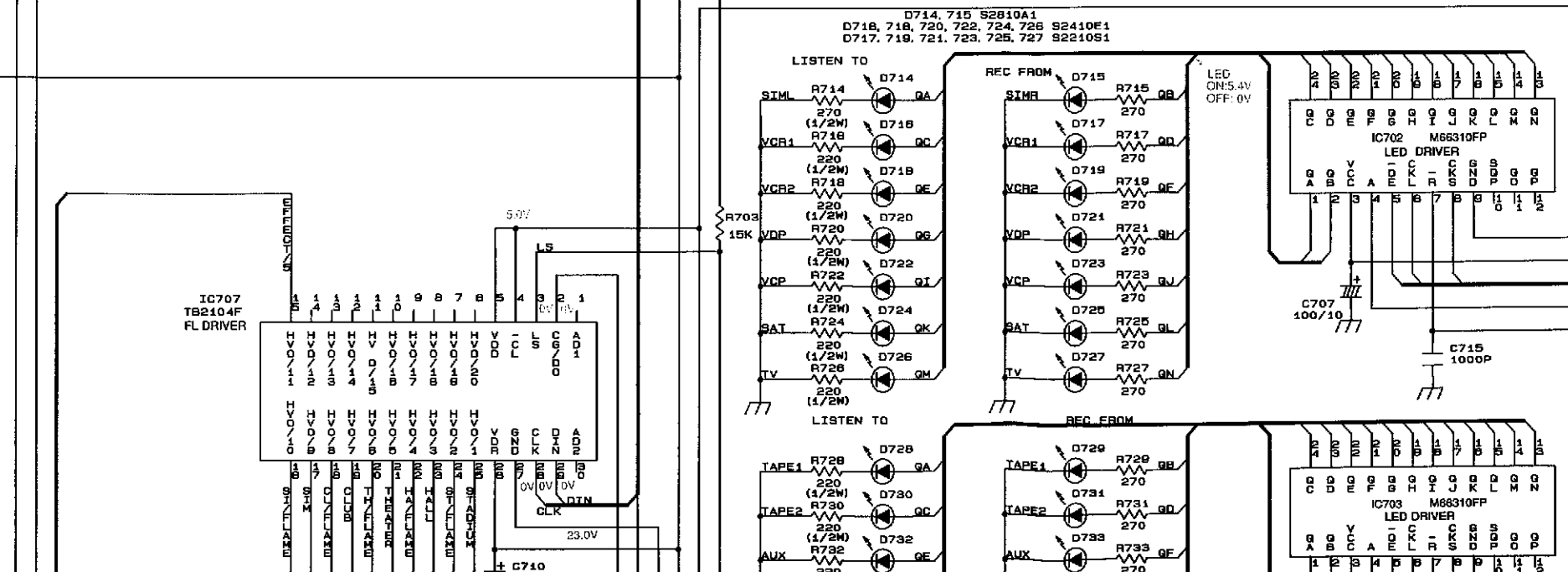

H I J K L M N

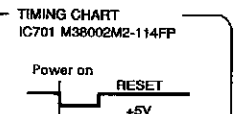
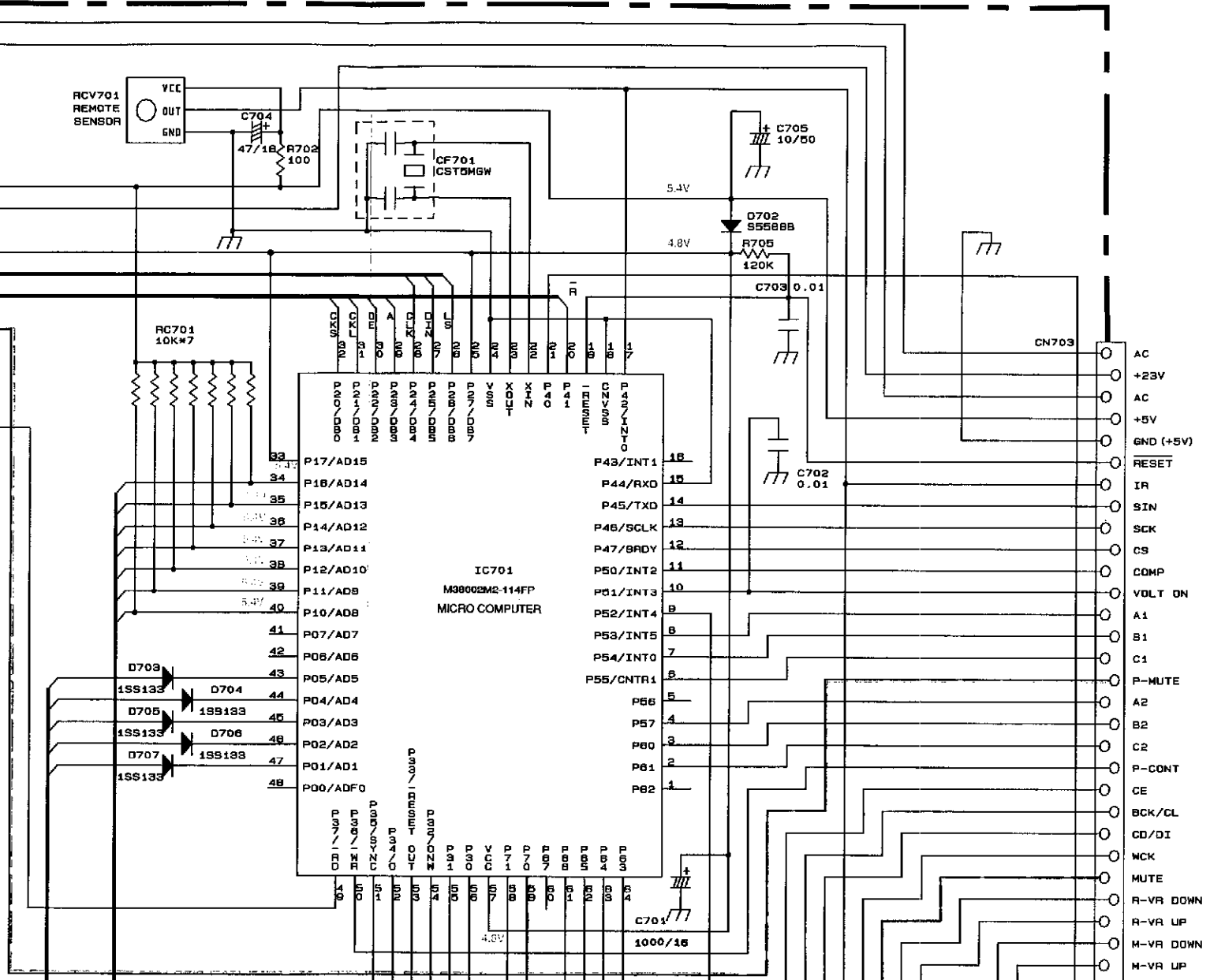

Page 44  
SCHEMATIC  
DIAGRAM(S)





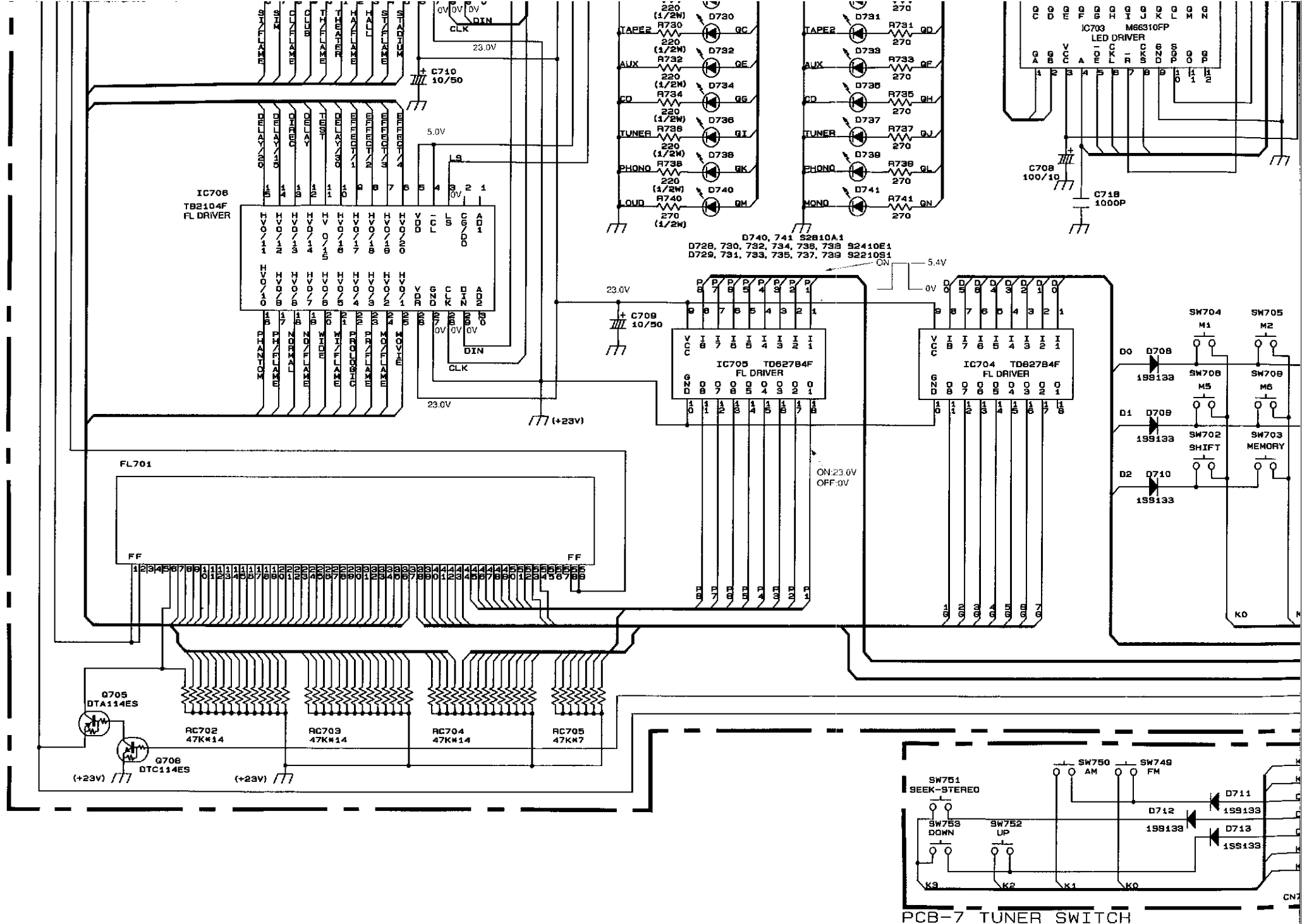

PCB-7 TUNER SWITCH

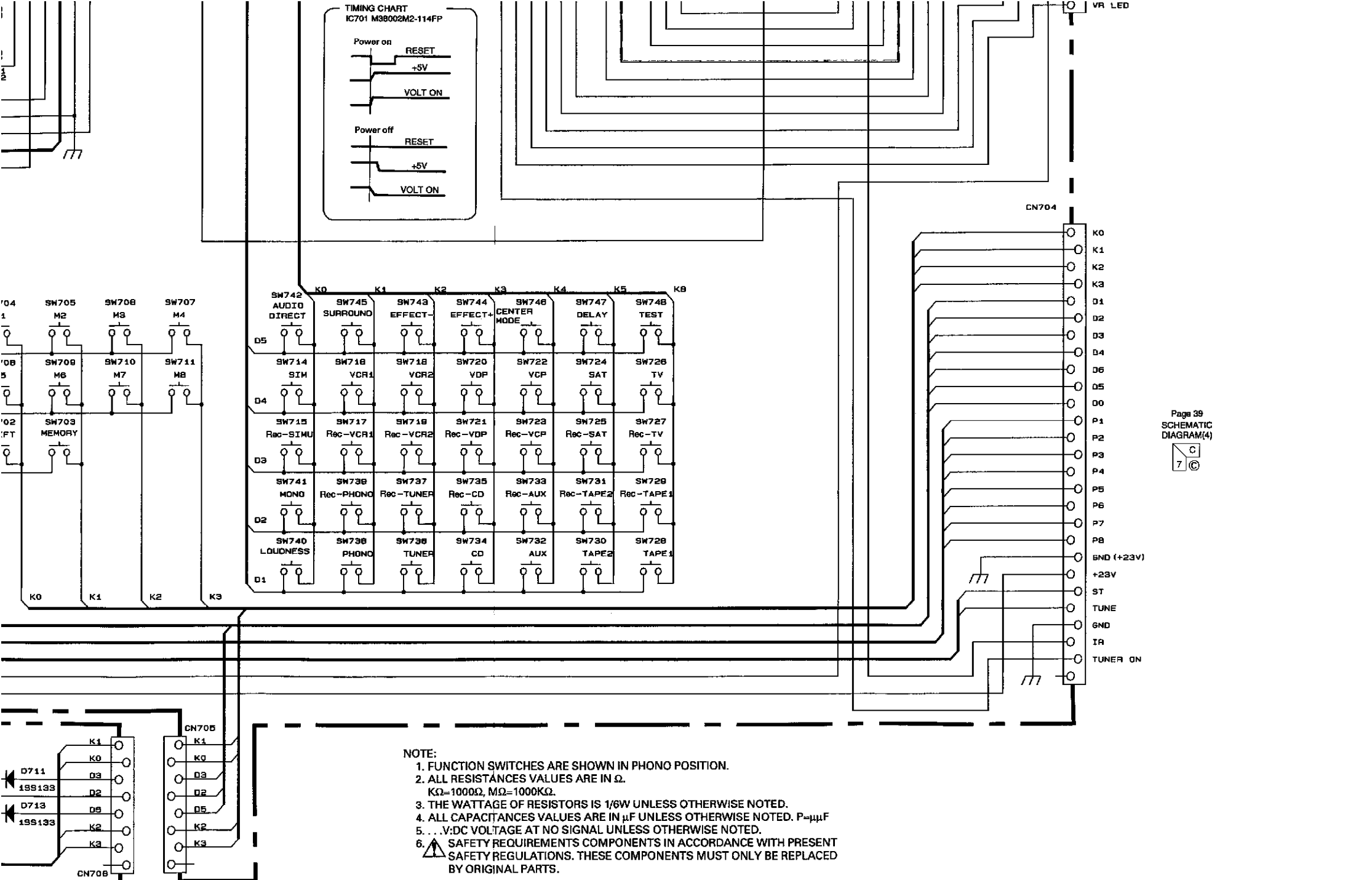

Page 39  
SCHEMATIC  
DIAGRAM(4)

7 ©

# WIRING DIAGRAM

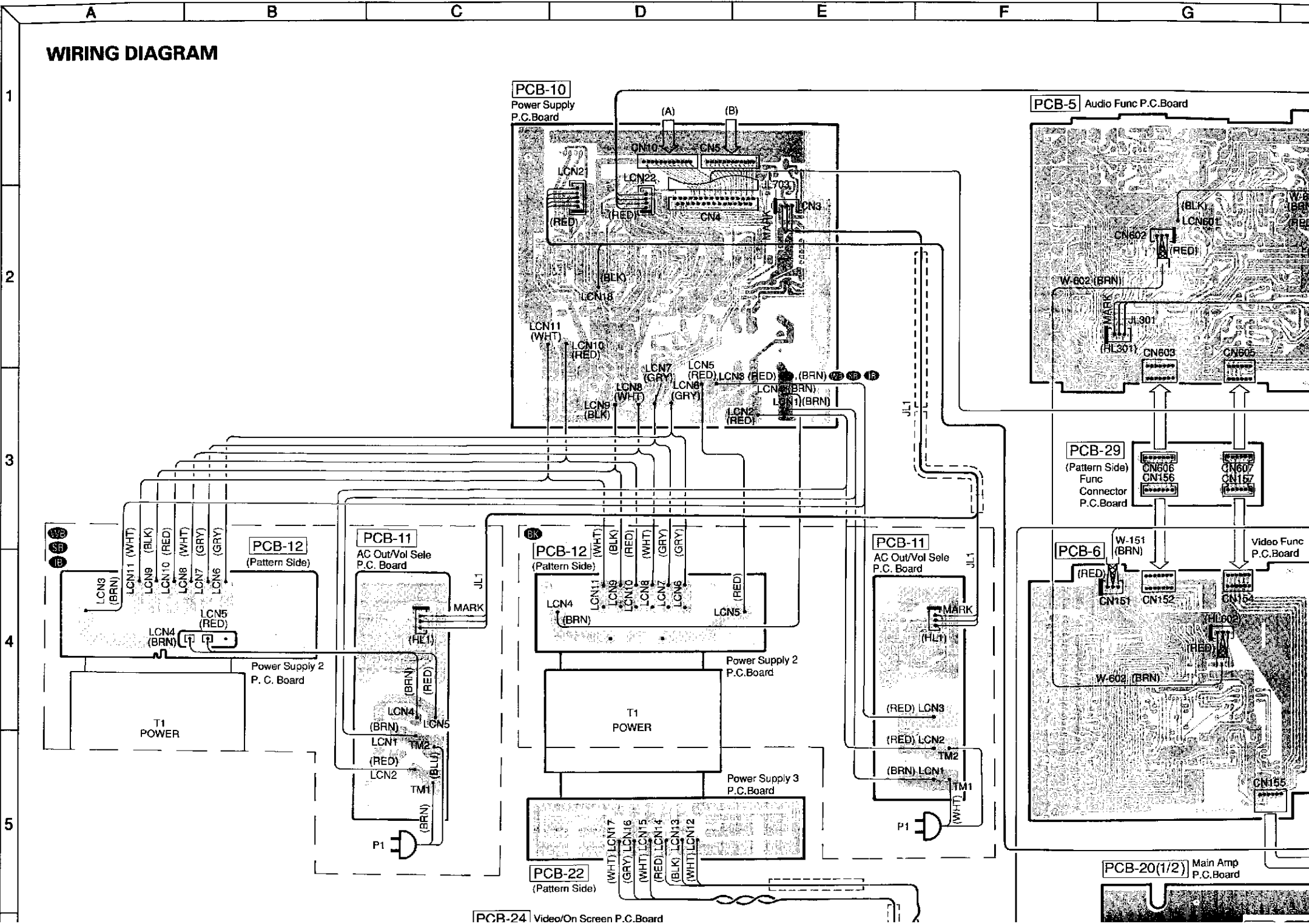

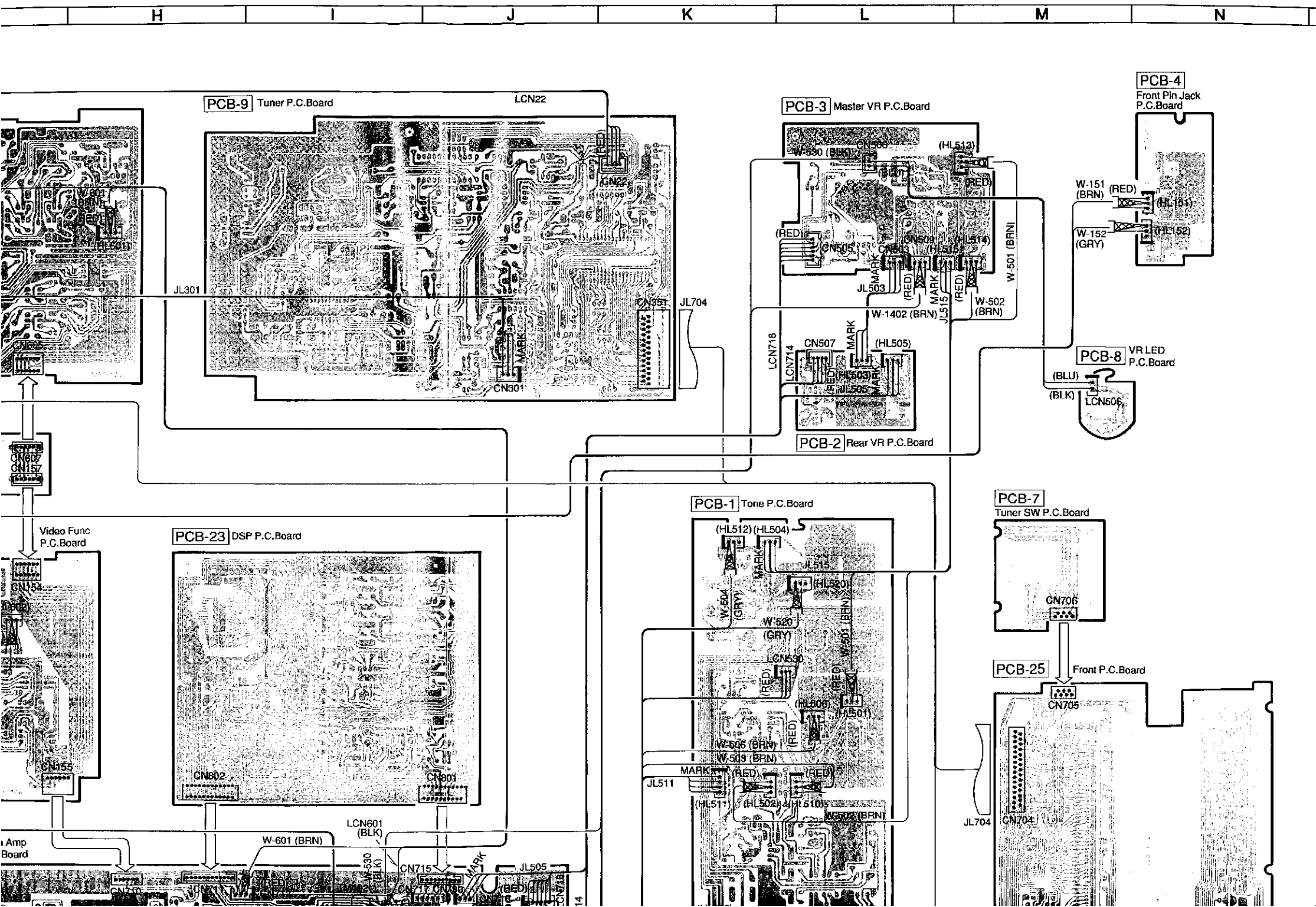

6  
7  
8  
9  
10

PCB-22  
(Pattern Side)

(WHT)  
(GRY)  
(WHT)  
(RED)  
(BLK)  
(WHT)

PCB-20(1/2)  
Main Amp  
P.C.Board

PCB-24  
Video/On Screen P.C.Board

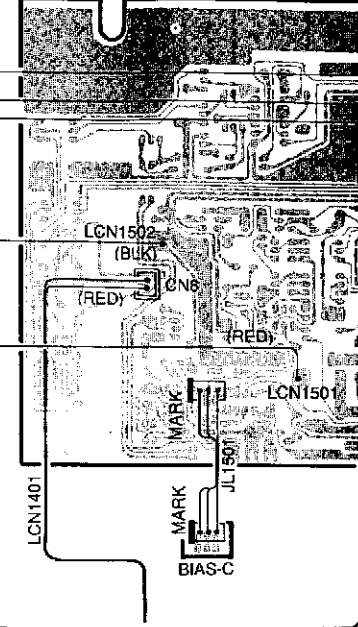
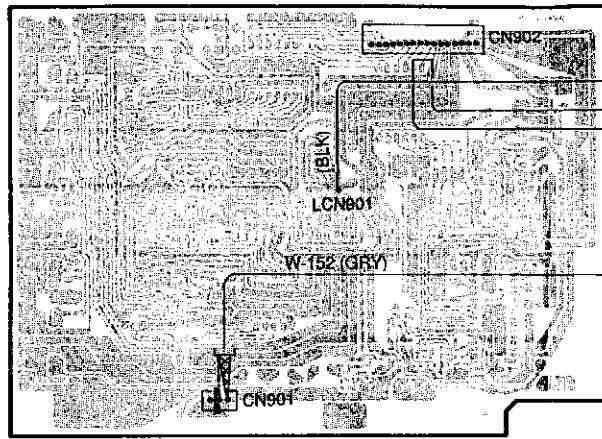

PCB-17  
Front SP P.C.Board

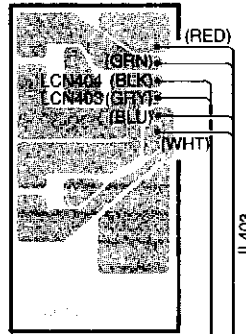

PCB-18  
Rear, Center SP  
P.C.Board

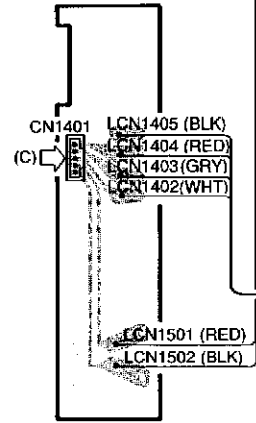

PCB-27  
Line Out 2  
P.C.Board

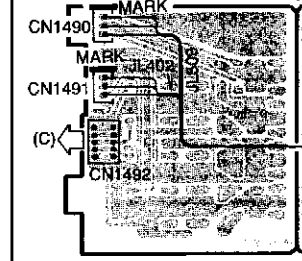

PCB-26  
Line Out 1  
P.C.Board



PCB-20(2/2)  
PCB-21

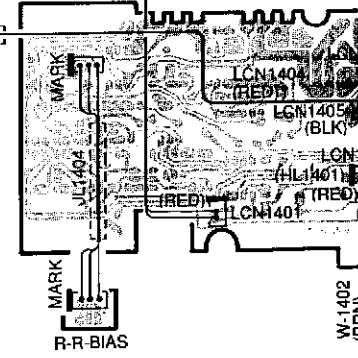

W-1402  
(GRN)

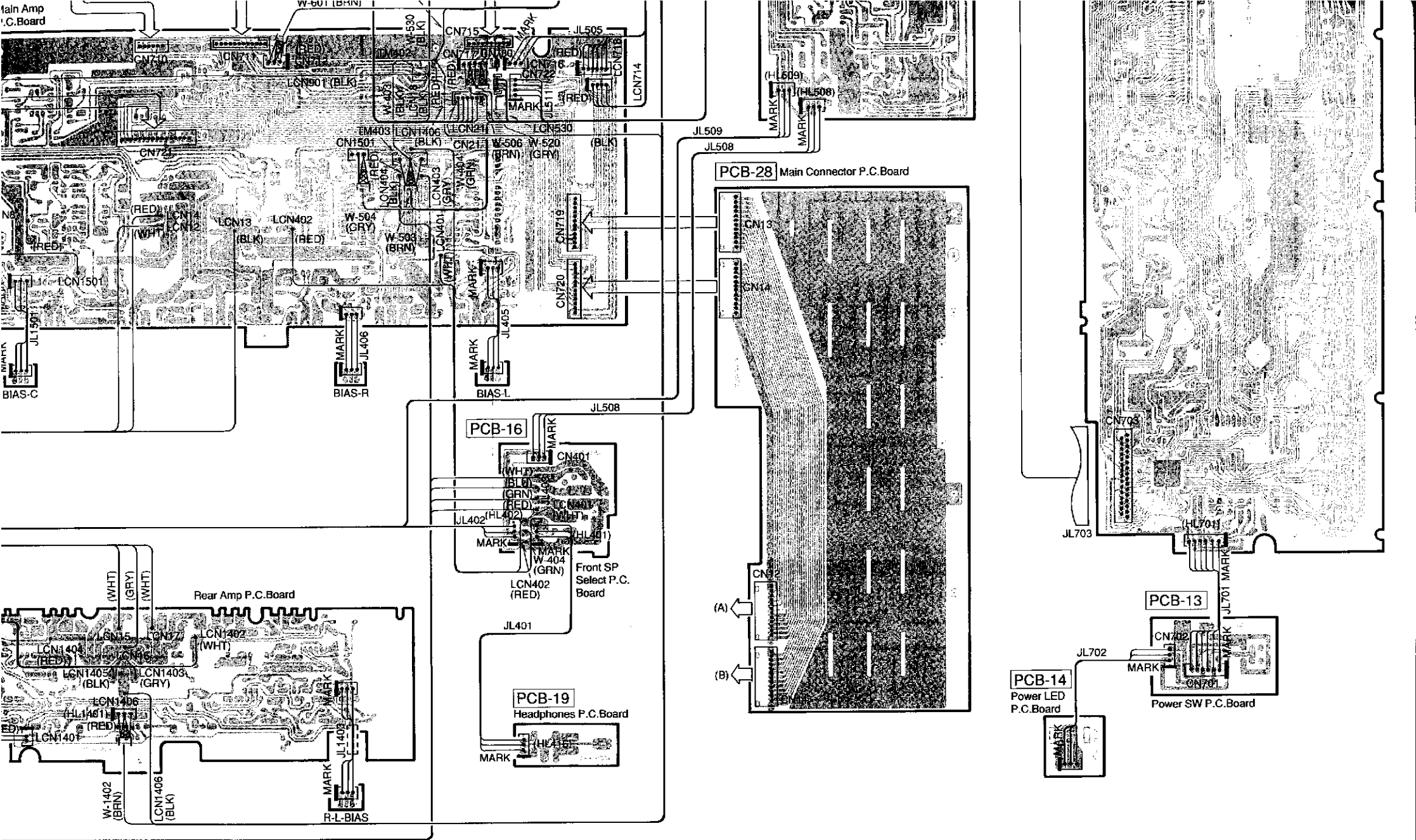

**WIRE COLOR ABBREVIATIONS**

RED : Red	YEL : Yellow
ORG : Orange	PUP : Purple
BLU : Blue	PIK : Pink
WHT : White	BRN : Brown
BLK : Black	