

harman/kardon

AVR330

7 X 55W 7.1 CHANNEL A/V RECEIVER

SERVICE MANUAL



CONTENTS

ESD WARNING.....	2	TECH TIP HKTT2003-01.....	22
LEAKAGE TESTING.....	3	UNIT EXPLODED VIEW.....	23
BASIC SPECIFICATIONS.....	4	BLOCK DIAGRAM.....	24
FRONT PANEL CONTROLS.....	5	AMP BIAS ADJUSTMENT.....	25
REAR PANEL CONNECTIONS.....	7	PCB DRAWINGS.....	27
REMOTE CONTROL FUNCTIONS.....	10	ELECTRICAL PARTS LIST.....	32
TROUBLESHOOTING GUIDE.....	14	SEMICONDUCTOR PINOUTS.....	72
PROCESSOR RESET.....	14	SCHEMATICS.....	113
DISASSEMBLY.....	15	WIRING DIAGRAM.....	129
BULLETIN HK2003-10.....	16	PACKAGING.....	130
TECH TIP HKTT2004-03.....	18		

harman/kardon, Inc.
250 Crossways Park Dr.
Woodbury, New York 11797

Rev3 4/2007

ELECTROSTATICALLY SENSITIVE (ES) DEVICES

Some semiconductor (solid state) devices can be damaged easily by static electricity. Such components commonly are called Electrostatically Sensitive (ES) Devices. Examples of typical ES devices are integrated circuits and some field effect transistors and semiconductor "chip" components.

The following techniques should be used to help reduce the incidence of component damage caused by static electricity.



1. Immediately before handling any semiconductor component or semiconductor-equipped assembly, drain off any electrostatic charge on your body by touching a known earth ground. Alternatively, obtain and wear a commercially available discharging wrist strap device, which should be removed for potential shock reasons prior to applying power to the unit under test.
2. After removing an electrical assembly equipped with ES devices, place the assembly on a conductive surface such as aluminum foil, to prevent electrostatic charge build-up or exposure of the assembly.
3. Use only a grounded-tip soldering iron to solder or unsolder ES devices.
4. Use only an anti-static solder removal device. Some solder removal devices not classified as "anti-static" can generate electrical charges sufficient to damage ES devices.
5. Do not use freon-propelled chemicals. These can generate electrical charge sufficient to damage ES devices.
6. Do not remove a replacement ES device from its protective package until immediately before you are ready to install it. (Most replacement ES devices are packaged with leads electrically shorted together by conductive foam, aluminum foil or comparable conductive material.)
7. Immediately before removing the protective material from the leads of a replacement ES device, touch the protective material to the chassis or circuit assembly into which the device will be installed.

CAUTION : Be sure no power is applied to the chassis or circuit, and observe all other safety precautions.

8. Minimize bodily motions when handling unpackaged replacement ES devices. (Otherwise harmless motion such as the brushing together of your clothes fabric or the lifting of your foot from a carpeted floor can generate static electricity sufficient to damage an ES devices.

PRODUCT SAFETY NOTICE

Each precaution in this manual should be followed during servicing.

Components identified with the IEC symbol  in the parts list are special significance to safety. When replacing a component identified with , use only the replacement parts designated, or parts with the same ratings or resistance, wattage, or voltage that are designated in the parts list in this manual. Leakage-current or resistance measurements must be made to determine that exposed parts are acceptably insulated from the supply circuit before returning the product to the customer.

SAFETY PRECAUTIONS

The following check should be performed for the continued protection of the customer and service technician.

LEAKAGE CURRENT CHECK

Measure leakage current to a known earth ground (water pipe, conduit, etc.) by connecting a leakage current tester between the earth ground and all exposed metal parts of the appliance (input/output terminals, screwheads, metal overlays, control shaft, etc.). Plug the AC line cord of the appliance directly into a 120V AC 60Hz outlet and turn the AC power switch on. Any current measured must not exceed 0.5mA.

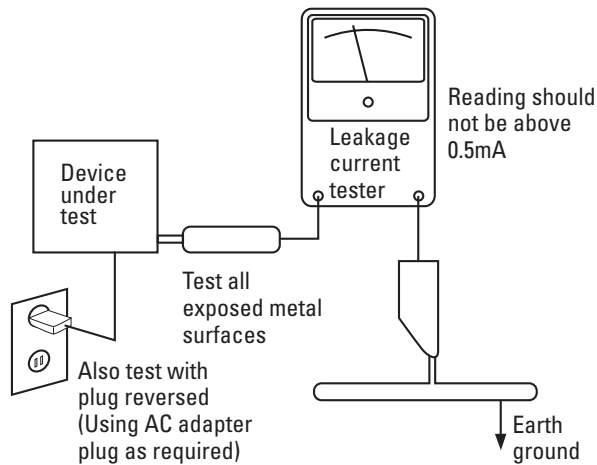

AC Leakage Test

ANY MEASUREMENTS NOT WITHIN THE LIMITS OUTLINED ABOVE ARE INDICATIVE OF A POTENTIAL SHOCK HAZARD AND MUST BE CORRECTED BEFORE RETURNING THE APPLIANCE TO THE CUSTOMER.

AVR 330 TECHNICAL SPECIFICATIONS

Audio Section

Stereo Mode	
Continuous Average Power (FTC)	
65 Watts per channel, 20Hz–20kHz, @ <0.07% THD, both channels driven into 8 ohms	
Seven-Channel Surround Modes	
Power per Individual Channel	
Front L&R channels:	
55 Watts per channel @ <0.07% THD, 20Hz–20kHz into 8 ohms	
Center channel:	
55 Watts @ <0.07% THD, 20Hz–20kHz into 8 ohms	
Surround (L & R side, L & R back) channels:	
55 Watts per channel @ <0.07% THD, 20Hz–20kHz into 8 ohms	
Input Sensitivity/Impedance	
Linear (High-Level)	200mV/47k ohms
Signal-to-Noise Ratio (IHF-A)	100dB
Surround System Adjacent Channel Separation	
Pro Logic I/II	40dB
Dolby Digital (AC-3)	55dB
DTS	55dB
Frequency Response	
@ 1W (+0dB, –3dB)	10Hz – 130kHz
High Instantaneous	
Current Capability (HCC)	±35 Amps
Transient Intermodulation	
Distortion (TIM)	Unmeasurable
Slew Rate	40V/μsec

FM Tuner Section

Frequency Range	87.5–108.0MHz
Usable Sensitivity	IHF 1.3μV/13.2dB
Signal-to-Noise Ratio	Mono/Stereo 70/68dB
Distortion	Mono/Stereo 0.2/0.3%
Stereo Separation	40dB @ 1kHz
Selectivity	±400kHz, 70dB
Image Rejection	80dB
IF Rejection	90dB

AM Tuner Section

Frequency Range	330–1710kHz
Signal-to-Noise Ratio	45dB
Usable Sensitivity	Loop 500μV
Distortion	1kHz, 50% Mod 0.8%
Selectivity	±10kHz, 30dB

Video Section

Television Format	NTSC
Input Level/Impedance	1Vp-p/75 ohms
Output Level/Impedance	1Vp-p/75 ohms
Video Frequency Response (Composite and S-Video)	10Hz–8MHz (–3dB)
Video Frequency Response (Component Video)	10Hz–30MHz (–3dB)

General

Power Requirement	AC 120V/60Hz	
Power Consumption	118W idle, 890W maximum (7 channels driven)	
Dimensions		
	(Product)	(Shipping)
Width	17.3 inches (440mm)	21.5 inches (545mm)
Height	6.6 inches (168mm)	9.9 inches (251mm)
Depth	15 inches (381mm)	17.9 inches (455mm)
Weight		
	(Product)	(Shipping)
	30.6 lb (13.9kg)	35.2 lb (16kg)

Depth measurement includes knobs, buttons and terminal connections.

Height measurement includes feet and chassis.

All features and specifications are subject to change without notice.

Harman Kardon and Power for the Digital Revolution are registered trademarks of Harman International Industries, Incorporated.

|||||EzSet™ is a trademark of Harman International Industries, Incorporated (patent no. 5,386,478).

*Manufactured under license from Dolby Laboratories. "Dolby," "Pro Logic" and the Double-D symbol are trademarks of Dolby Laboratories.

DTS, DTS Surround, DTS-ES and DTS Neo:6 are registered trademarks of Digital Theater Systems, Inc.

VMAx is a registered trademark of Harman International Industries, Incorporated, and is an implementation of Cooper Bauck Transaural Stereo under patent license.

Logic 7 is a registered trademark of Harman International Industries, Incorporated.

FRONT-PANEL CONTROLS

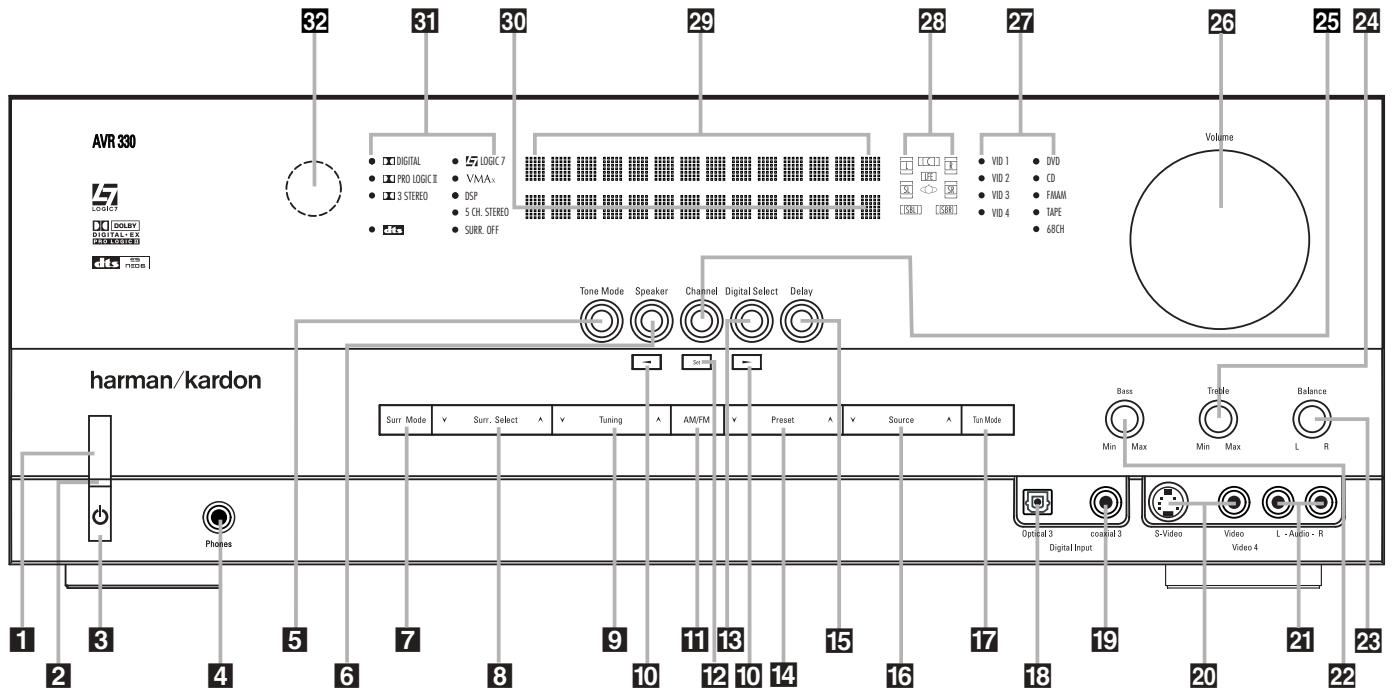

- | | | |
|---------------------------------------|-------------------------------------|--|
| 1 Main Power Switch | 12 Set Button | 23 Balance Control |
| 2 Power Indicator | 13 Digital Input Selector | 24 Treble Control |
| 3 Standby/On Switch | 14 Preset Station Selector | 25 Channel Adjust Selector |
| 4 Headphone Jack | 15 Delay Adjust Selector | 26 Volume Control |
| 5 Tone Mode | 16 Input Source Selector | 27 Input Indicators |
| 6 Speaker Selector | 17 Tuner Mode Selector | 28 Speaker/Channel Input Indicators |
| 7 Surround Mode Group Selector | 18 Optical 3 Digital Input | 29 Upper Display Line |
| 8 Surround Mode Selector | 19 Coaxial 3 Digital Input | 30 Lower Display Line |
| 9 Tuning Selector | 20 Video 4 Video Input Jacks | 31 Surround Mode Indicators |
| 10 ◀▶ Buttons | 21 Video 4 Audio Input Jacks | 32 Remote Sensor Window |
| 11 Tuner Band Selector | 22 Bass Control | |

NOTE: To make it easier to follow the instructions that refer to this illustration, a larger copy may be downloaded from the Product Support section for this product at www.harmankardon.com.

1 Main Power Switch: Press this button to apply power to the AVR 330. When the switch is pressed in, the unit is in a Standby mode, as indicated by the amber LED **2** above the **Standby/On Switch 3**. This button **MUST** be pressed in to operate the unit. To turn the unit off and prevent the use of the remote control, this switch should be pressed until it pops out from the front panel and the word "OFF" is seen at the top of the switch.

NOTE: This switch is normally left in the "ON" position.

2 Power Indicator: This LED lights amber when the unit is in the Standby mode to signal that the AVR is ready to be turned on. When the unit is in operation, the indicator is blue.

3 Standby/On Switch: When the **Main Power Switch 1** is "ON," press this button to turn on the

AVR 330; press it again to turn the unit off. The **Power Indicator 2** turns blue when the unit is on.

4 Headphone Jack: This jack may be used to listen to the AVR 330's output through a pair of headphones. The speakers will automatically be turned off when the headphone jack is in use.

5 Tone Mode: Pressing this button enables or disables the Bass and Treble tone controls. When the button is pressed so that **TONE IN** appears in the **Lower Display Line 30**, the **Bass 22** and **Treble 24** controls may be used to adjust the output signals. When the button is pressed once or twice so that the words **TONE OUT** appear in the **Lower Display Line 30**, the output signal will be "flat," no matter how the actual **Bass** and **Treble Controls 22/24** are adjusted.

6 Speaker Select Button: Press this button to begin the process of configuring the unit to match the

type of speakers used in your listening room. (See pages 17 and 20–22 for more information on speaker setup and configuration.)

7 Surround Mode Group Selector: Press this button to select the top-level group of surround modes. Each press of the button will select the current or last used mode in each of the surround mode groups (e.g., Dolby, DTS, DTS Neo:6, Logic 7, DSP, Stereo). When the button is pressed so that the name of the desired surround mode group appears in the on-screen display and in the **Lower Display Line 30**, press the **Surround Mode Selector 8** to cycle through the individual modes available. For example, press this button to select Dolby modes, and then press the **Surround Mode Selector 8** to choose from the various mode options.

8 Surround Mode Selector: Press this button to select from among the available surround mode

FRONT - PANEL CONTROLS

options for the mode group selected. The specific modes will vary based on the number of speakers available, the mode group and if the input source is digital or analog. For example, press the **Surround Mode Group Selector 7** to select a mode grouping such as Dolby or Logic 7, and then press this button to see the specific mode choices available. For more information on mode selection, see page 26.

9 Tuning Selector: Press the left side of the button to tune lower-frequency stations and the right side of the button to tune higher-frequency stations. When the tuner is in the Manual mode, each tap will increase or decrease the frequency by one increment. When the tuner receives a strong enough signal for adequate reception, **MANUAL TUNED** will appear in the on-screen display and the **Lower Display Line 30**. When the tuner is in the Auto mode, press the button once, and the tuner will scan for a station with acceptable signal strength. When the next station with a strong signal is tuned the scan will stop and the on-screen display and the **Lower Display Line 30** will indicate **AUTO TUNED**. When an FM Stereo station is tuned, the display will read **AUTO ST TUNED**.

To switch back and forth between the Auto and Manual tuning modes, press the **Tuning Mode Selector 17**.

10 ◀▶ Buttons: When configuring the AVR 330's settings, use these buttons to select from the available choices.

11 AM/FM Selector: Press this button to turn the AVR on and to select the Tuner as the input source. Press it again to switch between the AM and FM frequency bands. (See page 29 for more information on the tuner.)

12 Set Button: When making choices during the setup and configuration process, press this button to enter the desired setting into the AVR 330's memory.

13 Digital Input Selector: Press this button to select one of the digital inputs or the analog input for any source. (See pages 26–29 for more information on digital audio.)

14 Preset Station Selector: Press this button to scroll up or down through the list of stations that have been entered into the preset memory. (See page 29 for more information on tuner presets.)

15 Delay Adjust Selector: Press this button to begin the steps required to enter delay settings. (See page 22 for more information on delay times.)

16 Input Source Selector: Press this button to change the input by scrolling up or down through the list of **Input Indicators 27**.

17 Tuner Mode Selector: Press this button to select Auto or Manual tuning. When the button is pressed so that **AUTO** appears in the **Lower Display Line 30**, the tuner will search for the next station with an acceptable signal when the **Tuning Selector 9 21** is pressed. When the button is pressed so that **MANUAL** appears in the **Lower Display Line 30**, each press of the **Tuning Selector 9 21** will increase the frequency. This button may also be used to switch between Stereo and Mono modes for FM radio reception. When weak reception is encountered, press the button so that **MANUAL** appears in the **Lower Display Line 30** and on the on-screen display to switch to Mono reception. Press it again to switch back to Stereo mode. (See page 29 for more information on using the tuner.)

18 Optical 3 Digital Input: Connect the optical digital audio output of an audio or video product to this jack. When the input is not in use, be certain to keep the plastic cap installed to avoid dust contamination that might degrade future performance.

19 Coaxial 3 Digital Input: This jack is used for connection to the output of portable audio devices, video game consoles or other products that have a coax digital audio jack.

20 Video 4 Video Input Jacks: These jacks may be used for temporary connection to the composite or S-Video output of video games, camcorders or other portable video products. You may make a connection to either jack at any time, but not to both simultaneously.

21 Video 4 Audio Input Jacks: These audio jacks may be used for temporary connection to video games or portable audio/video products such as camcorders and portable audio players.

22 Bass Control: Turn this control to modify the low-frequency output of the left/right channels by as much as ± 10 dB.

23 Balance Control: Turn this control to change the relative volume for the front left/right channels.

NOTE: For proper operation of the surround modes this control should be at the midpoint or "12 o'clock" position.

24 Treble Control: Turn this control to modify the high frequency output of the left/right channels by as much as ± 10 dB.

25 Channel Adjust Selector: Press this button to begin the process of trimming the channel output levels using an external audio source. (For more information on output level trim adjustment, see page 30.)

26 Volume Control: Turn this knob clockwise to increase the volume, counterclockwise to decrease the volume. If the AVR 330 is muted, adjusting the **Volume Control 26 38** will automatically release the unit from the silenced condition.

27 Input Indicators: The current selected source will appear as one of these indicators. Note that when the unit is turned on, the entire list of available modes will light briefly, and then revert to normal operation with only the active mode indicator illuminated.

28 Speaker/Channel Input Indicators: These indicators are multipurpose, indicating both the speaker type selected for each channel and the incoming data-signal configuration. The left, center, right, right surround and left surround speaker indicators are composed of three boxes, while the subwoofer is a single box. The center box lights when a "small" speaker is selected, and the two outer boxes light when "large" speakers are selected. When none of the boxes are lit for the center, surround or subwoofer channels, no speaker has been assigned that position. (See page 20 for more information on configuring speakers.) The letters inside each box displays the active input channels. For standard analog inputs, only the L and R will light, indicating a stereo input. For a digital source, the indicators will light to display the channels being received at the digital input. When the letters flash, the digital input has been interrupted. (See page 28 for more information on the Channel Indicators.)

29 Upper Display Line: Depending on the unit's status, a variety of messages will appear here. In normal operation, this line will show the current input source and which analog or digital input is in use. When the tuner is the input, this line will identify the station as AM or FM and show the frequency and preset number, if any.

30 Lower Display Line: Depending on the unit's status, a variety of messages will appear here. In normal operation, the current surround mode will show here.

31 Surround Mode Indicators: The current selected surround mode will appear as one of these indicators. Note that when the unit is turned on, the entire list of available modes will light briefly, and then revert to normal operation with only the active mode indicator illuminated.

32 Remote Sensor Window: The sensor behind this window receives infrared signals from the remote control. Aim the remote at this area and do not block or cover it.

REAR-PANEL CONNECTIONS

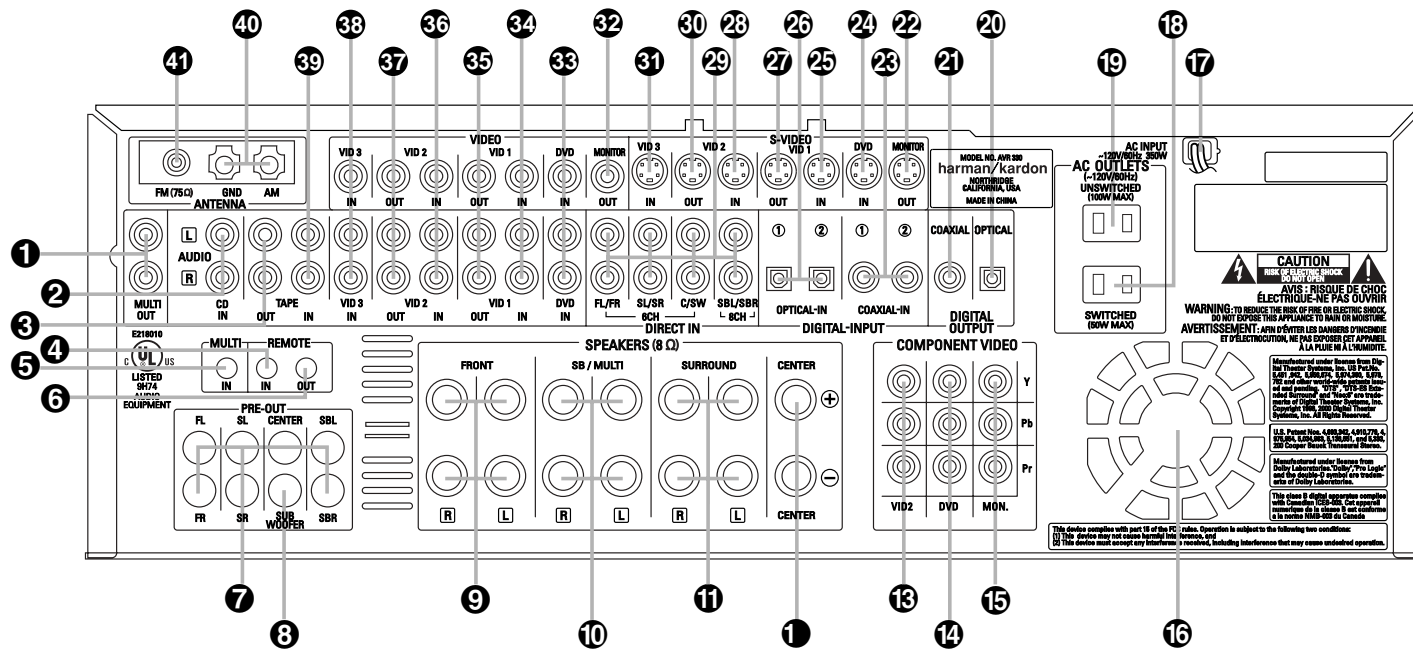

- 1 Multiroom Audio Outputs
- 2 CD Audio Inputs
- 3 Tape Outputs
- 4 Remote IR Input
- 5 Multiroom IR Input
- 6 Remote IR Output
- 7 Preamp Outputs
- 8 Subwoofer Output
- 9 Front Speaker Outputs
- 10 Surround Back/Multiroom Speaker Outputs
- 11 Surround Speaker Outputs
- 1 Center Speaker Output
- 13 Video 2 Component Video Inputs
- 14 DVD Component Video Inputs
- 15 Component Video Monitor Outputs
- 16 Fan Vents
- 17 AC Power Cord
- 18 Switched AC Accessory Outlet
- 19 Unswitched AC Accessory Outlet
- 20 Optical Digital Audio Output
- 21 Coaxial Digital Audio Output
- 22 S-Video Monitor Output
- 23 Coaxial Digital Audio Inputs
- 24 DVD S-Video Input
- 25 Video 1 S-Video Input
- 26 Optical Digital Audio Inputs
- 27 Video 1 S-Video Output
- 28 Video 2 S-Video Input
- 29 6/8-Channel Direct Inputs
- 30 Video 2 S-Video Output
- 31 Video 3 S-Video Input
- 32 Video Monitor Output
- 33 DVD Audio/Video Inputs
- 34 Video 1 Audio/Video Inputs
- 35 Video 1 Audio/Video Outputs
- 36 Video 2 Audio/Video Inputs
- 37 Video 2 Audio/Video Outputs
- 38 Video 3 Audio/Video Inputs
- 39 Tape Inputs
- 40 AM Antenna Terminals
- 41 FM Antenna Jack

NOTE: To make it easier to follow the instructions that refer to this illustration, a larger copy may be downloaded from the Product Support section for this product at www.harmankardon.com.

NOTE: To assist in making the correct connections for multichannel input, output and speaker connections, all connection jacks and terminals are color-coded in conformance with the CEA standards as follows:	Surround Left:	Blue	Component Video "Y":	Green
	Surround Right:	Gray	Component Video "Pr":	Red
	Surround Back Left:	Brown	Component Video "Pb":	Blue
	Surround Back Right:	Tan		
Front Left:	White	Subwoofer:	Purple	
Front Right:	Red	Coaxial Digital Audio:	Orange	
Center:	Green	Composite Video:	Yellow	

- 1 Multiroom Audio Outputs:** Connect these jacks to the optional external audio power amplifier and video distribution system that delivers the source selected for multizone distribution.
- 2 CD Audio Inputs:** Connect these jacks to the analog audio output of a compact disc player or changer.
- 3 Tape Outputs:** Connect these jacks to the RECORD/INPUT jacks of an audio recorder.
- 4 Remote IR Input:** If the AVR 330's front-panel IR sensor is blocked due to cabinet doors or other obstructions, an external IR sensor may be used. Connect the output of the sensor to this jack.
- 5 Multiroom IR Input:** Connect the output of an IR sensor in a remote room to this jack to operate the AVR 330's multiroom control system.
- 6 Remote IR Output:** This connection permits the IR sensor in the receiver to serve other remote controlled devices. Connect this jack to the "IR IN" jack on Harman Kardon (or other compatible) equipment.

REAR-PANEL CONNECTIONS

7 Preamp Outputs: Connect these jacks to an optional, external power amplifier for applications where higher power is desired.

8 Subwoofer Output: Connect this jack to the line-level input of a powered subwoofer. If an external subwoofer amplifier is used, connect this jack to the subwoofer amplifier input.

9 Front Speaker Outputs: Connect these outputs to the matching + or – terminals on your left and right speakers. When making speaker connections always make certain to maintain correct polarity by connecting the color-coded (white for front left and red for front right) (+) terminals on the AVR 330 to the red (+) terminals on the speakers and the black (–) terminals on the AVR 330 to the black (–) terminals on the speakers. See page 15 for more information on speaker polarity.

10 Surround Back/Multiroom Speaker Outputs: These speaker terminals are normally used to power the surround back left/surround back right speakers in a 7.1 channel system. However, they may also be used to power the speakers in a second zone, which will receive the output selected for a multiroom system. To change the output fed to these terminals from the default of the Surround Back speakers to the Multiroom Output, you must change a setting in the Advanced Menu of the OSD system. See page 31 for more information on configuring this speaker output. In normal surround system use, the brown and black terminals are the surround back left channel positive (+) and negative (–) connections and the tan and black terminals are the surround back right positive (+) and negative (–) terminals. For multiroom use, connect the brown and black SBL terminals to the red and black connections on the left remote zone speaker and connect the tan and black SBR terminals to the red and black terminals on the right remote zone speaker.

11 Surround Speaker Outputs: Connect these outputs to the matching + and – terminals on your surround channel speakers. In conformance with the CEA color-code specification, the blue terminal is the positive, or “+,” terminal that should be connected to the red (+) terminal on the Surround Left speaker with older color-coding, while the gray terminal should be connected to the red (+) terminal on the Surround Right speaker with the older color-coding. Connect the black (–) terminal on the AVR to the matching black negative (–) terminals for each surround speaker. (See page 15 for more information on speaker polarity.)

1 Center Speaker Output: Connect these outputs to the matching + and – terminals on your center channel speaker. In conformance with the CEA color-code specification, the green terminal is the positive, or “+,” terminal that should be connected to the red (+) terminal on speakers with the older color-coding.

Connect the black (–) terminal on the AVR to the black (–) terminal on your speaker. (See page 15 for more information on speaker polarity.)

13 Video 2 Component Video Inputs: Connect the Y/Pr/Pb component video outputs of an HDTV set-top converter, satellite receiver or other video source device with component video outputs to these jacks.

14 DVD Component Video Inputs: Connect the Y/Pr/Pb component video outputs of a DVD player to these jacks.

15 Component Video Monitor Outputs: Connect these outputs to the component video inputs of a video projector or monitor. When a source connected to one of the **Component Video Inputs 13 14** is selected, the signal will be sent to these jacks.

16 Fan Vents: These ventilation holes are the output of the AVR 330's airflow system. To ensure proper operation of the unit and to avoid possible damage to delicate surfaces, make certain that these holes are not blocked and that there is at least three inches of open space between the vent holes and any wooden or fabric surface. It is normal for the fan to remain off at most normal volume levels. An automatic temperature sensor turns the fan on only when it is needed.

17 AC Power Cord: Connect the AC power cord to a non-switched AC wall outlet.

18 Switched AC Accessory Outlet: These outlets may be used to power any device you wish to have turned on when the AVR 330 is turned on.

19 Unswitched AC Accessory Outlet: This outlet may be used to power any AC device. The power will remain on at this outlet regardless of whether the AVR 330 is on or off.

NOTE: The total power consumption of all devices connected to the accessory outlets should not exceed 100 watts.

20 Optical Digital Audio Output: Connect this jack to the optical digital input connector on a CD-R/RW, MiniDisc or other digital recorder.

21 Coaxial Digital Audio Output: Connect this jack to the coaxial digital input of a CD-R/RW, MiniDisc or other digital recorder.

22 S-Video Monitor Output: When your television or other video display is equipped with an S-Video input and you are using at least one source with S-Video capability, connect this jack to the S-Video input on the display.

23 Coaxial Digital Audio Inputs: Connect the coax digital output from a DVD player, HDTV receiver, LD player or CD player to these jacks. The signal may be a

Dolby Digital signal, DTS signal or a standard PCM digital source. Do not connect the RF digital output of an LD player to these jacks.

24 DVD S-Video Input: Connect the S-Video output of a DVD player or other video source to this jack.

25 Video 1 S-Video Input: If the product connected to the **Video 1 Audio Inputs 34** has S-Video capability, connect this jack to the PLAY/OUT S-Video jack on that unit and then make certain that the **S-Video Monitor Output 22** is connected as described above.

26 Optical Digital Audio Inputs: Connect the optical digital output from a DVD player, HDTV receiver, LD player or CD player to these jacks. The signal may be a Dolby Digital signal, a DTS signal or a standard PCM digital source.

27 Video 1 S-Video Output: If the product connected to the **Video 1 Audio Outputs 35** has S-Video capability, connect this jack to the REC/IN S-Video jack on that unit.

28 Video 2 S-Video Input: If the product connected to the **Video 2 Audio Inputs 36** has S-Video capability, connect this jack to the PLAY/OUT S-Video jack on that unit and then make certain that the **S-Video Monitor Output 22** is connected as described above.

29 8-Channel Direct Inputs: These jacks are used for connection to source devices such as DVD-Audio or SACD players with discrete analog outputs. Depending on the source device in use, all eight jacks may be used, though in many cases only connections to the front left/right, center, surround left/right and LFE (subwoofer input) jacks will be used for standard 5.1 audio signals.

30 Video 2 S-Video Output: If the product connected to the **Video 2 Audio Outputs 37** has S-Video capability, connect this jack to the REC/IN S-Video jack on that unit.

31 Video 3 S-Video Input: If the product connected to the **Video 3 Audio Inputs 38** has S-Video capability, connect this jack to the PLAY/OUT S-Video jack on that unit and then make certain that the **S-Video Monitor Output 22** is connected as described above.

32 Video Monitor Output: Connect this jack to the composite video input of a TV monitor or video projector to view the on-screen menus and the output of a standard video source.

33 DVD Audio/Video Inputs: Connect the composite video and L/R analog audio output jacks of a DVD player or other video source to these jacks.

REAR-PANEL CONNECTIONS

34 Video 1 Audio/Video Inputs: Connect the composite video and L/R analog audio PLAY/OUT jacks of a VCR or other video source to these jacks.

35 Video 1 Audio/Video Outputs: Connect the composite video and L/R analog audio REC/IN jacks of a VCR or other video recording device such as a DVD recorder or PVR to these jacks.

36 Video 2 Audio/Video Inputs: Connect the composite video and L/R analog audio PLAY/OUT jacks of a VCR or other video source to these jacks.

37 Video 2 Audio/Video Outputs: Connect the composite video and L/R analog audio REC/IN jacks of a VCR or other video recording device such as a DVD recorder or PVR to these jacks.

38 Video 3 Audio/Video Inputs: Connect the composite video and L/R analog audio PLAY/OUT jacks of a VCR or other video source to these jacks.

39 Tape Inputs: Connect these jacks to the PLAY/OUT jacks of an audio recorder.

40 AM Antenna Terminals: Connect the AM loop antenna supplied with the receiver to these terminals. If an external AM antenna is used, make connections to the AM and GND terminals in accordance with the instructions supplied with the antenna.

41 FM Antenna Jack: Connect the supplied indoor (or an optional external) FM antenna to this terminal.

Note on video connections: When connecting a source device, such as a VCR, DVD player, cable or satellite set-top box or video game, to the AVR, use either a composite or S-Video connection for each input, but not both.

MAIN REMOTE CONTROL FUNCTIONS

- 1 Power Off Button
- 2 IR Transmitter Window
- 3 Program/SPL Indicator
- 4 Power On Button
- 5 Input Selectors
- 6 AVR Selector
- 7 AM/FM Tuner Select
- 8 Dim Button
- 9 Test Button
- 10 Sleep Button
- 11 DSP Surround Mode Selector
- 12 Night Mode
- 13 Channel Select Button
- 14 ▲/▼ Buttons
- 15 ◀/▶ Buttons
- 16 Set Button
- 17 Digital Select
- 18 Numeric Keys
- 19 Tuner Mode
- 20 Direct Button
- 21 Tuning Up/Down
- 22 OSD Button
- 23 Dolby Mode Selector
- 24 DTS Digital Mode Selector
- 25 Logic 7 Mode Select Button
- 26 Skip Up/Down Buttons
- 27 Transport Controls
- 28 Stereo Mode Select Button
- 29 DTS Neo:6 Mode Select
- 30 Macro Buttons
- 31 Disc Skip Button
- 32 Preset Up/Down
- 33 Clear Button
- 34 Memory Button
- 35 Delay/Prev. Ch.
- 36 Speaker Select
- 37 Multiroom
- 38 Volume Up/Down
- 39 TV/Video Selector
- 40 SPL Selector
- 41 6-Channel/8-Channel Direct Input
- 42 Mute
- 43 EzSet Sensor Microphone

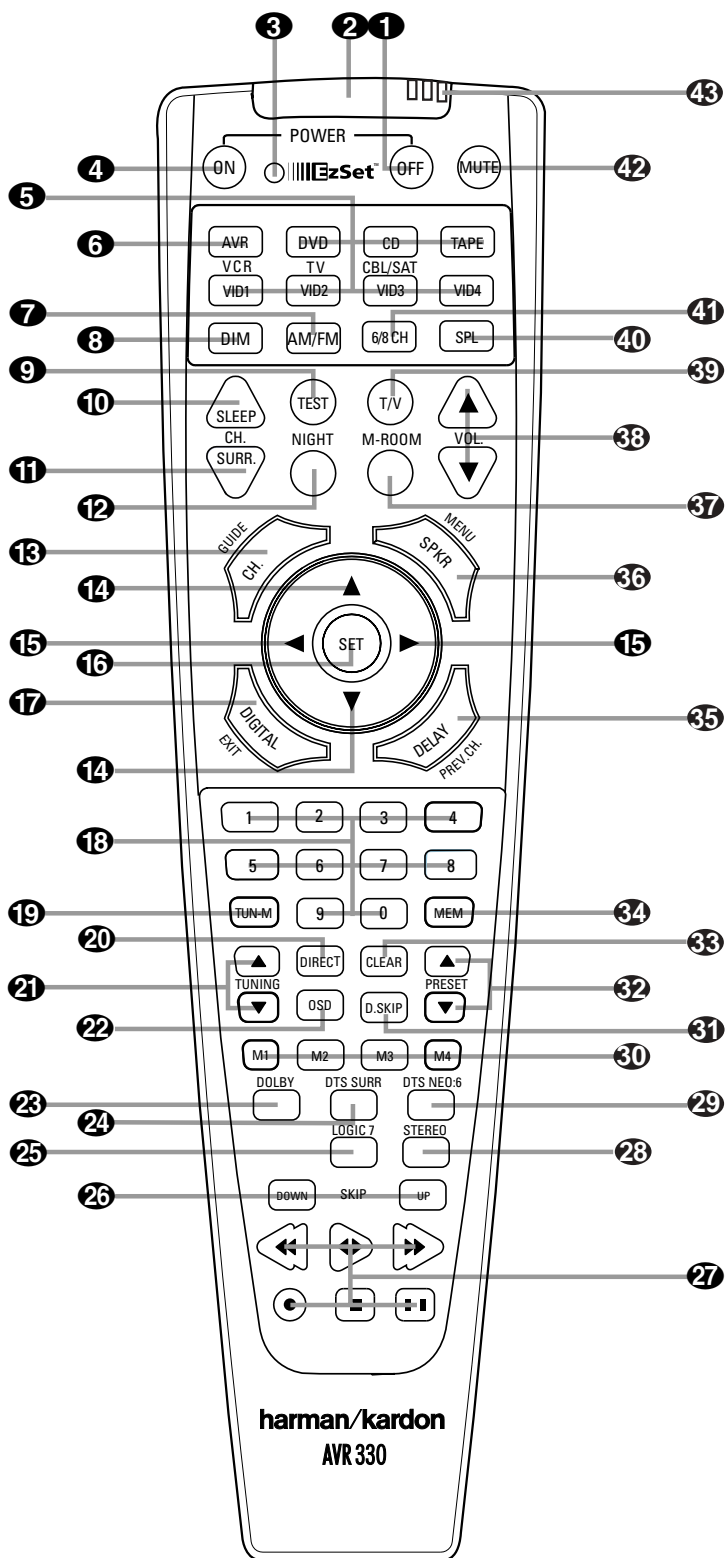

NOTE:

- The function names shown here are each button's feature when used with the AVR 330. Most buttons have additional functions when used with other devices. See pages 39–40 for a list of these functions.
- To make it easier to follow the instructions that refer to this illustration, a larger copy may be downloaded from the Product Support section for this product at www.harmankardon.com.

MAIN REMOTE CONTROL FUNCTIONS

IMPORTANT NOTE: The AVR 330's remote may be programmed to control up to eight devices, including the AVR 330. Before using the remote, it is important to remember to press the **Input Selector Button 5** that corresponds to the unit you wish to operate. In addition, the AVR 330's remote is shipped from the factory to operate the AVR 330 and most Harman Kardon CD or DVD players and cassette decks. The remote is also capable of operating a wide variety of other products using the control codes that are part of the remote. Before using the remote with other products, follow the instructions on pages 35–36 to program the proper codes for the products in your system.

It is also important to remember that many of the buttons on the remote take on different functions, depending on the product selected using the Device Control Selectors. The descriptions shown here primarily detail the functions of the remote when it is used to operate the AVR 330. (See page 36 for information about alternate functions for the remote's buttons.)

1 Power Off Button: Press this button to place the AVR 330 or a selected device in the Standby mode. Note that this will turn off the main room functions, but if the Multiroom system is activated, it will continue to function.

2 IR Transmitter Window: Point this window towards the AVR 330 when pressing buttons on the remote to make certain that infrared commands are properly received.

3 Program/SPL Indicator: This three-color indicator is used to guide you through the process of programming the remote, and it is also used as a level indicator when using the remote's EzSet capabilities. (See page 23 for more information on setting output levels, and see page 35 for information on programming the remote.)

4 Power On Button: Press this button to turn on the power to a device selected by pressing one of the **Input Selectors 5**.

5 Input Selectors: Pressing one of these buttons will perform three actions at the same time. First, if the AVR 330 is not turned on, this will power up the unit. Next, it will select the source shown on the button as the input to the AVR 330. Finally, it will change the remote control so that it controls the device selected. After pressing one of these buttons you must press the **AVR Selector Button 6** again to operate the AVR 330's functions with the remote.

6 AVR Selector: Pressing this button will switch the remote so that it will operate the AVR 330's functions. If the AVR 330 is in the Standby mode, it will also turn the AVR 330 on.

7 AM/FM Tuner Select: Press this button to select the AVR 330's tuner as the listening choice. Pressing this button when the tuner is already in use will select between the AM and FM bands.

8 Dim Button: Press this button to activate the Dimmer function, which reduces the brightness of the front panel display, or turns it off entirely. The first press of the button shows the default state, which is full brightness by indicating **DIMMER FULL** in the **Lower Display Line 30**. Press the button again within five seconds to reduce the brightness by 50%, as indicated by **DIMMER HALF** showing in the **Lower Display Line 30**. Press the button again within five seconds and the main display will go completely dark. Note that this setting is temporary, in that regardless of any changes, the display will always return to full brightness when the AVR is turned on. In addition, both the **Power Indicator 2** and the blue accent lighting inside the volume control will always remain at full brightness regardless of the setting. This is to remind you that the AVR is still turned on.

9 Test Button: Press this button to begin the sequence used to calibrate the AVR 330's output levels. (See page 23 for more information on calibrating the AVR 330.)

10 Sleep Button: Press this button to place the unit in the Sleep mode. After the time shown in the display, the AVR 330 will automatically go into the Standby mode. Each press of the button changes the time until turn-off in the following order:

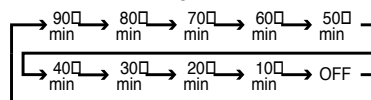

This button is also used to change channels on your TV when the TV is selected.

When the AVR 330 remote is being programmed with the codes to operate another device, this button is also used in the "Auto Search" process. (See page 35 for more information on programming the remote.)

11 DSP Surround Mode Selector: Press this button to cycle through the DSP, VMaX and Stereo surround modes such as Hall, Theater, VMaX Near and Far, and Surround Off. This button is also used to tune channels when the TV is selected using the device **Input Selector 5**. When the AVR 330 remote is being programmed with the codes of another device, this button is also used in the "Auto Search" process. (See page 35 for more information on programming the remote.)

12 Night Mode: Press this button to activate the Night mode. This mode is available in specially encoded digital sources, and it preserves dialogue (center channel) intelligibility at low volume levels.

13 Channel Select Button: This button is used to start the process of setting the AVR 330's output levels to an external source. Once this button is pressed, use the **▲/▼ Buttons 14** to select the channel being adjusted, then press the **Set Button 16**, followed by the **▲/▼ Buttons 14** again, to change the level setting. (See page 30 for more information.)

14 ▲/▼ Buttons: These multipurpose buttons are used to change or scroll through items in the on-screen menus, make configuration settings such as digital inputs or delay timing, or to select surround modes. When changing a setting, first press the button for the function or setting to be changed (e.g., press the **DSP Surround Mode Selector 11** to select a sound field mode or the **Digital Select Button 17** to change a digital input) and then press one of these buttons to scroll through the list of options or to increase or decrease a setting. The sections in this manual describing the individual features and functions contain specific information on using these buttons for each application.

15 ◀▶ Buttons: These buttons are used to change the menu selection or setting during some of the setup procedures for the AVR 330.

16 Set Button: This button is used to enter settings into the AVR 330's memory. It is also used in the setup procedures for delay time, speaker configuration and channel output level adjustment.

17 Digital Select: Press this button to assign one of the digital inputs **18 19 23 26** to a source. (See page 26 for more information on using digital inputs.)

18 Numeric Keys: These buttons serve as a 10-button numeric keypad to enter tuner preset positions. They are also used to select channel numbers when TV, Cable or SAT has been selected on the remote, or to select track numbers on a CD, DVD or LD player, depending on how the remote has been programmed.

19 Tuner Mode: Press this button when the tuner is in use to select between automatic tuning and manual tuning. When the button is pressed so that **MANUAL** appears in the **Lower Display Line 30**, pressing the **Tuning Buttons 21 9 E** will move the frequency up or down in single-step increments. When the FM band is in use, pressing this button when a station's signal is weak will change to monaural reception. (See page 29 for more information.)

MAIN REMOTE CONTROL FUNCTIONS

20 Direct Button: Press this button when the tuner is in use to start the sequence for direct entry of a station's frequency. After pressing the button, simply press the proper **Numeric Keys 18** to select a station. (See page 29 for more information on the tuner.)

21 Tuning Up/Down: When the tuner is in use, these buttons will tune up or down through the selected frequency band. If the **Tuner Mode Button 19/17** has been pressed so that **AUTO** appears in the on-screen and **Lower Display Line 30**, pressing and holding either of the buttons for three seconds will cause the tuner to seek the next station with acceptable signal strength for quality reception. When **MANUAL** appears in the **Lower Display Line 30**, pressing these buttons will tune stations in single-step increments. (See page 29 for more information.)

22 OSD Button: Press this button to activate the On-Screen Display (OSD) system used to set up or adjust the AVR 330's parameters.

23 Dolby Mode Selector: This button is used to select from among the available Dolby Surround processing modes. Each press of this button will select one of the Dolby Pro Logic II modes or Dolby 3 Stereo. When a Dolby Digital-encoded source is in use, the Dolby Digital mode may also be selected. (See page 27 for the available Dolby surround mode options.)

24 DTS Digital Mode Selector: When a DTS-encoded digital source is selected, each press of this button will scroll through the available DTS modes. The specific choice of modes will vary according to whether or not the source material contains DTS-ES 6.1 Discrete encoding. When a DTS source is not in use, this button has no function. (See page 27 for the available DTS Digital options.)

25 Logic 7 Mode Select Button: Press this button to select from among the available Logic 7 surround modes. (See page 27 for the available Logic 7 options.)

26 Skip Up/Down Buttons: These buttons do not have a direct function with the AVR 330, but when used with a compatibly programmed CD or DVD changer they will change to the previous disc in the changer or carousel.

27 Transport Controls: These buttons do not have any functions for the AVR 330, but they may be programmed for the forward/reverse play operation of a wide variety of CD or DVD players, and audio or video cassette recorders. (See page 36 for more information.)

28 Stereo Mode Select Button: Press this button to select a stereo listening mode. When the button is pressed so that **DSP SURR OFF** appears in the **Lower Display Line 30**, the AVR will operate in a bypass mode with true, fully analog, two-channel left/right stereo mode with no surround processing or bass management, as opposed to other modes where digital processing is used. When the button is pressed so that **SURROUND OFF** appears in the **Lower Display Line 30**, you may enjoy a two-channel presentation of the sound along with the benefits of bass management. Depending on whether your system is configured for 5.1 or 6.1/7.1 channels, the next press of the button will cause either **5 CH STEREO** or **7 CH STEREO** to appear, and the stereo signal will be routed to all five (or seven) speakers. (See page 27 for more information on stereo playback modes.)

29 DTS Neo:6 Mode Select: Press this button to select a DTS Neo:6 mode. These modes take a two-channel stereo- or matrix surround-encoded source and create a full five-, six- or seven-channel sound field. (See page 27 for the available DTS Neo:6 options.)

30 Macro Buttons: Press these buttons to store or recall a "Macro", which is a preprogrammed sequence of commands stored in the remote. (See page 35 for more information on storing and recalling macros.)

31 Disc Skip Button: This button has no direct function for the AVR 330 but is most often used to change to the next disc in a CD or DVD player when the remote is programmed for that type of device. (See page 36 for more information on using the remote with products other than the AVR 330.)

32 Preset Up/Down: When the tuner is in use, press these buttons to scroll through the stations programmed into the AVR 330's memory. When some source devices, such as CD players, VCRs and cassette decks, are selected using the device **Input Selectors 5**, these buttons may function as Chapter Step or Track Advance.

33 Clear Button: Press this button to clear incorrect entries when using the remote to directly enter a radio station's frequency.

34 Memory Button: Press this button to enter a radio station into the AVR 330's preset memory. First, tune the desired station, and then press this button. Two underline indicators will flash at the right side of the **Upper Display Line 29**, and within five seconds press the **Numeric Keys 18** for the preset number between 01 and 30 that you wish to assign to the station. (See page 29 for more information.)

35 Delay/Prev Ch.: Press this button to begin the process for setting the delay times used by the AVR 330 when processing surround sound. After pressing this button, the delay times are entered by pressing the **Set Button 16** and then using the **▲/▼ Buttons 14** to change the setting. Press the **Set Button 16** again to complete the process. (See page 22 for more information.)

36 Speaker Select: Press this button to begin the process of configuring the AVR 330's bass management system for use with the type of speakers used in your system. Once the button has been pressed, use the **▲/▼ Buttons 14** to select the channel you wish to set up. Press the **Set Button 16** and then select another channel to configure. When all adjustments have been completed, press the **Set Button 16** twice to exit the settings and return to normal operation. (See page 20 for more information.)

37 Multiroom: Press this button to activate the multiroom system or to begin the process of changing the input or volume level for the second zone. (See pages 31 and 33 for more information on the Multiroom system.)

38 Volume Up/Down: Press these buttons to raise or lower the system volume.

39 TV/Video Selector: This button does not have a direct function on the AVR 330, but when used with a compatibly programmed VCR, DVD or satellite receiver that has a "TV/Video" function, pressing this button will switch between the output of the player or receiver and the external video input to that player. Consult the owner's manual for your specific player or receiver for the details of how it implements this function.

40 SPL Selector: This button activates the AVR 330's EzSet function to quickly and accurately calibrate the AVR 330's output levels. Press and hold the button for three seconds and then release it. Press the "5" or "7" **Numeric Key 18** to indicate whether you are using a 5.1-channel or a 6.1/7.1-channel speaker system with the AVR 330. The test tone will begin circulating, and the **Program/SPL Indicator 3** will change colors. During this sequence, EzSet will automatically adjust the output levels for all channels until they are equal, as shown by the **Program/SPL Indicator 3** lighting green for each channel. Press this button again when the adjustment is complete to turn off the test tone. (See page 23 for more information on EzSet.)

41 6-Channel/8-Channel Direct Input: Press this button to select the device connected to the **8-Channel Direct Inputs 29** as the audio source. (See page 25 for more information.)

MAIN REMOTE CONTROL FUNCTIONS

When you wish to use the **6-Channel/8-Channel Direct Input 29** in conjunction with a video source, you must first select the video source by pressing one of the **Input Selectors 5**, then press this button to choose the device connected to the **6-Channel/8-Channel Direct Input 29** as the audio source.

42 Mute: Press this button to momentarily silence the AVR 330 or TV set being controlled, depending on which device has been selected. When the AVR 330 remote is being programmed to operate another device, this button is pressed with the **Input Selector Button 5** to begin the programming process. (See page 35 for more information on programming the remote.)

43 EzSet Sensor Microphone: The sensor microphone for the EzSet microphone is behind these slots. When using the remote to calibrate speaker output levels using EzSet, be sure that you do not hold the remote in a way that covers these slots. (See page 23 for more information on using EzSet.)

TROUBLESHOOTING GUIDE

SYMPTOM	CAUSE	SOLUTION
Unit does not function when Main Power Switch is pushed	<ul style="list-style-type: none"> No AC power 	<ul style="list-style-type: none"> Make certain AC power cord is plugged into a live outlet Check to see whether outlet is switch-controlled
Display lights, but no sound or picture	<ul style="list-style-type: none"> Intermittent input connections Mute is on Volume control is down 	<ul style="list-style-type: none"> Make certain that all input and speaker connections are secure Press Mute Button 42 Turn up volume control
Unit turns on, but front-panel display does not light up	<ul style="list-style-type: none"> Display brightness is turned off 	<ul style="list-style-type: none"> Follow the instructions in the Display Brightness section on page 31 so that the display is set to VFD FULL
No sound from any speaker; light around power switch is red	<ul style="list-style-type: none"> Amplifier is in protection mode due to possible short Amplifier is in protection mode due to internal problems 	<ul style="list-style-type: none"> Check speaker wire connections for shorts at receiver and speaker ends Contact your local Harman Kardon service center
No sound from surround or center speakers	<ul style="list-style-type: none"> Incorrect surround mode Input is monaural Incorrect configuration Stereo or Mono program material 	<ul style="list-style-type: none"> Select a mode other than Stereo There is no surround information from mono sources Check speaker mode configuration The surround decoder may not create center- or rear-channel information from nonencoded programs
Unit does not respond to remote commands	<ul style="list-style-type: none"> Weak batteries in remote Wrong device selected Remote sensor is obscured 	<ul style="list-style-type: none"> Change remote batteries Press the AVR selector Make certain front-panel sensor is visible to remote, or connect remote sensor
Intermittent buzzing in tuner	<ul style="list-style-type: none"> Local interference 	<ul style="list-style-type: none"> Move unit or antenna away from computers, fluorescent lights, motors or other electrical appliances
Letters flash in the channel indicator display and digital audio stops	<ul style="list-style-type: none"> Digital audio feed paused 	<ul style="list-style-type: none"> Resume play for DVD Check that Digital Input is selected
Fan does not appear to operate	<ul style="list-style-type: none"> Additional cooling may not be required 	<ul style="list-style-type: none"> The fan is activated only when additional cooling is required due to high internal temperature. It is normal for the fan to be inactive at normal volume levels.

Processor Reset

In the rare case where the unit's operation or the displays seem abnormal, the cause may involve the erratic operation of the system's memory or microprocessor.

To correct this problem, first unplug the unit from the AC wall outlet and wait at least three minutes. After the pause, reconnect the AC power cord and check the unit's operation. If the system still malfunctions, a system reset may clear the problem.

To clear the AVR 330's entire system memory including tuner presets, output level settings, delay times and speaker configuration data, press and hold the **Tone Mode Button 5** buttons for three seconds. The unit will turn on automatically.

NOTE: Resetting the processor will erase any configuration settings you have made for speakers, output levels, surround modes and digital input assignments, as well as the tuner presets. After a reset, the unit will be returned to the factory presets, and all settings for these items must be reentered.

If the system is still operating incorrectly, there may have been an electronic discharge or severe AC line interference that has corrupted the memory or microprocessor.

If these steps do not solve the problem, consult an authorized Harman Kardon service center.

1) REMOVAL OF TOP COVER

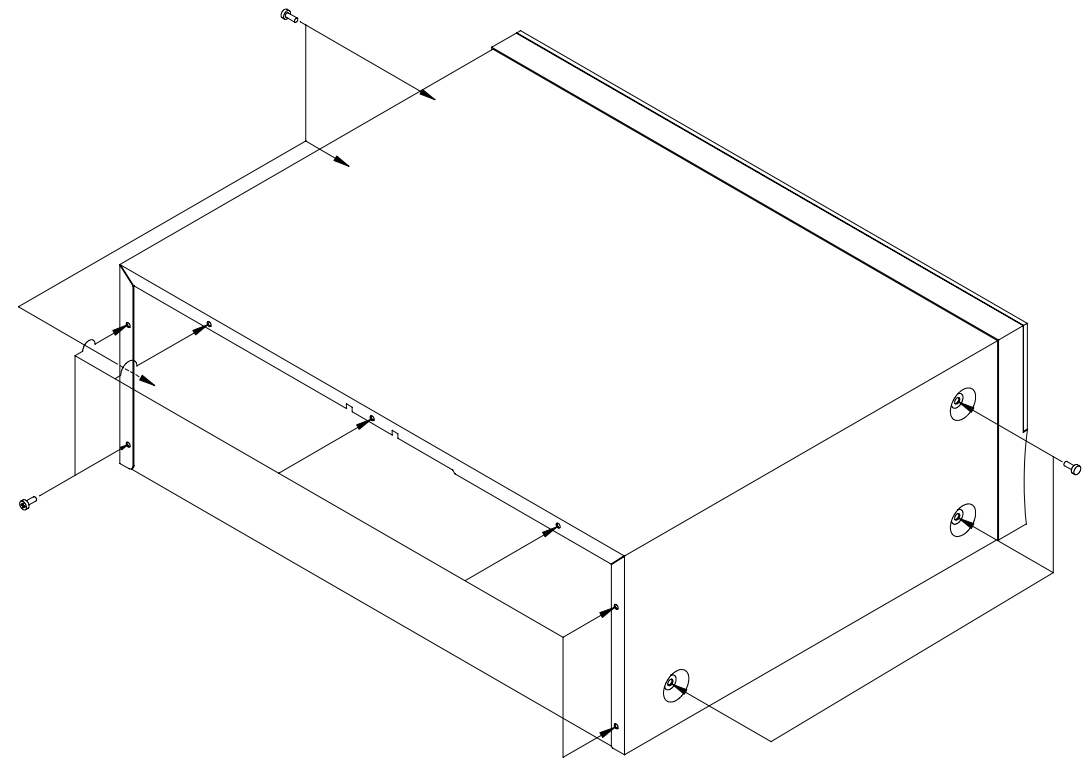

2) REMOVAL OF FRONT PANEL

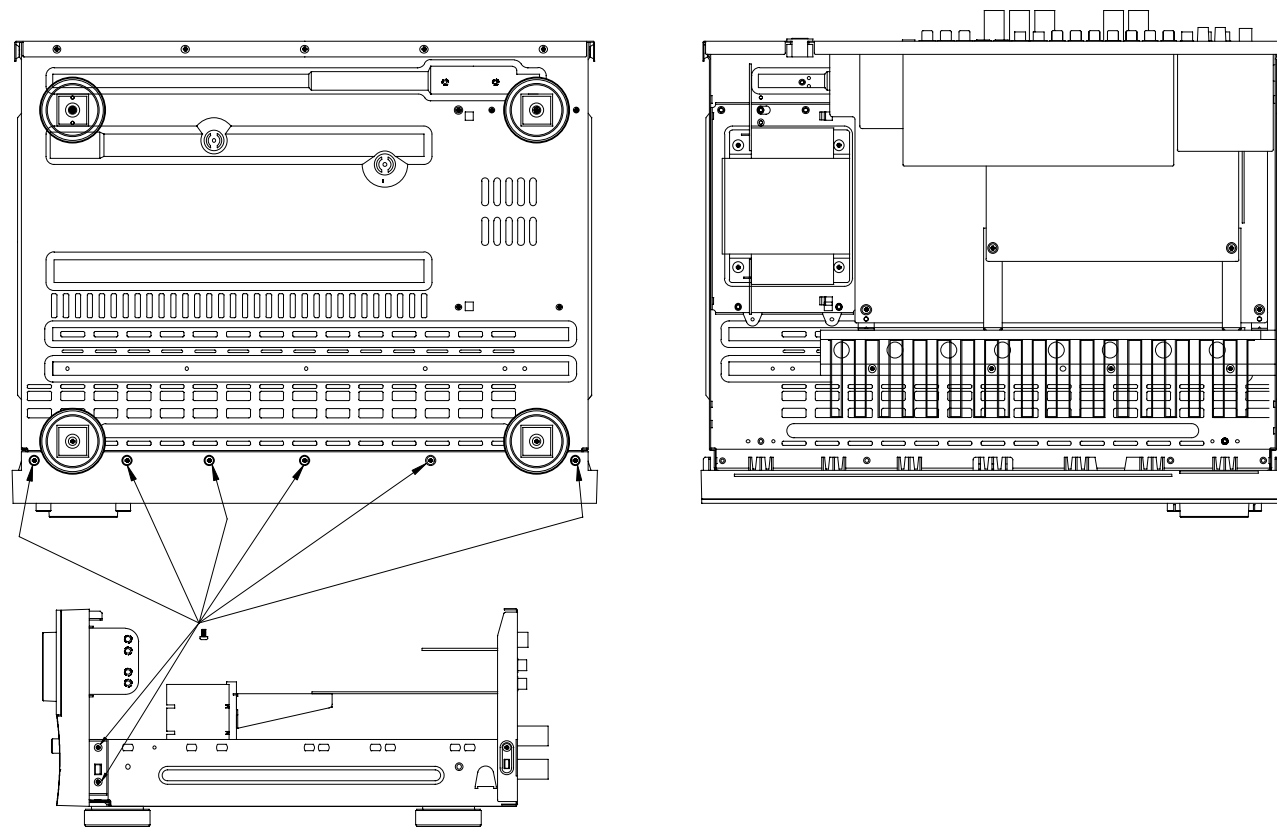

3) PRINCIPAL PARTS LOCATION

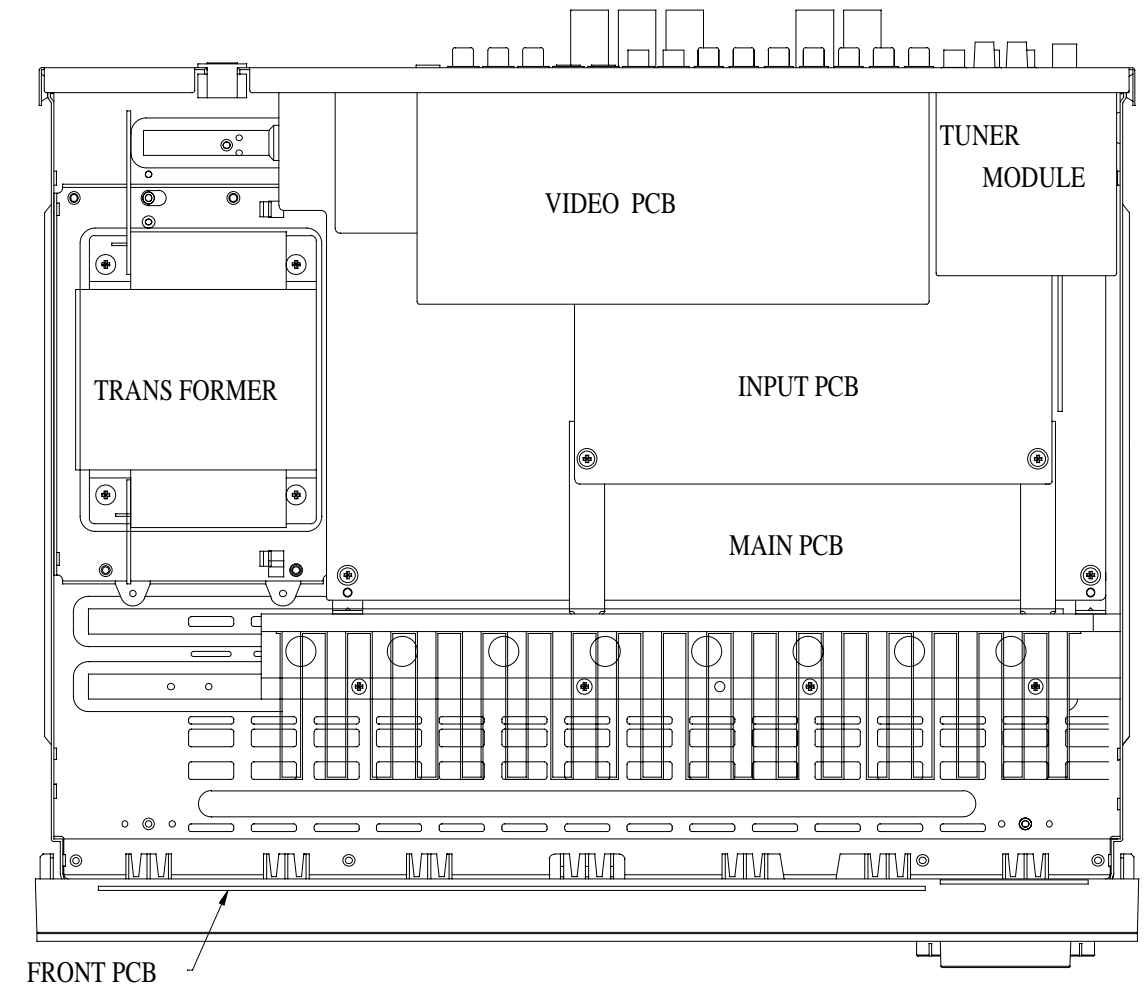

harman/kardon

Service Bulletin

Service bulletin # H/K2003-10 December 2003

Warranty labor rate: MAJOR repair

To: All harman/kardon Service Centers

Models: AVR130, AVR230, AVR330, HK3380, HK3480

Subject: Volume Level Changes

On early versions of the AVR130,AVR230,AVR330,HK3380,HK3480, when the volume control is turned, the volume level and display may be erratic, and not track accurately, or the level may progress in an unintended direction. This may happen on a random basis and depends on where the volume control knob is positioned after a volume adjustment. During a running production change, new volume encoders were installed.

In the event you receive an AVR model listed above with the complaint “The volume control on my receiver does not track accurately when turned”, perform the following procedure:

REPLACE VR74 (AVR130/230/330) or VR81 (HK3380/3480) VOLUME ENCODER

Note: It is important that the various screws do not get mixed up and inserted in other locations upon reassembly. Make note or label each removed screw set; keep them apart from other screw sets.

- 1) Remove the top cover, (13) Phillips screws.
- 2) Remove the volume, bass, treble and balance knobs by pulling them straight out and off. If a tool is necessary for removal of the smaller knobs, make sure the jaws are insulated to avoid knob damage.
- 3) Remove the (10) Phillips screws holding the front panel ass'y to the chassis: (6) at the bottom and (4) at the sides.
- 4) Cut all plastic cable ties that would prevent you detaching the front panel ass'y from the chassis. Draw a diagram if necessary, for a location reminder, to aid reassembly.
- 5) Unplug connector CN15 (6 cond) or CN89 (7 cond) at the left side of the unit. See below.
- 6) Remove single ground screw at the left side of the unit, near CN15 or CN89. (Black wire)
- 7) Unplug connector CN72 (32 cond) or CN81 (20 cond) on the DSP PCB, coming from the top of the front panel ass'y. See below.
- 8) There should now be enough slack in the connecting cables to lift and detach the front panel ass'y from the chassis. Pull the front panel as far away as the remaining connecting wires will allow, enough to tilt and gain access to the rear of the Tone/Volume PCB. See illustration Page 2.
- 9) Remove the (10) screws or (9) screws holding the Tone/Volume PCB to the front panel.
- 10) Detach and pull back the PCB; unplug top connector CN84 (7 cond) or CN83 (4 cond) if necessary.
- 11) Remove and replace VR74 or VR81 (5 soldered pads) with hk part# HSR2A029Z.
- 12) Reassemble in reverse order, taking care to replace all connectors, cable ties, and ground screw.
- 13) Power up receiver, and test volume control to assure setting no longer changes settings by itself, or when the volume knob is tapped.

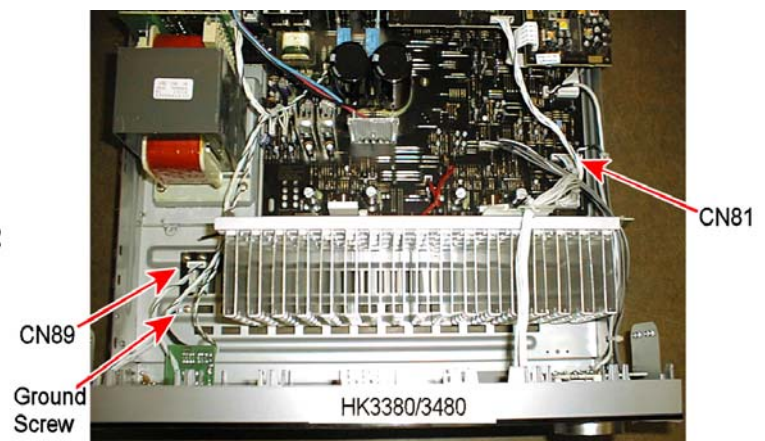
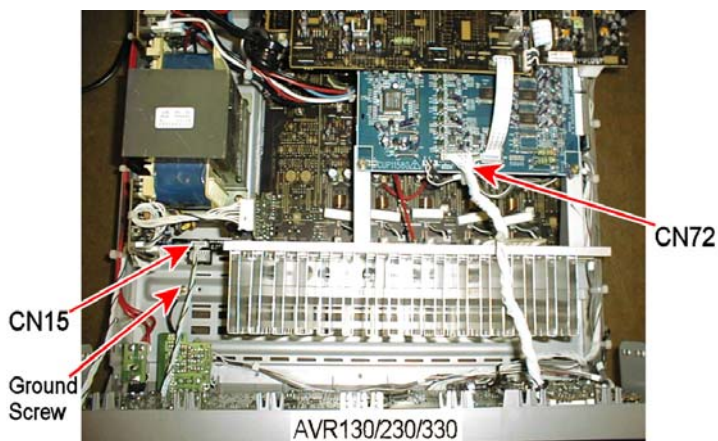

Ready for Volume/Tone PCB removal

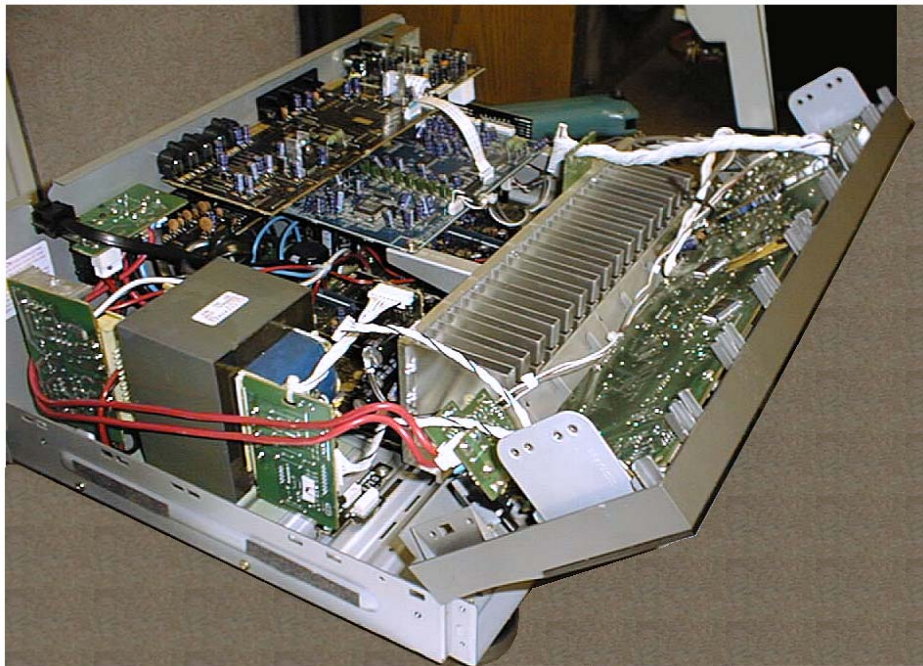

Model	Serial Number 120V	STATUS	ACTION
AVR130	AN0006-01000 to AN0006-13800	Volume control may not track accurately when turned; erratic operation	Change VR74 Rotary encoder
AVR130	AN0006-13801 and above	Modified By Factory	NONE REQUIRED
AVR230	AN0007-01000 to AN0007-11400	Volume control may not track accurately when turned; erratic operation	Change VR74 Rotary encoder
AVR230	AN0007-11401 and above	Modified By Factory	NONE REQUIRED
AVR330	AN0008-01000 to AN0008-08524	Volume control may not track accurately when turned; erratic operation	Change VR74 Rotary encoder
AVR330	AN0008-08525 and above	Modified By Factory	NONE REQUIRED
HK3380	AN0015-01000 to AN0015-02728	Volume control may not track accurately when turned; erratic operation	Change VR81 Rotary encoder
HK3380	AN0015-02729 and above	Modified By Factory	NONE REQUIRED
HK3480	AN0016-01000 to AN0016-01864	Volume control may not track accurately when turned; erratic operation	Change VR81 Rotary encoder
HK3480	AN0016-01865 and above	Modified By Factory	NONE REQUIRED

harman/kardon**TECH TIPS****Troubleshooting tips and solutions to common service problems****TIP# HKTT2004-03**

Isolating audio problems in an AVR receiver Using 6/8 Direct In

The following charts are used to help the tech quickly isolate audio problems in an AVR receiver. Use the following procedures to help find what is working, then to quickly locate the problem area.

Equipment needed:

- ✓ 1 set of (RCA) Y adaptors.
- ✓ Function/signal generator.
- ✓ Oscilloscope.

Models covered:	
AVR210	AVR310
AVR220	AVR320
AVR520	AVR225
AVR125	AVR525
AVR130	AVR230
AVR330	AVR430
AVR630	

Procedure:

- 1) Do a factory reset of the receiver. (This will eliminate any common micro processor problems.) Reset List can be found in this service manual.
- 2) Print the block diagram from the service manual.
- 3) With no inputs or speakers attached to the AVR turn on the receiver and turn the volume all the way down.
- 4) Turn unit off.
- 5) Hook up an oscillator to the 6/8 Direct in jacks using the Y adaptors. Adjust the oscillator to about 0db (.775Volts RMS).
- 6) Hook up an oscilloscope to monitor the line out jacks. Or, if there are no line out (preamp out) jacks monitor the input to the power amps or the speaker outs. (AVR125, 225, 130 do not have preamp out jacks)
- 7) Turn the AVR on. Select 6 or 8 direct in, depending on the receiver.
- 8) Slowly turn the volume control up until you can easily measure the voltage at the line out jacks. (-40 to -25db)

Isolating audio problems in an AVR receiver Using 6/8 Direct In

- 9) At this point you will be able to check and assure all output levels are the same.
- 10) IF THE OUTPUT LEVELS ARE NOT THE SAME STOP! Go no further. At this point you will need to use the charts to see where you are losing your signal. The chart shows the analog signal flow from the input jacks to the output jacks.
- 11) If the output levels are the same check the power out stage at the speaker out jacks.
- 12) If you find the levels at the speaker out jacks are OK, your problem will be in the DSP part of the receiver.

Congratulations! You have now eliminated 90% of the electronics in the AVR and confirmed that the problem is in the DSP section.

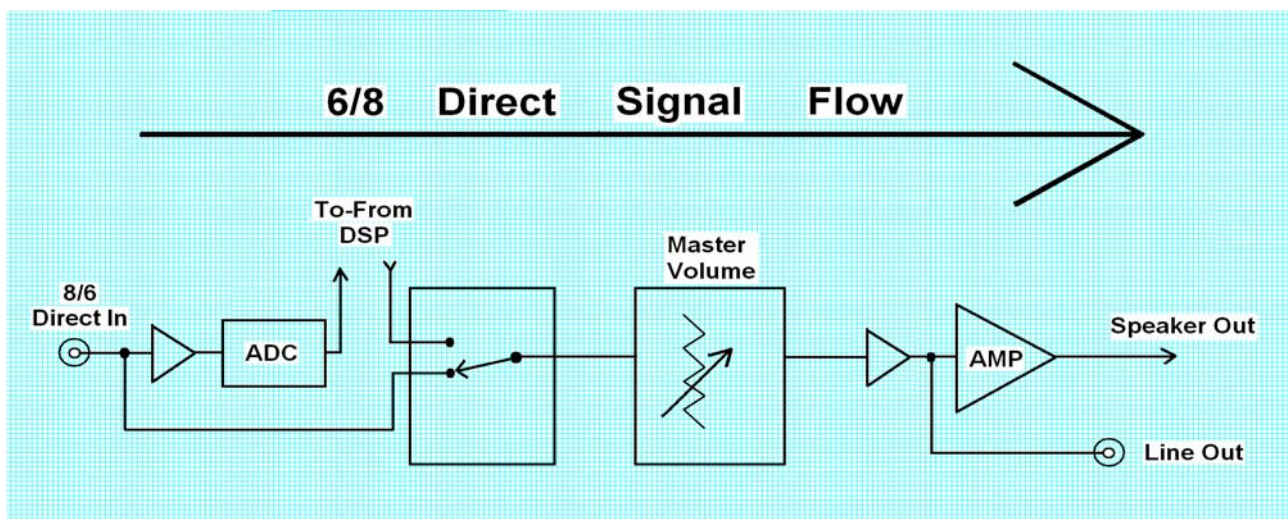

Isolating audio problems in an AVR receiver Using 6/8 Direct In

AVR,210,310,510

6 CH IN	IC 501 In	IC 501 Out	CN 408	IC 704 In	IC 704 Out	IC 705 In	IC 705 Out	IC 706 In	IC 706 Out	IC 705 In	IC 705 Out	IC 716 In	IC 716 Out	IC 717 In	IC 717 Out	IC 718 In	IC 718 Out	CP 405
FR	3	1	15	2	4	8	9	4	3	19	17	3	1					3
FL	5	7	13	27	25	21	20	25	26	10	12	5	7					1
SR			11	5	7			7	6				5	7				9
SL			9	24	22			22	23				3	1				7
C			5	21	19			19	20							3	1	5
SW			7	8	10			10	9						5	7	11	

AVR220

6 CH IN	IC 501 In	IC 501 Out	CN 408	IC 704 In	IC 704 Out	IC 705 In	IC 705 Out	IC 706 In	IC 706 Out	IC 714 In	IC 714 Out	IC 705 In	IC 705 Out	IC 716 In	IC 716 Out	IC 717 In	IC 717 Out	IC 718 In	IC 718 Out	CP 405	
FR	5	7	15	2	4	8	9	4	3	5	7	10	12	5	7						1
FL	3	1	13	27	25	21	20	25	26	3	1	19	17	3	1						3
SR			11	5	7			7	6							5	7				9
SL			9	24	22			22	23							3	1				7
C			5	21	19			19	20										3	1	5
SW			7	8	10			10	9										5	7	11

AVR320/520

8 CH IN	IC 501 In	IC 501 Out	CN 408	IC 704 In	IC 704 Out	IC 705 In	IC 705 Out	IC 706 In	IC 706 Out	IC 714 In	IC 714 Out	IC 705 In	IC 705 Out	IC 716 In	IC 716 Out	IC 717 In	IC 717 Out	IC 718 In	IC 718 Out	CP 405	
FR	5	7	15	2	4	8	9	4	3	5	7	10	12	5	7						1
FL	3	1	13	27	25	21	20	25	26	3	1	19	17	3	1						3
SR			11	5	7			7	6							5	7				9
SL			9	24	22			22	23							3	1				7
C			5	21	19			19	20										3	1	5
SW			7	8	10			10	9										5	7	11
			CN418																		
			CP102																		
SBR	3	3	3	4	21	23	5	7													
SBL	1	1	25	26	4	2	3	1													

AVR225/125

6 CH IN	IC 30 In	IC 30 Out	IC 31 In	IC 31 Out	IC 32 In	IC 32 Out	IC 33 In	IC 33 Out	IC 34 In	IC 34 Out	BN12	IC 81 In	IC 81 Out	IC 80 In	IC 80 Out	BN16 In	BN16 Out
L ch	27	25	19	20	5	7					1	3	1	9	10	1	2
R ch	24	22	22	23	3	1					3	5	7	15	14	4	5
SL	5	4	7	6					5	7	9						
SR	2	4	10	9					3	1	11						
C	8	18	4	3			3	1			7						
SW	21	19	25	26			5	7			5						

Isolating audio problems in an AVR receiver

Using 6/8 Direct In

AVR 525

In Jack	N404	P6	IC5 In	IC5 Out	IC3 In	IC3 Out	IC19 In	IC19 Out	IC18 In	IC20 In	IC20 Out	IC3 In	IC3 Out	IC18 Out	IC23 In	IC23 Out	IC25 In	IC25 Out	IC24 In	IC24 Out	IC26 In	IC26 Out	P9	N806
FL	1	1			10	9			4	2	3	1	3	5	3	1							1	1
FR	3	3			21	22			21	23	5	7	28	6	6	7							3	3
SL	5	5	2	4			4	3									3	1					5	5
SR	7	7	29	27			25	26									5	7					7	7
CTR	9	9	5	7			7	6											3	1			9	9
SW	11	11	26	24			22	23											5	7			11	11
SBL	13	13	8	10			10	9													3	1	13	13
SBR	15	15	23	21			19	20													6	7	15	15

AVR130

6 ch in	IC 23 In	IC 23 Out	IC 26 In	IC 26 Out	IC 42 In	IC 42 Out	IC 44 In	IC 44 Out	IC 43 In	IC 43 Out	IC 40 In	IC 40 Out	IC 49 In	IC 49 Out	BN 12	BN11
L	18	17			21	23									1	
R	19	12			4	2										14
SL			24	22			21	23							9	
SR			5	7			4	2							7	
C			27	25			21	23							5	
SUB			2	4			4	2							3	
SBL			21	19					21	23	5	7	13			
SBR			8	10					4	2	3	1	11			

AVR230/330

6 ch in	IC 23 In	IC 23 Out	IC 26 In	IC 26 Out	IC 42 In	IC 42 Out	IC 44 In	IC 44 Out	IC 43 In	IC 43 Out	IC 40 In	IC 40 Out	IC 49 In	IC 49 Out	BN 12	BN11
L	18	17			21	23									1	
R	19	12			4	2										14
SL			24	22			21	23							9	
SR			5	7			4	2							7	
C			27	25			21	23							5	
SUB			2	4			4	2							3	
SBL			21	19					21	23	5	7	13			
SBR			8	10					4	2	3	1	11			

AVR630/430

8 CH In	N404	IC 3	IC 3 Out	IC 14 In	IC 14 Out	IC 12 In	IC 12 Out	IC 3 In	IC 3 Out	IC 27 In	IC 27 Out	IC 18 In	IC 18 Out	IC 20 In	IC 20 Out	IC 3 In	IC 3 Out
FL	1	10	12	10	9	3	1	6	9	3	1	4	2	3	1	3	1
FR	3	19	17	19	20	5	7	23	20	5	7	21	23	5	7	26	7
SL	5	2	4	4	3	3	1										
SR	7	27	25	25	26	5	7										
CTR	9	5	7	7	6			3	1								
SW	11	24	22	22	23			5	7								
SBL	13	8	10	10	9					3	1						
SBR	15	21	19	19	20					5	7						

harman/kardon**TECH TIPS****Troubleshooting tips and solutions to common service problems**

For models:

TIP# HKTT2003-01 Rev5

AVR7000/7200/7300/8000

AVR100/200/300/500

AVR110/210/310/510

AVR120/220/320/520

AVR125/225/325/525

AVR130/230/330/430/630

AVR135/235/335/435/635

AVR10

DPR1001

DPR1005

DPR2005

HK3370/3470/3375/3475

HK3250

Subject: Backup Memory on AVR/DPR/HK series receivers**In the event of the complaint: “the receiver is losing its memory (any programmed system settings) when the unit is turned off, or after the unit is unplugged (briefly*)”:**

Check and replace:

Model	Designator	Location	Description	Part number
AVR10	C712 D709	Front PCB	0.047 Farad 5.5v capacitor and 1N4148 diode	#3439247315 #2058322101
AVR7000	C730	Front PCB	0.047 Farad 5.5v capacitor	# P10790-ND or # J3432147324X
AVR7200	C106	Front PCB	0.047 Farad 5.5v capacitor	# P10790-ND
AVR7300	C657	DSP PCB	0.047 Farad 5.5v capacitor	# H01-CEZXA0479MN-5
AVR8000	C726	Front PCB	0.047 Farad 5.5v capacitor	# 55230310NR or # P10790-ND
AVR100/200	C412	Front PCB	0.047 Farad 5.5v capacitor	# CEGT-B473J-0J0
AVR300	C906	Front PCB	0.1Farad 5.5v capacitor	# J4433210421X or # P10791-ND
AVR500	C906	Front PCB	0.1Farad 5.5v capacitor	# J4433210421X or # P10791-ND
AVR110/210/310/510 AVR120/220/320/520	C216	Front PCB	0.047 Farad 5.5v capacitor	# P10790-ND
AVR125/225	C734,C885	Front PCB	two 0.1F capacitors in parallel	# BCESOH104
AVR325/525	C106	Front PCB	0.047 Farad 5.5v capacitor	# P10790-ND
AVR130/230/330	BAT1	Front PCB	3.6v Battery	# HABGP40BVH3A3H
AVR135/235/335	BAT1	Front PCB	3.6v Battery	# HGP15BNH3A3H
AVR430/630	C657	DSP PCB	0.047 Farad 5.5v capacitor	# CEZXA0479MN-5
AVR435/635	C557	DSP PCB	0.047 Farad 5.5v capacitor	# H03-CEZXA0479MN-0
DPR1001	BC601	Main PCB	0.1Farad 5.5v capacitor	# CEGT-B104J-0J0
DPR1005/2005	C437	Processor PCB	0.047 Farad 5.5v capacitor	# CEZXA0479MN-5
HK3370/3470	C301	Front PCB	0.1Farad 5.5v capacitor	# CEGT-B104J-0J0
HK3375/3475	C301	Front PCB	0.1Farad 5.5v capacitor	# CEGT-B104J-0J0
HK3250	C712 D709	Front PCB	0.047 Farad 5.5v capacitor and 1N4148 diode	#3439247315 #2058322101

* After approximately two weeks of being disconnected from AC supply, even a normally functioning receiver may lose any programmed settings and switch to default settings. (Four weeks for the DPR1005 & 2005)

AVR330 EXPLODED VIEW

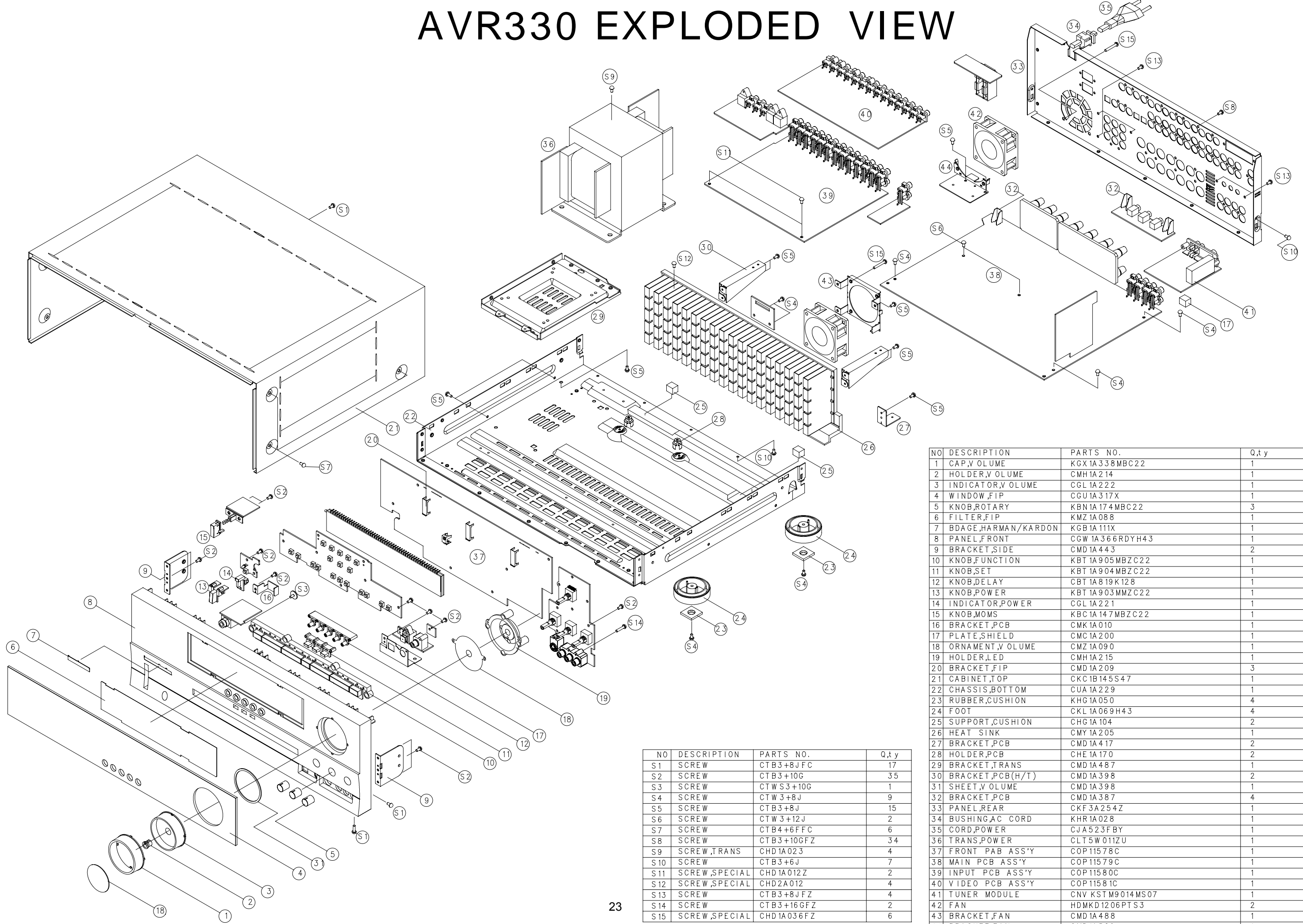

NO	DESCRIPTION	PARTS NO.	Q,t y
S1	SCREW	CTB3+8JFC	17
S2	SCREW	CTB3+10G	35
S3	SCREW	CTW S3+10G	1
S4	SCREW	CTW 3+8J	9
S5	SCREW	CTB3+8J	15
S6	SCREW	CTB3+12J	2
S7	SCREW	CTB4+6FFC	6
S8	SCREW	CTB3+10GFZ	34
S9	SCREW,TRANS	CHD1A023	4
S10	SCREW	CTB3+6J	7
S11	SCREW,SPECIAL	CHD1A012Z	2
S12	SCREW,SPECIAL	CHD2A012	4
S13	SCREW	CTB3+8JFZ	4
S14	SCREW	CTB3+16GFZ	2
S15	SCREW,SPECIAL	CHD1A036FZ	6

NO	DESCRIPTION	PARTS NO.	Q,t y
1	CAP,V OLUME	KGX1A338MBC22	1
2	HOLDER,V OLUME	CMH1A214	1
3	INDICATOR,V OLUME	CGL1A222	1
4	WINDOW,FIP	CGU1A317X	1
5	KNOB,ROTARY	KBN1A174MBC22	3
6	FILTER,FIP	KMZ1A088	1
7	BDAGE,HARMAN/KARDON	KGB1A111X	1
8	PANEL,FRONT	CGW1A366RDYH43	1
9	BRACKET,SIDE	CMD1A443	2
10	KNOB,FUNCTION	KBT1A905MBZC22	1
11	KNOB,SET	KBT1A904MBZC22	1
12	KNOB,DELAY	CBT1A819K128	1
13	KNOB,POWER	KBT1A903MMZC22	1
14	INDICATOR,POWER	CGL1A221	1
15	KNOB,MOMS	KBC1A147MBZC22	1
16	BRACKET,PCB	CMK1A010	1
17	PLATE,SHIELD	CMC1A200	1
18	ORNAMENT,V OLUME	CMZ1A090	1
19	HOLDER,LED	CMH1A215	1
20	BRACKET,FIP	CMD1A209	3
21	CABINET, TOP	CKC1B145S47	1
22	CHASSIS,BOTTOM	CUA1A229	1
23	RUBBER,CUSHION	KHG1A050	4
24	FOOT	CKL1A069H43	4
25	SUPPORT,CUSHION	CHG1A104	2
26	HEAT SINK	CMY1A205	1
27	BRACKET,PCB	CMD1A417	2
28	HOLDER,PCB	CHE1A170	2
29	BRACKET,TRANS	CMD1A487	1
30	BRACKET,PCB(H/T)	CMD1A398	2
31	SHEET,V OLUME	CMD1A398	1
32	BRACKET,PCB	CMD1A387	4
33	PANEL,REAR	CKF3A254Z	1
34	BUSHING,AC CORD	KHR1A028	1
35	CORD,POWER	CJA523FBY	1
36	TRANS,POWER	CLT5W011ZU	1
37	FRONT PAB ASS'Y	COP11578C	1
38	MAIN PCB ASS'Y	COP11579C	1
39	INPUT PCB ASS'Y	COP11580C	1
40	VIDEO PCB ASS'Y	COP11581C	1
41	TUNER MODULE	CNV KST M9014MS07	1
42	FAN	HDMKD1206PTS3	2
43	BRACKET,FAN	CMD1A488	1
44	BRACKET,FAN	CMD1A506	1

BLOCK DIAGRAM

AVR330

harman/kardon

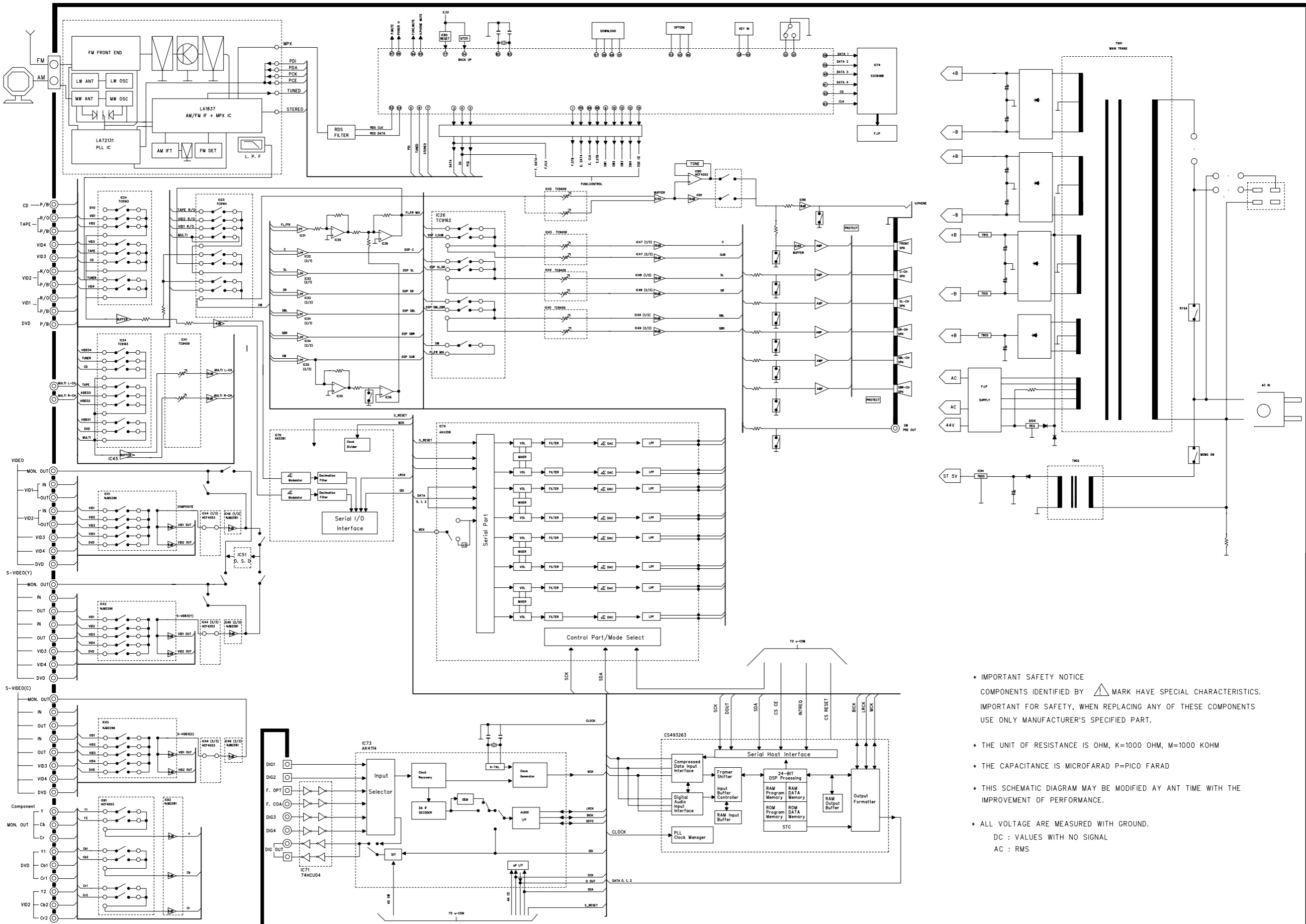

* IMPORTANT SAFETY NOTICE
COMPONENTS IDENTIFIED BY Δ MARK HAVE SPECIAL CHARACTERISTICS.
IMPORTANT FOR SAFETY, WHEN REPLACING ANY OF THESE COMPONENTS
USE ONLY MANUFACTURER'S SPECIFIED PART.

* THE UNIT OF RESISTANCE IS OHM, K=1000 OHM, M=1000 KOHM

* THE CAPACITANCE IS MICROFARAD P=PICO FARAD

* THIS SCHEMATIC DIAGRAM MAY BE MODIFIED AT ANY TIME WITH THE
IMPROVEMENT OF PERFORMANCE.

* ALL VOLTAGE ARE MEASURED WITH GROUND.
DC : VALUES WITH NO SIGNAL
AC : RMS

AMPLIFIER SECTION BIAS ADJUSTMENT

Measurement condition

. No input signal or volume position is minimum.

Standard value.

. Ideal current = 48mA (± 5%)

. Ideal DC Voltage = 25.92mV (± 5%)

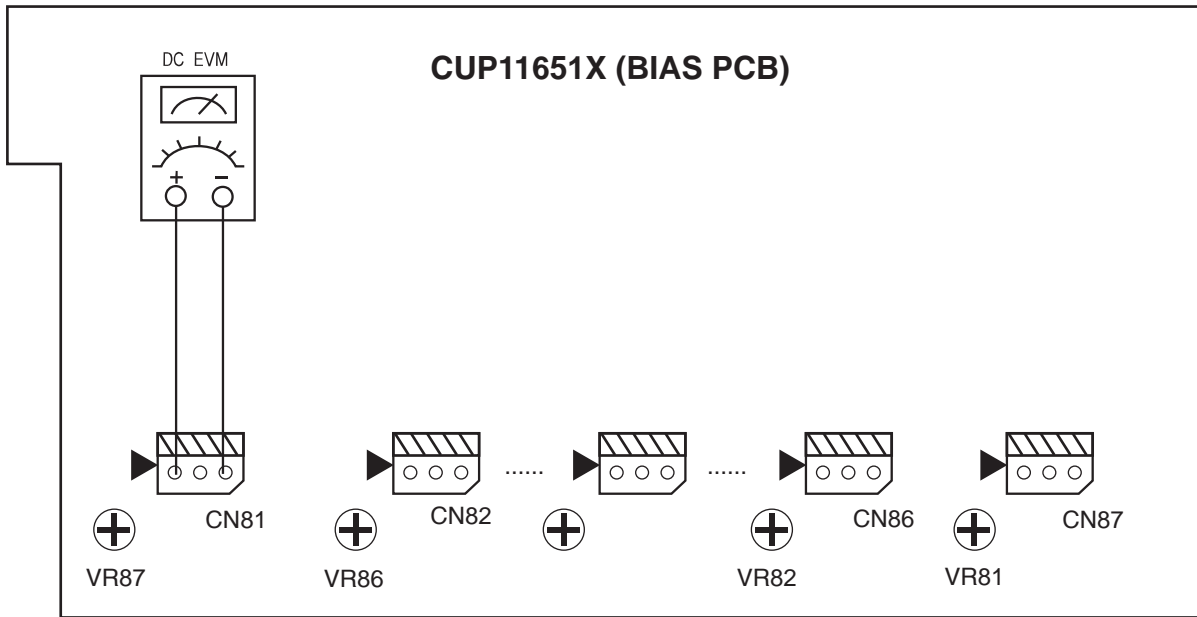

DC VOLTMETER.....Connect to CN81,CN82,CN83,CN84,CN85,CN86,CN87

NO.	Channel	Adjust for	Adjustment
1	Front Left	25.92mV (±5%)	VR83
2	Front Right	25.92mV (±5%)	VR84
3	Center	25.92mV (±5%)	VR85
4	Surround Left	25.92mV (±5%)	VR86
5	Surround Right	25.92mV (±5%)	VR87
6	Surround Back Left	25.92mV (±5%)	VR82(ONLY AVR230/330)
7	Surround Back Right	25.92mV (±5%)	VR81(ONLY AVR330)

VIDEO BOARD

DIPPING

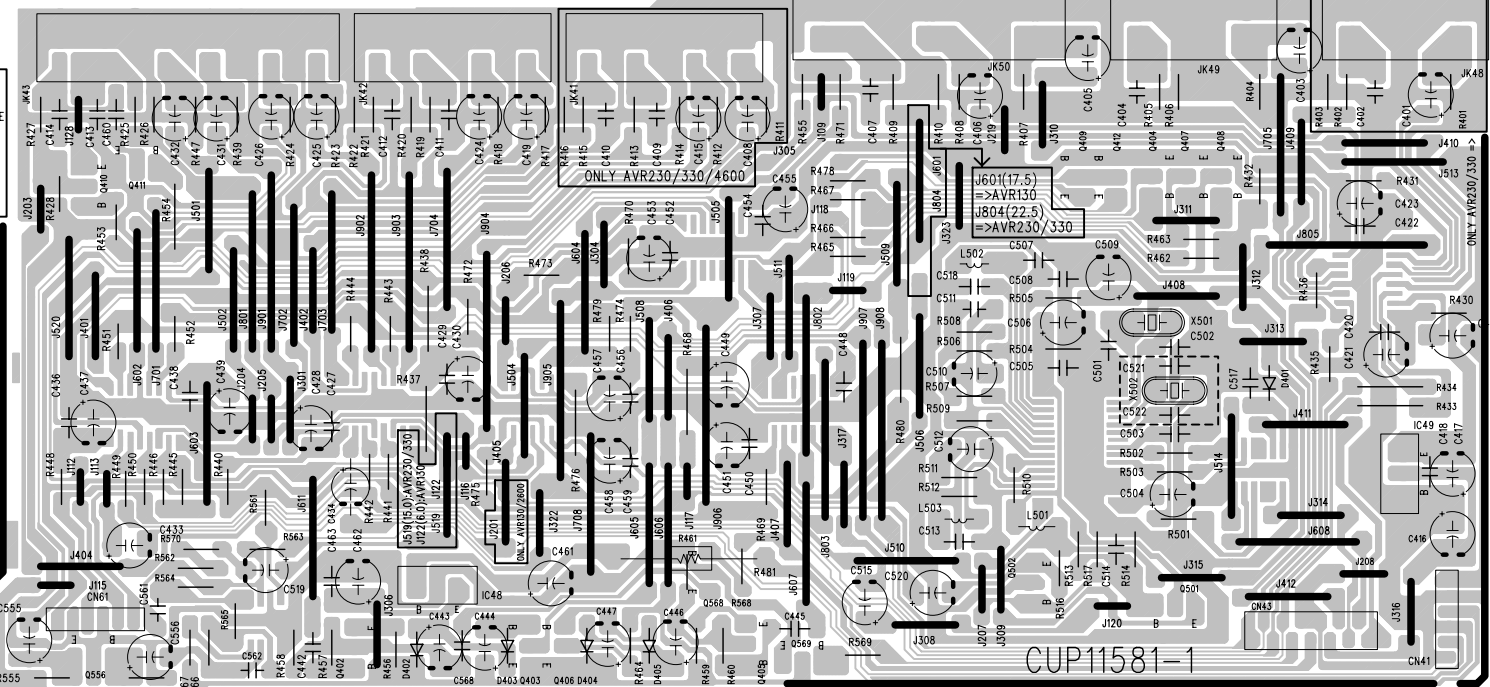
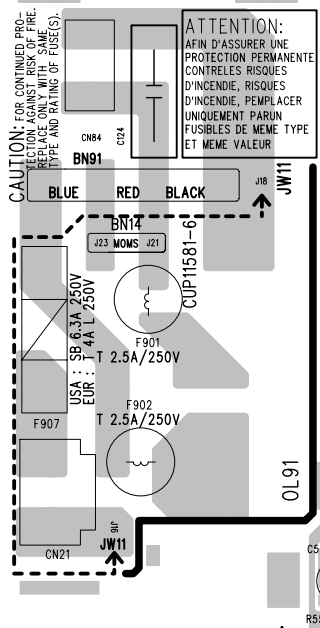
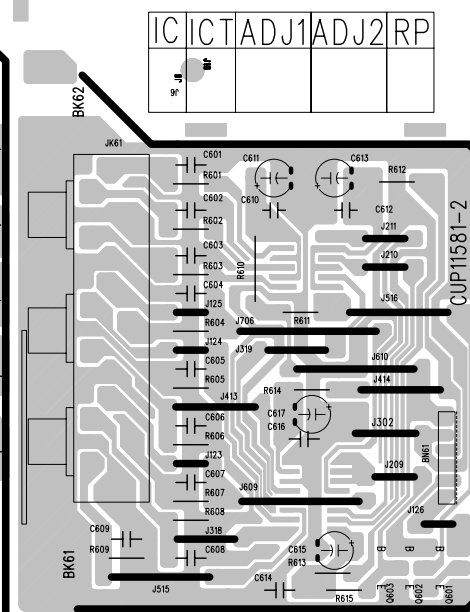
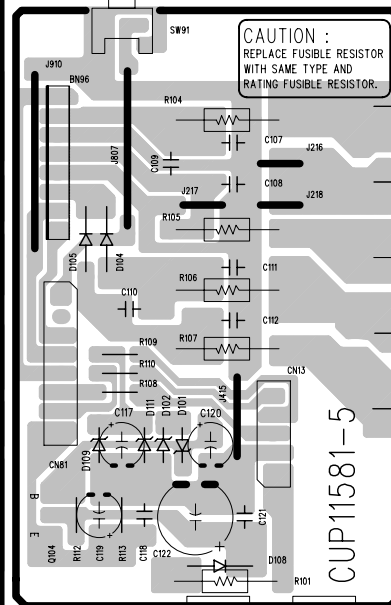
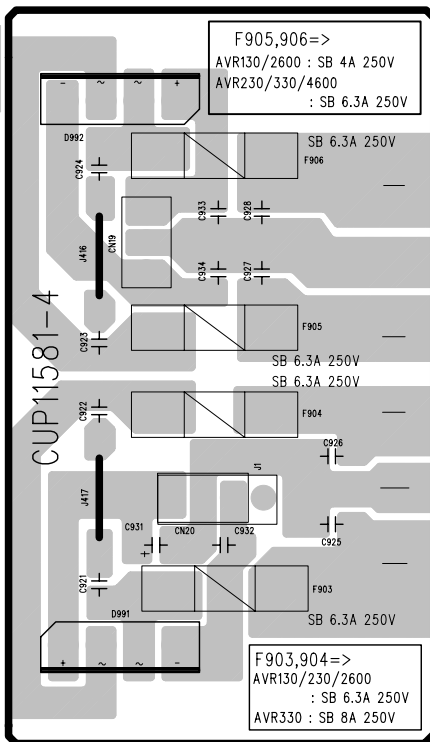
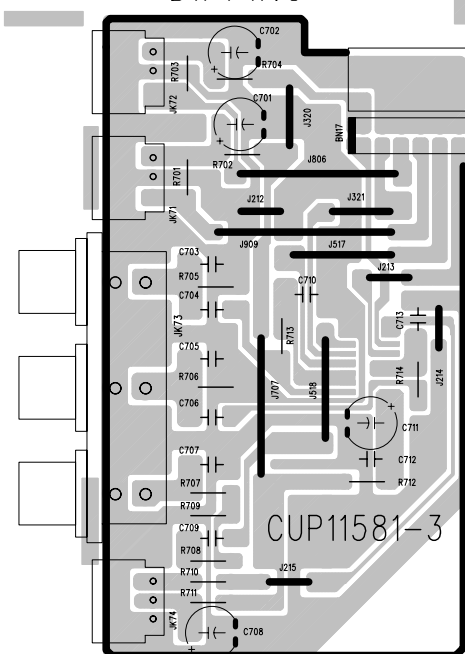

CENTER BAR CENTER BAR

CUP11581-1

VIDEO & COMPONENT & TRANS & OUTLET & DIGITAL BOARD

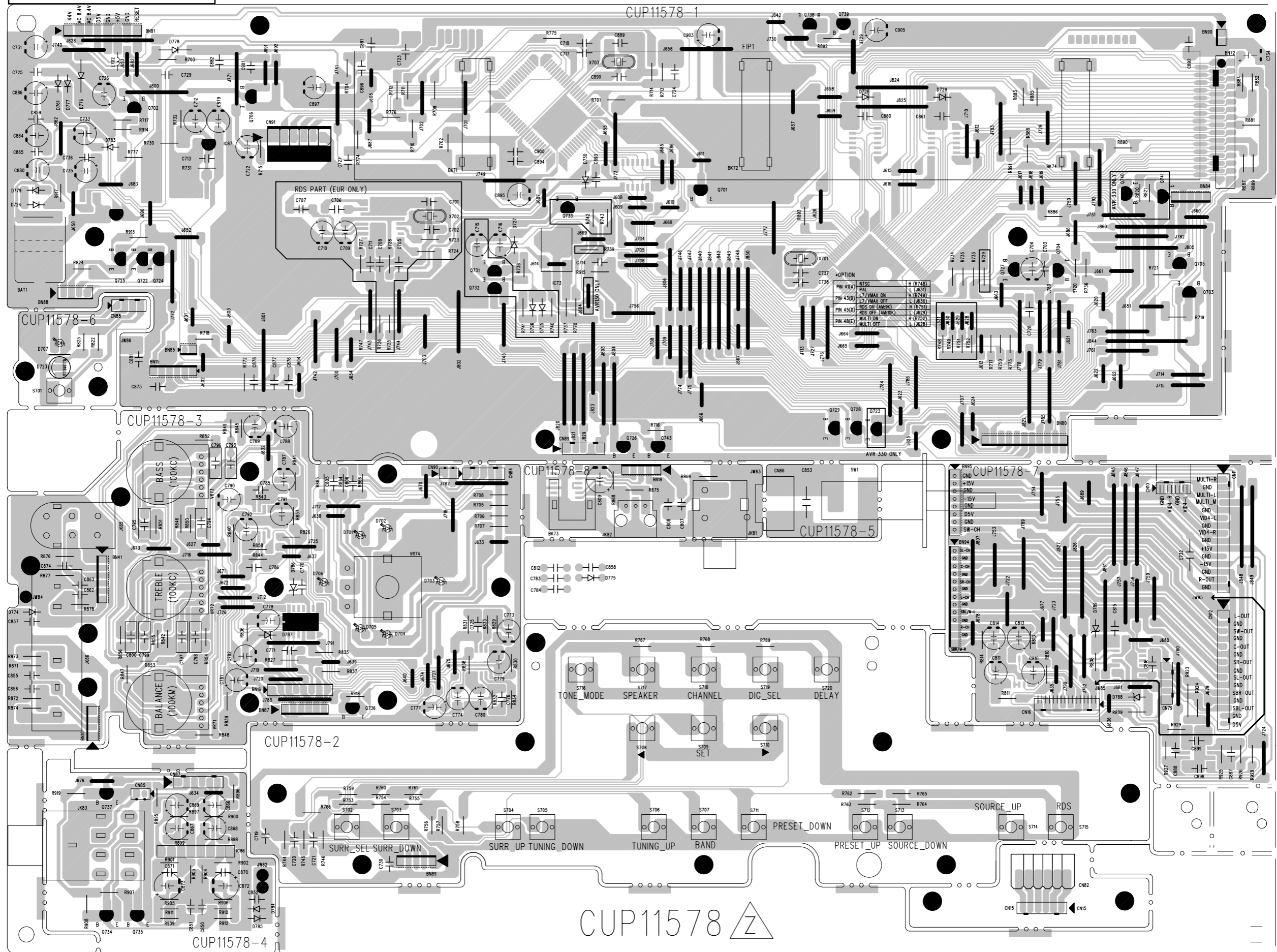

INPUT BOARD

BOTTOM VIEW

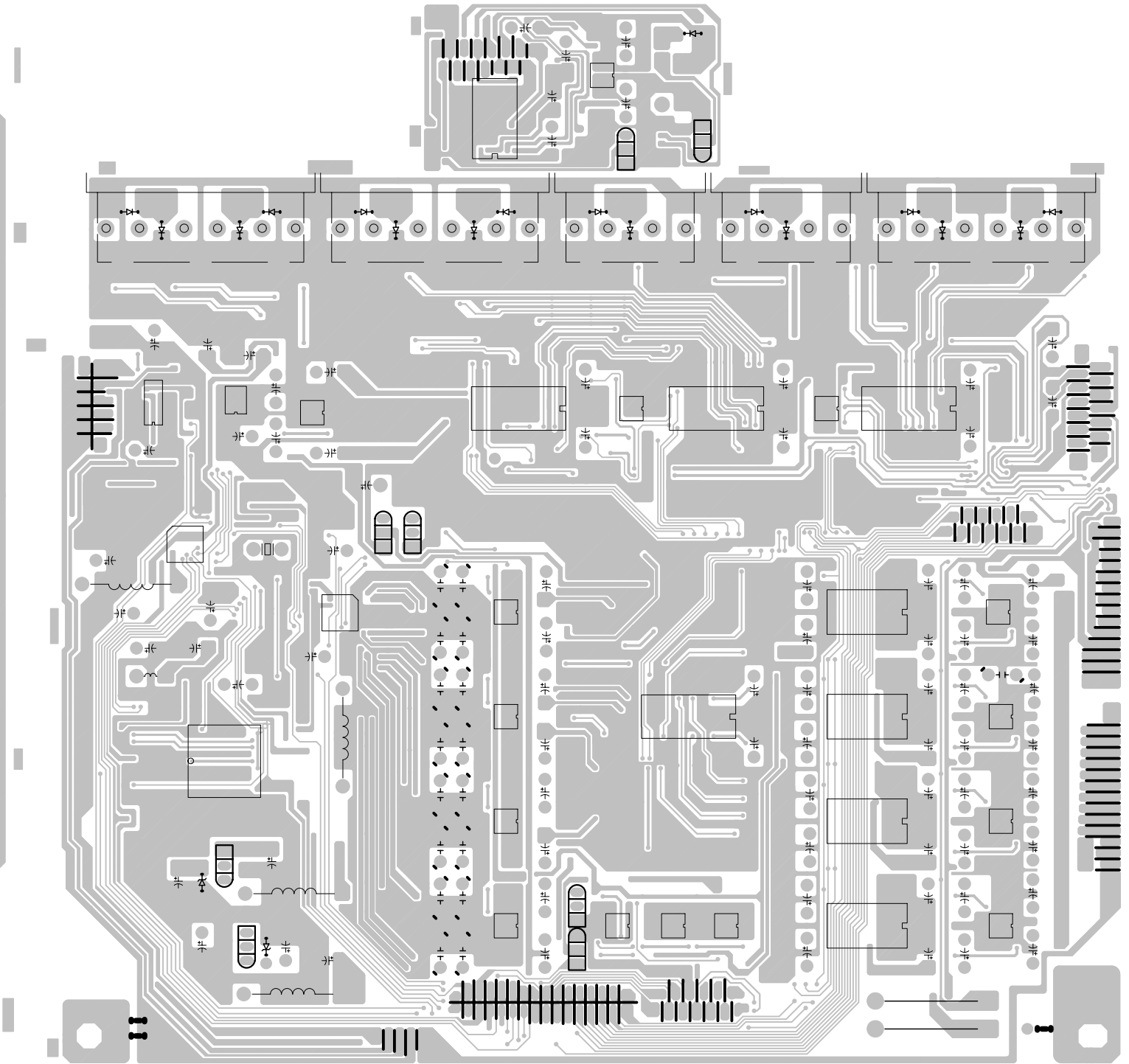

INPUT BOARD

TOP VIEW

VR2X
T B'D

DIPPING



IC ICT ADJ1 ADJ2 RP

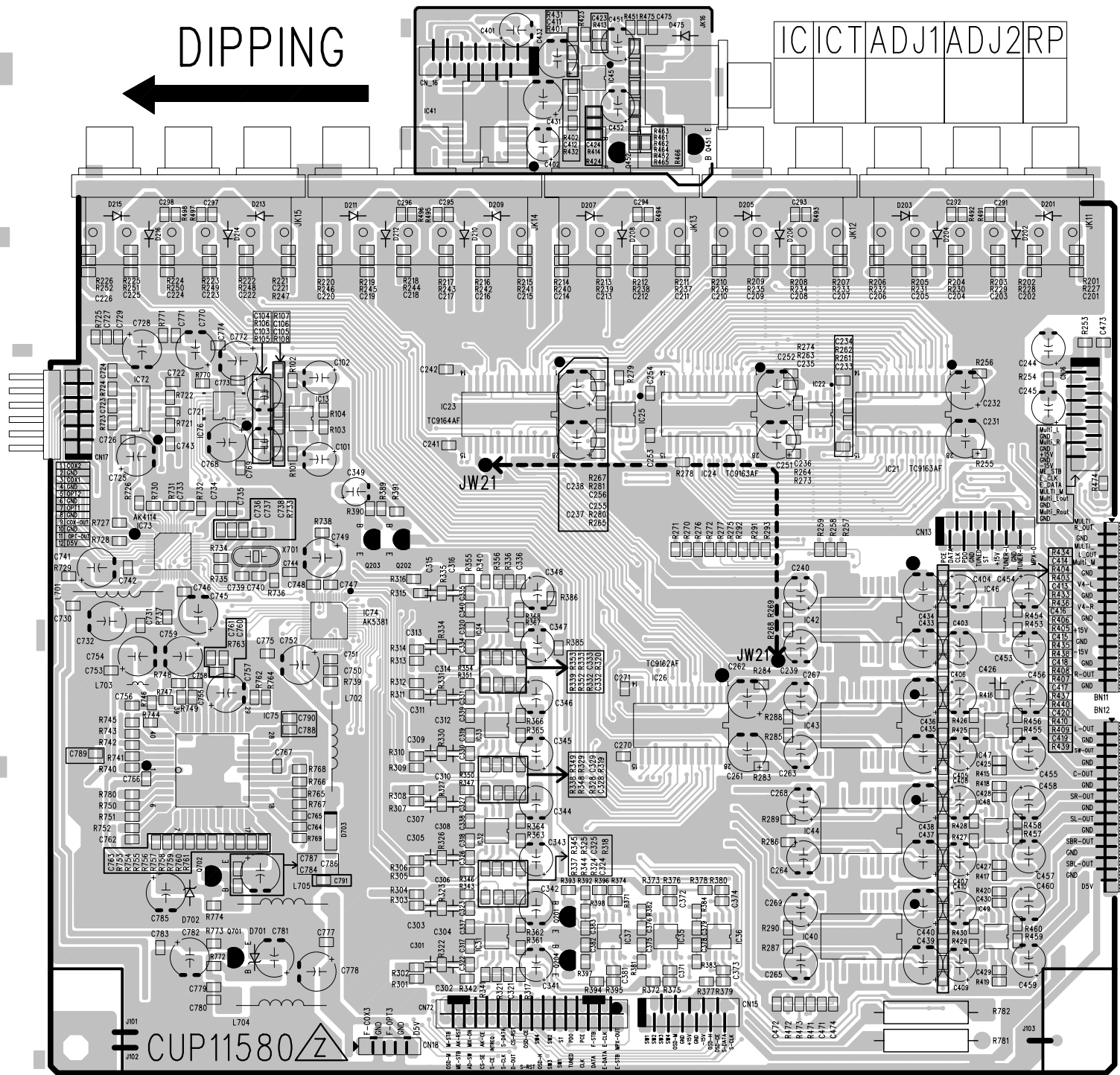

MAIN BOARD 1 (AMP)

CUP11579Z-8

AVR130 ONLY

CUP11579Z-5

-VCC CUP11579Z-6

CUP11579Z-7

+VCC

CUP11579Z-1

AVR330 ONLY

RENOTE
MUL-REM
3.0_GND
ST-1.5V

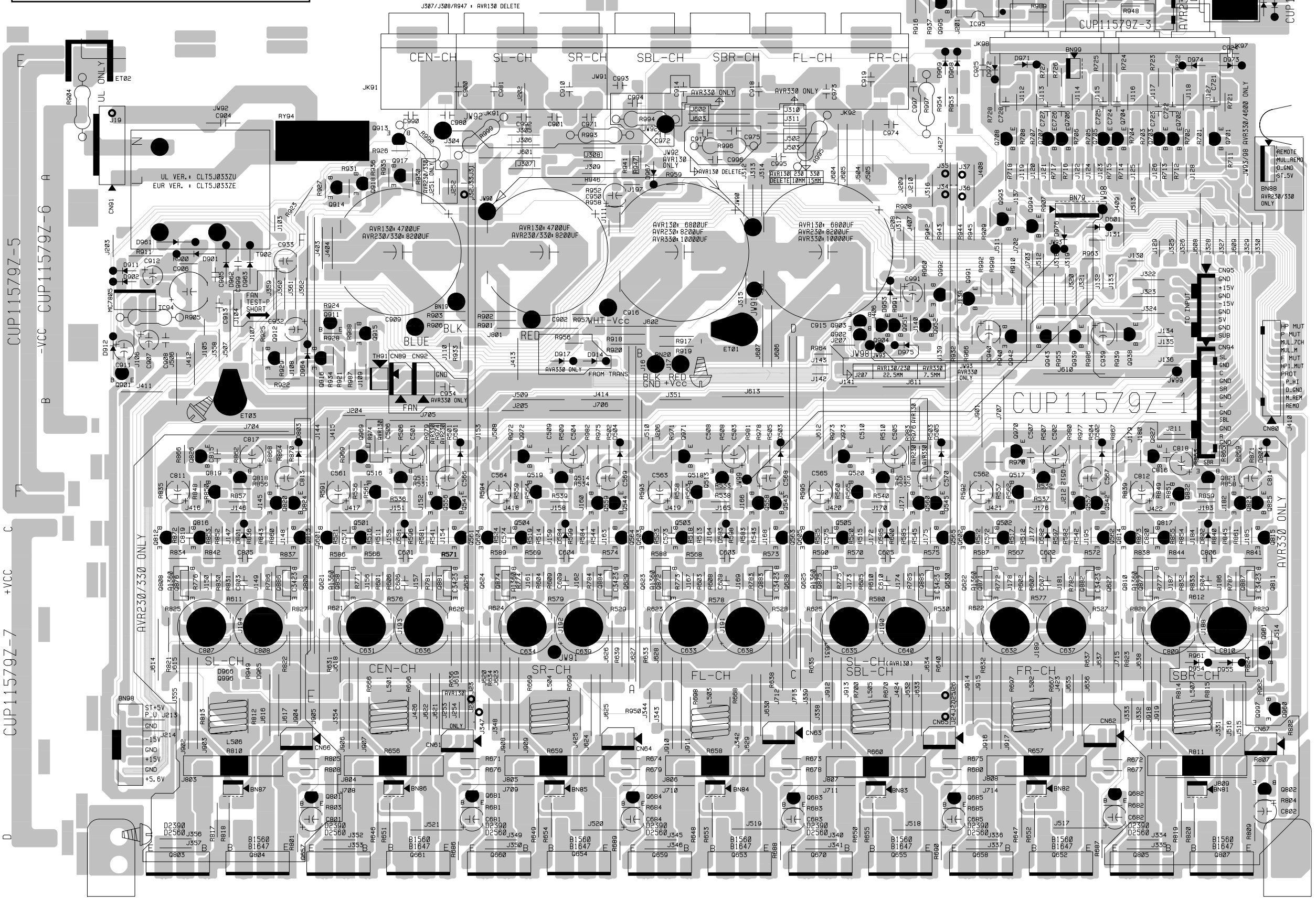

MAIN BOARD 2 (BIAS & REGULATOR)

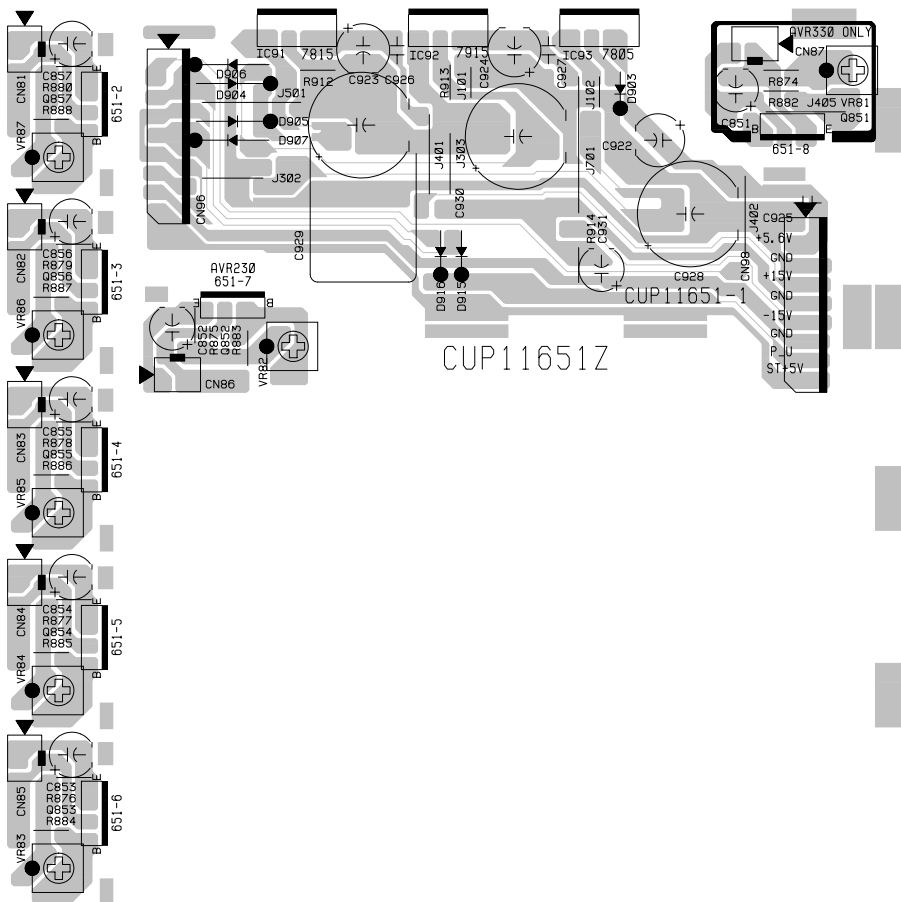

CUP11651-9

AVR330 Electrical Parts List			
Ref. Designator	Part Number	Description	
FRONT PCB ASS'Y			
<i>Capacitors</i>			
C703	HCBS1H821KBT	CAP , CERAMIC	820PF 50V K
C704	HCEA1VH100T	CAP , ELECT	10UF 35V
C712	HCEA1HH1R0T	CAP , ELECT	1UF 50V
C713	HCBS1H223ZFT	CAP , CERAMIC	0.022UF 50V Z
C714	HCBS1H151KBT	CAP , CERAMIC	150PF 50V K
C715	HCEA1HH4R7T	CAP , ELECT	4.7UF 50V
C716	HCEA1CH331T	CAP , ELECT	330UF 16V
C717	HCBS1H221KBT	CAP , CERAMIC	220PF 50V K
C718	HCBS1H221KBT	CAP , CERAMIC	220PF 50V K
C719	HCBS1H181KBT	CAP , CERAMIC	180PF 50V K
C720	HCBS1H181KBT	CAP , CERAMIC	180PF 50V K
C721	HCBS1H181KBT	CAP , CERAMIC	180PF 50V K
C722	HCEA1CH101T	CAP , ELECT	100UF 16V
C723	HCBS1H104ZFT	CAP , CERAMIC	0.1UF 50V Z
C724	HCBS1H223ZFT	CAP , CERAMIC	0.022UF 50V Z
C725	CCKT1H473ZF	CAP , CERAMIC	0.047UF 50V ZF
C726	HCEA0JH102T	CAP , ELECT	1000UF 6.3V
C727	HCBS1H221KBT	CAP , CERAMIC	220PF 50V K
C728	HCBS1H104ZFT	CAP , CERAMIC	0.1UF 50V Z
C729	CCKT1H473ZF	CAP , CERAMIC	0.047UF 50V ZF
C730	HCBS1H104ZFT	CAP , CERAMIC	0.1UF 50V Z
C731	HCEA1HH100T	CAP , ELECT	10UF 50V
C732	HCBS1H104ZFT	CAP , CERAMIC	0.1UF 50V Z
C733	HCEA1EH470T	CAP , ELECT	47UF 25V
C735	HCEA1VH100T	CAP , ELECT	10UF 35V
C736	HCBS1H223ZFT	CAP , CERAMIC	0.022UF 50V Z
C737	HCBS1H180JT	CAP , CERAMIC	18PF 50V
C738	HCBS1H180JT	CAP , CERAMIC	18PF 50V
C770	HCBS1H223ZFT	CAP , CERAMIC	0.022UF 50V Z
C771	HCBS1H223ZFT	CAP , CERAMIC	0.022UF 50V Z
C773	HCEA1VH100T	CAP , ELECT	10UF 35V
C774	HCEA1VH100T	CAP , ELECT	10UF 35V
C775	HCBS1H151KBT	CAP , CERAMIC	150PF 50V K
C776	HCBS1H151KBT	CAP , CERAMIC	150PF 50V K
C777	HCEA1VH100T	CAP , ELECT	10UF 35V
C778	HCEA1VH100T	CAP , ELECT	10UF 35V
C779	HCEA1CKS470T	CAP , ELECT	47UF 16V
C780	HCEA1CKS470T	CAP , ELECT	47UF 16V
C781	HCEA1CKS100T	CAP , ELECT	10UF 16V
C782	HCEA1CKS100T	CAP , ELECT	10UF 16V
C785	HCBS1H470JT	CAP , CERAMIC	47PF 50V J
C786	HCBS1H470JT	CAP , CERAMIC	47PF 50V J
C787	HCEA1CKS100T	CAP , ELECT	10UF 16V
C788	HCEA1CKS100T	CAP , ELECT	10UF 16V
C789	HCEA1CKS100T	CAP , ELECT	10UF 16V
C790	HCEA1CKS100T	CAP , ELECT	10UF 16V
C791	HCEA1CKS470T	CAP , ELECT	47UF 16V
C792	HCEA1CKS470T	CAP , ELECT	47UF 16V
C793	KCFE1J183JBT	CAP , FILM	0.018UF 63V J
C794	KCFE1J183JBT	CAP , FILM	0.018UF 63V J
C795	KCFE1J823JBT	CAP , FILM	0.082UF 63V J
C796	KCFE1J823JBT	CAP , FILM	0.082UF 63V J
C797	KCFE1J332JBT	CAP , FILM	0.0033UF 63V J
C798	KCFE1J332JBT	CAP , FILM	0.0033UF 63V J
C799	KCFE1J183JBT	CAP , FILM	0.018UF 63V J
C800	KCFE1J183JBT	CAP , FILM	0.018UF 63V J

Ref. Designator	Part Number	Description	
		FRONT PCB ASS'Y	
C805	HCBS1H223ZFT	CAP , CERAMIC	0.022UF 50V Z
C806	HCBS1H223ZFT	CAP , CERAMIC	0.022UF 50V Z
C807	CCKT1H104ZF	CAP , CERAMIC	50V 0.1UF
C808	CCKT1H181KB	CAP , CERAMIC	180PF 50V KB
C809	HCEA1AH471T	CAP , ELECT	470UF 10V
C810	HCEA1CH101T	CAP , ELECT	100UF 16V
C811	HCEA1CH101T	CAP , ELECT	100UF 16V
C812	HCBS1H104ZFT	CAP , CERAMIC	0.1UF 50V Z
C813	HCEA1HH4R7T	CAP , ELECT	4.7UF 50V
C814	HCEA1HH4R7T	CAP , ELECT	4.7UF 50V
C815	HCBS1H223ZFT	CAP , CERAMIC	0.022UF 50V Z
C816	HCBS1H223ZFT	CAP , CERAMIC	0.022UF 50V Z
C850	HCBS1H471KBT	CAP , CERAMIC	470PF 50V
C851	HCBS1H471KBT	CAP , CERAMIC	470PF 50V
C852	HCBS1H104ZFT	CAP , CERAMIC	0.1UF 50V Z
C855	HCBS1H101KBT	CAP , CERAMIC	100PF 50V K
C856	HCBS1H101KBT	CAP , CERAMIC	100PF 50V K
C857	HCBS1H104ZFT	CAP , CERAMIC	0.1UF 50V Z
C858	HCBS1H223ZFT	CAP , CERAMIC	0.022UF 50V Z
C859	HCBS1H223ZFT	CAP , CERAMIC	0.022UF 50V Z
C860	HCBS1H223ZFT	CAP , CERAMIC	0.022UF 50V Z
C861	HCBS1H223ZFT	CAP , CERAMIC	0.022UF 50V Z
C862	HCBS1H101KBT	CAP , CERAMIC	100PF 50V K
C863	HCBS1H101KBT	CAP , CERAMIC	100PF 50V K
C864	HCEA1VH100T	CAP , ELECT	10UF 35V
C865	CCKT1H473ZF	CAP , CERAMIC	0.047UF 50V ZF
C866	HCEA1CKS100T	CAP , ELECT	10UF 16V
C867	HCEA1CKS100T	CAP , ELECT	10UF 16V
C868	HCEA1CKS470T	CAP , ELECT	47UF 16V
C869	HCEA1CKS470T	CAP , ELECT	47UF 16V
C870	HCBS1H681KBT	CAP , CERAMIC	680PF 50V
C871	HCBS1H681KBT	CAP , CERAMIC	680PF 50V
C872	HCEA1CH331T	CAP , ELECT	330UF 16V
C873	HCEA1CH331T	CAP , ELECT	330UF 16V
C874	HCBS1H101KBT	CAP , CERAMIC	100PF 50V K
C875	HCBS1H473ZFT	CAP , CERAMIC	0.047UF 50V Z
C876	HCBS1H473ZFT	CAP , CERAMIC	0.047UF 50V Z
C877	HCBS1H473ZFT	CAP , CERAMIC	0.047UF 50V Z
C878	HCBS1H473ZFT	CAP , CERAMIC	0.047UF 50V Z
C880	HCEA1AH221T	CAP , ELECT	220UF 10V
C882	HCBS1H104ZFT	CAP , CERAMIC	0.1UF 50V Z
C886	HCEA0JH102T	CAP , ELECT	1000UF 6.3V
C889	HCBS1H220JT	CAP , CERAMIC	22PF 50V
C890	HCBS1H220JT	CAP , CERAMIC	22PF 50V
C891	HCBS1H223ZFT	CAP , CERAMIC	0.022UF 50V Z
C892	HCBS1H223ZFT	CAP , CERAMIC	0.022UF 50V Z
C893	HCBS1H223ZFT	CAP , CERAMIC	0.022UF 50V Z
C894	HCBS1H223ZFT	CAP , CERAMIC	0.022UF 50V Z
C895	HCEA1AH471T	CAP , ELECT	470UF 10V
C896	HCBS1H223ZFT	CAP , CERAMIC	0.022UF 50V Z
C897	HCEA1AH471T	CAP , ELECT	470UF 10V
C900	HCBS1H104ZFT	CAP , CERAMIC	0.1UF 50V Z
C902	HCEA1HH2R2T	CAP , ELECT	2.2UF 50V
C853	KCKDKS472ME	CAP , CERAMIC(X1/Y2/SC)	0.0047UF/2.5KV
<i>Semiconductors</i>			
D724	HVD1SS133MT	DIODE	1SS133T-77
D725	HVD1SS133MT	DIODE	1SS133T-77
D726	HVD1SS133MT	DIODE	1SS133T-77
D727	HVD1SS133MT	DIODE	1SS133T-77

Ref. Designator	Part Number	Description	
		FRONT PCB ASS'Y	
D728	HVD1SS133MT	DIODE	1SS133T-77
D729	HVD1SS133MT	DIODE	1SS133T-77
D730	HVD1SS133MT	DIODE	1SS133T-77
D761	HVD1SS133MT	DIODE	1SS133T-77
D774	HVD1SS133MT	DIODE	1SS133T-77
D775	HVD1SS133MT	DIODE	1SS133T-77
D776	KVD1N4003ST	DIODE	1N4003
D777	HVD1SS133MT	DIODE	1SS133T-77
D778	KVD1N4003ST	DIODE	1N4003
D779	HVD1SS133MT	DIODE	1SS133T-77
D783	HVD1SS133MT	DIODE	1SS133T-77
D784	HVD1SS133MT	DIODE	1SS133T-77
D785	HVD1SS133MT	DIODE	1SS133T-77
D786	HVDMTZJ5.6BT	DIODE , ZENER	5.6V ZENER
D787	HVDMTZJ5.6BT	DIODE , ZENER	5.6V ZENER
D788	HVDMTZJ5.6BT	DIODE , ZENER	5.6V ZENER
D789	HVDMTZJ5.6BT	DIODE , ZENER	5.6V ZENER
IC87	HVIRE5VL28CATZ	IC , RESET	2.8V I.C , RESET
Q701	HVTKRC107MT	TRANSISTOR NPN	KRC107M
Q702	HVTKRC107MT	TRANSISTOR NPN	KRC107M
Q703	HVTKRC107MT	TRANSISTOR NPN	KRC107M
Q704	HVTKRC107MT	TRANSISTOR NPN	KRC107M
Q705	HVTKRC107MT	TRANSISTOR NPN	KRC107M
Q706	HVTKRC107MT	TRANSISTOR NPN	KRC107M
Q722	HVTKRA107MT	TRANSISTOR NPN	KRA107M
Q723	HVTKRC107MT	TRANSISTOR NPN	KRC107M
Q724	HVTKRC107MT	TRANSISTOR NPN	KRC107M
Q725	HVTKRC107MT	TRANSISTOR NPN	KRC107M
Q726	HVTKRC107MT	TRANSISTOR NPN	KRC107M
Q727	HVTKRC107MT	TRANSISTOR NPN	KRC107M
Q728	HVTKRC107MT	TRANSISTOR NPN	KRC107M
Q729	HVTKRC107MT	TRANSISTOR NPN	KRC107M
Q731	KVTKSA1175YT	TRANSISTOR NPN	KSA1175Y
Q732	HVTKRC107MT	TRANSISTOR NPN	KRC107M
Q733	KVTKSC2785YT	TRANSISTOR NPN	KSC2785Y
Q734	HVTKTC2874BT	TRANSISTOR , NPN, MUTE	KTC2874B
Q735	HVTKTC2874BT	TRANSISTOR , NPN, MUTE	KTC2874B
Q736	HVTKTC2874BT	TRANSISTOR , NPN, MUTE	KTC2874B
Q737	HVTKTC2874BT	TRANSISTOR , NPN, MUTE	KTC2874B
Q738	HVTKRC107MT	TRANSISTOR NPN	KRC107M
Q739	HVTKTA1271YT	TRANSISTOR PNP	KTA1271Y
Q740	HVTKRC107MT	TRANSISTOR NPN	KRC107M
Q741	HVTKRC107MT	TRANSISTOR NPN	KRC107M
Q743	HVTKRA107MT	TRANSISTOR NPN	KRA107M
D702	CVD52CSBBCEAB2	BLUE L.E.D	
D703	CVD52CSBBCEAB2	BLUE L.E.D	
D704	CVD52CSBBCEAB2	BLUE L.E.D	
D706	CVD52CSBBCEAB2	BLUE L.E.D	
D707	CVD52CSBBCEAB2	BLUE L.E.D	
D723	CVD50BOBBWGA	L.E.D , 2 COLOR	
IC72	BVIMB90F482APFG	IC , FLASH U-COM	FUJITSU
IC73	HRVRPM6938H4	SENSOR , REMOTE	RPM6938-H4
IC74	HVIS3F84BB330	I.C , FLASH U-COM	S3F84BB
IC75	HVI74ACT04MTR	I.C , HEX	
IC76	HVITC74HCU04AFN	IC , INVERTER	TC74HCU04AFN
IC80	HVIHCF4053M013T	I.C	S.T
IC81	HVINJM2068MDTE1	I.C , OP AMP	NJM2068MD-TE1
IC82	HVINJM2068MDTE1	I.C , OP AMP	NJM2068MD-TE1
IC83	HVI74ACT04MTR	I.C , HEX	
IC84	HVI74ACT04MTR	I.C , HEX	
IC85	HVIRH5VT18C	I.C , RESET	1.8V I.C , RESET

Ref. Designator	Part Number	Description	
		FRONT PCB ASS'Y	
IC86	HVINJM4556AL	I.C	NJM4556AL
IC88	HVINJM2068MDTE1	I.C , OP AMP	NJM2068MD-TE1
IC89	HVIHCF4053M013T	I.C	S.T
<i>Resistors</i>			
R701	CRD20TJ103T	RES , CARBON	10K OHM 1/5W J
R702	CRD20TJ1R0T	RES , CARBON	1 OHM 1/5W J
R704	CRD20TJ100T	RES , CARBON	10 OHM 1/5W J
R705	CRD20TJ820T	RES , CARBON	82 OHM 1/5W J
R706	CRD20TJ820T	RES , CARBON	82 OHM 1/5W J
R707	CRD20TJ820T	RES , CARBON	82 OHM 1/5W J
R708	CRD20TJ820T	RES , CARBON	82 OHM 1/5W J
R709	CRD20TJ470T	RES , CARBON	47 OHM 1/5W J
R710	CRD20TJ470T	RES , CARBON	47 OHM 1/5W J
R711	CRD20TJ470T	RES , CARBON	47 OHM 1/5W J
R712	CRD20TJ470T	RES , CARBON	47 OHM 1/5W J
R713	CRD20TJ332T	RES , CARBON	3.3K OHM 1/5W J
R714	CRD20TJ470T	RES , CARBON	47 OHM 1/5W J
R715	CRD20TJ470T	RES , CARBON	47 OHM 1/5W J
R716	CRD20TJ102T	RES , CARBON	1K OHM 1/5W J
R717	CRD20TJ103T	RES , CARBON	10K OHM 1/5W J
R718	CRD20TJ222T	RES , CARBON	2.2K OHM 1/5W J
R719	CRD20TJ102T	RES , CARBON	1K OHM 1/5W J
R720	CRD20TJ102T	RES , CARBON	1K OHM 1/5W J
R721	CRD20TJ103T	RES , CARBON	10K OHM 1/5W J
R729	CRD20TJ103T	RES , CARBON	10K OHM 1/5W J
R730	CRD20TJ112T	RES , CARBON	1.1K OHM 1/5W J
R731	CRD20TJ223T	RES , CARBON	22K OHM 1/5W J
R732	CRD20TJ202T	RES , CARBON	2K OHM 1/5W J
R733	CRD20TJ272T	RES , CARBON	2.7K OHM 1/5W J
R734	CRD20TJ103T	RES , CARBON	10K OHM 1/5W J
R735	CRD20TJ103T	RES , CARBON	10K OHM 1/5W J
R736	CRD20TJ272T	RES , CARBON	2.7K OHM 1/5W J
R737	CRD20TJ100T	RES , CARBON	10 OHM 1/5W J
R738	CRD20TJ103T	RES , CARBON	10K OHM 1/5W J
R739	CRD20TJ103T	RES , CARBON	10K OHM 1/5W J
R740	CRD20TJ103T	RES , CARBON	10K OHM 1/5W J
R741	CRD20TJ103T	RES , CARBON	10K OHM 1/5W J
R742	CRD20TJ103T	RES , CARBON	10K OHM 1/5W J
R743	CRD20TJ103T	RES , CARBON	10K OHM 1/5W J
R744	CRD20TJ103T	RES , CARBON	10K OHM 1/5W J
R745	CRD20TJ103T	RES , CARBON	10K OHM 1/5W J
R746	CRD20TJ103T	RES , CARBON	10K OHM 1/5W J
R747	CRD20TJ103T	RES , CARBON	10K OHM 1/5W J
R748	CRD20TJ223T	RES , CARBON	22K OHM 1/5W J
R750	CRD20TJ223T	RES , CARBON	22K OHM 1/5W J
R752	CRD20TJ223T	RES , CARBON	22K OHM 1/5W J
R753	CRD20TJ102T	RES , CARBON	1K OHM 1/5W J
R754	CRD20TJ152T	RES , CARBON	1.5K OHM 1/5W J
R755	CRD20TJ182T	RES , CARBON	1.8K OHM 1/5W J
R756	CRD20TJ272T	RES , CARBON	2.7K OHM 1/5W J
R757	CRD20TJ332T	RES , CARBON	3.3K OHM 1/5W J
R758	CRD20TJ562T	RES , CARBON	5.6K OHM 1/5W J
R759	CRD20TJ102T	RES , CARBON	1K OHM 1/5W J
R760	CRD20TJ152T	RES , CARBON	1.5K OHM 1/5W J
R761	CRD20TJ182T	RES , CARBON	1.8K OHM 1/5W J
R762	CRD20TJ272T	RES , CARBON	2.7K OHM 1/5W J
R763	CRD20TJ332T	RES , CARBON	3.3K OHM 1/5W J
R764	CRD20TJ562T	RES , CARBON	5.6K OHM 1/5W J
R765	CRD20TJ752T	RES , CARBON	7.5K OHM 1/5W J

Ref. Designator	Part Number	Description	
		FRONT PCB ASS'Y	
R766	CRD20TJ102T	RES , CARBON	1K OHM 1/5W J
R767	CRD20TJ152T	RES , CARBON	1.5K OHM 1/5W J
R768	CRD20TJ182T	RES , CARBON	1.8K OHM 1/5W J
R769	CRD20TJ272T	RES , CARBON	2.7K OHM 1/5W J
R770	CRD20TJ100T	RES , CARBON	10 OHM 1/5W J
R771	CRD20TJ103T	RES , CARBON	10K OHM 1/5W J
R772	CRD20TJ103T	RES , CARBON	10K OHM 1/5W J
R773	CRD20TJ103T	RES , CARBON	10K OHM 1/5W J
R774	CRD20TJ222T	RES , CARBON	2.2K OHM 1/5W J
R775	CRD20TJ470T	RES , CARBON	47 OHM 1/5W J
R776	CRD20TJ470T	RES , CARBON	47 OHM 1/5W J
R777	CRD20TJ100T	RES , CARBON	10 OHM 1/5W J
R808	CRD20TJ102T	RES , CARBON	1K OHM 1/5W J
R809	CRD20TJ102T	RES , CARBON	1K OHM 1/5W J
R810	CRD20TJ101T	RES , CARBON	100 OHM 1/5W J
R811	CRD20TJ101T	RES , CARBON	100 OHM 1/5W J
R813	CRD20TJ104T	RES , CARBON	100K OHM 1/5W J
R814	CRD20TJ104T	RES , CARBON	100K OHM 1/5W J
R820	CRD20TJ103T	RES , CARBON	10K OHM 1/5W J
R821	CRD20TJ103T	RES , CARBON	10K OHM 1/5W J
R822	CRD20TJ471T	RES , CARBON	470 OHM 1/5W J
R824	CRD20TJ820T	RES , CARBON	82 OHM 1/5W J
R825	CRD20TJ181T	RES , CARBON	180 OHM 1/5W J
R826	CRD20TJ102T	RES , CARBON	1K OHM 1/5W J
R827	CRD20TJ102T	RES , CARBON	1K OHM 1/5W J
R829	CRD20TJ184T	RES , CARBON	180K OHM 1/5W J
R830	CRD20TJ184T	RES , CARBON	180K OHM 1/5W J
R831	CRD20TJ562T	RES , CARBON	5.6K OHM 1/5W J
R832	CRD20TJ562T	RES , CARBON	5.6K OHM 1/5W J
R833	CRD20TJ102T	RES , CARBON	1K OHM 1/5W J
R834	CRD20TJ102T	RES , CARBON	1K OHM 1/5W J
R835	CRD20TJ184T	RES , CARBON	180K OHM 1/5W J
R836	CRD20TJ184T	RES , CARBON	180K OHM 1/5W J
R837	CRD20TJ101T	RES , CARBON	100 OHM 1/5W J
R838	CRD20TJ101T	RES , CARBON	100 OHM 1/5W J
R839	CRD20TJ104T	RES , CARBON	100K OHM 1/5W J
R840	CRD20TJ104T	RES , CARBON	100K OHM 1/5W J
R841	CRD20TJ473T	RES , CARBON	47K OHM 1/5W J
R842	CRD20TJ473T	RES , CARBON	47K OHM 1/5W J
R843	CRD20TJ105T	RES , CARBON	1M OHM 1/5W J
R844	CRD20TJ105T	RES , CARBON	1M OHM 1/5W J
R845	CRD20TJ104T	RES , CARBON	100K OHM 1/5W J
R846	CRD20TJ104T	RES , CARBON	100K OHM 1/5W J
R847	CRD20TJ102T	RES , CARBON	1K OHM 1/5W J
R848	CRD20TJ102T	RES , CARBON	1K OHM 1/5W J
R849	CRD20TJ223T	RES , CARBON	22K OHM 1/5W J
R850	CRD20TJ223T	RES , CARBON	22K OHM 1/5W J
R851	CRD20TJ392T	RES , CARBON	3.9K OHM 1/5W J
R852	CRD20TJ392T	RES , CARBON	3.9K OHM 1/5W J
R853	CRD20TJ222T	RES , CARBON	2.2K OHM 1/5W J
R854	CRD20TJ222T	RES , CARBON	2.2K OHM 1/5W J
R855	CRD20TJ681T	RES , CARBON	680 OHM 1/5W J
R856	CRD20TJ681T	RES , CARBON	680 OHM 1/5W J
R857	CRD20TJ221T	RES , CARBON	220 OHM 1/5W J
R858	CRD20TJ221T	RES , CARBON	220 OHM 1/5W J
R864	CRD20TJ272T	RES , CARBON	2.7K OHM 1/5W J
R865	CRD20TJ102T	RES , CARBON	1K OHM 1/5W J
R866	CRD20TJ272T	RES , CARBON	2.7K OHM 1/5W J
R868	CRD20TJ1R0T	RES , CARBON	1 OHM 1/5W J
R869	CRD20TJ750T	RES , CARBON	75 OHM 1/5W J
R871	CRD20TJ104T	RES , CARBON	100K OHM 1/5W J

Ref. Designator	Part Number	Description	
		FRONT PCB ASS'Y	
R872	CRD20TJ104T	RES , CARBON	100K OHM 1/5W J
R873	CRD20TJ471T	RES , CARBON	470 OHM 1/5W J
R874	CRD20TJ471T	RES , CARBON	470 OHM 1/5W J
R875	CRD20TJ103T	RES , CARBON	10K OHM 1/5W J
R876	CRD20TJ750T	RES , CARBON	75 OHM 1/5W J
R877	CRD20TJ750T	RES , CARBON	75 OHM 1/5W J
R878	CRD20TJ750T	RES , CARBON	75 OHM 1/5W J
R881	CRD20TJ103T	RES , CARBON	10K OHM 1/5W J
R882	CRD20TJ103T	RES , CARBON	10K OHM 1/5W J
R883	CRD20TJ103T	RES , CARBON	10K OHM 1/5W J
R884	CRD20TJ103T	RES , CARBON	10K OHM 1/5W J
R885	CRD20TJ103T	RES , CARBON	10K OHM 1/5W J
R886	CRD20TJ103T	RES , CARBON	10K OHM 1/5W J
R887	CRD20TJ103T	RES , CARBON	10K OHM 1/5W J
R888	CRD20TJ103T	RES , CARBON	10K OHM 1/5W J
R889	CRD20TJ103T	RES , CARBON	10K OHM 1/5W J
R890	CRD20TJ103T	RES , CARBON	10K OHM 1/5W J
R891	CRD20TJ103T	RES , CARBON	10K OHM 1/5W J
R892	CRD20TJ222T	RES , CARBON	2.2K OHM 1/5W J
R893	CRD20TJ333T	RES , CARBON	33K OHM 1/5W J
R895	CRD20TJ101T	RES , CARBON	100 OHM 1/5W J
R896	CRD20TJ101T	RES , CARBON	100 OHM 1/5W J
R897	CRD20TJ101T	RES , CARBON	100 OHM 1/5W J
R898	CRD20TJ101T	RES , CARBON	100 OHM 1/5W J
R899	CRD20TJ104T	RES , CARBON	100K OHM 1/5W J
R900	CRD20TJ104T	RES , CARBON	100K OHM 1/5W J
R901	CRD20TJ152T	RES , CARBON	1.5K OHM 1/5W J
R902	CRD20TJ152T	RES , CARBON	1.5K OHM 1/5W J
R903	CRD20TJ102T	RES , CARBON	1K OHM 1/5W J
R904	CRD20TJ102T	RES , CARBON	1K OHM 1/5W J
R905	CRD20TJ104T	RES , CARBON	100K OHM 1/5W J
R906	CRD20TJ104T	RES , CARBON	100K OHM 1/5W J
R907	CRD20TJ562T	RES , CARBON	5.6K OHM 1/5W J
R908	CRD20TJ562T	RES , CARBON	5.6K OHM 1/5W J
R909	CRD20TJ221T	RES , CARBON	220 OHM 1/5W J
R910	CRD20TJ221T	RES , CARBON	220 OHM 1/5W J
R911	CRD20TJ221T	RES , CARBON	220 OHM 1/5W J
R912	CRD20TJ221T	RES , CARBON	220 OHM 1/5W J
R913	CRD20TJ102T	RES , CARBON	1K OHM 1/5W J
R914	CRD20TJ473T	RES , CARBON	47K OHM 1/5W J
R915	CRD20TJ473T	RES , CARBON	47K OHM 1/5W J
R917	CRD20TJ123T	RES , CARBON	12K OHM 1/5W J
R918	CRD20TJ562T	RES , CARBON	5.6K OHM 1/5W J
R919	CRD20TJ562T	RES , CARBON	5.6K OHM 1/5W J
VR71	CVV2X05M104Z	RES , VARIABLE(BALANCE)	RK14128030214Y
VR72	CVV2X07C104Z	RES , VARIABLE(TONE)	RK14128030214C
VR73	CVV2X07C104Z	RES , VARIABLE(TONE)	RK14128030214C
<i>Miscellaneous</i>			
VR74	HSR2A029Z	VR , ENCODER	
FIP1	HFLHCA18ML01	F.I.P	SAMSUNG S.D.I
L702	HLQ02C100KT	COIL , AXAIL	10 UH
S701	HST1A020ZT	SW , TACT	
S702	HST1A020ZT	SW , TACT	
S703	HST1A020ZT	SW , TACT	
S704	HST1A020ZT	SW , TACT	
S705	HST1A020ZT	SW , TACT	
S706	HST1A020ZT	SW , TACT	
S707	HST1A020ZT	SW , TACT	
S708	HST1A020ZT	SW , TACT	

Ref. Designator	Part Number	Description	
		FRONT PCB ASS'Y	
S709	HST1A020ZT	SW , TACT	
S710	HST1A020ZT	SW , TACT	
S711	HST1A020ZT	SW , TACT	
S712	HST1A020ZT	SW , TACT	
S713	HST1A020ZT	SW , TACT	
S714	HST1A020ZT	SW , TACT	
S715	HST1A020ZT	SW , TACT	
S716	HST1A020ZT	SW , TACT	
S717	HST1A020ZT	SW , TACT	
S718	HST1A020ZT	SW , TACT	
S719	HST1A020ZT	SW , TACT	
S720	HST1A020ZT	SW , TACT	
BAT1	HABGP40BVH3A3H	BATTERY , RECHARGEABLE	GP40BBVH3A3H
BK71	CMD1A209	BRACKET , FLT	A4-92-1739
BK72	CMD1A209	BRACKET , FLT	A4-92-1739
BK73	CMD1A387	BRACKET , PCB	
BK74	CMD1A209	BRACKET , FLT	A4-92-1739
BN10	CWZAVR230BN10	WIRE ASS'Y (SHIELD)	
BN15	CWB2B906150EN	WIRE ASS'Y	
BN16	CWZAVR2550BN16	WIRE ASS'Y (SHIELD)	
BN18	CWZAVR125BN18	WIRE ASS'Y (SHIELD)	
BN41	CWZAVR130BN41	WIRE ASS'Y (SHIELD)	
BN80	CWB2B911420EW	WIRE ASS'Y	
BN81	CWB2B908250BM	WIRE , ASS'Y	
BN84	CWB2B905080EN	WIRE ASS'Y	
BN85	CWB2B902090EN	WIRE ASS'Y	
BN87	CWZAVR2550BN87	WIRE ASS'Y (SHIELD)	
BN88	CWB2B904070EN	WIRE ASS'Y	
BN89	CWB2B905080EN	WIRE ASS'Y	
BN90	CWB2B902090EN	WIRE ASS'Y	
BN94	KJP13GB99ZM	CONNECTOR	MOLEX35237-1310
BN95	KJP08GB99ZM	CONNECTOR , HOUSING	MOLEX35237-0810
CN10	KJP04GB46ZM	WAFER	MOLEX 53015
CN11	KJP15GA98ZM	WAFER	MOLEX35336-1510
CN12	KJP15GA98ZM	WAFER	MOLEX35336-1510
CN15	KJP06GA19ZM	WAFER	MOLEX53014-0610
CN16	KJP08GB46ZM	WAFER	
CN72	KJP32GA161ZY	WAFER	YD200 SERIES
CN79	KJP05GA19ZM	WAFER	MOLEX53014-0510
CN82	KJP06HA37ZM	WAFER	MOLEX42140-2206
CN84	KJP05GA19ZM	WAFER	MOLEX53014-0510
CN85	KJP02GA19ZM	WAFER	
CN86	KJP02GA89ZM	WAFER	MOLEX35328-02
CN87	KJP06GA19ZM	WAFER	MOLEX53014-0610
CN88	KJP04GA19ZM	WAFER	
CN89	KJP05GA19ZM	WAFER	MOLEX53014-0510
CN90	KJP02GA19ZM	WAFER	
CN91	KJP06HA37ZM	WAFER	MOLEX42140-2206
JK81	CJJ4M041Y	JACK , BOARD (COAX)	
JK82	HJSTORX179L	MODULE , OPTICAL(RX)	TORX179L
JK83	CJJ2E026Z	JACK , HEADPHONE(SILVER PLATE)	
JK85	CJJ9M003Z	JACK , S-VIDEO	
JK86	CJJ4S023Y	JACK , BOARD	
JW82	CWZAVR2550JW82	WIRE , ASS'Y	
JW84	CWE8202110RV	WIRE , ASS'Y	
JW85	CWE8202070AA	WIRE ASS'Y	
SW01	CSH1A008ZV	SW , PUSH (MOMS)	
X701	HOX05000E160C	CRYSTAL	5 MHz
X703	HOX10000E220C	CRYSTAL	10 MHz
	CTB3+10G	SCREW	
	CTB3+16GFZ	SCREW	

Ref. Designator	Part Number	Description	
		MAIN PCB ASS'Y	
C723	CCKT1H221KB	CAP , MYLAR	220PF 50V KB
C724	CCKT1H221KB	CAP , MYLAR	220PF 50V KB
C725	CCKT1H221KB	CAP , MYLAR	220PF 50V KB
C726	CCKT1H221KB	CAP , MYLAR	220PF 50V KB
C727	CCKT1H221KB	CAP , MYLAR	220PF 50V KB
C728	CCKT1H221KB	CAP , MYLAR	220PF 50V KB
C801	HCEA1HH100T	CAP , ELECT	10UF 50V
C802	HCEA1HH100T	CAP , ELECT	10UF 50V
C803	CCCT1H330JC	CAP , CERAMIC	33PF 50V JC
C804	CCCT1H330JC	CAP , CERAMIC	33PF 50V JC
C805	CCCT1H120JC	CAP , CERAMIC	12PF 50V JC
C806	CCCT1H120JC	CAP , CERAMIC	12PF 50V JC
C811	HCEA1CH101T	CAP , ELECT	100UF 16V
C812	HCEA1CH101T	CAP , ELECT	100UF 16V
C813	HCEA1CH101T	CAP , ELECT	100UF 16V
C814	HCEA1CH101T	CAP , ELECT	100UF 16V
C815	CCKT1H331KB	CAP , CERAMIC	330PF 50V KB
C816	CCKT1H331KB	CAP , CERAMIC	330PF 50V KB
C817	HCEA1VH100T	CAP , ELECT	10UF 35V
C818	HCEA1VKS100T	CAP , ELECT	10UF 35V
C819	HCBS1H681KBT	CAP , CERAMIC	680PF 50V
C820	HCBS1H681KBT	CAP , CERAMIC	680PF 50V
C900	HCQI1H473JZT	CAP , MYLAR	0.047UF 50V J
C901	HCQI1H473JZT	CAP , MYLAR	0.047UF 50V J
C905	CCKT1H223ZF	CAP , CERAMIC	0.022UF 50V ZF
C907	HCEA1CH101T	CAP , ELECT	100UF 16V
C908	CCKT1H223ZF	CAP , CERAMIC	0.022UF 50V ZF
C910	HCQI1H473JZT	CAP , MYLAR	0.047UF 50V J
C911	HCEA1CH471T	CAP , ELECT	470UF 16V
C912	HCEA1CH221T	CAP , ELECT	220UF 16V
C913	CCFT1H104ZF	CAP , SEMICONDUCTOR	0.1UF 50V ZF
C914	HCQI1H473JZT	CAP , MYLAR	0.047UF 50V J
C917	HCQI1H473JZT	CAP , MYLAR	0.047UF 50V J
C918	HCQI1H473JZT	CAP , MYLAR	0.047UF 50V J
C919	HCQI1H473JZT	CAP , MYLAR	0.047UF 50V J
C932	HCEA1CH101T	CAP , ELECT	100UF 16V
C933	HCEA1CH221T	CAP , ELECT	220UF 16V
C934	CCKT1H223ZF	CAP , CERAMIC	0.022UF 50V ZF
C939	HCEA1HH4R7T	CAP , ELECT	4.7UF 50V
C940	HCEA1AH471T	CAP , ELECT	470UF 10V
C950	HCEA1CH101T	CAP , ELECT	100UF 16V
C955	HCBS1H101KBT	CAP , CERAMIC	100PF 50V K
C971	HCQI1H562JZT	CAP , MYLAR	5600PF 50V J
C972	HCQI1H562JZT	CAP , MYLAR	5600PF 50V J
C973	HCQI1H562JZT	CAP , MYLAR	5600PF 50V J
C974	HCQI1H562JZT	CAP , MYLAR	5600PF 50V J
C975	HCQI1H562JZT	CAP , MYLAR	5600PF 50V J
C980	HCQI1H562JZT	CAP , MYLAR	5600PF 50V J
C981	HCQI1H562JZT	CAP , MYLAR	5600PF 50V J
C990	HCQI1H473JZT	CAP , MYLAR	0.047UF 50V J
C991	HCEA1HH1R0T	CAP , ELECT	1UF 50V
C992	HCQI1H473JZT	CAP , MYLAR	0.047UF 50V J
C993	HCQI1H473JZT	CAP , MYLAR	0.047UF 50V J
C994	HCQI1H473JZT	CAP , MYLAR	0.047UF 50V J
C995	HCQI1H473JZT	CAP , MYLAR	0.047UF 50V J
C996	HCQI1H473JZT	CAP , MYLAR	0.047UF 50V J
C997	HCQI1H473JZT	CAP , MYLAR	0.047UF 50V J
C999	CCKT1H223ZF	CAP , CERAMIC	0.022UF 50V ZF
C631	CCEA1JH471E	CAP , ELECT	470UF 63V
C632	CCEA1JH471E	CAP , ELECT	470UF 63V
C633	CCEA1JH471E	CAP , ELECT	470UF 63V

Ref. Designator	Part Number	Description	
		MAIN PCB ASS'Y	
C634	CCEA1JH471E	CAP , ELECT	470UF 63V
C635	CCEA1JH471E	CAP , ELECT	470UF 63V
C636	CCEA1JH471E	CAP , ELECT	470UF 63V
C637	CCEA1JH471E	CAP , ELECT	470UF 63V
C638	CCEA1JH471E	CAP , ELECT	470UF 63V
C639	CCEA1JH471E	CAP , ELECT	470UF 63V
C640	CCEA1JH471E	CAP , ELECT	470UF 63V
C807	CCEA1JH471E	CAP , ELECT	470UF 63V
C808	CCEA1JH471E	CAP , ELECT	470UF 63V
C809	CCEA1JH471E	CAP , ELECT	470UF 63V
C810	CCEA1JH471E	CAP , ELECT	470UF 63V
C902	CCET50VKL4822NK	CAP , ELECT	8200UF/50V
C904	KCKDKS472ME	CAP , CERAMIC(X1/Y2/SC)	0.0047UF/2.5KV
C906	HCEA1EH102E	CAP , ELECT	1000UF 25V
C909	CCET50VKL4822NK	CAP , ELECT	8200UF/50V
C915	CCET50VKL4103NK	CAP , ELECT	10000UF/50V
C916	CCET50VKL4103NK	CAP , ELECT	10000UF/50V
<i>Semiconductors</i>			
D501	HVD1SS133MT	DIODE	1SS133T-77
D502	HVD1SS133MT	DIODE	1SS133T-77
D503	HVD1SS133MT	DIODE	1SS133T-77
D504	HVD1SS133MT	DIODE	1SS133T-77
D505	HVD1SS133MT	DIODE	1SS133T-77
D581	HVD1SS133MT	DIODE	1SS133T-77
D582	HVD1SS133MT	DIODE	1SS133T-77
D583	HVD1SS133MT	DIODE	1SS133T-77
D584	HVD1SS133MT	DIODE	1SS133T-77
D585	HVD1SS133MT	DIODE	1SS133T-77
D601	HVD1SS133MT	DIODE	1SS133T-77
D801	HVD1SS133MT	DIODE	1SS133T-77
D802	HVD1SS133MT	DIODE	1SS133T-77
D803	HVD1SS133MT	DIODE	1SS133T-77
D804	HVD1SS133MT	DIODE	1SS133T-77
D901	KVD1N4003ST	DIODE	1N4003
D902	HVD1SS133MT	DIODE	1SS133T-77
D911	HVD1SS133MT	DIODE	1SS133T-77
D912	HVD1SS133MT	DIODE	1SS133T-77
D914	HVD1SS133MT	DIODE	1SS133T-77
D917	HVD1SS133MT	DIODE	1SS133T-77
D951	HVD1SS133MT	DIODE	1SS133T-77
D952	HVD1SS133MT	DIODE	1SS133T-77
D953	HVD1SS133MT	DIODE	1SS133T-77
D954	KVD1N4003SRT	DIODE TW	1N4003
D955	KVD1N4003SRT	DIODE TW	1N4003
D961	KVD1N4003ST	DIODE	1N4003
D962	KVD1N4003ST	DIODE	1N4003
D963	KVD1N4003ST	DIODE	1N4003
D964	HVD1SS133MT	DIODE	1SS133T-77
D965	HVD1SS133MT	DIODE	1SS133T-77
D966	HVD1SS133MT	DIODE	1SS133T-77
D967	HVD1SS133MT	DIODE	1SS133T-77
D968	HVD1SS133MT	DIODE	1SS133T-77
D969	HVD1SS133MT	DIODE	1SS133T-77
D971	HVD1SS133MT	DIODE	1SS133T-77
D972	HVD1SS133MT	DIODE	1SS133T-77
D973	HVD1SS133MT	DIODE	1SS133T-77
D974	HVD1SS133MT	DIODE	1SS133T-77
D975	HVD1SS133MT	DIODE	1SS133T-77
D976	HVD1SS133MT	DIODE	1SS133T-77

Ref. Designator	Part Number	Description	
		MAIN PCB ASS'Y	
Q501	HVTKTA1268GRT	TRANSISTOR PNP	KTA1268GR
Q502	HVTKTA1268GRT	TRANSISTOR PNP	KTA1268GR
Q503	HVTKTA1268GRT	TRANSISTOR PNP	KTA1268GR
Q504	HVTKTA1268GRT	TRANSISTOR PNP	KTA1268GR
Q505	HVTKTA1268GRT	TRANSISTOR PNP	KTA1268GR
Q511	HVTKTC3200GRT	TRANSISTOR NPN	KTC3200GR
Q512	HVTKTC3200GRT	TRANSISTOR NPN	KTC3200GR
Q513	HVTKTC3200GRT	TRANSISTOR NPN	KTC3200GR
Q514	HVTKTC3200GRT	TRANSISTOR NPN	KTC3200GR
Q515	HVTKTC3200GRT	TRANSISTOR NPN	KTC3200GR
Q516	HVTKTC3200GRT	TRANSISTOR NPN	KTC3200GR
Q517	HVTKTC3200GRT	TRANSISTOR NPN	KTC3200GR
Q518	HVTKTC3200GRT	TRANSISTOR NPN	KTC3200GR
Q519	HVTKTC3200GRT	TRANSISTOR NPN	KTC3200GR
Q520	HVTKTC3200GRT	TRANSISTOR NPN	KTC3200GR
Q541	HVTKTC3198YT	TRANSISTOR NPN	KTC3198Y
Q542	HVTKTC3198YT	TRANSISTOR NPN	KTC3198Y
Q543	HVTKTC3198YT	TRANSISTOR NPN	KTC3198Y
Q544	HVTKTC3198YT	TRANSISTOR NPN	KTC3198Y
Q545	HVTKTC3198YT	TRANSISTOR NPN	KTC3198Y
Q556	HVTKTC3200GRT	TRANSISTOR NPN	KTC3200GR
Q557	HVTKTC3200GRT	TRANSISTOR NPN	KTC3200GR
Q558	HVTKTC3200GRT	TRANSISTOR NPN	KTC3200GR
Q559	HVTKTC3200GRT	TRANSISTOR NPN	KTC3200GR
Q560	HVTKTC3200GRT	TRANSISTOR NPN	KTC3200GR
Q561	HVTKTC3200GRT	TRANSISTOR NPN	KTC3200GR
Q562	HVTKTC3200GRT	TRANSISTOR NPN	KTC3200GR
Q563	HVTKTC3200GRT	TRANSISTOR NPN	KTC3200GR
Q564	HVTKTC3200GRT	TRANSISTOR NPN	KTC3200GR
Q565	HVTKTC3200GRT	TRANSISTOR NPN	KTC3200GR
Q601	HVTKTA1268GRT	TRANSISTOR PNP	KTA1268GR
Q602	HVTKTA1268GRT	TRANSISTOR PNP	KTA1268GR
Q603	HVTKTA1268GRT	TRANSISTOR PNP	KTA1268GR
Q604	HVTKTA1268GRT	TRANSISTOR PNP	KTA1268GR
Q605	HVTKTA1268GRT	TRANSISTOR PNP	KTA1268GR
Q681	KVTKSC2785YT	TRANSISTOR NPN	KSC2785Y
Q682	KVTKSC2785YT	TRANSISTOR NPN	KSC2785Y
Q683	KVTKSC2785YT	TRANSISTOR NPN	KSC2785Y
Q684	KVTKSC2785YT	TRANSISTOR NPN	KSC2785Y
Q685	KVTKSC2785YT	TRANSISTOR NPN	KSC2785Y
Q701	HVTKTC2874BT	TRANSISTOR, NPN, MUTE	KTC2874B
Q702	HVTKTC2874BT	TRANSISTOR, NPN, MUTE	KTC2874B
Q703	HVTKTC2874BT	TRANSISTOR, NPN, MUTE	KTC2874B
Q704	HVTKTC2874BT	TRANSISTOR, NPN, MUTE	KTC2874B
Q705	HVTKTC2874BT	TRANSISTOR, NPN, MUTE	KTC2874B
Q706	HVTKTC2874BT	TRANSISTOR, NPN, MUTE	KTC2874B
Q707	HVTKTC2874BT	TRANSISTOR, NPN, MUTE	KTC2874B
Q708	HVTKTC2874BT	TRANSISTOR, NPN, MUTE	KTC2874B
Q801	KVTKSC2785YT	TRANSISTOR NPN	KSC2785Y
Q802	KVTKSC2785YT	TRANSISTOR NPN	KSC2785Y
Q812	HVTKTA1268GRT	TRANSISTOR PNP	KTA1268GR
Q813	HVTKTC3200GRT	TRANSISTOR NPN	KTC3200GR
Q814	HVTKTA1268GRT	TRANSISTOR PNP	KTA1268GR
Q815	HVTKTC3200GRT	TRANSISTOR NPN	KTC3200GR
Q816	HVTKTA1268GRT	TRANSISTOR PNP	KTA1268GR
Q817	HVTKTA1268GRT	TRANSISTOR PNP	KTA1268GR
Q818	HVTKTC3200GRT	TRANSISTOR NPN	KTC3200GR
Q819	HVTKTC3200GRT	TRANSISTOR NPN	KTC3200GR
Q820	HVTKTC3200GRT	TRANSISTOR NPN	KTC3200GR
Q821	HVTKTC3200GRT	TRANSISTOR NPN	KTC3200GR
Q822	HVTKTC3200GRT	TRANSISTOR NPN	KTC3200GR

Ref. Designator	Part Number	Description	
		MAIN PCB ASS'Y	
Q823	HVTKTC3200GRT	TRANSISTOR NPN	KTC3200GR
Q824	HVTKTC3198YT	TRANSISTOR NPN	KTC3198Y
Q825	HVTKTC3198YT	TRANSISTOR NPN	KTC3198Y
Q826	HVTKTC2874BT	TRANSISTOR, NPN, MUTE	KTC2874B
Q827	HVTKTC2874BT	TRANSISTOR, NPN, MUTE	KTC2874B
Q901	KVTKSC2785YT	TRANSISTOR NPN	KSC2785Y
Q902	HVTKRA107MT	TRANSISTOR NPN	KRA107M
Q903	HVTKRA107MT	TRANSISTOR NPN	KRA107M
Q904	HVTKRC107MT	TRANSISTOR NPN	KRC107M
Q911	HVTKTA1271YT	TRANSISTOR PNP	KTA1271Y
Q912	HVTKTA1271YT	TRANSISTOR PNP	KTA1271Y
Q913	HVTKTA1271YT	TRANSISTOR PNP	KTA1271Y
Q914	HVTKTA1271YT	TRANSISTOR PNP	KTA1271Y
Q915	KVTKSC2785YT	TRANSISTOR NPN	KSC2785Y
Q916	KVTKSC2785YT	TRANSISTOR NPN	KSC2785Y
Q917	KVTKSC2785YT	TRANSISTOR NPN	KSC2785Y
Q918	KVTKSC2785YT	TRANSISTOR NPN	KSC2785Y
Q938	HVTKRA107MT	TRANSISTOR NPN	KRA107M
Q939	HVTKRA107MT	TRANSISTOR NPN	KRA107M
Q942	KVTKSC2785YT	TRANSISTOR NPN	KSC2785Y
Q943	KVTKSC2785YT	TRANSISTOR NPN	KSC2785Y
Q951	HVTKRC107MT	TRANSISTOR NPN	KRC107M
Q952	HVTKRA107MT	TRANSISTOR NPN	KRA107M
Q960	HVTKRC107MT	TRANSISTOR NPN	KRC107M
Q961	HVTKTA1024YT	TRANSISTOR PNP	KTA1024Y
Q969	HVTKTC2874BT	TRANSISTOR, NPN, MUTE	KTC2874B
Q970	HVTKTC2874BT	TRANSISTOR, NPN, MUTE	KTC2874B
Q971	HVTKTC2874BT	TRANSISTOR, NPN, MUTE	KTC2874B
Q972	HVTKTC2874BT	TRANSISTOR, NPN, MUTE	KTC2874B
Q973	HVTKTC2874BT	TRANSISTOR, NPN, MUTE	KTC2874B
Q991	HVTKRC107MT	TRANSISTOR NPN	KRC107M
Q992	HVTKRA107MT	TRANSISTOR NPN	KRA107M
Q993	HVTKRA107MT	TRANSISTOR NPN	KRA107M
Q994	HVTKRC107MT	TRANSISTOR NPN	KRC107M
Q995	HVTKRA107MT	TRANSISTOR NPN	KRA107M
Q652	BVT2SB1647-OKM	TRANSISTOR, NPN, POWER	2SB1647
Q653	BVT2SB1647-OKM	TRANSISTOR, NPN, POWER	2SB1647
Q654	BVT2SB1647-OKM	TRANSISTOR, NPN, POWER	2SB1647
Q655	BVT2SB1647-OKM	TRANSISTOR, NPN, POWER	2SB1647
Q657	BVT2SD2560-OKM	TRANSISTOR, NPN, POWER	2SD2560
Q658	BVT2SD2560-OKM	TRANSISTOR, NPN, POWER	2SD2560
Q659	BVT2SD2560-OKM	TRANSISTOR, NPN, POWER	2SD2560
Q660	BVT2SD2560-OKM	TRANSISTOR, NPN, POWER	2SD2560
Q661	BVT2SB1647-OKM	TRANSISTOR, NPN, POWER	2SB1647
Q670	BVT2SD2560-OKM	TRANSISTOR, NPN, POWER	2SD2560
Q803	BVT2SD2560-OKM	TRANSISTOR, NPN, POWER	2SD2560
Q804	BVT2SB1647-OKM	TRANSISTOR, NPN, POWER	2SB1647
Q805	BVT2SD2560-OKM	TRANSISTOR, NPN, POWER	2SD2560
Q807	BVT2SB1647-OKM	TRANSISTOR, NPN, POWER	2SB1647
IC94	HVIMC7805C	I.C, REGULATOR	KA7805-ABTU
IC95	BVIKP1010B	IC, PHOTO COUPLER	
IC96	BVIKP1010B	IC, PHOTO COUPLER	
Q858	HVT2SA1360O	TRANSISTOR PNP	2SA1360
Q871	HVT2SA1360O	TRANSISTOR PNP	2SA1360
Q872	HVT2SA1360O	TRANSISTOR PNP	2SA1360
Q874	HVT2SA1360O	TRANSISTOR PNP	2SA1360
Q875	HVT2SA1360O	TRANSISTOR PNP	2SA1360
Q876	HVT2SA1360O	TRANSISTOR PNP	2SA1360
Q877	HVT2SA1360O	TRANSISTOR PNP	2SA1360
Q881	HVT2SC3423O	TRANSISTOR PNP	2SA1360
Q882	HVT2SC3423O	TRANSISTOR PNP	2SA1360

Ref. Designator	Part Number	Description	
		MAIN PCB ASS'Y	
Q883	HVT2SC3423O	TRANSISTOR PNP	2SA1360
Q884	HVT2SC3423O	TRANSISTOR PNP	2SA1360
Q885	HVT2SC3423O	TRANSISTOR PNP	2SA1360
Q886	HVT2SC3423O	TRANSISTOR PNP	2SA1360
Q887	HVT2SC3423O	TRANSISTOR PNP	2SA1360
<i>Resistors</i>			
R501	CRD20TJ433T	RES , CARBON	43K OHM 1/5W J
R502	CRD20TJ433T	RES , CARBON	43K OHM 1/5W J
R503	CRD20TJ433T	RES , CARBON	43K OHM 1/5W J
R504	CRD20TJ433T	RES , CARBON	43K OHM 1/5W J
R505	CRD20TJ433T	RES , CARBON	43K OHM 1/5W J
R506	CRD20TJ333T	RES , CARBON	33K OHM 1/5W J
R507	CRD20TJ333T	RES , CARBON	33K OHM 1/5W J
R508	CRD20TJ333T	RES , CARBON	33K OHM 1/5W J
R509	CRD20TJ333T	RES , CARBON	33K OHM 1/5W J
R510	CRD20TJ333T	RES , CARBON	33K OHM 1/5W J
R511	CRD20TJ152T	RES , CARBON	1.5K OHM 1/5W J
R512	CRD20TJ152T	RES , CARBON	1.5K OHM 1/5W J
R513	CRD20TJ152T	RES , CARBON	1.5K OHM 1/5W J
R514	CRD20TJ152T	RES , CARBON	1.5K OHM 1/5W J
R515	CRD20TJ152T	RES , CARBON	1.5K OHM 1/5W J
R516	CRD20TJ152T	RES , CARBON	1.5K OHM 1/5W J
R517	CRD20TJ152T	RES , CARBON	1.5K OHM 1/5W J
R518	CRD20TJ152T	RES , CARBON	1.5K OHM 1/5W J
R519	CRD20TJ152T	RES , CARBON	1.5K OHM 1/5W J
R520	CRD20TJ152T	RES , CARBON	1.5K OHM 1/5W J
R521	CRD20TJ471T	RES , CARBON	470 OHM 1/5W J
R522	CRD20TJ471T	RES , CARBON	470 OHM 1/5W J
R523	CRD20TJ471T	RES , CARBON	470 OHM 1/5W J
R524	CRD20TJ471T	RES , CARBON	470 OHM 1/5W J
R525	CRD20TJ471T	RES , CARBON	470 OHM 1/5W J
R531	CRD20TJ221T	RES , CARBON	220 OHM 1/5W J
R532	CRD20TJ221T	RES , CARBON	220 OHM 1/5W J
R533	CRD20TJ221T	RES , CARBON	220 OHM 1/5W J
R534	CRD20TJ221T	RES , CARBON	220 OHM 1/5W J
R535	CRD20TJ221T	RES , CARBON	220 OHM 1/5W J
R536	CRD20TJ221T	RES , CARBON	220 OHM 1/5W J
R537	CRD20TJ221T	RES , CARBON	220 OHM 1/5W J
R538	CRD20TJ221T	RES , CARBON	220 OHM 1/5W J
R539	CRD20TJ221T	RES , CARBON	220 OHM 1/5W J
R540	CRD20TJ221T	RES , CARBON	220 OHM 1/5W J
R541	CRD20TJ271T	RES , CARBON	270 OHM 1/5W J
R542	CRD20TJ271T	RES , CARBON	270 OHM 1/5W J
R543	CRD20TJ271T	RES , CARBON	270 OHM 1/5W J
R544	CRD20TJ271T	RES , CARBON	270 OHM 1/5W J
R545	CRD20TJ271T	RES , CARBON	270 OHM 1/5W J
R556	CRD20TJ273T	RES , CARBON	27K OHM 1/5W J
R557	CRD20TJ273T	RES , CARBON	27K OHM 1/5W J
R558	CRD20TJ273T	RES , CARBON	27K OHM 1/5W J
R559	CRD20TJ273T	RES , CARBON	27K OHM 1/5W J
R560	CRD20TJ273T	RES , CARBON	27K OHM 1/5W J
R561	CRD20TJ182T	RES , CARBON	1.8K OHM 1/5W J
R562	CRD20TJ182T	RES , CARBON	1.8K OHM 1/5W J
R563	CRD20TJ182T	RES , CARBON	1.8K OHM 1/5W J
R564	CRD20TJ182T	RES , CARBON	1.8K OHM 1/5W J
R565	CRD20TJ182T	RES , CARBON	1.8K OHM 1/5W J
R566	CRD20TJ561T	RES , CARBON	560 OHM 1/5W J
R567	CRD20TJ561T	RES , CARBON	560 OHM 1/5W J
R568	CRD20TJ561T	RES , CARBON	560 OHM 1/5W J

Ref. Designator	Part Number	Description	
		MAIN PCB ASS'Y	
R569	CRD20TJ561T	RES , CARBON	560 OHM 1/5W J
R570	CRD20TJ561T	RES , CARBON	560 OHM 1/5W J
R571	CRD20TJ561T	RES , CARBON	560 OHM 1/5W J
R572	CRD20TJ561T	RES , CARBON	560 OHM 1/5W J
R573	CRD20TJ561T	RES , CARBON	560 OHM 1/5W J
R574	CRD20TJ561T	RES , CARBON	560 OHM 1/5W J
R575	CRD20TJ561T	RES , CARBON	560 OHM 1/5W J
R576	CRD20TJ100T	RES , CARBON	10 OHM 1/5W J
R577	CRD20TJ100T	RES , CARBON	10 OHM 1/5W J
R578	CRD20TJ100T	RES , CARBON	10 OHM 1/5W J
R579	CRD20TJ100T	RES , CARBON	10 OHM 1/5W J
R580	CRD20TJ100T	RES , CARBON	10 OHM 1/5W J
R581	CRD20TJ561T	RES , CARBON	560 OHM 1/5W J
R582	CRD20TJ561T	RES , CARBON	560 OHM 1/5W J
R583	CRD20TJ561T	RES , CARBON	560 OHM 1/5W J
R584	CRD20TJ561T	RES , CARBON	560 OHM 1/5W J
R585	CRD20TJ561T	RES , CARBON	560 OHM 1/5W J
R586	CRD20TJ561T	RES , CARBON	560 OHM 1/5W J
R587	CRD20TJ561T	RES , CARBON	560 OHM 1/5W J
R588	CRD20TJ561T	RES , CARBON	560 OHM 1/5W J
R589	CRD20TJ561T	RES , CARBON	560 OHM 1/5W J
R590	CRD20TJ561T	RES , CARBON	560 OHM 1/5W J
R591	CRD20TJ561T	RES , CARBON	560 OHM 1/5W J
R592	CRD20TJ561T	RES , CARBON	560 OHM 1/5W J
R593	CRD20TJ561T	RES , CARBON	560 OHM 1/5W J
R594	CRD20TJ561T	RES , CARBON	560 OHM 1/5W J
R595	CRD20TJ561T	RES , CARBON	560 OHM 1/5W J
R596	CRD20TJ561T	RES , CARBON	560 OHM 1/5W J
R597	CRD20TJ561T	RES , CARBON	560 OHM 1/5W J
R598	CRD20TJ561T	RES , CARBON	560 OHM 1/5W J
R599	CRD20TJ561T	RES , CARBON	560 OHM 1/5W J
R600	CRD20TJ561T	RES , CARBON	560 OHM 1/5W J
R601	CRD20TJ223T	RES , CARBON	22K OHM 1/5W J
R602	CRD20TJ223T	RES , CARBON	22K OHM 1/5W J
R603	CRD20TJ223T	RES , CARBON	22K OHM 1/5W J
R604	CRD20TJ223T	RES , CARBON	22K OHM 1/5W J
R605	CRD20TJ223T	RES , CARBON	22K OHM 1/5W J
R606	CRD20TJ223T	RES , CARBON	22K OHM 1/5W J
R607	CRD20TJ223T	RES , CARBON	22K OHM 1/5W J
R608	CRD20TJ223T	RES , CARBON	22K OHM 1/5W J
R609	CRD20TJ223T	RES , CARBON	22K OHM 1/5W J
R610	CRD20TJ223T	RES , CARBON	22K OHM 1/5W J
R611	CRD20TJ100T	RES , CARBON	10 OHM 1/5W J
R612	CRD20TJ100T	RES , CARBON	10 OHM 1/5W J
R631	KRD25FJ180T	RES , CARBON	18 OHM 1/4W F
R632	KRD25FJ180T	RES , CARBON	18 OHM 1/4W F
R633	KRD25FJ180T	RES , CARBON	18 OHM 1/4W F
R634	KRD25FJ180T	RES , CARBON	18 OHM 1/4W F
R635	KRD25FJ180T	RES , CARBON	18 OHM 1/4W F
R636	KRD25FJ180T	RES , CARBON	18 OHM 1/4W F
R637	KRD25FJ180T	RES , CARBON	18 OHM 1/4W F
R638	KRD25FJ180T	RES , CARBON	18 OHM 1/4W F
R639	KRD25FJ180T	RES , CARBON	18 OHM 1/4W F
R640	KRD25FJ180T	RES , CARBON	18 OHM 1/4W F
R646	KRD25FJ3R3T	RES , CARBON	3.3 OHM 1/4W F
R647	KRD25FJ3R3T	RES , CARBON	3.3 OHM 1/4W F
R648	KRD25FJ3R3T	RES , CARBON	3.3 OHM 1/4W F
R649	KRD25FJ3R3T	RES , CARBON	3.3 OHM 1/4W F
R650	KRD25FJ3R3T	RES , CARBON	3.3 OHM 1/4W F
R651	KRD25FJ3R3T	RES , CARBON	3.3 OHM 1/4W F
R652	KRD25FJ3R3T	RES , CARBON	3.3 OHM 1/4W F

Ref. Designator	Part Number	Description	
		MAIN PCB ASS'Y	
R653	KRD25FJ3R3T	RES , CARBON	3.3 OHM 1/4W F
R654	KRD25FJ3R3T	RES , CARBON	3.3 OHM 1/4W F
R655	KRD25FJ3R3T	RES , CARBON	3.3 OHM 1/4W F
R666	CRD25TJ470T	RES , CARBON	47 OHM 1/4W J
R667	CRD25TJ470T	RES , CARBON	47 OHM 1/4W J
R668	CRD25TJ470T	RES , CARBON	47 OHM 1/4W J
R669	CRD25TJ470T	RES , CARBON	47 OHM 1/4W J
R670	CRD25TJ470T	RES , CARBON	47 OHM 1/4W J
R671	CRD20TJ911T	RES , CARBON	910 OHM 1/5W J
R672	CRD20TJ911T	RES , CARBON	910 OHM 1/5W J
R673	CRD20TJ911T	RES , CARBON	910 OHM 1/5W J
R674	CRD20TJ911T	RES , CARBON	910 OHM 1/5W J
R675	CRD20TJ911T	RES , CARBON	910 OHM 1/5W J
R676	CRD20TJ182T	RES , CARBON	1.8K OHM 1/5W J
R677	CRD20TJ182T	RES , CARBON	1.8K OHM 1/5W J
R678	CRD20TJ182T	RES , CARBON	1.8K OHM 1/5W J
R679	CRD20TJ182T	RES , CARBON	1.8K OHM 1/5W J
R680	CRD20TJ182T	RES , CARBON	1.8K OHM 1/5W J
R681	CRD20TJ562T	RES , CARBON	5.6K OHM 1/5W J
R682	CRD20TJ562T	RES , CARBON	5.6K OHM 1/5W J
R683	CRD20TJ562T	RES , CARBON	5.6K OHM 1/5W J
R684	CRD20TJ562T	RES , CARBON	5.6K OHM 1/5W J
R685	CRD20TJ562T	RES , CARBON	5.6K OHM 1/5W J
R686	CRD20TJ103T	RES , CARBON	10K OHM 1/5W J
R687	CRD20TJ103T	RES , CARBON	10K OHM 1/5W J
R688	CRD20TJ103T	RES , CARBON	10K OHM 1/5W J
R689	CRD20TJ103T	RES , CARBON	10K OHM 1/5W J
R690	CRD20TJ103T	RES , CARBON	10K OHM 1/5W J
R696	CRD25TJ470T	RES , CARBON	47 OHM 1/4W J
R697	CRD25TJ470T	RES , CARBON	47 OHM 1/4W J
R698	CRD25TJ470T	RES , CARBON	47 OHM 1/4W J
R699	CRD25TJ470T	RES , CARBON	47 OHM 1/4W J
R700	CRD25TJ470T	RES , CARBON	47 OHM 1/4W J
R701	CRD20TJ102T	RES , CARBON	1K OHM 1/5W J
R702	CRD20TJ102T	RES , CARBON	1K OHM 1/5W J
R703	CRD20TJ102T	RES , CARBON	1K OHM 1/5W J
R704	CRD20TJ102T	RES , CARBON	1K OHM 1/5W J
R705	CRD20TJ102T	RES , CARBON	1K OHM 1/5W J
R706	CRD20TJ102T	RES , CARBON	1K OHM 1/5W J
R707	CRD20TJ102T	RES , CARBON	1K OHM 1/5W J
R708	CRD20TJ102T	RES , CARBON	1K OHM 1/5W J
R711	CRD20TJ472T	RES , CARBON	4.7K OHM 1/5W J
R712	CRD20TJ472T	RES , CARBON	4.7K OHM 1/5W J
R713	CRD20TJ472T	RES , CARBON	4.7K OHM 1/5W J
R714	CRD20TJ472T	RES , CARBON	4.7K OHM 1/5W J
R715	CRD20TJ472T	RES , CARBON	4.7K OHM 1/5W J
R716	CRD20TJ472T	RES , CARBON	4.7K OHM 1/5W J
R717	CRD20TJ472T	RES , CARBON	4.7K OHM 1/5W J
R718	CRD20TJ472T	RES , CARBON	4.7K OHM 1/5W J
R721	CRD20TJ104T	RES , CARBON	100K OHM 1/5W J
R722	CRD20TJ104T	RES , CARBON	100K OHM 1/5W J
R723	CRD20TJ104T	RES , CARBON	100K OHM 1/5W J
R724	CRD20TJ104T	RES , CARBON	100K OHM 1/5W J
R725	CRD20TJ104T	RES , CARBON	100K OHM 1/5W J
R726	CRD20TJ104T	RES , CARBON	100K OHM 1/5W J
R727	CRD20TJ104T	RES , CARBON	100K OHM 1/5W J
R728	CRD20TJ104T	RES , CARBON	100K OHM 1/5W J
R771	CRD20TJ750T	RES , CARBON	75 OHM 1/5W J
R772	CRD20TJ750T	RES , CARBON	75 OHM 1/5W J
R773	CRD20TJ750T	RES , CARBON	75 OHM 1/5W J
R774	CRD20TJ750T	RES , CARBON	75 OHM 1/5W J

Ref. Designator	Part Number	Description	
		MAIN PCB ASS'Y	
R775	CRD20TJ750T	RES , CARBON	75 OHM 1/5W J
R776	CRD20TJ750T	RES , CARBON	75 OHM 1/5W J
R777	CRD20TJ750T	RES , CARBON	75 OHM 1/5W J
R781	CRD20TJ750T	RES , CARBON	75 OHM 1/5W J
R782	CRD20TJ750T	RES , CARBON	75 OHM 1/5W J
R783	CRD20TJ750T	RES , CARBON	75 OHM 1/5W J
R784	CRD20TJ750T	RES , CARBON	75 OHM 1/5W J
R785	CRD20TJ750T	RES , CARBON	75 OHM 1/5W J
R786	CRD20TJ750T	RES , CARBON	75 OHM 1/5W J
R787	CRD20TJ750T	RES , CARBON	75 OHM 1/5W J
R801	CRD20TJ103T	RES , CARBON	10K OHM 1/5W J
R802	CRD20TJ103T	RES , CARBON	10K OHM 1/5W J
R803	CRD20TJ562T	RES , CARBON	5.6K OHM 1/5W J
R804	CRD20TJ562T	RES , CARBON	5.6K OHM 1/5W J
R805	CRD20TJ911T	RES , CARBON	910 OHM 1/5W J
R807	CRD20TJ911T	RES , CARBON	910 OHM 1/5W J
R808	CRD20TJ182T	RES , CARBON	1.8K OHM 1/5W J
R809	CRD20TJ182T	RES , CARBON	1.8K OHM 1/5W J
R812	CRD25TJ470T	RES , CARBON	47 OHM 1/4W J
R813	CRD25TJ470T	RES , CARBON	47 OHM 1/4W J
R814	CRD25TJ470T	RES , CARBON	47 OHM 1/4W J
R815	CRD25TJ470T	RES , CARBON	47 OHM 1/4W J
R817	KRD25FJ3R3T	RES , CARBON	3.3 OHM 1/4W F
R818	KRD25FJ3R3T	RES , CARBON	3.3 OHM 1/4W F
R819	KRD25FJ3R3T	RES , CARBON	3.3 OHM 1/4W F
R820	KRD25FJ3R3T	RES , CARBON	3.3 OHM 1/4W F
R821	KRD25FJ180T	RES , CARBON	18 OHM 1/4W F
R822	KRD25FJ180T	RES , CARBON	18 OHM 1/4W F
R823	KRD25FJ180T	RES , CARBON	18 OHM 1/4W F
R824	KRD25FJ180T	RES , CARBON	18 OHM 1/4W F
R830	CRD20TJ223T	RES , CARBON	22K OHM 1/5W J
R831	CRD20TJ223T	RES , CARBON	22K OHM 1/5W J
R832	CRD20TJ223T	RES , CARBON	22K OHM 1/5W J
R833	CRD20TJ223T	RES , CARBON	22K OHM 1/5W J
R834	CRD20TJ561T	RES , CARBON	560 OHM 1/5W J
R835	CRD20TJ561T	RES , CARBON	560 OHM 1/5W J
R836	CRD20TJ561T	RES , CARBON	560 OHM 1/5W J
R837	CRD20TJ561T	RES , CARBON	560 OHM 1/5W J
R838	CRD20TJ561T	RES , CARBON	560 OHM 1/5W J
R839	CRD20TJ561T	RES , CARBON	560 OHM 1/5W J
R840	CRD20TJ561T	RES , CARBON	560 OHM 1/5W J
R841	CRD20TJ561T	RES , CARBON	560 OHM 1/5W J
R842	CRD20TJ561T	RES , CARBON	560 OHM 1/5W J
R843	CRD20TJ561T	RES , CARBON	560 OHM 1/5W J
R844	CRD20TJ561T	RES , CARBON	560 OHM 1/5W J
R845	CRD20TJ561T	RES , CARBON	560 OHM 1/5W J
R848	CRD20TJ273T	RES , CARBON	27K OHM 1/5W J
R849	CRD20TJ273T	RES , CARBON	27K OHM 1/5W J
R850	CRD20TJ182T	RES , CARBON	1.8K OHM 1/5W J
R851	CRD20TJ182T	RES , CARBON	1.8K OHM 1/5W J
R852	CRD20TJ152T	RES , CARBON	1.5K OHM 1/5W J
R853	CRD20TJ152T	RES , CARBON	1.5K OHM 1/5W J
R854	CRD20TJ152T	RES , CARBON	1.5K OHM 1/5W J
R855	CRD20TJ152T	RES , CARBON	1.5K OHM 1/5W J
R856	CRD20TJ221T	RES , CARBON	220 OHM 1/5W J
R857	CRD20TJ221T	RES , CARBON	220 OHM 1/5W J
R858	CRD20TJ221T	RES , CARBON	220 OHM 1/5W J
R859	CRD20TJ221T	RES , CARBON	220 OHM 1/5W J
R860	CRD20TJ271T	RES , CARBON	270 OHM 1/5W J
R861	CRD20TJ271T	RES , CARBON	270 OHM 1/5W J
R862	CRD20TJ333T	RES , CARBON	33K OHM 1/5W J

Ref. Designator	Part Number	Description	
		MAIN PCB ASS'Y	
R863	CRD20TJ333T	RES , CARBON	33K OHM 1/5W J
R864	CRD20TJ331T	RES , CARBON	330 OHM 1/5W J
R865	CRD20TJ331T	RES , CARBON	330 OHM 1/5W J
R866	CRD20TJ472T	RES , CARBON	4.7K OHM 1/5W J
R867	CRD25TJ472T	RES , CARBON	4.7K OHM 1/4W J
R868	CRD20TJ473T	RES , CARBON	47K OHM 1/5W J
R869	CRD20TJ473T	RES , CARBON	47K OHM 1/5W J
R870	CRD20TJ433T	RES , CARBON	43K OHM 1/5W J
R871	CRD20TJ433T	RES , CARBON	43K OHM 1/5W J
R872	CRD20TJ471T	RES , CARBON	470 OHM 1/5W J
R873	CRD20TJ471T	RES , CARBON	470 OHM 1/5W J
R900	CRD20TJ103T	RES , CARBON	10K OHM 1/5W J
R901	CRD25TJ393T	RES , CARBON	39K OHM 1/4W J
R902	CRD25TJ393T	RES , CARBON	39K OHM 1/4W J
R903	CRD25TJ393T	RES , CARBON	39K OHM 1/4W J
R906	CRD25TJ393T	RES , CARBON	39K OHM 1/4W J
R907	CRD20TJ103T	RES , CARBON	10K OHM 1/5W J
R908	CRD20TJ105T	RES , CARBON	1M OHM 1/5W J
R909	CRD20TJ682T	RES , CARBON	6.8K OHM 1/5W J
R910	CRD20TJ105T	RES , CARBON	1M OHM 1/5W J
R911	CRD25TJ680T	RES , CARBON	68 OHM 1/4W J
R915	CRD20TJ470T	RES , CARBON	47 OHM 1/5W J
R916	CRD20TJ473T	RES , CARBON	47K OHM 1/5W J
R917	CRD25TJ393T	RES , CARBON	39K OHM 1/4W J
R918	CRD25TJ393T	RES , CARBON	39K OHM 1/4W J
R919	CRD25TJ393T	RES , CARBON	39K OHM 1/4W J
R920	CRD25TJ393T	RES , CARBON	39K OHM 1/4W J
R921	KRD25FJ180T	RES , CARBON	18 OHM 1/4W F
R922	CRD25TJ470T	RES , CARBON	47 OHM 1/4W J
R924	CRD20TJ473T	RES , CARBON	47K OHM 1/5W J
R925	CRD20TJ473T	RES , CARBON	47K OHM 1/5W J
R926	CRD20TJ473T	RES , CARBON	47K OHM 1/5W J
R927	CRD20TJ473T	RES , CARBON	47K OHM 1/5W J
R928	CRD20TJ222T	RES , CARBON	2.2K OHM 1/5W J
R929	CRD20TJ222T	RES , CARBON	2.2K OHM 1/5W J
R930	CRD20TJ222T	RES , CARBON	2.2K OHM 1/5W J
R931	CRD20TJ222T	RES , CARBON	2.2K OHM 1/5W J
R932	CRD20TJ103T	RES , CARBON	10K OHM 1/5W J
R933	CRD20TJ472T	RES , CARBON	4.7K OHM 1/5W J
R934	CRD20TJ104T	RES , CARBON	100K OHM 1/5W J
R935	CRD20TJ154T	RES , CARBON	150K OHM 1/5W J
R936	CRD20TJ184T	RES , CARBON	180K OHM 1/5W J
R937	CRD20TJ103T	RES , CARBON	10K OHM 1/5W J
R938	CRD20TJ271T	RES , CARBON	270 OHM 1/5W J
R939	CRD20TJ472T	RES , CARBON	4.7K OHM 1/5W J
R940	CRD20TJ152T	RES , CARBON	1.5K OHM 1/5W J
R941	CRD20TJ223T	RES , CARBON	22K OHM 1/5W J
R942	CRD20TJ223T	RES , CARBON	22K OHM 1/5W J
R943	CRD20TJ223T	RES , CARBON	22K OHM 1/5W J
R944	CRD25TJ223T	RES , CARBON	22K OHM 1/4W J
R945	CRD20TJ223T	RES , CARBON	22K OHM 1/5W J
R946	CRD25TJ223T	RES , CARBON	22K OHM 1/4W J
R947	CRD20TJ223T	RES , CARBON	22K OHM 1/5W J
R948	CRD20TJ271T	RES , CARBON	270 OHM 1/5W J
R949	CRD20TJ331T	RES , CARBON	330 OHM 1/5W J
R950	CRD20TJ273T	RES , CARBON	27K OHM 1/5W J
R951	CRD20TJ103T	RES , CARBON	10K OHM 1/5W J
R952	CRD20TJ223T	RES , CARBON	22K OHM 1/5W J
R953	CRD20TJ223T	RES , CARBON	22K OHM 1/5W J
R954	CRD20TJ223T	RES , CARBON	22K OHM 1/5W J
R955	CRD20TJ203T	RES , CARBON	20K OHM 1/5W J

Ref. Designator	Part Number	Description	
		MAIN PCB ASS'Y	
R956	CRD20TJ394T	RES , CARBON	390K OHM 1/5W J
R957	CRD20TJ153T	RES , CARBON	15K OHM 1/5W J
R958	CRD20TJ563T	RES , CARBON	56K OHM 1/5W J
R959	CRD20TJ223T	RES , CARBON	22K OHM 1/5W J
R960	CRD20TJ222T	RES , CARBON	2.2K OHM 1/5W J
R961	CRD20TJ331T	RES , CARBON	330 OHM 1/5W J
R962	CRD20TJ273T	RES , CARBON	27K OHM 1/5W J
R963	CRD20TJ105T	RES , CARBON	1M OHM 1/5W J
R964	CRD20TJ105T	RES , CARBON	1M OHM 1/5W J
R966	CRD20TJ472T	RES , CARBON	4.7K OHM 1/5W J
R969	CRD20TJ472T	RES , CARBON	4.7K OHM 1/5W J
R970	CRD20TJ472T	RES , CARBON	4.7K OHM 1/5W J
R971	CRD20TJ472T	RES , CARBON	4.7K OHM 1/5W J
R972	CRD20TJ472T	RES , CARBON	4.7K OHM 1/5W J
R973	CRD20TJ472T	RES , CARBON	4.7K OHM 1/5W J
R974	CRD20TJ331T	RES , CARBON	330 OHM 1/5W J
R975	CRD20TJ331T	RES , CARBON	330 OHM 1/5W J
R976	CRD20TJ331T	RES , CARBON	330 OHM 1/5W J
R977	CRD20TJ331T	RES , CARBON	330 OHM 1/5W J
R978	CRD20TJ331T	RES , CARBON	330 OHM 1/5W J
R979	CRD20TJ473T	RES , CARBON	47K OHM 1/5W J
R980	CRD20TJ473T	RES , CARBON	47K OHM 1/5W J
R981	CRD20TJ473T	RES , CARBON	47K OHM 1/5W J
R982	CRD20TJ473T	RES , CARBON	47K OHM 1/5W J
R983	CRD20TJ473T	RES , CARBON	47K OHM 1/5W J
R986	CRD20TJ102T	RES , CARBON	1K OHM 1/5W J
R987	CRD20TJ561T	RES , CARBON	560 OHM 1/5W J
R988	CRD20TJ562T	RES , CARBON	5.6K OHM 1/5W J
R989	CRD20TJ333T	RES , CARBON	33K OHM 1/5W J
R991	CRD20TJ822T	RES , CARBON	8.2K OHM 1/5W J
R992	CRD20TJ562T	RES , CARBON	5.6K OHM 1/5W J
R998	CRD20TJ103T	RES , CARBON	10K OHM 1/5W J
R656	CRF5EKR27HX2	RES , CEMENT	0.27OHM(*2) ,5W
R657	CRF5EKR27HX2	RES , CEMENT	0.27OHM(*2) ,5W
R658	CRF5EKR27HX2	RES , CEMENT	0.27OHM(*2) ,5W
R659	CRF5EKR27HX2	RES , CEMENT	0.27OHM(*2) ,5W
R660	CRF5EKR27HX2	RES , CEMENT	0.27OHM(*2) ,5W
R810	CRF5EKR27HX2	RES , CEMENT	0.27OHM(*2) ,5W
R811	CRF5EKR27HX2	RES , CEMENT	0.27OHM(*2) ,5W
R904	BRDERC12UGK335T	RES , CARBON JP	3.3M OHM 1/2W
R905	CRG1ANJ100H	RES , METAL OXIDE FILM	10 OHM 1W
R923	CRD25TJ220T	RES , CARBON	22 OHM 1/4W
R990	CRG1ANJ100H	RES , METAL OXIDE FILM	10 OHM 1W
R993	CRG1ANJ100H	RES , METAL OXIDE FILM	10 OHM 1W
R994	CRG1ANJ100H	RES , METAL OXIDE FILM	10 OHM 1W
R995	CRG1ANJ100H	RES , METAL OXIDE FILM	10 OHM 1W
R996	CRG1ANJ100H	RES , METAL OXIDE FILM	10 OHM 1W
R997	CRG1ANJ100H	RES , METAL OXIDE FILM	10 OHM 1W
R999	CRG1ANJ100H	RES , METAL OXIDE FILM	10 OHM 1W
<i>Miscellaneous</i>			
	CMD1A387	BRACKET , PCB	
	CMYAVR330CC	HEAT SINK ASS'Y	
	CHD1A012Z	SCREW , SPECIAL	AVR125CC
	CHD1A036FZ	SCREW , SPECIAL	AVR330/AVR4600
	CMD1A398	BRACKET , PCB	AG-D9320
	CMD1A417	BRACKET , PCB	AG-D8900
	CMD1A488	BRACKET , FAN	
	CMY1A205	HEAT SINK	
	CTB3+8J	SCREW	

Ref. Designator	Part Number	Description	
		MAIN PCB ASS'Y	
	CTW3+10J	SCREW	
	CTW3+12J	SCREW	
	HDMKD1206PTS3	MOTOR , FAN(60X60X25MM)	KD1206PTS3
	CTW3+8J	SCREW	
BN19	CWB3FE03250UP	WIRE ASS'Y	
BN20	CWB3FB43280UP	WIRE ASS'Y	
BN79	CWZAVR230BN79	WIRE ASS'Y (SHIELD)	
BN81	CWB1C902050EN	WIRE ASS'Y	
BN82	CWB1C902050EN	WIRE ASS'Y	
BN83	CWB1C902050EN	WIRE ASS'Y	
BN84	CWB1C902050EN	WIRE ASS'Y	
BN85	CWB1C902050EN	WIRE ASS'Y	
BN86	CWB1C902050EN	WIRE ASS'Y	
BN87	CWB1C902050EN	WIRE ASS'Y	
BN88	CWB2B904070EN	WIRE ASS'Y	
BN98	BJP08GA130ZK	WAFER	
CN61	KJP02GA01ZM	WAFER	MOLEX 5267-02A
CN62	KJP02GA01ZM	WAFER	MOLEX 5267-02A
CN63	KJP02GA01ZM	WAFER	MOLEX 5267-02A
CN64	KJP02GA01ZM	WAFER	MOLEX 5267-02A
CN65	KJP02GA01ZM	WAFER	MOLEX 5267-02A
CN66	KJP02GA01ZM	WAFER	MOLEX 5267-02A
CN67	KJP02GA01ZM	WAFER	MOLEX 5267-02A
CN80	KJP11GA19ZM	WAFER	MOLEX-53014
CN88	KJP02GA19ZM	WAFER	
CN89	KJP02GA01ZM	WAFER	MOLEX 5267-02A
CN91	KJP03GA89ZM	WAFER	MOLEX35328-0310
CN92	KJP02GA01ZM	WAFER	MOLEX 5267-02A
CN94	KJP13GA98ZM	WAFER	MOLEX35336-1310
CN95	KJP08GA98ZM	WAFER	MOLEX35336-0810
ET01	CNE75	PLATE , EARTH	
ET02	CMD1A387	BRACKET , PCB	
ET03	CNE75	PLATE , EARTH	
ET04	CMD1A387	BRACKET , PCB	
ET05	CMD1A387	BRACKET , PCB	
JK91	CJJ5R006Z	TERMINAL , SPEAKER	
JK92	CJJ5Q012Z	TERMINAL , SPEAKER	
JK94	CJJ2D008Z	JACK , STEREO	
JK95	CJJ2D008Z	JACK , STEREO	
JK96	CJJ2D008Z	JACK , STEREO	
JK97	CJJ4P041W	JACK IN/OUT	
JK98	CJJ4P042W	JACK IN/OUT	
JW90	CWEE212120VV	WIRE ASS'Y	
JW91	CWE8212180VV	WIRE ASS'Y	
JW93	CWE7202110AA	WIRE ASS'Y	
JW98	CWE7202110AA	WIRE ASS'Y	
JW99	CWE8202150AA	WIRE ASS'Y	
L501	CLEY0R5KAK	COIL , SPEAKER	0.5UH K
L502	CLEY0R5KAK	COIL , SPEAKER	0.5UH K
L503	CLEY0R5KAK	COIL , SPEAKER	0.5UH K
L504	CLEY0R5KAK	COIL , SPEAKER	0.5UH K
L505	CLEY0R5KAK	COIL , SPEAKER	0.5UH K
L506	CLEY0R5KAK	COIL , SPEAKER	0.5UH K
L507	CLEY0R5KAK	COIL , SPEAKER	0.5UH K
RY94	HSL1A008ZE	RELAY	SDT-S-112DMR
TH91	KRTP42T7D330B	THERMAL SENSOR , POSISTOR	P42T7D330BW20
T902	CLT5J033ZU	TRANS , SUB	SR-68

Ref. Designator	Part Number	Description	
INPUT PCB ASS'Y			
<i>Capacitors</i>			
C105	HCUS1H223KC	CAP , CHIP 0.022UF	
C106	HCUS1H223KC	CAP , CHIP 0.022UF	
C201	HCUS1H221JA	CAP , CHIP 220PF	
C202	HCUS1H221JA	CAP , CHIP 220PF	
C203	HCUS1H221JA	CAP , CHIP 220PF	
C204	HCUS1H221JA	CAP , CHIP 220PF	
C205	HCUS1H221JA	CAP , CHIP 220PF	
C206	HCUS1H221JA	CAP , CHIP 220PF	
C207	HCUS1H221JA	CAP , CHIP 220PF	
C208	HCUS1H221JA	CAP , CHIP 220PF	
C209	HCUS1H221JA	CAP , CHIP 220PF	
C210	HCUS1H221JA	CAP , CHIP 220PF	
C211	HCUS1H221JA	CAP , CHIP 220PF	
C212	HCUS1H221JA	CAP , CHIP 220PF	
C213	HCUS1H221JA	CAP , CHIP 220PF	
C214	HCUS1H221JA	CAP , CHIP 220PF	
C215	HCUS1H221JA	CAP , CHIP 220PF	
C216	HCUS1H221JA	CAP , CHIP 220PF	
C217	HCUS1H221JA	CAP , CHIP 220PF	
C218	HCUS1H221JA	CAP , CHIP 220PF	
C219	HCUS1H221JA	CAP , CHIP 220PF	
C220	HCUS1H221JA	CAP , CHIP 220PF	
C221	HCUS1H221JA	CAP , CHIP 220PF	
C222	HCUS1H221JA	CAP , CHIP 220PF	
C223	HCUS1H221JA	CAP , CHIP 220PF	
C224	HCUS1H221JA	CAP , CHIP 220PF	
C225	HCUS1H221JA	CAP , CHIP 220PF	
C226	HCUS1H221JA	CAP , CHIP 220PF	
C233	HCUS1H181JA	CAP , CHIP 180PF	
C234	HCUS1H471JA	CAP , CHIP 470PF	
C235	HCUS1H223KC	CAP , CHIP 0.022UF	
C236	HCUS1H223KC	CAP , CHIP 0.022UF	
C241	HCUS1H181JA	CAP , CHIP 180PF	
C242	HCUS1H471JA	CAP , CHIP 470PF	
C253	HCUS1H181JA	CAP , CHIP 180PF	
C254	HCUS1H471JA	CAP , CHIP 470PF	
C255	HCUS1H223KC	CAP , CHIP 0.022UF	
C256	HCUS1H223KC	CAP , CHIP 0.022UF	
C270	HCUS1H181JA	CAP , CHIP 180PF	
C271	HCUS1H471JA	CAP , CHIP 470PF	
C291	HCUS1E104ZF	CAP , CHIP , 0.1UF ZF	1608 SIZE
C292	HCUS1E104ZF	CAP , CHIP , 0.1UF ZF	1608 SIZE
C293	HCUS1E104ZF	CAP , CHIP , 0.1UF ZF	1608 SIZE
C294	HCUS1E104ZF	CAP , CHIP , 0.1UF ZF	1608 SIZE
C295	HCUS1E104ZF	CAP , CHIP , 0.1UF ZF	1608 SIZE
C296	HCUS1E104ZF	CAP , CHIP , 0.1UF ZF	1608 SIZE
C297	HCUS1E104ZF	CAP , CHIP , 0.1UF ZF	1608 SIZE
C298	HCUS1E104ZF	CAP , CHIP , 0.1UF ZF	1608 SIZE
C317	HCUS1H223KC	CAP , CHIP 0.022UF	
C318	HCUS1H223KC	CAP , CHIP 0.022UF	
C319	HCUS1H223KC	CAP , CHIP 0.022UF	
C320	HCUS1H223KC	CAP , CHIP 0.022UF	
C321	HCUS1H561JA	CAP , CHIP 560PF	
C322	HCUS1H561JA	CAP , CHIP 560PF	
C323	HCUS1H561JA	CAP , CHIP 560PF	
C324	HCUS1H561JA	CAP , CHIP 560PF	
C325	HCUS1H561JA	CAP , CHIP 560PF	
C326	HCUS1H561JA	CAP , CHIP 560PF	

Ref. Designator	Part Number	Description	
		INPUT PCB ASS'Y	
C327	HCUS1H561JA	CAP , CHIP 560PF	
C328	HCUS1H561JA	CAP , CHIP 560PF	
C329	HCUS1H561JA	CAP , CHIP 560PF	
C330	HCUS1H561JA	CAP , CHIP 560PF	
C331	HCUS1H561JA	CAP , CHIP 560PF	
C332	HCUS1H561JA	CAP , CHIP 560PF	
C333	HCUS1H561JA	CAP , CHIP 560PF	
C334	HCUS1H561JA	CAP , CHIP 560PF	
C335	HCUS1H561JA	CAP , CHIP 560PF	
C336	HCUS1H561JA	CAP , CHIP 560PF	
C337	HCUS1H223KC	CAP , CHIP 0.022UF	
C338	HCUS1H223KC	CAP , CHIP 0.022UF	
C339	HCUS1H223KC	CAP , CHIP 0.022UF	
C340	HCUS1H223KC	CAP , CHIP 0.022UF	
C371	HCUS1H221JA	CAP , CHIP 220PF	
C372	HCUS1H221JA	CAP , CHIP 220PF	
C373	HCUS1H221JA	CAP , CHIP 220PF	
C374	HCUS1H221JA	CAP , CHIP 220PF	
C375	HCUS1H223KC	CAP , CHIP 0.022UF	
C376	HCUS1H223KC	CAP , CHIP 0.022UF	
C378	HCUS1H223KC	CAP , CHIP 0.022UF	
C379	HCUS1H223KC	CAP , CHIP 0.022UF	
C381	HCUS1H561JA	CAP , CHIP 560PF	
C382	HCUS1H223KC	CAP , CHIP 0.022UF	
C383	HCUS1H223KC	CAP , CHIP 0.022UF	
C411	HCUS1H223KC	CAP , CHIP 0.022UF	
C412	HCUS1H223KC	CAP , CHIP 0.022UF	
C413	HCUS1H223KC	CAP , CHIP 0.022UF	
C414	HCUS1H223KC	CAP , CHIP 0.022UF	
C415	HCUS1H223KC	CAP , CHIP 0.022UF	
C416	HCUS1H223KC	CAP , CHIP 0.022UF	
C417	HCUS1H223KC	CAP , CHIP 0.022UF	
C418	HCUS1H223KC	CAP , CHIP 0.022UF	
C419	HCUS1H223KC	CAP , CHIP 0.022UF	
C420	HCUS1H223KC	CAP , CHIP 0.022UF	
C423	HCUS1H151JA	CAP , CHIP , 150PF JA	1608 SIZE
C424	HCUS1H151JA	CAP , CHIP , 150PF JA	1608 SIZE
C425	HCUS1H151JA	CAP , CHIP , 150PF JA	1608 SIZE
C427	HCUS1H151JA	CAP , CHIP , 150PF JA	1608 SIZE
C428	HCUS1H151JA	CAP , CHIP , 150PF JA	1608 SIZE
C429	HCUS1H151JA	CAP , CHIP , 150PF JA	1608 SIZE
C430	HCUS1H151JA	CAP , CHIP , 150PF JA	1608 SIZE
C471	HCUS1H181JA	CAP , CHIP 180PF	
C472	HCUS1H181JA	CAP , CHIP 180PF	
C473	HCUS1H181JA	CAP , CHIP 180PF	
C474	HCUS1H181JA	CAP , CHIP 180PF	
C475	HCUS1E104ZF	CAP , CHIP , 0.1UF ZF	1608 SIZE
C721	HCUS1H270JA	CAP , CHIP , 27PF JA	1608 SIZE
C722	HCUS1H270JA	CAP , CHIP , 27PF JA	1608 SIZE
C723	HCUS1H270JA	CAP , CHIP , 27PF JA	1608 SIZE
C724	HCUS1H270JA	CAP , CHIP , 27PF JA	1608 SIZE
C726	HCUS1H473ZF	CAP , CHIP 0.047UF	
C727	HCUS1E104ZF	CAP , CHIP , 0.1UF ZF	1608 SIZE
C729	HCUS1E104ZF	CAP , CHIP , 0.1UF ZF	1608 SIZE
C730	HCUS1E104ZF	CAP , CHIP , 0.1UF ZF	1608 SIZE
C731	HCUS1E104ZF	CAP , CHIP , 0.1UF ZF	1608 SIZE
C733	HCUS1H223KC	CAP , CHIP 0.022UF	
C734	HCUS1H101JA	CAP , CHIP 100PF	
C735	HCUS1H101JA	CAP , CHIP 100PF	
C736	HCUS1H101JA	CAP , CHIP 100PF	
C737	HCUS1H101JA	CAP , CHIP 100PF	

Ref. Designator	Part Number	Description	
		INPUT PCB ASS'Y	
C738	HCUS1E104ZF	CAP , CHIP , 0.1UF ZF	1608 SIZE
C739	HCUS1H330JA	CAP , CHIP 33PF	
C740	HCUS1H330JA	CAP , CHIP 33PF	
C742	HCUS1E104ZF	CAP , CHIP , 0.1UF ZF	1608 SIZE
C743	HCUS1E104ZF	CAP , CHIP , 0.1UF ZF	1608 SIZE
C744	HCUS1E104ZF	CAP , CHIP , 0.1UF ZF	1608 SIZE
C746	HCUS1E104ZF	CAP , CHIP , 0.1UF ZF	1608 SIZE
C747	HCUS1H223KC	CAP , CHIP 0.022UF	
C748	HCUS1E104ZF	CAP , CHIP , 0.1UF ZF	1608 SIZE
C750	HCUS1E104ZF	CAP , CHIP , 0.1UF ZF	1608 SIZE
C751	HCUS1E104ZF	CAP , CHIP , 0.1UF ZF	1608 SIZE
C753	HCUS1E104ZF	CAP , CHIP , 0.1UF ZF	1608 SIZE
C755	HCUS1H223KC	CAP , CHIP 0.022UF	
C756	HCUS1E104ZF	CAP , CHIP , 0.1UF ZF	1608 SIZE
C758	HCUS1E104ZF	CAP , CHIP , 0.1UF ZF	1608 SIZE
C760	HCUS1H471JA	CAP , CHIP 470PF	
C761	HCUS1H103KC	CAP , CHIP 0.01UF	
C762	HCUS1H120JA	CAP , CHIP 12PF	
C763	HCUS1H120JA	CAP , CHIP 12PF	
C764	HCUS1H102KC	CAP , CHIP 0.001UF	
C765	HCUS1H101JA	CAP , CHIP 100PF	
C766	HCUS1E104ZF	CAP , CHIP , 0.1UF ZF	1608 SIZE
C767	HCUS1E104ZF	CAP , CHIP , 0.1UF ZF	1608 SIZE
C769	HCUS1E104ZF	CAP , CHIP , 0.1UF ZF	1608 SIZE
C771	HCUS1E104ZF	CAP , CHIP , 0.1UF ZF	1608 SIZE
C773	HCUS1E104ZF	CAP , CHIP , 0.1UF ZF	1608 SIZE
C774	HCUS1E104ZF	CAP , CHIP , 0.1UF ZF	1608 SIZE
C775	HCUS1E104ZF	CAP , CHIP , 0.1UF ZF	1608 SIZE
C777	HCUS1H473ZF	CAP , CHIP 0.047UF	
C779	HCUS1E104ZF	CAP , CHIP , 0.1UF ZF	1608 SIZE
C780	HCUS1E104ZF	CAP , CHIP , 0.1UF ZF	1608 SIZE
C783	HCUS1H473ZF	CAP , CHIP 0.047UF	
C784	HCUS1E104ZF	CAP , CHIP , 0.1UF ZF	1608 SIZE
C787	HCUS1H473ZF	CAP , CHIP 0.047UF	
C101	HCEA1VH100T	CAP , ELECT	10UF 35V
C102	HCEA1VH100T	CAP , ELECT	10UF 35V
C103	HCEA1VH100T	CAP , ELECT	10UF 35V
C104	HCEA1VH100T	CAP , ELECT	10UF 35V
C231	HCEA1CH101T	CAP , ELECT	100UF 16V
C232	HCEA1CH101T	CAP , ELECT	100UF 16V
C237	HCEA1CH101T	CAP , ELECT	100UF 16V
C238	HCEA1CH101T	CAP , ELECT	100UF 16V
C239	HCEA1VH100T	CAP , ELECT	10UF 35V
C240	HCEA1VH100T	CAP , ELECT	10UF 35V
C244	HCEA1VH100T	CAP , ELECT	10UF 35V
C245	HCEA1VH100T	CAP , ELECT	10UF 35V
C251	HCEA1CH101T	CAP , ELECT	100UF 16V
C252	HCEA1CH101T	CAP , ELECT	100UF 16V
C261	HCEA1CH101T	CAP , ELECT	100UF 16V
C262	HCEA1CH101T	CAP , ELECT	100UF 16V
C263	HCEA1VH100T	CAP , ELECT	10UF 35V
C264	HCEA1VH100T	CAP , ELECT	10UF 35V
C265	HCEA1VH100T	CAP , ELECT	10UF 35V
C267	HCEA1VH100T	CAP , ELECT	10UF 35V
C268	HCEA1VH100T	CAP , ELECT	10UF 35V
C269	HCEA1VH100T	CAP , ELECT	10UF 35V
C301	HCQ11H332JZT	CAP , MYLAR	3300PF 50V J
C302	HCQ11H332JZT	CAP , MYLAR	3300PF 50V J
C303	HCQ11H332JZT	CAP , MYLAR	3300PF 50V J
C304	HCQ11H332JZT	CAP , MYLAR	3300PF 50V J
C305	HCQ11H332JZT	CAP , MYLAR	3300PF 50V J

Ref. Designator	Part Number	Description	
		INPUT PCB ASS'Y	
C306	HCQ1H332JZT	CAP , MYLAR	3300PF 50V J
C307	HCQ1H332JZT	CAP , MYLAR	3300PF 50V J
C308	HCQ1H332JZT	CAP , MYLAR	3300PF 50V J
C309	HCQ1H332JZT	CAP , MYLAR	3300PF 50V J
C310	HCQ1H332JZT	CAP , MYLAR	3300PF 50V J
C311	HCQ1H332JZT	CAP , MYLAR	3300PF 50V J
C312	HCQ1H332JZT	CAP , MYLAR	3300PF 50V J
C313	HCQ1H332JZT	CAP , MYLAR	3300PF 50V J
C314	HCQ1H332JZT	CAP , MYLAR	3300PF 50V J
C315	HCQ1H332JZT	CAP , MYLAR	3300PF 50V J
C316	HCQ1H332JZT	CAP , MYLAR	3300PF 50V J
C341	HCEA1VH100T	CAP , ELECT	10UF 35V
C342	HCEA1VH100T	CAP , ELECT	10UF 35V
C343	HCEA1VH100T	CAP , ELECT	10UF 35V
C344	HCEA1VH100T	CAP , ELECT	10UF 35V
C345	HCEA1VH100T	CAP , ELECT	10UF 35V
C346	HCEA1VH100T	CAP , ELECT	10UF 35V
C347	HCEA1VH100T	CAP , ELECT	10UF 35V
C348	HCEA1VH100T	CAP , ELECT	10UF 35V
C349	HCEA1HH1R0T	CAP , ELECT	1UF 50V
C401	HCEA1VKS100T	CAP , ELECT	10UF 35V
C402	HCEA1VH100T	CAP , ELECT	10UF 35V
C403	HCEA1VH100T	CAP , ELECT	10UF 35V
C404	HCEA1VH100T	CAP , ELECT	10UF 35V
C405	HCEA1VH100T	CAP , ELECT	10UF 35V
C406	HCEA1VH100T	CAP , ELECT	10UF 35V
C407	HCEA1VH100T	CAP , ELECT	10UF 35V
C408	HCEA1VH100T	CAP , ELECT	10UF 35V
C409	HCEA1VH100T	CAP , ELECT	10UF 35V
C410	HCEA1VH100T	CAP , ELECT	10UF 35V
C426	HCQ1H182JZT	CAP , MYLAR	1800PF 50V J
C431	HCEA1CH101T	CAP , ELECT	100UF 16V
C432	HCEA1CH101T	CAP , ELECT	100UF 16V
C433	HCEA1CH101T	CAP , ELECT	100UF 16V
C434	HCEA1CH101T	CAP , ELECT	100UF 16V
C435	HCEA1CH101T	CAP , ELECT	100UF 16V
C436	HCEA1CH101T	CAP , ELECT	100UF 16V
C437	HCEA1CH101T	CAP , ELECT	100UF 16V
C438	HCEA1CH101T	CAP , ELECT	100UF 16V
C439	HCEA1CH101T	CAP , ELECT	100UF 16V
C440	HCEA1CH101T	CAP , ELECT	100UF 16V
C451	HCEA1VH100T	CAP , ELECT	10UF 35V
C452	HCEA1VH100T	CAP , ELECT	10UF 35V
C453	HCEA1VH100T	CAP , ELECT	10UF 35V
C454	HCEA1VH100T	CAP , ELECT	10UF 35V
C455	HCEA1VH100T	CAP , ELECT	10UF 35V
C456	HCEA1VH100T	CAP , ELECT	10UF 35V
C457	HCEA1VH100T	CAP , ELECT	10UF 35V
C458	HCEA1VH100T	CAP , ELECT	10UF 35V
C459	HCEA1VH100T	CAP , ELECT	10UF 35V
C460	HCEA1VH100T	CAP , ELECT	10UF 35V
C725	HCEA1CH101T	CAP , ELECT	100UF 16V
C728	HCEA1EH470T	CAP , ELECT	47UF 25V
C732	HCEA1CH101T	CAP , ELECT	100UF 16V
C741	HCEA1CH101T	CAP , ELECT	100UF 16V
C745	HCEA1CH101T	CAP , ELECT	100UF 16V
C749	HCEA1CH101T	CAP , ELECT	100UF 16V
C752	HCEA1CH101T	CAP , ELECT	100UF 16V
C754	HCEA1VH100T	CAP , ELECT	10UF 35V
C757	HCEA1HH2R2T	CAP , ELECT	2.2UF 50V
C759	HCEA1VH100T	CAP , ELECT	10UF 35V

Ref. Designator	Part Number	Description	
		INPUT PCB ASS'Y	
C768	HCEA1HH2R2T	CAP , ELECT	2.2UF 50V
C770	HCEA1EH470T	CAP , ELECT	47UF 25V
C772	HCEA1EH470T	CAP , ELECT	47UF 25V
C776	HCEA1CH101T	CAP , ELECT	100UF 16V
C778	HCEA0JH102T	CAP , ELECT	1000UF 6.3V
C781	HCEA1CH101T	CAP , ELECT	100UF 16V
C782	HCEA1AH471T	CAP , ELECT	470UF 10V
C785	HCEA1CH101T	CAP , ELECT	100UF 16V
C786	HCEA1AH471T	CAP , ELECT	470UF 10V
<i>Semiconductors</i>			
D703	HVDRB160L60TE25	DIODE , SCHOTTKY BARRIER HK	RB160L-60TE25
IC13	HVINJM2068MDTE1	I.C , OP AMP	NJM2068MD-TE1
IC21	HVITC9163AF	I.C , FUNCTION	TC9163AF
IC22	HVINJM2068MDTE1	I.C , OP AMP	NJM2068MD-TE1
IC23	HVITC9164AF	I.C , FUNCTION	TC9164AF
IC24	HVITC9163AF	I.C , FUNCTION	TC9163AF
IC25	HVINJM2068MDTE1	I.C , OP AMP	NJM2068MD-TE1
IC26	HVITC9162AF	I.C , FUNCTION	TC9162AF
IC31	HVINJM2068MDTE1	I.C , OP AMP	NJM2068MD-TE1
IC32	HVINJM2068MDTE1	I.C , OP AMP	NJM2068MD-TE1
IC33	HVINJM2068MDTE1	I.C , OP AMP	NJM2068MD-TE1
IC34	HVINJM2068MDTE1	I.C , OP AMP	NJM2068MD-TE1
IC35	HVINJM2068MDTE1	I.C , OP AMP	NJM2068MD-TE1
IC36	HVINJM2068MDTE1	I.C , OP AMP	NJM2068MD-TE1
IC37	HVINJM2068MDTE1	I.C , OP AMP	NJM2068MD-TE1
IC40	HVITC9459F	I.C , VOLUME	TC9459F
IC41	HVITC9459F	I.C , VOLUME	TC9459F
IC42	HVITC9459F	I.C , VOLUME	TC9459F
IC43	HVITC9459F	I.C , VOLUME	TC9459F
IC44	HVITC9459F	I.C , VOLUME	TC9459F
IC45	HVINJM2068MDTE1	I.C , OP AMP	NJM2068MD-TE1
IC46	HVINJM2068MDTE1	I.C , OP AMP	NJM2068MD-TE1
IC47	HVINJM2068MDTE1	I.C , OP AMP	NJM2068MD-TE1
IC48	HVINJM2068MDTE1	I.C , OP AMP	NJM2068MD-TE1
IC49	HVINJM2068MDTE1	I.C , OP AMP	NJM2068MD-TE1
IC72	HVITC74HCU04AFN	IC , INVERTER	TC74HCU04AFN
IC73	HVIAK4114VQ	IC , DIR	A.K.M
IC74	HVIAK4358VQ	I.C , DAC(8CH)	A.K.M
IC75	HVICS493263-CLG	I.C , DSP HK	CS493263-CLG
IC76	HVIAK5381VT	I.C , ADC	A.K.M
D201	HVD1SS133MT	DIODE	1SS133T-77
D202	HVD1SS133MT	DIODE	1SS133T-77
D203	HVD1SS133MT	DIODE	1SS133T-77
D204	HVD1SS133MT	DIODE	1SS133T-77
D205	HVD1SS133MT	DIODE	1SS133T-77
D206	HVD1SS133MT	DIODE	1SS133T-77
D207	HVD1SS133MT	DIODE	1SS133T-77
D208	HVD1SS133MT	DIODE	1SS133T-77
D209	HVD1SS133MT	DIODE	1SS133T-77
D210	HVD1SS133MT	DIODE	1SS133T-77
D211	HVD1SS133MT	DIODE	1SS133T-77
D212	HVD1SS133MT	DIODE	1SS133T-77
D213	HVD1SS133MT	DIODE	1SS133T-77
D214	HVD1SS133MT	DIODE	1SS133T-77
D215	HVD1SS133MT	DIODE	1SS133T-77
D216	HVD1SS133MT	DIODE	1SS133T-77
D475	HVD1SS133MT	DIODE	1SS133T-77
D701	HVDMTZJ4.7BT	DIODE , ZENER	4.7V 1/2W
D702	HVDMTZJ3.3BT	DIODE , ZENER	3.3V 1/2W

Ref. Designator	Part Number	Description	
		INPUT PCB ASS'Y	
Q201	HVTKTD1302T	TRANSISTOR NPN	KTD1302
Q202	HVTKTC2874BT	TRANSISTOR, NPN, MUTE	KTC2874B
Q203	HVTKTC2874BT	TRANSISTOR, NPN, MUTE	KTC2874B
Q204	HVTKRA107MT	TRANSISTOR PNP	KRA107M
Q451	HVTKTC2874BT	TRANSISTOR, NPN, MUTE	KTC2874B
Q452	HVTKTC2874BT	TRANSISTOR, NPN, MUTE	KTC2874B
Q701	HVTKSC2316YT	TRANSISTOR NPN	KSC2316Y
Q702	HVTKSC2316YT	TRANSISTOR NPN	KSC2316Y
<i>Resistors</i>			
R101	HRJ10DJ562T	RES , CHIP 5.6K OHM	
R102	HRJ10DJ562T	RES , CHIP 5.6K OHM	
R103	HRJ10DJ682T	RES , CHIP 6.8K OHM	1608 SIZE
R104	HRJ10DJ682T	RES , CHIP 6.8K OHM	1608 SIZE
R105	HRJ10DJ151T	RES , CHIP 150 OHM	
R106	HRJ10DJ151T	RES , CHIP 150 OHM	
R107	HRJ10DJ101T	RES , CHIP (1/10W) , 100 OHM J	1608 SIZE
R108	HRJ10DJ101T	RES , CHIP (1/10W) , 100 OHM J	1608 SIZE
R201	HRJ10DJ471T	RES , CHIP 470 OHM	
R202	HRJ10DJ471T	RES , CHIP 470 OHM	
R203	HRJ10DJ471T	RES , CHIP 470 OHM	
R204	HRJ10DJ471T	RES , CHIP 470 OHM	
R205	HRJ10DJ471T	RES , CHIP 470 OHM	
R206	HRJ10DJ471T	RES , CHIP 470 OHM	
R207	HRJ10DJ471T	RES , CHIP 470 OHM	
R208	HRJ10DJ471T	RES , CHIP 470 OHM	
R209	HRJ10DJ471T	RES , CHIP 470 OHM	
R210	HRJ10DJ471T	RES , CHIP 470 OHM	
R211	HRJ10DJ471T	RES , CHIP 470 OHM	
R212	HRJ10DJ471T	RES , CHIP 470 OHM	
R213	HRJ10DJ471T	RES , CHIP 470 OHM	
R214	HRJ10DJ471T	RES , CHIP 470 OHM	
R215	HRJ10DJ471T	RES , CHIP 470 OHM	
R216	HRJ10DJ471T	RES , CHIP 470 OHM	
R217	HRJ10DJ471T	RES , CHIP 470 OHM	
R218	HRJ10DJ471T	RES , CHIP 470 OHM	
R219	HRJ10DJ471T	RES , CHIP 470 OHM	
R220	HRJ10DJ471T	RES , CHIP 470 OHM	
R221	HRJ10DJ471T	RES , CHIP 470 OHM	
R222	HRJ10DJ471T	RES , CHIP 470 OHM	
R223	HRJ10DJ471T	RES , CHIP 470 OHM	
R224	HRJ10DJ272T	RES , CHIP 2.7K OHM	
R225	HRJ10DJ471T	RES , CHIP 470 OHM	
R226	HRJ10DJ471T	RES , CHIP 470 OHM	
R227	HRJ10DJ474T	RES , CHIP 470K OHM	1608 SIZE
R228	HRJ10DJ474T	RES , CHIP 470K OHM	1608 SIZE
R229	HRJ10DJ474T	RES , CHIP 470K OHM	1608 SIZE
R230	HRJ10DJ474T	RES , CHIP 470K OHM	1608 SIZE
R231	HRJ10DJ474T	RES , CHIP 470K OHM	1608 SIZE
R232	HRJ10DJ474T	RES , CHIP 470K OHM	1608 SIZE
R233	HRJ10DJ474T	RES , CHIP 470K OHM	1608 SIZE
R234	HRJ10DJ474T	RES , CHIP 470K OHM	1608 SIZE
R235	HRJ10DJ474T	RES , CHIP 470K OHM	1608 SIZE
R236	HRJ10DJ474T	RES , CHIP 470K OHM	1608 SIZE
R237	HRJ10DJ474T	RES , CHIP 470K OHM	1608 SIZE
R238	HRJ10DJ474T	RES , CHIP 470K OHM	1608 SIZE
R239	HRJ10DJ474T	RES , CHIP 470K OHM	1608 SIZE
R240	HRJ10DJ474T	RES , CHIP 470K OHM	1608 SIZE
R241	HRJ10DJ474T	RES , CHIP 470K OHM	1608 SIZE
R242	HRJ10DJ474T	RES , CHIP 470K OHM	1608 SIZE

Ref. Designator	Part Number	Description	
		INPUT PCB ASS'Y	
R243	HRJ10DJ474T	RES , CHIP 470K OHM	1608 SIZE
R244	HRJ10DJ474T	RES , CHIP 470K OHM	1608 SIZE
R245	HRJ10DJ474T	RES , CHIP 470K OHM	1608 SIZE
R246	HRJ10DJ474T	RES , CHIP 470K OHM	1608 SIZE
R247	HRJ10DJ474T	RES , CHIP 470K OHM	1608 SIZE
R248	HRJ10DJ474T	RES , CHIP 470K OHM	1608 SIZE
R249	HRJ10DJ474T	RES , CHIP 470K OHM	1608 SIZE
R250	HRJ10DJ103T	RES , CHIP 10K OHM	
R251	HRJ10DJ474T	RES , CHIP 470K OHM	1608 SIZE
R252	HRJ10DJ474T	RES , CHIP 470K OHM	1608 SIZE
R253	HRJ10DJ184T	RES , CHIP 180K OHM	1608 SIZE
R254	HRJ10DJ184T	RES , CHIP 180K OHM	1608 SIZE
R255	HRJ10DJ101T	RES , CHIP (1/10W) , 100 OHM J	1608 SIZE
R256	HRJ10DJ101T	RES , CHIP (1/10W) , 100 OHM J	1608 SIZE
R257	HRJ10DJ472T	RES , CHIP (1/10W) ,4.7K OHM J	1608 SIZE
R258	HRJ10DJ472T	RES , CHIP (1/10W) ,4.7K OHM J	1608 SIZE
R259	HRJ10DJ472T	RES , CHIP (1/10W) ,4.7K OHM J	1608 SIZE
R261	HRJ10DJ104T	RES , CHIP 100K OHM	
R262	HRJ10DJ104T	RES , CHIP 100K OHM	
R263	HRJ10DJ101T	RES , CHIP (1/10W) , 100 OHM J	1608 SIZE
R264	HRJ10DJ101T	RES , CHIP (1/10W) , 100 OHM J	1608 SIZE
R265	HRJ10DJ101T	RES , CHIP (1/10W) , 100 OHM J	1608 SIZE
R267	HRJ10DJ101T	RES , CHIP (1/10W) , 100 OHM J	1608 SIZE
R268	HRJ10DJ184T	RES , CHIP 180K OHM	1608 SIZE
R269	HRJ10DJ184T	RES , CHIP 180K OHM	1608 SIZE
R270	HRJ10DJ472T	RES , CHIP (1/10W) ,4.7K OHM J	1608 SIZE
R271	HRJ10DJ472T	RES , CHIP (1/10W) ,4.7K OHM J	1608 SIZE
R272	HRJ10DJ472T	RES , CHIP (1/10W) ,4.7K OHM J	1608 SIZE
R273	HRJ10DJ101T	RES , CHIP (1/10W) , 100 OHM J	1608 SIZE
R274	HRJ10DJ101T	RES , CHIP (1/10W) , 100 OHM J	1608 SIZE
R275	HRJ10DJ472T	RES , CHIP (1/10W) ,4.7K OHM J	1608 SIZE
R276	HRJ10DJ472T	RES , CHIP (1/10W) ,4.7K OHM J	1608 SIZE
R277	HRJ10DJ472T	RES , CHIP (1/10W) ,4.7K OHM J	1608 SIZE
R278	HRJ10DJ104T	RES , CHIP 100K OHM	
R279	HRJ10DJ104T	RES , CHIP 100K OHM	
R280	HRJ10DJ101T	RES , CHIP (1/10W) , 100 OHM J	1608 SIZE
R281	HRJ10DJ101T	RES , CHIP (1/10W) , 100 OHM J	1608 SIZE
R283	HRJ10DJ101T	RES , CHIP (1/10W) , 100 OHM J	1608 SIZE
R284	HRJ10DJ101T	RES , CHIP (1/10W) , 100 OHM J	1608 SIZE
R285	HRJ10DJ184T	RES , CHIP 180K OHM	1608 SIZE
R286	HRJ10DJ184T	RES , CHIP 180K OHM	1608 SIZE
R287	HRJ10DJ184T	RES , CHIP 180K OHM	1608 SIZE
R288	HRJ10DJ184T	RES , CHIP 180K OHM	1608 SIZE
R289	HRJ10DJ184T	RES , CHIP 180K OHM	1608 SIZE
R290	HRJ10DJ184T	RES , CHIP 180K OHM	1608 SIZE
R291	HRJ10DJ472T	RES , CHIP (1/10W) ,4.7K OHM J	1608 SIZE
R292	HRJ10DJ472T	RES , CHIP (1/10W) ,4.7K OHM J	1608 SIZE
R293	HRJ10DJ472T	RES , CHIP (1/10W) ,4.7K OHM J	1608 SIZE
R301	HRJ10DJ332T	RES , CHIP 3.3K OHM	
R302	HRJ10DJ332T	RES , CHIP 3.3K OHM	
R303	HRJ10DJ332T	RES , CHIP 3.3K OHM	
R304	HRJ10DJ332T	RES , CHIP 3.3K OHM	
R305	HRJ10DJ332T	RES , CHIP 3.3K OHM	
R306	HRJ10DJ332T	RES , CHIP 3.3K OHM	
R307	HRJ10DJ332T	RES , CHIP 3.3K OHM	
R308	HRJ10DJ332T	RES , CHIP 3.3K OHM	
R309	HRJ10DJ332T	RES , CHIP 3.3K OHM	
R310	HRJ10DJ332T	RES , CHIP 3.3K OHM	
R311	HRJ10DJ332T	RES , CHIP 3.3K OHM	
R312	HRJ10DJ332T	RES , CHIP 3.3K OHM	
R313	HRJ10DJ332T	RES , CHIP 3.3K OHM	

Ref. Designator	Part Number	Description	
		INPUT PCB ASS'Y	
R314	HRJ10DJ332T	RES , CHIP 3.3K OHM	
R315	HRJ10DJ332T	RES , CHIP 3.3K OHM	
R316	HRJ10DJ332T	RES , CHIP 3.3K OHM	
R317	HRJ10DJ101T	RES , CHIP (1/10W) , 100 OHM J	1608 SIZE
R318	HRJ10DJ101T	RES , CHIP (1/10W) , 100 OHM J	1608 SIZE
R319	HRJ10DJ101T	RES , CHIP (1/10W) , 100 OHM J	1608 SIZE
R320	HRJ10DJ101T	RES , CHIP (1/10W) , 100 OHM J	1608 SIZE
R321	HRJ10DJ562T	RES , CHIP 5.6K OHM	
R322	HRJ10DJ562T	RES , CHIP 5.6K OHM	
R323	HRJ10DJ562T	RES , CHIP 5.6K OHM	
R324	HRJ10DJ562T	RES , CHIP 5.6K OHM	
R325	HRJ10DJ562T	RES , CHIP 5.6K OHM	
R326	HRJ10DJ562T	RES , CHIP 5.6K OHM	
R327	HRJ10DJ223T	RES , CHIP 5.6K OHM	1608 SIZE
R328	HRJ10DJ223T	RES , CHIP 5.6K OHM	1608 SIZE
R329	HRJ10DJ562T	RES , CHIP 5.6K OHM	
R330	HRJ10DJ562T	RES , CHIP 5.6K OHM	
R331	HRJ10DJ562T	RES , CHIP 5.6K OHM	
R332	HRJ10DJ562T	RES , CHIP 5.6K OHM	
R333	HRJ10DJ562T	RES , CHIP 5.6K OHM	
R334	HRJ10DJ562T	RES , CHIP 5.6K OHM	
R335	HRJ10DJ562T	RES , CHIP 5.6K OHM	
R336	HRJ10DJ562T	RES , CHIP 5.6K OHM	
R337	HRJ10DJ101T	RES , CHIP (1/10W) , 100 OHM J	1608 SIZE
R338	HRJ10DJ101T	RES , CHIP (1/10W) , 100 OHM J	1608 SIZE
R339	HRJ10DJ101T	RES , CHIP (1/10W) , 100 OHM J	1608 SIZE
R340	HRJ10DJ101T	RES , CHIP (1/10W) , 100 OHM J	1608 SIZE
R341	HRJ10DJ122T	RES , CHIP 1.2K OHM	
R342	HRJ10DJ122T	RES , CHIP 1.2K OHM	
R343	HRJ10DJ122T	RES , CHIP 1.2K OHM	
R344	HRJ10DJ122T	RES , CHIP 1.2K OHM	
R345	HRJ10DJ122T	RES , CHIP 1.2K OHM	
R346	HRJ10DJ122T	RES , CHIP 1.2K OHM	
R347	HRJ10DJ122T	RES , CHIP 1.2K OHM	
R348	HRJ10DJ122T	RES , CHIP 1.2K OHM	
R349	HRJ10DJ122T	RES , CHIP 1.2K OHM	
R350	HRJ10DJ122T	RES , CHIP 1.2K OHM	
R351	HRJ10DJ122T	RES , CHIP 1.2K OHM	
R352	HRJ10DJ122T	RES , CHIP 1.2K OHM	
R353	HRJ10DJ122T	RES , CHIP 1.2K OHM	
R354	HRJ10DJ122T	RES , CHIP 1.2K OHM	
R355	HRJ10DJ122T	RES , CHIP 1.2K OHM	
R356	HRJ10DJ122T	RES , CHIP 1.2K OHM	
R361	HRJ10DJ104T	RES , CHIP 100K OHM	
R362	HRJ10DJ104T	RES , CHIP 100K OHM	
R363	HRJ10DJ104T	RES , CHIP 100K OHM	
R364	HRJ10DJ104T	RES , CHIP 100K OHM	
R365	HRJ10DJ104T	RES , CHIP 100K OHM	
R366	HRJ10DJ104T	RES , CHIP 100K OHM	
R367	HRJ10DJ104T	RES , CHIP 100K OHM	
R368	HRJ10DJ104T	RES , CHIP 100K OHM	
R371	HRJ10DJ332T	RES , CHIP 3.3K OHM	
R372	HRJ10DJ332T	RES , CHIP 3.3K OHM	
R373	HRJ10DJ332T	RES , CHIP 3.3K OHM	
R374	HRJ10DJ332T	RES , CHIP 3.3K OHM	
R375	HRJ10DJ332T	RES , CHIP 3.3K OHM	
R376	HRJ10DJ332T	RES , CHIP 3.3K OHM	
R377	HRJ10DJ332T	RES , CHIP 3.3K OHM	
R378	HRJ10DJ332T	RES , CHIP 3.3K OHM	
R379	HRJ10DJ332T	RES , CHIP 3.3K OHM	
R380	HRJ10DJ332T	RES , CHIP 3.3K OHM	

Ref. Designator	Part Number	Description	
		INPUT PCB ASS'Y	
R381	HRJ10DJ101T	RES , CHIP (1/10W) , 100 OHM J	1608 SIZE
R382	HRJ10DJ101T	RES , CHIP (1/10W) , 100 OHM J	1608 SIZE
R383	HRJ10DJ101T	RES , CHIP (1/10W) , 100 OHM J	1608 SIZE
R384	HRJ10DJ101T	RES , CHIP (1/10W) , 100 OHM J	1608 SIZE
R385	HRJ10DJ101T	RES , CHIP (1/10W) , 100 OHM J	1608 SIZE
R386	HRJ10DJ101T	RES , CHIP (1/10W) , 100 OHM J	1608 SIZE
R389	HRJ10DJ332T	RES , CHIP 3.3K OHM	
R390	HRJ10DJ332T	RES , CHIP 3.3K OHM	
R391	HRJ10DJ105T	RES , CHIP (1/10W)	1608 SIZE
R392	HRJ10DJ105T	RES , CHIP (1/10W)	1608 SIZE
R393	HRJ10DJ332T	RES , CHIP 3.3K OHM	
R394	HRJ10DJ153T	RES , CHIP 15K OHM	
R395	HRJ10DJ153T	RES , CHIP 15K OHM	
R396	HRJ10DJ332T	RES , CHIP 3.3K OHM	
R397	HRJ10DJ101T	RES , CHIP (1/10W) , 100 OHM J	1608 SIZE
R398	HRJ10DJ101T	RES , CHIP (1/10W) , 100 OHM J	1608 SIZE
R401	HRJ10DJ184T	RES , CHIP 180K OHM	1608 SIZE
R402	HRJ10DJ184T	RES , CHIP 180K OHM	1608 SIZE
R403	HRJ10DJ184T	RES , CHIP 180K OHM	1608 SIZE
R404	HRJ10DJ184T	RES , CHIP 180K OHM	1608 SIZE
R405	HRJ10DJ184T	RES , CHIP 180K OHM	1608 SIZE
R406	HRJ10DJ184T	RES , CHIP 180K OHM	1608 SIZE
R407	HRJ10DJ184T	RES , CHIP 180K OHM	1608 SIZE
R408	HRJ10DJ184T	RES , CHIP 180K OHM	1608 SIZE
R409	HRJ10DJ184T	RES , CHIP 180K OHM	1608 SIZE
R410	HRJ10DJ184T	RES , CHIP 180K OHM	1608 SIZE
R413	HRJ10DJ562T	RES , CHIP 5.6K OHM	
R414	HRJ10DJ562T	RES , CHIP 5.6K OHM	
R415	HRJ10DJ562T	RES , CHIP 5.6K OHM	
R416	HRJ10DJ103T	RES , CHIP 10K OHM	
R417	HRJ10DJ562T	RES , CHIP 5.6K OHM	
R418	HRJ10DJ562T	RES , CHIP 5.6K OHM	
R419	HRJ10DJ562T	RES , CHIP 5.6K OHM	
R420	HRJ10DJ562T	RES , CHIP 5.6K OHM	
R423	HRJ10DJ122T	RES , CHIP 1.2K OHM	
R424	HRJ10DJ122T	RES , CHIP 1.2K OHM	
R425	HRJ10DJ102T	RES , CHIP (1/10W) , 1K OHM J	1608 SIZE
R426	HRJ10DJ102T	RES , CHIP (1/10W) , 1K OHM J	1608 SIZE
R427	HRJ10DJ102T	RES , CHIP (1/10W) , 1K OHM J	1608 SIZE
R428	HRJ10DJ102T	RES , CHIP (1/10W) , 1K OHM J	1608 SIZE
R429	HRJ10DJ102T	RES , CHIP (1/10W) , 1K OHM J	1608 SIZE
R430	HRJ10DJ102T	RES , CHIP (1/10W) , 1K OHM J	1608 SIZE
R431	HRJ10DJ101T	RES , CHIP (1/10W) , 100 OHM J	1608 SIZE
R432	HRJ10DJ101T	RES , CHIP (1/10W) , 100 OHM J	1608 SIZE
R433	HRJ10DJ101T	RES , CHIP (1/10W) , 100 OHM J	1608 SIZE
R434	HRJ10DJ101T	RES , CHIP (1/10W) , 100 OHM J	1608 SIZE
R435	HRJ10DJ101T	RES , CHIP (1/10W) , 100 OHM J	1608 SIZE
R436	HRJ10DJ101T	RES , CHIP (1/10W) , 100 OHM J	1608 SIZE
R437	HRJ10DJ101T	RES , CHIP (1/10W) , 100 OHM J	1608 SIZE
R438	HRJ10DJ101T	RES , CHIP (1/10W) , 100 OHM J	1608 SIZE
R439	HRJ10DJ101T	RES , CHIP (1/10W) , 100 OHM J	1608 SIZE
R440	HRJ10DJ101T	RES , CHIP (1/10W) , 100 OHM J	1608 SIZE
R451	HRJ10DJ184T	RES , CHIP 180K OHM	1608 SIZE
R452	HRJ10DJ184T	RES , CHIP 180K OHM	1608 SIZE
R453	HRJ10DJ184T	RES , CHIP 180K OHM	1608 SIZE
R454	HRJ10DJ184T	RES , CHIP 180K OHM	1608 SIZE
R455	HRJ10DJ184T	RES , CHIP 180K OHM	1608 SIZE
R456	HRJ10DJ184T	RES , CHIP 180K OHM	1608 SIZE
R457	HRJ10DJ184T	RES , CHIP 180K OHM	1608 SIZE
R458	HRJ10DJ184T	RES , CHIP 180K OHM	1608 SIZE
R459	HRJ10DJ184T	RES , CHIP 180K OHM	1608 SIZE

Ref. Designator	Part Number	Description	
		INPUT PCB ASS'Y	
R460	HRJ10DJ184T	RES , CHIP 180K OHM	1608 SIZE
R461	HRJ10DJ104T	RES , CHIP 100K OHM	
R462	HRJ10DJ104T	RES , CHIP 100K OHM	
R463	HRJ10DJ471T	RES , CHIP 470 OHM	
R464	HRJ10DJ471T	RES , CHIP 470 OHM	
R465	HRJ10DJ472T	RES , CHIP (1/10W) ,4.7K OHM J	1608 SIZE
R466	HRJ10DJ472T	RES , CHIP (1/10W) ,4.7K OHM J	1608 SIZE
R471	HRJ10DJ272T	RES , CHIP 2.7K OHM	
R472	HRJ10DJ272T	RES , CHIP 2.7K OHM	
R473	HRJ10DJ272T	RES , CHIP 2.7K OHM	
R474	HRJ10DJ272T	RES , CHIP 2.7K OHM	
R475	HRJ10DJ4R7T	RES , CHIP 4.7 OHM	1608 SIZE
R491	HRJ10DJ4R7T	RES , CHIP 4.7 OHM	1608 SIZE
R492	HRJ10DJ4R7T	RES , CHIP 4.7 OHM	1608 SIZE
R493	HRJ10DJ4R7T	RES , CHIP 4.7 OHM	1608 SIZE
R494	HRJ10DJ4R7T	RES , CHIP 4.7 OHM	1608 SIZE
R495	HRJ10DJ4R7T	RES , CHIP 4.7 OHM	1608 SIZE
R496	HRJ10DJ4R7T	RES , CHIP 4.7 OHM	1608 SIZE
R497	HRJ10DJ4R7T	RES , CHIP 4.7 OHM	1608 SIZE
R498	HRJ10DJ4R7T	RES , CHIP 4.7 OHM	1608 SIZE
R721	HRJ10DJ104T	RES , CHIP 100K OHM	
R722	HRJ10DJ104T	RES , CHIP 100K OHM	
R723	HRJ10DJ104T	RES , CHIP 100K OHM	
R724	HRJ10DJ104T	RES , CHIP 100K OHM	
R725	HRJ10DJ101T	RES , CHIP (1/10W) , 100 OHM J	1608 SIZE
R726	HRJ10DJ1R0T	RES , CHIP 1 OHM	
R727	HRJ10DJ1R0T	RES , CHIP 1 OHM	
R728	HRJ10DJ1R0T	RES , CHIP 1 OHM	
R729	HRJ10DJ101T	RES , CHIP (1/10W) , 100 OHM J	1608 SIZE
R730	HRJ10DJ1R0T	RES , CHIP 1 OHM	
R731	HRJ10DJ1R0T	RES , CHIP 1 OHM	
R732	HRJ10DJ183T	RES , CHIP 18K OHM	
R733	HRJ10DJ4R7T	RES , CHIP	1608 SIZE
R734	HRJ10DJ330T	RES , CHIP (1/10W) , 33 OHM J	1608 SIZE
R735	HRJ10DJ105T	RES , CHIP (1/10W)	1608 SIZE
R736	HRJ10DJ121T	RES , CHIP (1/10W)	1608 SIZE
R737	HRJ10DJ4R7T	RES , CHIP 4.7 OHM	1608 SIZE
R738	HRJ10DJ1R0T	RES , CHIP 1 OHM	
R739	HRJ10DJ2R7T	RES , CHIP 2.7 OHM	
R740	HRJ10DJ330T	RES , CHIP (1/10W) , 33 OHM J	1608 SIZE
R741	HRJ10DJ330T	RES , CHIP (1/10W) , 33 OHM J	1608 SIZE
R742	HRJ10DJ330T	RES , CHIP (1/10W) , 33 OHM J	1608 SIZE
R743	HRJ10DJ330T	RES , CHIP (1/10W) , 33 OHM J	1608 SIZE
R744	HRJ10DJ330T	RES , CHIP (1/10W) , 33 OHM J	1608 SIZE
R745	HRJ10DJ330T	RES , CHIP (1/10W) , 33 OHM J	1608 SIZE
R746	HRJ10DJ472T	RES , CHIP (1/10W) ,4.7K OHM J	1608 SIZE
R747	HRJ10DJ472T	RES , CHIP (1/10W) ,4.7K OHM J	1608 SIZE
R748	HRJ10DJ103T	RES , CHIP 10K OHM	
R749	HRJ10DJ101T	RES , CHIP (1/10W) , 100 OHM J	1608 SIZE
R750	HRJ10DJ332T	RES , CHIP 3.3K OHM	
R751	HRJ10DJ332T	RES , CHIP 3.3K OHM	
R752	HRJ10DJ102T	RES , CHIP (1/10W) , 1K OHM J	1608 SIZE
R753	HRJ10DJ101T	RES , CHIP (1/10W) , 100 OHM J	1608 SIZE
R754	HRJ10DJ103T	RES , CHIP 10K OHM	
R755	HRJ10DJ103T	RES , CHIP 10K OHM	
R756	HRJ10DJ103T	RES , CHIP 10K OHM	
R757	HRJ10DJ103T	RES , CHIP 10K OHM	
R758	HRJ10DJ103T	RES , CHIP 10K OHM	
R759	HRJ10DJ103T	RES , CHIP 10K OHM	
R760	HRJ10DJ103T	RES , CHIP 10K OHM	
R761	HRJ10DJ103T	RES , CHIP 10K OHM	

Ref. Designator	Part Number	Description	
		INPUT PCB ASS'Y	
R762	HRJ10DJ103T	RES , CHIP 10K OHM	
R763	HRJ10DJ333T	RES , CHIP 33K OHM	
R764	HRJ10DJ330T	RES , CHIP (1/10W) , 33 OHM J	1608 SIZE
R765	HRJ10DJ332T	RES , CHIP 3.3K OHM	
R766	HRJ10DJ103T	RES , CHIP 10K OHM	
R767	HRJ10DJ332T	RES , CHIP 3.3K OHM	
R768	HRJ10DJ330T	RES , CHIP (1/10W) , 33 OHM J	1608 SIZE
R769	HRJ10DJ101T	RES , CHIP (1/10W) , 100 OHM J	1608 SIZE
R770	HRJ10DJ103T	RES , CHIP 10K OHM	
R771	HRJ10DJ4R7T	RES , CHIP 4.7 OHM	1608 SIZE
R772	HRJ10DJ182T	RES , CHIP 1.8K OHM	
R773	HRJ10DJ8R2T	RES , CHIP 8.2 OHM	
R774	HRJ10DJ471T	RES , CHIP 470 OHM	
R780	HRJ10DJ330T	RES , CHIP (1/10W) , 33 OHM J	1608 SIZE
<i>Miscellaneous</i>			
L703	KLQ100J405T	COIL, PEAKING(RADIAL)	10UH J 4X5
BN11	KJP15GB99ZM	WAFER	35237(15PIN)
BN12	KJP15GB99ZM	WAFER	35237(15PIN)
CN13	CJP13GA115ZY	WAFER , CARD CABLE	
CN15	CJP13GA115ZY	WAFER , CARD CABLE	
CN16	CJP15GA115ZY	WAFER , CARD CABLE	
CN17	KJP12GB142ZP	PIN HEADER	2110 - DR12 - G
CN18	KJP05GA19ZM	WAFER	MOLEX53014-0510
CN72	KJP32GA161ZY	WAFER	YD200 SERIES
JK11	CJJ4R019W	TERMINAL , IN/OUT	
JK12	CJJ4P014W	JACK , IN/OUT	
JK13	CJJ4P014W	JACK , IN/OUT	
JK14	CJJ4R019W	TERMINAL , IN/OUT	
JK15	CJJ4R037W	JACK , BOARD	
JK16	CJJ4N034Z	JACK , IN/OUT	
JW21	CWE7202090AA	WIRE ASS'Y	
L701	KLZ9H001Z	BEAD , CORE	
L702	KLZ9H001Z	BEAD , CORE	
L704	KLZ9H001Z	BEAD , CORE	
L705	KLZ9H001Z	BEAD , CORE	
R781	CRG2ANJ150H	RES , METAL OXIDE FILM	15 OHM 2W J
R782	CRG2ANJ330H	RES , METAL OXIDE FILM	33 OHM 2W J
X701	HOX12288E220TF	CRYSTAL(HC-49/S,ATS)	12.288MHZ 22PF
VIDEO PCB ASS'Y			
<i>Capacitors</i>			
C107	CCKT1H103ZF	CAP , CERAMIC	0.01UF 50V ZF
C108	CCKT1H103ZF	CAP , CERAMIC	0.01UF 50V ZF
C109	CCFT1H104ZF	CAP , SEMICONDUCTOR	0.1UF 50V ZF
C110	CCFT1H104ZF	CAP , SEMICONDUCTOR	0.1UF 50V ZF
C111	CCKT1H103ZF	CAP , CERAMIC	0.01UF 50V ZF
C112	CCKT1H103ZF	CAP , CERAMIC	0.01UF 50V ZF
C117	HCEA1HH4R7T	CAP , ELECT	4.7UF 50V
C118	CCKT1H103ZF	CAP , CERAMIC	0.01UF 50V ZF
C119	HCEA1HH470T	CAP , ELECT	47UF 50V
C120	HCEA1HH470T	CAP , ELECT	47UF 50V
C121	CCKT1H103ZF	CAP , CERAMIC	0.01UF 50V ZF
C402	CCKT1H101KB	CAP , CERAMIC	100PF 50V KB
C404	CCKT1H101KB	CAP , CERAMIC	100PF 50V KB
C407	CCKT1H101KB	CAP , CERAMIC	100PF 50V KB
C409	CCKT1H101KB	CAP , CERAMIC	100PF 50V KB

Ref. Designator	Part Number	Description	
		VIDEO PCB ASS'Y	
C410	CCKT1H101KB	CAP , CERAMIC	100PF 50V KB
C411	HCBS1H101KBT	CAP , CERAMIC	100PF 50V K
C412	HCBS1H101KBT	CAP , CERAMIC	100PF 50V K
C413	HCBS1H101KBT	CAP , CERAMIC	100PF 50V K
C414	HCBS1H101KBT	CAP , CERAMIC	100PF 50V K
C416	HCEA1CH101T	CAP , ELECT	100UF 16V
C417	HCEA1CH101T	CAP , ELECT	100UF 16V
C418	HCBS1H223ZFT	CAP , CERAMIC	0.022UF 50V Z
C420	HCBS1H223ZFT	CAP , CERAMIC	0.022UF 50V Z
C421	HCEA1CH101T	CAP , ELECT	100UF 16V
C422	HCBS1H223ZFT	CAP , CERAMIC	0.022UF 50V Z
C423	HCEA1CH101T	CAP , ELECT	100UF 16V
C427	HCBS1H223ZFT	CAP , CERAMIC	0.022UF 50V Z
C428	HCEA1CH101T	CAP , ELECT	100UF 16V
C429	HCBS1H223ZFT	CAP , CERAMIC	0.022UF 50V Z
C430	HCEA1CH101T	CAP , ELECT	100UF 16V
C436	HCBS1H223ZFT	CAP , CERAMIC	0.022UF 50V Z
C437	HCEA1CH101T	CAP , ELECT	100UF 16V
C438	HCBS1H223ZFT	CAP , CERAMIC	0.022UF 50V Z
C439	HCEA1CH101T	CAP , ELECT	100UF 16V
C442	HCBS1H103ZFT	CAP , CERAMIC	0.01UF 50V Z
C443	HCEA1VKS100T	CAP , ELECT	10UF 35V
C444	HCEA1VKS100T	CAP , ELECT	10UF 35V
C445	HCBS1H103ZFT	CAP , CERAMIC	0.01UF 50V Z
C446	HCEA1VH100T	CAP , ELECT	10UF 35V
C447	HCEA1VH100T	CAP , ELECT	10UF 35V
C448	HCBS1H223ZFT	CAP , CERAMIC	0.022UF 50V Z
C449	HCEA1CH101T	CAP , ELECT	100UF 16V
C450	HCBS1H223ZFT	CAP , CERAMIC	0.022UF 50V Z
C451	HCEA1CH101T	CAP , ELECT	100UF 16V
C452	HCBS1H223ZFT	CAP , CERAMIC	0.022UF 50V Z
C453	HCEA1CH101T	CAP , ELECT	100UF 16V
C454	HCBS1H223ZFT	CAP , CERAMIC	0.022UF 50V Z
C455	HCEA1CH101T	CAP , ELECT	100UF 16V
C456	HCBS1H104ZFT	CAP , CERAMIC	0.1UF 50V Z
C457	HCEA1CH101T	CAP , ELECT	100UF 16V
C458	HCEA1CH101T	CAP , ELECT	100UF 16V
C459	HCBS1H104ZFT	CAP , CERAMIC	0.1UF 50V Z
C460	CCKT1H272KB	CAP , CERAMIC	2700PF 50V KB
C461	HCEA1CH101T	CAP , ELECT	100UF 16V
C462	HCEA1CH101T	CAP , ELECT	100UF 16V
C463	HCBS1H473ZFT	CAP , CERAMIC	0.047UF 50V Z
C501	HCBS1H330JT	CAP , CERAMIC	33PF 50V
C502	HCBS1H330JT	CAP , CERAMIC	33PF 50V
C503	HCBS1H181KBT	CAP , CERAMIC	180PF 50V K
C504	HCEA1HHR47T	CAP , ELECT	0.47UF 50V
C505	HCBS1H223ZFT	CAP , CERAMIC	0.022UF 50V Z
C506	HCEA1AH471T	CAP , ELECT	470UF 10V
C507	HCBS1H270JT	CAP , CERAMIC	27PF 50V
C508	HCBS1H270JT	CAP , CERAMIC	27PF 50V
C509	HCEA1HH1R0T	CAP , ELECT	1UF 50V
C510	HCEA1HH1R0T	CAP , ELECT	1UF 50V
C511	HCQ11H682JZT	CAP , MYLAR	6800PF 50V J
C512	HCEA1HH1R0T	CAP , ELECT	1UF 50V
C513	HCBS1H560JT	CAP , CERAMIC	56PF 50V J
C514	HCBS1H220JT	CAP , CERAMIC	22PF 50V
C515	HCEA1AH471T	CAP , ELECT	470UF 10V
C517	HCBS1H223ZFT	CAP , CERAMIC	0.022UF 50V Z
C518	HCBS1H223ZFT	CAP , CERAMIC	0.022UF 50V Z
C519	HCEA1CH101T	CAP , ELECT	100UF 16V
C520	HCEA0JH102T	CAP , ELECT	1000UF 6.3V

Ref. Designator	Part Number	Description	
		VIDEO PCB ASS'Y	
C561	CCCT1H010CC	CAP , CERAMIC	1PF 50V CC
C562	CCCT1H010CC	CAP , CERAMIC	1PF 50V CC
C568	HCBS1H104ZFT	CAP , CERAMIC	0.1UF 50V Z
C601	HCBS1H390JT	CAP , CERAMIC	39PF 50V J
C602	HCBS1H390JT	CAP , CERAMIC	39PF 50V J
C603	HCBS1H390JT	CAP , CERAMIC	39PF 50V J
C604	HCBS1H390JT	CAP , CERAMIC	39PF 50V J
C605	HCBS1H390JT	CAP , CERAMIC	39PF 50V J
C606	HCBS1H390JT	CAP , CERAMIC	39PF 50V J
C607	HCBS1H390JT	CAP , CERAMIC	39PF 50V J
C608	HCBS1H390JT	CAP , CERAMIC	39PF 50V J
C609	HCBS1H390JT	CAP , CERAMIC	39PF 50V J
C610	CCKT1H223ZF	CAP , CERAMIC	0.022UF 50V ZF
C611	HCEA1CH101T	CAP , ELECT	100UF 16V
C612	CCKT1H223ZF	CAP , CERAMIC	0.022UF 50V ZF
C613	HCEA1CH101T	CAP , ELECT	100UF 16V
C614	HCBS1H223ZFT	CAP , CERAMIC	0.022UF 50V Z
C615	HCEA1CH101T	CAP , ELECT	100UF 16V
C616	HCBS1H223ZFT	CAP , CERAMIC	0.022UF 50V Z
C617	HCEA1CH101T	CAP , ELECT	100UF 16V
C701	HCEA1AH471T	CAP , ELECT	470UF 10V
C702	HCEA1AH471T	CAP , ELECT	470UF 10V
C703	CCKT1H181KB	CAP , CERAMIC	180PF 50V KB
C704	CCFT1H104ZF	CAP , SEMICONDUCTOR	0.1UF 50V ZF
C705	CCKT1H181KB	CAP , CERAMIC	180PF 50V KB
C706	CCFT1H104ZF	CAP , SEMICONDUCTOR	0.1UF 50V ZF
C707	CCKT1H101KB	CAP , CERAMIC	100PF 50V KB
C708	HCEA1CKS101T	CAP , ELECT	100UF 16V
C709	CCFT1H104ZF	CAP , SEMICONDUCTOR	0.1UF 50V ZF
C710	CCCT1H270JC	CAP , CERAMIC	27PF 50V JC
C711	HCEA1CH101T	CAP , ELECT	100UF 16V
C712	CCKT1H473ZF	CAP , CERAMIC	0.047UF 50V ZF
C713	CCCT1H270JC	CAP , CERAMIC	27PF 50V JC
C921	HCQ11H104JZT	CAP , MYLAR	0.1UF 50V J
C922	HCQ11H104JZT	CAP , MYLAR	0.1UF 50V J
C923	HCQ11H104JZT	CAP , MYLAR	0.1UF 50V J
C924	HCQ11H104JZT	CAP , MYLAR	0.1UF 50V J
C925	HCQ11H103JZT	CAP , MYLAR	0.01UF 50V J
C926	HCQ11H103JZT	CAP , MYLAR	0.01UF 50V J
C927	HCQ11H103JZT	CAP , MYLAR	0.01UF 50V J
C928	HCQ11H103JZT	CAP , MYLAR	0.01UF 50V J
C931	HCQ11H473JZT	CAP , MYLAR	0.047UF 50V J
C932	HCQ11H473JZT	CAP , MYLAR	0.047UF 50V J
C933	HCQ11H473JZT	CAP , MYLAR	0.047UF 50V J
C934	HCQ11H473JZT	CAP , MYLAR	0.047UF 50V J
C122	HCEA1JH101E	CAP , ELECT	100UF 63V
C124	BCQE2E104KDE	CAP , LINE ACROSS	0.1UF 250V KD
C523	HCEA0JH102T	CAP , ELECT	1000UF 6.3V
<i>Semiconductors</i>			
D101	HVDMTZJ15BT	DIODE , ZENER	15V 1/2W
D102	HVDMTZJ27BT	DIODE , ZENER	27V 1/2W
D104	KVD1N4003ST	DIODE	1N4003
D105	KVD1N4003ST	DIODE	1N4003
D108	KVD1N4003ST	DIODE	1N4003
D109	HVDMTZ12BT	DIODE , ZENER(20MM)	12V 1/2W
D111	HVDMTZJ12BT	DIODE , ZENER	12V 1/2W
D401	HVD1SS133MT	DIODE	1SS133T-77
D402	HVD1SS133MT	DIODE	1SS133T-77
D403	HVD1SS133MT	DIODE	1SS133T-77

Ref. Designator	Part Number	Description	
		VIDEO PCB ASS'Y	
D404	HVD1SS133MT	DIODE	1SS133T-77
D405	HVD1SS133MT	DIODE	1SS133T-77
Q104	HVTKSC2316YT	TRANSISTOR NPN	KSC2316Y
Q402	HVTKSA733CYT	TRANSISTOR PNP	KSA733Y
Q403	HVTKRA107MT	TRANSISTOR NPN	KRA107M
Q404	HVTKRC107MT	TRANSISTOR NPN	KRC107M
Q405	HVTKSA733CYT	TRANSISTOR PNP	KSA733Y
Q406	HVTKRA107MT	TRANSISTOR NPN	KRA107M
Q407	HVTKRC107MT	TRANSISTOR NPN	KRC107M
Q408	HVTKRC107MT	TRANSISTOR NPN	KRC107M
Q409	HVTKRA104MT	TRANSISTOR PNP	KRA104M
Q410	HVTKTD1302T	TRANSISTOR NPN	KTD1302
Q411	HVTKTD1302T	TRANSISTOR NPN	KTD1302
Q412	HVTKRA104MT	TRANSISTOR PNP	KRA104M
Q501	KVTKSC2785YT	TRANSISTOR NPN	KSC2785Y
Q502	KVTKSA1175YT	TRANSISTOR PNP	KSA1175Y
Q568	HVTKTC2874BT	TRANSISTOR , NPN, MUTE	KTC2874B
Q569	HVTKRC107MT	TRANSISTOR NPN	KRC107M
Q601	HVTKRC107MT	TRANSISTOR NPN	KRC107M
Q602	HVTKRC107MT	TRANSISTOR NPN	KRC107M
Q603	HVTKRC107MT	TRANSISTOR NPN	KRC107M
IC41	HVINJM2296M	I.C , VIDEO SW	NJM2296M
IC42	HVINJM2296M	I.C , VIDEO SW	NJM2296M
IC43	HVINJM2296M	I.C , VIDEO SW	NJM2296M
IC44	HVIHCF4053M013T	I.C	S.T
IC45	HVIHCF4053M013T	I.C	S.T
IC46	HVINJM2581MTE1	I.C	NJM2581MTE1
IC47	HVINJM2137MTE1	I.C	NJM2137MTE1
IC51	HVILC74763M	I.C , OSD	LC74763M
IC52	HVI74ACT04MTR	I.C , HEX	
IC61	HVIHCF4053M013T	I.C	S.T
IC62	HVINJM2581MTE1	I.C	NJM2581MTE1
IC71	HVITC74HCU04AFN	IC , INVERTER	TC74HCU04AFN
<i>Resistors</i>			
R108	CRD20TJ4R7T	RES , CARBON	4.7 OHM 1/5W J
R109	CRD20TJ100T	RES , CARBON	10 OHM 1/5W J
R110	CRD20TJ4R7T	RES , CARBON	4.7 OHM 1/5W J
R112	CRD20TJ122T	RES , CARBON	1.2K OHM 1/5W J
R113	CRD20TJ473T	RES , CARBON	47K OHM 1/5W J
R401	CRD20TJ750T	RES , CARBON	75 OHM 1/5W J
R402	CRD20TJ750T	RES , CARBON	75 OHM 1/5W J
R403	CRD20TJ332T	RES , CARBON	3.3K OHM 1/5W J
R404	CRD20TJ750T	RES , CARBON	75 OHM 1/5W J
R405	CRD20TJ750T	RES , CARBON	75 OHM 1/5W J
R406	CRD20TJ332T	RES , CARBON	3.3K OHM 1/5W J
R407	CRD20TJ750T	RES , CARBON	75 OHM 1/5W J
R408	CRD20TJ750T	RES , CARBON	75 OHM 1/5W J
R409	CRD20TJ750T	RES , CARBON	75 OHM 1/5W J
R410	CRD20TJ332T	RES , CARBON	3.3K OHM 1/5W J
R411	CRD20TJ750T	RES , CARBON	75 OHM 1/5W J
R412	CRD20TJ750T	RES , CARBON	75 OHM 1/5W J
R413	CRD20TJ750T	RES , CARBON	75 OHM 1/5W J
R414	CRD20TJ332T	RES , CARBON	3.3K OHM 1/5W J
R415	CRD20TJ750T	RES , CARBON	75 OHM 1/5W J
R416	CRD20TJ332T	RES , CARBON	3.3K OHM 1/5W J
R417	CRD20TJ750T	RES , CARBON	75 OHM 1/5W J
R418	CRD20TJ750T	RES , CARBON	75 OHM 1/5W J
R419	CRD20TJ750T	RES , CARBON	75 OHM 1/5W J
R420	CRD20TJ332T	RES , CARBON	3.3K OHM 1/5W J

Ref. Designator	Part Number	Description	
		VIDEO PCB ASS'Y	
R421	CRD20TJ750T	RES , CARBON	75 OHM 1/5W J
R422	CRD20TJ332T	RES , CARBON	3.3K OHM 1/5W J
R423	CRD20TJ750T	RES , CARBON	75 OHM 1/5W J
R424	CRD20TJ750T	RES , CARBON	75 OHM 1/5W J
R425	CRD20TJ750T	RES , CARBON	75 OHM 1/5W J
R426	CRD20TJ332T	RES , CARBON	3.3K OHM 1/5W J
R427	CRD20TJ750T	RES , CARBON	75 OHM 1/5W J
R428	CRD20TJ332T	RES , CARBON	3.3K OHM 1/5W J
R430	CRD20TJ1R8T	RES , CARBON	1.8 OHM 1/5W J
R431	CRD20TJ102T	RES , CARBON	1K OHM 1/5W J
R432	CRD20TJ1R0T	RES , CARBON	1 OHM 1/5W J
R433	CRD20TJ102T	RES , CARBON	1K OHM 1/5W J
R434	CRD20TJ102T	RES , CARBON	1K OHM 1/5W J
R435	CRD20TJ102T	RES , CARBON	1K OHM 1/5W J
R436	CRD20TJ102T	RES , CARBON	1K OHM 1/5W J
R437	CRD25TJ102T	RES , CARBON	1K OHM 1/4W J
R438	CRD25TJ1R0T	RES , CARBON	1 OHM 1/4W J
R439	CRD20TJ750T	RES , CARBON	75 OHM 1/5W J
R440	CRD20TJ1R8T	RES , CARBON	1.8 OHM 1/5W J
R441	CRD20TJ102T	RES , CARBON	1K OHM 1/5W J
R442	CRD20TJ102T	RES , CARBON	1K OHM 1/5W J
R443	CRD20TJ102T	RES , CARBON	1K OHM 1/5W J
R444	CRD20TJ102T	RES , CARBON	1K OHM 1/5W J
R445	CRD20TJ1R0T	RES , CARBON	1 OHM 1/5W J
R446	CRD20TJ102T	RES , CARBON	1K OHM 1/5W J
R447	CRD20TJ750T	RES , CARBON	75 OHM 1/5W J
R448	CRD20TJ1R8T	RES , CARBON	1.8 OHM 1/5W J
R449	CRD20TJ102T	RES , CARBON	1K OHM 1/5W J
R450	CRD20TJ102T	RES , CARBON	1K OHM 1/5W J
R451	CRD20TJ102T	RES , CARBON	1K OHM 1/5W J
R452	CRD20TJ102T	RES , CARBON	1K OHM 1/5W J
R453	CRD20TJ332T	RES , CARBON	3.3K OHM 1/5W J
R454	CRD25TJ562T	RES , CARBON	5.6K OHM 1/4W J
R455	CRD20TJ105T	RES , CARBON	1M OHM 1/5W J
R456	CRD20TJ680T	RES , CARBON	68 OHM 1/5W J
R457	CRD20TJ333T	RES , CARBON	33K OHM 1/5W J
R458	CRD20TJ123T	RES , CARBON	12K OHM 1/5W J
R459	CRD20TJ680T	RES , CARBON	68 OHM 1/5W J
R460	CRD20TJ333T	RES , CARBON	33K OHM 1/5W J
R461	CRD20TJ123T	RES , CARBON	12K OHM 1/5W J
R462	CRD20TJ102T	RES , CARBON	1K OHM 1/5W J
R463	CRD20TJ103T	RES , CARBON	10K OHM 1/5W J
R464	CRD20TJ103T	RES , CARBON	10K OHM 1/5W J
R465	CRD20TJ103T	RES , CARBON	10K OHM 1/5W J
R466	CRD20TJ103T	RES , CARBON	10K OHM 1/5W J
R467	CRD20TJ103T	RES , CARBON	10K OHM 1/5W J
R468	CRD20TJ100T	RES , CARBON	10 OHM 1/5W J
R469	CRD20TJ100T	RES , CARBON	10 OHM 1/5W J
R470	CRD20TJ100T	RES , CARBON	10 OHM 1/5W J
R471	CRD20TJ100T	RES , CARBON	10 OHM 1/5W J
R472	CRD20TJ151T	RES , CARBON	150 OHM 1/5W J
R473	CRD20TJ181T	RES , CARBON	180 OHM 1/5W J
R474	CRD20TJ1R8T	RES , CARBON	1.8 OHM 1/5W J
R475	CRD20TJ1R0T	RES , CARBON	1 OHM 1/5W J
R476	CRD20TJ101T	RES , CARBON	100 OHM 1/5W J
R478	CRD20TJ223T	RES , CARBON	22K OHM 1/5W J
R479	CRD20TJ181T	RES , CARBON	180 OHM 1/5W J
R480	CRD25TJ223T	RES , CARBON	22K OHM 1/4W J
R501	CRD20TJ102T	RES , CARBON	1K OHM 1/5W J
R502	CRD20TJ102T	RES , CARBON	1K OHM 1/5W J
R503	CRD20TJ102T	RES , CARBON	1K OHM 1/5W J

Ref. Designator	Part Number	Description	
		VIDEO PCB ASS'Y	
R504	CRD20TJ104T	RES , CARBON	100K OHM 1/5W J
R505	CRD20TJ102T	RES , CARBON	1K OHM 1/5W J
R506	CRD20TJ102T	RES , CARBON	1K OHM 1/5W J
R507	CRD20TJ102T	RES , CARBON	1K OHM 1/5W J
R508	CRD20TJ682T	RES , CARBON	6.8K OHM 1/5W J
R509	CRD20TJ152T	RES , CARBON	1.5K OHM 1/5W J
R510	CRD20TJ393T	RES , CARBON	39K OHM 1/5W J
R511	CRD20TJ222T	RES , CARBON	2.2K OHM 1/5W J
R512	CRD20TJ102T	RES , CARBON	1K OHM 1/5W J
R513	CRD20TJ822T	RES , CARBON	8.2K OHM 1/5W J
R514	CRD20TJ103T	RES , CARBON	10K OHM 1/5W J
R516	CRD20TJ221T	RES , CARBON	220 OHM 1/5W J
R517	CRD20TJ273T	RES , CARBON	27K OHM 1/5W J
R561	CRD20TJ100T	RES , CARBON	10 OHM 1/5W J
R562	CRD20TJ202T	RES , CARBON	2K OHM 1/5W J
R563	CRD20TJ222T	RES , CARBON	2.2K OHM 1/5W J
R564	CRD20TJ222T	RES , CARBON	2.2K OHM 1/5W J
R565	CRD20TJ123T	RES , CARBON	12K OHM 1/5W J
R566	CRD20TJ123T	RES , CARBON	12K OHM 1/5W J
R567	CRD20TJ100T	RES , CARBON	10 OHM 1/5W J
R568	CRD20TJ223T	RES , CARBON	22K OHM 1/5W J
R569	CRD20TJ223T	RES , CARBON	22K OHM 1/5W J
R570	CRD20TJ101T	RES , CARBON	100 OHM 1/5W J
R601	CRD20TJ750T	RES , CARBON	75 OHM 1/5W J
R602	CRD20TJ750T	RES , CARBON	75 OHM 1/5W J
R603	CRD20TJ750T	RES , CARBON	75 OHM 1/5W J
R604	CRD20TJ750T	RES , CARBON	75 OHM 1/5W J
R605	CRD20TJ750T	RES , CARBON	75 OHM 1/5W J
R606	CRD20TJ750T	RES , CARBON	75 OHM 1/5W J
R607	CRD20TJ750T	RES , CARBON	75 OHM 1/5W J
R608	CRD20TJ750T	RES , CARBON	75 OHM 1/5W J
R609	CRD20TJ750T	RES , CARBON	75 OHM 1/5W J
R610	CRD20TJ1R0T	RES , CARBON	1 OHM 1/5W J
R611	CRD20TJ103T	RES , CARBON	10K OHM 1/5W J
R612	CRD20TJ1R8T	RES , CARBON	1.8 OHM 1/5W J
R613	CRD20TJ4R7T	RES , CARBON	4.7 OHM 1/5W J
R614	CRD20TJ4R7T	RES , CARBON	4.7 OHM 1/5W J
R615	CRD20TJ103T	RES , CARBON	10K OHM 1/5W J
R701	CRD20TJ103T	RES , CARBON	10K OHM 1/5W J
R702	CRD20TJ1R0T	RES , CARBON	1 OHM 1/5W J
R704	CRD20TJ1R0T	RES , CARBON	1 OHM 1/5W J
R705	CRD20TJ750T	RES , CARBON	75 OHM 1/5W J
R706	CRD20TJ750T	RES , CARBON	75 OHM 1/5W J
R707	CRD20TJ750T	RES , CARBON	75 OHM 1/5W J
R708	CRD20TJ101T	RES , CARBON	100 OHM 1/5W J
R709	CRD20TJ111T	RES , CARBON	110 OHM 1/5W J
R710	CRD20TJ1R0T	RES , CARBON	1 OHM 1/5W J
R711	CRD20TJ1R0T	RES , CARBON	1 OHM 1/5W J
R712	CRD20TJ101T	RES , CARBON	100 OHM 1/5W J
R713	CRD20TJ104T	RES , CARBON	100K OHM 1/5W J
R714	CRD20TJ104T	RES , CARBON	100K OHM 1/5W J
R101	KRQ1AJR47H	RES , FUSE	0.47 OHM 1W J
R104	KRQ1AJR47H	RES , FUSE	0.47 OHM 1W J
R105	KRQ1AJR47H	RES , FUSE	0.47 OHM 1W J
R106	KRQ1AJR47H	RES , FUSE	0.47 OHM 1W J
R107	KRQ1AJR47H	RES , FUSE	0.47 OHM 1W J
R481	CRG2ANJ150H	RES , METAL OXIDE FILM	15 OHM 2W J
Miscellaneous			
L501	HLQ02C101JT	COIL , AXAIL	100UH,J

Ref. Designator	Part Number	Description	
		VIDEO PCB ASS'Y	
L502	KLQ5R6G405T	COIL , PEAKING(RADIAL)	5.6UH
L503	KLQ220J405T	COIL, PEAKING(RADIAL)	22UH J 4X5
	CMC1A213	PLATE , SHIELD	AVR230
BK61	CMD1A387	BRACKET , PCB	
BK62	CMD1A387	BRACKET , PCB	
BN14	CWB4F232450PU	WIRE ASS'Y	
BN17	KJP12GB143ZP	DIP SOCKET	3011 - DR12 - G
BN61	CWB2B906120EN	WIRE ASS'Y	
BN91	CWB4FE53130PU	WIRE ASS'Y	
BN96	CWB1C908150BM	WIRE ASS'Y	
CN13	KJP05GA01ZM	WAFER	MOLEX 5267-05A
CN19	KJP03GA90ZM	WAFER	MOLEX35313-0310
CN20	KJP04GA90ZM	WAFER	MOLEX35313-0310
CN21	KJP02GA89ZM	WAFER	MOLEX35328-02
CN41	KJP06GA19ZM	WAFER	MOLEX53014-0610
CN43	CJP13GA115ZY	WAFER , CARD CABLE	
CN61	KJP06GA19ZM	WAFER	MOLEX53014-0610
CN81	KJP08GA01ZM	WAFER	MOLEX 5267-08A
CN84	KJP02KA060ZY	WAFER	7.92MM(YUNHO)
JK41	CJJ9N001Z	JACK , S-VIDEO (2P/H)	
JK42	CJJ9N001Z	JACK , S-VIDEO (2P/H)	
JK43	CJJ9S001Z	JACK , S-VIDEO (3P/H)	
JK48	CJJ4N043Z	JACK , BOARD	
JK49	CJJ4N043Z	JACK , BOARD	
JK50	CJJ4S010Z	JACK , BOARD	
JK61	CJJ4L004Z	JACK (Y/PB/PR)	
JK71	HJSTORX179L	MODULE , OPTICAL(RX)	TORX179L
JK72	HJSTORX179L	MODULE , OPTICAL(RX)	TORX179L
JK73	CJJ4S022Z	JACK , BOARD	
JK74	HJSTOTX179L	MODULE , OPTICAL(TX)	TOTX179L
JW11	CWEP202110VV	WIRE	
OL91	KJJ7A015Z	OUTLET , AC(UL/2P/SEP)	A204D0041P
SW91	KST1A010Z	SW , TACT CN	
X501	HOX14318E220C	CRYSTAL	14.318 MHz
BIAS TRANSISTOR PCB ASS'Y			
<i>Capacitors</i>			
C851	HCEA1HH100T	CAP , ELECT	10UF 50V
C852	HCEA1HH100T	CAP , ELECT	10UF 50V
C853	HCEA1HH100T	CAP , ELECT	10UF 50V
C854	HCEA1HH100T	CAP , ELECT	10UF 50V
C855	HCEA1HH100T	CAP , ELECT	10UF 50V
C856	HCEA1HH100T	CAP , ELECT	10UF 50V
C857	HCEA1HH100T	CAP , ELECT	10UF 50V
C922	HCEA1EH101T	CAP , ELECT	100UF 25V
C923	HCEA1EH101T	CAP , ELECT	100UF 25V
C924	HCEA1EH101T	CAP , ELECT	100UF 25V
C925	CCKT1H223ZF	CAP , CERAMIC	0.022UF 50V ZF
C926	CCKT1H223ZF	CAP , CERAMIC	0.022UF 50V ZF
C927	CCKT1H223ZF	CAP , CERAMIC	0.022UF 50V ZF
C931	HCEA1HH4R7T	CAP , ELECT	4.7UF 50V
C928	CCEA1CH472E	CAP , ELECT	4700UF 16V
C929	CCEA1EH332F	CAP , ELECT	3300UF 25V
C930	CCEA1EH222E	CAP. ELECT.	2200UF 25V
<i>Semiconductors</i>			
D903	KVD1N4003SRT	DIODE TW	1N4003









Ref. Designator	Part Number	Description	
		BIAS TRANSISTOR PCB ASS'Y	
D904	KVD1N4003ST	DIODE	1N4003
D905	KVD1N4003ST	DIODE	1N4003
D906	KVD1N4003ST	DIODE	1N4003
D907	KVD1N4003ST	DIODE	1N4003
D915	HVD1SS133MT	DIODE	1SS133T-77
D916	HVD1SS133MT	DIODE	1SS133T-77
IC91	HVIL7815CP	I.C, REGULATOR	L7815CP
IC92	HVIL7915CP	I.C, REGULATOR	L7915CP
IC93	HVIL7805CP	I.C, REGULATOR	L7805CP
Q851	HVTKTD600KGR	TRANSISTOR, NPN, BIAS	KTD600KGR
Q852	HVTKTD600KGR	TRANSISTOR, NPN, BIAS	KTD600KGR
Q853	HVTKTD600KGR	TRANSISTOR, NPN, BIAS	KTD600KGR
Q854	HVTKTD600KGR	TRANSISTOR, NPN, BIAS	KTD600KGR
Q855	HVTKTD600KGR	TRANSISTOR, NPN, BIAS	KTD600KGR
Q856	HVTKTD600KGR	TRANSISTOR, NPN, BIAS	KTD600KGR
Q857	HVTKTD600KGR	TRANSISTOR, NPN, BIAS	KTD600KGR
<i>Resistors</i>			
R874	CRD20TJ331T	RES , CARBON	330 OHM 1/5W J
R875	CRD20TJ331T	RES , CARBON	330 OHM 1/5W J
R876	CRD20TJ331T	RES , CARBON	330 OHM 1/5W J
R877	CRD20TJ331T	RES , CARBON	330 OHM 1/5W J
R878	CRD20TJ331T	RES , CARBON	330 OHM 1/5W J
R879	CRD20TJ331T	RES , CARBON	330 OHM 1/5W J
R880	CRD20TJ331T	RES , CARBON	330 OHM 1/5W J
R882	CRD20TJ122T	RES , CARBON	1.2K OHM 1/5W J
R883	CRD20TJ122T	RES , CARBON	1.2K OHM 1/5W J
R884	CRD20TJ122T	RES , CARBON	1.2K OHM 1/5W J
R885	CRD20TJ122T	RES , CARBON	1.2K OHM 1/5W J
R886	CRD20TJ122T	RES , CARBON	1.2K OHM 1/5W J
R887	CRD20TJ122T	RES , CARBON	1.2K OHM 1/5W J
R888	CRD20TJ122T	RES , CARBON	1.2K OHM 1/5W J
R912	CRD20TJ153T	RES , CARBON	15K OHM 1/5W J
R913	CRD20TJ153T	RES , CARBON	15K OHM 1/5W J
R914	CRD20TJ103T	RES , CARBON	10K OHM 1/5W J
VR81	HVN1RA221B01T	RES , SEMI FIXED(220 OHM)	RH0615C100221
VR82	HVN1RA221B01T	RES , SEMI FIXED(220 OHM)	RH0615C100221
VR83	HVN1RA221B01T	RES , SEMI FIXED(220 OHM)	RH0615C100221
VR84	HVN1RA221B01T	RES , SEMI FIXED(220 OHM)	RH0615C100221
VR85	HVN1RA221B01T	RES , SEMI FIXED(220 OHM)	RH0615C100221
VR86	HVN1RA221B01T	RES , SEMI FIXED(220 OHM)	RH0615C100221
VR87	HVN1RA221B01T	RES , SEMI FIXED(220 OHM)	RH0615C100221
<i>Miscellaneous</i>			
CN81	KJP02GB46ZM	WAFER	
CN82	KJP02GB46ZM	WAFER	
CN83	KJP02GB46ZM	WAFER	
CN84	KJP02GB46ZM	WAFER	
CN85	KJP02GB46ZM	WAFER	
CN86	KJP02GB46ZM	WAFER	
CN87	KJP02GB46ZM	WAFER	
CN96	KJP08GA01ZM	WAFER	MOLEX 5267-08A
CN98	BJP08GB131ZK	WAFER	

Ref. Designator	Part Number	Description	
BOTTOM CHASSIS/POWER SUPPLY ASS'Y			
<i>Capacitors</i>			
C117	HCEA1HH4R7T	CAP , ELECT	4.7UF 50V
C118	CCKT1H103ZF	CAP , CERAMIC	0.01UF 50V ZF
C119	HCEA1HH470T	CAP , ELECT	47UF 50V
C120	HCEA1HH470T	CAP , ELECT	47UF 50V
C121	CCKT1H103ZF	CAP , CERAMIC	0.01UF 50V ZF
C122	HCEA1JH101E	CAP , ELECT	100UF 63V
C931	HCQ11H473JZT	CAP , MYLAR	0.047UF 50V J
C932	HCQ11H473JZT	CAP , MYLAR	0.047UF 50V J
C933	HCQ11H473JZT	CAP , MYLAR	0.047UF 50V J
C934	HCQ11H473JZT	CAP , MYLAR	0.047UF 50V J
C925	HCQ11H103JZT	CAP , MYLAR	0.01UF 50V J
C926	HCQ11H103JZT	CAP , MYLAR	0.01UF 50V J
C931	HCQ11H473JZT	CAP , MYLAR	0.047UF 50V J
C932	HCQ11H473JZT	CAP , MYLAR	0.047UF 50V J
C933	HCQ11H473JZT	CAP , MYLAR	0.047UF 50V J
C934	HCQ11H473JZT	CAP , MYLAR	0.047UF 50V J
C925	HCQ11H103JZT	CAP , MYLAR	0.01UF 50V J
C926	HCQ11H103JZT	CAP , MYLAR	0.01UF 50V J
C927	HCQ11H103JZT	CAP , MYLAR	0.01UF 50V J
C928	HCQ11H103JZT	CAP , MYLAR	0.01UF 50V J
C921	HCQ11H104JZT	CAP , MYLAR	0.1UF 50V J
C922	HCQ11H104JZT	CAP , MYLAR	0.1UF 50V J
C923	HCQ11H104JZT	CAP , MYLAR	0.1UF 50V J
C924	HCQ11H104JZT	CAP , MYLAR	0.1UF 50V J
C107	CCKT1H103ZF	CAP , CERAMIC	0.01UF 50V ZF
C108	CCKT1H103ZF	CAP , CERAMIC	0.01UF 50V ZF
C109	CCFT1H104ZF	CAP , SEMICONDUCTOR	0.1UF 50V ZF
C110	CCFT1H104ZF	CAP , SEMICONDUCTOR	0.1UF 50V ZF
C111	CCKT1H103ZF	CAP , CERAMIC	0.01UF 50V ZF
C112	CCKT1H103ZF	CAP , CERAMIC	0.01UF 50V ZF
<i>Resistors</i>			
R101	KRQ1AJR47H	RES , FUSE	0.47 OHM 1W J
R104	KRQ1AJR47H	RES , FUSE	0.47 OHM 1W J
R105	KRQ1AJR47H	RES , FUSE	0.47 OHM 1W J
R106	KRQ1AJR47H	RES , FUSE	0.47 OHM 1W J
R107	KRQ1AJR47H	RES , FUSE	0.47 OHM 1W J
R108	CRD20TJ4R7T	RES , CARBON	4.7 OHM 1/5W J
R109	CRD20TJ100T	RES , CARBON	10 OHM 1/5W J
R110	CRD20TJ4R7T	RES , CARBON	4.7 OHM 1/5W J
R112	CRD20TJ122T	RES , CARBON	1.2K OHM 1/5W J
R113	CRD20TJ473T	RES , CARBON	47K OHM 1/5W J
<i>Semiconductors</i>			
D101	HVDMTZJ15BT	DIODE , ZENER	15V 1/2W
D102	HVDMTZJ27BT	DIODE , ZENER	27V 1/2W
D108	KVD1N4003ST	DIODE	1N4003
D109	HVDMTZ12BT	DIODE , ZENER(20MM)	12V 1/2W
D111	HVDMTZJ12BT	DIODE , ZENER	12V 1/2W
Q104	HVTKSC2316YT	TRANSISTOR NPN	KSC2316Y
D104	KVD1N4003ST	DIODE	1N4003
D105	KVD1N4003ST	DIODE	1N4003
D106	KVD1N4003ST	DIODE	1N4003
D107	KVD1N4003ST	DIODE	1N4003
D992	CVDKBU804FMA	BRIDGE DIODE ASS'Y	KBU804F
D991	CVDKBU804FMA	BRIDGE DIODE ASS'Y	KBU804F

Ref. Designator	Part Number	Description	
		BOTTOM CHASSIS/POWER SUPPLY ASS'Y	
	HVDKBU804F	DIODE , BRIDGE	
	HVDKBU804F	DIODE , BRIDGE	
IC48	CVIL7805CPNA	I.C ASS'Y	
	HVIL7805CP	I.C, REGULATOR	
IC49	CVIL7905CPNA	I.C ASS'Y	
	HVIL7905CP	I.C, REGULATOR	
Miscellaneous			
	CTB3+10GFZ	SCREW	
	CTB3+6J	SCREW	
	CTB3+8J	SCREW	
	CTB3+8JFZ	SCREW	
	CTW3+12J	SCREW	
	CTW3+8J	SCREW	
	CUA1A229	CHASSIS , BOTTOM	AVR130/230/330
	HDMKD1206PTS3	MOTOR , FAN(60X60X25MM)	KD1206PTS3
	KHE36-3	CLAMPER , WIRE	
	KHG1A050	RUBBER , CUSHION	
	KHR1A028	BUSHING , AC CORD	
	KHR301	CLAMPER	
CB13	CWC1C4A13B080B	CABLE , CARD 80mm 13P	
CB15	CWC1C4A13B100B	CABLE , CARD 100mm 13P	
CB16	CWC1C4A15B040B	CABLE , CARD	
F903	KBA2C8000TLUZ	FUSE	
F904	KBA2C8000TLUZ	FUSE	
F905	KBA2C6300TLUZ	FUSE	
F906	KBA2C6300TLUZ	FUSE	
F907	KBA2C6300TLUZ	FUSE	
T901	CLT5W011ZU	TRANS , POWER	
	KBN1A174MBC22	KNOB , ROTARY	AVR130/230/330
	KGB1A111X	BADGE , HARMAN/KARDON	
	KGX1A338MBC22	CAP , VOLUME	AVR130/230/330
	CGL1A222	INDICATOR , VOLUME	AVR130/230/330
	CGU1A317X	WINDOW , FIP	AVR330
	CGU1A318Z	ORNAMENT , VOLUME	AVR130/230/330
	CGWAVR330CC	FRONT PANEL ASS'Y	
	CBT1A819K128	KNOB , DELAY	
	CGL1A221	INDICATOR , POWER	AVR130/230/330
	CGW1A366RDYH43	PANEL , FRONT	
	CMC1A200	PLATE , SHIELD	AVR130/230/330
	CMD1A443	BRACKET , SIDE	
	CMH1A215	HOLDER , LED	AVR130/230/330
	CMK1A010	BRACKET , PCB	
	CMX1A148	INSULATOR , FUBCTION	
	CMX1A149	INSULATOR , SET	
	CMZ1A088	FILTER , FIP	AVR130/2600
	CHD1A012Z	SCREW , SPECIAL	AVR125CC
	CHD1A023	SCREW , TRANS	M4X10(SP/WA)
	CHD1A036FZ	SCREW , SPECIAL	AVR330/AVR4600
	CHD2A012	SCREW , TR	
	CHE170	HOLDER , PCB	
	CHG1A104	CUSHION , EVA	H=9.5(15X20)
	CHG1A157	CUSHION , RUBBER	
	CJA523FBYA	CORD , POWER	
	CKF3A254Z	PANEL , REAR	AVR330
	CKL1A069H43	FOOT	AVR125/225
	CLZ9W003Z	FERRITE , RING	29X7.7X19
	CMD1A487	BRACKET , TRANS	AVR130/230/330
	CMD1A506	BRACKET , FAN	AVR330/AVR4600
F903	KJCF5S	HOLDER , FUSE	

Ref. Designator	Part Number	Description	
		BOTTOM CHASSIS/POWER SUPPLY ASS'Y	
F904	KJCF5S	HOLDER , FUSE	
F905	KJCF5S	HOLDER , FUSE	
F906	KJCF5S	HOLDER , FUSE	
F907	KJCF5S	HOLDER , FUSE	
	CMY1A218	HEAT SINK(TR)	AVR130/230/330
	CTB3+8J	SCREW	
F901	KBA2D2500TLET	FUSE	
F902	KBA2D2500TLET	FUSE	
	CNVKSTM9014MS07	TUNER MODULE(USA)	

TRANSISTOR, REGULATOR IC BLOCK DIAGRAM

<p>TO-92M</p>  <p>1. Emitter 2. Collector 3. Base</p> <p>123</p> <p>KTC2874B KSC2785Y KRA107M KRC107M</p>	<p>TO-92</p>  <p>1. Emitter 2. Collector 3. Base</p> <p>123</p> <p>KTD1302T KTA1268GR KTC3200GR KTC3198Y KTA1271Y</p>	<p>TO-220</p>  <p>1. GND 2. INPUT 3. OUTPUT</p> <p>123</p> <p>MCNJM7905 MC7915C</p>	<p>TO-92L</p>  <p>1. Emitter 2. Collector 3. Base</p> <p>123</p> <p>KTA1024Y KSC2316Y</p>
<p>TO-126</p>  <p>1. Emitter 2. Collector 3. Base</p> <p>123</p> <p>2SA1360O 2SC3423O KTD600KG</p>	<p>TO-220</p>  <p>1. Base 2. Collector 3. Emitter</p> <p>123</p> <p>KSA614Y</p>	<p>TO-220</p>  <p>1. INPUT 2. GND 3. OUTPUT</p> <p>123</p> <p>MC7815C MC7805C</p>	<p>TO-3P</p>  <p>1. Base 2. Collector 3. Emitter</p> <p>1 2 3</p> <p>2SB1560 2SD2390</p>

TC9162AF (FUNCTION/INPUT : IC30)

■ BLOCK DIAGRAM

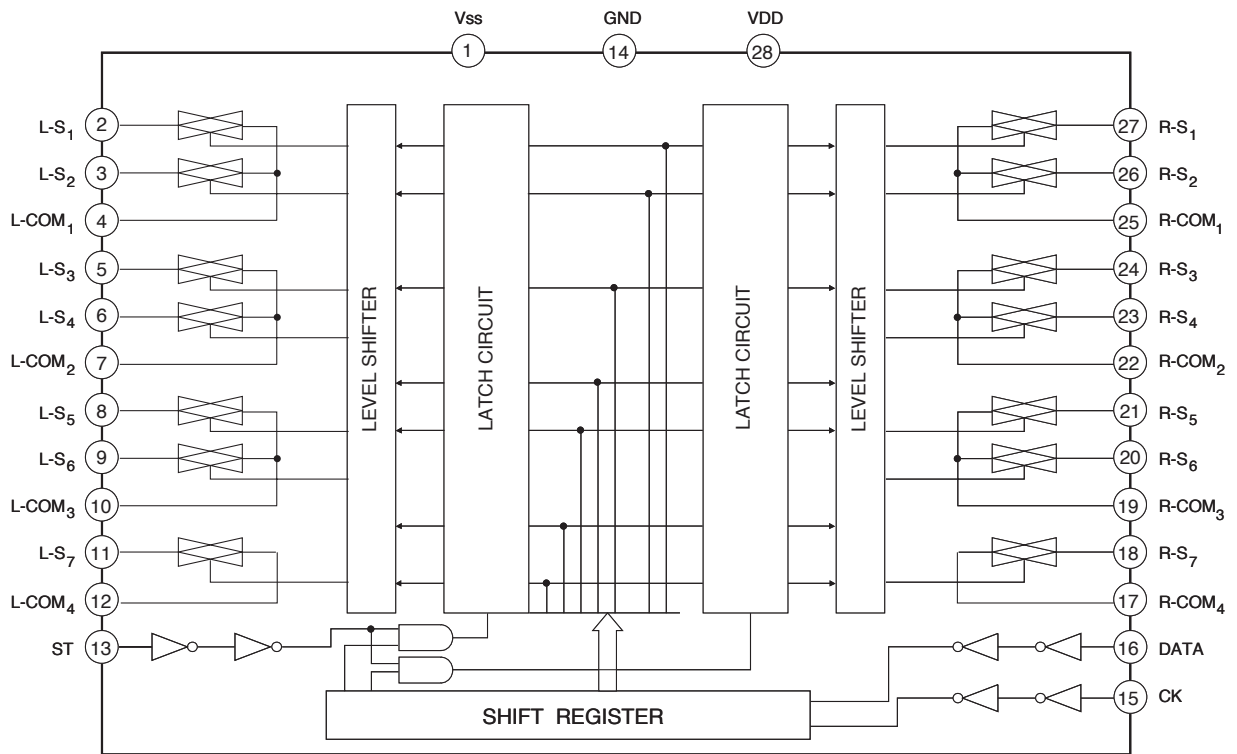



DUAL HIGH CURRENT OPERATIONAL AMPLIFIER

■ GENERAL DESCRIPTION

The NJM4556A integrated circuit is a high-gain, high output current dual operational amplifier capable of driving $\pm 70\text{mA}$ into $150\ \Omega$ loads ($\pm 10.5\text{V}$ output voltage), and operating low supply voltage ($V^+/V^- = \pm 2\text{V} \sim$).

The NJM4556A combines many of the fetures of the popular NJM4558 as well as having the capability of driving $150\ \Omega$ loads. In addition, the wide band-width, low noise, high slew rate and low distortion of the NJM4556A make it ideal for many audio, telecommunications and instrumentation applications.

■ FEATURES

- Operating Voltage ($\pm 2\text{V} \sim \pm 18\text{V}$)
- High Output Current ($I_o = 70\text{mA}$)
- Slew Rate ($3\text{V}/\mu\text{s}$ typ.)
- Gain Band Width Product (8MHz typ.)
- Package Outline DIP8, DMP8, SIP8, SSOP8
- Bipolar Technology

■ PACKAGE OUTLINE

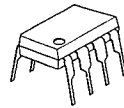

NJM4556AD



NJM4556AM

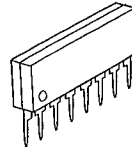

NJM4556AL



NJM4556AV

■ PIN CONFIGURATION

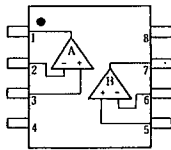

NJM4556AD
NJM4556AM
NJM4556AV

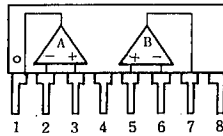

NJM4556AL

PIN FUNCTION

1. A OUTPUT
2. A- INPUT
3. A+ INPUT
4. V-
5. B+ INPUT
6. B- INPUT
7. B OUTPUT
8. V+

■ EQUIVALENT CIRCUIT (1/2 Shown)

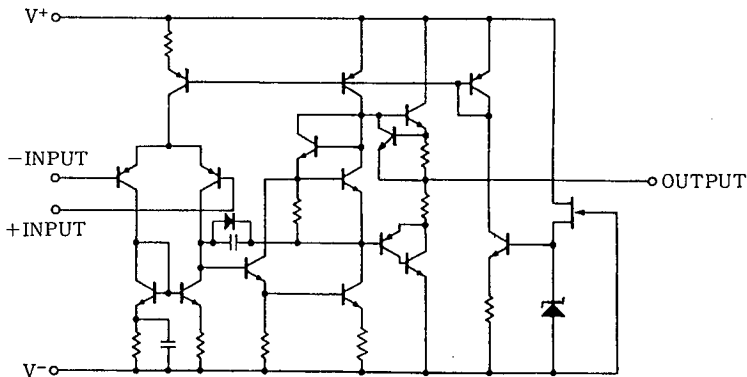

BLOCK DIAGRAM

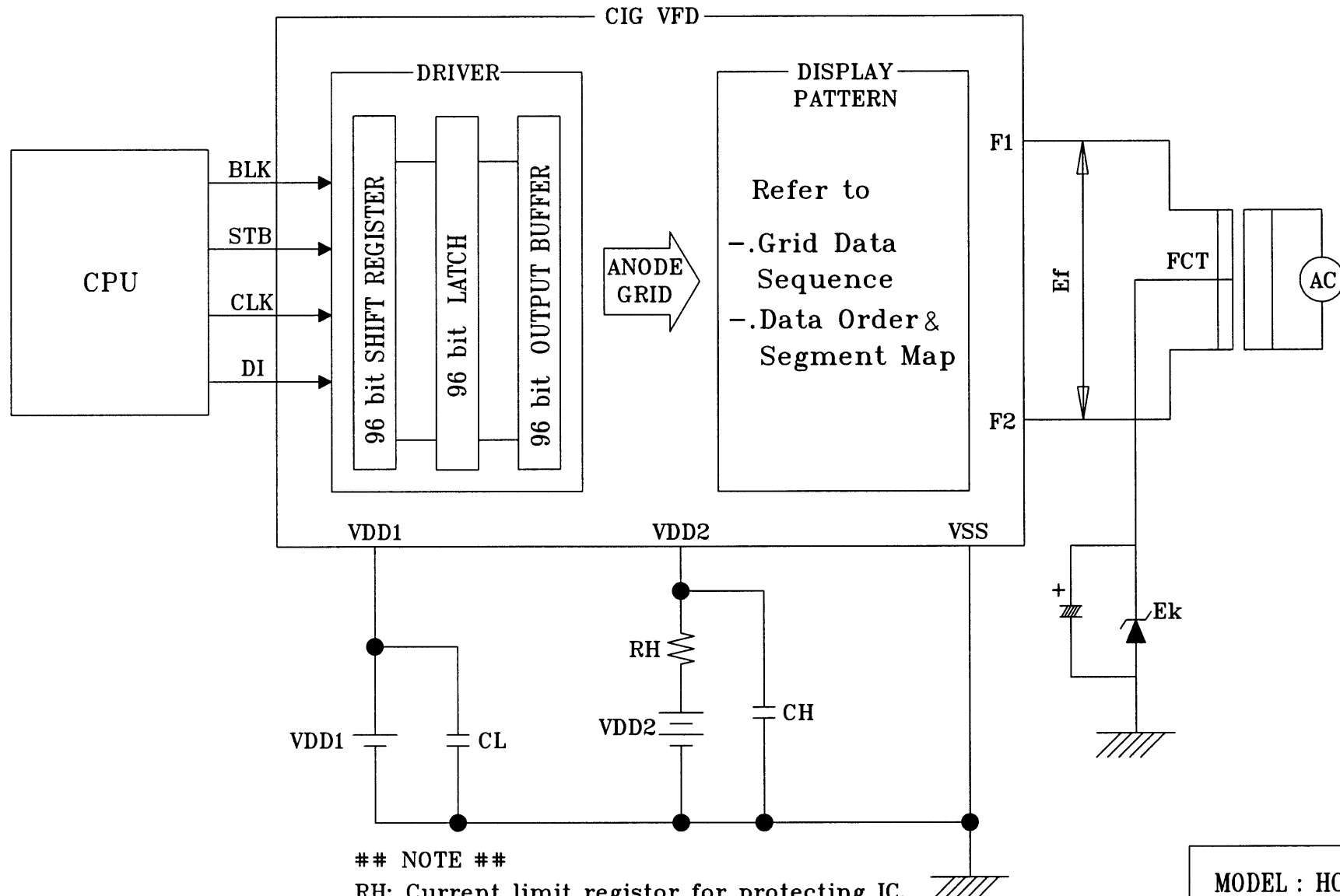

NOTE

RH: Current limit resistor for protecting IC.

CH,CL: Low pass filter for noise filtering.

RH: 22Ω, CH: 0.1 μF, CL: 0.1 μF

FCT: Filament is center-tab grounded.

MODEL : HCA-18ML01
 BLOCK DIAGRAM
 Rev. ① 20-Feb-2003

OUTER DIMENSIONS

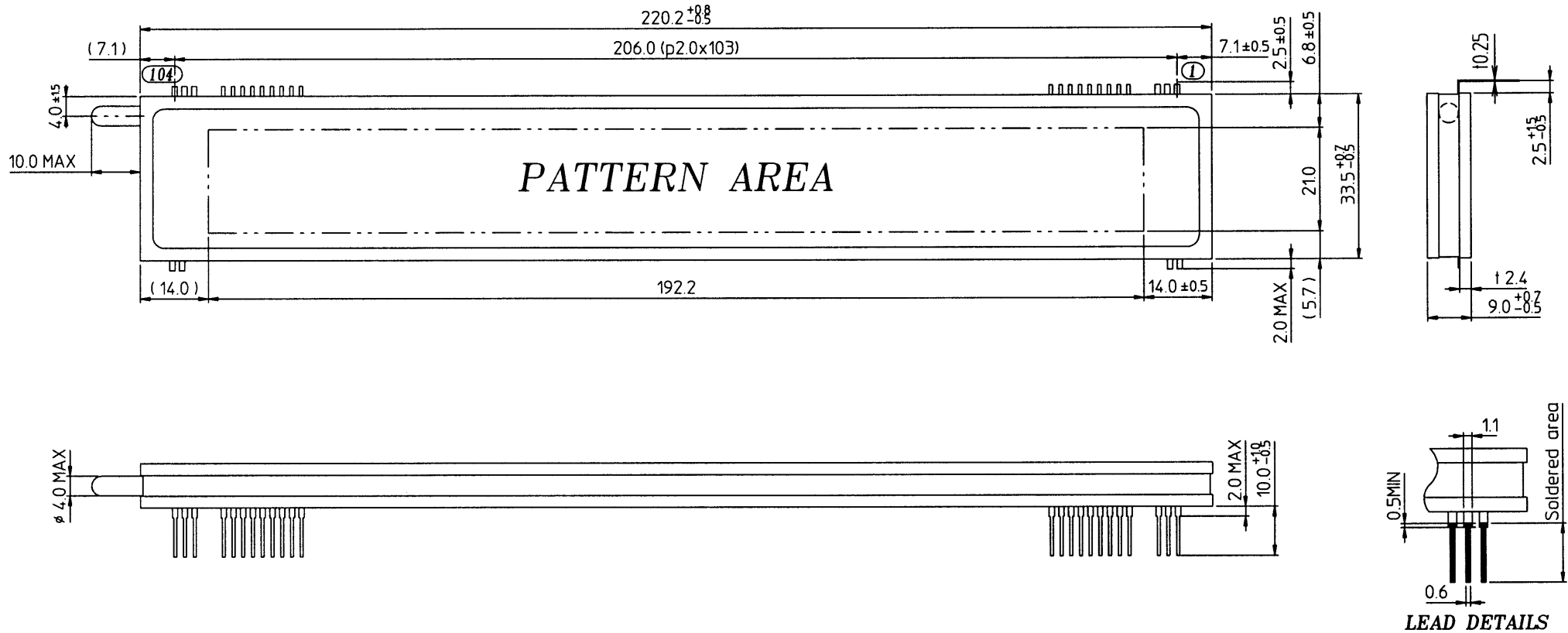

PIN CONNECTION

PIN NO.	104	103	102	101	100	99	98	97	96	95	94	93	92	91	90~15	14~6	5	4	3	2	1
CONNECTION	F2	F2	F2	NP	NP	VDD2	VSS	VSS	CLK	DO	DI	BLK	STB	VDD1	NP	NC	NP	NP	F1	F1	F1

***Notes**

Fn : Filament Pin

NP : No Pin

NC : No Connection Pin

* DO(Serial data output) : Be left open if not used.

MODEL : HCA-18ML01
 OUTER DIMENSIONS
 Rev. ① 20-Feb-2003

LC74763, 74763M

Pin Assignment

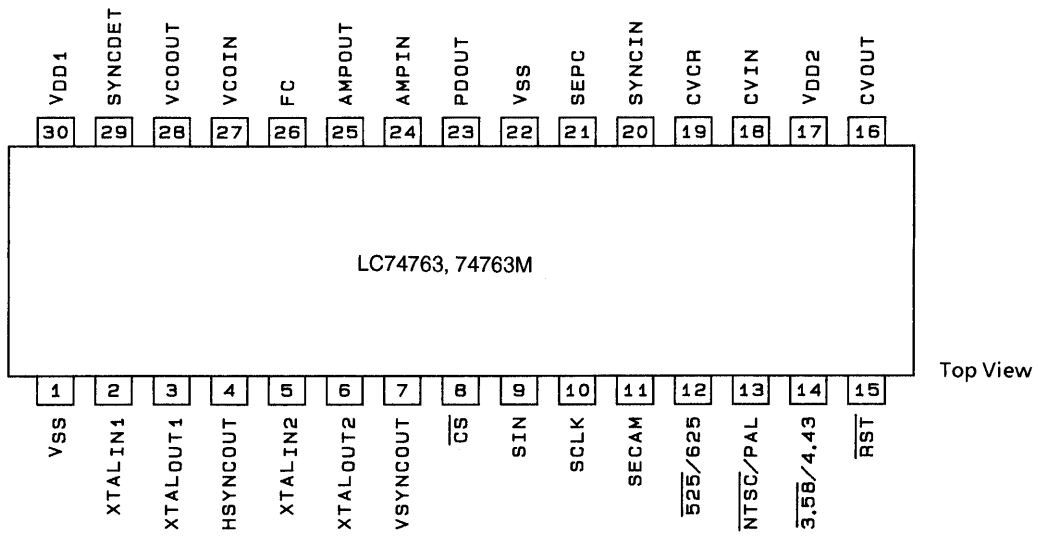

Top View

A03518

Top view

Serial Data Input Timing

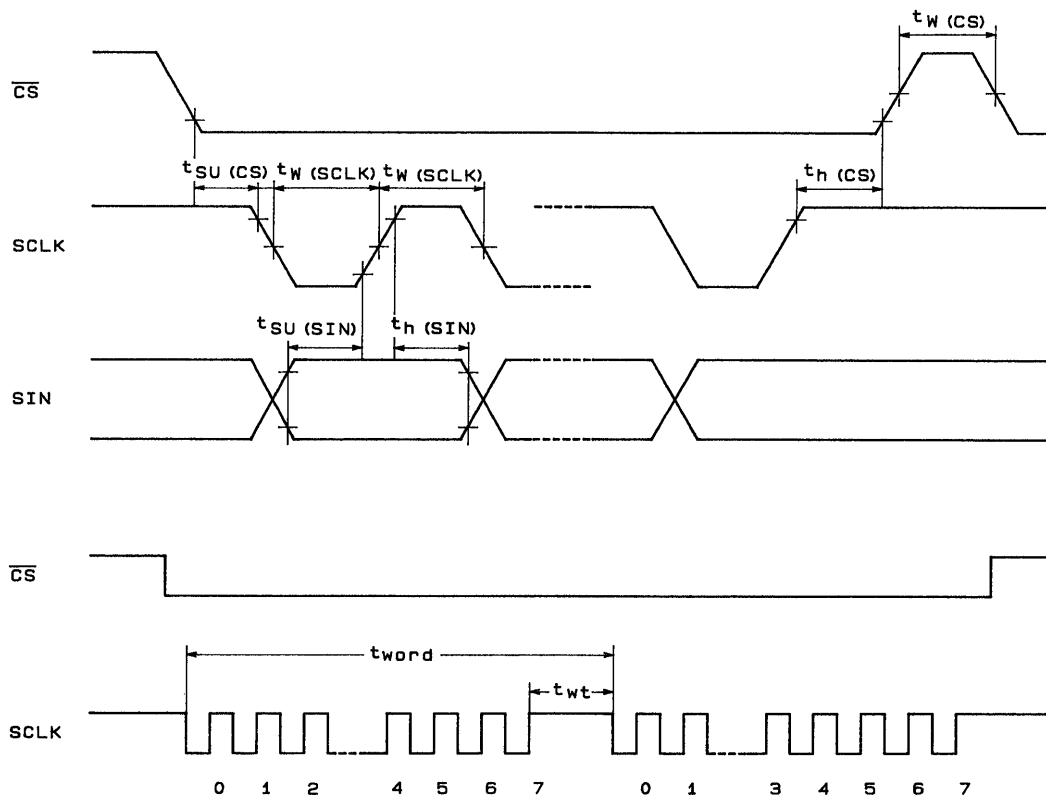

A03519

O.S.D IC (74763M)

Pin Functions (IC51)

Pin No.	Symbol	Function	Description
1	V _{SS}	Ground	Ground connection
2	Xtal _{IN1}	Crystal oscillator connection	Connection for the crystal and capacitor used to form the crystal oscillator that generates the internal synchronization signal. The oscillator can be selected with a command switch.
3	Xtal _{OUT1}		
4	HSYNC _{OUT}	Horizontal synchronization output	Outputs the horizontal synchronization signal (AFC). The output polarity can be selected (metal option). Also functions as general output port (command switch).
5	Xtal _{IN2}	Crystal oscillator connection	Connection for the crystal and capacitor used to form the crystal oscillator that generates the internal synchronization signal.
6	Xtal _{OUT2}		
7	VSYNC _{OUT}	Vertical synchronization output	Outputs the vertical synchronization signal. The output polarity can be selected (metal option). Also functions as general output port (command switch).
8	\overline{CS}	Enable input	Enables/disables serial data input. Serial data is enabled when this pin is low (hysteresis input). Pull-up resistor built in (metal option).
9	SIN	Data input	Serial data input (hysteresis input). Pull-up resistor built in (metal option).
10	SCLK	Clock input	Clock input for serial data input (hysteresis input). Pull-up resistor built in (metal option).
11	SECAM	SECAM mode switch input/output (command switch)	During input, switches between SECAM and other modes. During output, functions as general output port or internal V output (command switch). Low = other modes, high = SECAM mode
12	$\overline{525/625}$	525/625 switch input/output (command switch)	During input, switches between 525 scan lines and 625 scan lines. During output, functions as general output port or character data output (command switch). Low = 525 lines, high = 625 lines
13	$\overline{NTSC/PAL}$	NTSC/PAL switch input/output (command switch)	Switches the color mode between NTSC and PAL. During output, functions as general output port or frame data output (command switch). Low = NTSC, high = PAL
14	$\overline{3.58/4.43}$	3.58/4.43 switch input/output (command switch)	Switch FSC between 3.58 MHz and 4.43 MHz. During output, functions as general output port or halftone output (command switch). Low = 3.58, high = 4.43
15	\overline{RST}	Reset input	System reset input pin, low is active (hysteresis input). Pull-up resistor built in (metal option).
16	CV _{OUT}	Video signal output	Composite video output
17	V _{DD2}	Power supply connection	Power supply connection for composite video signal level generation
18	CV _{IN}	Video signal input	Composite video input
19	CV _{CR}	Video signal input	SECAM chroma signal input
20	SYNC _{IN}	Sync separator circuit input	Built-in sync separator circuit video signal input
21	SEP _C	Sync separator circuit	Built-in sync separator circuit
22	V _{SS}	Ground	Ground connection
23	PD _{OUT}	Control voltage output	AFC control voltage output
24	AMP _{IN}	AFC filter connection	Filter connection
25	AMP _{OUT}		
26	FC	Control voltage input	AFC control voltage input
27	VCO _{IN}	LC oscillator connection	VCO LC oscillator circuit coil and capacitor connection
28	VCO _{OUT}		
29	SYNC _{DET}	External synchronization signal detection output	Outputs the exclusive NOR of the horizontal synchronization signal (AFC) and CSYNC (sync separator). The output polarity can be selected (metal option). Also functions as general output port (command switch).
30	V _{DD1}	Power supply connection	Power supply connection (+5 V: digital system power supply)

System Block Diagram

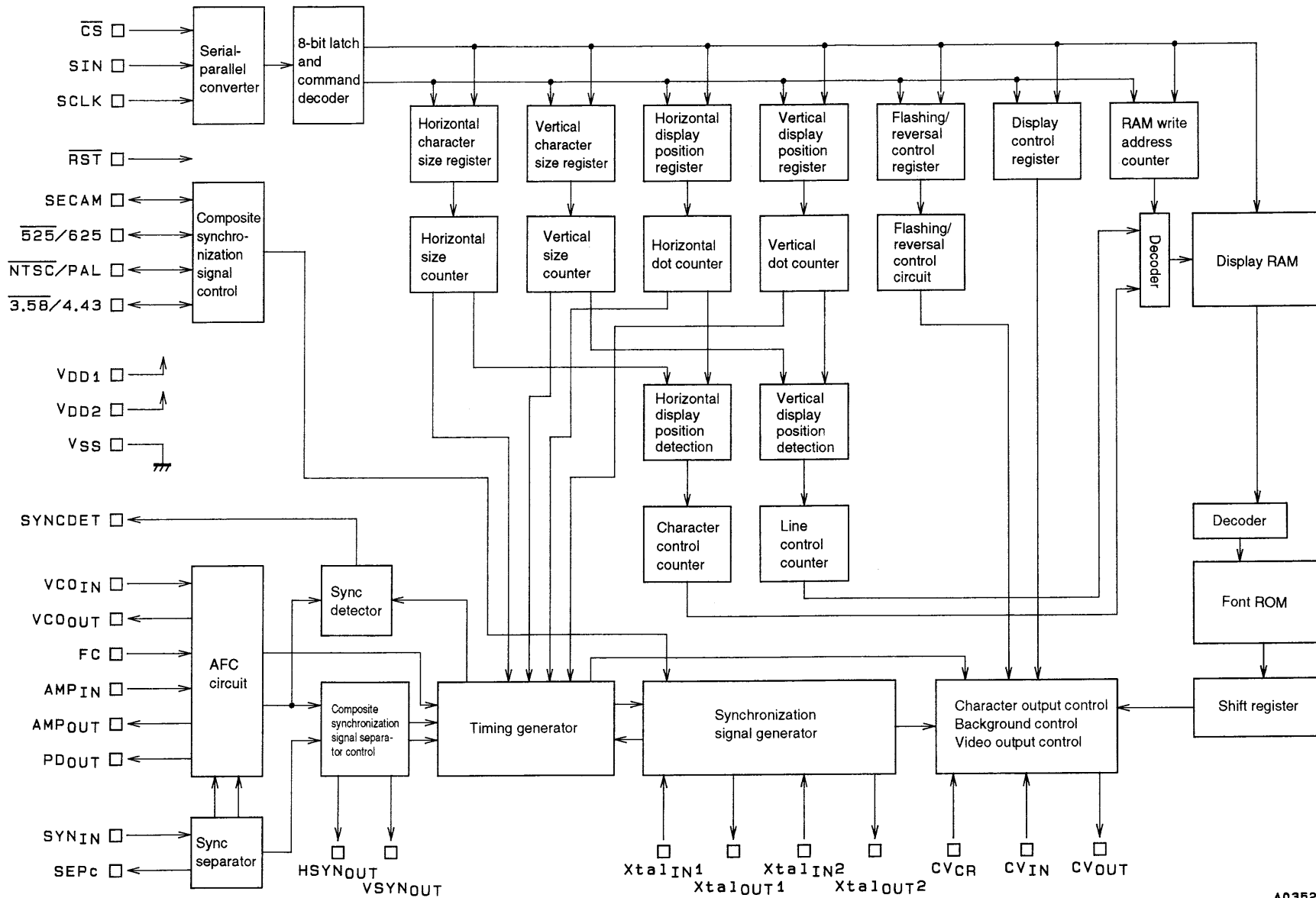

A03520

DIR IC PIN ASSIGNMENT & BLOCK DIAGRAM
PIN ASSIGNMENT (TOP VIEW) : IC73

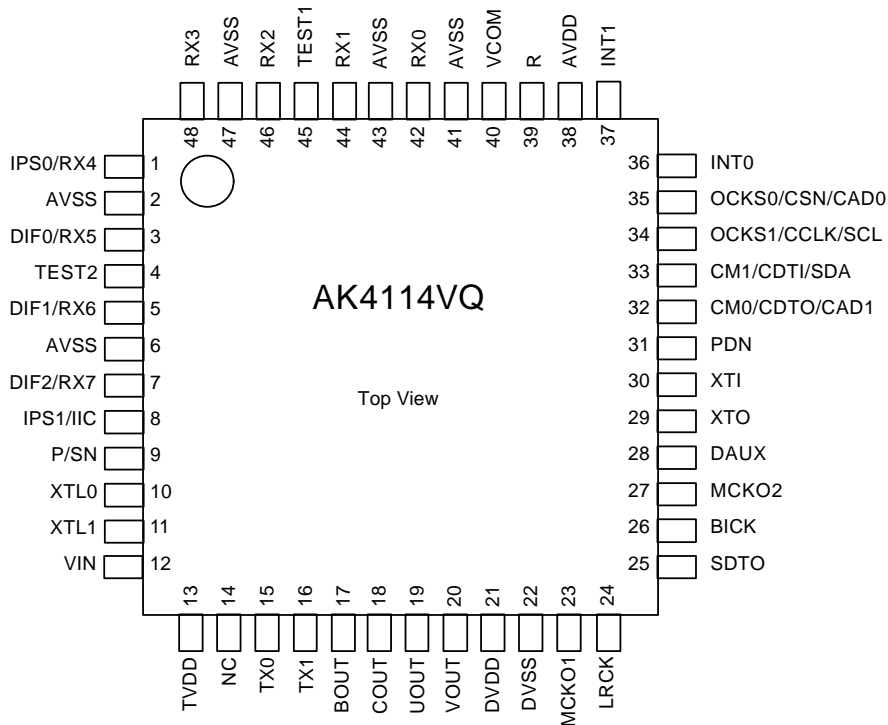

BLOCK DIAGRAM

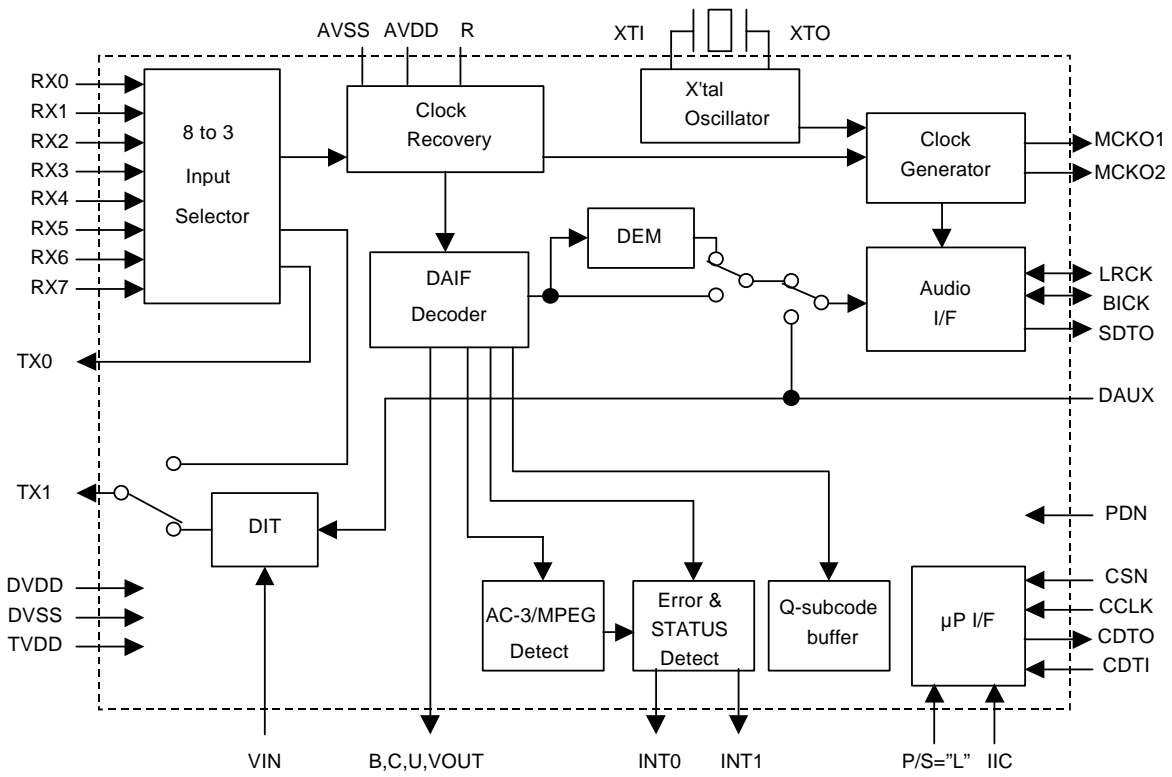

Serial Control Mode

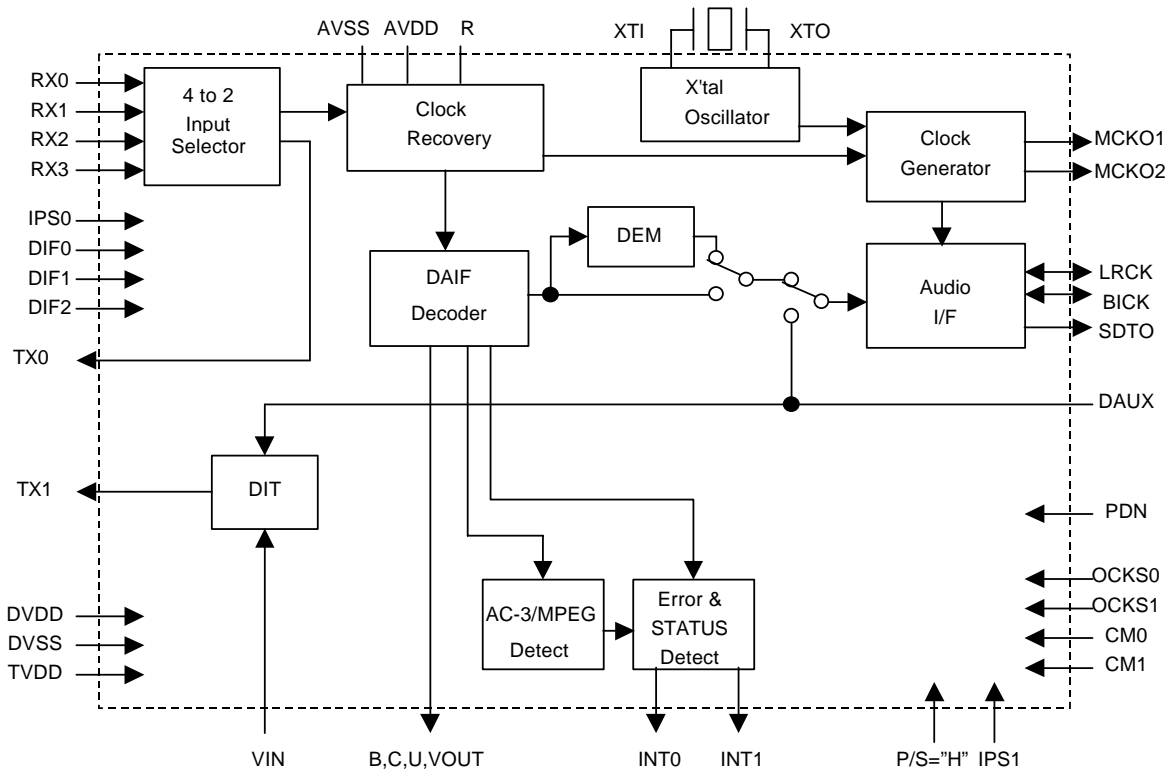

Parallel Control Mode

DIR IC PIN FUNCTION (AK4114VQ) : IC73 □

AVR330

harman/kardon

PIN/FUNCTION			
No.	Pin Name	I/O	Function
1	IPS0	I	Input Channel Select 0 Pin in Parallel Mode
	RX4	I	Receiver Channel 4 Pin in Serial Mode (Internal biased pin)
2	NC(AVSS)	I	No Connect No internal bonding. This pin should be connected to AVSS.
3	DIF0	I	Audio Data Interface Format 0 Pin in Parallel Mode
	RX5	I	Receiver Channel 5 Pin in Serial Mode (Internal biased pin)
4	TEST2	I	TEST 2 pin This pin should be connect to AVSS.
5	DIF1	I	Audio Data Interface Format 1 Pin in Parallel Mode
	RX6	I	Receiver Channel 6 Pin in Serial Mode (Internal biased pin)
6	NC(AVSS)	I	No Connect No internal bonding. This pin should be connected to AVSS.
7	DIF2	I	Audio Data Interface Format 2 Pin in Parallel Mode
	RX7	I	Receiver Channel 7 Pin in Serial Mode (Internal biased pin)
8	IPS1	I	Input Channel Select 1 Pin in Parallel Mode
	IIC	I	IIC Select Pin in Serial Mode. “L”: 4-wire Serial, “H”: IIC
9	P/SN	I	Parallel/Serial Select Pin “L”: Serial Mode, “H”: Parallel Mode
10	XTL0	I	X'tal Frequency Select 0 Pin
11	XTL1	I	X'tal Frequency Select 1 Pin
12	VIN	I	V-bit Input Pin for Transmitter Output
13	TVDD	I	Input Buffer Power Supply Pin, 3.3V or 5V
14	NC	I	No Connect No internal bonding. This pin should be open or connected to DVSS.
15	TX0	O	Transmit Channel (Through Data) Output 0 Pin
16	TX1	O	When TX bit = “0”, Transmit Channel (Through Data) Output 1 Pin. When TX bit = “1”, Transmit Channel (DAUX Data) Output Pin (Default).
17	BOUT	O	Block-Start Output Pin for Receiver Input “H” during first 40 frames.
18	COUT	O	C-bit Output Pin for Receiver Input
19	UOUT	O	U-bit Output Pin for Receiver Input
20	VOUT	O	V-bit Output Pin for Receiver Input
21	DVDD	I	Digital Power Supply Pin, 3.3V
22	DVSS	I	Digital Ground Pin
23	MCKO1	O	Master Clock Output 1 Pin
24	LRCK	I/O	Channel Clock Pin
25	SDTO	O	Audio Serial Data Output Pin
26	BICK	I/O	Audio Serial Data Clock Pin
27	MCKO2	O	Master Clock Output 2 Pin
28	DAUX	I	Auxiliary Audio Data Input Pin
29	XTO	O	X'tal Output Pin
30	XTI	I	X'tal Input Pin

PIN/FUNCTION (Continued)

No.	Pin Name	I/O	Function
31	PDN	I	Power-Down Mode Pin When "L", the AK4114 is powered-down and reset.
32	CM0	I	Master Clock Operation Mode 0 Pin in Parallel Mode
	CDTO	O	Control Data Output Pin in Serial Mode, IIC= "L".
	CAD1	I	Chip Address 1 Pin in Serial Mode, IIC= "H".
33	CM1	I	Master Clock Operation Mode 1 Pin in Parallel Mode
	CDTI	I	Control Data Input Pin in Serial Mode, IIC= "L".
	SDA	I/O	Control Data Pin in Serial Mode, IIC= "H".
34	OCKS1	I	Output Clock Select 1 Pin in Parallel Mode
	CCLK	I	Control Data Clock Pin in Serial Mode, IIC= "L"
	SCL	I	Control Data Clock Pin in Serial Mode, IIC= "H"
35	OCKS0	I	Output Clock Select 0 Pin in Parallel Mode
	CSN	I	Chip Select Pin in Serial Mode, IIC="L".
	CAD0	I	Chip Address 0 Pin in Serial Mode, IIC= "H".
36	INT0	O	Interrupt 0 Pin
37	INT1	O	Interrupt 1 Pin
38	AVDD	I	Analog Power Supply Pin, 3.3V
39	R	-	External Resistor Pin 18k Ω +/-1% resistor should be connected to AVSS externally.
40	VCOM	-	Common Voltage Output Pin 0.47 μ F capacitor should be connected to AVSS externally.
41	AVSS	I	Analog Ground Pin
42	RX0	I	Receiver Channel 0 Pin (Internal biased pin) This channel is default in serial mode.
43	NC(AVSS)	I	No Connect No internal bonding. This pin should be connected to AVSS.
44	RX1	I	Receiver Channel 1 Pin (Internal biased pin)
45	TEST1	I	TEST 1 pin. This pin should be connected to AVSS.
46	RX2	I	Receiver Channel 2 Pin (Internal biased pin)
47	NC(AVSS)	I	No Connect No internal bonding. This pin should be connected to AVSS.
48	RX3	I	Receiver Channel 3 Pin (Internal biased pin)

Note 1. All input pins except internal biased pins should not be left floating.

■ BLOCK DIAGAM (NJM2296M) : IC41, 42, 43

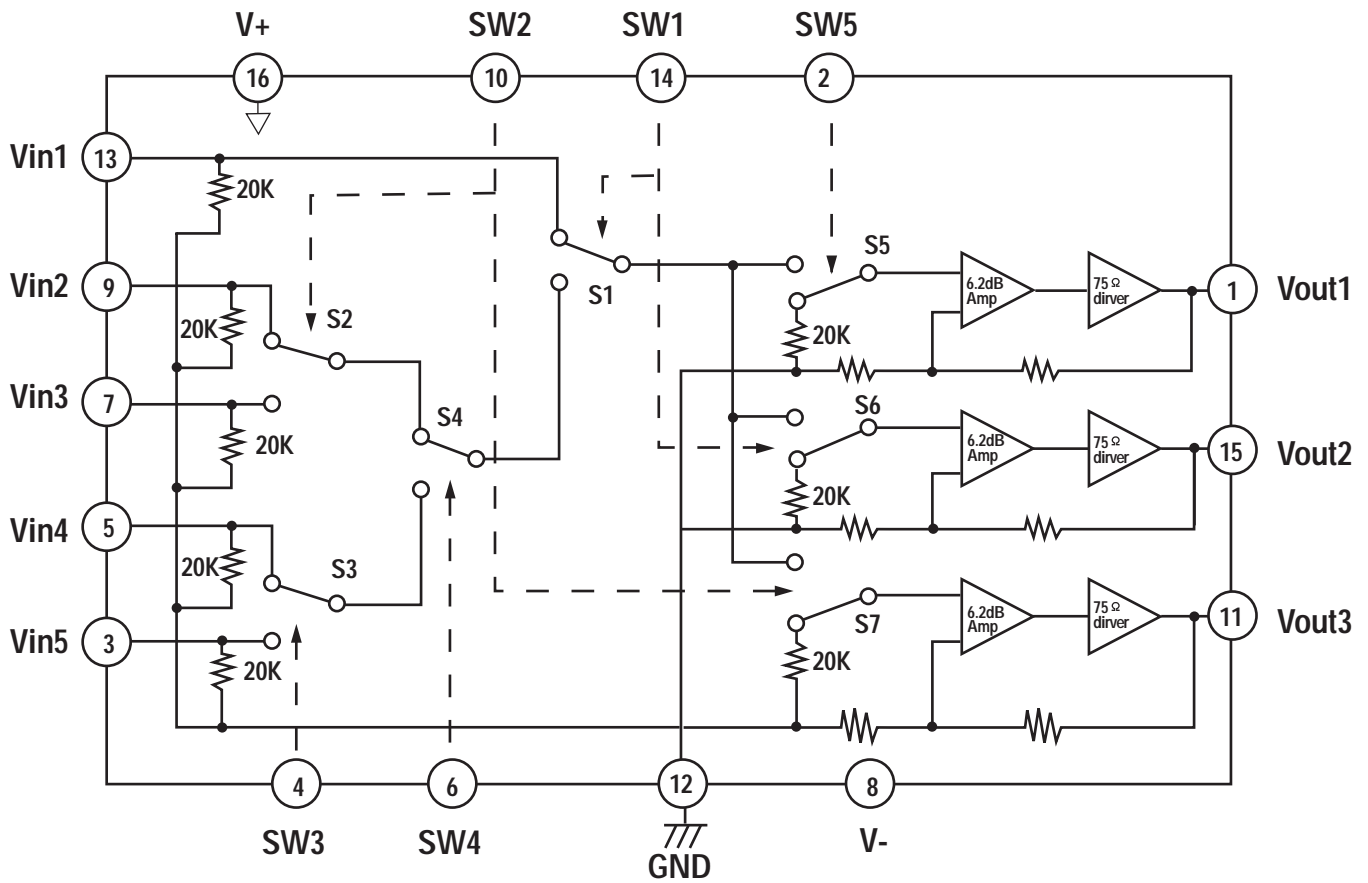

*** Normally mute**
Above circuits show that the switches are set at low.

PIN CONFIGURATION

• TO-92

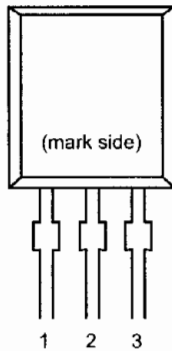

• SOT-89

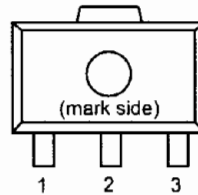

• SOT-23-5

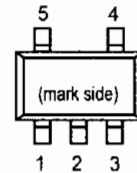

PIN DESCRIPTION

• TO-92

Pin No	Symbol
1	OUT
2	V _{DD}
3	GND

• SOT-89

Pin No	Symbol
1	OUT
2	V _{DD}
3	GND

• SOT-23-5

Pin No	Symbol
1	OUT
2	V _{DD}
3	GND
4	NC
5	NC

TC9164AF (FUNCTION/INPUT) : IC23

■ BLOCK DIAGRAM

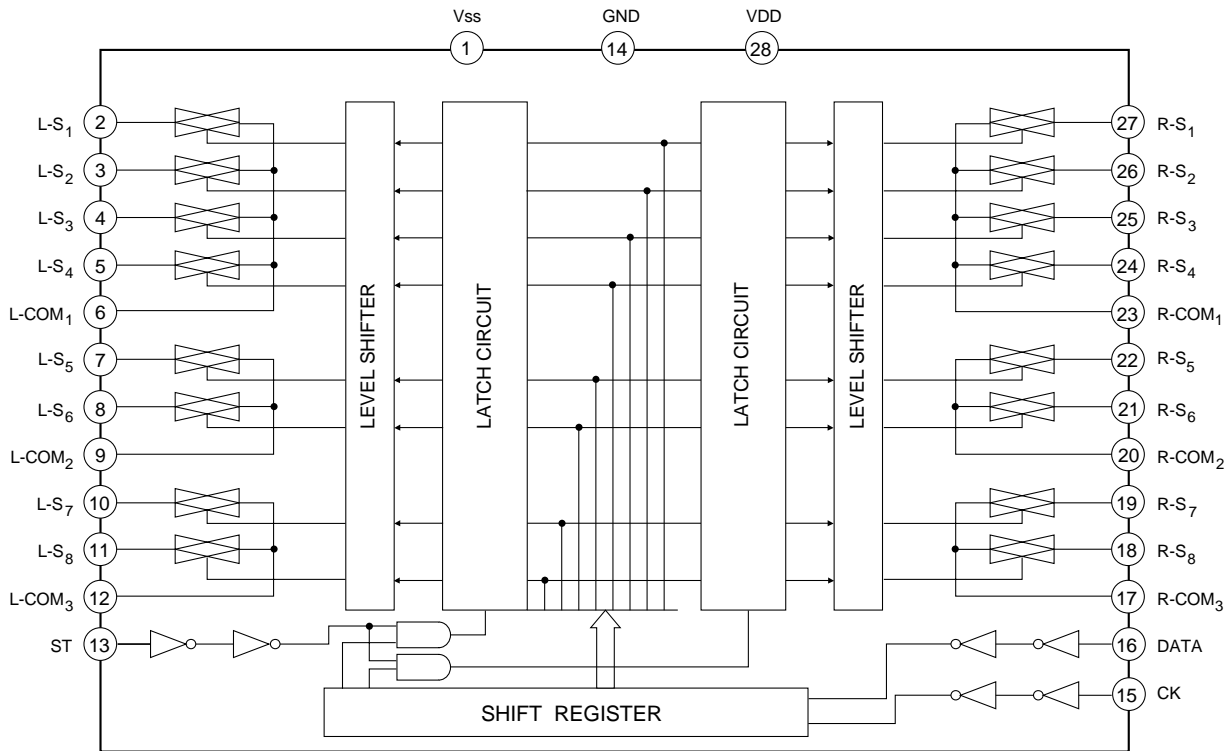

TC9163AF (FUNCTION/INPUT) : IC21,24

■ BLOCK DIAGRAM

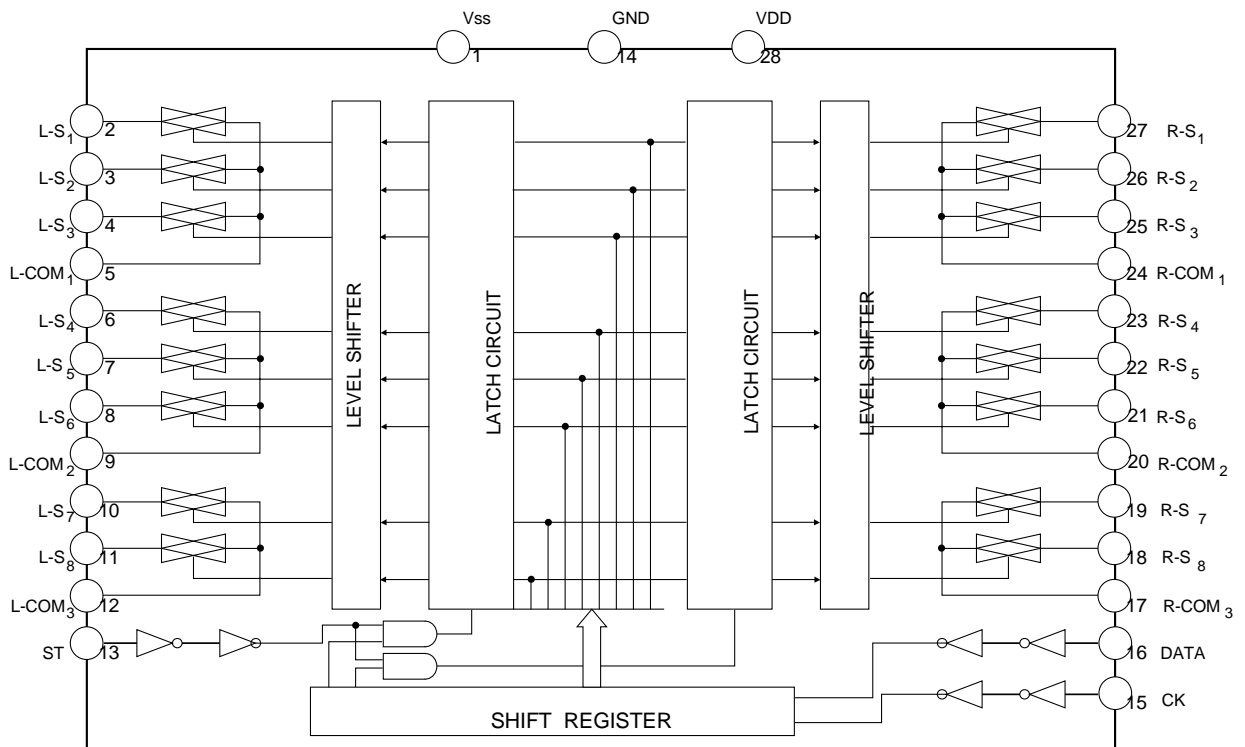



NJM2581

DUAL SUPPLY WIDE BAND 3ch VIDEO AMPLIFIER

GENERAL DESCRIPTION

The **NJM2581** is a dual supply voltage wide band 3ch video amplifier. It is suitable for Y, Pb, and Pr signal because frequency range is 50MHz.

The **NJM2581** is suitable for Set Top Box, AV amplifier, and other high quality AV systems.

PACKAGE OUTLINE

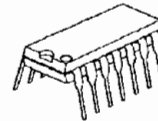

NJM2581D

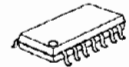

NJM2581M

FEATURES

- Operating Voltage ± 4.5 to $\pm 5.5V$
- Wide frequency range 50MHz at 0dB typ.
- Internal 6dB Amplifier
- Internal 75Ω Driver Circuit (2-system drive)
- Power Save Circuit
- Bipolar Technology
- Package Outline DIP14, DMP14

BLOCK DIAGRAM

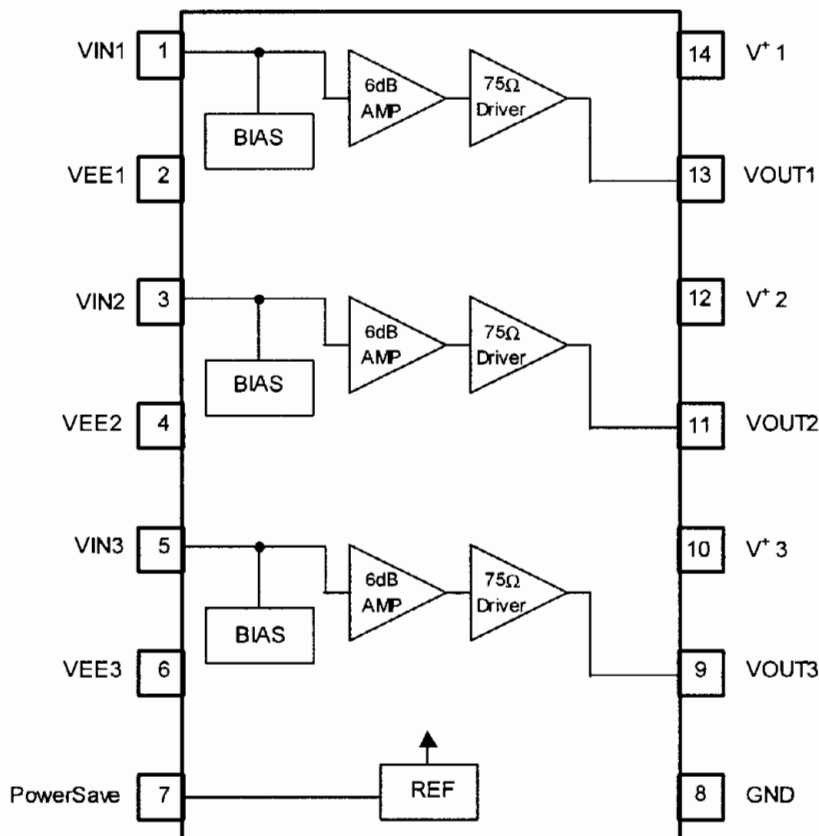

NJM2581

■ EQUIVALENT CIRCUIT

PIN No.	PIN NAME	FUNCTION	INSIDE EQUIVALENT CIRCUIT
1 3 5	VIN1 VIN2 VIN3	Input	
13 11 9	VOUT1 VOUT2 VOUT3	Output	
7	PowerSave	Power Save	
14 12 10	V ⁺ 1 V ⁺ 2 V ⁺ 3	V ⁺	_____
2 4 6	VEE1 VEE2 VEE3	V ⁻	_____
8	GND	GND	_____

BLOCK DIAGRAM (IC74)

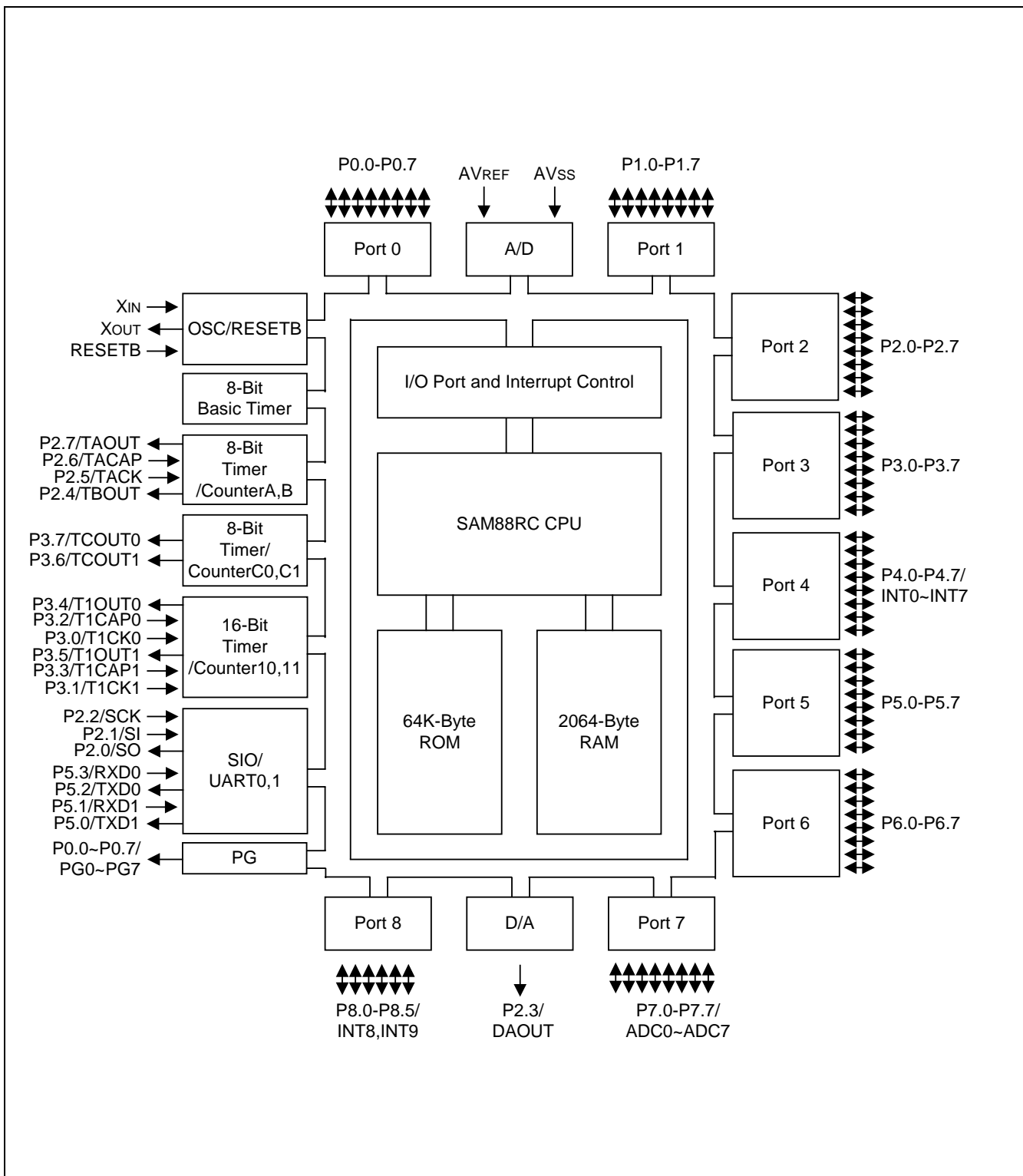

Figure 1-1. S3C84BB/F84BB Block Diagram

PIN ASSIGNMENT (IC74)

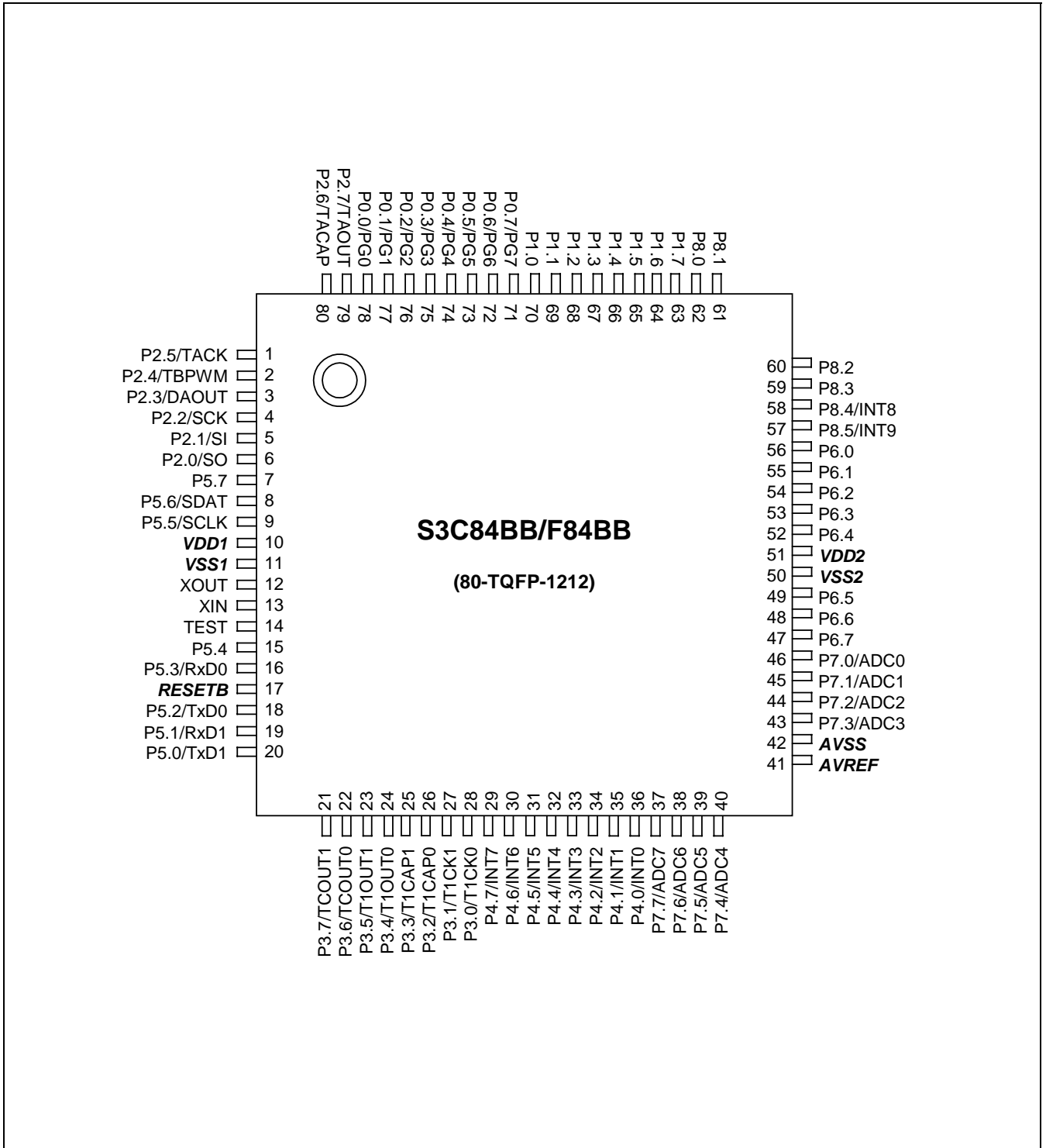

Figure 1-3. S3C84BB/F84BB Pin Assignment (80-TQFP)

PRODUCT OVERVIEW

S3C84BB/F84BB

PIN DESCRIPTIONS (IC74)

Table 1-1. S3C84BB/F84BB Pin Descriptions (80-QFP)

Pin Name	Pin Type	Pin Description	Circuit Type	Pin Number	Share Pins
P0.0 - P0.7	I/O	Bit programmable port; input or output mode selected by software; input or push-pull output. Software assignable pull-up. Alternately, P0.0-P0.7 can be used as the PG output port (PG0-PG7).	D	80-73	PG0-PG7
P1.0 - P1.7	I/O	Bit programmable port; input or output mode selected by software; input or push-pull output. Software assignable pull-up.	D	72-65	
P2.0 - P2.7	I/O	Bit programmable port; input or output mode selected by software; input or push-pull output. Software assignable pull-up. Alternately, P2.0~P2.7 can be used as I/O for TIMERA, TIMERB, D/A, SIO	D,D-2	8-1	SO SI SCK DAOUT TBPWM TACK TACAP TAOUT
P3.0 - P3.7	I/O	Bit programmable port; input or output mode selected by software; input or push-pull output. Software assignable pull-up. Alternately, P3.0~P3.7 can be used as I/O for TIMERC0/C1, TIMER10/11	D	30-23	T1CK0 T1CK1 T1CAP0 T1CAP1 T1OUT0 T1OUT1 TCOUT0 TCOUT1

Table 1-1. S3C84BB/F84BB Pin Descriptions (80-QFP) (Continued)

Pin Name	Pin Type	Pin Description	Circuit Type	Pin Number	Share Pins
P4.0 - P4.7	I/O	Bit programmable port; input or output mode selected by software; input or push-pull output. Software assignable pull-up. P4.0-P4.7 can alternately be used as inputs for external interrupts INT0-INT7, respectively (with noise filters and interrupt controller)	D-1	38-31	INT0-INT7
P5.0 - P5.7	I/O	Bit programmable port; input or output mode selected by software; input or push-pull output. Software assignable pull-up. Alternately, P5.0~P5.3 can be used as I/O for serial por, UART0, UART1, respectively.	G	22-17,11-9	TxD1 RxD1 TxD0 RxD0
P6.0 - P6.7	O	N-channel, open-drain output only port.	F	58-54,51-49	
P7.0 - P7.7	I	General-purpose digital input ports. Alternatively used as analog input pins for A/D converter modules.	E	48-45,42-39	ADC0-ADC7
P8.0 - P8.5	I/O	Bit programmable port; input or output mode selected by software; input or push-pull output. Software assignable pull-up. P8.4, P8.5 can alternately be used as inputs for external interrupts INT8, INT9, respectively (with noise filters and interrupt controller)	D,D-1	64-59	INT8,INT9

PRODUCT OVERVIEW

S3C84BB/F84BB

Table 1-1. S3C84BB/F84BB Pin Descriptions (80-QFP) (Continued)

Pin Name	Pin Type	Pin Description	Circuit Type	Pin Number	Share Pins
AD0 - AD7	I	Analog input pins for A/D converter module. Alternatively used as general-purpose digital input port 7.	E	48–45 42–39	P7.0–P7.7
AVREF, AVSS	-	A/D converter reference voltage and ground	-	43, 44	-
RxD0, RxD1	I/O	Serial data RxD pin for receive input and transmit output (mode 0)	D	18, 21	P5.3, P5.1
TxD0, TxD1	O	Serial data TxD pin for transmit output and shift clock input (mode 0)	D	20, 22	P5.2, P5.0
TACK	I	External clock input pins for timer A	D	3	P2.5
TACAP	I	Capture input pins for timer A	D	2	P2.6
TAOUT	O	Pulse width modulation output pins for timer A	D	1	P2.7
TBPWM	O	Carrier frequency output pins for timer B	D	4	P2.4
TCOUT0 TCOUT1	O	Timer C 8-bit PWM mode output or counter match toggle output pins	D	24,23	P3.6,P3.7
T1CK0 T1CK1	I	External clock input pins for timer 1	D	39,30	P3.0,P3.1
T1CAP0 T1CAP1	I	Capture input pins for timer 1	D	28,27	P3.2,P3.3
T1OUT0 T1OUT1	O	Timer 1 16-bit PWM mode output or counter match toggle output pins	D	26,25	P3.4,P3.5
SI,SO,SCK	I/O	Synchronous SIO pins	D	7,8,9	P2.1,P2.0, P2.2
RESETB	I	System reset pin (pull-up resistor: 240 k Ω)	B	19	-
TEST	I	Pull – down register connected internally	-	16	-
VDD1, VDD2, VSS1, VSS2	-	Power input pins	-	12,53, 13,52	-
XIN, XOUT	-	Main oscillator pins	-	15,14	-

U-COM IC PIN ASSIGNMENT & DESCRIPTIONS

■ PIN ASSIGNMENT (IC72)

(TOP VIEW)

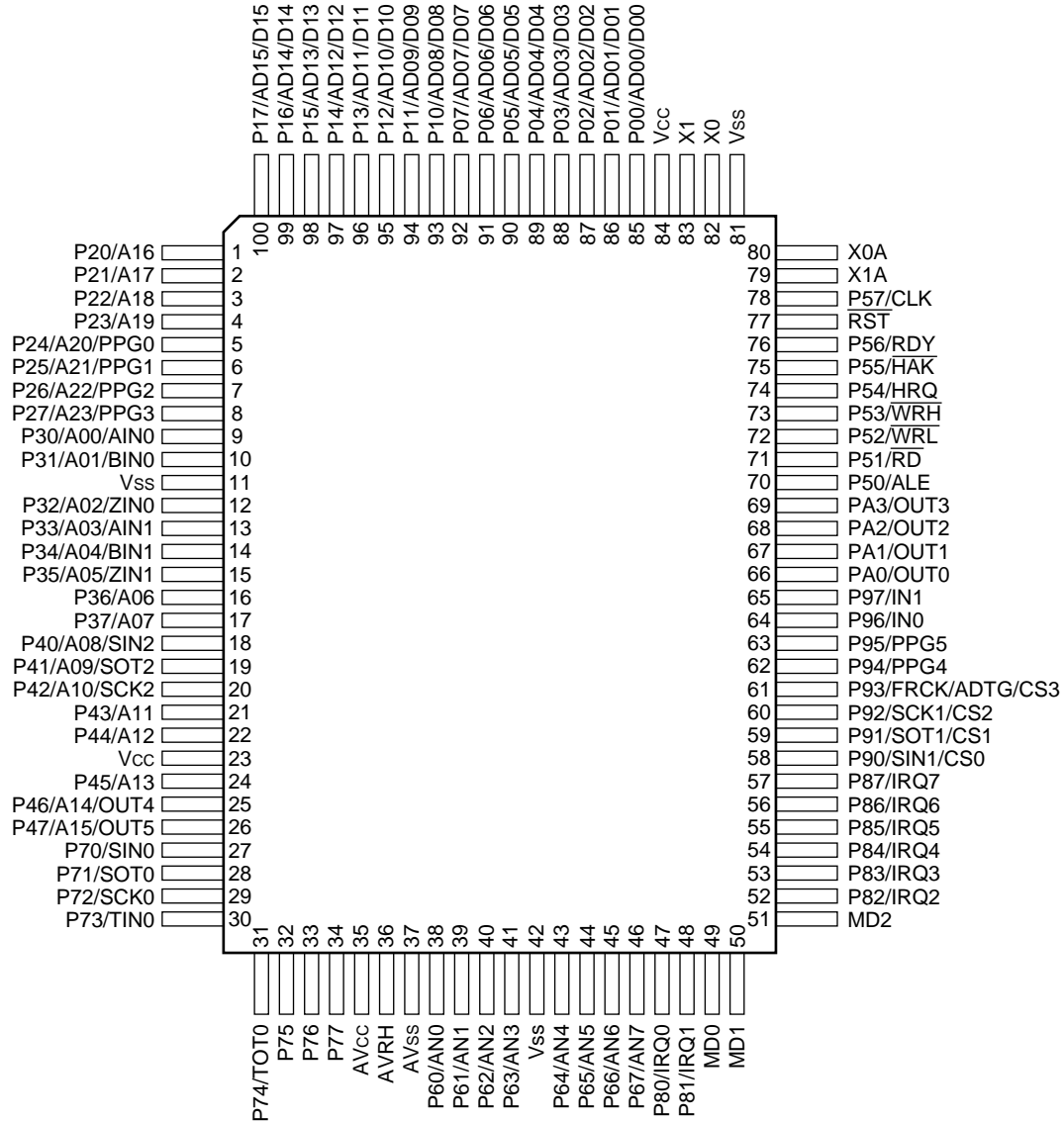

(FPT-100P-M06)

MB90482

■ PIN DESCRIPTIONS (IC72)

Pin No.		Pin name	Circuit type	Function
LQFP*1	QFP*2			
80	82	X0	A	Oscillator pin
81	83	X1	A	Oscillator pin
78	80	X0A	A	32 kHz oscillator pin
77	79	X1A	A	32 kHz oscillator pin
75	77	\overline{RST}	B	Reset input pin
83 to 90	85 to 92	P00 to P07	C (CMOS)	This is a general purpose I/O port. A setting in the pull-up resistance setting register (RDR0) can be used to apply pull-up resistance (RD00-RD07 = "1") . (Disabled when pin is set for output.)
		AD00 to AD07		In multiplex mode, these pins function as the external address/ data bus low I/O pins.
		D00 to D07		In non-multiplex mode, these pins function as the external data bus low output pins.
91 to 98	93 to 100	P10 to P17	C (CMOS)	This is a general purpose I/O port. A setting in the pull-up resistance setting register (RDR1) can be used to apply pull-up resistance (RD10-RD17 = "1") . (Disabled when pin is set for output.)
		AD08 to AD15		In multiplex mode, these pins function as the external address/ data bus high I/O pins.
		D08 to D15		In non-multiplex mode, these pins function as the external data bus high output pins.
99, 100, 1,2	1 to 4	P20 to P23	E (CMOS/H)	This is a general purpose I/O port. When the bits of external address output control register (HACR) are set to "1" in external bus mode, these pins function as general purpose I/O ports.
		A16 to A19		When the bits of external address output control register (HACR) are set to "0" in multiplex mode, these pins function as address high output pins (A16-A19).
		A16 to A19		When the bits of external address output control register (HACR) are set to "0" in non-multiplex mode, these pins function as address high output pins (A16-A19).
3 to 6	5 to 8	P24 to P27	E (CMOS/H)	This is a general purpose I/O port. When the bits of external address output control register (HACR) are set to "1" in external bus mode, these pins function as general purpose I/O ports.
		A20 to A23		When the bits of external address output control register (HACR) are set to "0" in multiplex mode, these pins function as address high output pins (A20-A23).
		A20 to A23		When the bits of external address output control register (HACR) are set to "0" in non-multiplex mode, these pins function as address high output pins (A20-A23).
		PPG0 to PPG3		PPG timer output pins.

(Continued)

MB90482

Pin No.		Pin name	Circuit type	Function
LQFP*1	QFP*2			
7	9	P30	E (CMOS/H)	This is a general purpose I/O port.
		A00		In non-multiplex mode, this pin functions as an external address pin.
		AIN0		8/16-bit up/down timer input pin (channel 0) .
8	10	P31	E (CMOS/H)	This is a general purpose I/O port.
		A01		In non-multiplex mode, this pin functions as an external address pin.
		BIN0		8/16-bit up/down counter input pin (channel0) .
10	12	P32	E (CMOS/H)	This is a general purpose I/O port.
		A02		In non-multiplex mode, this pin functions as an external address pin.
		ZIN0		8/16-bit up/down counter input pin (channel 0)
11	13	P33	E (CMOS/H)	This is a general purpose I/O port.
		A03		In non-multiplex mode, this pin functions as an external address pin.
		AIN1		8/16-bit up/down counter input pin (channel 1) .
12	14	P34	E (CMOS/H)	This is a general purpose I/O port.
		A04		In non-multiplex mode, this pin functions as an external address pin.
		BIN1		8/16-bit up/down counter input pin (channel 1) .
13	15	P35	E (CMOS/H)	This is a general purpose I/O port.
		A05		In non-multiplex mode, this pin functions as an external address pin.
		ZIN1		8/16-bit up/down counter input pin (channel 1)
14 15	16 17	P36, P37 A06, A07	D*3 (CMOS)	This is a general purpose I/O port. In non-multiplex mode, this pin functions as an external address pin.
16	18	P40	G (CMOS/H)	This is a general purpose I/O port.
		A08		In non-multiplex mode, this pin functions as an external address pin.
		SIN2		Simple serial I/O input pin.
17	19	P41	F (CMOS)	This is a general purpose I/O port.
		A09		In non-multiplex mode, this pin functions as an external address pin.
		SOT2		Simple serial I/O output pin.
18	20	P42	G (CMOS/H)	This is a general purpose I/O port.
		A10		In non-multiplex mode, this pin functions as an external address pin.
		SCK2		Simple serial I/O clock input/output pin.

(Continued)

MB90482

Pin No.		Pin name	Circuit type	Function
LQFP*1	QFP*2			
19 20	21 22	P43, P44	F (CMOS)	This is a general purpose I/O port.
		A11, A12		In non-multiplex mode, this pin functions as an external address pin.
22	24	P45	F*4 (CMOS)	This is a general purpose I/O port.
		A13		In non-multiplex mode, this pin functions as an external address pin.
23 24	25 26	P46, P47	F (CMOS)	This is a general purpose I/O port.
		A14, A15		In non-multiplex mode, this pin functions as an external address pin.
		OUT4/OUT5		Output compare event output pins.
68	70	P50	D (CMOS)	This is a general purpose I/O port. In external bus mode, this pin functions as the ALE pin.
		ALE		In external bus mode, this pin functions as the address load enable (ALE) signal pin.
69	71	P51	D (CMOS)	This is a general purpose I/O port. In external bus mode, this pin functions as the \overline{RD} pin.
		\overline{RD}		In external bus mode, this pin functions as the read strobe output (\overline{RD}) signal pin.
70	72	P52	D (CMOS)	This is a general purpose I/O port. In external bus mode, when the WRE pin in the EPCR register is set to "1", this pin functions as the \overline{WRL} pin.
		\overline{WRL}		In external bus mode, this pin functions as the lower data write strobe output (\overline{WRL}) pin. When the WRE bit in the EPCR register is set to "0", this pin functions as a general purpose I/O port.
71	73	P53	D (CMOS)	This is a general purpose I/O port. In external bus mode with 16-bit bus width, when the WRE bit in the EPCR register is set to "1", this pin functions as the \overline{WRH} pin.
		\overline{WRH}		In external bus mode with 16-bit bus width, this pin functions as the upper data write strobe output (\overline{WRH}) pin. When the WRE bit in the EPCR register is set to "0", this pin functions as a general purpose I/O port.
72	74	P54	D (CMOS)	This is a general purpose I/O port. In external bus mode, when the HDE bit in the EPCR register is set to "1", this pin functions as the HRQ pin.
		HRQ		In external bus mode, this pin functions as the hold request input (HRQ) pin. When the HDE bit in the EPCR register is set to "0", this pin functions as a general purpose I/O port.
73	75	P55	D (CMOS)	This is a general purpose I/O port. In external bus mode, when the HDE bit in the EPCR register is set to "1", this pin functions as the \overline{HAK} pin.
		\overline{HAK}		In external bus mode, this pin functions as the hold acknowledge (\overline{HAK}) pin. When the HDE bit in the EPCR register is set to "0", this pin functions as a general purpose I/O port.

(Continued)

MB90482

Pin No.		Pin name	Circuit type	Function
LQFP*1	QFP*2			
74	76	P56	D (CMOS)	This is a general purpose I/O port. In external bus mode, when the RYE bit in the EPCR register is set to "1", this pin functions as the RDY pin.
		RDY		In external bus mode, this pin functions as the external ready (RDY) input pin. When the RYE bit in the EPCR register is set to "0", this pin functions as a general purpose I/O port.
76	78	P57	D (CMOS)	This is a general purpose I/O port. In external bus mode, when the CKE bit in the EPCR register is set to "1", this pin functions as the CLK pin.
		CLK		In external bus mode, this pin functions as the machine cycle clock (CLK) output pin. When the CKE bit in the EPCR register is set to "0", this pin functions as a general purpose I/O port.
36 to 39	38 to 41	P60 to P63	H (CMOS)	These are general purpose I/O ports.
		AN0 to AN3		These are the analog input pins.
41 to 44	43 to 46	P64 to P67	H (CMOS)	These are general purpose I/O ports.
		AN4 to AN7		These are the analog input pins.
25	27	P70	G (CMOS/H)	This is a general purpose I/O port.
		SIN0		This is the UART data input pin.
26	28	P71	F (CMOS)	This is a general purpose I/O port.
		SOT0		This is the UART data output pin.
27	29	P72	G (CMOS/H)	This is a general purpose I/O port.
		SCK0		This is the UART clock I/O pin.
28	30	P73	G (CMOS/H)	This is a general purpose I/O port.
		TIN0		This is the 16-bit reload timer event input pin.
29	31	P74	F (CMOS)	This is a general purpose I/O port.
		TOT0		This is the 16-bit reload timer output pin.
30	32	P75	F*4 (CMOS)	This is a general purpose I/O port.
31	33	P76	F*5 (CMOS)	This is a general purpose I/O port.
32	34	P77	F*5 (CMOS)	This is a general purpose I/O port.
45, 46	47, 48	P80, P81	E (CMOS/H)	These are general purpose I/O ports.
		IRQ0, IRQ1		External interrupt input pins.
50 to 55	52 to 57	P82 to P87	E (CMOS/H)	These are general purpose I/O ports.
		IRQ2 to IRQ7		External interrupt input pins.

(Continued)

MB90482

(Continued)

Pin No.		Pin name	Circuit type	Function
LQFP*1	QFP*2			
56	58	P90	E (CMOS/H)	This is a general purpose I/O port.
		SIN1		Simple serial I/O data input pin.
		CS0		Chip select 0.
57	59	P91	D (CMOS)	This is a general purpose I/O port.
		SOT1		Simple serial I/O data output pin.
		CS1		Chip select 1.
58	60	P92	E (CMOS/H)	This is a general purpose I/O port.
		SCK1		Simple serial I/O data input/output pin.
		CS2		Chip select 2.
59	61	P93	E (CMOS/H)	This is a general purpose I/O port.
		FRCK		When the free run timer is in use, this pin functions as the external clock input pin.
		ADTG		When the A/D converter is in use, this pin functions as the external trigger input pin.
		CS3		Chip select 3.
60	62	P94	D (CMOS)	This is a general purpose I/O port.
		PPG4		PPG timer output pin.
61	63	P95	D (CMOS)	This is a general purpose I/O port.
		PPG5		PPG timer output pin.
62	64	P96	E (CMOS/H)	This is a general purpose I/O port.
		IN0		Input capture channel 0 trigger input pin.
63	65	P97	E (CMOS/H)	This is a general purpose I/O port.
		IN1		Input capture channel 1 trigger input pin.
64 to 67	66 to 69	PA0 to PA3	D (CMOS)	These are general purpose I/O ports.
		OUT0 to OUT3		Output compare event output pins.
33	35	AV _{cc}	—	A/D converter power supply pin.
34	36	AV _{RH}	—	A/D converter external reference voltage supply pin.
35	37	AV _{ss}	—	A/D converter power supply pin.
47 to 49	49 to 51	MD0 to MD2	J (CMOS/H)	Operating mode selection input pins.
21, 82	23, 84	V _{cc}	—	3.3 V ± 0.3 V power supply pins (V _{cc3}) .
9, 40, 79	11, 42, 81	V _{ss}	—	Power supply input pins (GND) .

*1 : LQFP : FPT-100P-M05

*2 : QFP : FPT-100P-M06

*3 : The circuit type of MB90V480 is E (CMOS/H).

*4 : The circuit type of MB90V480 is G (CMOS/H).

*5 : The circuit type of MB90V480 is I (NMOS/H)

■ PIN ASSIGNMENT (74HCU04AFN : IC71,72,76)

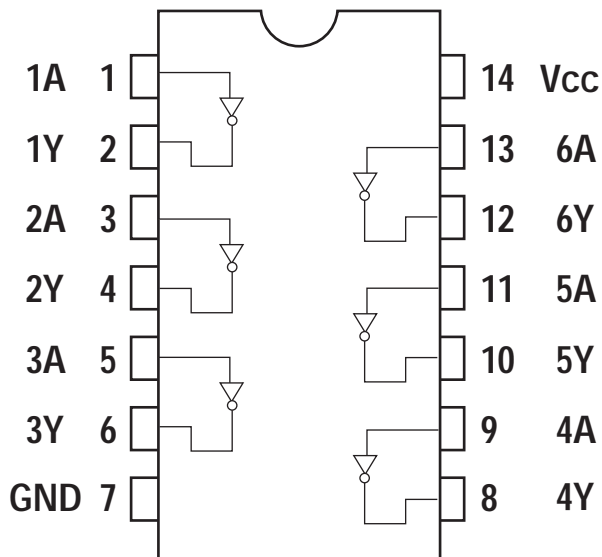

■ LOGIC SYMBOL

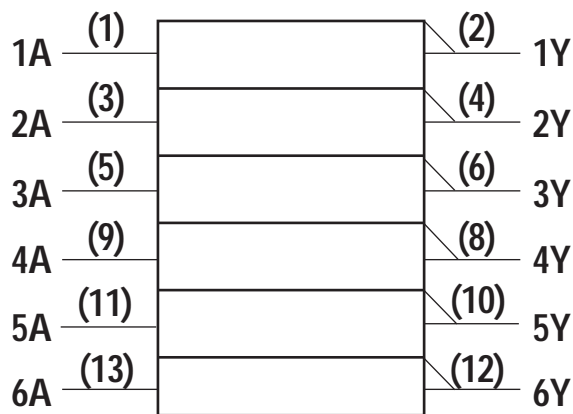

■ TRUTH TABLE

A	Y
L	H
H	L



NJM2068

LOW-NOISE DUAL OPERATIONAL AMPLIFIER

GENERAL DESCRIPTION

The NJM2068 is a high performance, low noise dual operational amplifier. This amplifier features popular pin-out, superior noise performance, and superior total harmonic distortion. This amplifier also features guaranteed noise performance with substantially higher gain-bandwidth product and slew rate which far exceeds that of the 4558 type amplifier. The specially designed low noise input transistors allow the NJM2068 to be used in very low noise signal processing applications such as audio preamplifiers and servo error amplifier.

FEATURES

- Operating Voltage (±4V ~ ±18V)
- Low Total Harmonic Distortion (0.001% typ.)
- Low Noise Voltage (FLAT+JISA, 0.56 μV typ.)
- High Slew Rate (6V/μs typ.)
- Unity Gain Bandwidth (27MHz @f=10kHz)
- Package Outline DIP8, DMP8, SIP8, SSOP8
- Bipolar Technology

PACKAGE OUTLINE

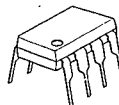

NJM2068D



NJM2068M



NJM2068V

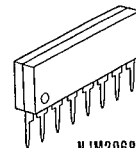

NJM2068L

4

PIN CONFIGURATION

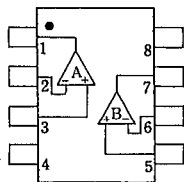

NJM2068D
NJM2068M
NJM2068V

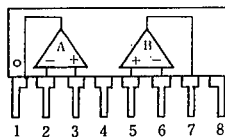

NJM2068L

PIN FUNCTION

1. A OUTPUT
2. A- INPUT
3. A+ INPUT
4. V-
5. B+ INPUT
6. B- INPUT
7. B OUTPUT
8. V+

EQUIVALENT CIRCUIT (1/2 Shown)

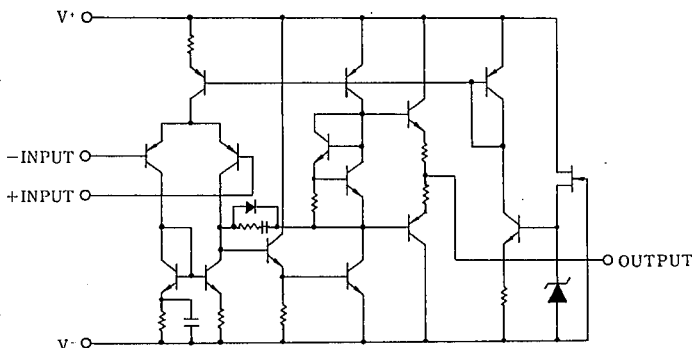

PIN ASSIGNMENT.(CS493263)

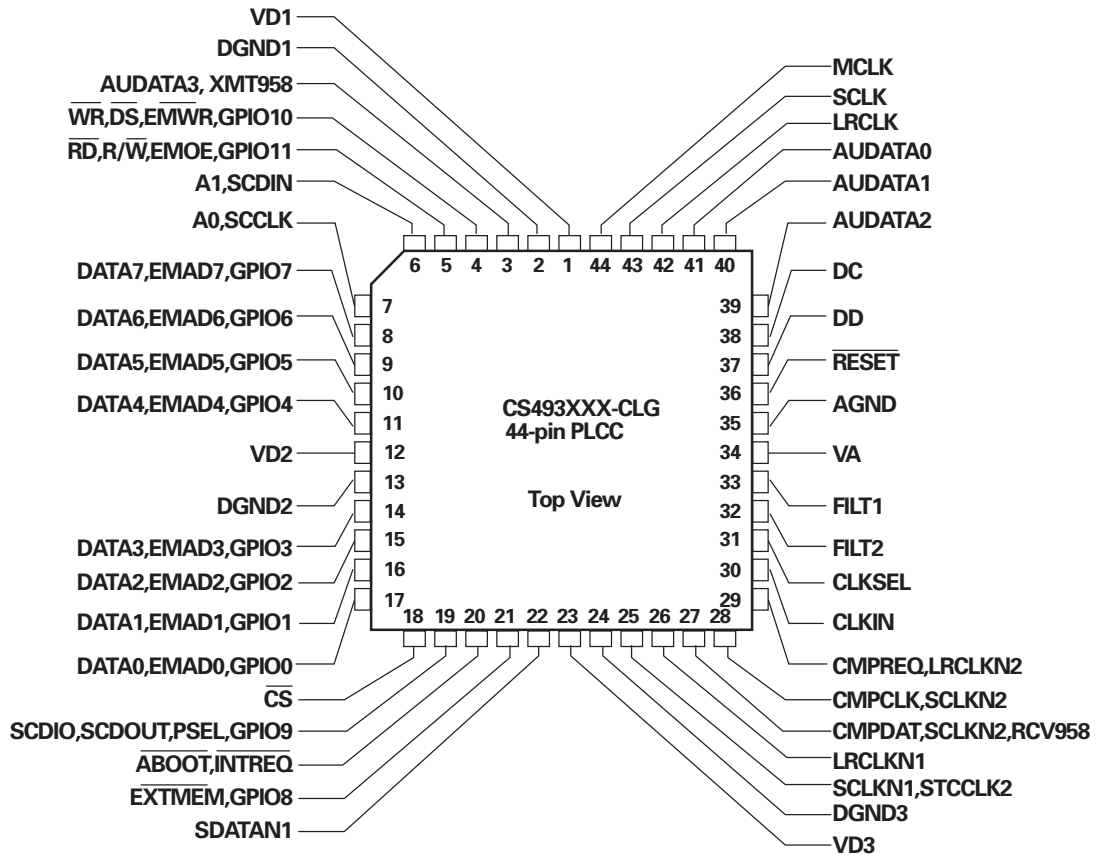

(TOP VIEW)

BLOCK DIAGRAM(CS493263)

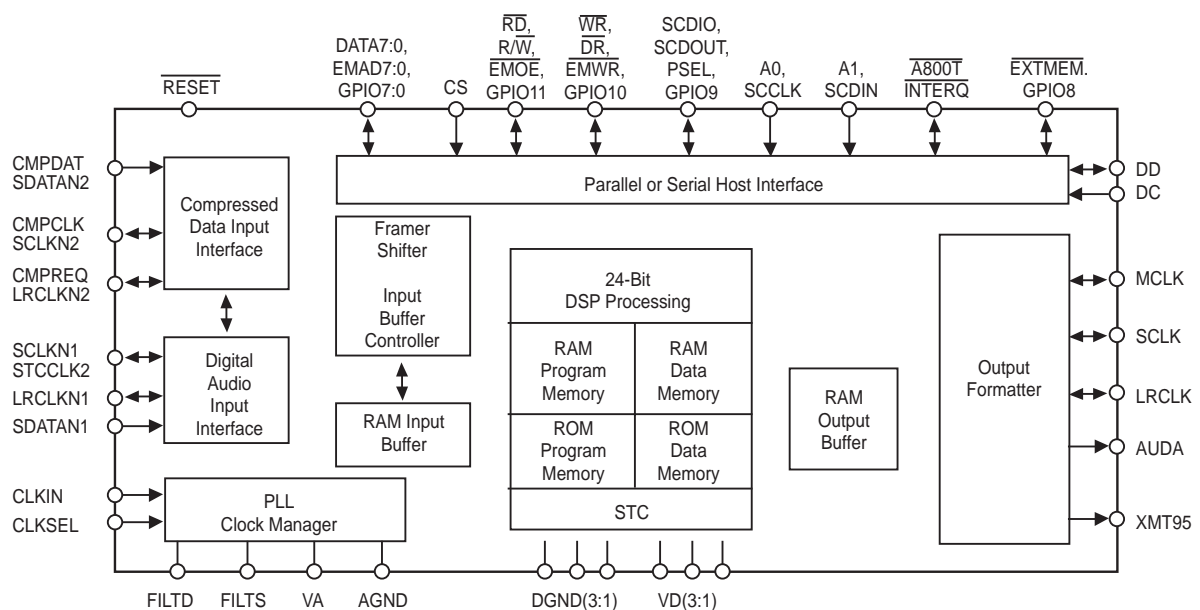

AUDIO DSP (CS493263 - CLG : IC75)

PIN No.	Pin Name	I/O	Function
1,12,23	+VD1	-	Digital Power supply. Normally +2.5v
2,13,24	DGND	-	Digital Ground
3	AUD3	O	SPDIF transmitter output/Digital audio output(N.C)
4	WR	I	Host write strobe pin(connected to GND with an external resistor)
5	RD	I	Host parallel output enable pin(pulled up with an external resistor)
6	CS_DA	I	SPI Serial data input pin
7	CS_CK	I	Serial control clock input pin
8	EMAD7	I/O	Serial data IN/OUTPUT pins(pulled up with an external resistor)
9	EMAD6	I/O	
10	EMAD5	I/O	
11	EMAD4	I/O	
14	EMAD3	I/O	
15	EMAD2	I/O	
16	EMAD1	I/O	
17	EMAD0	I/O	
18	CS_CE	I	Host parallel chip select pin
19	SCDIO(AK_DOUT)	O	Serial control port data ouput pin
20	INTREQ	O	Control port interrupt request output pin
21	EXTMEM	I/O	External Memory Chip Selector(pulled up with an external resistor)
22	SDATAN1(SDI)	I	PCM audio data input number 1 pin
25	SCLKN1(BICK)	I	PCM audio input bit clock pin
26	LRCLKN1(LRCK)	I	PCM audio input sample rate clock pin
27	CMPDAT(SDI)	I	PCM audio data input number 2 pin
28	CMPCLK(BICK)	I	PCM audio input bit clock pin
29	CREQ(LRCK)	I	PCM audio input sample rate clock pin
30	CLKIN(XIN)	I	Master clock input(used external clock)
31	CLKSEL(GND)	I	DSP clock mode select pin: connect the GND
32	FILT1		Connects to an external filter for the on-chip phase-locked loop
33	FILT1		Connects to an external filter for the on-chip phase-locked loop
34	+2.5V	-	Analog Power supply for clock generator . Normally +2.5V
35	AGND	-	Analog ground supply for clock generator PLL.
36	RESET(CS_RST)	I	Master reset input pin
37	DBDATA	-	Reserved pin and should be pulled up with an external resistor.
38	DBCLK	-	Reserved pin and should be pulled up with an external resistor.
39	AUD2(SDO2)	O	PCM multi-format digital-audio data ouput2 pin
40	AUD1(SDO1)	O	PCM multi-format digital-audio data ouput1 pin
41	AUD0(SDO0)	O	PCM multi-format digital-audio data ouput0 pin
42	LRCLK	I	Audio output sample rate clock pin
43	SCLK(BICK)	I	Audio ouput bit clock pin
44	MCLK	I	Audio master clock output pin

74AC04 • 74ACT04

Hex Inverter

74ACT04SC : IC52,75,83,84

General Description

The AC/ACT04 contains six inverters.

Features

- I_{CC} reduced by 50% on 74AC only
- Outputs source/sink 24 mA
- ACT04 has TTL-compatible inputs

Ordering Code:

Order Number	Package Number	Package Description
74AC04SC	M14A	14-Lead Small Outline Integrated Circuit (SOIC), JEDEC MS-120, 0.150" Narrow Body
74AC04SJ	M14D	14-Lead Small Outline Package (SOP), EIAJ TYPE II, 5.3mm Wide
74AC04MTC	MTC14	14-Lead Thin Shrink Small Outline Package (TSSOP), JEDEC MO-153, 4.4mm Wide
74AC04PC	N14A	14-Lead Plastic Dual-In-Line Package (PDIP), JEDEC MS-001, 0.300" Wide
74ACT04SC	M14A	14-Lead Small Outline Integrated Circuit (SOIC), JEDEC MS-120, 0.150" Narrow Body
74ACT04MTC	MTC14	14-Lead Thin Shrink Small Outline Package (TSSOP), JEDEC MO-153, 4.4mm Wide
74ACT04PC	N14A	14-Lead Plastic Dual-In-Line Package (PDIP), JEDEC MS-001, 0.300" Wide

Device also available in Tape and Reel. Specify by appending suffix letter "X" to the ordering code. (PC not available in Tape and Reel.)

Logic Symbol

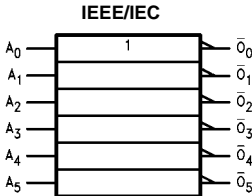

Connection Diagram

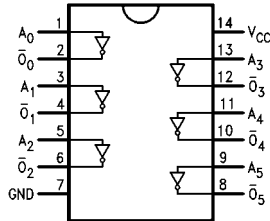

Pin Descriptions

Pin Names	Description
A_n	Inputs
\bar{O}_n	Outputs

	= Target Spec =	AK4358
192kHz 24-Bit 8ch DAC with DSD Input		

GENERAL DESCRIPTION

The AK4358 is eight channels 24bit DAC corresponding to digital audio system. Using AKM's advanced multi bit architecture for its modulator the AK4358 delivers a wide dynamic range while preserving linearity for improved THD+N performance. The AK4358 has full differential SCF outputs, removing the need for AC coupling capacitors and increasing performance for systems with excessive clock jitter. The AK4358 accepts 192kHz PCM data and 1-Bit DSD data, ideal for a wide range of applications including DVD-Audio and SACD.

FEATURES

- Sampling Rate Ranging from 8kHz to 192kHz
- 24Bit 8 times Digital Filter with Slow roll-off option
- THD+N: -94dB
- DR, S/N: 114dB
- High Tolerance to Clock Jitter
- Low Distortion Differential Output
- DSD Data input available
- Channel Independent Digital De-emphasis for 32, 44.1 & 48kHz sampling
- Zero Detect function
- Channel Independent Digital Attenuator with soft-transition (3 Speed mode)
- Soft Mute
- 3-wire Serial and I²C Bus μ P I/F for mode setting
- I/F format: MSB justified, LSB justified (16bit, 20bit, 24bit), I²S, TDM or DSD
- Master clock: 256fs, 384fs, 512fs or 768fs (PCM Normal Speed Mode)
128fs, 192fs, 256fs or 384fs (PCM Double Speed Mode)
128fs or 192fs (PCM Quad Speed Mode)
512fs or 768fs (DSD Mode)
- Power Supply: 4.75 to 5.25V
- 48pin LQFP Package

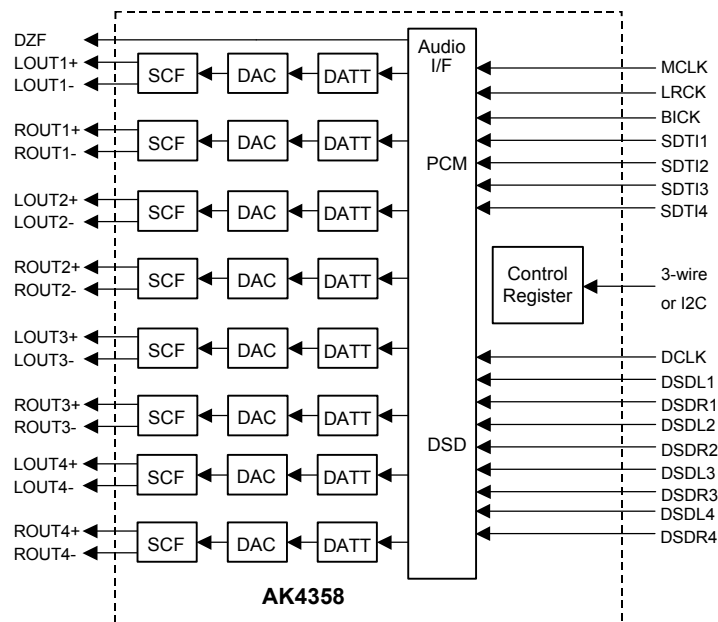

■ Ordering Guide

AK4358VQ
AKD4358

-40 ~ +85°C
Evaluation Board for AK4358

■ Pin Layout (To be determined)

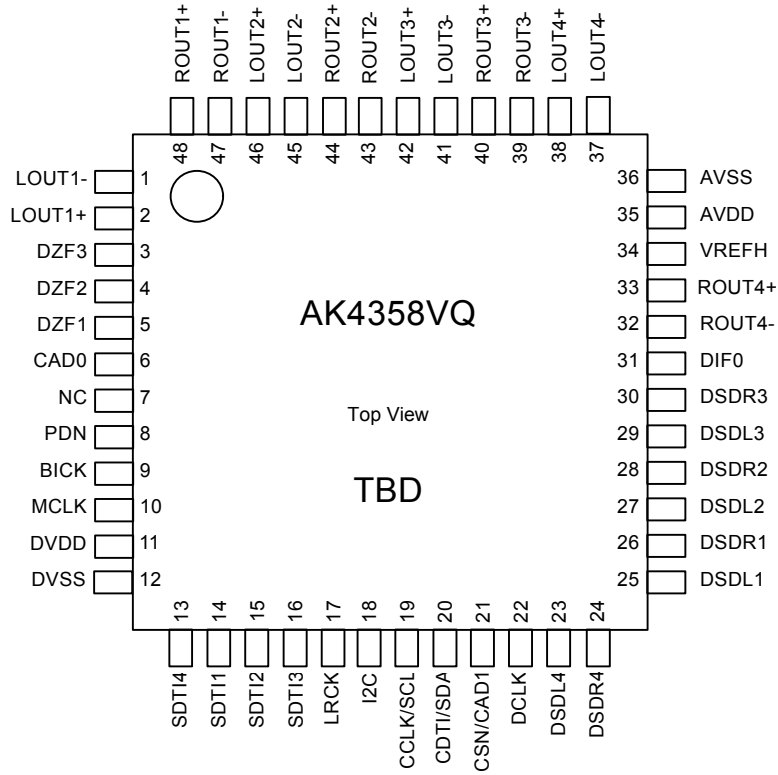

PIN/FUNCTION (TBD)

No.	Pin Name	I/O	Function
	LOUT1-	O	DAC1 Lch Negative Analog Output Pin
	LOUT1+	O	DAC1 Lch Positive Analog Output Pin
	DZF1	O	Zero Input Detect 1 Pin
	DZF2	O	Zero Input Detect 2 Pin
	DZF3	O	Zero Input Detect 3 Pin
	CAD0	I	Chip Address 0 Pin
	PDN	I	Power-Down Mode Pin When at "L", the AK4358 is in the power-down mode and is held in reset. The AK4358 should always be reset upon power-up.
	BICK	I	Audio Serial Data Clock Pin
	MCLK	I	Master Clock Input Pin An external TTL clock should be input on this pin.
	DVDD	-	Digital Power Supply Pin, +4.75~+5.25V
	DVSS	-	Digital Ground Pin
	SDTI1	I	DAC1 Audio Serial Data Input Pin
	SDTI2	I	DAC2 Audio Serial Data Input Pin
	SDTI3	I	DAC3 Audio Serial Data Input Pin
	SDTI4	I	DAC4 Audio Serial Data Input Pin
	LRCK	I	L/R Clock Pin
	I2C	I	Control Mode Select Pin "L": 3-wire Serial, "H": I ² C Bus
	CCLK/SCL	I	Control Data Clock Pin I2C = "L": CCLK (3-wire Serial), I2C = "H": SCL (I ² C Bus)
	CDTI/SDA	I/O	Control Data Input Pin I2C = "L": CDTI (3-wire Serial), I2C = "H": SDA (I ² C Bus)
	CSN/CAD1	I	Chip Select Pin I2C = "L": CSN (3-wire Serial), I2C = "H": CAD1 (I ² C Bus)
	DCLK	I	DSD Clock Pin
	DSDL1	I	DAC1 DSD Lch Data Input Pin
	DSDR1	I	DAC1 DSD Rch Data Input Pin
	DSDL2	I	DAC2 DSD Lch Data Input Pin
	DSDR2	I	DAC2 DSD Rch Data Input Pin
	DSDL3	I	DAC3 DSD Lch Data Input Pin
	DSDR3	I	DAC3 DSD Rch Data Input Pin
	DSDL4	I	DAC4 DSD Lch Data Input Pin
	DSDR4	I	DAC4 DSD Rch Data Input Pin
	DIF0	I	Audio Data Interface Format 0 Pin
	VREFH	I	Positive Voltage Reference Input Pin
	AVDD	-	Analog Power Supply Pin, +4.75~+5.25V
	AVSS	-	Analog Ground Pin
	ROUT4-	O	DAC4 Rch Negative Analog Output Pin
	ROUT4+	O	DAC4 Rch Positive Analog Output Pin
	LOUT4-	O	DAC4 Lch Negative Analog Output Pin
	LOUT4+	O	DAC4 Lch Positive Analog Output Pin
	ROUT3-	O	DAC3 Rch Negative Analog Output Pin
	ROUT3+	O	DAC3 Rch Positive Analog Output Pin
	LOUT3-	O	DAC3 Lch Negative Analog Output Pin
	LOUT3+	O	DAC3 Lch Positive Analog Output Pin
	ROUT2-	O	DAC2 Rch Negative Analog Output Pin
	ROUT2+	O	DAC2 Rch Positive Analog Output Pin
	LOUT2-	O	DAC2 Lch Negative Analog Output Pin
	LOUT2+	O	DAC2 Lch Positive Analog Output Pin
	ROUT1-	O	DAC1 Rch Negative Analog Output Pin

IC 76



= Preliminary =

AK5381

24Bit 96kHz $\Delta\Sigma$ ADC

GENERAL DESCRIPTION

The AK5381 is a stereo A/D Converter with wide sampling rate of 4kHz ~ 96kHz and is suitable for High-end audio system. The AK5381 achieves high accuracy and low cost by using Enhanced dual bit $\Delta\Sigma$ techniques. The AK5381 requires no external components because the analog inputs are single-ended. The audio interface has two formats (MSB justified, I^2S) and can correspond to many systems like music instrument and AV receiver.

FEATURES

- Stereo $\Delta\Sigma$ ADC
- On-Chip Digital Anti-Alias Filtering
- Single-ended Input
- Digital HPF for DC-Offset cancel
- S/(N+D): 96dB@5V for 48kHz
- DR: 106dB@5V for 48kHz
- S/N: 106dB@5V for 48kHz
- Sampling Rate Ranging from 4kHz to 96kHz
- Master Clock:
 - 256fs/384fs/512fs/768fs (~ 48kHz)
 - 256fs/384fs (~ 96kHz)
- Audio Interface: Master or Slave Mode selectable
- Input level: TTL/CMOS selectable
- Output format: 24bit MSB justified / I^2S selectable
- Power Supply: 4.5 ~ 5.5V (VA)
 - 2.7 ~ 5.5V (VD at 48kHz)
 - 3.0 ~ 5.5V (VD at 96kHz)
- Ta = -40 ~ 85°C
- Small 16pin TSSOP Package
- AK5380 Pin-compatible

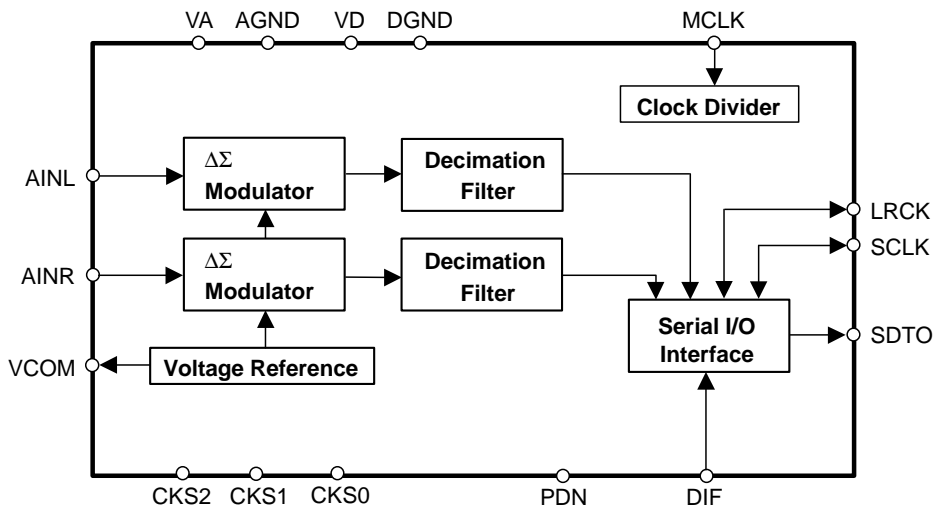

■ Ordering Guide

AK5381VT
AKD5381

-40 ~ +85°C
Evaluation Board for AK5381

16pin TSSOP (0.65mm pitch)

■ Pin Layout

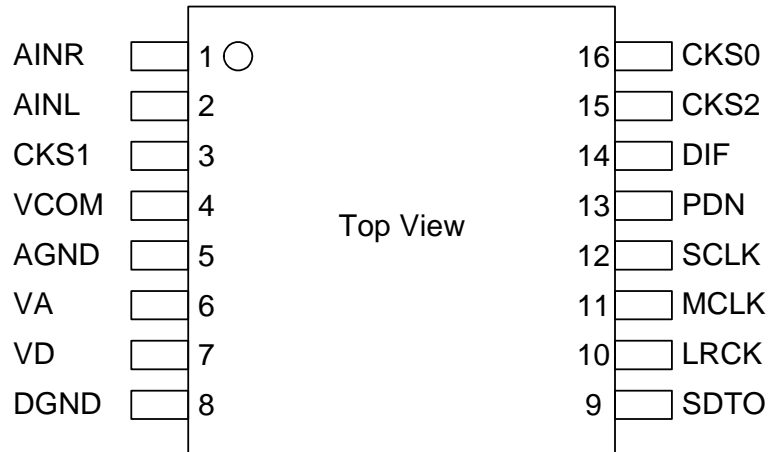

■ Compatibility with AK5380

	AK5380	AK5381
Master Mode	Not Available	Available
HPF OFF	Not Available	Available
VD (Digital Supply)	4.5 to 5.5V@fs=96kHz	3.0 to 5.5V@fs=96kHz
Pin #3	NC	CKS1
Pin #15	TTL	CKS2
Pin #16	TST	CKS0

PIN / FUNCTION

No.	Pin Name	I/O	Function
1	AINR	I	Rch Analog Input Pin
2	AINL	I	Lch Analog Input Pin
3	CKS1	I	Mode Select 1 Pin
4	VCOM	O	Common Voltage Output Pin, VA/2 Bias voltage of ADC input.
5	AGND	-	Analog Ground Pin
6	VA	-	Analog Power Supply Pin, 4.5 ~ 5.5V
7	VD	-	Digital Power Supply Pin, 2.7 ~ 5.5V(fs=4k ~ 48kHz), 3.0 ~ 5.5V(fs=48k ~ 96kHz)
8	DGND	-	Digital Ground Pin
9	SDTO	O	Audio Serial Data Output Pin “L” Output at Power-down mode.
10	LRCK	I/O	Output Channel Clock Pin “L” Output in Master Mode at Power-down mode.
11	MCLK	I	Master Clock Input Pin
12	SCLK	I/O	Audio Serial Data Clock Pin “L” Output in Master Mode at Power-down mode.
13	PDN	I	Power Down Mode Pin “H”: Power up, “L”: Power down
14	DIF	I	Audio Interface Format Pin “H” : 24bit I ² S Compatible, “L” : 24bit MSB justified
15	CKS2	I	Mode Select 2 Pin
16	CKS0	I	Mode Select 0 Pin

Note: All digital input pins should not be left floating.

HCF4053B FUNCTION DIAGRAM & PIN DESCRIPTION

INPUT EQUIVALENT CIRCUIT

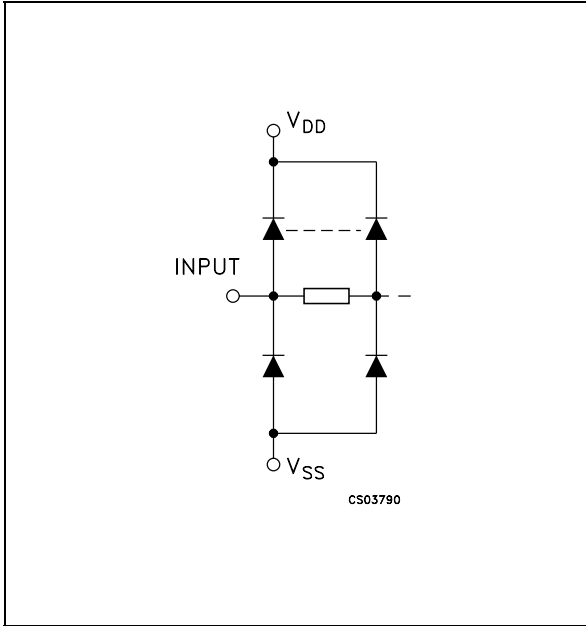

PIN DESCRIPTION (IC44,45,51,80,89)

PIN No	SYMBOL	NAME AND FUNCTION
11, 10, 9	A, B, C	Binary Control Inputs
6	INH	Inhibit Inputs
12, 13, 2, 1, 5, 3	IN/OUT	ax,ay,bx,by,cx,cy Input/Output
14	OUT/IN	ax or ay
15	OUT/IN	bx or by
4	OUT/IN	cx or cy
7	V _{EE}	Supply Voltage
8	V _{SS}	Negative Supply Voltage
16	V _{DD}	Positive Supply Voltage

TRUTH TABLE

INHIBIT	C or B or A	
0	0	ax or bx or cx
0	1	ay or by or cy
1	X	NONE

X : Don't Care

FUNCTIONAL DIAGRAM (IC44,45,51,80,89)

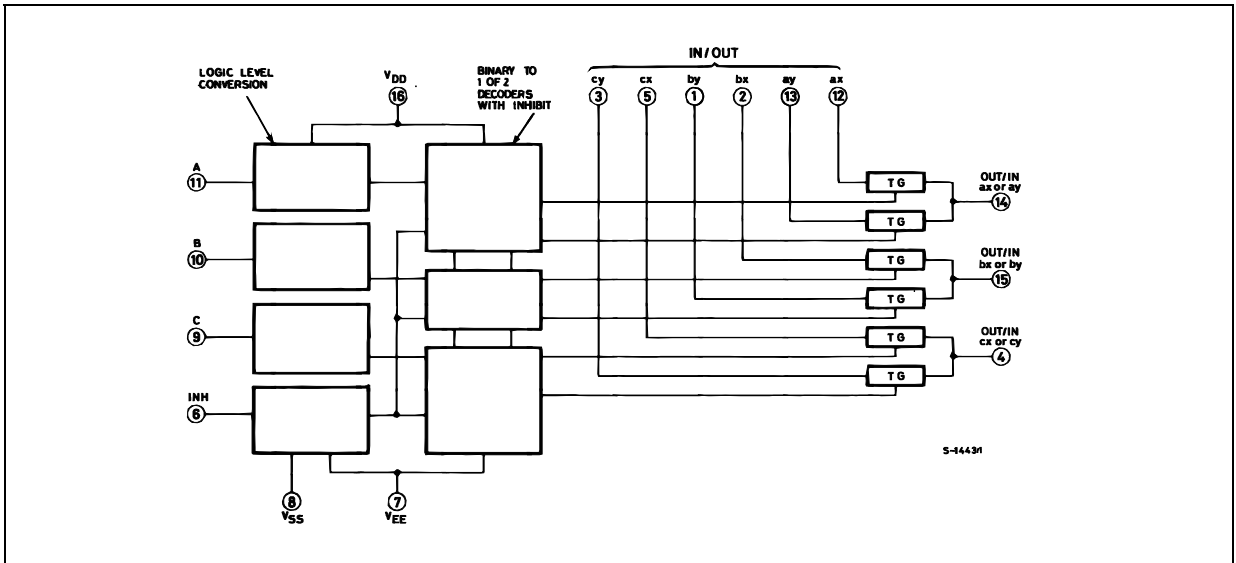

ELECTRONIC VOLUME CONTROL IC (IC40~44)

BLOCK DIAGRAM (TC9459F)

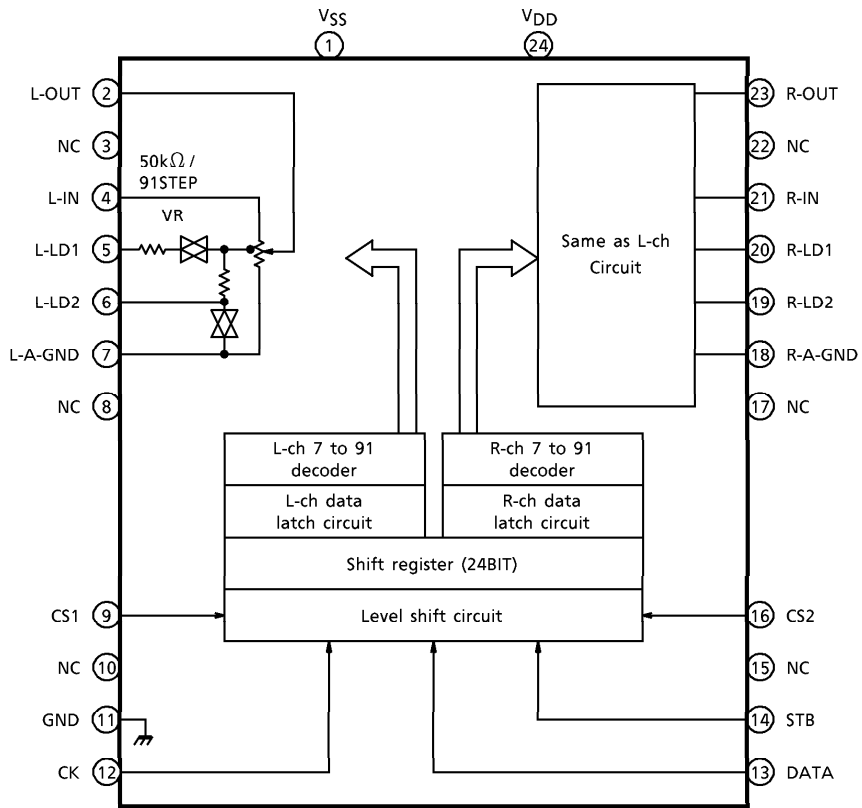

PIN DESCRIPTION

Numeral in () means the pin No. of TC9459F.

PIN No.	SYMBOL	PIN NAME	FUNCTION	REMARK										
1 (1)	V _{SS}	Negative power supply pin	When using dual power supplies <ul style="list-style-type: none"> — V_{DD} = 6.0~17V — GND = 0V — V_{SS} = -6.0~-17V When using a single power supply <ul style="list-style-type: none"> — V_{DD} = 6.0~18V — GND = V_{SS} = 0V 	—										
28 (24)	V _{DD}	Positive power supply pin												
13 (11)	GND	Digital GND pin												
3 (2)	L-OUT	Volume output pin	<ul style="list-style-type: none"> • Volume circuit 	—										
26 (23)	R-OUT													
5 (4)	L-IN	Volume input pin												
24 (21)	R-IN													
6 (5)	L-LD1	Loudness tap output pin			<table border="1" style="margin-left: auto; margin-right: auto;"> <thead> <tr> <th></th> <th>LA1</th> <th>LA2</th> </tr> </thead> <tbody> <tr> <td>LOUDNESS "ON"</td> <td>ON</td> <td>OFF</td> </tr> <tr> <td>LOUDNESS "OFF"</td> <td>OFF</td> <td>ON</td> </tr> </tbody> </table>		LA1	LA2	LOUDNESS "ON"	ON	OFF	LOUDNESS "OFF"	OFF	ON
	LA1					LA2								
LOUDNESS "ON"	ON					OFF								
LOUDNESS "OFF"	OFF					ON								
23 (20)	R-LD1													
7 (6)	L-LD2													
22 (19)	R-LD2													
8 (7)	L-A-GND	Analog GND pin												
21 (18)	R-A-GND													
10 (9)	CS1	Chip select input pin	Up to 4 chips on the same bus can be used by switching over chip select code.	—										
19 (16)	CS2													
14 (12)	CK	Clock input pin	Data transfer clock input	Low threshold value input pin										
15 (13)	DATA	Data input pin	Volume setup serial data input											
16 (14)	STB	Strobe input pin	Data write strobe input											
2 (3)	NC	No connection	—	—										
27 (22)														
4														
25														
9 (8)														
20 (17)														
11														
18														
12 (10)														
17 (15)														

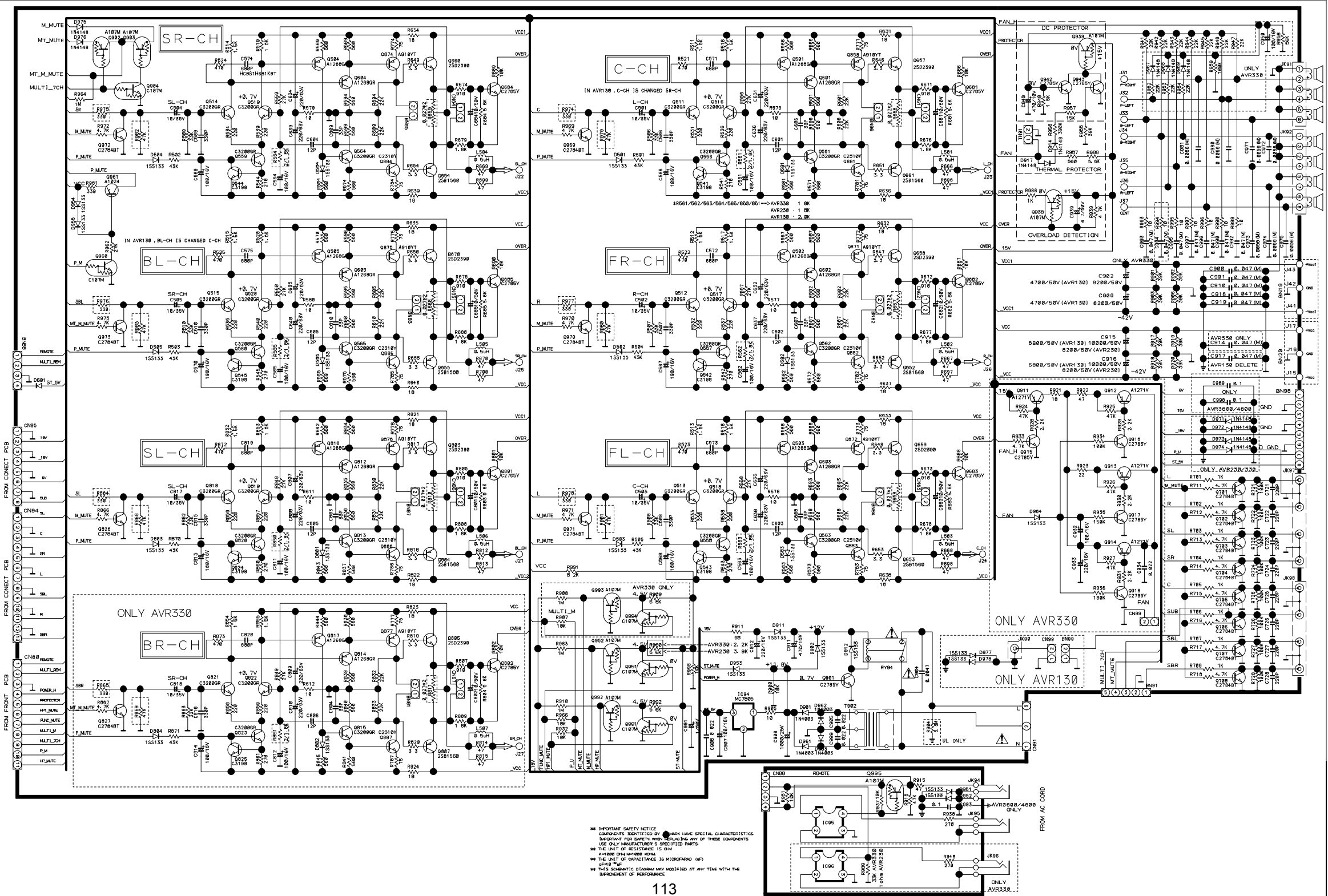

*** IMPORTANT SAFETY NOTICE
 COMPONENTS IDENTIFIED BY MARK HAVE SPECIAL CHARACTERISTICS
 ESSENTIAL FOR SAFETY WHEN REPLACING ANY OF THESE COMPONENTS
 USE ONLY MANUFACTURER'S SPECIFIED PARTS.
 ** THE UNIT OF RESISTANCE IS OHM.
 * 1000 OHMS = 1K OHMS.
 ** THE UNIT OF CAPACITANCE IS MICROFARAD (UF).
 ** 100 PF.
 *** THIS SCHEMATIC DIAGRAM MAY BE MODIFIED AT ANY TIME WITH THE
 IMPROVEMENT OF PERFORMANCE.

MAIN BOARD 1 (AMP)

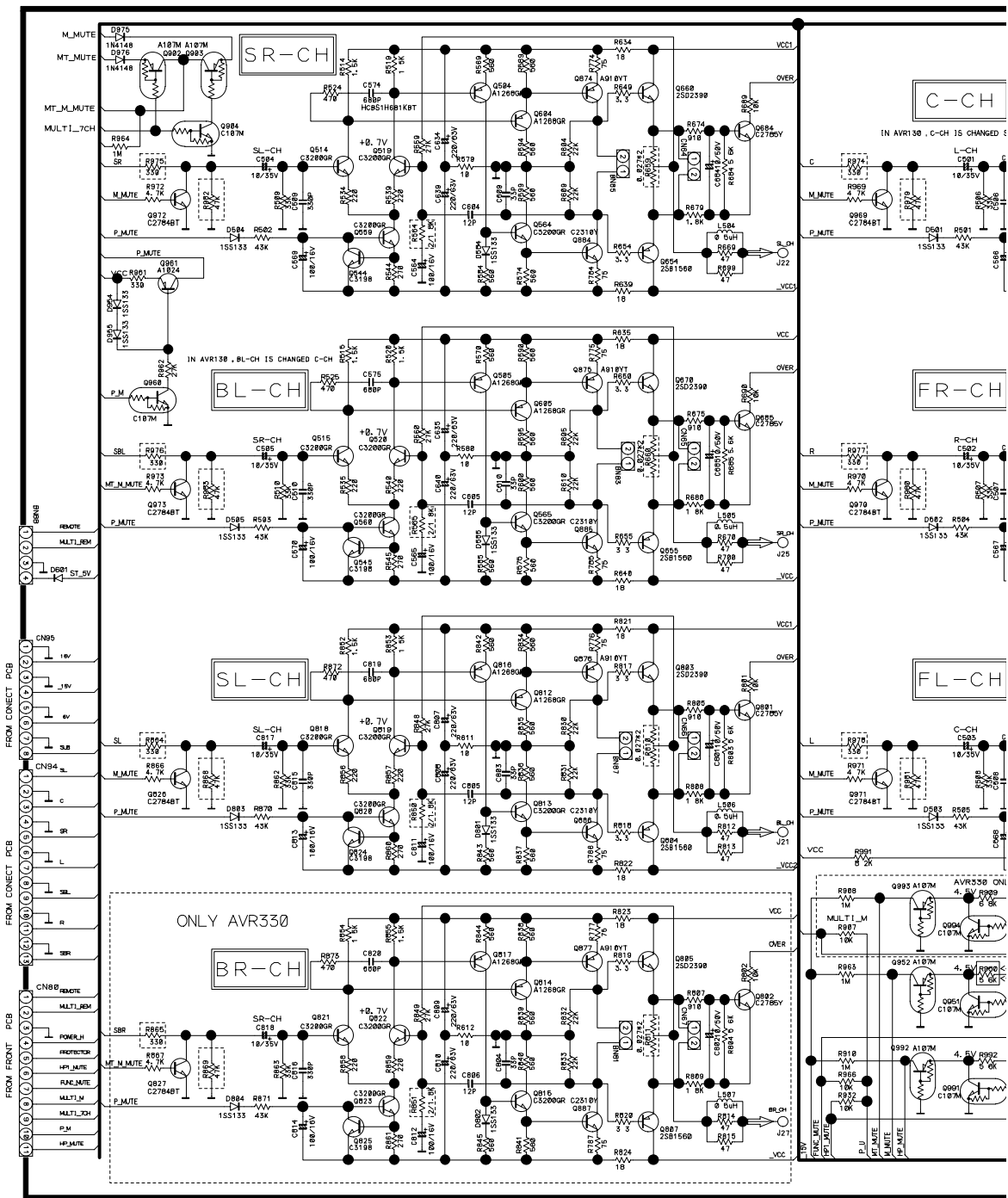

** IMPORTANT SAFETY NOTICE
 COMPONENTS IDENTIFIED BY
 HARMAN FOR SAFETY, WHEN
 USED ONLY MANUFACTURER'S SPEC
 THE UNIT OF RESISTANCE IS Ω
 K=1000 OHMS, M=1000 OHMS
 C=1000 CAPACITANCE IS μF
 ** THIS SCHEMATIC DIAGRAM MAY
 IMPROVEMENT OF PERFORMANCE

MAIN BOARD 1 (AMP)

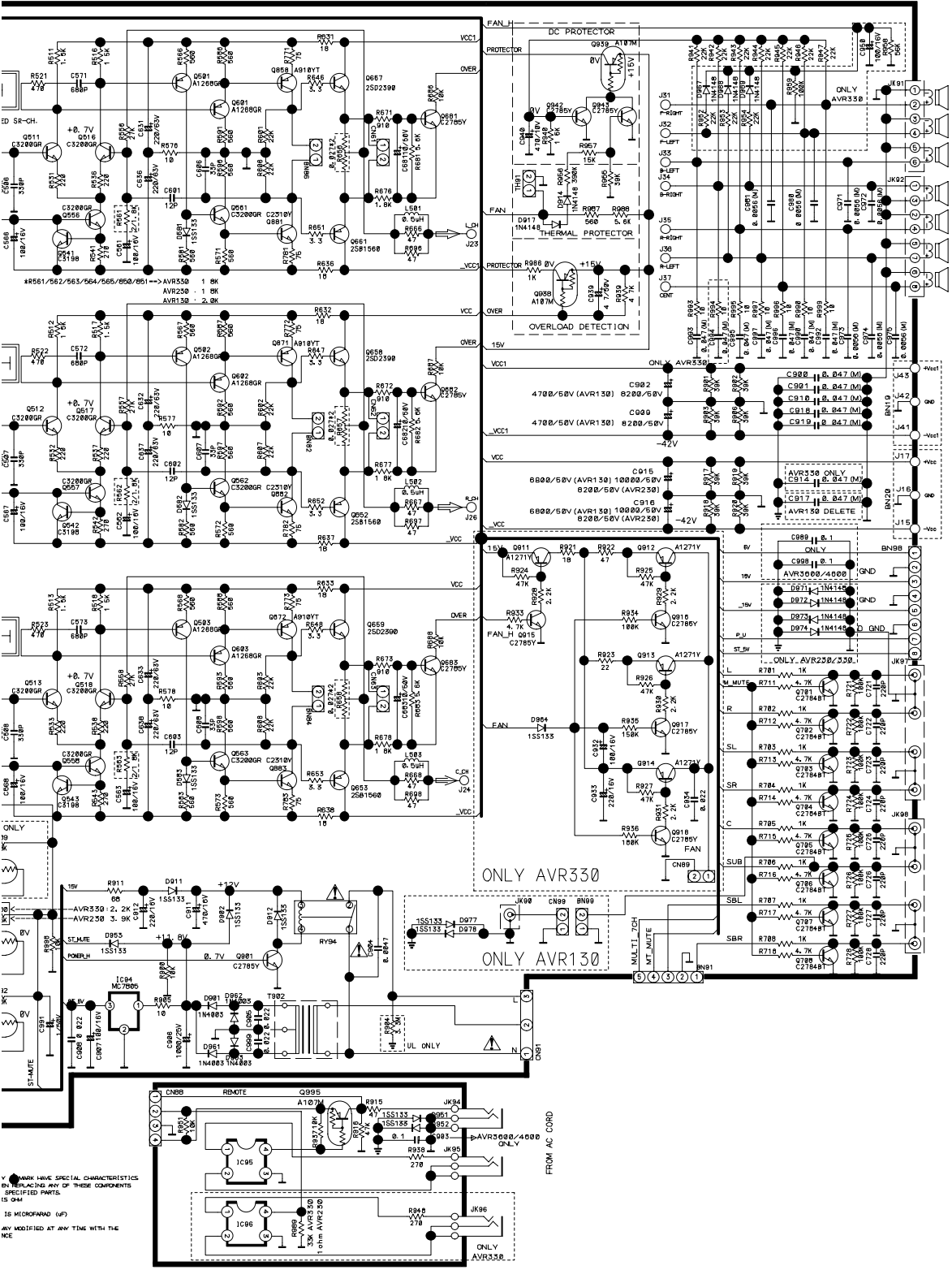

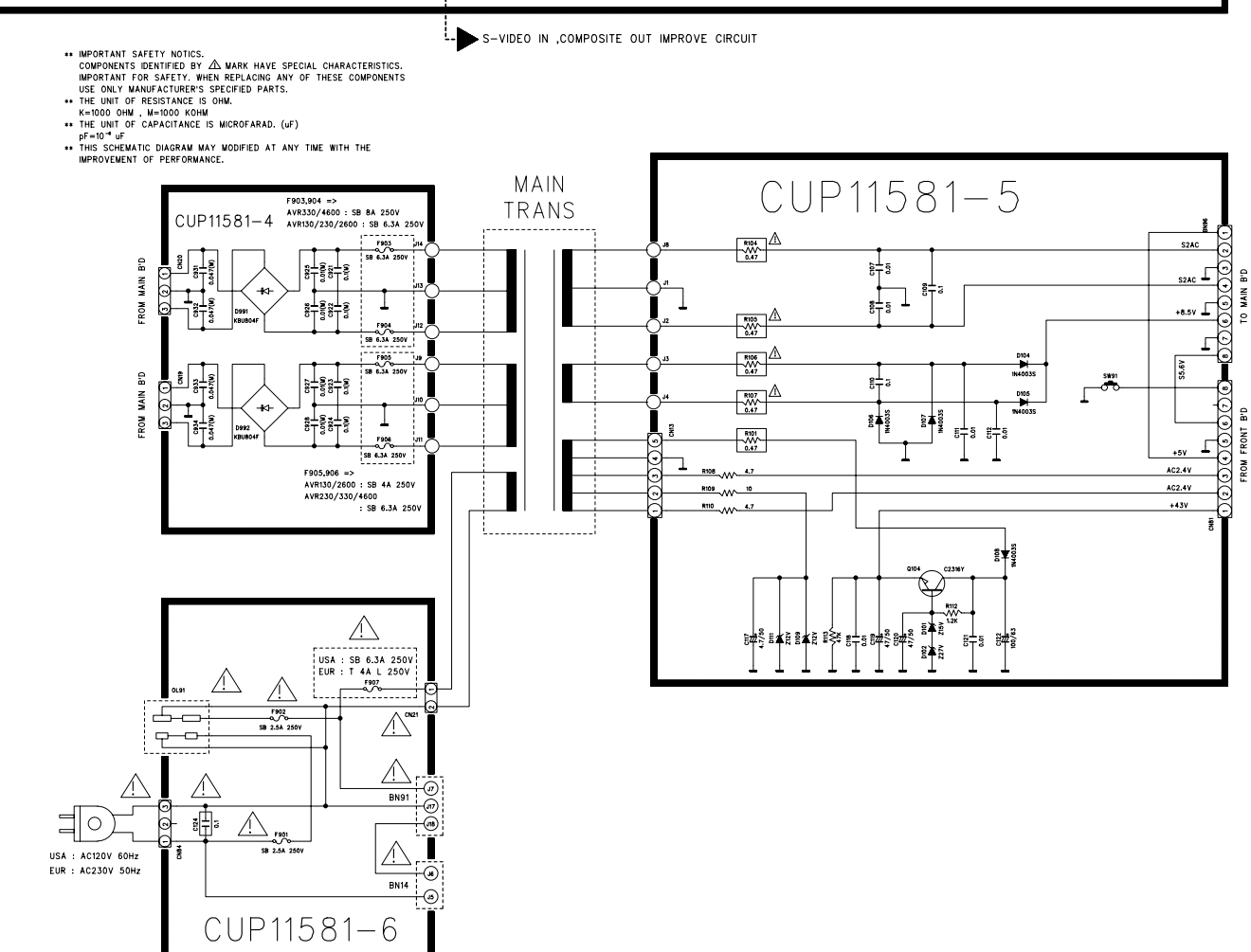
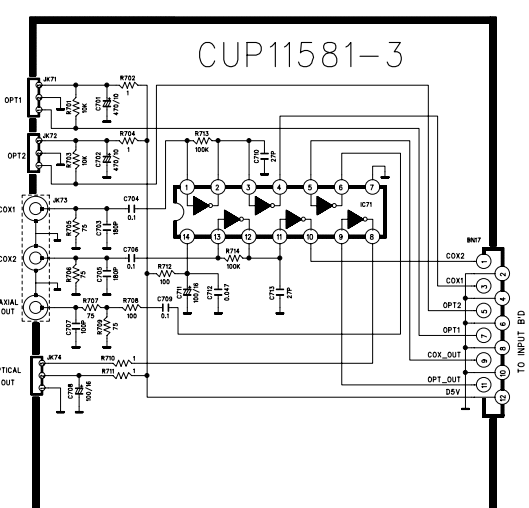
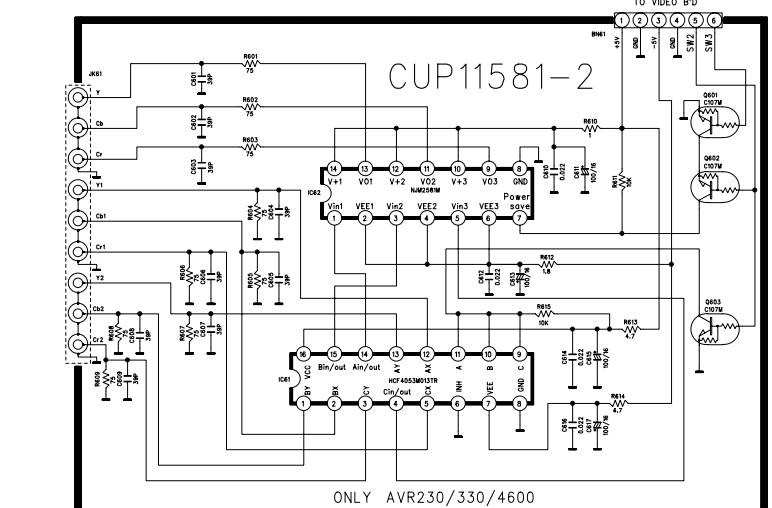
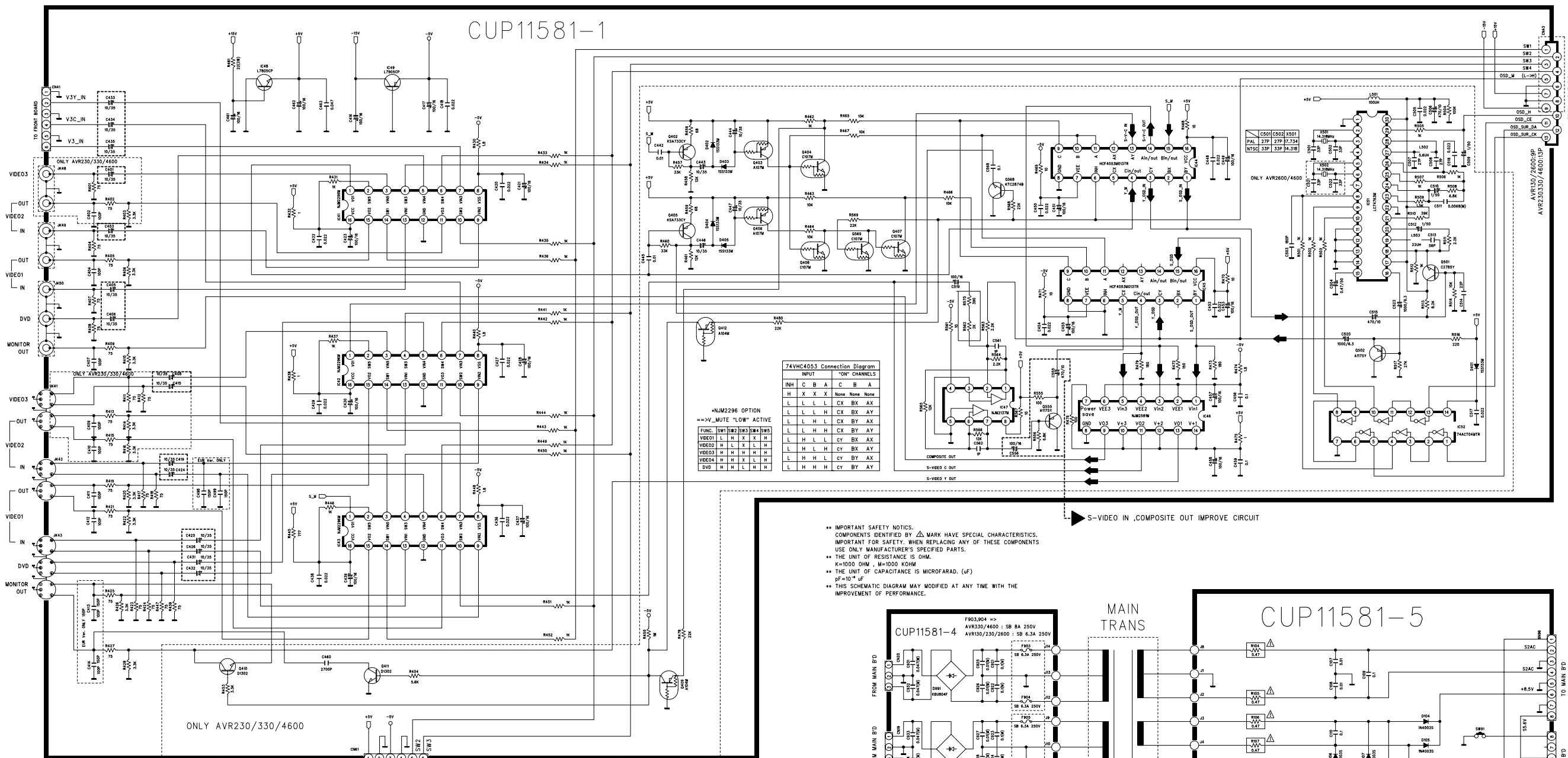

VIDEO BOARD

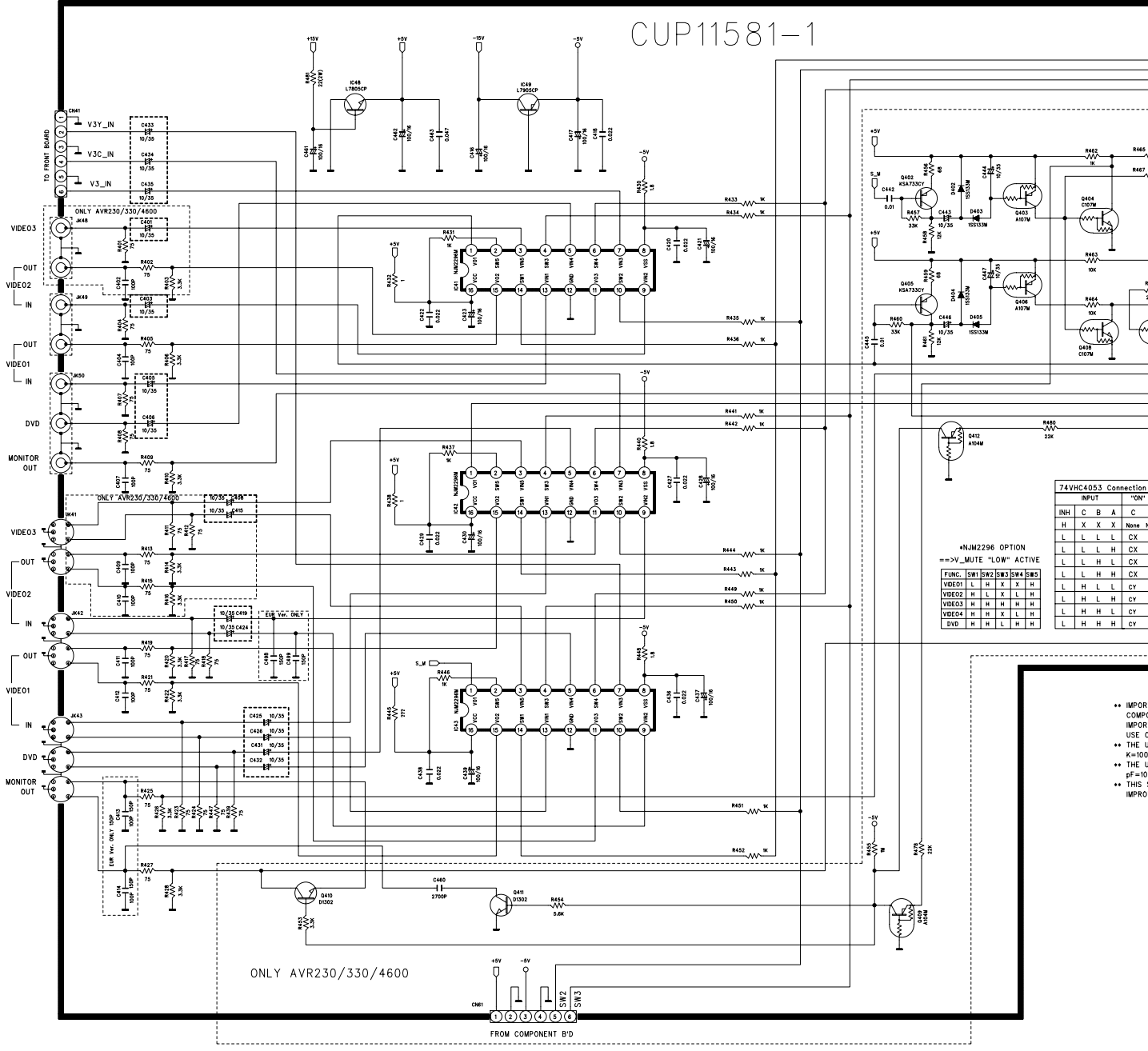

74VHC4053 Connection

INPUT	"LOW"		
INH	C	B	A
H	X	X	X
L	L	L	L
L	L	L	H
L	L	H	L
L	L	H	H
L	H	L	L
L	H	L	H
L	H	H	L
L	H	H	H

***NUM2296 OPTION**
=>V_MUTE "LOW" ACTIVE

FUNC.	SW1	SW2	SW3	SW4	SW5
VIDEO1	L	H	X	X	H
VIDEO2	H	L	X	X	L
VIDEO3	H	H	H	H	H
VIDEO4	H	H	X	L	H
DVD	H	H	L	H	H

- IMPRO COMP
- IMPRO USE 0
- THE U K=100
- THE U pF=10
- THIS : IMPRO

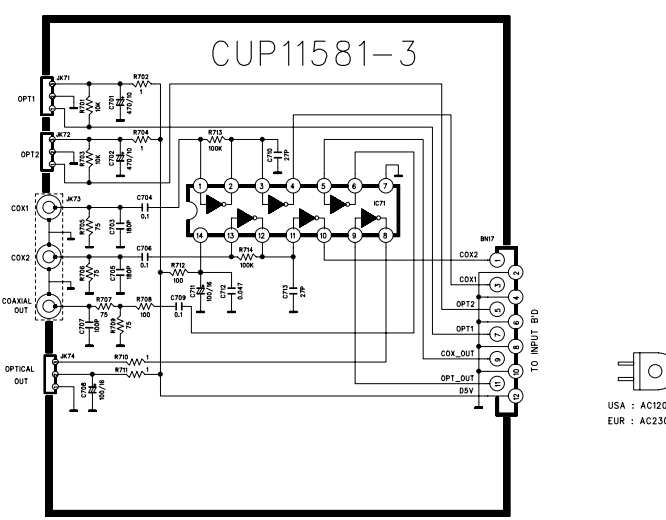
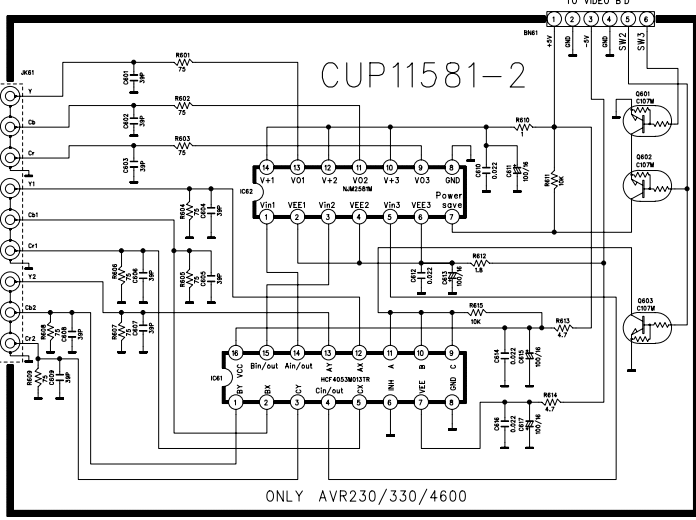

VIDEO BOARD

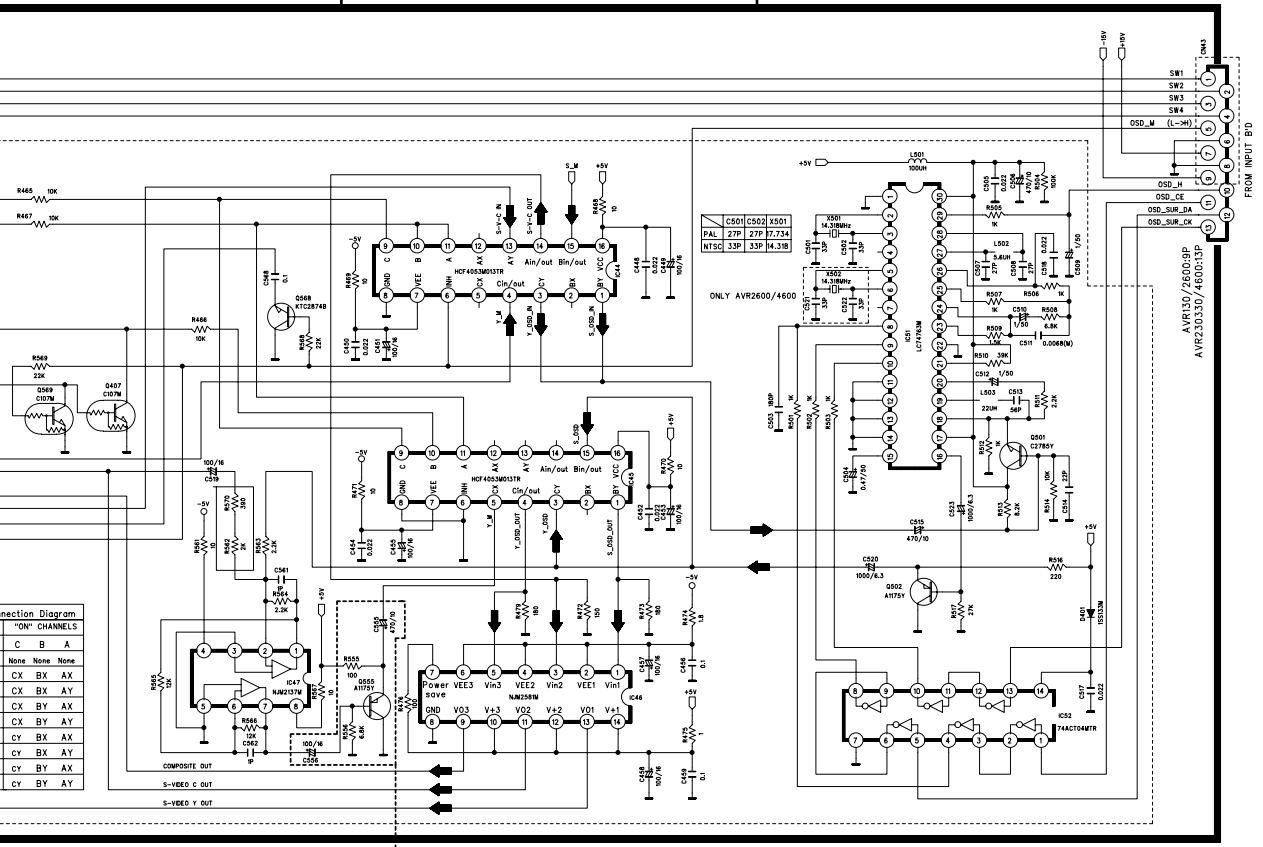

IMPORTANT SAFETY NOTICES.
 COMPONENTS IDENTIFIED BY Δ MARK HAVE SPECIAL CHARACTERISTICS.
 IMPORTANT FOR SAFETY: WHEN REPLACING ANY OF THESE COMPONENTS
 USE ONLY MANUFACTURER'S SPECIFIED PARTS.
 THE UNIT OF RESISTANCE IS OHM.
 K=1000 OHM , M=1000 KOHM
 THE UNIT OF CAPACITANCE IS MICROFARAD. (μF)
 pf=10⁻⁶ μF
 THIS SCHEMATIC DIAGRAM MAY MODIFY AT ANY TIME WITH THE
 IMPROVEMENT OF PERFORMANCE.

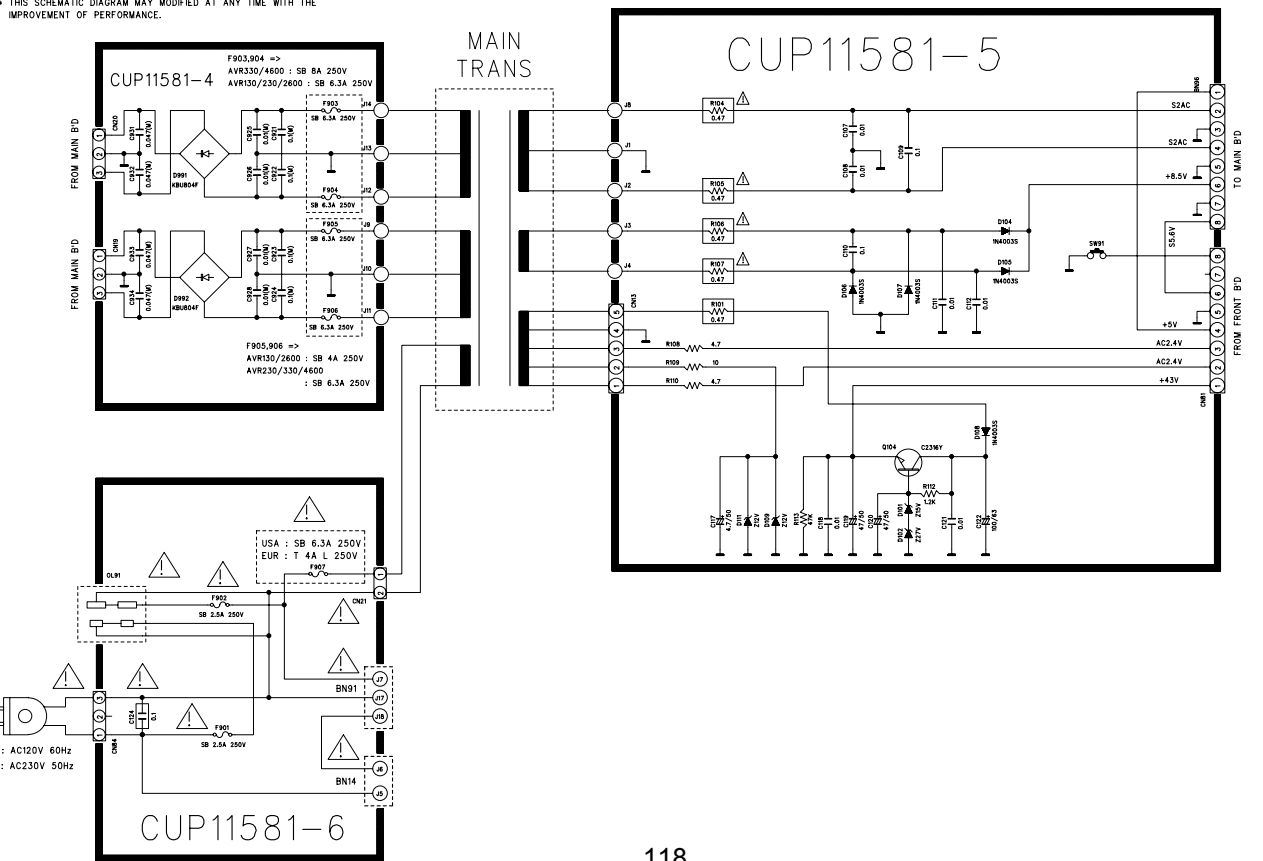

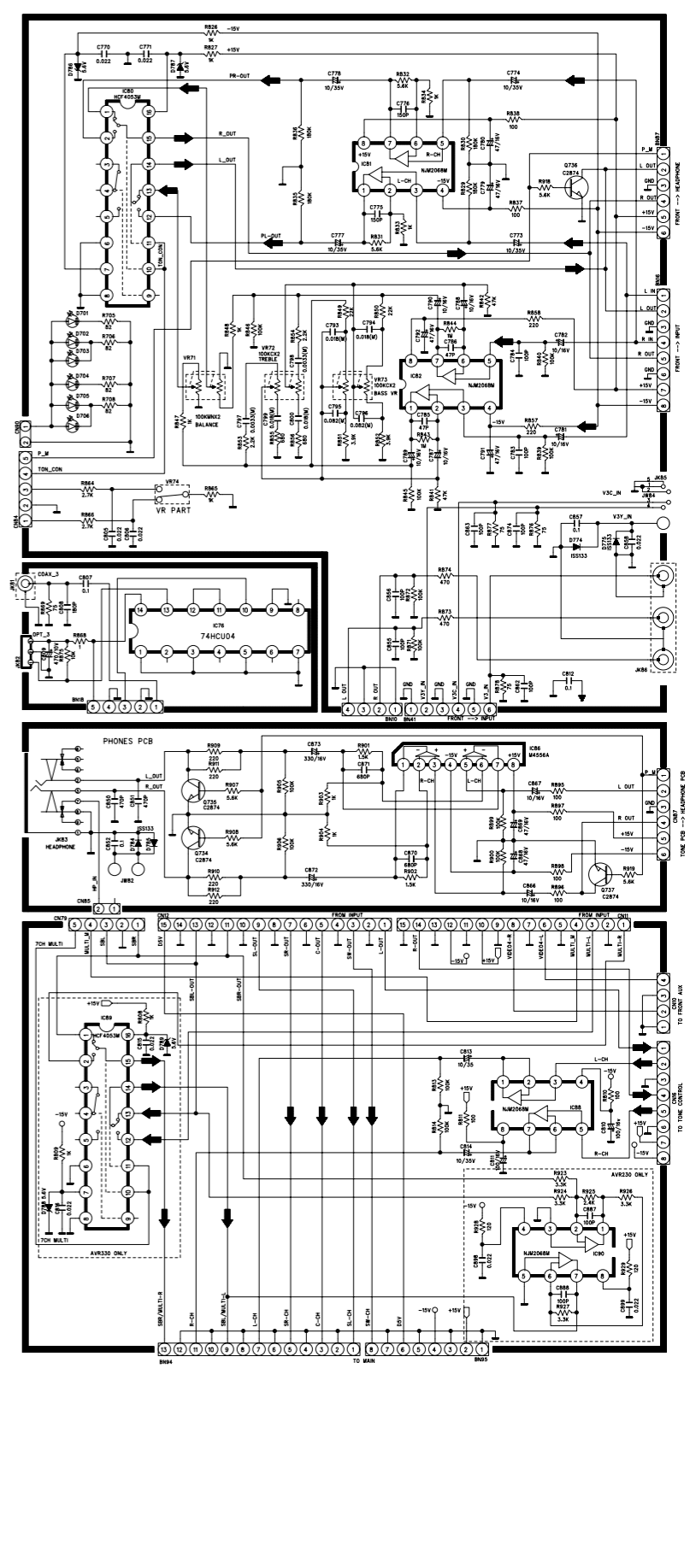
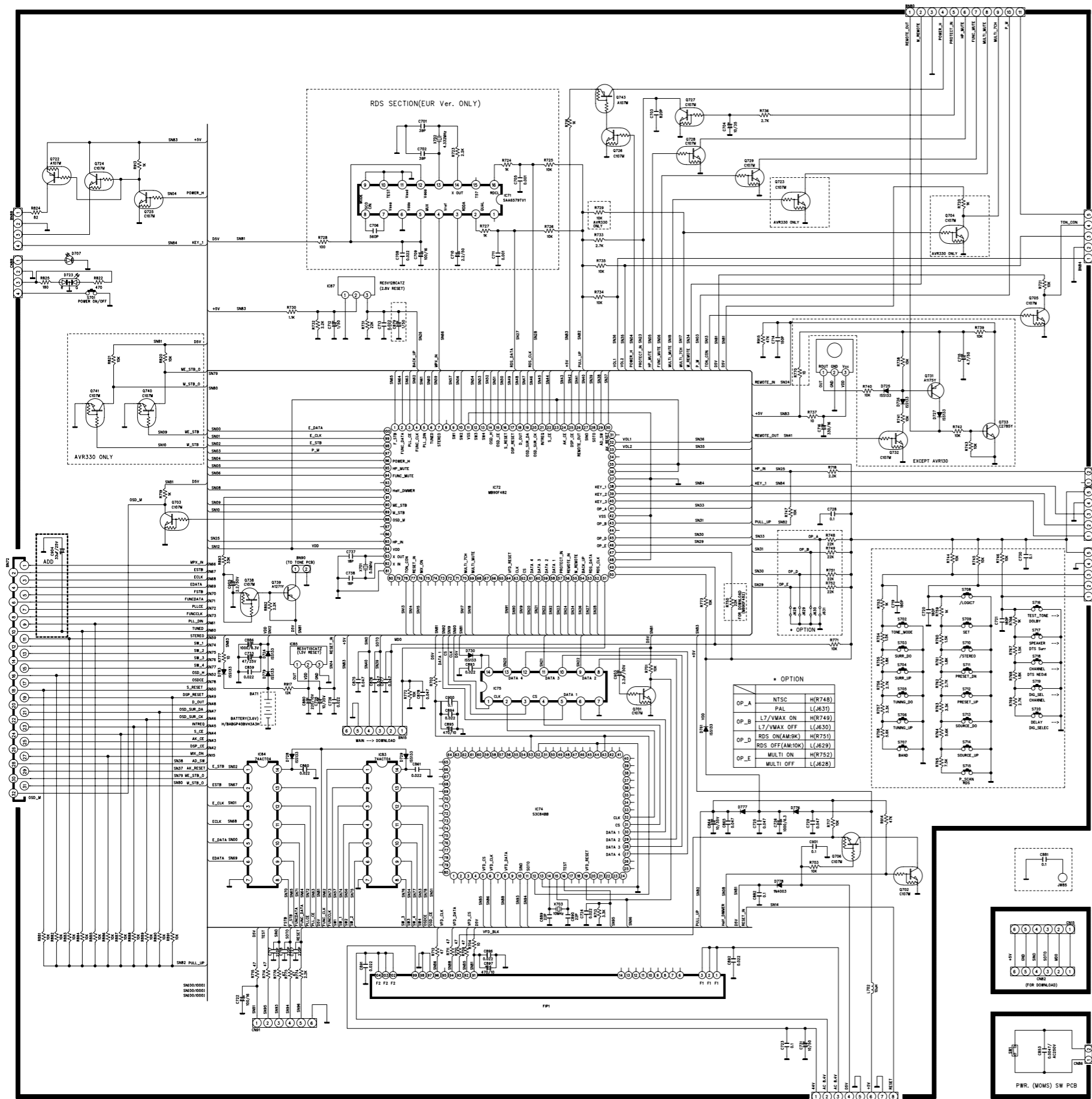

FRONT BOARD

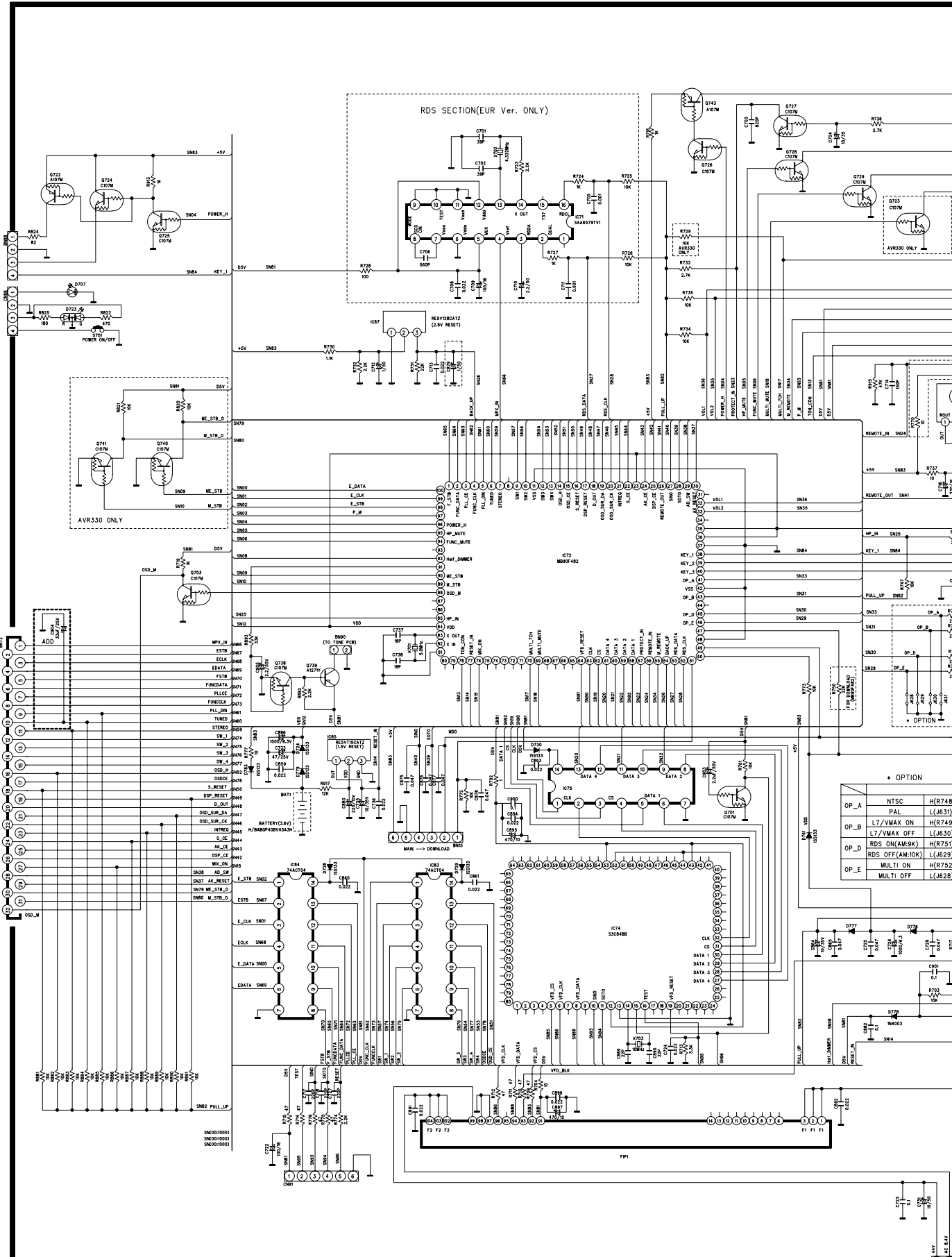

FRONT BOARD

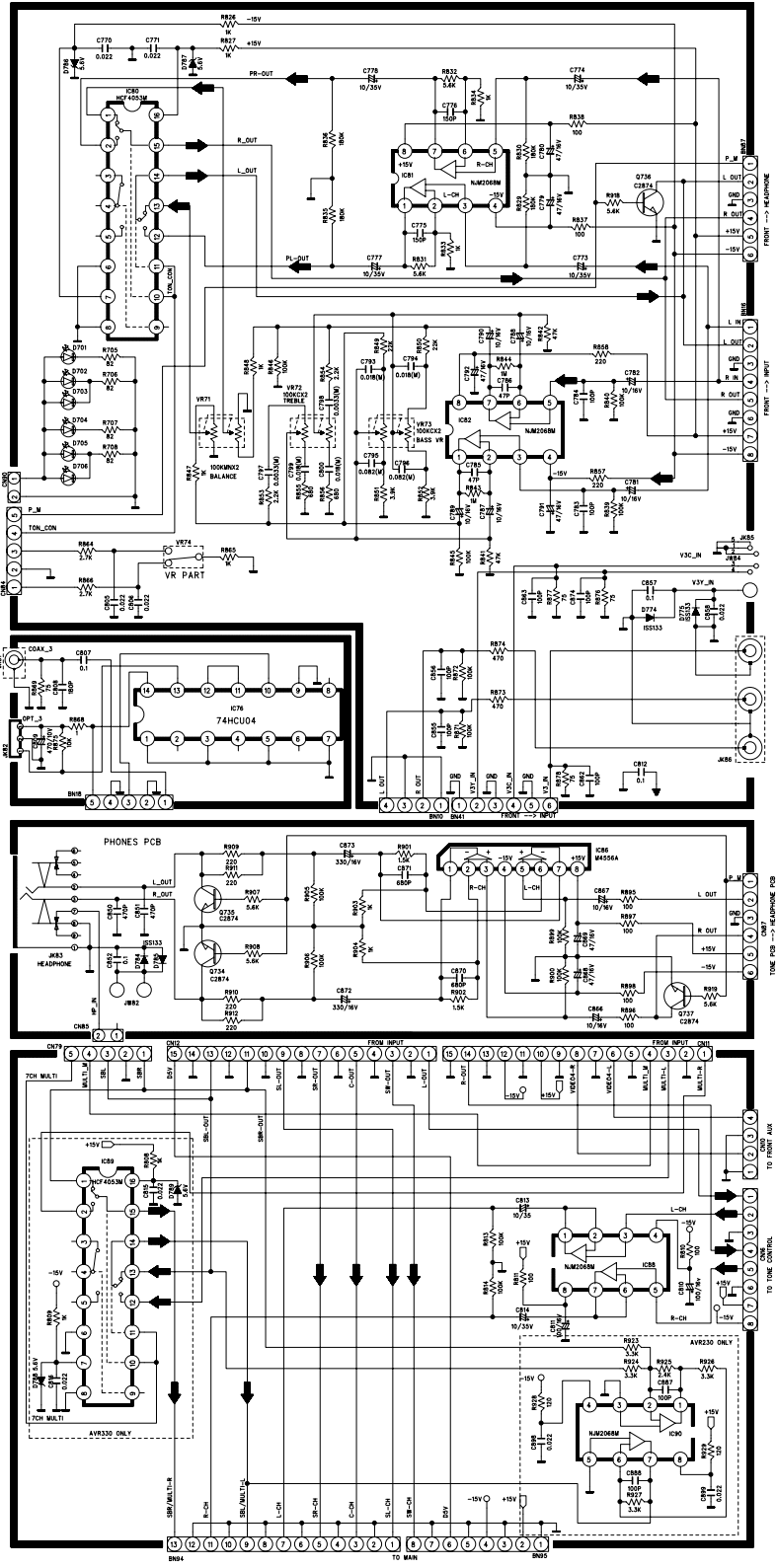
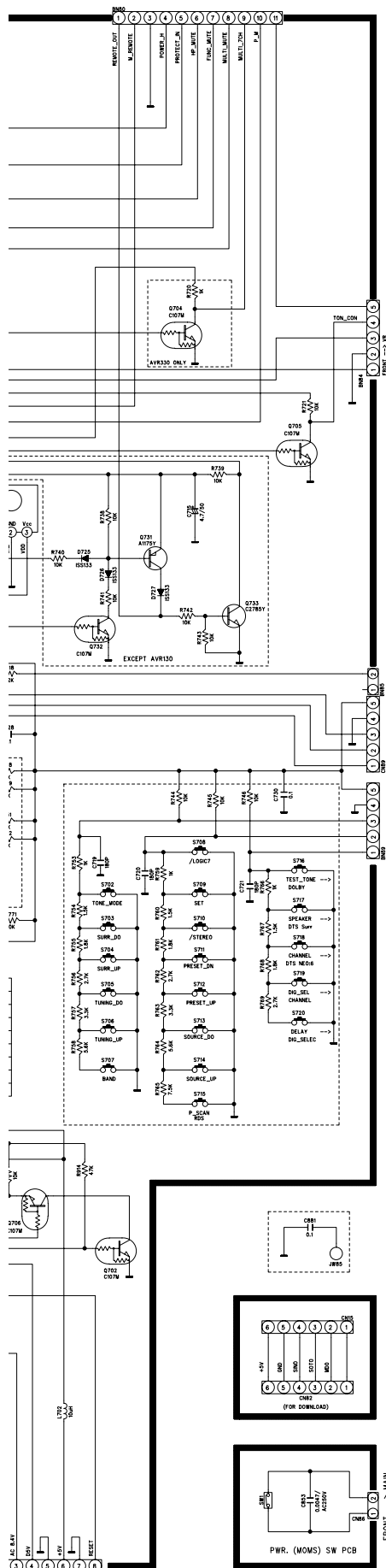

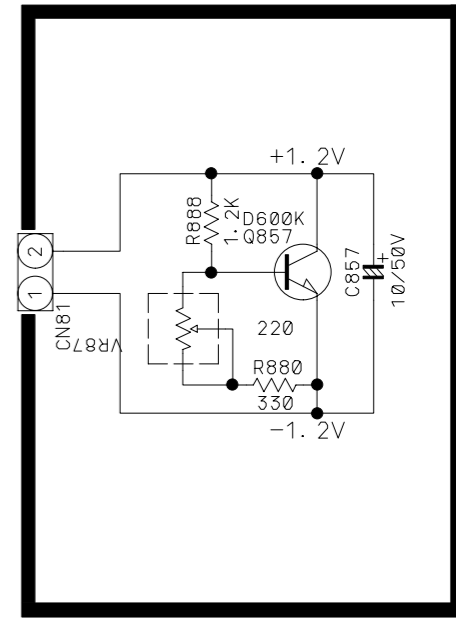
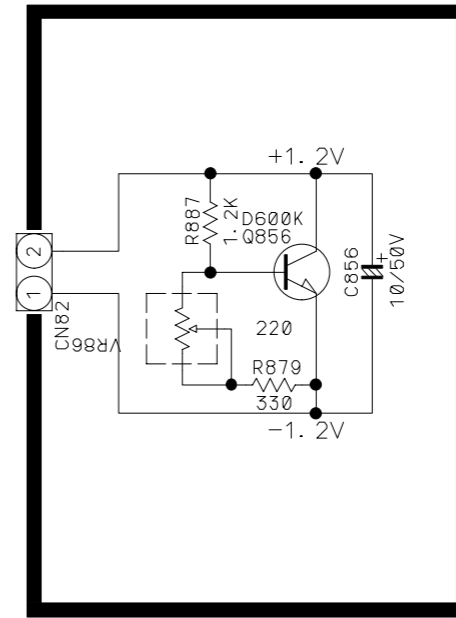
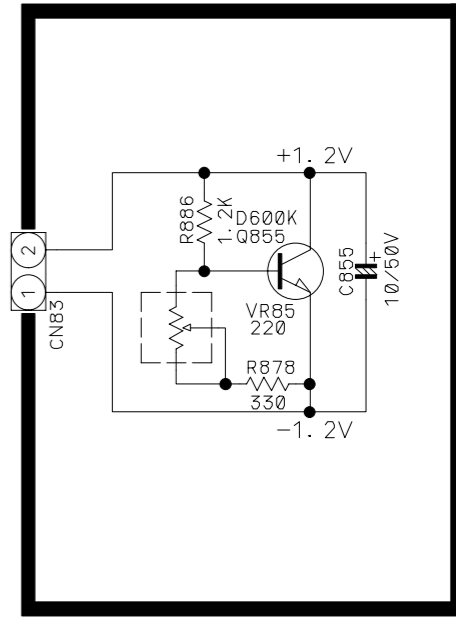
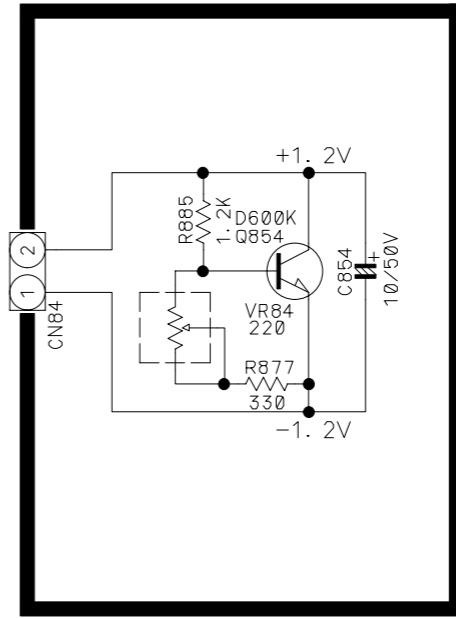
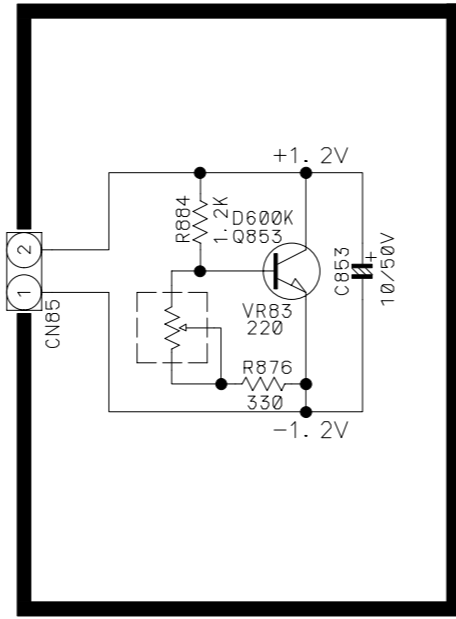
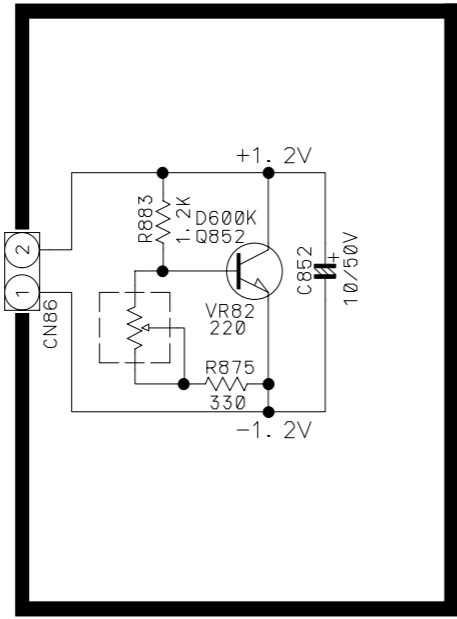
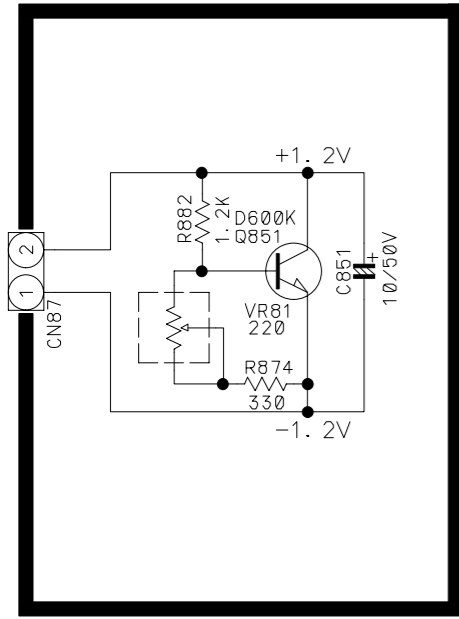

- ** IMPORTANT SAFETY NOTICE.
COMPONENTS IDENTIFIED BY MARK HAVE SPECIAL CHARACTERISTICS.
IMPORTANT FOR SAFETY. WHEN REPLACING ANY OF THESE COMPONENTS
USE ONLY MANUFACTURER'S SPECIFIED PARTS.
- ** THE UNIT OF RESISTANCE IS OHM.
K=1000 OHM, M=1000 KOHM.
- ** THE UNIT OF CAPACITANCE IS MICROFARAD (UF)
pF=10⁻⁶ uF
- ** THIS SCHEMATIC DIAGRAM MAY MODIFIED AT ANY TIME WITH THE
IMPROVEMENT OF PERFORMANCE

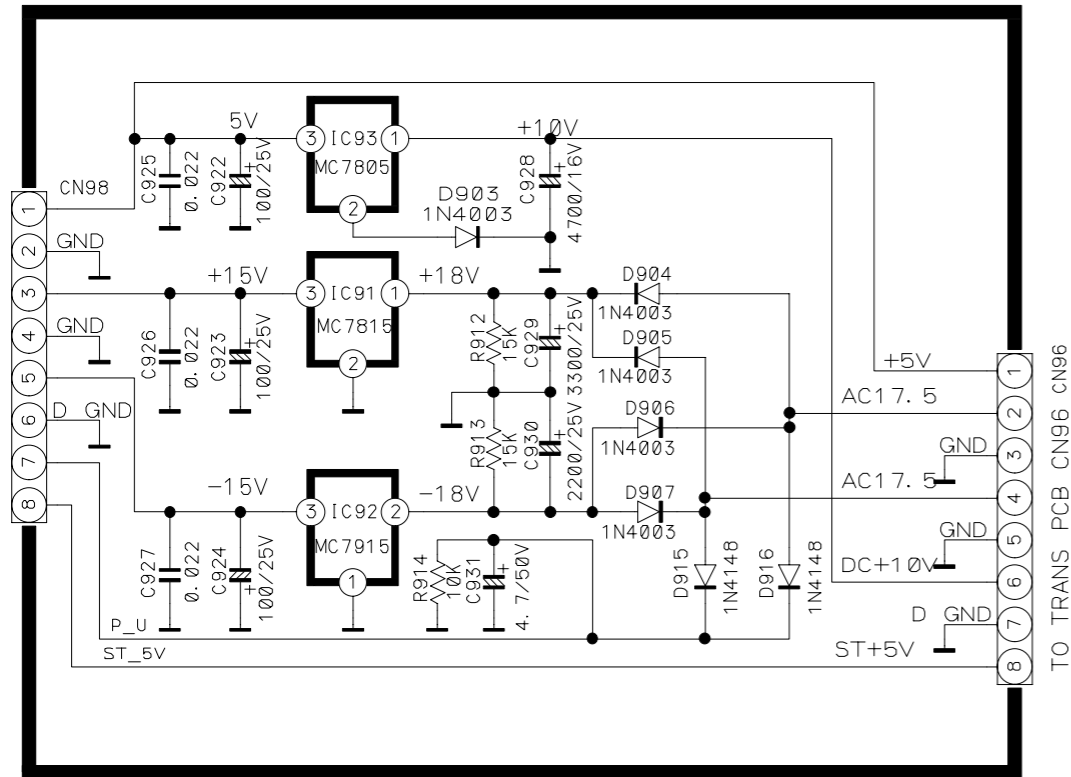

TO TRANS PCB CN96 CN96

INPUT BOARD 1 (ANALOG)

AVR330

harman/kardon

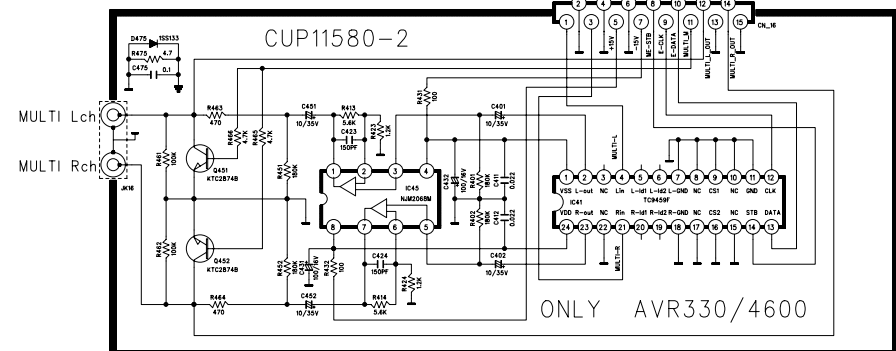
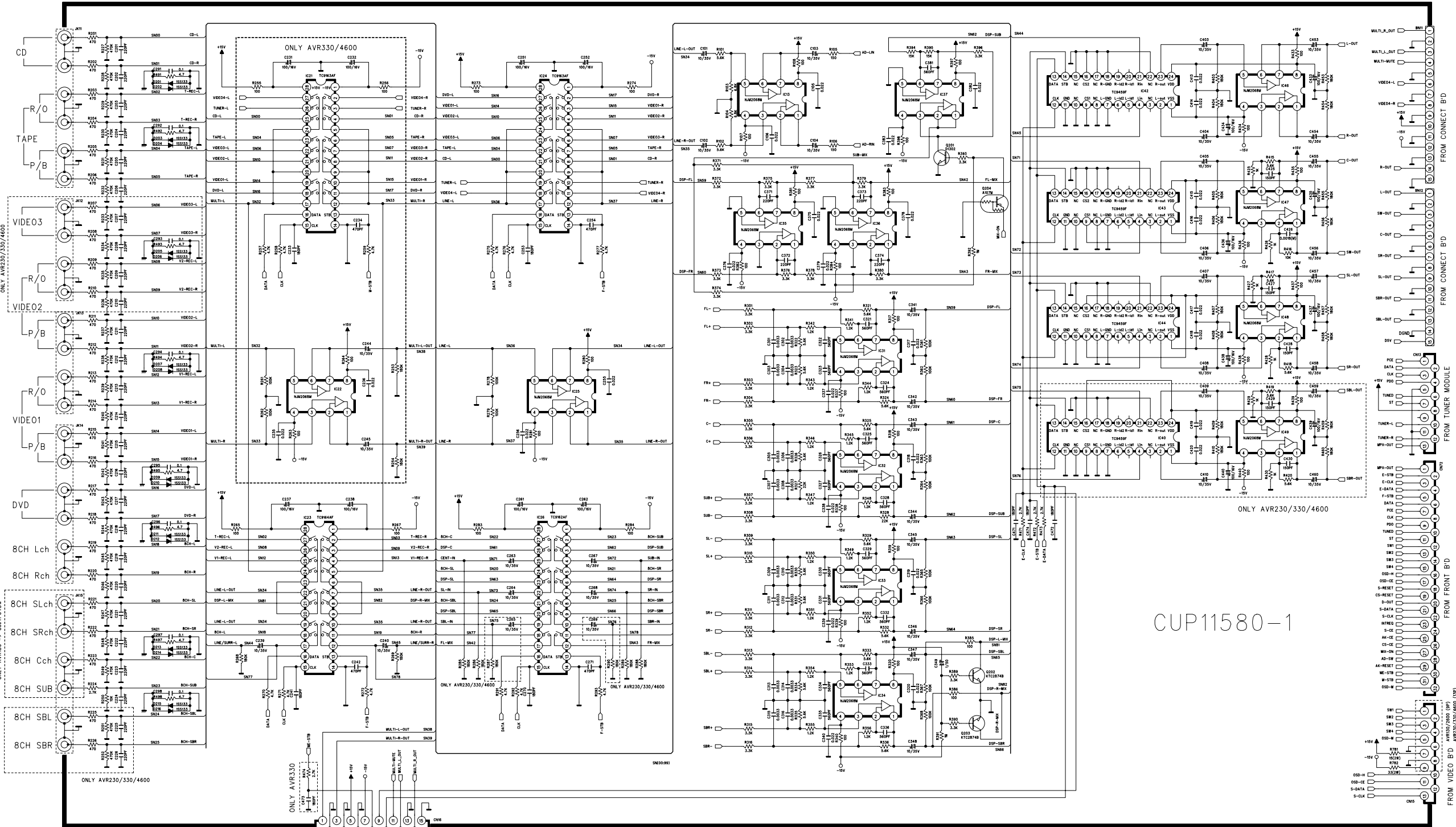

- IMPORTANT SAFETY NOTICES.
 COMPONENTS IDENTIFIED BY Δ MARK HAVE SPECIAL CHARACTERISTICS.
 IMPORTANT FOR SAFETY. WHEN REPLACING ANY OF THESE COMPONENTS
 USE ONLY MANUFACTURER'S SPECIFIED PARTS.
- THE UNIT OF RESISTANCE IS OHM.
 K=1000 OHM, M=1000 KOHM
- THE UNIT OF CAPACITANCE IS MICROFARAD. (μ F)
 μ F=10⁻⁶ F
- THIS SCHEMATIC DIAGRAM MAY MODIFIED AT ANY TIME WITH THE
 IMPROVEMENT OF PERFORMANCE.

INPUT BOARD 1 (ANALOG)

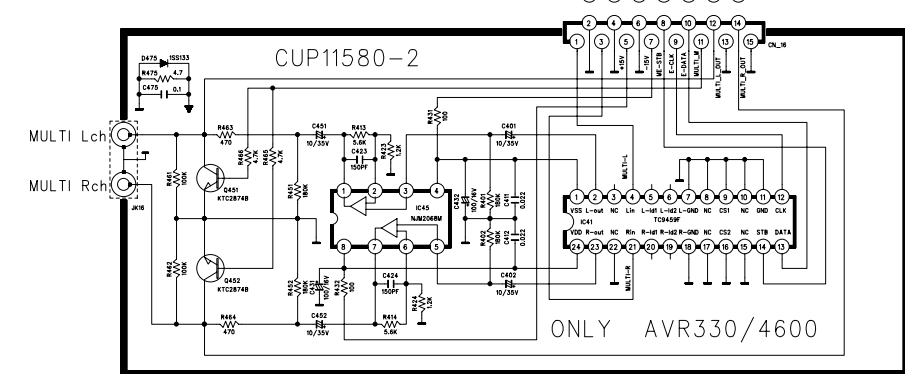
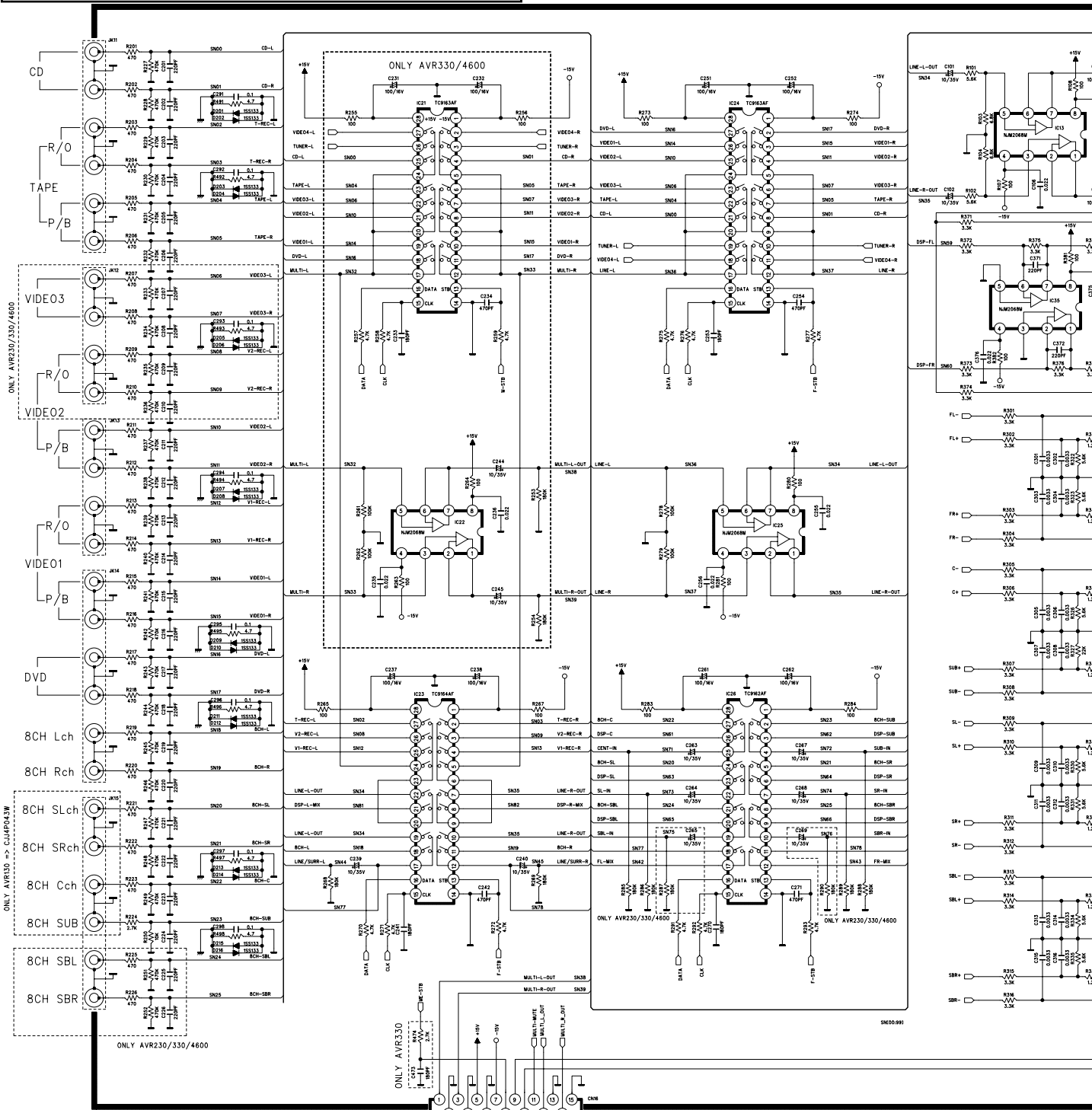

- IMPORTANT SAFETY NOTICES.
- COMPONENTS IDENTIFIED BY Δ MARK HAVE SPECIAL CHARACTERISTICS.
- IMPORTANT FOR SAFETY. WHEN REPLACING ANY OF THESE COMPONENTS USE ONLY MANUFACTURER'S SPECIFIED PARTS.
- THE UNIT OF RESISTANCE IS OHM.
- K=1000 OHM , M=1000 KOHM
- THE UNIT OF CAPACITANCE IS MICROFARAD. (μF)
- $pF=10^{-6} \mu F$
- THIS SCHEMATIC DIAGRAM MAY MODIFIED AT ANY TIME WITH THE IMPROVEMENT OF PERFORMANCE.

INPUT BOARD 1 (ANALOG)

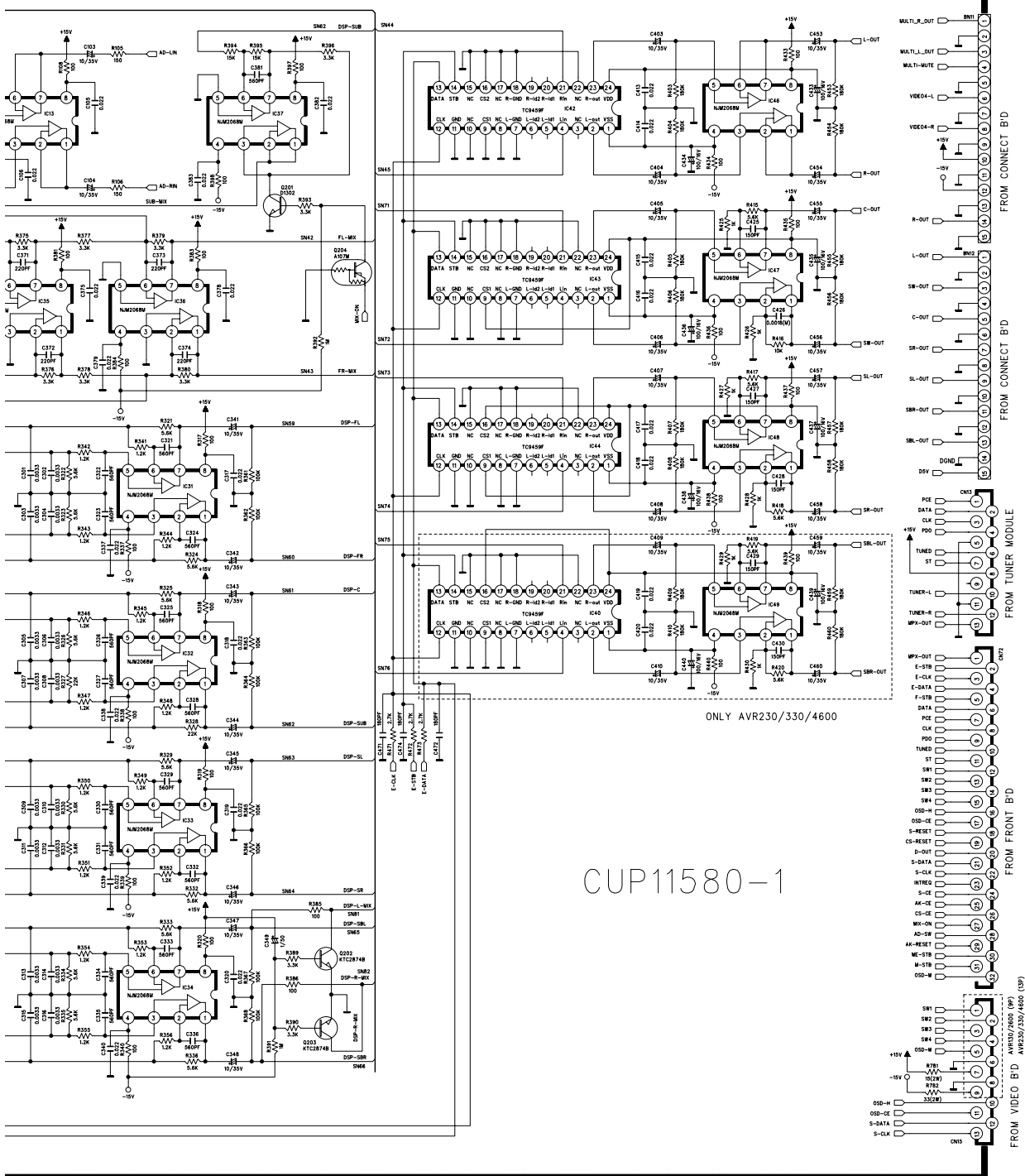

TERISTICS.
PONENTS

CUP11580-1

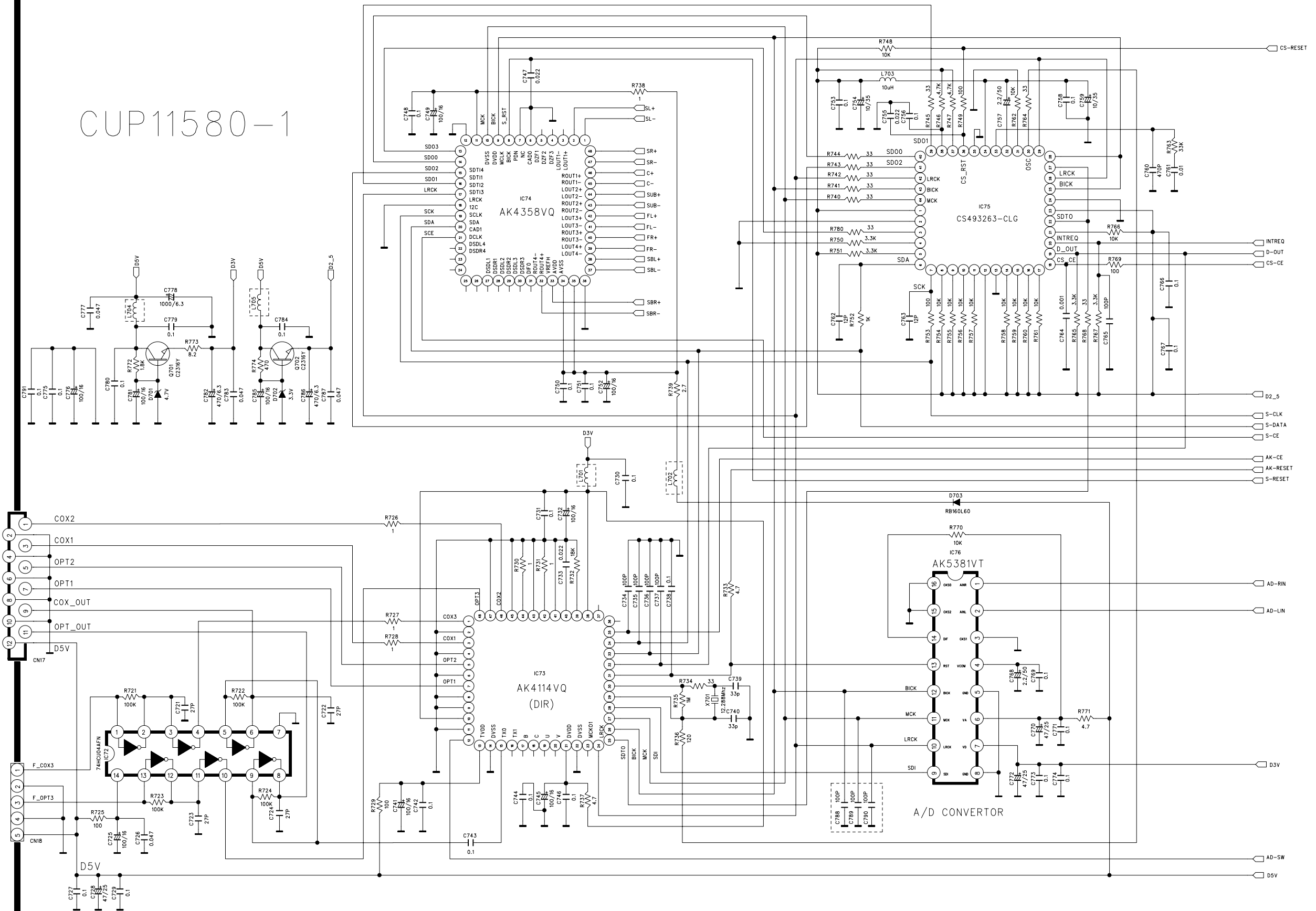

INPUT BOARD 2 (DIGITAL)

CUP11580-1

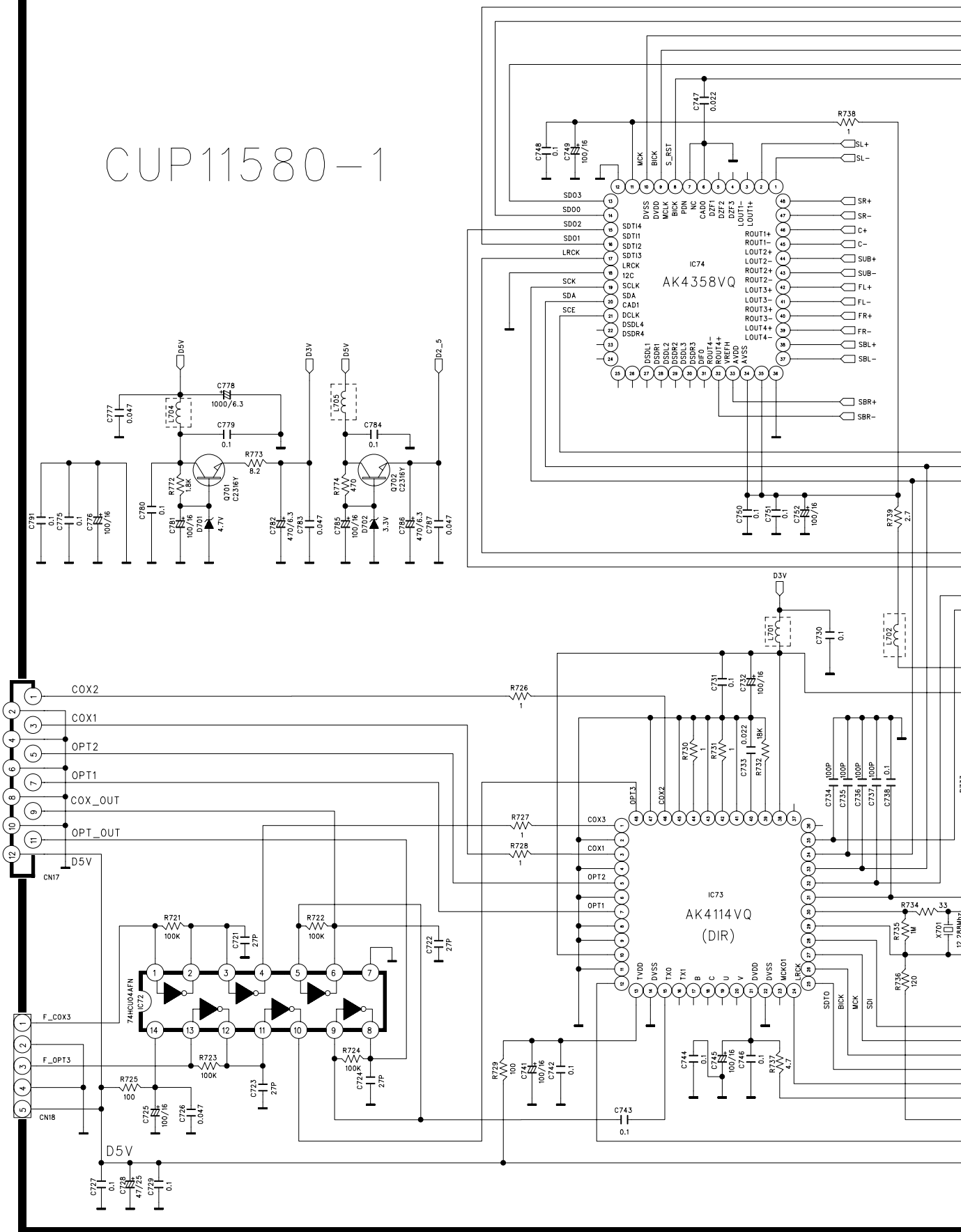

INPUT BOARD 2 (DIGITAL)

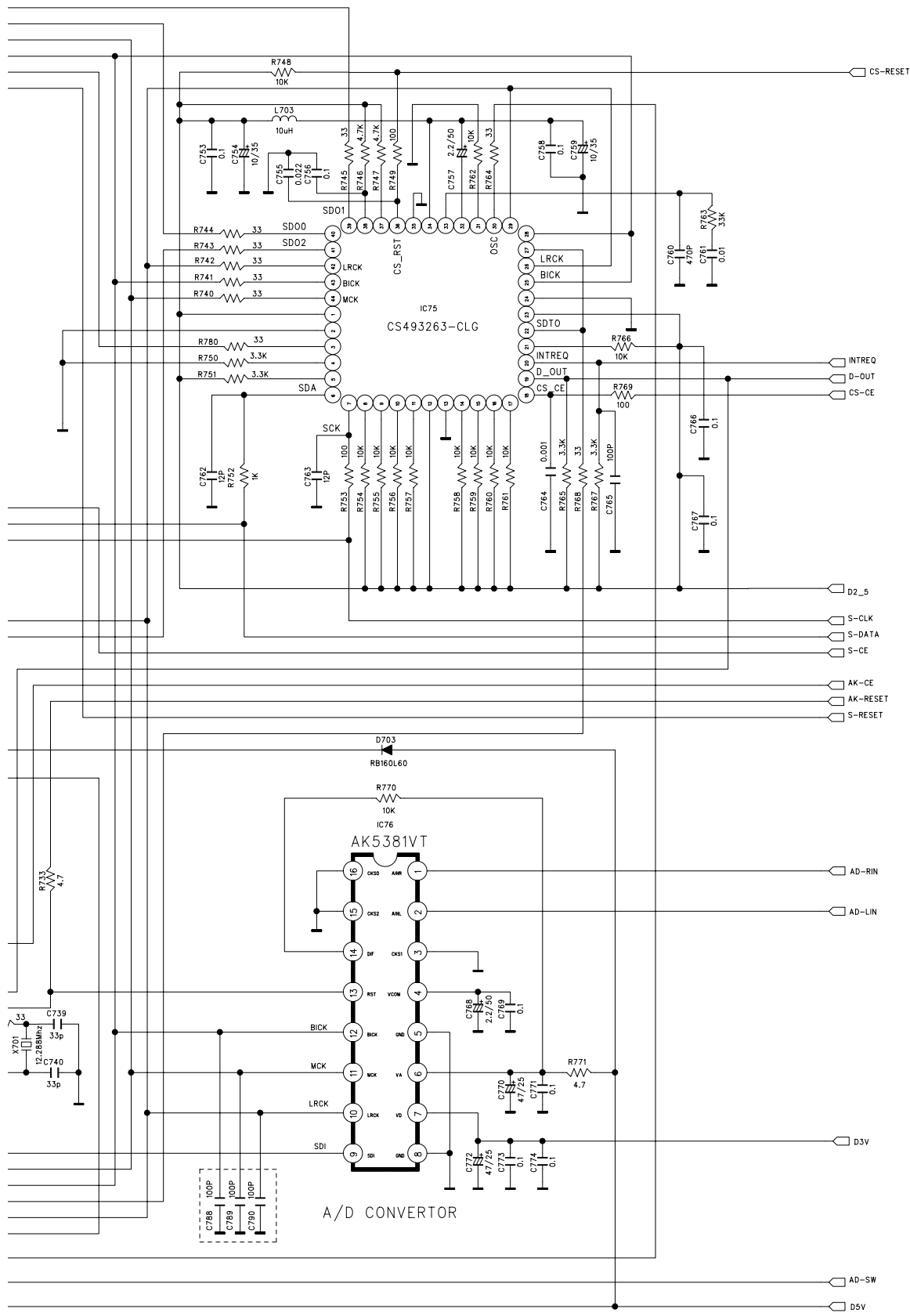

USA : 120V 60Hz
 EUR : 230V 50Hz

AVR130/230/330/2600/4600 WIRING DIAGRAM

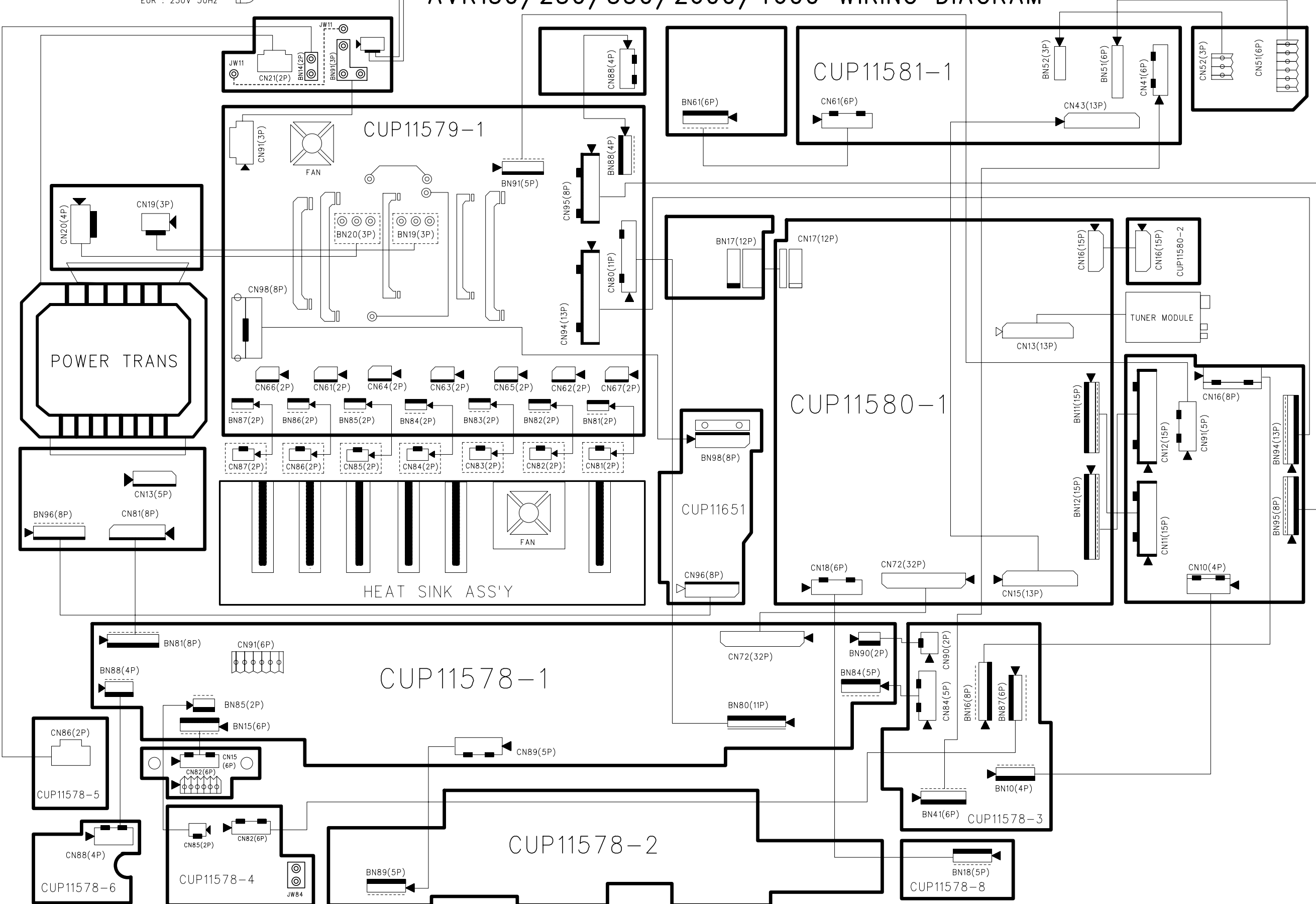

1. Instruction manual ass'y - Accessories

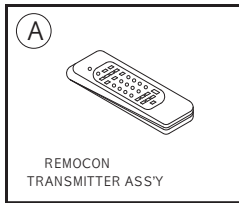
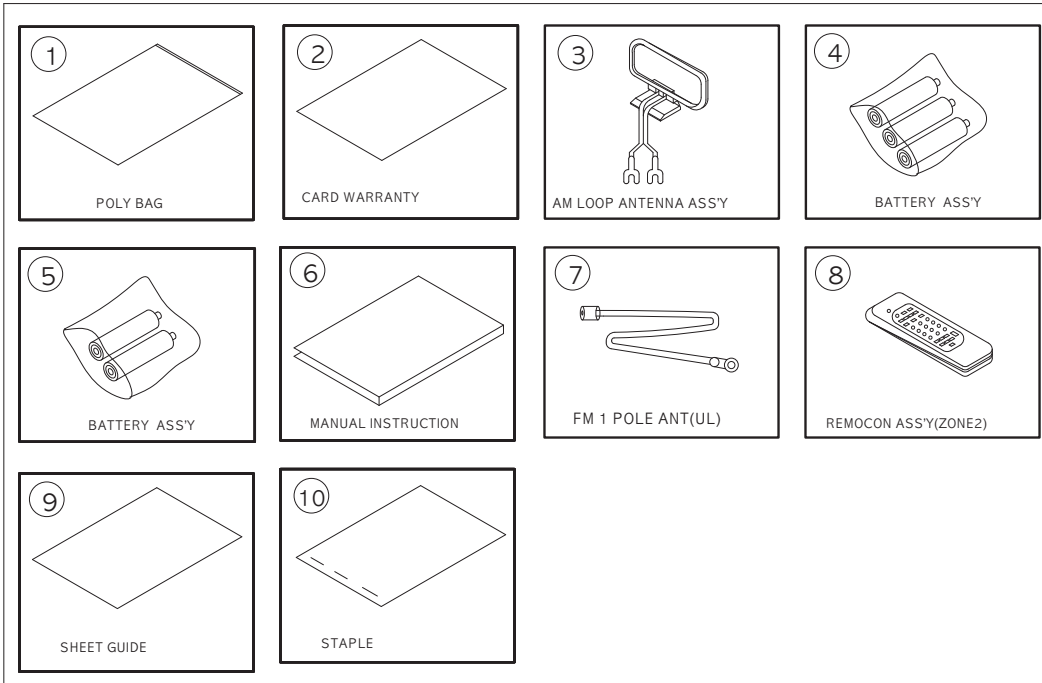

NO	DESCRIPTION	PARTS NO.	Q.ty
1	POLY BAG		1
2	CARD WARRANTY	CQE1A172X	1
3	AM LOOP ANTENNA ASS'Y	CSA3A012Z	1
4	BATTERY		3
5	BATTERY		2
6	INSTRUCTION MANUAL	CQX1A851Z	1
7	FM 1 POL ANT(UL)	CSA1A019Z	1
8	REMOCON ASS'Y(ZONE2)	HARTZONE2	1
9	SHEET GUIDE	CQE1A200Z	1
10	STAPLE		3
A	REMOCON ASS'Y	HARTAVR330CC	1

2. Package Drawing

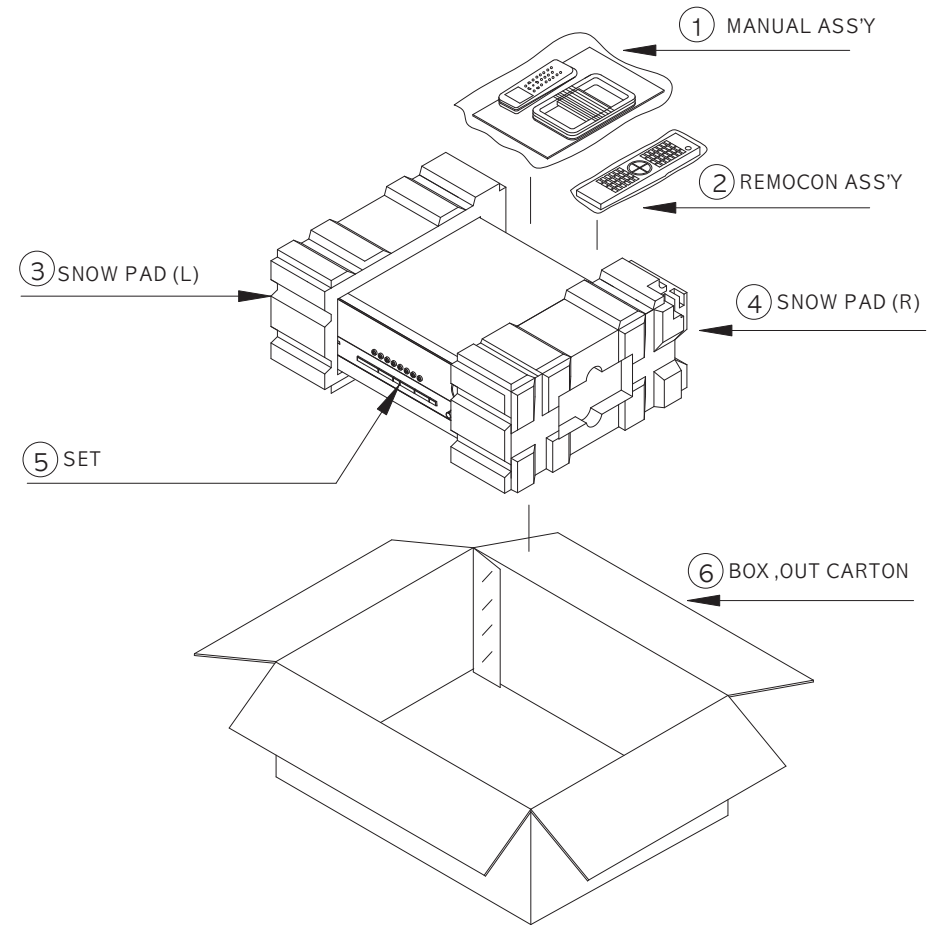

NO	DESCRIPTION	PARTS NO.	Q.ty
1	MANUAL ASS'Y		1
2	REMOCON ASS'Y	HARTAVR330CC	1
3	SNOW,PAD(L)	CPS4A564	1
4	SNOW,PAD(R)	CPS4A565	1
5	SET		1
6	BOX,OUT CARTON	CPG1A732P	1