

harman/kardon

AVR335

7 X 55W 7.1 CHANNEL A/V RECEIVER

SERVICE MANUAL



CONTENTS

ESD WARNING.....	2	DISASSEMBLY.....	23
LEAKAGE TESTING.....	3	AMP BIAS ADJUSTMENT.....	24
BASIC SPECIFICATIONS.....	4	TECH TIP HKTT2003-01.....	25
FRONT PANEL CONTROLS.....	5	BLOCK DIAGRAM.....	26
REAR PANEL CONNECTIONS.....	7	PCB DRAWINGS.....	27
REMOTE CONTROL FUNCTIONS.....	10	ELECTRICAL PARTS LIST.....	34
INSTALLATION/CONNECTIONS.....	13	SEMICONDUCTOR PINOUTS.....	77
OPERATION.....	15	SCHEMATICS.....	119
TROUBLESHOOTING GUIDE.....	21	WIRING DIAGRAM.....	126
PROCESSOR RESET.....	21	PACKAGING.....	127
UNIT EXPLODED VIEW.....	22		

harman/kardon, Inc.
250 Crossways Park Dr.
Woodbury, New York 11797

Rev1 5/2005

ELECTROSTATICALLY SENSITIVE (ES) DEVICES

Some semiconductor (solid state) devices can be damaged easily by static electricity. Such components commonly are called Electrostatically Sensitive (ES) Devices. Examples of typical ES devices are integrated circuits and some field effect transistors and semiconductor "chip" components.

The following techniques should be used to help reduce the incidence of component damage caused by static electricity.



1. Immediately before handling any semiconductor component or semiconductor-equipped assembly, drain off any electrostatic charge on your body by touching a known earth ground. Alternatively, obtain and wear a commercially available discharging wrist strap device, which should be removed for potential shock reasons prior to applying power to the unit under test.
2. After removing an electrical assembly equipped with ES devices, place the assembly on a conductive surface such as aluminum foil, to prevent electrostatic charge build-up or exposure of the assembly.
3. Use only a grounded-tip soldering iron to solder or unsolder ES devices.
4. Use only an anti-static solder removal device. Some solder removal devices not classified as "anti-static" can generate electrical charges sufficient to damage ES devices.
5. Do not use freon-propelled chemicals. These can generate electrical change sufficient to damage ES devices.
6. Do not remove a replacement ES device from its protective package until immediately before you are ready to install it. (Most replacement ES devices are packaged with leads electrically shorted together by conductive foam, aluminum foil or comparable conductive material.)
7. Immediately before removing the protective material from the leads of a replacement ES device, touch the protective material to the chassis or circuit assembly into which the device will be installed.

CAUTION : Be sure no power is applied to the chassis or circuit, and observe all other safety precautions.

8. Minimize bodily motions when handling unpackaged replacement ES devices. (Otherwise harmless motion such as the brushing together of your clothes fabric or the lifting of your foot from a carpeted floor can generate static electricity sufficient to damage an ES devices.

PRODUCT SAFETY NOTICE

Each precaution in this manual should be followed during servicing.

Components identified with the IEC symbol  in the parts list are special significance to safety. When replacing a component identified with , use only the replacement parts designated, or parts with the same ratings or resistance, wattage, or voltage that are designated in the parts list in this manual. Leakage-current or resistance measurements must be made to determine that exposed parts are acceptably insulated from the supply circuit before returning the product to the customer.

SAFETY PRECAUTIONS

The following check should be performed for the continued protection of the customer and service technician.

LEAKAGE CURRENT CHECK

Measure leakage current to a known earth ground (water pipe, conduit, etc.) by connecting a leakage current tester between the earth ground and all exposed metal parts of the appliance (input/output terminals, screwheads, metal overlays, control shaft, etc.). Plug the AC line cord of the appliance directly into a 120V AC 60Hz outlet and turn the AC power switch on. Any current measured must not exceed 0.5mA.

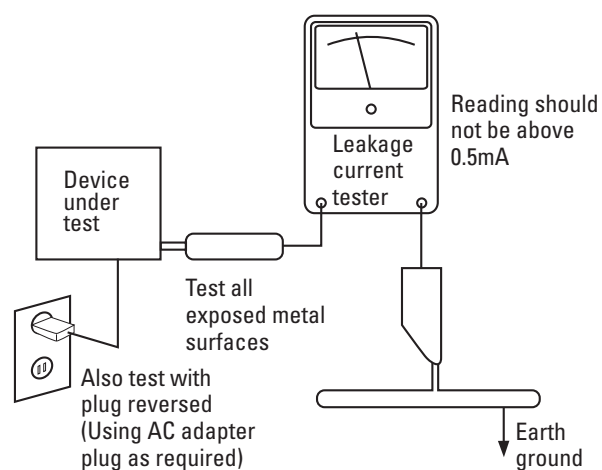

AC Leakage Test

ANY MEASUREMENTS NOT WITHIN THE LIMITS OUTLINED ABOVE ARE INDICATIVE OF A POTENTIAL SHOCK HAZARD AND MUST BE CORRECTED BEFORE RETURNING THE APPLIANCE TO THE CUSTOMER.

AVR 335 TECHNICAL SPECIFICATIONS

Audio Section

Stereo Mode	
Continuous Average Power (FTC)	
70 Watts per channel, 20Hz–20kHz, @ <0.07% THD, both channels driven into 8 ohms	
Seven-Channel Surround Modes	
Power per Individual Channel	
Front L&R channels:	
55 Watts per channel @ <0.07% THD, 20Hz–20kHz into 8 ohms	
Center channel:	
55 Watts @ <0.07% THD, 20Hz–20kHz into 8 ohms	
Surround (L & R side, L & R back) channels:	
55 Watts per channel @ <0.07% THD, 20Hz–20kHz into 8 ohms	
Input Sensitivity/Impedance	
Linear (High-Level)	200mV/75k ohms
Signal-to-Noise Ratio (IHF-A)	100dB
Surround System Adjacent Channel Separation	
Pro Logic I/II	40dB
Dolby Digital (AC-3)	55dB
DTS	55dB
Frequency Response	
@ 1W (+0dB, –3dB)	10Hz – 130kHz
High Instantaneous Current Capability (HCC)	±35 Amps
Transient Intermodulation Distortion (TIM)	Unmeasurable
Slew Rate	40V/μsec

FM Tuner Section

Frequency Range	87.5–108.0MHz
Usable Sensitivity	IHF 1.3μV/13.2dB
Signal-to-Noise Ratio	Mono/Stereo 70/68dB
Distortion	Mono/Stereo 0.2/0.3%
Stereo Separation	40dB @ 1kHz
Selectivity	±400kHz, 70dB
Image Rejection	80dB
IF Rejection	90dB

AM Tuner Section

Frequency Range	520–1720kHz
Signal-to-Noise Ratio	45dB
Usable Sensitivity	Loop 500μV
Distortion	1kHz, 50% Mod 0.8%
Selectivity	±10kHz, 30dB

Video Section

Television Format	NTSC
Input Level/Impedance	1Vp-p/75 ohms
Output Level/Impedance	1Vp-p/75 ohms
Video Frequency Response (Composite and S-Video)	10Hz–8MHz (–3dB)
Video Frequency Response (Component Video)	10Hz–50MHz (–3dB)

General

Power Requirement	AC 120V/60Hz
Power Consumption	118W idle, 890W maximum (7 channels driven)
Dimensions	(Product) (Shipping)
Width	17.3 inches (440mm) 21.5 inches (545mm)
Height	6.6 inches (168mm) 9.9 inches (251mm)
Depth	15 inches (381mm) 17.9 inches (455mm)
Weight	(Product) (Shipping)
	31 lb (14.1kg) 36.1 lb (16.4kg)

Depth measurement includes knobs, buttons and terminal connections.

Height measurement includes feet and chassis.

All features and specifications are subject to change without notice.

Harman Kardon, Power for the Digital Revolution and Logic 7 are registered trademarks, and **|||||EzSet+** is a trademark, of Harman International Industries, Incorporated.

*Manufactured under license from Dolby Laboratories. "Dolby," "Pro Logic" and the Double-D symbol are trademarks of Dolby Laboratories.

DTS, DTS Surround, DTS-ES and DTS Neo:6 are registered trademarks of Digital Theater Systems, Inc.

VMAx is a registered trademark of Harman International Industries, Incorporated, and is an implementation of Cooper Bauck Transaural Stereo under patent license.

Supplied Accessories

The following accessory items are supplied with the AVR 335. If any of these items are missing, please contact Harman Kardon customer service at www.harmankardon.com.

- A system remote control
- A Zone II remote control
- The EzSet+ microphone with a plug adaptor at the end of the unit's cord
- An AM loop antenna
- An FM wire antenna
- Five AAA batteries

FRONT-PANEL CONTROLS

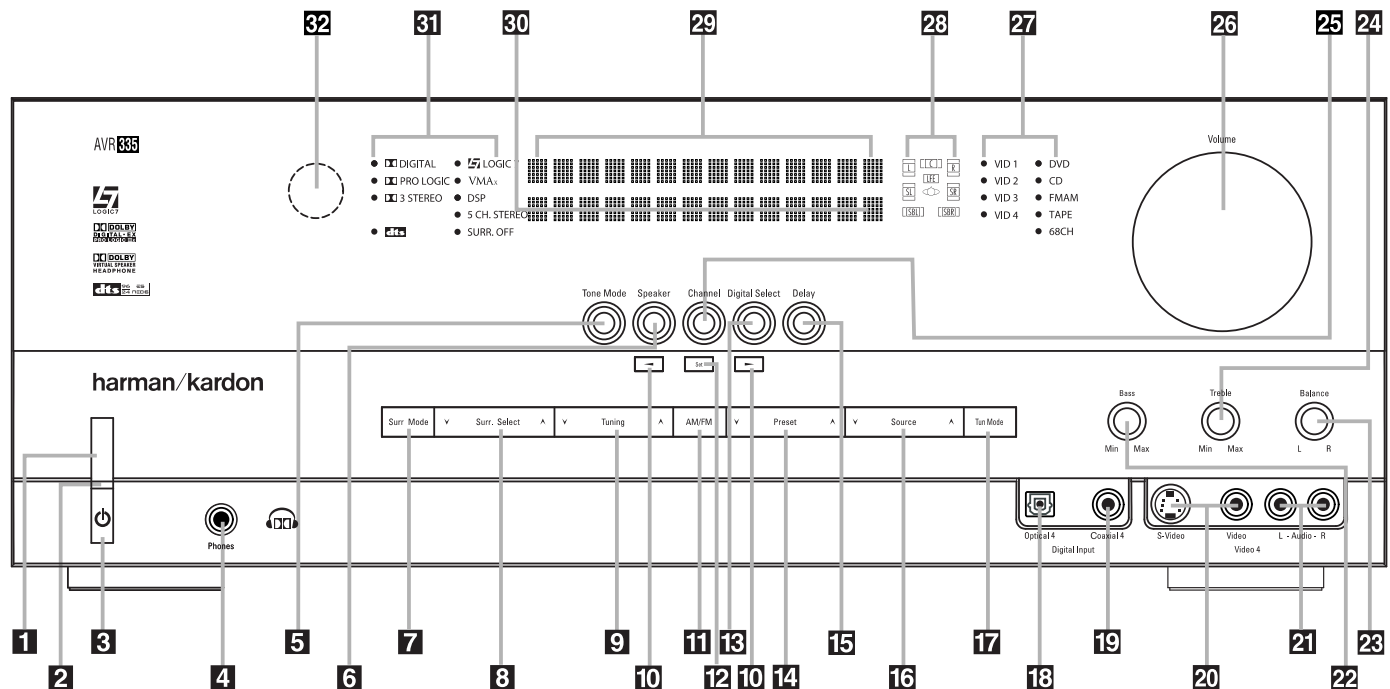

- | | | |
|---------------------------------------|-------------------------------------|--|
| 1 Main Power Switch | 12 Set Button | 23 Balance Control |
| 2 Power Indicator | 13 Digital Input Selector | 24 Treble Control |
| 3 Standby/On Switch | 14 Preset Station Selector | 25 Channel Adjust Selector |
| 4 Headphone Jack | 15 Delay Adjust Selector | 26 Volume Control |
| 5 Tone Mode | 16 Input Source Selector | 27 Input Indicators |
| 6 Speaker Selector | 17 Tuner Mode Selector | 28 Speaker/Channel Input Indicators |
| 7 Surround Mode Group Selector | 18 Optical 4 Digital Input | 29 Upper Display Line |
| 8 Surround Mode Selector | 19 Coaxial 4 Digital Input | 30 Lower Display Line |
| 9 Tuning Selector | 20 Video 4 Video Input Jacks | 31 Surround Mode Indicators |
| 10 ◀▶ Buttons | 21 Video 4 Audio Input Jacks | 32 Remote Sensor Window |
| 11 Tuner Band Selector | 22 Bass Control | |

NOTE: To make it easier to follow the instructions that refer to this illustration, a larger copy may be downloaded from the Product Support section for this product at www.harmankardon.com.

1 Main Power Switch: Press this button to apply power to the AVR 335. When the switch is pressed in, the unit is in a Standby mode, as indicated by the amber **Power Indicator 2** above the **Standby/On Switch 3**. This button **MUST** be pressed in to operate the unit. To turn the unit off and prevent the use of the remote control, this switch should be pressed until it pops out from the front panel and the word "OFF" is seen at the top of the switch.

NOTE: This switch is normally left in the "ON" position.

2 Power Indicator: This LED lights amber when the unit is in the Standby mode to signal that the AVR is ready to be turned on. When the unit is in operation, the indicator is blue.

3 Standby/On Switch: When the **Main Power Switch 1** is "ON," press this button to turn on the AVR 335; press it again to turn the unit off. The **Power Indicator 3** turns blue when the unit is on.

4 Headphone Jack: This jack may be used to listen to the AVR 335's output through a pair of headphones. The speakers will automatically be turned off when the headphone jack is in use. When configuring your system using EzSet+, the calibration microphone should be plugged into this jack using the supplied adaptor that converts the small mini-plug at the end of the microphone's cord to a 1/4" plug.

5 Tone Mode: Pressing this button enables or disables the Bass and Treble tone controls. When the button is pressed so that **TONE IN** appears in the **Lower Display Line 30**, the **Bass 22** and **Treble 24** controls may be used to adjust the output signals. When the button is pressed once or twice so that the words **TONE OUT** appear in the **Lower Display Line 30**, the output signal will be "flat," no matter how the actual **Bass** and **Treble Controls 22/24** are adjusted.

6 Speaker Select Button: Press this button to begin the process of configuring the unit to match the type of speakers used in your listening room. (See pages 22–24 for more information on speaker setup and configuration.)

7 Surround Mode Group Selector: Press this button to select the top-level group of surround modes. Each press of the button will select the current or last used mode in each of the surround mode groups (e.g., Dolby, DTS, DTS Neo:6, Logic 7, DSP, Stereo). When the button is pressed so that the name of the desired surround mode group appears in the on-screen display and in the **Lower Display Line 30**, press the **Surround Mode Selector 8** to cycle through the individual modes available. For example, press this button to select Dolby modes, and then press the **Surround Mode Selector 8** to choose from the various mode options.

FRONT - PANEL CONTROLS

8 Surround Mode Selector: Press this button to select from among the available surround mode options for the mode group selected. The specific modes will vary based on the number of speakers available, the mode group and if the input source is digital or analog. For example, press the **Surround Mode Group Selector 7** to select a mode grouping such as Dolby or Logic 7, and then press this button to see the specific mode choices available. For more information on mode selection, see page 28.

9 Tuning Selector: Press the left side of the button to tune lower-frequency stations and the right side of the button to tune higher-frequency stations. When the tuner is in the Manual mode, each tap will increase or decrease the frequency by one increment. When the tuner receives a strong enough signal for adequate reception, **MANUAL TUNED** will appear in the on-screen display and the **Lower Display Line 30**. When the tuner is in the Auto mode, press the button once, and the tuner will scan for a station with acceptable signal strength. When the next station with a strong signal is tuned the scan will stop and the on-screen display and the **Lower Display Line 30** will indicate **AUTO TUNED**. When an FM Stereo station is tuned, the display will read **AUTO ST TUNED**.

To switch back and forth between the Auto and Manual tuning modes, press the **Tuning Mode Selector 17**.

10 ◀▶ Buttons: When configuring the AVR 335's settings, use these buttons to select from the available choices.

11 AM/FM Selector: Press this button to turn the AVR on and to select the Tuner as the input source. Press it again to switch between the AM and FM frequency bands. (See page 31 for more information on the tuner.)

12 Set Button: When making choices during the setup and configuration process, press this button to enter the desired setting into the AVR 335's memory.

13 Digital Input Selector: Press this button to select one of the digital inputs or the analog input for any source. (See pages 28–31 for more information on digital audio.)

14 Preset Station Selector: Press this button to scroll up or down through the list of stations that have been entered into the preset memory. (See page 32 for more information on tuner presets.)

15 Delay Adjust Selector: Press this button to begin the steps required to enter delay settings. (See page 24 for more information on delay times.)

16 Input Source Selector: Press this button to change the input by scrolling up or down through the list of **Input Indicators 27**.

17 Tuner Mode Selector: Press this button to select Auto or Manual tuning. When the button is pressed so that **AUTO** appears in the **Lower Display Line 30**, the tuner will search for the next station with an acceptable signal when the **Tuning Selector 9 21** is pressed. When the button is pressed so that **MANUAL** appears in the **Lower Display Line 30**, each press of the **Tuning Selector 9 21** will increase the frequency. This button may also be used to switch between Stereo and Mono modes for FM radio reception. When weak reception is encountered, press the button so that **MANUAL** appears in the **Lower Display Line 30** and in the on-screen display to switch to Mono reception. Press it again to switch back to Stereo mode. (See pages 31–32 for more information on using the tuner.)

18 Optical 4 Digital Input: Connect the optical digital audio output of an audio or video product to this jack. When the input is not in use, be certain to keep the plastic cap installed to avoid dust contamination that might degrade future performance.

19 Coaxial 4 Digital Input: This jack is used for connection to the output of portable audio devices, video game consoles or other products that have a coax digital audio jack.

20 Video 4 Video Input Jacks: These jacks may be used for temporary connection to the composite or S-video output of video games, camcorders or other portable video products. You may make a connection to either jack at any time, but not to both simultaneously.

21 Video 4 Audio Input Jacks: These audio jacks may be used for temporary connection to video games or portable audio/video products such as camcorders and portable audio players.

22 Bass Control: Turn this control to modify the low-frequency output of the left/right channels by as much as ± 10 dB.

23 Balance Control: Turn this control to change the relative volume for the front left/right channels.

NOTE: For proper operation of the surround modes this control should be at the midpoint or "12 o'clock" position.

24 Treble Control: Turn this control to modify the high frequency output of the left/right channels by as much as ± 10 dB.

25 Channel Adjust Selector: Press this button to begin the process of trimming the channel output levels using an external audio source. (For more information on output level trim adjustment, see page 32.)

26 Volume Control: Turn this knob clockwise to increase the volume, counterclockwise to decrease the volume. If the AVR 335 is muted, adjusting the

Volume Control 26 44 will automatically release the unit from the silenced condition.

27 Input Indicators: The current selected source will appear as one of these indicators. Note that when the unit is turned on, the entire list of available modes will light briefly, and then revert to normal operation with only the active mode indicator illuminated.

28 Speaker/Channel Input Indicators: These indicators are multipurpose, indicating both the speaker type selected for each channel and the incoming data-signal configuration. The left, center, right, right surround and left surround speaker indicators are composed of three boxes, while the subwoofer is a single box. The center box lights when a "small" speaker is selected, and the two outer boxes light when "large" speakers are selected. When none of the boxes are lit for the center, surround or subwoofer channels, no speaker has been assigned that position. (See page 22 for more information on configuring speakers.) The letters inside each box displays the active input channels. For standard analog inputs, only the L and R will light, indicating a stereo input. For a digital source, the indicators will light to display the channels being received at the digital input. When the letters flash, the digital input has been interrupted. (See page 31 for more information on the Channel Indicators.)

29 Upper Display Line: Depending on the unit's status, a variety of messages will appear here. In normal operation, this line will show the current input source and which analog or digital input is in use. When the tuner is the input, this line will identify the station as AM or FM and show the frequency and preset number, if any.

30 Lower Display Line: Depending on the unit's status, a variety of messages will appear here. In normal operation, the current surround mode will show here.

31 Surround Mode Indicators: The current selected surround mode will appear as one of these indicators. Note that when the unit is turned on, the entire list of available modes will light briefly, and then revert to normal operation with only the active mode indicator illuminated.

32 Remote Sensor Window: The sensor behind this window receives infrared signals from the remote control. Aim the remote at this area and do not block or cover it.

REAR-PANEL CONNECTIONS

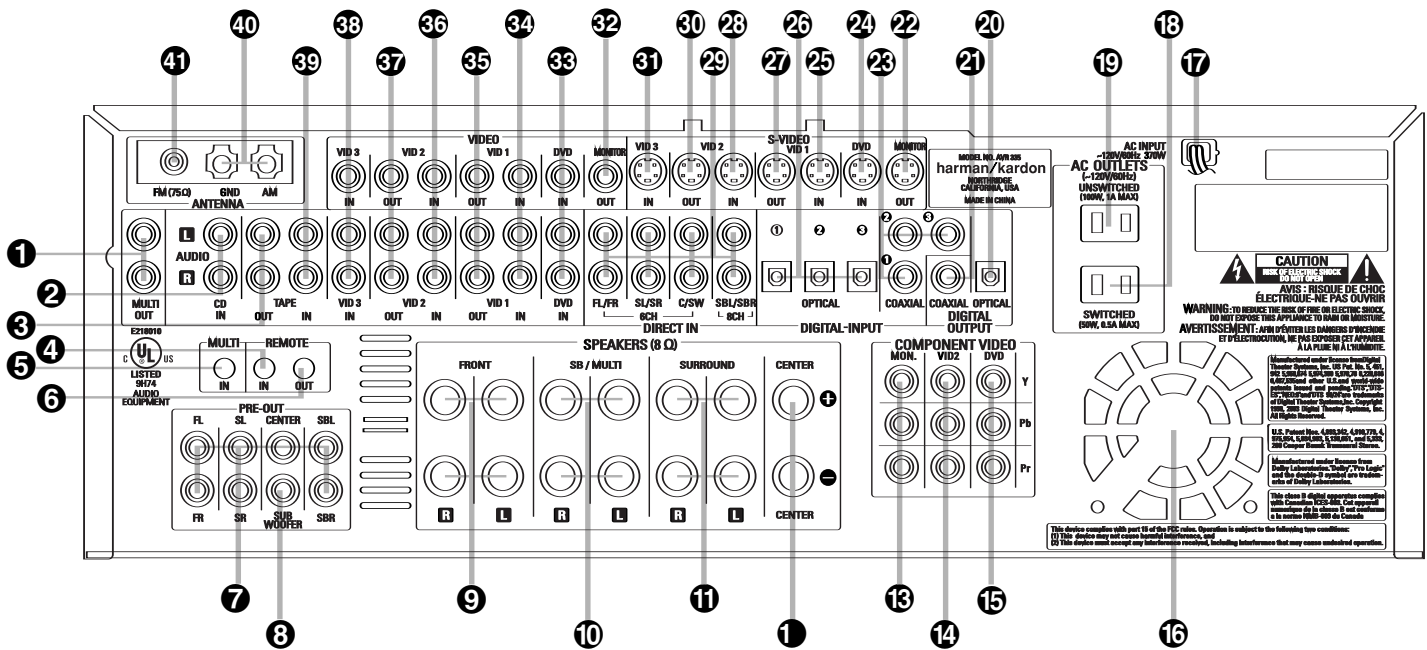

- 1 Multiroom Audio Outputs
- 2 CD Audio Inputs
- 3 Tape Outputs
- 4 Remote IR Input
- 5 Multiroom IR Input
- 6 Remote IR Output
- 7 Preamp Outputs
- 8 Subwoofer Output
- 9 Front Speaker Outputs
- 10 Surround Back/Multiroom Speaker Outputs
- 11 Surround Speaker Outputs
- 1 Center Speaker Output
- 13 Component Video Monitor Outputs
- 14 Video 2 Component Video Inputs
- 15 DVD Component Video Inputs
- 16 Fan Vents
- 17 AC Power Cord
- 18 Switched AC Accessory Outlet
- 19 Unswitched AC Accessory Outlet
- 20 Optical Digital Audio Output
- 21 Coaxial Digital Audio Output
- 22 S-Video Monitor Output
- 23 Coaxial Digital Audio Inputs
- 24 DVD S-Video Input
- 25 Video 1 S-Video Input
- 26 Optical Digital Audio Inputs
- 27 Video 1 S-Video Output
- 28 Video 2 S-Video Input
- 29 6/8-Channel Direct Inputs
- 30 Video 2 S-Video Output
- 31 Video 3 S-Video Input
- 32 Video Monitor Output
- 33 DVD Audio/Video Inputs
- 34 Video 1 Audio/Video Inputs
- 35 Video 1 Audio/Video Outputs
- 36 Video 2 Audio/Video Inputs
- 37 Video 2 Audio/Video Outputs
- 38 Video 3 Audio/Video Inputs
- 39 Tape Inputs
- 40 AM Antenna Terminals
- 41 FM Antenna Jack

NOTE: To make it easier to follow the instructions that refer to this illustration, a larger copy may be downloaded from the Product Support section for this product at www.harmankardon.com.

NOTE: To assist in making the correct connections for multichannel input, output and speaker connections, all connection jacks and terminals are color-coded in conformance with the CEA standards as follows:	Front Left:	White	Surround Left:	Blue	Component Video "Y":	Green
	Front Right:	Red	Surround Right:	Gray	Component Video "Pr":	Red
	Center:	Green	Surround Back Left:	Brown	Component Video "Pb":	Blue
			Surround Back Right:	Tan		
		Subwoofer:	Purple			
		Coaxial Digital Audio:	Orange			
		Composite Video:	Yellow			

- 1 **Multiroom Audio Outputs:** Connect these jacks to the optional external audio power amplifier and video distribution system that delivers the source selected for multizone distribution.
- 2 **CD Audio Inputs:** Connect these jacks to the analog audio output of a compact disc player or changer.
- 3 **Tape Outputs:** Connect these jacks to the RECORD/INPUT jacks of an audio recorder.
- 4 **Remote IR Input:** If the AVR 335's front-panel IR sensor is blocked due to cabinet doors or other obstructions, an external IR sensor may be used. Connect the output of the sensor to this jack.
- 5 **Multiroom IR Input:** Connect the output of an IR sensor in a remote room to this jack to operate the AVR 335's multiroom control system.
- 6 **Remote IR Output:** This connection permits the IR sensor in the receiver to serve other remote controlled devices. Connect this jack to the "IR IN" jack on Harman Kardon (or other compatible) equipment.

REAR-PANEL CONNECTIONS

- 7 Preamp Outputs:** Connect these jacks to an optional, external power amplifier for applications where higher power is desired.
- 8 Subwoofer Output:** Connect this jack to the line-level input of a powered subwoofer. If an external subwoofer amplifier is used, connect this jack to the subwoofer amplifier input.
- 9 Front Speaker Outputs:** Connect these outputs to the matching + or – terminals on your left and right speakers. When making speaker connections always make certain to maintain correct polarity by connecting the color-coded (white for front left and red for front right) (+) terminals on the AVR 335 to the red (+) terminals on the speakers and the black (–) terminals on the AVR 335 to the black (–) terminals on the speakers. See page 14 for more information on speaker polarity.
- 10 Surround Back/Multiroom Speaker Outputs:** These speaker terminals are normally used to power the surround back left/surround back right speakers in a 7.1-channel system. However, they may also be used to power the speakers in a second zone, which will receive the output selected for a multiroom system. To change the output fed to these terminals from the default of the Surround Back speakers to the Multiroom Output, you must change a setting in the **MULTIROOM MENU** of the OSD system. See page 35 for more information on configuring this speaker output. In normal surround system use, the brown and black terminals are the surround back left channel positive (+) and negative (–) connections and the tan and black terminals are the surround back right positive (+) and negative (–) terminals. For multiroom use, connect the brown and black SBL terminals to the red and black connections on the left remote zone speaker and connect the tan and black SBR terminals to the red and black terminals on the right remote zone speaker.
- 11 Surround Speaker Outputs:** Connect these outputs to the matching + and – terminals on your surround channel speakers. In conformance with the CEA color-code specification, the blue terminal is the positive, or "+," terminal that should be connected to the red (+) terminal on the Surround Left speaker with older color-coding, while the gray terminal should be connected to the red (+) terminal on the Surround Right speaker with the older color-coding. Connect the black (–) terminal on the AVR to the matching black negative (–) terminals for each surround speaker. (See page 14 for more information on speaker polarity.)
- 1 Center Speaker Output:** Connect these outputs to the matching + and – terminals on your center channel speaker. In conformance with the CEA color-code specification, the green terminal is the positive, or "+," terminal that should be connected to the red

(+) terminal on speakers with the older color-coding. Connect the black (–) terminal on the AVR to the black (–) terminal on your speaker. (See page 14 for more information on speaker polarity.)

- 13 Component Video Monitor Outputs:** Connect these outputs to the component video inputs of a video projector or monitor. When a source connected to one of the **Component Video Inputs 14 15** is selected, the signal will be sent to these jacks.
- 14 Video 2 Component Video Inputs:** Connect the Y/Pr/Pb component video outputs of an HDTV set-top converter, satellite receiver or other video source device with component video outputs to these jacks.
- 15 DVD Component Video Inputs:** Connect the Y/Pr/Pb component video outputs of a DVD player to these jacks.
- 16 Fan Vents:** These ventilation holes are the output of the AVR 335's airflow system. To ensure proper operation of the unit and to avoid possible damage to delicate surfaces, make certain that these holes are not blocked and that there is at least three inches of open space between the vent holes and any wooden or fabric surface. It is normal for the fan to remain off at most normal volume levels. An automatic temperature sensor turns the fan on only when it is needed.
- 17 AC Power Cord:** Connect the AC power cord to a non-switched AC wall outlet.
- 18 Switched AC Accessory Outlet:** These outlets may be used to power any device you wish to have turned on when the AVR 335 is turned on.
- 19 Unswitched AC Accessory Outlet:** This outlet may be used to power any AC device. The power will remain on at this outlet, regardless of whether the AVR 335 is on or off.
- NOTE:** The total power consumption of all devices connected to the accessory outlets should not exceed 100 watts.
- 20 Optical Digital Audio Output:** Connect this jack to the optical digital input connector on a CD-R/RW, MiniDisc or other digital recorder.
- 21 Coaxial Digital Audio Output:** Connect this jack to the coaxial digital input of a CD-R/RW, MiniDisc or other digital recorder.
- 22 S-Video Monitor Output:** When your television or other video display is equipped with an S-video input and you are using at least one source with S-video capability, connect this jack to the S-video input on the display.
- 23 Coaxial Digital Audio Inputs:** Connect the coax digital output from a DVD player, HDTV receiver, LD

player or CD player to these jacks. The signal may be a Dolby Digital signal, DTS signal or a standard PCM digital source. Do not connect the RF digital output of an LD player to these jacks.

- 24 DVD S-Video Input:** Connect the S-video output of a DVD player or other video source to this jack.
- 25 Video 1 S-Video Input:** If the product connected to the **Video 1 Audio Inputs 34** has S-video capability, connect this jack to the PLAY/OUT S-video jack on that unit and then make certain that the **S-Video Monitor Output 22** is connected as described above.
- 26 Optical Digital Audio Inputs:** Connect the optical digital output from a DVD player, HDTV receiver, LD player or CD player to these jacks. The signal may be a Dolby Digital signal, a DTS signal or a standard PCM digital source.
- 27 Video 1 S-Video Output:** If the product connected to the **Video 1 Audio Outputs 35** has S-video capability, connect this jack to the REC/IN S-video jack on that unit.
- 28 Video 2 S-Video Input:** If the product connected to the **Video 2 Audio Inputs 36** has S-video capability, connect this jack to the PLAY/OUT S-video jack on that unit and then make certain that the **S-Video Monitor Output 22** is connected as described above.
- 29 8-Channel Direct Inputs:** These jacks are used for connection to source devices such as DVD-Audio or SACD players with discrete analog outputs. Depending on the source device in use, all eight jacks may be used, though in many cases only connections to the front left/right, center, surround left/right and LFE (subwoofer input) jacks will be used for standard 5.1 audio signals.
- 30 Video 2 S-Video Output:** If the product connected to the **Video 2 Audio Outputs 37** has S-video capability, connect this jack to the REC/IN S-video jack on that unit.
- 31 Video 3 S-Video Input:** If the product connected to the **Video 3 Audio Inputs 38** has S-video capability, connect this jack to the PLAY/OUT S-video jack on that unit and then make certain that the **S-Video Monitor Output 22** is connected as described above.
- 32 Video Monitor Output:** Connect this jack to the composite video input of a TV monitor or video projector to view the on-screen menus and the output of a standard video source.
- 33 DVD Audio/Video Inputs:** Connect the composite video and L/R analog audio output jacks of a DVD player or other video source to these jacks.

REAR-PANEL CONNECTIONS

34 Video 1 Audio/Video Inputs: Connect the composite video and L/R analog audio PLAY/OUT jacks of a VCR or other video source to these jacks.

35 Video 1 Audio/Video Outputs: Connect the composite video and L/R analog audio REC/IN jacks of a VCR or other video recording device such as a DVD recorder or PVR to these jacks.

36 Video 2 Audio/Video Inputs: Connect the composite video and L/R analog audio PLAY/OUT jacks of a VCR or other video source to these jacks.

37 Video 2 Audio/Video Outputs: Connect the composite video and L/R analog audio REC/IN jacks of a VCR or other video recording device such as a DVD recorder or PVR to these jacks.

38 Video 3 Audio/Video Inputs: Connect the composite video and L/R analog audio PLAY/OUT jacks of a VCR or other video source to these jacks.

39 Tape Inputs: Connect these jacks to the PLAY/OUT jacks of an audio recorder.

40 AM Antenna Terminals: Connect the AM loop antenna supplied with the receiver to these terminals. If an external AM antenna is used, make connections to the **AM** and **GND** terminals in accordance with the instructions supplied with the antenna.

41 FM Antenna Jack: Connect the supplied indoor (or an optional external) FM antenna to this terminal.

NOTE ON VIDEO CONNECTIONS: When connecting a source device, such as a VCR, DVD player, cable or satellite set-top box or video game, to the AVR, use either a composite or S-video connection for each input, but not both.

MAIN REMOTE CONTROL FUNCTIONS

- 1 Power Off Button
- 2 IR Transmitter Window
- 3 Program Indicator
- 4 Power On Button
- 5 Input Selectors
- 6 AVR Selector
- 7 AM/FM Tuner Select
- 8 Dim Button
- 9 Test Button
- 10 Sleep Button
- 11 DSP Surround Mode Selector
- 12 Night Mode
- 13 Channel Select Button
- 14 ▲/▼ Buttons
- 15 ◀/▶ Buttons
- 16 Set Button
- 17 Digital Select
- 18 Numeric Keys
- 19 Tuner Mode
- 20 Direct Button
- 21 Tuning Up/Down
- 22 OSD Button
- 23 Dolby Mode Selector
- 24 DTS Digital Mode Selector
- 25 Logic 7 Mode Select Button
- 26 Skip Up/Down Buttons
- 27 Transport Controls
- 28 Stereo Mode Select Button
- 29 DTS Neo:6 Mode Select
- 30 Macro Buttons
- 31 Disc Skip Button
- 32 Preset Up/Down
- 33 Clear Button
- 34 Memory Button
- 35 Delay/Prev. Ch.
- 36 Speaker Select
- 37 Multiroom
- 38 Volume Up/Down
- 39 TV/Video Selector
- 40 6-Channel/8-Channel Direct Input
- 41 Mute

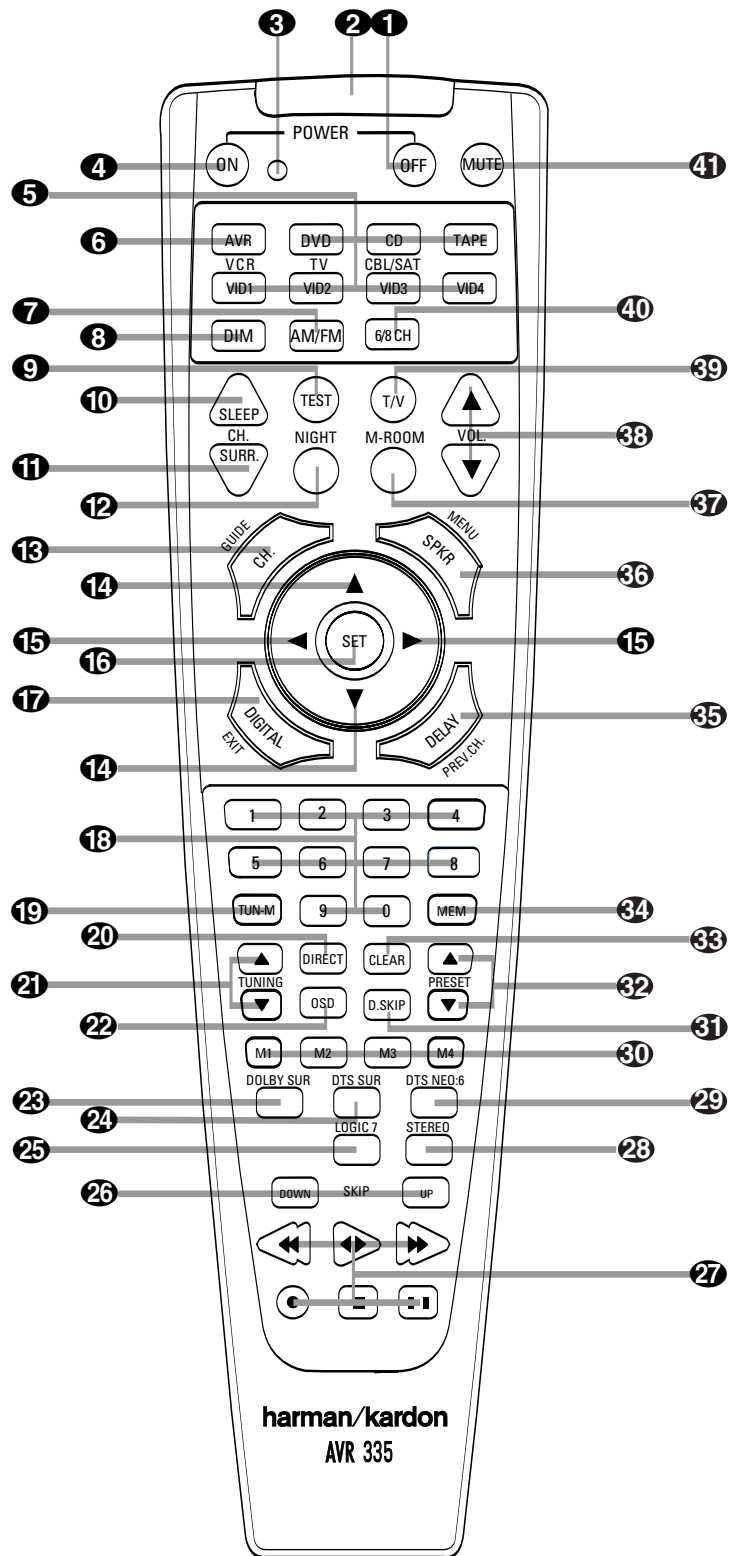

NOTE:

- The function names shown here are each button's feature when used with the AVR 335. Most buttons have additional functions when used with other devices. See pages 41–42 for a list of these functions.
- To make it easier to follow the instructions that refer to this illustration, a larger copy may be downloaded from the Product Support section for this product at www.harmankardon.com.

MAIN REMOTE CONTROL FUNCTIONS

IMPORTANT NOTE: The AVR 335's remote may be programmed to control up to eight devices, including the AVR 335. Before using the remote, it is important to remember to press the **Input Selector Button 5** that corresponds to the unit you wish to operate. In addition, the AVR 335's remote is shipped from the factory to operate the AVR 335 and most Harman Kardon CD or DVD players and cassette decks. The remote is also capable of operating a wide variety of other products using the control codes that are part of the remote. Before using the remote with other products, follow the instructions on pages 37–39 to program the proper codes for the products in your system.

It is also important to remember that many of the buttons on the remote take on different functions, depending on the product selected using the Device Control Selectors. The descriptions shown here primarily detail the functions of the remote when it is used to operate the AVR 335. (See page 38 for information about alternate functions for the remote's buttons.)

1 Power Off Button: Press this button to place the AVR 335 or a selected device in the Standby mode. Note that this will turn off the main room functions, but if the Multiroom system is activated, it will continue to function.

2 IR Transmitter Window: Point this window towards the AVR 335 when pressing buttons on the remote to make certain that infrared commands are properly received.

3 Program Indicator: This three-color indicator is used to guide you through the process of programming the remote. (See page 38 for information on programming the remote.)

4 Power On Button: Press this button to turn on the power to a device selected by pressing one of the **Input Selectors 5**.

5 Input Selectors: Pressing one of these buttons will perform three actions at the same time. First, if the AVR 335 is not turned on, this will power up the unit. Next, it will select the source shown on the button as the input to the AVR 335. Finally, it will switch the remote control so that it controls the device selected. After pressing one of these buttons you must press the **AVR Selector Button 6** again to operate the AVR 335's functions with the remote.

6 AVR Selector: Pressing this button will switch the remote so that it will operate the AVR 335's functions. If the AVR 335 is in the Standby mode, it will also turn the AVR 335 on.

7 AM/FM Tuner Select: Press this button to select the AVR 335's tuner as the listening choice. Pressing

this button when the tuner is already in use will select between the AM and FM bands.

8 Dim Button: Press this button to activate the Dimmer function, which reduces the brightness of the front panel display, or turns it off entirely. The first press of the button shows the default state, which is full brightness by indicating **DIMMER FULL** in the **Lower Display Line 30**. Press the button again within five seconds to reduce the brightness by 50%, as indicated by **DIMMER HALF** showing in the **Lower Display Line 30**. Press the button again within five seconds and the main display will go completely dark. Note that this setting is temporary, in that regardless of any changes, the display will always return to full brightness when the AVR is turned on. In addition, the **Power Indicator 2** will always remain at full brightness regardless of the setting. This is to remind you that the AVR is still turned on.

9 Test Button: Press this button to begin the sequence used to manually calibrate the AVR 335's output levels. (See pages 25 and 32 for more information on calibrating the AVR 335.)

10 Sleep Button: Press this button to place the unit in the Sleep mode. After the time shown in the display, the AVR 335 will automatically go into the Standby mode. Each press of the button changes the time until turn-off in the following order:

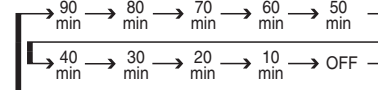

This button is also used to change channels on your TV when the TV is selected.

When the AVR 335 remote is being programmed with the codes to operate another device, this button is also used in the "Auto Search" process. (See page 37 for more information on programming the remote.)

11 DSP Surround Mode Selector: Press this button to cycle through the DSP, VMaX and Stereo surround modes such as Hall, Theater, VMaX Near and Far, and Surround Off. This button is also used to tune channels when the TV is selected using the device **Input Selector 5**. When the AVR 335 remote is being programmed with the codes of another device, this button is also used in the "Auto Search" process. (See page 37 for more information on programming the remote.)

12 Night Mode: Press this button to activate the Night mode. This mode is available in specially encoded digital sources, and it preserves dialogue (center channel) intelligibility at low volume levels.

13 Channel Select Button: This button is used to start the process of setting the AVR 335's output levels to

an external source. Once this button is pressed, use the **▲/▼ Buttons 14** to select the channel being adjusted, then press the **Set Button 16**, followed by the **▲/▼ Buttons 14** again, to change the level setting. (See pages 25 and 32 for more information.)

14 ▲/▼ Buttons: These multipurpose buttons are used to change or scroll through items in the on-screen menus, make configuration settings such as digital inputs or delay timing, or to select surround modes. When changing a setting, first press the button for the function or setting to be changed (e.g., press the **DSP Surround Mode Selector 11** to select a sound field mode or the **Digital Select Button 17** to change a digital input) and then press one of these buttons to scroll through the list of options or to increase or decrease a setting. The sections in this manual describing the individual features and functions contain specific information on using these buttons for each application.

15 ◀▶ Buttons: These buttons are used to change the menu selection or setting during some of the setup procedures for the AVR 335.

16 Set Button: This button is used to enter settings into the AVR 335's memory. It is also used in the setup procedures for delay time, speaker configuration and channel output level adjustment.

17 Digital Select: Press this button to assign one of the digital inputs **18 19 23 26** to a source. (See page 28 for more information on using digital inputs.)

18 Numeric Keys: These buttons serve as a 10-button numeric keypad to enter tuner preset positions. They are also used to select channel numbers when TV, Cable or SAT has been selected on the remote, or to select track numbers on a CD, DVD or LD player, depending on how the remote has been programmed.

19 Tuner Mode: Press this button when the tuner is in use to select between automatic tuning and manual tuning. When the button is pressed so that **MANUAL** appears in the **Lower Display Line 30**, pressing the **Tuning Buttons 21 9 E** will move the frequency up or down in single-step increments. When the FM band is in use, pressing this button when a station's signal is weak will change to monaural reception. (See page 31 for more information.)

20 Direct Button: Press this button when the tuner is in use to start the sequence for direct entry of a station's frequency. After pressing the button, simply press the proper **Numeric Keys 18** to select a station. (See page 31 for more information on the tuner.)

21 Tuning Up/Down: When the tuner is in use, these buttons will tune up or down through the selected frequency band. If the **Tuner Mode Button 19 17** has

MAIN REMOTE CONTROL FUNCTIONS

been pressed so that **AUTO** appears in the on-screen menu and **Lower Display Line 30**, pressing and holding either of the buttons for 3 seconds will cause the tuner to seek the next station with acceptable signal strength for quality reception. When **MANUAL** appears in the **Lower Display Line 30**, pressing these buttons will tune stations in single-step increments. (See page 31 for more information.)

22 OSD Button: Press this button to activate the On-Screen Display (OSD) system used to set up or adjust the AVR 335's parameters.

23 Dolby Mode Selector: This button is used to select from among the available Dolby Surround processing modes. Each press of this button will select one of the Dolby Pro Logic II modes or Dolby 3 Stereo. When a Dolby Digital-encoded source is in use, the Dolby Digital mode may also be selected. (See page 29 for the available Dolby surround mode options.)

24 DTS Digital Mode Selector: When a DTS-encoded digital source is selected, each press of this button will scroll through the available DTS modes. The specific choice of modes will vary according to whether or not the source material contains DTS-ES 6.1 Discrete encoding. When a DTS source is not in use, this button has no function. (See page 29 for the available DTS Digital options.)

25 Logic 7 Mode Select Button: Press this button to select from among the available Logic 7 surround modes. (See page 29 for the available Logic 7 options.)

26 Skip Up/Down Buttons: These buttons do not have a direct function with the AVR 335, but when used with a compatibly programmed CD or DVD changer they will change to the previous disc in the changer or carousel.

27 Transport Controls: These buttons do not have any functions for the AVR 335, but they may be programmed for the forward/reverse play operation of a wide variety of CD or DVD players, and audio or video cassette recorders. When the remote is used to control the AVR, the VID2/TV device or the VID3/CBL/SAT device, these buttons are programmed to operate the DVD player's transport controls. However, you may use the Transport Control Punch-Through feature described on page 39 to program these buttons to operate another device's transport controls when the AVR, VID2 or VID3 device has been selected.

28 Stereo Mode Select Button: Press this button to select a stereo listening mode. When the button is pressed so that **DSP SURR OFF** appears in the **Lower Display Line 30**, the AVR will operate in a

bypass mode with true, fully analog, two-channel left/right stereo mode with no surround processing or bass management, as opposed to other modes where digital processing is used. When the button is pressed so that **SURROUND OFF** appears in the **Lower Display Line 30**, you may enjoy a two-channel presentation of the sound along with the benefits of bass management. Depending on whether your system is configured for 5.1 or 6.1/7.1 channels, the next press of the button will cause either **5 CH STEREO** or **7 CH STEREO** to appear, and the stereo signal will be routed to all five (or seven) speakers. (See page 29 for more information on stereo playback modes.)

29 DTS Neo:6 Mode Select: Press this button to select a DTS Neo:6 mode. These modes take a two-channel stereo- or matrix surround-encoded source and create a full five-, six- or seven-channel sound field. (See page 29 for the available DTS Neo:6 options.)

30 Macro Buttons: Press these buttons to store or recall a "Macro", which is a preprogrammed sequence of commands stored in the remote. (See page 37 for more information on storing and recalling macros.)

31 Disc Skip Button: This button has no direct function for the AVR 335 but is most often used to change to the next disc in a CD or DVD player when the remote is programmed for that type of device. When the remote is used to control the AVR, the VID2/TV device or the VID3/CBL/SAT device, these buttons are programmed to operate the DVD player's transport controls. However, you may use the Transport Control Punch-Through feature described on page 39 to program these buttons to operate another device's transport controls when the AVR, VID2 or VID3 device has been selected. (See page 38 for more information on using the remote with products other than the AVR 335.)

32 Preset Up/Down: When the tuner is in use, press these buttons to scroll through the stations programmed into the AVR 335's memory. When some source devices, such as CD players, VCRs and cassette decks, are selected using the device **Input Selectors 5**, these buttons may function as Chapter Step or Track Advance.

33 Clear Button: Press this button to clear incorrect entries when using the remote to directly enter a radio station's frequency.

34 Memory Button: Press this button to enter a radio station into the AVR 335's preset memory. First, tune the desired station, and then press this button. Two underline indicators will flash at the right side of the **Upper Display Line 29**, and within 5 seconds press the **Numeric Keys 18** for the preset number

between 01 and 30 that you wish to assign to the station. (See page 32 for more information.)

35 Delay/Prev Ch.: Press this button to begin the process for setting the delay times used by the AVR 335 when processing surround sound. After pressing this button, the delay times are entered by pressing the **Set Button 16** and then using the **▲/▼ Buttons 14** to change the setting. Press the **Set Button 16** again to complete the process. (See page 24 for more information.)

36 Speaker Select: Press this button to begin the process of configuring the AVR 335's bass management system for use with the type of speakers used in your system. Once the button has been pressed, use the **▲/▼ Buttons 14** to select the channel you wish to set up. Press the **Set Button 16** and then select another channel to configure. When all adjustments have been completed, press the **Set Button 16** twice to exit the settings and return to normal operation (see page 16).

37 Multiroom: Press this button to activate the multiroom system or to begin the process of changing the input or volume level for the second zone. When used with the DVD player, it controls the Subtitle On/Off function (see page 35).

38 Volume Up/Down: Press these buttons to raise or lower the system volume.

39 TV/Video Selector: This button does not have a direct function on the AVR 335, but when used with a compatibly programmed VCR, DVD or satellite receiver that has a "TV/Video" function, pressing this button will switch between the output of the player or receiver and the external video input to that player. Consult the owner's manual for your specific player or receiver for the details of how it implements this function.

40 6-Channel/8-Channel Direct Input: Press this button to select the device connected to the **8-Channel Direct Inputs 29** as the audio source. (See page 27 for more information.)

When you wish to use the **6-Channel/8-Channel Direct Input 29** in conjunction with a video source, you must first select the video source by pressing one of the **Input Selectors 5**, then press this button to choose the device connected to the **6-Channel/8-Channel Direct Input 29** as the audio source.

41 Mute: Press this button to momentarily silence the AVR 335 or TV set being controlled, depending on which device has been selected. When the AVR 335 remote is being programmed to operate another device, this button is pressed with the **Input Selector Button 5** to begin the programming process. (See page 37 for more information on programming the remote.)

INSTALLATION AND CONNECTIONS

System Installation

After unpacking the unit, locating it in a place with adequate ventilation and placing it on a solid surface capable of supporting its weight, you will need to make the connections to your audio and video equipment.

IMPORTANT NOTE: For your personal safety and to avoid possible damage to your equipment and speakers, it is always a good practice to turn off and unplug the AVR and ALL source equipment from the AC output before making any audio or video system connections.

Audio Equipment Connections

We recommend that you use high-quality interconnect cables when making connections to source equipment and recorders to preserve the integrity of the signals.

1. Connect the analog output of a CD player to the **CD Audio Inputs 2**.

NOTE: When the CD player has both fixed and variable audio outputs, it is best to use the fixed output unless you find that the input to the receiver is so low that the sound is noisy, or so high that it is distorted.

2. Connect the analog Play/Out jacks of a cassette deck, MD, CD-R or other audio recorder to the **Tape Input Jacks 39**. Connect the analog Record/In jacks on the recorder to the **Tape Output Jacks 43** on the AVR 335.
3. Connect the output of any digital sources such as a CD or DVD changer or player, advanced video game, a digital satellite receiver, HDTV tuner or digital cable set-top box or the output of a compatible computer sound card to the **Optical and Coaxial Digital Audio Inputs 23 26 18 19**.
4. Connect the coaxial or optical **Digital Audio Outputs 20 21** on the rear panel of the AVR 335 to the matching digital input connections on a CD-R or MiniDisc recorder.
5. Assemble the AM Loop Antenna supplied with the unit so that the tabs at the bottom of the antenna loop snap into the holes in the base. Connect it to the **AM Antenna Terminals 40**.

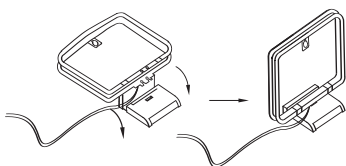

6. Connect the supplied FM antenna to the **FM (75-ohm) Connection 41**. The FM antenna may be an external roof antenna, an inside powered or wire-lead antenna or a connection from a cable TV system. If the antenna or connection uses 300-ohm twin-lead cable, you must use an optional

300-ohm-to-75-ohm adapter to make the connection.

7. Connect the front, center, surround and surround back speaker outputs **9 10 11 11** to the respective speakers.

To ensure that all the audio signals are carried to your speakers without loss of clarity or resolution, we suggest that you use high-quality speaker cable. Many brands of cable are available and the choice of cable may be influenced by the distance between your speakers and the receiver, the type of speakers you use, personal preferences and other factors. Your dealer or installer is a valuable resource to consult in selecting the proper cable.

Regardless of the brand of cable selected, we recommend that you use a cable constructed of multi-strand copper with a gauge of 14 or smaller. Remember that in specifying cable, the lower the number, the thicker the cable.

Cable with a gauge of 16 may be used for short runs of less than 10 feet. We do not recommend that you use cables with an AWG equivalent of 18 or higher, due to the power loss and degradation in performance that will occur.

Cables that are run inside walls should have the appropriate markings to indicate listing with UL, CSA or other appropriate testing agency standards. Questions about running cables inside walls should be referred to your installer or a licensed electrician who is familiar with the NEC and/or the applicable local building codes in your area.

When connecting wires to the speakers, be certain to observe proper polarity. Note that the positive (+) terminal of each speaker connection now carries a specific color code, as noted on page 7. However, most speakers still use a red terminal for the positive (+) connection. Connect the "negative" or "black" wire to the same terminal on both the receiver and the speaker.

NOTE: While most speaker manufacturers adhere to an industry convention of using black terminals for negative and red ones for positive, some may vary from this configuration. To ensure proper phase and optimal performance, consult the identification plate on your speaker or the speaker's manual to verify polarity. If you do not know the polarity of your speaker, ask your dealer for advice before proceeding, or consult the speaker's manufacturer.

We also recommend that the length of cable used to connect speaker pairs be identical. For example, use the same length piece of cable to connect the front-left and front-right or surround-left and surround-right speakers, even if the speakers are a different distance from the AVR 335.

8. Connections to a subwoofer are normally made via a line-level audio connection from the **Subwoofer Output 8** to the line-level input of a subwoofer with a built-in amplifier. When a passive subwoofer is used, the connection first goes to a power amplifier, which will be connected to one or more subwoofer speakers. If you are using a powered subwoofer that does not have line-level input connections, follow the instructions furnished with the speaker for connection information.
9. If an external multichannel audio source with 5.1- or 7.1-channel outputs such as an external digital processor/decoder, DVD-Audio or SACD player is used, connect the outputs of that device to the **8-Channel Direct Inputs 29**.

Video Equipment Connections

Video equipment is connected in the same manner as audio components. Again, the use of high-quality interconnect cables is recommended to preserve signal quality.

1. Connect a VCR's, personal video recorder's (PVR) or other video source's audio and video Play/Out jacks to the **Video 1 or Video 2 Audio/Video and S-Video Input Jacks 25 28 34 36** on the rear panel. The Audio and Video Record/In jacks on the VCR should be connected to the **Video 1 or Video 2 Audio/Video and S-Video Output Jacks 27 30 35 37** on the AVR 335. Although any video device may be connected to these jacks, we recommend connecting your video recorder to the **Video 1 Audio/Video and S-Video Input and Output Jacks 25 27 34 35** so that you may take advantage of the fact that the remote control is preprogrammed with video recorder product codes for the Video 1 device.
2. Connect the analog audio and video outputs of a satellite receiver, cable TV converter, television set or any other video source to the **Video 2 or Video 3 Audio/Video and S-Video Input Jacks 28 31 36 38**. Although any video device may be connected to these jacks, we recommend connecting your cable TV converter or satellite receiver so that you may take advantage of the fact that the remote control is preprogrammed with the product codes of these device types for the Video 2 device. If your device is capable of switching component video, we particularly recommend connecting it to the **Video 2 Audio Input Jacks 36**, as the **Video 2 Component Video Inputs 14** are assigned to the Video 2 device.
3. Connect the analog audio and video outputs of a television or other video device to the **Video 3 Audio/Video and S-Video Input Jacks 31 38**. Although any video or audio device may be connected to these jacks, we recommend connecting

INSTALLATION AND CONNECTIONS

your television so that you may take advantage of the fact that the remote control is preprogrammed with television product codes for the Video 3 device. **IMPORTANT:** If you are only using the television as a display device (i.e., if you receive your television programs through a cable box or satellite receiver), do not connect the TV's outputs to the **Video 3 Audio/Video and S-Video Input Jacks 31 38**, or to any other inputs on the AVR 335.

4. Connect the analog audio and video outputs of a DVD or laser disc player to the **DVD Audio/Video and S-Video Inputs 24 33**.
5. Connect the digital audio outputs of a DVD player, satellite receiver, cable box or HDTV converter to the appropriate **Optical or Coaxial Digital Inputs 23 26 18 19**.
6. Connect the **Video and/or S-Video Monitor Output 22 32** jacks on the receiver to the composite or S-video input of your television monitor or video projector.
7. If your DVD player and monitor both have component video connections, connect the component outputs of the DVD player to the **DVD Component Video Inputs 14**. Even when component video connections are used, the audio connections should still be made to either the analog **DVD Audio Inputs 33** or any of the **Optical or Coaxial Digital Input Jacks 23 26 18 19**.
8. If another device with component video outputs is available, connect it to the **Video 2 Component Video Inputs 13**. The audio connections for this device should be made to either the **Video 2 Audio Inputs 36** or any of the **Optical or Coaxial Digital Input Jacks 23 26 18 19**.
9. If the component video inputs are used, connect the **Component Video Monitor Outputs 13** to the component video inputs of your TV, projector or display device.
10. If you have a camcorder, video game or other device that is connected to the AVR on a temporary rather than permanent basis, connect its audio, video and digital audio outputs to the **Front-Panel Inputs 18 19 20 21**. A device connected here is selected as the Video 4 input, and the digital inputs must be assigned to the Video 4 input. (See page 17 for more information on input configuration.)

Video Connection Notes:

- When the component video jacks are used, the on-screen menus are not visible and you must switch to the standard composite or S-video input on your TV to view them.

- The AVR 335 will accept either standard composite, S-video or Y/Pr/Pb component video signals. However, it will not convert any of these signals to a different format.
- When connecting a video source to the AVR 335, you may use composite, component or S-video, but only one type of video may be connected for each device.
- When more than one video format is used, it is necessary to make a separate connection from the AVR to your video display for each format. For example, if both composite and component sources are connected to the AVR 335, both the **Composite and Component Video Monitor Outputs 13 32** must be connected to the appropriate inputs on your video display.

System and Power Connections

The AVR 335 is designed for flexible use with multi-room systems, external control components and power amplifiers.

Main Room Remote Control Extension

If the receiver is placed behind a solid or smoked glass cabinet door, the obstruction may prevent the remote sensor from receiving commands. In this event, an optional remote sensor may be used. Connect the output of the remote sensor to the **Remote IR Input 4** jack.

If other components are also prevented from receiving remote commands, only one sensor is needed. Simply use this unit's sensor or a remote eye by running a connection from the **Remote IR Output 6** jack to the Remote IR Input jack on Harman Kardon or other compatible equipment.

Multiroom IR Link

The remote room IR receiver should be connected to the AVR 335 via standard coaxial cable. Plug the IR connection cable into the **Multiroom IR Input 5** jack on the AVR 335's rear panel.

If Harman Kardon-compatible source equipment is part of the main room installation, the **Remote IR Output 6** jack on the rear panel should be connected to the IR IN jack on source equipment. This will enable the remote room sensor to control that equipment.

Multiroom Connections

The AVR 335 is equipped with multizone capabilities that allow it to send a separate audio source to the remote zone from the one selected for use in the main room.

Depending on your system's requirement, three options are available for audio connection:

Option 1: Use high-quality, shielded audio interconnect cable from the AVR 335's location to the remote

room. In the remote room, connect the interconnect cable to a stereo power amplifier. The amplifier will be connected to the room's speakers. At the AVR 335, plug the audio interconnect cables into the **Multiroom Audio Output 1** jacks on the AVR 335's rear panel.

Option 2: Connect the **Multiroom Audio Output 1** jacks on the AVR 335 to the inputs of an optional stereo power amplifier. Run high-quality speaker wire from the amplifier to the speakers in the remote room.

Option 3: Taking advantage of the AVR 335's built-in seven-channel amplifier, it is possible to use two of the amplifier channels to power speakers in the remote room. When using this option you will not be able to use the full 7.1-channel capabilities of the AVR 335 in the main listening room, but you will be able to add another listening room without additional external power amplifiers. To use the internal amplifiers to power a remote zone, connect the speakers for the remote room location to the **Surround Back/Multiroom Speaker Outputs 10**. Before using the remote room you will need to configure the amplifiers for surround operation by changing a setting in the **MULTIROOM** menu, following the instructions shown on page 35.

NOTE: For all options, you may connect an optional IR sensor in the remote room to the AVR 335 via an appropriate cable. Connect the sensor's cable to the **Multiroom IR Input 5** and use the Zone II remote to control the room volume. Alternatively, you may install an optional volume control between the output of the amplifiers and the speakers. See page 35 for more information on the multiroom system.

AC Power Connections

This unit is equipped with two accessory AC outlets. They may be used to power accessory devices, but they should not be used with high-current-draw equipment such as power amplifiers. The total power draw to each outlet may not exceed 100 watts.

The **Switched AC Accessory Outlet 18** will receive power only when the unit is on. This is recommended for devices that have no power switch or a mechanical power switch that may be left in the "ON" position.

NOTE: Many audio and video products go into a Standby mode when they are used with switched outlets, and cannot be fully turned on using the outlet alone without a remote control command.

The **Unswitched AC Accessory Outlet 19** will receive power as long as the unit is plugged into a powered AC outlet.

Once the **AC Power Cord 17** is connected, you are almost ready to enjoy the AVR 335!

OPERATION

Basic Operation

Once you have completed the initial setup and configuration of the AVR 335, it is simple to operate and enjoy. The following instructions will help you maximize the enjoyment of your new receiver:

Turning the AVR 335 On or Off

- When using the AVR 335 for the first time, you must press the **Main Power Switch 1** on the front panel to turn the unit on. This places the unit in a Standby mode, as indicated by the amber color of the **Power Indicator 2**. Once the unit is in Standby, you may begin a listening session by pressing the **Standby/On Switch 3** on the front panel, or the **Power On Button 4** or **AVR Selector 6** on the remote. The **Power Indicator 2** will turn blue. This will turn the unit on and return it to the input source that was last used. The unit may also be turned on from Standby by pressing any of the **Input Selector Buttons 5 7 C D** on the remote or the **Input Source Selector Button 16** on the front panel.

NOTE: After pressing one of the **Input Selector Buttons 5 7** to turn the unit on, press the **AVR Selector 6** to set the remote control to the AVR 335 functions.

To turn the unit off at the end of a listening session, simply press the **Standby/On Switch 3** on the front panel or the **Power Off Button 1 A** on the remote. Power will be shut off to any equipment plugged into the rear-panel **Switched AC Accessory Outlet 16** and the **Power Indicator 2** will turn amber.

When the remote is used to turn the unit "off" it is actually placing the system in a Standby mode, as indicated by the amber color of the **Power Indicator 2**.

- To program the AVR 335 for automatic turn-off, press the **Sleep Button 10** on the remote. Each press of the button will decrease the time before shutdown in the following sequence:

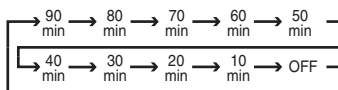

The sleep time will be displayed in the **Lower Display Line 30** and it will count down until the time has elapsed.

When the programmed sleep time has elapsed, the unit will automatically turn off. The front-panel display will dim to one-half brightness when the Sleep function is programmed. To cancel the Sleep function, press and hold the **Sleep Button 10** until the information display returns to normal brightness; the Sleep indicator numbers will disappear and the words

SLEEP OFF will appear in the **Lower Display Line 30**.

When you will be away from home for an extended period of time, it is always a good idea to completely turn the unit off with the front-panel **Main Power Switch 1**.

NOTE: All preset memories are lost if the unit is left turned off by using the **Main Power Switch 1** for more than four weeks.

Source Selection

- To select a source, press any of the **Input Selector Buttons 5 7 C D** on the remote.
- The input source may also be changed by pressing the front-panel **Input Source Selector Button 16**. Each press of the button will move the input selection through the list of available inputs.
- As the input is changed, the AVR 335 will automatically switch to the digital input (if selected), surround mode, speaker configuration, output levels, crossover frequency and night mode status that were entered during the configuration process for that source.
- The front-panel **Video 4 Inputs 20 21**, **Optical 3 Digital Input 18** or the **Coaxial 3 Digital Input 19** may be used to connect a device such as a video game or camcorder to your home entertainment system on a temporary basis.
- As the input source is changed, the new input name will appear momentarily as an on-screen display in the lower third of the video display. The input name will also appear in the **Upper Display Line 29** and in the front-panel **Input Indicators 27**.
- When an audio source is selected, the last video input used remains routed to the **Video 1/Video 2 Video Outputs 27 30 35 37** and **Video and S-Video Monitor Outputs 22 32**. This permits simultaneous viewing and listening to different sources. This also allows you to choose a video source and then select the **6/8-Channel Direct Inputs 29** as the audio source.
- When a composite or S-video source is selected, the video signal for that input will be routed to the **S-Video Monitor Output 22** and will be viewable on a TV monitor connected to the AVR 335.

6-Channel/8-Channel Direct Input

- There are two input choices available for use with sources such as a DVD-Audio or SACD player that are connected to the **6/8-Channel Direct Inputs 29**. Select the appropriate input according to how your system and source equipment are configured:
 - **6 CH DIRECT** should be used when the SBR and SBL inputs 29 are NOT in use. The AVR

presumes that the input source device has its own internal bass management system. This input passes the input from the source directly through to the volume control without any analog to digital conversion and it mutes the unused input jacks to prevent unwanted noise from interfering with system performance.

- **8 CH DIRECT** should be used when an input is connected to all eight **8-Channel Direct Inputs 29**. The AVR operates on the assumption that the input source device has its own internal bass management system. This input passes the input from the source directly through to the volume control without any analog-to-digital conversion and it mutes the unused input jacks to prevent unwanted noise from interfering with system performance.

Volume Control

- Adjust the volume to a comfortable level using the front-panel **Volume Control 26** or remote **Volume Up/Down Buttons 38 1**.
- When listening in one of the Stereo modes with the surround circuits off, the **Balance Control 23** may be used to adjust the relative sound output between the front left and right speakers. For all other modes, it is important that the **Balance Control 23** remain in the "12 o'clock" position in order to ensure a proper sound field presentation.
- To temporarily silence all speaker outputs, press the **Mute Button 41 K**. This will interrupt the output to all speakers and the headphone jack, but it will not affect any recording or dubbing that may be in progress. When the system is muted, the word **MUTE** will flash in the **Lower Display Line 30**. Press the **Mute Button 41 K** again to return to normal operation.
- You may adjust the bass and treble tone controls at any point during a listening session by simply turning the **Bass Control 22** or **Treble Control 24** until the desired setting is achieved. You may also totally remove the tone controls from the circuit so that the output is "flat" by pressing the **Tone Mode Button 5** and then pressing the **Left/Right Button 10** so that **TONE OFF** appears in the on-screen display and the **Lower Display Line 30**.
- For private listening, plug the 1/4" stereo phone plug from a pair of stereo headphones into the front-panel **Headphone Jack 4**. When the headphone plug is connected, all speakers will be silenced and **DOLBY H:BP** will scroll once across the **Lower Display Line 30**, indicating that the headphone output is in the Bypass mode, and

OPERATION

to confirm that no processing is being used. When the headphone plug is removed, the audio feed to the speakers will be restored.

- When the headphones are in use, you may take advantage of the Dolby Headphone modes to bring added spaciousness to headphone listening. Press the **Dolby Mode Select Button** **23** or the **Surround Mode Group Selector** **7** to cycle through the three Dolby Headphone modes and select the one that you prefer.

Surround Mode Selection

One of the most important features of the AVR 335 is its ability to reproduce a full multichannel surround sound field from digital sources, analog matrix surround-encoded programs and standard stereo programs.

Selection of a surround mode is based on personal taste, as well as the type of program source material being used. For example, motion pictures or TV programs bearing the logo of one of the major surround-encoding processes, such as Dolby Surround or DTS Stereo, may be played in either the Dolby Digital, Dolby Pro Logic II Cinema, DTS Neo:6 Cinema or Logic 7 Cinema surround modes, depending on the source material.

NOTE: Once a program has been encoded with matrix surround information, it retains the surround information as long as the program is broadcast in stereo. Thus, movies with surround sound may be decoded via any of the analog surround modes such as Dolby Pro Logic II Movie, Logic 7 Cinema or DTS Neo:6 Cinema, when they are broadcast via conventional TV stations, cable, pay-TV and satellite transmission. In addition, a growing number of made-for-television programs, sports broadcasts, radio dramas and music CDs are also recorded in surround sound.

Even when a program is not listed as carrying intentional surround information, you may find that the Dolby Pro Logic II, Logic 7 Enhanced or DTS Neo:6, VMAX and the Hall or Theater modes often deliver enveloping surround presentations through the use of the natural information present in all stereo recordings.

Surround modes may be changed at any time by using either the front panel or remote control. To select a new surround mode from the front panel, first press the **Surround Mode Group Selector Button** **7** until the desired major surround mode group such as Dolby, DTS or Logic 7 is selected. Next, press the **Surround Mode Selector Button** **8** to choose the specific individual surround mode.

To select a surround mode using the remote, press the button for the major surround mode group that includes the mode you wish to choose from: **Dolby** **23**, **DTS Surround** **24**, **DTS Neo:6** **29**, **Logic 7** **25**, **Stereo** **28** or **DSP Surround** **11**. The first press of the button will show the current mode from that group if it is already in use, or the first available mode if you are currently using another mode. To cycle through the available modes in that group, press the button again until the desired mode appears in the **Lower Display Line** **30**, in the on-screen display and in the **Surround Mode Indicators** **31**.

As the surround modes change, the appropriate **Surround Mode Indicator** **31** will light to indicate which mode has been selected.

The Dolby Digital, Dolby Digital EX and DTS 5.1, DTS-ES Matrix and DTS-ES Discrete modes may only be selected when a digital input is in use. In addition, when a digital source is present, the AVR 335 will automatically select and switch to the correct mode, regardless of the mode that has been previously selected. For more information on selecting digital sources, see the Digital Audio Playback section below.

The Dolby Pro Logic IIx modes are available only when the AVR 335 has been configured for 6.1/7.1 operation by setting the Surround Back speakers as either "Large" or "Small" as described on page 23. These modes provide a matrixed 6.1-channel presentation of analog sources. See page 29 for more information.

When the 6-channel/8-channel direct inputs are in use there is no surround processing, as these inputs take the analog output signals from an optional, external DVD-Audio or SACD player, or another source device and carry them straight through to the volume control without any further digital processing.

To listen to a program in traditional two-channel stereo, using the front left and front right speakers only (plus the subwoofer, if installed and configured), press the **Stereo Button** **23** until **SURR OFF** appears in the **Lower Display Line** **30**, or press the **Surround Mode Group Selector** **7** until the Stereo modes appear in the on-screen display and **Lower Display Line** **30**. Next, press the **Surround Mode Select Button** **8** until **SURROUND OFF** appears in the on-screen display and **Lower Display Line** **30**.

The Surround Off mode provides an analog bypass of the digital processing, including bass management. Scroll until **SURROUND OFF DSP** appears if you require bass management (usually used when the system includes a separate subwoofer).

Digital Audio Playback

Digital audio is a major advancement over older analog surround processing systems such as Dolby Pro Logic. It delivers five discrete channels: left front, center, right front, left surround and right surround. Each channel reproduces full frequency range (20Hz to 20kHz) and offers dramatically improved dynamic range and significant improvements to signal-to-noise ratios. In addition, digital systems have the capability to deliver an additional channel that is specifically devoted to low-frequency information. This is the ".1" channel referred to when you see these systems described as "5.1," "6.1" or "7.1." The bass channel is separate from the other channels, but since it is intentionally bandwidth-limited, sound designers have given it that unique designation.

Dolby Digital

Dolby Digital is a standard part of DVD, and is available on specially encoded LD discs and satellite broadcasts and it is a part of the high-definition television (HDTV) system.

An optional, external RF demodulator is required to use the AVR 335 to listen to the Dolby Digital soundtracks available on laser discs. Connect the RF output of the LD player to the demodulator and then connect the digital output of the demodulator to the **Optical or Coaxial Inputs** **18****19****23****26** of the AVR 335. No demodulator is required for use with DVD players or DTS-encoded laser discs.

DTS

DTS is another digital audio system that is capable of delivering 5.1 or 6.1 discrete or matrix sound field reproduction. Although both DTS and Dolby Digital are digital, they use different methods of encoding the signals, and thus they require different decoding circuits to convert the digital signals back to analog.

DTS-encoded soundtracks are available on select DVD and LD discs, as well as on special audio-only DTS discs. You may use any LD or CD player equipped with a digital output to play DTS-encoded discs with the AVR 335. All that is required is to connect the player's output to either an **Optical or Coaxial Input** on the rear panel **23****26** or front panel **18****19**.

In order to listen to DVDs encoded with DTS soundtracks, the DVD player must be compatible with the DTS signal as indicated by a DTS logo on the player's front panel. Early DVD players may not be able to play DTS-encoded DVDs. This does not indicate a problem with the AVR 335, as some players cannot pass the DTS signal through to the digital outputs. If you are in doubt as to the capability of your DVD player to handle DTS discs, consult the player's owner's manual.

Continued on page 30

OPERATION

Surround Mode Chart

MODE	FEATURES
Dolby Digital	Available only with digital input sources encoded with Dolby Digital data. It provides up to five separate main audio channels and a special dedicated low-frequency effects (LFE) channel.
Dolby Digital EX	Available when the receiver is configured for 6.1/7.1-channel operation, Dolby Digital EX is the latest version of Dolby Digital. When used with movies or other programs that have special encoding, Dolby Digital EX reproduces specially encoded soundtracks so that a full 6.1/7.1 sound field is available. When the receiver is set for 6.1/7.1 operation and a Dolby Digital signal is present, the EX mode is automatically selected. Even if specific EX encoding is not available to provide the additional channel, the special algorithms will derive a 6.1/7.1 output.
DTS 5.1	When the speaker configuration is set for 5.1-channel operation, the DTS 5.1 mode is available when DVD, audio-only music or laser discs encoded with DTS data are played. DTS 5.1 provides up to five separate main audio channels and a special dedicated low-frequency channel.
DTS-ES 6.1 Matrix DTS-ES 6.1 Discrete	When the speaker configuration is set for 6.1/7.1 operation, playback of a DTS-encoded program source will automatically trigger the selection of one of the two DTS-ES modes. Newer discs with special DTS-ES discrete encoding will be decoded to provide six discrete, full-bandwidth channels plus a separate low-frequency channel. All other DTS discs will be decoded using the DTS-ES Matrix mode, which creates a 6.1-channel sound field from the original 5.1-channel soundtrack.
Dolby Pro Logic II Movie Music Pro Logic	Dolby Pro Logic II is the latest version of Dolby Laboratory's benchmark surround technology that decodes full-range, discrete left, center right, right surround and left surround channels from either matrix surround-encoded programs and conventional stereo sources when an analog input is in use. The Dolby Pro Logic II Movie mode is optimized for movie soundtracks, while the Pro Logic II Music mode should be used with musical selections. The Pro Logic mode activates original Pro Logic processing for those who prefer that presentation.
Dolby Pro Logic IIx Music Movie	Dolby Pro Logic IIx is the latest extension of Dolby Pro Logic II technology that creates a discrete 6.1 and 7.1 sound field from matrix surround or two-channel stereo sources in systems configured for surround back speakers. Both Movie and Music versions of Pro Logic IIx are available.
Logic 7 Cinema Logic 7 Music Logic 7 Enhance	Exclusive to Harman Kardon for AV receivers, Logic 7 is an advanced mode that extracts the maximum surround information from either surround-encoded programs or conventional stereo material. Depending on the number of speakers in use and the selection made in the SURROUND SELECT menu, the "5.1" versions of Logic 7 modes are available when the 5.1 option is chosen, while the "7.1" versions of Logic 7 produce a full sound field presentation, including back surround speakers when the "6.1/7.1" option is chosen. The Logic 7 C (or Cinema) mode should be used with any source that contains Dolby Surround or similar matrix encoding. Logic 7 C delivers increased center-channel intelligibility, and more accurate placement of sounds with fades and pans that are much smoother and more realistic than with other decoding techniques. The Logic 7 M or Music mode should be used with analog or PCM stereo sources. Logic 7 M enhances the listening experience by presenting a wider front soundstage and greater rear ambience. Both Logic 7 modes also direct low-frequency information to the subwoofer (if installed and configured) to deliver maximum bass impact. The Logic 7 E (or Enhance) mode, available only when the 5.1 option is chosen, is an extension of the Logic 7 mode that is primarily used with musical programs. Logic 7 adds additional bass enhancement that circulates low frequencies in the 40Hz to 120Hz range to the front and surround speakers to deliver a less localized soundstage that appears broader and wider than when the subwoofer is the sole source of bass energy.
DTS Neo:6 Cinema DTS Neo:6 Music	These two modes are available when any analog source is playing to create a six-channel surround presentation from conventional Matrix-encoded and traditional Stereo sources. Select the Cinema version of Neo:6 when a program with any type of analog Matrix surround encoding is present. Select the Music version of Neo:6 for optimal processing when a nonencoded, two-channel stereo program is being played.
Dolby 3 Stereo	Uses the information contained in a surround-encoded or two-channel stereo program to create center-channel information. In addition, the information that is normally sent to the rear-channel surround speakers is carefully mixed in with the front-left and front-right channels for increased realism. Use this mode when you have a center channel speaker but no surround speakers.
Dolby Virtual Speaker Reference Wide	Dolby Virtual Speaker uses advanced technology to simulate the sonic signature of a speaker location even when there is no speaker physically present in that location. The Reference ("REF") mode activates any missing speakers to simulate a 5.1 presentation with accurate localization. The Wide mode virtualizes the locations of the front channel speakers to create a wider image and a more enveloping sound field. It is available no matter how many speakers are present.
Theater	The Theater mode creates a sound field that resembles the acoustic feeling of a standard live-performance theater.
Hall 1, Hall 2	The two Hall modes create sound fields that resemble a small (Hall 1) and medium-sized (Hall 2) concert hall.
VMAx Near VMAx Far	When only the two front-channel loudspeakers are used, Harman's patented VMAx mode delivers a three-dimensional sound space with the illusion of "phantom speakers" at the center and surround positions. The VMAx N, or "Near Field," mode should be selected when your listening position is less than five feet from the speakers. The VMAx F, or "Far Field," mode should be selected when your listening position is greater than five feet from the speakers. The VMAx modes are also available using the Headphones Output 4 . When headphones are being used, the Far Field mode will appear to push the sound field away from your ears, reducing the "inside the head" sensation often experienced when using headphones.
5-Channel Stereo 7-Channel Stereo	This mode takes advantage of multiple speakers to place a stereo signal at both the front and back of a room. Depending on whether the AVR has been configured for either 5.1 or 6.1/7.1 operation, one of these modes, but not both, is available at any time. Ideal for playing music in situations such as a party, it places the same signal at the front-left and surround-left, and front-right and surround-right speakers. The center channel is fed a summed mono mix of the in-phase material of the left and right channels.
Surround Off (Stereo)	This mode turns off all surround processing and presents the pure left- and right-channel presentation of two-channel stereo programs. When SURROUND OFF is selected, the unit is in a "bypass" mode with no bass management. When SURROUND OFF + DSP is selected, the signal is digitized and bass management settings are applied.
Dolby Headphone DH1 DH2 DH3	Dolby Headphone enables ordinary stereo headphones to portray the sound of a five-speaker surround-playback system. The DH1 mode creates a headphone presentation that resembles a small, well-damped room and is appropriate for use with both movies and music-only recordings. The DH2 mode creates a more acoustically live room particularly suited to music listening. The DH3 mode creates a larger room, more like a concert hall or movie theater. The Bypass mode sends a "pure stereo" feed to the headphones.

For additional information on the specifics of surround modes and processing, information about Dolby modes may be found at www.dolby.com/Consumer/Technologies.

Information about DTS modes is available at www.dtsonline.com/home&car/overview.php.

OPERATION

IMPORTANT NOTE: Many DVD players have a default setting that does not pass through the DTS data, even though the machine is capable of doing so. If your DVD player has the "DTS Digital Out" logo but does not trigger DTS playback in the AVR 335, change the player's settings in the "Audio" or "Bitstream" configuration menu so that DTS playback is enabled. The method for doing this will vary with each player. In some cases, the proper menu choice will be "Original," while in others it will be "DTS." Consult the owner's manual for your player to find the specific information to find the proper setting.

Selecting a Digital Source

To utilize either digital mode, you must have properly connected a digital source to the AVR 335. Connect the digital outputs from DVD players, HDTV receivers, satellite systems or CD players to the **Optical** or **Coaxial Inputs** **18****19****23****25**. In order to provide a backup signal and a source for analog stereo recording, the analog outputs provided on digital source equipment should also be connected to their appropriate inputs on the AVR 335 rear panel (e.g., connect the analog stereo audio output from a DVD to the **DVD Audio Inputs** **23** on the rear panel when you connect the source's digital outputs).

If you have not already configured an input for a digital source using the on-screen menus as shown on page 18, first select the input using the remote or front-panel controls, as outlined in this manual. Next, select the digital source by pressing the **Digital Select Button** **17****13** and then using the **▲/▼ Buttons** **14** on the remote or the **◀/▶ Selector Buttons** **10** on the front panel to choose any of the **OPTICAL** or **COAXIAL** inputs, as they appear in the **Upper Display Line** **29** or on-screen display. When the digital source is playing, the AVR 335 will automatically detect which type of digital data stream is being decoded and display that information in the **Upper Display Line** **29**.

Digital Bitstream Indications

When a digital source is playing, the AVR 335 senses the type of bitstream data that is present. Using this information, the correct surround mode will automatically be selected. For example, DTS bitstreams will cause the unit to switch to DTS decoding, and Dolby Digital bitstreams will enable Dolby Digital decoding. When the unit senses PCM data from CDs or LDs, you may select any of the standard surround modes, such as Dolby Pro Logic II or Logic 7. Since the range of available surround modes is dependent on the type of digital data that is present, the AVR 335 uses a variety of indicators to let you know what type of signal is present. This will help you to understand the choice of modes.

When a digital source is playing, the AVR 335 will display a variety of messages to indicate the type of bit-

stream being received. These messages will appear shortly after an input or surround mode is changed, and they will remain in the **Lower Display Line** **30** for about five seconds before that portion of the display returns to the normal surround mode indication.

Surround Mode Types

For Dolby Digital and DTS sources, a three-digit indication will appear, showing the number of channels present in the data. An example of this type of display is **3/2/.1**.

The first number indicates how many discrete front-channel signals are present.

- A "3" tells you that separate front left, center and front right signals are available. This will be displayed for Dolby Digital 5.1 and DTS 5.1 programs.
- A "2" tells you that separate front left and right signals are available, but there is no discrete center channel signal. This will be displayed for Dolby Digital bitstreams that have stereo program material.
- A "1" tells you that there is only a mono channel available in the Dolby Digital bitstream.

The middle number indicates how many discrete surround channel signals are present.

- A "2" tells you that separate surround left and right signals are available. This will be displayed for Dolby Digital 5.1 and DTS 5.1 programs.
- A "1" tells you that there is only a single, surround-encoded surround channel. This will appear for Dolby Digital bitstreams that have matrix encoding.
- A "0" indicates that there is no surround channel information. This will be displayed for two-channel stereo programs.

The last number indicates whether there is a discrete low-frequency effects (LFE) channel. This is the ".1" in the common abbreviation of "5.1" sound and it is a special channel that contains only bass frequencies.

- A ".1" tells you that an LFE channel is present. This will be displayed for Dolby Digital 5.1 and DTS 5.1 programs, as available.
- A "0" indicates that there is no LFE channel information available. However, even when there is no dedicated LFE channel, low-frequency sound will be present at the subwoofer output when the speaker configuration is set to show the presence of a subwoofer.

The information in the right side of the display will tell you if the digital audio data contains a special flag signal that will automatically activate the appropriate 6.1 or 7.1 mode. This will be shown as **EX-ON** or

EX-OFF for Dolby Digital bitstreams, and **ES-ON** or **ES-OFF** for DTS bitstreams.

An **UNLOCK** message may occasionally appear in the **Lower Display Line** **30**. It does not indicate a fault or problem with your receiver or the digital source. This is your indication that the digital audio data stream has been interrupted or is no longer present.

When the message appears and the indicators flash, the unit's digital signal processor has no signal to lock onto, and is thus "unlocked." You may see this message when a DVD is first started until the stream is playing and the processor determines which mode to apply; or any time the data stream is stopped or paused, such as when the menus of some discs are displayed or when the player is switching between the different sections of a disc. You may also see the message when a satellite receiver, cable set-top or HDTV tuner is in use if the digital audio is temporarily interrupted when channels are changed or when a cable box switches from a channel with a digital data stream to a channel with analog audio only. The **UNLOCK** message is normal, and does not indicate any problem with your receiver. Rather, it tells you that the incoming data has simply been paused or is not present for a variety of possible reasons.

When Dolby Digital 3/2/.1 or DTS 3/2/.1 signals are being played, the AVR will automatically switch to the proper surround mode, and no other processing may be selected. When a Dolby Digital signal with a 3/1/0 or 2/0/0 signal is detected, you may select any of the Dolby surround modes.

It is always a good idea to check the readout for the channel data to make certain that it matches the audio logo information shown on the back of a DVD package. In some cases, you will see an indication for "2/0/0" even when the disc contains a full 5.1, or 3/2/.1, signal. When this happens, check the audio output settings for your DVD player or the audio menu selections for the specific disc being played to make certain that the player is sending the correct signal to the AVR.

PCM Playback Indications

PCM is the abbreviation for Pulse Code Modulation, which is the type of digital signal used for standard CD playback, and other non-Dolby Digital and non-DTS digital sources such as Mini-Disc. When a PCM signal is detected, the **Lower Display Line** **30** will briefly show a message with the letters PCM, in addition to a readout of the sampling frequency of the digital signal.

In most cases, this will be **48kHz**, though in the case of specially mastered, high-resolution audio discs, you will see a **96kHz** indication.

OPERATION

Speaker/Channel Indicators

In addition to the bitstream indicators, the AVR 335 features a set of unique channel-input indicators that tell you how many channels of digital information are being received and/or whether the digital signal is interrupted (see Figure 12).

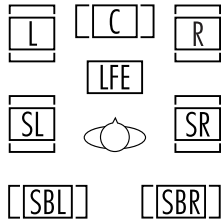

Figure 12

These indicators are the L/C/R/LFE/SL/SR/SBL/SBR letters that are inside the center boxes of the **Speaker/Channel Input Indicators 28** on the front panel. When a standard analog signal is in use, only the "L" and "R" indicators will light, as analog signals have only left and right channels.

Digital signals, however, may have two, five, six or seven channels, depending on the program material, the method of transmission and the way in which it was encoded. When a digital signal is playing, the letters in these indicators will light in response to the specific signal being received. It is important to note that although Dolby Digital, for example, is referred to as a "5.1" system, not all Dolby Digital DVDs or programs are encoded for 5.1. Thus, it is sometimes normal for a DVD with a Dolby Digital soundtrack to trigger only the "L" and "R" indicators.

NOTE: Many DVD discs are recorded with both "5.1" and "2.0" versions of the same soundtrack. When playing a DVD, always be certain to check the type of material on the disc. Most discs show this information in the form of a listing or icon on the back of the disc jacket. When a disc does offer multiple soundtrack choices, you may have to make some adjustments to your DVD player (usually with the "Audio Select" button or in a menu screen on the disc) to send a full 5.1 feed to the AVR 335. It is also possible for the type of signal feed to change during the course of a DVD playback. In some cases, the previews of special material will only be recorded in 2.0 audio, while the main feature is available in 5.1 audio. The AVR 335 will automatically sense changes to the bitstream and channel count and reflect them in these indicators.

Night Mode

A special feature of Dolby Digital is the Night mode, which enables specially encoded Dolby Digital input sources to be played back with full digital intelligibility while reducing the minimum peak level by 1/4 to 1/3. This prevents abruptly loud transitions from disturbing others, without reducing the impact of the digital source. The Night mode is available only when Dolby Digital signals with special data are being played.

The Night mode may be engaged when a Dolby Digital DVD is playing by pressing the **Night Mode Button 12** on the remote. Next, press the **▲/▼ Buttons 14** to select either the middle range or full-compression versions of the Night mode. To turn the Night mode off, press the **▲/▼ Buttons 14** until the message in the lower third of the video display and in the **Lower Display Line 30** reads **D - RANGE OFF**.

The Night mode may also be selected to always be on at either level of compression using the options in the **DOLBY** menu. See page 19 for information on using the menus to set this option.

IMPORTANT NOTES ON DIGITAL PLAYBACK:

- Although the AVR 335 will decode virtually all current DVDs, CDs and HDTV sources, it is possible that some future digital sources may not be compatible with it.
- Not all digitally encoded programs contain full 5.1- or 6.1-channel audio. Consult the program guide that accompanies the DVD or laser disc to determine which type of audio has been recorded on the disc. The AVR 335 will automatically sense the digital surround encoding used and accommodate it.
- When a digital source is playing, you may not be able to select some of the analog surround modes such as Dolby Pro Logic II, Dolby 3, Stereo, Hall, Theater or Logic 7.
- When a Dolby Digital or DTS source is playing, it is not possible to make an analog recording using the **Tape Outputs 3** and **Video 1 or Video 2 Audio Outputs 35/37**. However, the digital signals will be passed through to the **Digital Audio Outputs 20/21**.

PCM Audio Playback

PCM (Pulse Code Modulation) is the noncompressed digital audio system used for compact discs and laser discs. The digital circuits in the AVR 335 are capable of high-quality digital-to-analog decoding, and they may be connected directly to the digital audio output of your CD or LD player.

Connections may be made to either the rear-panel **Optical or Coaxial Inputs 23/26** or the front-panel **Digital Inputs 18/19**.

To listen to a PCM digital source, first select the input for the desired source (e.g., CD). Next press the **Digital Select Button 13/17** and then use the **▲/▼ Buttons 14** on the remote, or the **◀▶ Selector Buttons 10** on the front panel, until the desired choice appears in the **Upper Display Line 29**.

During PCM playback, you may select any Surround mode except Dolby Digital or DTS.

Tuner Operation

The AVR 335's tuner is capable of tuning AM, FM and FM Stereo broadcast stations. Stations may be tuned manually, or they may be stored as favorite station presets and recalled from a 30-position memory.

Station Selection

1. Press the **AM/FM Tuner Select Button 7/9** to select the tuner as an input. The tuner may be selected from the front panel by either pressing the **Input Source Selector 16** until the tuner is active or by pressing the **AM/FM Band Selector 11**.
2. Press the **AM/FM Tuner Select Button 7/9** or **AM/FM Band Selector 11** again to switch between AM and FM so that the desired frequency band is selected.
3. Press the **Tuner Mode Button 17/19** to select manual or automatic tuning.

When the button is pressed so that **AUTO** appears in the **Lower Display Line 30** each press of the **Tuning Selectors 9/21/E** will put the tuner in a scan mode that seeks the next higher or lower frequency station with acceptable signal strength. An **AUTO ST TUNED** indication will momentarily appear when the station stops at a stereo FM station, and an **AUTO TUNED** indication will momentarily appear when an AM or monaural FM station is tuned. Press the Tuning buttons again to scan to the next receivable station.

When the button is pressed so that **MANUAL** appears in the **Lower Display Line 30** each tap of the Selector will change the frequency by one increment. When the tuner receives a strong enough signal for reception, **MANUAL TUNED** will appear in the **Lower Display Line 30**.

4. Stations may also be tuned directly in either the automatic or manual mode. To enter a station's frequency directly, first select the AM or FM band as desired by pressing the **AM/FM Tuner Select Button 7/11**. Next, press the **Direct Button 20**. Within 5 seconds of when **DIRECT IN** scrolls in the **Upper Display Line 29**, enter the station frequency by pressing the **Numeric Keys 18**. If you press an incorrect button while entering

OPERATION

a direct frequency, press the **Clear Button** 35 to start over.

NOTE: When the FM reception of a station is weak, audio quality will be increased by switching to Mono mode by pressing the **Tuner Mode Button** 17/19 so that **MANUAL** appears momentarily in the **Lower Display Line** 30 and then goes out. This will also activate manual tuning mode.

Preset Tuning

Using the remote, up to 30 stations may be stored in the AVR 335's memory for easy recall using the front-panel controls or the remote.

To enter a station into the memory, first tune the station using the steps outlined above. Then:

1. Press the **Memory Button** 48 on the remote. The two underscore lines will appear at the far right side of the **Upper Display Line** 29.
2. Within 5 seconds, press the **Numeric Keys** 18 for the location where you wish to store this station's frequency. Once entered, the preset number will appear in the **Upper Display Line** 29.
3. Repeat the process after tuning any additional stations to be preset.

Recalling Preset Stations

- To manually select a station previously entered in the preset memory, press the **Numeric Keys** 18 for the desired station's memory location.
- To manually tune through the list of stored preset stations one by one, press the **Preset Stations Selector Buttons** 14 32 33.

Recording

In normal operation, the audio or video source selected for listening through the AVR 335 is sent to the record outputs. This means that any program you are watching or listening to may be recorded simply by placing machines connected to the **Tape Outputs** 3 or **Video 1/Video 2 Audio and Video Outputs** 27/30/35 37 in the Record mode.

When a digital audio recorder is connected to the **Digital Audio Outputs** 20/21, you are able to record the digital signal using a CD-R, MiniDisc or other digital recording system.

NOTES:

- The digital outputs are active only when a digital signal is present, and they do not convert an analog input to a digital signal, or change the format of the digital signal. In addition, the digital recorder must be compatible with the output signal. For example, the PCM digital input from a CD player may be

recorded on a CD-R or MiniDisc, but Dolby Digital or DTS signals may not.

- Please make certain that you are aware of any copyright restrictions on any material you copy. Unauthorized duplication of copyrighted materials is prohibited by federal law.

Output Level Trim Adjustment

Normal output level adjustment for the AVR 335 is established EzSet+, or the internal test tone, as outlined on page 25. However, you may wish to adjust the output levels using program material such as a test disc, or a selection you are familiar with.

To adjust the output levels using program material, first set the reference volume for the front left and front right channels using the **Volume Control** 26 33 1.

If you prefer, you may use a handheld SPL meter to guide you to the correct SPL levels. Set the meter to the C-Weighting Slow scale, and adjust the volume until the meter reads 75dB.

Once the reference level has been set, press the **Channel Select Button** 13 and **FRONT LEVEL** will appear in the **Lower Display Line** 30. To change the level, first press the **Set Button** 16, and then use the **▲/▼ Buttons** 14 to raise or lower the level. DO NOT use the volume control, as this will alter the reference setting.

Once the change has been made, press the **Set Button** 16 and then press the **▲/▼ Buttons** 14 to select the next output channel location that you wish to adjust. To adjust the subwoofer level, press the **▲/▼ Buttons** 14 until **WOOFER LEVEL** appears in the **Lower Display Line** 30.

Repeat the procedure as needed until all channels requiring adjustment have been set. When all adjustments have been made and no further adjustments are made for five seconds, the AVR 335 will return to normal operation.

The channel output for any input may also be adjusted using the full-OSD on-screen menu system. First, set the volume to a comfortable listening level using the **Volume Control** 26 33 1. Then, press the **OSD Button** 22 to bring up the **MASTER MENU** (Figure 1). Press the **▼ Button** 14 until the on-screen ► cursor is next to the **CHANNEL ADJUST** line. Press the **Set Button** 16 to activate the **CHANNEL ADJUST** menu (Figure 11).

Once the menu appears on your video screen, use the **▲/▼ Buttons** 14 to move the on-screen ► cursor so that it is next to the **TEST TONE** line. Press the **◀/▶ Buttons** 15 so that **OFF** appears. This

turns off the test tone and allows you to use external source material as the reference. Then, use the **▲/▼ Buttons** 14 to select the channels to be adjusted. At each channel position, use the **◀/▶ Buttons** 15 to change the output level. The goal is to have the output level at each channel equal when heard at the listening position.

If you wish to reset all the levels to their original factory default of 0dB offset, press the **▲/▼ Buttons** 14 so that the on-screen cursor is next to the **CHANNEL RESET** line and press the **◀/▶ Buttons** 15 so that the word **ON** appears. After the levels are reset, resume the procedure outlined above to reset the levels to the desired settings. When all adjustments are done, press the **▲/▼ Buttons** 14 to move the on-screen ► cursor so that it is next to **BACK TO MASTER MENU** and then press the **Set Button** 16 if you wish to go back to the main menu to make other adjustments. If you have no other adjustments to make, press the **OSD Button** 22 to exit the menu system.

NOTE: The output levels may be separately trimmed for each surround mode, by selecting that mode and following the instructions in the steps shown earlier.

Memory Backup

This product is equipped with a memory backup that preserves system configuration information and tuner presets if the unit is accidentally unplugged or subjected to a power outage. This memory lasts for approximately four weeks, after which time all information must be reentered.

TROUBLESHOOTING GUIDE

SYMPTOM	CAUSE	SOLUTION
Unit does not function when Main Power Switch is pushed	<ul style="list-style-type: none"> • No AC power 	<ul style="list-style-type: none"> • Make certain AC power cord is plugged into a live outlet • Check to see whether outlet is switch-controlled
Display lights, but no sound or picture	<ul style="list-style-type: none"> • Intermittent input connections • Mute is on • Volume control is down 	<ul style="list-style-type: none"> • Make certain that all input and speaker connections are secure • Press Mute Button 41 • Turn up volume control
Unit turns on, but front-panel display does not light up	<ul style="list-style-type: none"> • Display brightness is turned off 	<ul style="list-style-type: none"> • Follow the instructions in the Display Brightness section on page 33 so that the display is set to VFD FULL
No sound from any speaker; light around power switch is red	<ul style="list-style-type: none"> • Amplifier is in protection mode due to possible short • Amplifier is in protection mode due to internal problems 	<ul style="list-style-type: none"> • Check speaker wire connections for shorts at receiver and speaker ends • Contact your local Harman Kardon service center
No sound from surround or center speakers	<ul style="list-style-type: none"> • Incorrect surround mode • Input is monaural • Incorrect configuration • Stereo or Mono program material 	<ul style="list-style-type: none"> • Select a mode other than Stereo • There is no surround information from mono sources • Check speaker mode configuration • The surround decoder may not create center- or rear-channel information from nonencoded programs
Unit does not respond to remote commands	<ul style="list-style-type: none"> • Weak batteries in remote • Wrong device selected • Remote sensor is obscured 	<ul style="list-style-type: none"> • Change remote batteries • Press the AVR selector • Make certain front-panel sensor is visible to remote, or connect remote sensor
Intermittent buzzing in tuner	<ul style="list-style-type: none"> • Local interference 	<ul style="list-style-type: none"> • Move unit or antenna away from computers, fluorescent lights, motors or other electrical appliances
Letters flash in the channel indicator display and digital audio stops	<ul style="list-style-type: none"> • Digital audio feed paused 	<ul style="list-style-type: none"> • Resume play for DVD • Check that Digital Input is selected
Fan does not appear to operate	<ul style="list-style-type: none"> • Additional cooling may not be required 	<ul style="list-style-type: none"> • The fan is activated only when additional cooling is required due to high internal temperature. It is normal for the fan to be inactive at normal volume levels.

In addition to the items shown above, additional information on troubleshooting possible problems with your AVR 335, or installation-related issues, may be found in the list of "Frequently Asked Questions" which is located in the Product Support section of our Web site at www.harmankardon.com.

Processor Reset

In the rare case where the unit's operation or the displays seem abnormal, the cause may involve the erratic operation of the system's memory or microprocessor.

To correct this problem, first unplug the unit from the AC wall outlet and wait at least three minutes. After the pause, reconnect the AC power cord and check the unit's operation. If the system still malfunctions, a system reset may clear the problem.

To clear the AVR 335's entire system memory including tuner presets, output level settings, delay times and speaker configuration data, press and hold the **Tone Mode Button** **5** buttons for three seconds. The unit will turn on automatically.

NOTE: Resetting the processor will erase any configuration settings you have made for speakers, output levels, surround modes and digital input assignments, as well as the tuner presets. The unit will be returned to the factory presets, and all settings for these items must be reentered.

If the system is still operating incorrectly, there may have been an electronic discharge or severe AC line interference that has corrupted the memory or microprocessor.

If these steps do not solve the problem, consult an authorized Harman Kardon service center.

AVR335 EXPLODED VIEW

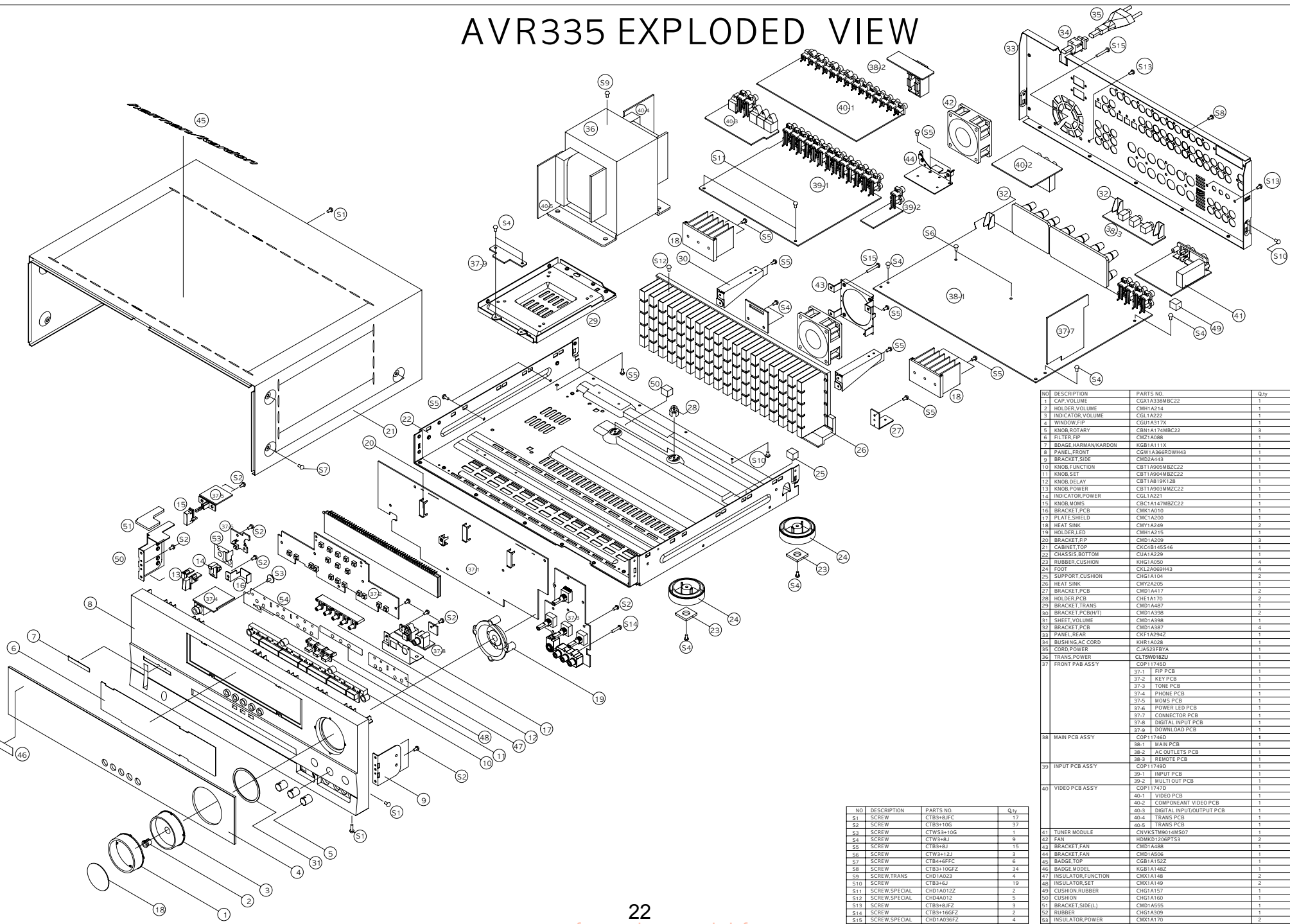

NO	DESCRIPTION	PARTS NO.	Qty
1	CAP.VOLUME	CGX1A338HBC22	1
2	HOLDER.VOLUME	CMH1A214	1
3	INDICATOR.VOLUME	CGL1A222	1
4	WINDOW.FIP	CGD1A317X	1
5	KNOB.ROTARY	CBT1A8174MBC22	3
6	FILTER.FIP	CMZ1A088	1
7	BADGE.HARMANKARDON	KG81A111X	1
8	PANEL.FRONT	CGW1A266D9WH43	1
9	BRACKET.SIDE	CMZ2A443	1
10	KNOB.FUNCTION	CBT1A903MBC22	1
11	KNOB.SET	CBT1A904HBC22	1
12	KNOB.DELAY	CBT1A819K128	1
13	KNOB.POWER	CBT1A903MBC22	1
14	INDICATOR.POWER	CGL1A221	1
15	KNOB.MOVIS	CBT1A174MBC22	1
16	BRACKET.PCB	CMK1A010	1
17	PLATE.SHIELD	CMC1A200	1
18	HEAT.SINK	CMY1A209	2
19	HOLDER.LED	CMH1A215	2
20	BRACKET.FIP	CMY1A209	3
21	CABINET.TOP	CKC4B145546	1
22	CHASSIS.BOTTOM	CUY1A229	2
23	RUBBER.CUSHION	KHG1A050	4
24	FOOT	CKL2A089H43	4
25	SUPPORT.CUSHION	CMY2A205	1
26	BRACKET.PCB	CMY1A417	2
27	HOLDER.PCB	CHE1A170	2
28	BRACKET.TRANS	CMY1A487	1
29	BRACKET.PCB(H/T)	CMY1A398	2
30	SHEET.VOLUME	CMY1A398	1
31	BRACKET.PCB	CMY1A397	4
32	PANEL.REAR	CKF1A294Z	1
33	BUSHING.AC.CORD	KHR1A028	1
34	CORD.POWER	CLAS2A374	1
35	TRANS.POWER	CLT5W0182U	1
36	FRONT.PAB.ASSY	COP11745D	1
37	FRONT.PAB.ASSY	COP11745D	1
37-1	FIP.PCB		1
37-2	KEY.PCB		1
37-3	PHONE.PCB		1
37-4	POWER.LED.PCB		1
37-5	CONNECTOR.PCB		1
37-6	DIGITAL.INPUT.PCB		1
37-9	DOWNLOAD.PCB		1
38	MAIN.PCB.ASSY	COP11746D	1
38-1	MAIN.PCB		1
38-2	AC.OUTLETS.PCB		1
38-3	REMOTE.PCB		1
39	INPUT.PCB.ASSY	COP11749D	1
39-1	INPUT.PCB		1
39-2	MULTI.OUT.PCB		1
40	VIDEO.PCB.ASSY	COP11747D	1
40-1	VIDEO.PCB		1
40-2	COMPONENT.VIDEO.PCB		1
40-3	DIGITAL.INPUT/OUTPUT.PCB		1
40-4	TRANS.PCB		1
40-5	TRANS.PCB		1
41	TUNER.MODULE	CHVKS1M9014M507	1
42	FAN	HDMKD1206PTS3	2
43	BRACKET.FAN	CMY1A488	1
44	BRACKET.FAN	CMY1A506	1
45	BADGE.TOP	CG81A152Z	1
46	BADGE.MODEL	KG81A148Z	1
47	INSULATOR.FUNCTION	CMX1A148	2
48	INSULATOR.SET	CMX1A149	2
49	CUSHION.RUBBER	CHG1A157	1
50	CUSHION	CHG1A150	1
51	BRACKET.SIDE(L)	CMY1A555	1
52	RUBBER	CHG1A309	1
53	INSULATOR.POWER	CMX1A170	2
54	INSULATOR.FUNCTION(L)	CMX1A173	2

DISASSEMBLY

AVR335

1. Removing the Top Cabinet
Remove the Screws

① ~ ⑬

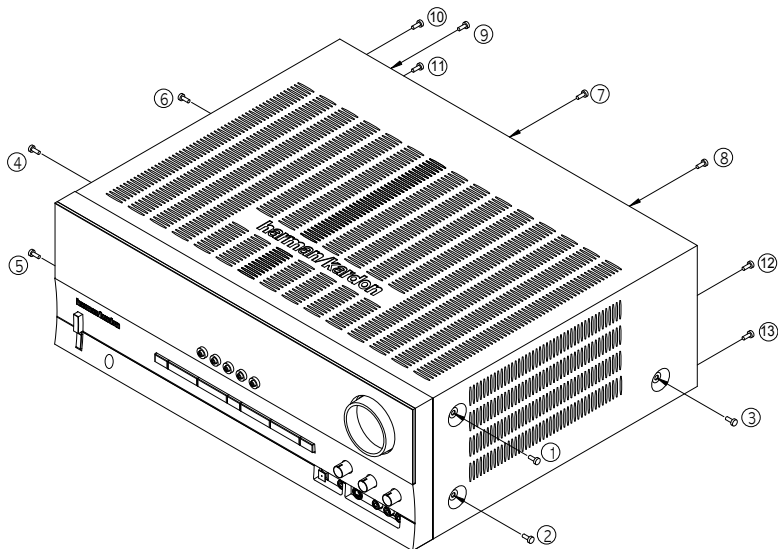

2. Removing the Front Panel
Remove the Screws

① ~ ⑨

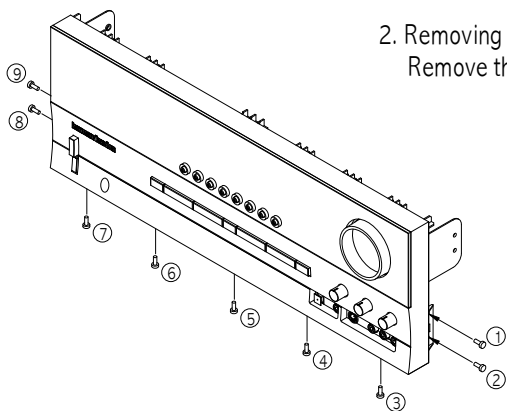

3. Removing the Rear Panel
Remove the Screws

① ~ ③⑥

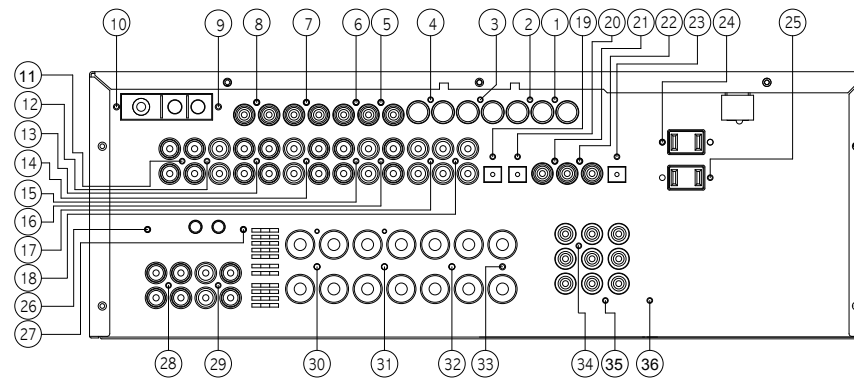

4. Removing the Main PCB
Remove the Screws

① ~ ⑧

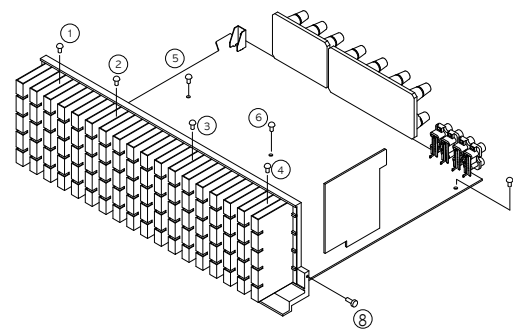

AMPLIFIER SECTION BIAS ADJUSTMENT

Measurement condition

. No input signal or volume position is minimum.

Standard value.

. Ideal current = 48mA (± 5%)

. Ideal DC Voltage = 25.92mV (± 5%)

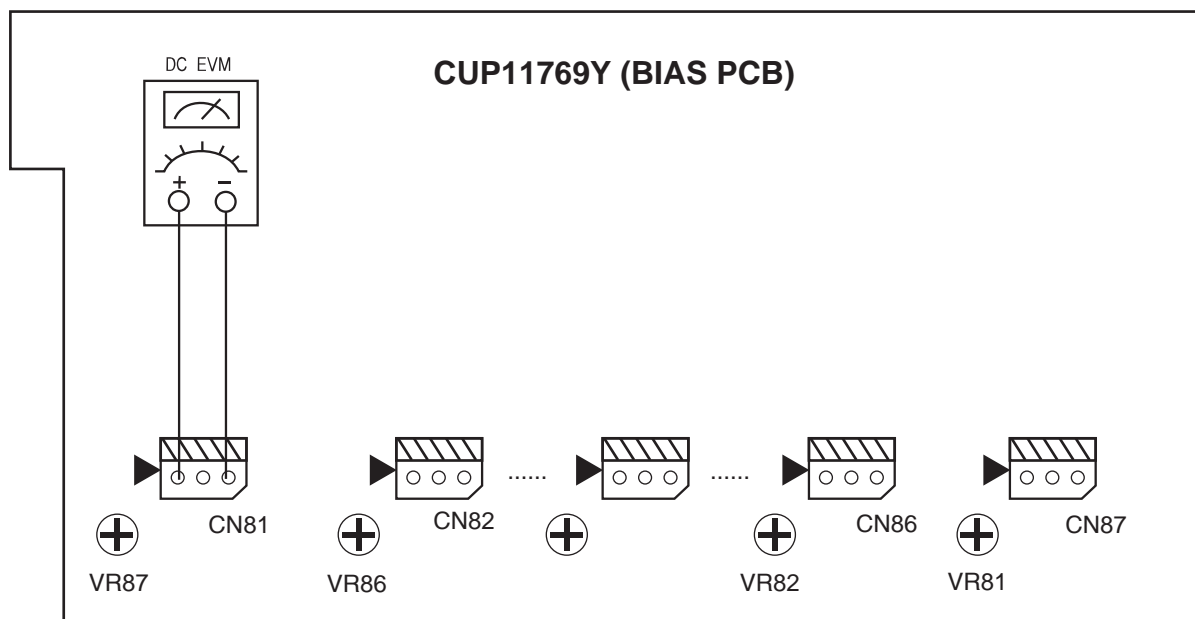

DC VOLTMETER.....Connect to CN81,CN82,CN83,CN84,CN85,CN86,CN87

NO.	Channel	Adjust for	Adjustment
1	Front Left	25.92mV (±5%)	VR83
2	Front Right	25.92mV (±5%)	VR84
3	Center	25.92mV (±5%)	VR85
4	Surround Left	25.92mV (±5%)	VR86
5	Surround Right	25.92mV (±5%)	VR87
6	Surround Back Left	25.92mV (±5%)	VR82
7	Surround Back Right	25.92mV (±5%)	VR81

harman/kardon**TECH TIPS****Troubleshooting tips and solutions to common service problems**

For models:

TIP# HKTT2003-01 Rev3

AVR7000/7200/7300/8000

AVR100/200/300/500

AVR110/210/310/510

AVR120/220/320/520

AVR125/225/325/525

AVR130/230/330/430/630

AVR135/235/335/435/635

AVR10

DPR1001

DPR1005

DPR2005

HK3370/3470/3375/3475

HK3250

Subject: Backup Memory on AVR/DPR/HK series receivers**In the event of the complaint: “the receiver is losing its memory (any programmed system settings) when the unit is turned off, or after the unit is unplugged (briefly*)”:**

Check and replace:

Model	Designator	Location	Description	Part number
AVR10	C712 D709	Front PCB	0.047 Farad 5.5v capacitor and 1N4148 diode	#3439247315 #2058322101
AVR7000	C730	Front PCB	0.047 Farad 5.5v capacitor	# 55134360 or # J3432147324X
AVR7200	C106	Front PCB	0.047 Farad 5.5v capacitor	# 55134360
AVR7300	C657	DSP PCB	0.047 Farad 5.5v capacitor	# H01-CEZXA0479MN-5
AVR8000	C726	Front PCB	0.047 Farad 5.5v capacitor	# 55230310NR or # 55134360
AVR100/200	C412	Front PCB	0.047 Farad 5.5v capacitor	# CEGT-B473J-0J0
AVR300	C906	Front PCB	0.1Farad 5.5v capacitor	# J4433210421X or # P10791-ND
AVR500	C906	Front PCB	0.1Farad 5.5v capacitor	# J4433210421X or # P10791-ND
AVR110/210/310/510 AVR120/220/320/520	C216	Front PCB	0.047 Farad 5.5v capacitor	# 55134360
AVR125/225	C734,C885	Front PCB	two 0.1F capacitors in parallel	# BCESOHD104
AVR325/525	C106	Front PCB	0.047 Farad 5.5v capacitor	# 55134360
AVR130/230/330	BAT1	Front PCB	3.6v Battery	# HABGP40BVH3A3H
AVR135/235/335	BAT1	Front PCB	3.6v Battery	# HGP15BNH3A3H
AVR430/630	C657	DSP PCB	0.047 Farad 5.5v capacitor	# CEZXA0479MN-5
AVR435/635	C657	DSP PCB	0.047 Farad 5.5v capacitor	# CEZXA0479MN-5
DPR1001	BC601	Main PCB	0.1Farad 5.5v capacitor	# CEGT-B104J-0J0
DPR1005/2005	C437	Processor PCB	0.047 Farad 5.5v capacitor	# CEZXA0479MN-5
HK3370/3470	C301	Front PCB	0.1Farad 5.5v capacitor	# CEGT-B104J-0J0
HK3375/3475	C301	Front PCB	0.1Farad 5.5v capacitor	# CEGT-B104J-0J0
HK3250	C712 D709	Front PCB	0.047 Farad 5.5v capacitor and 1N4148 diode	#3439247315 #2058322101

* After approximately two weeks of being disconnected from AC supply, even a normally functioning receiver may lose any programmed settings and switch to default settings. (Four weeks for the DPR1005 & 2005)

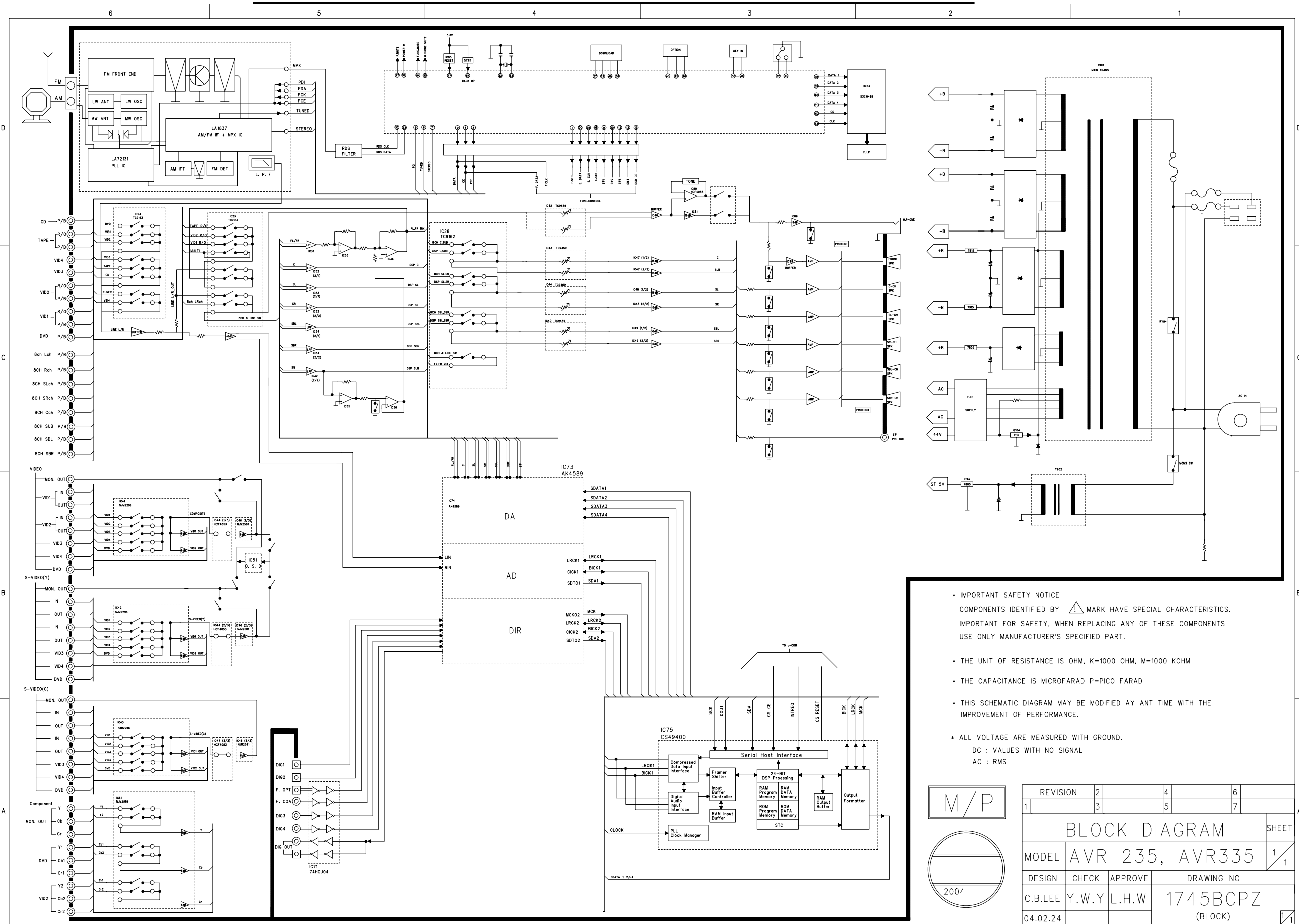

* IMPORTANT SAFETY NOTICE
 COMPONENTS IDENTIFIED BY MARK HAVE SPECIAL CHARACTERISTICS.
 IMPORTANT FOR SAFETY, WHEN REPLACING ANY OF THESE COMPONENTS
 USE ONLY MANUFACTURER'S SPECIFIED PART.

* THE UNIT OF RESISTANCE IS OHM, K=1000 OHM, M=1000 KOHM

* THE CAPACITANCE IS MICROFARAD P=PICO FARAD

* THIS SCHEMATIC DIAGRAM MAY BE MODIFIED AT ANY TIME WITH THE
 IMPROVEMENT OF PERFORMANCE.

* ALL VOLTAGE ARE MEASURED WITH GROUND.
 DC : VALUES WITH NO SIGNAL
 AC : RMS

M/P

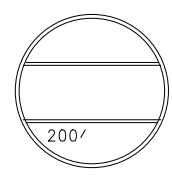

REVISION	2	4	6
1	3	5	7
BLOCK DIAGRAM			
MODEL	AVR 235, AVR335		
DESIGN	CHECK	APPROVE	DRAWING NO
C.B.LEE	Y.W.Y	L.H.W	1745BCPZ
04.02.24			(BLOCK)

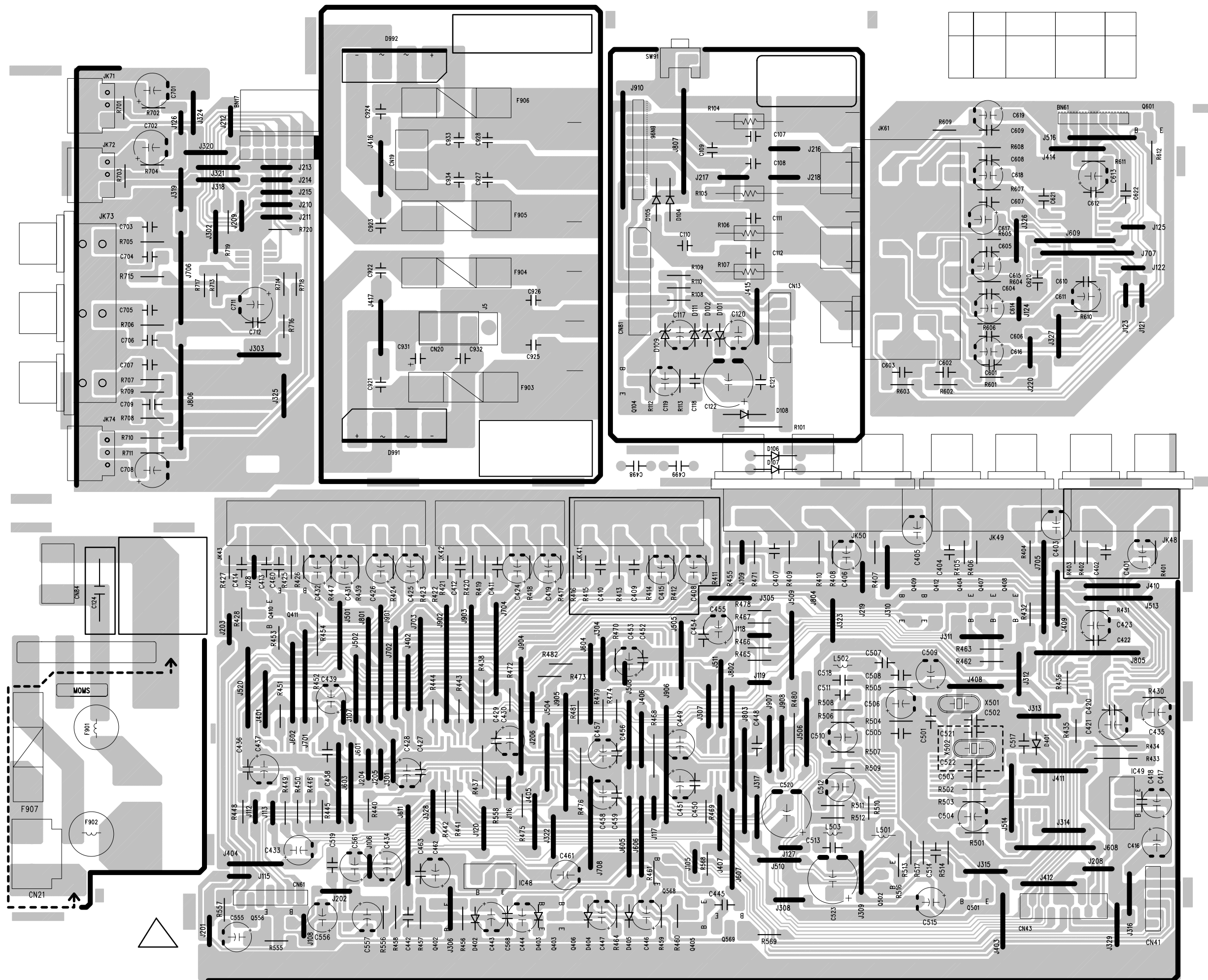

CUP11768

DIGITAL IN/OUT & HP & ROOM-EQ BOARD

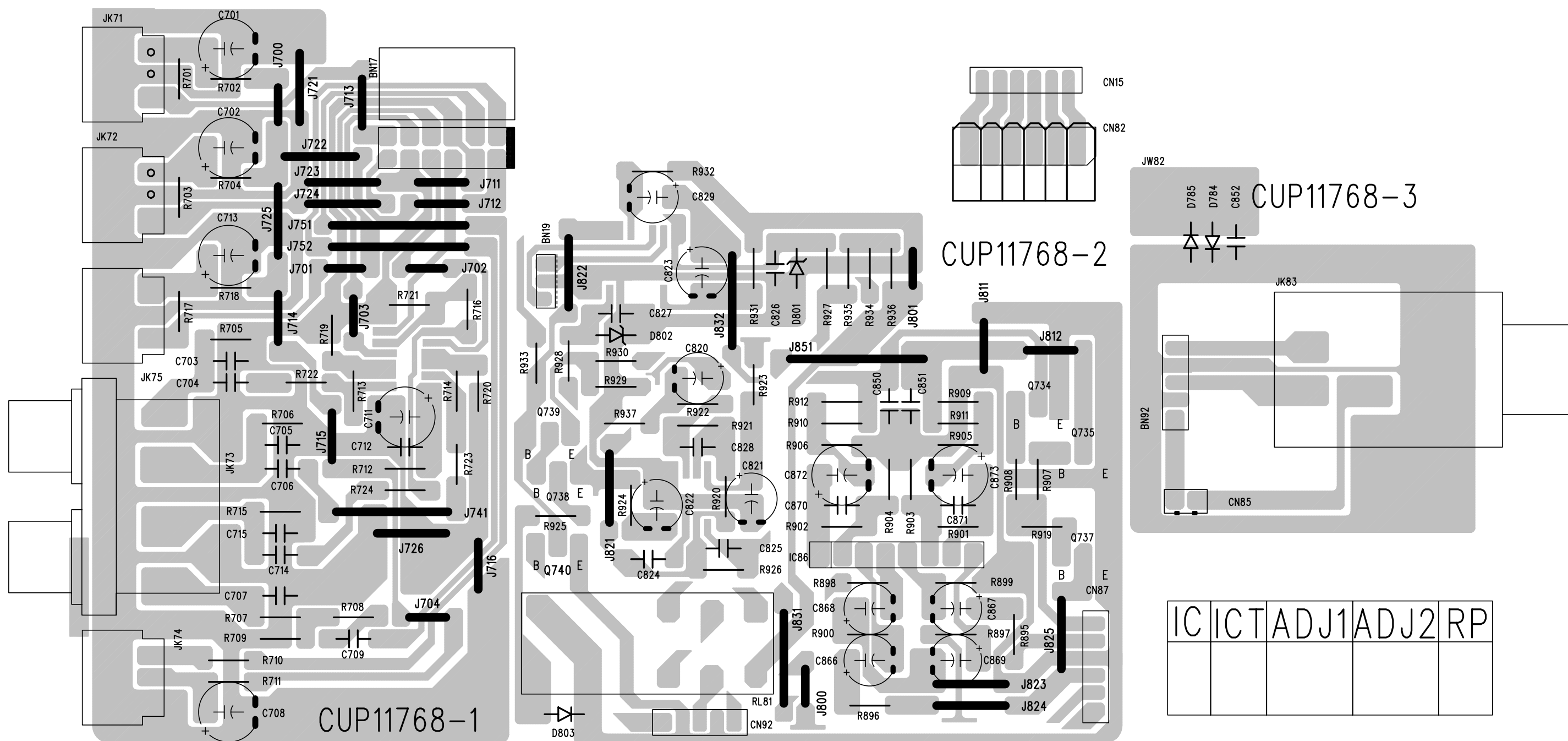

IC	ICT	ADJ1	ADJ2	RP

MAIN BOARD 1 (AMP)

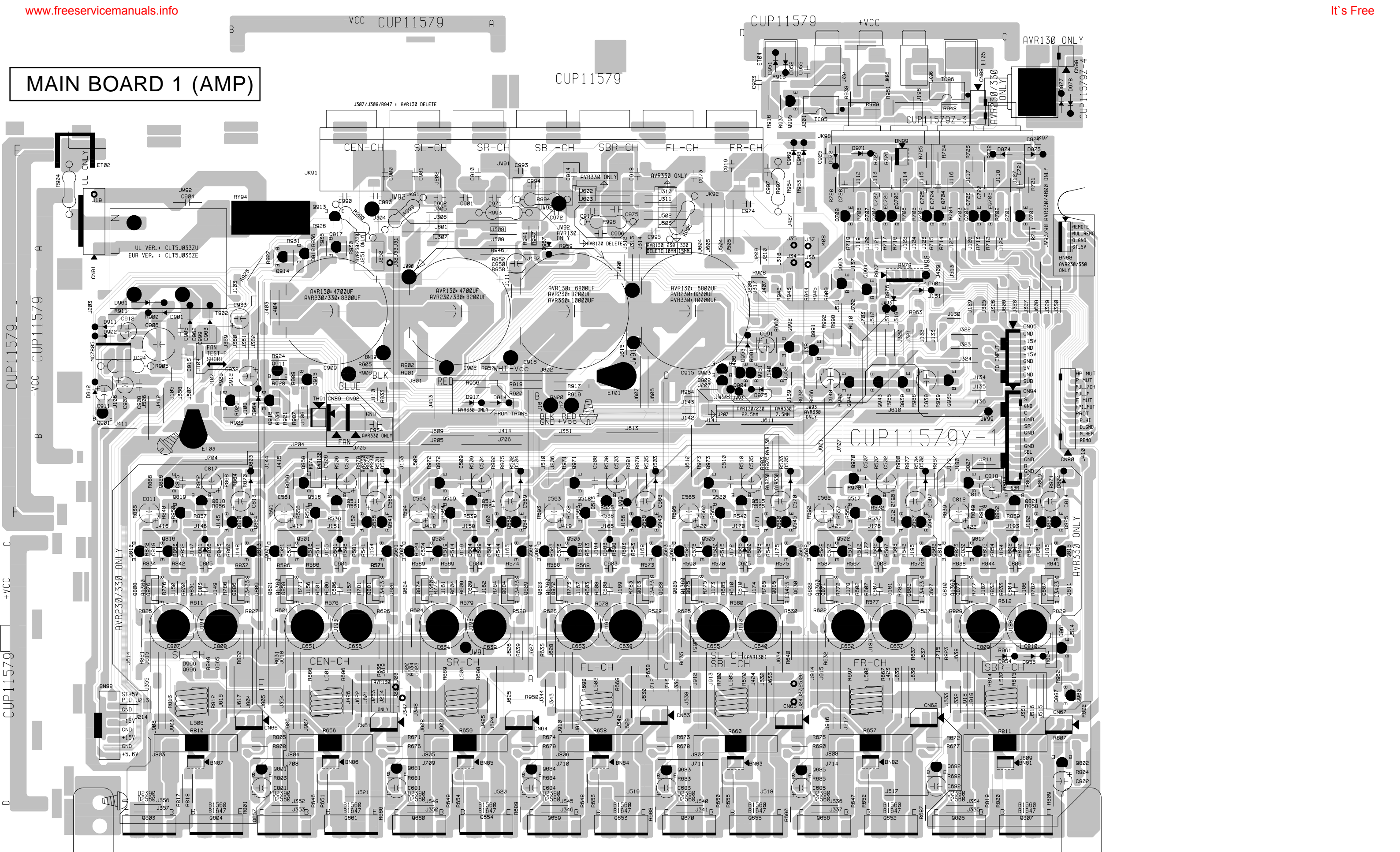

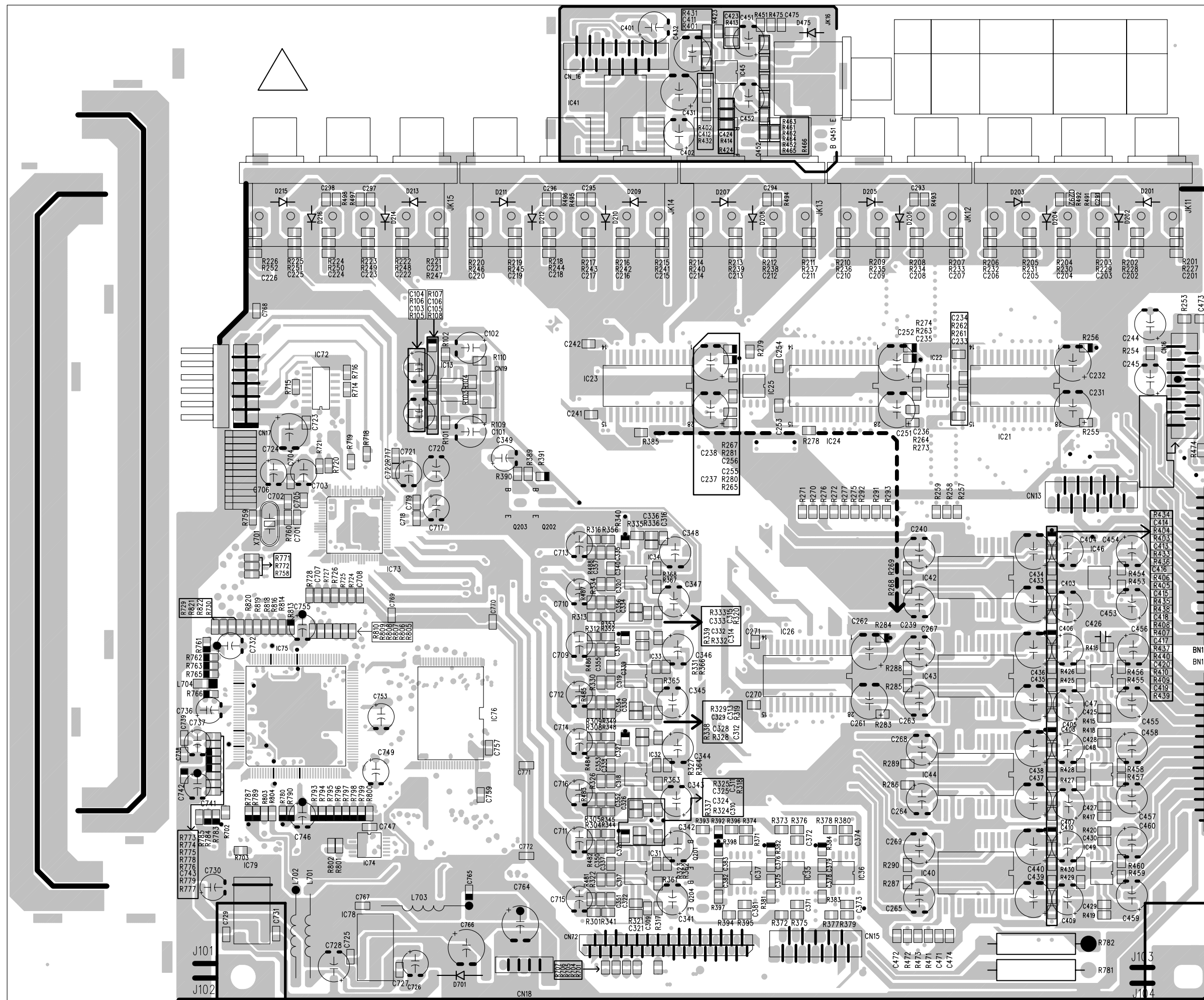

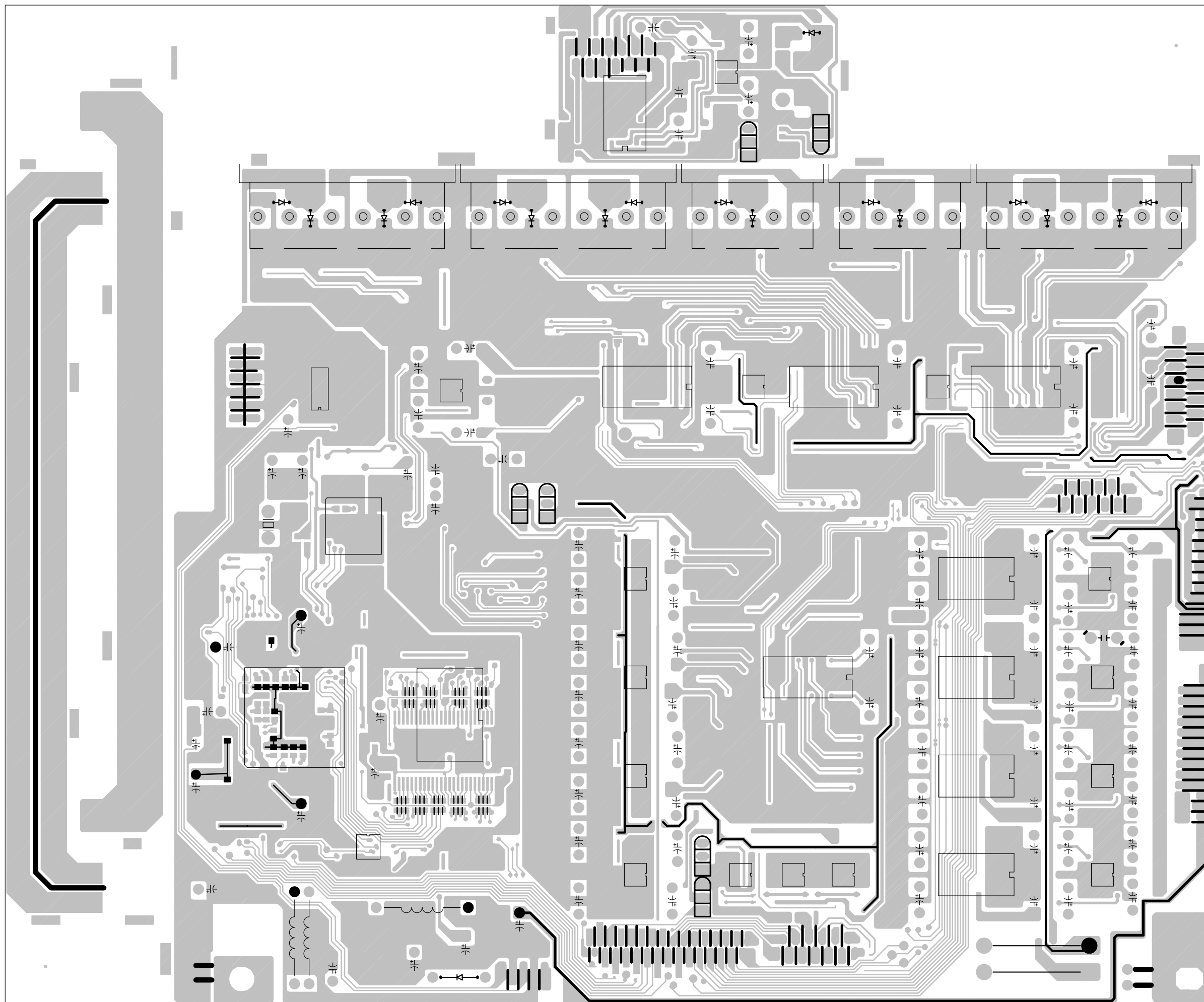

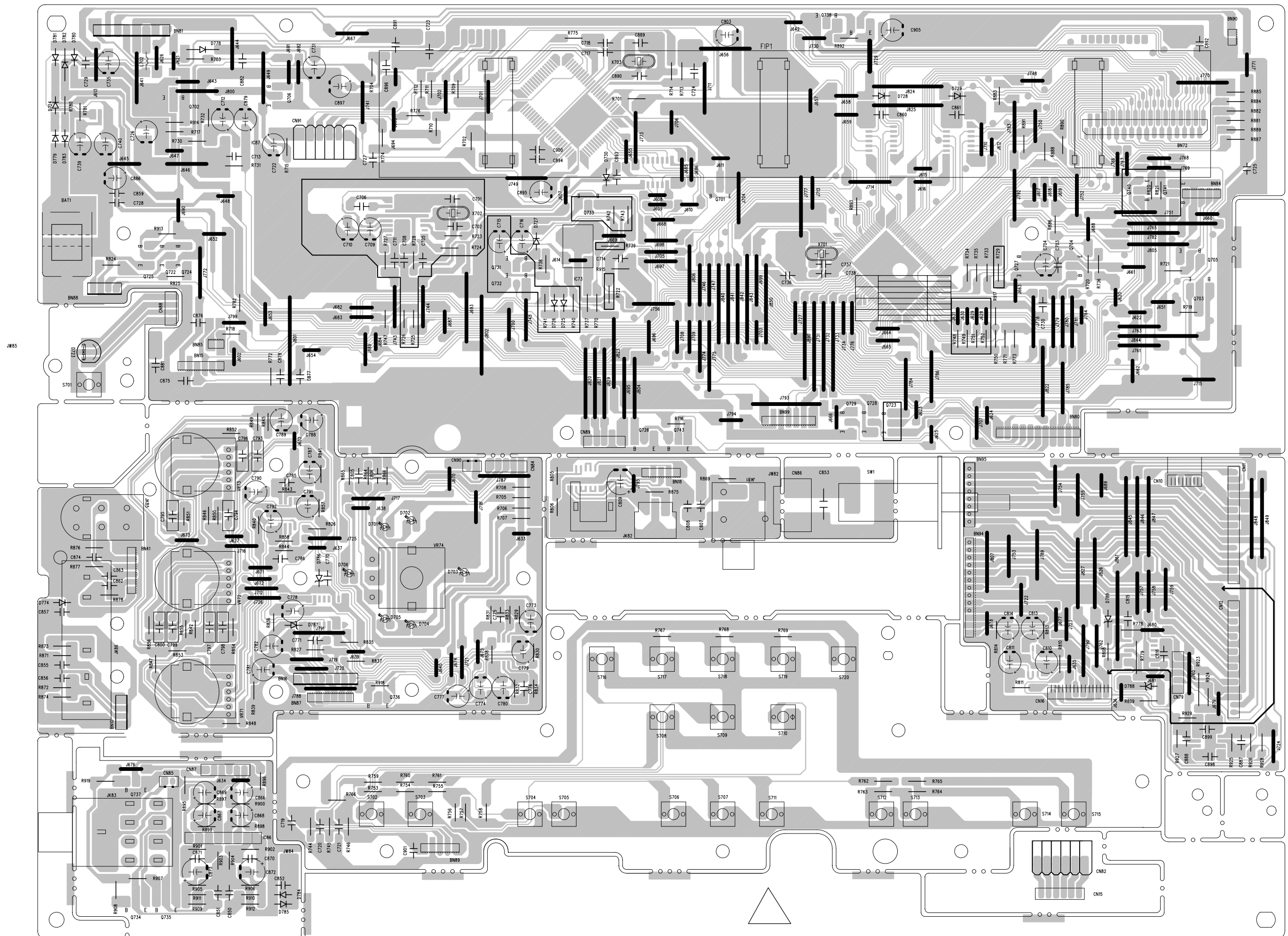

AVR335 Electrical Parts List

Ref. Designator	Part Number	Description	
FRONT PCB ASS'Y			
<i>Capacitors</i>			
C703	HCBS1H821KBT	CAP , CERAMIC	820PF 50V K
C704	HCEA1VH100T	CAP , ELECT	10UF 35V
C712	HCEA1HH1R0T	CAP , ELECT	1UF 50V
C713	HCBS1H223ZFT	CAP , CERAMIC	0.022UF 50V Z
C714	HCBS1H151KBT	CAP , CERAMIC	150PF 50V K
C715	HCEA1HH4R7T	CAP , ELECT	4.7UF 50V
C716	HCEA1CH331T	CAP , ELECT	330UF 16V
C717	HCBS1H221KBT	CAP , CERAMIC	220PF 50V K
C718	HCBS1H221KBT	CAP , CERAMIC	220PF 50V K
C719	HCBS1H181KBT	CAP , CERAMIC	180PF 50V K
C720	HCBS1H181KBT	CAP , CERAMIC	180PF 50V K
C721	HCBS1H181KBT	CAP , CERAMIC	180PF 50V K
C722	HCEA1CH101T	CAP , ELECT	100UF 16V
C723	HCBS1H104ZFT	CAP , CERAMIC	0.1UF 50V Z
C724	HCBS1H223ZFT	CAP , CERAMIC	0.022UF 50V Z
C725	CCKT1H473ZF	CAP , CERAMIC	0.047UF 50V ZF
C726	HCEA1CH101T	CAP , ELECT	100UF 16V
C727	HCBS1H221KBT	CAP , CERAMIC	220PF 50V K
C728	HCBS1H104ZFT	CAP , CERAMIC	0.1UF 50V Z
C729	CCKT1H473ZF	CAP , CERAMIC	0.047UF 50V ZF
C730	HCBS1H104ZFT	CAP , CERAMIC	0.1UF 50V Z
C731	HCEA1HH100T	CAP , ELECT	10UF 50V
C732	HCBS1H104ZFT	CAP , CERAMIC	0.1UF 50V Z
C735	CCEA1CH101T	CAP , ELECT	100UF 16V
C736	HCBS1H223ZFT	CAP , CERAMIC	0.022UF 50V Z
C737	HCBS1H120JCT	CAP , CERAMIC	12PF 50V J
C738	HCBS1H120JCT	CAP , CERAMIC	12PF 50V J
C739	CCEA1AH221T	CAP , ELECT	220UF/10V
C740	CCEA1VH100T	CAP , ELECT	10UF 35V
C770	HCBS1H223ZFT	CAP , CERAMIC	0.022UF 50V Z
C771	HCBS1H223ZFT	CAP , CERAMIC	0.022UF 50V Z
C773	HCEA1VH100T	CAP , ELECT	10UF 35V
C774	HCEA1VH100T	CAP , ELECT	10UF 35V
C775	HCBS1H151KBT	CAP , CERAMIC	150PF 50V K
C776	HCBS1H151KBT	CAP , CERAMIC	150PF 50V K
C777	HCEA1VH100T	CAP , ELECT	10UF 35V
C778	HCEA1VH100T	CAP , ELECT	10UF 35V
C779	HCEA1CKS470T	CAP , ELECT	47UF 16V
C780	HCEA1CKS470T	CAP , ELECT	47UF 16V
C781	HCEA1CKS100T	CAP , ELECT	10UF 16V
C782	HCEA1CKS100T	CAP , ELECT	10UF 16V
C783	HCBS1H101KBT	CAP , CERAMIC	100PF 50V K
C784	HCBS1H101KBT	CAP , CERAMIC	100PF 50V K
C785	HCBS1H470JT	CAP , CERAMIC	47PF 50V J
C786	HCBS1H470JT	CAP , CERAMIC	47PF 50V J
C787	HCEA1CKS100T	CAP , ELECT	10UF 16V
C788	HCEA1CKS100T	CAP , ELECT	10UF 16V
C789	HCEA1CKS100T	CAP , ELECT	10UF 16V
C790	HCEA1CKS100T	CAP , ELECT	10UF 16V
C791	HCEA1CKS470T	CAP , ELECT	47UF 16V
C792	HCEA1CKS470T	CAP , ELECT	47UF 16V
C793	KCFE1J183JBT	CAP , FILM	0.018UF 63V J
C794	KCFE1J183JBT	CAP , FILM	0.018UF 63V J
C795	KCFE1J823JBT	CAP , FILM	0.082UF 63V J
C796	KCFE1J823JBT	CAP , FILM	0.082UF 63V J
C797	KCFE1J332JBT	CAP , FILM	0.0033UF 63V J

Ref. Designator	Part Number	Description	
FRONT PCB ASS'Y			
C798	KCFE1J332JBT	CAP , FILM	0.0033UF 63V J
C799	KCFE1J183JBT	CAP , FILM	0.018UF 63V J
C800	KCFE1J183JBT	CAP , FILM	0.018UF 63V J
C802	HCBS1H104ZFT	CAP , CERAMIC	0.1UF 50V Z
C803	HCBS1H104ZFT	CAP , CERAMIC	0.1UF 50V Z
C805	HCBS1H223ZFT	CAP , CERAMIC	0.022UF 50V Z
C806	HCBS1H223ZFT	CAP , CERAMIC	0.022UF 50V Z
C807	CCFT1H104ZF	CAP , SEMICONDUCTOR	0.1UF 50V ZF
C808	CCKT1H181KB	CAP , CERAMIC	180PF 50V KB
C809	HCEA1AH471T	CAP , ELECT	470UF 10V
C810	HCEA1CH101T	CAP , ELECT	100UF 16V
C811	HCEA1CH101T	CAP , ELECT	100UF 16V
C813	HCEA1HH4R7T	CAP , ELECT	4.7UF 50V
C814	HCEA1HH4R7T	CAP , ELECT	4.7UF 50V
C815	HCBS1H223ZFT	CAP , CERAMIC	0.022UF 50V Z
C816	HCBS1H223ZFT	CAP , CERAMIC	0.022UF 50V Z
C855	HCBS1H101KBT	CAP , CERAMIC	100PF 50V K
C856	HCBS1H101KBT	CAP , CERAMIC	100PF 50V K
C857	HCBS1H104ZFT	CAP , CERAMIC	0.1UF 50V Z
C859	HCBS1H223ZFT	CAP , CERAMIC	0.022UF 50V Z
C860	HCBS1H223ZFT	CAP , CERAMIC	0.022UF 50V Z
C861	HCBS1H223ZFT	CAP , CERAMIC	0.022UF 50V Z
C862	HCBS1H101KBT	CAP , CERAMIC	100PF 50V K
C863	HCBS1H101KBT	CAP , CERAMIC	100PF 50V K
C874	HCBS1H101KBT	CAP , CERAMIC	100PF 50V K
C875	HCBS1H101KBT	CAP , CERAMIC	100PF 50V K
C876	HCBS1H101KBT	CAP , CERAMIC	100PF 50V K
C877	HCBS1H473ZFT	CAP , CERAMIC	0.047UF 50V Z
C878	HCBS1H473ZFT	CAP , CERAMIC	0.047UF 50V Z
C880	HCEA1HH2R2T	CAP , ELECT	2.2UF 50V
C882	HCBS1H104ZFT	CAP , CERAMIC	0.1UF 50V Z
C886	CCEA0JH102T	CAP , ELECT	1000UF 6.3V
C889	HCBS1H220JCT	CAP , CERAMIC	22PF 50V J
C890	HCBS1H220JCT	CAP , CERAMIC	22PF 50V J
C891	HCBS1H223ZFT	CAP , CERAMIC	0.022UF 50V Z
C892	HCBS1H223ZFT	CAP , CERAMIC	0.022UF 50V Z
C893	HCBS1H223ZFT	CAP , CERAMIC	0.022UF 50V Z
C894	HCBS1H223ZFT	CAP , CERAMIC	0.022UF 50V Z
C895	HCEA1AH471T	CAP , ELECT	470UF 10V
C896	HCBS1H223ZFT	CAP , CERAMIC	0.022UF 50V Z
C897	HCEA1AH471T	CAP , ELECT	470UF 10V
C900	HCBS1H104ZFT	CAP , CERAMIC	0.1UF 50V Z
C901	HCBS1H104ZFT	CAP , CERAMIC	0.1UF 50V Z
C902	HCEA1HH2R2T	CAP , ELECT	2.2UF 50V
C903	HCEA1HH2R2T	CAP , ELECT	2.2UF 50V
C905	HCEA1HH2R2T	CAP , ELECT	2.2UF 50V
C812	CCFT1H104ZF	CAP , SEMICONDUCTOR	0.1UF 50V ZF
C817	CCCT1H100DC	CAP , CERAMIC	10PF 50V DC
C853	KCKDKS471ME	CAP , CERAMIC(KH TYPE)	DKS471ME
<i>Semiconductors</i>			
D707	CVDLEBBL33T0	BLUE L.E.D	
D716	HVDLTL1CHGE	L.E.D , GREEN	
D724	HVD1SS133MT	DIODE	1SS133T-77
D725	HVD1SS133MT	DIODE	1SS133T-77
D726	HVD1SS133MT	DIODE	1SS133T-77
D727	HVD1SS133MT	DIODE	1SS133T-77
D728	HVD1SS133MT	DIODE	1SS133T-77
D729	HVD1SS133MT	DIODE	1SS133T-77
D730	HVD1SS133MT	DIODE	1SS133T-77

Ref. Designator	Part Number	Description	
FRONT PCB ASS'Y			
D770	HVD1SS133MT	DIODE	1SS133T-77
D771	HVD1SS133MT	DIODE	1SS133T-77
D772	HVD1SS133MT	DIODE	1SS133T-77
D773	HVD1SS133MT	DIODE	1SS133T-77
D774	HVD1SS133MT	DIODE	1SS133T-77
D778	KVD1N4003ST	DIODE	1N4003
D779	HVD1SS133MT	DIODE	1SS133T-77
D780	HVD1SS133MT	DIODE	1SS133T-77
D781	HVD1SS133MT	DIODE	1SS133T-77
D782	KVD1N4003ST	DIODE	1N4003
D783	HVD1SS133MT	DIODE	1SS133T-77
D786	HVDMTZJ5.6BT	DIODE , ZENER	5.6V 1/2W
D787	HVDMTZJ5.6BT	DIODE , ZENER	5.6V 1/2W
D788	HVDMTZJ5.6BT	DIODE , ZENER	5.6V 1/2W
D789	HVDMTZJ5.6BT	DIODE , ZENER	5.6V 1/2W
IC87	HVIRE5VL28CATZ	IC , RESET	RE5VL28C
Q701	HVTKRC107MT	TRANSISTOR NPN	KRC107M
Q702	HVTKRC107MT	TRANSISTOR NPN	KRC107M
Q703	HVTKRC107MT	TRANSISTOR NPN	KRC107M
Q704	HVTKRC107MT	TRANSISTOR NPN	KRC107M
Q705	HVTKRC107MT	TRANSISTOR NPN	KRC107M
Q706	HVTKRC107MT	TRANSISTOR NPN	KRC107M
Q722	HVTKRA107MT	TRANSISTOR NPN	KRA107M
Q723	HVTKRC107MT	TRANSISTOR NPN	KRC107M
Q724	HVTKRC107MT	TRANSISTOR NPN	KRC107M
Q725	HVTKRC107MT	TRANSISTOR NPN	KRC107M
Q726	HVTKRC107MT	TRANSISTOR NPN	KRC107M
Q727	HVTKRC107MT	TRANSISTOR NPN	KRC107M
Q728	HVTKRC107MT	TRANSISTOR NPN	KRC107M
Q729	HVTKRC107MT	TRANSISTOR NPN	KRC107M
Q731	KVTKSA1175YT	TRANSISTOR PNP	KSA1175Y
Q732	HVTKRC107MT	TRANSISTOR NPN	KRC107M
Q733	KVTKSC2785YT	TRANSISTOR NPN	KSC2785Y
Q736	HVTKTC2874BT	TRANSISTOR , MUTE NPN	KTC2874B
Q737	HVTKTC2874BT	TRANSISTOR , MUTE NPN	KTC2874B
Q738	HVTKRC107MT	TRANSISTOR NPN	KRC107M
Q739	HVTKTA1271YT	TRANSISTOR PNP	KTA1271Y
Q740	HVTKRC107MT	TRANSISTOR NPN	KRC107M
Q741	HVTKRC107MT	TRANSISTOR NPN	KRC107M
Q743	HVTKRA107MT	TRANSISTOR NPN	KRA107M
Q749	HVTKRC107MT	TRANSISTOR NPN	KRC107M
D701	CVD52CSBBCEAB2	BLUE L.E.D	
D702	CVD52CSBBCEAB2	BLUE L.E.D	
D702	HVD52CSBBCEAB2	BLUE L.E.D	
D703	CVD52CSBBCEAB2	BLUE L.E.D	
D703	HVD52CSBBCEAB2	BLUE L.E.D	
D704	CVD52CSBBCEAB2	BLUE L.E.D	
D704	HVD52CSBBCEAB2	BLUE L.E.D	
D705	CVD52CSBBCEAB2	BLUE L.E.D	
D706	CVD52CSBBCEAB2	BLUE L.E.D	
D706	HVD52CSBBCEAB2	BLUE L.E.D	
D707	HVD52CSBBCEAB2	BLUE L.E.D	
D723	CVD50BOBBWGA	L.E.D , 2 COLOR (ORG , BLUE)	TOL-50BOBBWGA
FIP1	HFLHCA18ML01	F.I.P	
IC72	BVIMB90F482APFG	IC , FLASH U-COM	MB90F482A
IC73	HRVRPM6938H4	SENSOR , REMOTE	RPM6938-H4
IC74	HVIANAM1385AT	I.C , U-COM	ANAM1385A
IC75	HVI74ACT04MTR	I.C , HEX	74ACT04M
IC76	HVITC74HCU04AFN	IC , INVERTER	TC74HCU04AFN
IC80	HVIHCF4053M013T	I.C , 2-CH MULTIPLEXER	HCF4053M013
IC81	HVINJM2068MDTE1	I.C , OP AMP	NJM2068MD-TE1

Ref. Designator	Part Number	Description	
FRONT PCB ASS'Y			
IC82	HVINJM2068MDTE1	I.C , OP AMP	NJM2068MD-TE1
IC83	HVI74ACT04MTR	I.C , HEX	74ACT04M
IC84	HVI74ACT04MTR	I.C , HEX	74ACT04M
IC85	HVIRH5VT18C	I.C , RESET	RICOH 1.8V
IC88	HVINJM2068MDTE1	I.C , OP AMP	NJM2068MD-TE1
IC89	HVIHCF4053M013T	I.C , 2-CH MULTIPLEXER	74ACT04M013
<i>Resistors</i>			
R701	CRD20TJ103T	RES , CARBON	10K OHM 1/5W J
R702	CRD20TJ1R0T	RES , CARBON	1 OHM 1/5W J
R703	CRD20TJ103T	RES , CARBON	10K OHM 1/5W J
R704	CRD20TJ100T	RES , CARBON	10 OHM 1/5W J
R705	CRD20TJ820T	RES , CARBON	82 OHM 1/5W J
R706	CRD20TJ820T	RES , CARBON	82 OHM 1/5W J
R708	CRD20TJ820T	RES , CARBON	82 OHM 1/5W J
R709	CRD20TJ470T	RES , CARBON	47 OHM 1/5W J
R710	CRD20TJ470T	RES , CARBON	47 OHM 1/5W J
R711	CRD20TJ470T	RES , CARBON	47 OHM 1/5W J
R712	CRD20TJ470T	RES , CARBON	47 OHM 1/5W J
R713	CRD20TJ332T	RES , CARBON	3.3K OHM 1/5W J
R714	CRD20TJ470T	RES , CARBON	47 OHM 1/5W J
R715	CRD20TJ470T	RES , CARBON	47 OHM 1/5W J
R716	CRD20TJ102T	RES , CARBON	1K OHM 1/5W J
R717	CRD20TJ103T	RES , CARBON	10K OHM 1/5W J
R718	CRD20TJ222T	RES , CARBON	2.2K OHM 1/5W J
R719	CRD20TJ102T	RES , CARBON	1K OHM 1/5W J
R720	CRD20TJ102T	RES , CARBON	1K OHM 1/5W J
R721	CRD20TJ103T	RES , CARBON	10K OHM 1/5W J
R723	CRD20TJ102T	RES , CARBON	1K OHM 1/5W J
R729	CRD20TJ103T	RES , CARBON	10K OHM 1/5W J
R730	CRD20TJ112T	RES , CARBON	1.1K OHM 1/5W J
R731	CRD20TJ223T	RES , CARBON	22K OHM 1/5W J
R732	CRD20TJ222T	RES , CARBON	2.2K OHM 1/5W J
R733	CRD20TJ272T	RES , CARBON	2.7K OHM 1/5W J
R734	CRD20TJ103T	RES , CARBON	10K OHM 1/5W J
R735	CRD20TJ103T	RES , CARBON	10K OHM 1/5W J
R736	CRD20TJ272T	RES , CARBON	2.7K OHM 1/5W J
R737	CRD20TJ100T	RES , CARBON	10 OHM 1/5W J
R738	CRD20TJ103T	RES , CARBON	10K OHM 1/5W J
R739	CRD20TJ103T	RES , CARBON	10K OHM 1/5W J
R740	CRD20TJ103T	RES , CARBON	10K OHM 1/5W J
R741	CRD20TJ103T	RES , CARBON	10K OHM 1/5W J
R742	CRD20TJ103T	RES , CARBON	10K OHM 1/5W J
R743	CRD20TJ103T	RES , CARBON	10K OHM 1/5W J
R744	CRD20TJ103T	RES , CARBON	10K OHM 1/5W J
R745	CRD20TJ103T	RES , CARBON	10K OHM 1/5W J
R746	CRD20TJ103T	RES , CARBON	10K OHM 1/5W J
R747	CRD20TJ103T	RES , CARBON	10K OHM 1/5W J
R748	CRD20TJ223T	RES , CARBON	22K OHM 1/5W J
R749	CRD20TJ223T	RES , CARBON	22K OHM 1/5W J
R752	CRD20TJ223T	RES , CARBON	22K OHM 1/5W J
R753	CRD20TJ102T	RES , CARBON	1K OHM 1/5W J
R754	CRD20TJ152T	RES , CARBON	1.5K OHM 1/5W J
R755	CRD20TJ182T	RES , CARBON	1.8K OHM 1/5W J
R756	CRD20TJ272T	RES , CARBON	2.7K OHM 1/5W J
R757	CRD20TJ332T	RES , CARBON	3.3K OHM 1/5W J
R758	CRD20TJ562T	RES , CARBON	5.6K OHM 1/5W J
R759	CRD20TJ102T	RES , CARBON	1K OHM 1/5W J
R760	CRD20TJ152T	RES , CARBON	1.5K OHM 1/5W J
R761	CRD20TJ182T	RES , CARBON	1.8K OHM 1/5W J

Ref. Designator	Part Number	Description	
FRONT PCB ASS'Y			
R762	CRD20TJ272T	RES , CARBON	2.7K OHM 1/5W J
R763	CRD20TJ332T	RES , CARBON	3.3K OHM 1/5W J
R764	CRD20TJ562T	RES , CARBON	5.6K OHM 1/5W J
R765	CRD20TJ752T	RES , CARBON	7.5K OHM 1/5W J
R766	CRD20TJ102T	RES , CARBON	1K OHM 1/5W J
R767	CRD20TJ152T	RES , CARBON	1.5K OHM 1/5W J
R768	CRD20TJ182T	RES , CARBON	1.8K OHM 1/5W J
R769	CRD20TJ272T	RES , CARBON	2.7K OHM 1/5W J
R770	CRD20TJ100T	RES , CARBON	10 OHM 1/5W J
R771	CRD20TJ103T	RES , CARBON	10K OHM 1/5W J
R772	CRD20TJ103T	RES , CARBON	10K OHM 1/5W J
R773	CRD20TJ103T	RES , CARBON	10K OHM 1/5W J
R774	CRD20TJ222T	RES , CARBON	2.2K OHM 1/5W J
R775	CRD20TJ470T	RES , CARBON	47 OHM 1/5W J
R776	CRD20TJ470T	RES , CARBON	47 OHM 1/5W J
R777	CRD20TJ103T	RES , CARBON	10K OHM 1/5W J
R780	CRD20TJ100T	RES , CARBON	10 OHM 1/5W J
R781	CRD20TJ123T	RES , CARBON	12K OHM 1/5W J
R782	CRD20TJ103T	RES , CARBON	10K OHM 1/5W J
R801	CRD20TJ473T	RES , CARBON	47K OHM 1/5W J
R802	CRD20TJ473T	RES , CARBON	47K OHM 1/5W J
R803	CRD20TJ473T	RES , CARBON	47K OHM 1/5W J
R804	CRD20TJ473T	RES , CARBON	47K OHM 1/5W J
R805	CRD20TJ104T	RES , CARBON	100K OHM 1/5W J
R806	CRD20TJ472T	RES , CARBON	4.7K OHM 1/5W J
R808	CRD20TJ102T	RES , CARBON	1K OHM 1/5W J
R809	CRD20TJ102T	RES , CARBON	1K OHM 1/5W J
R810	CRD20TJ101T	RES , CARBON	100 OHM 1/5W J
R811	CRD20TJ101T	RES , CARBON	100 OHM 1/5W J
R813	CRD20TJ104T	RES , CARBON	100K OHM 1/5W J
R814	CRD20TJ104T	RES , CARBON	100K OHM 1/5W J
R820	CRD20TJ103T	RES , CARBON	10K OHM 1/5W J
R821	CRD20TJ103T	RES , CARBON	10K OHM 1/5W J
R822	KRD25FJ180T	RES , CARBON	18 OHM 1/4W J
R824	CRD20TJ221T	RES , CARBON	220 OHM 1/5W J
R825	CRD20TJ681T	RES , CARBON	680 OHM 1/5W J
R826	CRD20TJ102T	RES , CARBON	1K OHM 1/5W J
R827	CRD20TJ102T	RES , CARBON	1K OHM 1/5W J
R829	CRD20TJ184T	RES , CARBON	180K OHM 1/5W J
R830	CRD20TJ184T	RES , CARBON	180K OHM 1/5W J
R831	CRD20TJ562T	RES , CARBON	5.6K OHM 1/5W J
R832	CRD20TJ562T	RES , CARBON	5.6K OHM 1/5W J
R833	CRD20TJ102T	RES , CARBON	1K OHM 1/5W J
R834	CRD20TJ102T	RES , CARBON	1K OHM 1/5W J
R835	CRD20TJ184T	RES , CARBON	180K OHM 1/5W J
R836	CRD20TJ184T	RES , CARBON	180K OHM 1/5W J
R837	CRD20TJ101T	RES , CARBON	100 OHM 1/5W J
R838	CRD20TJ101T	RES , CARBON	100 OHM 1/5W J
R839	CRD20TJ104T	RES , CARBON	100K OHM 1/5W J
R840	CRD20TJ104T	RES , CARBON	100K OHM 1/5W J
R841	CRD20TJ473T	RES , CARBON	47K OHM 1/5W J
R842	CRD20TJ473T	RES , CARBON	47K OHM 1/5W J
R843	CRD20TJ105T	RES , CARBON	1M OHM 1/5W J
R844	CRD20TJ105T	RES , CARBON	1M OHM 1/5W J
R845	CRD20TJ104T	RES , CARBON	100K OHM 1/5W J
R846	CRD20TJ104T	RES , CARBON	100K OHM 1/5W J
R847	CRD20TJ102T	RES , CARBON	1K OHM 1/5W J
R848	CRD20TJ102T	RES , CARBON	1K OHM 1/5W J
R849	CRD20TJ223T	RES , CARBON	22K OHM 1/5W J
R850	CRD20TJ223T	RES , CARBON	22K OHM 1/5W J
R851	CRD20TJ392T	RES , CARBON	3.9K OHM 1/5W J

Ref. Designator	Part Number	Description	
FRONT PCB ASS'Y			
R852	CRD20TJ392T	RES , CARBON	3.9K OHM 1/5W J
R853	CRD20TJ222T	RES , CARBON	2.2K OHM 1/5W J
R854	CRD20TJ222T	RES , CARBON	2.2K OHM 1/5W J
R855	CRD20TJ681T	RES , CARBON	680 OHM 1/5W J
R856	CRD20TJ681T	RES , CARBON	680 OHM 1/5W J
R857	CRD20TJ221T	RES , CARBON	220 OHM 1/5W J
R858	CRD20TJ221T	RES , CARBON	220 OHM 1/5W J
R861	CRD20TJ470T	RES , CARBON	47 OHM 1/5W J
R864	CRD20TJ272T	RES , CARBON	2.7K OHM 1/5W J
R865	CRD20TJ101T	RES , CARBON	100 OHM 1/5W J
R866	CRD20TJ272T	RES , CARBON	2.7K OHM 1/5W J
R867	CRD20TJ470T	RES , CARBON	47 OHM 1/5W J
R869	CRD20TJ750T	RES , CARBON	75 OHM 1/5W J
R871	CRD20TJ104T	RES , CARBON	100K OHM 1/5W J
R872	CRD20TJ104T	RES , CARBON	100K OHM 1/5W J
R873	CRD20TJ471T	RES , CARBON	470 OHM 1/5W J
R874	CRD20TJ471T	RES , CARBON	470 OHM 1/5W J
R875	CRD20TJ103T	RES , CARBON	10K OHM 1/5W J
R876	CRD20TJ750T	RES , CARBON	75 OHM 1/5W J
R877	CRD20TJ750T	RES , CARBON	75 OHM 1/5W J
R878	CRD20TJ750T	RES , CARBON	75 OHM 1/5W J
R881	CRD20TJ103T	RES , CARBON	10K OHM 1/5W J
R882	CRD20TJ103T	RES , CARBON	10K OHM 1/5W J
R883	CRD20TJ103T	RES , CARBON	10K OHM 1/5W J
R884	CRD20TJ103T	RES , CARBON	10K OHM 1/5W J
R885	CRD20TJ103T	RES , CARBON	10K OHM 1/5W J
R886	CRD20TJ103T	RES , CARBON	10K OHM 1/5W J
R887	CRD20TJ103T	RES , CARBON	10K OHM 1/5W J
R888	CRD20TJ103T	RES , CARBON	10K OHM 1/5W J
R889	CRD20TJ103T	RES , CARBON	10K OHM 1/5W J
R890	CRD20TJ103T	RES , CARBON	10K OHM 1/5W J
R891	CRD20TJ103T	RES , CARBON	10K OHM 1/5W J
R892	CRD20TJ222T	RES , CARBON	2.2K OHM 1/5W J
R893	CRD20TJ333T	RES , CARBON	33K OHM 1/5W J
R903	CRD20TJ102T	RES , CARBON	1K OHM 1/5W J
R904	CRD20TJ102T	RES , CARBON	1K OHM 1/5W J
R913	CRD20TJ102T	RES , CARBON	1K OHM 1/5W J
R914	CRD20TJ473T	RES , CARBON	47K OHM 1/5W J
R915	CRD20TJ473T	RES , CARBON	47K OHM 1/5W J
R917	CRD20TJ223T	RES , CARBON	22K OHM 1/5W J
R918	CRD20TJ562T	RES , CARBON	5.6K OHM 1/5W J
R919	CRD20TJ562T	RES , CARBON	5.6K OHM 1/5W J
R920	CRD20TJ100T	RES , CARBON	10 OHM 1/5W J
VR71	CVV2X05M104Z	RES , VARIABLE(BALANCE)	RK14128030214Y
VR72	CVV2X07C104Z	RES , VARIABLE(TONE)	RK14128030214C
VR73	CVV2X07C104Z	RES , VARIABLE(TONE)	RK14128030214C
<i>Miscellaneous</i>			
L702	HLQ02C100KT	COIL , AXAIL	10UH
S701	HST1A020ZT	SW , TACT	
S702	HST1A020ZT	SW , TACT	
S703	HST1A020ZT	SW , TACT	
S704	HST1A020ZT	SW , TACT	
S705	HST1A020ZT	SW , TACT	
S706	HST1A020ZT	SW , TACT	
S707	HST1A020ZT	SW , TACT	
S708	HST1A020ZT	SW , TACT	
S709	HST1A020ZT	SW , TACT	
S710	HST1A020ZT	SW , TACT	
S711	HST1A020ZT	SW , TACT	

Ref. Designator	Part Number	Description	
FRONT PCB ASS'Y			
S712	HST1A020ZT	SW , TACT	
S713	HST1A020ZT	SW , TACT	
S714	HST1A020ZT	SW , TACT	
S715	HST1A020ZT	SW , TACT	
S716	HST1A020ZT	SW , TACT	
S717	HST1A020ZT	SW , TACT	
S718	HST1A020ZT	SW , TACT	
S719	HST1A020ZT	SW , TACT	
S720	HST1A020ZT	SW , TACT	
BAT1	HGP15BNH3A3H	BATTERY , RECHARGEABLE	HGP15BNH3A3H
BK71	CMD1A209	BRACKET , FLT	A4-92-1739
BK72	CMD1A209	BRACKET , FLT	A4-92-1739
BK73	CMD1A387	BRACKET , PCB	
BK74	CMD1A209	BRACKET , FLT	A4-92-1739
BN10	CWZAVR230BN10	WIRE ASS'Y (SHIELD)	
BN15	CWB2B906150EN	WIRE ASS'Y	
BN16	CWZAVR2550BN16	WIRE ASS'Y (SHIELD)	
BN18	CWZAVR125BN18	WIRE ASS'Y (SHIELD)	
BN41	CWZAVR130BN41	WIRE ASS'Y (SHIELD)	
BN72	HJP32GA179ZJ	CONN,FFC 1M/M 32P STR,SMD_JST	32FMNNBMTTATF
BN80	CWB2B911420EW	WIRE ASS'Y	
BN81	CWB2B908250BM	WIRE , ASS'Y	
BN84	CWB2B905080EN	WIRE ASS'Y	
BN85	CWB2B902090EN	WIRE ASS'Y	
BN87	CWZAVR2550BN87	WIRE ASS'Y (SHIELD)	
BN88	CWB2B904070EN	WIRE ASS'Y	
BN89	CWB2B905080EN	WIRE ASS'Y	
BN90	CWB2B902090EN	WIRE ASS'Y	
BN94	KJP13GB99ZM	CONNECTOR	MOLEX35237-1310
BN95	KJP08GB99ZM	CONNECTOR , HOUSING	MOLEX35237-0810
CN10	KJP04GB46ZM	WAFER	MOLEX 53015
CN11	KJP15GA98ZM	WAFER	MOLEX35336-1510
CN12	KJP15GA98ZM	WAFER	MOLEX35336-1510
CN16	KJP08GB46ZM	WAFER	
CN72	CJP32GA117ZY	WAFER , CARD CABLE	
CN79	KJP05GA19ZM	WAFER	MOLEX53014-0510
CN84	KJP05GA19ZM	WAFER	MOLEX53014-0510
CN86	KJP02GA89ZM	WAFER	MOLEX35328-02
CN88	KJP04GA19ZM	WAFER	
CN89	KJP05GA19ZM	WAFER	MOLEX53014-0510
CN90	KJP02GA19ZM	WAFER	
CN91	KJP06HA37ZM	WAFER	MOLEX42140-2206
JK81	CJJ4M041Y	JACK , BOARD (COAX)	
JK82	HJSTORX179L	MODULE , OPTICAL(RX)	TORX179L
JK85	CJJ9M003Z	JACK , S-VIDEO	
JK86	CJJ4S023Y	JACK , BOARD	
JK86	CJJ4S029Z	JACK , BOARD(SILVER)	
JW81	CWE7202110AA	WIRE ASS'Y	
JW83	CWE8202150RV	WIRE ASS'Y	
JW84	CWE8202110RV	WIRE , ASS'Y	
JW85	CWE8202070AA	WIRE ASS'Y	
JW86	CWE7202060AA	WIRE ASS'Y	
SW01	CSH1A008ZV	SW , PUSH (MOMS)	
VR74	HSR2A029Z	VR , ENCODER	
X701	HOX04194E120CS	CRYSTAL	
X703	HOX10000E220CS	CRYSTAL	

Ref. Designator	Part Number	Description	
BIAS/REGULATOR PCB's			
<i>Capacitors</i>			
C851	HCEA1HH100T	CAP , ELECT	10UF 50V
C852	HCEA1HH100T	CAP , ELECT	10UF 50V
C853	HCEA1HH100T	CAP , ELECT	10UF 50V
C854	HCEA1HH100T	CAP , ELECT	10UF 50V
C855	HCEA1HH100T	CAP , ELECT	10UF 50V
C856	HCEA1HH100T	CAP , ELECT	10UF 50V
C857	HCEA1HH100T	CAP , ELECT	10UF 50V
C922	HCEA1EH101T	CAP , ELECT	100UF 25V
C923	HCEA1EH101T	CAP , ELECT	100UF 25V
C924	HCEA1EH101T	CAP , ELECT	100UF 25V
C925	CCKT1H223ZF	CAP , CERAMIC	0.022UF 50V ZF
C926	CCKT1H223ZF	CAP , CERAMIC	0.022UF 50V ZF
C927	CCKT1H223ZF	CAP , CERAMIC	0.022UF 50V ZF
C931	HCEA1HH4R7T	CAP , ELECT	4.7UF 50V
C928	CCEA1CH472E	CAP , ELECT	4700UF 16V
C929	CCEA1EH332F	CAP , ELECT	3300UF 25V
C930	CCEA1EH222E	CAP. ELECT.	2200UF 25V
<i>Semiconductors</i>			
IC91	HVIL7815CP	I.C, REGULATOR	L7815C
IC92	HVIL7915CP	I.C, REGULATOR	L7915C
IC93	HVIL7805CP	I.C, REGULATOR	L7805C
Q851	HVTKTD600KGR	TRANSISTOR , BIAS NPN	KTD600KGR
Q852	HVTKTD600KGR	TRANSISTOR , BIAS NPN	KTD600KGR
Q853	HVTKTD600KGR	TRANSISTOR , BIAS NPN	KTD600KGR
Q854	HVTKTD600KGR	TRANSISTOR , BIAS NPN	KTD600KGR
Q855	HVTKTD600KGR	TRANSISTOR , BIAS NPN	KTD600KGR
Q856	HVTKTD600KGR	TRANSISTOR , BIAS NPN	KTD600KGR
Q857	HVTKTD600KGR	TRANSISTOR , BIAS NPN	KTD600KGR
D903	HVD1N5819T	DIODE , SCHOTTKY	1N5819
D904	KVD1N4003ST	DIODE	1N4003
D905	KVD1N4003ST	DIODE	1N4003
D906	KVD1N4003ST	DIODE	1N4003
D907	KVD1N4003ST	DIODE	1N4003
D915	HVD1SS133MT	DIODE	1SS133T-77
D916	HVD1SS133MT	DIODE	1SS133T-77
<i>Resistors</i>			
R874	CRD20TJ331T	RES , CARBON	330 OHM 1/5W J
R875	CRD20TJ331T	RES , CARBON	330 OHM 1/5W J
R876	CRD20TJ331T	RES , CARBON	330 OHM 1/5W J
R877	CRD20TJ331T	RES , CARBON	330 OHM 1/5W J
R878	CRD20TJ331T	RES , CARBON	330 OHM 1/5W J
R879	CRD20TJ331T	RES , CARBON	330 OHM 1/5W J
R880	CRD20TJ331T	RES , CARBON	330 OHM 1/5W J
R882	CRD20TJ122T	RES , CARBON	1.2K OHM 1/5W J
R883	CRD20TJ122T	RES , CARBON	1.2K OHM 1/5W J
R884	CRD20TJ122T	RES , CARBON	1.2K OHM 1/5W J
R885	CRD20TJ122T	RES , CARBON	1.2K OHM 1/5W J
R886	CRD20TJ122T	RES , CARBON	1.2K OHM 1/5W J
R887	CRD20TJ122T	RES , CARBON	1.2K OHM 1/5W J
R888	CRD20TJ122T	RES , CARBON	1.2K OHM 1/5W J
R912	CRD20TJ153T	RES , CARBON	15K OHM 1/5W J
R913	CRD20TJ153T	RES , CARBON	15K OHM 1/5W J
R914	CRD20TJ103T	RES , CARBON	10K OHM 1/5W J
VR81	HVN1RA221B01T	RES , SEMI FIXED(220 OHM)	RH0615C100221
VR82	HVN1RA221B01T	RES , SEMI FIXED(220 OHM)	RH0615C100221

Ref. Designator	Part Number	Description	
BIAS/REGULATOR PCB's			
VR83	HVN1RA221B01T	RES , SEMI FIXED(220 OHM)	RH0615C100221
VR84	HVN1RA221B01T	RES , SEMI FIXED(220 OHM)	RH0615C100221
VR85	HVN1RA221B01T	RES , SEMI FIXED(220 OHM)	RH0615C100221
VR86	HVN1RA221B01T	RES , SEMI FIXED(220 OHM)	RH0615C100221
VR87	HVN1RA221B01T	RES , SEMI FIXED(220 OHM)	RH0615C100221
<i>Miscellaneous</i>			
CN81	KJP02GB46ZM	WAFER	
CN82	KJP02GB46ZM	WAFER	
CN83	KJP02GB46ZM	WAFER	
CN84	KJP02GB46ZM	WAFER	
CN85	KJP02GB46ZM	WAFER	
CN86	KJP02GB46ZM	WAFER	
CN87	KJP02GB46ZM	WAFER	
CN96	KJP08GA01ZM	WAFER	MOLEX 5267-08A
CN98	BJP08GB131ZK	WAFER	
MAIN PCB ASS'Y			
<i>Capacitors</i>			
C501	HCEA1VH100T	CAP , ELECT	10UF 35V
C502	HCEA1VH100T	CAP , ELECT	10UF 35V
C503	HCEA1VH100T	CAP , ELECT	10UF 35V
C504	HCEA1VH100T	CAP , ELECT	10UF 35V
C505	HCEA1VH100T	CAP , ELECT	10UF 35V
C506	CCKT1H331KB	CAP , CERAMIC	330PF 50V KB
C507	CCKT1H331KB	CAP , CERAMIC	330PF 50V KB
C508	CCKT1H331KB	CAP , CERAMIC	330PF 50V KB
C509	CCKT1H331KB	CAP , CERAMIC	330PF 50V KB
C510	CCKT1H331KB	CAP , CERAMIC	330PF 50V KB
C561	HCEA1CH101T	CAP , ELECT	100UF 16V
C562	HCEA1CH101T	CAP , ELECT	100UF 16V
C563	HCEA1CH101T	CAP , ELECT	100UF 16V
C564	HCEA1CH101T	CAP , ELECT	100UF 16V
C565	HCEA1CH101T	CAP , ELECT	100UF 16V
C566	HCEA1CH101T	CAP , ELECT	100UF 16V
C567	HCEA1CH101T	CAP , ELECT	100UF 16V
C568	HCEA1CH101T	CAP , ELECT	100UF 16V
C569	HCEA1CH101T	CAP , ELECT	100UF 16V
C570	HCEA1CH101T	CAP , ELECT	100UF 16V
C571	HCBS1H681KBT	CAP , CERAMIC	680PF 50V J
C572	HCBS1H681KBT	CAP , CERAMIC	680PF 50V J
C573	HCBS1H681KBT	CAP , CERAMIC	680PF 50V J
C574	HCBS1H681KBT	CAP , CERAMIC	680PF 50V J
C575	HCBS1H681KBT	CAP , CERAMIC	680PF 50V J
C601	CCCT1H120JC	CAP , CERAMIC	12PF 50V JC
C602	CCCT1H120JC	CAP , CERAMIC	12PF 50V JC
C603	CCCT1H120JC	CAP , CERAMIC	12PF 50V JC
C604	CCCT1H120JC	CAP , CERAMIC	12PF 50V JC
C605	CCCT1H120JC	CAP , CERAMIC	12PF 50V JC
C606	CCCT1H330JC	CAP , CERAMIC	33PF 50V JC
C607	CCCT1H330JC	CAP , CERAMIC	33PF 50V JC
C608	CCCT1H330JC	CAP , CERAMIC	33PF 50V JC
C609	CCCT1H330JC	CAP , CERAMIC	33PF 50V JC
C610	CCCT1H330JC	CAP , CERAMIC	33PF 50V JC
C681	HCEA1HH100T	CAP , ELECT	10UF 50V
C682	HCEA1HH100T	CAP , ELECT	10UF 50V
C683	HCEA1HH100T	CAP , ELECT	10UF 50V
C684	HCEA1HH100T	CAP , ELECT	10UF 50V

Ref. Designator	Part Number	Description	
MAIN PCB ASS'Y			
C685	HCEA1HH100T	CAP , ELECT	10UF 50V
C721	CCKT1H221KB	CAP , MYLAR	220PF 50V KB
C722	CCKT1H221KB	CAP , MYLAR	220PF 50V KB
C723	CCKT1H221KB	CAP , MYLAR	220PF 50V KB
C724	CCKT1H221KB	CAP , MYLAR	220PF 50V KB
C725	CCKT1H221KB	CAP , MYLAR	220PF 50V KB
C726	CCKT1H221KB	CAP , MYLAR	220PF 50V KB
C727	CCKT1H221KB	CAP , MYLAR	220PF 50V KB
C728	CCKT1H221KB	CAP , MYLAR	220PF 50V KB
C801	HCEA1HH100T	CAP , ELECT	10UF 50V
C802	HCEA1HH100T	CAP , ELECT	10UF 50V
C803	CCCT1H330JC	CAP , CERAMIC	33PF 50V JC
C804	CCCT1H330JC	CAP , CERAMIC	33PF 50V JC
C805	CCCT1H120JC	CAP , CERAMIC	12PF 50V JC
C806	CCCT1H120JC	CAP , CERAMIC	12PF 50V JC
C811	HCEA1CH101T	CAP , ELECT	100UF 16V
C812	HCEA1CH101T	CAP , ELECT	100UF 16V
C813	HCEA1CH101T	CAP , ELECT	100UF 16V
C814	HCEA1CH101T	CAP , ELECT	100UF 16V
C815	CCKT1H331KB	CAP , CERAMIC	330PF 50V KB
C816	CCKT1H331KB	CAP , CERAMIC	330PF 50V KB
C817	HCEA1VH100T	CAP , ELECT	10UF 35V
C818	HCEA1VKS100T	CAP , ELECT	10UF 35V
C819	HCBS1H681KBT	CAP , CERAMIC	680PF 50V J
C820	HCBS1H681KBT	CAP , CERAMIC	680PF 50V J
C851	HCEA1HH100T	CAP , ELECT	10UF 50V
C852	HCEA1HH100T	CAP , ELECT	10UF 50V
C853	HCEA1HH100T	CAP , ELECT	10UF 50V
C854	HCEA1HH100T	CAP , ELECT	10UF 50V
C855	HCEA1HH100T	CAP , ELECT	10UF 50V
C856	HCEA1HH100T	CAP , ELECT	10UF 50V
C857	HCEA1HH100T	CAP , ELECT	10UF 50V
C900	HCQI1H473JZT	CAP , MYLAR	0.047UF 50V J
C901	HCQI1H473JZT	CAP , MYLAR	0.047UF 50V J
C905	CCKT1H223ZF	CAP , CERAMIC	0.022UF 50V ZF
C907	HCEA1CH101T	CAP , ELECT	100UF 16V
C908	CCKT1H223ZF	CAP , CERAMIC	0.022UF 50V ZF
C910	HCQI1H473JZT	CAP , MYLAR	0.047UF 50V J
C911	HCEA1CH471T	CAP , ELECT	470UF 16V
C912	HCEA1CH221T	CAP , ELECT	220UF 16V
C913	CCFT1H104ZF	CAP , SEMICONDUCTOR	0.1UF 50V ZF
C914	HCQI1H473JZT	CAP , MYLAR	0.047UF 50V J
C917	HCQI1H473JZT	CAP , MYLAR	0.047UF 50V J
C918	HCQI1H473JZT	CAP , MYLAR	0.047UF 50V J
C919	HCQI1H473JZT	CAP , MYLAR	0.047UF 50V J
C922	HCEA1EH101T	CAP , ELECT	100UF 25V
C923	HCBS1H104ZFT	CAP , CERAMIC	0.1UF 50V Z
C924	HCBS1H104ZFT	CAP , CERAMIC	0.1UF 50V Z
C925	HCBS1H104ZFT	CAP , CERAMIC	0.1UF 50V Z
C926	CCKT1H223ZF	CAP , CERAMIC	0.022UF 50V ZF
C927	CCKT1H223ZF	CAP , CERAMIC	0.022UF 50V ZF
C931	HCEA1HH4R7T	CAP , ELECT	4.7UF 50V
C932	HCEA1CH101T	CAP , ELECT	100UF 16V
C933	HCEA1CH221T	CAP , ELECT	220UF 16V
C934	CCKT1H223ZF	CAP , CERAMIC	0.022UF 50V ZF
C939	HCEA1HH4R7T	CAP , ELECT	4.7UF 50V
C940	HCEA1AH471T	CAP , ELECT	470UF 10V
C950	HCEA1CH101T	CAP , ELECT	100UF 16V
C955	CCKT1H101KB	CAP , CERAMIC	100PF 50V KB
C971	HCQI1H562JZT	CAP , MYLAR	5600PF 50V J
C972	HCQI1H562JZT	CAP , MYLAR	5600PF 50V J

Ref. Designator	Part Number	Description	
MAIN PCB ASS'Y			
C973	HCQI1H562JZT	CAP , MYLAR	5600PF 50V J
C974	HCQI1H562JZT	CAP , MYLAR	5600PF 50V J
C975	HCQI1H562JZT	CAP , MYLAR	5600PF 50V J
C980	HCQI1H562JZT	CAP , MYLAR	5600PF 50V J
C981	HCQI1H562JZT	CAP , MYLAR	5600PF 50V J
C990	HCQI1H473JZT	CAP , MYLAR	0.047UF 50V J
C991	HCEA1HH1R0T	CAP , ELECT	1UF 50V
C992	HCQI1H473JZT	CAP , MYLAR	0.047UF 50V J
C993	HCQI1H473JZT	CAP , MYLAR	0.047UF 50V J
C994	HCQI1H473JZT	CAP , MYLAR	0.047UF 50V J
C995	HCQI1H473JZT	CAP , MYLAR	0.047UF 50V J
C996	HCQI1H473JZT	CAP , MYLAR	0.047UF 50V J
C997	HCQI1H473JZT	CAP , MYLAR	0.047UF 50V J
C999	CCKT1H223ZF	CAP , CERAMIC	0.022UF 50V ZF
C631	CCEA1JH221E	CAP , ELECT	220UF 63V
C632	CCEA1JH221E	CAP , ELECT	220UF 63V
C633	CCEA1JH221E	CAP , ELECT	220UF 63V
C634	CCEA1JH221E	CAP , ELECT	220UF 63V
C635	CCEA1JH221E	CAP , ELECT	220UF 63V
C636	CCEA1JH221E	CAP , ELECT	220UF 63V
C637	CCEA1JH221E	CAP , ELECT	220UF 63V
C638	CCEA1JH221E	CAP , ELECT	220UF 63V
C639	CCEA1JH221E	CAP , ELECT	220UF 63V
C640	CCEA1JH221E	CAP , ELECT	220UF 63V
C807	CCEA1JH221E	CAP , ELECT	220UF 63V
C808	CCEA1JH221E	CAP , ELECT	220UF 63V
C809	CCEA1JH221E	CAP , ELECT	220UF 63V
C810	CCEA1JH221E	CAP , ELECT	220UF 63V
C902	CCET63VKL5822NK	CAP , ELECT	8200/63V (30*50
C904	KCKDKS472ME	CAP , CERAMIC(X1/Y2/SC)	0.0047UF/2.5KV
C906	HCEA1EH102E	CAP , ELECT	1000UF 25V
C909	CCET63VKL5822NK	CAP , ELECT	8200/63V (30*50
C915	CCET63VKL5123NK	CAP , ELECT	12000/63V (30*5
C916	CCET63VKL5123NK	CAP , ELECT	12000/63V (30*5
C928	HCEA1CH332E	CAP , ELECT	4700UF 16V
C929	HCEA1EH332E	CAP , ELECT	3300UF 25V
C930	HCEA1EH222E	CAP , ELECT	2200UF 25V
C961	HCEA1CH472E	CAP , ELECT	4700UF 16V
			4700UF , 16V
<i>Semiconductors</i>			
D501	HVD1SS133MT	DIODE	1SS133T-77
D502	HVD1SS133MT	DIODE	1SS133T-77
D503	HVD1SS133MT	DIODE	1SS133T-77
D504	HVD1SS133MT	DIODE	1SS133T-77
D505	HVD1SS133MT	DIODE	1SS133T-77
D581	HVD1SS133MT	DIODE	1SS133T-77
D582	HVD1SS133MT	DIODE	1SS133T-77
D583	HVD1SS133MT	DIODE	1SS133T-77
D584	HVD1SS133MT	DIODE	1SS133T-77
D585	HVD1SS133MT	DIODE	1SS133T-77
D601	HVD1SS133MT	DIODE	1SS133T-77
D801	HVD1SS133MT	DIODE	1SS133T-77
D802	HVD1SS133MT	DIODE	1SS133T-77
D803	HVD1SS133MT	DIODE	1SS133T-77
D804	HVD1SS133MT	DIODE	1SS133T-77
D901	KVD1N4003ST	DIODE	1N4003
D902	HVD1SS133MT	DIODE	1SS133T-77
D903	KVD1N4003SRT	DIODE TW	1N4003
D904	KVD1N4003ST	DIODE	1N4003
D905	KVD1N4003ST	DIODE	1N4003

Ref. Designator	Part Number	Description	
MAIN PCB ASS'Y			
D906	KVD1N4003ST	DIODE	1N4003
D907	KVD1N4003ST	DIODE	1N4003
D911	HVD1SS133MT	DIODE	1SS133T-77
D912	HVD1SS133MT	DIODE	1SS133T-77
D914	HVD1SS133MT	DIODE	1SS133T-77
D915	HVD1SS133MT	DIODE	1SS133T-77
D916	HVD1SS133MT	DIODE	1SS133T-77
D917	HVD1SS133MT	DIODE	1SS133T-77
D951	HVD1SS133MT	DIODE	1SS133T-77
D952	HVD1SS133MT	DIODE	1SS133T-77
D953	HVD1SS133MT	DIODE	1SS133T-77
D954	KVD1N4003SRT	DIODE TW	1N4003
D955	KVD1N4003SRT	DIODE TW	1N4003
D956	HVD1SS133MT	DIODE	1SS133T-77
D961	KVD1N4003ST	DIODE	1N4003
D962	KVD1N4003ST	DIODE	1N4003
D963	KVD1N4003ST	DIODE	1N4003
D964	HVD1SS133MT	DIODE	1SS133T-77
D965	HVD1SS133MT	DIODE	1SS133T-77
D966	HVD1SS133MT	DIODE	1SS133T-77
D967	HVD1SS133MT	DIODE	1SS133T-77
D968	HVD1SS133MT	DIODE	1SS133T-77
D969	HVD1SS133MT	DIODE	1SS133T-77
D971	HVD1SS133MT	DIODE	1SS133T-77
D972	HVD1SS133MT	DIODE	1SS133T-77
D973	HVD1SS133MT	DIODE	1SS133T-77
D974	HVD1SS133MT	DIODE	1SS133T-77
D975	HVD1SS133MT	DIODE	1SS133T-77
D976	HVD1SS133MT	DIODE	1SS133T-77
Q501	HVTKTA1268GRT	TRANSISTOR PNP	KTA1268GR
Q502	HVTKTA1268GRT	TRANSISTOR PNP	KTA1268GR
Q503	HVTKTA1268GRT	TRANSISTOR PNP	KTA1268GR
Q504	HVTKTA1268GRT	TRANSISTOR PNP	KTA1268GR
Q505	HVTKTA1268GRT	TRANSISTOR PNP	KTA1268GR
Q511	HVTKTC3200GRT	TRANSISTOR NPN	KTC3200GR
Q512	HVTKTC3200GRT	TRANSISTOR NPN	KTC3200GR
Q513	HVTKTC3200GRT	TRANSISTOR NPN	KTC3200GR
Q514	HVTKTC3200GRT	TRANSISTOR NPN	KTC3200GR
Q515	HVTKTC3200GRT	TRANSISTOR NPN	KTC3200GR
Q516	HVTKTC3200GRT	TRANSISTOR NPN	KTC3200GR
Q517	HVTKTC3200GRT	TRANSISTOR NPN	KTC3200GR
Q518	HVTKTC3200GRT	TRANSISTOR NPN	KTC3200GR
Q519	HVTKTC3200GRT	TRANSISTOR NPN	KTC3200GR
Q520	HVTKTC3200GRT	TRANSISTOR NPN	KTC3200GR
Q541	HVTKTC3198YT	TRANSISTOR NPN	KTC3198Y
Q542	HVTKTC3198YT	TRANSISTOR NPN	KTC3198Y
Q543	HVTKTC3198YT	TRANSISTOR NPN	KTC3198Y
Q544	HVTKTC3198YT	TRANSISTOR NPN	KTC3198Y
Q545	HVTKTC3198YT	TRANSISTOR NPN	KTC3198Y
Q556	HVTKTC3200GRT	TRANSISTOR NPN	KTC3200GR
Q557	HVTKTC3200GRT	TRANSISTOR NPN	KTC3200GR
Q558	HVTKTC3200GRT	TRANSISTOR NPN	KTC3200GR
Q559	HVTKTC3200GRT	TRANSISTOR NPN	KTC3200GR
Q560	HVTKTC3200GRT	TRANSISTOR NPN	KTC3200GR
Q561	HVTKTC3200GRT	TRANSISTOR NPN	KTC3200GR
Q562	HVTKTC3200GRT	TRANSISTOR NPN	KTC3200GR
Q563	HVTKTC3200GRT	TRANSISTOR NPN	KTC3200GR
Q564	HVTKTC3200GRT	TRANSISTOR NPN	KTC3200GR
Q565	HVTKTC3200GRT	TRANSISTOR NPN	KTC3200GR
Q601	HVTKTA1268GRT	TRANSISTOR PNP	KTA1268GR
Q602	HVTKTA1268GRT	TRANSISTOR PNP	KTA1268GR

Ref. Designator	Part Number	Description	
MAIN PCB ASS'Y			
Q603	HVTKTA1268GRT	TRANSISTOR PNP	KTA1268GR
Q604	HVTKTA1268GRT	TRANSISTOR PNP	KTA1268GR
Q605	HVTKTA1268GRT	TRANSISTOR PNP	KTA1268GR
Q681	KVTKSC2785YT	TRANSISTOR NPN	KSC2785Y
Q682	KVTKSC2785YT	TRANSISTOR NPN	KSC2785Y
Q683	KVTKSC2785YT	TRANSISTOR NPN	KSC2785Y
Q684	KVTKSC2785YT	TRANSISTOR NPN	KSC2785Y
Q685	KVTKSC2785YT	TRANSISTOR NPN	KSC2785Y
Q701	HVTKTC2874BT	TRANSISTOR , MUTE NPN	KTC2874B
Q702	HVTKTC2874BT	TRANSISTOR , MUTE NPN	KTC2874B
Q703	HVTKTC2874BT	TRANSISTOR , MUTE NPN	KTC2874B
Q704	HVTKTC2874BT	TRANSISTOR , MUTE NPN	KTC2874B
Q705	HVTKTC2874BT	TRANSISTOR , MUTE NPN	KTC2874B
Q706	HVTKTC2874BT	TRANSISTOR , MUTE NPN	KTC2874B
Q707	HVTKTC2874BT	TRANSISTOR , MUTE NPN	KTC2874B
Q708	HVTKTC2874BT	TRANSISTOR , MUTE NPN	KTC2874B
Q801	KVTKSC2785YT	TRANSISTOR NPN	KSC2785Y
Q802	KVTKSC2785YT	TRANSISTOR NPN	KSC2785Y
Q812	HVTKTA1268GRT	TRANSISTOR PNP	KTA1268GR
Q813	HVTKTC3200GRT	TRANSISTOR NPN	KTC3200GR
Q814	HVTKTA1268GRT	TRANSISTOR PNP	KTA1268GR
Q815	HVTKTC3200GRT	TRANSISTOR NPN	KTC3200GR
Q816	HVTKTA1268GRT	TRANSISTOR PNP	KTA1268GR
Q817	HVTKTA1268GRT	TRANSISTOR PNP	KTA1268GR
Q818	HVTKTC3200GRT	TRANSISTOR NPN	KTC3200GR
Q819	HVTKTC3200GRT	TRANSISTOR NPN	KTC3200GR
Q820	HVTKTC3200GRT	TRANSISTOR NPN	KTC3200GR
Q821	HVTKTC3200GRT	TRANSISTOR NPN	KTC3200GR
Q822	HVTKTC3200GRT	TRANSISTOR NPN	KTC3200GR
Q823	HVTKTC3200GRT	TRANSISTOR NPN	KTC3200GR
Q824	HVTKTC3198YT	TRANSISTOR NPN	KTC3198Y
Q825	HVTKTC3198YT	TRANSISTOR NPN	KTC3198Y
Q826	HVTKTC2874BT	TRANSISTOR , MUTE NPN	KTC2874B
Q827	HVTKTC2874BT	TRANSISTOR , MUTE NPN	KTC2874B
Q901	KVTKSC2785YT	TRANSISTOR NPN	KSC2785Y
Q902	HVTKRA107MT	TRANSISTOR PNP	KRA107M
Q903	HVTKRA107MT	TRANSISTOR PNP	KRA107M
Q904	HVTKRC107MT	TRANSISTOR NPN	KRC107M
Q911	HVTKTA1271YT	TRANSISTOR PNP	KTA1271Y
Q912	HVTKTA1271YT	TRANSISTOR PNP	KTA1271Y
Q913	HVTKTA1271YT	TRANSISTOR PNP	KTA1271Y
Q914	HVTKTA1271YT	TRANSISTOR PNP	KTA1271Y
Q915	KVTKSC2785YT	TRANSISTOR NPN	KSC2785Y
Q916	KVTKSC2785YT	TRANSISTOR NPN	KSC2785Y
Q917	KVTKSC2785YT	TRANSISTOR NPN	KSC2785Y
Q918	KVTKSC2785YT	TRANSISTOR NPN	KSC2785Y
Q938	HVTKRA107MT	TRANSISTOR PNP	KRA107M
Q939	HVTKRA107MT	TRANSISTOR PNP	KRA107M
Q942	KVTKSC2785YT	TRANSISTOR NPN	KSC2785Y
Q943	KVTKSC2785YT	TRANSISTOR NPN	KSC2785Y
Q951	HVTKRC107MT	TRANSISTOR NPN	KRC107M
Q952	HVTKRA107MT	TRANSISTOR PNP	KRA107M
Q960	HVTKRC107MT	TRANSISTOR NPN	KRC107M
Q961	HVTKTA1024YT	TRANSISTOR PNP	KTA1024Y
Q969	HVTKTC2874BT	TRANSISTOR , MUTE	KTC2874B
Q970	HVTKTC2874BT	TRANSISTOR , MUTE	KTC2874B
Q971	HVTKTC2874BT	TRANSISTOR , MUTE	KTC2874B
Q972	HVTKTC2874BT	TRANSISTOR , MUTE	KTC2874B
Q973	HVTKTC2874BT	TRANSISTOR , MUTE	KTC2874B
Q991	HVTKRC107MT	TRANSISTOR NPN	KRC107M
Q992	HVTKRA107MT	TRANSISTOR PNP	KRA107M

Ref. Designator	Part Number	Description	
MAIN PCB ASS'Y			
Q993	HVTKRA107MT	TRANSISTOR PNP	KRA107M
Q994	HVTKRC107MT	TRANSISTOR NPN	KRC107M
Q995	HVTKRA107MT	TRANSISTOR PNP	KRA107M
Q996	HVTKTA1024YT	TRANSISTOR PNP	KTA1024Y
Q997	HVTKRC107MT	TRANSISTOR NPN	KRC107M
Q998	HVTKRA107MT	TRANSISTOR PNP	KRA107M
Q652	BVT2SB1647-OKM	TRANSISTOR , POWER PNP	2SB1647
Q653	BVT2SB1647-OKM	TRANSISTOR , POWER PNP	2SB1647
Q654	BVT2SB1647-OKM	TRANSISTOR , POWER PNP	2SB1647
Q655	BVT2SB1647-OKM	TRANSISTOR , POWER PNP	2SB1647
Q657	BVT2SD2560-OKM	TRANSISTOR , POWER NPN	2SD2560
Q658	BVT2SD2560-OKM	TRANSISTOR , POWER NPN	2SD2560
Q659	BVT2SD2560-OKM	TRANSISTOR , POWER NPN	2SD2560
Q660	BVT2SD2560-OKM	TRANSISTOR , POWER NPN	2SD2560
Q661	BVT2SB1647-OKM	TRANSISTOR , POWER PNP	2SB1647
Q670	BVT2SD2560-OKM	TRANSISTOR , POWER NPN	2SD2560
Q803	BVT2SD2560-OKM	TRANSISTOR , POWER NPN	2SD2560
Q804	BVT2SB1647-OKM	TRANSISTOR , POWER PNP	2SB1647
Q805	BVT2SD2560-OKM	TRANSISTOR , POWER NPN	2SD2560
Q807	BVT2SB1647-OKM	TRANSISTOR , POWER PNP	2SB1647
IC91	HVIL7815CP	I.C, REGULATOR	L7815C
IC92	HVIL7915CP	I.C, REGULATOR	L7915C
IC93	HVIL7805CP	I.C, REGULATOR	L7805C
IC94	HVIMC7805C	I.C, REGULATOR	KA7805-ABTU
IC95	BVIKP1010B	IC, PHOTO COUPLER	KP1010B
IC96	BVIKP1010B	IC, PHOTO COUPLER	KP1010B
Q858	HVT2SA1360O	TRANSISTOR PNP	2SA1360
Q871	HVT2SA1360O	TRANSISTOR PNP	2SA1360
Q872	HVT2SA1360O	TRANSISTOR PNP	2SA1360
Q874	HVT2SA1360O	TRANSISTOR PNP	2SA1360
Q875	HVT2SA1360O	TRANSISTOR PNP	2SA1360
Q876	HVT2SA1360O	TRANSISTOR PNP	2SA1360
Q877	HVT2SA1360O	TRANSISTOR PNP	2SA1360
Q881	HVT2SC3423O	TRANSISTOR NPN	2SC3423
Q882	HVT2SC3423O	TRANSISTOR NPN	2SC3423
Q883	HVT2SC3423O	TRANSISTOR NPN	2SC3423
Q884	HVT2SC3423O	TRANSISTOR NPN	2SC3423
Q885	HVT2SC3423O	TRANSISTOR NPN	2SC3423
Q886	HVT2SC3423O	TRANSISTOR NPN	2SC3423
Q887	HVT2SC3423O	TRANSISTOR NPN	2SC3423
Resistors			
R501	CRD20TJ433T	RES , CARBON	43K OHM 1/5W J
R502	CRD20TJ433T	RES , CARBON	43K OHM 1/5W J
R503	CRD20TJ433T	RES , CARBON	43K OHM 1/5W J
R504	CRD20TJ433T	RES , CARBON	43K OHM 1/5W J
R505	CRD20TJ433T	RES , CARBON	43K OHM 1/5W J
R506	CRD20TJ333T	RES , CARBON	33K OHM 1/5W J
R507	CRD20TJ333T	RES , CARBON	33K OHM 1/5W J
R508	CRD20TJ333T	RES , CARBON	33K OHM 1/5W J
R509	CRD20TJ333T	RES , CARBON	33K OHM 1/5W J
R510	CRD20TJ333T	RES , CARBON	33K OHM 1/5W J
R511	CRD20TJ152T	RES , CARBON	1.5K OHM 1/5W J
R512	CRD20TJ152T	RES , CARBON	1.5K OHM 1/5W J
R513	CRD20TJ152T	RES , CARBON	1.5K OHM 1/5W J
R514	CRD20TJ152T	RES , CARBON	1.5K OHM 1/5W J
R515	CRD20TJ152T	RES , CARBON	1.5K OHM 1/5W J
R516	CRD20TJ152T	RES , CARBON	1.5K OHM 1/5W J
R517	CRD20TJ152T	RES , CARBON	1.5K OHM 1/5W J
R518	CRD20TJ152T	RES , CARBON	1.5K OHM 1/5W J

Ref. Designator	Part Number	Description	
MAIN PCB ASS'Y			
R519	CRD20TJ152T	RES , CARBON	1.5K OHM 1/5W J
R520	CRD20TJ152T	RES , CARBON	1.5K OHM 1/5W J
R521	CRD20TJ471T	RES , CARBON	470 OHM 1/5W J
R522	CRD20TJ471T	RES , CARBON	470 OHM 1/5W J
R523	CRD20TJ471T	RES , CARBON	470 OHM 1/5W J
R524	CRD20TJ471T	RES , CARBON	470 OHM 1/5W J
R525	CRD20TJ471T	RES , CARBON	470 OHM 1/5W J
R527	CRD20TJ151T	RES , CARBON	150 OHM 1/5W J
R529	CRD20TJ151T	RES , CARBON	150 OHM 1/5W J
R530	CRD20TJ151T	RES , CARBON	150 OHM 1/5W J
R531	CRD20TJ221T	RES , CARBON	220 OHM 1/5W J
R532	CRD20TJ221T	RES , CARBON	220 OHM 1/5W J
R533	CRD20TJ221T	RES , CARBON	220 OHM 1/5W J
R534	CRD20TJ221T	RES , CARBON	220 OHM 1/5W J
R535	CRD20TJ221T	RES , CARBON	220 OHM 1/5W J
R536	CRD20TJ221T	RES , CARBON	220 OHM 1/5W J
R537	CRD20TJ221T	RES , CARBON	220 OHM 1/5W J
R538	CRD20TJ221T	RES , CARBON	220 OHM 1/5W J
R539	CRD20TJ221T	RES , CARBON	220 OHM 1/5W J
R540	CRD20TJ221T	RES , CARBON	220 OHM 1/5W J
R541	CRD20TJ271T	RES , CARBON	270 OHM 1/5W J
R542	CRD20TJ271T	RES , CARBON	270 OHM 1/5W J
R543	CRD20TJ271T	RES , CARBON	270 OHM 1/5W J
R544	CRD20TJ271T	RES , CARBON	270 OHM 1/5W J
R545	CRD20TJ271T	RES , CARBON	270 OHM 1/5W J
R556	CRD20TJ273T	RES , CARBON	27K OHM 1/5W J
R557	CRD20TJ273T	RES , CARBON	27K OHM 1/5W J
R558	CRD20TJ273T	RES , CARBON	27K OHM 1/5W J
R559	CRD20TJ273T	RES , CARBON	27K OHM 1/5W J
R560	CRD20TJ273T	RES , CARBON	27K OHM 1/5W J
R561	CRD20TJ182T	RES , CARBON	1.8K OHM 1/5W J
R562	CRD20TJ182T	RES , CARBON	1.8K OHM 1/5W J
R563	CRD20TJ182T	RES , CARBON	1.8K OHM 1/5W J
R564	CRD20TJ182T	RES , CARBON	1.8K OHM 1/5W J
R565	CRD20TJ182T	RES , CARBON	1.8K OHM 1/5W J
R566	CRD20TJ561T	RES , CARBON	560 OHM 1/5W J
R567	CRD20TJ561T	RES , CARBON	560 OHM 1/5W J
R568	CRD20TJ561T	RES , CARBON	560 OHM 1/5W J
R569	CRD20TJ561T	RES , CARBON	560 OHM 1/5W J
R570	CRD20TJ561T	RES , CARBON	560 OHM 1/5W J
R571	CRD20TJ561T	RES , CARBON	560 OHM 1/5W J
R572	CRD20TJ561T	RES , CARBON	560 OHM 1/5W J
R573	CRD20TJ561T	RES , CARBON	560 OHM 1/5W J
R574	CRD20TJ561T	RES , CARBON	560 OHM 1/5W J
R575	CRD20TJ561T	RES , CARBON	560 OHM 1/5W J
R576	CRD20TJ100T	RES , CARBON	10 OHM 1/5W J
R577	CRD20TJ100T	RES , CARBON	10 OHM 1/5W J
R578	CRD20TJ100T	RES , CARBON	10 OHM 1/5W J
R579	CRD20TJ100T	RES , CARBON	10 OHM 1/5W J
R580	CRD20TJ100T	RES , CARBON	10 OHM 1/5W J
R581	CRD20TJ561T	RES , CARBON	560 OHM 1/5W J
R582	CRD20TJ561T	RES , CARBON	560 OHM 1/5W J
R583	CRD20TJ561T	RES , CARBON	560 OHM 1/5W J
R584	CRD20TJ561T	RES , CARBON	560 OHM 1/5W J
R585	CRD20TJ561T	RES , CARBON	560 OHM 1/5W J
R586	CRD20TJ561T	RES , CARBON	560 OHM 1/5W J
R587	CRD20TJ561T	RES , CARBON	560 OHM 1/5W J
R588	CRD20TJ561T	RES , CARBON	560 OHM 1/5W J
R589	CRD20TJ561T	RES , CARBON	560 OHM 1/5W J
R590	CRD20TJ561T	RES , CARBON	560 OHM 1/5W J
R591	CRD20TJ561T	RES , CARBON	560 OHM 1/5W J

Ref. Designator	Part Number	Description	
MAIN PCB ASS'Y			
R592	CRD20TJ561T	RES , CARBON	560 OHM 1/5W J
R593	CRD20TJ561T	RES , CARBON	560 OHM 1/5W J
R594	CRD20TJ561T	RES , CARBON	560 OHM 1/5W J
R595	CRD20TJ561T	RES , CARBON	560 OHM 1/5W J
R596	CRD20TJ561T	RES , CARBON	560 OHM 1/5W J
R597	CRD20TJ561T	RES , CARBON	560 OHM 1/5W J
R598	CRD20TJ561T	RES , CARBON	560 OHM 1/5W J
R599	CRD20TJ561T	RES , CARBON	560 OHM 1/5W J
R600	CRD20TJ561T	RES , CARBON	560 OHM 1/5W J
R601	CRD20TJ223T	RES , CARBON	22K OHM 1/5W J
R602	CRD20TJ223T	RES , CARBON	22K OHM 1/5W J
R603	CRD20TJ223T	RES , CARBON	22K OHM 1/5W J
R604	CRD20TJ223T	RES , CARBON	22K OHM 1/5W J
R605	CRD20TJ223T	RES , CARBON	22K OHM 1/5W J
R606	CRD20TJ223T	RES , CARBON	22K OHM 1/5W J
R607	CRD20TJ223T	RES , CARBON	22K OHM 1/5W J
R608	CRD20TJ223T	RES , CARBON	22K OHM 1/5W J
R609	CRD20TJ223T	RES , CARBON	22K OHM 1/5W J
R610	CRD20TJ223T	RES , CARBON	22K OHM 1/5W J
R611	CRD20TJ100T	RES , CARBON	10 OHM 1/5W J
R612	CRD20TJ100T	RES , CARBON	10 OHM 1/5W J
R631	KRD25FJ180T	RES , CARBON	18 OHM 1/4W J
R632	KRD25FJ180T	RES , CARBON	18 OHM 1/4W J
R633	KRD25FJ180T	RES , CARBON	18 OHM 1/4W J
R634	KRD25FJ180T	RES , CARBON	18 OHM 1/4W J
R635	KRD25FJ180T	RES , CARBON	18 OHM 1/4W J
R636	KRD25FJ180T	RES , CARBON	18 OHM 1/4W J
R637	KRD25FJ180T	RES , CARBON	18 OHM 1/4W J
R638	KRD25FJ180T	RES , CARBON	18 OHM 1/4W J
R639	KRD25FJ180T	RES , CARBON	18 OHM 1/4W J
R640	KRD25FJ180T	RES , CARBON	18 OHM 1/4W J
R646	KRD25FJ3R3T	RES , CARBON	3.3 OHM 1/4W J
R647	KRD25FJ3R3T	RES , CARBON	3.3 OHM 1/4W J
R648	KRD25FJ3R3T	RES , CARBON	3.3 OHM 1/4W J
R649	KRD25FJ3R3T	RES , CARBON	3.3 OHM 1/4W J
R650	KRD25FJ3R3T	RES , CARBON	3.3 OHM 1/4W J
R651	KRD25FJ3R3T	RES , CARBON	3.3 OHM 1/4W J
R652	KRD25FJ3R3T	RES , CARBON	3.3 OHM 1/4W J
R653	KRD25FJ3R3T	RES , CARBON	3.3 OHM 1/4W J
R654	KRD25FJ3R3T	RES , CARBON	3.3 OHM 1/4W J
R655	KRD25FJ3R3T	RES , CARBON	3.3 OHM 1/4W J
R666	CRD25TJ470T	RES , CARBON	47 OHM 1/4W J
R667	CRD25TJ470T	RES , CARBON	47 OHM 1/4W J
R668	CRD25TJ470T	RES , CARBON	47 OHM 1/4W J
R669	CRD25TJ470T	RES , CARBON	47 OHM 1/4W J
R670	CRD25TJ470T	RES , CARBON	47 OHM 1/4W J
R671	CRD20TJ911T	RES , CARBON	910 OHM 1/5W J
R672	CRD20TJ911T	RES , CARBON	910 OHM 1/5W J
R673	CRD20TJ911T	RES , CARBON	910 OHM 1/5W J
R674	CRD20TJ911T	RES , CARBON	910 OHM 1/5W J
R675	CRD20TJ911T	RES , CARBON	910 OHM 1/5W J
R676	CRD20TJ182T	RES , CARBON	1.8K OHM 1/5W J
R677	CRD20TJ182T	RES , CARBON	1.8K OHM 1/5W J
R678	CRD20TJ182T	RES , CARBON	1.8K OHM 1/5W J
R679	CRD20TJ182T	RES , CARBON	1.8K OHM 1/5W J
R680	CRD20TJ182T	RES , CARBON	1.8K OHM 1/5W J
R681	CRD20TJ562T	RES , CARBON	5.6K OHM 1/5W J
R682	CRD20TJ562T	RES , CARBON	5.6K OHM 1/5W J
R683	CRD20TJ562T	RES , CARBON	5.6K OHM 1/5W J
R684	CRD20TJ562T	RES , CARBON	5.6K OHM 1/5W J
R685	CRD20TJ562T	RES , CARBON	5.6K OHM 1/5W J

Ref. Designator	Part Number	Description	
MAIN PCB ASS'Y			
R686	CRD20TJ103T	RES , CARBON	10K OHM 1/5W J
R687	CRD20TJ103T	RES , CARBON	10K OHM 1/5W J
R688	CRD20TJ103T	RES , CARBON	10K OHM 1/5W J
R689	CRD20TJ103T	RES , CARBON	10K OHM 1/5W J
R690	CRD20TJ103T	RES , CARBON	10K OHM 1/5W J
R696	CRD25TJ470T	RES , CARBON	47 OHM 1/4W J
R697	CRD25TJ470T	RES , CARBON	47 OHM 1/4W J
R698	CRD25TJ470T	RES , CARBON	47 OHM 1/4W J
R699	CRD25TJ470T	RES , CARBON	47 OHM 1/4W J
R700	CRD25TJ470T	RES , CARBON	47 OHM 1/4W J
R701	CRD20TJ102T	RES , CARBON	1K OHM 1/5W J
R702	CRD20TJ102T	RES , CARBON	1K OHM 1/5W J
R703	CRD20TJ102T	RES , CARBON	1K OHM 1/5W J
R704	CRD20TJ102T	RES , CARBON	1K OHM 1/5W J
R705	CRD20TJ102T	RES , CARBON	1K OHM 1/5W J
R706	CRD20TJ102T	RES , CARBON	1K OHM 1/5W J
R707	CRD20TJ102T	RES , CARBON	1K OHM 1/5W J
R708	CRD20TJ102T	RES , CARBON	1K OHM 1/5W J
R711	CRD20TJ472T	RES , CARBON	4.7K OHM 1/5W J
R712	CRD20TJ472T	RES , CARBON	4.7K OHM 1/5W J
R713	CRD20TJ472T	RES , CARBON	4.7K OHM 1/5W J
R714	CRD20TJ472T	RES , CARBON	4.7K OHM 1/5W J
R715	CRD20TJ472T	RES , CARBON	4.7K OHM 1/5W J
R716	CRD20TJ472T	RES , CARBON	4.7K OHM 1/5W J
R717	CRD20TJ472T	RES , CARBON	4.7K OHM 1/5W J
R718	CRD20TJ472T	RES , CARBON	4.7K OHM 1/5W J
R721	CRD20TJ104T	RES , CARBON	100K OHM 1/5W J
R722	CRD20TJ104T	RES , CARBON	100K OHM 1/5W J
R723	CRD20TJ104T	RES , CARBON	100K OHM 1/5W J
R724	CRD20TJ104T	RES , CARBON	100K OHM 1/5W J
R725	CRD20TJ104T	RES , CARBON	100K OHM 1/5W J
R726	CRD20TJ104T	RES , CARBON	100K OHM 1/5W J
R727	CRD20TJ104T	RES , CARBON	100K OHM 1/5W J
R728	CRD20TJ104T	RES , CARBON	100K OHM 1/5W J
R771	CRD20TJ750T	RES , CARBON	75 OHM 1/5W J
R772	CRD20TJ750T	RES , CARBON	75 OHM 1/5W J
R773	CRD20TJ750T	RES , CARBON	75 OHM 1/5W J
R774	CRD20TJ750T	RES , CARBON	75 OHM 1/5W J
R775	CRD20TJ750T	RES , CARBON	75 OHM 1/5W J
R776	CRD20TJ750T	RES , CARBON	75 OHM 1/5W J
R777	CRD20TJ750T	RES , CARBON	75 OHM 1/5W J
R781	CRD20TJ750T	RES , CARBON	75 OHM 1/5W J
R782	CRD20TJ750T	RES , CARBON	75 OHM 1/5W J
R783	CRD20TJ750T	RES , CARBON	75 OHM 1/5W J
R784	CRD20TJ750T	RES , CARBON	75 OHM 1/5W J
R785	CRD20TJ750T	RES , CARBON	75 OHM 1/5W J
R786	CRD20TJ750T	RES , CARBON	75 OHM 1/5W J
R787	CRD20TJ750T	RES , CARBON	75 OHM 1/5W J
R801	CRD20TJ103T	RES , CARBON	10K OHM 1/5W J
R802	CRD20TJ103T	RES , CARBON	10K OHM 1/5W J
R803	CRD20TJ562T	RES , CARBON	5.6K OHM 1/5W J
R804	CRD20TJ562T	RES , CARBON	5.6K OHM 1/5W J
R805	CRD20TJ911T	RES , CARBON	910 OHM 1/5W J
R807	CRD20TJ911T	RES , CARBON	910 OHM 1/5W J
R808	CRD20TJ182T	RES , CARBON	1.8K OHM 1/5W J
R809	CRD20TJ182T	RES , CARBON	1.8K OHM 1/5W J
R812	CRD25TJ470T	RES , CARBON	47 OHM 1/4W J
R813	CRD25TJ470T	RES , CARBON	47 OHM 1/4W J
R814	CRD25TJ470T	RES , CARBON	47 OHM 1/4W J
R815	CRD25TJ470T	RES , CARBON	47 OHM 1/4W J
R817	KRD25FJ3R3T	RES , CARBON	3.3 OHM 1/4W J

Ref. Designator	Part Number	Description	
MAIN PCB ASS'Y			
R818	KRD25FJ3R3T	RES , CARBON	3.3 OHM 1/4W J
R819	KRD25FJ3R3T	RES , CARBON	3.3 OHM 1/4W J
R820	KRD25FJ3R3T	RES , CARBON	3.3 OHM 1/4W J
R821	KRD25FJ180T	RES , CARBON	18 OHM 1/4W J
R822	KRD25FJ180T	RES , CARBON	18 OHM 1/4W J
R823	KRD25FJ180T	RES , CARBON	18 OHM 1/4W J
R824	KRD25FJ180T	RES , CARBON	18 OHM 1/4W J
R830	CRD20TJ223T	RES , CARBON	22K OHM 1/5W J
R831	CRD20TJ223T	RES , CARBON	22K OHM 1/5W J
R832	CRD20TJ223T	RES , CARBON	22K OHM 1/5W J
R833	CRD20TJ223T	RES , CARBON	22K OHM 1/5W J
R834	CRD20TJ561T	RES , CARBON	560 OHM 1/5W J
R835	CRD20TJ561T	RES , CARBON	560 OHM 1/5W J
R836	CRD20TJ561T	RES , CARBON	560 OHM 1/5W J
R837	CRD20TJ561T	RES , CARBON	560 OHM 1/5W J
R838	CRD20TJ561T	RES , CARBON	560 OHM 1/5W J
R839	CRD20TJ561T	RES , CARBON	560 OHM 1/5W J
R840	CRD20TJ561T	RES , CARBON	560 OHM 1/5W J
R841	CRD20TJ561T	RES , CARBON	560 OHM 1/5W J
R842	CRD20TJ561T	RES , CARBON	560 OHM 1/5W J
R843	CRD20TJ561T	RES , CARBON	560 OHM 1/5W J
R844	CRD20TJ561T	RES , CARBON	560 OHM 1/5W J
R845	CRD20TJ561T	RES , CARBON	560 OHM 1/5W J
R848	CRD20TJ273T	RES , CARBON	27K OHM 1/5W J
R849	CRD20TJ273T	RES , CARBON	27K OHM 1/5W J
R850	CRD20TJ182T	RES , CARBON	1.8K OHM 1/5W J
R851	CRD20TJ182T	RES , CARBON	1.8K OHM 1/5W J
R852	CRD20TJ152T	RES , CARBON	1.5K OHM 1/5W J
R853	CRD20TJ152T	RES , CARBON	1.5K OHM 1/5W J
R854	CRD20TJ152T	RES , CARBON	1.5K OHM 1/5W J
R855	CRD20TJ152T	RES , CARBON	1.5K OHM 1/5W J
R856	CRD20TJ221T	RES , CARBON	220 OHM 1/5W J
R857	CRD20TJ221T	RES , CARBON	220 OHM 1/5W J
R858	CRD20TJ221T	RES , CARBON	220 OHM 1/5W J
R859	CRD20TJ221T	RES , CARBON	220 OHM 1/5W J
R860	CRD20TJ271T	RES , CARBON	270 OHM 1/5W J
R861	CRD20TJ271T	RES , CARBON	270 OHM 1/5W J
R862	CRD20TJ333T	RES , CARBON	33K OHM 1/5W J
R863	CRD20TJ333T	RES , CARBON	33K OHM 1/5W J
R864	CRD20TJ331T	RES , CARBON	330 OHM 1/5W J
R865	CRD20TJ331T	RES , CARBON	330 OHM 1/5W J
R866	CRD20TJ472T	RES , CARBON	4.7K OHM 1/5W J
R867	CRD25TJ472T	RES , CARBON	4.7K OHM 1/4W J
R868	CRD20TJ473T	RES , CARBON	47K OHM 1/5W J
R869	CRD20TJ473T	RES , CARBON	47K OHM 1/5W J
R870	CRD20TJ433T	RES , CARBON	43K OHM 1/5W J
R871	CRD20TJ433T	RES , CARBON	43K OHM 1/5W J
R872	CRD20TJ471T	RES , CARBON	470 OHM 1/5W J
R873	CRD20TJ471T	RES , CARBON	470 OHM 1/5W J
R874	CRD20TJ331T	RES , CARBON	330 OHM 1/5W J
R875	CRD20TJ331T	RES , CARBON	330 OHM 1/5W J
R876	CRD20TJ331T	RES , CARBON	330 OHM 1/5W J
R877	CRD20TJ331T	RES , CARBON	330 OHM 1/5W J
R878	CRD20TJ331T	RES , CARBON	330 OHM 1/5W J
R879	CRD20TJ331T	RES , CARBON	330 OHM 1/5W J
R880	CRD20TJ331T	RES , CARBON	330 OHM 1/5W J
R882	CRD20TJ122T	RES , CARBON	1.2K OHM 1/5W J
R883	CRD20TJ122T	RES , CARBON	1.2K OHM 1/5W J
R884	CRD20TJ122T	RES , CARBON	1.2K OHM 1/5W J
R885	CRD20TJ122T	RES , CARBON	1.2K OHM 1/5W J
R886	CRD20TJ122T	RES , CARBON	1.2K OHM 1/5W J

Ref. Designator	Part Number	Description	
MAIN PCB ASS'Y			
R887	CRD20TJ122T	RES , CARBON	1.2K OHM 1/5W J
R888	CRD20TJ122T	RES , CARBON	1.2K OHM 1/5W J
R900	CRD20TJ103T	RES , CARBON	10K OHM 1/5W J
R901	CRD25TJ393T	RES , CARBON	39K OHM 1/4W J
R902	CRD25TJ393T	RES , CARBON	39K OHM 1/4W J
R903	CRD25TJ393T	RES , CARBON	39K OHM 1/4W J
R906	CRD25TJ393T	RES , CARBON	39K OHM 1/4W J
R907	CRD20TJ103T	RES , CARBON	10K OHM 1/5W J
R908	CRD20TJ105T	RES , CARBON	1M OHM 1/5W J
R909	CRD20TJ682T	RES , CARBON	6.8K OHM 1/5W J
R910	CRD20TJ105T	RES , CARBON	1M OHM 1/5W J
R911	CRD25TJ680T	RES , CARBON	68 OHM 1/4W J
R912	CRD20TJ153T	RES , CARBON	15K OHM 1/5W J
R913	CRD20TJ153T	RES , CARBON	15K OHM 1/5W J
R914	CRD20TJ103T	RES , CARBON	10K OHM 1/5W J
R915	CRD20TJ470T	RES , CARBON	47 OHM 1/5W J
R916	CRD20TJ473T	RES , CARBON	47K OHM 1/5W J
R917	CRD25TJ393T	RES , CARBON	39K OHM 1/4W J
R918	CRD25TJ393T	RES , CARBON	39K OHM 1/4W J
R919	CRD25TJ393T	RES , CARBON	39K OHM 1/4W J
R920	CRD25TJ393T	RES , CARBON	39K OHM 1/4W J
R921	KRD25FJ180T	RES , CARBON	18 OHM 1/4W J
R922	CRD25TJ470T	RES , CARBON	47 OHM 1/4W J
R923	CRD25TJ220T	RES , CARBON	22 OHM 1/4W J
R924	CRD20TJ473T	RES , CARBON	47K OHM 1/5W J
R925	CRD20TJ473T	RES , CARBON	47K OHM 1/5W J
R926	CRD20TJ473T	RES , CARBON	47K OHM 1/5W J
R927	CRD20TJ473T	RES , CARBON	47K OHM 1/5W J
R928	CRD20TJ222T	RES , CARBON	2.2K OHM 1/5W J
R929	CRD20TJ222T	RES , CARBON	2.2K OHM 1/5W J
R930	CRD20TJ222T	RES , CARBON	2.2K OHM 1/5W J
R931	CRD20TJ222T	RES , CARBON	2.2K OHM 1/5W J
R932	CRD20TJ103T	RES , CARBON	10K OHM 1/5W J
R933	CRD20TJ472T	RES , CARBON	4.7K OHM 1/5W J
R934	CRD20TJ104T	RES , CARBON	100K OHM 1/5W J
R935	CRD20TJ154T	RES , CARBON	150K OHM 1/5W J
R936	CRD20TJ184T	RES , CARBON	180K OHM 1/5W J
R937	CRD20TJ103T	RES , CARBON	10K OHM 1/5W J
R938	CRD20TJ271T	RES , CARBON	270 OHM 1/5W J
R939	CRD20TJ472T	RES , CARBON	4.7K OHM 1/5W J
R940	CRD20TJ152T	RES , CARBON	1.5K OHM 1/5W J
R941	CRD20TJ223T	RES , CARBON	22K OHM 1/5W J
R942	CRD20TJ223T	RES , CARBON	22K OHM 1/5W J
R943	CRD20TJ223T	RES , CARBON	22K OHM 1/5W J
R944	CRD25TJ223T	RES , CARBON	22K OHM 1/4W J
R945	CRD20TJ223T	RES , CARBON	22K OHM 1/5W J
R946	CRD25TJ223T	RES , CARBON	22K OHM 1/4W J
R947	CRD20TJ223T	RES , CARBON	22K OHM 1/5W J
R948	CRD20TJ271T	RES , CARBON	270 OHM 1/5W J
R949	CRD20TJ331T	RES , CARBON	330 OHM 1/5W J
R950	CRD20TJ273T	RES , CARBON	27K OHM 1/5W J
R951	CRD20TJ103T	RES , CARBON	10K OHM 1/5W J
R952	CRD20TJ223T	RES , CARBON	22K OHM 1/5W J
R953	CRD20TJ223T	RES , CARBON	22K OHM 1/5W J
R954	CRD20TJ223T	RES , CARBON	22K OHM 1/5W J
R955	CRD20TJ203T	RES , CARBON	20K OHM 1/5W J
R956	CRD20TJ394T	RES , CARBON	390K OHM 1/5W J
R957	CRD20TJ153T	RES , CARBON	15K OHM 1/5W J
R958	CRD20TJ563T	RES , CARBON	56K OHM 1/5W J
R959	CRD20TJ223T	RES , CARBON	22K OHM 1/5W J
R960	CRD20TJ222T	RES , CARBON	2.2K OHM 1/5W J

Ref. Designator	Part Number	Description	
MAIN PCB ASS'Y			
R961	CRD20TJ331T	RES , CARBON	330 OHM 1/5W J
R962	CRD20TJ273T	RES , CARBON	27K OHM 1/5W J
R963	CRD20TJ105T	RES , CARBON	1M OHM 1/5W J
R964	CRD20TJ105T	RES , CARBON	1M OHM 1/5W J
R966	CRD20TJ472T	RES , CARBON	4.7K OHM 1/5W J
R969	CRD20TJ472T	RES , CARBON	4.7K OHM 1/5W J
R970	CRD20TJ472T	RES , CARBON	4.7K OHM 1/5W J
R971	CRD20TJ472T	RES , CARBON	4.7K OHM 1/5W J
R972	CRD20TJ472T	RES , CARBON	4.7K OHM 1/5W J
R973	CRD20TJ472T	RES , CARBON	4.7K OHM 1/5W J
R974	CRD20TJ331T	RES , CARBON	330 OHM 1/5W J
R975	CRD20TJ331T	RES , CARBON	330 OHM 1/5W J
R976	CRD20TJ331T	RES , CARBON	330 OHM 1/5W J
R977	CRD20TJ331T	RES , CARBON	330 OHM 1/5W J
R978	CRD20TJ331T	RES , CARBON	330 OHM 1/5W J
R979	CRD20TJ473T	RES , CARBON	47K OHM 1/5W J
R980	CRD20TJ473T	RES , CARBON	47K OHM 1/5W J
R981	CRD20TJ473T	RES , CARBON	47K OHM 1/5W J
R982	CRD20TJ473T	RES , CARBON	47K OHM 1/5W J
R983	CRD20TJ473T	RES , CARBON	47K OHM 1/5W J
R986	CRD20TJ102T	RES , CARBON	1K OHM 1/5W J
R987	CRD20TJ561T	RES , CARBON	560 OHM 1/5W J
R988	CRD20TJ562T	RES , CARBON	5.6K OHM 1/5W J
R989	CRD20TJ333T	RES , CARBON	33K OHM 1/5W J
R991	CRD20TJ822T	RES , CARBON	8.2K OHM 1/5W J
R992	CRD20TJ562T	RES , CARBON	5.6K OHM 1/5W J
R998	CRD20TJ103T	RES , CARBON	10K OHM 1/5W J
VR81	HVN1RA221B01T	RES , SEMI FIXED(220 OHM)	RH0615C100221
VR82	HVN1RA221B01T	RES , SEMI FIXED(220 OHM)	RH0615C100221
VR83	HVN1RA221B01T	RES , SEMI FIXED(220 OHM)	RH0615C100221
VR84	HVN1RA221B01T	RES , SEMI FIXED(220 OHM)	RH0615C100221
VR85	HVN1RA221B01T	RES , SEMI FIXED(220 OHM)	RH0615C100221
VR86	HVN1RA221B01T	RES , SEMI FIXED(220 OHM)	RH0615C100221
VR87	HVN1RA221B01T	RES , SEMI FIXED(220 OHM)	RH0615C100221
R656	CRF5EKR27HX2K	RES , CEMENT	0.27ohm, X 2
R657	CRF5EKR27HX2K	RES , CEMENT	0.27ohm, X 2
R658	CRF5EKR27HX2K	RES , CEMENT	0.27ohm, X 2
R659	CRF5EKR27HX2K	RES , CEMENT	0.27ohm, X 2
R660	CRF5EKR27HX2K	RES , CEMENT	0.27ohm, X 2
R810	CRF5EKR27HX2K	RES , CEMENT	0.27ohm, X 2
R811	CRF5EKR27HX2K	RES , CEMENT	0.27ohm, X 2
R904	BRDERC12UGK335T	RES , CARBON JP	3.3M OHM 1/2W
R905	CRG1ANJ100H	RES , METAL OXIDE FILM	10Ω , 1W
R923	CRD25TJ220T	RES , CARBON	22Ω , 1/4W
R990	CRG1ANJ100H	RES , METAL OXIDE FILM	10Ω , 1W
R993	CRG1ANJ100H	RES , METAL OXIDE FILM	10Ω , 1W
R994	CRG1ANJ100H	RES , METAL OXIDE FILM	10Ω , 1W
R995	CRG1ANJ100H	RES , METAL OXIDE FILM	10Ω , 1W
R996	CRG1ANJ100H	RES , METAL OXIDE FILM	10Ω , 1W
R997	CRG1ANJ100H	RES , METAL OXIDE FILM	10Ω , 1W
R999	CRG1ANJ100H	RES , METAL OXIDE FILM	10Ω , 1W
<i>Miscellaneous</i>			
	CMD1A387	BRACKET , PCB	
	CMYAVR335	HEAT SINK ASS'Y	
	CHD1A012Z	SCREW , SPECIAL	AVR125CC
	CHD1A036	SCREW , SPECIAL	
	CHD1A036FZ	SCREW , SPECIAL	AVR330/AVR4600
	CHD3A012	SCREW , TR	ACR130
	CMD1A398	BRACKET , PCB	AG-D9320

Ref. Designator	Part Number	Description	
MAIN PCB ASS'Y			
	CMD1A417	BRACKET , PCB	AG-D8900
	CMD1A488	BRACKET , FAN	
	CMY1A249	HEAT SINK	
	CMY2A205	HEAT SINK,SUB	
	CTB3+10J	SCREW	
	CTB3+8J	SCREW	
	CTW3+10J	SCREW	
	CTW3+12J	SCREW	
	HDMKD1206PTS3	MOTOR , FAN(60X60X25MM)	KD1206PTS3
	CTW3+8J	SCREW	
BN19	CWB3FE03250UP	WIRE ASS'Y	
BN20	CWB3FB43280UP	WIRE ASS'Y	
BN79	CWZAVR230BN79	WIRE ASS'Y (SHIELD)	
BN80	CWB1C902050EN	WIRE ASS'Y	
BN81	CWB1C902050EN	WIRE ASS'Y	
BN82	CWB1C902050EN	WIRE ASS'Y	
BN83	CWB1C902050EN	WIRE ASS'Y	
BN84	CWB1C902050EN	WIRE ASS'Y	
BN85	CWB1C902050EN	WIRE ASS'Y	
BN86	CWB1C902050EN	WIRE ASS'Y	
BN87	CWB1C902050EN	WIRE ASS'Y	
BN88	CWB2B904070EN	WIRE ASS'Y	
BN98	BJP08GA130ZK	WAFER	
CN61	KJP02GA01ZM	WAFER	MOLEX 5267-02A
CN62	KJP02GA01ZM	WAFER	MOLEX 5267-02A
CN63	KJP02GA01ZM	WAFER	MOLEX 5267-02A
CN64	KJP02GA01ZM	WAFER	MOLEX 5267-02A
CN65	KJP02GA01ZM	WAFER	MOLEX 5267-02A
CN66	KJP02GA01ZM	WAFER	MOLEX 5267-02A
CN67	KJP02GA01ZM	WAFER	MOLEX 5267-02A
CN80	KJP11GA19ZM	WAFER	MOLEX-53014
CN87	KJP02GA19ZM	WAFER	
CN88	CJP04GA19ZY	WAFER, STRAIGHT, 4PIN	
CN89	KJP02GA01ZM	WAFER	MOLEX 5267-02A
CN91	KJP03GA89ZM	WAFER	MOLEX35328-0310
CN92	KJP02GA01ZM	WAFER	MOLEX 5267-02A
CN94	KJP13GA98ZM	WAFER	MOLEX35336-1310
CN95	KJP08GA98ZM	WAFER	MOLEX35336-0810
ET01	CMD1A387	BRACKET , PCB	
ET01	CNE75	PLATE , EARTH	
ET02	CMD1A387	BRACKET , PCB	
ET03	CNE75	PLATE , EARTH	
ET04	CMD1A387	BRACKET , PCB	
ET05	CMD1A387	BRACKET , PCB	
JK91	CJJ5R006Z	TERMINAL , SPEAKER	
JK92	CJJ5Q012Z	TERMINAL , SPEAKER	
JK94	CJJ2D008Z	JACK , STEREO	
JK95	CJJ2D008Z	JACK , STEREO	
JK96	CJJ2D008Z	JACK , STEREO	
JK97	CJJ4P041W	JACK IN/OUT	
JK98	CJJ4P042W	JACK IN/OUT	
JW89	CWE7202110AA	WIRE ASS'Y	
JW90	CWEE212120VV	WIRE ASS'Y	
JW91	CWE8212180VV	WIRE ASS'Y	
JW93	CWE7202110AA	WIRE ASS'Y	
JW98	CWE7202110AA	WIRE ASS'Y	
JW99	CWE8202150AA	WIRE ASS'Y	
L501	CLEY0R5KAK	COIL , SPEAKER	0.5UH K
L502	CLEY0R5KAK	COIL , SPEAKER	0.5UH K
L503	CLEY0R5KAK	COIL , SPEAKER	0.5UH K
L504	CLEY0R5KAK	COIL , SPEAKER	0.5UH K

AVR335

Ref. Designator	Part Number	Description	
MAIN PCB ASS'Y			
L505	CLEY0R5KAK	COIL , SPEAKER	0.5UH K
L506	CLEY0R5KAK	COIL , SPEAKER	0.5UH K
L507	CLEY0R5KAK	COIL , SPEAKER	0.5UH K
RY94	HSL1A008ZE	RELAY	SDT-S-112DMR
TH91	KRTP42T7D330B	THERMAL SENSOR , POSISTOR	P42T7D330BW20
T902	CLT5J033ZU	TRANS , SUB	SR-68
VIDEO PCB			
<i>Capacitors</i>			
C107	CCKT1H103ZF	CAP , CERAMIC	0.01UF 50V ZF
C108	CCKT1H103ZF	CAP , CERAMIC	0.01UF 50V ZF
C109	CCFT1H104ZF	CAP , SEMICONDUCTOR	0.1UF 50V ZF
C110	CCFT1H104ZF	CAP , SEMICONDUCTOR	0.1UF 50V ZF
C111	CCKT1H103ZF	CAP , CERAMIC	0.01UF 50V ZF
C112	CCKT1H103ZF	CAP , CERAMIC	0.01UF 50V ZF
C114	HCEA1EH101T	CAP , ELECT	100UF 25V
C115	CCKT1H223ZF	CAP , CERAMIC	0.022UF 50V ZF
C116	HCEA1HH470T	CAP , ELECT	47UF 50V
C117	HCEA1HH4R7T	CAP , ELECT	4.7UF 50V
C118	CCKT1H103ZF	CAP , CERAMIC	0.01UF 50V ZF
C119	HCEA1HH470T	CAP , ELECT	47UF 50V
C120	HCEA1HH470T	CAP , ELECT	47UF 50V
C121	CCKT1H103ZF	CAP , CERAMIC	0.01UF 50V ZF
C122	HCEA1HH101T	CAP , ELECT	100UF 50V
C123	CCKT1H103ZF	CAP , CERAMIC	0.01UF 50V ZF
C401	CCEA1VH101T	CAP , ELECT	100UF 50V
C402	CCKT1H101KB	CAP , CERAMIC	100PF 50V KB
C403	HCEA1VH100T	CAP , ELECT	10UF 35V
C404	CCKT1H101KB	CAP , CERAMIC	100PF 50V KB
C405	HCEA1VH100T	CAP , ELECT	10UF 35V
C406	HCEA1VH100T	CAP , ELECT	10UF 35V
C407	CCKT1H101KB	CAP , CERAMIC	100PF 50V KB
C408	CCEA1VH101T	CAP , ELECT	100UF 50V
C409	CCKT1H101KB	CAP , CERAMIC	100PF 50V KB
C410	CCKT1H101KB	CAP , CERAMIC	100PF 50V KB
C411	HCBS1H101KBT	CAP , CERAMIC	100PF 50V K
C412	HCBS1H101KBT	CAP , CERAMIC	100PF 50V K
C413	HCBS1H101KBT	CAP , CERAMIC	100PF 50V K
C414	HCBS1H101KBT	CAP , CERAMIC	100PF 50V K
C415	CCEA1VH101T	CAP , ELECT	100UF 50V
C416	HCEA1CH101T	CAP , ELECT	100UF 16V
C417	HCEA1CH101T	CAP , ELECT	100UF 16V
C418	HCBS1H223ZFT	CAP , CERAMIC	0.022UF 50V Z
C419	HCEA1VH100T	CAP , ELECT	10UF 35V
C420	HCBS1H223ZFT	CAP , CERAMIC	0.022UF 50V Z
C421	HCEA1CH101T	CAP , ELECT	100UF 16V
C422	HCBS1H223ZFT	CAP , CERAMIC	0.022UF 50V Z
C423	HCEA1CH101T	CAP , ELECT	100UF 16V
C424	HCEA1VH100T	CAP , ELECT	10UF 35V
C425	HCEA1VH100T	CAP , ELECT	10UF 35V
C426	HCEA1VH100T	CAP , ELECT	10UF 35V
C427	HCBS1H223ZFT	CAP , CERAMIC	0.022UF 50V Z
C428	HCEA1CH101T	CAP , ELECT	100UF 16V
C429	HCBS1H223ZFT	CAP , CERAMIC	0.022UF 50V Z
C430	HCEA1CH101T	CAP , ELECT	100UF 16V
C431	HCEA1VH100T	CAP , ELECT	10UF 35V
C432	HCEA1VH100T	CAP , ELECT	10UF 35V
C433	HCEA1VH100T	CAP , ELECT	10UF 35V
C434	CCEA1VH100T	CAP , ELECT	10UF 35V

Ref. Designator	Part Number	Description	
VIDEO PCB			
C435	HCEA1VH100T	CAP , ELECT	10UF 35V
C436	HCBS1H223ZFT	CAP , CERAMIC	0.022UF 50V Z
C437	HCEA1CH101T	CAP , ELECT	100UF 16V
C438	HCBS1H223ZFT	CAP , CERAMIC	0.022UF 50V Z
C439	HCEA1CH101T	CAP , ELECT	100UF 16V
C442	HCBS1H103ZFT	CAP , CERAMIC	0.01UF 50V Z
C443	HCEA1VKS100T	CAP , ELECT	10UF 35V
C444	HCEA1VKS100T	CAP , ELECT	10UF 35V
C445	HCBS1H103ZFT	CAP , CERAMIC	0.01UF 50V Z
C446	HCEA1VH100T	CAP , ELECT	10UF 35V
C447	HCEA1VH100T	CAP , ELECT	10UF 35V
C448	HCBS1H223ZFT	CAP , CERAMIC	0.022UF 50V Z
C449	HCEA1CH101T	CAP , ELECT	100UF 16V
C450	HCBS1H223ZFT	CAP , CERAMIC	0.022UF 50V Z
C451	HCEA1CH101T	CAP , ELECT	100UF 16V
C452	HCBS1H223ZFT	CAP , CERAMIC	0.022UF 50V Z
C453	HCEA1CH101T	CAP , ELECT	100UF 16V
C454	HCBS1H223ZFT	CAP , CERAMIC	0.022UF 50V Z
C455	HCEA1CH101T	CAP , ELECT	100UF 16V
C456	HCBS1H104ZFT	CAP , CERAMIC	0.1UF 50V Z
C457	HCEA1CH101T	CAP , ELECT	100UF 16V
C458	HCEA1CH101T	CAP , ELECT	100UF 16V
C459	HCBS1H104ZFT	CAP , CERAMIC	0.1UF 50V Z
C460	HCBS1C272MXT	CAP , CERAMIC	2.7UF 16V
C461	HCEA1CH101T	CAP , ELECT	100UF 16V
C462	HCEA1CH101T	CAP , ELECT	100UF 16V
C463	HCBS1H473ZFT	CAP , CERAMIC	0.047UF 50V Z
C501	HCBS1H330JT	CAP , CERAMIC	33PF 50V Z
C502	HCBS1H330JT	CAP , CERAMIC	33PF 50V Z
C503	HCBS1H181KBT	CAP , CERAMIC	180PF 50V K
C504	HCEA1HHR47T	CAP , ELECT	0.47UF , 50V
C505	HCBS1H223ZFT	CAP , CERAMIC	0.022UF 50V Z
C506	HCEA1AH471T	CAP , ELECT	470UF 10V
C507	HCBS1H270JT	CAP , CERAMIC	22PF , 50V Z
C508	HCBS1H270JT	CAP , CERAMIC	22PF , 50V Z
C509	HCEA1HH1R0T	CAP , ELECT	1UF 50V
C510	HCEA1HH1R0T	CAP , ELECT	1UF 50V
C511	HCQ1H682JZT	CAP , MYLAR	6800PF 50V J
C512	HCEA1HH1R0T	CAP , ELECT	1UF 50V
C513	HCBS1H560JT	CAP , CERAMIC	56PF 50V J
C514	HCBS1H220JCT	CAP , CERAMIC	22PF 50V J
C515	HCEA1AH471T	CAP , ELECT	470UF 10V
C517	HCBS1H223ZFT	CAP , CERAMIC	0.022UF 50V Z
C518	HCBS1H223ZFT	CAP , CERAMIC	0.022UF 50V Z
C519	CCFT1H104ZF	CAP , SEMICONDUCTOR	0.1UF 50V ZF
C520	CCEA0JKR3222E	CAP , ELECTROLYTIC	2200UF , KR3
C555	HCEA1AH471T	CAP , ELECT	470UF 10V
C556	HCEA1CH101T	CAP , ELECT	100UF 16V
C557	HCEA1CH101T	CAP , ELECT	100UF 16V
C561	HCEA1CH101T	CAP , ELECT	100UF 16V
C568	HCBS1H104ZFT	CAP , CERAMIC	0.1UF 50V Z
C601	HCBS1H101KBT	CAP , CERAMIC	100PF 50V K
C602	HCBS1H101KBT	CAP , CERAMIC	100PF 50V K
C603	HCBS1H101KBT	CAP , CERAMIC	100PF 50V K
C604	HCBS1H101KBT	CAP , CERAMIC	100PF 50V K
C605	HCBS1H101KBT	CAP , CERAMIC	100PF 50V K
C606	HCBS1H101KBT	CAP , CERAMIC	100PF 50V K
C607	HCBS1H101KBT	CAP , CERAMIC	100PF 50V K
C608	HCBS1H101KBT	CAP , CERAMIC	100PF 50V K
C609	HCBS1H101KBT	CAP , CERAMIC	100PF 50V K
C610	HCBS1H223ZFT	CAP , CERAMIC	0.022UF 50V Z

Ref. Designator	Part Number	Description	
VIDEO PCB			
C611	HCEA1CH101T	CAP , ELECT	100UF 16V
C612	HCBS1H223ZFT	CAP , CERAMIC	0.022UF 50V Z
C613	HCEA1CH101T	CAP , ELECT	100UF 16V
C614	C3A206	WIRE , COPPER	SN95/PB5 , 0.6
C615	C3A206	WIRE , COPPER	SN95/PB5 , 0.6
C616	C3A206	WIRE , COPPER	SN95/PB5 , 0.6
C617	C3A206	WIRE , COPPER	SN95/PB5 , 0.6
C618	C3A206	WIRE , COPPER	SN95/PB5 , 0.6
C619	C3A206	WIRE , COPPER	SN95/PB5 , 0.6
C620	HCBS1H223ZFT	CAP , CERAMIC	0.022UF 50V Z
C621	HCBS1H223ZFT	CAP , CERAMIC	0.022UF 50V Z
C622	HCBS1H223ZFT	CAP , CERAMIC	0.022UF 50V Z
C710	CCCT1H270JC	CAP , CERAMIC	22PF 50V JC
C713	CCCT1H270JC	CAP , CERAMIC	22PF 50V JC
C921	HCQI1H104JZT	CAP , MYLAR	0.1UF 50V J
C922	HCQI1H104JZT	CAP , MYLAR	0.1UF 50V J
C923	HCQI1H104JZT	CAP , MYLAR	0.1UF 50V J
C924	HCQI1H104JZT	CAP , MYLAR	0.1UF 50V J
C925	HCQI1H103JZT	CAP , MYLAR	0.01UF 50V J
C926	HCQI1H103JZT	CAP , MYLAR	0.01UF 50V J
C927	HCQI1H103JZT	CAP , MYLAR	0.01UF 50V J
C928	HCQI1H103JZT	CAP , MYLAR	0.01UF 50V J
C931	HCQI1H473JZT	CAP , MYLAR	0.047UF 50V J
C932	HCQI1H473JZT	CAP , MYLAR	0.047UF 50V J
C933	HCQI1H473JZT	CAP , MYLAR	0.047UF 50V J
C934	HCQI1H473JZT	CAP , MYLAR	0.047UF 50V J
C122	HCEA1JH101E	CAP , ELECT	100UF 63V
C434	HCEA1VH100T	CAP , ELECT	10UF 35V
C507	CCCT1H220JC	CAP , CERAMIC	22PF 50V JC
C508	CCCT1H270JC	CAP , CERAMIC	22PF 50V JC
C520	CCEA0JKR3222E	CAP , ELECTROLYTIC	2200UF 6.3V
C523	CCEA0JKR3222E	CAP , ELECTROLYTIC	2200UF 6.3V
<i>Semiconductors</i>			
D101	HVDMTZJ15BT	DIODE , ZENER	15V 1/2W
D102	HVDMTZJ27BT	DIODE , ZENER	27V , 1/2W
D104	KVD1N4003ST	DIODE	1N4003
D105	KVD1N4003ST	DIODE	1N4003
D106	KVD1N4003ST	DIODE	1N4003
D107	KVD1N4003ST	DIODE	1N4003
D108	KVD1N4003ST	DIODE	1N4003
D109	HVDMTZJ12BT	DIODE , ZENER	12V 1/2W
D110	KVD1N4003ST	DIODE	1N4003
D111	HVDMTZJ12BT	DIODE , ZENER	12V 1/2W
D401	HVD1SS133MT	DIODE	1SS133T-77
D402	HVD1SS133MT	DIODE	1SS133T-77
D403	HVD1SS133MT	DIODE	1SS133T-77
D404	HVD1SS133MT	DIODE	1SS133T-77
D405	HVD1SS133MT	DIODE	1SS133T-77
Q104	HVTKSC2316YT	TRANSISTOR NPN	KSC2316Y
Q402	HVTKSA733CYT	TRANSISTOR PNP	KSA733CY
Q403	HVTKRA107MT	TRANSISTOR PNP	KRA107M
Q404	HVTKRC107MT	TRANSISTOR NPN	KRC107M
Q405	HVTKSA733CYT	TRANSISTOR PNP	KSA733CY
Q406	HVTKRA107MT	TRANSISTOR PNP	KRA107M
Q407	HVTKRC107MT	TRANSISTOR NPN	KRC107M
Q408	HVTKRC107MT	TRANSISTOR NPN	KRC107M
Q409	HVTKRA104MT	TRANSISTOR PNP	KRA104M
Q410	HVTKTD1302T	TRANSISTOR NPN	KTD1302
Q411	HVTKTD1302T	TRANSISTOR NPN	KTD1302

AVR335

Ref. Designator	Part Number	Description	
VIDEO PCB			
Q412	HVTKRA104MT	TRANSISTOR PNP	KRA104M
Q501	KVTKSC2785YT	TRANSISTOR NPN	KSC2785Y
Q502	KVTKSA1175YT	TRANSISTOR PNP	KSA1175Y
Q555	KVTKSA1175YT	TRANSISTOR PNP	KSA1175Y
Q556	KVTKSA1175YT	TRANSISTOR PNP	KSA1175Y
Q568	HVTKTC2874BT	TRANSISTOR , MUTE	KTC2874B
Q569	HVTKRC107MT	TRANSISTOR NPN	KRC107M
Q601	HVTKRC114MT	TRANSISTOR NPN	2SC114Y
IC41	HVINJM2296M	I.C , VIDEO SW	NJM2296M
IC42	HVINJM2296M	I.C , VIDEO SW	NJM2296M
IC43	HVINJM2296M	I.C , VIDEO SW	NJM2296M
IC44	HVIHCF4053M013T	I.C , 2-CH MULTIPLEXER	HCF4053M013
IC45	HVIHCF4053M013T	I.C , 2-CH MULTIPLEXER	HCF4053M013
IC46	HVINJM2581MTE1	I.C , 3-CH VIDEO AMP	NJM2581
IC47	HVIMM1511XNRE	IC, Y/C-MIX	MM1511
IC48	CVIL7805CPNA	I.C ASS'Y	
D991	CVDKBU804FMA	BRIDGE DIODE ASS'Y	KBU804F
D991	HVDKBU804F	DIODE , BRIDGE	
D992	CVDKBU804FMA	BRIDGE DIODE ASS'Y	KBU804F
D992	HVDKBU804F	DIODE , BRIDGE	
IC49	CVIL7905CPNA	I.C ASS'Y	
	HVIL7805CP	I.C, REGULATOR	+5V
IC51	HVILC74763M	I.C , OSD	LC74763M
IC52	HVI74ACT04MTR	I.C , HEX	74ACT04M
IC61	HVINJM2586AMTE1	I.C , VIDEO SW	NJM2586AMTE1
<i>Resistors</i>			
J304	CRD25TJ2R2T	RES , CARBON	2.2 OHM 1/4W
R101	KRD25FJ3R3T	RES , CARBON	3.3 OHM 1/4W
R108	CRD20TJ4R7T	RES , CARBON	4.7 OHM 1/5W
R109	CRD20TJ100T	RES , CARBON	10 OHM 1/5W J
R110	CRD20TJ4R7T	RES , CARBON	4.7 OHM 1/5W
R111	CRD20TJ154T	RES , CARBON	150k 1/5W
R112	CRD20TJ122T	RES , CARBON	1.2K OHM 1/5W J
R113	CRD20TJ473T	RES , CARBON	47K OHM 1/5W J
R401	CRD20TJ750T	RES , CARBON	75 OHM 1/5W J
R402	CRD20TJ750T	RES , CARBON	75 OHM 1/5W J
R403	CRD20TJ332T	RES , CARBON	3.3K OHM 1/5W J
R404	CRD20TJ750T	RES , CARBON	75 OHM 1/5W J
R405	CRD20TJ750T	RES , CARBON	75 OHM 1/5W J
R406	CRD20TJ332T	RES , CARBON	3.3K OHM 1/5W J
R407	CRD20TJ750T	RES , CARBON	75 OHM 1/5W J
R408	CRD20TJ750T	RES , CARBON	75 OHM 1/5W J
R409	CRD20TJ750T	RES , CARBON	75 OHM 1/5W J
R410	CRD20TJ332T	RES , CARBON	3.3K OHM 1/5W J
R411	CRD20TJ750T	RES , CARBON	75 OHM 1/5W J
R412	CRD20TJ750T	RES , CARBON	75 OHM 1/5W J
R413	CRD20TJ750T	RES , CARBON	75 OHM 1/5W J
R414	CRD20TJ332T	RES , CARBON	3.3K OHM 1/5W J
R415	CRD20TJ750T	RES , CARBON	75 OHM 1/5W J
R416	CRD20TJ332T	RES , CARBON	3.3K OHM 1/5W J
R417	CRD20TJ750T	RES , CARBON	75 OHM 1/5W J
R418	CRD20TJ750T	RES , CARBON	75 OHM 1/5W J
R419	CRD20TJ750T	RES , CARBON	75 OHM 1/5W J
R420	CRD20TJ332T	RES , CARBON	3.3K OHM 1/5W J
R421	CRD20TJ750T	RES , CARBON	75 OHM 1/5W J
R422	CRD20TJ332T	RES , CARBON	3.3K OHM 1/5W J
R423	CRD20TJ750T	RES , CARBON	75 OHM 1/5W J
R424	CRD20TJ750T	RES , CARBON	75 OHM 1/5W J
R425	CRD20TJ750T	RES , CARBON	75 OHM 1/5W J

Ref. Designator	Part Number	Description	
VIDEO PCB			
R426	CRD20TJ332T	RES , CARBON	3.3K OHM 1/5W J
R427	CRD20TJ750T	RES , CARBON	75 OHM 1/5W J
R428	CRD20TJ332T	RES , CARBON	3.3K OHM 1/5W J
R430	CRD20TJ1R8T	RES , CARBON	1.8 OHM 1/5W J
R431	CRD20TJ102T	RES , CARBON	1K OHM 1/5W J
R432	CRD20TJ1R0T	RES , CARBON	1 OHM 1/5W J
R433	CRD20TJ102T	RES , CARBON	1K OHM 1/5W J
R434	CRD20TJ102T	RES , CARBON	1K OHM 1/5W J
R435	CRD20TJ102T	RES , CARBON	1K OHM 1/5W J
R436	CRD20TJ102T	RES , CARBON	1K OHM 1/5W J
R437	CRD25TJ102T	RES , CARBON	1K OHM 1/4W J
R438	CRD25TJ1R0T	RES , CARBON	1 OHM 1/4W J
R439	CRD20TJ750T	RES , CARBON	75 OHM 1/5W J
R440	CRD20TJ1R8T	RES , CARBON	1.8 OHM 1/5W J
R441	CRD20TJ102T	RES , CARBON	1K OHM 1/5W J
R442	CRD20TJ102T	RES , CARBON	1K OHM 1/5W J
R443	CRD20TJ102T	RES , CARBON	1K OHM 1/5W J
R444	CRD20TJ102T	RES , CARBON	1K OHM 1/5W J
R445	CRD20TJ1R0T	RES , CARBON	1 OHM 1/5W J
R446	CRD20TJ102T	RES , CARBON	1K OHM 1/5W J
R447	CRD20TJ750T	RES , CARBON	75 OHM 1/5W J
R448	CRD20TJ1R8T	RES , CARBON	1.8 OHM 1/5W J
R449	CRD20TJ102T	RES , CARBON	1K OHM 1/5W J
R450	CRD20TJ102T	RES , CARBON	1K OHM 1/5W J
R451	CRD20TJ102T	RES , CARBON	1K OHM 1/5W J
R452	CRD20TJ102T	RES , CARBON	1K OHM 1/5W J
R453	CRD20TJ332T	RES , CARBON	3.3K OHM 1/5W J
R454	CRD25TJ562T	RES , CARBON	5.6K OHM 1/4W J
R455	CRD20TJ105T	RES , CARBON	1M OHM 1/5W J
R456	CRD20TJ680T	RES , CARBON	68 OHM 1/5W J
R457	CRD20TJ333T	RES , CARBON	33K OHM 1/5W J
R458	CRD20TJ123T	RES , CARBON	12K OHM 1/5W J
R459	CRD20TJ680T	RES , CARBON	68 OHM 1/5W J
R460	CRD20TJ333T	RES , CARBON	33K OHM 1/5W J
R461	CRD20TJ123T	RES , CARBON	12K OHM 1/5W J
R462	CRD20TJ102T	RES , CARBON	1K OHM 1/5W J
R463	CRD20TJ103T	RES , CARBON	10K OHM 1/5W J
R464	CRD20TJ103T	RES , CARBON	10K OHM 1/5W J
R465	CRD20TJ103T	RES , CARBON	10K OHM 1/5W J
R466	CRD20TJ103T	RES , CARBON	10K OHM 1/5W J
R467	CRD20TJ103T	RES , CARBON	10K OHM 1/5W J
R468	CRD20TJ100T	RES , CARBON	10 OHM 1/5W J
R469	CRD20TJ100T	RES , CARBON	10 OHM 1/5W J
R470	CRD20TJ100T	RES , CARBON	10 OHM 1/5W J
R471	CRD20TJ100T	RES , CARBON	10 OHM 1/5W J
R472	CRD20TJ151T	RES , CARBON	150 OHM 1/5W J
R473	CRD20TJ181T	RES , CARBON	180 OHM 1/5W J
R474	CRD20TJ1R8T	RES , CARBON	1.8 OHM 1/5W J
R475	CRD20TJ1R0T	RES , CARBON	1 OHM 1/5W J
R476	CRD20TJ101T	RES , CARBON	100 OHM 1/5W J
R478	CRD20TJ223T	RES , CARBON	22K OHM 1/5W J
R479	CRD20TJ181T	RES , CARBON	180 OHM 1/5W J
R480	CRD25TJ223T	RES , CARBON	22K OHM 1/4W J
R481	CRD20TJ183T	RES , CARBON	18K OHM 1/5W J
R482	CRD20TJ392T	RES , CARBON	3.9K OHM 1/5W J
R501	CRD20TJ102T	RES , CARBON	1K OHM 1/5W J
R502	CRD20TJ102T	RES , CARBON	1K OHM 1/5W J
R503	CRD20TJ102T	RES , CARBON	1K OHM 1/5W J
R504	CRD20TJ104T	RES , CARBON	100K OHM 1/5W J
R505	CRD20TJ102T	RES , CARBON	1K OHM 1/5W J
R506	CRD20TJ102T	RES , CARBON	1K OHM 1/5W J

Ref. Designator	Part Number	Description	
VIDEO PCB			
R507	CRD20TJ102T	RES , CARBON	1K OHM 1/5W J
R508	CRD20TJ682T	RES , CARBON	6.8K OHM 1/5W J
R509	CRD20TJ152T	RES , CARBON	1.5K OHM 1/5W J
R510	CRD20TJ393T	RES , CARBON	39K OHM 1/5W J
R511	CRD20TJ222T	RES , CARBON	2.2K OHM 1/5W J
R512	CRD20TJ102T	RES , CARBON	1K OHM 1/5W J
R513	CRD20TJ822T	RES , CARBON	8.2K OHM 1/5W J
R514	CRD20TJ103T	RES , CARBON	10K OHM 1/5W J
R515	CRD20TJ100T	RES , CARBON	10 OHM 1/5W J
R516	CRD20TJ221T	RES , CARBON	220 OHM 1/5W J
R517	CRD20TJ273T	RES , CARBON	27K OHM 1/5W J
R555	CRD20TJ101T	RES , CARBON	100 OHM 1/5W J
R556	CRD20TJ183T	RES , CARBON	18K OHM 1/5W J
R557	C3A206	WIRE , COPPER	SN95/PB5 , 0.6
R558	CRD20TJ102T	RES , CARBON	1K OHM 1/5W J
R562	CRD20TJ222T	RES , CARBON	2.2K OHM 1/5W J
R565	CRD20TJ182T	RES , CARBON	1.8K OHM 1/5W J
R566	CRD20TJ561T	RES , CARBON	560 OHM 1/5W J
R567	CRD20TJ100T	RES , CARBON	10 OHM 1/5W J
R568	CRD20TJ223T	RES , CARBON	22K OHM 1/5W J
R569	CRD20TJ223T	RES , CARBON	22K OHM 1/5W J
R570	CRD20TJ101T	RES , CARBON	100 OHM 1/5W J
R601	CRD20TJ750T	RES , CARBON	75 OHM 1/5W J
R602	CRD20TJ750T	RES , CARBON	75 OHM 1/5W J
R603	CRD20TJ750T	RES , CARBON	75 OHM 1/5W J
R604	CRD20TJ750T	RES , CARBON	75 OHM 1/5W J
R605	CRD20TJ750T	RES , CARBON	75 OHM 1/5W J
R606	CRD20TJ750T	RES , CARBON	75 OHM 1/5W J
R607	CRD20TJ750T	RES , CARBON	75 OHM 1/5W J
R608	CRD20TJ750T	RES , CARBON	75 OHM 1/5W J
R609	CRD20TJ750T	RES , CARBON	75 OHM 1/5W J
R610	CRD20TJ4R7T	RES , CARBON	4.7 OHM 1/5W J
R611	CRD20TJ4R7T	RES , CARBON	4.7 OHM 1/5W J
R612	CRD20TJ472T	RES , CARBON	4.7K OHM 1/5W J
J519	CRD25TJ102T	RES , CARBON	1k 1/4W J
R101	KRD25FJ3R3T	RES , CARBON	3.3 OHM 1/4W
R104	KRQ1AJR47H	RES , FUSE	0.47 OHM 1W J
R105	KRQ1AJR47H	RES , FUSE	0.47 OHM 1W J
R106	KRQ1AJR47H	RES , FUSE	0.47 OHM 1W J
R107	KRQ1AJR47H	RES , FUSE	0.47 OHM 1W J
<i>Miscellaneous</i>			
L501	HLQ02C101JT	COIL , AXAIL	100UH,J
L502	KLQ5R6G405T	COIL , PEAKING(RADIAL)	5.6UH , 4X5
L503	KLQ220J405T	COIL , PEAKING(RADIAL)	22UH , J 4X5
	CMC1A213	PLATE , SHIELD	
BN61	CWB2B907120EN	WIRE ASS'Y	
BN96	CWB1C908150BM	WIRE ASS'Y	
CN13	KJP05GA01ZM	WAFER	MOLEX 5267-05A
CN19	KJP03GA90ZM	WAFER	MOLEX35313-0310
CN20	KJP04GA90ZM	WAFER	MOLEX35313-0310
CN41	KJP06GA19ZM	WAFER	MOLEX53014-0610
CN43	CJP13GA115ZY	WAFER , CARD CABLE	
CN61	KJP07GA19ZM	WAFER	MOLEX53014-0710
CN81	CJP08GA01ZY	WAFER , STRAIGHT , 8PIN	
CN84	KJP02KA060ZY	WAFER	7.92MM(YUNHO)
	CMY1A219	HEAT SINK (BRIDGE DIODE)	
	CTB3+10J	SCREW	
	CTB3+12J	SCREW	
	CMY1A218	HEAT SINK(TR)	

AVR335

Ref. Designator	Part Number	Description	
VIDEO PCB			
	CTB3+8J	SCREW	
JK41	CJJ9N001Z	JACK , S-VIDEO (2P/H)	
JK42	CJJ9N001Z	JACK , S-VIDEO (2P/H)	
JK43	CJJ9S001Z	JACK , S-VIDEO (3P/H)	
JK48	CJJ4N043Z	JACK , BOARD	
JK49	CJJ4N043Z	JACK , BOARD	
JK50	CJJ4S010Z	JACK , BOARD	
JK61	CJJ4L009Z	JACK 9P (RRR/BBB/GGG)	
JW11	CWEP202110VV	WIRE	
SW91	KST1A010Z	SW , TACT CN	
X501	HOX14318E220C	CRYSTAL	
INPUT PCB			
<i>Capacitors</i>			
C105	HCUS1H223ZF	CAP , CHIP	0.022uF
C106	HCUS1H223ZF	CAP , CHIP	0.022uF
C201	HCUS1H221JA	CAP , CHIP	220pF
C202	HCUS1H221JA	CAP , CHIP	220pF
C203	HCUS1H221JA	CAP , CHIP	220pF
C204	HCUS1H221JA	CAP , CHIP	220pF
C205	HCUS1H221JA	CAP , CHIP	220pF
C206	HCUS1H221JA	CAP , CHIP	220pF
C207	HCUS1H221JA	CAP , CHIP	220pF
C208	HCUS1H221JA	CAP , CHIP	220pF
C209	HCUS1H221JA	CAP , CHIP	220pF
C210	HCUS1H221JA	CAP , CHIP	220pF
C211	HCUS1H221JA	CAP , CHIP	220pF
C212	HCUS1H221JA	CAP , CHIP	220pF
C213	HCUS1H221JA	CAP , CHIP	220pF
C214	HCUS1H221JA	CAP , CHIP	220pF
C215	HCUS1H221JA	CAP , CHIP	220pF
C216	HCUS1H221JA	CAP , CHIP	220pF
C217	HCUS1H221JA	CAP , CHIP	220pF
C218	HCUS1H221JA	CAP , CHIP	220pF
C219	HCUS1H221JA	CAP , CHIP	220pF
C220	HCUS1H221JA	CAP , CHIP	220pF
C221	HCUS1H221JA	CAP , CHIP	220pF
C222	HCUS1H221JA	CAP , CHIP	220pF
C223	HCUS1H221JA	CAP , CHIP	220pF
C224	HCUS1H221JA	CAP , CHIP	220pF
C225	HCUS1H221JA	CAP , CHIP	220pF
C226	HCUS1H221JA	CAP , CHIP	220pF
C233	HCUS1H181JA	CAP , CHIP	180pF
C234	HCUS1H471JA	CAP , CHIP	470pF
C235	HCUS1H223ZF	CAP , CHIP	0.022uF
C236	HCUS1H223ZF	CAP , CHIP	0.022uF
C241	HCUS1H181JA	CAP , CHIP	180pF
C242	HCUS1H471JA	CAP , CHIP	470pF
C253	HCUS1H181JA	CAP , CHIP	180pF
C254	HCUS1H471JA	CAP , CHIP	470pF
C255	HCUS1H223ZF	CAP , CHIP	0.022uF
C256	HCUS1H223ZF	CAP , CHIP	0.022uF
C270	HCUS1H181JA	CAP , CHIP	180pF
C271	HCUS1H471JA	CAP , CHIP	470pF
C291	HCUS1H104ZF	CAP , CHIP	0.1uF
C292	HCUS1H104ZF	CAP , CHIP	0.1uF
C293	HCUS1H104ZF	CAP , CHIP	0.1uF
C294	HCUS1H104ZF	CAP , CHIP	0.1uF
C295	HCUS1H104ZF	CAP , CHIP	0.1uF

Ref. Designator	Part Number	Description	
INPUT PCB			
C296	HCUS1H104ZF	CAP , CHIP	0.1uF
C297	HCUS1H104ZF	CAP , CHIP	0.1uF
C298	HCUS1H104ZF	CAP , CHIP	0.1uF
C309	HCUS1H102KC	CAP , CHIP	1000pF
C310	HCUS1H102KC	CAP , CHIP	1000pF
C311	HCUS1H102KC	CAP , CHIP	1000pF
C312	HCUS1H102KC	CAP , CHIP	1000pF
C313	HCUS1H102KC	CAP , CHIP	1000pF
C314	HCUS1H102KC	CAP , CHIP	1000pF
C315	HCUS1H102KC	CAP , CHIP	1000pF
C316	HCUS1H102KC	CAP , CHIP	1000pF
C317	HCUS1H223ZF	CAP , CHIP	0.022uF
C318	HCUS1H223ZF	CAP , CHIP	0.022uF
C319	HCUS1H223ZF	CAP , CHIP	0.022uF
C320	HCUS1H223ZF	CAP , CHIP	0.022uF
C321	HCUS1H271JA	CAP , CHIP	270pF
C322	HCUS1H122KC	CAP , CHIP	1200pF
C323	HCUS1H122KC	CAP , CHIP	1200pF
C324	HCUS1H271JA	CAP , CHIP	270pF
C325	HCUS1H271JA	CAP , CHIP	270pF
C326	HCUS1H122KC	CAP , CHIP	1200pF
C327	HCUS1H122KC	CAP , CHIP	1200pF
C328	HCUS1H561JA	CAP , CHIP	560pF
C329	HCUS1H271JA	CAP , CHIP	270pF
C330	HCUS1H122KC	CAP , CHIP	1200pF
C331	HCUS1H122KC	CAP , CHIP	1200pF
C332	HCUS1H271JA	CAP , CHIP	270pF
C333	HCUS1H271JA	CAP , CHIP	270pF
C334	HCUS1H122KC	CAP , CHIP	1200pF
C335	HCUS1H122KC	CAP , CHIP	1200pF
C336	HCUS1H271JA	CAP , CHIP	270pF
C337	HCUS1H223ZF	CAP , CHIP	0.022uF
C338	HCUS1H223ZF	CAP , CHIP	0.022uF
C339	HCUS1H223ZF	CAP , CHIP	0.022uF
C340	HCUS1H223ZF	CAP , CHIP	0.022uF
C350	HCUS1H331JA	CAP , CHIP	330pF
C351	HCUS1H331JA	CAP , CHIP	330pF
C352	HCUS1H331JA	CAP , CHIP	330pF
C353	HCUS1H331JA	CAP , CHIP	330pF
C354	HCUS1H331JA	CAP , CHIP	330pF
C355	HCUS1H331JA	CAP , CHIP	330pF
C356	HCUS1H331JA	CAP , CHIP	330pF
C357	HCUS1H331JA	CAP , CHIP	330pF
C371	HCUS1H221JA	CAP , CHIP	220pF
C372	HCUS1H221JA	CAP , CHIP	220pF
C373	HCUS1H221JA	CAP , CHIP	220pF
C374	HCUS1H221JA	CAP , CHIP	220pF
C375	HCUS1H223ZF	CAP , CHIP	0.022uF
C376	HCUS1H223ZF	CAP , CHIP	0.022uF
C378	HCUS1H223ZF	CAP , CHIP	0.022uF
C379	HCUS1H223ZF	CAP , CHIP	0.022uF
C381	HCUS1H561JA	CAP , CHIP	560pF
C382	HCUS1H223ZF	CAP , CHIP	0.022uF
C383	HCUS1H223ZF	CAP , CHIP	0.022uF
C411	HCUS1H223ZF	CAP , CHIP	0.022uF
C412	HCUS1H223ZF	CAP , CHIP	0.022uF
C413	HCUS1H223ZF	CAP , CHIP	0.022uF
C414	HCUS1H223ZF	CAP , CHIP	0.022uF
C415	HCUS1H223ZF	CAP , CHIP	0.022uF
C416	HCUS1H223ZF	CAP , CHIP	0.022uF
C417	HCUS1H223ZF	CAP , CHIP	0.022uF

Ref. Designator	Part Number	Description	
INPUT PCB			
C418	HCUS1H223ZF	CAP , CHIP	0.022uF
C419	HCUS1H223ZF	CAP , CHIP	0.022uF
C420	HCUS1H223ZF	CAP , CHIP	0.022uF
C423	HCUS1H151JA	CAP , CHIP , 150PF JA	150pF
C424	HCUS1H151JA	CAP , CHIP , 150PF JA	150pF
C425	HCUS1H151JA	CAP , CHIP , 150PF JA	150pF
C427	HCUS1H151JA	CAP , CHIP , 150PF JA	150pF
C428	HCUS1H151JA	CAP , CHIP , 150PF JA	150pF
C429	HCUS1H151JA	CAP , CHIP , 150PF JA	150pF
C430	HCUS1H151JA	CAP , CHIP , 150PF JA	150pF
C471	HCUS1H181JA	CAP , CHIP	180pF
C472	HCUS1H181JA	CAP , CHIP	180pF
C473	HCUS1H181JA	CAP , CHIP	180pF
C474	HCUS1H181JA	CAP , CHIP	180pF
C475	HCUS1H104ZF	CAP , CHIP	0.1uF
C701	HCUS1H330JA	CAP , CHIP	33pF
C702	HCUS1H330JA	CAP , CHIP	33pF
C704	HCUS1H104ZF	CAP , CHIP	0.1uF
C705	HCUS1H104ZF	CAP , CHIP	0.1uF
C707	HCUS1H102KC	CAP , CHIP	1000pF
C708	HCUS1H104ZF	CAP , CHIP	0.1uF
C718	HCUS1H104ZF	CAP , CHIP	0.1uF
C719	HCUS1H104ZF	CAP , CHIP	0.1uF
C722	HCUS1H104ZF	CAP , CHIP	0.1uF
C723	HCUS1H473ZF	CAP , CHIP	0.047pF
C725	HCUS1H104ZF	CAP , CHIP	0.1uF
C727	HCUS1H104ZF	CAP , CHIP	0.1uF
C729	HCUS1H104ZF	CAP , CHIP	0.1uF
C731	HCUS1H104ZF	CAP , CHIP	0.1uF
C733	HCUS1H104ZF	CAP , CHIP	0.1uF
C734	HCUS1H122KC	CAP , CHIP	1200pF
C735	HCUS1H680JA	CAP , CHIP	68pF
C738	HCUS1C105ZF	CAP , CHIP	1uF
C739	HCUS1H103KC	CAP , CHIP	0.01uF
C740	HCUS1H104ZF	CAP , CHIP	0.1uF
C742	HCUS1H104ZF	CAP , CHIP	0.1uF
C743	HCUS1H104ZF	CAP , CHIP	0.1uF
C744	HCUS1H104ZF	CAP , CHIP	0.1uF
C745	HCUS1H104ZF	CAP , CHIP	0.1uF
C747	HCUS1H104ZF	CAP , CHIP	0.1uF
C748	HCUS1H104ZF	CAP , CHIP	0.1uF
C750	HCUS1H104ZF	CAP , CHIP	0.1uF
C751	HCUS1H104ZF	CAP , CHIP	0.1uF
C752	HCUS1H104ZF	CAP , CHIP	0.1uF
C754	HCUS1H104ZF	CAP , CHIP	0.1uF
C756	HCUS1H104ZF	CAP , CHIP	0.1uF
C757	HCUS1H104ZF	CAP , CHIP	0.1uF
C758	HCUS1H104ZF	CAP , CHIP	0.1uF
C759	HCUS1H104ZF	CAP , CHIP	0.1uF
C760	HCUS1H104ZF	CAP , CHIP	0.1uF
C761	HCUS1H104ZF	CAP , CHIP	0.1uF
C762	HCUS1H104ZF	CAP , CHIP	0.1uF
C763	HCUS1H104ZF	CAP , CHIP	0.1uF
C765	HCUS1H104ZF	CAP , CHIP	0.1uF
C767	HCUS1H104ZF	CAP , CHIP	0.1uF
C768	HCUS1H104ZF	CAP , CHIP	0.1uF
C769	HCUS1H104ZF	CAP , CHIP	0.1uF
C770	HCUS1H104ZF	CAP , CHIP	0.1uF
C771	HCUS1H104ZF	CAP , CHIP	0.1uF
C772	HCUS1H104ZF	CAP , CHIP	0.1uF
C773	HCUS1H104ZF	CAP , CHIP	0.1uF

Ref. Designator	Part Number	Description	
INPUT PCB			
C101	CCEA1VH100T	CAP , ELECT	10UF 35V
C102	CCEA1VH100T	CAP , ELECT	10UF 35V
C103	CCEA1VH100T	CAP , ELECT	10UF 35V
C104	CCEA1VH100T	CAP , ELECT	10UF 35V
C231	CCEA1CH101T	CAP , ELECT	100UF 16V
C232	CCEA1CH101T	CAP , ELECT	100UF 16V
C237	CCEA1CH101T	CAP , ELECT	100UF 16V
C238	CCEA1CH101T	CAP , ELECT	100UF 16V
C239	CCEA1VH100T	CAP , ELECT	10UF 35V
C240	CCEA1VH100T	CAP , ELECT	10UF 35V
C244	CCEA1VH100T	CAP , ELECT	10UF 35V
C245	CCEA1VH100T	CAP , ELECT	10UF 35V
C251	CCEA1CH101T	CAP , ELECT	100UF 16V
C252	CCEA1CH101T	CAP , ELECT	100UF 16V
C261	CCEA1CH101T	CAP , ELECT	100UF 16V
C262	CCEA1CH101T	CAP , ELECT	100UF 16V
C263	CCEA1VH100T	CAP , ELECT	10UF 35V
C264	CCEA1VH100T	CAP , ELECT	10UF 35V
C265	CCEA1VH100T	CAP , ELECT	10UF 35V
C267	CCEA1VH100T	CAP , ELECT	10UF 35V
C268	CCEA1VH100T	CAP , ELECT	10UF 35V
C269	CCEA1VH100T	CAP , ELECT	10UF 35V
C341	CCEA1VH100T	CAP , ELECT	10UF 35V
C342	CCEA1VH100T	CAP , ELECT	10UF 35V
C343	CCEA1VH100T	CAP , ELECT	10UF 35V
C344	CCEA1VH100T	CAP , ELECT	10UF 35V
C345	CCEA1VH100T	CAP , ELECT	10UF 35V
C346	CCEA1VH100T	CAP , ELECT	10UF 35V
C347	CCEA1VH100T	CAP , ELECT	10UF 35V
C348	CCEA1VH100T	CAP , ELECT	10UF 35V
C349	CCEA1HH1R0T	CAP , ELECT	1UF 50V
C401	CCEA1VH101T	CAP , ELECT	100UF 50V
C402	CCEA1VH100T	CAP , ELECT	10UF 35V
C403	CCEA1VH100T	CAP , ELECT	10UF 35V
C404	CCEA1VH100T	CAP , ELECT	10UF 35V
C405	CCEA1VH100T	CAP , ELECT	10UF 35V
C406	CCEA1VH100T	CAP , ELECT	10UF 35V
C407	CCEA1VH100T	CAP , ELECT	10UF 35V
C408	CCEA1VH100T	CAP , ELECT	10UF 35V
C409	CCEA1VH100T	CAP , ELECT	10UF 35V
C410	CCEA1VH100T	CAP , ELECT	10UF 35V
C426	HCQI1H182JZT	CAP , MYLAR	1800PF 50V J
C431	CCEA1CH101T	CAP , ELECT	100UF 16V
C432	CCEA1CH101T	CAP , ELECT	100UF 16V
C433	CCEA1CH101T	CAP , ELECT	100UF 16V
C434	CCEA1CH101T	CAP , ELECT	100UF 16V
C435	CCEA1CH101T	CAP , ELECT	100UF 16V
C436	CCEA1CH101T	CAP , ELECT	100UF 16V
C437	CCEA1CH101T	CAP , ELECT	100UF 16V
C438	CCEA1CH101T	CAP , ELECT	100UF 16V
C439	CCEA1CH101T	CAP , ELECT	100UF 16V
C440	CCEA1CH101T	CAP , ELECT	100UF 16V
C451	CCEA1VH100T	CAP , ELECT	10UF 35V
C452	CCEA1VH100T	CAP , ELECT	10UF 35V
C453	CCEA1VH100T	CAP , ELECT	10UF 35V
C454	CCEA1VH100T	CAP , ELECT	10UF 35V
C455	CCEA1VH100T	CAP , ELECT	10UF 35V
C456	CCEA1VH100T	CAP , ELECT	10UF 35V
C457	CCEA1VH100T	CAP , ELECT	10UF 35V
C458	CCEA1VH100T	CAP , ELECT	10UF 35V
C459	CCEA1VH100T	CAP , ELECT	10UF 35V

Ref. Designator	Part Number	Description	
INPUT PCB			
C460	CCEA1VH100T	CAP , ELECT	10UF 35V
C703	CCEA1EH220T	CAP , ELECT	22UF/25V
C706	CCEA1EH220T	CAP , ELECT	22UF/25V
C709	CCEA1EH220T	CAP , ELECT	22UF/25V
C710	CCEA1EH220T	CAP , ELECT	22UF/25V
C711	CCEA1EH220T	CAP , ELECT	22UF/25V
C712	CCEA1EH220T	CAP , ELECT	22UF/25V
C713	CCEA1EH220T	CAP , ELECT	22UF/25V
C714	CCEA1EH220T	CAP , ELECT	22UF/25V
C715	CCEA1EH220T	CAP , ELECT	22UF/25V
C716	CCEA1EH220T	CAP , ELECT	22UF/25V
C717	CCEA1CH101T	CAP , ELECT	100UF 16V
C720	CCEA1AH471T	CAP , ELECT	470UF 10V
C721	CCEA1AH471T	CAP , ELECT	470UF 10V
C724	CCEA1AH471T	CAP , ELECT	470UF 10V
C726	CCEA1AH101T	CAP , ELECT	100UF 10V
C728	CCEA1AH471T	CAP , ELECT	470UF 10V
C730	CCEA1AH101T	CAP , ELECT	100UF 10V
C732	CCEA1EH220T	CAP , ELECT	22UF/25V
C736	CCEA1HH2R2T	CAP , ELECT	2.2UF 50V
C737	CCEA1CH470T	CAP , ELECT	47UF 25V
C741	CCEA1EH220T	CAP , ELECT	22UF/25V
C746	CCEA1AH471T	CAP , ELECT	470UF 10V
C749	CCEA1EH220T	CAP , ELECT	22UF/25V
C753	CCEA1EH220T	CAP , ELECT	22UF/25V
C755	CCEA1EH220T	CAP , ELECT	22UF/25V
C764	CCEA0JKR3222E	CAP , ELECTROLYTIC	2200UF , KR3
C766	CCEA0JH102T	CAP , ELECT	1000UF 6.3V
C749	CCEA1AH471T	CAP , ELECT	470UF 10V
C753	CCEA1EH220T	CAP , ELECT	22UF/25V
<i>Semiconductors</i>			
D703	HVDRB160L60TE25	DIODE , SCHOTTKEY BARRIER HK	RB160L-60TE25
IC13	HVINJM2068MDTE1	I.C , OP AMP	NJM2068MD-TE1
IC21	HVITC9163AF	I.C , FUNCTION	TC9163AF
IC22	HVINJM2068MDTE1	I.C , OP AMP	NJM2068MD-TE1
IC23	HVITC9164AF	I.C , FUNCTION	TC9164AF
IC24	HVITC9163AF	I.C , FUNCTION	TC9163AF
IC25	HVINJM2068MDTE1	I.C , OP AMP	NJM2068MD-TE1
IC26	HVITC9162AF	I.C , FUNCTION	TC9162AF
IC31	HVINJM2068MDTE1	I.C , OP AMP	NJM2068MD-TE1
IC32	HVINJM2068MDTE1	I.C , OP AMP	NJM2068MD-TE1
IC33	HVINJM2068MDTE1	I.C , OP AMP	NJM2068MD-TE1
IC34	HVINJM2068MDTE1	I.C , OP AMP	NJM2068MD-TE1
IC35	HVINJM2068MDTE1	I.C , OP AMP	NJM2068MD-TE1
IC36	HVINJM2068MDTE1	I.C , OP AMP	NJM2068MD-TE1
IC37	HVINJM2068MDTE1	I.C , OP AMP	NJM2068MD-TE1
IC40	HVITC9459F	I.C , VOLUME	TC9459F
IC41	HVITC9459F	I.C , VOLUME	TC9459F
IC42	HVITC9459F	I.C , VOLUME	TC9459F
IC43	HVITC9459F	I.C , VOLUME	TC9459F
IC44	HVITC9459F	I.C , VOLUME	TC9459F
IC45	HVINJM2068MDTE1	I.C , OP AMP	NJM2068MD-TE1
IC46	HVINJM2068MDTE1	I.C , OP AMP	NJM2068MD-TE1
IC47	HVINJM2068MDTE1	I.C , OP AMP	NJM2068MD-TE1
IC48	HVINJM2068MDTE1	I.C , OP AMP	NJM2068MD-TE1
IC49	HVINJM2068MDTE1	I.C , OP AMP	NJM2068MD-TE1
IC72	HVITC74HCU04AFN	IC , INVERTER	TC74HCU04AFN
IC73	HVIAK4589VQ-T	I.C , CODEC + DIR	
IC74	HVI74LCX32TTR	I.C , OR-GATE	74LCX32

AVR335

Ref. Designator	Part Number	Description	
INPUT PCB			
IC75	HVICS49400-CQ	I.C , DECODER	CS49400-CQ
IC76	HVIM29W800DT70N	I.C, 4M FLASH MEMORY	29W800DT70N
IC77	HVI57V161610ET7	SDRAM 16M 7NS	HY57V161610ET-7
IC78	HVINJM2391DL133	I.C , CHIP REGULATOR (+3.3V)	
IC79	HVINJM2391DL125	I.C , CHIP REGULATOR (+2.5V)	
D201	HVD1SS133MT	DIODE	1SS133T-77
D202	HVD1SS133MT	DIODE	1SS133T-77
D203	HVD1SS133MT	DIODE	1SS133T-77
D204	HVD1SS133MT	DIODE	1SS133T-77
D205	HVD1SS133MT	DIODE	1SS133T-77
D206	HVD1SS133MT	DIODE	1SS133T-77
D207	HVD1SS133MT	DIODE	1SS133T-77
D208	HVD1SS133MT	DIODE	1SS133T-77
D209	HVD1SS133MT	DIODE	1SS133T-77
D210	HVD1SS133MT	DIODE	1SS133T-77
D211	HVD1SS133MT	DIODE	1SS133T-77
D212	HVD1SS133MT	DIODE	1SS133T-77
D213	HVD1SS133MT	DIODE	1SS133T-77
D214	HVD1SS133MT	DIODE	1SS133T-77
D215	HVD1SS133MT	DIODE	1SS133T-77
D216	HVD1SS133MT	DIODE	1SS133T-77
D475	HVD1SS133MT	DIODE	1SS133T-77
D701	KVD1N4003ST	DIODE	1N4003
J103	HVD1SS133MT	DIODE	1SS133T-77
Q201	HVTKTC2874BT	TRANSISTOR , MUTE NPN	KTC2874B
Q202	HVTKTC2874BT	TRANSISTOR , MUTE NPN	KTC2874B
Q203	HVTKTC2874BT	TRANSISTOR , MUTE NPN	KTC2874B
Q204	HVTKRA107MT	TRANSISTOR PNP	KRA107M
Q451	HVTKTC2874BT	TRANSISTOR , MUTE NPN	KTC2874B
Q452	HVTKTC2874BT	TRANSISTOR , MUTE NPN	KTC2874B
<i>Resistors</i>			
RN71	CRJ104DJ101T	RES, ARRAY, 100R (1608)	100R (1608)
RN72	CRJ104DJ101T	RES, ARRAY, 100R (1608)	100R (1608)
RN73	CRJ104DJ101T	RES, ARRAY, 100R (1608)	100R (1608)
RN74	CRJ104DJ101T	RES, ARRAY, 100R (1608)	100R (1608)
RN75	CRJ104DJ101T	RES, ARRAY, 100R (1608)	100R (1608)
RN76	CRJ104DJ101T	RES, ARRAY, 100R (1608)	100R (1608)
RN77	CRJ104DJ101T	RES, ARRAY, 100R (1608)	100R (1608)
RN78	CRJ104DJ101T	RES, ARRAY, 100R (1608)	100R (1608)
RN79	CRJ104DJ101T	RES, ARRAY, 100R (1608)	100R (1608)
R101	CRJ10DJ562T	RES , CHIP	5.6K Ohm
R102	CRJ10DJ562T	RES , CHIP	5.6K Ohm
R103	CRJ10DJ682T	RES , CHIP	6.8K Ohm
R104	CRJ10DJ682T	RES , CHIP	6.8K Ohm
R105	CRJ10DJ151T	RES, CHIP	150 Ohm
R106	CRJ10DJ151T	RES, CHIP	150 Ohm
R107	CRJ10DJ101T	RES , CHIP	100 Ohm
R108	CRJ10DJ101T	RES , CHIP	100 Ohm
R109	CRJ10DJ562T	RES , CHIP	5.6K Ohm
R110	CRJ10DJ562T	RES , CHIP	5.6K Ohm
R201	CRJ10DJ471T	RES , CHIP	470 Ohm
R202	CRJ10DJ471T	RES , CHIP	470 Ohm
R203	CRJ10DJ471T	RES , CHIP	470 Ohm
R204	CRJ10DJ471T	RES , CHIP	470 Ohm
R205	CRJ10DJ471T	RES , CHIP	470 Ohm
R206	CRJ10DJ471T	RES , CHIP	470 Ohm
R207	CRJ10DJ471T	RES , CHIP	470 Ohm
R208	CRJ10DJ471T	RES , CHIP	470 Ohm
R209	CRJ10DJ471T	RES , CHIP	470 Ohm

Ref. Designator	Part Number	Description	
INPUT PCB			
R210	CRJ10DJ471T	RES , CHIP	470 Ohm
R211	CRJ10DJ471T	RES , CHIP	470 Ohm
R212	CRJ10DJ471T	RES , CHIP	470 Ohm
R213	CRJ10DJ471T	RES , CHIP	470 Ohm
R214	CRJ10DJ471T	RES , CHIP	470 Ohm
R215	CRJ10DJ471T	RES , CHIP	470 Ohm
R216	CRJ10DJ471T	RES , CHIP	470 Ohm
R217	CRJ10DJ471T	RES , CHIP	470 Ohm
R218	CRJ10DJ471T	RES , CHIP	470 Ohm
R219	CRJ10DJ471T	RES , CHIP	470 Ohm
R220	CRJ10DJ471T	RES , CHIP	470 Ohm
R221	CRJ10DJ471T	RES , CHIP	470 Ohm
R222	CRJ10DJ471T	RES , CHIP	470 Ohm
R223	CRJ10DJ471T	RES , CHIP	470 Ohm
R224	CRJ10DJ272T	RES , CHIP	2.7K Ohm
R225	CRJ10DJ471T	RES , CHIP	470 Ohm
R226	CRJ10DJ471T	RES , CHIP	470 Ohm
R227	CRJ10DJ474T	RES , CHIP	470K Ohm
R228	CRJ10DJ474T	RES , CHIP	470K Ohm
R229	CRJ10DJ474T	RES , CHIP	470K Ohm
R230	CRJ10DJ474T	RES , CHIP	470K Ohm
R231	CRJ10DJ474T	RES , CHIP	470K Ohm
R232	CRJ10DJ474T	RES , CHIP	470K Ohm
R233	CRJ10DJ474T	RES , CHIP	470K Ohm
R234	CRJ10DJ474T	RES , CHIP	470K Ohm
R235	CRJ10DJ474T	RES , CHIP	470K Ohm
R236	CRJ10DJ474T	RES , CHIP	470K Ohm
R237	CRJ10DJ474T	RES , CHIP	470K Ohm
R238	CRJ10DJ474T	RES , CHIP	470K Ohm
R239	CRJ10DJ474T	RES , CHIP	470K Ohm
R240	CRJ10DJ474T	RES , CHIP	470K Ohm
R241	CRJ10DJ474T	RES , CHIP	470K Ohm
R242	CRJ10DJ474T	RES , CHIP	470K Ohm
R243	CRJ10DJ474T	RES , CHIP	470K Ohm
R244	CRJ10DJ474T	RES , CHIP	470K Ohm
R245	CRJ10DJ474T	RES , CHIP	470K Ohm
R246	CRJ10DJ474T	RES , CHIP	470K Ohm
R247	CRJ10DJ474T	RES , CHIP	470K Ohm
R248	CRJ10DJ474T	RES , CHIP	470K Ohm
R249	CRJ10DJ474T	RES , CHIP	470K Ohm
R250	CRJ10DJ103T	RES , CHIP	10K Ohm
R251	CRJ10DJ474T	RES , CHIP	470K Ohm
R252	CRJ10DJ474T	RES , CHIP	470K Ohm
R253	CRJ10DJ184T	RES , CHIP	180K Ohm
R254	CRJ10DJ184T	RES , CHIP	180K Ohm
R255	CRJ10DJ101T	RES , CHIP	100 Ohm
R256	CRJ10DJ101T	RES , CHIP	100 Ohm
R257	CRJ10DJ472T	RES , CHIP	4.7K Ohm
R258	CRJ10DJ472T	RES , CHIP	4.7K Ohm
R259	CRJ10DJ472T	RES , CHIP	4.7K Ohm
R261	CRJ10DJ104T	RES , CHIP	100K Ohm
R262	CRJ10DJ104T	RES , CHIP	100K Ohm
R263	CRJ10DJ101T	RES , CHIP	100 Ohm
R264	CRJ10DJ101T	RES , CHIP	100 Ohm
R265	CRJ10DJ101T	RES , CHIP	100 Ohm
R267	CRJ10DJ101T	RES , CHIP	100 Ohm
R268	CRJ10DJ184T	RES , CHIP	180K Ohm
R269	CRJ10DJ184T	RES , CHIP	180K Ohm
R270	CRJ10DJ472T	RES , CHIP	4.7K Ohm
R271	CRJ10DJ472T	RES , CHIP	4.7K Ohm
R272	CRJ10DJ472T	RES , CHIP	4.7K Ohm

Ref. Designator	Part Number	Description	
INPUT PCB			
R273	CRJ10DJ101T	RES , CHIP	100 Ohm
R274	CRJ10DJ101T	RES , CHIP	100 Ohm
R275	CRJ10DJ472T	RES , CHIP	4.7K Ohm
R276	CRJ10DJ472T	RES , CHIP	4.7K Ohm
R277	CRJ10DJ472T	RES , CHIP	4.7K Ohm
R278	CRJ10DJ104T	RES , CHIP	100K Ohm
R279	CRJ10DJ104T	RES , CHIP	100K Ohm
R280	CRJ10DJ101T	RES , CHIP	100 Ohm
R281	CRJ10DJ101T	RES , CHIP	100 Ohm
R283	CRJ10DJ101T	RES , CHIP	100 Ohm
R284	CRJ10DJ101T	RES , CHIP	100 Ohm
R285	CRJ10DJ184T	RES , CHIP	180K Ohm
R286	CRJ10DJ184T	RES , CHIP	180K Ohm
R287	CRJ10DJ184T	RES , CHIP	180K Ohm
R288	CRJ10DJ184T	RES , CHIP	180K Ohm
R289	CRJ10DJ184T	RES , CHIP	180K Ohm
R290	CRJ10DJ184T	RES , CHIP	180K Ohm
R291	CRJ10DJ472T	RES , CHIP	4.7K Ohm
R292	CRJ10DJ472T	RES , CHIP	4.7K Ohm
R293	CRJ10DJ472T	RES , CHIP	4.7K Ohm
R301	CRJ10DJ152T	RES , CHIP	15K Ohm
R304	CRJ10DJ152T	RES , CHIP	15K Ohm
R305	CRJ10DJ152T	RES , CHIP	15K Ohm
R308	CRJ10DJ152T	RES , CHIP	15K Ohm
R309	CRJ10DJ152T	RES , CHIP	15K Ohm
R312	CRJ10DJ152T	RES , CHIP	15K Ohm
R313	CRJ10DJ152T	RES , CHIP	15K Ohm
R316	CRJ10DJ152T	RES , CHIP	15K Ohm
R317	CRJ10DJ101T	RES , CHIP	100 Ohm
R318	CRJ10DJ101T	RES , CHIP	100 Ohm
R319	CRJ10DJ101T	RES , CHIP	100 Ohm
R320	CRJ10DJ101T	RES , CHIP	100 Ohm
R321	CRJ10DJ183T	RES , CHIP	18K Ohm
R322	CRJ10DJ103T	RES , CHIP	10K Ohm
R323	CRJ10DJ103T	RES , CHIP	10K Ohm
R324	CRJ10DJ183T	RES , CHIP	18K Ohm
R325	CRJ10DJ183T	RES , CHIP	18K Ohm
R326	CRJ10DJ103T	RES , CHIP	10K Ohm
R327	CRJ10DJ332T	RES , CHIP	3.3K Ohm
R328	CRJ10DJ183T	RES , CHIP	18K Ohm
R329	CRJ10DJ183T	RES , CHIP	18K Ohm
R330	CRJ10DJ103T	RES , CHIP	10K Ohm
R331	CRJ10DJ103T	RES , CHIP	10K Ohm
R332	CRJ10DJ183T	RES , CHIP	18K Ohm
R333	CRJ10DJ183T	RES , CHIP	18K Ohm
R334	CRJ10DJ103T	RES , CHIP	10K Ohm
R335	CRJ10DJ103T	RES , CHIP	10K Ohm
R336	CRJ10DJ183T	RES , CHIP	18K Ohm
R337	CRJ10DJ101T	RES , CHIP	100 Ohm
R338	CRJ10DJ101T	RES , CHIP	100 Ohm
R339	CRJ10DJ101T	RES , CHIP	100 Ohm
R340	CRJ10DJ101T	RES , CHIP	100 Ohm
R341	CRJ10DJ102T	RES , CHIP	1K Ohm
R344	CRJ10DJ102T	RES , CHIP	1K Ohm
R345	CRJ10DJ102T	RES , CHIP	1K Ohm
R348	CRJ10DJ102T	RES , CHIP	1K Ohm
R349	CRJ10DJ102T	RES , CHIP	1K Ohm
R352	CRJ10DJ102T	RES , CHIP	1K Ohm
R353	CRJ10DJ102T	RES , CHIP	1K Ohm
R356	CRJ10DJ102T	RES , CHIP	1K Ohm
R361	CRJ10DJ104T	RES , CHIP	100K Ohm

Ref. Designator	Part Number	Description	
INPUT PCB			
R362	CRJ10DJ104T	RES , CHIP	100K Ohm
R363	CRJ10DJ104T	RES , CHIP	100K Ohm
R364	CRJ10DJ104T	RES , CHIP	100K Ohm
R365	CRJ10DJ104T	RES , CHIP	100K Ohm
R366	CRJ10DJ104T	RES , CHIP	100K Ohm
R367	CRJ10DJ104T	RES , CHIP	100K Ohm
R368	CRJ10DJ104T	RES , CHIP	100K Ohm
R371	CRJ10DJ332T	RES , CHIP	3.3K Ohm
R372	CRJ10DJ332T	RES , CHIP	3.3K Ohm
R373	CRJ10DJ332T	RES , CHIP	3.3K Ohm
R374	CRJ10DJ332T	RES , CHIP	3.3K Ohm
R375	CRJ10DJ332T	RES , CHIP	3.3K Ohm
R376	CRJ10DJ332T	RES , CHIP	3.3K Ohm
R377	CRJ10DJ332T	RES , CHIP	3.3K Ohm
R378	CRJ10DJ332T	RES , CHIP	3.3K Ohm
R379	CRJ10DJ332T	RES , CHIP	3.3K Ohm
R380	CRJ10DJ332T	RES , CHIP	3.3K Ohm
R381	CRJ10DJ101T	RES , CHIP	100 Ohm
R382	CRJ10DJ101T	RES , CHIP	100 Ohm
R383	CRJ10DJ101T	RES , CHIP	100 Ohm
R384	CRJ10DJ101T	RES , CHIP	100 Ohm
R385	CRJ10DJ101T	RES , CHIP	100 Ohm
R386	CRJ10DJ101T	RES , CHIP	100 Ohm
R389	CRJ10DJ332T	RES , CHIP	3.3K Ohm
R390	CRJ10DJ332T	RES , CHIP	3.3K Ohm
R391	CRJ10DJ105T	RES , CHIP	100K Ohm
R392	CRJ10DJ105T	RES , CHIP	100K Ohm
R393	CRJ10DJ332T	RES , CHIP	3.3K Ohm
R394	CRJ10DJ153T	RES , CHIP	150K Ohm
R395	CRJ10DJ153T	RES , CHIP	150K Ohm
R396	CRJ10DJ332T	RES , CHIP	3.3K Ohm
R397	CRJ10DJ101T	RES , CHIP	100 Ohm
R398	CRJ10DJ101T	RES , CHIP	100 Ohm
R401	CRJ10DJ184T	RES , CHIP	180K Ohm
R402	CRJ10DJ184T	RES , CHIP	180K Ohm
R403	CRJ10DJ184T	RES , CHIP	180K Ohm
R404	CRJ10DJ184T	RES , CHIP	180K Ohm
R405	CRJ10DJ184T	RES , CHIP	180K Ohm
R406	CRJ10DJ184T	RES , CHIP	180K Ohm
R407	CRJ10DJ184T	RES , CHIP	180K Ohm
R408	CRJ10DJ184T	RES , CHIP	180K Ohm
R409	CRJ10DJ184T	RES , CHIP	180K Ohm
R410	CRJ10DJ184T	RES , CHIP	180K Ohm
R413	CRJ10DJ562T	RES , CHIP	5.6K Ohm
R414	CRJ10DJ562T	RES , CHIP	5.6K Ohm
R415	CRJ10DJ562T	RES , CHIP	5.6K Ohm
R416	CRJ10DJ103T	RES , CHIP	10K Ohm
R417	CRJ10DJ562T	RES , CHIP	5.6K Ohm
R418	CRJ10DJ562T	RES , CHIP	5.6K Ohm
R419	CRJ10DJ562T	RES , CHIP	5.6K Ohm
R420	CRJ10DJ562T	RES , CHIP	5.6K Ohm
R423	CRJ10DJ122T	RES , CHIP	1.2K Ohm
R424	CRJ10DJ122T	RES , CHIP	1.2K Ohm
R425	CRJ10DJ102T	RES , CHIP	1K Ohm
R426	CRJ10DJ102T	RES , CHIP	1K Ohm
R427	CRJ10DJ102T	RES , CHIP	1K Ohm
R428	CRJ10DJ102T	RES , CHIP	1K Ohm
R429	CRJ10DJ102T	RES , CHIP	1K Ohm
R430	CRJ10DJ102T	RES , CHIP	1K Ohm
R431	CRJ10DJ101T	RES , CHIP	100 Ohm
R432	CRJ10DJ101T	RES , CHIP	100 Ohm

Ref. Designator	Part Number	Description	
INPUT PCB			
R433	CRJ10DJ101T	RES , CHIP	100 Ohm
R434	CRJ10DJ101T	RES , CHIP	100 Ohm
R435	CRJ10DJ101T	RES , CHIP	100 Ohm
R436	CRJ10DJ101T	RES , CHIP	100 Ohm
R437	CRJ10DJ101T	RES , CHIP	100 Ohm
R438	CRJ10DJ101T	RES , CHIP	100 Ohm
R439	CRJ10DJ101T	RES , CHIP	100 Ohm
R440	CRJ10DJ101T	RES , CHIP	100 Ohm
R451	CRJ10DJ184T	RES , CHIP	180K Ohm
R452	CRJ10DJ184T	RES , CHIP	180K Ohm
R453	CRJ10DJ184T	RES , CHIP	180K Ohm
R454	CRJ10DJ184T	RES , CHIP	180K Ohm
R455	CRJ10DJ184T	RES , CHIP	180K Ohm
R456	CRJ10DJ184T	RES , CHIP	180K Ohm
R457	CRJ10DJ184T	RES , CHIP	180K Ohm
R458	CRJ10DJ184T	RES , CHIP	180K Ohm
R459	CRJ10DJ184T	RES , CHIP	180K Ohm
R460	CRJ10DJ184T	RES , CHIP	180K Ohm
R461	CRJ10DJ104T	RES , CHIP	100K Ohm
R462	CRJ10DJ104T	RES , CHIP	100K Ohm
R463	CRJ10DJ102T	RES , CHIP	1K Ohm
R464	CRJ10DJ102T	RES , CHIP	1K Ohm
R465	CRJ10DJ472T	RES , CHIP	4.7K Ohm
R466	CRJ10DJ472T	RES , CHIP	4.7K Ohm
R471	CRJ10DJ272T	RES , CHIP	2.7K Ohm
R472	CRJ10DJ272T	RES , CHIP	2.7K Ohm
R473	CRJ10DJ272T	RES , CHIP	2.7K Ohm
R474	CRJ10DJ272T	RES , CHIP	2.7K Ohm
R475	CRJ10DJ4R7T	RES , CHIP	4.7 Ohm
R481	CRJ10DJ223T	RES , CHIP	22K Ohm
R482	CRJ10DJ223T	RES , CHIP	22K Ohm
R483	CRJ10DJ223T	RES , CHIP	22K Ohm
R484	CRJ10DJ223T	RES , CHIP	22K Ohm
R485	CRJ10DJ223T	RES , CHIP	22K Ohm
R486	CRJ10DJ223T	RES , CHIP	22K Ohm
R487	CRJ10DJ223T	RES , CHIP	22K Ohm
R488	CRJ10DJ223T	RES , CHIP	22K Ohm
R491	CRJ10DJ4R7T	RES , CHIP	4.7 Ohm
R492	CRJ10DJ4R7T	RES , CHIP	4.7 Ohm
R493	CRJ10DJ4R7T	RES , CHIP	4.7 Ohm
R494	CRJ10DJ4R7T	RES , CHIP	4.7 Ohm
R495	CRJ10DJ4R7T	RES , CHIP	4.7 Ohm
R496	CRJ10DJ4R7T	RES , CHIP	4.7 Ohm
R497	CRJ10DJ4R7T	RES , CHIP	4.7 Ohm
R498	CRJ10DJ4R7T	RES , CHIP	4.7 Ohm
R701	CRJ10DJ101T	RES , CHIP	100 Ohm
R702	CRJ10DJ101T	RES , CHIP	100 Ohm
R703	CRJ10DJ101T	RES , CHIP	100 Ohm
R704	CRJ10DJ101T	RES , CHIP	100 Ohm
R705	CRJ10DJ102T	RES , CHIP	1K Ohm
R706	CRJ10DJ101T	RES , CHIP	100 Ohm
R707	CRJ10DJ101T	RES , CHIP	100 Ohm
R708	CRJ10DJ0R0T	RES , CHIP	0 Ohm
R714	CRJ10DJ104T	RES , CHIP	100K Ohm
R715	CRJ10DJ104T	RES , CHIP	100K Ohm
R716	CRJ10DJ472T	RES , CHIP	4.7K Ohm
R717	CRJ10DJ3R3T	RES , CHIP	3.3 Ohm
R718	CRJ10DJ105T	RES , CHIP	12K Ohm
R718	CRJ10DJ123T	RES , CHIP	47K Ohm
R720	CRJ10DJ473T	RES , CHIP	47K Ohm
R721	CRJ10DJ330T	RES , CHIP	33 Ohm

Ref. Designator	Part Number	Description	
INPUT PCB			
R723	CRJ10DJ1R8T	RES , CHIP	1.8 Ohm
R724	CRJ10DJ101T	RES , CHIP	100 Ohm
R725	CRJ10DJ473T	RES , CHIP	47K Ohm
R726	CRJ10DJ473T	RES , CHIP	47K Ohm
R727	CRJ10DJ473T	RES , CHIP	47K Ohm
R728	CRJ10DJ330T	RES , CHIP	33 Ohm
R729	CRJ10DJ330T	RES , CHIP	33 Ohm
R730	CRJ10DJ330T	RES , CHIP	33 Ohm
R758	CRJ10DJ330T	RES , CHIP	33 Ohm
R759	CRJ10DJ181T	RES , CHIP	180 Ohm
R760	CRJ10DJ105T	RES , CHIP	100K Ohm
R761	CRJ10DJ103T	RES , CHIP	10K Ohm
R762	CRJ10DJ103T	RES , CHIP	10K Ohm
R763	CRJ10DJ103T	RES , CHIP	10K Ohm
R764	CRJ10DJ330T	RES , CHIP	33 Ohm
R765	CRJ10DJ103T	RES , CHIP	10K Ohm
R766	CRJ10DJ103T	RES , CHIP	10K Ohm
R767	CRJ10DJ152T	RES , CHIP	15K Ohm
R768	CRJ10DJ152T	RES , CHIP	15K Ohm
R769	CRJ10DJ103T	RES , CHIP	10K Ohm
R770	CRJ10DJ103T	RES , CHIP	10K Ohm
R771	CRJ10DJ330T	RES , CHIP	33 Ohm
R772	CRJ10DJ330T	RES , CHIP	33 Ohm
R773	CRJ10DJ103T	RES , CHIP	10K Ohm
R774	CRJ10DJ330T	RES , CHIP	33 Ohm
R775	CRJ10DJ103T	RES , CHIP	10K Ohm
R776	CRJ10DJ332T	RES , CHIP	3.3K Ohm
R777	CRJ10DJ101T	RES , CHIP	100 Ohm
R778	CRJ10DJ103T	RES , CHIP	10K Ohm
R779	CRJ10DJ103T	RES , CHIP	10K Ohm
R780	CRJ10DJ332T	RES , CHIP	3.3K Ohm
R783	CRJ10DJ332T	RES , CHIP	3.3K Ohm
R784	CRJ10DJ332T	RES , CHIP	3.3K Ohm
R785	CRJ10DJ332T	RES , CHIP	3.3K Ohm
R786	CRJ10DJ103T	RES , CHIP	10K Ohm
R787	CRJ10DJ332T	RES , CHIP	3.3K Ohm
R788	CRJ10DJ332T	RES , CHIP	3.3K Ohm
R789	CRJ10DJ103T	RES , CHIP	10K Ohm
R790	CRJ10DJ103T	RES , CHIP	10K Ohm
R791	CRJ10DJ103T	RES , CHIP	10K Ohm
R792	CRJ10DJ103T	RES , CHIP	10K Ohm
R793	CRJ10DJ103T	RES , CHIP	10K Ohm
R794	CRJ10DJ103T	RES , CHIP	10K Ohm
R795	CRJ10DJ103T	RES , CHIP	10K Ohm
R796	CRJ10DJ103T	RES , CHIP	10K Ohm
R797	CRJ10DJ103T	RES , CHIP	10K Ohm
R798	CRJ10DJ103T	RES , CHIP	10K Ohm
R799	CRJ10DJ103T	RES , CHIP	10K Ohm
R800	CRJ10DJ103T	RES , CHIP	10K Ohm
R801	CRJ10DJ103T	RES , CHIP	10K Ohm
R802	CRJ10DJ103T	RES , CHIP	10K Ohm
R803	CRJ10DJ330T	RES , CHIP	33 Ohm
R804	CRJ10DJ103T	RES , CHIP	10K Ohm
R805	CRJ10DJ330T	RES , CHIP	33 Ohm
R806	CRJ10DJ330T	RES , CHIP	33 Ohm
R807	CRJ10DJ330T	RES , CHIP	33 Ohm
R808	CRJ10DJ330T	RES , CHIP	33 Ohm
R809	CRJ10DJ330T	RES , CHIP	33 Ohm
R810	CRJ10DJ330T	RES , CHIP	33 Ohm
R811	CRJ10DJ103T	RES , CHIP	10K Ohm
R812	CRJ10DJ103T	RES , CHIP	10K Ohm

AVR335

Ref. Designator	Part Number	Description	
INPUT PCB			
R813	CRJ10DJ103T	RES , CHIP	10K Ohm
R814	CRJ10DJ100T	RES , CHIP	10 Ohm
R815	CRJ10DJ103T	RES , CHIP	10K Ohm
R816	CRJ10DJ330T	RES , CHIP	33 Ohm
R817	CRJ10DJ103T	RES , CHIP	10K Ohm
R818	CRJ10DJ330T	RES , CHIP	33 Ohm
R819	CRJ10DJ330T	RES , CHIP	33 Ohm
R820	CRJ10DJ330T	RES , CHIP	33 Ohm
R821	CRJ10DJ330T	RES , CHIP	33 Ohm
R822	CRJ10DJ330T	RES , CHIP	33 Ohm
R823	CRJ10DJ101T	RES , CHIP	100 Ohm
R781	CRG2ANJ270H	RES , METAL OXIDE FILM	27 OHM 2W J
R782	CRG2ANJ330H	RES , METAL OXIDE FILM	33 OHM 2W J
<i>Miscellaneous</i>			
BN11	KJP15GB99ZM	WAFER	35237(15PIN)
BN12	KJP15GB99ZM	WAFER	35237(15PIN)
CN13	CJP13GA115ZY	WAFER , CARD CABLE	
CN15	CJP13GA115ZY	WAFER , CARD CABLE	
CN16	CJP15GA115ZY	WAFER , CARD CABLE	
CN17	KJP12GB142ZP	PIN HEADER	2110 - DR12 - G
CN18	CJP05GA19ZY	WAFER, STRAIGHT, 5PIN	
CN19	CJP03GA19ZY	WAFER, STRAIGHT, 3PIN	
CN72	KJP32GA117ZG	WAFER , CARD CABLE	GF102-32S-TS
JK11	CJJ4R019W	TERMINAL , IN/OUT	
JK12	CJJ4P014W	JACK , IN/OUT	
JK13	CJJ4P014W	JACK , IN/OUT	
JK14	CJJ4R019W	TERMINAL , IN/OUT	
JK15	CJJ4R037W	JACK , BOARD	
JK16	CJJ4N034Z	JACK , IN/OUT	
JW21	CWE7202090AA	WIRE ASS'Y	
L701	KLZ9H001Z	BEAD , CORE	
L702	KLZ9H001Z	BEAD , CORE	
L703	KLZ9H001Z	BEAD , CORE	
X701	HOX12288E220CS	CRYSTAL	
L704	HLZ9Z014Z	CHIP , BEAD	HU-1H4516-600JT
HEADPHONE/OPTICAL INPUT PCB's			
<i>Capacitors</i>			
C852	HCBS1H104ZFT	CAP , CERAMIC	0.1UF 50V Z
C701	CCEA1AH471T	CAP , ELECT	470UF 10V
C702	CCEA1AH471T	CAP , ELECT	470UF 10V
C703	HCBS1H181KBT	CAP , CERAMIC	180PF 50V K
C704	HCBS1H104ZFT	CAP , CERAMIC	0.1UF 50V Z
C705	HCBS1H181KBT	CAP , CERAMIC	180PF 50V K
C706	HCBS1H104ZFT	CAP , CERAMIC	0.1UF 50V Z
C707	HCBS1H101KBT	CAP , CERAMIC	100PF 50V K
C708	CCEA1CH101T	CAP , ELECT	100UF 16V
C709	HCBS1H104ZFT	CAP , CERAMIC	0.1UF 50V Z
C711	CCEA1CH101T	CAP , ELECT	100UF 16V
C712	HCBS1H473ZFT	CAP , CERAMIC	0.047UF 50V Z
C713	CCEA1AH471T	CAP , ELECT	470UF 10V
C714	HCBS1H104ZFT	CAP , CERAMIC	0.1UF 50V Z
C715	HCBS1H181KBT	CAP , CERAMIC	180PF 50V K
C820	CCEA1CH100T	CAP , ELECT	10UF 16V
C821	CCEA1CH470T	CAP , ELECT	47UF 16V
C822	CCEA1CH470T	CAP , ELECT	47UF 16V
C823	CCEA1CH100T	CAP , ELECT	10UF 16V

AVR335

Ref. Designator	Part Number	Description	
HEADPHONE/OPTICAL INPUT PCB's			
C824	HCBS1H471KBT	CAP , CERAMIC	470PF 50V K
C825	HCBS1H151KBT	CAP , CERAMIC	150PF 50V K
C826	HCBS1H223ZFT	CAP , CERAMIC	0.022UF 50V Z
C827	HCBS1H223ZFT	CAP , CERAMIC	0.022UF 50V Z
C828	HCBS1H470JT	CAP , CERAMIC	47PF 50V J
C829	CCEA1CH100T	CAP , ELECT	10UF 25V
C850	HCBS1H471KBT	CAP , CERAMIC	470PF 50V K
C851	HCBS1H471KBT	CAP , CERAMIC	470PF 50V K
C866	CCEA1CH100T	CAP , ELECT	10UF 16V
C867	CCEA1CH100T	CAP , ELECT	10UF 16V
C868	CCEA1CH470T	CAP , ELECT	47UF 25V
C869	CCEA1CH470T	CAP , ELECT	47UF 25V
C870	HCBS1H681KBT	CAP , CERAMIC	680PF 50V K
C871	HCBS1H681KBT	CAP , CERAMIC	680PF 50V K
C872	CCEA1CH331T	CAP , ELECT	330UF 16V
C873	CCEA1CH331T	CAP , ELECT	330UF 16V
<i>Semiconductors</i>			
D784	HVD1SS133MT	DIODE	1SS133T-77
D785	HVD1SS133MT	DIODE	1SS133T-77
D801	HVDMTZJ5.6BT	DIODE , ZENER	5.6V 1/2W
D802	HVDMTZJ5.6BT	DIODE , ZENER	5.6V 1/2W
D803	HVD1SS133MT	DIODE	1SS133T-77
Q734	HVTKTC2874BT	TRANSISTOR , MUTE NPN	KTC2874B
Q735	HVTKTC2874BT	TRANSISTOR , MUTE NPN	KTC2874B
Q737	HVTKTC2874BT	TRANSISTOR , MUTE NPN	KTC2874B
Q738	HVTKRC107MT	TRANSISTOR , MUTE NPN	KRC107M
Q739	HVTKRA107MT	TRANSISTOR PNP	KRA107M
Q740	HVTKRC107MT	TRANSISTOR , MUTE NPN	KRC107M
IC71	HVITC74HCU04AFN	IC , INVERTER	TC74HCU04AFN
IC86	HVINJM4556AL	I.C , HEADPHONE	NJM4556AL
IC87	HVINJM2068MDTE1	I.C , OP AMP	NJM2068MD-TE1
IC88	HVIHCF4053M013T	I.C , 2-CH MULTIPLEXER	HCF4053M013
<i>Resistors</i>			
R701	CRD20TJ103T	RES , CARBON	10K OHM 1/5W J
R702	CRD20TJ1R0T	RES , CARBON	1 OHM 1/5W J
R703	CRD20TJ103T	RES , CARBON	10K OHM 1/5W J
R704	CRD20TJ1R0T	RES , CARBON	1 OHM 1/5W J
R705	CRD20TJ750T	RES , CARBON	75 OHM 1/5W J
R706	CRD20TJ750T	RES , CARBON	75 OHM 1/5W J
R707	CRD20TJ100T	RES , CARBON	10 OHM 1/5W J
R708	CRD20TJ241T	RES , CARBON	240OHM 1/5W J
R709	CRD20TJ750T	RES , CARBON	75 OHM 1/5W J
R710	CRD20TJ1R0T	RES , CARBON	1 OHM 1/5W J
R711	CRD20TJ1R0T	RES , CARBON	1 OHM 1/5W J
R712	CRD20TJ101T	RES , CARBON	100 OHM 1/5W J
R713	CRD20TJ104T	RES , CARBON	100K OHM 1/5W J
R714	CRD20TJ104T	RES , CARBON	100K OHM 1/5W J
R715	CRD20TJ750T	RES , CARBON	75 OHM 1/5W J
R716	CRD20TJ104T	RES , CARBON	100K OHM 1/5W J
R717	CRD20TJ103T	RES , CARBON	10K OHM 1/5W J
R718	CRD20TJ1R0T	RES , CARBON	1 OHM 1/5W J
R719	CRD20TJ472T	RES , CARBON	4.7K OHM 1/5W J
R720	CRD20TJ472T	RES , CARBON	4.7K OHM 1/5W J
R721	CRD20TJ472T	RES , CARBON	4.7K OHM 1/5W J
R722	CRD20TJ102T	RES , CARBON	1K OHM 1/5W J
R723	CRD20TJ102T	RES , CARBON	1K OHM 1/5W J
R724	CRD20TJ102T	RES , CARBON	1K OHM 1/5W J

Ref. Designator	Part Number	Description	
HEADPHONE/OPTICAL INPUT PCB's			
R895	CRD20TJ101T	RES , CARBON	100 OHM 1/5W J
R896	CRD20TJ101T	RES , CARBON	100 OHM 1/5W J
R897	CRD20TJ101T	RES , CARBON	100 OHM 1/5W J
R898	CRD20TJ101T	RES , CARBON	100 OHM 1/5W J
R899	CRD20TJ104T	RES , CARBON	100K OHM 1/5W J
R900	CRD20TJ104T	RES , CARBON	100K OHM 1/5W J
R901	CRD20TJ152T	RES , CARBON	1.5K OHM 1/5W J
R902	CRD20TJ152T	RES , CARBON	1.5K OHM 1/5W J
R903	CRD20TJ102T	RES , CARBON	1K OHM 1/5W J
R904	CRD20TJ102T	RES , CARBON	1K OHM 1/5W J
R905	CRD20TJ104T	RES , CARBON	100K OHM 1/5W J
R906	CRD20TJ104T	RES , CARBON	100K OHM 1/5W J
R907	CRD20TJ562T	RES , CARBON	5.6K OHM 1/5W J
R908	CRD20TJ562T	RES , CARBON	5.6K OHM 1/5W J
R909	CRD20TJ221T	RES , CARBON	220 OHM 1/5W J
R910	CRD20TJ221T	RES , CARBON	220 OHM 1/5W J
R911	CRD20TJ221T	RES , CARBON	220 OHM 1/5W J
R912	CRD20TJ221T	RES , CARBON	220 OHM 1/5W J
R919	CRD20TJ562T	RES , CARBON	5.6K OHM 1/5W J
R920	CRD20TJ102T	RES , CARBON	1K OHM 1/5W J
R921	CRD20TJ103T	RES , CARBON	10K OHM 1/5W J
R922	CRD20TJ102T	RES , CARBON	1K OHM 1/5W J
R923	CRD20TJ101T	RES , CARBON	100 OHM 1/5W J
R924	CRD20TJ101T	RES , CARBON	100 OHM 1/5W J
R925	CRD20TJ680T	RES , CARBON	68 OHM 1/5W J
R926	CRD20TJ103T	RES , CARBON	10K OHM 1/5W J
R927	CRD20TJ102T	RES , CARBON	1K OHM 1/5W J
R928	CRD20TJ102T	RES , CARBON	1K OHM 1/5W J
R929	CRD20TJ562T	RES , CARBON	5.6K OHM 1/5W J
R930	CRD20TJ103T	RES , CARBON	10K OHM 1/5W J
R931	CRD20TJ104T	RES , CARBON	100K OHM 1/5W J
R932	CRD20TJ104T	RES , CARBON	100K OHM 1/5W J
R933	CRD20TJ103T	RES , CARBON	10K OHM 1/5W J
R934	CRD20TJ222T	RES , CARBON	2.2K OHM 1/5W J
R935	CRD20TJ103T	RES , CARBON	10K OHM 1/5W J
R936	CRD20TJ152T	RES , CARBON	1.5K OHM 1/5W J
R937	CRD20TJ104T	RES , CARBON	100K OHM 1/5W J
R725	CRD20TJ225T	RES , CARBON	2.2M 1/5W J
R726	CRD20TJ225T	RES , CARBON	2.2M 1/5W J
R727	CRD20TJ225T	RES , CARBON	2.2M 1/5W J
<i>Miscellaneous</i>			
JK83	CJJ2E026Z	JACK , HEADPHONE(SILVER PLATE)	
CN85	CJP02GA19ZY	WAFER, 2PIN	CJP02GA19ZY
BN92	CWB2B905080EN	WIRE ASS'Y	
JW82	CWE8202110RV	WIRE, ASS'Y	
BN17	KJP12GB143ZP	DIP SOCKET	3011 - DR12 - G
BN19	CWZAVR335BN19	WIRE ASS'Y	
CN15	CJP06GA19ZY	WAFER, STRAIGHT, 6PIN	
CN82	KJP06HA37ZM	WAFER	MOLEX42140-2206
CN87	CJP06GA19ZY	WAFER, STRAIGHT, 6PIN	
CN92	CJP05GA19ZY	WAFER, STRAIGHT, 5PIN	
JK71	HJSTORX179L	MODULE , OPTICAL(RX)	TORX179L
JK72	HJSTORX179L	MODULE , OPTICAL(RX)	TORX179L
JK73	CJJ4P053Z	JACK , RCA (4P ALL ORG)	
JK73	CJJ4S022Z	JACK , BOARD	
JK74	HJSTOTX179L	MODULE , OPTICAL(TX)	TOTX179L

Ref. Designator	Part Number	Description	
MISCELLANEOUS/CHASSIS			
JK75	HJSTORX179L	MODULE , OPTICAL(RX)	TORX179L
JW82	CWZAVR2550JW82	WIRE , ASS'Y	
RL81	HSL4A011ZE	RELAY	OMI-SS-212L
C124	BCQE2E104KDE	CAP , LINE ACROSS	0.1UF 250V KD
	CUA1A229	CHASSIS , BOTTOM	AVR130/230/330
	HDMKD1206PTS3	MOTOR , FAN(60X60X25MM)	KD1206PTS3
	KHE36-3	CLAMPER , WIRE	
	KHG1A050	RUBBER , CUSHION	
	KHG1A308	CUSHION, TRANS	
	KHR1A028	BUSHING , AC CORD	
	KHR301	CLAMPER	
CB13	CWC1C4A13B080B	CABLE , CARD	
CB15	CWC1C4A13B100B	CABLE , CARD	
CB16	CWC1C4A15B040B	CABLE , CARD	
CN21	KJP02GA89ZM	WAFER	MOLEX35328-02
OL91	KJJ7A015Z	OUTLET , AC(UL/2P/SEP)	A204D0041P
BN91	CWB4FE53130PU	WIRE ASS'Y	
BN14	CWB4F232450PU	WIRE ASS'Y	
F901	KBA2D2500TLET	FUSE	2.5A
F902	KBA2D2500TLET	FUSE	2.5A
F903	KBA2C8000TLUZ	FUSE	8A 250V SLO-BLO
F904	KBA2C8000TLUZ	FUSE	8A 250V SLO-BLO
F905	KBA2C6300TLUZ	FUSE	6.3A 250V SLO-BLO
F906	KBA2C6300TLUZ	FUSE	6.3A 250V SLO-BLO
F907	KBA2C8000TLUZ	FUSE	8A 250V SLO-BLO
	KJCFC5S	HOLDER , FUSE	for F905
	KJCFC5S	HOLDER , FUSE	for F906
	KJCFC5S	HOLDER , FUSE	for F907
	KJCFC5S	HOLDER , FUSE	for F903
	KJCFC5S	HOLDER , FUSE	for F904
T901	CLT5W018ZU	TRANS , POWER	
	CBN1A174MBC22	KNOB , ROTARY	
	CGB1A152Z	BADGE , HARMAN/KARDON(TOP)	
	CGL1A222	INDICATOR , VOLUME	AVR130/230/330
	KGB1A111X	BADGE , HARMAN/KARDON	
	KGB1A145Z	BADGE , TOP	
	CGUAVR335	WINDOW ASS'Y	
	KGB1A148Z	BADGE , MODEL NO	
	CGU1A318Z	ORNAMENT , VOLUME	AVR130/230/330
	CGWAVR335	FRONT PANEL ASS'Y	
	CBC1A147MBZC22	KNOB , MOMS	
	CBT1A819K128	KNOB , DELAY	AVR230
	CBT1A903MMZC22	KNOB , POWER	
	CBT1A904MBZC22	KNOB , SET	
	CBT1A905MBZC22	KNOB , FUNCTION	
	CGL1A221	INDICATOR , POWER	AVR130/230/330
	CGW1A366RDWH43	PANEL , FRONT	
	CHG1A309	RUBBER	
	CMC1A200	PLATE , SHIELD	AVR130/230/330
	CMC1A261	PLATE , EARTH	
	CMD1A443	BRACKET , SIDE	
	CMD1A555	BRACKET , SIDE (L)	
	CMH1A215	HOLDER , LED	AVR130/230/330
	CMK1A010	BRACKET , PCB	
	CMX1A148	INSULATOR , FUNCTION	AVR130
	CMX1A149	INSULATOR , SET	AVR130
	CMX1A170	INSULATOR , POWER	
	CMX1A173	INSULATOR , FUNCTION(L)	
	CMZ1A088	FILTER , FIP	AVR130/2600
	CMZ1A090	SHEET , VOLUME	AVR130/230/330
	CTB3+8JFC	SCREW	

Ref. Designator	Part Number	Description	
MISCELLANEOUS/CHASSIS			
	CTB4+6FFC	SCREW	
	CUAAVR335	BOTTOM CHASSIS ASS'Y	
	CHD1A012Z	SCREW , SPECIAL	AVR125CC
	CHD1A023	SCREW , TRANS	M4X10(SP/WA)
	CHD4A012	SCREW , TR	AVR130
	CHE170	HOLDER , PCB	
	CHG1A104	CUSHION , EVA	H=9.5(15X20)
	CHG1A157	CUSHION , RUBBER	
	CHG1A160	RUBBER	H=16 (15X20)
	CJA523FBYA	CORD , POWER	
	CKF1A294Z	PANEL,REAR	
	CKL2A069H43	FOOT	
	CLZ9W003Z	FERRITE , RING	29X7.7X19
	CMD1A487	BRACKET , TRANS	AVR130/230/330
	CMD1A506	BRACKET , FAN	AVR330/AVR4600
	CTB3+10G	SCREW	
	CTB3+16GFZ	SCREW	
	CTWS3+10G	SCREW	
	KHR301	CLAMPER	
CB72	CWC1B2A32A250B	CABLE , CARD	
	CGX1A338MBC22	CAP , VOLUME	
	CKC4B145S46	CABINET , TOP	
	CLZ9Z028Z	FERRITE CORE(21.2X6.4X12.7)	K5C T
	CMH1A214	HOLDER , VOLUME	AVR130/230/330
	CTB3+10GFZ	SCREW	
	CTB3+6J	SCREW	
	CTB3+8J	SCREW	
	CTB3+8JFZ	SCREW	
	CTW3+12J	SCREW	
	CTW3+8J	SCREW	
	CNVM9014MS070L	TUNER MODULE(USA)	

FAIRCHILD
SEMICONDUCTOR™

November 1988

Revised November 1999

74AC04 • 74ACT04

Hex Inverter

74ACT04SC : IC52,75,83,84

General Description

The AC/ACT04 contains six inverters.

Features

- I_{CC} reduced by 50% on 74AC only
- Outputs source/sink 24 mA
- ACT04 has TTL-compatible inputs

Ordering Code:

Order Number	Package Number	Package Description
74AC04SC	M14A	14-Lead Small Outline Integrated Circuit (SOIC), JEDEC MS-120, 0.150" Narrow Body
74AC04SJ	M14D	14-Lead Small Outline Package (SOP), EIAJ TYPE II, 5.3mm Wide
74AC04MTC	MTC14	14-Lead Thin Shrink Small Outline Package (TSSOP), JEDEC MO-153, 4.4mm Wide
74AC04PC	N14A	14-Lead Plastic Dual-In-Line Package (PDIP), JEDEC MS-001, 0.300" Wide
74ACT04SC	M14A	14-Lead Small Outline Integrated Circuit (SOIC), JEDEC MS-120, 0.150" Narrow Body
74ACT04MTC	MTC14	14-Lead Thin Shrink Small Outline Package (TSSOP), JEDEC MO-153, 4.4mm Wide
74ACT04PC	N14A	14-Lead Plastic Dual-In-Line Package (PDIP), JEDEC MS-001, 0.300" Wide

Device also available in Tape and Reel. Specify by appending suffix letter "X" to the ordering code. (PC not available in Tape and Reel.)

Logic Symbol

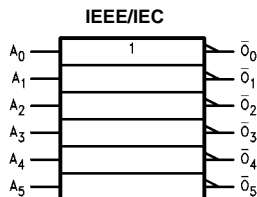

Connection Diagram

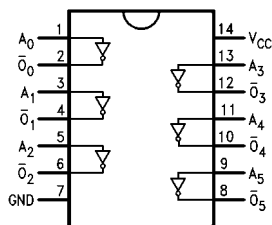

Pin Descriptions

Pin Names	Description
A_n	Inputs
\bar{O}_n	Outputs

FACT™ is a trademark of Fairchild Semiconductor Corporation.

■ PIN ASSIGNMENT (74HCU04AFN : IC71,72,76)

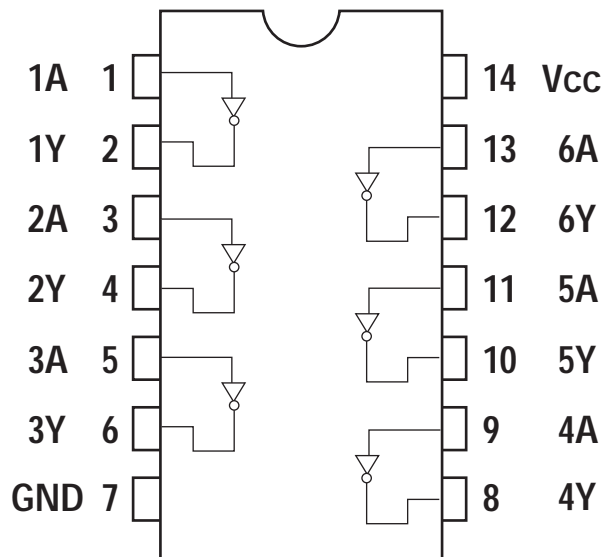

■ LOGIC SYMBOL

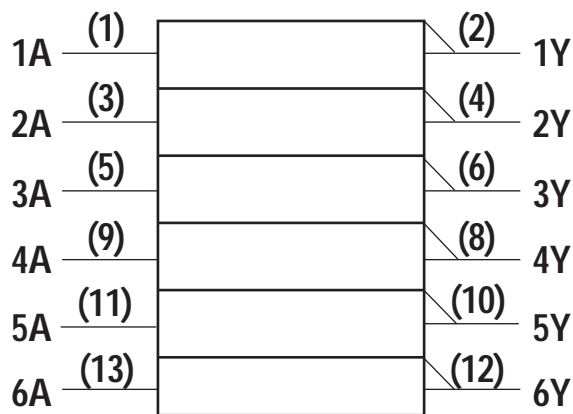

■ TRUTH TABLE

A	Y
L	H
H	L

DIR IC PIN ASSIGNMENT & BLOCK DIAGRAM
PIN ASSIGNMENT (TOP VIEW) : IC73

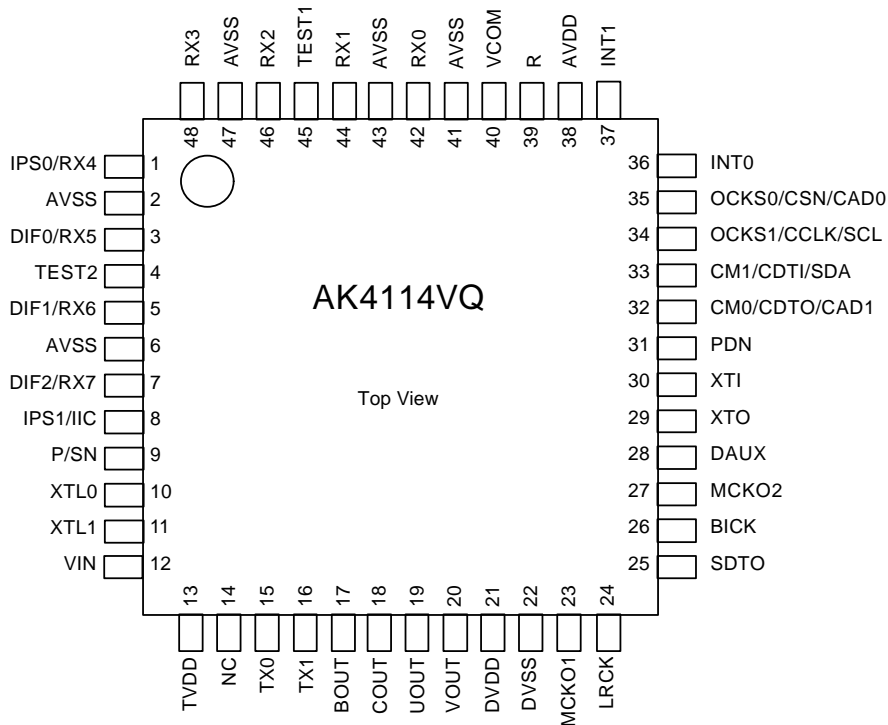

BLOCK DIAGRAM

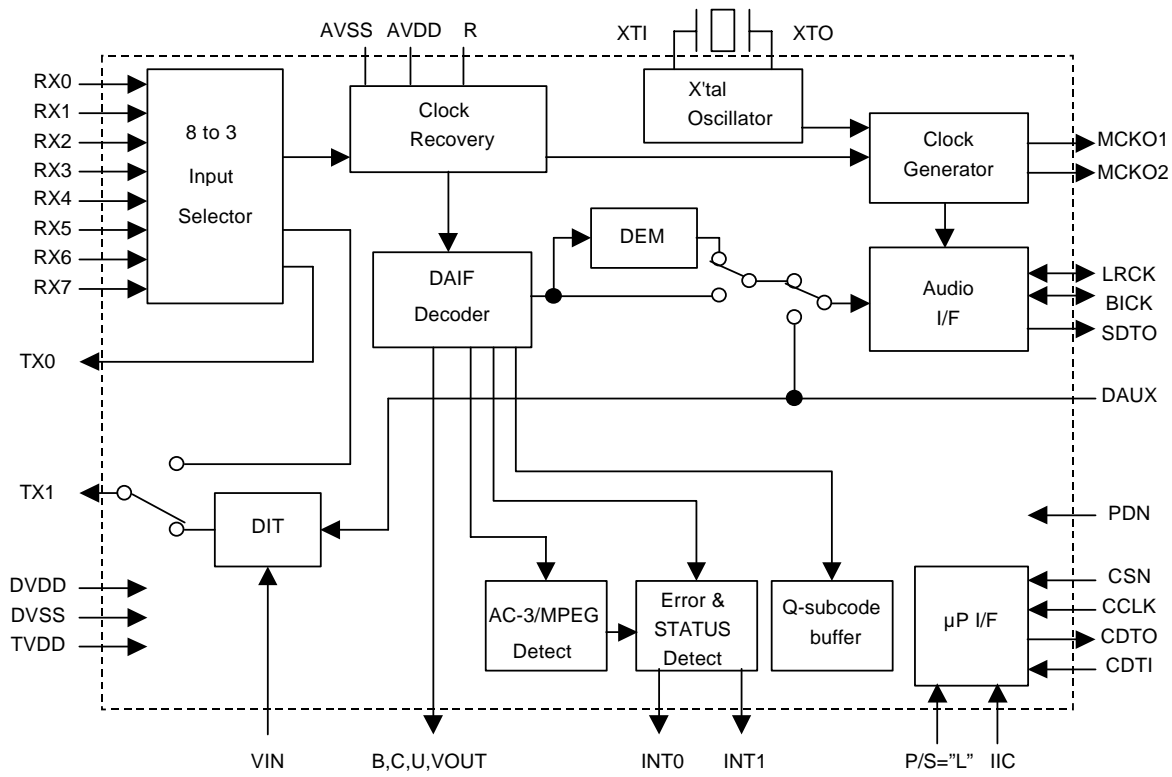

Serial Control Mode

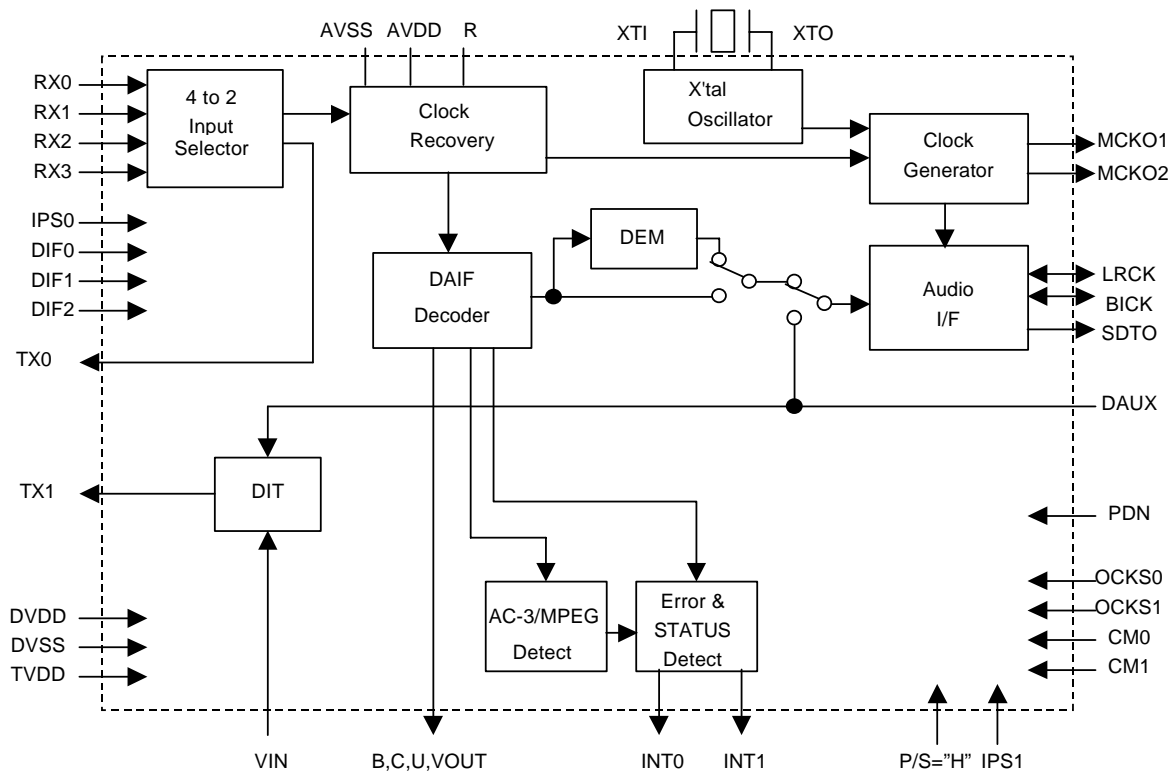

Parallel Control Mode

DIR IC PIN FUNCTION (AK4114VQ) : IC73□

PIN/FUNCTION			
No.	Pin Name	I/O	Function
1	IPS0	I	Input Channel Select 0 Pin in Parallel Mode
	RX4	I	Receiver Channel 4 Pin in Serial Mode (Internal biased pin)
2	NC(AVSS)	I	No Connect No internal bonding. This pin should be connected to AVSS.
3	DIF0	I	Audio Data Interface Format 0 Pin in Parallel Mode
	RX5	I	Receiver Channel 5 Pin in Serial Mode (Internal biased pin)
4	TEST2	I	TEST 2 pin This pin should be connect to AVSS.
5	DIF1	I	Audio Data Interface Format 1 Pin in Parallel Mode
	RX6	I	Receiver Channel 6 Pin in Serial Mode (Internal biased pin)
6	NC(AVSS)	I	No Connect No internal bonding. This pin should be connected to AVSS.
7	DIF2	I	Audio Data Interface Format 2 Pin in Parallel Mode
	RX7	I	Receiver Channel 7 Pin in Serial Mode (Internal biased pin)
8	IPS1	I	Input Channel Select 1 Pin in Parallel Mode
	IIC	I	IIC Select Pin in Serial Mode. “L”: 4-wire Serial, “H”: IIC
9	P/SN	I	Parallel/Serial Select Pin “L”: Serial Mode, “H”: Parallel Mode
10	XTL0	I	X'tal Frequency Select 0 Pin
11	XTL1	I	X'tal Frequency Select 1 Pin
12	VIN	I	V-bit Input Pin for Transmitter Output
13	TVDD	I	Input Buffer Power Supply Pin, 3.3V or 5V
14	NC	I	No Connect No internal bonding. This pin should be open or connected to DVSS.
15	TX0	O	Transmit Channel (Through Data) Output 0 Pin
16	TX1	O	When TX bit = “0”, Transmit Channel (Through Data) Output 1 Pin. When TX bit = “1”, Transmit Channel (DAUX Data) Output Pin (Default).
17	BOUT	O	Block-Start Output Pin for Receiver Input “H” during first 40 frames.
18	COUT	O	C-bit Output Pin for Receiver Input
19	UOUT	O	U-bit Output Pin for Receiver Input
20	VOUT	O	V-bit Output Pin for Receiver Input
21	DVDD	I	Digital Power Supply Pin, 3.3V
22	DVSS	I	Digital Ground Pin
23	MCKO1	O	Master Clock Output 1 Pin
24	LRCK	I/O	Channel Clock Pin
25	SDTO	O	Audio Serial Data Output Pin
26	BICK	I/O	Audio Serial Data Clock Pin
27	MCKO2	O	Master Clock Output 2 Pin
28	DAUX	I	Auxiliary Audio Data Input Pin
29	XTO	O	X'tal Output Pin
30	XTI	I	X'tal Input Pin

PIN/FUNCTION (Continued)

No.	Pin Name	I/O	Function
31	PDN	I	Power-Down Mode Pin When "L", the AK4114 is powered-down and reset.
32	CM0	I	Master Clock Operation Mode 0 Pin in Parallel Mode
	CDTO	O	Control Data Output Pin in Serial Mode, IIC= "L".
	CAD1	I	Chip Address 1 Pin in Serial Mode, IIC= "H".
33	CM1	I	Master Clock Operation Mode 1 Pin in Parallel Mode
	CDTI	I	Control Data Input Pin in Serial Mode, IIC= "L".
	SDA	I/O	Control Data Pin in Serial Mode, IIC= "H".
34	OCKS1	I	Output Clock Select 1 Pin in Parallel Mode
	CCLK	I	Control Data Clock Pin in Serial Mode, IIC= "L"
	SCL	I	Control Data Clock Pin in Serial Mode, IIC= "H"
35	OCKS0	I	Output Clock Select 0 Pin in Parallel Mode
	CSN	I	Chip Select Pin in Serial Mode, IIC="L".
	CAD0	I	Chip Address 0 Pin in Serial Mode, IIC= "H".
36	INT0	O	Interrupt 0 Pin
37	INT1	O	Interrupt 1 Pin
38	AVDD	I	Analog Power Supply Pin, 3.3V
39	R	-	External Resistor Pin 18k Ω +/-1% resistor should be connected to AVSS externally.
40	VCOM	-	Common Voltage Output Pin 0.47 μ F capacitor should be connected to AVSS externally.
41	AVSS	I	Analog Ground Pin
42	RX0	I	Receiver Channel 0 Pin (Internal biased pin) This channel is default in serial mode.
43	NC(AVSS)	I	No Connect No internal bonding. This pin should be connected to AVSS.
44	RX1	I	Receiver Channel 1 Pin (Internal biased pin)
45	TEST1	I	TEST 1 pin. This pin should be connected to AVSS.
46	RX2	I	Receiver Channel 2 Pin (Internal biased pin)
47	NC(AVSS)	I	No Connect No internal bonding. This pin should be connected to AVSS.
48	RX3	I	Receiver Channel 3 Pin (Internal biased pin)

Note 1. All input pins except internal biased pins should not be left floating.

AKM

= Target Spec =

AK4358**192kHz 24-Bit 8ch DAC with DSD Input****GENERAL DESCRIPTION**

The AK4358 is eight channels 24bit DAC corresponding to digital audio system. Using AKM's advanced multi bit architecture for its modulator the AK4358 delivers a wide dynamic range while preserving linearity for improved THD+N performance. The AK4358 has full differential SCF outputs, removing the need for AC coupling capacitors and increasing performance for systems with excessive clock jitter. The AK4358 accepts 192kHz PCM data and 1-Bit DSD data, ideal for a wide range of applications including DVD-Audio and SACD.

FEATURES

- Sampling Rate Ranging from 8kHz to 192kHz
- 24Bit 8 times Digital Filter with Slow roll-off option
- THD+N: -94dB
- DR, S/N: 114dB
- High Tolerance to Clock Jitter
- Low Distortion Differential Output
- DSD Data input available
- Channel Independent Digital De-emphasis for 32, 44.1 & 48kHz sampling
- Zero Detect function
- Channel Independent Digital Attenuator with soft-transition (3 Speed mode)
- Soft Mute
- 3-wire Serial and I²C Bus μ P I/F for mode setting
- I/F format: MSB justified, LSB justified (16bit, 20bit, 24bit), I²S, TDM or DSD
- Master clock: 256fs, 384fs, 512fs or 768fs (PCM Normal Speed Mode)
128fs, 192fs, 256fs or 384fs (PCM Double Speed Mode)
128fs or 192fs (PCM Quad Speed Mode)
512fs or 768fs (DSD Mode)
- Power Supply: 4.75 to 5.25V
- 48pin LQFP Package

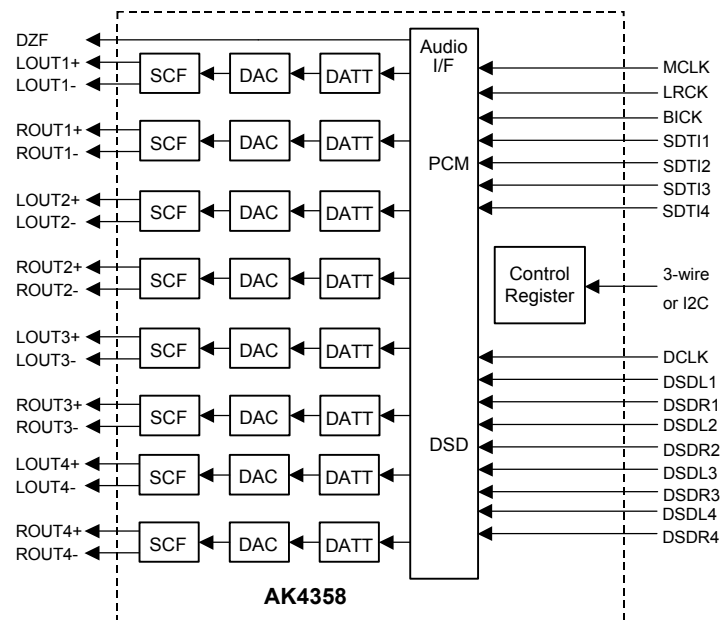

ASAHI KASEI

AKM CONFIDENTIAL

[AK4358]

■ Ordering Guide

AK4358VQ	-40 ~ +85°C	48LQFP
AKD4358	Evaluation Board for AK4358	

■ Pin Layout (To be determined)

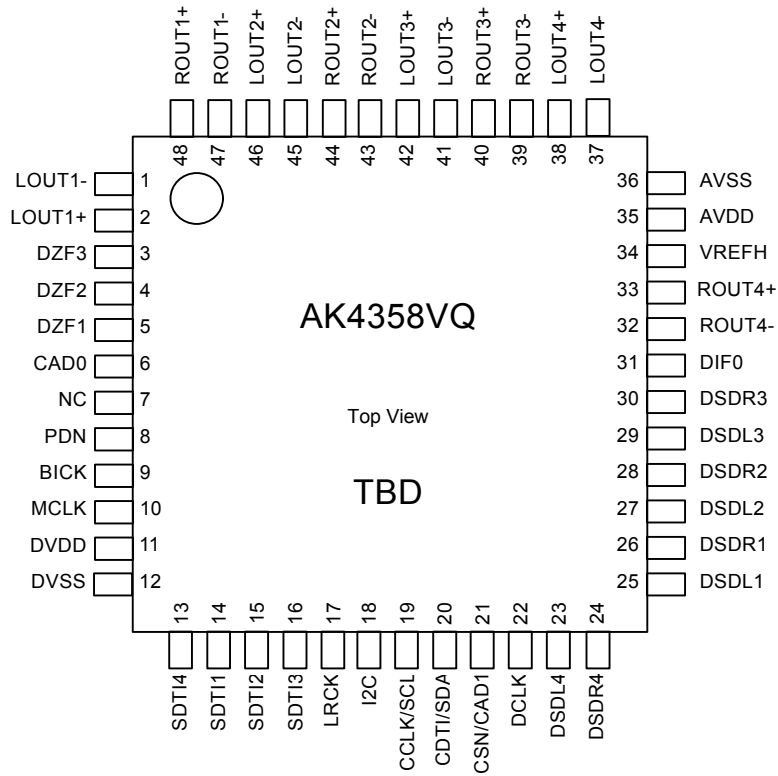

ASAHI KASEI

[AK4358]

■ Compatibility with AK4357

1. Function & Performance

Function	AK4357	AK4358
# of channels	AK4357	AK4358
DR	106dB	114B
48kHz/96kHz TDM	Not available	Available
I2C	Not available	Available
DSDM control	Pin/Register	Register
Input channel of DZF pin	Fixed	Programmable

2. Pin Configuration (To be determined)

Pin #	AK4357	AK4358
3	DZFL1	DZF3
4	DZFR1	DZF2
5	DZF23	DZF1
7	CAD1	NC
12	NC	DVSS
13	DVSS	SDTI4
18	SMUTE	I2C
22	DSDM	DCLK
23	DCLK	DSDL4
24	NC	DSDR4
32	DIF1	ROUT4-
33	DIF2	ROUT4+
37	AVSS	LOUT4-
38	AVSS	LOUT4-

3. Register

Addr	Bit	AK4357	AK4358
00H	D5	DZFM	0
01H	D6	0	PW4
04H	D7	ATT7	ATTE
05H	D7	ATT7	ATTE
06H	D7	ATT7	ATTE
07H	D7	ATT7	ATTE
08H	D7	ATT7	ATTE
09H	D7	ATT7	ATTE
0AH	D7, D6	0, 0	TDM1, TDM0
0BH		Not available	LOUT4 ATT Control
0CH		Not available	ROUT4 ATT Control
0DH		Not available	DZF1 control
0EH		Not available	DZF2 control
0FH		Not available	DZF3 control

ASAHI KASEI

IC 74

[AK4358]

PIN/FUNCTION (TBD)

No.	Pin Name	I/O	Function
	LOUT1-	O	DAC1 Lch Negative Analog Output Pin
	LOUT1+	O	DAC1 Lch Positive Analog Output Pin
	DZF1	O	Zero Input Detect 1 Pin
	DZF2	O	Zero Input Detect 2 Pin
	DZF3	O	Zero Input Detect 3 Pin
	CAD0	I	Chip Address 0 Pin
	PDN	I	Power-Down Mode Pin When at "L", the AK4358 is in the power-down mode and is held in reset. The AK4358 should always be reset upon power-up.
	BICK	I	Audio Serial Data Clock Pin
	MCLK	I	Master Clock Input Pin An external TTL clock should be input on this pin.
	DVDD	-	Digital Power Supply Pin, +4.75~+5.25V
	DVSS	-	Digital Ground Pin
	SDTI1	I	DAC1 Audio Serial Data Input Pin
	SDTI2	I	DAC2 Audio Serial Data Input Pin
	SDTI3	I	DAC3 Audio Serial Data Input Pin
	SDTI4	I	DAC4 Audio Serial Data Input Pin
	LRCK	I	L/R Clock Pin
	I2C	I	Control Mode Select Pin "L": 3-wire Serial, "H": I ² C Bus
	CCLK/SCL	I	Control Data Clock Pin I2C = "L": CCLK (3-wire Serial), I2C = "H": SCL (I ² C Bus)
	CDTI/SDA	I/O	Control Data Input Pin I2C = "L": CDTI (3-wire Serial), I2C = "H": SDA (I ² C Bus)
	CSN/CAD1	I	Chip Select Pin I2C = "L": CSN (3-wire Serial), I2C = "H": CAD1 (I ² C Bus)
	DCLK	I	DSD Clock Pin
	DSDL1	I	DAC1 DSD Lch Data Input Pin
	DSDR1	I	DAC1 DSD Rch Data Input Pin
	DSDL2	I	DAC2 DSD Lch Data Input Pin
	DSDR2	I	DAC2 DSD Rch Data Input Pin
	DSDL3	I	DAC3 DSD Lch Data Input Pin
	DSDR3	I	DAC3 DSD Rch Data Input Pin
	DSDL4	I	DAC4 DSD Lch Data Input Pin
	DSDR4	I	DAC4 DSD Rch Data Input Pin
	DIF0	I	Audio Data Interface Format 0 Pin
	VREFH	I	Positive Voltage Reference Input Pin
	AVDD	-	Analog Power Supply Pin, +4.75~+5.25V
	AVSS	-	Analog Ground Pin
	ROUT4-	O	DAC4 Rch Negative Analog Output Pin
	ROUT4+	O	DAC4 Rch Positive Analog Output Pin
	LOUT4-	O	DAC4 Lch Negative Analog Output Pin
	LOUT4+	O	DAC4 Lch Positive Analog Output Pin
	ROUT3-	O	DAC3 Rch Negative Analog Output Pin
	ROUT3+	O	DAC3 Rch Positive Analog Output Pin
	LOUT3-	O	DAC3 Lch Negative Analog Output Pin
	LOUT3+	O	DAC3 Lch Positive Analog Output Pin
	ROUT2-	O	DAC2 Rch Negative Analog Output Pin
	ROUT2+	O	DAC2 Rch Positive Analog Output Pin
	LOUT2-	O	DAC2 Lch Negative Analog Output Pin
	LOUT2+	O	DAC2 Lch Positive Analog Output Pin
	ROUT1-	O	DAC1 Rch Negative Analog Output Pin



= Preliminary =

AK5381
24Bit 96kHz $\Delta\Sigma$ ADC

GENERAL DESCRIPTION

The AK5381 is a stereo A/D Converter with wide sampling rate of 4kHz ~ 96kHz and is suitable for High-end audio system. The AK5381 achieves high accuracy and low cost by using Enhanced dual bit $\Delta\Sigma$ techniques. The AK5381 requires no external components because the analog inputs are single-ended. The audio interface has two formats (MSB justified, I²S) and can correspond to many systems like music instrument and AV receiver.

FEATURES

- Stereo $\Delta\Sigma$ ADC**
- On-Chip Digital Anti-Alias Filtering**
- Single-ended Input**
- Digital HPF for DC-Offset cancel**
- S/(N+D): 96dB@5V for 48kHz**
- DR: 106dB@5V for 48kHz**
- S/N: 106dB@5V for 48kHz**
- Sampling Rate Ranging from 4kHz to 96kHz**
- Master Clock:**
 - 256fs/384fs/512fs/768fs (~ 48kHz)
 - 256fs/384fs (~ 96kHz)
- Audio Interface: Master or Slave Mode selectable**
- Input level: TTL/CMOS selectable**
- Output format: 24bit MSB justified / I²S selectable**
- Power Supply: 4.5 ~ 5.5V (VA)**
 - 2.7 ~ 5.5V (VD at 48kHz)
 - 3.0 ~ 5.5V (VD at 96kHz)
- Ta = -40 ~ 85°C**
- Small 16pin TSSOP Package**
- AK5380 Pin-compatible**

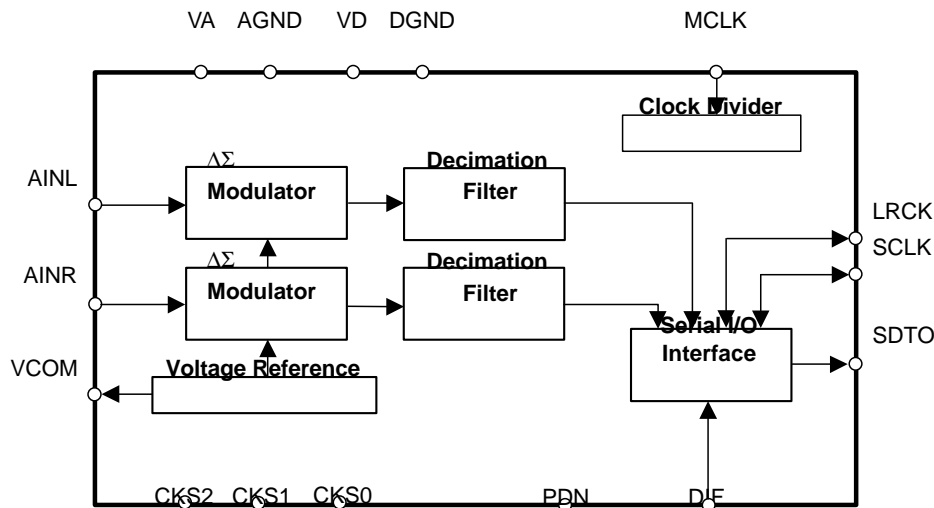

ASAHI KASEI

[AK5381]

■ **Ordering Guide**

AK5381VT
AKD5381

-40 ~ +85°C
Evaluation Board for AK5381

16pin TSSOP (0.65mm pitch)

■ **Pin Layout**

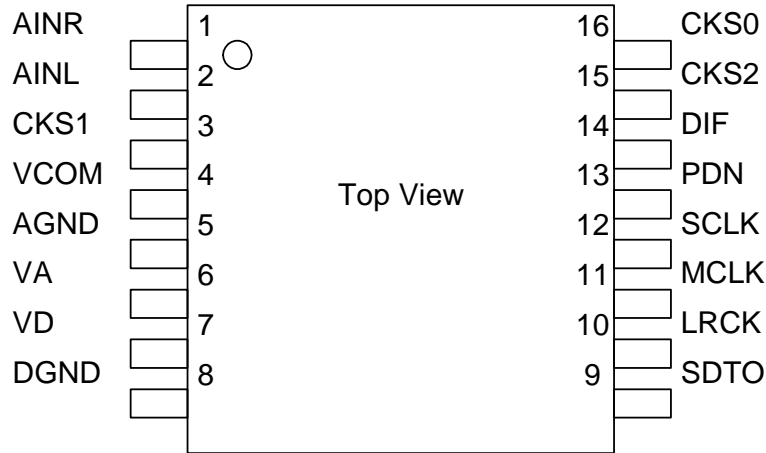

■ **Compatibility with AK5380**

	AK5380	AK5381
Master Mode	Not Available	Available
HPF OFF	Not Available	Available
VD (Digital Supply)	4.5 to 5.5V@fs=96kHz	3.0 to 5.5V@fs=96kHz
Pin #3	NC	CKS1
Pin #15	TTL	CKS2
Pin #16	TST	CKS0

PIN / FUNCTION

No	Pin Name	I/O	Function
1	AINR	I	Rch Analog Input Pin
2	AINL	I	Lch Analog Input Pin
3	CKS1	I	Mode Select 1 Pin
4	VCOM	O	Common Voltage Output Pin, VA/2 Bias voltage of ADC input.
5	AGND	-	Analog Ground Pin
6	VA	-	Analog Power Supply Pin, 4.5 ~ 5.5V
7	VD	-	Digital Power Supply Pin, 2.7 ~ 5.5V(fs=4k ~ 48kHz), 3.0 ~ 5.5V(fs=48k ~ 96kHz)
8	DGND	-	Digital Ground Pin
9	SDTO	O	Audio Serial Data Output Pin “L” Output at Power-down mode.
10	LRCK	I/O	Output Channel Clock Pin “L” Output in Master Mode at Power-down mode.
11	MCLK	I	Master Clock Input Pin
12	SCLK	I/O	Audio Serial Data Clock Pin “L” Output in Master Mode at Power-down mode.
13	PDN	I	Power Down Mode Pin “H”: Power up, “L”: Power down
14	DIF	I	Audio Interface Format Pin “H” : 24bit I ² S Compatible, “L” : 24bit MSB justified
15	CKS2	I	Mode Select 2 Pin
16	CKS0	I	Mode Select 0 Pin

Note: All digital input pins should not be left floating.

AUDIO DSP (CS493263 - CLG : IC75)

PIN No.	Pin Name	I/O	Function
1,12,23	+VD1	-	Digital Power supply. Normally +2.5v
2,13,24	DGND	-	Digital Ground
3	AUD3	O	SPDIF transmitter output/Digital audio output(N.C)
4	WR	I	Host write strobe pin(connected to GND with an external resistor)
5	RD	I	Host parallel output enable pin(pulled up with an external resistor)
6	CS_DA	I	SPI Serial data input pin
7	CS_CK	I	Serial control clock input pin
8	EMAD7	I/O	Serial data IN/OUTPUT pins(pulled up with an external resistor)
9	EMAD6	I/O	
10	EMAD5	I/O	
11	EMAD4	I/O	
14	EMAD3	I/O	
15	EMAD2	I/O	
16	EMAD1	I/O	
17	EMAD0	I/O	
18	CS_CE	I	Host parallel chip select pin
19	SCDIO(AK_DOUT)	O	Serial control port data ouput pin
20	INTREQ	O	Control port interrupt request output pin
21	EXTMEM	I/O	External Memory Chip Selector(pulled up with an external resistor)
22	SDATAN1(SDI)	I	PCM audio data input number 1 pin
25	SCLKN1(BICK)	I	PCM audio input bit clock pin
26	LRCLKN1(LRCK)	I	PCM audio input sample rate clock pin
27	CMPDAT(SDI)	I	PCM audio data input number 2 pin
28	CMPCLK(BICK)	I	PCM audio input bit clock pin
29	CREQ(LRCK)	I	PCM audio input sample rate clock pin
30	CLKIN(XIN)	I	Master clock input(used external clock)
31	CLKSEL(GND)	I	DSP clock mode select pin: connect the GND
32	FILT1		Connects to an external filter for the on-chip phase-locked loop
33	FILT1		Connects to an external filter for the on-chip phase-locked loop
34	+2.5V	-	Analog Power supply for clock generator . Normally +2.5V
35	AGND	-	Analog ground supply for clock generator PLL.
36	RESET(CS_RST)	I	Master reset input pin
37	DBDATA	-	Reserved pin and should be pulled up with an external resistor.
38	DBCLK	-	Reserved pin and should be pulled up with an external resistor.
39	AUD2(SDO2)	O	PCM multi-format digital-audio data ouput2 pin
40	AUD1(SDO1)	O	PCM multi-format digital-audio data ouput1 pin
41	AUD0(SDO0)	O	PCM multi-format digital-audio data ouput0 pin
42	LRCLK	I	Audio output sample rate clock pin
43	SCLK(BICK)	I	Audio ouput bit clock pin
44	MCLK	I	Audio master clock output pin

PIN ASSIGNMENT.(CS493263)

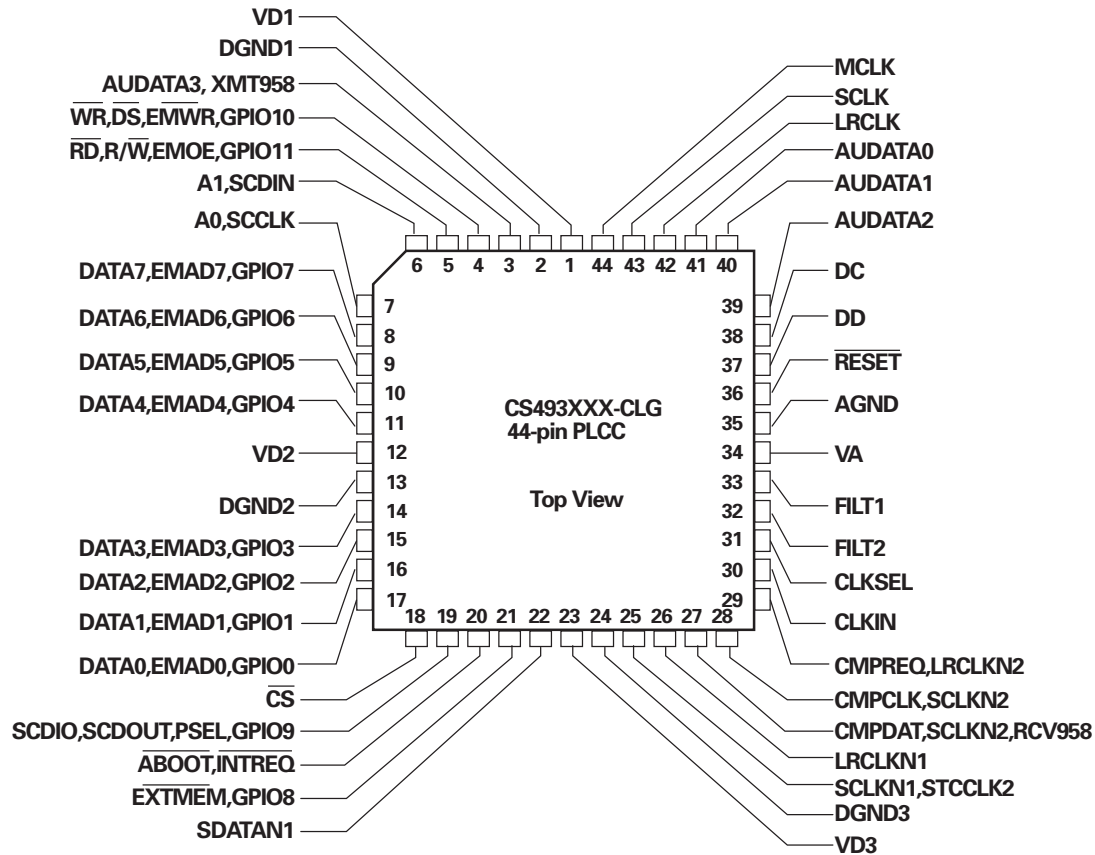

(TOP VIEW)

BLOCK DIAGRAM(CS493263)

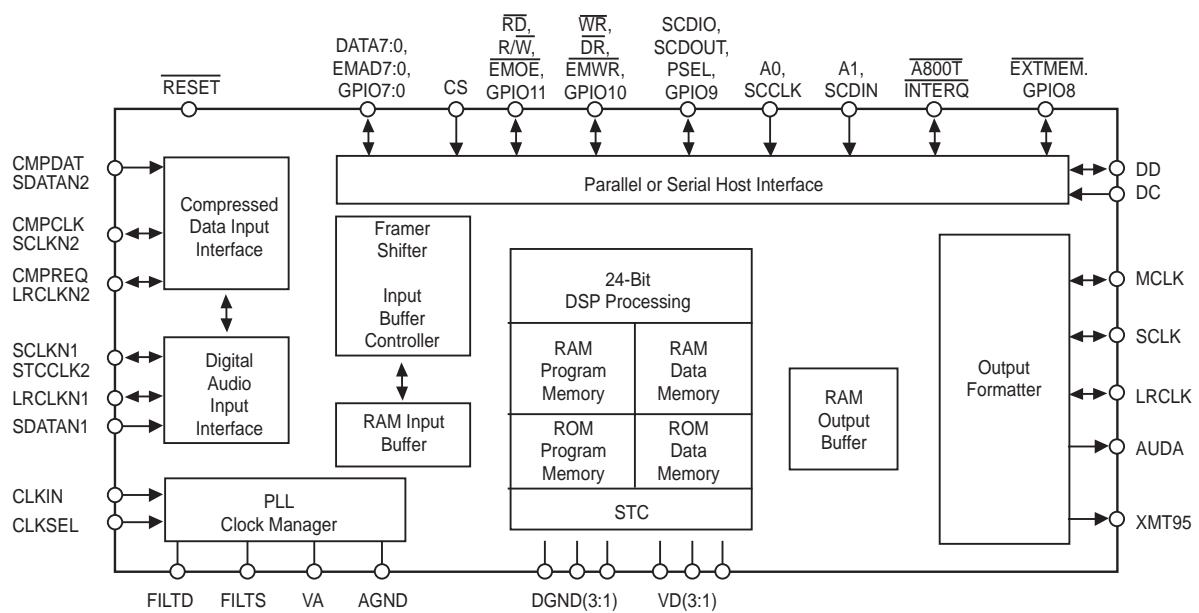

BLOCK DIAGRAM

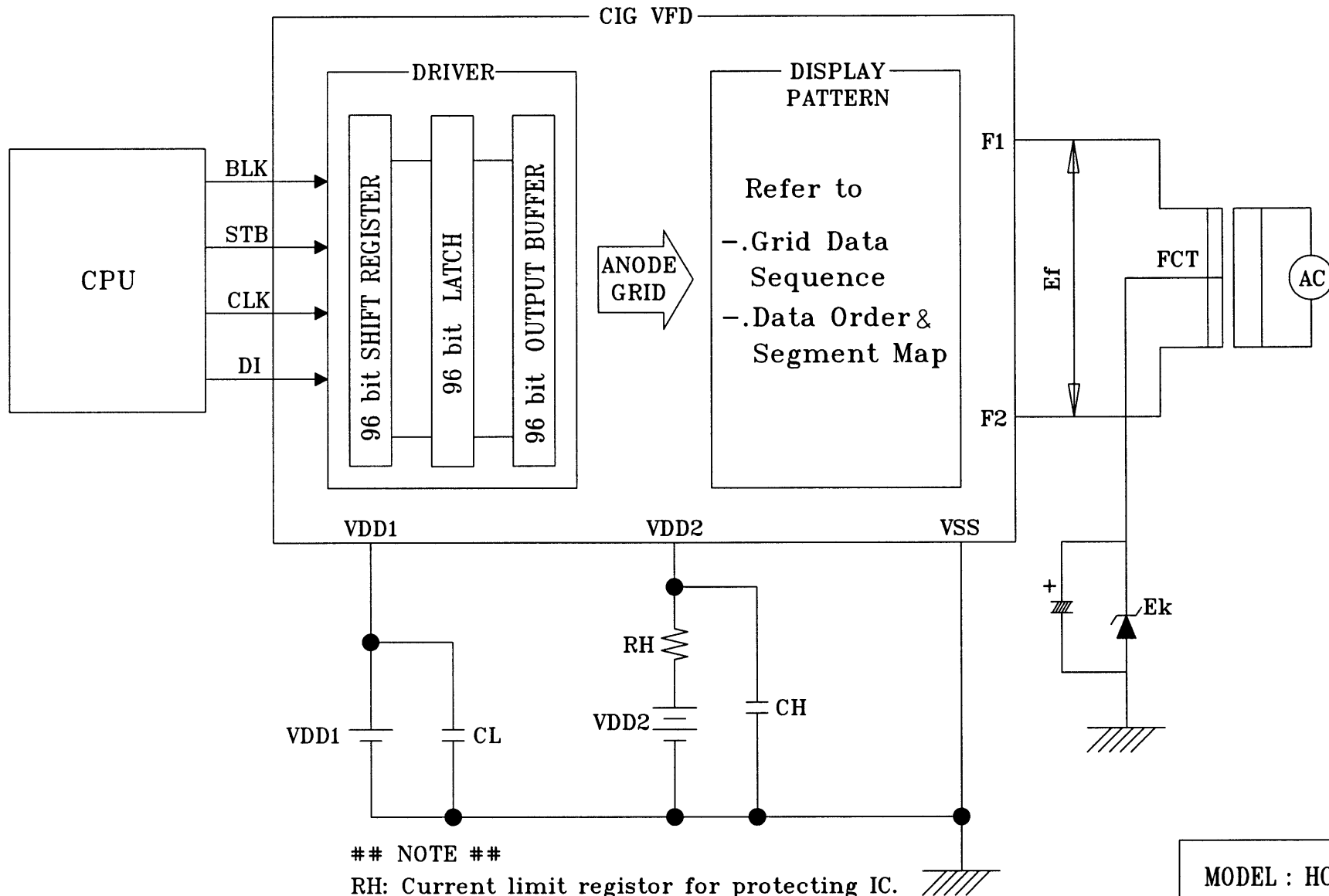

NOTE

RH: Current limit resistor for protecting IC.

CH,CL: Low pass filter for noise filtering.

RH: 22Ω, CH: 0.1 μF, CL: 0.1 μF

FCT: Filament is center-tab grounded.

MODEL : HCA-18ML01
 BLOCK DIAGRAM
 Rev. ① 20-Feb-2003

OUTER DIMENSIONS

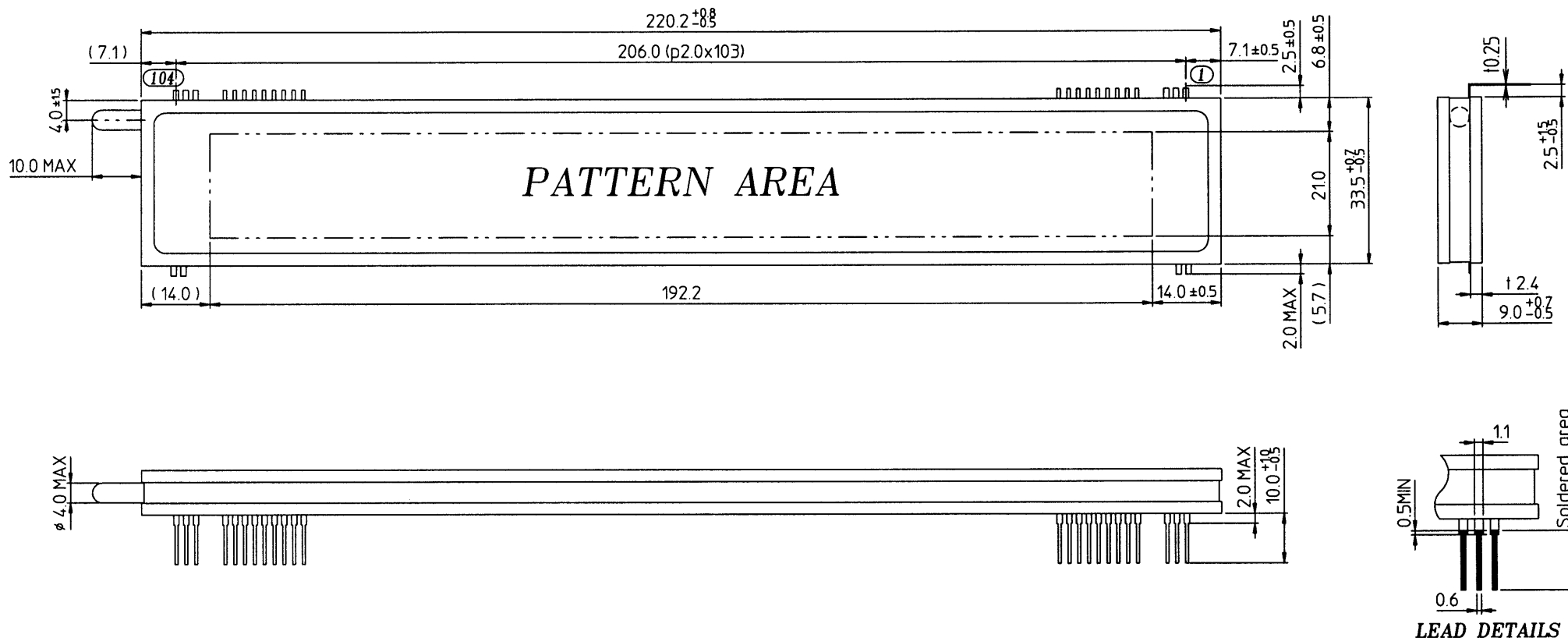

PIN CONNECTION

PIN NO.	104	103	102	101	100	99	98	97	96	95	94	93	92	91	90~15	14~6	5	4	3	2	1
CONNECTION	F2	F2	F2	NP	NP	VDD2	VSS	VSS	CLK	D0	DI	BLK	STB	VDD1	NP	NC	NP	NP	F1	F1	F1

***Notes**

Fn : Filament Pin

* D0(Serial data output) : Be left open if not used.

NP : No Pin

NC : No Connection Pin

MODEL : HCA-18ML01
 OUTER DIMENSIONS
 Rev. ① 20-Feb-2003

HCF4053B FUNCTION DIAGRAM & PIN DESCRIPTION

INPUT EQUIVALENT CIRCUIT

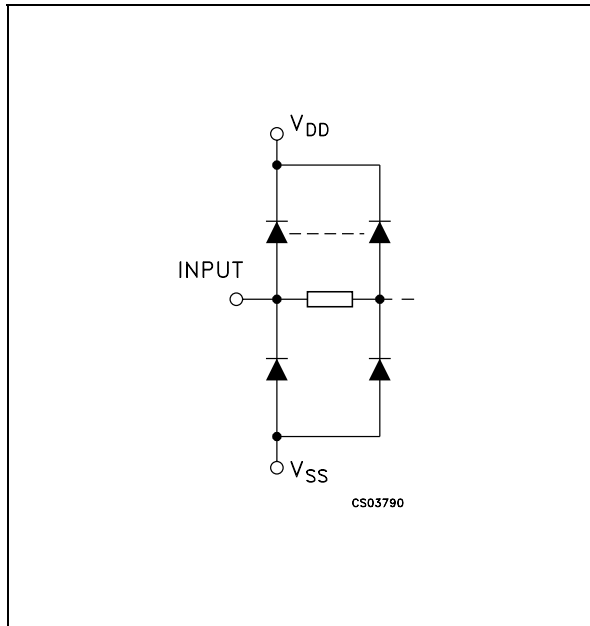

PIN DESCRIPTION (IC44,45,51,80,89)

PIN No	SYMBOL	NAME AND FUNCTION
11, 10, 9	A, B, C	Binary Control Inputs
6	INH	Inhibit Inputs
12, 13, 2, 1, 5, 3	IN/OUT	ax,ay,bx,by,cx,cy Input/Output
14	OUT/IN	ax or ay
15	OUT/IN	bx or by
4	OUT/IN	cx or cy
7	V _{EE}	Supply Voltage
8	V _{SS}	Negative Supply Voltage
16	V _{DD}	Positive Supply Voltage

TRUTH TABLE

INHIBIT	C or B or A	
0	0	ax or bx or cx
0	1	ay or by or cy
1	X	NONE

X : Don't Care

FUNCTIONAL DIAGRAM (IC44,45,51,80,89)

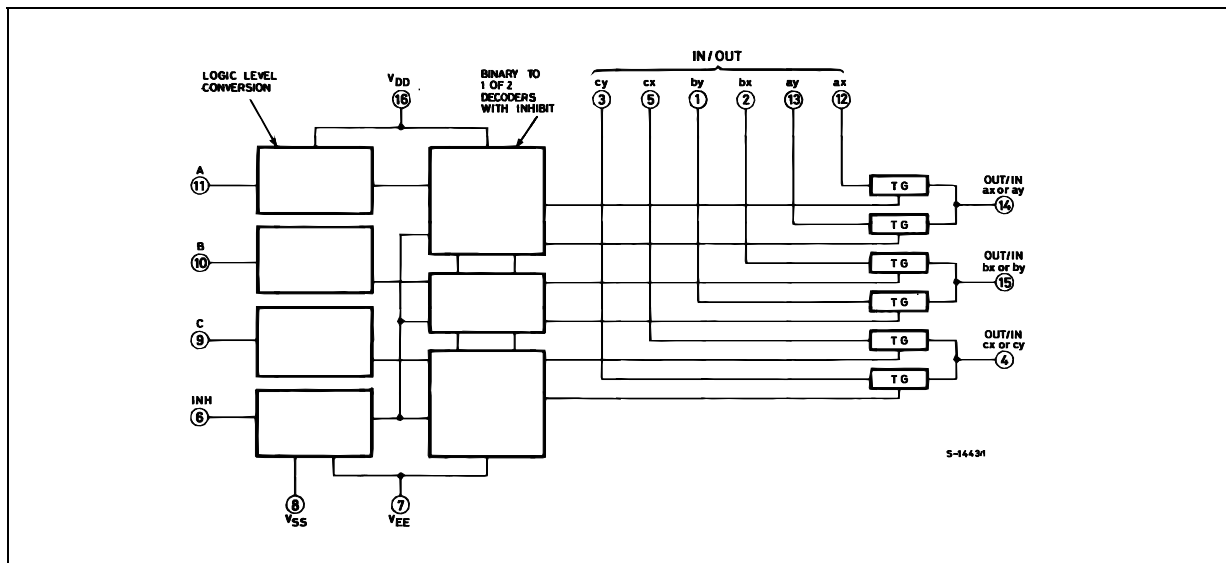

O.S.D IC (74763M)

Pin Functions (IC51)

Pin No.	Symbol	Function	Description
1	V _{SS}	Ground	Ground connection
2	Xtal _{IN1}	Crystal oscillator connection	Connection for the crystal and capacitor used to form the crystal oscillator that generates the internal synchronization signal. The oscillator can be selected with a command switch.
3	Xtal _{OUT1}		
4	HSYNC _{OUT}	Horizontal synchronization output	Outputs the horizontal synchronization signal (AFC). The output polarity can be selected (metal option). Also functions as general output port (command switch).
5	Xtal _{IN2}	Crystal oscillator connection	Connection for the crystal and capacitor used to form the crystal oscillator that generates the internal synchronization signal.
6	Xtal _{OUT2}		
7	VSYNC _{OUT}	Vertical synchronization output	Outputs the vertical synchronization signal. The output polarity can be selected (metal option). Also functions as general output port (command switch).
8	\overline{CS}	Enable input	Enables/disables serial data input. Serial data is enabled when this pin is low (hysteresis input). Pull-up resistor built in (metal option).
9	SIN	Data input	Serial data input (hysteresis input). Pull-up resistor built in (metal option).
10	SCLK	Clock input	Clock input for serial data input (hysteresis input). Pull-up resistor built in (metal option).
11	SECAM	SECAM mode switch input/output (command switch)	During input, switches between SECAM and other modes. During output, functions as general output port or internal V output (command switch). Low = other modes, high = SECAM mode
12	$\overline{525/625}$	525/625 switch input/output (command switch)	During input, switches between 525 scan lines and 625 scan lines. During output, functions as general output port or character data output (command switch). Low = 525 lines, high = 625 lines
13	$\overline{NTSC/PAL}$	NTSC/PAL switch input/output (command switch)	Switches the color mode between NTSC and PAL. During output, functions as general output port or frame data output (command switch). Low = NTSC, high = PAL
14	$\overline{3.58/4.43}$	3.58/4.43 switch input/output (command switch)	Switch FSC between 3.58 MHz and 4.43 MHz. During output, functions as general output port or halftone output (command switch). Low = 3.58, high = 4.43
15	\overline{RST}	Reset input	System reset input pin, low is active (hysteresis input). Pull-up resistor built in (metal option).
16	CV _{OUT}	Video signal output	Composite video output
17	V _{DD2}	Power supply connection	Power supply connection for composite video signal level generation
18	CV _{IN}	Video signal input	Composite video input
19	CV _{CR}	Video signal input	SECAM chroma signal input
20	SYNC _{IN}	Sync separator circuit input	Built-in sync separator circuit video signal input
21	SEP _C	Sync separator circuit	Built-in sync separator circuit
22	V _{SS}	Ground	Ground connection
23	PD _{OUT}	Control voltage output	AFC control voltage output
24	AMP _{IN}	AFC filter connection	Filter connection
25	AMP _{OUT}		
26	FC	Control voltage input	AFC control voltage input
27	VCO _{IN}	LC oscillator connection	VCO LC oscillator circuit coil and capacitor connection
28	VCO _{OUT}		
29	SYNC _{DET}	External synchronization signal detection output	Outputs the exclusive NOR of the horizontal synchronization signal (AFC) and CSYNC (sync separator). The output polarity can be selected (metal option). Also functions as general output port (command switch).
30	V _{DD1}	Power supply connection	Power supply connection (+5 V: digital system power supply)

LC74763, 74763M

Pin Assignment

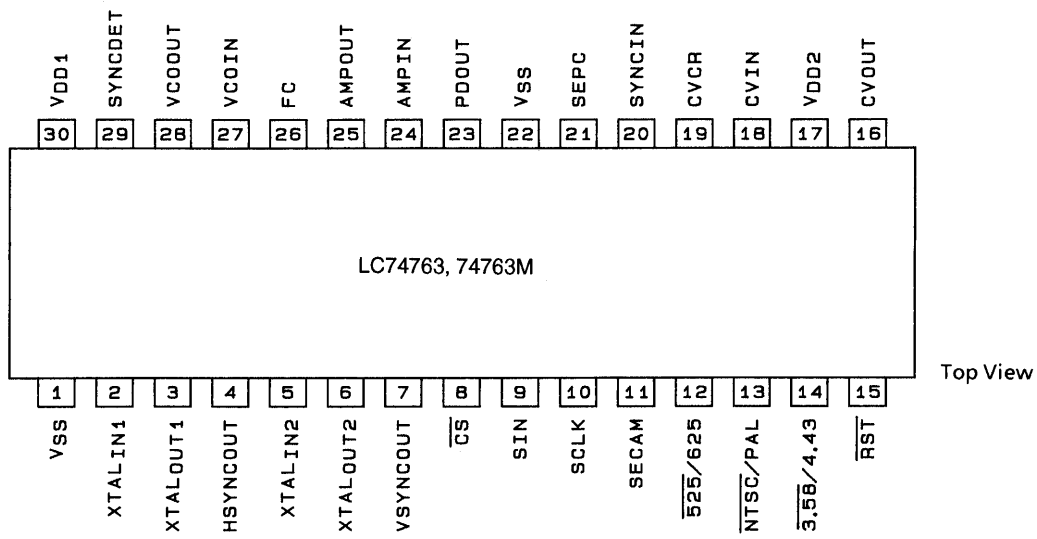

Top View

A03518

Top view

Serial Data Input Timing

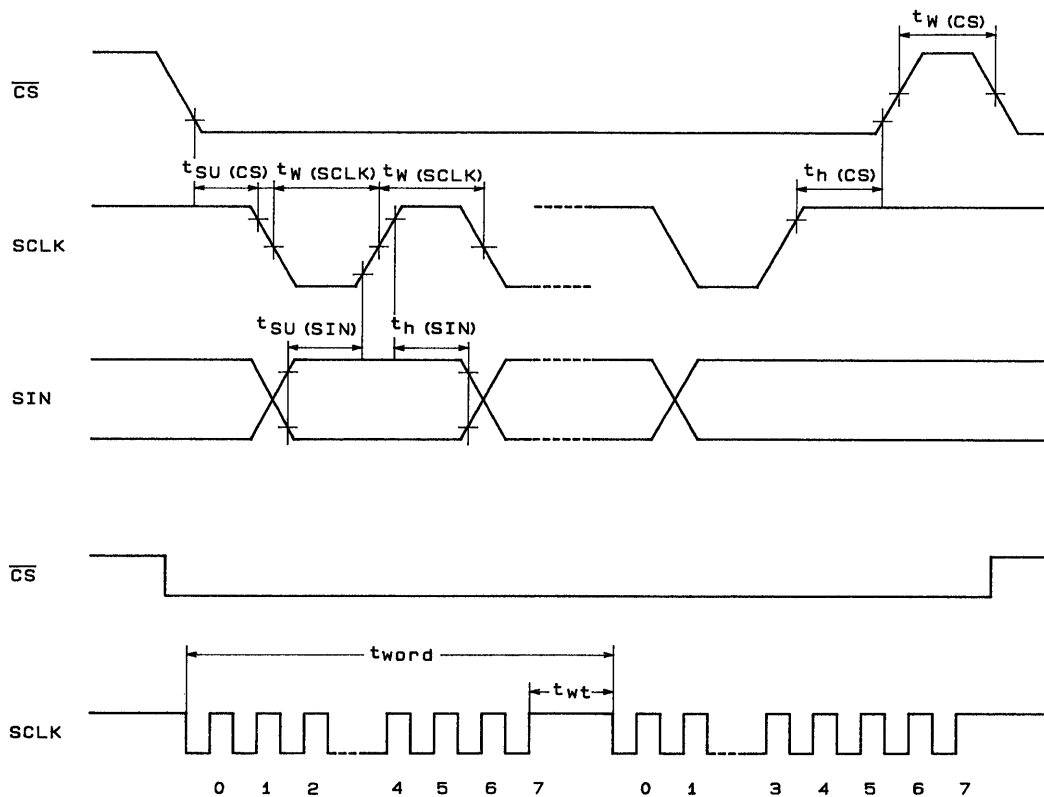

A03519

LC74763, 74763M

System Block Diagram

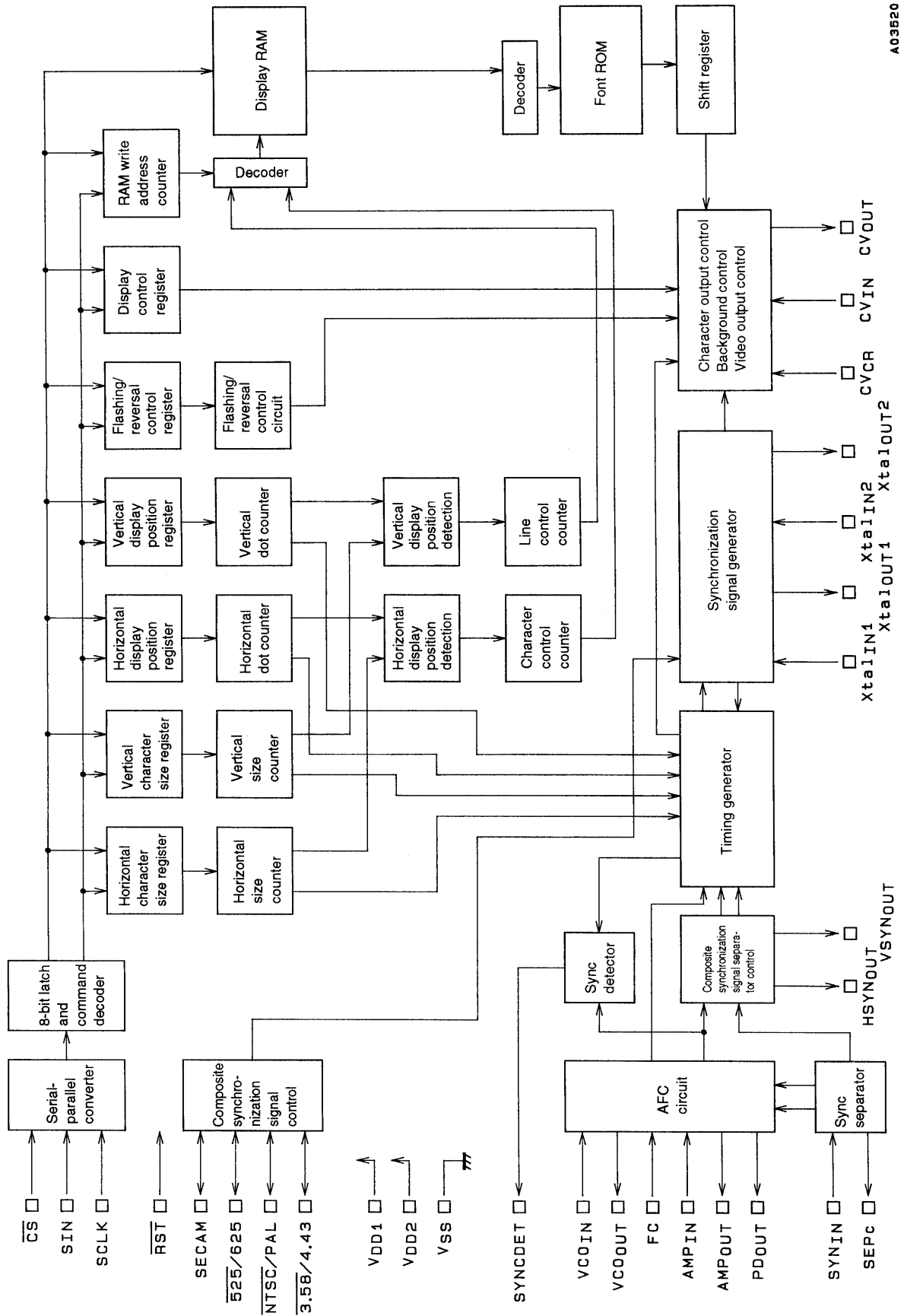

A03520

U-COM IC PIN ASSIGNMENT & DESCRIPTIONS

■ PIN ASSIGNMENT (IC72)

(TOP VIEW)

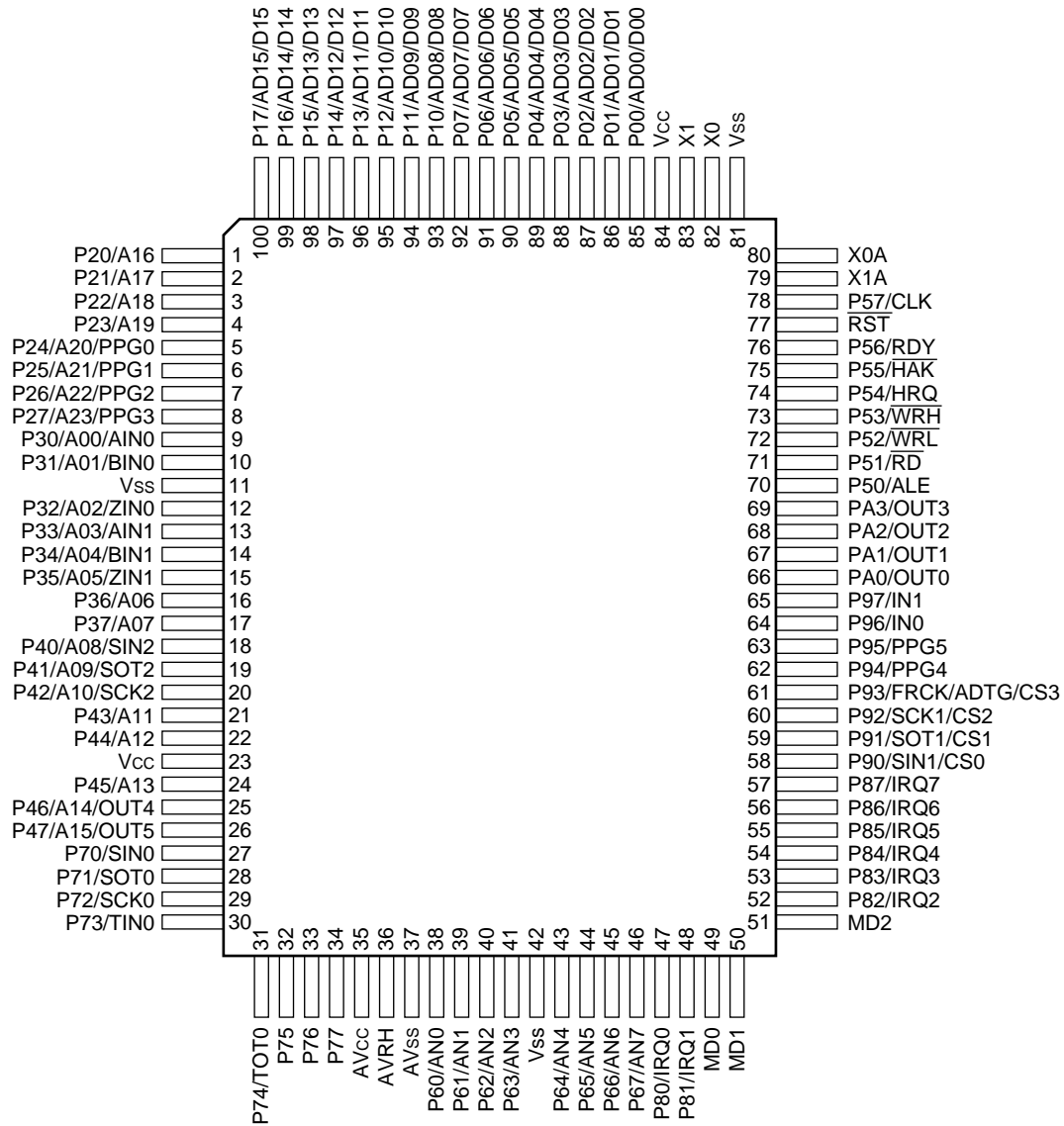

(FPT-100P-M06)

MB90482

■ PIN DESCRIPTIONS (IC72)

Pin No.		Pin name	Circuit type	Function
LQFP*1	QFP*2			
80	82	X0	A	Oscillator pin
81	83	X1	A	Oscillator pin
78	80	X0A	A	32 kHz oscillator pin
77	79	X1A	A	32 kHz oscillator pin
75	77	\overline{RST}	B	Reset input pin
83 to 90	85 to 92	P00 to P07	C (CMOS)	This is a general purpose I/O port. A setting in the pull-up resistance setting register (RDR0) can be used to apply pull-up resistance (RD00-RD07 = "1") . (Disabled when pin is set for output.)
		AD00 to AD07		In multiplex mode, these pins function as the external address/ data bus low I/O pins.
		D00 to D07		In non-multiplex mode, these pins function as the external data bus low output pins.
91 to 98	93 to 100	P10 to P17	C (CMOS)	This is a general purpose I/O port. A setting in the pull-up resistance setting register (RDR1) can be used to apply pull-up resistance (RD10-RD17 = "1") . (Disabled when pin is set for output.)
		AD08 to AD15		In multiplex mode, these pins function as the external address/ data bus high I/O pins.
		D08 to D15		In non-multiplex mode, these pins function as the external data bus high output pins.
99, 100, 1,2	1 to 4	P20 to P23	E (CMOS/H)	This is a general purpose I/O port. When the bits of external address output control register (HACR) are set to "1" in external bus mode, these pins function as general purpose I/O ports.
		A16 to A19		When the bits of external address output control register (HACR) are set to "0" in multiplex mode, these pins function as address high output pins (A16-A19).
		A16 to A19		When the bits of external address output control register (HACR) are set to "0" in non-multiplex mode, these pins function as address high output pins (A16-A19).
3 to 6	5 to 8	P24 to P27	E (CMOS/H)	This is a general purpose I/O port. When the bits of external address output control register (HACR) are set to "1" in external bus mode, these pins function as general purpose I/O ports.
		A20 to A23		When the bits of external address output control register (HACR) are set to "0" in multiplex mode, these pins function as address high output pins (A20-A23).
		A20 to A23		When the bits of external address output control register (HACR) are set to "0" in non-multiplex mode, these pins function as address high output pins (A20-A23).
		PPG0 to PPG3		PPG timer output pins.

(Continued)

MB90482

Pin No.		Pin name	Circuit type	Function
LQFP*1	QFP*2			
7	9	P30	E (CMOS/H)	This is a general purpose I/O port.
		A00		In non-multiplex mode, this pin functions as an external address pin.
		AIN0		8/16-bit up/down timer input pin (channel 0) .
8	10	P31	E (CMOS/H)	This is a general purpose I/O port.
		A01		In non-multiplex mode, this pin functions as an external address pin.
		BIN0		8/16-bit up/down counter input pin (channel0) .
10	12	P32	E (CMOS/H)	This is a general purpose I/O port.
		A02		In non-multiplex mode, this pin functions as an external address pin.
		ZIN0		8/16-bit up/down counter input pin (channel 0)
11	13	P33	E (CMOS/H)	This is a general purpose I/O port.
		A03		In non-multiplex mode, this pin functions as an external address pin.
		AIN1		8/16-bit up/down counter input pin (channel 1) .
12	14	P34	E (CMOS/H)	This is a general purpose I/O port.
		A04		In non-multiplex mode, this pin functions as an external address pin.
		BIN1		8/16-bit up/down counter input pin (channel 1) .
13	15	P35	E (CMOS/H)	This is a general purpose I/O port.
		A05		In non-multiplex mode, this pin functions as an external address pin.
		ZIN1		8/16-bit up/down counter input pin (channel 1)
14 15	16 17	P36, P37 A06, A07	D*3 (CMOS)	This is a general purpose I/O port. In non-multiplex mode, this pin functions as an external address pin.
16	18	P40	G (CMOS/H)	This is a general purpose I/O port.
		A08		In non-multiplex mode, this pin functions as an external address pin.
		SIN2		Simple serial I/O input pin.
17	19	P41	F (CMOS)	This is a general purpose I/O port.
		A09		In non-multiplex mode, this pin functions as an external address pin.
		SOT2		Simple serial I/O output pin.
18	20	P42	G (CMOS/H)	This is a general purpose I/O port.
		A10		In non-multiplex mode, this pin functions as an external address pin.
		SCK2		Simple serial I/O clock input/output pin.

(Continued)

MB90482

Pin No.		Pin name	Circuit type	Function
LQFP*1	QFP*2			
19 20	21 22	P43, P44	F (CMOS)	This is a general purpose I/O port.
		A11, A12		In non-multiplex mode, this pin functions as an external address pin.
22	24	P45	F*4 (CMOS)	This is a general purpose I/O port.
		A13		In non-multiplex mode, this pin functions as an external address pin.
23 24	25 26	P46, P47	F (CMOS)	This is a general purpose I/O port.
		A14, A15		In non-multiplex mode, this pin functions as an external address pin.
		OUT4/OUT5		Output compare event output pins.
68	70	P50	D (CMOS)	This is a general purpose I/O port. In external bus mode, this pin functions as the ALE pin.
		ALE		In external bus mode, this pin functions as the address load enable (ALE) signal pin.
69	71	P51	D (CMOS)	This is a general purpose I/O port. In external bus mode, this pin functions as the \overline{RD} pin.
		\overline{RD}		In external bus mode, this pin functions as the read strobe output (\overline{RD}) signal pin.
70	72	P52	D (CMOS)	This is a general purpose I/O port. In external bus mode, when the WRE pin in the EPCR register is set to "1", this pin functions as the \overline{WRL} pin.
		\overline{WRL}		In external bus mode, this pin functions as the lower data write strobe output (\overline{WRL}) pin. When the WRE bit in the EPCR register is set to "0", this pin functions as a general purpose I/O port.
71	73	P53	D (CMOS)	This is a general purpose I/O port. In external bus mode with 16-bit bus width, when the WRE bit in the EPCR register is set to "1", this pin functions as the \overline{WRH} pin.
		\overline{WRH}		In external bus mode with 16-bit bus width, this pin functions as the upper data write strobe output (\overline{WRH}) pin. When the WRE bit in the EPCR register is set to "0", this pin functions as a general purpose I/O port.
72	74	P54	D (CMOS)	This is a general purpose I/O port. In external bus mode, when the HDE bit in the EPCR register is set to "1", this pin functions as the HRQ pin.
		HRQ		In external bus mode, this pin functions as the hold request input (HRQ) pin. When the HDE bit in the EPCR register is set to "0", this pin functions as a general purpose I/O port.
73	75	P55	D (CMOS)	This is a general purpose I/O port. In external bus mode, when the HDE bit in the EPCR register is set to "1", this pin functions as the \overline{HAK} pin.
		\overline{HAK}		In external bus mode, this pin functions as the hold acknowledge (\overline{HAK}) pin. When the HDE bit in the EPCR register is set to "0", this pin functions as a general purpose I/O port.

(Continued)

MB90482

Pin No.		Pin name	Circuit type	Function
LQFP*1	QFP*2			
74	76	P56	D (CMOS)	This is a general purpose I/O port. In external bus mode, when the RYE bit in the EPCR register is set to "1", this pin functions as the RDY pin.
		RDY		In external bus mode, this pin functions as the external ready (RDY) input pin. When the RYE bit in the EPCR register is set to "0", this pin functions as a general purpose I/O port.
76	78	P57	D (CMOS)	This is a general purpose I/O port. In external bus mode, when the CKE bit in the EPCR register is set to "1", this pin functions as the CLK pin.
		CLK		In external bus mode, this pin functions as the machine cycle clock (CLK) output pin. When the CKE bit in the EPCR register is set to "0", this pin functions as a general purpose I/O port.
36 to 39	38 to 41	P60 to P63	H (CMOS)	These are general purpose I/O ports.
		AN0 to AN3		These are the analog input pins.
41 to 44	43 to 46	P64 to P67	H (CMOS)	These are general purpose I/O ports.
		AN4 to AN7		These are the analog input pins.
25	27	P70	G (CMOS/H)	This is a general purpose I/O port.
		SIN0		This is the UART data input pin.
26	28	P71	F (CMOS)	This is a general purpose I/O port.
		SOT0		This is the UART data output pin.
27	29	P72	G (CMOS/H)	This is a general purpose I/O port.
		SCK0		This is the UART clock I/O pin.
28	30	P73	G (CMOS/H)	This is a general purpose I/O port.
		TIN0		This is the 16-bit reload timer event input pin.
29	31	P74	F (CMOS)	This is a general purpose I/O port.
		TOT0		This is the 16-bit reload timer output pin.
30	32	P75	F*4 (CMOS)	This is a general purpose I/O port.
31	33	P76	F*5 (CMOS)	This is a general purpose I/O port.
32	34	P77	F*5 (CMOS)	This is a general purpose I/O port.
45, 46	47, 48	P80, P81	E (CMOS/H)	These are general purpose I/O ports.
		IRQ0, IRQ1		External interrupt input pins.
50 to 55	52 to 57	P82 to P87	E (CMOS/H)	These are general purpose I/O ports.
		IRQ2 to IRQ7		External interrupt input pins.

(Continued)

MB90482

(Continued)

Pin No.		Pin name	Circuit type	Function
LQFP*1	QFP*2			
56	58	P90	E (CMOS/H)	This is a general purpose I/O port.
		SIN1		Simple serial I/O data input pin.
		CS0		Chip select 0.
57	59	P91	D (CMOS)	This is a general purpose I/O port.
		SOT1		Simple serial I/O data output pin.
		CS1		Chip select 1.
58	60	P92	E (CMOS/H)	This is a general purpose I/O port.
		SCK1		Simple serial I/O data input/output pin.
		CS2		Chip select 2.
59	61	P93	E (CMOS/H)	This is a general purpose I/O port.
		FRCK		When the free run timer is in use, this pin functions as the external clock input pin.
		ADTG		When the A/D converter is in use, this pin functions as the external trigger input pin.
		CS3		Chip select 3.
60	62	P94	D (CMOS)	This is a general purpose I/O port.
		PPG4		PPG timer output pin.
61	63	P95	D (CMOS)	This is a general purpose I/O port.
		PPG5		PPG timer output pin.
62	64	P96	E (CMOS/H)	This is a general purpose I/O port.
		IN0		Input capture channel 0 trigger input pin.
63	65	P97	E (CMOS/H)	This is a general purpose I/O port.
		IN1		Input capture channel 1 trigger input pin.
64 to 67	66 to 69	PA0 to PA3	D (CMOS)	These are general purpose I/O ports.
		OUT0 to OUT3		Output compare event output pins.
33	35	AV _{cc}	—	A/D converter power supply pin.
34	36	AVRH	—	A/D converter external reference voltage supply pin.
35	37	AV _{ss}	—	A/D converter power supply pin.
47 to 49	49 to 51	MD0 to MD2	J (CMOS/H)	Operating mode selection input pins.
21, 82	23, 84	V _{cc}	—	3.3 V ± 0.3 V power supply pins (V _{cc3}) .
9, 40, 79	11, 42, 81	V _{ss}	—	Power supply input pins (GND) .

*1 : LQFP : FPT-100P-M05

*2 : QFP : FPT-100P-M06

*3 : The circuit type of MB90V480 is E (CMOS/H).

*4 : The circuit type of MB90V480 is G (CMOS/H).

*5 : The circuit type of MB90V480 is I (NMOS/H)

NJM2068M (OP - AMP)



NJM2068

LOW-NOISE DUAL OPERATIONAL AMPLIFIER

■ **GENERAL DESCRIPTION**

The NJM2068 is a high performance, low noise dual operational amplifier. This amplifier features popular pin-out, superior noise performance, and superior total harmonic distortion. This amplifier also features guaranteed noise performance with substantially higher gain-bandwidth product and slew rate which far exceeds that of the 4558 type amplifier. The specially designed low noise input transistors allow the NJM2068 to be used in very low noise signal processing applications such as audio preamplifiers and servo error amplifier.

■ **PACKAGE OUTLINE**

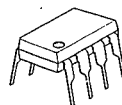

NJM2068D



NJM2068M



NJM2068V

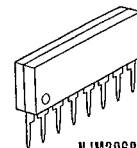

NJM2068L

■ **FEATURES**

- Operating Voltage (±4V ~ ±18V)
- Low Total Harmonic Distortion (0.001% typ.)
- Low Noise Voltage (FLAT+JISA, 0.56 μV typ.)
- High Slew Rate (6V/μs typ.)
- Unity Gain Bandwidth (27MHz @f=10kHz)
- Package Outline DIP8, DMP8, SIP8, SSOP8
- Bipolar Technology

■ **PIN CONFIGURATION**

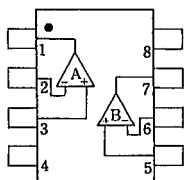

NJM2068D
NJM2068M
NJM2068V

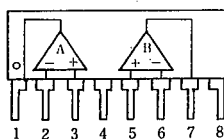

NJM2068L

PIN FUNCTION

1. A OUTPUT
2. A-INPUT
3. A+INPUT
4. V-
5. B+INPUT
6. B-INPUT
7. B OUTPUT
8. V+

■ **EQUIVALENT CIRCUIT (1/2 Shown)**

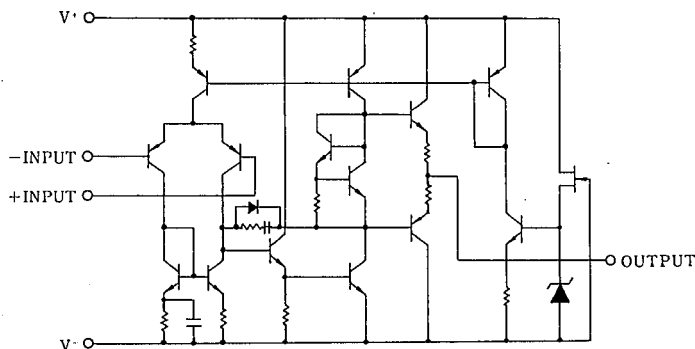

■ BLOCK DIAGAM (NJM2296M) : IC41, 42, 43

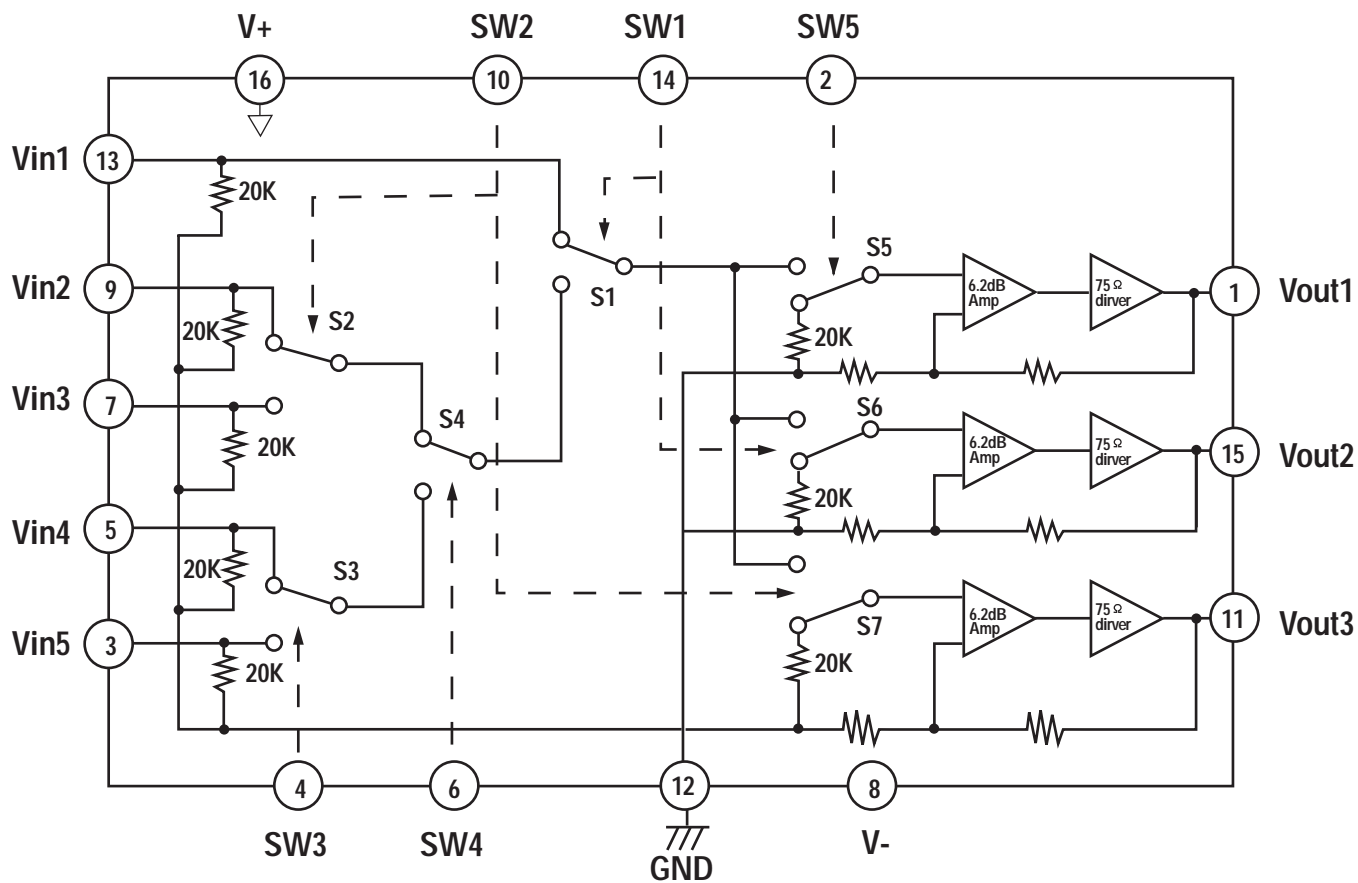

*** Normally mute**

Above circuits show that the switches are set at low.



IC86

NJM4556A

DUAL HIGH CURRENT OPERATIONAL AMPLIFIER

■ GENERAL DESCRIPTION

The NJM4556A integrated circuit is a high-gain, high output current dual operational amplifier capable of driving $\pm 70\text{mA}$ into $150\ \Omega$ loads ($\pm 10.5\text{V}$ output voltage), and operating low supply voltage ($V^+/V^- = \pm 2\text{V} \sim$).

The NJM4556A combines many of the features of the popular NJM4558 as well as having the capability of driving $150\ \Omega$ loads. In addition, the wide band-width, low noise, high slew rate and low distortion of the NJM4556A make it ideal for many audio, telecommunications and instrumentation applications.

■ FEATURES

- Operating Voltage ($\pm 2\text{V} \sim \pm 18\text{V}$)
- High Output Current ($I_o = 70\text{mA}$)
- Slew Rate ($3\text{V}/\mu\text{s}$ typ.)
- Gain Band Width Product (8MHz typ.)
- Package Outline DIP8, DMP8, SIP8, SSOP8
- Bipolar Technology

■ PACKAGE OUTLINE

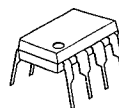

NJM4556AD



NJM4556AM

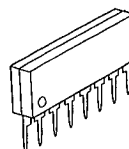

NJM4556AL



NJM4556AV

■ PIN CONFIGURATION

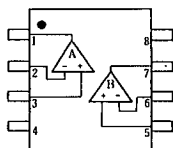

NJM4556AD
NJM4556AM
NJM4556AV

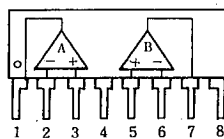

NJM4556AL

PIN FUNCTION

1. A OUTPUT
2. A-INPUT
3. A+INPUT
4. V-
5. B+INPUT
6. B-INPUT
7. B OUTPUT
8. V+

■ EQUIVALENT CIRCUIT (1/2 Shown)

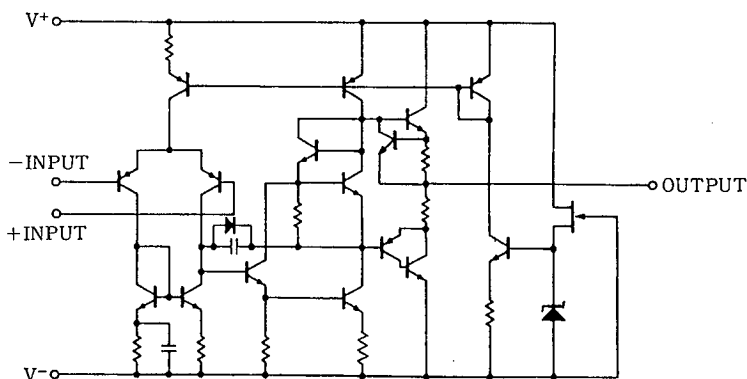

S3C84BB/F84BB

U-COM BLOCK DIAGRAM , PIN ASSIGNMENT & PIN DESCRIPTIONS

BLOCK DIAGRAM (IC74)

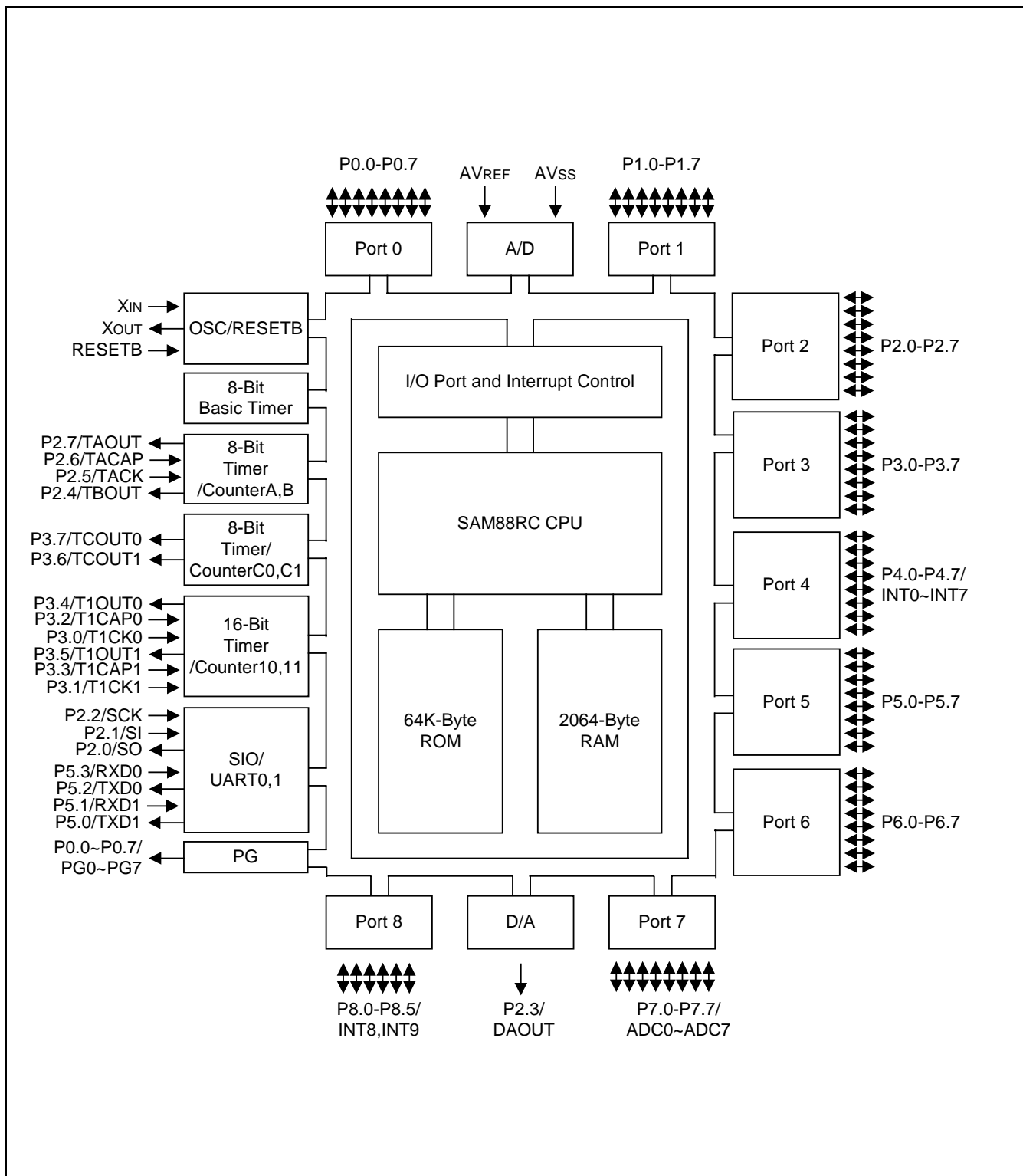

Figure 1-1. S3C84BB/F84BB Block Diagram

S3C84BB/F84BB

PRODUCT OVERVIEW

PIN ASSIGNMENT (IC74)

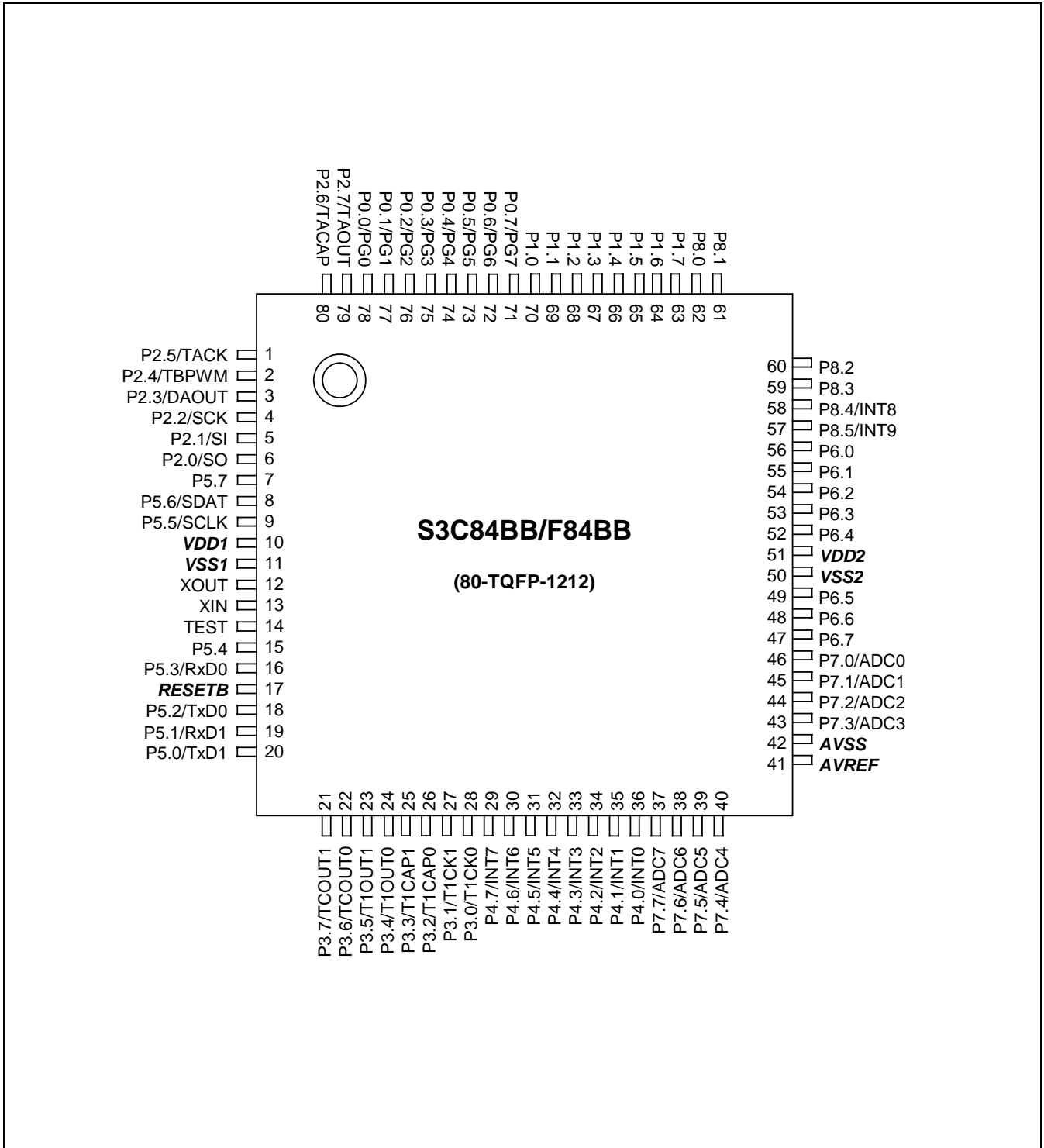

Figure 1-3. S3C84BB/F84BB Pin Assignment (80-TQFP)

PRODUCT OVERVIEW

S3C84BB/F84BB

PIN DESCRIPTIONS (IC74)

Table 1-1. S3C84BB/F84BB Pin Descriptions (80-QFP)

Pin Name	Pin Type	Pin Description	Circuit Type	Pin Number	Share Pins
P0.0 - P0.7	I/O	Bit programmable port; input or output mode selected by software; input or push-pull output. Software assignable pull-up. Alternately, P0.0-P0.7 can be used as the PG output port (PG0-PG7).	D	80-73	PG0-PG7
P1.0 - P1.7	I/O	Bit programmable port; input or output mode selected by software; input or push-pull output. Software assignable pull-up.	D	72-65	
P2.0 - P2.7	I/O	Bit programmable port; input or output mode selected by software; input or push-pull output. Software assignable pull-up. Alternately, P2.0~P2.7 can be used as I/O for TIMERA, TIMERB, D/A, SIO	D,D-2	8-1	SO SI SCK DAOUT TBPWM TACK TACAP TAOUT
P3.0 - P3.7	I/O	Bit programmable port; input or output mode selected by software; input or push-pull output. Software assignable pull-up. Alternately, P3.0~P3.7 can be used as I/O for TIMERC0/C1, TIMER10/11	D	30-23	T1CK0 T1CK1 T1CAP0 T1CAP1 T1OUT0 T1OUT1 TCOUT0 TCOUT1

S3C84BB/F84BB

PRODUCT OVERVIEW

Table 1-1. S3C84BB/F84BB Pin Descriptions (80-QFP) (Continued)

Pin Name	Pin Type	Pin Description	Circuit Type	Pin Number	Share Pins
P4.0 - P4.7	I/O	Bit programmable port; input or output mode selected by software; input or push-pull output. Software assignable pull-up. P4.0-P4.7 can alternately be used as inputs for external interrupts INT0-INT7, respectively (with noise filters and interrupt controller)	D-1	38-31	INT0-INT7
P5.0 - P5.7	I/O	Bit programmable port; input or output mode selected by software; input or push-pull output. Software assignable pull-up. Alternately, P5.0~P5.3 can be used as I/O for serial por, UART0, UART1, respectively.	G	22-17,11-9	TxD1 RxD1 TxD0 RxD0
P6.0 - P6.7	O	N-channel, open-drain output only port.	F	58-54,51-49	
P7.0 - P7.7	I	General-purpose digital input ports. Alternatively used as analog input pins for A/D converter modules.	E	48-45,42-39	ADC0-ADC7
P8.0 - P8.5	I/O	Bit programmable port; input or output mode selected by software; input or push-pull output. Software assignable pull-up. P8.4, P8.5 can alternately be used as inputs for external interrupts INT8, INT9, respectively (with noise filters and interrupt controller)	D,D-1	64-59	INT8,INT9

PRODUCT OVERVIEW

S3C84BB/F84BB

Table 1-1. S3C84BB/F84BB Pin Descriptions (80-QFP) (Continued)

Pin Name	Pin Type	Pin Description	Circuit Type	Pin Number	Share Pins
AD0 - AD7	I	Analog input pins for A/D converter module. Alternatively used as general-purpose digital input port 7.	E	48–45 42–39	P7.0–P7.7
AVREF, AVSS	-	A/D converter reference voltage and ground	-	43, 44	-
RxD0, RxD1	I/O	Serial data RxD pin for receive input and transmit output (mode 0)	D	18, 21	P5.3, P5.1
TxD0, TxD1	O	Serial data TxD pin for transmit output and shift clock input (mode 0)	D	20, 22	P5.2, P5.0
TACK	I	External clock input pins for timer A	D	3	P2.5
TACAP	I	Capture input pins for timer A	D	2	P2.6
TAOUT	O	Pulse width modulation output pins for timer A	D	1	P2.7
TBPWM	O	Carrier frequency output pins for timer B	D	4	P2.4
TCOUT0 TCOUT1	O	Timer C 8-bit PWM mode output or counter match toggle output pins	D	24,23	P3.6,P3.7
T1CK0 T1CK1	I	External clock input pins for timer 1	D	39,30	P3.0,P3.1
T1CAP0 T1CAP1	I	Capture input pins for timer 1	D	28,27	P3.2,P3.3
T1OUT0 T1OUT1	O	Timer 1 16-bit PWM mode output or counter match toggle output pins	D	26,25	P3.4,P3.5
SI,SO,SCK	I/O	Synchronous SIO pins	D	7,8,9	P2.1,P2.0, P2.2
RESETB	I	System reset pin (pull-up resistor: 240 k Ω)	B	19	-
TEST	I	Pull – down register connected internally	-	16	-
VDD1, VDD2, VSS1, VSS2	-	Power input pins	-	12,53, 13,52	-
XIN, XOUT	-	Main oscillator pins	-	15,14	-

TC9162AF (FUNCTION/INPUT : IC30)

■ BLOCK DIAGRAM

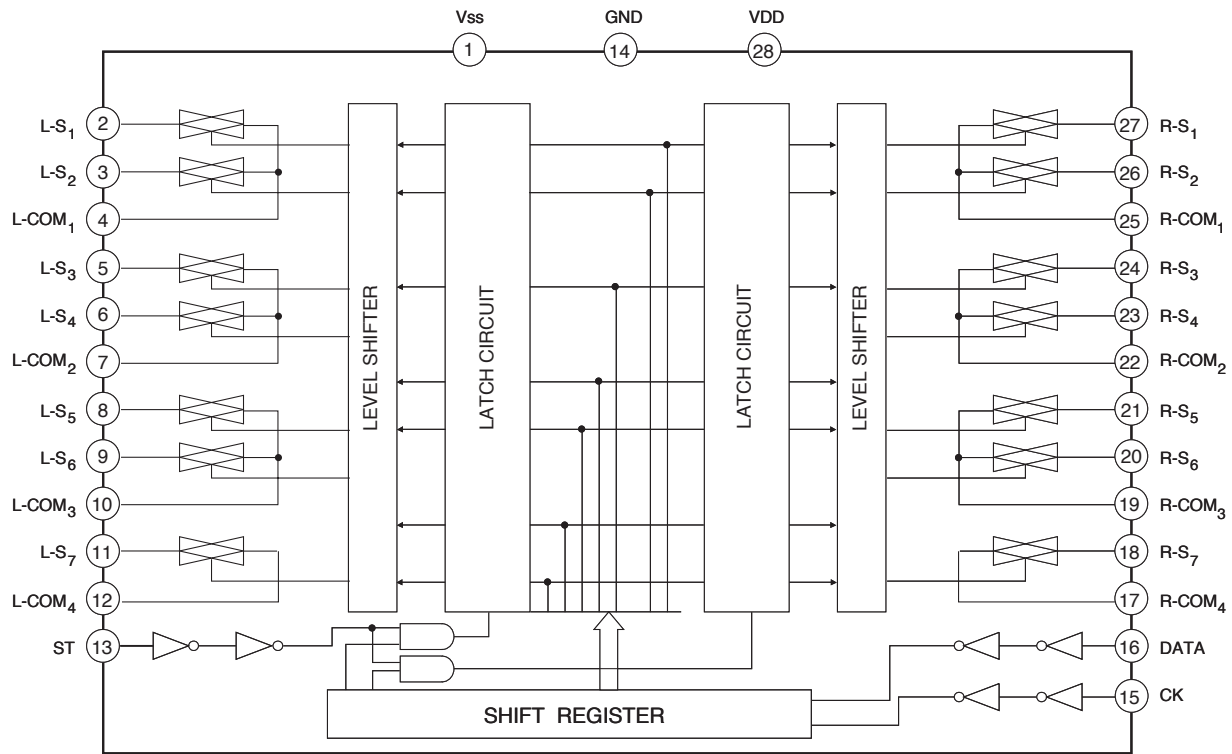

TC9164AF (FUNCTION/INPUT) : IC23

■ BLOCK DIAGRAM

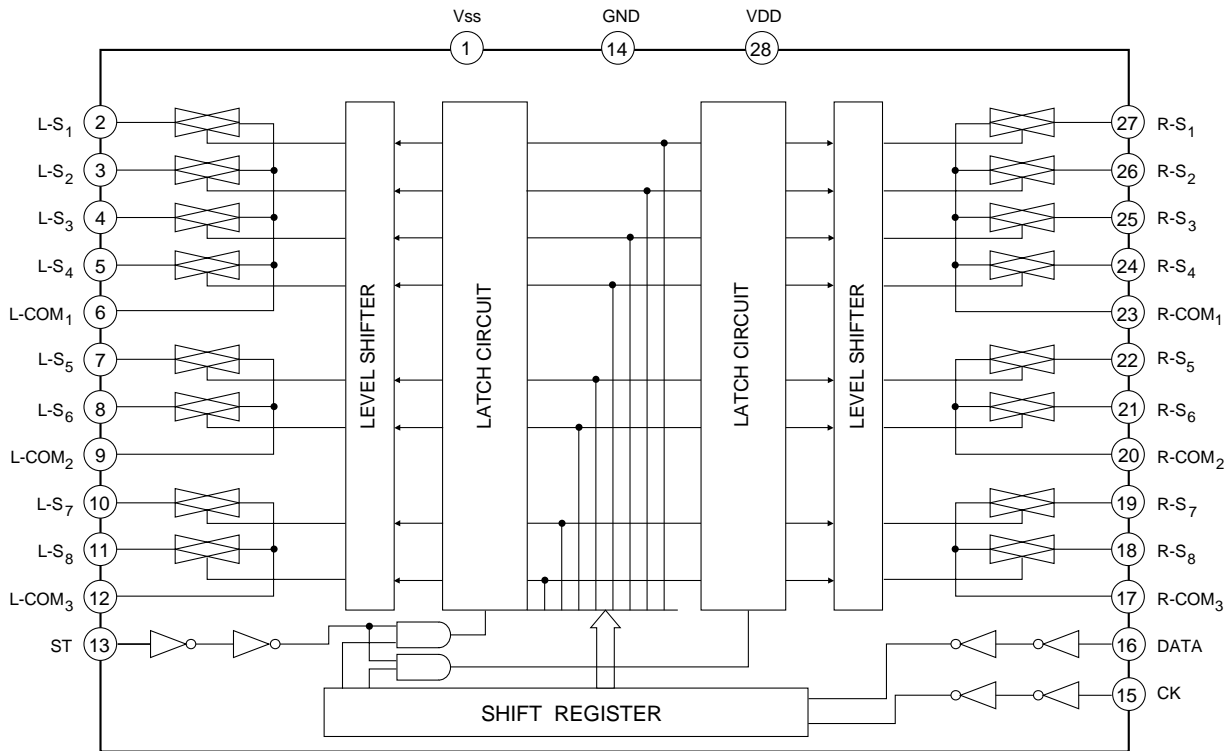

TC9163AF (FUNCTION/INPUT) : IC21,24

■ BLOCK DIAGRAM

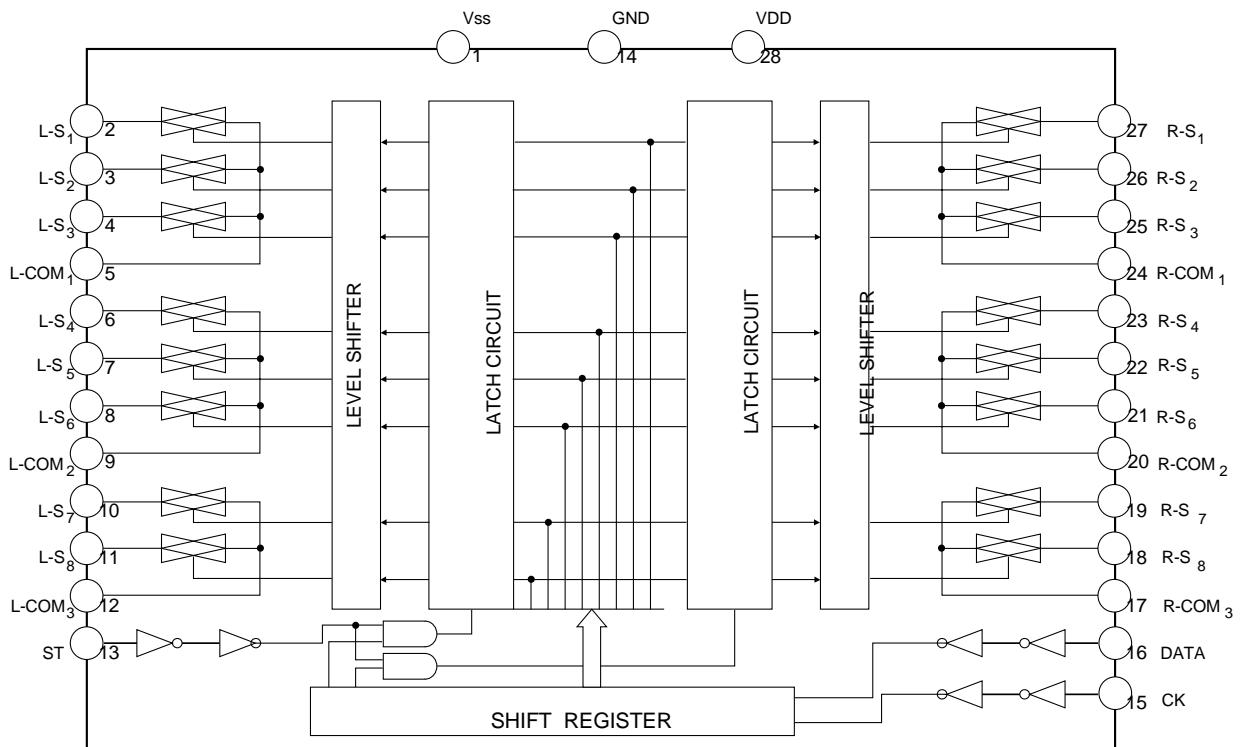

TOSHIBA

TC9459N/F

ELECTRONIC VOLUME CONTROL IC (IC40~44)

BLOCK DIAGRAM (TC9459F)

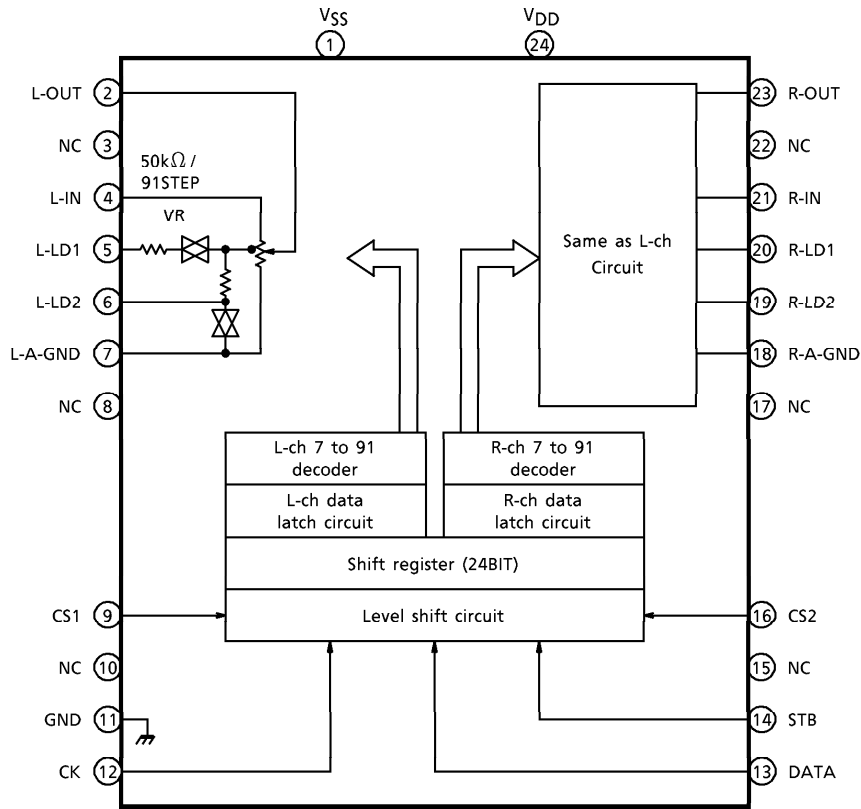

TOSHIBA

TC9459N/F

PIN DESCRIPTION

Numeral in () means the pin No. of TC9459F.

PIN No.	SYMBOL	PIN NAME	FUNCTION	REMARK										
1 (1)	V _{SS}	Negative power supply pin	When using dual power supplies $V_{DD} = 6.0 \sim 17V$ $GND = 0V$ $V_{SS} = -6.0 \sim -17V$ When using a single power supply $V_{DD} = 6.0 \sim 18V$ $GND = V_{SS} = 0V$	—										
28 (24)	V _{DD}	Positive power supply pin												
13 (11)	GND	Digital GND pin												
3 (2)	L-OUT	Volume output pin	• Volume circuit 	—										
26 (23)	R-OUT													
5 (4)	L-IN	Volume input pin												
24 (21)	R-IN													
6 (5)	L-LD1	Loudness tap output pin			<table border="1"> <tr> <td></td> <td>LA1</td> <td>LA2</td> </tr> <tr> <td>LOUDNESS "ON"</td> <td>ON</td> <td>OFF</td> </tr> <tr> <td>LOUDNESS "OFF"</td> <td>OFF</td> <td>ON</td> </tr> </table>		LA1	LA2	LOUDNESS "ON"	ON	OFF	LOUDNESS "OFF"	OFF	ON
	LA1					LA2								
LOUDNESS "ON"	ON					OFF								
LOUDNESS "OFF"	OFF					ON								
23 (20)	R-LD1													
7 (6)	L-LD2													
22 (19)	R-LD2													
8 (7)	L-A-GND	Analog GND pin												
21 (18)	R-A-GND													
10 (9)	CS1	Chip select input pin	Up to 4 chips on the same bus can be used by switching over chip select code.	—										
19 (16)	CS2													
14 (12)	CK	Clock input pin	Data transfer clock input	Low threshold value input pin										
15 (13)	DATA	Data input pin	Volume setup serial data input											
16 (14)	STB	Strobe input pin	Data write strobe input											
2 (3)	NC	No connection	—	—										
27 (22)														
4														
25														
9 (8)														
20 (17)														
11														
18														
12 (10)														
17 (15)														

RICOH

VOLTAGE DETECTOR

R×5VL SERIES

R×5VT SERIES

R×5VL

PIN CONFIGURATION

• TO-92

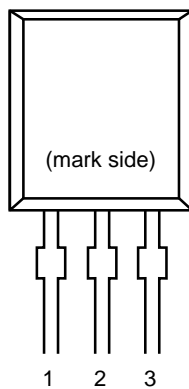

• SOT-89

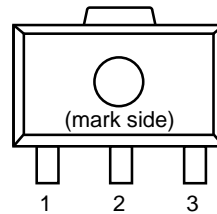

• SOT-23-5

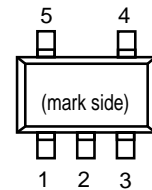

PIN DESCRIPTION

• TO-92

Pin No	Symbol
1	OUT
2	VDD
3	GND

• SOT-89

Pin No	Symbol
1	OUT
2	VDD
3	GND

• SOT-23-5

Pin No	Symbol
1	OUT
2	VDD
3	GND
4	NC
5	NC



NJM2581

DUAL SUPPLY WIDE BAND 3ch VIDEO AMPLIFIER

■ GENERAL DESCRIPTION

The **NJM2581** is a dual supply voltage wide band 3ch video amplifier. It is suitable for Y, Pb, and Pr signal because frequency range is 50MHz.

The **NJM2581** is suitable for Set Top Box, AV amplifier, and other high quality AV systems.

■ PACKAGE OUTLINE

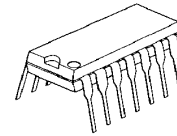

NJM2581D

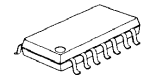

NJM2581M







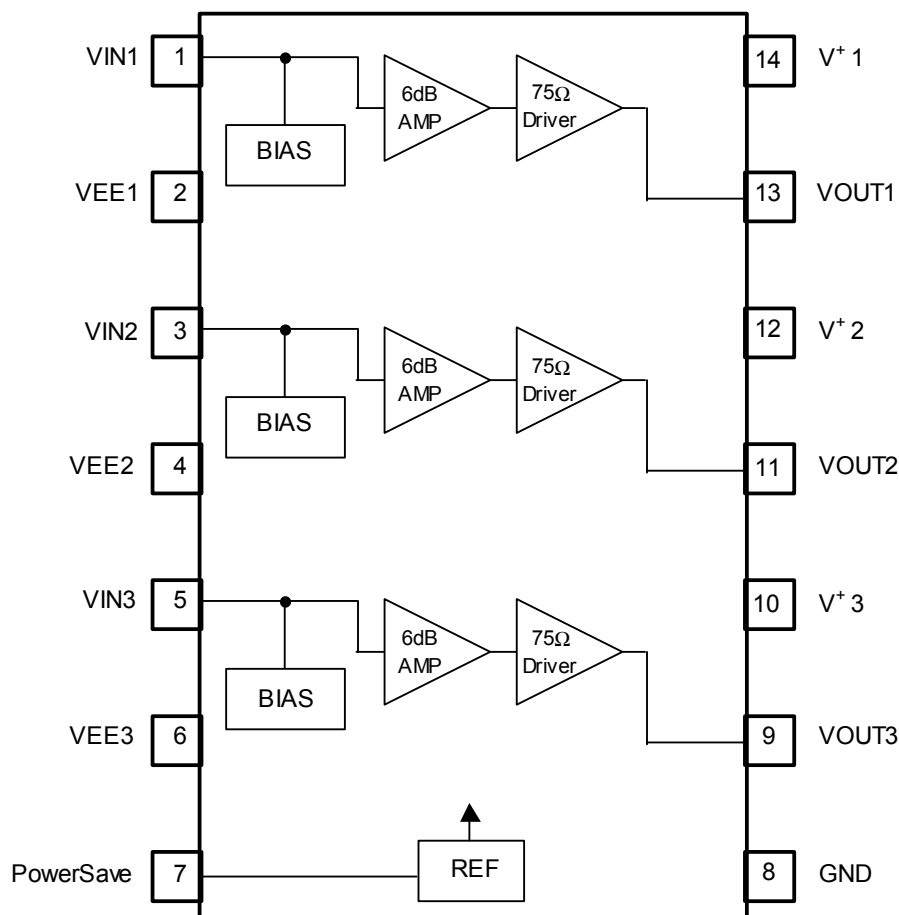

■ FEATURES

- Operating Voltage ± 4.5 to ± 5.5 V
- Wide frequency range 50MHz at 0dB typ.
- Internal 6dB Amplifier
- Internal 75Ω Driver Circuit (2-system drive)
- Power Save Circuit
- Bipolar Technology
- Package Outline DIP14, DMP14

■ BLOCK DIAGRAM



TRANSISTOR, REGULATOR IC BLOCK DIAGRAM

<p>TO-92M</p>  <p>1. Emitter 2. Collector 3. Base</p> <p>123</p> <p>KTC2874B KSC2785Y KRA107M KRC107M</p>	<p>TO-92</p>  <p>1. Emitter 2. Collector 3. Base</p> <p>123</p> <p>KTD1302T KTA1268GR KTC3200GR KTC3198Y KTA1271Y</p>	<p>TO-220</p>  <p>1. GND 2. INPUT 3. OUTPUT</p> <p>123</p> <p>MCNJM7905 MC7915C</p>	<p>TO-92L</p>  <p>1. Emitter 2. Collector 3. Base</p> <p>123</p> <p>KTA1024Y KSC2316Y</p>
<p>TO-126</p>  <p>1. Emitter 2. Collector 3. Base</p> <p>123</p> <p>2SA1360O 2SC3423O KTD600KG</p>	<p>TO-220</p>  <p>1. Base 2. Collector 3. Emitter</p> <p>123</p> <p>KSA614Y</p>	<p>TO-220</p>  <p>1. INPUT 2. GND 3. OUTPUT</p> <p>123</p> <p>MC7815C MC7805C</p>	<p>TO-3P</p>  <p>1. Base 2. Collector 3. Emitter</p> <p>1 2 3</p> <p>2SB1560 2SD2390</p>

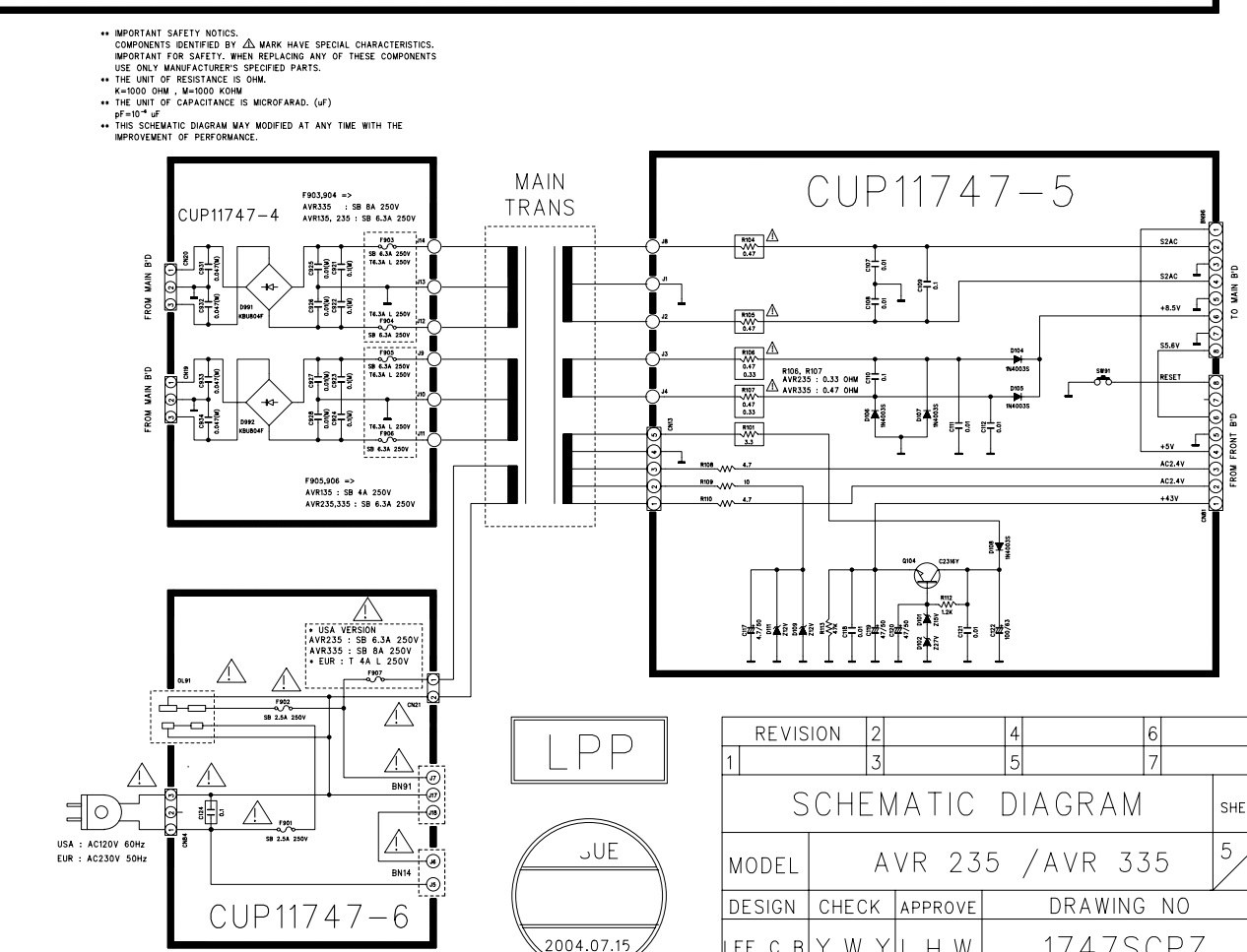
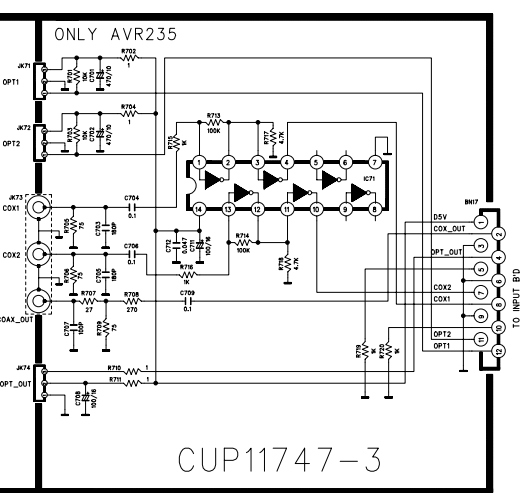
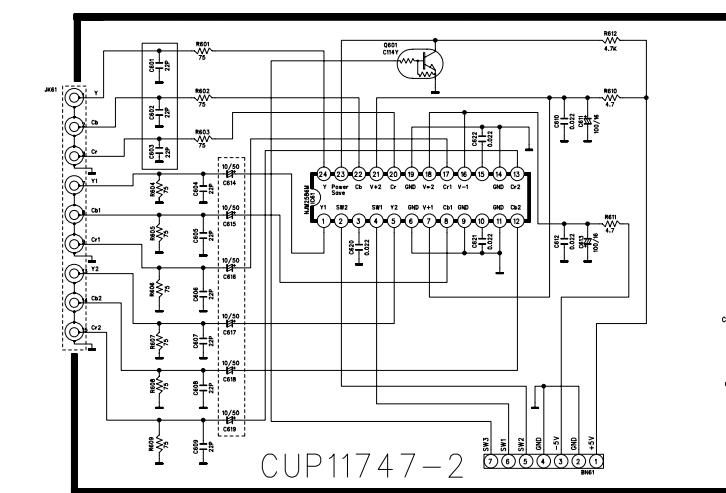
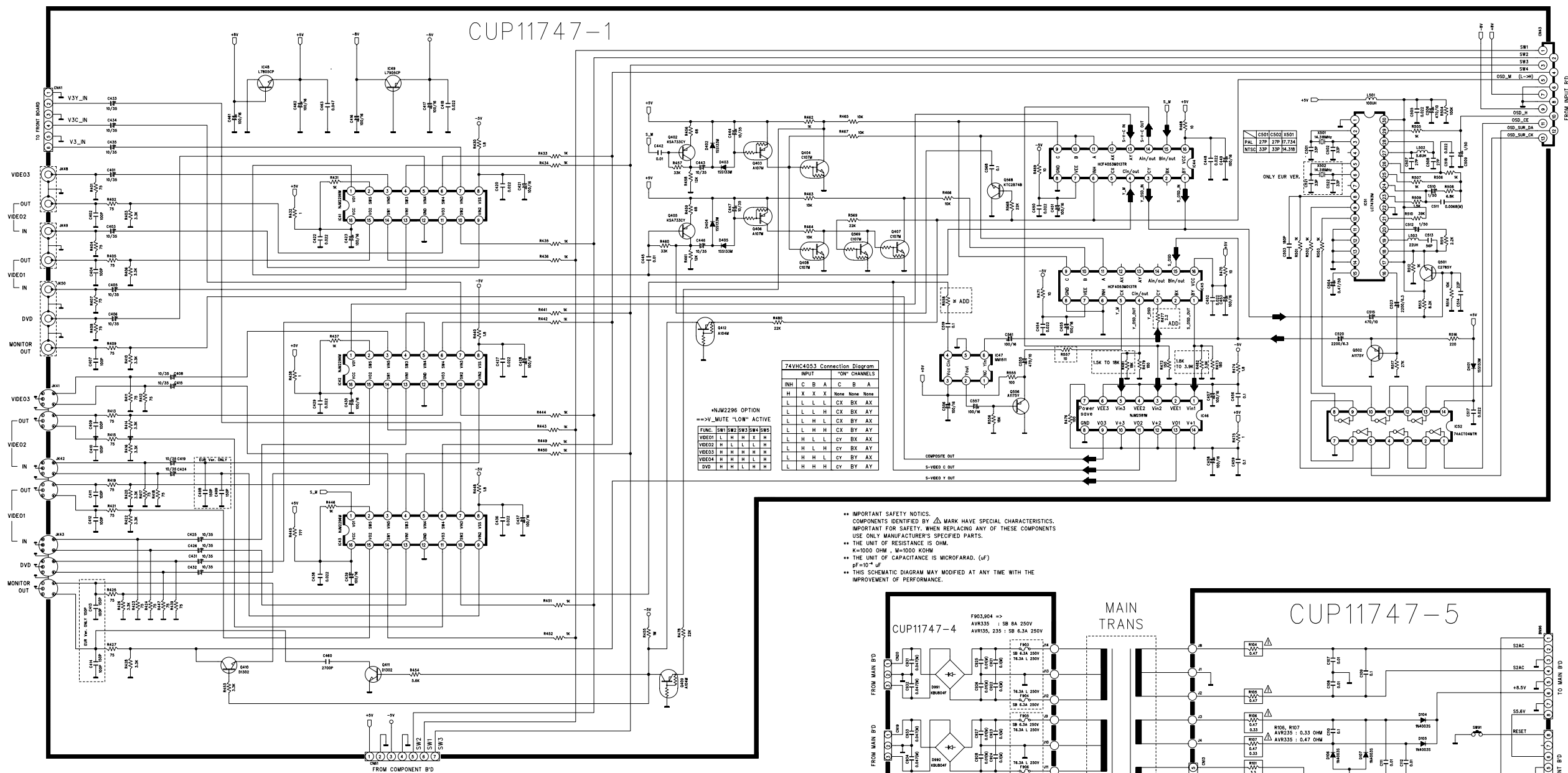

AVR335

harman/kardon

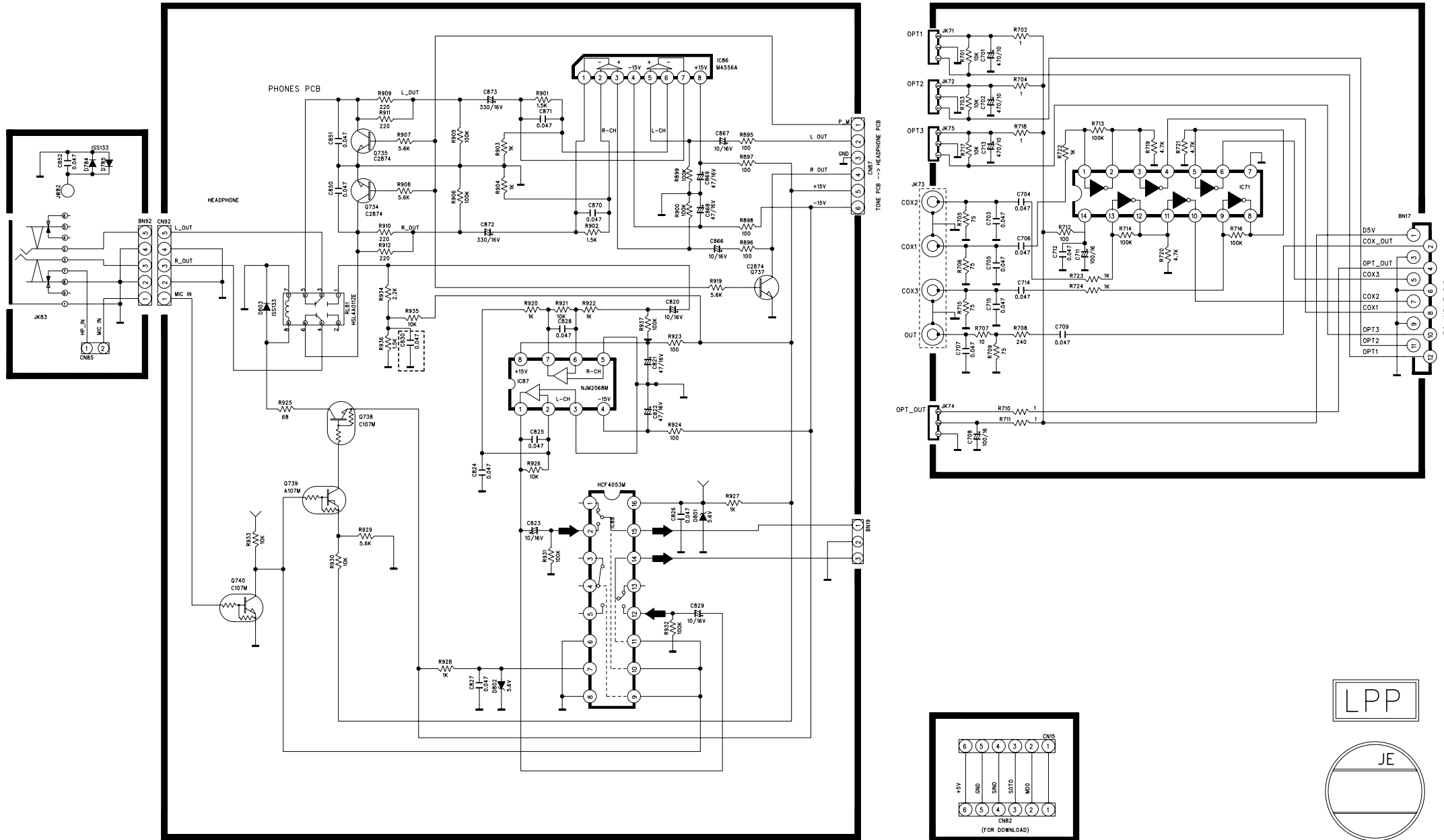

LPP

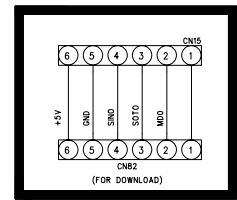
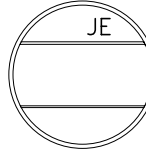

REVISION	2	4	6
1	3	5	7
SCHEMATIC DIAGRAM			
MODEL	AVR335		
DESIGN	CHECK	APPROVE	DRAWING NO
LEE C	BY .W .Y	LEE H W	1768SCLZ
04.05.22			

MAIN BOARD 1 (AMP)

AVR335

harman/kardon

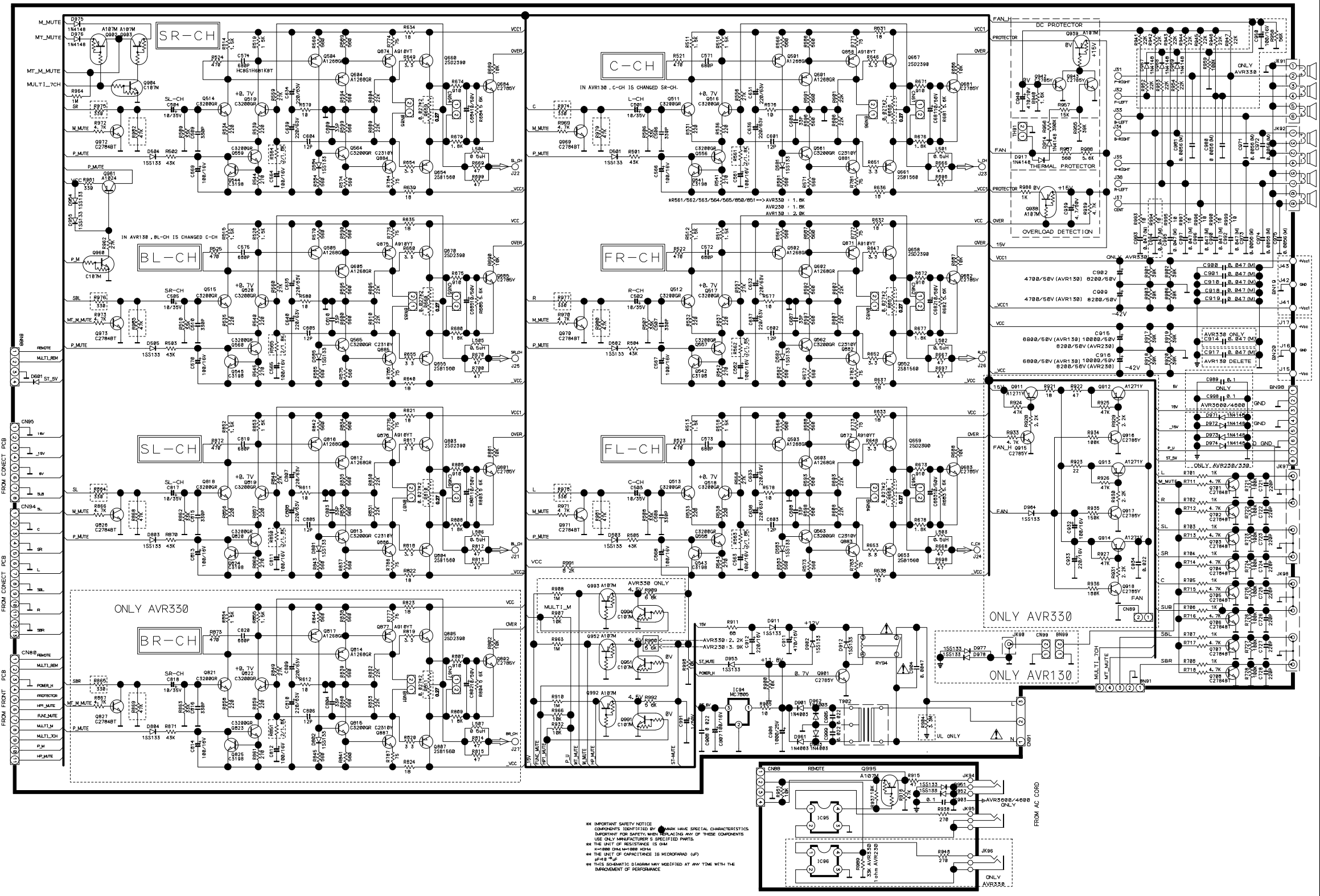

AVR335

harman/kardon

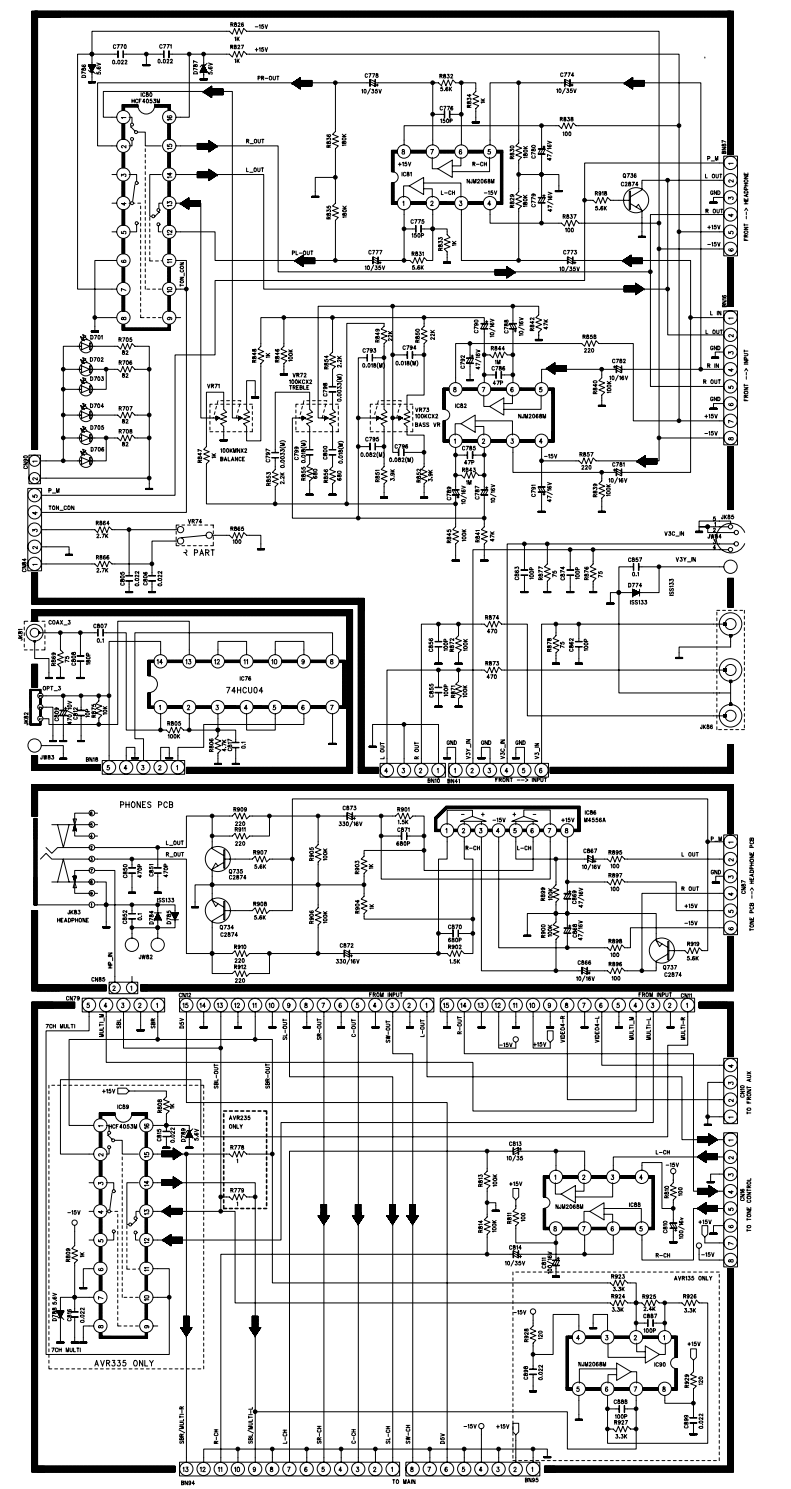
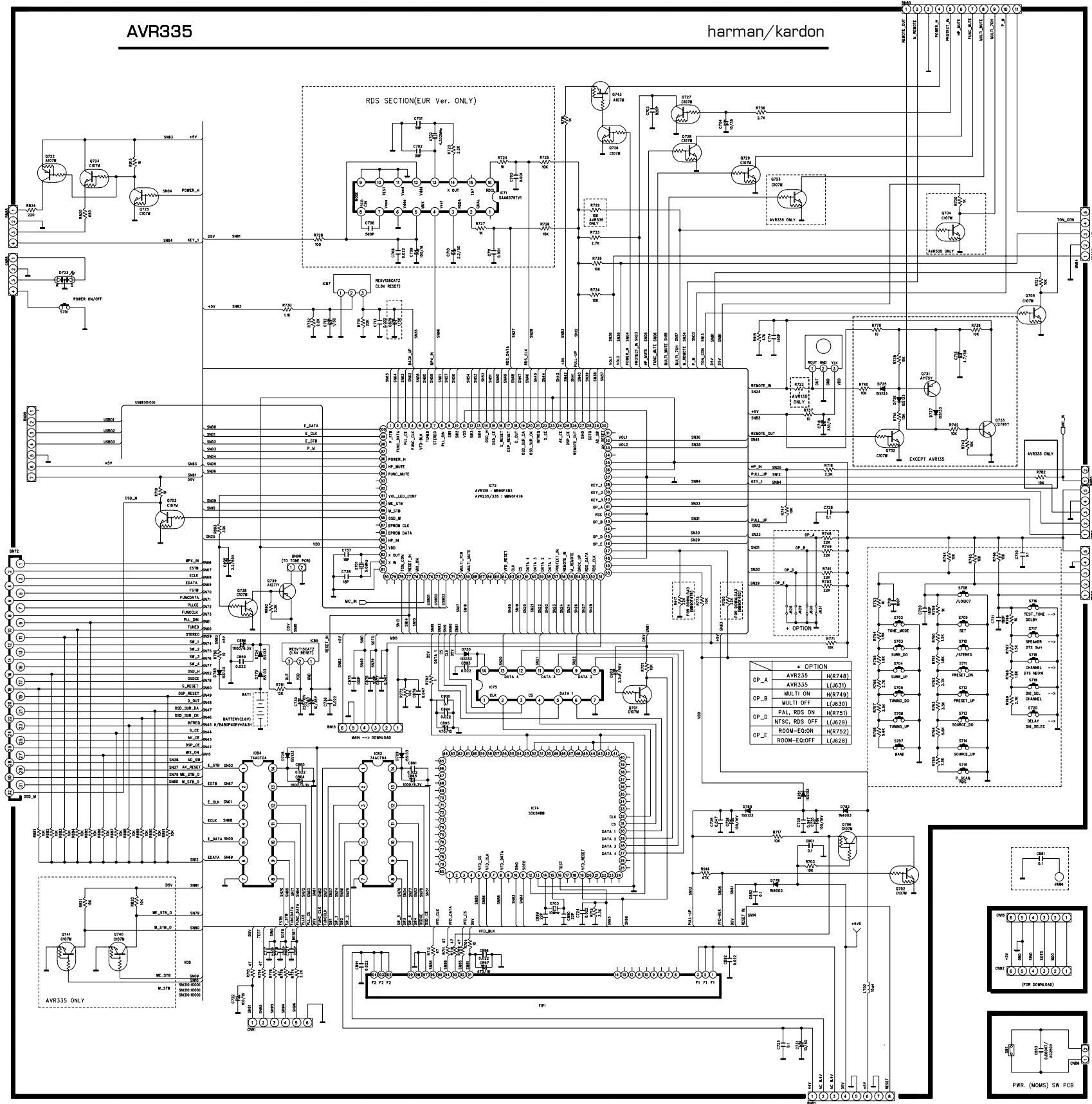

LPP

MUL I
2004.07.16

REVISION	2	4	6
1	3	5	7
SCHEMATIC DIAGRAM			
MODEL	AVR235/AVR335		
DESIGN	CHECK	APPROVE	DRAWING NO
LEE C B	Y.W.Y	LEE H W	1745SCPZ
04.02.24			(FRONT)

AVR335

harman/kardon

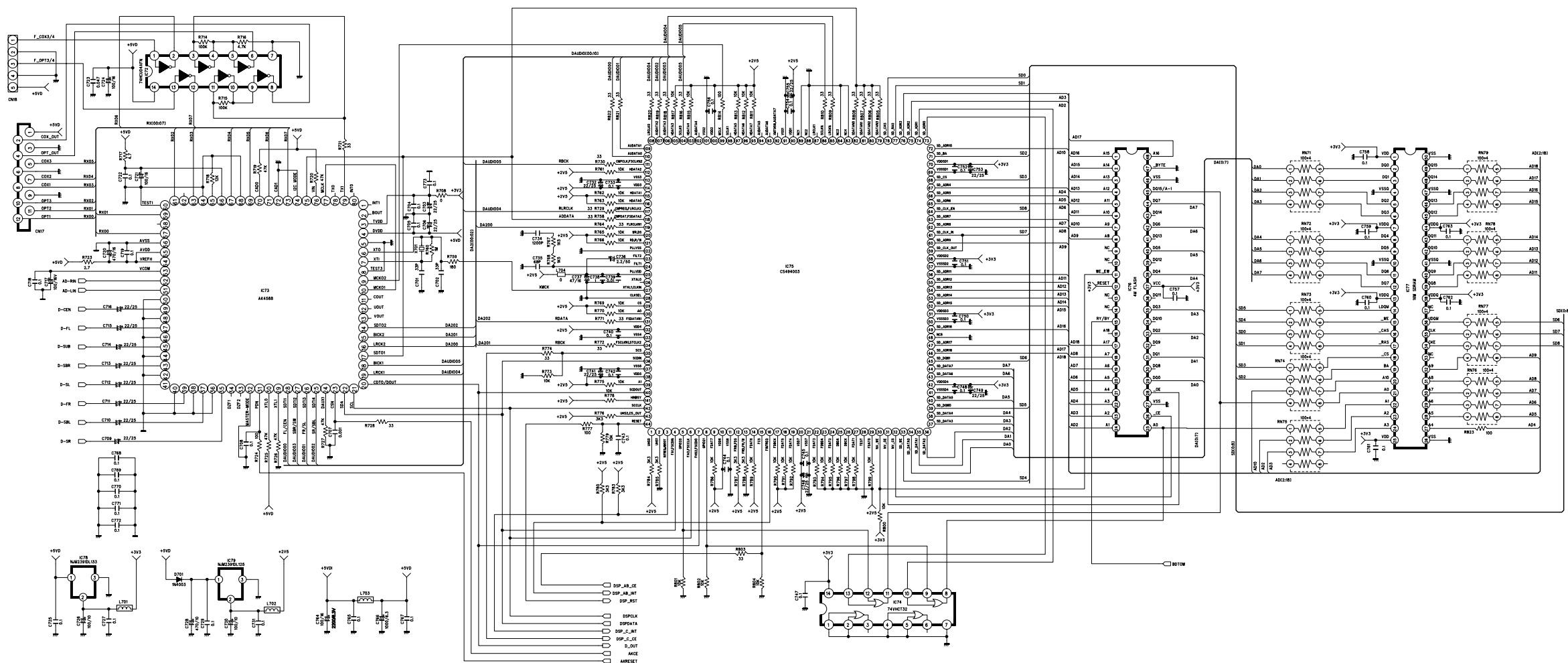

CUP11749-3

DPP

REVISION	2	4	6
1	3	5	7
SCHMATIC DIAGRAM			
MODEL	AVR235/335		
DESIGN	CHECK	APPROVE	DRAWING NO
K.M.S	Y.W.Y	L.H.W	1749SCEZ

MAIN BOARD 2 (BIAS & REGULATOR)

AVR335

harman/kardon

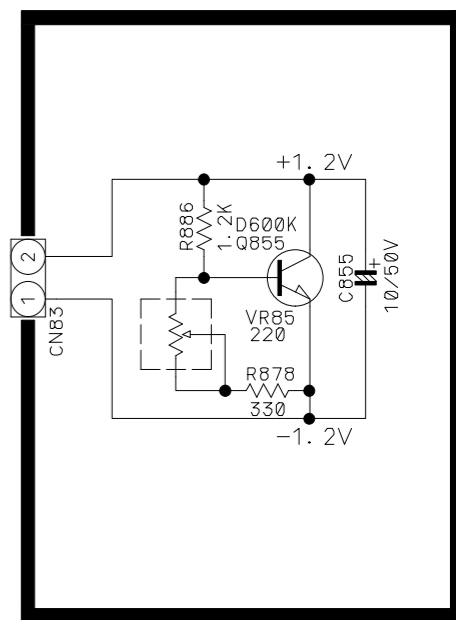
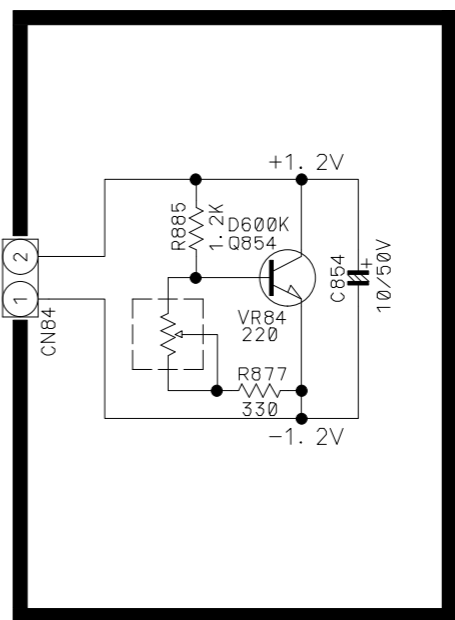
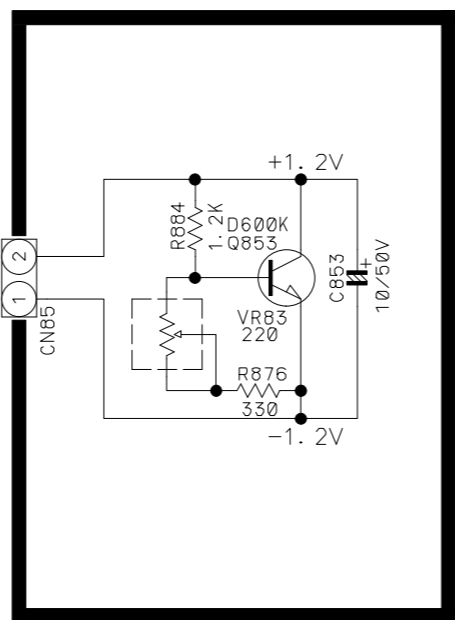
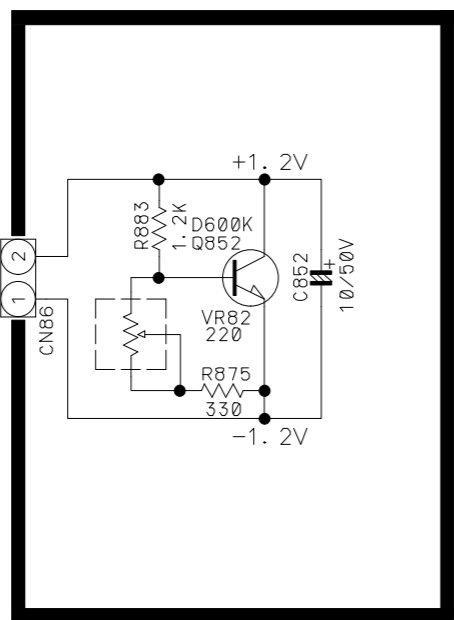
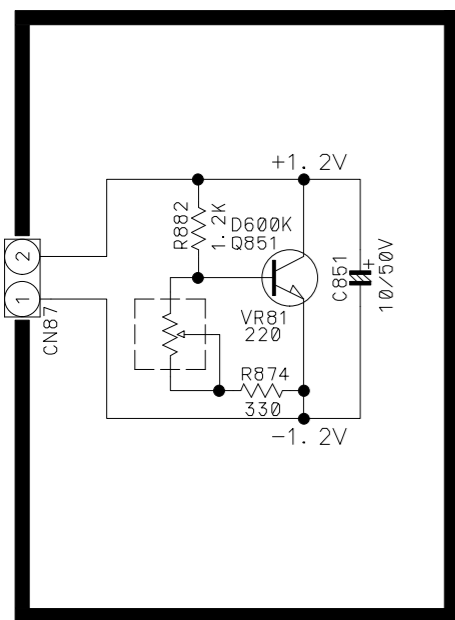

** IMPORTANT SAFETY NOTICE.
COMPONENTS IDENTIFIED BY MARK HAVE SPECIAL CHARACTERISTICS.
IMPORTANT FOR SAFETY, WHEN REPLACING ANY OF THESE COMPONENTS
USE ONLY MANUFACTURER'S SPECIFIED PARTS.

** THE UNIT OF RESISTANCE IS OHM.
K=1000 OHM, M=1000 KOHM.

** THE UNIT OF CAPACITANCE IS MICROFARAD (uF)
pF=10⁻⁶ uF

** THIS SCHEMATIC DIAGRAM MAY MODIFIED AT ANY TIME WITH THE
IMPROVEMENT OF PERFORMANCE

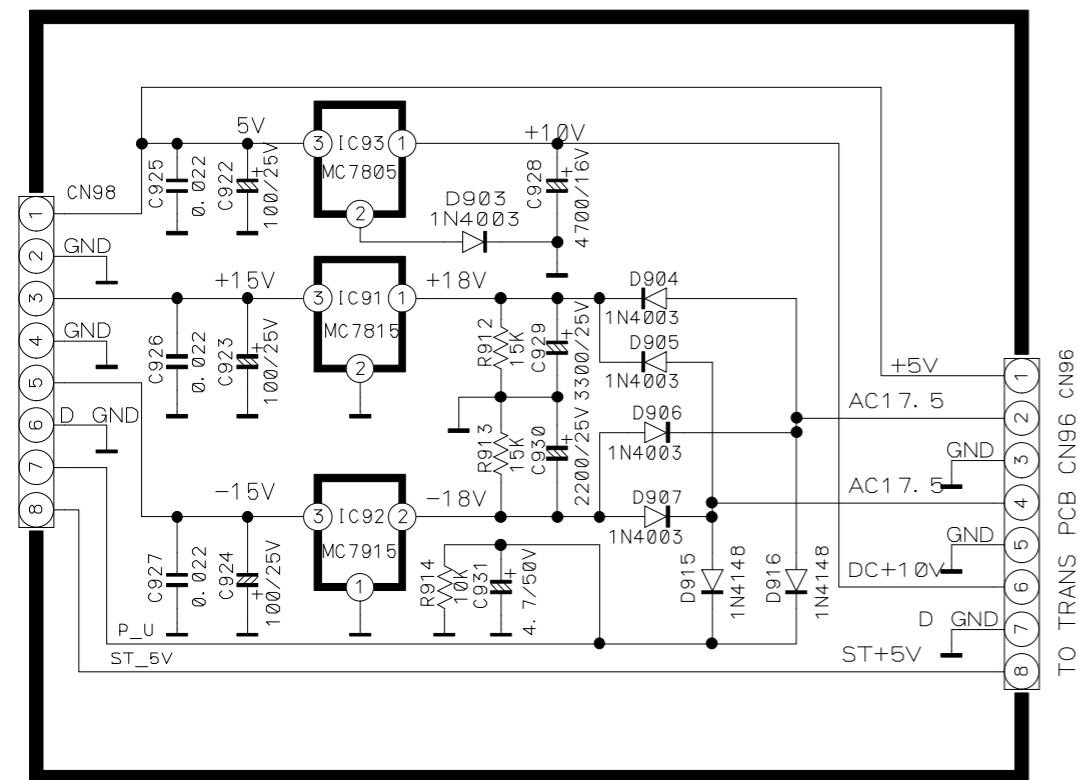
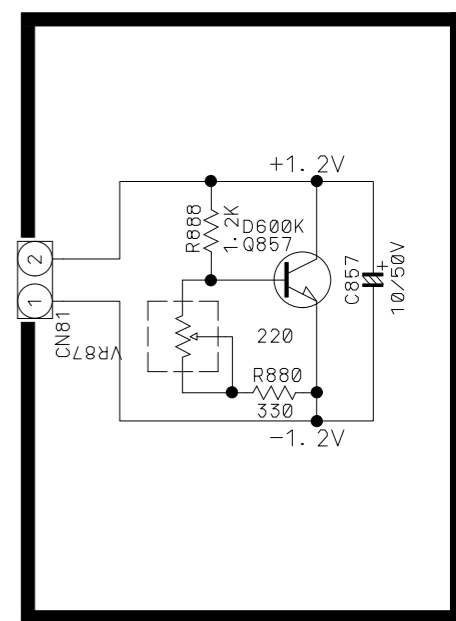
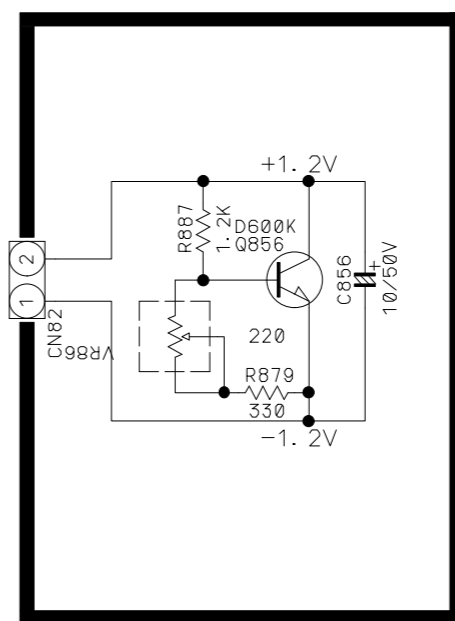

TO TRANS PCB CN96 CN96

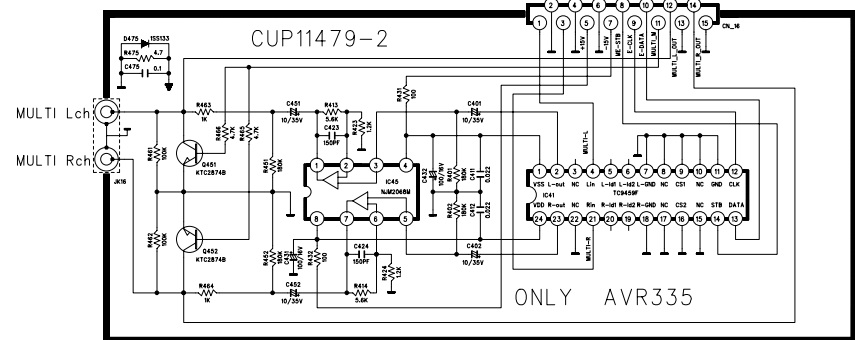
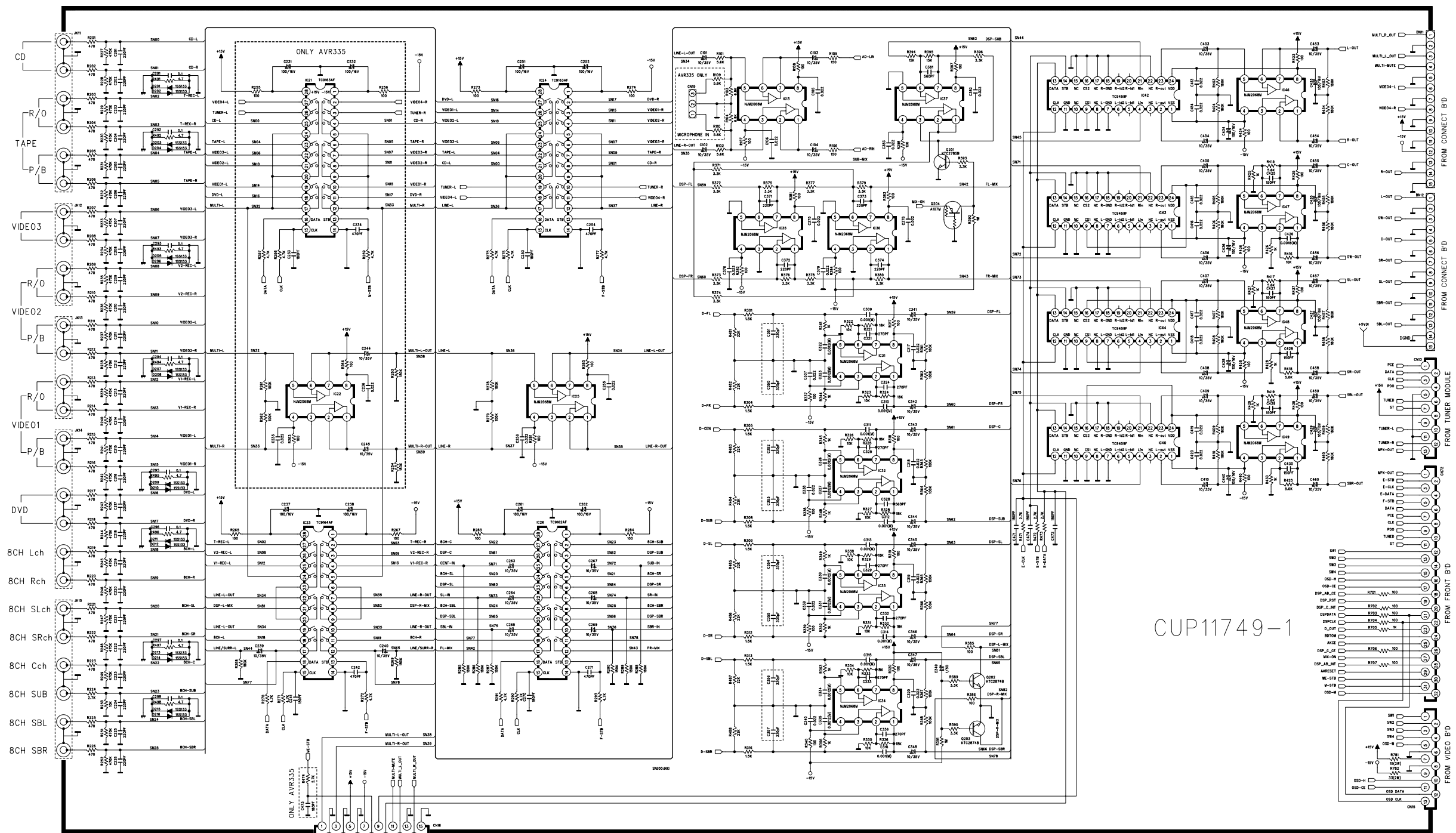

•• IMPORTANT SAFETY NOTICES.
 COMPONENTS IDENTIFIED BY Δ MARK HAVE SPECIAL CHARACTERISTICS.
 IMPORTANT FOR SAFETY, WHEN REPLACING ANY OF THESE COMPONENTS
 USE ONLY MANUFACTURER'S SPECIFIED PARTS.
 •• THE UNIT OF RESISTANCE IS OHM.
 K=1000 OHM , M=1000 KOHM
 •• THE UNIT OF CAPACITANCE IS MICROFARAD. (μ F)
 pF=10⁻¹² uF
 •• THIS SCHEMATIC DIAGRAM MAY MODIFIED AT ANY TIME WITH THE
 IMPROVEMENT OF PERFORMANCE.

LPP

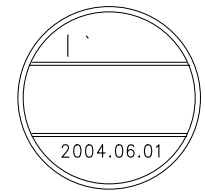

CUP11749-1

REVISION	2	4	6
1	3	5	7
SCHEMATIC DIAGRAM			SHEET
MODEL	AVR235/335		3
DESIGN	CHECK	APPROVE	DRAWING NO
K.M.S	Y.W.Y	L.H.W	1749SCPZ
04.02.20			(INPUT)

USA : 120V 60Hz
EUR : 230V 50Hz

AVR235, 335 WIRING DIAGRAM

D

D

C

C

B

B

A

A

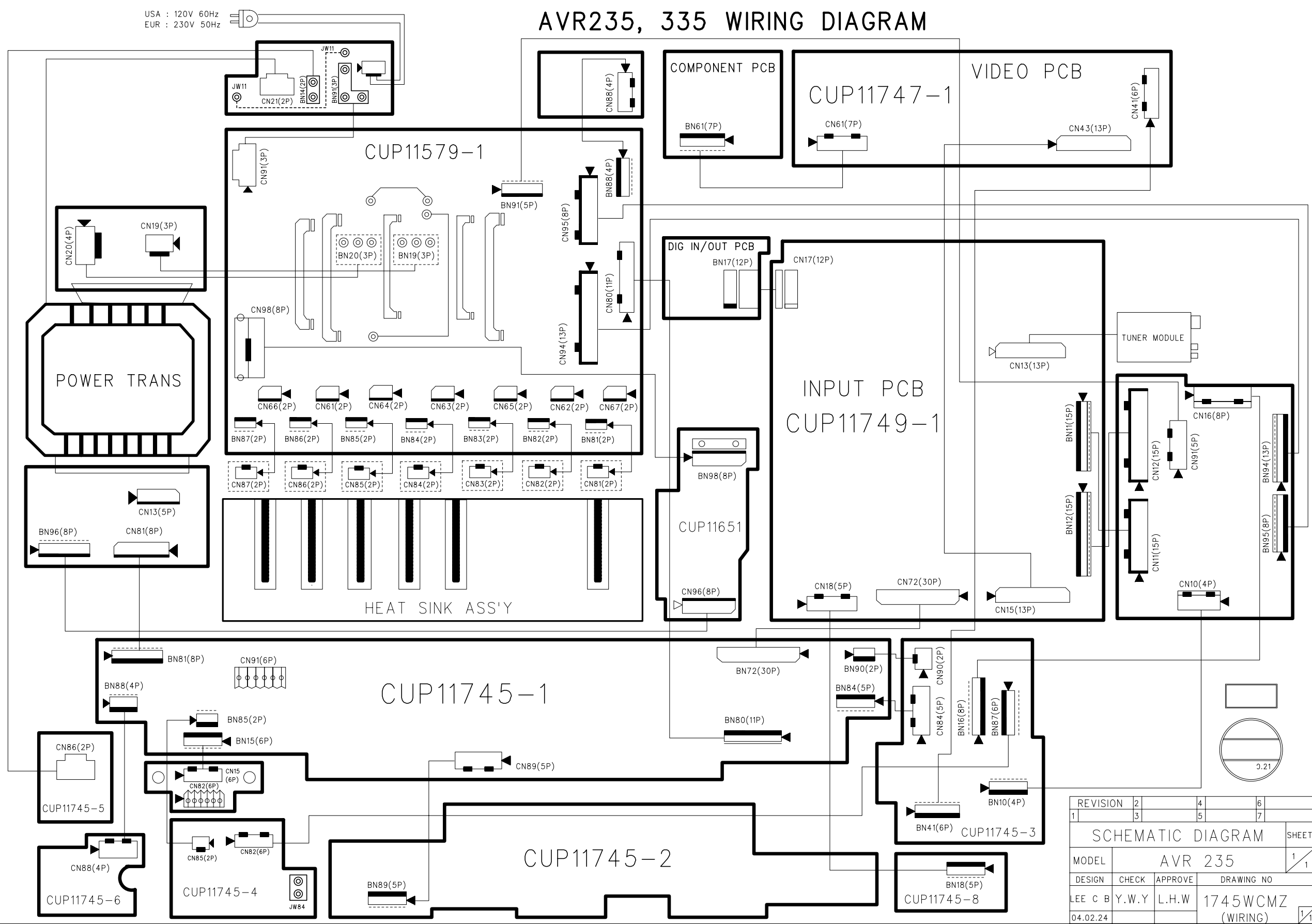

REVISION	2	4	6	
1	3	5	7	
SCHEMATIC DIAGRAM				SHEET
MODEL	AVR 235			1/1
DESIGN	CHECK	APPROVE	DRAWING NO	
LEE C B	Y.W.Y	L.H.W	1745WCMZ	
04.02.24			(WIRING)	

1. Instruction manual ass'y - Accessories

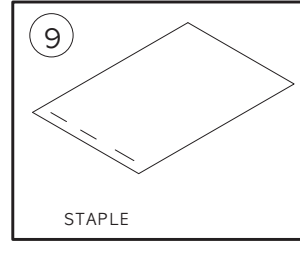
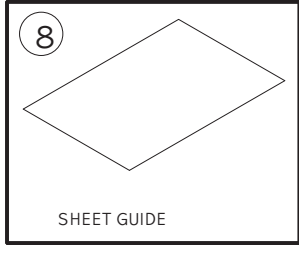
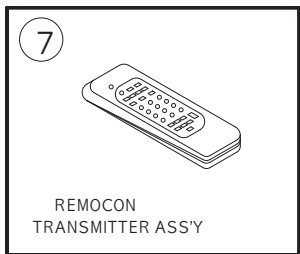
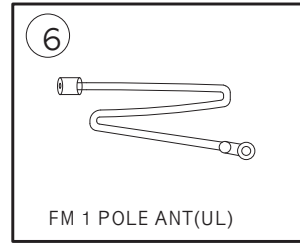
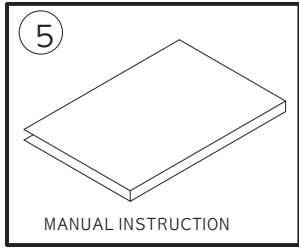
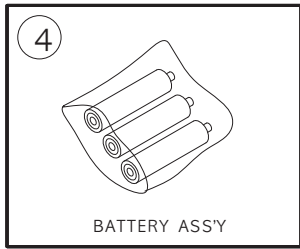
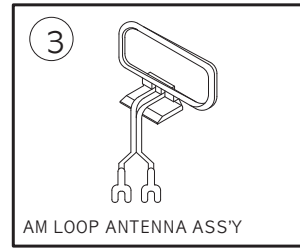
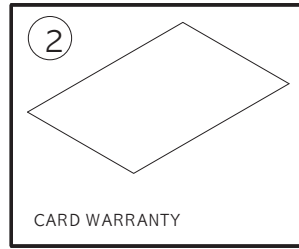
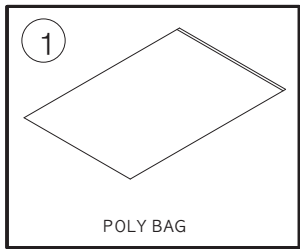

NO	DESCRIPTION	PARTS NO.	Q.ty
1	POLY BAG		1
2	CARD WARRANTY	ZKC1113HA00-9	1
3	AM LOOP ANTENNA ASS'Y	CSA1A027Z	1
4	BATTERY		3
5	INSTRUCTION MANUAL	CQX1A951Z	1
6	FM 1 POL ANT(UL)	CSA1A019Z	1
7	REMOCON TRANSMITTER ASS'Y	RB30C00	1
8	SHEET GUIDE	CQE1A227Z	1
9	STAPLE		3

2. Package Drawing

AVR335

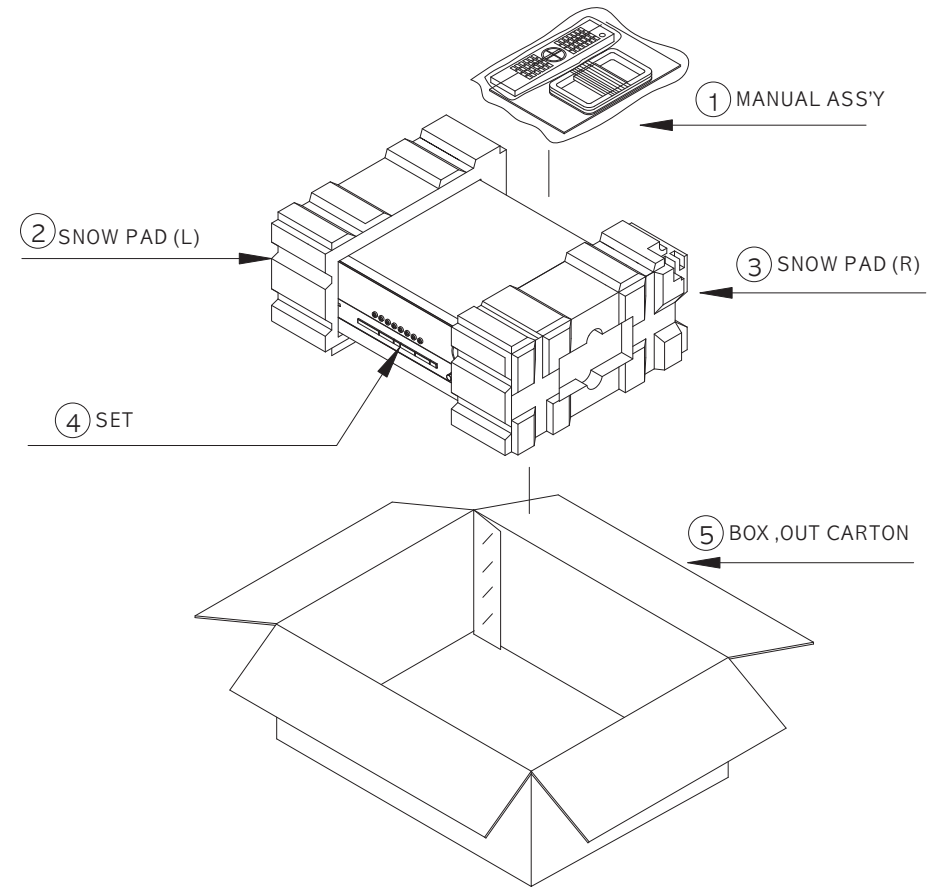

NO	DESCRIPTION	PARTS NO.	Q.ty
1	MANUAL ASSY		1
2	SNOW,PAD(L)	CPS4A564	1
3	SNOW,PAD(R)	CPS4A565	1
4	SET	AVR 335	1
5	BOX,OUT CARTON	CPG1A775X	1