

1차 초안 97.11/3

The Harman Kardon Model AVR40/41

Manual A

AUDIO AND VIDEO RECEIVER

Technical Manual

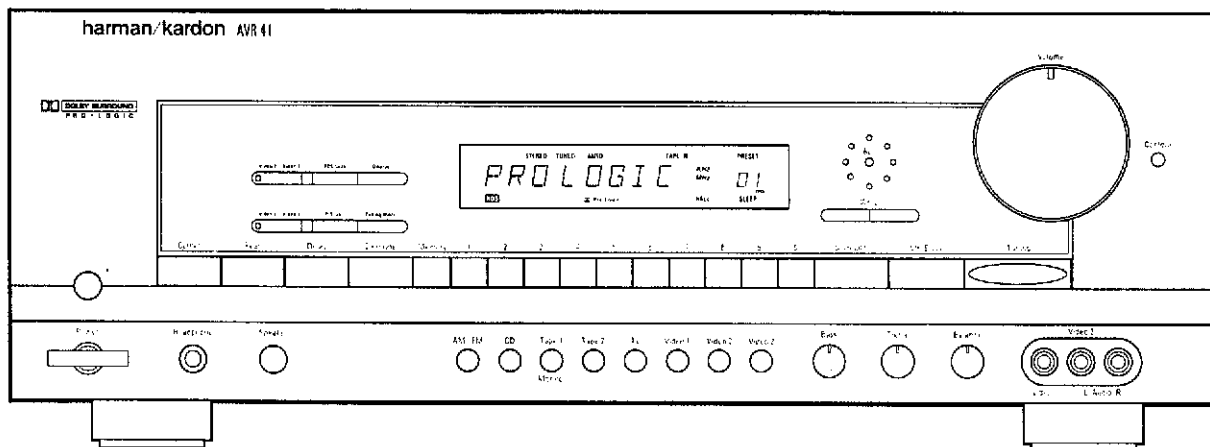

■ CONTENTS ■

SPECIFICATIONS	2	GENERAL UNIT EXPLODED VIEW	26
LEAKAGE TEST	3	PRINTED CIRCUIT BOARDS	27
CONTROLS AND FUNCTIONS	4	ELECTRICAL PARTS LIST	30
BLOCK DIAGRAM	5	IC FUNCTIONAL BLOCK DIAGRAM	36
DISASSEMBLY PROCEDURES	6	SCHEMATIC DIAGRAMS (I), (II), (III), (IV)	41
CIRCUIT DESCRIPTION	8	SCHEMATIC DIAGRAMS (V), (VI), (VII)	45
ALIGNMENT PROCEDURES	19	SCHEMATIC DIAGRAMS (VIII), (IX), (X)	48
TROUBLESHOOTING	22	WIRING DIAGRAM	51
GENERAL UNIT PARTS LIST	25	PACKAGE	52

harman/kardon

Parts and Service Office
80 Crossways Park West, Woodbury, N.Y. 11797
1112-AVR40/41 G9710 1200 Printed in Korea

SPECIFICATIONS

⊙ FRONT AMP SECTION

	Nominal	Limit
RMS Output Power		
THD: 0.09%, 8 ohms	≥ 70 W	≥ 65 W
Both Channel Driven (20 Hz - 20 kHz)		
THD at 65 W, 8 ohms		
20 Hz	≤ 0.09%	≤ 0.2%
1 kHz	≤ 0.09%	≤ 0.2%
20 kHz	≤ 0.09%	≤ 0.2%
IM Distortion at 65 W, 8 ohms		
60:7000 Hz = 4:1	≤ 0.2%	≤ 0.3%
Input Sensitivity at 65 W, 8 ohms		
CD, AUX, VCR	200 ± 15 mV	200 ± 30 mV
S/N Ratio Input Shorted at Volume Max.		
(WTD IHF-A) at 65 W, 8 ohms		
CD, AUX	≥ 95 dB	≥ 92 dB
TV, VCR1,2	≥ 93 dB	≥ 90 dB
Tone Control		
Bass: 50 Hz	± 10 dB ± 1.5 dB	± 10 dB ± 2 dB
Treble: 10 kHz	± 10 dB ± 1.5 dB	± 10 dB ± 2 dB
Frequency Response at 1 W, 8 ohms (CD/AUX)		
20 Hz, 20 kHz	± 0.5 dB	± 1 dB
Channel Crosstalk Input Shorted at 65 W, 8 ohms		
1 kHz	≥ 60 dB	≥ 55 dB
10 kHz	≥ 45 dB	≥ 40 dB

⊙ CENTER AMP SECTION

	Nominal	Limit
RMS Output Power		
THD (0.3%, 8 ohms, 1 kHz)		
Only Center Channel Driven	≥ 55 W	≥ 50 W
S/N Ratio (Input Level : 300mV at 1W)		
Input Shorted, IHF-A WTD	≥ 75 dB	≥ 70 dB
Frequency Response at -3 dB		
Normal	120 Hz - 60 kHz	120 Hz - 50 kHz
Wide	40 Hz - 60 kHz	50 Hz - 50 kHz

⊙ REAR AMP SECTION

	Nominal	Limit
RMS Output Power		
THD (0.7%, 8 ohms, 1 kHz)		
Both Rear Channel Driven	≥ 55 W	≥ 50 W
S/N Ratio (Input Level : 300mA at 1W)		
Input Shorted, IHF-A WTD		
Dolby	≥ 68 dB	≥ 65 dB
Hall	≥ 68 dB	≥ 65 dB
Frequency Response at -3 dB		
8 ohms, Dolby Pro-Logic	60 Hz - 7 kHz (± 0.5 k)	80 Hz - 6.5 kHz (± 1.0 k)

⊙ VIDEO AMP SECTION

	Nominal	Limit
Input Sensitivity/Impedance		
Video 1, Video 2, Video 3	1 V _{p-p} /75 Ω	1 V _{p-p} /75 Ω
Output Level/Impedance		
Video 1, REC out, TV Monitor out	1 V _{p-p} /75 Ω	1 V _{p-p} /75 Ω
Frequency Response at -3 dB	DC-10 MHz	5 - 6 MHz
Crosstalk at 1.0 MHz	≥ 50 dB	≥ 45 dB

⊙ FM SECTION

	Nominal	Limit
Tuning Cover Range		
USA/Canada : 75 kHz Div. (100kHz Step)	87.5 - 108.0 MHz	
Europe : 40 kHz Div. (50kHz Step)	87.5 - 108.0 MHz	
Usable Sensitivity		
USA/Canada : 30 dB S/N	≤ 14.2 dbf	≤ 17.2 dbf
Europe : 26 dB S/N		
Image Rejection (at 106 MHz)		
USA/Canada	≥ 40 dB	≥ 30 dB
Europe	≥ 80 dB	≥ 70 dB
IF Rejection (at 90 MHz)	≥ 80 dB	≥ 70 dB
Full Limiting (at -3dB)	≤ 12.2 dbf	≤ 15.2 dbf
Quieting Sensitivity (at 98.1 MHz)		
IHF Band Pass Filter		
Mono	≤ 19.2 dbf	≤ 23.2 dbf
Stereo :		

USA/Canada (50dB S/N)	≤ 40.2 dbf	≤ 43.2 dbf
Europe (46dB S/N)	≤ 45.3 dbf	≤ 48.3 dbf
Distortion (1 kHz, at 98.1 MHz)		
IHF Band Pass Filter		
Mono	≤ 0.3 %	≤ 0.5 %
Stereo	≤ 0.5 %	≤ 0.8 %
S/N Ratio (1 mV Input, at 98.1 MHz)		
IHF Band Pass Filter		
Mono	≥ 70 dB	≥ 63 dB
Stereo	≥ 65 dB	≥ 60 dB
Frequency Response (at +1dB, -3dB)	10 Hz - 15 kHz	20 Hz - 15.3 kHz
AM Rejection Ratio (100 uV - 20 mV Input)	≥ 55 dB	≥ 50 dB
Search Level (at 98.1 MHz)	31.2 ± 3 dbf	31.2 ± 6 dbf
Automatic Stereo Threshold (at 98.1 MHz)		
	29.2 ± 3 dbf	29.2 ± 6 dbf
Muting Threshold (at 98.1 MHz)	29.2 ± 3 dbf	29.2 ± 6 dbf
Overload at 98.1 MHz		
(100% MOD, 100mV RF Input)	≤ 0.2 %	≤ 0.5 %
Suprious Response (at 98.1 MHz)		
Antenna Input 3uV	≥ 90 dB	≥ 80 dB
Capture Ratio at 40/60 dbf	≤ 2 dB	≤ 2.5 dB
Alternative Channel Selectivity (at 98.1 MHz ± 400 kHz)	≥ 50 dB	≥ 45 dB
Stereo Separation (at 98.1 MHz, 1mV Input)		
IHF Band Pass Filter		
100 Hz	≥ 40 dB	≥ 35 dB
1 kHz	≥ 45 dB	≥ 40 dB
10 kHz	≥ 35 dB	≥ 30 dB
Output Voltage (at 1mV Input)		
Mono	500 ± 100 mV	500 ± 150 mV
Stereo	450 ± 100 mV	450 ± 150 mV

⊙ AM SECTION

	Nominal	Limit
Tuning Cover Range		
USA/Canada : 10 kHz Step	520 - 1710 kHz	
Europe : 9 kHz Step	522 - 1611 kHz	
Usable Sensitivity (400 Hz, 30% MOD, S/N 20 dB)	≤ 500 uV/m	≤ 800 uV/m
Image Rejection (at 1400 kHz)	≥ 35 dB	≥ 30 dB
IF Rejection (at 600 kHz)	≥ 60 dB	≥ 50 dB
AGC Figure of Merit (From 100mV/m at 1000 kHz)		
	≥ 55 dB	≥ 50 dB
Distortion (400 Hz, 30% MOD, 10mV/m Input)		
	≤ 0.8 %	≤ 1.5 %
IF Bandwidth (6dB Down, 350uV/m)	5 - 6 kHz	4 - 9 kHz
Audio Response (5mV/m Input 1 kHz 0 dB, 1000 kHz)		
at -6dB	80 Hz - 2.3 kHz	100 Hz - 2 kHz
Selectivity (at 350uV/m)		
± 10 kHz	≥ 25 dB	≥ 20 dB
S/N Ratio (1000kHz, With antenna Input 10mV/m)	≥ 45 dB	≥ 40 dB
RF Overload (400 Hz 80% MOD, 100mV/m input)		
	≤ 5 %	≤ 10 %
Search Level (at 1000kHz)	800 uV ± 5 dB	800 uV ± 6 dB
Output Voltage (400 Hz 30% MOD, 10Mv/M Input)	165 ± 30 mV	165 ± 40mV
Whistle	≤ 10 %	≤ 15 %

⊙ GENERAL

Power Consumption :		
USA/Canada		2 A
Europe		570 W
Power Supplies :		
USA/Canada		AC 120 V, 60 Hz
Europe		AC 230 V, 50 Hz
Dimensions (W x H x D);		
inches		17 ^{3/8} x 5 ²⁵ x 15
mm		440 x 141.5 x 380 mm
Weight (lbs/kgs)		27 lbs, 12.3 kg

These specifications are service target specs.
Specifications and components are subject to change without notice.
Overall performance will maintained or improved.

LEAKAGE TEST

Before returning the unit to the user, perform the following safety checks:

1. Inspect all lead dress to make certain that leads are not pinched or that hardware is not lodged between the chassis and other metallic parts in the unit.
2. Be sure that any protective devices such as nonmetallic control knobs, insulating fishpapers, cabinet backs, adjustment and compartment covers or shields, isolation resistor-capacity networks, mechanical insulators, etc., which were removed for servicing are properly reinstalled.
3. Be sure that no shock hazard exists; check for leakage current using Simpson Model 229 Leakage Tester, standard equipment item No. 21641, RCA Model WT540A or use alternate method as follows: Plug the power cord directly into a 230-volt AC receptacle (do not use an Isolation Transformer for this test).

Using two clip leads, connect a 1500 Ohm, 10-watt resistor paralleled by a 0.15 μ F capacitor, in series with all exposed metal cabinet parts and a known earth ground, such as a water pipe or conduit. Use a VTVM or VOM with 1000 Ohms per volt, or higher sensitivity to measure the AC voltage drop across the resistor. (See Diagram.) Move the resistor connection to each exposed metal part having a return path to the chassis (antenna, metal cabinet, screw heads, knobs and control shafts, escutcheon, etc.) and measure the AC voltage drop across the resistor. (This test should be performed with the power switch in both the On and Off positions.)

A reading of 0.35 volt RMS or more is excessive and indicates a potential shock hazard which must be corrected before returning the unit to the owner.

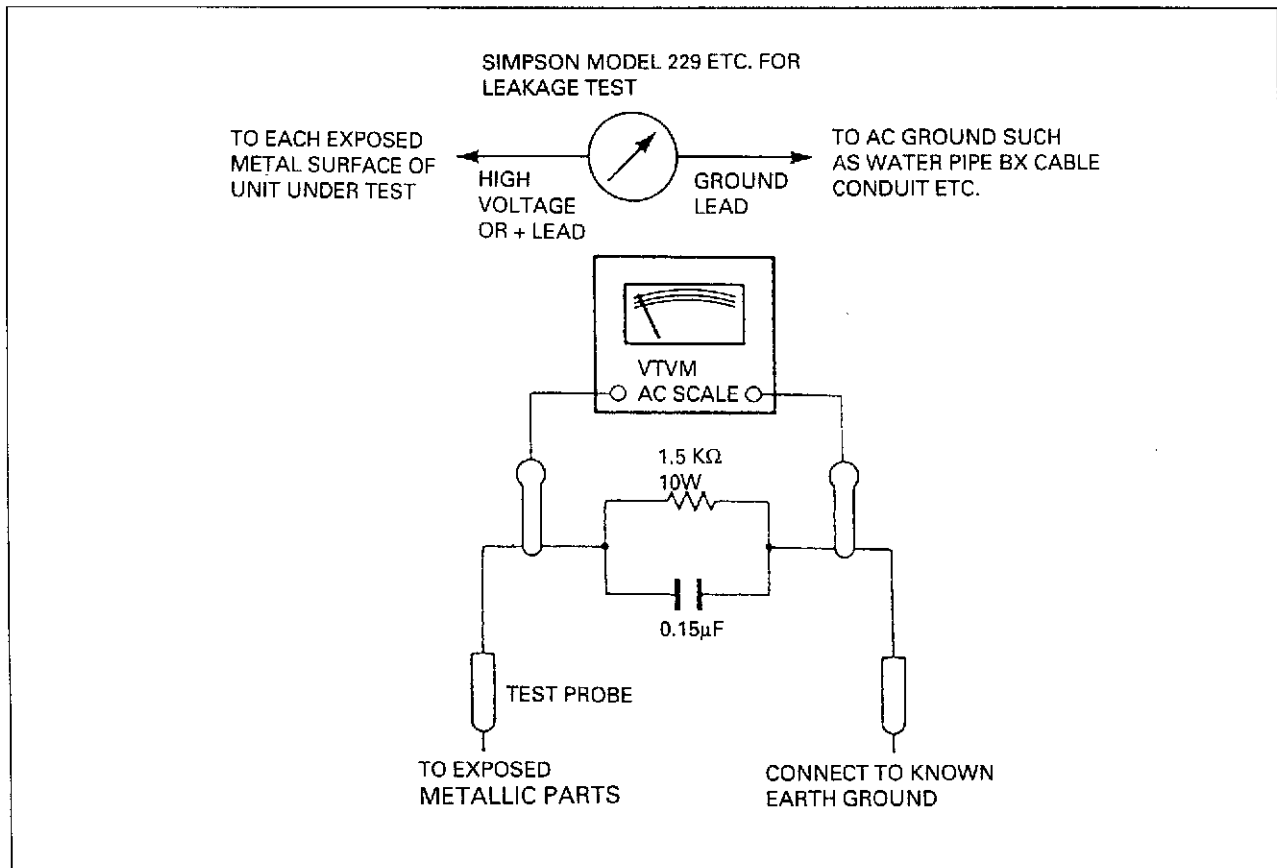

DISASSEMBLY PROCEDURES

REFER TO PAGES 26-29.

1 COVER TOP REMOVAL.

Remove 6 screws (S98 to S100) and then remove the Cover Top 1.

2 COVER BOTTOM REMOVAL.

Remove 13 screws (S3 to S6 , S62 to S65 , S67 , S68 and S70 to S72) and then remove the Cover Bottom 2.

3 FRONT PANEL ASSEMBLY REMOVAL

1. Remove the Cover Top 1, referring to the previous step 1.
2. Disconnect (Connector703-1) from the Tuner P.C.Board (PCB15).
3. Disconnect (Connector113-1) from the VCR2 P.C.Board (PCB9).
4. Disconnect (Connector116, Connector111) from the Main P.C.Board (PCB1).
5. Disconnect (Connector702-1, Connector603) from the Power P.C.Board (PCB6).
6. Remove the Card Cable from (Connector107) on the Main P.C.Board (PCB1).
7. Remove 10 screws (S1 to S10) and then remove the Front Panel Assembly AA.

4 VCR2 P.C.BOARD (PCB9) REMOVAL

1. Remove the Cover Top 1, referring to the previous step 1.
2. Remove the Front Panel Assembly AA, referring to the previous step 3.
3. Remove 2 screws (S25 and S26) and then remove the VCR2 P.C.Board (PCB9).

5 TONE P.C.BOARD (PCB2) REMOVAL

1. Remove the Cover Top 1, referring to the previous step 1.
2. Remove the Front Panel Assembly AA, referring to the previous step 3.
3. Pull out the knobs 42 (Bass/Treble/Balance)
4. Remove the Hex Nuts from the variable resistors 15, 16 and then remove the Tone P.C.Board (PCB2).

6 VOLUME P.C.BOARD (PCB4) REMOVAL

1. Remove the Cover Top 1, referring to the previous step 1.
2. Remove the Front Panel Assembly AA, referring to the previous step 3.
3. Disconnect (Connector700, Connector705-1) from the Volume P.C.Board (PCB4).

4. Pull out the volume knob 41 with volume LED P.C.Board (PCB5)
5. Remove the Hex Nut from Volume-motor and then remove the Volume P.C.Board (PCB4).

7 HEADPHONE P.C.BOARD (PCB8) REMOVAL

1. Remove the Cover Top 1, referring to the previous step 1.
2. Remove the Front Panel Assembly AA, referring to the previous step 3.
3. Remove 2 screws (S13 and S14) and then remove the Headphone P.C.Board (PCB8).

8 FRONT & POWER SW P.C.BOARD (PCB4 & PCB7) REMOVAL

1. Remove the Cover Top 1, referring to the previous step 1.
2. Do steps 3 and 7.
3. Disconnect (Connector705-1) from the Volume P.C.Board (PCB4).
4. Remove 11 screws (S11, S12, S16 to S24) and then remove the Front & Power SW P.C.Board (PCB4 & PCB7).

9 TUNER P.C.BOARD (PCB15) REMOVAL

1. Remove the Cover Top 1, referring to the previous step 1.
2. Disconnect (Connector703-1) from the Tuner P.C.Board (PCB15).
3. Remove 2 screws (S92 and S95) and then remove the Tuner P.C.Board (PCB15).

10 SURROUND P.C.BOARD (PCB11) REMOVAL

1. Remove the Cover Top 1, referring to the previous step 1.
2. Remove 2 screws (S90 and S91) and then remove the Surround P.C.Board (PCB11).

11 VIDEO P.C.BOARD (PCB12) REMOVAL

1. Remove the Cover Top 1, referring to the previous step 1.
2. Remove 2 screws (S87 and S88) and then remove the Video P.C.Board (PCB12).

12 CENTER SPEAKER P.C.BOARD (PCB13) REMOVAL

1. Remove the Cover Top 1, referring to the previous step 1.
2. Disconnect (Connector117-1) from the Center Speaker P.C.Board (PCB13).
3. Remove 2 screws (S83 and S84) and then remove the Center Speaker P.C.Board (PCB13).

**13 SURROUND AMP & REAR SPEAKER
P.C.BOARD (PCB10 & PCB14) REMOVAL**

1. Remove the Cover Top ①, referring to the previous step ①.
2. Disconnect (Connector117-1) from the Center Speaker P.C.Board (PCB13).
3. Unsolder all leads of (Q414, Q410, Q413, Q427, Q424 and Q428) from copper track on the Surround AMP P.C.Board (PCB8).
4. Remove 4 screws (S42, S43, S80, S82) and then remove the Surround AMP & Rear Speaker P.C.Board (PCB10 & PCB14).

14 MAIN P.C.BOARD (PCB1) REMOVAL

1. Remove the Cover Top ①, referring to the previous step ①.
2. Do steps ②, ③, ⑧, ⑨, ⑩, and ⑫.
3. Disconnect (Connector102, Connector103, Connector104) from the Main P.C.Board (PCB1).
4. Unsolder all leads of (Q216L/R, Q211L/R, Q215L/R, Q186, IC105, P201,) from copper track on the Main P.C.Board (PCB1)
5. Remove 8 screws (S44, S46, S51, S67, S71, S74 ~ S76) and then remove the Main P.C.Board (PCB1).

CIRCUIT DESCRIPTION

1. CPU CIRCUITS (IC 301: CXP82432A 153Q DWP467)

1) PIN DESCRIPTION & BLOCK DIAGRAM

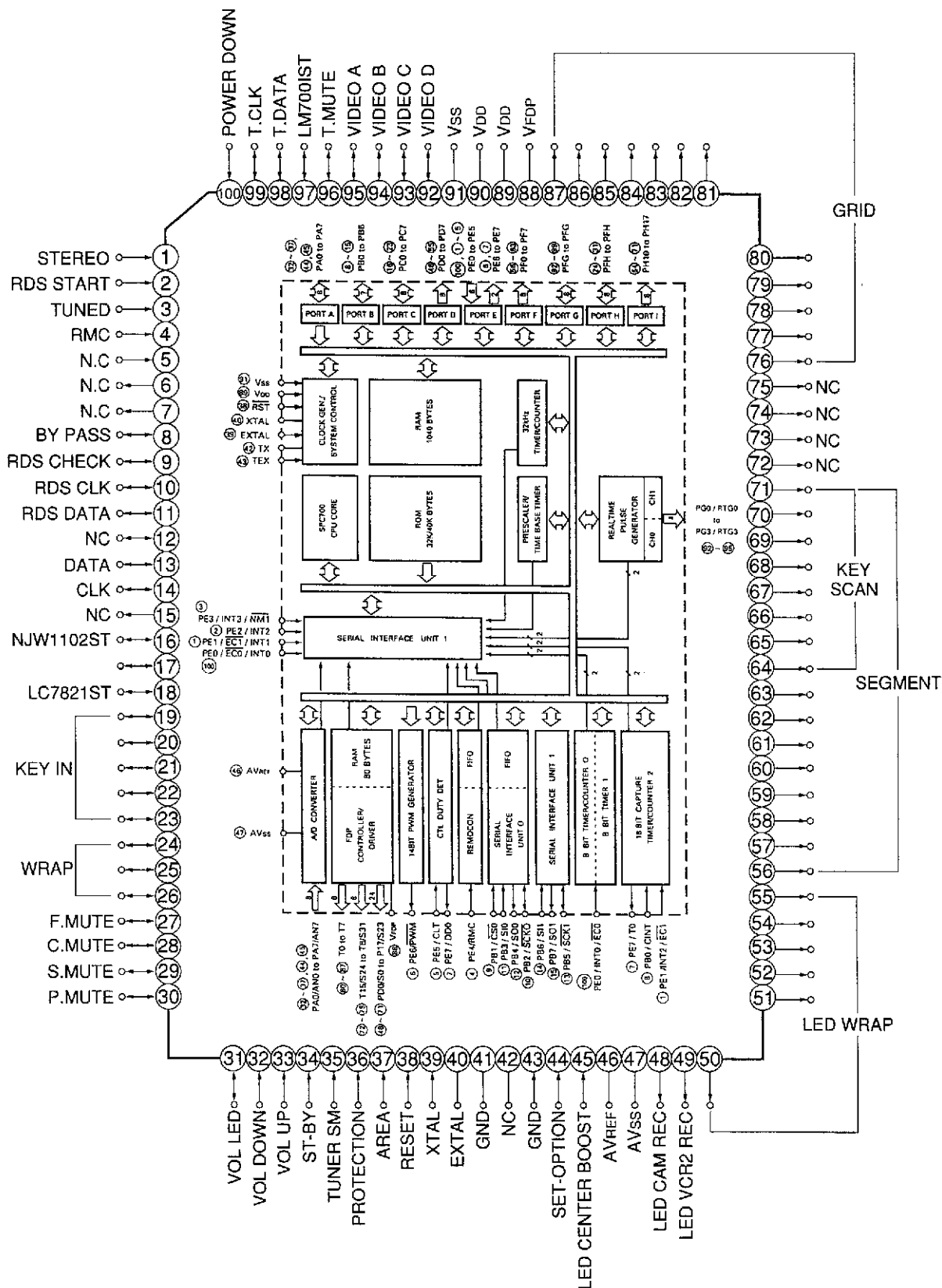

2) INPUT/OUTPUT TERMINAL FUNCTIONS

Pin No.	Symbol	Description
1	STEREO	When receiving low level, it turn on the stereo flag of FL.
2	RDS START	Input for LC7073 data start.
3	TUNED	Input for station detector signal in searching tuning. Searching up or down stops when station detector reached a certain level.
4	RMC	Input for remote control signal. (At "L", it is active)
5 ~ 7	NC	Not Used!
8	BY PASS	Output signal is as follows to control surround mode. (H : By Pass , L : Others)
9	RDS CHECK	
10, 11	RDS CLK/DATA	Input for LC7073 clock and data signal.
12, 15	NC	Not Used!
13, 14	DATA/CLK	Output for data and clock signal to LC7821, NJW1102, NJU9702 and TC9299, LM7001.
16	NJW1102ST	Output to enable NJW1102, NJU9702 and TC9299.
17		Pull Down
18	LC7821ST	Output to enable LC7821.
19 ~ 23	KEY IN	Input data of K1~ K5 for keyscan.
24 ~ 26	WRAP	Output voltage to control wrap LED.
27	F. MUTE	Output for main mute. Output low level under the following conditions. 1. When power is turned on or off. 2. When function is changed. 3. When mono or stereo is changed. 4. When the protection terminal's level is low. 5. When "-∞ mute signal "is received from the commander.
28	C. MUTE	Output for center mute. Output low level under the following conditions. 1. When power is turned on or off. 2. When center mode is turned on or off. 3. When center mode is selected. 4. When test tone mode is switched on, or when output is not directed to center. 5. When the protection terminal's level is low. 6. When "-∞ mute signal "is received from the commander.
29	S. MUTE	Output for surround mute. Output low level under the following conditions. 1. When power is turned on or off. 2. When surround mode is turned on or off. 3. When test tone mode is switched on, or when output is not directed to surround. 4. When delay time is selected. 5. When the protection terminal's level is low. 6. When "-∞ mute signal "is received from the commander.
30	P. MUTE	Output for all amplifier mute. Output high level under the following conditions. 1. When power is turned on or off. 2. When the protection terminal's level is low.

31	VOL LED	Output signal to turn on or off the LED which is used master volume indicator It is high in turning on and low level in turning off.												
32, 33	VOL DOWN/UP	Output signal to turn up or down volume motor (at high, it is active)												
34	ST-BY	Output voltage to control stand-by LED is as follows. When power is turned on by power switch or remocon, it is high level. Else, it is low level. (keeping last level)												
35	TUNER SM													
36	PROTECTION	Input for protection signal. If it is low, all channel mute signal levels are turned to high.												
37	AREA	Input to select frequency band & step according to regions. <table border="1" data-bbox="586 618 1103 760"> <thead> <tr> <th>AREA</th> <th>USA</th> <th>EUROPE</th> </tr> </thead> <tbody> <tr> <td>Step FM/AM</td> <td>100 K / 10 K</td> <td>50 K / 9 K</td> </tr> <tr> <td>Voltage</td> <td>0 V</td> <td>1 V</td> </tr> <tr> <td>μ - Com A/D</td> <td>0 V</td> <td>1.4 ~ 0.6 V</td> </tr> </tbody> </table>	AREA	USA	EUROPE	Step FM/AM	100 K / 10 K	50 K / 9 K	Voltage	0 V	1 V	μ - Com A/D	0 V	1.4 ~ 0.6 V
AREA	USA	EUROPE												
Step FM/AM	100 K / 10 K	50 K / 9 K												
Voltage	0 V	1 V												
μ - Com A/D	0 V	1.4 ~ 0.6 V												
38	RESET	Input to reset micom.												
39, 40	XTAL/EXTAL	Input and Output pin for connecting a crystal oscillator.												
41, 43, 47	GND	Provides the ground potential.												
42	NC	Not Used!												
44	SET-OPTION	Output to select the of AVR40 or AVR41. <table border="1" data-bbox="586 945 1108 1050"> <thead> <tr> <th>MODEL</th> <th>AVR 40</th> <th>AVR 41</th> </tr> </thead> <tbody> <tr> <td>Voltage</td> <td>0 V</td> <td>2.5 V</td> </tr> <tr> <td>μ - Com A/D</td> <td>0 ~ 1 V</td> <td>2 ~ 3 V</td> </tr> </tbody> </table>	MODEL	AVR 40	AVR 41	Voltage	0 V	2.5 V	μ - Com A/D	0 ~ 1 V	2 ~ 3 V			
MODEL	AVR 40	AVR 41												
Voltage	0 V	2.5 V												
μ - Com A/D	0 ~ 1 V	2 ~ 3 V												
45	LED CENTER BOOST	Output voltage to control Center Boost LED is as follows. When Center Boost is selected.												
46	AVREF	Provides the reference potential.												
47	AVSS	Ground.												
48	LED CAM REC	Output voltage to control CAM REC LED is as follows. When CAM REC is selected.												
49	LED VCR2 REC	Output voltage to control VCR2 REC LED is as follows. When VCR REC is selected.												
50 ~ 55	LED WRAP	Output voltage to control WRAP LED is as follows. When WRAP up or down button is pressed.												
56 ~ 63	SEGMENT	Segment signal output for FIP.												
64 ~ 71	SEGMENT/KEY SCAN	Segment signal output for FIP and Data output for key scan.												
72 ~ 75	NC	Not Used!												
76 ~ 87	GRID	Grid signal output for FIP.												
88	VFDD	Power supply of the FIP controller.												
89, 90	VDD	Power supply.												
91	VSS	Ground.												
92 ~ 95	VIDEO	Switch control for Video IC BA7625 (IC601).												
96	T. MUTE	Output for tuner mute. Output high level under the following conditions. <ol style="list-style-type: none"> 1. When Power is turned on or off. 2. When Tuner band or FM mode is changed. 3. When Tuner Up or Down button is pressed. 4. When preset button is pressed. 5. When preset number displayed changes during memory scan. 6. When the protection terminal's level is low. 7. When "-∞ mute signal" is received from the commander. 												
97	LC7001ST	Output to enable LM7001.												

98, 99	T · DATA/T · CLK	Output data and clock signal to LM7001.
100	POWER DOWN	Input for power down. (at low, it is active)

3) KEY MATRIX (AVR40 Only)

PIN NO.	64	65	66	67	68	69	70	71
19		ST-BY	Video 2 -> Video 1	Video 3 -> Video 1		P. SCAN	Tuning Mode	
20	Rear	Center			Delay	Calibrate	Memory	1
21	6	7	8	9	5	4	3	2
22	TV	Video 1	Video 2	Video 3	TAPE 2	Tape 1 Monitor	CD	AM/FM
23	Tuning Up	Tuning Down	WRAP Up	WRAP Down	CTR · BOOST	Surround	∅	

3) KEY MATRIX (AVR41 Only)

PIN NO.	64	65	66	67	68	69	70	71
19		ST-BY	P · SCAN	Tuning Mode	Video 2 -> Video 1	RDS Seek	Display	
20	Rear	Center		Video 3 -> Video 1	Delay	Calibrate	Memory	1
21	6	7	8	9	5	4	3	2
22	TV	Video 1	Video 2	Video 3	TAPE 2	Tape 1 Monitor	CD	AM/FM
23	Tuning Up	Tuning Down	WRAP Up	WRAP Down	CTR · BOOST	Surround	∅	

2. DIGITAL TUNING SYSTEM DESCRIPTION

1) DIGITAL TUNING SYSTEM

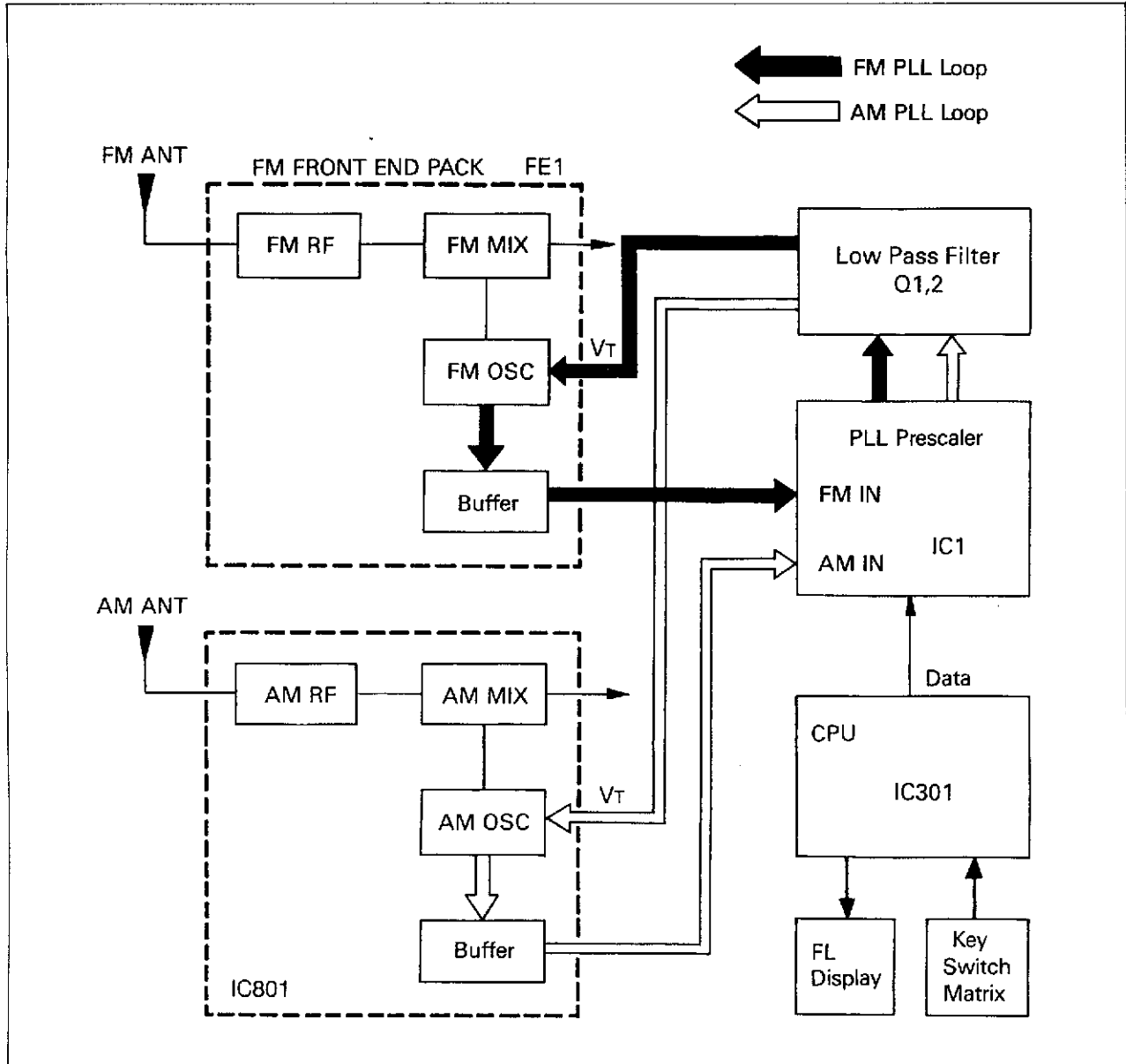

2) VCO VS. FM BAND FREQUENCY CURVE

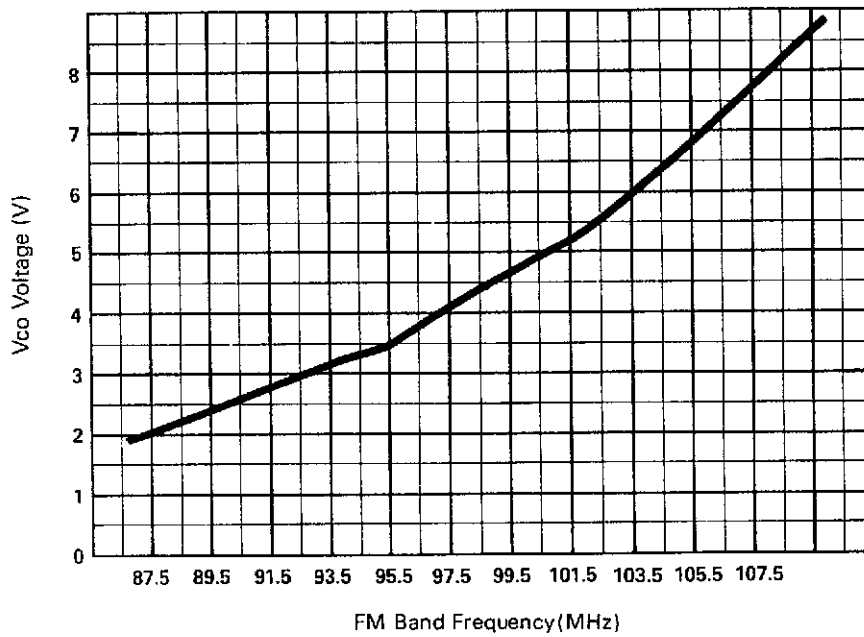

3) VCO VS. AM BAND FREQUENCY CURVE

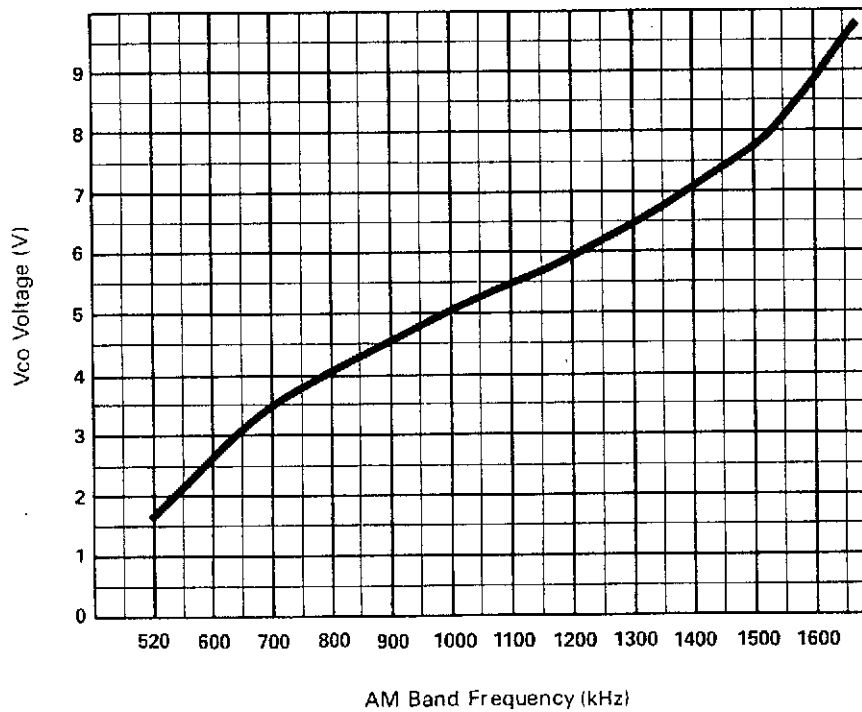

3. PROTECTION CIRCUITS

1) SPEAKER PROTECTION CIRCUIT

The CPU protects both this unit and the speakers when an abnormally high current flows in Q215 L/R/C/SL and Q216 L/R/C/SL due to excessive input drive, too low of a load impedance, or short of the speaker terminals. If current increase is excessive the voltage across R227 L/R/C/SL turns on Q217 L/R/C/SL then Q218 turns on Q219.

It makes the protection port of the CPU to low state. Then the power is turned off.

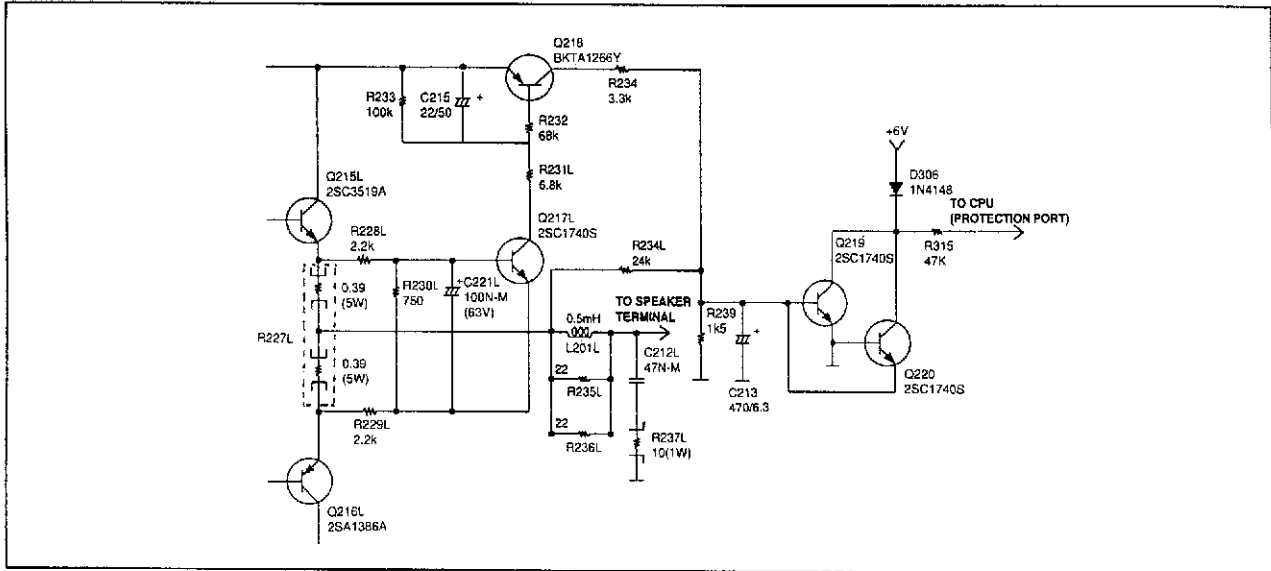

2) THERMAL PROTECTION CIRCUIT

This receiver has an overload thermal protection circuits to guard against abnormal operation. When the temperature of TRANS POSISTOR installed with the main tranformer or H/SINK POSISTOR rises abnormally, the resistance of the posistor becomes large Q219 is turned on. It makes the protection port of the CPU to low state. Then the power is turned off.

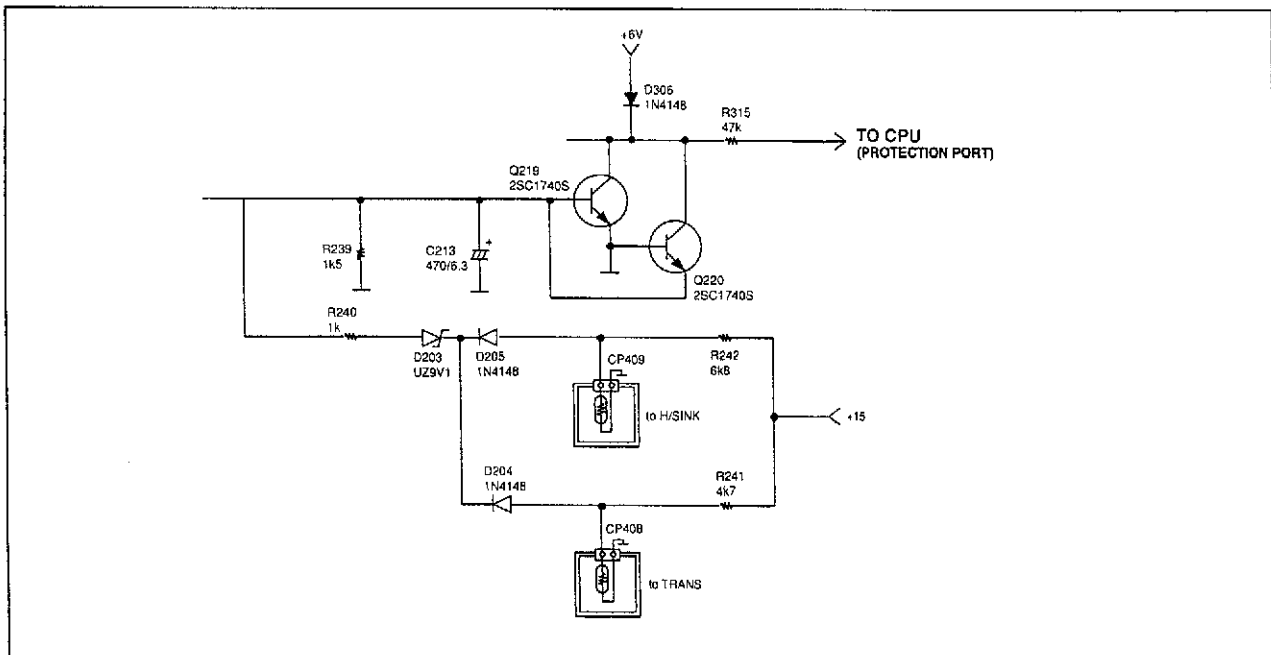

4. SURROUND CIRCUITS

This model incorporates a surround processor circuit.

Fig. 1 is a block diagram of the surround processor circuit.

The microprocessor transfers the data to the Dolby Pro-Logic decoder and Time Delay Device to operate the circuits in each made.

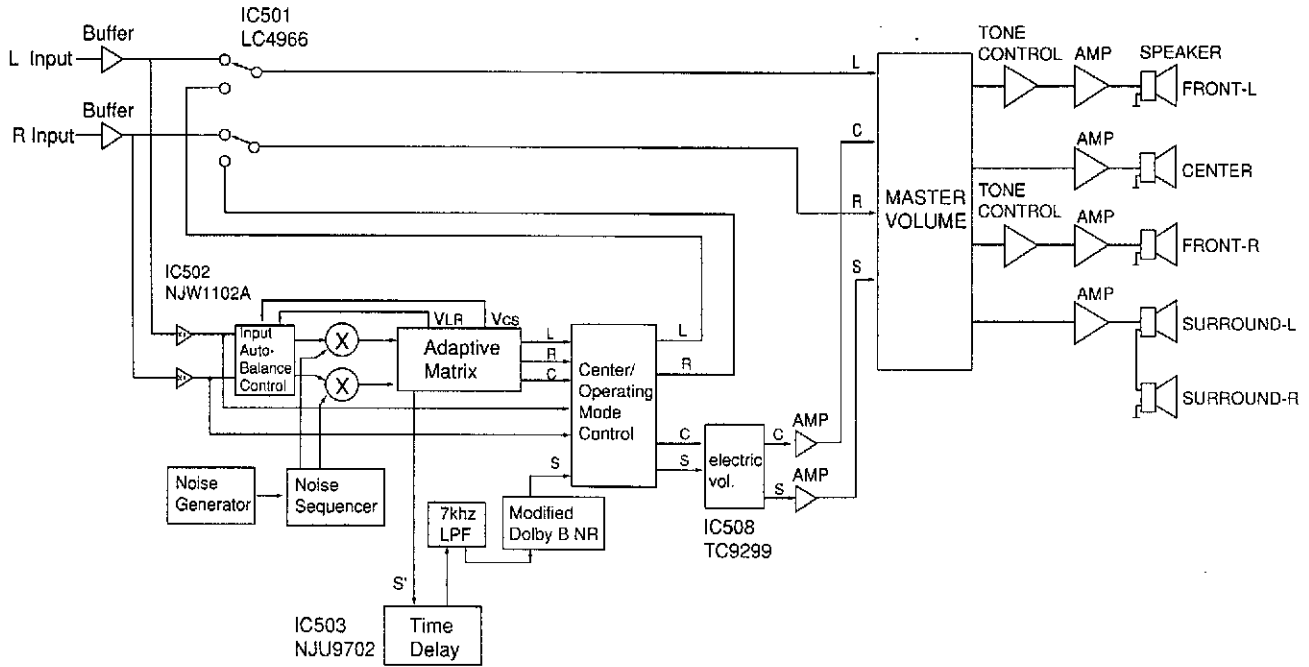

<Block diagram of the surround processor circuit>

Fig. 1

1) OFF

Set to this mode to listen to ordinary stereo sound.

The rear L/R and center outputs will be muted.

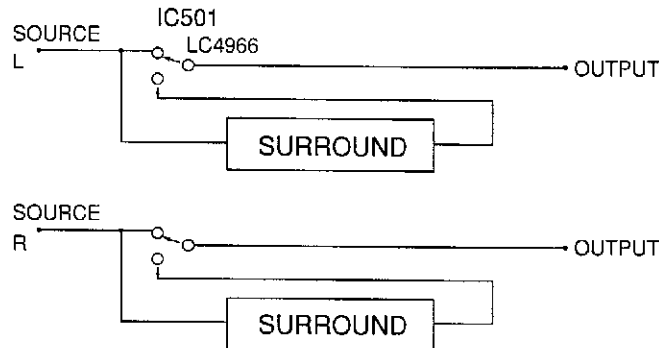

Fig. 2

2) DOLBY PRO-LOGIC CIRCUIT (MOVIE)

Dolby Pro-Logic is a sound effect system for movies developed by the Dolby Laboratories Licensing Corp. IC502 (NJW1102A) is a Dolby Pro-Logic decoder IC.

When an audio signal recorded using the Dolby-Logic system is sent to this IC, the left, right, center and surround components are separated.

The surround signal component is delayed by the delay IC503 (NJU9702).

Fig. 3 shows the configuration of the dolby decoder.

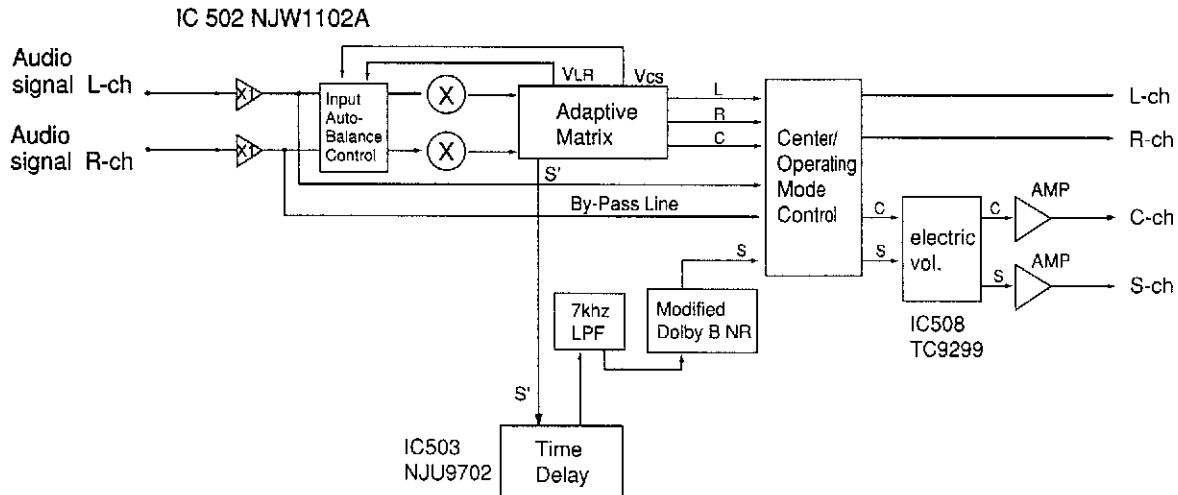

< Flow of signals within the system in the Dolby Pro-Logic mode >

Fig. 3

With Dolby pro logic, three center modes depend on the use of a center speaker as follows.

SMALL	: Bass frequencies are sent only to the Left and Right Front channels. Select this mode when the Center Speaker is smaller than the Left and Right speakers.
LARGE	: Bass frequencies are sent to the Left, Center and Right speakers. Select this mode when the Center speaker is approximately the same size as the Left and Right speakers.
PHANTOM (MUSIC)	: Center channel information is sent to the Left and Right speakers. Select this mode when you do not have a center channel speaker.

3) 3-STEREO CIRCUIT (Pro-Logic. No Rear)

In 3-stereo mode, surround sound is sent to front Left channel and front Right channel and no surround sound is sent to surround channel.

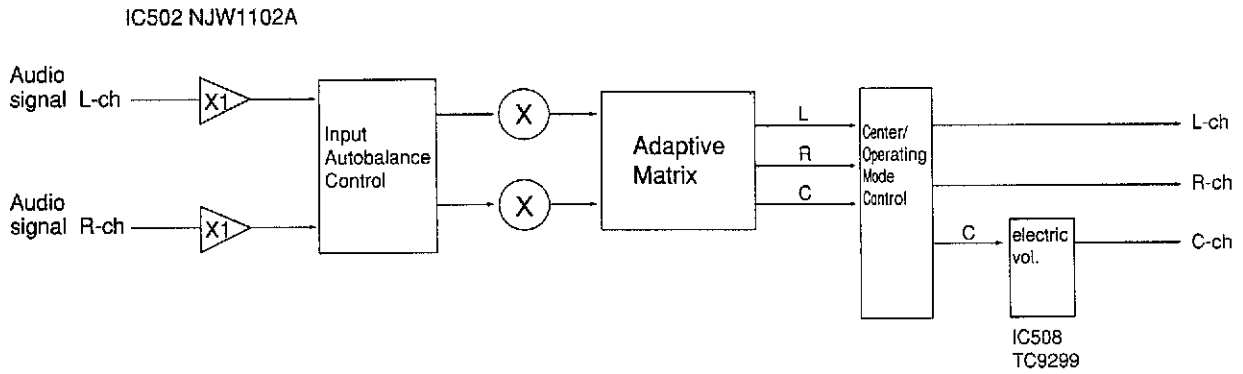

< Flow of signal within the system in the 3-stereo mode >

Fig. 4

5. RDS CIRCUITS

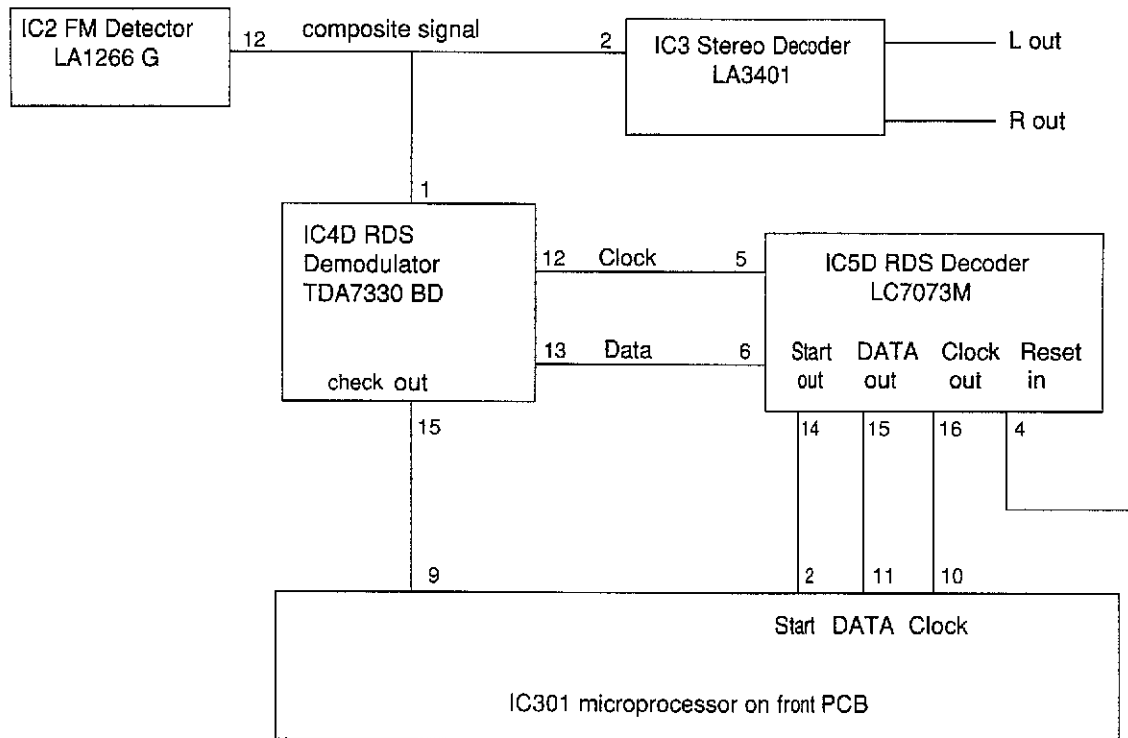

< RDS decoder, block diagram>

Fig. 6

IC301 Pin and function description for RDS

Pin 9 R1 => Output for RDS indication

Pin 2 Start => Serial data start output

Pin 11 DATA => Serial data output

Pin 10 Clock => Serial data output clock

RDS information in the composite signal is fed to pin 1 of RDS Detector (IC4D).

IC4D performs the following functions;

- Remove Low frequency audio information and pass the 57 kHz subcarrier.

- Lock onto the 57 kHz subcarrier, recover the clock signal and get the demodulation of original RDS data.

The Low level signal from pin 15 of IC4D is fed to pin 9 of the microprocessor (IC301).

The recovered clock signal from pin 12 of IC4D is fed to pin 5 of the RDS decoder (IC5D).

The decoded Low signal from pin 3 of IC4D is fed to pin 6 of IC5D.

The RDS Decoder (IC5D) performs the following functions;

Logic reset (During power on, pin 4 is momentarily connected to ground for chip reset.)

Convert serial data from pin 6 (Data in) and pin 5 (Clock) into parallel data.

Error detection and correction.

It provide group synchronization.

The Low level momentarily signal from pin 14 of IC5D, is fed to pin 2 of the microprocessor (IC301), and let you know the start point of one block of RDS data.

The data signal from pin 15 of IC5D, fed to pin 11 of the microprocessor (IC301), and let you know the content of RDS data.

The clock signal from pin 16 of IC5D, is fed to pin 10 of the microprocessor (IC301), and let you know the frequency clock of RDS data.

ALIGNMENT PROCEDURES

1. Equipment Required

- AM Standard Signal Generator (AM SSG)
- Oscilloscope
- AC Voltmeter
- FM Standard Signal Generator (FM SSG)
- Stereo Modulator
- AM Standar
- Distortion Meter
- DC Voltmeter
- Frequency Counter

Note : Disconnect external FM antenna prior to alignment.

2. Alignment and Test Points (PCB1)

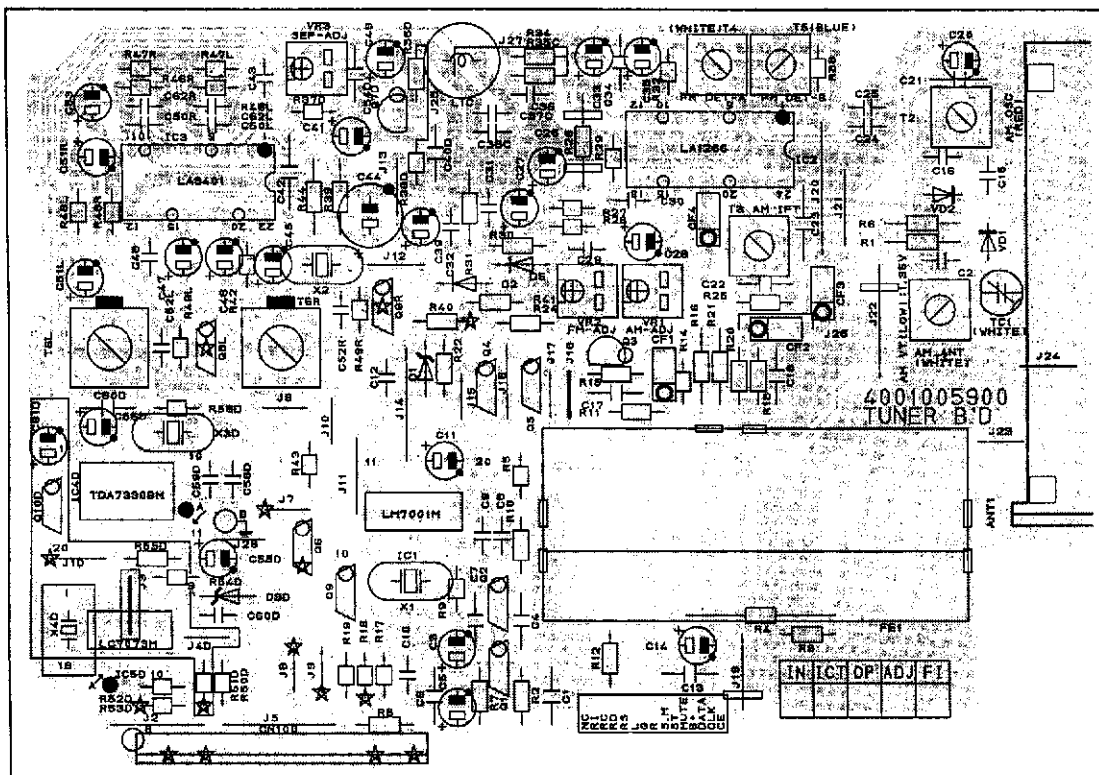

3. AM IF and RF Alignment

Preparation

1. Output of Signal Generator should not be higher than necessary to an optimum output reading.
2. Signal Generator Modulation : 30%
3. Switch : Press to AM.

Step	Signal Generator Frequency	Receiver Frequency on the Display	Equipment Connection	Adjustment Point	Adjust for
1	999 kHz (400 Hz, Mod.)	522 kHz	DC Voltmeter J 22	T2	1.2 V reading
2	594 kHz (400 Hz, Mod.)	594 kHz	AC Voltmeter to TAPE OUT jack	T1 (ANT Coil)	Maximum reading
3	1404 kHz (400 Hz, Mod.)	1404 kHz	AC Voltmeter to TAPE OUT jack	TC1 (ANT Trimmer)	Maximum reading

4	999 kHz (400 Hz, Mod.)	999 kHz	AC Voltmeter to TAPE OUT jack	TC3 (IFT)	Maximum reading
5	999 kHz (400 Hz, Mod.)	999 kHz		VR1	FL display 'TUNED' indication on receiver with AM SSG Output level of 800 $\mu\text{V}/\text{m}$

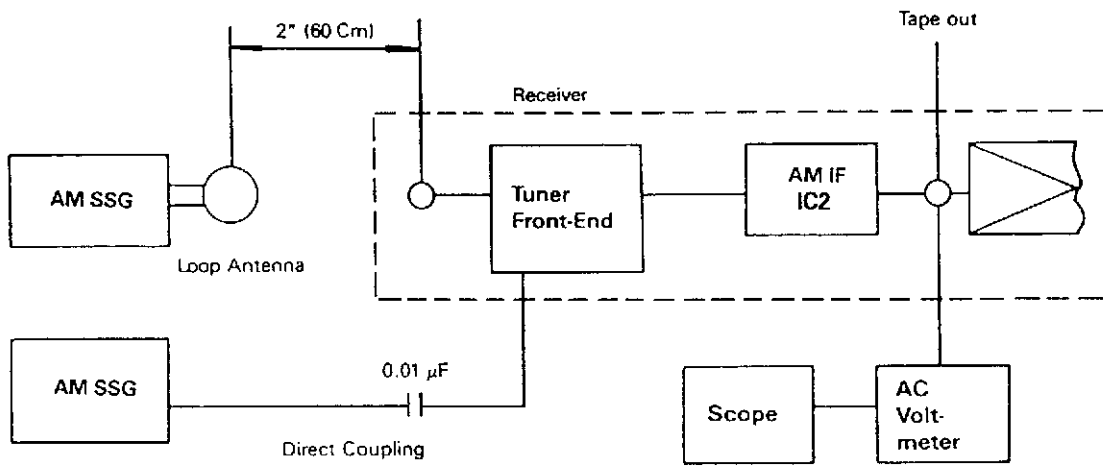

AM Alignment Connection

4. FM IF Alignment

Preparation

1. Signal Generator output should be no higher than necessary to obtain an optimum output reading.
2. Switch Press to FM.
3. Signal generator deviation : 40 kHz (for Europe)
75 kHz (for USA/Canada)

Step	Signal Generator Frequency	Receiver Frequency Display	Equipment Connection	Adjustment Point	Adjust for
1	98.0 kHz (1 kHz, Mod.)	98.0 MHz	DC Voltmeter to R26 (TP1 and TP2)	T4 (WHITE)	Zero Reading on DC Voltmeter
2	98.0 kHz (1 kHz, Mod.)	98.0 MHz	Distortion meter to TAPE OUT jack	T5 (BLUE)	Minimum distortion
3	98.0 kHz (1 kHz, Mod.)	98.0 MHz		VR2	FL display 'TUNED' indication on receiver with FM SSG Output level of 10 $\mu\text{V}/\text{m}$

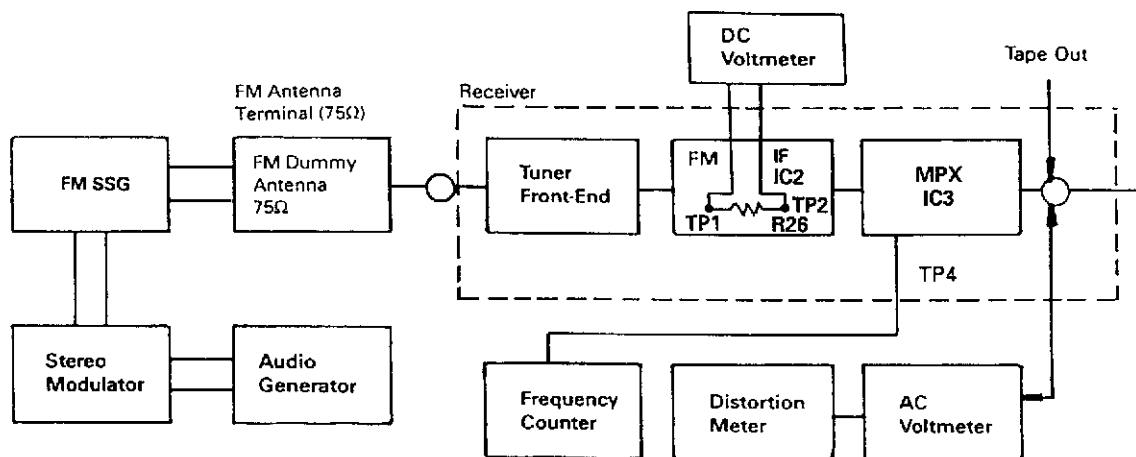

FM RF/IF and MPX Alignment Connection

5. MPX Alignment

Preparation

1. Switch : Press to FM.
2. Tuner for 98 MHz on band.
3. Signal Generator output level : 1000 μ V
4. Deviation : 40 kHz for Europe
75 kHz for USA/Canada
5. Connect Signal Generator to FM antenna terminal through FM dummy antenna (75 Ω)

Step	19kHz Modulation Level	Signal Generator Frequency setting	Equipment Connection	Adjustment Point	Adjust for
1	8% Mod.	Composite to channel 1kHz R	Distortion meter to TAPE OUT jack	FM IFT Coil (in F/E Pack)	Minimum Distortion
2	8% Mod.	Composite to channel 1kHz R	AC Voltmeter to TAPE OUT jack of R channel		Confirm Audio output as about 520 mV and ref. as "0 dB"
3	8% Mod.	Composite to channel 1kHz L	AC Voltmeter to TAPE OUT jack of R channel	VR3	AC Voltmeter reading should be at least 40 dB below.
4	8% Mod.	Composite to channel 1kHz L	AC Voltmeter to TAPE OUT jack of L channel		Same as Step 2.
5	8% Mod.	Composite to channel 1kHz R	AC Voltmeter to TAPE OUT jack of R channel	VR3	AC Voltmeter reading should be at least 40 dB below.

If you could not obtain -40dB readings in Steps 4 and 5 (compared with Step 2 and 4), readjust VR3 until you obtain -40dB readings for both Steps 4 and 5. Nominal is -45dB.

TROUBLESHOOTING

Symptom	Cause and Remedy
Receiver inoperative. (FL indicator does not light.)	<p>A) Faulty AC power cord. Replace.</p> <p>B) Defective the power switch. Replace.</p> <p>C) Broken wire in the power transformer. Replace the power transformer.</p> <p>D) Blown fuse. Replace the fuse.</p>
Fuse blows when power is turned on.	<p>A) Defective power transformer. Replace.</p> <p>B) Short on the primary or secondary of the transformer circuitry. Repair the short.</p> <p>C) Damaged rectifier (D108 to D111) or damaged transistor (Q215L/R/C/SL to Q216L/R/C/SL) Replace the defective component(s).</p> <p>D) Short circuit in the amplifier circuit. Replace the shorted component(s) in the amplifier circuit.</p>
Power indicator lights but no sound from both channels.	<p>A) Defect in transistor Q215L/R, Q216L/R on the Main Amp Board. Replace the defective component(s).</p>
One channel does not work when volume is at maximum with a test signal applied to the center terminal of volume control VR5 of the dead channel.	<p>A) Defect in transistors Q215L/R, Q216L/R on the Main Amp Board. Locate and correct the defect.</p> <p>B) Break in copper foil of printed circuit board. Repair the trace.</p> <p>C) Short in speaker output terminal. Repair or replace.</p>
FM inoperative.	<p>A) Defective front-end. (FTA3-506H) Replace.</p> <p>B) Defective FM switch. Replace the switch.</p> <p>C) Defective transistors Q1, Q2, Q3, IC1, IC2 Replace the defective transistor(s) or IC(s).</p> <p>D) Defective coil T4 or T5. Replace the coil(s).</p> <p>E) Defective lead-in. Repair or replace the lead-in.</p> <p>F) Ceramic filters CF803 (Europe Only) defective. Replace the defective ceramic filter(s).</p> <p>G) Defective controller circuit component. Replace.</p>

Speaker works normally but headphones inoperative.	A) Headphone plug does not mate with jack. Replace the jack. B) Defective resistor R395L/R. Replace.
Poor multiplex separation.	A) Improper adjustment. Readjust VR3. (Refer to MPX Alignment.) B) IC3 defective. Replace. C) Variable resistor VR3 defective. Replace the variable resistor(s).
STEREO indicator does not light.	A) Defective indicator in FL. Replace. B) Defective IC3. Replace the defective component.
FM volume not sufficient.	A) If volume from both L and R channels is not loud enough: Front end section defective. Faulty IC2, Coil T4, T5. If sound of one channel is not loud enough: Defective T6L, T6R.
FM Mono has no effect.	A) Defective FM MODE switch. Replace.
AM inoperative.	A) Damaged IC2 of tuner board. Replace. B) Defective T1, T2, T3, or CF4 of Tuner Board. Replace the defective component(s). C) Defective AM switch. Replace. D) Defective varicap diodes VD1, VD2 Replace varicap diods(s). E) Damaged AM loop antenna. Repair or replace. F) Defective controller circuit component. Replace.
Bass control has no effect.	A) Variable resistor BASS defective. Replace. B) Defective R705L/R, R706L/R, C705L/R, C706L/R. Replace the defective component(s).
Treble control has no effect.	A) Variable resistor TREBLE defective. B) Defective R707L/R, R708L/R, C707L/R, C708L/R. Replace the defective components(s).
Manual tune inoperative.(UP/DOWN) (AM or FM)	A) Poor contact in Up/Down key. Replace. B) Defective IC301. Replace.

Auto tune inoperative.(Up/Down)	<p>A) Poor contact in Up/Down key. Repair or replace.</p> <p>B) Defective IC301. Replace.</p> <p>C) Defective tuner circuit components. Replace.</p> <p>D) In case of FM only, improper adjustment of FM front-end. Readjust.</p>
Memory setting (Keys 1-10) inoperative.	<p>A) Poor contact in memory keys 1-10. Replace.</p> <p>B) Poor contact in memory set key. Replace.</p> <p>C) Defective IC301. Replace the defective component.</p>
FL inoperative.	<p>A) FL defective. Replace.</p> <p>B) Defective IC301. Replace.</p> <p>C) Defective X301. Replace.</p>
Noisy volume control.	<p>A) Defective volume control. Replace.</p> <p>B) Defective capacitors C566 or C568 Replace the defective capacitor(s).</p>
Remote Control Unit inoperative.	<p>A) Weak battery. Replace.</p> <p>B) Defective. Replace.</p> <p>C) Defective IC301 (Front Board) or RMC301. Replace.</p>

GENERAL UNIT PARTS LIST

REF. NO.	DESCRIPTION	New Part No	Q't	Version	REF. NO.	DESCRIPTION	New Part No	Q't	Version
	PACKAGE				S76-S80	SCREW #B WPTT3x6Y	B020030081W10	5	
	BOX CARTON	6017040990120	1		S81-S87	SCREW #B BTT3x8B	B020030083B10	7	
	BOX CARTON	6017040990130	1	AVR41(Only)	S88/S89	SCREW HEAT SINK	1507041136010	2	
	POLY BAG	833704122201A	1		S90	SCREW #B BTT3x8B	B020030083B10	1	
	FILM SOFT PE	8327040302010	1		S91	SCREW HEAT SINK	1507041136010	1	
	CUSHION POLY	6230043784010	1		S92	SCREW GUIDE 3X16Y	1507041456010	1	
					S93	SCREW #B BTT3x8B	B020030083B10	1	
	ACCESSORIES				S94-S96	SCREW HEAT SINK	1507041136010	3	
	ANTENNA AM LOOP STAND-TYPE	E601010000000	1		S97	SCREW GUIDE 3X16Y	1507041456010	1	
	ANTENNA WIRE FM	E605010010000	1		S98/S99	SCREW #B BTT3x8B	B020030083B10	2	
	MATCHING TRANS	L108284007100	1	AVR40(USA Only)	S101-S104	SCREW #B BTT3x8B	B020030083B10	4	
	MATCHING TRANS	L108284007200	1		S105	SCREW GUIDE 3X16Y	1507041456010	1	
	COMMANDER ASS'Y	8300040601010	1		S106	SCREW HEAT SINK	1507041136010	1	
	COMMANDER ASS'Y	8300040602010	1	AVR41(Only)	S107	SCREW #B BTT3x8B	B020030083B10	1	
	BATTERY 1.5V AA(R6M)	G670001R50010	2		S108	SCREW HEAT SINK	1507041136010	1	
	MANUAL INSTRUCTION	5707045960010	1	AVR40(USA Only)	S109-S112	SCREW #B WPTT3x6Y	B020030081W10	4	
	MANUAL INSTRUCTION	5707045970010	1		S113-S125	SCREW #B BTT3x8B	B020030083B10	12	
	RCA CORD 1P 3.5 MM	L063041230000	2		S126-S129	SCREW #B WPTT3x6Y	B020030081W10	4	
					S130-S135	SCREW #B BTT3x8B	B020030083B10	6	
	CABINET & CHASSIS				S136	SCREW GROUND	1507040998010	1	
1	WINDOW, FL	5077040913010	1		S137	SCREW #B BTT3x8B	B020030083B10	1	
1	WINDOW, FL	5077040923010	1	AVR41(Only)	S138	SCREW GROUND	1507040998010	1	
2	FILTER, FL	5200041222010	1		S139	SCREW #B BTT3x8B	B020030083B10	1	
3	DEFUSER	1230040100010	1		S140	SCREW GROUND	1507040999010	1	
4	KNOB ROTARY	5097064701010	3		S141-S145	SCREW #B BTT3x8B	B020030083B10	5	
5	PANEL FRONT	3067042251010	1		S146/S147	SCREW GROUND	1507040998010	2	
5	PANEL FRONT	3067042251020	1	AVR41(Only)	S148	SCREW #B BTT3x8B	B020030083B10	1	
6	BUTTON POWER	508704537101A	1		S149/S150	SCREW GROUND	1507040996010	2	
7	LIGHT SHIELD	4470042662010	1		S151	SCREW #B BTT3x8B	B020030083B10	1	
8	INDICATOR POWER	5160040573010	1		S152	SCREW GROUND	1507040996010	1	
9	BUTTON PUSH	5097054691010	1		S153-S156	SCREW #B BTT3x8B	B020030083B10	4	
10	BUTTON 4KEY	5097046581010	1						
10	BUTTON 8KEY	5097046511010	1	AVR41(Only)		MISCELLANEOUS			
11	BUTTON LEVEL (4KEY)	5097046521010	1			ST/BY TRANS 120V/60HZ	8200281011410	1	AVR40(USA Only)
12	BUTTON TUNNING (11KEY)	5097046561010	1			ST/BY TRANS 230V/50HZ	8200281011510	1	
13	BUTTON FUNCTION (8KEY)	5097046551010	1			LOCKING TIE	4330040533010	1	
14	BUTTON SURROUND(3KEY)	5097046531010	1			CABLE TIE	4330040343010	6	
15	BUTTON 2KEY(A)	5097054671010	1						
16	JACK RCA 3P(GOLD)	G806040300000	1						
17	KNOB VOLUME	5087046501010	1						
18	INDICATOR VOLUME	516004083301A	1						
19	BUTTON LOUD	5087053861010	1						
20	ROTARY VOLUME	C452111402200	1						
21	ROTARY VOLUME	C454121402800	2						
22	SPONGE CUSHION B	4050043895010	1						
23	SHIELD FENCE	3070046326010	1						
24	SPONGE	4050043325010	1						
25	FL CM1564C AVR40/41	K530001790010	1						
26	BUTTON SPEAKER	5097053841010	2						
27	BUTTON S/W JACK	4010056196010	1						
28	H/PONE JACK(GOLD,3P)	G402040161330	1						
29	BUFFER RS-717	4050045669010	1						
30	COVER TOP	3000045396010	1						
31	CHASSIS FRONT	3210041066010	1						
32	FASTENER	4420040323010	2						
33	MOTOR VOLUME	C49514530322	1						
34	COVER BOTTOM	4310041986010	1						
35	FOOT P/L (H/S)	4007040255010	4						
36	FRAME R	3200047716010	1						
37	HOLD PCB	4320044741010	1						
38	RCA JACK (6P)	G803600480010	3						
39	SPK TERMINAL (4P)	G040404204220	1						
40	HEAT SINK REG TR(15X30)	2120044338010	1						
41	HEAT SINK REG TR(24X45)	2120044298010	2						
42	HEAT SINK REG TR(15X30)	2120044338010	6						
43	BRACKET PCB	4010056206010	1						
44	HEAT SINK POWER	2120040898010	1						
45	FRAME L	3200047706010	1						
46	POWER TRANS 120V/60HZ	8200281011610	1	AVR40(USA Only)					
46	POWER TRANS 230V/50HZ	8200281011310	1						
47	INSULATION COVER	1240044032010	1	AVR41(Only)					
48	AC OUTLET	G435040110000	1						
48	AC OUTLET	G435040060000	1	AVR40(USA Only)					
49	SPK TERMINAL (2P)	G611040350000	1						
50	SPK TERMINAL (4P)	G594040540000	1						
51	BUSHING TERMINAL	2410040270010	6						
52	RCA JACK 2P(Y)	G601201150010	2						
53	MULTY ROOM JACK (2P)	G402042130000	1						
54	RCA JACK (4P)	G602400450020	1						
55	RCA JACK (6P)	G603600480010	1						
56	ANT TERMINAL	G59004048000A	1						
56	ANT TERMINAL	G580040470000	1	AVR40(USA Only)					
57	CHASSIS BACK	3207042756010	1	AVR40(USA Only)					
57	CHASSIS BACK	3207042756020	1	AVR41(Only)					
57	CHASSIS BACK	3207042756030	1						
58	PLUG JUMPER	L063040750000	2						
59	AC POWER CORD	L081041210010	1	AVR40(USA Only)					
59	AC POWER CORD 2.5A/250V	L081040411030	1						
60	CORD STOPPER	4380040162010	1						
	SWITCHES								
SW1	POWER S/W(TVS)	G000041610000	1						
SW2	TACT S/W	G180040500010	1						
SW3	PUSH S/W(2Z)	G000040960000	1						
SW4-SW36	TACT S/W	G180040500010	32						
SW39	PUSH S/W	G000041830000	1						
	HARDWARE KIT								
S1-S5	SCREW #B BTT3x8B	B020030083B10	5						
S6-S11	SCREW #B WPTT3x6Y	B020030081W10	6						
S12-S58	SCREW #B BTT3x8B	B020030083B10	46						
S59-S66	SCREW #B WPTT3x6Y	B020030081W10	5						
S67-S69	SCREW #B BTT3x8B	B020030083B10	3						
S71-S75	SCREW #B BTT3x8B	B020030083B10	5						

PRODUCT SAFETY NOTICE

Each precaution in this manual should be followed during servicing. Components identified with the IEC symbol Δ in the parts list are of special significance to safety. When replacing a component identified with Δ , use only the replacement parts designated, or parts with the same ratings of resistance, wattage or voltage that are designated in the parts list in this manual. Leakage-current or resistance measurements must be made to determine that exposed parts are acceptably insulated from the supply circuit before returning the product to the customer.

PCB9 (SPKR-TER)

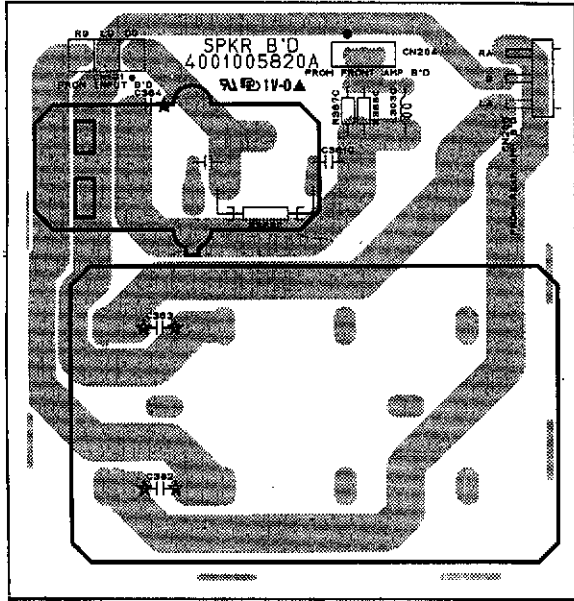

PCB15 (TONE)

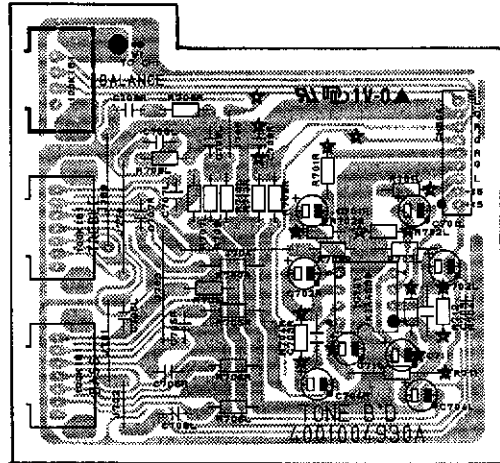

PCB10 (CAM)

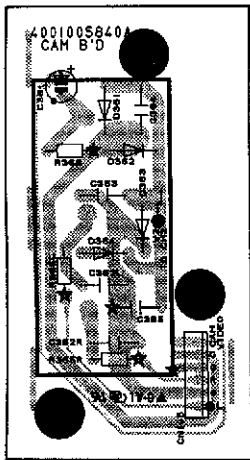

PCB6 (POWER PUSH-SW)

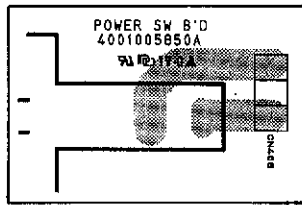

PCB7 (ST-BY SW)

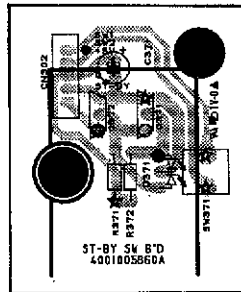

PCB11 (LOUDNESS)

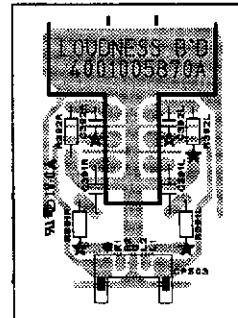

PCB12 (RMC)

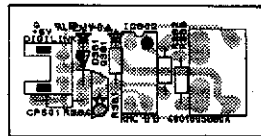

PCB14 (VIDEO)

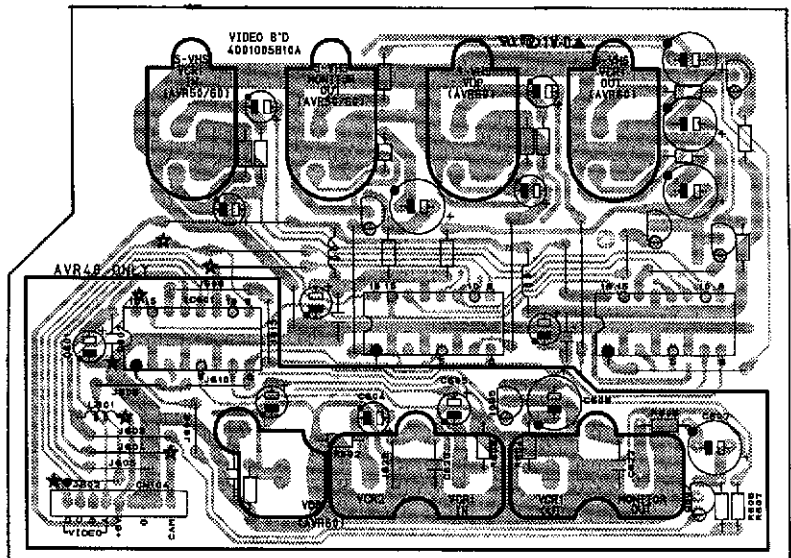

PCB8 (HEAD-PHONE)

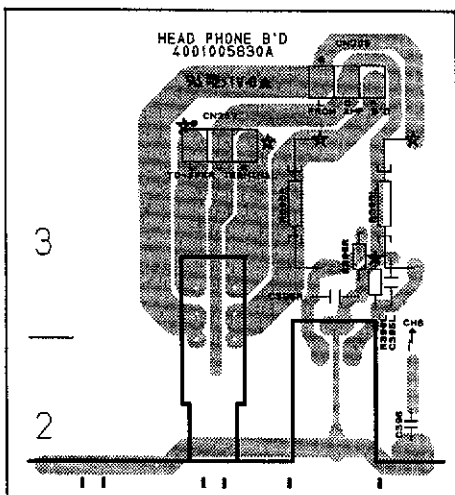

PCB17 (ST-BY)

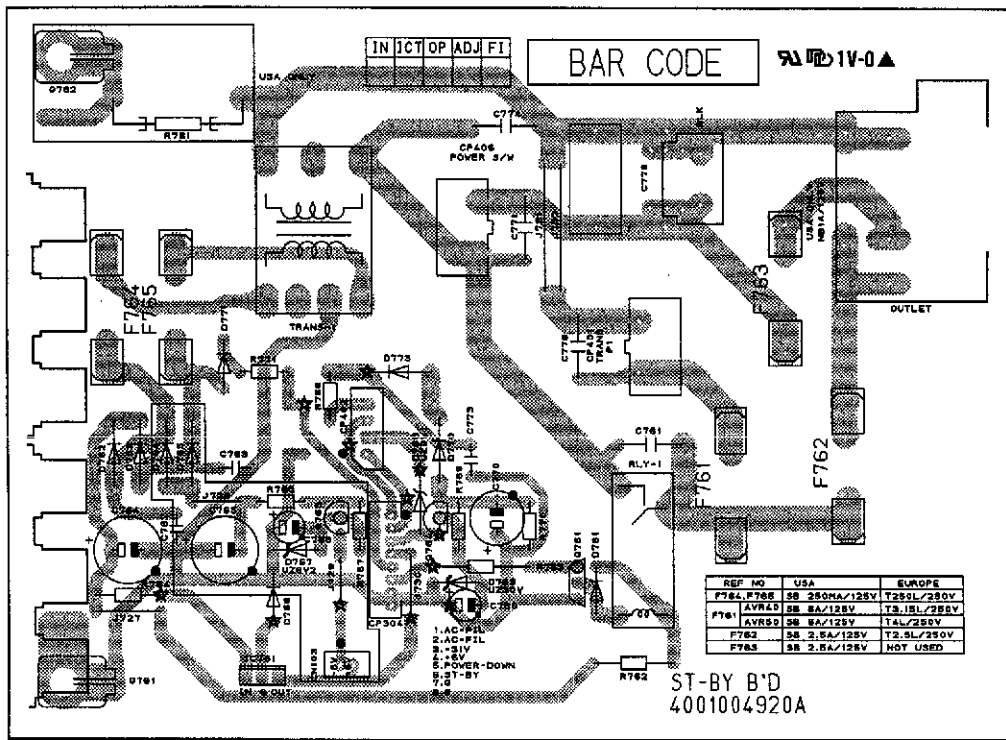

PCB1 (TUNER)

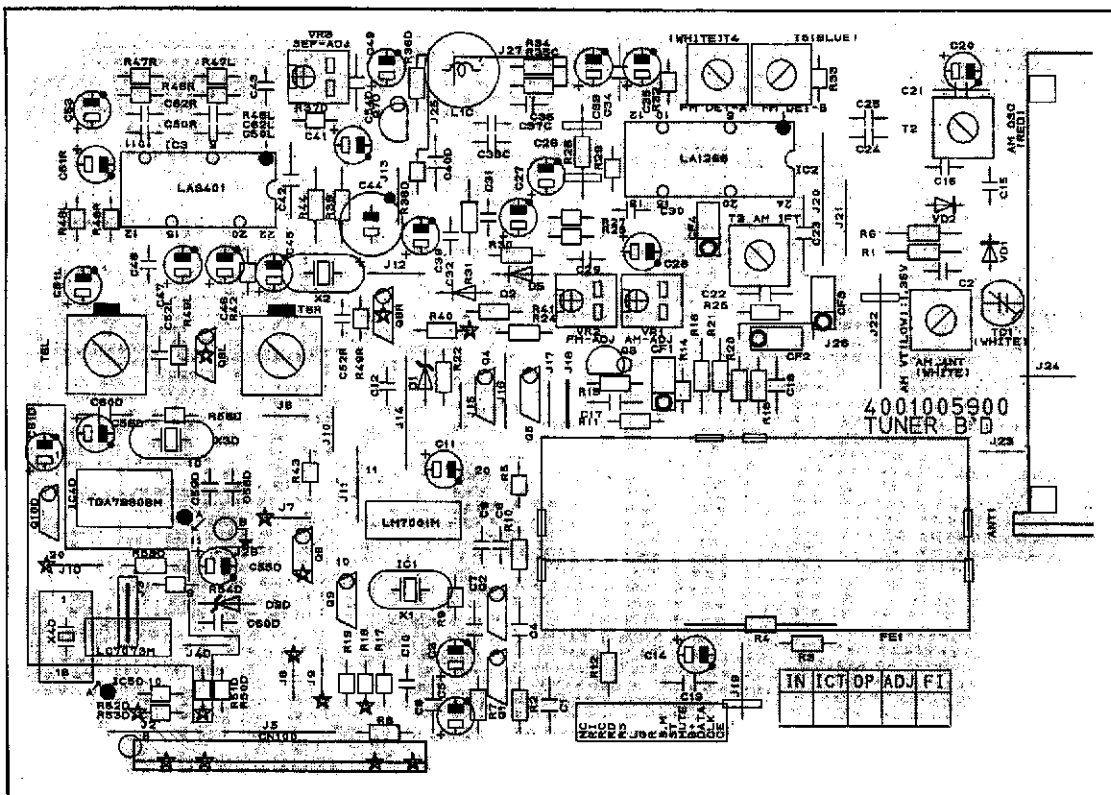

ELECTRICAL PARTS LIST

REF. NO.	DESCRIPTION	New Part No	Q't	Version	REF. NO.	DESCRIPTION	New Part No	Q't	Version
R1	CARBON FILM	100 kohm	1/5W	J	C00001046P520	1			
R2	CARBON FILM	5.6 kohm	1/5W	J	C00005626P520	1			
R3	CARBON FILM	22 kohm	1/5W	J	C00002236P520	1			
R4	CARBON FILM	100 kohm	1/5W	J	C00001046P520	1			
R5	METAR FILM	220 ohm	1/5W	J	C06002216P520	1			
R6	METAR FILM	470 ohm	1/5W	J	C06004716P520	1			AVR41(Only)
R7	CARBON FILM	100 kohm	1/5W	J	C00001046P520	1			
R8	CARBON FILM	10 kohm	1/5W	J	C00001036P520	1			
R9	METAR FILM	270 ohm	1/5W	J	C06002716P520	1			
R10	METAR FILM	560 ohm	1/5W	J	C06005616P520	1			
R11	METAR FILM	1 kohm	1/5W	J	C06001026P520	1			
R12	METAR FILM	180 ohm	1/5W	J	C06001816P520	1			
R13	METAR FILM	560 ohm	1/5W	J	C06005616P520	1			
R14	METAR FILM	3.3 kohm	1/5W	J	C0600336P520	1			
R15	METAR FILM	470 ohm	1/5W	J	C06004716P520	1			
R16	METAR FILM	560 ohm	1/5W	J	C06005616P520	1			
R17-R19	METAR FILM	1 kohm	1/5W	J	C06001026P520	3			
R20	METAR FILM	330 ohm	1/5W	J	C0600336P520	1			
R21	METAR FILM	270 ohm	1/5W	J	C06002716P520	1			
R22	METAR FILM	470 ohm	1/5W	J	C06004716P520	1			
R24	METAR FILM	4.7 kohm	1/5W	J	C06004726P520	1			
R25	CARBON FILM	68 kohm	1/5W	J	C00006836P520	1			
R26	CARBON FILM	27 kohm	1/5W	J	C00002736P520	1			AVR40(USA Only)
R26	CARBON FILM	39 kohm	1/5W	J	C00003936P520	1			
R27	CARBON FILM	10 kohm	1/5W	J	C00001036P520	1			
R28	CARBON FILM	22 kohm	1/5W	J	C00002236P520	1			
R29	METAR FILM	22 ohm	1/5W	J	C06002206P520	1			
R30	METAR FILM	4.7 kohm	1/5W	J	C06004726P520	1			
R31	CARBON FILM	10 kohm	1/5W	J	C00001036P520	1			
R31	CARBON FILM	2.7 kohm	1/5W	J	C06002726P520	1			AVR41(Only)
R32	CARBON FILM	5.6 kohm	1/5W	J	C00005626P520	1			
R33	METAR FILM	3.3 kohm	1/5W	J	C0600336P520	1			
R34	METAR FILM	100 ohm	1/5W	J	C06001016P520	1			
R35C	METAR FILM	1.8 kohm	1/5W	J	C06001826P520	1			AVR40(EU Only)
R37D	METAR FILM	22 ohm	1/5W	J	C06002206P520	1			AVR40(EU Only)
R38D	METAR FILM	1 kohm	1/5W	J	C06001026P520	1			AVR40(EU Only)
R39	METAR FILM	100 ohm	1/5W	J	C06001016P520	1			
R40	CARBON FILM	47 kohm	1/5W	J	C00004736P520	1			
R41	CARBON FILM	22 kohm	1/5W	J	C00002236P520	1			
R42	METAR FILM	3.3 kohm	1/5W	J	C0600336P520	1			
R43	CARBON FILM	22 kohm	1/5W	J	C00002236P520	1			
R44	CARBON FILM	47 kohm	1/5W	J	C00004736P520	1			
R46L/R	CARBON FILM	120 kohm	1/5W	J	C00001246P520	2			AVR40(USA Only)
R46L/R	CARBON FILM	220 kohm	1/5W	J	C00002246P520	2			
R47L/R	CARBON FILM	180 kohm	1/5W	J	C00001846P520	2			AVR40(USA Only)
R47L/R	CARBON FILM	270 kohm	1/5W	J	C00002746P520	2			
R48L/R	METAR FILM	2.7 kohm	1/5W	J	C06002726P520	2			
R49L/R	METAR FILM	3.3 kohm	1/5W	J	C0600336P520	2			
R50D	METAR FILM	680 ohm	1/5W	J	C06006816P520	1			AVR41(Only)
R51D-R54D	CARBON FILM	10 kohm	1/5W	J	C00001036P520	4			AVR41(Only)
R55D	METAR FILM	1 kohm	1/5W	J	C06001026P520	1			AVR41(Only)
R56D	CARBON FILM	47 kohm	1/5W	J	C00004736P520	1			AVR40(EU Only)
R56D	CARBON FILM	2.2 ohm	1/5W	J	C0000226P520	1			AVR41(Only)
R57L/R	METAR FILM	1.5 kohm	1/5W	J	C06001526P520	2			
T1	COILS								
T2	AM-ANT				D304564300000	1			
T3	AM-Osc				D940111027000	1			
T4	AM-IFT P-7SB				D950010050000	1			
T5	FM-DET-A				D970010040000	1			
T5	FM-DET-B				D970010060000	1			
T6L/R	MPX(18/38KHz) BLK				E401500100000	2			
L1C	20MH				D330208001120	1			AVR41(Only)
VR1	SEMI FIXED VARIABLE RESISTORS								
VR2	SEMI, 5K(B)				50 V	C541502115000	1		
VR3	SEMI, 50K(B)				50 V	C541503115000	1		
VR3	SEMI, 200K(B)				50 V	C541204115000	1		
TC1	MISCELLANEOUS								
X1	TRIMMER	10	µf		D110100901100	1			
X2	X7M2				E80072000080	1			
X3D	CSB450F				E83045800050	1			
X4D	X4M332				E800433200060	1			AVR41(Only)
X4D	CST4M				E830400000070	1			AVR41(Only)
FE1	PTH4-460H				E900446000110	1			
FE1	FTA3-506H				E900350600110	1			AVR40(USA Only)
IC1	LM7001M	J124700100010	1						
IC2	LA1286G	J124126800010	1						
IC3	LA3401	J124340100010	1						
IC4D	TDAT7330BD	J020733000010	1		AVR41(Only)				
IC5D	TD7073M	J124707300010	1		AVR41(Only)				
Q1/Q2	2SC1740S, NPN	J502174050010	2						
Q3	KTC1823Y/KTC3194Y, NPN	J5023194Y0050	1						
Q4-Q6	KRA107M/DTA114YS,PNP	J601107M00050	3						
Q7D	2SC1740S, NPN	J502174050010	1		AVR40(EU Only)				
Q8L/R	DTU232TS, NPN	J602323TS0050	2						
Q9	KRA107M/DTA114YS,PNP	J601107M00050	1						
Q10D	DTC114YS, NPN	J6020114Y0050	1		AVR41(Only)				
R122	RESISTORS								
C112/C113	CAPACITORS								
C120L/R	ELECTROLYTIC SG	47	µf	16 V	M	D040470083100	2		
C121L/R	ELECTROLYTIC SG	47	µf	16 V	M	D040470083100	2		
C122L/R	CERAMIC TUBULAR	47	µf	50 V	M	D001470087530	2		
C123L/R	CERAMIC TUBULAR	47	µf	50 V	M	D001470087530	2		
C124L/R	MYLAR	0.016	µf	100 V	J	D02033206C060	2		
C125L/R	MYLAR	0.047	µf	100 V	J	D02047306C060	2		
C128L/R	ELECTROLYTIC SG	47	µf	16 V	M	D040470083100	2		
C127	ELECTROLYTIC SG	47	µf	16 V	M	D040470083100	1		

REF. NO.	DESCRIPTION	New Part No	Q't	Version
C566	ELECTROLYTIC SG	100 µF 10 V M D040101082080	1	
C567	ELECTROLYTIC SG	100 µF 16 V M D040101083100	1	
C568	ELECTROLYTIC SG	100 µF 10 V M D040101082080	1	
C569-C576	ELECTROLYTIC SG	47 µF 16 V M D040470083100	8	
C577	ELECTROLYTIC SG	0.47 µF 50 V M D040R47087100	1	
C578	ELECTROLYTIC SG	10 µF 50 V M D040100087080	1	
C579	CERAMIC TUBULAR	1000 µF 50 V D005102077530	1	
C580	CERAMIC TUBULAR	100 µF 50 V D001101077530	1	
C581	ELECTROLYTIC SG	0.47 µF 50 V M D040R47087100	1	
C582	ELECTROLYTIC SG	10 µF 50 V M D040100087080	1	
C583	CERAMIC TUBULAR	0.1 µF 50 V D005104087530	1	
C584/C585	ELECTROLYTIC SG	1 µF 50 V M D040010087080	2	
C586	ELECTROLYTIC SG	220 µF 18 V M D040221083100	1	
C587	CERAMIC TUBULAR	0.1 µF 50 V D005104087530	1	
C588	ELECTROLYTIC SG	47 µF 35 V M D040470085100	1	
C589	CERAMIC TUBULAR	0.1 µF 50 V D005104087530	1	
C591	ELECTROLYTIC SG	10 µF 50 V M D040100087080	1	
C592	ELECTROLYTIC SG	0.47 µF 50 V M D040R47087100	1	
CONNECTORS				
CN102	HOUSING, 8P	L122524190800	1	
CN107	HOUSING, 8P	L122524190800	1	
CN502	LEAD ASSY, 12P	L022120833320	1	
CN503	LEAD ASSY, 5P	L022051033320	1	
CP106	WAFER 3P	L101220030000	1	
CP303	WAFER 10P	L101220100000	1	
CP504	WAFER 9P	L101220090000	1	
DIODE				
D501	SWITCHING, 1N4148M	K000414801520	1	
D502	ZENER, UZ 11.0 BSC	K060110024520	1	
D503	SWITCHING, 1N4148M	K000414801520	1	
INTEGRATED CIRCUITS				
IC501	LC4966	J080496600000	1	
IC502	NJW1102AFG1	J081110200000	1	
IC503	NJU8702G	J120970200010	1	
IC504	KIA4559P/KIA75559P	J121455900010	1	
IC505	TA7291S, MOTOR DRIVER	J1272729100000	1	
IC506	NJM2068DD	J121206800000	1	
IC507	KIA4559P/KIA75559P	J121455900010	1	
IC508	TC9269P	J084828900000	1	
TRANSISTORS				
Q501	DTC114YS, NPN	J6020114Y0050	1	
Q502	DTA114YS/KRA107M, PNP	J6000114Y0010	1	
Q503/Q504	DTC114YS, NPN	J6020114Y0050	2	
RESISTORS				
R501/R502	METAL FILM	100 ohm 1/5W J C06001016P520	2	
R503	CARBON FILM	150 kohm 1/5W J C00001546P520	1	
R504/R505	CARBON FILM	100 kohm 1/5W J C00001046P520	2	
R506	CARBON FILM	15 kohm 1/5W J C00001536P520	1	
R507	CARBON FILM	47 kohm 1/5W J C00004736P520	1	
R508	CARBON FILM	7.5 kohm 1/5W J C00007526P520	1	
R509	CARBON FILM	15 kohm 1/5W J C00001536P520	1	
R510	CARBON FILM	47 kohm 1/5W J C00004736P520	1	
R511	CARBON FILM	7.5 kohm 1/5W J C00007526P520	1	
R512/R513	CARBON FILM	22 kohm 1/5W J C00002236P520	2	
R514	CARBON FILM	4.7 ohm 1/5W J C00004756P520	1	
R515	CARBON FILM	3 kohm 1/5W J C00003026P520	1	
R516	METAL FILM	82 ohm 1/5W J C06006206P520	1	
R517	CARBON FILM	100 kohm 1/5W J C00001046P520	1	
R518	CARBON FILM	10 kohm 1/5W J C00001036P520	1	
R519	METAL FILM	1 kohm 1/5W J C06001026P520	1	
R520	CARBON FILM	10 kohm 1/5W J C00001036P520	1	
R521	METAL FILM	4.7 kohm 1/5W J C06004726P520	1	
R522	CARBON FILM	100 kohm 1/5W J C00001046P520	1	
R523	CARBON FILM	15 kohm 1/5W J C00001536P520	1	
R524	CARBON FILM	22 kohm 1/5W J C00002236P520	1	
R525	CARBON FILM	330 kohm 1/5W J C00003346P520	1	
R526/R527	CARBON FILM	15 kohm 1/5W J C00001536P520	2	
R528	CARBON FILM	10 kohm 1/5W J C00001036P520	1	
R529	CARBON FILM	15 kohm 1/5W J C00001536P520	1	
R530/R531	METAL FILM	22 ohm 1/5W J C06002206P520	2	
R532	CARBON FILM	15 kohm 1/5W J C00001536P520	1	
R533	CARBON FILM	10 kohm 1/5W J C00001036P520	1	
R534	CARBON FILM	43 kohm 1/5W J C00004336P520	1	
R535/R536	METAL FILM	100 ohm 1/5W J C06001018P520	1	
R537	CARBON FILM	1 ohm 1/5W J C00001058P520	1	
R538-R540	METAL FILM	1 kohm 1/5W J C06001028P520	3	
R541/R542	METAL FILM	100 ohm 1/5W J C06001018P520	1	
R543/R544	CARBON FILM	100 kohm 1/5W J C00001046P520	1	
R545/R546	CARBON FILM	3.6 kohm 1/5W J C00003628P520	1	
R547/R548	METAL FILM	1.2 kohm 1/5W J C06001228P520	1	
R549	CARBON FILM	10 kohm 1/5W J C00001036P520	1	
R550	CARBON FILM	100 kohm 1/5W J C00001046P520	1	
R551	METAL FILM	4.7 ohm 1/5W J C0604R706P520	1	
R552	CARBON FILM	10 kohm 1/5W J C00001036P520	1	
R553/R554	METAL FILM	100 ohm 1/5W J C06001016P520	2	
R555-R558	CARBON FILM	100 kohm 1/5W J C00001046P520	4	
R559/R560	METAL FILM	100 ohm 1/5W J C06001016P520	2	

REF. NO.	DESCRIPTION	New Part No	Q't	Version
R561/R562	CARBON FILM	47 kohm 1/5W J C00004736P520	2	
R563/R564	METAL FILM	820 ohm 1/5W J C06008216P520	1	
R565	CARBON FILM	9.1 kohm 1/5W J C00009126P520	1	
R566	CARBON FILM	10 kohm 1/5W J C00001036P520	1	
R567-R570	CARBON FILM	100 kohm 1/5W J C00001046P520	4	
R571/R572	METAL FILM	4.7 kohm 1/5W J C06004726P520	2	
R573/R574	METAL FILM	5.1 kohm 1/5W J C06005126P520	2	
R575	METAL FILM	1 kohm 1/5W J C06001026P520	1	
R576/R577	METAL FILM	100 ohm 1/5W J C06001016P520	2	
R578-R580	METAL FILM	1 kohm 1/5W J C06001026P520	3	
R581/R582	CARBON FILM	100 kohm 1/5W J C00001046P520	2	
R591/R592	CARBON FILM	5.1 kohm 1/5W J C00005126P520	2	
MISCELLANEOUS				
X501	RESONATOR, CST2M	E830200000050	1	
RESISTORS				
C602	CERAMIC TUBULAR	0.1 µF 50 V D005104097530	1	
C604/C605	ELECTROLYTIC SG	2.2 µF 50 V M D0402R2087100	2	
C606/C607	ELECTRIC(SG)10X12	470 µF 16 V M D040471083200	2	
C620	CERAMIC TUBULAR	0.1 µF 50 V D005104087530	1	
C622	CERAMIC TUBULAR	0.1 µF 50 V D005104087530	1	
R602-R605	METAL FILM	75 ohm 1/5W J C06007508P520	4	
R606/R607	METAL FILM	100 ohm 1/5W J C06001016P520	2	
Q601	BKTA1266/KTA1015Y, PNP	J5001266Y0050	1	
Q602	BKTA1266/KTA1015Y, PNP	J5001266Y0050	1	
L601	INDUCTOR, 100UH	D330101001020	1	
IC601	BA7625	J121206800000	1	
CN104	LEAD ASSY, 9P	L022091433320	1	
RESISTORS				
C701LR	ELECTROLYTIC SG	4.7 µF 50 V M D0404R7087100	2	
C702LR	ELECTROLYTIC SG	4.7 µF 50 V M D0404R7087100	2	
C703LR	CERAMIC TUBULAR	22 µF 50 V J D00522067530	2	
C704LR	ELECTROLYTIC SG	4.7 µF 50 V M D0404R7087100	2	
C705LR	MYLAR BOX	0.033 µF 63 V J D02033068050	2	
C706LR	MYLAR BOX	0.1 µF 63 V J D020154068050	2	
C707LR	MYLAR BOX	0.004 µF 63 V J D02039208C050	2	
C708LR	MYLAR BOX	0.018 µF 100 V J D02018308C050	2	
C709LR	CERAMIC DISC	100 µF 50 V J D0804101067060	2	
C710/C711	ELECTROLYTIC SG	47 µF 18 V M D040470083100	2	
CONNECTOR				
CN504	LEAD ASSY, 9P	L012092288320	1	
INTEGRATED CIRCUIT				
IC701	KIA4559P/KIA75559P	J121455900010	1	
RESISTORS				
R701LR	METAL FILM	1 kohm 1/5W J C06001026P520	2	
R702LR	CARBON FILM	100 kohm 1/5W J C00001046P520	2	
R703LR	CARBON FILM	100 kohm 1/5W J C00001046P520	2	
R704LR	CARBON FILM	1 ohm 1/5W J C00001058P520	2	
R705LR	CARBON FILM	18 kohm 1/5W J C00001836P520	2	
R706LR	METAL FILM	3.9 kohm 1/5W J C06003928P520	2	
R707LR	METAL FILM	1.2 kohm 1/5W J C06001228P520	2	
R708LR	METAL FILM	560 ohm 1/5W J C06005618P520	2	
R709LR	METAL FILM	1 kohm 1/5W J C06001026P520	2	
R710LR	CARBON FILM	100 kohm 1/5W J C00001046P520	2	
R711/R712	METAL FILM	470 ohm 1/5W J C06004718P520	2	
RESISTORS				
C721C/SL	ELECTROLYTIC SG	4.7 µF 50 V M D0404R7087100	2	
C722C/SL	CERAMIC TUBULAR	100 µF 50 V D001101077530	2	
C723C/SL	CERAMIC TUBULAR	100 µF 50 V D001101077530	2	
C724C/SL	ELECTROLYTIC SG	4.7 µF 50 V M D0404R7087100	2	
C725C/SL	CERAMIC TUBULAR	100 µF 50 V D001101077530	2	
C729/C727	ELECTROLYTIC SG	47 µF 16 V M D040470083100	2	
C728LR	CERAMIC DISC	100 µF 50 V J D004101067060	2	
C729LR	CERAMIC TUBULAR	150 µF 50 V K D005151077530	2	
C730LR	ELECTROLYTIC SG	47 µF 16 V M D040470083100	2	
C731LR	CERAMIC TUBULAR	1000 µF 50 V D005102077530	2	
C732LR	ELECTROLYTIC SG	4.7 µF 50 V M D0404R7087100	2	
C733/C734	ELECTROLYTIC SG	47 µF 16 V M D040470083100	2	
C735C	CERAMIC DISC	100 µF 50 V J D004101067060	1	
C735SL	CERAMIC DISC	100 µF 50 V J D004101067060	2	
C736LR	CERAMIC DISC	100 µF 50 V J D004101067060	2	
C737	CERAMIC TUBULAR	0.1 µF 50 V D005104097530	1	
C737C/SL	CERAMIC TUBULAR	1000 µF 50 V D005102077530	2	
C738	CERAMIC TUBULAR	0.1 µF 50 V D005104097530	1	
CONNECTOR				
CN201	LEAD ASSY, 9P	L012092288320	1	
CN209	LEAD ASSY, 3P	L021035071320	1	
CP502	WAFER 12P	L101220120000	1	
INTEGRATED CIRCUITS				
IC721	KIA4559S/KIA75559P	J121455900010	1	
IC722	KIA4559S/KIA75559P	J121455900010	1	
RESISTORS				

REF. NO.	DESCRIPTION			New Part No	Q't	Version
R721C/SL	METAL FILM	1 kohm	1/5W J	C06001026P520	2	
R722C/SL	CARBON FILM	100 kohm	1/5W J	C00001046P520	2	
R723C/SL	CARBON FILM	100 kohm	1/5W J	C00001046P520	2	
R724C/SL	METAL FILM	1 kohm	1/5W J	C06001026P520	2	
R725C/SL	METAL FILM	1 kohm	1/5W J	C06001026P520	2	
R726C/SL	CARBON FILM	100 kohm	1/5W J	C00001046P520	2	
R727/R728	METAL FILM	470 ohm	1/5W J	C06004716P520	2	
R728C	METAL FILM	3.3 kohm	1/5W J	C06003326P520	1	
R729L/R	METAL FILM	3.3 kohm	1/5W J	C06003326P520	2	
R729SL	METAL FILM	3.3 kohm	1/5W J	C06003326P520	2	
R730	METAL FILM	3.3 kohm	1/5W J	C06003326P520	1	
R730C/SL	METAL FILM	3.3 kohm	1/5W J	C06003326P520	2	
R731	CARBON FILM	10 kohm	1/5W J	C00001036P520	1	
R731C/SL	CARBON FILM	10 kohm	1/5W J	C00001036P520	2	
R732L/R	METAL FILM	1 kohm	1/5W J	C06001026P520	2	
R733L/R	CARBON FILM	47 kohm	1/5W J	C00004736P520	2	
R734L/R	CARBON FILM	100 kohm	1/5W J	C00001046P520	2	
R735/R736	METAL FILM	470 ohm	1/5W J	C06004716P520	2	
R737C	METAL FILM	1 kohm	1/5W J	C06001026P520	1	
R737L/R	METAL FILM	1 kohm	1/5W J	C06001026P520	2	
R737SL	METAL FILM	1 kohm	1/5W J	C06001026P520	1	
R738L/R	METAL FILM	1 kohm	1/5W J	C06001026P520	2	

DIODE

D721	SWITCHING, 1N4148M			K000414801520	1	
D721C/SL	SWITCHING, 1N4148M			K000414801520	2	

TRANSISTORS

Q721C/SL	DTC323TS, NPN			J602323TS0050	2	
Q722C	KTD1302, NPN			J5031302B005A	1	
Q722L/R	KTD1302, NPN			J5031302B005A	2	
Q722SL	KTD1302, NPN			J5031302B005A	1	
Q723	DTA114YS/KRA107M, PNP			J8000114Y0010	1	
Q723C/SL	DTA114YS/KRA107M, PNP			J8000114Y0010	2	
Q724	2SC1740S, NPN			J5021740S0010	1	
Q724C/SL	2SC1740S, NPN			J5021740S0010	2	
Q725L/R	DTC323TS, NPN			J602323TS0050	2	

PCB1788 ASSEMBLY

C761	CERAMIC(RADIAL)	0.005	µF	400 V Z	D00847208K040	1
C762/C763	MYLAR	0.047	µF	100 V J	D02047306C060	2
C764	ELECTRIC(SG) 13X20	1000	µF	25 V M	D040102084200	1
C769	ELECTROLYTIC SG	10	µF	50 V M	D040100087050	1
C770	ELECTROLYTIC SG	47	µF	50 V M	D040470087100	1
C771	CERAMIC(RADIAL)	0.005	µF	400 V Z	D00847208K040	1
C773	MYLAR	0.22	µF	63 V M	D020224078060	1
C774	CERAMIC(RADIAL)	0.005	µF	400 V Z	D00847208K040	1
C775	MYLAR	0.1	µF	250 V K	D02010407H080	1
C776	CERAMIC(RADIAL)	0.005	µF	400 V Z	D00847208K040	1

DIODES

D761	SWITCHING, 1N4148M			K000414801520	1	
D762/D763	RECTIFIER, 1N4003			K040400300520	2	
D766	SWITCHING, 1N4148M			K000414801520	1	
D768	ZENER, UZ 9.1 BSC			K06008R124520	1	
D769	ZENER, UZ 30.0 BSD			K060300034520	1	
D770	RECTIFIER, 1N4003			K040400300520	1	
D771	SWITCHING, 1N4148M			K000414801520	1	
D773	RECTIFIER, 1N4003			K040400300520	1	

FUSES

F761	SB6A/125V			G650632121150	1	AVR40(USA Only)
F762/F763	SB2.5A/125V			G65025251140	2	
F764/F765	SB250mA/125V			G650251251140	2	

INTEGRATED CIRCUIT

IC761	GL7805			J126780500260	1	
-------	--------	--	--	---------------	---	--

TRANSISTORS

Q761	2SC1740S, NPN			J5021740S0010	1	
Q764	MPSA56, PNP			J5005600Y0050	1	

RESISTORS

R761	METAL FILM	3.3 ohm	1/2W J	C060033574530	1	
R762	METAL FILM	120 ohm	1/5W J	C06001216P520	1	
R763	METAL FILM	3.3 kohm	1/5W J	C06003326P520	1	
R764	METAL FILM	56 ohm	1/5W J	C06005606P520	1	
R766	METAL FILM	56 ohm	1/5W J	C06005606P520	1	
R769	METAL FILM	1 kohm	1/5W J	C06001026P520	1	
R770	CARBON FILM	10 kohm	1/5W J	C00001036P520	1	
R771	METAL FILM	4.7 kohm	1/5W J	C06004726P520	1	

CONNECTOR

CN103	LEAD ASSY			L022024533320	1	
CP301	FFC WAFER 25P			L131520452500	1	
CP304	WAFER 8P			L101220080000	1	
CP401	FFC WAFER 25P			L104353130300	1	
CP402	WAFER 4P			L102526703010	1	
CP406	WAFER 3P			L104353130300	1	

REF. NO.	DESCRIPTION	New Part No	Q't	Version
----------	-------------	-------------	-----	---------

★ THE ASSY PCB FRONT(PCB5) INCLUDE BELOWS.

- (1) THE ASSY PCB POWER PUSH-SW(PCB6).
- (2) THE ASSY PCB ST-BY SW(PCB7).
- (3) THE ASSY PCB HEAD-PHONE(PCB8).
- (4) THE ASSY PCB SPKR-TER(PCB9).
- (5) THE ASSY PCB CAM(PCB10).
- (6) THE ASSY PCB LOUDNESS(PCB11).
- (7) THE ASSY PCB RMC(PCB12).
- (8) THE ASSY PCB VIDEO(PCB14).

★ THE ASSY PCB SURROUND(PCB13) INCLUDE BELOWS.

- (1) THE ASSY PCB TONE(PCB15).
- (2) THE ASSY PCB PRE IN/OUT(PCB16).
- (3) THE ASSY PCB ST-BY(PCB17).

IC FUNCTIONAL BLOCK DIAGRAM

IC102, IC103 : LC7821

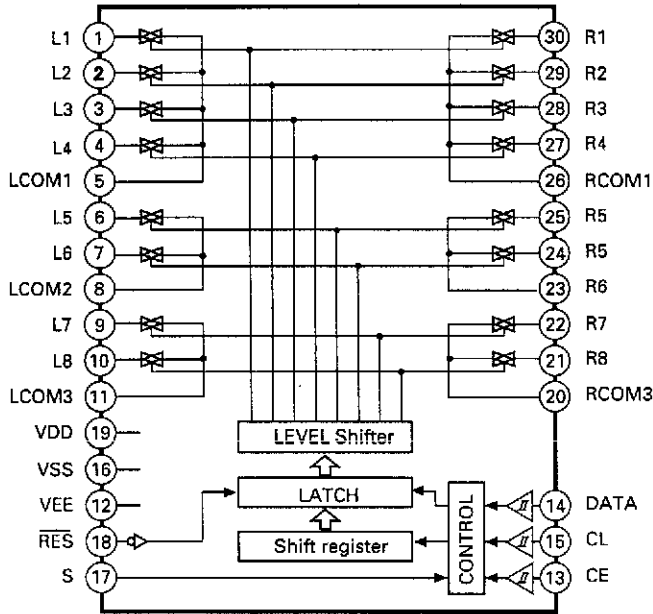

IC105, IC506 : NJM2068DD

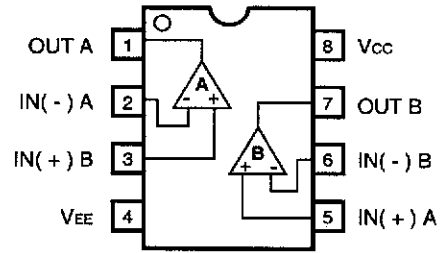

IC106L/R, IC701, IC721, IC722, IC504, IC507 : KIA4559P

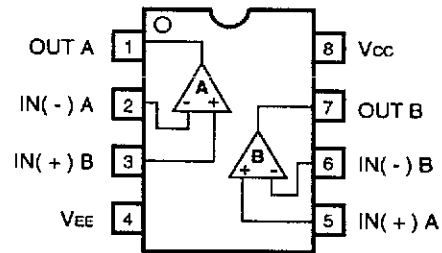

IC501 : LC4966B

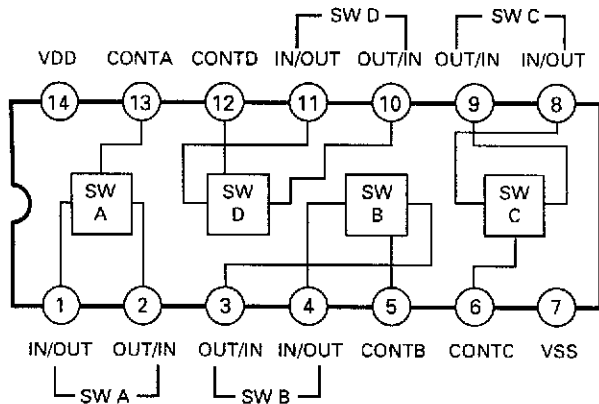

IC2 : LA1266G

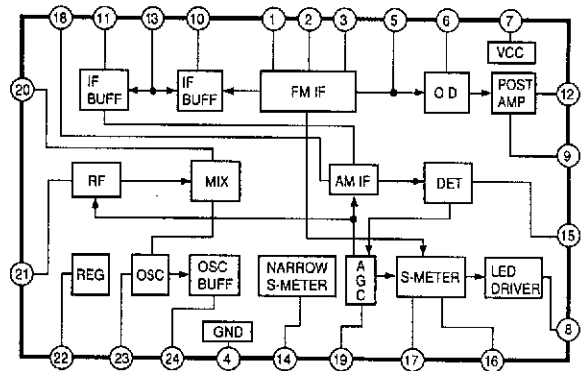

IC503 : NJU9702

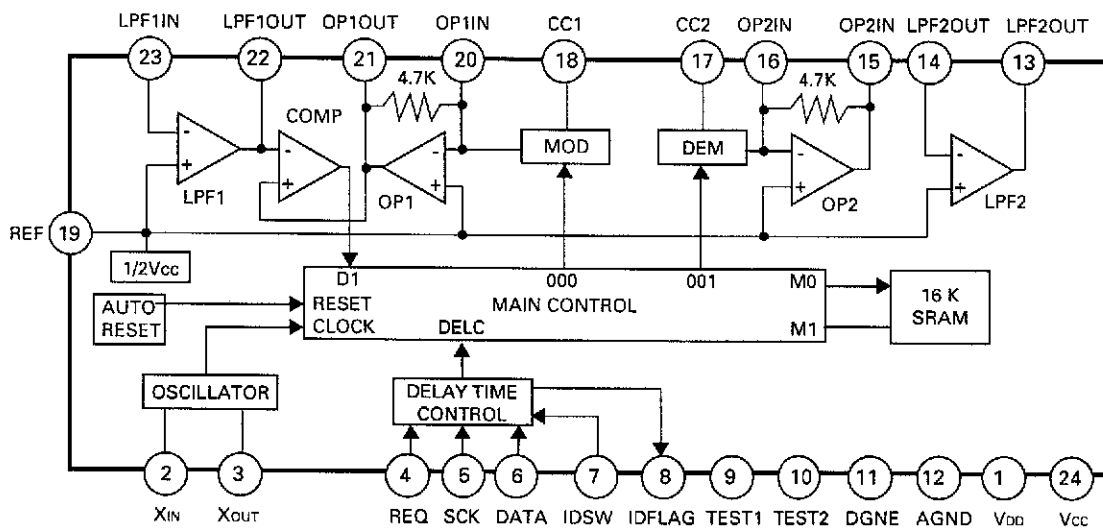

IC110 : KA7806PI
IC108 : KA7815PI
IC761 : GD7805

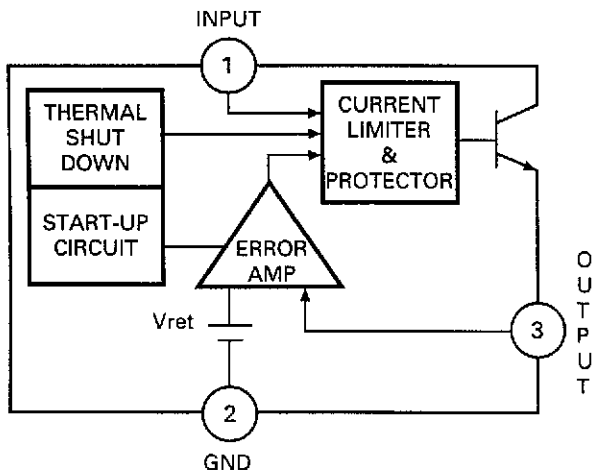

IC109 : KA7915PI

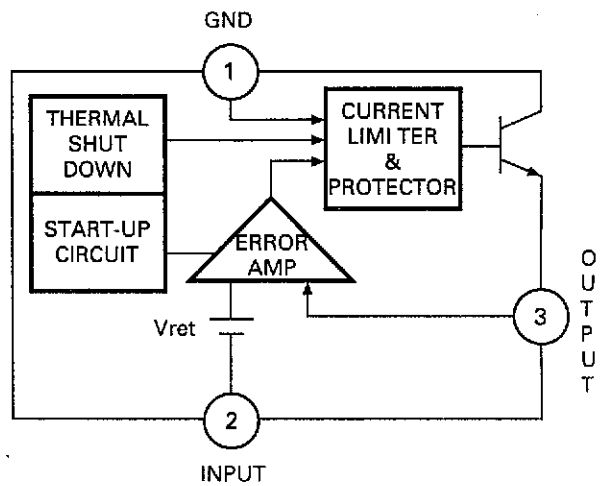

IC505 : TA7291S

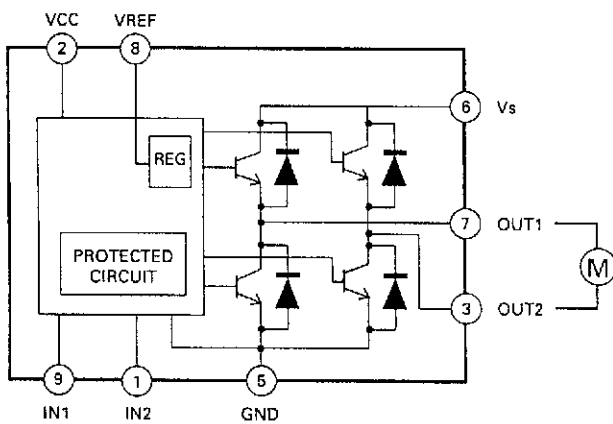

IC3 : LA3401

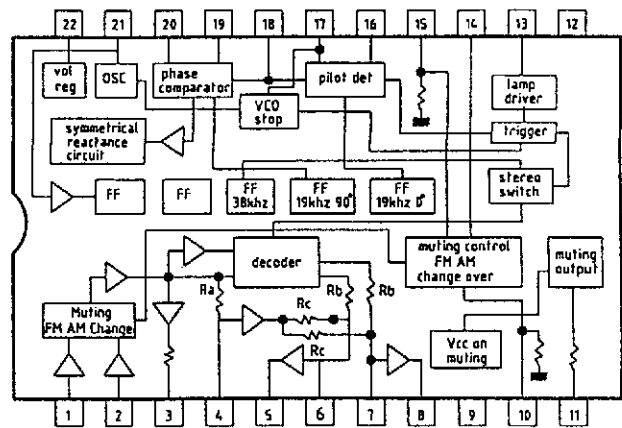

IC4D : TDA7330BD

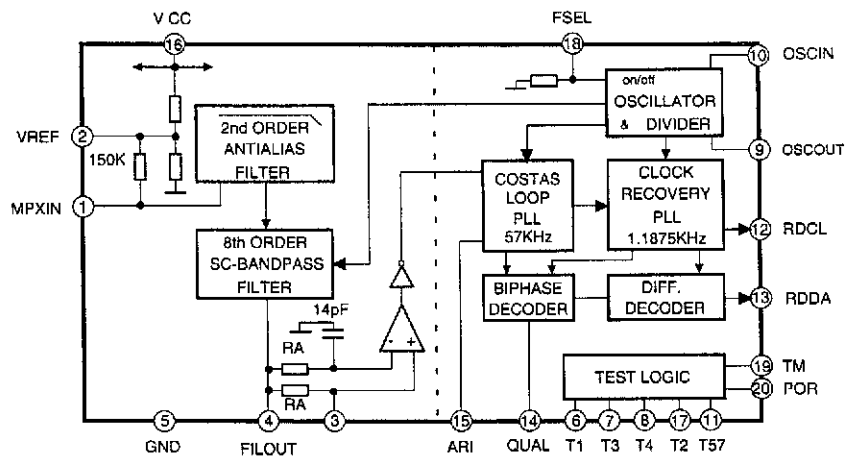

IC5D : LC7073M

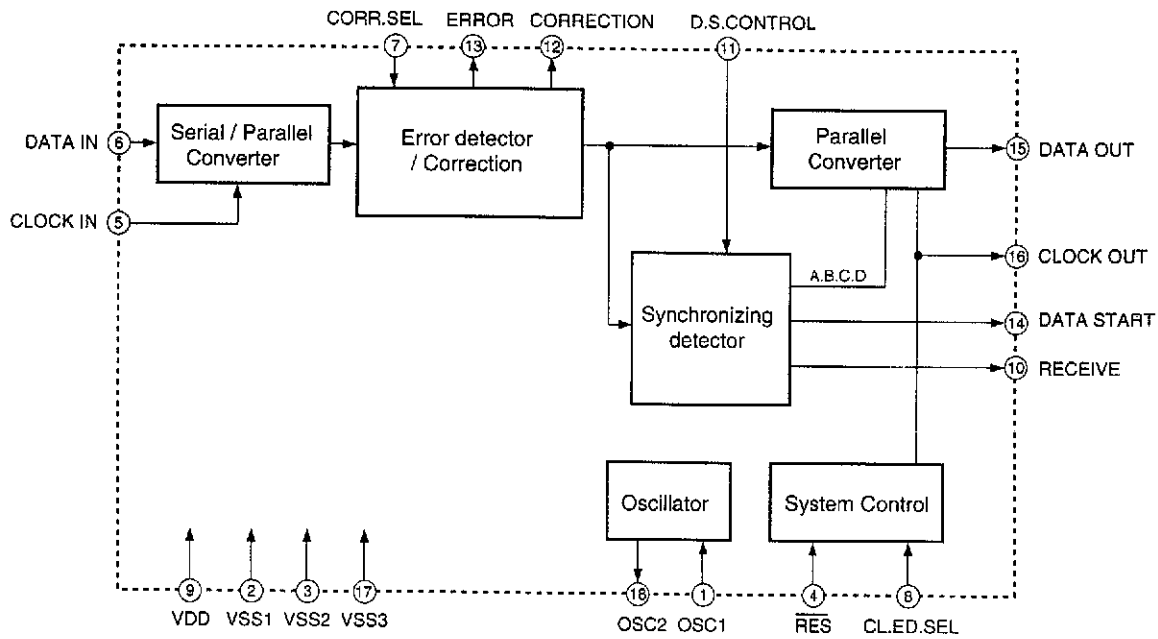

IC107L/R : GD4051

TRUTH TABLE

INPUTS				CHANNELS							
E	A ₂	A ₁	A ₀	Y _{0-Z}	Y _{1-Z}	Y _{2-Z}	Y _{3-Z}	Y _{4-Z}	Y _{5-Z}	Y _{6-Z}	Y _{7-Z}
L	L	L	L	ON	OFF	OFF	OFF	OFF	OFF	OFF	OFF
L	L	L	H	OFF	ON	OFF	OFF	OFF	OFF	OFF	OFF
L	L	H	L	OFF	OFF	ON	OFF	OFF	OFF	OFF	OFF
L	L	H	H	OFF	OFF	OFF	ON	OFF	OFF	OFF	OFF
L	H	L	L	OFF	OFF	OFF	OFF	ON	OFF	OFF	OFF
L	H	L	H	OFF	OFF	OFF	OFF	OFF	ON	OFF	OFF
L	H	H	L	OFF	OFF	OFF	OFF	OFF	OFF	ON	OFF
L	H	H	H	OFF	OFF	OFF	OFF	OFF	OFF	OFF	ON
H	X	X	X	OFF	OFF	OFF	OFF	OFF	OFF	OFF	OFF

L = LOW Level
 H = HIGH Level
 X = Don't Care

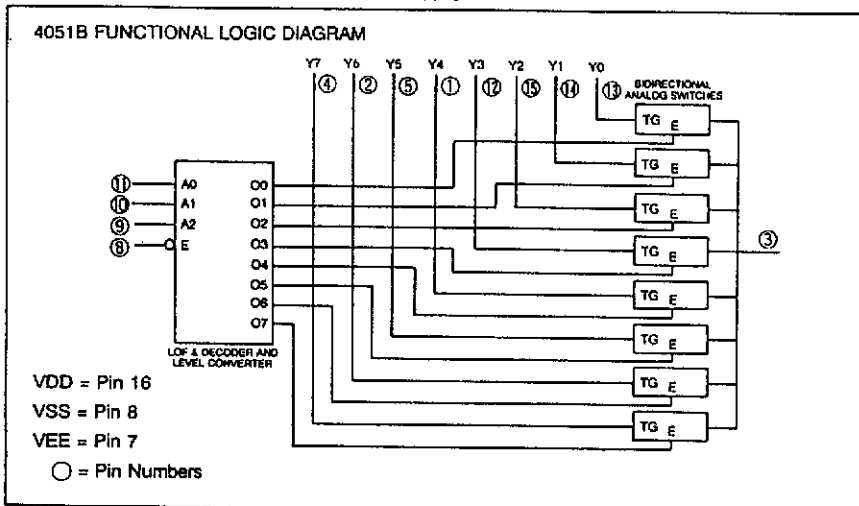

Top View

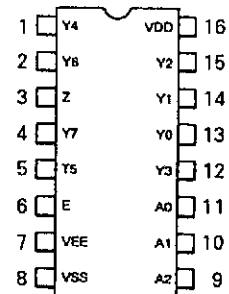

IC502 : NJW1102AFGI

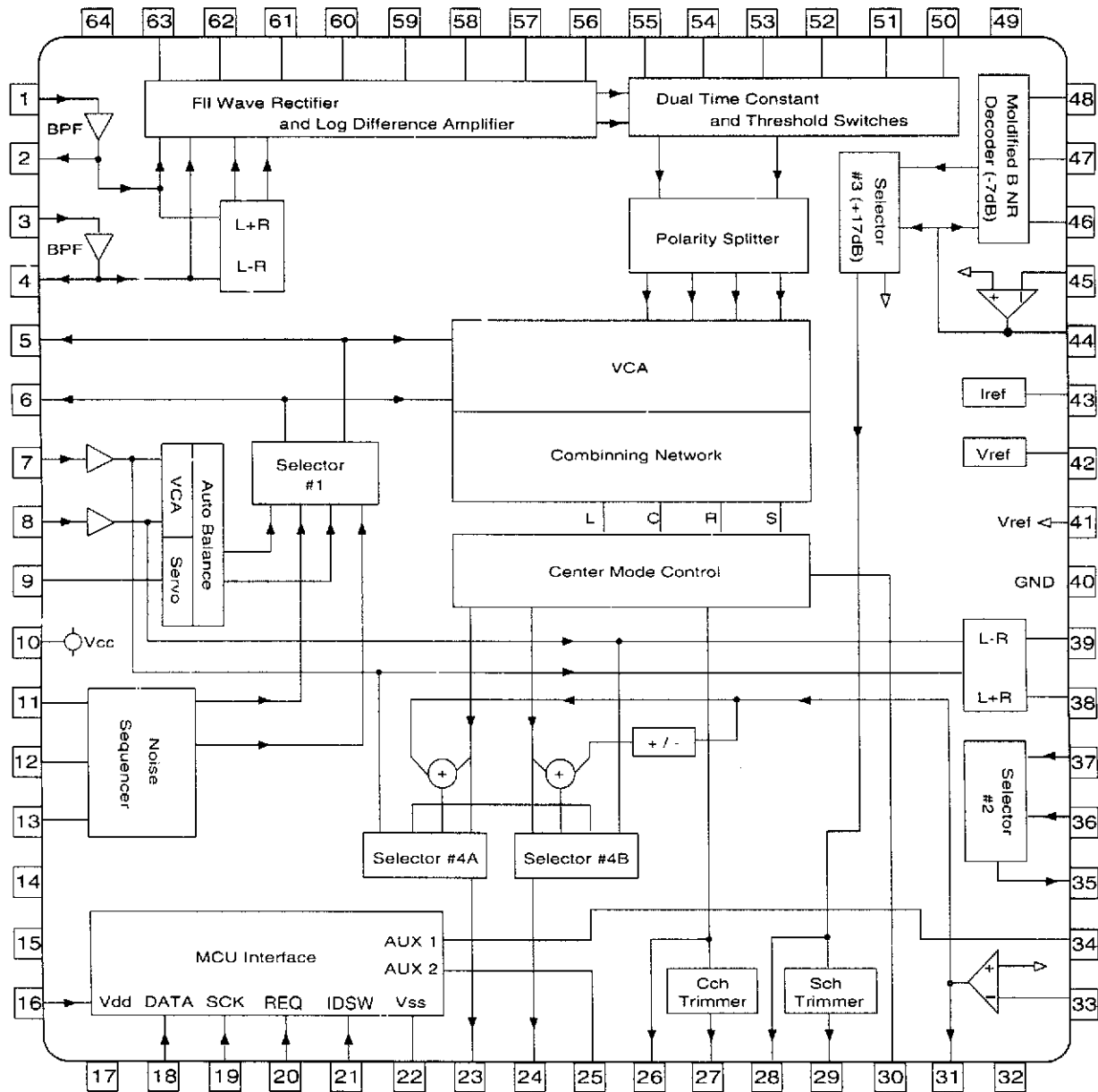

IC508 : TC9299

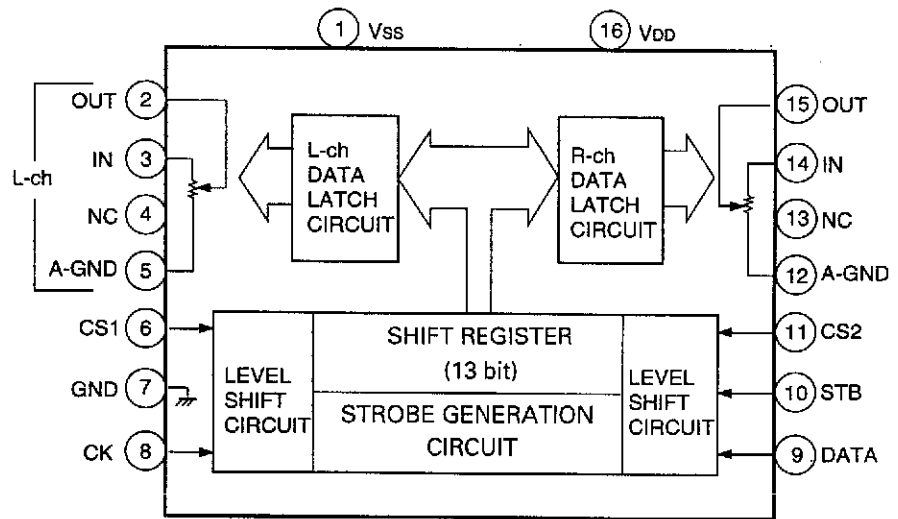

IC1 : LM7001

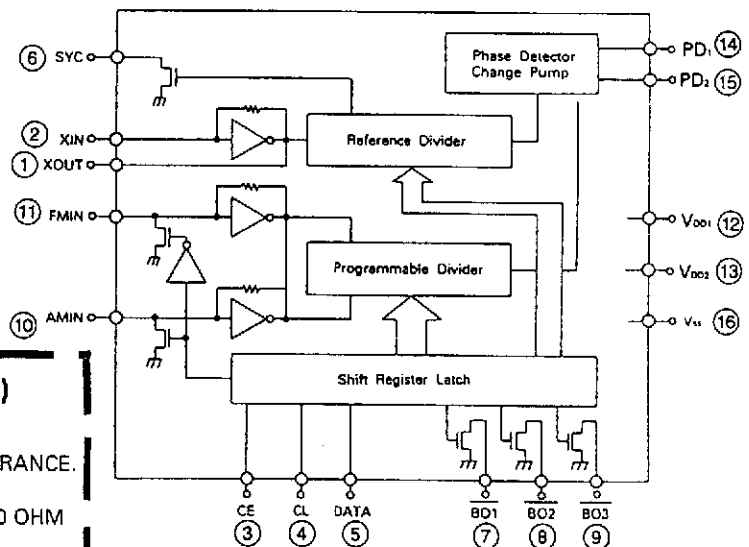

FE1 : FM FRONT - END (FE 407-G60)

NOTES

- 1) TERMINAL NUMBER REFER TO OVERALL APPEARANCE.
- 2) RECEIVING FREQUENCY : 87.5 ~ 108 MHz
- 3) INPUT IMPEDANCE : ① ~ ④ 75 OHM, ① ~ ② 300 OHM
- 4) OUTPUT IMPEDANCE : 360 OHMS
- 5) SUPPLY VOLTAGE : +B → 12 V
- 6) TUNING VOLTAGE : V_t 1.6 ~ 8.0 V
- 7) AGC VOLTAGE : 5 V

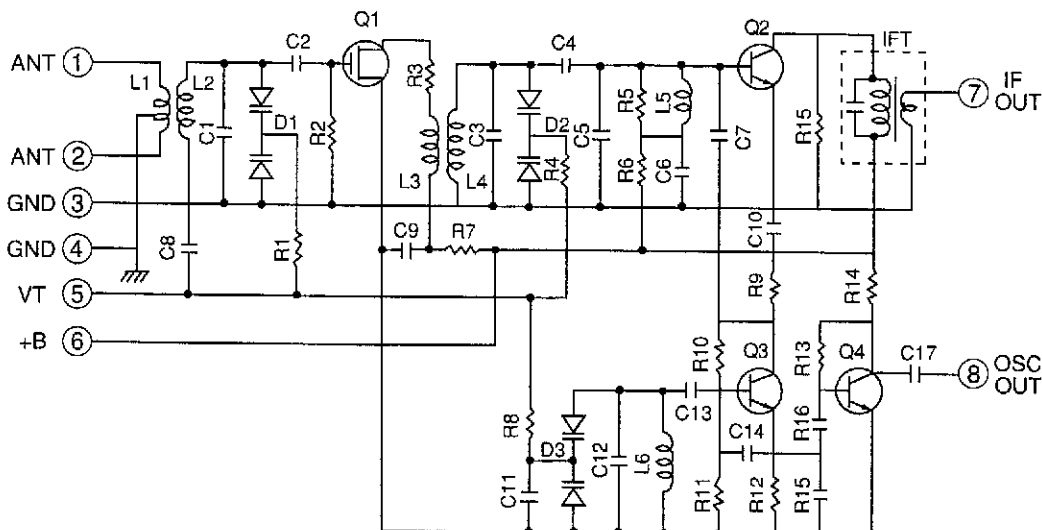

SCHEMATIC DIAGRAM (I)

PCB4 (REAR)

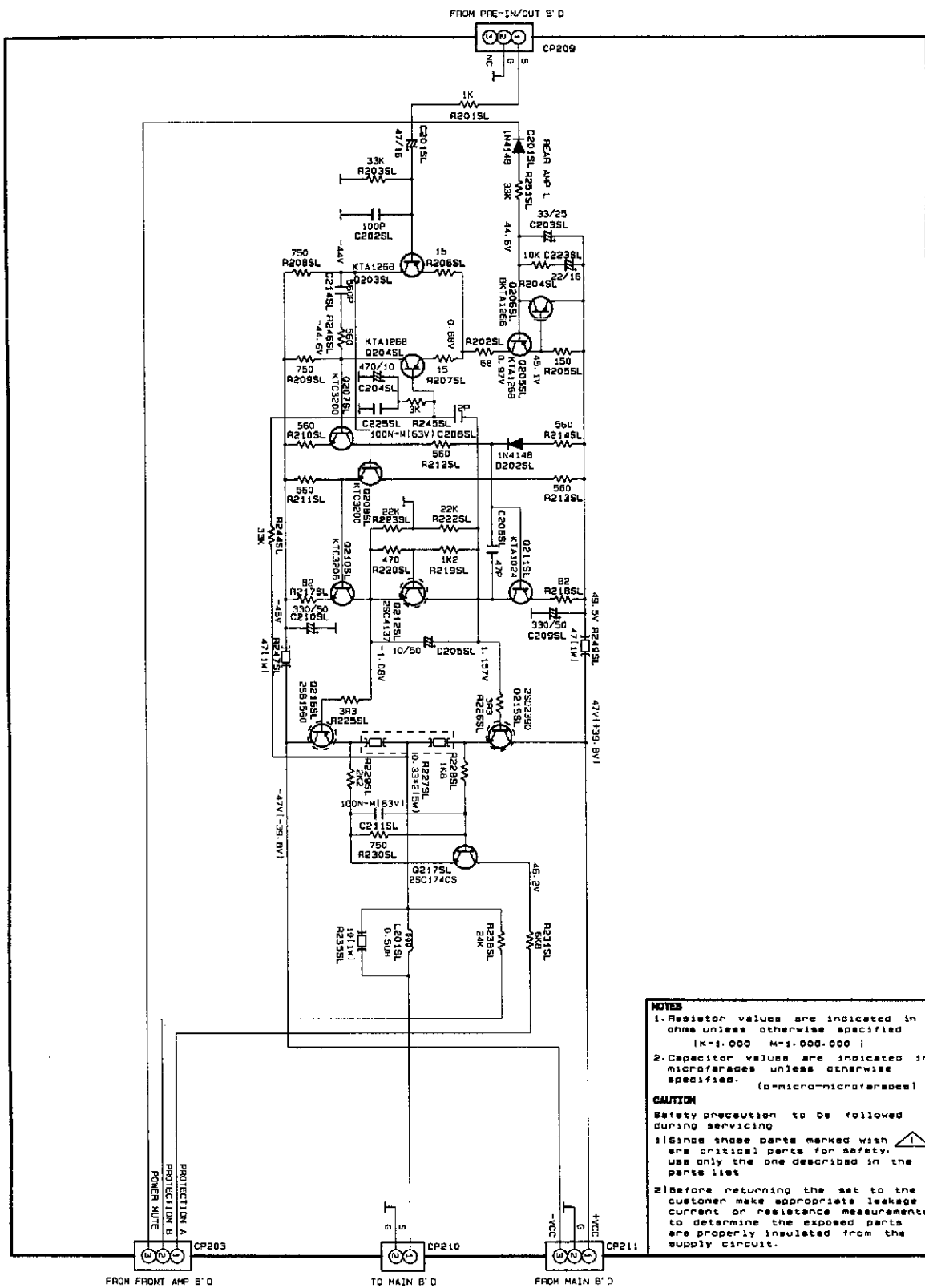

NOTES

1. Resistor values are indicated in ohms unless otherwise specified
 [K=1,000 M=1,000,000]
2. Capacitor values are indicated in microfarads unless otherwise specified. (µ=micro-microfarads)

CAUTION

Safety precautions to be followed during servicing

- 1) Since these parts marked with  are critical parts for safety, use only the one described in the parts list
- 2) Before returning the set to the customer make appropriate leakage current or resistance measurements to determine the exposed parts are properly insulated from the supply circuit.

PACKAGE

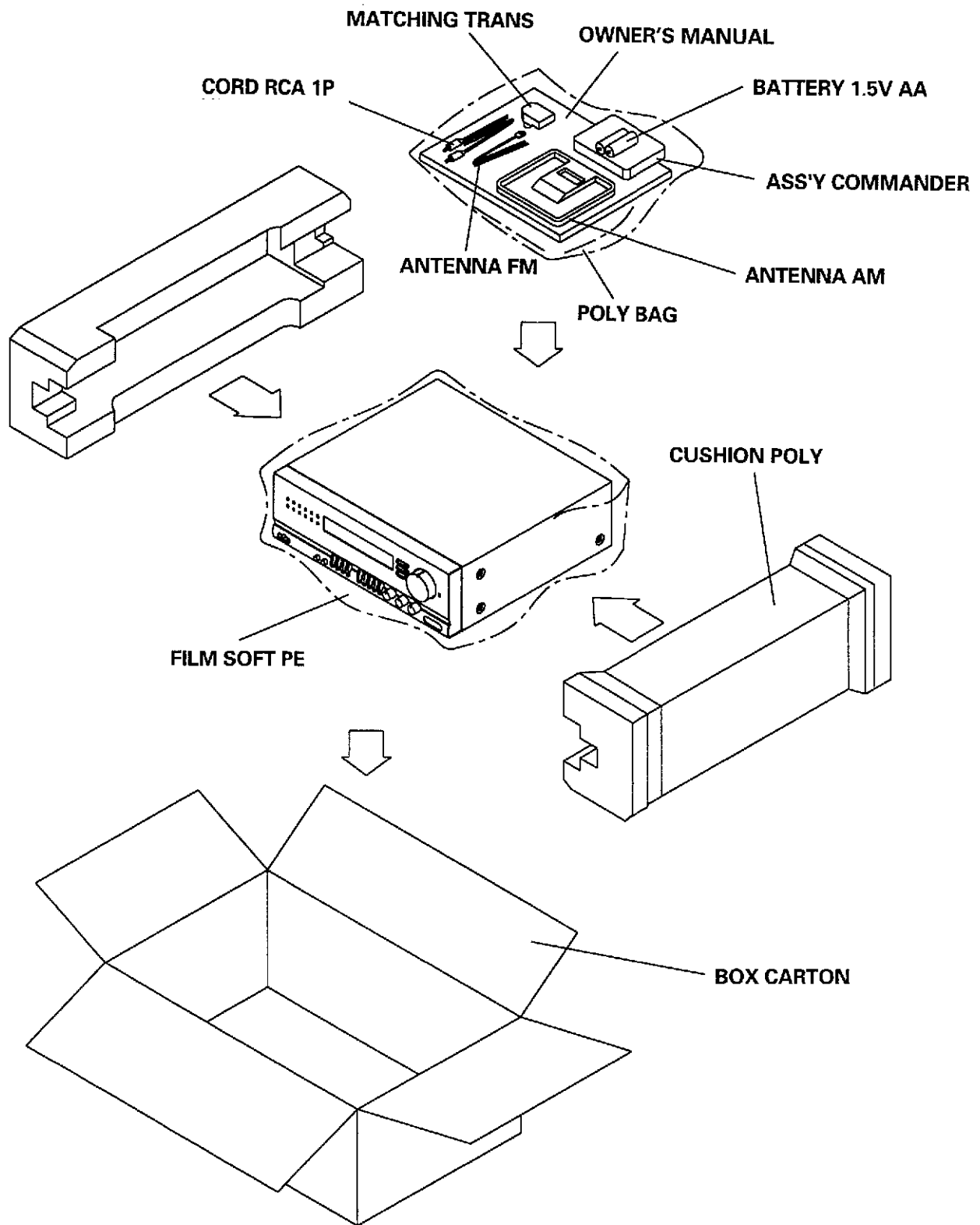

CONTROLS AND FUNCTIONS

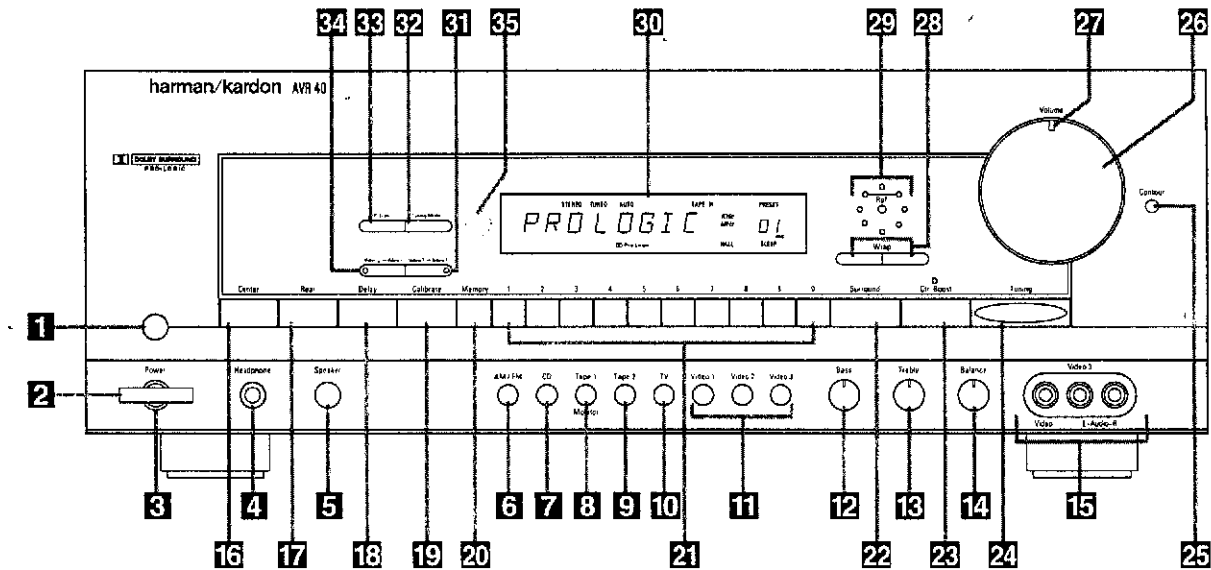

1 Main Power Switch : Press this button to apply power to the AVR40 & AVR41. When the switch is pressed the unit is placed in a Standby mode, as indicated by the amber LED **3** surrounding the System Power control **2**. This button MUST be pressed in to operate the unit regardless of the status of the Power switch at the bottom of the front panel. To turn the unit off and prevent the use of the remote control this switch should be pressed until it pops out to extend from the front panel so that the word "OFF" may be read at the top of the switch.

NOTE : In normal operation this switch may be left in the "on" position.

2 System Power Control : When the Main Power Switch **1** is pressed in, press this button to turn on the AVR40 & AVR41, press it again to turn the unit off. Note that the Power Indicator surrounding the switch **3** will turn green when the unit is on.

3 Power Indicator : This LED will illuminate in amber when the unit is in the Standby mode, to signal that the unit is ready to be turned on. When the unit is in operation the indicator will turn green.

4 Headphone Jack : Stereo headphones can be plugged into this jack for private listening headphone impedance should be between 8 and 2k ohms. Best results between 200 and 400 ohms.

5 Speaker Switch : Press this button to turn off the front left/right speakers. When the speakers are off the selected program source may still be heard through the headphone jack.

6 AM/FM Selector : Press this button to select the tuner as your listening source. Press it again to change between AM and FM frequency bands.

7 CD : Press this button to select your CD player as the listening source.

8 Tape 1/Monitor : Set Tape 1 Monitor to the "off" position when you want to hear the other input functions. Press this button to monitor the cassette deck connected to the Tape 1 Mon input jacks.

9 Tape 2 : Press this button to select the recorder connected to the TV inputs on the rear panel as your listening source.

10 TV : Press this button to select the device recorder connected to the Tape 2 inputs as your listening source.

11 Video Sources : Press these buttons to select any of the sources connected to an audio video input as your listening source. The selected input will also be routed to the device connected to the Video Monitor Output on the rear panel.

NOTE : When the AVR40&AVR41 is in the Standby mode, as indicated by the Power Indicator **3** illuminating in amber, the unit may be turned on by pressing any of the Source Selection buttons.

12 Bass Control : Turn this control to modify the low frequency output of the left/right channels by as much as $\pm 10\text{dB}$. Set this control to a suitable position for your taste and room acoustics.

13 Treble Control : Turn this control to modify the high frequency output of the left/right channels by as much as $\pm 10\text{dB}$. Set this control to a suitable position for your taste and room acoustics.

14 Balance Control : Turn this control to change the relative volume for the front left/right channels.

NOTE : For normal operation of the surround modes this control should be at the midpoint, or "12 O'clock" position.

15 Video 3 : This alternate set of Audio/Video inputs may be used for the connection of a camcorder or video game. Select this input by pressing the Video 3 button on the front panel.

16 Center Channel Mode Selector : Press this button to select the type of center channel speaker used. If there is no center channel speaker press the button until the information display reads No Center.

The mode changes as below, when the button is pressed in succession.

Center Mode
 Small Center Large Center No Center

The Display window shows each mode
 Small : Select this mode if you use a small Center speaker. The bass Sound of the Center channel is reproduced from the front speakers, because the small speaker cannot produce enough bass
 Large : Select this mode if you use a medium-to-Large Center speaker. The bass Sound is reproduced from the Center Speaker.

NOTE : Select this mode if you not use a Center Speakers.

17 Rear Channel : Press this button to configure the AVR40 & AVR41 for the presence or absence of rear speakers.

18 Delay Time Adjust : Press this button to adjust the delay time between the front and rear channels. Adjusts the surround delay time in steps. For Dolby surround 20ms is standard.

15ms 20ms 25ms 30ms

19 Calibrate : Press this button to turn on the calibration circuits that are used to adjust the output levels of the AVR40 & AVR41. Once the button is pressed you may adjust the levels of the center and rear channels using the Level - / Level + buttons on the remote control while listening to the current input source.

To calibrate the system using the internal test tone, press this button first, and then press the Calibrate button on the remote.

20 Tuner Memory Button : Press this button to store an AM or Fm frequency in the unit's memory. The MEM indicator will flash in the display to remind you to choose a numeric location using Numeric Buttons on the front panel. Storing a station in a memory location that has already been used will overwrite the existing data.

NOTE : The preset memories are protected from power loss for two weeks. If the unit is unplugged for more two weeks, all stored frequencies will be erased.

21 Numeric Buttons : Use these buttons to enter or recall stations from the tuner memory.

22 Surround Mode : Press this button to select the desired surround listening mode.

The mode is changed between Pro-Logic and Phantom and Hall.

23 Center Boost : Press this button to increase the level of the center channel output $\pm 4\text{dB}$ above that of the left/right channels for increased dialog intelligibility. A red LED will illuminate above the button when the circuit is engaged.

24 Tuning Button : Press the left side of the button to tune lower frequency stations and the right side of the button to tune higher frequency stations. When a station with a strong frequency is tuned, the TUNED indicator will illuminate in the information display.

25 Contour : Press this button when listening at low levels to activate special circuits that compensate for the response of the human ear at lower volumes. In the off position the unit will provide flat frequency response.

26 Volume Control : Rotate this control to raise or lower the volume. Note that this is motorized control, and when the volume is changed using the remote control it will move in response to remote commands.

27 Mute/Volume Indicator : In normal operation this green LED provides a relative indication of the unit's volume level. When the AVR40 & AVR41 is in the MUTE mode, this indicator flashes to remind you that output to the speakers has momentarily been silenced.

28 Wrap : When the Dolby Pro Logic or Hall modes are in use, press these buttons to increase or decrease the amount of effect for the Wrap circuit.

29 Wrap Indicator : These LEDs indicate the degree of Wrap that has been selected.

30 Information Display : The indicators in this display illuminate to provide visual display of the unit's operation.

AVR40 31 , AVR41 36
Video 3 -> Video 1 Dubbing : Press this button to make a recording from the device connected to the front panel Video 3 input **15** to Video 1. The copy may be made while another input is the listening source for the main system outputs.

AVR40 32 , AVR41 31
FM Mode : Press this button to select the stereo or mono mode for FM tuning. In the STEREO mode a STEREO indicator will illuminate in the information display, and stereo reception will be provided when stations are transmitting stereo signals. In the MONO mode

the left and right signals from stereo broadcasts will be mixed together and reproduced through all channels. Select MONO for better reception of weak signals. This button is also used to select AUTO or MANUAL tuning. In the AUTO mode the tuner will stop only at stations with a strong signal.

AVR41 32 **Display :** When the FM Tuner is in use, press this button to select any type of RDS information to be displayed, or hold it in to dim or extinguish the front panel display. For all other inputs. Press and hold this button once to dim the front panel display to half brightness. Pressing it again will turn the display off. Press the display button or any other front panel button to return the display to full brightness.

33 P-Scan Button : Press this button to scan the stations entered in the unit's memory. When the desired station is reached, press the button again to stop the scan.

AVR40 34 , AVR41 35
Video 2 -> Video 1 Dubbing : Press this button to make a recording from the device connected to the Video 2 Input to VCR 1. The copy may be made while another input is the listening source for the main system outputs.

AVR41 34
RDS Seek : Press this button to tune only RDS Stations of a specific "PTY" or programme type. Each press of the button will cycle through the list of PTY types. To seek any station with an acceptable signal press the Tuning Mode button **31** until the RDS indicator goes out, and press the Tuning button **24**.

AVR40 35 , AVR41 37
Remote Sensor : This sensor receives the signals from the remote control to operate the unit. Do not block this area.

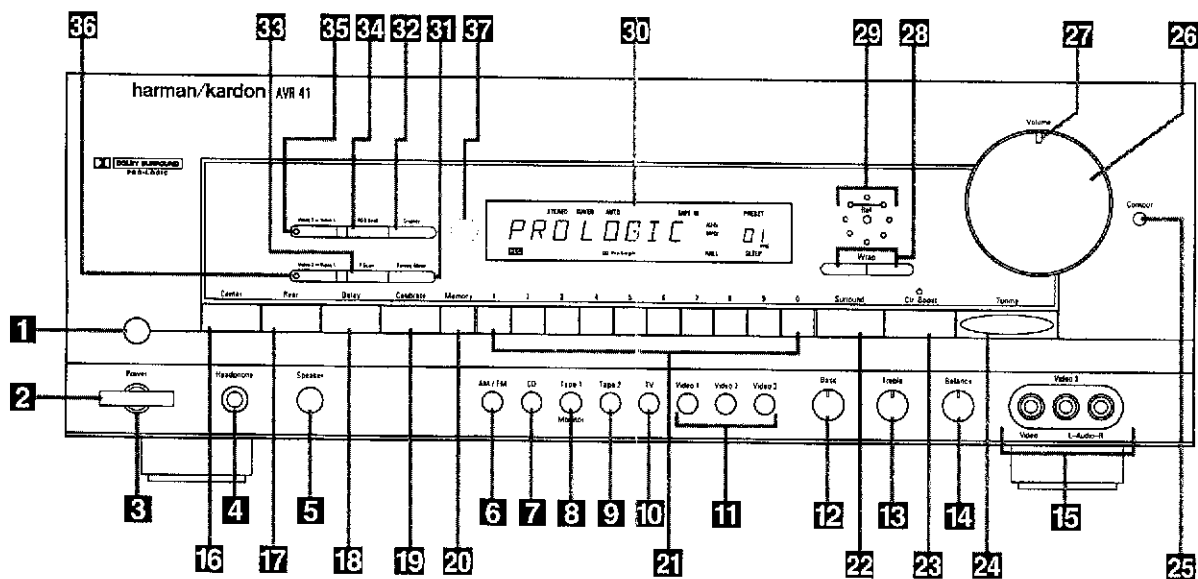

BLOCK DIAGRAM

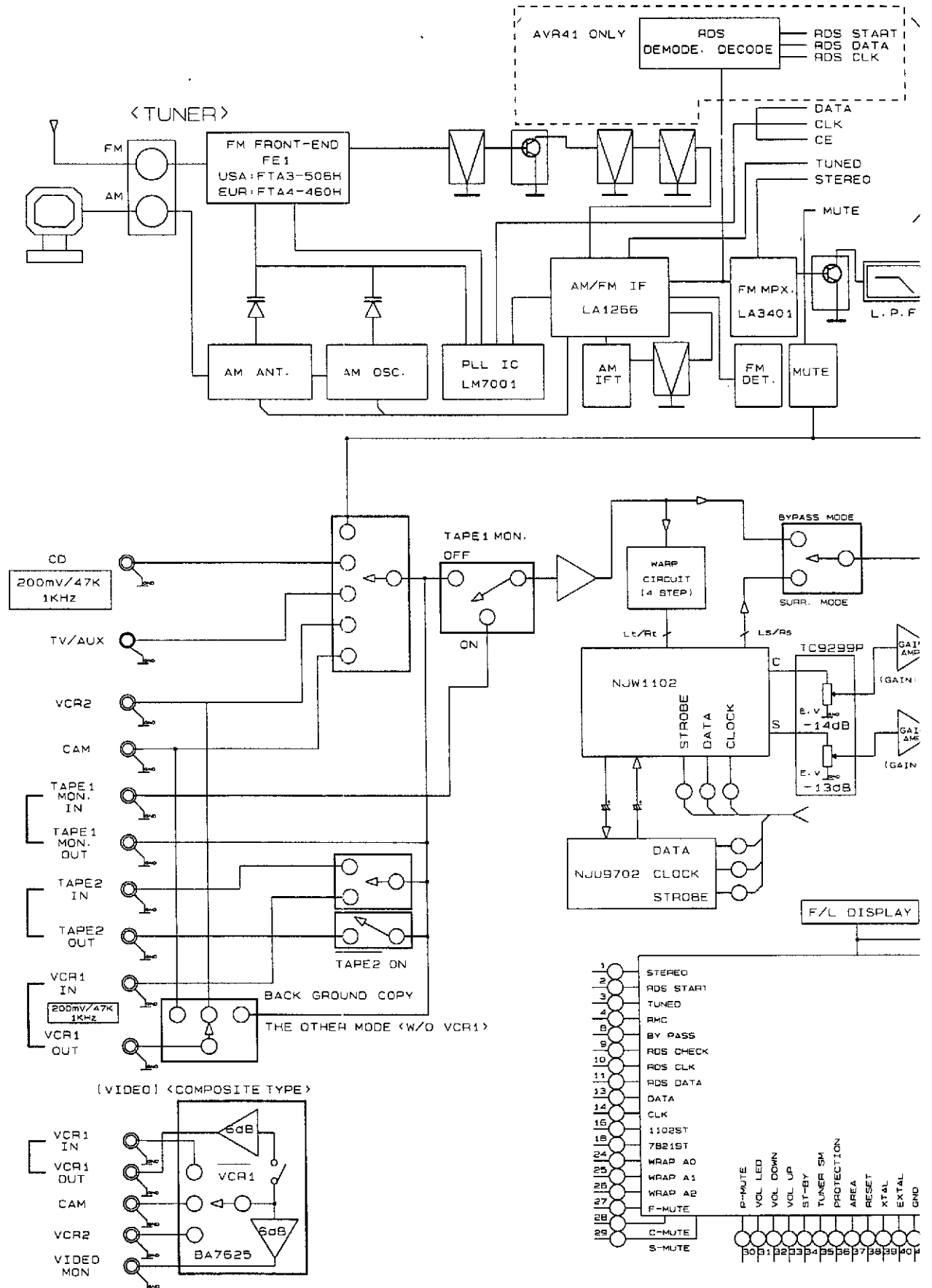

- RDS START
 - RDS DATA
 - RDS CLK
 - DATA
 - CLK
 - CE
 - TUNED
 - STEREO
 - MUTE

CPU

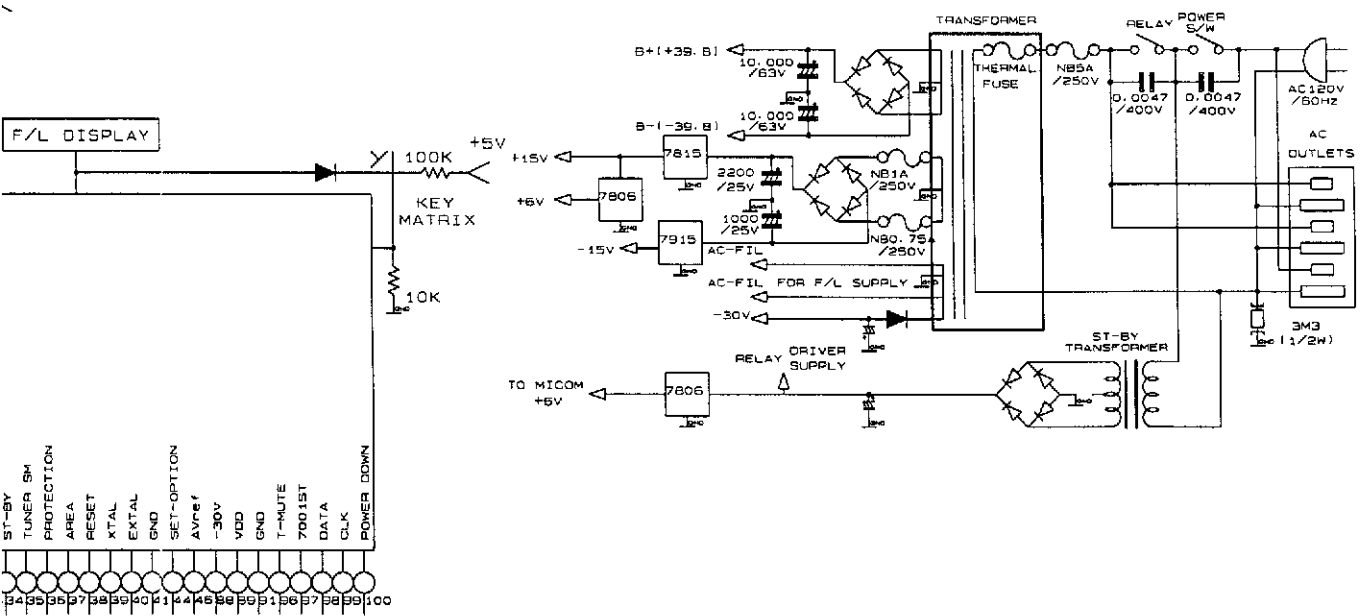
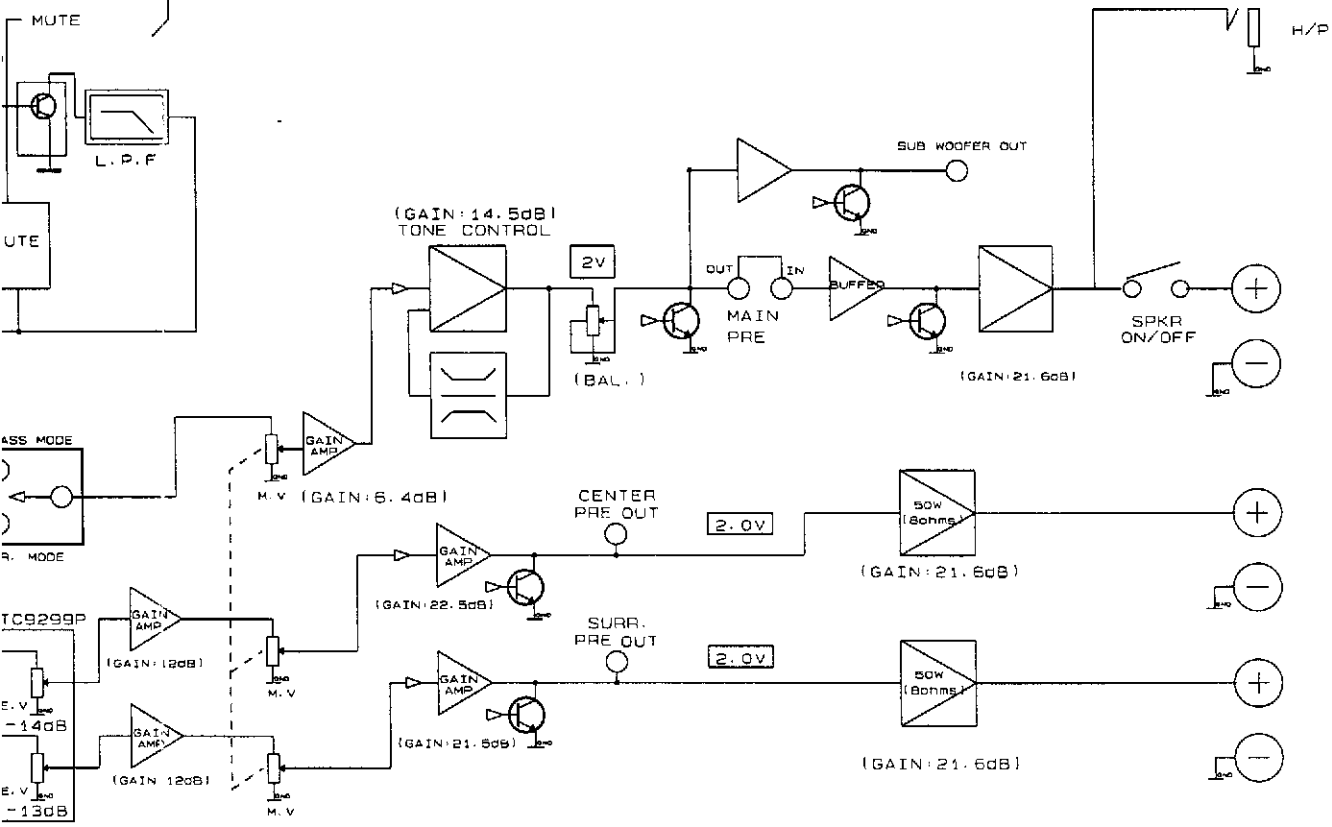

ST-BY
 TUNER SM
 PROTECTION
 AREA
 RESET
 XTAL
 XTAL
 GND
 SET-OPTION
 AVref
 -30V
 VDD
 VDD
 GND
 T-MUTE
 7001ST
 DATA
 CLK
 POWER DOWN

GENERAL UNIT EXPLODED VIEW

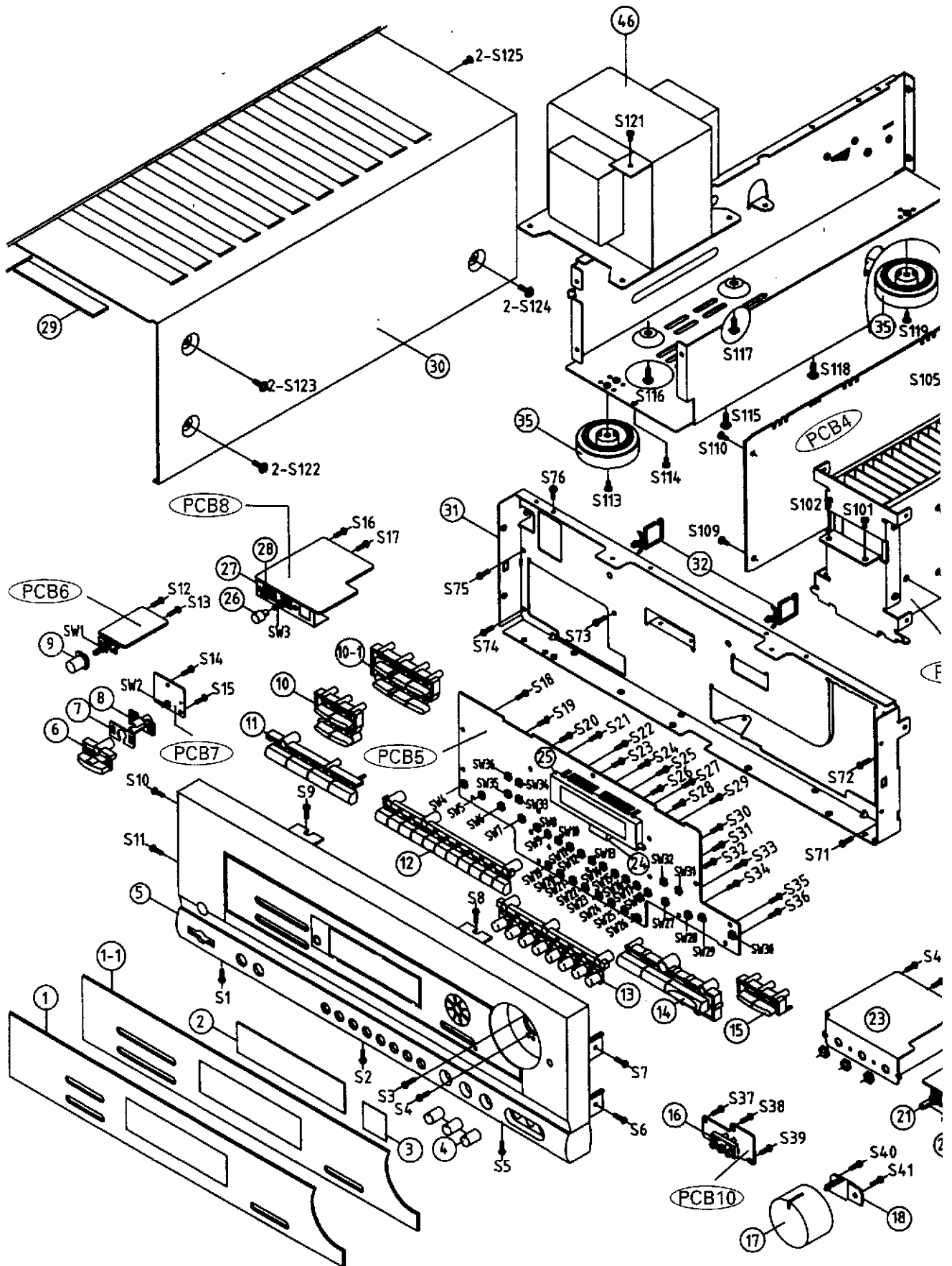

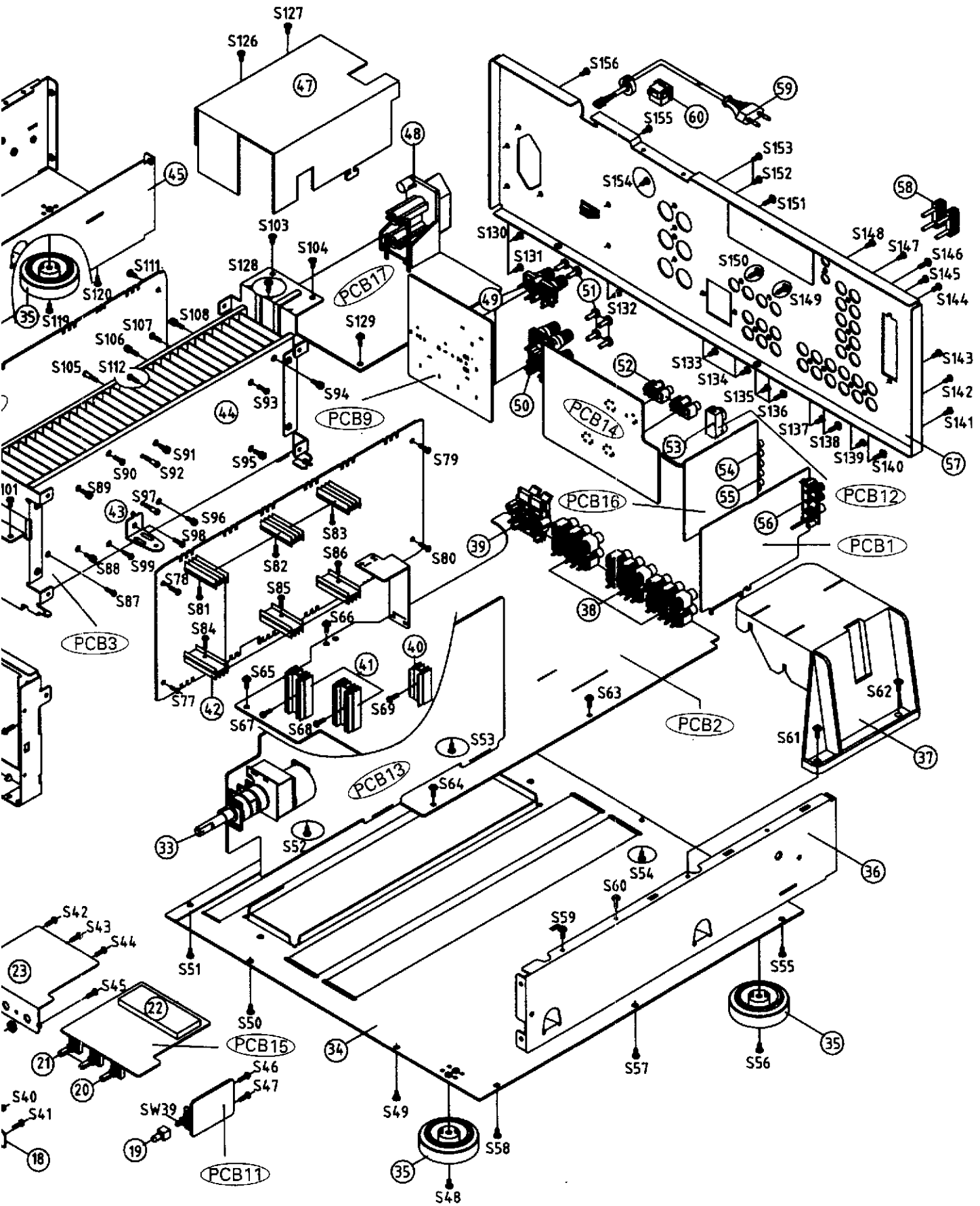

PRINTED CIRCUIT BOARDS

PCB2 (MAIN)

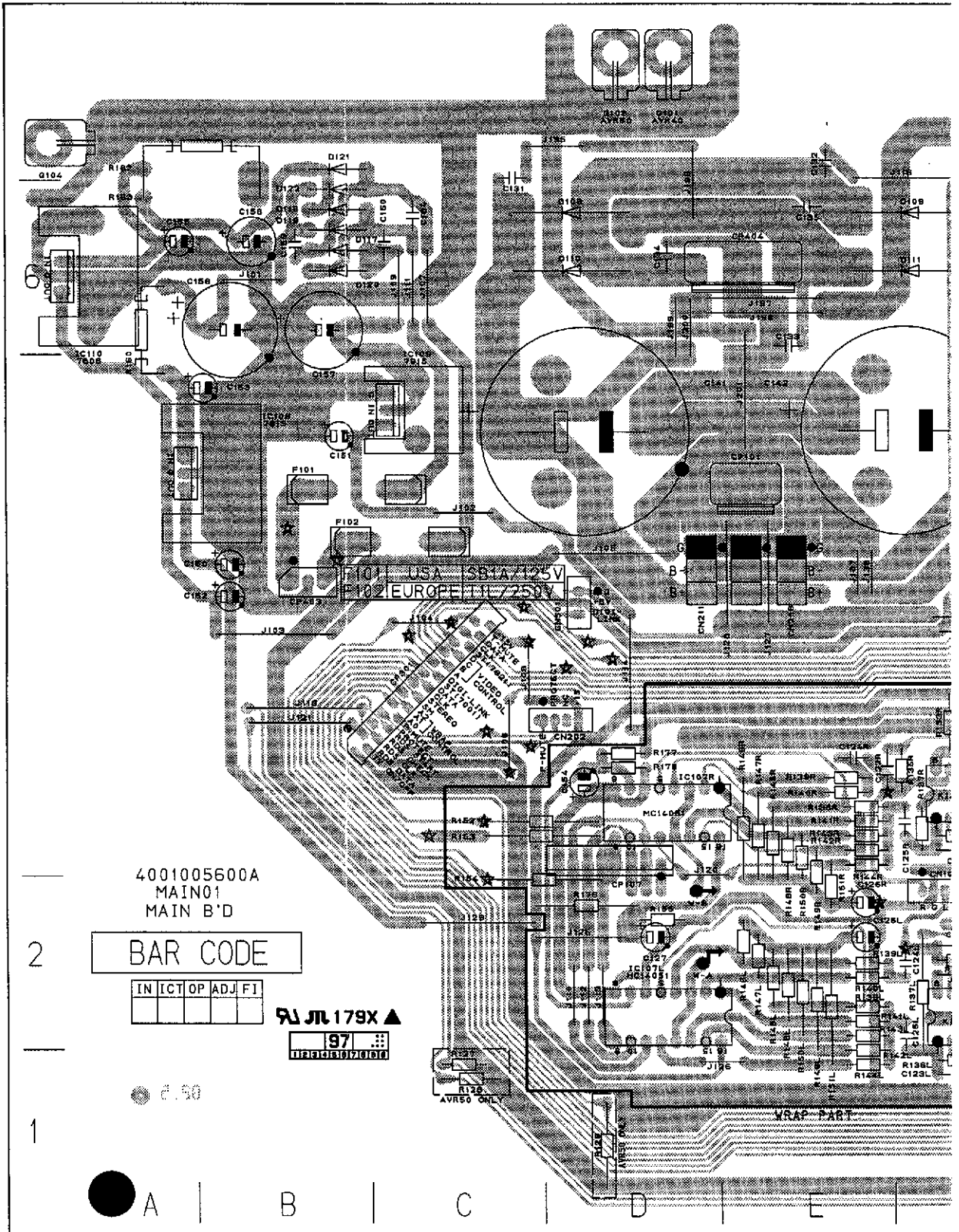

MAIN)

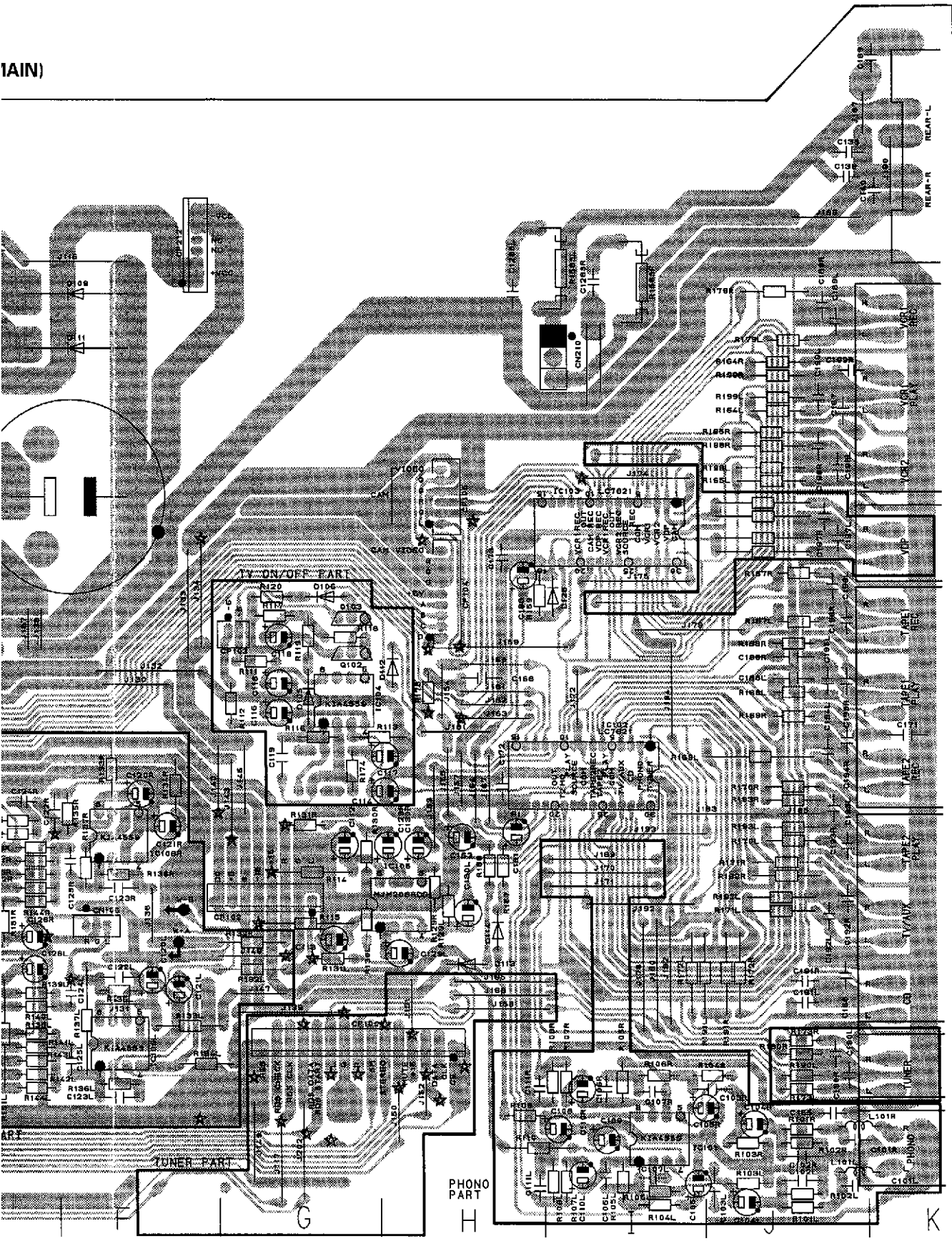

FRONT-AMP)

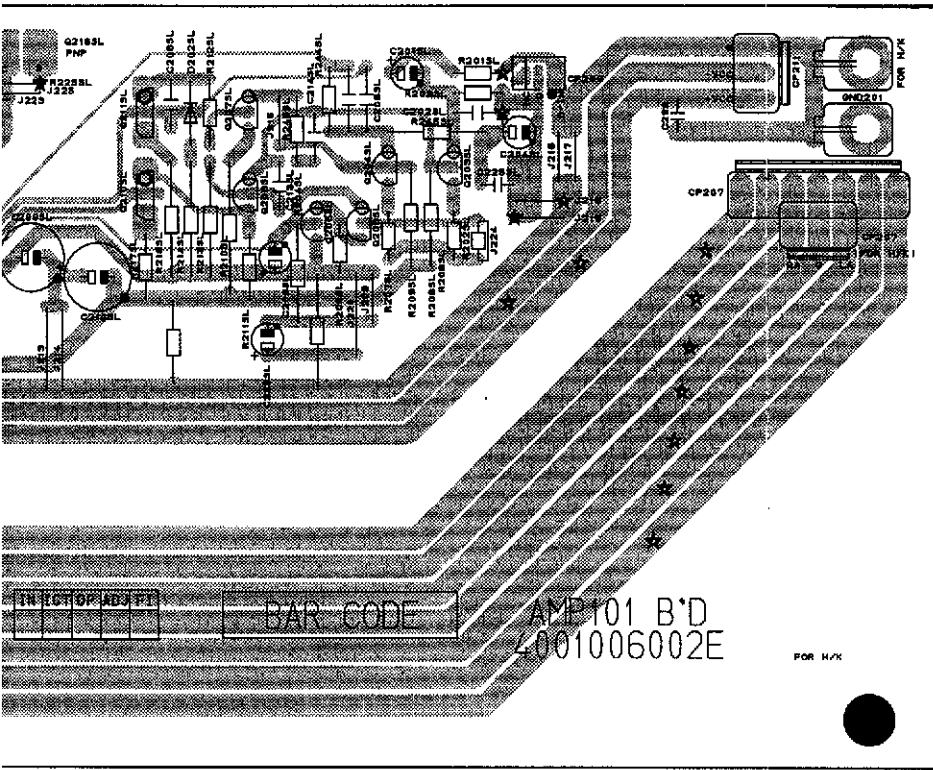

REAR-AMP)

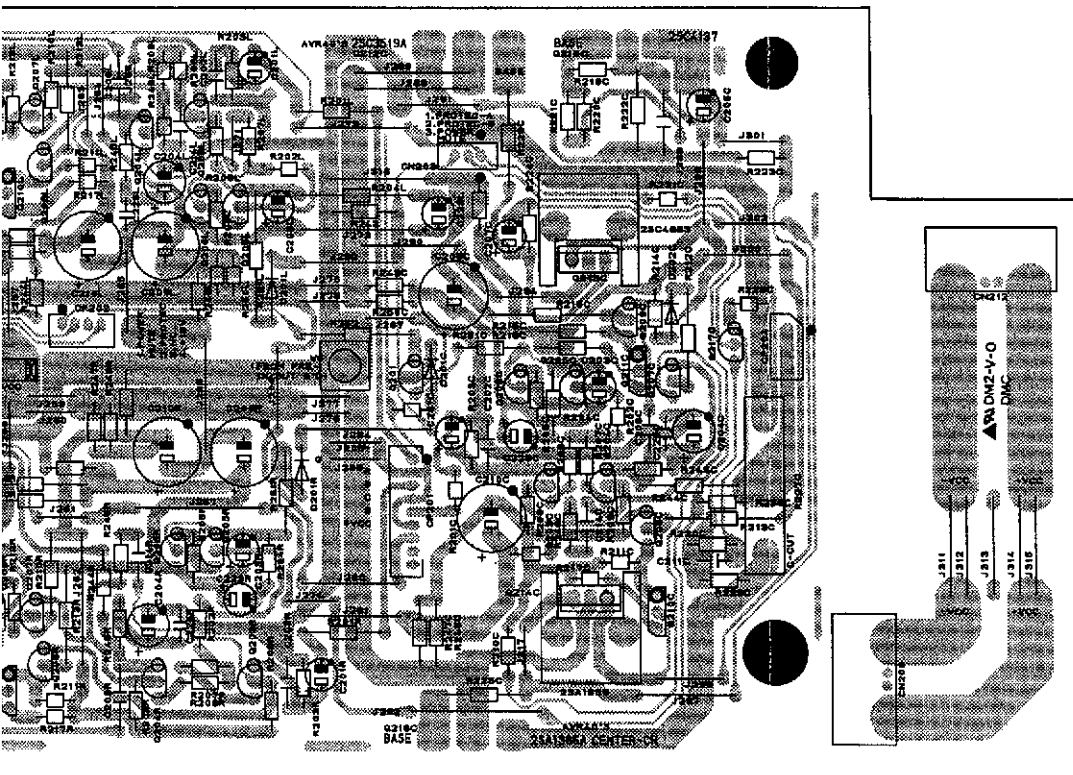

PCB5 (FRONT)

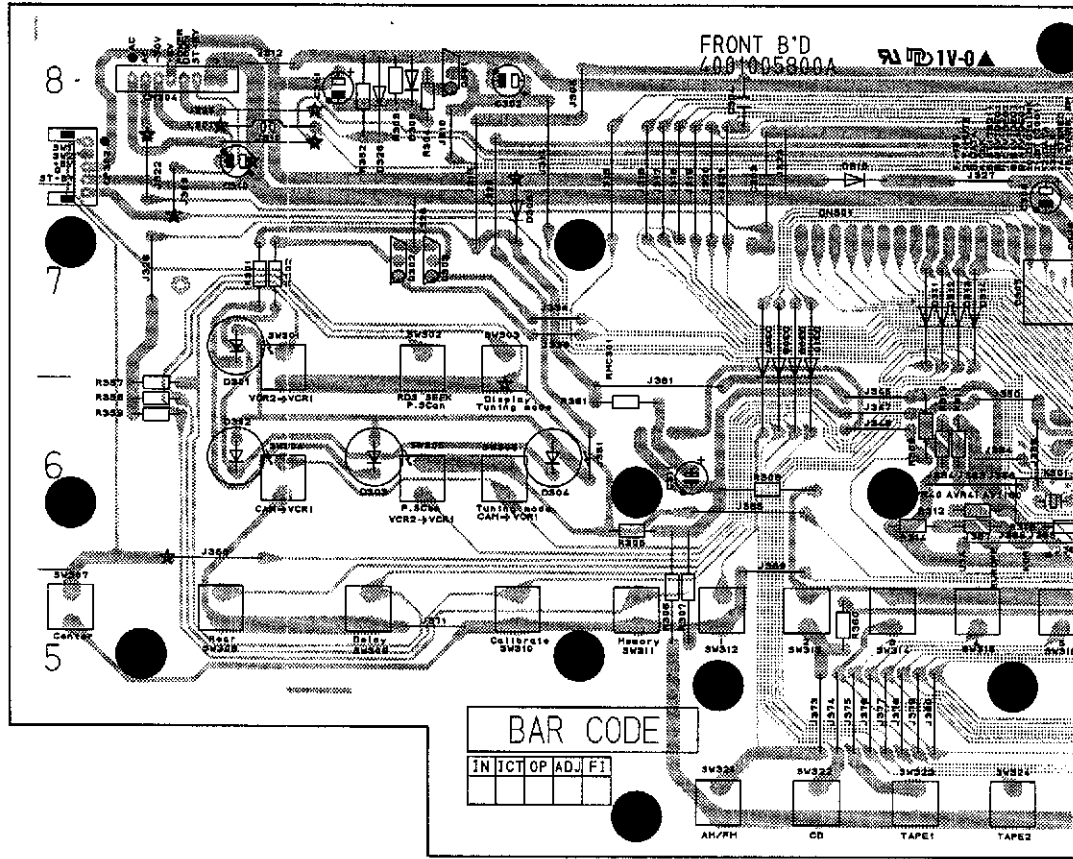

PCB13 (SURROUND)

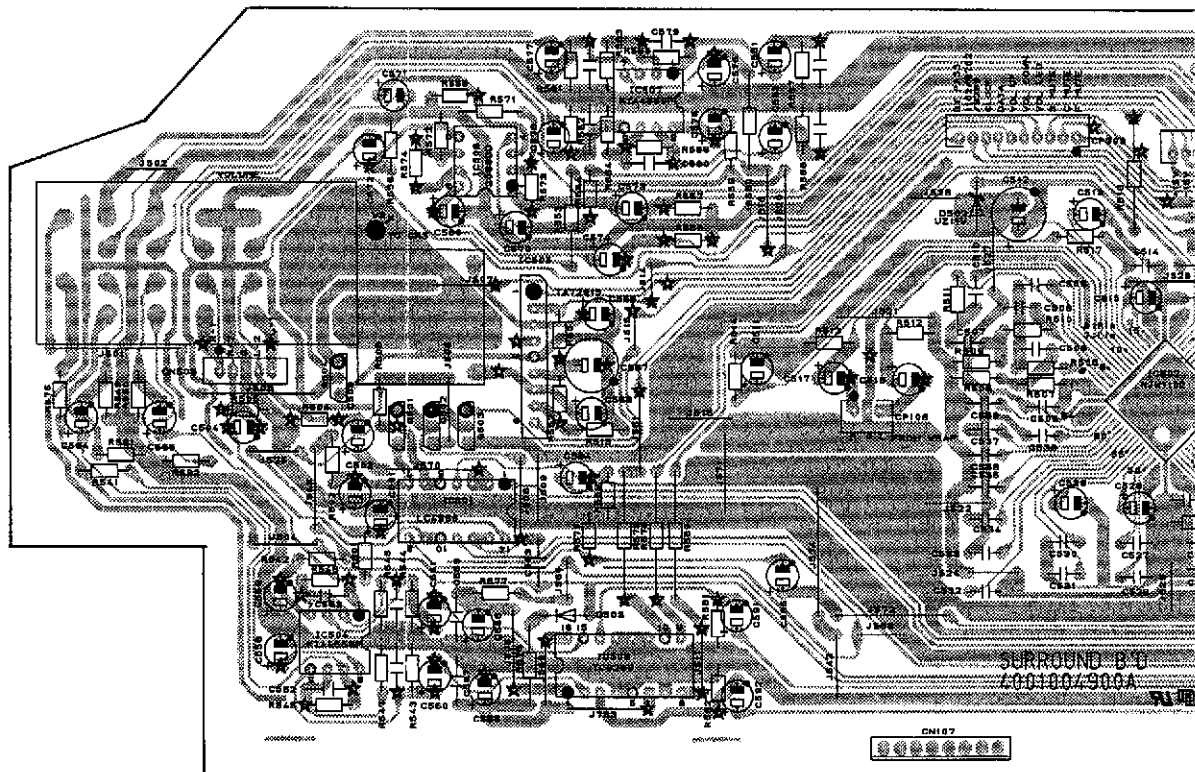

SCHEMATIC DIAGRAM (II)

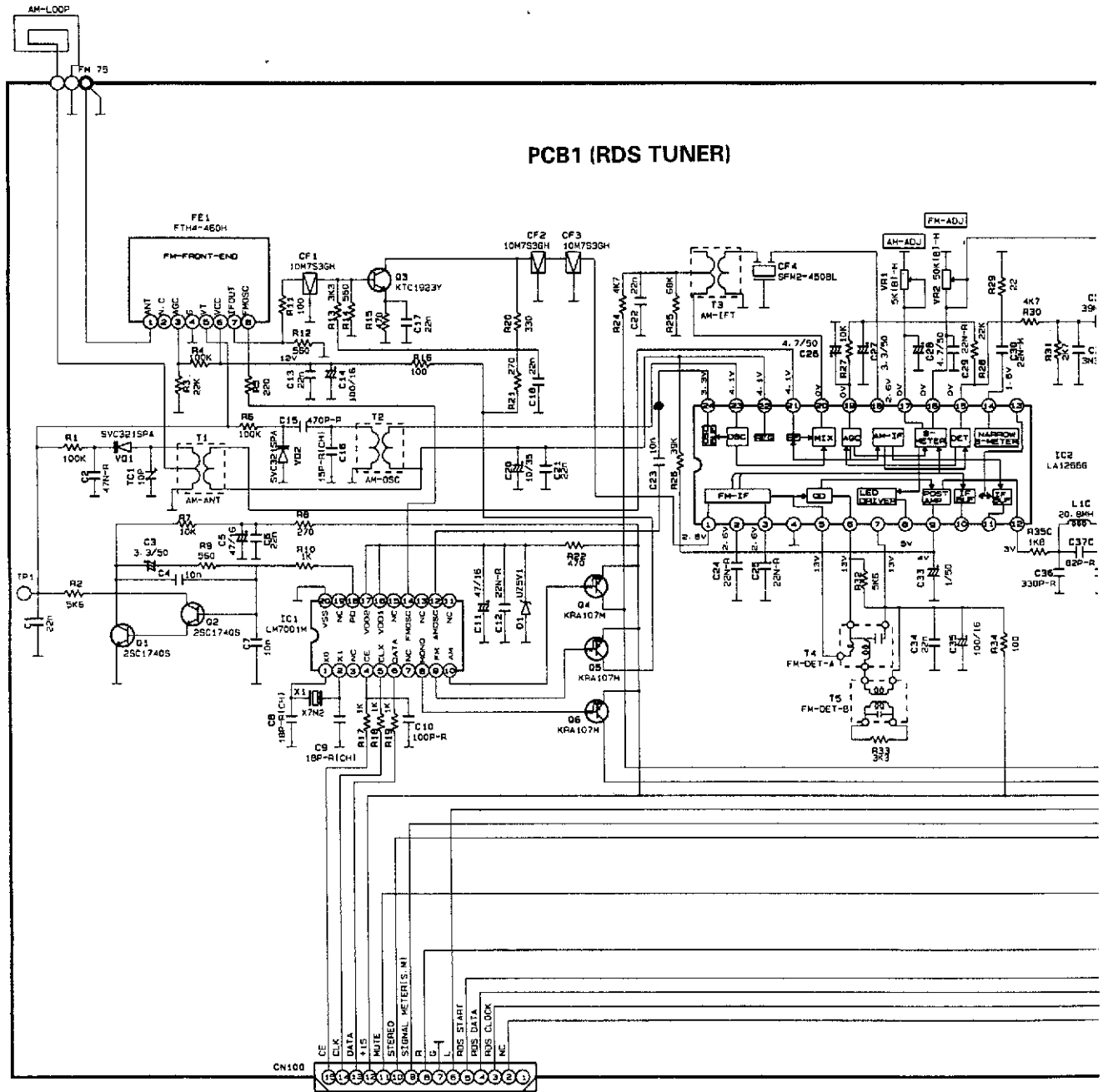

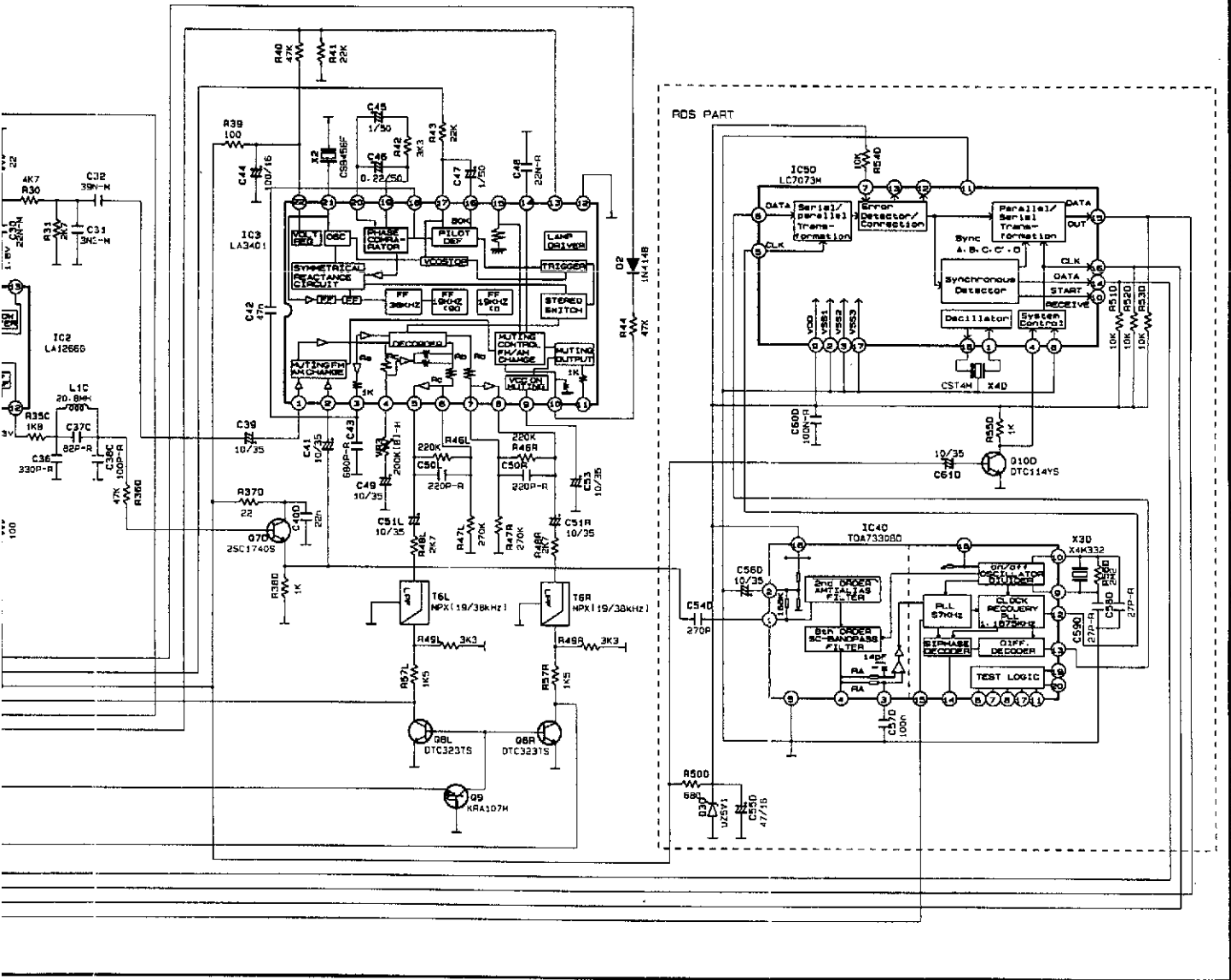

NOTES

1. Resistor values are indicated in ohms unless otherwise specified (K=1,000 M=1,000,000)
2. Capacitor values are indicated in microfarads unless otherwise specified. (p=micro-microfarad)

CAUTION

Safety precautions to be followed during servicing

1. Since those parts marked with  are critical parts for safety, use only the one described in the parts list.
2. Before returning the set to the customer make appropriate leakage current or resistance measurements to determine the exposed parts are properly insulated from the supply circuit.

05
09
R56
C52

SCHEMATIC DIAGRAM (III)

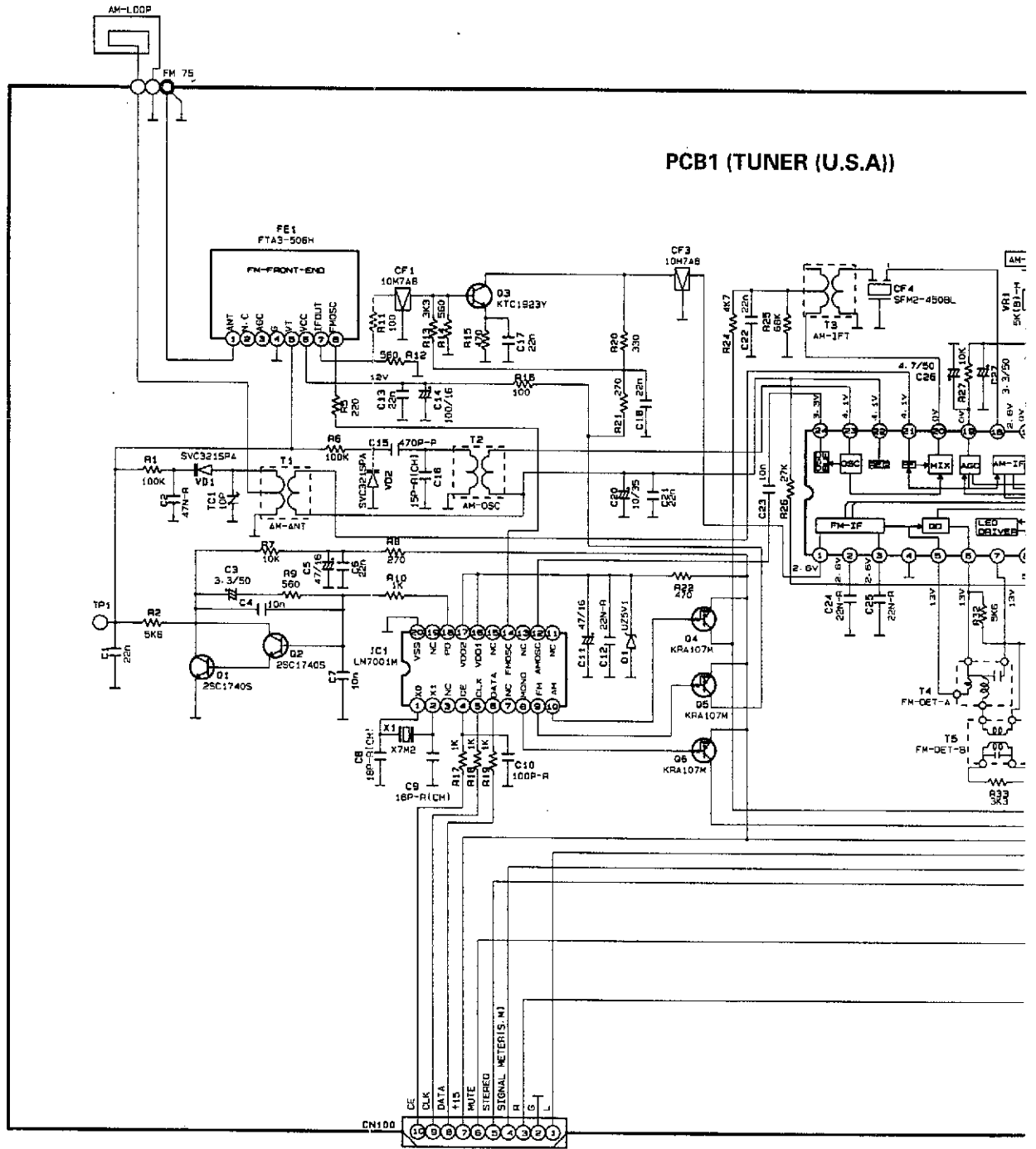

A))

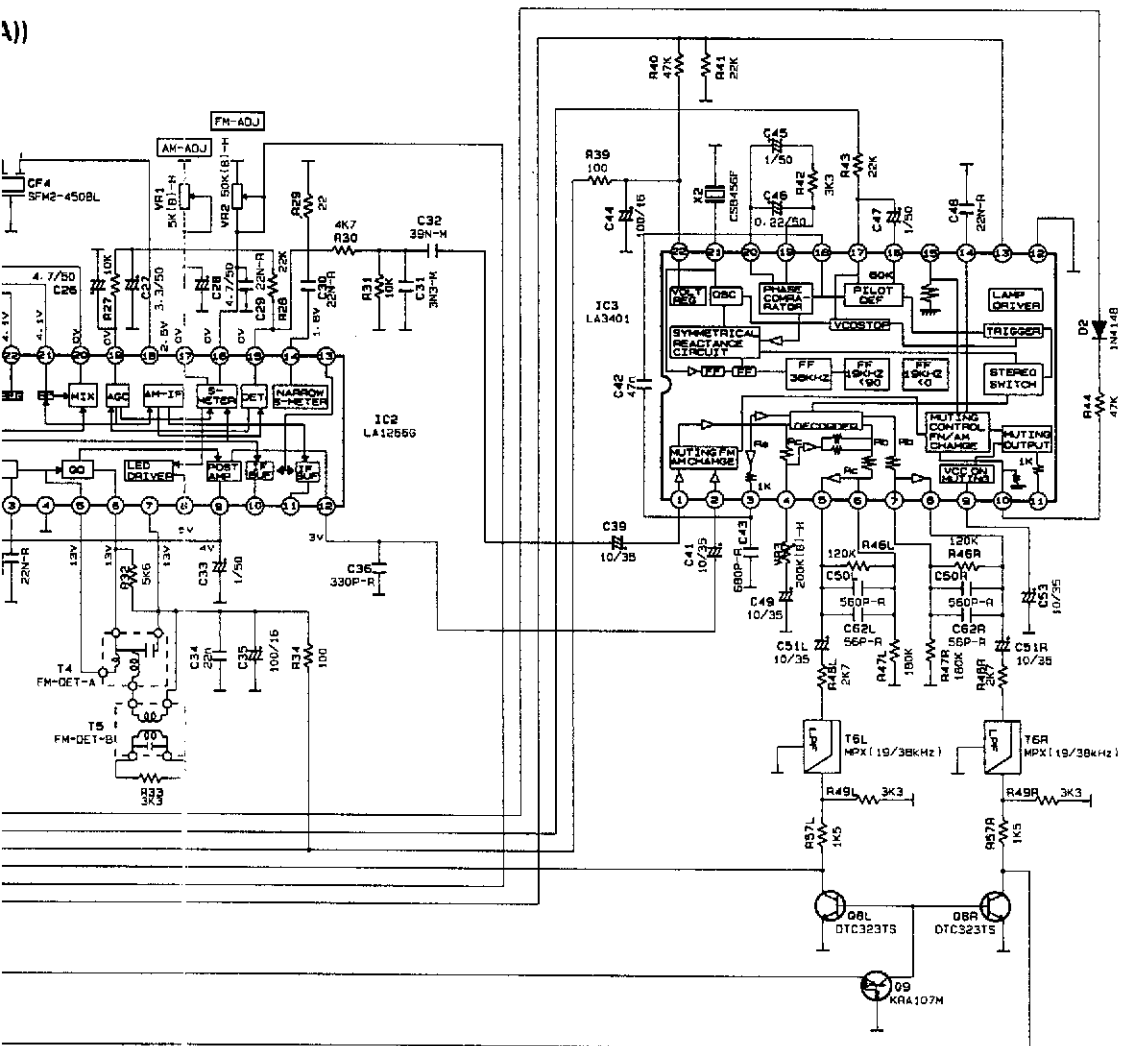

NOTES

1. Resistor values are indicated in ohms unless otherwise specified
[K=1,000 M=1,000,000]
2. Capacitor values are indicated in microfarads unless otherwise specified. [p=picofarads]

CAUTION

Safety precaution to be followed during servicing

- 1) Since those parts marked with  are critical parts for safety, use only the one described in the parts list
- 2) Before returning the set to the customer make appropriate leakage current or resistance measurements to determine the exposed parts are properly insulated from the supply circuit.

05
09
R56
052

SCHEMATIC DIAGRAM (IV)

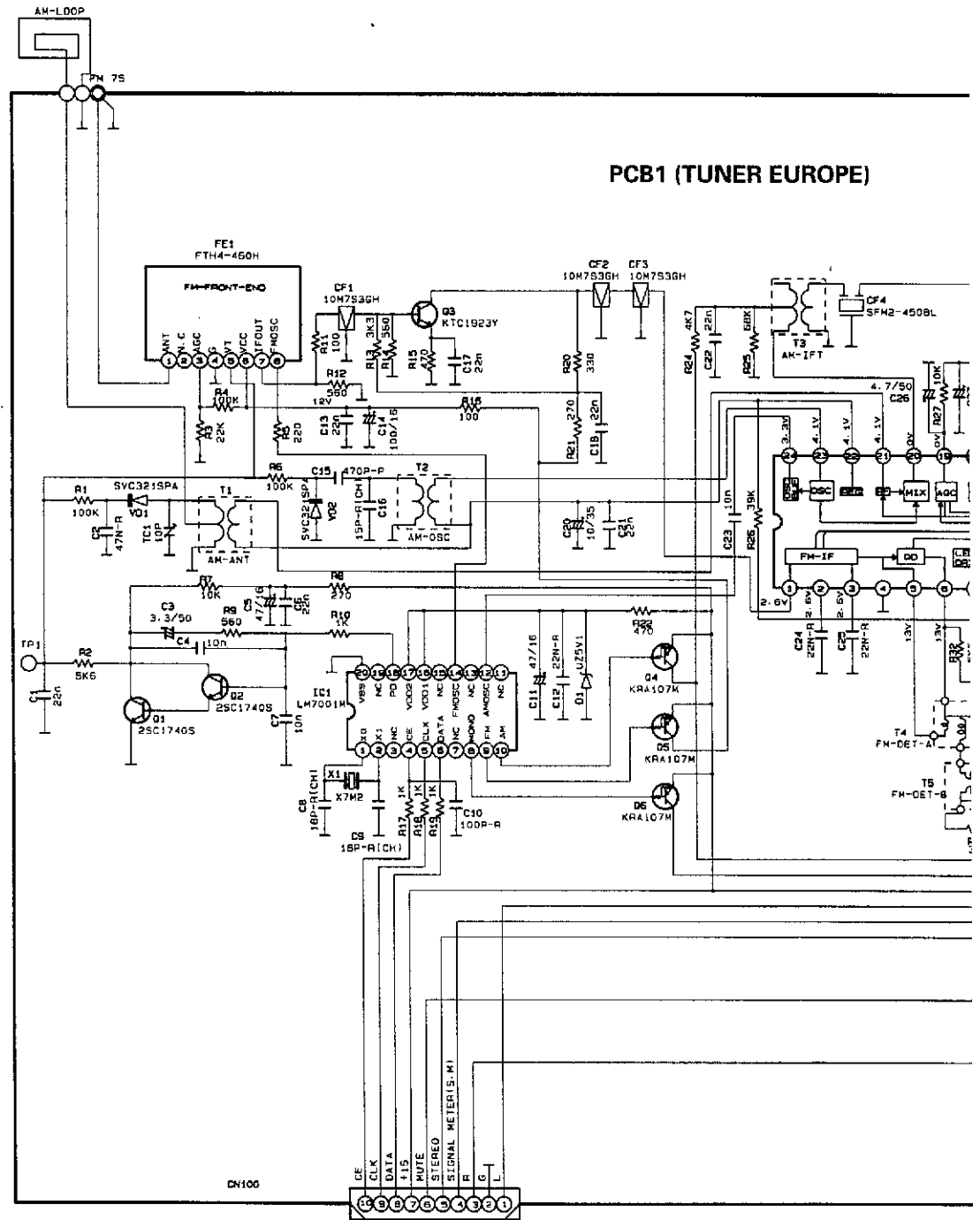

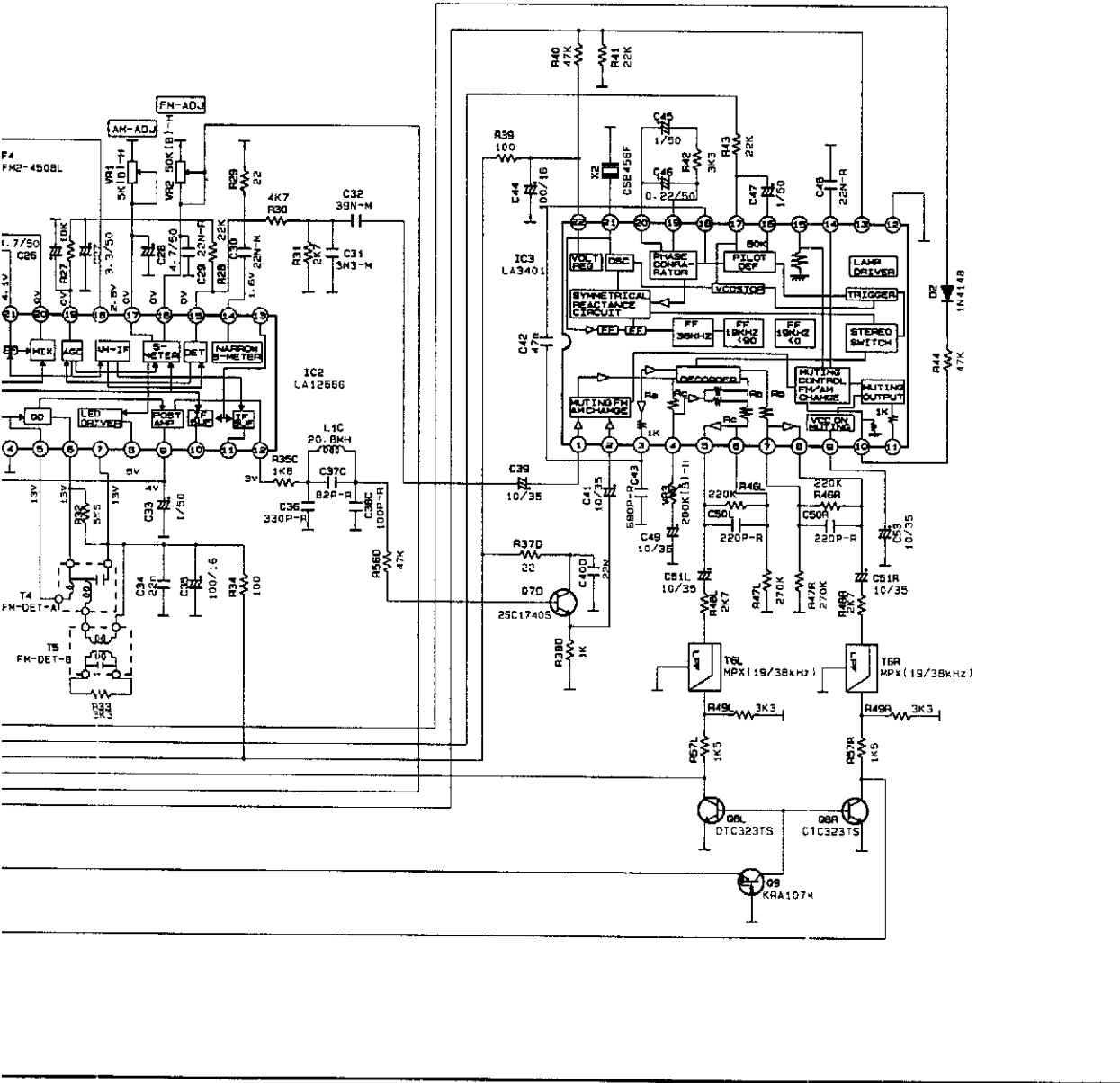

NOTES

1. Resistor values are indicated in ohms unless otherwise specified [K=1,000 M=1,000,000]
2. Capacitor values are indicated in microfarads unless otherwise specified. [p=micro=microfarads]

CAUTION

Safety precaution to be followed during servicing.

1. Since those parts marked with  are critical parts for safety, use only the one described in the parts list.
2. Before returning the set to the customer make appropriate leakage current or resistance measurements to determine the exposed parts are properly insulated from the supply circuit.

D5
D9
R56
C62

SCHEMATIC DIAGRAM (V)

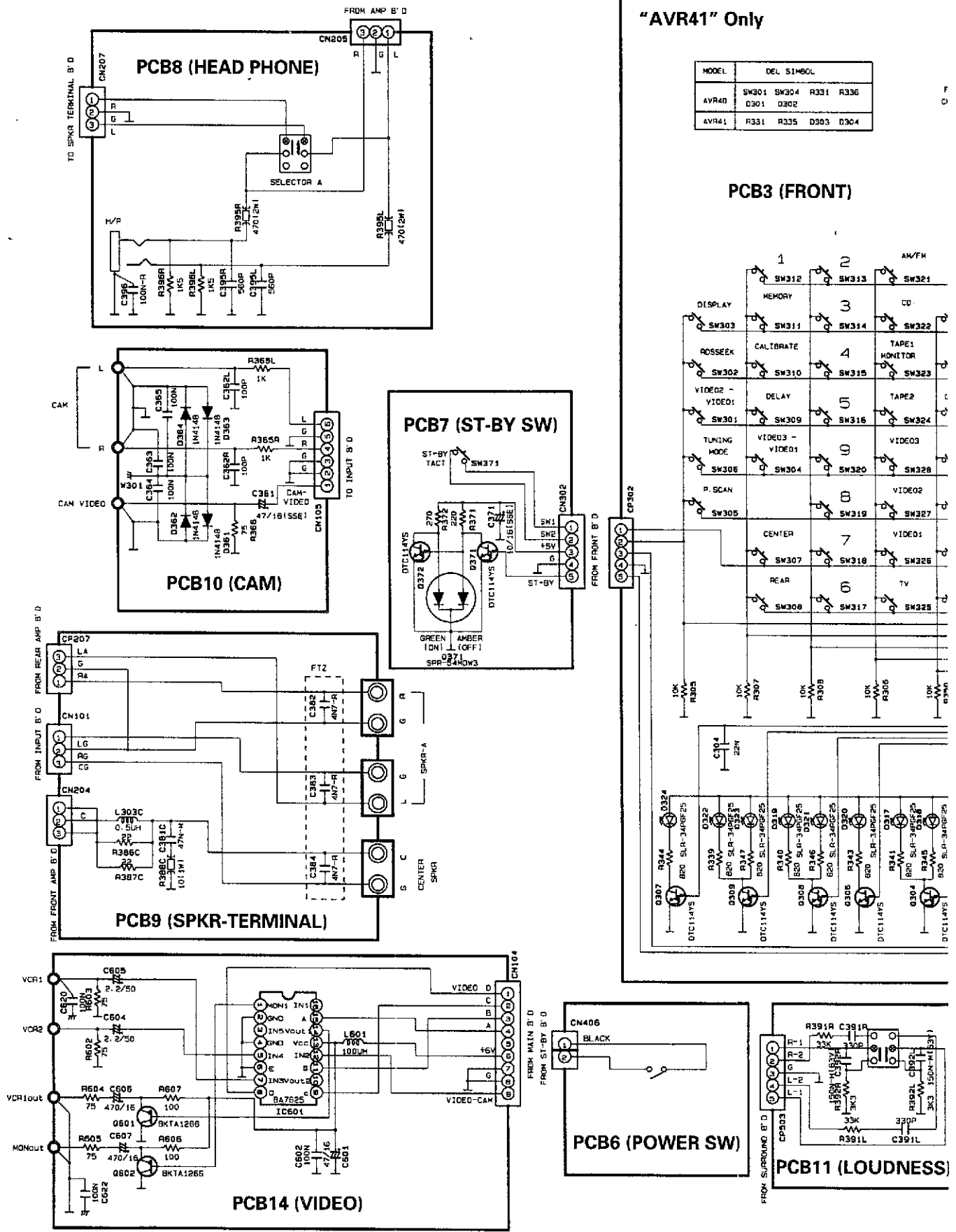

"AVR41" Only

MODEL	DEL SYMBOL
AVR40	SW301 SW304 R331 R336 D301 D302
AVR41	R331 R335 D303 D304

PCB3 (FRONT)

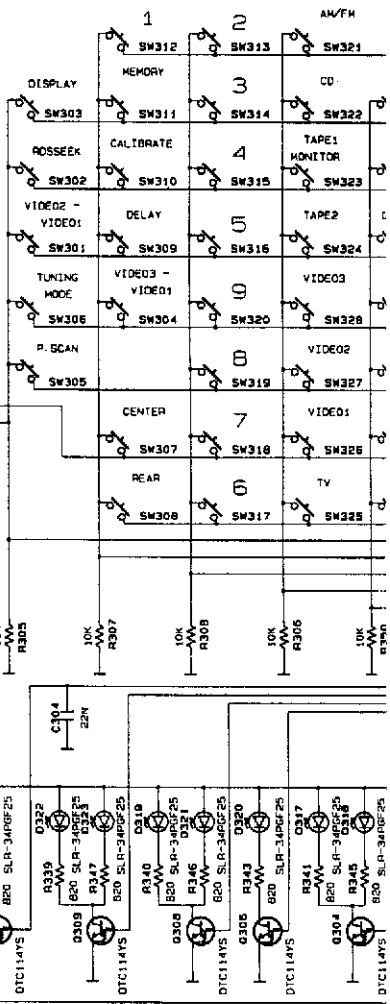

FL304
CM1351C

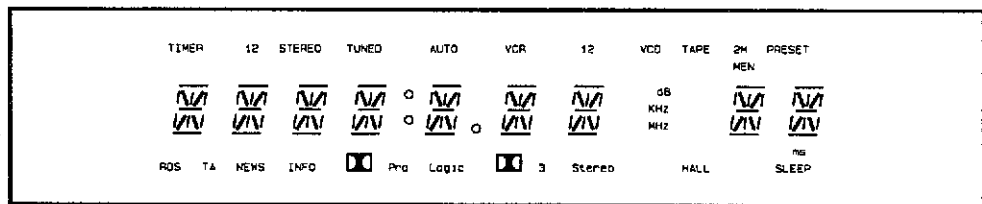

MODEL	AVR40	AVR41
J356	6J	4J

AREA	USA	EUROPE	KOREA	B
J366	6J	6J	4J	2J

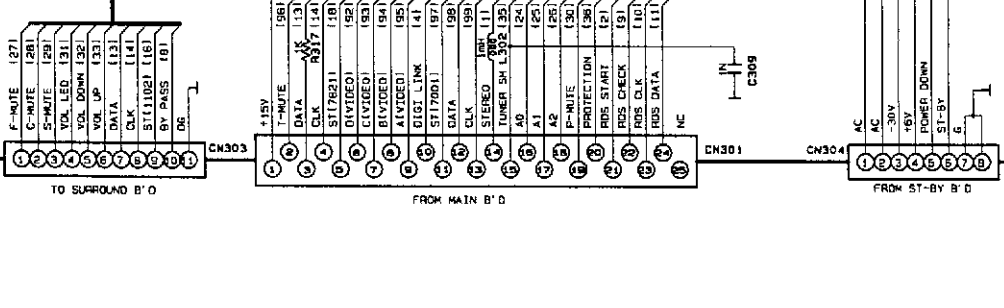
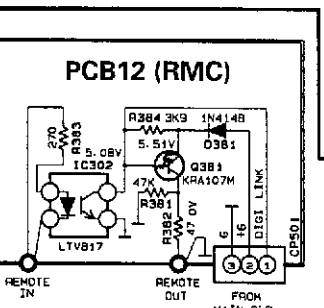
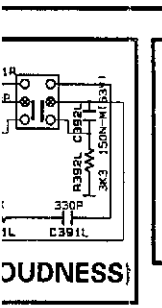
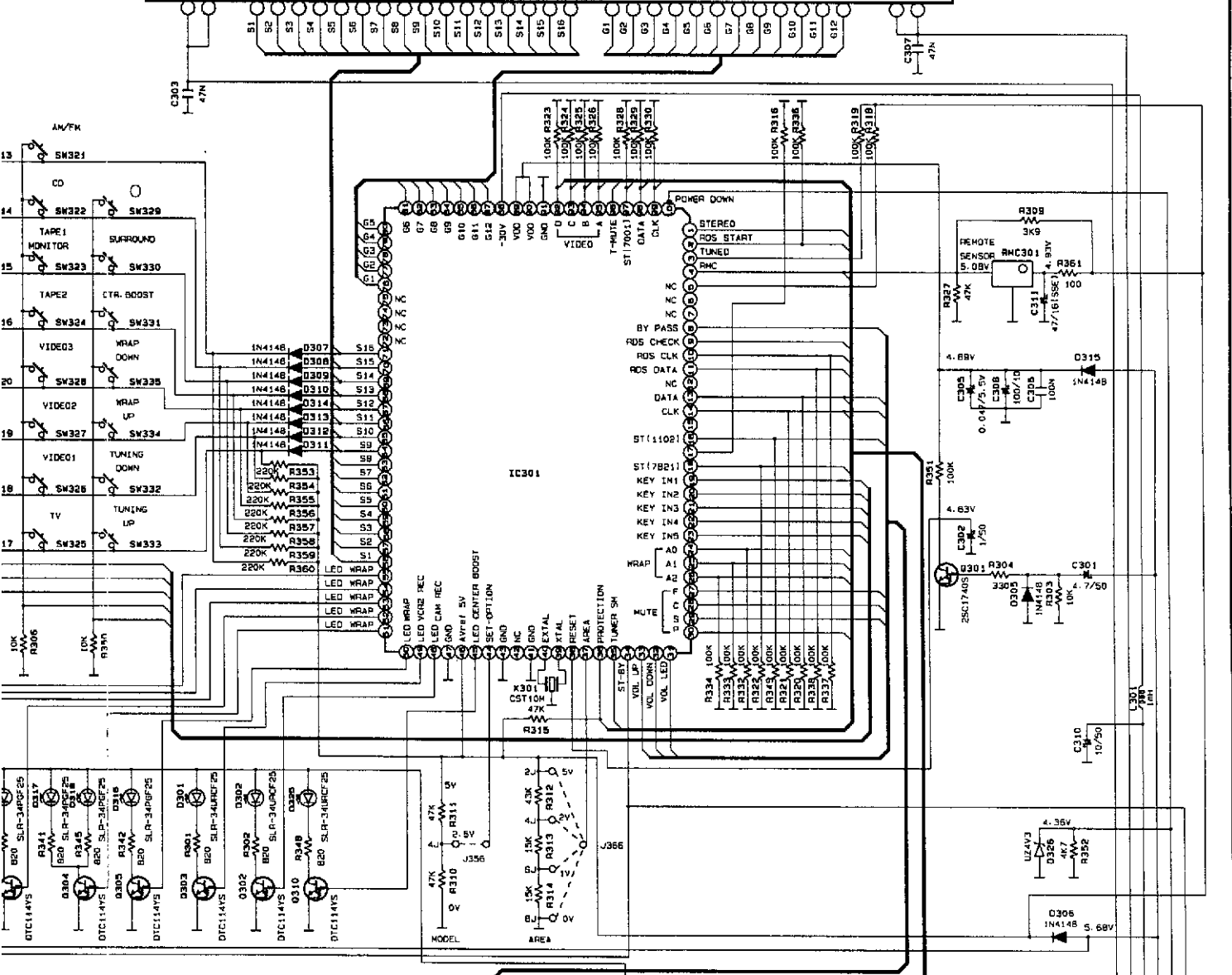

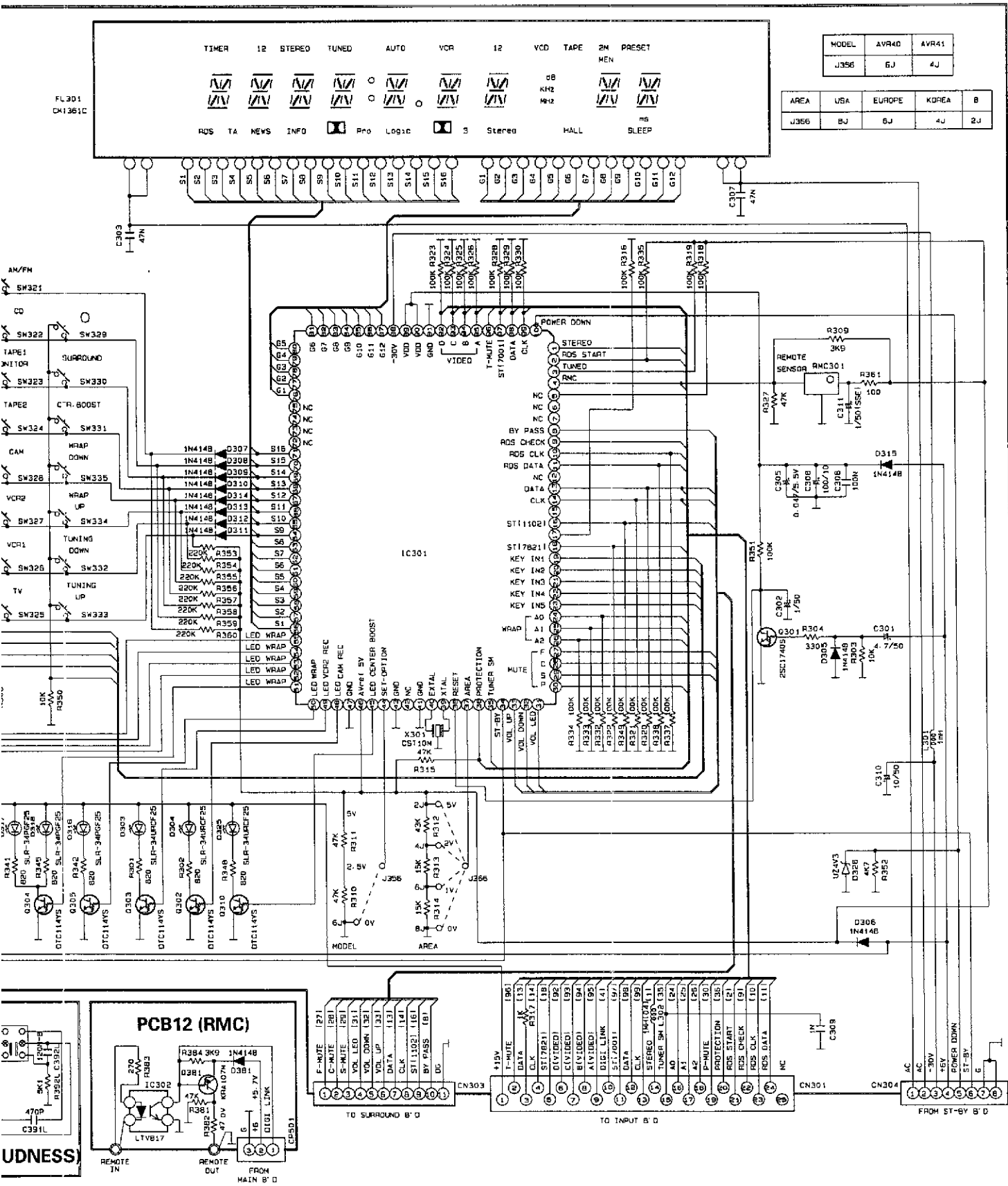

UDNESS

PCB12 (RMC)

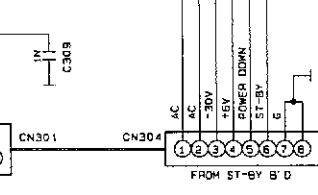
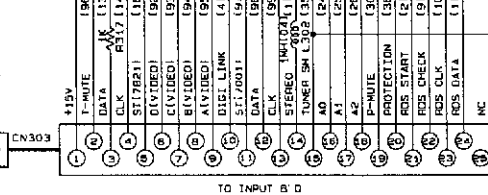
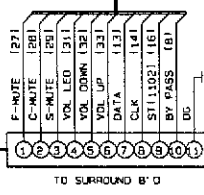
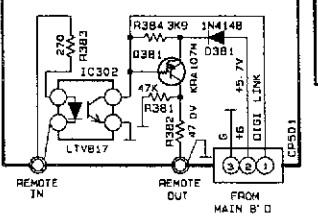

SCHEMATIC DIGRAM (VII)

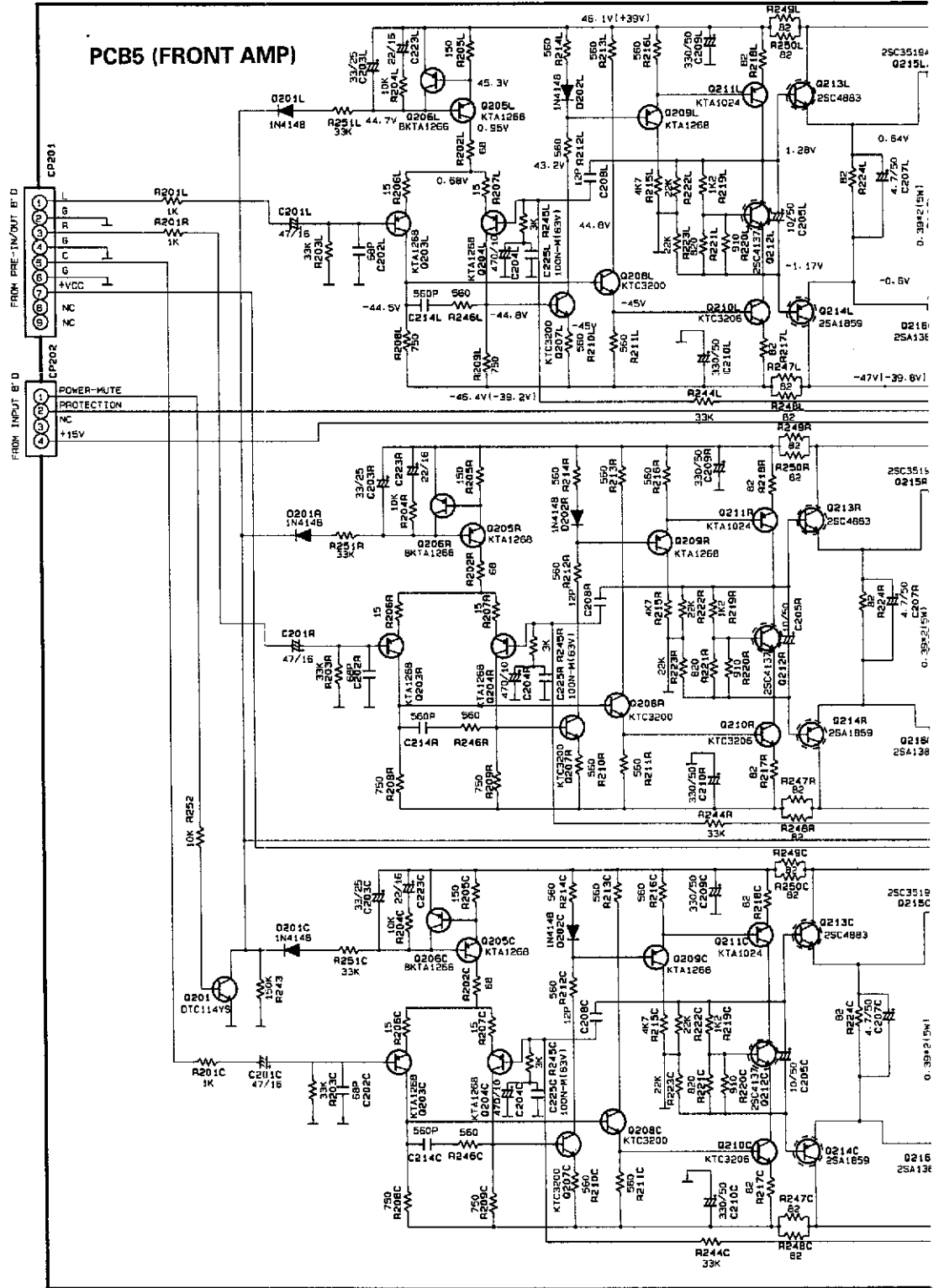

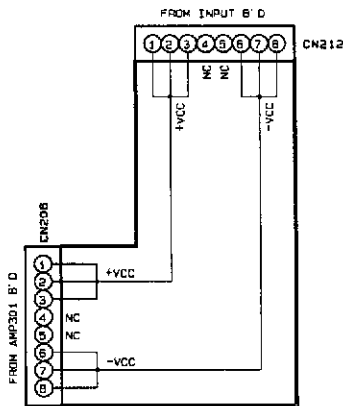
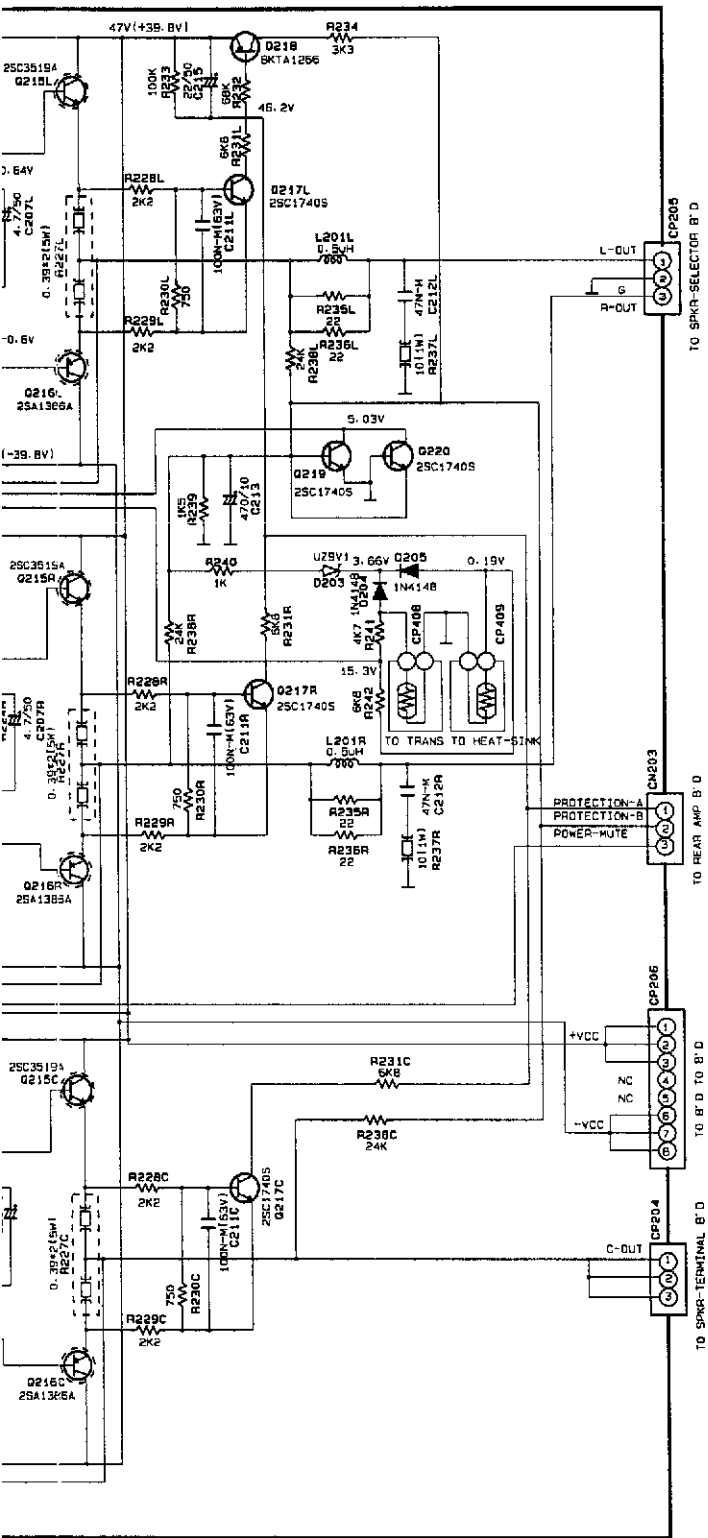

NOTES

1. Resistor values are indicated in ohms unless otherwise specified (K=1,000 M=1,000,000)
2. Capacitor values are indicated in microfarads unless otherwise specified. (p=micro-microfarads)

CAUTION

Safety precaution to be followed during servicing:

1. Since those parts marked with are critical parts for safety, use only the one described in the parts list.
2. Before returning the set to the customer, make appropriate leakage current or resistance measurements to determine the exposed parts are properly insulated from the supply circuit.

SCHEMATIC DIAGRAM (X)

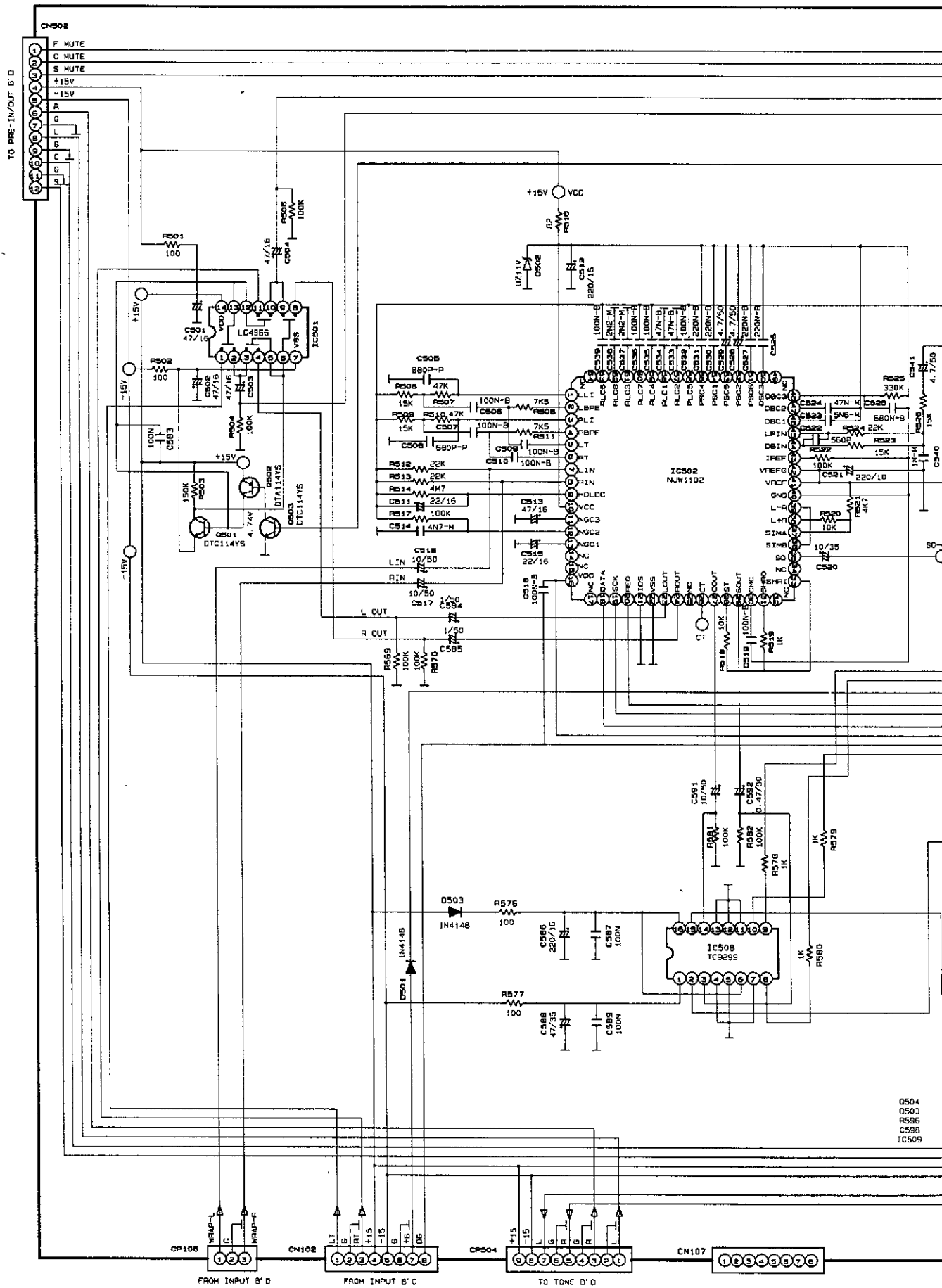

PCB13 (SURROUND)

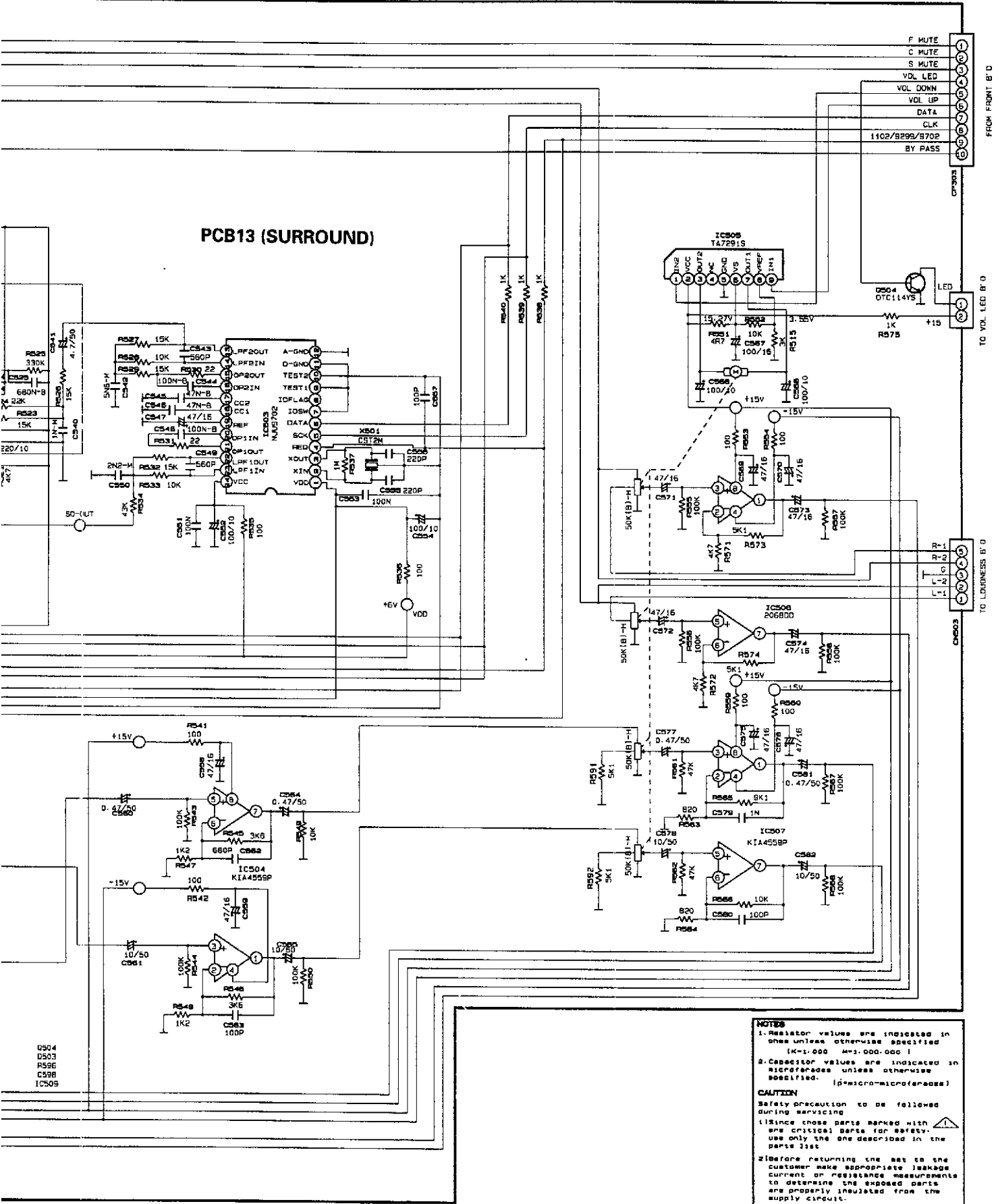

NOTES

1. Resistor values are indicated in ohms unless otherwise specified
[K=1,000 M=1,000,000]
2. Capacitor values are indicated in microfarads unless otherwise specified. (p=picofarads)

CAUTION
Safety precautions to be followed during servicing

1. Since these parts marked with are critical parts for safety, use only the one described in the parts list.
2. Before returning the set to the customer make appropriate leakage current or resistance measurements to determine the exposed parts are properly insulated from the supply circuit.

WIRING DIAGRAM

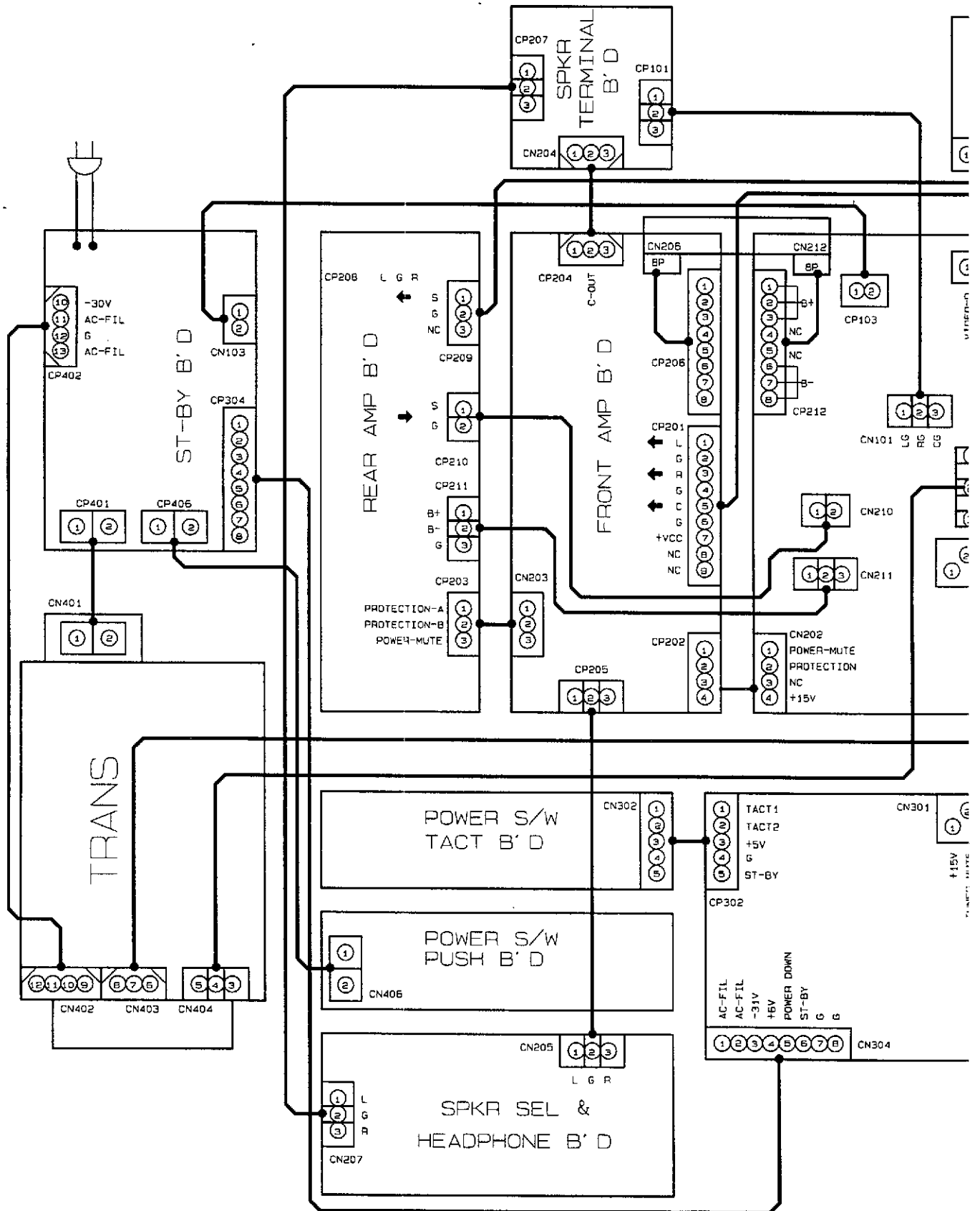

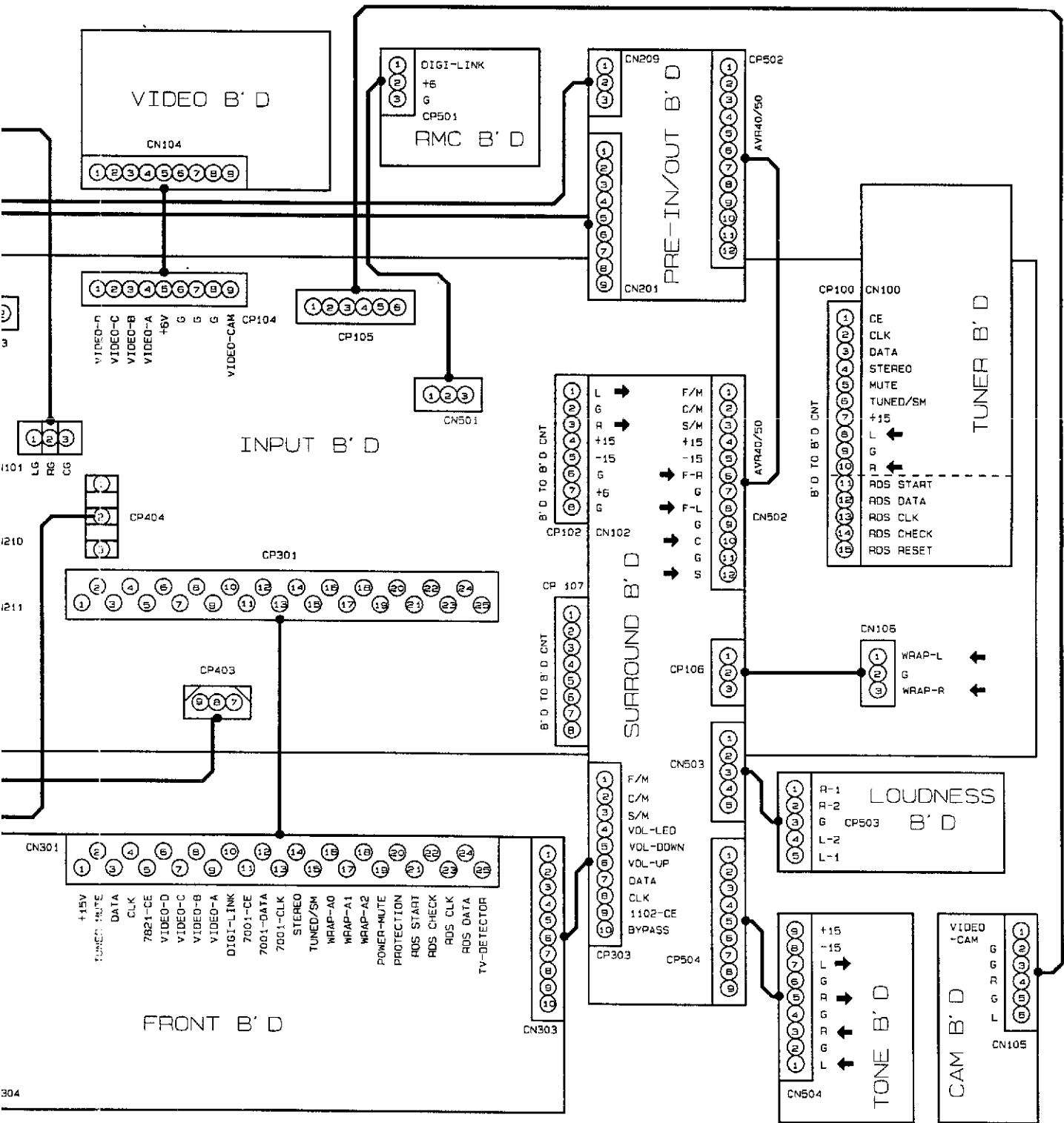

SCHEMATIC DIGRAM (VIII)

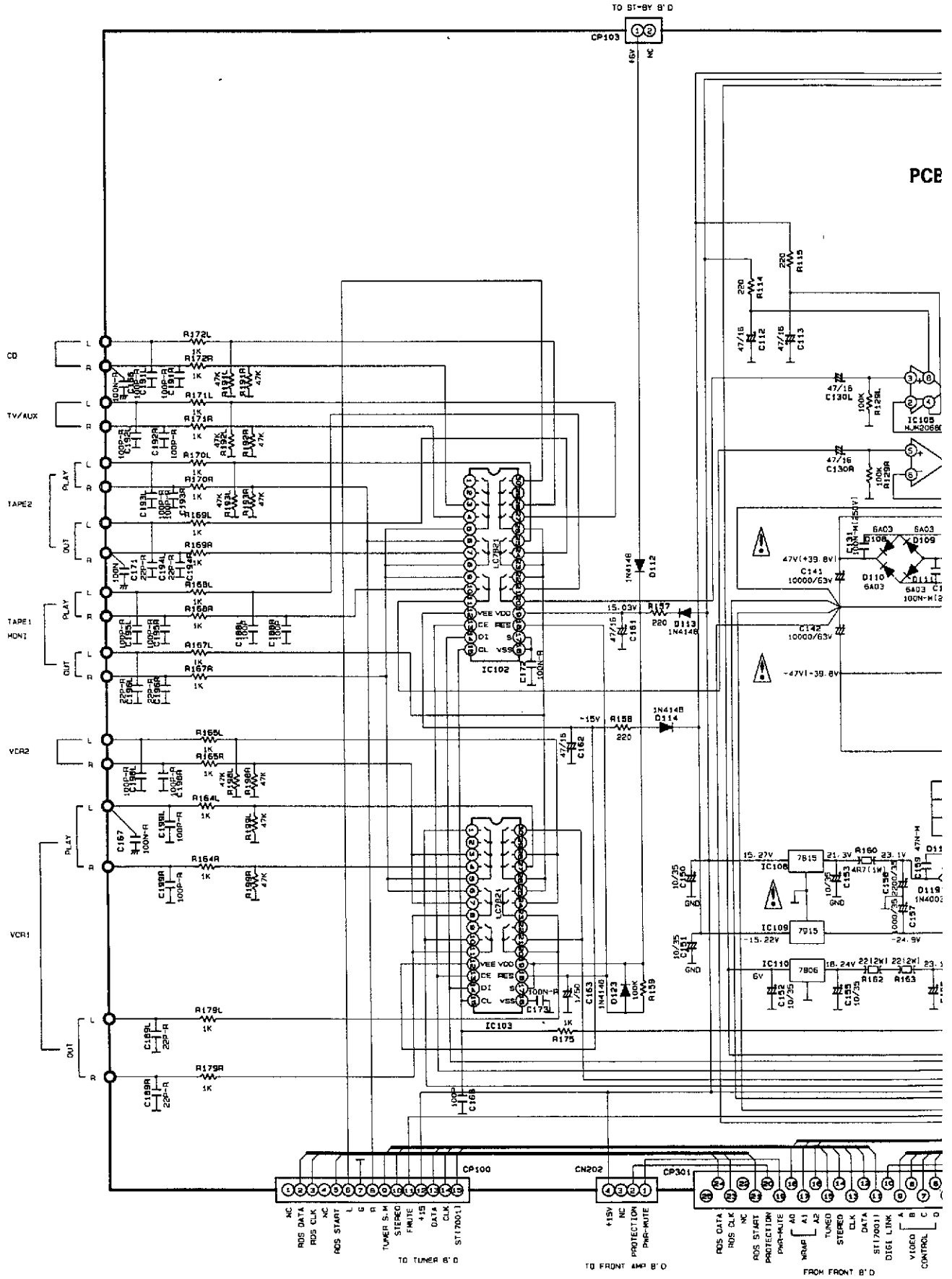

PCB2 (MAIN)

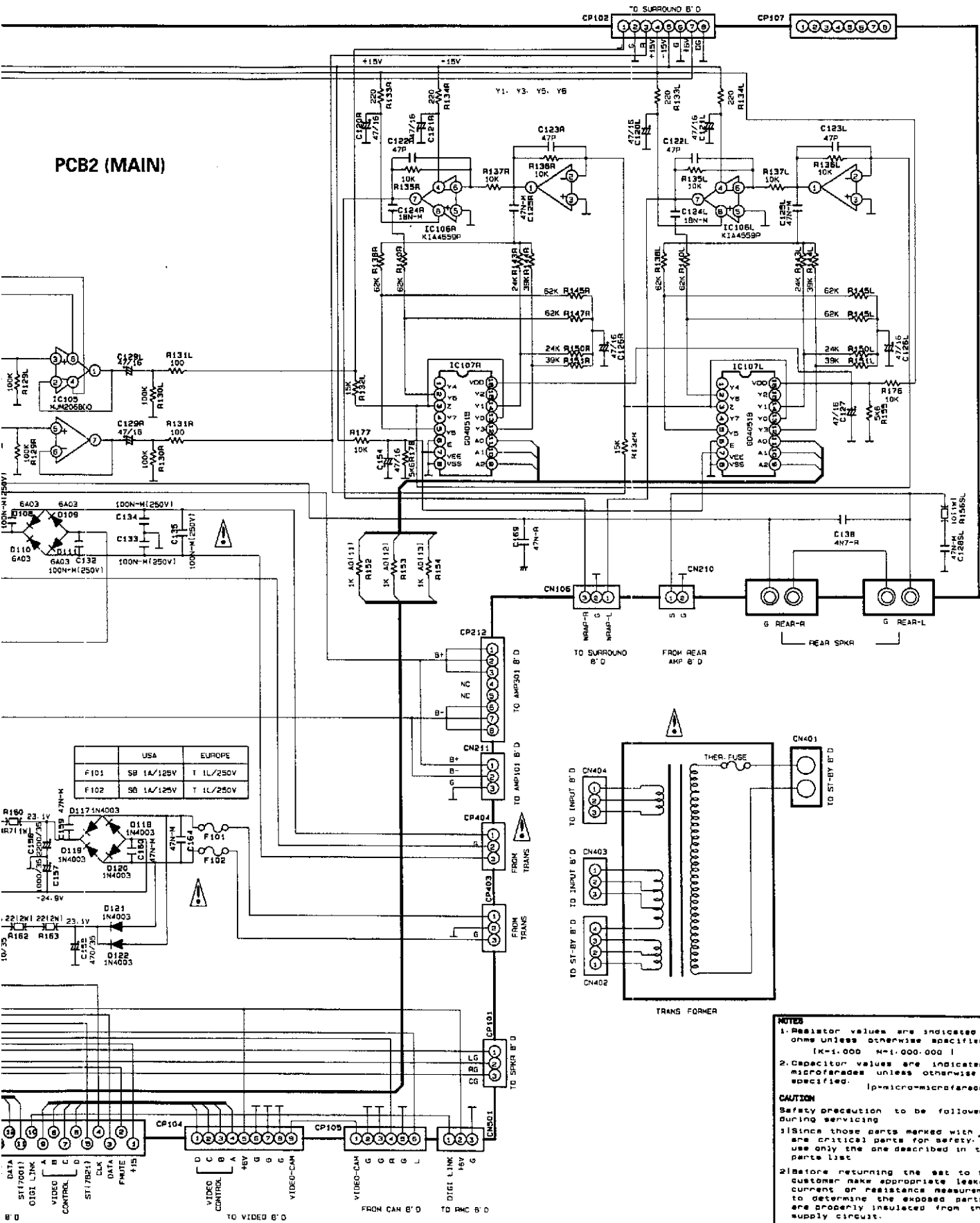

NOTES

1. Resistor values are indicated in ohms unless otherwise specified
[K=1,000 M=1,000,000]
2. Capacitor values are indicated in microfarads unless otherwise specified. [p=picofarads]

CAUTION

Safety precautions to be followed during servicing

- 1) Since those parts marked with a triangle symbol are critical parts for safety, use only the one described in the parts list
- 2) Before returning the set to the customer, make appropriate leakage current or resistance measurements to determine the exposed parts are properly insulated from the supply circuit.

SCHEMATIC DIGRAM (IX)

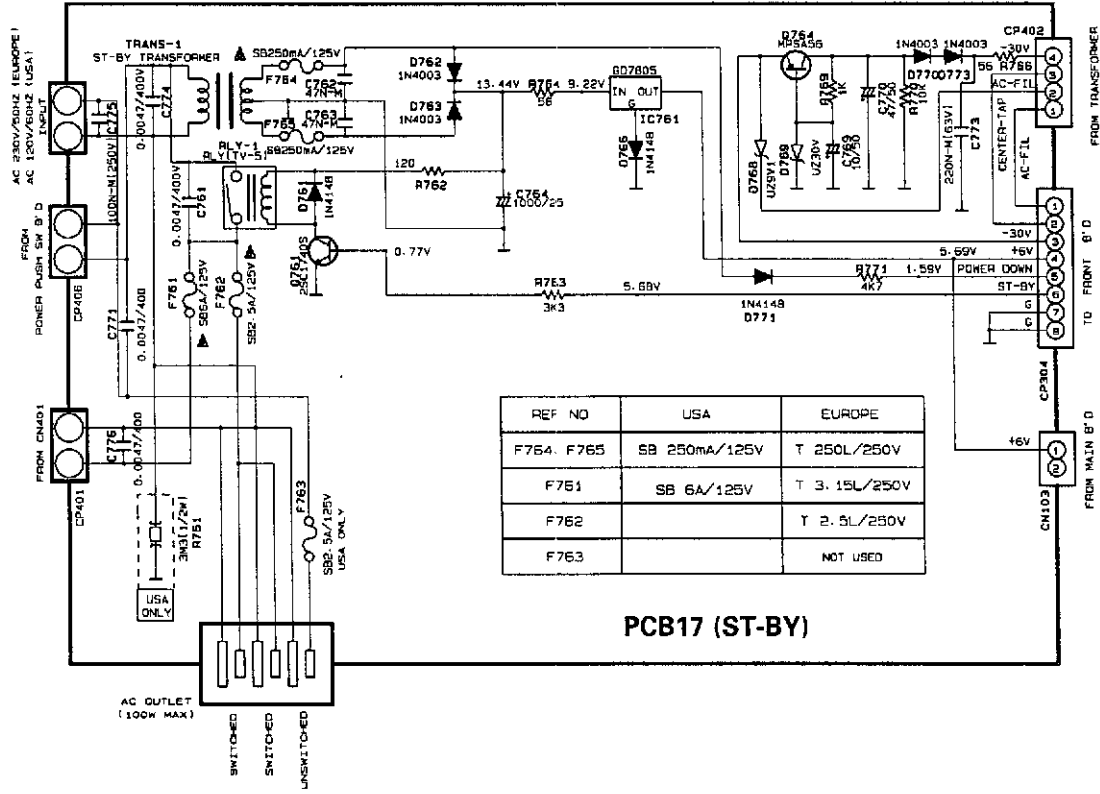
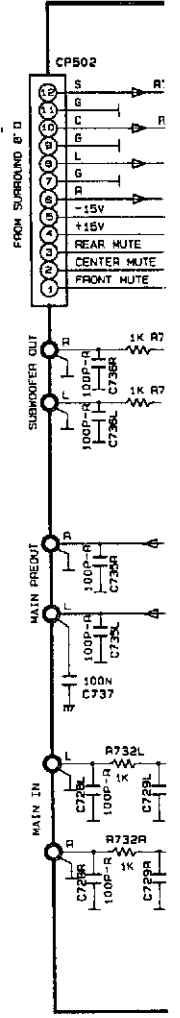
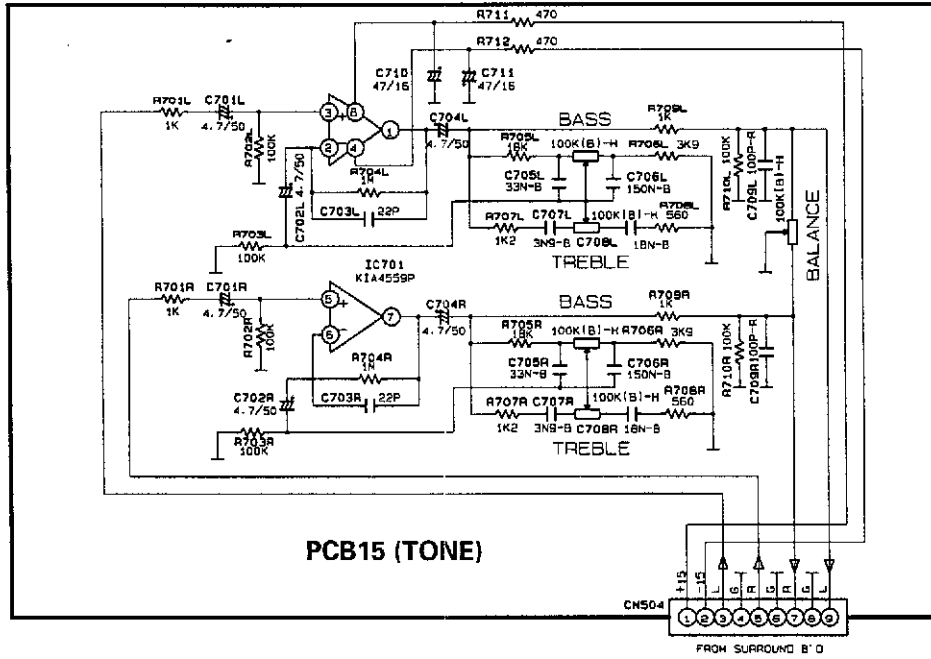

PCB16 (PRE IN/OUT)

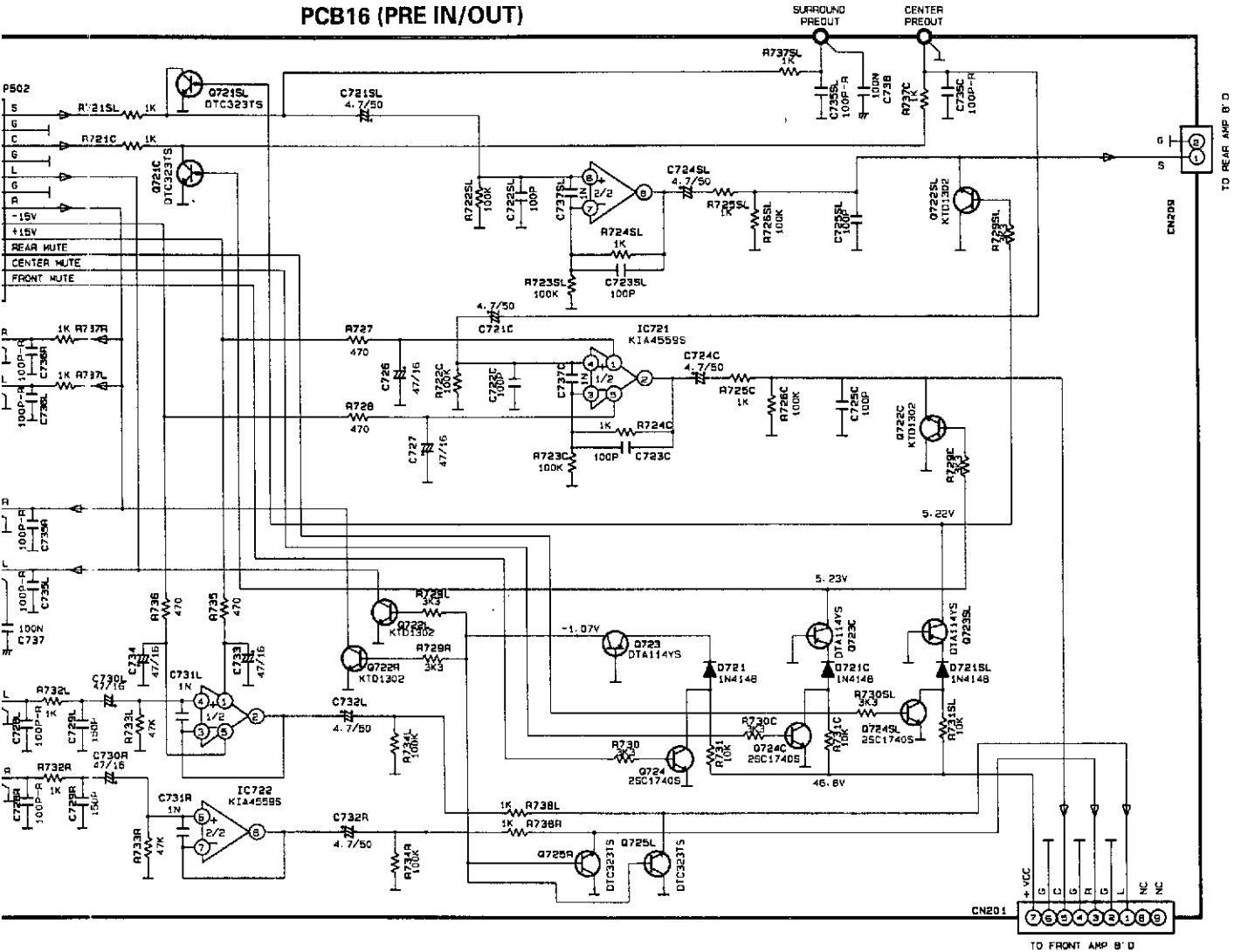

NOTES

1. Resistor values are indicated in ohms unless otherwise specified [K=1,000 M=1,000,000]
2. Capacitor values are indicated in microfarads unless otherwise specified. [p=micro-microfarads]

CAUTION

Safety precaution to be followed during servicing

- 1) Since those parts marked with  are critical parts for safety, use only the one described in the parts list
- 2) Before returning the set to the customer make appropriate leakage current or resistance measurements to determine the exposed parts are properly insulated from the supply circuit.