

harman/kardon

AVR445

A/V DOLBY DIGITAL RECEIVER

SERVICE MANUAL



CONTENTS

ESD WARNING.....	2	PROCESSOR RESET.....	28
LEAKAGE TESTING.....	3	UNIT EXPLODED VIEW.....	29
BASIC SPECIFICATIONS.....	4	EXPLODED VIEW PARTS LIST.....	30
PACKAGE.....	5	BLOCK DIAGRAM(S).....	33
PACKAGE PARTS LIST.....	6	CIRCUIT DESCRIPTION.....	35
FRONT PANEL CONTROLS.....	7	IDLE CURRENT ADJUST.....	36
REAR PANEL CONNECTIONS.....	10	SEMICONDUCTOR PINOUTS.....	39
REMOTE CONTROL FUNCTIONS.....	13	PCB DRAWINGS.....	86
INSTALLATION/CONNECTIONS.....	17	ELECTRICAL PARTS LIST.....	100
OPERATION.....	20	SCHEMATICS.....	122
TROUBLESHOOTING GUIDE.....	28	WIRING DIAGRAM.....	137

harman/kardon, Inc.
250 Crossways Park Dr.
Woodbury, New York 11797

Rev0 – 12/2006

ELECTROSTATICALLY SENSITIVE (ES) DEVICES

Some semiconductor (solid state) devices can be damaged easily by static electricity. Such components commonly are called Electrostatically Sensitive (ES) Devices. Examples of typical ES devices are integrated circuits and some field effect transistors and semiconductor "chip" components.

The following techniques should be used to help reduce the incidence of component damage caused by static electricity.



1. Immediately before handling any semiconductor component or semiconductor-equipped assembly, drain off any electrostatic charge on your body by touching a known earth ground. Alternatively, obtain and wear a commercially available discharging wrist strap device, which should be removed for potential shock reasons prior to applying power to the unit under test.
2. After removing an electrical assembly equipped with ES devices, place the assembly on a conductive surface such as aluminum foil, to prevent electrostatic charge build-up or exposure of the assembly.
3. Use only a grounded-tip soldering iron to solder or unsolder ES devices.
4. Use only an anti-static solder removal device. Some solder removal devices not classified as "anti-static" can generate electrical charges sufficient to damage ES devices.
5. Do not use freon-propelled chemicals. These can generate electrical change sufficient to damage ES devices.
6. Do not remove a replacement ES device from its protective package until immediately before you are ready to install it. (Most replacement ES devices are packaged with leads electrically shorted together by conductive foam, aluminum foil or comparable conductive material.)
7. Immediately before removing the protective material from the leads of a replacement ES device, touch the protective material to the chassis or circuit assembly into which the device will be installed.

CAUTION : Be sure no power is applied to the chassis or circuit, and observe all other safety precautions.

8. Minimize bodily motions when handling unpackaged replacement ES devices. (Otherwise harmless motion such as the brushing together of your clothes fabric or the lifting of your foot from a carpeted floor can generate static electricity sufficient to damage an ES devices.

PRODUCT SAFETY NOTICE

Each precaution in this manual should be followed during servicing.

Components identified with the IEC symbol  in the parts list are special significance to safety. When replacing a component identified with , use only the replacement parts designated, or parts with the same ratings or resistance, wattage, or voltage that are designated in the parts list in this manual. Leakage-current or resistance measurements must be made to determine that exposed parts are acceptably insulated from the supply circuit before returning the product to the customer.

SAFETY PRECAUTIONS

The following check should be performed for the continued protection of the customer and service technician.

LEAKAGE CURRENT CHECK

Measure leakage current to a known earth ground (water pipe, conduit, etc.) by connecting a leakage current tester between the earth ground and all exposed metal parts of the appliance (input/output terminals, screwheads, metal overlays, control shaft, etc.). Plug the AC line cord of the appliance directly into a 120V AC 60Hz outlet and turn the AC power switch on. Any current measured must not exceed 0.5mA.

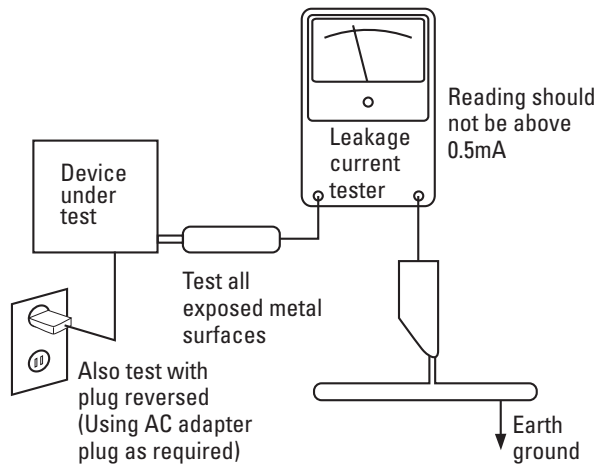

AC Leakage Test

ANY MEASUREMENTS NOT WITHIN THE LIMITS OUTLINED ABOVE ARE INDICATIVE OF A POTENTIAL SHOCK HAZARD AND MUST BE CORRECTED BEFORE RETURNING THE APPLIANCE TO THE CUSTOMER.

AVR 445 TECHNICAL SPECIFICATIONS

Audio Section

Stereo Mode

Continuous Average Power (FTC)

80 Watts per channel, 20Hz–20kHz,
@ <0.07% THD, both channels driven into 8 ohms

Seven-Channel Surround Modes

Power per Individual Channel

Front L & R channels:
65 Watts per channel
@ <0.07% THD, 20Hz–20kHz into 8 ohms

Center channel:
65 Watts @ <0.07% THD, 20Hz–20kHz into 8 ohms

Surround (L & R Side, L & R back) channels:
65 Watts per channel
@ <0.07% THD, 20Hz–20kHz into 8 ohms

Input Sensitivity/Impedance

Linear (High-Level) 200mV/47k ohms

Signal-to-Noise Ratio (IHF-A) 100dB

Surround System Adjacent Channel Separation

Dolby Pro Logic 40dB

Dolby Digital 55dB

DTS 55dB

Frequency Response

@ 1W (+0dB, -3dB) 10Hz – 130kHz

High Instantaneous

Current Capability (HCC) ±40 Amps

Transient Intermodulation

Distortion (TIM) Unmeasurable

Slew Rate

40V/μsec

FM Tuner Section

Frequency Range 87.5–108.0MHz

Usable Sensitivity IHF 1.3μV/13.2dBf

Signal-to-Noise Ratio Mono/Stereo 70/68dB

Distortion Mono/Stereo 0.2/0.3%

Stereo Separation 40dB @ 1kHz

Selectivity ±400kHz, 70dB

Image Rejection 80dB

IF Rejection 90dB

Supplied Accessories

The AVR 445 is supplied with the following accessory items. If any item is missing, please contact Harman Kardon customer service at www.harmankardon.com.

- Six AAA batteries
- System remote control
- ZR 10 remote control
- **III B Set/EQ** microphone
- Extender rod for microphone
- AM loop antenna
- FM wire antenna
- AC power cord

AM Tuner Section

Frequency Range 520–1720kHz

Signal-to-Noise Ratio 45dB

Usable Sensitivity Loop 500μV

Distortion 1kHz, 50% Mod 0.8%

Selectivity ±10kHz, 30dB

Video Section

Television Format NTSC

Input Level/Impedance 1V p-p/75 ohms

Output Level/Impedance 1V p-p/75 ohms

Video Frequency Response (Composite and S-Video) 10Hz–8MHz (-3dB)

Video Frequency Response (Component Video) 10Hz–60MHz (-3dB)

General

Power Requirement AC 120V/60Hz

Power Consumption 120W at Power On, idle; 1,025W at rated power output (7 channels driven)

Dimensions

Product 17-5/16 inches (440mm) 20-1/16 inches (510mm)

Width 6-1/2 inches (165mm) 10 inches (254mm)

Height 17-1/16 inches (435mm) 22-3/16 inches (565mm)

Depth 39 lb (17.7kg) 46 lb (20.9kg)

Depth measurement includes knobs, buttons and terminal connections.

Height measurement includes feet and chassis.

All features and specifications are subject to change without notice.

Harman Kardon, Harman International and Logic 7 are registered trademarks of Harman International Industries, Incorporated.

III B and **III B Set/EQ** are trademarks of Harman International Industries, Incorporated.

Dolby, Pro Logic and the Double-D symbol are registered trademarks of Dolby Laboratories.

Manufactured under license from Dolby Laboratories.

DTS, DTS Surround, DTS-ES, DTS 96/24 and DTS Neo:6 are registered trademarks of DTS, Inc.

A-BUS and A-BUS/*READY* are registered trademarks of Leisure Tech Electronics Pty Ltd Australia.

SACD is a trademark of Sony Corporation.

iPod and iTunes are registered trademarks of Apple Computer, Inc.

HD-DVD is a trademark of the DVD Format/Logo Licensing Corporation (DVD FLLC).

HDMI, the HDMI logo and High-Definition Multimedia Interface are trademarks or registered trademarks of HDMI Licensing, LLC.

Microsoft, Windows and Windows Media are registered trademarks of Microsoft Corporation in the United States and other countries.

XM Ready is a registered trademark of XM Satellite Radio, Inc.

RealPlayer is a registered trademark of RealNetworks.

Winamp is a registered trademark of America Online, Inc.

TiVo is a registered trademark of TiVo Inc.

AVR445 PACKAGING

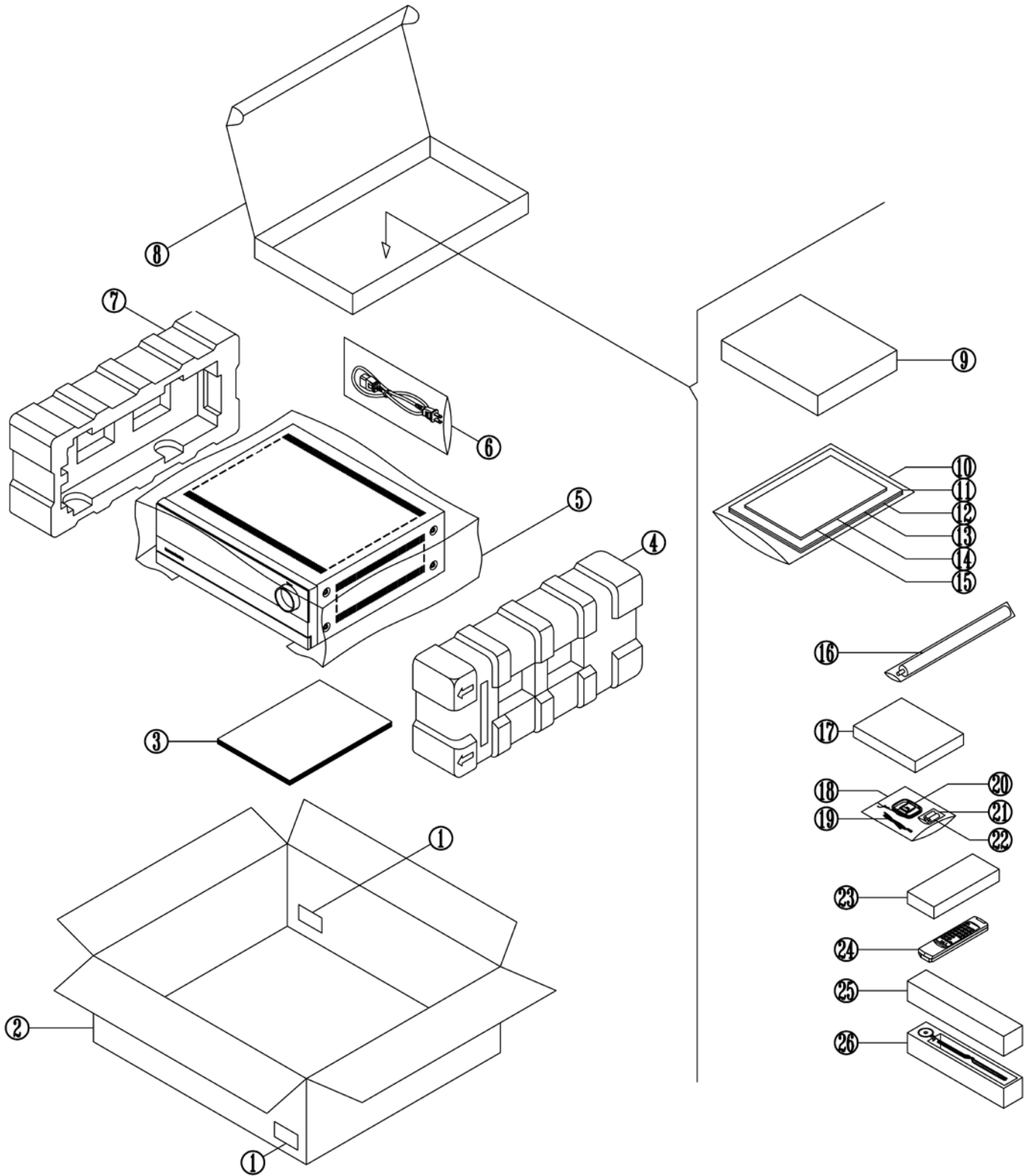

AVR445 PACKAGE CHART

Item#	Part Number	Description	Qty
1		LABEL BARCODE AVR445 US (120v)	1
	H03-RYD3101HA00-R	LABEL BARCODE AVR445 EU TF PRINT (230v)	2
2	ZKD3194HA00-R	BOX CARTON AVR445 US (120v)	1
	ZKD3204HA01-R	BOX CARTON AVR445 EU (230v)	1
3	ZKD3101HA00-R	OWNER'S MANUAL AVR445US (120v)	1
	ZKD3201HA00-R	OWNER'S MANUAL AVR445EU (230v)	1
4	ZQD1201HAWH-R	CUSHION POLY EPS RIGHT AVR445	1
5		FILM SHEET PE 920 X 1000	1
6	H03-WAUSA2103BK-R	120V POWER CORD WS-004C+002E SJT#14*2C L=2M	1
	H03-WAD022000BK-R	230V POWER CORD WR002 H05VVF 0.75MMSQ 2G BLACK 2000MM	1
7	ZQD1202HAWH-R	CUSHION POLY EPS LEFT AVR445	1
8		AVR445 TOTAL ACCESSORY BOX	1
9	RB18G00	REMOTE CONTROL AVR445 US (120v)	1
	H03-RYD3201HA00-R	REMOTE CONTROL AVR445 US (230v)	1
10		BAG PE 330 X245 T0.05	1
11		QUICK SETUP GUIDE AVR445	1
12		LABEL SAFETY LEAFLET	1
13	ZKC1113HA00-R	CARD WARRANTY	1
14		BROCHURE AVR US	1
15		INSERT RS232 NOTE PAPER	1
16	H03-ZPD1212INBK-R	MICROPHONE ASSY EXTENSION PIECE	1
17		BOX, ANTENNA	1
18		BAG PE 160X180MM	1
19	H03-WAB01200203-R	ANTENNA WIRE 75 T15011N-1 US (120v)	1
	H03-WAD01200303-R	ANTENNA WIRE 75 OHM WIRE T15011F-1 EU (230v)	1
20	H03-ATALF039ABK-R	ANTENNA WIRE ANTENNA LOOP-300	1
21		POLYBAG, BATTERY	1
22		BATTERY ALKALINE 1.5V AAA	2
23		BOX, ZONE II REMOTE CONTROL	1
24	RH15B00	REMOTE CONTROL ZONE 2 AVR445 (120v)	1
	H03-RYD2702HA01-R	REMOTE CONTROL ZONE 2 AVR445 (230v)	1
25		BOX, MIC	1
26	H03-MCD12TWBKNN	AVR445 MICROPHONE ASSY	1

FRONT-PANEL CONTROLS

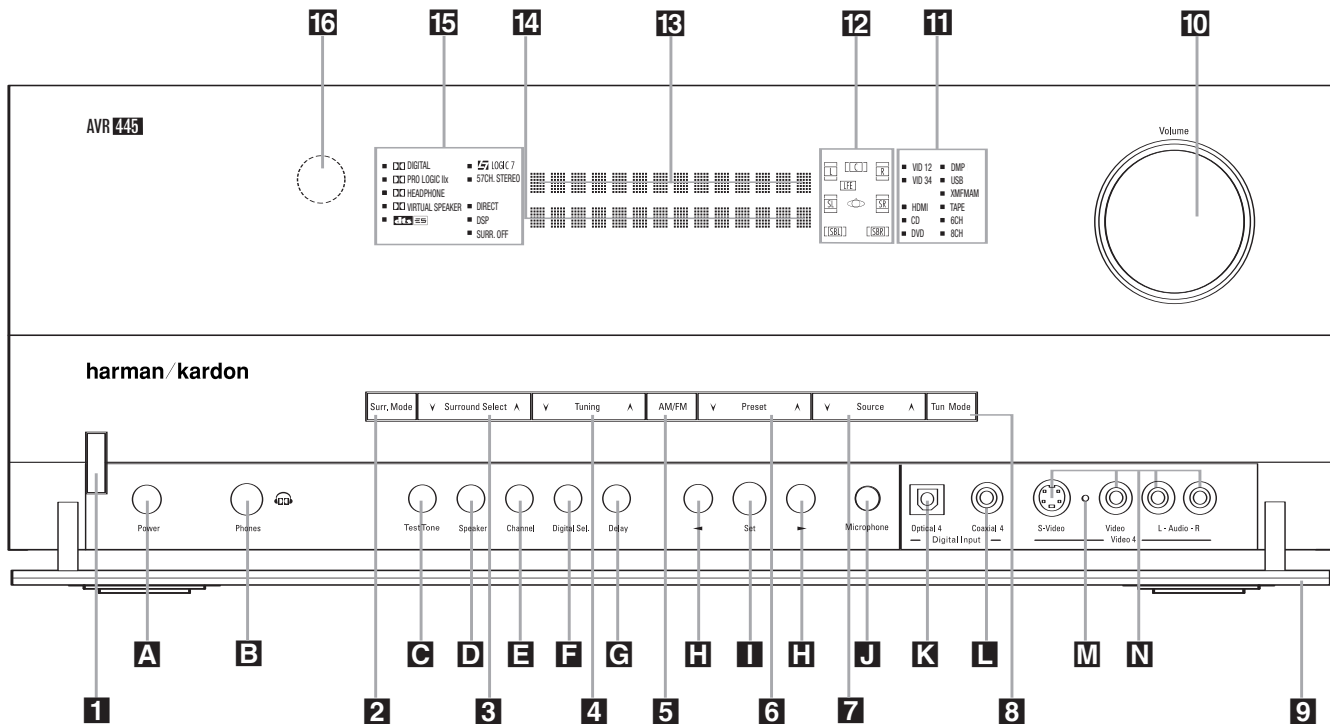

NOTE: To make it easier to follow the instructions that refer to this illustration, a larger copy may be downloaded from the Product Support section for this product at www.harmankardon.com.

The following controls and indicators are available on the AVR 445's front panel:

- | | | |
|---------------------------------------|--|------------------------------------|
| 1 Standby/On Switch | 7 Input Source Selector | 13 Upper Display Line |
| 2 Surround Mode Group Selector | 8 Tuning Mode Selector | 14 Lower Display Line |
| 3 Surround Mode Selector | 9 Front-Panel Door | 15 Surround Mode Indicators |
| 4 Tuning Selector | 10 Volume Control | 16 Remote Sensor Window |
| 5 Tuner Band Selector | 11 Input Indicators | |
| 6 Preset Station Selector | 12 Speaker/Channel Input Indicators | |

The following controls and jacks are located behind the front-panel door. To open the door, place the edge of a finger on the left or right edge of the panel and gently swing the door down toward you.

- | | | |
|----------------------------------|-----------------------------------|--|
| A Main Power Switch | F Digital Input Selector | K Optical 4 Digital Input |
| B Headphone Jack | G Delay Adjust Selector | L Coaxial 4 Digital Input |
| C Tone Mode Button | H ◀▶ Buttons | M Input/Output Status Indicator |
| D Speaker Selector Button | I Set Button | N Video 4 Input/Output Jacks |
| E Channel Adjust Selector | J EzSet/EQ Microphone Jack | |

1 Standby/On Switch: When the **Main Power Switch A** is "ON," press this button to turn on the AVR 445; press it again to turn the unit off. Note that the illumination surrounding the switch will turn blue when the unit is on, or in the Multiroom mode.

2 Surround Mode Group Selector: Press this button to select the top-level group of surround modes. Each press of the button will select one of the surround mode categories. Once the button is pressed so

that the name of the desired surround mode category appears in the on-screen display and in the **Lower Display Line 14**, press the **Surround Mode Selector 3** to cycle through the individual modes available. For example, press this button to select Dolby modes, and then press the **Surround Mode Selector 3** to choose from the various mode options.

3 Surround Mode Selector: Press this button to select from among the available surround mode

options for the surround mode category selected. The specific modes will vary based on the number of speakers available, the surround mode category and whether the input source is digital or analog. For example, press the **Surround Mode Group Selector 2** to select a category such as Dolby or Logic 7, and then press this button to see the specific mode choices that are available. For more information on mode selection, see pages 24, 35 and 58.

FRONT - PANEL CONTROLS

4 Tuning Selector: Press the left side of the button to tune lower-frequency stations and the right side of the button to tune higher-frequency stations. When the tuner is in the **MANUAL/MONO** mode, each tap of the Selector will increase or decrease the frequency by one increment. When the tuner receives a signal strong enough for adequate reception, **MANUAL TUNED** will appear in the **Lower Display Line 14** and in the on-screen display. When the tuner is in the **AUTO/STEREO** mode, press the button once, and the tuner will scan for a station with acceptable signal strength. When the next higher- or lower-frequency station is tuned, the frequency scan will stop and the **Lower Display Line 14** and the on-screen display will indicate **AUTO TUNED**. When an FM stereo station is tuned, the display will read **AUTO ST TUNED**. See page 39 for more information on using the tuner. When an XM Ready module is connected and activated, and when there is sufficient signal strength for the XM system to operate, pressing this button will also change the XM Radio channel.

5 Tuner Band Selector: Pressing this button will automatically switch the AVR 445 to the Tuner mode. Pressing it again will select the AM or FM frequency band, or XM Radio. (See page 39 for more information on the tuner.)

6 Preset Station Selector: Press this button to scroll up or down through the list of stations that have been entered into the preset memory. (See page 39 for more information on tuner programming.)

7 Input Source Selector: Press this button to change the input by scrolling up or down through the list of input sources.

8 Tuning Mode Selector: Press this button to select Auto or Manual tuning. When the button is pressed so that **AUTO/STEREO** appears in the **Upper Display Line 13**, the tuner will search for the next station with an acceptable signal when the **Tuning Selector 4 23 P** is pressed. When the button is pressed so that **MANUAL/MONO** appears in the **Upper Display Line 13**, each press of the **Tuning Selector 4 23 P** will increase the frequency. (See page 39 for more information on using the tuner.)

This button may also be used to switch between Stereo and Mono modes for FM radio reception. When weak reception is encountered, select the Manual/Mono tuning mode. Press and hold again to switch back to Stereo mode. (See pages 39 for more information on using the tuner.)

When an optional XM Connect & Play module is connected and activated, and when there is sufficient signal strength for the XM system to operate, this button has a different set of functions than when traditional AM or FM radio is in use. See page 39 for more information on XM Radio operation.

9 Front-Panel Door: To open the door so that the front-panel jacks and controls behind this door may be accessed, gently pull the door down and toward you, using either upper corner of the door.

10 Volume Control: Turn this knob clockwise to increase the volume, counterclockwise to decrease the volume. If the AVR 445 is muted, adjusting the volume control will automatically release the unit from the silenced condition.

11 Input Indicators: One of these indicators will light to identify the currently selected input. Note that the entire list will light briefly each time the unit is turned on, as a test.

12 Speaker/Channel Input Indicators: These indicators are multipurpose, indicating both the speaker type selected for each channel and the incoming data-signal configuration. The left, center, right, right surround and left surround speaker indicators are composed of three boxes, while the subwoofer is indicated by one box. The center box lights when a "small" speaker is selected, and the two outer boxes light when "large" speakers are selected. When none of the boxes are lit for the center, surround or subwoofer channels, no speaker has been assigned that position. The letters inside each box display the active input channels. For standard analog inputs, only the L and R will light, indicating a stereo input. For a digital source, the indicators will light to display the channels being received at the digital input. When the letters flash, the digital input has been interrupted. (See page 38 for more information on the Channel Indicators.)

13 Upper Display Line: Depending on the unit's status, a variety of messages will appear here. In normal operation, this line will show the current input source and identify whether an analog or digital input is in use. When the tuner is selected as the input, this line will identify the station as AM or FM and show the frequency and preset number, if any.

When an XM Connect & Play module is connected and activated, and when there is sufficient signal strength for the XM system to operate, the XM channel number and signal strength will appear here.

14 Lower Display Line: Depending on the unit's status, a variety of messages will appear here. In normal operation, the current surround mode will appear on this line. When an XM Ready module is connected and activated, and when there is sufficient signal strength for the XM system to operate, a variety of messages and information, including the XM channel title name, the current artist and track title, the XM Radio channel category and, when available, local traffic and weather information, will appear here.

15 Surround Mode Indicators: One of these indicators will light to show the surround mode in use. Depending on the specific combination of input sources and surround mode selected, more than one indicator may light. (See page 36 for more information.)

16 Remote Sensor Window: The sensor behind this window receives infrared signals from the remote control. Aim the remote control at this area, and do not block or cover it unless an external remote sensor is installed.

FRONT - PANEL CONTROLS

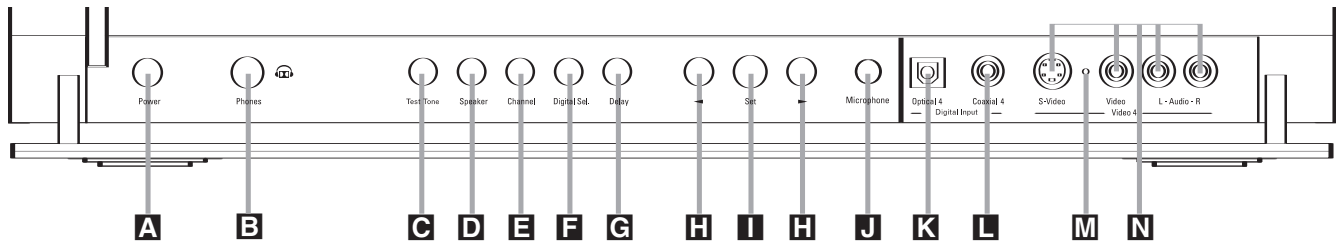

The following controls and jacks are located behind the front-panel door. To open the door, place the edge of a finger on the left or right edge of the panel and gently swing the door down toward you.

A Main Power Switch: Press this switch to apply power to the AVR 445. When the switch is pressed in, the unit is placed in a Standby mode, as indicated by the amber illumination surrounding the **Standby/On Switch** **I**. This button **MUST** be pressed in to operate the unit. To turn the unit off and prevent the use of the remote control, this switch should be pressed until it pops out from the front panel so that the word "OFF" may be read at the top of the switch.

NOTE: This switch is normally left in the "ON" position.

B Headphone Jack: This jack may be used to listen to the AVR 445's output through a pair of headphones. Be certain that the headphones have a standard 1/4" stereo phone plug, or that you use an adapter, as needed, to convert the plug on your headphones to the 1/4" jack used on the AVR. When the headphone jack is in use, the main room speakers will automatically be turned off and the unit will output a standard stereo signal. You may also use the Dolby Headphone mode for an enhanced listening experience.

C Tone Mode Button: This button controls the tone mode settings, enabling adjustment of the bass and treble boost/cut. You may also use it to take the tone controls out of the signal path completely for "flat" response. The first press of the button displays a **TONE MODE** message in the **Lower Display Line** **14** and in the on-screen display. To take the controls out of the signal path, press either of the **◀▶ Buttons** **H** until the display reads **TONE OUT**. To change the bass or treble settings, press the button again until the desired option appears in the **Lower Display Line** **14** and in the on-screen display and then press either of the **◀▶ Buttons** **H** to enter the desired boost or cut setting. See page 35 for more information on the tone controls.

D Speaker Selector Button: Press this button to begin the process of manually configuring the AVR 445 for the type of speakers it is being used with. For complete information on configuring the speaker settings, see page 29.

E Channel Adjust Selector: Press the button to begin the process of manually adjusting the channel level outputs using the source currently playing through your AVR. For complete information on adjusting the channel output level, see page 41.

F Digital Input Selector: Press this button to begin the process of selecting a digital source for use with the currently selected input. Once the button has been pressed, use the **◀▶ Buttons** **H** to choose the desired input and then press the **Set Button** **I** to enter the setting into the unit's memory. See page 35 for more information on digital audio.

G Delay Adjust Selector: Press this button to begin the process of adjusting the delay settings. See page 30 for more information on delay adjustments.

H ◀▶ Buttons: When making system configuration changes using the front-panel controls, press these buttons to scroll through the available choices for the option being adjusted.

I Set Button: When making system configuration changes using the front-panel controls, press this button to enter a setting into the unit's memory.

J EzSet/EQ Microphone Jack: Before starting the EzSet/EQ automated setup process, plug the microphone into this jack. The microphone does not need to be plugged in at other times.

K Optical 4 Digital Input: Connect the optical digital output of an audio or video product to this jack.

L Coaxial 4 Digital Input: Connect the coaxial digital output of a digital audio product such as a portable audio player or video game to this jack.

M Input/Output Status Indicator: This LED indicator will normally light green to show that the front-panel **Video 4 Input/Output Jacks** **N** are operating as inputs. When these jacks are configured for use as outputs, the indicator will turn red to show that the jack may be used as an output for recording. (See pages 22 and 40 for more information on configuring the front-panel jacks as outputs, rather than inputs.)

N Video 4 Input/Output Jacks: These audio/video jacks may be used as either inputs or outputs for temporary connection to video games or portable audio/video products such as camcorders and portable audio players. (See pages 22 and 40 for more information on switching these jacks between inputs and outputs.)

REAR-PANEL CONNECTIONS

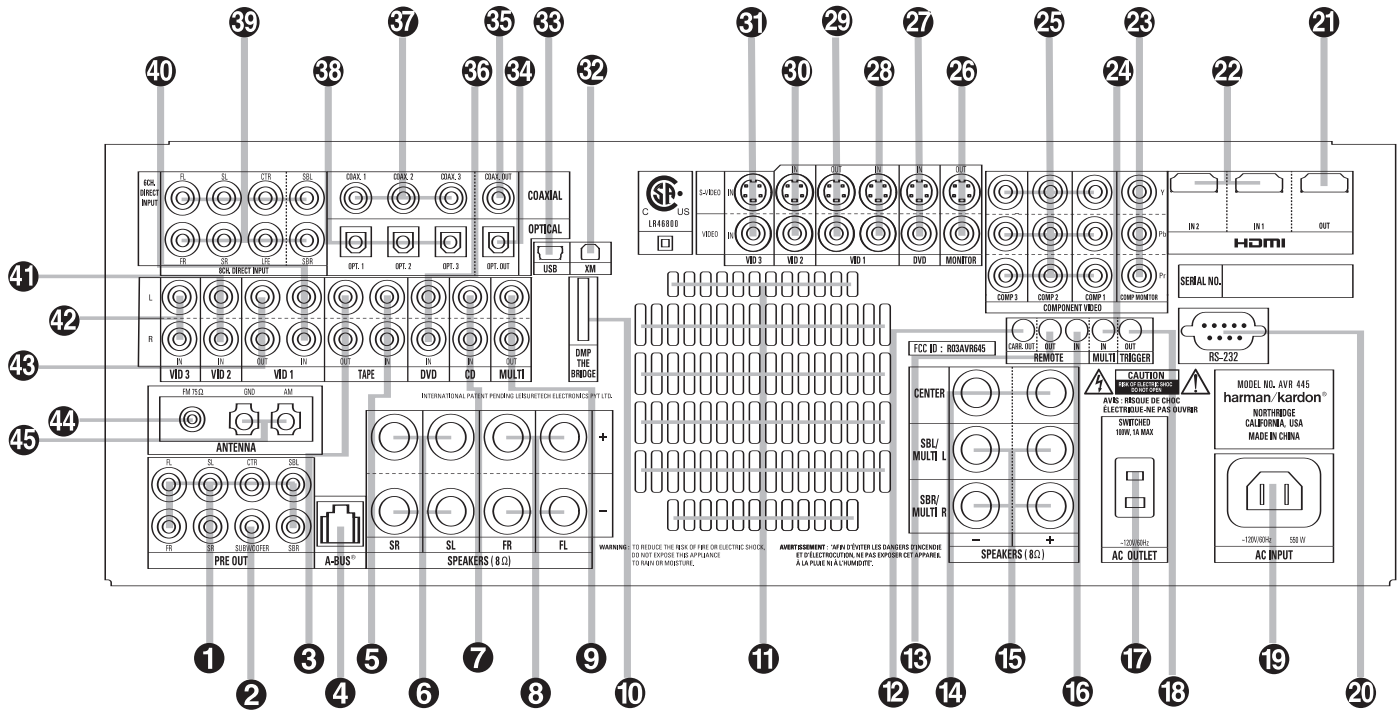

NOTE: To make it easier to follow the instructions that refer to this illustration, a larger copy may be downloaded from the Product Support section for this product at www.harmankardon.com.

- | | | |
|---|------------------------------------|---------------------------------|
| 1 Preamp Outputs | 17 Switched AC Accessory Outlet | 33 USB Connector |
| 2 Subwoofer Output | 18 Trigger Output | 34 Optical Digital Audio Output |
| 3 Tape Outputs | 19 AC Power Cord Socket | 35 Coaxial Digital Audio Output |
| 4 A-BUS Connector | 20 RS-232 Port | 36 DVD Audio Inputs |
| 5 Tape Inputs | 21 HDMI Output | 37 Coaxial Digital Audio Inputs |
| 6 Surround Speaker Outputs | 22 HDMI Inputs | 38 Optical Digital Audio Inputs |
| 7 CD Audio Input | 23 Component Video Monitor Outputs | 39 8-Channel Direct Inputs |
| 8 Front Speaker Outputs | 24 Multiroom IR Input | 40 Video 1 Audio Inputs |
| 9 Multiroom Audio Outputs | 25 Component Video Inputs | 41 Video 2 Audio Inputs |
| 10 [™] Bridge Digital Media Player (DMP) Input | 26 Video Monitor Outputs | 42 Video 3 Audio Inputs |
| 11 Fan Vents | 27 DVD Video Inputs | 43 Video 1 Audio Outputs |
| 12 Full Carrier IR Output | 28 Video 1 Video Inputs | 44 FM Antenna Jack |
| 13 IR Output | 29 Video 1 Video Outputs | 45 AM Antenna Connections |
| 14 Center Channel Speaker Outputs | 30 Video 2 Video Inputs | |
| 15 Surround Back/Multiroom Speaker Outputs | 31 Video 3 Video Inputs | |
| 16 IR Input | 32 XM Ready Input | |

NOTE: To assist in making the correct connections for multichannel input, output and speaker connections, all connection jacks and terminals are color-coded as follows:

Front Left:	White
Front Right:	Red
Center:	Green

Surround Left:	Blue
Surround Right:	Gray
Surround Back Left:	Brown
Surround Back Right:	Tan
Subwoofer:	Purple
Coaxial Digital Audio:	Orange

Composite Video:	Yellow
Component Video "Y":	Green
Component Video "Pr":	Red
Component Video "Pb":	Blue
Optical Digital In:	Black
Optical Digital Out:	Gray

REAR-PANEL CONNECTIONS

1 Preamp Outputs: Connect these jacks to an optional, external power amplifier for applications where higher power is desired.

2 Subwoofer Output: Connect this jack to the line-level input of a powered subwoofer. If an external subwoofer amplifier is used, connect this jack to the subwoofer amplifier input.

3 Tape Outputs: Connect these jacks to the Record/Input jacks of an audio recorder.

4 A-BUS Connector: Connect this jack to optional A-BUS®-certified products to extend the multiroom capabilities of your AVR 445. See page 19 for more information on A-BUS.

5 Tape Inputs: Connect these jacks to the Play/Out jacks of an audio recorder.

6 Surround Speaker Outputs: Connect these outputs to the matching + and – terminals on your surround channel speakers. In conformance with the CEA color-code specification, the blue terminal is the positive (+) terminal that should be connected to the red (+) terminal on the Surround Left speaker with older color-coding, while the gray terminal should be connected to the red (+) terminal on the Surround Right speaker with the older color-coding. Connect the black (–) terminal on the AVR to the matching black negative (–) terminals for each surround speaker. (See page 17 for more information on speaker polarity.)

7 CD Audio Inputs: Connect these jacks to the left/right analog audio output of a compact disc player or CD changer or other audio source.

8 Front Speaker Outputs: Connect these outputs to the matching + or – terminals on your left and right speakers. When making speaker connections, always make certain to maintain correct polarity by connecting the color-coded (white for front left and red for front right) (+) terminals on the AVR 445 to the red (+) terminals on the speakers and the black (–) terminals on the AVR 445 to the black (–) terminals on the speakers. See page 17 for more information on speaker polarity.

9 Multiroom Audio Outputs: Connect these jacks to the optional external audio power amplifier and video distribution system that delivers the source selected for multizone distribution.

10 The Bridge™ Digital Media Player (DMP) Input: With the AVR 445 turned off, connect the optional Harman Kardon The Bridge™ to this connector. Once this is done and with a compatible iPod® (optional) docked in The Bridge/DMP input allows you to play audio from the iPod and view navigation menus on the AVR's front panel and any video display connected to the AVR. You may control the iPod's functions and select tracks using the ▲/▼/◀▶ **14 G**, Set **16 Q** and Transport **17 19 20 P** buttons. See page 39 for more information.

11 Fan Vents: These ventilation holes are the output of the AVR 445's airflow system. To ensure proper operation of the unit and to avoid possible damage to delicate surfaces, make certain that these holes are not blocked and that there is at least 3 inches of open space between the vent holes and any wooden or fabric surface. It is normal for the fan to remain off at most normal volume levels. An automatic temperature sensor turns the fan on only when it is needed.

12 Full Carrier IR Output: The output of this jack is the full signal received at the Remote Sensor Window **16** or input through the IR Input **16** including the carrier frequency that is removed from signals at the IR Output **13**. Use this output to extend IR signals to the input of compatible products either by direct connection or through the use of optional, external IR "blasters". If you are in doubt as to which of the IR Output jacks to use, we recommend that you consult with your dealer or installer, or check with the manufacturer of the external equipment you wish to control.

13 IR Output: This connection permits the IR sensor in the receiver to serve remote controlled devices with "stripped carrier." Connect this jack to the "IR IN" jack on compatible Harman Kardon equipment.

14 Center Channel Speaker Outputs: Connect these outputs to the matching + and – terminals on your center channel speaker. In conformance with the CEA color-code specification, the green terminal is the positive (+) terminal that should be connected to the red (+) terminal on speakers with the older color-coding. Connect the black (–) terminal on the AVR to the black negative (–) terminal on your speaker. (See page 17 for more information on speaker polarity.)

15 Surround Back/Multiroom Speaker Outputs: These speaker terminals are normally used to power the surround back left/surround back right speakers in a 7.1-channel system. However, they may also be used to power the speakers in a second zone, which will receive the output selected for a multiroom system. To change the output fed to these terminals from the default of the Surround Back speakers to the Multiroom Output, you must change a setting in the Multiroom menu of the OSD system. See page 44 for more information on configuring this speaker output.

In normal surround system use, the brown and black terminals are the surround back left channel positive (+) and negative (–) connections and the tan and black terminals are the surround back right positive (+) and negative (–) terminals. For multiroom use, connect the brown and black SBL terminals to the red and black connections on the left remote zone speaker and connect the tan and black SBR terminals to the red and black terminals on the right remote zone speaker.

16 IR Input: If the AVR 445's front-panel IR sensor is blocked due to cabinet doors or other obstructions, an external IR sensor may be used. Connect the output of the sensor to this jack.

17 Switched AC Accessory Outlet: This outlet may be used to power any device you wish to have turned on when the AVR 445 is turned on with the Standby/On Switch **1**.

IMPORTANT NOTE: The power consumption of any device connected to the accessory outlet should not exceed 100 watts. Never connect high-power devices such as amplifiers or video displays to the accessory outlet.

18 Trigger Output: Connect this jack to the "Trigger In" jack of an optional external component such as an audio power amplifier that you want to be controlled to mirror the power state of the AVR 445. When this connection is used, the AVR 445 will automatically send a low-voltage signal to the connected device that turns it on when the AVR 445 is on, and off when the AVR 445 is placed in the Standby mode. The connected component must respond to a 6-volt presence as the control signal.

19 AC Power Cord Socket: Connect the AC power cord here when the installation is complete. To ensure safe operation, use only the power cord supplied with the unit. If a replacement is required, it must be of the same type and capacity.

20 RS-232 Port: This jack may be used to control the AVR 445 over a bidirectional RS-232 serial control link to a compatible computer or programmable remote control system. Due to the complexity of programming RS-232 commands, we strongly recommend that connections to this port for control purposes be made by a trained and qualified technician or installer.

21 HDMI Output: Connect this jack to the HDMI input on a compatible HDMI-equipped video display.

22 HDMI Inputs: Connect the HDMI output of video sources such as a DVD player, set-top box or HDTV tuner to either of these jacks.

23 Component Video Monitor Outputs: Connect these outputs to the component video inputs of a video display.

24 Multiroom IR Input: Connect the output of an IR sensor in a remote room to this jack to operate the AVR 445's multiroom control system.

25 Component Video Inputs: These inputs may be used with any source device that is equipped with analog component video outputs, as assigned through the IN/OUT SETUP menu. See page 23 for more information on configuring the component video inputs.

REAR-PANEL CONNECTIONS

- 26 Video Monitor Outputs:** Connect these jacks to the composite or S-video input of a TV monitor or video projector to view the on-screen menus and the output of any standard video source selected by the receiver's video switcher.
- 27 DVD Video Inputs:** Connect the composite or S-video outputs of a DVD player or other video source to these jacks.
- 28 Video 1 Video Inputs:** Connect the composite or S-video PLAY/OUT jacks of a VCR or other video source to these jacks.
- 29 Video 1 Video Outputs:** Connect the composite or S-video REC/IN jacks of a VCR or other video recording device such as a DVD recorder or PVR to these jacks.
- 30 Video 2 Video Inputs:** Connect the composite or S-video PLAY/OUT jacks of a VCR or other video source to these jacks.
- 31 Video 3 Video Inputs:** Connect the composite or S-video PLAY/OUT jacks of a VCR or other video source to these jacks.
- 32 XM Ready Input:** When an optional XM Connect & Play module is connected to this jack, and the XM service activated, you will be able to enjoy the XM Radio through your AVR 445. See page 39 for more information.
- 33 USB Connector:** Connect a cable with a USB "Mini B" connector to the AVR and the other end to a compatible computer running Windows® 2000, Windows XP or higher with the latest service packs installed, to use this port to listen to audio from the computer through the AVR 445. This connection is also used to connect a compatible computer to the AVR for system upgrades, when available. See page 37 for more information on playback of computer audio with the AVR. Instructions for upgrades will accompany the upgrade file download package.
- 34 Optical Digital Audio Output:** Connect this jack to the optical digital input connector on a CD-R/RW, MiniDisc or other compatible digital recorder.
- 35 Coaxial Digital Audio Output:** Connect this jack to the coaxial digital input of a CD-R/RW, MiniDisc or other compatible digital recorder.
- 36 DVD Audio Inputs:** Connect the left/right analog outputs of a DVD player or other audio source to these jacks.
- 37 Coaxial Digital Audio Inputs:** Connect the coax digital output from a DVD player, HDTV receiver, LD player or CD player to these jacks. The signal may be a Dolby Digital signal, DTS signal or a standard PCM digital source. Do not connect the RF digital output of an LD player to these jacks.
- 38 Optical Digital Audio Inputs:** Connect the optical digital output from a DVD player, HDTV receiver, LD player or CD player to these jacks. The signal may be a Dolby Digital signal, a DTS signal or a standard PCM digital source.
- 39 8-Channel Direct Inputs:** These jacks are used for connection to source devices such as high-resolution DVD players, DVD-Audio or SACD players with discrete analog audio outputs. Depending on the source device in use, all eight jacks may be used, though in many cases only connections to the front left/right, center, surround left/right and LFE (sub-woofer input) jacks will be used for 5.1 audio signals.
- 40 Video 1 Audio Inputs:** Connect the left/right PLAY/OUT audio output jacks on a VCR or other video source to these jacks.
- 41 Video 2 Audio Inputs:** Connect the left/right PLAY/OUT audio output jacks on a VCR or other video source to these jacks.
- 42 Video 3 Audio Inputs:** Connect the left/right PLAY/OUT audio output jacks on a VCR, PVR, cable set-top, satellite receiver, HDTV receiver or other video source to these jacks.
- 43 Video 1 Audio Outputs:** Connect the left/right REC/IN audio input jacks on a VCR or other video source to these jacks.
- 44 FM Antenna Jack:** Connect the supplied indoor or an optional external FM antenna to this terminal.
- 45 AM Antenna Connections:** Connect the AM loop antenna supplied with the receiver to these terminals. If an external AM antenna is used, make connections to the **AM** and **GND** terminals in accordance with the instructions supplied with the antenna.

MAIN REMOTE CONTROL FUNCTIONS

- 1 Power Off Button
- 2 Power On Button
- 3 LCD Information Display
- 4 Input Selectors
- 5 AVR Selector
- 6 Test Button
- 7 DSP Surround Mode Selector
- 8 Logic 7 Mode Select Button
- 9 Direct Button
- 10 Clear Button
- 11 EzSet/EQ On/Off Button
- 12 Tuning Mode Button
- 13 Channel Select Button
- 14 Navigation Button
- 15 Digital Select Button
- 16 Set Button
- 17 Transport Play Buttons
- 18 Volume Up/Down Selectors
- 19 Transport Fast-Play/Scan Buttons
- 20 Main Transport Controls
- 21 Track Skip Up/Down Buttons
- 22 Preset Up/Down Button
- 23 Tuning Up/Down Button
- 24 Disc Skip Button
- 25 Program Button
- 26 Light Button
- 27 Multiroom Button
- 28 Macro Buttons
- 29 Sleep Button
- 30 Night Mode Button
- 31 OSD Button
- 32 Tone Control Button
- 33 Dim Button
- 34 Tuner/FM Select Button
- 35 Channel Up/Down Selector
- 36 Delay Select Button
- 37 Speaker Select Button
- 38 Memory Button
- 39 Numeric Keys
- 40 Stereo Mode Select Button
- 41 DTS Neo:6 Mode Select Button
- 42 DTS Digital Mode Select Button
- 43 Dolby Mode Select Button
- 44 6-Channel/8-Channel Input Select
- 45 Mute Button
- 46 Lens

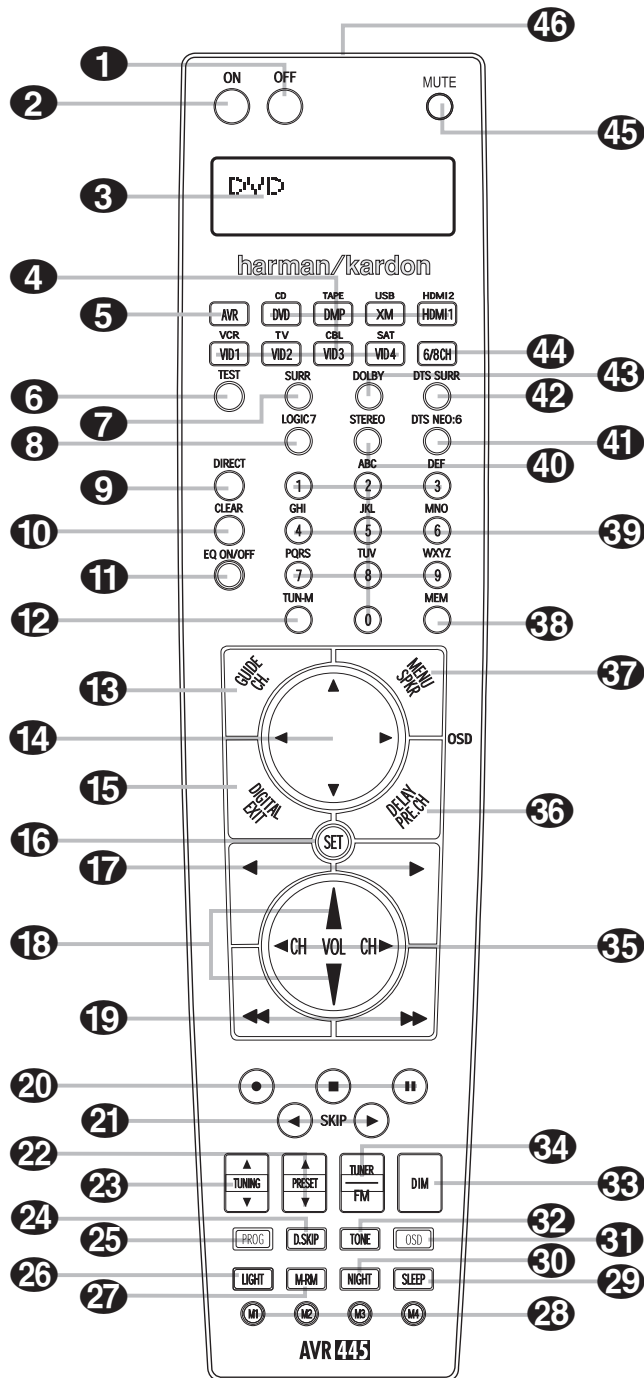

NOTES:

- The function names shown here are each button's feature when used with the AVR 445. Most buttons have additional functions when used with other devices. When a button is pressed, the function name will appear in the bottom line of the LCD Information Display 3.
- The jack on the upper right side of the remote is reserved for future use. Do not remove the plug provided or connect any device to the jack.
- To make it easier to follow the instructions that refer to this illustration, a larger copy may be downloaded from the Product Support section for this product at www.harmankardon.com.

MAIN REMOTE CONTROL FUNCTIONS

IMPORTANT NOTE: The AVR 445's remote may be programmed to control up to thirteen devices, including the AVR 445. Before using the remote, it is important to remember to press the **Input Selector Button 4** that corresponds to the unit you wish to operate. In addition, the AVR 445's remote is shipped from the factory to operate the AVR 445 and most Harman Kardon brand products. The remote is also capable of operating a wide variety of other products using the control codes that are part of the remote. Before using the remote with other products, follow the instructions on pages 46–49 to program the proper codes for the products in your system.

It is also important to remember that many of the buttons on the remote take on different functions, depending on the product selected using the **Input Selectors 4**. The descriptions shown here primarily detail the functions of the remote when it is used to operate the AVR 445.

1 Power Off Button: Press this button to place the AVR 445 or a selected device in the Standby mode. Note that this will turn off the main room functions, but if the Multiroom system is activated, it will continue to function.

2 Power On Button: Press this button to turn on the power to a device selected by first pressing one of the **Input Selectors 4**.

3 LCD Information Display: This two-line screen displays various information, depending on the commands that have been entered into the remote.

4 Input Selectors: Pressing one of these buttons will perform three actions at the same time. First, if the AVR 445 is not turned on, this will power up the unit. Next, it will select the source shown on the button as the input to the AVR 445. Finally, it will change the remote control so that it controls the device selected.

The buttons labeled DVD, DMP, XM and HDMI 1 are each used to select either of two input sources:

- The first press of the DVD Button selects the component connected to the DVD inputs. A second press of this button selects the component connected to the CD inputs.
- The first press of the button labeled DMP selects The Bridge as the input. A second press of this button selects the device connected to the Tape inputs.
- The first press of the XM button selects XM Radio as the input. A second press selects the source connected to the USB jack as the input.
- The first press of the HDMI 1 button selects the device that is connected to the HDMI 1 jack. A second press selects the device connected to the HDMI 2 jack.

In normal operation, the remote will revert to controlling the AVR when no button is pressed for 6 seconds. This allows the remote to automatically return to control of important functions such as volume, mute and surround mode selection after you have used the remote to control another device. If you wish to change the length of time that the remote operates another device, or to have the remote remain active for control of the other device (such as a DVD player or set-top box) until you manually return control to the AVR by pressing the **AVR Selector 5**, follow the instructions on page 55.

5 AVR Selector: Pressing this button will switch the remote so that it will operate the AVR 445's functions. If the AVR 445 is in the Standby mode, it will also turn the AVR 445 on.

6 Test Button: Press this button to begin the sequence used to manually calibrate the AVR 445's output levels. (See page 31 for more information on manually calibrating the AVR 445.)

7 DSP Surround Mode Selector: Press this button to select one of the DSP surround modes, such as Hall 1, Hall 2 or Theater. Each press of the button selects another mode. (See page 58 for more information on surround modes.)

8 Logic 7 Mode Select Button: Press this button to select from among the available Logic 7 surround modes. (See page 58 for available Logic 7 options.)

9 Direct Button: Press this button when the tuner is in use to start the sequence for direct entry of a station's frequency. After pressing the button, simply press the proper **Numeric Keys 39** to select a station. (See page 39 for more information on the tuner.)

10 Clear Button: When programming the remote or using the EzSet feature, press this button to cancel the current function. When using the remote to enter frequencies for direct tuner access, press this button to clear previous entries.

11 EzSet/EQ Button: Press this button to turn the filters used by EzSet/EQ on or off. This allows you to hear the difference in system performance when EzSet/EQ is engaged or out of the signal path.

12 Tuning Mode Button: When using listening to AM or FM stations, press this button to change the tuner mode between manual and automatic. When the button is pressed so that **AUTO/STEREO** appears in the **Upper Display Line 13** and in the on-screen display, only stations with acceptable signal quality will be tuned, and the tuner will play FM stations in stereo, when available. In the **AUTO** mode, when the **Tuning Up/Down Buttons 4 23 P** are pressed, the unit will automatically search for the next available station with good signal strength. When this button is pressed so that **MANUAL/MONO**

appears in the **Upper Display Line 13** and in the on-screen display, each press of the **Tuning Up/Down Buttons 4 23 P** will move the frequency up or down in single-step increments. When the FM band is in use, pressing the button so that the **MANUAL** mode is activated will enable you to tune stations with weak signals by changing to monaural reception. (See page 39 for more information on AM/FM tuner operation.) When listening to XM Radio, press this button to scroll through the following display options for the **Lower Display Line 14**: Channel Name → Channel Category → Artist → Title. (See pages 39–40 for more information on XM Radio operation.)

13 Channel Select Button: This button is used to start the process of manually setting the AVR 445's output levels to an external source. Once this button is pressed, press the **▲/▼ Navigation Button 14** to select the channel being adjusted, then press the **Set Button 16**, followed by the **▲/▼ Navigation Button 14** again, to change the level setting. (See page 41 for more information.)

14 Navigation Button: This disc-like button is used to navigate through the on-screen configuration menus, to scroll through option lists and to select choices for the various settings such as delay, speakers, surround modes, digital inputs, etc. To use the button, simply press it left, right, up or down in the direction indicated by the **▲/▼/◀/▶** icons printed on the button disc. Depending on the specific task, pressing the button will either change the menu or a configuration choice, or change the option shown in the on-screen or front-panel display. The sections in this manual describing the unit's individual features and configuration options contain specific information on how navigation controls are used.

15 Digital Select Button: Press this button to assign one of the digital inputs **37 38 K/L** to a source.

16 Set Button: This button is used to enter settings into the AVR 445's memory. It is also used in the setup procedures for delay time, speaker configuration and channel output level adjustment.

17 Transport Play Buttons: These buttons have no direct function on the AVR 445, but they are used when the remote is programmed for a compatible DVD, CD or tape player. Pressing these buttons will transmit a forward- or reverse-play command, according to the capabilities of the player being controlled. In the factory default setting, these buttons are programmed for Harman Kardon DVD players so that you may control a compatible player without having to switch devices.

18 Volume Up/Down Selectors: These controls share the common disc in the lower section of the remote. To raise the volume, press the button marked **▲** by pressing toward the top of the remote. To lower

MAIN REMOTE CONTROL FUNCTIONS

the volume, press the button marked ▼ by pressing toward the bottom of the remote. The ◀▶ buttons on the left and right sides of this disc change channels up or down when the TV, cable box or satellite **Input Selectors** 4 have been pressed.

19 Transport Fast-Play/Scan Buttons: These buttons have no direct function on the AVR 445, but they are used when the remote is programmed for a compatible DVD, CD or tape player. Pressing these buttons will transmit a fast-play forward, fast-play reverse, or fast-forward or -reverse scan command, according to the capabilities of the player being controlled. In the factory default setting, these buttons are preprogrammed with the remote codes for Harman Kardon DVD players so that you may control a compatible player without having to switch devices.

20 Main Transport Controls: These buttons have no direct function on the AVR 445, but they are used when the remote is programmed for a compatible DVD, CD or tape player. Pressing these buttons will transmit a stop (■), record (●), or pause (⏸) command, according to the capabilities of the player being controlled. In the factory default setting, these buttons are programmed with the remote codes for Harman Kardon DVD players so that you may control a compatible player without having to switch devices.

21 Track Skip Up/Down Buttons: These buttons do not have a direct function with the AVR 445, but when used with a compatibly programmed CD or DVD changer, they will change the track or chapter currently being played. In the factory default setting, these buttons are programmed with the remote codes for Harman Kardon DVD players so that you may control a compatible player without having to switch devices.

22 Preset Up/Down Button: When the tuner is in use, press this button to scroll through the stations programmed into the AVR 445's memory.

NOTE: When the AVR 445 is used with The Bridge (optional) and your iPod, some of the buttons that are used to control the various transport functions on source devices are used to control the iPod, and navigate through its menus and content. Consult the owner's manual packed with The Bridge for more information.

23 Tuning Up/Down Button: Press this button when the tuner is in use to change the station to one with a higher or lower frequency, or to change the XM channel. When the tuner is in the **MANUAL / MONO** mode, each tap of the selector will increase or decrease the frequency by one increment. When the tuner receives a signal sufficient for adequate reception, **MANUAL TUNED** will appear in the **Lower Display Line** 14 and in the on-screen display. When the tuner is in the **AUTO / STEREO** mode, press the button once, and the tuner will scan for a

station with acceptable signal strength. When the next higher- or lower-frequency station with a strong-enough signal is tuned, the frequency scan will stop and the **Lower Display Line** 14 and the on-screen display will indicate **AUTO TUNED**. When an FM Stereo station is tuned, the display will read **AUTO ST TUNED**. See page 39 for more information on using the tuner.

24 Disc Skip Button: This button has no direct function for the AVR 445 but may be used to change the disc in a CD or DVD changer when the remote is programmed for that type of device.

25 Program Button: This button is used to begin the process of programming the remote. Press and hold this button for 3 seconds to place the remote in the programming mode. Once the red LED under the **Set Button** 16 lights, release the button. You may then select from the desired option. (See pages 46–56 for more information on configuring the remote.)

26 Light Button: Press this button to activate the remote's backlight for ease of use in darkened rooms.

27 Multiroom Button: Press this button to begin the process of activating the multiroom system or to change the input or volume level for the second zone. (See page 44 for additional information on the multiroom system.)

28 Macro Buttons: Press these buttons to store or recall a "Macro", which is a preprogrammed sequence of commands stored in the remote. (See page 49 for more information on macros.)

29 Sleep Button: Press this button to place the unit in the Sleep mode. After the time shown in the display, the AVR 445 will automatically go into the Standby mode. Each press of the button changes the time until turn-off in the following order:



When the Sleep timer is in use, the front-panel display indicators will dim to half-brightness.

30 Night Mode Button: Press this button to activate the Night mode. The Night mode is available in specially encoded Dolby Digital sources, and it preserves dialogue (center channel) intelligibility at low volume levels.

31 OSD Button: Press this button to activate or turn off the On-Screen Display (OSD) system used to set up or adjust the AVR 445's parameters.

32 Tone Control Button: This button controls the tone mode settings, enabling adjustment of the bass and treble boost/cut. You may also use it to take the tone controls out of the signal path completely for "flat" response. The first press of the button displays a **TONE IN** message in the on-screen display and

in the **Lower Display Line** 14. To take the controls out of the signal path, press either of the ▲/▼ **Navigation Buttons** 14 until the display reads **TONE OUT**. To change the bass or treble settings, press the button again until the desired option appears in the **Lower Display Line** 14 and in the on-screen display and then press either of the ▲/▼ **Navigation Buttons** 14 to enter the desired boost or cut setting. See page 35 for more information on the tone controls.

33 Dim Button: Press this button to activate the Dimmer function, which reduces the brightness of the front-panel display, or turns it off entirely. Press the button once to change the display to reduce the brightness by 50%, and press it again within 5 seconds and the main display will go completely dark. Note that this setting is temporary; regardless of any changes, the display will always return to full-brightness when the AVR is turned on. The blue illumination around the **Standby/On Switch** 1 will always remain at full-brightness, regardless of the setting, to remind you that the AVR is still turned on. The blue accent lighting inside the volume control will also remain at full-brightness when the panel is at 50%, but go out when the panel lights are fully dimmed.

34 Tuner/FM Select Button: This button functions in two ways. Press it up, toward the top of the remote, to select the tuner as the AVR's input. The first press will call up the last-used station (or XM channel). Subsequent presses will select the last-used FM, AM and XM Radio station or channel. When the button is pressed down, toward the bottom of the remote, the last-tuned FM station is selected as the AVR's input.

35 Channel Up/Down Selector: This button has no function when the AVR is being controlled, but when programmed for use with a VCR, TV, cable box, satellite receiver or other similar product, it will change the channel up or down. See pages 46–56 for more information on programming the remote.

36 Delay Select Button: This button selects adjustments to the AV Sync Delay and the individual channel displays. The first press of the button displays an **A/V SYNC DELAY** message in the **Lower Display Line** 14 and in the on-screen display, which means that you may change the amount of time that all channels are delayed together behind the video. This enables you to compensate for the loss of lip sync that may be caused by digital video processing in your display or by television stations. To change the A/V Sync Delay, press the **Set Button** 16 while the **A/V SYNC DELAY** message is visible, and then use the ▲/▼ **Navigation Buttons** 14 to change the setting so that the sound and the video image are in sync. To change the delay for an individual output channel, press the ▲/▼ **Navigation Button** 14 until the desired channel name is shown, and then press the **Set Button** 16.

MAIN REMOTE CONTROL FUNCTIONS

Use the ▲/▼ **Navigation Buttons 14** to change the delay amount. (See page 30 for more information on delay options.)

37 Speaker Select Button: Press this button to begin the process of manually configuring the AVR 445's bass management system. Then press the ▲/▼ **Navigation Buttons 14** to select the channel you wish to set up. Press the **Set Button 16** and then select another channel to configure. When all adjustments have been completed, press the **Set Button 16** twice to exit the settings and return to normal operation. (See page 28 for more information on manual speaker setup.)

38 Memory Button: Press this button to enter a radio station in the AVR 445's preset memory. First, tune the desired station, and then press this button. Within 5 seconds of when you see the station's frequency flash in the **Upper Display Line 13** and in the on-screen display, press the numeric keys for the preset number between 01 and 30 that you wish to assign to the station. (See page 39 for more information on the tuner, and see page 40 for information on storing XM channel numbers in the preset memory.)

39 Numeric Keys: These buttons serve as a 10-button numeric keypad to enter tuner preset positions. They are also used to select channel numbers when TV, Cable or SAT has been selected on the remote, or to select track numbers on a CD, DVD or LD player, depending on how the remote has been programmed. These buttons are also used to enter letters and numbers when renaming devices in the LCD Information Display. (See page 53 for more information on renaming devices and keys.)

40 Stereo Mode Select Button: Press this button to select a stereo listening mode. When the button is pressed so that **SURROUND OFF** appears in the **Lower Display Line 14**, the AVR will operate in a bypass mode with true, fully analog, two-channel left/right stereo mode with no surround processing or bass management, as opposed to other modes where digital processing is used. When the button is pressed so that **SURROUND OFF** appears in the **Lower Display Line 14**, and both the **DSP** and **Surround Off Surround Mode Indicators 15** are lit, you will enjoy a two-channel presentation of the sound, along with the benefits of bass management. Depending on whether your system is configured for 5.1 or 6.1/7.1 channels, the next press of the button will cause either **5 CH STEREO** or **7 CH STEREO** to appear, and the stereo signal will be routed to all five (or seven) speakers. (See page 58 for more information on stereo playback modes.)

41 DTS Neo:6 Mode Select Button: Press this button to select a DTS Neo:6 mode. (See page 58 for the available DTS Neo:6 options.)

42 DTS Digital Mode Select Button: When a DTS-encoded digital source is playing, each press of this button will scroll through the available DTS modes. The specific choice of modes will vary according to the type of encoding on the disc and your system's speaker configuration. When a DTS source is not in use, this button has no function. (See page 58 for the available DTS digital options.)

43 Dolby Mode Select Button: This button is used to select from the available Dolby Surround modes. Each press of this button selects a Dolby Pro Logic II, Dolby Pro Logic IIx or Dolby Virtual Speaker mode, as available for the number of speakers in your system. When a Dolby Digital-encoded source is in use, the Dolby Digital mode may also be selected. (See page 58 for the available Dolby surround mode options.)

44 6-Channel/8-Channel Input Select: Press this button to select the device connected to the **8-Channel Direct Inputs 39**.

45 Mute Button: Press this button to momentarily silence the AVR 445 or TV set being controlled, depending on which device has been selected.

46 Lens: The infrared emitters behind the plastic lens at the top of the remote communicate the remote codes to the AVR 445. Be certain that the lens is not covered when using the remote, and point the lens toward the AVR for best results. In learning mode, the remote receives IR codes to be learned through a sensor behind the lens.

NOTE: DO NOT remove the rubber plug that covers the jack on the upper right side of the remote. The jack is not active and is reserved for future use.

INSTALLATION AND CONNECTIONS

System Installation

After unpacking the unit, locating it in a place with adequate ventilation and placing it on a solid surface capable of supporting its weight, you will need to make the connections to your audio and video equipment.

IMPORTANT NOTE: For your personal safety and to avoid possible damage to your equipment and speakers, it is always good practice to turn off and unplug the AVR and ALL source equipment from the AC output before making any audio or video system connections.

Audio Equipment Connections

We recommend that you use high-quality interconnect cables when making connections to source equipment and recorders to preserve the integrity of the signals.

1. Connect the analog output of a CD player to the **CD Audio Inputs 7**.

NOTE: If your CD player has both fixed and variable audio outputs, it is best to use the fixed output unless you find that the input to the receiver is so low that the sound is noisy, or so high that it is distorted.

2. Connect the analog Play/Out jacks of a cassette deck, MD, CD-R or other audio recorder to the **Tape Inputs 5**. Connect the analog Record/In jacks on the recorder to the **Tape Outputs 3** on the AVR 445.
3. Connect the output of a digital source such as a CD or DVD changer or player, a video game, a digital satellite receiver, an HDTV tuner or digital cable set-top box or the output of a compatible computer sound card to the **Optical and Coaxial Digital Audio Inputs 37 38 K L**.
4. Connect the coaxial or optical **Digital Audio Outputs 34 35** on the rear panel of the AVR 445 to the matching digital input connections on a CD-R, MiniDisc or other digital recorder.
5. Assemble the AM loop antenna supplied with the unit so that the tabs at the bottom of the antenna loop snap into the holes in the base. Connect it to the **AM Antenna Connections 45**.

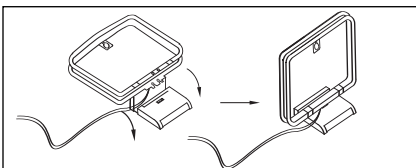

6. Connect the supplied FM antenna to the **FM Antenna Jack 44**. The FM antenna may be an external roof antenna, an inside powered or wire-lead antenna or a connection from a cable TV system. If the antenna or connection uses 300-ohm twin-lead cable, you must use an optional 300-ohm-to-75-ohm adapter to make the connection.

7. Connect the front, center, surround and surround back speaker outputs **6 8 14 15** to the respective speakers.

To ensure that all the audio signals are carried to your speakers without loss of clarity or resolution, we suggest that you use high-quality speaker cable. Many brands of cable are available and the choice of cable may be influenced by the distance between your speakers and the receiver, the type of speakers you use, personal preferences and other factors. Your dealer or installer is a valuable resource to consult in selecting the proper cable.

Regardless of the brand of cable selected, we recommend that you use cable with a gauge of 14 or smaller. Remember that when specifying cable, the lower the number, the thicker the cable.

Cable with a gauge of 16 may be used for short runs of less than 10 feet. We do not recommend that you use cables with an AWG equivalent of 18 or higher, due to the power loss and degradation in performance that will occur.

Cables that are run inside walls should have the appropriate markings to indicate listing with UL, CSA or other appropriate testing agency standards. Questions about running cables inside walls should be referred to your installer or a licensed electrician who is familiar with the NEC and/or the applicable building codes in your area.

When connecting wires to the speakers, be certain to observe proper polarity. Note that the positive (+) terminal of each speaker connection has a specific color code, as noted on page 8. However, most speakers still use a red terminal for the positive (+) connection. Connect the "negative" or "black" wire to the same terminal on both the receiver and the speaker.

NOTE: While most speaker manufacturers adhere to an industry convention of using black terminals for negative and red ones for positive, some may vary from this configuration. To ensure proper phase and optimal performance, consult the identification label on your speaker or the speaker's manual to verify polarity. If you do not know the polarity of your speaker, ask your dealer for advice before proceeding, or consult the speaker's manufacturer.

We also recommend that the length of cable used to connect speaker pairs be identical. For example, use the same length piece of cable to connect the front-left and front-right or surround-left and surround-right speakers, even if the speakers are a different distance from the AVR 445.

8. Connections to a subwoofer are normally made via a line-level audio connection from the **Subwoofer Output 2** to the line-level input of a subwoofer with a built-in amplifier. When a passive subwoofer is used, the connection first goes to a power

amplifier, which will be connected to one or more subwoofer speakers. If you are using a powered subwoofer that does not have line-level input connections, follow the instructions furnished with the speaker for connection information.

9. If an external audio source such as a DVD-Audio, SACD or high-definition optical disc player with 5.1 or 7.1 analog audio outputs is part of your system, connect the outputs of the source to the **8-Channel Direct Inputs 39**.

Analog Video Equipment Connections

Analog video components are connected in the same manner as audio components. Again, the use of high-quality interconnect cables is recommended to preserve signal quality.

1. Connect the Video Play/Out jacks of a standard (composite) video (or S-video outputs of a digital video) recorder or conventional VCR to the **Video 1 Video Inputs 23** on the AVR 445. Connect the Record/In jacks from that device to the **Video 1 Video Outputs 29** on the AVR.
2. Connect the analog Audio Left/Right Play/Out jacks of the device connected to the Video 1 Inputs to the **Video 1 Audio Inputs 40** on the AVR. Connect the analog Audio Left/Right Record/In jacks from that device to the **Video 1 Audio Outputs 43** on the AVR. If the device has a digital audio output, connect it to one of the **Coaxial 37** or **Optical 38** digital audio inputs.
3. Connect the Play/Out jacks of a standard (composite) video or (S-video outputs of a digital video) playback source such as a set-top box or video game console to the **Video 2 Video Inputs 30** or **Video 3 Video Inputs 31**. If the device has analog component video (Y/Pr/Pb) outputs, connect them to one of the **Component Video Inputs 25**.
4. Connect the analog audio outputs from the source to the matching **Video 2 Audio Inputs 41** or **Video 3 Audio Inputs 42**. If the device has a digital audio output, connect it to one of the **Coaxial 37** or **Optical 38** digital audio inputs.
5. If any of the video source devices has analog component video (Y/Pr/Pb) outputs, but not HDMI, connect them to **Component Video Inputs 25**. The chart on page 59 has the default settings for various source devices, but you may make any connection and change the configuration setting using the **IN/OUT SETUP** menu, as described on page 23.
6. The default video connection for a DVD player is to use the **Component Video Input 3 Jacks 25** on the AVR, but you may change this assignment in the **IN/OUT SETUP** menu (see page 23). A DVD player's composite and S-video outputs may also be connected to the **DVD Video Inputs 27**. Only one connection type is required.

INSTALLATION AND CONNECTIONS

7. The default audio connection for a conventional DVD player is to link the coaxial digital audio output on the DVD player to the **Coaxial 1 Digital Audio Input 37**, but you may also make a connection to either the **Coaxial 37** or **Optical 38** digital inputs, or to the **Analog DVD Audio Inputs 36**. You may change the assignment in the **IN/OUT SETUP** menu as described on page 22, or by using the front-panel **Digital Input Selector F**.
8. To use a portable audio/video product such as a camcorder, media player or digital still camera with the AVR, or connect a video game console or other source that may not always be connected to the AVR, connect the video outputs of the source to the **Video 4 Input/Output Jacks N**, behind the **Front-Panel Door 9**. If the source has digital audio outputs, connect them to the **Optical 4 Digital Input K** or the **Coaxial 4 Digital Input L**.
- CONNECTION NOTES:**

- When making connections to the **Component Video Inputs 25** or the **Coaxial 37** or **Optical 38** digital audio inputs, it is a good idea to make note of which jacks are connected to which source, using the Worksheet in the Appendix. This will help simplify the configuration process.
 - When connecting a source device such as a cable set-top box where the audio streams may change between digital and analog as you change channels, we recommend that you make both analog and digital connections. The AVR's Auto Poll feature will automatically sense when the digital stream is replaced by an analog output and switch the input accordingly. (See page 22 for more information on the Auto-Poll feature.) This dual connection is not required for sources (such as DVD players or video games) that always output a digital stream.
9. Connect the AVR to your video display using one of the following connections, even if you will also use an HDMI connection:

- If your video display has component video inputs (Y/Pr/Pb), connect the **Component Video/Monitor Outputs 25**.
- If your display does not have digital or component video inputs, connect the **Video Monitor Output 25** on the AVR to the matching input on your display. Only one connection is needed, and S-video is the higher quality signal.

HDMI Connections

HDMI™ is the abbreviation for High-Definition Multimedia Interface, which is quickly becoming the standard for connections between high-definition video/audio source products and displays. HDMI is a digital connection, eliminating the need to convert signals back and forth from digital to analog.

Some source or display components in your system may use DVI (Digital Video Interface) for digital video connections. DVI carries the same digital video signals as HDMI but uses a larger connector and does not transport audio or control signals. In most cases, you may mix and match DVI and HDMI digital video connections by using optional connector adapters. Note, however, that some DVI-equipped video displays are not compatible with the HDCP copy protection coding that is increasingly carried with signals connected via HDMI. If you have an HDMI source and a DVI-equipped display, you may occasionally be unable to view a program if the display does not include HDCP. This is not the fault of the AVR or your source; it simply indicates that the video display is not compatible.

The AVR 445 is equipped for HDMI switching, which means that it is able to select either of the two HDMI inputs as the source that feeds your system's video display. This preserves the digital signal in its original form by passing it directly through from source to display. However, this also means that the AVR does not have access to the signal and thus it is not able to add menus or on-screen messages to HDMI signals, or to process the audio that may be part of the signal in an HDMI connection.

Therefore, the following connections are required when the AVR 445 is used with HDMI sources:

- Connect the HDMI output of a source to either of the **HDMI Inputs 22**.
- Connect the **HDMI Output 21** of the AVR to an HDMI input on your display.
- Connect either an optical or coaxial digital audio output from the source to the AVR. The default connections are **Optical 3 38** for a source connected to **HDMI 1 22** and **Coaxial 3 37** for a source connected to **HDMI 2 22**. You may use any digital or analog audio source in conjunction with the HDMI inputs, but if it varies from the default you must make a change to the input's setting, as shown on page 22.
- *Even when HDMI inputs are used, it is important to make sure that a component, S-video or composite video connection is made between the AVR and your display. This is needed to view both the setup menus and on-screen messages, and to view other (non-HDMI) video sources. The AVR 445 does not convert analog video signals to HDMI.*

System and Power Connections

The AVR 445 is designed for flexible use with multiroom systems, external control components and power amplifiers.

Main Room Remote Control Extension

If the receiver is placed behind a solid or smoked-glass cabinet door, the obstruction may prevent the remote sensor from receiving commands. In this event, an optional remote sensor may be used.

Connect the output of the remote sensor to the **IR Input 15**.

If other components are also prevented from receiving remote commands, only one sensor is needed. Simply use this unit's sensor or a remote eye by running a connection from the **IR Output 13** to the Remote IR Input jack on Harman Kardon or other compatible equipment.

If other Harman Kardon-compatible source equipment is part of the main room installation, the **IR Output Jack 13** on the rear panel should be connected to the **IR IN** jack on source equipment. This enables the remote room location to control source equipment functions.

When a remote IR sensor is used to control non-Harman Kardon source equipment, we recommend that you make a hard-wire connection or use an optional, external IR "blaster" connected to the **Full Carrier IR Output 12**. If you are in doubt as to which IR Output jack to use for the equipment in your system, contact your dealer or installer, or the manufacturer's support site and ask whether the unit to be controlled uses "full carrier" IR commands. When "full carrier" commands are used, make the connection to the **Full Carrier IR Output 1**. Otherwise, make the connection to the **IR Output 13**.

NOTE: All remotely controlled components must be linked together in a "daisy chain." Connect the **IR OUT** jack of one unit to the **IR IN** of the next to establish this chain.

Multiroom Audio Connections

The AVR 445 is equipped with multizone capabilities that allow it to send a separate audio source to the remote zone from the one selected for use in the main room.

Depending on your system's requirements, three options are available for audio connection:

Option 1: Use high-quality, shielded audio interconnect cable from the AVR 445's location to the remote room. In the remote room, connect the interconnect cable to a stereo power amplifier. The amplifier will be connected to the room's speakers. At the AVR 445, plug the audio interconnect cables into the **Multiroom Audio Outputs 9** on the AVR 445's rear panel.

Option 2: Connect the **Multiroom Audio Outputs 9** on the AVR 445 to the inputs of an optional stereo power amplifier. Run high-quality speaker wire from the amplifier to the speakers in the remote room.

Option 3: Taking advantage of the AVR 445's built-in seven-channel amplifier, it is possible to use two of the amplifier channels to power speakers in the remote room. When using this option, you will not be able to use the full 7.1-channel capabilities of the AVR 445 in the main listening room, but you will be able to add another listening room without external power amplifiers. To use the internal amplifiers to power a remote

INSTALLATION AND CONNECTIONS

zone, connect the speakers for the remote room location to the **Surround Back/Multiroom Speaker Outputs 15**. Before using the remote room, you will need to configure the amplifiers for surround operation by changing a setting in the **MULTIROOM** menu, following the instructions shown on page 44.

NOTE: For all options, you may connect an optional IR sensor in the remote room to the AVR 445 via an appropriate cable. Connect the sensor's cable to the **Multiroom IR Input 24** on the AVR 445 and use the ZR 10 remote to control the room volume. You may install an optional volume control between the output of the amplifiers and the speakers in options 1 and 2.

A-BUS® Installation Connections

The AVR 445 is among the few receivers available that offer built-in A-BUS/*READY* operation. When used with an optional A-BUS product, you have all the benefits of remote zone operation without the need for an external power amplifier.

To use the AVR 445 with an approved A-BUS product, simply connect it to the AVR 445 using standard Category 5 wiring that is properly rated for the specific in-wall installation. Terminate the wiring at the receiver end to a standard RJ-45 connector in compliance with the instructions furnished with the A-BUS product.

No further installation or adjustment is needed, as the A-BUS jack on the AVR 445 routes the signals to their proper destination for power, signal source and control. The output fed to the A-BUS jack is determined by the AVR 445's multiroom system and menus.

RS-232 Connections

The AVR 445 is equipped with an **RS-232 Serial Connection Port 20** that may be connected to a compatible, optional, external computer, keypad or control system for bidirectional communications that enable the external system to control the AVR, and for the AVR to report status and handshake data back to the controller. Use of the RS-232 port for this type of control requires specific technical knowledge, and we recommend that any connection and programming for control be made by a trained installer or technician familiar with the equipment being used.

The physical connection to the AVR 445's RS-232 port is a standard D-SUB 9 connection, but to ensure compatible and proper operation, specific software commands and pin wiring schemes may be required.

USB Connections

The AVR 445 is one of the few A/V receivers to offer a USB connection that may be used for both playback of compatible audio content from a computer and for loading of system updates (when available).

The physical connection between a computer and the AVR is a simple one, requiring only a cable with a USB "A" type connector on one side and a USB "Mini B" on the other.

Connect the larger, "A" connector on the cable to your computer or a USB hub and the end with the "Mini" USB connector to the **USB Port 33** on the AVR's rear panel.

NOTES ON USB:

- The USB port on the AVR 445 is to be used only for connection to a computer or a hub connected directly to a computer. DO NOT connect it to other devices such as portable audio players, card readers, USB memory storage devices, external hard drives, USB accessories, digital cameras or cellular phones. Connection to these devices may cause damage to the device and/or the AVR that is not covered by the AVR's warranty.
- The AVR 445's USB connection may only be used for audio playback and system upgrades. It may not be used for other purposes, such as system control, video or still-image playback.

Trigger Connection

The AVR 445 is equipped with a low-voltage trigger that may be used to control a wide variety of compatible, optional devices that respond to voltage actuation commands. This includes external audio power amplifiers, video screens, motorized blinds and other compatible products in a home theater or automation system.

Due to the complexity of interfacing with power-controlled devices, we strongly recommend that they be installed by a qualified professional.

The **Trigger Output 18** delivers 6 volts DC when activated, and removes the voltage when the AVR is turned off. The connection is a 3.5mm mono mini plug with the signal on the center pin ("tip") and the outer shaft ("ring") acting as the negative or ground connection.

The **Trigger Output 18** is for use with devices such as power amplifiers that you wish to activate whenever the AVR is turned on, regardless of the input selected.

After checking for voltage, current and polarity compatibility between the device being controlled and the AVR, simply connect one end of the trigger cable to the device being controlled and the other end to the **Trigger Output 18** on the AVR.

IMPORTANT NOTE ON THE TRIGGER CONNECTION:

The current draw from the trigger jack cannot exceed 1.0mA.

XM Radio Connections

XM Radio is a satellite-delivered, subscription-based, programming service that provides a wide range of music, sports, news and information programming with digital audio quality. The AVR 445 is XM Connect & Play-ready, which means that you can easily add the XM service to your home audio system by purchasing an XM antenna module, activating an account with XM and then making a simple, single-cable connection to your AVR.

To purchase an XM antenna module, consult your dealer, or contact XM Radio at www.xmradio.com. After following the instructions packed with the module, place the XM antenna near a south-facing window and run the cable to the AVR. Connect the plug at the end of the cable to the **XM Ready Input 32**. Once the connection is made, follow the instructions on page 39 for more information on listening to XM Radio.

NOTES on XM Radio:

- XM Radio requires the purchase of additional, optional hardware and a separate subscription to the XM service.
- XM Radio is available only in the continental United States and Canada. It is not available in Alaska or Hawaii.
- XM reception requires that the antenna be able to "see" the XM satellites or receive a signal from one of the XM ground-based repeaters. Depending on your installation and location, XM service may not be available in some areas.

AC Power Connections

This unit is equipped with an accessory AC outlet that may be used to power accessory devices, but it should not be used with high-current draw equipment such as power amplifiers. The total power draw may not exceed 100 watts.

This **Switched AC Accessory Outlet 17** is powered only when the unit is on. This is recommended only for devices that have a mechanical power switch that may be left in the "ON" position.

NOTE: Many audio and video products go into a Standby mode when they are used with switched outlets. This type of product may not operate properly when used with the switched outlet.

The AVR 445 features a removable power cord that allows wires to be run in advance to a complex installation so that the unit itself need not be installed until it is ready for connection. When all needed connections have been made, connect the AC power cord to the **AC Power Cord Jack 19**.

The AVR 445 draws significantly more current than other household devices, such as computers, that use removable power cords. For that reason, it is important that only the cord supplied with the unit (or a direct replacement of identical capacity) be used.

Once the power cord is connected, you are almost ready to enjoy the AVR 445's incredible power and fidelity!

OPERATION

Basic Operation

Once you have completed the initial setup and configuration, the AVR 445 is simple to operate and enjoy. The following instructions will help you maximize the enjoyment of your new receiver:

Turning the AVR 445 On or Off

- When using the AVR for the first time, you must press the **Main Power Switch A** in until it latches. This places the unit in a Standby mode, as indicated by the amber illumination surrounding the **Standby/On Switch 1**.
- To turn the AVR on or off from the front panel, press the **Standby/On Switch 1**.
- To turn the unit on and select the input source that was in use the last time the AVR was on, press the **AVR Selector 5 C** on either remote.
- To turn the unit on and select a specific source, press any one of the **Input Selectors 4 34 44** on the main remote or **DEFR** on the ZR 10 remote .
 - When using the **Input Selector Buttons 4** labeled DVD, DMP, XM or HDMI on the main remote, remember that these are dual-input selectors. The first press of any button will turn the unit on and select the input name printed on the button. A second press of the button will select the input name printed above the button.
 - To turn the AVR on and select the Tuner as an input, press the **Tuner/FM Select Button 34** by pressing the button up towards the top of the remote. The first press of the button selects the frequency band and station or XM channel that was last tuned. Press the button again to select between FM, AM and XM.
 - To turn the AVR on and select the FM tuner as the input, press the **Tuner/FM Select Button 34** down towards the bottom of the remote.
 - When using any of the Input Selectors to turn the unit on (or when using them to change a source at any time) press the **AVR Selector 5 C** after the unit turns on to use any of the buttons on the remote to control AVR functions other than volume or source selection.

Whenever the AVR is turned on, you will see all of the front-panel indicators light up for a few seconds. This is normal, and it is part of the unit's power-on self-test procedure.

To turn the unit off at the end of a listening session, simply press the **Standby/On Switch 1** on the front panel or the **Power Off Button 1 A** on the remote. Power will be shut off to any equipment plugged into the rear-panel **Switched AC Accessory Outlet 17** and the illumination around the **Standby/On Switch 1** will turn amber.

When the remote is used to turn the unit "off," it is actually placing the system in a Standby mode, as indicated by the amber lighting around the **Standby/On Switch 1**.

- To put the AVR in the Sleep mode, press the **Sleep Button 29**. Each press of the button will decrease the time before the AVR shuts down in the following sequence.

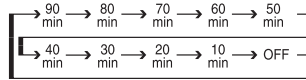

Once you have set the desired Sleep Time, the front-panel display will automatically dim to half-brightness. The display will return to full-brightness when any button on the front panel or a remote is pressed, and then return again to half-brightness. To view the time remaining until the unit shuts down, press the **Sleep Button 29** once. To cancel the Sleep function, press the **Sleep Button 29** as many times as needed until the words **SLEEP OFF** appear in the **Lower Display Line 14**.

When you will be away from home for an extended period of time, it is always a good idea to completely turn the unit off with the front-panel **Main Power Switch A**.

NOTE: All preset memories are lost if the unit is left turned off by using the **Main Power Switch A** for more than four weeks.

Source Selection

- To select an input source from the front panel, press the **Input Source Selector Button 7**. Each press of the button will move the input selection through the list of available choices. If the button is pressed when the AVR is in the Standby mode, the first press of the button will turn the unit on and select the last used input.
- When the AVR is already turned on, you may select the tuner directly by pressing the **Tuner Band Selector 5**. The first press will select the last tuned frequency band and station. Each subsequent press will change the band to the last tuned station or XM preset.
- To select a specific source using the main remote, press any one of the **Input Selectors 4 34 44** on the main remote. Remember that the Input Selector Buttons labeled DVD, DMP, XM or HDMI are dual-input selectors. The first press of any button will turn the unit on and select the input name printed on the button. A second press of the button will select the input name printed above the button.
- To directly select the Tuner as an input, press the **Tuner/FM Select Button 34** by pressing the button up towards the top of the remote. The first press of the button selects the frequency band and station or

XM channel that was last tuned. Press the button again to select between FM, AM and XM.

- To directly select the FM tuner as the input, press the **Tuner/FM Select Button 34** down towards the bottom of the remote.
- To select a specific source using the ZR 10 remote, press any of the **Input Selectors DEF** **R**. When selecting the Tuner as the input, each press of the **Tuner Selector E** scrolls through the choice of FM, AM or XM Radio (when an optional XM Ready module is installed and the XM service has been activated).

REMINDER: When using any of the Input Selectors to change a source, you must press the **AVR Selector 5 C** to control AVR functions other than volume or source selection.

- When a new input is selected, the AVR will automatically switch to the digital input (if selected), surround mode, component video input, A/V sync delay and Night mode configurations that were in effect the last time that input was used.
- The front-panel **Video 4 Inputs N**, **Optical 4 Digital Input K** or **Coaxial 4 Digital Input L** may be used to connect a device such as a video game or camera to your home entertainment system on a temporary basis.
- As the input source is changed, the new input name will appear momentarily as an on-screen display in the lower third of the video display (except when HDMI, 720p or 1080i sources are in use). The input name will also appear in the **Upper Display Line 13** and in the front-panel **Input Indicators 11**.
- When an audio only source is selected, the last video input used remains routed to the **Video 1/Video Monitor Outputs 26 29**. This permits simultaneous viewing and listening to different sources.

6-Channel/8-Channel Direct Input

There are four input choices available for use with sources such as DVD-Audio SACD player or HD-DVD or Blu-ray disc player that are connected to the **8-Channel Direct Inputs 39**. Select the appropriate input according to the way your system and source equipment is configured:

- The **6 CH DIRECT** input should be used when the SBR and SBL inputs are NOT in use and the input source device has its own internal bass management system. This input passes the input from the source directly through to the volume control without any analog-to-digital conversion, and it mutes the unused input jacks to prevent unwanted noise from interfering with system performance.
- The **6 CH DVD AUDIO** input should be used when the SBR and SBL inputs are NOT in use and when the input source does NOT have its own

internal bass-management system. When this input is in use, the analog source is converted to digital so that you may use the same bass-management options for the direct input as are used for all other inputs. This input also mutes the unused input jacks to prevent unwanted noise from interfering with system performance.

- The **8 CH DIRECT** input should be used when an input is connected to all eight **8-Channel Direct Inputs** **49** and when the input source device has its own internal bass-management system. This input passes the input from the source directly through to the volume control without any analog-to-digital conversion.
- The **8 CH DVD AUDIO** input should be used when an input is connected to all eight **8-Channel Direct Inputs** **49** and when the input source does not have its own internal bass-management system. When this input is in use, the analog source is converted to digital so that you may use the same bass-management options for the direct input as are used for all other inputs.

Volume and Tone Control

- Adjust the volume to a comfortable level using the front-panel **Volume Control** **10** or remote **Volume Up/Down Buttons** **18 H**.
- To temporarily silence all speaker outputs, press the **Mute Button** **45 S**. This will interrupt the output to all speakers and the headphone jack, but it will not affect any recording or dubbing that may be in progress. When the system is muted, the word **MUTE** will flash in the on-screen display (except when HDMI, 720p or 1080i sources are in use) and in the **Upper Display Line** **13**; press the **Mute Buttons** **45 S** again to return to normal operation.
- The unit's tone controls may be taken out of the signal path by pressing the **Tone Mode Button** **C 42**. The first button press will show a message in the on-screen display (except when HDMI, 720p or 1080i sources are in use) and **Lower Display Line** **14** with the current status of the tone controls. The system default is **TONE IN**, which indicates that the bass and treble controls are active. Press the **▲/▼ Navigation Buttons** **14 G** on the remote control or the **◀/▶ Buttons** **H** on the front panel to change the setting to **TONE OUT**, which is "flat" response without the tone controls being active.
- When the tone controls are active, the amount of bass and treble boost/cut may be adjusted up to ± 10 dB in 2dB steps by pressing the **Tone Mode Button** **C 42** two or three times until the desired setting (**BASS MODE** or **TREBLE MODE**) appears in the on-screen display and in

the **Lower Display Line** **14**. Next, use the **◀/▶ Navigation Buttons** **14 G** on the remote or the **◀/▶ Navigation Buttons** on the front panel **H** to change the setting as desired. The unit will return to normal operation within five seconds after the setting is changed.

- For private listening, simply place a standard 1/4" stereo headphone plug or adapter into the **Headphone Jack** **B** behind the door **9** on the front panel. The speakers will automatically mute and a two-channel stereo signal will be sent to the headphones. The **Lower Display Line** **14** will read **DOLBY H: BP**, indicating that the headphone output is in the Bypass mode, and to confirm that no processing is being used. To listen through the headphones using the Dolby Headphone mode, simply press the buttons on the remote or front panel as shown below for changing a Dolby mode. **DOLBY H: DH** will appear in the Lower Display Line when the Dolby Headphone mode is in use.

Surround Mode Selection

One of the most important features of the AVR 445 is its ability to reproduce a full multichannel surround sound field from digital sources, analog matrix surround-encoded programs and standard stereo programs.

Selection of a surround mode is based on personal taste, as well as the type of program source material being used. For example, motion pictures or TV programs bearing the logo of one of the major surround-encoding processes, such as Dolby Surround or DTS Stereo may be played in either the Dolby Digital, Dolby Pro Logic II Cinema, DTS Neo:6 Cinema, or Logic 7 Cinema surround modes, depending on the source material.

NOTE: Once a program has been encoded with matrix surround information, it retains the surround information as long as the program is broadcast in stereo. Thus, movies with surround sound may be decoded via any of the analog surround modes (e.g., Dolby Pro Logic II Cinema, Logic 7 Cinema or DTS Neo:6 Cinema) when they are broadcast via conventional TV stations, cable, pay-TV and satellite transmission. In addition, a growing number of made-for-TV programs, sports broadcasts, radio dramas and music CDs are also produced in surround sound. You may view a list of these programs at the Dolby Laboratories Web site at www.dolby.com.

Even when a program is not listed as carrying intentional surround information, you may find that the Dolby Pro Logic II, Dolby Pro Logic IIx, Logic 7 or DTS Neo:6, and the Hall or Theater modes often deliver enveloping surround presentations through the use of the natural information present in all stereo recordings.

Surround modes may be changed at any time by using either the front panel or remote control. To select a new surround mode from the front panel, first press the **Surround Mode Group Selector Button** **2** until the desired major surround mode group such as Dolby, DTS or Logic 7 is selected. Next, press the **Surround Mode Selector Button** **3** to choose the specific individual surround mode.

To choose a surround mode using the remote, first press the button for the major surround mode group that includes the desired mode. These buttons are the **Dolby Mode Select** **43**, the **DTS Digital Model Select** **42**, the **DTS Neo:6 Mode Select** **41**, the **DSP Surround Mode Select** **7** and the **Stereo Mode Select** **40** buttons. The first press of a button will show the current mode from that group if it is already in use, or the first available mode if you are currently using another mode. To cycle through the available modes in that group, press the button again until the desired mode appears in the **Lower Display Line** **14**, the on-screen display (when a 480i source is in use) and the front-panel **Surround Mode Indicators** **15**.

The Dolby Digital, Dolby Digital EX, DTS 5.1, DTS-ES Matrix and DTS-ES Discrete modes may only be selected when a digital input is in use. In addition, when a digital source is present, the AVR 445 will automatically select and switch to the correct mode, regardless of the mode that has been previously selected. For more information on selecting digital sources, see the Digital Audio Playback section below.

When the 6-channel/8-channel direct inputs are in use, there is no surround processing, as these inputs take the analog output signals from an external source device and carry them straight through to the volume control without any further digital processing.

To listen to a program in traditional two-channel stereo, using the front left and front right speakers only (plus the subwoofer, if installed and configured), press the **Stereo Mode Select Button** **40** until **SURROUND OFF** appears in the **Lower Display Line** **14**. From the front panel, press the **Surround Mode Group Selector** **2** until the **Stereo** modes appear in the on-screen display and **Lower Display Line** **14**. Next, press the **Surround Mode Selector Button** **3** until **SURROUND OFF** appears in the on-screen display and **Lower Display Line** **14**.

Digital Audio Playback

Digital audio is a major advancement over older analog surround processing systems. It delivers up to six discrete channels, and each channel reproduces a full-frequency range (20Hz to 20kHz) and offers dramatically improved dynamic range and significant improvements to signal-to-noise ratios. In addition, digital systems have the capability to deliver an additional channel that is

OPERATION

specifically devoted to low-frequency information. This is the “.1” channel referred to when you see these systems described as “5.1,” “6.1” or “7.1.” The bass channel is separate from the other channels, but since it is intentionally bandwidth-limited, sound designers have given it that unique designation. When a digital soundtrack is playing, the number of channels available will vary according to the way in which the program was recorded. Although most movies recorded with digital sound have 5.1 soundtracks, some have 6.1 or 7.1 sound, while others retain the original two-channel or even monaural sound. When the program source is a broadcast, cable or satellite delivered digital program, only one type of soundtrack may be delivered at a time, while optical sources such as DVD may provide more than one audio option. In either case, the decision of what type of sound track and how many channels to offer is up to the program’s producer. With the AVR 445 you are able to not only play back the original compatible digital format, but using the processing power of the Texas Instruments DSP processor, it is possible to decode the basic digital track for 2.0 or 5.1 sound and then select an additional “post-processing” mode to deliver additional channels.

Dolby Digital

Dolby Digital is the default format for DVD discs and for the (ATSC) high-definition system used in the United States and Canada. It is also used by the digital satellite program services and is available on most digital cable set-top boxes. When the AVR 445 is connected to a blue-laser-based high-definition optical disc player via a coaxial or optical digital audio connection, the soundtrack may be available in the standard Dolby Digital or DTS format so that it may be decoded by the AVR.

An optional, external RF demodulator is required to use the AVR 445 to listen to the Dolby Digital soundtracks available on laser discs. Connect the RF output of the LD player to the demodulator and then connect the digital output of the demodulator to the **Optical** or **Coaxial Inputs** **K L** **37** **38** of the AVR 445. A demodulator is not required for use with high-definition optical disc or DVD players, or with DTS-encoded laser discs.

In order to provide maximum playback compatibility with DVDs, the AVR 445 receiver will always default first to the playback mode embedded in a disc’s digital “flag” information. For Dolby Digital discs, the following playback modes are initially selected after the AVR locks on to the incoming digital audio data stream:

- When a Dolby Digital 5.1 data stream is detected, the choice of which surround mode is activated is determined by the setting on the **DEFAULT SURR** line of the **SURROUND SETUP** menu (Figure 5), as shown on page 24.
- When a disc with the Dolby Digital EX flag is played, your system will automatically switch to the EX mode when seven main speakers are available.
- When a disc with 2.0 Dolby Digital data is detected, the default mode is Dolby Digital with Pro Logic II postprocessing when you have a 5.1 speaker system, or Dolby Digital with Dolby Pro Logic IIx postprocessing when you have a 7.1 speaker system.
- Depending on the number of speaker channels available in your system, once the AVR locks on to the digital signal, you may select any surround mode or postprocessing option that is available, based on the incoming data stream’s possible restrictions and the number of speakers in your system. For example, when a 5.1 or 2.0 audio stream is in use, you may select alternate postprocessing such as Logic 7/7.1-channel Movie mode postprocessing to create the rear surrounds in 7.1 speaker systems.

DTS

DTS is another digital audio system that is capable of delivering 5.1 or 6.1 discrete or matrix sound field reproduction. Although both DTS and Dolby Digital are digital, they use different methods of encoding the signals, and thus they require different decoding circuits to convert the digital signals back to analog.

DTS-encoded soundtracks are available on select DVD and LD discs, as well as on special audio-only DTS discs. You may use any LD or CD player equipped with a digital output to play DTS-encoded discs with the AVR 445. All that is required is to connect the player’s output to either an **Optical** or **Coaxial Input** on the rear panel **37** **38** or front panel **K L**.

In order to listen to DVDs encoded with DTS soundtracks, the DVD player must be compatible with the DTS signal, which is indicated by a DTS logo on the player’s front panel. Early DVD players may not be able to play DTS-encoded DVDs. If you are in doubt as to the capability of your DVD player to handle DTS discs, consult the player’s owner’s manual.

When the AVR 445 is connected to a blue-laser-based high-definition optical disc player via an HDMI, coaxial or optical digital connection, the soundtrack from the player is also available in the standard DTS format so that it may be decoded by the AVR.

NOTE:

- Some DVD players have a default setting that does not pass through the DTS signal. Before playing DVDs with a DTS soundtrack, make certain that the settings in your DVD player have been properly adjusted so that DTS audio is passed through. Consult the owner’s manual for your DVD player for more information on making these settings.

- When selecting surround modes, any mode where the setting in its mode group (Dolby, DTS, Logic 7, PCM, etc.) has been set to **OFF** in one of the **SURROUND CONFIG** menus will not appear and may not be selected. You may change the settings in this list at any time by following the instructions on pages 24–25.

Selecting a Digital Source

To utilize either digital mode, you must have properly connected a digital source to the AVR 445. Connect the digital outputs from DVD players, HDTV receivers, satellite systems or CD players to the **Optical** or **Coaxial Inputs** **K L** **37** **38**. In order to provide a backup signal and a source for analog stereo recording, the analog outputs provided on digital source equipment should also be connected to their appropriate inputs on the AVR 445 rear panel (e.g., connect the analog stereo audio output from a DVD to the **DVD Audio Inputs** **36** on the rear panel when you connect the source’s digital outputs).

If you have not already configured an input for a digital source using the on-screen menus, as shown on page 22, first select the input using the remote or front-panel controls, as outlined in this manual. Next, press the **Digital Select Button** **15**, then press the **Navigation Buttons** **14** **15** on the remote or the **Button** **H** on the front panel to choose any of the **OPTICAL** or **COAXIAL** inputs, as they appear in the **Upper Display Line** **13** or on-screen display. When the digital source is playing, the AVR 445 will automatically detect which type of digital data stream is being decoded and display that information in the **Upper Display Line** **13**.

When both a digital and an analog connection are made between a source device and the AVR, the digital input is the default. If the digital stream is not present or is interrupted, the unit will automatically switch over to the analog inputs for the selected source.

If you wish to disable the auto-polling feature, you may do so by following the instructions shown for the **IN/OUT SETUP** menu (Figure 2), as shown on page 22.

Digital Bitstream and Surround Mode Indications

When a digital source is playing, the AVR 445 senses the type of bitstream data that is present, and automatically selects the proper surround mode. For example, DTS bitstreams will cause the unit to switch to DTS decoding, and Dolby Digital bitstreams will enable Dolby Digital decoding. When the unit senses PCM data from CDs or LDs, you may select any of the standard Dolby or DTS surround modes or Logic 7. Since the range of available surround modes is dependent on the type of digital data that is present, the AVR 445 shows you what type of signal is present to help you understand the choice of modes.

When a digital source is first detected, the AVR 445 will display a message to indicate the type of bitstream being received. It will remain in the **Lower Display Line 14** for about 5 seconds before that portion of the display returns to the normal surround mode indication.

For Dolby Digital and DTS sources, a numerical indication (such as **3/2/.1**) will appear, showing the number of channels present in the data.

The first number in the display message indicates how many discrete front-channel signals are present.

- A "3" tells you that separate front left, center and front right signals are available. This will be displayed for Dolby Digital 5.1, Dolby Digital EX and DTS 5.1 or DTS-EX programs.
- A "2" tells you that separate front left and right signals are available, but there is no discrete center channel signal. This will be displayed for Dolby Digital bitstreams that have stereo program material.
- A "1" tells you that there is only a mono channel available in the Dolby Digital bitstream.

The middle number in the display message indicates how many discrete surround channel signals are present.

- A "3" tells you that separate, discrete left surround, center surround and right surround signals are present. This is available only on discs with DTS-ES digital audio.
- A "2" tells you that separate surround left and right signals are available. This will be displayed for Dolby Digital 5.1 and DTS 5.1 programs.
- A "1" tells you that there is only a single, surround-encoded surround channel. This will appear for Dolby Digital bitstreams that have matrix encoding.
- A "0" indicates that there is no surround channel information. This will be displayed for two-channel stereo programs.

The last number indicates whether there is a discrete low-frequency effects (LFE) channel. This is the ".1" in the common abbreviation of "5.1" sound and it is a special channel that contains only bass frequencies.

- A ".1" tells you that an LFE channel is present. This will be displayed for Dolby Digital and DTS programs, as available.
- A "0" indicates that there is no LFE channel information available. However, even when there is no dedicated LFE channel, low-frequency sound will be present at the subwoofer output when the speaker configuration is set to show the presence of a subwoofer.
- The information on the right side of the display will tell you whether the digital audio data contains a special flag signal that will automatically activate the

appropriate 6.1 or 7.1 mode. This will be shown as EX-ON or EX-OFF for Dolby Digital bitstreams and ES-ON or ES-OFF for DTS bitstreams.

When a 2.0 or 5.1 digital source is playing on a system configured for 5.1 operation, you may use Dolby Digital EX, DTS-ES, Logic 7/7.1 or Dolby Pro Logic IIx to add rear channels for full 7.1 sound fields. Note, however, that the availability of specific modes for postprocessing is dependent on the format of the incoming source material. While some combinations (e.g., a Dolby Digital or DTS 5.1 source with Logic 7/7.1 or Dolby Pro Logic IIx postprocessing) are allowable, others (e.g., a Dolby Digital 5.1 source with DTS Neo:6) are not. If you wish to add surround back channels to a 2.0 or 5.1 source, we recommend that you experiment with the various options to see which may be available and which are best suited to your taste and listening environment.

It is always a good idea to check the readout for the channel data to make certain that it matches the audio logo information shown on the back of a DVD package. In some cases, you will see an indication for "2/0/0" even when the disc contains a full 5.1, or 3/2/.1, signal. When this happens, check the audio output settings for your DVD player or the audio menu selections for the specific disc being played to make certain that the player is sending the correct signal to the AVR.

NOTE: When an HDMI-equipped video display is in use, regardless of the type of source and whether or not it is connected through the AVR 445, it communicates with the source device using a technology called "EDID" so that the capabilities of the source and display are properly matched. In some cases, this may cause configuration problems when the video display is not capable of handling multichannel audio. In those cases, it will send a signal back to the source (such as a DVD player or set-top box), limiting the digital audio output to two channels, even though a separate digital audio connection is made to the AVR.

If you encounter a situation in which an HDMI source and display are in use and a multichannel soundtrack does not trigger a "3/2/.1" message when playback begins, it may be necessary to change a setting in the source. In many cases, the setting is called "Audio Output," though it may vary from brand to brand. Change the setting to "bitstream" or "original" so that the digital audio output is returned to the multichannel data stream. For information about the specific setting on your source player, consult the manufacturer. This is not a problem with the AVR 445, but rather it is a by-product of HDMI and its associated content protection systems.

PCM Playback

PCM is the abbreviation for Pulse Code Modulation, the digital signal format used for standard CD playback, and other non-Dolby Digital and non-DTS digital sources such as MiniDisc. When a **PCM** signal is detected, the **Lower Display Line 14** will briefly show a message with the letters PCM, in addition to a readout of the sampling frequency of the digital signal.

In most cases, this will be **PCM 44.1kHz** or **PCM 48kHz**, though in the case of specially mastered, high-resolution audio discs, you will see a **PCM 96kHz** indication. Note that the sampling rate displayed is that of the incoming digital signal, and not the upsampled rate that may be applied to PCM sources when Dolby Pro Logic or Dolby Pro Logic II processing is applied, as shown on page 24.

During PCM playback, you may select any surround mode except Dolby Digital or DTS/DTS-ES mode.

USB Playback

The AVR 445 is among the very few A/V receivers capable of direct connection to a computer for audio playback. Once the AVR is connected, audio streams and playback are possible through your AVR, with all the power and performance of the high-current amplifier, your own speakers, and the enhanced multichannel playback made possible through the use of Logic 7, Dolby Pro Logic II/IIx or DTS Neo:6 processing.

The AVR 445's USB connectivity may be used with PC-compatible computers running either Microsoft® Windows® 2000 with Service Pack 4 or higher installed, or Windows XP or Windows XP Media Center Edition with Service Pack 1 or higher installed. Connect one of the available USB ports on your computer or a USB hub to the **USB Port 43** on the AVR using a cable with a standard USB plug on one side and a USB "Mini B" plug on the other side. You may use an optional cable available at most electronics and computer stores for this purpose.

In addition, you will need to have a media player installed on the computer. The AVR 445 has been tested for operation with Windows Media® Player Version 8.0 and above, but it is also compatible with many other popular players such as iTunes®, Winamp® and RealPlayer.® In most cases, it is best to always make certain that you have the latest version of the player installed to ensure the best compatibility.

When the connection between a computer and the AVR is made for the first time, or if the USB connection is plugged into a different USB port on a computer or hub that has not been previously connected to the AVR, you will see a series of pop-up messages from Windows to indicate that the computer is configuring itself for the new device. Since the AVR provides a number of different functions, you may see the "Found New Hardware" message up to four times, one each

OPERATION

for "AV Receiver," "Compatible Device," "Audio Receiver" and "Human Interface Device." When all messages have appeared and then cleared the screen, you are almost ready to begin.

Before selecting the USB input, first make certain that one of the media players listed above has been opened on the computer. Then you may select the USB input in any of the following ways:

- To select USB as a source from the front panel, press the **Input Source Selector Button 7** until USB appears as the input name in the **Upper Display Line 13** and in the semi-OSD display, if available. The **USB Input Source Indicator 11** will also light up on the front panel.
- To select USB as the input using the main remote press the **Input Selector 5** with DMP printed on the button twice.
- To select USB as the input using the ZR 10 remote, press the **USB Input Selector D**.

When the USB input is selected and the AVR 445 is connected to a compatible computer with one of the media players mentioned above open, you may then use either remote's transport controls to start and stop playback, as well as move to the next track. Activity of the Transport buttons may vary from one media player to another, but at the very least you will be able to use the Play and Stop buttons.

Once playback is started, the audio from a USB source is treated the same as any other two-channel audio source, and you may apply any of the appropriate surround processing modes. When playing back audio from a computer via the USB connection, the internal speakers in a laptop computer are often muted.

Speaker/Channel Indicators

In addition to the bitstream indicators, the AVR 445 features a set of unique channel-input indicators that tell you how many channels of digital information are being received and/or whether the digital signal is interrupted (Figure 22).

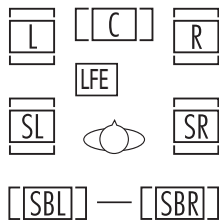

Figure 22

The letters inside the boxes tell you which channels are receiving an input signal. Since conventional analog audio is only two channels, the "L" and "R" letters will light with any analog source. When a digital source is in use, you will see letters displayed that correspond to the number of channels in the incoming data

stream, which may be just the L and R for two-channel PCM or 2.0 Dolby Digital material. When a 5.1 signal is being received, the L/C/R/SL/SR indicators will light, with the LFE indication also being shown when an LFE signal is present. All seven indicators, including the SBL/SBR letters, will light for a 7.1 signal, and a horizontal line is shown to connect the SBL/SBR indicators when a 6.1 source is in use.

It is important to note that although Dolby Digital, for example, is referred to as a "5.1" system, not all Dolby Digital DVDs or programs are encoded for 5.1. Thus, it is sometimes normal for a DVD with a Dolby Digital soundtrack to trigger only the "L" and "R" indicators.

NOTE: Many DVD discs are recorded with both "5.1" and "2.0" versions of the same soundtrack. When playing a DVD, always be certain to check the type of material on the disc. Most discs show this information in the form of a listing or icon on the back of the disc jacket. When a disc does offer multiple soundtrack choices, you may have to make some adjustments to your DVD player (usually with the "Audio Select" button or in a menu screen on the disc) to send a full 5.1 feed to the AVR 445. It is also possible for the type of signal feed to change during the course of a DVD's playback. In some cases, the previews of special material will only be recorded in 2.0 audio, while the main feature is available in 5.1 audio. The AVR 445 will automatically sense changes to the bitstream and channel count and reflect them in these indicators.

The letters used by the **Speaker/Channel Input Indicators 12** will flash to indicate when a bitstream has been interrupted. This will happen when a digital input source is selected before the playback starts, or when a digital source such as a DVD is paused. The flashing indicators remind you that the playback has stopped due to the absence of a digital signal and not through any fault of the AVR 445. This is normal, and the digital playback will resume once the playback is started again.

The boxes around the channel indication letters are used to show which speakers are configured in your system. A small box around the letter indicates that a "Small" speaker has been assigned to that position, while a larger, double box indicates a "Large" speaker assignment.

Note that in some cases, such as an analog stereo or 2.0 digital sources you will see empty speaker position boxes, which indicates that the speaker is active and will receive sound, but that there is no discrete signal for that channel. In other cases you may see letters with no speaker boxes. This indicates that there is a discrete signal for that channel, but due to the mode in use (e.g., Dolby VS with a 5.1 source) there is no signal being sent to the channel.

Night Mode

A special feature of Dolby Digital is the Night mode, which enables specially encoded Dolby Digital input sources to be played back with full digital intelligibility while reducing the minimum peak level by 1/4 to 1/3. This prevents abruptly loud transitions from disturbing others, without reducing the impact of the digital source. The Night mode is available only when Dolby Digital signals with special data are being played.

The Night mode may be engaged at any time when a Dolby Digital source is playing by pressing the **Night Mode Button 30**. Each press of the button will change the Night mode setting, as shown in the lower third of the on-screen display (except when HDMI, 720p or 1080i sources are in use). To turn the Night mode off, press the button as described, until **D-RANGE OFF** is shown.

The Night mode may also be selected to always be on at either level of compression using the options in the **DOLBY SURROUND** menu. See page 25 for information on using the menus to set this option.

IMPORTANT NOTES ON DIGITAL PLAYBACK:

- When playing DVDs, please note that even when you have selected a specific digital audio format for playback, an individual disc may change formats or the number of available channels during playback. For example, even if you select a DTS mode for the movie, you may see Dolby Digital in use when the trailers, menus or copyright warnings are playing. This is not a fault with either the AVR or your DVD player, as both are responding to the way the disc was created.
- When viewing digital television signals, note that the number of audio channels available may vary during the course of a program, depending on the content. For example, while a sports event may have 5.1 sound, the commercials or local station content may be in 2.0. In addition, not all local stations are currently equipped for carrying the 5.1 digital audio signals. This may mean that even though the actual program is produced with 5.1, it may be transmitted in a 2.0 configuration in some areas. Your AVR will automatically change to react to the proper type of audio stream if it is changed by the broadcast station.
- Although the AVR 445 will decode virtually all current DVD movies, CDs and HDTV sources, it is possible that some future digital sources may not be compatible with the AVR 445.
- Not all digitally encoded programs contain full 5.1- or 6.1-channel audio. Consult the program guide that accompanies the DVD or laser disc to determine which type of audio has been recorded on the disc. The AVR 445 will automatically sense the type of digital surround encoding used and adjust to accommodate it.



- When a digital source is playing, you may not be able to select some of the analog surround modes such as Dolby Pro Logic II, Dolby Pro Logic IIx, Stereo, Hall, Theater or Logic 7.
- When a Dolby Digital or DTS source is playing, to make an analog recording using the **Tape Outputs** **3** and **Video 1 Audio Outputs** **43**, you must change the **REC OUT** setting on the second page of the **IN/OUT SETUP** menu (Fig. 3) to **DSP DOWNMIX**. The digital signals will be passed through to the **Digital Audio Outputs** **34** **35**.

Using

The AVR 445 is equipped for use with Harman Kardon's optional  iPod docking station.

When The Bridge is connected to the AVR and an iPod properly docked, you may use either remote to control the iPod for audio playback while using the front-panel display and on-screen semi-OSD messages to help you locate tracks or view information about the track being played. In addition, connecting an iPod to the AVR 445 through The Bridge also charges the iPod's battery. You may even have the AVR 445 automatically turn on with your iPod as a playback source whenever the iPod is turned on, by using the **DMP AUTO POWER** menu option, described on page 43.

To select The Bridge as the AVR's input source:

- From the front panel, press the **Input Source Selector** **7** on the front panel as needed.
- From the main remote, press the **DMP Input Selector** **4**.
- From the ZR 10 remote, press the  /DMP S .

When The Bridge is connected and a compatible iPod properly docked, the iPod's menu will be replaced with "harman/kardon" at the top of the iPod's screen and the front-panel display and semi-OSD message will show messages that will guide you through the menu and content selection. If the **Lower Display Line** **14** shows an **UNPLUGGED**... message, please check to see that the correct iPod adapter is used in The Bridge and that the iPod is properly seated.

The AVR's front-panel controls may also be used to access a limited number of iPod functions. Press the **Tuning Mode Button** **8** to play or pause the current track. The **Tuning Selector** **4** may be used to search in reverse (left side of button) or forward (right side of button) through the tracks. Press the **Tuner Band Selector** **5** to call up the iPod's menu. Press the **Preset Station Selectors** **6** to scroll and the **Set Button** **1** to select. For complete information on using the remote or front-panel controls to operate

an iPod, see the instructions that are included with The Bridge.

AM/FM Tuner Operation

The AVR 445's AM/FM tuner is capable of tuning AM, FM and FM Stereo broadcast stations. Stations may be tuned manually, or they may be stored as favorite station presets and recalled from a 30-position memory.

Tuner and Station Selection

The AVR 445's AM/FM tuner may be selected as the unit's source, and stations changed, by following one of these steps:

- From the front panel, press the **Input Source Selector** **7** until the desired tuner frequency band (AM, FM or XM) appears. To change stations within a frequency band, press the **Tuning Selection** **4**.
- You may also press the front panel's **Tuner Band Selector** **5** to select the tuner. The first press will select the last used frequency band and station. Subsequent presses will change the frequency bands, selecting the last used station or XM program used. Press the **Tuning Selection** **4** to change stations within a frequency band.
- From the main remote, press the **Tuner/FM Select Button** **34** by pressing the button up towards the top of the remote. The first press of the button selects the frequency band and station or XM channel that was last tuned. Press the button again to select between FM, AM and XM. You may also directly select the FM tuner by pressing the **Tuner/FM Select Button** **34** down toward the bottom of the remote. To change stations, press the **Tuning Up/Down Button** **23**.
- To select the tuner from the ZR 10 remote, press the **Tuner Selector** **E**, or for XM Radio press the **XM Radio Selector Button** **F** (when an optional XM Connect & Play module is connected and the programming service has been activated).
- To change the tuning mode, press the **Tuning Mode Button** **8** **12** **O**.

When the button is pressed so that **AUTO / STEREO** appears in the **Upper Display Line** **13**, each press will put the tuner in a scan mode that seeks the next higher or lower frequency station with acceptable signal strength. An **AUTO ST TUNED** indication will momentarily appear when the station stops at a stereo FM station, and an **AUTO TUNED** indication will momentarily appear when an AM or monaural FM station is tuned. Press the Tuning buttons again to scan to the next receivable station.

When the button is pressed so that **MANUAL / MONO** appears in the **Upper Display Line** **13**, each tap of the Selector will increase or decrease the frequency by one increment. When the tuner

receives a strong-enough signal for adequate reception, **MANUAL TUNED** will appear in the **Lower Display Line** **14**.

- Stations may also be tuned directly in either the automatic or manual mode. To enter a station's frequency directly, first select the AM or FM band as shown above. Next, press the **Direct Button** **9** **M**. Within 5 seconds of when **DIRECT IN** scrolls in the **Upper Display Line** **13**, enter the station frequency by pressing the **Numeric Keys** **1** **J**. If you press an incorrect button while entering a direct frequency, press the **Clear Button** **10** **L** to start over.

NOTE: When FM reception of a station is weak, audio quality will be increased by switching to Mono mode by switching to the **MANUAL / MONO** mode.

Preset Tuning

Using the remote, up to 30 AM or FM stations may be stored in the AVR 445's memory for easy recall, using the front-panel controls or the remote.

To enter a station into the memory, first tune the station using the steps outlined above. Then:

1. Press the **Memory Button** **38** **N**; the station's frequency will flash.
2. Within 5 seconds, press the **Numeric Keys** **39** **J** corresponding to the location where you wish to store this station's frequency. Once entered, the preset number will appear in the **Upper Display Line** **13**.
3. Repeat the process after tuning any additional stations to be preset.

Recalling Preset Stations

- To manually select a station previously entered in the preset memory, press the **Numeric Keys** **39** **J** that correspond to the desired station's memory location.
- To manually tune through the list of stored preset stations one by one, press the **Preset Buttons** **6** **22** on the front panel or the main remote, or the **Prev/Next Transport Controls** **P** on the ZR 10 remote.

XM Radio Operation

XM Radio is a satellite-delivered service that offers hundreds of program channels, as well as local traffic and weather information for select cities. The AVR 445 is "XM Ready," which means that the unit is able to receive the XM service when an optional XM Connect & Play module is connected and the service activated. You may purchase the antenna module needed for XM Radio from many electronics or online retailers, or directly from XM Radio through the "Home Receivers" section of the XM Radio Store at www.xmradio.com.

OPERATION

Once you have purchased the XM module, follow the instructions accompanying it to activate the XM Service. Connect the plug on the XM module to the **XM Ready Input** **22** on the rear panel of the AVR 445. For best results, point the antenna module out a window, again, following the instructions packed with the XM product. If a window view is not available for the antenna, XM Radio operates a series of terrestrial repeater stations that may be able to provide reception, though this service is not available everywhere.

IMPORTANT NOTE: XM Radio requires both the optional, external antenna module and a subscription to the XM Radio service. Antenna and service sold separately; XM Radio is not available in Alaska or Hawaii.

If you need to view the antenna module's number, connect it to the AVR and then follow one of the steps shown below to select XM Radio as the input source. Tune to "000" to get a readout of the number.

Once you have an activated module connected, follow one of these steps to select XM Radio as your system's audio source:

- From the front panel, press the **Input Source Selector** **7**. If XM was the last-used tuner source, it will appear; or press the button again until XM Radio is heard. Press the **Tuning Selector** **4** to change stations within a frequency band. Press the **Tuning Selector** **4** to select a different XM channel.
- From the main remote, press the **Tuner/FM Select Button** **34** by pressing the button up towards the top of the remote as needed until XM Radio is shown as the source. To change stations, press the **Tuning Up/Down Button** **23**.
- To select the tuner from the ZR 10 remote control, press the **XM Radio Selector Button** **F**. Channels are selected using the **Prev/Next Transport Controls** **P**.

While using XM Radio is similar in many ways to AM/FM terrestrial radio, the wide range of program choices available, as well as the ability of the XM service to add special data and information tags into the digital audio data stream, means that some of the front-panel and remote controls traditionally used for tuner operation have different functions with XM Radio.

- When XM Radio is the AVR's source, the channel number will appear in the **Upper Display Line** **13**, along with an indication of the Preset number, if any, and a series of bars at the far right end of the display. These bars (not shown in the semi-OSD message), show the current signal strength similar to the signal strength displays on a cellular phone.
- The current channel's name will normally appear in the **Lower Display Line** **14**. For local traffic information, the name of a city will be shown in place of

the channel name. You may change this display to show the current artist and track title information by pressing the **Tuning Mode Selector** **8 12** **6**. When you are listening to a channel with local traffic information in the "200" series of channel numbers, these buttons change the display to show the temperature and current weather for the selected city.

- To tune a channel number directly, simply press the **Numeric Keys** **39** **J**. Unlike standard AM/FM tuner operation, it is not necessary to press the Direct button first.
- The AVR 445 has five banks of preset memories for XM Radio, each with eight memory positions and designated by a letter ("A" through "E"). To store a channel into a memory group, first press the **Set Button** **16** **C** until **PRESET SEARCH** appears in the **Upper Display Line** **13** and on the top line of the semi-OSD display. Next, press the **Navigation Buttons** **14** **G** until the desired preset memory bank letter appears in the **Lower Display Line** **14** and in the bottom line of the semi-OSD display. Next, press the **Memory Button** **38** **N** and note that a dash will start to flash next to the preset memory bank letter. Within five seconds, press the **Numeric Button** **39** **J** from 1 to 8 for the memory slot you wish to use.
- To tune up or down through a list of channels stored in the currently active preset memory, press the **Preset Up/Down Buttons** **22**. You may also use the **Preset Station Selector** **6** on the front panel, or the **Prev/Next Transport Controls** **P** on the ZR 10 remote. To change to another preset bank, press the **Set Button** **16** **C** and then press the **Navigation Buttons** **H 14** **G** until the desired preset memory bank letter appears in the **Lower Display Line** **14** and in the bottom line of the semi-OSD display.
- Each XM Radio channel is assigned a category, which may be viewed by pressing the **Tuning Mode Selector** **12 8** **6**. You may search for an XM channel in any of the categories by first pressing the **Set Button** **16** **C** and then pressing the **Navigation Buttons** **H 14** **G** until the desired category name appears in the **Lower Display Line** **14** and in the bottom line of the semi-OSD display. Press the **Set Button** **16** **C** again to start the search for the next channel in that category.
- Note that you may see a **LOADING** message, indicating that the XM tuner is downloading content and may not be able to operate. If the message continues to appear, check to see whether the XM antenna is properly positioned toward a south-facing window, experiment with the antenna position, or change to another input and then reselect XM Radio.

Recording

In normal operation, the audio or video source selected for listening through the AVR 445 is sent to the record outputs. This means that any program you are watching or listening to may be recorded simply by placing machines connected to the outputs for **Tape Outputs** **3** or **Video 1 Audio and Video Outputs** **29 43** in the record mode. Remember that if your source is Dolby Digital or DTS, and you wish to make an analog recording, you must change the **REC OUT** setting on the second page of the **IN/OUT SETUP** menu (Figure 3) to **DSP DWNMIX**.

When a digital audio recorder is connected to the **Digital Audio Outputs** **34 35**, you are able to record the digital signal using a CD-R, MiniDisc or other digital recording system.

NOTES:

- The digital outputs are active only when a digital signal is present, and they do not convert an analog input to a digital signal, or change the format of the digital signal. In addition, the digital recorder must be compatible with the output signal. For example, the PCM digital input from a CD player may be recorded on a CD-R or MiniDisc, but Dolby Digital or DTS signals may not.
- The **Front-Panel Video 4** **N** jacks may be configured for use as outputs, allowing connection to a recorder, when the steps shown in the section below are followed.
- Please make certain that you are aware of any copyright restrictions on any material you copy. Unauthorized duplication of copyrighted materials is prohibited by federal law.

Front-Panel Connections

In addition to the rear-panel digital and analog outputs, the AVR 445 offers Harman Kardon's exclusive configurable front-panel output-jack feature. For easy connection of portable devices, you may switch the front-panel **Video 4 Jacks** **N** from an input to an output by changing the **VIDEO 4** setting on the second page of the **IN/OUT SETUP** menu (Figure 3) from **IN** to **OUT**.

Once the setting is made, the **Input/Output Status Indicator** **M** will turn red, indicating that the jacks are now outputs, instead of the default setting as inputs. Once changed to an output, the setting will remain as long as the AVR 445 is turned on, unless the setting is changed in the OSD menu system. However, once the AVR 445 is turned off, the setting is canceled. When the unit is turned on again, the front-panel jacks will return to their normal default setting as inputs.

Output Level Trim Adjustment

Normal output level adjustment for the AVR 445 is established using EzSet/EQ, as outlined on pages 26–28. In some cases, however, it may be desirable to trim the output levels using program material such as a test disc, or a selection you are familiar with. Additionally, the output level for the subwoofer can only be adjusted using this procedure.

To adjust the output levels using program material, first set the reference volume for the front left and front right channels using the **Volume Control** **10** **18** **H**.

Once the reference level has been set, press the **Channel Select Button** **13** **E** and **FRONT LEVEL** will appear in the **Lower Display Line** **14**. To change the level, first press the **Set Button** **11** **16**, and then use the **▲/▼ Navigation Buttons** **H** **14** to raise or lower the level. DO NOT use the volume control, as this will alter the reference setting.

Once the change has been made, press the **Set Button** **11** **16**, then press the **▲/▼ Navigation Buttons** **H** **14** to select the next output-channel location that you wish to adjust. To adjust the subwoofer level, press the **▲/▼ Navigation Button** **H** **15** until **WOOFER LEVEL** appears in the **Lower Display Line** **14** or on-screen display.

Repeat the procedure as needed until all channels requiring adjustment have been set. When all adjustments have been made and no further adjustments are made for 5 seconds, the AVR 445 will return to normal operation.

The output levels may also be adjusted using the on-screen menu system to either the internal test tone or an external test disc by following the instructions shown on page 31.

EzSet/EQ On/Off

If you wish to turn the filter settings established by EzSet/EQ on or off to demonstrate the impact EzSet/EQ has on the sound of your system, simply press the **EzSet/EQ On/Off button** **11**. Using this feature does not change the settings; it merely puts them in or out of the signal path.

Dim Function

Since the AVR 445 will often be used when movies or other kinds of video programming are viewed under low-light conditions, you may wish to lower the brightness of the front-panel displays and indicators so that they do not distract from the video presentation. You may dim the displays using the menu system, as shown on page 42, or you may control the brightness directly from the remote.

Simply press the **Dim Button** **33** once to dim the front panel to half the normal brightness level; press it again to turn the displays off. Note that when the displays are dimmed or turned off, the blue lighting around the **Standby/On Switch** **1** will continue to stay lit as a reminder that the AVR is still turned on. The accent lighting for the **Volume Control** **10** will remain at its normal level, rather than dim when the panel displays are at half-brightness.

Note that all changes to the front-panel brightness level are temporary; the displays will return to full-brightness after the AVR is turned off and then on again. To return the displays to full-brightness without turning the unit off, press **Dim Button** **33** as needed until the displays are on.

In addition to lowering the brightness of the displays or turning them off completely, you may wish to have them appear whenever a button on the remote or front panel is pushed, and then gradually fade out after a set time period. You may do this by making the appropriate settings in the **VFD FADE TIME OUT** line of the **ADVANCED SELECT** menu, as shown on page 42.

Memory Backup

This product is equipped with a memory backup system that preserves the system configuration information and tuner presets if the unit is accidentally unplugged or subjected to a power outage. This memory will last for at least four weeks, after which time all information must be reentered.

TROUBLESHOOTING GUIDE

SYMPTOM	CAUSE	SOLUTION
Unit does not function when Main Power Switch is pushed	<ul style="list-style-type: none"> No AC Power 	<ul style="list-style-type: none"> Make certain that AC power cord firmly connected to the AC Power Cord Socket 19 and is plugged into a live outlet Check to see whether outlet is switch-controlled
Display lights, but there is no sound or picture	<ul style="list-style-type: none"> Intermittent input connections Mute is on Volume control is down 	<ul style="list-style-type: none"> Make certain that all input and speaker connections are secure Press Mute Button 45 S Turn up volume control
Unit turns on, but front-panel display does not light up	<ul style="list-style-type: none"> Display brightness is turned off 	<ul style="list-style-type: none"> Follow the instructions in the Dim and Display Brightness sections on pages 41 and 42 so that the display is set to VFD FULL
No sound from any speaker; light around power switch is red	<ul style="list-style-type: none"> Amplifier is in protection mode due to possible short Amplifier is in protection mode due to internal problems 	<ul style="list-style-type: none"> Check speaker wire connections for shorts at receiver and speaker ends Contact your local Harman Kardon service center
No sound from surround or center speakers	<ul style="list-style-type: none"> Incorrect surround mode Input is monaural Incorrect configuration Stereo or Mono program material 	<ul style="list-style-type: none"> Select a mode other than Stereo There is no surround information from mono sources Check speaker mode configuration The surround decoder may not create center- or rear-channel information from nonencoded programs
Unit does not respond to remote commands	<ul style="list-style-type: none"> Weak batteries in remote Wrong device selected Remote sensor is obscured 	<ul style="list-style-type: none"> Change remote batteries Press the AVR selector Make certain front-panel sensor is visible to remote or connect remote sensor
Intermittent buzzing in tuner	<ul style="list-style-type: none"> Local interference 	<ul style="list-style-type: none"> Move unit or antenna away from computers, fluorescent lights, motors or other electrical appliances
Letters flash in the channel indicator display and digital audio stops	<ul style="list-style-type: none"> Digital audio feed paused 	<ul style="list-style-type: none"> Resume play for DVD Check that Digital Input is selected
Fan does not appear to operate	<ul style="list-style-type: none"> Additional cooling may not be required 	<ul style="list-style-type: none"> The fan is activated only when additional cooling is required due to high internal temperature, it is normal for the fan to be inactive at normal volume levels

In addition to the items shown above, additional information on troubleshooting possible problems with your AVR 445, or installation-related issues, may be found in the list of "Frequently Asked Questions" which is located in the Product Support section of our Web site at www.harmankardon.com.

Processor Reset

In the rare case where the unit's operation or the displays seem abnormal, the cause may involve the erratic operation of the system's memory or microprocessor.

To correct this problem, first unplug the unit from the AC wall outlet and wait at least 3 minutes. After the pause, reconnect the AC power cord and check the unit's operation. If the system still malfunctions, a system reset may clear the problem.

To clear the AVR 445's entire system memory including tuner presets, output level settings, delay times and speaker configuration data, first put the unit in the

Standby mode by pressing the **Standby/On Switch**

1. Next, press and hold the **Surround Mode Group Selector 2** and the **Tuning Mode Selector 3** buttons for 3 seconds.

The unit will turn on automatically and display the **RESET** message in the **Upper Display Line 13**.

NOTE: Resetting the processor will erase any configuration settings you have made for speakers, output levels, surround modes, and digital input assignments, as well as the tuner presets. After a reset, the unit will be returned to the factory presets, and all settings for these items must be reentered.

If the system is still operating incorrectly, there may have been an electronic discharge or severe AC line interference that has corrupted the memory or microprocessor.

If these steps do not solve the problem, consult an authorized Harman Kardon service center.

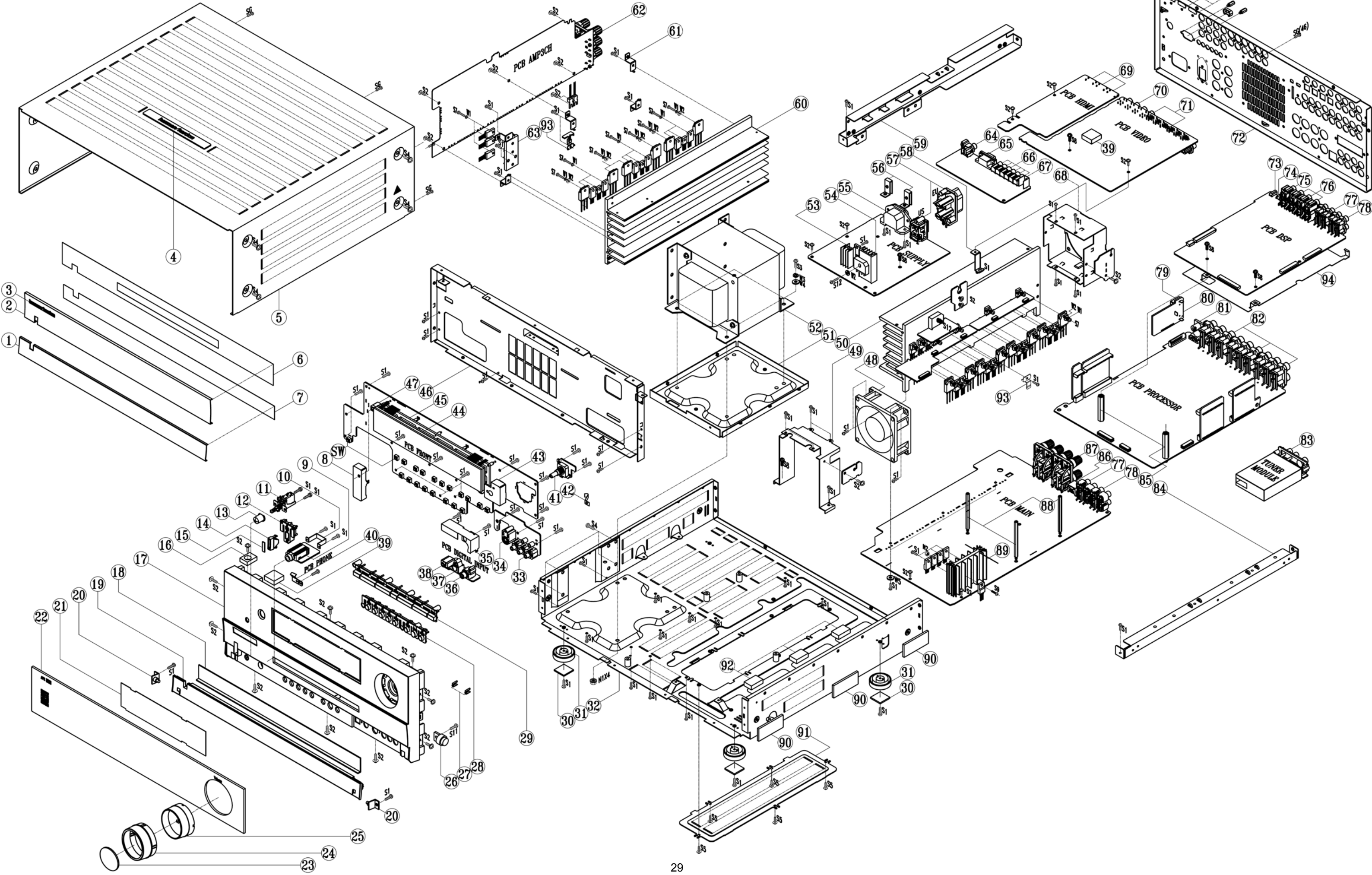

AVR445 EXPLODED VIEW PART LIST

Item #	Description	Part Number	Qty
1	AL DOOR AVR445	H03-ZMC11S00200	1
2	AL PANEL FRONT AVR445	H03-ZMD2702GAGY	1
3	BADGE FRONT AL AVR445 GREY HOT STAMPING	H03-ZMD2703GAGY	1
4	BADGE harman/kardon COVER TOP AVR445	H03-ZMD27S20A00	1
5	COVER TOP AVR445	H03-ZMD27S08A00	1
6	TAPE PANEL	H03-ZVC11DWT200	1
7	TAPE DOOR	H03-ZVC11DWT100	1
8	SHIELD IR	H03-ZMD12S01A00	1
9	JACK PHONE 6.35 H70980110S 9P BK	H03-SOSS9CKX3NN	1
10	BKT HEADPHONE	H03-ZMB01S00100	1
11	SW PUSH POWER SDDL15700	H03-SWA2B21PDA-R	1
12	BUTTON STANDBY	ZPC1006GAWH	1
13	BUTTON POWER	ZPC1003GAGY	1
14	INDICATOR STAND-BY	ZPC1007GAMW	1
15	CAP BUTTON STAND-BY AVR445	H03-ZMC11S12A00	1
16	RUBBER TOP AVR445	ZFD122062SB	1
17	PANEL FRONT AVR445	ZPD2901GAGY	1
	PANEL FRONT AVR445 EU	ZPD3001GAGY-R-2	1
18	BRACKET DOOR	H03-ZMC11S14A00	1
19	DOOR AVR445	ZPC1002GAGY	1
20	BKT HINGE AVR445	H03-ZMD05S16A00	2
21	FILTER VFD	H03-ZPC1018GART	1
22	WINDOW DISPLAY AVR445+ BADGE NAME AVR445	H03-ZPD3119GABT	1
23	CAP KNOB VOLUME	H03-ZPD0317GACR	1
24	COVER KNOB	H03-ZPD0316GASG	1
25	VOLUME KNOB	H03-ZPD0315GAMW	1
26	DAMPER GEAR DP120	H03-ZVC11GEAR01	2
27	INDICATOR VIDEO	ZPC1102GAMW	1
28	BUTTON 8 KEY	ZPC1005GAGY	1
29	BUTTON 7 KEY	H03-ZPC1004GASG	1
	BUTTON 7 KEY EU	H03-ZPD1004GASG	1
30	RUBBER FOOT 19.7X19.7X2T BK	ZFNR19720SB	4
31	FOOT 50MM 15.8MM	ZPC1103GAGY	4
32	CHASSIS MAIN AVR445	H03-ZMD27S13A00	1
33	CON PHONO SCKT RCA-313P3PINS	H03-SORA3313PNN	1
34	JACK S-VIDEO 1P C40160261N	H03-SORA8OSC5N8	1
35	AC PUN SHIELD DIGITAL ET	H03-ZMC12S17A00	1
36	JACK RCA 1P JE010003MN GND OR	H03-SORA1JE01NN	1
37	FIBER OPTIC RECEIVING TORX177L (F, T)	H03-SOTORX177LT	1
38	JACK PHONE 3.5PI PJ0435179N	H03-SO3P5179NNN	3
39	RUBBER TOP AVR445	ZFD122072SB	1
40	SPRING STOPPER AVR445	H03-ZMC11S06A00	1
41	SWIROT EC 16B24204A9 5V 500UOA 10T 3P 00	H03-SWE3A0505S1	1
42	SPRING PLATE GND C5212 0.2T	H03-ZMB01S02200	9
43	SHIELD MICROPHONE	H03-ZMD12S01B00	1
44	VFD 18-BT-19GINK	H03-XD18BT19GNA	1
45	HOLDER VFD AVR445	ZPC1017GABK	1
46	CHASSIS FRONT AVR445	H03-ZMC11S07A00	1
47	REMOCON RECEIVER MODULE ROM-N338TEC	H03-ICROMN338EC	1
48	DC FAN JF0925S1M-003C651R 12V 92x92x25mm	H03-ZVJF0925S00-R	1
49	BKT FAN FRONT AVR445	H03-ZMC11S09A00	1
50	H/SINK MAIN AVR445	H03-ZMD27HS0200	1
51	BKT TRANS BOTTOM	H03-ZMC12S08B00	1
52	POWER TRANSFORMER AVR445 MAIN TRANS 120V60HZ	H03-TXPWMEI94B0	1
	POWER TRANSFORMER AVR445EU MAIN TRANS 230V 50Hz	H03-TXPWMEI92B0	1

53	AC HEATSINK 17x15x30 AVR520--ME	H03-ZMC12HS0100	1
54	HEATSINK DIODE 47x26x12 AVR630	H03-ZMC11HS0400	1
55	CON MAINS INLETAIC A/C INLET7014-NGP	H03-SOXA27014NN	1
56	BKT AC INLET	H03-ZMC12S19A00	2
57	A202D0031P 2P	H03-SOXA2202DNN	1
	A302D0061P AC Out Let (1P) EU 230V	H03-SOXA0302DNN-R-3	1
58	BKT VIDEO	H03-ZMD27S06A00	1
59	BKT FRAME GUIDE AVR745	H03-ZMD27S04A00	1
60	H/SINK AMP AVR445	H03-ZMD29HS0100	1
61	BKT HEATSINK	H03-ZMC12S09A00	6
62	JACK SPEAKER 6P SH061M707G GN BN TA	H03-SOPA61M707G	1
63	HEATSINK AMP SMALL	H03-ZMD27HS0300	1
64	JACK RCA 1P JE010003SG GND YELLOW GOCD COLOR	H03-SORA10003GN	1
65	JACK D-SUB 9P 87204-6063 W/DUST COVER BK	SOPA96063NN	1
66	JACK PHONE 3.6 EP-1401A 1P BK	H03-SOJW2350SNN-R	5
67	BKT GROUND	H03-ZMC12S16A00	1
68	BKT FAN REAR AVR430/630	H03-ZMC11S10A00	1
69	JACKI HDMI YKF45-7009 JALCO	H03-SOYKF457009	3
70	JACK RCA 12P BJ120154JG R4 BU4 G4 GOLD COLOR	H03-SOR12BJ12GN	1
71	JACK RCA+S-VIDEO 6P C80300312GGOLD COLOR	H03-SORA60031GN	1
72	PANEL REAR AVR445US	H03-ZMD31S02A00	2
	PANEL REAR AVR445EU	H03-ZMD32S02A00	2
73	JACK R41-5810B (Mitsumi) XM/DT connector	H03-SOUSB45810B	1
74	AU6-EC-005K0	H03-SOUSB5005K0	1
75	JACK RCA+ OPTICAL TX YKC22-0732N GOLD COLOR	H03-SOTX22073GN	1
76	JACK RCA+ OPTICAL RX YKC22-0733N GOLD COLOR	H03-SORX22073GN	3
77	JACK RCA 4P JB040131ZG GN BN PP TA GOLD COLOR	H03-SORA40RSAGN	2
78	JACK RCA 4P JB040131QG WH BU RD GY GOLD COLOR	H03-SORA40RSCGN	1
79	BKT IPOD	H03-ZMD27S05A00	1
80	DA1R018H91E	H03-SO1R018H91E	1
81	JACK RCA 1P PPJ-440FEG PP GOLD COLOR	H03-SORA1J440GE	1
82	JACK RCA 6P JB060132PG WWWRRR GOLD COLOR	H03-SORA64105GN	3
83	TUNER MODULE KST-MB011MW0-81 US	H03-ZVC11TUNE01	1
	TUNER MODULE KST-MB114MW1-81 OEM EU	H03-ZVD01TUNE00	1
84	BKT FRAME-GUIDE	H03-ZMC11S04B00	1
85	STANDOFF HEX M4x0.7 6x31.9H	ZMC12S13AYE	2
86	JACK-TELE SNAPG-IN GDLDEN TELECOM 1-8P8C 8T BK	SO0A18P8CNN	1
87	JACK SPEAKER 8P SH081M367G GY BU RD WH WH	H03-SOPA81M367G	1
88	STANDOFF HEX M4X0.7 6X61.9H	ZMC12S14AYE	6
89	H/SINK REG. TR AVR745	H03-ZMD27HS0400	1
90	RUBBER SIDE	ZFNR13830SB	6
91	COVER BOTTOM	H03-ZMC12S07A00	1
92	SPONGE 30X30X10T BK	ZUC1201AABK	6
93	BRACKET POSISTOR,METAL,AVR745	H03-ZMD2701ZANI	2
94	SHIELD DSP AVR745	H03-ZMD12S01C00	1
95	BKT HDMI AVR440 US	H03-ZMD31S03A00	1
	BKT HDMI AVR440 EU	H03-ZMD31S03A00	1
96	SPEAKER TERMINAL KNOB CORK B3M790BO	H03-ZPD1019ZABK	14
97	SHIELD AL	H03-ZMD27S07A00	1
98	SPONGE-UL 30X30X12T BK	H03-ZUD0301ABBK	1
99	BRACKET BKT XM	H03-ZMD27S09A00	1
100	SWITACT VERTICAL SKQNADD010	H03-SWC2A112FS1	20
N1	NUT M4 HEXAGON CIRCULAR EXTERNAL	ZNSSM4045HZ	4
N2	NUT M3 ZN PLATED	ZNSSM3023HZ	1
S1	SCREW ST BH 3X10	ZSTBM3010BB 65	64
S2	SCREW ST WPH 3X8	ZSTWM3008BY 44	45
S3	SCREW BM 4X10	ZSMCM4010BB	4
S4	SCREW ST WPH 4X8 SILVER CHROM	ZSTWM4008BC	14

S5	SCREW ST WPH 3X6	ZSTWM3006BB	7
S7	SCREW ST BH 3X12 PIVOT	ZSTBM3012BY	43
S8	SCREW BM 4X8	ZSMCM4008BY	5
S9	SCREW M.S M3X14 ZN PLATED	ZSMBM3014BZ	1
S10	SCREW M.S.M3X6 P/HD BLACK	ZSMPM3006LB	3
S11	SCREW ST BH 3X8	ZSTBM3008BY	1
S12	SCREW ST BH 3X14 PIVOT	ZSTBM3014BY	1
SG	SCREW ST BH 3X10 GROUND	ZSTGM3010BB	51
W1	WASHER SPRING 3	ZWM623108SZ	42
W2	WASHER PLAIN 3	ZWM803305PZ	19
W3	AC SPRING WAS HER RT2250(PAV5005)	ZWM763109SZ	4
W4	WASHER PLAIN 4	ZWMC04810PZ	4

AVR445 BLOCK DIAGRAM

REVISION RECORD		
NO.	Date	Contents

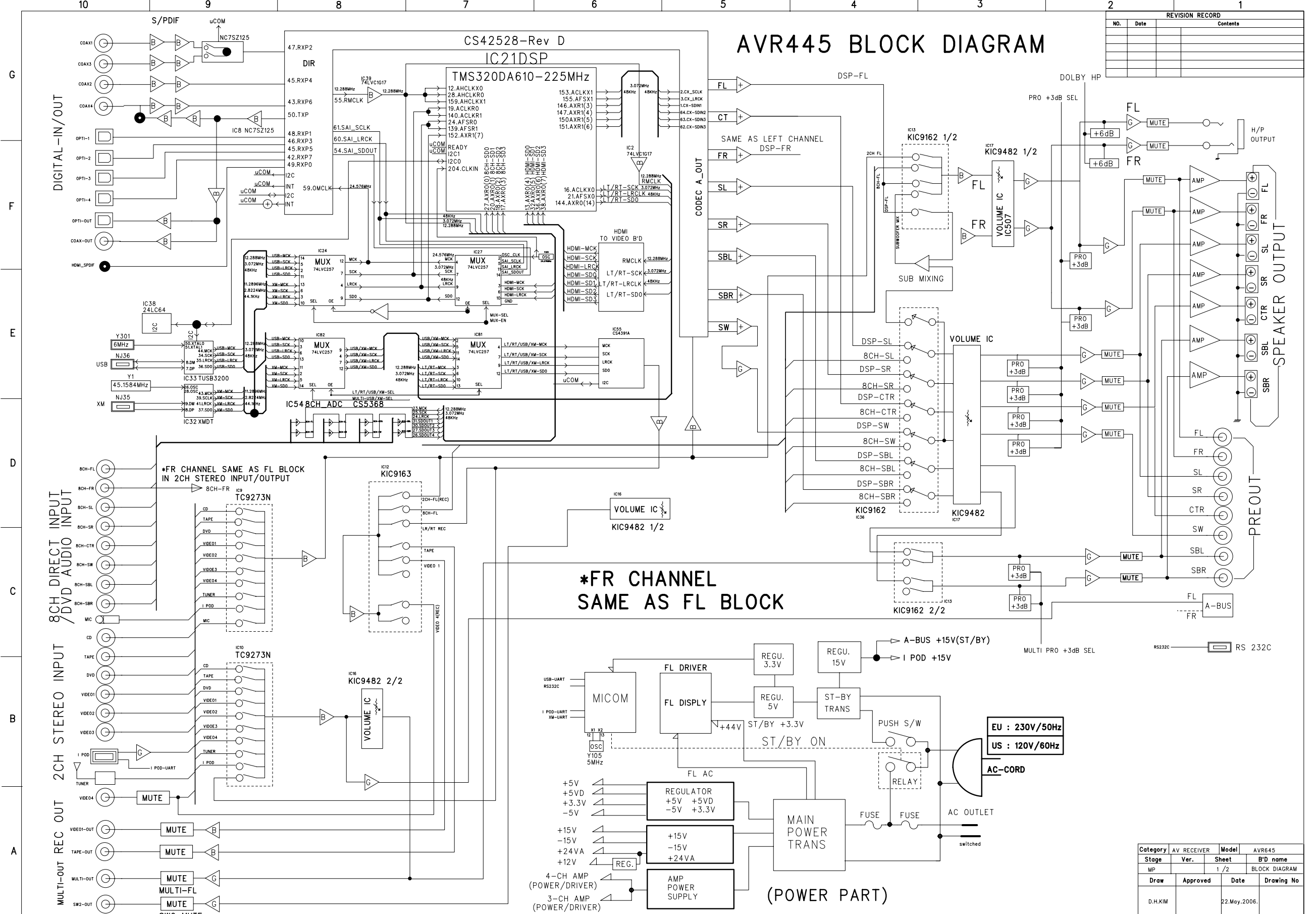

Category	AV RECEIVER	Model	AVR645
Stage	MP	Sheet	1 / 2
Draw	Approved	Date	22.May.2006.
Block Diagram		Drawing No	

AVR445 VIDEO BLOCK DIAGRAM

REVISION RECORD		
NO.	Date	Contents

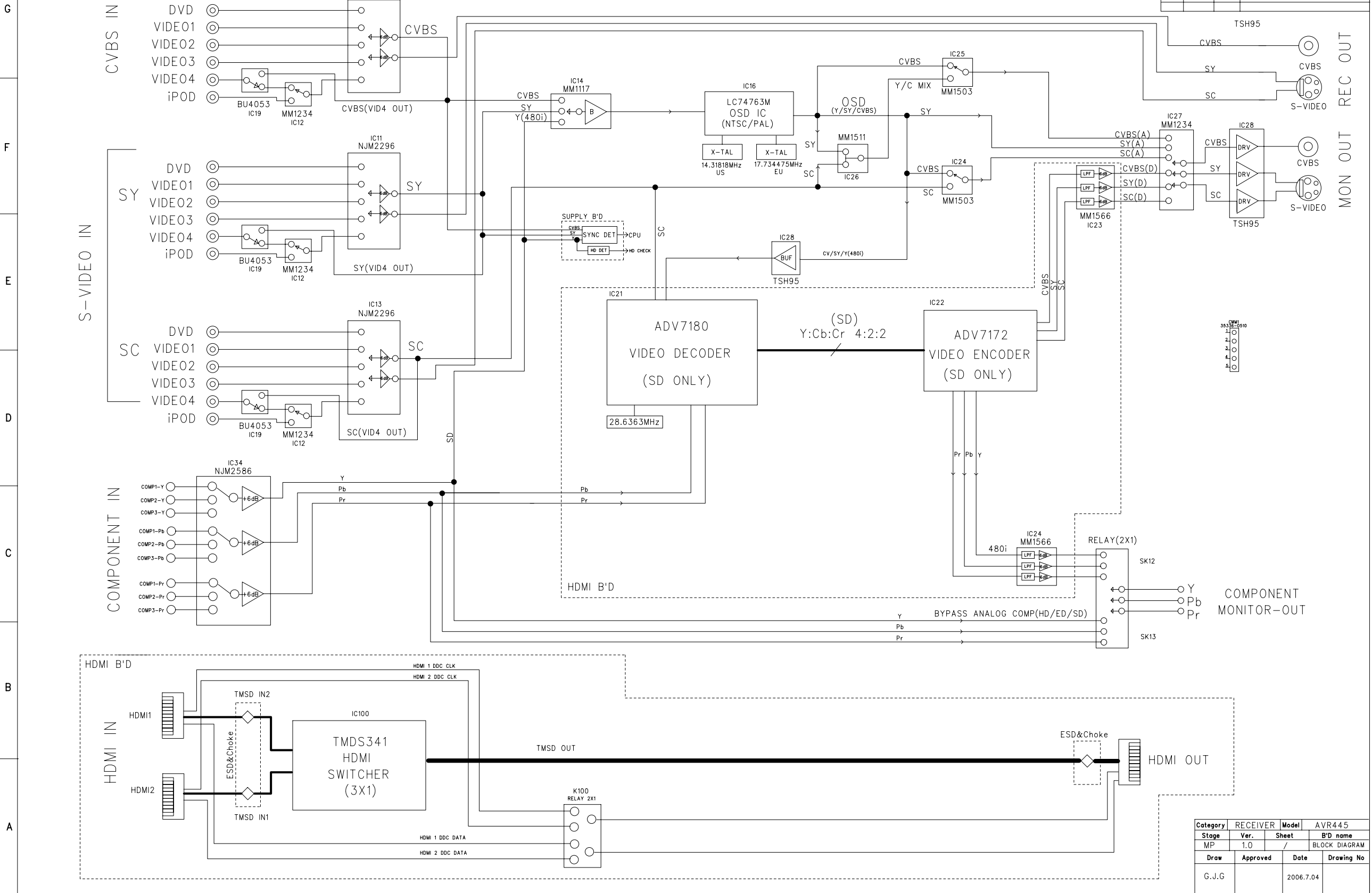

Category	RECEIVER	Model	AVR445
Stage	Ver.	Sheet	B'D name
MP	1.0	/	BLOCK DIAGRAM
Draw	Approved	Date	Drawing No
G.J.G		2006.7.04	

AVR645/445-CIRCUIT DESCRIPTION

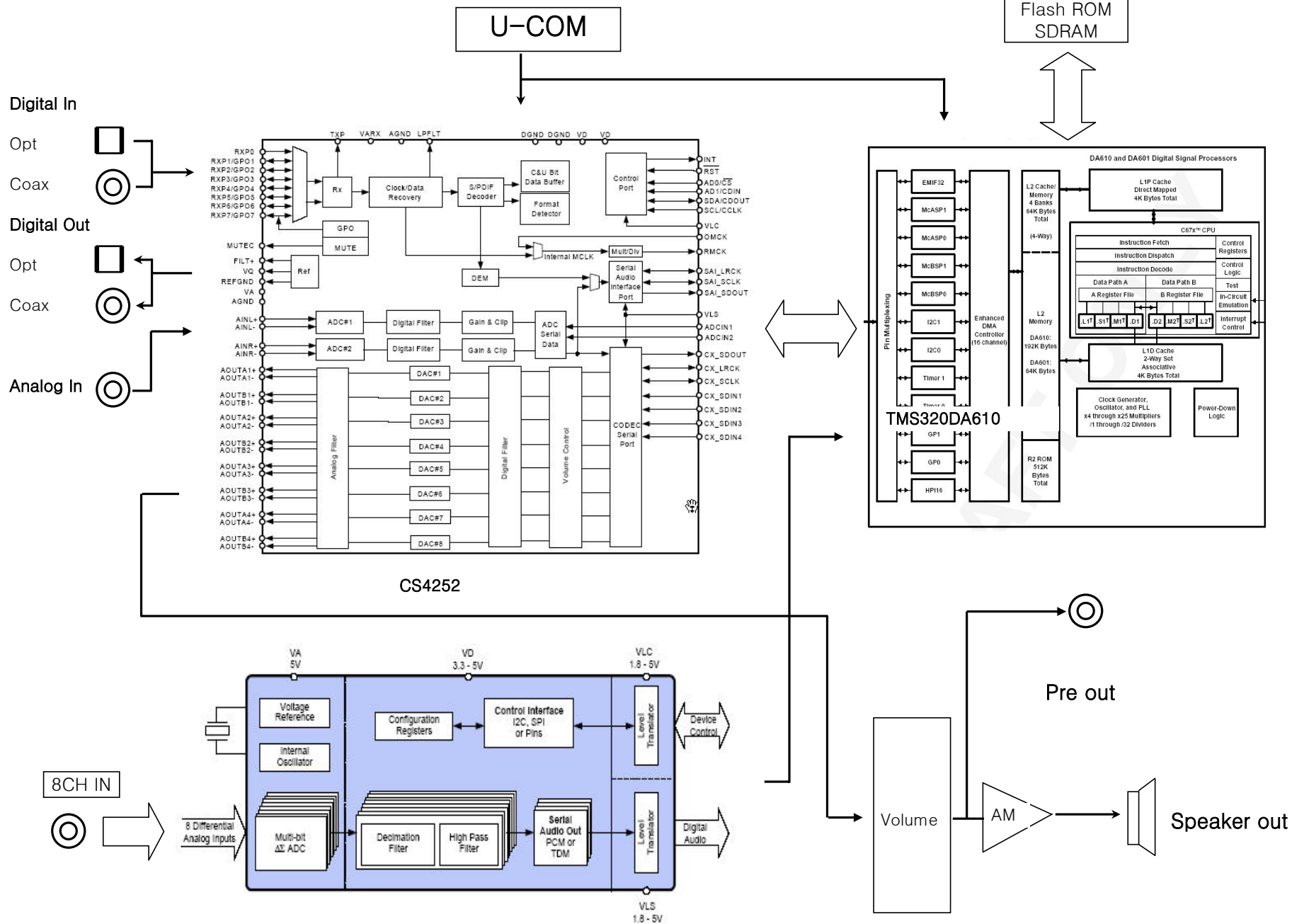

SERVICE PROCEDURE

ALIGNMENT PROCEDURES

1.MAIN AMP idling Adjustment

SET CONDITION

- 1) SEMI VOLUME POSITION at MAIN/SURROUND AMP Board

MAIN:VR71.VR72

SURROUND:VR73.VR74

NO Signal/No Load

AC Line Voltage:120V/60Hz.230V/50Hz

- 2) After turning on the unit keep it over than 25min (keep the power/Driver TR as normal temperature)
- 3) Adjust the voltage value of primary&secondary of wafer to be 25mV by rotating the semi volume of each channel to the right

CHANNEL	ADJUSTMENT	MEASUREMENT	VOLTAGE
FRONT-L CH	VR71	P817	23+/-2mV
FRONT-R CH	VR72	P805	23+/-2mV
SURROUND-L CH	VR73	P818	23+/-2mV
SURROUND-R CH	VR74	P806	23+/-2mV

- 4) CAUTION

In case that power TR or DRIVER TR is needed to be replace for repairing the corresponding channel should be adjusted again

FRONT AMP:Q437.Q433.Q435.Q439.Q438.Q434.Q436.Q440

SURROUND AMP:Q333.Q329.Q331.Q335.Q334.Q330.Q332.Q336

2.SURROUND BACK AMP idling Adjustment

SET CONDITION

- 1) SEMI VOLUME POSITION at CENTER/SURROUND BACK AMP Board

CENTER:VR501

SURROUND BACK:VR201.VR301

NO Signal/No Load

AC Line Voltage:120V/60Hz.230V/50Hz

- 2) After turning on the unit keep it over than 25min (keep the power/Driver TR as normal temperature)
- 3) Adjust the voltage value of primary&secondary of wafer to be 25mV by rotating the semi volume of each channel to the right

CHANNEL	ADJUSTMENT	MEASUREMENT	VOLTAGE
CENTER	VR501	P501	23+/-2mV
SURR BACK-L CH	VR201	P201	23+/-2mV
SURR BACK-R CH	VR301	P301	23+/-2mV

- 4) CAUTION

In case that power TR or DVIER TR is needed to be replace for repairing the corresponding channel should be adjusted again

CENTER AMP:Q519,Q517.Q516,Q518

SUR BACK AMP:Q319.Q317.Q316.Q318.Q219.Q217.Q216.Q218

3.Cautions for main adjustment

- 1) At MAIN/SUPPLY BOARD.use the below capacitor after discharging for sufficient time for preventing possible damage from electrical spark

MAIN BOARD	C571.C572	AVR745/645 15000/63V
	C571.C572	AVR445 12000/63V
SUPPLY BOARD	C201,C202	AVR745/645 10000/63V
	C201,C202	AVR445 8200/63V

- 2)The checking for MAIN/SUPPLY BOARD should have the discharging circuit discharge over 30sec.through(4R70hm 10W)resistor after push power sw off

Alignment and test position (MAIN AMP BOARD)

MAIN BOARD

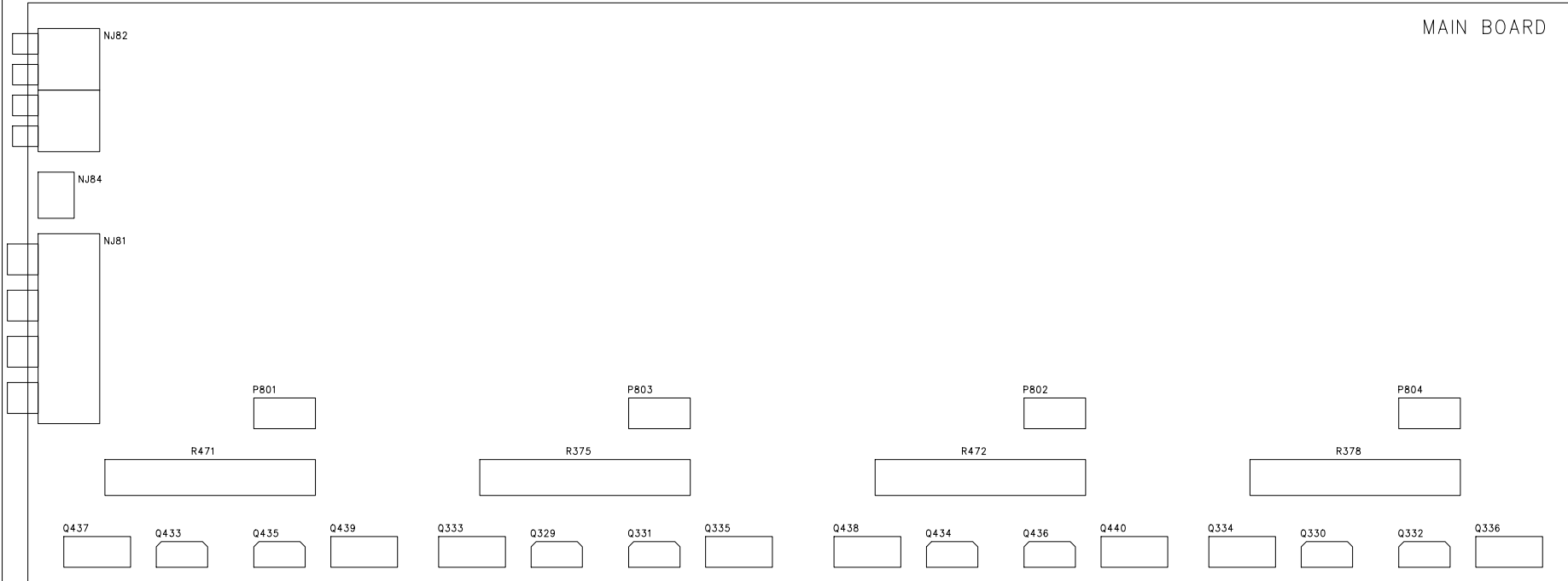

HEATSINK

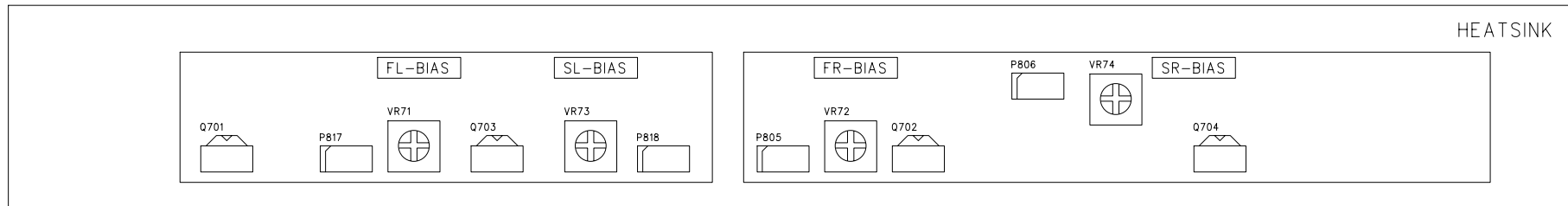

Alignment and test position (SURROUND BOARD)

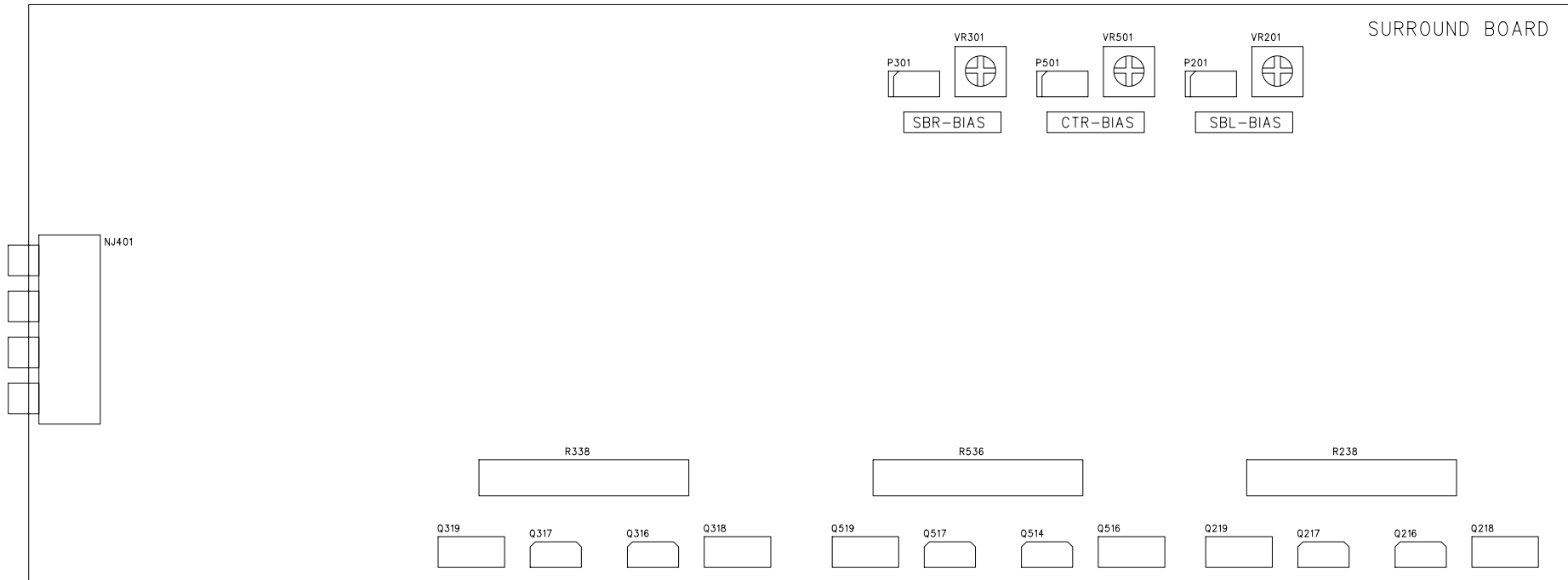

UPD70F3261YGC-8EA-A LQFP100 PORT DEFINE FOR AVR645_445

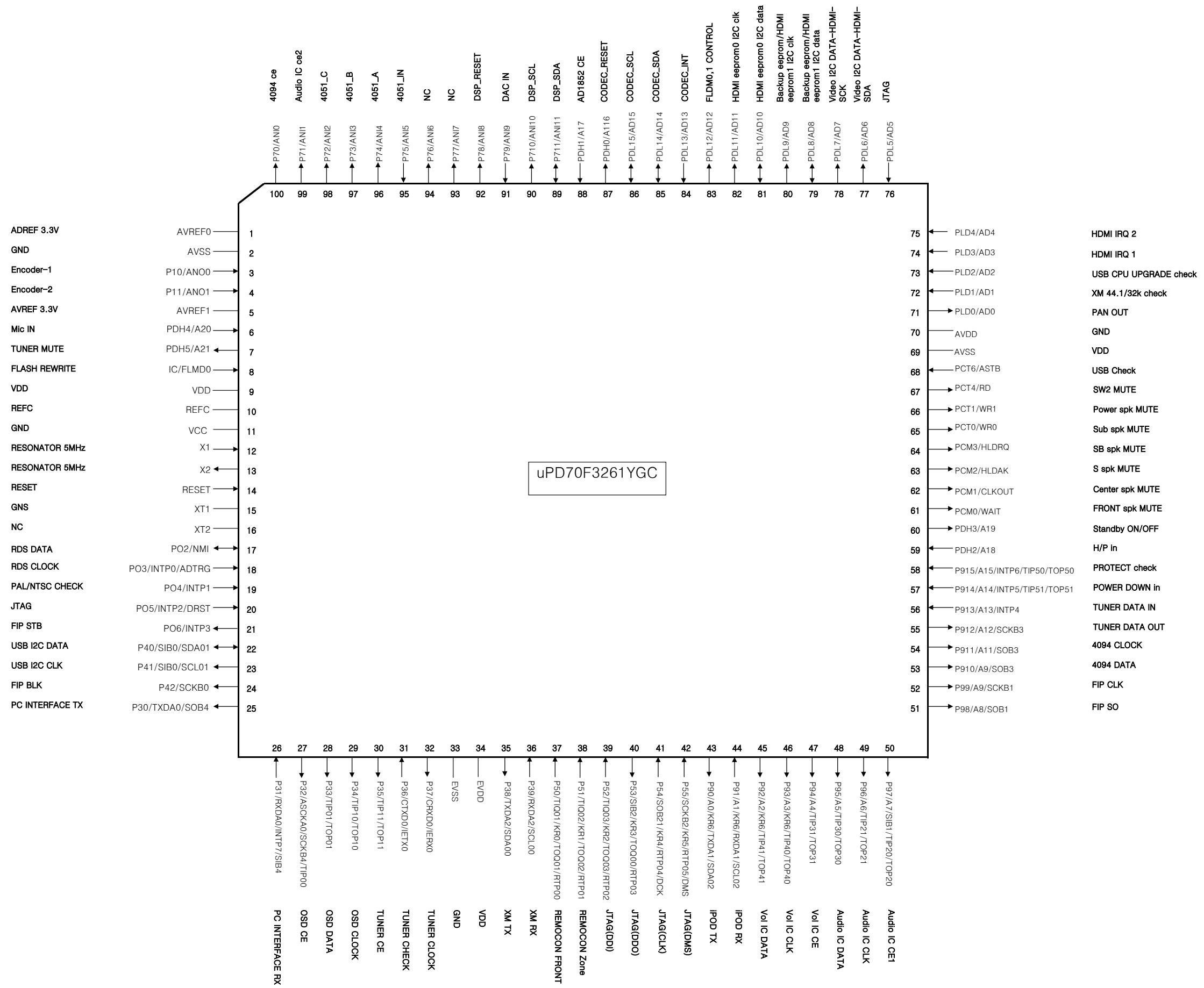

AVR645_445 MICOM PORT ASSIGN

PIN	PIN NAME	RECEIVER NAME	IN/OUT	FUNCTION
1	AV _{REF0}	3.3V	Supply	AD ref
2	AV _{SS}	GND	Supply	GND
3	P10/AN00	Encoder 1	IN	VOLUME ENCODER INPUT 1
4	P11/AN01	Encoder 2	IN	VOLUME ENCODER INPUT 2
5	AV _{REF1}	AVREF1	Supply	VDD
6	PDH4/A20	Mic in	IN	ROOM EQ mic in check
7	PDH5/A21	Tuner Mute	OUT	TUNER MUTE OUT
8	IC/FLMD0	Flash Rewrite	IC	Debug port
9	V _{DD}	VDD	Supply	VDD
10	REGC	REFC	Supply	VDD
11	V _{SS}	GND	Supply	GND
12	X1	RESONATOR 5MHz	IN	5.00MHz RESONATOR
13	X2	RESONATOR 5MHz	OUT	5.00MHz RESONATOR
14	/RESET	RESET	IN	LOW ACTIVE
15	XT1	GND	GND	clock port
16	XT2	NC	Open	NC
17	P02/NMI	RDS DATA(XM-IRQ)	IN/OUT	RDS_DATA (ext interrupt)
18	P03/INTP0/ADTRG	RDS Clock(XM-C/D)	IN	RDS_CLK (ext interrupt)
19	P04/INTP1	PAL/NTSC check	IN	ext interrupt
20	P05/INTP2/DRST	JTAG(DRST)	IN	Debug port
21	P06/INTP3	FIP STB	OUT	FIP DRIVER IC RESET / FL STROBE
22	P40/SIB0/SDA01	USB I2C DATA	IN/OUT	USB-SDA
23	P41/SOB0/SCL01	USB I2C CLK	OUT	USB-CLK
24	P42/SCKB0	FIP BLK	OUT	FIP DRIVER IC DATA IN / FL BLANK
25	P30/TXDA0/SOB4	PC INTERFACE TX	OUT	UART Interface
26	P31/RXDA0/INTP7/SIB4	PC INTERFACE RX	IN	UART Interface
27	P32/ASCKA0/SCKB4/TIP00	OSD CE	OUT	OSD CHIP ENABLE
28	P33/TIP01/TOP01	OSC DATA	OUT	OSD DATA
29	P34/TIP10/TOP10	OSC CLOCK	OUT	OSD CLK
30	P35/TIP11/TOP11	Tuner CE	OUT	TUNER PLL IC(LC72131) CHIP ENABLE
31	P36/CTXD0/IETX0	Tuned check	IN	TUNER PLL IC(LC72131) DATA IN / STEREO CHECK
32	P37/CRXD0/IERX0	Tuner CLOCK	OUT	TUNER PLL IC(LC72131) CLOCK
33	EV _{SS}	GND	Supply	GND
34	EV _{DD}	VDD	Supply	VDD
35	P38/TXDA2/SDA00	XM TX	OUT	UART Interface
36	P39/RXDA2/SCL00	XM RX	IN	UART Interface
37	P50/TIQ01/KR0/TOQ01/RTP00	Remocon Front	IN	Remocon Port
38	P51/TIQ02/KR1/TOQ02/RTP01	Remocon Zone	IN	Remocon Port
39	P52/TIQ03/KR2/TOQ03/RTP02	JTAG(DDI)	IN	Debug port
40	P53/SIB2/KR3/TOQ00/RTP03	JTAG(DDO)	OUT	Debug port
41	P54/SOB2/KR4/RTP04/DCK	JTAG(CLK)	IN	Debug port
42	P55/SCKB2/KR5/RTP05/DMS	JTAG(DMS)	IN	Debug port
43	P90/A0/KR6/TXDA1/SDA02	iPOD TX	OUT	UART Interface
44	P91/A1/RXDA1/SCL02	iPOD RX	IN	UART Interface
45	P92/A2/TIP41/TOP41	Vol IC DATA	OUT	TC9482/TC9459 DATA
46	P93/A3/TIP40/TOP40	Vol IC CLOCK	OUT	TC9482/TC9459 CLK
47	P94/A4/TIP31/TOP31	Vol IC CE	OUT	TC9482/TC9459 CE
48	P95/A5/TIP30/TOP30	Audio IC data	OUT	A DATA
49	P96/A6/TIP21/TOP21	Audio IC clk	OUT	A CLK
50	P97/A7/SIB1/TIP20/TOP20	Audio IC ce 1	OUT	TC9273/TC9162/TC9163 CE
51	P98/A8/SOB1	FIP SO	OUT	FIP DRIVER IC DATA OUT / FL DI
52	P99/A9/SCKB1	FIP CLK	OUT	FIP DRIVER IC CLOCK OUT / FL CLK
53	P910/A10/SIB3	4094 DATA	OUT	4094 DATA
54	P911/A11/SOB3	4094 CLOCK	OUT	4094 CLK
55	P912/A12/SCKB3	Tuner DATA out	OUT	72131 DIN
56	P913/A13/INTP4	Tuner DATA in	IN	72131 DOUT
57	P914/A14/INTP5/TIP51/TOP51	POWER DOWN check	IN	Ext Interrupt
58	P915/A15/INTP6/TIP50/TOP50	Protect check	IN	PROTECTION IN
59	PDH2/A18	H/P in	IN	HEADPHONE INPUT
60	PDH3/A19	Standby ON/OFF	OUT	MAIN POWER Relay control
61	PCM0/WAIT	Front spk Mute	OUT	FRONT SPEAKER MUTE
62	PCM1/CLKOUT	Gen spk Mute	OUT	CENTER SPEAKER MUTE
63	PCM2/HLDAK	S spk Mute	OUT	SURROUND SPEAKER MUTE
64	PCM3/HLDRQ	SB spk Mute	OUT	SURR BACK SPEAKER MUTE
65	PCT0/WR0	Sub spk Mute	OUT	SUB WOOFER MUTE
66	PCT1/WR1	Power Mute	OUT	POWER MUTE
67	PCT4/RD	SW2 MUTE	OUT	SUBWOOFER MUTE
68	PCT6/ASTB	USB CHECK	IN	USB CNT CHECK
69	BV _{SS}	VDD	Supply	VDD
70	BV _{DD}	GND	Supply	GND
71	PDL0/AD0	Fan Out	OUT	PWM control
72	PDL1/AD1	XM 44.1/32K CHECK	IN	XM-44.1/32K-CHECK
73	PDL2/AD2	USB CPU UPGRAD CHECK	IN	USB-UPGRADE
74	PDL3/AD3	HDMI IRQ 1	IN	HDMI IRQ 1
75	PDL4/AD4	HDMI IRQ 2	IN	HDMI IRQ 2

PIN	PIN NAME	RECEIVER NAME	IN/OUT	FUNCTION
76	PDL5/AD5/FLMD1	JTAG	IN	Debug port
77	PDL6/AD6	Video I2C DATA-HDMI-SDA	IN/OUT	HDMI i2c
78	PDL7/AD7	Video I2C CLK-HDMI-SCK	OUT	HDMI i2c
79	PDL8/AD8	backup eeprom/HDMI eeprom1 I2C data	IN/OUT	EEPROM DATA
80	PDL9/AD9	backup eeprom/HDMI eeprom1 I2C clk	OUT	EEPROM CLK
81	PDL10/AD10	HDMI eeprom0 I2C data	IN/OUT	EEPROM DATA
82	PDL11/AD11	HDMI eeprom0 I2C clk	OUT	EEPROM CLK
83	PDL12/AD12	FLDM0,1 CONTROL	OUT	Flash programming mode
84	PDL13/AD13	CODEC_INT	IN	CS42528
85	PDL14/AD14	CODEC_SDA	IN/OUT	CS42528
86	PDL15/AD15	CODEC_SCL	IN/OUT	CS42528
87	PDH0/A16	CODEC_RESET	OUT	CS42528
88	PDH1/A17	DAC CE	IN	DAC CE
89	P711/ANI11	DSP_SDA	IN/OUT	DSP I2C DATA
90	P710/ANI10	DSP_SCL	OUT	DSP I2C CLOCK
91	P79/ANI9	DAC IN	IN	CS4391A M1
92	P78/ANI8	DSP_RESET	OUT	DA610 RESET
93	P77/ANI7	NC	OUT	NC
94	P76/ANI6	NC	OUT	NC
95	P75/ANI5	4051_IN	IN	4051_IN
96	P74/ANI4	4051_A	OUT	4051_A
97	P73/ANI3	4051_B	OUT	4051_B
98	P72/ANI2	4051_C	OUT	4051_C
99	P71/ANI1	Audio ic ce2	OUT	TC9162_CE
100	P70/ANI0	4094 ce	OUT	4094 CHIP ENABLE

Semiconductor pinout drawings

•IC

1. 24LC256 (DSP: IC12)

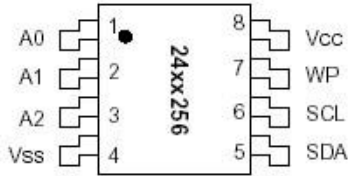

PIN FUNCTION TABLE

Name	Function
A0, A1, A2	User Configurable Chip Selects
Vss	Ground
SDA	Serial Data
SCL	Serial Clock
WP	Write Protect Input
Vcc	+1.8 to 5.5V (24AA256) +2.5 to 5.5V (24LC256)

BLOCK DIAGRAM

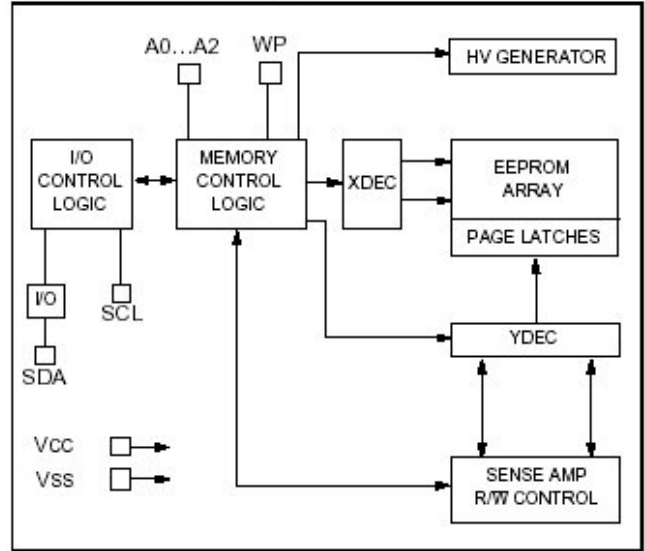

2. 24LC64-I/SNG (DSP: IC38)

Block Diagram

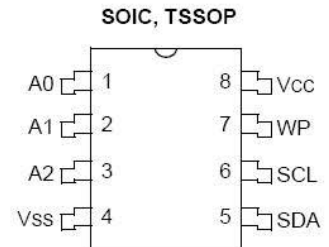
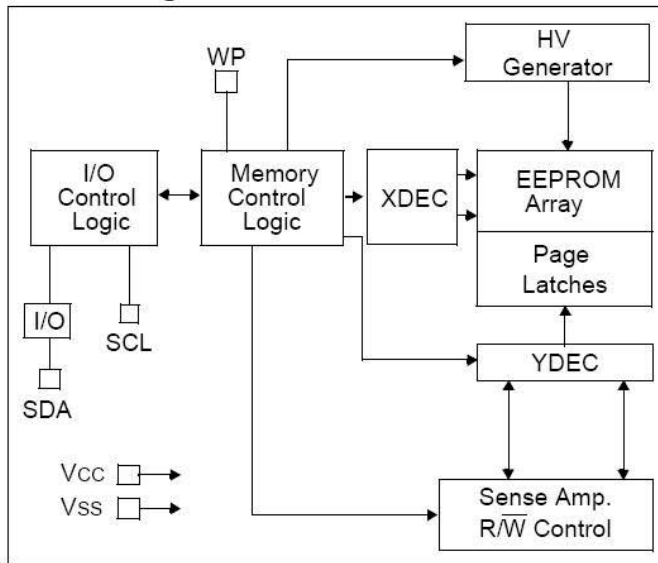

PIN FUNCTION TABLE

Name	Function
A0,A1,A2	User Configurable Chip Selects
Vss	Ground
SDA	Serial Data
SCL	Serial Clock
WP	Write Protect Input
Vcc	+1.8 to 5.5V (24AA64) +2.5 to 5.5V (24LC64)

**3. BU4094BCF SOP16 (DSP: IC14 IC15 IC17)
(SUPPLY: IC406)
(VIDEO: IC20 IC21 IC22)**

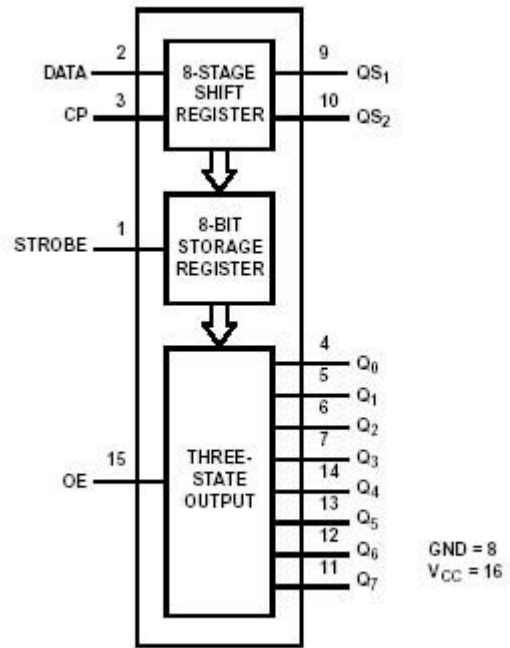
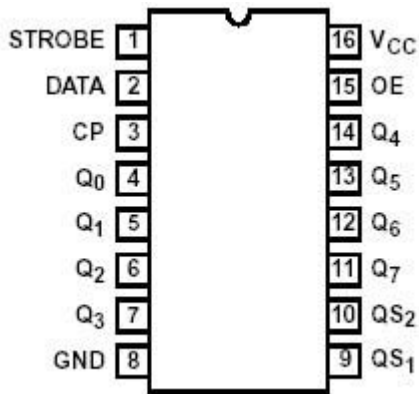

4. BU4051BCF SOP16 (DSP: IC1)

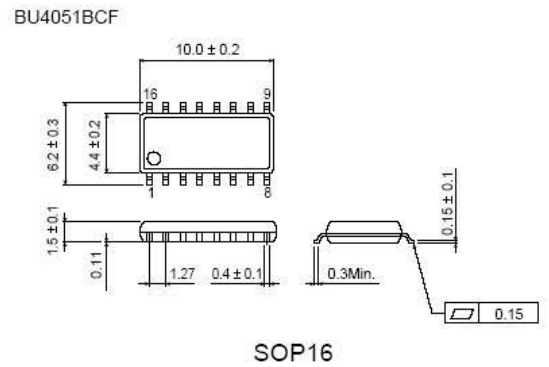
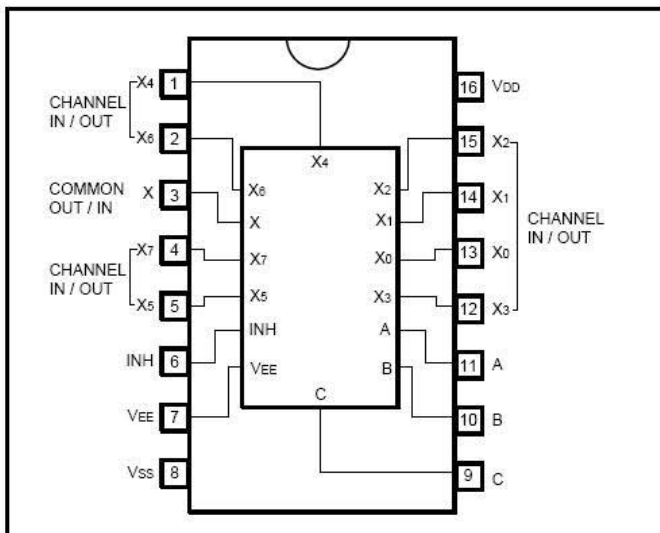

5. BU4052BCF SOP16 (SUPPLY: IC34)

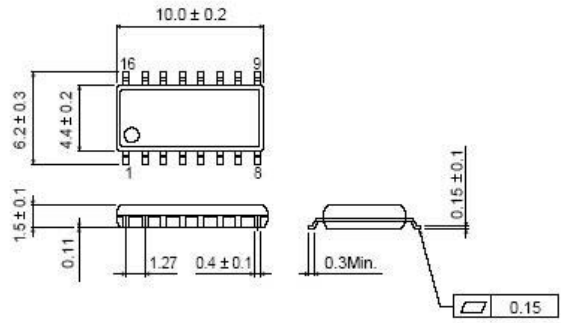
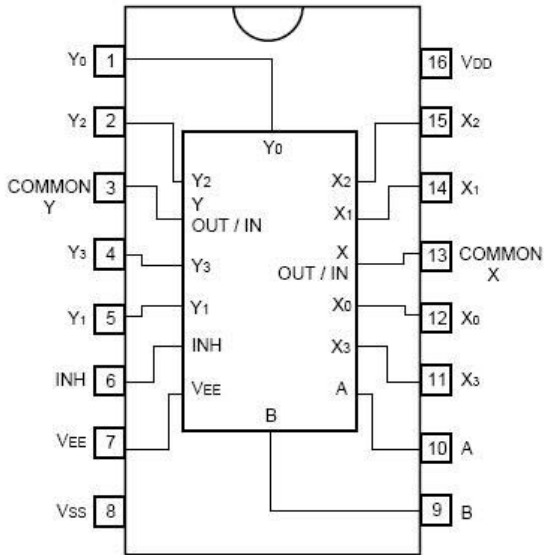

6. 74HCU04M (DSP: IC34 IC35)

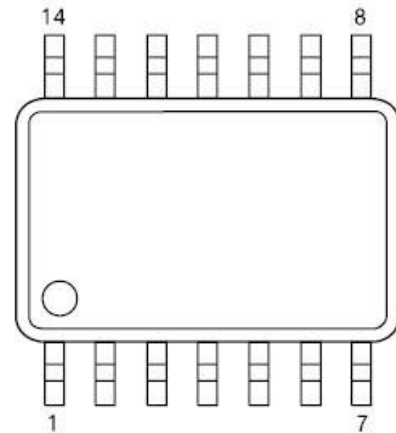
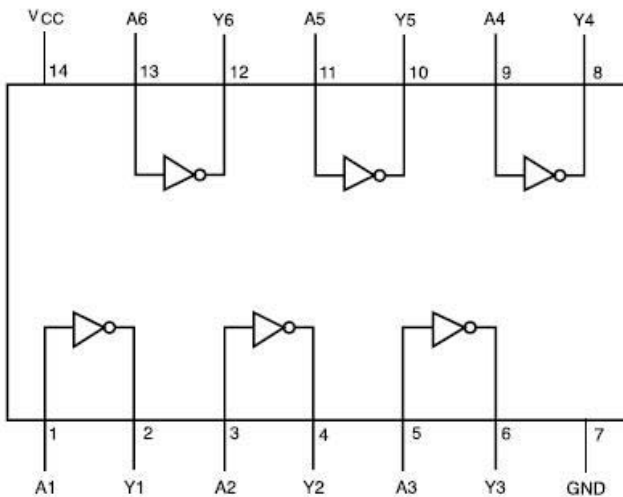

7. SN74ALVC244PWR (VIDEO: IC50 IC51 IC53)

LOGIC DIAGRAM (POSITIVE LOGIC)

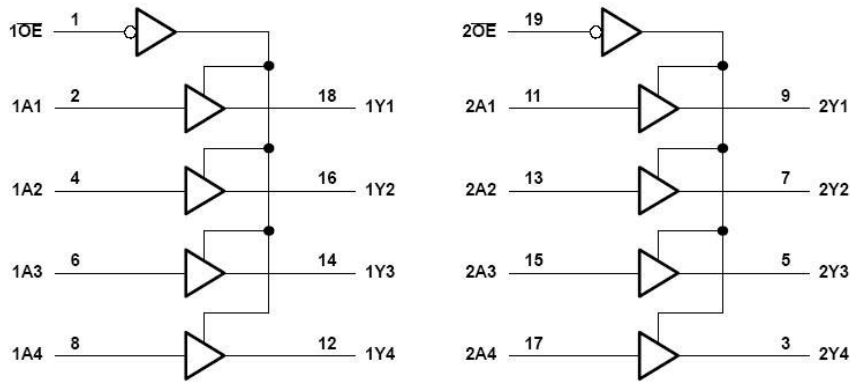

DIM	PINS **					
	8	14	16	20	24	28
A MAX	3,10	5,10	5,10	6,60	7,90	9,80
A MIN	2,90	4,90	4,90	6,40	7,70	9,60

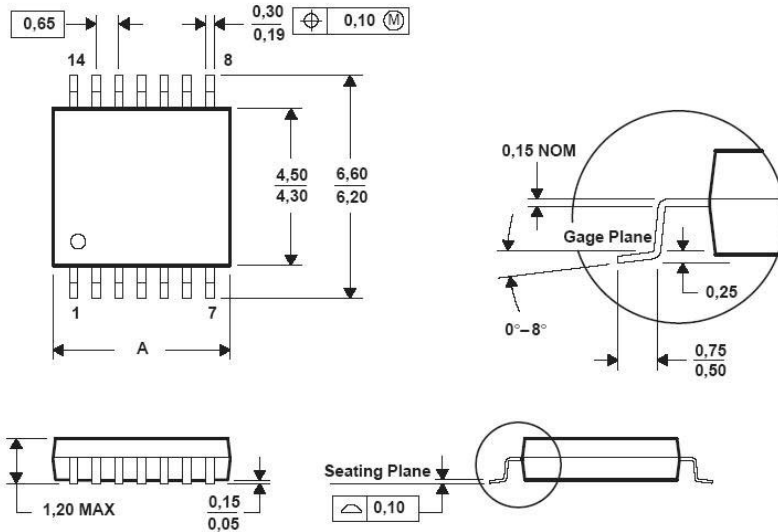

8. XMDIC QFP48 (DSP: IC32)

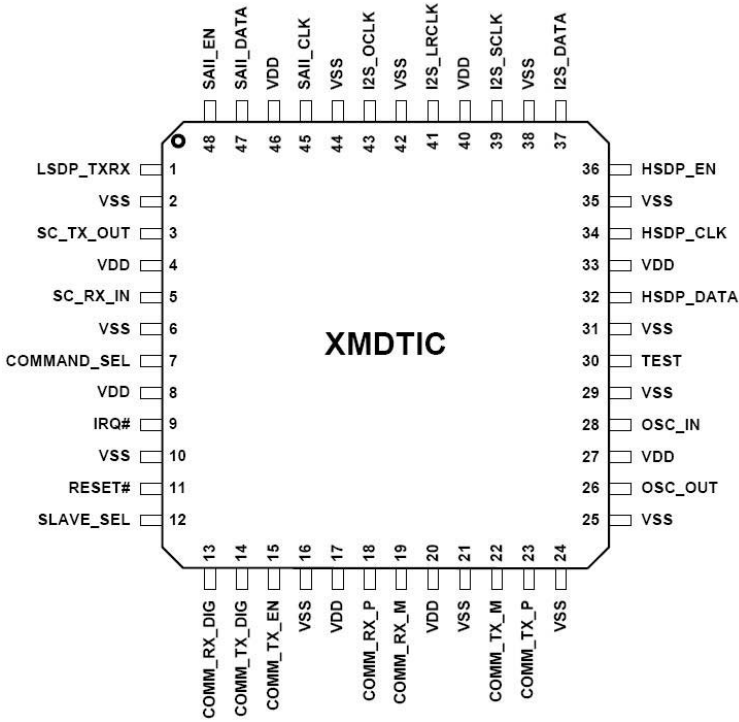
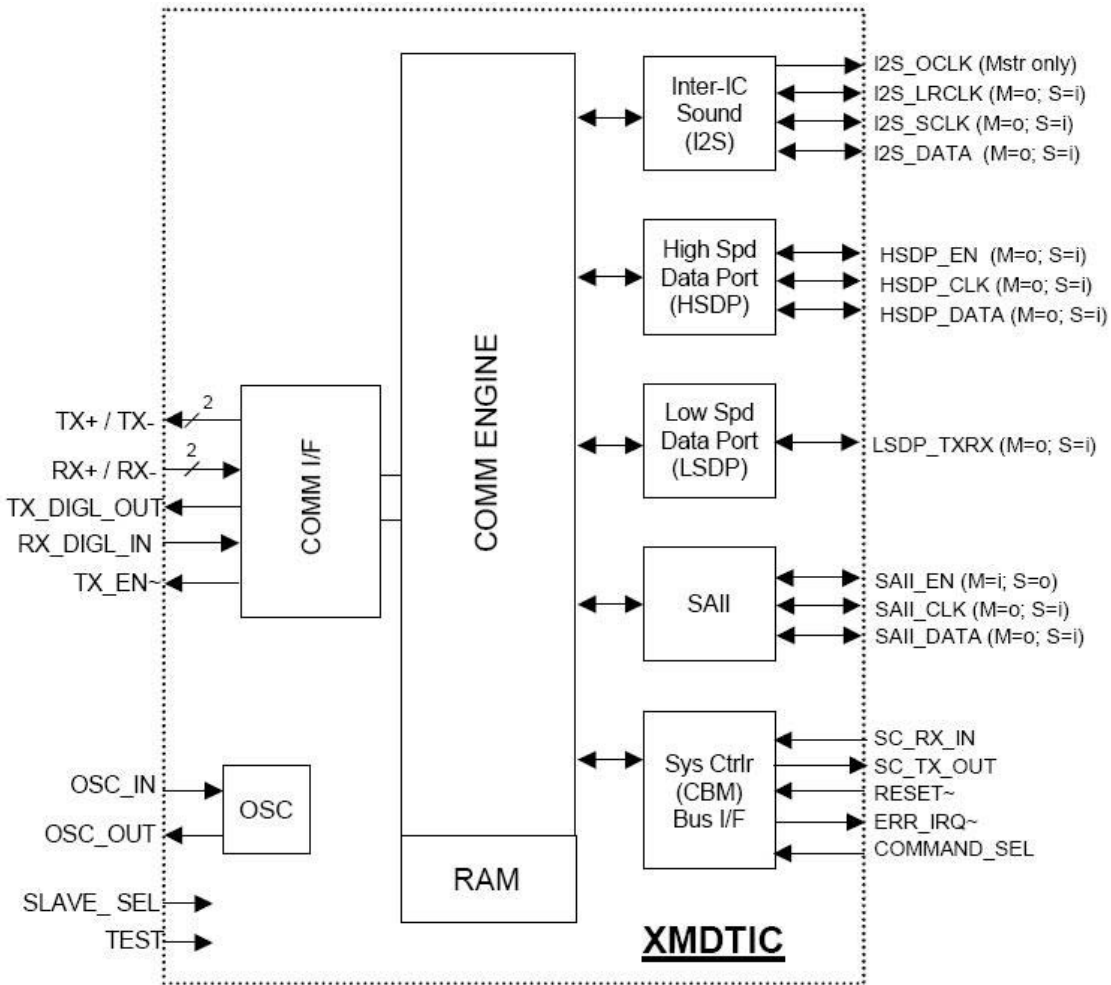

9. TMS320DA610-250 PQFP208 (DSP:IC21)

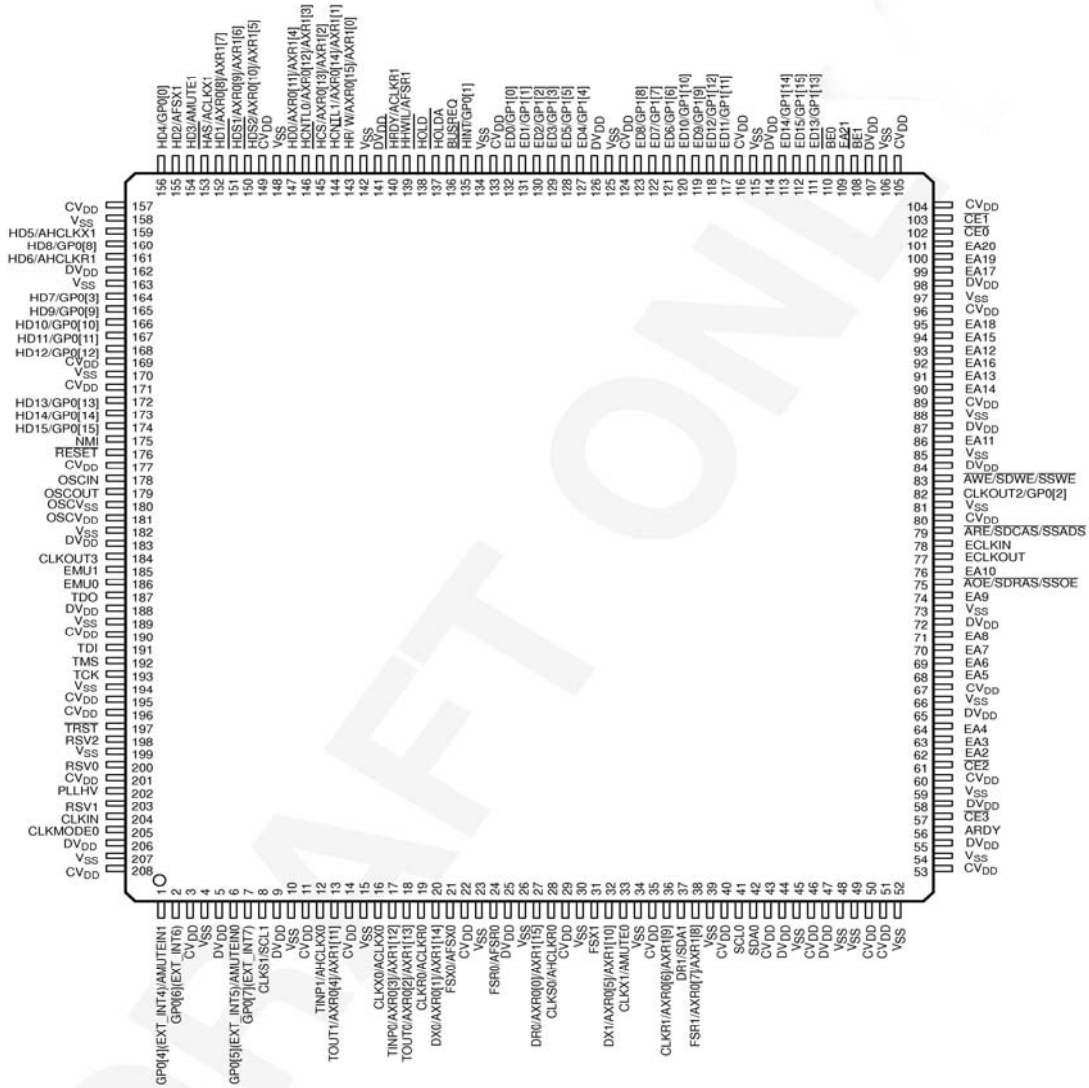

functional block and CPU (DSP core) diagram

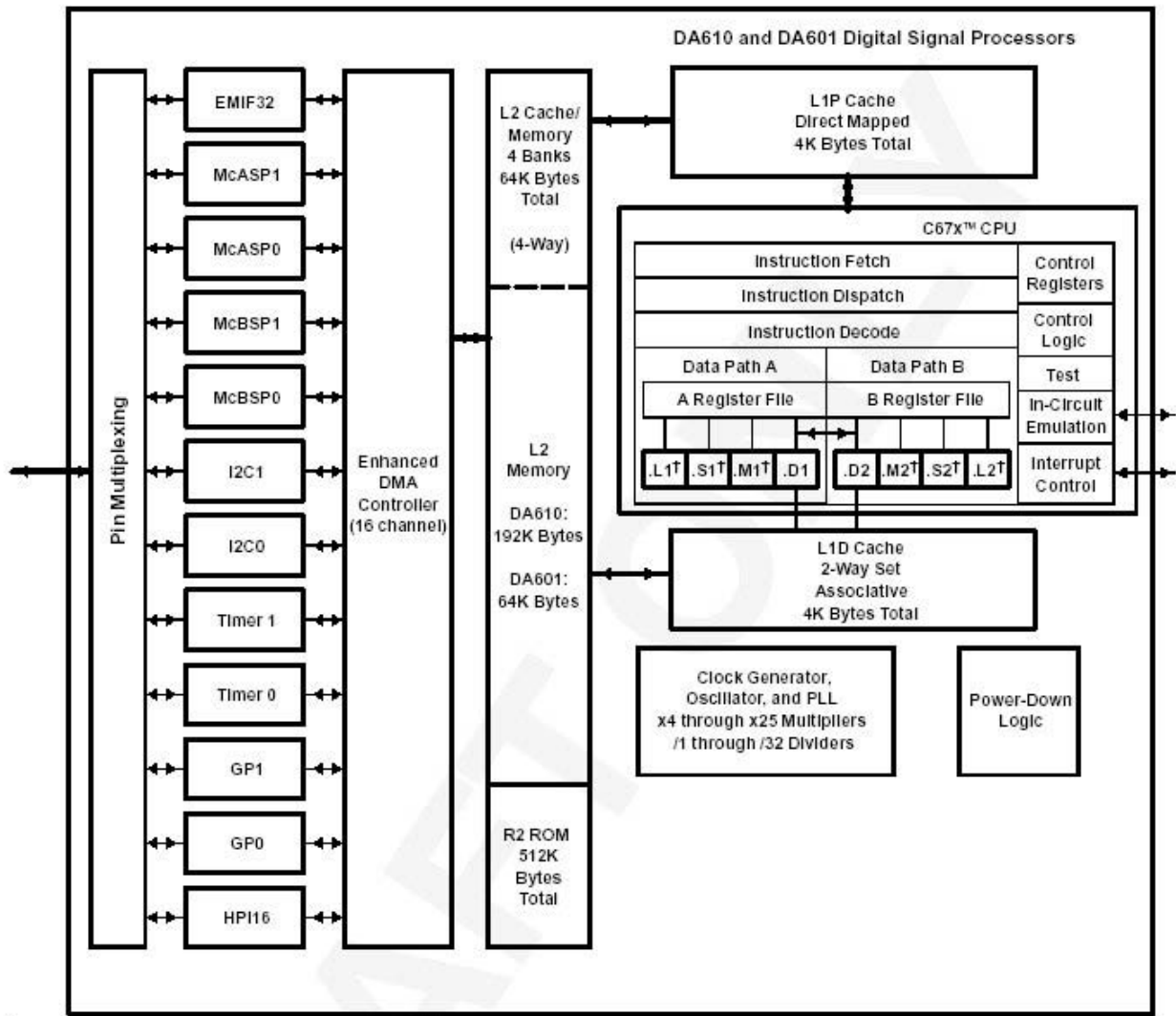

10. SN74LVC1G125DCKT (DSP: IC8, 36, 37)

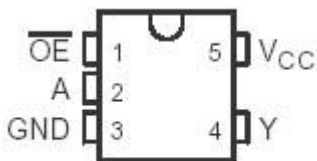

logic symbol†

FUNCTION TABLE

INPUTS		OUTPUT
OE	A	Y
L	H	H
L	L	L
H	X	Z



logic diagram (positive logic)

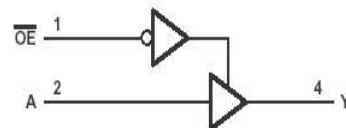

11. 74VHC244M (DSP:IC16)



PIN CONNECTION AND IEC LOGIC SYMBOLS

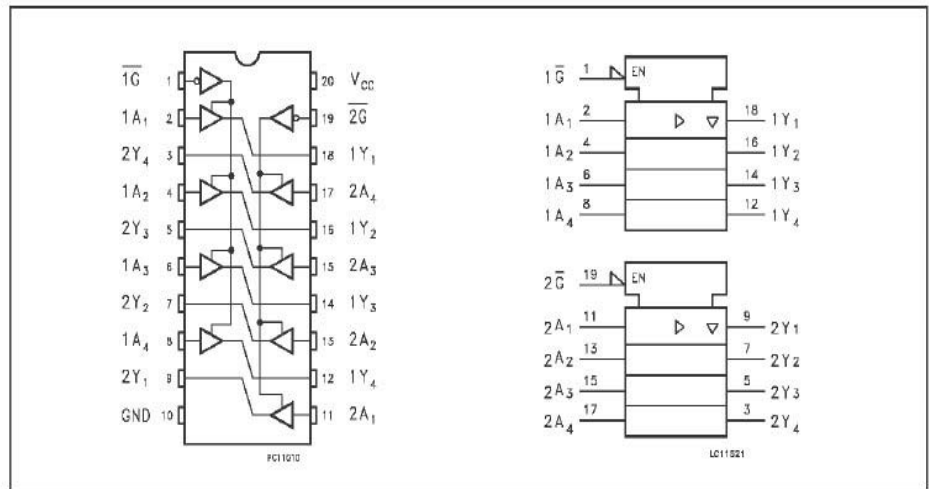

12. AT49BV163DT (DSP:IC22)

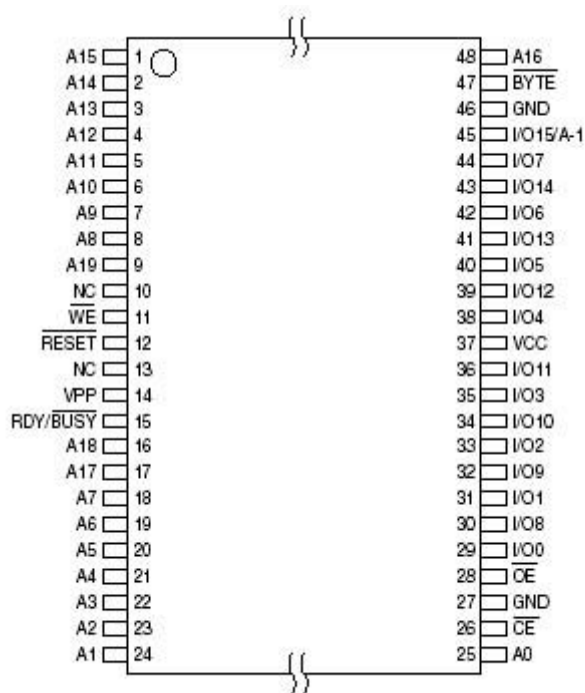

Block Diagram

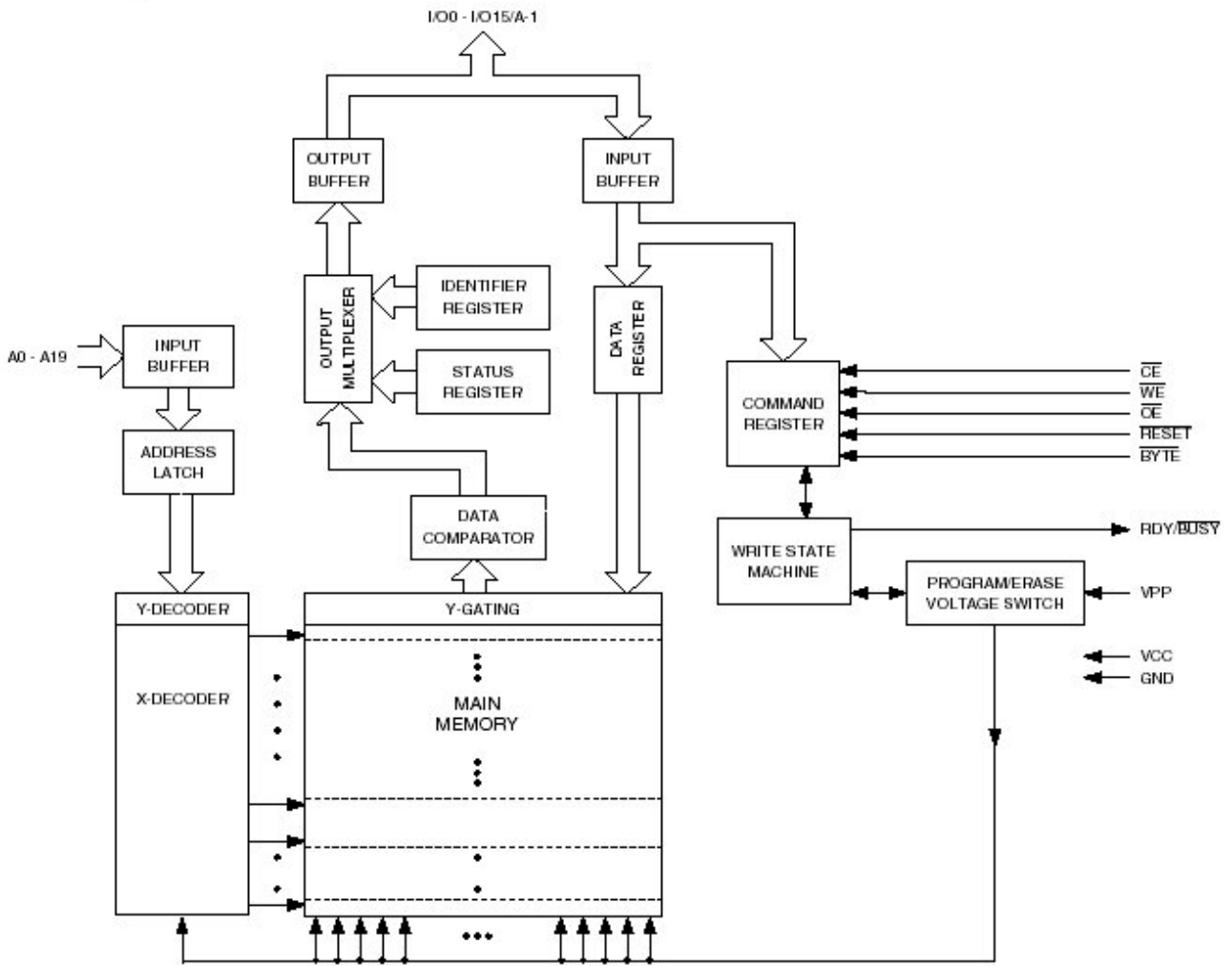

13. 74AHC1G (DSP: IC7)

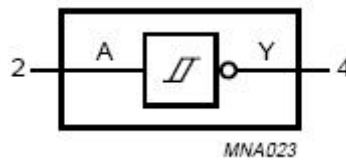
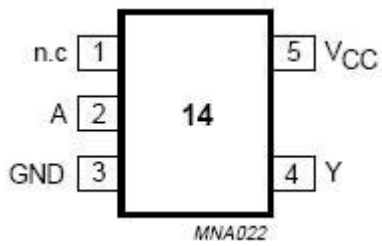

14. DS1233AZ (DSP: IC4)

BLOCK DIAGRAM Figure 1

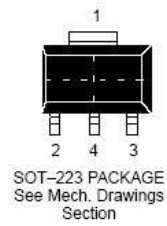
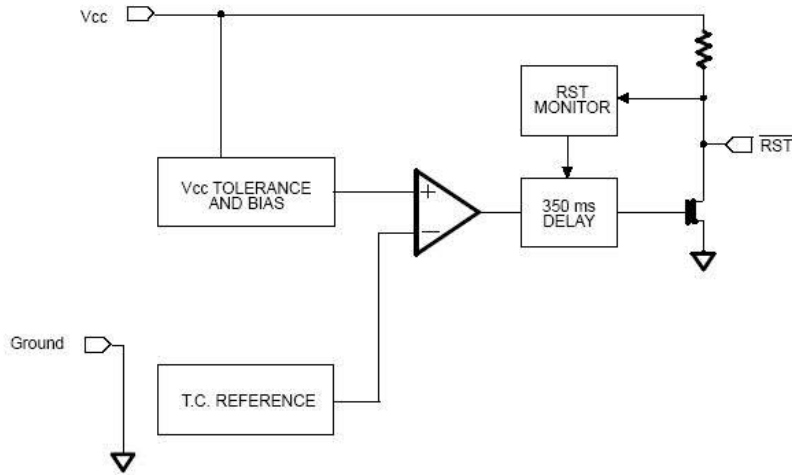

PIN DESCRIPTION

- PIN 1 GROUND
- PIN 2 RESET
- PIN 3 V_{CC}
- PIN 4 GROUND (SOT-223 ONLY)

15. BU4053BCF (VIDEO: IC19)

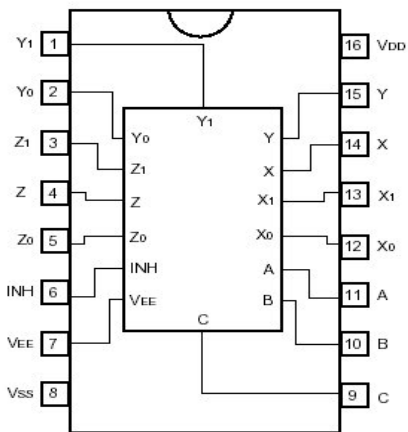

● Logic circuit diagram

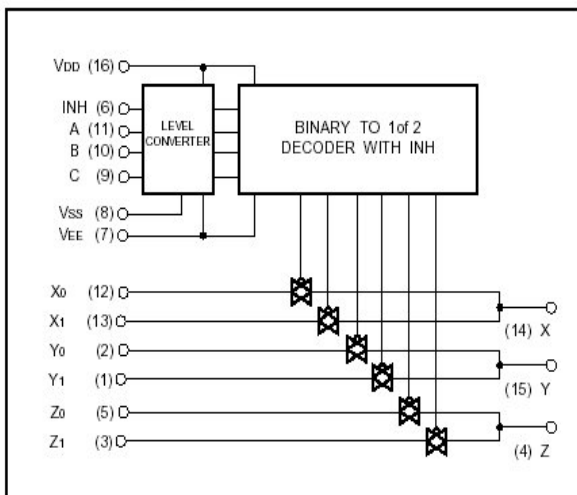

● Truth table

INH	A	B	C	ON SWITCH
L	L	L	L	X ₀ Y ₀ Z ₀
L	H	L	L	X ₁ Y ₀ Z ₀
L	L	H	L	X ₀ Y ₁ Z ₀
L	H	H	L	X ₁ Y ₁ Z ₀
L	L	L	H	X ₀ Y ₀ Z ₁
L	H	L	H	X ₁ Y ₀ Z ₁
L	L	H	H	X ₀ Y ₁ Z ₁
L	H	H	H	X ₁ Y ₁ Z ₁
H	X	X	X	NONE

X: Irrelevant

16. TUSB3200A (DSP: IC33)

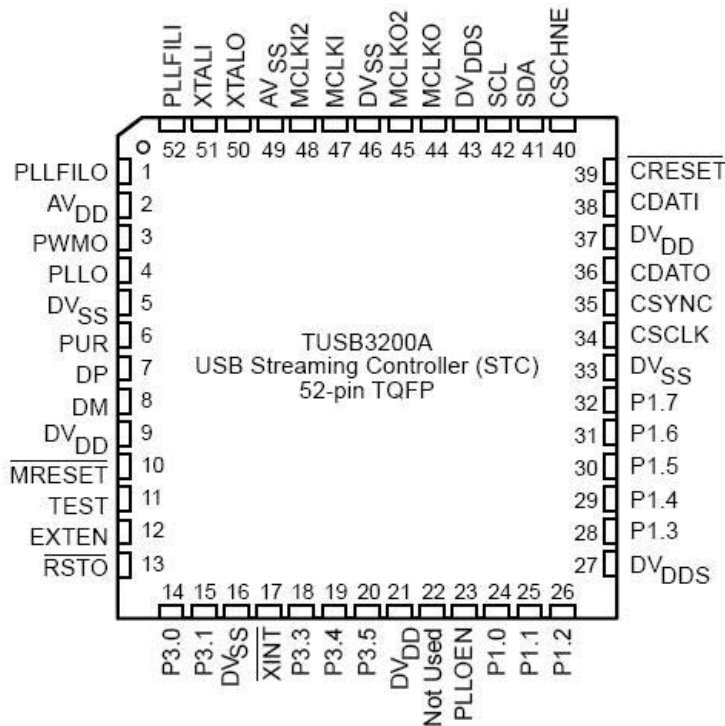
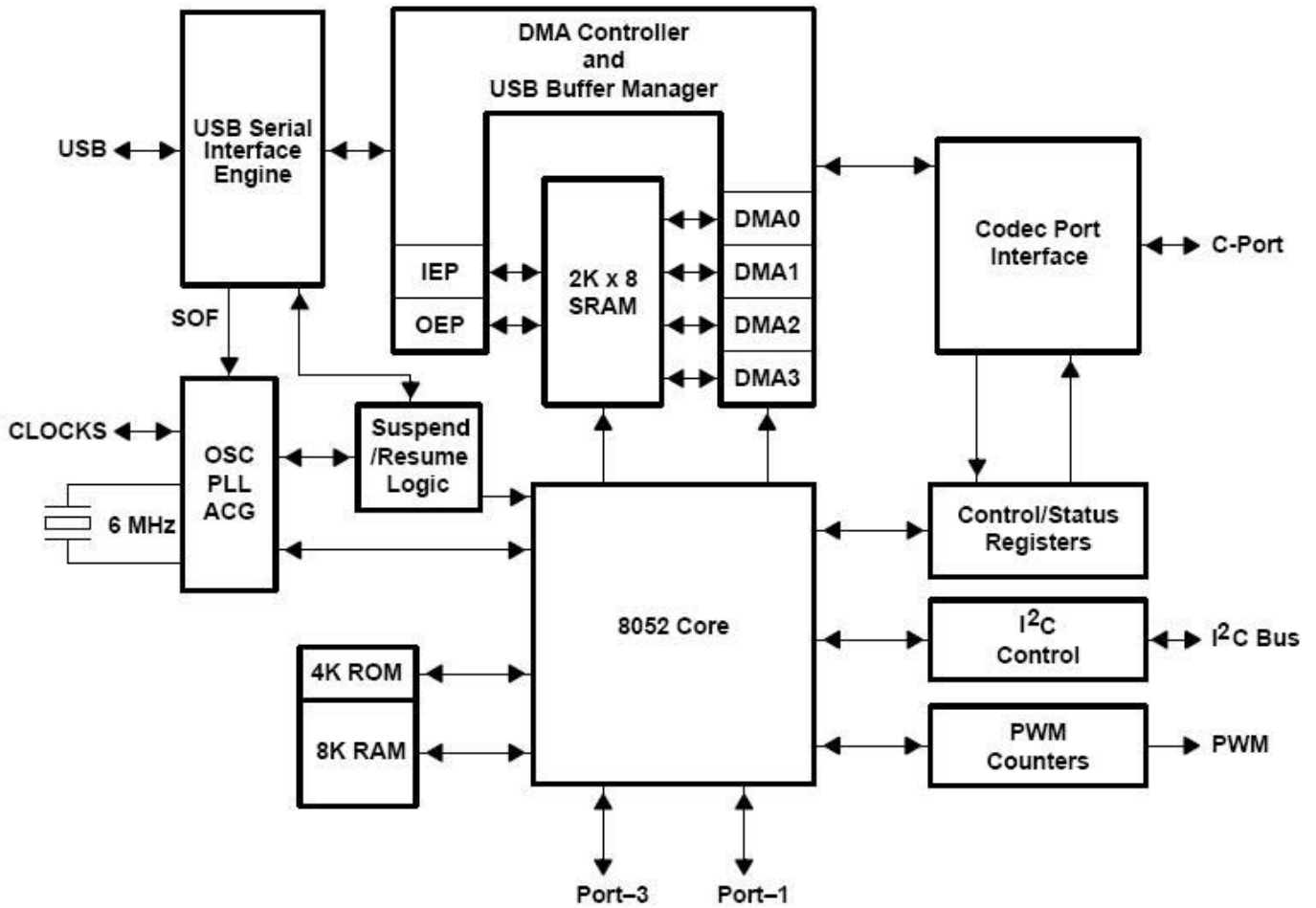

17. K4S161622H-UC60 (DSP:IC23)

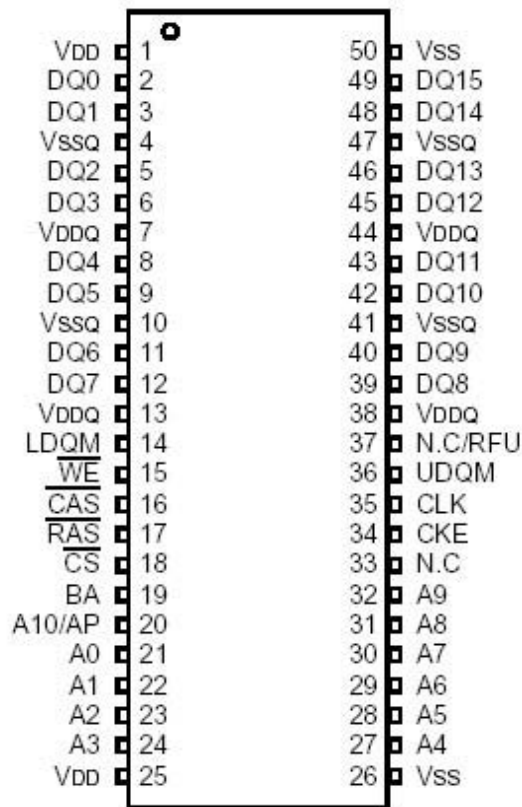

FUNCTIONAL BLOCK DIAGRAM

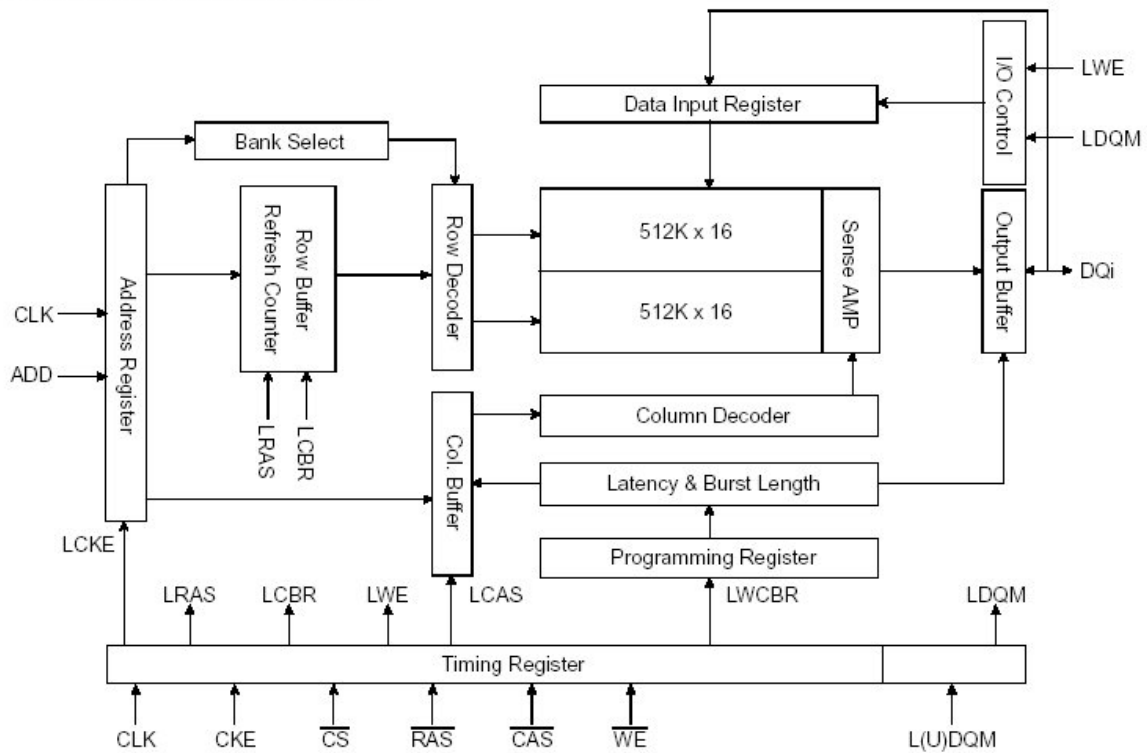

PIN FUNCTION DESCRIPTION

Pin	Name	Input Function
CLK	<i>System Clock</i>	Active on the positive going edge to sample all inputs.
$\overline{\text{CS}}$	<i>Chip Select</i>	Disables or enables device operation by masking or enabling all inputs except CLK, CKE and L(U)DQM
CKE	<i>Clock Enable</i>	Masks system clock to freeze operation from the next clock cycle. CKE should be enabled at least one cycle prior to new command. Disable input buffers for power down in standby.
A0 ~ A10/AP	<i>Address</i>	Row / column addresses are multiplexed on the same pins. Row address : RA0 ~ RA10, column address : CA0 ~ CA7
BA	<i>Bank Select Address</i>	Selects bank to be activated during row address latch time. Selects bank for read/write during column address latch time.
$\overline{\text{RAS}}$	<i>Row Address Strobe</i>	Latches row addresses on the positive going edge of the CLK with $\overline{\text{RAS}}$ low. Enables row access & precharge.
$\overline{\text{CAS}}$	<i>Column Address Strobe</i>	Latches column addresses on the positive going edge of the CLK with $\overline{\text{CAS}}$ low. Enables column access.
$\overline{\text{WE}}$	<i>Write Enable</i>	Enables write operation and row precharge. Latches data in starting from CAS, WE active.
L(U)DQM	<i>Data Input/Output Mask</i>	Makes data output Hi-Z, tSHZ after the clock and masks the output. Blocks data input when L(U)DQM active.
DQ0 ~ 15	<i>Data Input/Output</i>	Data inputs/outputs are multiplexed on the same pins.
VDD/VSS	<i>Power Supply/Ground</i>	Power and ground for the input buffers and the core logic.
VDDQ/VSSQ	<i>Data Output Power/Ground</i>	Isolated power supply and ground for the output buffers to provide improved noise immunity.
N.C/RFU	<i>No Connection/ Reserved for Future Use</i>	This pin is recommended to be left No Connection on the device.

18. KIC9162CFG (DSP: IC56 PROCESSOR: IC15)
 KIC9163CFG (PROCESSOR: IC12)

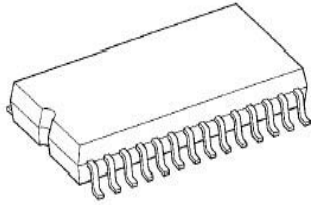

V _{SS}	1	28	V _{DD}
L-S ₁	2	27	R-S ₁
L-S ₂	3	26	R-S ₂
L-COM ₁	4	25	R-COM ₁
L-S ₃	5	24	R-S ₃
L-S ₄	6	23	R-S ₄
L-COM ₂	7	22	R-COM ₂
L-S ₅	8	21	R-S ₅
L-S ₆	9	20	R-S ₆
L-COM ₃	10	19	R-COM ₃
L-S ₇	11	18	R-S ₇
L-COM ₄	12	17	R-COM ₄
ST	13	16	DATA
GND	14	15	CK

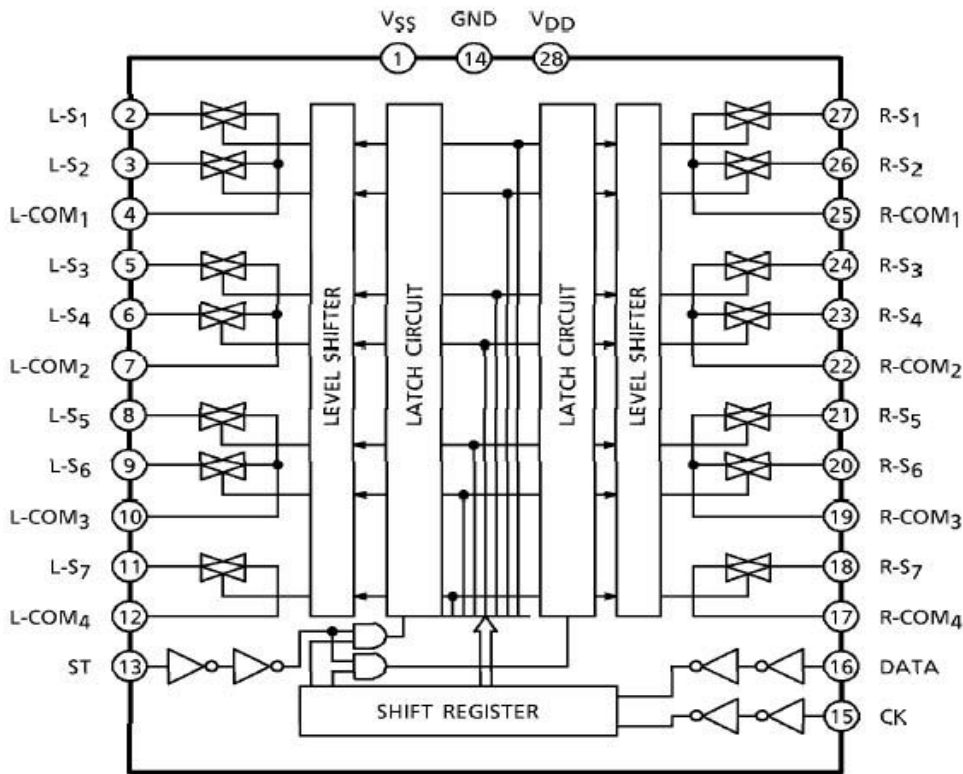

19. LC74763M (VIDEO:IC16)

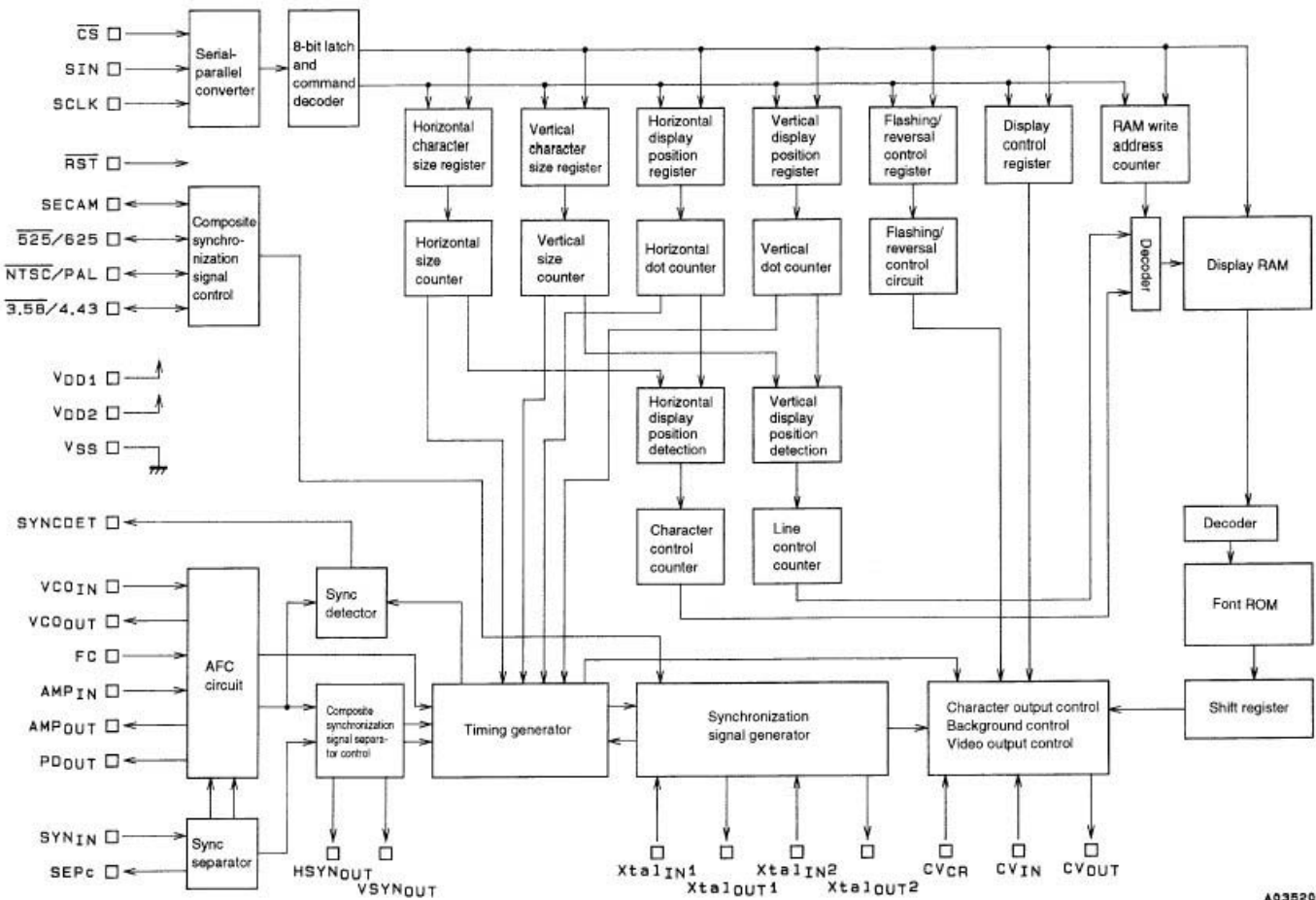
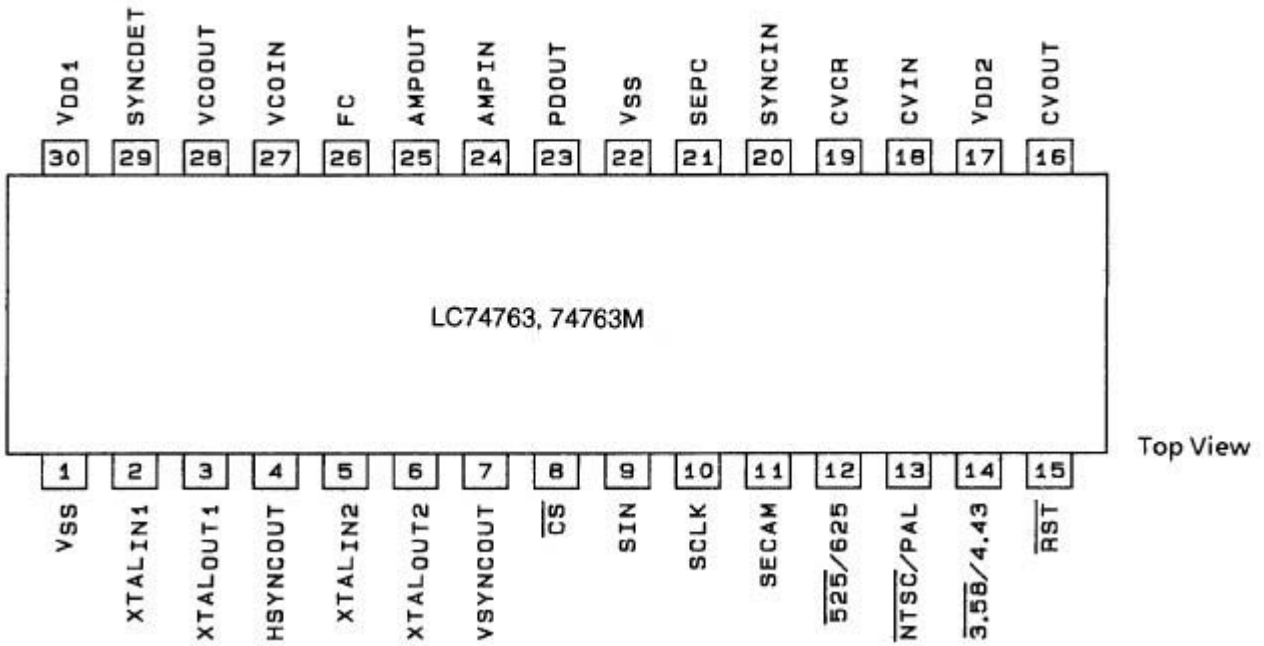

A03520

20. NJM2068M (DSP: IC61, 62, 63, 64, 65, 66, 67, 68, 69, 71, 72, 73, 74, 75, 76, 77, 78, 80)
 (FRONT: IC50, MAIN: IC22)
 (PROCESSOR: IC2, 3, 4, 5, 6, 7, 10, 11, 25, 13, 14, 18, 19, 21, 22, 23, 24, 26)

NJM4580M (PROCESSOR: IC1)

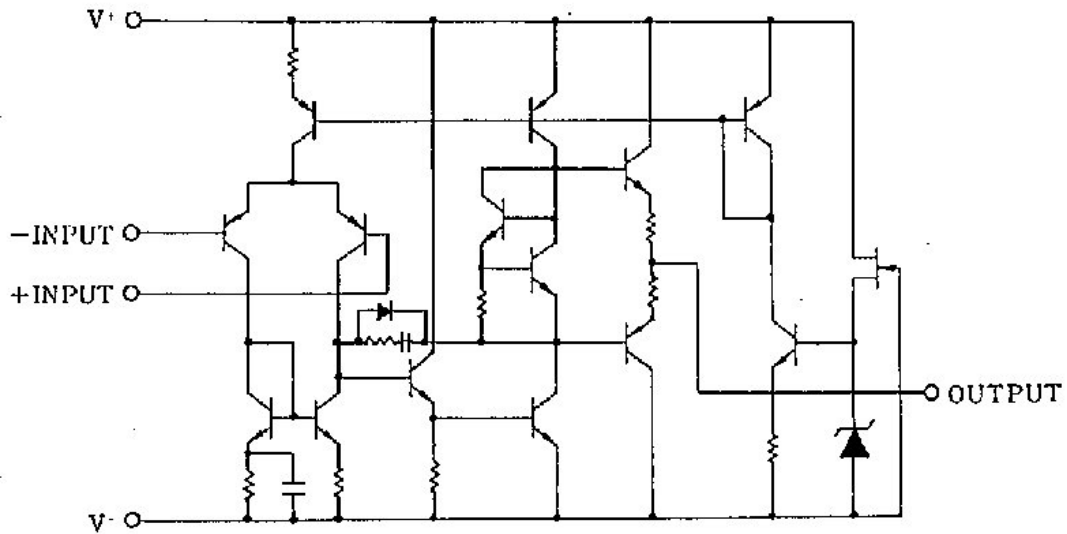

21. TC9482BFG (PROCESSOR:IC16, 17)

TC9482F

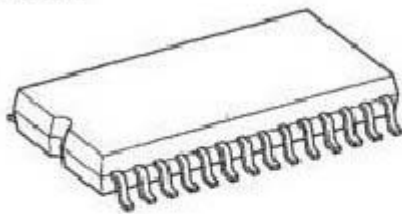

SOP28-P-450-1.27

V _{SS}	1	28	V _{DD}
NC	2	27	TEST
L-OUTA	3	26	R-OUTA
L-INA	4	25	R-INA
L-A-GNDA	5	24	R-A-GNDA
L-OUTB	6	23	R-OUTB
L-INB	7	22	R-INB
L-A-GNDB	8	21	R-A-GNDB
L-OUTC	9	20	R-OUTC
L-INC	10	19	R-INC
L-A-GNDC	11	18	R-A-GNDC
CS1	12	17	CS2
GND	13	16	STB
CK	14	15	DATA

22. NJM317DL1 (DSP: IC25)

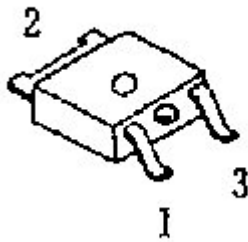

- 1. Adjustment
- 2. Output
- 3. Input

23. MAX3223CDWR (SUPPLY: IC31)

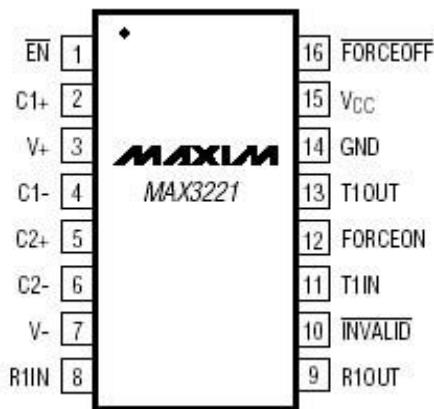

PIN			NAME	FUNCTION
MAX3221	MAX3223	MAX3243		
1	1	—	$\overline{\text{EN}}$	Receiver Enable Control. Drive low for normal operation. Drive high to force the receiver outputs into a high-Z state.
5	5	1	C2+	Positive terminal of inverting charge-pump capacitor
6	6	2	C2-	Negative terminal of inverting charge-pump capacitor
7	7	3	V-	-5.5V generated by the charge pump
8	9, 16	4-8	R_IN	RS-232 Receiver Inputs
13	8, 17	9, 10, 11	T_OUT	RS-232 Transmitter Outputs
11	12, 13	12, 13, 14	T_IN	TTL/CMOS Transmitter Inputs
9	10, 15	15-19	R_OUT	TTL/CMOS Receiver Outputs
—	—	20	R2OUTB	Noninverting Receiver Output—active in shutdown
10	11	21	INVALID	Output of the valid signal detector. Indicates if a valid RS-232 level is present on receiver inputs logic "1".
16	20	22	FORCEOFF	Drive low to shut down transmitters and on-board power supply. This overrides all automatic circuitry and FORCEON (Table 1).
12	14	23	FORCEON	Drive high to override automatic circuitry keeping transmitters on (FORCEOFF must be high) (Table 1).
4	4	24	C1-	Negative terminal of the voltage doubler charge-pump capacitor
14	18	25	GND	Ground
15	19	26	VCC	+3.0V to +5.5V Supply Voltage
3	3	27	V+	+5.5V generated by the charge pump
2	2	28	C1+	Positive terminal of the voltage doubler charge-pump capacitor

24. MM1511XNRE (VIDEO: IC26)

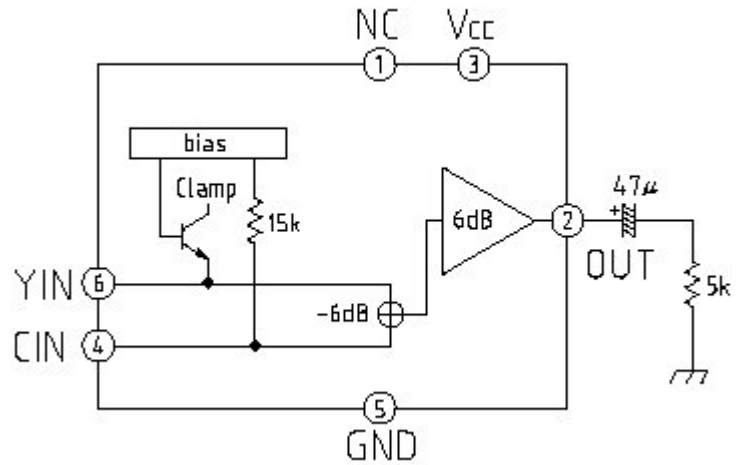
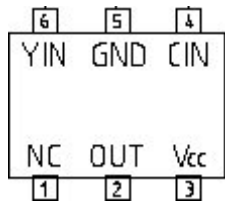

25. MM1503XNRE (VIDEO: IC24 IC25)

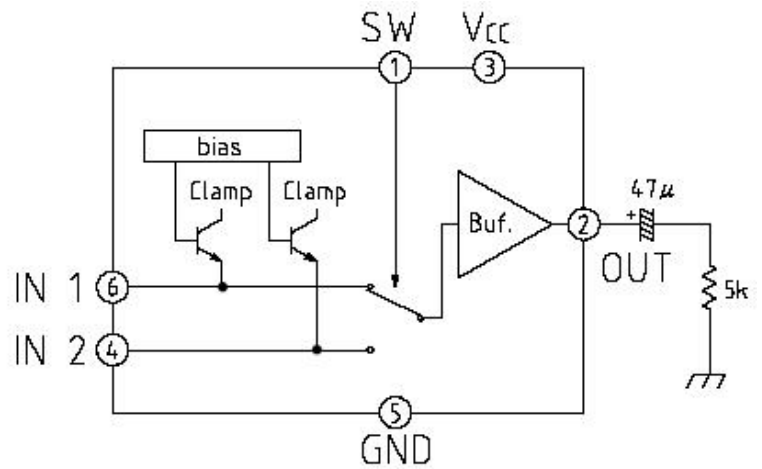

26. NJM2872AF33 (DSP: 6)

■ PIN CONFIGURATION

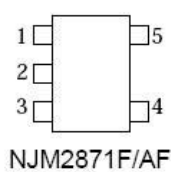

- PIN FUNCTION
1. CONTROL (Active High)
 2. GND
 3. NOISE BYPASS
 4. V_{OUT}
 5. V_{IN}

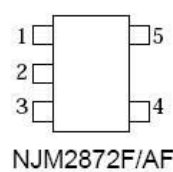

- PIN FUNCTION
1. V_{IN}
 2. GND
 3. CONTROL (Active High)
 4. NOISE BYPASS
 5. V_{OUT}

■ EQUIVALENT CIRCUIT

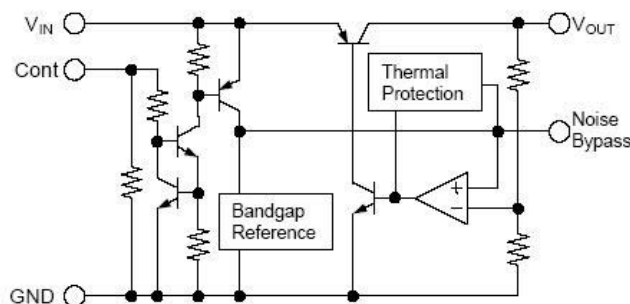

27. NJM2296M (VIDEO: IC10 IC11 IC13)

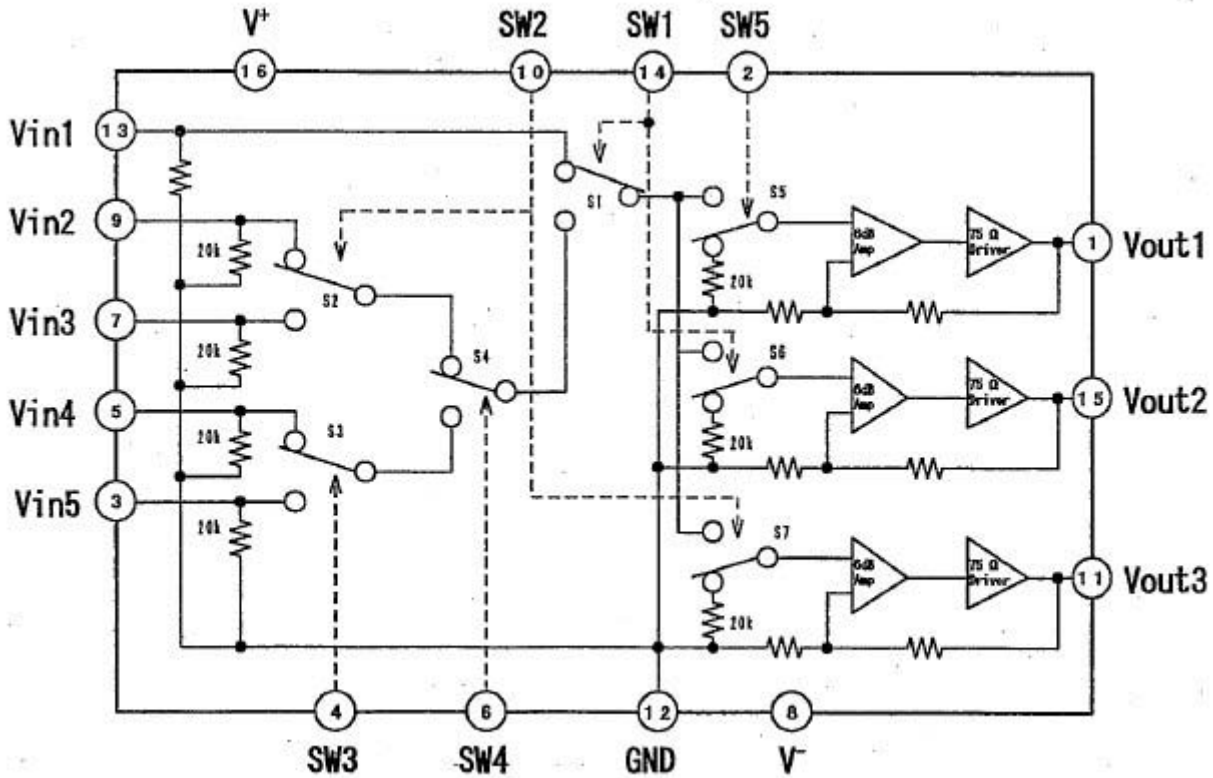
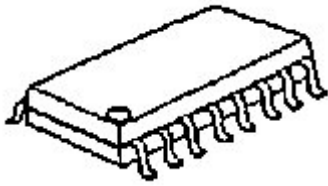

28. NJM2586M (VIDEO:IC34)

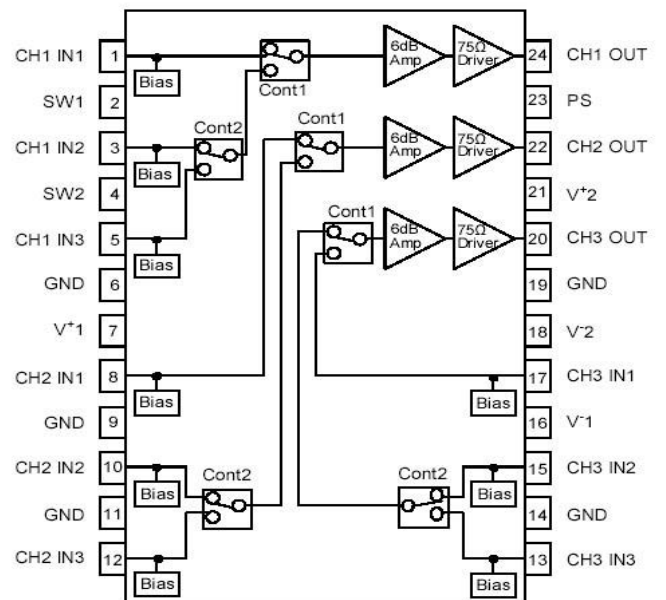
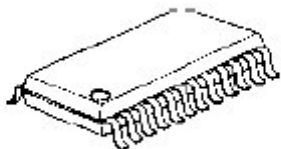

29. NJM4556AD (PROCESSOR:IC20)

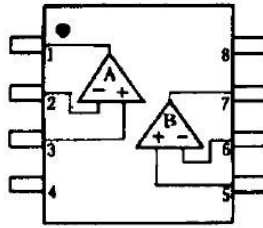
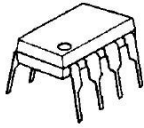

PIN FUNCTION

1.A OUTPUT

2.A -INPUT

3.A +INPUT

4.V⁻

5.B +INPUT

6.B -INPUT

7.B OUTPUT

8.V⁺

30. PC-17T1 (DSP: PC11 SUPPLY: IC32, 33)

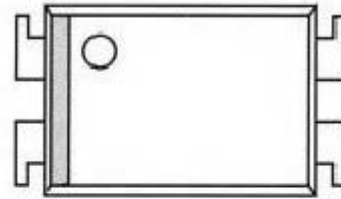
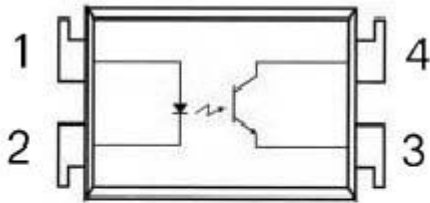

PIN Connections

1.Anode

2.Cathode

3.Emitter

4.Collector

31. TC9273CFG-004 (PROCESSOR: IC8, 9)

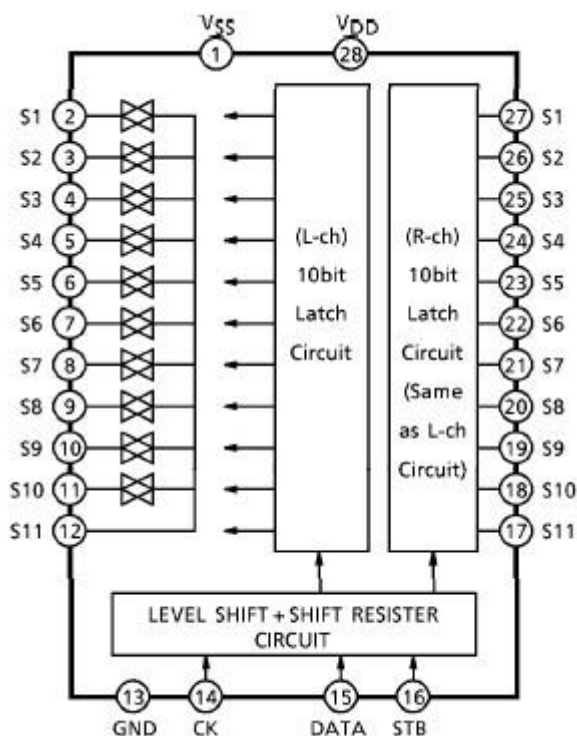
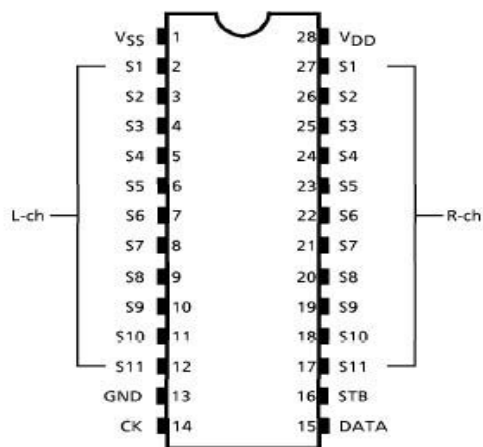
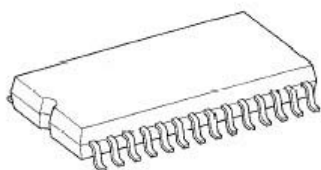

32. TSH95ID (VIDEO: IC 28)

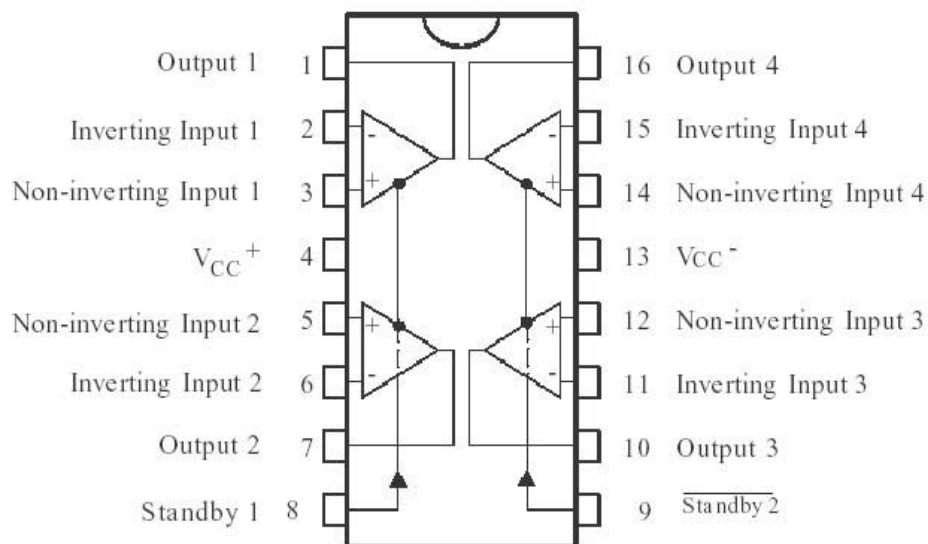
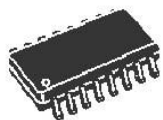

33. SN74LVC1G17DBVR SOT(SOT-23)DBV (DSP: IC2, 39)

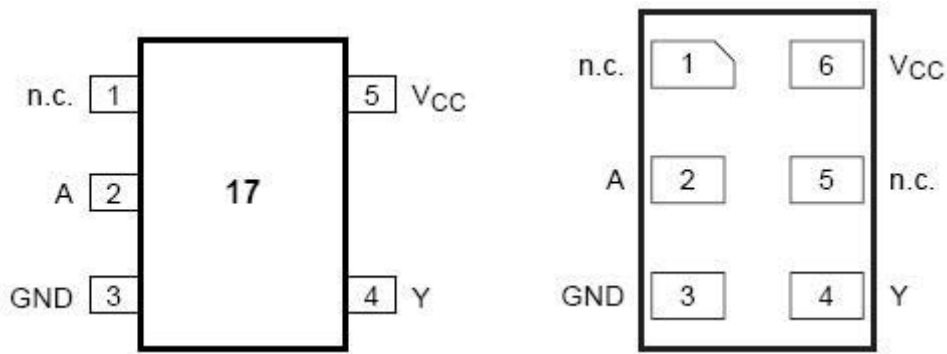

34. SN74LVC257AD (DSP: IC24, 27, 81, 82)

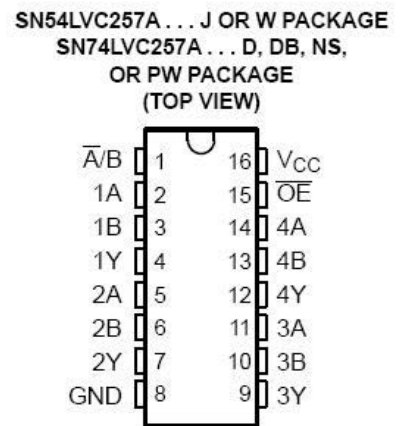
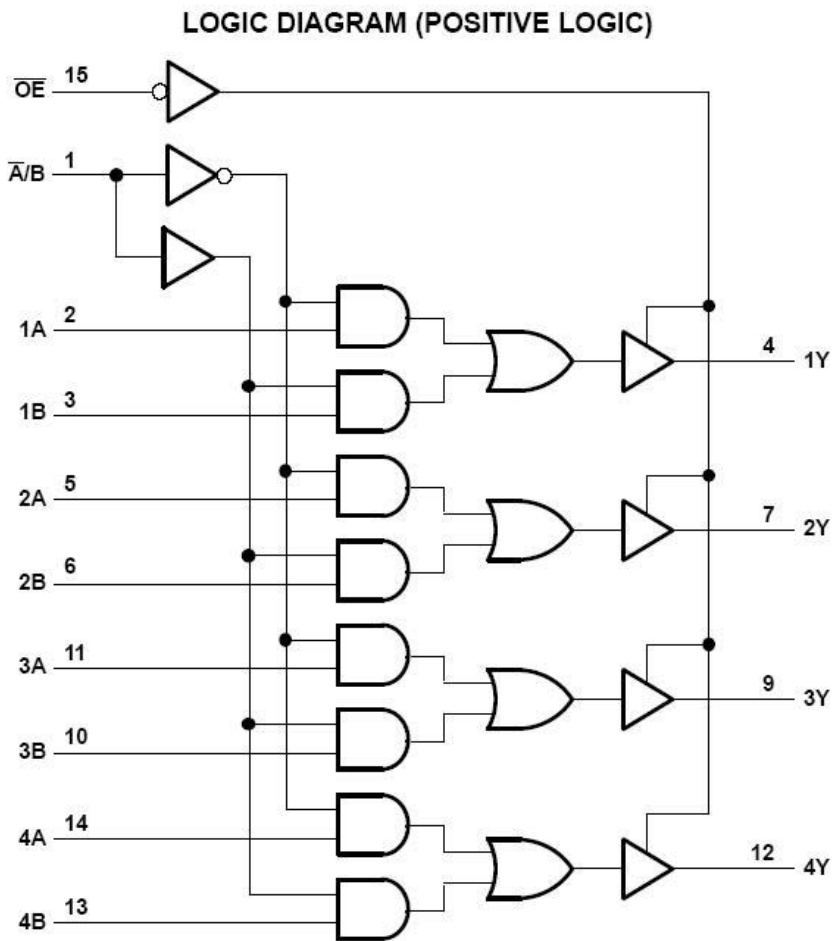

Pin numbers shown are for the D, DB, J, NS, PW, RGY, and W packages.

35. ACF451832-333-T (E901)

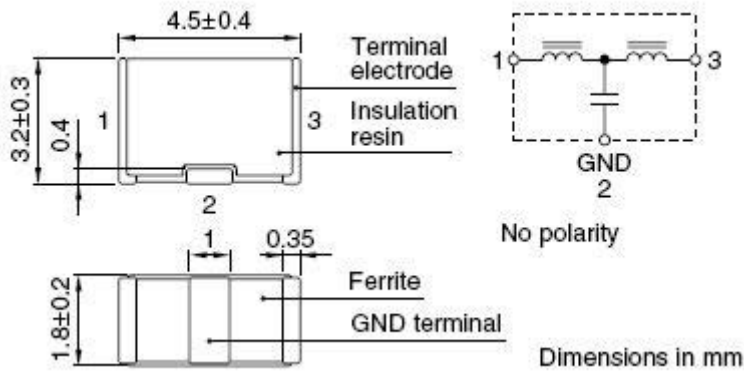

36. CS4391A-KZZ SOP20 (DSP: IC55)

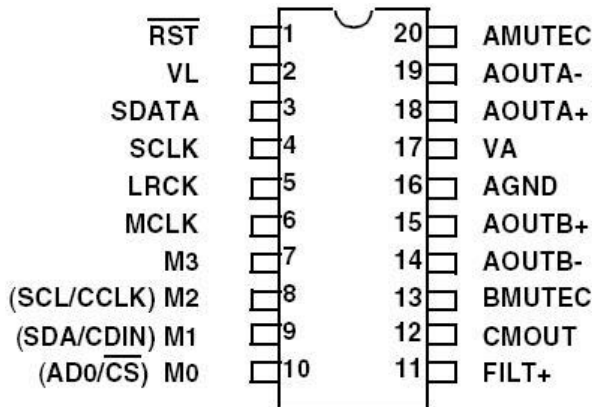
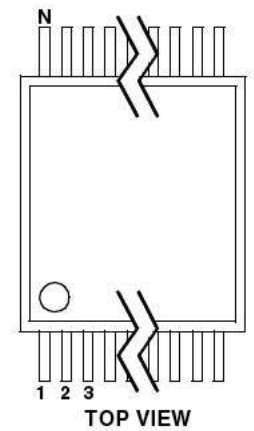
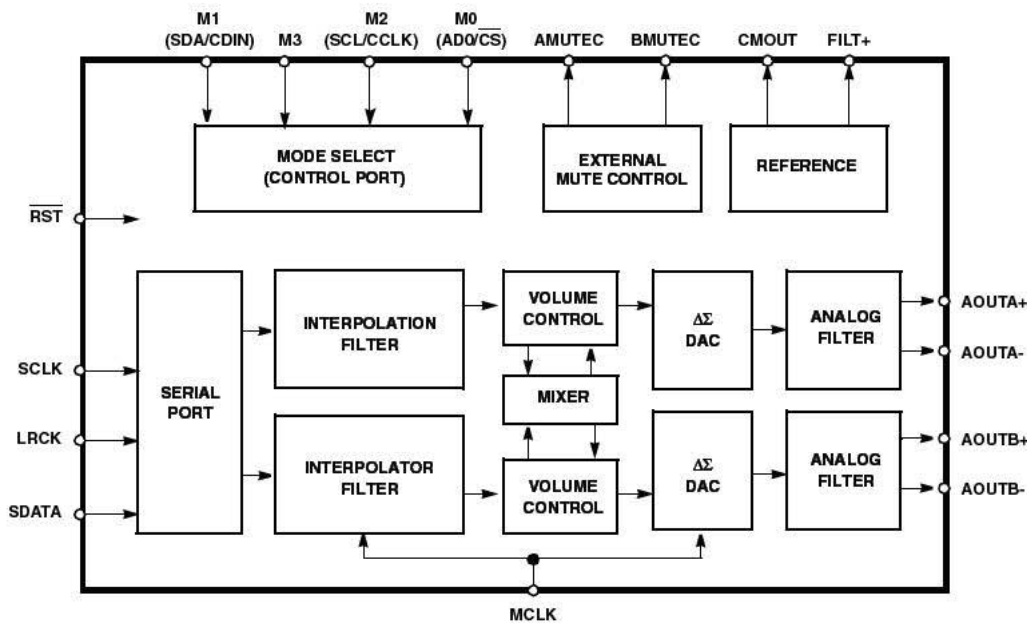

37. SDRAMK4S643232H (VIDEO: IC48)

FUNCTIONAL BLOCK DIAGRAM

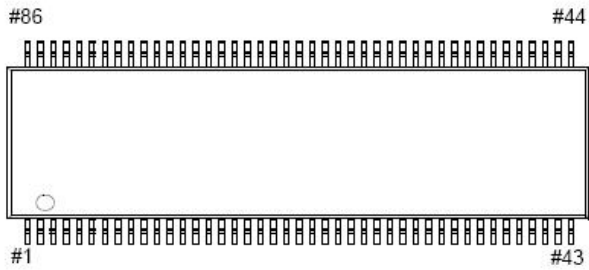
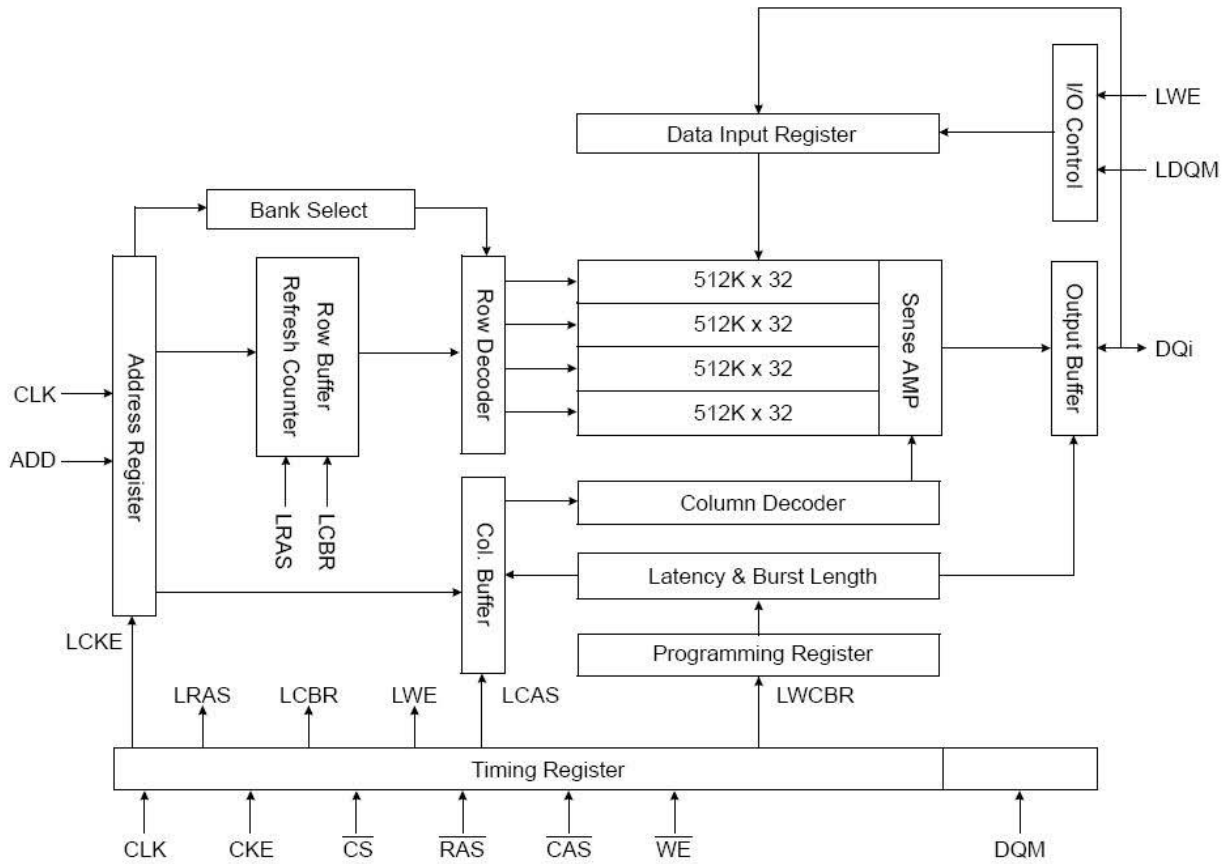

38. SN74CB3T3306DCTR (DSP: IC5)

(TOP VIEW)

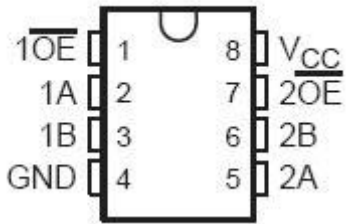

FUNCTION TABLE
(each bus switch)

INPUT \overline{OE}	INPUT/OUTPUT A	FUNCTION
L	B	A port = B port
H	Z	Disconnect

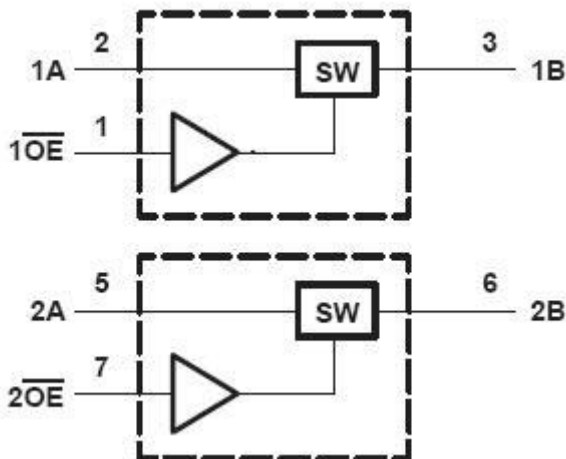
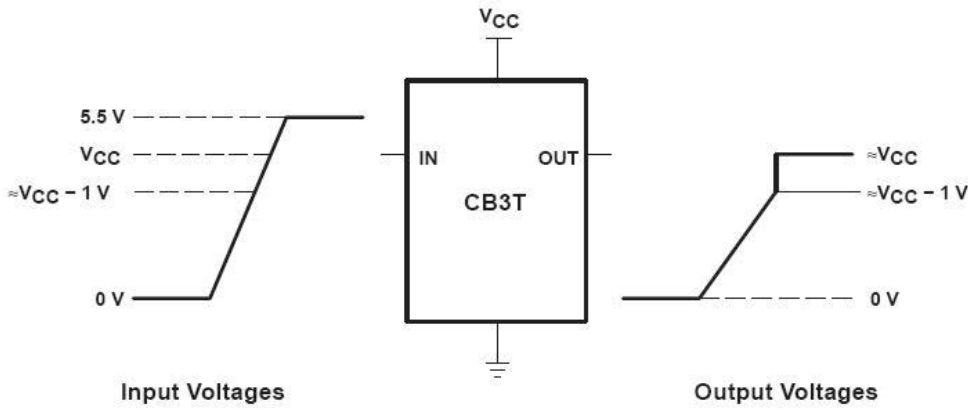

39. FLI2300-BD PQFP-208 (VIDEO: IC47)

Figure 2.1: FLI2300– Simplified Internal Block Diagram

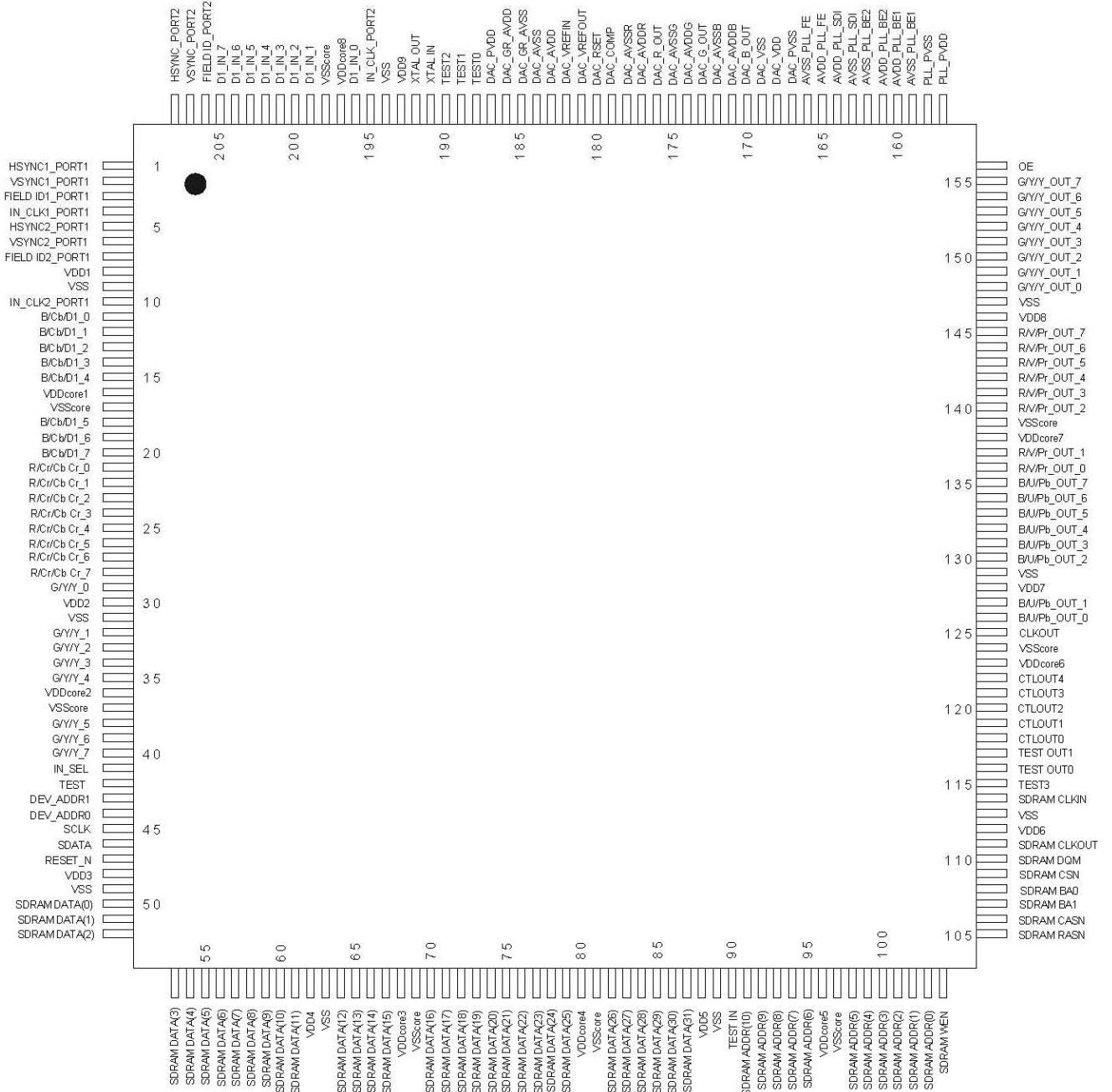
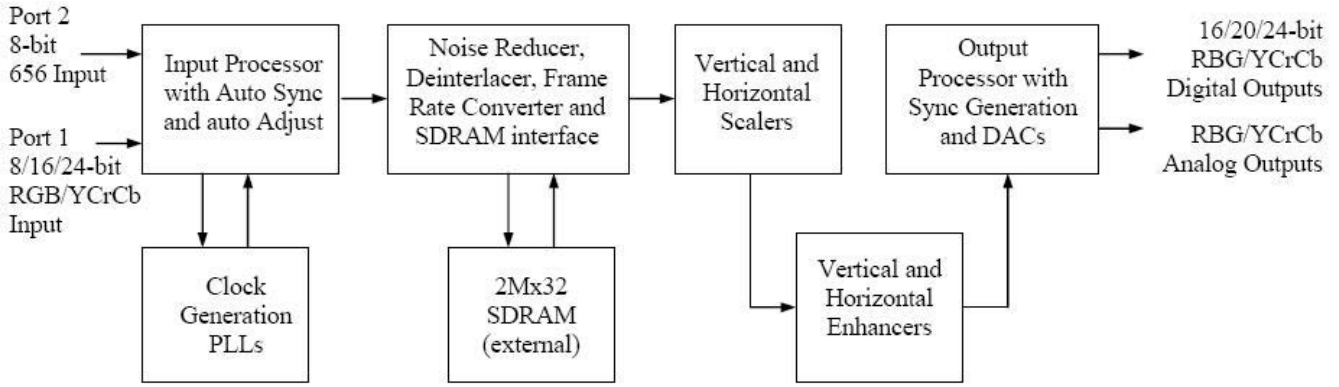

40. UPD70F3261YGC-8EA-A LQFP100 (DSP: IC11)

Internal block diagram

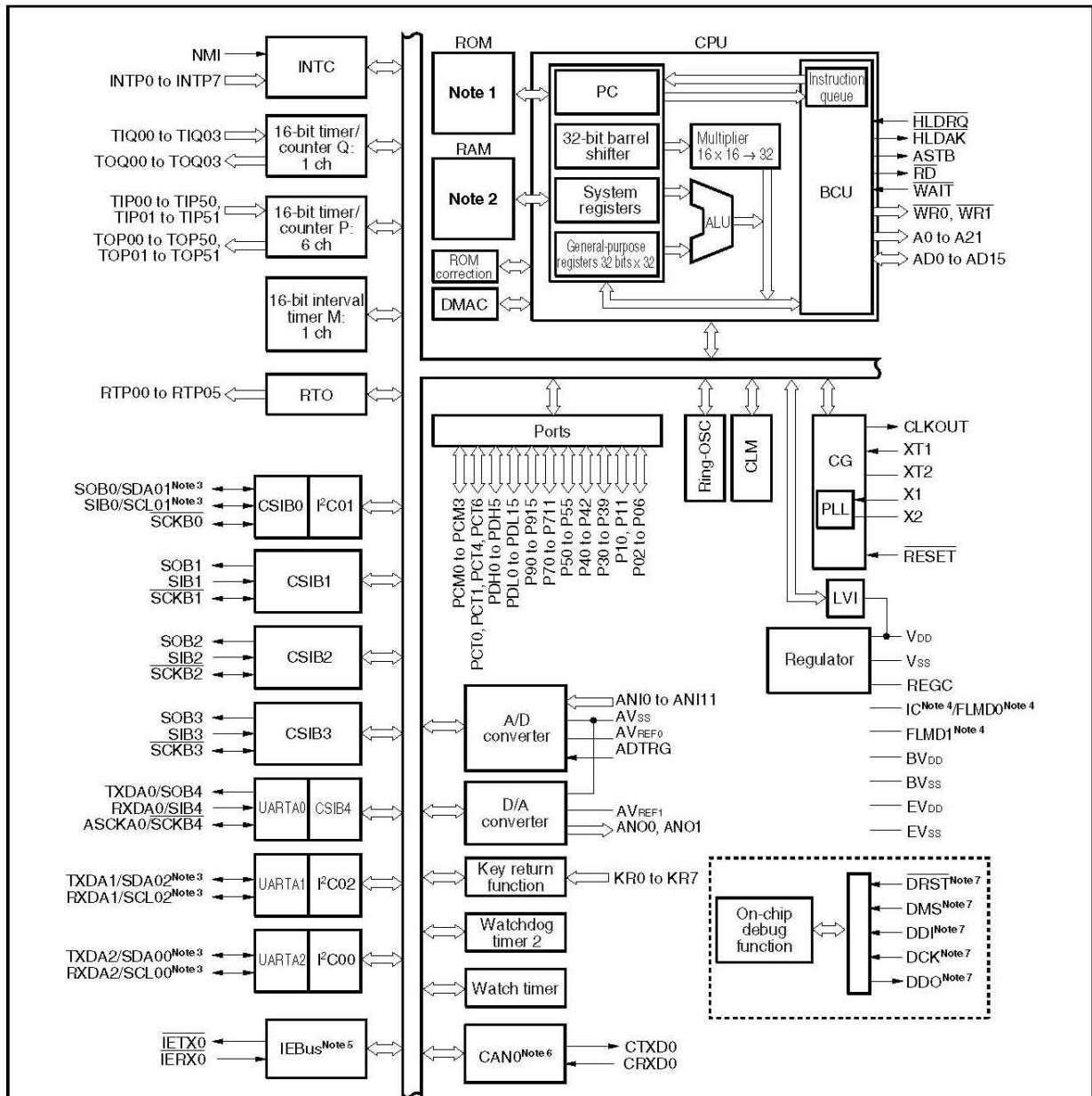

- Notes**
1. 256/384/512/640 KB (mask ROM) (see **Table 1-1**)
384/640 KB (flash memory) (see **Table 1-1**)
 2. 24/32/40/48 KB (see **Table 1-1**)
 3. I²C bus version (Y version) only
 4. IC: Mask ROM version only
FLMD0, FLMD1: Flash memory version
 5. IEBus controller version only
 6. CAN controller version only
 7. Flash memory version only

UPD70F3261YGC-8EA-A LQFP100

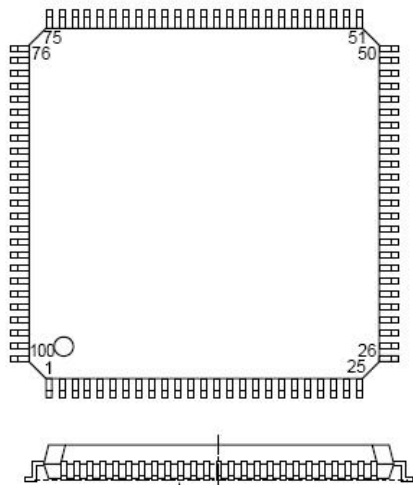
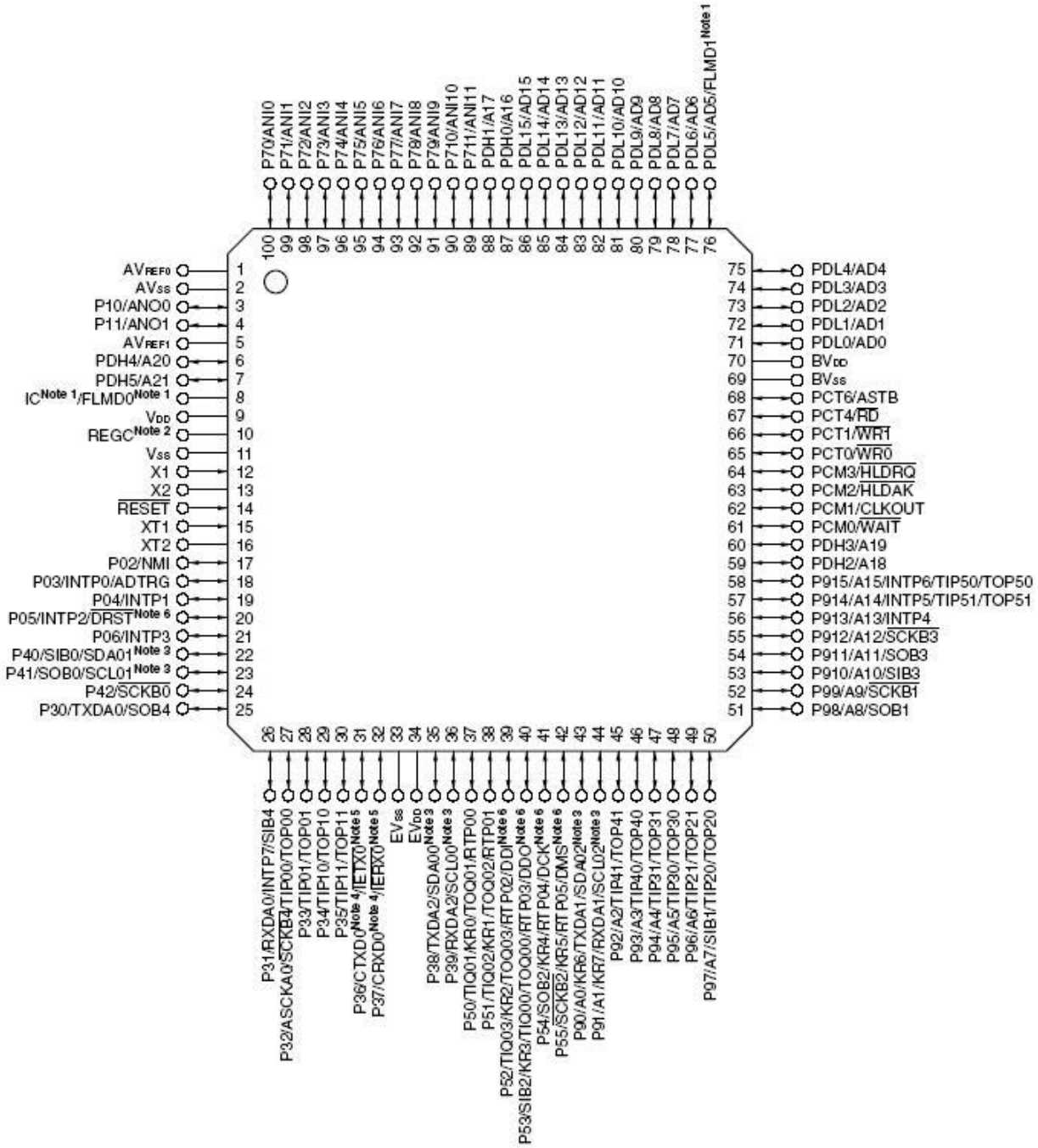

41. SN74CB3T3306DCTR SSOP-8 (DSP: IC96)

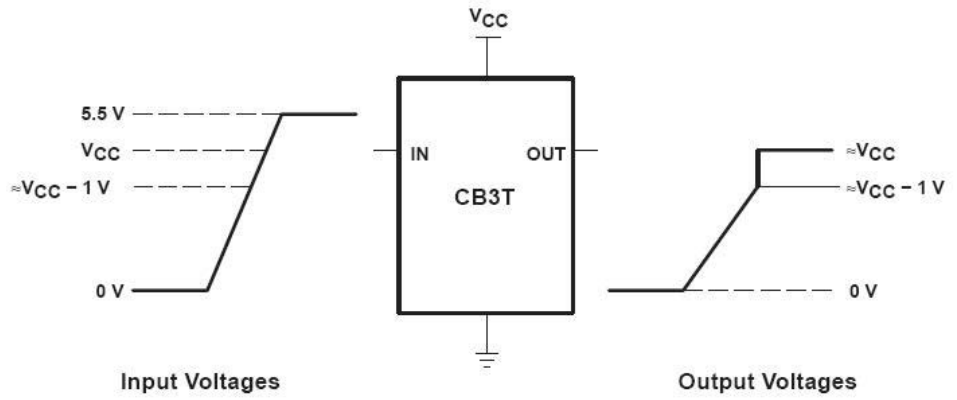
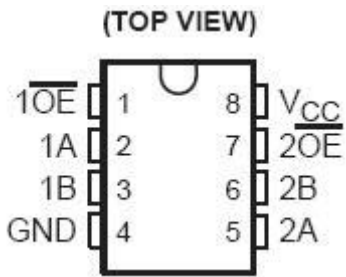

FUNCTION TABLE
(each bus switch)

INPUT \overline{OE}	INPUT/OUTPUT A	FUNCTION
L	B	A port = B port
H	Z	Disconnect

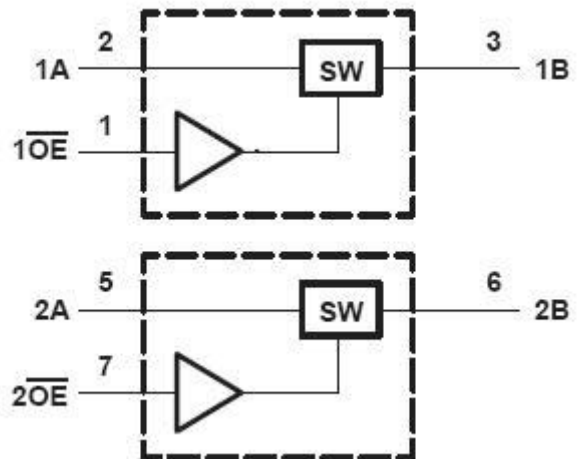

42. CS5368-CQZ LQFP48 (DSP: IC54)

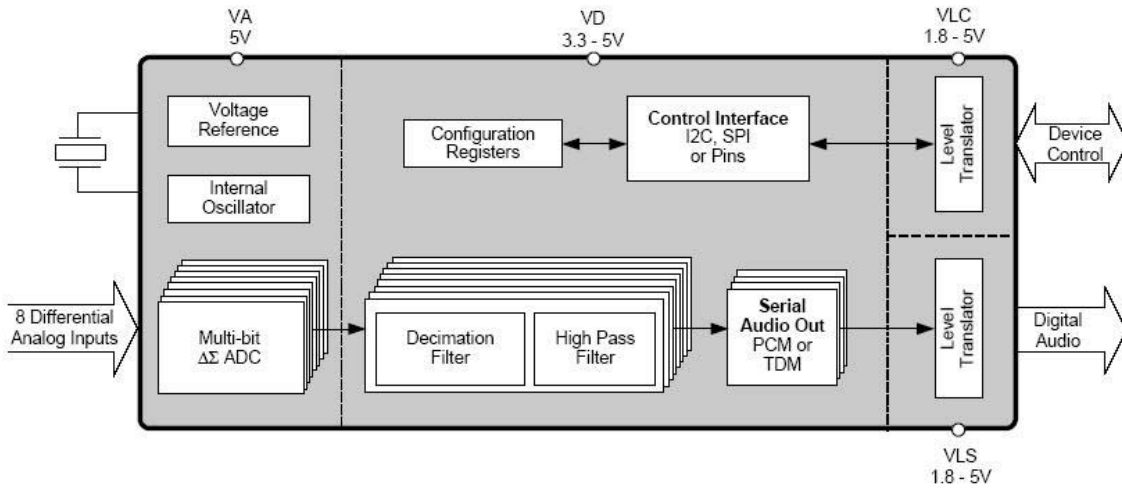
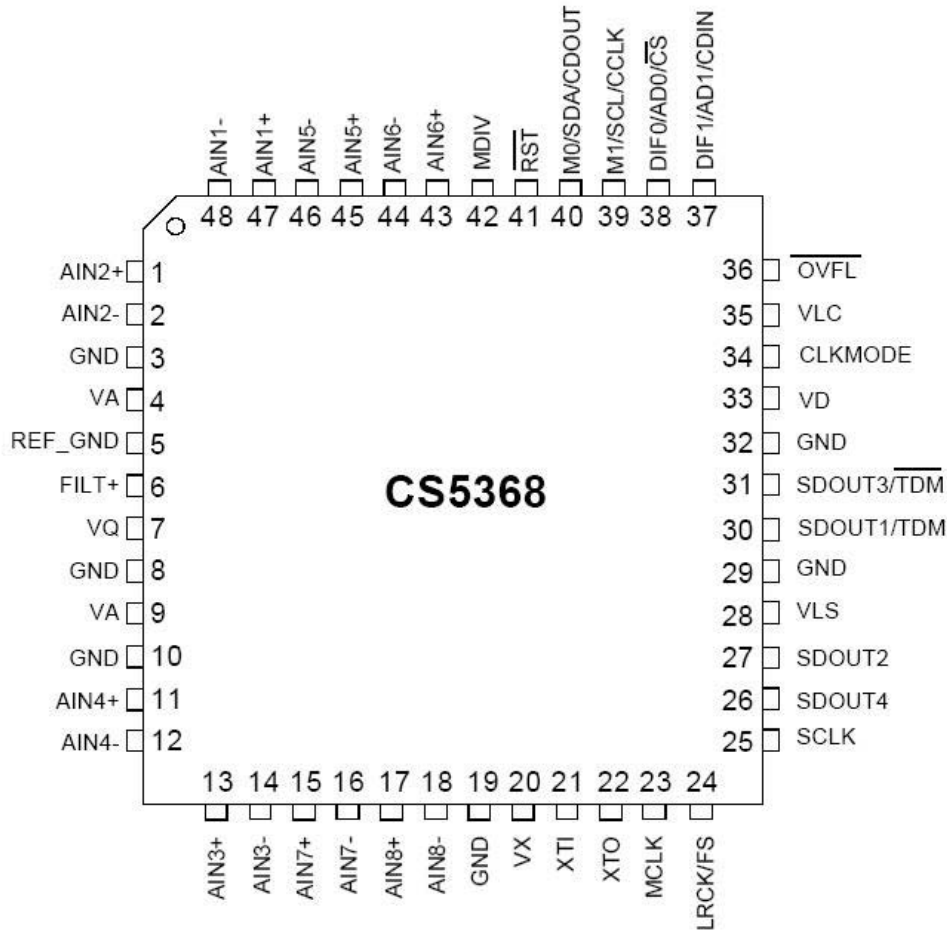

43. CS42528-CQZ-D (DSP: IC31)

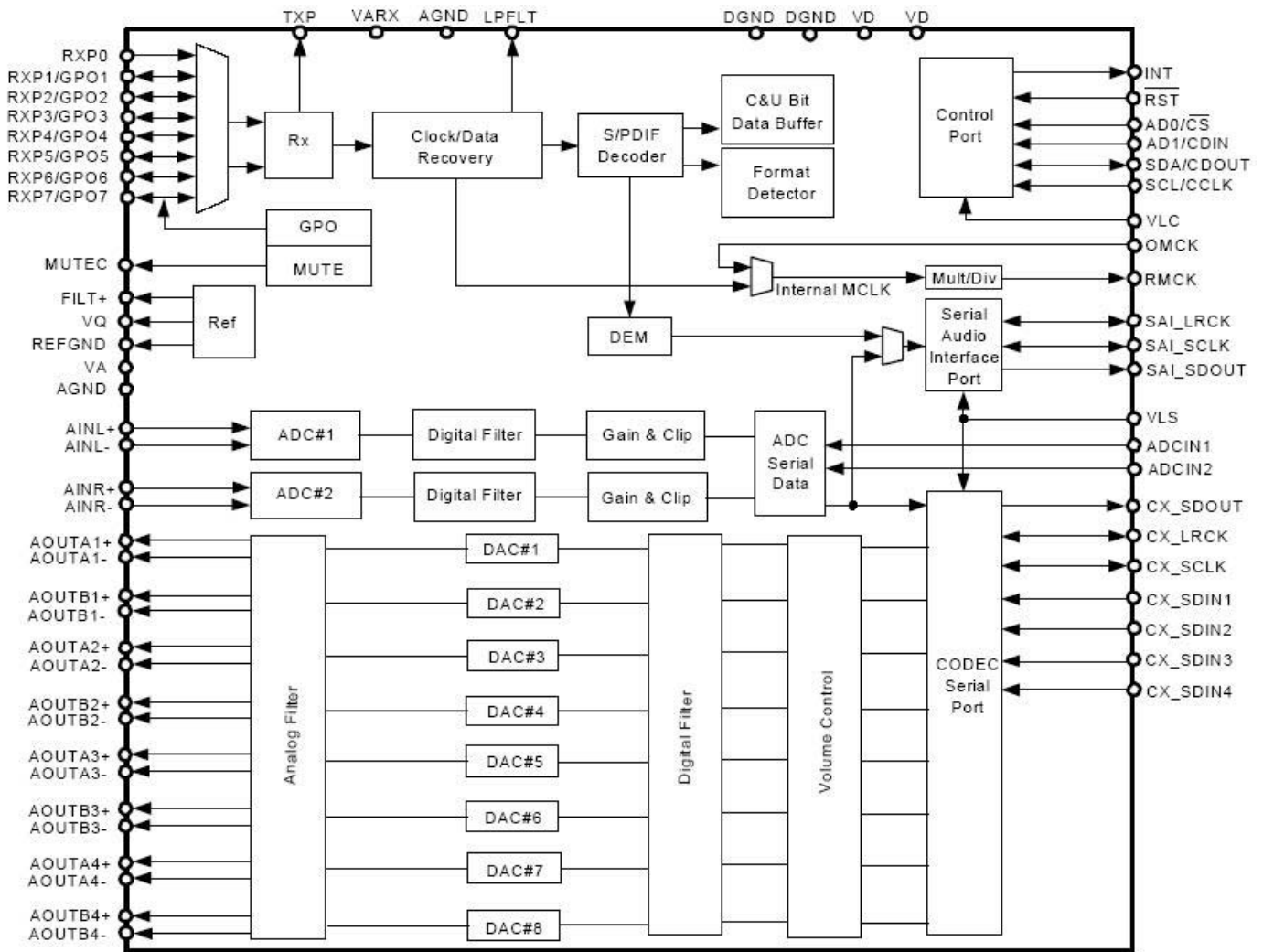

44. IL1117S (VIDEO: IC35)

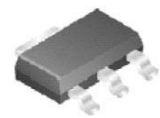
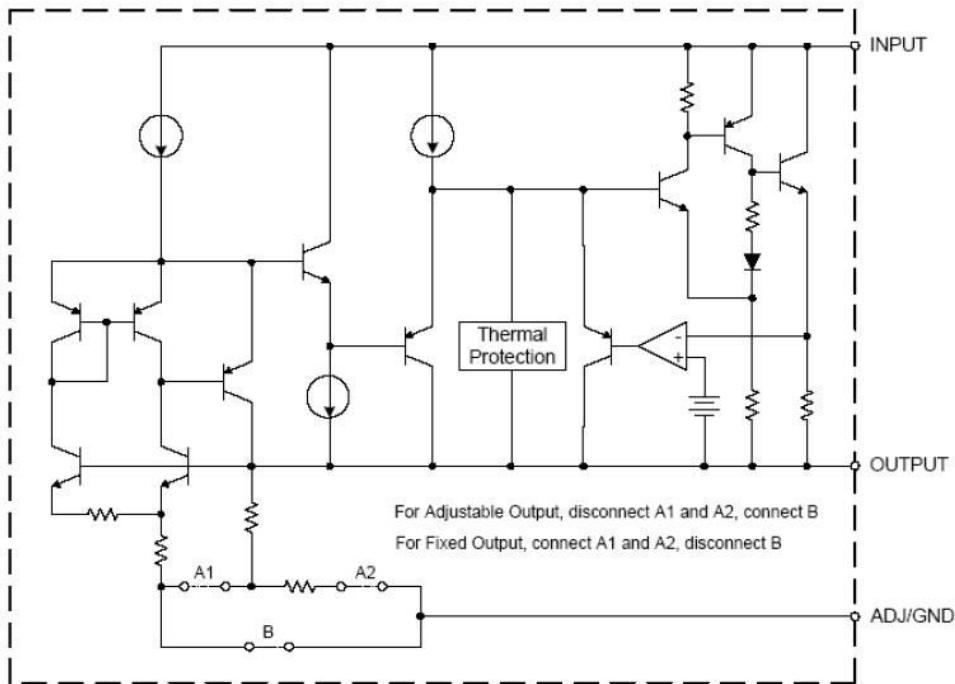

SOT-223

45. MM1566AFBE (VIDEO: IC23, IC24)

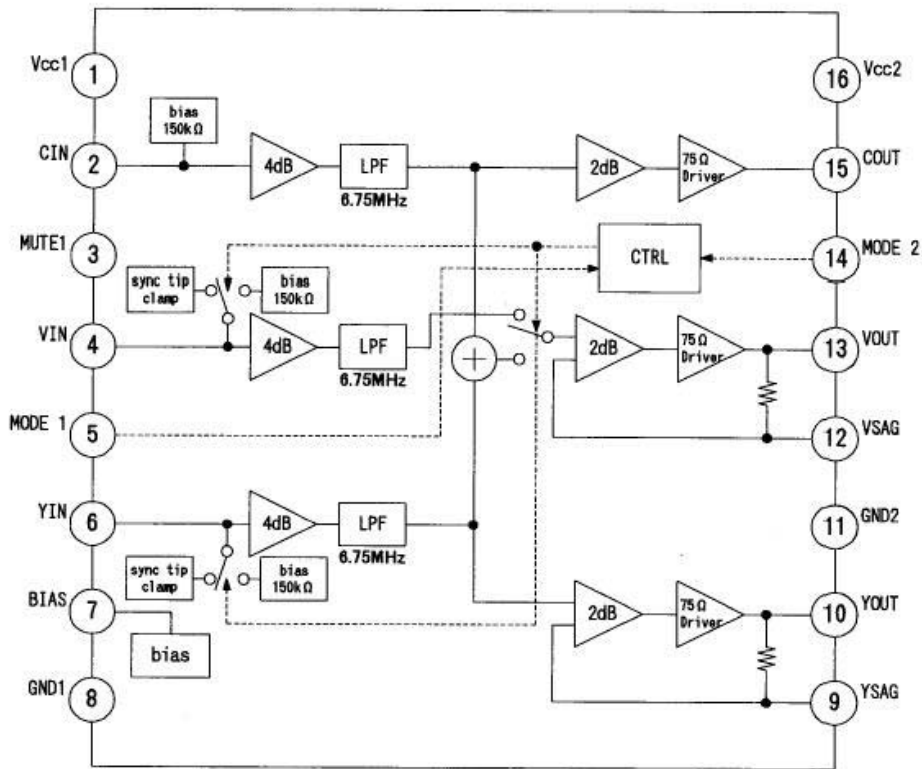

46. ADV7172KSTZ LQFP48 (VIDEO: IC22)

FUNCTIONAL BLOCK DIAGRAM

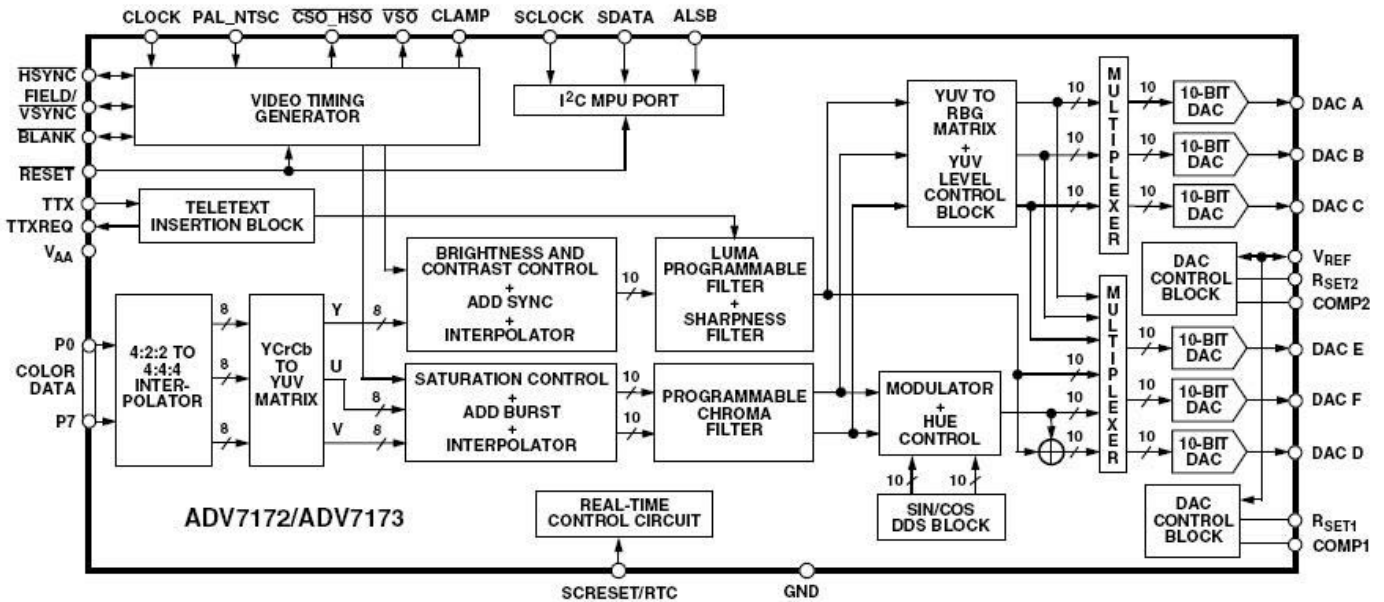

47. ADV7180BSTZ LQFP-64 VIDEO (IC: 21)

FUNCTIONAL BLOCK DIAGRAM

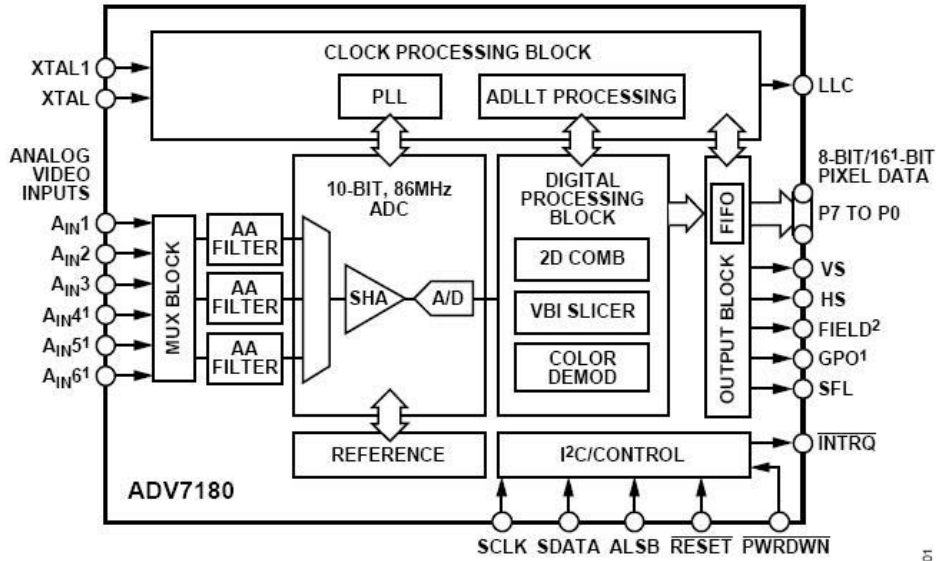

1 ONLY AVAILABLE ON 64-LEAD PACKAGE.
240-LEAD PACKAGE USES ONE LEAD FOR VS/FIELD.

05709-001

48. MM1117XFBE (VIDEO: IC14)

MM1117

SOP-8C

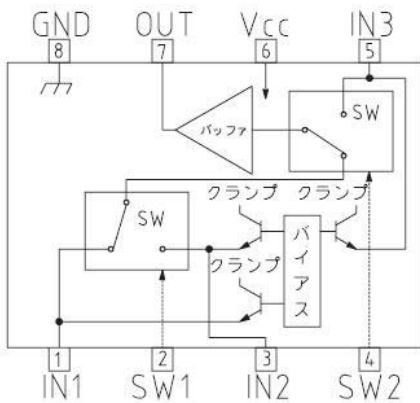

SIP-8A

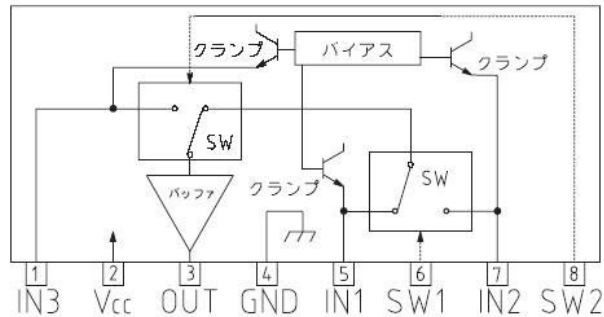

Control input truth table

SW1	SW2	OUT
L	L	IN1
H	L	IN2
-	H	IN3

49. MM1234XFBE (VIDEO: IC12, IC27)

MM1234

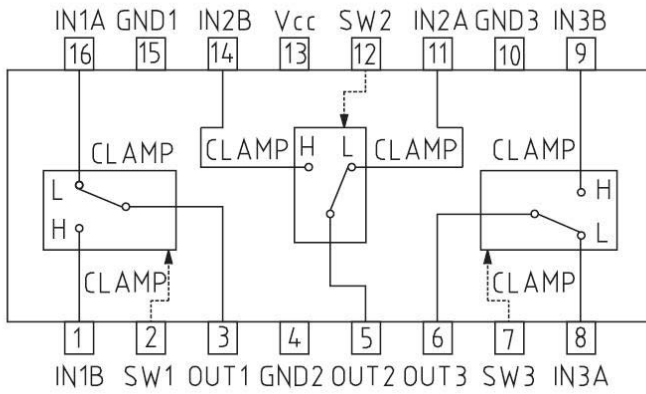

Control input truth table

SW	OUT
L	IN1A
	IN2A
	IN3A
H	IN1B
	IN2B
	IN3B

**50. KIA278R33API (MAIN: IC71)
KIA278R06API (MAIN: IC73)
KIA378R05PI (SURROUND: IC64)**

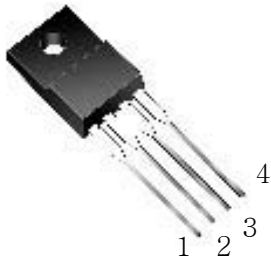

- ① DC INPUT (V_{IN})
- ② DC OUTPUT (V_O)
- ③ GND
- ④ ON/OFF CONTROL

**51. KIA7805API (MAIN: IC72 SUPPLY: IC12 VIDEO: IC37)
KIA7812API (MAIN: IC59)
KIA7815API (MAIN: IC51, 60)
KIA7824API (MAIN: IC54)
KIA78D33PI (SUPPLY: IC11 SURROUND: IC61)**



- 1. INPUT
- 2. COMMON
- 3. OUTPUT

52. KIA7915API (MAIN: IC52)
KIA7905PI (SURROUNDY: IC63)



1. COMMON
2. INPUT
3. OUTPUT

•TRANSISTORS

1. KRA107S

(DSP: Q113)

(FRONT: Q824, 831, 832)

(PROCESSOR: Q109, 203, 301, 605, 608, 611, 614, 615, 618, 620, 623, 626
629, 754, 692, 751)

(SUPPLY: Q301, 302)

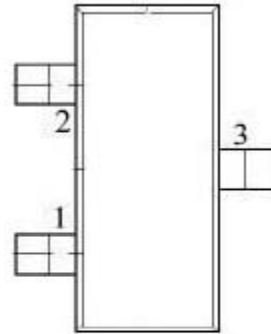
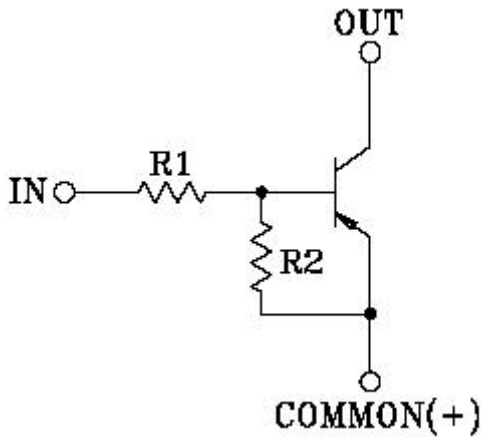

- 1. COMMON (EMITTER)
- 2. IN (BASE)
- 3. OUT (COLLECTOR)

2. KRC107S

(DSP: Q1 Q2 Q3 Q4 Q101 Q102 Q103 Q104 Q105 Q106 Q107 Q108
Q109 Q110 Q201 Q301 Q303)

(FRONT: Q800, 801, 802, 803, 820, 822, 833)

(SUPPLY: Q303, 304)

(VIDEO: Q120, 121)

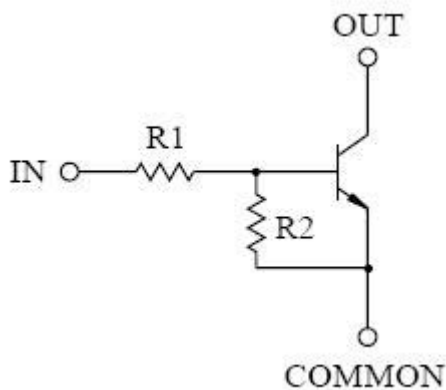

3. KTA1504Y (SUPPLY: Q305 Q306)

(FRONT: Q703)

(PROCESSOR: Q601, 602, 621, 622, 624, 625, 627, 628, 630, 631, 104, 105, 107, 108, 201, 202, 204, 205, 221, 222, 302, 303, 603, 604, 606, 607, 609, 610, 612, 613, 616, 617, 690, 691, 752, 753)

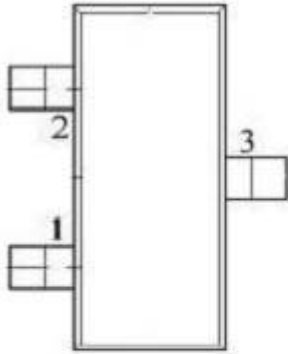

- 1. COMMON (EMITTER)
- 2. IN (BASE)
- 3. OUT (COLLECTOR)

4. KTC3875S (FRONT: Q701 Q702)

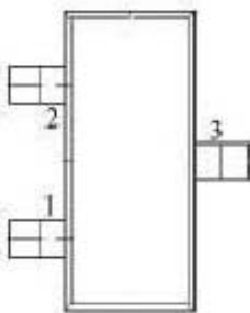

- 1. COMMON (EMITTER)
- 2. IN (BASE)
- 3. OUT (COLLECTOR)

5. KTA1267-GR (SUPPLY: Q106 Q107 Q108 Q109)

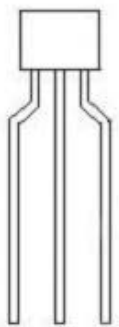

- (1) Emitter
- (2) Collector
- (3) Base

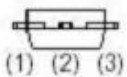

6. KTA1360 (MAIN: Q327 Q328 Q431 Q432 -AVR745,645 ONLY) SURROUND: Q215 Q315 Q515)
 KTA1360 (MAIN: Q417 Q418 Q315 Q316 -AVR445 ONLY) SURROUND: Q208 Q508 Q308)
 KTC3114 (MAIN: Q701 Q702 Q703 Q704) SURROUND: Q214 Q314 Q514)
 KTC3423 (MAIN: Q323 Q324 Q429 Q430 -AVR745,645 ONLY) SURROUND: Q213 Q313 Q513)
 KTC3423 (MAIN: Q419 Q420 Q317 Q318 -AVR445 ONLY) SURROUND: Q209 Q509 Q309)



1. EMITTER
2. COLLECTOR
3. BASE

7. 2SA1859A (MAIN: Q329 Q330 Q433 Q434) SURROUND: Q216 Q316 Q516)
 2SC4883A (MAIN: Q331 Q332 Q435 Q436) SURROUND: Q217 Q317 Q517)



1. BASE
2. COLLECTOR
3. EMITTER

8. KTA1268BL (MAIN: Q311 Q312 Q410 Q413 Q414 SURROUND: Q101 Q206 Q306 Q506)
 KTC3198BL (MAIN: Q307 Q308 Q407 Q408 Q426 Q441 SURROUND: Q204 Q304 Q504)
 KTC3200BL (MAIN: Q301 Q302 Q303 Q304 Q305 Q306 Q313 Q314 Q337 Q338 Q401 Q402
 Q403 Q404 Q405 Q406 Q409 Q415 Q416 Q425)
 (SURROUND: Q201 Q202 Q203 Q207 Q220 Q301 Q302 Q303 Q307 Q320
 Q501 Q502 Q503 Q507 Q520)
 KTD1302 (MAIN: Q601)
 MPSA06 (DSP: Q112 FRONT: Q821 SUPPLY: Q102, Q102)
 MPSA56 (FRONT: Q823)



1. EMITTER
2. COLLECTOR
3. BASE

9. KTA1024Y (MAIN: Q315 Q316 Q319 Q320 Q417 Q418 Q421 Q422 Q442
 SURROUND: Q208 Q211 Q308 Q311 Q508 Q511)-AVR745,645 ONLY
 KTC3206Y (MAIN: Q317 Q318 Q321 Q322 Q419 Q420 Q423 Q424
 SURROUND: Q209 Q212 Q309 Q312 Q509 Q512)-AVR745,645 ONLY



- 1. EMITTER
- 2. COLLECTOR
- 3. BASE

10. KRA107M (DSP: Q851 SUPPLY: Q301, 302)
 KRC107M (MAIN:C443)



- 1. EMITTER
- 2. COLLECTOR
- 3. BASE

11. 2SA1145Y (MAIN: Q309 Q310 Q411 Q412 SURROUND: Q205 Q305 Q505)

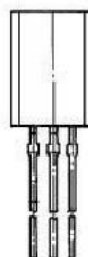
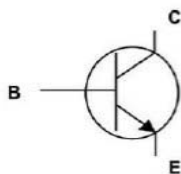

- 1. EMITTER
- 2. COLLECTOR
- 3. BASE

- 12. 2SA1986-R (MAIN: Q335 Q336 Q439 Q440
SURROUND: Q219 Q319 Q519)-AVR745,645 ONLY
- 2SC5358-R (MAIN: Q333 Q334 Q437 Q438
SURROUND: Q218 Q318 Q518)-AVR745,645 ONLY
- 2SD2560 (MAIN: Q333 Q334 Q437 Q438
SURROUND: Q218 Q318 Q518)-AVR445 ONLY
- 2SB1647 (MAIN: Q335 Q336 Q439 Q440
SURROUND: Q219 Q319 Q519)-AVR445 ONLY

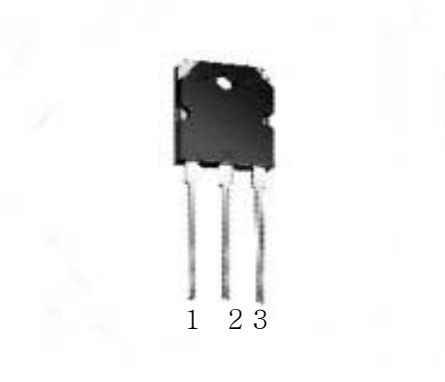

1.BASE
2.COLLECTOR
3.EMITTOR

2SD2560

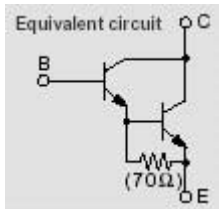

2SB1647

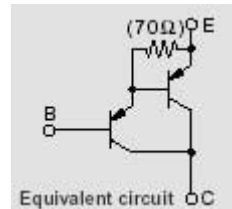

- 13. LM19CIZ 2.4V TO-92
(DSP: PO91 MAIN: PO71)

TO-92

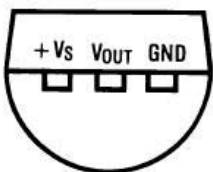

BOTTOM VIEW

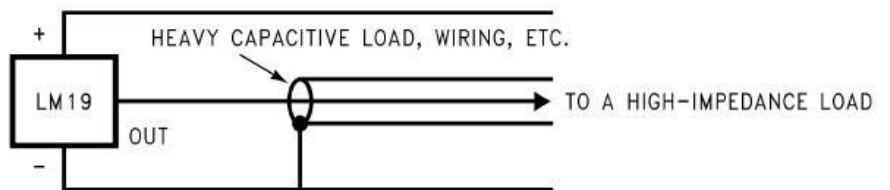

2. VCXO 24M576HZ (DSP Y201)

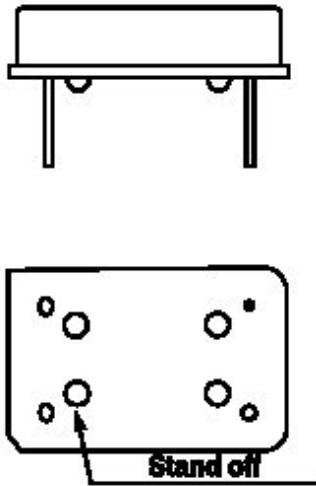

<14 PIN DIP>

PIN	CONNECTION
# 1	INH or No Connection
# 7	Ground
# 8	Output
# 14	Vdc

3. OPTICAL RX YKC22-0733N (DSP: NJ31 NJ32 NJ33)

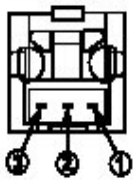

Pin connection

- 1. GND
- 2. Vcc
- 3. Input

Fiber optic connector insertion side

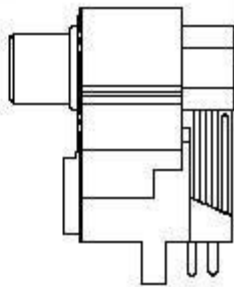
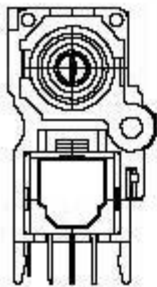
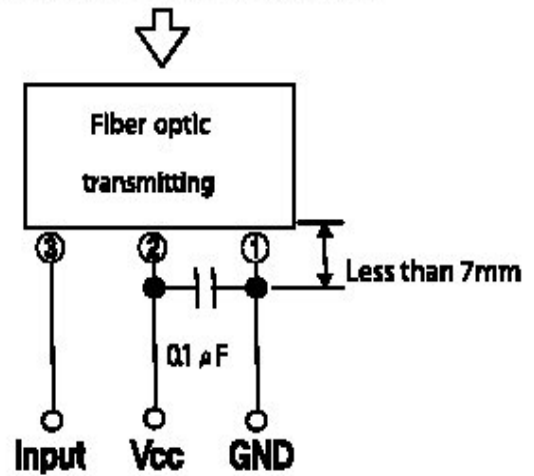

4. TX YKC22-0732N (DSP: NJ34)

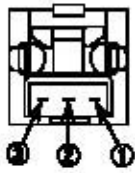

Pin connection

- 1. Output
- 2. GND
- 3. Vcc

Fiber optic connector insertion side

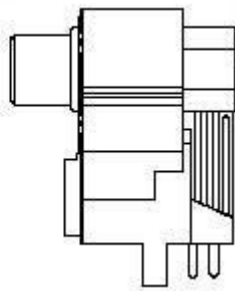
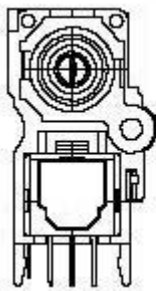
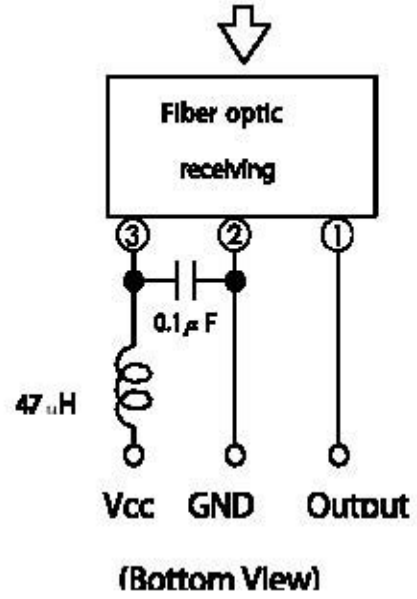

5. TORX177L (FRONT: NJ79)

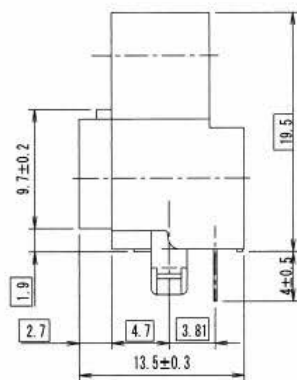
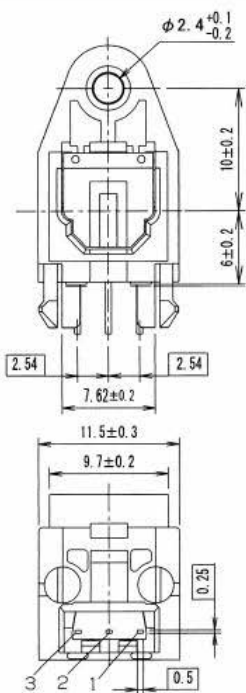

Shutter Color : Black

Pin Connection

- 1. Output
- 2. GND
- 3. Vcc

Fiber optic connector insertion side

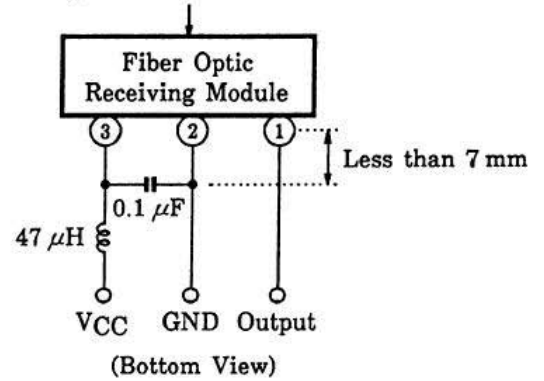

6. RPM6938-RSIP-A3 (FRONT: RM71)

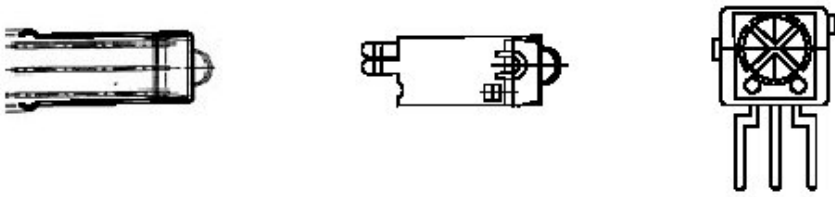

PIN NO.	
①	ROUT
②	GND
③	Vcc

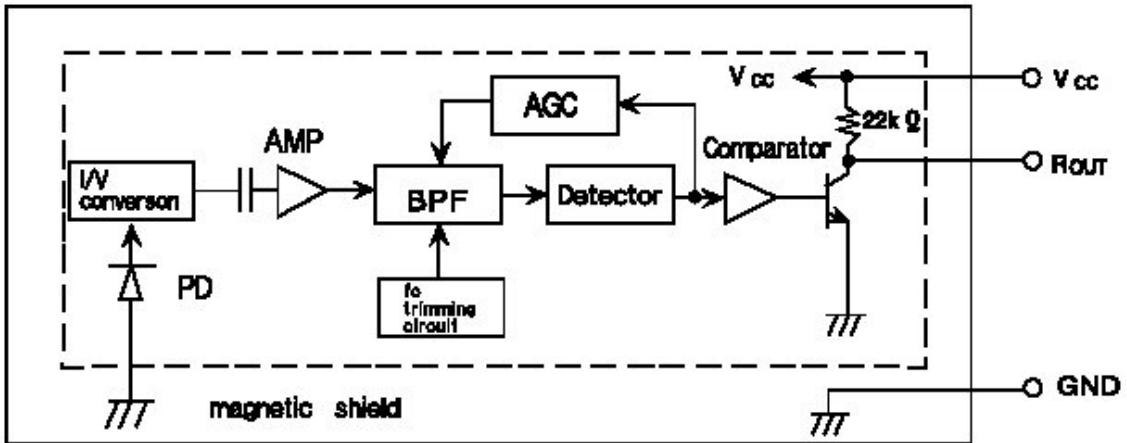

7. LP-200TL (FRONT: RM72)

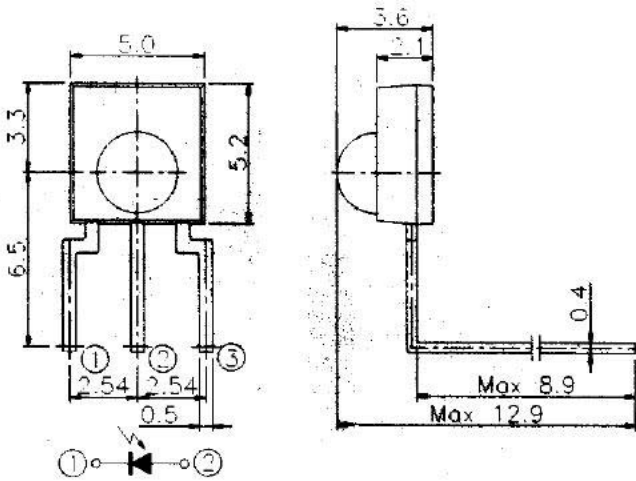

1. Pin Config.
 - ① Cathode
 - ② Anode
 - ③ No connect
2. G.T : ±0.2

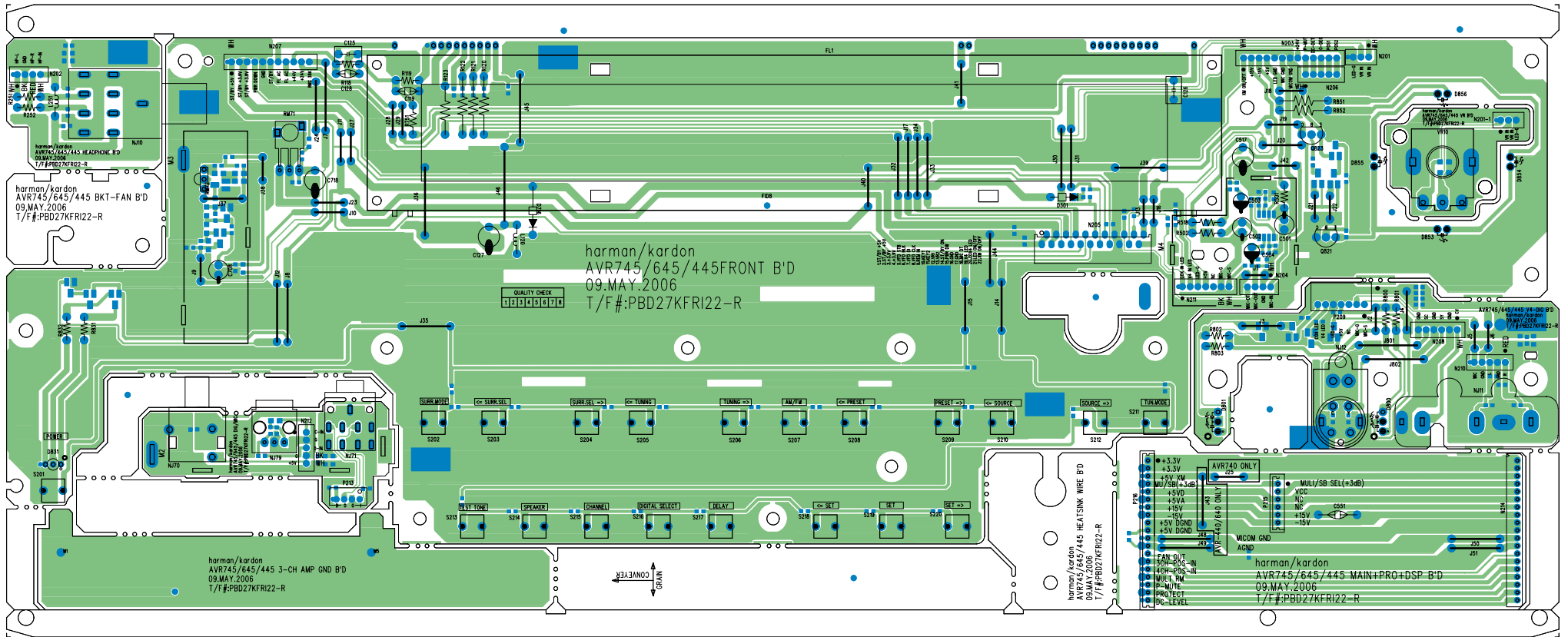

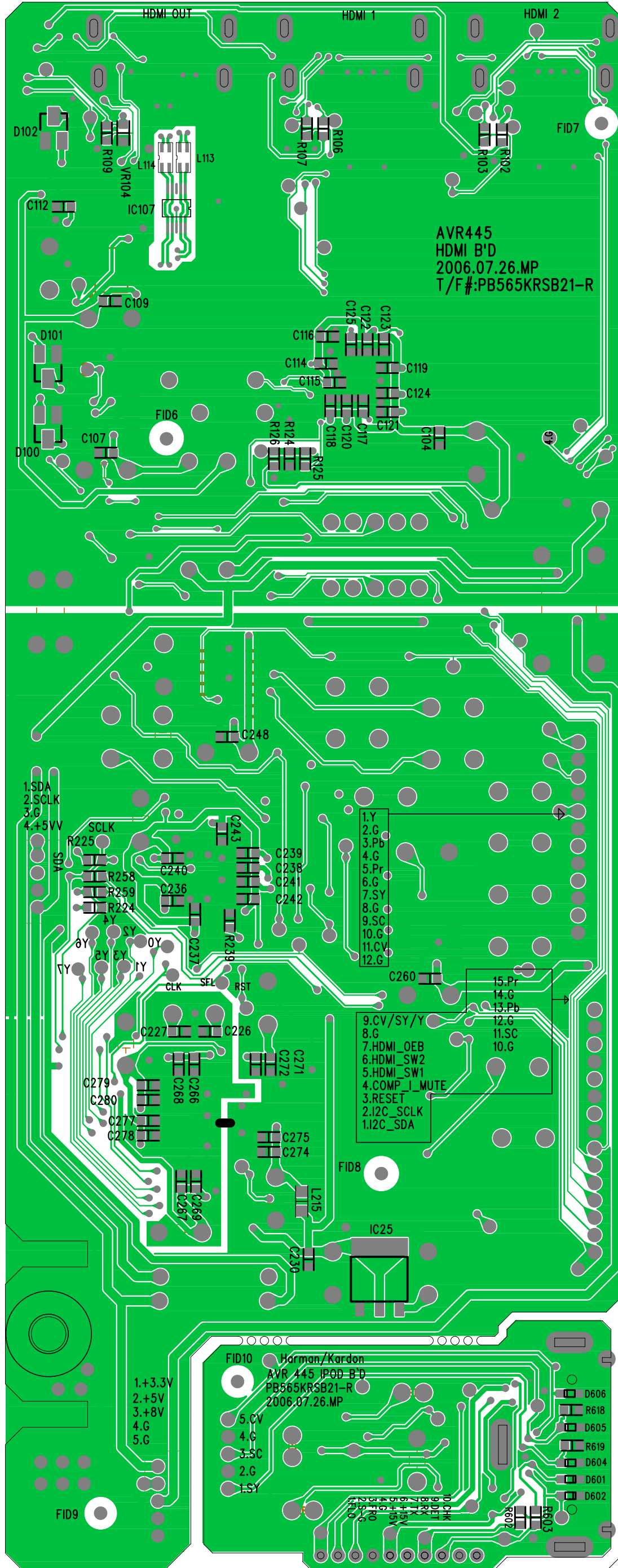

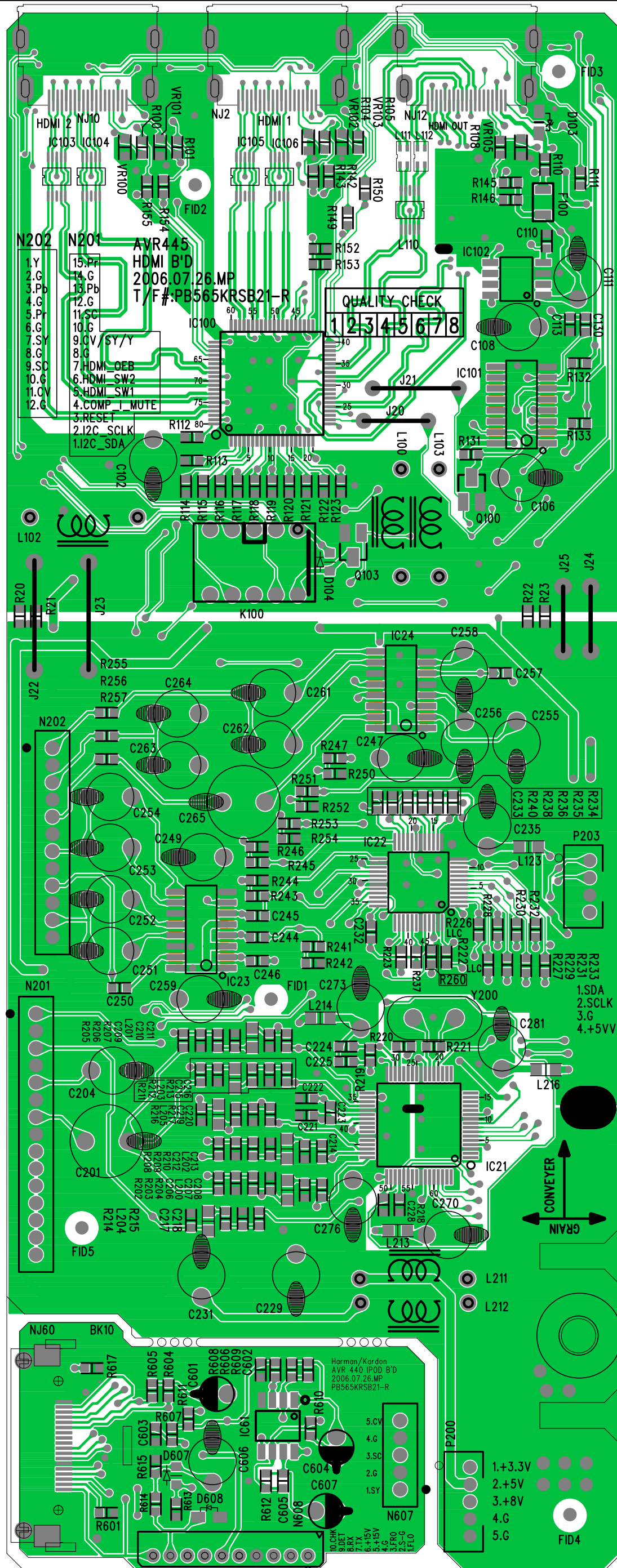

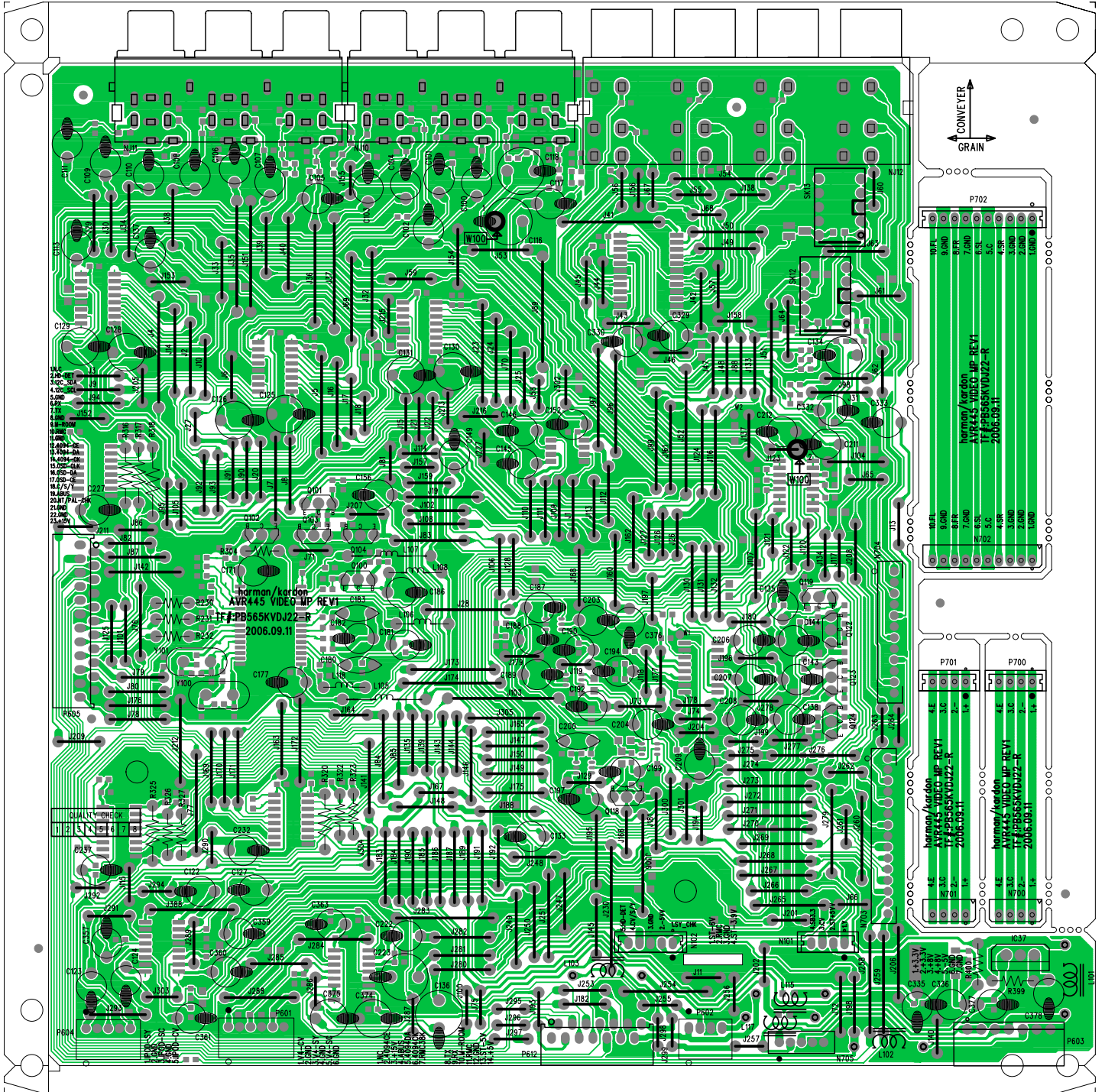

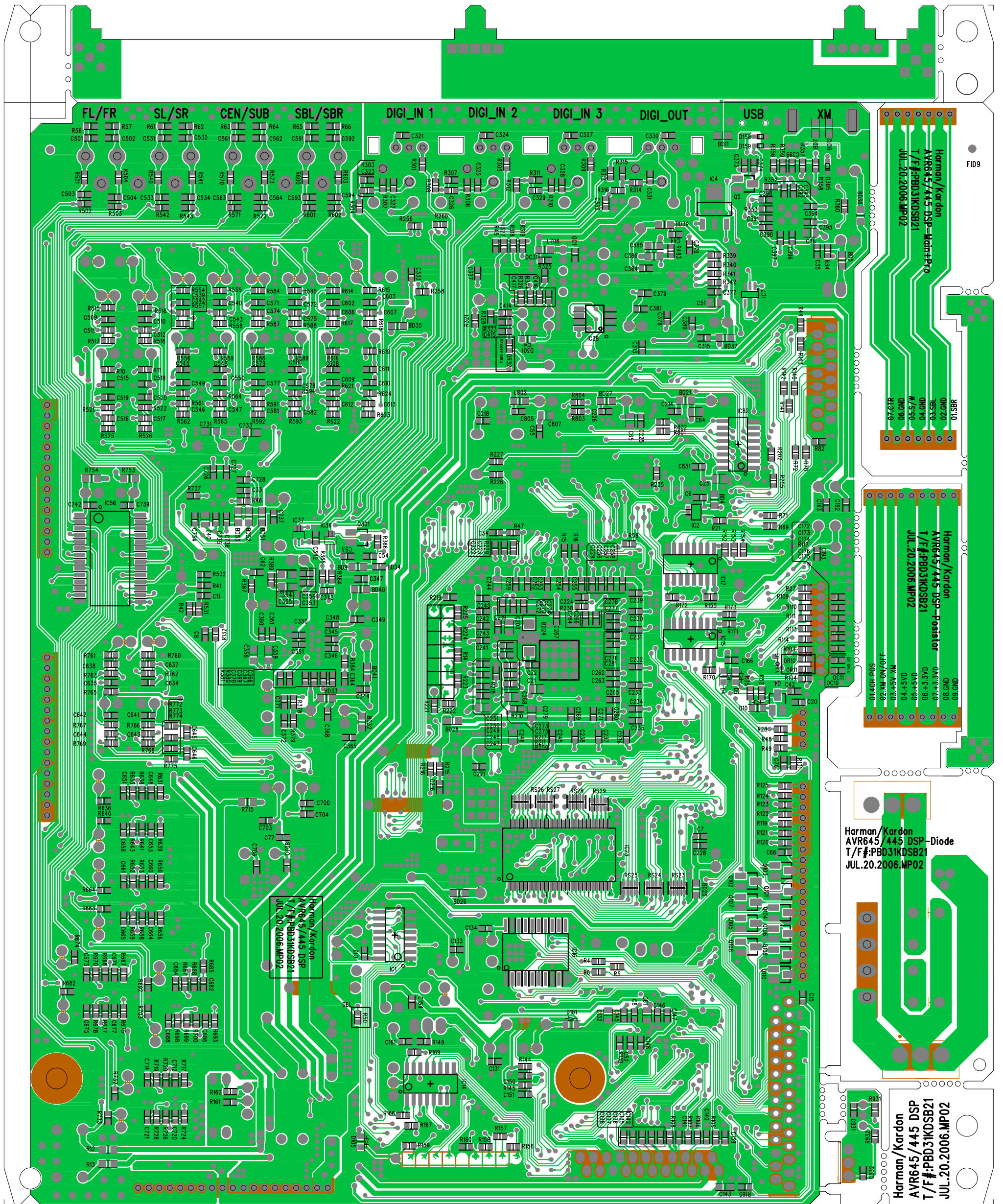

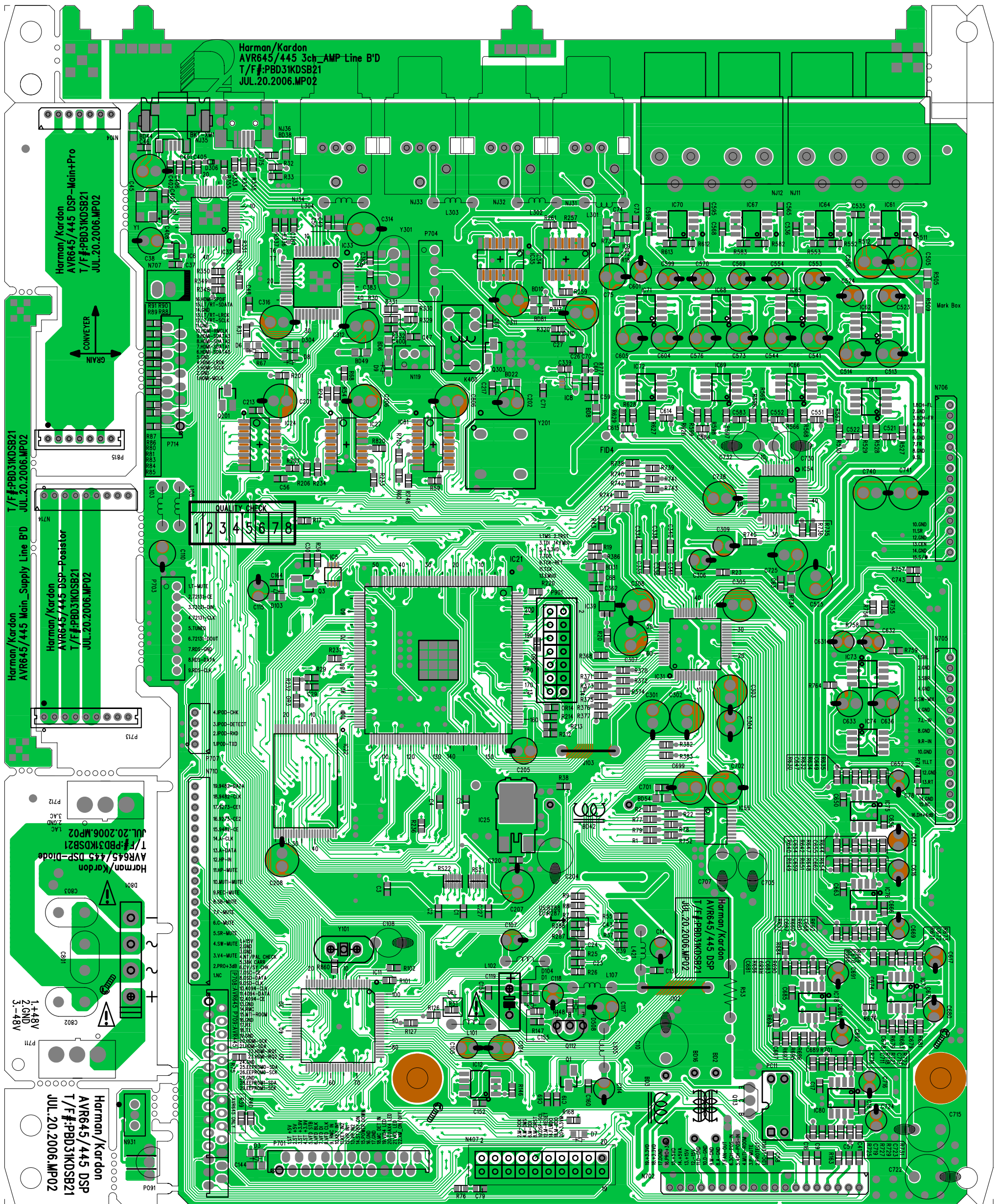

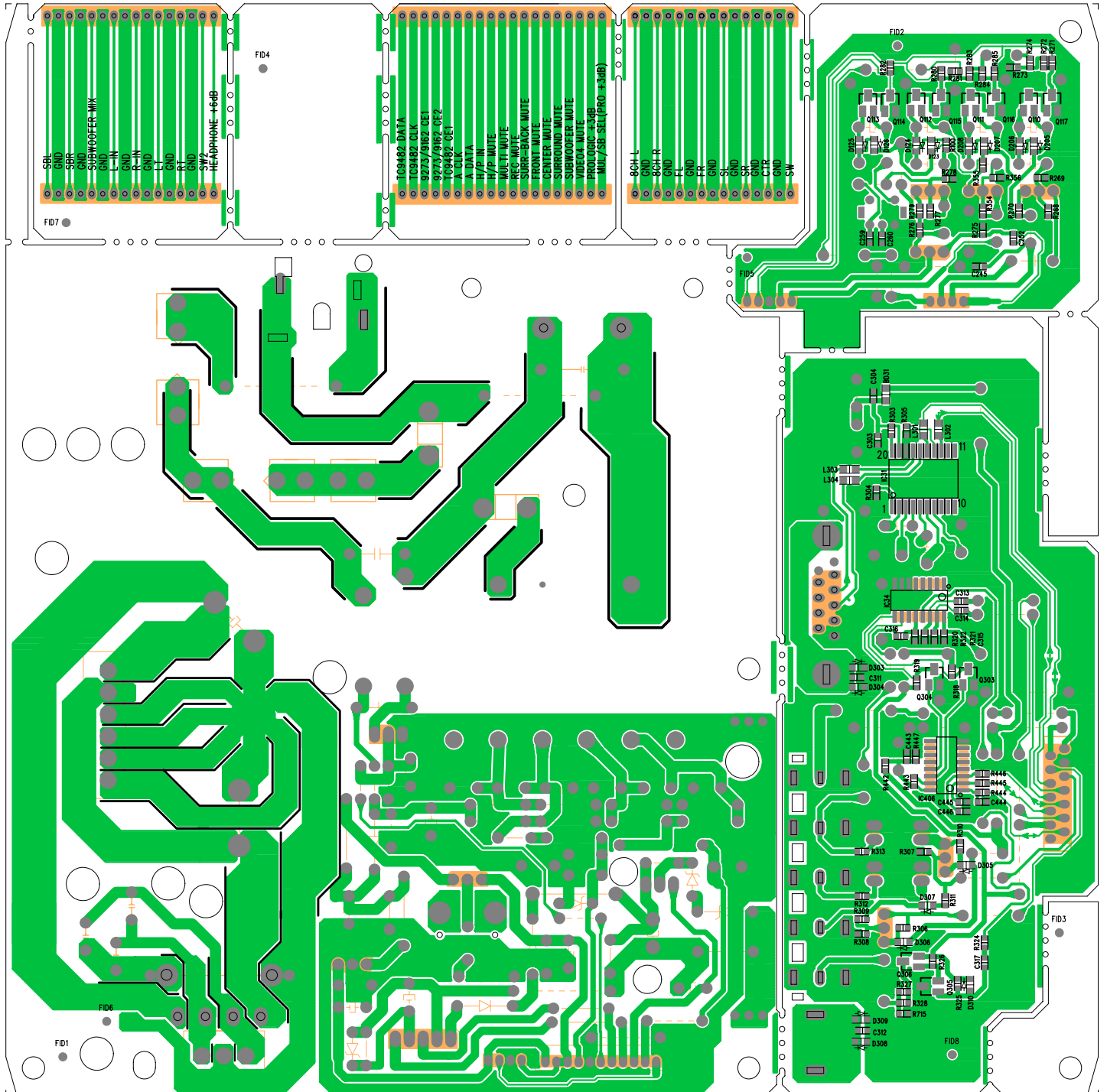

harman/kardon
AVR745/645/445 BKT PCB-3 B'D
11.SEP.2006.
T/F NO:PBD27KSRI21-R

AVR745/645/445 SURROUND B'D MP01
T/F NO:PBD27KSRI21 R 11.SEP.2006.

QUALITY CHECK									
1	2	3	4	5	6	7	8	9	10

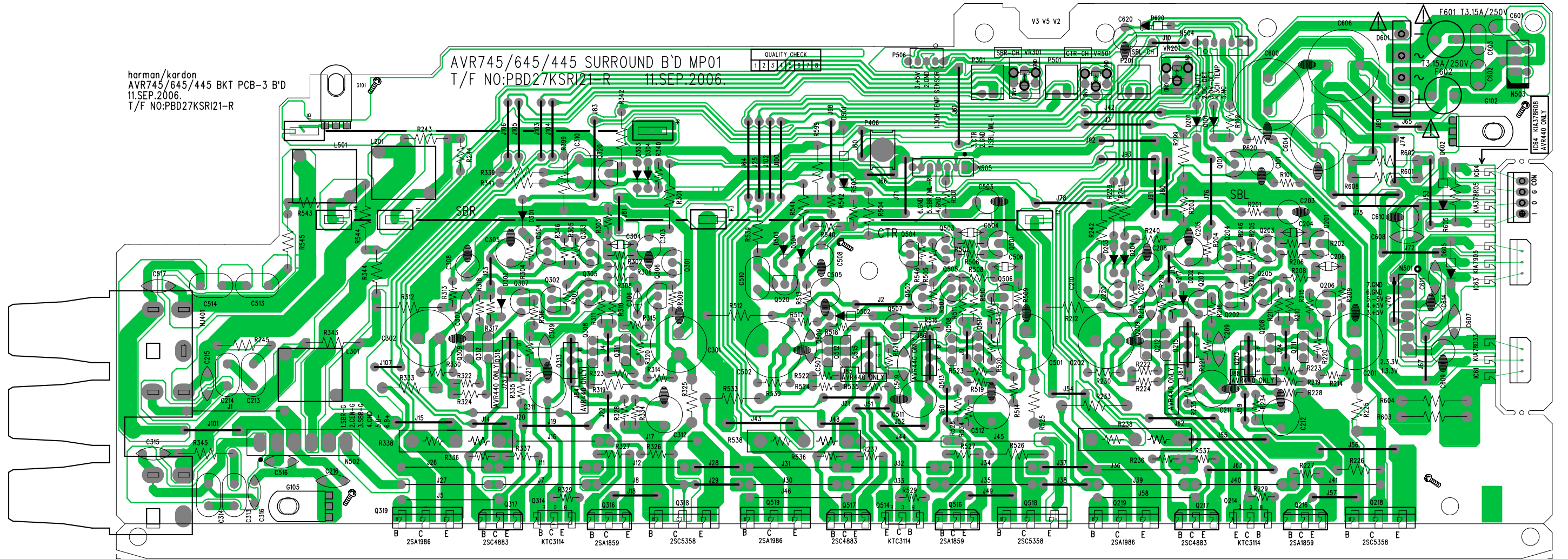

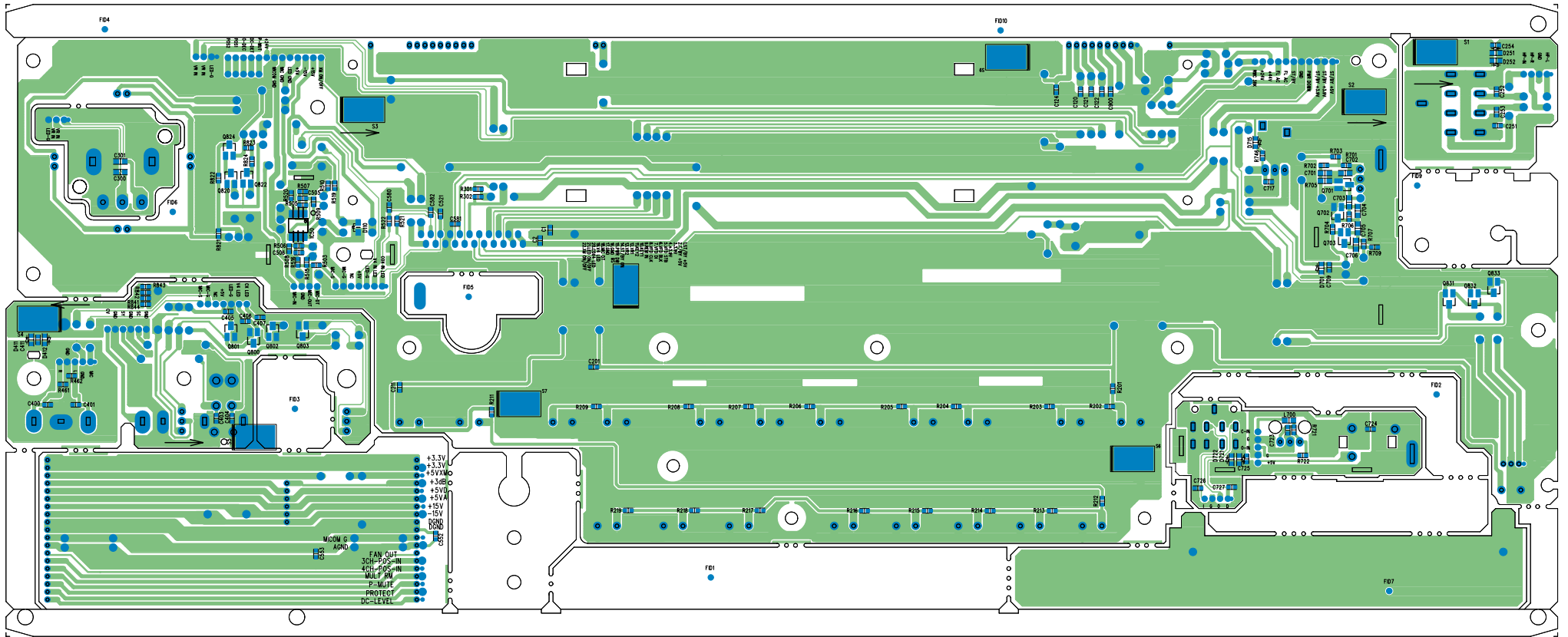

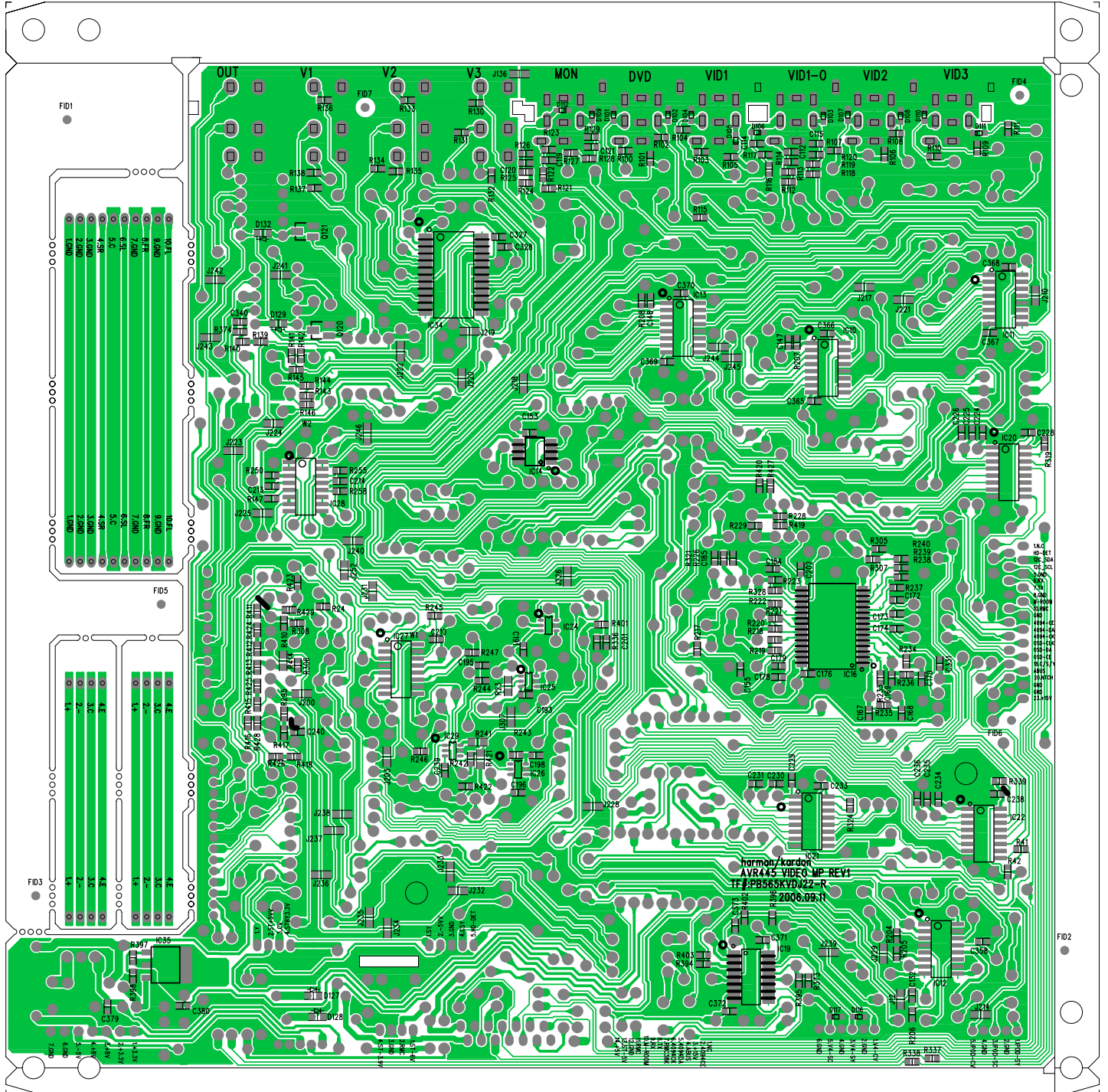

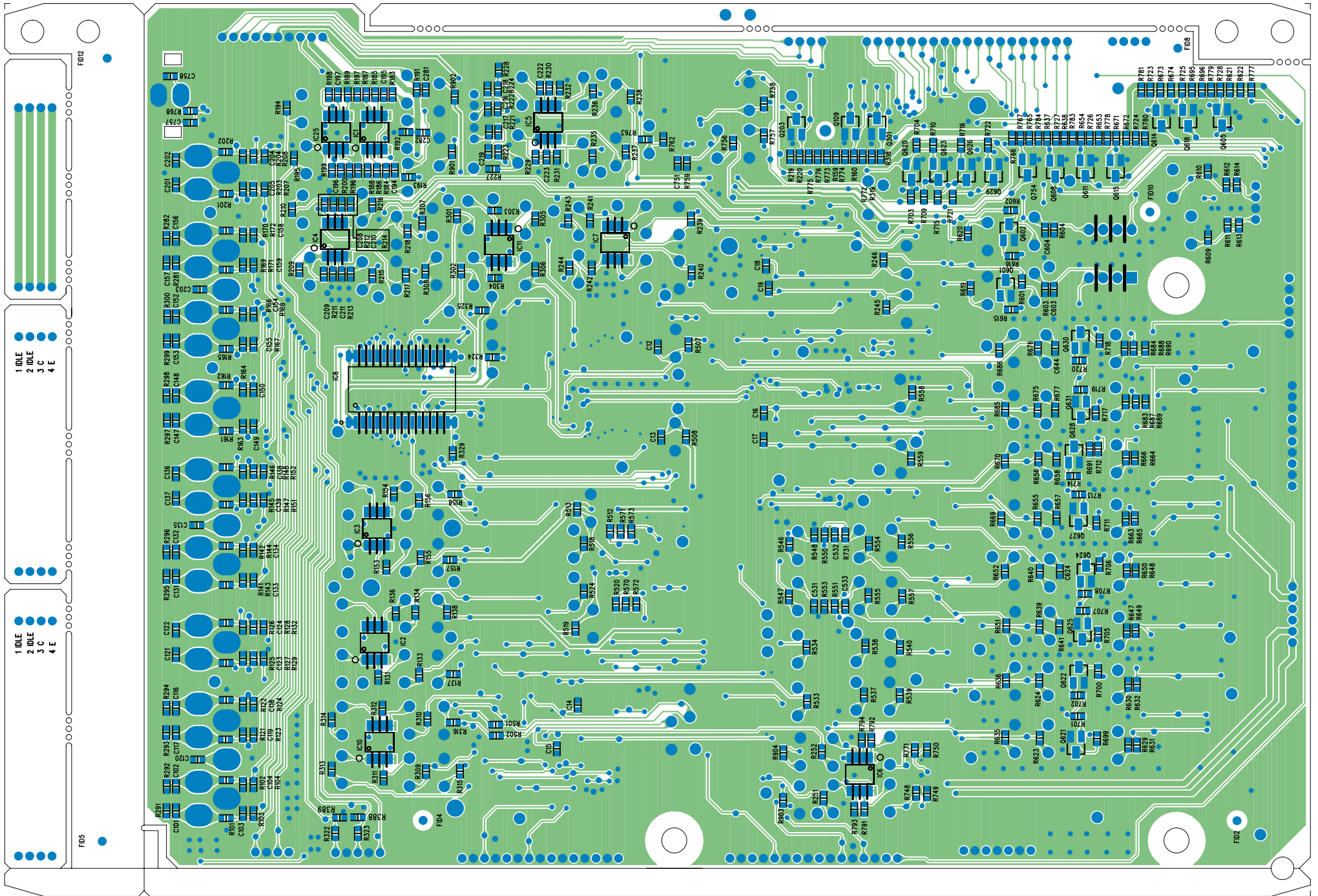

1 IDLE
2 IDLE
3 C
4 E

1 IDLE
2 IDLE
3 C
4 E

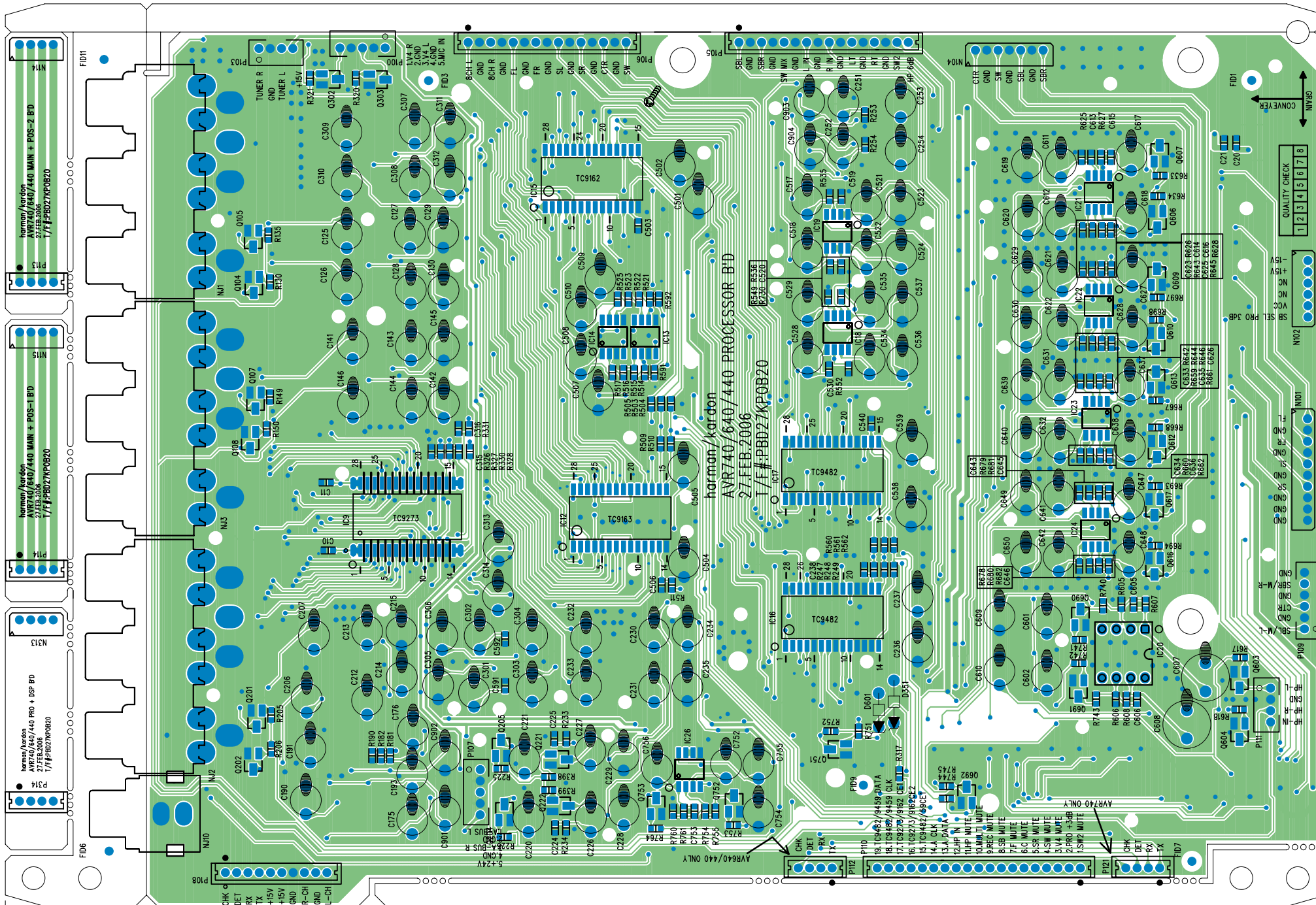

Ref. Designator	Part Number	Description	
DSP PCB ASS'Y			
C6 C8 C11 C12 C15 C20 C22 C35 C42 C44 C52 C53 C54 C55 C62 C131 C133 C134 C145 C146 C147 C148 C154 C161 C163 C166 C192 C193 C214 C218 C219 C221 C222 C225 C226 C229 C230 C231 C232 C233 C234 C235 C236 C237 C238 C239 C240 C241 C242 C243 C245 C248 C249 C250 C251 C252 C253 C254 C255 C256 C257 C258 C259 C262 C263 C264 C265 C266 C267 C269 C270 C271 C272 C273 C274 C275 C276 C277 C278 C280 C281 C313 C315 C321 C324 C327 C330 C332 C333 C337 C342 C344 C345 C347 C348 C356 C360 C365 C366 C368 C369 C376 C377 C378 C379 C380 C381 C384 C390 C391 C392 C393 C394 C395 C396 C397 C399 C417 C509 C510 C515 C518 C519 C520 C539 C540 C545 C548 C549 C550 C571 C572 C577 C578 C579 C580 C602 C603 C608 C609 C610 C611 C634 C635 C641 C642 C700 C703 C704 C706 C708 C726 C727 C728 C734 C735 C736 C737 C739 C742 C805 C851 C931	CZZFI0104BF-R	CAP CHIP 100N0F +80% -20% 16.0V Y5V 0603	
C228	CZZFI0224BF-R	CAP CHIP 220NF 16V Y5V +80%-20% 0603	
C21 C25 C36 C40 C51 C61 C64 C65 C132 C203 C244 C246 C247 C268 C279 C807	H03-CTKDE0106FK-R	CAPACITOR MLCC 10UF 6.3V +- 10% C2012X5R0J106K	
C415	CZJII0220BE-R	CCCFMIC 22P0F +5% -5% 50.0V NP0	
C382 C383	CSJIE0270BG-R	CAP CHIP FORM,27P,+5%,50V,0603,COG.	
C407 C408	CSJIE0300BG-R	CAP,CHIP FORM 30P +/-5% 50V COG 0603	
C144	CZIKI0104CC-R	CAP CHIP 100nF 100V X7R 10% 0805	
C23 C24 C743	CZJII0101BE-R	CAP CHIP 100P0F +5% -5% 50.0V NP0 0603	
C29	CZJII0220BE-R	CCCFMIC 22P0F +5% -5% 50.0V NP0	
C713 C723	CZJII0471BE-R	CCCFMIC 470P0F +5% -5% 50.0V NP0	
C43 C521 C522 C551 C552 C583 C584 C614 C615	CZKII0102BC-R	CAP CHIP 1N0F +10% -10% 50.0V X7R 0603	
C32 C37 C50 C70 C338 C339	CZKII0103BC-R	CAP CHIP 10N0F +10% -10% 50.0V X7R 0603	
C387	CZKII0122BC-R	CAP CHIP 1N2F +10% -10% 50.0V X7R 0603	
C687 C711 C719	CZKII0272BC-R	CAP CHIP 2N7F +10% -10% 50.0V X7R 0603	
C647 C654 C659 C667 C670 C678 C681	CZKII0392BC-R	3n9F 50V X7R K 0603	
C649 C655 C662 C668 C672 C679 C683	CZKII0561BC-R	CAP CHIP 560P0F +10% -10% 50.0V X7R 0603	
C689	CZKII0821BC-R	CAP CHIP 820P0F +10% -10% 50.0V X7R 0603	
C9 C13 C16 C17 C18 C19 C30 C39 C41 C46 C47 C48 C56 C57 C58 C59 C60 C63 C67 C69 C71 C72 C78 C79 C152 C153 C155 C160 C164 C213 C217 C220 C362 C375 C400 C405 C406 C535 C536 C565 C568 C595 C598 C650 C656 C663 C666 C674 C676 C685 C690 C701	CZZFI0104BF-R	CAP CHIP 100N0F +80% -20% 16.0V Y5V 0603	
C1 C2 C3 C4 C5 C227	CZZFI0224BF-R	CAP CHIP 220NF 16V Y5V +80%-20% 0603	
C49 C68	H03-CTKDE0106FK-R	CAPACITOR MLCC 10UF 6.3V +- 10% C2012X5R0J106K	
<i>Semiconductors</i>			
D306	H03-DS05GBUSCNB-R	DIODE PG05GBUSC	US

Ref. Designator	Part Number	Description	
DSP PCB ASS'Y			
D1 D3 D6 D7 D8 D9 D103 D104 D304 D508	H03-DS1S50094NB-R	D-SLP 1SS355 35.0V 225MIOA	
IC12	H03-IC24LC256D2-R	IC CMOS SERIAL EEPROM 24LC256T-I/SNG SOIC-8P(150MIL)	
IC11	H03-IC70F3261E1-R	UPD70F3261YGC-8EA-A LQFP100 32-bit single-chip microcontroller	
IC5	H03-IC74CB3T3D2-R	IC SN74CB3T3306DCTR SSOP-8 Dual Bus Switch Voltage Translator	
IC39	H03-IC74LC1G1DL-R	IC SINGLE SCHMITT BUFFER SN74LVC1G17DBVR SOT(SOT-23)DBV	
IC24 IC27 IC81	H03-IC74LVC254D-R	IC SN74LVC257AD SOIC-16 Quadruple 2-Line To 1-Line Data Selector/Multiplexer	
IC22	H03-ICM29W160ET-R	IC FLASH MEMORY M29W160ET TSOP48 ST	
IC31	H03-ICCS42528E6-R	IC CS42528-CQZ-D 114 DB, 192 KHZ 8-CH CODEC WITH S/PDIF RECEIVER	
IC54	H03-ICCS5368BE8-R	CS5368-CQZ LQFP48 114 DB, 192 KHZ, 8-CHANNEL A/D CONVERTER	
IC61 IC62 IC63 IC64 IC65 IC66 IC67 IC68 IC69 IC70 IC71 IC72 IC73 IC74 IC75 IC76 IC77 IC78 IC80	H03-ICLM02068D2-R	IC-OPERAMP NJM2068M-TE1 DUAL OP-AMP SOP8	
IC25	H03-ICM317TO252-R	IC 3-TERMINAL POS ADJ VOL REG NJM317DL1-TE1 TO-252	
IC6	H03-ICNJM2872D0-R	NJM2872AF33-TE1 3.3V SOT-23(MPT5) LOW DROPOUT VOLTAGE REGULATOR	US
IC55	H03-ICS4391AKZZ-R	CS4391A-KZZ SOP20 24-BIT, 192 kHz STEREO DAC W VOLUME CNTRL	
IC34 IC35	H03-ICSN74HCU04-R	IC SN74HCU04D HEX INVERTER	
IC21	H03-ICTMS320DA6-R	IC FLOATING-POINT DSP TMS320D610A PQFP208	
IC33	H03-ICTUSB320EB-R	IC TUSB3200A TQFP52 USB Streaming Controller	
IC32	H03-ICXMDIC00E8-R	IC DIGITAL TRANCEIVER XMDIC QFP48	US
IC36 IC37	H03-ICC1G125DCK-R	IC SINGLE BUS BUFFER GATE SN74LVC1G125DCKT SOT(SC-70)DCKT	
Q113	H03-TRKTA107MNA-R	TR-SLPSWA KRA107M PNP	
Q112	H03-TRMPSA06NNA-R	TR-SLPLF MPSA06 N 500MIOA TO-92	
D801	H03-DURS10040NA-R	RS1004 RS-10	
D158 D159	H03-DS05GBUSCNB-R	DIODE PG05GBUSC	
D305	H03-DS05GBUSCNB-R	DIODE PG05GBUSC	US
D4 D5 D10 D101	H03-DS1S50094NB-R	D-SLP 1SS355 35.0V 225MIOA	
IC38	H03-IC24LC64ID2-R	24LC64-I/SNG SOIC-8P(150mil) Serial EEPROM	
IC7	H03-IC74AHC1G14-R	74AHC1G14 SOT753 Inverting Schmitt trigger	
IC2	H03-IC74LC1G1DL-R	IC SINGLE SCHMITT BUFFER SN74LVC1G17DBVR SOT(SOT-23)DBV	
IC82	H03-IC74LVC254D-R	IC SN74LVC257AD SOIC-16 Quadruple 2-Line To 1-Line Data Selector/Multiplexer	
IC16	H03-IC74VC244G5-R	IC-LOGIC 74VHC244MX or 74VHC244MX_NL M20B INVERTER CMOS	
IC1	H03-ICBU4051BD3-R	IC ANALOG MPX/DEMPX BU4051BCF SOP16	
IC14 IC15 IC17	H03-ICBU4094BCF3-R	IC CMOS BU4094BCF SOP16 8-bit compatible shift / store register	
IC4	H03-ICDS1233ADK-R	IC 3.3V ECONO RESET DS1233AZ-15+TR SOT-223	
IC23	H03-ICK4S1616UC-R	K4S161622H-UC60 OR UC80 TSOP50 512K x 16Bit x 2 Banks SDRAM	
IC56	H03-ICTC9162CDA-R	IC CMOS TC9162CFG SOP28 HIGH VOL ANALOG FUN SWITCH ARRAY	
Q2 Q4 Q101 Q102 Q103 Q104 Q105 Q106 Q107 Q108 Q109 Q110 Q301	H03-TSKRC107SND-R	KRC107S SOT-23 NPN	
Q1 Q3 Q201	H03-TSKRC107SND-R	KRC107S SOT-23 NPN	
PC11	H03-ICPC17T10B1-R	IC PHOTOCOUPLER PC-17T1 DIP4 KODENSHI	
<i>Resistors</i>			
R53	RC3DI010AIN-R	RCF 1R0 OHM +5% 250MIOW	
RS23 RS24 RS25 RS26 RS27 RS28 RS29	RN3AY0220NA-R	RES NETWORK RCA 220OHM 1/16W 5% CN34JT220	
R389	RS1AD1371NA-R	RES.CHIP,1.37K OHM ,1/16W,+/-1%,0603	
R483	RS1AD3091NA-R	RES CHIP 3.09K OHM 1/16W 1% 0603	
OR32 R44 R50	RS3AD0000NA-R	RES CHIP, 0 R 1/16W +/-5%, 0603	
R103 R104	RS3AD0000NA-R	RES CHIP, 0 R 1/16W +/-5%, 0603	US
R21 R48 R49 R69 R70 R71 R72 R119 R120 R121 R122 R123 R124 R125 R143 R202 R205 R235 R301 R305 R309 R314 R801 R802 R803 R804	RS3AD0100NA-R	RMGCFMIC 10R0 OHM +5% 0603	
R10 R11 R132 R226 R227 R313 R357 R358 R364 R365 R556 R559 R586 R589 R616 R619 R765 R932	RS3AD0101NA-R	RES CHIP,100R 1/16W +/-5%,0603	
R113 R114 R216 R304 R308 R312 R356 R359	RS3AD0102NA-R	RES CHIP,1K 1/16W +/-5% ,0603	
OR10 OR11	RS3AD0102NA-R	RES CHIP,1K 1/16W +/-5% ,0603	EU

Ref. Designator	Part Number	Description
DSP PCB ASS'Y		
R35 R52 R131 R149 R215 R517 R518 R521 R522 R525 R526 R557 R558 R561 R562 R563 R564 R587 R588 R591 R592 R593 R594 R617 R618 R621 R622 R623 R624 R737 R762 R763 R766 R767 R768 R769	RS3AD0103NA-R	RES CHIP,10K 1/16W +/-5% ,0603
R34 R155 R165 R169 R170 R303 R307 R311 R328 R352 R353 R502 R503 R542 R543 R571 R601 R602 R636 R646 R663 R664 R674 R682 R692 R703 R732 R733	RS3AD0104NA-R	RES CHIP,100K 1/16W +/-5% ,0603
R319 R633 R643 R652 R659 R670 R678 R687 R698	RS3AD0122NA-R	RMGCFMIC 1K2 OHM +5% 0603
R256 R258 R260	RS3AD0152NA-R	RES CHIP 1K5 1/16W +5% 0603
R15 R16 R117 R219 R318	RS3AD0153NA-R	RES CHIP,15K 1/16W,+/-5%,0603.
R210 R218	RS3AD0182NA-R	RES CHIP,1.8K,1/16W,+/-5%,0603.
R699	RS3AD0183NA-R	RMGCFMIC 18K0 OHM +5% 0603
R719 R728	RS3AD0202NA-R	RMGCFMIC 2K0 OHM +5% 0603
R515 R516 R554 R555 R584 R585 R614 R615 R760 R761	RS3AD0203NA-R	RMGCFMIC 20K0 OHM +5% 62MI5W 0603
R6 R105 R106 R107 R108	RS3AD0221NA-R	RMGCFMIC 220R0 OHM +5% 0603
R27 R144 R145 R378 R379	RS3AD0222NA-R	RMGCFMIC 2K2 OHM +5% 0603
BD34 R321	RS3AD022ANA-R	RMGCFMIC 2R2 OHM +5% 0603
R316 R326	RS3AD0241NA-R	RES CHIP 240 OHM 1/16W +/-5% 0603
R772 R773 R774 R775	RS3AD0331NA-R	RMGCFMIC 330R0 OHM +5% 0603
R573	RS3AD0332NA-R	RMGCFMIC 3K3 OHM +5% 0603
R387	RS3AD033ANA-R	RMGCFMIC 3R3 OHM +5% 0603
R162 R209 R211 R217 R229 R230	RS3AD0392NA-R	RMGCFMIC 3K9 OHM +5% 0603
R717 R724	RS3AD0432NA-R	RMGCFMIC 4K3 OHM +5% 0603
R4 R5 R152 R153 R154 R166 R167 R171 R172 R173 R931	RS3AD0471NA-R	RMGCFMIC 470R0 OHM +5% 0603
R28 R109 R110 R111 R161 R339 R340 R341 R342 R366 R531 R532 R631 R639 R650 R656 R667 R675 R685 R693 R720 R726	RS3AD0472NA-R	RES CHIP,4K7 1/16W +/-5%,0603
R3 R82 R130 R380 R381	RS3AD0473NA-R	RES CHIP,47K 1/16W +/-5%,0603
R41 R42	RS3AD0474NA-R	RMGCFMIC 470K0 OHM +5% 0603
R638 R641 R653 R658 R668 R677 R688	RS3AD0562NA-R	RMGCFMIC 5K6 OHM +5% 0603
R327 R700	RS3AD0681NA-R	RES CHIP,680R 1/16W +/-5%,0603
R572	RS3AD0682NA-R	RMGCFMIC 6K8 OHM +5% 0603
R46 R47 R302 R306 R310 R315 R323 R325 R384	RS3AD0750NA-R	RMGCFMIC 75R0 OHM +5% 0603
R501 R504 R540 R541 R570 R600 R603	RS3AD0821NA-R	RMGCFMIC 820R0 OHM +5% 0603
R56 R57 R61 R62 R63 R64 R65 R66	RS3AD0823NA-R	RES,CHIP 82K,1/16W,+/-5%,0603
R12 R13 R753 R754	RS3BB0101NA-R	RES,CHIP,100 OHM 1/10W +/-5%., 0805
R715	RS3BB0150NA-R	RES,CHIP,15 OHM 1/10W +/-5% 0805
R360	RS3AD0105NA-R	RES CHIP 1M 1/16W +5% 0603
BD7 BD11 BD12	RS3BB0000NA-R	RES CHIP 0 OHM +5% 100MI0W 0805
R58	RS3AD0470NA-R	RMGCFMIC 47R0 OHM +5% 0603
R140 R141 R142	RS3AD0220NA-R	RES CHIP,22R 1/16W +/-5%,0603
R45	RS3AD0124NA-R	RES CHIP,120K 1/16W +/-5%,0603
RS21 RS22	RN3AY0220NA-R	RES NETWORK RCA 22OHM 1/16W 5% CN34JT220
R17 R20 R738 R739 R750	RS1AD0100NA-R	RES CHIP 10 OHM 1/16W 1% 0603
R32	RS1AD3321NA-R	RES CHIP 3.32K OHM 1/16W 1% 0603
R33	RS1AD4751NA-R	RES.CHIP 4.75K 1/16W +/-1% 0603
R734	RS1BB022ANA-R	RES.CHIP,2.2 OHM ,1/16W,+/-1%,0805
R51 R126 R127 R317 R320 C334 C335 C336 C341 OR2 OR3	RS3AD0000NA-R	RES CHIP, 0 R 1/16W +/-5%, 0603
R24 R54 R68 R206 R207 R233 R234 R331 R332 R748 R820 C340	RS3AD0100NA-R	RMGCFMIC 10R0 OHM +5% 0603

Ref. Designator	Part Number	Description	
DSP PCB ASS'Y			
R2 R30 R74 R382 R383 R745 R764	RS3AD0101NA-R	RES CHIP,100R 1/16W +/-5%,0603	
R7 R8 R9 R31 R354 R755 R756 R757 R860	RS3AD0102NA-R	RES CHIP,1K 1/16W +/-5% ,0603	
R25 R26 R36 R39 R101 R236 R288 R735 R736	RS3AD0103NA-R	RES CHIP,10K 1/16W +/-5% ,0603	
R288	RS3AD0103NA-R	RES CHIP,10K 1/16W +/-5% ,0603	US
R287	RS3AD0103NA-R	RES CHIP,10K 1/16W +/-5% ,0603	EU
R632 R642 R651 R660 R669 R679 R686 R697	RS3AD0122NA-R	RMGCFMIC 1K2 OHM +5% 0603	
R333	RS3AD0152NA-R	RES CHIP 1K5 1/16W +5% 0603	
R257 R259 R261	RS3AD0153NA-R	RES CHIP,15K 1/16W,+/-5%,0603.	
OR14 R212 R213 R214 R740	RS3AD0182NA-R	RES CHIP,1.8K,1/16W,+/-5%,0603.	
R696	RS3AD0183NA-R	RMGCFMIC 18K0 OHM +5% 0603	
R718 R727	RS3AD0202NA-R	RMGCFMIC 2K0 OHM +5% 0603	
R777	RS3AD022ANA-R	RMGCFMIC 2R2 OHM +5% 0603	
R334 R335	RS3AD0270NA-R	RES,CHIP 27 OHM 1/16W +/-5% 0603	
R527 R528 R529 R530 R566 R567 R568 R569 R596 R597 R598 R599 R626 R627 R628 R629	RS3AD0331NA-R	RMGCFMIC 330R0 OHM +5% 0603	
R220	RS3AD0392NA-R	RMGCFMIC 3K9 OHM +5% 0603	
R716 R725	RS3AD0432NA-R	RMGCFMIC 4K3 OHM +5% 0603	
R19 R22 R59 R60 R75 R76 R77 R78 R368 R370 R371 R372 R373 R374 R375 R376 R377 R386 R741 R742 R743 R744	RS3AD0470NA-R	RMGCFMIC 47R0 OHM +5% 0603	
R163 R168	RS3AD0471NA-R	RMGCFMIC 470R0 OHM +5% 0603	
R67 R146 R148 R201 R232 R329 R330 R336 R337 R630 R640 R649 R657 R666 R676 R684 R694 R721 R729	RS3AD0472NA-R	RES CHIP,4K7 1/16W +/-5%,0603	
R80 R81 R83 R84 R85 R86 R87 R88 R89 R90 R91 R102 R511 R512 R552 R553 R582 R583 R612 R613 R758 R759	RS3AD0473NA-R	RES CHIP,47K 1/16W +/-5%,0603	
R37	RS3AD0474NA-R	RMGCFMIC 470K0 OHM +5% 0603	
R635 R644 R654 R662 R673 R681 R690 R701 R722 R731	RS3AD0561NA-R	RES CHIP,560R 1/16W +/-5%,0603	
R634 R647 R648 R661 R671 R683 R689	RS3AD0562NA-R	RMGCFMIC 5K6 OHM +5% 0603	
R695	RS3AD0681NA-R	RES CHIP,680R 1/16W +/-5%,0603	
R73 BD38 BD44	RS3BB0000NA-R	RES CHIP 0 OHM +5% 100MIOH 0805	
R505 R509	RS3BB0101NA-R	RES,CHIP,100 OHM 1/10W +/-5%, 0805	
IC8	H03-ICC1G125DCK-R	IC SINGLE BUS BUFFER GATE SN74LVC1G125DCKT SOT(SC-70)DCKT	
R1 R752	RS3AD0221NA-R	RMGCFMIC 220R0 OHM +5% 0603	
R23	RS3AD0390NA-R	RES,CHIP 39 OHM 1/16W +/-5% 0603	
R231	RS3AD0750NA-R	RMGCFMIC 75R0 OHM +5% 0603	
R79	RS3AD0220NA-R	RES CHIP,22R 1/16W +/-5%,0603	
<i>Miscellaneous</i>			
BD2 BD3 BD16 BD42	H03-FB05B3580NN-R	BEAD AXIAL/TAP,HC3580 80.5ohm	
L301 L302 L303 L304	H03-LAINB0470CR-R	LF 47U0H +10% 5.8 OHM 500MIOA	
L101 L102 L103 L105 L107 L108 L421	H03-LAINB047ACR-R	LF 4U7H +10% 1.7 OHM 190.0A	
PO91	H03-ICLM19CIZIE-R	IC TEMPERATURE SENSOR LM19CIZ 2.4V TO-92	
Y101	H03-OSCEM05MORU-R	CERAMIC RESONATOR CSTLS_G 5.0MHz	
Y201	H03-OSCEM24M5RU-R	VCXO 24M576 HZ +50 PPM -50 PPM 0 OHM 3.3V	
Y301	H03-OSX06M0HZ00-R	CRYSTAL 6MHz 2P WOOIN HC-49/S_22PF	
NJ12	H03-SORA40RSANN-R	JACK RCA 4P JB040131ZN GN BN PP TA	
NJ11	H03-SORA40RSCNN-R	JACK RCA 4P JB040131QN WH BU RD GY	
NJ31 NJ32 NJ33	H03-SORX220751N-R	YKC22-0751N	
NJ34	H03-SOTX220750N-R	YKC22-0750N	
N931	H03-WE03B012000-R	WIRE ASS'Y UL1007#26 120MM 2.0MM 3P WHT	
N707	H03-WN02SD00000-R	CONN 2.5MM 2 MA ST NAT 5267-02A 0 0	US
P711 P712	H03-WN03SE00000-R	CON 3.96MM PITCH MOLEX 35313-0310	
P707	H03-WN04AB100WH-R	CONN WAFER 2.0MM 4P 35237-0410 WHT	
P704	H03-WN05SB00000-R	CONNECT 2.0mm 5P GIL-S-5P-S2T2-EF	

Ref. Designator	Part Number	Description	
DSP PCB ASS'Y			
N104	H03-WN07AB100WH-R	CONN WAFER 2.0MM 7P 35237-0710 WHT	
P815	H03-WN07SB100WH-R	CONN WAFER 2.0MM 7P 35336-0710 WHT	
N714	H03-WN09AB100WH-R	CONNECT WAFER 2.0mm 9P 35237-0910 WHT	
P703	H03-WN09SB0000-R	CONNECT 2.0mm 9P GIL-S-9P-S2T2-EF	
P713	H03-WN09SB100WH-R	CONNECT WAFER 2.0mm 9P 35336-0910 WHT	
N706	H03-WN15AB100WH-R	CONNECT WAFER 2.0mm 15P 35237-1510 WHT	
N705	H03-WN16AB100WH-R	CONNECT WAFER 2.0mm 16P 35237-1610 WHT	
N702 N710	H03-WN19AB0000-R	CONN 2.0MM 19 MA R NAT SOCKET MOLEX 35237-1910	
P701	H03-WN22DI0000-R	GF120-22S-TS 1.25mm 22P	
P709	H03-WN23DI0000-R	CONNECT GF120-23S-TS 1.25mm 23P	
BK10	H03-ZMD27S09A00-R	BRACKET BKT XM	
BD4 BD9 BD21 BD25 BD26 BD27 BD28 BD32 BD33 BD35 BD37 BD39 BD40 BD41 BD51 BD52 BD53 L706 L802	H03-FB3012012CF-R	FCM2012CF-301T04 0805	
BD5 BD36	H03-FB3012012CF-R	FCM2012CF-301T04 0805	US
BD24	H03-FYACF333TNN-R	FILTER ACF451832-333-T	
BD81	H03-FB2522012HF-R	FCM2012HF-252T02 2500ohm SURFACE MT 2012	
BD6 BD8 BD10 BD22 BD31 BD49 BD54	H03-FB3012012CF-R	FCM2012CF-301T04 0805	
Y1	H03-OSXNL4515B0-R	CRYSTAL 45.1584MHz 22p SO22320D5-45.1584-T&R	US
NJ35	H03-SOUSB45810B-R	JACK R41-5810B (Mitsumi) XM/DT connector	US
NJ36	H03-SOUSB5005K0-R	AU6-EC-005K0	
FRONT PCB ASS'Y			
<i>Capacitors</i>			
C119 C128 C551	CCZID0104NA-R	CC 100N0F +80% -20% 50.0V F	
C517	H03-CEHEC02275E-R	CE 220UF +20% 10.0V P=5MM 85C SK 220/10V 5 X11	
C503 C504	H03-CEHFC01062S-R	CE 10UF +20% 16V D4XL7 P2.5MM 2000hours 85C	
C127	CEHFC0107NN-R	CE 100U0F +20% 16.0V 85C	
C718	H03-CEHFC04765E-R	CE47UF +20% 16.0V D5XL11 P5MM 85C SK 47/16V 5 X11	
C501 C502	H03-CEHFC04762S-R	CE 47UF +20% 16V D5XL7 P2.5MM 2000hours 85C	
C125 C126	H03-CFHKA0473NN-R	CAP POLYESTER METAL 47NF 100V 20% CPM	
C708	H03-CEHFC01072S-R	CE 100UF +20% 16V D6.3XL7 P2.5MM 2000hours 85C	
C701 C704 C706	CZDII0100CE-R	CAP CERAMIC/CHIP 10PF 50V CH D N 0805	
C120 C121 C122 C400 C401 C403 C404 C717 C725 C726 C727 C900	CZJII0101BE-R	CAP CHIP 100P0F +5% -5% 50.0V NP0 0603	
C702	CZJII0101CE-R	CAP CERAMIC/CHIP 100PF 50V CH J NPO 0805	
C703 C705	CZJII0122CC-R	CAPCHIP 1n2F 50V SL J X7R 0805 +/-5%	
C300 C301	CZJII0821CE-R	CAP CHIP 820pF 50V SL J NP0 0805	
C506	CZKII0221BA-R	CAP CHIP 220PF 50V K SL 0603	
C252 C253	CZKII0222BC-R	CAP CHIP 2N2F +10% -10% 50.0V X7R 0603	
C201 C211	CZKII0223BC-R	CAP CHIP 22N0F +10% -10% 50.0V X7R 0603	
C1 C2 C124 C251 C254 C405 C406 C407 C411 C521 C552 C553 C580 C581 C582 C709 C723	CZZFI0104BF-R	CAP CHIP 100N0F +80% -20% 16.0V Y5V 0603	
C724 R505 R841 R842 R843 R844	RS3AD0000NA-R	RES CHIP, 0 R 1/16W +/-5%, 0603	
<i>Semiconductors</i>			
D301	H03-DG1N04148NB-R	D-SLP 1N4148 100.0V 150E-3A	
D716	H03-DR1N04004NA-R	D-SR 1N4004 400.0V 1.0A	
D853 D854 D855 D856	H03-DL30B2015AA-R	D-LEM 30B3-20-15 GaN SUPER BLUE WATER CLEAR 15 ML37B23H-CED	
D831	H03-DL3BA05V0BA-R	D-LEM BLUE/AMBER 3PIE RD RND L-3VYMB	
D800	H03-DLRED3FRDBA-R	D-LEM RED/GREEN 3F RD RND CL	
Q821	H03-TRMPSA06NNA-R	TR-SLPLF MPSA06 N 500MIOA TO-92 NPN	
Q823	H03-TRMPSA56YNA-R	TR-SLPLF MPSA56 Y PNP -500MIOA -300V	
D251 D252 D411 D412 D701 D715 D721 D722	H03-DS1S50094NB-R	D-SLP 1SS355 35.0V 225MIOA	
D110	H03-DSUDZ05V1NB-R	DIODE ZENER UDZ5.1B 5.1V 200MIOW	
IC50	H03-ICLM02068D2-R	IC-OPERAMP NJM2068M-TE1 DUAL SOP8	
Q800 Q801 Q820 Q822 Q833	H03-TSKRC107SND-R	KRC107S SOT-23 NPN	
Q703	H03-TRKTA1504ND-R	TRANSISTOR PNP KTA1504Y(S)SOT-23	
Q701 Q702	H03-TRKTC3875ND-R	TRANSISTOR NPN KTC3875S SOT23	

Ref. Designator	Part Number	Description
FRONT PCB ASS'Y		
Q824 Q831 Q832	H03-TSKRA107SNI-R	KRA107S SOT-23 PNP
<i>Resistors</i>		
R118 R119	RC3DI0100IN-R	RCF 10R0 OHM +5% 250MI0W
R122 R123 R501 R502	RC3DI0101IN-R	RCF 100R0 OHM +5% 250MI0W
R831	RC3DI0151IN-R	RCF 150 OHM 5% 1/4W
R518	RC3DI0182IN-R	RCF 1K8 OHM 5% 1/4W
R801	RC3DI0201IN-R	RCF 200R0 OHM +5% 250MI0W
R251 R252	RC3DI022AIN-R	RCF 2R2 OHM +5% 250MI0W
R800	RC3DI0271IN-R	RCF 270R0 OHM +5% 250MI0W
R832	RC3DI0331IN-R	RCF 330R0 OHM +5% 250MI0W
R120 R121	RC3DI0471IN-R	RCF 470R0 OHM +5% 250MI0W
R751	RC3DI0473IN-R	RCF 47K OHM +5% 250MI0W
R851 R852	RC3DI0561IN-R	RCF 560R0 OHM +5% 250MI0W
R522 R722 R746	RS3AD0101NA-R	RES CHIP,100R 1/16W +/-5%,0603
R201 R211 R503 R515 R721 R824	RS3AD0102NA-R	RES CHIP,1K 1/16W +/-5% ,0603
R702 R704 R709 R822	RS3AD0103NA-R	RES CHIP,10K 1/16W +/-5% ,0603
R516	RS3AD0104NA-R	RES CHIP,100K 1/16W +/-5% ,0603
R706 R707	RS3AD0105NA-R	RES CHIP 1M 1/16W +5% 0603
R202 R212	RS3AD0122NA-R	RMGCFMIC 1K2 OHM +5% 0603
R203 R213	RS3AD0152NA-R	RES CHIP 1K5 1/16W +5% 0603
R209 R219	RS3AD0183NA-R	RMGCFMIC 18K0 OHM +5% 0603
R823	RS3AD0221NA-R	RMGCFMIC 220R0 OHM +5% 0603
R204 R214 R510 R519	RS3AD0222NA-R	RMGCFMIC 2K2 OHM +5% 0603
R205 R215 R703	RS3AD0272NA-R	RMGCFMIC 2K7 OHM +5% 0603
R206 R216 R506	RS3AD0332NA-R	RMGCFMIC 3K3 OHM +5% 0603
R509	RS3AD0472NA-R	RES CHIP,4K7 1/16W +/-5%,0603
R520	RS3AD0473NA-R	RES CHIP,47K 1/16W +/-5%,0603
R207 R217	RS3AD0562NA-R	RMGCFMIC 5K6 OHM +5% 0603
R821	RS3AD0563NA-R	RES CHIP, 56K 1/16W +/-5%, 0603.
R301 R302 R701	RS3AD0683NA-R	RMGCFMIC 68K0 OHM +5% 0603
R461 R462	RS3AD0753NA-R	RES CHIP 75K 1/16W +/-5% 0603.
R208 R218	RS3AD0822NA-R	RMGCFMIC 8K2 OHM +5% 0603
R508	RS3AD0911NA-R	RMGCFMIC 910 OHM +5% 0603
R705	RS3BB0564NA-R	RES,CHIP,560K OHM,1/10W +/-5%,0805
VR10	H03-SWE3A0505S1-R	SWIROT EC16B24204A9 5V 500U0A 10T 3P 0 0
<i>Miscellaneous</i>		
L700	H03-FB2522012HF-R	FCM2012HF-252T02 2500ohm SURFACE MT 2012
L251	H03-LAINB0470CR-R	LF 47U0H +10% 5.8 OHM 500M0A
L120	H03-LAINB047ACR-R	LF 4U7H +10% 1.7 OHM 190.0A
RM72	H03-DPLP200LNNN-R	PIN PHOTO DIODE LP-200TL
NJ79	H03-SOTORX177LT-R	FIBER OPTIC RECEIVING TORX177L (F, T)
NJ71	H03-SO3P5179NNN-R	JACK PHONE 3.5PI PJ0435179N
NJ70	H03-SORA1JE01NN-R	JACK RCA 1P JE010003MN GND OR
NJ11	H03-SORA3313PNN-R	CON PHONO SCKT RCA-313P 3 PINS
NJ12	H03-SORA8OSC5N8-R	JACK S-VIDEO 1P C40160261N
NJ10	H03-SOSS9CKX3NN-R	JACK PHONE 6.35 H70980110S 9P BK
N207	H03-WE11B041000-R	WIRE ASS'Y UL1007#26 410MM 2.0MM 11P WHT
N201	H03-WG03AB80900-R	WIRECONASY DL 2.0MM 03P 90MM ANG-DOWN UL1007 RIBBON 26 1 B20
N206	H03-WG05SB83500-R	WIRE ASS'Y UL1007#26(TA) 350mm 2.0mm 5p GRY
N203	H03-WG13SB82000-R	UL1007#26 STR 200mm 2.0mm 13P WHT
P213	H03-WN04SB00000-R	CONNECT 2.0mm 4P GIL-S-4P-S2T2-EF
P215	H03-WN06SB01000-R	CNT PLUG BD'BD PLUG 2.0mm 35336-0610
P209	H03-WN07AB00000-R	CONNECT 2.0MM 7P GIL-S-07P-S2L2-EF
N214	H03-WN19AB00000-R	CONN 2.0MM 19 MA R NAT SOCKET MOLEX 35237-1910
P216	H03-WN19SB00000-R	CONN 2.0MM 19 MA ST NAT MOLEX 35336-1910 0 0
N205	H03-WN22AI00000-R	GF120-22S-LS 1.25mm 22P
N204	H03-WS4261005FN-R	WIRE ASS'Y UL2547/1007#26 100MM 4P 2.0MM WHT
N202	H03-WS4265913FN-R	CNT ASSY 2.0MM 4P 590MM SHIELD 26AWG UL2547 1/3
N210	H03-WS5263805NG-R	WIRE ASS'Y UL2547#26(TA) 380mm 2.0mm 5P GRY
N212	H03-WS5248505CW-R	WIRE ASS'Y UL1007/1533#24(TA)850mm 2.0mm 5P WHT
N208	H03-WS6265105EN-R	WIRECONASY DL 2.0MM 6P 510MM UL1533 SHIELD 26 1
N211	H03-WS7260805EN-R	WIRE ASS'Y UL1533/1007#26 80MM 2.0MM 7P WHT SHILED
FL1	H03-XD18BT19GNA-R	18-BT-19GINK
S1 S2 S3 S4 S5 S6 S7 S8 S9	H03-ZMB01S02200-R	SPRING PLATE GND C5212 0.2T
M2	H03-ZMC12S17A00-R	AC PUN SHIELD DIGITAL ET

Ref. Designator	Part Number	Description
HDMI PCB		
M3	H03-ZMD12S01A00-R	SHIELD IR
M4	H03-ZMD12S01B00-R	SHIELD MICROPHONE
RM71	H03-ICROMN338EC-R	REMOCON RECEIVER MODULE ROM-N338TEC
RM71	ZFNR1SENSOR-R	RUBBER SENSOR
	ZPD2703ZANA-R	LED SPACER SUPPORT AVR745,NYLON66(UL),94V-2,LED3-1A
	WC1260205AB-R	WIRE,UL26 2CM,BLACK
S201 S202 S203 S204 S205 S206 S207 S208 S209 S210 S211 S212 S213 S214 S215 S216 S217 S218 S219 S220	H03-SWC2A112FS1-R	SWI TACT VERTICAL SKQNADD010
<i>Capacitors</i>		
C201 C265	H03-CEHDC0108NN-R	CE 1000UF +20% 6.3V 8X11.5 85C P5MM
C247	H03-CEHEC01075E-R	CE 100U0F +20% 10.0V 5X11 85C P5MM SK 100/10V 5 X11
C262	CEHEC02275E-R	CE 220UF +20% 10.0V D6.3XL11 P5MM 85C
C601 C604 C607	H03-CEHFC01062S-R	CE 10UF +20% 16V D4XL7 P2.5MM 2000hours 85C
C106 C108 C231 C235 C270 C273 C276 C281	H03-CEHFC0106NN-R	CE 10U0F +20% 16.0V 85C 5X11 P5MM SK 10/16V 5 X11
C204 C251 C253 C259 C263	H03-CEHFC01075E-R	CE 100UF +-20% 16.0V D5XL11 P5MM 85C SK 100/16V 5 X11
C229	H03-CEHFC04765E-R	CE47UF +20% 16.0V D5XL11 P5MM 85C SK 47/16V 5 X11
C255 C256 C606	H03-CEHIC01055E-R	CE 1UF +20% 50V D5XL11 P5MM 85C SK 1/50V 5 X11
C102 C111 C249 C252 C254 C258 C261 C264	H03-CEMFC0226NN-R	CAP ELEC 22UF 16V M P5MM SK 22/16V 5 X11
C114 C115 C116 C117 C118 C119 C120 C121 C122 C123 C124 C125 C248 C260 C268 C269 C272 C275 C279 C280	CZKII0103BC-R	CAP CHIP 10N0F +10% -10% 50.0V X7R 0603
C104 C107 C109 C230 C236 C237 C238 C239 C240 C241 C242 C243 C266 C267 C271 C274 C277 C278	CZZFI0104BF-R	CAP CHIP 100N0F +80% -20% 16.0V Y5V 0603
C112	CZZFI0334BF-R	0.33uF 16V -20/+80% Y5V 0603
C226 C227	CZJII0330BE-R	CAP CHIP 33P0F +5% -5% 50.0V NPO 0603
C207 C213 C228	CZJII0101BE-R	CAP CHIP 100P0F +5% -5% 50.0V NPO 0603
C602 C605	CZJII0330BE-R	CAP CHIP 33P0F +5% -5% 50.0V NPO 0603
C217 C219	CZJII0331BE-R	CAP CHIP 330P0F +5% -5% 50.0V NPO 0603
C110	CZJII0471BE-R	CCCFMIC 470P0F +5% -5% 50.0V NPO
C206 C209 C212	CZJII0680BE-R	CAPACITOR CERAMIC CHIP 68PF 50V CH J NPO 0603
C225	CZKFI0823BC-R	CAP CHIP 82NF +/-10% 16V 0603 X7R
C113	CZKII0102BC-R	CAP CHIP 1N0F +10% -10% 50.0V X7R 0603
C224	CZKII0103BC-R	CAP CHIP 10N0F +10% -10% 50.0V X7R 0603
C215	CZKII0221BA-R	CAP CHIP 220PF 50V K SL 0603
C603 C221 C222 C223 C232 C233 C244 C245 C246 C250 C257	CZZFI0104BF-R	CAP CHIP 100N0F +80% -20% 16.0V Y5V 0603
C208 C211 C214 C216 C218 C220	CZZFI0224BF-R	CAP CHIP 220NF 16V Y5V +80%-20% 0603
C130 R100 R101 R104 R105 R108 R110 R111 R153	RS3AD0000NA-R	RES CHIP, 0 R 1/16W +/-5%, 0603
C210	CZJII0470BE-R	CAP CHIP 47P0F +5% -5% 50.0V NPO 0603
<i>Semiconductors</i>		
IC102	H03-ICMM1665AD2-R	IC MONOLITHIC MM1665AHBE HOSP-8
D601 D602 D604 D605 D606	H03-DS05GBUSCNB-R	DIODE PG05GBUSC
IC107	H03-DSAMP0514MN-R	DIODE TVS ARRAY RCLAMP0514M MSOP-10L
D100 D101 D102	H03-DSBAV99LTNB-R	DIODE SWITCHING BAV99LT1G SOT-23
IC25	H03-ICIL1117SDG-R	IC LOW DROP REGULATOR IL1117S-1.8 1.8V SOT-223
D104 D607	H03-DS1S50094NB-R	D-SLP 1SS355 35.0V 225M10A
IC103 IC104 IC105 IC106 L110	H03-DSAMP0514MN-R	DIODE TVS ARRAY RCLAMP0514M MSOP-10L
D608	H03-DSKDZ3V30NB-R	DIODE ZENER,KDZ3.3EV KEC
D103	H03-DZMTZ06V2NB-R	UDZS 6.2B 6.2V 200mW UMD2
IC101	H03-IC74LVC254D-R	IC SN74LVC257AD SOIC-16 Quadruple 2-Line To 1-Line Data Selector/Multiplexer With 3-State Outputs
IC22	H03-ICADV717248-R	IC DIGITAL PAL/NTSC ADV7172KSTZ LQFP48
IC21	H03-ICADV7180E6-R	IC SDTV VIDEO DECODER,ADV7180BSTZ LQFP-64
IC61	H03-ICLM02068D2-R	IC-OPERAMP NJM2068M-TE1 DUAL SOP8
IC23 IC24	H03-ICMM1566AD2-R	MM1566AFBE SOP8
IC100	H03-ICTMDS341E9-R	IC DVI/HDMI SWITCH,TMDS341 TQFP-80

Ref. Designator	Part Number	Description
HDMI PCB		
Q100 Q103	H03-TSKRC107SND-R	KRC107S SOT-23 NPN
<i>Resistors</i>		
R618 R619	RS1AD0750NA-R	RES CHIP 75OHM 1% 1/16W 0603
R109 R124 R602 R603	RS3AD0000NA-R	RES CHIP, 0 R 1/16W +/-5%, 0603
R258 R259	RS3AD0101NA-R	RES CHIP,100R 1/16W +/-5%,0603
R102 R103 R106 R107	RS3AD0102NA-R	RES CHIP,1K 1/16W +/-5% ,0603
R224 R225	RS3AD0222NA-R	RMGCFMIC 2K2 OHM +5% 0603
R239	RS1AD0604NA-R	604 ohm 1/16W 1% 0603
VR104	H03-VR0603V150R-R	VARISTOR CHIP CT0603V150RFG
R240	RS1AD0604NA-R	604 ohm 1/16W 1% 0603
R203 R206 R209 R211 R212 R214 R215 R216 R217 R255 R256 R257 R617	RS1AD0750NA-R	RES CHIP 75OHM 1% 1/16W 0603
R241 R243 R253	RS1AD1430NA-R	RESISTOR CHIP,143 ohm 1/16W 1% 0603
R202 R205 R208 R245 R247 R251	RS1AD1470NA-R	147 ohm 1/16W 1% 0603
R219	RS1AD1691NA-R	RES CHIP 1K69 ohm 1/16W 1% 0603
R123	RS1AD4641NA-R	4.64K ohm 1/16W 1% 0603
R260	RS3AD0102NA-R	RES CHIP,1K 1/16W +/-5% ,0603
R132 R133 R218 R234 R235 R236 R237 R238 R606 R610 R611	RS3AD0103NA-R	RES CHIP,10K 1/16W +/-5% ,0603
R615	RS3AD0104NA-R	RES CHIP,100K 1/16W +/-5% ,0603
R612	RS3AD0124NA-R	RES CHIP,120K 1/16W +/-5%,0603
R204 R207 R210	RS3AD0151NA-R	RMGCFMIC 150R0 OHM +5% 0603
R213	RS3AD020ANA-R	2 ohm 1/16W 5% 0603
R607 R608	RS3AD0223NA-R	RES CHIP,22K 1/16W +/-5%,0603
R609	RS3AD0224NA-R	RES CHIP,220K 1/16W +/-5%,0603
R222 R223 R226 R227 R228 R229 R230 R231 R232 R233 R614	RS3AD0470NA-R	RMGCFMIC 47R0 OHM +5% 0603
R112 R113 R114 R115 R116 R117 R118 R119 R120 R121 R122 R131 R220	RS3AD0472NA-R	RES CHIP,4K7 1/16W +/-5%,0603
R604 R605 R613	RS3AD0473NA-R	RES CHIP,47K 1/16W +/-5%,0603
R601	RS1AD5493NA-R	RES,CHIP 549K 1/16W +/-1% 0603
R221	RS3AD0105NA-R	RES CHIP 1M 1/16W +5% 0603
R145 R146	RS3AD0822NA-R	RMGCFMIC 8K2 OHM +5% 0603
R242 R244	RS3AD082ANA-R	RES, CHIP, 8.2, 1/16W, +/-5%, 0603
R246	RS3AD0120NA-R	RES, CHIP, 12 OHM, 1/16W, +/-5%, 0603
R250	RS3AD051ANA-R	RES.CHIP 5R1 1/16W +/-5% 0603
R252	RS3AD0200NA-R	RES,CHIP 20 OHM 1/16W +/-5% 0603
R254	RS3AD0240NA-R	RES CHIP, 24 OHM 1/16W +/-5% 0603
VR100 VR101 VR102 VR103 VR105	H03-VR0603V150R-R	VARISTOR CHIP CT0603V150RFG
<i>Miscellaneous</i>		
L111 L112	H03-LS2012H9002-R	CHOKE COIL ACM2012H-900-2P
L100 L102 L103 L211 L212	H03-FB05B3580NN-R	BEAD AXIAL/TAP,HC3580 80.5ohm
Y200	H03-OSX2863HZ00-R	CRYSTAL,28.6363MHz HC-49/S
P203	H03-WN04SB00000-R	CONNECT 2.0mm 4P GIL-S-4P-S2T2-EF
P200	H03-WN05SB00000-R	CONNECT 2.0mm 5P GIL-S-5P-S2T2-EF
N607	H03-WN05SB26000-R	WIRE ASS'Y,UL1533/2547#26(TA) 260mm 2.0mm 5P GRY
N608	H03-WN10AB000WH-R	CONNECT WAFER 2.0mm 10P 35237-1010 WHT
BK10	H03-ZMD27S05A00-R	BKT IPOD
K100	H03-RL0517811A-R	RELAY D3009(1-1462033-4)
N202	H03-WG12SB06000-R	WIRE ASS'Y UL1007#26(TA) 60mm 2.0mm 12P WHT
N201	H03-WG15SB06000-R	WIRE ASS'Y UL1007#26(TA) 60mm 2.0mm 15P WHT
L123 L213 L214 L216	H03-FB1212012KF-R	FCM2012KF-121T08 120ohm 2012
L203 L204 L205	H03-FB2012F1R5K-R	FCI2012F-1R5K 1.5UH 0805
L200 L201 L202	H03-FB2012F3R9K-R	FCI2012F-3R9K 3.9UH 0805
L113 L114	H03-LS2012H9002-R	CHOKE COIL ACM2012H-900-2P
L215	H03-FB1212012KF-R	FCM2012KF-121T08 120ohm 2012
NJ60	H03-SO1R018H91E-R	DA1R018H91E
NJ10 NJ2 NJ12	H03-SOYKF457009-R	JACK HDMI YKF45-7009 JALCO
F100	H03-SWNANDC1502-R	SWITCH POLY NANOSMDC150F-2 SMD

Ref. Designator	Part Number	Description	
MAIN PCB ASS'Y			
<i>Capacitors</i>			
C101 C102 C103 C104 C107 C108 C109 C110 C111 C112 C113 C114 C115 C116 C117 C118 C205	CCKID0101NA-R	CC 100P0F +10% -10% 50.0V Y5P	
C313 C314 C569 C570	CCKID0271NN-R	CC 270P0F +10% -10% 50.0V 2B4	
C433	CCMFD0103NN-R	CC 10N0F +20% -20% 16.0V Y5S	
C119 C120 C203 C212 C214 C527 C531 C709 C711 C712 C713	CCZID0104NA-R	CC 100N0F +80% -20% 50.0V F	
C307 C308 C403 C404	CCJID0680NA-R	CAPACITOR CERAMIC AXIAL 68PF 50V +5% -5%	
C329 C330 C425 C426	CCKIC0222NA-R	CC 2N2F +10% -10% 50.0V Y5P	
C707	CCZGC0104NA-R	CAP CERAMIC 100NF 25V Z Z5U TAP	
C331 C332 C407 C408	H03-CEHEC02275E-R	CE 220UF +20% 10.0V P=5MM 85C SK 220/10V 5 X11	
C206 C208 C213 C309 C310 C405 C406 C526 C710	H03-CEHGC01075E-R	CE 100U0F +20% 25.0V 6.3X11 85C P5MM SK 100/25V 6.3 X11	
C210	H03-CEHIC01055E-R	CE 1UF +20% 50V D5XL11 P5MM 85C SK 1/50V 5 X11	
C301 C302 C401 C402 C518 C519 C521 C530 C708 C429	H03-CEHIC01065E-R	CE 10U0F +20% 50.0V 85C P5MM 5X11 SK 10/50V 5 X11	
C207	H03-CEHIC04755E-R	CE 4U7F +20% 50.0V 85C P5MM SK 4.7/50V 5 X11	
C303 C304 C305 C306 C421 C422 C423 C424	H03-CEHJA0477MN-R	CE 470U0F +20% 63.0V 85C SK 470/63V 13 X21	
C706	H03-CEMFA0828J0-R	CAP ELECTROYTIC 8200uF 16V M 16x32 P7.5mm SM1C822MNN1632 ELITE	
C432	H03-CEMGC04775E-R	CE 470U0F +/-20% 25.0V 10X13 85C SK 470/25V 10 X13	
C323 C324 C430 C431	CFLJC0683NN-R	CPM 68N0F +5% 63.0V	
C506 C507 C508 C516 C528 C529 C701 C702 C703	CPIKC0473NN-R	CPF 47N0F +10% 100.0V	
C211 C319 C320 C413 C414	H03-CEMKC0106NA-R	CAP ELECTROYTIC,10uF 100V M 6.3x11 P=5.0MM	
C315 C316 C409 C410	CCJIC0120NN-R	CAP CERAMIC 12PF 50V J CH TAP	
C317 C318 C411 C412	CCJIC0330NE-R	CAP CERAMIC 33PF 50V +-5% NPO	
C325 C326 C327 C328 C417 C418 C419 C420	H03-CPJJC0104NN-R	CAP POLYESTER NON METAL 0.1uF 63V J TAP PCMT365 76104	
C573	H03-CEMDC0478KA-R	CAP ELECTROYTIC 4700UF 6.3V M 12.5X21 (SKP472M0J121R)I	
C509 C510	CEHHC0228MN-R	CE 2M12F +20% 35.0V 85C	
C571 C572	H03-CEMJA0129KB-R	12000uF 63V M 35x45 LSW123M1JQ45M	
C517	H03-CEHIA0228MN-R	CE 2200UF +20% 50.0V 85C 16X35	
C705	H03-CEMFA0688BK-R	CAP ELEC 6800UF 16V M 16X25 85C 120HZ SK 6800/16V 16 X25	
C333 C335 C336 C434	CCKIC0103NA-R	CC 10N0F +10% -10% 50.0V Y5P	
C201 C202	CZJII0101BE-R	CAP CHIP 100P0F +5% -5% 50.0V NP0 0603	
C105 C106	CZZFI0104BF-R	CAP CHIP 100N0F +80% -20% 16.0V Y5V 0603	
<i>Semiconductors</i>			
D104 D205 D206 D301 D302 D303 D304 D305 D306 D307 D308 D401 D402 D403 D404 D405 D406 D407 D408 D409 D410 D411 D412D603	H03-DG1N04148NB-R	D-SLP 1N4148 100.0V 150E-3A	
D101 D102 D103 D508 D509 D703	H03-DR1N04004NA-R	D-SR 1N4004 400.0V 1.0A	
D204	H03-DZGE12V10MA-R	MZ0.5GE12V-10 12V 10mA	
D207	H03-DZGE3V320MA-R	DIODE ZENER MZ0.5GE3V3-20 3.3V 20mA	
Q309 Q310 Q411 Q412	H03-TR2SA1145YF-R	TRANSISTOR PNP 2SA1145-Y(F) TO-92 HFE:120-240	
Q443	H03-TRKRC107MNA-R	TR-SLPSWA KRC107M NPN	
Q442	H03-TRKTA1024NA-R	TR-SLPLF KTA1024 Y PNP 50MI0A -150V	
Q311 Q312 Q410 Q413 Q414	H03-TRKTA1268NA-R	TR-SHPLF KTA1268BL PNP 100MI0A 120V	
Q307 Q308 Q407 Q408 Q426 Q441	H03-TRKTC3198NA-R	TR-SLPLF KTC3198BL NPN 150MI0A	
Q301 Q302 Q303 Q304 Q305 Q306 Q313 Q314 Q337 Q338 Q401 Q402 Q403 Q404 Q405 Q406 Q409 Q415 Q416 Q425	H03-TRKTC3200NA-R	TR-SHPLF KTC3200BL NPN 100MI0A 120V	
Q601	H03-TRKTD1302NA-R	TR-SLPLF KTD1302 B NPN 300MI0A 20V	
D502 D505	H03-DU2W04MMF00-R	DIODE 2W04M-MF RC-2 Kink Type	
D701	H03-DUKBU6GMF6N-R	KBU6G-MF RS-6 Kink Type	
IC73	H03-ICKIA278R06-R	IC VOLTAGE REGULATOR KIA278R06PI TO-220IS-4	
IC71	H03-ICKIA278R33-R	IC VOLTAGE REGULATOR KIA278R33PI TO-220IS-4	

Ref. Designator	Part Number	Description
MAIN PCB ASS'Y		
IC72	H03-ICKIA7805I2-R	IC-REGULATOR KIA7805API NORMAL TO-220IS + 5v
IC59	H03-ICKIA7812I2-R	IC-REGULATOR KIA7812API NORMAL +12V
IC54	H03-ICKIA7824I2-R	IC-REGULATOR KIA7824API TO-220IS NORMAL +24V
IC51 IC60	H03-ICLM07815BD-R	IC-REGULATOR KIA7815API NORMAL +15V
IC52	H03-ICLM07915BD-R	IC-REGULATOR KIA7915API NORMAL TO-220AB -15V
Q335 Q336 Q439 Q440	H03-TR2SB1647B0-R	2SB1647 MT-100 PNP
Q333 Q334 Q437 Q438	H03-TR2SD2560B0-R	2SD2560 MT-100 NPN
Q315 Q316 Q417 Q418	H03-TRKTA1360BE-R	TRANSISTOR PNP KTA1360 TO-126
Q701 Q702 Q703 Q704	H03-TRKTC3114NE-R	TRANSISTOR NPN KTC3114 TO-126
Q317 Q318 Q419 Q420	H03-TRKTC3423BE-R	TRANSISTOR NPN KTC3423 TO-126
IC22	H03-ICLM02068D2-R	IC-OPERAMP NJM2068M-TE1 DUAL SOP8
D210	H03-DS05GBUSCNB-R	DIODE PG05GBUSC
<i>Resistors</i>		
R702 R705 R708 R709	RC3DI0911IN-R	RCF 910R0 OHM +5% 250MI0W
R351 R352 R367 R368 R445 R446 R447 R448	H03-RM3EG0100LN-R	RMF 10R0 OHM +5% 500MI0W
R303 R304 R388 R389 R473 R474 R477 R478	RC3DI0100IN-R	RCF 10R0 OHM +5% 250MI0W
R213 R221 R717	RC3DI0101IN-R	RCF 100R0 OHM +5% 250MI0W
R211 R508 R601	RC3DI0102IN-R	RCF 1K0 OHM +5% 250MI0W
R485 R706 R714	RC3DI0103IN-R	RCF 10K0 OHM +5% 250MI0W
R207 R214 R216 R217 R218 R219 R220 R309 R310 R479 R480 R602	RC3DI0104IN-R	RCF 100K0 OHM +5% 250MI0W
R103 R104	RC3DI010AIN-R	RCF 1R0 OHM +5% 250MI0W
R311 R312 R313 R314 R380 R381 R386 R387 R405 R406 R407 R408 R481 R483 R488 R490	RC3DI0152IN-R	RCF 1K5 OHM +5% 250MI0W
R384 R385 R482 R489	RC3DI0153IN-R	RCF 15K0 OHM +5% 250MI0W
R215 R317 R318 R319 R320 R409 R410 R411 R412	RC3DI0221IN-R	RCF 220R0 OHM +5% 250MI0W
R341 R342 R343 R344 R390 R391 R437 R438 R439 R440 R486 R492 R516	RC3DI0223IN-R	RCF 22K0 OHM +5% 250MI0W
R107 R108 R616	RC3DI022AIN-R	RCF 2R2 OHM +5% 250MI0W
R321 R322 R413 R414 R497	RC3DI0271IN-R	RCF 270R0 OHM +5% 250MI0W
R209 R498 R506	RC3DI0273IN-R	RCF 27K0 OHM +5% 250MI0W
R224	RC3DI0274IN-R	RCF 270K0 OHM +5% 250MI0W
R701 R707 R710 R711	RC3DI0282IN-R	RCF 2K8 OHM +5% 250MI0W
R301 R302 R401 R402	RC3DI0331IN-R	RCF 330R0 OHM +5% 250MI0W
R225 R305 R306 R403 R404 R509 R515	RC3DI0333IN-R	RCF 33K0 OHM +5% 250MI0W
R363 R364 R365 R366 R461 R462 R463 R464	RC3DI033AIN-R	RCF 3R3 OHM +5% 250MI0W
R382 R383 R484 R487 R491	RC3DI0393IN-R	RCF 39K0 OHM +5% 250MI0W
R307 R308 R415 R416	RC3DI0433IN-R	RCF 43K0 OHM +5% 250MI0W
R101 R102 R105 R106 R109 R110 R113 R114 R315 R316 R593 R594 R718	RC3DI0471IN-R	RCF 470R0 OHM +5% 250MI0W
R223	RC3DI0513IN-R	RCF 51K0 OHM +5% 250MI0W
R323 R324 R325 R326 R329 R330 R333 R334 R335 R336 R337 R338 R421 R422 R423 R424 R425 R426 R427 R428 R429 R430 R431 R432	RC3DI0561IN-R	RCF 560R0 OHM +5% 250MI0W
R493	RC3DI0822IN-R	RCF 8K2 OHM +5% 250MI0W
R327 R328 R417 R418	RM1DI0333IN-R	RMF 33K0 OHM +1% 250MI0W
R331 R332 R419 R420	RM1DI1701NA-R	RESISTOR METAL OXIDE,1K7 ohm 1/4W 1%
R339 R340 R345 R346 R433 R434 R435 R436	RC3DI0470NN-R	REC,CARBON,47,1/4W,+/-5%,SIZE=1/8W
R378 R379 R471 R472	H03-RI3IC022BEN-R	RW 220MI0 OHM +5% 5.0W 100PPM/C -100PPM/C
R392 R393 R475 R476	H03-RM3FC0100BN-R	RES METAL OXIDE 10R OHM+5% 1.0W
R514 R517 R518	H03-RM3GC022ACN-R	RESISTOR METAL OXIDE 2R2 OHM +5% 2.0W
R504 R507 R510 R703 R704 R715 R716	H03-RM3GC033ACN-R	RESISTOR METAL OXIDE 3R3 OHM +5% 2.0W

Ref. Designator	Part Number	Description	
MAIN PCB ASS'Y			
R505	H03-RM3GC047ACN-R	RESISTOR METAL OXIDE 4R7 +5% 2.0W	
VR74	H03-RT7EA0201NB-R	PR 200R0 OHM +20% 500M10W	
VR71 VR72 VR73	RT6BA0201NB-R	PR 200R0 OHM +30% 100M10W	
<i>Miscellaneous</i>			
F501 F502 F505 F506	H03-FURN22000SR-R	FUSE SR-5 SERIES 3821200 SR-5-2A 250V 35A	
F701 F702	H03-FURN23150SR-R	FUSE SR-5 SERIES 3821315 SR-5-3.15A 250V 35A	
G102 G103	H03-ZNMSA4004SN-R	TERMLUG GND	
PO71	H03-ICLM19CIZIE-R	IC TEMPERATURE SENSOR LM19CIZ 2.4V TO-92	
L301 L302 L401 L402	H03-LCNNNA050NA-R	LFA 1MM 10MM 5 LEFT 0.0MM NONE SP-2516	
NJ81	H03-SOPA81900NN-R	CONN-SPE TERMINAL SPKR 8P SH081136JP FE 19MM 8 -- 0 0	
NJ83	H03-SORA40RSANN-R	JACK RCA 4P JB040131ZN GN BN PP TA	
NJ82	H03-SORA40RSCNN-R	JACK RCA 4P JB040131QN WH BU RD GY	
N706	H03-WG02SD03801-R	WIRE ASS'Y,UL1007#24(TA) GRY 380mm 2.5mm 2P	US
N814	H03-WG03SE03700-R	WIRE ASS'Y UL1007#16(TA) 370mm 3P GRY	
N807	H03-WG05AB81900-R	WIRE ASS'Y UL1007#26(TA)190MM 2.0MM 5P WHT	
P503 P805 P806 P809 P817 P818	H03-WN02SD00000-R	CONN 2.5MM 2 MA ST NAT 5267-02A 0 0	
N819 N820 N821 N823	H03-WN04AB100WH-R	CONN WAFER 2.0MM 4P 35237-0410 WHT	
P801 P802 P803 P804	H03-WN04SB100WH-R	CONN WAFER 2.0MM 4P 35336-0410 WHT	
P808	H03-WN05SD100WH-R	CONN WAFER 2.5MM 5P 5267-05A WHT	
P815	H03-WN07SB100WH-R	CONN WAFER 2.0MM 7P 35336-0710 WHT	
N822	H03-WN09AB100WH-R	CONNECT WAFER 2.0mm 9P 35237-0910 WHT	
P811	H03-WN09SB100WH-R	CONNECT WAFER 2.0mm 9P 35336-0910 WHT	
P816	H03-WN10SB100WH-R	CONNECT WAFER 2.0mm 10P 35336-1010 WHT	
P812	H03-WN13SB00000-R	CONN 2.0MM 13P GIL-S-13P-S2T2	
P813	H03-WN19SB00000-R	CONN 2.0MM 19 MA ST NAT MOLEX 35336-1910 0 0	
NJ84	SO0A18P8CNN-R	JACK-TELE SNAP-IN GOLDEN TELECOM GDL1-8P8C 8T BK 0 0	
	H03-ZH740MSQ6WH-R	MICA SHEET SIZE 19X22X0.05	
	ZNMSM3023HN-R	M3 NUT, 2.3MM THICK, NI-PLATE	
	ZSMBM3014BZ-R	SCREW M.S M3X14 ZN PLATED	
PROCESSOR PCB			
<i>Capacitors</i>			
C125 C126 C127 C128 C141 C143 C144 C146 C190 C191 C206 C207 C212 C213 C220 C221 C226 C227 C230 C231 C232 C233 C251 C252 C253 C254 C301 C302 C303 C304 C307 C308 C309 C310 C508 C510 C517 C518 C521 C522 C528 C529 C534 C535 C601 C602 C611 C612 C617 C618 C621 C622 C627 C628 C631 C632 C637 C638 C641 C642 C647 C648	H03-CEHFC0106NN-R	CE 10U0F +20% 16.0V 85C 5X11 P5MM SK 10/16V 5 X11	
C214 C215 C609 C610	H03-CEHFC01075E-R	CE 100UF +-20% 16.0V D5XL11 P5MM 85C SK 100/16V 5 X11	
C607 C608	H03-CEHGC0337NN-R	CE 330UI0F +20% 25V 85C P5MM SK 330/25V 8 X11 SKR331M1EF11M	
C175 C176 C193	H03-CEHIC01055E-R	CE 1UF +20% 50V D5XL11 P5MM 85C SK 1/50V 5 X11	
C101 C102 C103 C104 C116 C117 C118 C119 C121 C122 C123 C124 C131 C132 C133 C134 C136 C137 C138 C139 C147 C148 C149 C150 C152 C153 C154 C155 C156 C157 C158 C159 C194 C195 C196 C197 C201 C202 C204 C205 C210 C211 C216 C217 C218 C219 C531 C603 C604 C624 C644	CZJII0101BE-R	CAP CHIP 100P0F +5% -5% 50.0V NP0 0603	
C281 C282	CZJII0121BE-R	CAP CHIP 120PF 50V J NP0 0603	
C208 C209 C222 C223	CZJII0151BE-R	CAP CHIP 150PF 50V J NP0 0603	
C532 C533	CZJII0330BE-R	CAP CHIP 33P0F +5% -5% 50.0V NP0 0603	
C12 C13 C14 C15 C16 C17 C18 C19 C120 C135 C203	CZZFI0104BF-R	CAP CHIP 100N0F +80% -20% 16.0V Y5V 0603	

Ref. Designator	Part Number	Description
PROCESSOR PCB		
R103 R104 R123 R124 R129 R131 R132 R136 R143 R144 R151 R152 R153 R154 R163 R164 R167 R168 R171 R172 R183 R184 R185 R186 R189 R194 R195 R196 R197 R198 R199 R200 R207 R208 R213 R214 R227 R228 R241 R242 R303 R304 R305 R306 R311 R312 R313 R314 R388 R389 R518 R524 R537 R538 R548 R554 R555 R603 R604 R609 R610 R629 R630 R641 R647 R648 R657 R658 R663 R664 R677 R683 R684 R689 R690 R749 R750	RS3AD0104NA-R	RES CHIP,100K 1/16W +/-5% ,0603
R570 R571	RS3AD0122NA-R	RMGCFMIC 1K2 OHM +5% 0603
R793 R794	RS3AD0123NA-R	RES CHIP,12K 1/16W +/-5%,0603
R791 R792	RS3AD0152NA-R	RES CHIP 1K5 1/16W +5% 0603
R704 R710 R716 R722	RS3AD0183NA-R	RMGCFMIC 18K0 OHM +5% 0603
R553 R705 R706 R711 R717 R718	RS3AD0202NA-R	RMGCFMIC 2K0 OHM +5% 0603
R611 R612 R613 R614 R691	RS3AD0221NA-R	RMGCFMIC 220R0 OHM +5% 0603
R615 R616 R701 R702 R707 R708 R713 R714 R719 R720 R712	RS3AD0222NA-R	RMGCFMIC 2K2 OHM +5% 0603
R231 R232	RS3AD0272NA-R	RMGCFMIC 2K7 OHM +5% 0603
R699 R700	RS3AD0362NA-R	RMGCFMIC 3K6 OHM +5% 0603
R572 R573	RS3AD0430NA-R	RES CHIP 43R0 OHM +5% 62MI5W 0603
R125 R126 R133 R134 R145 R146 R155 R156 R201 R202 R215 R216 R235 R236 R243 R244 R251 R252 R301 R302 R309 R310 R533 R534 R546 R547 R601 R602 R623 R624 R639 R640 R655 R656 R675 R676	RS3AD0471NA-R	RMGCFMIC 470R0 OHM +5% 0603
R159 R160 R187 R188 R219 R220 R318 R319 R621 R622 R637 R638 R653 R654 R671 R672 R673 R674 R695 R696 R723 R724 R725 R726 R727 R728 R772 R773 R774 R775 R776 R777 R778 R779 R780 R781 R783	RS3AD0473NA-R	RES CHIP,47K 1/16W +/-5%,0603
R703 R709 R715 R721	RS3AD0474NA-R	RMGCFMIC 470K0 OHM +5% 0603
R209 R210	RS3AD0512NA-R	RES CHIP 5K1 1/16W +5% 0603
R281 R282 R291 R292 R293 R294 R295 R296 R297 R298 R299 R300	RS3AD0823NA-R	RES,CHIP 82K,1/16W,+/-5%,0603
R223 R224	RS3AD0820NA-R	RMGCFMIC 82R0 OHM +5% 0603
R229 R230	RS3AD0432NA-R	RMGCFMIC 4K3 OHM +5% 0603
R247 R248 R249 R326 R327 R328 R330 R331 R503 R504 R505 R509 R510 R511 R560 R561 R562 R643 R644 R659 R660 R679 R680 R730 R740 R743	RS3AD0102NA-R	RES CHIP,1K 1/16W +/-5% ,0603
R181 R182 R233 R234 R253 R254 R535 R536 R549 R625 R626 R642 R678	RS3AD0104NA-R	RES CHIP,100K 1/16W +/-5% ,0603
R515 R522	RS3AD0123NA-R	RES CHIP,12K 1/16W +/-5%,0603
R591 R592 R627 R628	RS3AD0152NA-R	RES CHIP 1K5 1/16W +5% 0603
R744	RS3AD0183NA-R	RMGCFMIC 18K0 OHM +5% 0603
R552	RS3AD0202NA-R	RMGCFMIC 2K0 OHM +5% 0603
R130 R135 R149 R150 R205 R206 R225 R226 R320 R321 R398 R399 R617 R618 R633 R634 R667 R668 R693 R694 R697 R698 R741 R742	RS3AD0222NA-R	RMGCFMIC 2K2 OHM +5% 0603

Ref. Designator	Part Number	Description
PROCESSOR PCB		
R516 R517 R523 R525	RS3AD0332NA-R	RMGCFMIC 3K3 OHM +5% 0603
R607 R608	RS3AD0432NA-R	RMGCFMIC 4K3 OHM +5% 0603
R317 R745	RS3AD0474NA-R	RMGCFMIC 470K0 OHM +5% 0603
R645 R646 R661 R681 R682	RS3AD0562NA-R	RMGCFMIC 5K6 OHM +5% 0603
R190	RS3AD0753NA-R	RES CHIP 75K 1/16W +-5% 0603.
R662	RS3AD0912NA-R	RMGCFMIC 9K1 OHM +5% 0603
R514 R521	RS3AD0103NA-R	RES CHIP,10K 1/16W +/-5% .0603
R605 R606	RS3AD0182NA-R	RES CHIP,1.8K,1/16W,+5%,0603.
<i>Miscellaneous</i>		
NJ1 NJ2 NJ3	H03-SORA64105NN-R	JACK RCA 6P JB060132PN
N114 N115 N313	H03-WN04AB100WH-R	CONN WAFER 2.0MM 4P 35237-0410 WHT
P103 P111	H03-WN04SB00000-R	CONNECT 2.0mm 4P GIL-S-4P-S2T2-EF
P112 P113 P114 P314	H03-WN04SB100WH-R	CONN WAFER 2.0MM 4P 35336-0410 WHT
P100 P107	H03-WN05SB00000-R	CONNECT 2.0mm 5P GIL-S-5P-S2T2-EF
N102	H03-WN06AB00001-R	CNT PLUG BD'BD SOCKET 2.0mm 35237-0610
P109	H03-WN06SB00000-R	CONNECT 2.0mm 6P GIL-S-6P-S2T2-EF
N104	H03-WN07AB100WH-R	CONN WAFER 2.0MM 7P 35237-0710 WHT
N101	H03-WN10AB000WH-R	CONNECT WAFER 2.0mm 10P 35237-1010 WHT
P108	H03-WN10SB100WH-R	CONNECT WAFER 2.0mm 10P 35336-1010 WHT
P106	H03-WN15SB100WH-R	CONNECT WAFER 2.0mm 15P 35336-1510 WHT
P105	H03-WN16SB100WH-R	CONNECT WAFER 2.0mm 16P 35336-1610 WHT
P110	H03-WN19SB00000-R	CONN 2.0MM 19 MA ST NAT MOLEX 35336-1910 0 0
STANDBY POWER SUPPLY & RS232 PCB's		
<i>Capacitors</i>		
C113 C115 C118 C121 C244	CCZID0104NA-R	CC 100N0F +80% -20% 50.0V F
C102 C103 C104 C108 C109 C110	CKKIC0103NA-R	CC 10N0F +10% -10% 50.0V Y5P
C101	CCMOC0472NF-R	CC 4N7F +20% -20% 250.0V Y5V
C302	H03-CEHFC01075E-R	CE 100UF +-20% 16.0V D5XL11 P5MM 85C SK 100/16V 5 X11
C442	H03-CEHFC04765E-R	CE47UF +20% 16.0V D5XL11 P5MM 85C SK 47/16V 5 X11
C125	H03-CEHGC0687NN-R	CE 680U0F +20% 25.0V 85C P5MM SK 680/25V 10 X21
C114	H03-CEHIC01055E-R	CE 1UF +20% 50V D5XL11 P5MM 85C SK 1/50V 5 X11
C119 C120 C248 C251 C258 C262	H03-CEHIC01065E-R	CE 10U0F +20% 50.0V 85C P5MM 5X11 SK 10/50V 5 X11
C106	CEHIC0107NN-R	100uF 50V M 8x11 SKR101M1HF11M
C307 C308 C309	H03-CEMIC0334AH-R	CAP ELEC 0.33UF M 5X11 SHL 50V SAMYOUNG
C107 C111	H03-CEMGC04775E-R	CE 470U0F +/-20% 25.0V 10X13 85C SK 470/25V 10 X13
C305	H03-CEMIC01045E-R	CAP ELEC 0.1uF 50v M 5x11 SHL P5MM SK 0.1/50V 5X11
C105	H03-CEMJC02275E-R	CAP ELEC 220UF 63V M 10X16 85C 120HZ P5MM SK 220/63V 10X13
C306	CPIKC0473NN-R	CPF 47N0F +10% 100.0V
C116	H03-CEMHC0227AH-R	CAP ELEC 220UF 35V M 8X11.5 SHL SAMYOUNG
C250 C256 C257 C261	H03-CEHIC02255E-R	CE 2U2F +20% 50V D5XL11 P5MM 85C SK 2.2/50V 5 X11
C249 C254	CKKIC0223NN-R	22nF 50V +10% -10% Z5R
C444 C445 C446	CZJII0101BE-R	CAP CHIP 100POF +5% -5% 50.0V NP0 0603
C313 C314 C316 C317	CZKII0122BC-R	CAP CHIP 1N2F +10% -10% 50.0V X7R 0603
C252 C303 C304 C311 C312 C315 C443	CZZFI0104BF-R	CAP CHIP 100N0F +80% -20% 16.0V Y5V 0603
C203 204 C205	H03-CFHOA0104NN-R	CAP POLY METAL CPM 100NF 250V 20% TAE YANG
C100	CFMVA0104NN-R	CPPMX 100N0F +20% -20%
C201 C202	H03-CEMJA0828KA-R	8200uF 63V M 30x40 LSW822M1JP40M
C245	CZKII0103BC-R	CAP CHIP 10N0F +10% -10% 50.0V X7R 0603
C259	CZKII0153BC-R	CAP CHIP 15N0F +10% -10% 50.0V X7R 0603
C260	CZKII0822BC-R	CAP CHIP 8N2F +10% -10% 50.0V X7R 0603
<i>Semiconductors</i>		
D101 D111	H03-DG1N04148NB-R	D-SLP 1N4148 100.0V 150E-3A
D102 D103 D105 D106 D107 D108	H03-DR1N04004NA-R	D-SR 1N4004 400.0V 1.0A
D119 D120	H03-DZGE22V05MA-R	MZ0.5GE22V-5 22V 5mA
D116	H03-DZGE4V320MA-R	MZ0.5GE4V3-20 4.3V 20mA
D104	H03-DZGE9V120MA-R	MZ0.5GE9V1-20 9.1V 20mA
Q301 Q302	H03-TRKTA107MNA-R	TR-SLPSWA KRA107M PNP
Q101 Q102	H03-TRMPSA06NNA-R	TR-SLPLF MPSA06 NPN 500MIOA TO-92
Q106 Q107 Q108 Q109	H03-TRKTA1267GR-R	KTA1267-GR TO-92M PNP
D201	H03-DURS10040NA-R	RS1004 RS-10

Ref. Designator	Part Number	Description	
STANDBY POWER SUPPLY & RS232 PCB's			
IC12	H03-ICKIA7805I2-R	IC-REGULATOR KIA7805API NORMAL TO-220IS +5V	
IC11	H03-ICKIA78D3A0-R	IC VOLTAGE REGULATOR KIA78D33PI 3.3V TO-220IS	
IC32 IC33	H03-ICPC17T10B1-R	IC PHOTOCOUPLER PC-17T1 DIP4 KODENSHI	
D123 D124 D125 D126 D303 D304 D305 D205 D206 D207 D208 D306 D307 D308 D309 D310	H03-DS1S50094NB-R	D-SLP 1SS355 35.0V 225MI0A	
IC34	H03-ICBU4052BCF-R	IC CMOS BU4052BCF SOP16 Dual 4-channel analog multiplexer / demultiplexer	
IC406	H03-ICBU4094BD3-R	IC CMOS BU4094BCF SOP16 8-bit compatible shift / store register	
IC31	H03-ICMAX322316-R	IC RS-232 LINE DRIVER MAX3223CDWR SOIC16P	
Q303 Q304 Q114 Q115 Q116 Q117	H03-TSKRC107SND-R	KRC107S SOT-23 NPN	
Q305 Q306	H03-TRKTA1504ND-R	TRANSISTOR PNP KTA1504Y(S)SOT-23	
Q110 Q111 Q112 Q113	H03-TSKRA107SNI-R	KRA107S SOT-23 PNP	
<i>Resistors</i>			
R317	RC3DI0101IN-R	RCF 100R0 OHM +5% 250MI0W	
R103	RC3DI0102IN-R	RCF 1K0 OHM +5% 250MI0W	
R102 R109	RC3DI0103IN-R	RCF 10K0 OHM +5% 250MI0W	
R110	RC3DI0104IN-R	RCF 100K0 OHM +5% 250MI0W	
R106 R107	RC3DI010AIN-R	RCF 1R0 OHM +5% 250MI0W	
R104	RC3DI0153IN-R	RCF 15K0 OHM +5% 250MI0W	
R105	RC3DI0222IN-R	RCF 2K2 OHM +5% 250MI0W	
R112	RC3DI0272IN-R	RCF 2K7 OHM +5% 250MI0W	
R113	RC3DI0470NN-R	REC,CARBON,47,1/4W,+/-5%,SIZE=1/8W	
R314 R315	RC3DI0471IN-R	RCF 470R0 OHM +5% 250MI0W	
R111	RC3DI0562IN-R	RCF 5K6 OHM +5% 250MI0W	
R115 R116	H03-RM3FC0100BN-R	RES METAL OXIDE 10R OHM+5% 1.0W	
R108	H03-RM3GC0330CN-R	RESISTOR METAL OXIDE 33 OHM +5% 2.0W	
R442	RS1AD0101NA-R	RES CHIP 100 OHM 1/16W 1% 0603	
R271 R280 R285 R326 R444 R445 R446 R447 R715	RS3AD0102NA-R	RES CHIP,1K 1/16W +/-5% ,0603	
R282 R306 R318 R319 R325	RS3AD0103NA-R	RES CHIP,10K 1/16W +/-5% ,0603	
R275 R320 R321 R322	RS3AD0104NA-R	RES CHIP,100K 1/16W +/-5% ,0603	
R443	RS3AD0123NA-R	RES CHIP,12K 1/16W +/-5%,0603	
R327 R328	RS3AD0221NA-R	RMGCFMIC 220R0 OHM +5% 0603	
R312	RS3AD0271NA-R	RMGCFMIC 270R0 OHM +5% 0603	
R276 R310	RS3AD0392NA-R	RMGCFMIC 3K9 OHM +5% 0603	
R309 R311	RS3AD0470NA-R	RMGCFMIC 47R0 OHM +5% 0603	
R313	RS3AD0471NA-R	RMGCFMIC 470R0 OHM +5% 0603	
R303 R304 R305	RS3AD0472NA-R	RES CHIP,4K7 1/16W +/-5%,0603	
R307 R308	RS3AD0473NA-R	RES CHIP,47K 1/16W +/-5%,0603	
R324	RS3AD0511NA-R	RMGCFMIC 510R0 OHM +5% 0603	
R268 R277 R354	RS3AD0333NA-R	RMGCFMIC 33K0 OHM +5% 0603	
R269 R356	RS3AD0222NA-R	RMGCFMIC 2K2 OHM +5% 0603	
R270 R279 R355	RS3AD0680NA-R	RMGCFMIC 68R0 OHM +5% 0603	
R272 R273 R281 R284	RS3AD0154NA-R	RMGCFMIC 150K0 OHM +5% 0603	
R274 R283	RS3AD0753NA-R	RES CHIP 75K 1/16W +5% 0603.	
<i>Miscellaneous</i>			
L301 L302 L303 L304	H03-FB2522012HF-R	FCM2012HF-252T02 2500ohm SURFACE MT 2012	
BD31	H03-FB3012012CF-R	FCM2012CF-301T04 0805	
FH10 FH12 FH23 FH24	H03-SOPS1FEHDNN-R	TERMFUSEHLDR FUSE-HOLDER J4210020001X	
G101 G103	H03-ZNMSA4004SN-R	TERMLUG GND	
F101	H03-FUGF210A065-R	FUSE 65TS SERIES 65 TS 250V 10A 326010	US
F201	H03-FUGF23000XX-R	FUSE 239 SERIES 003 250V 3A&3.15A 2183.15MXP	US
F101	H03-FUGF205A0XX-R	FUSVDETIMELG 5A 250.0 V 5X20	EU
F201	H03-FUGF202A0XX-R	FUSVDETIMELG 2.0A 250.0 V 5X20 218002MXP	EU
SK11	H03-RL1227111K-R	RELAYPWR SDT-S-112DMR	
NJ33 NJ34 NJ35 NJ36 NJ37	H03-SOJW2350SNN-R	JACK PHONE 3.6 EP-1401A 1P BK	
NS31	H03-SOXA2202DNN-R	A202D0031P 2P	
NS30	H03-SOXA27014NN-R	CON MAINS INLET A/C INLET 7014-NGP	
TP11	H03-TXPWMR740B0-R	AVR745 POWER TRANSFORMER (ST/BY)	US
TP11	H03-TXPWME145B0-R	AVR745EU POWER TRANSFORMER (ST/BY)-230V	EU
N307	H03-WG04SB82000-R	WIRECONASY DL 2.0MM 4P 200MM UL1007#26 WHT	
P305	H03-WN02SE00000-R	CON 3.96MM PITCH HEADER 2 POS MOLEX 35328-0210	
P306	H03-WN02SE00002-R	CONNECT WAFER,YW396-03V 7.92mm 2P ,DONG HO	

Ref. Designator	Part Number	Description
STANDBY POWER SUPPLY & RS232 PCB's		
P301	H03-WN03SE00000-R	CON 3.96MM PITCH MOLEX 35313-0310
P302	H03-WN05SD100WH-R	CONN WAFER 2.5MM 5P 5267-05A WHT
P304	H03-WN06SE00000-R	CONNECT 6P 3.96MM 35313-0610
P303	H03-WN11SB00001-R	CONN 2.0MM 11P GIL-S-11P-S2T2-EF
P351	H03-WN14DI00000-R	CONNECT GF120-14S-TS 1.25MM 14P
N310	H03-WN15AB100WH-R	CONNECT WAFER 2.0mm 15P 35237-1510 WHT
P308	H03-WN15SB100WH-R	CONNECT WAFER 2.0mm 15P 35336-1510 WHT
N311	H03-WN16AB100WH-R	CONNECT WAFER 2.0mm 16P 35237-1610 WHT
P309	H03-WN16SB100WH-R	CONNECT WAFER 2.0mm 16P 35336-1610 WHT
N312	H03-WN19AB00000-R	CONN 2.0MM 19 MA R NAT SOCKET MOLEX 35237-1910
P313	H03-WN19SB00000-R	CONN 2.0MM 19 MA ST NAT MOLEX 35336-1910 0 0
HK11	H03-ZMC12HS0100-R	AC HEATSINK 17*15*30 AVR520 -- ME
GND1	H03-ZMC12S16A00-R	BKT GROUND
NJ32	SOPA96063NN-R	JACK D-SUB 9P 87204-6063 W/DUST COVER BK
P211	H03-WN04AB100WH-R	CONN WAFER 2.0MM 4P 35237-0410 WHT
L116	H03-FY0100101N8-R	FILTER MPX 01011-101
P311	H03-WN05AB100WH-R	CONNECT WAFER 2.0MM 5P 35237-0510 WHT
SURROUND/CENTER PCB		
<i>Capacitors</i>		
C206 C306 C506	CCKID0271NN-R	CC 270P0F +10% -10% 50.0V 2B4
C215 C315 C517	CCKIC0332NA-R	CC 3N3F +10% -10% 50.0V Y5P
C607 C608 C611	CCZGC0104NA-R	CAP CERAMIC 100NF 25V Z Z5U TAP
C208 C308 C508	H03-CEHEC02275E-R	CE 220UF +20% 10.0V P=5MM 85C SK 220/10V 5 X11
C205 C305 C505	H03-CEHGC01075E-R	CE 100U0F +20% 25.0V 6.3X11 85C P5MM SK 100/25V 6.3 X11
C101 C203 C303 C503 C609 C610 C614	H03-CEHIC01065E-R	CE 100U0F +20% 50.0V 85C P5MM 5X11 SK 10/50V 5 X11
C201 C202 C301 C302 C501 C502	H03-CEHJA0477MN-R	CE 470U0F +20% 63.0V 85C SK 470/63V 13 X21
C604	CEMFA02285E-R	CE 2200UF 16V M 12.5X20 P5MM
C600	CEMFA0478BK-R	CAP ELEC 4700UF 16V M 16X25 85C 120HZ ELITE
C601 C602 C603	CPKIC0473NN-R	CPF 47N0F +10% 100.0V
C210 C310 C510	CPJJC0683NN-R	CAP POLY NON METAL 68NF 63V J TAP
C211 C311 C511	H03-CEMKC0106AH-R	CAP ELEC 10UF 100V M 6.3X11 SHL
C204 C304 C504	CCJID0680NA-R	CAPACITOR CERAMIC AXIAL 68PF 50V +5% -5%
C216 C316 C516	CCKIC0103NA-R	CC 10N0F +10% -10% 50.0V Y5P
C606	H03-CEMFA0688BK-R	CAP ELEC 6800UF 16V M 16X25 85C 120HZ SK 6800/16V 16 X25
C207 C307C507	CCJIC0120NN-R	CAP CERAMIC 12PF 50V J CH TAP
C209 C309 C509	CCJIC0330NE-R	CAP CERAMIC 33PF 50V +5% NPO
C213 C214 C313 C314 C513 C514	H03-CPJJC0104NN-R	CAP POLYESTER NON METAL 0.1uF 63V J TAP PCMT365 76104
C620	H03-CEHFC0106NN-R	CE 100U0F +20% 16.0V 85C 5X11 P5MM SK 10/16V 5 X11
<i>Semiconductors</i>		
D101 D201 D202 D203 D204 D301 D302 D303 D304 D501 D502 D503 D504	H03-DG1N04148NB-R	D-SLP 1N4148 100.0V 150E-3A
D602 D605	H03-DR1N04004NA-R	D-SR 1N4004 400.0V 1.0A
Q205 Q305 Q505	H03-TR2SA1145YF-R	TRANSISTOR PNP 2SA1145-Y(F) TO-92 HFE:120-240
Q101 Q206 Q306 Q506	H03-TRKTA1268NA-R	TR-SHPLF KTA1268BL PNP 100MIOA 120V
Q204 Q304 Q504	H03-TRKTC3198NA-R	TR-SLPLF KTC3198BL NPN 150MIOA
Q201 Q202 Q203 Q207 Q220 Q301 Q302 Q303 Q307 Q320 Q501 Q502 Q503 Q507 Q520	H03-TRKTC3200NA-R	TR-SHPLF KTC3200BL NPN 100MIOA 120V
D620	H03-DZGE5V120MA-R	MZ0.5GE5V1-20 5.1V 20mA
D601	H03-DUKBU6GMF6N-R	KBU6G-MF RS-6 Kink Type
IC64	H03-ICKA378R08P-R	KIA378R08PI 4 TERMINAL 3A OUTPUT LOW DROP VOLT REGULATOR 8V
IC61	H03-ICKIA78D3A0-R	IC VOLTAGE REGULATOR KIA78D33PI 3.3V TO-220IS
IC63	H03-ICKIA7905I2-R	IC-REGULATOR KIA7905PI NORMAL -5V
Q219 Q319 Q519	H03-TR2SB1647B0-R	2SB1647 MT-100 PNP
Q218 Q318 Q518	H03-TR2SD2560B0-R	2SD2560 MT-100 NPN
Q208 Q308 Q508	H03-TRKTA1360BE-R	TRANSISTOR PNP KTA1360 TO-126
Q214 Q314 Q514	H03-TRKTC3114NE-R	TRANSISTOR NPN KTC3114 TO-126
Q209 Q309 Q509	H03-TRKTC3423BE-R	TRANSISTOR NPN KTC3423 TO-126

Ref. Designator	Part Number	Description	
SURROUND/CENTER PCB			
<i>Resistors</i>			
R225 R233 R325 R333 R525 R533	H03-RM3EG0100LN-R	RMF 10R0 OHM +5% 500MI0W	
R243 R299 R343 R399 R543 R599	RC3DI0100IN-R	RCF 10R0 OHM +5% 250MI0W	
R101 R605	RC3DI0103IN-R	RCF 10K0 OHM +5% 250MI0W	
R246 R346 R546	RC3DI0104IN-R	RCF 100K0 OHM +5% 250MI0W	
R239 R241 R209 R210 R309 R310 R339 R341 R509 R510 R539 R541	RC3DI0152IN-R	RCF 1K5 OHM +5% 250MI0W	
R240 R340 R540	RC3DI0153IN-R	RCF 15K0 OHM +5% 250MI0W	
R206 R207 R306 R307 R506 R507	RC3DI0221IN-R	RCF 220R0 OHM +5% 250MI0W	
R220 R221 R244 R320 R321 R344 R520 R521 R544	RC3DI0223IN-R	RCF 22K0 OHM +5% 250MI0W	
R229 R329 R529	RC3DI0282IN-R	RCF 2K8 OHM +5% 250MI0W	
R201 R301 R501	RC3DI0331IN-R	RCF 330R0 OHM +5% 250MI0W	
R202 R302 R502	RC3DI0333IN-R	RCF 33K0 OHM +5% 250MI0W	
R228 R235 R328 R335 R528 R535	RC3DI033AIN-R	RCF 3R3 OHM +5% 250MI0W	
R102 R242 R342 R542	RC3DI0393IN-R	RCF 39K0 OHM +5% 250MI0W	
R204 R304 R504	RC3DI0433IN-R	RCF 43K0 OHM +5% 250MI0W	
R208 R308 R508	RC3DI0471IN-R	RCF 470R0 OHM +5% 250MI0W	
R211 R214 R215 R216 R217 R218 R311 R314 R315 R316 R317 R318 R511 R514 R515 R516 R517 R518	RC3DI0561IN-R	RCF 560R0 OHM +5% 250MI0W	
R212 R312 R512	RM1DI0333IN-R	RMF 33K0 OHM +1% 250MI0W	
R213 R313 R513	RM1DI1701NA-R	RESISTOR METAL OXIDE,1K7 ohm 1/4W 1%	
R205 R305 R505	RC3DI0271IN-R	RCF 270R0 OHM +5% 250MI0W	
R219 R222 R319 R322 R519 R522	RC3DI0470NN-R	REC,CARBON,47,1/4W,+/-5%,SIZE=1/8W	
R230 R330 R530	RC3DI0911IN-R	RCF 910R0 OHM +5% 250MI0W	
R620	RC3DI0151IN-R	RCF 150 OHM 5% 1/4W	
R238 R338 R538	H03-RI3IC022BEN-R	RW 220MI0 OHM +5% 5.0W 100PPM/C -100PPM/C	
R245 R345 R545	H03-RM3FC0100BN-R	RES METAL OXIDE 10R OHM+5% 1.0W	
R601 R602	H03-RM3GC010ACN-R	RESISTOR METAL OXIDE 1R0 OHM +5% 2.0W	
R603 R604	H03-RM3GC039ACN-R	RESISTOR METAL OXIDE 3R9 OHM +5% 2.0W	
VR201 VR301 VR501	H03-RT7EA0201NB-R	PR 200R0 OHM +20% 500MI0W	
<i>Miscellaneous</i>			
F601 F602	H03-FURN23150SR-R	FUSE SR-5 SERIES 3821315 SR-5-3.15A 250V 35A	
G101 G102 G105	H03-ZNMSA4004SN-R	TERMLUG GND	
L201 L301 L501	H03-LCNNNA050NA-R	LFA 1MM 10MM 5 LEFT 0.0MM NONE SP-2516	
NJ401	H03-SOPA8SH0612-R	JACK SPEAKER 6P SH0612707P GN BN TA	
N502	H03-WG06SE81200-R	WIRE ASS'Y UL1007#16 120mm 3.96mm 6P RED	
N501	H03-WG07AD02700-R	WIRE ASS'Y,UL1007#20(TA) 270mm 2.5mm 7P WHT	
P201 P301 P501	H03-WN02AD00000-R	CONNECT WAFER 2.5mm 2P 5268-02A WHT ANGLE	
P506	H03-WN03SB00000-R	CONNECT 2.0mm 3P GIL-S-3P-S2T2-EF	
N503	H03-WN03SD100WH-R	CONN WAFER 2.5MM 3P 5267-03A WHT	
N504	H03-WN05SB00000-R	CONNECT 2.0mm 5P GIL-S-5P-S2T2-EF	
N505	H03-WS6262605EN-R	WIRECONASY DL 2.0MM 6P 260MM UL1533 SHIELD 26 1	
	H03-ZH740MSQ6WH-R	MICA SHEET SIZE 19X22X0.05	
VIDEO PCB			
<i>Capacitors</i>			
C200	CCKIC0103NA-R	CC 10N0F +10% -10% 50.0V Y5P	
C136 C138 C223	H03-CEHDC0108NN-R	CE 1000UF +20% 6.3V 8X11.5 85C P5MM	
C152 C177 C186 C190 C192 C197 C209 C211 C212 C329 C330 C357	H03-CEHEC01075E-R	CE 1000UF +20% 10.0V 5X11 85C P5MM SK 100/10V 5 X11	
C100 C102 C103 C105 C106 C108 C109 C111 C122 C124 C127 C133 C143 C189 C194 C199 C204 C206 C207 C332 C333 C359 C360 C376	H03-CEHEC02275E-R	CE 220UF +20% 10.0V P=5MM 85C SK 220/10V 5 X11	

Ref. Designator	Part Number	Description
VIDEO PCB		
C125 C126 C128 C129 C130 C131 C374 C375	H03-CEHEC0477MN-R	CE 470U0F +20% 10.0V 85C P=5MM SK 470/10V 6.3 X11
C101 C104 C107 C110 C113 C117 C123 C137 C187 C188 C203 C208 C336 C361 C363 C378	H03-CEHFC0106NN-R	CE 10U0F +20% 16.0V 85C 5X11 P5MM SK 10/16V 5 X11
C135 C144 C145 C146 C149 C222 C227 C232 C237 C335 C377	H03-CEHFC04765E-R	CE47UF +20% 16.0V D5XL11 P5MM 85C SK 47/16V 5 X11
C171 C182	H03-CEHIC01055E-R	CE 1UF +20% 50V D5XL11 P5MM 85C SK 1/50V 5 X11
C156	H03-CEMIC01045E-R	CAP ELEC 0.1uF 50v M 5x11 SHL P5MM SK 0.1/50V 5X11
C180	CPiIC0223NN-R	CPF 22N0F +10% 50.0V
C183	CPiIC0682NN-R	CPF 6N8F +10% 50.0V
C134	H03-CEMEC0337NA-R	CAP ELECTROYTIC,330uF 10V M 6.3x11
C181	H03-CEMIC0564AH-R	CAP ELEC 0.56UF 50V M 5X11 SHL SAMYOUNG
C155	CZDII0100BE-R	CAP CHIP 10PF 50V CH D NPO 0603
C112 C114 C115 C120 C121 C172 C173 C174 C224 C225 C226 C229 C230 C231 C234 C235 C236	CZJII0101BE-R	CAP CHIP 100POF +5% -5% 50.0V NP0 0603
C179	CZJII0270BE-R	CAP CHIP 27P0F +5% -5% 50.0V NPO 0603
C178	CZJII0300BE-R	CAPA CHIP 30PF 50V CH NP0 +5% 0603
C147	CZJII0331BE-R	CAP CHIP 330P0F +5% -5% 50.0V NP0 0603
C167 C168 C169 C170	CZJII0390BE-R	CAP CHIP 39PF 50V CH J NPO 0603
C331	CZKII0102BC-R	CAP CHIP 1N0F +10% -10% 50.0V X7R 0603
C153 C176 C184 C185 C191 C193 C196 C210 C358 C371 C372	CZKII0103BC-R	CAP CHIP 10N0F +10% -10% 50.0V X7R 0603
C119 C201	CZKII0221BA-R	CAP CHIP 220PF 50V K SL 0603
C148	CZKII0561BC-R	CAP CHIP 560P0F +10% -10% 50.0V X7R 0603
C213 C214 C228 C233 C238 C327 C328 C365 C366 C367 C368 C369 C370 C379 C380	CZZFI0104BF-R	CAP CHIP 100N0F +80% -20% 16.0V Y5V 0603
C198	CZJII0470BE-R	CAP CHIP 47P0F +5% -5% 50.0V NPO 0603
C373	CZJII0560BE-R	CAP CHIP 56PF 50V CH J NPO 0603
<i>Semiconductors</i>		
Q104 Q122 Q123 Q124	H03-TRKTA1267GR-R	KTA1267-GR TO-92M PNP
Q100 Q102 Q103	H03-TRKTC3199GR-R	KTC3199-GR TO-92M NPN
IC37	H03-ICKIA7805I2-R	IC-REGULATOR KIA7805API NORMAL TO-220IS +5V
D101 D102 D103 D104 D105 D106 D107 D108 D109 D110 D111 D112 D116	H03-DS05GBUSCNB-R	DIODE PG05GBUSC
D127 D128 D129 D132	H03-DS1S50094NB-R	D-SLP 1SS355 35.0V 225MI0A
IC19	H03-ICBU4053BB4-R	IC BU4053BCF SOP16 ANALOG MPX/DEMPX
IC20 IC21 IC22	H03-ICBU4094BD3-R	IC CMOS BU4094BCF SOP16 8-bit compatible shift / store register
IC35	H03-ICIL1117SJ2-R	IC VOLTAGE REGULATOR IL1117S-ADJ SOT-223
IC16	H03-ICLC74763ME-R	LC74763M-9602-E SOP30 On-Screen Display LSI
IC24 IC25	H03-ICM1503XNRE-R	MM1503XNRE SOT-26B
IC14	H03-ICMM1117NDG-R	MM1117XFBE SOP-8C
IC12 IC27	H03-ICMM1234S16-R	MM1234XFBE SOP16
IC26	H03-ICMM1511XDL-R	IC-VIDEO SW MM1511XNRE SOT-26B
IC10 IC11 IC13	H03-ICNJM2296D3-R	IC-LINEAR NJM2296M-TE1 5-INPUT 3-OUTPUT VIDEO SWITCH
IC34	H03-ICNJM2586MN-R	IC VIDEO AMP NJM2586M-TE1 DMP24
IC28	H03-ICTSH95IDB4-R	IC-VIDEOPROC TSH95ID VIDEO AMPLIFIER
Q120 Q121	H03-TSKRC107SND-R	KRC107S SOT-23 NPN
D117	H03-VR0603V150R-R	VARISTOR CHIP CT0603V150RFG
<i>Resistors</i>		
R230 R231 R232 R316 R317 R318 R320 R322 R323 R325 R326 R327	RC3DI0102IN-R	RCF 1K0 OHM +5% 250MI0W
R304	RC3DI0103IN-R	RCF 10K0 OHM +5% 250MI0W
R400	RC3DI010AIN-R	RCF 1R0 OHM +5% 250MI0W
R399	RC3DI022AIN-R	RCF 2R2 OHM +5% 250MI0W

Ref. Designator	Part Number	Description	
VIDEO PCB			
R100 R101 R102 R103 R104 R105 R106 R107 R108 R109 R110 R111 R112 R115 R118 R124 R130 R131 R132 R133 R134 R135 R136 R137 R138 R139 R141 R143	RS1AD0750NA-R	RES CHIP 75OHM 1% 1/16W 0603	
R395 R403	RS1AD1470NA-R	147 ohm 1/16W 1% 0603	
R41 R42 R24 R116 R142 R144 R242 R245 R246 R247 R308 R337 R338 R401 R424 R425 R426 R427 R429	RS3AD0000NA-R	RES CHIP, 0 R 1/16W +/-5%, 0603	
R295 R328	RS3AD0101NA-R	RES CHIP,100R 1/16W +/-5%,0603	
R217 R219 R237 R238 R239 R240	RS3AD0102NA-R	RES CHIP,1K 1/16W +/-5% ,0603	
R114 R117 R120 R123 R126 R129 R222 R229 R250 R255 R258	RS3AD0103NA-R	RES CHIP,10K 1/16W +/-5% ,0603	
R235 R236	RS3AD0105NA-R	RES CHIP 1M 1/16W +5% 0603	
R218 R233 R234 R412	RS3AD0121NA-R	RMGCFMIC 120R0 OHM +5% 0603	
R319 R324 R339	RS3AD0123NA-R	RES CHIP,12K 1/16W +/-5%,0603	
R321	RS3AD0124NA-R	RES CHIP,120K 1/16W +/-5%,0603	
R221	RS3AD0152NA-R	RES CHIP 1K5 1/16W +5% 0603	
R208	RS3AD0154NA-R	RMGCFMIC 150K0 OHM +5% 0603	
R243 R418	RS3AD0181NA-R	RMGCFMIC 180R0 OHM +5% 0603	
R397 R415	RS3AD0201NA-R	RES.CHIP,200 1/16W +/-5%,0603.	
R226	RS3AD0224NA-R	RES CHIP,220K 1/16W +/-5%,0603	
R307 R416	RS3AD0243NA-R	RMGCFMIC 24K0 OHM +5% 0603	
R336	RS3AD0271NA-R	RMGCFMIC 270R0 OHM +5% 0603	
R305	RS3AD0272NA-R	RMGCFMIC 2K7 OHM +5% 0603	
R396	RS3AD0331NA-R	RMGCFMIC 330R0 OHM +5% 0603	
R228	RS3AD0392NA-R	RMGCFMIC 3K9 OHM +5% 0603	
R113 R119 R128 R140	RS3AD043ANA-R	RESISTOR CHIP 4R3 OHM 1/16W 5% 0603	
R121 R127	RS3AD0680NA-R	RMGCFMIC 68R0 OHM +5% 0603	
R220	RS3AD0682NA-R	RMGCFMIC 6K8 OHM +5% 0603	
R398	RS3AD0751NA-R	RES.CHIP,750OHM,1/16W,+5%,0603.	
R207	RS3AD0822NA-R	RMGCFMIC 8K2 OHM +5% 0603	
R23 J12 J136 J200 J203 J210 J214 J217 J218 J219 J220 J221 J222 J223 J224 J225 J226 J228 J229 J231 J232 J233 J234 J235 J236 J237 J238 J239 J240 J241 J242 J243 J244 J245 J246 J252 J307	RS3BB0000NA-R	RES CHIP 0 OHM +5% 100MIOW 0805	
R145 R146	RS1AD0750NA-R	RES CHIP 75OHM 1% 1/16W 0603	
R417	RS3AD0912NA-R	RMGCFMIC 9K1 OHM +5% 0603	
R122	RS3AD056ANA-R	RES. CHIP, 5.6R, 1/16W, +/-5%, 0603	
R125	RS3AD015ANA-R	RESISTOR CHIP 1.5 ohm 1/16W 5% 0603	
R306	RS3AD0300NA-R	RESISTOR CHIP 30ohm 1/16W 5% 0603	
R402	RS3AD0361NA-R	RES CHIP,360 OHM,1/16W,+/-5%,0603	
R410	RS3AD0562NA-R	RMGCFMIC 5K6 OHM +5% 0603	
R411 R413	RS3AD0104NA-R	RES CHIP,100K 1/16W +/-5% ,0603	
R414	RS3AD0223NA-R	RES CHIP,22K 1/16W +/-5%,0603	
<i>Miscellaneous</i>			
Y100	H03-OSXBE14M3AU-R	CRYSTAL 14.31818MHz WOOIN	
Y101	H03-OSXBE17M7AU-R	CRYSTAL 17.734475MHz WOOIN	
SK12 SK13	H03-RLL0517811A-R	RELAY D3009(1-1462033-4)	
NJ12	H03-SOR12BJ12NN-R	JACK RCA 12P BJ120154JN	
NJ10 NJ11	H03-SORA60031YN-R	JACK RCA+S-VIDEO 6P C8030031YN	
P602	H03-WN04AB00000-R	CONN 2.0MM GIL-S-04P-S2L2-EF 4P	
N700 N701	H03-WN04AB100WH-R	CONN WAFER 2.0MM 4P 35237-0410 WHT	
P700 P701 N101	H03-WN04SB100WH-R	CONN WAFER 2.0MM 4P 35336-0410 WHT	
P604	H03-WN05AB00000-R	GIL-S-05P-S2L2-EF 5P	
P601	H03-WN06AB00000-R	CONNECT 2.0mm 6P GIL-S-6P-S2L2-EF	
P603	H03-WN07AD00000-R	CONNECT WAFER 2.5MM 7P 5268-07A WHT ANGLE	
N702	H03-WN10AB000WH-R	CONNECT WAFER 2.0mm 10P 35237-1010 WHT	
P702	H03-WN10SB100WH-R	CONNECT WAFER 2.0mm 10P 35336-1010 WHT	
P612	H03-WN14AI00000-R	CONNECT 1.25mm 14P,GF120-14S-LS 1.25mm 14P	

Ref. Designator	Part Number	Description	
VIDEO PCB			
P605	H03-WN23AI000WH-R	CONN 1.25MM 23 FE ANG WH GF120-23S-LS 2794 A6	
N102	H03-WN05SB100WH-R	CONNECT WAFER 2.0MM 35336-0510 5P WHT	
N704	H03-WN12SB00001-R	GIL-S-12P-S2T2-EF 12P	
N703	H03-WN15SB00001-R	GIL-S-15P-S2T2-EF 15P	
N705	H03-WG05SB11000-R	WIRE ASS'Y UL1007#26(TA) 110mm 2.0mm 5P WHT	
L101 L102 L103 L115 L117	H03-FB05B3580NN-R	BEAD AXIAL/TAP,HC3580 80.5ohm	
L105 L106 L107 L108	H03-LAINB0470CR-R	LF 47U0H +10% 5.8 OHM 500M0A	
L118	H03-LALNB056ACR-R	INDUCTOR COIL AL02TB5R6J 5.6UH 1.9OHM +5%	
MECHANICAL ASSEMBLY			
	H03-SWA2B21PDA&-R	SW PUSH POWER SDDL15700	
	H03-TXPWMEI94B0-R	POWER TRANSFORMER AVR445 MAIN TRANS 120V 60Hz	US
	H03-TXPWMEI92B0-R	POWER TRANSFORMER AVR445EU MAIN TRANS 230V 50Hz	EU
	H03-WF14S2205ST-R	WIRE FFC (CARD CABLE) DHCDT-14/220-P1.25-ST(5/5,10/10)	
	H03-WF22S2605RT-R	DHCDT-22/260-P1.25-RT(5/5,10/10)	
	H03-WF23S2005ST-R	WIRE FFC(CARD CABLE) DHCDT-23/200-P1.25-ST(5/5,10/10)	
	H03-WG02SG8532A-R	WIRECONASY UNIQUE 2P 530MM UL1617 PVC DOUBLE INSULATED	
	H03-WG04SB81400-R	UL1007#26 STR 140mm 2.0mm 4P WHT	
	H03-WG09SB82000-R	WIRE ASS'Y UL1007#26(TA) 200mm 2.0mm 9P WHT	
	H03-ZMB01S00100-R	BKT HEADPHONE	
	H03-ZMC11S00200-R	AL DOOR AVR430/630	
	H03-ZMC11S04B00-R	BKT FRAME GUIDE	
	H03-ZMC11S06A00-R	SPRING STOPPER AVR430/630	
	H03-ZMC11S07A00-R	CHASSIS FRONT AVR430/630	
	H03-ZMC11S09A00-R	BKT FAN FRONT AVR430/630	
	H03-ZMC11S10A00-R	BKT FAN REAR AVR430/630	
	H03-ZMC11S12A00-R	CAP BUTTON STAND-BY AVR430/630	
	H03-ZMC11S14A00-R	BRACKET DOOR	
	H03-ZMC12S07A00-R	COVER BOTTOM	
	H03-ZMC12S08B00-R	BKT TRANS BOTTOM	
	H03-ZMC12S09A00-R	BKT HEATSINK	
	H03-ZMC12S19A00-R	BKT AC INLET	
	H03-ZMD05S16A00-R	BKT HINGE AVR7300	
	H03-ZMD2701ZANI-R	BRACKET POSISTOR,METAL,AVR745	
	H03-ZMD2702GAGY-R	AL PANEL FRONT,AVR745	
	H03-ZMD2703GAGY-R	BADGE FRONT,AL,AVR745,GREY,HOT STAMPING	
	H03-ZMD27HS0200-R	H/SINK MAIN AVR745	
	H03-ZMD27HS0300-R	HEATSINK AMP SMALL	
	H03-ZMD27S04A00-R	BKT FRAME GUIDE AVR745	
	H03-ZMD27S06A00-R	BKT VIDEO	
	H03-ZMD27S08A00-R	COVER TOP AVR745	
	H03-ZMD27S13A00-R	CHASSIS MAIN AVR745	
	H03-ZMD27S20A00-R	BADGE harman/kardon COVER TOP AVR745	
	H03-ZMD29HS0100-R	H/SINK AMP AVR445	
	H03-ZMD31S02A00-R	PANEL REAR AVR445US	
	H03-ZPC1004GASG-R	BUTTON 7 KEY	
	H03-ZPC1018GART-R	FILTER VFD	
	H03-ZPD0315GAMW-R	VOLUMN KNOB	
	H03-ZPD0316GASG-R	COVER KNOB	
	H03-ZPD0317GACR-R	CAP KNOB VOLUME	
	H03-ZPD3119GABT-R	WINDOW DISPLAY AVR445+BADGE NAME AVR445	
	H03-ZVC11DWT100-R	TAPE DOOR	
	H03-ZVC11DWT200-R	TAPE PANEL	
	H03-ZVC11GEAR01-R	DAMPER GEAR DP120	
	H03-ZVJF0925S00-R	DC FAN JF0925S1M-003C651R 12V 92x92x25mm	
	ZFD122062SB-R	RUBBER TOP AVR635	
	ZFD122072SB-R	RUBBER TOP AVR635	
	ZFNR13830SB-R	RUBBER SIDE	
	ZFNR19720SB-R	RUBBER FOOT 19.7X19.7X2T BK	
	ZMC12S13AYE-R	STANDOFF HEX M4X0.7 6X31.9H	
	ZMC12S14AYE-R	STANDOFF HEX M4X0.7 6X61.9H	
	ZNSSM4045HZ-R	NUT M4 HEXAGON CIRCULAR EXTERNAL	
	ZPC1002GAGY-R	DOOR AVR430/630	
	ZPC1003GAGY-R	BUTTON POWER	
	ZPC1005GAGY-R	BUTTON 8 KEY	
	ZPC1006GAWH-R	BUTTON STANDBY	
	ZPC1007GAMW-R	INDICATOR STAND-BY	
	ZPC1017GABK-R	HOLDER VFD AVR430/630	
	ZPC1102GAMW-R	INDICATOR VIDEO	
	ZPC1103GAGY-R	FOOT 50MM 15.8MM	

Ref. Designator	Part Number	Description	
MECHANICAL ASSEMBLY			
	ZPD2901GAGY-R	PANEL FRONT FOR AVR445US	
	ZSMCM4008BY-R	SCREW BM 4X8	
	ZSMCM4010BB-R	SCREW BM 4X10	
	ZSMPM3006LB-R	SCREW.M.S.M3X6 P/HD BLACK	
	ZSTBM3008BY-R	SCREW ST BH 3X8	
	ZSTBM3010BB-R	SCREW ST BH 3X10	
	ZSTBM3012BY-R	SCREW ST BH 3X12 PIVOT	
	ZSTGM3010BB-R	SCREW ST BH 3X10 GROUND	
	ZSTWM3006BB-R	SCREW ST WPH 3X6	
	ZSTWM3008BY-R	SCREW ST WPH 3X8	
	ZSTWM3A08BY-R	SCREW ST W7.5PH 3X8	
	ZSTWM4008BC-R	SCREW ST WPH 4X8 SILVER CHROM	
	ZUC1201AABK-R	SPONGE 30X30X10T BK	
	ZWF793008PO-R	WASHER FIBER 3 0.8T	
	ZWM623108SZ-R	WASHER SPRING 3	
	ZWM763109SZ-R	AC SPRING WASHER RT2250(PAV5005)	
	ZWM803305PZ-R	WASHER PLAIN 3	
	ZWMC04810PZ-R	WASHER PLAIN 4	
	H03-ZMD27S07A00-R	SHIELD AL	
	ZMD27S14AYE-R	STANDOFF HEX M4*0.76*123.5	
	H03-FBD0480BR00-R	FCORE CLAMP FILTER LF80BR W5 SRH 16X28X9	
	H03-ZUD0301ABBK-R	SPONGE-UL 30X30X12T BK	
	H03-ZMD27HS0400-R	H/SINK REG. TR AVR745	
	ZSTBM3014BY-R	SCREW ST BH 3X14 PIVOT	
	ZFNR19730SB-R	RUBBER FOOT 19.7X19.7X3.0T BK	
	H03-ZVC11TUNE01-R	TUNER MODULE KST-MB011MW0-81 US	US
	H03-ZVD01TUNE00-R	TUNER MODULE KST-MB114MW1-81 OEM EU	EU

REVISION RECORD		
NO.	Date	Contents

SCHEMATIC DIAGRAM AVR445-US CENTER SB AMP B'D

harman kardon

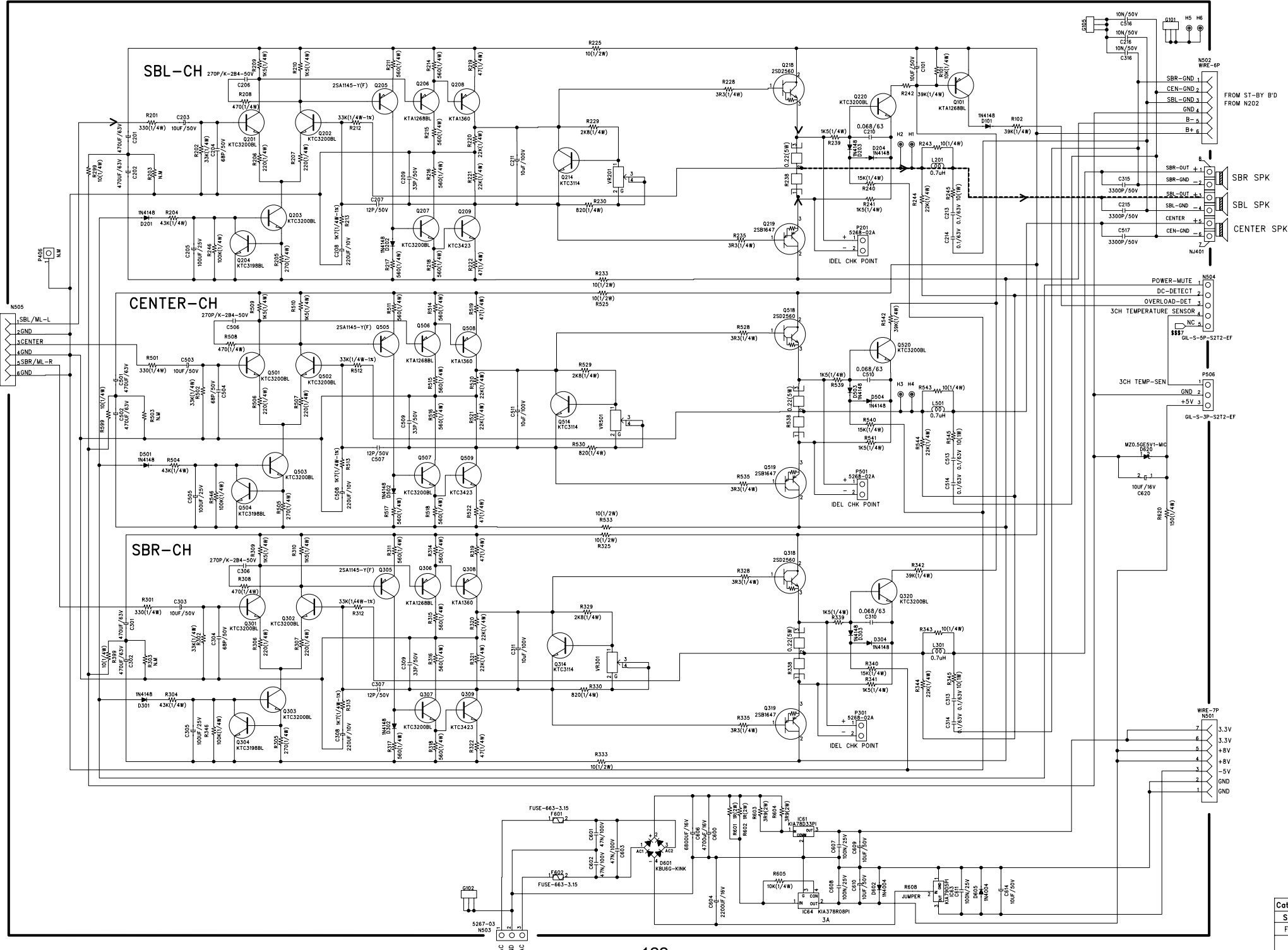

Category	AV RECEIVER	Model	AVR445-US
Stage	Ver.	Sheet	B'D name
FTMS		1 / 1	SURROUND
Draw	Approved	Date	Drawing No
KIM.S.Y		23.May.2006	

SCHEMATIC DIAGRAM harman/kardon AVR445 HDMI(US)

REVISION RECORD		
NO.	Date	Contents

G
F
E
D
C
B
A

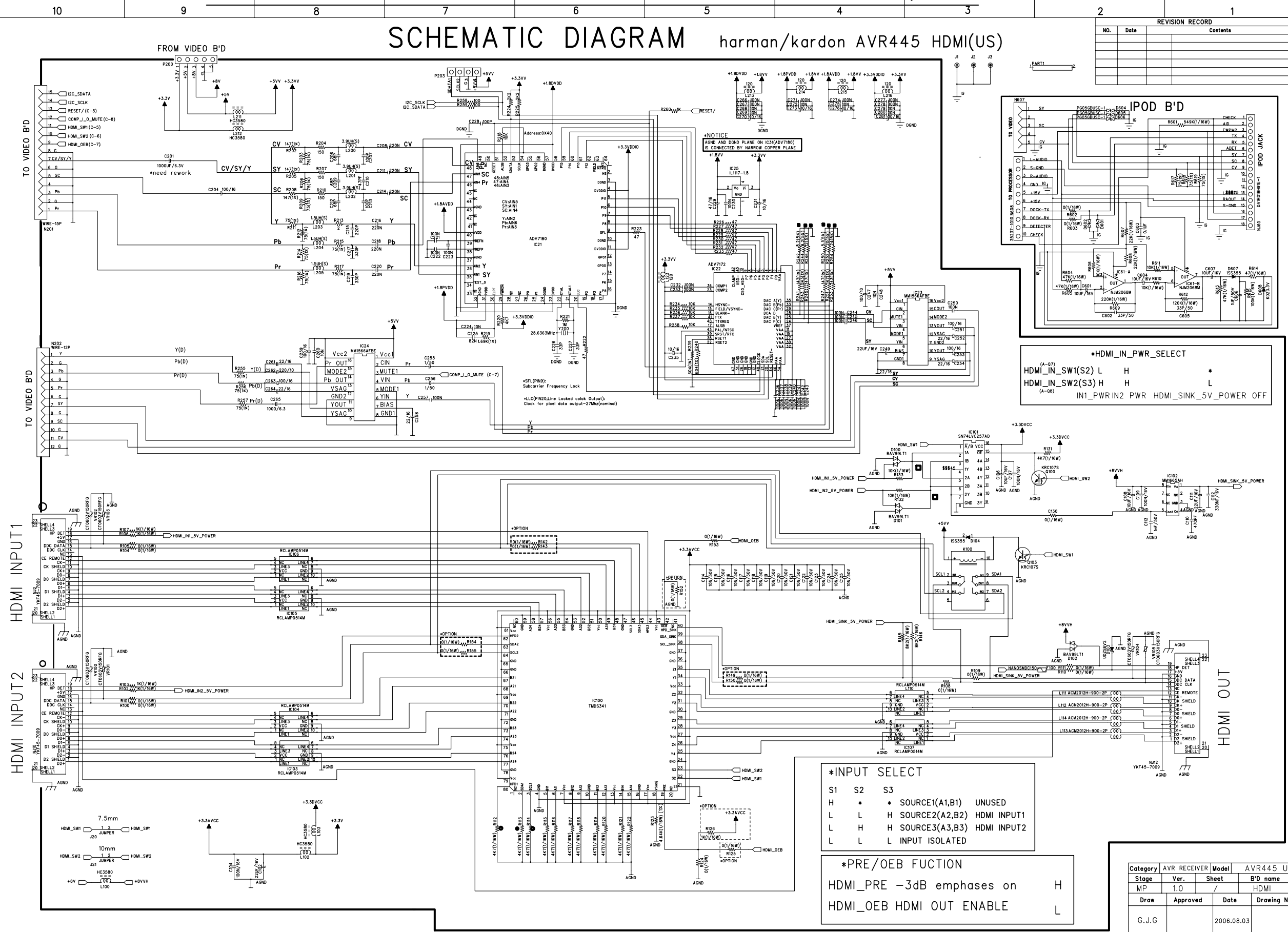

***NOTICE**
AGND AND DGND PLANE ON IC3(ADV7180) IS CONNECTED BY NARROW COPPER PLANE

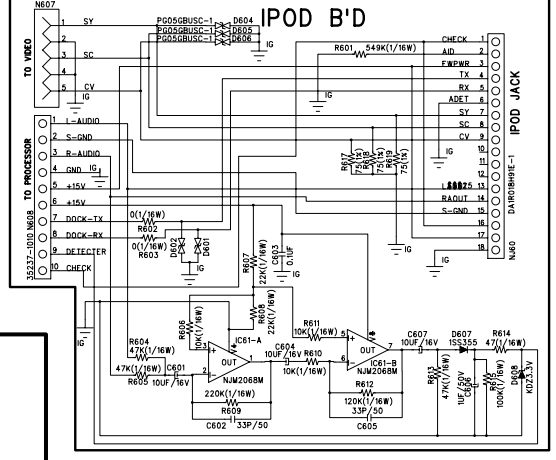

***HDMI_IN_PWR_SELECT**
HDMI_IN_SW1(S2) L H *
HDMI_IN_SW2(S3) H H L
(A-07) (A-08) IN1_PWR IN2_PWR HDMI_SINK_5V_POWER OFF

***INPUT SELECT**

S1	S2	S3	FUNCTION
H	*	*	SOURCE1(A1,B1) UNUSED
L	L	H	SOURCE2(A2,B2) HDMI INPUT1
L	H	H	SOURCE3(A3,B3) HDMI INPUT2
L	L	L	INPUT ISOLATED

***PRE/OEB FUCTION**

FUNCTION	Setting
HDMI_PRE -3dB emphases on	H
HDMI_OEB HDMI OUT ENABLE	L

Category	AVR RECEIVER	Model	AVR445 US
Stage	Ver.	Sheet	B'D name
MP	1.0	/	HDMI
Draw	Approved	Date	Drawing No
G.J.G		2006.08.03	

SCHEMATIC DIAGRAM

harman/kardon AVR445 VIDEO

REVISION RECORD		
No.	Date	Contents

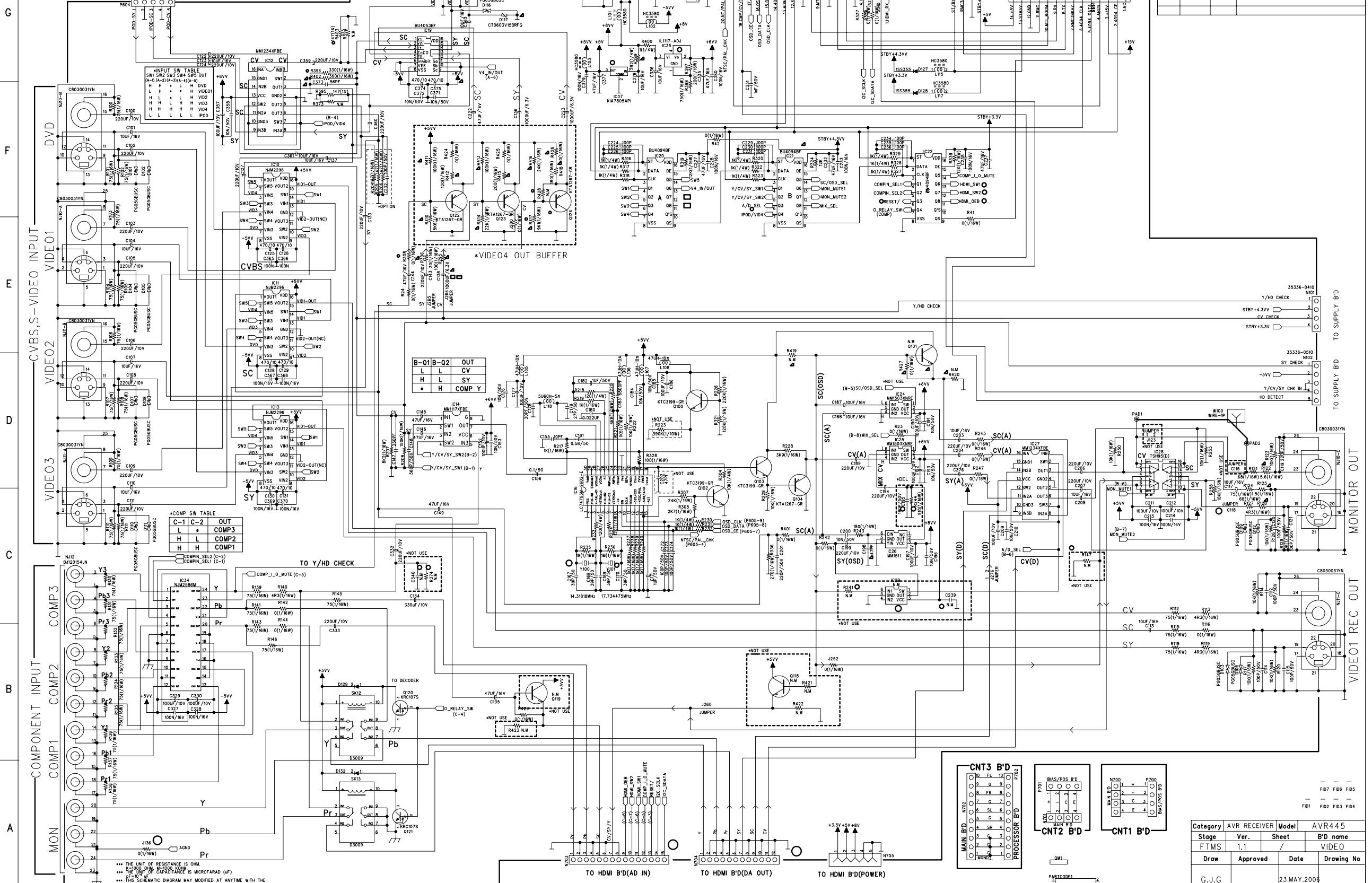

G
F
E
D
C
B
A

10 9 8 7 6 5 4 3 2 1

FROM IPOD B'D

TO FRONT B'D

FROM SURROUND B'D

TO DSP B'D

FROM SUPPLY B'D

TO RS232 B'D

CVBS, S-VIDEO INPUT

VIDEO 01

VIDEO 02

VIDEO 03

COMP 1

COMP 2

COMP 3

MON

TO Y/HD CHECK

TO DECODER

TO HDMI B'D (AD IN)

TO HDMI B'D (DA OUT)

TO HDMI B'D (POWER)

TO MAIN B'D

TO PROCESSOR B'D

TO BIAS/PDS B'D

TO MAIN B'D

TO BIAS/PDS B'D

TO MAIN B'D

TO BIAS/PDS B'D

TO MAIN B'D

TO BIAS/PDS B'D

TO MAIN B'D

TO BIAS/PDS B'D

TO MAIN B'D

TO BIAS/PDS B'D

TO MAIN B'D

TO BIAS/PDS B'D

TO MAIN B'D

TO BIAS/PDS B'D

TO MAIN B'D

TO BIAS/PDS B'D

TO MAIN B'D

TO BIAS/PDS B'D

TO MAIN B'D

TO BIAS/PDS B'D

TO MAIN B'D

TO BIAS/PDS B'D

TO MAIN B'D

TO BIAS/PDS B'D

TO MAIN B'D

Category	AVR RECEIVER	Model	AVR445
Stage	Ver. 1.1	Sheet	B'D name
FTMS	1.1		VIDEO
Draw	Approved	Date	Drawing No
G.J.G		23.MAY.2006	

SCHEMATIC DIAGRAM

REVISION RECORD		
No.	Date	Contents

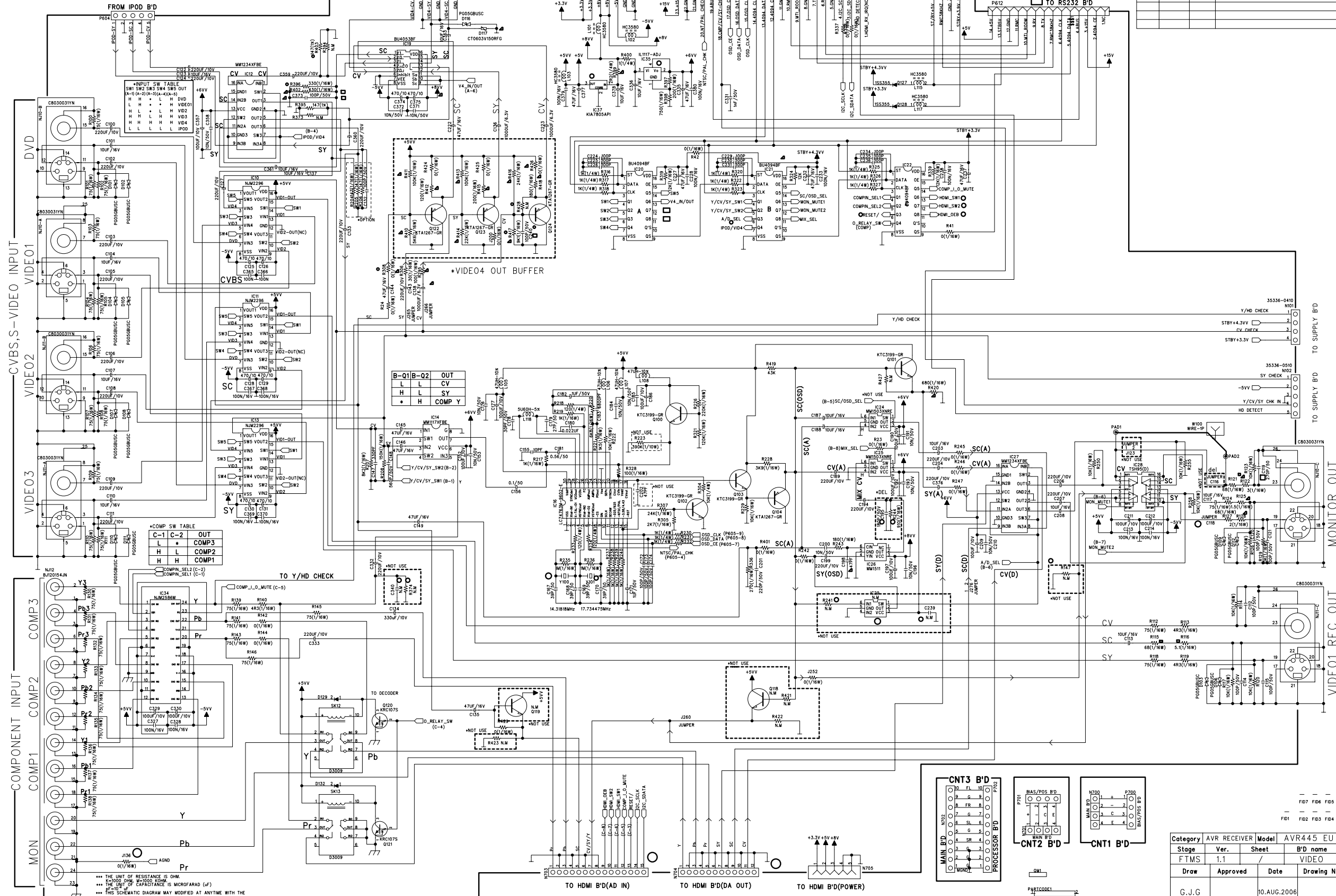

G
F
E
D
C
B
A

Category	AVR RECEIVER	Model	AVR445 EU
Stage	Ver.	Sheet	B'D name
FTMS	1.1	/	VIDEO
Draw	Approved	Date	Drawing No
G.J.G		10.AUG.2006	

REVISION RECORD		
NO.	Date	Contents

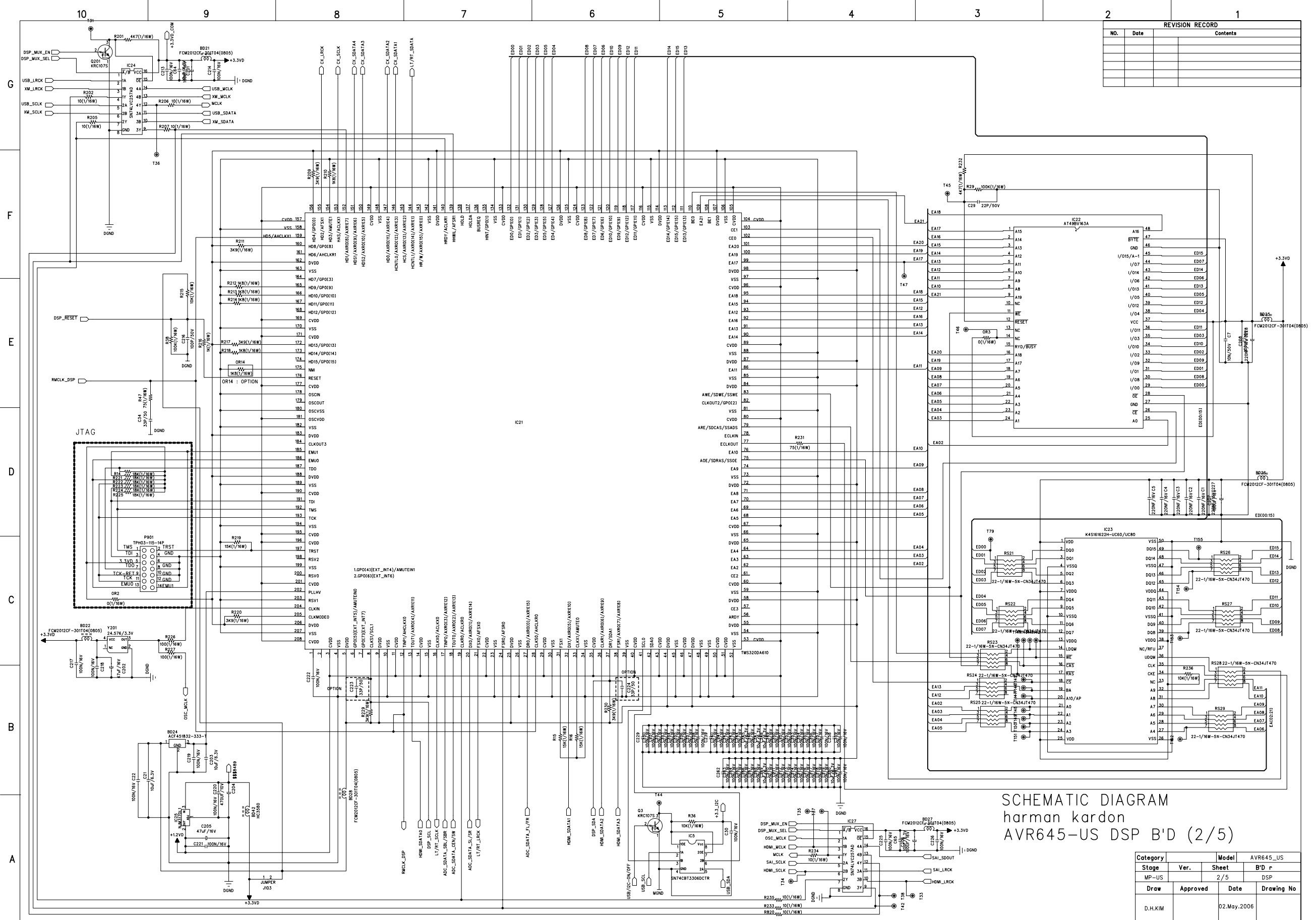

SCHMATIC DIAGRAM
harman kardon
AVR645-US DSP B'D (2/5)

Category	Model	AVR645_US
Stage	Ver.	B'D r
MP-US	2/5	DSP
Draw	Approved	Date
D.H.KIM		02.May.2006

REVISION RECORD		
NO.	Date	Contents

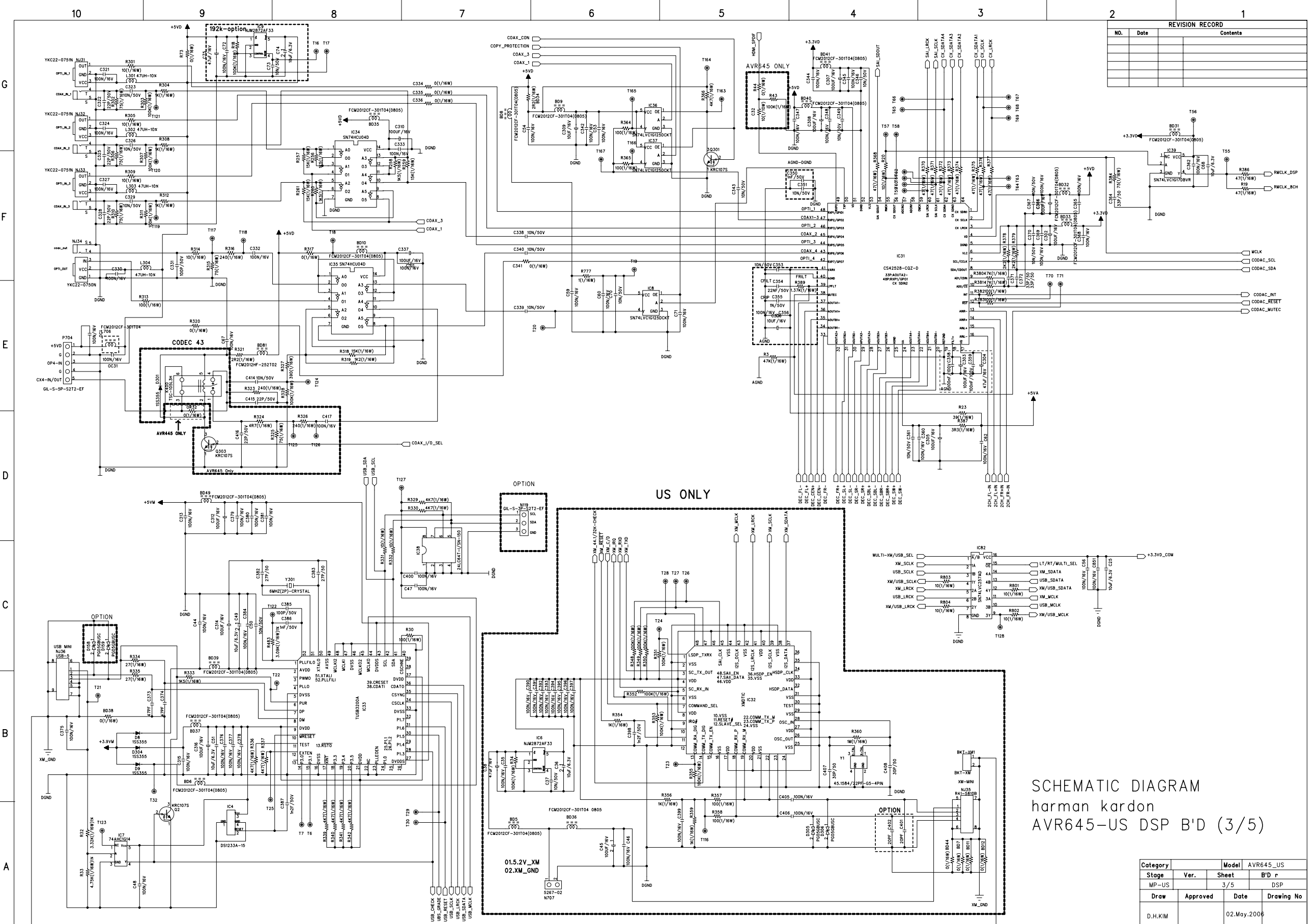

SCHEMATIC DIAGRAM
harman kardon
AVR645-US DSP B'D (3/5)

Category	Model
MP-US	AVR645_US
Draw	Approved
Sheet	Date
3/5	02.May.2006
B'D r	Drawing No
DSP	

REVISION RECORD		
NO.	Date	Contents

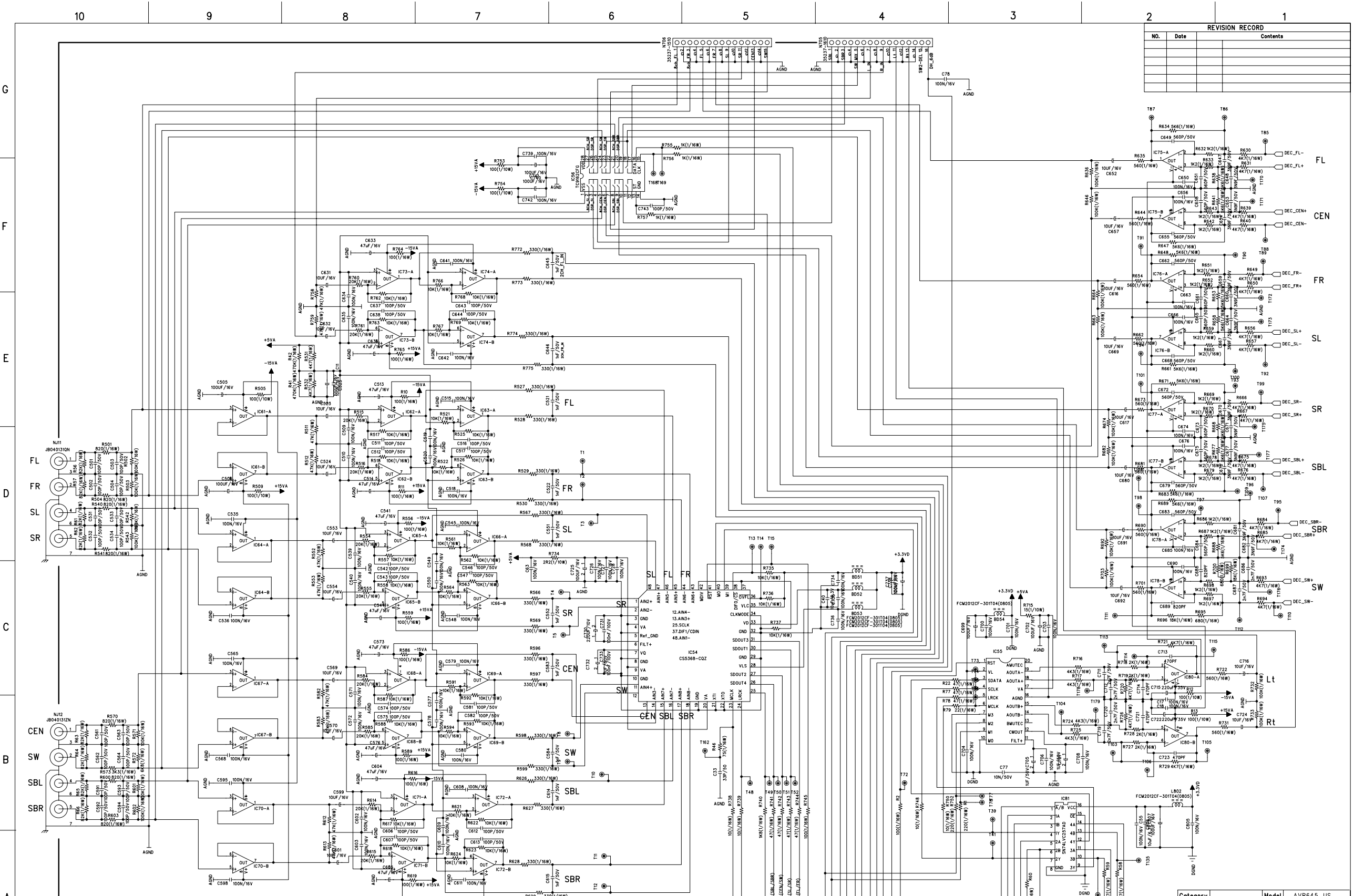

SCHEMATIC DIAGRAM
 harman kardon
 AVR645-US DSP B'D (4/5) 129

Category	Model	AVR645_US
Stage	Ver.	Sheet
MP-US		4/5
Draw	Approved	Date
D.H.KIM		02.May.2006
		DSP
		Draw No

SCHEMATIC DIAGRAM AVR645-US SUPPLY & RS232
harman kardon

REVISION RECORD		
NO.	Date	Contents

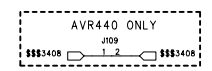
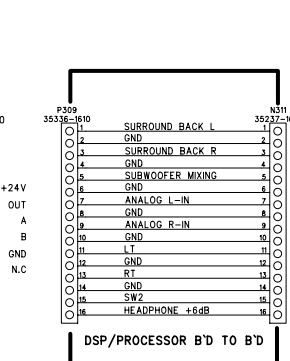
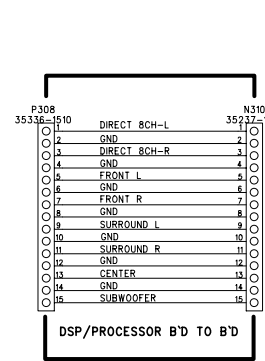
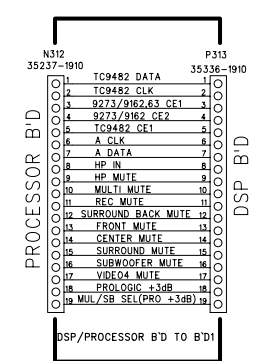
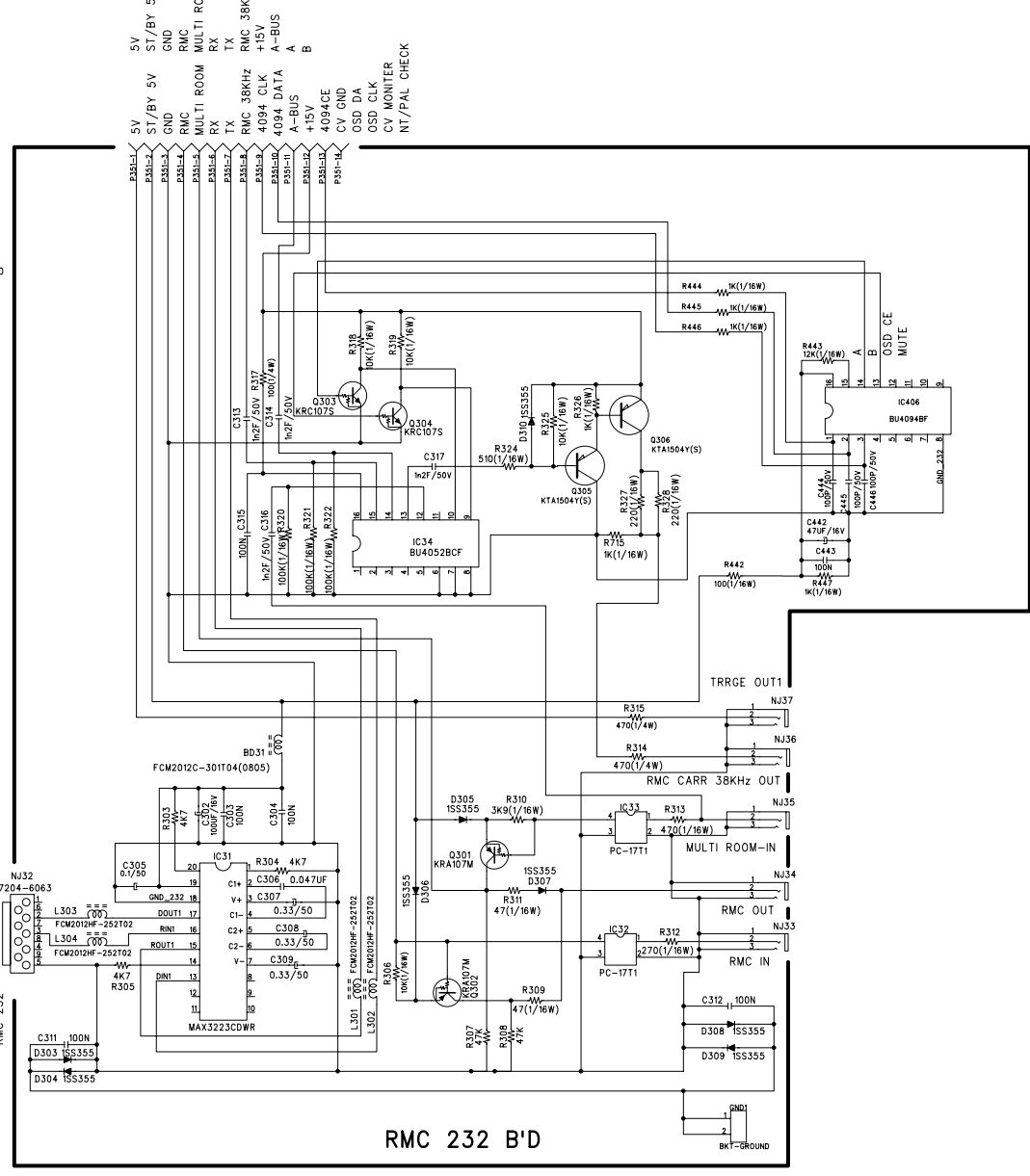
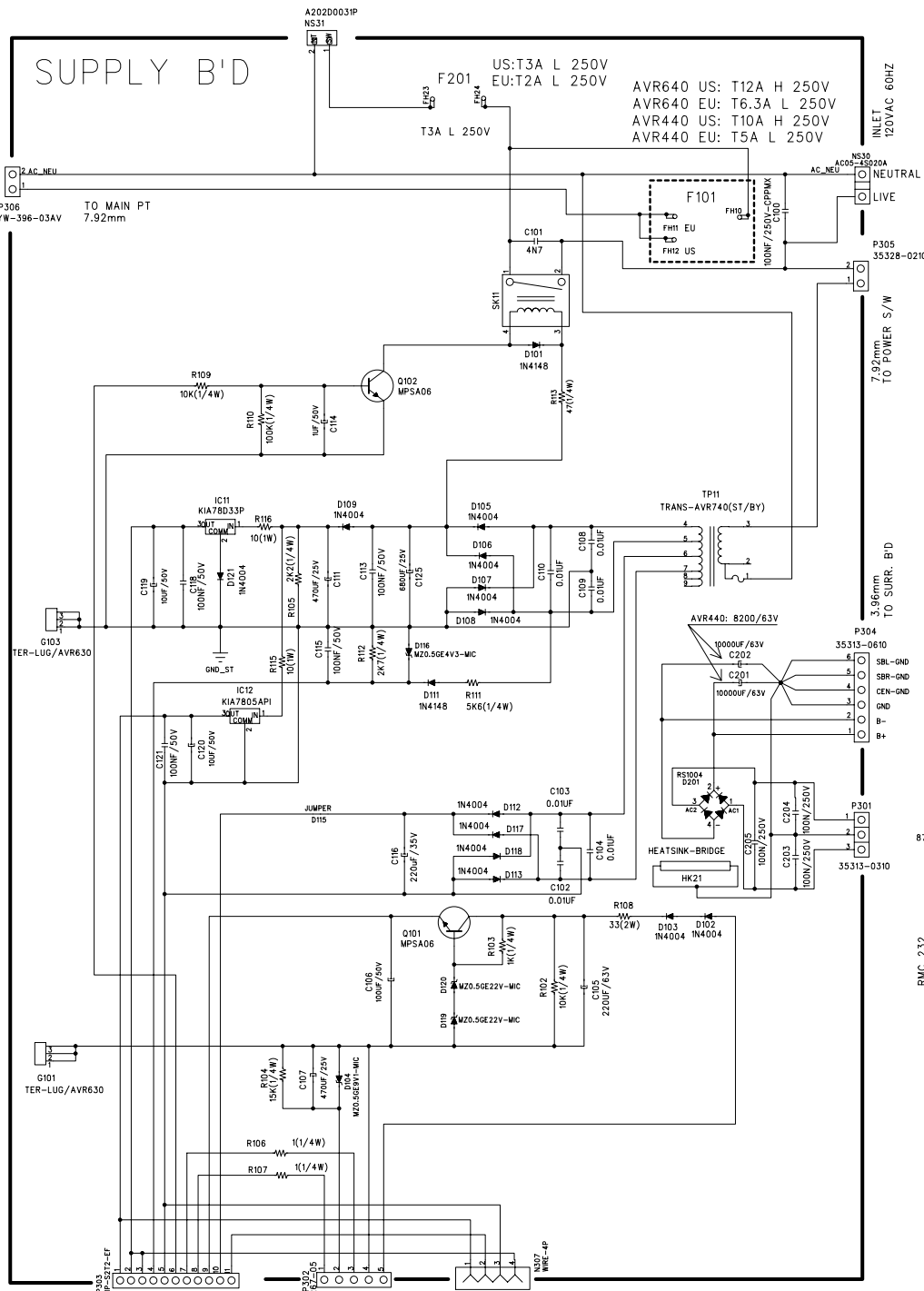

Category	A/V RECEIVER	Model	AVR645-US
Stage	Ver.	Sheet	B'D name
FTMS		1 / 1	SUPP/REGU
Draw	Approved	Date	Drawing No
S.Y. .KIM		04.May.2006	

SCHMATIC DIAGRAM AVR745 PROCESSOR(1/2)
harman kardon PROCESSOR B'D

REVISION RECORD		
NO.	Date	Contents

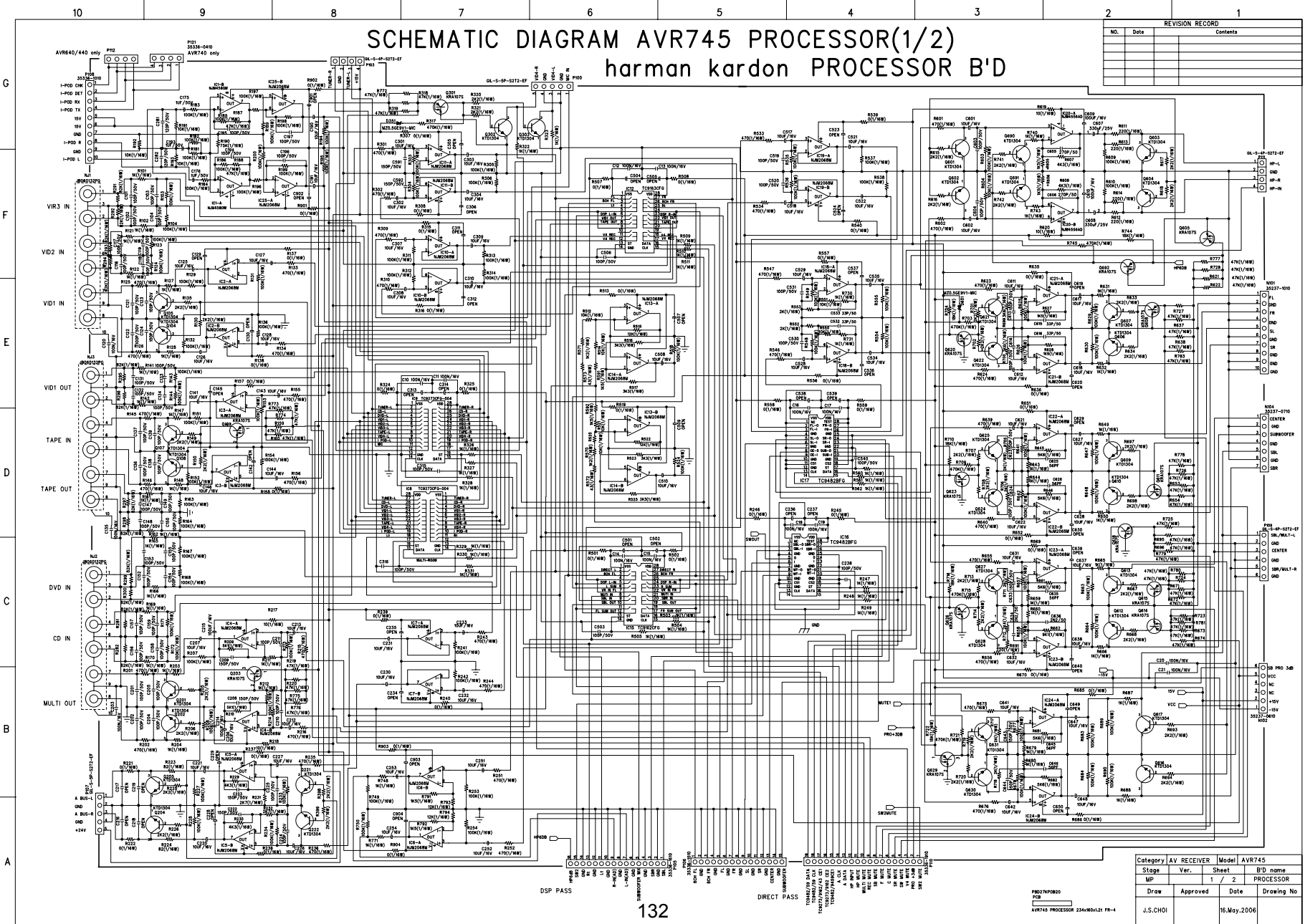

Category	AV RECEIVER	Model	AVR745
Stage	Ver.	Sheet	B'D name
MP	1	2	PROCESSOR
Draw	Approved	Date	Drawing No
J.S.CHOI		18.May.2006	

10 9 8 7 6 5 4 3 2 1

REVISION RECORD		
No.	Date	Contents

SCHEMATIC DIAGRAM AVR745 PROCESSOR (2/2)
harman kardon PROCESSOR B'D

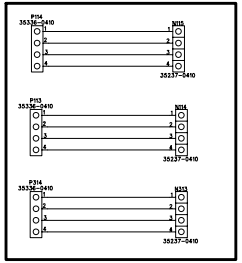
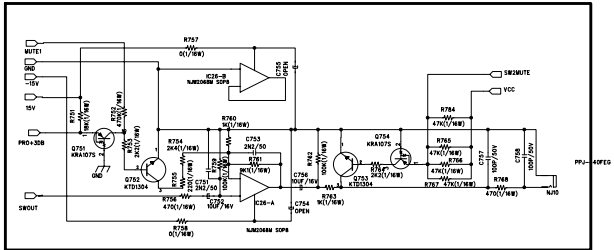

Category	AV RECEIVER	Model	AVR745
Stage	Ver.	Sheet	B'D name
MP		2 / 2	PROCESSOR
Draw	Approved	Date	Drawing No
J.S.CHOI		16.May.2006	

AVR445-US MAIN AMP SCHEMATIC DIAGRAM

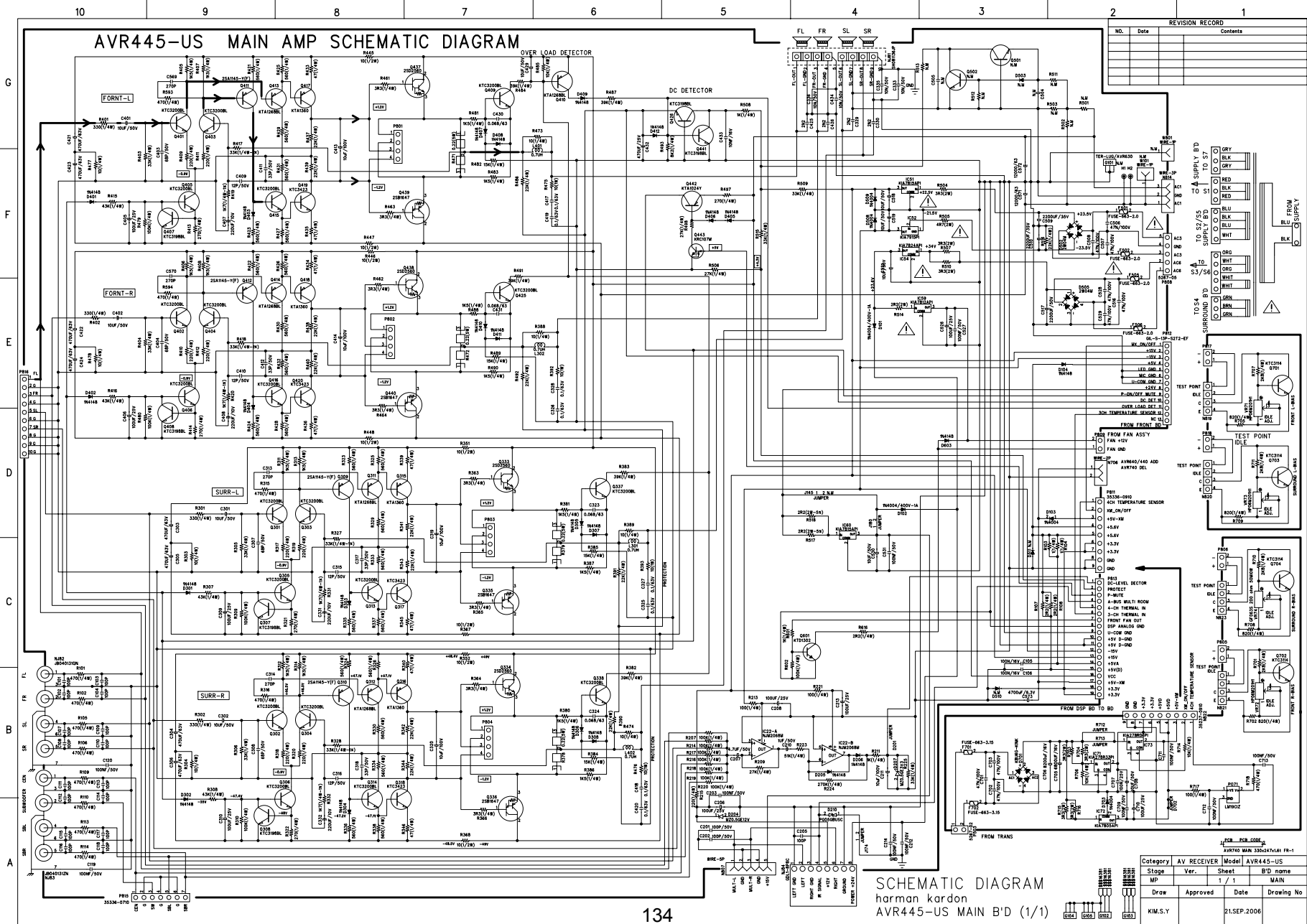

REVISION RECORD		
NO.	Date	Contents

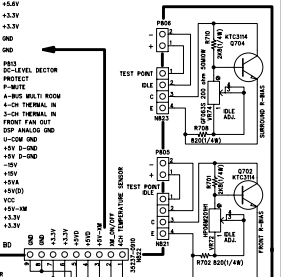
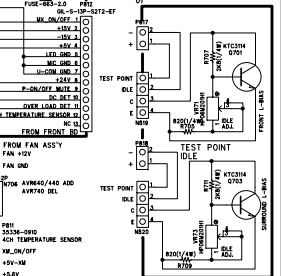
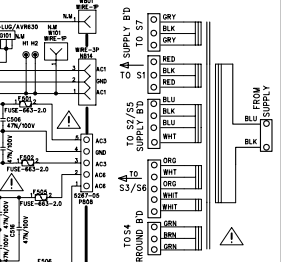

Category	AV RECEIVER	Model	AVR445-US
Stage	Ver.	Sheet	B'D name
MP	1 / 1	MAN	MAN
Draw	Approved	Date	Drawing No
KIM.S.Y		21.SEP.2006	

SCHEMATIC DIAGRAM
 harman kardon
 AVR445-US MAIN B'D (1/1)

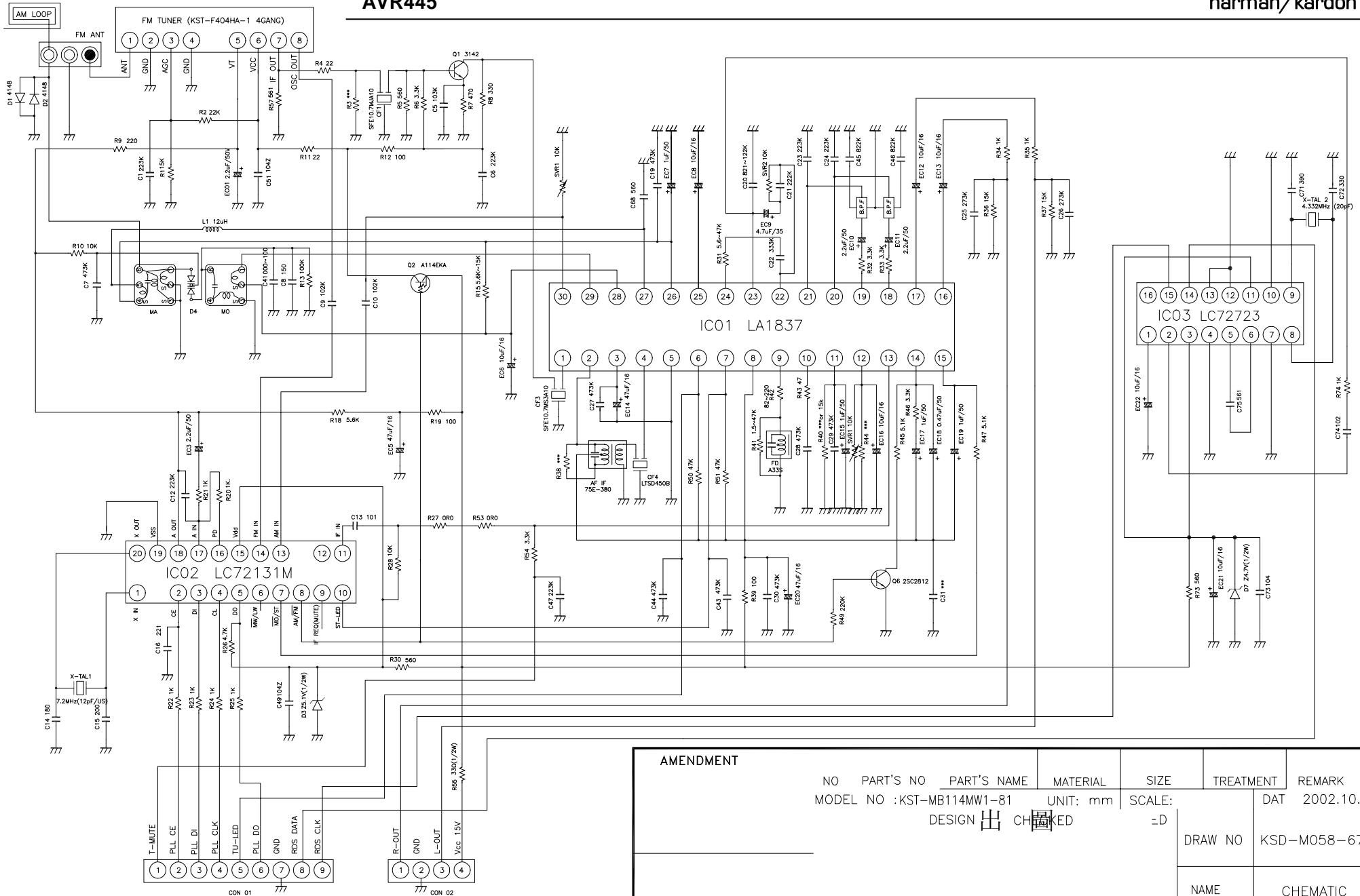

AMENDMENT

NO	PART'S NO	PART'S NAME	MATERIAL	SIZE	TREATMENT	REMARK
	MODEL NO : KST-MB114MW1-81	UNIT: mm	SCALE:			DAT 2002.10.19
	DESIGN	CHANGED		-D		

DRAW NO	KSD-M058-67RS
NAME	CHEMATIC

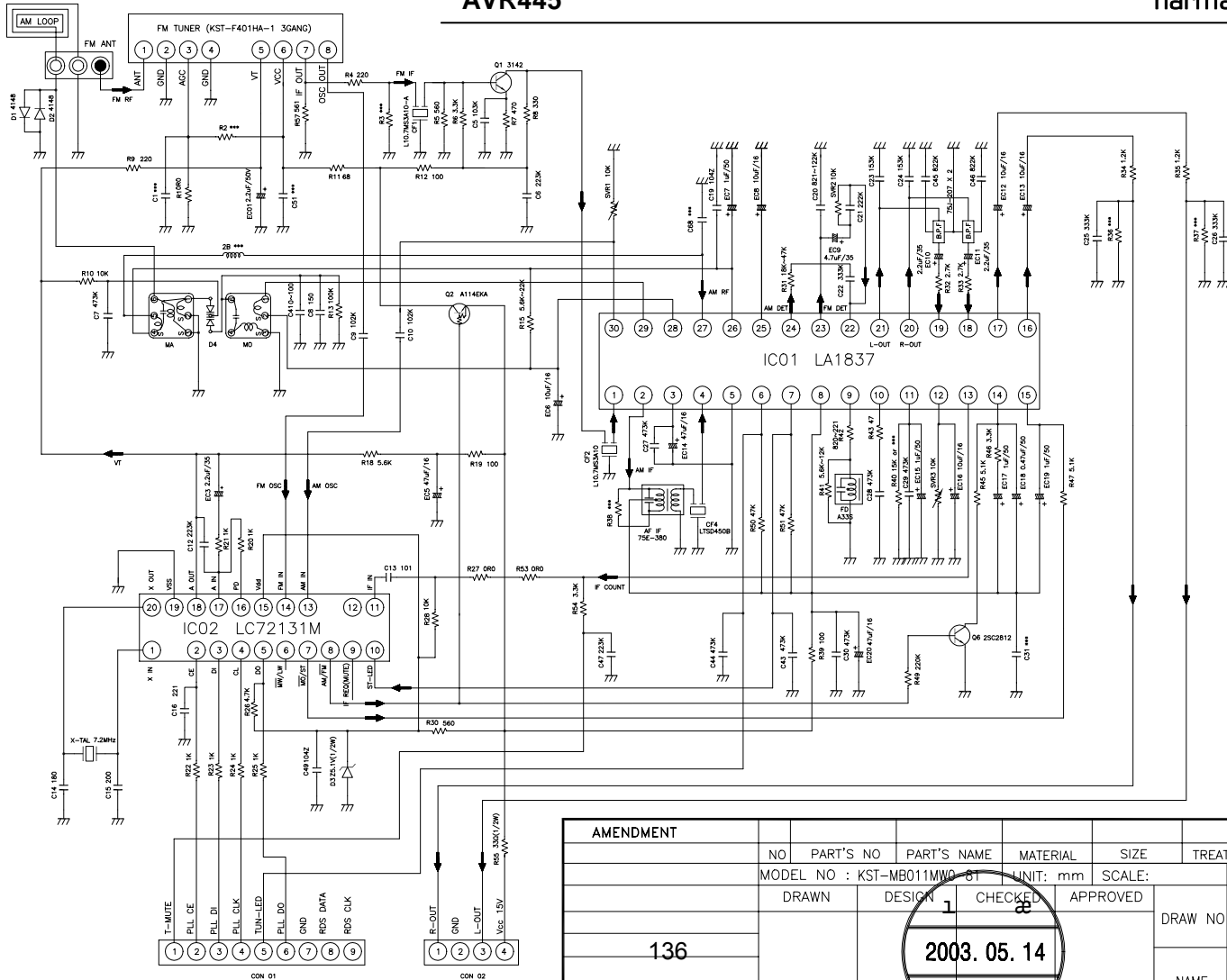

AMENDMENT		NO	PART'S NO	PART'S NAME	MATERIAL	SIZE	TREATMENT	REMARK
				MODEL NO : KST-MB011MWO-8T	UNIT: mm	SCALE:		DATE: 2002.09.06
		DRAWN	DESIGN	CHECKED	APPROVED		DRAW NO	KSD-M058-672
				1			NAME	SCHEMATIC DIAGRAM
136				2003. 05. 14				

