

# harman/kardon

# AVR45

## A/V DOLBY DIGITAL RECEIVER

# SERVICE MANUAL



The following marks found in the parts list of this manual  
Identify the models as follows:

- BK** AVR 45 : North America area model Black version
- IB** AVR 45 RDS : Europe area model Black version
- AB** AVR 45 SNG : Asia area model Black version

## CONTENTS

ELECTROSTATICALLY SENSITIVE(ES)DEVICES.....2	SERVICE BULLETIN HK9903.....22
LEAKAGE TEST..... 3	SERVICE BULLETIN HK2000-01.....23
SPECIFICATIONS.....4	SERVICE BULLETIN HK2001-02.....25
CONTROLS AND FUNCTIONS.....6	PC . BOARDS.....27
REAR PANEL CONNECTIONS.....8	ELECTRICAL PARTS LIST .....32
SERVICE PROCEDURE.....9	IC BLOCK DIAGRAMS .....48
ALIGNMENT PROCEDURES.....9	CPU BLOCK DIAGRAM.....59
MAIN AMP IDLING CURRENT ADJUSTMENT.....10	DISPLAY SEGMENTS.....67
ALIGNMENT AND TEST POINTS..... 11	FLT PIN CONFIGURATION .....68
CIRCUIT DESCRIPTION .....13	SCHEMATIC DIAGRAMS.....69
BLOCK DIAGRAM.....16	SCHEMATIC DIAGRAMS (RDS/SG).....76
DISASSEMBLY PROCEDURES .....17	SEMICONDUCTOR PIN DIAGRAM.....85
GENERAL UNIT PARTS LIST.....18	WIRING DIAGRAM .....86
GENERAL UNIT EXPLODED VIEW.....20	PACKING MATERIAL AND PARTS LIST .....87
SERVICE BULLETIN HK9804.....21	

## **ELECTROSTATICALLY SENSITIVE (ES) DEVICES**

Some semiconductor (solid state) devices can be damaged easily by static electricity. Such components commonly are called Electrostatically Sensitive (ES) Devices. Examples of typical ES devices are integrated circuits and some field effect transistors and semiconductor "chip" components.

The following techniques should be used to help reduce the incidence of component damage caused by static electricity.



1. Immediately before handling any semiconductor component or semiconductor-equipped assembly, drain off any electrostatic charge on your body by touching a known earth ground. Alternatively, obtain and wear a commercially available discharging wrist strap device, which should be removed for potential shock reasons prior to applying power to the unit under test.
2. After removing an electrical assembly equipped with ES devices, place the assembly on a conductive surface such as aluminum foil, to prevent electrostatic charge build-up or exposure of the assembly.
3. Use only a grounded-tip soldering iron to solder or unsolder ES devices.
4. Use only an anti-static solder removal device. Some solder removal devices not classified as "anti-static" can generate electrical charges sufficient to damage ES devices.
5. Do not use freon-propelled chemicals. These can generate electrical charge sufficient to damage ES devices.
6. Do not remove a replacement ES device from its protective package until immediately before you are ready to install it. (Most replacement ES devices are packaged with leads electrically shorted together by conductive foam, aluminum foil or comparable conductive material.)
7. Immediately before removing the protective material from the leads of a replacement ES device, touch the protective material to the chassis or circuit assembly into which the device will be installed.

**CAUTION** : Be sure no power is applied to the chassis or circuit, and observe all other safety precautions.

8. Minimize bodily motions when handling unpackaged replacement ES devices. (Otherwise harmless motion such as the brushing together of your clothes fabric or the lifting of your foot from a carpeted floor can generate static electricity sufficient to damage an ES devices.

## **PRODUCT SAFETY NOTICE**

Each precaution in this manual should be followed during servicing.

Components identified with the IEC symbol  in the parts list are special significance to safety. When replacing a component identified with , use only the replacement parts designated, or parts with the same ratings or resistance, wattage, or voltage that are designated in the parts list in this manual. Leakage-current or resistance measurements must be made to determine that exposed parts are acceptably insulated from the supply circuit before returning the product to the customer.

## LEAKAGE TEST(FOR SERVICE ENGINEERS IN THE U.S.A)

Before returning the unit to the user, perform the following safety checks :

1. Inspect all lead dress to make certain that leads are not pinched or that hardware is not lodged between the chassis and other metal parts in the unit.

2. Be sure that any protective devices such as nonmetallic control knobs, insulating fish-papers, cabinet backs, adjustment and compartment covers or shields, isolation resistor-capacity networks, mechanical insulators, etc. Which were removed for the servicing are properly re-installed.

3. Be sure that no shock hazard exists ; check for leakage current using Simpson Model 229 Leakage Tester, standard equipment item No. 21641, RCA Model WT540A or use alternate method as follows : Plug the power cord directly into a 120 volt AC receptacle (do not use an Isolation Transformer for this test). Using two clip leads, connect a

1500 ohms, 10watt Resistor paralleled by a 0.15uF capacitor, in series with all exposed metal cabinet parts and a known earth ground, such as a water pipe or conduit. Use a VTVM or VOM with 1000 ohms per volt, or higher sensitivity to measure the AC voltage drop across the resistor. (See diagram) Move the resistor connection to each exposed metal part having a return path to the chassis (antenna, metal, cabinet, screw heads, knobs and control shafts, escutcheon, etc.) and measure the AC voltage drop across the resistor. (This test should be performed with the 0.35 volt RMS or more is excessive and indicates a potential shock hazard which must be corrected before returning the unit to the owner.

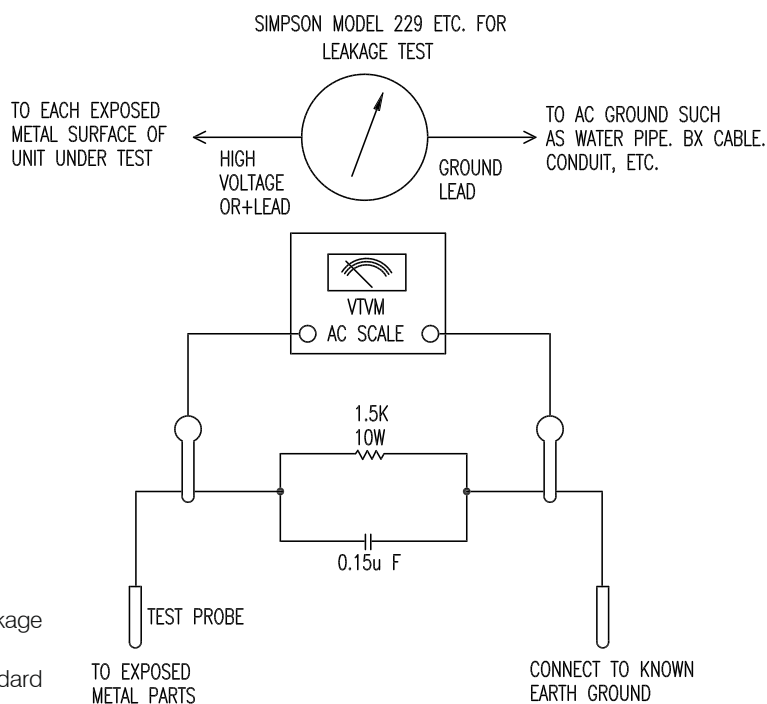

**AVR-45/45RDS/45SG**
**SPECIFICATIONS**
**FRONT AMP SECTION**

	Nominal	Limit
Continuous Power Output		
(STEREO MODE), Input : CD	≥ 65W	≥ 60W
THD : 0.08%, 8 ohms		
Both Channel Driven(20Hz-20kHz)		
(SURROUND MODE)	≥ 55W	≥ 50W
THD : 0.5%, 8 ohms, 1kHz		
THD : at 60W, 8 ohms, Input : CD		
20Hz	≤ 0.03%	≤ 0.08%
1kHz	≤ 0.03%	≤ 0.08%
20kHz	≤ 0.03%	≤ 0.08%
IM Distortion at 70W, 8 ohms, Vol : Max.		
	≤ 0.03%	≤ 0.08%
Input Sensitivity for Rated Power Output(60W)		
CD/DVD/TAPE MONITOR	200mV	170~230mV
VID1/VID2/VID3	200mV	170~230mV
S/N Ratio Input Shorted at 1 kHz 1W Output(WTD IHF-A)		
CD	> 82dB	
Tone Control		
Bass : 100Hz	+ 10dB	+ 10dB ± 3dB
	- 10dB	- 10dB ± 3dB
Treble : 10kHz	+ 10dB	+ 10dB ± 3dB
	- 10dB	- 10dB ± 3dB
Frequency Response at-3dB		
Mode : Stereo(1Watt)		
	10Hz-80kHz	10Hz-70kHz
Channel Crosstalk Input Shorted by 1 K Ohms		
100Hz	≥ 63dB	≥ 55dB
1kHz	≥ 63dB	≥ 55dB
10kHz	≥ 62dB	≥ 45dB

**CENTER AMP SECTION**

	Normal	Limit
RMS Output Power		
THD(0.5%, 8 ohms, 1kHz)		
All Channel Driven	≥ 55W	≥ 50W
S/N Ratio(Input Level : 200mV)		
Input Shorted, IHF-A WTD	≥ 65dB	≥ 60dB
Frequency Responses at-3dB		
8 ohms, Dolby Pro Logic	100Hz-20kHz	150Hz-20kHz

**REAR AMP SECTION**

	Normal	Limit
RMS Output Power		
THD(0.5%, 8 ohms, 1kHz)		
All Channel Driven	≥ 55W	≥ 50W
S/N Ratio(Input Shorted, IHF-A WTD)		
Delay : 20ms, Input Level : 200mV	≥ 65dB	≥ 60dB
Frequency Response at-3dB		
8 ohms, Dolby Pro Logic	100Hz-20kHz	150Hz-20kHz

**SUB WOOFER SECTION**

Line level at pre-out	
Surround mode : BYPASS(STEREO)	
Input Signal : L ch (only) 200mV	
Master Volume : + 5dB	
Low pass crossover frequency	70Hz cut off
Slope (Low Pass Filter)	24dB/octave

**VIDEO AMP SECTION**

Input Sensitivity / Impedance	
VID1/MID2/MID3	1Vp-p/75 ohm +/- 1dB
Output Level / Impedance	
VID1/MID2/MID3	1Vp-p/75 ohm +/- 1dB
Frequency Response at-3dB	DC-8 MHz DC-6 MHz

**FM SECTION**

Tuning Cover Range 100kHz Step for AVR-45	87.50-108.00MHz
---	-----------------

Tuning Cover Range 50 kHz Step for AVR-45RDS/SG		
Mono Usable Sensitivity(75 ohms Input, 98MHz)	≤ 14.2dbf	≤ 17.2dbf
Image Rejection(at 98MHz)	≥ 80dB	≥ 70dB
IF Rejection(at 90MHz)	≥ 90dB	≥ 80dB
46dB Quieting Sensitivity(at 98MHz, 100% MOD.)		
Stereo	≤ 39.2dbf	≤ 43.3dbf
Distortion(1kHz, 75kHz dev. At 98MHz, 71dbf Input)		
Mono	≤ 0.3%	≤ 0.5%
S/N Ratio(500uV Input, 100% MOD. At 98MHz)		
Stereo	≥ 65dB	≥ 60dB
Frequency Response(30Hz-15kHz)		
AVR-45 De-Emphasis : 75 $\mu$ s	+ 0.5dB	+ 1.0dB
AVR-45RDS/SG De-Emphasis : 50 $\mu$ s	- 2.0dB	- 4.0dB
AM Suppression at 98MHz	≥ 50dB	≥ 45dB
Muting Threshold(at 98MHz)	31.2dbf	39.2dbf
Overload Break-up at 98 MHz	71dbf	65dbf
Capture Ratio at 65dbf	71dbf	65dbf
Stereo Separation(at 98MHz, 100% MOD, 500 $\mu$ V Input)		
IHF Band Pass Filter	≤ 2dB	≤ 2.5dB
1kHz	≥ 40dB	≥ 35dB
Tape out Level(at 98MHz)	500mV	350-650mV

**AM SECTION**

	Nominal	Limit
Tuning Cover Range(MW)		
AVR-45 : 10kHz/Step	520-1710kHz	
AVR-45RDS/SG : 9kHz Step	522-1611kHz	
Usable Sensitivity(MW, at 999 / 1000kHz)	≤ 500uV/m	≤ 1000uV/m

Image Rejection(at 999kHz)	≥ 40dB	≥ 30dB
IF Rejection(at 999/1000kHz)	≥ 50dB	≥ 45dB
AGC Figure of Merit(From 100mV/m at 999/1000kHz)	≥ 50dB	≥ 45dB
Distortion(999/1000kHz, 30% MOD, 50mV/m Input)	≤ 1.0%	≤ 2.0%
Frequency Response(999/1000Hz)	At-3dB	100Hz-2.2kHz 150Hz-1.8kHz
Selectivity(999/1000Hz)		
9kHz/10kHz	≥ 30dB	≥ 25dB
S/N Ratio(999/1000kHz, With Antenna Input 5mV/m)	≥ 45dB	≥ 40dB
Overload Break-up at 999/1000kHz(THD 10%)	≥ 1000mV/m	≥ 500mV/m
Tape Output Level at 999/1000kHz(5mV/m Input)		
	200mV	160-240mV

**GENERAL**

Power Consumption	
At Rated Power All Channel Driven	332W
Idling at Minimum Volume Control	72W
Power Supplies :	
USA/Canada(AVR-65)	AC120V, 60Hz
Europe(AVR-65RDS/SG)	AC230V, 50Hz
Dimension(W x H x D)	
Inches	17.3 × 6.5 × 17.1
MM	440 × 165 × 435
Weight(lbs/kgs)	29/13.2

These specifications are service target specs.

specifications and components are subject to change without notice.

Overall performance will be maintained or improved.

# CONTROLS AND FUNCTIONS

## Front Panel

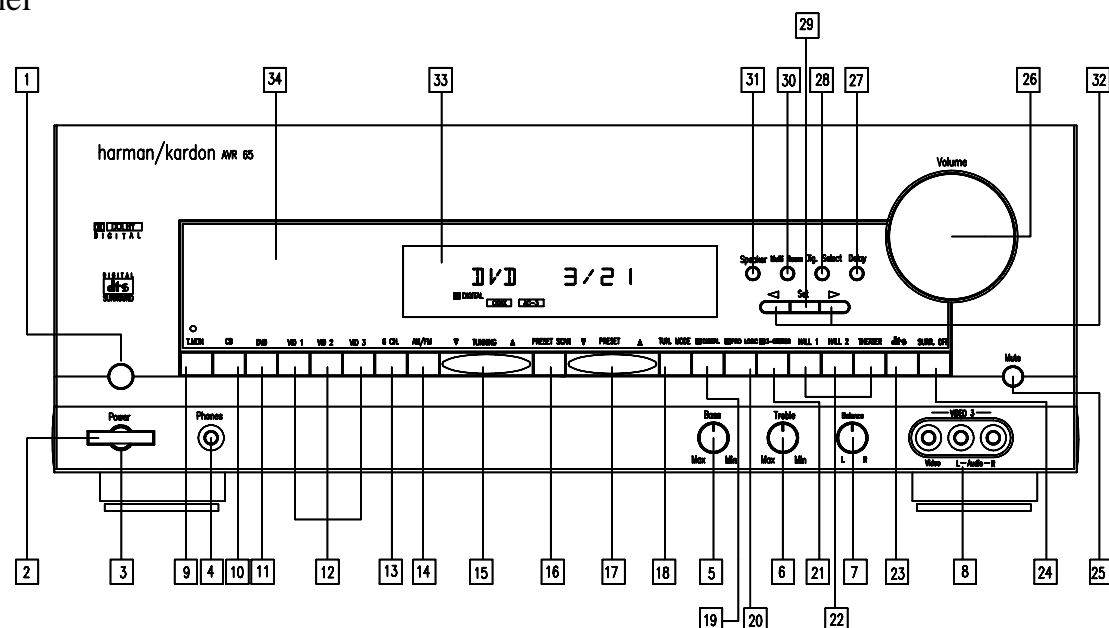

**1 Main Power Switch** : Press this button to apply power to the AVR-65.

When the switch is pressed the unit is placed in a Standby mode, as indicated by the amber LED.

This button **MUST** be pressed in to operate the unit. To turn the unit off and prevent the use of the remote control, this switch should be pressed until it pops out from the panel so that the word "OFF" may be read at the top of the switch.

**NOTE** : In normal operation this switch is left in the "ON" position.

**2 System Power Control** : When the Main Power Switch **1** is "ON", press this button to turn on the AVR-65 ; press it again to turn the unit off. Note that the **Power Indicator** surrounding the switch **3** will turn green when the unit is on.

**3 Power Indicator** : This LED will illuminate in amber when the unit is in the Standby mode to signal that the unit is ready to be turned on. When the unit is in operation, the indicator will turn green.

**4 Head Phone Jack** : This jack may be used to listen to the AVR-65's output through a pair of headphones. Be certain that the headphones have a standard 1/4" stereo phone plug.

**5 Bass Control** : Turn this control to modify the lower frequency output of the left / right channels by as much as +/-10dB. Set this control to a suitable position for your taste and room acoustics.

**6 Treble Control** : Turn this control to modify the high frequency output of the left / right channels by as much as +/-10dB. Set this control to a suitable position for your taste and room acoustics.

**7 Balance Control** : Turn this control to change the relative volume for the front left / right channels.

**NOTE** : For proper operation of the surround modes this control should be at the midpoint, or "12 o'clock" position.

**8 Video 3 Inputs** : These audio / video inputs may be used for temporary connection of video games, camcorder, digital still cameras or portable audio products. To select a source connected to these jacks, press the Video 3 Input Selector **12**.

**9 T-Mon Selector** : Press this button to select the device connected to the **Tape Monitor** jacks (24) as the listening source. The previously selected source will continue to show in the

information Display **33**, and the red LED above the button will illuminate to remind you that you are listening to the tape monitor output.

**10 CD** : Press this button to select the device connected to the CD Input jacks (6) as the listening source.

**11 DVD** : Press this button to select the device connected to the DVD play jacks (7) as the listening and viewing source.

**12 Video Input Selectors** : Press one of these buttons to select a source connected to the rear panel **Audio/Video** inputs (3), (16), or the front panel **Audio/Video** input **8**.

**13 6-Channel director Selector** : Press this button to select the output of an optional, external 6-channel decoder connected to the **6 Ch Direct** inputs (5) as the listening source.

**14 AM/FM** : Press this button to select the tuner as the AVR-65's input source. When it is first pressed the last station tuned will be heard. Press it again to change between AM and FM bands.

**15 Tuning button** : Press the left side of the button to tune lower frequency station and the right side of the button to tune higher frequency

stations. When a station with a strong signal is tuned, the **TUNED** indicator **R** will illuminate in the Information Display **33**. A brief(1/2 second) press of the button will manually tune to the next frequency increment, while pressing and holding the button for a long period will automatically tune to the next station with a signal strong enough for acceptable reception.

**16 Preset Scan** : Press this button to automatically scan through the station that have been programmed in the AVR-65's memory. The tuner will play five seconds of each station before moving to the next preset station. To stop the scan when the desired station is heard, press the button again.

**17 Preset Stations Selector** : Press this button to select stations that have been entered into the preset memory.

**18 TUN.MODE/RDS** : Press this button to select the auto or mono mode for FM tuning. In the AUTO mode, **AUTO** indicator will illuminate in the information display, and when stations are transmitting stereo signals, the stereo reception will be provided and **Stereo** indicator will also be illuminated in the information display. In the MONO mode the left and right signals from stereo broadcasts will be mixed together and reproduced through all channels. Select MONO for better reception of weak signals.

**19 Dolby Digital Selector** : Press this button to select the Dolby Digital surround mode when listening to a program that carries the Dolby Digital surround mode when listening to a

program that carries the Dolby Digital information.

**20 Dolby Pro Logic Selector** : Press this button to select the Dolby Pro Logic surround mode when listening to an analog or digital(PCM) program that is encoded with surround-sound information.

**21 Dolby 3 Stereo Selector** : Press this button to select the Dolby 3 Stereo listening mode. This mode is used primarily when a program has surround information when a center channel speaker, but no surround speakers, is installed.

**22 Surround Mode Selectors** : Press one of these buttons to select the analog surround modes. These modes may be used with any analog program source to create a pleasing surround effect.

**23 DTS Selector** : press this button to select DTS decoding when listening to an audio or video program that is encoded with DTS data.(See page 25 for more information on surround modes and digital audio.)

**24 Surround Off** : Press this button to turn off all surround processing, and to listen to a program in traditional stereo from the left front and right front speakers only.

**25 Mute** : Press this button to momentarily silence the speaker output of the AVR-65.

**26 Volume Control** : Turn the knob clockwise to increase volume, counter clockwise to decrease the volume.

**27 Delay** : Press this button to begin the sequence of steps required to enter delay time settings.

**28 Digital Input Selector** : When playing a source that has a digital output, press this button to select between the **Optical** (19) and **Coaxial** (18) Digital inputs.

**29 Set Button** : When making choices during the setup and configuration process, press this button to enter the desired setting, as shown in the information Display, into the AVR-65's memory.

**30 Multi-room** : Press this button to begin the process of selecting and configuring the AVR-65's output channels.

**31 Speaker Selector Button** : Press this button to begin the process of selecting the speaker positions that are used in your listening room.

**32 Selector Buttons** : When you are establishing the AVR-65's configuration settings, use these buttons to select between the choices available. as shown in the information Display **33**.

**33 Information Display** : This display delivers messages and status indications to help you operate the receiver.

**34 Remote Sensor Window** : The sensor behind this window receives infrared signals from the remote control. Aim the remote at this area and do not block or cover it unless an external remote sensor is installed.

## Remote Control

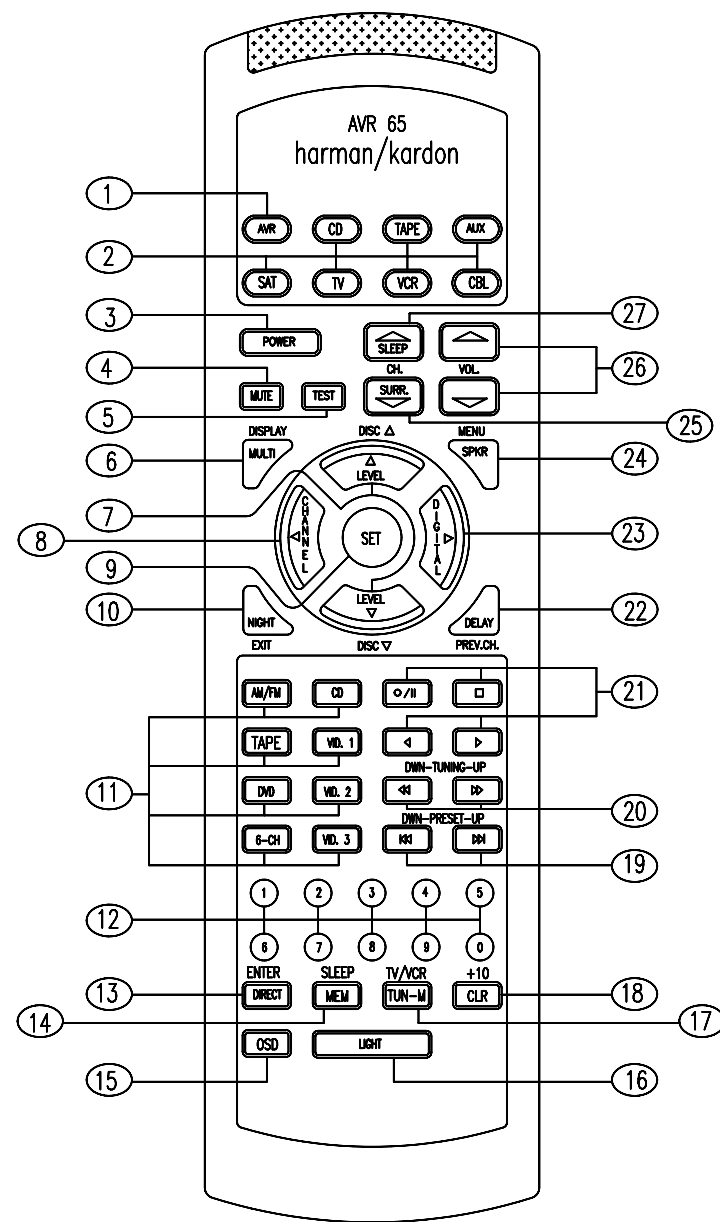

**1 AVR Selector** : Press this button to use the remote control for operation of the AVR-65. Note that the button will briefly turn red after it has been pressed to confirm your selection.

**2 Device Control Selectors** : Press one of these button to use the remote to control the functions of another audio/video device. Note that the button will briefly turn red after it has been pressed to confirm your selection.

**3 Power Button** : Press this button to turn the currently selected device on or off.

**4 Mute** : Press this button to momentarily silence the AVR-65 or TV set being controlled, depending on which device has been selected.

**5 Test** : Press this button to begin the sequence used to calibrate the AVR-65's output levels.

**6 Display/Multiroom Button** : This button does not function with AVR-65, but it is available for use with other devices.

**7 ▲/▼ Buttons** : These are multi purpose buttons. They will be used most frequently to

select a surround mode.

To change the surround mode, first press the **SURR/CH ▲/▼** button **25**. Next press these buttons to scroll up or down through the list of surround modes that appear in the Information Display **33**. These buttons are also used to increase or decrease output levels used to lower the AVR-65's output levels when configuring the unit with either the internal test tone or and external source. They are also used to enter delay time settings after the **Delay** button **22** has been pressed.

**8 ◀/▶ Channel Button** : This button is used to start the process of setting the AVR-65's output levels to an external source. Once this button is pressed, use the **▲/▼** buttons **7** to select the channel being adjusted, then press the **Set** button **9**, followed by the **▲/▼** buttons again to change the level setting.

**9 Set Button** : This button is used to enter settings into the AVR-65's memory. It is also used in the setup procedures for delay time, speaker configuration and channel output level adjustment.

**10 Night Mode** : Press this button to activate the "Night" mode, preventing loud playback when the digital modes are in use without altering the dynamic range of the output signal.

When the AVR-65 remote is being programmed to operate other devices, this button is pressed to begin a readout of a programmed code.

**11 Source Selectors** : Press these buttons to select an input source for the AVR-65. The AM/FM button is also used to switch between frequency bands when the tuner in use.

**NOTE** : Pressing one of these buttons selects the source only. In order to control the actual source machine using the remote you must press the **Press Control Selector** button **2** for the desired product.

**12 Numeric Keys** : These buttons serve as a ten-button numeric key-pad to enter tuner preset positions. They are also to be used to select channel numbers when TV has been selected on the remote, or to select track numbers on a CD, DVD or LD player, depending on how the remote has been programmed.

**NOTE** : The 0 button has a dual function. It also serves as the **CLEAR** button for use in programming the tuner or clearing the system memory.

**13 Direct/Enter** : Press this button to select a radio station by entering its frequency using the Numeric Key **12**.

**14 Memory Button** : Press this button to enter a radio station into the AVR-65's preset memory. After pressing the button the **MEMORY** indicator **N** will flash, and you then have five seconds to enter a present memory location using the Numeric Keys **12**.

**NOTE** : Although the word "Sleep" appears above this button, it refers to control of devices other than the AVR-65. Use the **Sleep** button **27** to control the AVR-65's Sleep function.

**15 OSD Button** : This button dose on screen display function with the AVR-65.

→ Semi → Full → OFF ←

**16 Light Button** : Press this button to activate the remote's built-in back-light for better legibility of the buttons in a darkened room.

**17 Tuner Mode** : Press this button when the tuner is in use to select between automatic tuning and manual tuning. When the button is pressed so that the **AUTO** indicator **Q** goes out, pressing the **Tuning** buttons **20** will move the frequency up or down in single-step increments. When the FM band is in use, pressing this button when a station's signal is weak will change to monaural reception, as indicated by the **MONO**

indicator **Q**.

**18 Clear Button** : This button dose not function with the AVR-65, but it is available for use with other devices.

**19 Press Up/Down** : When the tuner is in use, these buttons scroll through the stations that have been programmed into the AVR-65's memory. When many source devices, such as CD players, VCRs and cassette decks, are selected using the **Device Control Selectors** **2**, these buttons will normally function as chapter step or track advance.

**20 Tuning Up/Down** : When the tuner is in use, these buttons will tune up or down through the selected frequency band. If the **Tuner Mode** button **17** has been pressed so that the **AUTO** indicator **Q** is illuminated, pressing these buttons will cause the tuner to seek the next station with acceptable signal strength for quality reception. When the **AUTO** indicator **Q** is NOT illuminated, pressing these buttons will tune stations in single-step increments.

**21 Transport Control** : These controls do not control any function of the AVR-65, but they are used extensively when operating a wide variety of CD players, cassette decks and VCRs.

**22 Delay/Prev Ch.** : Press this button to begin the process for setting the delay times used by the AVR-65 when processing surround sound. After pressing this button the delay times are entered by pressing the **Set** button **9**, and then using **▲/▼** buttons **7** to change the setting. Press the **Set** button again to complete the process.

**23 ◀/▶ Digital Button** : This button is used to select the type of digital input used with any one of the input sources connected to the AVR-65. After pressing this button, use the **▲/▼** buttons (7) to make your selection between **OPTICAL** **E** or **COAXIAL** **G** digital. Press the **Set** button **9**

to enter your choice.

**24 Speaker Configuration** : Press this button to begin the process of configuring the AVR-65's Bass Management System for use with the type of speaker used in your system.

Once the button has been pressed, use the **▲/▼** buttons **7** to select the channel you wish to set up. Press the **Set** button **9**, and then select another channel to configure. When all adjustments have been completed, press the **Set** button twice to exit the settings and return to normal operation.

**25 Surround Mode Selector** : Press this button to begin the process of changing the surround mode. After the button has been pressed, use the **▲/▼** buttons **7** to select the desired surround mode. Note that this button is also used in the "Auto Search" process.

**26 Volume** : Press these buttons to raise or lower the system volume.

**27 Sleep Button** : Press this button to place the unit in the Sleep Mode. After the time shown in the display, the AVR-65 will automatically go into the standby mode. Each press of the button changes the time until turn-off in the following order:

→ 90 → 80 → 70 → 60 → 50 → 40 ←  
 → 30 → 20 → 10 → 5 → 1 → OFF ←

Note that this button is also used to change channels on your TV when the TV is selected using the **Device Control Selector** **2**.

When the AVR-65 remote is being programmed for the codes of another device, this button is also used in the "Auto Search" process.

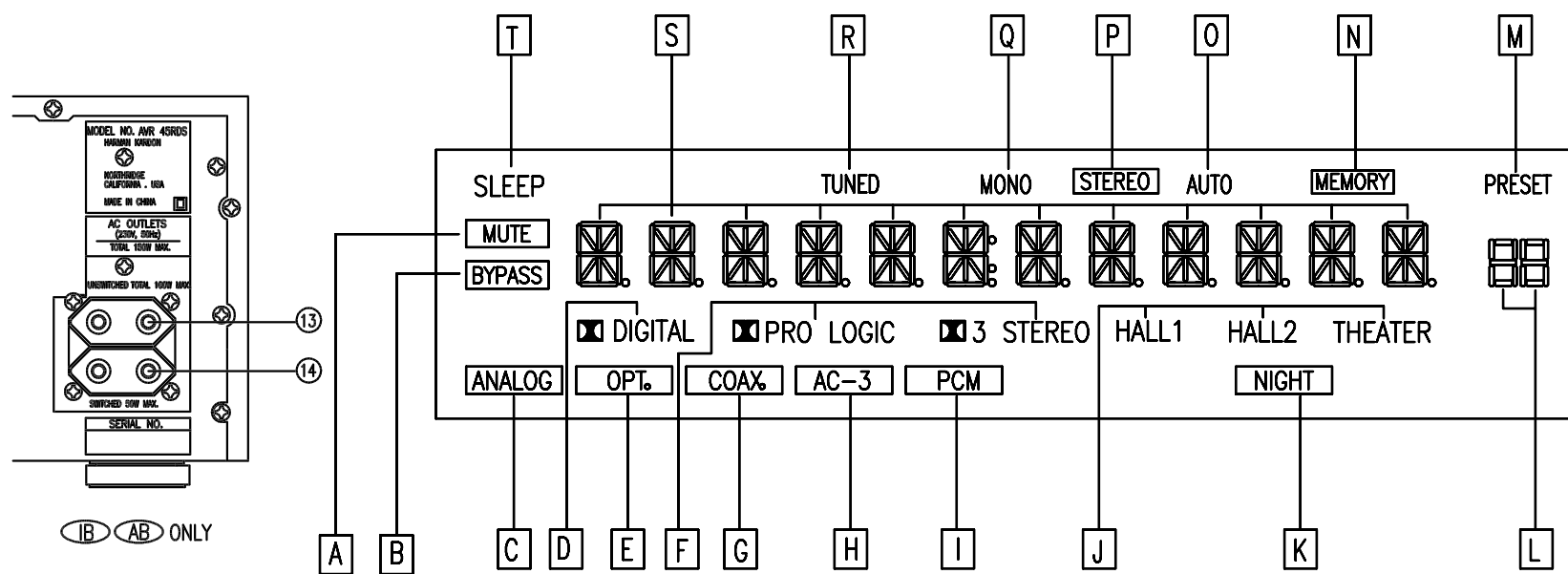
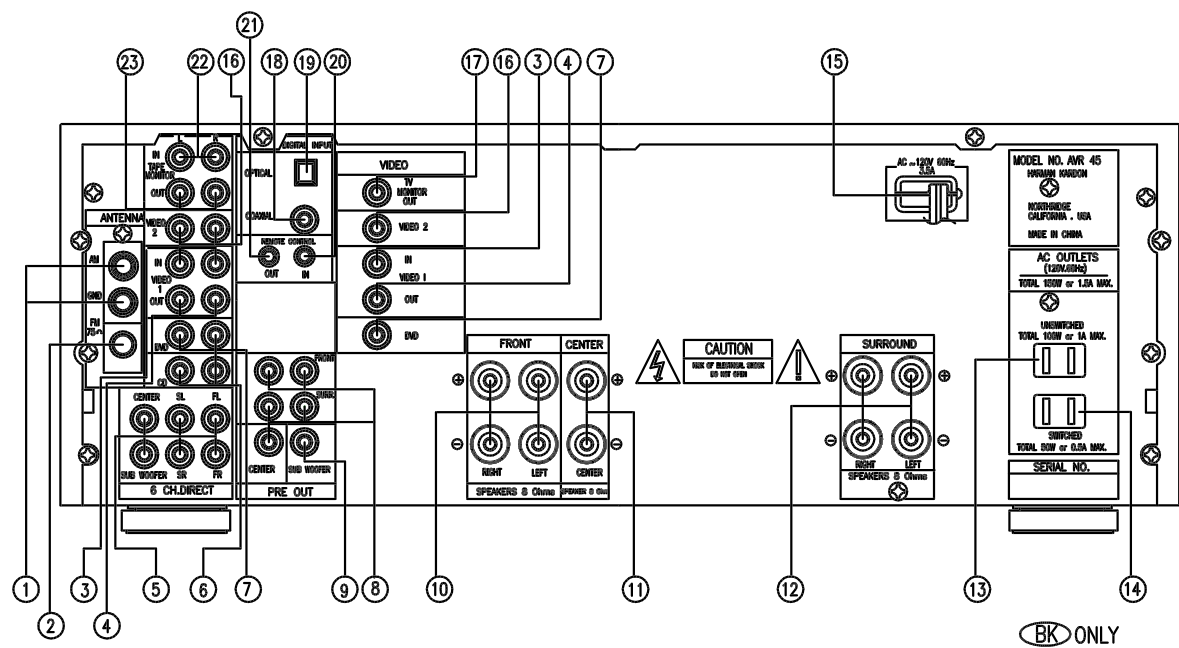

- 1 AM Antenna** : Connect the AM loop antenna supplied with the receiver to these terminals. If an external AM antenna is used, make connections to the AM and GND terminals in accordance with the instructions supplied with antenna.
- 2 FM Antenna** : Connect an indoor or external FM antenna to this terminal.
- 3 Video 1 Input** : Connect these jacks to the audio and video PLAY/OUT jacks of a VCR.
- 4 Video 1 Output** : Connect these jacks to the audio and video RECORD INPUT jacks of a VCR.
- 5 6-Channel Direct Inputs** : If an external digital audio decoder is used for 5.1(Dolby AT-3)audio, connect the outputs of that decoder to these terminals.
- 6 CD Inputs** : Connect these jacks to the output of a compact disc player or CD changer.
- 7 DVD Inputs** : Connect the analog audio outputs and composite video output of a DVD or LD player to these jacks.
- 8 Pre-Outs** : If external power amplifiers are used for any channels, connect them to these jacks.
- 9 Subwoofer Pre-Out** : Connect this jack to the line level input a powered subwoofer. If an

- external subwoofer amplifier is used, connect this jack to the subwoofer amplifier input.
- 10 Front** : Connect these terminals to the front left/right speakers.
- 11 Center** : Connect these terminals to the center speaker.
- 12 Surround** : Connect these terminals to the surround speaker.
- 13 Unswitched AC Outlet** : This outlet may be used to power any AC device. The power will remain on at this outlet regardless of whether the AVR-45 is on or not.
- 14 Switched AC Outlet** : This outlet may be used to power any device that you wish to turn on when the unit is turned on with the System Power Control switch. **2**
- 15 Power Cable** : Connect the AC plug to non-switched AC wall output.
- 16 Video 2 Inputs** : Connect these jacks to the audio and video outputs of a TV Tuner. Cable TV converter box, satellite receiver or any other audio/video source.
- 17 TV Monitor Video Output** : Connect this

- jack to the standard(composite) video input of a TV monitor or video projector to view the on-screen menus and the output of any standards video source selected by the receiver's video switcher.
- 18 AC-3/PCM Coaxial Input** : Connect the coax digital output from a DVD player to this jack. The signal may be either a Dolby Digital (AC-3) signal or a standard PCM digital source.
- 19 AC-3/PCM Optical Input** : Connect the optical digital output from a DVD player, HDTV receiver, LD player or CD player to this jack. The signal may be either a Dolby Digital (AC-3) signal or a standard PCM digital source .
- 20 Remote IR In** : If the AVR-45's front panel IR sensor is blocked due to cabinet door or other obstructions, an external IR sensor may be used. Connect the output of the sensor to this jack.
- 21 Remote IR Out** : This connection permits the IR sensor in the receiver to serve other remote controlled devices. Connect this jack to the "IR IN" jack on Harman Kardon or other compatible equipment.
- 22 Tape Monitor In** : Connect these jacks to the PLAY/OUT jacks of an audio recorder.
- 23 Tape Monitor Out** : Connect these jacks to the RECORD / INPUT jacks of an audio recorder.

- A Mute** : This indicator illuminates to remind you that the AVR 45's output has been silenced by pressing the Mute button **25**. Press the Mute button again to return to the previously selected output level.
- B Bypass** : This indicator illuminates when the surround processing has been disabled by pressing Surround Off button **24**. When this indicator is lit, the AVR-45 will play transitional stereo sound using the front left and right speakers only.
- C Analog** : This indicator illuminates when an analog input source is in use.
- D Dolby Digital Indicator** : This indicator illuminates when a Dolby Digital source is being played.
- E OPT.** : This indicator illuminates when a digital source is in use via a connection to the Optical Digital input **19**.
- F Dolby Pro-Logic Surround Mode Indicators** : These indicators illuminate when one of the analog (matrix) or Digital(PCM) Dolby Surround modes is in use.
- G COAX.Source** : This indicator illuminates when a digital source is in use via a connection

- to the Coaxial Digital input **18**.
- H AC-3 Indicator** : This indicator illuminates when a AVR-45 is decoding a Dolby Digital input source.
- I PCM Indicator** : This indicator illuminates to show that a standard PCM(SP/DIF) digital audio signal is being decoded by the digital-to-analog converter.
- J Surround Mode Indicators** : These indicators illuminate when one of the DSP generated analog surround modes is in use with an analog input source.
- K Night Indicator** : This indicator lights when the AVR-45 is in the Night mode, which prevents the AVR-45 from loud playback when digital sources are in use.
- L Preset Number** : This two-digit display indicates the station preset number that is currently in use, or of that is being entered.
- M Preset Indicator** : This indicator illuminates when one of the stations entered into the preset memory is tuned. The number that appears below the indicator is the preset station's memory.

- N Memory** : This indicator flashes when entering presets and other information into the tuner's memory.
- O Auto** : This indicator illuminates when the "Auto" mode is in use for FM tuning.
- P Stereo Indicator** : This indicator illuminates when an FM station is being tuned in stereo.
- Q Mono Indicator** : This indicator illuminates when the tuner has been placed in the monaural mode by pressing the FM Mode button **18**. Set the tuner for mono listening to cut noise and improve the quality of distant stereo signals.
- R Tuned Indicator** : This indicator illuminates when a station is being received with sufficient signal strength to allow for acceptable listening quality.
- S Main Information Display** : This display shows messages relating to the status, input source, surround mode, tuner, volume level or other aspects of unit's operation.
- T Sleep Indicator** : This indicator is illuminated when the Sleep function is in use. The number that appears above the indicator is the number of minutes remaining before the AVR-45 will return to the Standby mode.



## SERVICE PROCEDURE

### 1. All Clear

This service program can clear all memorized operations and functions.  
When the POWER ON, press the "AM/FM" button while pressing the "PRO LOGIC" button.  
After this, Preset memory will be set to these frequencies.

	VERSION	P1	P2	P3	P4	P5	P6	P7	P8
FM	120	87.5	88.0	90.0	95.0	98.0	99.0	106.0	108.0
	230,230RDS	87.50	88.00	90.00	95.00	98.00	99.00	106.00	108.00
	VERSION	P9	P10	P11	P12	P13	P14	P15	
AM	120	520	600	610	1000	1400	1500	1710	
	230,230RDS	522	594	999	1395	1611			

### 2. VFD segment illumination & text

This service procedure will illuminate all segments by the following steps  
(1) Press the Power ON button(Push Knob) while you are holding the TEST TONE (dts) button.  
(2) Then "TEST MODE" character will be shown on VFD Display.  
(3) This set do not have Auto VFD segment check function. So For your checking the VFD states according to each function, Please press any function button which you want to test.  
(4) for example : Tape monitor & CD  
1) Press the POWER ON button(push knob) while you are holding the TEST TONE (dts) button.  
2) Then "TEST MODE" character will be shown on VFD Display.  
3) Press the t.MON button on Front, then you are able to see " TAPE MONITOR" Character on VFD Display.  
4) Press the CD button on FRont, then you are able to see "CD" Character on VFD Display.

BUTTON	SEGMENT(Large)	SEGMENT(Small)
ST. POWER	POWER	
T. MON	TAPE MONITOR	
CD	CD	
DVD	DVD	
VID 1	VIDEO 1	
VID 2	VIDEO 2	
VID 3	VIDEO 3	
6 CH	6 CH DIRECT	
AM/FM	TUNER	TUNED, MONO, STEREO, AUTO, MEMORY, PRESET, 88
▼ TUNING	TUNING DOWN	
TUNING ▲	TUNING UP	
PRESET SCAN	PRESET SCAN	
▼ PRESET	PRESET DOWN	
PRESET ▲	PRESET UP	
TUN. MODE(RDS)	NO RDS	RDS, PTY, CT, RT
DIGITAL	DOLBY AC-3	DIGITAL, AC-3, NIGHT
PRO LOGIC	PRO LOGIC	PRO LOGIC, PCM
3 STEREO	3 STEREO	3-STEREO
HALL 1	HALL 1	HALL 1
HALL 2	HALL 2	HALL 2
THEATER	THEATER	THEATER
TEST TONE	TEST TONE	
SURR. OFF	SURR OFF	
SPEAKER	FRNT SPEAKER	
CHANNEL	FRONT L LEV	
DIG. SELECT	COAXIAL	ANALOG, OPT, COAX
DELAY	S DELAY TIME	
MUTE	MUTE	MUTE
VOLUME UP	VOLUME UP	
VOLUME DOWN	VOLUME DOWN	
SET	SET	
◀	COMM DOWN	
▶	COMM UP	

## TEST EQUIPMENT REQUIRED

- 1) AM/FM Signal generator
- 2) Digital Multimeter
- 3) Distortion lever meter

## ALIGNMENT PROCEDURES

### 1. FM MONO. Distortion adjustment

step	Input Signal Source Connection	Signal Frequency	Source Signal Output Level and Modulation	Reception Frequency	Adjustment Point	Adjustment Value
1	Signal generator output to FM antenna terminal.(750hm)	98MHz	1000uV/m (60dBu) MONO 1kHz/	98MHz (P5)	T804	0mV ± 0.5mV (R831)
2			Dev. 75kHz		T805	Distortion level Minimum at TAPE-OUT

### 2. FM MUTING LEVEL ADJUSTMENT

Turn variable resistor VR801 and stop at position "TUNED" is not shown (not indicated), then again turn the variable resistor VR801 to the opposite revolution and stop at a position "TUNED" is shown.

step	Input Signal Source Connection	Signal Frequency	Source Signal Output Level and Modulation	Reception Frequency	Adjustment Point	Adjustment Value
1	Signal generator output to FM antenna terminal.(750hm)	98MHz	10uV/m (20dBu) MONO 1kHz/ Dev. 75kHz	98MHz (P5)	VR801	"TUNED" indicate on VFD
2					AUTO SCAN	Only confirm

### 3. FM STEREO Separation Adjustment

step	Input Signal Source Connection	Signal Frequency	Source Signal Output Level and Modulation	Reception Frequency	Adjustment Point	Adjustment Value
1	Signal generator output to FM antenna terminal.(750hm)	98MHz	same specification as FM STEREO distortion adjustment. Input only L channel	98MHz (P5)	VR803	Output level Minimum at TAPE-OUT channel R
2						same specification as FM STEREO distortion adjustment. Input only R channel

4. AM OSC Adujstment

step	Input Signal Source Connection	Signal Frequency	Source Signal Output Level and Modulation	Reception Frequency	Adjustment Point	Adjustment Value
1	Signal Generator output to transmission loop antenna (standard required loop)	522kHz (230,230RDS) 520kHz(120)	5mV/m(74dBu) 400Hz MOD.30%	522kHz (230,230RDS) 520kHz (120) (P9)	T802	1.1V~1.2V

5. AM-Tracking Adjustment (MW)

step	Input Signal Source Connection	Signal Frequency	Source Signal Output Level and Modulation	Reception Frequency	Adjustment Point	Adjustment Value
1	Signal Generator output to transmission loop antenna (standard required loop)	594kHz (230,230RDS) 600kHz(120)	5mV/m(74dBu) 400Hz MOD.30%	594kHz (230,230RDS) 600kHz(120)	T801	Output level(L or R) <b>Minimum</b> at TAPE-OUT
2		1395kHz (230,230RDS) 1400kHz(120)			CT801	Output level(L or R) <b>Minimum</b> at TAPE-OUT

6. AM IF Adjustment

step	Input Signal Source Connection	Signal Frequency	Source Signal Output Level and Modulation	Reception Frequency	Adjustment Point	Adjustment Value
1	Signal Generator output to transmission loop antenna (standard required loop)	999kHz (230,230RDS) 1000kHz(120)	5mV/m(74dBu) 400Hz MOD.30%	999kHz (230,230RDS) 1000kHz (120)	T803	Output level(L or R) <b>Maximum</b> at TAPE-OUT  Output level(L or R) <b>Maximum</b> at TAPE-OUT

7. AM auto stop Adjustment

step	Input Signal Source Connection	Signal Frequency	Source Signal Output Level and Modulation	Reception Frequency	Adjustment Point	Adjustment Value
1	Signal Generator output to transmission loop antenna (standard required loop)	999kHz (230,230RDS) 1000kHz (120)	1000uV/m(60dBu) 400Hz MOD.30%	999kHz (230,230RDS) 1000kHz(120)	VR802	"TUNED" indicate on VFD
2				AUTO SCAN	Only Confirm	"TUNED" indicate on VFD

8. Main Amp Idling current Adjustment

1) Alignment condition

(1) Adjust each of the variable resistors below in both the main and surround boards to the center position :

MAIN AMP BOARD : VR401, VR402, VR501

SURROUND AMP BOARD : VR601, VR602

2) Warming up system

After he above adjustment, turn the power ON and let the receiver warm up for 5 minutes to achieve a stable temperature for the driver and power transistors.

3) Measurement condition

Adjust each variable resistor listed below clockwise for each channel, and adjust refer the following table for the details.

CHANNEL	ADJUSTING LOCATION	MEASURE LOC.	VOL. DROP
FRONT-L	VR401	R471	15mV ± 3mV
FRONT-R	VR402	R472	15mV ± 3mV
CENTER	VR501	R536	15mV ± 3mV
SURR-L	VR601	R671	15mV ± 3mV
SURR-R	VR602	R672	15mV ± 3mV

4) CAUTION

(1) whenever power or driver transistors are changed, after repair you must re-adjust the idle current for repair, have to re-adjust that idle current again.

(2) Discharge each large elec. Capacitor C481, and C482(8200u) on main amp board, and C691, C692(6800uF/50V) on surround amp board.

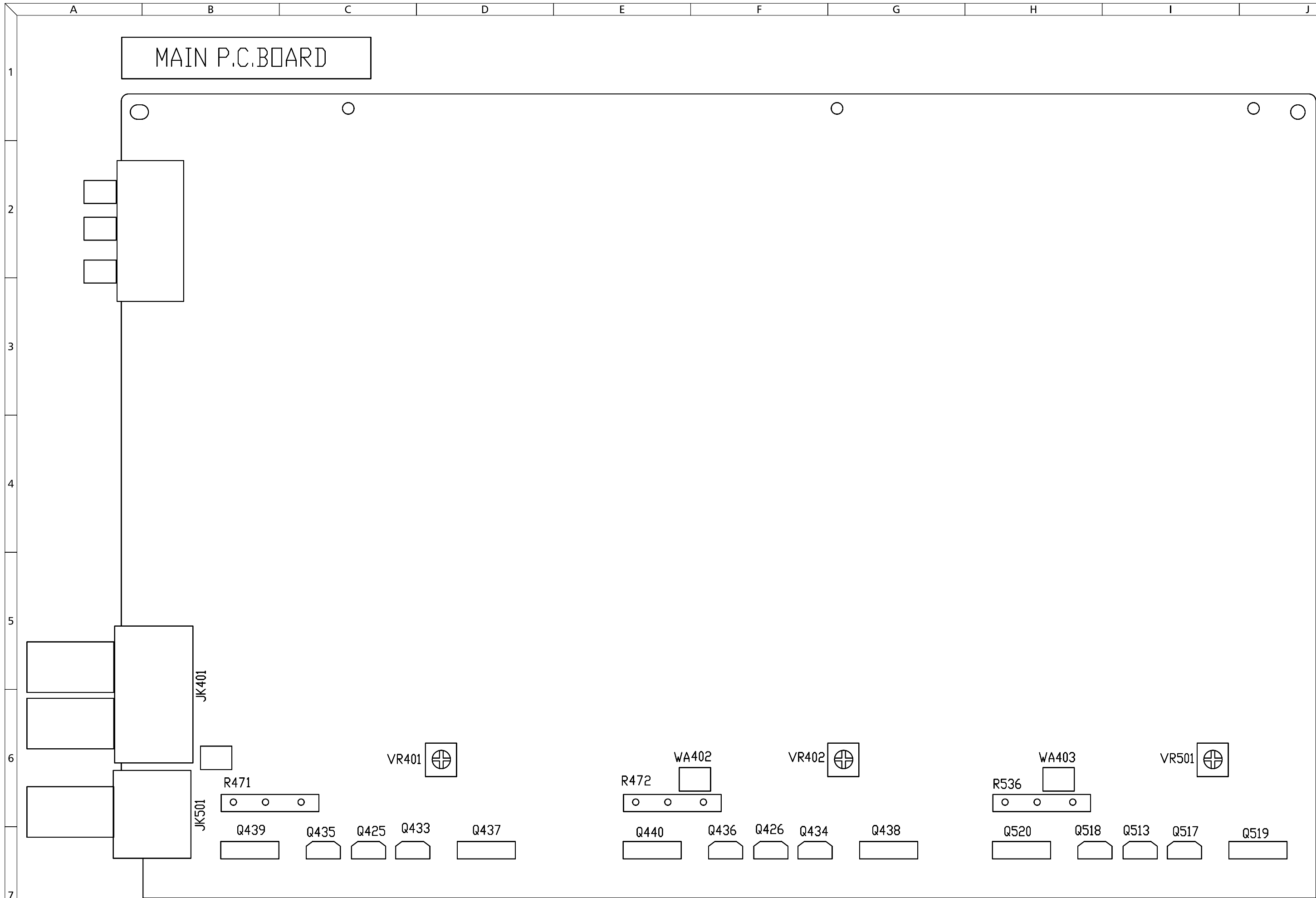

A B C D E F G H I J

1  
2  
3  
4  
5  
6  
7

TUNER P.C.BOARD

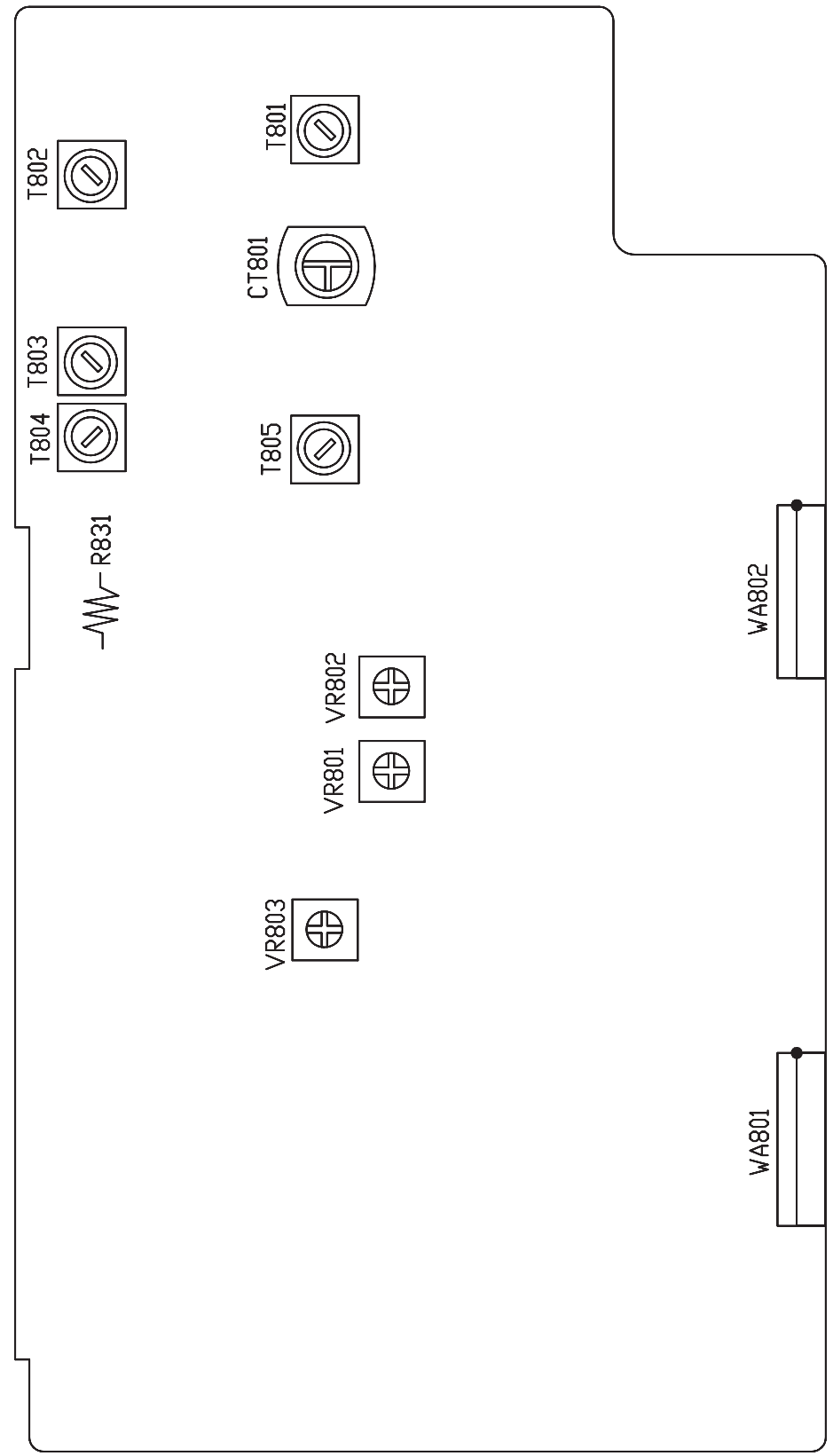

SURROUND P.C.BOARD

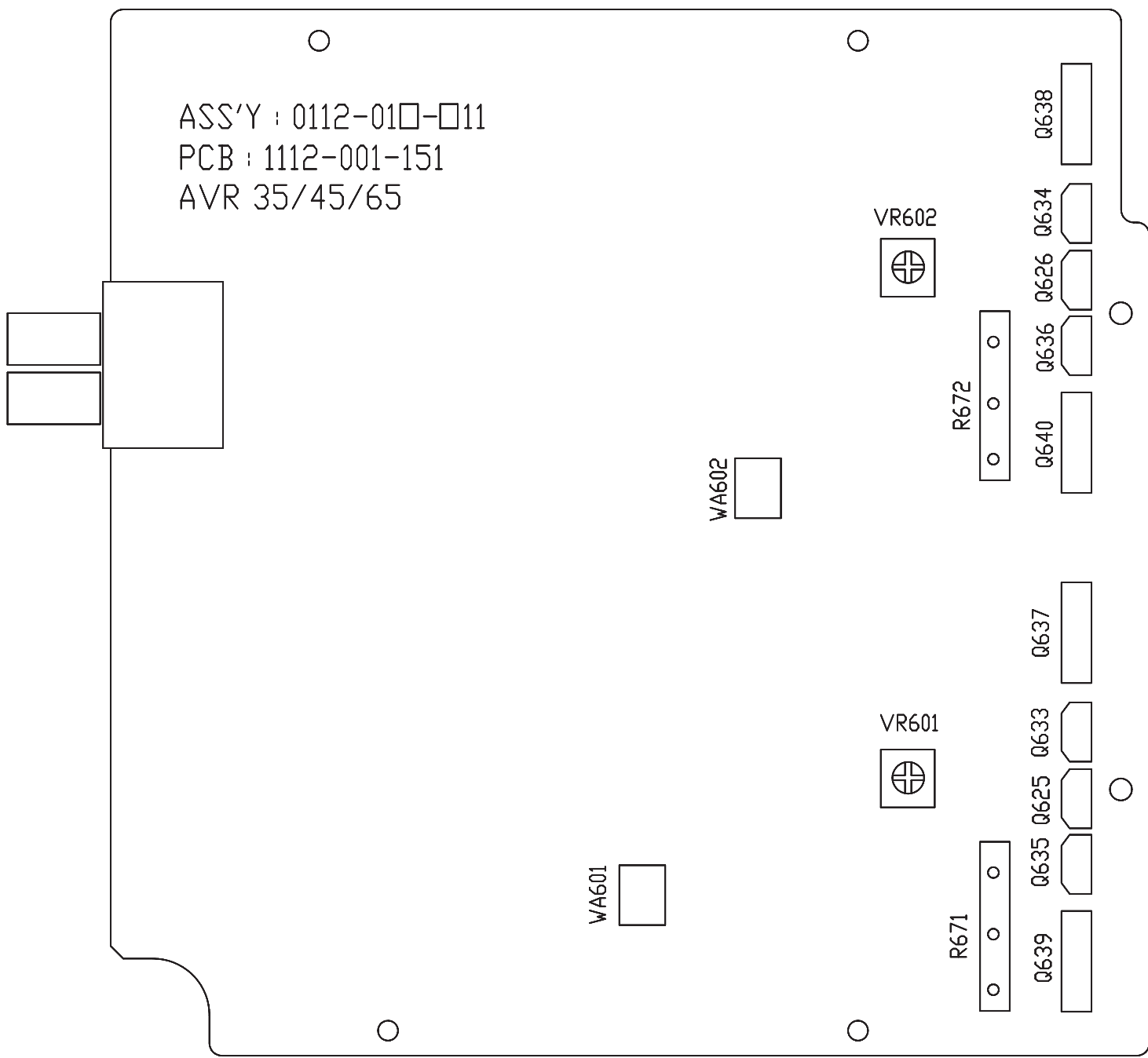

# CIRCUIT DESCRIPTION

## 1. SURROUND CIRCUIT

This model incorporates a surround processor circuit that provides 6 types of the surround sound and level trim and Bass management Fig-1 is a block diagram of the surround processor circuit. The microprocessor transfers the data to the parameter control (int-req, serial data, Serial clock, Chip selector) to operate the circuits in each mode.

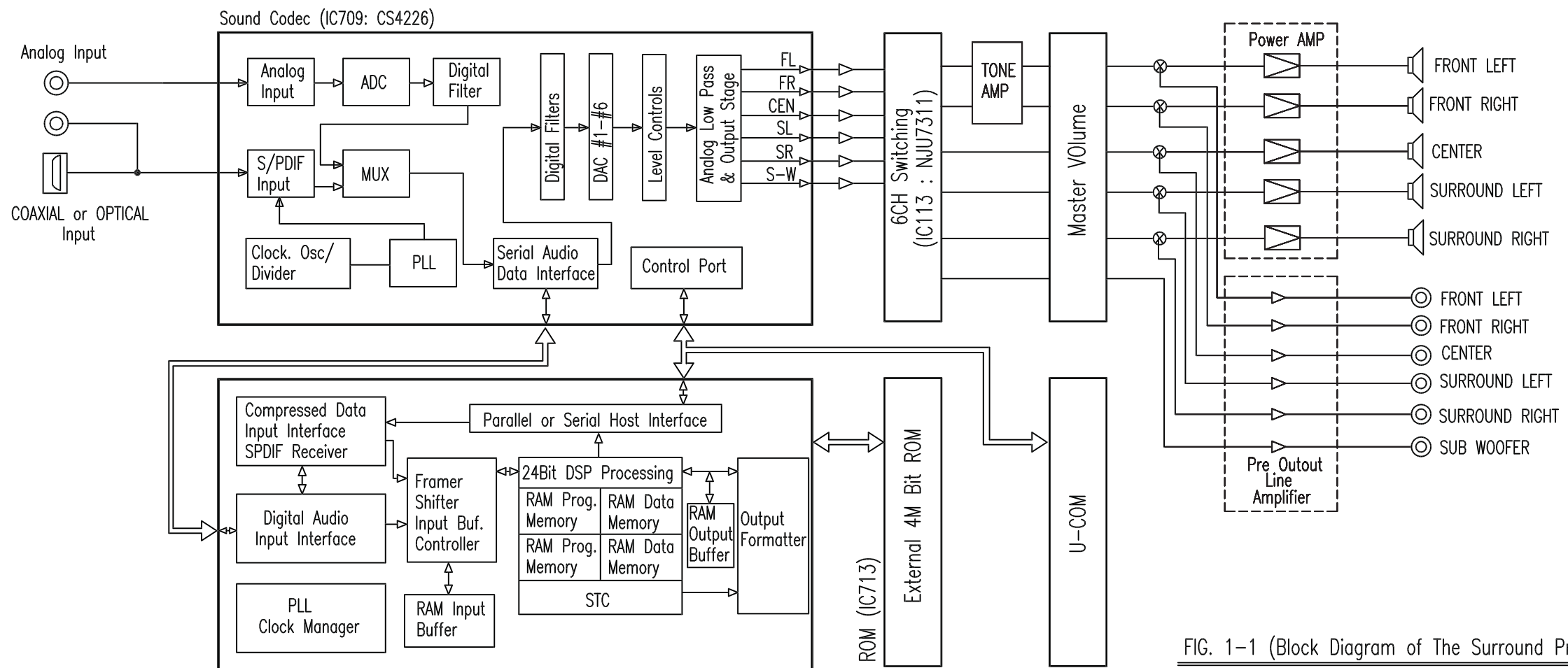

FIG. 1-1 (Block Diagram of The Surround Processor circuit)

DSP Audio Decoder (IC710)  
 AVR 35/45 : CS4923  
 AVR 65 : CS4926

## 2. DOLBY DIGITAL (AC-3)

Fig. 1-2 is a function block diagram of the application code when configured for Dolby Digital. It gives an idea of the interaction between the various application modules when AC3 is enabled

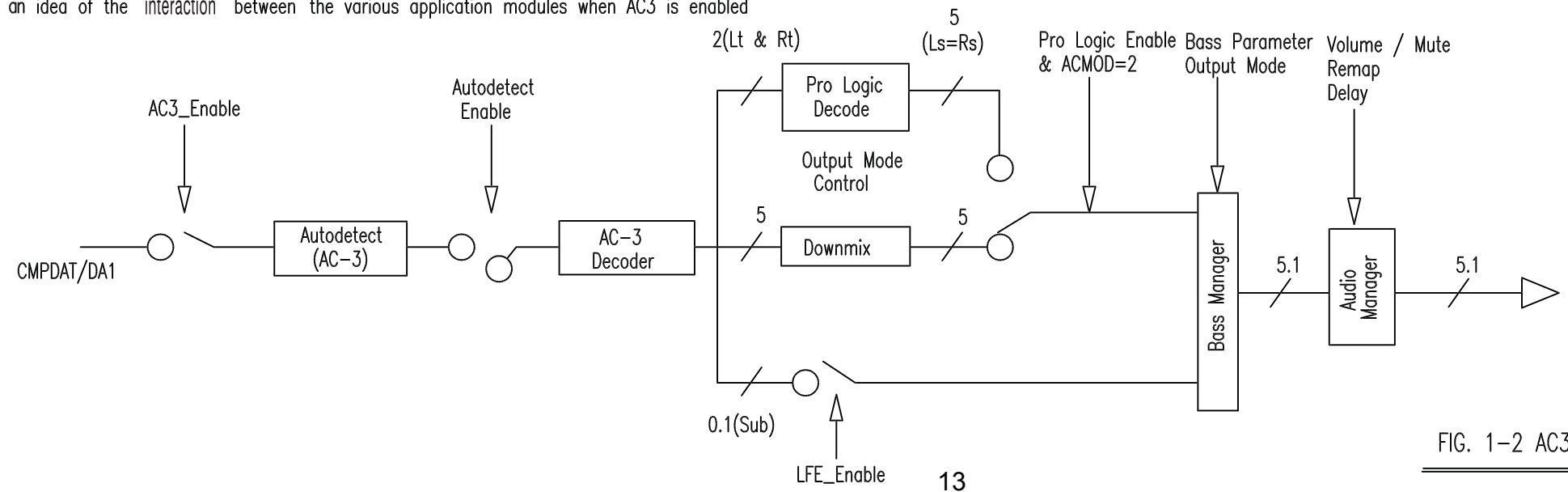

FIG. 1-2 AC3 Code Configured for AC3

3. PCM Input (Dolby Pro-Logic, Dolby 3 Stereo)

Fig 1-3 is a function block diagram of the application code when configured for PCM pass-through. It gives an idea of the interaction between the various application modules when PCM is enabled.

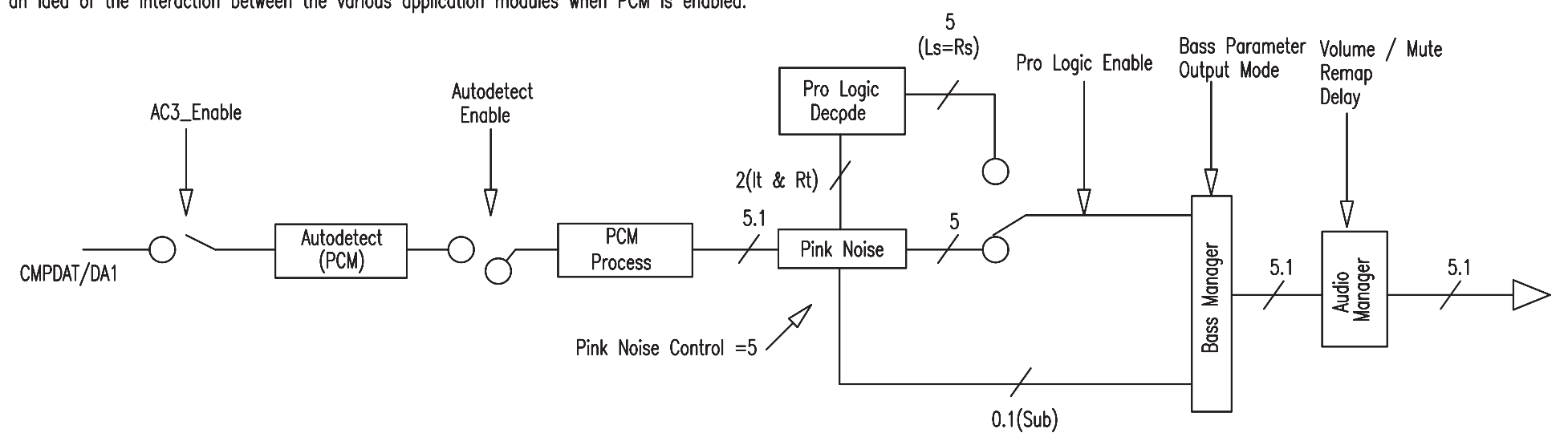

Fig 1-3 AC3 Code Configured for PCM

4. Sound Field Effect (Hall1, Hall2, Hall3)

Fig 1-4 is a function block diagram of the application when configured for Effects processing. It gives an idea of the interaction between the various application modules when the effects are enabled.

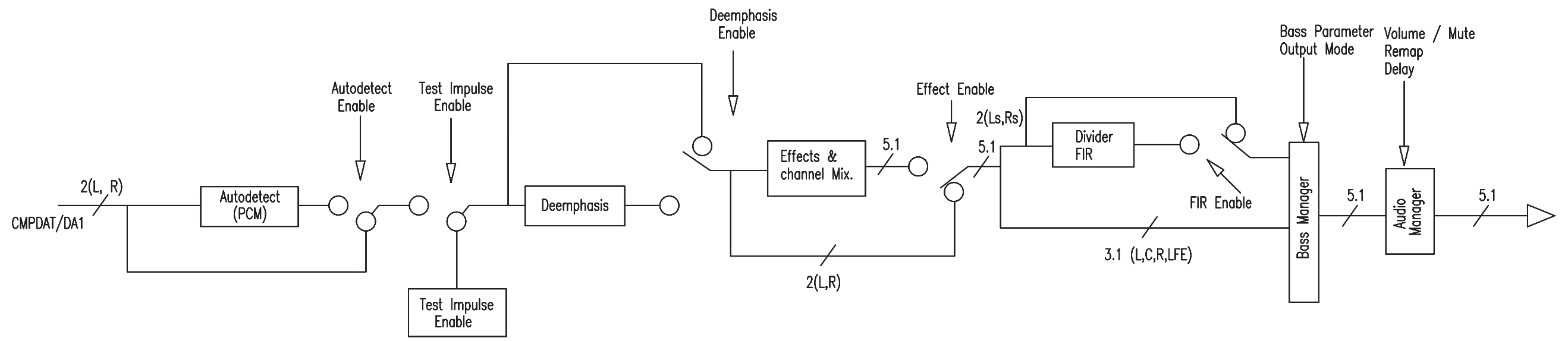

Fig 1-4 Effects Code Block Diagram

5. Bass Management

The Bass Manager is best described with the use of a block diagram. The default 3dB frequency for this filter is 100Hz. Fig 1-5 shows the topology of the filters cascaded to implement a second order filter. Depending on the coefficient values, either a second order low pass or second order high pass can be implemented. The corner frequency can be changed by downloading new values for the coefficients a1, b0 and b1.

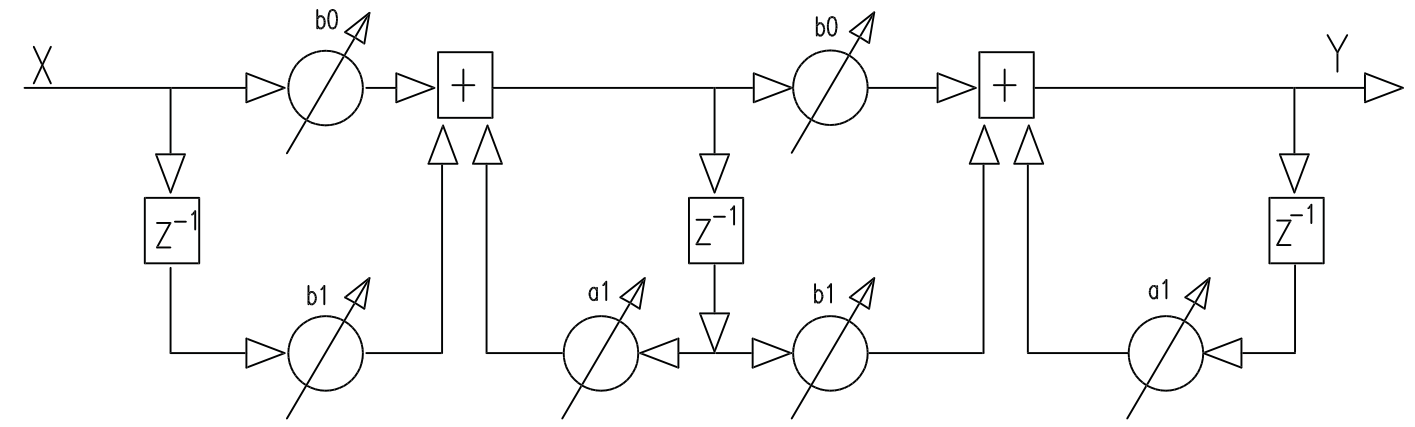

Fig 1-6 Filter Topology

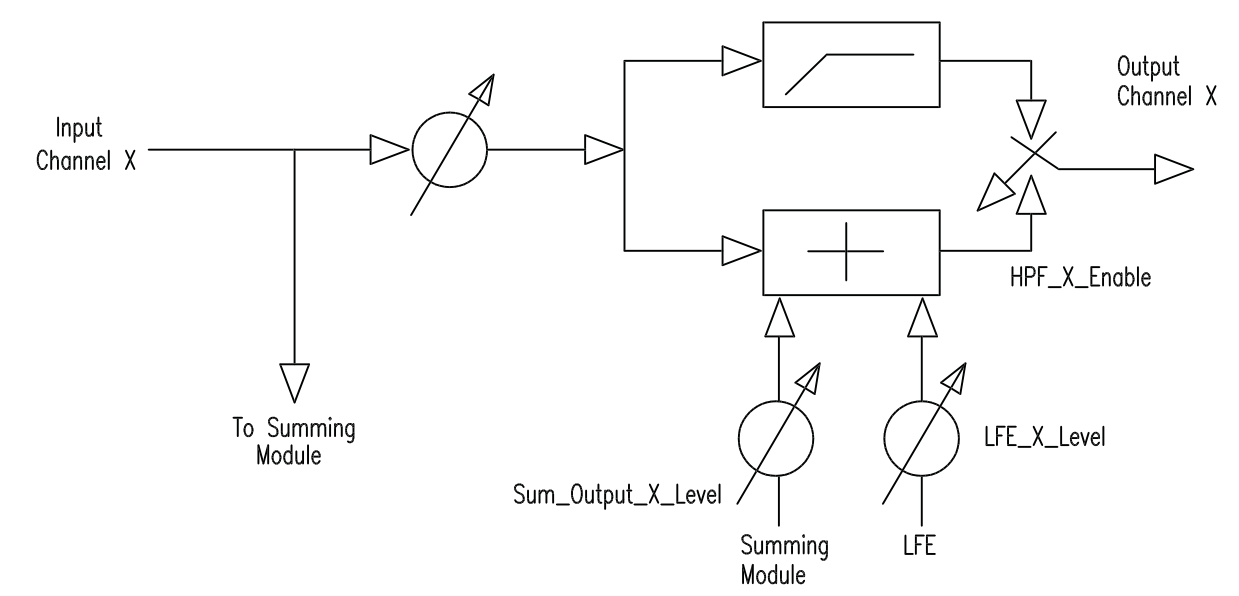

Fig 1-7 Bass manager Processing Unit

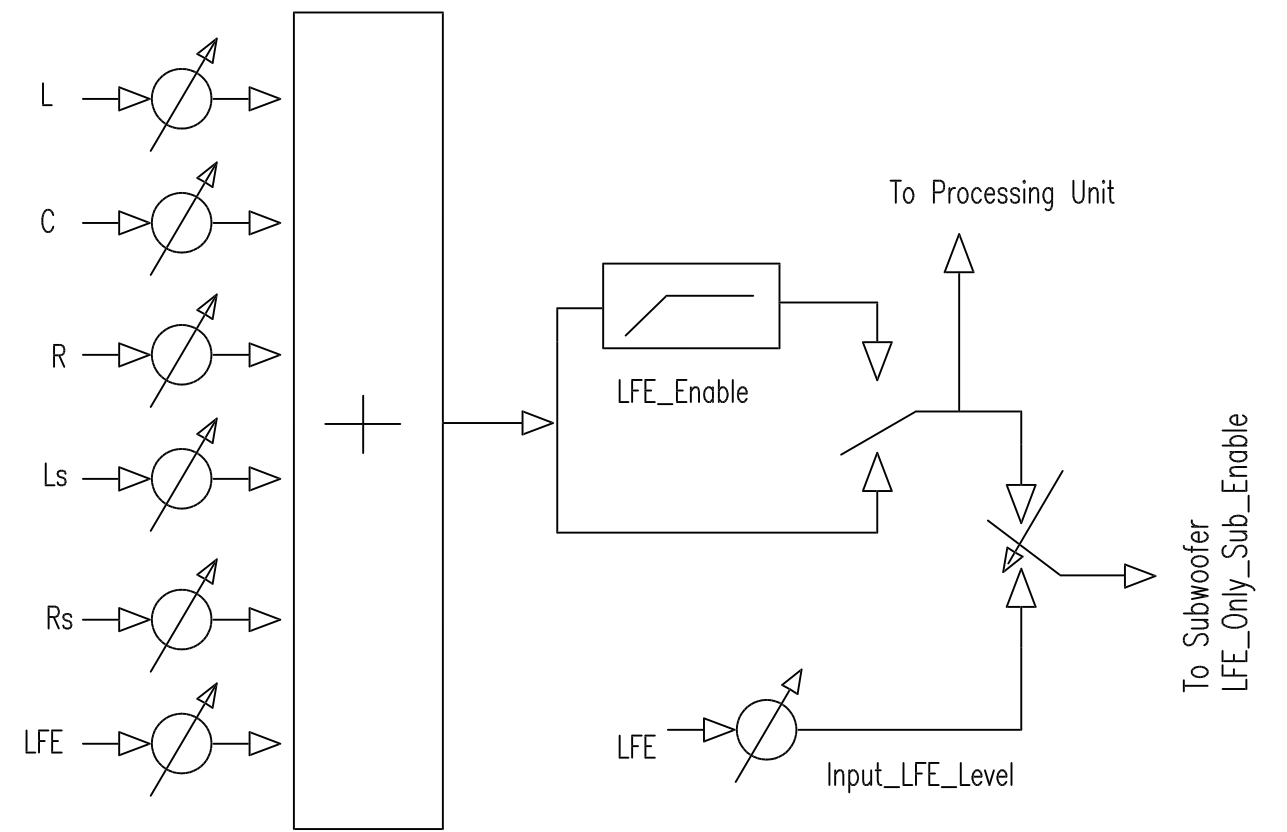
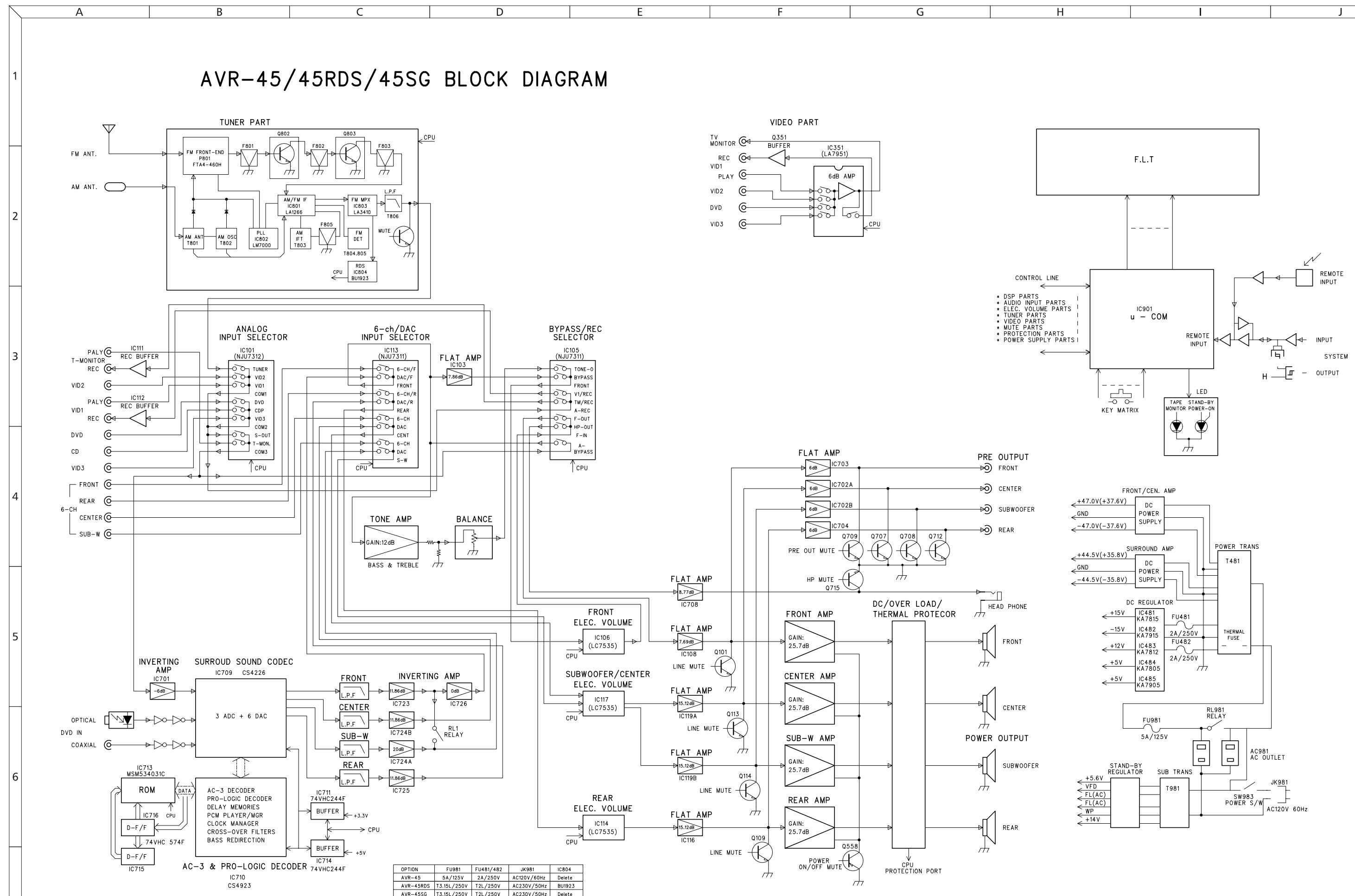

Fig 1-7 Bass manager Processing Unit

# AVR-45/45RDS/45SG BLOCK DIAGRAM





# DISASSEMBLY PROCEDURE

1. Removing the top cover, and  
Remove screws ① ~ ⑫

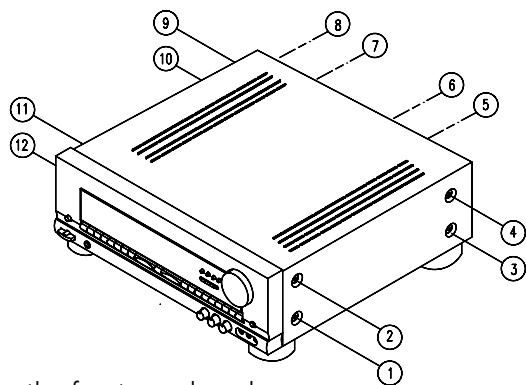

2. Removing the front panel, and  
Remove screws ① ~ ⑪

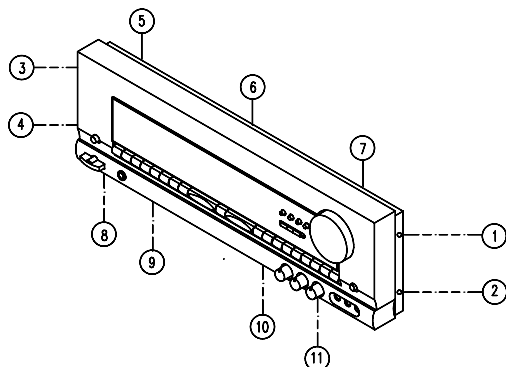

3. Removing the rear panel, and  
Remove screws ① ~ ⑧

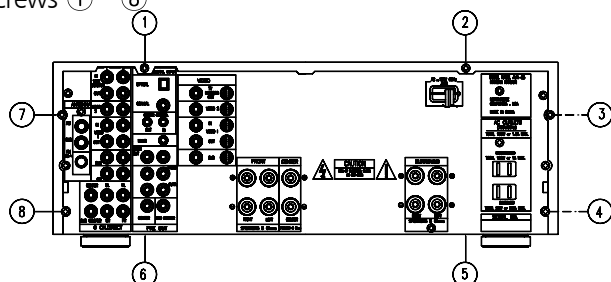

4. Removing the main PCB block, and  
Remove screws ① ~ ⑪

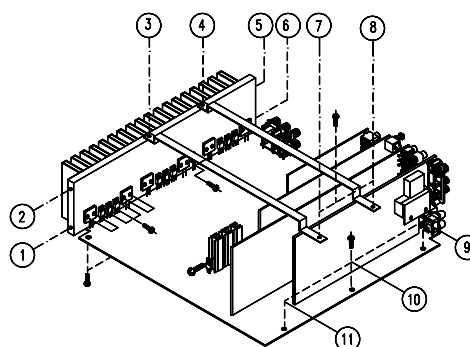

5. Removing the power PCB block, and  
Remove ① ~ ⑦

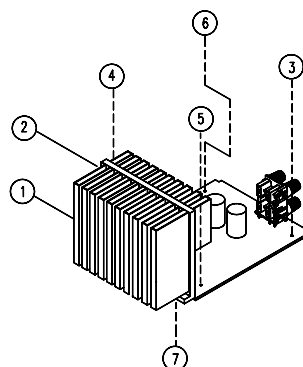

6. Removing the sub PCB block, and  
Remove screws ① ~ ④

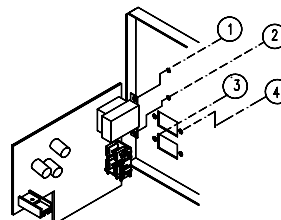

## MAIN AMP PCB BLOCK

1. Remove all of the screws on Rear panel.
2. Remove the Rear panel.
3. Remove PCB Brk't and Guide Brk't from Main Ass'y.
4. Remove all of the screws that connect with main Ass'y.
5. Remove the Main PCB block.

## POWER PCB BLOCK

1. Remove PCB Brk't and Guide Brk't from Main Ass'y.
2. Remove 4 screws for Power PCB mounting
3. Remove the POWER PCB block.

## SUB PCB BLOCK

1. Remove 4 screws on Rear panel.
2. Remove the Rear panel.
3. Remove PCB Brk't and Guide Brk't from Main Ass'y.
4. Remove the SUB PCB block.

## FRONT PCB BLOCK

1. Remove Main Ass'y.
2. Remove volume and rotary knob from the front Ass'y.
3. Remove all of the screws on back side of Front function PCB.
4. Remove the Front function PCB.

## GENERAL UNIT PARTS LIST

REF NO.	PART NO.	DESCRIPTION	Q'TY
1	5111-005-010	PANEL. FRONT <b>BK</b> <b>AB</b>	1
1-A	5111-008-010	PANEL. FRONT <b>IB</b>	1
2	5131-003-010	KNOB. FUNCTION (A)	1
3	5131-003-020	KNOB. FUNCTION (B)	1
4	5131-003-030	KNOB. FUNCTION (C)	2
5	5131-003-040	KNOB. POWER	1
6	5131-003-050	KNOB. PUSH	1
7	5131-003-060	KNOB. TACT	1
8	5131-003-070	KNOB. VOLUME	1
9	5131-003-080	KNOB. ROTARY	3
10	5141-005-010	WINDOW. FRONT <b>BK</b> <b>AB</b>	1
10-A	5141-008-010	WINDOW. FRONT <b>IB</b>	1
11	5141-003-020	FILTER. WINDOW	1
12	5142-003-010	LENS. POWER	1
13	5179-000-060	BUSHING. STRAIN R	1
14	5212-005-010	PANEL. REAR <b>BK</b>	1
14-A	5212-008-010	PANEL. REAR <b>IB</b>	1
14-B	5212-011-010	PANEL. REAR <b>AB</b>	1
15	5213-003-010	COVER TOP	1
16	5214-003-010	CHASSIS. FRONT	1
17	5214-003-020	CHASSIS. MAIN	1
18	5214-003-030	COVER. BOTTOM	1
19	5214-003-040	TRANS. BOTTOM	1
20	5214-003-050	FRAME. GUIDE	2
21	5214-003-060	BRK'T. PCB	2
22	5283-003-010	FOOT ASS'Y	4
23	5451-003-010	CUSHION. PCB	5
24	5451-003-040	CUSHION (A)	1
25	5451-003-050	SHEET. POWER	1
26	5451-003-060	CUSHION. BRK'T	2
27	1419-000-003	TRANS. POWER <b>BK</b>	1
27-A	1419-001-003	TRANS. POWER <b>IB</b>	1
27-B	1419-002-005	TRANS. POWER <b>AB</b>	1
28	2161-000-032	CORD. POWER <b>BK</b> <b>AB</b>	1
28-A	2161-001-032	CORD. POWER <b>IB</b>	1
29	5241-003-010	HEAT SINK. MAIN	1
30	5241-003-020	HEATSINK. SUB	1
31	5226-003-030	CASE. SHIELD (D)	1
32	5226-003-010	CASE. SHIELD (F)	1
33	5226-003-020	CASE. SHIELD (T)	1
34	5241-003-040	HEAT SINK. REG	1
35	5241-000-110	HEAT SINK. PIN	5
36	5451-003-020	CUSHION. FLT	2
37	5226-003-040	CASE. SHIELD (T2)	1
38	5421-003-070	CUSHION (B)	2
39	A0191-065-000	REMOCON ASS'Y <b>BK</b>	1
39-A	A0191-065-001	REMOCON ASS'Y <b>IB</b>	1
39-B	A0191-095-001	REMOCON ASS'Y <b>AB</b>	1

## UNIT PARTS LIST

REF NO.	PART NO.	DESCRIPTION	Q'TY
39-B	A0191-075-001	REMO CON ASSY AB	1
S1	5636-140-010	SCREW 3*10 TEETH COPPER	42
S2	5636-140-040	SCREW A183008000	13
S3	5636-140-060	SCREW S30C BTTN D12.3X10 MC	3
S4	5636-140-100	SCREW A123008002	76
S5	5636-140-050	SCREW A183006002	8
S6	5636-140-220	SCREW A183006002	8
S7	5636-140-080	SCREW A124008000	4
S8	5636-140-030	SCREW A113016000	10
W1	5541-001-030	WASHER. SPRING N2.0 M4.0 MC	4
W2	5541-001-040	WASHER. PLAT P/W 4.7X12X1.0 MC	4
W3	5541-001-010	WASHER. SPRING NO2 M3.0 MC	20
W4	5541-001-020	WASHER. PLAT P/W 3.3X8X0.5 MC	20
MAIN AMP	0112-001-160	ASSY-PCB : MAIN AMP	
REAR AMP	0112-001-1611	ASSY-PCB : REAR AMP	
SUB	0112-001-1612	ASSY-PCB : SUB	
C-VIDEO	0112-001-151	ASSY-PCB : C-VIDEO	
S-VIDEO	0112-001-161	ASSY-PCB : S-VIDEO	
AUDIO INPUT	0112-001-152	ASSY-PCB : AUDIO INPUT	
TUNER	0112-001-1632	ASSY-PCB : TUNER	
FRONT	0112-001-1631	ASSY-PCB : FRONT	
POWER	0112-001-1633	ASSY-PCB : POWER	
HEAD PHONE	0112-001-154	ASSY-PCB : HEADPHONE	
DSP1	0112-001-154	ASSY-PCB : DSP1	
DSP2	0112-001-154	ASSY-PCB : DSP2	
STAND-BY	0112-001-1634	ASSY-PCB : STAND-BY	



Service bulletin # HK9804 December 1998

Repair rate does not apply

To: All harman/kardon Service Centers

Models: AVR35/45/65 North America/RDS/Singapore (all versions)

Subject: Remote Control Functions Do Not Work

---

When the batteries are replaced in the AVR35/45/65 remote control, capacitor C1 (.1 Farad, 5.5V) maintains memory functions for 4-5 hours. When C1 is discharged or the remote control is stored for 2 months or more without batteries, the remote goes in the factory default mode. This condition may occur from the time delay in shipping the unit from the factory to the customer. When the batteries are installed, and the customer presses a button on the remote, it may emit a "corrupted" noise signal (caused by capacitor C1) rather than the normal output signal.

As result, certain remote functions may no longer work properly.

**In the event you receive an AVR35,45 or 65 with the complaint of "Certain buttons on the remote control do not work", perform the necessary steps listed below:**

1. Make sure there are fresh batteries in the remote, and they are installed correctly.
2. Make sure the area between the remote control and receiver is not blocked by some object, and the distance is no more than 15 feet at an angle no greater than 30 degrees from the front of the receiver.
3. Make sure strong lighting is not directed towards the IR sensor of the receiver.
4. Press each button on the remote and verify proper operation.

**If these steps are taken and remote control still does not function properly –**

5. This step discharges the capacitor and resets the remote control. (You do *not* need to point the remote control at the receiver or even have the receiver turned on.)

A: **AVR35** – Press the TV and the M4 buttons at the same time and hold for 12 seconds.

B: **AVR45 or AVR65** – Press the TV and the LIGHT buttons at the same time and hold for 12 seconds.

To Test: Make sure your AVR35/45/65 is ON, press each button on the remote and verify proper operation of your receiver.

# harman/kardon

# Service Bulletin

Service bulletin # H/K9903 August 1999

To: All harman/kardon Service Centers

Models: AVR35/45/65 Dolby Digital A/V Receivers

Subject: Interference on Television

One of the measurements of a good signal strength, whether it be audio or RF, is called the signal to noise ratio. In other words, given a set level of interference or noise, the stronger the signal, the less noticeable the noise. Similarly, when a signal is not as strong as desired, you can attempt to lower the noise to improve the signal.

Digital products such as newer FAX machines and state of the art audio products like the AVR35, AVR45 and AVR65 often produce more RF interference than traditional analogue designs. The parts and procedure we recommend below will reduce RF interference, and lower the noise level by improving the signal to noise ratio.

**In the event you receive an AVR35, AVR45 or AVR65 Receiver with the complaint "There is video distortion on my television on certain channels when my TV is attached to my AVR receiver, and I am using an external TV antenna", perform the steps listed below.** We have also included recommendations which can be made to the customer.

- 1) Order h/k part# KT65A which consists of two Ferrite chokes, and 12 new black screws for the rear panel, h/k part# A123010002.
- 2) Attach the larger of the two ferrite chokes on to the receiver's power (AC) cord, approximately 2 inches from the rear panel: Open the block, lay the cord inside, and then wind the power cord around the choke at least 3 times. Close block.
- 3) Locate the 6 -12 (depending on model) black Phillips screws at the outer rear panel of the unit, only in the area of: the Video panel, Digital Input panel, Remote control panel, *and Pre-Out panel (AVR45 & 65 only)*. Remove and replace these screws with h/k part# A123010002. (The new screws have "teeth" on the bottom of the head for assuring proper contact with rear panel.)
- 4) Test unit.

*Further recommendations which can be made to the customer:*

- 1) To limit the interference coming into the cable that goes into the television, clip the smaller ferrite choke (part of kit KT65A) on to the coaxial antenna cable, about 2 inches from the rear of your television set.
- 2) Change any #RG-59 coaxial cable going into the television with #RG-06 coaxial cable, which has improved shielding.
- 3) Disconnect all power (AC) cords from the convenience (switched or unswitched) AC outlets on the back of the AVR receiver, as they may behave like antennas.
- 4) If there is still an unacceptable level of interference, use an antenna amplifier to improve the TV signal strength.

Model	Serial numbers	Screws - action	Ferrite choke from kit# KT65A
AVR35 (120v) AVR45 (120v) AVR65 (120v)	All serial numbers All serial numbers JS0003-01001 to JS0003-11078	Replace Replace  Replace	Clip on cord Clip on cord  Clip on cord
AVR65 (120v)	JS0003-11079 and above	Changed by factory	Installed by factory internally
AVR35 (230v) AVR45 (230v) AVR65 (230v)	All serial numbers All serial numbers All serial numbers	Replace Replace Replace	Installed by factory internally Installed by factory internally Installed by factory internally

# harman/kardon

# Service Bulletin

Service bulletin # HK2000-01 Rev1 April 2001

Warranty labor rate: MINOR repair

To: All harman/kardon Service Centers

Models: AVR35/AVR45/AVR65

Subject: No Output in Surround Modes

In early versions of the AVR35, AVR45 and AVR65, the IC484 +5v regulator may overheat and go into thermal protection. Its +5 volt output will cease; when this happens the AC-3 and Surround Processor cannot function normally, and the audio output may go dead, or experience a long delay before any surround mode comes on.

**In the event you receive an AVR35, AVR45 or AVR65 A/V receiver with the complaint “when attempting to use the surround modes, the unit’s output goes dead after several minutes, or may not change from stereo into the surround modes until after a long delay, or not change at all” (the words ‘No Data’ may also appear in the display), perform the following modification:**

- 1) Remove the top cover, (14) Philips screws; set the unit on its side and remove the bottom cover, (8) Philips screws.
- 2) Locate R486, R495 (10 ohm 1 watt resistors) and IC484 (+5v regulator) on the MAIN PCB. See Figure 1. The parts are located near the front right corner of the MAIN PCB when viewed from the front. IC484 is attached to a rectangular aluminum heatsink.
- 3) Desolder and remove R486, R495 and IC484. The IC484’s heatsink has two additional soldered connections at the bottom of the MAIN PCB. See Figure 2.
- 4) Replace R486 and R495 with (2) 15 ohm 3 watt resistors, (h/k part# J1771150771X), soldered in series to measure 30 ohms each. See Figure 3. Replace IC484 with +5v regulator, J1217780002X).
- 5) Replace heatsink with new larger part, (h/k part# J5241003040XX)
- 6) Use silicon grease when attaching the new regulator to the heatsink, and tighten it sufficiently with its single mounting screw before re-soldering in place.
- 7) When all new parts are installed, replace both the top & bottom cover.
- 8) Test the unit by connecting a music source to a digital input, either optical or coaxial, powering it up and monitor the receiver playing normally for extended period of time.

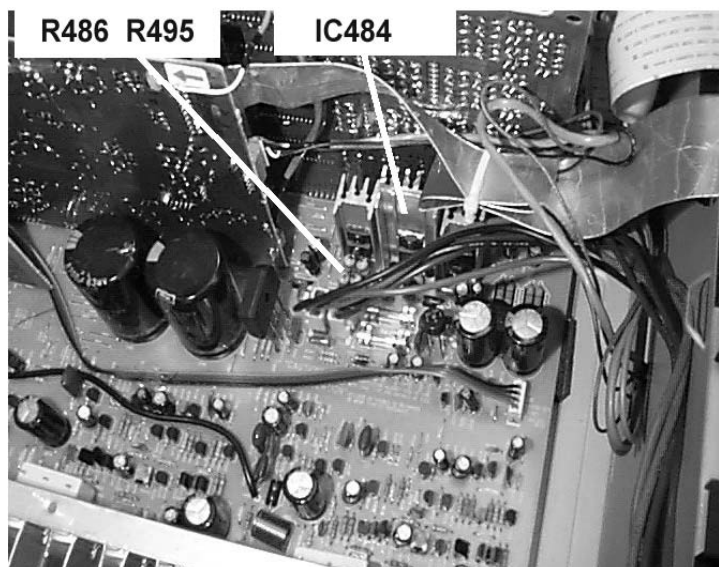

FIGURE 1

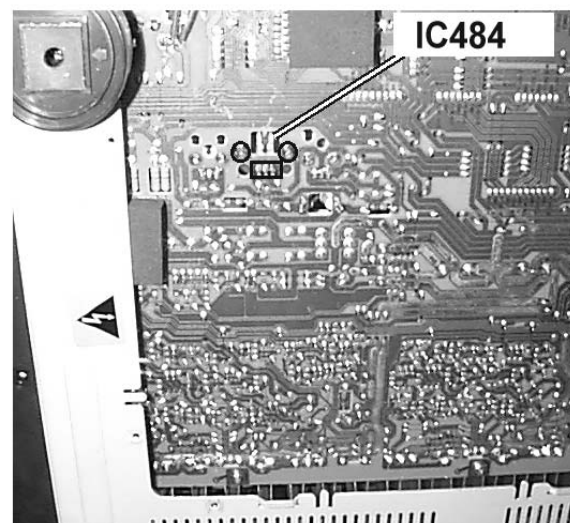
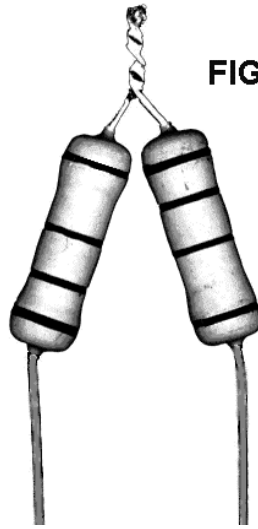

FIGURE 2

Models: AVR35/AVR45/AVR65 Subject: No Output in Digital Playback Mode



**FIGURE 3**

Model	Serial number 120V	Serial number 230V RDS	Status	Action
AVR35	JS0007-01000 to JS0007-14748	JS0005-01000 to JS0005-05956	IC484 Overheating; Unit's output ceases and "No data" appears in the display when using digital inputs	Replace R486 and R495 with (2) 15 ohm 3 watt resistors, soldered in series to equal 30 ohms. Replace IC484 +5v regulator. Replace IC484 Heatsink
AVR45	JS0001-01000 to JS0001-11139	JS0004-01000 to JS0004-04434		
AVR65	JS0003-01000 to JS0003-02319	Modified by factory		
AVR35	JS0007-14749 Or higher	JS0005-05957 Or higher	Modified by factory	NONE REQUIRED
AVR45	JS0001-11140 Or higher	JS0004-04435 Or higher		
AVR65	JS0003-02320 Or higher	Modified by factory		



# harman/kardon

# Service Bulletin

Service bulletin # HK2001-02 June 2001

Warranty labor rate: MAJOR repair

To: All harman/kardon Service Centers

Models: AVR35/45/65, (US,SG,RDS Models)

Subject: Left, Right, or Center channel Dead

**In the event you receive an AVR35, 45, or 65 A/V receiver with the complaint: "One channel has no output", check the item below:**

One or more of the 10 ohm fusible resistors R445,446,447,448,523, or 524 on the main PCB may be damaged. Perform with an ohmmeter an in-circuit resistance test of these 6 resistors. The Ohmmeter should read 10 ohms  $\pm 10\%$ . If one or more resistors are out of tolerance, all 6 resistors (R445,446,447,448,523,524) should be changed to 10 ohm 1/4W metal film type, h/k part# 271-10.

- 1) Disconnect all external cables; remove the top cover (16 Black Phillips screws).
- 2) See page 2 for exact location of R445,446,447,448,523,524. If any resistors are found out of tolerance, proceed with the following steps:
- 3) Lay unit on its left side on a padded surface; remove the (8) Phillips screws holding the bottom chassis grille on, which will expose the Main PCB. Remove the two "feet" that are partially covering the grille.
- 4) Recommended procedure for resistor replacement is to cut each part off the main PCB from the top, then solder the replacement part on the bottom of the PCB in the same location. There may be a square foam cushion on the bottom of the PCB covering the area(s) of one or more resistors pads; remove it. Use caution when correctly identifying each location, comparing the top and bottom of the main PCB. Tip: Resistors are represented by a silkscreen on the bottom of the main PCB by this line: 

Model	Serial Number 120V	Serial Number 230V	STATUS	ACTION
AVR35	JS0007-01001 to JS0007-16390	n/a	R445,446,447,448,523, 524 are fusible resistors	If damaged, replace with 10 ohm 1/4W metal film resistors
AVR35RDS	n/a	JS0005-01001 to JS0005-06000	R445,446,447,448,523, 524 are fusible resistors	If damaged, replace with 10 ohm 1/4W metal film resistors
AVR35SG	n/a	JS0009-01001 to JS0009-02537	R445,446,447,448,523, 524 are fusible resistors	If damaged, replace with 10 ohm 1/4W metal film resistors
AVR45	JS0001-01001 to JS0001-12782	n/a	R445,446,447,448,523, 524 are fusible resistors	If damaged, replace with 10 ohm 1/4W metal film resistors
AVR45RDS	n/a	JS0004-01001 to JS0004-04453	R445,446,447,448,523, 524 are fusible resistors	If damaged, replace with 10 ohm 1/4W metal film resistors
AVR45SG	n/a	JS0008-01001 to J30008-02980	R445,446,447,448,523, 524 are fusible resistors	If damaged, replace with 10 ohm 1/4W metal film resistors
AVR65	JS0003-01001 to JS0003-06422	n/a	R445,446,447,448,523, 524 are fusible resistors	If damaged, replace with 10 ohm 1/4W metal film resistors
AVR65RDS	n/a	JS0006-01001 to JS0006-01777	R445,446,447,448,523, 524 are fusible resistors	If damaged, replace with 10 ohm 1/4W metal film resistors
AVR65SG	n/a	JS0010-01001 to JS0010-01464	R445,446,447,448,523, 524 are fusible resistors	If damaged, replace with 10 ohm 1/4W metal film resistors

AVR 34/45/65 VIEWED FROM THE TOP (COMPONENT) SIDE

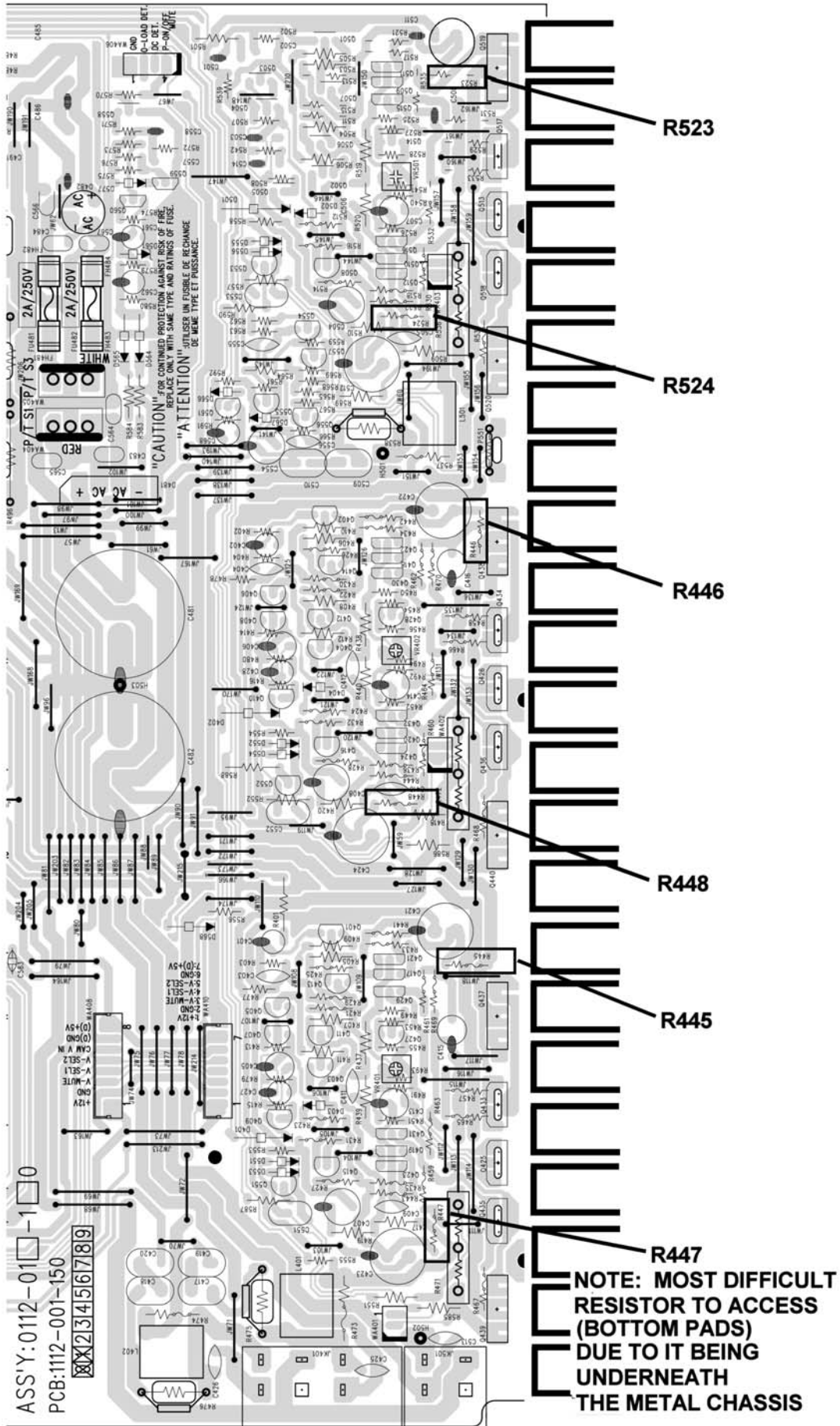

A B C D E F G H I J

1 2 3 4 5 6 7

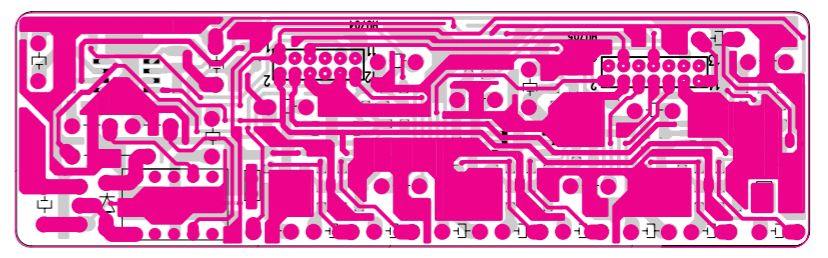

DSP2 P.C.Board DSP1 P.C.Board (TOP)

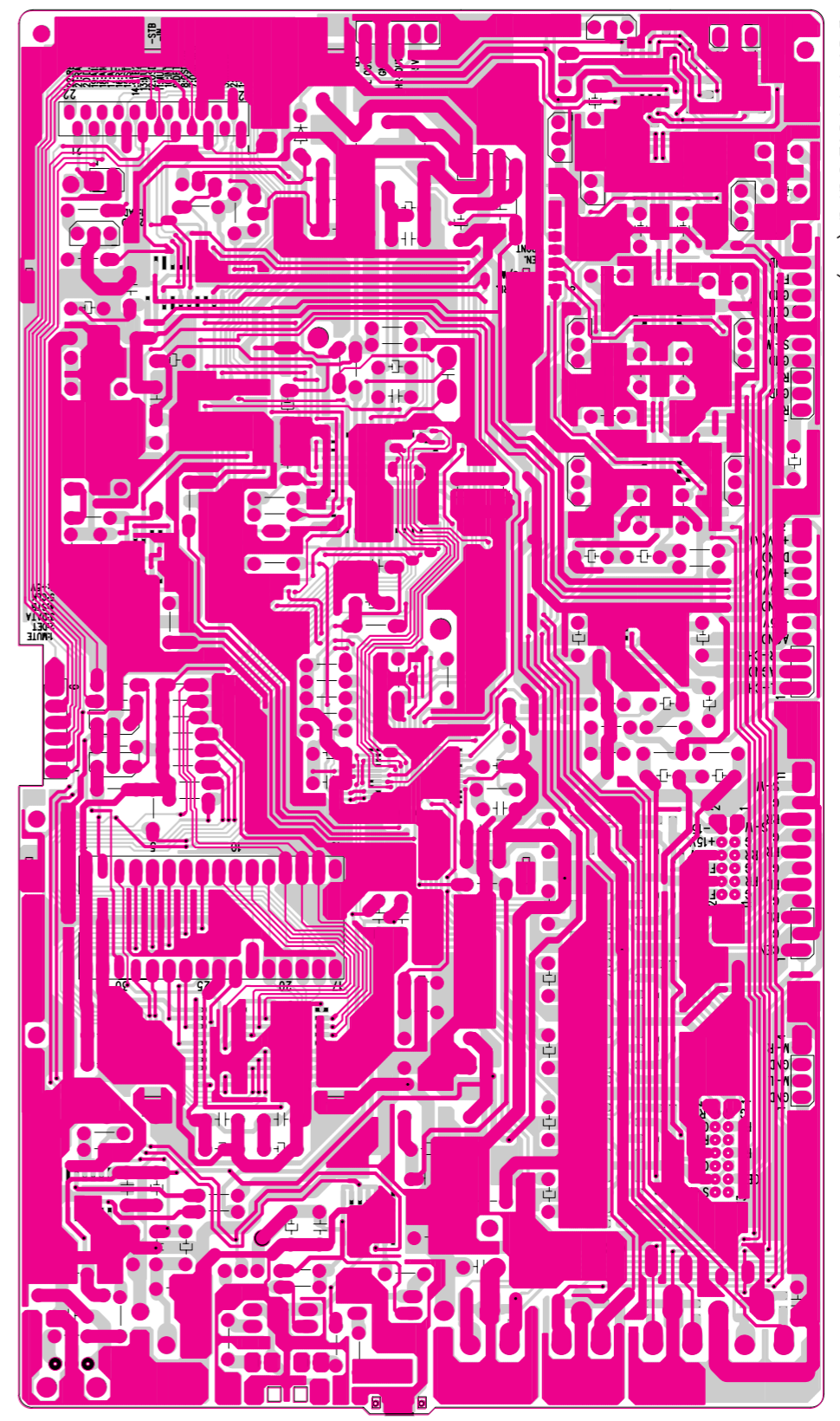

DSP1 P.C.Board (BOTTOM)

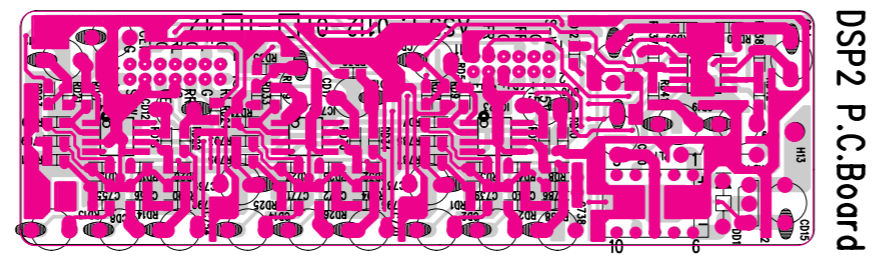

DSP2 P.C.Board

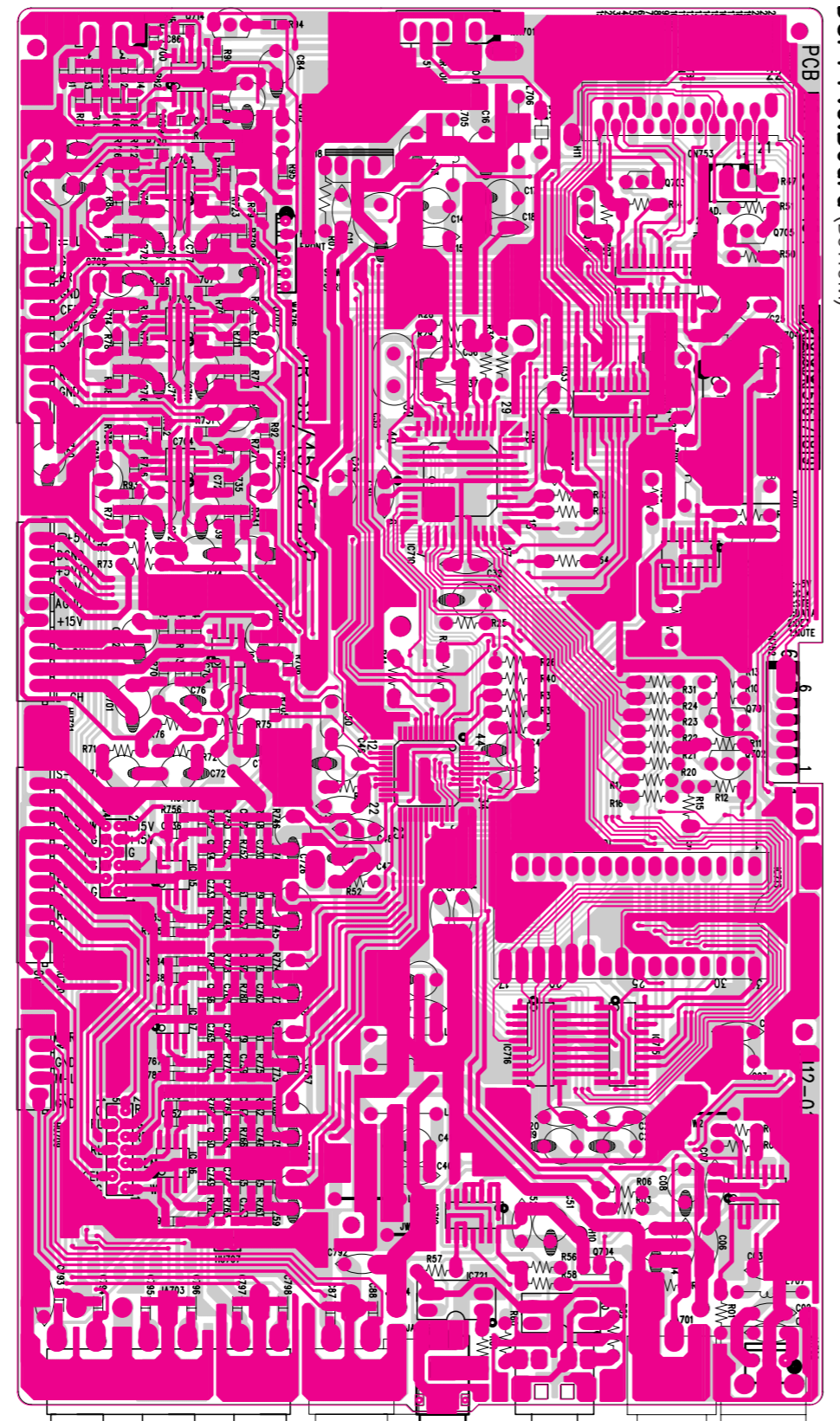



MAIN AMP P.C.Board

AVR-35/45/65,MAIN

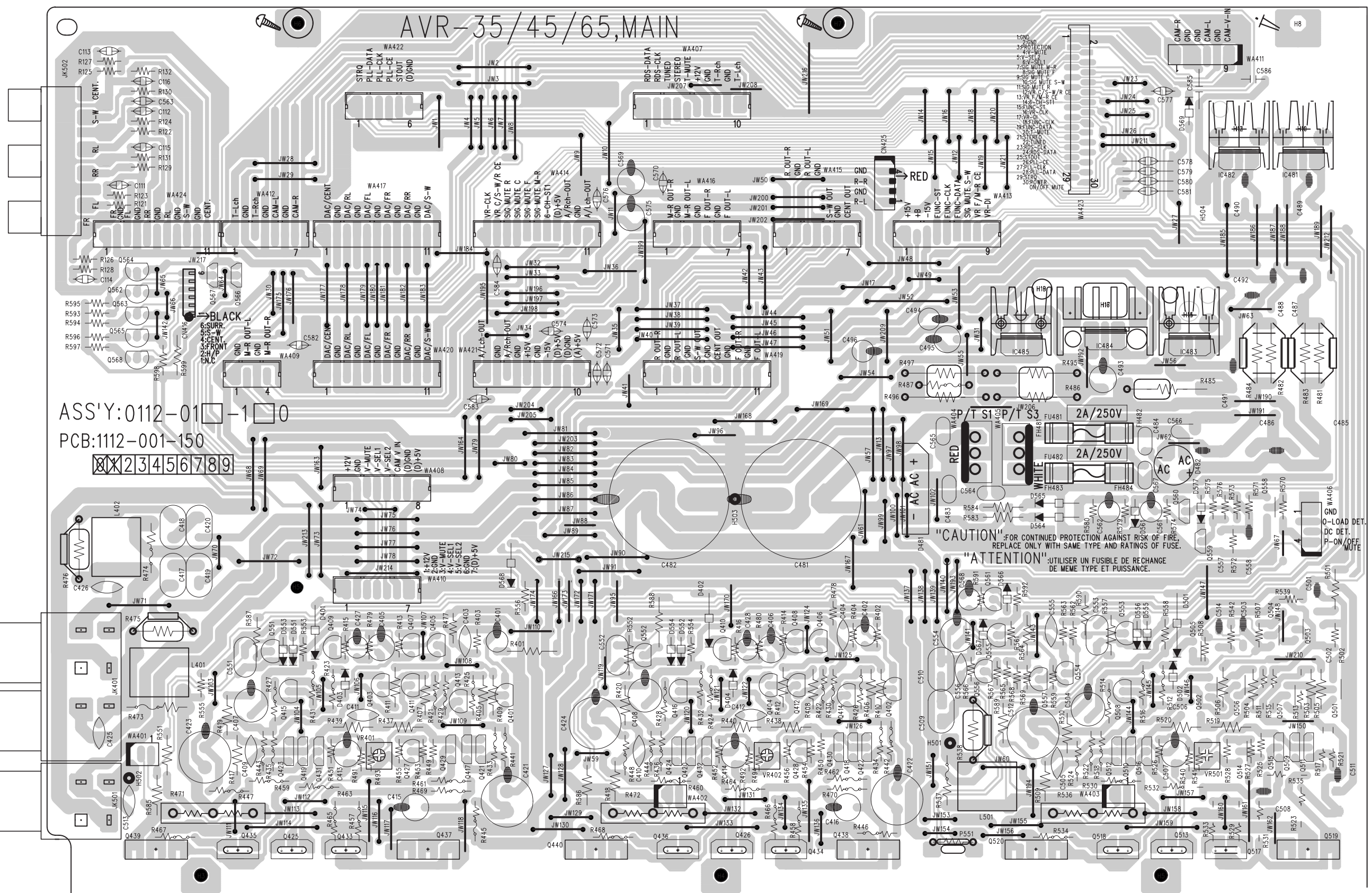

ASS'Y: 0112-01-1-0  
PCB: 1112-001-150

23456789

"CAUTION" FOR CONTINUED PROTECTION AGAINST RISK OF FIRE, REPLACE ONLY WITH SAME TYPE AND RATINGS OF FUSE.  
"ATTENTION" UTILISER UN FUSIBLE DE RECHANGE DE MEME TYP ET PUISSANCE.

A B C D E F G H I J

1  
2  
3  
4  
5  
6  
7

FRONT P.C.Board

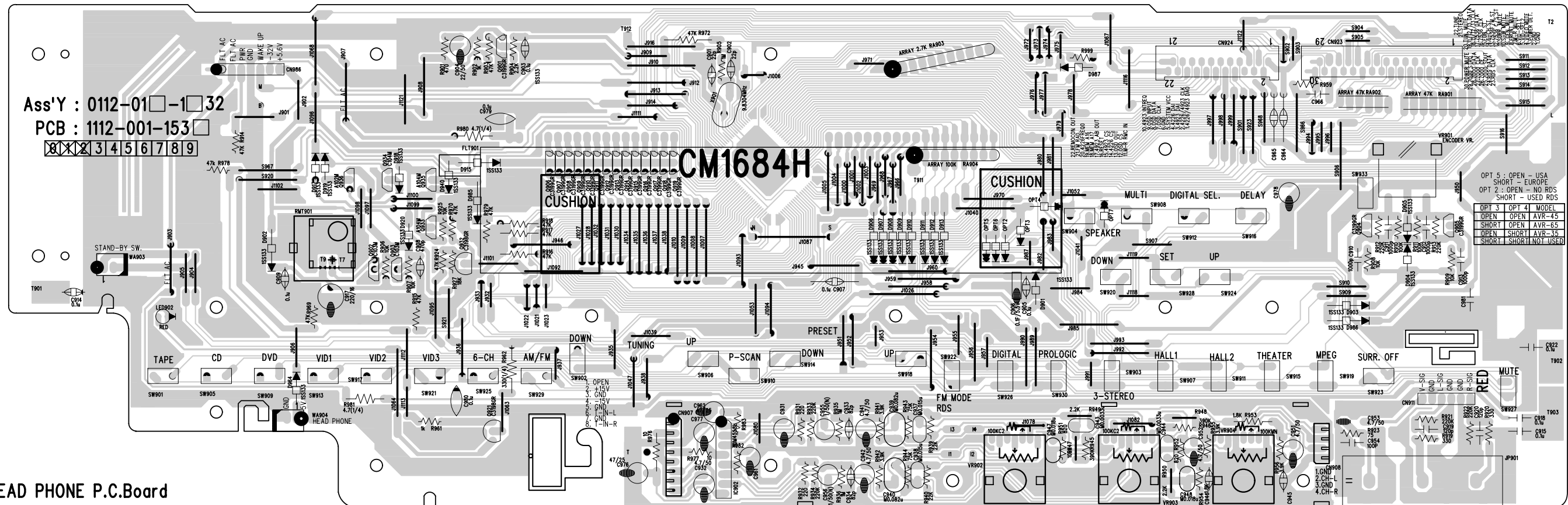

HEAD PHONE P.C.Board

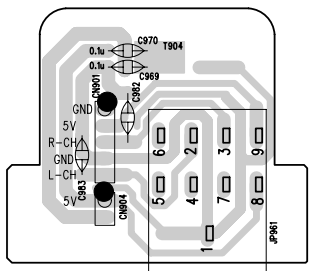

POWER P.C.Board

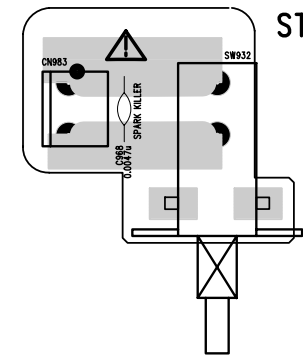

STD-BY P.C.Board

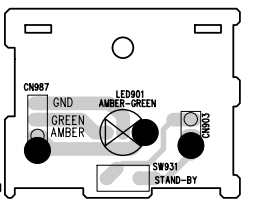

TUNER P.C.Board

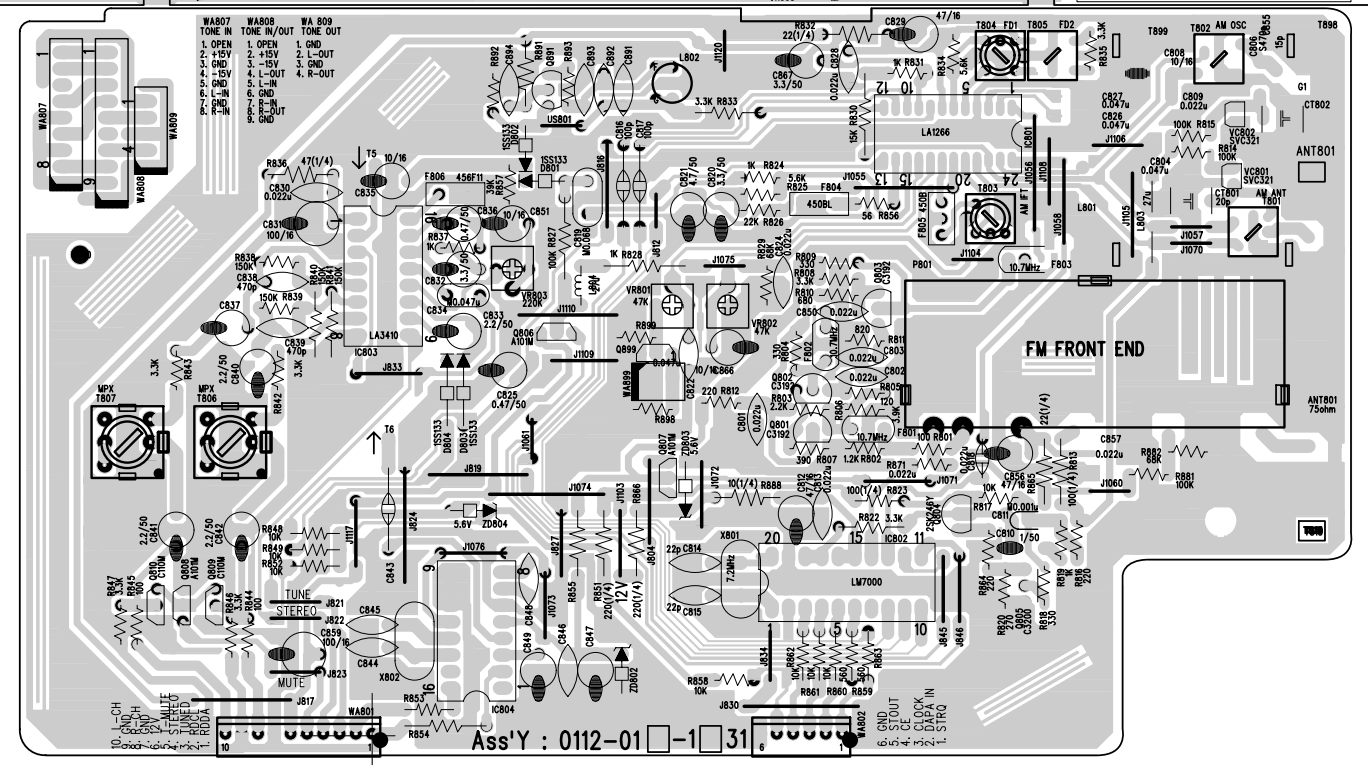



# ELECTRICAL PARTS LIST(45Series)

REF NO.	PART NO	DESCRIPTION
<b>0112-011-150 MAIN AMP PC.BOARD</b>		
<b>INTEGRATED CIRCUITS</b>		
▲	IC 481 1217-781-001	IC 7815 REGULATOR
▲	IC 482 1217-791-001	IC 7915 REGULATOR
▲	IC 483 1217-782-001	IC 7812 REGULATOR
▲	IC 484 1217-780-002	IC 7805 REGULATOR
▲	IC 485 1217-780-002	IC 7805 REGULATOR
<b>TRANSISTORS</b>		
▲	Q 437 1241-524-001	POWER 2SC5242-R(130W) NPN
▲	Q 438 1241-524-001	POWER 2SC5242-R(130W) NPN
▲	Q 519 1241-524-001	POWER 2SC5242-R(130W) NPN
▲	Q 439 1242-196-001	POWER 2SA1962-R(130W) PNP
▲	Q 440 1242-196-001	POWER 2SA1962-R(130W) PNP
▲	Q 520 1242-196-001	POWER 2SA1962-R(130W) PNP
	Q 559 1243-102-001	KRC102M NPN
	Q 560 1243-102-001	KRC102M NPN
	Q 566 1243-102-001	KRC102M NPN
	Q 567 1243-102-001	KRC102M NPN
	Q 407 1243-319-001	KTC3198-GR NPN
	Q 408 1243-319-001	KTC3198-GR NPN
	Q 504 1243-319-001	KTC3198-GR NPN
	Q 554 1243-319-001	KTC3198-GR NPN
	Q 555 1243-319-001	KTC3198-GR NPN
	Q 556 1243-319-001	KTC3198-GR NPN
	Q 401 1243-320-001	KTC3200-GR NPN
	Q 402 1243-320-001	KTC3200-GR NPN
	Q 403 1243-320-001	KTC3200-GR NPN
	Q 404 1243-320-001	KTC3200-GR NPN
	Q 405 1243-320-001	KTC3200-GR NPN
	Q 406 1243-320-001	KTC3200-GR NPN
	Q 415 1243-320-001	KTC3200-GR NPN
	Q 416 1243-320-001	KTC3200-GR NPN
	Q 427 1243-320-001	KTC3200-GR NPN
	Q 428 1243-320-001	KTC3200-GR NPN
	Q 501 1243-320-001	KTC3200-GR NPN
	Q 502 1243-320-001	KTC3200-GR NPN
	Q 503 1243-320-001	KTC3200-GR NPN
	Q 508 1243-320-001	KTC3200-GR NPN
	Q 514 1243-320-001	KTC3200-GR NPN
	Q 551 1243-320-001	KTC3200-GR NPN
	Q 552 1243-320-001	KTC3200-GR NPN
	Q 553 1243-320-001	KTC3200-GR NPN
	Q 419 1243-326-001	KTC3206-Y NPN
	Q 420 1243-326-001	KTC3206-Y NPN
	Q 423 1243-326-001	KTC3206-Y NPN
	Q 424 1243-326-001	KTC3206-Y NPN
	Q 429 1243-326-001	KTC3206-Y NPN
	Q 430 1243-326-001	KTC3206-Y NPN
	Q 510 1243-326-001	KTC3206-Y NPN
	Q 512 1243-326-001	KTC3206-Y NPN
	Q 515 1243-326-001	KTC3206-Y NPN
	Q 425 1243-437-001	KTC4370-Y NPN
	Q 426 1243-437-001	KTC4370-Y NPN
	Q 435 1243-437-001	KTC4370-Y NPN
	Q 436 1243-437-001	KTC4370-Y NPN
	Q 513 1243-437-001	KTC4370-Y NPN
	Q 518 1243-437-001	KTC4370-Y NPN
	Q 417 1244-124-002	KTA1024-Y PNP
	Q 418 1244-124-002	KTA1024-Y PNP
	Q 421 1244-124-002	KTA1024-Y PNP
	Q 422 1244-124-002	KTA1024-Y PNP
	Q 431 1244-124-002	KTA1024-Y PNP

REF NO.	PART NO	DESCRIPTION
Q 432	1244-124-002	KTA1024-Y PNP
Q 509	1244-124-002	KTA1024-Y PNP
Q 511	1244-124-002	KTA1024-Y PNP
Q 516	1244-124-002	KTA1024-Y PNP
Q 557	1244-126-004	KTA1266-GR PNP
Q 558	1244-126-004	KTA1266-GR PNP
Q 564	1244-126-004	KTA1266-GR PNP
Q 562	1244-126-004	KTA1266-GR PNP
Q 563	1244-126-004	KTA1266-GR PNP
Q 565	1244-126-004	KTA1266-GR PNP
Q 568	1244-126-004	KTA1266-GR PNP
Q 411	1244-128-001	KTA1268-GR PNP
Q 412	1244-128-001	KTA1268-GR PNP
Q 413	1244-128-001	KTA1268-GR PNP
Q 414	1244-128-001	KTA1268-GR PNP
Q 506	1244-128-001	KTA1268-GR PNP
Q 507	1244-128-001	KTA1268-GR PNP
Q 561	1244-128-001	KTA1268-GR PNP
Q 433	1244-169-001	KTA1659-Y PNP
Q 434	1244-169-001	KTA1659-Y PNP
Q 517	1244-169-001	KTA1659-Y PNP
<b>FET</b>		
Q 409	1248-000-004	2SK373-GR N-CH
Q 410	1248-000-004	2SK373-GR N-CH
Q 505	1248-000-004	2SK373-GR N-CH
<b>DIODES</b>		
D 566	1252-000-017	1SS133 ,SW.
D 567	1252-000-017	1SS133 ,SW.
D 401	1252-000-017	1SS133 ,SW.
D 402	1252-000-017	1SS133 ,SW.
D 501	1252-000-017	1SS133 ,SW.
D 568	1252-000-017	1SS133 ,SW.
D 569	1252-000-017	1SS133 ,SW.
D 577	1252-000-017	1SS133 ,SW.
D 403	1252-000-017	1SS133 ,SW.
D 404	1252-000-017	1SS133 ,SW.
D 502	1252-000-017	1SS133 ,SW.
D 551	1252-000-017	1SS133 ,SW.
D 552	1252-000-017	1SS133 ,SW.
D 553	1252-000-017	1SS133 ,SW.
D 554	1252-000-017	1SS133 ,SW.
D 555	1252-000-017	1SS133 ,SW.
D 556	1252-000-017	1SS133 ,SW.
▲	D 564 1252-001-004	1N4004 1A/400V
▲	D 565 1252-001-004	1N4004 1A/400V
▲	D 482 1253-000-004	W2-04F BRIDGE
▲	D 481 1253-000-005	BU8-04F BRIDGE
▲	D 561 1254-5R1-021	ZENER 5.1V
<b>RESISTORS(CARBON)</b>		
R 449	1742-102-721	1/8W 1KW-J
R 450	1742-102-721	1/8W 1KW-J
R 477	1742-100-721	1/8W 10W-J
R 478	1742-100-721	1/8W 10W-J
R 525	1742-102-721	1/8W 1KW-J
R 539	1742-100-721	1/8W 10W-J
R 566	1742-101-721	1/8W 100W-J
R 567	1742-103-721	1/8W 10KW-J
R 568	1742-103-721	1/8W 10KW-J
R 569	1742-103-721	1/8W 10KW-J
R 571	1742-102-721	1/8W 1KW-J
R 573	1742-103-721	1/8W 10KW-J
R 574	1742-103-721	1/8W 10KW-J

\* Note  
J : +5% ~ - 5%  
(Tolerance)





REF NO.	PART NO	DESCRIPTION		
⚠	R 427	1761-561-731	1/4W	560W-J
⚠	R 428	1761-561-731	1/4W	560W-J
⚠	R 429	1761-561-731	1/4W	560W-J
⚠	R 430	1761-561-731	1/4W	560W-J
⚠	R 431	1761-561-731	1/4W	560W-J
⚠	R 432	1761-561-731	1/4W	560W-J
⚠	R 511	1761-561-731	1/4W	560W-J
⚠	R 512	1761-561-731	1/4W	560W-J
⚠	R 513	1761-561-731	1/4W	560W-J
⚠	R 514	1761-561-731	1/4W	560W-J
⚠	R 515	1761-561-731	1/4W	560W-J
⚠	R 516	1761-561-731	1/4W	560W-J
⚠	R 469	1761-820-731	1/4W	82W-J
⚠	R 470	1761-820-731	1/4W	82W-J
⚠	R 535	1761-820-731	1/4W	82W-J

**RESISTORS(METAL)**

⚠	R 445	1772-100-731	1/4W	10W-J
⚠	R 446	1772-100-731	1/4W	10W-J
⚠	R 447	1772-100-731	1/4W	10W-J
⚠	R 448	1772-100-731	1/4W	10W-J
⚠	R 523	1772-100-731	1/4W	10W-J
⚠	R 524	1772-100-731	1/4W	10W-J
	R 475	1771-100-751	1W	10W-J
	R 476	1771-100-751	1W	10W-J
	R 538	1771-100-751	1W	10W-J
	R 481	1771-220-751	1W	22W-J
	R 482	1771-220-751	1W	22W-J
	R 483	1771-220-751	1W	22W-J
	R 484	1771-220-751	1W	22W-J
	R 485	1771-100-731	3W	10W-J
	R 486	1771-150-771	3W	15W-J
	R 495	1771-150-771	3W	15W-J
	R 496	1771-150-771	3W	15W-J
	R 497	1771-150-771	3W	15W-J

**RESISTORS(CEMENT)**

	R 471	1775-R22-782	5W	0.22W-J
	R 472	1775-R22-782	5W	0.22W-J
	R 536	1775-R22-782	5W	0.22W-J

**CAPACITORS**

	C 419	1822-030-311	CERA/RA	50V	3pF-C
	C 410	1822-030-311	CERA/RA	50V	3pF-C
	C 505	1822-030-311	CERA/RA	50V	3pF-C
	C 411	1822-101-772	CERA/RA	50V	100pF-J
	C 412	1822-101-772	CERA/RA	50V	100pF-J
	C 506	1822-101-772	CERA/RA	50V	100pF-J
	C 557	1822-102-882	CERA/RA	50V	0.001uF-K
	C 555	1822-103-822	CERA/RA	50V	103pF-K
	C 556	1822-103-822	CERA/RA	50V	103pF-K
	C 403	1822-680-712	CERA/RA	50V	68pF-J
	C 404	1822-680-712	CERA/RA	50V	68pF-J
	C 502	1822-680-712	CERA/RA	50V	68pF-J
	C 563	1832-104-002	CERA/AX	50V	0.1uF-Z
	C 582	1832-104-002	CERA/AX	50V	0.1uF-Z
	C 583	1832-104-002	CERA/AX	50V	0.1uF-Z
	C 584	1832-104-002	CERA/AX	50V	0.1uF-Z
	C 585	1832-104-002	CERA/AX	50V	0.1uF-Z
	C 586	1832-104-002	CERA/AX	50V	0.1uF-Z
	C 111	1832-121-712	CERA/AX	50V	120pF-J
	C 112	1832-121-712	CERA/AX	50V	120pF-J
	C 113	1832-121-712	CERA/AX	50V	120pF-J
	C 114	1832-121-712	CERA/AX	50V	120pF-J
	C 115	1832-121-712	CERA/AX	50V	120pF-J
	C 116	1832-121-712	CERA/AX	50V	120pF-J
	C 485	1861-222-710	ELECT	35V	2200uF-M
	C 486	1861-222-710	ELECT	35V	2200uF-M
	C 481	1861-822-214	ELECT	63V	8200uF-M

REF NO.	PART NO	DESCRIPTION			
	C 482	1861-822-214	ELECT	63V	8200uF-M
	C 561	1862-010-804	ELECT	50V	1.0uF-M
	C 413	1862-100-017	ELECT	100V	10uF-M
	C 414	1862-100-017	ELECT	100V	10uF-M
	C 415	1862-100-017	ELECT	100V	10uF-M
	C 416	1862-100-017	ELECT	100V	10uF-M
	C 507	1862-100-017	ELECT	100V	10uF-M
	C 508	1862-100-017	ELECT	100V	10uF-M
	C 568	1862-100-504	ELECT	16V	10uF-M
	C 558	1862-100-706	ELECT	35V	10uF-M
	C 562	1862-100-804	ELECT	50V	10uF-M
	C 427	1862-220-604	ELECT	25V	22uF-M
	C 428	1862-220-604	ELECT	25V	22uF-M
	C 514	1862-220-604	ELECT	25V	22uF-M
	C 489	1862-470-604	ELECT	25V	47uF-M
	C 490	1862-470-604	ELECT	25V	47uF-M
	C 492	1862-470-604	ELECT	25V	47uF-M
	C 494	1862-470-604	ELECT	25V	47uF-M
	C 496	1862-470-604	ELECT	25V	47uF-M
	C 487	1862-470-814	ELECT	50V	47uF-M
	C 488	1862-470-814	ELECT	50V	47uF-M
	C 491	1862-470-814	ELECT	50V	47uF-M
	C 493	1862-470-814	ELECT	50V	47uF-M
	C 421	1862-471-011	ELECT	63V	470uF-M
	C 422	1862-471-011	ELECT	63V	470uF-M
	C 423	1862-471-011	ELECT	63V	470uF-M
	C 424	1862-471-011	ELECT	63V	470uF-M
	C 511	1862-471-011	ELECT	63V	470uF-M
	C 512	1862-471-011	ELECT	63V	470uF-M
	C 554	1862-471-306	ELECT	10V	470uF-M
	C 405	1862-101-605	ELECT	25V	100uF-M
	C 406	1862-101-605	ELECT	25V	100uF-M
	C 503	1862-101-605	ELECT	25V	100uF-M
	C 401	1862-100-604	ELECT	25V	10uF-M
	C 402	1862-100-604	ELECT	25V	10uF-M
	C 501	1862-100-604	ELECT	25V	10uF-M
	C 407	1862-221-317	ELECT	10V	220uF-M
	C 408	1862-221-317	ELECT	10V	220uF-M
	C 504	1862-221-317	ELECT	10V	220uF-M
	C 484	1876-103-811	MYLAR	100V	0.01uF-K
	C 566	1876-103-811	MYLAR	100V	0.01uF-K
	C 567	1876-103-811	MYLAR	100V	0.01uF-K
	C 417	1876-104-811	MYLAR	100V	0.1uF-K
	C 418	1876-104-811	MYLAR	100V	0.1uF-K
	C 419	1876-104-811	MYLAR	100V	0.1uF-K
	C 420	1876-104-811	MYLAR	100V	0.1uF-K
	C 509	1876-104-811	MYLAR	100V	0.1uF-K
	C 510	1876-104-811	MYLAR	100V	0.1uF-K
	C 551	1876-683-811	MYLAR	100V	0.068uF-K
	C 552	1876-683-811	MYLAR	100V	0.068uF-K
	C 553	1876-683-811	MYLAR	100V	0.068uF-K
	C 483	1879-103-004	FILM	400	0.01uF-K
	C 564	1879-103-004	FILM	400V	0.01uF-K
	C 565	1879-103-004	FILM	400V	0.01uF-K

**WAFERS**

	WA 401	2111-023-002	2P	5267-02A
	WA 402	2111-023-002	2P	5267-02A
	WA 403	2111-023-002	2P	5267-02A
	WA 406	2111-023-004	4P	5267-04A
	WA 411	2111-023-006	6P	5267-06A
	WA 405	2111-027-003	3P	JE202-1T-03
	WA 404	2111-028-003	3P	JE202-1T-03R
	WA 423	2113-030-001	30P	00-8370-301-000-800
	WA 422	2114-604-006	6P	JE-604-06,PLUG
	WA 412	2114-604-007	7P	JE-604-07,PLUG
	WA 415	2114-604-007	7P	JE-604-07,PLUG
	WA 416	2114-604-007	7P	JE-604-07,PLUG
	WA 408	2114-604-008	8P	JE-604-08,PLUG

REF NO.	PART NO	DESCRIPTION
WA 413	2114-604-009	9P JE-604-09,PLUG
WA 407	2114-604-010	10P JE-604-10,PLUG
WA 421	2114-604-010	10P JE-604-10,PLUG
WA 414	2114-604-011	11P JE-604-11,PLUG
WA 417	2114-604-011	11P JE-604-11,PLUG
WA 419	2114-604-011	11P JE-604-11,PLUG
WA 420	2114-604-011	11P JE-604-11,PLUG
WA 424	2114-604-011	11P JE-604-11,PLUG
WA 409	2121-605-004	4P JE-605-04, SOCKET

**WIRES**

CN 425	2141-010-013	4P 1533#26,650m/m,
H 501	2141-010-014	1P 1672#22,250m/m
CN416	2141-060-012	6P 1007#26,200m/m,
H 503	2141-010-025	1P 1672#22,165m/m

**MISCELLANEOUS**

L 401	1451-000-030	COIL-AF CHOKE 0.7uH
L 402	1451-000-030	COIL-AF CHOKE 0.7uH
L 501	1451-000-030	COIL-AF CHOKE 0.7uH
JK 502	1514-060-001	PIN JACK;6P,JW-4105R
JK 501	1531-020-381	TERMINAL-SPEAKER;2P
JK 401	1531-040-373	TERMINAL-SPEAKER;4P
⚠ FU 481	1541-2R0-013	FUSE;250V 2A,21GS(5×20mm)Slo-Blo <b>BK</b>
⚠ FU 482	1541-2R0-013	FUSE;250V 2A,21GS(5×20mm)Slo-Blo <b>BK</b>
⚠ FU 481	1543-2R0-001	FUSE;250V T2L,21GL(5×20mm)Slo-Blo <b>IB/AB</b>
⚠ FU 482	1543-2R0-001	FUSE;250V T2L,21GL(5×20mm)Slo-Blo <b>IB/AB</b>
FH 481	1551-000-011	HOLDER-FUSE;5φ
FH 482	1551-000-011	HOLDER-FUSE;5φ
FH 483	1551-000-011	HOLDER-FUSE;5φ
FH 484	1551-000-011	HOLDER-FUSE;5φ
VR 401	1731-102-006	VR-SEMI;1kohm
VR 402	1731-102-006	VR-SEMI;1kohm
VR 501	1731-102-006	VR-SEMI;1kohm
P 551	1782-000-001	POSISTOR;P42T8D100B04

**0112-011-150 REAR AMP P.C.BOARD**

**TRANSISTORS**

⚠ Q 637	1241-524-001	POWER 2SC5242-R(130W)	NPN
⚠ Q 638	1241-524-001	POWER 2SC5242-R(130W)	NPN
⚠ Q 639	1242-196-001	POWER 2SA1962-R(130W)	PNP
⚠ Q 640	1242-196-001	POWER 2SA1962-R(130W)	PNP
⚠ Q 607	1243-319-001	KTC3198-GR	NPN
Q 608	1243-319-001	KTC3198-GR	NPN
Q 601	1243-320-001	KTC3200-GR	NPN
Q 602	1243-320-001	KTC3200-GR	NPN
Q 603	1243-320-001	KTC3200-GR	NPN
Q 604	1243-320-001	KTC3200-GR	NPN
Q 605	1243-320-001	KTC3200-GR	NPN
Q 606	1243-320-001	KTC3200-GR	NPN
Q 615	1243-320-001	KTC3200-GR	NPN
Q 616	1243-320-001	KTC3200-GR	NPN
Q 627	1243-320-001	KTC3200-GR	NPN
Q 628	1243-320-001	KTC3200-GR	NPN
Q 681	1243-320-001	KTC3200-GR	NPN
Q 682	1243-320-001	KTC3200-GR	NPN
Q 619	1243-326-001	KTC3206-Y	NPN
Q 620	1243-326-001	KTC3206-Y	NPN
Q 623	1243-326-001	KTC3206-Y	NPN
Q 624	1243-326-001	KTC3206-Y	NPN
Q 629	1243-326-001	KTC3206-Y	NPN
Q 630	1243-326-001	KTC3206-Y	NPN
Q 625	1243-437-001	KTC4370-Y	NPN
Q 626	1243-437-001	KTC4370-Y	NPN
Q 635	1243-437-001	KTC4370-Y	NPN
Q 636	1243-437-001	KTC4370-Y	NPN
Q 617	1244-124-002	KTA1024-Y	PNP

REF NO.	PART NO	DESCRIPTION	
Q 618	1244-124-002	KTA1024-Y	PNP
Q 621	1244-124-002	KTA1024-Y	PNP
Q 622	1244-124-002	KTA1024-Y	PNP
Q 631	1244-124-002	KTA1024-Y	PNP
Q 632	1244-124-002	KTA1024-Y	PNP
Q 611	1244-128-001	KTA1268-GR	PNP
Q 612	1244-128-001	KTA1268-GR	PNP
Q 613	1244-128-001	KTA1268-GR	PNP
Q 614	1244-128-001	KTA1268-GR	PNP
Q 683	1244-128-001	KTA1268-GR	PNP
Q 633	1244-169-001	KTA1659-Y	PNP
Q 634	1244-169-001	KTA1659-Y	PNP

**FET**

Q 609	1248-000-004	FET;2SK373-GR	N-CH
Q 610	1248-000-004	FET;2SK373-GR	N-CH

**DIODES(REAR AMP)**

D 601	1252-000-017	1SS133 , SW.	
D 602	1252-000-017	1SS133 , SW.	
D 603	1252-000-017	1SS133 , SW.	
D 604	1252-000-017	1SS133 , SW.	
D 681	1252-000-017	1SS133 , SW.	
D 682	1252-000-017	1SS133 , SW.	
D 683	1252-000-017	1SS133 , SW.	
D 684	1252-000-017	1SS133 , SW.	
D 685	1252-000-017	1SS133 , SW.	
⚠ D 691	1253-000-006	BU6-04F, BRIDGE	

**RESISTORS(CARBON)**

R 677	1742-100-721	1/8W	10W-J
R 678	1742-100-721	1/8W	10W-J
R 650	1742-102-721	1/8W	1KW-J
R 691	1742-103-721	1/8W	10KW-J
R 697	1742-103-721	1/8W	10KW-J
R 649	1742-102-721	1/8W	1KW-J
R 698	1742-103-721	1/8W	10KW-J
R 683	1742-153-721	1/8W	15KW-J
R 684	1742-153-721	1/8W	15KW-J
R 685	1742-183-721	1/8W	18KW-J
R 686	1742-183-721	1/8W	18KW-J
R 613	1742-271-721	1/8W	270W-J
R 614	1742-271-721	1/8W	270W-J
R 601	1742-331-721	1/8W	330W-J
R 602	1742-331-721	1/8W	330W-J
R 603	1742-393-721	1/8W	39KW-J
R 604	1742-393-721	1/8W	39KW-J
R 689	1742-393-721	1/8W	39KW-J
R 690	1742-393-721	1/8W	39KW-J
R 692	1742-393-721	1/8W	39KW-J
R 653	1742-472-721	1/8W	4.7KW-J
R 654	1742-472-721	1/8W	4.7KW-J
R 651	1742-561-721	1/8W	560W-J
R 652	1742-561-721	1/8W	560W-J
R 655	1742-562-721	1/8W	5.6KW-J
R 656	1742-562-721	1/8W	5.6KW-J
R 681	1744-102-731	1/4W	1KW-J
R 682	1744-102-731	1/4W	1KW-J
R 687	1744-102-731	1/4W	1KW-J
R 688	1744-102-731	1/4W	1KW-J
R 605	1744-152-731	1/4W	1.5KW-J
R 606	1744-152-731	1/4W	1.5KW-J
R 607	1744-152-731	1/4W	1.5KW-J
R 608	1744-152-731	1/4W	1.5KW-J
R 637	1744-153-731	1/4W	15KW-J
R 638	1744-153-731	1/4W	15KW-J
R 639	1744-153-731	1/4W	15KW-J
R 640	1744-153-731	1/4W	15KW-J
R 619	1744-202-731	1/4W	2KW-J

REF NO.	PART NO	DESCRIPTION	
R 620	1744-202-731	1/4W	2KW-J
R 609	1744-331-731	1/4W	330W-J
R 610	1744-331-731	1/4W	330W-J
R 611	1744-331-731	1/4W	330W-J
R 612	1744-331-731	1/4W	330W-J
R 617	1744-393-731	1/4W	39KW-J
R 618	1744-393-731	1/4W	39KW-J
R 615	1742-273-721	1/8W	27KW-J
R 616	1742-273-721	1/8W	27KW-J

**RESISTORS(FUSIBLE)**

⚠ R 673	1761-100-731	1/4W	10W-J
⚠ R 674	1761-100-731	1/4W	10W-J
⚠ R 657	1761-101-731	1/4W	100W-J
⚠ R 658	1761-101-731	1/4W	100W-J
⚠ R 659	1761-101-731	1/4W	100W-J
⚠ R 660	1761-101-731	1/4W	100W-J
⚠ R 661	1761-150-731	1/4W	15W-J
⚠ R 662	1761-150-731	1/4W	15W-J
⚠ R 663	1761-150-731	1/4W	15W-J
⚠ R 664	1761-150-731	1/4W	15W-J
⚠ R 633	1761-151-731	1/4W	150W-J
⚠ R 634	1761-151-731	1/4W	150W-J
⚠ R 635	1761-151-731	1/4W	150W-J
⚠ R 636	1761-151-731	1/4W	150W-J
⚠ R 641	1761-151-731	1/4W	150W-J
⚠ R 642	1761-151-731	1/4W	150W-J
⚠ R 643	1761-151-731	1/4W	150W-J
⚠ R 644	1761-151-731	1/4W	150W-J
⚠ R 665	1761-2R2-731	1/4W	2.2W-J
⚠ R 666	1761-2R2-731	1/4W	2.2W-J
⚠ R 667	1761-2R2-731	1/4W	2.2W-J
⚠ R 621	1761-561-731	1/4W	560W-J
⚠ R 622	1761-561-731	1/4W	560W-J
⚠ R 623	1761-561-731	1/4W	560W-J
⚠ R 624	1761-561-731	1/4W	560W-J
⚠ R 625	1761-561-731	1/4W	560W-J
⚠ R 627	1761-561-731	1/4W	560W-J
⚠ R 628	1761-561-731	1/4W	560W-J
⚠ R 629	1761-561-731	1/4W	560W-J
⚠ R 630	1761-561-731	1/4W	560W-J
⚠ R 631	1761-561-731	1/4W	560W-J
⚠ R 632	1761-561-731	1/4W	560W-J
⚠ R 669	1761-820-731	1/4W	82W-J
⚠ R 670	1761-820-731	1/4W	82W-J

**RESISTORS(METAL)**

⚠ R 675	1771-100-751	1W	10W-J
⚠ R 676	1771-100-751	1W	10W-J
⚠ R 645	1761-100-731	1/4W	10W-J
⚠ R 646	1761-100-731	1/4W	10W-J
⚠ R 647	1761-100-731	1/4W	10W-J
⚠ R 648	1761-100-731	1/4W	10W-J

**RESISTORS(CEMENT)**

⚠ R 671	1775-R22-782	5W	0.22W-J
⚠ R 672	1775-R22-782	5W	0.22W-J

**CAPACITORS**

C 609	1822-030-311	CERA	50V	3pF-C
C 610	1822-030-311	CERA	50V	3pF-C
C 611	1822-101-772	CERA	50V	100pF-J
C 612	1822-101-772	CERA	50V	100pF-J
C 603	1822-680-712	CERA	50V	68pF-J
C 604	1822-680-712	CERA	50V	68pF-J
C 621	1861-471-811	ELECT	50V	470uF-M
C 622	1861-471-811	ELECT	50V	470uF-M
C 623	1861-471-811	ELECT	50V	470uF-M
C 624	1861-471-811	ELECT	50V	470uF-M

REF NO.	PART NO	DESCRIPTION	
C 691	1861-682-800	ELECT	50V 6800uF-M
C 692	1861-682-800	ELECT	50V 6800uF-M
C 613	1862-100-017	ELECT	100V 10uF-M
C 614	1862-100-017	ELECT	100V 10uF-M
C 615	1862-100-017	ELECT	100V 10uF-M
C 616	1862-100-017	ELECT	100V 10uF-M
C 696	1862-100-504	ELECT	16V 10uF-M
C 627	1862-220-604	ELECT	25V 22uF-M
C 628	1862-220-604	ELECT	25V 22uF-M
C 605	1862-101-605	ELECT	25V 100uF-M
C 606	1862-101-605	ELECT	25V 100uF-M
C 601	1862-100-604	ELECT	25V 10uF-M
C 619	1876-104-811	MYLAR	100V 0.1uF-K
C 681	1876-683-811	MYLAR	100V 0.068uF-K
C 682	1876-683-811	MYLAR	100V 0.068uF-K

**WAFERS**

WA 601	2111-023-002	2P	5267-02A
WA 602	2111-023-002	2P	5267-02A
WA 625	2111-023-004	4P	5267-04A
WA 603	2111-029-003	3P	JE202-1T-03Y

**MISCELLANEOUS**

CN 606	2141-010-015	WIRE 4P	1007#26,750m/m
L 601	1451-000-030	COIL-AF	CHOKE
L 602	1451-000-030	COIL-AF	CHOKE
JK 601	1531-040-373	TERMINAL-SPEAKER;	4P
VR 601	1731-102-006	VR-SEMI	1kohm
VR 602	1731-102-006	VR-SEMI	1kohm

**0112-011-1512 SUB P.C.BOARD**

**INTEGRATED CIRCUITS**

⚠ IC 981	1217-780-002	IC 7805	REGULATOR
----------	--------------	---------	-----------

**TRANSISTORS**

Q 985	1243-103-004	KRC103M	NPN
Q 984	1243-103-004	KRC103M	NPN
Q 981	1244-128-001	KTA1268-GR	PNP
Q 983	1243-319-001	KTC3198-GR	NPN
Q 982	1243-319-001	KTC3198-GR	NPN

**DIODES**

D 987	1252-000-017	1SS133 ,	SW .
D 988	1252-000-017	1SS133 ,	SW .
D 992	1252-000-017	1SS133 ,	SW .
⚠ D 981	1252-001-004	IN4004	1A/400V, RECT
⚠ D 982	1252-001-004	IN4004	1A/400V, RECT
⚠ D 983	1252-001-004	IN4004	1A/400V, RECT
⚠ D 984	1252-001-004	IN4004	1A/400V, RECT
⚠ D 985	1252-001-004	IN4004	1A/400V, RECT
⚠ D 986	1252-001-004	IN4004	1A/400V, RECT
⚠ D 989	1252-001-004	IN4004	1A/400V, RECT
⚠ D 990	1252-001-004	IN4004	1A/400V, RECT
D 991	1254-300-001	ZENER	30V
D 996	1254-4R7-025	ZENER	4.7V
D 994	1254-7R5-001	ZENER	7.5V

**RESISTORS(CARBON)**

R 983	1742-102-721	1/8W	1KW-J
R 990	1742-103-721	1/8W	10KW-J
R 994	1742-103-721	1/8W	10KW-J
R 991	1742-151-721	1/8W	150W-J
R 986	1742-222-721	1/8W	2.2KW-J
R 984	1742-272-721	1/8W	2.7KW-J
R 992	1742-471-721	1/8W	470W-J
R 988	1744-1R0-731	1/4W	1W-J
R 989	1744-1R0-731	1/4W	1W-J

REF NO.	PART NO	DESCRIPTION
R 982	1744-222-731	1/4W 2.2KW-J
R 987	1744-561-731	1/4W 560W-J
R 993	1742-682-721	1/8W 6.8KW-J

**RESISTORS(FUSIBLE)**

⚠ R 985	1761-220-731	1/4W 22W-J
⚠ R 981	1761-4R7-731	1/4W 4.7W-J

**CAPACITORS**

C 983	1822-103-822	CERA/RA 50V 103pF-K
C 997	1822-103-822	CERA/RA 50V 103pF-K
C 998	1822-103-822	CERA/RA 50V 103pF-K
C 999	1822-103-822	CERA/RA 50V 103pF-K
C 988	1832-473-002	CERA/AX 50V 0.047uF-Z
C 985	1832-104-002	CERA/AX 50V 0.1uF-Z
C 993	1832-104-002	CERA/AX 50V 0.1uF-Z
C 994	1832-104-002	CERA/AX 50V 0.1uF-Z
C 995	1832-104-002	CERA/AX 50V 0.1uF-Z
C 996	1832-104-002	CERA/AX 50V 0.1uF-Z
⚠ C 982	1825-000-010	AC 250V 0.0047uF-M
⚠ C 981	1825-104-000	AC 275V 0.1uF
C 992	1861-101-706	ELELT 35V 100uF-M
C 984	1861-471-811	ELECT 50V 470uF-M
C 989	1861-471-811	ELECT 50V 470uF-M
C 990	1861-471-811	ELECT 50V 470uF-M
C 986	1862-010-804	ELECT 50V 1.0uF-M
C 987	1862-100-804	ELECT 50V 10uF-M
C 991	1862-470-814	ELECT 50V 47uF-M

**WAFERS**

WA 987	2111-023-003	5267-03A,3P
WA 986	2111-023-007	5267-07A,7P
WA 983	2111-026-002	2P;35328-0210
WA 985	2111-028-002	2P;JE202A-1T-02R
WA 981	2111-027-002	JE202A-1T-02(3-2)

**MISCELLANEOUS**

⚠ FU 981	1541-6R3-125	FUSE;125V,6.3A,21GS,(5×20mm),SLO-BLO	<b>BK</b>
⚠ FU 981	1543-4R0-001	FUSE;125V,7.4L,21GL,(5×20mm),SLO-BLO	<b>IB/AB</b>
⚠ T 981	1411-000-004	TRANS-SUB;AVR-45/65	
⚠ T 981	1411-000-005	TRANS-SUB;AVR-45/65(RDS)	
FH 981	1551-000-011	HOLDER-FUSE	
FH 982	1551-000-011	HOLDER-FUSE	
⚠ AC 981	1561-000-005	AC OUTLET S2-764T-200	
⚠ AC 981	1561-000-006	AC OUTLET S2-762T-206	
⚠ R 995	1783-335-001	COMPOSITION,1/2,3.3M	
⚠ RL 981	2022-000-002	RELAY;DH12D1-O(M),DEC	

**0112-011-152 AUDIO INPUT P.C.BOARD**

**INTEGRATED CIRCUITS**

IC 103	1211-455-001	IC NJM4558L OP AMP
IC 107	1211-455-001	IC NJM4558L OP AMP
IC 108	1211-455-001	IC NJM4558L OP AMP
IC 111	1211-455-001	IC NJM4558L OP AMP
IC 112	1211-455-001	IC NJM4558L OP AMP
IC 115	1211-455-001	IC NJM4558L OP AMP
IC 116	1211-455-001	IC NJM4558L OP AMP
IC 118	1211-455-001	IC NJM4558L OP AMP
IC 119	1211-455-001	IC NJM4558L OP AMP
IC 105	1212-731-002	IC NJU7311 ANALOG SW
IC 113	1212-731-002	IC NJU7311 ANALOG SW
IC 101	1212-731-003	IC NJU7312 ANALOG SW
IC 106	1212-753-001	IC LC7536 ELEC Volume
IC 114	1212-753-001	IC LC7536 ELEC Volume
IC 117	1212-753-001	IC LC7536 ELEC Volume

**TRANSISTORS**

Q 104	1243-101-018	KRC101M	NPN
-------	--------------	---------	-----

REF NO.	PART NO	DESCRIPTION	
Q 112	1243-101-018	KRC101M	NPN
Q 116	1243-101-018	KRC101M	NPN
Q 117	1243-101-018	KRC101M	PNP
Q 101	1243-130-003	KTD1302	PNP
Q 102	1243-130-003	KTD1302	NPN
Q 109	1243-130-003	KTD1302	NPN
Q 110	1243-130-003	KTD1302	NPN
Q 113	1243-130-003	KTD1302	NPN
Q 114	1243-130-003	KTD1302	NPN
Q 103	1244-126-004	KTA1266-GR	NPN
Q 111	1244-126-004	KTA1266-GR	NPN
Q 115	1244-126-004	KTA1266-GR	NPN
Q 118	1244-126-004	KTA1266-GR	NPN

**DIODE**

D 101	1252-000-017	1SS133, SW.
-------	--------------	-------------

**RESISTORS(CARBAN)**

R 133	1742-101-721	1/8W 100W-J
R 134	1742-101-721	1/8W 100W-J
R 137	1742-101-721	1/8W 100W-J
R 138	1742-101-721	1/8W 100W-J
R 141	1742-101-721	1/8W 100W-J
R 142	1742-101-721	1/8W 100W-J
R 157	1742-101-721	1/8W 100W-J
R 158	1742-101-721	1/8W 100W-J
R 165	1742-101-721	1/8W 100W-J
R 166	1742-101-721	1/8W 100W-J
R 173	1742-101-721	1/8W 100W-J
R 174	1742-101-721	1/8W 100W-J
R 177	1742-101-721	1/8W 100W-J
R 178	1742-101-721	1/8W 100W-J
R 181	1742-101-721	1/8W 100W-J
R 182	1742-101-721	1/8W 100W-J
R 213	1742-101-721	1/8W 100W-J
R 214	1742-101-721	1/8W 100W-J
R 217	1742-101-721	1/8W 100W-J
R 218	1742-101-721	1/8W 100W-J
R 221	1742-101-721	1/8W 100W-J
R 222	1742-101-721	1/8W 100W-J
R 237	1742-101-721	1/8W 100W-J
R 238	1742-101-721	1/8W 100W-J
R 241	1742-101-721	1/8W 100W-J
R 242	1742-101-721	1/8W 100W-J
R 245	1742-101-721	1/8W 100W-J
R 246	1742-101-721	1/8W 100W-J
R 261	1742-102-721	1/8W 1KW-J
R 262	1742-102-721	1/8W 1KW-J
R 263	1742-102-721	1/8W 1KW-J
R 279	1742-102-721	1/8W 1KW-J
R 280	1742-102-721	1/8W 1KW-J
R 281	1742-102-721	1/8W 1KW-J
R 285	1742-102-721	1/8W 1KW-J
R 286	1742-102-721	1/8W 1KW-J
R 287	1742-102-721	1/8W 1KW-J
R 291	1742-102-721	1/8W 1KW-J
R 292	1742-102-721	1/8W 1KW-J
R 293	1742-102-721	1/8W 1KW-J
R 297	1742-102-721	1/8W 1KW-J
R 298	1742-102-721	1/8W 1KW-J
R 299	1742-102-721	1/8W 1KW-J
R 303	1742-102-721	1/8W 1KW-J
R 304	1742-102-721	1/8W 1KW-J
R 305	1742-102-721	1/8W 1KW-J
R 189	1742-102-721	1/8W 1KW-J
R 190	1742-102-721	1/8W 1KW-J
R 229	1742-102-721	1/8W 1KW-J
R 230	1742-102-721	1/8W 1KW-J
R 253	1742-102-721	1/8W 1KW-J

REF NO.	PART NO	DESCRIPTION	REF NO.	PART NO	DESCRIPTION
R 254	1742-102-721	1/8W 1KW-J	R 256	1742-224-721	1/8W 220KW-J
R 267	1742-102-721	1/8W 1KW-J	R 147	1742-224-721	1/8W 220KW-J
R 227	1742-822-721	1/8W 8.2KW-J	R 148	1742-224-721	1/8W 220KW-J
R 228	1742-822-721	1/8W 8.2KW-J	R 151	1742-224-721	1/8W 220KW-J
R 251	1742-822-721	1/8W 8.2KW-J	R152	1742-224-721	1/8W 220KW-J
R 252	1742-822-721	1/8W 8.2KW-J	R 155	1742-224-721	1/8W 220KW-J
R 311	1742-103-721	1/8W 10KW-J	R 156	1742-224-721	1/8W 220KW-J
R 312	1742-103-721	1/8W 10KW-J	R 199	1742-224-721	1/8W 220KW-J
R 161	1742-152-721	1/8W 1.5KW-J	R 200	1742-224-721	1/8W 220KW-J
R 162	1742-152-721	1/8W 1.5KW-J	R 207	1742-224-721	1/8W 220KW-J
R 169	1742-152-721	1/8W 1.5KW-J	R 208	1742-224-721	1/8W 220KW-J
R 170	1742-152-721	1/8W 1.5KW-J	R 101	1742-331-721	1/8W 330W-J
R 195	1742-183-721	1/8W 18KW-J	R 102	1742-331-721	1/8W 330W-J
R 235	1742-183-721	1/8W 18KW-J	R 105	1742-331-721	1/8W 330W-J
R 259	1742-183-721	1/8W 18KW-J	R 106	1742-331-721	1/8W 330W-J
R 310	1742-183-721	1/8W 18KW-J	R 109	1742-331-721	1/8W 330W-J
R 211	1742-183-721	1/8W 18KW-J	R 110	1742-331-721	1/8W 330W-J
R 196	1742-223-721	1/8W 22KW-J	R 113	1742-331-721	1/8W 330W-J
R 212	1742-223-721	1/8W 22KW-J	R 114	1742-331-721	1/8W 330W-J
R 236	1742-223-721	1/8W 22KW-J	R 117	1742-331-721	1/8W 330W-J
R 260	1742-223-721	1/8W 22KW-J	R 118	1742-331-721	1/8W 330W-J
R 309	1742-223-721	1/8W 22KW-J	R 193	1742-331-721	1/8W 330W-J
R 103	1742-224-721	1/8W 220KW-J	R 194	1742-331-721	1/8W 330W-J
R 104	1742-224-721	1/8W 220KW-J	R 233	1742-331-721	1/8W 330W-J
R 107	1742-224-721	1/8W 220KW-J	R 234	1742-331-721	1/8W 330W-J
R 108	1742-224-721	1/8W 220KW-J	R 257	1742-331-721	1/8W 330W-J
R 111	1742-224-721	1/8W 220KW-J	R 258	1742-331-721	1/8W 330W-J
R 112	1742-224-721	1/8W 220KW-J	R 209	1742-331-721	1/8W 330W-J
R 115	1742-224-721	1/8W 220KW-J	R 210	1742-331-721	1/8W 330W-J
R 116	1742-224-721	1/8W 220KW-J	R 187	1742-333-721	1/8W 33KW-J
R 119	1742-224-721	1/8W 220KW-J	R 188	1742-333-721	1/8W 33KW-J
R 120	1742-224-721	1/8W 220KW-J	R 185	1742-473-721	1/8W 47KW-J
R 135	1742-224-721	1/8W 220KW-J	R 186	1742-473-721	1/8W 47KW-J
R 136	1742-224-721	1/8W 220KW-J	R 225	1742-473-721	1/8W 47KW-J
R 139	1742-224-721	1/8W 220KW-J	R 226	1742-473-721	1/8W 47KW-J
R 140	1742-224-721	1/8W 220KW-J	R 249	1742-473-721	1/8W 47KW-J
R 143	1742-224-721	1/8W 220KW-J	R 250	1742-473-721	1/8W 47KW-J
R 144	1742-224-721	1/8W 220KW-J	R 264	1742-473-721	1/8W 47KW-J
R 159	1742-224-721	1/8W 220KW-J	R 265	1742-473-721	1/8W 47KW-J
R 160	1742-224-721	1/8W 220KW-J	R 266	1742-473-721	1/8W 47KW-J
R 163	1742-224-721	1/8W 220KW-J	R 282	1742-473-721	1/8W 47KW-J
R 164	1742-224-721	1/8W 220KW-J	R 283	1742-473-721	1/8W 47KW-J
R 167	1742-224-721	1/8W 220KW-J	R 284	1742-473-721	1/8W 47KW-J
R 168	1742-224-721	1/8W 220KW-J	R 288	1742-473-721	1/8W 47KW-J
R 171	1742-224-721	1/8W 220KW-J	R 289	1742-473-721	1/8W 47KW-J
R 172	1742-224-721	1/8W 220KW-J	R 290	1742-473-721	1/8W 47KW-J
R 175	1742-224-721	1/8W 220KW-J	R 294	1742-473-721	1/8W 47KW-J
R 176	1742-224-721	1/8W 220KW-J	R 295	1742-473-721	1/8W 47KW-J
R 179	1742-224-721	1/8W 220KW-J	R 296	1742-473-721	1/8W 47KW-J
R 180	1742-224-721	1/8W 220KW-J	R 300	1742-473-721	1/8W 47KW-J
R 183	1742-224-721	1/8W 220KW-J	R 301	1742-473-721	1/8W 47KW-J
R 184	1742-224-721	1/8W 220KW-J	R 302	1742-473-721	1/8W 47KW-J
R 191	1742-224-721	1/8W 220KW-J	R 306	1742-473-721	1/8W 47KW-J
R 192	1742-224-721	1/8W 220KW-J	R 307	1742-473-721	1/8W 47KW-J
R 215	1742-224-721	1/8W 220KW-J	R 308	1742-473-721	1/8W 47KW-J
R 216	1742-224-721	1/8W 220KW-J	R 270	1742-473-721	1/8W 47KW-J
R 219	1742-224-721	1/8W 220KW-J	R 271	1742-473-721	1/8W 47KW-J
R 220	1742-224-721	1/8W 220KW-J	R 272	1742-473-721	1/8W 47KW-J
R 223	1742-224-721	1/8W 220KW-J	R 276	1742-473-721	1/8W 47KW-J
R 224	1742-224-721	1/8W 220KW-J	R 277	1742-473-722	1/8W 47KW-J
R 231	1742-224-721	1/8W 220KW-J	R 278	1742-473-723	1/8W 47KW-J
R 232	1742-224-721	1/8W 220KW-J	R 201	1742-473-724	1/8W 47KW-J
R 239	1742-224-721	1/8W 220KW-J	R 202	1742-473-725	1/8W 47KW-J
R 240	1742-224-721	1/8W 220KW-J	R 313	1742-682-721	1/8W 6.8KW-J
R 243	1742-224-721	1/8W 220KW-J	R 314	1742-682-721	1/8W 6.8KW-J
R 244	1742-224-721	1/8W 220KW-J	R 203	1742-682-721	1/8W 6.8KW-J
R 247	1742-224-721	1/8W 220KW-J	R 204	1742-682-721	1/8W 6.8KW-J
R 248	1742-224-721	1/8W 220KW-J			
R 255	1742-224-721	1/8W 220KW-J			

REF NO.	PART NO	DESCRIPTION	REF NO.	PART NO	DESCRIPTION
<b>CAPACITORS</b>					
C 199	1832-104-002	CERA/AX 50V 0.1uF-Z	C 137	1862-4R7-804	ELECT 50V 4.7uF-M
C 200	1832-104-002	CERA/AX 50V 0.1uF-Z	C 138	1862-4R7-804	ELECT 50V 4.7uF-M
C 203	1832-104-002	CERA/AX 50V 0.1uF-Z	C 145	1862-4R7-804	ELECT 50V 4.7uF-M
C 204	1832-104-002	CERA/AX 50V 0.1uF-Z	C 146	1862-4R7-804	ELECT 50V 4.7uF-M
C 211	1832-104-002	CERA/AX 50V 0.1uF-Z	C 147	1862-4R7-804	ELECT 50V 4.7uF-M
C 212	1832-104-002	CERA/AX 50V 0.1uF-Z	C 148	1862-4R7-804	ELECT 50V 4.7uF-M
C 213	1832-104-002	CERA/AX 50V 0.1uF-Z	C 149	1862-4R7-804	ELECT 50V 4.7uF-M
C 214	1832-104-002	CERA/AX 50V 0.1uF-Z	C 150	1862-4R7-804	ELECT 50V 4.7uF-M
C 215	1832-104-002	CERA/AX 50V 0.1uF-Z	C 151	1862-4R7-804	ELECT 50V 4.7uF-M
C 216	1832-104-002	CERA/AX 50V 0.1uF-Z	C 152	1862-4R7-804	ELECT 50V 4.7uF-M
C 217	1832-104-002	CERA/AX 50V 0.1uF-Z	C 153	1862-4R7-804	ELECT 50V 4.7uF-M
C 218	1832-104-002	CERA/AX 50V 0.1uF-Z	C 154	1862-4R7-804	ELECT 50V 4.7uF-M
C 219	1832-104-002	CERA/AX 50V 0.1uF-Z	C 155	1862-4R7-804	ELECT 50V 4.7uF-M
C 220	1832-104-002	CERA/AX 50V 0.1uF-Z	C 156	1862-4R7-804	ELECT 50V 4.7uF-M
C 221	1832-104-002	CERA/AX 50V 0.1uF-Z	C 157	1862-4R7-804	ELECT 50V 4.7uF-M
C 101	1832-121-712	CERA/AX 50V 120pF-J	C 158	1862-4R7-804	ELECT 50V 4.7uF-M
C 102	1832-121-712	CERA/AX 50V 120pF-J	C 161	1862-4R7-804	ELECT 50V 4.7uF-M
C 103	1832-121-712	CERA/AX 50V 120pF-J	C 162	1862-4R7-804	ELECT 50V 4.7uF-M
C 104	1832-121-712	CERA/AX 50V 120pF-J	C 163	1862-4R7-804	ELECT 50V 4.7uF-M
C 105	1832-121-712	CERA/AX 50V 120pF-J	C 164	1862-4R7-804	ELECT 50V 4.7uF-M
C 106	1832-121-712	CERA/AX 50V 120pF-J	C 165	1862-4R7-804	ELECT 50V 4.7uF-M
C 107	1832-121-712	CERA/AX 50V 120pF-J	C 166	1862-4R7-804	ELECT 50V 4.7uF-M
C 108	1832-121-712	CERA/AX 50V 120pF-J	C 167	1862-4R7-804	ELECT 50V 4.7uF-M
C 109	1832-121-712	CERA/AX 50V 120pF-J	C 168	1862-4R7-804	ELECT 50V 4.7uF-M
C 110	1832-121-712	CERA/AX 50V 120pF-J	C 171	1862-4R7-804	ELECT 50V 4.7uF-M
C 173	1832-471-712	CERA/AX 50V 470pF-J	C 172	1862-4R7-804	ELECT 50V 4.7uF-M
C 174	1832-471-712	CERA/AX 50V 470pF-J	C 123	1862-4R7-804	ELECT 50V 4.7uF-M
C 175	1832-471-712	CERA/AX 50V 470pF-J	<b>WAFERS</b>		
C 176	1832-471-712	CERA/AX 50V 470pF-J	WA 101	2111-023-003	3P 5267-03A
C 177	1832-471-712	CERA/AX 50V 470pF-J	HU 112	2121-605-007	7P JE-605-07
C 178	1832-471-712	CERA/AX 50V 470pF-J	HU 115	2121-605-007	7P JE-605-07
C 179	1832-471-712	CERA/AX 50V 470pF-J	HU 116	2121-605-007	7P JE-605-07
C 180	1832-471-712	CERA/AX 50V 470pF-J	HU 114	2121-605-011	11P JE-605-11
C 181	1832-471-712	CERA/AX 50V 470pF-J	HU 117	2121-605-011	11P JE-605-11
C 182	1832-471-712	CERA/AX 50V 470pF-J	HU 121	2121-605-011	11P JE-605-11
C 183	1832-471-712	CERA/AX 50V 470pF-J	<b>MISCELLANEOUS</b>		
C 184	1832-471-712	CERA/AX 50V 470pF-J	CN 107	2141-090-050	WIRE 9P;1007#26,200m/m
C 188	1832-471-712	CERA/AX 50V 470pF-J	JP 101	1514-000-021	JACK-RCA;4P,JW-4104R
C 189	1832-471-712	CERA/AX 50V 470pF-J	JP 102	1514-000-021	JACK-RCA;4P,JW-4104R
C 190	1832-471-712	CERA/AX 50V 470pF-J	JP 103	1514-060-001	PIN JACK;6P,JW-4105R
C 194	1832-471-712	CERA/AX 50V 470pF-J	<b>0112-011-1532 FRONT PC.BOARD</b>		
C 195	1832-471-712	CERA/AX 50V 470pF-J	<b>INTEGRATED CIRCUITS</b>		
C 196	1832-471-712	CERA/AX 50V 470pF-J	IC 901	1216-828-141	IC CXP828P60Q-141C MAIN MI-COM
C 135	1862-100-804	ELECT 50V 10uF-M	IC 902	1211-455-001	IC NJM4558L OP AMP
C 136	1862-100-804	ELECT 50V 10uF-M	<b>TRANSISTORS</b>		
C 159	1862-100-804	ELECT 50V 10uF-M	Q 902	1243-103-004	KRC103M NPN
C 160	1862-100-804	ELECT 50V 10uF-M	Q 903	1243-103-004	KRC103M NPN
C 169	1862-100-804	ELECT 50V 10uF-M	Q 934	1243-104-014	KRC104M NPN
C 170	1862-100-804	ELECT 50V 10uF-M	Q 921	1243-319-001	KTC3198-GR NPN
C 197	1862-470-604	ELECT 25V 47uF-M	Q 932	1243-319-001	KTC3198-GR NPN
C 198	1862-470-604	ELECT 25V 47uF-M	Q 901	1243-319-007	KTC3199-GR NPN
C 201	1862-470-604	ELECT 25V 47uF-M	Q 904	1243-319-007	KTC3199-GR NPN
C 202	1862-470-604	ELECT 25V 47uF-M	Q 905	1243-319-007	KTC3199-GR NPN
C 205	1862-470-604	ELECT 25V 47uF-M	Q 906	1243-319-007	KTC3199-GR NPN
C 209	1862-470-604	ELECT 25V 47uF-M	Q 907	1243-319-007	KTC3199-GR NPN
C 210	1862-470-604	ELECT 25V 47uF-M	Q 908	1243-319-007	KTC3199-GR NPN
C 117	1862-4R7-804	ELECT 50V 4.7uF-M	Q 909	1243-319-007	KTC3199-GR NPN
C 118	1862-4R7-804	ELECT 50V 4.7uF-M	Q 910	1243-319-007	KTC3199-GR NPN
C 119	1862-4R7-804	ELECT 50V 4.7uF-M	Q 911	1243-319-007	KTC3199-GR NPN
C 120	1862-4R7-804	ELECT 50V 4.7uF-M	Q 912	1243-319-007	KTC3199-GR NPN
C 129	1862-4R7-804	ELECT 50V 4.7uF-M	Q 913	1243-319-007	KTC3199-GR NPN
C 130	1862-4R7-804	ELECT 50V 4.7uF-M	Q 914	1243-319-007	KTC3199-GR NPN
C 131	1862-4R7-804	ELECT 50V 4.7uF-M			
C 132	1862-4R7-804	ELECT 50V 4.7uF-M			
C 133	1862-4R7-804	ELECT 50V 4.7uF-M			
C 134	1862-4R7-804	ELECT 50V 4.7uF-M			

REF NO.	PART NO	DESCRIPTION	
Q 914	1243-319-007	KTC3199-GR	NPN
Q 915	1243-319-007	KTC3199-GR	NPN
Q 916	1243-319-007	KTC3199-GR	NPN
Q 917	1243-319-007	KTC3199-GR	NPN
Q 918	1243-319-007	KTC3199-GR	NPN
Q 919	1243-319-007	KTC3199-GR	NPN
Q 936	1244-102-003	KRA102M	PNP
Q 933	1244-104-011	KRA104M	PNP
Q 935	1244-104-011	KRA104M	PNP

**DIODES**

D 901	1252-000-017	1SS133 , SW	
D 902	1252-000-017	1SS133 , SW	
D 903	1252-000-017	1SS133 , SW	
D 904	1252-000-017	1SS133 , SW	
D 905	1252-000-017	1SS133 , SW	
D 906	1252-000-017	1SS133 , SW	
D 907	1252-000-017	1SS133 , SW	
D 908	1252-000-017	1SS133 , SW	
D 909	1252-000-017	1SS133 , SW	
D 986	1252-000-017	1SS133 , SW	
D 910	1252-000-017	1SS133 , SW	
D 911	1252-000-017	1SS133 , SW	
D 912	1252-000-017	1SS133 , SW	
D 913	1252-000-017	1SS133 , SW	
D 915	1252-000-017	1SS133 , SW	
D 917	1252-000-017	1SS133 , SW	
D 918	1252-000-017	1SS133 , SW	
D 919	1252-000-017	1SS133 , SW	
D 920	1252-000-017	1SS133 , SW	
D 940	1252-000-017	1SS133 , SW	
D 964	1252-000-017	1SS133 , SW	
D 985	1252-000-017	1SS133 , SW	
OPT2	1252-000-017	1SS133 , SW	<b>IB/AB</b>
OPT5	1252-000-017	1SS133 , SW	<b>IB/AB</b>
LED 902	1271-000-037	LED SLR-342VR3	

Stand-By P.C.Board

**RESISTORS(CARBON)**

R 976	1742-100-721	1/8W	10W-J
R 977	1742-100-721	1/8W	10W-J
R 902	1742-102-721	1/8W	1KW-J
R 961	1742-102-721	1/8W	1KW-J
R 999	1742-102-721	1/8W	1KW-J
R 906	1742-103-721	1/8W	10KW-J
R 907	1742-103-721	1/8W	10KW-J
R 908	1742-103-721	1/8W	10KW-J
R 909	1742-103-721	1/8W	10KW-J
R 925	1742-103-721	1/8W	10KW-J
R 910	1742-104-721	1/8W	100KW-J
R 911	1742-104-721	1/8W	100KW-J
R 905	1742-105-721	1/8W	1MW-J
R 937	1742-154-721	1/8W	150KW-J
R 953	1742-182-721	1/8W	1.8KW-J
R 954	1742-182-721	1/8W	1.8KW-J
R 955	1742-392-721	1/8W	3.9KW-J
R 927	1742-183-721	1/8W	18KW-J
R 931	1742-221-721	1/8W	220W-J
R 932	1742-221-721	1/8W	220W-J
R 904	1742-222-721	1/8W	2.2KW-J
R 912	1742-224-721	1/8W	220KW-J
R 913	1742-224-721	1/8W	220KW-J
R 921	1742-224-721	1/8W	220KW-J
R 922	1742-224-721	1/8W	220KW-J
R 933	1742-224-721	1/8W	220KW-J
R 934	1742-224-721	1/8W	220KW-J
R 919	1742-331-721	1/8W	330W-J
R 920	1742-331-721	1/8W	330W-J
R 955	1742-392-721	1/8W	3.9KW-J

REF NO.	PART NO	DESCRIPTION	
R 956	1742-392-721	1/8W	3.9KW-J
R 901	1742-471-721	1/8W	470W-J
R 914	1742-473-721	1/8W	47KW-J
R 915	1742-473-721	1/8W	47KW-J
R 916	1742-473-721	1/8W	47KW-J
R 917	1742-473-721	1/8W	47KW-J
R 918	1742-473-721	1/8W	47KW-J
R 972	1742-473-721	1/8W	47KW-J
R 978	1742-473-721	1/8W	47KW-J
R 979	1742-473-721	1/8W	47KW-J
R 924	1742-473-721	1/8W	47KW-J
R 959	1742-473-721	1/8W	47KW-J
R 969	1742-473-721	1/8W	47KW-J
R 970	1742-473-721	1/8W	47KW-J
R 923	1742-750-721	1/8W	75W-J
R 943	1742-753-721	1/8W	75KW-J
R 944	1742-753-721	1/8W	75KW-J
R 939	1742-752-721	1/8W	7.5KW-J
R 940	1742-752-721	1/8W	7.5KW-J
R 951	1742-561-721	1/8W	560W-J
R 952	1742-561-721	1/8W	560W-J
R 936	1742-154-721	1/8W	150KW-J
R 945	1742-394-721	1/8W	390KW-J
R 946	1742-394-721	1/8W	390KW-J
R 982	1742-393-721	1/8W	39KW-J
R 983	1742-393-721	1/8W	39KW-J
R 941	1742-272-721	1/8W	2.7KW-J
R 942	1742-272-721	1/8W	2.7KW-J
R 962	1744-331-731	1/4W	330W-J
R 980	1744-4R7-731	1/4W	4.7W-J
R 981	1744-4R7-731	1/4W	4.7W-J

**CAPACITORS**

C 979	1822-104-822	CERA/RA	50V	0.1uF-K
C 980	1822-104-822	CERA/RA	50V	0.1uF-K
C 901	1832-220-772	CERA/AX	50V	22PF-J
C 902	1832-220-772	CERA/AX	50V	22PF-J
C 910	1832-102-772	CERA/AX	50V	0.001uF-J
C 911	1832-102-772	CERA/AX	50V	0.001uF-J
C 912	1832-102-772	CERA/AX	50V	0.001uF-J
C 913	1832-102-772	CERA/AX	50V	0.001uF-J
C 954	1832-101-712	CERA/AX	50V	100PF-J
C 903	1832-104-002	CERA/AX	50V	0.1uF-Z
C 905	1832-104-002	CERA/AX	50V	0.1uF-Z
C 907	1832-104-002	CERA/AX	50V	0.1uF-Z
C 909	1832-104-002	CERA/AX	50V	0.1uF-Z
C 914	1832-104-002	CERA/AX	50V	0.1uF-Z
C 915	1832-104-002	CERA/AX	50V	0.1uF-Z
C 918	1832-104-002	CERA/AX	50V	0.1uF-Z
C 922	1832-104-002	CERA/AX	50V	0.1uF-Z
C 919	1832-121-712	CERA/AX	50V	20pF-J
C 920	1832-121-712	CERA/AX	50V	20pF-J
C 908	1832-471-712	CERA/AX	50V	470pF-J
C 945	1832-221-822	CERA/AX	50V	220pF-J
C 946	1832-221-822	CERA/AX	50V	220pF-J
C 933	1832-151-772	CERA/AX	50V	150PF-J
C 934	1832-151-772	CERA/AX	50V	150PF-J
C 904	1862-220-604	ELECT	25V	22uF-M
C 917	1862-221-506	ELECT	16V	220uF-M
C 977	1862-470-814	ELECT	50V	47uF-M
C 931	1862-4R7-804	ELECT	50V	4.7uF-M
C 932	1862-4R7-804	ELECT	50V	4.7uF-M
C 941	1862-4R7-804	ELECT	50V	4.7uF-M
C 942	1862-4R7-804	ELECT	50V	4.7uF-M
C 951	1862-4R7-804	ELECT	50V	4.7uF-M
C 952	1862-4R7-804	ELECT	50V	4.7uF-M
C 953	1862-4R7-804	ELECT	50V	4.7uF-M
C 955	1864-010-804	ELECT	50V	1.0uF-M
C 956	1864-010-804	ELECT	50V	1.0uF-M



REF NO.	PART NO	DESCRIPTION
C 961	1862-220-804	ELECT 50V 22uF-M
C 962	1862-220-804	ELECT 50V 22uF-M
C 939	1879-823-712	FILM 100V 0.082uF-J
C 940	1879-823-712	FILM 100V 0.082uF-J
C 937	1879-333-712	FILM 100V 0.033uF-J
C 938	1879-333-712	FILM 100V 0.033uF-J
C 947	1879-393-712	FILM 100V 0.039uF-J
C 948	1879-393-712	FILM 100V 0.039uF-J
C 943	1879-822-761	FILM 400V 0.0082uF-J
C 944	1879-822-761	FILM 400V 0.0082uF-J
C 906	1881-10A-001	SCAP 5.5V 0.1F
C 968	1825-000-010	AC 250V 0.0047uF-M
C 969	1832-104-002	CERA/AX 0.1F-Z
C 970	1832-104-002	CERA/AX 0.1F-Z

**WAFERS**

WA 903	2111-023-002	2P 5267-02A
WA 904	2111-023-002	2P 5267-02A
CN 924	2113-022-007	22P FFC
CN 923	2113-030-007	30P FFC

**WIRES**

TO DSP	2133-220-002	FFC;22P;320
TO MAIN	2133-300-002	FFC;30P;280
T911<->T912	2141-010-051	1P,1007#24,100m/m
T 901	2141-020-114	1P,1007#22,150m/m
T 902	2141-020-114	1P,1007#22,150m/m
T 903	2141-020-114	1P,1007#22,150m/m
T 904	2141-020-114	1P,1007#22,150m/m
CN 904	2141-020-600	2P,1007#26,100m/m
CN 908	2141-040-011	4P,1533#26,350m/m
CN 911	2141-060-013	6P,1533#26,300m/m
CN 986	2141-070-016	7P,1007#24,430m/m
CN 907	2141-080-117	8P,500m/m

**MISCELLANEOUS**

	5226-003-010	CASE,SHIELD(F)
	5451-003-020	CUSHION-FLT
RMT 901	1264-000-020	SENSOR-REMOTE LTM9433D
FLT 901	1277-000-012	VFD CM1684CB
X 901	1352-000-003	X-TAL;ATS-49/U,9.8304MHz
JP 901	1514-030-003	JACK-PIN 3P(Video3)
JP 961	1515-000-010	JACK-H/P
VR 901	1640-111-001	VR-ENCODER
SW 901	1671-000-020	SW-TACT SKHV10910A,2P
SW 902	1671-000-020	SW-TACT SKHV10910A,2P
SW 903	1671-000-020	SW-TACT SKHV10910A,2P
SW 904	1671-000-020	SW-TACT SKHV10910A,2P
SW 905	1671-000-020	SW-TACT SKHV10910A,2P
SW 906	1671-000-020	SW-TACT SKHV10910A,2P
SW 907	1671-000-020	SW-TACT SKHV10910A,2P
SW 908	1671-000-020	SW-TACT SKHV10910A,2P
SW 909	1671-000-020	SW-TACT SKHV10910A,2P
SW 910	1671-000-020	SW-TACT SKHV10910A,2P
SW 911	1671-000-020	SW-TACT SKHV10910A,2P
SW 912	1671-000-020	SW-TACT SKHV10910A,2P
SW 913	1671-000-020	SW-TACT SKHV10910A,2P
SW 914	1671-000-020	SW-TACT SKHV10910A,2P
SW 915	1671-000-020	SW-TACT SKHV10910A,2P
SW 916	1671-000-020	SW-TACT SKHV10910A,2P
SW 917	1671-000-020	SW-TACT SKHV10910A,2P
SW 918	1671-000-020	SW-TACT SKHV10910A,2P
SW 919	1671-000-020	SW-TACT SKHV10910A,2P
SW 920	1671-000-020	SW-TACT SKHV10910A,2P
SW 921	1671-000-020	SW-TACT SKHV10910A,2P
SW 922	1671-000-020	SW-TACT SKHV10910A,2P
SW 923	1671-000-020	SW-TACT SKHV10910A,2P
SW 924	1671-000-020	SW-TACT SKHV10910A,2P
SW 925	1671-000-020	SW-TACT SKHV10910A,2P

REF NO.	PART NO	DESCRIPTION
SW 926	1671-000-020	SW-TACT SKHV10910A,2P
SW 927	1671-000-020	SW-TACT SKHV10910A,2P
SW 928	1671-000-020	SW-TACT SKHV10910A,2P
SW 929	1671-000-020	SW-TACT SKHV10910A,2P
SW 930	1671-000-020	SW-TACT SKHV10910A,2P
SW 933	1671-000-020	SW-TACT SKHV10910A,2P
VR 902	1721-503-212	VR-ROTARY 100KC
VR 903	1721-503-212	VR-ROTARY 100KC
VR 904	1721-503-213	VR-ROTARY 100KMN

**0112-011-1533 POWER P.C.BOARD**

SW932	1671-000-017	SW-POWER SY-16-32-2
C968	1825-000-010	AC AC250V 0.0047uF-M
CN983	2111-026-002	2P 35328-0210
CN983→S	2141-010-167	2P,1672#18,500m/m

**0112-011-1534 STAND-BY P.C.BOARD**

CN987	2141-030-003	3P,1007\$24
LED901	1271-000-061	LED SLR-54MWW
SW931	1671-000-020	SW-TACT SKHV10910A,2P
CN903	2141-020-118	2P,1007#26,100m/m

**0112-011-153 HEAD PHONE P.C.BOARD**

CN901	2141-050-015	5P,1007#26/2547,600n/n
C969	1832-104-002	CERA/AX 50V 0.1uF-Z
C970	1832-104-002	CERA/AX 50V 0.1uF-Z
C982	1832-152-983	CERA/AX 50V 0.0015uF-M <b>IB/AB</b>
C983	1832-152-983	CERA/AX 50V 0.0015uF-M <b>IB/AB</b>
C982	1832-152-983	CERA/AX 50V 0.0015uF-M <b>IB/AB</b>
C983	1832-152-983	CERA/AX 50V 0.0015uF-M <b>IB/AB</b>

**0112-011-154 DSP1 P.C.BOARD**

**INTEGRATED CIRCUITS**

IC 712	1212-004-001	IC 74VHC04F HEX INVERTER
IC 718	1212-033-001	IC 3.3V REGULATOR
IC 717	1212-074-001	IC TC74VHC74F D-FLIP FLOP
IC 719	1212-132-001	IC TC74VHC132F NAND GATE
IC 711	1212-244-001	IC 74VHC244F BUFFER
IC 714	1212-244-001	IC 74VHC244F BUFFER
IC 709	1212-422-001	IC CS4226,5.5V CODEC
IC 710	1212-492-002	IC CS4926,3.3V DSP
IC 713	1212-534-006	IC MSM534031E,3.3V ROM
IC 715	1212-574-001	IC 74VHC574F D-FILP FLOP
IC 716	1212-574-001	IC 74VHC574F D-FILP FLOP
IC 701	1215-072-001	IC NJM072M OP AMP
IC 705	1215-072-001	IC NJM072M OP AMP
IC 706	1215-072-001	IC NJM072M OP AMP
IC 707	1215-072-001	IC NJM072M OP AMP
IC 702	1215-455-001	IC NJM4558M OP AMP
IC 703	1215-455-001	IC NJM4558M OP AMP
IC 704	1215-455-001	IC NJM4558M OP AMP
IC 708	1215-455-001	IC NJM4558M OP AMP

**TRANSISTORS**

Q 703	1243-101-018	KRC101M	NPN
Q 716	1243-101-018	KRC101M	NPN
Q 704	1244-102-003	KRA102M	NPN
Q 701	1244-126-004	KTA1266-GR	NPN
Q 702	1244-126-004	KTA1266-GR	NPN
Q 705	1244-126-004	KTA1266-GR	NPN
Q 707	1243-130-003	KTD1302	NPN
Q 708	1243-130-003	KTD1302	NPN
Q 709	1243-130-003	KTD1302	NPN
Q 710	1243-130-003	KTD1302	NPN
Q 712	1243-130-003	KTD1302	NPN
Q 713	1243-130-003	KTD1302	NPN
Q 714	1243-130-003	KTD1302	NPN

REF NO.	PART NO	DESCRIPTION	
Q 715	1243-130-003	KTD1302	NPN
<b>DIODE</b>			
D 01	1252-000-017	1SS133 , SW.	
<b>RESISTORS(CARBON)</b>			
R 71	1742-100-721	1/8W	10W-J
R 72	1742-100-721	1/8W	10W-J
R 73	1742-100-721	1/8W	10W-J
R 74	1742-100-721	1/8W	10W-J
R 75	1742-100-721	1/8W	10W-J
R 76	1742-100-721	1/8W	10W-J
R 01	1742-101-721	1/8W	100W-J
R 03	1742-101-721	1/8W	100W-J
R 06	1742-101-721	1/8W	100W-J
R 54	1742-102-721	1/8W	1KW-J
R 55	1742-102-721	1/8W	1KW-J
R 56	1742-102-721	1/8W	1KW-J
R 15	1742-103-721	1/8W	10KW-J
R 16	1742-103-721	1/8W	10KW-J
R 17	1742-103-721	1/8W	10KW-J
R 20	1742-103-721	1/8W	10KW-J
R 21	1742-103-721	1/8W	10KW-J
R 22	1742-103-721	1/8W	10KW-J
R 23	1742-103-721	1/8W	10KW-J
R 24	1742-103-721	1/8W	10KW-J
R 25	1742-103-721	1/8W	10KW-J
R 26	1742-103-721	1/8W	10KW-J
R 28	1742-103-721	1/8W	10KW-J
R 30	1742-103-721	1/8W	10KW-J
R 31	1742-103-721	1/8W	10KW-J
R 33	1742-103-721	1/8W	10KW-J
R 37	1742-103-721	1/8W	10KW-J
R 40	1742-103-721	1/8W	10KW-J
R 41	1742-103-721	1/8W	10KW-J
R 52	1742-103-721	1/8W	10KW-J
R 58	1742-103-721	1/8W	10KW-J
R 53	1742-220-721	1/8W	22W-J
R 60	1742-220-721	1/8W	22W-J
R 05	1742-222-721	1/8W	2.2KW-J
R 10	1742-222-721	1/8W	2.2KW-J
R 13	1742-222-721	1/8W	2.2KW-J
R 50	1742-222-721	1/8W	2.2KW-J
R 51	1742-222-721	1/8W	2.2KW-J
R 57	1742-222-721	1/8W	2.2KW-J
R 59	1742-271-721	1/8W	270W-J
R 08	1742-330-721	1/8W	33W-J
R 09	1742-330-721	1/8W	33W-J
R 27	1742-330-721	1/8W	33W-J
R 49	1742-433-721	1/8W	43KW-J
R 38	1742-470-721	1/8W	47W-J
R 39	1742-470-721	1/8W	47W-J
R 11	1742-472-721	1/8W	4.7KW-J
R 12	1742-472-721	1/8W	4.7KW-J
R 14	1742-472-721	1/8W	4.7KW-J
R 29	1742-472-721	1/8W	4.7KW-J
R 32	1742-472-721	1/8W	4.7KW-J
R 797	1742-472-721	1/8W	4.7KW-J
R 04	1742-473-721	1/8W	47KW-J
R 02	1742-750-721	1/8W	75W-J
R 07	1744-4R7-731	1/4W	4.7W-J
<b>RESISTORS(CHIP)</b>			
R 707	1746-101-771	1/10	100W-J
R 708	1746-101-771	1/10	100W-J
R 717	1746-101-771	1/10	100W-J
R 718	1746-101-771	1/10	100W-J
R 719	1746-101-771	1/10	100W-J
R 720	1746-101-771	1/10	100W-J

REF NO.	PART NO	DESCRIPTION	
R 729	1746-101-771	1/10	100W-J
R 730	1746-101-771	1/10	100W-J
R 731	1746-101-771	1/10	100W-J
R 732	1746-101-771	1/10	100W-J
R 741	1746-101-771	1/10	100W-J
R 742	1746-101-771	1/10	100W-J
R 705	1746-101-771	1/10	100W-J
R 706	1746-101-771	1/10	100W-J
R 703	1746-103-771	1/10	10KW-J
R 704	1746-103-771	1/10	10KW-J
R 81	1746-102-771	1/10	1KW-J
R 82	1746-102-771	1/10	1KW-J
R 83	1746-104-771	1/10	100KW-J
R 84	1746-104-771	1/10	100KW-J
R 743	1746-104-771	1/10	100KW-J
R 744	1746-104-771	1/10	100KW-J
R 757	1746-104-771	1/10	100KW-J
R 758	1746-104-771	1/10	100KW-J
R 771	1746-104-771	1/10	100KW-J
R 772	1746-104-771	1/10	100KW-J
R 77	1746-222-771	1/10	2.2KW-J
R 78	1746-222-771	1/10	2.2KW-J
R 79	1746-222-771	1/10	2.2KW-J
R 80	1746-222-771	1/10	2.2KW-J
R 92	1746-222-771	1/10	2.2KW-J
R 93	1746-222-771	1/10	2.2KW-J
R 94	1746-222-771	1/10	2.2KW-J
R 95	1746-222-771	1/10	2.2KW-J
R 755	1746-123-771	1/10	12KW-J
R 756	1746-123-771	1/10	12KW-J
R 770	1746-123-771	1/10	12KW-J
R 783	1746-123-771	1/10	12KW-J
R 784	1746-123-771	1/10	12KW-J
R 748	1746-152-771	1/10	1.5KW-J
R 750	1746-152-771	1/10	1.5KW-J
R 747	1746-152-771	1/10	1.5KW-J
R 749	1746-152-771	1/10	1.5KW-J
R 762	1746-152-771	1/10	1.5KW-J
R 764	1746-152-771	1/10	1.5KW-J
R 761	1746-152-771	1/10	1.5KW-J
R 763	1746-152-771	1/10	1.5KW-J
R 776	1746-152-771	1/10	1.5KW-J
R 778	1746-152-771	1/10	1.5KW-J
R 775	1746-152-771	1/10	1.5KW-J
R 777	1746-152-771	1/10	1.5KW-J
R 714	1746-183-771	1/10	18KW-J
R 701	1746-203-771	1/10	20KW-J
R 702	1746-203-771	1/10	20KW-J
R 709	1746-224-771	1/10	220KW-J
R 710	1746-224-771	1/10	220KW-J
R 715	1746-224-771	1/10	220KW-J
R 716	1746-224-771	1/10	220KW-J
R 721	1746-224-771	1/10	220KW-J
R 722	1746-224-771	1/10	220KW-J
R 727	1746-224-771	1/10	220KW-J
R 728	1746-224-771	1/10	220KW-J
R733	1746-224-771	1/10	220KW-J
R734	1746-224-771	1/10	220KW-J
R 739	1746-224-771	1/10	220KW-J
R 740	1746-224-771	1/10	220KW-J
R 753	1746-272-771	1/10	2.7KW-J
R 754	1746-272-771	1/10	2.7KW-J
R 767	1746-272-771	1/10	2.7KW-J
R 768	1746-272-771	1/10	2.7KW-J
R 781	1746-272-771	1/10	2.7KW-J
R 782	1746-272-771	1/10	2.7KW-J
R 745	1746-302-771	1/10	3KW-J
R 746	1746-302-771	1/10	3KW-J
R 759	1746-302-771	1/10	3KW-J

REF NO.	PART NO	DESCRIPTION	REF NO.	PART NO	DESCRIPTION
R 760	1746-302-771	1/10 3KW-J	C 727	1846-222-882	CERA 50V 0.0022uF-K
R 773	1746-302-771	1/10 3KW-J	C 728	1846-222-882	CERA 50V 0.0022uF-K
R 774	1746-302-771	1/10 3KW-J	C 731	1846-222-882	CERA 50V 0.0022uF-K
R 711	1746-473-771	1/10 47KW-J	C 732	1846-222-882	CERA 50V 0.0022uF-K
R 712	1746-473-771	1/10 47KW-J	C 743	1846-222-882	CERA 50V 0.0022uF-K
R 713	1746-473-771	1/10 47KW-J	C 744	1846-222-882	CERA 50V 0.0022uF-K
R 723	1746-473-771	1/10 47KW-J	C 747	1846-222-882	CERA 50V 0.0022uF-K
R 724	1746-473-771	1/10 47KW-J	C 748	1846-222-882	CERA 50V 0.0022uF-K
R 725	1746-473-771	1/10 47KW-J	C 759	1846-222-882	CERA 50V 0.0022uF-K
R 726	1746-473-771	1/10 47KW-J	C 760	1846-222-882	CERA 50V 0.0022uF-K
R 735	1746-473-771	1/10 47KW-J	C 763	1846-222-882	CERA 50V 0.0022uF-K
R 736	1746-473-771	1/10 47KW-J	C 764	1846-222-882	CERA 50V 0.0022uF-K
R 737	1746-473-771	1/10 47KW-J	C 81	1846-470-712	CERA 50V 47pF-J
R 738	1746-473-771	1/10 47KW-J	C 82	1846-470-712	CERA 50V 47pF-J
R 87	1746-683-771	1/10 68KW-J	C 729	1846-472-882	CERA 50V 0.0047uF-K
R 88	1746-683-771	1/10 68KW-J	C 730	1846-472-882	CERA 50V 0.0047uF-K
R 751	1746-821-771	1/10 820W-J	C 745	1846-472-882	CERA 50V 0.0047uF-K
R 752	1746-821-771	1/10 820W-J	C 746	1846-472-882	CERA 50V 0.0047uF-K
R 765	1746-821-771	1/10 820W-J	C 761	1846-472-882	CERA 50V 0.0047uF-K
R 766	1746-821-771	1/10 820W-J	C 762	1846-472-882	CERA 50V 0.0047uF-K
R 779	1746-821-771	1/10 820W-J	C 733	1846-682-882	CERA 50V 0.0068uF-K
R 780	1746-821-771	1/10 820W-J	C 734	1846-682-882	CERA 50V 0.0068uF-K
R 89	1746-2R2-771	1/10 2.2W-J	C 749	1846-682-882	CERA 50V 0.0068uF-K
R 90	1746-2R2-771	1/10 2.2W-J	C 750	1846-682-882	CERA 50V 0.0068uF-K
R 85	1746-393-771	1/10 39KW-J	C 765	1846-682-882	CERA 50V 0.0068uF-K
R 86	1746-393-771	1/10 39KW-J	C 766	1846-682-882	CERA 50V 0.0068uF-K
R 787	1746-102-771	1/10 1KW-J	C 5	1862-010-804	ELECT 50V 1.0uF-M
R 788	1746-102-771	1/10 1KW-J	C 8	1862-010-804	ELECT 50V 1.0uF-M
<b>CAPACITORS</b>					
C 44	1822-101-772	CERA/RA 50V 100pF-J	C 9	1862-010-804	ELECT 50V 1.0uF-M
C 45	1822-101-772	CERA/RA 50V 100pF-J	C 19	1862-010-804	ELECT 50V 1.0uF-M
C 01	1822-102-882	CERA/RA 50V 0.001uF-K	C 23	1862-010-804	ELECT 50V 1.0uF-M
C 04	1822-102-882	CERA/RA 50V 0.001uF-K	C 25	1862-010-804	ELECT 50V 1.0uF-M
C 2	1822-104-822	CERA/RA 50V 0.1uF-K	C 28	1862-010-804	ELECT 50V 1.0uF-M
C 3	1822-104-822	CERA/RA 50V 0.1uF-K	C 29	1862-010-804	ELECT 50V 1.0uF-M
C 6	1822-104-822	CERA/RA 50V 0.1uF-K	C 31	1862-010-804	ELECT 50V 1.0uF-M
C 7	1822-104-822	CERA/RA 50V 0.1uF-K	C 33	1862-010-804	ELECT 50V 1.0uF-M
C 10	1822-104-822	CERA/RA 50V 0.1uF-K	C 36	1862-010-804	ELECT 50V 1.0uF-M
C 11	1822-104-822	CERA/RA 50V 0.1uF-K	C 39	1862-010-804	ELECT 50V 1.0uF-M
C 15	1822-104-822	CERA/RA 50V 0.1uF-K	C 42	1862-010-804	ELECT 50V 1.0uF-M
C 18	1822-104-822	CERA/RA 50V 0.1uF-K	C 46	1862-010-804	ELECT 50V 1.0uF-M
C 20	1822-104-822	CERA/RA 50V 0.1uF-K	C 47	1862-010-804	ELECT 50V 1.0uF-M
C 22	1822-104-822	CERA/RA 50V 0.1uF-K	C 51	1862-100-804	ELECT 50V 10uF-M
C 24	1822-104-822	CERA/RA 50V 0.1uF-K	C 83	1862-100-804	ELECT 50V 10uF-M
C 26	1822-104-822	CERA/RA 50V 0.1uF-K	C 84	1862-100-804	ELECT 50V 10uF-M
C 27	1822-104-822	CERA/RA 50V 0.1uF-K	C 725	1862-100-804	ELECT 50V 10uF-M
C 30	1822-104-822	CERA/RA 50V 0.1uF-K	C 726	1862-100-804	ELECT 50V 10uF-M
C 32	1822-104-822	CERA/RA 50V 0.1uF-K	C 741	1862-100-804	ELECT 50V 10uF-M
C 34	1822-104-822	CERA/RA 50V 0.1uF-K	C 742	1862-100-804	ELECT 50V 10uF-M
C 37	1822-104-822	CERA/RA 50V 0.1uF-K	C 757	1862-100-804	ELECT 50V 10uF-M
C 38	1822-104-822	CERA/RA 50V 0.1uF-K	C 758	1862-100-804	ELECT 50V 10uF-M
C 40	1822-104-822	CERA/RA 50V 0.1uF-K	C 12	1861-102-218	ELECT 6.3V 1000uF-M
C 43	1822-104-822	CERA/RA 50V 0.1uF-K	C 13	1862-470-604	ELECT 25V 47uF-M
C 48	1822-104-822	CERA/RA 50V 0.1uF-K	C 14	1862-470-604	ELECT 25V 47uF-M
C 52	1822-104-822	CERA/RA 50V 0.1uF-K	C 16	1862-470-604	ELECT 25V 47uF-M
C 53	1822-104-822	CERA/RA 50V 0.1uF-K	C 17	1862-470-604	ELECT 25V 47uF-M
C 791	1822-104-822	CERA/RA 50V 0.1uF-K	C 71	1862-470-503	ELECT 16V 47uF-M
C 792	1822-104-822	CERA/RA 50V 0.1uF-K	C 72	1862-470-503	ELECT 16V 47uF-M
C 49	1822-152-882	CERA/RA 50V 0.0015uF-K	C 75	1862-470-503	ELECT 16V 47uF-M
<b>CAPACITORS(CHIP)</b>					
C 703	1846-101-712	CERA 50V 100pF-J	C 76	1862-470-503	ELECT 16V 47uF-M
C 704	1846-101-712	CERA 50V 100pF-J	C 73	1862-470-604	ELECT 25V 47uF-M
C 735	1846-101-712	CERA 50V 100pF-J	C 74	1862-470-604	ELECT 25V 47uF-M
C 736	1846-101-712	CERA 50V 100pF-J	C 701	1862-4R7-800	ELECT 50V 4.7uF-M
C 752	1846-101-712	CERA 50V 100pF-J	C 702	1862-4R7-800	ELECT 50V 4.7uF-M
C 767	1846-101-712	CERA 50V 100pF-J	C 705	1862-100-800	ELECT 50V 10uF-M
C 768	1846-101-712	CERA 50V 100pF-J	C 706	1862-100-800	ELECT 50V 10uF-M
			C 707	1862-4R7-804	ELECT 50V 4.7uF-M
			C 708	1862-4R7-804	ELECT 50V 4.7uF-M
			C 711	1862-4R7-804	ELECT 50V 4.7uF-M
			C 712	1862-4R7-804	ELECT 50V 4.7uF-M

REF NO.	PART NO	DESCRIPTION		
C 713	1862-4R7-804	ELECT	50V	4.7uF-M
C 714	1862-4R7-804	ELECT	50V	4.7uF-M
C 717	1862-4R7-804	ELECT	50V	4.7uF-M
C 718	1862-4R7-804	ELECT	50V	4.7uF-M
C 719	1862-4R7-804	ELECT	50V	4.7uF-M
C 720	1862-4R7-804	ELECT	50V	4.7uF-M
C 723	1862-4R7-804	ELECT	50V	4.7uF-M
C 724	1862-4R7-804	ELECT	50V	4.7uF-M
C 50	1876-153-811	MYLAR		0.015uF-K
C 35	1879-224-750	FILM	63V	0.22uF-J

**0112-011-154 DSP2 P.C.BOARD**

**INTEGRATED CIRCUITS**

IC 723	1215-455-001	IC	NJM4558M	OP AMP
IC 724	1215-455-001	IC	NJM4558M	OP AMP
IC 725	1215-455-001	IC	NJM4558M	OP AMP
IC 726	1215-455-001	IC	NJM4558M	OP AMP

**TRANSISTOR**

QD 2	1243-103-004	KRC103M	NPN
------	--------------	---------	-----

**DIODE**

DD1	1252-000-017	1SS133, SW.
-----	--------------	-------------

**RESISTORS**

RD43	1744-561-731	1/4W	560W-J
------	--------------	------	--------

**RESISTORS(CHIP)**

RD 1	1746-101-771	1/10W	100W-J
RD 2	1746-101-771	1/10W	100W-J
RD 13	1746-101-771	1/10W	100W-J
RD 13	1746-101-771	1/10W	100W-J
RD 14	1746-101-771	1/10W	100W-J
RD 23	1746-101-771	1/10W	100W-J
RD 24	1746-101-771	1/10W	100W-J
RD 25	1746-101-771	1/10W	100W-J
RD 26	1746-101-771	1/10W	100W-J
RD 35	1746-101-771	1/10W	100W-J
RD 36	1746-101-771	1/10W	100W-J
R 787	1746-102-771	1/10W	1KW-J
R 788	1746-102-771	1/10W	1KW-J
R 791	1746-102-771	1/10W	1KW-J
R 792	1746-102-771	1/10W	1KW-J
R 795	1746-102-771	1/10W	1KW-J
R 796	1746-102-771	1/10W	1KW-J
RD 19	1746-103-771	1/10W	10KW-J
RD17	1746-104-771	1/10W	100KW-J
R 785	1746-104-771	1/10W	100KW-J
R 786	1746-104-771	1/10W	100KW-J
R 789	1746-104-771	1/10W	100KW-J
R 790	1746-104-771	1/10W	100KW-J
R 793	1746-104-771	1/10W	100KW-J
R 794	1746-104-771	1/10W	100KW-J
RD 7	1746-123-771	1/10W	12KW-J
RD 8	1746-123-771	1/10W	12KW-J
RD 11	1746-123-771	1/10W	12KW-J
RD 12	1746-123-771	1/10W	12KW-J
RD 20	1746-123-771	1/10W	12KW-J
RD 31	1746-123-771	1/10W	12KW-J
RD 32	1746-123-771	1/10W	12KW-J
RD 37	1746-123-771	1/10W	12KW-J
RD 38	1746-123-771	1/10W	12KW-J
RD 41	1746-123-771	1/10W	12KW-J
RD 42	1746-123-771	1/10W	12KW-J
RD 3	1746-224-771	1/10W	220KW-J
RD 4	1746-224-771	1/10W	220KW-J
RD 9	1746-224-771	1/10W	220KW-J

REF NO.	PART NO	DESCRIPTION	
RD 10	1746-224-771	1/10W	220KW-J
RD 15	1746-224-771	1/10W	220KW-J
RD 16	1746-224-771	1/10W	220KW-J
RD 21	1746-224-771	1/10W	220KW-J
RD 22	1746-224-771	1/10W	220KW-J
RD 27	1746-224-771	1/10W	220KW-J
RD 28	1746-224-771	1/10W	220KW-J
RD 33	1746-224-771	1/10W	220KW-J
RD 34	1746-224-771	1/10W	220KW-J

**WAFERS**

WA 716	2111-010-006	6P	53014-0610
WA 701	2111-023-005	5P	5267-05A
WA 702	2113-022-007	22P	FFC
HU 706	2114-002-113	2P	JE113-D3T-02
HU 707	2114-002-113	2P	JE113-D3T-02
WA 704	2114-012-114	12P	JE114-D1T-12
WA 705	2114-014-114	14P	JE114-D1T-14
HU 721	2121-605-010	10P	JE-605-10
HU 719	2121-605-011	11P	JE-605-11
HU 720	2121-605-011	11P	JE-605-11

**WIRES**

H10 <-->H11	2141-010-052	1P;1007#24220m/m
CN753	2141-020-031	2P;1533#26,180m/m
R48<-->TUNER C3199BASE	2141-020-120	1P+2P;1533#26,180m/m
CN 701	2141-030-031	3P;2547#26,200m/m

**MISCELLANEOUS**

	5226-003-030	CASE-SHIELD(D)
IC 720	1261-171-000	TR-PHOTO;PC-17T1
IC 721	1261-171-000	TR-PHOTO;PC-17T1
X 701	1353-049-152	X-TAL;49.152MHz,SUNNY
L 707	1444-470-009	COIL ,AL02-470K,47uH(A)
JA 701	1514-001-001	JACK-RCA 1P
JA 703	1514-060-001	PIN JACK;6P;PW-4105R
JA 702	1516-000-001	OPTICAL JACK; TORX178A
JA 705	1519-650-201	REMOTE JACK;2P
L 701	1784-000-006	BEAD;6mm,AXIAL
L 702	1784-000-006	BEAD;6mm,AXIAL
L 704	1784-000-006	BEAD;6mm,AXIAL
L 705	1784-000-006	BEAD;6mm,AXIAL
L 706	1784-000-006	BEAD;6mm,AXIAL
L 709	1784-000-006	BEAD;6mm,AXIAL
L 711	1784-000-006	BEAD;6mm,AXIAL
L 710	1742-000-0003	WIRE P=10mm, SND=0.6mm
JA 706	1514-010-002	MULTI-ROOM JACK ;1P
JA 704	1514-020-004	PIN JACK;2P;JK0200440N
HU 709	2114-604-004	WAFER; 4P;PLUG

**CAPACITORS**

C 755	1846-334-883	CERA(CHIP) 50V	0.33uF-K
C 739	1846-682-882	CERA(CHIP) 50V	0.0068uF-K
C 740	1846-682-882	CERA(CHIP) 50V	0.0068uF-K
C 756	1846-682-882	CERA(CHIP) 50V	0.0068uF-K
C 771	1846-682-882	CERA(CHIP) 50V	0.0068uF-K
C 772	1846-682-882	CERA(CHIP) 50V	0.0068uF-K
CD 15	1862-010-804	ELECT 50V	1.0uF-M
CD 9	1862-100-504	ELECT 16V	10uF-M
CD 19	1862-100-504	ELECT 16V	10uF-M
C 737	1862-100-804	ELECT 50V	10uF-M
C 738	1862-100-804	ELECT 50V	10uF-M
C 753	1862-100-804	ELECT 50V	10uF-M
C 754	1862-100-804	ELECT 50V	10uF-M
C 769	1862-100-804	ELECT 50V	10uF-M
C 770	1862-100-804	ELECT 50V	10uF-M
CD 1	1862-4R7-804	ELECT 50V	4.7uF-M
CD 2	1862-4R7-804	ELECT 50V	4.7uF-M
CD 5	1862-4R7-804	ELECT 50V	4.7uF-M

REF NO.	PART NO	DESCRIPTION		
CD 6	1862-4R7-804	ELECT	50V	4.7uF-M
CD 7	1862-4R7-804	ELECT	50V	4.7uF-M
CD 8	1862-4R7-804	ELECT	50V	4.7uF-M
CD 11	1862-4R7-804	ELECT	50V	4.7uF-M
CD 12	1862-4R7-804	ELECT	50V	4.7uF-M
CD 13	1862-4R7-804	ELECT	50V	4.7uF-M
CD 14	1862-4R7-804	ELECT	50V	4.7uF-M
CD 17	1862-4R7-804	ELECT	50V	4.7uF-M
CD 18	1862-4R7-804	ELECT	50V	4.7uF-M
CD 3	1862-4R7-804	ELECT	50V	4.7uF-M
CD 4	1862-4R7-804	ELECT	50V	4.7uF-M
CD 10	1862-4R7-804	ELECT	50V	4.7uF-M

**WAFERS**

HU 704	2121-012-602	12P	JE602-A1G-12
HU 705	2121-014-602	14P	JE602-A1G-14

**MISCELLANEOUS**

R47<----->H13	2141-010-024	WIRE;1P;1007#24,150m/m
RL1	2022-000-012	RELAY;CP-12

**0112-011-151 C-VIDEO P.C.BOARD**

**INTEGRATED CIRCUITS**

IC 351	1212-795-001	IC,LA7951	VIDEO SW,6dB
IC 355	1212-106-001	IC;MM1067XD,SYNC SEPARATE SYNC	
IC 353	1215-762-001	IC;BA7622/F,75ohm DRIVER	
IC 354	1215-900-001	IC;MB90089,OSD,FUJITSU	
IC 352	1211-226-001	IC-DIP;NJM2267D,VIDEO,JRC	

**TRANSISTORS**

Q 351	1243-319-001	TR,KTC3198-GR	NPN
Q 357	1243-319-001	TR,KTC3198-GR	NPN
Q 358	1243-319-001	TR,KTC3198-GR	NPN
Q 353	1243-103-004	TR;KRC103M	NPN
Q 359	1243-103-004	TR;KRC103M	NPN
Q 352	1243-103-003	TR;KTD1302	NPN
Q 261	1243-103-003	TR;KTD1302	NPN
Q 362	1243-103-003	TR;KTD1302	NPN
Q 360	1244-103-004	TR;KRA103M	PNP

**RESISTORS**

R 357	1742-122-721	1/8W	1.2KW-J
R 356	1742-151-721	1/8W	150W-J
R 368	1742-151-721	1/8W	150W-J
R 354	1742-680-721	1/8W	68W-J
R 355	1742-680-721	1/8W	68W-J
R 351	1742-750-721	1/8W	75W-J
R 352	1742-750-721	1/8W	75W-J
R 353	1742-750-721	1/8W	75W-J
R 358	1742-750-721	1/8W	75W-J
R 359	1742-750-721	1/8W	75W-J
R 367	1742-100-721	1/8W	10W-J
R 373	1742-103-721	1/8W	10KW-J
R 374	1742-103-721	1/8W	10KW-J
R 375	1742-103-721	1/8W	10KW-J
R 378	1742-103-721	1/8W	10KW-J
R 364	1742-103-721	1/8W	10KW-J
R 366	1742-103-721	1/8W	10KW-J
R 376	1742-104-721	1/8W	100KW-J
R 360	1742-222-721	1/8W	2.2KW-J
R 380	1742-222-721	1/8W	2.2KW-J
R 396	1742-222-721	1/8W	2.2KW-J
R 397	1742-222-721	1/8W	2.2KW-J
R 379	1742-272-721	1/8W	2.7KW-J
R 371	1742-391-721	1/8W	390W-J
R 381	1742-391-721	1/8W	390W-J
R 381	1742-221-721	1/8W	220W-J

**BK**

REF NO.	PART NO	DESCRIPTION		
R 361	1742-102-721	1/8W	1KW-J	<b>IB/AB</b>
R 362	1742-102-721	1/8W	1KW-J	
R 363	1742-102-721	1/8W	1KW-J	
R 365	1742-330-721	1/8W	33W-J	
R 369	1742-330-721	1/8W	33W-J	
R 377	1742-562-721	1/8W	5.6KW-J	
R 372	1742-823-721	1/8W	82KW-J	

**CAPACITORS**

C 351	1822-101-772	CERA/RA	50V	100pF-J
C 353	1822-101-772	CERA/RA	50V	100pF-J
C 355	1822-101-772	CERA/RA	50V	100pF-J
C 357	1822-101-772	CERA/RA	50V	100pF-J
C 358	1822-101-772	CERA/RA	50V	100pF-J
C 361	1862-100-504	CERA/RA	50V	100pF-J
C 360	1862-331-318	ELECT	16V	10uF-M
C 363	1862-470-604	ELECT	10V	33uF-M
C 367	1862-470-604	ELECT	25V	47uF-M
C 369	1862-470-604	ELECT	25V	47uF-M
C 352	1862-4R7-804	ELECT	25V	47uF-M
C 354	1862-4R7-804	ELECT	50V	4.7uF-M
C 356	1862-4R7-804	ELECT	50V	4.7uF-M
C 362	1832-104-002	ELECT	50V	4.7uF-M
C 364	1832-104-002	CERA/AX	50V	0.1uF-Z
C 365	1832-104-002	CERA/AX	50V	0.1uF-Z
C 366	1832-104-002	CERA/AX	50V	0.1uF-Z
C 368	1832-104-002	CERA/AX	50V	0.1uF-Z
C 384	1832-104-002	CERA/AX	50V	0.1uF-Z
C 379	1822-030-212	CERA/AX	50V	0.1uF-Z
C 380	1822-030-212	CERA/AX	50V	30pF-J
C 373	1822-222-882	CERA/AX	50V	30pF-J
C 381	1822-270-712	CERA/AX	50V	0.0022uF-J
C 378	1832-103-772	CERA/AX	50V	27pF-J
C 393	1832-103-772	CERA/AX	50V	0.01uF-J
C 388	1832-221-822	CERA/AX	50V	0.01uF-J
C 387	1832-332-772	CERA/AX	50V	220pF-K
C 387	1832-472-772	CERA/AX	50V	0.0033uF-J
C 391	1832-471-712	CERA/AX	50V	0.0047uF-J
C 385	1832-473-002	CERA/AX	50V	470pF-J
C 377	1862-010-804	CERA/AX	50V	0.047uF-Z
C 386	1862-010-804	ELEC	50V	1.0uF-M
C 389	1862-010-804	ELEC	50V	1.0uF-M
C 383	1862-100-804	ELEC	50V	10uF-M
C 392	1862-R47-804	ELEC	50V	0.47uF-M
C 372	1862-R22-804	ELEC	50V	0.22uF-M
C 371	1862-2R2-804	ELEC	50V	2.2uF-M
C 374	1861-102-218	ELEC	6.3V	1000uF-M
C 370	1861-102-218	ELEC	6.3V	1000uF-M
C 359	1861-102-218	ELEC	6.3V	1000uF-M
C 379	1822-150-712	CERA/RA	50V	15pF-J
C 380	1822-150-712	CERA/RA	50V	15pF-J
C 382	1822-240-712	CERA/RA	50V	24pF-J

**BK  
IB/AB**

**MISCELLANEOUS**

HU 351	2121-605-008	WAFER 8P, JE-605-08
L 351	1444-270-003	INDUCTOR/AX; 27uH(A)
L 352	1444-270-003	INDUCTOR/AX; 27uH(A)
L 353	1444-270-003	INDUCTOR/AX; 27uH(A)
JP 352	1514-030-002	PIN JACK;3P
JP 351	1514-020-002	PIN JACK;2P
WA 352	2111-023-006	WAFER;5267-06A,6P
CN 353	2141-070-017	WIRE;7P;1007#26,80m/m
XT 352	1341-500-040	FILTER;CSB500F40
XT 352	1341-503-001	FILTER;CSB503F2
XT 351	1352-14R-001	X-TAL;14.31818MHZ
XT 351	1352-17R-001	X-TAL;17.734475MHZ

**IB/AB  
BK  
BK  
IB/AB**

**0112-011-1632 TUNER P.C.BOARD**

REF NO.	PART NO	DESCRIPTION			
<b>INTEGRATED CIRCUITS</b>					
IC 801	1212-126-002	IC	LA1266	AM/FM IF	
IC 803	1212-341-001	IC	LA3410	FM MPX	
IC 802	1212-700-002	IC	LM7000	PLL	
IC 804	1212-923-000	IC	BU1923	RDS	<b>IB</b>
<b>TRANSISTORS</b>					
Q 809	1243-110-005	KRC110M		NPN	
Q 810	1243-110-005	KRC110M		NPN	
Q 801	1243-319-008	KTC3192-O		NPN	
Q 802	1243-319-008	KTC3192-O		NPN	
Q 803	1243-319-008	KTC3192-O		NPN	
Q 891	1243-319-008	KTC3192-O		NPN	<b>IB/AB</b>
Q 805	1243-320-001	KTC3200-GR		NPN	
Q 899	1243-319-007	KTC-3199GR		NPN	
Q 806	1244-101-010	KRA101M		PNP	
Q 807	1244-101-010	KRA101M		PNP	
Q 808	1244-101-010	KRA101M		PNP	
<b>FET</b>					
Q 804	1248-246-001	FET,2SK246-Y		N-CH	
<b>DIODES</b>					
D 801	1252-000-017	1SS133			
D 802	1252-000-017	1SS133			
D 803	1252-000-017	1SS133			
D 804	1252-000-017	1SS133			
VC 801	1252-000-040	VVC;AM,SVC321SPA-D2			
VC 802	1252-000-040	VVC;AM,SVC321SPA-D2			
ZD 803	1254-5R6-009	ZENER 5.6V			
ZD 804	1254-4R7-025	ZENER 4.7V			
ZD 802	1254-5R1-021	ZENER 5.1V			<b>IB</b>
<b>FILTERS</b>					
F 805	1321-001-002	AHCFM2-450BL			
F 801	1321-000-005	SFE10.7MA5-A(REDF)			<b>BK</b>
F 802	1321-000-005	SFE10.7MA5-A(REDF)			<b>BK</b>
F 801	1321-000-013	SFE10.7MS3-A			<b>IB/AB</b>
F 802	1321-000-013	SFE10.7MS3-A			<b>IB/AB</b>
F 803	1321-000-005	SFE10.7MA5-A(REDF)			
F 806	1341-000-015	CSB456F11			
F 804	1341-000-061	BFU450C4N			
<b>COILS</b>					
T 804	1422-000-051	FM DET1			
T 805	1422-000-052	FM DET2			
T 803	1422-000-055	AM IFT			
T 802	1432-000-053	AM OSC			
T 801	1432-000-054	AM ANT			
T 806	1432-001-001	MPX			
T 807	1432-001-001	MPX			
<b>RESISTORS(CARBON)</b>					
R 801	1742-101-721	1/8W		100W-J	
R 844	1742-101-721	1/8W		100W-J	
R 845	1742-101-721	1/8W		100W-J	
R 819	1742-102-721	1/8W		1KW-J	
R 824	1742-102-721	1/8W		1KW-J	
R 828	1742-102-721	1/8W		1KW-J	
R 831	1742-102-721	1/8W		1KW-J	
R 837	1742-102-721	1/8W		1KW-J	
R 892	1742-102-721	1/8W		1KW-J	<b>IB</b>
R 817	1742-103-721	1/8W		10KW-J	
R 848	1742-103-721	1/8W		10KW-J	
R 849	1742-103-721	1/8W		10KW-J	
R 852	1742-103-721	1/8W		10KW-J	
R 858	1742-103-721	1/8W		10KW-J	
R 860	1742-103-721	1/8W		10KW-J	

REF NO.	PART NO	DESCRIPTION			
R 861	1742-103-721	1/8W		10KW-J	
R 862	1742-103-721	1/8W		10KW-J	
R 893	1742-103-721	1/8W		10KW-J	<b>IB</b>
R 814	1742-104-721	1/8W		100KW-J	
R 815	1742-104-721	1/8W		100KW-J	
R 827	1742-104-721	1/8W		100KW-J	
R 881	1742-104-721	1/8W		100KW-J	
R 805	1742-121-721	1/8W		120W-J	
R 802	1742-122-721	1/8W		1.2KW-J	
R 830	1742-153-721	1/8W		15KW-J	<b>BK</b>
R 838	1742-154-721	1/8W		150KW-J	
R 839	1742-154-721	1/8W		150KW-J	
R 840	1742-154-721	1/8W		150KW-J	
R 841	1742-154-721	1/8W		150KW-J	
R 812	1742-221-721	1/8W		220W-J	
R 816	1742-221-721	1/8W		220W-J	
R 864	1742-221-721	1/8W		220W-J	
R 803	1742-222-721	1/8W		2.2KW-J	
R 826	1742-223-721	1/8W		22KW-J	
R 820	1742-271-721	1/8W		270W-J	
R 830	1742-273-721	1/8W		27KW-J	
R 804	1742-331-721	1/8W		330W-J	
R 809	1742-331-721	1/8W		330W-J	<b>IB/BK</b>
R818	1742-331-721	1/8W		330W-J	
R 871	1742-331-721	1/8W		330W-J	
R 808	1742-332-721	1/8W		3.3KW-J	
R 822	1742-332-721	1/8W		3.3KW-J	
R 835	1742-332-721	1/8W		3.3KW-J	
R 846	1742-332-721	1/8W		3.3KW-J	
R 847	1742-332-721	1/8W		3.3KW-J	
R 807	1742-391-721	1/8W		390W-J	
R 806	1742-392-721	1/8W		3.9KW-J	
R 857	1742-393-721	1/8W		39KW-J	
R 899	1742-472-721	1/8W		4.7KW-J	
R 856	1742-560-721	1/8W		56W-J	
R 859	1742-561-721	1/8W		560W-J	
R 863	1742-561-721	1/8W		560W-J	
R 825	1742-562-721	1/8W		5.6KW-J	
R 834	1742-562-721	1/8W		5.6KW-J	<b>IB</b>
R 810	1742-681-721	1/8W		680W-J	<b>IB</b>
R 829	1742-683-721	1/8W		68KW-J	
R 882	1742-683-721	1/8W		68KW-J	
R 811	1742-821-721	1/8W		820W-J	
R 842	1742-272-721	1/8W		2.7KW-J	
R 843	1742-272-721	1/8W		2.7KW-J	
R 888	1744-100-731	1/4W		10W-J	
R 813	1744-101-731	1/4W		100W-J	
R 823	1744-101-731	1/4W		100W-J	
R 832	1744-220-731	1/4W		22W-J	
R 865	1744-220-731	1/4W		22W-J	<b>IB</b>
R 891	1744-220-731	1/4W		22W-J	
R 851	1744-221-731	1/4W		220W-J	
R 836	1744-470-731	1/4W		47W-J	
R 866	1744-331-731	1/4W		330W-J	
R 855	1744-331-731	1/4W		330W-J	<b>IB</b>
<b>MISCELLANEOUS</b>					
	5226-003-040	CASE-SHIELD(T2)			
ANT 801	1514-021-393	TERMINAL-JACK	M 75ohm		
ANT 801	1514-021-392	TERMINAL-JACK	M 75ohm		<b>IB/AB</b>
P 801	1291-000-006	TUNER PACK	FTA4-460H		
X 801	1352-000-072	X-TAL	7.2MHz		
X 802	1352-432-001	X-TAL	4.332MHz		<b>IB</b>
L 803	1444-270-003	COIL	L02-270K,27uH(A)		
L 804	1444-270-003	COIL	L02-270K,27uH(A)		
L 802	1471-200-005	COIL	20.8mH		<b>IB</b>
VR 803	1731-224-002	VR-SEMI	220kohm		
VR 801	1731-473-004	VR-SEMI	47kohm		
VR 802	1731-473-004	VR-SEMI	47kohm		

REF NO.	PART NO	DESCRIPTION			
CT 801	1815-020-001	C-TRIM		20pF	
<b>CAPACITORS</b>					
C 855	1822-150-712	CERA/RA	50V	15pF-J	<b>IB</b>
C 844	1822-300-712	CERA/RA	50V	30pF-J	<b>IB</b>
C 845	1822-300-712	CERA/RA	50V	30pF-J	
C 814	1822-330-712	CERA/RA	50V	33pF-J	
C 815	1822-330-712	CERA/RA	50V	33pF-J	<b>AB/IB</b>
C 891	1822-331-712	CERA/RA	50V	33pF-J	<b>AB/IB</b>
C 838	1822-331-712	CERA/RA	50V	33pF-J	<b>AB/IB</b>
C 839	1822-331-712	CERA/RA	50V	33pF-J	<b>AB/IB</b>
C 892	1822-820-772	CERA/RA	50V	82pF-J	<b>AB/IB</b>
C 893	1822-101-772	CERA/RA	50V	100pF-J	
C 801	1822-223-001	CERA/RA	50V	0.022uF-Z	
C 802	1822-223-001	CERA/RA	50V	0.022uF-Z	
C 803	1822-223-001	CERA/RA	50V	0.022uF-Z	
C 809	1822-223-001	CERA/RA	50V	0.022uF-Z	
C 813	1822-223-001	CERA/RA	50V	0.022uF-Z	
C 824	1822-223-001	CERA/RA	50V	0.022uF-Z	
C 828	1822-223-001	CERA/RA	50V	0.022uF-Z	
C 830	1822-223-001	CERA/RA	50V	0.022uF-Z	
C 850	1822-223-001	CERA/RA	50V	0.022uF-Z	
C 857	1822-223-001	CERA/RA	50V	0.022uF-Z	
C 894	1822-223-001	CERA/RA	50V	0.022uF-Z	<b>AB/IB</b>
C 846	1822-223-001	CERA/RA	50V	0.022uF-Z	<b>IB</b>
C 838	1822-471-822	CERA/RA	50V	470pF-K	<b>BK</b>
C 839	1822-471-822	CERA/RA	50V	470pF-K	<b>BK</b>
C 848	1822-561-712	CERA/RA	50V	560pF-J	<b>IB</b>
C 804	1822-473-001	CERA/RA	50V	0.047uF-Z	
C 822	1822-473-001	CERA/RA	50V	0.047uF-Z	
C 826	1822-473-001	CERA/RA	50V	0.047uF-Z	
C 827	1822-473-001	CERA/RA	50V	0.047uF-Z	
C 816	1832-101-712	CERA/AX	50V	100pF-J	
C 817	1832-101-712	CERA/AX	50V	100pF-J	
C 843	1832-331-822	CERA/AX	50V	330pF-K	<b>IB</b>
C 818	1832-223-001	CERAA/AX	50V	0.022uF-Z	
C 810	1862-010-804	ELECT	50V	1.0uF-M	
C 808	1862-100-504	ELECT	16V	10uF-M	
C 835	1862-100-504	ELECT	16V	10uF-M	
C 851	1862-100-504	ELECT	16V	10uF-M	
C 866	1862-100-504	ELECT	16V	10uF-M	
C 837	1862-100-504	ELECT	16V	10uF-M	
C 840	1862-100-504	ELECT	16V	10uF-M	
C 831	1862-101-517	ELECT	16V	100uF-M	
C 859	1862-101-517	ELECT	16V	100uF-M	
C 833	1862-2R2-804	ELECT	50V	2.2uF-M	
C 849	1862-2R2-804	ELECT	50V	2.2uF-M	<b>IB</b>
C 820	1862-3R3-804	ELECT	50V	3.3uF-M	
C 832	1862-3R3-804	ELECT	50V	3.3uF-M	
C 867	1862-3R3-804	ELECT	50V	3.3uF-M	
C 812	1862-470-404	ELECT	16V	47uF-M	
C 829	1862-470-404	ELECT	16V	47uF-M	
C 847	1862-470-404	ELECT	16V	47uF-M	<b>IB</b>
C 856	1862-470-404	ELECT	16V	47uF-M	
C 821	1862-4R7-804	ELECT	50V	4.7uF-M	
C 825	1862-R47-804	ELECT	50V	0.47uF-M	
C 836	1862-R47-804	ELECT	50V	0.47uF-M	
C 806	1872-471-731	STYROL	50V	470pF-J	
C 811	1876-102-811	POLYESTER	100V	0.001uF-K	
C 834	1876-473-811	POLYESTER	100V	0.047uF-K	
C 819	1876-124-811	POLYESTER	100V	0.12uF-K	

<b>WAFERS</b>					
WA 809	2111-023-004	4P		5267-04A	
WA 807	2111-023-008	8P		5267-08A	
WA 808	2111-023-009	9P		5267-09A	
WA 802	2121-605-006	6P		JE-605-06	
WA 801	2121-605-010	10P		JE-605-10	
WA 899	2111-023-002	2P		5267-02A	

# IC BLOCK DIAGRAMS

IC 352 : NJM 2267  
VIDEO SWITCHING

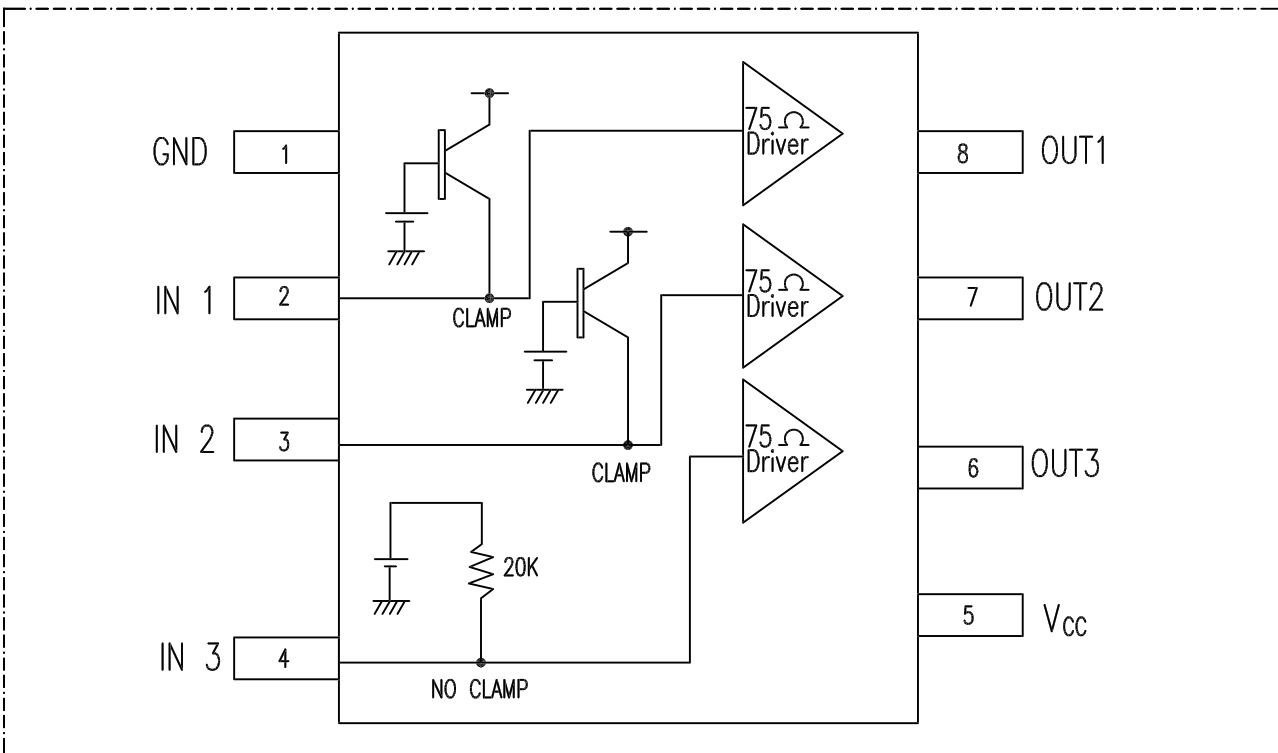

IC 353 : BA7622F  
VIDEO 6dB AMPLIFIER

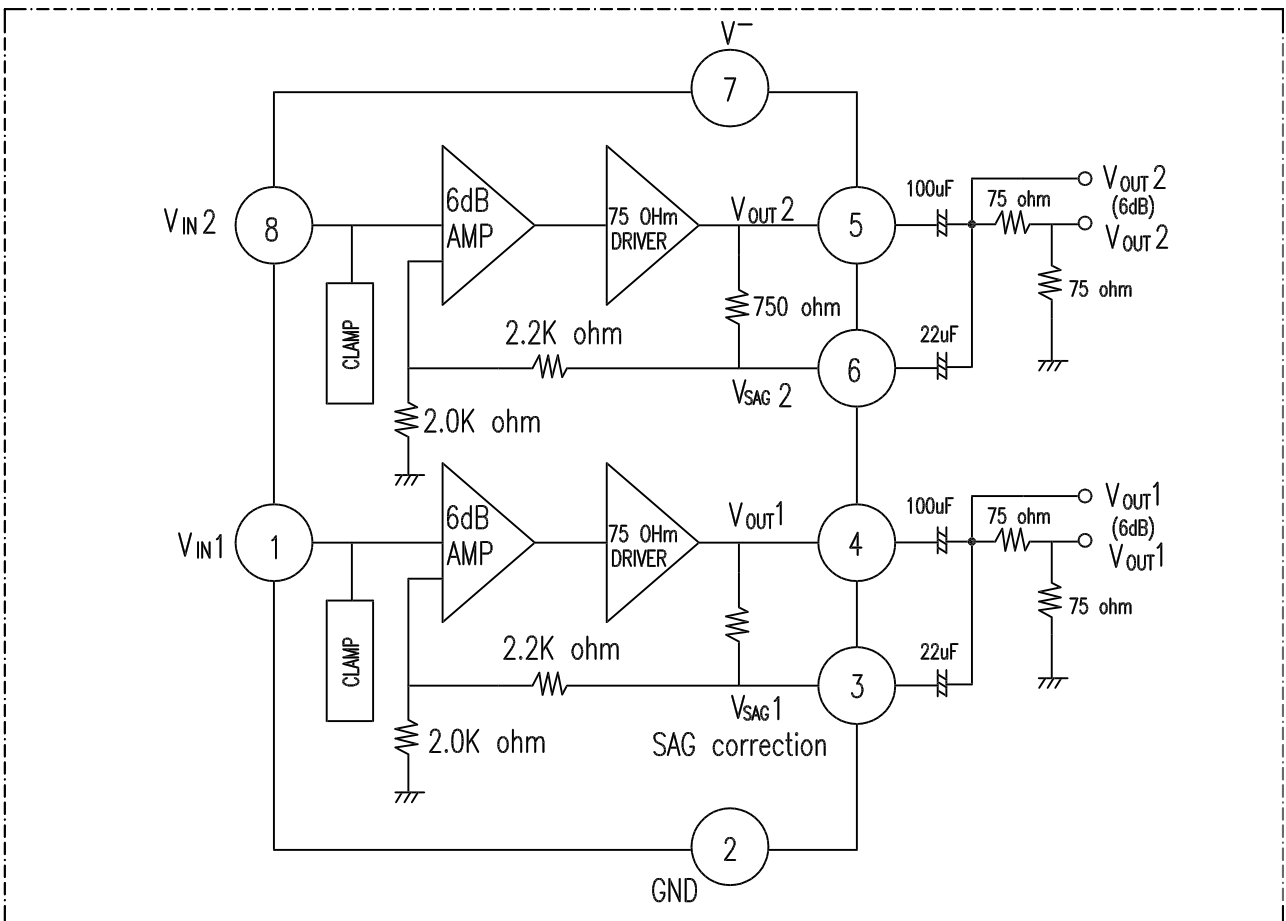



IC354 : MB90089

ON-SCREEN DISPLAY

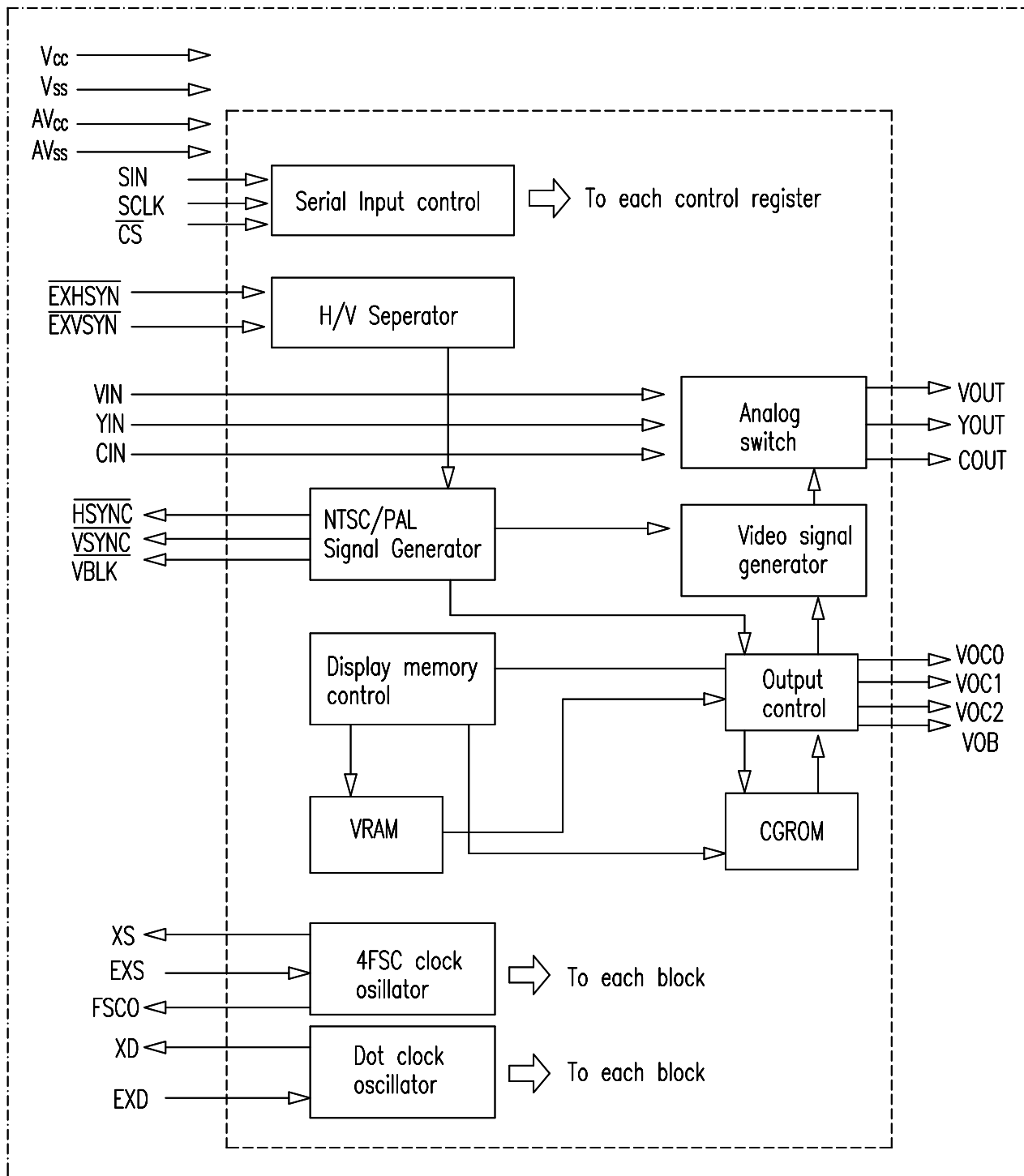

# IC 355 : MM1067

## NO-ADJUSTMENT SYNC SEPERATOR & SYNC DETECTOR

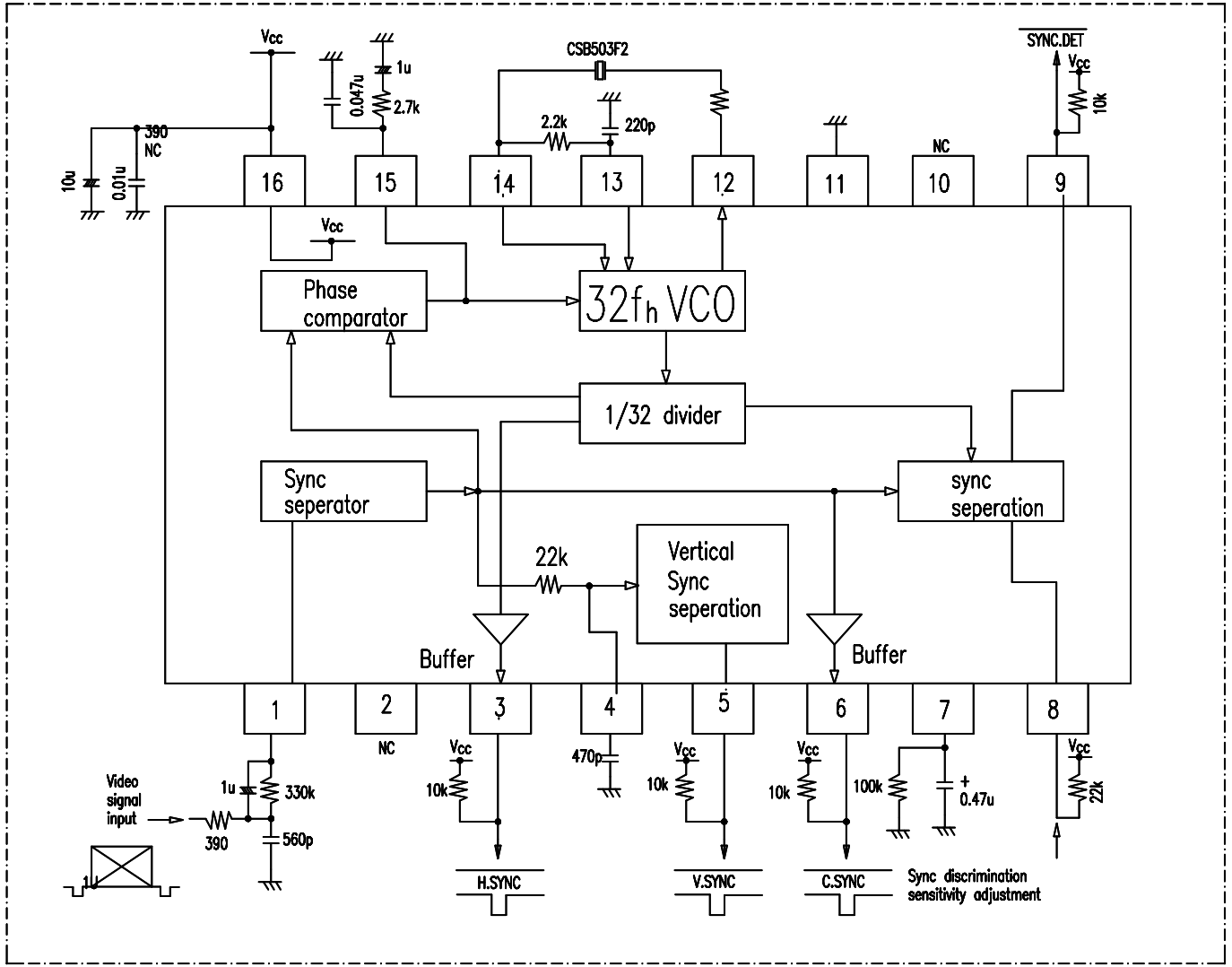

IC710 : CS4923 CS4926

AC-3 DECODER

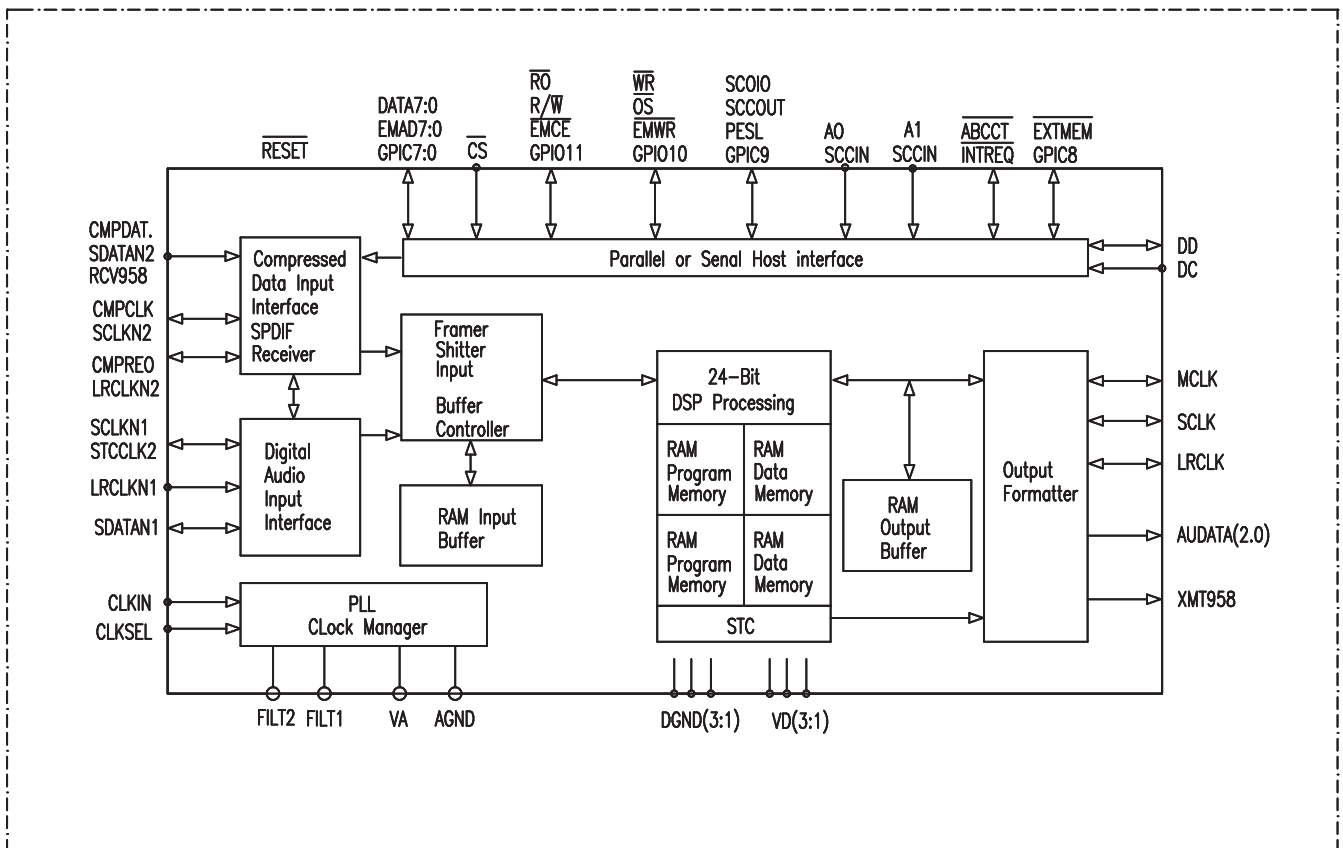

IC709 : CS4226

SURROUND SOUND CODEC

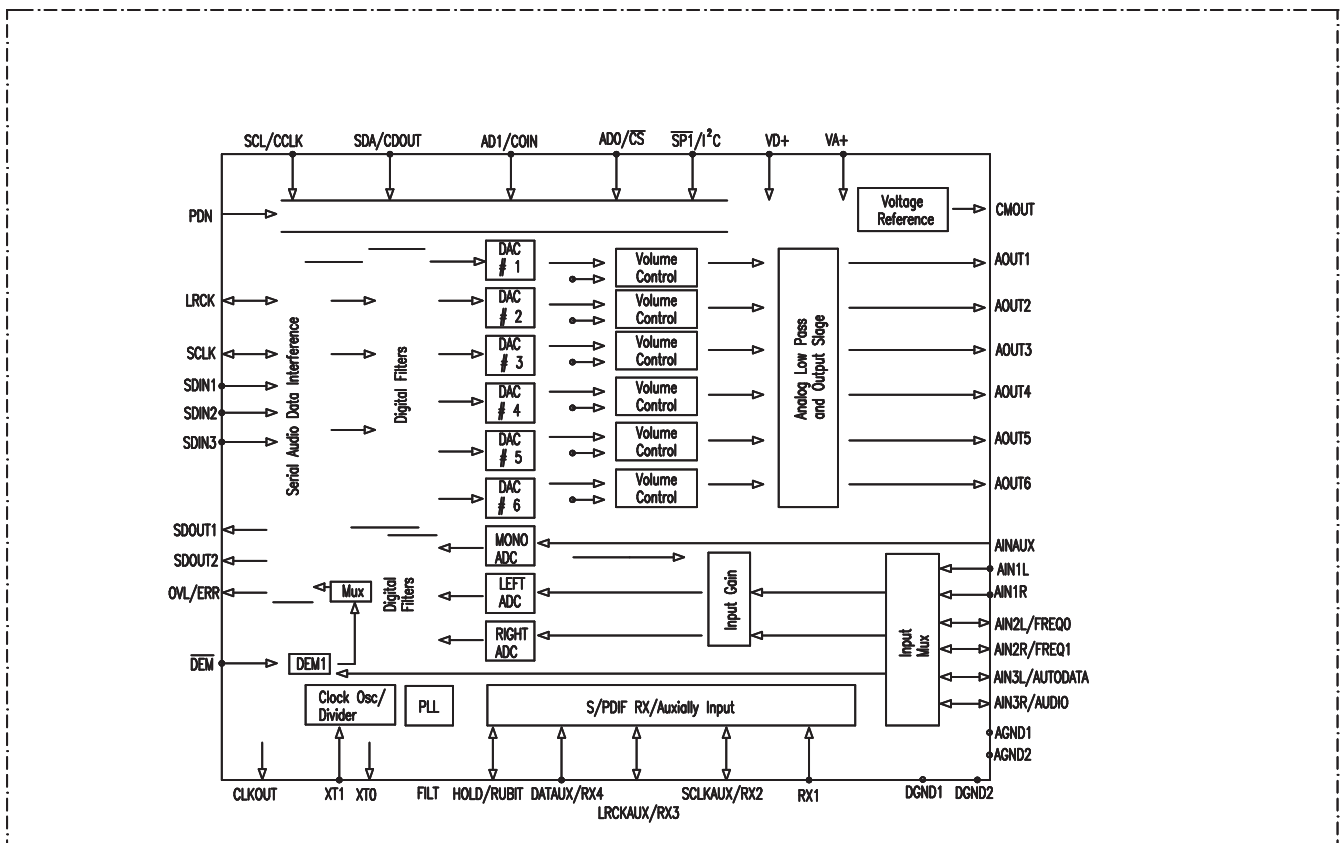

IC713 : MSM534031C  
ROM IC

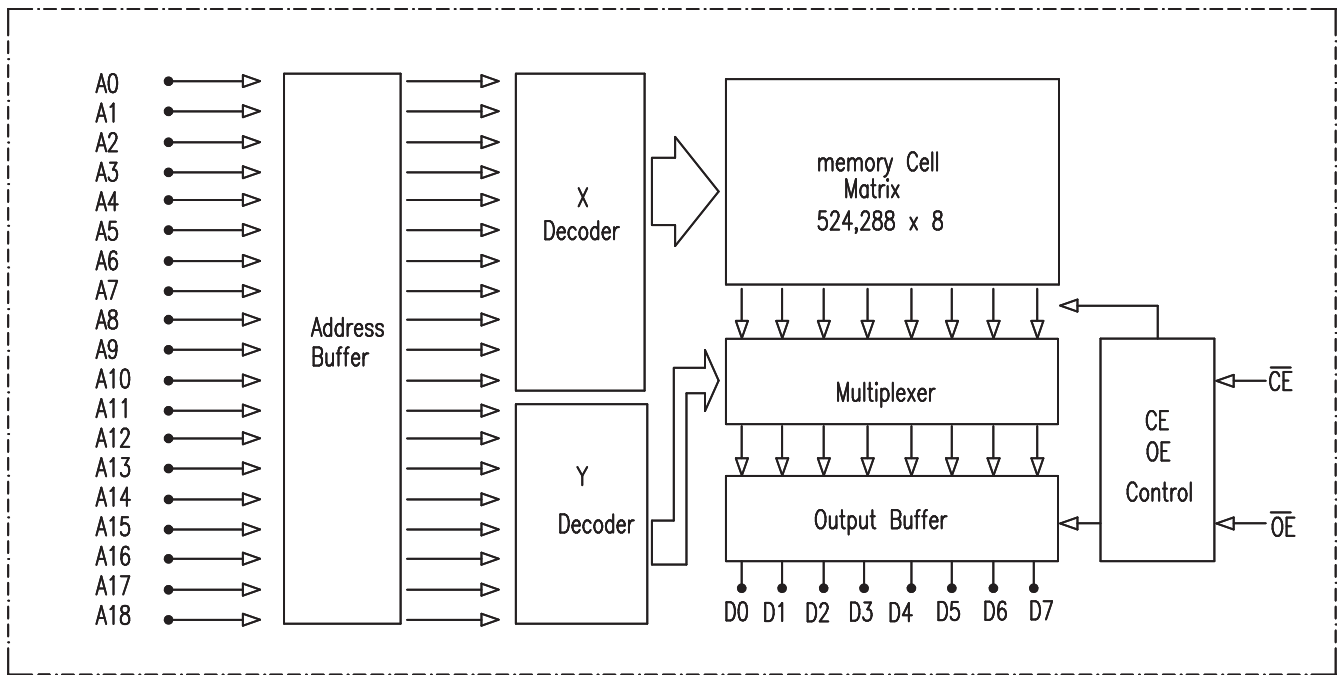

IC801 : LA1266  
FM/AM IF

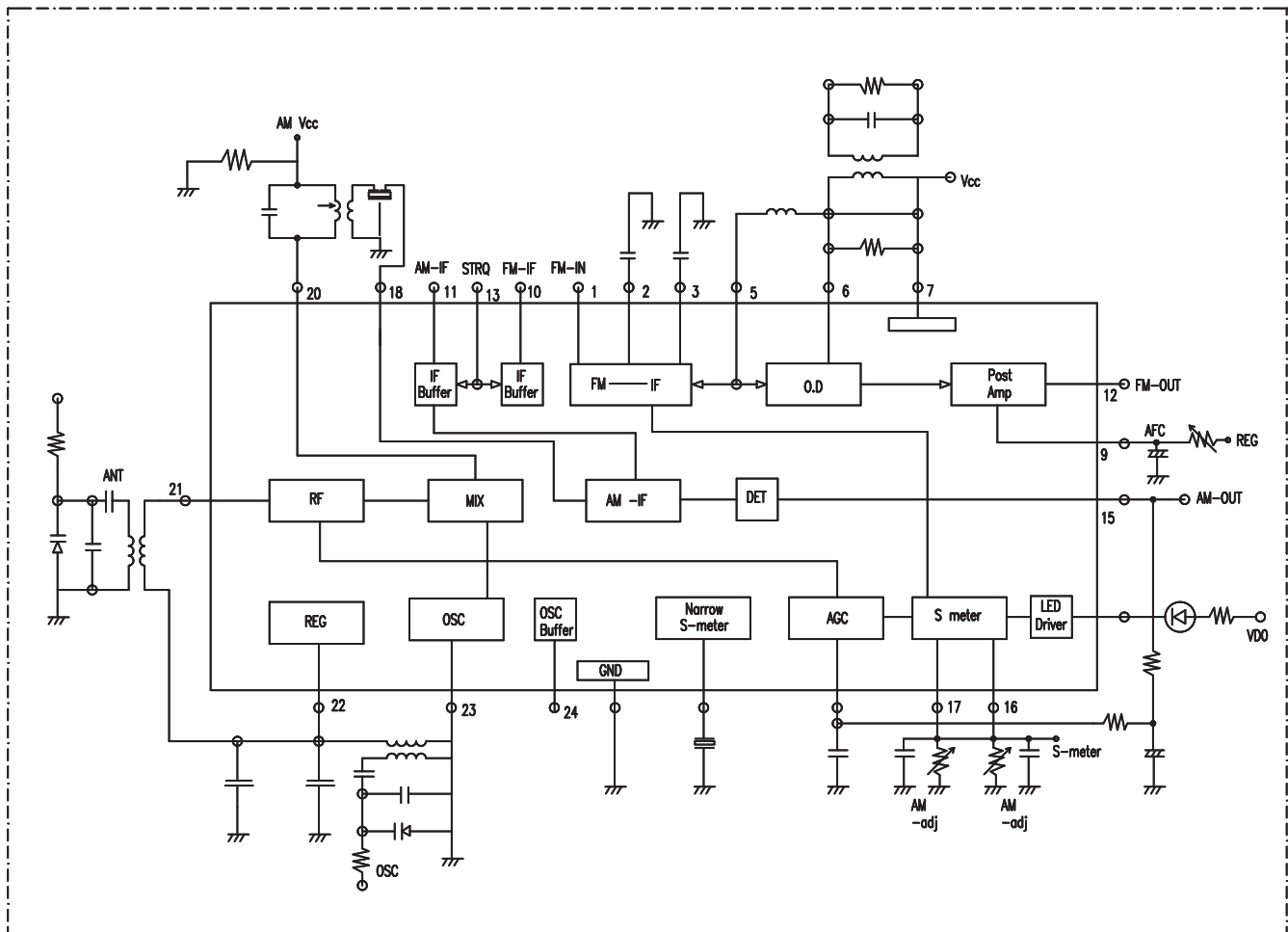

# IC804 : LM7000 PLL FREQ. SYNTHESIZER

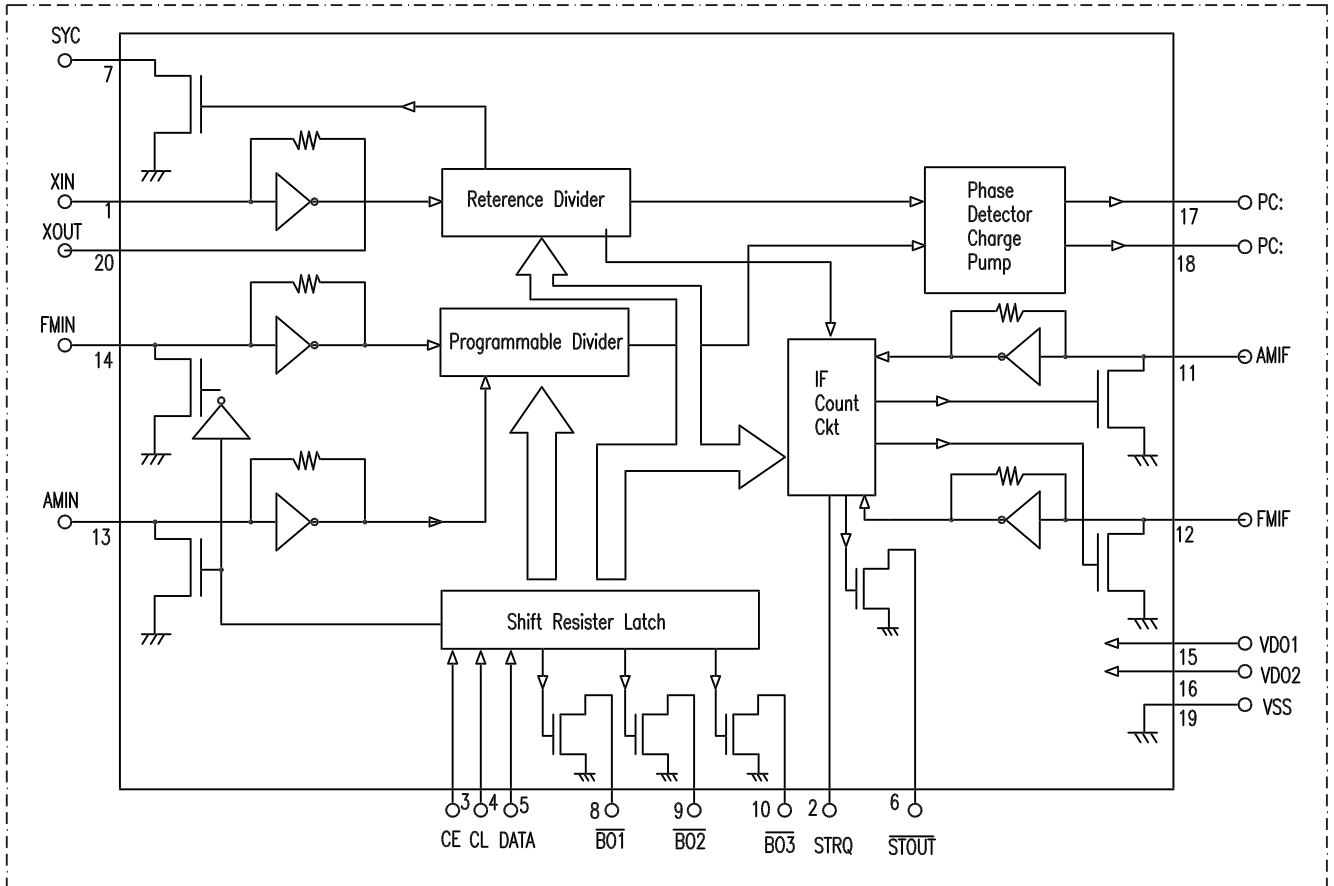

# IC803 : LA3410 MPX DEMODULATOR

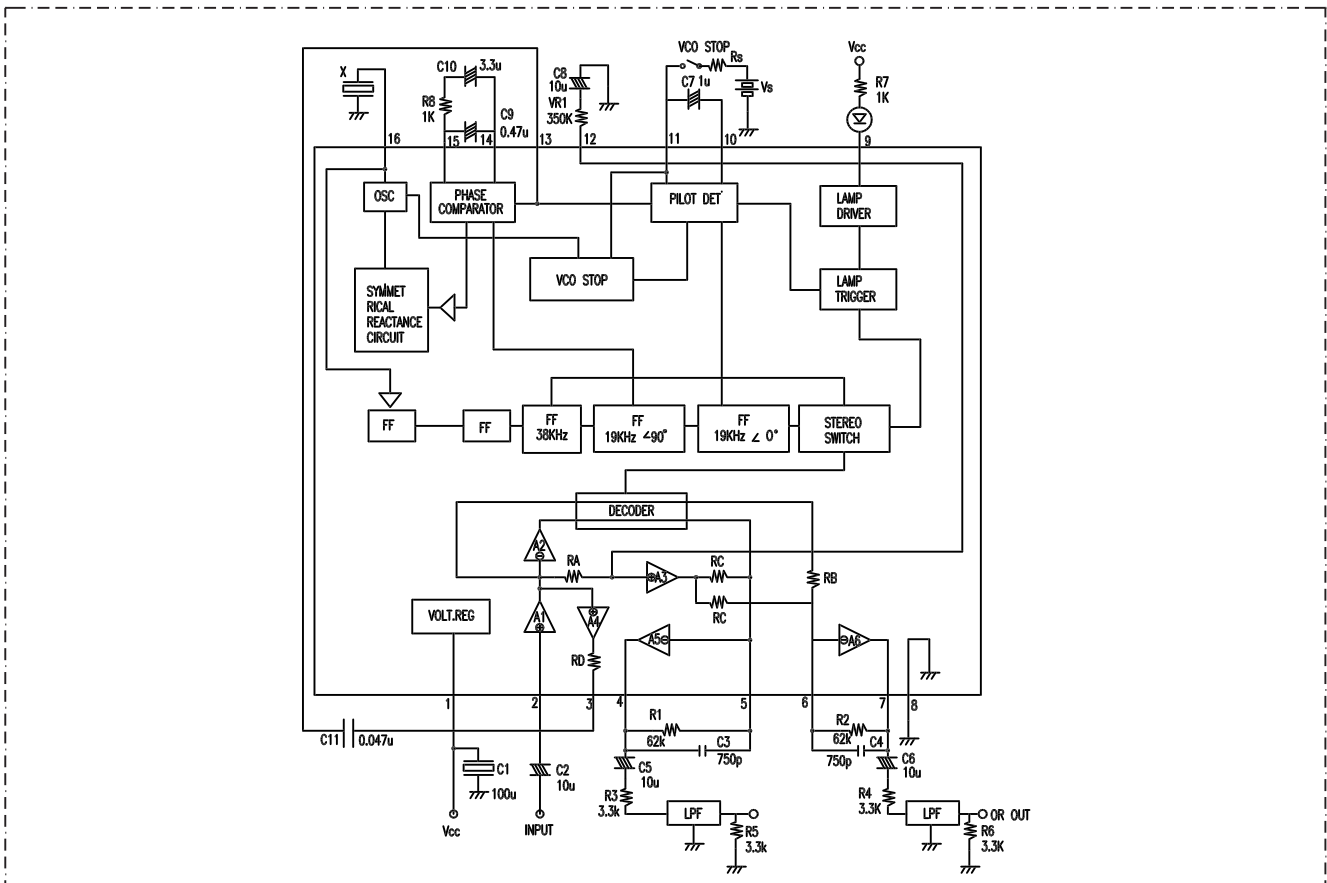

# IC804 : BU1923 RDS DECODER (IB)

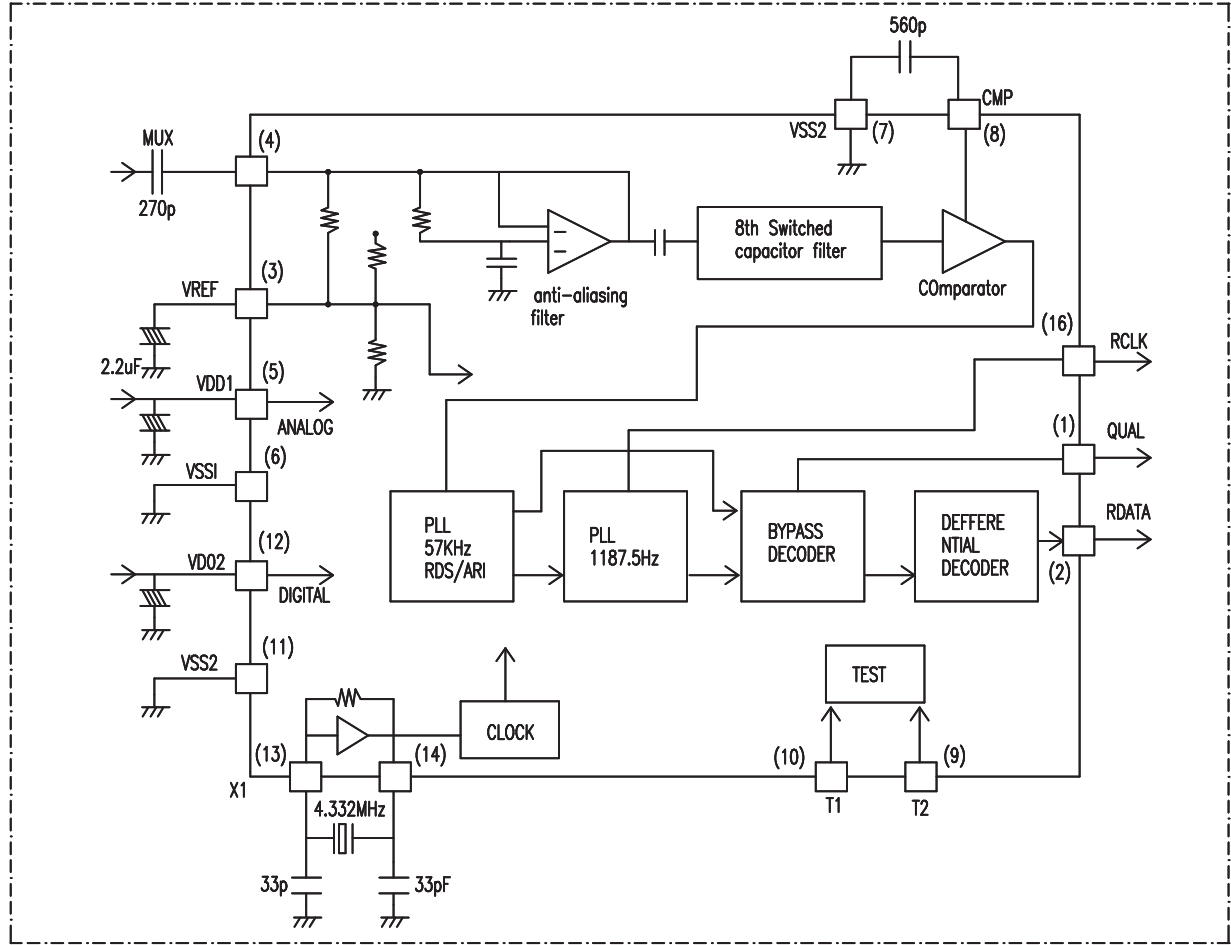

# IC 106, 109, 114, 117 : LC7536 ELECTRONIC VOLUME CONTROL

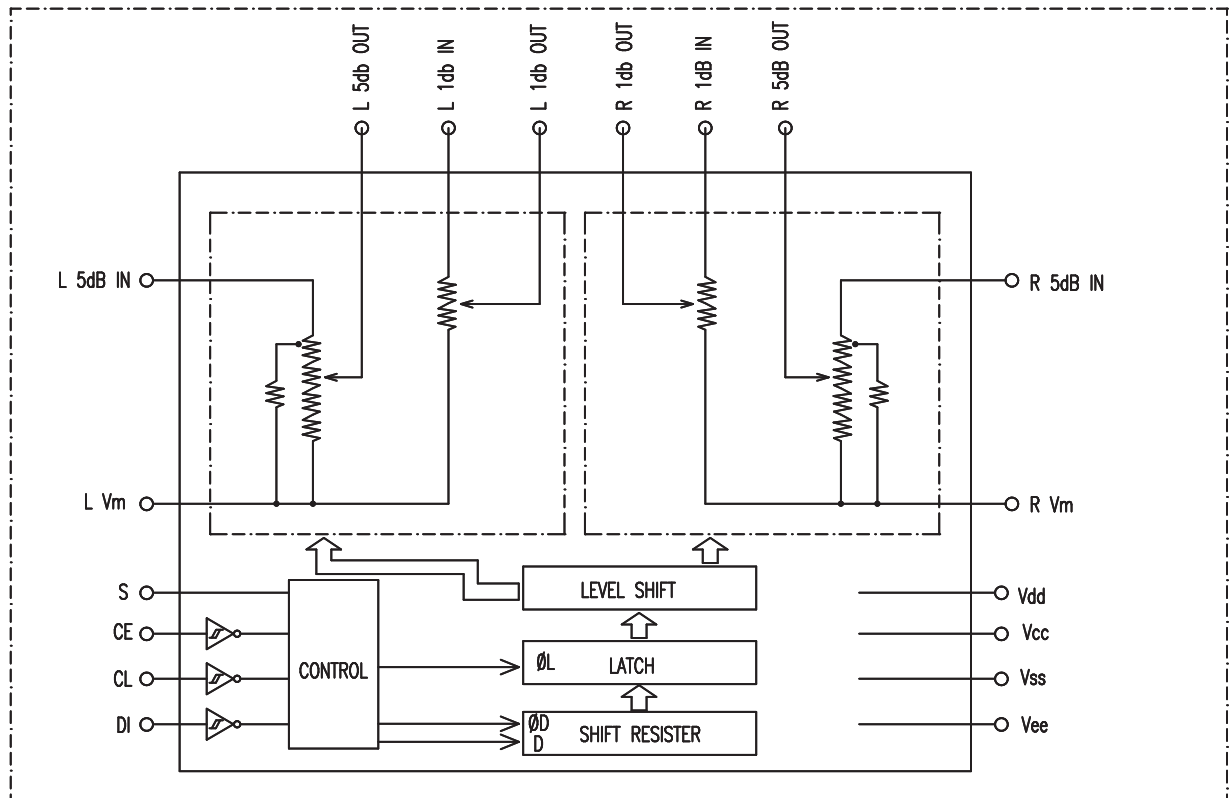

IC351, 371, 372 : LA7951  
VIDEO SWITCH

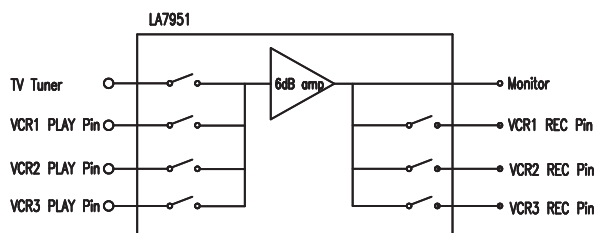

Figure 1. Editing System Switch Connections

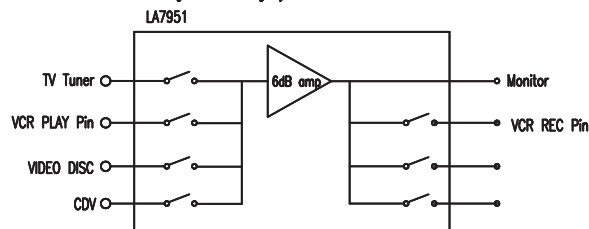
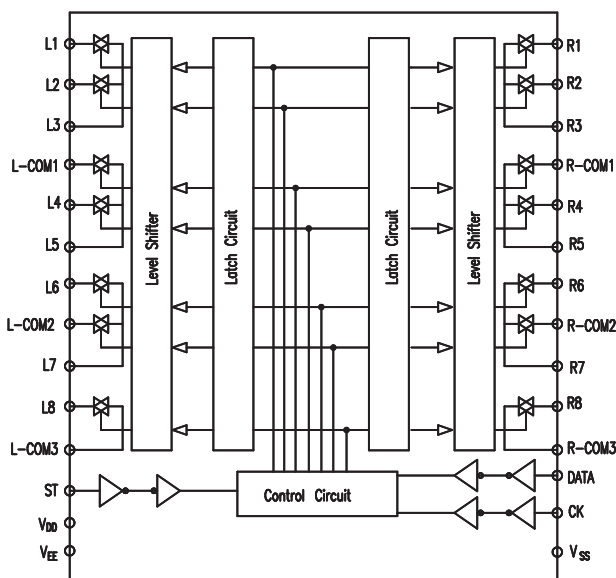
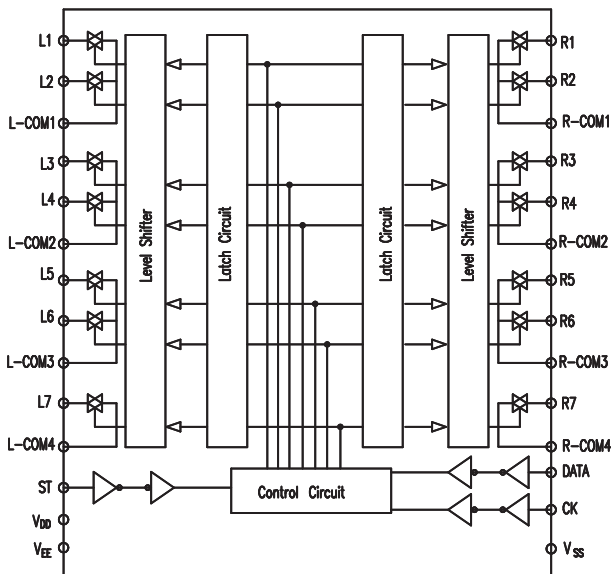

Figure 2. Video Selector Switch Connections

IC 101 : NJU7312  
ANALOG FUNCTION SW.



IC 105, 113 : NJU7311  
ANALOG FUNCTION SW.



IC 103,104,107,108,110,111,112,115,116,118,119,120,702,703  
704,708,723,724,725,726,902 :

NJM4558L/NJM4668M

DUAL OP-AMP

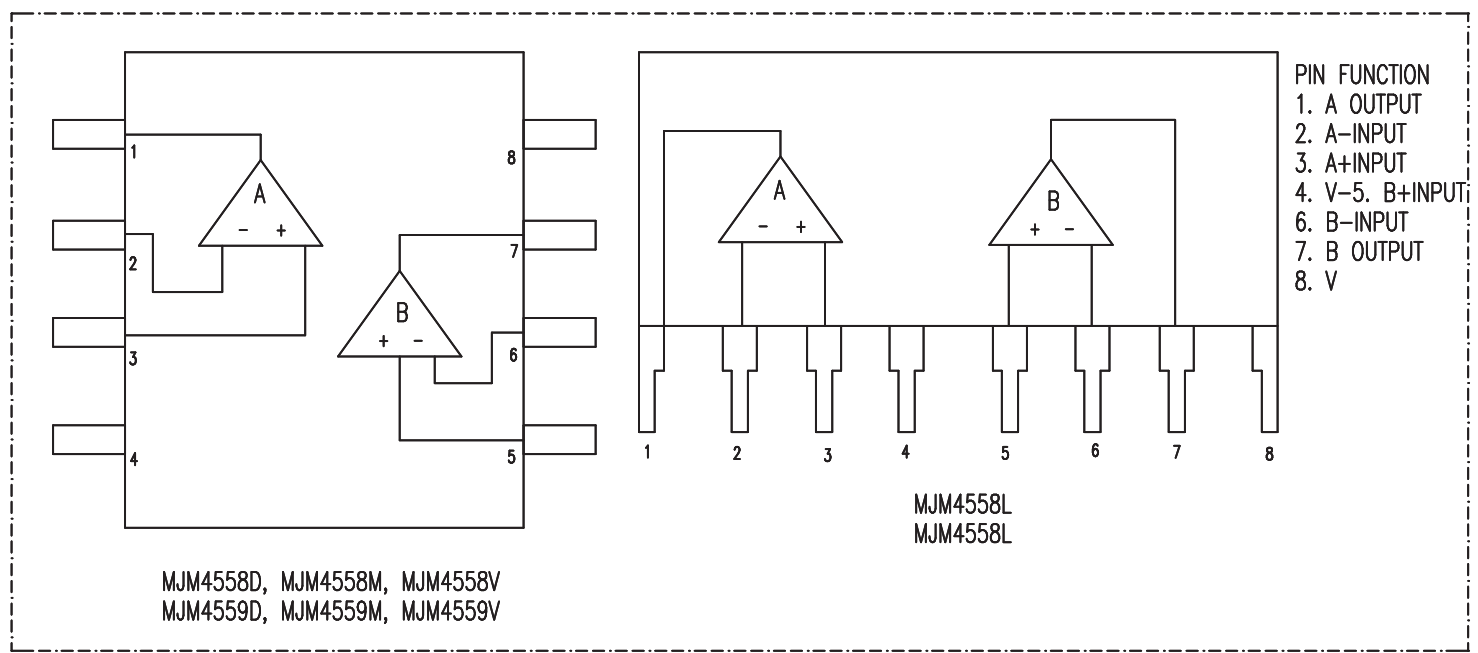

IC 701,705,706,707 :NJM072M  
DUAL J-FET INPUT OP-AMP

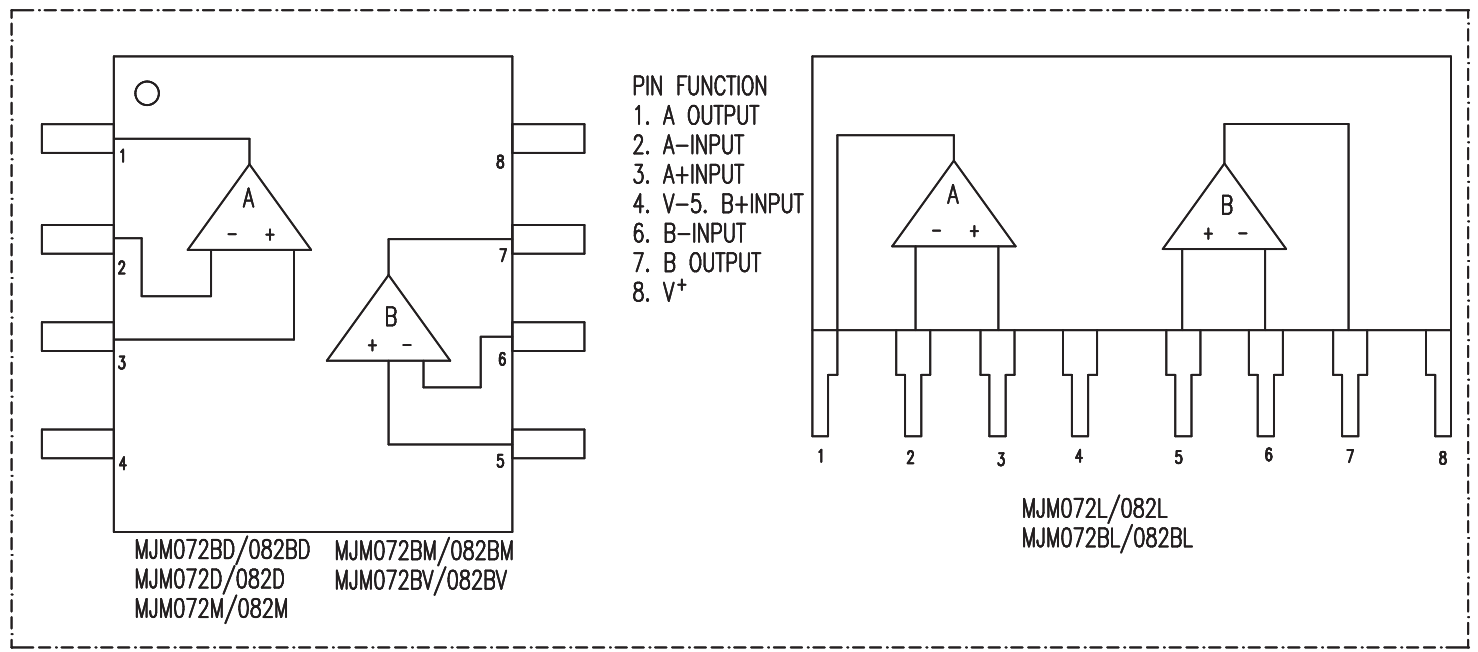



IC 712 : 74VHC04F  
HEX INVERTER

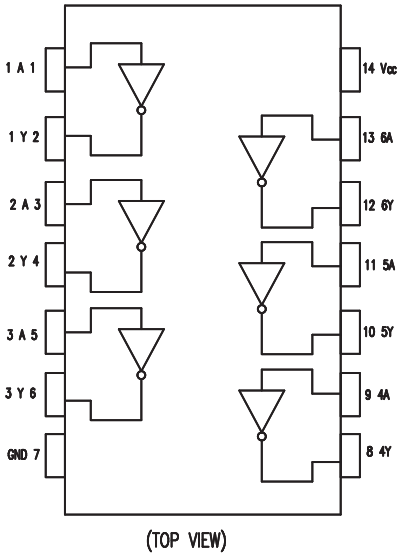

IC 711, 714 : TC74VHC244F  
OCTAL BUS BUFFER  
WITH NONINVERTED 3-STATE OUTPUTS

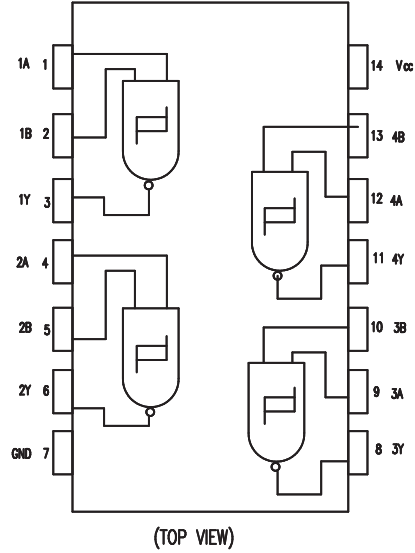

IC 717 : TC74VHC74F  
DUAL D-FLIP FLOP

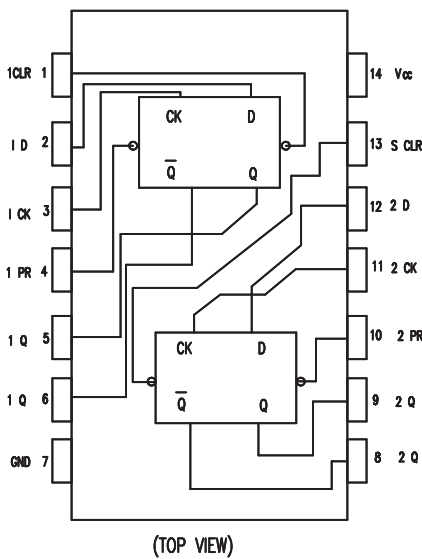

IC 719 : TC74VHC132F  
QUAD 2-INPUT SCHMITT NAND GATE

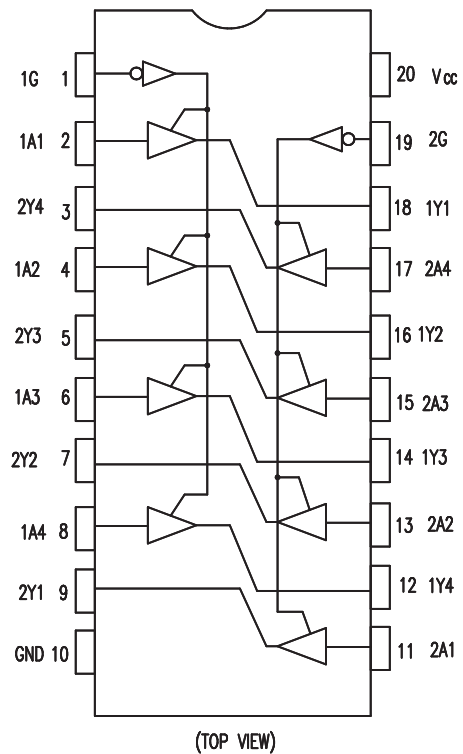

IC 715, 716 : TC74VHC574F  
 OCTAL D-TYPE FLIP-FLOP WITH 3-STATE OUTPUT

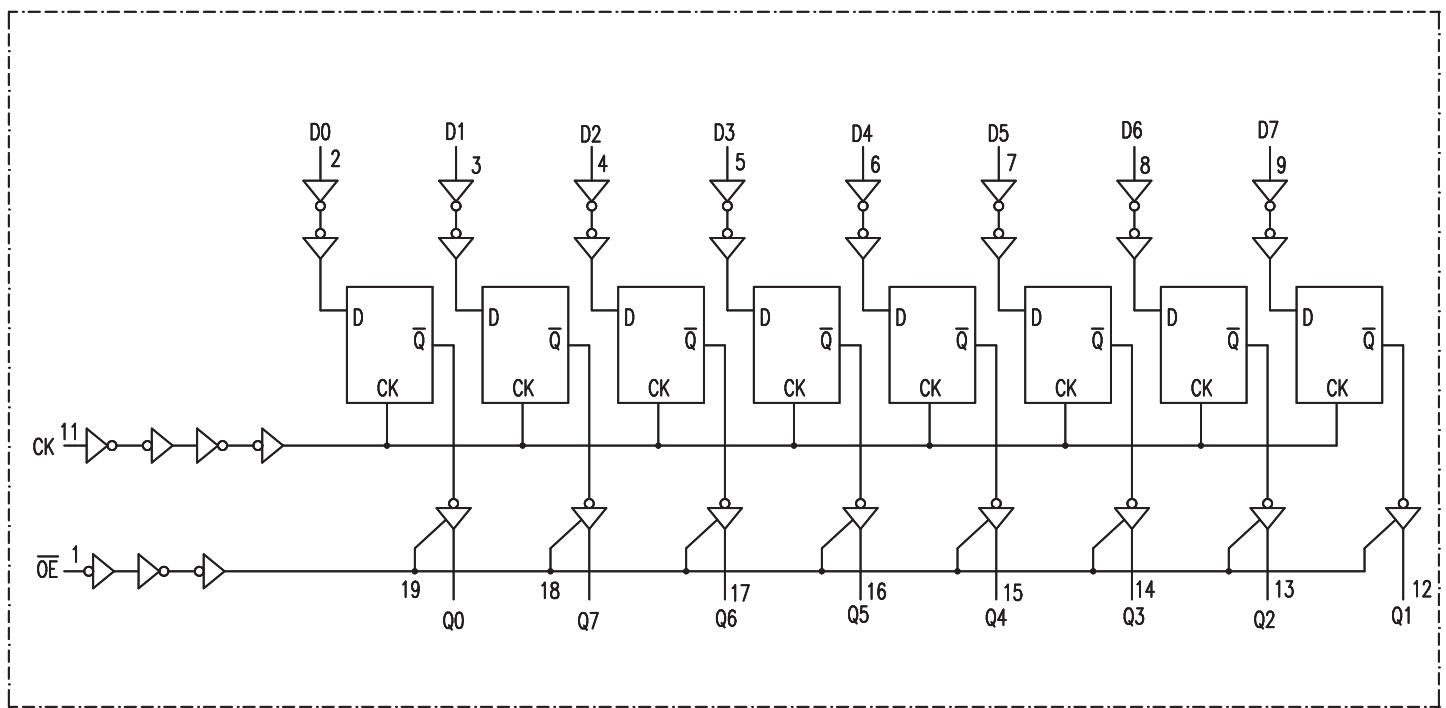

IC 102 : NJU7313  
 ANALOG FUNCTION SW.

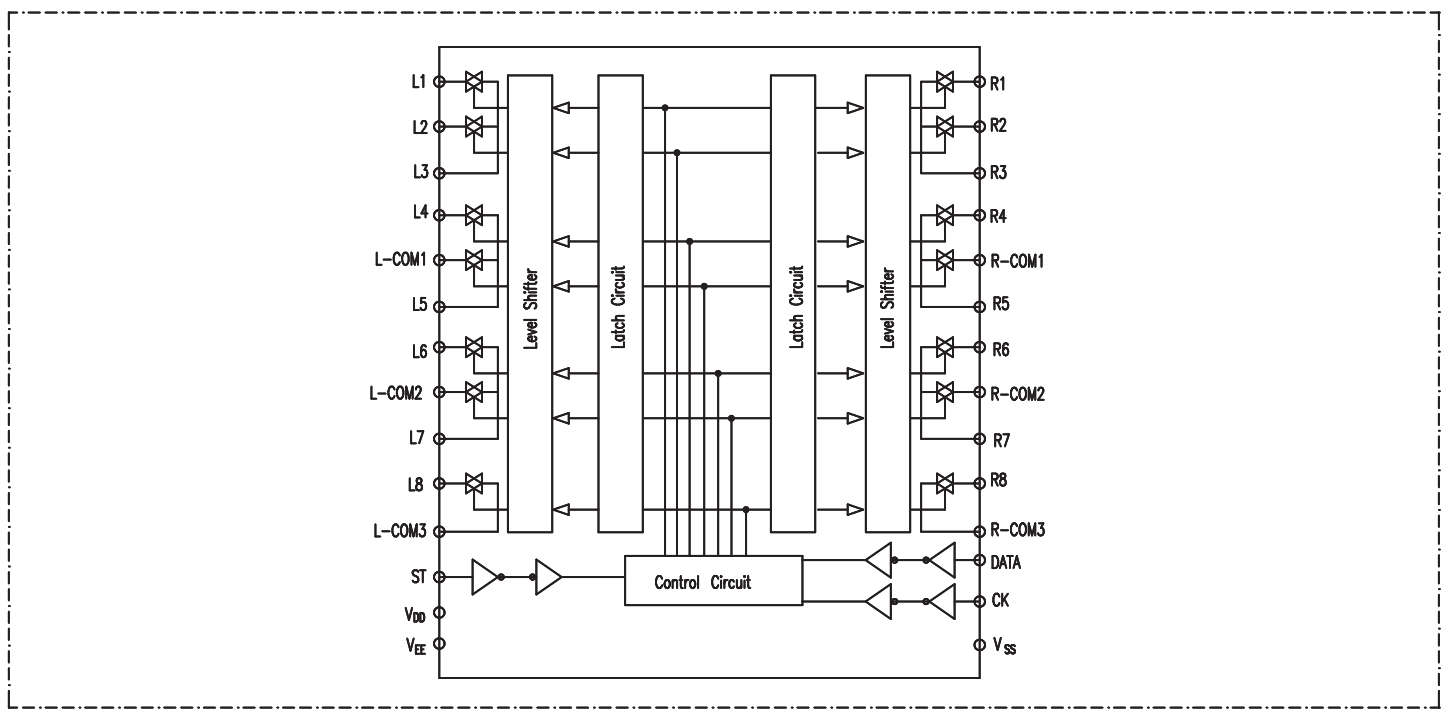

# IC901 : CXP82852 BLOCK DIAGRAM

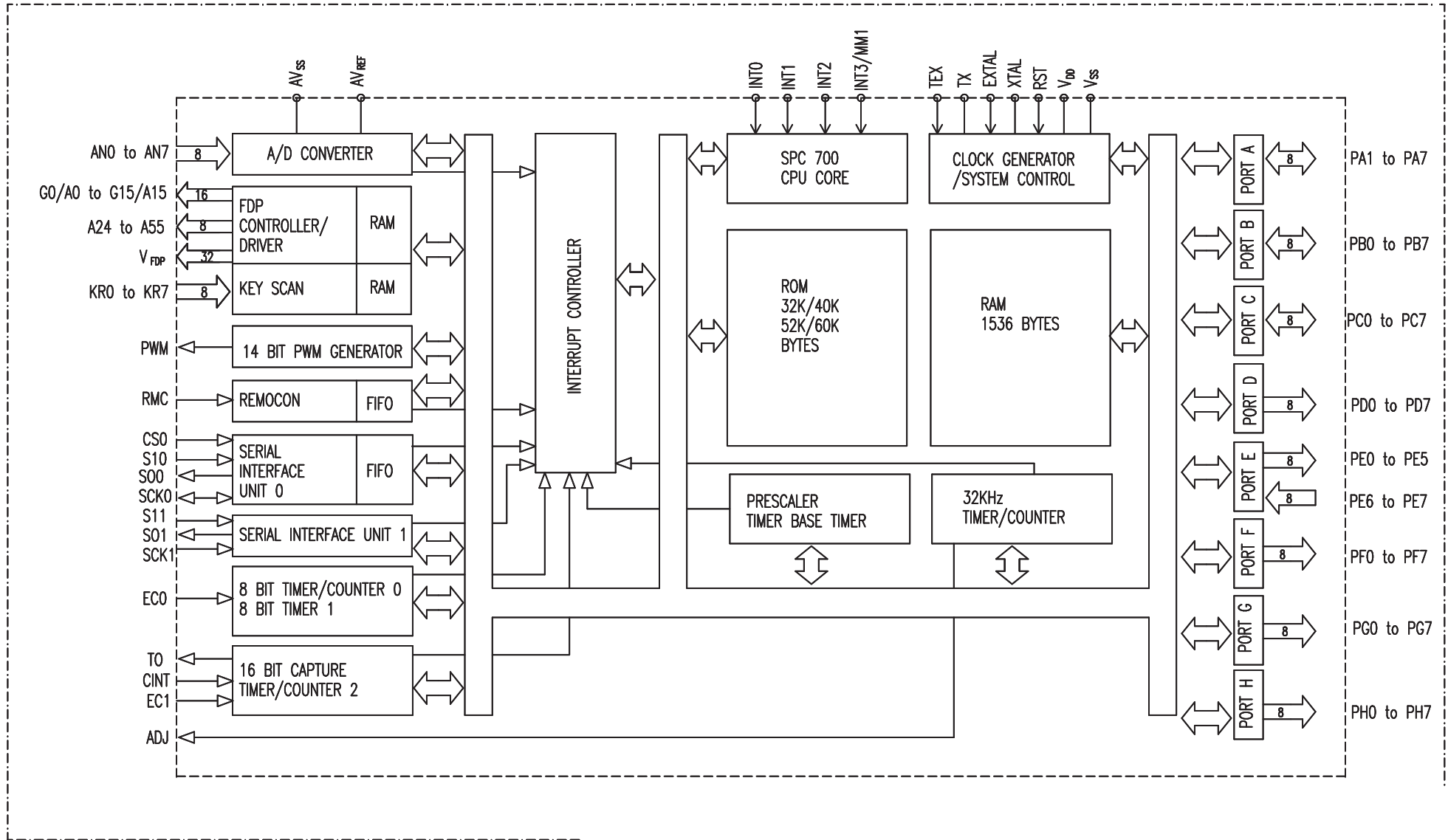

# IC 901 : PIN DESCRIPTION

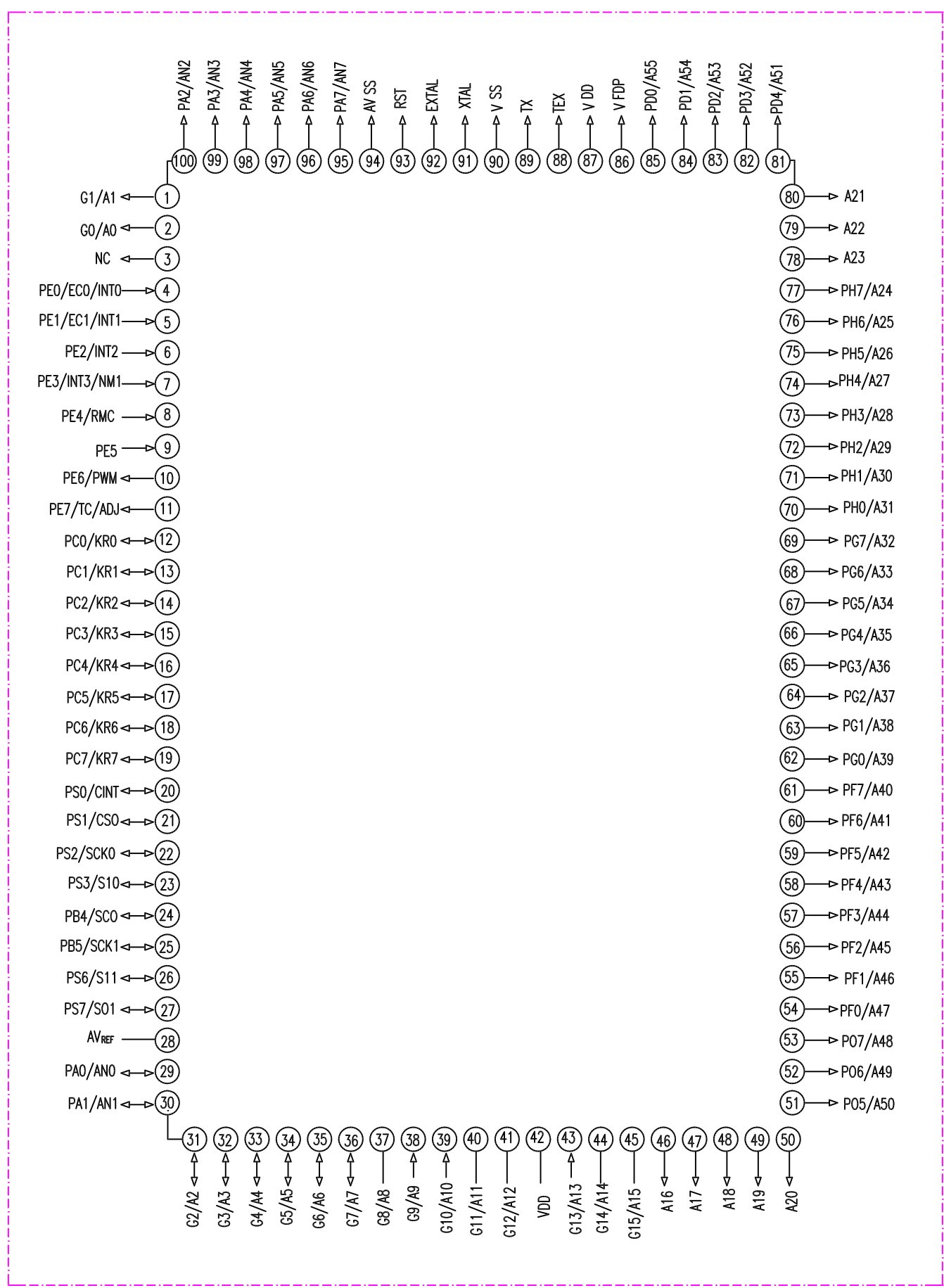

AC-3/DTS RDS RECEIVER CPU PIN CONFIGURATION

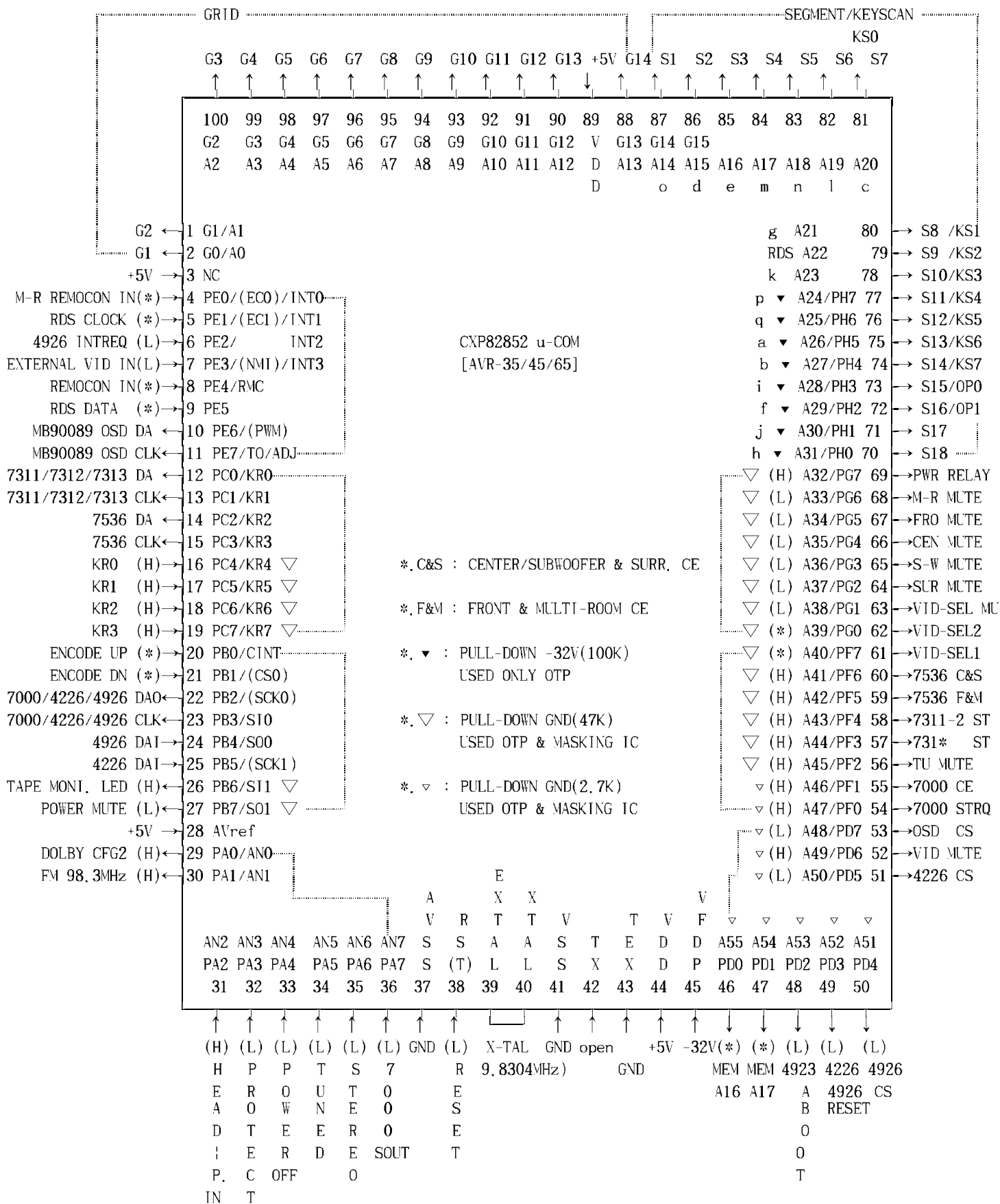

1. KEY MATRIX

	KS0 (81)	KS1 (80)	KS2 (79)	KS3 (78)	KS4 (77)	KS5 (76)	KS6 (75)	KS7 (74)
KR0 (16)	TAPE 0. MONITOR	4. CD	8. DVD	C. VIDI	10. VID2	14. VID3	18. 6CHANNEL	1C. AM/FM
KR1 (17)	TUNING 1. -DOWN	TUNING 5. -UP	PRESET 9. SCAN	PRESET D. -DOWN	PRESET 11. -UP	(RDS) 15. TUN. MODE	DOLBY 19. DIGITAL	DOLBY 1D. PROLOGIC
KR2 (18)	DOLBY 2. 3STEREO	6. HALL1	A. HALL2	E. THEATER	12. DTS	SURR. 16. OFF	1A. MUTE	1E.
KR3 (19)	3. SPEAKER	MULTI 7. -ROOM	DIG. B. SELECT	F. DELAY	DOWN 13. ( ◀ )	UP 17. ( ▶ )	1B. SET	1F. POWER

2. OPTION DEFINITION

	OP0 (73)	OP1 (72)
KR0 (16)	OPTION1	OPTION5
KR1 (17)	OPTION2	
KR2 (18)	OPTION3	OPTION6
KR3 (19)	OPTION4	OPTION7

1) OPTION1 : Not used

2) OPTION2(RDS) : LOW(OPEN) NO FUNCTION  
HIGH(DIODE) FUNCTION

3) OPTION4, OPTION3(MODEL SELECT-1) :

OPTION4	OPTION3	MODEL
LOW	LOW	AVR-35/AVR-45(refer. OPTION7)
LOW	HIGH	AVR-65

4) OPTION5(BAND) : LOW(OPEN) USA 87.5~108.0 , 520~1710  
HIGH(DIODE) EUROPE 87.50~108.00 , 522~1611

5) OPTION6(TV MODE) : LOW(OPEN) NTSC  
HIGH(DIODE) PAL

6) OPTION7(MODEL SELECT-2) : LOW(OPEN) AVR-45  
HIGH(DIODE) AVR-35(Except 6-CH)

3. CS4226, CS4926 PORT INITIAL

- 1) CS4226 : PIN7 SPI/I2C PULL-DOWN(GND)
- 2) CS4926 : PIN4 WR PULL-DOWN(GND)  
PIN5 RD PULL-UP(+3.3V)

## 4. IN/OUT PORT DESCRIPTION

Pin No.	Description	IN/OUT	Active	Function
1	GRID2	OUT	H	VFD GRID OUTPUT. (+5V ~ -32V)
2	GRID1	OUT	H	
3	NC	IN	H	+5V SUPPLY.
4	M-R REMOCON INPUT	IN	*	REMOTE INPUT FROM EXTERNAL MULTI-ROOM REMOTE MODULE. [ONLY 65 SERIES]
5	RDS CLOCK	IN	*	RDS CLOCK INPUT. [ONLY RDS VERSION]
6	CS4923 INTREQ	IN	L	SINGLE PULSE INPUT DURING OPTICAL/COAXIAL DIGITAL SELECTION.
7	EXTERNAL VIDEO INPUT	IN	L	ACTIVE WHEN VIDEO INPUT IS DETECTED FROM VIDEO FUNCTION. (DVD/VIDEO1/VIDEO2/VIDEO3) [ONLY 65 SERIES]
8	REMOCON IN	IN	*	INPUT FROM REMOTE SENSOR IN FRONT OR MULTI-ROOM REMOTE CONTROL.
9	RDS DATA	IN	*	RDS DATA INPUT. [ONLY RDS VERSION]
10	MB90089 OSD DATA	OUT	*	OSD CONTROL SIGNAL OUTPUT. [ONLY 65 SERIES]
11	MB90089 OSD CLOCK	OUT	*	
12	7311/7312/7313 DATA	OUT	*	CONTROL SIGNAL OUTPUT WHILE SELECTING FUNCTION OR SURROUND MODE.
13	7311/7312/7313 CLOCK	OUT	*	
14	7536 DATA	OUT	*	CONTROL SIGNAL OUTPUT DURING TURNING VOLUME.
15	7536 CLOCK	OUT	*	
16	KR0	IN	H	HIGH PULSE INPUT WHILE ANY ONE FUNCTION FROM TAPE MONITOR, CD, DVD, VIDEO1, VIDEO2, VIDEO3, 6-CHANNEL AND AM/FM KEY IS SELECTED.
17	KR1	IN	H	HIGH PULSE INPUT WHILE ANY KEY FROM TUNING-DOWN, TUNING-UP, PRESET SCAN, PRESET-DOWN, PRESET-UP, TUNING MODE(RDS), DOLBY DIGITAL AND DOLBY PROLOGIC IS SELECTED.
18	KR2	IN	H	HIGH PULSE INPUT WHILE ANY ONE KEY FROM THE DOLBY 3 STEREO, HALL1, HALL2, THEATER, TEST-TONE(DTS), SURR OFF AND MUTE KEY IS SELECTED.
19	KR3	IN	H	HIGH PULSE INPUT WHILE ANY ONE KEY FROM THE SPEAKER MODE, CHANNEL(MULTI-ROOM), DIGITAL SELECTION, DELAY TIME, DOWN, UP, SET AND POWER KEY IS SELECTED.
20	ENCODE UP	IN	*	PULSE INPUT WHEN MASTER VOLUME IN FRONT PANEL IS TURNED UP AND DOWN. THERE IS 90° PHASE DIFFERENCE BETWEEN ENCODER UP AND DOWN.
21	ENCODE DOWN	IN	*	
22	4226/4923/7000 DATA	OUT	*	COMMON PORT FOR CONTROL OF TUNER PLL(LM7000), DSP(CS4923), CODEC(CS4226) FOR EXAMPLE, CONTROL SIGNAL OF FREQUENCY SELECTION AT TUNER PLL, FUNCTION SELECTION, SURROUND MODE, SPEAKER MODE, CHANNEL SELECTION, DIGITAL SELECT, DELAY TIME ADJUSTMENT ETC.
23	4226/4923/7000 CLOCK	OUT	*	
24	4923 DATA INPUT	IN	*	PULSE INPUT FROM DSP IC AT OPTICAL/COAXIAL DIGITAL SELECTION.
25	4226 DATA INPUT	IN	*	PULSE INPUT FROM CODEC IC AT OPTICAL/COAXIAL DIGITAL SELECTION.
26	TAPE MONITOR LED	OUT	H	OUTPUT WHEN TAPE MONITOR IS ON.
27	POWER MUTE	OUT	L	PULSE OUTPUT WHILE FUNCTION OR SURROUND MODE IS SELECTED AT POWER-ON OR HEAD PHONE JACK IN STATUS.

Pin No.	Description	IN/OUT	Active	Function
28	AVref	IN	H	+5V SUPPLY
29	DOLBY CFG2	OUT	H	HIGH AT CONFIGURATION 2 IN DOLBY DIGITAL AND SUB-WOOFER OFF IN DTS. CONFIGURATION 2 IS AS BELOW: SPEAKER MODE : FRONT CENTER SURROUND SUBWOOFER LARGE SMALL SMALL ON/OFF LARGE SMALL NONE ON/OFF LARGE NONE SMALL ON/OFF LARGE NONE NONE ON/OFF NOTE: NO RELATION WITH DOLBY PRO LOGIC MODE.
30	FM 98.3	OUT	H	HIGH WHILE TUNER FREQUENCY IS 98.30MHz.
31	HEAD-PHONE INPUT	IN	H	HIGH WHILE HEAD-PHONE JACK IS INSERTED.
32	PROTECT	IN	L	LOW INPUT AT PROTECTION MODE. THIS CAN BE RESET BY POWER ON AGAIN AFTER TAKING OFF PROTECTION PROBLEMS.
33	POWER OFF	IN	L	LOW INPUT WHILE DETECTING POWER OFF
34	TUNED	IN	L	LOW INPUT WHEN STATION IS TUNED.
35	STEREO	IN	L	LOW WHEN THE TUNER RECEPTION IS STEREO.
36	7000 SOUT	IN	L	LOW PULSE INPUT WHILE STATION IS TUNED AT AUTO-TUNING MODE.
37	AVSS	IN	L	GND.
38	RESET	IN	L	LOW PULSE INPUT AT THE MOMENT OF POWER ON AND OFF. BACKUP IS ACTIVATED ONLY WHEN THIS PORT IS HIGH AT POWER OFF (POWER OFF PORT IS LOW).
39	EXTAL	IN	*	u-COM X-TAL INPUT. (9.8304MHz)
40	XTAL	IN	*	
41	VSS	IN	L	GND.
42	TX	IN	open	OPEN
43	TEX	IN	L	GND.
44	VDD	IN	H	+5V POWER SUPPLY. BACKUP IS ACTIVATED WHEN THIS PORT IS HIGH AT POWER OFF (POWER OFF PORT IS LOW).
45	VFDP	IN	-32V	-32V POWER SUPPLY TO VFD
46	MEMORY ADDRESS16	OUT	H/L	ADDR.17 ADDR.16 SURROUND MODE LOW LOW DOLBY DIGITAL/PROLOGIC/3 STEREO/SURR OFF LOW HIGH HALL1/HALL2/THEATER HIGH LOW DTS : ONLY 65 SERIES HIGH HIGH DTS : ONLY 65 SERIES
47	MEMORY ADDRESS17	OUT	H/L	
48	CS4923 ABOUT	OUT	L	LOW PULSE OUTPUT WHILE ANY ONE FROM POWER, FUNCTION, SURROUND MODE OR DIGITAL SELECT IS SELECTED.
49	4226/4923 RESET	OUT	L	
50	CS4923 CS	OUT	L	LOW PULSE OUT WHILE ANY ONE FROM POWER, FUNCTION, SURROUND MODE, SPEAKER MODE, CHANNEL, DIGITAL SELECT AND DELAY TIME IS SELECTED. IT IS CHIP SELECTION PORT OF CS4923(DSP), CS4226(CODEC).
51	CS4226 CS	OUT	L	
52	VID MUTE	OUT	H	KEEP HIGH LEVEL FOR 4 SECONDS AT POWER-ON.
53	OSD CS	OUT	L	CONTROL SIGNAL OUTPUT FOR OSD IC. [ONLY 65 SERIES]
54	7000 STRQ	OUT	H	HIGH PULSE OUT AT AUTO TUNING MODE.
55	7000 CE	OUT	H	CONTROL SIGNAL OUTPUT WHILE THE FREQUENCY IS CHANGED AT TUNER FUNCTION. IT IS CHIP ENABLE PORT CONTROL OF LM7000.



Pin No.	Description	IN/OUT	Active	Function
56	TUNER MUTE	OUT	H	HIGH PULSE OUT WHILE THE FREQUENCY IS CHANGED AT TUNER FUNCTION.
57	731* ST	OUT	H	STROBE(ENABLE) TO 7311-1, 7312, 7313
58	7311-2 ST	OUT	H	STROBE(ENABLE) TO 7311-2
59	7536 F&M	OUT	H	CHIP ENABLE OF FRONT L/R, MULTI-ROOM L/R VOLUME. HIGH PULSE OUTPUT AT VOLUME ADJUSTMENT.
60	7536 C&S	OUT	H	CHIP ENABLE CENTER, SUB-WOOFER, SURROUND L/R VOLUME. WHEN CONTROL THE VOLUME, IT WILL BE HIGH PULSE OUTPUT.
61	VID-SEL1	OUT	H/L	SEL2 SEL1 VIDEO FUNCTION LOW LOW VIDEO3 LOW HIGH VIDEO2
62	VID-SEL2	OUT	H/L	HIGH LOW DVD HIGH HIGH VIDEO1
63	VID-SEL MU	OUT	L	LOW PULSE OUT AT SELECTING VIDEO FUNCTION.
64	SURROUND MUTE	OUT	L	LOW PULSE OUT AT SELECTING POWER, FUNCTION, SURROUND MODE, SPEAKER MODE AND DIGITAL SELECT. BUT LOW OUTPUT AT SELECTING SURROUND SPEAKER MODE "NONE".
65	SUBWOOFER MUTE	OUT	L	LOW PULSE OUT AT SELECTING POWER, FUNCTION, SURROUND MODE, SPEAKER MODE AND DIGITAL SELECT. BUT LOW OUTPUT AT SELECTING SUB-WOOFER MODE "NONE".
66	CENTER MUTE	OUT	L	LOW PULSE OUT AT SELECTING POWER, FUNCTION, SURROUND MODE, SPEAKER MODE AND DIGITAL SELECT. BUT LOW OUTPUT AT SELECTING CENTER SPEAKER MODE "NONE".
67	FRONT MUTE	OUT	L	LOW PULSE OUT AT SELECTING POWER, FUNCTION, SURROUND MODE, SPEAKER MODE AND DIGITAL SELECT. BUT LOW OUTPUT AT MUTE OR VOLUME LEVEL IS -64dB.
68	MULTI-ROOM MUTE	OUT	L	LOW PULSE OUT AT SELECTING MULTI-ROOM ON/OFF, MULTI-ROOM FUNCTION. BUT LOW OUTPUT AT MULTI-ROOM OR MULTI-ROOM LEVEL IS -64dB. (ONLY 65 SERIES)
69	POWER RELAY	OUT	H	HIGH OUTPUT AT STAND-BY POWER SWITCH ON
70	SEG18	OUT	H	PULSE OUTPUT FOR VFD SEGMENT. (+5V ~ -32V)
71	SEG17	OUT	H	
72	SEG16/ OPTION1	OUT	H	HIGH PULSE OUT FOR CHECKING SYSTEM OPTION AT POWER ON, AND HIGH PULSE FOR VFD SEGMENT. (+5V ~ -32V)
73	SEG15/ OPTION0	OUT	H	
74	SEG14/KS7	OUT	H	
75	SEG13/KS6	OUT	H	PULSE OUTPUT FOR KEY SCAN AND VFD SEGMENT. (+5V ~ -32V)
76	SEG12/KS5	OUT	H	
77	SEG11/KS4	OUT	H	
78	SEG10/KS3	OUT	H	
79	SEG9/KS2	OUT	H	
80	SEG8/KS1	OUT	H	
81	SEG7/KS0	OUT	H	
82	SEG6	OUT	H	
83	SEG5	OUT	H	
84	SEG4	OUT	H	

Pin No.	Description	IN/OUT	Active	Function
85	SEG3	OUT	H	PULSE OUTPUT FOR VFD SEGMENT. (+5V ~ -32V)
86	SEG2	OUT	H	
87	SEG1	OUT	H	
88	GRID14	OUT	H	VFD GRID SUPPLY. (+5V ~ -32V)
89	VDD	OUT	H	+5V POWER SUPPLY. HIGH OUT FOR BACKUP AT POWER OFF (POWER OFF PORT IS LOW).
90	GRID13	OUT	H	
91	GRID12	OUT	H	
92	GRID11	OUT	H	
93	GRID10	OUT	H	
94	GRID9	OUT	H	
95	GRID8	OUT	H	
96	GRID7	OUT	H	
97	GRID6	OUT	H	
98	GRID5	OUT	H	
99	GRID4	OUT	H	
100	GRID3	OUT	H	

TYPE : CM1684C

ANODE & GRID ASSIGNMENT

G1	G2	G3	G4	G5	G6	G7	G8	G9	G10	G11	G12	G13	G14
SLEEP	RDS	PTY	CT	RT	TUNED		MONO	STEREO		AUTO	MEMORY		PRESET
MUTE													
BYPASS													
DSP	DIGITAL	PRO LOGIC	3 STEREO	HALL1	HALL2	THEATER	DTS	MPEG					
ANALOG	OPT.	COAX	AC-3	PCM	MULTI	NIGHT	DISPLAY	VMAx					

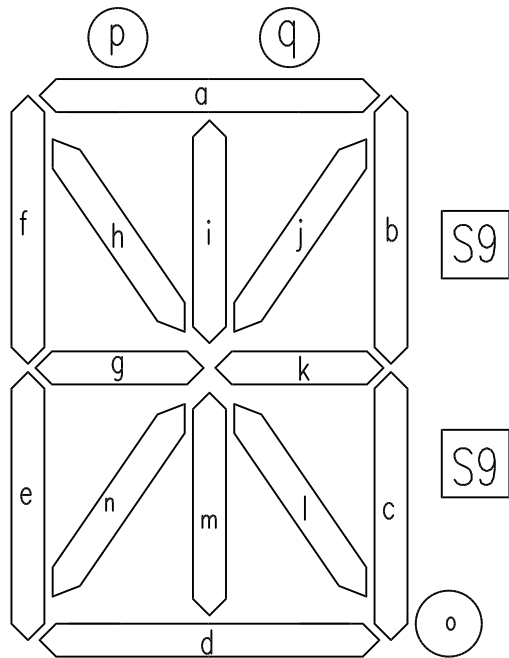

G2~G13

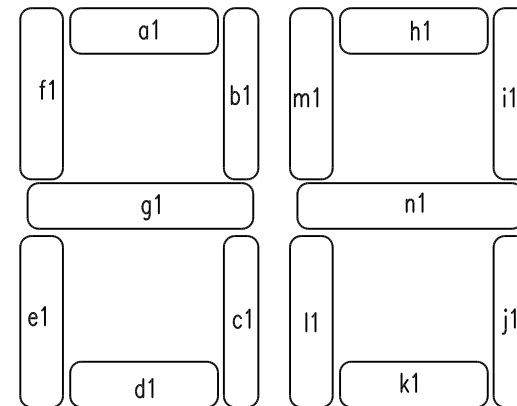

G14

TYPE: CM1684C  
ANODE & GRID ASSIGNMENT

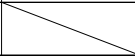
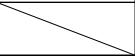
	G1	G2	G3	G4	G5	G6	G7	G8	G9	G10	G11	G12	G13	G14
S1	THEATER	o	o	o	o	o	o	o	o	o	o	o	o	MPEG
S2	HALL 2	d	d	d	d	d	d	d	d	d	d	d	d	DTS
S3	HALL 1	e	e	e	e	e	e	e	e	e	e	e	e	k1
S4	3-STEREO	m	m	m	m	m	m	m	m	m	m	m	m	d1
S5	PLO LOGIC	n	n	n	n	n	n	n	n	n	n	n	n	e1
S6	DIGITAL	i	i	i	i	i	i	i	i	i	i	i	i	c1
S7	DISPLAY	c	c	c	c	c	c	c	c	c	c	c	c	l1
S8	NIGHT	g	g	g	g	g	g	g	g	g	g	g	g	J1
S9	MULTI	RDS	PTY	CT	RT	TUNED		MONO	STEREO		AUTO	MEMORY		VMAX
S10	PCM	k	k	k	k	k	k	k	k	k	k	k	k	g1
S11	SLEEP	p	p	p	p	p	p	p	p	p	p	p	p	PRESET
S12	MUTE	q	q	q	q	q	q	q	q	q	q	q	q	a1
S13	BYPASS	a	a	a	a	a	a	a	a	a	a	a	a	h1
S14	DSP	b	b	b	b	b	b	b	b	b	b	b	b	i1
S15	ALALOG	i	i	i	i	i	i	i	i	i	i	i	i	m1
S16	OPT	f	f	f	f	f	f	f	f	f	f	f	f	f1
S17	COAX	j	j	j	j	j	j	j	j	j	j	j	j	b1
S18	AC-3	h	h	h	h	h	h	h	h	h	h	h	h	n1

PIN ASSIGNMENT

Pin No.	1	2	3	4	5	6	7	8	9	10	11	12	13	14	15	16	17	18	19~33	34	
Assignment	F1	F1	NP	NL	G1	G2	G3	G4	G5	G6	G7	G8	G9	G10	G11	G12	G13	G14	NL	S1	
Pin No.	35	36	37	38	39	40	41	42	43	44	45	46	47	48	49	50	51	52	53	54	55
Assignment	S2	S3	S4	S5	S6	S7	S8	G4	S10	S11	S12	S13	S14	S15	S16	S17	S18	NL	NP	F2	F2

F1, F2 : Filament G1 ~ G14 : Grid S1 ~ S18 : Anode NL : No Lead NP : No Pin

# AVR-45 SCHEMATIC DIAGRAM (MAIN AMP P.C.Board)

(FRONT & CENTER) MAIN AMP ASS'Y

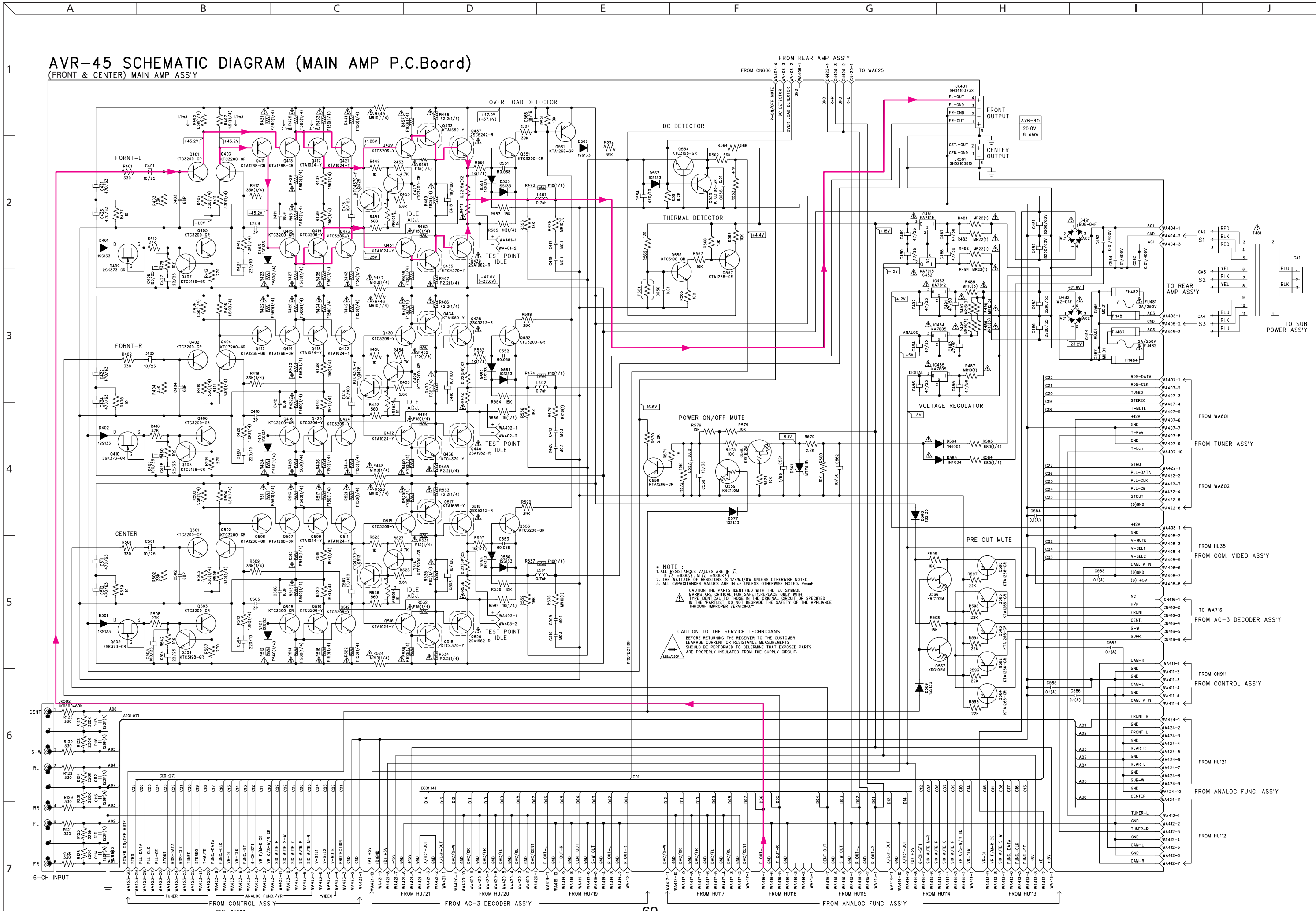

NOTE:  
 1. ALL RESISTANCE VALUES ARE IN  $\Omega$ .  
 2. THE WATTAGE OF RESISTORS IS 1/4W./1/8W UNLESS OTHERWISE NOTED.  
 3. ALL CAPACITANCE VALUES ARE IN  $\mu$ F UNLESS OTHERWISE NOTED. P.P.M.F.

CAUTION THE PARTS IDENTIFIED WITH THE IEC SYMBOL MARKS ARE CRITICAL FOR SAFETY. REPLACE ONLY WITH TYPE IDENTICAL TO THOSE IN THE ORIGINAL CIRCUIT OR SPECIFIED IN THE "PARTS LIST" DO NOT DEGRADE THE SAFETY OF THE APPLIANCE THROUGH IMPROPER SERVING.

CAUTION TO THE SERVICE TECHNICIANS BEFORE RETURNING THE RECEIVER TO THE CUSTOMER LEAKAGE CURRENT OR RESISTANCE MEASUREMENTS SHOULD BE PERFORMED TO DETERMINE THAT EXPOSED PARTS ARE PROPERLY INSULATED FROM THE SUPPLY CIRCUIT.

# AVR-45 SCHEMATIC DIAGRAM (REAR AMP. C-VIDEO. SUB P.C.Board)

REAR AMP ASS'Y

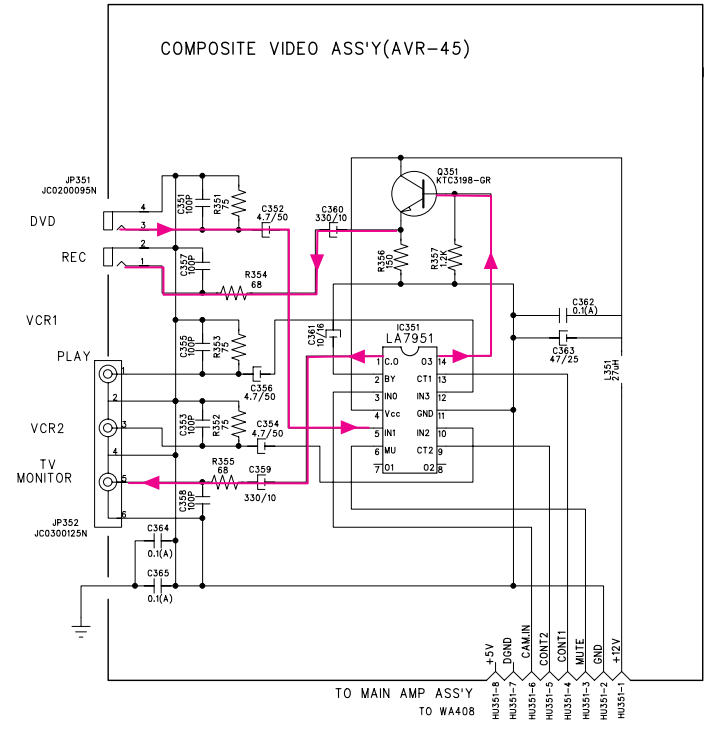
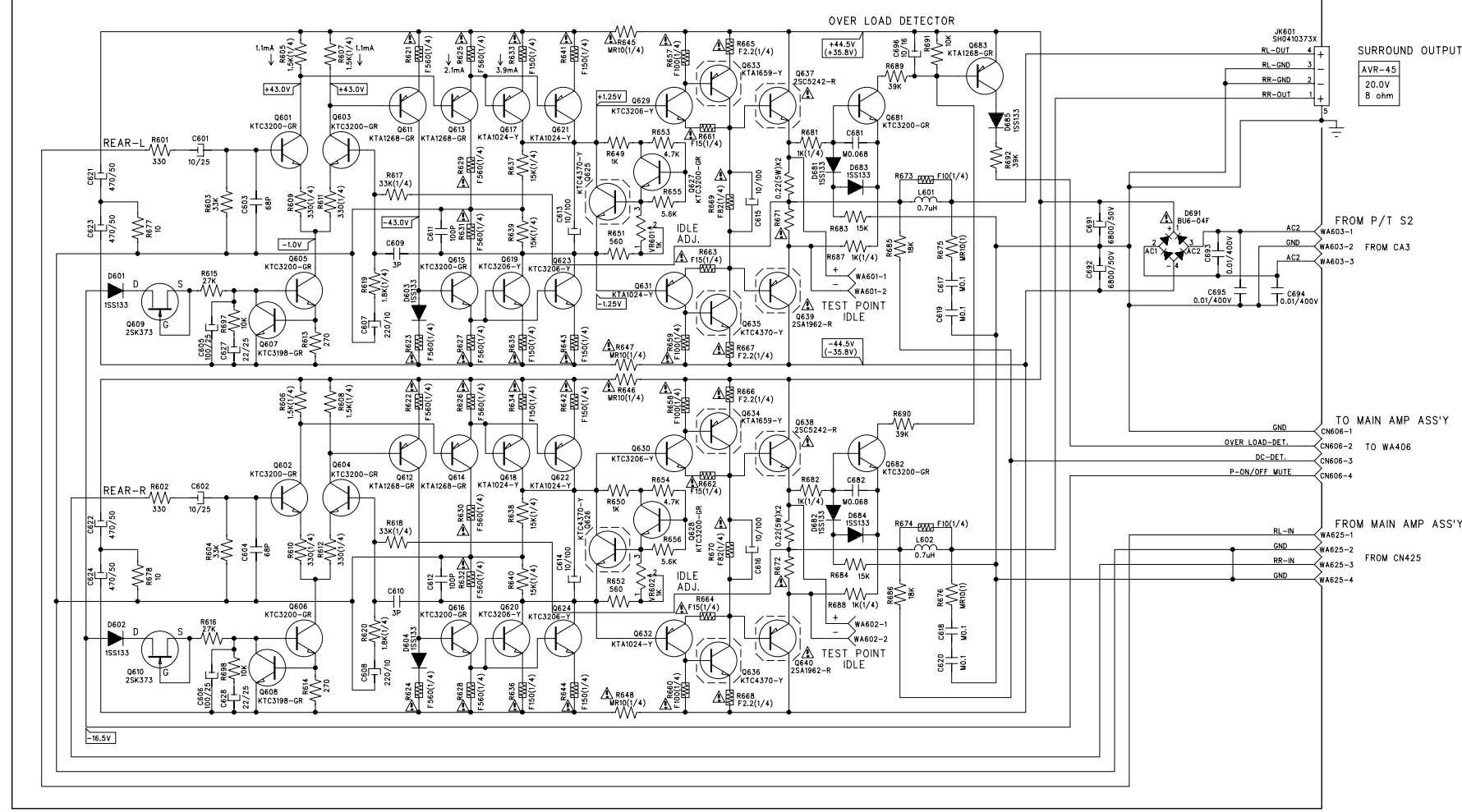

COMPOSITE & S-VIDEO

INPUT	FUNCTION	MUTE	CT1	CT2	OUTPUT
OTHER	L	L	L	L	OFF
CAMCODER	H	L	L	L	CAMCODER
VCR	H	H	H	H	VCR
VCR1	H	H	H	H	VCR1 OFF

SUB POWER SUPPLY ASS'Y

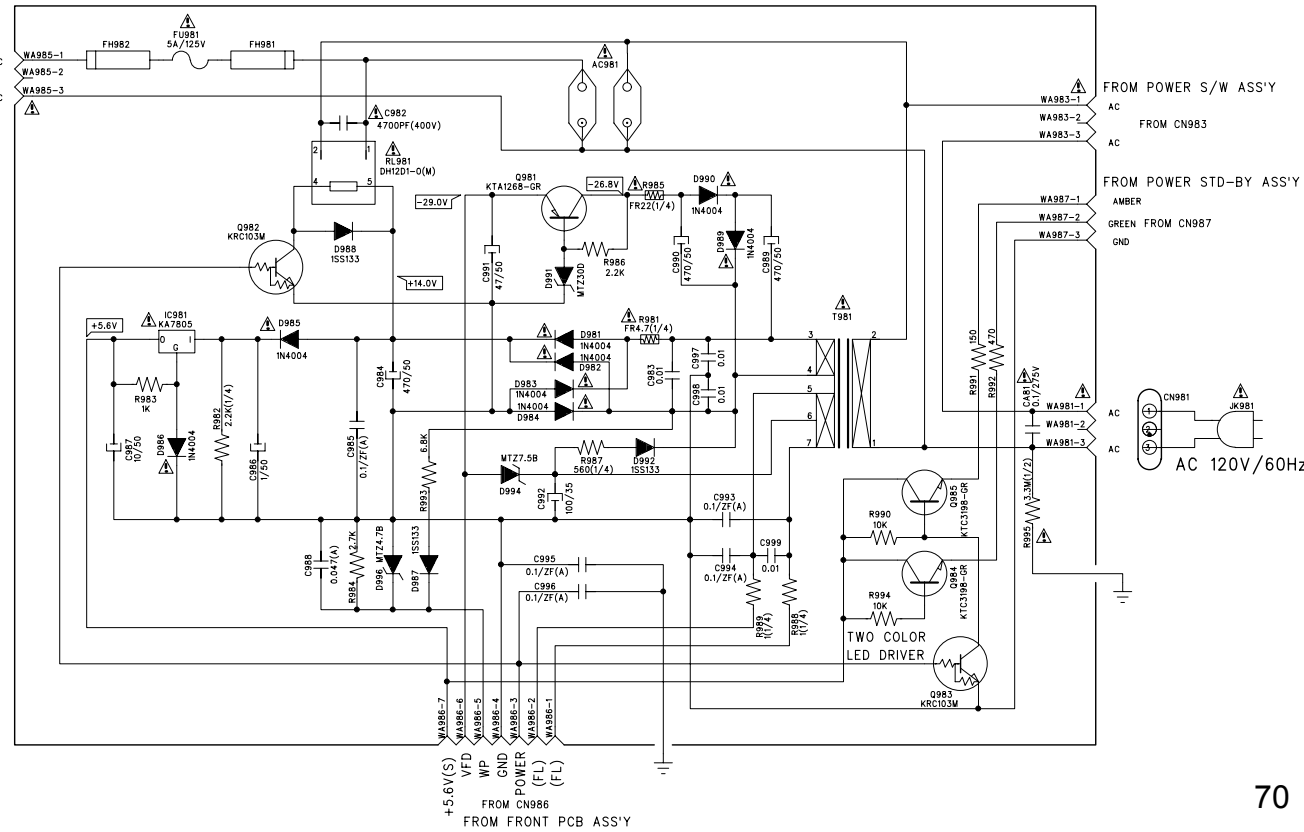

# AVR-45 SCHEMATIC DIAGRAM (DSP1 P.C.Board)

DSP1 ASS'Y

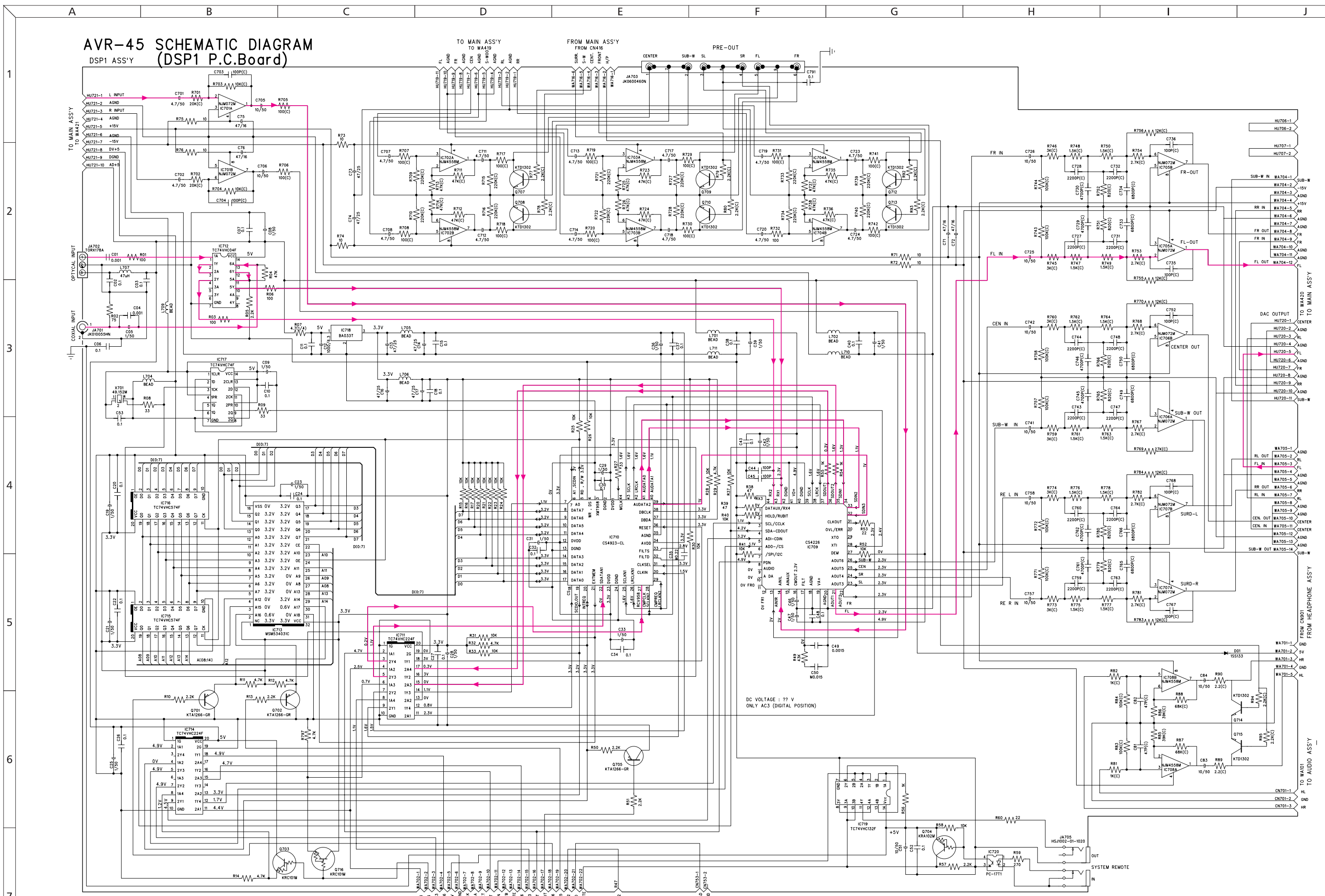

A B C D E F G H I J

1

2

3

4

5

6

7

### AVR-45 SCHEMATIC DIAGRAM (DSP2 P.C.Board)

DSP2 ASS'Y

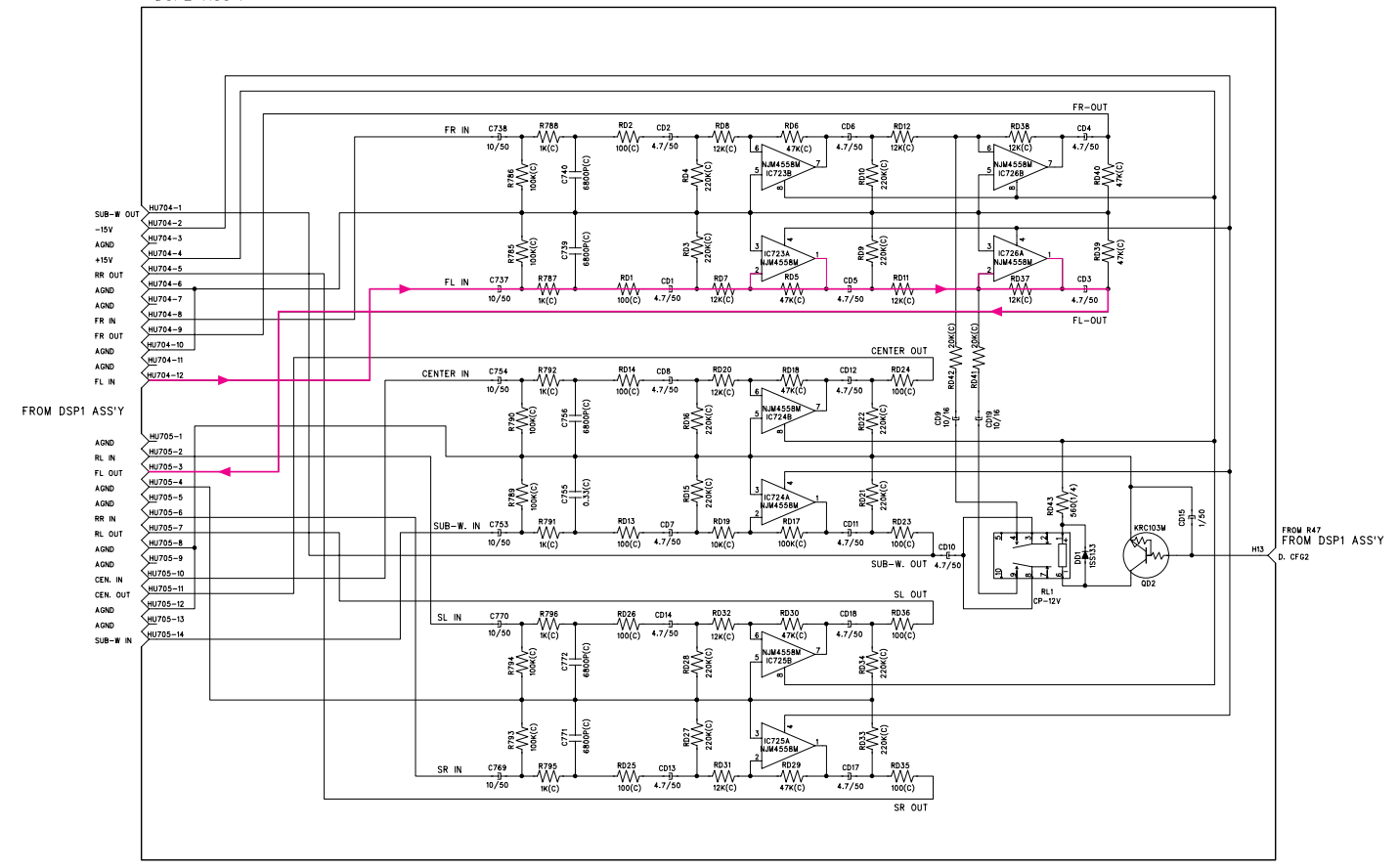



# AVR-45 SCHEMATIC DIAGRAM (AUDIO INPUT P.C.Board) AUDIO INPUT ASS'Y

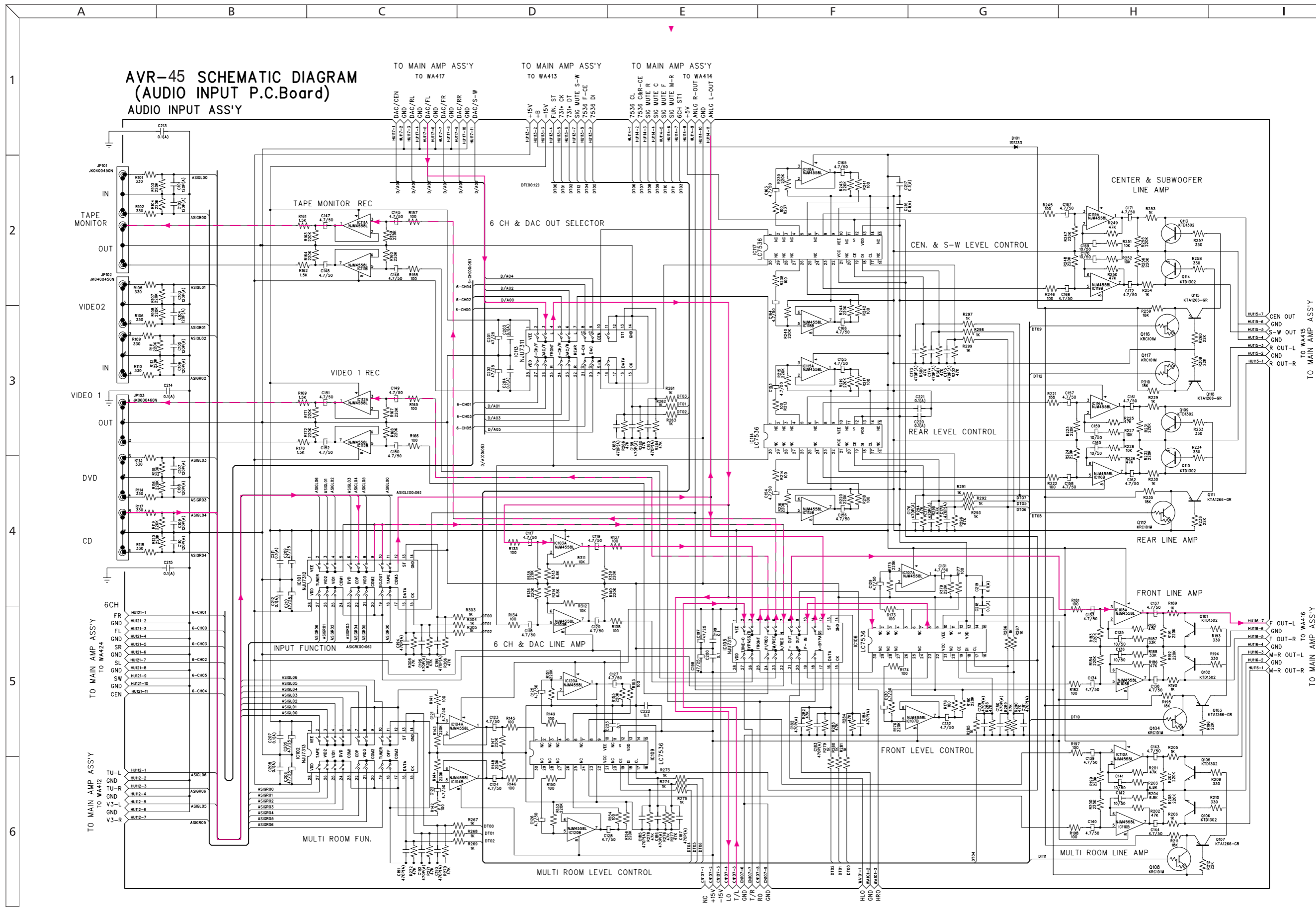

# AVR-45 TUNER SCHEMATIC DIAGRAM (TUNER P.C.Board)

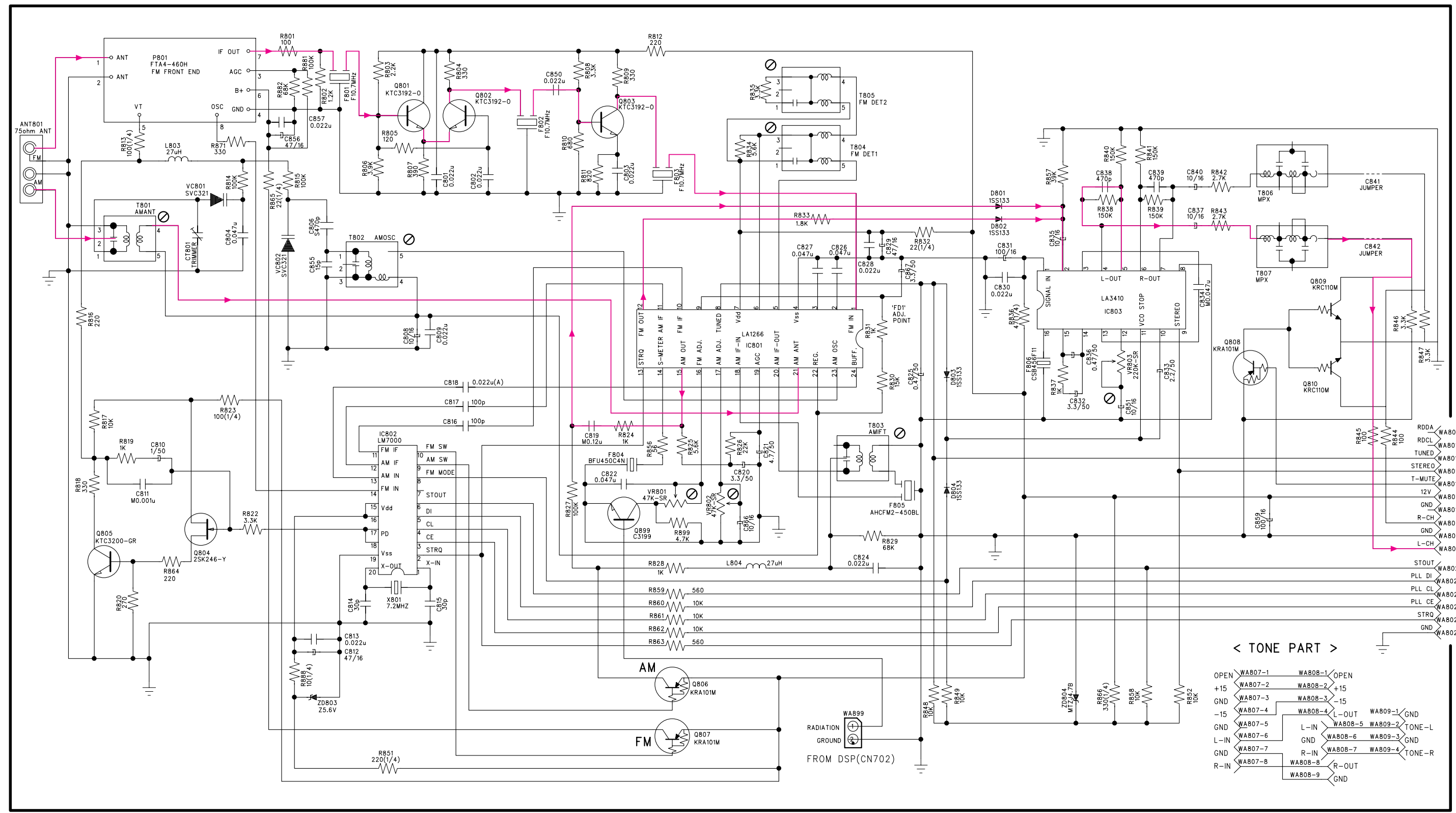

**< TONE PART >**

OPEN	WAB07-1	WAB08-1	OPEN
+15	WAB07-2	WAB08-2	+15
GND	WAB07-3	WAB08-3	-15
-15	WAB07-4	WAB08-4	L-OUT
WAB07-5	WAB08-5	WAB09-1	GND
L-IN	WAB08-6	WAB09-2	TONE-L
GND	WAB08-7	WAB09-3	GND
WAB07-7	R-IN	WAB08-7	WAB09-4
GND	WAB08-8	WAB09-4	TONE-R
R-IN	WAB08-9	R-OUT	
		GND	

1

AVR-45 u-COM & F.L.DISPLAY SCHEMATIC DIAGRAM (FRONT P.C.Board)

2

3

4

5

6

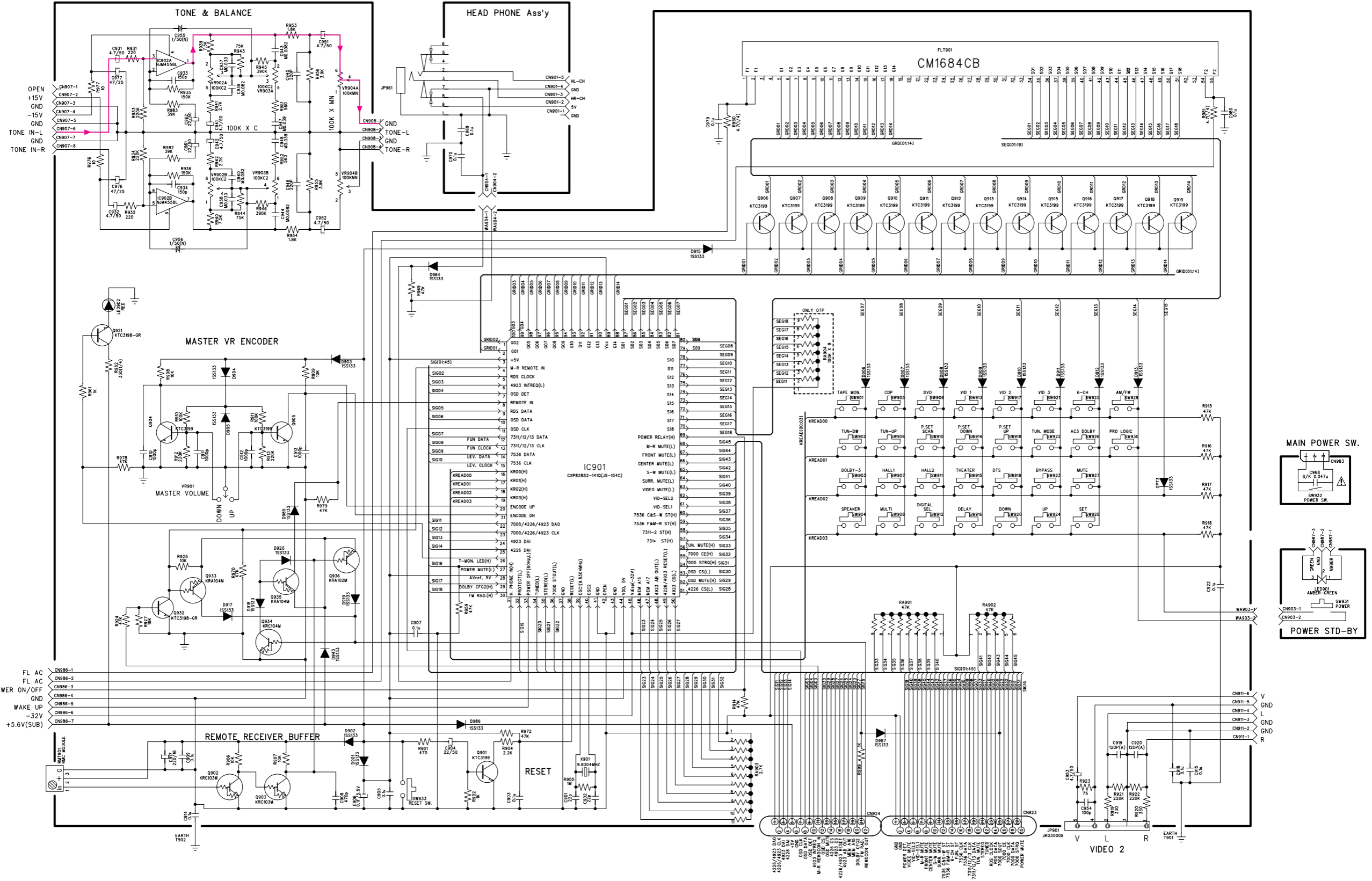

# AVR-45 RDS/45SG SCHEMATIC DIAGRAM (MAIN AMP P.C.Board)

(FRONT & CENTER) MAIN AMP ASS'Y

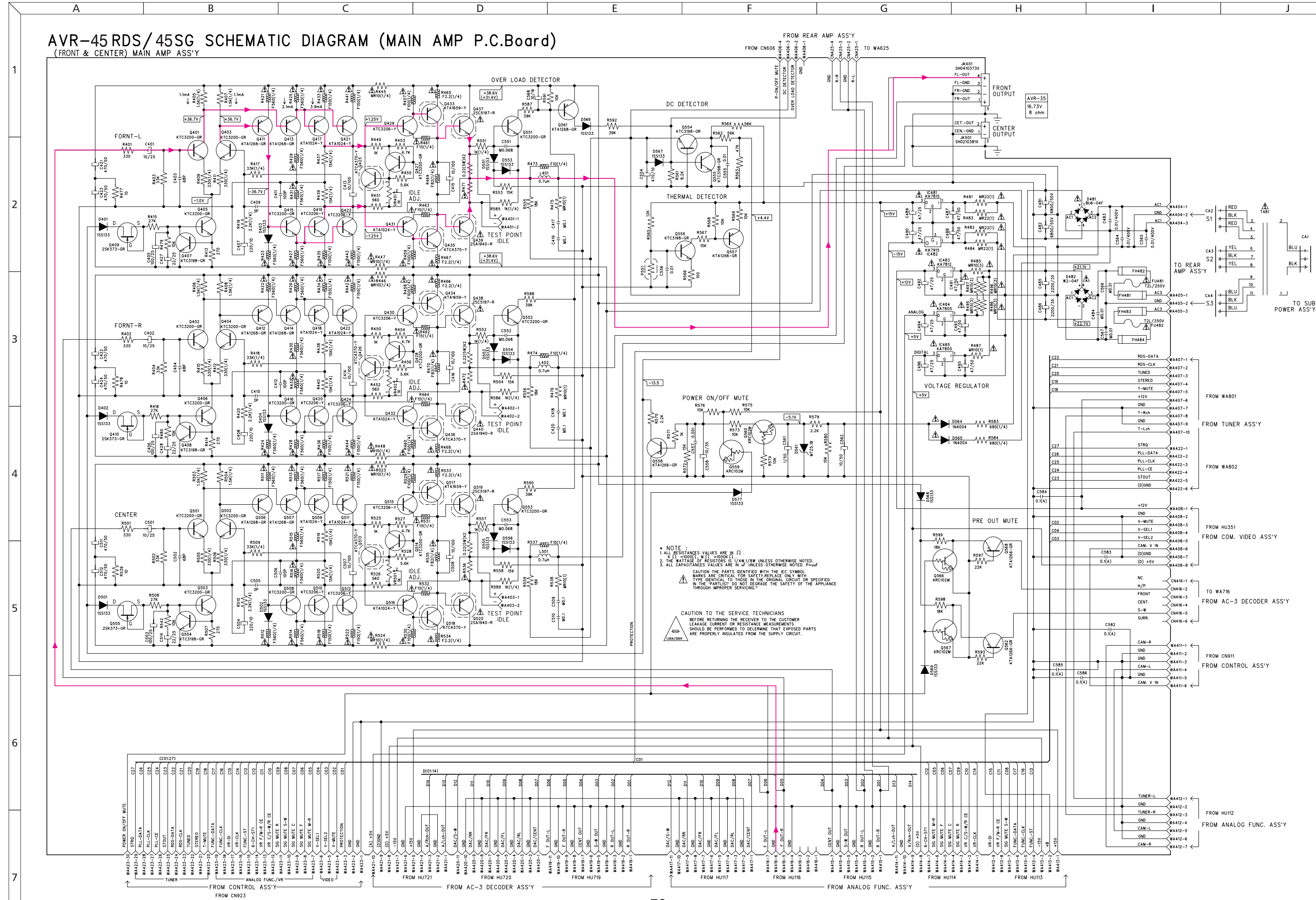

# AVR-45RDS/45SG SCHEMATIC DIAGRAM (REAR AMP. C-VIDEO. SUB P.C.Board)

REAR AMP ASS'Y

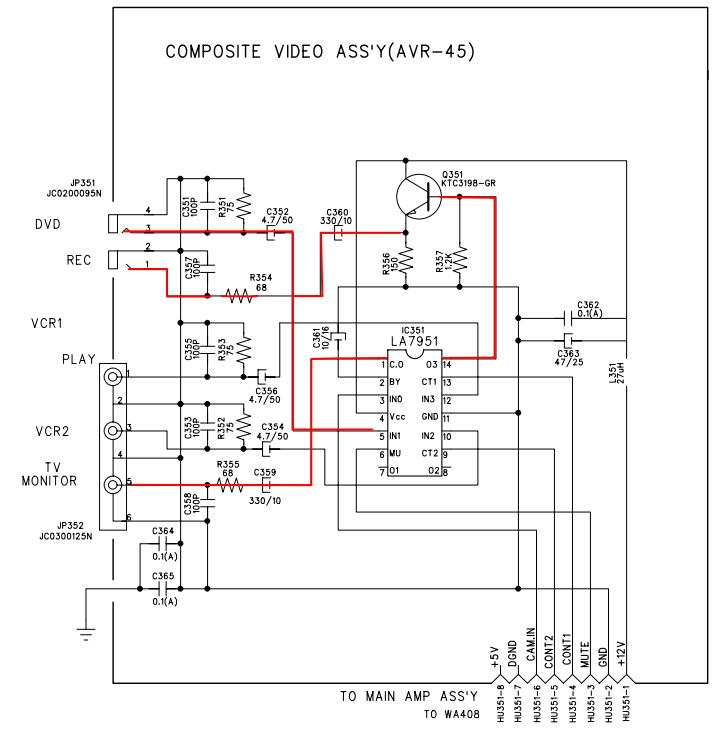
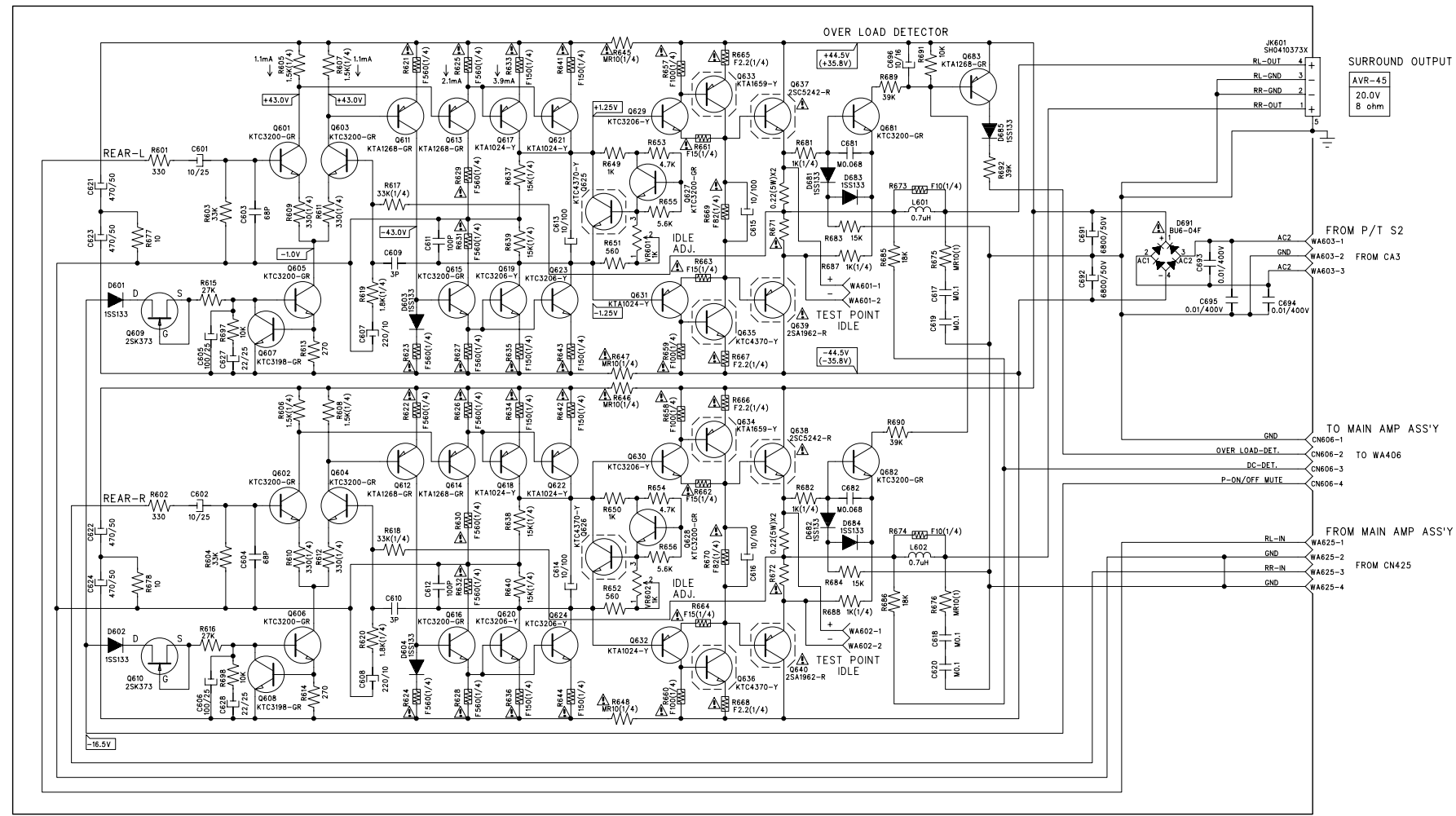

COMPOSITE & S-VIDEO

INPUT	FUNCTION	CONTROL	MUTE	CT1	CT2	S-OUTPUT
OTHER	L	+	+	+	+	OFF
COMCODER	H	L	L	L	L	CAMCODER
LDIP	H	H	H	H	H	LDIP
LVCR1	H	H	H	H	H	LVCR1 OFF

SUB POWER SUPPLY ASS'Y

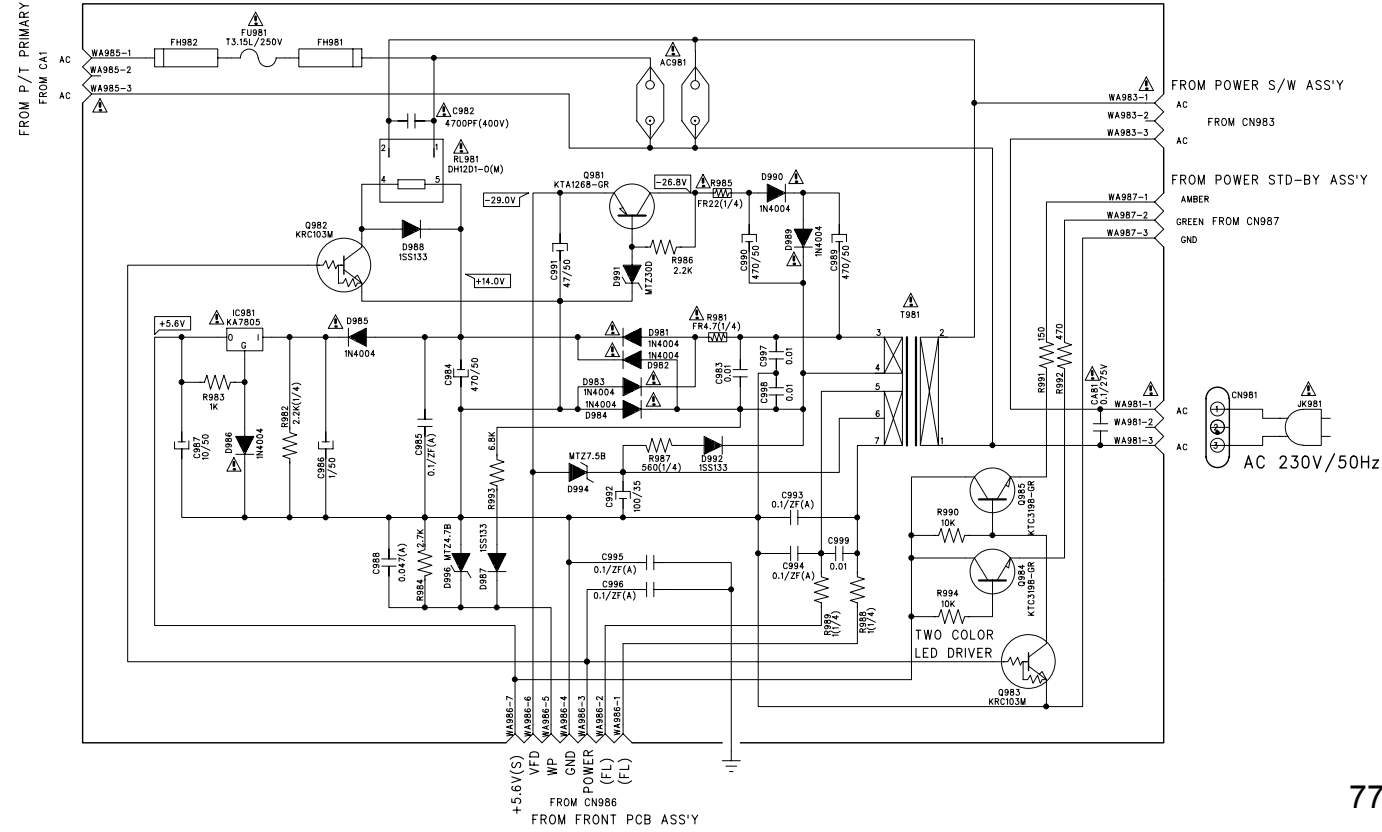

# AVR-45RDS/45SG SCHEMATIC DIAGRAM (DSP1 P.C.Board)

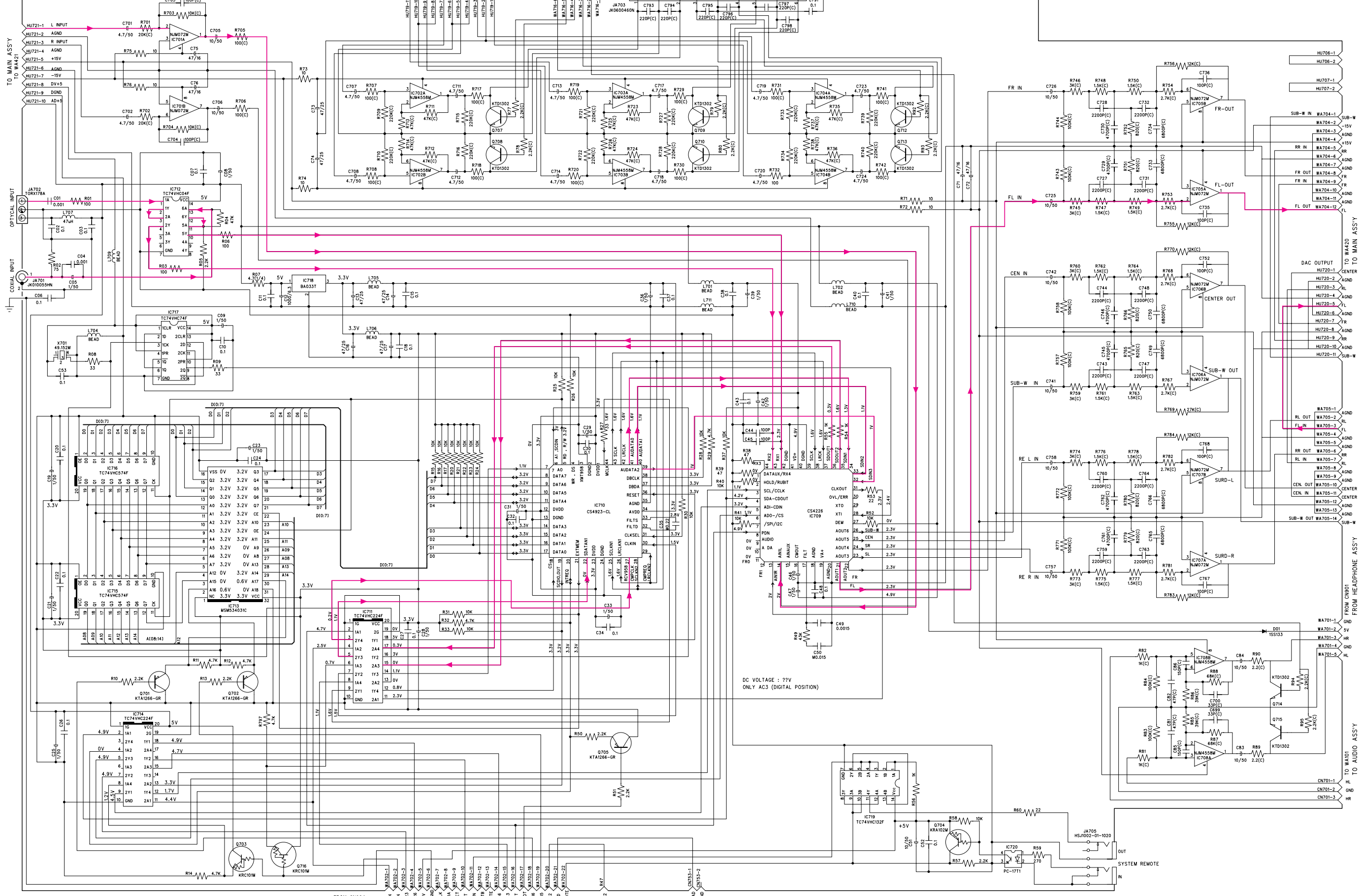

A B C D E F G H I J

1

### AVR-45RDS/45SG SCHEMATIC DIAGRAM (DSP2 P.C.Board)

2

DSP2 ASS'Y

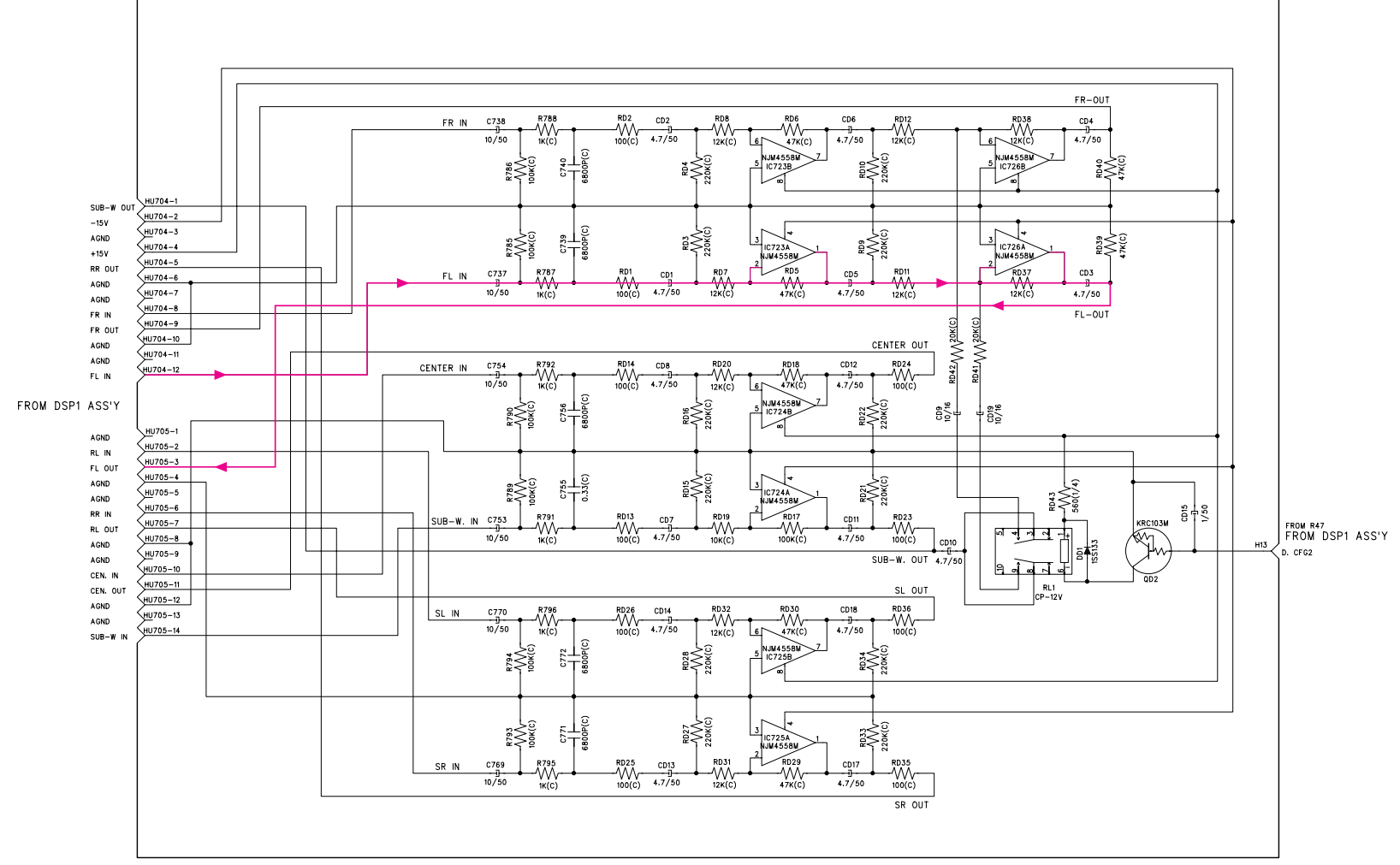

3

4

5

6

7

# AVR-45RDS/45SG SCHEMATIC DIAGRAM (AUDIO INPUT P.C.Board)

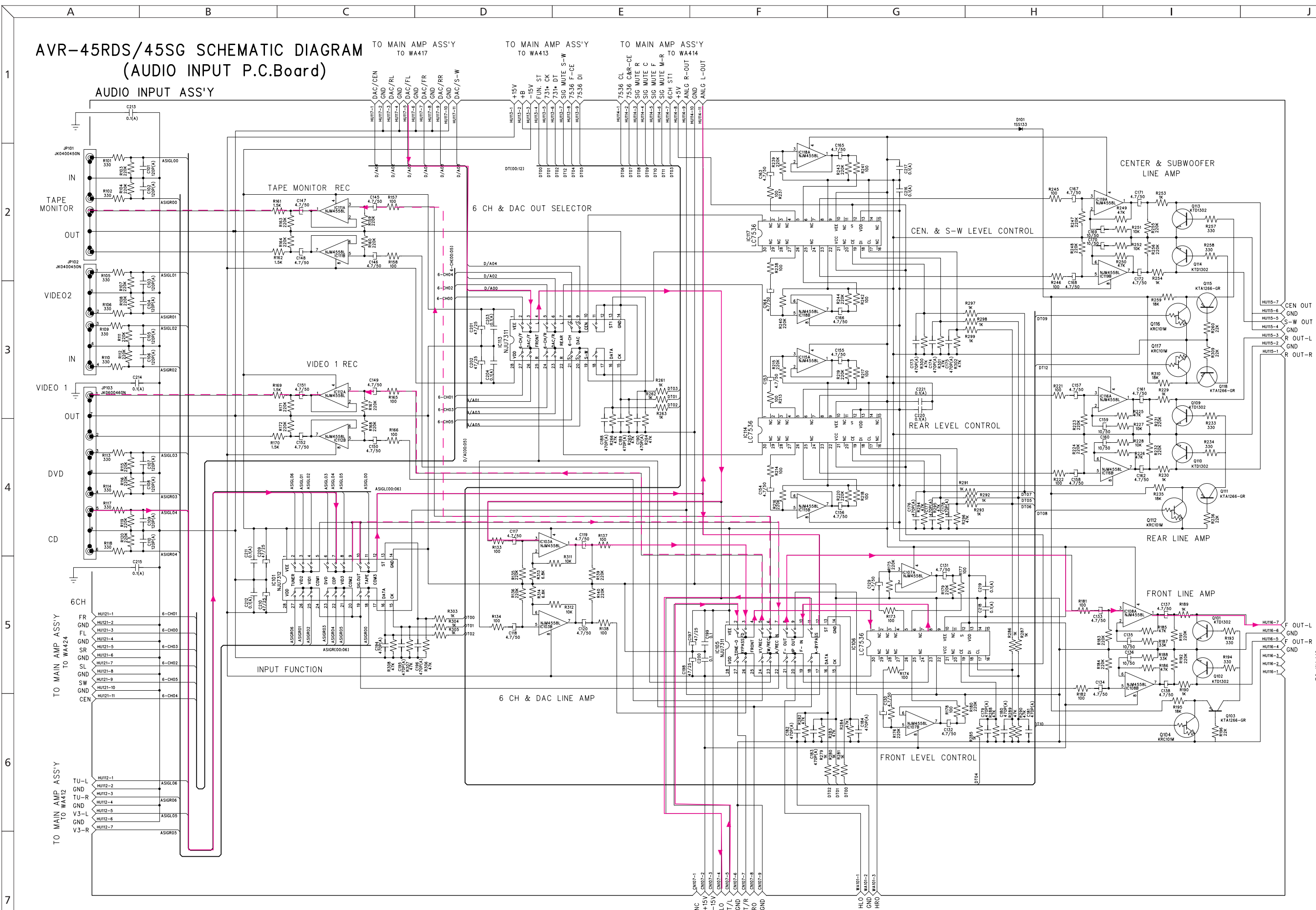



# AVR-45RDS TUNER SCHEMATIC DIAGRAM (TUNER P.C.Board)

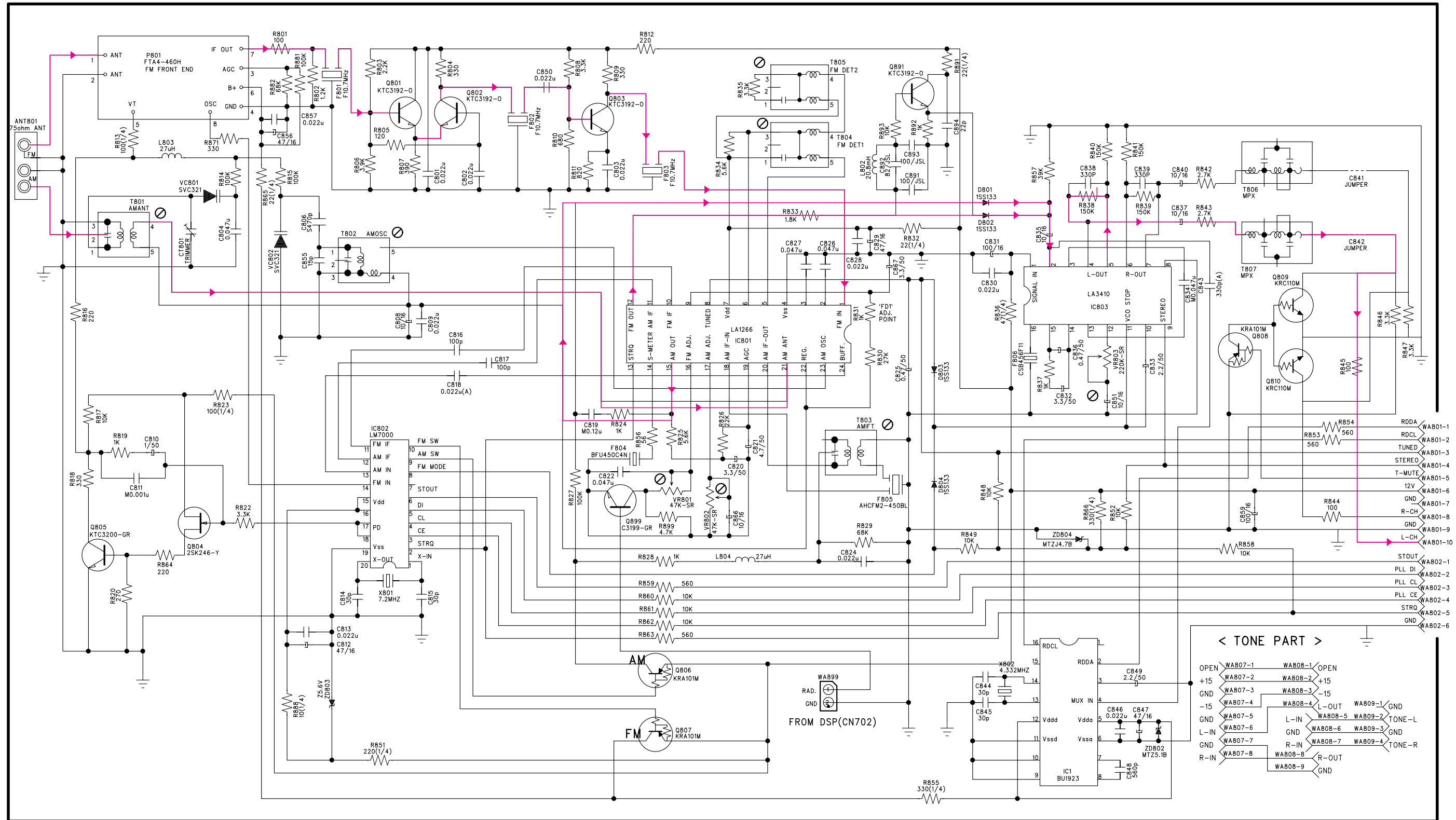

# AVR-45SG u-COM & F.L.DISPLAY SCHEMATIC DIAGRAM (FRONT P.C.Board)

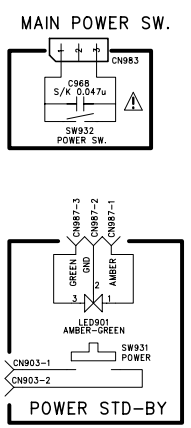
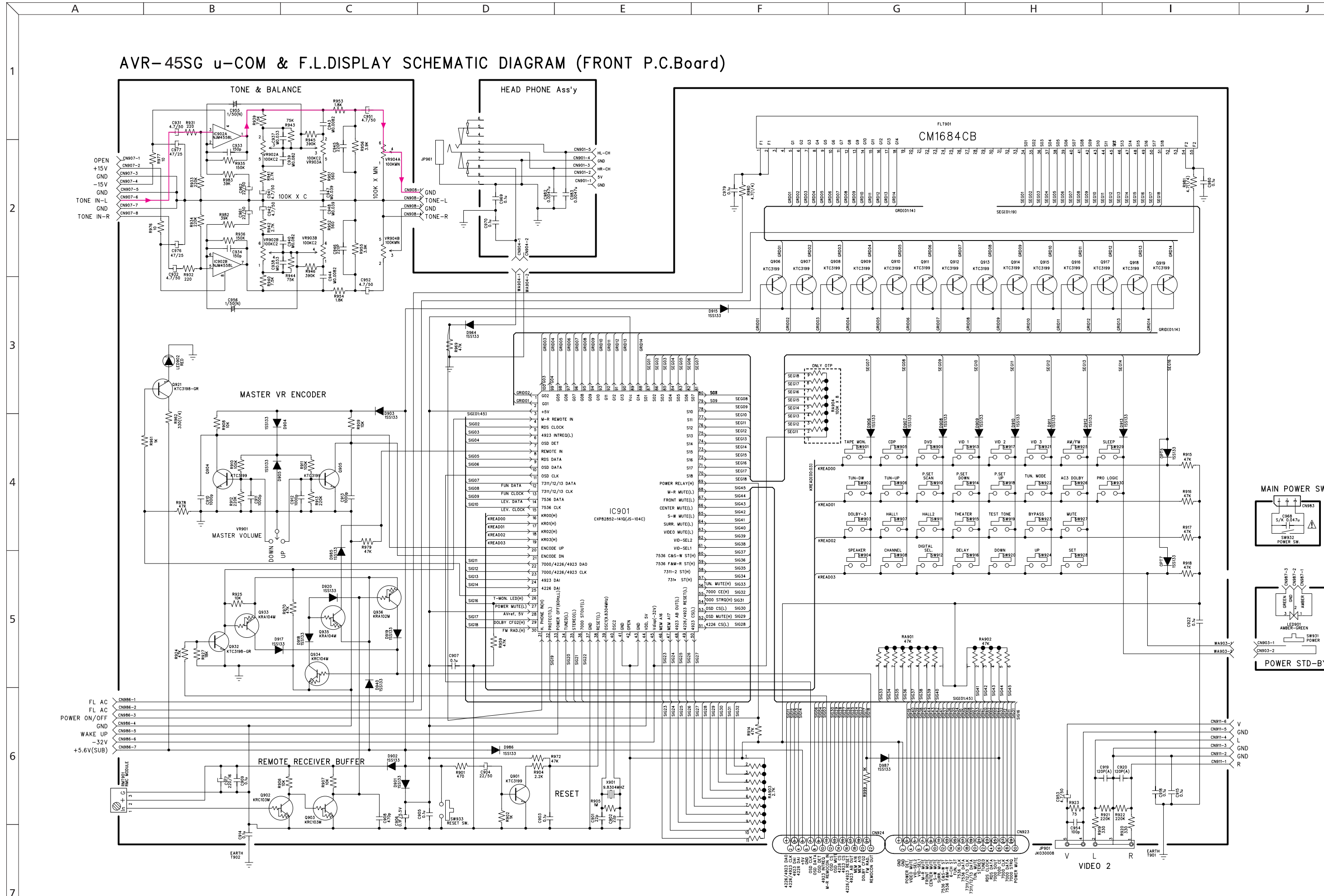

# AVR-45SG TUNER SCHEMATIC DIAGRAM (TUNER P.C.Board)

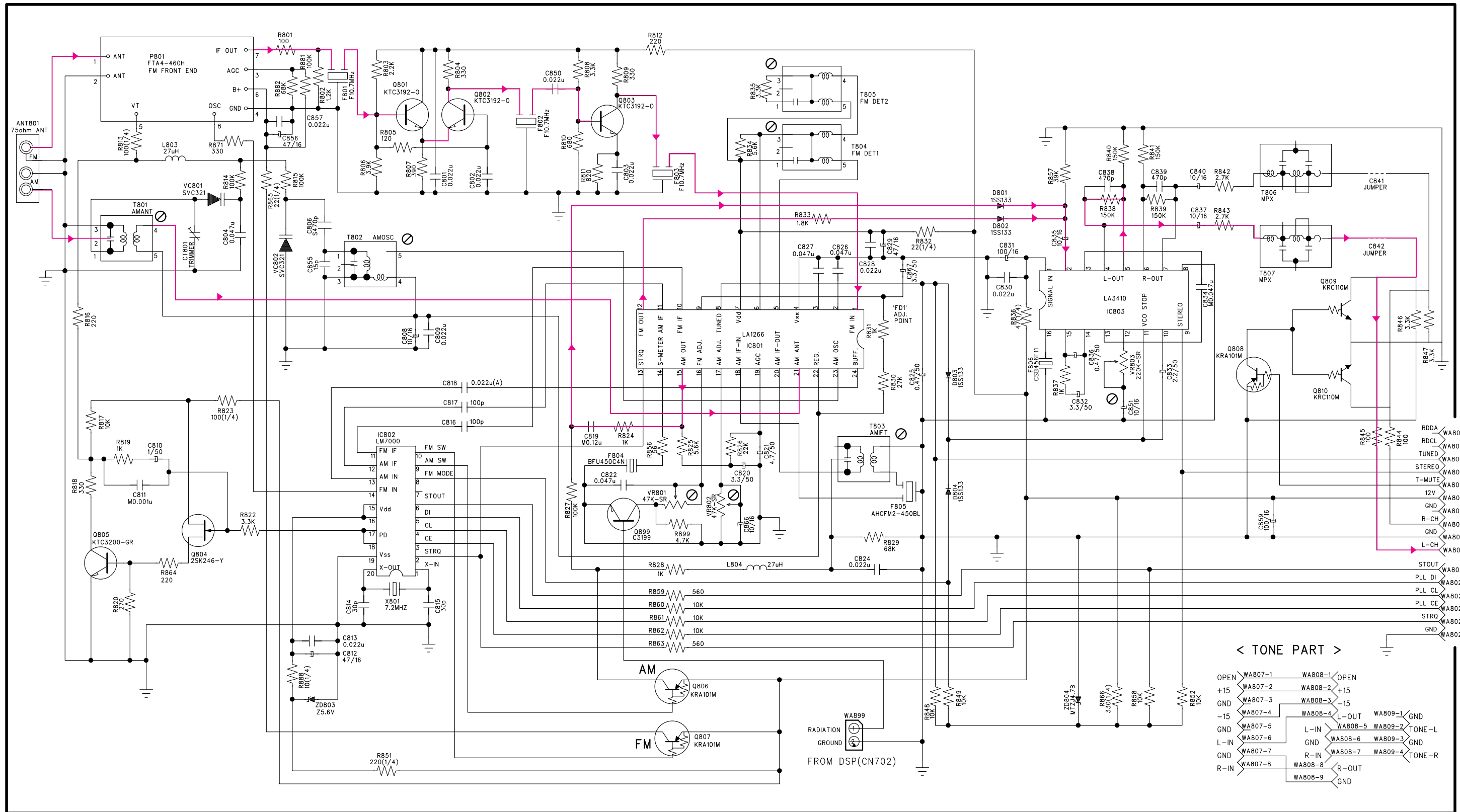

# AVR-35SG u-COM & F.L.DISPLAY SCHEMATIC DIAGRAM (FRONT P.C.Board)

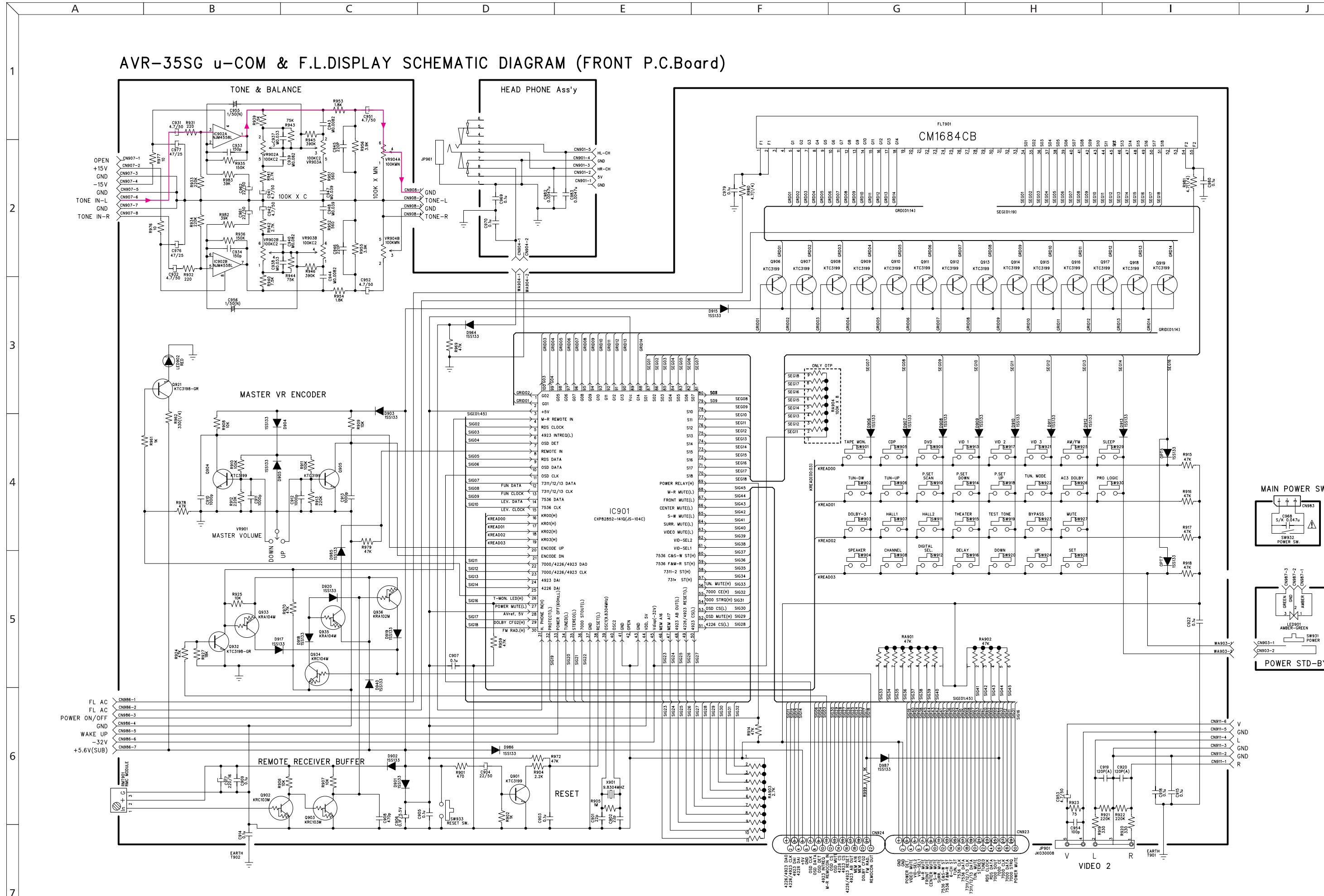

PIN CONNECTION DIAGRAM

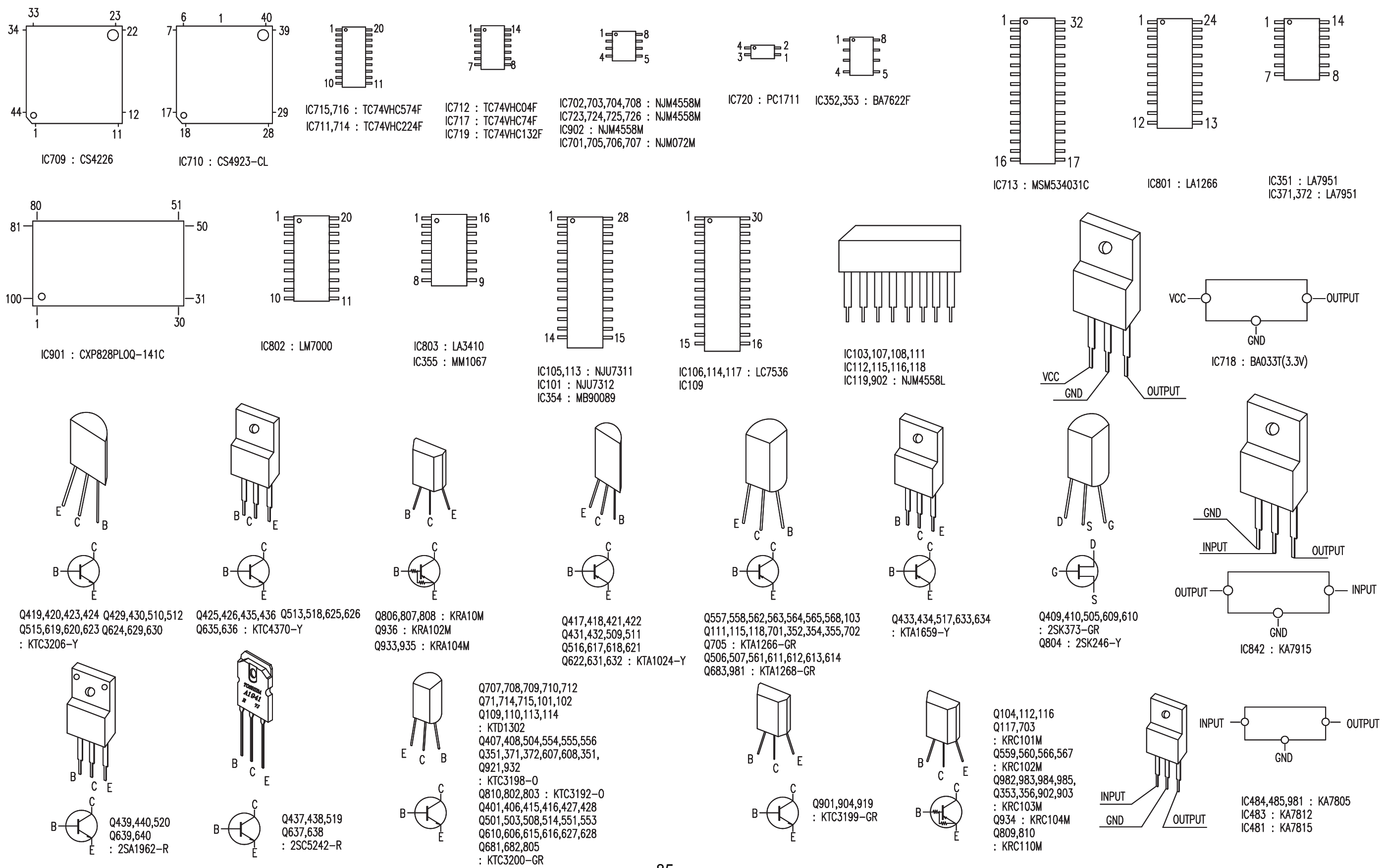

A B C D E F G H I J

1  
2  
3  
4  
5  
6  
7

# AVR-45/45RDS/45SG WIRING DIAGRAM

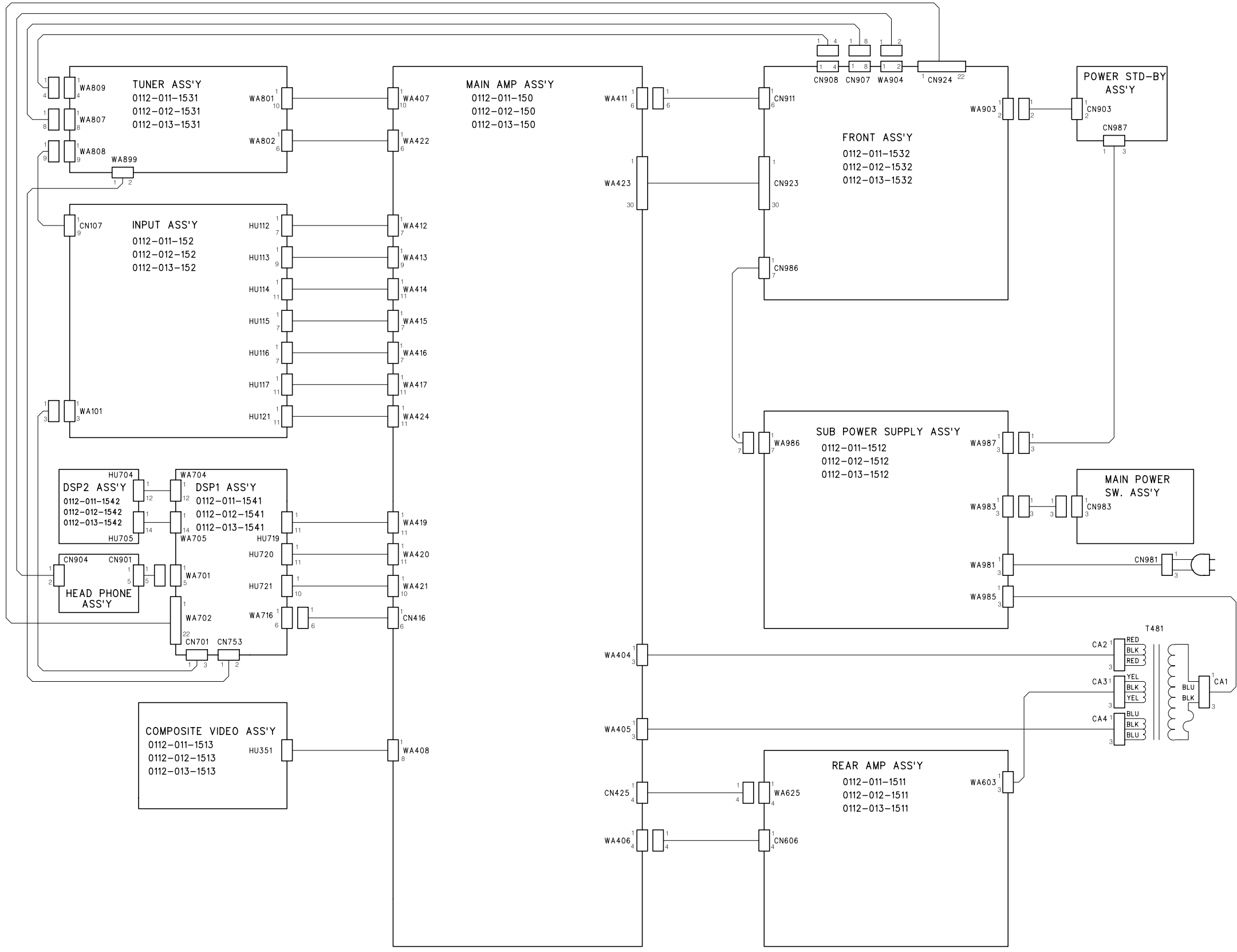

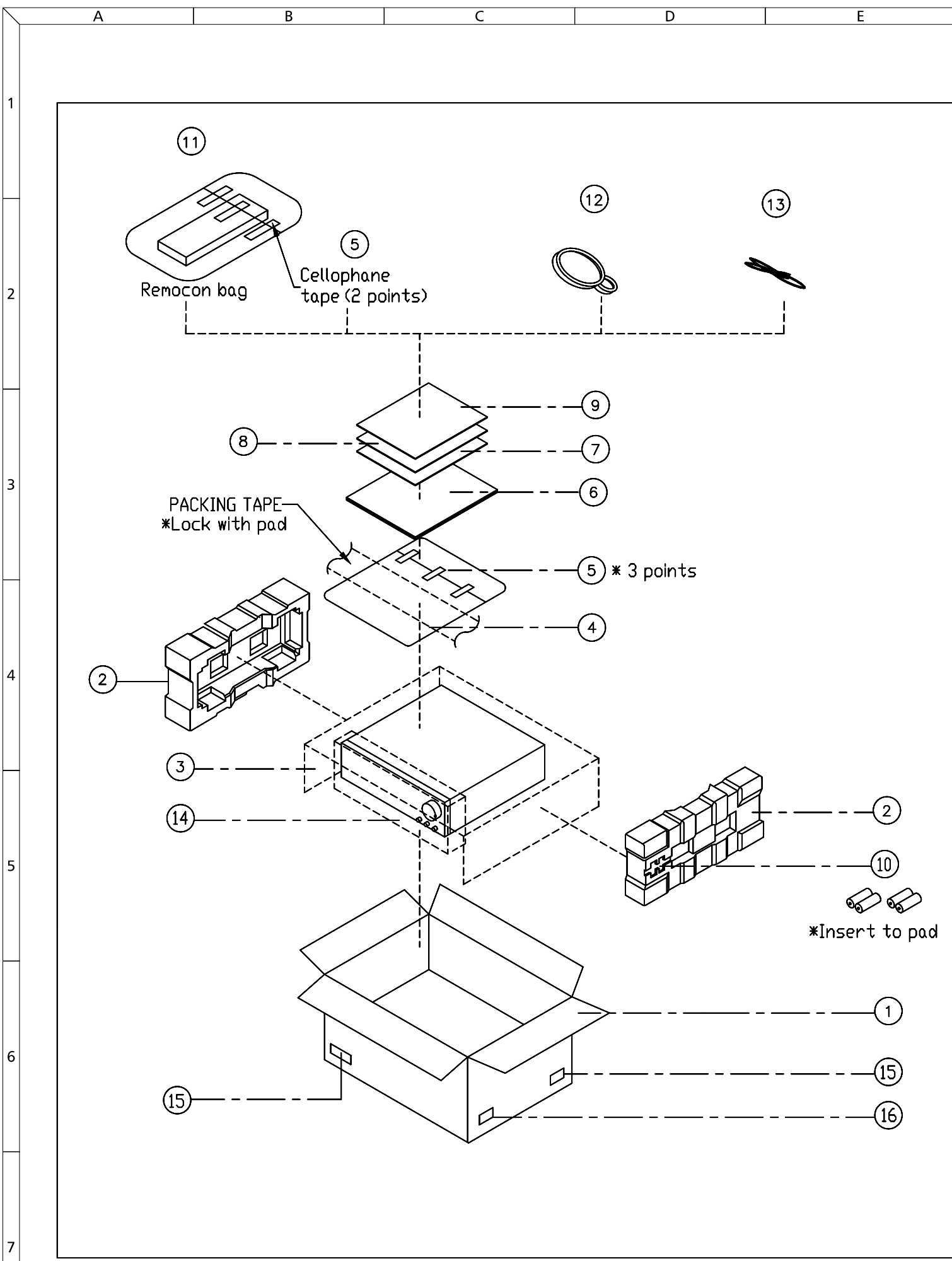

## \*PACKING PARTS LIST

NO.	PARTS NAME	PARTS NO.	MATERIAL	Q' TY	MODEL NO.
1	MASTER CARTON	6121-003-021	DW-1, BROWN	1	AVR 45USA
		6121-006-010	DW-1, BROWN	1	AVR 45RDS
		6121-009-010	DW-1, BROWN	1	AVR 45SG
2	PAD. SIDE	6151-003-010	PS-FM50, EPS	2	
3	SHEET. POLY	6132-003-010	PE-FOAM	1	
4	BAG. POLY	6131-003-010	PE T 0.05	1	
5	TAPE. CELLOPHANE	9931-001-020		10cm	
6	INSTRUCTION MANUAL	6311-003-010	PAPER	1	AVR 45USA
		6311-006-010	PAPER	1	AVR 45RDS
		6311-009-010	PAPER	1	AVR 45SG
7	CARD. WARRANTY	6331-003-010	PAPER	1	AVR 45USA
		6331-003-010	PAPER	0	AVR 45RDS
		6331-003-010	PAPER	0	AVR 45SG
8	CARD. POST	6331-003-030	PAPER	1	AVR 45USA
		6331-003-030	PAPER	0	AVR 45RDS
		6331-003-030	PAPER	0	AVR 45SG
9	CARD. SAFETY GUARD	6331-003-020	PAPER	1	AVR 45USA
		6331-003-020	PAPER	0	AVR 45RDS
		6331-003-020	PAPER	0	AVR 45SG
10	BATTERY. ASS'Y	6453-001-002	AAA	2	
11	REMOCON ASS'Y	A0191-045-000		1	AVR 45USA
		A0191-045-001		1	AVR 45RDS
		A0191-075-001		1	AVR 45SG
12	AM LOOP ANTENNA	6457-000-012		1	
13	ANT. FM	6457-000-011		1	
14	COVER. POLY	6132-003-020	PE-FOAM	1	
15	LABEL. BARCODE	6234-003-030	PAPER	4	AVR 45USA
		6234-006-020	PAPER	4	AVR 45RDS
		6234-009-020	PAPER	4	AVR 45SG
16	LABEL. ORIGIN	6234-003-100	PAPER	1	1