

harman/kardon

# AVR500

A/V DOLBY DIGITAL RECEIVER

## SERVICE MANUAL



### CONTENTS

SPECIFICATIONS .....	2	DISASSEMBLY PROCEDURES .....	23
ESD WARNINGS.....	4	GENERAL UNIT PARTS LIST .....	24
LEAKAGE TEST.....	5	GENERAL UNIT EXPLODED VIEW.....	26
CONTROLS AND FUNCTIONS.....	6	PC . BOARDS .....	27
SERVICE PROCEDURE.....	9	ELECTRICAL PARTS LIST .....	32
TEST EQUIPMENT REQUIRED.....	9	IC BLOCK DIAGRAMS .....	55
ALIGNMENT PROCEDURES.....	9	CPU PIN CONFIGURATION.....	75
ALIGNMENT AND TEST POINTS.....	11	FLT PIN CONFIGURATION.....	76
CIRCUIT DESCRIPTION.....	13	SCHEMATIC DIAGRAMS .....	83
BLOCK DIAGRAM .....	16	PIN CONNECTION DIAGRAM .....	92
BULLETIN HK2000-02.....	17	WIRING DIAGRAM .....	93
BULLETIN HK2000-04.....	19	PACKING MATERIAL AND PARTS LIST.....	94
BULLETIN HK2000-05.....	21		

harman/kardon, Inc.  
250 Crossways Park Dr.  
Woodbury, New York 11797

Rev1 – 11/2003

**AVR-500/500RDS**
**SPECIFICATIONS**
**FRONT AMP SECTION**

	Nominal	Limit
Continuous Power Output		
(STEREO MODE), Input : CD	≥75W	≥70W
THD : 0.08%, 8 ohms		
Both Channel Driven(20Hz-20kHz)		
(SURROUND MODE)	≥65W	≥60W
THD : 0.5%, 8 ohms, 1kHz		
THD : at 60W, 8 ohms, Input : CD		
20Hz	≤0.03%	≤0.08%
1kHz	≤0.03%	≤0.08%
20kHz	≤0.03%	≤0.08%
IM Distortion at 70W, 8 ohms, Vol : Max.		
	≤0.03%	≤0.08%
Input Sensitivity for Rated Power Output(60W)		
CD/DVD/TAPE MONITOR	200mV	170~230mV
MID1/MID2/MID3	200mV	170~230mV
S/N Ratio Input Shorted at 1 kHz 1W Output(WTD IHF-A)		
CD	> 82dB	
Tone Control		
Bass : 100Hz	+ 10dB	+ 10dB±3dB
	- 10dB	- 10dB±3dB
Treble : 10kHz	+ 10dB	+ 10dB±3dB
	- 10dB	- 10dB±3dB
Frequency Response at-3dB		
Mode : Stereo(1Watt)	10Hz-80kHz	10Hz-70kHz
Channel Crosstalk Input Shorted by 1 K Ohms		
10Hz	≥63dB	≥55dB
1kHz	≥63dB	≥55dB
10kHz	≥62dB	≥45dB

**CENTER AMP SECTION**

	Nominal	Limit
RMS Output Power		
THD(0.5%, 8 ohms, 1kHz)		
All Channel Driven	≥65W	≥65W
S/N Ratio(Input Level : 200mV)		
Input Shorted, IHF-A WTD	≥65dB	≥60dB
Frequency Responses at-3dB		
8 ohms, Dolby Pro Logic	100Hz-20kHz	150Hz-20kHz
(Center Speaker : Small)		

**REAR AMP SECTION**

	Nominal	Limit
RMS Output Power		
THD(0.5%, 8 ohms, 1kHz)		
All Channel Driven	≥65W	≥65W
S/N Ratio(Input Shorted, IHF-A WTD)		
Delay : 20ms, Input Level : 200mV	≥65dB	≥60dB
Frequency Response at-3dB		
8 ohms, Dolby Pro Logic	100Hz-7kHz	150Hz - 7kHz
(Center Speaker : Small)		

**SUB WOOFER SECTION**

Line level at Pre-Out		≥1V
Surround mode : BYPASS(STEREO)		
Input Signal : L ch (only) 200mV		
Master Volume : + 5dB		
Low pass crossover frequency		70Hz cut off
Slope (Low Pass Filter)		24dB/octave

**VIDEO AMP SECTION**

Input sensitivity / impedance		
VID1/MID2/MID3		1Vp-p/75Ohm + / - 1dB
Output Level / Impedance		1Vp-p/75
VID1/MID2/MID3		1Vp-p/75 Ohm + / - 1dB
Frequency Response at-3dB	DC-8 MHz	DC-6 MHz

**FM SECTION**

Tuning Cover Range 100kHz Step for AVR-500	87.50-108.00MHz
--	-----------------

Tuning Cover Range 50 kHz Step for AVR-500RDS		
Mono Usable Sensitivity(75 ohms Input, 98MHz)	≤14.2dbf	≤17.2dbf
Image Rejection(at 98MHz)	≥80dB	≥70dB
IF Rejection(at 90MHz)	≥90dB	≥80dB
46dB Quieting Sensitivity(at 98MHz, 100% MOD.)		
Stereo	≤39.2dbf	≤43.3dbf
Distortion(1kHz, 75kHz dev. At 98MHz, 71dbf Input)		
Mono	≤0.3%	≤0.5%
S/N Ratio(500uV Input, 100% MOD. At 98MHz)		
Stereo	≥65dB	≥60dB
Frequency Response(30Hz-15kHz)		
AVR-500 De-Emphasis : 75μs	+ 0.5dB	+ 1.0dB
AVR-500RDS De-Emphasis : 50μs	- 2.0dB	- 4.0dB
AM Suppression at 98MHz	≥50dB	≥45dB
Muting Threshold(at 98MHz)	31.2dbf	39.2dbf
Overload Break-up at 98MHz	71dbf	65dbf
Capture Ratio at 65dbf	71dbf	65dbf
Stereo Separation(at 98MHz, 100% MOD, 500μV Input)		
IHF Band Pass Filter	≤2dB	≤2dB
1kHz	≥40dB	≥40dB
Tape out Level(at 98MHz)	500mV	350-650mV

Image Rejection(at 999kHz)	≥40dB	≥30dB
IF Rejection(at 999/1000kHz)	≥50dB	≥45dB
AGC Figure of Merit(From 100mV/m at 999/1000kHz)	≥50dB	≥45dB
Distortion(999/1000kHz, 30% MOD, 50mV/m Input)	≤1.0%	≤2.0%
Frequency Response(999/1000Hz)	At-3dB	100Hz-2.2kHz 150Hz-1.8kHz
Selectivity(999/1000Hz)		
9kHz/10kHz	≥30dB	≥25dB
S/N Ratio(999/1000kHz, With Antenna Input 5mV/m)	≥45dB	≥40dB
Overload Break-up at 999/1000kHz(THD 10%)	≥100mV/m	≥500mV/m
Tape Output Level at 999/1000kHz(5mV/m Input)		
	200mV	160-240mV

**AM SECTION**

	Nominal	Limit
Tuning Cover Range(MW)		
AVR-500 : 10kHz/Step	520-1710kHz	
AVR-500RDS : 9kHz Step	522-1611kHz	
Usable Sensitivity(MW, at 999 / 1000kHz)	≤500uV/m	≤1000uV/m

**GENERAL**

Power Consumption	
At Rated Power All Channel Driven	420W
Idling at Minimum Volume Control	78W
Power Supplies :	
USA/Canada(AVR-500)	AC120V, 60Hz
Europe(AVR-500RDS)	AC230V, 50Hz
Dimension(W x H x D)	
Inches	17.3×6.5×17.1
MM	440×165×435
Weight(lbs/kgs)	32/14.5

These specifications are service target specs.

Specifications and components are subject to change without notice.

Overall performance will be maintained or improved.

## **ELECTROSTATICALLY SENSITIVE (ES) DEVICES**

Some semiconductor (solid state) devices can be damaged easily by static electricity. Such components commonly are called Electrostatically Sensitive (ES) Devices. Examples of typical ES devices are integrated circuits and some field effect transistors and semiconductor "chip" components.

The following techniques should be used to help reduce the incidence of component damage caused by static electricity.



1. Immediately before handling any semiconductor component or semiconductor-equipped assembly, drain off any electrostatic charge on your body by touching a known earth ground. Alternatively, obtain and wear a commercially available discharging wrist strap device, which should be removed for potential shock reasons prior to applying power to the unit under test.
2. After removing an electrical assembly equipped with ES devices, place the assembly on a conductive surface such as aluminum foil, to prevent electrostatic charge build-up or exposure of the assembly.
3. Use only a grounded-tip soldering iron to solder or unsolder ES devices.
4. Use only an anti-static solder removal device. Some solder removal devices not classified as "anti-static" can generate electrical charges sufficient to damage ES devices.
5. Do not use freon-propelled chemicals. These can generate electrical charge sufficient to damage ES devices.
6. Do not remove a replacement ES device from its protective package until immediately before you are ready to install it. (Most replacement ES devices are packaged with leads electrically shorted together by conductive foam, aluminum foil or comparable conductive material.)
7. Immediately before removing the protective material from the leads of a replacement ES device, touch the protective material to the chassis or circuit assembly into which the device will be installed.

**CAUTION** : Be sure no power is applied to the chassis or circuit, and observe all other safety precautions.

8. Minimize bodily motions when handling unpackaged replacement ES devices. (Otherwise harmless motion such as the brushing together of your clothes fabric or the lifting of your foot from a carpeted floor can generate static electricity sufficient to damage an ES devices.

## **PRODUCT SAFETY NOTICE**

Each precaution in this manual should be followed during servicing.

Components identified with the IEC symbol  in the parts list are special significance to safety. When replacing a component identified with , use only the replacement parts designated, or parts with the same ratings or resistance, wattage, or voltage that are designated in the parts list in this manual. Leakage-current or resistance measurements must be made to determine that exposed parts are acceptably insulated from the supply circuit before returning the product to the customer.

## LEAKAGE TEST(FOR SERVICE ENGINEERS IN THE U.S.A)

Before returning the unit to the user, perform the following safety checks :

1. Inspect all lead dress to make certain that leads are not pinched or that hardware is not lodged between the chassis and other metal parts in the unit.
2. Be sure that any protective devices such as nonmetallic control knobs, insulating fish-papers, cabinet backs, adjustment and compartment covers or shields, isolation resistor-capacity networks, mechanical insulators, etc. Which were removed for the servicing are properly re-installed.
3. Be sure that no shock hazard exists ; check for leakage current using Simpson Model 229 Leakage Tester, standard equipment item No. 21641, RCA Model WT540A or use alternate method as follows : Plug the power cord directly into a 120 volt AC receptacle (do not use an Isolation Transformer for this test). Using two clip leads, connect a 1500 ohms, 10watt Resistor paralleled by a 0.15uF capacitor, in series with all exposed metal cabinet parts and a known earth ground, such as a water pipe or conduit. Use a VTVM or VOM with 1000 ohms per volt, or higher sensitivity to measure the AC voltage drop across the resistor. (See diagram) Move the resistor connection to each exposed metal part having a return path to the chassis (antenna, metal, be performed with the 0.35 volt RMS or more is excessive and indicates a potential shock hazard which must be corrected before returning the unit to the owner.

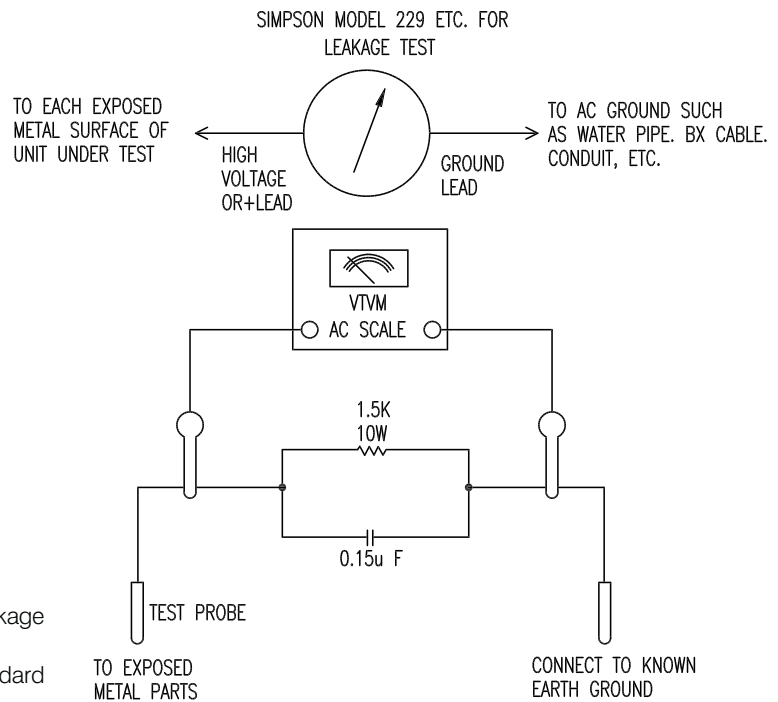

# CONTROLS AND FUNCTIONS

## Front Panel

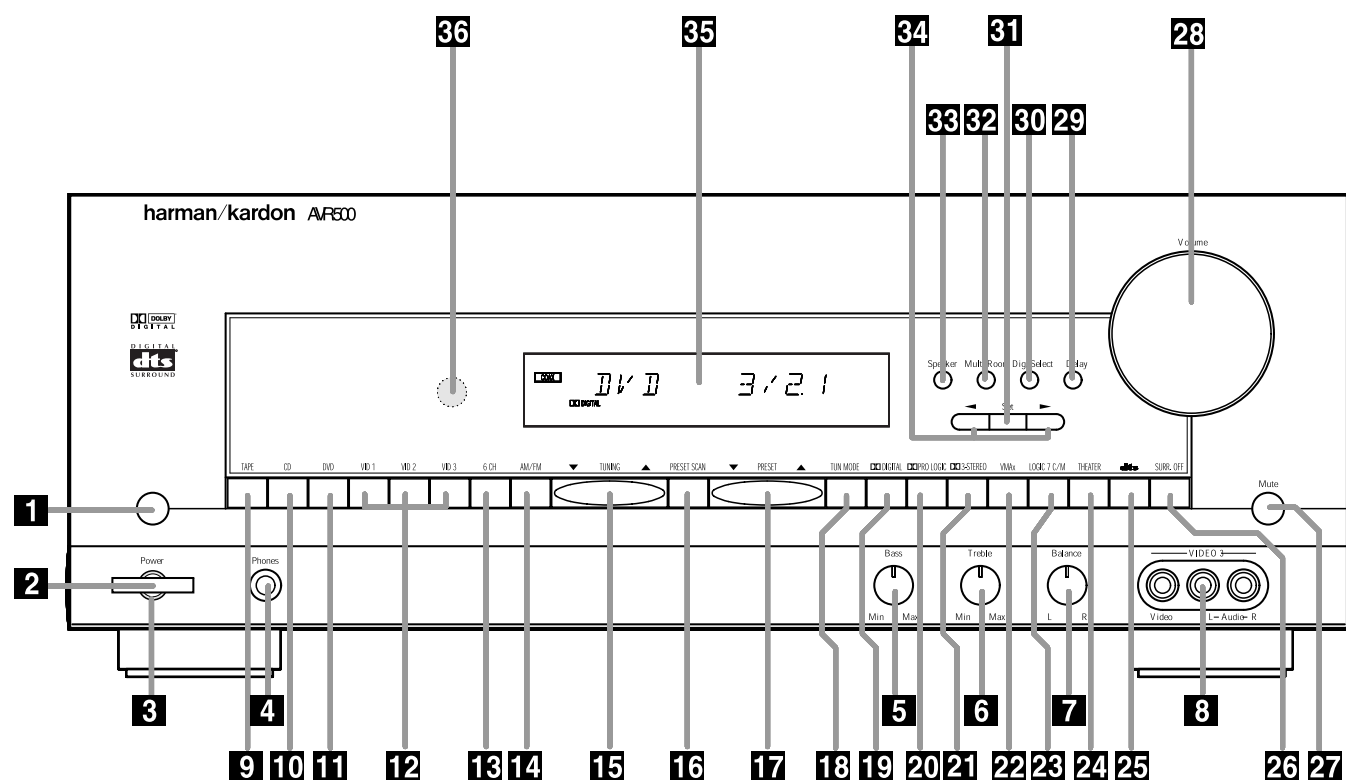

- 1** Main Power Switch
- 2** System Power Control
- 3** Power Indicator
- 4** Headphone Jack
- 5** Bass Control
- 6** Treble Control
- 7** Balance Control
- 8** Video 3 Inputs
- 9** Tape Selector
- 10** CD
- 11** DVD Input Selector
- 12** Video Input Selectors
- 13** 6-Channel Direct Selector
- 14** AM/FM
- 15** Tuning Button
- 16** Preset Scan
- 17** Preset Stations Selector
- 18** Tune Mode
- 19** Dolby Digital Selector
- 20** Dolby Pro Logic Selector
- 21** Dolby 3 Stereo Selector
- 22** VMAx mode Selector
- 23** Logic 7 Mode Selector
- 24** Theater Mode Selector
- 25** DTS Selector
- 26** Surround Off
- 27** Mute
- 28** Volume Control
- 29** Delay
- 30** Digital Input Selector
- 31** Set Button
- 32** Multiroom Selector
- 33** Speaker Select Button
- 34** Selector Buttons
- 35** Information Display
- 36** Remote Sensor Window

**1 Main Power Switch:** Press this button to apply power to the AVR500. When the switch is pressed in, the unit is placed in a Standby mode, as indicated by the amber LED **3** surrounding the **System Power** control **2**. This button MUST be pressed in to operate the unit. To turn the unit off and prevent the use of the remote control, this switch should be pressed until it pops out from the front panel so that the word "OFF" may be read at the top of the switch.

NOTE: In normal operation this switch is left in the ON position.

**2 System Power Control:** When the **Main Power Switch 1** is "ON," press this button

to turn on the AVR500; press it again to turn the unit off. Note that the **Power Indicator** surrounding the switch **3** will turn green when the unit is on.

**3 Power Indicator:** This LED will illuminate in amber when the unit is in the Standby mode to signal that the unit is ready to be turned on. When the unit is in operation, the indicator will turn green.

**4 Headphone Jack:** This jack may be used to listen to the AVR500's output through a pair of headphones. Be certain that the headphones have a standard 1/4" stereo phone plug. Note that the main speakers will automatically be turned off when the headphone jack is in use.

**5 Bass Control:** Turn this control to modify the low-frequency output of the left/right channels by as much as ±10dB. Set this control to a suitable position for your taste or room acoustics.

**6 Treble Control:** Turn this control to modify the high-frequency output of the left/right channels by as much as ±10dB. Set this control to a suitable position for your taste or room acoustics.

**7 Balance Control:** Turn this control to change the relative volume for the front left/right channels.

NOTE: For proper operation of the surround modes this control should be at the midpoint, or "12 o'clock" position.

**8 Video 3 Inputs:** These audio/video inputs may be used for temporary connection of video games, camcorders, digital still cameras or portable audio products. To select a source connected to these jacks, press the **Vid 3 Input Selector 12**.

**9 Tape Selector:** Press this button to select the device connected to the **Tape In** jacks **25** as the listening source.

**10 CD:** Press this button to select the device connected to the **CD Input** jacks **7** as the listening source.

**11 DVD Input Selector:** Press this button to select the device connected to the **DVD Input** jacks **5** as the listening and viewing source.

**12 Video Input Selectors:** Press one of these buttons to select a source connected to the rear panel **Video** inputs **1-20**, or the front panel **Video 3** input **8**.

**13 6-Channel Direct Selector:** Press this button to select the output of an optional, external 6-channel decoder connected to the **6-Ch Direct** inputs **6** as the listening source.

**14 AM/FM:** Press this button to select the tuner as the AVR500's input source. When it is first pressed the last station tuned will be heard. Press it again to change between AM and FM bands.

**15 Tuning Button:** Press the left side of the button to tune lower frequency stations and the right side of the button to tune higher frequency stations. When a station with a strong signal is reached, the **TUNED** indicator **U** will illuminate in the **Information Display 35**.

To tune manually, tap the button lightly and note that the tuner will step up one frequency step button press. When the button is held for a few seconds you will note that the unit will quickly search the frequency band. Release it once the fast tuning starts and the tuner will automatically scan for the next station with an acceptable signal and then stop.

**16 Preset Scan:** Press this button to automatically scan through the stations that have been programmed in the AVR500's memory. The tuner will play five seconds of each station before moving to the next preset station. To stop the scan when the desired station is heard, press the button again. (See pages 24-25 for more information on the tuner memory system.)

**17 Preset Stations Selector:** Press this button to select stations that have been entered into the preset memory. (See pages 24-25 for more information on tuner programming.)

**18 Tune Mode:** Press this button to select the stereo or mono mode for FM tuning. In the STEREO mode a **Stereo** indicator **T** will illuminate in the information display, and stereo reception will be provided when stations are transmitting stereo signals. In the MONO mode the left and right signals from stereo broadcasts will be mixed together and reproduced through all channels. Select MONO for better reception of weak signals.

**19 Dolby Digital Selector:** Press this button to select the Dolby Digital surround mode when listening to a program that carries the Dolby Digital information. (See pages 21-24 for more information on surround modes and digital audio.)

**20 Dolby Pro Logic Selector:** Press this button to select the Dolby Pro Logic surround mode when listening to an analog program that is encoded with surround-sound information. (See page 22 for more information on surround modes.)

**21 Dolby 3 Stereo Selector:** Press this button to select the Dolby 3 Stereo listening mode. This mode is used primarily when a center channel speaker, but no surround speakers, are installed. (See page 22 for more information on surround modes.)

**22 VMAx Mode Selectors:** Press this button to activate the VMAx mode. When only front left and right speakers are installed, VMAx uses proprietary circuits to create a virtual surround sound. (See page 22 for more information on VMAx.)

**23 Logic 7 Mode Selector:** Press this button to activate the Logic 7 modes. One press brings up the Logic 7 Cinema mode, another press brings up the Logic 7 Music Mode. When a stereo source is in use, Logic 7 delivers sound to all five speakers, creating a multi-channel soundfield. (See page 32 for more information on Logic 7.)

**24 Theater Mode Selector:** Press this button to activate the Theater Mode as an alternate surround mode when stereo sources are in use.

**25 DTS Selector:** Press this button to select DTS decoding when listening to an audio or video program that is encoded in the DTS format. (See pages 22-24 for more information on surround modes and digital audio.)

**26 Surround Off:** Press this button to turn off all surround processing, and to listen to a program in traditional stereo from the left front and right front speakers only.

**27 Mute:** Press this button to momentarily silence the speaker and headphone outputs of the AVR500.

**28 Volume Control:** Turn the knob clockwise to increase volume, counterclockwise to decrease the volume. If the AVR is muted, adjusting volume control will automatically release the unit from the silenced condition.

**29 Delay:** Press this button to begin the sequence of steps required to enter delay time settings. (See page 18 for more information on delay times.)

**30 Digital Input Selector:** When playing a source that has a digital output, press this button to select between the **Optical 24** and **Coaxial 23** Digital inputs. (See page 23 for more information on digital audio.)

**31 Set Button:** When making choices during the setup and configuration process, press this button to enter the desired setting, as shown in the **Information Display 35**, into the AVR500's memory.

**32 Multiroom Selector:** Press this button to activate the AVR500's Multiroom system. (See page 26 for complete information on Multiroom operation.)

**33 Speaker Select Button:** Press this button to begin the process of selecting the speaker positions that are used in your listening room. (See page 16 for more information on setup and configuration.)

**34 Selector Buttons:** When you are establishing the AVR500's configuration settings, use these buttons to select between the choices available, as shown in the **Information Display 35**.

**35 Information Display:** This display delivers messages and status indications to help you operate the receiver. (See page 7 for a complete explanation of the Information Display.)

**36 Remote Sensor Window:** The sensor behind this window receives infrared signals from the remote control. Aim the remote at this area and do not block or cover it unless an external remote sensor is installed.

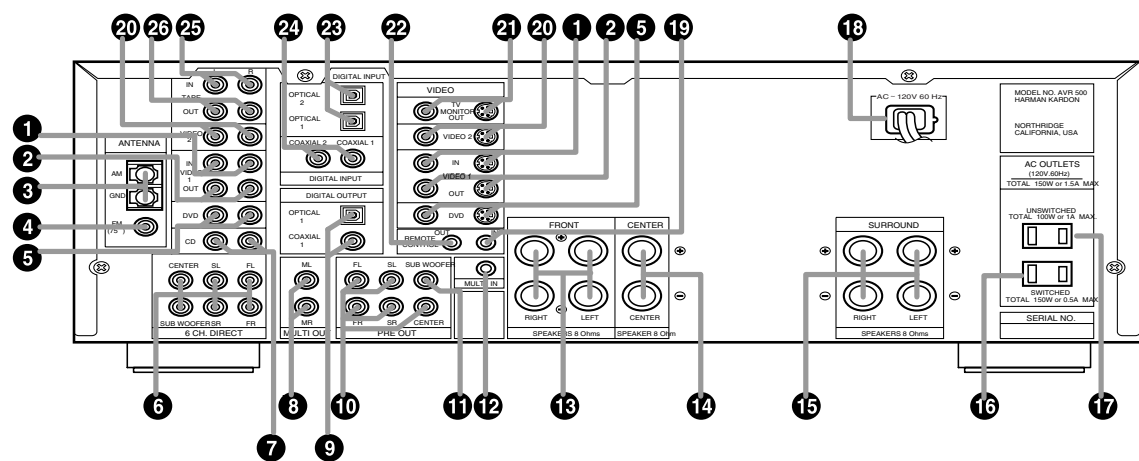

- 1 Video 1 Inputs
- 2 Video 1 Outputs
- 3 AM Antenna
- 4 FM Antenna
- 5 DVD Inputs
- 6 6-Channel Direct Inputs
- 7 CD Inputs
- 8 Multiroom Audio Outputs
- 9 Digital Outputs
- 10 Preamp Outputs
- 11 Subwoofer Output
- 12 Multiroom IR Input
- 13 Front Speaker Terminals
- 14 Center Speaker Terminals
- 15 Surround Speaker Terminals
- 16 Switched AC Outlet
- 17 Unswitched AC Outlet
- 18 AC Power Cord
- 19 Remote IR Input
- 20 Video 2 Inputs
- 21 TV Monitor Outputs
- 22 Remote IR Output
- 23 Optical Digital Inputs
- 24 Coaxial Digital Inputs
- 25 Tape Inputs
- 26 Tape Outputs

- 1 Video 1 Inputs:** Connect these jacks to the audio and video PLAY/OUT jacks of a VCR.
- 2 Video 1 Outputs:** Connect these jacks to the audio and video RECORD/IN jacks of a VCR.
- 3 AM Antenna:** Connect the AM loop antenna supplied with the receiver to these terminals. If an external AM antenna is used, make connections to the **AM** and **GND** terminals in accordance with the instructions supplied with the antenna.
- 4 FM Antenna:** Connect an indoor or external FM antenna to this terminal.
- 5 DVD Inputs:** Connect the analog audio outputs and composite video output of a DVD or LV player to these jacks.
- 6 6-Channel Direct Inputs:** If an external digital audio decoder is used, connect the outputs of that decoder to these jacks.
- 7 CD Inputs:** Connect these jacks to the output of a compact disc player or CD changer.
- 8 Multiroom Audio Outputs:** Connect these jacks to the inputs of an optional audio power amplifier so that the input selected by the multiroom control system will be heard in a remote room.
- 9 Digital Audio Outputs:** Connect these jacks to the matching digital input connector on a digital recorder such as a CD-R or MiniDisc recorder.
- 10 Pre-Outs:** If external power amplifiers

- are used for any channels, connect them to these jacks.
- 11 Subwoofer Pre-Out:** Connect this jack to the line level input of a powered subwoofer. If an external subwoofer amplifier is used, connect this jack to the subwoofer amplifier input.
- 12 Multiroom IR Input:** Connect the output of an IR sensor in a remote room to this jack to operate the AVR500's multiroom control system.
- 13 Front Speaker Terminals:** Connect the front left/right speakers to these terminals.
- 14 Center Speaker Terminals:** Connect the center speaker to these terminals.
- 15 Surround Speaker Terminals:** Connect the surround speakers to these terminals.
- NOTE:** When making connections to the Speaker Terminals **13 14 15** always be certain to maintain correct polarity between the speaker's terminals and those on the AVR by connecting red (+) terminals to red and black (-) terminals to black. See page 13 for more information on speaker polarity.
- 16 Switched AC Outlet:** This outlet may be used to power any device that you wish to have turn on when the unit is turned on with the **System Power Control** switch **2**.
- 17 Unswitched AC Outlet:** This outlet may be used to power any AC device. The power will remain on at this outlet regardless of whether the AVR500 is on or off.  
NOTE: The power consumption of the device

NOTE: For all video inputs and outputs **1 2 5 20 21**, the same number is used to indicate the audio, composite video and S-Video connections related to that input. This accounts for the same number appearing in more than one place on the rear panel drawing.

- plugged into each of these outlets should not exceed 100 watts.
- 18 AC Power Cord:** Connect the AC plug to a non-switched AC wall output
- 19 Remote IR In:** If the AVR500's front panel IR sensor is blocked due to cabinet doors or other obstructions, an external IR sensor may be used. Connect the output of the sensor to this jack.
- 20 Video 2 Inputs:** Connect these jacks to the audio and video outputs of a TV Tuner, Cable TV converter box, satellite receiver or any other audio/video source.
- 21 TV Monitor Video Output:** Connect this jack to the composite or S Video input of a TV monitor or video projector to view the on-screen menus and the output of any standard video source selected by the receiver's video switcher.
- 22 Remote IR Out:** This connection permits the IR sensor in the receiver to serve other remote controlled devices. Connect this jack to the **IR IN** jack on Harman Kardon or other compatible equipment.
- 23 Optical Digital Inputs:** Connect the optical digital output from a DVD player, HDTV receiver, LV player or CD player to these jacks. The signal may be either a Dolby Digital signal, a DTS signal or a standard PCM digital source.
- 24 Coaxial Digital Inputs:** Connect the coax digital output from a DVD player, HDTV receiver,

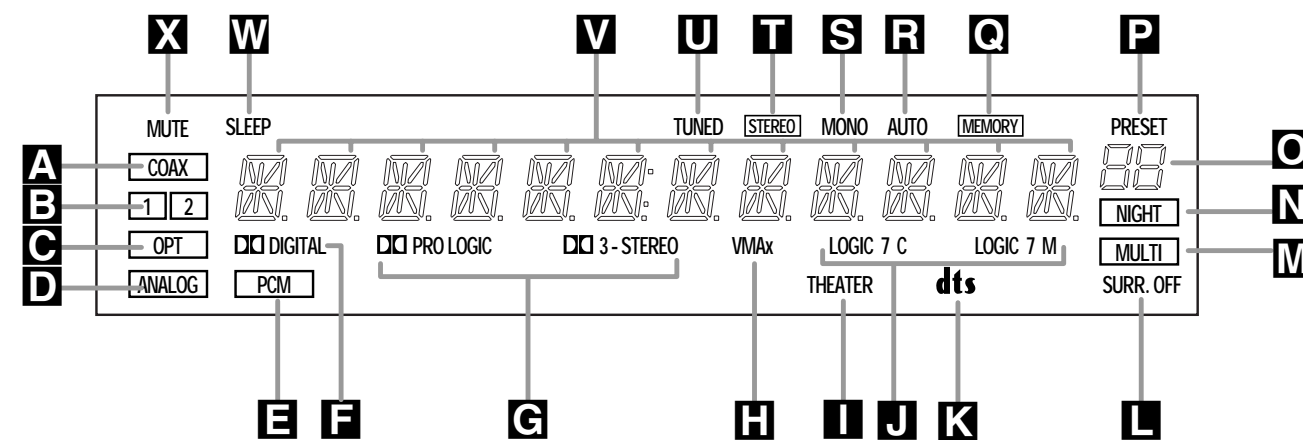

- A** Coax Source
- B** Digital Source Input Number
- C** Optical Source
- D** Analog Source Indicator
- E** PCM Indicator
- F** Dolby Digital Indicator
- G** Analog Dolby Surround Mode Indicators
- H** VMAx Mode Indicator
- I** Theater Mode Indicator
- J** Logic 7 Mode Indicators
- K** DTS Mode Indicator
- L** Surround Off
- M** Multiroom System Indicator
- N** Night Mode Indicator
- O** Preset Number
- P** Preset Indicator
- Q** Memory
- R** Auto
- S** Mono Indicator
- T** Stereo Indicator
- U** Tuned Indicator
- V** Main Information Display
- W** Sleep Indicator
- X** Mute

- A Coax Source:** This indicator illuminates when a digital source is in use via a connection to the **Coaxial Digital** inputs **24**.
- B Digital Source Input Number:** These indicators tell you which of the two digital inputs is selected. This indicator works in conjunction with the **Coax Source A** and **Optical Source C** indicators to show which form of digital signal is in use.
- C Optical Source:** This indicator illuminates when a digital source is in use via a connection to the **Optical Digital** input **23**.
- D Analog Source Indicator:** This indicator illuminates when an analog input source is in use.
- E PCM Indicator:** This indicator illuminates to show that a standard PCM (S/P-DIF) digital audio signal is being decoded by the digital-to-analog converter.
- F Dolby Digital Indicator:** This indicator illuminates when a Dolby Digital source is being played.
- G Analog Dolby Surround Mode Indicators:** These indicators illuminate when one of the analog (matrix) Dolby Surround modes is in use.
- H VMAx Mode Indicator:** This indicator illuminates to show that the VMAx mode is in use.
- I Theater Mode Indicator:** This indicator illuminates to show that the Theater mode is in use.
- J Logic 7 Mode Indicators:** These indicators illuminate when the Logic 7 mode is in use. **LOGIC 7C** appears for the Cinema version of Logic 7, **LOGIC 7M** appears for the Music version of Logic 7.
- K DTS Mode Indicator:** This indicator illuminates when a DTS-encoded source is playing.
- L Surround Off:** This indicator illuminates when the surround processing has been disabled by pressing the **Surround Off** button **26**. When this indicator is lit, the AVR 500 will play traditional stereo sound using the front-left and front-right speakers only.
- M Multiroom System Indicator:** This indicator illuminates when the multiroom system is in operation. (See page 26 for more information on the multiroom system.)
- N Night Mode Indicator:** This indicator lights when the AVR 500 is in the Night mode, which preserves the dynamic range of digital program material at low volume levels.
- O Preset Number:** This two-digit display indicates the station preset number that is currently in use, or that is being entered.
- P Preset Indicator:** This indicator illuminates when a station previously entered into the preset memory is tuned. The number that appears below the indicator is the preset station's memory.
- Q Memory:** This indicator flashes when entering presets and other information into the tuner's memory.
- R Auto:** This indicator illuminates when the Auto mode is in use for FM tuning.
- S Mono Indicator:** This indicator illuminates when the tuner has been placed in the monaural mode by pressing the **Tune Mode** button **18**. Set the tuner for mono listening to reduce noise and improve the quality of distant stereo signals.
- T Stereo Indicator:** This indicator illuminates when an FM station is being tuned in stereo.
- U Tuned Indicator:** This indicator illuminates when a station is being received with sufficient signal strength to provide acceptable listening quality.
- V Main Information Display:** This display shows messages relating to the status, input source, surround mode, tuner, volume level or other aspects of unit's operation.
- W Sleep Indicator:** This indicator is illuminated when the Sleep function is in use. The number that appears above the indicator is the number of minutes remaining before the AVR 500 will return to the Standby mode.
- X Mute:** This indicator illuminates to remind you that the AVR 500's output has been silenced by pressing the **Mute** button **27 6**. Press the Mute button again to return to the previously selected output level.

- 1 AVR Selector
- 2 CD/Tape/DVD Input Selectors
- 3 Video Remote Selectors
- 4 Power Off Button
- 5 Test Tone
- 6 Mute
- 7 ▲/▼ Buttons
- 8 Channel Button
- 9 Set Button
- 10 ◀ Button
- 11 Digital Select
- 12 6 Ch. Direct Input
- 13 Video Input Selectors
- 14 AM/FM tuner Select
- 15 Tuner Mode
- 16 Memory Button
- 17 Numeric Keys
- 18 Macro 1/2 Buttons
- 19 OSD Button
- 20 Light Button
- 21 Direct/Macro Button
- 22 Clear/Macro Button
- 23 Preset Up/Down
- 24 Tuning Up/Down
- 25 Forward/Reverse Transport Buttons
- 26 Night Mode
- 27 Multi-Room
- 28 Delay
- 29 ▶ Button
- 30 Speaker Select
- 31 Surround Mode Selector
- 32 Volume Up/Down
- 33 Sleep Button

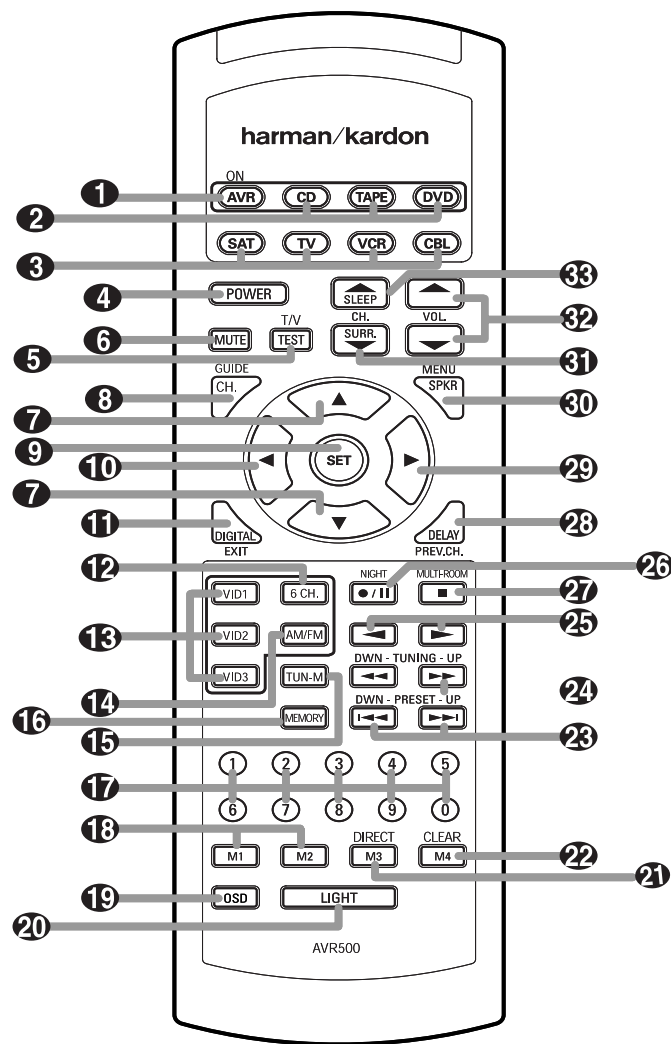

**IMPORTANT NOTE:** The AVR500's remote may be programmed to control up to eight devices, including the AVR500. Before using the remote, it is important to remember to press the **Device Control Selector** button 1 2 3 that corresponds to the unit you wish to operate. In addition, the AVR500's remote is shipped from the factory to operate the AVR500 and most Harman Kardon CD or DVD players and cassette decks. The remote is also capable of operating a wide variety of other products using the control codes that are part of the remote. Before using the remote with other products, follow the instructions on pages 27-29 to program the proper codes for the products in your system.

It is also important to remember that many of the buttons on the remote take on different functions, depending on the product selected using the Device Control Selectors. The descriptions shown here primarily detail the functions of the remote when it is used to operate the AVR500. (See page 29 for information about alternate functions for the remote's buttons.)

**1 AVR Selector:** Pressing this button will switch the remote so that it will operate the AVR's functions. If the AVR is in the Standby mode, it will also turn the AVR on.

**2 CD/Tape/DVD Input Selectors:** Pressing one of these buttons will perform three actions at the same time. First, if the AVR is not turned on, this will power up the unit. Next, it will select the source shown on the button as the input to the AVR. Finally, it will change the remote control so that it controls the device selected. After pressing one of these buttons you must press the **AVR Button** 1 again to operate the AVR's functions with the remote.

**3 Video Remote Selectors:** Press one of these buttons to use the remote to control the functions of the device shown on the button. (For more information on programming the remote to operate these devices, see pages 27-29.)

**NOTE:** As any of these buttons is pressed, it will briefly flash red to confirm your selection.

**4 Power Off Button:** Press this button to place the unit in the Standby mode. Note that this will turn off the main room functions, but if the Multi-room system is activated, it will continue to function.

**5 Test Tone:** Press this button to begin the sequence used to calibrate the AVR500's output

levels. (See page 17 for more information on calibrating the AVR500.)

**6 Mute:** Press this button to momentarily silence the AVR500 or TV set being controlled, depending on which device has been selected.

When the AVR500 remote is being programmed to operate another device, this button is pressed with the **Device Control Selector** button 2 3 to begin the programming process. (See page 27 for more information on programming the remote.)

**7 ▲/▼ Buttons:** These are multi-purpose buttons. They will be used most frequently to select a surround mode. To change the surround mode, first press the **SURR/CH** ▼ button 31. Next press these buttons to scroll up or down through the list of surround modes that appear in the **Information Display** 35. These buttons are also used to increase or decrease output levels used to lower the AVR500's output levels when configuring the unit with either the internal test tone or an external source. They are also used to enter delay time settings after the **Delay** button 28 has been pressed.

**8 Channel Select Button:** This button is used to start the process of setting the AVR500's

output levels to an external source. Once this button is pressed, use the ▲/▼ buttons to select the channel being adjusted, then press the **Set** button 9, followed by the ▲/▼ buttons again to change the level setting. (See page 25 for more information.)

**9 Set Button:** This button is used to enter settings into the AVR500's memory. It is also used in the setup procedures for delay time, speaker configuration and channel output level adjustment.

**10 ◀ Button:** This button is used to change the menu selection or setting during some of the set-up procedures for the AVR.

**11 Digital Select:** Press this button to assign one of the digital inputs 23 24 to a source. (See page 23 for more information on using digital inputs.)

**12 6 Ch. Direct Input:** Press this button to select the component connected to the 6 Ch. direct Inputs 6 as the source

**13 Video Input Selectors:** Press this button to select one of the video inputs as the listening and viewing source.

**14 AM/FM Tuner Select:** Press this button to select this AVR's tuner as the listening choice. Pressing this button when a tuner is in use will select between the AM and FM bands.

**15 Tuner Mode:** Press this button when the tuner is in use to select between automatic tuning and manual tuning. When the button is pressed so that the **AUTO** indicator goes out, pressing the **Tuning** buttons will move the frequency up or down in single-step increments. When the FM band is in use, pressing this button when a station's signal is weak will change to monaural reception, as indicated by the **MONO** indicator. (See page 25 for more information.)

**16 Memory Button:** Press this button to enter a radio station into the AVR500's preset memory. After pressing the button the **MEMORY** indicator will flash, and you then have five seconds to enter a preset memory location using the **Numeric Keys**. (See page 25 for more information.)

**17 Numeric Keys:** These buttons serve as a ten-button numeric keypad to enter tuner preset positions. They are also to be used to select channel numbers when **TV** has been selected on the remote, or to select track numbers on a CD, DVD or LD player, depending on how the remote has been programmed.

**18 Macro 1/2 Buttons:** These buttons are used to recall or enter the programming sequence for a pre-programmed Macro sequence. (See page 28 for more information on programming and using Macros.)

**19 OSD Button:** Press this button to view the

on-screen displays.

**20 Light Button:** Press this button to activate the remote's built-in backlight for better legibility of the buttons in a darkened room.

**21 Direct/Macro Button:** This button has two functions. Pressing it when the tuner is in use will start the sequence for direct entry of a station's frequency. After pressing the button simply press the proper **Numeric Keys** to select a station. This button may also be used to store or recall a macro sequence. (See page 25 for more information on the tuner. See page 28 for more information on programming and using Macros.)

**22 Clear/Macro Button:** This button may be used to store and recall a macro, and it may also be programmed for use with other devices. (See page 28 for more information on macros.)

**23 Preset Up/Down:** When the tuner is in use, these buttons scroll through the stations that have been programmed into the AVR500's memory. When many source devices, such as CD players, VCRs and cassette decks, are selected using the **Device Control Selectors** 2 3, these buttons will normally function as chapter step or track advance.

**24 Tuning Up/Down:** When the tuner is in use, these buttons will tune up or down through the selected frequency band. If the **Tuner Mode** button has been pressed so that the **AUTO** indicator is illuminated, pressing and holding the buttons for three seconds will cause the tuner to seek the next station with acceptable signal strength for quality reception. When the **AUTO** indicator is NOT illuminated, pressing these buttons will tune stations in single-step increments. (See page 25 for more information.)

**25 Forward/Reverse Transport Buttons:** These buttons do not have any functions for the AVR, but they may be programmed for the forward/reverse play operation of a wide variety of CD or DVD players, and audio or video cassette recorders. (See page 27 for more information on programming the remote.)

**26 Night Mode:** Press this button to activate the Night mode. This mode is available in specially encoded digital sources, and it preserves dialog (center channel) intelligibility at low volume levels.

**27 Multi-Room:** Press this button to activate the Multi-room system or to begin the process of changing the input or volume level for the second zone. (See page 26 for more information on the Multiroom system.)

**28 Delay/Prev. Ch.:** Press this button to begin the process for setting the delay times used by the AVR500 when processing surround sound. After pressing this button the delay times are entered by pressing the **Set** button 9, and then using the ▲/▼ buttons 7 to change the setting. Press the Set button again to complete

the process. (See page 18 for more information.)

**29 ▶ Button:** Press this button to change a setting or selection when configuring many of the AVR's settings.

**30 Speaker Select:** Press this button to begin the process of configuring the AVR500's Bass Management System for use with the type of speakers used in your system. Once the button has been pressed, use the ▲/▼ buttons 9 to select the channel you wish to set up. Press the **Set** button 9, and then select another channel to configure. When all adjustments have been completed, press the Set button twice to exit the settings and return to normal operation. (See page 16 for more information.)

**31 Surround Mode Selector:** Press this button to begin the process of changing the surround mode. After the button has been pressed, use the ▲/▼ buttons 7 to select the desired surround mode. (See page xx for more information.) Note that this button is also used to tune channels when the TV is selected using the **Device Control Selector** 2. When the AVR500 remote is being programmed for the codes of another device, this button is also used in the "Auto Search" process. (See page 27 for more information on programming the AVR500 remote.)

**32 Volume Up/Down:** Press these buttons to raise or lower the system volume.

**33 Sleep Button:** Press this button to place the unit in the Sleep mode. After the time shown in the display, the AVR500 will automatically go into the Standby mode. Each press of the button changes the time until turn-off in the following order:

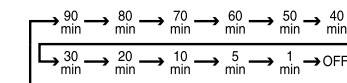

Press and hold the button for two seconds to turn off the sleep mode setting.

Note that this button is also used to change channels on your TV when the TV is selected using the **Device Control Selectors** 2 3.

When the AVR500 remote is being programmed for the codes of another device, this button is also used in the Auto Search process. (See page 27 for more information on programming the AVR500 remote.)



## SERVICE PROCEDURE

### 1. All Clear

This service program can clear all memorized operations and functions.  
When the POWER ON, press the "AM/FM" button while pressing the "PRO LOGIC" button.  
After this, Preset memory will be set to these frequencies.

	VERSION	P1	P2	P3	P4	P5	P6	P7	P8
FM	120	87.5	88.0	90.0	95.0	98.0	99.0	106.0	108.0
	230RDS	87.50	88.00	90.00	95.00	98.00	99.00	106.00	108.00

	VERSION	P9	P10	P11	P12	P13	P14	P15
AM	120	520	600	610	1000	1400	1500	1710
	230RDS	522	594	999	1395	1611		

### 2. VFD segment illumination & text

This set do not have VFD segment check function because lack of u-com memory size  
So For your checking VFD states according to each function  
Please refer to owners manual process.

## TEST EQUIPMENT REQUIRED

- 1) AM/FM Signal generator
- 2) Digital Multimeter
- 3) Distortion lever meter

## ALIGNMENT PROCEDURES

### 1. FM MONO. Distortion adjustment

step	Input Signal Source Connection	Signal Frequency	Source Signal Output Level and Modulation	Reception Frequency	Adjustment Point	Adjustment Value
1	Signal generator output to FM antenna terminal.(750hm)	98MHz	1000uV/m (60dBu) MONO 1kHz/ Dev. 75kHz	98MHz (P5)	T804	0mV±0.5mV (R831)
2					T805	Distortion level <b>Minimum</b> at TAPE-OUT

### 2. FM MUTING LEVEL ADJUSTMENT

Turn variable resistor VR801 and stop at position "TUNED" is not shown (not indicated), then again turn the variable resistor VR801 to the opposite revolution and stop at a position "TUNED" is shown.

step	Input Signal Source Connection	Signal Frequency	Source Signal Output Level and Modulation	Reception Frequency	Adjustment Point	Adjustment Value
1	Signal generator output to FM antenna terminal.(750hm)	98MHz	10uV/m (20dBu) MONO 1kHz/ Dev. 75kHz	98MHz (P5)	VR801	"TUNED" indicate on VFD
2					AUTO SCAN	Only confirm

### 4. FM STEREO Separation Adjustment

step	Input Signal Source Connection	Signal Frequency	Source Signal Output Level and Modulation	Reception Frequency	Adjustment Point	Adjustment Value
1	Signal generator output to FM antenna terminal.(750hm)	98MHz	same specification as <b>FM STEREO</b> distortion adjustment. Input only L channel	98MHz (P5)	VR803	Output level <b>Minimum</b> at TAPE-OUT channel R
2			same specification as <b>FM STEREO</b> distortion adjustment. Input only R channel	98MHz (P5)	VR803	Output level <b>Minimum</b> at TAPE-OUT channel R

### 4. AM OSC Adujstment

step	Input Signal Source Connection	Signal Frequency	Source Signal Output Level and Modulation	Reception Frequency	Adjustment Point	Adjustment Value
1	Signal Generator output to transmission loop antenna (standard required loop)	522kHz (230,230RDS) 520kHz(120)	5mV/m(74dBu) 400Hz MOD.30%	522kHz (230,230RDS) 520kHz (120) (P9)	T802	1.1V~1.2V

### 5. AM-Tracking Adjustment (MW)

step	Input Signal Source Connection	Signal Frequency	Source Signal Output Level and Modulation	Reception Frequency	Adjustment Point	Adjustment Value
1	Signal Generator output to transmission loop antenna (standard required loop)	594kHz (230,230RDS) 600kHz(120)	5mV/m(74dBu) 400Hz MOD.30%	594kHz (230,230RDS) 600kHz(120)	T801	Output level(L or R) <b>Minimum</b> at TAPE-OUT
2		1395kHz (230,230RDS) 1400kHz(120)			CT801	Output level(L or R) <b>Minimum</b> at TAPE-OUT

### 6. AM IF Adjustment

step	Input Signal Source Connection	Signal Frequency	Source Signal Output Level and Modulation	Reception Frequency	Adjustment Point	Adjustment Value
1	Signal Generator output to transmission loop antenna (standard required loop)	999kHz (230,230RDS) 1000kHz(120)	5mV/m(74dBu) 400Hz MOD.30%	999kHz (230,230RDS) 1000kHz (120)	T803	Output level(L or R) <b>Maximum</b> at TAPE-OUT Output level(L or R) <b>Maximum</b> at TAPE-OUT

**7. AM auto stop Adjustment**

step	Input Signal Source Connection	Signal Frequency	Source Signal Output Level and Modulation	Reception Frequency	Adjustment Point	Adjustment Value
1	Signal Generator output to transmission loop antenna (standard required loop)	999kHz (230,230RDS)	1000uV/m(60dBu) 400Hz MOD.30%	999kHz (230,230RDS) 1000kHz(120)	VR802	"TUNED" indicate on VFD
2		1000kHz (120)		AUTO SCAN	Only Confirm	"TUNED" indicate on VFD

**8. Main Amp Idling current Adjustment**

(1) SET CONDITION

- 1) SEMI VOLUME POSITION at MAIN/SURROUND AMP Board; CENTER  
 MAIN : VR401, VR402, VR501  
 SURROUND : VR601, VR602
- 2) NO signal / NO LOAD
- 3) AC LINE VOLTAGE : 120V/60Hz, 230V/50Hz

(2) After turning on the unit, keep it over than 5MIN. (Keep the Power/Drive TR as normal temperature)

(3) Adjust the voltage value of primary & secondary of wafer to be 10mV by rotating the semi-volume of each channel to the right

CHANNEL	ADJUSTMENT	MEASUREMENT	VOLAGE	OTHERS
FRONT-L ch	VR401	WA401	10±3mV	R401:22.7mA
FRONT-R ch	VR402	WA402	10±3mV	R472:22.7mA
CENTER ch	VR501	WA501	10±3mV	R501:22.7mA
SURROUND-L ch	VR601	WA601	10±3mV	R601:22.7mA
SURROUND-R ch	VR602	WA602	10±3mV	R602:22.7mA

(4) CAUTION

- 1) In case that POWER TR or DREVE TR is needed to be replaced for repairing, the corresponding channel should be adjusted again  
 \* FRONT AMP : Q433~Q440  
 \* CENTER AMP : Q517~Q520  
 \* SURROUND AMP : Q633~Q640

**9. Main Amp DC OFFSET VOLTAGE Adjustment**

(1) SET CONDITION

- 1) SEMI VOLUME POSITION at MAIN/SURROUND AMP Board; CENTER  
 MAIN : VR403, VR404, VR502  
 SURROUND : VR603, VR604
- 2) NO signal / NO LOAD
- 3) AC LINE VOLTAGE : 120V/60Hz, 230V/50Hz

(2) After turning on the unit, keep it over than 5MIN. (Keep the Power/Drive TR as normal temperature)

(3) Adjust the voltage value of primary & secondary of wafer to be 10mV by rotating the semi-volume of each channel to the right

CHANNEL	ADJUSTMENT	MEASUREMENT	VOLAGE	OTHERS
FRONT-L ch	VR403	JK401	0±10mV	
FRONT-R ch	VR404	JK402	0±10mV	
CENTER ch	VR502	JK501	0±10mV	
SURROUND-L ch	VR603	JK601	0±10mV	
SURROUND-R ch	Vr604	JK601	0±10mV	

(4) CAUTION

- 1) In case that POWER TR or DREVE TR is needed to be replaced for repairing, the corresponding channel should be adjusted again  
 \* FRONT AMP : Q401~Q440, Q411~Q414  
 \* CENTER AMP : Q501, Q502, Q506, Q507  
 \* SURROUND AMP : Q601~Q604, Q611~Q614

**10. Cautions for main Amp adjustment**

(1) At MAIN/SURROUND BOARD, use the below condensers after discharging for sufficient time for preventing possible damage from electrical spark.

MAIN BOARD	C481, C482 (10000/63V, 8200uF/63V)
SURROUND BOARD	C691, C692 (6800/63V, 6800uF/50V)

(2) The checker for MAIN/SURROUND BOARD should have the discharging circuit.  
 Discharge over 30sec. through (407ohm 10w) resistor after turning off

A B C D E F G H I J

# Alignment and Test Position (Main Amp P.C.Board)

1  
2  
3  
4  
5  
6  
7

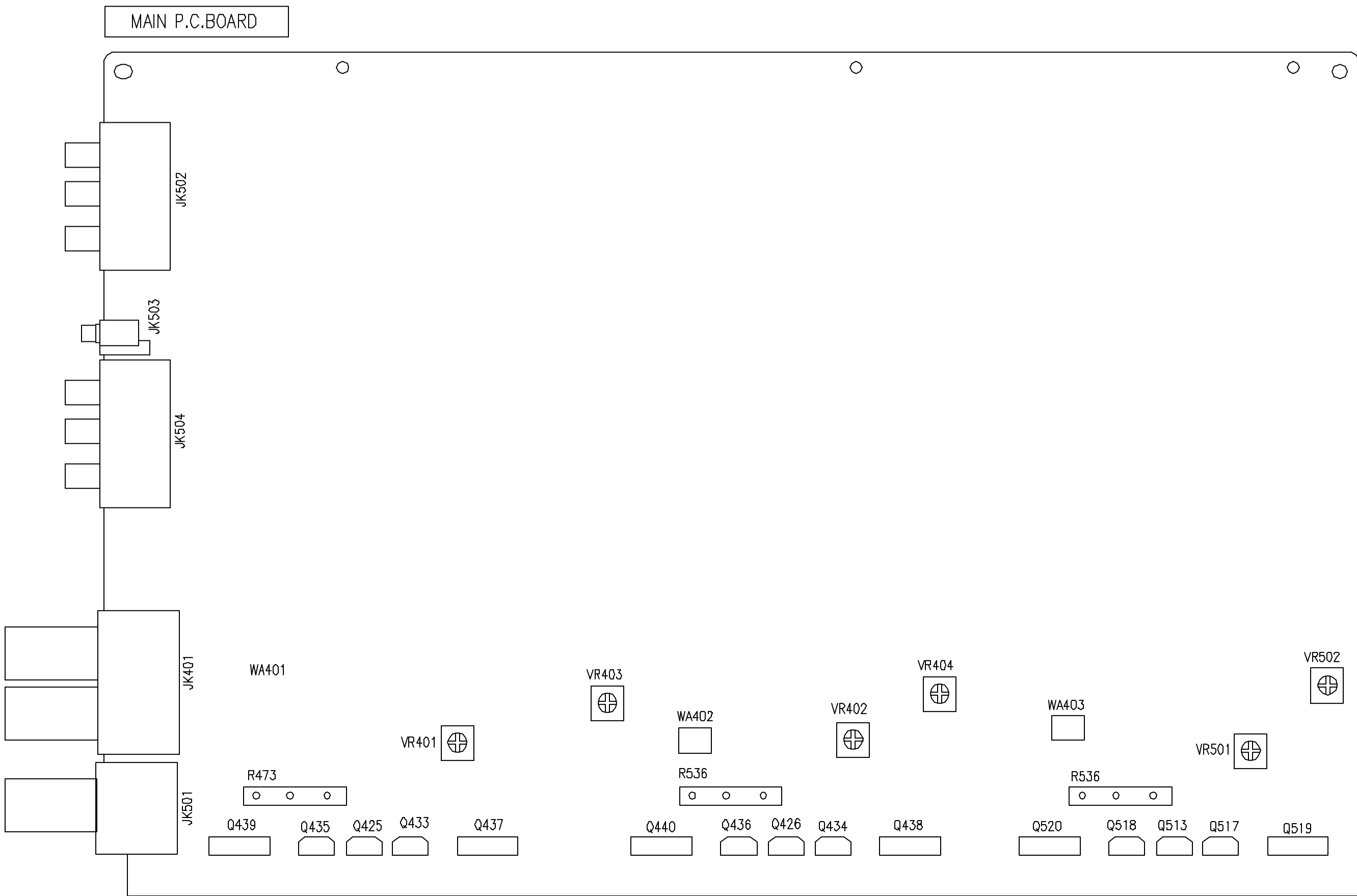

A B C D E F G H I J

1  
2  
3  
4  
5  
6  
7

# Alignment and Test Position

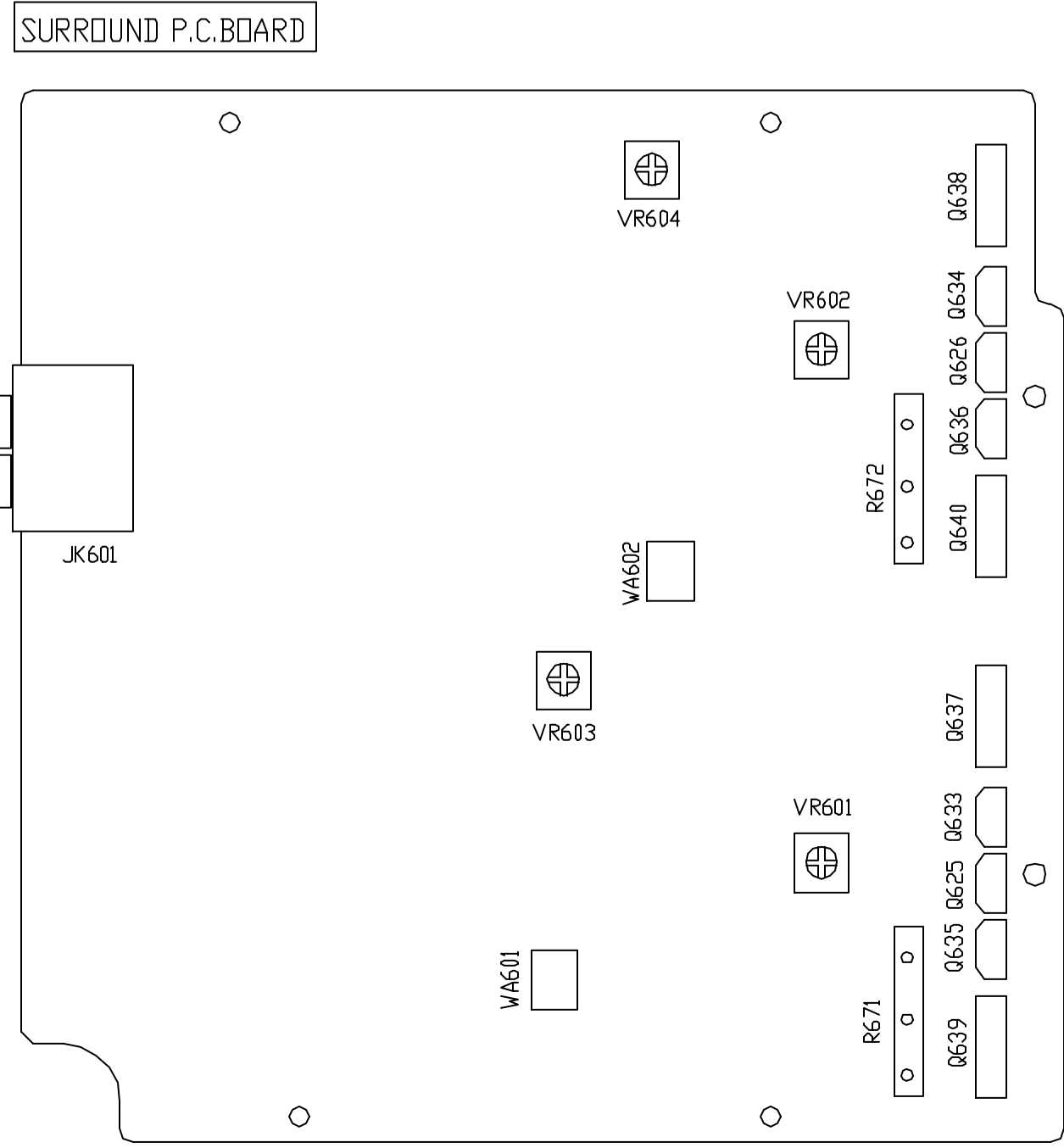
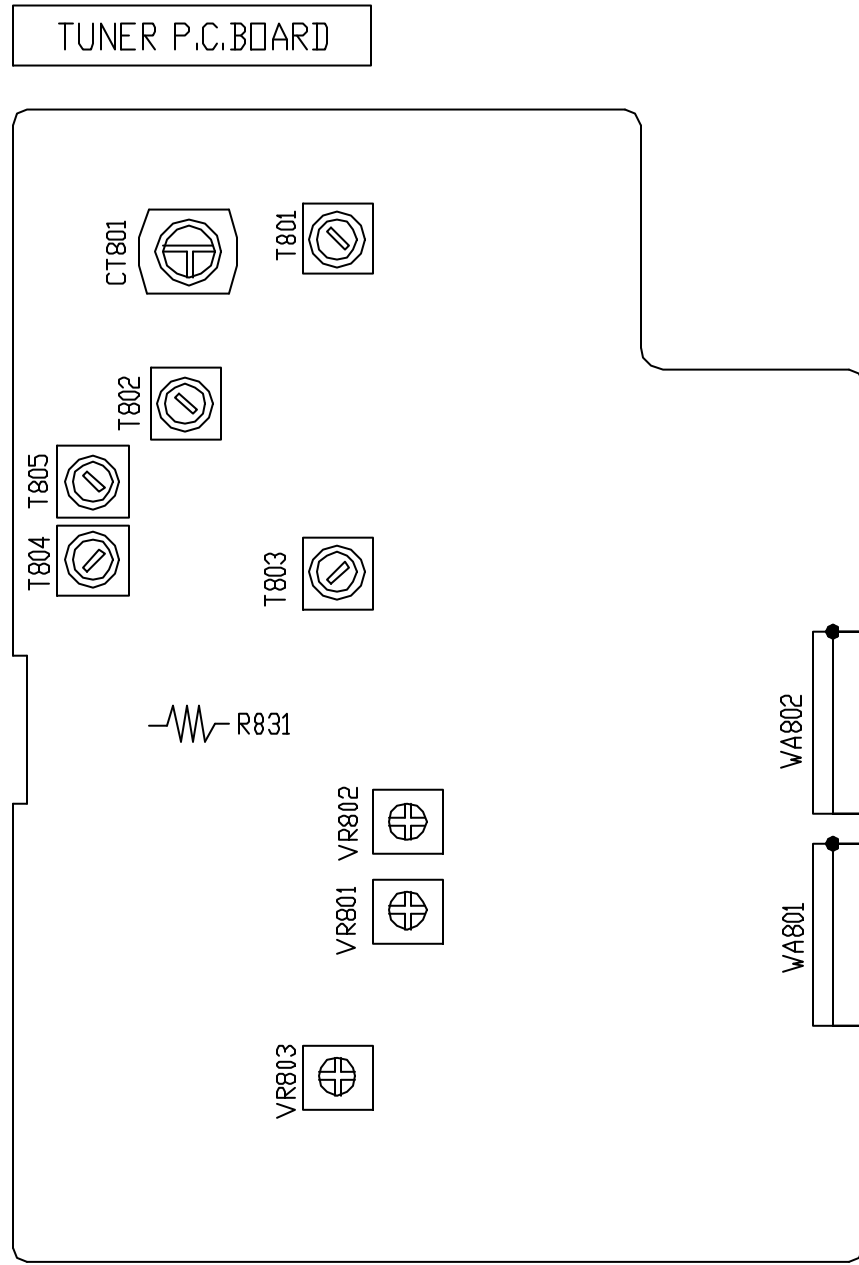

CIRCUIT DESCRIPTION

1. SURROUND CIRCUIT

This model incorporates a surround processor circuit that provides 6 types of surround sound and level trim and Bass management  
 Fig. 1 is a block diagram of the surround processor circuit.  
 The microprocessor transfers the data to the parameter control (Int-req, serial data, Serial clock, Chip selector) to operate the circuits in each mode.

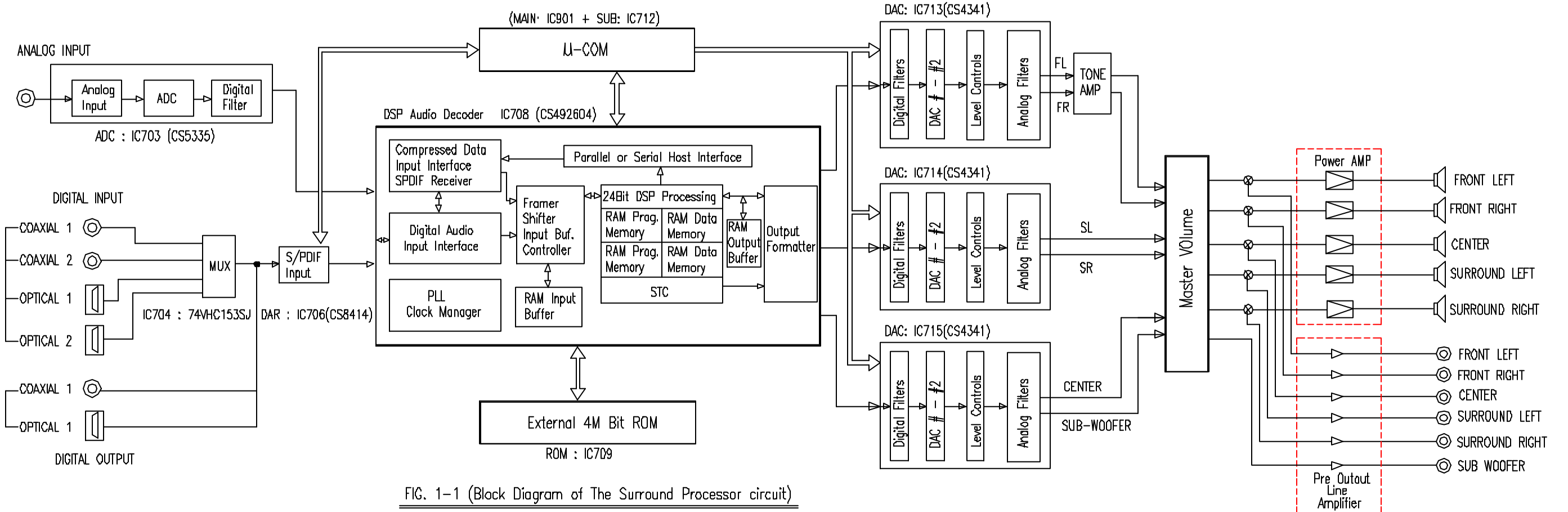

FIG. 1-1 (Block Diagram of The Surround Processor circuit)

2. DOLBY DIGITAL (AC-3)

Fig. 1-2 is a function block diagram of the application code when configured for Dolby Digital.  
 It gives an idea of the interaction between the various application modules when AC3 is enabled.

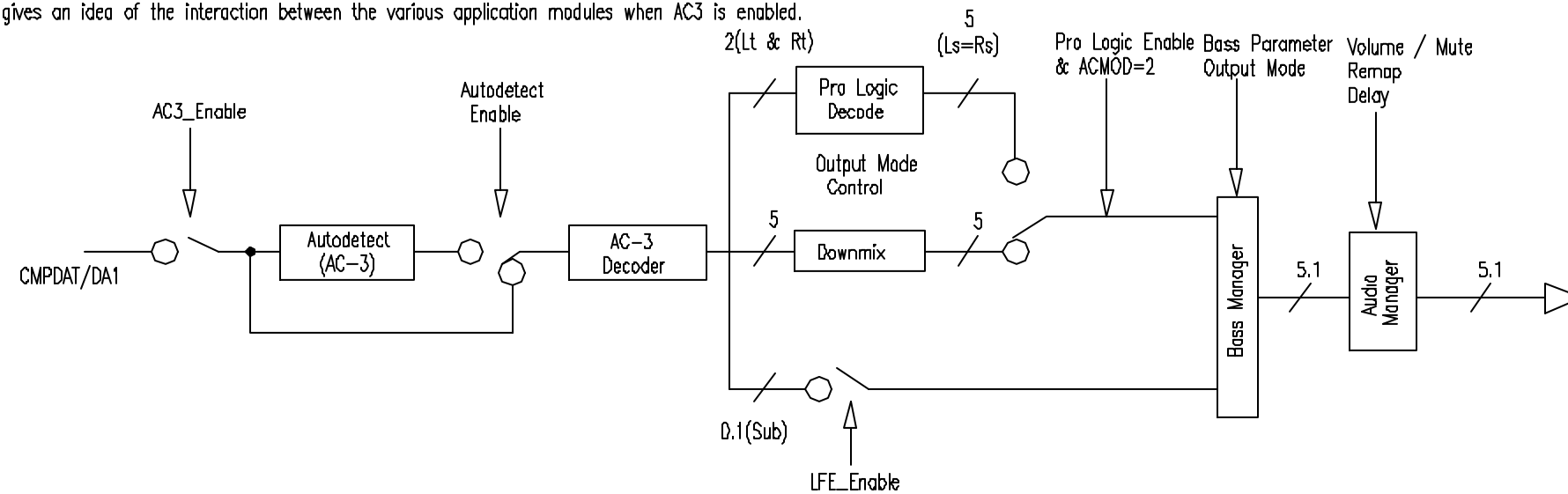

FIG. 1-2 AC3 Code Configured for AC3

3. PCM Input (Dolby Pro, Dolby 3 Stereo)

Fig 1-3 is a function block diagram of the application code when configured for PCM pass-through. It gives an idea of the interaction between the various application modules when PCM is enabled.

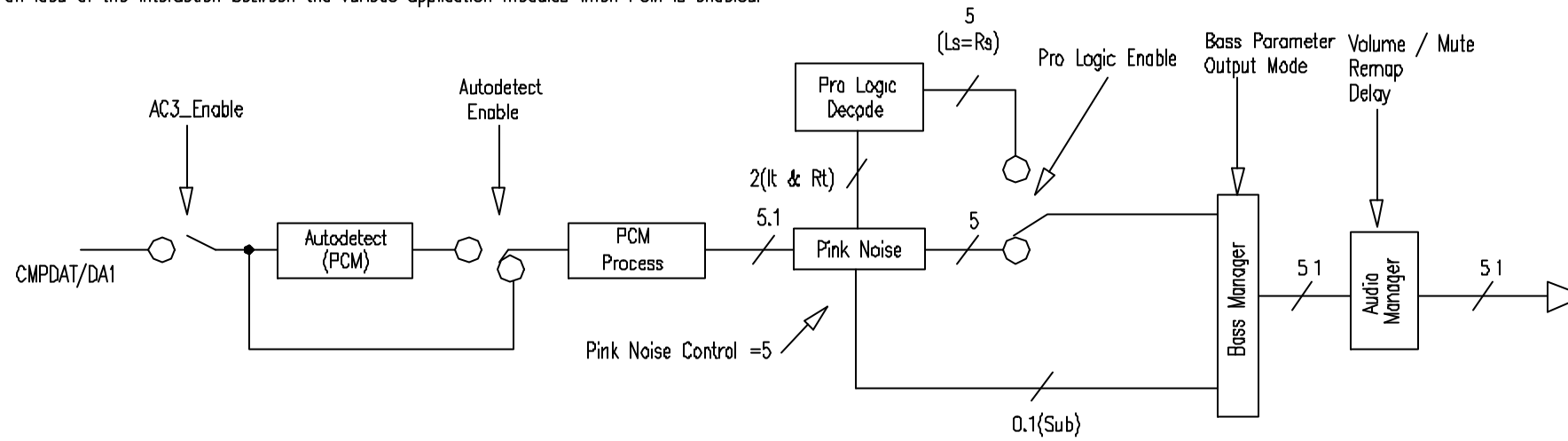

Fig 1-3 AC3 Code Configured for PCM

4. Sound Field Effect (Hall 1, Hall 2, Theater)

Fig 1-4 is a function block diagram of the application when configured for Effects processing. It gives an idea of the interaction between the various application modules when the effects are enabled.

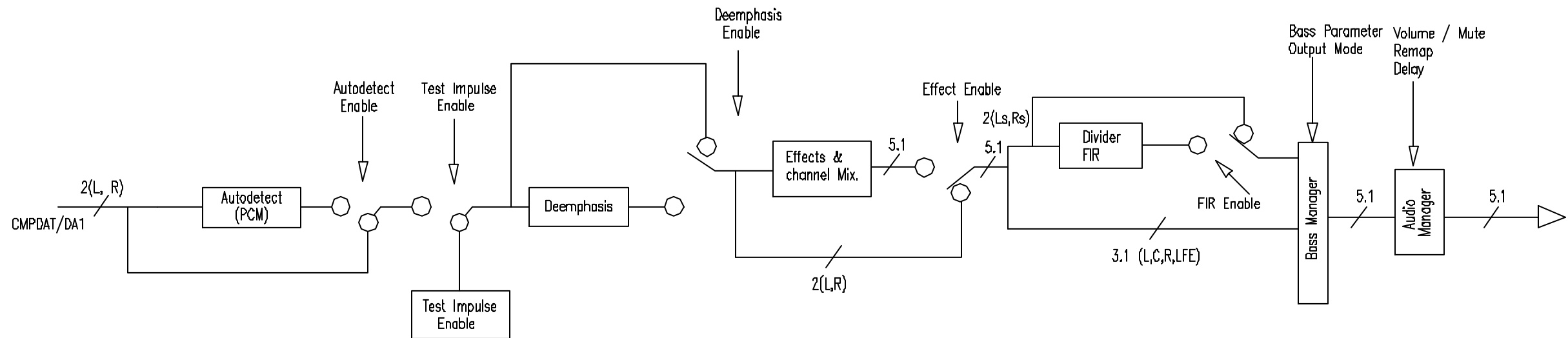

Fig 1-4 Effects Code Block Diagram

# 5. Bass Management

The Bass Manager is best described with the use of block diagram.  
 The default 3dB frequency for this filter is 100Hz.  
 Fig 1-5 shows the topology of the filters cascaded to implement a second order filter.  
 Depending on the coefficient values, either a second order low pass or second order high pass can be implement.  
 The corner frequency can be changed by downloading new values for the coefficients a1, b0 and b1.

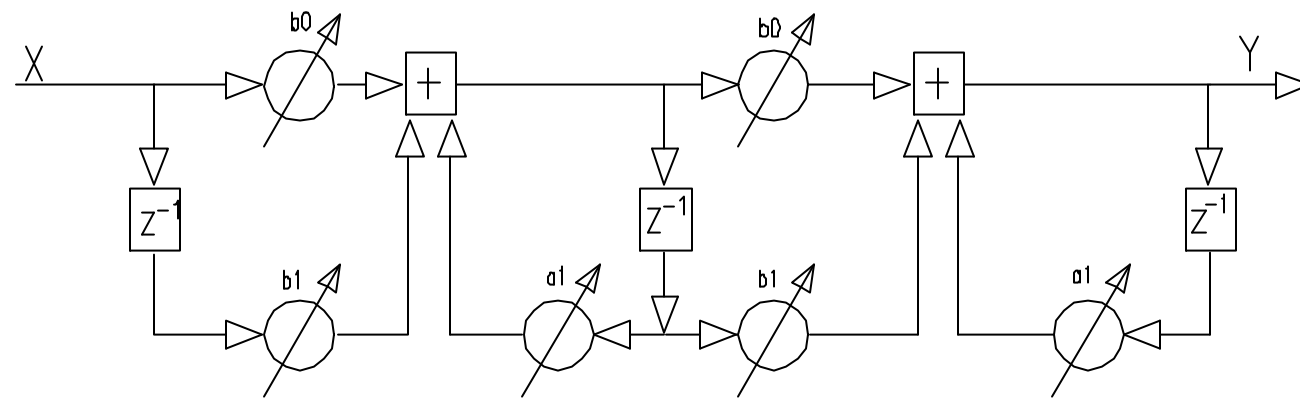

Fig 1-6 Filter Topology

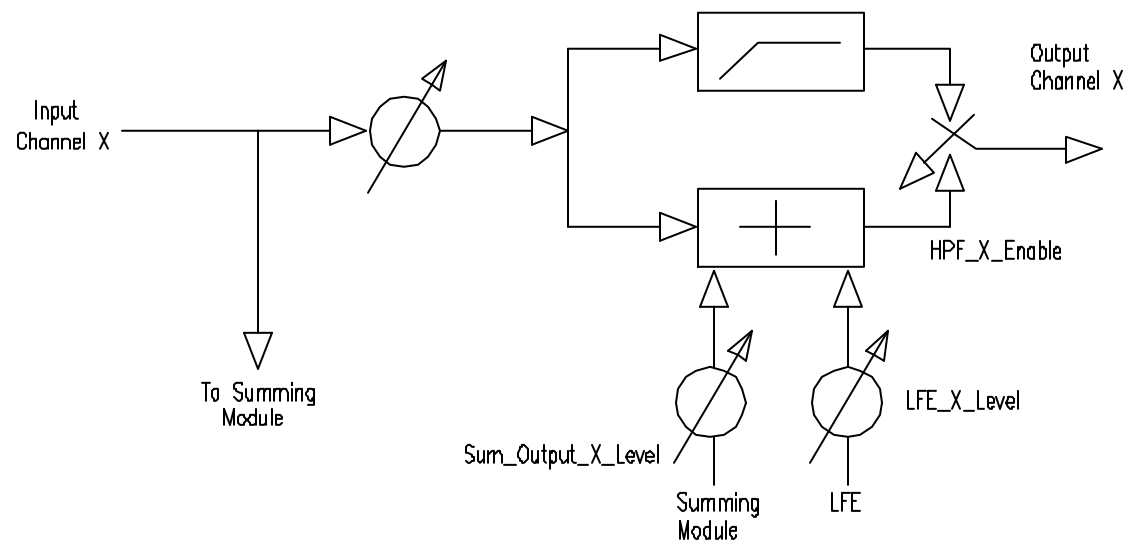

Fig 1-7 Bass manager Processing Unit

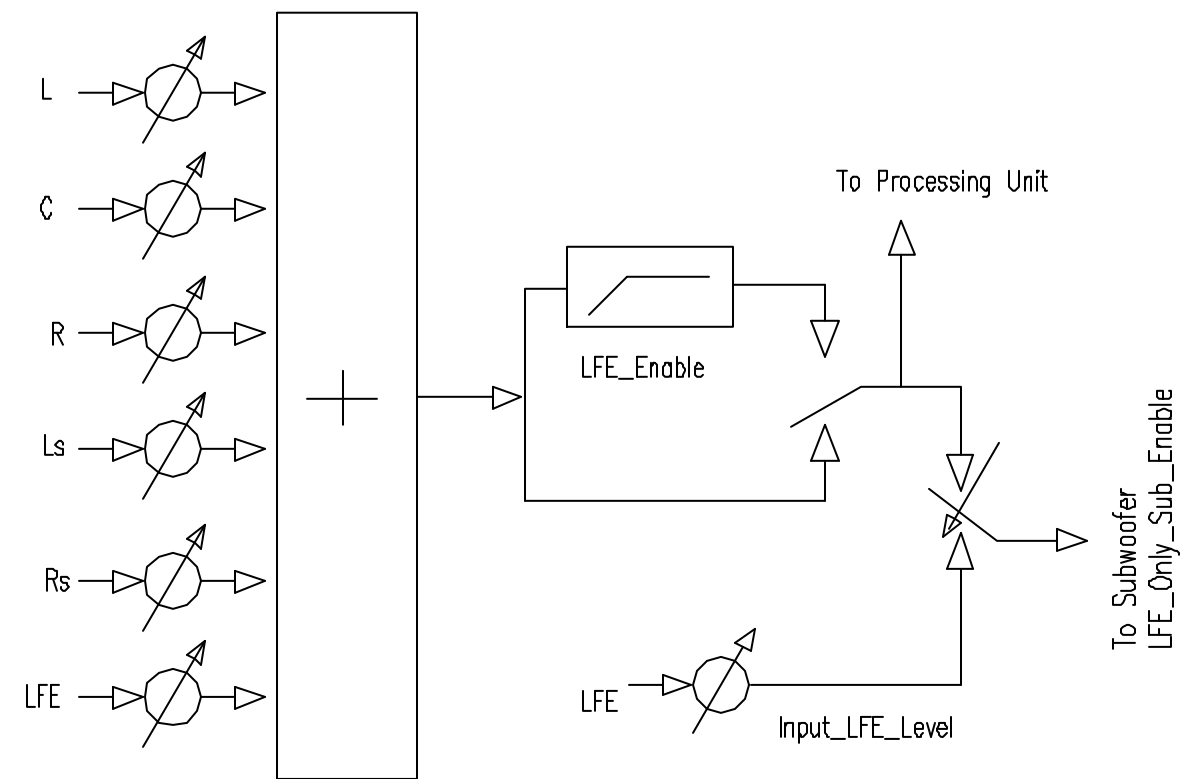
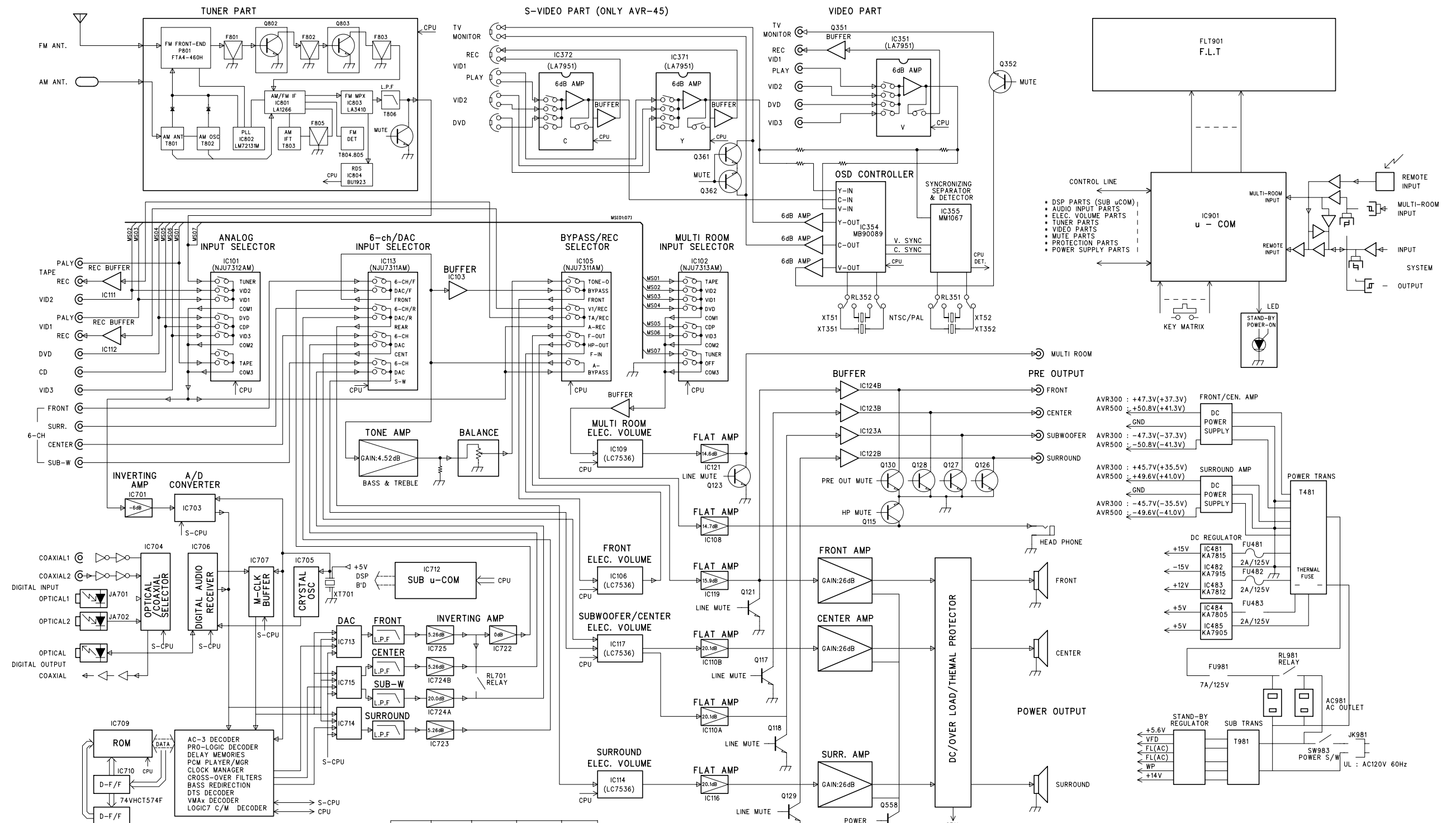

Fig 1-7 Bass manager Processing Unit

# AVR-300,500/UL, RDS BLOCK DIAGRAM



OPTION	FU981	FU481/482/483	JK981	IC804
AVR-300	5A/125V	2A/125V	AC120V/60Hz	Delete
AVR-500	7A/125V	2A/125V	AC120V/60Hz	Delete
AVR-300RDS	T3.15L/250V	T2L/250V	AC230V/50Hz	BU1923
AVR-500RDS	T4L/250V	T2L/250V	AC230V/50Hz	BU1923



# harman/kardon

# Service Bulletin

Service bulletin # H/K2000-02 Rev1 January 2001

Warranty labor rate: MAJOR repair

To: All harman/kardon Service Centers

Models: AVR300, AVR500

Subject: Random Noise, Erratic Output in DTS Mode

**In the event you receive an AVR300 or AVR500 receiver with the complaint “there is distortion, random noise or gaps in the program material when in the DTS mode”, perform the following procedure:**

### REMOVAL AND MODIFICATION OF THE DSP BOARD

- 1) Remove the top cover, (14) Black Phillips screws.
- 2) Locate the DSP PC Board; Figure 1. Remove the two metal braces at the top of the unit. If necessary, cut the cable ties attached to the braces to move any wires away from the area.
- 3) Pull the white 22 conductor ribbon cable at the rear of the DSP PC Board straight out of its receptacle.
- 4) Unplug the white 5 conductor molex cable at the top of the DSP PC Board.
- 5) Remove the (33) plated Phillips screws on the left side of the rear backplate; see Figure 2. Do not remove any additional screws on the right side. If using a power tool, use care and minimum effort to avoid damaging the various plastic receptacles.
- 6) Remove all three black plastic plugs that cover the optical inputs at the rear of the DSP PC Board.
- 7) Pull on the left side of the rear backplate, away from the receiver chassis; you should be able to pull it away enough to allow the DSP PC Board to be pulled straight up and out of the receiver.
- 8) Proceed with the modifications on page 2.

FIGURE 1

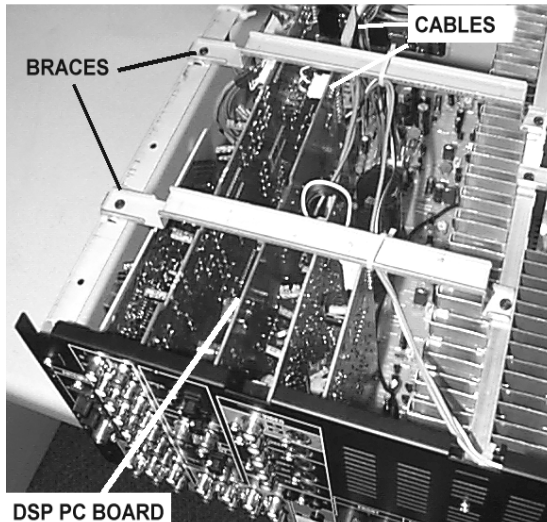
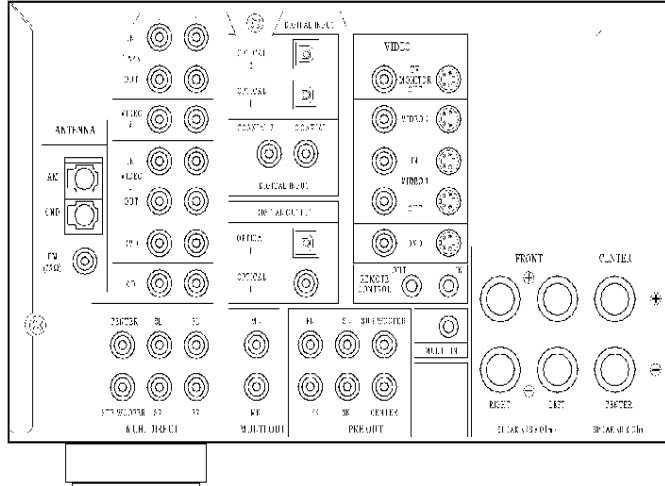

FIGURE 2

REMOVE ALL PHILIPS SCREWS ON THIS SIDE OF THE RECEIVER



Model	Serial Number 120V	Serial Number 230V RDS	STATUS	ACTION
AVR300	TH0001-01000 To TH0001-13886	TH0005-01000 To TH0005-03317	Random Noise, Erratic Output or Gaps in Program Material when in DTS Mode	Modifications to DSP Board: Add ground wire; Change R756 & R755 from 600Ω resistor or Capacitor to 33Ω resistor
AVR500	TH0002-01000 To TH0002-10460	TH0006-01000 To TH0006-02795		
AVR300	TH0001-13887 Or higher	TH0005-03318 Or higher	Modified by factory	NONE REQUIRED
AVR500	TH0002-10461 Or higher	TH0006-02796 Or higher		

Models: AVR300, AVR500 Subject: Random Noise, Erratic Output in DTS Mode

9) Ground Reinforcement:

Using an insulated 16AWG wire, Connect **Negative** sides of the following capacitors on the bottom side of the PCB as shown below. Negative side of each cap will have a white mark on the component side of the PCB.

- A. **Negative polarity of C746** Elec Cap (1uF/50V) in the proximity of ROM IC709
- B. **Negative polarity of C749** Elec Cap (1uF/50V) in the proximity of IC708 DSP IC
- C. **Negative polarity of C744** Elec Cap (1uF/50V) in the proximity of IC710 74VHC574

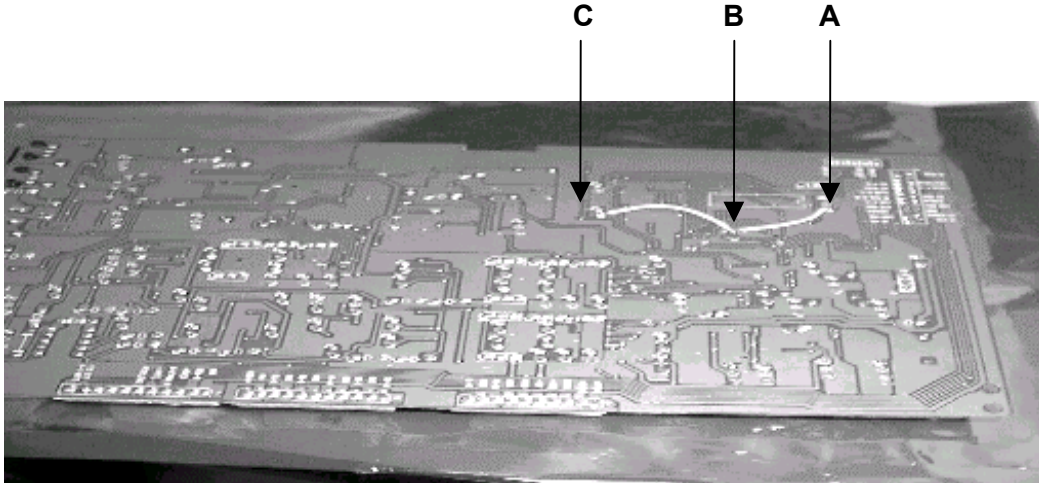

10) Replace:

**R756 & R755.** Original parts may be 600Ω resistors, or Capacitors. Change both to 33Ω 1/10W SMD resistors (h/k part# 292-33.2). See location below.

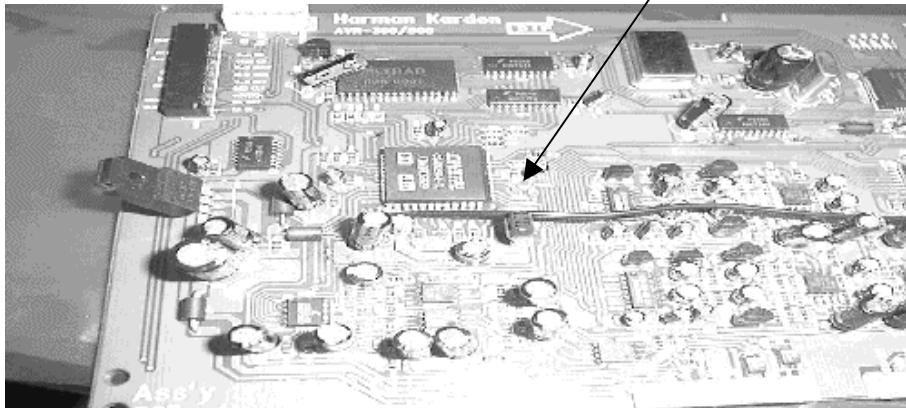

- 11) Replace DSP PC Board back into its (3) receptacle plugs atop the MAIN PCB.
- 12) Replace all screws, braces, and any cable ties that were cut during disassembly. Before tightening the screws, make sure all PCB's and their RCA jacks are firmly seated in their respective holes in the rear backplate. If using a power tool, use care and minimum effort to avoid damaging the various plastic receptacles.
- 13) Plug both the 22 conductor ribbon cable and the 5 conductor moxex cable back into their receptacles.
- 14) Replace the top cover and optical plugs.
- 15) Test unit by powering up the receiver and playing a source with DTS encoded material; confirm the complaint of Random Noise or Erratic Output is no longer occurring.

Service bulletin # H/K2000-04 Rev1 February 2003

To: All harman/kardon Service Centers

Models: AVR500/AVR7000

Subject: Noise in Logic 7 Mode

Warranty labor rate:	
AVR500	MAJOR repair
AVR7000	MINOR repair

In the event you receive an AVR500 or AVR7000 receiver with the complaint “There is crackling, noise, or distortion coming from my loudspeakers when my receiver is in the Logic 7 mode with certain program material playing”, perform the following procedure:

**AVR500 ONLY: REMOVAL AND MODIFICATION OF THE DSP BOARD (replace IC709 TRAD ROM-0001)**

WARNING: FOLLOW PROPER STATIC CONTROL PROCEDURES and use caution during the removal of the DSP board, and during installation of new IC709 to prevent damage.

- 1) Remove the top cover, (14) Black Phillips screws at the sides and rear of the unit.
- 2) Locate the DSP PC Board; Figure 1. Remove the two metal braces at the top of the unit. If necessary, cut the cable ties attached to the braces to move any wires away from the area.
- 3) Pull the white 22 conductor ribbon cable at the rear of the DSP PC Board straight out of its receptacle.
- 4) Unplug the white 5 conductor moxex cable at the top of the DSP PC Board.
- 5) Remove the (33) plated Phillips screws on the left side of the rear backplate; see Figure 2. Do not remove any additional screws on the right side. If using a power tool, use care and minimum effort to avoid damaging the various plastic receptacles.
- 6) Remove all three black plastic plugs that cover the optical inputs at the rear of the DSP PC Board.
- 7) Pull on the left side of the rear backplate, away from the receiver chassis; you should be able to pull it away enough to allow the DSP PC Board to be pulled straight up and out of the receiver.
- 8) Unsolder IC709 TRAD ROM-0001 and replace with hk part# J21310030011. See illustration on following page for location on PCB.

FIGURE 1

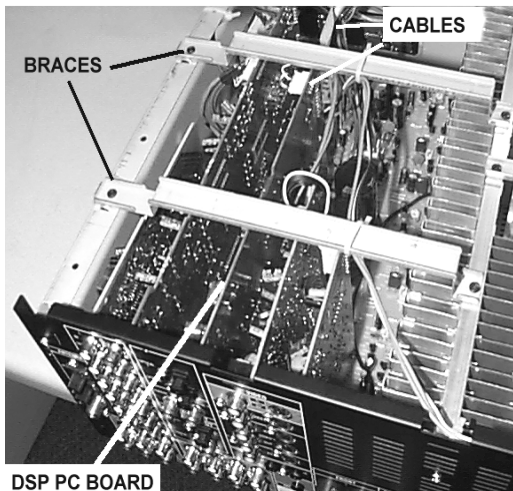
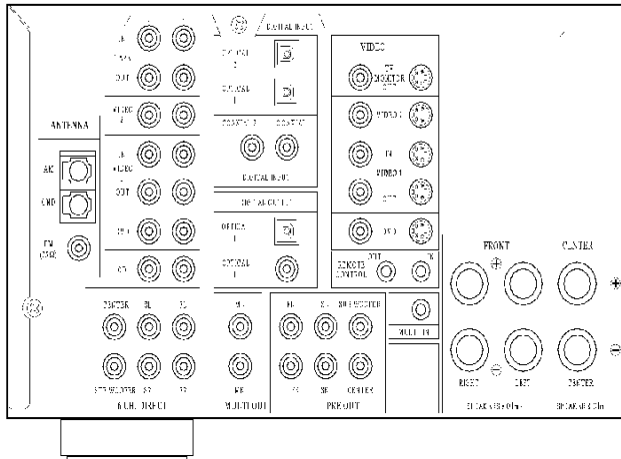
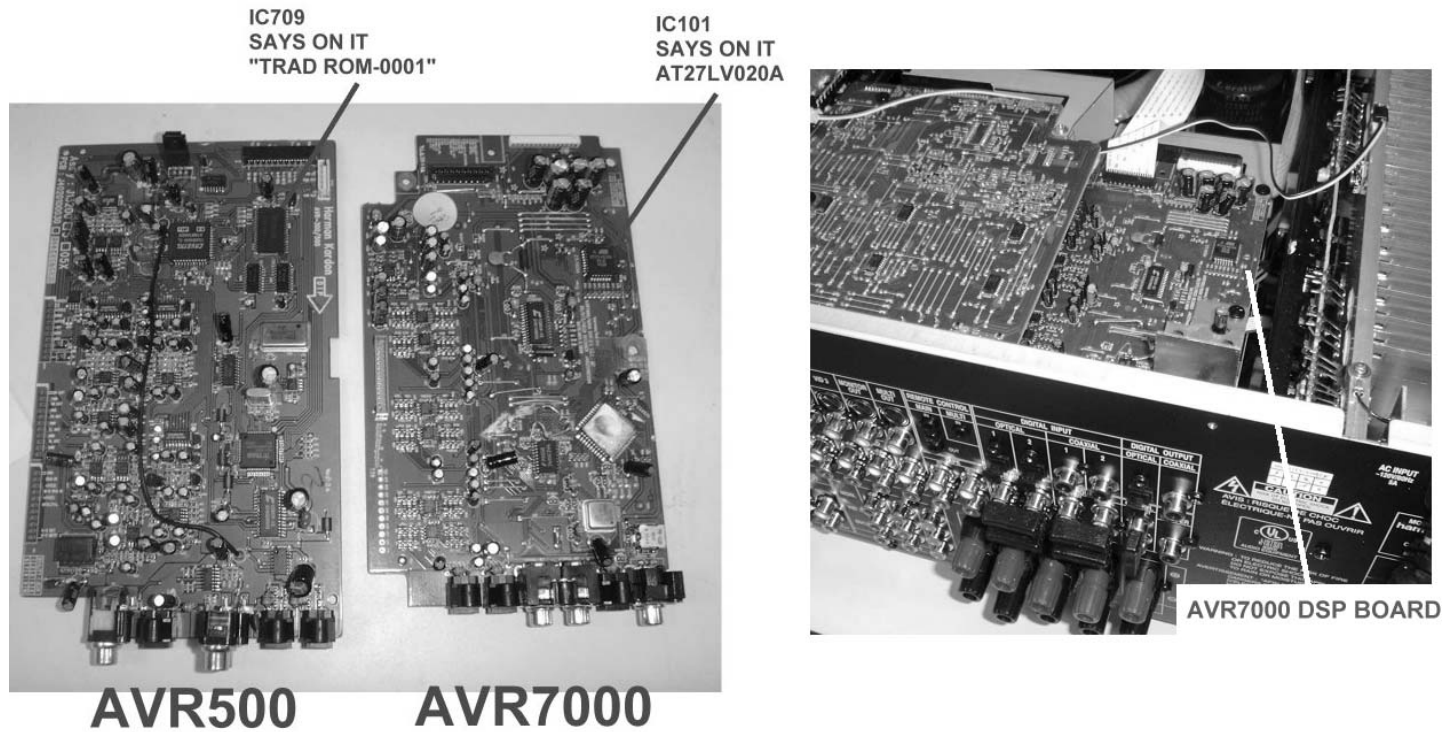

FIGURE 2  
REMOVE ALL PHILIPS SCREWS ON THIS SIDE OF THE RECEIVER



Model	Serial Number 120V	Serial Number 230V RDS	STATUS	ACTION
AVR500	TH0002-01000 To TH0002-14977	TH0006-01000 To TH0006-05105	Noise in Logic 7 Mode	Replace IC709 TRAD ROM-0001
AVR500	TH0002-14978 or higher	TH0006-05106 or higher	Modified by factory	NONE REQUIRED

Location of IC upgrade for the AVR500/AVR7000:



- 9) Replace DSP PC Board back into its (3) receptacle plugs atop the MAIN PCB.
- 10) Replace all screws, braces, and any cable ties that were cut during disassembly. Before tightening the screws, make sure all PCB's and their RCA jacks are firmly seated in their respective holes in the rear backplate. If using a power tool, use care and minimum effort to avoid damaging the various plastic receptacles.
- 11) Plug both the 22 conductor ribbon cable and the 5 conductor molex cable back into their receptacles.
- 12) Replace the top cover and optical plugs.
- 13) Test unit by powering up the receiver and playing a music source in the Logic 7 mode.

**AVR7000 ONLY: MODIFICATION OF THE DSP BOARD (replace IC101 AT27LV020A)**

WARNING: FOLLOW PROPER STATIC CONTROL PROCEDURES and use caution during the installation of new IC101 to prevent damage.

- 1) Remove the top cover, (16) Black Phillips screws at the sides and rear of the unit.
- 2) Locate the DSP PC Board and IC101 with the illustrations above.
- 3) Unsolder IC101 AT27LV020A and replace with hk part# 55172540AVR7000. See illustration above for location on PCB.
- 4) Replace top cover and all Phillips screws.
- 5) Test unit by powering up the receiver and playing a music source in the Logic 7 mode.

Model	Serial Number 120V	Serial Number 230V RDS	STATUS	ACTION
AVR7000	TH0003-01000 To TH0003-05222	Modified by factory	Noise in Logic 7 Mode	Replace IC101 AT27LV020A
AVR7000	TH0003-05223 Or higher	Modified by factory	Modified by factory	NONE REQUIRED

Service bulletin # H/K2000-05 May 2000

Warranty labor rate: MAJOR repair

To: All harman/kardon Service Centers

Models: AVR300, AVR500

Subject: Volume Level Changes

On early versions of the AVR300 or AVR500 the volume level may change by itself, or when the volume knob is tapped. This may happen on an occasional random basis and depends on where the volume control knob is positioned after a volume adjustment. During a running production change, new volume encoders were installed.

**In the event you receive an AVR300 or AVR500 with the complaint “The volume on my receiver changes by itself”, perform the following procedure:**

## REPLACE VR901 VOLUME ENCODER

- 1) Remove the top cover, (14) Black Phillips screws.
- 2) Remove the (11) Black Phillips screws holding the plastic front panel to the chassis.
- 3) Remove the single Phillips screw on both right & left side of the chassis with a dual black ground wire.
- 4) Remove the volume, bass, treble and balance knobs by pulling them straight off.
- 5) Remove the single nut holding the volume encoder to the front panel.
- 6) Pull the loaded front panel off the chassis; cut any plastic cable ties necessary to fully disengage it
- 7) Lift and set the receiver on its right side for the remainder of the procedure.
- 8) Remove molex connector CN983 at the power switch; see Figure 1.
- 9) Pull the front panel as far away as the remaining connecting wires will allow.
- 10) Unsolder the connections at the rear of the front PCB to the volume encoder.
- 11) Using a “stubby” Phillips screwdriver, remove the (19) Black Phillips screws holding the front PCB to the front panel; two plated screws at the rear of the headphone jack also must be removed.
- 12) Pull the front PCB away from the front panel.
- 13) Remove and replace the volume encoder with h/k part# J32612050102; resolder the new encoder in place.
- 14) Replace the front PCB and reassemble the receiver in reverse order, following the instructions above. Replace all cable ties that were cut, and reattach any connectors that were unplugged. Make sure the two ground wires on both sides of the receiver are reattached.
- 15) Power up receiver, and test volume control to assure it no longer changes settings by itself, or when the volume knob is tapped.

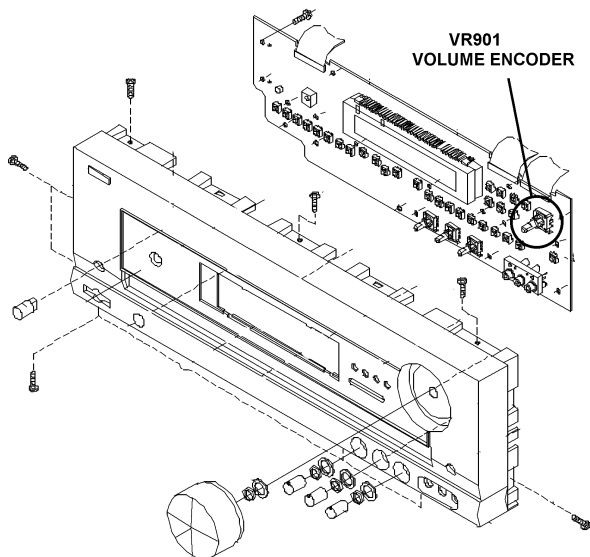
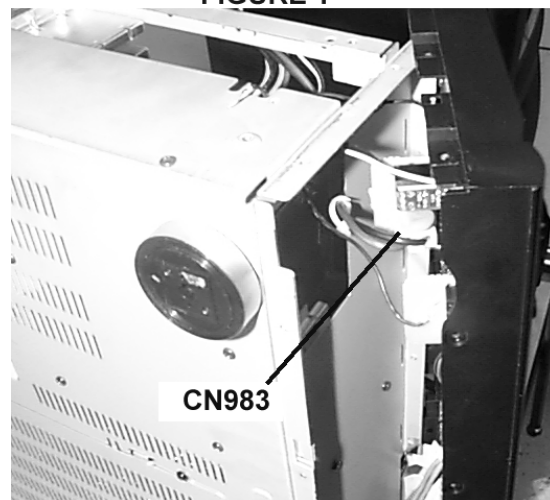

FIGURE 1



Model	Serial Number 120V	Serial Number 230V RDS	STATUS	ACTION
AVR300  AVR500	TH0001-01000 To TH0001-08402  TH0002-01000 To TH0002-05565	TH0005-01000 To TH0005-01001  TH0006-01000 To TH0006-01001	Volume level changes by itself or when volume knob is tapped	Change VR901 Rotary encoder
AVR300  AVR500	TH0001-08403 Or higher TH0002-05566 Or higher	TH0005-01002 Or higher TH0006-01002 Or higher	Modified by factory	NONE REQUIRED

# DISASSEMBLY PROCEDURE

1. Removing the top cover and  
Remove screws ① ~ ⑫

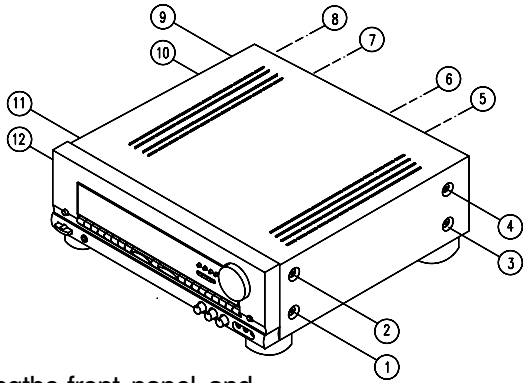

2. Removing the front panel, and  
Remove screws ① ~ ⑪

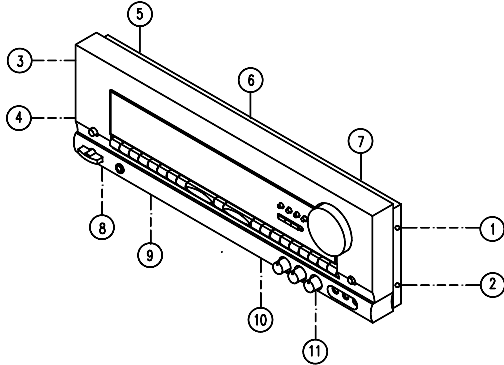

3. Removing the rear panel, and  
Remove screws ① ~ ⑧

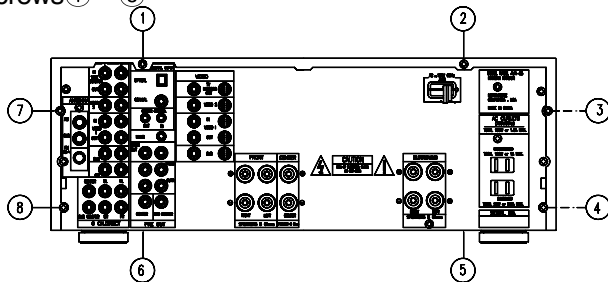

4. Removing the main PCB block, and  
Remove screws ① ~ ⑪

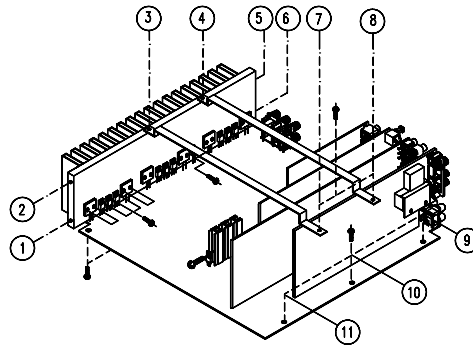

5. Removing the power PCB block, and  
Remove ① ~ ⑦

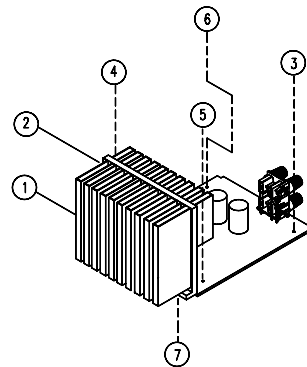

6. Removing the sub PCB block, and  
Remove screws ① ~ ④

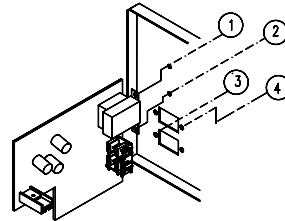

## MAIN AMP PCB BLOCK

1. Remove all of the screws on Rear panel.
2. Remove the Rear panel.
3. Remove PCB Bracket and Guide Bracket from Main Assy.
4. Remove all of the screws that connect with main Assy.
5. Remove the Main PCB block.

## POWER PCB BLOCK

1. Remove PCB Bracket and Guide Bracket from Main Assy.
2. Remove 4 screws for Power PCB mounting
3. Remove the POWER PCB block.

## SUB PCB BLOCK

1. Remove 4 screws on Rear panel.
2. Remove the Rear panel.
3. Remove PCB Bracket and Guide Bracket from Main Assy.
4. Remove the SUB PCB block.

## FRONT PCB BLOCK

1. Remove Main Assy.
2. Remove volume and rotary knob from the front Assy.
3. Remove all of the screws on back side of Front function PCB.
4. Remove the Front function PCB.

# GENERAL UNIT PARTS LIST

REF NO.	PARTS NO.	DESCRIPTION	Q'TY	
1	J85000502000	PANEL. FRONT	1	<b>BK</b>
1-A	J85300504000	PANEL. FRONT	1	<b>IB</b>
2	J85200501000	KNOB. FUNCTION (A)	1	
3	J85200502000	KNOB. FUNCTION (B)	1	
4	J85200503000	KNOB. FUNCTION (C)	2	
5	J85200504000	KNOB. POWER	1	
6	J85200505000	KNOB. PUSH	1	
7	J85200506000	KNOB. TACT	1	
8	J85100501000	KNOB. VOLUME	1	
9	J85100502000	KNOB. ROTARY	3	
10	J85300504000	WINDOW. FRONT	1	<b>BK</b>
10-A	J85300506000	WINDOW. FRONT	1	<b>IB</b>
11	J85300502000	FILTER. WINDOW	1	
12	J85300503000	LENS. POWER	1	
13	J65100000100	BUSHING. STRAIN R	1	
14	J60110502000	PANEL. REAR	1	<b>BK</b>
14-A	J60110504000	PANEL. REAR	1	<b>IB</b>
15	J60100501000	COVER TOP	1	
16	J60020501000	CHASSIS. FRONT	1	
17	J60000501000	CHASSIS. MAIN	1	
18	J60120501000	COVER. BOTTOM	1	
19	J60120502000	TRANS. BOTTOM	1	
20	J60200502000	FRAME. GUIDE	2	
21	J60300501000	BRK'T. PCB	2	
22	J85900501000	FOOT ASS'Y	4	
23	J97200501000	CUSHION. PCB	5	
24	J97200502000	CUSHION (A)	1	
25	J67400501000	SHEET. POWER	1	
26	J97200503000	CUSHION. BRK'T	2	
27	J2802210014X	TRANS. POWER	1	<b>BK</b>
27-A	J2802410024X	TRANS. POWER	1	<b>IB</b>
28	J43730100100	CORD. POWER	1	<b>BK</b>
28-A	2161-001-032	CORD. POWER	1	<b>IB</b>
29	J60520051000	HEAT SINK. MAIN	1	
30	J60520052000	HEATSINK. POWER	1	
31	J60610503000	CASE. SHIELD (D)	1	
32	J60610501000	CASE. SHIELD (F)	1	
33	J60610502000	CASE. SHIELD (T2)	1	
34	J60530502000	HEAT SINK. R3	1	
35	J60530601000	HEAT SINK. R2		
36	5241-000110	HEAT SINK. PIN	5	
37	J97200505000	CUSHION. FLT	2	
38	J97200504000	CUSHION (B)	2	
39	J54000502000	REMOCON ASS'Y	1	<b>BK</b>
39-A	J54000504000	REMOCON ASS'Y	1	<b>IB</b>
40	J60550002000	BADGE. HARMAN	1	



## GENERAL UNIT PARTS LIST

REF NO.	PARTS NO.	DESCRIPTION	Q'TY	
41	J97200506000	CUSHION SIDE	4	
42	J97200505000	CUSHION.EMI	3	
S1	J80720301090	SCREW 3*10 TEETH COPPER	42	
S2	J5636140040X	SCREW A183008000	13	
S3	J5636140060X	SCREW S30C BTTN D12.3X10 MC	3	
S4	J5636140100X	SCREW A123008002	76	
S5	J5636140220X	SCREW A183006002	8	
S6	J5636140150X	SCREW A184008002	8	
S7	J5636140080X	SCREW A124008000	4	
S8		SCREW A113016000	10	
W1	J5541001030X	WASHER. SPRING N2.0 M4.0 MC	4	
W2	J5541001040X	WASHER. PLAT P/W 4.7X12X1.0 MC	4	
W3	J5541001010X	WASHER. SPRING NO2 M3.0 MC	20	
W4	J5541001020X	WASHER. PLAT P/W 3.3X8X0.5 MC	20	
MAIN AMP	J1320045101X	ASS'Y-PCB : MAIN AMP (BK)	1	<b>BK</b>
	J1320045201X	ASS'Y-PCB : MAIN AMP (IB)	1	<b>IB</b>
REAR AMP	J13200451021	ASS'Y-PCB : REAR AMP (BK)	1	<b>BK</b>
	J13200452021	ASS'Y-PCB : REAR AMP (IB)	1	<b>IB</b>
SUB	J13200451022	ASS'Y-PCB : SUB (BK)	1	<b>BK</b>
	J13200452022	ASS'Y-PCB : SUB (IB)	1	<b>IB</b>
C-VIDEO	J13200451023	ASS'Y-PCB : C-VIDEO (BK)	1	<b>BK</b>
	J13200452023	ASS'Y-PCB : C-VIDEO (IB)	1	<b>IB</b>
S-VIDEO	J13200451024	ASS'Y-PCB : S-VIDEO (BK)	1	<b>BK</b>
	J13200452024	ASS'Y-PCB : S-VIDEO (IB)	1	<b>IB</b>
AUDIO INPUT	J1320045103X	ASS'Y-PCB : AUDIO INPUT (BK)	1	<b>BK</b>
	J1320045203X	ASS'Y-PCB : AUDIO INPUT (IB)	1	<b>IB</b>
TUNER	J13200451041	ASS'Y-PCB : TUNER (BK)	1	<b>BK</b>
	J13200452041	ASS'Y-PCB : TUNER (IB)	1	<b>IB</b>
FRONT	J13200451041	ASS'Y-PCB : FRONT (BK)	1	<b>BK</b>
	J13200452041	ASS'Y-PCB : FRONT (IB)	1	<b>IB</b>
HEADPHONE	J13200451041	ASS'Y-PCB : HEADPHONE (BK)	1	<b>BK</b>
	J13200452041	ASS'Y-PCB : HEADPHONE (IB)	1	<b>IB</b>
DSP	J1320045105X	ASS'Y-PCB : DSP (BK)	1	<b>BK</b>
	J1320045205X	ASS'Y-PCB : DSP (IB)	1	<b>IB</b>
STAND-BY	J13200451041	ASS'Y-PCB : STAND-BY (BK)	1	<b>BK</b>
	J13200452041	ASS'Y-PCB : STAND-BY (IB)	1	<b>IB</b>

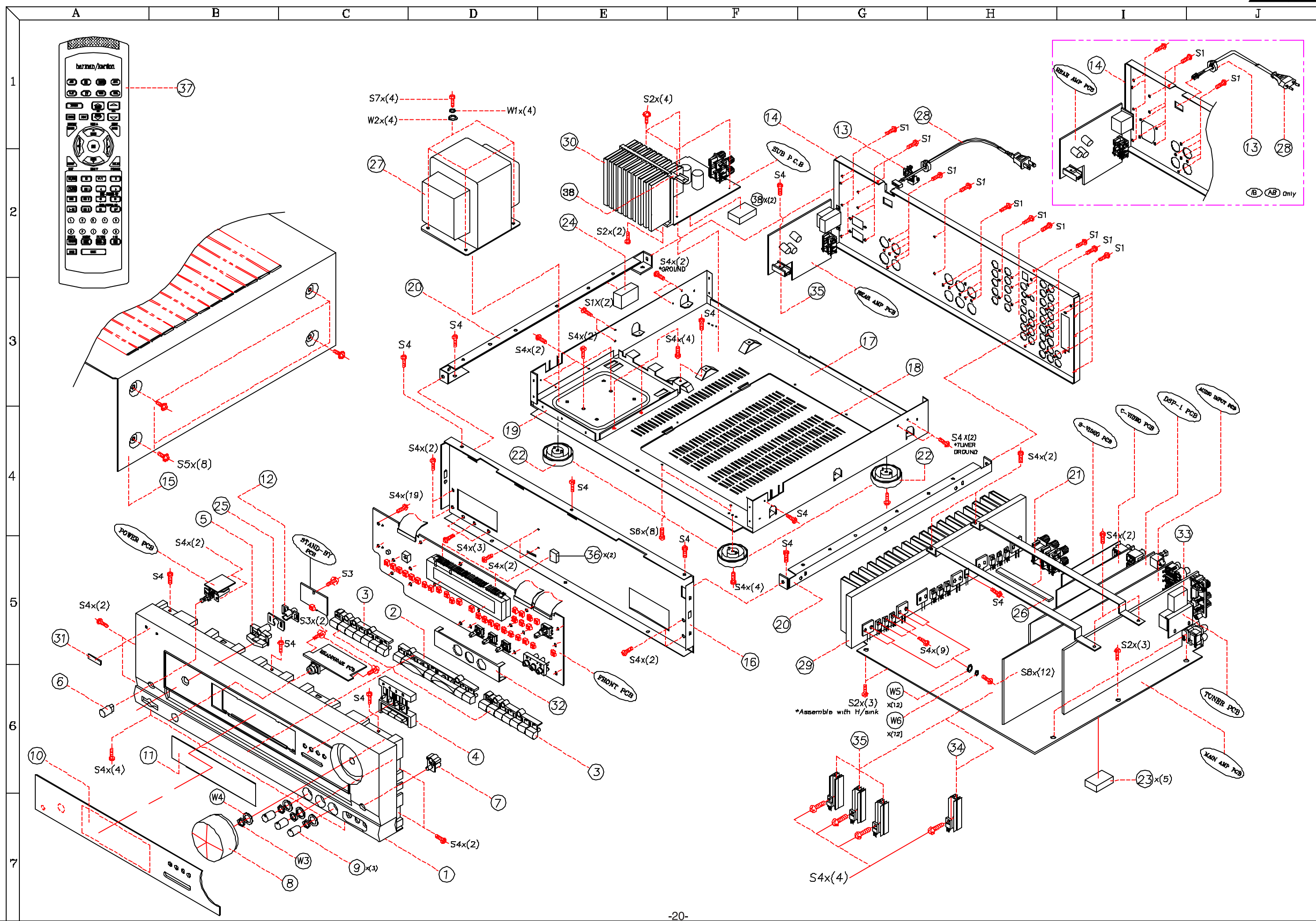

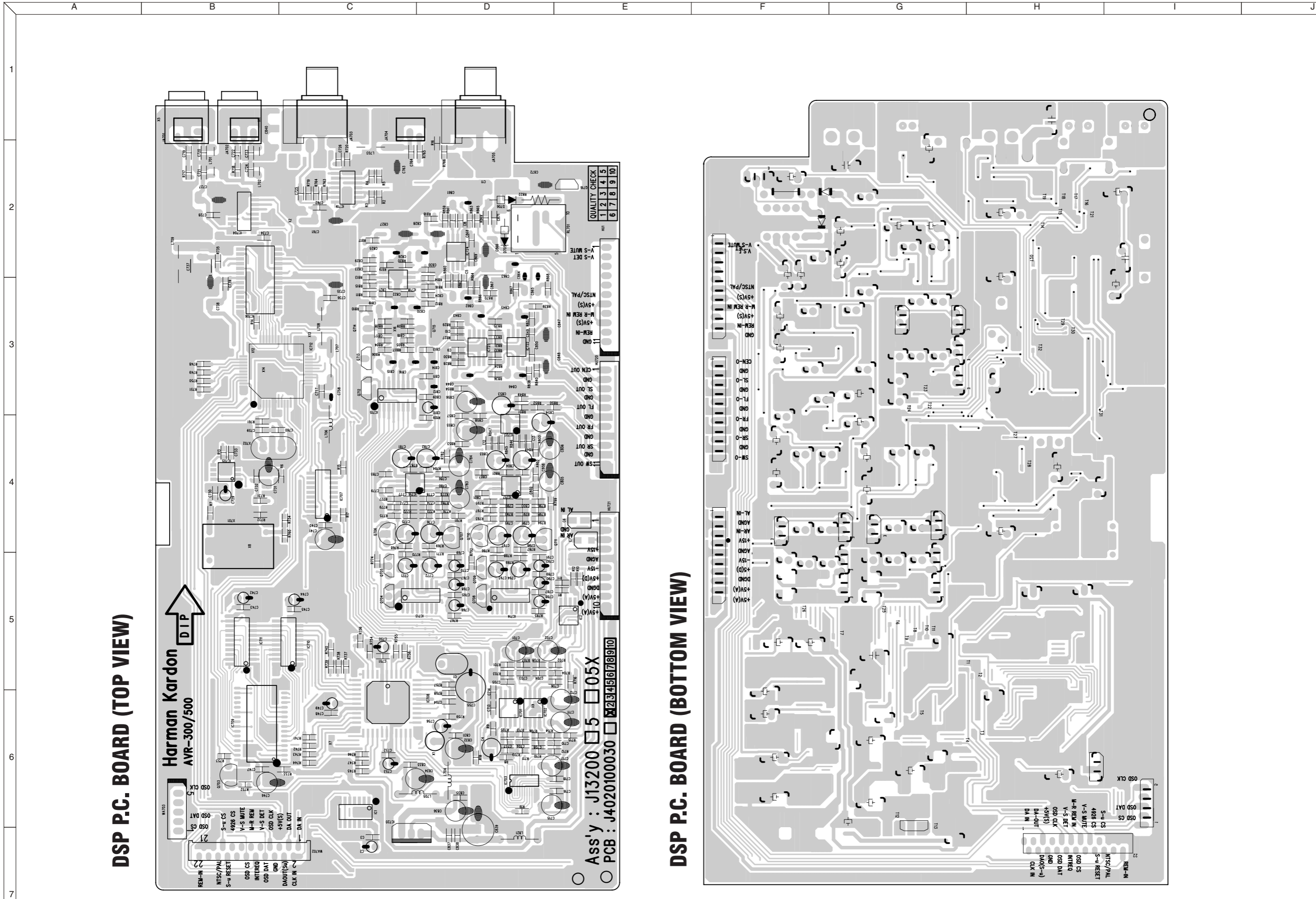

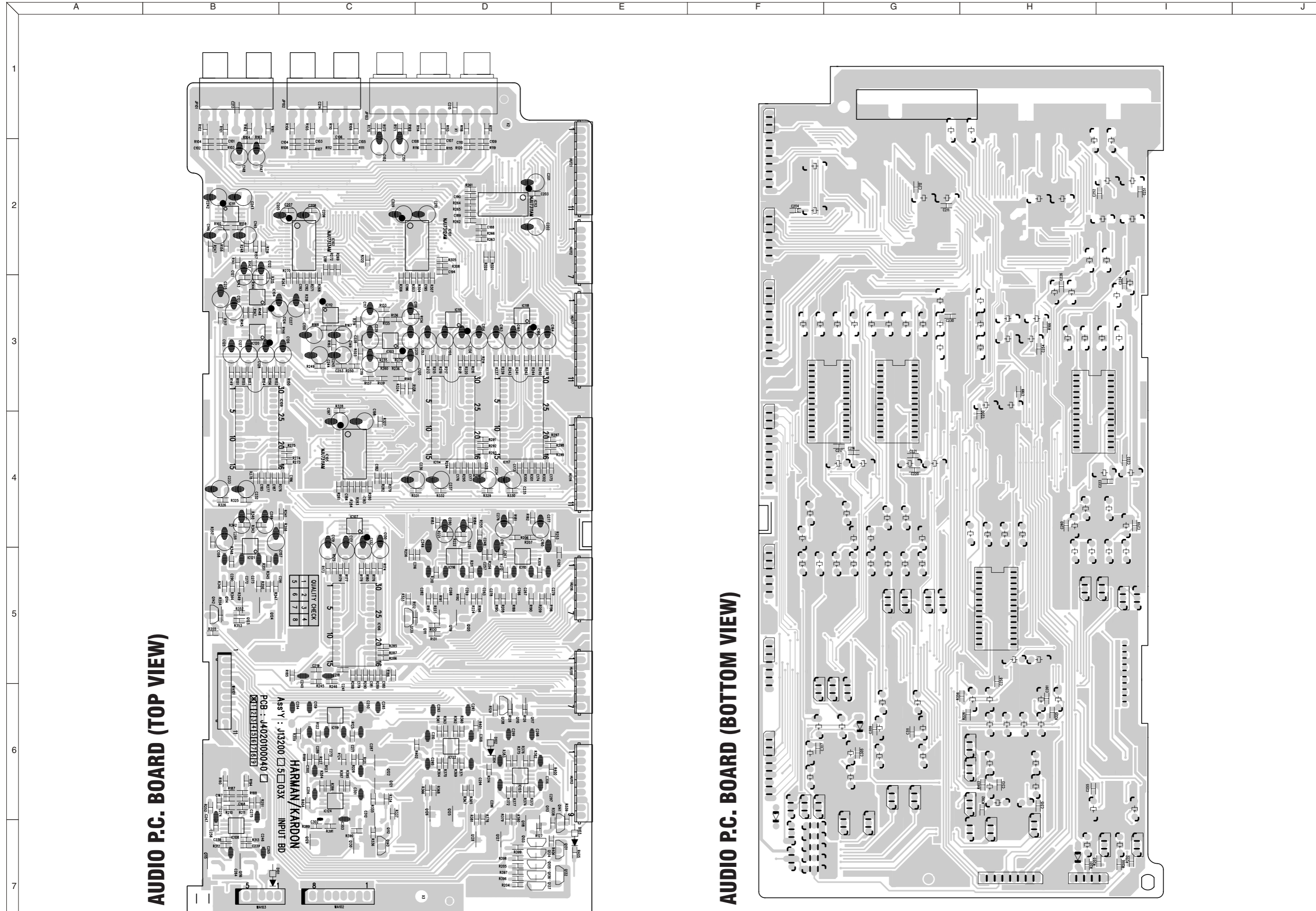

**AUDIO P.C. BOARD (TOP VIEW)**

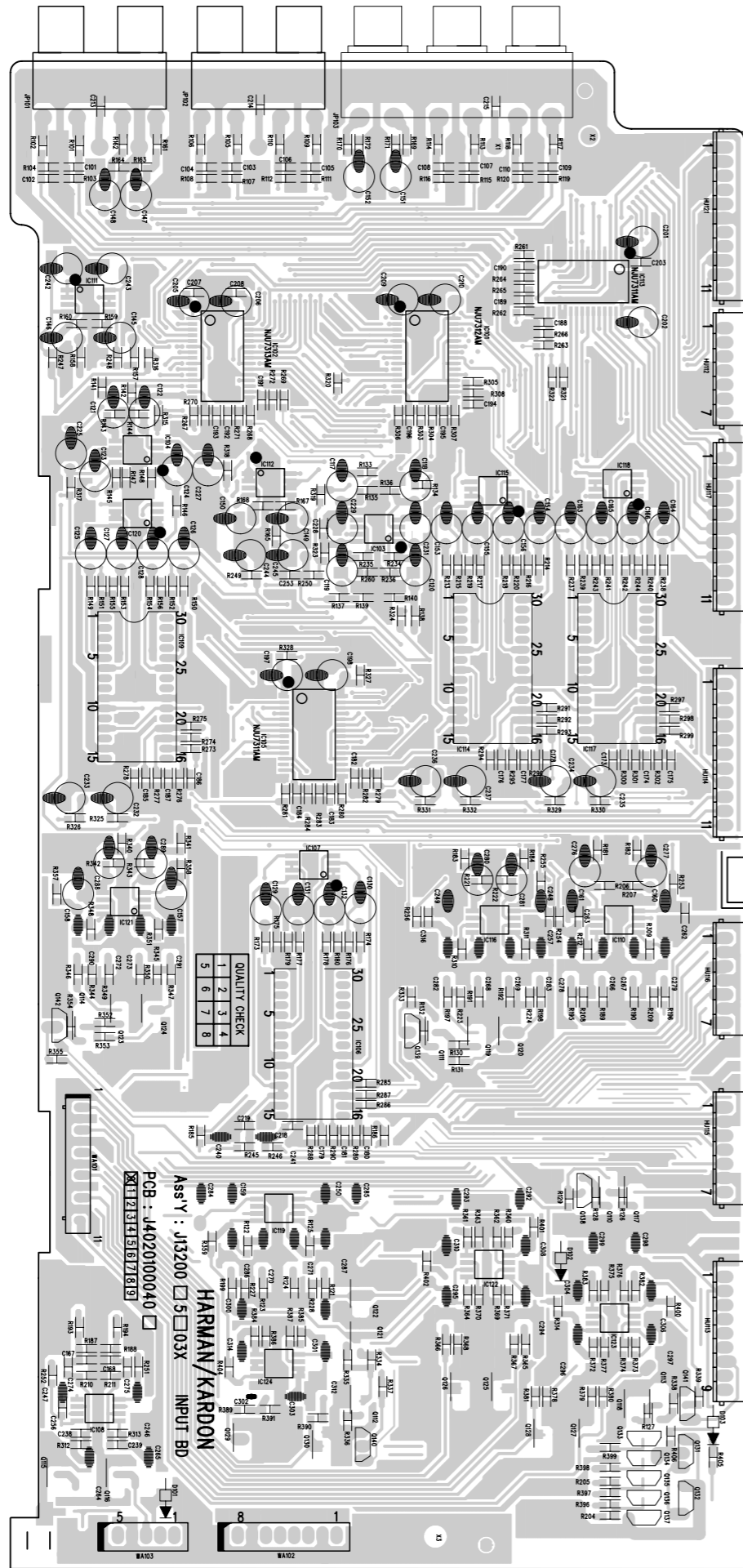

**AUDIO P.C. BOARD (BOTTOM VIEW)**

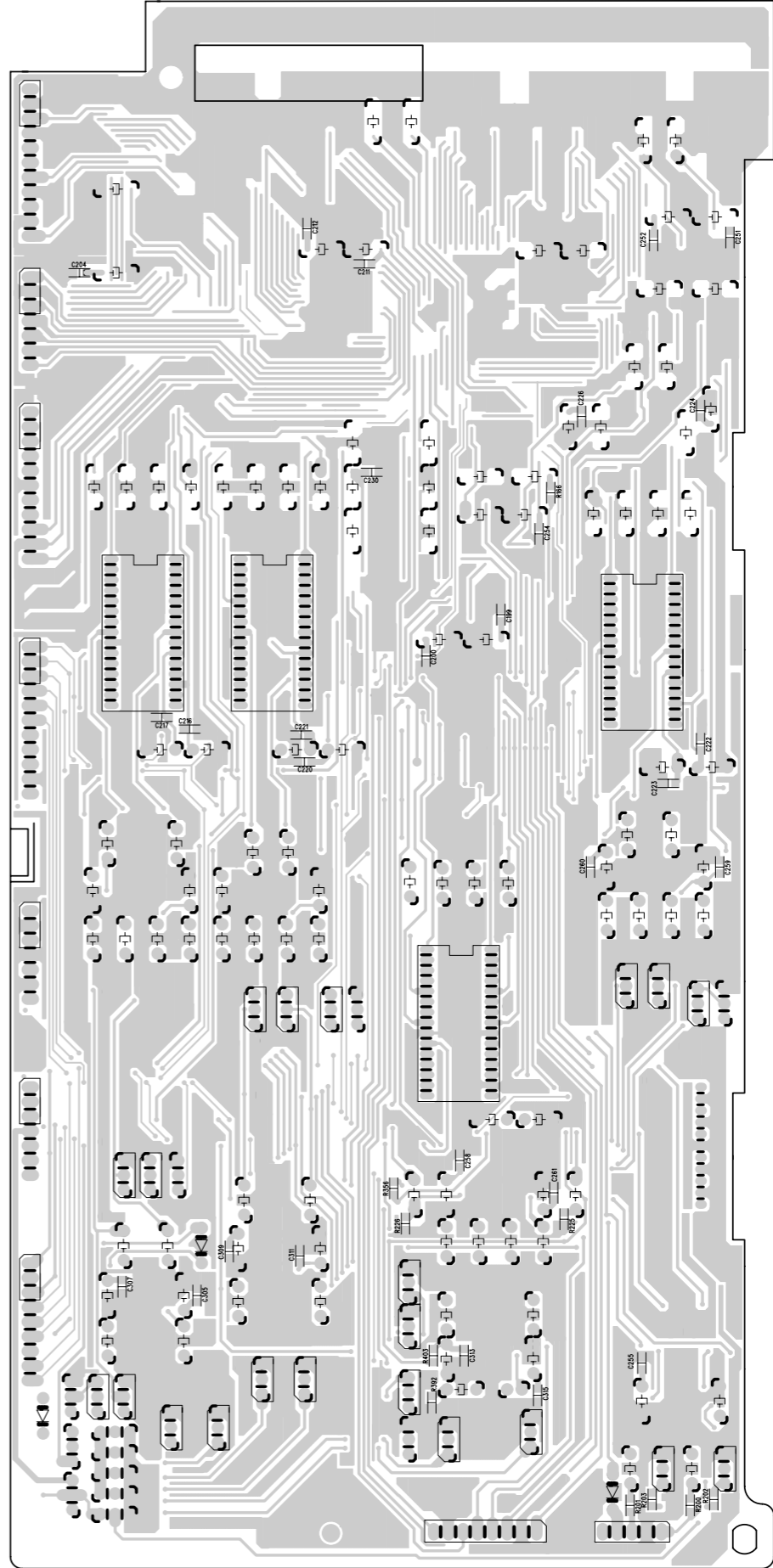

# MAIN AMP P.C. BOARD

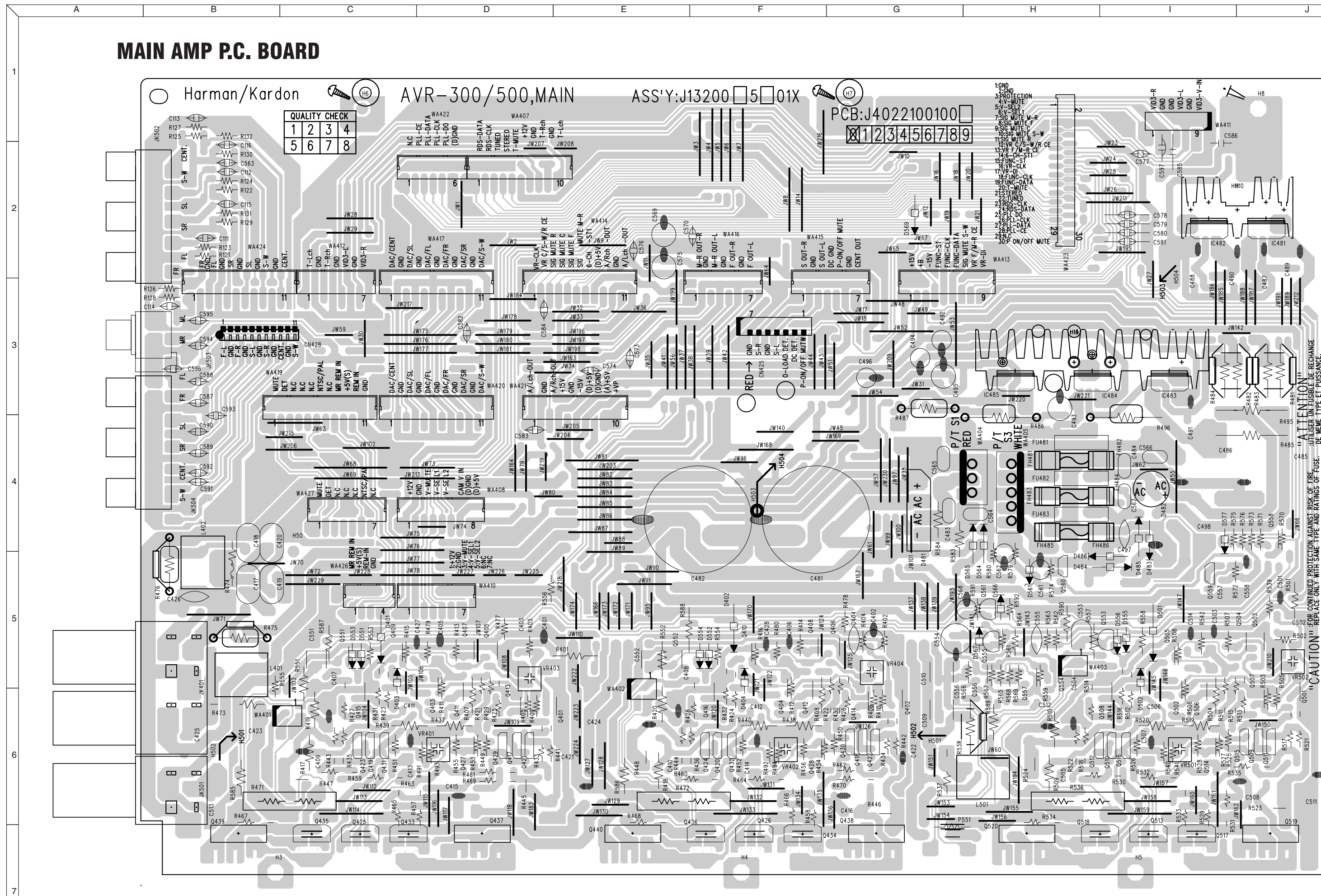

**ATTENTION**  
- UTILISER UN FUSIBLE DE RECHANGE  
DE MEME TYPE ET POUSSANCE.

**CAUTION!**  
FOR CONTINUED PROTECTION AGAINST RISK OF FIRE  
- REPLACE ONLY WITH SAME TYPE AND RATINGS OF FUSE.

# FRONT P.C. BOARD

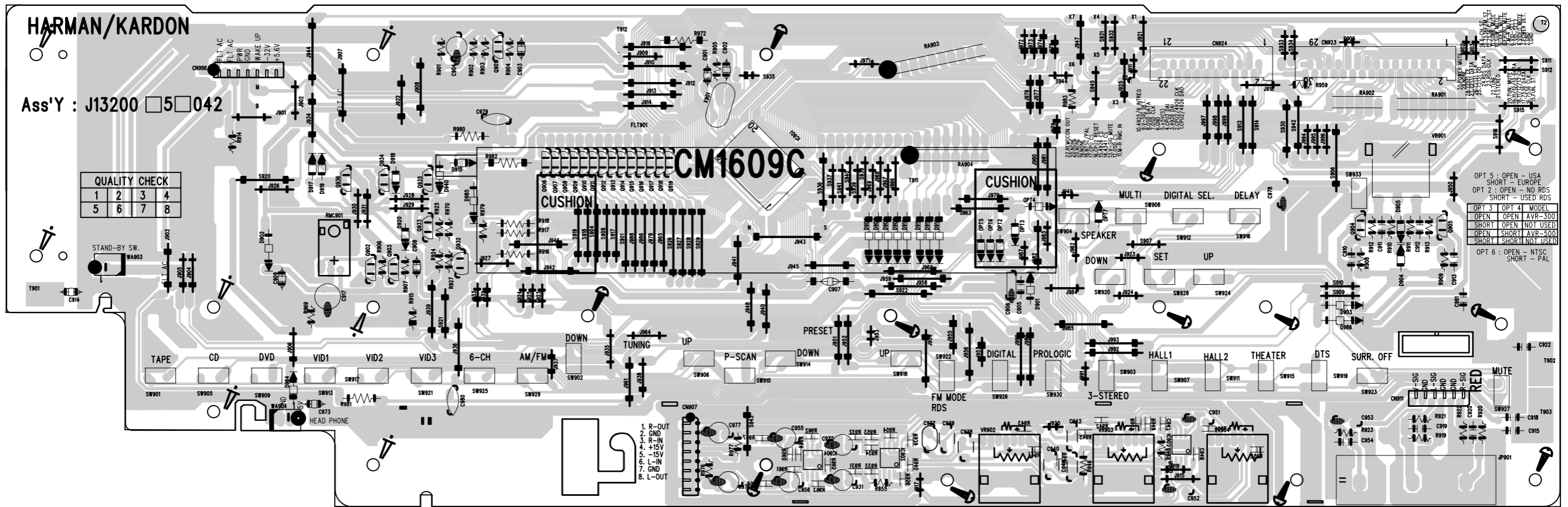

# TUNER P.C. BOARD

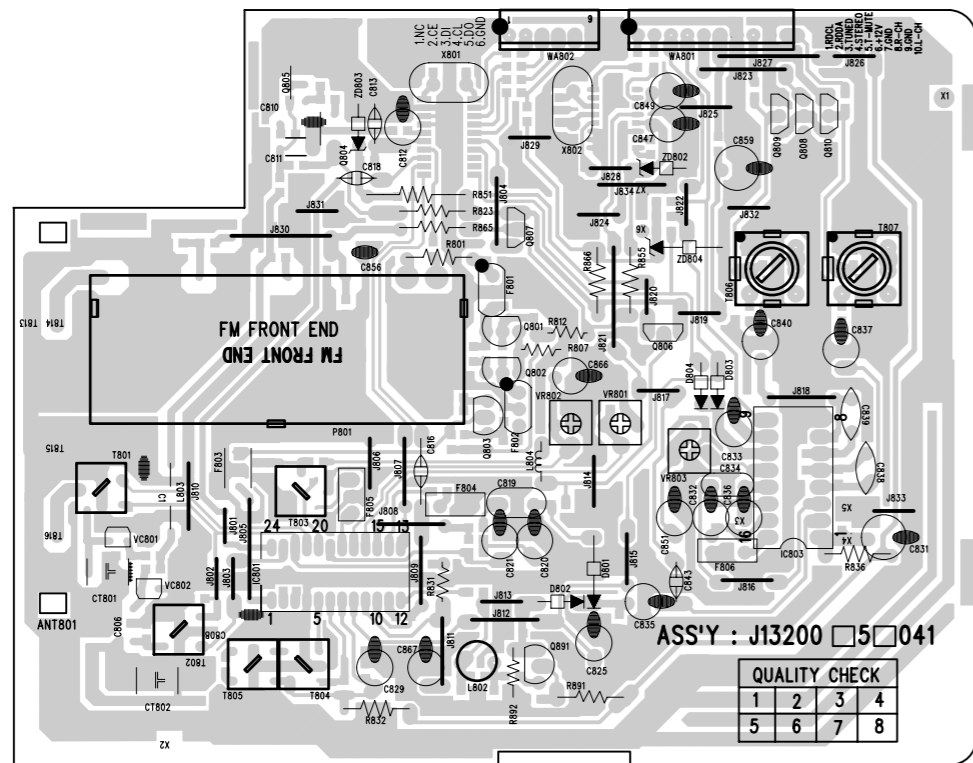

# HEADPHONE P.C. BOARD

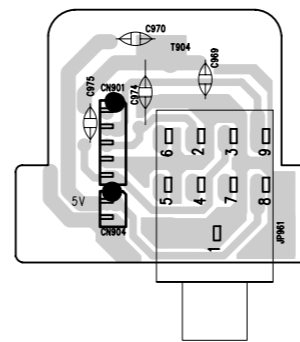

# POWER PC BOARD

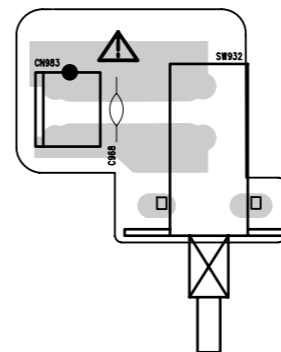

# STAND-BY SWITCH P.C. BOARD

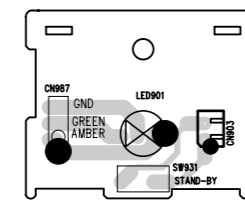

**C-VIDEO P.C. BOARD**

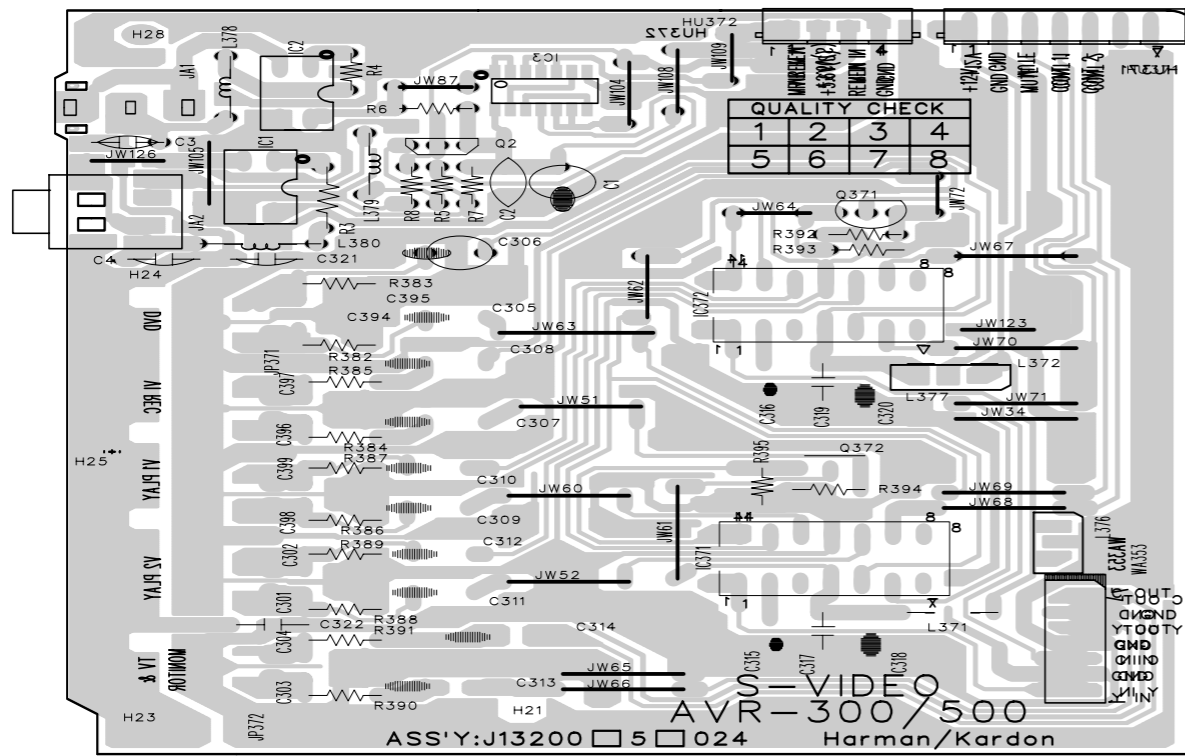

**REAR AMP P.C. BOARD**

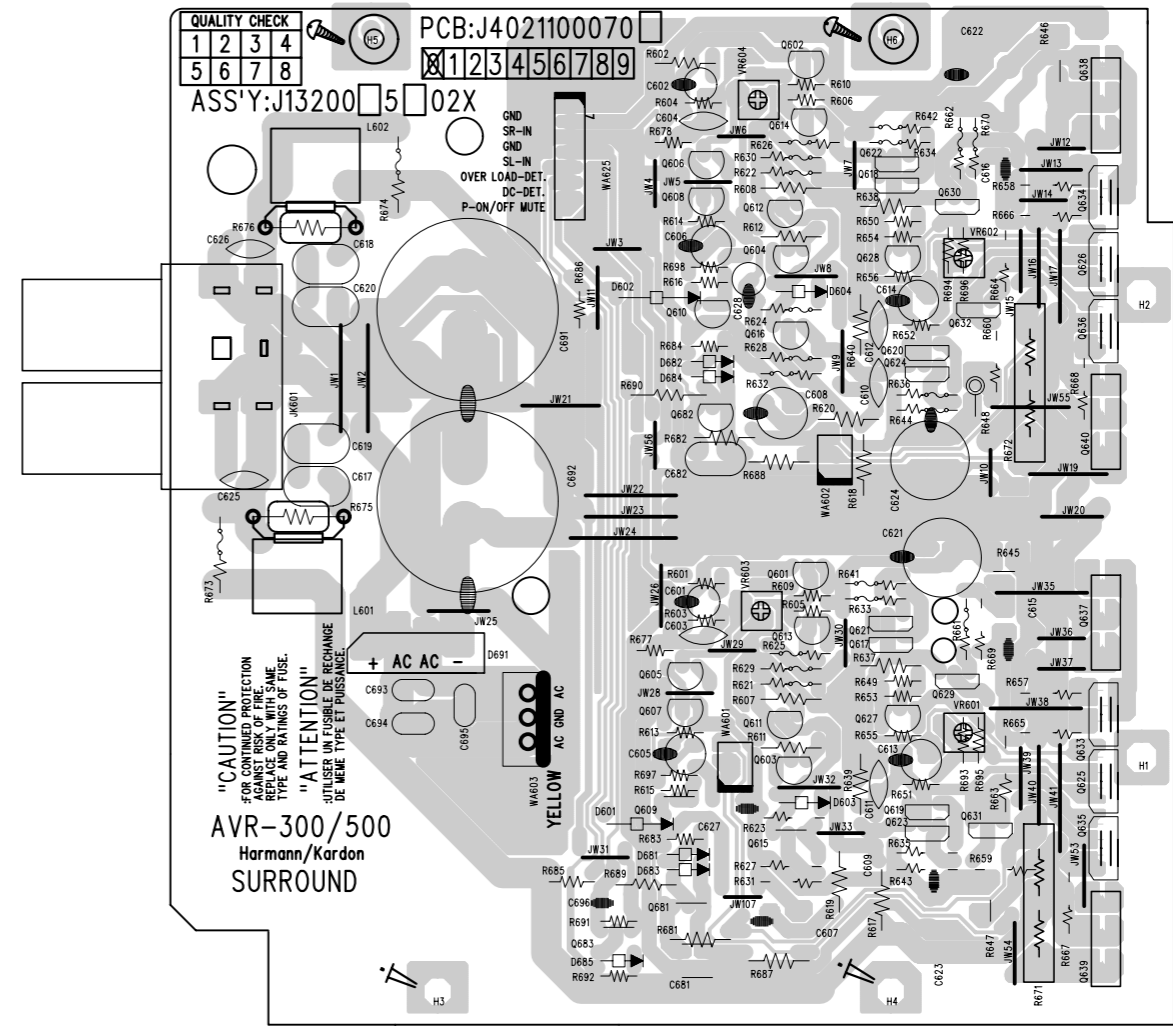

**S-VIDEO P.C. BOARD**

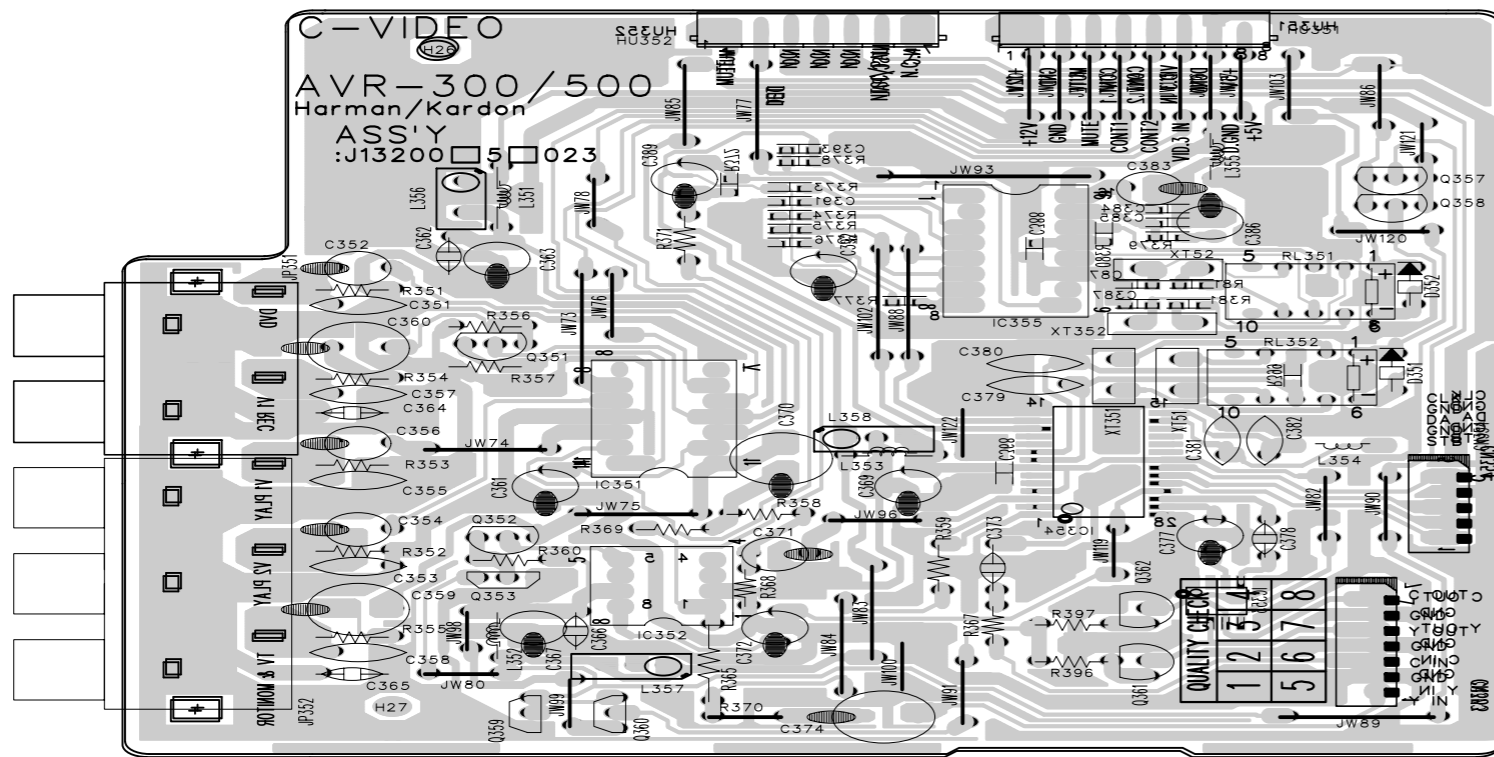

**SUB P.C. BOARD**

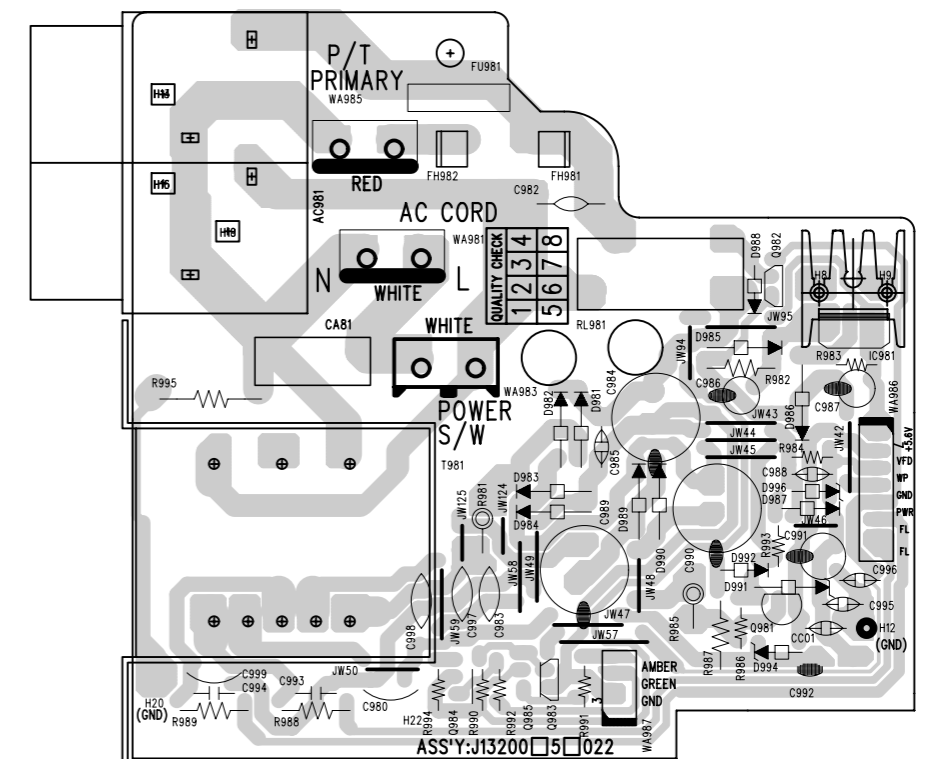

# ELECTRIC PART LIST(500Serie) DSP P.C BOARD

REF NO.	PART NO.	DESCRIPTION	REF NO.	PART NO.	DESCRIPTION			
J1320045205X	DSP P.C. BOARD	IB	<b>BEADs</b>					
J1320045105X	DSP P.C. BOARD	BK	L 704	J2631200010X	HC3550 9.4ohm	AXIAL		
<b>INTEGRATED CIRCUITS</b>			L 705	J2631200010X	HC3550 9.4ohm	AXIAL		
IC 1	J2142930002X	74VHCT04SJX	HEX INVERT	L 706	J2631200010X	HC3550 9.4ohm	AXIAL	
IC 2	J2120012001X	NJM4558M	OP-AMP	L 707	J2631200010X	HC3550 9.4ohm	AXIAL	
IC 701	J2120012002X	NJM072M	OP-AMP	L 708	J2631200010X	HC3550 9.4ohm	AXIAL	
IC 702	J2120012002X	NJM072M	OP-AMP	L 709	J2631200010X	HC3550 9.4ohm	AXIAL	
IC 703	J2133926002X	CS5360-KS	A/D CONVERTER	L 821	J2631200010X	HC3550 9.4ohm	AXIAL	
IC 704	J2142930001X	74VHC153SJX	MULTIPLEXER	R 6	J2631300174X	HB-1T2012-601	CHIP	
IC 705	J2129012001X	NJU6324M	QUARTZ OSC	R 7	J2631300174X	HB-1T2012-601	CHIP	
IC 706	J2136926001X	CS8414-CS	DIGITAL AUDIO Rx.	R 13	J2631300184X	HB-1T2012-202	CHIP	
IC 707	J2142930003X	74VHCT244SJX	OCTAL NON-INVERT	R 14	J2631300174X	HB-1T2012-601	CHIP	
IC 708	J2135326003X	CS492604D	DECODER	R 15	J2631300174X	HB-1T2012-601	CHIP	
IC 709	J2131003001X	KM23C4000DG-8	ROM-0001	R 17	J2631300174X	HB-1T2012-601	CHIP	
IC 709	J2131328002X	AT27C040-100JC	ROM OTP	R 18	J2631300174X	HB-1T2012-601	CHIP	
IC 710	J2142930004X	74VHCT574SJX	OCTAL D-FILP FLOP	R 19	J2631300174X	HB-1T2012-601	CHIP	
IC 711	J2142930004X	74VHCT574SJX	OCTAL D-FILP FLOP	R 109	J2631300174X	HB-1T2012-601	CHIP	
IC 712	J2132321002X	HD404354A52H	MCU-0002	R 731	J2631300174X	HB-1T2012-601	CHIP	
IC 712	J2132321001X	HD407A435PH	SUB-u-COM OTP	R 732	J2631300174X	HB-1T2012-601	CHIP	
IC 713	J2133926003X	CS4341-KS	D/A CONVERTER	R 734	J2631300174X	HB-1T2012-601	CHIP	
IC 714	J2133926003X	CS4341-KS	D/A CONVERTER	R 755	J2631300174X	HB-1T2012-601	CHIP	
IC 715	J2133926003X	CS4341-KS	D/A CONVERTER	R 756	J2631300174X	HB-1T2012-601	CHIP	
IC 716	J2120012002X	NJM072M	OP-AMP	R 760	J2631300174X	HB-1T2012-601	CHIP	
IC 717	J2120012002X	NJM072M	OP-AMP	R 767	J2631300174X	HB-1T2012-601	CHIP	
IC 718	J2120012002X	NJM072M	OP-AMP	R 781	J2631300174X	HB-1T2012-601	CHIP	
IC 719	J2142930006X	74VHCU04MX	HEX INVERT	R 782	J2631300174X	HB-1T2012-601	CHIP	
IC 720	J2112504001X	BA033T	REGULATOR 3.3V	R 785	J2631300174X	HB-1T2012-601	CHIP	
IC 722	J2120012001X	NJM4558M	OP-AMP	R 799	J2631300174X	HB-1T2012-601	CHIP	
IC 723	J2120012001X	NJM4558M	OP-AMP	R 800	J2631300174X	HB-1T2012-601	CHIP	
IC 724	J2120012001X	NJM4558M	OP-AMP	R 817	J2631300174X	HB-1T2012-601	CHIP	
IC 725	J2120012001X	NJM4558M	OP-AMP	R 818	J2631300174X	HB-1T2012-601	CHIP	
<b>TRANSISTORs</b>			R 839	J2631300174X	HB-1T2012-601	CHIP		
Q 703	J2021000201X	KTA1266-Y	PNP	R 840	J2631300174X	HB-1T2012-601	CHIP	
Q 704	J2021220101X	KRC101M	NPN	R 853	J2631300174X	HB-1T2012-601	CHIP	
Q 705	J2021200101X	KRA101M	PNP	R 854	J2631300174X	HB-1T2012-601	CHIP	
Q 706	J2021060001X	KTD1302-B	NPN	R 869	J2631300174X	HB-1T2012-601	CHIP	
Q 707	J2021060001X	KTD1302-B	NPN	R 870	J2631300174X	HB-1T2012-601	CHIP	
Q 708	J2021220101X	KRC101M	NPN	<b>RESISTORs</b>				
Q 709	J2021200101X	KRA101M	PNP	R 822	J3013561320X	1/5W	CARBON	560W-J
Q 710	J2021060001X	KTD1302-B	NPN	R 1	J3024101120X	1/10W	CHIP	100W-J
Q 711	J2021060001X	KTD1302-B	NPN	R 2	J3024222120X	1/10W	CHIP	2K2W-J
Q 712	J2021220101X	KRC101M	NPN	R 3	J3024473120X	1/10W	CHIP	47KW-J
Q 713	J2021200101X	KRA101M	PNP	R 4	J3024473120X	1/10W	CHIP	47KW-J
Q 714	J2021060001X	KTD1302-B	NPN	R 5	J3024222120X	1/10W	CHIP	2K2W-J
Q 715	J2021060001X	KTD1302-B	NPN	R 8	J3024472120X	1/10W	CHIP	4K7W-J
Q 716	J2021220301X	KRC103M	NPN	R 9	J3024472120X	1/10W	CHIP	4K7W-J
<b>DIODES</b>			R 10	J3024101120X	1/10W	CHIP	100W-J	
D 705	J2221010100X	1SS133	SW.	R 11	J3024474120X	1/10W	CHIP	470KW-J
D 706	J2221010100X	1SS133	SW.	R 12	J3024474120X	1/10W	CHIP	470KW-J
<b>COILs</b>			R 701	J3024203120X	1/10W	CHIP	20KW-J	
L 701	J2616247020X	AXIAL LAL02	47uH-K	R 702	J3024203120X	1/10W	CHIP	20KW-J
L 702	J2616247020X	AXIAL LAL02	47uH-K	R 703	J3024103120X	1/10W	CHIP	10KW-J
	J2616247020X	AXIAL LAL02	47uH-K	R 704	J3024103120X	1/10W	CHIP	10KW-J
				R 705	J3024103120X	1/10W	CHIP	10KW-J



REF NO.	PART NO.	DESCRIPTION	REF NO.	PART NO.	DESCRIPTION
R 706	J3024103120X	1/10W CHIP 10KW-J	R 788	J3024103120X	1/10W CHIP 10KW-J
R 707	J3024473120X	1/10W CHIP 47KW-J	R 789	J3024103120X	1/10W CHIP 10KW-J
R 708	J3024473120X	1/10W CHIP 47KW-J	R 790	J3024223120X	1/10W CHIP 22KW-J
R 709	J3024103120X	1/10W CHIP 10KW-J	R 791	J3024223120X	1/10W CHIP 22KW-J
R 710	J3024103120X	1/10W CHIP 10KW-J	R 792	J3024101120X	1/10W CHIP 100W-J
R 711	J3024151120X	1/10W CHIP 150W-J	R 793	J3024103120X	1/10W CHIP 10KW-J
R 712	J3024151120X	1/10W CHIP 150W-J	R 794	J3024103120X	1/10W CHIP 10KW-J
R 713	J3024151120X	1/10W CHIP 150W-J	R 795	J3024122120X	1/10W CHIP 1K2W-J
R 714	J3024151120X	1/10W CHIP 150W-J	R 796	J3024122120X	1/10W CHIP 1K2W-J
R 715	J3024100120X	1/10W CHIP 10W-J	R 797	J3024203120X	1/10W CHIP 20KW-J
R 716	J3024100120X	1/10W CHIP 10W-J	R 798	J3024203120X	1/10W CHIP 20KW-J
R 717	J3024101120X	1/10W CHIP 100W-J	R 801	J3024473120X	1/10W CHIP 47KW-J
R 718	J3024101120X	1/10W CHIP 100W-J	R 802	J3024473120X	1/10W CHIP 47KW-J
R 719	J3024750120X	1/10W CHIP 75W-J	R 804	J3024561120X	1/10W CHIP 560W-J
R 720	J3024750120X	1/10W CHIP 75W-J	R 805	J3024561120X	1/10W CHIP 560W-J
R 735	J3024471120X	1/10W CHIP 470W-J	R 806	J3024103120X	1/10W CHIP 10KW-J
R 736	J3024103120X	1/10W CHIP 10KW-J	R 807	J3024103120X	1/10W CHIP 10KW-J
R 737	J3024103120X	1/10W CHIP 10KW-J	R 808	J3024223120X	1/10W CHIP 22KW-J
R 738	J3024103120X	1/10W CHIP 10KW-J	R 809	J3024223120X	1/10W CHIP 22KW-J
R 739	J3024103120X	1/10W CHIP 10KW-J	R 810	J3024101120X	1/10W CHIP 100W-J
R 740	J3024103120X	1/10W CHIP 10KW-J	R 811	J3024103120X	1/10W CHIP 10KW-J
R 741	J3024103120X	1/10W CHIP 10KW-J	R 812	J3024103120X	1/10W CHIP 10KW-J
R 742	J3024103120X	1/10W CHIP 10KW-J	R 813	J3024122120X	1/10W CHIP 1K2W-J
R 743	J3024103120X	1/10W CHIP 10KW-J	R 814	J3024122120X	1/10W CHIP 1K2W-J
R 744	J3024103120X	1/10W CHIP 10KW-J	R 815	J3024203120X	1/10W CHIP 20KW-J
R 745	J3024103120X	1/10W CHIP 10KW-J	R 816	J3024203120X	1/10W CHIP 20KW-J
R 746	J3024103120X	1/10W CHIP 10KW-J	R 819	J3024473120X	1/10W CHIP 47KW-J
R 747	J3024472120X	1/10W CHIP 4K7W-J	R 820	J3024473120X	1/10W CHIP 47KW-J
R 748	J3024473120X	1/10W CHIP 47KW-J	R 827	J3024123120X	1/10W CHIP 12KW-J
R 749	J3024473120X	1/10W CHIP 47KW-J	R 828	J3024123120X	1/10W CHIP 12KW-J
R 750	J3024473120X	1/10W CHIP 47KW-J	R 829	J3024223120X	1/10W CHIP 22KW-J
R 751	J3024473120X	1/10W CHIP 47KW-J	R 831	J3024224120X	1/10W CHIP 220KW-J
R 752	J3024100120X	1/10W CHIP 10W-J	R 832	J3024224120X	1/10W CHIP 220KW-J
R 753	J3024222120X	1/10W CHIP 2K2W-J	R 833	J3024123120X	1/10W CHIP 12KW-J
R 754	J3024103120X	1/10W CHIP 10KW-J	R 834	J3024123120X	1/10W CHIP 12KW-J
R 757	J3024103120X	1/10W CHIP 10KW-J	R 835	J3024123120X	1/10W CHIP 12KW-J
R 758	J3024472120X	1/10W CHIP 4K7W-J	R 836	J3024123120X	1/10W CHIP 12KW-J
R 759	J3024103120X	1/10W CHIP 10KW-J	R 837	J3024473120X	1/10W CHIP 47KW-J
R 761	J3024105120X	1/10W CHIP 1MW-J	R 838	J3024473120X	1/10W CHIP 47KW-J
R 763	J3024473120X	1/10W CHIP 47KW-J	R 845	J3024123120X	1/10W CHIP 12KW-J
R 764	J3024222120X	1/10W CHIP 2K2W-J	R 846	J3024123120X	1/10W CHIP 12KW-J
R 765	J3024182120X	1/10W CHIP 1K8W-J	R 847	J3024223120X	1/10W CHIP 22KW-J
R 766	J3024181120X	1/10W CHIP 180W-J	R 848	J3024223120X	1/10W CHIP 22KW-J
R 768	J3024561120X	1/10W CHIP 560W-J	R 849	J3024101120X	1/10W CHIP 100W-J
R 769	J3024561120X	1/10W CHIP 560W-J	R 850	J3024101120X	1/10W CHIP 100W-J
R 770	J3024103120X	1/10W CHIP 10KW-J	R 851	J3024224120X	1/10W CHIP 220KW-J
R 771	J3024103120X	1/10W CHIP 10KW-J	R 852	J3024224120X	1/10W CHIP 220KW-J
R 772	J3024223120X	1/10W CHIP 22KW-J	R 859	J3024123120X	1/10W CHIP 12KW-J
R 773	J3024223120X	1/10W CHIP 22KW-J	R 860	J3024242120X	1/10W CHIP 2K4W-J
R 774	J3024101120X	1/10W CHIP 100W-J	R 861	J3024223120X	1/10W CHIP 22KW-J
R 775	J3024103120X	1/10W CHIP 10KW-J	R 862	J3024243120X	1/10W CHIP 24KW-J
R 776	J3024103120X	1/10W CHIP 10KW-J	R 863	J3024224120X	1/10W CHIP 220KW-J
R 777	J3024122120X	1/10W CHIP 1K2W-J	R 864	J3024224120X	1/10W CHIP 220KW-J
R 778	J3024122120X	1/10W CHIP 1K2W-J	R 865	J3024101120X	1/10W CHIP 100W-J
R 779	J3024203120X	1/10W CHIP 20KW-J	R 866	J3024101120X	1/10W CHIP 100W-J
R 780	J3024203120X	1/10W CHIP 20KW-J	R 867	J3024203120X	1/10W CHIP 20KW-J
R 783	J3024473120X	1/10W CHIP 47KW-J	R 868	J3024203120X	1/10W CHIP 20KW-J
R 784	J3024473120X	1/10W CHIP 47KW-J	R 930	J3024223120X	1/10W CHIP 22KW-J
R 786	J3024561120X	1/10W CHIP 560W-J			
R 787	J3024561120X	1/10W CHIP 560W-J			

REF NO.	PART NO.	DESCRIPTION	REF NO.	PART NO.	DESCRIPTION
<b>CAPACITORS</b>			C 827	J3470147041X	ELEC 25V 47uF-M
C 6	J3442110041X	ELEC/CHIP 16V 10uF-K	C 828	J3470147041X	ELEC 25V 47uF-M
C 7	J3442110041X	ELEC/CHIP 16V 10uF-K	C 832	J3470110971X	ELEC 50V 1uF-M
C 3	J3471610971X	ELEC 50V 1uF-M	C 834	J3470110971X	ELEC 50V 1uF-M
C 4	J3471622041X	ELEC 25V 22uF-M	C 836	J3470110071X	ELEC 50V 10uF-M
C 701	J3470110071X	ELEC 50V 10uF-M	C 839	J3470110216X	ELEC 6.3V 1000uF-M
C 702	J3470110071X	ELEC 50V 10uF-M	C 843	J3471647971X	ELEC 50V 4.7uF-M
C 711	J3470147041X	ELEC 25V 47uF-M	C 844	J3471647971X	ELEC 50V 4.7uF-M
C 712	J3470147041X	ELEC 25V 47uF-M	C 845	J3471647971X	ELEC 50V 4.7uF-M
C 715	J3470110971X	ELEC 50V 1uF-M	C 846	J3471647971X	ELEC 50V 4.7uF-M
C 717	J3470110971X	ELEC 50V 1uF-M	C 847	J3470147041X	ELEC 25V 47uF-M
C 727	J3470110216X	ELEC 6.3V 1000uF-M	C 848	J3470147041X	ELEC 25V 47uF-M
C 729	J3471610971X	ELEC 50V 1uF-M	C 853	J3471647971X	ELEC 50V 4.7uF-M
C 731	J3470110216X	ELEC 6.3V 1000uF-M	C 854	J3471647971X	ELEC 50V 4.7uF-M
C 735	J3470110971X	ELEC 50V 1uF-M	C 855	J3470147041X	ELEC 25V 47uF-M
C 738	J3470110216X	ELEC 6.3V 1000uF-M	C 856	J3470147041X	ELEC 25V 47uF-M
C 741	J3470110971X	ELEC 50V 1uF-M	C 861	J3471647971X	ELEC 50V 4.7uF-M
C 742	J3471610971X	ELEC 50V 1uF-M	C 862	J3471647971X	ELEC 50V 4.7uF-M
C 744	J3471610971X	ELEC 50V 1uF-M	C 863	J3471647971X	ELEC 50V 4.7uF-M
C 746	J3470110971X	ELEC 50V 1uF-M	C 864	J3471610031X	ELEC 16V 10uF-M
C 749	J3471610971X	ELEC 50V 1uF-M	C 865	J3471610031X	ELEC 16V 10uF-M
C 750	J3471610971X	ELEC 50V 1uF-M	C 866	J3470147041X	ELEC 25V 47uF-M
C 753	J3471610971X	ELEC 50V 1uF-M	C 867	J3470147041X	ELEC 25V 47uF-M
C 755	J3471647031X	ELEC 16V 47uF-M	C 872	J3470110971X	ELEC 50V 1uF-M
C 756	J3471622971X	ELEC 50V 2.2uF-M	C 11	J3523104540X	CERA/DISC F 25V 0.1uF-Z
C 758	J3471610971X	ELEC 50V 1uF-M	C 840	J3523104540X	CERA/DISC F 25V 0.1uF-Z
C 761	J3470110971X	ELEC 50V 1uF-M	C 2	J3525104540X	CERA/CHIP F 25V 0.1uF-Z
C 763	J3470110971X	ELEC 50V 1uF-M	C 5	J3525103170X	CERA/CHIP B 50V 0.01uF-K
C 766	J3471610971X	ELEC 50V 1uF-M	C 8	J3515101270X	CERA/CHIP CH 50V 100pF-J
C 768	J3471610971X	ELEC 50V 1uF-M	C 9	J3515101270X	CERA/CHIP CH 50V 100pF-J
C 770	J3471610971X	ELEC 50V 1uF-M	C 10	J3515101270X	CERA/CHIP CH 50V 100pF-J
C 771	J3471633971X	ELEC 50V 3.3uF-M	C 12	J3515101270X	CERA/CHIP CH 50V 100pF-J
C 772	J3471633971X	ELEC 50V 3.3uF-M	C 13	J3515101270X	CERA/CHIP CH 50V 100pF-J
C 775	J3471610031X	ELEC 16V 10uF-M	C 703	J3525104540X	CERA/CHIP F 25V 0.1uF-Z
C 776	J3471610031X	ELEC 16V 10uF-M	C 704	J3525104540X	CERA/CHIP F 25V 0.1uF-Z
C 781	J3471610031X	ELEC 16V 10uF-M	C 705	J3515470270X	CERA/CHIP CH 50V 47pF-J
C 782	J3471610031X	ELEC 16V 10uF-M	C 706	J3515470270X	CERA/CHIP CH 50V 47pF-J
C 783	J3470147041X	ELEC 25V 47uF-M	C 707	J3515100270X	CERA/CHIP CH 50V 10pF-D
C 784	J3470147041X	ELEC 25V 47uF-M	C 708	J3515100270X	CERA/CHIP CH 50V 10pF-D
C 788	J3471610971X	ELEC 50V 1uF-M	C 709	J3525222170X	CERA/CHIP B 50V 2200pF-K
C 790	J3471610971X	ELEC 50V 1uF-M	C 710	J3525222170X	CERA/CHIP B 50V 2200pF-K
C 792	J3471610971X	ELEC 50V 1uF-M	C 713	J3525104540X	CERA/CHIP F 25V 0.1uF-Z
C 793	J3471633971X	ELEC 50V 3.3uF-M	C 714	J3525104540X	CERA/CHIP F 25V 0.1uF-Z
C 794	J3471633971X	ELEC 50V 3.3uF-M	C 716	J3525104540X	CERA/CHIP F 25V 0.1uF-Z
C 797	J3471610031X	ELEC 16V 10uF-M	C 718	J3525104540X	CERA/CHIP F 25V 0.1uF-Z
C 798	J3471610031X	ELEC 16V 10uF-M	C 719	J3525103170X	CERA/CHIP B 50V 0.01uF-K
C 803	J3471610031X	ELEC 16V 10uF-M	C 720	J3525104540X	CERA/CHIP F 25V 0.1uF-Z
C 804	J3471610031X	ELEC 16V 10uF-M	C 721	J3525104540X	CERA/CHIP F 25V 0.1uF-Z
C 805	J3470147041X	ELEC 25V 47uF-M	C 722	J3525103170X	CERA/CHIP B 50V 0.01uF-K
C 806	J3470147041X	ELEC 25V 47uF-M	C 723	J3525104540X	CERA/CHIP F 25V 0.1uF-Z
C 810	J3471610971X	ELEC 50V 1uF-M	C 724	J3525104540X	CERA/CHIP F 25V 0.1uF-Z
C 812	J3471610971X	ELEC 50V 1uF-M	C 725	J3525103170X	CERA/CHIP B 50V 0.01uF-K
C 814	J3471610971X	ELEC 50V 1uF-M	C 726	J3525103170X	CERA/CHIP B 50V 0.01uF-K
C 815	J3471633971X	ELEC 50V 3.3uF-M	C 728	J3525104540X	CERA/CHIP F 25V 0.1uF-Z
C 816	J3471633971X	ELEC 50V 3.3uF-M	C 730	J3525104540X	CERA/CHIP F 25V 0.1uF-Z
C 819	J3471610031X	ELEC 16V 10uF-M	C 732	J3525104540X	CERA/CHIP F 25V 0.1uF-Z
C 820	J3471610031X	ELEC 16V 10uF-M	C 733	J3515150270X	CERA/CHIP CH 50V 15pF-J
C 825	J3471610031X	ELEC 16V 10uF-M	C 734	J3525103170X	CERA/CHIP B 50V 0.01uF-K
C 826	J3471610031X	ELEC 16V 10uF-M			

REF NO.	PART NO.	DESCRIPTION
C 736	J3525104540X	CERA/CHIP F 25V 0.1uF-Z
C 739	J3525104540X	CERA/CHIP F 25V 0.1uF-Z
C 740	J3525104540X	CERA/CHIP F 25V 0.1uF-Z
C 743	J3525104540X	CERA/CHIP F 25V 0.1uF-Z
C 745	J3525104540X	CERA/CHIP F 25V 0.1uF-Z
C 747	J3525104540X	CERA/CHIP F 25V 0.1uF-Z
C 748	J3525104540X	CERA/CHIP F 25V 0.1uF-Z
C 751	J3525104540X	CERA/CHIP F 25V 0.1uF-Z
C 752	J3525104540X	CERA/CHIP F 25V 0.1uF-Z
C 754	J3525104540X	CERA/CHIP F 25V 0.1uF-Z
C 757	J3525104540X	CERA/CHIP F 25V 0.1uF-Z
C 759	J3515220270X	CERA/CHIP CH 50V 22pF
C 760	J3515220270X	CERA/CHIP CH 50V 22pF
C 762	J3525104540X	CERA/CHIP F 25V 0.1uF-Z
C 764	J3525104540X	CERA/CHIP F 25V 0.1uF-Z
C 765	J3525104540X	CERA/CHIP F 25V 0.1uF-Z
C 767	J3525104540X	CERA/CHIP F 25V 0.1uF-Z
C 769	J3525104540X	CERA/CHIP F 25V 0.1uF-Z
C 773	J3525123170X	CERA/CHIP B 50V 0.012uF-K
C 774	J3525123170X	CERA/CHIP B 50V 0.012uF-K
C 777	J3525562170X	CERA/CHIP B 50V 5600pF-K
C 778	J3525562170X	CERA/CHIP B 50V 5600pF-K
C 779	J3515221270X	CERA/CHIP CH 50V 220pF-J
C 780	J3515221270X	CERA/CHIP CH 50V 220pF-J
C 785	J3525104540X	CERA/CHIP F 25V 0.1uF-Z
C 786	J3525104540X	CERA/CHIP F 25V 0.1uF-Z
C 787	J3525104540X	CERA/CHIP F 25V 0.1uF-Z
C 789	J3525104540X	CERA/CHIP F 25V 0.1uF-Z
C 791	J3525104540X	CERA/CHIP F 25V 0.1uF-Z
C 795	J3525123170X	CERA/CHIP B 50V 0.012uF-K
C 796	J3525123170X	CERA/CHIP B 50V 0.012uF-K
C 799	J3525562170X	CERA/CHIP B 50V 5600pF-K
C 800	J3525562170X	CERA/CHIP B 50V 5600pF-K
C 801	J3515221270X	CERA/CHIP CH 50V 220pF-J
C 802	J3515221270X	CERA/CHIP CH 50V 220pF-J
C 807	J3525104540X	CERA/CHIP F 25V 0.1uF-Z
C 808	J3525104540X	CERA/CHIP F 25V 0.1uF-Z
C 809	J3525104540X	CERA/CHIP F 25V 0.1uF-Z
C 811	J3525104540X	CERA/CHIP F 25V 0.1uF-Z
C 813	J3525104540X	CERA/CHIP F 25V 0.1uF-Z
C 817	J3525123170X	CERA/CHIP B 50V 0.012uF-K
C 818	J3525334540X	CERA/CHIP F 25V 0.33uF-Z
C 821	J3525562170X	CERA/CHIP B 50V 5600pF-K
C 822	J3525562170X	CERA/CHIP B 50V 5600pF-K
C 823	J3515221270X	CERA/CHIP CH 50V 220pF-J
C 824	J3515221270X	CERA/CHIP CH 50V 220pF-J
C 829	J3525104540X	CERA/CHIP F 25V 0.1uF-Z
C 830	J3525104540X	CERA/CHIP F 25V 0.1uF-Z
C 831	J3525104540X	CERA/CHIP F 25V 0.1uF-Z
C 833	J3525104540X	CERA/CHIP F 25V 0.1uF-Z
C 835	J3525104540X	CERA/CHIP F 25V 0.1uF-Z
C 837	J3525104540X	CERA/CHIP F 25V 0.1uF-Z
C 838	J3525104540X	CERA/CHIP F 25V 0.1uF-Z
C 849	J3525104540X	CERA/CHIP F 25V 0.1uF-Z
C 850	J3525104540X	CERA/CHIP F 25V 0.1uF-Z
C 857	J3525104540X	CERA/CHIP F 25V 0.1uF-Z
C 858	J3525104540X	CERA/CHIP F 25V 0.1uF-Z
C 868	J3525104540X	CERA/CHIP F 25V 0.1uF-Z
C 869	J3525104540X	CERA/CHIP F 25V 0.1uF-Z
C 871	J3525104540X	CERA/CHIP F 25V 0.1uF-Z

REF NO.	PART NO.	DESCRIPTION
C 1	J3681224731X	MET POLYCARBO 63V 0.22uF-J
C 737	J3640683220X	MET POLY/RA 63V 0.068uF-J

#### WAFERs

HU 1	J4423341160X	2.5mm	11P	JE605-11
HU 720	J4423341160X	2.5mm	11P	JE605-11
HU 721	J4423341060X	2.5mm	10P	JE605-10
WA 702	J4422112220X	1.25mm	22P	8370-227
WA 703	J4420040500X	2.5mm	5P	5267-05A

#### WIRES

X 1	J43199011729	1P,1007#22(HI-WAP),170m/m
-----	--------------	---------------------------

#### MISCELLANIES

JA 701	J2123806001X	TORX178A	OPTIC Rx
JA 702	J2123806001X	TORX178A	OPTIC Rx
JA 703	J44302201101	JW-1609RSRANGE	2P RCA JACK
JA 704	J2123806002X	TOTX178	OPTIC Tx
JA 705	J44302101102	JW-1409S RORANGE	1P RCA JACK
RL 701	J5513300002X	P-12 MEISEI	12V RELAY
X 701	J3914010015X	12.288MHZ SCO-K1-12288	OSC
X 702	J3913010045X	5MHZ	30pF X-TAL

# ELECTRIC PART LIST(500Serie) INPUT P.C. BOARD

REF NO.	PART NO.	DESCRIPTION	
J1320045203X	INPUT P.C. BOARD		IB
J1320045103X	INPUT P.C. BOARD		BK

## INTEGRATED CIRCUITS

IC 101	J2121712002X	NJU7312AM	FUNC. SW.
IC 102	J2121712003X	NJU7313AM	FUNC. SW.
IC 103	J2120012001X	NJM4558M	OP-AMP
IC 104	J2120012001X	NJM4558M	OP-AMP
IC 105	J2121712001X	NJU7311AM	FUNC. SW.
IC 106	J2115211003X	LC7536	ELEC. VR.
IC 107	J2120012001X	NJM4558M	OP-AMP
IC 108	J2120012001X	NJM4558M	OP-AMP
IC 109	J2115211003X	LC7536	ELEC. VR.
IC 110	J2120012001X	NJM4558M	OP-AMP
IC 111	J2120012001X	NJM4558M	OP-AMP
IC 112	J2120012001X	NJM4558M	OP-AMP
IC 113	J2121712001X	NJU7311AM	FUNC. SW.
IC 114	J2115211003X	LC7536	ELEC. VR.
IC 115	J2120012001X	NJM4558M	OP-AMP
IC 116	J2120012001X	NJM4558M	OP-AMP
IC 117	J2115211003X	LC7536	ELEC. VR.
IC 118	J2120012001X	NJM4558M	OP-AMP
IC 119	J2120012001X	NJM4558M	OP-AMP
IC 120	J2120012001X	NJM4558M	OP-AMP
IC 121	J2120012001X	NJM4558M	OP-AMP
IC 122	J2120012001X	NJM4558M	OP-AMP
IC 123	J2120012001X	NJM4558M	OP-AMP
IC 124	J2120012001X	NJM4558M	OP-AMP

## TRANSISTORS

Q 110	J2021000201X	KTA1266-Y	PNP
Q 111	J2021000201X	KTA1266-Y	PNP
Q 112	J2021000201X	KTA1266-Y	PNP
Q 113	J2021000201X	KTA1266-Y	PNP
Q 114	J2021000201X	KTA1266-Y	PNP
Q 115	J20210600011	KTD1302-B	NPN
Q 116	J20210600011	KTD1302-B	NPN
Q 117	J2021060001X	KTD1302-B	NPN
Q 118	J2021060001X	KTD1302-B	NPN
Q 119	J2021060001X	KTD1302-B	NPN
Q 120	J2021060001X	KTD1302-B	NPN
Q 121	J2021060001X	KTD1302-B	NPN
Q 122	J2021060001X	KTD1302-B	NPN
Q 123	J2021060001X	KTD1302-B	NPN
Q 124	J2021060001X	KTD1302-B	NPN
Q 125	J2021060001X	KTD1302-B	NPN
Q 126	J2021060001X	KTD1302-B	NPN
Q 127	J2021060001X	KTD1302-B	NPN
Q 128	J2021060001X	KTD1302-B	NPN
Q 129	J2021060001X	KTD1302-B	NPN
Q 130	J2021060001X	KTD1302-B	NPN
Q 131	J2021220201X	KRC102M	NPN
Q 132	J2021220201X	KRC102M	NPN
Q 133	J2021200301X	KRA103M	PNP
Q 134	J2021200301X	KRA103M	PNP
Q 135	J2021200301X	KRA103M	PNP
Q 136	J2021200301X	KRA103M	PNP
Q 137	J2021200301X	KRA103M	PNP

REF NO.	PART NO.	DESCRIPTION	
Q 138	J2021220101X	KRC101M	NPN
Q 139	J2021220101X	KRC101M	NPN
Q 140	J2021220101X	KRC101M	NPN
Q 141	J2021220101X	KRC101M	NPN
Q 142	J2021220101X	KRC101M	NPN

## DIODEs

D 101	J2221010100X	1SS133	SW.
D 102	J2221010100X	1SS133	SW.
D 103	J2221010100X	1SS133	SW.

## RESISTORs

R 101	J3024331120X	1/10W	CHIP	330W-J
R 102	J3024331120X	1/10W	CHIP	330W-J
R 103	J3024474120X	1/10W	CHIP	470KW-J
R 104	J3024474120X	1/10W	CHIP	470KW-J
R 105	J3024331120X	1/10W	CHIP	330W-J
R 106	J3024331120X	1/10W	CHIP	330W-J
R 107	J3024474120X	1/10W	CHIP	470KW-J
R 108	J3024474120X	1/10W	CHIP	470KW-J
R 109	J3024331120X	1/10W	CHIP	330W-J
R 110	J3024331120X	1/10W	CHIP	330W-J
R 111	J3024474120X	1/10W	CHIP	470KW-J
R 112	J3024474120X	1/10W	CHIP	470KW-J
R 113	J3024331120X	1/10W	CHIP	330W-J
R 114	J3024331120X	1/10W	CHIP	330W-J
R 115	J3024474120X	1/10W	CHIP	470KW-J
R 116	J3024474120X	1/10W	CHIP	470KW-J
R 117	J3024331120X	1/10W	CHIP	330W-J
R 118	J3024331120X	1/10W	CHIP	330W-J
R 119	J3024474120X	1/10W	CHIP	470KW-J
R 120	J3024474120X	1/10W	CHIP	470KW-J
R 121	J3024102120X	1/10W	CHIP	1KW-J
R 122	J3024433120X	1/10W	CHIP	43KW-J
R 123	J3024822120X	1/10W	CHIP	8K2W-J
R 124	J3024822120X	1/10W	CHIP	8K2W-J
R 125	J3024433120X	1/10W	CHIP	43KW-J
R 126	J3024331120X	1/10W	CHIP	330W-J
R 127	J3024331120X	1/10W	CHIP	330W-J
R 128	J3024223120X	1/10W	CHIP	22KW-J
R 129	J3024183120X	1/10W	CHIP	18KW-J
R 130	J3024331120X	1/10W	CHIP	330W-J
R 131	J3024331120X	1/10W	CHIP	330W-J
R 132	J3024223120X	1/10W	CHIP	22KW-J
R 133	J3024101120X	1/10W	CHIP	100W-J
R 134	J3024101120X	1/10W	CHIP	100W-J
R 135	J3024474120X	1/10W	CHIP	470KW-J
R 136	J3024474120X	1/10W	CHIP	470KW-J
R 137	J3024101120X	1/10W	CHIP	100W-J
R 138	J3024101120X	1/10W	CHIP	100W-J
R 139	J3024224120X	1/10W	CHIP	220KW-J
R 140	J3024224120X	1/10W	CHIP	220KW-J
R 141	J3024101120X	1/10W	CHIP	100W-J
R 142	J3024101120X	1/10W	CHIP	100W-J
R 143	J3024474120X	1/10W	CHIP	470KW-J
R 144	J3024474120X	1/10W	CHIP	470KW-J
R 145	J3024101120X	1/10W	CHIP	100W-J
R 146	J3024101120X	1/10W	CHIP	100W-J

REF NO.	PART NO.	DESCRIPTION	REF NO.	PART NO.	DESCRIPTION
R 147	J3024224120X	1/10W CHIP 220KW-J	R 207	J3024224120X	1/10W CHIP 220KW-J
R 148	J3024224120X	1/10W CHIP 220KW-J	R 208	J3024224120X	1/10W CHIP 220KW-J
R 149	J3024101120X	1/10W CHIP 100W-J	R 209	J3024224120X	1/10W CHIP 220KW-J
R 150	J3024101120X	1/10W CHIP 100W-J	R 210	J3024472120X	1/10W CHIP 4K7W-J
R 151	J3024224120X	1/10W CHIP 220KW-J	R 211	J3024472120X	1/10W CHIP 4K7W-J
R 152	J3024224120X	1/10W CHIP 220KW-J	R 212	J3024203120X	1/10W CHIP 20KW-J
R 153	J3024101120X	1/10W CHIP 100W-J	R 213	J3024101120X	1/10W CHIP 100W-J
R 154	J3024101120X	1/10W CHIP 100W-J	R 214	J3024101120X	1/10W CHIP 100W-J
R 155	J3024224120X	1/10W CHIP 220KW-J	R 215	J3024224120X	1/10W CHIP 220KW-J
R 156	J3024224120X	1/10W CHIP 220KW-J	R 216	J3024224120X	1/10W CHIP 220KW-J
R 157	J3024101120X	1/10W CHIP 100W-J	R 217	J3024101120X	1/10W CHIP 100W-J
R 158	J3024101120X	1/10W CHIP 100W-J	R 218	J3024101120X	1/10W CHIP 100W-J
R 159	J3024474120X	1/10W CHIP 470KW-J	R 219	J3024224120X	1/10W CHIP 220KW-J
R 160	J3024474120X	1/10W CHIP 470KW-J	R 220	J3024224120X	1/10W CHIP 220KW-J
R 161	J3024152120X	1/10W CHIP 1K5W-J	R 221	J3024224120X	1/10W CHIP 220KW-J
R 162	J3024152120X	1/10W CHIP 1K5W-J	R 222	J3024224120X	1/10W CHIP 220KW-J
R 163	J3024224120X	1/10W CHIP 220KW-J	R 223	J3024224120X	1/10W CHIP 220KW-J
R 164	J3024224120X	1/10W CHIP 220KW-J	R 224	J3024224120X	1/10W CHIP 220KW-J
R 165	J3024101120X	1/10W CHIP 100W-J	R 225	J3024224120X	1/10W CHIP 220KW-J
R 166	J3024101120X	1/10W CHIP 100W-J	R 226	J3024224120X	1/10W CHIP 220KW-J
R 167	J3024474120X	1/10W CHIP 470KW-J	R 227	J3024224120X	1/10W CHIP 220KW-J
R 168	J3024474120X	1/10W CHIP 470KW-J	R 228	J3024224120X	1/10W CHIP 220KW-J
R 169	J3024152120X	1/10W CHIP 1K5W-J	R 234	J3024822120X	1/10W CHIP 8K2W-J
R 170	J3024152120X	1/10W CHIP 1K5W-J	R 235	J3024822120X	1/10W CHIP 8K2W-J
R 171	J3024224120X	1/10W CHIP 220KW-J	R 236	J3024123120X	1/10W CHIP 12KW-J
R 172	J3024224120X	1/10W CHIP 220KW-J	R 237	J3024101120X	1/10W CHIP 100W-J
R 173	J3024101120X	1/10W CHIP 100W-J	R 238	J3024101120X	1/10W CHIP 100W-J
R 174	J3024101120X	1/10W CHIP 100W-J	R 239	J3024224120X	1/10W CHIP 220KW-J
R 175	J3024224120X	1/10W CHIP 220KW-J	R 240	J3024224120X	1/10W CHIP 220KW-J
R 176	J3024224120X	1/10W CHIP 220KW-J	R 241	J3024101120X	1/10W CHIP 100W-J
R 177	J3024101120X	1/10W CHIP 100W-J	R 242	J3024101120X	1/10W CHIP 100W-J
R 178	J3024101120X	1/10W CHIP 100W-J	R 243	J3024224120X	1/10W CHIP 220KW-J
R 179	J3024224120X	1/10W CHIP 220KW-J	R 244	J3024224120X	1/10W CHIP 220KW-J
R 180	J3024224120X	1/10W CHIP 220KW-J	R 245	J3024479120X	1/10W CHIP 4R7W-J
R 181	J3024101120X	1/10W CHIP 100W-J	R 246	J3024479120X	1/10W CHIP 4R7W-J
R 182	J3024101120X	1/10W CHIP 100W-J	R 247	J3024479120X	1/10W CHIP 4R7W-J
R 183	J3024101120X	1/10W CHIP 100W-J	R 248	J3024479120X	1/10W CHIP 4R7W-J
R 184	J3024101120X	1/10W CHIP 100W-J	R 249	J3024479120X	1/10W CHIP 4R7W-J
R 185	J3024101120X	1/10W CHIP 100W-J	R 250	J3024479120X	1/10W CHIP 4R7W-J
R 186	J3024101120X	1/10W CHIP 100W-J	R 251	J3024479120X	1/10W CHIP 4R7W-J
R 187	J3024104120X	1/10W CHIP 100KW-J	R 252	J3024479120X	1/10W CHIP 4R7W-J
R 188	J3024104120X	1/10W CHIP 100KW-J	R 253	J3024479120X	1/10W CHIP 4R7W-J
R 189	J3024222120X	1/10W CHIP 2K2W-J	R 254	J3024479120X	1/10W CHIP 4R7W-J
R 190	J3024222120X	1/10W CHIP 2K2W-J	R 255	J3024479120X	1/10W CHIP 4R7W-J
R 191	J3024222120X	1/10W CHIP 2K2W-J	R 256	J3024479120X	1/10W CHIP 4R7W-J
R 192	J3024222120X	1/10W CHIP 2K2W-J	R 260	J3024123120X	1/10W CHIP 12KW-J
R 193	J3024102120X	1/10W CHIP 1KW-J	R 261	J3024102120X	1/10W CHIP 1KW-J
R 194	J3024102120X	1/10W CHIP 1KW-J	R 262	J3024102120X	1/10W CHIP 1KW-J
R 195	J3024102120X	1/10W CHIP 1KW-J	R 263	J3024102120X	1/10W CHIP 1KW-J
R 196	J3024102120X	1/10W CHIP 1KW-J	R 264	J3024473120X	1/10W CHIP 47KW-J
R 197	J3024102120X	1/10W CHIP 1KW-J	R 265	J3024473120X	1/10W CHIP 47KW-J
R 198	J3024102120X	1/10W CHIP 1KW-J	R 266	J3024473120X	1/10W CHIP 47KW-J
R 199	J3024102120X	1/10W CHIP 1KW-J	R 267	J3024102120X	1/10W CHIP 1KW-J
R 200	J3024229120X	1/10W CHIP 2R2W-J	R 268	J3024102120X	1/10W CHIP 1KW-J
R 201	J3024229120X	1/10W CHIP 2R2W-J	R 269	J3024102120X	1/10W CHIP 1KW-J
R 202	J3024222120X	1/10W CHIP 2K2W-J	R 270	J3024473120X	1/10W CHIP 47KW-J
R 203	J3024222120X	1/10W CHIP 2K2W-J	R 271	J3024473120X	1/10W CHIP 47KW-J
R 204	J3024222120X	1/10W CHIP 2K2W-J	R 272	J3024473120X	1/10W CHIP 47KW-J
R 205	J3024222120X	1/10W CHIP 2K2W-J	R 273	J3024102120X	1/10W CHIP 1KW-J
R 206	J3024224120X	1/10W CHIP 220KW-J	R 274	J3024102120X	1/10W CHIP 1KW-J

REF NO.	PART NO.	DESCRIPTION	REF NO.	PART NO.	DESCRIPTION
R 275	J3024102120X	1/10W CHIP 1KW-J	R 335	J3024331120X	1/10W CHIP 330W-J
R 276	J3024473120X	1/10W CHIP 47KW-J	R 336	J3024223120X	1/10W CHIP 22KW-J
R 277	J3024473120X	1/10W CHIP 47KW-J	R 337	J3024183120X	1/10W CHIP 18KW-J
R 278	J3024473120X	1/10W CHIP 47KW-J	R 338	J3024223120X	1/10W CHIP 22KW-J
R 279	J3024102120X	1/10W CHIP 1KW-J	R 339	J3024183120X	1/10W CHIP 18KW-J
R 280	J3024102120X	1/10W CHIP 1KW-J	R 340	J3024101120X	1/10W CHIP 100W-J
R 281	J3024102120X	1/10W CHIP 1KW-J	R 341	J3024101120X	1/10W CHIP 100W-J
R 282	J3024473120X	1/10W CHIP 47KW-J	R 342	J3024224120X	1/10W CHIP 220KW-J
R 283	J3024473120X	1/10W CHIP 47KW-J	R 343	J3024224120X	1/10W CHIP 220KW-J
R 284	J3024473120X	1/10W CHIP 47KW-J	R 344	J3024224120X	1/10W CHIP 220KW-J
R 285	J3024102120X	1/10W CHIP 1KW-J	R 345	J3024224120X	1/10W CHIP 220KW-J
R 286	J3024102120X	1/10W CHIP 1KW-J	R 346	J3024102120X	1/10W CHIP 1KW-J
R 287	J3024102120X	1/10W CHIP 1KW-J	R 347	J3024102120X	1/10W CHIP 1KW-J
R 288	J3024473120X	1/10W CHIP 47KW-J	R 348	J3024333120X	1/10W CHIP 33KW-J
R 289	J3024473120X	1/10W CHIP 47KW-J	R 349	J3024752120X	1/10W CHIP 7K5W-J
R 290	J3024473120X	1/10W CHIP 47KW-J	R 350	J3024752120X	1/10W CHIP 7K5W-J
R 291	J3024102120X	1/10W CHIP 1KW-J	R 351	J3024333120X	1/10W CHIP 33KW-J
R 292	J3024102120X	1/10W CHIP 1KW-J	R 352	J3024331120X	1/10W CHIP 330W-J
R 293	J3024102120X	1/10W CHIP 1KW-J	R 353	J3024331120X	1/10W CHIP 330W-J
R 294	J3024473120X	1/10W CHIP 47KW-J	R 354	J3024223120X	1/10W CHIP 22KW-J
R 295	J3024473120X	1/10W CHIP 47KW-J	R 355	J3024183120X	1/10W CHIP 18KW-J
R 296	J3024473120X	1/10W CHIP 47KW-J	R 356	J3024479120X	1/10W CHIP 4R7W-J
R 297	J3024102120X	1/10W CHIP 1KW-J	R 357	J3024479120X	1/10W CHIP 4R7W-J
R 298	J3024102120X	1/10W CHIP 1KW-J	R 358	J3024479120X	1/10W CHIP 4R7W-J
R 299	J3024102120X	1/10W CHIP 1KW-J	R 359	J3024479120X	1/10W CHIP 4R7W-J
R 300	J3024473120X	1/10W CHIP 47KW-J	R 360	J3024101120X	1/10W CHIP 100W-J
R 301	J3024473120X	1/10W CHIP 47KW-J	R 361	J3024101120X	1/10W CHIP 100W-J
R 302	J3024473120X	1/10W CHIP 47KW-J	R 362	J3024224120X	1/10W CHIP 220KW-J
R 303	J3024102120X	1/10W CHIP 1KW-J	R 363	J3024224120X	1/10W CHIP 220KW-J
R 304	J3024102120X	1/10W CHIP 1KW-J	R 364	J3024000120X	1/10W CHIP 0W-J
R 305	J3024102120X	1/10W CHIP 1KW-J	R 365	J3024101120X	1/10W CHIP 100W-J
R 306	J3024473120X	1/10W CHIP 47KW-J	R 366	J3024101120X	1/10W CHIP 100W-J
R 307	J3024473120X	1/10W CHIP 47KW-J	R 367	J3024224120X	1/10W CHIP 220KW-J
R 308	J3024473120X	1/10W CHIP 47KW-J	R 368	J3024224120X	1/10W CHIP 220KW-J
R 309	J3024203120X	1/10W CHIP 20KW-J	R 371	J3024000120X	1/10W CHIP 0W-J
R 310	J3024203120X	1/10W CHIP 20KW-J	R 372	J3024000120X	1/10W CHIP 0W-J
R 311	J3024203120X	1/10W CHIP 20KW-J	R 373	J3024000120X	1/10W CHIP 0W-J
R 312	J3024124120X	1/10W CHIP 120KW-J	R 375	J3024224120X	1/10W CHIP 220KW-J
R 313	J3024124120X	1/10W CHIP 120KW-J	R 376	J3024224120X	1/10W CHIP 220KW-J
R 314	J3024479120X	1/10W CHIP 4R7W-J	R 378	J3024224120X	1/10W CHIP 220KW-J
R 315	J3024479120X	1/10W CHIP 4R7W-J	R 379	J3024224120X	1/10W CHIP 220KW-J
R 316	J3024479120X	1/10W CHIP 4R7W-J	R 380	J3024101120X	1/10W CHIP 100W-J
R 317	J3024479120X	1/10W CHIP 4R7W-J	R 381	J3024101120X	1/10W CHIP 100W-J
R 318	J3024479120X	1/10W CHIP 4R7W-J	R 382	J3024101120X	1/10W CHIP 100W-J
R 319	J3024479120X	1/10W CHIP 4R7W-J	R 383	J3024101120X	1/10W CHIP 100W-J
R 320	J3024479120X	1/10W CHIP 4R7W-J	R 384	J3024101120X	1/10W CHIP 100W-J
R 321	J3024479120X	1/10W CHIP 4R7W-J	R 385	J3024101120X	1/10W CHIP 100W-J
R 322	J3024479120X	1/10W CHIP 4R7W-J	R 386	J3024224120X	1/10W CHIP 220KW-J
R 323	J3024479120X	1/10W CHIP 4R7W-J	R 387	J3024224120X	1/10W CHIP 220KW-J
R 324	J3024479120X	1/10W CHIP 4R7W-J	R 389	J3024101120X	1/10W CHIP 100W-J
R 325	J3024479120X	1/10W CHIP 4R7W-J	R 390	J3024101120X	1/10W CHIP 100W-J
R 326	J3024479120X	1/10W CHIP 4R7W-J	R 391	J3024224120X	1/10W CHIP 220KW-J
R 327	J3024479120X	1/10W CHIP 4R7W-J	R 392	J3024224120X	1/10W CHIP 220KW-J
R 328	J3024479120X	1/10W CHIP 4R7W-J	R 396	J3024222120X	1/10W CHIP 2K2W-J
R 329	J3024479120X	1/10W CHIP 4R7W-J	R 397	J3024222120X	1/10W CHIP 2K2W-J
R 330	J3024479120X	1/10W CHIP 4R7W-J	R 398	J3024222120X	1/10W CHIP 2K2W-J
R 331	J3024479120X	1/10W CHIP 4R7W-J	R 399	J3024222120X	1/10W CHIP 2K2W-J
R 332	J3024479120X	1/10W CHIP 4R7W-J	R 400	J3024479120X	1/10W CHIP 4R7W-J
R 333	J3024183120X	1/10W CHIP 18KW-J	R 401	J3024479120X	1/10W CHIP 4R7W-J
R 334	J3024331120X	1/10W CHIP 330W-J	R 402	J3024479120X	1/10W CHIP 4R7W-J

REF NO.	PART NO.	DESCRIPTION		REF NO.	PART NO.	DESCRIPTION	
R 403	J3024479120X	1/10W	CHIP	4R7W-J	C 237	J34701470411	ELEC 25V 47uF-M
R 404	J3024479120X	1/10W	CHIP	4R7W-J	C 240	J3470147041X	ELEC 25V 47uF-M
R 405	J3024183120X	1/10W	CHIP	18KW-J	C 241	J3470147041X	ELEC 25V 47uF-M
R 406	J3024183120X	1/10W	CHIP	18KW-J	C 242	J34701470411	ELEC 25V 47uF-M
<b>CAPACITORS</b>				C 243	J34701470411	ELEC	25V 47uF-M
C 117	J3470147971X	ELEC	50V	4.7uF-M	C 244	J34701470411	ELEC 25V 47uF-M
C 118	J3470147971X	ELEC	50V	4.7uF-M	C 245	J3470147041X	ELEC 25V 47uF-M
C 119	J3470647931X	ELEC	16V	4.7uF-M	C 246	J34701470411	ELEC 25V 47uF-M
C 120	J3470647931X	ELEC	16V	4.7uF-M	C 247	J3470147041X	ELEC 25V 47uF-M
C 121	J3470147971X	ELEC	50V	4.7uF-M	C 248	J3470147041X	ELEC 25V 47uF-M
C 122	J3470147971X	ELEC	50V	4.7uF-M	C 249	J3470147041X	ELEC 25V 47uF-M
C 123	J3470647931X	ELEC	16V	4.7uF-M	C 250	J34701470411	ELEC 25V 47uF-M
C 124	J3470647931X	ELEC	16V	4.7uF-M	C 264	J34701101311	ELEC 16V 100uF-M
C 125	J3470647931X	ELEC	16V	4.7uF-M	C 265	J34701101311	ELEC 16V 100uF-M
C 126	J3470647931X	ELEC	16V	4.7uF-M	C 266	J3470610031X	ELEC 16V 10uF-M
C 127	J3470647931X	ELEC	16V	4.7uF-M	C 267	J3470610031X	ELEC 16V 10uF-M
C 128	J3470647931X	ELEC	16V	4.7uF-M	C 268	J3470610031X	ELEC 16V 10uF-M
C 129	J3470647931X	ELEC	16V	4.7uF-M	C 269	J3470610031X	ELEC 16V 10uF-M
C 130	J3470647931X	ELEC	16V	4.7uF-M	C 270	J3470610031X	ELEC 16V 10uF-M
C 131	J3470647931X	ELEC	16V	4.7uF-M	C 271	J3470610031X	ELEC 16V 10uF-M
C 132	J3470647931X	ELEC	16V	4.7uF-M	C 272	J3470610031X	ELEC 16V 10uF-M
C 145	J3470647931X	ELEC	16V	4.7uF-M	C 273	J3470610031X	ELEC 16V 10uF-M
C 146	J3470647931X	ELEC	16V	4.7uF-M	C 276	J3470647931X	ELEC 16V 4.7uF-M
C 147	J3470647931X	ELEC	16V	4.7uF-M	C 277	J3470647931X	ELEC 16V 4.7uF-M
C 148	J3470647931X	ELEC	16V	4.7uF-M	C 278	J3470647931X	ELEC 16V 4.7uF-M
C 149	J3470647931X	ELEC	16V	4.7uF-M	C 279	J3470647931X	ELEC 16V 4.7uF-M
C 150	J34706479311	ELEC	16V	4.7uF-M	C 280	J3470147971X	ELEC 50V 4.7uF-M
C 151	J3470647931X	ELEC	16V	4.7uF-M	C 281	J3470147971X	ELEC 50V 4.7uF-M
C 152	J3470647931X	ELEC	16V	4.7uF-M	C 282	J3470647931X	ELEC 16V 4.7uF-M
C 153	J3470647931X	ELEC	16V	4.7uF-M	C 283	J3470647931X	ELEC 16V 4.7uF-M
C 154	J3470647931X	ELEC	16V	4.7uF-M	C 284	J34706479311	ELEC 16V 4.7uF-M
C 155	J3470147971X	ELEC	50V	4.7uF-M	C 285	J3470647931X	ELEC 16V 4.7uF-M
C 156	J3470147971X	ELEC	50V	4.7uF-M	C 286	J3470647931X	ELEC 16V 4.7uF-M
C 157	J34701470411	ELEC	25V	47uF-M	C 287	J3470647931X	ELEC 16V 4.7uF-M
C 158	J34701470411	ELEC	25V	47uF-M	C 288	J3470147971X	ELEC 50V 4.7uF-M
C 159	J34701470411	ELEC	25V	47uF-M	C 289	J3470147971X	ELEC 50V 4.7uF-M
C 160	J3470147041X	ELEC	25V	47uF-M	C 290	J3470647931X	ELEC 16V 4.7uF-M
C 161	J3470147041X	ELEC	25V	47uF-M	C 291	J3470647931X	ELEC 16V 4.7uF-M
C 163	J3470147971X	ELEC	50V	4.7uF-M	C 292	J3470647931X	ELEC 16V 4.7uF-M
C 164	J3470647931X	ELEC	16V	4.7uF-M	C 293	J3470647931X	ELEC 16V 4.7uF-M
C 165	J3470147971X	ELEC	50V	4.7uF-M	C 294	J3470647931X	ELEC 16V 4.7uF-M
C 166	J3470147971X	ELEC	50V	4.7uF-M	C 295	J3470647931X	ELEC 16V 4.7uF-M
C 197	J34701470411	ELEC	25V	47uF-M	C 296	J3470647931X	ELEC 16V 4.7uF-M
C 198	J34701470411	ELEC	25V	47uF-M	C 297	J3470647931X	ELEC 16V 4.7uF-M
C 201	J3470147041X	ELEC	25V	47uF-M	C 298	J3470647931X	ELEC 16V 4.7uF-M
C 202	J34701470411	ELEC	25V	47uF-M	C 299	J3470647931X	ELEC 16V 4.7uF-M
C 205	J3470147041X	ELEC	25V	47uF-M	C 300	J3470647931X	ELEC 16V 4.7uF-M
C 206	J3470147041X	ELEC	25V	47uF-M	C 301	J3470647931X	ELEC 16V 4.7uF-M
C 209	J34701470411	ELEC	25V	47uF-M	C 302	J3471647931X	ELEC 16V 4.7uF-M
C 210	J34701470411	ELEC	25V	47uF-M	C 303	J34706479311	ELEC 16V 4.7uF-M
C 225	J34701470411	ELEC	25V	47uF-M	C 304	J34701470411	ELEC 25V 47uF-M
C 227	J34701470411	ELEC	25V	47uF-M	C 306	J34701470411	ELEC 25V 47uF-M
C 229	J3470147041X	ELEC	25V	47uF-M	C 308	J34701470411	ELEC 25V 47uF-M
C 231	J34701470411	ELEC	25V	47uF-M	C 310	J34701470411	ELEC 25V 47uF-M
C 232	J34701470411	ELEC	25V	47uF-M	C 312	J34701470411	ELEC 25V 47uF-M
C 233	J34701470411	ELEC	25V	47uF-M	C 314	J34701470411	ELEC 25V 47uF-M
C 234	J34701470411	ELEC	25V	47uF-M	C 101	J3515121270X	CERA/CHIP CH 50V 120pF-J
C 235	J34701470411	ELEC	25V	47uF-M	C 102	J3515121270X	CERA/CHIP CH 50V 120pF-J
C 236	J34701470411	ELEC	25V	47uF-M	C 103	J3515121270X	CERA/CHIP CH 50V 120pF-J

REF NO.	PART NO.	DESCRIPTION			
C 104	J3515121270X	CERA/CHIP	CH	50V	120pF-J
C 105	J3515121270X	CERA/CHIP	CH	50V	120pF-J
C 106	J3515121270X	CERA/CHIP	CH	50V	120pF-J
C 107	J3515121270X	CERA/CHIP	CH	50V	120pF-J
C 108	J3515121270X	CERA/CHIP	CH	50V	120pF-J
C 109	J3515121270X	CERA/CHIP	CH	50V	120pF-J
C 110	J3515121270X	CERA/CHIP	CH	50V	120pF-J
C 167	J3515470270X	CERA/CHIP	CH	50V	47pF-J
C 168	J3515470270X	CERA/CHIP	CH	50V	47pF-J
C 173	J3515471170X	CERA/CHIP	CH	50V	470pF-J
C 174	J3515471170X	CERA/CHIP	CH	50V	470pF-J
C 175	J3515471170X	CERA/CHIP	CH	50V	470pF-J
C 176	J3515471170X	CERA/CHIP	CH	50V	470pF-J
C 177	J3515471170X	CERA/CHIP	CH	50V	470pF-J
C 178	J3515471170X	CERA/CHIP	CH	50V	470pF-J
C 179	J3515471170X	CERA/CHIP	CH	50V	470pF-J
C 180	J3515471170X	CERA/CHIP	CH	50V	470pF-J
C 181	J3515471170X	CERA/CHIP	CH	50V	470pF-J
C 182	J3515471170X	CERA/CHIP	CH	50V	470pF-J
C 183	J3515471170X	CERA/CHIP	CH	50V	470pF-J
C 184	J3515471170X	CERA/CHIP	CH	50V	470pF-J
C 185	J3515471170X	CERA/CHIP	CH	50V	470pF-J
C 186	J3515471170X	CERA/CHIP	CH	50V	470pF-J
C 187	J3515471170X	CERA/CHIP	CH	50V	470pF-J
C 188	J3515471170X	CERA/CHIP	CH	50V	470pF-J
C 189	J3515471170X	CERA/CHIP	CH	50V	470pF-J
C 190	J3515471170X	CERA/CHIP	CH	50V	470pF-J
C 191	J3515471170X	CERA/CHIP	CH	50V	470pF-J
C 192	J3515471170X	CERA/CHIP	CH	50V	470pF-J
C 193	J3515471170X	CERA/CHIP	CH	50V	470pF-J
C 194	J3515471170X	CERA/CHIP	CH	50V	470pF-J
C 195	J3515471170X	CERA/CHIP	CH	50V	470pF-J
C 196	J3515471170X	CERA/CHIP	CH	50V	470pF-J
C 199	J3525104540X	CERA/CHIP	F	25V	0.1uF-Z
C 200	J3525104540X	CERA/CHIP	F	25V	0.1uF-Z
C 203	J3525104540X	CERA/CHIP	F	25V	0.1uF-Z
C 204	J3525104540X	CERA/CHIP	F	25V	0.1uF-Z
C 207	J3525104540X	CERA/CHIP	F	25V	0.1uF-Z
C 208	J3525104540X	CERA/CHIP	F	25V	0.1uF-Z
C 211	J3525104540X	CERA/CHIP	F	25V	0.1uF-Z
C 212	J3525104540X	CERA/CHIP	F	25V	0.1uF-Z
C 213	J3525104540X	CERA/CHIP	F	25V	0.1uF-Z
C 214	J3525104540X	CERA/CHIP	F	25V	0.1uF-Z
C 215	J3525104540X	CERA/CHIP	F	25V	0.1uF-Z
C 216	J3525104540X	CERA/CHIP	F	25V	0.1uF-Z
C 217	J3525104540X	CERA/CHIP	F	25V	0.1uF-Z
C 218	J3525104540X	CERA/CHIP	F	25V	0.1uF-Z
C 219	J3525104540X	CERA/CHIP	F	25V	0.1uF-Z
C 220	J3525104540X	CERA/CHIP	F	25V	0.1uF-Z
C 221	J3525104540X	CERA/CHIP	F	25V	0.1uF-Z
C 222	J3525104540X	CERA/CHIP	F	25V	0.1uF-Z
C 223	J3525104540X	CERA/CHIP	F	25V	0.1uF-Z
C 224	J3525104540X	CERA/CHIP	F	25V	0.1uF-Z
C 226	J3525104540X	CERA/CHIP	F	25V	0.1uF-Z
C 228	J3525104540X	CERA/CHIP	F	25V	0.1uF-Z
C 230	J3525104540X	CERA/CHIP	F	25V	0.1uF-Z
C 238	J3515270270X	CERA/CHIP	CH	50V	27pF-J <b>IB</b>
C 239	J3515270270X	CERA/CHIP	CH	50V	27pF-J <b>IB</b>
C 251	J3525104540X	CERA/CHIP	F	25V	0.1uF-Z
C 252	J3525104540X	CERA/CHIP	F	25V	0.1uF-Z

REF NO.	PART NO.	DESCRIPTION			
C 253	J3525104540X	CERA/CHIP	F	25V	0.1uF-Z
C 254	J3525104540X	CERA/CHIP	F	25V	0.1uF-Z
C 255	J3525104540X	CERA/CHIP	F	25V	0.1uF-Z
C 256	J3525104540X	CERA/CHIP	F	25V	0.1uF-Z
C 257	J3525104540X	CERA/CHIP	F	25V	0.1uF-Z
C 258	J3525104540X	CERA/CHIP	F	25V	0.1uF-Z
C 259	J3525104540X	CERA/CHIP	F	25V	0.1uF-Z
C 260	J3525104540X	CERA/CHIP	F	25V	0.1uF-Z
C 261	J3525104540X	CERA/CHIP	F	25V	0.1uF-Z
C 262	J3525104540X	CERA/CHIP	F	25V	0.1uF-Z
C 263	J3525104540X	CERA/CHIP	F	25V	0.1uF-Z
C 274	J3515471170X	CERA/CHIP	CH	50V	470pF-J <b>IB</b>
C 275	J3515471170X	CERA/CHIP	CH	50V	470pF-J <b>IB</b>
C 305	J3525104540X	CERA/CHIP	F	25V	0.1uF-Z
C 307	J3525104540X	CERA/CHIP	F	25V	0.1uF-Z
C 309	J3525104540X	CERA/CHIP	F	25V	0.1uF-Z
C 311	J3525104540X	CERA/CHIP	F	25V	0.1uF-Z
C 313	J3525104540X	CERA/CHIP	F	25V	0.1uF-Z
C 315	J3525104540X	CERA/CHIP	F	25V	0.1uF-Z
C 316	J3525104540X	CERA/CHIP	F	25V	0.1uF-Z

#### WAFERS

HU 112	J4423340760X	JE605-07	7P	2.5mm
HU 113	J4423340960X	JE605-09	9P	2.5mm
HU 114	J4423341160X	JE605-11	11P	2.5mm
HU 115	J4423340760X	JE605-07	7P	2.5mm
HU 116	J4423340760X	JE605-07	7P	2.5mm
HU 117	J4423341160X	JE605-11	11P	2.5mm
HU 121	J4423341160X	JE605-11	11P	2.5mm
WA 101	J4420031100X	53014-1110	11P	2.0mm
WA 102	J4420040800X	5267-08A	8P	2.5mm
WA 103	J4420040500X	5267-05A	5P	2.5mm

#### MISCELLANIES

JP 101	J44302401201	JW4104RS	4P	RCA JACK
JP 102	J44302401201	JW4104RS	4P	RCA JACK
JP 103	J44302602101	JW4105RSS	6P	RCA JACK



# ELECTRIC PART LIST(500Serie) MAIN P.C. BOARD

REF NO.	PART NO.	DESCRIPTION	REF NO.	PART NO.	DESCRIPTION
J1320045201X	MAIN P.C. BOARD	IB	Q 511	J2021000101X KTA1024-Y	PNP
J1320045101X	MAIN P.C. BOARD	BK	Q 512	J2021020501X KTC3206-Y	NPN
<b>INTEGRATED CIRCUITS</b>			Q 513	J2002520101X KTC4370-Y	NPN
! IC 481	J2112505021X KIA7815PI	REGULATOR 15V	Q 514	J2021020701X KTC3200-BL	NPN
! IC 482	J2112505018X KIA7915PI	REGULATOR -15V	Q 515	J2021020501X KTC3206-Y	NPN
! IC 483	J2112505020X KIA7812PI	REGULATOR 12V	Q 516	J2021000101X KTA1024-Y	PNP
! IC 484	J2112505019X KIA7805PI	REGULATOR 5V	Q 517	J2002500101X KTA1659-Y	PNP
! IC 485	J2112505019X KIA7805PI	REGULATOR 5V	Q 518	J2002520101X KTC4370-Y	NPN
<b>TRANSISTORS</b>			! Q 519	J2002520103X 2SC5358-R(150W)	NPN
Q 401	J2021020701X KTC3200-BL	NPN	! Q 520	J2002500103X 2SA1986-R(150W)	PNP
Q 402	J2021020701X KTC3200-BL	NPN	Q 551	J2021020701X KTC3200-BL	NPN
Q 403	J2021020701X KTC3200-BL	NPN	Q 552	J2021020701X KTC3200-BL	NPN
Q 404	J2021020701X KTC3200-BL	NPN	Q 553	J2021020701X KTC3200-BL	NPN
Q 405	J2021020701X KTC3200-BL	NPN	Q 554	J2021020201X KTC3198-BL	NPN
Q 406	J2021020701X KTC3200-BL	NPN	Q 555	J2021020201X KTC3198-BL	NPN
Q 407	J2021020201X KTC3198-BL	NPN	Q 556	J2021020201X KTC3198-BL	NPN
Q 408	J2021020201X KTC3198-BL	NPN	Q 557	J2021000801X KTA1266-GR	PNP
Q 411	J2021005101X KTA1268-BL	PNP	Q 558	J2021000801X KTA1266-GR	PNP
Q 412	J2021005101X KTA1268-BL	PNP	Q 559	J2021220201X KRC102M	NPN
Q 413	J2021005101X KTA1268-BL	PNP	Q 560	J2021220201X KRC102M	NPN
Q 414	J2021005101X KTA1268-BL	PNP	Q 561	J2021005101X KTA1268-BL	PNP
Q 415	J2021020701X KTC3200-BL	NPN	<b>FETs</b>		
Q 416	J2021020701X KTC3200-BL	NPN	Q 409	J2021120303X 2SK373-GR	N-CH
Q 417	J2021000101X KTA1024-Y	PNP	Q 410	J2021120303X 2SK373-GR	N-CH
Q 418	J2021000101X KTA1024-Y	PNP	Q 505	J2021120303X 2SK373-GR	N-CH
Q 419	J2021020501X KTC3206-Y	NPN	<b>DIODEs</b>		
Q 420	J2021020501X KTC3206-Y	NPN	D 401	J2221010100X 1SS133	SW.
Q 421	J2021000101X KTA1024-Y	PNP	D 402	J2221010100X 1SS133	SW.
Q 422	J2021000101X KTA1024-Y	PNP	D 403	J2221010100X 1SS133	SW.
Q 423	J2021020501X KTC3206-Y	NPN	D 404	J2221010100X 1SS133	SW.
Q 424	J2021020501X KTC3206-Y	NPN	D 481	J2202306007X BU8-04F	BRIDGE
Q 425	J2002520101X KTC4370-Y	NPN	D 482	J2203336007X W2-04F	BRIDGE
Q 426	J2002520101X KTC4370-Y	NPN	! D 483	J2221216000X 1N4004	1A.00V RECTIFIED
Q 427	J2021020701X KTC3200-BL	NPN	! D 484	J2221216000X 1N4004	1A.00V RECTIFIED
Q 428	J2021020701X KTC3200-BL	NPN	! D 485	J2221216000X 1N4004	1A.00V RECTIFIED
Q 429	J2021020501X KTC3206-Y	NPN	! D 486	J2221216000X 1N4004	1A.00V RECTIFIED
Q 430	J2021020501X KTC3206-Y	NPN	D 501	J2221010100X 1SS133	SW.
Q 431	J2021000101X KTA1024-Y	PNP	D 502	J2221010100X 1SS133	SW.
Q 432	J2021000101X KTA1024-Y	PNP	D 551	J2221010100X 1SS133	SW.
Q 433	J2002500101X KTA1659-Y	PNP	D 552	J2221010100X 1SS133	SW.
Q 434	J2002500101X KTA1659-Y	PNP	D 553	J2221010100X 1SS133	SW.
Q 435	J2002520101X KTC4370-Y	NPN	D 554	J2221010100X 1SS133	SW.
Q 436	J2002520101X KTC4370-Y	NPN	D 555	J2221010100X 1SS133	SW.
! Q 437	J2002520103X 2SC5358-R(150W)	NPN	D 556	J2221010100X 1SS133	SW.
! Q 438	J2002520103X 2SC5358-R(150W)	NPN	D 561	J2221451534X 0.5W	5.1V ZENER
! Q 439	J2002500103X 2SA1986-R(150W)	PNP	! D 564	J2221216000X 1N4004	RECTIFIED
! Q 440	J2002500103X 2SA1986-R(150W)	PNP	! D 565	J2221216000X 1N4004	RECTIFIED
Q 501	J2021020701X KTC3200-BL	NPN	D 566	J2221010100X 1SS133	SW.
Q 502	J2021020701X KTC3200-BL	NPN	D 567	J2221010100X 1SS133	SW.
Q 503	J2021020701X KTC3200-BL	NPN	D 569	J2221010100X 1SS133	SW.
Q 504	J2021020201X KTC3198-BL	NPN	D 577	J2221010100X 1SS133	SW.
Q 506	J2021005101X KTA1268-BL	PNP	<b>RESISTORS</b>		
Q 507	J2021005101X KTA1268-BL	PNP	R 121	J3003331220X 1/8W	330W-J
Q 508	J2021020701X KTC3200-BL	NPN	R 122	J3003331220X 1/8W	330W-J
Q 509	J2021000101X KTA1024-Y	PNP	R 123	J3003224220X 1/8W	220KW-J
Q 510	J2021020501X KTC3206-Y	NPN			

REF NO.	PART NO.	DESCRIPTION	REF NO.	PART NO.	DESCRIPTION
R 124	J3003224220X	1/8W 220KW-J	R 564	J3003563220X	1/8W 56KW-J
R 125	J3003331220X	1/8W 330W-J	R 565	J3003123220X	1/8W 12KW-J
R 126	J3003331220X	1/8W 330W-J	R 566	J3003101220X	1/8W 100W-J
R 127	J3003224220X	1/8W 220KW-J	R 567	J3003103220X	1/8W 10KW-J
R 128	J3003224220X	1/8W 220KW-J	R 568	J3003103220X	1/8W 10KW-J
R 129	J3003331220X	1/8W 330W-J	R 569	J3003103220X	1/8W 10KW-J
R 130	J3003331220X	1/8W 330W-J	R 570	J3003222220X	1/8W 2K2W-J
R 131	J3003224220X	1/8W 220KW-J	R 571	J3003102220X	1/8W 1KW-J
R 132	J3003224220X	1/8W 220KW-J	R 572	J3003153220X	1/8W 15KW-J
R 401	J3003331220X	1/8W 330W-J	R 573	J3003103220X	1/8W 10KW-J
R 402	J3003331220X	1/8W 330W-J	R 574	J3003103220X	1/8W 10KW-J
R 403	J3003393220X	1/8W 39KW-J	R 575	J3003103220X	1/8W 10KW-J
R 404	J3003393220X	1/8W 39KW-J	R 576	J3003103220X	1/8W 10KW-J
R 405	J3003152220X	1/8W 1K5W-J	R 579	J3003222220X	1/8W 2K2W-J
R 406	J3003152220X	1/8W 1K5W-J	R 580	J3003103220X	1/8W 10KW-J
R 407	J3003152220X	1/8W 1K5W-J	R 587	J3003393220X	1/8W 39KW-J
R 408	J3003152220X	1/8W 1K5W-J	R 588	J3003393220X	1/8W 39KW-J
R 409	J3003221220X	1/8W 220W-J	R 590	J3003393220X	1/8W 39KW-J
R 410	J3003221220X	1/8W 220W-J	R 591	J3003103220X	1/8W 10KW-J
R 411	J3003221220X	1/8W 220W-J	R 592	J3003393220X	1/8W 39KW-J
R 412	J3003221220X	1/8W 220W-J			
R 413	J3003271220X	1/8W 270W-J	R 417	J3003393420X	1/4W 39KW-J
R 414	J3003271220X	1/8W 270W-J	R 418	J3003393420X	1/4W 39KW-J
R 415	J3003273220X	1/8W 27KW-J	R 419	J3003202420X	1/4W 2KW-J
R 416	J3003273220X	1/8W 27KW-J	R 420	J3003202420X	1/4W 2KW-J
R 449	J3003102220X	1/8W 1KW-J	R 421	J3003153420X	1/4W 15KW-J
R 450	J3003102220X	1/8W 1KW-J	R 422	J3003153420X	1/4W 15KW-J
R 451	J3003561220X	1/8W 560W-J	R 423	J3003153420X	1/4W 15KW-J
R 452	J3003561220X	1/8W 560W-J	R 424	J3003153420X	1/4W 15KW-J
R 453	J3003472220X	1/8W 4K7W-J	R 425	J3003153420X	1/4W 15KW-J
R 454	J3003472220X	1/8W 4K7W-J	R 426	J3003153420X	1/4W 15KW-J
R 455	J3003562220X	1/8W 5K6W-J	R 427	J3003153420X	1/4W 15KW-J
R 456	J3003562220X	1/8W 5K6W-J	R 428	J3003153420X	1/4W 15KW-J
R 477	J3003100220X	1/8W 10W-J	R 429	J3003153420X	1/4W 15KW-J
R 478	J3003100220X	1/8W 10W-J	R 430	J3003152420X	1/4W 1K5W-J
R 479	J3003103220X	1/8W 10KW-J	R 431	J3003152420X	1/4W 1K5W-J
R 480	J3003103220X	1/8W 10KW-J	R 432	J3003152420X	1/4W 1K5W-J
R 501	J3003331220X	1/8W 330W-J	R 433	J3003152420X	1/4W 1K5W-J
R 502	J3003393220X	1/8W 39KW-J	R 434	J3003152420X	1/4W 1K5W-J
R 503	J3003152220X	1/8W 1K5W-J	R 435	J3003152420X	1/4W 1K5W-J
R 504	J3003152220X	1/8W 1K5W-J	R 436	J3003152420X	1/4W 1K5W-J
R 505	J3003221220X	1/8W 220W-J	R 437	J3003152420X	1/4W 1K5W-J
R 506	J3003221220X	1/8W 220W-J	R 438	J3003152420X	1/4W 1K5W-J
R 507	J3003271220X	1/8W 270W-J	R 439	J3003152420X	1/4W 1K5W-J
R 508	J3003273220X	1/8W 27KW-J	R 440	J3003152420X	1/4W 1K5W-J
R 525	J3003102220X	1/8W 1KW-J	R 441	J3003152420X	1/4W 1K5W-J
R 526	J3003561220X	1/8W 560W-J	R 442	J3003152420X	1/4W 1K5W-J
R 527	J3003472220X	1/8W 4K7W-J			
R 528	J3003562220X	1/8W 5K6W-J			
R 539	J3003100220X	1/8W 10W-J			
R 542	J3003103220X	1/8W 10KW-J			
R 553	J3003153220X	1/8W 15KW-J			
R 554	J3003153220X	1/8W 15KW-J			
R 555	J3003183220X	1/8W 18KW-J			
R 556	J3003183220X	1/8W 18KW-J			
R 558	J3003153220X	1/8W 15KW-J			
R 559	J3003183220X	1/8W 18KW-J			
R 561	J3003822220X	1/8W 8K2W-J			
R 562	J3003563220X	1/8W 56KW-J			
R 563	J3003473220X	1/8W 47KW-J			

REF NO.	PART NO.	DESCRIPTION	REF NO.	PART NO.	DESCRIPTION
!	R 443	J3063151421X	1/4W	FUSIBLE	150W-J
!	R 444	J3063151421X	1/4W	FUSIBLE	150W-J
!	R 457	J3063101421X	1/4W	FUSIBLE	100W-J
!	R 458	J3063101421X	1/4W	FUSIBLE	100W-J
!	R 459	J3063101421X	1/4W	FUSIBLE	100W-J
!	R 460	J3063101421X	1/4W	FUSIBLE	100W-J
!	R 461	J3063150421X	1/4W	FUSIBLE	15W-J
!	R 462	J3063150421X	1/4W	FUSIBLE	15W-J
!	R 463	J3063150421X	1/4W	FUSIBLE	15W-J
!	R 464	J3063150421X	1/4W	FUSIBLE	15W-J
!	R 465	J3063229421X	1/4W	FUSIBLE	2R2W-J
!	R 466	J3063229421X	1/4W	FUSIBLE	2R2W-J
!	R 467	J3063229421X	1/4W	FUSIBLE	2R2W-J
!	R 468	J3063229421X	1/4W	FUSIBLE	2R2W-J
!	R 469	J3063820421X	1/4W	FUSIBLE	82W-J
!	R 470	J3063820421X	1/4W	FUSIBLE	82W-J
!	R 473	J3063100421X	1/4W	FUSIBLE	10W-J
!	R 474	J3063100421X	1/4W	FUSIBLE	10W-J
!	R 487	J3063229421X	1/4W	FUSIBLE	2R2W-J
!	R 487	J3013100621X	1/4W	FUSIBLE	10W-J
!	R 511	J3063561421X	1/4W	FUSIBLE	560W-J
!	R 512	J3063561421X	1/4W	FUSIBLE	560W-J
!	R 513	J3063561421X	1/4W	FUSIBLE	560W-J
!	R 514	J3063561421X	1/4W	FUSIBLE	560W-J
!	R 515	J3063561421X	1/4W	FUSIBLE	560W-J
!	R 516	J3063561421X	1/4W	FUSIBLE	560W-J
!	R 517	J3063151421X	1/4W	FUSIBLE	150W-J
!	R 518	J3063151421X	1/4W	FUSIBLE	150W-J
!	R 521	J3063151421X	1/4W	FUSIBLE	150W-J
!	R 522	J3063151421X	1/4W	FUSIBLE	150W-J
!	R 529	J3063101421X	1/4W	FUSIBLE	100W-J
!	R 530	J3063101421X	1/4W	FUSIBLE	100W-J
!	R 531	J3063150421X	1/4W	FUSIBLE	15W-J
!	R 532	J3063150421X	1/4W	FUSIBLE	15W-J
!	R 533	J3063229421X	1/4W	FUSIBLE	2R2W-J
!	R 534	J3063229421X	1/4W	FUSIBLE	2R2W-J
!	R 535	J3063820421X	1/4W	FUSIBLE	82W-J
!	R 537	J3063100421X	1/4W	FUSIBLE	10W-J
!	R 445	J3017100421X	1/4W	MF	10W-J
!	R 446	J3017100421X	1/4W	MF	10W-J
!	R 447	J3017100421X	1/4W	MF	10W-J
!	R 448	J3017100421X	1/4W	MF	10W-J
!	R 475	J3013100621X	1W	MF	10W-J
!	R 476	J3013100621X	1W	MF	10W-J
!	R 481	J3013220620X	1W	MF	22W-J
!	R 482	J3013220620X	1W	MF	22W-J
!	R 483	J3013220620X	1W	MF	22W-J
!	R 484	J3013220620X	1W	MF	22W-J
!	R 523	J3017100421X	1/4W	MF	10W-J
!	R 524	J3017100421X	1/4W	MF	10W-J
!	R 538	J3013100621X	1W	MF	10W-J
!	R 485	J3030100820X	3W	OXIDE	10W-J
!	R 485	J3030220820X	3W	OXIDE	22W-J
!	R 486	J3030100820X	3W	OXIDE	10W-J
!	R 495	J3030100820X	3W	OXIDE	10W-J
!	R 495	J3030220820X	3W	OXIDE	22W-J
!	R 496	J3030100820X	3W	OXIDE	10W-J
!	R 471	J3076228421X	5W	MPR DUAL	0.22W-J
!	R 472	J3076228421X	5W	MPR DUAL	0.22W-J
!	R 536	J3076228421X	5W	MPR DUAL	0.22W-J
VR 401	J3211310222X	EVNDJAA03B13	SEMI-R		1KW-J
VR 402	J3211310222X	EVNDJAA03B13	SEMI-R		1KW-J
VR 403	J3211322122X	EVNDJAA03BE2	SEMI-R		220W-J
VR 404	J3211322122X	EVNDJAA03BE2	SEMI-R		220W-J
VR 501	J3211310222X	EVNDJAA03B13	SEMI-R		1KW-J
VR 502	J3211322122X	EVNDJAA03BE2	SEMI-R		220W-J
C 401	J3470110041X	ELEC		25V	10uF-M
C 402	J3470110041X	ELEC		25V	10uF-M
C 405	J3470110141X	ELEC		25V	100uF-M
C 406	J3470110141X	ELEC		25V	100uF-M
C 407	J3470122121X	ELEC		10V	220uF-M
C 408	J3470122121X	ELEC		10V	220uF-M
C 413	J3470110091X	ELEC		100V	10uF-M
C 414	J3470110091X	ELEC		100V	10uF-M
C 415	J3470110091X	ELEC		100V	10uF-M
C 416	J3470110091X	ELEC		100V	10uF-M
C 421	J3470147181X	ELEC		63V	470uF-M
C 422	J3470147181X	ELEC		63V	470uF-M
C 423	J3470147181X	ELEC		63V	470uF-M
C 424	J3470147181X	ELEC		63V	470uF-M
C 427	J3470122041X	ELEC		25V	22uF-M
C 428	J3470122041X	ELEC		25V	22uF-M
C 481	J3420482266X	ELEC		63V	8200uF-M
C 482	J3420482266X	ELEC		63V	8200uF-M
C 485	J3470122261X	ELEC		35V	2200uF-M
C 486	J3470122261X	ELEC		35V	2200uF-M
C 487	J3470147071X	ELEC		50V	47uF-M
C 488	J3470147071X	ELEC		50V	47uF-M
C 489	J3470147041X	ELEC		25V	47uF-M
C 490	J3470147041X	ELEC		25V	47uF-M
C 491	J3470147071X	ELEC		50V	47uF-M
C 492	J3470147041X	ELEC		25V	47uF-M
C 493	J3470147071X	ELEC		50V	47uF-M
C 494	J3470147041X	ELEC		25V	47uF-M
C 495	J3470147071X	ELEC		50V	47uF-M
C 496	J3470147041X	ELEC		25V	47uF-M
C 498	J3470122231X	ELEC		16V	2200uF-M
C 501	J3470110041X	ELEC		25V	10uF-M
C 503	J3470110141X	ELEC		25V	100uF-M
C 504	J3470122121X	ELEC		10V	220uF-M
C 507	J3470110091X	ELEC		100V	10uF-M
C 508	J3470110091X	ELEC		100V	10uF-M
C 511	J3470147181X	ELEC		63V	470uF-M
C 512	J3470147181X	ELEC		63V	470uF-M
C 514	J3470122041X	ELEC		25V	22uF-M
C 554	J3470147121X	ELEC		10V	470uF-M
C 558	J3470110061X	ELEC		35V	10uF-M
C 561	J3470110971X	ELEC		50V	1uF-M
C 562	J3470110071X	ELEC		50V	10uF-M
C 568	J3470110031X	ELEC		16V	10uF-M
C 403	J3513680270X	CERA/DISC	CH	50V	68pF-J
C 404	J3513680270X	CERA/DISC	CH	50V	68pF-J
WA 410	J4423240760X	JE604-07	7P		2.5mm
WA 411	J4420046080X	5267-06A	6P		2.5mm

REF NO.	PART NO.	DESCRIPTION
C 409	J3513309070X	CERA/DISC CJ 50V 3pF-C
C 410	J3513309070X	CERA/DISC CJ 50V 3pF-C
C 411	J3513101270X	CERA/DISC CH 50V 100pF-J
C 412	J3513101270X	CERA/DISC CH 50V 100pF-J
C 497	J3523103170X	CERA/DISC B 50V 0.01uF-K
C 502	J3513680270X	CERA/DISC CH 50V 68pF-J
C 505	J3513309070X	CERA/DISC CJ 50V 3pF-C
C 506	J3513101270X	CERA/DISC CH 50V 100pF-J
C 555	J3523103170X	CERA/DISC B 50V 0.01uF-K
C 556	J3523103170X	CERA/DISC B 50V 0.01uF-K
C 557	J3513102170X	CERA/DISC B 50V 1000pF-K
C 111	J3514121270X	CERA/AX CH 50V 120pF-K
C 112	J3514121270X	CERA/AX CH 50V 120pF-K
C 113	J3514121270X	CERA/AX CH 50V 120pF-K
C 114	J3514121270X	CERA/AX CH 50V 120pF-K
C 115	J3514121270X	CERA/AX CH 50V 120pF-K
C 116	J3514121270X	CERA/AX CH 50V 120pF-K
C 563	J3524104540X	CERA/AX F 25V 0.1uF-Z
C 582	J3524104540X	CERA/AX F 25V 0.1uF-Z
C 583	J3524104540X	CERA/AX F 25V 0.1uF-Z
C 584	J3524104540X	CERA/AX F 25V 0.1uF-Z
C 585	J3524104540X	CERA/AX F 25V 0.1uF-Z
C 586	J3524104540X	CERA/AX F 25V 0.1uF-Z
C 587	J3524221170X	CERA/AX B 50V 220pF-K <b>IB</b>
C 588	J3524221170X	CERA/AX B 50V 220pF-K <b>IB</b>
C 589	J3524221170X	CERA/AX B 50V 220pF-K <b>IB</b>
C 590	J3524221170X	CERA/AX B 50V 220pF-K <b>IB</b>
C 591	J3524221170X	CERA/AX B 50V 220pF-K <b>IB</b>
C 592	J3524221170X	CERA/AX B 50V 220pF-K <b>IB</b>
C 593	J3524104540X	CERA/AX F 25V 0.1uF-Z
C 594	J3524221170X	CERA/AX B 50V 220pF-K <b>IB</b>
C 595	J3524221170X	CERA/AX B 50V 220pF-K <b>IB</b>
C 596	J3524104540X	CERA/AX F 25V 0.1uF-Z
C 597	J3524104540X	CERA/AX F 25V 0.1uF-Z
C 417	J3610104330X	POLYESTER/RA 100V 0.1uF-K
C 418	J3610104330X	POLYESTER/RA 100V 0.1uF-K
C 419	J3610104330X	POLYESTER/RA 100V 0.1uF-K
C 420	J3610104330X	POLYESTER/RA 100V 0.1uF-K
C 484	J3600103330X	POLYESTER/RA 100V 0.01uF-K
C 509	J3610104330X	POLYESTER/RA 100V 0.1uF-K
C 510	J3610104330X	POLYESTER/RA 100V 0.1uF-K
C 551	J3610683330X	POLYESTER/RA 100V 0.068uF-K
C 552	J3610683330X	POLYESTER/RA 100V 0.068uF-K
C 553	J3610683330X	POLYESTER/RA 100V 0.068uF-K
C 566	J3600103330X	POLYESTER/RA 100V 0.01uF-K
C 567	J3600103330X	POLYESTER/RA 100V 0.01uF-K
C 483	J3640103260X	MET POLY/RA 400V 0.01uF-J
C 564	J3640103260X	MET POLY/RA 400V 0.01uF-J
C 565	J3640103260X	MET POLY/RA 400V 0.01uF-J

### WAFERS

WA 401	J4420040200X	5267-02A	2P	2.5mm
WA 402	J4420040200X	5267-02A	2P	2.5mm
WA 403	J4420040200X	5267-02A	2P	2.5mm
WA 404	4420060361	JE202-1T-03R	3P	3.96mm
WA 405	J4420050560X	JE202-1T-05W	5P	3.96mm
WA 407	J4423241060X	JE604-10	10P	2.5mm

REF NO.	PART NO.	DESCRIPTION
WA 408	J4423240860X	JE604-08 8P 2.5mm
WA 410	J4423240760X	JE604-07 7P 2.5mm
WA 411	J4420040600X	5267-06A 6P 2.5mm
WA 412	J4423240760X	JE604-07 7P 2.5mm
WA 413	J4423240960X	JE604-09 9P 2.5mm
WA 414	J4423241160X	JE604-11 11P 2.5mm
WA 415	J4423240760X	JE604-07 7P 2.5mm
WA 416	J4423240760X	JE604-07 7P 2.5mm
WA 417	J4423241160X	JE604-11 11P 2.5mm
WA 419	J4423241160X	JE604-11 11P 2.5mm
WA 420	J4423241160X	JE604-11 11P 2.5mm
WA 421	J4423241060X	JE604-10 10P 2.5mm
WA 422	J4423240660X	JE604-06 6P 2.5mm
WA 423	J4422013020X	8370-301 30P 1.25mm
WA 424	J4423241160X	JE604-11 11P 2.5mm
WA 426	J4423240460X	JE604-04 4P 2.5mm
WA 427	J4423240760X	JE604-07 7P 2.5mm

### WIRES

CN 425	J43344076541	7P,2.5,1533#26/1007#26,650m/m
CN 428	J43343113041	11P,2.0mm,1533#26/2547#26,300mm,
H 501	J43199012529	1P,1672#22,250m/m
H 503	J43199011629	1P,1672#22,165m/m

### MISCELLANIES

FH 481	J4210020001X	FUSE CLIP
FH 482	J4210020001X	FUSE CLIP
FH 483	J4210020001X	FUSE CLIP
FH 484	J4210020001X	FUSE CLIP
FH 485	J4210020001X	FUSE CLIP
FH 486	J4210020001X	FUSE CLIP
! FU481	J5503320330X	T 2L/250V 50T FUSE <b>IB</b>
! FU481	J5502220320X	2A/125V 51S FUSE <b>BK</b>
FU481	J97100517001	T2L/250V,15mmx4mm LABEL-FUSE <b>IB</b>
FU481	J97100515000	2A/125V,15mmx4mm LABEL-FUSE <b>BK</b>
! FU482	J5503320330X	T 2L/250V 50T FUSE <b>IB</b>
! FU482	J5502220320X	2A/125V 51S FUSE <b>BK</b>
FU482	J97100517001	T2L/250V,15mmx4mm LABEL-FUSE <b>IB</b>
FU482	J97100515000	2A/125V,15mmx4mm LABEL-FUSE <b>BK</b>
! FU483	J5503320330X	T 2L/250V 50T FUSE <b>IB</b>
! FU483	J5502220320X	2A/125V 51S FUSE <b>BK</b>
FU483	J97100517001	T2L/250V,15mmx4mm LABEL-FUSE <b>IB</b>
FU483	J97100515000	2A/125V,15mmx4mm LABEL-FUSE <b>BK</b>
JK 401	J4462340110X	JW-6014 4P TERMINAL <b>IB</b>
JK 401	J4462340210X	JW-6014B 4P TERMINAL <b>BK</b>
JK 501	J4462320110X	JW-6012 2P TERMINAL <b>IB</b>
JK 501	J4462320210X	JW-6012B 2P TERMINAL <b>BK</b>
JK 502	J44302602101	JW4105RSS R/W 6P RCA JACK
JK 503	J4430220210X	JW1609R R/W 2P RCA JACK
JK 504	J44302602101	JW4105RSS R/W 6P RCA JACK
L 401	J2613207070X	SPRING COIL 0.7uH
L 402	J2613207070X	SPRING COIL 0.7uH
L 501	J2613207070X	SPRING COIL 0.7uH
P 551	J2431100002X	P42T8D100B04 POSISTOR
J48100050100	MICA SHEET	
J5541001010X	WASHER,SPRING;NO.2,M3.0,MC,TOYO	
J5541001020X	WASHER,PLAT;P/W,3.3*8.0*0.5,MC,TOYO	
J5636140030X	A113016000,TOYO SCREW	
J5636140040X	A183008000,TOYO SCREW	
J5636140100X	A123008002,TOYO SCREW	
J60520501000	MAIN AL6063-T5+PL T0.3HEAT SINK	
J60530501000	AL, L=40mm, PIN 2EA HEAT SINK	
J60530502000	AL, L=50mm, PIN 3EA HEAT SINK	

# ELECTRIC PART LIST(500Serie) Rear & Sub-Power, Video P.C. BOARD

REF NO.	PART NO.	DESCRIPTION	REF NO.	PART NO.	DESCRIPTION
<b>J13200452021</b>	<b>REAR P.C. BOARD</b>	<b>IB</b>	D 684	J2221010100X	1SS133 SW.
<b>J13200451021</b>	<b>REAR P.C. BOARD</b>	<b>BK</b>	D 685	J2221010100X	1SS133 SW.
			D 691	J2202366007X	BU6-04F BRIDGE
<b>TRANSISTORS</b>			<b>RESISTORS</b>		
Q 601	J2021020701X	KTC3200-BL NPN	R 601	J3003331220X	1/8W CARBON 330W-J
Q 602	J2021020701X	KTC3200-BL NPN	R 602	J3003331220X	1/8W CARBON 330W-J
Q 603	J2021020701X	KTC3200-BL NPN	R 603	J3003393220X	1/8W CARBON 39KW-J
Q 604	J2021020701X	KTC3200-BL NPN	R 604	J3003393220X	1/8W CARBON 39KW-J
Q 605	J2021020701X	KTC3200-BL NPN	R 605	J3003152220X	1/8W CARBON 1K5W-J
Q 606	J2021020701X	KTC3200-BL NPN	R 606	J3003152220X	1/8W CARBON 1K5W-J
Q 607	J2021020201X	KTC3198-BL NPN	R 607	J3003152220X	1/8W CARBON 1K5W-J
Q 608	J2021020201X	KTC3198-BL NPN	R 608	J3003152220X	1/8W CARBON 1K5W-J
Q 611	J2021005101X	KTA1268-BL PNP	R 609	J3003221220X	1/8W CARBON 220W-J
Q 612	J2021005101X	KTA1268-BL PNP	R 610	J3003221220X	1/8W CARBON 220W-J
Q 613	J2021005101X	KTA1268-BL PNP	R 611	J3003221220X	1/8W CARBON 220W-J
Q 614	J2021005101X	KTA1268-BL PNP	R 612	J3003221220X	1/8W CARBON 220W-J
Q 615	J2021020701X	KTC3200-BL NPN	R 613	J3003271220X	1/8W CARBON 270W-J
Q 616	J2021020701X	KTC3200-BL NPN	R 614	J3003271220X	1/8W CARBON 270W-J
Q 617	J2021000101X	KTA1024-Y PNP	R 615	J3003273220X	1/8W CARBON 27KW-J
Q 618	J2021000101X	KTA1024-Y PNP	R 616	J3003273220X	1/8W CARBON 27KW-J
Q 619	J2021020501X	KTC3206-Y NPN	R 649	J3003102220X	1/8W CARBON 1KW-J
Q 620	J2021020501X	KTC3206-Y NPN	R 650	J3003102220X	1/8W CARBON 1KW-J
Q 621	J2021000101X	KTA1024-Y PNP	R 651	J3003561220X	1/8W CARBON 560W-J
Q 622	J2021000101X	KTA1024-Y PNP	R 652	J3003561220X	1/8W CARBON 560W-J
Q 623	J2021020501X	KTC3206-Y NPN	R 653	J3003472220X	1/8W CARBON 4K7W-J
Q 624	J2021020501X	KTC3206-Y NPN	R 654	J3003472220X	1/8W CARBON 4K7W-J
Q 625	J2002520101X	KTC4370-Y NPN	R 655	J3003562220X	1/8W CARBON 5K6W-J
Q 626	J2002520101X	KTC4370-Y NPN	R 656	J3003562220X	1/8W CARBON 5K6W-J
Q 627	J2021020701X	KTC3200-BL NPN	R 677	J3003100220X	1/8W CARBON 10W-J
Q 628	J2021020701X	KTC3200-BL NPN	R 678	J3003100220X	1/8W CARBON 10W-J
Q 629	J2021020501X	KTC3206-Y NPN	R 683	J3003153220X	1/8W CARBON 15KW-J
Q 630	J2021020501X	KTC3206-Y NPN	R 684	J3003153220X	1/8W CARBON 15KW-J
Q 631	J2021000101X	KTA1024-Y PNP	R 685	J3003183220X	1/8W CARBON 18KW-J
Q 632	J2021000101X	KTA1024-Y PNP	R 686	J3003183220X	1/8W CARBON 18KW-J
Q 633	J2002500101X	KTA1659-Y PNP	R 689	J3003393220X	1/8W CARBON 39KW-J
Q 634	J2002500101X	KTA1659-Y PNP	R 690	J3003393220X	1/8W CARBON 39KW-J
Q 635	J2002520101X	KTC4370-Y NPN	R 691	J3003103220X	1/8W CARBON 10KW-J
Q 636	J2002520101X	KTC4370-Y NPN	R 692	J3003393220X	1/8W CARBON 39KW-J
Q 637	J2002520103X	2SC5358-R(150W) NPN	R 697	J3003103220X	1/8W CARBON 10KW-J
Q 638	J2002520103X	2SC5358-R(150W) NPN	R 698	J3003103220X	1/8W CARBON 10KW-J
Q 639	J2002500103X	2SA1986-R(150W) PNP			
Q 640	J2002500103X	2SA1986-R(150W) PNP	R 617	J3003393420X	1/4W CARBON 39KW-J
Q 681	J2021020701X	KTC3200-BL NPN	R 618	J3003393420X	1/4W CARBON 39KW-J
Q 682	J2021020701X	KTC3200-BL NPN	R 619	J3003202420X	1/4W CARBON 2KW-J
Q 683	J2021005101X	KTA1268-BL PNP	R 620	J3003202420X	1/4W CARBON 2KW-J
			R 637	J3003153420X	1/4W CARBON 15KW-J
			R 638	J3003153420X	1/4W CARBON 15KW-J
			R 639	J3003153420X	1/4W CARBON 15KW-J
			R 640	J3003153420X	1/4W CARBON 15KW-J
			R 681	J3003152420X	1/4W CARBON 1K5W-J
			R 682	J3003152420X	1/4W CARBON 1K5W-J
			R 687	J3003152420X	1/4W CARBON 1K5W-J
			R 688	J3003152420X	1/4W CARBON 1K5W-J
			R 621	J3063561421X	1/4W FUSIBLE 560W-J
			R 622	J3063561421X	1/4W FUSIBLE 560W-J
			R 623	J3063561421X	1/4W FUSIBLE 560W-J
<b>FETs</b>					
Q 609	J2021120303X	2SK373-GR N-CH			
Q 610	J2021120303X	2SK373-GR N-CH			
<b>DIODEs</b>					
D 601	J2221010100X	1SS133 SW.			
D 602	J2221010100X	1SS133 SW.			
D 603	J2221010100X	1SS133 SW.			
D 604	J2221010100X	1SS133 SW.			
D 681	J2221010100X	1SS133 SW.			
D 682	J2221010100X	1SS133 SW.			
D 683	J2221010100X	1SS133 SW.			

REF NO.	PART NO.	DESCRIPTION
R 624	J3063561421X 1/4W	FUSIBLE 560W-J
R 625	J3063561421X 1/4W	FUSIBLE 560W-J
R 626	J3063561421X 1/4W	FUSIBLE 560W-J
R 627	J3063561421X 1/4W	FUSIBLE 560W-J
R 628	J3063561421X 1/4W	FUSIBLE 560W-J
R 629	J3063561421X 1/4W	FUSIBLE 560W-J
R 630	J3063561421X 1/4W	FUSIBLE 560W-J
R 631	J3063561421X 1/4W	FUSIBLE 560W-J
R 632	J3063561421X 1/4W	FUSIBLE 560W-J
R 633	J3063151421X 1/4W	FUSIBLE 150W-J
R 634	J3063151421X 1/4W	FUSIBLE 150W-J
R 635	J3063151421X 1/4W	FUSIBLE 150W-J
R 636	J3063151421X 1/4W	FUSIBLE 150W-J
R 641	J3063151421X 1/4W	FUSIBLE 150W-J
R 642	J3063151421X 1/4W	FUSIBLE 150W-J
R 643	J3063151421X 1/4W	FUSIBLE 150W-J
R 644	J3063151421X 1/4W	FUSIBLE 150W-J
R 657	J3063101421X 1/4W	FUSIBLE 100W-J
R 658	J3063101421X 1/4W	FUSIBLE 100W-J
R 659	J3063101421X 1/4W	FUSIBLE 100W-J
R 660	J3063101421X 1/4W	FUSIBLE 100W-J
R 661	J3063150421X 1/4W	FUSIBLE 15W-J
R 662	J3063150421X 1/4W	FUSIBLE 15W-J
R 663	J3063150421X 1/4W	FUSIBLE 15W-J
R 664	J3063150421X 1/4W	FUSIBLE 15W-J
R 665	J3063229421X 1/4W	FUSIBLE 2R2W-J
R 666	J3063229421X 1/4W	FUSIBLE 2R2W-J
R 667	J3063229421X 1/4W	FUSIBLE 2R2W-J
R 668	J3063229421X 1/4W	FUSIBLE 2R2W-J
R 669	J3063820421X 1/4W	FUSIBLE 82W-J
R 670	J3063820421X 1/4W	FUSIBLE 82W-J
R 673	J3063100421X 1/4W	FUSIBLE 10W-J
R 674	J3063100421X 1/4W	FUSIBLE 10W-J
R 645	J3017100421X 1/4W	MF 10W-J
R 646	J3017100421X 1/4W	MF 10W-J
R 647	J3017100421X 1/4W	MF 10W-J
R 648	J3017100421X 1/4W	MF 10W-J
R 675	J3013100621X 1W	MF 10W-J
R 676	J3013100621X 1W	MF 10W-J
R 671	J3076228421X 5W	MPR DUAL 0.22W-J
R 672	J3076228421X 5W	MPR DUAL 0.22W-J
VR 601	J3211310322X EVNDJAA03B13 SEMI-R	1KW-J
VR 602	J3211310322X EVNDJAA03B13 SEMI-R	1KW-J
VR 603	J3211322122X EVNDJAA03BE2 SEMI-R	220W-J
VR 604	J3211322122X EVNDJAA03BE2 SEMI-R	220W-J

**CAPACITORS**

C 621	J3470147181X ELEC	63V 470uF-M
C 622	J3470147181X ELEC	63V 470uF-M
C 623	J3470147181X ELEC	63V 470uF-M
C 624	J3470147181X ELEC	63V 470uF-M
C 691	J3420468266X ELEC	63V 6800uF-M
C 692	J3420468266X ELEC	63V 6800uF-M
C 613	J3470110091X ELEC	100V 10uF-M
C 614	J3470110091X ELEC	100V 10uF-M
C 615	J3470110091X ELEC	100V 10uF-M
C 616	J3470110091X ELEC	100V 10uF-M

REF NO.	PART NO.	DESCRIPTION
C 696	J3470110031X ELEC	16V 10uF-M
C 601	J3470110041X ELEC	25V 10uF-M
C 602	J3470110041X ELEC	25V 10uF-M
C 605	J3470110141X ELEC	25V 100uF-M
C 606	J3470110141X ELEC	25V 100uF-M
C 627	J3470122041X ELEC	25V 22uF-M
C 628	J3470122041X ELEC	25V 22uF-M
C 607	J3470122121X ELEC	10V 220uF-M
C 608	J3470122121X ELEC	10V 220uF-M
C 609	J3513309070X CERA/DISC	CJ 50V 3pF-C
C 610	J3513309070X CERA/DISC	CJ 50V 3pF-C
C 611	J3513101270X CERA/DISC	CH 50V 100pF-J
C 612	J3513101270X CERA/DISC	CH 50V 100pF-J
C 603	J3513680270X CERA/DISC	CH 50V 68pF-J
C 604	J3513680270X CERA/DISC	CH 50V 68pF-J
C 617	J3610104330X POLYESTER/RA	100V 0.1uF-K
C 618	J3610104330X POLYESTER/RA	100V 0.1uF-K
C 619	J3610104330X POLYESTER/RA	100V 0.1uF-K
C 620	J3610104330X POLYESTER/RA	100V 0.1uF-K
C 681	J3610683330X POLYESTER/RA	100V 0.068uF-K
C 682	J3610683330X POLYESTER/RA	100V 0.068uF-K
C 693	J3640103260X MET POLY/RA	400V 0.01uF-J
C 694	J3640103260X MET POLY/RA	400V 0.01uF-J
C 695	J3640103260X MET POLY/RA	400V 0.01uF-J

**WAFERS**

WA 601	J4420040200X 5267-02A	2P 2.5mm
WA 602	J4420040200X 5267-02A	2P 2.5mm
WA 625	J4420040700X 5267-07A	7P 2.5mm
WA 603	J4420060362X JE202-1T-03Y	3P 3.96mm

**MISCELLANIES**

JK 601	J4462340110X JW-6014	4P TERMINAL <b>IB</b>
JK 601	J4462340210X JW-6014B	4P TERMINAL <b>BK</b>
L 601	J2613207070X SPRING COIL	0.7uH
L 602	J2613207070X SPRING COIL	0.7uH
J48100050100	MICA SHEET	
J5541001010X	WASHER,SPRING;NO.2,M3.0,MC,TOYO	
J5541001020X	WASHER,PLAT;P/W,3.3*8.0*0.5,MC,TOYC	
J5636140030X	A113016000,TOYO	SCREW
J5636140040X	A183008000,TOYO	SCREW
J5636140100X	A123008002,TOYO	SCREW
J60520506000	POWER AL6063-T5+PL THEAT SINK	

<b>J13200452022</b>	<b>SUB-POWER P.C. BOARD</b>	<b>IB</b>
<b>J13200451022</b>	<b>SUB-POWER P.C. BOARD</b>	<b>BK</b>

**INTEGRATED CIRCUITS**

! IC 981	J2112505019X KIA7805PI	REGULATOR 5V
----------	------------------------	--------------

**TRANSISTORS**

Q 981	J2021005101X KTA1268-BL	PNP
Q 982	J2021220301X KRC103M	NPN
Q 983	J2021220301X KRC103M	NPN
Q 984	J2021020201X KTC3198-BL	NPN
Q 985	J2021020201X KTC3198-BL	NPN

REF NO.	PART NO.	DESCRIPTION		
<b>DIODEs</b>				
D 981	J2221216000X	1N4004	1A 100V	RECTIFIED
D 982	J2221216000X	1N4004	1A 100V	RECTIFIED
D 983	J2221216000X	1N4004	1A 100V	RECTIFIED
D 984	J2221216000X	1N4004	1A 100V	RECTIFIED
D 985	J2221216000X	1N4004	1A 100V	RECTIFIED
D 986	J2221216000X	1N4004	1A 100V	RECTIFIED
D 987	J2221010100X	1SS133		SW.
D 988	J2221010100X	1SS133		SW.
D 989	J2221216000X	1N4004	1A 100V	RECTIFIED
D 990	J2221216000X	1N4004	1A 100V	RECTIFIED
D 991	J2221430634X	30V	0.5W	ZENER
D 992	J2221010100X	1SS133		SW.
D 994	J2221475534X	7.5V	0.5W	ZENER
D 996	J2221447534X	4.7V	0.5W	ZENER

<b>RESISTORs</b>				
R 983	J3003102220X	1/8W	CARBON	1KW-J
R 984	J3003272220X	1/8W	CARBON	2K7W-J
R 986	J3003222220X	1/8W	CARBON	2K2W-J
R 990	J3003103220X	1/8W	CARBON	10KW-J
R 991	J3003151220X	1/8W	CARBON	150W-J
R 992	J3003471220X	1/8W	CARBON	470W-J
R 993	J3003682220X	1/8W	CARBON	6K8W-J
R 994	J3003103220X	1/8W	CARBON	10KW-J
R 982	J3003222420X	1/4W	CARBON	2K2W-J
R 987	J3003561420X	1/4W	CARBON	560W-J
R 988	J3003109420X	1/4W	CARBON	1W-J
R 989	J3003109420X	1/4W	CARBON	1W-J
R 981	J3013479420X	1/4W	MF	4K7W-J
R 985	J3013220420X	1/4W	MF	22W-J
! R 995	J3091335033X	1/2W	COMPOSITION	3M3W-J BK

<b>CAPACITORs</b>				
C 984	J3470147171X	ELEC	50V	470uF-M
C 986	J3470110971X	ELEC	50V	1uF-M
C 987	J3470110071X	ELEC	50V	10uF-M
C 989	J3470147171X	ELEC	50V	470uF-M
C 990	J3470147171X	ELEC	50V	470uF-M
C 991	J3470147071X	ELEC	50V	47uF-M
C 992	J3470110161X	ELEC	35V	100uF-M
C 983	J3523103170X	CERA/DISC	B 50V	0.01uF-K
C 997	J3523103170X	CERA/DISC	B 50V	0.01uF-K
C 998	J3523103170X	CERA/DISC	B 50V	0.01uF-K
C 999	J3523103170X	CERA/DISC	B 50V	0.01uF-K
C 985	J3524104540X	CERA/AX	F 25V	0.1uF-Z
C 988	J3524473540X	CERA/AX	F 25V	0.047uF-Z
C 993	J3524104540X	CERA/AX	F 25V	0.1uF-Z
C 994	J3524104540X	CERA/AX	F 25V	0.1uF-Z
C 995	J3524104540X	CERA/AX	F 25V	0.1uF-Z
C 996	J3524104540X	CERA/AX	F 25V	0.1uF-Z
C 892	J3531472412X	SPARK-KILLER	AC250V	0.0047uF-M
CA 81	J3926100001X	X-CAP, 33514683	275V	0.068uF

REF NO.	PART NO.	DESCRIPTION		
<b>WAFERs</b>				
WA 981	J4420060261X	JE202-1T-02(3-2	2P	7.92mm
WA 983	J4420060200X	35328-0210	2P	7.92mm
WA 985	J4420060262X	JE202A-1T-02R	2P	7.92mm
WA 986	J4420040700X	5267-07A	7P	2.5mm
WA 987	J4420040300X	5267-03A	3P	2.5mm

<b>WIRES</b>				
H 12	J43199011529	1P,1007#22,150m/m		
H 20	J43199012029	1P,1007#22,200m/m		BK

<b>MISCELLANIES</b>				
AC 981	J4200015020X	S2-762T-206SE	AC OUTLET	IB
AC 981	J4200015010X	S2-764T-200SA	AC OUTLET	BK
FH 981	J4210020001X	FUSE CLIP		
FH 982	J4210020001X	FUSE CLIP		
! FU981	J5503340330X	T4L/250V 50T	FUSE	IB
! FU981	J5502270320X	7A/125V 51S	FUSE	BK
FU 981	J97100518000	T4L/250V,15mmx4mm	LABEL-FUSE	IB
FU 981	J97100516000	7A/125V,15mmx4mm	LABEL-FUSE	BK
RL 981	J5511300010X	SDT-S-112DMR 10A 12V	RELAY	
T 981	J2812410024X	ST-BY 230/50	TRANSFORMER	IB
! T 981	J2812210014X	ST-BY 120/60	TRANSFORMER	BK
	J5241000110X	AL6063S-T5,W/PIN,L:40n	HEAT SINK	
	J5636140100X	A123008002,TOYO	SCREW	

<b>J13200452023</b>	<b>VIDEO P.C. BOARD</b>	<b>IB</b>
<b>J13200451023</b>	<b>VIDEO P.C. BOARD</b>	<b>BK</b>

<b>INTEGRATED CIRCUITs</b>				
IC 351	J2121211006X	LA7951	VIDEO SW.	
IC 352	J2116212002X	NJM2267	75W DRIVER	
IC 353	J2126232001X	MM1067	VIDEO SYNC DET.	
IC 354	J2126031001X	MB90089	OSD GEN.	
IC 355	J2126004001X	BA7622F	VIDEO 6dB AMP	

<b>TRANSISTORs</b>				
Q 351	J2021020201X	KTC3198-BL	NPN	
Q 352	J2021060001X	KTD1302-B	NPN	
Q 353	J2021220301X	KRC103M	NPN	
Q 357	J2021220301X	KRC103M	NPN	
Q 358	J2021220301X	KRC103M	NPN	
Q 359	J2021220301X	KRC103M	NPN	
Q 360	J2021200301X	KRA103M	PNP	
Q 361	J2021060001X	KTD1302-B	NPN	
Q 362	J2021060001X	KTD1302-B	NPN	

<b>DIODEs</b>				
D 351	J2221010100X	1SS133	SW.	
D 352	J2221010100X	1SS133	SW.	

<b>FILTERs</b>				
XT 352	J3911010021X	CSB503F2	RESONATOR	
XT 52	J3911010011X	CSB500F40	RESONATOR	

<b>COILs</b>				
L 354	J2616222020X	AXIAL LAL02	22uH-K	
L 351	J2616227029X	AXIAL LAL02	27uH-K	
L 352	J2616227029X	AXIAL LAL02	27uH-K	
L 353	J2616227029X	AXIAL LAL02	27uH-K	

REF NO.	PART NO.	DESCRIPTION
<b>BEAD</b>		
L 355	J2631200010X	HC3550 9.4ohm AXIAL

**RESISTORS**

R 351	J3003750220X	1/8W CARBON 75W-J
R 352	J3003750220X	1/8W CARBON 75W-J
R 353	J3003750220X	1/8W CARBON 75W-J
R 354	J3003680220X	1/8W CARBON 68W-J
R 355	J3003121220X	1/8W CARBON 120W-J
R 356	J3003151220X	1/8W CARBON 150W-J
R 357	J3003122220X	1/8W CARBON 1K2W-J
R 358	J3003750220X	1/8W CARBON 75W-J
R 359	J3003750220X	1/8W CARBON 75W-J
R 360	J3003222220X	1/8W CARBON 2K2W-J
R 365	J3003330220X	1/8W CARBON 33W-J
R 367	J3003100220X	1/8W CARBON 10W-J
R 368	J3003151220X	1/8W CARBON 150W-J
R 369	J3003330220X	1/8W CARBON 33W-J
R 396	J3003222220X	1/8W CARBON 2K2W-J
R 397	J3003222220X	1/8W CARBON 2K2W-J
R 81	J3024221120X	1/10W CHIP 220W-J
R 372	J3024823120X	1/10W CHIP 82KW-J
R 373	J3024103120X	1/10W CHIP 10KW-J
R 374	J3024103120X	1/10W CHIP 10KW-J
R 375	J3024103120X	1/10W CHIP 10KW-J
R 376	J3024104120X	1/10W CHIP 100KW-J
R 377	J3024562120X	1/10W CHIP 5K6W-J
R 378	J3024103120X	1/10W CHIP 10KW-J
R 379	J3024272120X	1/10W CHIP 2K7W-J
R 380	J3024222120X	1/10W CHIP 2K2W-J
R 381	J3024391120X	1/10W CHIP 390W-J
R 399	J3024105120X	1/10W CHIP 1MW-J

**CAPACITORS**

C 352	J3470147971X	ELEC 50V 4.7uF-M
C 354	J3470147971X	ELEC 50V 4.7uF-M
C 356	J3470147971X	ELEC 50V 4.7uF-M
C 359	J3470110216X	ELEC 6.3V 1000uF-M
C 360	J3470133121X	ELEC 10V 330uF-M
C 361	J3470110031X	ELEC 16V 10uF-M
C 363	J3470147041X	ELEC 25V 47uF-M
C 367	J3470147041X	ELEC 25V 47uF-M
C 369	J3470147041X	ELEC 25V 47uF-M
C 370	J3470110216X	ELEC 6.3V 1000uF-M
C 371	J3470122971X	ELEC 50V 2.2uF-M
C 372	J3470122871X	ELEC 50V 0.22uF-M
C 374	J3470110216X	ELEC 6.3V 1000uF-M
C 377	J3470110971X	ELEC 50V 1uF-M
C 383	J3470110031X	ELEC 16V 10uF-M
C 386	J3470110971X	ELEC 50V 1uF-M
C 389	J3470110971X	ELEC 50V 1uF-M
C 392	J3470147871X	ELEC 50V 0.47uF-M
C 351	J3513101270X	CERA/DISC CH 50V 100pF-J
C 353	J3513101270X	CERA/DISC CH 50V 100pF-J
C 355	J3513101270X	CERA/DISC CH 50V 100pF-J
C 357	J3513101270X	CERA/DISC CH 50V 100pF-J
C 358	J3513101270X	CERA/DISC CH 50V 100pF-J
C 379	J3513300270X	CERA/DISC CH 50V 30pF-J

REF NO.	PART NO.	DESCRIPTION
C 380	J3513300270X	CERA/DISC CH 50V 30pF-J
C 381	J3513270270X	CERA/DISC CH 50V 27pF-J
C 382	J3513240270X	CERA/DISC CH 50V 24pF-J

C 362	J3524104540X	CERA/AX F 25V 0.1uF-Z
C 366	J3524104540X	CERA/AX F 25V 0.1uF-Z
C 373	J3524222730X	CERA/AX X 16V 2200pF-M
C 378	J3524103630X	CERA/AX Y 16V 0.01uF-M
C 87	J3525472170X	CERA/CHIP B 50V 4700pF-K
C 368	J3525104540X	CERA/CHIP F 25V 0.1uF-Z
C 384	J3525104540X	CERA/CHIP F 25V 0.1uF-Z
C 385	J3525473170X	CERA/CHIP B 50V 0.047uF-K
C 387	J3525332170X	CERA/CHIP B 50V 3300pF-K
C 388	J3515221270X	CERA/CHIP CH 50V 220pF-J
C 391	J3515471270X	CERA/CHIP CH 50V 470pF-J
C 393	J3525103170X	CERA/CHIP B 50V 0.01uF-K

**WAFERS**

HU 351	J4423340860X	JE605-08 8P 2.5mm
HU 352	J4423340760X	JE605-07 7P 2.5mm

**WIRES**

CN 353	J43244071041	WIRE-ASS'Y;7P,1007#24,100m/m
CN 354	J43344051541	WIRE-ASS'Y; 5P,2547#26/1533#26,150mm

**MISCELLANIES**

JP 351	J44302902201	JW-1502S Y 2P RCA JACK
JP 352	J44302903201	JW-1503S Y 3P RCA JACK
RL 351	J5513300002X	P-12 MEISEI 12V RELAY
RL 352	J5513300002X	P-12 MEISEI 12V RELAY
XT 51	J3913010065X	17.734475MHz 30pF X-TAL
XT 351	J3913010055X	14.31818MHz 30pF X-TAL

<b>J13200452024</b>	<b>S-VIDEO P.C. BOARD</b>	<b>IB</b>
<b>J13200451024</b>	<b>S-VIDEO P.C. BOARD</b>	<b>BK</b>

**INTEGRATED CIRCUITS**

IC 1	J2413400016X	PC-17T1 PHOTO
IC 2	J2413400016X	PC-17T1 PHOTO
IC 3	J2142930005X	74VHC132SJX NAND GATE
IC 371	J2121211006X	LA7951 VIDEO SW.
IC 372	J2121211006X	LA7951 VIDEO SW.

**TRANSISTORS**

Q 2	J2021200201X	KRA102M PNP
Q 371	J2021020201X	KTC3198-BL NPN
Q 372	J2021020201X	KTC3198-BL NPN

**COILS**

L 371	J2616227029X	AXIAL LAL02 27uH-K
L 372	J2616227029X	AXIAL LAL02 27uH-K

**BEADS**

L 378	J2631200010X	HC3550 9.4ohm AXIAL
L 379	J2631200010X	HC3550 9.4ohm AXIAL
L 380	J2631200010X	HC3550 9.4ohm AXIAL

**RESISTORS**

R 3	J3003271220X	1/8W CARBON 270W-J
-----	--------------	--------------------



REF NO.	PART NO.	DESCRIPTION
R 4	J3003271220X 1/8W	CARBON 270W-J
R 5	J3003022220X 1/8W	CARBON 22W-J
R 6	J3003102220X 1/8W	CARBON 1KW-J
R 7	J3003103220X 1/8W	CARBON 10KW-J
R 8	J3003222220X 1/8W	CARBON 2K2W-J
R 382	J3003750220X 1/8W	CARBON 75W-J
R 383	J3003750220X 1/8W	CARBON 75W-J
R 384	J3003680220X 1/8W	CARBON 68W-J
R 385	J3003680220X 1/8W	CARBON 68W-J
R 386	J3003750220X 1/8W	CARBON 75W-J
R 387	J3003750220X 1/8W	CARBON 75W-J
R 388	J3003750220X 1/8W	CARBON 75W-J
R 389	J3003750220X 1/8W	CARBON 75W-J
R 390	J3003680220X 1/8W	CARBON 68W-J
R 391	J3003680220X 1/8W	CARBON 68W-J
R 392	J3003151220X 1/8W	CARBON 150W-J
R 393	J3003122220X 1/8W	CARBON 1K2W-J
R 394	J3003151220X 1/8W	CARBON 150W-J
R 395	J3003122220X 1/8W	CARBON 1K2W-J

REF NO.	PART NO.	DESCRIPTION
<b>MISCELLANIES</b>		
JA 1	J4433210120X HTJ035-12EBT	1P JACK
JA 2	J4433220130X HSJ1002-01-102	2P JACK
JP 371	J44310050309 M1821-HA2	2P S-JACK
JP 372	J44310050409 M1820-PA3	3P S-JACK

### CAPACITORS

C 1	J3470110031X ELEC	16V 10uF-M
C 305	J3470147971X ELEC	50V 4.7uF-M
C 306	J3470147971X ELEC	50V 4.7uF-M
C 307	J3470133121X ELEC	10V 330uF-M
C 308	J3470133121X ELEC	10V 330uF-M
C 309	J3470147971X ELEC	50V 4.7uF-M
C 310	J3470147971X ELEC	50V 4.7uF-M
C 311	J3470147971X ELEC	50V 4.7uF-M
C 312	J3470147971X ELEC	50V 4.7uF-M
C 313	J3470147121X ELEC	10V 470uF-M
C 314	J3470147121X ELEC	10V 470uF-M
C 315	J3470110031X ELEC	16V 10uF-M
C 316	J3470110031X ELEC	16V 10uF-M
C 318	J3470147041X ELEC	25V 47uF-M
C 320	J3470147041X ELEC	25V 47uF-M
C 2	J3523104540X CERA/DISC	F 25V 0.1uF-Z
C 301	J3513101270X CERA/DISC	CH 50V 100pF-J
C 302	J3513101270X CERA/DISC	CH 50V 100pF-J
C 303	J3513101270X CERA/DISC	CH 50V 100pF-J
C 304	J3513101270X CERA/DISC	CH 50V 100pF-J
C 394	J3513101270X CERA/DISC	CH 50V 100pF-J
C 395	J3513101270X CERA/DISC	CH 50V 100pF-J
C 396	J3513101270X CERA/DISC	CH 50V 100pF-J
C 397	J3513101270X CERA/DISC	CH 50V 100pF-J
C 398	J3513101270X CERA/DISC	CH 50V 100pF-J
C 399	J3513101270X CERA/DISC	CH 50V 100pF-J
C 317	J3524104540X CERA/AX	F 25V 0.1uF-Z
C 319	J3524104540X CERA/AX	F 25V 0.1uF-Z
C 321	J3524104540X CERA/AX	F 25V 0.1uF-Z
C 322	J3524104540X CERA/AX	F 25V 0.1uF-Z

### WAFERS

HU 371	J4423340760X JE605-07	7P 2.5mm
HU 372	J4423340460X JE605-04	4P 2.5mm
WA 353	J4420040700X 5267-07A	7P 2.5mm

# ELECTRIC PART LIST(500Serie)

# TUNER & FRONT P.C.BOARD

REF NO. PART NO. DESCRIPTION

**J13200452041 TUNER P.C. BOARD IB**  
**J13200451041 TUNER P.C. BOARD BK**

## INTEGRATED CIRCUITs

IC 801 J2115211000X LA1266 AM/FM IF  
IC 803 J2115211005X LA3410 FM MPX  
IC 802 J2115611002X LC72131M PLL  
IC 804 J2125004001X BU1923F RDS DECODER **IB**

## TRANSISTORs

Q 801 J2021021001X KTC3192-O NPN  
Q 802 J2021021001X KTC3192-O NPN  
Q 803 J2021021001X KTC3192-O NPN  
Q 805 J2021020701X KTC3200-BL NPN  
Q 806 J2021200101X KRA101M PNP  
Q 807 J2021200101X KRA101M PNP  
Q 808 J2021200101X KRA101M PNP  
Q 809 J2021220601X KRC231M NPN  
Q 810 J2021220601X KRC231M NPN  
Q 891 J2021021001X KTC3192-O NPN **IB**

## FET

Q 804 J2021120203X 2SK246-Y N-CH

## DIODEs

D 801 J2221010100X 1SS133 SW.  
D 802 J2221010100X 1SS133 SW.  
D 803 J2221010100X 1SS133 SW.  
D 804 J2221010100X 1SS133 SW.  
J2200630001X SVC321SPA-D2 VARACTOR  
J2200630001X SVC321SPA-D2 VARACTOR  
J2221451534X 0.5W, 5.1V ZENER **IB**  
J2221451534X 0.5W, 5.1V ZENER  
J2221447534X 0.5W, 4.7V ZENER

## FILTERs

F 801 J3921200031X SFE10.7MS3-A C.FILTER **IB**  
F 801 J3921200011X SFE10.7MA5-A C.FILTER **BK**  
F 802 J3921200031X SFE10.7MS3-A C.FILTER **IB**  
F 802 J3921200011X SFE10.7MA5-A C.FILTER **BK**  
F 803 J3921200031X SFE10.7MS3-A C.FILTER **IB**  
F 803 J3921200011X SFE10.7MA5-A C.FILTER **BK**  
F 804 J3921200021X BFU450C4N C.FILTER  
F 805 J3921100012X CF01 450BL C.FILTER  
F 806 J3912010009X CSB456F11 RESONATOR

## COILs

L 802 J2613220320X CHOKE COIL 20.8mH-K **IB**  
L 803 J2616227029X AXIAL LAL02 27uH-K  
L 804 J2616227029X AXIAL LAL02 27uH-K  
T 801 J2621000022X M7ZN-K5643A-KR AM ANT  
T 802 J2621000012X 7BR-K111027X2-KR AM OSC  
T 803 J2625100012X A71MC-K672713N4-KR AM IFT  
T 804 J2625200012X 292BCA-K5713TKG/W FM DET1  
T 805 J2625200022X 292BCA-K5714X/B FM DET2  
T 806 J3923210022X 253AGG-K5001-KR MPX FILTER  
T 807 J3923210022X 253AGG-K5001-KR MPX FILTER

## RESISTORs

R 807 J3003391220X 1/8W CARBON 390W-J  
R 812 J3003221220X 1/8W CARBON 220W-J  
R 831 J3003102220X 1/8W CARBON 1KW-J

REF NO. PART NO. DESCRIPTION

R 892 J3003102220X 1/8W CARBON 1KW-J **IB**

R 832 J3003220420X 1/4W CARBON 22W-J

R 836 J3003470420X 1/4W CARBON 47W-J

R 851 J3003331420X 1/4W CARBON 330W-J

R 855 J3003331420X 1/4W CARBON 330W-J **IB**

R 865 J3003220420X 1/4W CARBON 22W-J

R 866 J3003331420X 1/4W CARBON 330W-J

R 823 J3013101320X 1/5W CARBON 100W-J

R 891 J3013220320X 1/5W CARBON 22W-J **IB**

R 801 J3024101120X 1/10W CHIP 100W-J

R 802 J3024122120X 1/10W CHIP 1K2W-J

R 803 J3024222120X 1/10W CHIP 2K2W-J

R 804 J3024331120X 1/10W CHIP 330W-J

R 805 J3024121120X 1/10W CHIP 120W-J

R 806 J3024392120X 1/10W CHIP 3K9W-J

R 808 J3024332120X 1/10W CHIP 3K3W-J

R 809 J3024331120X 1/10W CHIP 330W-J

R 810 J3024689120X 1/10W CHIP 6K8W-J

R 811 J3024821120X 1/10W CHIP 820W-J

R 813 J3024101120X 1/10W CHIP 100W-J

R 814 J3024104120X 1/10W CHIP 100KW-J

R 815 J3024104120X 1/10W CHIP 100KW-J

R 816 J3024221120X 1/10W CHIP 220W-J

R 817 J3024103120X 1/10W CHIP 10KW-J

R 818 J3024331120X 1/10W CHIP 330W-J

R 819 J3024102120X 1/10W CHIP 1KW-J

R 820 J3024271120X 1/10W CHIP 270W-J

R 822 J3024332120X 1/10W CHIP 3K3W-J

R 824 J3024102120X 1/10W CHIP 1KW-J

R 825 J3024562120X 1/10W CHIP 5K6W-J

R 826 J3024223120X 1/10W CHIP 22KW-J

R 827 J3024104120X 1/10W CHIP 100KW-J

R 828 J3024102120X 1/10W CHIP 1KW-J

R 829 J3024683120X 1/10W CHIP 68KW-J

R 830 J3024273120X 1/10W CHIP 27KW-J

R 833 J3024182120X 1/10W CHIP 1K8W-J

R 834 J3024562120X 1/10W CHIP 5K6W-J

R 835 J3024332120X 1/10W CHIP 3K3W-J

R 837 J3024102120X 1/10W CHIP 1KW-J

R 838 J3024154120X 1/10W CHIP 150KW-J

R 839 J3024154120X 1/10W CHIP 150KW-J

R 840 J3024154120X 1/10W CHIP 150KW-J

R 841 J3024154120X 1/10W CHIP 150KW-J

R 842 J3024332120X 1/10W CHIP 3K3W-J **BK**

R 842 J3024272120X 1/10W CHIP 2K7W-J **IB**

R 843 J3024332120X 1/10W CHIP 3K3W-J **BK**

R 843 J3024272120X 1/10W CHIP 2K7W-J **IB**

R 844 J3024101120X 1/10W CHIP 100W-J

R 845 J3024101120X 1/10W CHIP 100W-J

R 846 J3024332120X 1/10W CHIP 3K3W-J

R 847 J3024332120X 1/10W CHIP 3K3W-J

R 848 J3024103120X 1/10W CHIP 10KW-J

R 849 J3024103120X 1/10W CHIP 10KW-J

R 852 J3024103120X 1/10W CHIP 10KW-J

R 853 J3024561120X 1/10W CHIP 560W-J

R 854 J3024561120X 1/10W CHIP 560W-J

R 856 J3024560120X 1/10W CHIP 56W-J

R 857 J3024473120X 1/10W CHIP 47KW-J

R 859 J3024561120X 1/10W CHIP 560W-J

R 860	J3024103120X	1/10W	CHIP	10KW-J
R 861	J3024103120X	1/10W	CHIP	10KW-J
R 862	J3024103120X	1/10W	CHIP	10KW-J
R 864	J3024221120X	1/10W	CHIP	220W-J
R 871	J3024331120X	1/10W	CHIP	330W-J
R 881	J3024104120X	1/10W	CHIP	100KW-J
R 882	J3024223120X	1/10W	CHIP	22KW-J
R 888	J3024100120X	1/10W	CHIP	10W-J
R 893	J3024103120X	1/10W	CHIP	10KW-J <b>IB</b>
R 895	J3024681120X	1/10W	CHIP	680W-J
R 899	J3024103120X	1/10W	CHIP	10KW-J

VR 801	J3211347322X	EVNDJAA03B	SEMI-RES	47KW-J
VR 802	J3211347322X	EVNDJAA03B	SEMI-RES	47KW-J
VR 803	J3211322422X	EVNDJAA03B	SEMI-RES	220KW-J

**CAPACITORS**

C 808	J3470610031X	ELEC	16V	10uF-M
C 810	J3470610971X	ELEC	50V	1uF-M
C 812	J3470147031X	ELEC	16V	47uF-M
C 820	J3470633941X	ELEC	25V	3.3uF-M
C 821	J3470647931X	ELEC	16V	4.7uF-M
C 825	J3470147871X	ELEC	50V	0.47uF-M
C 829	J3470147031X	ELEC	16V	47uF-M
C 831	J3470110131X	ELEC	16V	100uF-M
C 832	J3470633941X	ELEC	25V	3.3uF-M
C 833	J3470122971X	ELEC	50V	2.2uF-M
C 835	J3470610031X	ELEC	16V	10uF-M
C 836	J3471647871X	ELEC	50V	0.47uF-M
C 837	J3470610031X	ELEC	16V	10uF-M <b>BK</b>
C 837	J3470168971X	ELEC	50V	6.8uF-M <b>IB</b>
C 840	J3470610031X	ELEC	16V	10uF-M <b>BK</b>
C 840	J3470168971X	ELEC	50V	6.8uF-M <b>IB</b>
C 847	J3470147031X	ELEC	16V	47uF-M <b>IB</b>
C 849	J3470122971X	ELEC	50V	2.2uF-M <b>IB</b>
C 851	J3470610031X	ELEC	16V	10uF-M
C 856	J3470147031X	ELEC	16V	47uF-M
C 859	J3470110131X	ELEC	16V	100uF-M
C 866	J3470610031X	ELEC	16V	10uF-M
C 867	J3470633941X	ELEC	25V	3.3uF-M

C 838	J3513471170X	CERA/DISC	SL 50V	470pF-J <b>BK</b>
C 838	J3513331170X	CERA/DISC	SL 50V	330pF-J <b>IB</b>
C 839	J3513471170X	CERA/DISC	SL 50V	470pF-J <b>BK</b>
C 839	J3513331170X	CERA/DISC	SL 50V	330pF-J <b>IB</b>

C 813	J3524223540X	CERA/AX	Z 25V	0.022uF-Z
C 816	J3514820270X	CERA/AX	CH 50V	82pF-K
C 818	J3524223540X	CERA/AX	F 25V	0.022uF-Z
C 843	J3524331170X	CERA/AX	K 50V	330pF-K <b>IB</b>
C 846	J3524223540X	CERA/AX	Z 25V	0.022uF-Z <b>IB</b>

C 801	J3525223170X	CERA/CHIP	B 50V	0.022uF-K
C 802	J3525223170X	CERA/CHIP	B 50V	0.022uF-K
C 803	J3525223170X	CERA/CHIP	B 50V	0.022uF-K
C 804	J3525473170X	CERA/CHIP	B 50V	0.047uF-K
C 809	J3525223170X	CERA/CHIP	B 50V	0.022uF-K
C 814	J3515360270X	CERA/CHIP	CH 50V	36pF-J
C 815	J3515360270X	CERA/CHIP	CH 50V	36pF-J
C 817	J3515820270X	CERA/CHIP	CH 50V	82pF-J
C 822	J3525473170X	CERA/CHIP	B 50V	0.047uF-K
C 824	J3525223170X	CERA/CHIP	B 50V	0.022uF-K
C 826	J3525473170X	CERA/CHIP	B 50V	0.047uF-K

C 828	J3525223170X	CERA/CHIP	B 50V	0.022uF-K
C 830	J3525223170X	CERA/CHIP	B 50V	0.022uF-K
C 844	J3515300270X	CERA/CHIP	CH 50V	30pF-J <b>IB</b>
C 845	J3515300270X	CERA/CHIP	CH 50V	30pF-J <b>IB</b>
C 846	J3525223170X	CERA/CHIP	B 50V	0.022uF-K
C 848	J3515561170X	CERA/CHIP	SL 50V	560pF-J <b>IB</b>
C 850	J3525223170X	CERA/CHIP	B 50V	0.022uF-K
C 855	J3515150270X	CERA/CHIP	CH 50V	15pF-J
C 857	J3525223170X	CERA/CHIP	B 50V	0.022uF-K
C 863	J3525223170X	CERA/CHIP	B 50V	0.022uF-K
C 891	J3515331170X	CERA/CHIP	SL 50V	330pF-J <b>IB</b>
C 892	J3515820270X	CERA/CHIP	CH 50V	82pF-J <b>IB</b>
C 893	J3515101270X	CERA/CHIP	CH 50V	100pF-J <b>IB</b>
C 894	J3525223170X	CERA/CHIP	B 50V	0.022uF-K <b>IB</b>

C 811	J3600102330X	POLYESTER/RA	100V	0.001uF-K
C 819	J3610683330X	POLYESTER/RA	100V	0.068uF-K
C 834	J3600473330X	POLYESTER/RA	100V	0.047uF-K

C 806	J3670471210X	STYROL	50V	470pF-J
-------	--------------	--------	-----	---------

C 801	J3801201001X	TRIMER		20pF-J
-------	--------------	--------	--	--------

**WAFERS**

WA 801	J4423341060X	JE605-10	10P	2.5mm
WA 802	J4423340660X	JE605-06	6P	2.5mm

**MISCELLANIES**

ANT 801	J4435230100X	SC0210393N	ANT TERMINAL	<b>BK</b>
ANT 801	J4435230200X	SC0210392N	ANT TERMINAL	<b>IB</b>
P 801	J3903200012X	PACK	F.E. PACK	
X 801	J3913010015X	7.2MHz	20pF	X-TAL
X 802	J3913010025X	4.332MHz	20pF	X-TAL <b>IB</b>

**J13200452041 FRONT P.C. BOARD **IB****

**J13200451041 FRONT P.C. BOARD **BK****

**INTEGRATED CIRCUITS**

IC 901	J2132314024X	CXP82860-174Q(MCU-0)	u-COM	
IC 902	J2120012001X	NJM4558M	OP-AMP	
IC 903	J2120012001X	NJM4558M	OP-AMP	
IC 904	J2120012001X	NJM4558M	OP-AMP	

**TRANSISTORS**

Q 901	J2021020301X	KTC3199-GR	NPN	
Q 902	J2021220301X	KRC103M	NPN	
Q 903	J2021220301X	KRC103M	NPN	
Q 904	J2021020301X	KTC3199-GR	NPN	
Q 905	J2021020301X	KTC3199-GR	NPN	
Q 906	J2021020301X	KTC3199-GR	NPN	
Q 907	J2021020301X	KTC3199-GR	NPN	
Q 908	J2021020301X	KTC3199-GR	NPN	
Q 909	J2021020301X	KTC3199-GR	NPN	
Q 910	J2021020301X	KTC3199-GR	NPN	
Q 911	J2021020301X	KTC3199-GR	NPN	
Q 912	J2021020301X	KTC3199-GR	NPN	
Q 913	J2021020301X	KTC3199-GR	NPN	
Q 914	J2021020301X	KTC3199-GR	NPN	
Q 915	J2021020301X	KTC3199-GR	NPN	
Q 916	J2021020301X	KTC3199-GR	NPN	
Q 917	J2021020301X	KTC3199-GR	NPN	
Q 918	J2021020301X	KTC3199-GR	NPN	
Q 919	J2021020301X	KTC3199-GR	NPN	
Q 932	J2021020201X	KTC3198-BL	NPN	

REF NO.	PART NO.	DESCRIPTION	REF NO.	PART NO.	DESCRIPTION
C 827	J3525473170X	CERA/CHIP B 50V 0.047uF-K	Q 933	J2021200401X	KRA104M PNP

-45

Q 934	J2021220401X	KRC104M	NPN
Q 935	J2021200401X	KRA104M	PNP
Q 936	J2021200201X	KRA102M	PNP

R 946	J3003103220X	1/8W	10KW-J
R 948	J3003103220X	1/8W	10KW-J
R 949	J3003470220X	1/8W	47W-J
R 950	J3003470220X	1/8W	47W-J
R 955	J3003473220X	1/8W	47KW-J
R 959	J3003473220X	1/8W	47KW-J
R 969	J3003473220X	1/8W	47KW-J
R 970	J3003473220X	1/8W	47KW-J
R 972	J3003473220X	1/8W	47KW-J
R 976	J3003100220X	1/8W	10W-J
R 977	J3003100220X	1/8W	10W-J
R 979	J3003473220X	1/8W	47KW-J
R 983	J3003103220X	1/8W	10KW-J
R 980	J3003479420X	1/4W	4R7W-J
R 981	J3003479420X	1/4W	4R7W-J
R 931	J3024221120X	1/10W	CHIP 220W-J
R 932	J3024221120X	1/10W	CHIP 220W-J
R 933	J3024474120X	1/10W	CHIP 470KW-J
R 934	J3024474120X	1/10W	CHIP 470KW-J
R 939	J3024223120X	1/10W	CHIP 22KW-J
R 940	J3024223120X	1/10W	CHIP 22KW-J
R 941	J3024223120X	1/10W	CHIP 22KW-J
R 942	J3024223120X	1/10W	CHIP 22KW-J
R 945	J3024103120X	1/10W	CHIP 10KW-J
R 947	J3024103120X	1/10W	CHIP 10KW-J
R 949	J3024470120X	1/10W	CHIP 47W-J
R 950	J3024470120X	1/10W	CHIP 47W-J
R 951	J3024473120X	1/10W	CHIP 47KW-J
R 952	J3024473120X	1/10W	CHIP 47KW-J
R 953	J3024473120X	1/10W	CHIP 47KW-J
R 954	J3024473120X	1/10W	CHIP 47KW-J
R 956	J3024473120X	1/10W	CHIP 47KW-J
R 957	J3024101120X	1/10W	CHIP 100W-J
R 958	J3024101120X	1/10W	CHIP 100W-J
R 960	J3024474120X	1/10W	CHIP 470KW-J
R 961	J3024474120X	1/10W	CHIP 470KW-J
R 962	J3024822120X	1/10W	CHIP 8K2W-J
R 963	J3024822120X	1/10W	CHIP 8K2W-J
R 964	J3024123120X	1/10W	CHIP 12KW-J
R 965	J3024123120X	1/10W	CHIP 12KW-J

RA 901	J3040473094X	RMNS-08-47R	ERRAY 9P	47KW-J
RA 902	J3040473064X	RMNS-05-47R	ERRAY 6P	47KW-J
RA 903	J3040272114X	RMNS-10-27R	ERRAY 11P	2K7W-J
VR 902	J3220210422X	GPVN17.5FS-L1B100K	ROTARY VR.	
VR 903	J3220210422X	GPVN17.5FS-L1B100K	ROTARY VR.	
VR 904	J3220810422X	GPVN17.5FS-L1Z100K	ROTARY VR.	

### CAPACITORS

C 904	J3470122041X	ELEC	25V	22uF-M
C 917	J3470122131X	ELEC	16V	220uF-M
C 931	J3470647971X	ELEC	50V	4.7uF-M
C 932	J3470647971X	ELEC	50V	4.7uF-M
C 951	J3470647971X	ELEC	50V	4.7uF-M
C 952	J3470647971X	ELEC	50V	4.7uF-M
C 953	J3470647971X	ELEC	50V	4.7uF-M
C 955	J3470647971X	ELEC	50V	4.7uF-M
C 956	J3470647971X	ELEC	50V	4.7uF-M
C 976	J3470647041X	ELEC	25V	47uF-M
C 977	J3470647041X	ELEC	25V	47uF-M

### DIODES

D 901	J2221010100X	1SS133	SW.
D 902	J2221010100X	1SS133	SW.
D 903	J2221010100X	1SS133	SW.
D 904	J2221010100X	1SS133	SW.
D 905	J2221010100X	1SS133	SW.
D 906	J2221010100X	1SS133	SW.
D 907	J2221010100X	1SS133	SW.
D 908	J2221010100X	1SS133	SW.
D 909	J2221010100X	1SS133	SW.
D 910	J2221010100X	1SS133	SW.
D 911	J2221010100X	1SS133	SW.
D 912	J2221010100X	1SS133	SW.
D 913	J2221010100X	1SS133	SW.
D 915	J2221010100X	1SS133	SW.
D 917	J2221010100X	1SS133	SW.
D 918	J2221010100X	1SS133	SW.
D 919	J2221010100X	1SS133	SW.
D 920	J2221010100X	1SS133	SW.
D 940	J2221010100X	1SS133	SW.
D 964	J2221010100X	1SS133	SW.
D 985	J2221010100X	1SS133	SW.
D 986	J2221010100X	1SS133	SW.
OPT 2	J2221010100X	1SS133	SW. <b>IB</b>
OPT 4	J2221010100X	1SS133	SW.
OPT 5	J2221010100X	1SS133	SW. <b>IB</b>
OPT 6	J2221010100X	1SS133	SW. <b>IB</b>

### BEADS

R 982	J2631200011X	HF70BTL3.5*9R	AXIAL	BEAD
-------	--------------	---------------	-------	------

### RESISTORS

R 901	J3003471220X	1/8W	470W-J
R 902	J3003102220X	1/8W	1KW-J
R 904	J3003222220X	1/8W	2K2W-J
R 905	J3003105220X	1/8W	1MW-J
R 906	J3003103220X	1/8W	10KW-J
R 907	J3003103220X	1/8W	10KW-J
R 908	J3003103220X	1/8W	10KW-J
R 909	J3003103220X	1/8W	10KW-J
R 910	J3003104220X	1/8W	100KW-J
R 911	J3003104220X	1/8W	100KW-J
R 912	J3003224220X	1/8W	220KW-J
R 913	J3003224220X	1/8W	220KW-J
R 914	J3003473220X	1/8W	47KW-J
R 915	J3003473220X	1/8W	47KW-J
R 916	J3003473220X	1/8W	47KW-J
R 917	J3003473220X	1/8W	47KW-J
R 918	J3003473220X	1/8W	47KW-J
R 919	J3003331220X	1/8W	330W-J
R 920	J3003331220X	1/8W	330W-J
R 921	J3003224220X	1/8W	220KW-J
R 922	J3003224220X	1/8W	220KW-J
R 923	J3003750220X	1/8W	75W-J
R 924	J3003473220X	1/8W	47KW-J
R 925	J3003103220X	1/8W	10KW-J
R 927	J3003183220X	1/8W	18KW-J
R 943	J3003103220X	1/8W	10KW-J

REF NO.	PART NO.	DESCRIPTION
R 944	J3003103220X 1/8W	10KW-J

REF NO.	PART NO.	DESCRIPTION
---------	----------	-------------

-46

C 901	J3514220270X	CERA/AX	CH	50V	22pF-J
C 902	J3514220270X	CERA/AX	CH	50V	22pF-J
C 903	J3524104540X	CERA/AX	F	25V	0.1uF-Z
C 905	J3524104540X	CERA/AX	F	25V	0.1uF-Z
C 907	J3524104540X	CERA/AX	F	25V	0.1uF-Z
C 908	J3524471170X	CERA/AX	B	50V	470pF-K
C 909	J3524104540X	CERA/AX	F	25V	0.1uF-Z
C 910	J3524102170X	CERA/AX	B	50V	1000pF-K
C 911	J3524102170X	CERA/AX	B	50V	1000pF-K
C 912	J3524102170X	CERA/AX	B	50V	1000pF-K
C 913	J3524102170X	CERA/AX	B	50V	1000pF-K
C 914	J3524104540X	CERA/AX	F	25V	0.1uF-Z
C 915	J3524104540X	CERA/AX	F	25V	0.1uF-Z
C 918	J3524104540X	CERA/AX	F	25V	0.1uF-Z
C 919	J3514121270X	CERA/AX	CH	50V	120pF-K
C 920	J3514121270X	CERA/AX	CH	50V	120pF-K
C 922	J3524104540X	CERA/AX	F	25V	0.1uF-Z
C 954	J3514101270X	CERA/AX	CH	50V	100pF-K
C 973	J3524104540X	CERA/AX	F	25V	0.1uF-Z
C 974	J3524152730X	CERA/AX	X	16V	1500pF-M BK
C 974	J3524472730X	CERA/AX	X	16V	4700pF-M IB
C 975	J3524152730X	CERA/AX	X	16V	1500pF-M BK
C 975	J3524472730X	CERA/AX	X	16V	4700pF-M IB
C 979	J3524104540X	CERA/AX	F	25V	0.1uF-Z
C 980	J3524104540X	CERA/AX	F	25V	0.1uF-Z

C 947	J3515470270X	CERA/CHIF	CH	50V	47pF-J
C 948	J3515470270X	CERA/CHIF	CH	50V	47pF-J

C 937	J3600223238X	FOIL POLY/RA		100V	0.022uF-J
C 938	J3600223238X	FOIL POLY/RA		100V	0.022uF-J
C 939	J3600223238X	FOIL POLY/RA		100V	0.022uF-J
C 940	J3600223238X	FOIL POLY/RA		100V	0.022uF-J
C 943	J3600182238X	FOIL POLY/RA		100V	1800pF-J
C 944	J3600182238X	FOIL POLY/RA		100V	1800pF-J

C 906	J4433210421X	SCDA5R5104H		5.5V	0.1F
-------	--------------	-------------	--	------	------

#### WAFERS

CN 923	J4422113020X	8370-307	30P	1.25mm
CN 924	J4422112220X	8370-227	22P	1.25mm
WA 903	J4420040200X	5267-02A	2P	2.5mm
WA 904	J4420040200X	5267-02A	2P	2.5mm

#### WIRES

CN 907	J43344084341	8P,1007/2547#26*2C,430m/m
CN 911	J43344062641	6P,1533#26,260m/m
CN 986	J43244244331	7P,1007#24,430m/m
T 901	J43199011529	1P,1007#22,150m/m
T 902	J43199011529	1P,1007#22,150m/m
T 903	J43199011529	1P,1007#22,150m/m
T 904	J43199011529	1P,1007#22,150m/m
!	J43217025001	2P,1672#18,500m/m CN983<->SUB
	J4112223201X	FFC 320mm1.25mm 22P TO DSP
	J4112302801X	FFC 280mm1.25mm 30P TO MAIN

#### MISCELLANIES

FLT 901	J2352220011X	CM1906C	VFD
JP 901	J4430130110X	JK0300081G Y/W/R	3P RCA JACK
RMT 901	J2411320014X	RPM6938-H4 38kHz	RMC SENSOR
SW 901	J46500500002	SKHV10910A	2P TACT SW.

SW 904	J46500500002	SKHV10910A	2P TACT SW.
SW 905	J46500500002	SKHV10910A	2P TACT SW.
SW 906	J46500500002	SKHV10910A	2P TACT SW.
SW 907	J46500500002	SKHV10910A	2P TACT SW.
SW 908	J46500500002	SKHV10910A	2P TACT SW.
SW 909	J46500500002	SKHV10910A	2P TACT SW.
SW 910	J46500500002	SKHV10910A	2P TACT SW.
SW 911	J46500500002	SKHV10910A	2P TACT SW.
SW 912	J46500500002	SKHV10910A	2P TACT SW.
SW 913	J46500500002	SKHV10910A	2P TACT SW.
SW 914	J46500500002	SKHV10910A	2P TACT SW.
SW 915	J46500500002	SKHV10910A	2P TACT SW.
SW 916	J46500500002	SKHV10910A	2P TACT SW.
SW 917	J46500500002	SKHV10910A	2P TACT SW.
SW 918	J46500500002	SKHV10910A	2P TACT SW.
SW 919	J46500500002	SKHV10910A	2P TACT SW.
SW 920	J46500500002	SKHV10910A	2P TACT SW.
SW 921	J46500500002	SKHV10910A	2P TACT SW.
SW 922	J46500500002	SKHV10910A	2P TACT SW.
SW 923	J46500500002	SKHV10910A	2P TACT SW.
SW 924	J46500500002	SKHV10910A	2P TACT SW.
SW 925	J46500500002	SKHV10910A	2P TACT SW.
SW 926	J46500500002	SKHV10910A	2P TACT SW.
SW 927	J46500500002	SKHV10910A	2P TACT SW.
SW 928	J46500500002	SKHV10910A	2P TACT SW.
SW 929	J46500500002	SKHV10910A	2P TACT SW.
SW 930	J46500500002	SKHV10910A	2P TACT SW.
SW 933	J46500500002	SKHV10910A	2P TACT SW.
VR 901	J32612050102	EC16B24D0002ZZZ	ENCODER VR.
X 901	J3913010035X	9.8304MHz	22pF X-TAL
	J60610501000	CASE,SHIELD(F);SPT	O,3
	J97200505000	CUSHION-FLT;SPONGE	25

#### HEAD PHONE P.C. BOARD

JP 961	J4432210120X	HTJ-064-07BGOLD	1P	H/P JACK
CN 901	J43344054141	5P,1007#26/2547#26,410m/m		
CN 904	J43244021041	2P,1007#26,STRAIGHT,100m/m		
C 969	J3524104540X	CERA/AX	F	25V 0.1uF-Z
C 970	J3524104540X	CERA/AX	F	25V 0.1uF-Z

#### MAIN SW. P.C. BOARD

! SW 932	J46205050108	SY-16-32-2(U99S2),TV5	POWER SW.
! C 968	J3531472412X	SPARK-KILLER AC250V	1.0047uF-M
! CN 983	J4420060200X	35328-0210	2P 7.92mm

#### STAND-BY SW. P.C. BOARD

SW 931	J46500500002	SKHV10910A	2P TACT SW.
LED 901	J2332301011X	SPR-54MVRED/GREEN	LED
CN 903	J43254021041	2P,1007#26,100m/m,ANGLE	
CN 987	J43244034531	3P,1007#24,450m/m	

<u>REF NO.</u>	<u>PART NO.</u>	<u>DESCRIPTION</u>
SW 902	J46500500002	SKHV10910A 2P TACT SW.
SW 903	J46500500002	SKHV10910A 2P TACT SW.

<u>REF NO.</u>	<u>PART NO.</u>	<u>DESCRIPTION</u>
----------------	-----------------	--------------------

# IC BLOCK DIAGRAM

IC NAME : 74VHCU04MX (IC 719)

HEX INVERTER

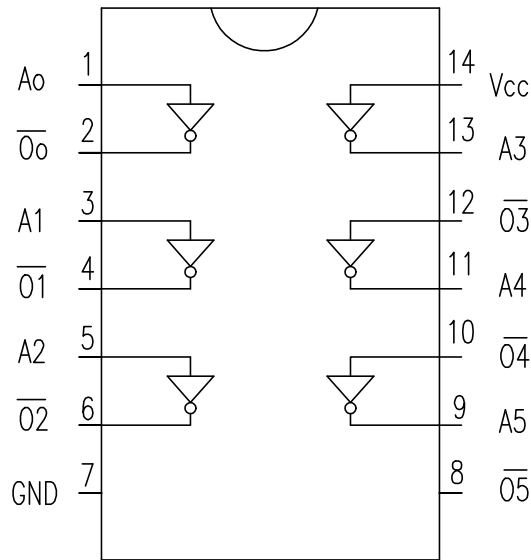

Connection Diagram

IC NAME : 74VHCT244SJX (IC 707)

Octal Buffer/Line Driver with 3-STATE Outputs

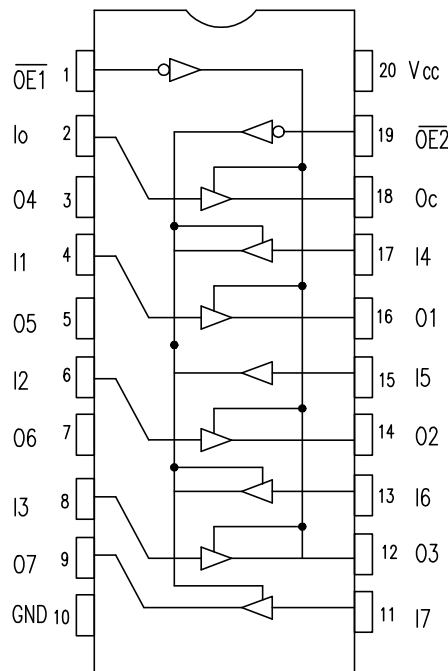

Connection Diagram

IC NAME : 74VHCT574A (IC 710, 711)

OCTAL D-TYPE FLIP-FLOP WITH 3-STATE OUTPUT

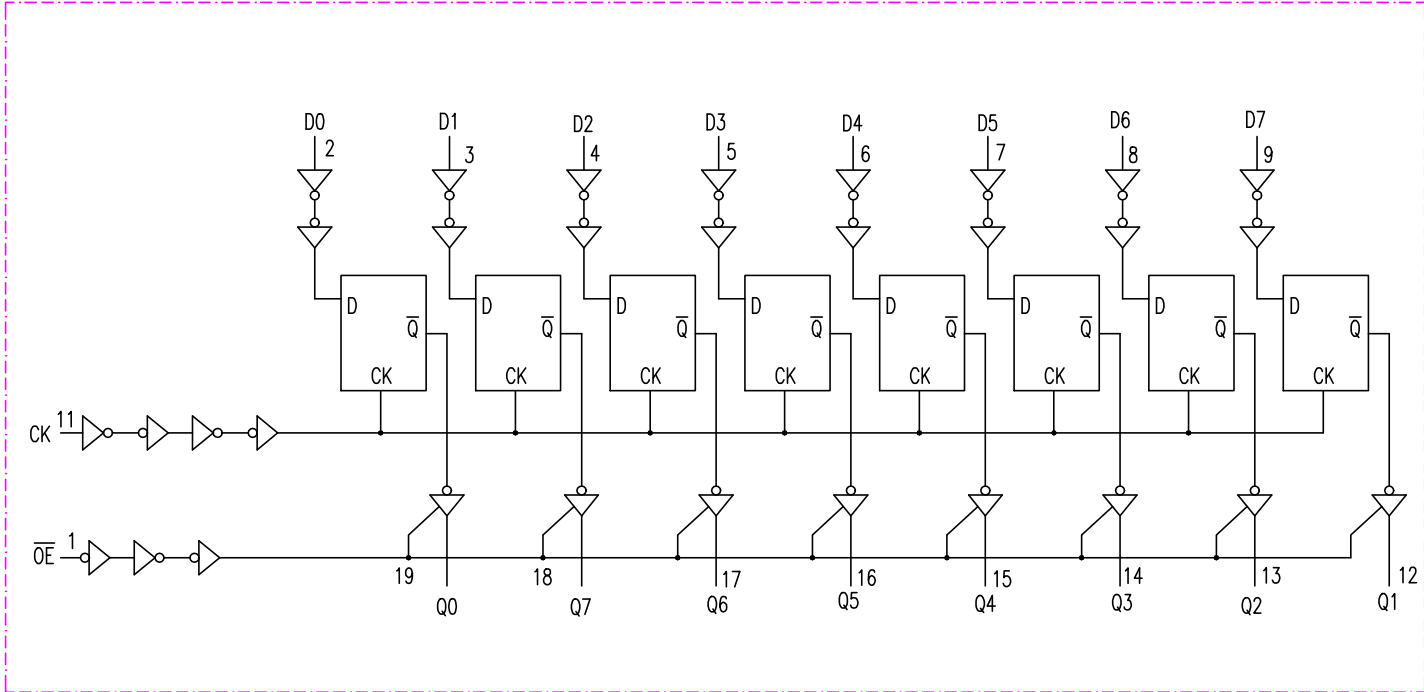



IC NAME : 74VHCU04MX (IC 719)

HEX INVERTER

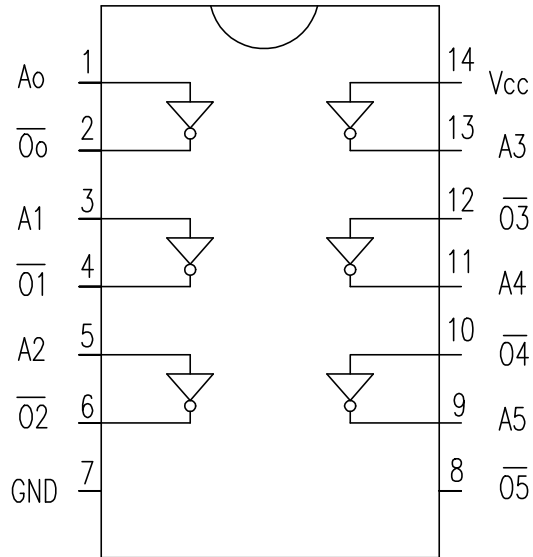

Connection Diagram

IC NAME : BA033T (IC 720)

Low Saturation voltage type 3-Pin Regulator

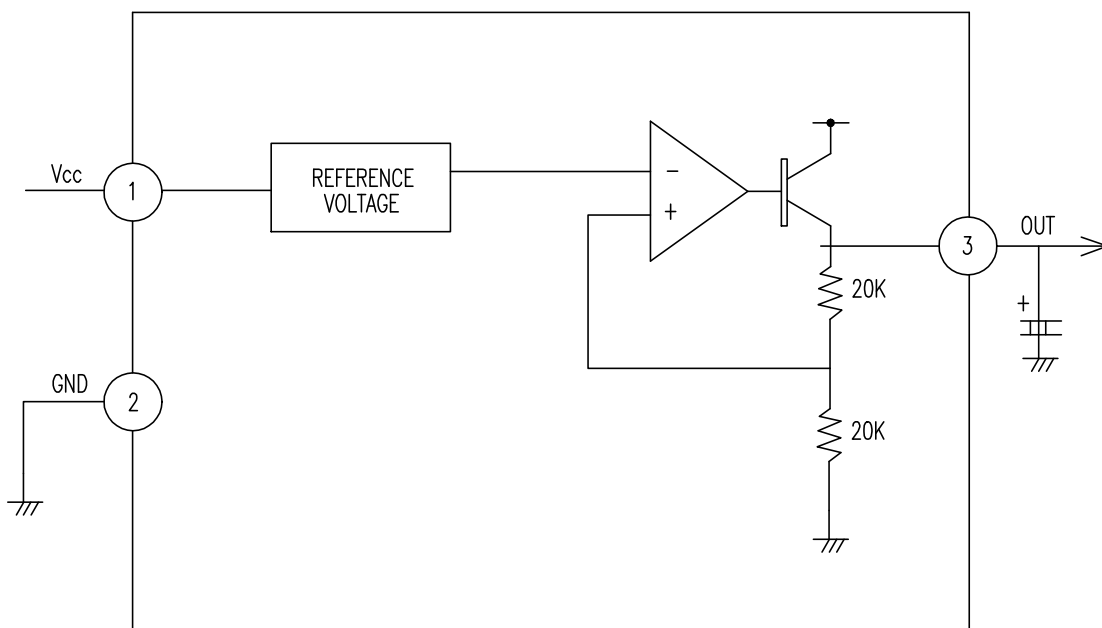

Block Diagram

IC NAME : BA7522F (IC 355)

Low Saturation voltage type 3-Pin Regulator

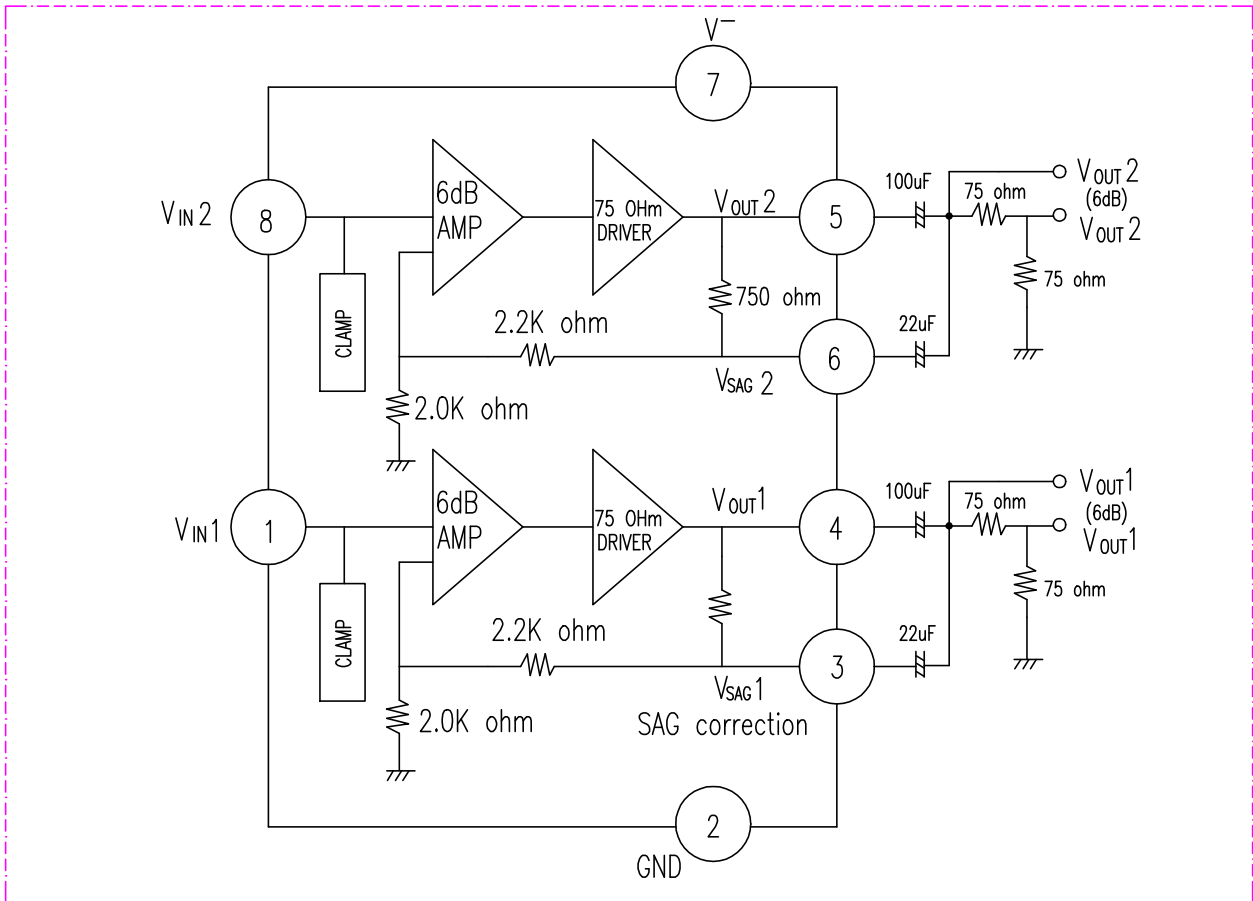

IC NAME : BU1923F (IC 804)

RDS DECODER IC

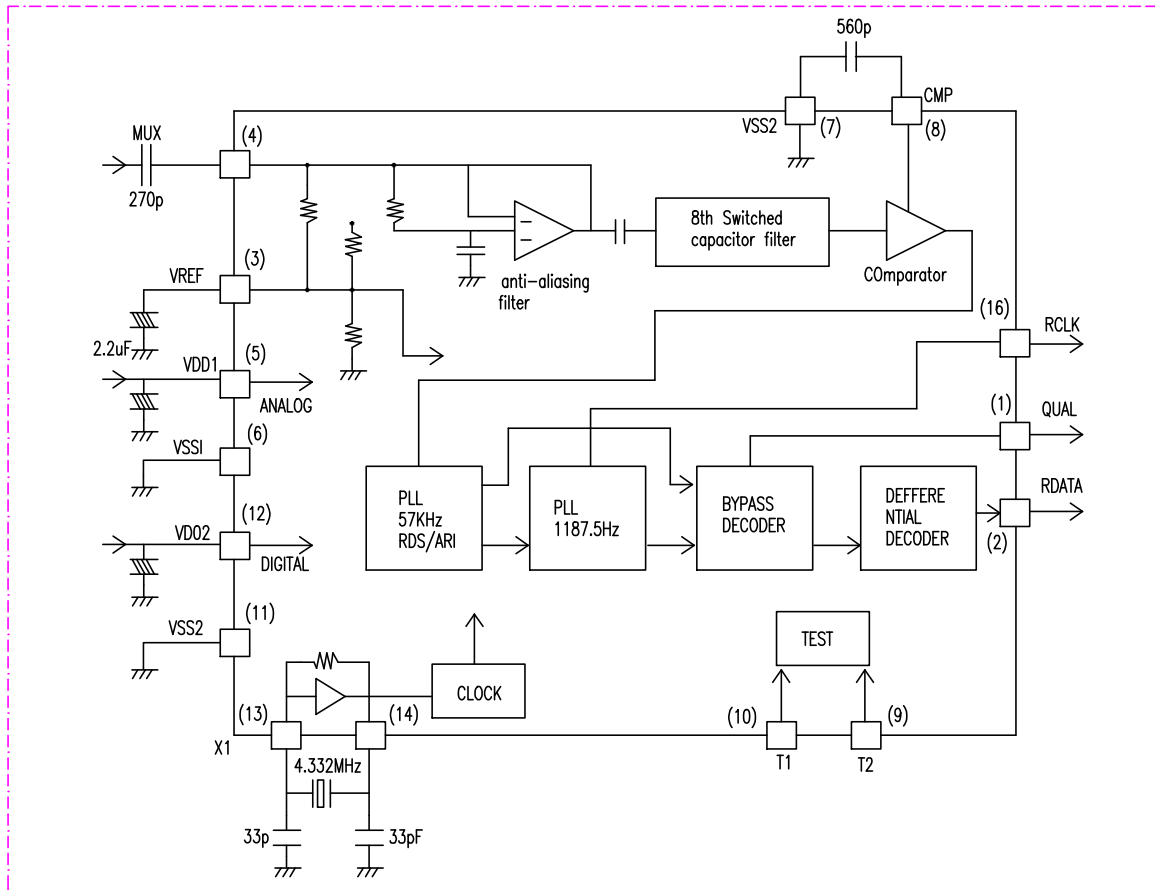

IC NAME : CS4341-KS (IC 713, 714, 715)

24-Bit, 96kHz Stereo DAC with Volume Control

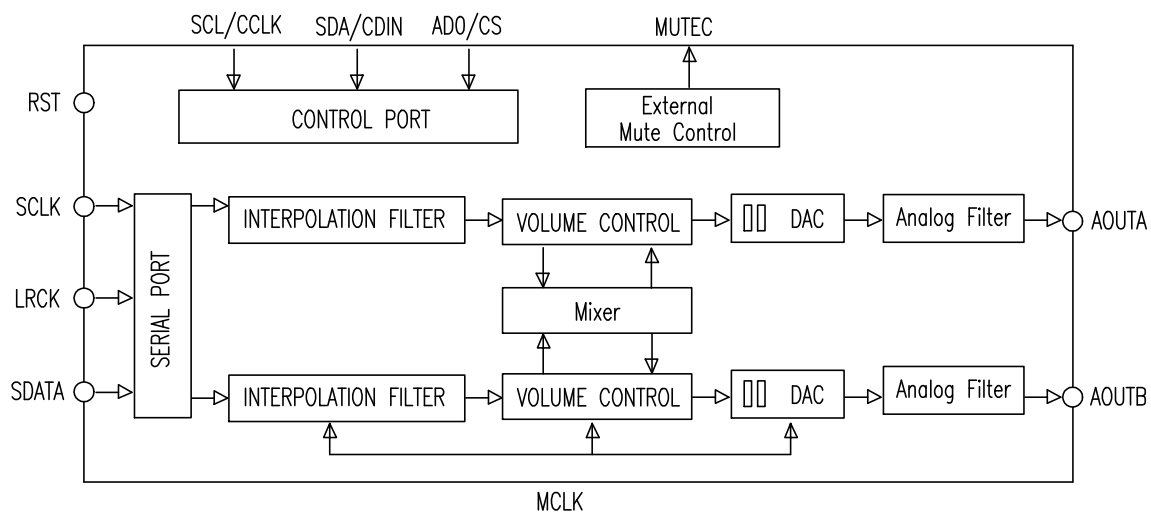

IC NAME : CS492604 (IC 708)

AC-3 DECODER

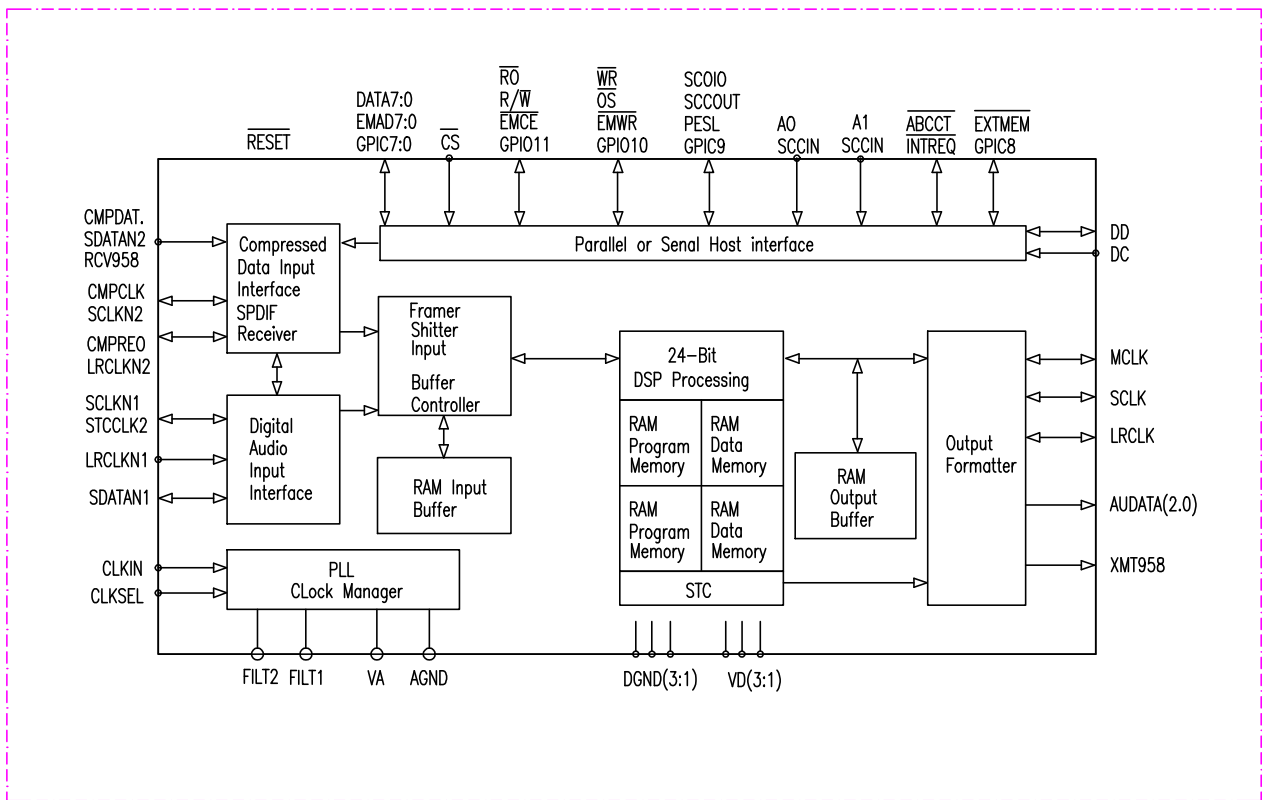

IC NAME : CS8414-CS (IC 706)

96kHz Digital Audio Receiver

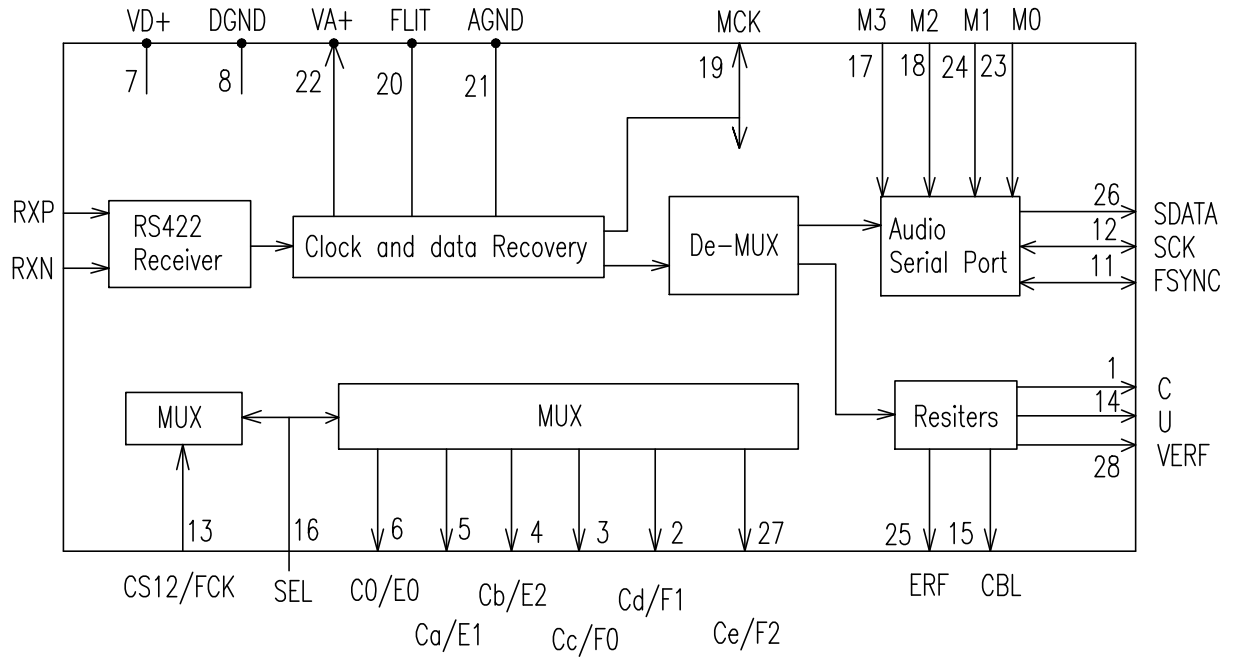

IC NAME : KM23C4000DG-8ROM-0001 (IC 709)

4M-BIT(512Kx8) CMOS MASK ROM

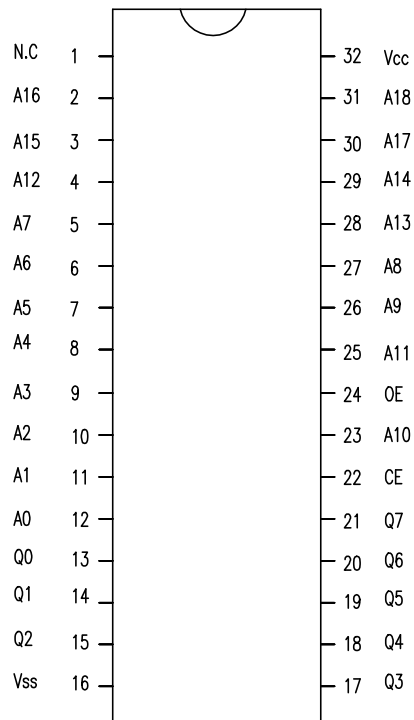

Connection Diagram

IC NAME : PC17TA (IC 1, 2)

PHOTO COUPLER

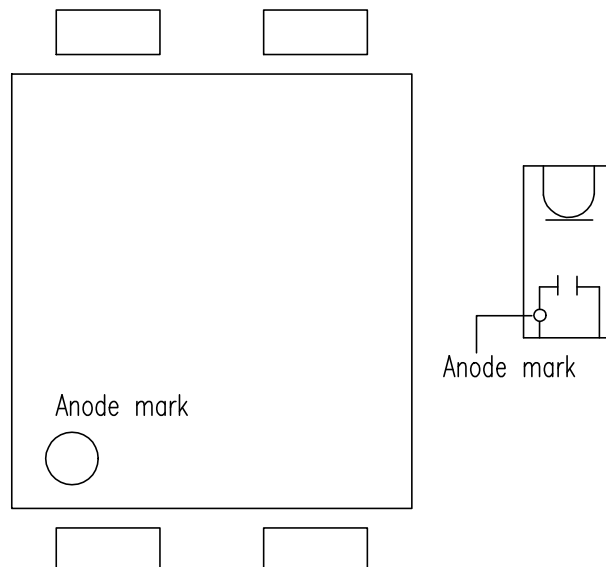

IC NAME : 74VHC132 (IC 3)

Quad 2-Input NAND Schmitt Trigger

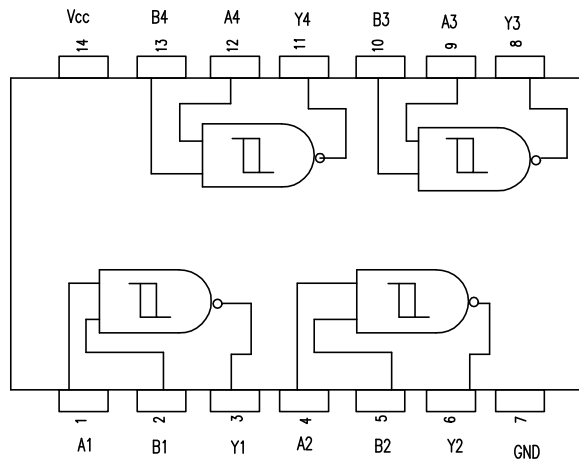

Connection Diagram

IC NAME : 74VHC135SJX (IC 704)

Dual 4-Input Multiplexer

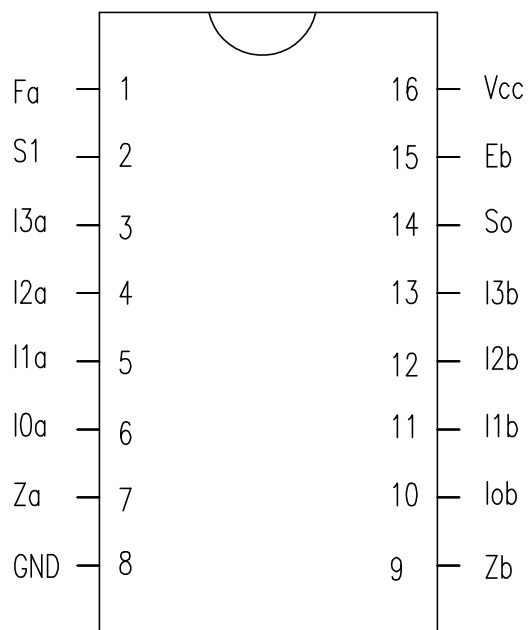

Connection Diagram



IC NAME : LA1266 (IC801)

FM / AM IF IC

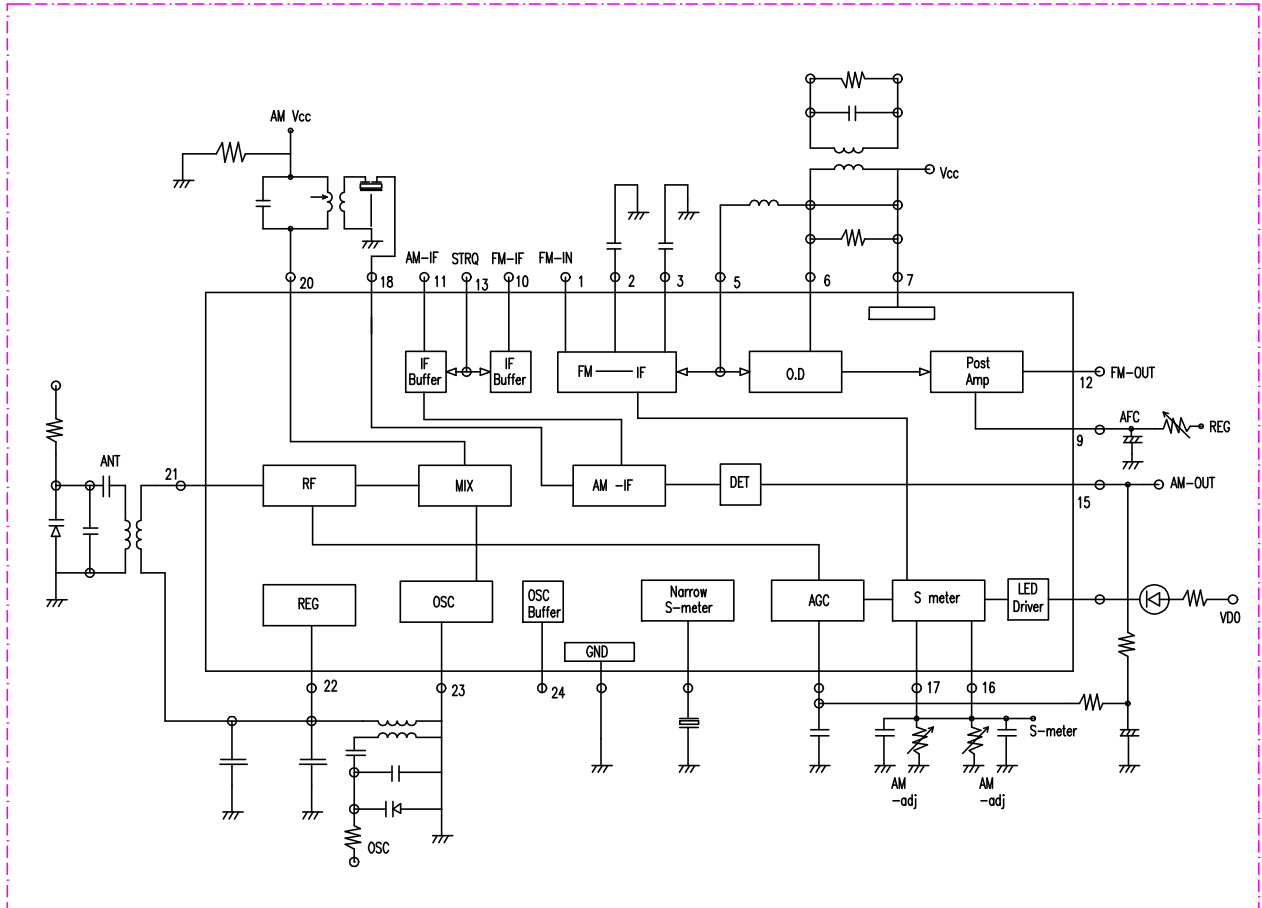

IC NAME : LA7951 (IC351,371,372)

VIDEO SWITCH IC

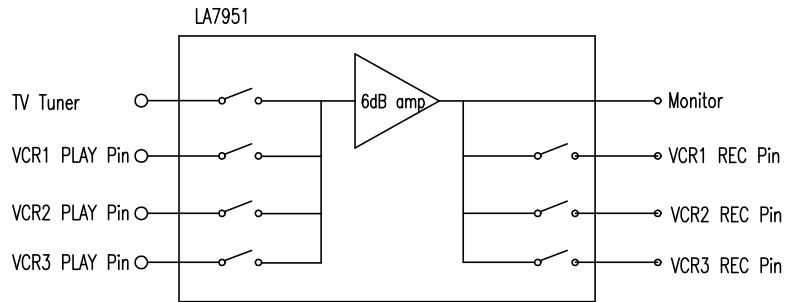

Figure 1. Editing System Switch Connections

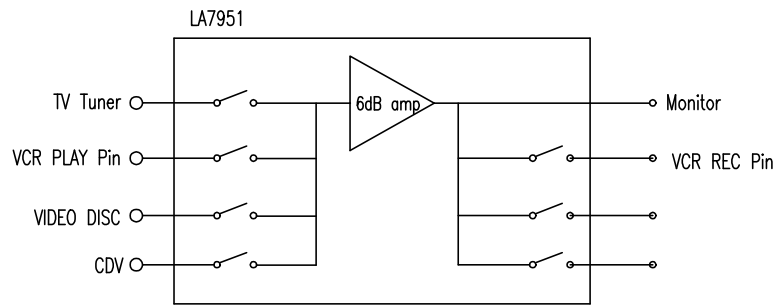
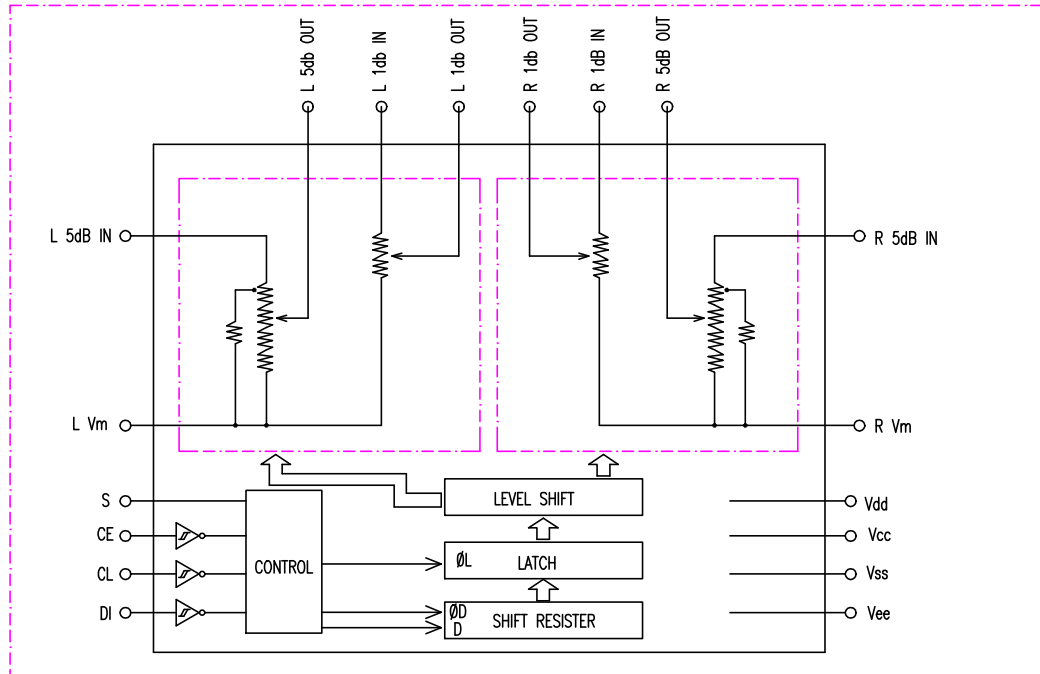

Figure 2. Video Selector Switch Connections

IC NAME : LA7536 (IC 106,109,114,117)

ELECTRONIC VOLUME CONTROL



IC NAME : LA3410 (IC 803)

FM MPX DEMODULATOR

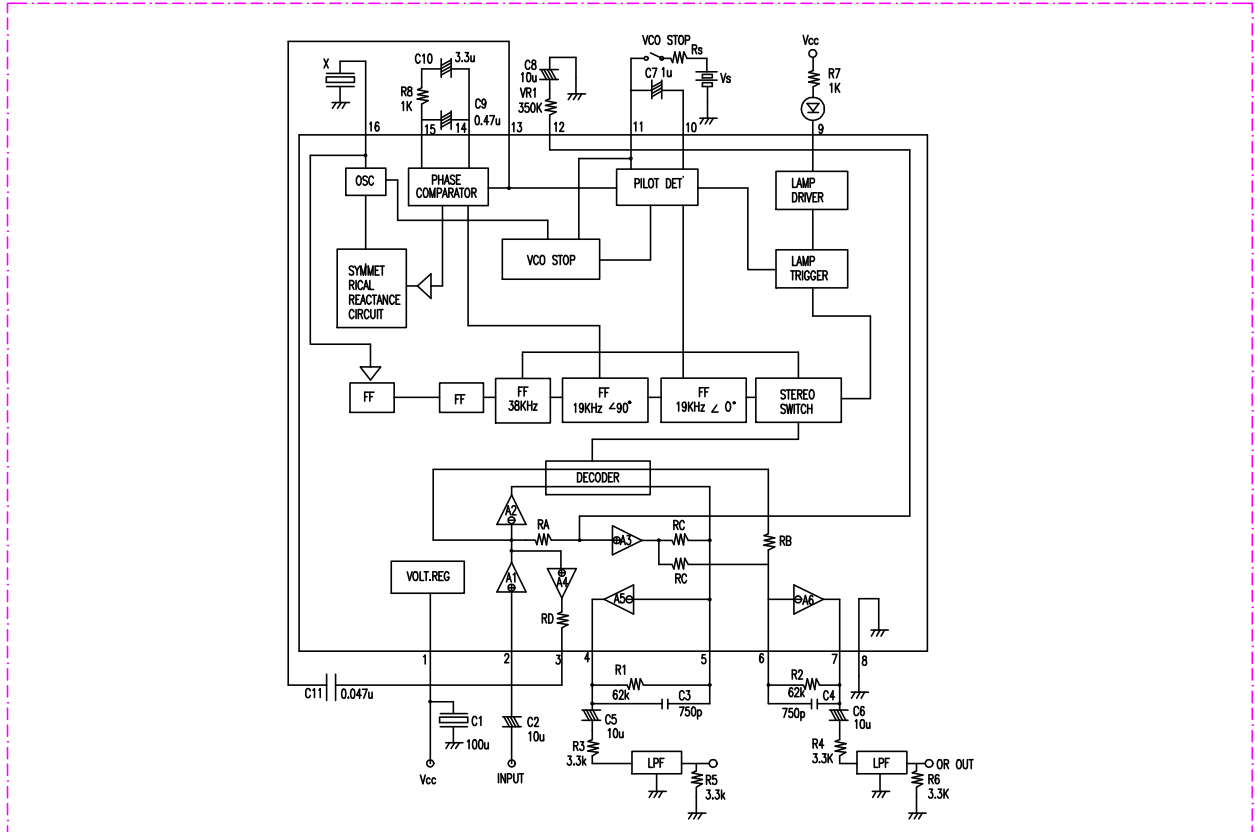

IC NAME : MB90089 (IC 354)

ON-SCREEN DISPLAY

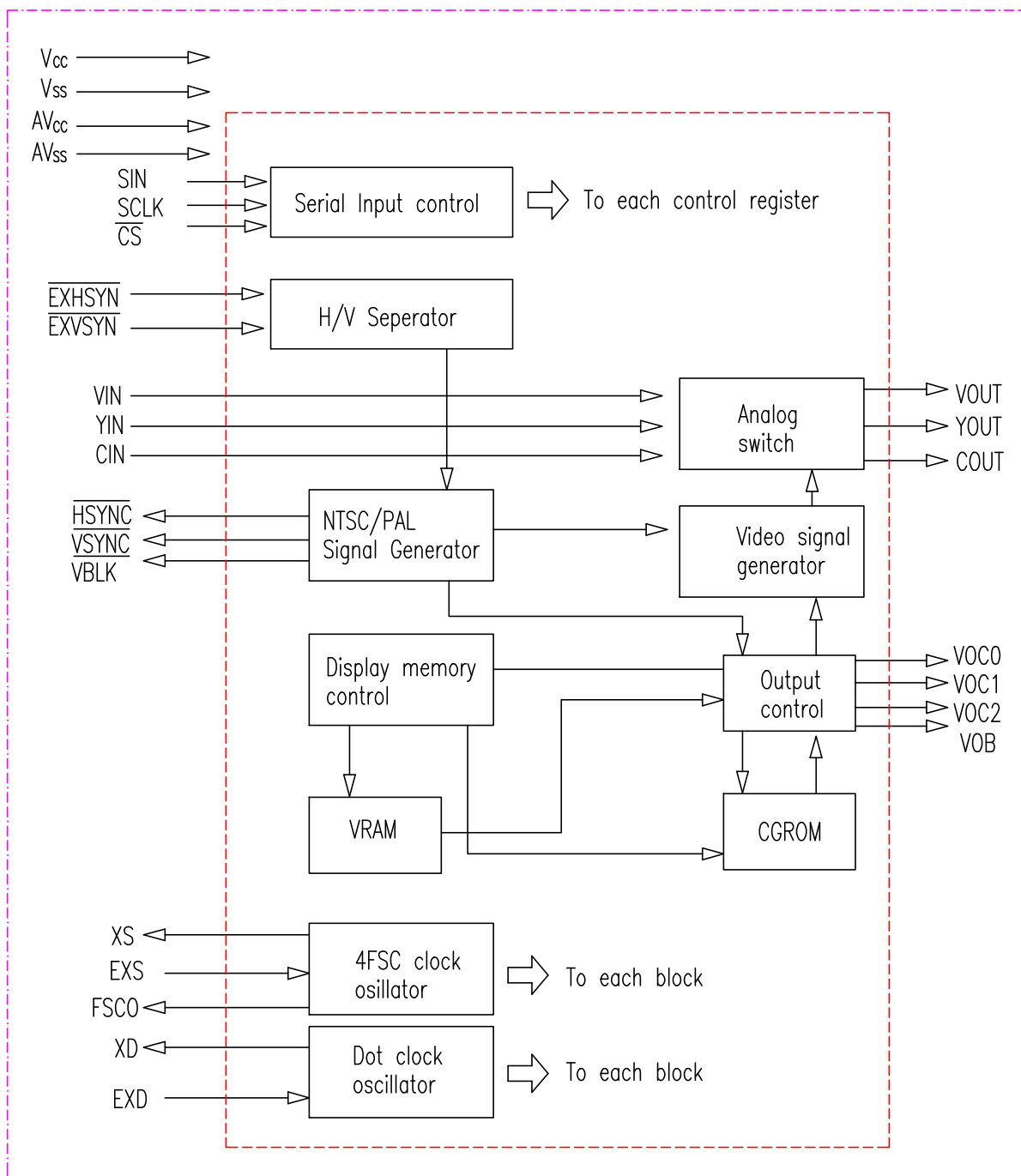

IC NAME : MM1067 (IC 353)

NO-ADJUSTMENT SYNC SEPERATOR  
& SYNC DETECTOR

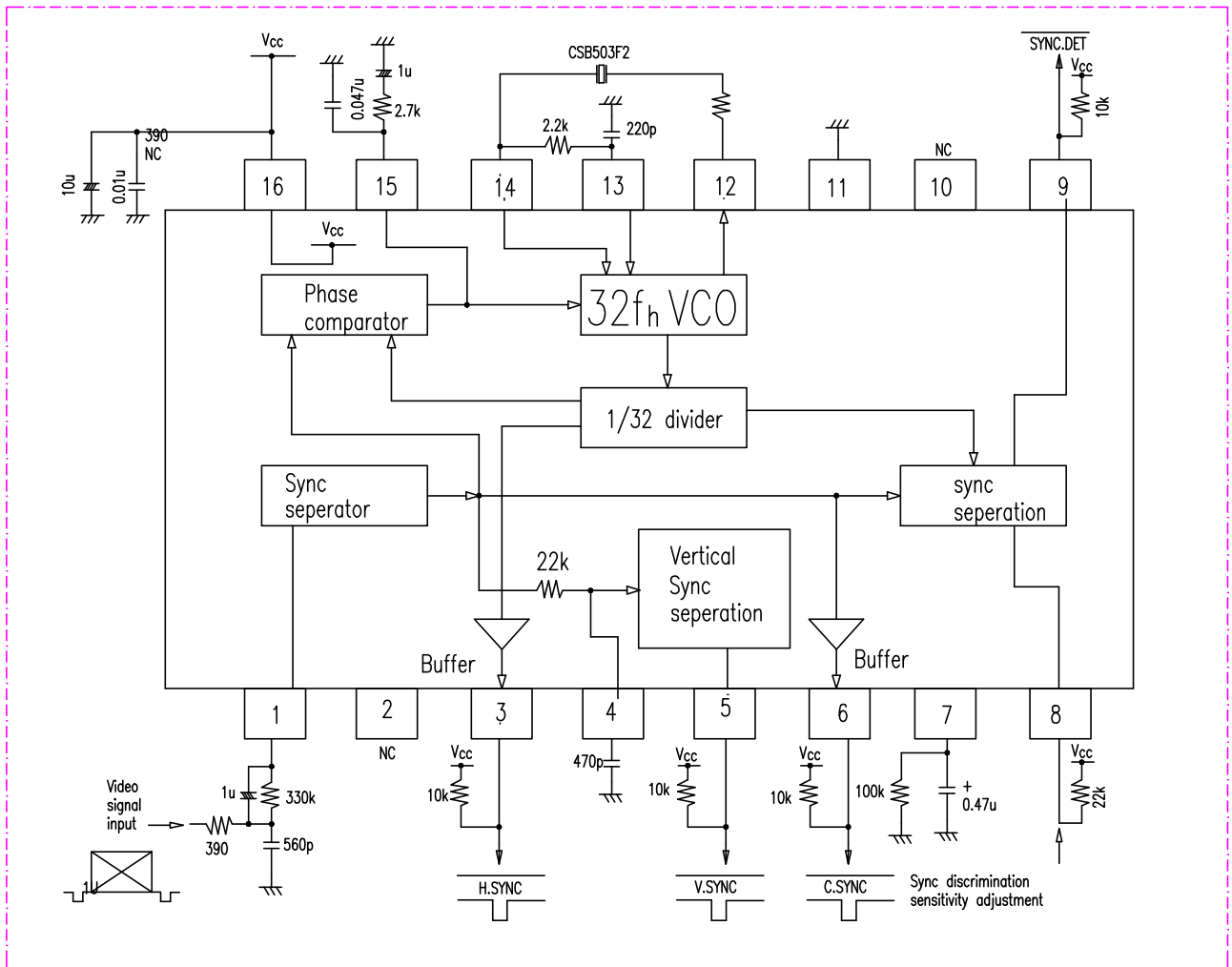

IC NAME : NJM 072M

IC 701,702,716,717,718 IC 103,104,107,108,110,111,112,115,116  
 DUAL J-FET INPUT OP-AMP

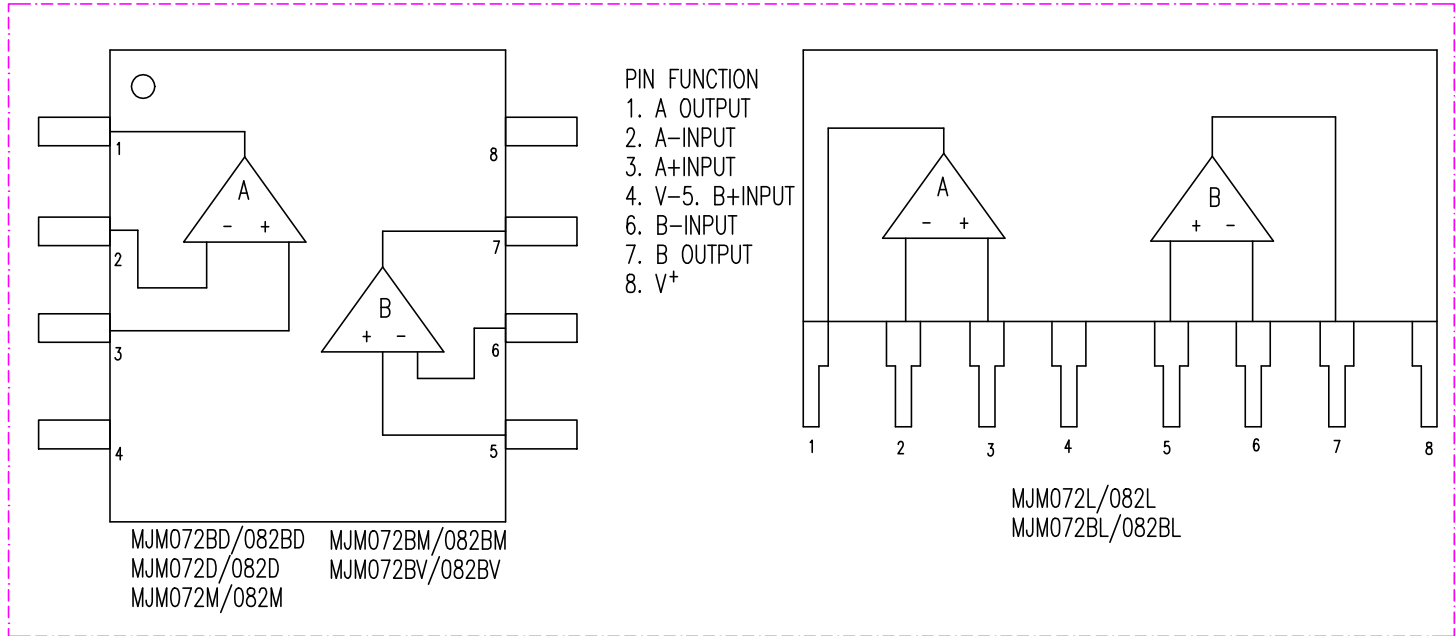

IC NAME : NJM2267

IC 118,119,120,121,122,123,124,2,722,723,724,725,902,903,904  
 VIDEO SWITCHING

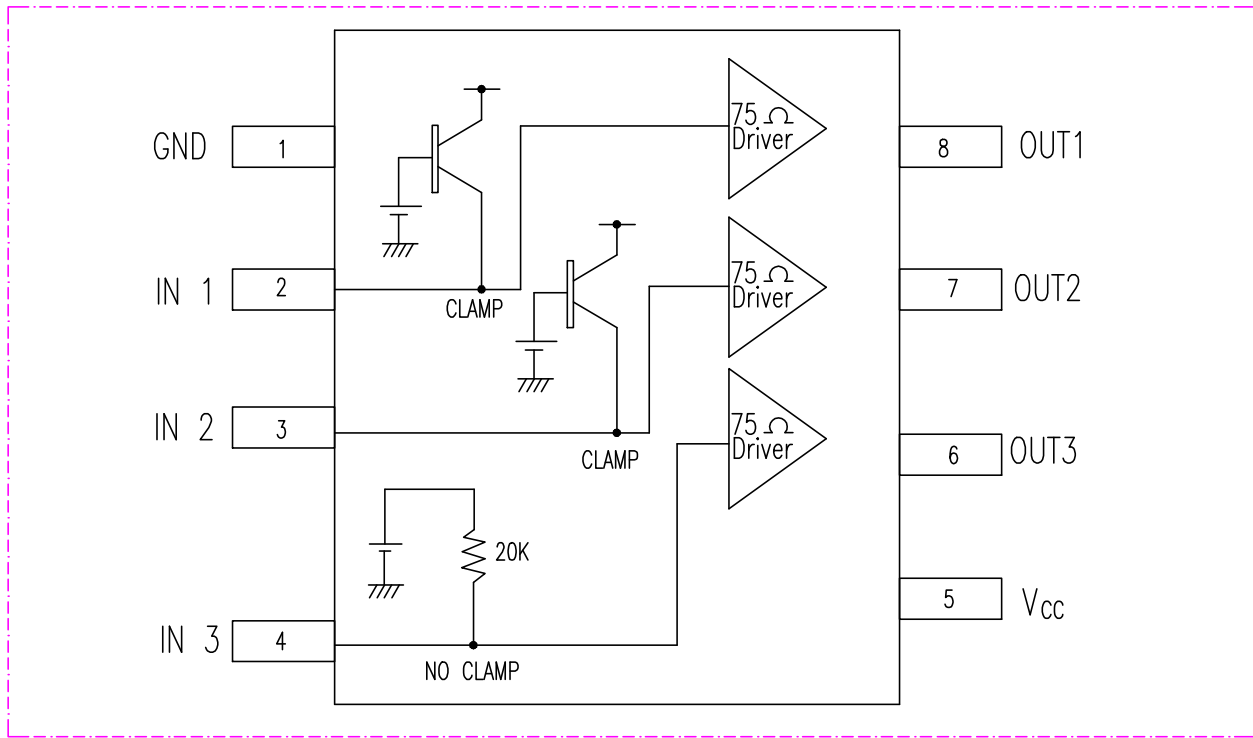

IC NAME : NJM4558M

IC 118,119,120,121,122,123,124,2,722,723  
OP AMP IC

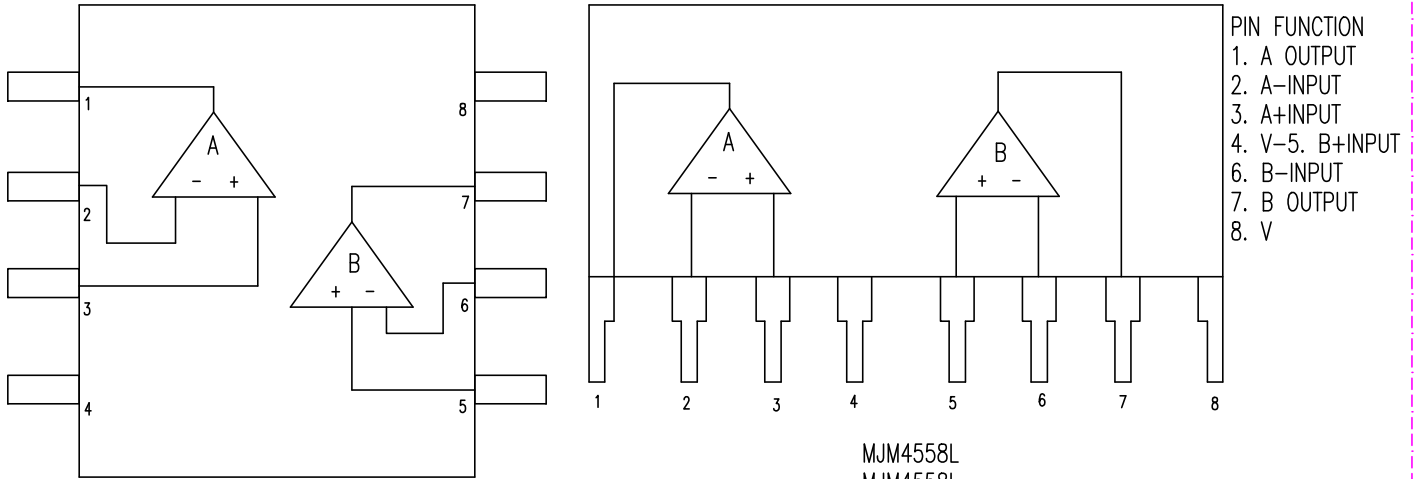

MJM4558D, MJM4558M, MJM4558V  
MJM4559D, MJM4559M, MJM4559V

MJM4558L  
MJM4558L

IC NAME : NJU7311AM (IC 105)

IC 105, 113 : NJU7311  
ANALOG FUNCTION SW.

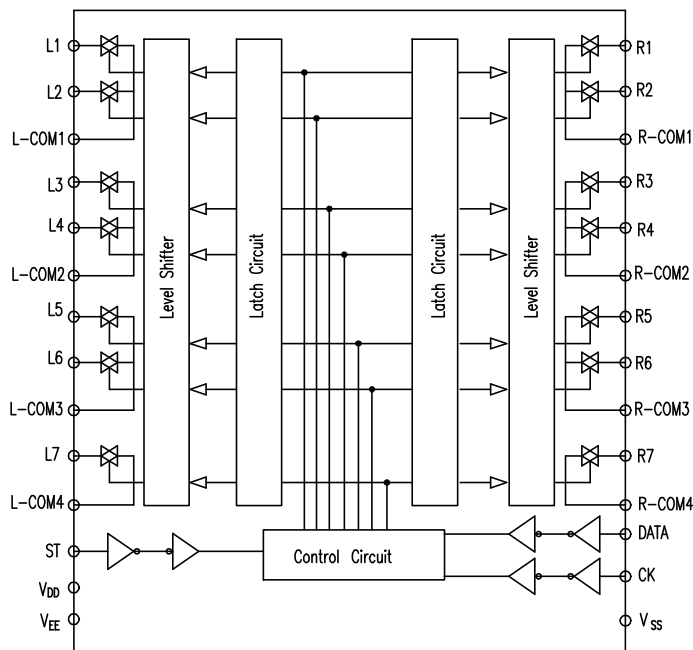

IC NAME : NJU7312AM (IC 101)

ANALOG FUNCTION SW.

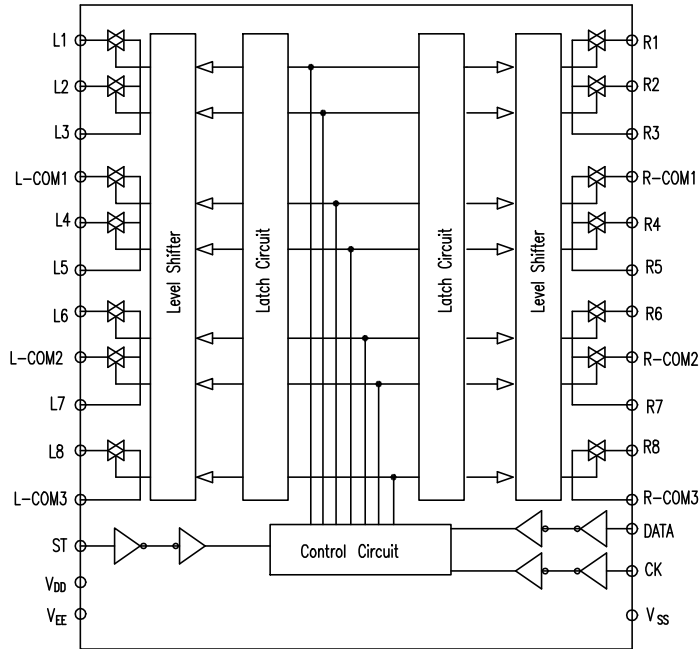

IC NAME : NJU7313AM (IC 102)

ANALOG FUNCTION SW.

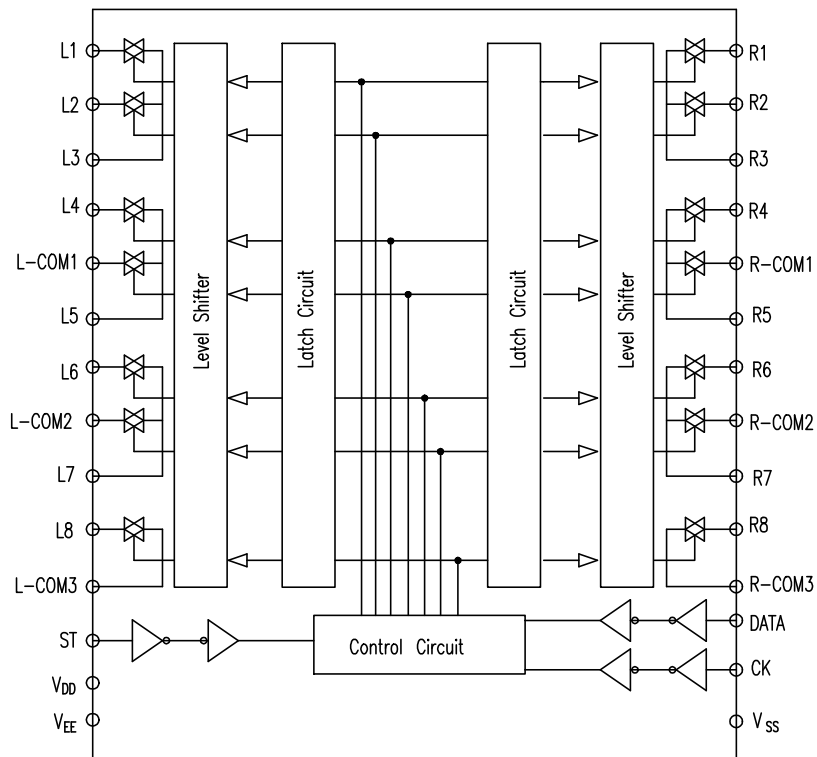



CXP82860-180Q (MCU-0006) : IC901

BLCK DIAGRAM

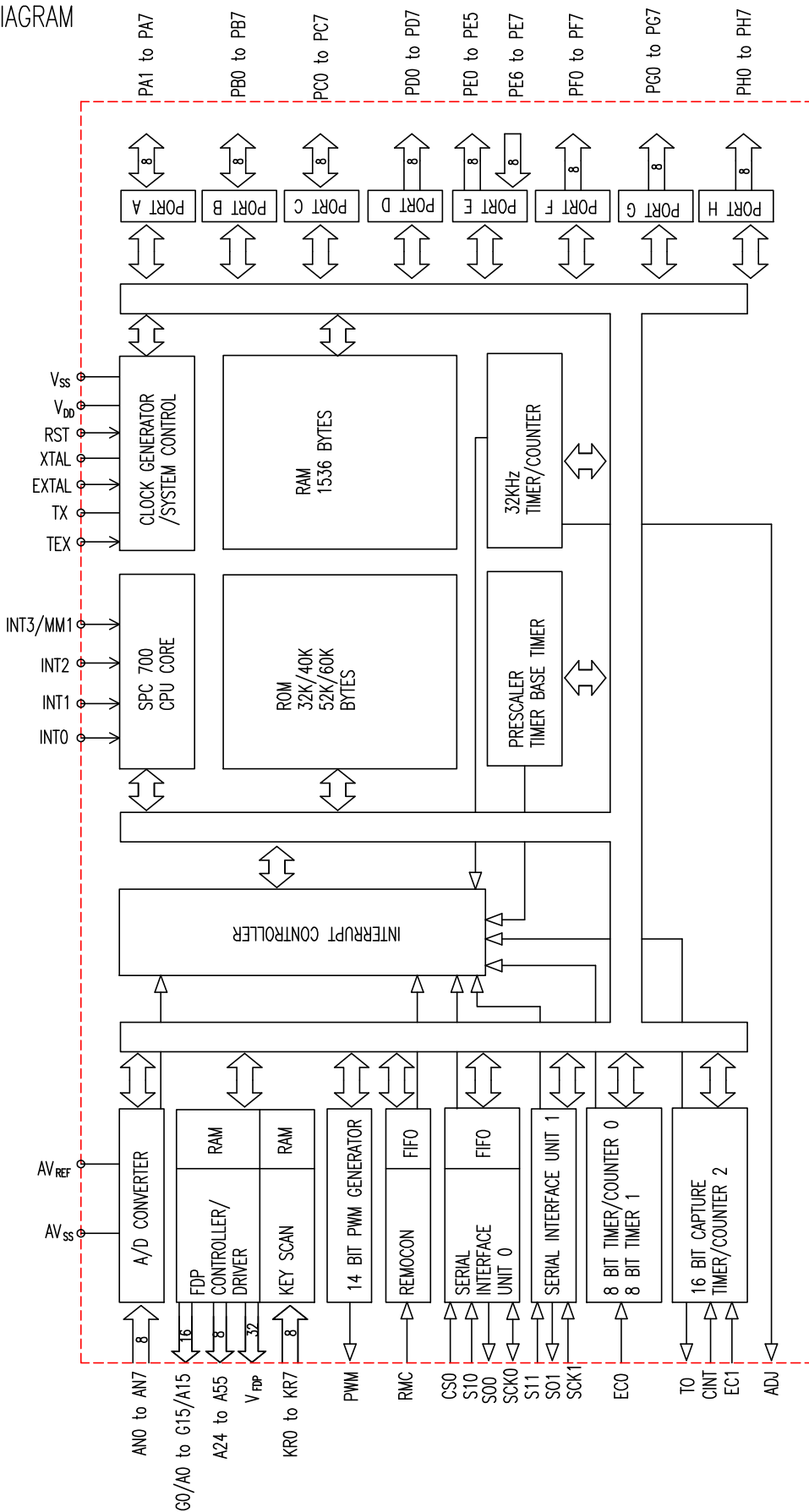

CXP82860-180Q-0006 : IC901

PIN DESCRIPTION

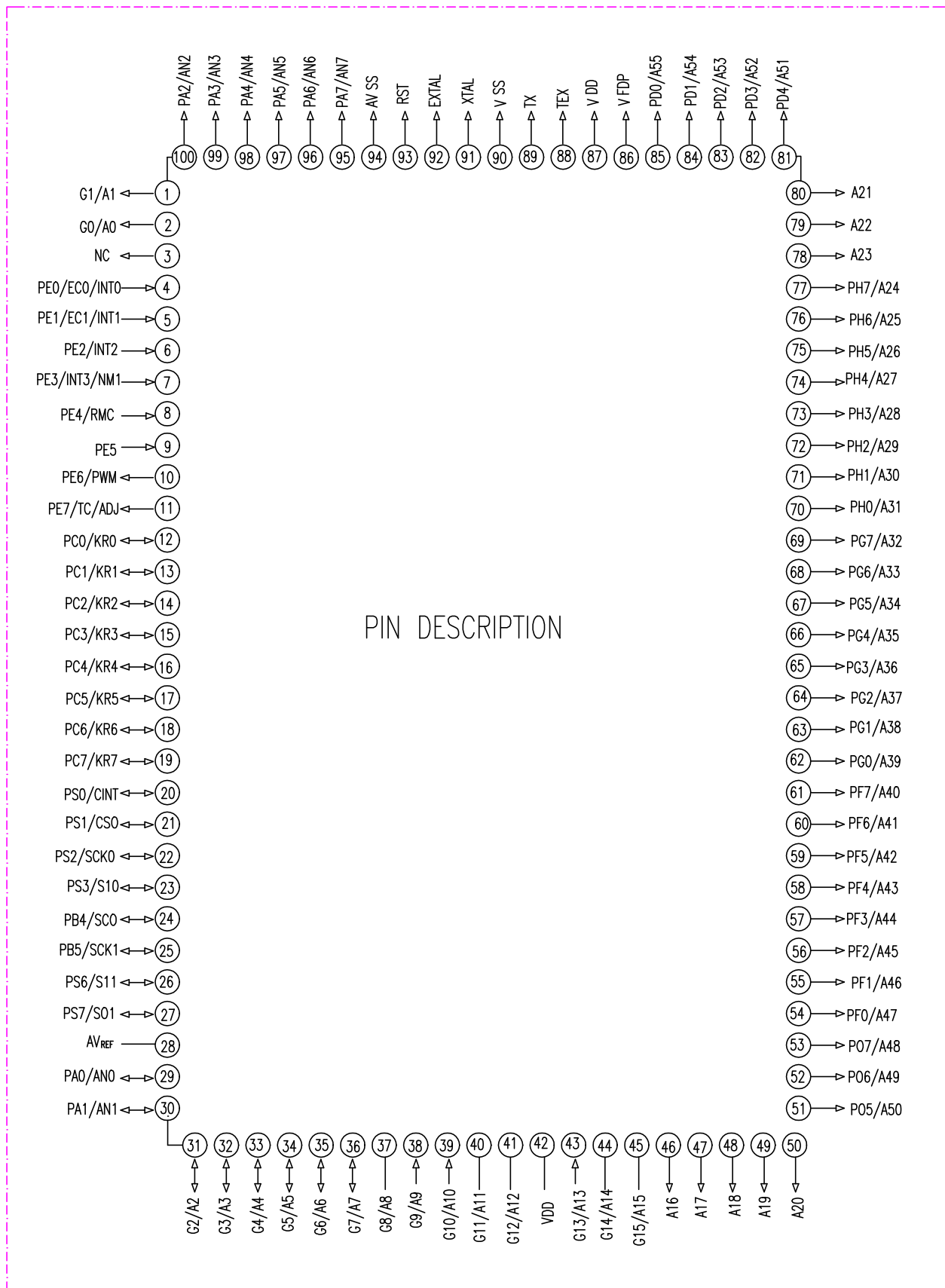

## AC-3/DTS RDS RECEIVER CPU PIN CONFIGURATION

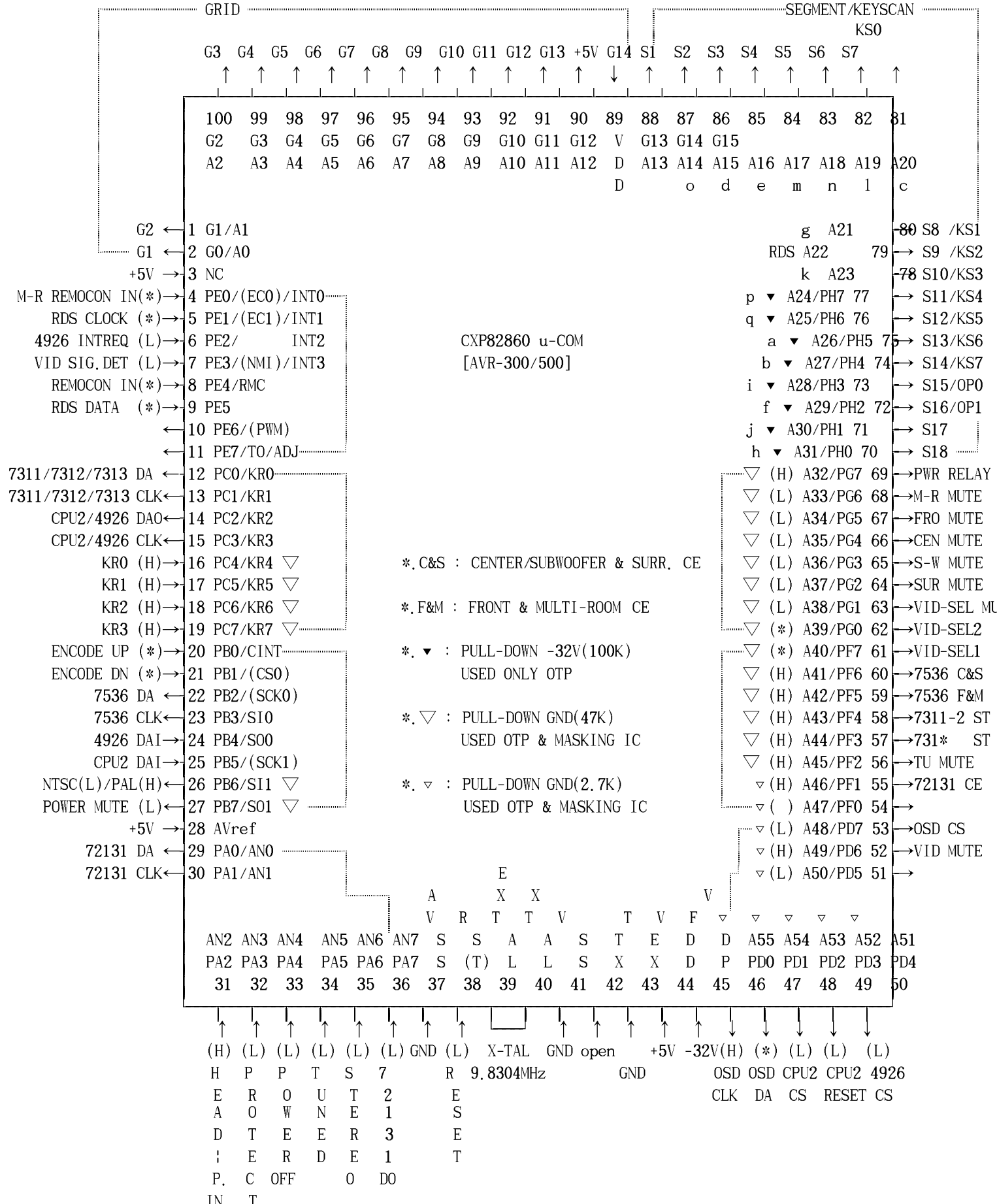

DOLBY CFG2(H), MEM ADDRESS-18/17/16, IN/OUT MUX CONTROL : CPU2(DSP BOARD u-COM)

## 1. KEY MATRIX

	KS0 (81)	KS1 (80)	KS2 (79)	KS3 (78)	KS4 (77)	KS5 (76)	KS6 (75)	KS7 (74)
KR0 (16)	0. TAPE	4. CD	8. DVD	C. VID1	10. VID2	14. VID3	18. 6CHANNEL	1C. AM/FM
KR1 (17)	TUNING 1. -DOWN	TUNING 5. -UP	PRESET 9. SCAN	PRESET D. -DOWN	PRESET 11. -UP	(RDS) 15. TUN. MODE	DOLBY 19. DIGITAL	DOLBY 1D. PROLOGIC
KR2 (18)	DOLBY 2. 3 STEREO	(300:HALL1) 6. VMAx	(300:HALL2) A. LOGIC7 CM	E. THEATER	12. DTS	SURR. 16. OFF	1A. MUTE	1E.
KR3 (19)	3. SPEAKER	MULTI- 7. ROOM	DIG. B. SELECT	F. DELAY	13. DOWN	17. UP	1B. SET	1F. POWER

## 2. DEFINE OPTION

	OP0 (73)	OP1 (72)
KR0 (16)	OPTION1	OPTION5
KR1 (17)	OPTION2	
KR2 (18)	OPTION3	OPTION6
KR3 (19)	OPTION4	

1) OPTION1 : NOT USED

2) OPTION2(RDS) : LOW(OPEN) RDS FUNCTION  
HIGH(DIODE) NO RDS

3) OPTION4, OPTION3(MODEL SELECT) :

OPTION4	OPTION3	MODEL
LOW	LOW	AVR-300-120V(AC-3 & DTS & HALL1/2)
LOW	HIGH	
HIGH	LOW	AVR-500(AC-3 & DTS & VMAx & LOGIC7)
HIGH	HIGH	

4) OPTION5(BAND) : LOW(OPEN) USA 87.5~108.0 , 520 ~1720  
HIGH(DIODE) EUROPE 87.50~108.00 , 522~1611

5) OPTION6(TV MODE) : LOW(OPEN) NTSC  
HIGH(DIODE) PAL

3. 1) FACTORY INTIAL : AM/FM & PROLOGIC & PUSH POWER ON  
2) NTSC MODE : VIDEO3 & PUSH POWER ON  
3) PAL MODE : VIDEO2 & PUSH POWER ON

### 4. CS4926 PORT INITIAL

- 1) CS4926 : PIN4 WR PULL-DOWN(GND)  
PIN5 RD PULL-UP(+3.3V)

### 5. IN/OUT PORT DESCRIPTION

Pin No.	Description	IN/OUT	Active	FUNCTION
1	GRID2	OUT	H	VFD GRID OUTPUT.(+5V ~ -32V)
2	GRID1	OUT	H	
3	NC	IN	H	+5V SUPPLY.
4	M-R REMOCON INPUT	IN	*	REMOTE INPUT FROM EXTERNAL MULTI-ROOM REMOTE MODULE.
5	RDS CLOCK	IN	*	RDS CLOCK INPUT. [ONLY RDS VERSION]
6	CS4926 INTREQ	IN	L	SINGLE PULSE INPUT DURING OPTICAL/COAXIAL DIGITAL SELECTION.
7	V I D E O SIGNAL DETECT	IN	L	ACTIVE WHEN VIDEO INPUT IS DETECTED FROM VIDEO FUNCTION. (DVD/VIDEO1/VIDEO2/VIDEO3)
8	REMOCON IN	IN	*	INPUT FROM REMOTE SENSOR IN FRONT OR MULTI-ROOM REMOTE CONTROL.
9	RDS DATA	IN	*	RDS DATA INPUT. [ONLY RDS VERSION]
10	PE6	OUT	L	OPEN
11	PE7	OUT	L	
12	7311/7312/ 7313 DATA	OUT	*	CONTROL SIGNAL OUTPUT WHILE SELECTING FUNCTION OR SURROUND MODE.
13	7311/7312/ 7313 CLOCK	OUT	*	
14	CPU2/CS4926 DATA	OUT	*	CONTROL SIGNAL OF FUNCTION SELECTION, SURROUND MODE, SPEAKER MODE, CHANNEL SELECTION, DIGITAL SELECT, DELAY TIME ADJUSTMENT ETC.
15	CPU2/CS4926 CLOCK	OUT	*	
16	KR0	IN	H	HIGH PULSE INPUT WHILE ANY ONE FUNCTION FROM TAPE, CD, DVD, VIDEO1, VIDEO2, VIDEO3, 6-CHANNEL AND AM/FM KEY IS SELECTED.
17	KR1	IN	H	HIGH PULSE INPUT WHILE ANY KEY FROM TUNING-DOWN, TUNING-UP, PRESET SCAN, PRESET-DOWN, PRESET-UP, TUNING MODE(RDS), DOLBY DIGITAL AND DOLBY PROLOGIC IS SELECTED.
18	KR2	IN	H	HIGH PULSE INPUT WHILE ANY ONE KEY FROM THE DOLBY 3 STEREO, HALL1 (VM <sub>ax</sub> ), HALL2(LOGIC 7C/M), THEATER, DTS, SURR OFF AND MUTE KEY IS SELECTED.
19	KR3	IN	H	HIGH PULSE INPUT WHILE ANY ONE KEY FROM THE SPEAKER MODE, MULTI-ROOM, DIGITAL SELECT, DELAY TIME, DOWN, UP, SET AND POWER KEY IS SELECTED.
20	ENCODE UP	IN	*	PULSE INPUT WHEN MASTER VOLUME IN FRNT PANEL IS TURENED UP AND DOWN. THERE IS 90° PHASE DIFFERENCE BETWEEN ENCODER UP AND DOWN.
21	ENCODE DOWN	IN	*	
22	7536 DATA	OUT	*	CONTROL SIGNAL OUTPUT DURING TURING VOLUME.
23	7536 CLOCK	OUT	*	
24	4926 DATA INPUT	IN	*	PULSE INPUT FROM DSP IC AT OPTICAL/COAXIAL DIGITAL SELECTION.
25	CPU2 DATA INPUT	IN	*	PULSE INPUT FROM DSP BOARD CPU2(u-COM) AT OPTICAL/COAXIAL DIGITAL SELECTION.
26	NTSC/PAL SELECT	OUT	L/H	LOW AT NTSC MODE HIGH AT PAL MODE
27	POWER MUTE	OUT	L	PULSE OUTPUT WHILE FUNCTION OR SURROUND MODE IS SELECTED AT POWER-ON OR HEAD PHONE JACK IN STATUS.

Pin No.	Description	IN/OUT	Active	Function
28	AVref	IN	H	+5V SUPPLY
29	72131 DATA	OUT	*	CONTROL SIGNAL OF FREQUENCY SELECTION AT TUNER FUNCTION EXAMPLE, TUNING-UP/DOWN, PRESET-UP/DOWN, DIRECT PRESET NUMBER, AND DIRECT FREQUENCY
30	72131 CLOCK	OUT	*	
31	HEAD-PHONE INPUT	IN	H	HIGH WHILE HEAD-PHONE JACK IS INSERTED.
32	PROTECT	IN	L	LOW INPUT AT PROTECTION MODE. THIS CAN BE RESET BY POWER ON AGAIN AFTER TAKING OFF PROTECTION PROBLEMS.
33	POWER OFF	IN	L	LOW INPUT WHILE DETECTING POWER OFF
34	TUNED	IN	L	LOW INPUT WHEN STATION IS TUNED.
35	STEREO	IN	L	LOW WHEN THE TUNER RECEPTION IS STEREO.
36	72131 DO	IN	*	PULSE INPUT WHEN AUTO-TUNING MODE.
37	AVSS	IN	L	GND.
38	RESET	IN	L	LOW PULSE INPUT AT THE MOMENT OF POWER ON AND OFF. BACKUP IS ACTIVATED ONLY WHEN THIS PORT IS HIGH AT POWER OFF ("POWER OFF" PORT IS LOW).
39	EXTAL	IN	*	u-COM X-TAL INPUT. (9.8304MHz)
40	XTAL	IN	*	
41	VSS	IN	L	GND.
42	TX	IN	open	OPEN
43	TEX	IN	L	GND.
44	VDD	IN	H	+5V POWER SUPPLY. BACKUP IS ACTIVATED WHEN THIS PORT IS HIGH AT POWER OFF (POWER OFF PORT IS LOW).
45	VFDP	IN	-32V	-32V POWER SUPPLY TO VFD
46	MB90089 OSD CLOCK	OUT	*	OSD CONTROL SIGNAL OUTPUT
47	MB90089 OSD DATA	OUT	*	
48	CPU2 CS	OUT	L	LOW PULE OUT WHILE ANY ONE FROM POWER, FUNCTION, SURROUND MODE, SPEAKER MODE, CHANNEL, DIGITAL SELECT AND DELAY TIME IS SELECTED. IT IS CHIP SELECTION PORT OF CPU2(DSP BOARD u-COM)
49	CPU2 RESET	OUT	L	LOW PULE OUTPUT AT POWER ON.
50	CS4926 CS	OUT	L	LOW PULE OUT WHILE ANY ONE FROM POWER, FUNCTION, SURROUND MODE, SPEAKER MODE, CHANNEL, DIGITAL SELECT AND DELAY TIME IS SELECTED. IT IS CHIP SELECTION PORT OF CS4926(DSP)
51	PD5	OUT	L	OPEN
52	VID MUTE	OUT	H	KEEP HIGH LEVEL FOR 4 SECONDS AT POWER-ON.
53	OSD CS	OUT	L	CONTROL SIGNAL OUTPUT FOR OSD IC.
54	PF0	OUT	L	OPEN
55	72131 CE	OUT	H	CONTROL SIGNAL OUTPUT WHILE THE FREQUENCY IS CHANGED AT TUNER FUNCTION. IT IS CHIP ENABLE PORT CONTROL OF LC72131

Pin No.	Description	IN/OUT	Active	Function
56	TUNER MUTE	OUT	H	HIGH PULSE OUT WHILE THE FREQUENCY IS CHANGED AT TUNER FUNCTION.
57	731* ST	OUT	H	STROBE(ENABLE) TO 7311-1, 7312, 7313
58	7311-2 ST	OUT	H	STROBE(ENABLE) TO 7311-2
59	7536 F&M	OUT	H	CHIP ENABLE OF FRONT L/R, MULTI-ROOM L/R VOLUME. HIGH PULSE OUTPUT AT VOLUME ADJUSTMENT.
60	7536 C&S	OUT	H	CHIP ENABLE OF CENTER, SUBWOOFER, SURROUND L/R VOLUME. WHEN CONTROL THE VOLUME, IT WILL BE HIGH PULSE OUTPUT.
61	VID-SEL1	OUT	H/L	SEL2 SEL1 VIDEO FUNCTION LOW LOW VIDEO3 LOW HIGH VIDEO2 HIGH LOW DVD HIGH HIGH VIDEO1
62	VID-SEL2	OUT	H/L	
63	VID-SEL MU	OUT	L	LOW PULSE OUT AT SELECTING VIDEO FUNCTION.
64	SURROUND MUTE	OUT	L	LOW PULSE OUT AT SELECTING POWER, FUNCTION, SURROUND MODE, SPEAKER MODE AND DIGITAL SELECT. BUT LOW OUTPUT AT SELECTING SURROUND SPEAKER MODE "NONE".
65	SUBWOOFER MUTE	OUT	L	LOW PULSE OUT AT SELECTING POWER, FUNCTION, SURROUND MODE, SPEAKER MODE AND DIGITAL SELECT. BUT LOW OUTPUT AT SELECTING SUB-WOOFER MODE "OFF".
66	CENTER MUTE	OUT	L	LOW PULSE OUT AT SELECTING POWER, FUNCTION, SURROUND MODE, SPEAKER MODE AND DIGITAL SELECT. BUT LOW OUTPUT AT SELECTING CENTER SPEAKER MODE "NONE".
67	FRONT MUTE	OUT	L	LOW PULSE OUT AT SELECTING POWER, FUNCTION, SURROUND MODE, SPEAKER MODE AND DIGITAL SELECT. BUT LOW OUTPUT AT MUTE OR VOLUME LEVEL IS -64dB.
68	MULTI-ROOM MUTE	OUT	L	LOW PULSE OUT AT SELECTING MULTI-ROOM ON/OFF, MULTI-ROOM FUNCTION. BUT LOW OUTPUT AT MULTI-ROOM OR MULTI-ROOM LEVEL IS -64dB.
69	POWER RELAY	OUT	H	HIGH OUTPUT AT STANDBY POWER SWITCH ON.
70	SEG18	OUT	H	PULSE OUTPUT FOR VFD SEGMENT. (+5V ~ -32V)
71	SEG17	OUT	H	
72	SEG16/ OPTION1	OUT	H	HIGH PULSE OUT FOR CHECKING SYSTEM OPTION AT POWER ON, AND HIGH PULSE FOR VFD SEGMENT. (+5V ~ -32V)
73	SEG15/ OPTION0	OUT	H	
74	SEG14/KS7	OUT	H	PULSE OUTPUT FOR KEY SCAN AND VFD SEGMENT. (+5V ~ -32V)
75	SEG13/KS6	OUT	H	
76	SEG12/KS5	OUT	H	
77	SEG11/KS4	OUT	H	
78	SEG10/KS3	OUT	H	
79	SEG9/KS2	OUT	H	
80	SEG8/KS1	OUT	H	
81	SEG7/KS0	OUT	H	
82	SEG6	OUT	H	PULSE OUTPUT FOR VFD SEGMENT. ( +5V ~ -32V)
83	SEG5	OUT	H	
84	SEG4	OUT	H	

Pin No.	Description	IN/OUT	Active	Function
85	SEG3	OUT	H	PULSE OUTPUT FOR VFD SEGMENT. (+5V ~ -32V)
86	SEG2	OUT	H	
87	SEG1	OUT	H	
88	GRID14	OUT	H	VFD GRID SUPPLY. (+5V ~ -32V)
89	VDD	OUT	H	+5V POWER SUPPLY. HIGH OUT FOR BACKUP AT POWER OFF(POWER OFF PORT IS LOW).
90	GRID13	OUT	H	VFD GRID OUTPUT. (+5V ~ -32V)
91	GRID12	OUT	H	
92	GRID11	OUT	H	
93	GRID10	OUT	H	
94	GRID9	OUT	H	
95	GRID8	OUT	H	
96	GRID7	OUT	H	
97	GRID6	OUT	H	
98	GRID5	OUT	H	
99	GRID4	OUT	H	
100	GRID3	OUT	H	



TYPE : CM1684C

ANODE & GRID ASSIGNMENT

G1	G2	G3	G4	G5	G6	G7	G8	G9	G10	G11	G12	G13	G14
SLEEP	RDS	PTY	CT	RT	TUNED		MONO	STEREO		AUTO	MEMORY		PRESET
MUTE													
BYPASS													
DSP	DIGITAL	PRO LOGIC	3 STEREO	HALL1	HALL2	THEATER	DTS MPEG						
ANALOG	OPT.	COAX	AC-3	PCM				MULTI	NIGHT	DISPLAY	VMAx		

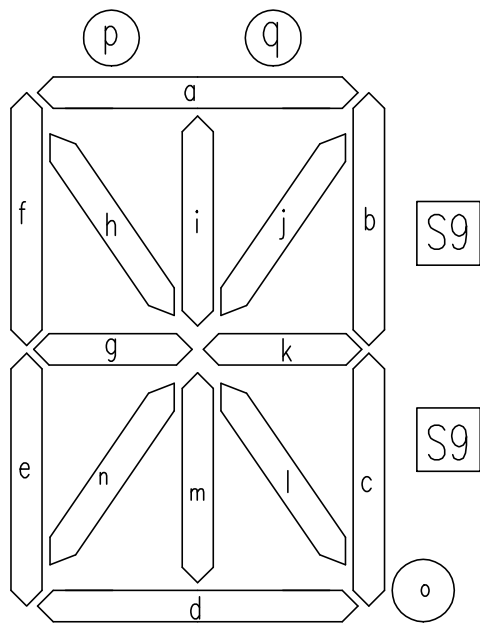

G2~G13

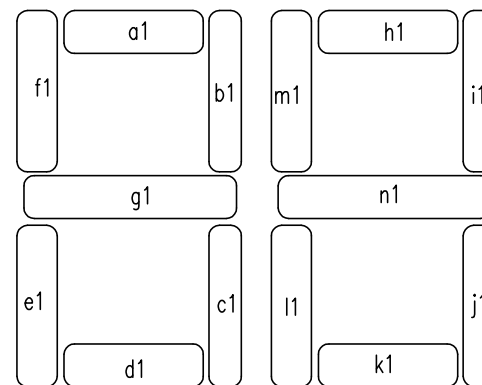

G14

TYPECM1684C  
ANODE& GRIDASIGNMENT

	G1	G2	G3	G4	G5	G6	G7	G8	G9	G10	G11	G12	G13	G14
S1	THEATER	o	o	o	o	o	o	o	o	o	o	o	o	MPEG
S2	HALL2	d	d	d	d	d	d	d	d	d	d	d	d	DTS
S3	HALL1	e	e	e	e	e	e	e	e	e	e	e	e	k1
S4	3-STEREO	m	m	m	m	m	m	m	m	m	m	m	m	d1
S5	PIO LOGIC	n	n	n	n	n	n	n	n	n	n	n	n	e1
S6	DIGITAL	i	i	i	i	i	i	i	i	i	i	i	i	c1
S7	DISPLX	c	c	c	c	c	c	c	c	c	c	c	c	l1
S8	NIGHT	g	g	g	g	g	g	g	g	g	g	g	g	J1
S9	MULTI	RDS	PTY	CT	RT	TUNED		MONO	STEREO		AUTO	MEMORY		VMAX
S10	PCM	k	k	k	k	k	k	k	k	k	k	k	k	g1
S11	SLEEP	p	p	p	p	p	p	p	p	p	p	p	p	PRESET
S12	MUTE	q	q	q	q	q	q	q	q	q	q	q	q	a1
S13	BYPASS	a	a	a	a	a	a	a	a	a	a	a	a	h1
S14	DSP	b	b	b	b	b	b	b	b	b	b	b	b	i1
S15	ALAI0G	i	i	i	i	i	i	i	i	i	i	i	i	m1
S16	OPT	f	f	f	f	f	f	f	f	f	f	f	f	f1
S17	COAX	j	j	j	j	j	j	j	j	j	j	j	j	b1
S18	AC-3	h	h	h	h	h	h	h	h	h	h	h	h	n1

PINASSIGNMENT

PinNo.	1	2	3	4	5	6	7	8	9	10	11	12	13	14	15	16	17	18	19~33	34	
Assignment	F1	F1	NP	NL	G1	G2	G3	G4	G5	G6	G7	G8	G9	G10	G11	G12	G13	G14	NL	S1	
PinNo.	35	36	37	38	39	40	41	42	43	44	45	46	47	48	49	50	51	52	53	54	55
Assignment	S2	S3	S4	S5	S6	S7	S8	G4	S10	S11	S12	S13	S14	S15	S16	S17	S18	NL	NP	F2	F2

F1,F2: Filament G1~G14: Grid S1~S18: Anode NL: No Lead NP: No Pin

AVR-300/500,UL/RDS SCHEMATIC DIAGRAM(MAIN AMP P.C.BOARD)

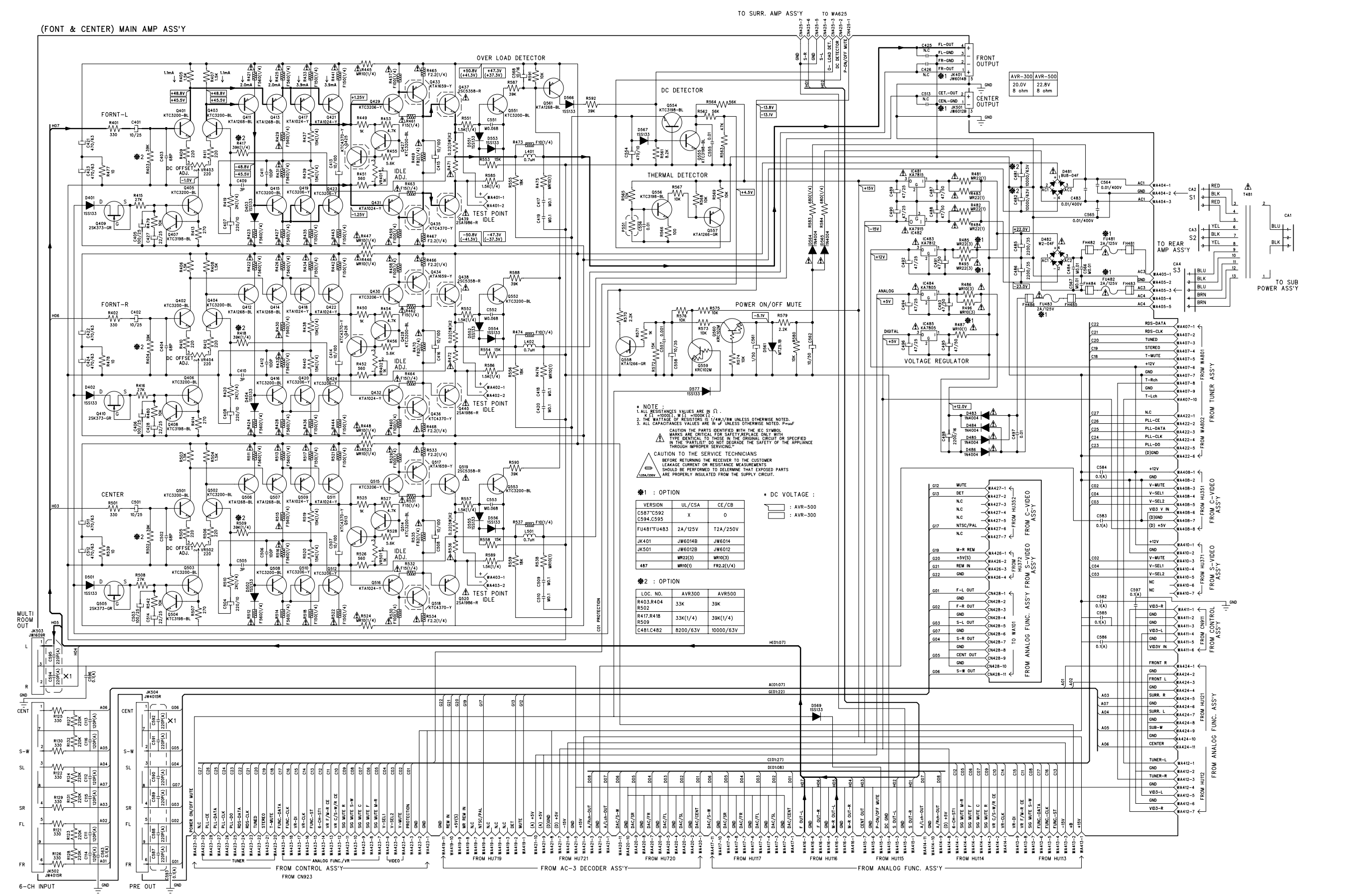

1  
2  
3  
4  
5  
6  
7

AVR-300/500,UL/RDS SCHEMATIC DIAGRAM(C-VIDEO, S-VIDEO P.C.BOARD)

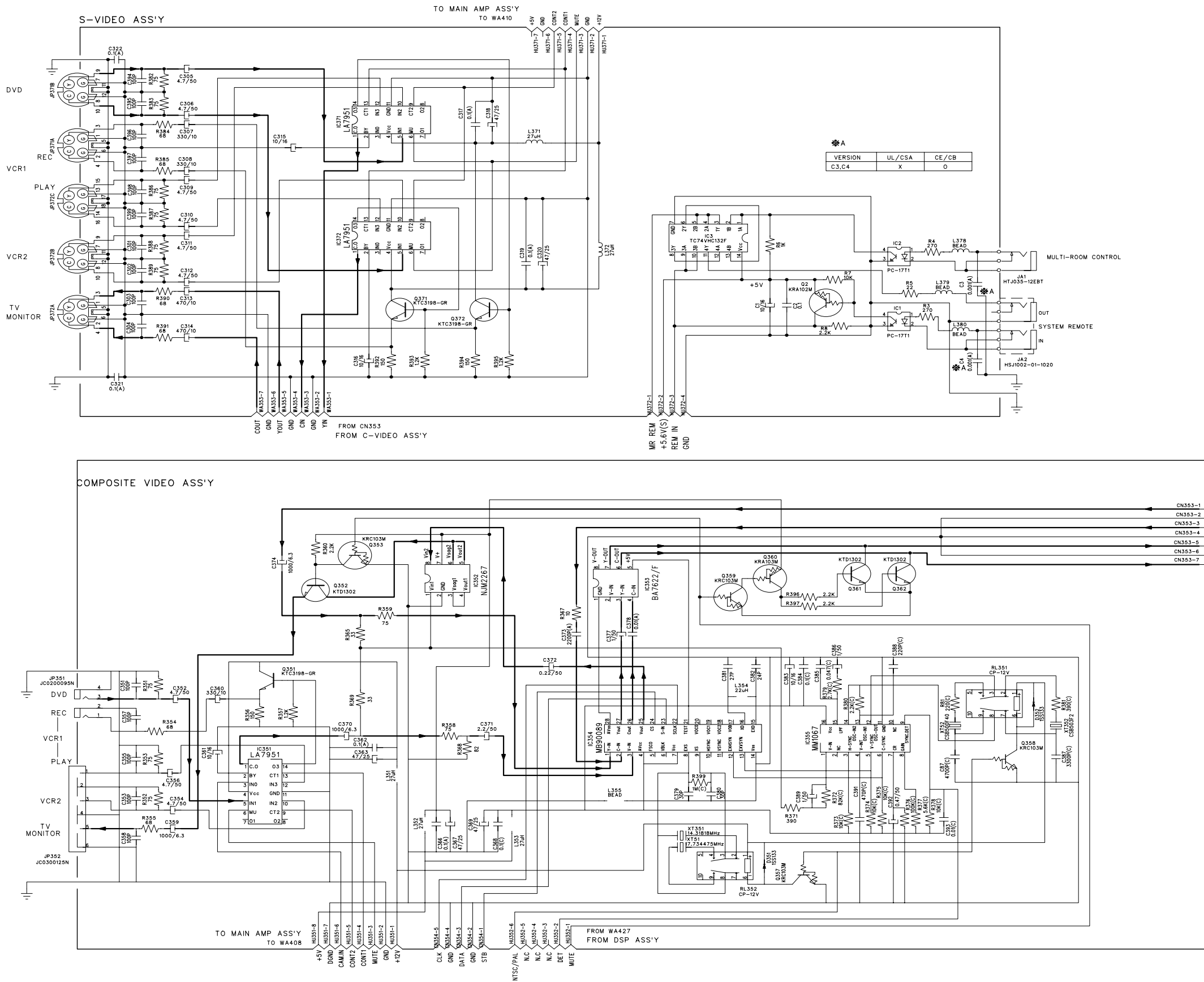

VERSION	UL/CSA	CE/CB
C3,C4	X	O

COMPOSITE & S-VIDEO

INPUT FUNCTION	CONTROL	OUTPUT
OTHER	MULTI	OFF
COMP/ORDER	L	COMP/ORDER
DVD	H	COMP/ORDER
VCR1	H	LEVEL OFF

	NTSC	PAL
XT352	CSB503F2	CSB500F40
R381	390	220
C387	3300pF	4700pF
XT351	14.31818MHz	17.734475MHz

AVR-300/500,UL/RDS SCHEMATIC DIAGRAM(REAR AMP, SUB P.C.BOARD)

REAR AMP ASS'Y

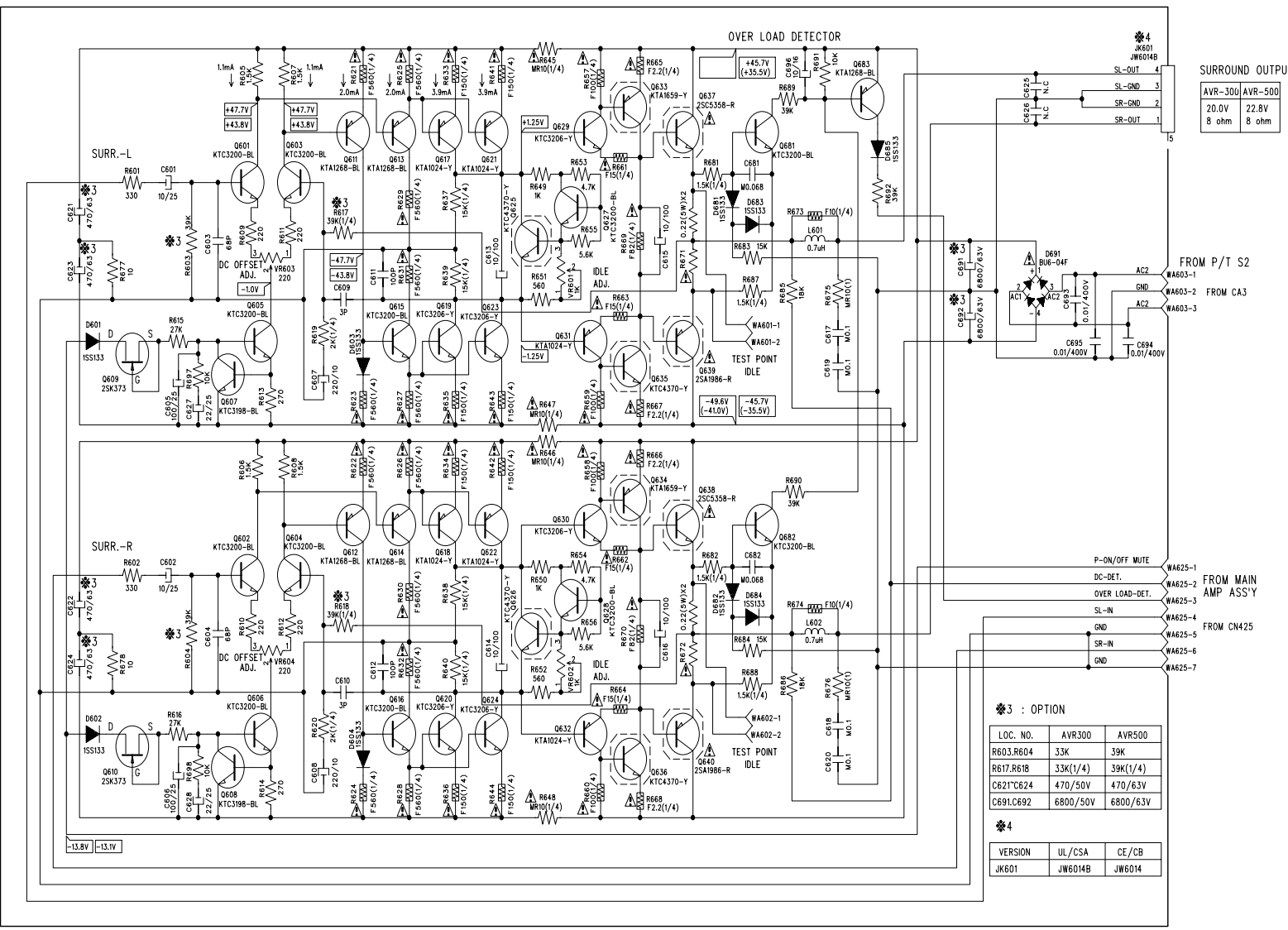

\*3 : OPTION

LOC. NO.	AVR300	AVR500
R603,R604	33K	39K
R617,R618	33K(1/4)	39K(1/4)
C621,C624	470/50V	470/63V
C691,C692	6800/50V	6800/63V

\*4

VERSION	UL/CSA	CE/CB
JW601	JW604B	JW604

SUB POWER SUPPLY ASS'Y

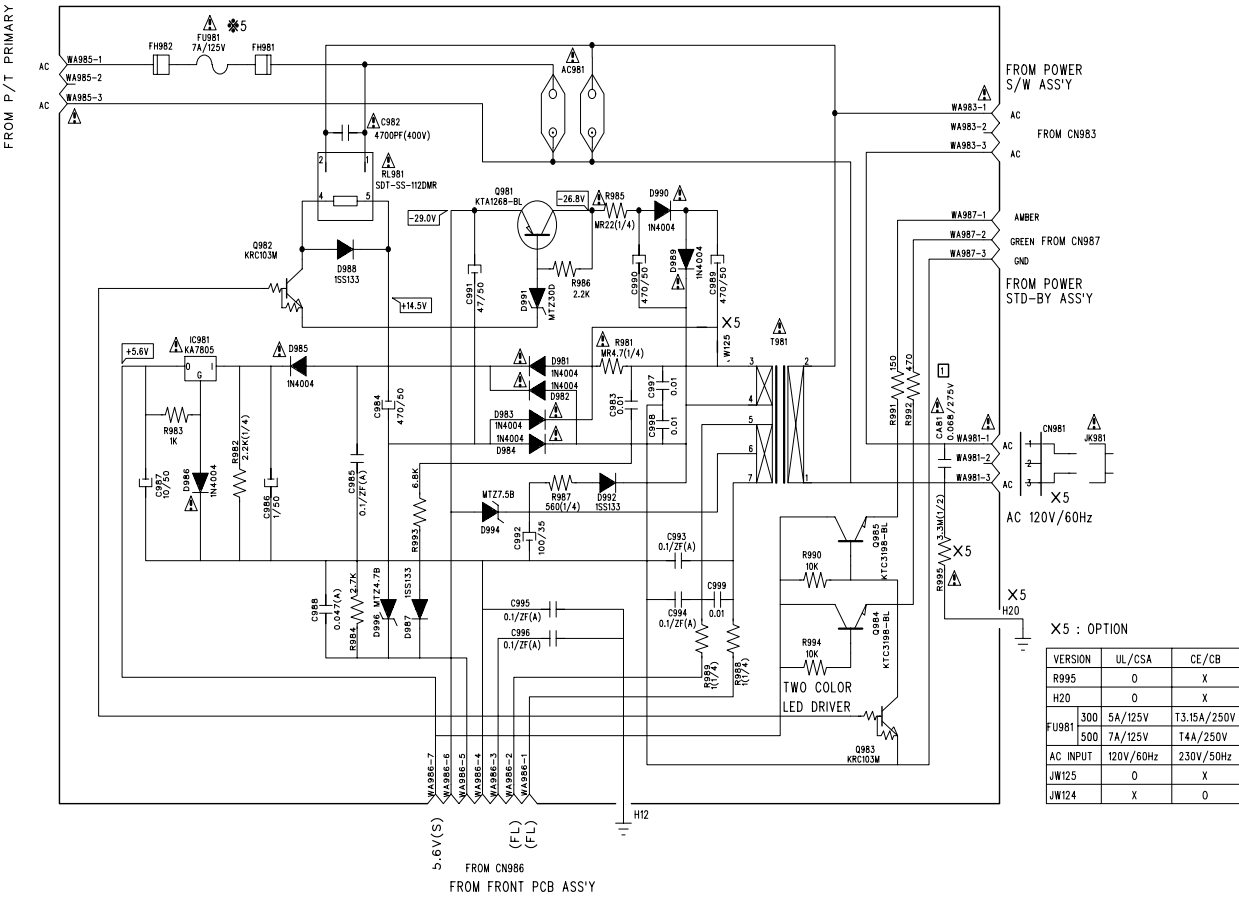

X5 : OPTION

VERSION	UL/CSA	CE/CB
R995	0	X
H20	0	X
F981	300	5A/125V
	500	7A/125V
AC INPUT	120V/60Hz	230V/50Hz
JW125	0	X
JW124	X	0

AVR-300/500,UL/RDS SCHEMATIC DIAGRAM(DSP P.C.BOARD)

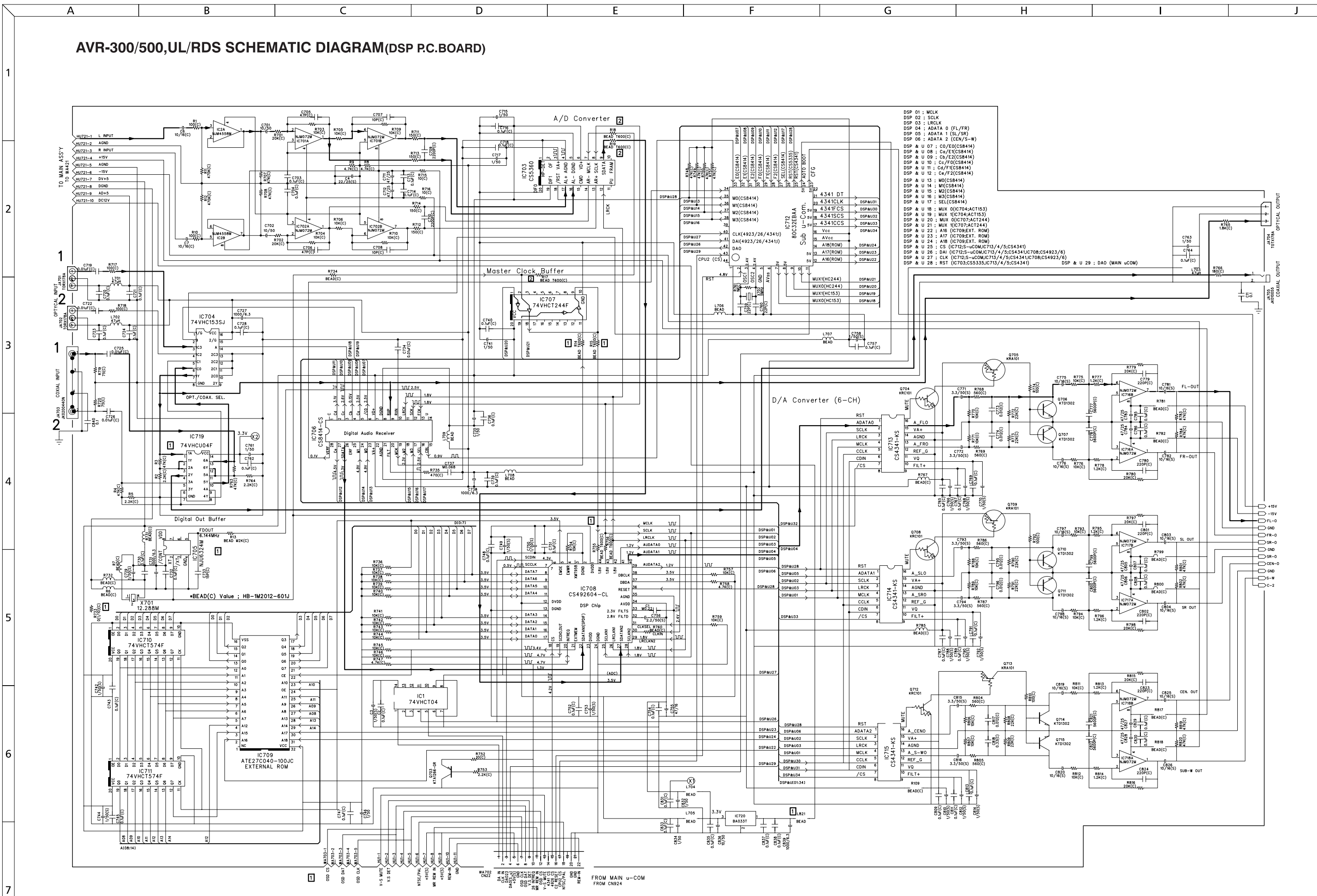

- DSP U 01 : MCLK
- DSP U 02 : SCLK
- DSP U 03 : LRCLK
- DSP U 04 : ADATA 0 (FL/FR)
- DSP U 05 : ADATA 1 (SL/SR)
- DSP U 06 : ADATA 2 (CEV/S-V)
- DSP U 07 : Co/E(CS8414)
- DSP U 08 : Co/E1(CS8414)
- DSP U 09 : Co/E2(CS8414)
- DSP U 10 : Co/F(CS8414)
- DSP U 11 : Co/F1(CS8414)
- DSP U 12 : Co/F2(CS8414)
- DSP U 13 : M0(CS8414)
- DSP U 14 : M1(CS8414)
- DSP U 15 : M2(CS8414)
- DSP U 16 : M3(CS8414)
- DSP U 17 : SEL(CS8414)
- DSP U 18 : MUX 0(IC704-ACT153)
- DSP U 19 : MUX 1(IC704-ACT153)
- DSP U 20 : MUX 0(IC707-ACT244)
- DSP U 21 : MUX 1(IC707-ACT244)
- DSP U 22 : A18 (IC709-EXT. ROM)
- DSP U 23 : A17 (IC709-EXT. ROM)
- DSP U 24 : A18 (IC709-EXT. ROM)
- DSP U 25 : CS (IC712S-uCOM,IC713/4/5;CS4341,IC708;CS4923/6)
- DSP U 26 : DA1 (IC712S-uCOM,IC713/4/5;CS4341,IC708;CS4923/6)
- DSP U 27 : CLK (IC712S-uCOM,IC713/4/5;CS4341,IC708;CS4923/6)
- DSP U 28 : RST (IC703;CS5360,IC713/4/5;CS4341)

FROM MAIN u-COM  
FROM CN94

AVR-300/500,UL/RDS SCHEMATIC DIAGRAM(AUDIO INPUT P.C.BOARD)

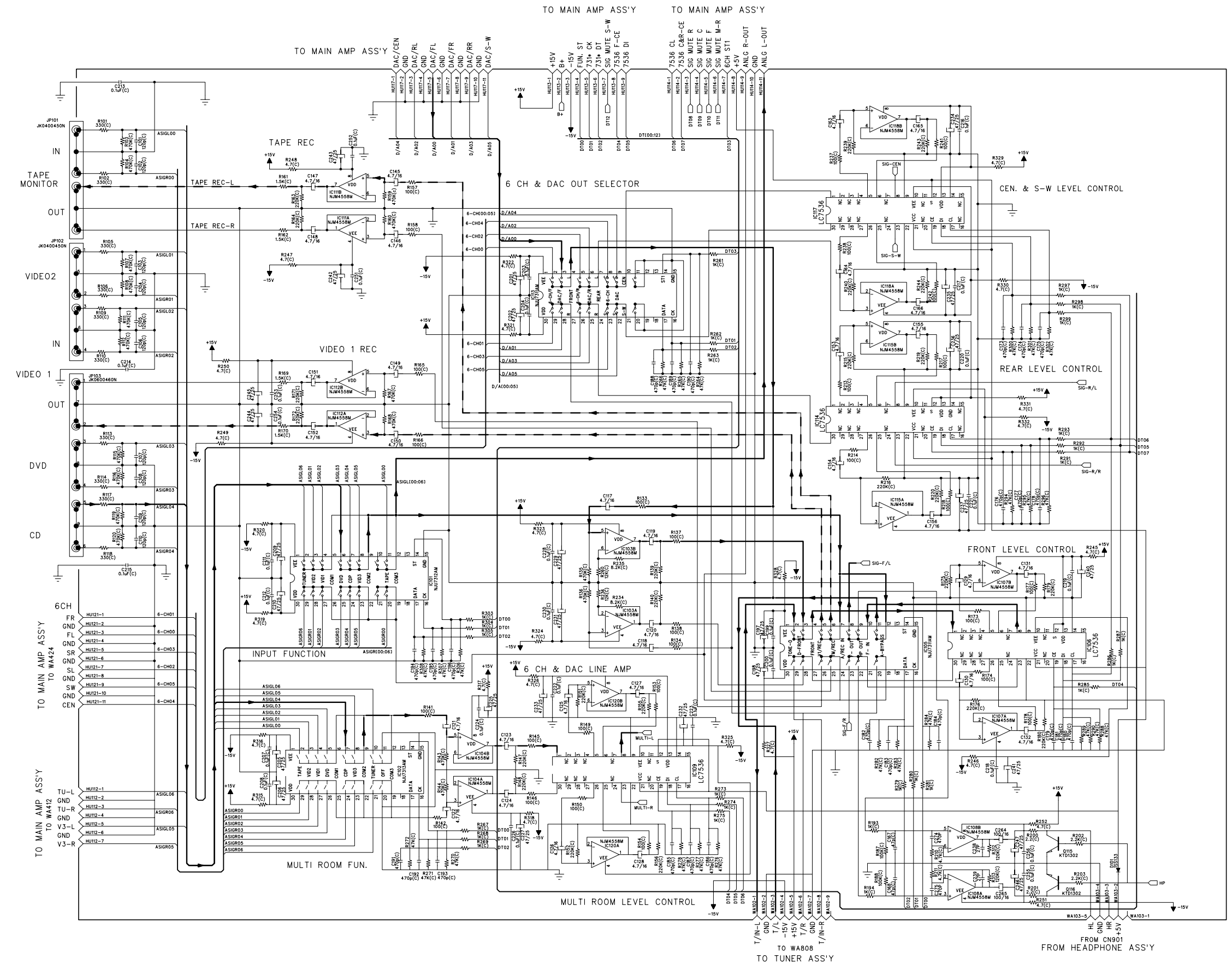

	AVR300/500(CE)	AVR300/500(UL)
C 274	470pF	×
C 275	470pF	×
C 238	27pF	×
C 239	27pF	×

# AVR-500 SCHEMATIC DIAGRAM(2)

## AUDIO INPUT ASS'Y

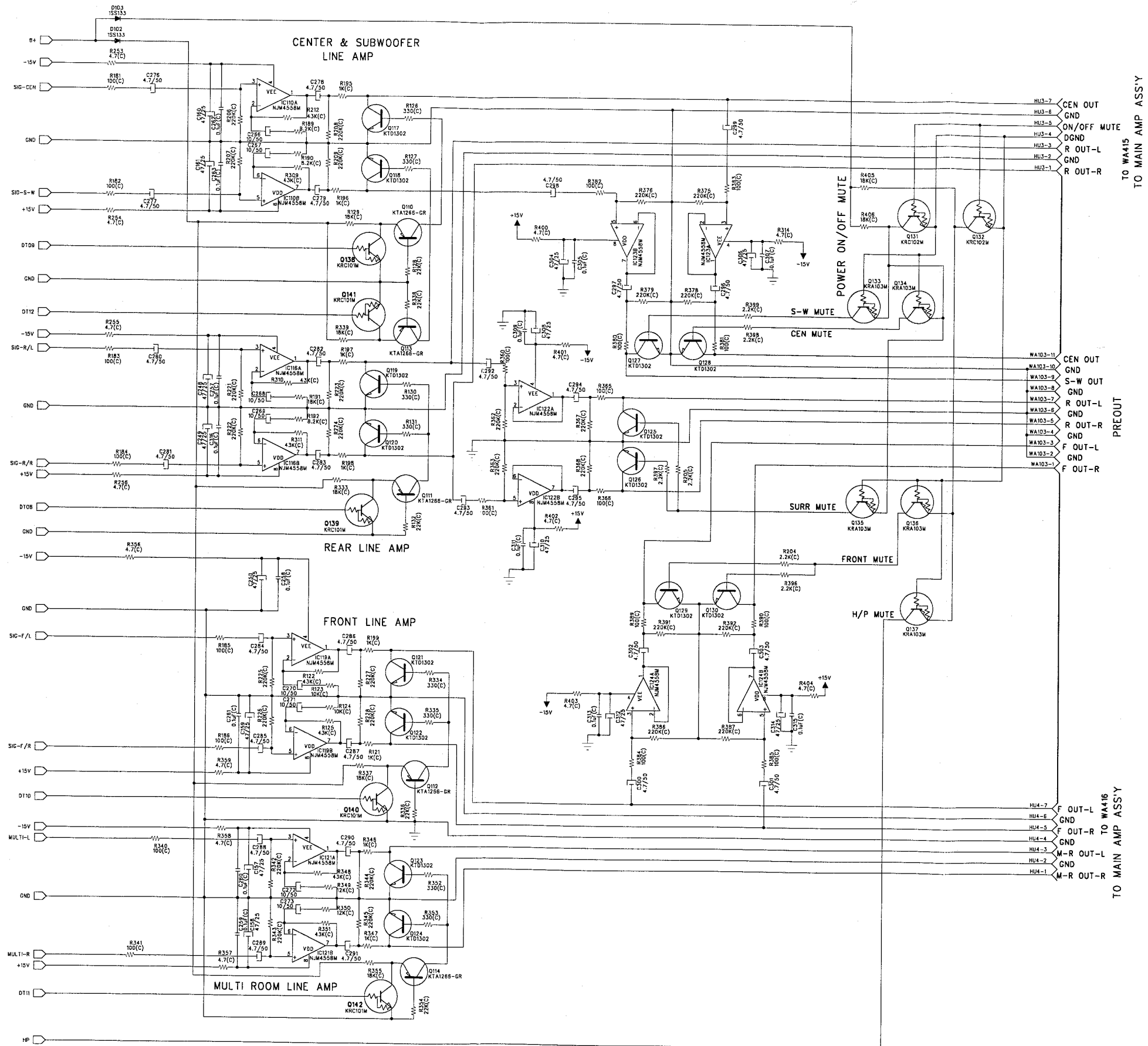



AVR-300/500,UL/RDS SCHEMATIC DIAGRAM(TUNER P.C.BOARD)

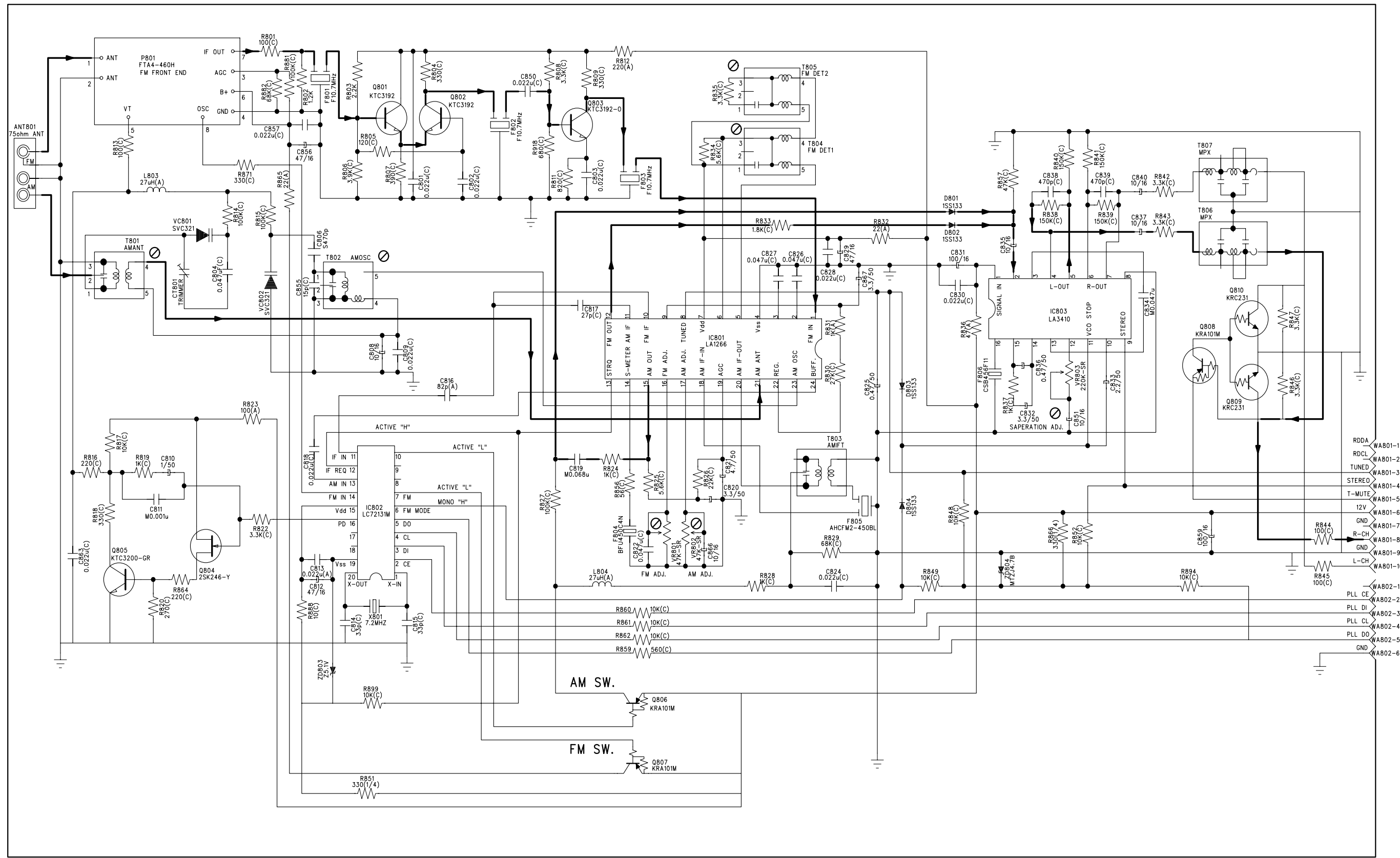

AVR-300/500,UL/RDS SCHEMATIC DIAGRAM(U-COM, FLT,FRONT P.C.BOARD)

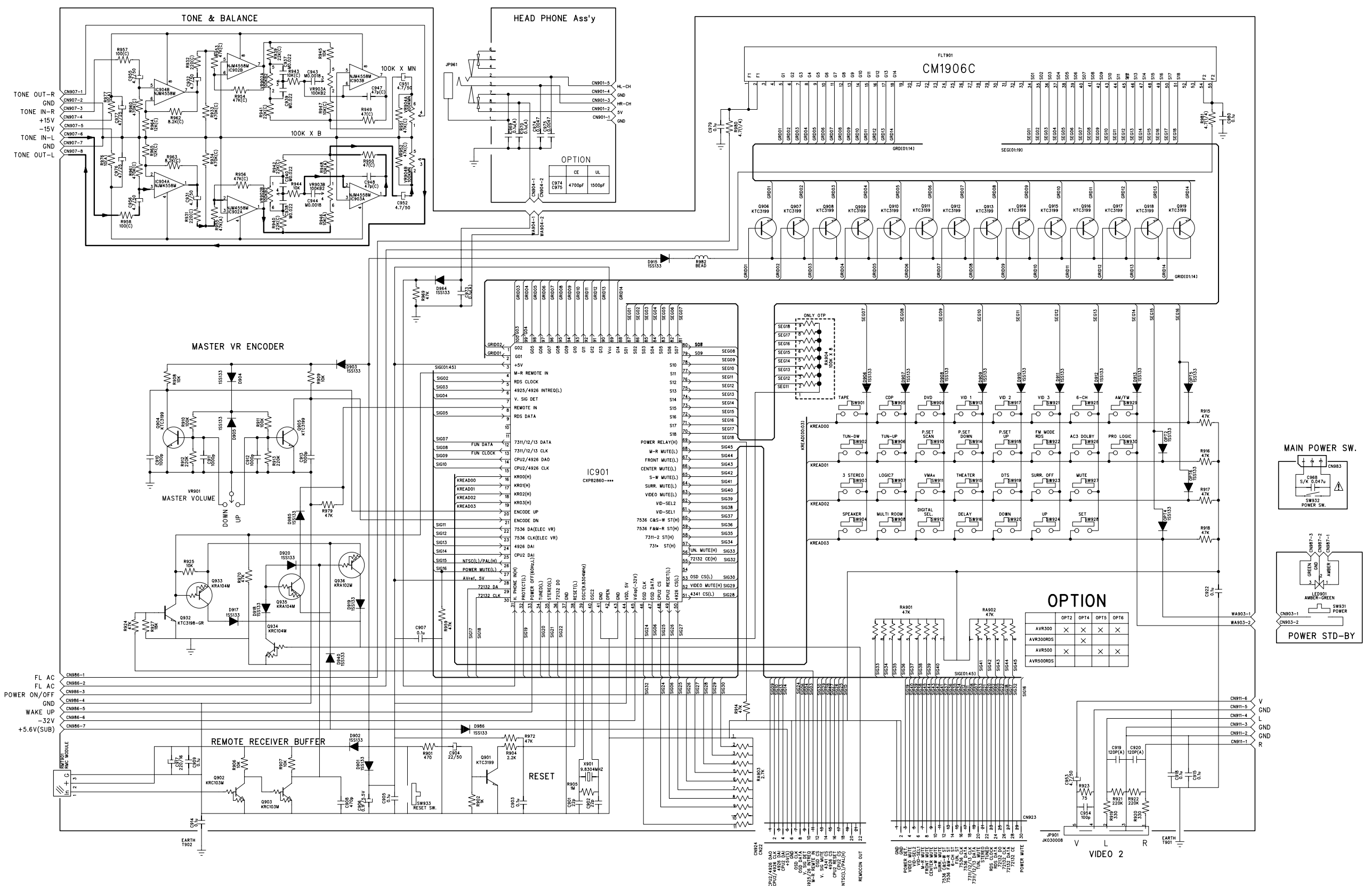

AVR-300/500,UL/RDS SCHEMATIC DIAGRAM(TUNER P.C.BOARD)

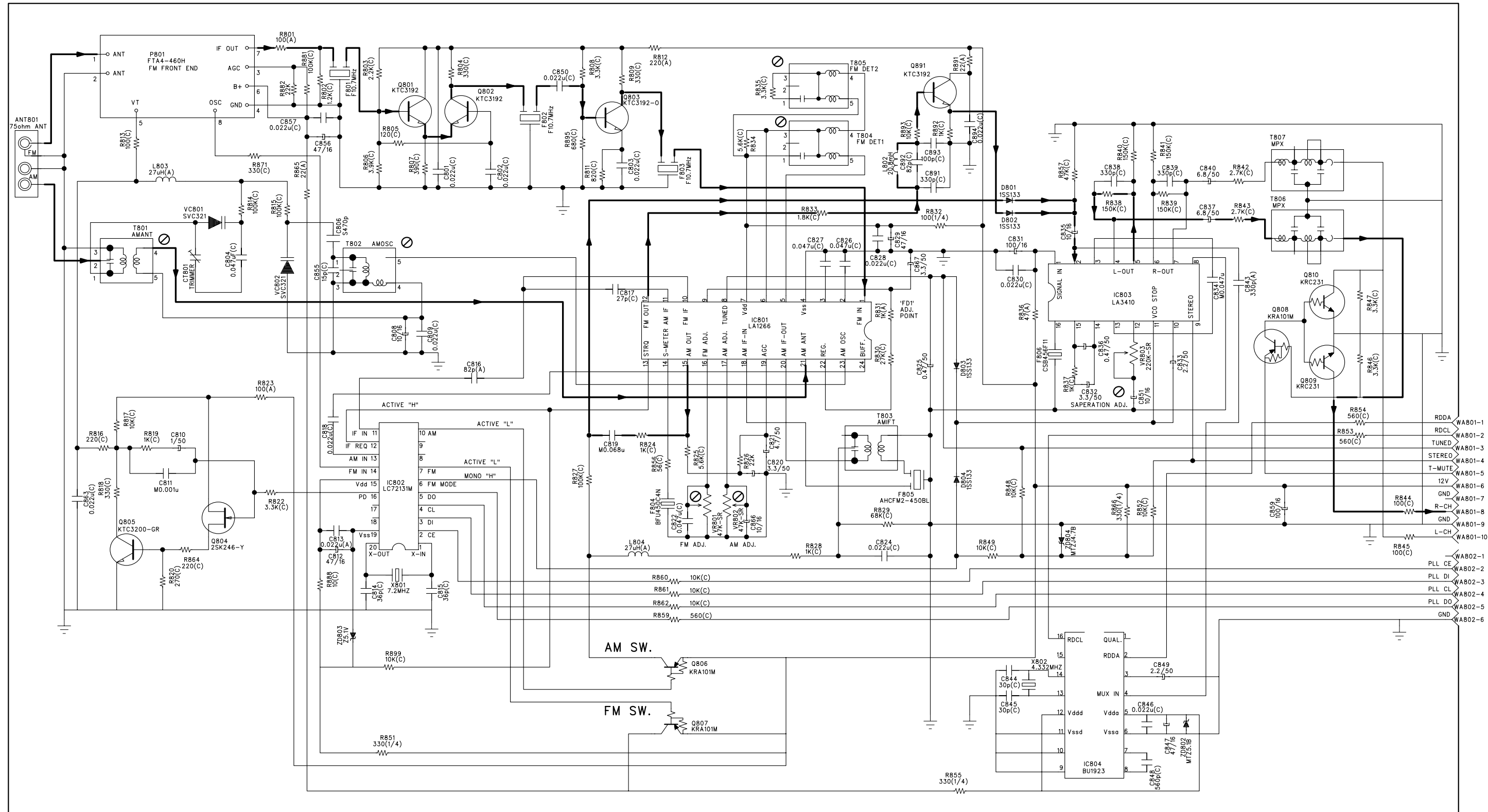

PIN CONNECTION DIAGRAM

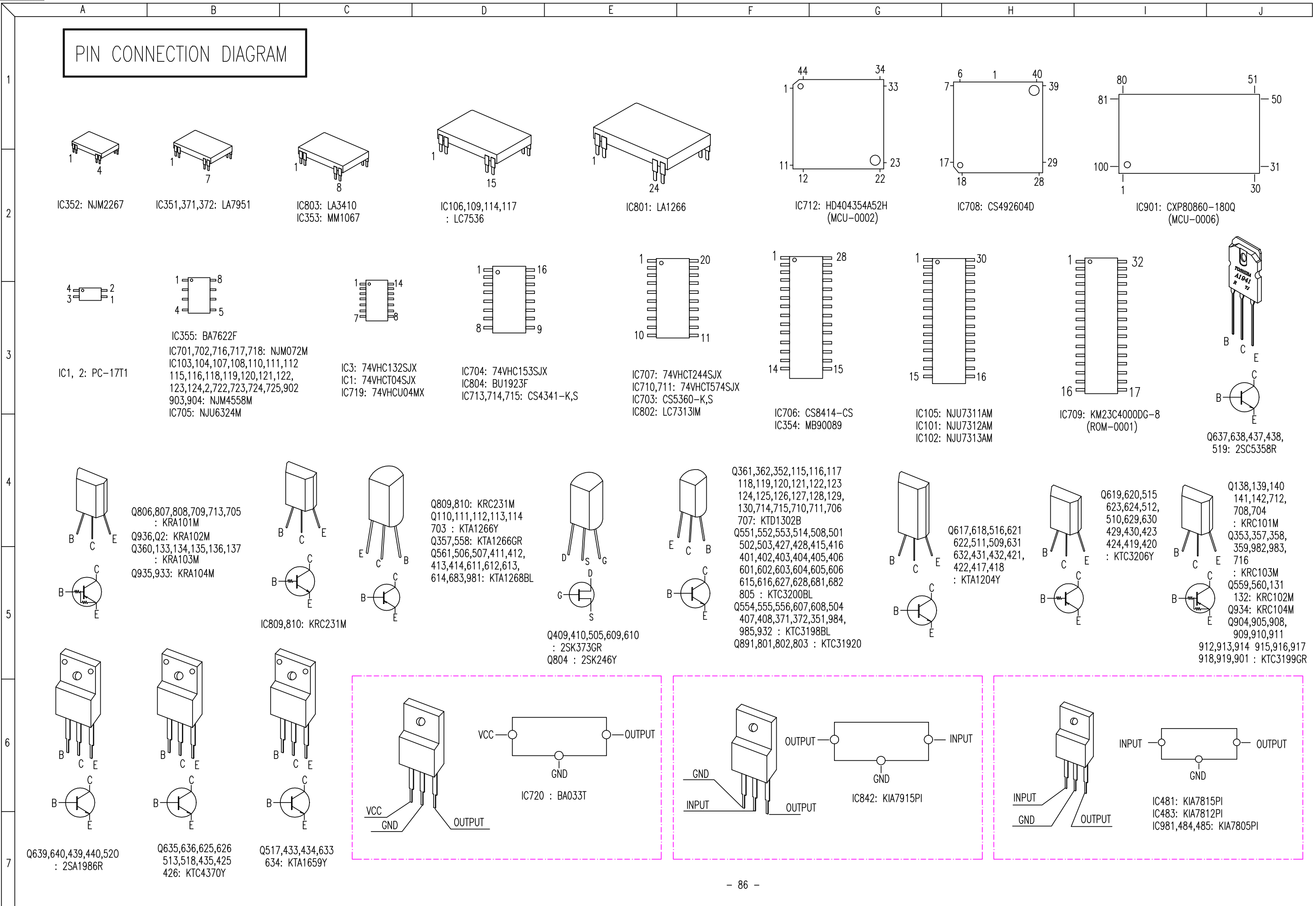

AVR-300/500,UL/RDS SCHEMATIC DIAGRAM(U-COM, FLT, FRONT P.C.BOARD)

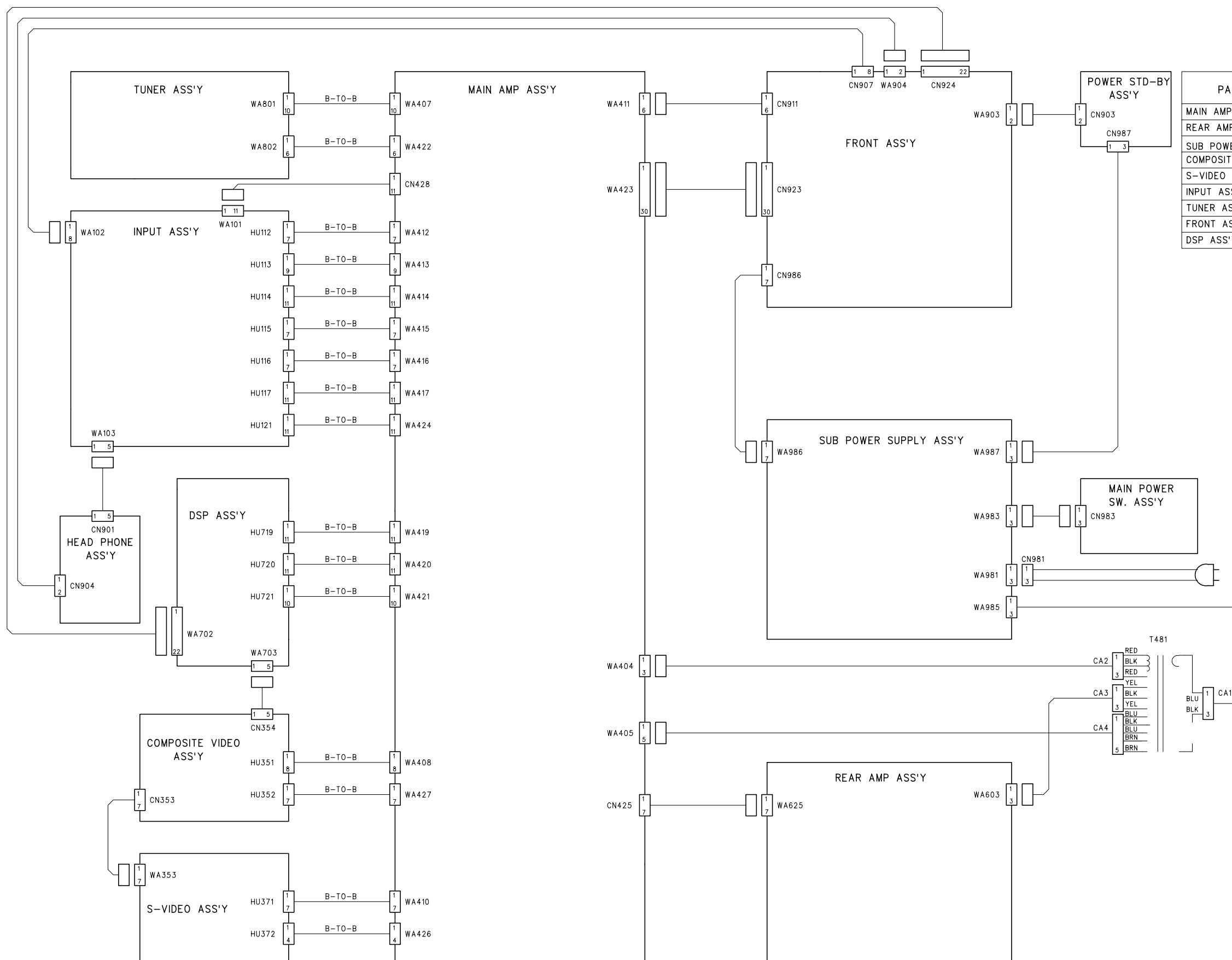

PART NAME	ASS'Y NO.			
	AVR300	AVR500	AVR300RDS	AVR500RDS
MAIN AMP ASS'Y	J1320035101X	J1320045101X	J1320035201X	J1320045201X
REAR AMP ASS'Y	J13200351021	J13200451021	J13200352021	J13200452021
SUB POWER ASS'Y	J13200351022	J13200451022	J13200352022	J13200452022
COMPOSITE VIDEO ASS'Y	J13200351023	J13200451023	J13200352023	J13200452023
S-VIDEO ASS'Y	J13200351024	J13200451024	J13200352024	J13200452024
INPUT ASS'Y	J1320035103X	J1320045103X	J1320035203X	J1320045203X
TUNER ASS'Y	J13200351041	J13200451041	J13200352041	J13200452041
FRONT ASS'Y	J13200351042	J13200451042	J13200352042	J13200452042
DSP ASS'Y	J1320035105X	J1320045105X	J1320035205X	J1320045205X

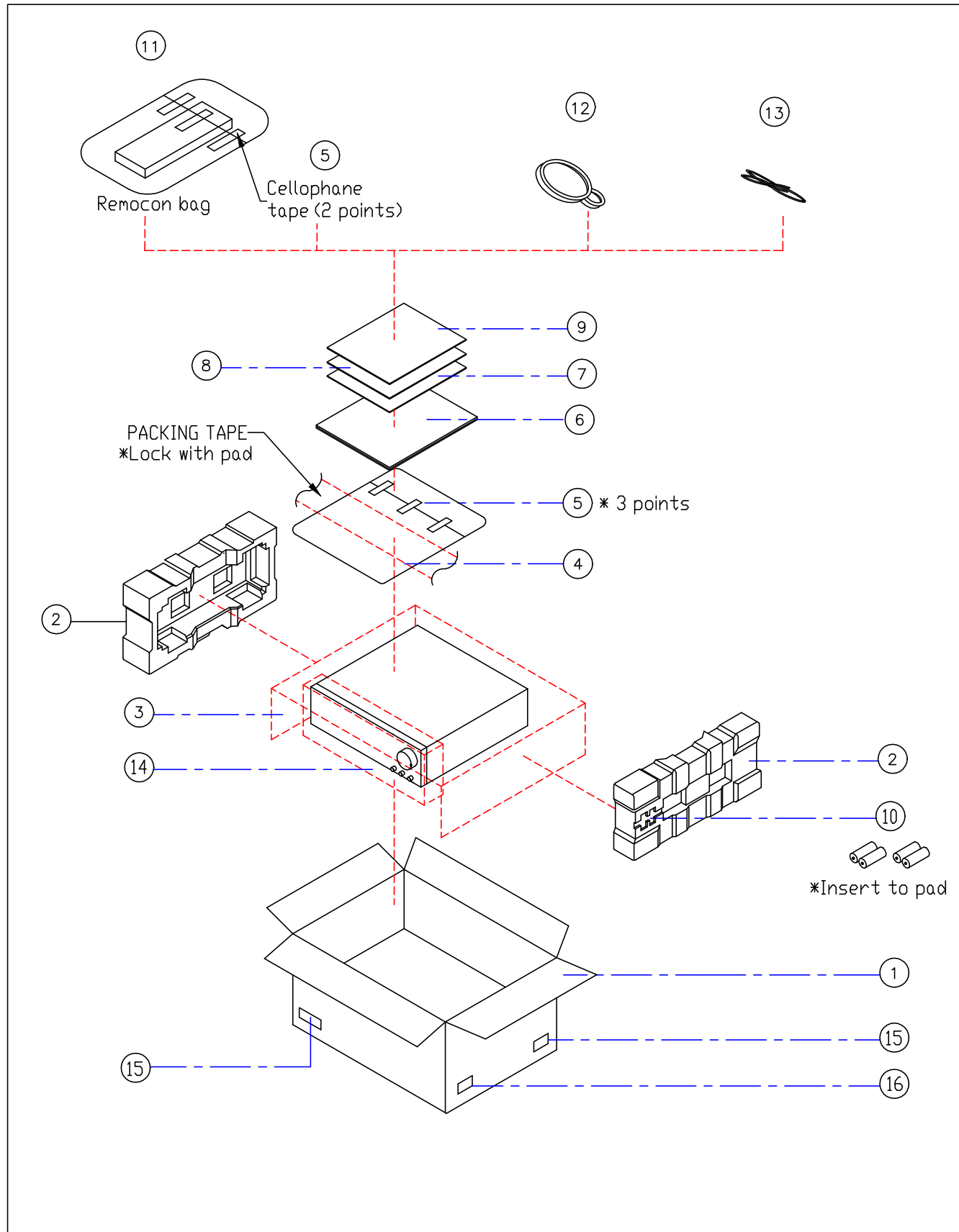

**\*PACKING PARTS LIST**

NO	PARTS NAME	PARTS NO.	MATERIAL	Q'TY	MODEL NO.
1	MASTER CARTON	J96000502000	DW-1, BROWN	1	BK
		J96000504000	DW-1, BROWN	1	IB
2	PAD. SIDE	J97300501000	PS-FM50, EPS	2	BK, IB
3	SHEET. POLY	J97000502000	PE-FDAM	1	BK, IB
4	BAG. POLY	J97000501000	PE T0.05	1	BK, IB
5	TAPE. CELLOPHANE			10cm	BK, IB
6	INSTRUCTION MANUAL	J93000502000	PAPER	1	BK
		J93000504000	PAPER	1	IB
7	CARD. WARRANTY	J97100505000	PAPER	1	BK
		J97100505000	PAPER	0	IB
8	CARD. POST	J97100506000	PAPER	1	BK
		J97100506000	PAPER	0	IB
9	CARD. SAFETYGUARD	J97100507000	PAPER	1	BK
		J97100507000	PAPER	0	IB
10	BATTERY. ASS'Y	J55100001000	AAA	2	BK, IB
11	REMOCON ASS'Y	J54000502000		1	BK
		J54000504000		1	IB
12	AM LOOP ANTENNA	J4482250031		1	BK, IB
13	ANT. FM	J4482250031		1	BK, IB
14	COVER. POLY	J97000503000	PE-FDAM	1	BK, IB
15	LABEL.BARCODE	J97100510000	PAPER	4	BK
		J97100514000	PAPER	4	IB
16	LABEL.ORIGIN	J97100508000	PAPER	1	BK, IB