

AVR 5550 Audio/Video Receiver

SERVICE MANUAL

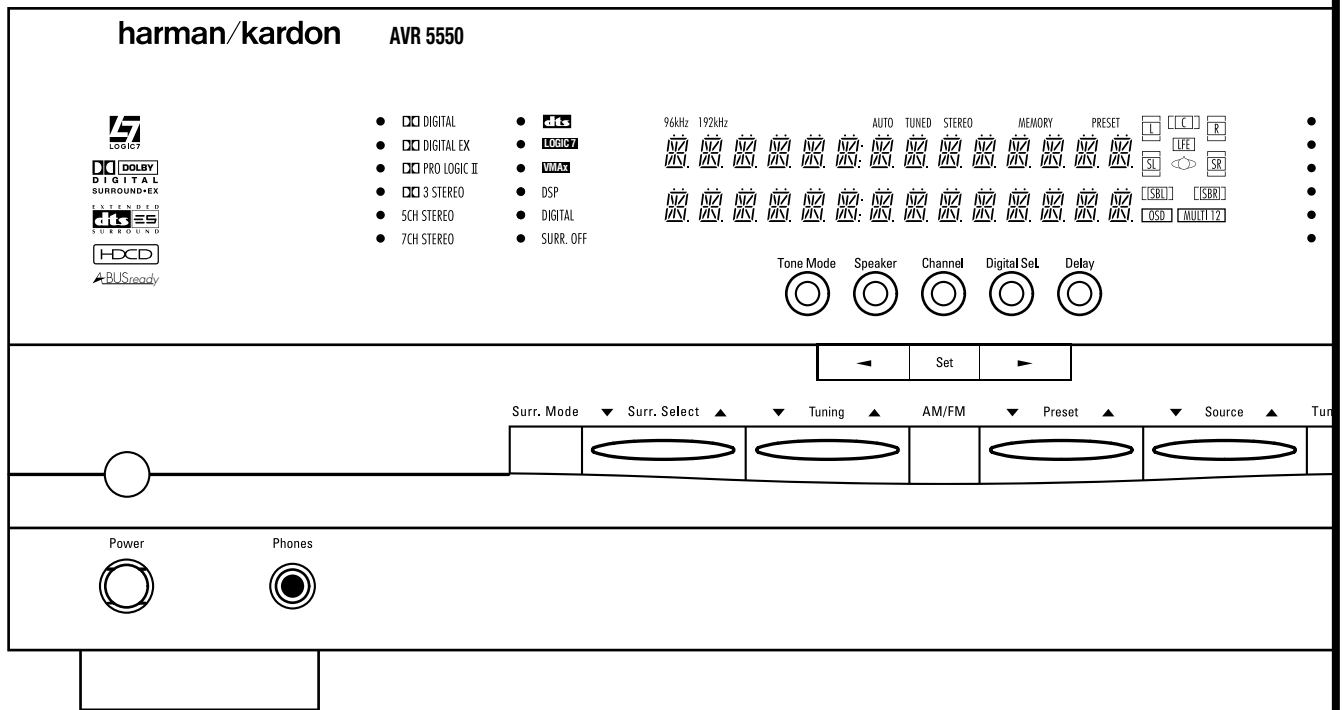

harman/kardon®

Power for the Digital Revolution™

Technical Specifications

Audio Section

Stereo Mode

Continuous Average Power (FTC)

85 Watts per channel, 20Hz–20kHz,
@ < 0.07% THD, both channels driven into 8 ohms

5/7 Channel Surround Modes

Power Per Individual Channel

Front L&R channels:
70 Watts per channel,
@ < 0.07% THD, 20Hz–20kHz into 8 ohms

Center channel:
70 Watts, @ < 0.07% THD, 20Hz–20kHz into 8 ohms

Surround (L & R Side, L & R Back) channels:
70 Watts per channel,
@ < 0.07% THD, 20Hz–20kHz into 8 ohms

Input Sensitivity/Impedance

Linear (High Level) 200mV/47kohms

Signal-to-Noise Ratio (IHF-A) 95dB

Surround System Adjacent Channel Separation

Analog Decoding 40dB
(Pro Logic, etc.)

Dolby Digital (AC-3) 55dB
DTS 55dB

Frequency Response

@ 1W (+0dB, -3dB) 10Hz– 100kHz

High Instantaneous

Current Capability (HCC) ±45 Amps

Transient Intermodulation

Distortion (TIM) Unmeasurable

Rise Time 16 µsec

Slew Rate 40V/µsec**

FM Tuner Section

Frequency Range	87.5–108MHz
Usable Sensitivity	IHF 1.3 µV/13.2dBf
Signal-to-Noise Ratio	Mono/Stereo: 70/65dB (DIN)
Distortion	Mono/Stereo: 0.15/0.3%
Stereo Separation	35dB @ 1kHz
Selectivity	±300kHz: 65dB
Image Rejection	80dB
IF Rejection	90dB

AM Tuner Section

Frequency Range	522–1611kHz
Signal-to-Noise Ratio	45dB
Usable Sensitivity	Loop: 500µV
Distortion	1kHz, 50% Mod: 0.8%
Selectivity	±9kHz: 30dB

Video Section

Video Format	PAL/NTSC
Input Level/Impedance	1Vp-p/75 ohms
Output Level/Impedance	1Vp-p/75 ohms
Video Frequency Response (Composite and S-Video)	10Hz–8MHz (-3dB)
Video Frequency Response (Component)	10Hz-35MHz (-3dB)

General

Power Requirement	AC 220-240V/50Hz
Power Consumption	120W idle, 1040W maximum (7 channels driven)

Dimensions (Max)

Width	440mm
Height	165mm
Depth	435mm
Weight	20 kg

Depth measurement includes knobs, buttons and terminal connections.

Height measurement includes feet and chassis.

All features and specifications are subject to change without notice.

Harman Kardon is a registered trademark, and Power for the digital revolution is a trademark, of Harman International Industries, Inc.

|||EzSet™ is a trademark of Harman International Industries, Inc. (Patent No. 5,386,478).

*Manufactured under license from Dolby Laboratories.

"Dolby," "Pro Logic," "Pro Logic II" and the Double-D symbol are trademarks of Dolby Laboratories. Confidential Unpublished Works. ©1992–1999 Dolby Laboratories, Inc. All rights reserved.

DTS and DTS Surround, DTS-ES and DTS Neo:6 are trademarks of Digital Theater Systems, Inc.

UltraStereo is a trademark of UltraStereo Corp.

VMAx is a trademark of Harman International Industries, Inc., and is an implementation of Cooper Bauck Transaural Stereo under patent license.

Logic 7 is a registered trademark of Harman International Industries, Incorporated.

Crystal is a registered trademark of Cirrus Logic Corp.

HDCD is a registered trademark of Pacific Microsonics, Inc.

A-BUS and A-BUS Ready are registered trademarks of Leisure Tech Electronics Pty Ltd Australia.

**Without input anti slewing and output isolation networks.

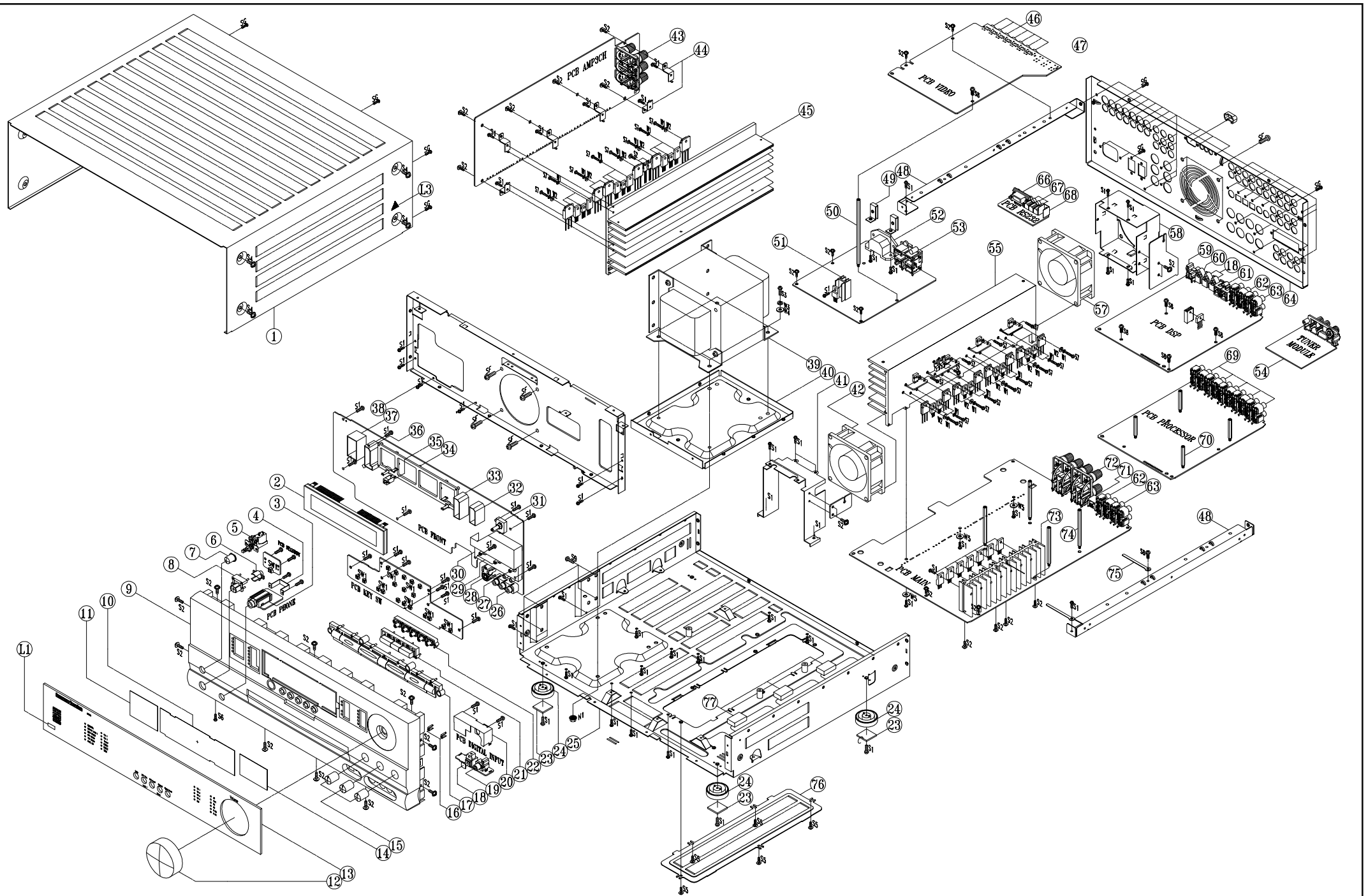

APPROVAL	CHECK	DRAWING	DESIGN	MODEL	AVR325	PARTS NAME	EXPLODED VIEW
02.05.22			02.05.22		TOLERANCE		
				NONE	LESS:±	PARTS	
				SCALE	LESS:±	NO.	
				UNIT	LESS:±	DWG.	

Part list Exploded view AVR5550

1/2

#	Part Number	Q'ty	Description
1	55178050	1	AC PUN COVER TOP
2	55142780	1	DISPLAY HNA-15LL01
3	XXX	1	CONN-PHJAC 6.35 ST HORZ CKX3-6.35-04 BK 0 0
4	55124350	1	AC PUN BRACKET HEADPHONE
5	55178000	1	SW PUSH POWER SWITCH 5.0A 250.0V 100MIOOHM 1T 2P
6	55178020	1	AC MLD BUTTON INDICATOR STAND-BY
7	55177810	1	AC DEC BUTTON POWER
8	5177820X	1	AC DEC BUTTON STANDBY
9	XXX	1	AC DEC CABINET PANEL FRONT5550
10	55177800	1	AC DEC CRYSTAL FILTER DISPLAY
11	55191560	1	AC NON-METAL DIFFUSER 0.2T 62.5*41 WH
12	55177740	1	AC DEC KNOB MAIN HIPS 94H
13	55575870	1	AC DEC CRYSTAL DISPLAY AV5550
14	55177990	1	AC NON-METAL DIFFUSER 0.2T 59.6*41 WH
15	55177750	3	AC DEC KNOB TONE
16	55178030	2	AC MLD BUTTON INDICATOR VIDEO 4
17	XXX	1	AC DEC BUTTON 7 KEY
18	55125440	3	D-LEM TOTX178B RD RND CL
19	55175950	1	CON PHONO SCKT RCA 1P W/GND JE010003MN
20	55182550	1	AC PUN SHIELD DIGITAL ET
21	XXX	1	AC DEC BUTTON 3 KEY
22	XXX	1	AC DEC BUTTON 5 KEY
23	55174760	4	AC FOOT RUBBER ROUND 3.0MM 25.0MM JIS 60 Y DIA
24	XXX	4	AC FOOT ASSY ROUND 12.5MM 50MM
25	55406540	1	AC CPL CABINET CHASSIS MAIN SECC 1.0T
26	55171510	1	CON PHONO SCKT RCA-313P 3 PINS
27	55179910	1	PR-ROT 100K0 OHM NON-LINEAR RK14K12400BQ 0 0
28	55113960	1	CON DIN SCKT SOCKET CONNECTOR SVHS EST-S408J
29	55179920	2	2 PR-ROT 100K0 OHM NON-LINEAR RK14K12400BR 0 0
30	55177570	1	AC PUN SHIELD FENCE TONE
31	55134900	1	SWIROT EC16B24204A5 5V 500U0A 10T 3P 0 0
32	55191530	1	AC PLASTIC MOLD REFRACTOR B WH
33	55178940	1	AC PLASTIC MOLD REFRACTOR E WH
34	55178440	1	AC MLD HOLDER FL-GUIDE
35	55155930	1	IC-REMOTE RPM6938-RSIP-A3 RECEIVER 38KHZ
36	55177960	1	AC NON-METAL DIFFUSER REFLECTOR C WH
37	55178930	1	AC PLASTIC MOLD REFRACTOR F WH
38	55406440	1	AC CPL CABINET CHASSIS FRONT AVR325/525
39	55589450	1	TF-LAM POWER-TRANSFORMER 230V
40	55406640	1	AC PUN COVER TRANS BOTTOM AVR325/525 --
41	55406840	1	AC PUN BRACKET FAN FRONT AVR325/525
42	55509100	1	FAN RDL8025B C185HS10H1910 (WIRE:300MM) 0 A0
43	55436090	1	CONN-SPE TERMINAL SPKR 6P SH0611708P FE 19MM 6
44	55168710	6	AC PUN BRACKET HEATSINK SECIT RT2250(PAV5005)
45	55406340	1	AC METAL HEATSINK(AMP) 3CH AVR525 --
46	55149520	7	CON DIN SCKT MIX SOCKET RCA-118JP1S
47	55436080	1	CON PHONO SCKT RCA 9P W/GND CAP JW-4109RS
48	55178170	2	AC PUN BRACKET FRAME-GUIDE SECC T1.0
49	55222020	2	AC PUN BRACKET AC INLET

Part list Exploded view AVR5550

1/2

#	Part Number	Q'ty	Description
50	55407240	1	AC METAL STANDOFF HEX MF M4X8 6MMOD 111.2H
51	55176410	1	AC METAL HEATSINK 17*15*30 AVR525 --
52	55222010	1	CON MAINS INLET A/C INLET 7014-NGP
53	55206550	1	CONN-SPE AC OUTLET 2P 110V FE 12.75MM 2 BK 0 0
54	55506060	1	EPR TUNER MODULE KST-MB114MVW1-80 AVR4550/5550 EU
55	55555910	1	AC METAL HEATSINK(MAIN) AVR525 --
56	56 BLANK	1	56 BLANK
57	55509110	1	FAN RDL8025B C185HS10H1910 (WIRE:400MM) 0 A0
58	55406940	1	AC PUN BRACKET FAN REAR AVR325/525
59	55246370	1	CON PHONO SCKT RCA 1P W/GND JE010003LN OG
60	55125440	1	D-LEM TOTX178B RD RND CL
61	55191600	1	CON PHONO SCKT RCA 2P W/GNDCAP JW-1502SN OO
62	55191420	2	CON PHONO SCKT RCA 4P JW-4104RSA
63	55191450	2	CON PHONO SCKT RCA 4P JW-4104RSC

Front board AVR5550

1/10

Pos	Tocom#	SName
C103	20267830	CE 47U0F +20% 16.0V 85C 20251640
C104	20269010	CE 47U0F +20% 50.0V 85C
C107	20268880	CE 10U0F +20% 50.0V 85C
C108	20268950	CE 100N0F +20% 50.0V 85C
C110	20269010	CE 47U0F +20% 50.0V 85C
C119	20268880	CE 10U0F +20% 50.0V 85C
C131	20267830	CE 47U0F +20% 16.0V 85C 20251640
C132	20267830	CE 47U0F +20% 16.0V 85C 20251640
C133	20267830	CE 47U0F +20% 16.0V 85C 20251640
C134	20267830	CE 47U0F +20% 16.0V 85C 20251640
C135	10364820	CPF 47N0F +10% 100.0V
C136	10364820	CPF 47N0F +10% 100.0V
C137	20267830	CE 47U0F +20% 16.0V 85C 20251640
C138	20267830	CE 47U0F +20% 16.0V 85C 20251640
C141	15002130	CE 10U0F +20% 16.0V 85C
C142	15002130	CE 10U0F +20% 16.0V 85C
C143	20268880	CE 10U0F +20% 50.0V 85C
C300	15002130	CE 10U0F +20% 16.0V 85C
C301	15002130	CE 10U0F +20% 16.0V 85C
C302	30936230	CC 100P0F +5% -5% 50.0V NP0
C303	30936230	CC 100P0F +5% -5% 50.0V NP0
C304	80434590	CC 22P0F +5% -5% 50.0V NP0
C305	80434590	CC 22P0F +5% -5% 50.0V NP0
C306	15002130	CE 10U0F +20% 16.0V 85C
C307	15002130	CE 10U0F +20% 16.0V 85C
C308	20267830	CE 47U0F +20% 16.0V 85C 20251640
C309	20267830	CE 47U0F +20% 16.0V 85C 20251640
C310	15002130	CE 10U0F +20% 16.0V 85C
C311	15002130	CE 10U0F +20% 16.0V 85C
C312	55179370	CPM 18N0F +5% 100.0V
C313	55179370	CPM 18N0F +5% 100.0V
C316	55179390	CPM 3N3F +5% 100.0V
C317	55179390	CPM 3N3F +5% 100.0V
C318	55179370	CPM 18N0F +5% 100.0V
C319	55179370	CPM 18N0F +5% 100.0V
Q100	55142670	TR-SLPLF MP5A06 N 500M10A
Q101	55133350	TR-SLPLF MP5A56 Y P -500M10A -300V
Q106	55133210	TR-SLPLF DTC114YSA N 100M10A
Q107	55133210	TR-SLPLF DTC114YSA N 100M10A
Q108	55133210	TR-SLPLF DTC114YSA N 100M10A
Q109	55133210	TR-SLPLF DTC114YSA N 100M10A
Q110	55133210	TR-SLPLF DTC114YSA N 100M10A
Q116	55179220	TR-SLPSWA KRA107M P
C100	10138420	CCCFMIC 820P0F +10% -10% 50.0V X7R
C101	10138420	CCCFMIC 820P0F +10% -10% 50.0V X7R
C102	20288040	CCCFMIC 100N0F +80% -20% 16.0V Y5V
C105	20288040	CCCFMIC 100N0F +80% -20% 16.0V Y5V
C109	20288040	CCCFMIC 100N0F +80% -20% 16.0V Y5V
C111	20506590	CCCFMIC 100P0F +5% -5% 50.0V NP0
C112	20506590	CCCFMIC 100P0F +5% -5% 50.0V NP0
C113	20506590	CCCFMIC 100P0F +5% -5% 50.0V NP0
C114	20288040	CCCFMIC 100N0F +80% -20% 16.0V Y5V
C115	20506590	CCCFMIC 100P0F +5% -5% 50.0V NP0
C116	20506590	CCCFMIC 100P0F +5% -5% 50.0V NP0
C117	20288040	CCCFMIC 100N0F +80% -20% 16.0V Y5V
C118	20288040	CCCFMIC 100N0F +80% -20% 16.0V Y5V

Front board AVR5550

2/10

Pos	Tocom#	SName
C120	20506590	CCCFMIC 100P0F +5% -5% 50.0V NP0
C121	20506590	CCCFMIC 100P0F +5% -5% 50.0V NP0
C122	20506590	CCCFMIC 100P0F +5% -5% 50.0V NP0
C123	20506590	CCCFMIC 100P0F +5% -5% 50.0V NP0
C124	20506590	CCCFMIC 100P0F +5% -5% 50.0V NP0
C125	20506590	CCCFMIC 100P0F +5% -5% 50.0V NP0
C126	20506590	CCCFMIC 100P0F +5% -5% 50.0V NP0
C127	20506590	CCCFMIC 100P0F +5% -5% 50.0V NP0
C128	20506590	CCCFMIC 100P0F +5% -5% 50.0V NP0
C129	20288040	CCCFMIC 100N0F +80% -20% 16.0V Y5V
C130	20288040	CCCFMIC 100N0F +80% -20% 16.0V Y5V
C139	20288040	CCCFMIC 100N0F +80% -20% 16.0V Y5V
C140	20288040	CCCFMIC 100N0F +80% -20% 16.0V Y5V
C144	20288040	CCCFMIC 100N0F +80% -20% 16.0V Y5V
C320	20288040	CCCFMIC 100N0F +80% -20% 16.0V Y5V
D100	20496510	D-SLP 1SS355 35.0V 225MI0A
D101	20496510	D-SLP 1SS355 35.0V 225MI0A
D102	20496510	D-SLP 1SS355 35.0V 225MI0A
D103	20496510	D-SLP 1SS355 35.0V 225MI0A
D104	20496510	D-SLP 1SS355 35.0V 225MI0A
D105	20496510	D-SLP 1SS355 35.0V 225MI0A
D106	20496510	D-SLP 1SS355 35.0V 225MI0A
D110	20496510	D-SLP 1SS355 35.0V 225MI0A
D111	20496510	D-SLP 1SS355 35.0V 225MI0A
D112	20496510	D-SLP 1SS355 35.0V 225MI0A
D113	20496510	D-SLP 1SS355 35.0V 225MI0A
D114	20496510	D-SLP 1SS355 35.0V 225MI0A
D115	20496510	D-SLP 1SS355 35.0V 225MI0A
D116	20496510	D-SLP 1SS355 35.0V 225MI0A
D117	20496510	D-SLP 1SS355 35.0V 225MI0A
D119	20496510	D-SLP 1SS355 35.0V 225MI0A
IC11	20718660	IC-LOGIC BU4094BF SHIFT REGISTER CMOS
IC12	20718660	IC-LOGIC BU4094BF SHIFT REGISTER CMOS
IC13	20718660	IC-LOGIC BU4094BF SHIFT REGISTER CMOS
IC14	20718660	IC-LOGIC BU4094BF SHIFT REGISTER CMOS
IC15	55087180	IC-LOGIC BU4051BCF MULTIPLEXER HCT
J177	10328750	RMGCFMIC 0 OHM +0% 62MI5W
J178	10328750	RMGCFMIC 0 OHM +0% 62MI5W
J179	10328750	RMGCFMIC 0 OHM +0% 62MI5W
J180	10328750	RMGCFMIC 0 OHM +0% 62MI5W
J181	10328750	RMGCFMIC 0 OHM +0% 62MI5W
J182	10328750	RMGCFMIC 0 OHM +0% 62MI5W
J183	10328750	RMGCFMIC 0 OHM +0% 62MI5W
J184	10328750	RMGCFMIC 0 OHM +0% 62MI5W
J185	10328750	RMGCFMIC 0 OHM +0% 62MI5W
J186	10328750	RMGCFMIC 0 OHM +0% 62MI5W
J187	10328750	RMGCFMIC 0 OHM +0% 62MI5W
J188	10328750	RMGCFMIC 0 OHM +0% 62MI5W
J189	10328750	RMGCFMIC 0 OHM +0% 62MI5W
J190	10328750	RMGCFMIC 0 OHM +0% 62MI5W
J191	10328750	RMGCFMIC 0 OHM +0% 62MI5W
J192	10328750	RMGCFMIC 0 OHM +0% 62MI5W
J193	10328750	RMGCFMIC 0 OHM +0% 62MI5W
J194	10328750	RMGCFMIC 0 OHM +0% 62MI5W
J195	10328750	RMGCFMIC 0 OHM +0% 62MI5W
J196	10328750	RMGCFMIC 0 OHM +0% 62MI5W

Front board AVR5550

3/10

Pos	Tocom#	SName
J197	10328750	RMGCFMIC 0 OHM +0% 62MI5W
J198	10328750	RMGCFMIC 0 OHM +0% 62MI5W
J200	10328750	RMGCFMIC 0 OHM +0% 62MI5W
J201	10328750	RMGCFMIC 0 OHM +0% 62MI5W
J202	10328750	RMGCFMIC 0 OHM +0% 62MI5W
J203	10328750	RMGCFMIC 0 OHM +0% 62MI5W
J208	10328750	RMGCFMIC 0 OHM +0% 62MI5W
J310	10328750	RMGCFMIC 0 OHM +0% 62MI5W
J400	10328750	RMGCFMIC 0 OHM +0% 62MI5W
J401	10328750	RMGCFMIC 0 OHM +0% 62MI5W
J402	10328750	RMGCFMIC 0 OHM +0% 62MI5W
Q102	55133180	TR-SSD DTC114YKA N 10K0 OHM 47K0 OHM
Q103	55133180	TR-SSD DTC114YKA N 10K0 OHM 47K0 OHM
Q104	55133180	TR-SSD DTC114YKA N 10K0 OHM 47K0 OHM
Q105	55133180	TR-SSD DTC114YKA N 10K0 OHM 47K0 OHM
Q111	55133180	TR-SSD DTC114YKA N 10K0 OHM 47K0 OHM
Q112	55133180	TR-SSD DTC114YKA N 10K0 OHM 47K0 OHM
Q113	55133180	TR-SSD DTC114YKA N 10K0 OHM 47K0 OHM
Q114	55133180	TR-SSD DTC114YKA N 10K0 OHM 47K0 OHM
Q115	55133180	TR-SSD DTC114YKA N 10K0 OHM 47K0 OHM
Q700	55133330	TR-SSD DTC114TKA N 10K0 OHM
Q701	55133330	TR-SSD DTC114TKA N 10K0 OHM
Q702	55133330	TR-SSD DTC114TKA N 10K0 OHM
Q703	55133330	TR-SSD DTC114TKA N 10K0 OHM
Q704	55133330	TR-SSD DTC114TKA N 10K0 OHM
Q705	55133330	TR-SSD DTC114TKA N 10K0 OHM
Q706	55133330	TR-SSD DTC114TKA N 10K0 OHM
Q707	55133330	TR-SSD DTC114TKA N 10K0 OHM
Q708	55133330	TR-SSD DTC114TKA N 10K0 OHM
Q709	55133330	TR-SSD DTC114TKA N 10K0 OHM
Q710	55133330	TR-SSD DTC114TKA N 10K0 OHM
Q711	55133330	TR-SSD DTC114TKA N 10K0 OHM
Q712	55133330	TR-SSD DTC114TKA N 10K0 OHM
Q713	55133330	TR-SSD DTC114TKA N 10K0 OHM
Q714	55133330	TR-SSD DTC114TKA N 10K0 OHM
Q715	55133330	TR-SSD DTC114TKA N 10K0 OHM
Q716	55133330	TR-SSD DTC114TKA N 10K0 OHM
Q717	55133330	TR-SSD DTC114TKA N 10K0 OHM
Q718	55133330	TR-SSD DTC114TKA N 10K0 OHM
Q719	55133330	TR-SSD DTC114TKA N 10K0 OHM
Q720	55133330	TR-SSD DTC114TKA N 10K0 OHM
Q721	55133330	TR-SSD DTC114TKA N 10K0 OHM
Q722	55133330	TR-SSD DTC114TKA N 10K0 OHM
R100	10135290	RMGCFMIC 68K0 OHM +5% 62MI5W
R101	10135290	RMGCFMIC 68K0 OHM +5% 62MI5W
R102	10135940	RMGCFMIC 4K7 OHM +5% 62MI5W
R103	10134410	RMGCFMIC 10R0 OHM +5% 62MI5W
R104	10135220	RMGCFMIC 47K0 OHM +5% 62MI5W
R105	10135340	RMGCFMIC 100K0 OHM +5% 62MI5W
R106	10136000	RMGCFMIC 8K2 OHM +5% 62MI5W
R108	10135010	RMGCFMIC 10K0 OHM +5% 62MI5W
R109	10134830	RMGCFMIC 220R0 OHM +5% 62MI5W
R110	10135770	RMGCFMIC 1K0 OHM +5% 62MI5W
R111	10134910	RMGCFMIC 470R0 OHM +5% 62MI5W
R112	10134910	RMGCFMIC 470R0 OHM +5% 62MI5W
R113	10134890	RMGCFMIC 390R0 OHM +5% 62MI5W

Front board AVR5550

4/10

Pos	Tocom#	SName
R114	10134890	RMGCFMIC 390R0 OHM +5% 62MI5W
R115	10134910	RMGCFMIC 470R0 OHM +5% 62MI5W
R116	10134910	RMGCFMIC 470R0 OHM +5% 62MI5W
R117	10134890	RMGCFMIC 390R0 OHM +5% 62MI5W
R118	10134890	RMGCFMIC 390R0 OHM +5% 62MI5W
R119	10135010	RMGCFMIC 10K0 OHM +5% 62MI5W
R120	10135010	RMGCFMIC 10K0 OHM +5% 62MI5W
R121	10135010	RMGCFMIC 10K0 OHM +5% 62MI5W
R122	10135010	RMGCFMIC 10K0 OHM +5% 62MI5W
R123	10135940	RMGCFMIC 4K7 OHM +5% 62MI5W
R124	10135940	RMGCFMIC 4K7 OHM +5% 62MI5W
R125	10135940	RMGCFMIC 4K7 OHM +5% 62MI5W
R126	10135770	RMGCFMIC 1K0 OHM +5% 62MI5W
R127	10135770	RMGCFMIC 1K0 OHM +5% 62MI5W
R128	10135770	RMGCFMIC 1K0 OHM +5% 62MI5W
R129	10135770	RMGCFMIC 1K0 OHM +5% 62MI5W
R130	10135770	RMGCFMIC 1K0 OHM +5% 62MI5W
R131	10135940	RMGCFMIC 4K7 OHM +5% 62MI5W
R132	10135940	RMGCFMIC 4K7 OHM +5% 62MI5W
R133	10135770	RMGCFMIC 1K0 OHM +5% 62MI5W
R134	10135770	RMGCFMIC 1K0 OHM +5% 62MI5W
R135	10135940	RMGCFMIC 4K7 OHM +5% 62MI5W
R136	10135010	RMGCFMIC 10K0 OHM +5% 62MI5W
R137	10135940	RMGCFMIC 4K7 OHM +5% 62MI5W
R140	10135770	RMGCFMIC 1K0 OHM +5% 62MI5W
R141	10135770	RMGCFMIC 1K0 OHM +5% 62MI5W
R142	10135770	RMGCFMIC 1K0 OHM +5% 62MI5W
R143	10135010	RMGCFMIC 10K0 OHM +5% 62MI5W
R144	10135010	RMGCFMIC 10K0 OHM +5% 62MI5W
R145	10135770	RMGCFMIC 1K0 OHM +5% 62MI5W
R146	10134740	RMGCFMIC 100R0 OHM +5% 62MI5W
R147	10135770	RMGCFMIC 1K0 OHM +5% 62MI5W
R148	10135770	RMGCFMIC 1K0 OHM +5% 62MI5W
R149	10135770	RMGCFMIC 1K0 OHM +5% 62MI5W
R150	10135770	RMGCFMIC 1K0 OHM +5% 62MI5W
R151	10134740	RMGCFMIC 100R0 OHM +5% 62MI5W
R152	10135770	RMGCFMIC 1K0 OHM +5% 62MI5W
R153	10135770	RMGCFMIC 1K0 OHM +5% 62MI5W
R154	10135770	RMGCFMIC 1K0 OHM +5% 62MI5W
R155	10135770	RMGCFMIC 1K0 OHM +5% 62MI5W
R156	10134740	RMGCFMIC 100R0 OHM +5% 62MI5W
R157	10135770	RMGCFMIC 1K0 OHM +5% 62MI5W
R158	10135770	RMGCFMIC 1K0 OHM +5% 62MI5W
R159	10135770	RMGCFMIC 1K0 OHM +5% 62MI5W
R160	10135770	RMGCFMIC 1K0 OHM +5% 62MI5W
R161	10134740	RMGCFMIC 100R0 OHM +5% 62MI5W
R162	10135770	RMGCFMIC 1K0 OHM +5% 62MI5W
R163	10135770	RMGCFMIC 1K0 OHM +5% 62MI5W
R164	10135770	RMGCFMIC 1K0 OHM +5% 62MI5W
R165	10135010	RMGCFMIC 10K0 OHM +5% 62MI5W
R166	10135010	RMGCFMIC 10K0 OHM +5% 62MI5W
R167	10135010	RMGCFMIC 10K0 OHM +5% 62MI5W
R168	10135010	RMGCFMIC 10K0 OHM +5% 62MI5W
R169	10134740	RMGCFMIC 100R0 OHM +5% 62MI5W
R170	10328750	RMGCFMIC 0 OHM +0% 62MI5W
R171	10328750	RMGCFMIC 0 OHM +0% 62MI5W

Front board AVR5550

5/10

Pos	Tocom#	SName
R173	10135010	RMGCFMIC 10K0 OHM +5% 62MI5W
R174	10135010	RMGCFMIC 10K0 OHM +5% 62MI5W
R176	10135220	RMGCFMIC 47K0 OHM +5% 62MI5W
R177	10135920	RMGCFMIC 3K9 OHM +5% 62MI5W
R302	10135770	RMGCFMIC 1K0 OHM +5% 62MI5W
R303	10135770	RMGCFMIC 1K0 OHM +5% 62MI5W
R304	10135340	RMGCFMIC 100K0 OHM +5% 62MI5W
R305	10135340	RMGCFMIC 100K0 OHM +5% 62MI5W
R306	10135620	RMGCFMIC 1M0 OHM +10% 62MI5W
R307	10135620	RMGCFMIC 1M0 OHM +10% 62MI5W
R308	10135220	RMGCFMIC 47K0 OHM +5% 62MI5W
R309	10135220	RMGCFMIC 47K0 OHM +5% 62MI5W
R310	10134830	RMGCFMIC 220R0 OHM +5% 62MI5W
R311	10134830	RMGCFMIC 220R0 OHM +5% 62MI5W
R312	10134910	RMGCFMIC 470R0 OHM +5% 62MI5W
R313	10134910	RMGCFMIC 470R0 OHM +5% 62MI5W
R314	10135340	RMGCFMIC 100K0 OHM +5% 62MI5W
R315	10135340	RMGCFMIC 100K0 OHM +5% 62MI5W
R316	10135120	RMGCFMIC 22K0 OHM +5% 62MI5W
R317	10135120	RMGCFMIC 22K0 OHM +5% 62MI5W
R318	10135920	RMGCFMIC 3K9 OHM +5% 62MI5W
R319	10135920	RMGCFMIC 3K9 OHM +5% 62MI5W
R320	10135860	RMGCFMIC 2K2 OHM +5% 62MI5W
R321	10135860	RMGCFMIC 2K2 OHM +5% 62MI5W
R322	10134950	RMGCFMIC 680R0 OHM +5% 62MI5W
R323	10134950	RMGCFMIC 680R0 OHM +5% 62MI5W
R501	10135340	RMGCFMIC 100K0 OHM +5% 62MI5W
R502	10135340	RMGCFMIC 100K0 OHM +5% 62MI5W
R503	10135340	RMGCFMIC 100K0 OHM +5% 62MI5W
R504	10135340	RMGCFMIC 100K0 OHM +5% 62MI5W
R505	10135340	RMGCFMIC 100K0 OHM +5% 62MI5W
R506	10135340	RMGCFMIC 100K0 OHM +5% 62MI5W
R507	10135340	RMGCFMIC 100K0 OHM +5% 62MI5W
R508	10135340	RMGCFMIC 100K0 OHM +5% 62MI5W
R509	10135340	RMGCFMIC 100K0 OHM +5% 62MI5W
R510	10135340	RMGCFMIC 100K0 OHM +5% 62MI5W
R511	10135340	RMGCFMIC 100K0 OHM +5% 62MI5W
R512	10135340	RMGCFMIC 100K0 OHM +5% 62MI5W
R513	10135340	RMGCFMIC 100K0 OHM +5% 62MI5W
R514	10135340	RMGCFMIC 100K0 OHM +5% 62MI5W
R515	10135340	RMGCFMIC 100K0 OHM +5% 62MI5W
R516	10135340	RMGCFMIC 100K0 OHM +5% 62MI5W
R517	10135340	RMGCFMIC 100K0 OHM +5% 62MI5W
R518	10135340	RMGCFMIC 100K0 OHM +5% 62MI5W
R519	10135340	RMGCFMIC 100K0 OHM +5% 62MI5W
R520	10135340	RMGCFMIC 100K0 OHM +5% 62MI5W
R521	10135340	RMGCFMIC 100K0 OHM +5% 62MI5W
R522	10135340	RMGCFMIC 100K0 OHM +5% 62MI5W
R523	10135340	RMGCFMIC 100K0 OHM +5% 62MI5W
R524	10135340	RMGCFMIC 100K0 OHM +5% 62MI5W
R525	10135340	RMGCFMIC 100K0 OHM +5% 62MI5W
R526	10135340	RMGCFMIC 100K0 OHM +5% 62MI5W
R527	10135340	RMGCFMIC 100K0 OHM +5% 62MI5W
R528	10135340	RMGCFMIC 100K0 OHM +5% 62MI5W
R529	10135340	RMGCFMIC 100K0 OHM +5% 62MI5W
R530	10135340	RMGCFMIC 100K0 OHM +5% 62MI5W

Front board AVR5550

6/10

Pos	Tocom#	SName
R531	10135340	RMGCFMIC 100K0 OHM +5% 62MI5W
R532	10135340	RMGCFMIC 100K0 OHM +5% 62MI5W
R533	10135340	RMGCFMIC 100K0 OHM +5% 62MI5W
R534	10135340	RMGCFMIC 100K0 OHM +5% 62MI5W
R535	10135340	RMGCFMIC 100K0 OHM +5% 62MI5W
R700	10134650	RMGCFMIC 47R0 OHM +5% 62MI5W
R701	10134650	RMGCFMIC 47R0 OHM +5% 62MI5W
R702	10134650	RMGCFMIC 47R0 OHM +5% 62MI5W
R703	10134650	RMGCFMIC 47R0 OHM +5% 62MI5W
R704	10134650	RMGCFMIC 47R0 OHM +5% 62MI5W
R705	10134650	RMGCFMIC 47R0 OHM +5% 62MI5W
R706	10134780	RMGCFMIC 150R0 OHM +5% 62MI5W
R707	10134650	RMGCFMIC 47R0 OHM +5% 62MI5W
R709	10134650	RMGCFMIC 47R0 OHM +5% 62MI5W
R711	10134650	RMGCFMIC 47R0 OHM +5% 62MI5W
R713	10134650	RMGCFMIC 47R0 OHM +5% 62MI5W
R715	10134650	RMGCFMIC 47R0 OHM +5% 62MI5W
R717	10134650	RMGCFMIC 47R0 OHM +5% 62MI5W
R718	10134780	RMGCFMIC 150R0 OHM +5% 62MI5W
R720	10134650	RMGCFMIC 47R0 OHM +5% 62MI5W
R722	10134650	RMGCFMIC 47R0 OHM +5% 62MI5W
R724	10134780	RMGCFMIC 150R0 OHM +5% 62MI5W
R725	10134780	RMGCFMIC 150R0 OHM +5% 62MI5W
R726	10134780	RMGCFMIC 150R0 OHM +5% 62MI5W
R727	10134780	RMGCFMIC 150R0 OHM +5% 62MI5W
R728	10134780	RMGCFMIC 150R0 OHM +5% 62MI5W
R729	10134780	RMGCFMIC 150R0 OHM +5% 62MI5W
R730	10134780	RMGCFMIC 150R0 OHM +5% 62MI5W
R731	10134780	RMGCFMIC 150R0 OHM +5% 62MI5W
R732	10134780	RMGCFMIC 150R0 OHM +5% 62MI5W
R733	10134780	RMGCFMIC 150R0 OHM +5% 62MI5W
R734	10134780	RMGCFMIC 150R0 OHM +5% 62MI5W
R735	10134780	RMGCFMIC 150R0 OHM +5% 62MI5W
R736	10134780	RMGCFMIC 150R0 OHM +5% 62MI5W
R737	10134780	RMGCFMIC 150R0 OHM +5% 62MI5W
R738	10134780	RMGCFMIC 150R0 OHM +5% 62MI5W
R739	10134780	RMGCFMIC 150R0 OHM +5% 62MI5W
R740	10134780	RMGCFMIC 150R0 OHM +5% 62MI5W
R741	10134780	RMGCFMIC 150R0 OHM +5% 62MI5W
R742	10134780	RMGCFMIC 150R0 OHM +5% 62MI5W
R743	10134780	RMGCFMIC 150R0 OHM +5% 62MI5W
R744	10134780	RMGCFMIC 150R0 OHM +5% 62MI5W
R745	10134780	RMGCFMIC 150R0 OHM +5% 62MI5W
R746	10134780	RMGCFMIC 150R0 OHM +5% 62MI5W
C106	55134360	CM 47MIOF +80% -20% 5.5V 70C
C119	20268880	CE 10U0F +20% 50.0V 85C
C132	20267830	CE 47U0F +20% 16.0V 85C 20251640
C133	20267830	CE 47U0F +20% 16.0V 85C 20251640
C143	20268880	CE 10U0F +20% 50.0V 85C
C314	55179410	CPM 82N0F +5% 100.0V
C315	55179410	CPM 82N0F +5% 100.0V
D107	55179310	D-LEM RED/GREEN 3PIE RD RND CL
D108	20415060	D-SR 1N4004 400.0V 1.0A
D109	55179310	D-LEM RED/GREEN 3PIE RD RND CL
D120	20415060	D-SR 1N4004 400.0V 1.0A
D700	55179290	D-LEM LTL-1CHGEC P-GN RND CL

Front board AVR5550

7/10

Pos	Tocom#	SName
D700	55179290	D-LEM LTL-1CHGEC P-GN RND CL
D700	55199400	D-LEM CT-3SGTA GN RND 3.0 CL 60M0CD
D701	55179290	D-LEM LTL-1CHGEC P-GN RND CL
D701	55179290	D-LEM LTL-1CHGEC P-GN RND CL
D701	55199400	D-LEM CT-3SGTA GN RND 3.0 CL 60M0CD
D702	55179290	D-LEM LTL-1CHGEC P-GN RND CL
D702	55179290	D-LEM LTL-1CHGEC P-GN RND CL
D702	55199400	D-LEM CT-3SGTA GN RND 3.0 CL 60M0CD
D703	55179290	D-LEM LTL-1CHGEC P-GN RND CL
D703	55179290	D-LEM LTL-1CHGEC P-GN RND CL
D703	55199400	D-LEM CT-3SGTA GN RND 3.0 CL 60M0CD
D704	55179290	D-LEM LTL-1CHGEC P-GN RND CL
D704	55179290	D-LEM LTL-1CHGEC P-GN RND CL
D704	55199400	D-LEM CT-3SGTA GN RND 3.0 CL 60M0CD
D705	55179290	D-LEM LTL-1CHGEC P-GN RND CL
D705	55179290	D-LEM LTL-1CHGEC P-GN RND CL
D705	55199400	D-LEM CT-3SGTA GN RND 3.0 CL 60M0CD
D706	55179290	D-LEM LTL-1CHGEC P-GN RND CL
D706	55179290	D-LEM LTL-1CHGEC P-GN RND CL
D706	55199400	D-LEM CT-3SGTA GN RND 3.0 CL 60M0CD
D707	55179290	D-LEM LTL-1CHGEC P-GN RND CL
D707	55179290	D-LEM LTL-1CHGEC P-GN RND CL
D707	55199400	D-LEM CT-3SGTA GN RND 3.0 CL 60M0CD
D708	55179290	D-LEM LTL-1CHGEC P-GN RND CL
D708	55179290	D-LEM LTL-1CHGEC P-GN RND CL
D708	55199400	D-LEM CT-3SGTA GN RND 3.0 CL 60M0CD
D709	55179290	D-LEM LTL-1CHGEC P-GN RND CL
D709	55179290	D-LEM LTL-1CHGEC P-GN RND CL
D709	55199400	D-LEM CT-3SGTA GN RND 3.0 CL 60M0CD
D710	55179290	D-LEM LTL-1CHGEC P-GN RND CL
D710	55179290	D-LEM LTL-1CHGEC P-GN RND CL
D710	55199400	D-LEM CT-3SGTA GN RND 3.0 CL 60M0CD
D711	55179290	D-LEM LTL-1CHGEC P-GN RND CL
D711	55179290	D-LEM LTL-1CHGEC P-GN RND CL
D711	55199400	D-LEM CT-3SGTA GN RND 3.0 CL 60M0CD
D712	55179290	D-LEM LTL-1CHGEC P-GN RND CL
D712	55179290	D-LEM LTL-1CHGEC P-GN RND CL
D712	55199400	D-LEM CT-3SGTA GN RND 3.0 CL 60M0CD
D713	55179290	D-LEM LTL-1CHGEC P-GN RND CL
D713	55179290	D-LEM LTL-1CHGEC P-GN RND CL
D713	55199400	D-LEM CT-3SGTA GN RND 3.0 CL 60M0CD
D714	55179290	D-LEM LTL-1CHGEC P-GN RND CL
D714	55179290	D-LEM LTL-1CHGEC P-GN RND CL
D714	55199400	D-LEM CT-3SGTA GN RND 3.0 CL 60M0CD
D715	55179290	D-LEM LTL-1CHGEC P-GN RND CL
D715	55179290	D-LEM LTL-1CHGEC P-GN RND CL
D715	55199400	D-LEM CT-3SGTA GN RND 3.0 CL 60M0CD
D716	55179290	D-LEM LTL-1CHGEC P-GN RND CL
D716	55179290	D-LEM LTL-1CHGEC P-GN RND CL
D716	55199400	D-LEM CT-3SGTA GN RND 3.0 CL 60M0CD
D717	55179290	D-LEM LTL-1CHGEC P-GN RND CL
D717	55179290	D-LEM LTL-1CHGEC P-GN RND CL
D717	55199400	D-LEM CT-3SGTA GN RND 3.0 CL 60M0CD
D718	55179290	D-LEM LTL-1CHGEC P-GN RND CL
D718	55179290	D-LEM LTL-1CHGEC P-GN RND CL
D718	55199400	D-LEM CT-3SGTA GN RND 3.0 CL 60M0CD

Front board AVR5550

8/10

Pos	Tocom#	SName
D719	55179290	D-LEM LTL-1CHGEC P-GN RND CL
D719	55179290	D-LEM LTL-1CHGEC P-GN RND CL
D719	55199400	D-LEM CT-3SGTA GN RND 3.0 CL 60M0CD
D720	55179290	D-LEM LTL-1CHGEC P-GN RND CL
D720	55179290	D-LEM LTL-1CHGEC P-GN RND CL
D720	55199400	D-LEM CT-3SGTA GN RND 3.0 CL 60M0CD
D721	55179290	D-LEM LTL-1CHGEC P-GN RND CL
D721	55179290	D-LEM LTL-1CHGEC P-GN RND CL
D721	55199400	D-LEM CT-3SGTA GN RND 3.0 CL 60M0CD
D722	55179290	D-LEM LTL-1CHGEC P-GN RND CL
D722	55179290	D-LEM LTL-1CHGEC P-GN RND CL
D722	55199400	D-LEM CT-3SGTA GN RND 3.0 CL 60M0CD
D723	55179290	D-LEM LTL-1CHGEC P-GN RND CL
D723	55179290	D-LEM LTL-1CHGEC P-GN RND CL
D723	55199400	D-LEM CT-3SGTA GN RND 3.0 CL 60M0CD
D724	55179290	D-LEM LTL-1CHGEC P-GN RND CL
D724	55179290	D-LEM LTL-1CHGEC P-GN RND CL
D724	55199400	D-LEM CT-3SGTA GN RND 3.0 CL 60M0CD
D725	55179290	D-LEM LTL-1CHGEC P-GN RND CL
D725	55179290	D-LEM LTL-1CHGEC P-GN RND CL
D725	55199400	D-LEM CT-3SGTA GN RND 3.0 CL 60M0CD
D726	55179290	D-LEM LTL-1CHGEC P-GN RND CL
D726	55179290	D-LEM LTL-1CHGEC P-GN RND CL
D726	55199400	D-LEM CT-3SGTA GN RND 3.0 CL 60M0CD
D727	55179290	D-LEM LTL-1CHGEC P-GN RND CL
D727	55179290	D-LEM LTL-1CHGEC P-GN RND CL
D727	55199400	D-LEM CT-3SGTA GN RND 3.0 CL 60M0CD
D728	55179290	D-LEM LTL-1CHGEC P-GN RND CL
D728	55179290	D-LEM LTL-1CHGEC P-GN RND CL
D728	55199400	D-LEM CT-3SGTA GN RND 3.0 CL 60M0CD
D730	55179290	D-LEM LTL-1CHGEC P-GN RND CL
D730	55179290	D-LEM LTL-1CHGEC P-GN RND CL
D730	55199400	D-LEM CT-3SGTA GN RND 3.0 CL 60M0CD
D731	55179290	D-LEM LTL-1CHGEC P-GN RND CL
D731	55179290	D-LEM LTL-1CHGEC P-GN RND CL
D731	55199400	D-LEM CT-3SGTA GN RND 3.0 CL 60M0CD
D732	55179290	D-LEM LTL-1CHGEC P-GN RND CL
D732	55179290	D-LEM LTL-1CHGEC P-GN RND CL
D732	55199400	D-LEM CT-3SGTA GN RND 3.0 CL 60M0CD
D733	55179290	D-LEM LTL-1CHGEC P-GN RND CL
D733	55179290	D-LEM LTL-1CHGEC P-GN RND CL
D733	55199400	D-LEM CT-3SGTA GN RND 3.0 CL 60M0CD
D734	55179290	D-LEM LTL-1CHGEC P-GN RND CL
D734	55179290	D-LEM LTL-1CHGEC P-GN RND CL
D734	55199400	D-LEM CT-3SGTA GN RND 3.0 CL 60M0CD
D735	55179290	D-LEM LTL-1CHGEC P-GN RND CL
D735	55179290	D-LEM LTL-1CHGEC P-GN RND CL
D735	55199400	D-LEM CT-3SGTA GN RND 3.0 CL 60M0CD
D736	55179290	D-LEM LTL-1CHGEC P-GN RND CL
D736	55179290	D-LEM LTL-1CHGEC P-GN RND CL
D736	55199400	D-LEM CT-3SGTA GN RND 3.0 CL 60M0CD
D737	55179290	D-LEM LTL-1CHGEC P-GN RND CL
D737	55179290	D-LEM LTL-1CHGEC P-GN RND CL
D737	55199400	D-LEM CT-3SGTA GN RND 3.0 CL 60M0CD
D738	55179290	D-LEM LTL-1CHGEC P-GN RND CL
D738	55179290	D-LEM LTL-1CHGEC P-GN RND CL

Front board AVR5550

9/10

Pos	Tocom#	SName
D738	55199400	D-LEM CT-3SGTA GN RND 3.0 CL 60M0CD
D739	55179290	D-LEM LTL-1CHGEC P-GN RND CL
D739	55179290	D-LEM LTL-1CHGEC P-GN RND CL
D739	55199400	D-LEM CT-3SGTA GN RND 3.0 CL 60M0CD
D740	55179290	D-LEM LTL-1CHGEC P-GN RND CL
D740	55179290	D-LEM LTL-1CHGEC P-GN RND CL
D740	55199400	D-LEM CT-3SGTA GN RND 3.0 CL 60M0CD
D741	55179290	D-LEM LTL-1CHGEC P-GN RND CL
D741	55179290	D-LEM LTL-1CHGEC P-GN RND CL
D741	55199400	D-LEM CT-3SGTA GN RND 3.0 CL 60M0CD
D742	55179290	D-LEM LTL-1CHGEC P-GN RND CL
D742	55179290	D-LEM LTL-1CHGEC P-GN RND CL
D742	55199400	D-LEM CT-3SGTA GN RND 3.0 CL 60M0CD
D743	55179290	D-LEM LTL-1CHGEC P-GN RND CL
D743	55179290	D-LEM LTL-1CHGEC P-GN RND CL
D743	55199400	D-LEM CT-3SGTA GN RND 3.0 CL 60M0CD
D744	55179290	D-LEM LTL-1CHGEC P-GN RND CL
D744	55179290	D-LEM LTL-1CHGEC P-GN RND CL
D744	55199400	D-LEM CT-3SGTA GN RND 3.0 CL 60M0CD
D745	55179290	D-LEM LTL-1CHGEC P-GN RND CL
D745	55179290	D-LEM LTL-1CHGEC P-GN RND CL
D745	55199400	D-LEM CT-3SGTA GN RND 3.0 CL 60M0CD
D746	55179290	D-LEM LTL-1CHGEC P-GN RND CL
D746	55179290	D-LEM LTL-1CHGEC P-GN RND CL
D746	55199400	D-LEM CT-3SGTA GN RND 3.0 CL 60M0CD
D747	55179290	D-LEM LTL-1CHGEC P-GN RND CL
D747	55179290	D-LEM LTL-1CHGEC P-GN RND CL
D747	55199400	D-LEM CT-3SGTA GN RND 3.0 CL 60M0CD
D748	55179290	D-LEM LTL-1CHGEC P-GN RND CL
D748	55179290	D-LEM LTL-1CHGEC P-GN RND CL
D748	55199400	D-LEM CT-3SGTA GN RND 3.0 CL 60M0CD
D749	55179290	D-LEM LTL-1CHGEC P-GN RND CL
D749	55179290	D-LEM LTL-1CHGEC P-GN RND CL
D749	55199400	D-LEM CT-3SGTA GN RND 3.0 CL 60M0CD
D750	55179290	D-LEM LTL-1CHGEC P-GN RND CL
D750	55179290	D-LEM LTL-1CHGEC P-GN RND CL
D750	55199400	D-LEM CT-3SGTA GN RND 3.0 CL 60M0CD
D751	55179290	D-LEM LTL-1CHGEC P-GN RND CL
D751	55179290	D-LEM LTL-1CHGEC P-GN RND CL
D751	55199400	D-LEM CT-3SGTA GN RND 3.0 CL 60M0CD
D752	55179290	D-LEM LTL-1CHGEC P-GN RND CL
D752	55179290	D-LEM LTL-1CHGEC P-GN RND CL
D752	55199400	D-LEM CT-3SGTA GN RND 3.0 CL 60M0CD
D753	55179290	D-LEM LTL-1CHGEC P-GN RND CL
D753	55179290	D-LEM LTL-1CHGEC P-GN RND CL
D753	55199400	D-LEM CT-3SGTA GN RND 3.0 CL 60M0CD
DP10	55142780	DISPLAY HNA-15LL01
FN10	55177570	AC PUN SHIELD FENCE TONE
IC10	55519340	IC-MICROCONT CXP82860-376Q MAIN AVR525
IC10	55646060	IC-MICROCONT CXP82860-382Q MAIN AVR5550
IC16	55179630	PHOTCOUP PC-17T1 PHOTOCOUPLER DIP4
IC30	55142240	IC-OPERAMP NJM2068DD DUAL OP
J215	55179380	LF 4U7H +10% 1.7 OHM 190.0A
L100	55179380	LF 4U7H +10% 1.7 OHM 190.0A
L101	55179380	LF 4U7H +10% 1.7 OHM 190.0A
N102	55213140	WIRECONASY UNIQUE 4P 220MM UL1007 PVC DISCRETE 26

Front board AVR5550

10/10

Pos	Tocom#	SName
N103	55559140	WIRECONASY DL 2.0MM 4P 600MM UL1007 RIBBON 26 1
N103	5555914A	WIRECONASY DL 2.0MM 4P 650MM UL1007 RIBBON 26 1
N104	55503680	WIRECONASY DL 2.0MM 10P 650MM UL1533 SHIELD 26 1
N104	55596550	WIRECONASY DL 2.0MM 10P 580MM UL1533 SHIELD 26 1
N105	55212800	WIRECONASY UNIQUE 7P 450MM UL1007 PVC DISCRETE 26
N105	55516480	WIRECONASY DL 2.0MM 7P 550MM UL1007 RIBBON 26 1
N105	55681380	WIRECONASY UNIQUE 7P 480MM UL1007 PVC DISCRETE 26
N106	55558760	WIRECONASY DL 2.0MM 9P 450MM UL1007 RIBBON 26 1
N107	55510380	WIRECONASY UNIQUE 4 600MM UL1533 SHIELD 26 1
N107	55558750	WIRECONASY DL 2.0MM 3P 600MM UL2547 26 1
N108	55558740	WIRECONASY DL 2.0MM 6P 550MM UL1533 SHIELD 26 1
N109	55175880	WIRECONASY UNIQUE 2P 100MM UL1007 PVC DISCRETE 26 1
N110	55503060	WIRECONASY DL 2.5MM 7P 350MM UL1007 RIBBON 24 1
N110	5550306A	WIRECONASY DL 2.5MM 7P 400MM UL1007 RIBBON 24 1
N111	55213230	WIRECONASY UNIQUE 4P 100MM UL1007 PVC DISCRETE 26
NJ80	55171510	CON PHONO SCKT RCA-313P 3 PINS
NJ81	55113960	CON DIN SCKT SOCKET CONNECTOR SVHS EST-S408J
P100	55123320	CONN 2.0MM 5 MA ST NAT LW2002P05 0 0
P101	55123340	CONN 2.0MM 8 MA ST NAT LW2002P08 0 0
P103	55230490	CONN 1.25MM 31 FE R BK 00-6216-031-120-808 0 0
R175	50882970	RCF 470R0 OHM +5% 250MI0W
R180	40435670	RCF 47K0 OHM +5% 250MI0W
RM10	55155930	IC-REMOTE RPM6938-RSIP-A3 RECEIVER 38KHZ
RV10	55134900	SWIROT EC16B24204A5 5V 500U0A 10T 3P 0 0
RV30	55179920	PR-ROT 100K0 OHM NON-LINEAR RK14K12400BR 0 0
RV31	55179920	PR-ROT 100K0 OHM NON-LINEAR RK14K12400BR 0 0
RV32	55179910	PR-ROT 100K0 OHM NON-LINEAR RK14K12400BQ 0 0
W100	55213360	WIRECONASY UNIQUE 1P 300MM UL1007 PVC DISCRETE 22 1
W101	55213360	WIRECONASY UNIQUE 1P 300MM UL1007 PVC DISCRETE 22 1
W102	55213360	WIRECONASY UNIQUE 1P 300MM UL1007 PVC DISCRETE 22 1
Y100	55126140	CRESONATOR 10M0 HZ 25.0 OHM 0F

Key board AVR5550

1/3

Pos	Tocom#	SName
C600	20251830	CE 1U0F +20% 50.0V 85C
C601	20251830	CE 1U0F +20% 50.0V 85C
C602	20251830	CE 1U0F +20% 50.0V 85C
C603	20251830	CE 1U0F +20% 50.0V 85C
C604	20251830	CE 1U0F +20% 50.0V 85C
C605	20252050	CE 100U0F +20% 6.3V 85C
Q600	55179220	TR-SLPSWA KRA107M P
Q601	55179220	TR-SLPSWA KRA107M P
S200	55145270	SWITACT VERTICAL TACTILE F/B 50MI0A 12.0V 500MI0OHM
S201	55145270	SWITACT VERTICAL TACTILE F/B 50MI0A 12.0V 500MI0OHM
S202	55145270	SWITACT VERTICAL TACTILE F/B 50MI0A 12.0V 500MI0OHM
S203	55145270	SWITACT VERTICAL TACTILE F/B 50MI0A 12.0V 500MI0OHM
S204	55145270	SWITACT VERTICAL TACTILE F/B 50MI0A 12.0V 500MI0OHM
S205	55145270	SWITACT VERTICAL TACTILE F/B 50MI0A 12.0V 500MI0OHM
S206	55145270	SWITACT VERTICAL TACTILE F/B 50MI0A 12.0V 500MI0OHM
S207	55145270	SWITACT VERTICAL TACTILE F/B 50MI0A 12.0V 500MI0OHM
S208	55145270	SWITACT VERTICAL TACTILE F/B 50MI0A 12.0V 500MI0OHM
S209	55145270	SWITACT VERTICAL TACTILE F/B 50MI0A 12.0V 500MI0OHM
S211	55145270	SWITACT VERTICAL TACTILE F/B 50MI0A 12.0V 500MI0OHM
S212	55145270	SWITACT VERTICAL TACTILE F/B 50MI0A 12.0V 500MI0OHM
S213	55145270	SWITACT VERTICAL TACTILE F/B 50MI0A 12.0V 500MI0OHM
S214	55145270	SWITACT VERTICAL TACTILE F/B 50MI0A 12.0V 500MI0OHM
S215	55145270	SWITACT VERTICAL TACTILE F/B 50MI0A 12.0V 500MI0OHM
S216	55145270	SWITACT VERTICAL TACTILE F/B 50MI0A 12.0V 500MI0OHM
S217	55145270	SWITACT VERTICAL TACTILE F/B 50MI0A 12.0V 500MI0OHM
S218	55145270	SWITACT VERTICAL TACTILE F/B 50MI0A 12.0V 500MI0OHM
S219	55145270	SWITACT VERTICAL TACTILE F/B 50MI0A 12.0V 500MI0OHM
S220	55145270	SWITACT VERTICAL TACTILE F/B 50MI0A 12.0V 500MI0OHM
C140	20288040	CCCFMIC 100N0F +80% -20% 16.0V Y5V
C141	20288040	CCCFMIC 100N0F +80% -20% 16.0V Y5V
C142	20288040	CCCFMIC 100N0F +80% -20% 16.0V Y5V
C143	20506590	CCCFMIC 100P0F +5% -5% 50.0V NP0
C144	20506590	CCCFMIC 100P0F +5% -5% 50.0V NP0
C220	10138790	CCCFMIC 22N0F +80% -20% 50.0V Y5V
C221	10138790	CCCFMIC 22N0F +80% -20% 50.0V Y5V
C222	20288040	CCCFMIC 100N0F +80% -20% 16.0V Y5V
C606	20288040	CCCFMIC 100N0F +80% -20% 16.0V Y5V
C900	20288040	CCCFMIC 100N0F +80% -20% 16.0V Y5V
C901	10138620	CCCFMIC 2N2F +10% -10% 50.0V X7R
C902	10138620	CCCFMIC 2N2F +10% -10% 50.0V X7R
C903	20288040	CCCFMIC 100N0F +80% -20% 16.0V Y5V
D600	20496510	D-SLP 1SS355 35.0V 225MI0A
D601	20496510	D-SLP 1SS355 35.0V 225MI0A
D602	20496510	D-SLP 1SS355 35.0V 225MI0A
D900	20496510	D-SLP 1SS355 35.0V 225MI0A
D901	20496510	D-SLP 1SS355 35.0V 225MI0A
IC62	55197900	IC-SPECFUNC UPD4721 DRIVERS/RECEIVER CMOS RS-232C
IC62	55197900	IC-SPECFUNC UPD4721 DRIVERS/RECEIVER CMOS RS-232C
L102	55126690	FBEAD SURFACE MT 2500OHM FCM2012H-252T02
L103	55126690	FBEAD SURFACE MT 2500OHM FCM2012H-252T02
L600	55126690	FBEAD SURFACE MT 2500OHM FCM2012H-252T02
L601	55126690	FBEAD SURFACE MT 2500OHM FCM2012H-252T02
L602	55126690	FBEAD SURFACE MT 2500OHM FCM2012H-252T02
L603	55126690	FBEAD SURFACE MT 2500OHM FCM2012H-252T02
Q800	55133180	TR-SSD DTC114YKA N 10K0 OHM 47K0 OHM
R172	10135770	RMGCFMIC 1K0 OHM +5% 62MI5W

Key board AVR5550

2/3

Pos	Tocom#	SName
R201	10135770	RMGCFMIC 1K0 OHM +5% 62MI5W
R202	10135790	RMGCFMIC 1K2 OHM +5% 62MI5W
R203	10135820	RMGCFMIC 1K5 OHM +5% 62MI5W
R204	10135860	RMGCFMIC 2K2 OHM +5% 62MI5W
R205	10135880	RMGCFMIC 2K7 OHM +5% 62MI5W
R206	10135900	RMGCFMIC 3K3 OHM +5% 62MI5W
R207	10135960	RMGCFMIC 5K6 OHM +5% 62MI5W
R208	10136000	RMGCFMIC 8K2 OHM +5% 62MI5W
R209	10135080	RMGCFMIC 18K0 OHM +5% 62MI5W
R211	10135770	RMGCFMIC 1K0 OHM +5% 62MI5W
R212	10135790	RMGCFMIC 1K2 OHM +5% 62MI5W
R213	10135820	RMGCFMIC 1K5 OHM +5% 62MI5W
R214	10135860	RMGCFMIC 2K2 OHM +5% 62MI5W
R215	10135880	RMGCFMIC 2K7 OHM +5% 62MI5W
R216	10135900	RMGCFMIC 3K3 OHM +5% 62MI5W
R217	10135960	RMGCFMIC 5K6 OHM +5% 62MI5W
R218	10136000	RMGCFMIC 8K2 OHM +5% 62MI5W
R219	10135080	RMGCFMIC 18K0 OHM +5% 62MI5W
R220	10135010	RMGCFMIC 10K0 OHM +5% 62MI5W
R221	10135010	RMGCFMIC 10K0 OHM +5% 62MI5W
R600	10134910	RMGCFMIC 470R0 OHM +5% 62MI5W
R601	10135920	RMGCFMIC 3K9 OHM +5% 62MI5W
R602	10134650	RMGCFMIC 47R0 OHM +5% 62MI5W
R603	10135220	RMGCFMIC 47K0 OHM +5% 62MI5W
R604	10134650	RMGCFMIC 47R0 OHM +5% 62MI5W
R605	10134850	RMGCFMIC 270R0 OHM +5% 62MI5W
R606	10135010	RMGCFMIC 10K0 OHM +5% 62MI5W
R606	10135340	RMGCFMIC 100K0 OHM +5% 62MI5W
R607	10135220	RMGCFMIC 47K0 OHM +5% 62MI5W
R608	10135940	RMGCFMIC 4K7 OHM +5% 62MI5W
R609	10135940	RMGCFMIC 4K7 OHM +5% 62MI5W
R800	10134950	RMGCFMIC 680R0 OHM +5% 62MI5W
R801	10134950	RMGCFMIC 680R0 OHM +5% 62MI5W
R802	10134810	RMGCFMIC 180R0 OHM +5% 62MI5W
R803	10134810	RMGCFMIC 180R0 OHM +5% 62MI5W
BK60	55176420	AC PUN BRACKET BKT GROUND ET 0.5T AVR520 --
BK61	55182550	AC PUN SHIELD DIGITAL ET
C901	20178570	CC 47N0F +80% -20% 50.0V Z5V
C901	20178570	CC 47N0F +80% -20% 50.0V Z5V
C902	20178570	CC 47N0F +80% -20% 50.0V Z5V
C902	20178570	CC 47N0F +80% -20% 50.0V Z5V
D800	55179330	D-LEM RED/GREEN 5 RD RND CL
IC60	55179630	PHOTCOUP PC-17T1 PHOTOCOUPLER DIP4
IC61	55179630	PHOTCOUP PC-17T1 PHOTOCOUPLER DIP4
L900	55168840	LF 47U0H +10% 5.8 OHM 70MIOA
N702	55175800	WIRECONASY UNIQUE 8P 100MM UL1007 PVC DISCRETE 26 1
N703	55175820	WIRECONASY UNIQUE 5P 100MM UL1007 PVC DISCRETE 26 1
N741	55504170	WIRECONASY DL 2.0MM 5P 800MM UL1007 RIBBON 26 1
N790	55503280	WIRECONASY DL 2.0MM 3P 600MM UL1007 RIBBON 26 1
NJ60	55176390	CON PHONO SCKT STEREO JACK JW350S
NJ61	55176390	CON PHONO SCKT STEREO JACK JW350S
NJ62	55176390	CON PHONO SCKT STEREO JACK JW350S
NJ63	55554510	CONN-SPE 87204-6063 WITH DUST COVER FOR AVR325/525
NJ64	55125430	D-LEM TORX178B RD RND CL
NJ65	55175950	CON PHONO SCKT RCA 1P W/GND JE010003MN
NJ66	55050690	CONN-PHJAC 6.35 ST HORZ CKX3-6.35-04 BK 0 0

Key board AVR5550

3/3

Pos	Tocom#	SName
P760	55123310	CONN 2.0MM 4 MA ST NAT LW2002P04 0 0
P761	55123310	CONN 2.0MM 4 MA ST NAT LW2002P04 0 0
P780	55123310	CONN 2.0MM 4 MA ST NAT LW2002P04 0 0
P791	55090070	CONN 2.0MM 2 MA ST NAT LW2002P0200T 0 0
R173	40438910	RCF 2R2 OHM +5% 250MI0W
R173	40438910	RCF 2R2 OHM +5% 250MI0W
R174	40438910	RCF 2R2 OHM +5% 250MI0W
R174	40438910	RCF 2R2 OHM +5% 250MI0W
W100	55213360	WIRECONASY UNIQUE 1P 300MM UL1007 PVC DISCRETE 22 1
W900	55213360	WIRECONASY UNIQUE 1P 300MM UL1007 PVC DISCRETE 22 1

DSP board AVR5550

Pos	Tocom#	SName
C1	10138960	CCCFMIC 10N0F +10% -10% 50.0V X7R
C104	20506590	CCCFMIC 100P0F +5% -5% 50.0V NP0
C105	20506590	CCCFMIC 100P0F +5% -5% 50.0V NP0
C115	20506590	CCCFMIC 100P0F +5% -5% 50.0V NP0
C116	20506590	CCCFMIC 100P0F +5% -5% 50.0V NP0
C117	20288040	CCCFMIC 100N0F +80% -20% 16.0V Y5V
C118	11058710	CCCFMIN 560P0F +5% -5% 50.0V NP0
C118	20506680	CCCFMIC 470P0F +5% -5% 50.0V NP0
C119	11058710	CCCFMIN 560P0F +5% -5% 50.0V NP0
C119	20506680	CCCFMIC 470P0F +5% -5% 50.0V NP0
C120	11058710	CCCFMIN 560P0F +5% -5% 50.0V NP0
C120	20506680	CCCFMIC 470P0F +5% -5% 50.0V NP0
C121	11058710	CCCFMIN 560P0F +5% -5% 50.0V NP0
C121	20506680	CCCFMIC 470P0F +5% -5% 50.0V NP0
C122	10138390	CCCFMIC 560P0F +10% -10% 50.0V X7R
C123	10138390	CCCFMIC 560P0F +10% -10% 50.0V X7R
C124	11058710	CCCFMIN 560P0F +5% -5% 50.0V NP0
C124	20506680	CCCFMIC 470P0F +5% -5% 50.0V NP0
C125	11058710	CCCFMIN 560P0F +5% -5% 50.0V NP0
C125	20506680	CCCFMIC 470P0F +5% -5% 50.0V NP0
C126	11058710	CCCFMIN 560P0F +5% -5% 50.0V NP0
C126	20506680	CCCFMIC 470P0F +5% -5% 50.0V NP0
C127	11058710	CCCFMIN 560P0F +5% -5% 50.0V NP0
C127	20506680	CCCFMIC 470P0F +5% -5% 50.0V NP0
C131	20506590	CCCFMIC 100P0F +5% -5% 50.0V NP0
C132	20506590	CCCFMIC 100P0F +5% -5% 50.0V NP0
C134	10138630	CCCFMIC 2N7F +10% -10% 50.0V X7R
C135	10138630	CCCFMIC 2N7F +10% -10% 50.0V X7R
C136	10138630	CCCFMIC 2N7F +10% -10% 50.0V X7R
C137	10138630	CCCFMIC 2N7F +10% -10% 50.0V X7R
C138	10138630	CCCFMIC 2N7F +10% -10% 50.0V X7R
C139	10138630	CCCFMIC 2N7F +10% -10% 50.0V X7R
C140	10138630	CCCFMIC 2N7F +10% -10% 50.0V X7R
C141	10138630	CCCFMIC 2N7F +10% -10% 50.0V X7R
C145	20506590	CCCFMIC 100P0F +5% -5% 50.0V NP0
C154	20506590	CCCFMIC 100P0F +5% -5% 50.0V NP0
C155	20506590	CCCFMIC 100P0F +5% -5% 50.0V NP0
C156	20506590	CCCFMIC 100P0F +5% -5% 50.0V NP0
C157	10138550	CCCFMIC 1N0F +10% -10% 50.0V X7R
C166	20506590	CCCFMIC 100P0F +5% -5% 50.0V NP0
C167	20506590	CCCFMIC 100P0F +5% -5% 50.0V NP0
C169	20506590	CCCFMIC 100P0F +5% -5% 50.0V NP0
C170	20288040	CCCFMIC 100N0F +80% -20% 16.0V Y5V
C171	20288040	CCCFMIC 100N0F +80% -20% 16.0V Y5V
C173	20288040	CCCFMIC 100N0F +80% -20% 16.0V Y5V
C174	20288040	CCCFMIC 100N0F +80% -20% 16.0V Y5V
C176	20506590	CCCFMIC 100P0F +5% -5% 50.0V NP0
C177	10138550	CCCFMIC 1N0F +10% -10% 50.0V X7R
C179	11058710	CCCFMIN 560P0F +5% -5% 50.0V NP0
C179	20506680	CCCFMIC 470P0F +5% -5% 50.0V NP0
C180	11058710	CCCFMIN 560P0F +5% -5% 50.0V NP0
C180	20506680	CCCFMIC 470P0F +5% -5% 50.0V NP0
C181	11058710	CCCFMIN 560P0F +5% -5% 50.0V NP0
C181	20506680	CCCFMIC 470P0F +5% -5% 50.0V NP0
C182	11058710	CCCFMIN 560P0F +5% -5% 50.0V NP0

DSP board AVR5550

2/22

Pos	Tocom#	SName
C184	11058710	CCCFMIN 560P0F +5% -5% 50.0V NP0
C184	20506680	CCCFMIC 470P0F +5% -5% 50.0V NP0
C185	11058710	CCCFMIN 560P0F +5% -5% 50.0V NP0
C185	20506680	CCCFMIC 470P0F +5% -5% 50.0V NP0
C186	11058710	CCCFMIN 560P0F +5% -5% 50.0V NP0
C186	20506680	CCCFMIC 470P0F +5% -5% 50.0V NP0
C188	20506590	CCCFMIC 100P0F +5% -5% 50.0V NP0
C189	20506590	CCCFMIC 100P0F +5% -5% 50.0V NP0
C190	10138630	CCCFMIC 2N7F +10% -10% 50.0V X7R
C191	10138630	CCCFMIC 2N7F +10% -10% 50.0V X7R
C192	10138630	CCCFMIC 2N7F +10% -10% 50.0V X7R
C193	10138630	CCCFMIC 2N7F +10% -10% 50.0V X7R
C195	10138630	CCCFMIC 2N7F +10% -10% 50.0V X7R
C196	10138630	CCCFMIC 2N7F +10% -10% 50.0V X7R
C197	10138630	CCCFMIC 2N7F +10% -10% 50.0V X7R
C198	10138630	CCCFMIC 2N7F +10% -10% 50.0V X7R
C199	20288040	CCCFMIC 100N0F +80% -20% 16.0V Y5V
C2	10138960	CCCFMIC 10N0F +10% -10% 50.0V X7R
C201	20506590	CCCFMIC 100P0F +5% -5% 50.0V NP0
C202	20506590	CCCFMIC 100P0F +5% -5% 50.0V NP0
C203	10138550	CCCFMIC 1N0F +10% -10% 50.0V X7R
C205	20506590	CCCFMIC 100P0F +5% -5% 50.0V NP0
C206	20506590	CCCFMIC 100P0F +5% -5% 50.0V NP0
C218	20506590	CCCFMIC 100P0F +5% -5% 50.0V NP0
C219	20288040	CCCFMIC 100N0F +80% -20% 16.0V Y5V
C220	20288040	CCCFMIC 100N0F +80% -20% 16.0V Y5V
C223	20506590	CCCFMIC 100P0F +5% -5% 50.0V NP0
C224	20506590	CCCFMIC 100P0F +5% -5% 50.0V NP0
C225	20506590	CCCFMIC 100P0F +5% -5% 50.0V NP0
C226	10138550	CCCFMIC 1N0F +10% -10% 50.0V X7R
C227	20288040	CCCFMIC 100N0F +80% -20% 16.0V Y5V
C228	20288040	CCCFMIC 100N0F +80% -20% 16.0V Y5V
C233	20506520	CCCFMIC 22P0F +5% -5% 50.0V NP0
C235	20506590	CCCFMIC 100P0F +5% -5% 50.0V NP0
C236	10138960	CCCFMIC 10N0F +10% -10% 50.0V X7R
C237	20506590	CCCFMIC 100P0F +5% -5% 50.0V NP0
C238	10138550	CCCFMIC 1N0F +10% -10% 50.0V X7R
C241	20288040	CCCFMIC 100N0F +80% -20% 16.0V Y5V
C245	20506590	CCCFMIC 100P0F +5% -5% 50.0V NP0
C246	20288040	CCCFMIC 100N0F +80% -20% 16.0V Y5V
C247	20288040	CCCFMIC 100N0F +80% -20% 16.0V Y5V
C249	20506590	CCCFMIC 100P0F +5% -5% 50.0V NP0
C250	10138550	CCCFMIC 1N0F +10% -10% 50.0V X7R
C251	20288040	CCCFMIC 100N0F +80% -20% 16.0V Y5V
C252	20288040	CCCFMIC 100N0F +80% -20% 16.0V Y5V
C254	20506520	CCCFMIC 22P0F +5% -5% 50.0V NP0
C255	10138960	CCCFMIC 10N0F +10% -10% 50.0V X7R
C257	20288040	CCCFMIC 100N0F +80% -20% 16.0V Y5V
C258	20288040	CCCFMIC 100N0F +80% -20% 16.0V Y5V
C259	20506590	CCCFMIC 100P0F +5% -5% 50.0V NP0
C260	20506590	CCCFMIC 100P0F +5% -5% 50.0V NP0
C261	10138550	CCCFMIC 1N0F +10% -10% 50.0V X7R
C264	20506590	CCCFMIC 100P0F +5% -5% 50.0V NP0
C265	20288040	CCCFMIC 100N0F +80% -20% 16.0V Y5V
C266	20288040	CCCFMIC 100N0F +80% -20% 16.0V Y5V

DSP board AVR5550

3/22

Pos	Tocom#	SName
C267	20288040	CCCFMIC 100N0F +80% -20% 16.0V Y5V
C269	20506590	CCCFMIC 100P0F +5% -5% 50.0V NP0
C270	10138550	CCCFMIC 1N0F +10% -10% 50.0V X7R
C271	20288040	CCCFMIC 100N0F +80% -20% 16.0V Y5V
C272	20288040	CCCFMIC 100N0F +80% -20% 16.0V Y5V
C275	20288040	CCCFMIC 100N0F +80% -20% 16.0V Y5V
C276	20288040	CCCFMIC 100N0F +80% -20% 16.0V Y5V
C280	20288040	CCCFMIC 100N0F +80% -20% 16.0V Y5V
C283	20288040	CCCFMIC 100N0F +80% -20% 16.0V Y5V
C3	20506520	CCCFMIC 22P0F +5% -5% 50.0V NP0
C347	20288040	CCCFMIC 100N0F +80% -20% 16.0V Y5V
C348	20288040	CCCFMIC 100N0F +80% -20% 16.0V Y5V
C4	10138960	CCCFMIC 10N0F +10% -10% 50.0V X7R
C401	20506520	CCCFMIC 22P0F +5% -5% 50.0V NP0
C901	10138960	CCCFMIC 10N0F +10% -10% 50.0V X7R
D100	20496510	D-SLP 1SS355 35.0V 225MIOA
D102	20496510	D-SLP 1SS355 35.0V 225MIOA
IC01	55204170	IC-SWITCH NJU201AM ANALOG SWITCH
IC03	55142610	IC-OPERAMP NJM2068M DUAL OP
IC04	55204160	IC-CONV CS5360-KS A/D
IC05	55142610	IC-OPERAMP NJM2068M DUAL OP
IC06	55451460	IC-CONV CS4382-KQ 8CH D/A
IC07	55142610	IC-OPERAMP NJM2068M DUAL OP
IC08	55204160	IC-CONV CS5360-KS A/D
IC09	55133310	IC-LOGIC M74HCU04M1R INVERTER HCT
IC10	55204160	IC-CONV CS5360-KS A/D
IC11	55510180	IC-ASIC M4A3-32-10VC-12VI COMPLEX PLD
IC12	55519370	IC-MICROCONT CXP82852-377Q SUB AVR525
IC12	55645960	IC-MICROCONT CXP82852-383Q SUB AVR5550
IC13	55204160	IC-CONV CS5360-KS A/D
IC14	55133310	IC-LOGIC M74HCU04M1R INVERTER HCT
IC15	55157760	IC-EPROM AT27LV040A-90JC
IC16	55476130	IC-SPECFUNC AK4114VQ LQFP48 DIGITAL INTERFACE TRANS
IC17	55125380	IC-LOWFREQ CS493263-CL DSP
IC17	5512538A	IC-LOWFREQ CS493263-CL G VERSION DSP
IC17	5512538A	IC-LOWFREQ CS493263-CL G VERSION DSP
IC35	55142610	IC-OPERAMP NJM2068M DUAL OP
L100	55126690	FBEAD SURFACE MT 2500OHM FCM2012H-252T02
L101	55126650	FBEAD SURFACE MT 300OHM FCM2012V-301T07
L102	55126650	FBEAD SURFACE MT 300OHM FCM2012V-301T07
L103	55126690	FBEAD SURFACE MT 2500OHM FCM2012H-252T02
L104	55126690	FBEAD SURFACE MT 2500OHM FCM2012H-252T02
L105	55126650	FBEAD SURFACE MT 300OHM FCM2012V-301T07
L106	55126690	FBEAD SURFACE MT 2500OHM FCM2012H-252T02
L107	55126690	FBEAD SURFACE MT 2500OHM FCM2012H-252T02
L109	55126650	FBEAD SURFACE MT 300OHM FCM2012V-301T07
L110	55126690	FBEAD SURFACE MT 2500OHM FCM2012H-252T02
L111	55126690	FBEAD SURFACE MT 2500OHM FCM2012H-252T02
L112	55126690	FBEAD SURFACE MT 2500OHM FCM2012H-252T02
L118	55126650	FBEAD SURFACE MT 300OHM FCM2012V-301T07
L999	55126650	FBEAD SURFACE MT 300OHM FCM2012V-301T07
Q100	55133180	TR-SSD DTC114YKA N 10K0 OHM 47K0 OHM
Q101	55133180	TR-SSD DTC114YKA N 10K0 OHM 47K0 OHM
Q102	55133190	TR-SSD DTA114YKA P 10K0 OHM 47K0 OHM
Q103	55138710	TR-SLPSWA KTD1304 N 20V 300MIOA

DSP board AVR5550

4/22

Pos	Tocom#	SName
Q104	55133180	TR-SSD DTC114YKA N 10K0 OHM 47K0 OHM
R10	10134710	RMGCFMIC 75R0 OHM +5% 62MI5W
R100	10135770	RMGCFMIC 1K0 OHM +5% 62MI5W
R101	10135770	RMGCFMIC 1K0 OHM +5% 62MI5W
R102	10135220	RMGCFMIC 47K0 OHM +5% 62MI5W
R103	10135340	RMGCFMIC 100K0 OHM +5% 62MI5W
R104	10135340	RMGCFMIC 100K0 OHM +5% 62MI5W
R105	10135340	RMGCFMIC 100K0 OHM +5% 62MI5W
R106	10135340	RMGCFMIC 100K0 OHM +5% 62MI5W
R107	10135340	RMGCFMIC 100K0 OHM +5% 62MI5W
R108	10135340	RMGCFMIC 100K0 OHM +5% 62MI5W
R109	10135770	RMGCFMIC 1K0 OHM +5% 62MI5W
R11	10135220	RMGCFMIC 47K0 OHM +5% 62MI5W
R110	10135220	RMGCFMIC 47K0 OHM +5% 62MI5W
R111	10135770	RMGCFMIC 1K0 OHM +5% 62MI5W
R112	10135960	RMGCFMIC 5K6 OHM +5% 62MI5W
R113	10135960	RMGCFMIC 5K6 OHM +5% 62MI5W
R114	10134930	RMGCFMIC 560R0 OHM +5% 62MI5W
R115	10134930	RMGCFMIC 560R0 OHM +5% 62MI5W
R116	10135960	RMGCFMIC 5K6 OHM +5% 62MI5W
R117	10135960	RMGCFMIC 5K6 OHM +5% 62MI5W
R118	10134930	RMGCFMIC 560R0 OHM +5% 62MI5W
R119	10135790	RMGCFMIC 1K2 OHM +5% 62MI5W
R12	10134930	RMGCFMIC 560R0 OHM +5% 62MI5W
R120	10135790	RMGCFMIC 1K2 OHM +5% 62MI5W
R121	10134930	RMGCFMIC 560R0 OHM +5% 62MI5W
R122	10134930	RMGCFMIC 560R0 OHM +5% 62MI5W
R123	10135790	RMGCFMIC 1K2 OHM +5% 62MI5W
R124	10135790	RMGCFMIC 1K2 OHM +5% 62MI5W
R125	10134930	RMGCFMIC 560R0 OHM +5% 62MI5W
R126	10135010	RMGCFMIC 10K0 OHM +5% 62MI5W
R127	10135010	RMGCFMIC 10K0 OHM +5% 62MI5W
R128	10135790	RMGCFMIC 1K2 OHM +5% 62MI5W
R129	10135770	RMGCFMIC 1K0 OHM +5% 62MI5W
R130	10135770	RMGCFMIC 1K0 OHM +5% 62MI5W
R131	10135790	RMGCFMIC 1K2 OHM +5% 62MI5W
R132	10135770	RMGCFMIC 1K0 OHM +5% 62MI5W
R133	10135790	RMGCFMIC 1K2 OHM +5% 62MI5W
R134	10135960	RMGCFMIC 5K6 OHM +5% 62MI5W
R135	10135960	RMGCFMIC 5K6 OHM +5% 62MI5W
R136	10135790	RMGCFMIC 1K2 OHM +5% 62MI5W
R137	10135790	RMGCFMIC 1K2 OHM +5% 62MI5W
R138	10135960	RMGCFMIC 5K6 OHM +5% 62MI5W
R139	10135960	RMGCFMIC 5K6 OHM +5% 62MI5W
R140	10135790	RMGCFMIC 1K2 OHM +5% 62MI5W
R141	10135770	RMGCFMIC 1K0 OHM +5% 62MI5W
R142	10135220	RMGCFMIC 47K0 OHM +5% 62MI5W
R143	10135770	RMGCFMIC 1K0 OHM +5% 62MI5W
R144	10135770	RMGCFMIC 1K0 OHM +5% 62MI5W
R145	10135930	RMGCFMIC 4K3 OHM +5% 62MI5W
R146	10135930	RMGCFMIC 4K3 OHM +5% 62MI5W
R147	10135930	RMGCFMIC 4K3 OHM +5% 62MI5W
R148	10135930	RMGCFMIC 4K3 OHM +5% 62MI5W
R149	10135930	RMGCFMIC 4K3 OHM +5% 62MI5W
R150	10135930	RMGCFMIC 4K3 OHM +5% 62MI5W

DSP board AVR5550

5/22

Pos	Tocom#	SName
R151	10135930	RMGCFMIC 4K3 OHM +5% 62MI5W
R152	10135930	RMGCFMIC 4K3 OHM +5% 62MI5W
R153	10135770	RMGCFMIC 1K0 OHM +5% 62MI5W
R154	10135220	RMGCFMIC 47K0 OHM +5% 62MI5W
R155	10135220	RMGCFMIC 47K0 OHM +5% 62MI5W
R156	10134780	RMGCFMIC 150R0 OHM +5% 62MI5W
R157	10135010	RMGCFMIC 10K0 OHM +5% 62MI5W
R158	10134780	RMGCFMIC 150R0 OHM +5% 62MI5W
R159	10135010	RMGCFMIC 10K0 OHM +5% 62MI5W
R16	10135940	RMGCFMIC 4K7 OHM +5% 62MI5W
R160	10135010	RMGCFMIC 10K0 OHM +5% 62MI5W
R161	10135220	RMGCFMIC 47K0 OHM +5% 62MI5W
R162	10134410	RMGCFMIC 10R0 OHM +5% 62MI5W
R163	10135770	RMGCFMIC 1K0 OHM +5% 62MI5W
R164	10135340	RMGCFMIC 100K0 OHM +5% 62MI5W
R165	10135340	RMGCFMIC 100K0 OHM +5% 62MI5W
R166	10135340	RMGCFMIC 100K0 OHM +5% 62MI5W
R167	10135340	RMGCFMIC 100K0 OHM +5% 62MI5W
R168	10135090	RMGCFMIC 20K0 OHM +5% 62MI5W
R169	10135010	RMGCFMIC 10K0 OHM +5% 62MI5W
R17	10135940	RMGCFMIC 4K7 OHM +5% 62MI5W
R170	10135010	RMGCFMIC 10K0 OHM +5% 62MI5W
R171	10135770	RMGCFMIC 1K0 OHM +5% 62MI5W
R172	10135770	RMGCFMIC 1K0 OHM +5% 62MI5W
R173	10135220	RMGCFMIC 47K0 OHM +5% 62MI5W
R174	10135220	RMGCFMIC 47K0 OHM +5% 62MI5W
R175	10134780	RMGCFMIC 150R0 OHM +5% 62MI5W
R176	10135010	RMGCFMIC 10K0 OHM +5% 62MI5W
R177	10134780	RMGCFMIC 150R0 OHM +5% 62MI5W
R178	10135010	RMGCFMIC 10K0 OHM +5% 62MI5W
R179	10135010	RMGCFMIC 10K0 OHM +5% 62MI5W
R180	10134410	RMGCFMIC 10R0 OHM +5% 62MI5W
R181	10135960	RMGCFMIC 5K6 OHM +5% 62MI5W
R182	10135960	RMGCFMIC 5K6 OHM +5% 62MI5W
R183	10135960	RMGCFMIC 5K6 OHM +5% 62MI5W
R184	10135960	RMGCFMIC 5K6 OHM +5% 62MI5W
R185	10135090	RMGCFMIC 20K0 OHM +5% 62MI5W
R186	10135010	RMGCFMIC 10K0 OHM +5% 62MI5W
R187	10135010	RMGCFMIC 10K0 OHM +5% 62MI5W
R188	10134930	RMGCFMIC 560R0 OHM +5% 62MI5W
R189	10135790	RMGCFMIC 1K2 OHM +5% 62MI5W
R190	10135790	RMGCFMIC 1K2 OHM +5% 62MI5W
R191	10134930	RMGCFMIC 560R0 OHM +5% 62MI5W
R192	10134930	RMGCFMIC 560R0 OHM +5% 62MI5W
R193	10135790	RMGCFMIC 1K2 OHM +5% 62MI5W
R194	10135790	RMGCFMIC 1K2 OHM +5% 62MI5W
R195	10134930	RMGCFMIC 560R0 OHM +5% 62MI5W
R196	10135940	RMGCFMIC 4K7 OHM +5% 62MI5W
R197	10135980	RMGCFMIC 6K8 OHM +5% 62MI5W
R198	10135790	RMGCFMIC 1K2 OHM +5% 62MI5W
R199	10135960	RMGCFMIC 5K6 OHM +5% 62MI5W
R200	10135960	RMGCFMIC 5K6 OHM +5% 62MI5W
R201	10135790	RMGCFMIC 1K2 OHM +5% 62MI5W
R202	10135790	RMGCFMIC 1K2 OHM +5% 62MI5W
R203	10135960	RMGCFMIC 5K6 OHM +5% 62MI5W

DSP board AVR5550

6/22

Pos	Tocom#	SName
R204	10135960	RMGCFMIC 5K6 OHM +5% 62MI5W
R205	10135790	RMGCFMIC 1K2 OHM +5% 62MI5W
R206	10135770	RMGCFMIC 1K0 OHM +5% 62MI5W
R207	10135010	RMGCFMIC 10K0 OHM +5% 62MI5W
R208	10135930	RMGCFMIC 4K3 OHM +5% 62MI5W
R209	10135930	RMGCFMIC 4K3 OHM +5% 62MI5W
R21	10135940	RMGCFMIC 4K7 OHM +5% 62MI5W
R210	10135930	RMGCFMIC 4K3 OHM +5% 62MI5W
R211	10135930	RMGCFMIC 4K3 OHM +5% 62MI5W
R212	10135930	RMGCFMIC 4K3 OHM +5% 62MI5W
R213	10135930	RMGCFMIC 4K3 OHM +5% 62MI5W
R214	10135930	RMGCFMIC 4K3 OHM +5% 62MI5W
R215	10135930	RMGCFMIC 4K3 OHM +5% 62MI5W
R216	10135770	RMGCFMIC 1K0 OHM +5% 62MI5W
R217	10135220	RMGCFMIC 47K0 OHM +5% 62MI5W
R218	10134780	RMGCFMIC 150R0 OHM +5% 62MI5W
R219	10135010	RMGCFMIC 10K0 OHM +5% 62MI5W
R22	10135940	RMGCFMIC 4K7 OHM +5% 62MI5W
R220	10134780	RMGCFMIC 150R0 OHM +5% 62MI5W
R221	10135010	RMGCFMIC 10K0 OHM +5% 62MI5W
R222	10135220	RMGCFMIC 47K0 OHM +5% 62MI5W
R223	10134410	RMGCFMIC 10R0 OHM +5% 62MI5W
R224	10135770	RMGCFMIC 1K0 OHM +5% 62MI5W
R225	10135220	RMGCFMIC 47K0 OHM +5% 62MI5W
R226	10135090	RMGCFMIC 20K0 OHM +5% 62MI5W
R227	10135010	RMGCFMIC 10K0 OHM +5% 62MI5W
R228	10135010	RMGCFMIC 10K0 OHM +5% 62MI5W
R229	10135220	RMGCFMIC 47K0 OHM +5% 62MI5W
R230	10134780	RMGCFMIC 150R0 OHM +5% 62MI5W
R231	10135010	RMGCFMIC 10K0 OHM +5% 62MI5W
R232	10134780	RMGCFMIC 150R0 OHM +5% 62MI5W
R233	10135770	RMGCFMIC 1K0 OHM +5% 62MI5W
R234	10135220	RMGCFMIC 47K0 OHM +5% 62MI5W
R235	10135770	RMGCFMIC 1K0 OHM +5% 62MI5W
R236	10135090	RMGCFMIC 20K0 OHM +5% 62MI5W
R237	10135010	RMGCFMIC 10K0 OHM +5% 62MI5W
R238	10135010	RMGCFMIC 10K0 OHM +5% 62MI5W
R239	10135010	RMGCFMIC 10K0 OHM +5% 62MI5W
R240	10135010	RMGCFMIC 10K0 OHM +5% 62MI5W
R241	10134410	RMGCFMIC 10R0 OHM +5% 62MI5W
R242	10135220	RMGCFMIC 47K0 OHM +5% 62MI5W
R243	10135860	RMGCFMIC 2K2 OHM +5% 62MI5W
R244	10134710	RMGCFMIC 75R0 OHM +5% 62MI5W
R245	10135220	RMGCFMIC 47K0 OHM +5% 62MI5W
R246	10134780	RMGCFMIC 150R0 OHM +5% 62MI5W
R247	10135010	RMGCFMIC 10K0 OHM +5% 62MI5W
R248	10134780	RMGCFMIC 150R0 OHM +5% 62MI5W
R249	10135010	RMGCFMIC 10K0 OHM +5% 62MI5W
R250	10135010	RMGCFMIC 10K0 OHM +5% 62MI5W
R251	10135220	RMGCFMIC 47K0 OHM +5% 62MI5W
R252	10134410	RMGCFMIC 10R0 OHM +5% 62MI5W
R253	10134410	RMGCFMIC 10R0 OHM +5% 62MI5W
R254	10134410	RMGCFMIC 10R0 OHM +5% 62MI5W
R255	10134410	RMGCFMIC 10R0 OHM +5% 62MI5W
R256	10134410	RMGCFMIC 10R0 OHM +5% 62MI5W

DSP board AVR5550

7/22

Pos	Tocom#	SName
R257	10134410	RMGCFMIC 10R0 OHM +5% 62MI5W
R258	10134410	RMGCFMIC 10R0 OHM +5% 62MI5W
R259	10135220	RMGCFMIC 47K0 OHM +5% 62MI5W
R260	10135090	RMGCFMIC 20K0 OHM +5% 62MI5W
R261	10135010	RMGCFMIC 10K0 OHM +5% 62MI5W
R262	10135010	RMGCFMIC 10K0 OHM +5% 62MI5W
R263	10134930	RMGCFMIC 560R0 OHM +5% 62MI5W
R264	10135220	RMGCFMIC 47K0 OHM +5% 62MI5W
R265	10135860	RMGCFMIC 2K2 OHM +5% 62MI5W
R266	10135220	RMGCFMIC 47K0 OHM +5% 62MI5W
R267	10134780	RMGCFMIC 150R0 OHM +5% 62MI5W
R268	10135010	RMGCFMIC 10K0 OHM +5% 62MI5W
R269	10134780	RMGCFMIC 150R0 OHM +5% 62MI5W
R270	10135090	RMGCFMIC 20K0 OHM +5% 62MI5W
R271	10135010	RMGCFMIC 10K0 OHM +5% 62MI5W
R272	10135010	RMGCFMIC 10K0 OHM +5% 62MI5W
R273	10135010	RMGCFMIC 10K0 OHM +5% 62MI5W
R274	10135010	RMGCFMIC 10K0 OHM +5% 62MI5W
R275	10134410	RMGCFMIC 10R0 OHM +5% 62MI5W
R277	10135940	RMGCFMIC 4K7 OHM +5% 62MI5W
R278	10135940	RMGCFMIC 4K7 OHM +5% 62MI5W
R279	10134710	RMGCFMIC 75R0 OHM +5% 62MI5W
R280	10135770	RMGCFMIC 1K0 OHM +5% 62MI5W
R281	10135220	RMGCFMIC 47K0 OHM +5% 62MI5W
R282	10134410	RMGCFMIC 10R0 OHM +5% 62MI5W
R283	10134410	RMGCFMIC 10R0 OHM +5% 62MI5W
R284	10134410	RMGCFMIC 10R0 OHM +5% 62MI5W
R285	10134410	RMGCFMIC 10R0 OHM +5% 62MI5W
R286	10134410	RMGCFMIC 10R0 OHM +5% 62MI5W
R287	10134410	RMGCFMIC 10R0 OHM +5% 62MI5W
R288	10135220	RMGCFMIC 47K0 OHM +5% 62MI5W
R289	10134780	RMGCFMIC 150R0 OHM +5% 62MI5W
R290	10135010	RMGCFMIC 10K0 OHM +5% 62MI5W
R291	10134780	RMGCFMIC 150R0 OHM +5% 62MI5W
R292	10135010	RMGCFMIC 10K0 OHM +5% 62MI5W
R293	10135010	RMGCFMIC 10K0 OHM +5% 62MI5W
R294	10135220	RMGCFMIC 47K0 OHM +5% 62MI5W
R295	10134410	RMGCFMIC 10R0 OHM +5% 62MI5W
R296	10134930	RMGCFMIC 560R0 OHM +5% 62MI5W
R297	10135090	RMGCFMIC 20K0 OHM +5% 62MI5W
R298	10135010	RMGCFMIC 10K0 OHM +5% 62MI5W
R299	10135010	RMGCFMIC 10K0 OHM +5% 62MI5W
R300	10135220	RMGCFMIC 47K0 OHM +5% 62MI5W
R301	10134780	RMGCFMIC 150R0 OHM +5% 62MI5W
R302	10135010	RMGCFMIC 10K0 OHM +5% 62MI5W
R303	10134780	RMGCFMIC 150R0 OHM +5% 62MI5W
R304	10135090	RMGCFMIC 20K0 OHM +5% 62MI5W
R305	10135010	RMGCFMIC 10K0 OHM +5% 62MI5W
R306	10135010	RMGCFMIC 10K0 OHM +5% 62MI5W
R307	10135010	RMGCFMIC 10K0 OHM +5% 62MI5W
R308	10135010	RMGCFMIC 10K0 OHM +5% 62MI5W
R309	10134410	RMGCFMIC 10R0 OHM +5% 62MI5W
R310	10135770	RMGCFMIC 1K0 OHM +5% 62MI5W
R312	10135860	RMGCFMIC 2K2 OHM +5% 62MI5W
R319	10135220	RMGCFMIC 47K0 OHM +5% 62MI5W

DSP board AVR5550

8/22

Pos	Tocom#	SName
R320	10135770	RMGCFMIC 1K0 OHM +5% 62MI5W
R322	10135010	RMGCFMIC 10K0 OHM +5% 62MI5W
R323	10135010	RMGCFMIC 10K0 OHM +5% 62MI5W
R324	10135010	RMGCFMIC 10K0 OHM +5% 62MI5W
R325	10135010	RMGCFMIC 10K0 OHM +5% 62MI5W
R326	10135010	RMGCFMIC 10K0 OHM +5% 62MI5W
R327	10135010	RMGCFMIC 10K0 OHM +5% 62MI5W
R328	10135010	RMGCFMIC 10K0 OHM +5% 62MI5W
R329	10135010	RMGCFMIC 10K0 OHM +5% 62MI5W
R330	10135010	RMGCFMIC 10K0 OHM +5% 62MI5W
R331	10134940	RMGCFMIC 620R0 OHM +5% 62MI5W
R333	10134410	RMGCFMIC 10R0 OHM +5% 62MI5W
R335	10134410	RMGCFMIC 10R0 OHM +5% 62MI5W
R335	10134830	RMGCFMIC 220R0 OHM +5% 62MI5W
R336	10134410	RMGCFMIC 10R0 OHM +5% 62MI5W
R336	10134830	RMGCFMIC 220R0 OHM +5% 62MI5W
R337	10134740	RMGCFMIC 100R0 OHM +5% 62MI5W
R338	10134940	RMGCFMIC 620R0 OHM +5% 62MI5W
R339	10134740	RMGCFMIC 100R0 OHM +5% 62MI5W
R347	10134410	RMGCFMIC 10R0 OHM +5% 62MI5W
R348	10134410	RMGCFMIC 10R0 OHM +5% 62MI5W
R350	10134410	RMGCFMIC 10R0 OHM +5% 62MI5W
R351	10134410	RMGCFMIC 10R0 OHM +5% 62MI5W
R352	10135010	RMGCFMIC 10K0 OHM +5% 62MI5W
R353	10134410	RMGCFMIC 10R0 OHM +5% 62MI5W
R355	10135010	RMGCFMIC 10K0 OHM +5% 62MI5W
R356	10134410	RMGCFMIC 10R0 OHM +5% 62MI5W
R357	10134410	RMGCFMIC 10R0 OHM +5% 62MI5W
R357	10134740	RMGCFMIC 100R0 OHM +5% 62MI5W
R359	10134950	RMGCFMIC 680R0 OHM +5% 62MI5W
R360	10134940	RMGCFMIC 620R0 OHM +5% 62MI5W
R361	10134560	RMGCFMIC 27R0 OHM +5% 62MI5W
R361	10134650	RMGCFMIC 47R0 OHM +5% 62MI5W
R362	10134410	RMGCFMIC 10R0 OHM +5% 62MI5W
R363	10134410	RMGCFMIC 10R0 OHM +5% 62MI5W
R364	10135010	RMGCFMIC 10K0 OHM +5% 62MI5W
R365	10134410	RMGCFMIC 10R0 OHM +5% 62MI5W
R365	10134830	RMGCFMIC 220R0 OHM +5% 62MI5W
R366	10135940	RMGCFMIC 4K7 OHM +5% 62MI5W
R367	10134740	RMGCFMIC 100R0 OHM +5% 62MI5W
R368	10135010	RMGCFMIC 10K0 OHM +5% 62MI5W
R369	10135010	RMGCFMIC 10K0 OHM +5% 62MI5W
R370	10135010	RMGCFMIC 10K0 OHM +5% 62MI5W
R371	10135010	RMGCFMIC 10K0 OHM +5% 62MI5W
R372	10134410	RMGCFMIC 10R0 OHM +5% 62MI5W
R372	10134830	RMGCFMIC 220R0 OHM +5% 62MI5W
R373	10134410	RMGCFMIC 10R0 OHM +5% 62MI5W
R373	10134830	RMGCFMIC 220R0 OHM +5% 62MI5W
R374	10135010	RMGCFMIC 10K0 OHM +5% 62MI5W
R375	10134410	RMGCFMIC 10R0 OHM +5% 62MI5W
R375	10134830	RMGCFMIC 220R0 OHM +5% 62MI5W
R376	10134410	RMGCFMIC 10R0 OHM +5% 62MI5W
R377	10134410	RMGCFMIC 10R0 OHM +5% 62MI5W
R378	10134410	RMGCFMIC 10R0 OHM +5% 62MI5W
R4	10135940	RMGCFMIC 4K7 OHM +5% 62MI5W

DSP board AVR5550

9/22

Pos	Tocom#	SName
R425	10134410	RMGCFMIC 10R0 OHM +5% 62MI5W
R434	10134410	RMGCFMIC 10R0 OHM +5% 62MI5W
R5	10135940	RMGCFMIC 4K7 OHM +5% 62MI5W
R6	10135940	RMGCFMIC 4K7 OHM +5% 62MI5W
R7	10135940	RMGCFMIC 4K7 OHM +5% 62MI5W
R8	10135940	RMGCFMIC 4K7 OHM +5% 62MI5W
R9	10135940	RMGCFMIC 4K7 OHM +5% 62MI5W
R901	10134740	RMGCFMIC 100R0 OHM +5% 62MI5W
R902	10134740	RMGCFMIC 100R0 OHM +5% 62MI5W
R903	10134740	RMGCFMIC 100R0 OHM +5% 62MI5W
R904	10134740	RMGCFMIC 100R0 OHM +5% 62MI5W
R905	10134740	RMGCFMIC 100R0 OHM +5% 62MI5W
R908	10135940	RMGCFMIC 4K7 OHM +5% 62MI5W
R909	10328750	RMGCFMIC 0 OHM +0% 62MI5W
R910	20288040	CCCFMIC 100N0F +80% -20% 16.0V Y5V
C1	10138960	CCCFMIC 10N0F +10% -10% 50.0V X7R
C104	20506590	CCCFMIC 100P0F +5% -5% 50.0V NP0
C105	20506590	CCCFMIC 100P0F +5% -5% 50.0V NP0
C115	20506590	CCCFMIC 100P0F +5% -5% 50.0V NP0
C116	20506590	CCCFMIC 100P0F +5% -5% 50.0V NP0
C117	20288040	CCCFMIC 100N0F +80% -20% 16.0V Y5V
C118	11058710	CCCFMIN 560P0F +5% -5% 50.0V NP0
C118	20506680	CCCFMIC 470P0F +5% -5% 50.0V NP0
C119	11058710	CCCFMIN 560P0F +5% -5% 50.0V NP0
C119	20506680	CCCFMIC 470P0F +5% -5% 50.0V NP0
C120	11058710	CCCFMIN 560P0F +5% -5% 50.0V NP0
C120	20506680	CCCFMIC 470P0F +5% -5% 50.0V NP0
C121	11058710	CCCFMIN 560P0F +5% -5% 50.0V NP0
C121	20506680	CCCFMIC 470P0F +5% -5% 50.0V NP0
C122	10138390	CCCFMIC 560P0F +10% -10% 50.0V X7R
C123	10138390	CCCFMIC 560P0F +10% -10% 50.0V X7R
C124	11058710	CCCFMIN 560P0F +5% -5% 50.0V NP0
C124	20506680	CCCFMIC 470P0F +5% -5% 50.0V NP0
C125	11058710	CCCFMIN 560P0F +5% -5% 50.0V NP0
C125	20506680	CCCFMIC 470P0F +5% -5% 50.0V NP0
C126	11058710	CCCFMIN 560P0F +5% -5% 50.0V NP0
C126	20506680	CCCFMIC 470P0F +5% -5% 50.0V NP0
C127	11058710	CCCFMIN 560P0F +5% -5% 50.0V NP0
C127	20506680	CCCFMIC 470P0F +5% -5% 50.0V NP0
C131	20506590	CCCFMIC 100P0F +5% -5% 50.0V NP0
C132	20506590	CCCFMIC 100P0F +5% -5% 50.0V NP0
C134	10138630	CCCFMIC 2N7F +10% -10% 50.0V X7R
C135	10138630	CCCFMIC 2N7F +10% -10% 50.0V X7R
C136	10138630	CCCFMIC 2N7F +10% -10% 50.0V X7R
C137	10138630	CCCFMIC 2N7F +10% -10% 50.0V X7R
C138	10138630	CCCFMIC 2N7F +10% -10% 50.0V X7R
C139	10138630	CCCFMIC 2N7F +10% -10% 50.0V X7R
C140	10138630	CCCFMIC 2N7F +10% -10% 50.0V X7R
C141	10138630	CCCFMIC 2N7F +10% -10% 50.0V X7R
C145	20506590	CCCFMIC 100P0F +5% -5% 50.0V NP0
C154	20506590	CCCFMIC 100P0F +5% -5% 50.0V NP0
C155	20506590	CCCFMIC 100P0F +5% -5% 50.0V NP0
C156	20506590	CCCFMIC 100P0F +5% -5% 50.0V NP0
C157	10138550	CCCFMIC 1N0F +10% -10% 50.0V X7R
C166	20506590	CCCFMIC 100P0F +5% -5% 50.0V NP0

DSP board AVR5550

10/22

Pos	Tocom#	SName
C167	20506590	CCCFMIC 100P0F +5% -5% 50.0V NP0
C169	20506590	CCCFMIC 100P0F +5% -5% 50.0V NP0
C170	20288040	CCCFMIC 100N0F +80% -20% 16.0V Y5V
C171	20288040	CCCFMIC 100N0F +80% -20% 16.0V Y5V
C173	20288040	CCCFMIC 100N0F +80% -20% 16.0V Y5V
C174	20288040	CCCFMIC 100N0F +80% -20% 16.0V Y5V
C176	20506590	CCCFMIC 100P0F +5% -5% 50.0V NP0
C177	10138550	CCCFMIC 1N0F +10% -10% 50.0V X7R
C179	11058710	CCCFMIN 560P0F +5% -5% 50.0V NP0
C179	20506680	CCCFMIC 470P0F +5% -5% 50.0V NP0
C180	11058710	CCCFMIN 560P0F +5% -5% 50.0V NP0
C180	20506680	CCCFMIC 470P0F +5% -5% 50.0V NP0
C181	11058710	CCCFMIN 560P0F +5% -5% 50.0V NP0
C181	20506680	CCCFMIC 470P0F +5% -5% 50.0V NP0
C182	11058710	CCCFMIN 560P0F +5% -5% 50.0V NP0
C182	20506680	CCCFMIC 470P0F +5% -5% 50.0V NP0
C183	11058710	CCCFMIN 560P0F +5% -5% 50.0V NP0
C183	20506680	CCCFMIC 470P0F +5% -5% 50.0V NP0
C184	11058710	CCCFMIN 560P0F +5% -5% 50.0V NP0
C184	20506680	CCCFMIC 470P0F +5% -5% 50.0V NP0
C185	11058710	CCCFMIN 560P0F +5% -5% 50.0V NP0
C185	20506680	CCCFMIC 470P0F +5% -5% 50.0V NP0
C186	11058710	CCCFMIN 560P0F +5% -5% 50.0V NP0
C186	20506680	CCCFMIC 470P0F +5% -5% 50.0V NP0
C188	20506590	CCCFMIC 100P0F +5% -5% 50.0V NP0
C189	20506590	CCCFMIC 100P0F +5% -5% 50.0V NP0
C190	10138630	CCCFMIC 2N7F +10% -10% 50.0V X7R
C191	10138630	CCCFMIC 2N7F +10% -10% 50.0V X7R
C192	10138630	CCCFMIC 2N7F +10% -10% 50.0V X7R
C193	10138630	CCCFMIC 2N7F +10% -10% 50.0V X7R
C195	10138630	CCCFMIC 2N7F +10% -10% 50.0V X7R
C196	10138630	CCCFMIC 2N7F +10% -10% 50.0V X7R
C197	10138630	CCCFMIC 2N7F +10% -10% 50.0V X7R
C198	10138630	CCCFMIC 2N7F +10% -10% 50.0V X7R
C199	20288040	CCCFMIC 100N0F +80% -20% 16.0V Y5V
C2	10138960	CCCFMIC 10N0F +10% -10% 50.0V X7R
C201	20506590	CCCFMIC 100P0F +5% -5% 50.0V NP0
C202	20506590	CCCFMIC 100P0F +5% -5% 50.0V NP0
C203	10138550	CCCFMIC 1N0F +10% -10% 50.0V X7R
C205	20506590	CCCFMIC 100P0F +5% -5% 50.0V NP0
C206	20506590	CCCFMIC 100P0F +5% -5% 50.0V NP0
C218	20506590	CCCFMIC 100P0F +5% -5% 50.0V NP0
C219	20288040	CCCFMIC 100N0F +80% -20% 16.0V Y5V
C220	20288040	CCCFMIC 100N0F +80% -20% 16.0V Y5V
C223	20506590	CCCFMIC 100P0F +5% -5% 50.0V NP0
C224	20506590	CCCFMIC 100P0F +5% -5% 50.0V NP0
C225	20506590	CCCFMIC 100P0F +5% -5% 50.0V NP0
C226	10138550	CCCFMIC 1N0F +10% -10% 50.0V X7R
C227	20288040	CCCFMIC 100N0F +80% -20% 16.0V Y5V
C228	20288040	CCCFMIC 100N0F +80% -20% 16.0V Y5V
C233	20506520	CCCFMIC 22P0F +5% -5% 50.0V NP0
C235	20506590	CCCFMIC 100P0F +5% -5% 50.0V NP0
C236	10138960	CCCFMIC 10N0F +10% -10% 50.0V X7R
C237	20506590	CCCFMIC 100P0F +5% -5% 50.0V NP0
C238	10138550	CCCFMIC 1N0F +10% -10% 50.0V X7R

DSP board AVR5550

11/22

Pos	Tocom#	SName
C241	20288040	CCCFMIC 100N0F +80% -20% 16.0V Y5V
C245	20506590	CCCFMIC 100P0F +5% -5% 50.0V NP0
C246	20288040	CCCFMIC 100N0F +80% -20% 16.0V Y5V
C247	20288040	CCCFMIC 100N0F +80% -20% 16.0V Y5V
C249	20506590	CCCFMIC 100P0F +5% -5% 50.0V NP0
C250	10138550	CCCFMIC 1N0F +10% -10% 50.0V X7R
C251	20288040	CCCFMIC 100N0F +80% -20% 16.0V Y5V
C252	20288040	CCCFMIC 100N0F +80% -20% 16.0V Y5V
C254	20506520	CCCFMIC 22P0F +5% -5% 50.0V NP0
C255	10138960	CCCFMIC 10N0F +10% -10% 50.0V X7R
C257	20288040	CCCFMIC 100N0F +80% -20% 16.0V Y5V
C258	20288040	CCCFMIC 100N0F +80% -20% 16.0V Y5V
C259	20506590	CCCFMIC 100P0F +5% -5% 50.0V NP0
C260	20506590	CCCFMIC 100P0F +5% -5% 50.0V NP0
C261	10138550	CCCFMIC 1N0F +10% -10% 50.0V X7R
C264	20506590	CCCFMIC 100P0F +5% -5% 50.0V NP0
C265	20288040	CCCFMIC 100N0F +80% -20% 16.0V Y5V
C266	20288040	CCCFMIC 100N0F +80% -20% 16.0V Y5V
C267	20288040	CCCFMIC 100N0F +80% -20% 16.0V Y5V
C269	20506590	CCCFMIC 100P0F +5% -5% 50.0V NP0
C270	10138550	CCCFMIC 1N0F +10% -10% 50.0V X7R
C271	20288040	CCCFMIC 100N0F +80% -20% 16.0V Y5V
C272	20288040	CCCFMIC 100N0F +80% -20% 16.0V Y5V
C275	20288040	CCCFMIC 100N0F +80% -20% 16.0V Y5V
C276	20288040	CCCFMIC 100N0F +80% -20% 16.0V Y5V
C280	20288040	CCCFMIC 100N0F +80% -20% 16.0V Y5V
C283	20288040	CCCFMIC 100N0F +80% -20% 16.0V Y5V
C3	20506520	CCCFMIC 22P0F +5% -5% 50.0V NP0
C347	20288040	CCCFMIC 100N0F +80% -20% 16.0V Y5V
C348	20288040	CCCFMIC 100N0F +80% -20% 16.0V Y5V
C4	10138960	CCCFMIC 10N0F +10% -10% 50.0V X7R
C401	20506520	CCCFMIC 22P0F +5% -5% 50.0V NP0
C901	10138960	CCCFMIC 10N0F +10% -10% 50.0V X7R
D100	20496510	D-SLP 1SS355 35.0V 225MI0A
D102	20496510	D-SLP 1SS355 35.0V 225MI0A
IC01	55204170	IC-SWITCH NJU201AM ANALOG SWITCH
IC03	55142610	IC-OPERAMP NJM2068M DUAL OP
IC04	55204160	IC-CONV CS5360-KS A/D
IC05	55142610	IC-OPERAMP NJM2068M DUAL OP
IC06	55451460	IC-CONV CS4382-KQ 8CH D/A
IC07	55142610	IC-OPERAMP NJM2068M DUAL OP
IC08	55204160	IC-CONV CS5360-KS A/D
IC09	55133310	IC-LOGIC M74HCU04M1R INVERTER HCT
IC10	55204160	IC-CONV CS5360-KS A/D
IC11	55510180	IC-ASIC M4A3-32-10VC-12VI COMPLEX PLD
IC12	55519370	IC-MICROCONT CXP82852-377Q SUB AVR525
IC12	55645960	IC-MICROCONT CXP82852-383Q SUB AVR5550
IC13	55204160	IC-CONV CS5360-KS A/D
IC14	55133310	IC-LOGIC M74HCU04M1R INVERTER HCT
IC15	55157760	IC-EPROM AT27LV040A-90JC
IC16	55476130	IC-SPECFUNC AK4114VQ LQFP48 DIGITAL INTERFACE TRANS
IC17	55125380	IC-LOWFREQ CS493263-CL DSP
IC17	5512538A	IC-LOWFREQ CS493263-CL G VERSION DSP
IC17	5512538A	IC-LOWFREQ CS493263-CL G VERSION DSP
IC35	55142610	IC-OPERAMP NJM2068M DUAL OP

DSP board AVR5550

12/22

Pos	Tocom#	SName
L100	55126690	FBEAD SURFACE MT 2500OHM FCM2012H-252T02
L101	55126650	FBEAD SURFACE MT 300OHM FCM2012V-301T07
L102	55126650	FBEAD SURFACE MT 300OHM FCM2012V-301T07
L103	55126690	FBEAD SURFACE MT 2500OHM FCM2012H-252T02
L104	55126690	FBEAD SURFACE MT 2500OHM FCM2012H-252T02
L105	55126650	FBEAD SURFACE MT 300OHM FCM2012V-301T07
L106	55126690	FBEAD SURFACE MT 2500OHM FCM2012H-252T02
L107	55126690	FBEAD SURFACE MT 2500OHM FCM2012H-252T02
L109	55126650	FBEAD SURFACE MT 300OHM FCM2012V-301T07
L110	55126690	FBEAD SURFACE MT 2500OHM FCM2012H-252T02
L111	55126690	FBEAD SURFACE MT 2500OHM FCM2012H-252T02
L112	55126690	FBEAD SURFACE MT 2500OHM FCM2012H-252T02
L118	55126650	FBEAD SURFACE MT 300OHM FCM2012V-301T07
L999	55126650	FBEAD SURFACE MT 300OHM FCM2012V-301T07
Q100	55133180	TR-SSD DTC114YKA N 10K0 OHM 47K0 OHM
Q101	55133180	TR-SSD DTC114YKA N 10K0 OHM 47K0 OHM
Q102	55133190	TR-SSD DTA114YKA P 10K0 OHM 47K0 OHM
Q103	55138710	TR-SLPSWA KTD1304 N 20V 300MI0A
Q104	55133180	TR-SSD DTC114YKA N 10K0 OHM 47K0 OHM
R10	10134710	RMGCFMIC 75R0 OHM +5% 62MI5W
R100	10135770	RMGCFMIC 1K0 OHM +5% 62MI5W
R101	10135770	RMGCFMIC 1K0 OHM +5% 62MI5W
R102	10135220	RMGCFMIC 47K0 OHM +5% 62MI5W
R103	10135340	RMGCFMIC 100K0 OHM +5% 62MI5W
R104	10135340	RMGCFMIC 100K0 OHM +5% 62MI5W
R105	10135340	RMGCFMIC 100K0 OHM +5% 62MI5W
R106	10135340	RMGCFMIC 100K0 OHM +5% 62MI5W
R107	10135340	RMGCFMIC 100K0 OHM +5% 62MI5W
R108	10135340	RMGCFMIC 100K0 OHM +5% 62MI5W
R109	10135770	RMGCFMIC 1K0 OHM +5% 62MI5W
R11	10135220	RMGCFMIC 47K0 OHM +5% 62MI5W
R110	10135220	RMGCFMIC 47K0 OHM +5% 62MI5W
R111	10135770	RMGCFMIC 1K0 OHM +5% 62MI5W
R112	10135960	RMGCFMIC 5K6 OHM +5% 62MI5W
R113	10135960	RMGCFMIC 5K6 OHM +5% 62MI5W
R114	10134930	RMGCFMIC 560R0 OHM +5% 62MI5W
R115	10134930	RMGCFMIC 560R0 OHM +5% 62MI5W
R116	10135960	RMGCFMIC 5K6 OHM +5% 62MI5W
R117	10135960	RMGCFMIC 5K6 OHM +5% 62MI5W
R118	10134930	RMGCFMIC 560R0 OHM +5% 62MI5W
R119	10135790	RMGCFMIC 1K2 OHM +5% 62MI5W
R12	10134930	RMGCFMIC 560R0 OHM +5% 62MI5W
R120	10135790	RMGCFMIC 1K2 OHM +5% 62MI5W
R121	10134930	RMGCFMIC 560R0 OHM +5% 62MI5W
R122	10134930	RMGCFMIC 560R0 OHM +5% 62MI5W
R123	10135790	RMGCFMIC 1K2 OHM +5% 62MI5W
R124	10135790	RMGCFMIC 1K2 OHM +5% 62MI5W
R125	10134930	RMGCFMIC 560R0 OHM +5% 62MI5W
R126	10135010	RMGCFMIC 10K0 OHM +5% 62MI5W
R127	10135010	RMGCFMIC 10K0 OHM +5% 62MI5W
R128	10135790	RMGCFMIC 1K2 OHM +5% 62MI5W
R129	10135770	RMGCFMIC 1K0 OHM +5% 62MI5W
R130	10135770	RMGCFMIC 1K0 OHM +5% 62MI5W
R131	10135790	RMGCFMIC 1K2 OHM +5% 62MI5W
R132	10135770	RMGCFMIC 1K0 OHM +5% 62MI5W

DSP board AVR5550

Pos	Tocom#	SName
R133	10135790	RMGCFMIC 1K2 OHM +5% 62MI5W
R134	10135960	RMGCFMIC 5K6 OHM +5% 62MI5W
R135	10135960	RMGCFMIC 5K6 OHM +5% 62MI5W
R136	10135790	RMGCFMIC 1K2 OHM +5% 62MI5W
R137	10135790	RMGCFMIC 1K2 OHM +5% 62MI5W
R138	10135960	RMGCFMIC 5K6 OHM +5% 62MI5W
R139	10135960	RMGCFMIC 5K6 OHM +5% 62MI5W
R140	10135790	RMGCFMIC 1K2 OHM +5% 62MI5W
R141	10135770	RMGCFMIC 1K0 OHM +5% 62MI5W
R142	10135220	RMGCFMIC 47K0 OHM +5% 62MI5W
R143	10135770	RMGCFMIC 1K0 OHM +5% 62MI5W
R144	10135770	RMGCFMIC 1K0 OHM +5% 62MI5W
R145	10135930	RMGCFMIC 4K3 OHM +5% 62MI5W
R146	10135930	RMGCFMIC 4K3 OHM +5% 62MI5W
R147	10135930	RMGCFMIC 4K3 OHM +5% 62MI5W
R148	10135930	RMGCFMIC 4K3 OHM +5% 62MI5W
R149	10135930	RMGCFMIC 4K3 OHM +5% 62MI5W
R150	10135930	RMGCFMIC 4K3 OHM +5% 62MI5W
R151	10135930	RMGCFMIC 4K3 OHM +5% 62MI5W
R152	10135930	RMGCFMIC 4K3 OHM +5% 62MI5W
R153	10135770	RMGCFMIC 1K0 OHM +5% 62MI5W
R154	10135220	RMGCFMIC 47K0 OHM +5% 62MI5W
R155	10135220	RMGCFMIC 47K0 OHM +5% 62MI5W
R156	10134780	RMGCFMIC 150R0 OHM +5% 62MI5W
R157	10135010	RMGCFMIC 10K0 OHM +5% 62MI5W
R158	10134780	RMGCFMIC 150R0 OHM +5% 62MI5W
R159	10135010	RMGCFMIC 10K0 OHM +5% 62MI5W
R16	10135940	RMGCFMIC 4K7 OHM +5% 62MI5W
R160	10135010	RMGCFMIC 10K0 OHM +5% 62MI5W
R161	10135220	RMGCFMIC 47K0 OHM +5% 62MI5W
R162	10134410	RMGCFMIC 10R0 OHM +5% 62MI5W
R163	10135770	RMGCFMIC 1K0 OHM +5% 62MI5W
R164	10135340	RMGCFMIC 100K0 OHM +5% 62MI5W
R165	10135340	RMGCFMIC 100K0 OHM +5% 62MI5W
R166	10135340	RMGCFMIC 100K0 OHM +5% 62MI5W
R167	10135340	RMGCFMIC 100K0 OHM +5% 62MI5W
R168	10135090	RMGCFMIC 20K0 OHM +5% 62MI5W
R169	10135010	RMGCFMIC 10K0 OHM +5% 62MI5W
R17	10135940	RMGCFMIC 4K7 OHM +5% 62MI5W
R170	10135010	RMGCFMIC 10K0 OHM +5% 62MI5W
R171	10135770	RMGCFMIC 1K0 OHM +5% 62MI5W
R172	10135770	RMGCFMIC 1K0 OHM +5% 62MI5W
R173	10135220	RMGCFMIC 47K0 OHM +5% 62MI5W
R174	10135220	RMGCFMIC 47K0 OHM +5% 62MI5W
R175	10134780	RMGCFMIC 150R0 OHM +5% 62MI5W
R176	10135010	RMGCFMIC 10K0 OHM +5% 62MI5W
R177	10134780	RMGCFMIC 150R0 OHM +5% 62MI5W
R178	10135010	RMGCFMIC 10K0 OHM +5% 62MI5W
R179	10135010	RMGCFMIC 10K0 OHM +5% 62MI5W
R180	10134410	RMGCFMIC 10R0 OHM +5% 62MI5W
R181	10135960	RMGCFMIC 5K6 OHM +5% 62MI5W
R182	10135960	RMGCFMIC 5K6 OHM +5% 62MI5W
R183	10135960	RMGCFMIC 5K6 OHM +5% 62MI5W
R184	10135960	RMGCFMIC 5K6 OHM +5% 62MI5W
R185	10135090	RMGCFMIC 20K0 OHM +5% 62MI5W

DSP board AVR5550

14/22

Pos	Tocom#	SName
R186	10135010	RMGCFMIC 10K0 OHM +5% 62MI5W
R187	10135010	RMGCFMIC 10K0 OHM +5% 62MI5W
R188	10134930	RMGCFMIC 560R0 OHM +5% 62MI5W
R189	10135790	RMGCFMIC 1K2 OHM +5% 62MI5W
R190	10135790	RMGCFMIC 1K2 OHM +5% 62MI5W
R191	10134930	RMGCFMIC 560R0 OHM +5% 62MI5W
R192	10134930	RMGCFMIC 560R0 OHM +5% 62MI5W
R193	10135790	RMGCFMIC 1K2 OHM +5% 62MI5W
R194	10135790	RMGCFMIC 1K2 OHM +5% 62MI5W
R195	10134930	RMGCFMIC 560R0 OHM +5% 62MI5W
R196	10135940	RMGCFMIC 4K7 OHM +5% 62MI5W
R197	10135980	RMGCFMIC 6K8 OHM +5% 62MI5W
R198	10135790	RMGCFMIC 1K2 OHM +5% 62MI5W
R199	10135960	RMGCFMIC 5K6 OHM +5% 62MI5W
R200	10135960	RMGCFMIC 5K6 OHM +5% 62MI5W
R201	10135790	RMGCFMIC 1K2 OHM +5% 62MI5W
R202	10135790	RMGCFMIC 1K2 OHM +5% 62MI5W
R203	10135960	RMGCFMIC 5K6 OHM +5% 62MI5W
R204	10135960	RMGCFMIC 5K6 OHM +5% 62MI5W
R205	10135790	RMGCFMIC 1K2 OHM +5% 62MI5W
R206	10135770	RMGCFMIC 1K0 OHM +5% 62MI5W
R207	10135010	RMGCFMIC 10K0 OHM +5% 62MI5W
R208	10135930	RMGCFMIC 4K3 OHM +5% 62MI5W
R209	10135930	RMGCFMIC 4K3 OHM +5% 62MI5W
R21	10135940	RMGCFMIC 4K7 OHM +5% 62MI5W
R210	10135930	RMGCFMIC 4K3 OHM +5% 62MI5W
R211	10135930	RMGCFMIC 4K3 OHM +5% 62MI5W
R212	10135930	RMGCFMIC 4K3 OHM +5% 62MI5W
R213	10135930	RMGCFMIC 4K3 OHM +5% 62MI5W
R214	10135930	RMGCFMIC 4K3 OHM +5% 62MI5W
R215	10135930	RMGCFMIC 4K3 OHM +5% 62MI5W
R216	10135770	RMGCFMIC 1K0 OHM +5% 62MI5W
R217	10135220	RMGCFMIC 47K0 OHM +5% 62MI5W
R218	10134780	RMGCFMIC 150R0 OHM +5% 62MI5W
R219	10135010	RMGCFMIC 10K0 OHM +5% 62MI5W
R22	10135940	RMGCFMIC 4K7 OHM +5% 62MI5W
R220	10134780	RMGCFMIC 150R0 OHM +5% 62MI5W
R221	10135010	RMGCFMIC 10K0 OHM +5% 62MI5W
R222	10135220	RMGCFMIC 47K0 OHM +5% 62MI5W
R223	10134410	RMGCFMIC 10R0 OHM +5% 62MI5W
R224	10135770	RMGCFMIC 1K0 OHM +5% 62MI5W
R225	10135220	RMGCFMIC 47K0 OHM +5% 62MI5W
R226	10135090	RMGCFMIC 20K0 OHM +5% 62MI5W
R227	10135010	RMGCFMIC 10K0 OHM +5% 62MI5W
R228	10135010	RMGCFMIC 10K0 OHM +5% 62MI5W
R229	10135220	RMGCFMIC 47K0 OHM +5% 62MI5W
R230	10134780	RMGCFMIC 150R0 OHM +5% 62MI5W
R231	10135010	RMGCFMIC 10K0 OHM +5% 62MI5W
R232	10134780	RMGCFMIC 150R0 OHM +5% 62MI5W
R233	10135770	RMGCFMIC 1K0 OHM +5% 62MI5W
R234	10135220	RMGCFMIC 47K0 OHM +5% 62MI5W
R235	10135770	RMGCFMIC 1K0 OHM +5% 62MI5W
R236	10135090	RMGCFMIC 20K0 OHM +5% 62MI5W
R237	10135010	RMGCFMIC 10K0 OHM +5% 62MI5W
R238	10135010	RMGCFMIC 10K0 OHM +5% 62MI5W

DSP board AVR5550

15/22

Pos	Tocom#	SName
R239	10135010	RMGCFMIC 10K0 OHM +5% 62MI5W
R240	10135010	RMGCFMIC 10K0 OHM +5% 62MI5W
R241	10134410	RMGCFMIC 10R0 OHM +5% 62MI5W
R242	10135220	RMGCFMIC 47K0 OHM +5% 62MI5W
R243	10135860	RMGCFMIC 2K2 OHM +5% 62MI5W
R244	10134710	RMGCFMIC 75R0 OHM +5% 62MI5W
R245	10135220	RMGCFMIC 47K0 OHM +5% 62MI5W
R246	10134780	RMGCFMIC 150R0 OHM +5% 62MI5W
R247	10135010	RMGCFMIC 10K0 OHM +5% 62MI5W
R248	10134780	RMGCFMIC 150R0 OHM +5% 62MI5W
R249	10135010	RMGCFMIC 10K0 OHM +5% 62MI5W
R250	10135010	RMGCFMIC 10K0 OHM +5% 62MI5W
R251	10135220	RMGCFMIC 47K0 OHM +5% 62MI5W
R252	10134410	RMGCFMIC 10R0 OHM +5% 62MI5W
R253	10134410	RMGCFMIC 10R0 OHM +5% 62MI5W
R254	10134410	RMGCFMIC 10R0 OHM +5% 62MI5W
R255	10134410	RMGCFMIC 10R0 OHM +5% 62MI5W
R256	10134410	RMGCFMIC 10R0 OHM +5% 62MI5W
R257	10134410	RMGCFMIC 10R0 OHM +5% 62MI5W
R258	10134410	RMGCFMIC 10R0 OHM +5% 62MI5W
R259	10135220	RMGCFMIC 47K0 OHM +5% 62MI5W
R260	10135090	RMGCFMIC 20K0 OHM +5% 62MI5W
R261	10135010	RMGCFMIC 10K0 OHM +5% 62MI5W
R262	10135010	RMGCFMIC 10K0 OHM +5% 62MI5W
R263	10134930	RMGCFMIC 560R0 OHM +5% 62MI5W
R264	10135220	RMGCFMIC 47K0 OHM +5% 62MI5W
R265	10135860	RMGCFMIC 2K2 OHM +5% 62MI5W
R266	10135220	RMGCFMIC 47K0 OHM +5% 62MI5W
R267	10134780	RMGCFMIC 150R0 OHM +5% 62MI5W
R268	10135010	RMGCFMIC 10K0 OHM +5% 62MI5W
R269	10134780	RMGCFMIC 150R0 OHM +5% 62MI5W
R270	10135090	RMGCFMIC 20K0 OHM +5% 62MI5W
R271	10135010	RMGCFMIC 10K0 OHM +5% 62MI5W
R272	10135010	RMGCFMIC 10K0 OHM +5% 62MI5W
R273	10135010	RMGCFMIC 10K0 OHM +5% 62MI5W
R274	10135010	RMGCFMIC 10K0 OHM +5% 62MI5W
R275	10134410	RMGCFMIC 10R0 OHM +5% 62MI5W
R277	10135940	RMGCFMIC 4K7 OHM +5% 62MI5W
R278	10135940	RMGCFMIC 4K7 OHM +5% 62MI5W
R279	10134710	RMGCFMIC 75R0 OHM +5% 62MI5W
R280	10135770	RMGCFMIC 1K0 OHM +5% 62MI5W
R281	10135220	RMGCFMIC 47K0 OHM +5% 62MI5W
R282	10134410	RMGCFMIC 10R0 OHM +5% 62MI5W
R283	10134410	RMGCFMIC 10R0 OHM +5% 62MI5W
R284	10134410	RMGCFMIC 10R0 OHM +5% 62MI5W
R285	10134410	RMGCFMIC 10R0 OHM +5% 62MI5W
R286	10134410	RMGCFMIC 10R0 OHM +5% 62MI5W
R287	10134410	RMGCFMIC 10R0 OHM +5% 62MI5W
R288	10135220	RMGCFMIC 47K0 OHM +5% 62MI5W
R289	10134780	RMGCFMIC 150R0 OHM +5% 62MI5W
R290	10135010	RMGCFMIC 10K0 OHM +5% 62MI5W
R291	10134780	RMGCFMIC 150R0 OHM +5% 62MI5W
R292	10135010	RMGCFMIC 10K0 OHM +5% 62MI5W
R293	10135010	RMGCFMIC 10K0 OHM +5% 62MI5W
R294	10135220	RMGCFMIC 47K0 OHM +5% 62MI5W

DSP board AVR5550

16/22

Pos	Tocom#	SName
R295	10134410	RMGCFMIC 10R0 OHM +5% 62MI5W
R296	10134930	RMGCFMIC 560R0 OHM +5% 62MI5W
R297	10135090	RMGCFMIC 20K0 OHM +5% 62MI5W
R298	10135010	RMGCFMIC 10K0 OHM +5% 62MI5W
R299	10135010	RMGCFMIC 10K0 OHM +5% 62MI5W
R300	10135220	RMGCFMIC 47K0 OHM +5% 62MI5W
R301	10134780	RMGCFMIC 150R0 OHM +5% 62MI5W
R302	10135010	RMGCFMIC 10K0 OHM +5% 62MI5W
R303	10134780	RMGCFMIC 150R0 OHM +5% 62MI5W
R304	10135090	RMGCFMIC 20K0 OHM +5% 62MI5W
R305	10135010	RMGCFMIC 10K0 OHM +5% 62MI5W
R306	10135010	RMGCFMIC 10K0 OHM +5% 62MI5W
R307	10135010	RMGCFMIC 10K0 OHM +5% 62MI5W
R308	10135010	RMGCFMIC 10K0 OHM +5% 62MI5W
R309	10134410	RMGCFMIC 10R0 OHM +5% 62MI5W
R310	10135770	RMGCFMIC 1K0 OHM +5% 62MI5W
R312	10135860	RMGCFMIC 2K2 OHM +5% 62MI5W
R319	10135220	RMGCFMIC 47K0 OHM +5% 62MI5W
R320	10135770	RMGCFMIC 1K0 OHM +5% 62MI5W
R322	10135010	RMGCFMIC 10K0 OHM +5% 62MI5W
R323	10135010	RMGCFMIC 10K0 OHM +5% 62MI5W
R324	10135010	RMGCFMIC 10K0 OHM +5% 62MI5W
R325	10135010	RMGCFMIC 10K0 OHM +5% 62MI5W
R326	10135010	RMGCFMIC 10K0 OHM +5% 62MI5W
R327	10135010	RMGCFMIC 10K0 OHM +5% 62MI5W
R328	10135010	RMGCFMIC 10K0 OHM +5% 62MI5W
R329	10135010	RMGCFMIC 10K0 OHM +5% 62MI5W
R330	10135010	RMGCFMIC 10K0 OHM +5% 62MI5W
R331	10134940	RMGCFMIC 620R0 OHM +5% 62MI5W
R333	10134410	RMGCFMIC 10R0 OHM +5% 62MI5W
R335	10134410	RMGCFMIC 10R0 OHM +5% 62MI5W
R335	10134830	RMGCFMIC 220R0 OHM +5% 62MI5W
R336	10134410	RMGCFMIC 10R0 OHM +5% 62MI5W
R336	10134830	RMGCFMIC 220R0 OHM +5% 62MI5W
R337	10134740	RMGCFMIC 100R0 OHM +5% 62MI5W
R338	10134940	RMGCFMIC 620R0 OHM +5% 62MI5W
R339	10134740	RMGCFMIC 100R0 OHM +5% 62MI5W
R347	10134410	RMGCFMIC 10R0 OHM +5% 62MI5W
R348	10134410	RMGCFMIC 10R0 OHM +5% 62MI5W
R350	10134410	RMGCFMIC 10R0 OHM +5% 62MI5W
R351	10134410	RMGCFMIC 10R0 OHM +5% 62MI5W
R352	10135010	RMGCFMIC 10K0 OHM +5% 62MI5W
R353	10134410	RMGCFMIC 10R0 OHM +5% 62MI5W
R355	10135010	RMGCFMIC 10K0 OHM +5% 62MI5W
R356	10134410	RMGCFMIC 10R0 OHM +5% 62MI5W
R357	10134410	RMGCFMIC 10R0 OHM +5% 62MI5W
R357	10134740	RMGCFMIC 100R0 OHM +5% 62MI5W
R359	10134950	RMGCFMIC 680R0 OHM +5% 62MI5W
R360	10134940	RMGCFMIC 620R0 OHM +5% 62MI5W
R361	10134560	RMGCFMIC 27R0 OHM +5% 62MI5W
R361	10134650	RMGCFMIC 47R0 OHM +5% 62MI5W
R362	10134410	RMGCFMIC 10R0 OHM +5% 62MI5W
R363	10134410	RMGCFMIC 10R0 OHM +5% 62MI5W
R364	10135010	RMGCFMIC 10K0 OHM +5% 62MI5W
R365	10134410	RMGCFMIC 10R0 OHM +5% 62MI5W

DSP board AVR5550

17/22

Pos	Tocom#	SName
R365	10134830	RMGCFMIC 220R0 OHM +5% 62MI5W
R366	10135940	RMGCFMIC 4K7 OHM +5% 62MI5W
R367	10134740	RMGCFMIC 100R0 OHM +5% 62MI5W
R368	10135010	RMGCFMIC 10K0 OHM +5% 62MI5W
R369	10135010	RMGCFMIC 10K0 OHM +5% 62MI5W
R370	10135010	RMGCFMIC 10K0 OHM +5% 62MI5W
R371	10135010	RMGCFMIC 10K0 OHM +5% 62MI5W
R372	10134410	RMGCFMIC 10R0 OHM +5% 62MI5W
R372	10134830	RMGCFMIC 220R0 OHM +5% 62MI5W
R373	10134410	RMGCFMIC 10R0 OHM +5% 62MI5W
R373	10134830	RMGCFMIC 220R0 OHM +5% 62MI5W
R374	10135010	RMGCFMIC 10K0 OHM +5% 62MI5W
R375	10134410	RMGCFMIC 10R0 OHM +5% 62MI5W
R375	10134830	RMGCFMIC 220R0 OHM +5% 62MI5W
R376	10134410	RMGCFMIC 10R0 OHM +5% 62MI5W
R377	10134410	RMGCFMIC 10R0 OHM +5% 62MI5W
R378	10134410	RMGCFMIC 10R0 OHM +5% 62MI5W
R4	10135940	RMGCFMIC 4K7 OHM +5% 62MI5W
R425	10134410	RMGCFMIC 10R0 OHM +5% 62MI5W
R434	10134410	RMGCFMIC 10R0 OHM +5% 62MI5W
R5	10135940	RMGCFMIC 4K7 OHM +5% 62MI5W
R6	10135940	RMGCFMIC 4K7 OHM +5% 62MI5W
R7	10135940	RMGCFMIC 4K7 OHM +5% 62MI5W
R8	10135940	RMGCFMIC 4K7 OHM +5% 62MI5W
R9	10135940	RMGCFMIC 4K7 OHM +5% 62MI5W
R901	10134740	RMGCFMIC 100R0 OHM +5% 62MI5W
R902	10134740	RMGCFMIC 100R0 OHM +5% 62MI5W
R903	10134740	RMGCFMIC 100R0 OHM +5% 62MI5W
R904	10134740	RMGCFMIC 100R0 OHM +5% 62MI5W
R905	10134740	RMGCFMIC 100R0 OHM +5% 62MI5W
R908	10135940	RMGCFMIC 4K7 OHM +5% 62MI5W
R909	10328750	RMGCFMIC 0 OHM +0% 62MI5W
R910	20288040	CCCFMIC 100N0F +80% -20% 16.0V Y5V
C103	20342060	CE 47U0F +20% 16.0V 85C
C106	10121000	CE 10U0F +20% 16.0V 85C
C107	20342060	CE 47U0F +20% 16.0V 85C
C108	10121000	CE 10U0F +20% 16.0V 85C
C109	10121000	CE 10U0F +20% 16.0V 85C
C110	10121000	CE 10U0F +20% 16.0V 85C
C111	10121000	CE 10U0F +20% 16.0V 85C
C112	10121000	CE 10U0F +20% 16.0V 85C
C113	10121000	CE 10U0F +20% 16.0V 85C
C114	10121000	CE 10U0F +20% 16.0V 85C
C133	10121000	CE 10U0F +20% 16.0V 85C
C142	20269020	CE 100U0F +20% 16.0V 85C
C143	10121000	CE 10U0F +20% 16.0V 85C
C144	10121000	CE 10U0F +20% 16.0V 85C
C146	10121000	CE 10U0F +20% 16.0V 85C
C147	10121000	CE 10U0F +20% 16.0V 85C
C148	10121000	CE 10U0F +20% 16.0V 85C
C149	10121000	CE 10U0F +20% 16.0V 85C
C150	10121000	CE 10U0F +20% 16.0V 85C
C151	10121000	CE 10U0F +20% 16.0V 85C
C152	10121000	CE 10U0F +20% 16.0V 85C
C153	10121000	CE 10U0F +20% 16.0V 85C

DSP board AVR5550

18/22

Pos	Tocom#	SName
C158	10121000	CE 10U0F +20% 16.0V 85C
C159	10244270	CE 100U0F +20% 16.0V 85C
C160	10244270	CE 100U0F +20% 16.0V 85C
C161	10121000	CE 10U0F +20% 16.0V 85C
C162	10121000	CE 10U0F +20% 16.0V 85C
C163	10121000	CE 10U0F +20% 16.0V 85C
C164	10121000	CE 10U0F +20% 16.0V 85C
C165	20269020	CE 100U0F +20% 16.0V 85C
C168	10121000	CE 10U0F +20% 16.0V 85C
C172	10121000	CE 10U0F +20% 16.0V 85C
C175	10121000	CE 10U0F +20% 16.0V 85C
C178	10244270	CE 100U0F +20% 16.0V 85C
C187	10121000	CE 10U0F +20% 16.0V 85C
C194	20342060	CE 47U0F +20% 16.0V 85C
C200	10121000	CE 10U0F +20% 16.0V 85C
C204	10121000	CE 10U0F +20% 16.0V 85C
C207	10121000	CE 10U0F +20% 16.0V 85C
C208	10244270	CE 100U0F +20% 16.0V 85C
C209	10244270	CE 100U0F +20% 16.0V 85C
C210	10121000	CE 10U0F +20% 16.0V 85C
C211	10121000	CE 10U0F +20% 16.0V 85C
C212	10121000	CE 10U0F +20% 16.0V 85C
C213	10121000	CE 10U0F +20% 16.0V 85C
C214	10121000	CE 10U0F +20% 16.0V 85C
C215	10121000	CE 10U0F +20% 16.0V 85C
C216	10121000	CE 10U0F +20% 16.0V 85C
C217	10121000	CE 10U0F +20% 16.0V 85C
C221	10121000	CE 10U0F +20% 16.0V 85C
C222	10121000	CE 10U0F +20% 16.0V 85C
C229	10244270	CE 100U0F +20% 16.0V 85C
C234	10121000	CE 10U0F +20% 16.0V 85C
C242	10244270	CE 100U0F +20% 16.0V 85C
C243	10244270	CE 100U0F +20% 16.0V 85C
C244	10121000	CE 10U0F +20% 16.0V 85C
C248	10121000	CE 10U0F +20% 16.0V 85C
C253	10244270	CE 100U0F +20% 16.0V 85C
C256	10121000	CE 10U0F +20% 16.0V 85C
C262	10244270	CE 100U0F +20% 16.0V 85C
C263	10244270	CE 100U0F +20% 16.0V 85C
C268	10121000	CE 10U0F +20% 16.0V 85C
C273	10244270	CE 100U0F +20% 16.0V 85C
C274	10121000	CE 10U0F +20% 16.0V 85C
C278	10121000	CE 10U0F +20% 16.0V 85C
C279	20268850	CE 2U2F +20% 50.0V 85C
C281	20268830	CE 470N0F +20% 50.0V 85C
C282	10121000	CE 10U0F +20% 16.0V 85C
C284	10121000	CE 10U0F +20% 16.0V 85C
C285	10244270	CE 100U0F +20% 16.0V 85C
C232	20288040	CCCFMIC 100N0F +80% -20% 16.0V Y5V
C286	20288040	CCCFMIC 100N0F +80% -20% 16.0V Y5V
C288	20288040	CCCFMIC 100N0F +80% -20% 16.0V Y5V
C289	20288040	CCCFMIC 100N0F +80% -20% 16.0V Y5V
C290	20288040	CCCFMIC 100N0F +80% -20% 16.0V Y5V
C291	20288040	CCCFMIC 100N0F +80% -20% 16.0V Y5V
C292	20288040	CCCFMIC 100N0F +80% -20% 16.0V Y5V

DSP board AVR5550

19/22

Pos	Tocom#	SName
C293	20288040	CCCFMIC 100N0F +80% -20% 16.0V Y5V
C294	20288040	CCCFMIC 100N0F +80% -20% 16.0V Y5V
C295	20288040	CCCFMIC 100N0F +80% -20% 16.0V Y5V
C296	20288040	CCCFMIC 100N0F +80% -20% 16.0V Y5V
C297	20288040	CCCFMIC 100N0F +80% -20% 16.0V Y5V
C298	20288040	CCCFMIC 100N0F +80% -20% 16.0V Y5V
C299	20288040	CCCFMIC 100N0F +80% -20% 16.0V Y5V
C300	20288040	CCCFMIC 100N0F +80% -20% 16.0V Y5V
C301	20288040	CCCFMIC 100N0F +80% -20% 16.0V Y5V
C302	20288040	CCCFMIC 100N0F +80% -20% 16.0V Y5V
C303	20288040	CCCFMIC 100N0F +80% -20% 16.0V Y5V
C304	20288040	CCCFMIC 100N0F +80% -20% 16.0V Y5V
C305	20288040	CCCFMIC 100N0F +80% -20% 16.0V Y5V
C306	20288040	CCCFMIC 100N0F +80% -20% 16.0V Y5V
C307	20288040	CCCFMIC 100N0F +80% -20% 16.0V Y5V
C308	20288040	CCCFMIC 100N0F +80% -20% 16.0V Y5V
C309	20288040	CCCFMIC 100N0F +80% -20% 16.0V Y5V
C310	20288040	CCCFMIC 100N0F +80% -20% 16.0V Y5V
C311	20288040	CCCFMIC 100N0F +80% -20% 16.0V Y5V
C312	20288040	CCCFMIC 100N0F +80% -20% 16.0V Y5V
C313	20288040	CCCFMIC 100N0F +80% -20% 16.0V Y5V
C314	20288040	CCCFMIC 100N0F +80% -20% 16.0V Y5V
C315	20288040	CCCFMIC 100N0F +80% -20% 16.0V Y5V
C316	20288040	CCCFMIC 100N0F +80% -20% 16.0V Y5V
C317	20288040	CCCFMIC 100N0F +80% -20% 16.0V Y5V
C318	20288040	CCCFMIC 100N0F +80% -20% 16.0V Y5V
C319	20288040	CCCFMIC 100N0F +80% -20% 16.0V Y5V
C320	20288040	CCCFMIC 100N0F +80% -20% 16.0V Y5V
C321	20288040	CCCFMIC 100N0F +80% -20% 16.0V Y5V
C322	20288040	CCCFMIC 100N0F +80% -20% 16.0V Y5V
C323	20288040	CCCFMIC 100N0F +80% -20% 16.0V Y5V
C324	20288040	CCCFMIC 100N0F +80% -20% 16.0V Y5V
C325	20288040	CCCFMIC 100N0F +80% -20% 16.0V Y5V
C326	20288040	CCCFMIC 100N0F +80% -20% 16.0V Y5V
C327	20288040	CCCFMIC 100N0F +80% -20% 16.0V Y5V
C328	20288040	CCCFMIC 100N0F +80% -20% 16.0V Y5V
C329	20288040	CCCFMIC 100N0F +80% -20% 16.0V Y5V
C330	20288040	CCCFMIC 100N0F +80% -20% 16.0V Y5V
C331	20288040	CCCFMIC 100N0F +80% -20% 16.0V Y5V
C332	20288040	CCCFMIC 100N0F +80% -20% 16.0V Y5V
C333	20288040	CCCFMIC 100N0F +80% -20% 16.0V Y5V
C334	20288040	CCCFMIC 100N0F +80% -20% 16.0V Y5V
C335	20288040	CCCFMIC 100N0F +80% -20% 16.0V Y5V
C336	20288040	CCCFMIC 100N0F +80% -20% 16.0V Y5V
C337	20288040	CCCFMIC 100N0F +80% -20% 16.0V Y5V
C338	20288040	CCCFMIC 100N0F +80% -20% 16.0V Y5V
C339	20678070	CCCFMIC 330P0F +5% -5% 50.0V NP0
C340	20288040	CCCFMIC 100N0F +80% -20% 16.0V Y5V
C341	20288060	CCCFMIC 220N0F +80% -20% 16.0V Y5V
C342	20678070	CCCFMIC 330P0F +5% -5% 50.0V NP0
C343	20288040	CCCFMIC 100N0F +80% -20% 16.0V Y5V
C344	20288040	CCCFMIC 100N0F +80% -20% 16.0V Y5V
C345	20506640	CCCFMIC 220P0F +5% -5% 50.0V NP0
C346	20288040	CCCFMIC 100N0F +80% -20% 16.0V Y5V
C349	20288040	CCCFMIC 100N0F +80% -20% 16.0V Y5V

DSP board AVR5550

20/22

Pos	Tocom#	SName
C350	20288040	CCCFMIC 100N0F +80% -20% 16.0V Y5V
C351	20288040	CCCFMIC 100N0F +80% -20% 16.0V Y5V
C352	20288040	CCCFMIC 100N0F +80% -20% 16.0V Y5V
C400	20288040	CCCFMIC 100N0F +80% -20% 16.0V Y5V
D103	20496510	D-SLP 1SS355 35.0V 225M10A
IC18	55142610	IC-OPERAMP NJM2068M DUAL OP
IC19	55142610	IC-OPERAMP NJM2068M DUAL OP
IC20	55142610	IC-OPERAMP NJM2068M DUAL OP
IC21	55142610	IC-OPERAMP NJM2068M DUAL OP
IC22	55142610	IC-OPERAMP NJM2068M DUAL OP
IC23	55142610	IC-OPERAMP NJM2068M DUAL OP
IC24	55142610	IC-OPERAMP NJM2068M DUAL OP
IC25	55142610	IC-OPERAMP NJM2068M DUAL OP
IC26	55142610	IC-OPERAMP NJM2068M DUAL OP
IC27	55142610	IC-OPERAMP NJM2068M DUAL OP
IC28	55125420	IC-LOGIC 74VHC244MX INVERTER CMOS
IC28	55125420	IC-LOGIC 74VHC244MX INVERTER CMOS
IC29	55142610	IC-OPERAMP NJM2068M DUAL OP
IC30	55142610	IC-OPERAMP NJM2068M DUAL OP
IC31	55142610	IC-OPERAMP NJM2068M DUAL OP
IC33	55170220	IC-LOGIC F/F 74VHC574MX FLIP/FLOP HCMOS
IC33	55170220	IC-LOGIC F/F 74VHC574MX FLIP/FLOP HCMOS
IC34	55170220	IC-LOGIC F/F 74VHC574MX FLIP/FLOP HCMOS
IC34	55170220	IC-LOGIC F/F 74VHC574MX FLIP/FLOP HCMOS
L113	55126690	FBEAD SURFACE MT 2500OHM FCM2012H-252T02
L114	55126650	FBEAD SURFACE MT 300OHM FCM2012V-301T07
L115	55126690	FBEAD SURFACE MT 2500OHM FCM2012H-252T02
L116	55126650	FBEAD SURFACE MT 300OHM FCM2012V-301T07
L117	55126690	FBEAD SURFACE MT 2500OHM FCM2012H-252T02
L120	55126690	FBEAD SURFACE MT 2500OHM FCM2012H-252T02
L121	55126690	FBEAD SURFACE MT 2500OHM FCM2012H-252T02
L122	55126650	FBEAD SURFACE MT 300OHM FCM2012V-301T07
Q105	55138710	TR-SLPSWA KTD1304 N 20V 300M10A
Q106	55133190	TR-SSD DTA114YKA P 10K0 OHM 47K0 OHM
R1	10135940	RMGCFMIC 4K7 OHM +5% 62MI5W
R15	10328750	RMGCFMIC 0 OHM +0% 62MI5W
R16	10135940	RMGCFMIC 4K7 OHM +5% 62MI5W
R17	10135940	RMGCFMIC 4K7 OHM +5% 62MI5W
R2	10135940	RMGCFMIC 4K7 OHM +5% 62MI5W
R20	10134540	RMGCFMIC 22R0 OHM +5% 62MI5W
R20	10328750	RMGCFMIC 0 OHM +0% 62MI5W
R21	10135940	RMGCFMIC 4K7 OHM +5% 62MI5W
R22	10135940	RMGCFMIC 4K7 OHM +5% 62MI5W
R276	10135010	RMGCFMIC 10K0 OHM +5% 62MI5W
R3	10135940	RMGCFMIC 4K7 OHM +5% 62MI5W
R313	20740280	RMGCFMIC 3R3 OHM +5% 62MI5W
R314	20740280	RMGCFMIC 3R3 OHM +5% 62MI5W
R379	10134740	RMGCFMIC 100R0 OHM +5% 62MI5W
R380	10134780	RMGCFMIC 150R0 OHM +5% 62MI5W
R381	10135340	RMGCFMIC 100K0 OHM +5% 62MI5W
R382	10135340	RMGCFMIC 100K0 OHM +5% 62MI5W
R385	10135340	RMGCFMIC 100K0 OHM +5% 62MI5W
R386	10134740	RMGCFMIC 100R0 OHM +5% 62MI5W
R387	10135340	RMGCFMIC 100K0 OHM +5% 62MI5W
R388	10134780	RMGCFMIC 150R0 OHM +5% 62MI5W

DSP board AVR5550

Pos	Tocom#	SName
R389	10134780	RMGCFMIC 150R0 OHM +5% 62MI5W
R390	10135340	RMGCFMIC 100K0 OHM +5% 62MI5W
R391	10135340	RMGCFMIC 100K0 OHM +5% 62MI5W
R392	10135340	RMGCFMIC 100K0 OHM +5% 62MI5W
R393	10135340	RMGCFMIC 100K0 OHM +5% 62MI5W
R394	10134780	RMGCFMIC 150R0 OHM +5% 62MI5W
R396	10135940	RMGCFMIC 4K7 OHM +5% 62MI5W
R397	10134780	RMGCFMIC 150R0 OHM +5% 62MI5W
R398	10135940	RMGCFMIC 4K7 OHM +5% 62MI5W
R399	10135340	RMGCFMIC 100K0 OHM +5% 62MI5W
R400	10135340	RMGCFMIC 100K0 OHM +5% 62MI5W
R401	10135340	RMGCFMIC 100K0 OHM +5% 62MI5W
R402	10135340	RMGCFMIC 100K0 OHM +5% 62MI5W
R403	10134780	RMGCFMIC 150R0 OHM +5% 62MI5W
R404	10134780	RMGCFMIC 150R0 OHM +5% 62MI5W
R405	10135940	RMGCFMIC 4K7 OHM +5% 62MI5W
R407	10135340	RMGCFMIC 100K0 OHM +5% 62MI5W
R408	10135340	RMGCFMIC 100K0 OHM +5% 62MI5W
R409	10135940	RMGCFMIC 4K7 OHM +5% 62MI5W
R410	10135340	RMGCFMIC 100K0 OHM +5% 62MI5W
R411	10135340	RMGCFMIC 100K0 OHM +5% 62MI5W
R412	10134780	RMGCFMIC 150R0 OHM +5% 62MI5W
R413	10135940	RMGCFMIC 4K7 OHM +5% 62MI5W
R415	10135940	RMGCFMIC 4K7 OHM +5% 62MI5W
R416	10135940	RMGCFMIC 4K7 OHM +5% 62MI5W
R418	10135940	RMGCFMIC 4K7 OHM +5% 62MI5W
R421	10135900	RMGCFMIC 3K3 OHM +5% 62MI5W
R422	10135900	RMGCFMIC 3K3 OHM +5% 62MI5W
R423	10135010	RMGCFMIC 10K0 OHM +5% 62MI5W
R424	10135080	RMGCFMIC 18K0 OHM +5% 62MI5W
R428	10135010	RMGCFMIC 10K0 OHM +5% 62MI5W
R429	10135940	RMGCFMIC 4K7 OHM +5% 62MI5W
R430	10135900	RMGCFMIC 3K3 OHM +5% 62MI5W
R431	10135010	RMGCFMIC 10K0 OHM +5% 62MI5W
R432	10135010	RMGCFMIC 10K0 OHM +5% 62MI5W
R433	10135900	RMGCFMIC 3K3 OHM +5% 62MI5W
R907	10134830	RMGCFMIC 220R0 OHM +5% 62MI5W
C108	10121000	CE 10U0F +20% 16.0V 85C
C109	10121000	CE 10U0F +20% 16.0V 85C
C112	10121000	CE 10U0F +20% 16.0V 85C
C113	10121000	CE 10U0F +20% 16.0V 85C
C144	10121000	CE 10U0F +20% 16.0V 85C
C163	10121000	CE 10U0F +20% 16.0V 85C
C172	10121000	CE 10U0F +20% 16.0V 85C
C200	10121000	CE 10U0F +20% 16.0V 85C
C214	10121000	CE 10U0F +20% 16.0V 85C
C215	10121000	CE 10U0F +20% 16.0V 85C
C216	10121000	CE 10U0F +20% 16.0V 85C
C222	10121000	CE 10U0F +20% 16.0V 85C
C230	20269180	CE 1MI0F +20% 6.3V 85C
C231	20269180	CE 1MI0F +20% 6.3V 85C
C234	10121000	CE 10U0F +20% 16.0V 85C
C239	20269180	CE 1MI0F +20% 6.3V 85C
C240	20269180	CE 1MI0F +20% 6.3V 85C
C248	10121000	CE 10U0F +20% 16.0V 85C

DSP board AVR5550

22/22

Pos	Tocom#	SName
C256	10121000	CE 10U0F +20% 16.0V 85C
C268	10121000	CE 10U0F +20% 16.0V 85C
C500	20506570	CCCFMIC 47P0F +5% -5% 50.0V NP0
N400	55174670	CONN 2.0MM 19 MA R NAT SOCKET MOLEX 35237-1910 0 0
N401	55164150	WIRECONASY UNIQUE 4P 160MM UL1007 PVC DISCRETE 26 1
N401	55164170	WIRECONASY UNIQUE 4P 140MM UL1007 PVC DISCRETE 26 1
N402	55504060	WIRECONASY DL 2.0MM 15P 100MM UL1533 SHIELD 26 1
N402	55597160	WIRECONASY DL 2.0MM 15P 110MM UL1533 SHIELD 26 1
N403	55504120	WIRECONASY DL 2.0MM 3P 100MM UL2547 26 1
N403	55597170	WIRECONASY DL 2.0MM 3P 110MM UL2547 26 1
N404	55504060	WIRECONASY DL 2.0MM 15P 100MM UL1533 SHIELD 26 1
N404	55597160	WIRECONASY DL 2.0MM 15P 110MM UL1533 SHIELD 26 1
NJ71	55191450	CON PHONO SCKT RCA 4P JW-4104RSC
NJ72	55191420	CON PHONO SCKT RCA 4P JW-4104RSA
NJ73	55191600	CON PHONO SCKT RCA 2P W/GND CAP JW-1502SN OO
NJ74	55125430	D-LEM TORX178B RD RND CL
NJ75	55125430	D-LEM TORX178B RD RND CL
NJ76	55125440	D-LEM TOTX178B RD RND CL
NJ77	55246370	CON PHONO SCKT RCA 1P W/GND JE010003LN OG
P102	55598650	CON 2.54MM PITCH 8P HEADER LW0640-08 2.5MM PITCH
P402	55123320	CONN 2.0MM 5 MA ST NAT LW2002P05 0 0
P403	55090050	CONN 2.0MM 10 MA ST NAT LW2002P10 0 0
SK10	55179930	RELAYPWR 5.0V 166.0OHM 1.0A 24.0V
T100	55176550	TFPULSE TRANSFORMER 110UH FP-120 FERRIT MAGNET
T101	55176540	TFPULSE TRANSFORMER 110UH FP-110 FERRIT MAGNET
W402	55622850	WCL 330-05-05 UL1007 HOOK-UP 16 330MM BK 5 5 55622750
Y100	55126140	CRESONATOR 10M0 HZ 25.0 OHM 0F
Y101	55348350	VCXO 12M288 HZ +50 PPM -50 PPM 0 OHM 3.3V

MAIN board AVR5550

1/11

Pos	Tocom#	SName
80	55178320	SCREW-ST 3MM 12MM JIS B 1122 53 0 A4
90	55127310	WASHER 3.3MM 8.0MM 0.5MM Y 53 0 A4
C101	20936650	CC 100P0F +10% -10% 50.0V Y5P
C102	20936650	CC 100P0F +10% -10% 50.0V Y5P
C103	20936650	CC 100P0F +10% -10% 50.0V Y5P
C104	20936650	CC 100P0F +10% -10% 50.0V Y5P
C107	20936650	CC 100P0F +10% -10% 50.0V Y5P
C108	20936650	CC 100P0F +10% -10% 50.0V Y5P
C109	20936650	CC 100P0F +10% -10% 50.0V Y5P
C110	20936650	CC 100P0F +10% -10% 50.0V Y5P
C111	20936650	CC 100P0F +10% -10% 50.0V Y5P
C112	20936650	CC 100P0F +10% -10% 50.0V Y5P
C113	20936650	CC 100P0F +10% -10% 50.0V Y5P
C114	20936650	CC 100P0F +10% -10% 50.0V Y5P
C115	20936650	CC 100P0F +10% -10% 50.0V Y5P
C116	20936650	CC 100P0F +10% -10% 50.0V Y5P
C117	20936650	CC 100P0F +10% -10% 50.0V Y5P
C118	20936650	CC 100P0F +10% -10% 50.0V Y5P
C119	20246470	CC 100N0F +80% -20% 25.0V Z5V
C119	20293470	CC 100N0F +80% -20% 50.0V F
C120	20246470	CC 100N0F +80% -20% 25.0V Z5V
C120	20293470	CC 100N0F +80% -20% 50.0V F
C209	20936650	CC 100P0F +10% -10% 50.0V Y5P
C307	20762640	CC 270P0F +10% -10% 50.0V 2B4
C308	20762640	CC 270P0F +10% -10% 50.0V 2B4
C313	55126070	CC 680P0F +10% -10% 50.0V 2B4
C314	55126070	CC 680P0F +10% -10% 50.0V 2B4
C329	20737600	CC 2N2F +80% -20% 16.0V 3F4
C330	20737600	CC 2N2F +80% -20% 16.0V 3F4
C333	20513990	CC 4N7F +20% -20% 16.0V Y5R
C403	20762640	CC 270P0F +10% -10% 50.0V 2B4
C404	20762640	CC 270P0F +10% -10% 50.0V 2B4
C425	20737600	CC 2N2F +80% -20% 16.0V 3F4
C426	20737600	CC 2N2F +80% -20% 16.0V 3F4
C433	20449010	CC 10N0F +20% -20% 16.0V Y5S
C434	20513990	CC 4N7F +20% -20% 16.0V Y5R
C527	20293470	CC 100N0F +80% -20% 50.0V F
C569	55126070	CC 680P0F +10% -10% 50.0V 2B4
C570	55126070	CC 680P0F +10% -10% 50.0V 2B4
C601	20449010	CC 10N0F +20% -20% 16.0V Y5S
C602	20449010	CC 10N0F +20% -20% 16.0V Y5S
D204	55178040	D-ZENER MTZJ 12.0V 500MI0W
D205	70436540	D-SLP 1N4148 100.0V 150E-3A
D206	70436540	D-SLP 1N4148 100.0V 150E-3A
D207	20526960	D-ZENER 1N5231B 5.1V 500MI0W
D301	70436540	D-SLP 1N4148 100.0V 150E-3A
D302	70436540	D-SLP 1N4148 100.0V 150E-3A
D303	70436540	D-SLP 1N4148 100.0V 150E-3A
D304	70436540	D-SLP 1N4148 100.0V 150E-3A
D305	70436540	D-SLP 1N4148 100.0V 150E-3A
D306	70436540	D-SLP 1N4148 100.0V 150E-3A
D307	70436540	D-SLP 1N4148 100.0V 150E-3A
D308	70436540	D-SLP 1N4148 100.0V 150E-3A
D401	70436540	D-SLP 1N4148 100.0V 150E-3A
D402	70436540	D-SLP 1N4148 100.0V 150E-3A
D403	70436540	D-SLP 1N4148 100.0V 150E-3A

MAIN board AVR5550

2/11

Pos	Tocom#	SName
D404	70436540	D-SLP 1N4148 100.0V 150E-3A
D405	70436540	D-SLP 1N4148 100.0V 150E-3A
D406	70436540	D-SLP 1N4148 100.0V 150E-3A
D407	70436540	D-SLP 1N4148 100.0V 150E-3A
D408	70436540	D-SLP 1N4148 100.0V 150E-3A
D409	70436540	D-SLP 1N4148 100.0V 150E-3A
D410	70436540	D-SLP 1N4148 100.0V 150E-3A
D411	70436540	D-SLP 1N4148 100.0V 150E-3A
D412	70436540	D-SLP 1N4148 100.0V 150E-3A
R101	50882950	RCF 100R0 OHM +5% 250MI0W
R102	50882950	RCF 100R0 OHM +5% 250MI0W
R105	50882950	RCF 100R0 OHM +5% 250MI0W
R106	50882950	RCF 100R0 OHM +5% 250MI0W
R109	50882950	RCF 100R0 OHM +5% 250MI0W
R110	50882950	RCF 100R0 OHM +5% 250MI0W
R113	50882950	RCF 100R0 OHM +5% 250MI0W
R114	50882950	RCF 100R0 OHM +5% 250MI0W
R207	30939510	RCF 100K0 OHM +5% 250MI0W
R209	80437030	RCF 27K0 OHM +5% 250MI0W
R211	11059640	RCF 1K0 OHM +5% 250MI0W
R213	50882950	RCF 100R0 OHM +5% 250MI0W
R214	30939510	RCF 100K0 OHM +5% 250MI0W
R215	50882950	RCF 100R0 OHM +5% 250MI0W
R216	30939510	RCF 100K0 OHM +5% 250MI0W
R217	30939510	RCF 100K0 OHM +5% 250MI0W
R218	30939510	RCF 100K0 OHM +5% 250MI0W
R219	30939510	RCF 100K0 OHM +5% 250MI0W
R220	30939510	RCF 100K0 OHM +5% 250MI0W
R221	50882950	RCF 100R0 OHM +5% 250MI0W
R223	70430600	RCF 51K0 OHM +5% 250MI0W
R224	70430620	RCF 270K0 OHM +5% 250MI0W
R225	30939490	RCF 33K0 OHM +5% 250MI0W
R301	60441550	RCF 330R0 OHM +5% 250MI0W
R302	60441550	RCF 330R0 OHM +5% 250MI0W
R303	30939360	RCF 10R0 OHM +5% 250MI0W
R304	30939360	RCF 10R0 OHM +5% 250MI0W
R305	30939490	RCF 33K0 OHM +5% 250MI0W
R306	30939490	RCF 33K0 OHM +5% 250MI0W
R307	20469510	RCF 43K0 OHM +5% 250MI0W
R308	20469510	RCF 43K0 OHM +5% 250MI0W
R309	30939510	RCF 100K0 OHM +5% 250MI0W
R310	30939510	RCF 100K0 OHM +5% 250MI0W
R311	50882990	RCF 1K6 OHM +5% 250MI0W
R312	50882990	RCF 1K6 OHM +5% 250MI0W
R313	50882990	RCF 1K6 OHM +5% 250MI0W
R314	50882990	RCF 1K6 OHM +5% 250MI0W
R315	50882970	RCF 470R0 OHM +5% 250MI0W
R316	50882970	RCF 470R0 OHM +5% 250MI0W
R317	20469450	RCF 220R0 OHM +5% 250MI0W
R318	20469450	RCF 220R0 OHM +5% 250MI0W
R319	20469450	RCF 220R0 OHM +5% 250MI0W
R320	20469450	RCF 220R0 OHM +5% 250MI0W
R321	20469450	RCF 220R0 OHM +5% 250MI0W
R322	20469450	RCF 220R0 OHM +5% 250MI0W
R323	60441560	RCF 560R0 OHM +5% 250MI0W
R324	60441560	RCF 560R0 OHM +5% 250MI0W

MAIN board AVR5550

3/11

Pos	Tocom#	SName
R325	60441560	RCF 560R0 OHM +5% 250MI0W
R326	60441560	RCF 560R0 OHM +5% 250MI0W
R327	55498510	RMF 33K0 OHM +1% 250MI0W
R328	55498510	RMF 33K0 OHM +1% 250MI0W
R329	60441560	RCF 560R0 OHM +5% 250MI0W
R330	60441560	RCF 560R0 OHM +5% 250MI0W
R331	55498500	RMF 1K45 OHM +1% 250MI0W
R332	55498500	RMF 1K45 OHM +1% 250MI0W
R333	60441560	RCF 560R0 OHM +5% 250MI0W
R334	60441560	RCF 560R0 OHM +5% 250MI0W
R335	60441560	RCF 560R0 OHM +5% 250MI0W
R336	60441560	RCF 560R0 OHM +5% 250MI0W
R337	60441560	RCF 560R0 OHM +5% 250MI0W
R338	60441560	RCF 560R0 OHM +5% 250MI0W
R339	90571090	RCF 200R0 OHM +5% 250MI0W
R340	90571090	RCF 200R0 OHM +5% 250MI0W
R341	50883010	RCF 15K0 OHM +5% 250MI0W
R342	50883010	RCF 15K0 OHM +5% 250MI0W
R343	50883010	RCF 15K0 OHM +5% 250MI0W
R344	50883010	RCF 15K0 OHM +5% 250MI0W
R345	90571090	RCF 200R0 OHM +5% 250MI0W
R346	90571090	RCF 200R0 OHM +5% 250MI0W
R347	90571090	RCF 200R0 OHM +5% 250MI0W
R348	90571090	RCF 200R0 OHM +5% 250MI0W
R349	90571090	RCF 200R0 OHM +5% 250MI0W
R350	90571090	RCF 200R0 OHM +5% 250MI0W
R351	55232810	RMF 10R0 OHM +5% 500MI0W
R352	55232810	RMF 10R0 OHM +5% 500MI0W
R353	50882950	RCF 100R0 OHM +5% 250MI0W
R354	50882950	RCF 100R0 OHM +5% 250MI0W
R363	30939370	RCF 15R0 OHM +5% 250MI0W
R364	30939370	RCF 15R0 OHM +5% 250MI0W
R365	30939370	RCF 15R0 OHM +5% 250MI0W
R366	30939370	RCF 15R0 OHM +5% 250MI0W
R367	55232810	RMF 10R0 OHM +5% 500MI0W
R368	55232810	RMF 10R0 OHM +5% 500MI0W
R369	50882950	RCF 100R0 OHM +5% 250MI0W
R370	50882950	RCF 100R0 OHM +5% 250MI0W
R371	40438910	RCF 2R2 OHM +5% 250MI0W
R372	40438910	RCF 2R2 OHM +5% 250MI0W
R373	40438910	RCF 2R2 OHM +5% 250MI0W
R374	40438910	RCF 2R2 OHM +5% 250MI0W
R375	11059590	RCF 82R0 OHM +5% 250MI0W
R376	11059590	RCF 82R0 OHM +5% 250MI0W
R380	40435630	RCF 1K5 OHM +5% 250MI0W
R381	40435630	RCF 1K5 OHM +5% 250MI0W
R382	90571130	RCF 39K0 OHM +5% 250MI0W
R383	90571130	RCF 39K0 OHM +5% 250MI0W
R384	50883010	RCF 15K0 OHM +5% 250MI0W
R385	50883010	RCF 15K0 OHM +5% 250MI0W
R386	40435630	RCF 1K5 OHM +5% 250MI0W
R387	40435630	RCF 1K5 OHM +5% 250MI0W
R388	30939360	RCF 10R0 OHM +5% 250MI0W
R388	55242290	RCF 10R0 OHM +5% 250MI0W
R389	30939360	RCF 10R0 OHM +5% 250MI0W
R389	55242290	RCF 10R0 OHM +5% 250MI0W

MAIN board AVR5550

4/11

Pos	Tocom#	SName
R390	60441580	RCF 22K0 OHM +5% 250MI0W
R391	60441580	RCF 22K0 OHM +5% 250MI0W
R401	60441550	RCF 330R0 OHM +5% 250MI0W
R402	60441550	RCF 330R0 OHM +5% 250MI0W
R403	30939490	RCF 33K0 OHM +5% 250MI0W
R404	30939490	RCF 33K0 OHM +5% 250MI0W
R405	50882990	RCF 1K6 OHM +5% 250MI0W
R406	50882990	RCF 1K6 OHM +5% 250MI0W
R407	50882990	RCF 1K6 OHM +5% 250MI0W
R408	50882990	RCF 1K6 OHM +5% 250MI0W
R409	20469450	RCF 220R0 OHM +5% 250MI0W
R410	20469450	RCF 220R0 OHM +5% 250MI0W
R411	20469450	RCF 220R0 OHM +5% 250MI0W
R412	20469450	RCF 220R0 OHM +5% 250MI0W
R413	20469450	RCF 220R0 OHM +5% 250MI0W
R414	20469450	RCF 220R0 OHM +5% 250MI0W
R415	20469510	RCF 43K0 OHM +5% 250MI0W
R416	20469510	RCF 43K0 OHM +5% 250MI0W
R417	55498510	RMF 33K0 OHM +1% 250MI0W
R418	55498510	RMF 33K0 OHM +1% 250MI0W
R419	55498500	RMF 1K45 OHM +1% 250MI0W
R420	55498500	RMF 1K45 OHM +1% 250MI0W
R421	60441560	RCF 560R0 OHM +5% 250MI0W
R422	60441560	RCF 560R0 OHM +5% 250MI0W
R423	60441560	RCF 560R0 OHM +5% 250MI0W
R424	60441560	RCF 560R0 OHM +5% 250MI0W
R425	60441560	RCF 560R0 OHM +5% 250MI0W
R426	60441560	RCF 560R0 OHM +5% 250MI0W
R427	60441560	RCF 560R0 OHM +5% 250MI0W
R428	60441560	RCF 560R0 OHM +5% 250MI0W
R429	60441560	RCF 560R0 OHM +5% 250MI0W
R430	60441560	RCF 560R0 OHM +5% 250MI0W
R431	60441560	RCF 560R0 OHM +5% 250MI0W
R432	60441560	RCF 560R0 OHM +5% 250MI0W
R433	90571090	RCF 200R0 OHM +5% 250MI0W
R434	90571090	RCF 200R0 OHM +5% 250MI0W
R435	90571090	RCF 200R0 OHM +5% 250MI0W
R436	90571090	RCF 200R0 OHM +5% 250MI0W
R437	50883010	RCF 15K0 OHM +5% 250MI0W
R438	50883010	RCF 15K0 OHM +5% 250MI0W
R439	50883010	RCF 15K0 OHM +5% 250MI0W
R440	50883010	RCF 15K0 OHM +5% 250MI0W
R441	90571090	RCF 200R0 OHM +5% 250MI0W
R442	90571090	RCF 200R0 OHM +5% 250MI0W
R443	90571090	RCF 200R0 OHM +5% 250MI0W
R444	90571090	RCF 200R0 OHM +5% 250MI0W
R445	55232810	RMF 10R0 OHM +5% 500MI0W
R446	55232810	RMF 10R0 OHM +5% 500MI0W
R447	55232810	RMF 10R0 OHM +5% 500MI0W
R448	55232810	RMF 10R0 OHM +5% 500MI0W
R457	50882950	RCF 100R0 OHM +5% 250MI0W
R458	50882950	RCF 100R0 OHM +5% 250MI0W
R459	50882950	RCF 100R0 OHM +5% 250MI0W
R460	50882950	RCF 100R0 OHM +5% 250MI0W
R461	30939370	RCF 15R0 OHM +5% 250MI0W
R462	30939370	RCF 15R0 OHM +5% 250MI0W

MAIN board AVR5550

5/11

Pos	Tocom#	SName
R463	30939370	RCF 15R0 OHM +5% 250MI0W
R464	30939370	RCF 15R0 OHM +5% 250MI0W
R465	40438910	RCF 2R2 OHM +5% 250MI0W
R466	40438910	RCF 2R2 OHM +5% 250MI0W
R467	40438910	RCF 2R2 OHM +5% 250MI0W
R468	40438910	RCF 2R2 OHM +5% 250MI0W
R469	11059590	RCF 82R0 OHM +5% 250MI0W
R470	11059590	RCF 82R0 OHM +5% 250MI0W
R473	30939360	RCF 10R0 OHM +5% 250MI0W
R473	55242290	RCF 10R0 OHM +5% 250MI0W
R474	30939360	RCF 10R0 OHM +5% 250MI0W
R474	55242290	RCF 10R0 OHM +5% 250MI0W
R477	30939360	RCF 10R0 OHM +5% 250MI0W
R478	30939360	RCF 10R0 OHM +5% 250MI0W
R479	30939510	RCF 100K0 OHM +5% 250MI0W
R480	30939510	RCF 100K0 OHM +5% 250MI0W
R481	40435630	RCF 1K5 OHM +5% 250MI0W
R482	50883010	RCF 15K0 OHM +5% 250MI0W
R483	40435630	RCF 1K5 OHM +5% 250MI0W
R484	90571130	RCF 39K0 OHM +5% 250MI0W
R485	30939480	RCF 10K0 OHM +5% 250MI0W
R486	60441580	RCF 22K0 OHM +5% 250MI0W
R487	90571130	RCF 39K0 OHM +5% 250MI0W
R488	40435630	RCF 1K5 OHM +5% 250MI0W
R489	50883010	RCF 15K0 OHM +5% 250MI0W
R490	40435630	RCF 1K5 OHM +5% 250MI0W
R491	90571130	RCF 39K0 OHM +5% 250MI0W
R492	60441580	RCF 22K0 OHM +5% 250MI0W
R493	70430570	RCF 8K2 OHM +5% 250MI0W
R497	11059610	RCF 270R0 OHM +5% 250MI0W
R498	80437030	RCF 27K0 OHM +5% 250MI0W
R501	30939510	RCF 100K0 OHM +5% 250MI0W
R501	90571130	RCF 39K0 OHM +5% 250MI0W
R502	30939510	RCF 100K0 OHM +5% 250MI0W
R502	90571130	RCF 39K0 OHM +5% 250MI0W
R503	30939510	RCF 100K0 OHM +5% 250MI0W
R503	60441580	RCF 22K0 OHM +5% 250MI0W
R512	90571090	RCF 200R0 OHM +5% 250MI0W
R513	11059630	RCF 680R0 OHM +5% 250MI0W
R593	50882970	RCF 470R0 OHM +5% 250MI0W
R594	50882970	RCF 470R0 OHM +5% 250MI0W
R601	11059640	RCF 1K0 OHM +5% 250MI0W
R602	30939510	RCF 100K0 OHM +5% 250MI0W
R603	11059640	RCF 1K0 OHM +5% 250MI0W
R604	30939510	RCF 100K0 OHM +5% 250MI0W
R605	30939480	RCF 10K0 OHM +5% 250MI0W
R606	30939480	RCF 10K0 OHM +5% 250MI0W
R607	90571120	RCF 12K0 OHM +5% 250MI0W
R608	30939480	RCF 10K0 OHM +5% 250MI0W
R609	50882950	RCF 100R0 OHM +5% 250MI0W
R610	30939480	RCF 10K0 OHM +5% 250MI0W
R611	30939480	RCF 10K0 OHM +5% 250MI0W
R612	90571120	RCF 12K0 OHM +5% 250MI0W
R613	30939480	RCF 10K0 OHM +5% 250MI0W
R614	50882950	RCF 100R0 OHM +5% 250MI0W
R615	40438910	RCF 2R2 OHM +5% 250MI0W

MAIN board AVR5550

6/11

Pos	Tocom#	SName
R616	40438910	RCF 2R2 OHM +5% 250MI0W
R701	80437000	RCF 1K2 OHM +5% 250MI0W
R702	55261230	RCF 330R0 OHM +5% 250MI0W
R702	60441550	RCF 330R0 OHM +5% 250MI0W
R705	55261230	RCF 330R0 OHM +5% 250MI0W
R705	60441550	RCF 330R0 OHM +5% 250MI0W
R707	80437000	RCF 1K2 OHM +5% 250MI0W
R708	55261230	RCF 330R0 OHM +5% 250MI0W
R708	60441550	RCF 330R0 OHM +5% 250MI0W
R709	55261230	RCF 330R0 OHM +5% 250MI0W
R709	60441550	RCF 330R0 OHM +5% 250MI0W
R710	80437000	RCF 1K2 OHM +5% 250MI0W
R711	80437000	RCF 1K2 OHM +5% 250MI0W
C206	20269070	CE 100U0F +20% 25.0V 85C
C207	20268870	CE 4U7F +20% 50.0V 85C
C208	20269070	CE 100U0F +20% 25.0V 85C
C210	20268840	CE 1U0F +20% 50.0V 85C
C211	20268880	CE 10U0F +20% 50.0V 85C
C213	20269070	CE 100U0F +20% 25.0V 85C
C301	20268880	CE 10U0F +20% 50.0V 85C
C302	20268880	CE 10U0F +20% 50.0V 85C
C309	20269070	CE 100U0F +20% 25.0V 85C
C310	20269070	CE 100U0F +20% 25.0V 85C
C315	20246330	CC 3P0F +0P25F -0P25F 50.0V NP0
C316	20246330	CC 3P0F +0P25F -0P25F 50.0V NP0
C317	80434720	CC 180P0F +10% -10% 50.0V Y5P
C318	80434720	CC 180P0F +10% -10% 50.0V Y5P
C319	20268880	CE 10U0F +20% 50.0V 85C
C320	20268880	CE 10U0F +20% 50.0V 85C
C321	20268880	CE 10U0F +20% 50.0V 85C
C322	20268880	CE 10U0F +20% 50.0V 85C
C323	55179400	CPM 68N0F +5% 63.0V
C324	55179400	CPM 68N0F +5% 63.0V
C325	55179360	CPM 100N0F +10% 63.0V
C326	55179360	CPM 100N0F +10% 63.0V
C327	55179360	CPM 100N0F +10% 63.0V
C328	55179360	CPM 100N0F +10% 63.0V
C329	11055540	CC 2N2F +10% -10% 50.0V Y5P
C330	11055540	CC 2N2F +10% -10% 50.0V Y5P
C331	20269080	CE 220U0F +20% 10.0V 85C
C332	20269080	CE 220U0F +20% 10.0V 85C
C401	20268880	CE 10U0F +20% 50.0V 85C
C402	20268880	CE 10U0F +20% 50.0V 85C
C405	20269070	CE 100U0F +20% 25.0V 85C
C406	20269070	CE 100U0F +20% 25.0V 85C
C407	20269080	CE 220U0F +20% 10.0V 85C
C408	20269080	CE 220U0F +20% 10.0V 85C
C409	20246330	CC 3P0F +0P25F -0P25F 50.0V NP0
C410	20246330	CC 3P0F +0P25F -0P25F 50.0V NP0
C411	80434720	CC 180P0F +10% -10% 50.0V Y5P
C412	80434720	CC 180P0F +10% -10% 50.0V Y5P
C413	20268880	CE 10U0F +20% 50.0V 85C
C414	20268880	CE 10U0F +20% 50.0V 85C
C415	20268880	CE 10U0F +20% 50.0V 85C
C416	20268880	CE 10U0F +20% 50.0V 85C
C417	55179360	CPM 100N0F +10% 63.0V

MAIN board AVR5550

7/11

Pos	Tocom#	SName
C418	55179360	CPM 100N0F +10% 63.0V
C419	55179360	CPM 100N0F +10% 63.0V
C420	55179360	CPM 100N0F +10% 63.0V
C425	11055540	CC 2N2F +10% -10% 50.0V Y5P
C426	11055540	CC 2N2F +10% -10% 50.0V Y5P
C429	20268880	CE 10U0F +20% 50.0V 85C
C430	55179400	CPM 68N0F +5% 63.0V
C431	55179400	CPM 68N0F +5% 63.0V
C432	20252670	CE 470U0F +20% 10.0V 85C
C501	55095430	CPM 100N0F +10% 250.0V
C502	55095430	CPM 100N0F +10% 250.0V
C503	55095430	CPM 100N0F +10% 250.0V
C506	10364820	CPF 47N0F +10% 100.0V
C507	10364820	CPF 47N0F +10% 100.0V
C508	10364820	CPF 47N0F +10% 100.0V
C511	10364820	CPF 47N0F +10% 100.0V
C512	10364820	CPF 47N0F +10% 100.0V
C513	10364820	CPF 47N0F +10% 100.0V
C516	10364820	CPF 47N0F +10% 100.0V
C518	20268880	CE 10U0F +20% 50.0V 85C
C519	20268880	CE 10U0F +20% 50.0V 85C
C520	20268880	CE 10U0F +20% 50.0V 85C
C521	20268880	CE 10U0F +20% 50.0V 85C
C522	20268880	CE 10U0F +20% 50.0V 85C
C523	20268880	CE 10U0F +20% 50.0V 85C
C524	20268880	CE 10U0F +20% 50.0V 85C
C526	20269070	CE 100U0F +20% 25.0V 85C
C528	10364820	CPF 47N0F +10% 100.0V
C529	10364820	CPF 47N0F +10% 100.0V
Q301	20556600	TR-SHPLF KTC3200BL N 100MI0A 120V
Q302	20556600	TR-SHPLF KTC3200BL N 100MI0A 120V
Q303	20556600	TR-SHPLF KTC3200BL N 100MI0A 120V
Q304	20556600	TR-SHPLF KTC3200BL N 100MI0A 120V
Q305	20556600	TR-SHPLF KTC3200BL N 100MI0A 120V
Q306	20556600	TR-SHPLF KTC3200BL N 100MI0A 120V
Q307	20508080	TR-SLPLF KTC3198BL N 150MI0A
Q308	20508080	TR-SLPLF KTC3198BL N 150MI0A
Q309	55233090	TR-SLPLF 2SA1145Y TO-92MOD P -50MI0A -150V
Q310	55233090	TR-SLPLF 2SA1145Y TO-92MOD P -50MI0A -150V
Q311	20647850	TR-SHPLF KTA1268BL P 100MI0A 120V
Q312	20647850	TR-SHPLF KTA1268BL P 100MI0A 120V
Q313	20556600	TR-SHPLF KTC3200BL N 100MI0A 120V
Q314	20556600	TR-SHPLF KTC3200BL N 100MI0A 120V
Q315	55133260	TR-SLPLF KTA1024 Y P 50MI0A -150V
Q316	55133260	TR-SLPLF KTA1024 Y P 50MI0A -150V
Q317	55133240	TR-SLPLF KTC3206 Y N 50MI0A 150V
Q318	55133240	TR-SLPLF KTC3206 Y N 50MI0A 150V
Q319	55133260	TR-SLPLF KTA1024 Y P 50MI0A -150V
Q320	55133260	TR-SLPLF KTA1024 Y P 50MI0A -150V
Q321	55133240	TR-SLPLF KTC3206 Y N 50MI0A 150V
Q322	55133240	TR-SLPLF KTC3206 Y N 50MI0A 150V
Q323	55133240	TR-SLPLF KTC3206 Y N 50MI0A 150V
Q324	55133240	TR-SLPLF KTC3206 Y N 50MI0A 150V
Q327	55133260	TR-SLPLF KTA1024 Y P 50MI0A -150V
Q328	55133260	TR-SLPLF KTA1024 Y P 50MI0A -150V
Q337	20556600	TR-SHPLF KTC3200BL N 100MI0A 120V

MAIN board AVR5550

8/11

Pos	Tocom#	SName
Q338	20556600	TR-SHPLF KTC3200BL N 100MI0A 120V
Q401	20556600	TR-SHPLF KTC3200BL N 100MI0A 120V
Q402	20556600	TR-SHPLF KTC3200BL N 100MI0A 120V
Q403	20556600	TR-SHPLF KTC3200BL N 100MI0A 120V
Q404	20556600	TR-SHPLF KTC3200BL N 100MI0A 120V
Q405	20556600	TR-SHPLF KTC3200BL N 100MI0A 120V
Q406	20556600	TR-SHPLF KTC3200BL N 100MI0A 120V
Q407	20508080	TR-SLPLF KTC3198BL N 150MI0A
Q408	20508080	TR-SLPLF KTC3198BL N 150MI0A
Q409	20556600	TR-SHPLF KTC3200BL N 100MI0A 120V
Q410	20647850	TR-SHPLF KTA1268BL P 100MI0A 120V
Q411	55233090	TR-SLPLF 2SA1145Y TO-92MOD P -50MI0A -150V
Q412	55233090	TR-SLPLF 2SA1145Y TO-92MOD P -50MI0A -150V
Q413	20647850	TR-SHPLF KTA1268BL P 100MI0A 120V
Q414	20647850	TR-SHPLF KTA1268BL P 100MI0A 120V
Q415	20556600	TR-SHPLF KTC3200BL N 100MI0A 120V
Q416	20556600	TR-SHPLF KTC3200BL N 100MI0A 120V
Q417	55133260	TR-SLPLF KTA1024 Y P 50MI0A -150V
Q418	55133260	TR-SLPLF KTA1024 Y P 50MI0A -150V
Q419	55133240	TR-SLPLF KTC3206 Y N 50MI0A 150V
Q420	55133240	TR-SLPLF KTC3206 Y N 50MI0A 150V
Q421	55133260	TR-SLPLF KTA1024 Y P 50MI0A -150V
Q422	55133260	TR-SLPLF KTA1024 Y P 50MI0A -150V
Q423	55133240	TR-SLPLF KTC3206 Y N 50MI0A 150V
Q424	55133240	TR-SLPLF KTC3206 Y N 50MI0A 150V
Q425	20556600	TR-SHPLF KTC3200BL N 100MI0A 120V
Q426	20508080	TR-SLPLF KTC3198BL N 150MI0A
Q429	55133240	TR-SLPLF KTC3206 Y N 50MI0A 150V
Q430	55133240	TR-SLPLF KTC3206 Y N 50MI0A 150V
Q431	55133260	TR-SLPLF KTA1024 Y P 50MI0A -150V
Q432	55133260	TR-SLPLF KTA1024 Y P 50MI0A -150V
Q441	20508080	TR-SLPLF KTC3198BL N 150MI0A
Q442	55133260	TR-SLPLF KTA1024 Y P 50MI0A -150V
Q443	55179230	TR-SLPSWA KRC107M N
Q601	55133290	TR-SLPLF KTD1302 B N 300MI0A 20V
Q602	55133290	TR-SLPLF KTD1302 B N 300MI0A 20V
Q605	20508210	TR-SLPLF KTA1266 Y P 150MI0A
Q606	20508080	TR-SLPLF KTC3198BL N 150MI0A
Q607	20508210	TR-SLPLF KTA1266 Y P 150MI0A
Q608	20508080	TR-SLPLF KTC3198BL N 150MI0A
C209	20936650	CC 100P0F +10% -10% 50.0V Y5P
C212	20267290	CCCFMIN 100N0F +80% -20% 50.0V Y5V
C212	20293470	CC 100N0F +80% -20% 50.0V F
C214	20267290	CCCFMIN 100N0F +80% -20% 50.0V Y5V
C214	20293470	CC 100N0F +80% -20% 50.0V F
C303	13076940	CE 470U0F +20% 63.0V 85C
C304	13076940	CE 470U0F +20% 63.0V 85C
C305	13076940	CE 470U0F +20% 63.0V 85C
C306	13076940	CE 470U0F +20% 63.0V 85C
C421	13076940	CE 470U0F +20% 63.0V 85C
C422	13076940	CE 470U0F +20% 63.0V 85C
C423	13076940	CE 470U0F +20% 63.0V 85C
C424	13076940	CE 470U0F +20% 63.0V 85C
C504	55507480	CE 12MI0F +20% 63.0V 85C
C505	55507480	CE 12MI0F +20% 63.0V 85C
C509	40433130	CE 2MI2F +20% 35.0V 85C

MAIN board AVR5550

9/11

Pos	Tocom#	SName
C510	40433130	CE 2MI2F +20% 35.0V 85C
C514	55126160	CE 6MI8F +20% 16.0V 85C
C515	13039870	CE 2MI2F +20% 16.0V 85C
C517	13039590	CE 1MI0F +20% 35.0V 85C
C517	13039900	CE 2MI2F +20% 50.0V 85C
D501	55179320	D-BRDLC BRIDGE BU10-04
D502	55179300	D-BRDLC BRIDGE W2-04F FRONTIER
D503	55125540	D-BRDLC BU6-04F
D505	55179300	D-BRDLC BRIDGE W2-04F FRONTIER
F501	55505200	FUSTIM 2.0 A 250.0 V 0 A1
F502	55505200	FUSTIM 2.0 A 250.0 V 0 A1
F503	55505200	FUSTIM 2.0 A 250.0 V 0 A1
F504	55505200	FUSTIM 2.0 A 250.0 V 0 A1
F505	55505190	FUSTIM 1.0 A 250.0 V 0 A1
F506	55505190	FUSTIM 1.0 A 250.0 V 0 A1
G101	55135980	TERMLUG GND
G102	55135980	TERMLUG GND
HK11	55176400	AC HEATSINK REG 118*20*50H AVR520 -- ME
HK12	55554410	AC HEATSINK DIODE 39X26X12 AVR525 -- ME
IC22	55142610	IC-OPERAMP NJM2068M DUAL OP
IC51	20832440	IC-REGPOSFXD KIA7815API NORMAL
IC52	55124020	IC-REGNEGFXD KIA7915PI NORMAL
IC53	55125450	IC-REGPOSFXD BA033T NORMAL
IC54	55505780	IC-REGPOSFXD KIA7824API TO-220IS NORMAL
IC55	55123960	IC-REGPOSFXD KIA7805API NORMAL
IC56	55123990	IC-REGNEGFXD KIA7905PI NORMAL
IC57	55179240	IC-REGULADJ KA337 TO-220
IC57	55179240	IC-REGULADJ KA337 TO-220
IC59	55094390	IC-REGPOSFXD KIA7812API NORMAL
L301	55179560	LFA 1MM 10MM 5 LEFT 0.0MM NONE
N801	55158680	WIRECONASY UNIQUE 2 80MM UL1007 PVC DISCRETE 26
N802	55158680	WIRECONASY UNIQUE 2 80MM UL1007 PVC DISCRETE 26
N803	55158680	WIRECONASY UNIQUE 2 80MM UL1007 PVC DISCRETE 26
N804	55158680	WIRECONASY UNIQUE 2 80MM UL1007 PVC DISCRETE 26
N805	55504030	WIRECONASY DL 2.0MM 8P 150MM UL1533 SHIELD 26 1
N805	55597850	WIRECONASY DL 2.0MM 8P 180MM UL1533 SHIELD 26 1
N806	55504040	WIRECONASY DL 2.0MM 15P 350MM UL1533 SHIELD 26 1
N807	55432960	WIRECONASY DL 2.0MM 3P 210MM UL1007 RIBBON 26 12
N807	55503510	WIRECONASY DL 2.0MM 3P 280MM UL1007 RIBBON 26 1
N808	55191240	WIRECONASY UNIQUE 3P 500MM UL1007 PVC DISCRETE 26 1
N808	55287670	WIRECONASY UNIQUE 3P 540MM UL1007 PVC DISCRETE 26 1
N809	55559240	WIRECONASY DL 2.0MM 3P 250MM UL1007 RIBBON 26 1
NJ11	55191450	CON PHONO SCKT RCA 4P JW-4104RSC
NJ12	55191420	CON PHONO SCKT RCA 4P JW-4104RSA
NJ13	55426050	JACK-TELE SNAP-IN GOLDEN TELECOM GDL1-8P8C 8T BK 0 0
NJ14	55436070	CONN-SPE TERMINAL SPKR 8P SH081136JP FE 19MM 8 -- 0 0
P801	55146560	CONN 2.5MM 2 MA ST NAT 0 0
P802	55146560	CONN 2.5MM 2 MA ST NAT 0 0
P803	55146560	CONN 2.5MM 2 MA ST NAT 0 0
P804	55146560	CONN 2.5MM 2 MA ST NAT 0 0
P805	55090080	CONN 2.0MM 3 MA ST NAT LW2002P03 0 0
P806	55123310	CONN 2.0MM 4 MA ST NAT LW2002P04 0 0
P807	55171550	CON 3.96MM PITCH MOLEX 35313-0310
P808	55146630	CONN 2.5MM 8 MA ST NAT 0 0
P809	55146560	CONN 2.5MM 2 MA ST NAT 0 0
P810	55146560	CONN 2.5MM 2 MA ST NAT 0 0

MAIN board AVR5550

10/11

Pos	Tocom#	SName
P811	55174630	CONN 2.0MM 19 MA ST NAT MOLEX 35336-1910 0 0
P812	55090070	CONN 2.0MM 2 MA ST NAT LW2002P0200T 0 0
P813	55090070	CONN 2.0MM 2 MA ST NAT LW2002P0200T 0 0
P814	55090080	CONN 2.0MM 3 MA ST NAT LW2002P03 0 0
P815	55090070	CONN 2.0MM 2 MA ST NAT LW2002P0200T 0 0
P816	55090070	CONN 2.0MM 2 MA ST NAT LW2002P0200T 0 0
PO71	55505180	POS 100R0 OHM 16.0V
PO72	55179640	POS 100R0 OHM 16.0V
Q329	55179190	TR-SHPLF 2SA1859A P -2.0A
Q330	55179190	TR-SHPLF 2SA1859A P -2.0A
Q331	55179200	TR-SHPLF 2SC4883A N 2.0A
Q332	55179200	TR-SHPLF 2SC4883A N 2.0A
Q333	55179180	TR-SHPLF 2SC5358-R N 15.0A
Q334	55179180	TR-SHPLF 2SC5358-R N 15.0A
Q335	55179150	TR-SHPLF 2SA1986-R P -15.0A
Q336	55179150	TR-SHPLF 2SA1986-R P -15.0A
Q433	55179190	TR-SHPLF 2SA1859A P -2.0A
Q434	55179190	TR-SHPLF 2SA1859A P -2.0A
Q435	55179200	TR-SHPLF 2SC4883A N 2.0A
Q436	55179200	TR-SHPLF 2SC4883A N 2.0A
Q437	55179180	TR-SHPLF 2SC5358-R N 15.0A
Q438	55179180	TR-SHPLF 2SC5358-R N 15.0A
Q439	55179150	TR-SHPLF 2SA1986-R P -15.0A
Q440	55179150	TR-SHPLF 2SA1986-R P -15.0A
Q701	55133270	TR-SHPLF 2SC4137 N 100MI0A 20V
Q702	55133270	TR-SHPLF 2SC4137 N 100MI0A 20V
Q703	55133270	TR-SHPLF 2SC4137 N 100MI0A 20V
Q704	55133270	TR-SHPLF 2SC4137 N 100MI0A 20V
R378	55179340	RW 220MI0 OHM +5% 5.0W 100PPM/C -100PPM/C
R379	55179340	RW 220MI0 OHM +5% 5.0W 100PPM/C -100PPM/C
R392	60442550	RMOF 10R0 OHM +5% 1.0W
R393	60442550	RMOF 10R0 OHM +5% 1.0W
R471	55179340	RW 220MI0 OHM +5% 5.0W 100PPM/C -100PPM/C
R472	55179340	RW 220MI0 OHM +5% 5.0W 100PPM/C -100PPM/C
R475	60442550	RMOF 10R0 OHM +5% 1.0W
R476	60442550	RMOF 10R0 OHM +5% 1.0W
R504	40440550	RMOF 3R3 OHM +5% 2.0W
R505	15022710	RMOF 10R0 OHM +5% 2.0W
R506	15022710	RMOF 10R0 OHM +5% 2.0W
R507	80442770	RMOF 2R2 OHM +5% 2.0W
R507	80442780	RMOF 4R7 OHM +5% 2.0W
R508	80442780	RMOF 4R7 OHM +5% 2.0W
R509	80442780	RMOF 4R7 OHM +5% 2.0W
R510	40440550	RMOF 3R3 OHM +5% 2.0W
R514	40440550	RMOF 3R3 OHM +5% 2.0W
R515	80442780	RMOF 4R7 OHM +5% 2.0W
VR71	55152180	PR 1K0 OHM +30% 100MI0W
VR71	55244060	PR 220R0 OHM +30% 100MI0W
VR71	55307870	PR 200R0 OHM +30% 100MI0W
VR72	55152180	PR 1K0 OHM +30% 100MI0W
VR72	55244060	PR 220R0 OHM +30% 100MI0W
VR72	55307870	PR 200R0 OHM +30% 100MI0W
VR73	55152180	PR 1K0 OHM +30% 100MI0W
VR73	55244060	PR 220R0 OHM +30% 100MI0W
VR73	55307870	PR 200R0 OHM +30% 100MI0W
VR74	55152180	PR 1K0 OHM +30% 100MI0W

MAIN board AVR5550

11/11

Pos	Tocom#	SName
VR74	55244060	PR 220R0 OHM +30% 100MI0W
VR74	55307870	PR 200R0 OHM +30% 100MI0W
W801	55310330	WCL 110-10-10 UL1007 HOOK-UP 22 110MM RD 10 10 20300350 0.0MM

SURROUND board AVR5550

1/5

Pos	Tocom#	SName
D301	70436540	D-SLP 1N4148 100.0V 150E-3A
D302	70436540	D-SLP 1N4148 100.0V 150E-3A
D303	70436540	D-SLP 1N4148 100.0V 150E-3A
D304	70436540	D-SLP 1N4148 100.0V 150E-3A
D401	70436540	D-SLP 1N4148 100.0V 150E-3A
D402	70436540	D-SLP 1N4148 100.0V 150E-3A
D403	70436540	D-SLP 1N4148 100.0V 150E-3A
D404	70436540	D-SLP 1N4148 100.0V 150E-3A
D501	70436540	D-SLP 1N4148 100.0V 150E-3A
D502	70436540	D-SLP 1N4148 100.0V 150E-3A
D503	70436540	D-SLP 1N4148 100.0V 150E-3A
D504	70436540	D-SLP 1N4148 100.0V 150E-3A
D601	70436540	D-SLP 1N4148 100.0V 150E-3A
R301	60441550	RCF 330R0 OHM +5% 250MIOW
R302	30939490	RCF 33K0 OHM +5% 250MIOW
R303	55232810	RMF 10R0 OHM +5% 500MIOW
R304	20469510	RCF 43K0 OHM +5% 250MIOW
R305	20469450	RCF 220R0 OHM +5% 250MIOW
R306	20469450	RCF 220R0 OHM +5% 250MIOW
R307	20469450	RCF 220R0 OHM +5% 250MIOW
R308	50882970	RCF 470R0 OHM +5% 250MIOW
R309	50882990	RCF 1K6 OHM +5% 250MIOW
R310	50882990	RCF 1K6 OHM +5% 250MIOW
R311	60441560	RCF 560R0 OHM +5% 250MIOW
R312	55498510	RMF 33K0 OHM +1% 250MIOW
R313	55498500	RMF 1K45 OHM +1% 250MIOW
R314	60441560	RCF 560R0 OHM +5% 250MIOW
R315	60441560	RCF 560R0 OHM +5% 250MIOW
R316	60441560	RCF 560R0 OHM +5% 250MIOW
R317	60441560	RCF 560R0 OHM +5% 250MIOW
R318	60441560	RCF 560R0 OHM +5% 250MIOW
R319	90571090	RCF 200R0 OHM +5% 250MIOW
R320	50883010	RCF 15K0 OHM +5% 250MIOW
R321	50883010	RCF 15K0 OHM +5% 250MIOW
R322	90571090	RCF 200R0 OHM +5% 250MIOW
R323	90571090	RCF 200R0 OHM +5% 250MIOW
R324	90571090	RCF 200R0 OHM +5% 250MIOW
R325	55232810	RMF 10R0 OHM +5% 500MIOW
R326	50882950	RCF 100R0 OHM +5% 250MIOW
R327	40438910	RCF 2R2 OHM +5% 250MIOW
R328	30939370	RCF 15R0 OHM +5% 250MIOW
R329	80437000	RCF 1K2 OHM +5% 250MIOW
R330	60441550	RCF 330R0 OHM +5% 250MIOW
R333	55232810	RMF 10R0 OHM +5% 500MIOW
R334	11059590	RCF 82R0 OHM +5% 250MIOW
R335	30939370	RCF 15R0 OHM +5% 250MIOW
R336	50882950	RCF 100R0 OHM +5% 250MIOW
R337	40438910	RCF 2R2 OHM +5% 250MIOW
R339	40435630	RCF 1K5 OHM +5% 250MIOW
R340	50883010	RCF 15K0 OHM +5% 250MIOW
R341	40435630	RCF 1K5 OHM +5% 250MIOW
R342	90571130	RCF 39K0 OHM +5% 250MIOW
R343	55242290	RCF 10R0 OHM +5% 250MIOW
R344	60441580	RCF 22K0 OHM +5% 250MIOW
R346	30939510	RCF 100K0 OHM +5% 250MIOW
R401	60441550	RCF 330R0 OHM +5% 250MIOW

SURROUND board AVR5550

2/5

Pos	Tocom#	SName
R402	30939490	RCF 33K0 OHM +5% 250MI0W
R403	55232810	RMF 10R0 OHM +5% 500MI0W
R404	20469510	RCF 43K0 OHM +5% 250MI0W
R405	20469450	RCF 220R0 OHM +5% 250MI0W
R406	20469450	RCF 220R0 OHM +5% 250MI0W
R407	20469450	RCF 220R0 OHM +5% 250MI0W
R408	50882970	RCF 470R0 OHM +5% 250MI0W
R409	50882990	RCF 1K6 OHM +5% 250MI0W
R410	50882990	RCF 1K6 OHM +5% 250MI0W
R411	60441560	RCF 560R0 OHM +5% 250MI0W
R412	55498510	RMF 33K0 OHM +1% 250MI0W
R413	55498500	RMF 1K45 OHM +1% 250MI0W
R414	60441560	RCF 560R0 OHM +5% 250MI0W
R415	60441560	RCF 560R0 OHM +5% 250MI0W
R416	60441560	RCF 560R0 OHM +5% 250MI0W
R417	60441560	RCF 560R0 OHM +5% 250MI0W
R418	60441560	RCF 560R0 OHM +5% 250MI0W
R419	90571090	RCF 200R0 OHM +5% 250MI0W
R420	50883010	RCF 15K0 OHM +5% 250MI0W
R421	50883010	RCF 15K0 OHM +5% 250MI0W
R422	90571090	RCF 200R0 OHM +5% 250MI0W
R423	90571090	RCF 200R0 OHM +5% 250MI0W
R424	90571090	RCF 200R0 OHM +5% 250MI0W
R425	55232810	RMF 10R0 OHM +5% 500MI0W
R426	50882950	RCF 100R0 OHM +5% 250MI0W
R427	40438910	RCF 2R2 OHM +5% 250MI0W
R428	30939370	RCF 15R0 OHM +5% 250MI0W
R429	80437000	RCF 1K2 OHM +5% 250MI0W
R430	60441550	RCF 330R0 OHM +5% 250MI0W
R433	55232810	RMF 10R0 OHM +5% 500MI0W
R434	11059590	RCF 82R0 OHM +5% 250MI0W
R435	30939370	RCF 15R0 OHM +5% 250MI0W
R436	50882950	RCF 100R0 OHM +5% 250MI0W
R437	40438910	RCF 2R2 OHM +5% 250MI0W
R439	40435630	RCF 1K5 OHM +5% 250MI0W
R440	50883010	RCF 15K0 OHM +5% 250MI0W
R441	40435630	RCF 1K5 OHM +5% 250MI0W
R442	90571130	RCF 39K0 OHM +5% 250MI0W
R443	55242290	RCF 10R0 OHM +5% 250MI0W
R444	60441580	RCF 22K0 OHM +5% 250MI0W
R446	30939510	RCF 100K0 OHM +5% 250MI0W
R501	60441550	RCF 330R0 OHM +5% 250MI0W
R502	30939490	RCF 33K0 OHM +5% 250MI0W
R503	55232810	RMF 10R0 OHM +5% 500MI0W
R504	20469510	RCF 43K0 OHM +5% 250MI0W
R505	20469450	RCF 220R0 OHM +5% 250MI0W
R506	20469450	RCF 220R0 OHM +5% 250MI0W
R507	20469450	RCF 220R0 OHM +5% 250MI0W
R508	50882970	RCF 470R0 OHM +5% 250MI0W
R509	50882990	RCF 1K6 OHM +5% 250MI0W
R510	50882990	RCF 1K6 OHM +5% 250MI0W
R511	60441560	RCF 560R0 OHM +5% 250MI0W
R512	55498510	RMF 33K0 OHM +1% 250MI0W
R513	55498500	RMF 1K45 OHM +1% 250MI0W
R514	60441560	RCF 560R0 OHM +5% 250MI0W
R515	60441560	RCF 560R0 OHM +5% 250MI0W

SURROUND board AVR5550

3/5

Pos	Tocom#	SName
R516	60441560	RCF 560R0 OHM +5% 250MI0W
R517	60441560	RCF 560R0 OHM +5% 250MI0W
R518	60441560	RCF 560R0 OHM +5% 250MI0W
R519	90571090	RCF 200R0 OHM +5% 250MI0W
R520	50883010	RCF 15K0 OHM +5% 250MI0W
R521	50883010	RCF 15K0 OHM +5% 250MI0W
R522	90571090	RCF 200R0 OHM +5% 250MI0W
R523	90571090	RCF 200R0 OHM +5% 250MI0W
R524	90571090	RCF 200R0 OHM +5% 250MI0W
R525	55232810	RMF 10R0 OHM +5% 500MI0W
R526	50882950	RCF 100R0 OHM +5% 250MI0W
R527	40438910	RCF 2R2 OHM +5% 250MI0W
R528	30939370	RCF 15R0 OHM +5% 250MI0W
R529	80437000	RCF 1K2 OHM +5% 250MI0W
R530	60441550	RCF 330R0 OHM +5% 250MI0W
R533	55232810	RMF 10R0 OHM +5% 500MI0W
R534	11059590	RCF 82R0 OHM +5% 250MI0W
R535	30939370	RCF 15R0 OHM +5% 250MI0W
R536	50882950	RCF 100R0 OHM +5% 250MI0W
R537	40438910	RCF 2R2 OHM +5% 250MI0W
R539	40435630	RCF 1K5 OHM +5% 250MI0W
R540	50883010	RCF 15K0 OHM +5% 250MI0W
R541	40435630	RCF 1K5 OHM +5% 250MI0W
R542	90571130	RCF 39K0 OHM +5% 250MI0W
R543	55242290	RCF 10R0 OHM +5% 250MI0W
R544	60441580	RCF 22K0 OHM +5% 250MI0W
R546	30939510	RCF 100K0 OHM +5% 250MI0W
R601	30939480	RCF 10K0 OHM +5% 250MI0W
R602	90571130	RCF 39K0 OHM +5% 250MI0W
C303	20268880	CE 10U0F +20% 50.0V 85C
C304	70428390	CC 270P0F +10% -10% 50.0V Y5P
C305	20269070	CE 100U0F +20% 25.0V 85C
C306	40433580	CC 680P0F +10% -10% 50.0V Y5P
C307	20246330	CC 3P0F +0P25F -0P25F 50.0V NP0
C308	20269080	CE 220U0F +20% 10.0V 85C
C309	80434720	CC 180P0F +10% -10% 50.0V Y5P
C310	55179400	CPM 68N0F +5% 63.0V
C311	20268880	CE 10U0F +20% 50.0V 85C
C312	20268880	CE 10U0F +20% 50.0V 85C
C313	55179360	CPM 100N0F +10% 63.0V
C314	55179360	CPM 100N0F +10% 63.0V
C320	11055580	CC 4N7F +10% -10% 50.0V Y5P
C331	11055560	CC 3N3F +10% -10% 50.0V Y5P
C403	20268880	CE 10U0F +20% 50.0V 85C
C404	70428390	CC 270P0F +10% -10% 50.0V Y5P
C405	20269070	CE 100U0F +20% 25.0V 85C
C406	40433580	CC 680P0F +10% -10% 50.0V Y5P
C407	20246330	CC 3P0F +0P25F -0P25F 50.0V NP0
C408	20269080	CE 220U0F +20% 10.0V 85C
C409	80434720	CC 180P0F +10% -10% 50.0V Y5P
C410	55179400	CPM 68N0F +5% 63.0V
C411	20268880	CE 10U0F +20% 50.0V 85C
C412	20268880	CE 10U0F +20% 50.0V 85C
C413	55179360	CPM 100N0F +10% 63.0V
C414	55179360	CPM 100N0F +10% 63.0V
C420	11055580	CC 4N7F +10% -10% 50.0V Y5P

SURROUND board AVR5550

4/5

Pos	Tocom#	SName
C431	11055560	CC 3N3F +10% -10% 50.0V Y5P
C503	20268880	CE 10U0F +20% 50.0V 85C
C504	70428390	CC 270P0F +10% -10% 50.0V Y5P
C505	20269070	CE 100U0F +20% 25.0V 85C
C506	40433580	CC 680P0F +10% -10% 50.0V Y5P
C507	20246330	CC 3P0F +0P25F -0P25F 50.0V NP0
C508	20269080	CE 220U0F +20% 10.0V 85C
C509	80434720	CC 180P0F +10% -10% 50.0V Y5P
C510	55179400	CPM 68N0F +5% 63.0V
C511	20268880	CE 10U0F +20% 50.0V 85C
C512	20268880	CE 10U0F +20% 50.0V 85C
C513	55179360	CPM 100N0F +10% 63.0V
C514	55179360	CPM 100N0F +10% 63.0V
C520	11055580	CC 4N7F +10% -10% 50.0V Y5P
C531	11055560	CC 3N3F +10% -10% 50.0V Y5P
C601	15002130	CE 10U0F +20% 16.0V 85C
Q301	20556600	TR-SHPLF KTC3200BL N 100MIOA 120V
Q302	20556600	TR-SHPLF KTC3200BL N 100MIOA 120V
Q303	20556600	TR-SHPLF KTC3200BL N 100MIOA 120V
Q304	20508080	TR-SLPLF KTC3198BL N 150MIOA
Q305	55233090	TR-SLPLF 2SA1145Y TO-92MOD P -50MIOA -150V
Q306	20647850	TR-SHPLF KTA1268BL P 100MIOA 120V
Q307	20556600	TR-SHPLF KTC3200BL N 100MIOA 120V
Q308	55133260	TR-SLPLF KTA1024 Y P 50MIOA -150V
Q309	55133240	TR-SLPLF KTC3206 Y N 50MIOA 150V
Q311	55133260	TR-SLPLF KTA1024 Y P 50MIOA -150V
Q312	55133240	TR-SLPLF KTC3206 Y N 50MIOA 150V
Q313	55133240	TR-SLPLF KTC3206 Y N 50MIOA 150V
Q315	55133260	TR-SLPLF KTA1024 Y P 50MIOA -150V
Q320	20556600	TR-SHPLF KTC3200BL N 100MIOA 120V
Q401	20556600	TR-SHPLF KTC3200BL N 100MIOA 120V
Q402	20556600	TR-SHPLF KTC3200BL N 100MIOA 120V
Q403	20556600	TR-SHPLF KTC3200BL N 100MIOA 120V
Q404	20508080	TR-SLPLF KTC3198BL N 150MIOA
Q405	55233090	TR-SLPLF 2SA1145Y TO-92MOD P -50MIOA -150V
Q406	20647850	TR-SHPLF KTA1268BL P 100MIOA 120V
Q407	20556600	TR-SHPLF KTC3200BL N 100MIOA 120V
Q408	55133260	TR-SLPLF KTA1024 Y P 50MIOA -150V
Q409	55133240	TR-SLPLF KTC3206 Y N 50MIOA 150V
Q411	55133260	TR-SLPLF KTA1024 Y P 50MIOA -150V
Q412	55133240	TR-SLPLF KTC3206 Y N 50MIOA 150V
Q413	55133240	TR-SLPLF KTC3206 Y N 50MIOA 150V
Q415	55133260	TR-SLPLF KTA1024 Y P 50MIOA -150V
Q420	20556600	TR-SHPLF KTC3200BL N 100MIOA 120V
Q501	20556600	TR-SHPLF KTC3200BL N 100MIOA 120V
Q502	20556600	TR-SHPLF KTC3200BL N 100MIOA 120V
Q503	20556600	TR-SHPLF KTC3200BL N 100MIOA 120V
Q504	20508080	TR-SLPLF KTC3198BL N 150MIOA
Q505	55233090	TR-SLPLF 2SA1145Y TO-92MOD P -50MIOA -150V
Q506	20647850	TR-SHPLF KTA1268BL P 100MIOA 120V
Q507	20556600	TR-SHPLF KTC3200BL N 100MIOA 120V
Q508	55133260	TR-SLPLF KTA1024 Y P 50MIOA -150V
Q509	55133240	TR-SLPLF KTC3206 Y N 50MIOA 150V
Q511	55133260	TR-SLPLF KTA1024 Y P 50MIOA -150V
Q512	55133240	TR-SLPLF KTC3206 Y N 50MIOA 150V
Q513	55133240	TR-SLPLF KTC3206 Y N 50MIOA 150V

SURROUND board AVR5550

5/5

Pos	Tocom#	SName
Q515	55133260	TR-SLPLF KTA1024 Y P 50MI0A -150V
Q520	20556600	TR-SHPLF KTC3200BL N 100MI0A 120V
Q601	20647850	TR-SHPLF KTA1268BL P 100MI0A 120V
C301	13076940	CE 470U0F +20% 63.0V 85C
C302	13076940	CE 470U0F +20% 63.0V 85C
C401	13076940	CE 470U0F +20% 63.0V 85C
C402	13076940	CE 470U0F +20% 63.0V 85C
C501	13076940	CE 470U0F +20% 63.0V 85C
C502	13076940	CE 470U0F +20% 63.0V 85C
G601	55135980	TERMLUG GND
G602	55135980	TERMLUG GND
G603	55135980	TERMLUG GND
G604	55135980	TERMLUG GND
G605	55135980	TERMLUG GND
L301	55179560	LFA 1MM 10MM 5 LEFT 0.0MM NONE
L401	55179560	LFA 1MM 10MM 5 LEFT 0.0MM NONE
L501	55179560	LFA 1MM 10MM 5 LEFT 0.0MM NONE
N306	55504010	WIRECONASY DL 2.0MM 6P 250MM UL1533 SHIELD 26 1
NJ31	55436090	CONN-SPE TERMINAL SPKR 6P SH0611708P FE 19MM 6 BK 0 0
P301	55104560	CONN 2.5MM 2 MA R NAT 0 0
P303	55171550	CON 3.96MM PITCH MOLEX 35313-0310
P304	55175430	CON 3.96MM PITCH MOREX 35313-0410
P307	55090080	CONN 2.0MM 3 MA ST NAT LW2002P03 0 0
P308	55104560	CONN 2.5MM 2 MA R NAT 0 0
P309	55104560	CONN 2.5MM 2 MA R NAT 0 0
P310	55090080	CONN 2.0MM 3 MA ST NAT LW2002P03 0 0
PO51	55179640	POS 100R0 OHM 16.0V
PO52	55505180	POS 100R0 OHM 16.0V
Q314	55133270	TR-SHPLF 2SC4137 N 100MI0A 20V
Q316	55179190	TR-SHPLF 2SA1859A P -2.0A
Q317	55179200	TR-SHPLF 2SC4883A N 2.0A
Q318	55179180	TR-SHPLF 2SC5358-R N 15.0A
Q319	55179150	TR-SHPLF 2SA1986-R P -15.0A
Q414	55133270	TR-SHPLF 2SC4137 N 100MI0A 20V
Q416	55179190	TR-SHPLF 2SA1859A P -2.0A
Q417	55179200	TR-SHPLF 2SC4883A N 2.0A
Q418	55179180	TR-SHPLF 2SC5358-R N 15.0A
Q419	55179150	TR-SHPLF 2SA1986-R P -15.0A
Q514	55133270	TR-SHPLF 2SC4137 N 100MI0A 20V
Q516	55179190	TR-SHPLF 2SA1859A P -2.0A
Q517	55179200	TR-SHPLF 2SC4883A N 2.0A
Q518	55179180	TR-SHPLF 2SC5358-R N 15.0A
Q519	55179150	TR-SHPLF 2SA1986-R P -15.0A
R338	55179340	RW 220MI0 OHM +5% 5.0W 100PPM/C -100PPM/C
R345	60442550	RMOF 10R0 OHM +5% 1.0W
R438	55179340	RW 220MI0 OHM +5% 5.0W 100PPM/C -100PPM/C
R445	60442550	RMOF 10R0 OHM +5% 1.0W
R538	55179340	RW 220MI0 OHM +5% 5.0W 100PPM/C -100PPM/C
R545	60442550	RMOF 10R0 OHM +5% 1.0W
VR31	55250320	PR 200R0 OHM +20% 500MI0W
VR41	55250320	PR 200R0 OHM +20% 500MI0W
VR51	55250320	PR 200R0 OHM +20% 500MI0W
W301	20649250	WCL 060-05-05 UL1007 HOOK-UP 22 60MM BK 5 5 20297640

Processor board AVR5550

1/16

Pos	Tocom#	SName
C111	20506560	CCCFMIC 33P0F +5% -5% 50.0V NP0
C115	20506560	CCCFMIC 33P0F +5% -5% 50.0V NP0
C130	20506560	CCCFMIC 33P0F +5% -5% 50.0V NP0
C134	20506560	CCCFMIC 33P0F +5% -5% 50.0V NP0
C137	20506560	CCCFMIC 33P0F +5% -5% 50.0V NP0
C141	20506560	CCCFMIC 33P0F +5% -5% 50.0V NP0
C150	10138620	CCCFMIC 2N2F +10% -10% 50.0V X7R
C154	20506560	CCCFMIC 33P0F +5% -5% 50.0V NP0
C157	20506560	CCCFMIC 33P0F +5% -5% 50.0V NP0
C161	20506560	CCCFMIC 33P0F +5% -5% 50.0V NP0
C167	20506560	CCCFMIC 33P0F +5% -5% 50.0V NP0
C171	20506560	CCCFMIC 33P0F +5% -5% 50.0V NP0
C199	20506560	CCCFMIC 33P0F +5% -5% 50.0V NP0
C200	20506560	CCCFMIC 33P0F +5% -5% 50.0V NP0
C66	20506560	CCCFMIC 33P0F +5% -5% 50.0V NP0
C68	20506560	CCCFMIC 33P0F +5% -5% 50.0V NP0
C93	10138620	CCCFMIC 2N2F +10% -10% 50.0V X7R
D1	55506380	D-ZENER UDZS 9.1B 9.1V 200MI0W
D10	55506380	D-ZENER UDZS 9.1B 9.1V 200MI0W
D11	55506380	D-ZENER UDZS 9.1B 9.1V 200MI0W
D12	55506380	D-ZENER UDZS 9.1B 9.1V 200MI0W
D13	55506380	D-ZENER UDZS 9.1B 9.1V 200MI0W
D14	55506380	D-ZENER UDZS 9.1B 9.1V 200MI0W
D15	20496510	D-SLP 1SS355 35.0V 225MI0A
D16	20496510	D-SLP 1SS355 35.0V 225MI0A
D17	20496510	D-SLP 1SS355 35.0V 225MI0A
D20	55506380	D-ZENER UDZS 9.1B 9.1V 200MI0W
D21	55506380	D-ZENER UDZS 9.1B 9.1V 200MI0W
D5	55506380	D-ZENER UDZS 9.1B 9.1V 200MI0W
D6	20496510	D-SLP 1SS355 35.0V 225MI0A
D7	55506380	D-ZENER UDZS 9.1B 9.1V 200MI0W
D8	55506380	D-ZENER UDZS 9.1B 9.1V 200MI0W
D9	55506380	D-ZENER UDZS 9.1B 9.1V 200MI0W
IC1	55142610	IC-OPERAMP NJM2068M DUAL OP
IC11	55142610	IC-OPERAMP NJM2068M DUAL OP
IC12	55142610	IC-OPERAMP NJM2068M DUAL OP
IC13	55142610	IC-OPERAMP NJM2068M DUAL OP
IC14	55506480	IC-SWITCH NJU7311AM ANALOG SWITCH
IC15	55142610	IC-OPERAMP NJM2068M DUAL OP
IC16	55142610	IC-OPERAMP NJM2068M DUAL OP
IC17	55142610	IC-OPERAMP NJM2068M DUAL OP
IC18	55142720	IC-LOWFREQ KIC9459F SOP24 TONE/VOL/BAL/MUTE
IC19	55179480	IC-LOWFREQ TC9482F SOP28 TONE/VOL/BAL/MUTE
IC2	55142720	IC-LOWFREQ KIC9459F SOP24 TONE/VOL/BAL/MUTE
IC20	55142590	IC-OPERAMP NJM5532M DUAL OP
IC21	55142610	IC-OPERAMP NJM2068M DUAL OP
IC22	55142610	IC-OPERAMP NJM2068M DUAL OP
IC23	55142610	IC-OPERAMP NJM2068M DUAL OP
IC24	55142610	IC-OPERAMP NJM2068M DUAL OP
IC25	55142610	IC-OPERAMP NJM2068M DUAL OP
IC26	55142610	IC-OPERAMP NJM2068M DUAL OP
IC3	55506490	IC-SWITCH NJU7312AM ANALOG SWITCH
IC4	55142610	IC-OPERAMP NJM2068M DUAL OP
IC5	55506480	IC-SWITCH NJU7311AM ANALOG SWITCH
IC7	55142610	IC-OPERAMP NJM2068M DUAL OP
IC8	55142610	IC-OPERAMP NJM2068M DUAL OP

Processor board AVR5550

2/16

Pos	Tocom#	SName
IC9	55142610	IC-OPERAMP NJM2068M DUAL OP
J23	10328750	RMGCFMIC 0 OHM +0% 62MI5W
J24	10328750	RMGCFMIC 0 OHM +0% 62MI5W
J25	10328750	RMGCFMIC 0 OHM +0% 62MI5W
Q10	55138710	TR-SLPSWA KTD1304 N 20V 300MI0A
Q11	55138710	TR-SLPSWA KTD1304 N 20V 300MI0A
Q12	55138710	TR-SLPSWA KTD1304 N 20V 300MI0A
Q13	55133190	TR-SSD DTA114YKA P 10K0 OHM 47K0 OHM
Q14	55133190	TR-SSD DTA114YKA P 10K0 OHM 47K0 OHM
Q15	55138710	TR-SLPSWA KTD1304 N 20V 300MI0A
Q16	55138710	TR-SLPSWA KTD1304 N 20V 300MI0A
Q17	55133190	TR-SSD DTA114YKA P 10K0 OHM 47K0 OHM
Q20	55133190	TR-SSD DTA114YKA P 10K0 OHM 47K0 OHM
Q23	55133190	TR-SSD DTA114YKA P 10K0 OHM 47K0 OHM
Q25	55133190	TR-SSD DTA114YKA P 10K0 OHM 47K0 OHM
Q3	55133190	TR-SSD DTA114YKA P 10K0 OHM 47K0 OHM
Q32	55133190	TR-SSD DTA114YKA P 10K0 OHM 47K0 OHM
Q34	55133190	TR-SSD DTA114YKA P 10K0 OHM 47K0 OHM
Q35	55133190	TR-SSD DTA114YKA P 10K0 OHM 47K0 OHM
Q37	55133190	TR-SSD DTA114YKA P 10K0 OHM 47K0 OHM
Q41	55133190	TR-SSD DTA114YKA P 10K0 OHM 47K0 OHM
Q43	55133190	TR-SSD DTA114YKA P 10K0 OHM 47K0 OHM
Q50	55133190	TR-SSD DTA114YKA P 10K0 OHM 47K0 OHM
Q51	55138710	TR-SLPSWA KTD1304 N 20V 300MI0A
Q52	55133190	TR-SSD DTA114YKA P 10K0 OHM 47K0 OHM
Q53	55138710	TR-SLPSWA KTD1304 N 20V 300MI0A
Q58	55138710	TR-SLPSWA KTD1304 N 20V 300MI0A
Q59	55138710	TR-SLPSWA KTD1304 N 20V 300MI0A
Q7	55138710	TR-SLPSWA KTD1304 N 20V 300MI0A
Q8	55138710	TR-SLPSWA KTD1304 N 20V 300MI0A
Q9	55138710	TR-SLPSWA KTD1304 N 20V 300MI0A
R122	10135770	RMGCFMIC 1K0 OHM +5% 62MI5W
R125	10135770	RMGCFMIC 1K0 OHM +5% 62MI5W
R135	10135030	RMGCFMIC 12K0 OHM +5% 62MI5W
R156	10135900	RMGCFMIC 3K3 OHM +5% 62MI5W
R157	10135900	RMGCFMIC 3K3 OHM +5% 62MI5W
R158	10135030	RMGCFMIC 12K0 OHM +5% 62MI5W
R159	10135900	RMGCFMIC 3K3 OHM +5% 62MI5W
R160	10135900	RMGCFMIC 3K3 OHM +5% 62MI5W
R19	10135170	RMGCFMIC 33K0 OHM +5% 62MI5W
R190	10135170	RMGCFMIC 33K0 OHM +5% 62MI5W
R197	10134650	RMGCFMIC 47R0 OHM +5% 62MI5W
R201	10134650	RMGCFMIC 47R0 OHM +5% 62MI5W
R208	10134410	RMGCFMIC 10R0 OHM +5% 62MI5W
R209	10134410	RMGCFMIC 10R0 OHM +5% 62MI5W
R210	10135860	RMGCFMIC 2K2 OHM +5% 62MI5W
R211	10135530	RMGCFMIC 470K0 OHM +5% 62MI5W
R213	10135860	RMGCFMIC 2K2 OHM +5% 62MI5W
R214	10135080	RMGCFMIC 18K0 OHM +5% 62MI5W
R217	10135860	RMGCFMIC 2K2 OHM +5% 62MI5W
R218	10135860	RMGCFMIC 2K2 OHM +5% 62MI5W
R219	10135170	RMGCFMIC 33K0 OHM +5% 62MI5W
R223	10135080	RMGCFMIC 18K0 OHM +5% 62MI5W
R224	10135860	RMGCFMIC 2K2 OHM +5% 62MI5W
R225	10135530	RMGCFMIC 470K0 OHM +5% 62MI5W
R227	10135530	RMGCFMIC 470K0 OHM +5% 62MI5W

Processor board AVR5550

3/16

Pos	Tocom#	SName
R228	10135860	RMGCFMIC 2K2 OHM +5% 62MI5W
R23	10135860	RMGCFMIC 2K2 OHM +5% 62MI5W
R232	10134740	RMGCFMIC 100R0 OHM +5% 62MI5W
R24	10135860	RMGCFMIC 2K2 OHM +5% 62MI5W
R242	10134740	RMGCFMIC 100R0 OHM +5% 62MI5W
R243	10134740	RMGCFMIC 100R0 OHM +5% 62MI5W
R253	10134740	RMGCFMIC 100R0 OHM +5% 62MI5W
R257	10135860	RMGCFMIC 2K2 OHM +5% 62MI5W
R258	10135530	RMGCFMIC 470K0 OHM +5% 62MI5W
R260	10135530	RMGCFMIC 470K0 OHM +5% 62MI5W
R261	10135860	RMGCFMIC 2K2 OHM +5% 62MI5W
R262	10135080	RMGCFMIC 18K0 OHM +5% 62MI5W
R265	10135170	RMGCFMIC 33K0 OHM +5% 62MI5W
R266	10135170	RMGCFMIC 33K0 OHM +5% 62MI5W
R267	10135170	RMGCFMIC 33K0 OHM +5% 62MI5W
R271	10135080	RMGCFMIC 18K0 OHM +5% 62MI5W
R272	10135860	RMGCFMIC 2K2 OHM +5% 62MI5W
R273	10135530	RMGCFMIC 470K0 OHM +5% 62MI5W
R275	10135530	RMGCFMIC 470K0 OHM +5% 62MI5W
R276	10135860	RMGCFMIC 2K2 OHM +5% 62MI5W
R280	10134740	RMGCFMIC 100R0 OHM +5% 62MI5W
R290	10134740	RMGCFMIC 100R0 OHM +5% 62MI5W
R291	10135170	RMGCFMIC 33K0 OHM +5% 62MI5W
R295	10135080	RMGCFMIC 18K0 OHM +5% 62MI5W
R296	10135860	RMGCFMIC 2K2 OHM +5% 62MI5W
R297	10135530	RMGCFMIC 470K0 OHM +5% 62MI5W
R299	10135530	RMGCFMIC 470K0 OHM +5% 62MI5W
R300	10135860	RMGCFMIC 2K2 OHM +5% 62MI5W
R304	10134740	RMGCFMIC 100R0 OHM +5% 62MI5W
R314	10134740	RMGCFMIC 100R0 OHM +5% 62MI5W
R315	10134410	RMGCFMIC 10R0 OHM +5% 62MI5W
R316	10134410	RMGCFMIC 10R0 OHM +5% 62MI5W
R317	10135860	RMGCFMIC 2K2 OHM +5% 62MI5W
R318	10135860	RMGCFMIC 2K2 OHM +5% 62MI5W
R322	10135050	RMGCFMIC 15K0 OHM +5% 62MI5W
R323	10135050	RMGCFMIC 15K0 OHM +5% 62MI5W
R328	10135530	RMGCFMIC 470K0 OHM +5% 62MI5W
R330	10135860	RMGCFMIC 2K2 OHM +5% 62MI5W
R331	10135530	RMGCFMIC 470K0 OHM +5% 62MI5W
R332	10135170	RMGCFMIC 33K0 OHM +5% 62MI5W
R333	10135860	RMGCFMIC 2K2 OHM +5% 62MI5W
R37	10135860	RMGCFMIC 2K2 OHM +5% 62MI5W
R38	10135860	RMGCFMIC 2K2 OHM +5% 62MI5W
R53	10135860	RMGCFMIC 2K2 OHM +5% 62MI5W
R54	10135860	RMGCFMIC 2K2 OHM +5% 62MI5W
R55	10135170	RMGCFMIC 33K0 OHM +5% 62MI5W
R7	10135860	RMGCFMIC 2K2 OHM +5% 62MI5W
R72	10135340	RMGCFMIC 100K0 OHM +5% 62MI5W
R8	10135860	RMGCFMIC 2K2 OHM +5% 62MI5W
R83	10135170	RMGCFMIC 33K0 OHM +5% 62MI5W
R84	10135170	RMGCFMIC 33K0 OHM +5% 62MI5W
R87	10135170	RMGCFMIC 33K0 OHM +5% 62MI5W
R89	10135170	RMGCFMIC 33K0 OHM +5% 62MI5W
R90	10135170	RMGCFMIC 33K0 OHM +5% 62MI5W
R97	10135170	RMGCFMIC 33K0 OHM +5% 62MI5W
AI01	55583740	AC ESABD SMD TOP PRO BD AVR5550

Processor board AVR5550

4/16

Pos	Tocom#	SName
20	55514200	AC PCB PRE BD AVR525 DUAL LAYERS
20	5551420A	AC PCB PRE BD AVR525 DUAL LAYERS
42	55015690	SOLDER PASTE SN63/PB37 NO CLEAN
C111	20506560	CCCFMIC 33P0F +5% -5% 50.0V NP0
C115	20506560	CCCFMIC 33P0F +5% -5% 50.0V NP0
C130	20506560	CCCFMIC 33P0F +5% -5% 50.0V NP0
C134	20506560	CCCFMIC 33P0F +5% -5% 50.0V NP0
C137	20506560	CCCFMIC 33P0F +5% -5% 50.0V NP0
C141	20506560	CCCFMIC 33P0F +5% -5% 50.0V NP0
C150	10138620	CCCFMIC 2N2F +10% -10% 50.0V X7R
C154	20506560	CCCFMIC 33P0F +5% -5% 50.0V NP0
C157	20506560	CCCFMIC 33P0F +5% -5% 50.0V NP0
C161	20506560	CCCFMIC 33P0F +5% -5% 50.0V NP0
C167	20506560	CCCFMIC 33P0F +5% -5% 50.0V NP0
C171	20506560	CCCFMIC 33P0F +5% -5% 50.0V NP0
C199	20506560	CCCFMIC 33P0F +5% -5% 50.0V NP0
C200	20506560	CCCFMIC 33P0F +5% -5% 50.0V NP0
C66	20506560	CCCFMIC 33P0F +5% -5% 50.0V NP0
C68	20506560	CCCFMIC 33P0F +5% -5% 50.0V NP0
C93	10138620	CCCFMIC 2N2F +10% -10% 50.0V X7R
D1	55506380	D-ZENER UDZS 9.1B 9.1V 200MI0W
D10	55506380	D-ZENER UDZS 9.1B 9.1V 200MI0W
D11	55506380	D-ZENER UDZS 9.1B 9.1V 200MI0W
D12	55506380	D-ZENER UDZS 9.1B 9.1V 200MI0W
D13	55506380	D-ZENER UDZS 9.1B 9.1V 200MI0W
D14	55506380	D-ZENER UDZS 9.1B 9.1V 200MI0W
D15	20496510	D-SLP 1SS355 35.0V 225MI0A
D16	20496510	D-SLP 1SS355 35.0V 225MI0A
D17	20496510	D-SLP 1SS355 35.0V 225MI0A
D20	55506380	D-ZENER UDZS 9.1B 9.1V 200MI0W
D21	55506380	D-ZENER UDZS 9.1B 9.1V 200MI0W
D5	55506380	D-ZENER UDZS 9.1B 9.1V 200MI0W
D6	20496510	D-SLP 1SS355 35.0V 225MI0A
D7	55506380	D-ZENER UDZS 9.1B 9.1V 200MI0W
D8	55506380	D-ZENER UDZS 9.1B 9.1V 200MI0W
D9	55506380	D-ZENER UDZS 9.1B 9.1V 200MI0W
IC1	55142610	IC-OPERAMP NJM2068M DUAL OP
IC11	55142610	IC-OPERAMP NJM2068M DUAL OP
IC12	55142610	IC-OPERAMP NJM2068M DUAL OP
IC13	55142610	IC-OPERAMP NJM2068M DUAL OP
IC14	55506480	IC-SWITCH NJU7311AM ANALOG SWITCH
IC15	55142610	IC-OPERAMP NJM2068M DUAL OP
IC16	55142610	IC-OPERAMP NJM2068M DUAL OP
IC17	55142610	IC-OPERAMP NJM2068M DUAL OP
IC18	55142720	IC-LOWFREQ KIC9459F SOP24 TONE/VOL/BAL/MUTE
IC19	55179480	IC-LOWFREQ TC9482F SOP28 TONE/VOL/BAL/MUTE
IC2	55142720	IC-LOWFREQ KIC9459F SOP24 TONE/VOL/BAL/MUTE
IC20	55142590	IC-OPERAMP NJM5532M DUAL OP
IC21	55142610	IC-OPERAMP NJM2068M DUAL OP
IC22	55142610	IC-OPERAMP NJM2068M DUAL OP
IC23	55142610	IC-OPERAMP NJM2068M DUAL OP
IC24	55142610	IC-OPERAMP NJM2068M DUAL OP
IC25	55142610	IC-OPERAMP NJM2068M DUAL OP
IC26	55142610	IC-OPERAMP NJM2068M DUAL OP
IC3	55506490	IC-SWITCH NJU7312AM ANALOG SWITCH
IC4	55142610	IC-OPERAMP NJM2068M DUAL OP

Processor board AVR5550

5/16

Pos	Tocom#	SName
IC5	55506480	IC-SWITCH NJU7311AM ANALOG SWITCH
IC7	55142610	IC-OPERAMP NJM2068M DUAL OP
IC8	55142610	IC-OPERAMP NJM2068M DUAL OP
IC9	55142610	IC-OPERAMP NJM2068M DUAL OP
J23	10328750	RMGCFMIC 0 OHM +0% 62MI5W
J24	10328750	RMGCFMIC 0 OHM +0% 62MI5W
J25	10328750	RMGCFMIC 0 OHM +0% 62MI5W
Q10	55138710	TR-SLPSWA KTD1304 N 20V 300MI0A
Q11	55138710	TR-SLPSWA KTD1304 N 20V 300MI0A
Q12	55138710	TR-SLPSWA KTD1304 N 20V 300MI0A
Q13	55133190	TR-SSD DTA114YKA P 10K0 OHM 47K0 OHM
Q14	55133190	TR-SSD DTA114YKA P 10K0 OHM 47K0 OHM
Q15	55138710	TR-SLPSWA KTD1304 N 20V 300MI0A
Q16	55138710	TR-SLPSWA KTD1304 N 20V 300MI0A
Q17	55133190	TR-SSD DTA114YKA P 10K0 OHM 47K0 OHM
Q20	55133190	TR-SSD DTA114YKA P 10K0 OHM 47K0 OHM
Q23	55133190	TR-SSD DTA114YKA P 10K0 OHM 47K0 OHM
Q25	55133190	TR-SSD DTA114YKA P 10K0 OHM 47K0 OHM
Q3	55133190	TR-SSD DTA114YKA P 10K0 OHM 47K0 OHM
Q32	55133190	TR-SSD DTA114YKA P 10K0 OHM 47K0 OHM
Q34	55133190	TR-SSD DTA114YKA P 10K0 OHM 47K0 OHM
Q35	55133190	TR-SSD DTA114YKA P 10K0 OHM 47K0 OHM
Q37	55133190	TR-SSD DTA114YKA P 10K0 OHM 47K0 OHM
Q41	55133190	TR-SSD DTA114YKA P 10K0 OHM 47K0 OHM
Q43	55133190	TR-SSD DTA114YKA P 10K0 OHM 47K0 OHM
Q50	55133190	TR-SSD DTA114YKA P 10K0 OHM 47K0 OHM
Q51	55138710	TR-SLPSWA KTD1304 N 20V 300MI0A
Q52	55133190	TR-SSD DTA114YKA P 10K0 OHM 47K0 OHM
Q53	55138710	TR-SLPSWA KTD1304 N 20V 300MI0A
Q58	55138710	TR-SLPSWA KTD1304 N 20V 300MI0A
Q59	55138710	TR-SLPSWA KTD1304 N 20V 300MI0A
Q7	55138710	TR-SLPSWA KTD1304 N 20V 300MI0A
Q8	55138710	TR-SLPSWA KTD1304 N 20V 300MI0A
Q9	55138710	TR-SLPSWA KTD1304 N 20V 300MI0A
R122	10135770	RMGCFMIC 1K0 OHM +5% 62MI5W
R125	10135770	RMGCFMIC 1K0 OHM +5% 62MI5W
R135	10135030	RMGCFMIC 12K0 OHM +5% 62MI5W
R156	10135900	RMGCFMIC 3K3 OHM +5% 62MI5W
R157	10135900	RMGCFMIC 3K3 OHM +5% 62MI5W
R158	10135030	RMGCFMIC 12K0 OHM +5% 62MI5W
R159	10135900	RMGCFMIC 3K3 OHM +5% 62MI5W
R160	10135900	RMGCFMIC 3K3 OHM +5% 62MI5W
R19	10135170	RMGCFMIC 33K0 OHM +5% 62MI5W
R190	10135170	RMGCFMIC 33K0 OHM +5% 62MI5W
R197	10134650	RMGCFMIC 47R0 OHM +5% 62MI5W
R201	10134650	RMGCFMIC 47R0 OHM +5% 62MI5W
R208	10134410	RMGCFMIC 10R0 OHM +5% 62MI5W
R209	10134410	RMGCFMIC 10R0 OHM +5% 62MI5W
R210	10135860	RMGCFMIC 2K2 OHM +5% 62MI5W
R211	10135530	RMGCFMIC 470K0 OHM +5% 62MI5W
R213	10135860	RMGCFMIC 2K2 OHM +5% 62MI5W
R214	10135080	RMGCFMIC 18K0 OHM +5% 62MI5W
R217	10135860	RMGCFMIC 2K2 OHM +5% 62MI5W
R218	10135860	RMGCFMIC 2K2 OHM +5% 62MI5W
R219	10135170	RMGCFMIC 33K0 OHM +5% 62MI5W
R223	10135080	RMGCFMIC 18K0 OHM +5% 62MI5W

Processor board AVR5550

6/16

Pos	Tocom#	SName
R224	10135860	RMGCFMIC 2K2 OHM +5% 62MI5W
R225	10135530	RMGCFMIC 470K0 OHM +5% 62MI5W
R227	10135530	RMGCFMIC 470K0 OHM +5% 62MI5W
R228	10135860	RMGCFMIC 2K2 OHM +5% 62MI5W
R23	10135860	RMGCFMIC 2K2 OHM +5% 62MI5W
R232	10134740	RMGCFMIC 100R0 OHM +5% 62MI5W
R24	10135860	RMGCFMIC 2K2 OHM +5% 62MI5W
R242	10134740	RMGCFMIC 100R0 OHM +5% 62MI5W
R243	10134740	RMGCFMIC 100R0 OHM +5% 62MI5W
R253	10134740	RMGCFMIC 100R0 OHM +5% 62MI5W
R257	10135860	RMGCFMIC 2K2 OHM +5% 62MI5W
R258	10135530	RMGCFMIC 470K0 OHM +5% 62MI5W
R260	10135530	RMGCFMIC 470K0 OHM +5% 62MI5W
R261	10135860	RMGCFMIC 2K2 OHM +5% 62MI5W
R262	10135080	RMGCFMIC 18K0 OHM +5% 62MI5W
R265	10135170	RMGCFMIC 33K0 OHM +5% 62MI5W
R266	10135170	RMGCFMIC 33K0 OHM +5% 62MI5W
R267	10135170	RMGCFMIC 33K0 OHM +5% 62MI5W
R271	10135080	RMGCFMIC 18K0 OHM +5% 62MI5W
R272	10135860	RMGCFMIC 2K2 OHM +5% 62MI5W
R273	10135530	RMGCFMIC 470K0 OHM +5% 62MI5W
R275	10135530	RMGCFMIC 470K0 OHM +5% 62MI5W
R276	10135860	RMGCFMIC 2K2 OHM +5% 62MI5W
R280	10134740	RMGCFMIC 100R0 OHM +5% 62MI5W
R290	10134740	RMGCFMIC 100R0 OHM +5% 62MI5W
R291	10135170	RMGCFMIC 33K0 OHM +5% 62MI5W
R295	10135080	RMGCFMIC 18K0 OHM +5% 62MI5W
R296	10135860	RMGCFMIC 2K2 OHM +5% 62MI5W
R297	10135530	RMGCFMIC 470K0 OHM +5% 62MI5W
R299	10135530	RMGCFMIC 470K0 OHM +5% 62MI5W
R300	10135860	RMGCFMIC 2K2 OHM +5% 62MI5W
R304	10134740	RMGCFMIC 100R0 OHM +5% 62MI5W
R314	10134740	RMGCFMIC 100R0 OHM +5% 62MI5W
R315	10134410	RMGCFMIC 10R0 OHM +5% 62MI5W
R316	10134410	RMGCFMIC 10R0 OHM +5% 62MI5W
R317	10135860	RMGCFMIC 2K2 OHM +5% 62MI5W
R318	10135860	RMGCFMIC 2K2 OHM +5% 62MI5W
R322	10135050	RMGCFMIC 15K0 OHM +5% 62MI5W
R323	10135050	RMGCFMIC 15K0 OHM +5% 62MI5W
R328	10135530	RMGCFMIC 470K0 OHM +5% 62MI5W
R330	10135860	RMGCFMIC 2K2 OHM +5% 62MI5W
R331	10135530	RMGCFMIC 470K0 OHM +5% 62MI5W
R332	10135170	RMGCFMIC 33K0 OHM +5% 62MI5W
R333	10135860	RMGCFMIC 2K2 OHM +5% 62MI5W
R37	10135860	RMGCFMIC 2K2 OHM +5% 62MI5W
R38	10135860	RMGCFMIC 2K2 OHM +5% 62MI5W
R53	10135860	RMGCFMIC 2K2 OHM +5% 62MI5W
R54	10135860	RMGCFMIC 2K2 OHM +5% 62MI5W
R55	10135170	RMGCFMIC 33K0 OHM +5% 62MI5W
R7	10135860	RMGCFMIC 2K2 OHM +5% 62MI5W
R72	10135340	RMGCFMIC 100K0 OHM +5% 62MI5W
R8	10135860	RMGCFMIC 2K2 OHM +5% 62MI5W
R83	10135170	RMGCFMIC 33K0 OHM +5% 62MI5W
R84	10135170	RMGCFMIC 33K0 OHM +5% 62MI5W
R87	10135170	RMGCFMIC 33K0 OHM +5% 62MI5W
R89	10135170	RMGCFMIC 33K0 OHM +5% 62MI5W

Processor board AVR5550

7/16

Pos	Tocom#	SName
R90	10135170	RMGCFMIC 33K0 OHM +5% 62MI5W
R97	10135170	RMGCFMIC 33K0 OHM +5% 62MI5W
C100	20267830	CE 47U0F +20% 16.0V 85C 20251640
C101	20267830	CE 47U0F +20% 16.0V 85C 20251640
C102	20267830	CE 47U0F +20% 16.0V 85C 20251640
C103	20267830	CE 47U0F +20% 16.0V 85C 20251640
C104	20267830	CE 47U0F +20% 16.0V 85C 20251640
C105	20267830	CE 47U0F +20% 16.0V 85C 20251640
C106	15002130	CE 10U0F +20% 16.0V 85C
C107	15002130	CE 10U0F +20% 16.0V 85C
C108	20267830	CE 47U0F +20% 16.0V 85C 20251640
C109	20267830	CE 47U0F +20% 16.0V 85C 20251640
C112	20267830	CE 47U0F +20% 16.0V 85C 20251640
C113	55558540	CE 10U0F +20% 16.0V 85C
C114	55558540	CE 10U0F +20% 16.0V 85C
C116	55558540	CE 10U0F +20% 16.0V 85C
C118	55558540	CE 10U0F +20% 16.0V 85C
C119	20267830	CE 47U0F +20% 16.0V 85C 20251640
C120	20267830	CE 47U0F +20% 16.0V 85C 20251640
C121	15002130	CE 10U0F +20% 16.0V 85C
C122	20267830	CE 47U0F +20% 16.0V 85C 20251640
C123	15002130	CE 10U0F +20% 16.0V 85C
C124	15002130	CE 10U0F +20% 16.0V 85C
C125	15002130	CE 10U0F +20% 16.0V 85C
C126	15002130	CE 10U0F +20% 16.0V 85C
C127	20267830	CE 47U0F +20% 16.0V 85C 20251640
C129	20267830	CE 47U0F +20% 16.0V 85C 20251640
C13	15002130	CE 10U0F +20% 16.0V 85C
C131	15002130	CE 10U0F +20% 16.0V 85C
C132	20267830	CE 47U0F +20% 16.0V 85C 20251640
C133	20267830	CE 47U0F +20% 16.0V 85C 20251640
C138	20267830	CE 47U0F +20% 16.0V 85C 20251640
C139	55558540	CE 10U0F +20% 16.0V 85C
C14	15002130	CE 10U0F +20% 16.0V 85C
C140	55558540	CE 10U0F +20% 16.0V 85C
C142	55558540	CE 10U0F +20% 16.0V 85C
C144	55558540	CE 10U0F +20% 16.0V 85C
C145	20267830	CE 47U0F +20% 16.0V 85C 20251640
C146	20267830	CE 47U0F +20% 16.0V 85C 20251640
C147	15002130	CE 10U0F +20% 16.0V 85C
C149	15002130	CE 10U0F +20% 16.0V 85C
C15	20267830	CE 47U0F +20% 16.0V 85C 20251640
C151	15002130	CE 10U0F +20% 16.0V 85C
C152	15002130	CE 10U0F +20% 16.0V 85C
C153	20267830	CE 47U0F +20% 16.0V 85C 20251640
C158	20267830	CE 47U0F +20% 16.0V 85C 20251640
C159	15002130	CE 10U0F +20% 16.0V 85C
C16	15002130	CE 10U0F +20% 16.0V 85C
C160	15002130	CE 10U0F +20% 16.0V 85C
C162	15002130	CE 10U0F +20% 16.0V 85C
C164	15002130	CE 10U0F +20% 16.0V 85C
C165	20267830	CE 47U0F +20% 16.0V 85C 20251640
C168	20267830	CE 47U0F +20% 16.0V 85C 20251640
C169	15002130	CE 10U0F +20% 16.0V 85C
C17	15002130	CE 10U0F +20% 16.0V 85C
C170	15002130	CE 10U0F +20% 16.0V 85C

Processor board AVR5550

8/16

Pos	Tocom#	SName
C172	15002130	CE 10U0F +20% 16.0V 85C
C174	15002130	CE 10U0F +20% 16.0V 85C
C175	20267830	CE 47U0F +20% 16.0V 85C 20251640
C176	40433090	CE 1MIOF +20% 6.3V 85C
C177	40433090	CE 1MIOF +20% 6.3V 85C
C18	20267830	CE 47U0F +20% 16.0V 85C 20251640
C19	15002130	CE 10U0F +20% 16.0V 85C
C195	15002130	CE 10U0F +20% 16.0V 85C
C196	15002130	CE 10U0F +20% 16.0V 85C
C197	15002130	CE 10U0F +20% 16.0V 85C
C198	15002130	CE 10U0F +20% 16.0V 85C
C20	15002130	CE 10U0F +20% 16.0V 85C
C201	20267830	CE 47U0F +20% 16.0V 85C 20251640
C202	20267830	CE 47U0F +20% 16.0V 85C 20251640
C37	15002130	CE 10U0F +20% 16.0V 85C
C38	15002130	CE 10U0F +20% 16.0V 85C
C39	20267830	CE 47U0F +20% 16.0V 85C 20251640
C40	15002130	CE 10U0F +20% 16.0V 85C
C41	15002130	CE 10U0F +20% 16.0V 85C
C42	20267830	CE 47U0F +20% 16.0V 85C 20251640
C5	20267830	CE 47U0F +20% 16.0V 85C 20251640
C53	15002130	CE 10U0F +20% 16.0V 85C
C54	15002130	CE 10U0F +20% 16.0V 85C
C55	20267830	CE 47U0F +20% 16.0V 85C 20251640
C56	15002130	CE 10U0F +20% 16.0V 85C
C57	15002130	CE 10U0F +20% 16.0V 85C
C58	20267830	CE 47U0F +20% 16.0V 85C 20251640
C59	15002130	CE 10U0F +20% 16.0V 85C
C6	15002130	CE 10U0F +20% 16.0V 85C
C60	15002130	CE 10U0F +20% 16.0V 85C
C7	15002130	CE 10U0F +20% 16.0V 85C
C74	20267830	CE 47U0F +20% 16.0V 85C 20251640
C75	15002130	CE 10U0F +20% 16.0V 85C
C76	15002130	CE 10U0F +20% 16.0V 85C
C77	20267830	CE 47U0F +20% 16.0V 85C 20251640
C78	20267830	CE 47U0F +20% 16.0V 85C 20251640
C79	55558540	CE 10U0F +20% 16.0V 85C
C8	20267830	CE 47U0F +20% 16.0V 85C 20251640
C80	55558540	CE 10U0F +20% 16.0V 85C
C81	20267830	CE 47U0F +20% 16.0V 85C 20251640
C82	55558540	CE 10U0F +20% 16.0V 85C
C83	55558540	CE 10U0F +20% 16.0V 85C
C84	15002130	CE 10U0F +20% 16.0V 85C
C85	15002130	CE 10U0F +20% 16.0V 85C
C86	20267830	CE 47U0F +20% 16.0V 85C 20251640
C87	15002130	CE 10U0F +20% 16.0V 85C
C88	15002130	CE 10U0F +20% 16.0V 85C
C89	20267830	CE 47U0F +20% 16.0V 85C 20251640
C90	15002130	CE 10U0F +20% 16.0V 85C
C91	15002130	CE 10U0F +20% 16.0V 85C
C92	20267830	CE 47U0F +20% 16.0V 85C 20251640
C95	20267830	CE 47U0F +20% 16.0V 85C 20251640
C96	20267830	CE 47U0F +20% 16.0V 85C 20251640
C97	20267830	CE 47U0F +20% 16.0V 85C 20251640
C98	20267830	CE 47U0F +20% 16.0V 85C 20251640
C99	20267830	CE 47U0F +20% 16.0V 85C 20251640

Processor board AVR5550

9/16

Pos	Tocom#	SName
Q18	55133290	TR-SLPLF KTD1302 B N 300MI0A 20V
Q2	55142670	TR-SLPLF MP5A06 N 500MI0A
Q22	55133290	TR-SLPLF KTD1302 B N 300MI0A 20V
Q47	55133290	TR-SLPLF KTD1302 B N 300MI0A 20V
Q48	55133350	TR-SLPLF MP5A56 Y P -500MI0A -300V
Q49	55142670	TR-SLPLF MP5A06 N 500MI0A
Q5	55133350	TR-SLPLF MP5A56 Y P -500MI0A -300V
Q6	55133290	TR-SLPLF KTD1302 B N 300MI0A 20V
C1	20506590	CCCFMIC 100P0F +5% -5% 50.0V NP0
C10	20506590	CCCFMIC 100P0F +5% -5% 50.0V NP0
C11	20506590	CCCFMIC 100P0F +5% -5% 50.0V NP0
C110	20506560	CCCFMIC 33P0F +5% -5% 50.0V NP0
C117	20506560	CCCFMIC 33P0F +5% -5% 50.0V NP0
C12	20506590	CCCFMIC 100P0F +5% -5% 50.0V NP0
C128	10138420	CCCFMIC 820P0F +10% -10% 50.0V X7R
C128	20678070	CCCFMIC 330P0F +5% -5% 50.0V NP0
C135	10138420	CCCFMIC 820P0F +10% -10% 50.0V X7R
C135	20678070	CCCFMIC 330P0F +5% -5% 50.0V NP0
C136	20506560	CCCFMIC 33P0F +5% -5% 50.0V NP0
C143	20506560	CCCFMIC 33P0F +5% -5% 50.0V NP0
C148	20506560	CCCFMIC 33P0F +5% -5% 50.0V NP0
C155	20506560	CCCFMIC 33P0F +5% -5% 50.0V NP0
C156	20506560	CCCFMIC 33P0F +5% -5% 50.0V NP0
C163	20506560	CCCFMIC 33P0F +5% -5% 50.0V NP0
C166	20506560	CCCFMIC 33P0F +5% -5% 50.0V NP0
C173	20506560	CCCFMIC 33P0F +5% -5% 50.0V NP0
C178	20506590	CCCFMIC 100P0F +5% -5% 50.0V NP0
C179	20506590	CCCFMIC 100P0F +5% -5% 50.0V NP0
C180	20506590	CCCFMIC 100P0F +5% -5% 50.0V NP0
C181	20506590	CCCFMIC 100P0F +5% -5% 50.0V NP0
C182	20506590	CCCFMIC 100P0F +5% -5% 50.0V NP0
C183	20506590	CCCFMIC 100P0F +5% -5% 50.0V NP0
C184	20506590	CCCFMIC 100P0F +5% -5% 50.0V NP0
C185	20288040	CCCFMIC 100N0F +80% -20% 16.0V Y5V
C186	20288040	CCCFMIC 100N0F +80% -20% 16.0V Y5V
C187	20288040	CCCFMIC 100N0F +80% -20% 16.0V Y5V
C188	20506560	CCCFMIC 33P0F +5% -5% 50.0V NP0
C191	20506590	CCCFMIC 100P0F +5% -5% 50.0V NP0
C192	20506590	CCCFMIC 100P0F +5% -5% 50.0V NP0
C193	20506590	CCCFMIC 100P0F +5% -5% 50.0V NP0
C194	20506590	CCCFMIC 100P0F +5% -5% 50.0V NP0
C2	20506590	CCCFMIC 100P0F +5% -5% 50.0V NP0
C203	20506560	CCCFMIC 33P0F +5% -5% 50.0V NP0
C204	20506560	CCCFMIC 33P0F +5% -5% 50.0V NP0
C21	20506590	CCCFMIC 100P0F +5% -5% 50.0V NP0
C22	20506590	CCCFMIC 100P0F +5% -5% 50.0V NP0
C23	20506590	CCCFMIC 100P0F +5% -5% 50.0V NP0
C24	20506590	CCCFMIC 100P0F +5% -5% 50.0V NP0
C25	20506590	CCCFMIC 100P0F +5% -5% 50.0V NP0
C26	20506590	CCCFMIC 100P0F +5% -5% 50.0V NP0
C27	20506590	CCCFMIC 100P0F +5% -5% 50.0V NP0
C28	20506590	CCCFMIC 100P0F +5% -5% 50.0V NP0
C29	20506590	CCCFMIC 100P0F +5% -5% 50.0V NP0
C3	20506590	CCCFMIC 100P0F +5% -5% 50.0V NP0
C30	20506590	CCCFMIC 100P0F +5% -5% 50.0V NP0
C31	20506590	CCCFMIC 100P0F +5% -5% 50.0V NP0

Processor board AVR5550

10/16

Pos	Tocom#	SName
C32	20506590	CCCFMIC 100P0F +5% -5% 50.0V NP0
C33	20506590	CCCFMIC 100P0F +5% -5% 50.0V NP0
C34	20506590	CCCFMIC 100P0F +5% -5% 50.0V NP0
C35	20506590	CCCFMIC 100P0F +5% -5% 50.0V NP0
C36	20506590	CCCFMIC 100P0F +5% -5% 50.0V NP0
C4	20506590	CCCFMIC 100P0F +5% -5% 50.0V NP0
C43	20506590	CCCFMIC 100P0F +5% -5% 50.0V NP0
C44	20506590	CCCFMIC 100P0F +5% -5% 50.0V NP0
C45	20506590	CCCFMIC 100P0F +5% -5% 50.0V NP0
C46	20506590	CCCFMIC 100P0F +5% -5% 50.0V NP0
C47	20506590	CCCFMIC 100P0F +5% -5% 50.0V NP0
C48	20506590	CCCFMIC 100P0F +5% -5% 50.0V NP0
C49	20506590	CCCFMIC 100P0F +5% -5% 50.0V NP0
C50	20506590	CCCFMIC 100P0F +5% -5% 50.0V NP0
C51	20288040	CCCFMIC 100N0F +80% -20% 16.0V Y5V
C52	20288040	CCCFMIC 100N0F +80% -20% 16.0V Y5V
C61	20506590	CCCFMIC 100P0F +5% -5% 50.0V NP0
C62	20506590	CCCFMIC 100P0F +5% -5% 50.0V NP0
C63	20506590	CCCFMIC 100P0F +5% -5% 50.0V NP0
C64	20506590	CCCFMIC 100P0F +5% -5% 50.0V NP0
C65	20506590	CCCFMIC 100P0F +5% -5% 50.0V NP0
C67	20506560	CCCFMIC 33P0F +5% -5% 50.0V NP0
C69	20506560	CCCFMIC 33P0F +5% -5% 50.0V NP0
C70	20506590	CCCFMIC 100P0F +5% -5% 50.0V NP0
C71	20506590	CCCFMIC 100P0F +5% -5% 50.0V NP0
C72	20506590	CCCFMIC 100P0F +5% -5% 50.0V NP0
C73	20506590	CCCFMIC 100P0F +5% -5% 50.0V NP0
C9	20506590	CCCFMIC 100P0F +5% -5% 50.0V NP0
C94	10138620	CCCFMIC 2N2F +10% -10% 50.0V X7R
D18	55506380	D-ZENER UDZS 9.1B 9.1V 200MI0W
D19	55177710	D-ZENER UDZS 5.1 B 5.1V 200MI0W
D2	20496510	D-SLP 1SS355 35.0V 225MI0A
D26	10328750	RMGCFMIC 0 OHM +0% 62MI5W
J10	10328750	RMGCFMIC 0 OHM +0% 62MI5W
J11	10328750	RMGCFMIC 0 OHM +0% 62MI5W
J12	10328750	RMGCFMIC 0 OHM +0% 62MI5W
J26	10328750	RMGCFMIC 0 OHM +0% 62MI5W
J31	10328750	RMGCFMIC 0 OHM +0% 62MI5W
J34	10328750	RMGCFMIC 0 OHM +0% 62MI5W
J38	10328750	RMGCFMIC 0 OHM +0% 62MI5W
J39	10328750	RMGCFMIC 0 OHM +0% 62MI5W
J40	10328750	RMGCFMIC 0 OHM +0% 62MI5W
J41	10328750	RMGCFMIC 0 OHM +0% 62MI5W
J7	10328750	RMGCFMIC 0 OHM +0% 62MI5W
J8	10328750	RMGCFMIC 0 OHM +0% 62MI5W
J9	10328750	RMGCFMIC 0 OHM +0% 62MI5W
Q1	55138710	TR-SLPSWA KTD1304 N 20V 300MI0A
Q19	55138710	TR-SLPSWA KTD1304 N 20V 300MI0A
Q21	55133190	TR-SSD DTA114YKA P 10K0 OHM 47K0 OHM
Q24	55138710	TR-SLPSWA KTD1304 N 20V 300MI0A
Q26	55138710	TR-SLPSWA KTD1304 N 20V 300MI0A
Q27	55138710	TR-SLPSWA KTD1304 N 20V 300MI0A
Q28	55138710	TR-SLPSWA KTD1304 N 20V 300MI0A
Q29	55138710	TR-SLPSWA KTD1304 N 20V 300MI0A
Q30	55138710	TR-SLPSWA KTD1304 N 20V 300MI0A
Q31	55138710	TR-SLPSWA KTD1304 N 20V 300MI0A

Processor board AVR5550

11/16

Pos	Tocom#	SName
Q33	55138710	TR-SLPSWA KTD1304 N 20V 300MI0A
Q36	55138710	TR-SLPSWA KTD1304 N 20V 300MI0A
Q38	55138710	TR-SLPSWA KTD1304 N 20V 300MI0A
Q39	55138710	TR-SLPSWA KTD1304 N 20V 300MI0A
Q4	55133180	TR-SSD DTC114YKA N 10K0 OHM 47K0 OHM
Q40	55138710	TR-SLPSWA KTD1304 N 20V 300MI0A
Q42	55138710	TR-SLPSWA KTD1304 N 20V 300MI0A
Q44	55138710	TR-SLPSWA KTD1304 N 20V 300MI0A
Q45	55138710	TR-SLPSWA KTD1304 N 20V 300MI0A
Q46	55138710	TR-SLPSWA KTD1304 N 20V 300MI0A
Q54	55133180	TR-SSD DTC114YKA N 10K0 OHM 47K0 OHM
R1	10134740	RMGCFMIC 100R0 OHM +5% 62MI5W
R10	10134740	RMGCFMIC 100R0 OHM +5% 62MI5W
R100	10135340	RMGCFMIC 100K0 OHM +5% 62MI5W
R101	10134740	RMGCFMIC 100R0 OHM +5% 62MI5W
R103	10135340	RMGCFMIC 100K0 OHM +5% 62MI5W
R104	10135340	RMGCFMIC 100K0 OHM +5% 62MI5W
R106	10134740	RMGCFMIC 100R0 OHM +5% 62MI5W
R107	10134740	RMGCFMIC 100R0 OHM +5% 62MI5W
R109	10135340	RMGCFMIC 100K0 OHM +5% 62MI5W
R11	10134740	RMGCFMIC 100R0 OHM +5% 62MI5W
R110	10135340	RMGCFMIC 100K0 OHM +5% 62MI5W
R112	10134740	RMGCFMIC 100R0 OHM +5% 62MI5W
R113	10135340	RMGCFMIC 100K0 OHM +5% 62MI5W
R114	10135340	RMGCFMIC 100K0 OHM +5% 62MI5W
R115	10135170	RMGCFMIC 33K0 OHM +5% 62MI5W
R116	10135170	RMGCFMIC 33K0 OHM +5% 62MI5W
R117	10135170	RMGCFMIC 33K0 OHM +5% 62MI5W
R118	10135170	RMGCFMIC 33K0 OHM +5% 62MI5W
R119	10135340	RMGCFMIC 100K0 OHM +5% 62MI5W
R12	10135340	RMGCFMIC 100K0 OHM +5% 62MI5W
R120	10135340	RMGCFMIC 100K0 OHM +5% 62MI5W
R121	10134740	RMGCFMIC 100R0 OHM +5% 62MI5W
R123	10135340	RMGCFMIC 100K0 OHM +5% 62MI5W
R124	10135340	RMGCFMIC 100K0 OHM +5% 62MI5W
R126	10134740	RMGCFMIC 100R0 OHM +5% 62MI5W
R127	10134910	RMGCFMIC 470R0 OHM +5% 62MI5W
R128	10135940	RMGCFMIC 4K7 OHM +5% 62MI5W
R129	10135340	RMGCFMIC 100K0 OHM +5% 62MI5W
R13	10134740	RMGCFMIC 100R0 OHM +5% 62MI5W
R130	10135340	RMGCFMIC 100K0 OHM +5% 62MI5W
R131	10134740	RMGCFMIC 100R0 OHM +5% 62MI5W
R132	10135850	RMGCFMIC 2K0 OHM +5% 62MI5W
R133	10134740	RMGCFMIC 100R0 OHM +5% 62MI5W
R134	10135030	RMGCFMIC 12K0 OHM +5% 62MI5W
R136	10134740	RMGCFMIC 100R0 OHM +5% 62MI5W
R137	10134740	RMGCFMIC 100R0 OHM +5% 62MI5W
R138	10135770	RMGCFMIC 1K0 OHM +5% 62MI5W
R139	10135770	RMGCFMIC 1K0 OHM +5% 62MI5W
R14	10135340	RMGCFMIC 100K0 OHM +5% 62MI5W
R140	10135770	RMGCFMIC 1K0 OHM +5% 62MI5W
R141	10134740	RMGCFMIC 100R0 OHM +5% 62MI5W
R142	10134740	RMGCFMIC 100R0 OHM +5% 62MI5W
R143	10135770	RMGCFMIC 1K0 OHM +5% 62MI5W
R144	10135770	RMGCFMIC 1K0 OHM +5% 62MI5W
R145	10135770	RMGCFMIC 1K0 OHM +5% 62MI5W

Processor board AVR5550

12/16

Pos	Tocom#	SName
R146	10135340	RMGCFMIC 100K0 OHM +5% 62MI5W
R147	10135340	RMGCFMIC 100K0 OHM +5% 62MI5W
R148	10134910	RMGCFMIC 470R0 OHM +5% 62MI5W
R149	10134910	RMGCFMIC 470R0 OHM +5% 62MI5W
R15	10135340	RMGCFMIC 100K0 OHM +5% 62MI5W
R150	10135770	RMGCFMIC 1K0 OHM +5% 62MI5W
R151	10135770	RMGCFMIC 1K0 OHM +5% 62MI5W
R152	10135770	RMGCFMIC 1K0 OHM +5% 62MI5W
R153	10135770	RMGCFMIC 1K0 OHM +5% 62MI5W
R154	10135770	RMGCFMIC 1K0 OHM +5% 62MI5W
R155	10135770	RMGCFMIC 1K0 OHM +5% 62MI5W
R16	10135340	RMGCFMIC 100K0 OHM +5% 62MI5W
R161	10135340	RMGCFMIC 100K0 OHM +5% 62MI5W
R162	10135340	RMGCFMIC 100K0 OHM +5% 62MI5W
R163	10135030	RMGCFMIC 12K0 OHM +5% 62MI5W
R164	10135030	RMGCFMIC 12K0 OHM +5% 62MI5W
R165	10135030	RMGCFMIC 12K0 OHM +5% 62MI5W
R166	10134740	RMGCFMIC 100R0 OHM +5% 62MI5W
R167	10134740	RMGCFMIC 100R0 OHM +5% 62MI5W
R168	10135770	RMGCFMIC 1K0 OHM +5% 62MI5W
R169	10135770	RMGCFMIC 1K0 OHM +5% 62MI5W
R17	10135340	RMGCFMIC 100K0 OHM +5% 62MI5W
R170	10135770	RMGCFMIC 1K0 OHM +5% 62MI5W
R171	10134740	RMGCFMIC 100R0 OHM +5% 62MI5W
R172	10134740	RMGCFMIC 100R0 OHM +5% 62MI5W
R173	10134980	RMGCFMIC 820R0 OHM +5% 62MI5W
R174	10134740	RMGCFMIC 100R0 OHM +5% 62MI5W
R175	10135340	RMGCFMIC 100K0 OHM +5% 62MI5W
R176	10135340	RMGCFMIC 100K0 OHM +5% 62MI5W
R177	10135930	RMGCFMIC 4K3 OHM +5% 62MI5W
R178	10134910	RMGCFMIC 470R0 OHM +5% 62MI5W
R179	10135930	RMGCFMIC 4K3 OHM +5% 62MI5W
R18	10134740	RMGCFMIC 100R0 OHM +5% 62MI5W
R180	10134980	RMGCFMIC 820R0 OHM +5% 62MI5W
R181	10135340	RMGCFMIC 100K0 OHM +5% 62MI5W
R182	10134910	RMGCFMIC 470R0 OHM +5% 62MI5W
R183	10135340	RMGCFMIC 100K0 OHM +5% 62MI5W
R184	10134740	RMGCFMIC 100R0 OHM +5% 62MI5W
R185	10134740	RMGCFMIC 100R0 OHM +5% 62MI5W
R186	10135340	RMGCFMIC 100K0 OHM +5% 62MI5W
R187	10134910	RMGCFMIC 470R0 OHM +5% 62MI5W
R188	10135340	RMGCFMIC 100K0 OHM +5% 62MI5W
R189	10134740	RMGCFMIC 100R0 OHM +5% 62MI5W
R191	10135340	RMGCFMIC 100K0 OHM +5% 62MI5W
R192	10135340	RMGCFMIC 100K0 OHM +5% 62MI5W
R193	10135340	RMGCFMIC 100K0 OHM +5% 62MI5W
R194	10135340	RMGCFMIC 100K0 OHM +5% 62MI5W
R195	10134740	RMGCFMIC 100R0 OHM +5% 62MI5W
R196	10135030	RMGCFMIC 12K0 OHM +5% 62MI5W
R198	10134740	RMGCFMIC 100R0 OHM +5% 62MI5W
R2	10135340	RMGCFMIC 100K0 OHM +5% 62MI5W
R20	10135170	RMGCFMIC 33K0 OHM +5% 62MI5W
R200	10135820	RMGCFMIC 1K5 OHM +5% 62MI5W
R202	10135820	RMGCFMIC 1K5 OHM +5% 62MI5W
R203	10135030	RMGCFMIC 12K0 OHM +5% 62MI5W
R204	10134740	RMGCFMIC 100R0 OHM +5% 62MI5W

Processor board AVR5550

13/16

Pos	Tocom#	SName
R205	10135770	RMGCFMIC 1K0 OHM +5% 62MI5W
R207	10135910	RMGCFMIC 3K6 OHM +5% 62MI5W
R21	10135340	RMGCFMIC 100K0 OHM +5% 62MI5W
R212	10135940	RMGCFMIC 4K7 OHM +5% 62MI5W
R215	10135910	RMGCFMIC 3K6 OHM +5% 62MI5W
R216	10135940	RMGCFMIC 4K7 OHM +5% 62MI5W
R22	10134910	RMGCFMIC 470R0 OHM +5% 62MI5W
R220	10135860	RMGCFMIC 2K2 OHM +5% 62MI5W
R221	10135770	RMGCFMIC 1K0 OHM +5% 62MI5W
R222	10135910	RMGCFMIC 3K6 OHM +5% 62MI5W
R226	10135860	RMGCFMIC 2K2 OHM +5% 62MI5W
R229	10135770	RMGCFMIC 1K0 OHM +5% 62MI5W
R230	10135910	RMGCFMIC 3K6 OHM +5% 62MI5W
R231	10135940	RMGCFMIC 4K7 OHM +5% 62MI5W
R233	10135340	RMGCFMIC 100K0 OHM +5% 62MI5W
R234	10135340	RMGCFMIC 100K0 OHM +5% 62MI5W
R235	10135820	RMGCFMIC 1K5 OHM +5% 62MI5W
R236	10135170	RMGCFMIC 33K0 OHM +5% 62MI5W
R237	10135820	RMGCFMIC 1K5 OHM +5% 62MI5W
R238	10135940	RMGCFMIC 4K7 OHM +5% 62MI5W
R239	10135340	RMGCFMIC 100K0 OHM +5% 62MI5W
R240	10135950	RMGCFMIC 5K1 OHM +5% 62MI5W
R241	10135340	RMGCFMIC 100K0 OHM +5% 62MI5W
R244	10135340	RMGCFMIC 100K0 OHM +5% 62MI5W
R245	10135340	RMGCFMIC 100K0 OHM +5% 62MI5W
R246	10135340	RMGCFMIC 100K0 OHM +5% 62MI5W
R247	10135770	RMGCFMIC 1K0 OHM +5% 62MI5W
R248	10136010	RMGCFMIC 9K1 OHM +5% 62MI5W
R249	10135770	RMGCFMIC 1K0 OHM +5% 62MI5W
R25	10134910	RMGCFMIC 470R0 OHM +5% 62MI5W
R250	10135950	RMGCFMIC 5K1 OHM +5% 62MI5W
R251	10135340	RMGCFMIC 100K0 OHM +5% 62MI5W
R252	10135340	RMGCFMIC 100K0 OHM +5% 62MI5W
R254	10135770	RMGCFMIC 1K0 OHM +5% 62MI5W
R255	10135850	RMGCFMIC 2K0 OHM +5% 62MI5W
R256	10135770	RMGCFMIC 1K0 OHM +5% 62MI5W
R259	10135860	RMGCFMIC 2K2 OHM +5% 62MI5W
R26	10135340	RMGCFMIC 100K0 OHM +5% 62MI5W
R263	10135840	RMGCFMIC 1K8 OHM +5% 62MI5W
R264	10135770	RMGCFMIC 1K0 OHM +5% 62MI5W
R268	10135860	RMGCFMIC 2K2 OHM +5% 62MI5W
R269	10135770	RMGCFMIC 1K0 OHM +5% 62MI5W
R27	10134910	RMGCFMIC 470R0 OHM +5% 62MI5W
R270	10135850	RMGCFMIC 2K0 OHM +5% 62MI5W
R274	10135860	RMGCFMIC 2K2 OHM +5% 62MI5W
R277	10135770	RMGCFMIC 1K0 OHM +5% 62MI5W
R278	10135850	RMGCFMIC 2K0 OHM +5% 62MI5W
R279	10135770	RMGCFMIC 1K0 OHM +5% 62MI5W
R28	10135340	RMGCFMIC 100K0 OHM +5% 62MI5W
R281	10135340	RMGCFMIC 100K0 OHM +5% 62MI5W
R282	10135340	RMGCFMIC 100K0 OHM +5% 62MI5W
R283	10135950	RMGCFMIC 5K1 OHM +5% 62MI5W
R284	10134910	RMGCFMIC 470R0 OHM +5% 62MI5W
R285	10135950	RMGCFMIC 5K1 OHM +5% 62MI5W
R286	10135770	RMGCFMIC 1K0 OHM +5% 62MI5W
R287	10135340	RMGCFMIC 100K0 OHM +5% 62MI5W

Processor board AVR5550

14/16

Pos	Tocom#	SName
R288	10134740	RMGCFMIC 100R0 OHM +5% 62MI5W
R289	10135340	RMGCFMIC 100K0 OHM +5% 62MI5W
R29	10134910	RMGCFMIC 470R0 OHM +5% 62MI5W
R292	10135860	RMGCFMIC 2K2 OHM +5% 62MI5W
R293	10135770	RMGCFMIC 1K0 OHM +5% 62MI5W
R294	10135850	RMGCFMIC 2K0 OHM +5% 62MI5W
R298	10135860	RMGCFMIC 2K2 OHM +5% 62MI5W
R3	10134910	RMGCFMIC 470R0 OHM +5% 62MI5W
R30	10134740	RMGCFMIC 100R0 OHM +5% 62MI5W
R301	10135770	RMGCFMIC 1K0 OHM +5% 62MI5W
R302	10135850	RMGCFMIC 2K0 OHM +5% 62MI5W
R303	10135770	RMGCFMIC 1K0 OHM +5% 62MI5W
R305	10135340	RMGCFMIC 100K0 OHM +5% 62MI5W
R306	10135340	RMGCFMIC 100K0 OHM +5% 62MI5W
R307	10135950	RMGCFMIC 5K1 OHM +5% 62MI5W
R308	10135340	RMGCFMIC 100K0 OHM +5% 62MI5W
R309	10135950	RMGCFMIC 5K1 OHM +5% 62MI5W
R31	10134740	RMGCFMIC 100R0 OHM +5% 62MI5W
R310	10135770	RMGCFMIC 1K0 OHM +5% 62MI5W
R311	10135340	RMGCFMIC 100K0 OHM +5% 62MI5W
R312	10135950	RMGCFMIC 5K1 OHM +5% 62MI5W
R313	10135340	RMGCFMIC 100K0 OHM +5% 62MI5W
R319	10135340	RMGCFMIC 100K0 OHM +5% 62MI5W
R32	10134910	RMGCFMIC 470R0 OHM +5% 62MI5W
R320	10135770	RMGCFMIC 1K0 OHM +5% 62MI5W
R321	10135170	RMGCFMIC 33K0 OHM +5% 62MI5W
R324	10135770	RMGCFMIC 1K0 OHM +5% 62MI5W
R325	10135770	RMGCFMIC 1K0 OHM +5% 62MI5W
R326	10135770	RMGCFMIC 1K0 OHM +5% 62MI5W
R327	10135860	RMGCFMIC 2K2 OHM +5% 62MI5W
R329	10135770	RMGCFMIC 1K0 OHM +5% 62MI5W
R33	10135340	RMGCFMIC 100K0 OHM +5% 62MI5W
R334	10135770	RMGCFMIC 1K0 OHM +5% 62MI5W
R335	10134910	RMGCFMIC 470R0 OHM +5% 62MI5W
R336	10135860	RMGCFMIC 2K2 OHM +5% 62MI5W
R337	10135860	RMGCFMIC 2K2 OHM +5% 62MI5W
R34	10134910	RMGCFMIC 470R0 OHM +5% 62MI5W
R343	10135770	RMGCFMIC 1K0 OHM +5% 62MI5W
R344	10135770	RMGCFMIC 1K0 OHM +5% 62MI5W
R345	10135770	RMGCFMIC 1K0 OHM +5% 62MI5W
R346	10135770	RMGCFMIC 1K0 OHM +5% 62MI5W
R347	10135770	RMGCFMIC 1K0 OHM +5% 62MI5W
R348	10135770	RMGCFMIC 1K0 OHM +5% 62MI5W
R349	10135770	RMGCFMIC 1K0 OHM +5% 62MI5W
R35	10135340	RMGCFMIC 100K0 OHM +5% 62MI5W
R350	10135770	RMGCFMIC 1K0 OHM +5% 62MI5W
R351	10135870	RMGCFMIC 2K4 OHM +5% 62MI5W
R352	10135870	RMGCFMIC 2K4 OHM +5% 62MI5W
R353	10134910	RMGCFMIC 470R0 OHM +5% 62MI5W
R354	10134910	RMGCFMIC 470R0 OHM +5% 62MI5W
R355	10134910	RMGCFMIC 470R0 OHM +5% 62MI5W
R356	10134910	RMGCFMIC 470R0 OHM +5% 62MI5W
R357	10134910	RMGCFMIC 470R0 OHM +5% 62MI5W
R358	10134910	RMGCFMIC 470R0 OHM +5% 62MI5W
R359	10134910	RMGCFMIC 470R0 OHM +5% 62MI5W
R36	10134910	RMGCFMIC 470R0 OHM +5% 62MI5W

Processor board AVR5550

15/16

Pos	Tocom#	SName
R360	10134910	RMGCFMIC 470R0 OHM +5% 62MI5W
R361	10134910	RMGCFMIC 470R0 OHM +5% 62MI5W
R362	10134910	RMGCFMIC 470R0 OHM +5% 62MI5W
R363	10134910	RMGCFMIC 470R0 OHM +5% 62MI5W
R364	10134910	RMGCFMIC 470R0 OHM +5% 62MI5W
R365	10134910	RMGCFMIC 470R0 OHM +5% 62MI5W
R366	10134910	RMGCFMIC 470R0 OHM +5% 62MI5W
R367	10134910	RMGCFMIC 470R0 OHM +5% 62MI5W
R368	10134910	RMGCFMIC 470R0 OHM +5% 62MI5W
R369	10134910	RMGCFMIC 470R0 OHM +5% 62MI5W
R370	10134910	RMGCFMIC 470R0 OHM +5% 62MI5W
R371	10134910	RMGCFMIC 470R0 OHM +5% 62MI5W
R372	10134910	RMGCFMIC 470R0 OHM +5% 62MI5W
R373	10134910	RMGCFMIC 470R0 OHM +5% 62MI5W
R374	10134910	RMGCFMIC 470R0 OHM +5% 62MI5W
R375	10134910	RMGCFMIC 470R0 OHM +5% 62MI5W
R39	10134910	RMGCFMIC 470R0 OHM +5% 62MI5W
R4	10134910	RMGCFMIC 470R0 OHM +5% 62MI5W
R40	10135340	RMGCFMIC 100K0 OHM +5% 62MI5W
R41	10135340	RMGCFMIC 100K0 OHM +5% 62MI5W
R42	10135340	RMGCFMIC 100K0 OHM +5% 62MI5W
R43	10135340	RMGCFMIC 100K0 OHM +5% 62MI5W
R44	10134740	RMGCFMIC 100R0 OHM +5% 62MI5W
R45	10135340	RMGCFMIC 100K0 OHM +5% 62MI5W
R46	10134910	RMGCFMIC 470R0 OHM +5% 62MI5W
R47	10135340	RMGCFMIC 100K0 OHM +5% 62MI5W
R48	10134910	RMGCFMIC 470R0 OHM +5% 62MI5W
R49	10134910	RMGCFMIC 470R0 OHM +5% 62MI5W
R5	10135340	RMGCFMIC 100K0 OHM +5% 62MI5W
R50	10135340	RMGCFMIC 100K0 OHM +5% 62MI5W
R51	10134910	RMGCFMIC 470R0 OHM +5% 62MI5W
R52	10135340	RMGCFMIC 100K0 OHM +5% 62MI5W
R56	10135170	RMGCFMIC 33K0 OHM +5% 62MI5W
R57	10134910	RMGCFMIC 470R0 OHM +5% 62MI5W
R58	10135340	RMGCFMIC 100K0 OHM +5% 62MI5W
R59	10134910	RMGCFMIC 470R0 OHM +5% 62MI5W
R6	10134910	RMGCFMIC 470R0 OHM +5% 62MI5W
R60	10135340	RMGCFMIC 100K0 OHM +5% 62MI5W
R61	10135770	RMGCFMIC 1K0 OHM +5% 62MI5W
R62	10135170	RMGCFMIC 33K0 OHM +5% 62MI5W
R63	10134740	RMGCFMIC 100R0 OHM +5% 62MI5W
R64	10134740	RMGCFMIC 100R0 OHM +5% 62MI5W
R65	10135340	RMGCFMIC 100K0 OHM +5% 62MI5W
R66	10135340	RMGCFMIC 100K0 OHM +5% 62MI5W
R67	10135340	RMGCFMIC 100K0 OHM +5% 62MI5W
R68	10135340	RMGCFMIC 100K0 OHM +5% 62MI5W
R69	10135950	RMGCFMIC 5K1 OHM +5% 62MI5W
R70	10135950	RMGCFMIC 5K1 OHM +5% 62MI5W
R71	10135770	RMGCFMIC 1K0 OHM +5% 62MI5W
R73	10134910	RMGCFMIC 470R0 OHM +5% 62MI5W
R74	10135170	RMGCFMIC 33K0 OHM +5% 62MI5W
R75	10134740	RMGCFMIC 100R0 OHM +5% 62MI5W
R76	10134910	RMGCFMIC 470R0 OHM +5% 62MI5W
R77	10134740	RMGCFMIC 100R0 OHM +5% 62MI5W
R78	10134740	RMGCFMIC 100R0 OHM +5% 62MI5W
R79	10134740	RMGCFMIC 100R0 OHM +5% 62MI5W

Processor board AVR5550

16/16

Pos	Tocom#	SName
R85	10135340	RMGCFMIC 100K0 OHM +5% 62MI5W
R86	10135340	RMGCFMIC 100K0 OHM +5% 62MI5W
R9	10134910	RMGCFMIC 470R0 OHM +5% 62MI5W
R91	10135770	RMGCFMIC 1K0 OHM +5% 62MI5W
R92	10135770	RMGCFMIC 1K0 OHM +5% 62MI5W
R93	10135770	RMGCFMIC 1K0 OHM +5% 62MI5W
R94	10135770	RMGCFMIC 1K0 OHM +5% 62MI5W
R95	10135770	RMGCFMIC 1K0 OHM +5% 62MI5W
R96	10135770	RMGCFMIC 1K0 OHM +5% 62MI5W
R99	10135340	RMGCFMIC 100K0 OHM +5% 62MI5W
C152	15002130	CE 10U0F +20% 16.0V 85C
GND1	55135980	TERMLUG GND
IC10	55142750	IC-SWITCH TC9273N-007 DIP28 ANALOG SWITCH
IC6	55142750	IC-SWITCH TC9273N-007 DIP28 ANALOG SWITCH
N2	55174670	CONN 2.0MM 19 MA R NAT SOCKET MOLEX 35237-1910 0 0
NJ51	55176330	CON PHONO SCKT RCA 4P JW4104RS GND
NJ52	55176330	CON PHONO SCKT RCA 4P JW4104RS GND
NJ53	55176330	CON PHONO SCKT RCA 4P JW4104RS GND
NJ54	55176330	CON PHONO SCKT RCA 4P JW4104RS GND
NJ55	55176330	CON PHONO SCKT RCA 4P JW4104RS GND
P1	55090080	CONN 2.0MM 3 MA ST NAT LW2002P03 0 0
P10	55123340	CONN 2.0MM 8 MA ST NAT LW2002P08 0 0
P11	55090080	CONN 2.0MM 3 MA ST NAT LW2002P03 0 0
P12	55123310	CONN 2.0MM 4 MA ST NAT LW2002P04 0 0
P13	55090080	CONN 2.0MM 3 MA ST NAT LW2002P03 0 0
P3	55090080	CONN 2.0MM 3 MA ST NAT LW2002P03 0 0
P3	55123310	CONN 2.0MM 4 MA ST NAT LW2002P04 0 0
P4	55123330	CONN 2.0MM 6 MA ST NAT LW2002P06 0 0
P5	55090050	CONN 2.0MM 10 MA ST NAT LW2002P10 0 0
P6	55123380	CONN 2.0MM 15 MA ST NAT LW2002P15 0 0
P7	55123380	CONN 2.0MM 15 MA ST NAT LW2002P15 0 0
P8	55230480	CONN 1.25MM 31 FE ST BK 00-6216-131-821-808 0 0
P9	55123380	CONN 2.0MM 15 MA ST NAT LW2002P15 0 0
SK1	55506590	RELAYSGNL 12.0V 960.0OHM 3.0A

VIDEO board AVR5550

1/8

Pos	Tocom#	SName
D100	70436540	D-SLP 1N4148 100.0V 150E-3A
D101	70436540	D-SLP 1N4148 100.0V 150E-3A
D102	70436540	D-SLP 1N4148 100.0V 150E-3A
D104	70436540	D-SLP 1N4148 100.0V 150E-3A
D115	70436540	D-SLP 1N4148 100.0V 150E-3A
L101	55179500	LFBEAD 80.582OHM 100M0HZ FB-30 HC-3580
L102	55179500	LFBEAD 80.582OHM 100M0HZ FB-30 HC-3580
L103	55168840	LF 47U0H +10% 5.8 OHM 70MI0A
L104	55168840	LF 47U0H +10% 5.8 OHM 70MI0A
L105	55168840	LF 47U0H +10% 5.8 OHM 70MI0A
L106	55168840	LF 47U0H +10% 5.8 OHM 70MI0A
L107	55179350	LF 22U0H +10% 3.4 OHM 130.0A
L108	55179350	LF 22U0H +10% 3.4 OHM 130.0A
L110	55168840	LF 47U0H +10% 5.8 OHM 70MI0A
R130	11059640	RCF 1K0 OHM +5% 250MI0W
R131	11059640	RCF 1K0 OHM +5% 250MI0W
R132	11059640	RCF 1K0 OHM +5% 250MI0W
R133	11059640	RCF 1K0 OHM +5% 250MI0W
R134	11059640	RCF 1K0 OHM +5% 250MI0W
R135	11059640	RCF 1K0 OHM +5% 250MI0W
R154	50883030	RCF 150K0 OHM +5% 250MI0W
R161	11059640	RCF 1K0 OHM +5% 250MI0W
R162	11059640	RCF 1K0 OHM +5% 250MI0W
R163	11059640	RCF 1K0 OHM +5% 250MI0W
R255	11067570	RCF 1R0 OHM +5% 250MI0W
C100	20269080	CE 220U0F +20% 10.0V 85C
C101	15002130	CE 10U0F +20% 16.0V 85C
C102	20269080	CE 220U0F +20% 10.0V 85C
C103	20269080	CE 220U0F +20% 10.0V 85C
C104	15002130	CE 10U0F +20% 16.0V 85C
C105	20269080	CE 220U0F +20% 10.0V 85C
C106	20269080	CE 220U0F +20% 10.0V 85C
C107	15002130	CE 10U0F +20% 16.0V 85C
C108	20269080	CE 220U0F +20% 10.0V 85C
C109	20269080	CE 220U0F +20% 10.0V 85C
C110	15002130	CE 10U0F +20% 16.0V 85C
C111	20269080	CE 220U0F +20% 10.0V 85C
C116	15002130	CE 10U0F +20% 16.0V 85C
C122	15002130	CE 10U0F +20% 16.0V 85C
C127	40433090	CE 1MI0F +20% 6.3V 85C
C128	15002130	CE 10U0F +20% 16.0V 85C
C128	20268840	CE 1U0F +20% 50.0V 85C
C129	40433090	CE 1MI0F +20% 6.3V 85C
C130	20252670	CE 470U0F +20% 10.0V 85C
C131	20252670	CE 470U0F +20% 10.0V 85C
C132	20252670	CE 470U0F +20% 10.0V 85C
C133	20252670	CE 470U0F +20% 10.0V 85C
C134	20252670	CE 470U0F +20% 10.0V 85C
C135	20252670	CE 470U0F +20% 10.0V 85C
C136	20269080	CE 220U0F +20% 10.0V 85C
C137	15002130	CE 10U0F +20% 16.0V 85C
C138	20269080	CE 220U0F +20% 10.0V 85C
C139	20269080	CE 220U0F +20% 10.0V 85C
C140	20269080	CE 220U0F +20% 10.0V 85C
C141	20267830	CE 47U0F +20% 16.0V 85C 20251640
C145	20252670	CE 470U0F +20% 10.0V 85C

VIDEO board AVR5550

2/8

Pos	Tocom#	SName
C146	20252670	CE 470U0F +20% 10.0V 85C
C147	20252670	CE 470U0F +20% 10.0V 85C
C149	20252670	CE 470U0F +20% 10.0V 85C
C151	20269020	CE 100U0F +20% 16.0V 85C
C152	20269080	CE 220U0F +20% 10.0V 85C
C153	20267830	CE 47U0F +20% 16.0V 85C 20251640
C161	20267830	CE 47U0F +20% 16.0V 85C 20251640
C164	20268840	CE 1U0F +20% 50.0V 85C
C165	20268960	CE 330N0F +20% 50.0V 85C
C166	20268840	CE 1U0F +20% 50.0V 85C
C168	20268940	CE 100U0F +20% 10.0V 85C
C171	80434590	CC 22P0F +5% -5% 50.0V NP0
C172	20268940	CE 100U0F +20% 10.0V 85C
C174	80434590	CC 22P0F +5% -5% 50.0V NP0
C175	40433350	CC 18P0F +5% -5% 50.0V NP0
C176	20268840	CE 1U0F +20% 50.0V 85C
C183	70428520	CC 10N0F +10% -10% 50.0V Y5P
C184	20268850	CE 2U2F +20% 50.0V 85C
C185	20268880	CE 10U0F +20% 50.0V 85C
C186	20268940	CE 100U0F +20% 10.0V 85C
C188	20269020	CE 100U0F +20% 16.0V 85C
C190	20269020	CE 100U0F +20% 16.0V 85C
C192	20269020	CE 100U0F +20% 16.0V 85C
C194	20269020	CE 100U0F +20% 16.0V 85C
C196	20268940	CE 100U0F +20% 10.0V 85C
C198	20268880	CE 10U0F +20% 50.0V 85C
C201	20268850	CE 2U2F +20% 50.0V 85C
C202	20267250	CC 22N0F +10% -10% 50.0V Z5R
C203	20269080	CE 220U0F +20% 10.0V 85C
C204	15002130	CE 10U0F +20% 16.0V 85C
C205	20269080	CE 220U0F +20% 10.0V 85C
C206	15002130	CE 10U0F +20% 16.0V 85C
C252	20268880	CE 10U0F +20% 50.0V 85C
C254	20268880	CE 10U0F +20% 50.0V 85C
C256	20268880	CE 10U0F +20% 50.0V 85C
C258	20268880	CE 10U0F +20% 50.0V 85C
C260	20268880	CE 10U0F +20% 50.0V 85C
C262	20268880	CE 10U0F +20% 50.0V 85C
C289	20269080	CE 220U0F +20% 10.0V 85C
C291	20269020	CE 100U0F +20% 16.0V 85C
C293	20269020	CE 100U0F +20% 16.0V 85C
C295	20269080	CE 220U0F +20% 10.0V 85C
C300	20268840	CE 1U0F +20% 50.0V 85C
C301	20268840	CE 1U0F +20% 50.0V 85C
C302	20268840	CE 1U0F +20% 50.0V 85C
C303	20268840	CE 1U0F +20% 50.0V 85C
C304	20268840	CE 1U0F +20% 50.0V 85C
C305	20268840	CE 1U0F +20% 50.0V 85C
C306	20267830	CE 47U0F +20% 16.0V 85C 20251640
C308	20268940	CE 100U0F +20% 10.0V 85C
C309	20268940	CE 100U0F +20% 10.0V 85C
C310	20268940	CE 100U0F +20% 10.0V 85C
C313	20267830	CE 47U0F +20% 16.0V 85C 20251640
C314	20267830	CE 47U0F +20% 16.0V 85C 20251640
Q100	55133250	TR-SLPLF 2SC1740S R N 150MIOA 50V
Q101	55101930	TR-SLPLF 2SA933ASR P -3.0A -20V

VIDEO board AVR5550

3/8

Pos	Tocom#	SName
Q104	55101930	TR-SLPLF 2SA933ASR P -3.0A -20V
Q105	55133210	TR-SLPLF DTC114YSA N 100MI0A
Q105	55133220	TR-SLPLF DTA114YSA P 100MI0A
Q106	55133290	TR-SLPLF KTD1302 B N 300MI0A 20V
Q107	55133210	TR-SLPLF DTC114YSA N 100MI0A
Q110	55133210	TR-SLPLF DTC114YSA N 100MI0A
Q111	55101930	TR-SLPLF 2SA933ASR P -3.0A -20V
Q112	55133250	TR-SLPLF 2SC1740S R N 150MI0A 50V
C112	20506590	CCCFMIC 100P0F +5% -5% 50.0V NP0
C113	20506590	CCCFMIC 100P0F +5% -5% 50.0V NP0
C114	20506590	CCCFMIC 100P0F +5% -5% 50.0V NP0
C118	20506590	CCCFMIC 100P0F +5% -5% 50.0V NP0
C119	20506590	CCCFMIC 100P0F +5% -5% 50.0V NP0
C120	20506590	CCCFMIC 100P0F +5% -5% 50.0V NP0
C123	20506680	CCCFMIC 470P0F +5% -5% 50.0V NP0
C124	20506590	CCCFMIC 100P0F +5% -5% 50.0V NP0
C125	20506590	CCCFMIC 100P0F +5% -5% 50.0V NP0
C126	20506590	CCCFMIC 100P0F +5% -5% 50.0V NP0
C148	20288040	CCCFMIC 100N0F +80% -20% 16.0V Y5V
C150	20288040	CCCFMIC 100N0F +80% -20% 16.0V Y5V
C154	20288040	CCCFMIC 100N0F +80% -20% 16.0V Y5V
C155	20506590	CCCFMIC 100P0F +5% -5% 50.0V NP0
C156	20506590	CCCFMIC 100P0F +5% -5% 50.0V NP0
C157	20506590	CCCFMIC 100P0F +5% -5% 50.0V NP0
C158	20506590	CCCFMIC 100P0F +5% -5% 50.0V NP0
C159	20506590	CCCFMIC 100P0F +5% -5% 50.0V NP0
C160	20506590	CCCFMIC 100P0F +5% -5% 50.0V NP0
C162	20288040	CCCFMIC 100N0F +80% -20% 16.0V Y5V
C163	20506540	CCCFMIC 10P0F +0P5F -0P5F 50.0V NP0
C167	10138620	CCCFMIC 2N2F +10% -10% 50.0V X7R
C169	20506590	CCCFMIC 100P0F +5% -5% 50.0V NP0
C170	10138390	CCCFMIC 560P0F +10% -10% 50.0V X7R
C173	10138960	CCCFMIC 10N0F +10% -10% 50.0V X7R
C177	20506560	CCCFMIC 33P0F +5% -5% 50.0V NP0
C178	20506590	CCCFMIC 100P0F +5% -5% 50.0V NP0
C180	20506590	CCCFMIC 100P0F +5% -5% 50.0V NP0
C181	10138960	CCCFMIC 10N0F +10% -10% 50.0V X7R
C187	10138960	CCCFMIC 10N0F +10% -10% 50.0V X7R
C189	20288040	CCCFMIC 100N0F +80% -20% 16.0V Y5V
C191	20288040	CCCFMIC 100N0F +80% -20% 16.0V Y5V
C193	20288040	CCCFMIC 100N0F +80% -20% 16.0V Y5V
C195	20288040	CCCFMIC 100N0F +80% -20% 16.0V Y5V
C197	10138960	CCCFMIC 10N0F +10% -10% 50.0V X7R
C200	20678070	CCCFMIC 330P0F +5% -5% 50.0V NP0
C248	20288040	CCCFMIC 100N0F +80% -20% 16.0V Y5V
C251	10328750	RMGCFMIC 0 OHM +0% 62MI5W
C251	20288040	CCCFMIC 100N0F +80% -20% 16.0V Y5V
C253	10328750	RMGCFMIC 0 OHM +0% 62MI5W
C253	20288040	CCCFMIC 100N0F +80% -20% 16.0V Y5V
C255	10328750	RMGCFMIC 0 OHM +0% 62MI5W
C255	20288040	CCCFMIC 100N0F +80% -20% 16.0V Y5V
C257	10328750	RMGCFMIC 0 OHM +0% 62MI5W
C257	20288040	CCCFMIC 100N0F +80% -20% 16.0V Y5V
C259	20288040	CCCFMIC 100N0F +80% -20% 16.0V Y5V
C261	20288040	CCCFMIC 100N0F +80% -20% 16.0V Y5V
C292	20288040	CCCFMIC 100N0F +80% -20% 16.0V Y5V

VIDEO board AVR5550

4/8

Pos	Tocom#	SName
C294	20288040	CCCFMIC 100N0F +80% -20% 16.0V Y5V
C307	20288040	CCCFMIC 100N0F +80% -20% 16.0V Y5V
C311	20288040	CCCFMIC 100N0F +80% -20% 16.0V Y5V
C312	20288040	CCCFMIC 100N0F +80% -20% 16.0V Y5V
D106	20496510	D-SLP 1SS355 35.0V 225MI0A
D107	20496510	D-SLP 1SS355 35.0V 225MI0A
D109	20496510	D-SLP 1SS355 35.0V 225MI0A
D110	20496510	D-SLP 1SS355 35.0V 225MI0A
IC10	55125370	IC-SWITCH NJM2296 SOP16 VIDEO
IC11	55125370	IC-SWITCH NJM2296 SOP16 VIDEO
IC12	55125370	IC-SWITCH NJM2296 SOP16 VIDEO
IC13	55489850	IC-VIDEOPROC MM1505XNRE AMPLIFIER&DRIVER
IC13	55489850	IC-VIDEOPROC MM1505XNRE AMPLIFIER&DRIVER
IC14	55489680	IC-VIDEOPROC MM1501XNRE AMPLIFIER&DRIVER
IC14	55489680	IC-VIDEOPROC MM1501XNRE AMPLIFIER&DRIVER
IC15	55489850	IC-VIDEOPROC MM1505XNRE AMPLIFIER&DRIVER
IC15	55489850	IC-VIDEOPROC MM1505XNRE AMPLIFIER&DRIVER
IC16	20718770	IC-LOGIC BU4053BF MULTIPLEXER CMOS
IC17	55175530	IC-VIDEOPROC TSH95D VIDEO AMPLIFIER
IC19	20718660	IC-LOGIC BU4094BF SHIFT REGISTER CMOS
IC20	20718660	IC-LOGIC BU4094BF SHIFT REGISTER CMOS
IC23	55489850	IC-VIDEOPROC MM1505XNRE AMPLIFIER&DRIVER
IC23	55489850	IC-VIDEOPROC MM1505XNRE AMPLIFIER&DRIVER
IC25	55489680	IC-VIDEOPROC MM1501XNRE AMPLIFIER&DRIVER
IC25	55489680	IC-VIDEOPROC MM1501XNRE AMPLIFIER&DRIVER
IC26	55489680	IC-VIDEOPROC MM1501XNRE AMPLIFIER&DRIVER
IC26	55489680	IC-VIDEOPROC MM1501XNRE AMPLIFIER&DRIVER
IC27	55489750	IC-VIDEOPROC MM1511XNRE AMPLIFIER&DRIVER
IC27	55489750	IC-VIDEOPROC MM1511XNRE AMPLIFIER&DRIVER
J101	10328750	RMGCFMIC 0 OHM +0% 62MI5W
J105	10328750	RMGCFMIC 0 OHM +0% 62MI5W
J108	10328750	RMGCFMIC 0 OHM +0% 62MI5W
J125	10328750	RMGCFMIC 0 OHM +0% 62MI5W
J126	10328750	RMGCFMIC 0 OHM +0% 62MI5W
J132	10328750	RMGCFMIC 0 OHM +0% 62MI5W
J134	10328750	RMGCFMIC 0 OHM +0% 62MI5W
J135	10328750	RMGCFMIC 0 OHM +0% 62MI5W
J198	10328750	RMGCFMIC 0 OHM +0% 62MI5W
J199	10328750	RMGCFMIC 0 OHM +0% 62MI5W
J202	10328750	RMGCFMIC 0 OHM +0% 62MI5W
J203	10328750	RMGCFMIC 0 OHM +0% 62MI5W
J234	10328750	RMGCFMIC 0 OHM +0% 62MI5W
J257	10328750	RMGCFMIC 0 OHM +0% 62MI5W
J301	10328750	RMGCFMIC 0 OHM +0% 62MI5W
J307	10328750	RMGCFMIC 0 OHM +0% 62MI5W
J308	10328750	RMGCFMIC 0 OHM +0% 62MI5W
J309	10328750	RMGCFMIC 0 OHM +0% 62MI5W
J310	10328750	RMGCFMIC 0 OHM +0% 62MI5W
J315	10328750	RMGCFMIC 0 OHM +0% 62MI5W
J316	10328750	RMGCFMIC 0 OHM +0% 62MI5W
J317	10328750	RMGCFMIC 0 OHM +0% 62MI5W
Q102	55133190	TR-SSD DTA114YKA P 10K0 OHM 47K0 OHM
Q103	55133190	TR-SSD DTA114YKA P 10K0 OHM 47K0 OHM
R100	10134710	RMGCFMIC 75R0 OHM +5% 62MI5W
R100	10134720	RMGCFMIC 82R0 OHM +5% 62MI5W
R101	10134700	RMGCFMIC 68R0 OHM +5% 62MI5W

VIDEO board AVR5550

5/8

Pos	Tocom#	SName
R101	10134720	RMGCFMIC 82R0 OHM +5% 62MI5W
R102	10134710	RMGCFMIC 75R0 OHM +5% 62MI5W
R102	10134720	RMGCFMIC 82R0 OHM +5% 62MI5W
R103	10134710	RMGCFMIC 75R0 OHM +5% 62MI5W
R103	10134720	RMGCFMIC 82R0 OHM +5% 62MI5W
R104	10134700	RMGCFMIC 68R0 OHM +5% 62MI5W
R104	10134720	RMGCFMIC 82R0 OHM +5% 62MI5W
R105	10134710	RMGCFMIC 75R0 OHM +5% 62MI5W
R105	10134720	RMGCFMIC 82R0 OHM +5% 62MI5W
R106	10134710	RMGCFMIC 75R0 OHM +5% 62MI5W
R106	10134720	RMGCFMIC 82R0 OHM +5% 62MI5W
R107	10134700	RMGCFMIC 68R0 OHM +5% 62MI5W
R107	10134720	RMGCFMIC 82R0 OHM +5% 62MI5W
R108	10134710	RMGCFMIC 75R0 OHM +5% 62MI5W
R108	10134720	RMGCFMIC 82R0 OHM +5% 62MI5W
R109	10134710	RMGCFMIC 75R0 OHM +5% 62MI5W
R109	10134720	RMGCFMIC 82R0 OHM +5% 62MI5W
R110	10134700	RMGCFMIC 68R0 OHM +5% 62MI5W
R110	10134720	RMGCFMIC 82R0 OHM +5% 62MI5W
R111	10134710	RMGCFMIC 75R0 OHM +5% 62MI5W
R111	10134720	RMGCFMIC 82R0 OHM +5% 62MI5W
R112	10135010	RMGCFMIC 10K0 OHM +5% 62MI5W
R113	10135010	RMGCFMIC 10K0 OHM +5% 62MI5W
R114	10135010	RMGCFMIC 10K0 OHM +5% 62MI5W
R115	10134710	RMGCFMIC 75R0 OHM +5% 62MI5W
R115	10134720	RMGCFMIC 82R0 OHM +5% 62MI5W
R116	10134700	RMGCFMIC 68R0 OHM +5% 62MI5W
R116	10134720	RMGCFMIC 82R0 OHM +5% 62MI5W
R117	10134710	RMGCFMIC 75R0 OHM +5% 62MI5W
R117	10134720	RMGCFMIC 82R0 OHM +5% 62MI5W
R118	10135010	RMGCFMIC 10K0 OHM +5% 62MI5W
R119	10135010	RMGCFMIC 10K0 OHM +5% 62MI5W
R120	10135010	RMGCFMIC 10K0 OHM +5% 62MI5W
R121	10134710	RMGCFMIC 75R0 OHM +5% 62MI5W
R121	10134720	RMGCFMIC 82R0 OHM +5% 62MI5W
R122	10134700	RMGCFMIC 68R0 OHM +5% 62MI5W
R122	10134720	RMGCFMIC 82R0 OHM +5% 62MI5W
R123	10134710	RMGCFMIC 75R0 OHM +5% 62MI5W
R123	10134720	RMGCFMIC 82R0 OHM +5% 62MI5W
R124	10135010	RMGCFMIC 10K0 OHM +5% 62MI5W
R125	10135010	RMGCFMIC 10K0 OHM +5% 62MI5W
R126	10135010	RMGCFMIC 10K0 OHM +5% 62MI5W
R127	10134700	RMGCFMIC 68R0 OHM +5% 62MI5W
R127	10134710	RMGCFMIC 75R0 OHM +5% 62MI5W
R128	10134700	RMGCFMIC 68R0 OHM +5% 62MI5W
R128	10134710	RMGCFMIC 75R0 OHM +5% 62MI5W
R129	10134700	RMGCFMIC 68R0 OHM +5% 62MI5W
R129	10134710	RMGCFMIC 75R0 OHM +5% 62MI5W
R136	10134870	RMGCFMIC 330R0 OHM +5% 62MI5W
R136	25481560	RMGCFMIC 174R0 OHM +1% 62MI5W
R137	25419270	RMGCFMIC 162R0 OHM +1% 62MI5W
R137	25481560	RMGCFMIC 174R0 OHM +1% 62MI5W
R138	10134870	RMGCFMIC 330R0 OHM +5% 62MI5W
R138	21061670	RMGCFMIC 392R0 OHM +1% 62MI5W
R139	10135120	RMGCFMIC 22K0 OHM +5% 62MI5W
R140	10135120	RMGCFMIC 22K0 OHM +5% 62MI5W

VIDEO board AVR5550

6/8

Pos	Tocom#	SName
R141	10135120	RMGCFMIC 22K0 OHM +5% 62MI5W
R142	10135010	RMGCFMIC 10K0 OHM +5% 62MI5W
R143	10135010	RMGCFMIC 10K0 OHM +5% 62MI5W
R144	10135010	RMGCFMIC 10K0 OHM +5% 62MI5W
R145	10135010	RMGCFMIC 10K0 OHM +5% 62MI5W
R146	10135030	RMGCFMIC 12K0 OHM +5% 62MI5W
R147	10135030	RMGCFMIC 12K0 OHM +5% 62MI5W
R148	10135770	RMGCFMIC 1K0 OHM +5% 62MI5W
R149	10135530	RMGCFMIC 470K0 OHM +5% 62MI5W
R150	10135010	RMGCFMIC 10K0 OHM +5% 62MI5W
R151	10135530	RMGCFMIC 470K0 OHM +5% 62MI5W
R152	10135620	RMGCFMIC 1M0 OHM +10% 62MI5W
R153	10135380	RMGCFMIC 150K0 OHM +5% 62MI5W
R155	10135620	RMGCFMIC 1M0 OHM +10% 62MI5W
R156	10134910	RMGCFMIC 470R0 OHM +5% 62MI5W
R157	10135090	RMGCFMIC 20K0 OHM +5% 62MI5W
R157	10328750	RMGCFMIC 0 OHM +0% 62MI5W
R158	10135420	RMGCFMIC 220K0 OHM +5% 62MI5W
R159	10135980	RMGCFMIC 6K8 OHM +5% 62MI5W
R160	10135860	RMGCFMIC 2K2 OHM +5% 62MI5W
R164	10135480	RMGCFMIC 390K0 OHM +5% 62MI5W
R165	10134740	RMGCFMIC 100R0 OHM +5% 62MI5W
R166	10135170	RMGCFMIC 33K0 OHM +5% 62MI5W
R167	10135860	RMGCFMIC 2K2 OHM +5% 62MI5W
R168	10134700	RMGCFMIC 68R0 OHM +5% 62MI5W
R169	10134810	RMGCFMIC 180R0 OHM +5% 62MI5W
R169	10136000	RMGCFMIC 8K2 OHM +5% 62MI5W
R170	10134640	RMGCFMIC 43R0 OHM +5% 62MI5W
R170	10328750	RMGCFMIC 0 OHM +0% 62MI5W
R171	10134810	RMGCFMIC 180R0 OHM +5% 62MI5W
R171	10135380	RMGCFMIC 150K0 OHM +5% 62MI5W
R172	10135170	RMGCFMIC 33K0 OHM +5% 62MI5W
R173	10135860	RMGCFMIC 2K2 OHM +5% 62MI5W
R174	10134700	RMGCFMIC 68R0 OHM +5% 62MI5W
R175	10134870	RMGCFMIC 330R0 OHM +5% 62MI5W
R176	10134480	RMGCFMIC 15R0 OHM +5% 62MI5W
R176	10135000	RMGCFMIC 910R0 OHM +5% 62MI5W
R177	10134640	RMGCFMIC 43R0 OHM +5% 62MI5W
R177	10134850	RMGCFMIC 270R0 OHM +5% 62MI5W
R178	10134870	RMGCFMIC 330R0 OHM +5% 62MI5W
R178	21061670	RMGCFMIC 392R0 OHM +1% 62MI5W
R180	10134920	RMGCFMIC 510R0 OHM +5% 62MI5W
R181	10134870	RMGCFMIC 330R0 OHM +5% 62MI5W
R182	10134710	RMGCFMIC 75R0 OHM +5% 62MI5W
R183	10135770	RMGCFMIC 1K0 OHM +5% 62MI5W
R184	10328750	RMGCFMIC 0 OHM +0% 62MI5W
R185	10134720	RMGCFMIC 82R0 OHM +5% 62MI5W
R186	10135360	RMGCFMIC 120K0 OHM +5% 62MI5W
R187	10328750	RMGCFMIC 0 OHM +0% 62MI5W
R188	10135010	RMGCFMIC 10K0 OHM +5% 62MI5W
R189	10135920	RMGCFMIC 3K9 OHM +5% 62MI5W
R200	10134850	RMGCFMIC 270R0 OHM +5% 62MI5W
R251	10134410	RMGCFMIC 10R0 OHM +5% 62MI5W
R251	10328750	RMGCFMIC 0 OHM +0% 62MI5W
R252	10134410	RMGCFMIC 10R0 OHM +5% 62MI5W
R252	10328750	RMGCFMIC 0 OHM +0% 62MI5W

VIDEO board AVR5550

7/8

Pos	Tocom#	SName
R253	10134410	RMGCFMIC 10R0 OHM +5% 62MI5W
R253	10328750	RMGCFMIC 0 OHM +0% 62MI5W
R254	10134410	RMGCFMIC 10R0 OHM +5% 62MI5W
R254	10328750	RMGCFMIC 0 OHM +0% 62MI5W
R255	10134410	RMGCFMIC 10R0 OHM +5% 62MI5W
R256	10134410	RMGCFMIC 10R0 OHM +5% 62MI5W
R300	10134710	RMGCFMIC 75R0 OHM +5% 62MI5W
R301	10134710	RMGCFMIC 75R0 OHM +5% 62MI5W
R302	10134710	RMGCFMIC 75R0 OHM +5% 62MI5W
R303	10134710	RMGCFMIC 75R0 OHM +5% 62MI5W
R304	10134710	RMGCFMIC 75R0 OHM +5% 62MI5W
R305	10134710	RMGCFMIC 75R0 OHM +5% 62MI5W
R306	10135120	RMGCFMIC 22K0 OHM +5% 62MI5W
R307	10135120	RMGCFMIC 22K0 OHM +5% 62MI5W
R308	10135120	RMGCFMIC 22K0 OHM +5% 62MI5W
R309	10134710	RMGCFMIC 75R0 OHM +5% 62MI5W
R310	10134710	RMGCFMIC 75R0 OHM +5% 62MI5W
R311	10134710	RMGCFMIC 75R0 OHM +5% 62MI5W
R312	10134930	RMGCFMIC 560R0 OHM +5% 62MI5W
R313	10134920	RMGCFMIC 510R0 OHM +5% 62MI5W
R314	10135010	RMGCFMIC 10K0 OHM +5% 62MI5W
R315	10134930	RMGCFMIC 560R0 OHM +5% 62MI5W
R316	10134920	RMGCFMIC 510R0 OHM +5% 62MI5W
R317	10135010	RMGCFMIC 10K0 OHM +5% 62MI5W
R318	10135010	RMGCFMIC 10K0 OHM +5% 62MI5W
R319	10134920	RMGCFMIC 510R0 OHM +5% 62MI5W
R320	10134930	RMGCFMIC 560R0 OHM +5% 62MI5W
C115	20267830	CE 47U0F +20% 16.0V 85C 20251640
C117	20267830	CE 47U0F +20% 16.0V 85C 20251640
C121	15002130	CE 10U0F +20% 16.0V 85C
C199	20269080	CE 220U0F +20% 10.0V 85C
IC18	20361320	IC-REGPOSFXD KIA7806PI NORMAL
IC21	40440440	IC-LIN BA7046 2856 A0 00
IC22	55179610	IC-SPECFUNC M35013 OSD
IC22	55179610	IC-SPECFUNC M35013 OSD
L100	55179500	LFBEAD 80.582OHM 100M0HZ FB-30 HC-3580
L101	55179500	LFBEAD 80.582OHM 100M0HZ FB-30 HC-3580
L102	55179500	LFBEAD 80.582OHM 100M0HZ FB-30 HC-3580
N601	55158730	WIRECONASY UNIQUE 10P 320MM UL1007 RIBBON 26 1
N601	55548950	WIRECONASY DL 2.0MM 10P 380MM UL1007 RIBBON 26 1
N602	55174670	CONN 2.0MM 19 MA R NAT SOCKET MOLEX 35237-1910 0 0
NJ91	55436080	CON PHONO SCKT RCA 9P W/GND CAP JW-4109RS
NJ92	55149520	CON DIN SCKT MIX SOCKET RCA-118JP1S
NJ93	55149520	CON DIN SCKT MIX SOCKET RCA-118JP1S
NJ94	55149520	CON DIN SCKT MIX SOCKET RCA-118JP1S
NJ95	55149520	CON DIN SCKT MIX SOCKET RCA-118JP1S
NJ96	55149520	CON DIN SCKT MIX SOCKET RCA-118JP1S
NJ97	55149520	CON DIN SCKT MIX SOCKET RCA-118JP1S
NJ98	55149520	CON DIN SCKT MIX SOCKET RCA-118JP1S
P600	55123330	CONN 2.0MM 6 MA ST NAT LW2002P06 0 0
P601	55090060	CONN 2.0MM 7 MA ST NAT LW2002P07 0 0
P602	55174630	CONN 2.0MM 19 MA ST NAT MOLEX 35336-1910 0 0
P603	55174630	CONN 2.0MM 19 MA ST NAT MOLEX 35336-1910 0 0
SK10	55489950	RELAYPWR 5.0V 178.0OHM
SK11	55489950	RELAYPWR 5.0V 178.0OHM
SK12	55489950	RELAYPWR 5.0V 178.0OHM

VIDEO board AVR5550

8/8

Pos	Tocom#	SName
Y100	55252250	FILQZ 17M734475 HZ +30 PPM 30K0 OHM PARALLEL 22P0 F
Y101	55179470	FILQZ 14M31818 HZ +30 PPM 30K0 OHM PARALLEL 22P0 F

MECH AVR5550

1/2

Qty	Tocom#	SName
Qty	Tocom#	SName
1	55575850	AC DEC CABINET PANEL FRONT AVR5550
40	55127120	SCREW-ST 3MM 8MM JIS B 1122 J5636140040X 53 0 0
1	55164800	SCREW 3MM 8MM DIN963 62 2182 B7
62	55127070	SCREW-ST 3MM 10MM JIS B 1122 19 0 0
1	55445110	AC DEC BUTTON 3 KEY HIPS 9 HIPS 94HB
1	55445160	AC DEC BUTTON 5 KEY HIPS 94HB
1	55445260	AC DEC BUTTON 7 KEY HIPS 94HB
1	55177820	AC DEC BUTTON STANDBY --
1	55178020	AC MLD BUTTON INDICATOR STAND-BY AVR520 --
2	55178030	AC MLD BUTTON INDICATOR VIDEO 4 AVR520 --
1	55177800	AC DEC CRYSTAL FILTER DISPLAY
1	55191560	AC DIFFUSER 0.2T 62.5*41 WH NON-METAL
1	55177990	AC DIFFUSER 0.2T 59.6*41 WH NON-METAL
1	55575870	AC DEC CRYSTAL WINDOW DISPLAY AVR5550
1	55177740	AC DEC KNOB MAIN HIPS 94H
3	55177750	AC DEC KNOB TONE HIPS
1	55178000	SWIPUSH POWER SWITCH 5.0A 250.0V 100MIOHM 1T 2P
1	55177810	AC DEC BUTTON POWER HIPS DVD10 --
4	55184350	SHRINK-PREF 20278040 30.0MM 1537 A4
2	55127070	SCREW-ST 3MM 10MM JIS B 1122 19 0 0
1	55124350	AC PUN BRACKET HEADPHONE RT2280/RT2250(PAV5007/5005) --
1	55178440	AC MLD HOLDER FL-GUIDE HIPS 94HB AVR520
1	55178930	AC MOLD REFRACTOR F WH PL
1	55177960	AC DIFFUSER REFLECTOR C WH NON-METAL
1	55178940	AC MOLD REFRACTOR E WH PL
1	55191530	AC MOLD REFRACTOR B WH PL
1	55178960	AC SPRING PLATE SPRING GND C5212 0.2T AVR520
1	55406440	AC CPL CABINET CHASSIS FRONT AVR325/525
2	55178170	AC PUN BRACKET FRAME-GUIDE SECC T1.0 --
1	55178050	AC PUN COVER TOP AVR520 METAL --
12	55127090	SCREW-ST 4MM 8MM JIS B 1122 25 0 0
1	55406540	AC CPL CABINET CHASSIS MAIN AVR325/525
29	55170390	CABLE-FIX WIRE-TIE MELLERMAI NYLON6 0 0
1	55406740	AC PUN COVER BOTTOM AVR325/525 METAL --
5	55127280	SCREW-ST 3MM 6MM JIS B 1122 25 0 0
1	55406640	AC PUN COVER TRANS BOTTOM AVR325/525 METAL --
4	55309240	SCREW-SPEC 4MM 10MM -- 08 0 A4
4	55309350	NUT-HEXAGON 4.0MM 5.0MM CIRCULAR EXTERNAL 53 0 0
4	55131550	WASHER-SPR 4.2MM 7.2MM 1.0MM N/A 53 0 0
4	55131730	WASHER 4.8MM 12MM 1.0MM -- 53 0 15
4	55445360	AC FOOT HIPS 94HB ROUND 15.8MM 50MM NOT DEFINED Y DIA
4	55174760	AC FOOT RUBBER ROUND 3.0MM 25.0MM JIS 60 Y DIA
1	55555910	AC HEATSINK(MAIN) AVR525 -- ME
35	55178320	SCREW-ST 3MM 12MM JIS B 1122 53 0 A4
20	55127300	WASHER-SPR 3.1MM 6.2MM 0.8MM Y 53 0 I4
8	55127310	WASHER 3.3MM 8.0MM 0.5MM Y 53 0 A4
1	55406340	AC HEATSINK(AMP) 3CH AVR525 -- ME
6	55168710	AC PUN BRACKET HEATSINK SECIT RT2250(PAV5005) --
2	55091680	FCORE FERRIT MAGNET SRH9.9X20.0X5.1+CASE(LF-50BR) W5
15	55127300	WASHER-SPR 3.1MM 6.2MM 0.8MM Y 53 0 I4
6	55127310	WASHER 3.3MM 8.0MM 0.5MM Y 53 0 A4
1	55406840	AC PUN BRACKET FAN FRONT AVR325/525 --
1	55406940	AC PUN BRACKET FAN REAR AVR325/525 --
1	55575770	AC CPL REAR PANEL AVR5550
46	55135460	SCREW-SPEC 3MM 10MM JIS 27 0 0

Packing AVR5550

1/1

Pos	Tocom#	SName
Pos	Tocom#	SName
50	55575750	AC CARTON AVR5550 DW-2
80	55178610	AC CPL ENDCAP CUSHION POLY 0.024
90	55178620	AC PRI LABEL "PLEASE" AVR520
100	55575810	AC PRI LABEL BARCODE AVR5550
110	55178770	AC PRI LABEL SAFETY LEAF
120	55164890	AC CPL BAG POLY PE T0.05 500MM X 300MM
130	55170660	AC SHEET EPE DVD5 920MM X 1000MM
140	55575890	AC BOOK INSTR AVR5550
170	20357620	TAPE-ADH ROLL 3M #373 0.06MM 76MM TRA
180	20194840	TAPE-ADH ROLL 3M#610 0.11MM 12.7MM --
190	55127490	ANTENNA WIRE ANTENNA LOOP CT01-AM 0 0
200	55127460	ANTENNA WIRE 75 OHM WIRE CT03-FM 0 0
210	55575830	EPR RCT REMOCON AVR5550 OEM -- W/O BATTERY --
220	55178550	EPR RCT REMOCON AVR520 ZONE OEM -- W/O BATTERY --
230	5502022A	BATNCALK 1.5V AAA 1.15 AH
240	55339780	WIRE-MCRDM 0.82MM2 2000MM BK CE
250	55688670	AC PRI LABEL FUSE RATING AVR4550/5550
260	55207970	AC BOOK INSTR SETUP CODE BOOKLET

MECH AVR5550

2/2

Qty	Tocom#	SName
4	55453660	SCREW-ST 5MM 10MM SAM 53 0 A4
2	55178420	AC PRI LABEL RISK
1	55174780	AC PRI LABEL DATE
1	55575790	AC PRI LABEL SERIAL AVR5550
1	55575810	AC PRI LABEL BARCODE AVR5550
2	20932870	AC PRI LABEL QC CHECK CRKD1217(20 X 13MM)
1	55451560	AC PRI LABEL LICENSE AVR525
3	55125220	AC RAW BUFFER PCB
4	55407040	AC STANDOFF HEX MF M4X0.7 6MMOD 31.9H -- ME
4	55407140	AC STANDOFF HEX MF M4X0.7 6MMOD 61.9H -- ME
1	55407240	AC STANDOFF HEX MF M4X0.7 6MMOD 111.2H -- ME
1	55273330	WIRECONASY UNIQUE 2P 500MM UL1617 PVC DOUBLE INSULA
1	55643470	TF-LAM POWER-TRANSFORMER 230V
1	55638760	EPR TUNER MODULE KST-MB114MW1-80 AVR4550/5550 OEM EU
1	55509100	FAN RDM8025S C185HK10H1910 (WIRE:300MM) 0 A0
1	55509110	FAN RDM8025S C185HK10H1920 (WIRE:400MM) 0 A0
2	55212250	CABLE-FIX CLAMP WIRE UL DENNISON 0 0
5	55231250	SCREW-ST 4MM 8MM D020400800 53 0 0
4	20372500	WASHER 3.0MM 7.9MM 0.8MM N/A 00 0 0
1	55559340	WIRECONASY DL 2.0MM 4P 230MM UL1007 RIBBON 26 1
1	55178300	AC RAW BUFFER CUSHION-BRK'T EVA
14	55261080	AC KNOB CORK SH08M790B0 BK PL
1	55505880	FFC-JUMPER 31X 1.25MM 600MM

AVR325/525 Alignment spec.

rev01.

1. MAIN B'D

: 5 Min. After power on, please set up Bias as below,

Front Left > use RV71, set P401 as 23mV +2mV/- 1mV.

Surr Left > use RV73 then set P303 as 23mV +2mV/-1mV.

Front Right > use RV72 make P402 to 23mV +2mV/-1mV.

Surr Right > use RV73 then make P303 to 23mV +2mV/-1mV.

P401 FRONT L-CH

P303 SURROUND L-CH

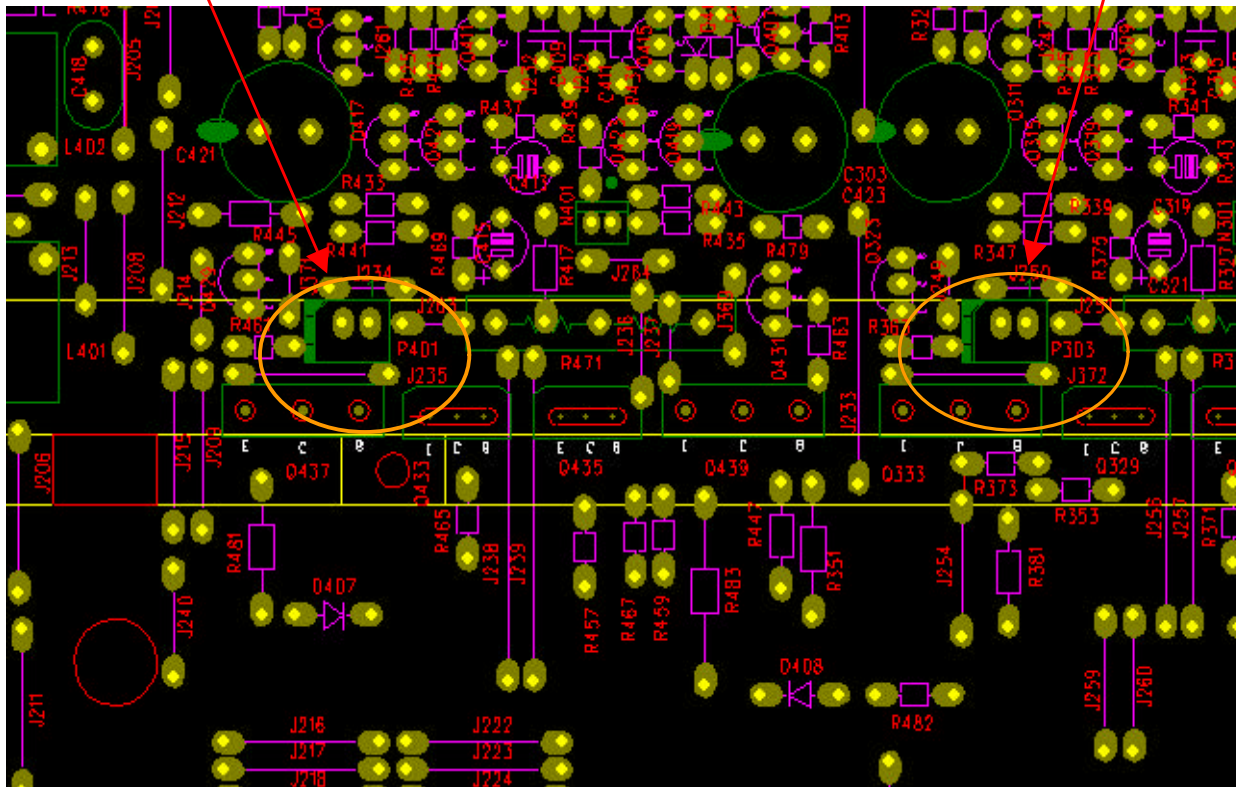



RV72 FRONT R-CH

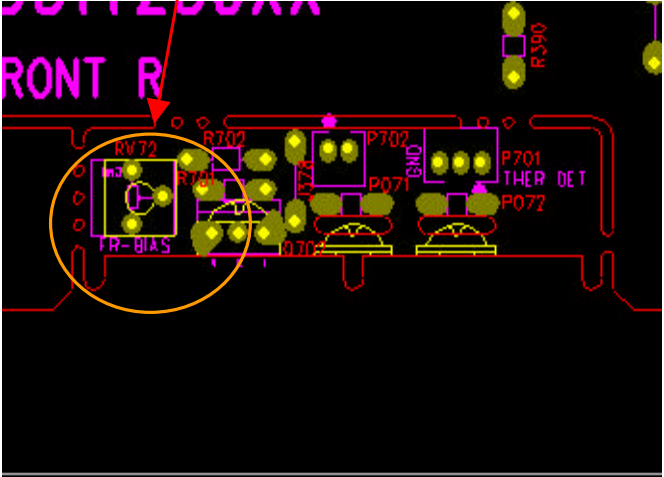

RV74 SURROUND R-CH

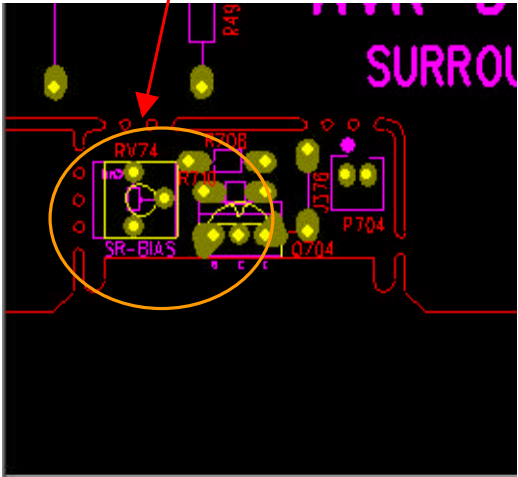

2. BACK SURROUND B'D

: 5 Min. After power on, please set up Bias as below,

SBL > use VR31 then set P301 as 23mV +2mV/-1mV.

Center > use VR41 make P401 to 23mV +2mV/-1mV.

SBR > use VR51 then make P501 to 25mV +2mV/-1mV.

P301 VR31 BACK SURROUND L-CH

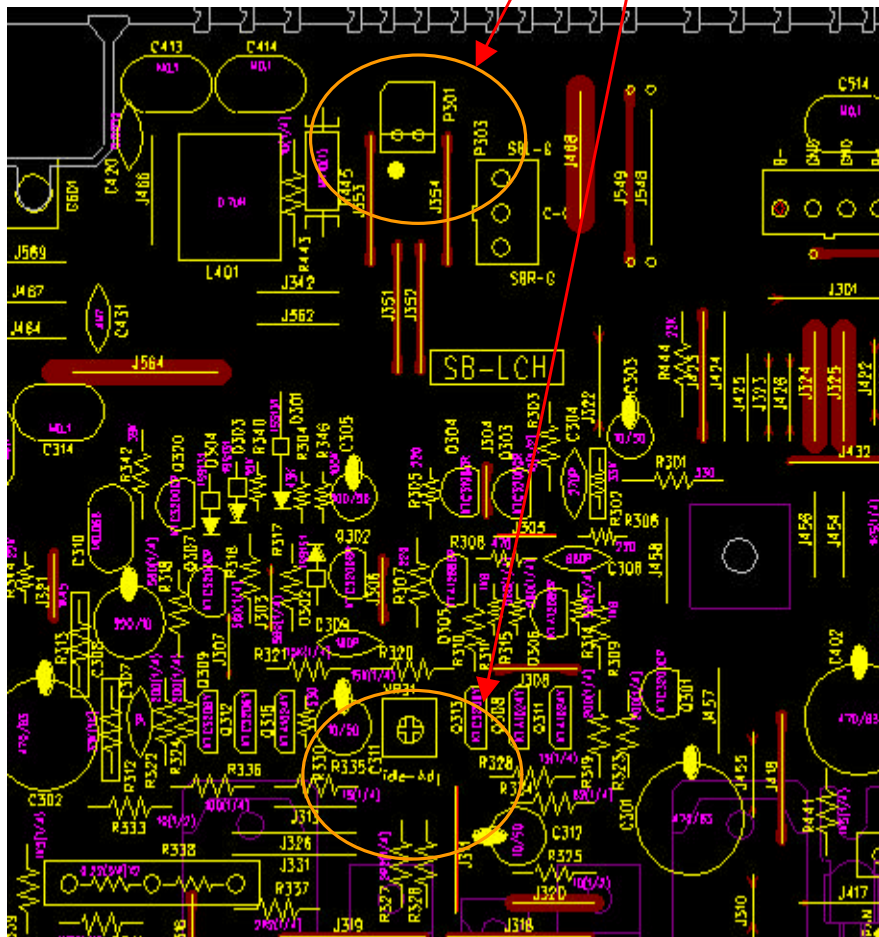

P401 VR41 CENTER-CH

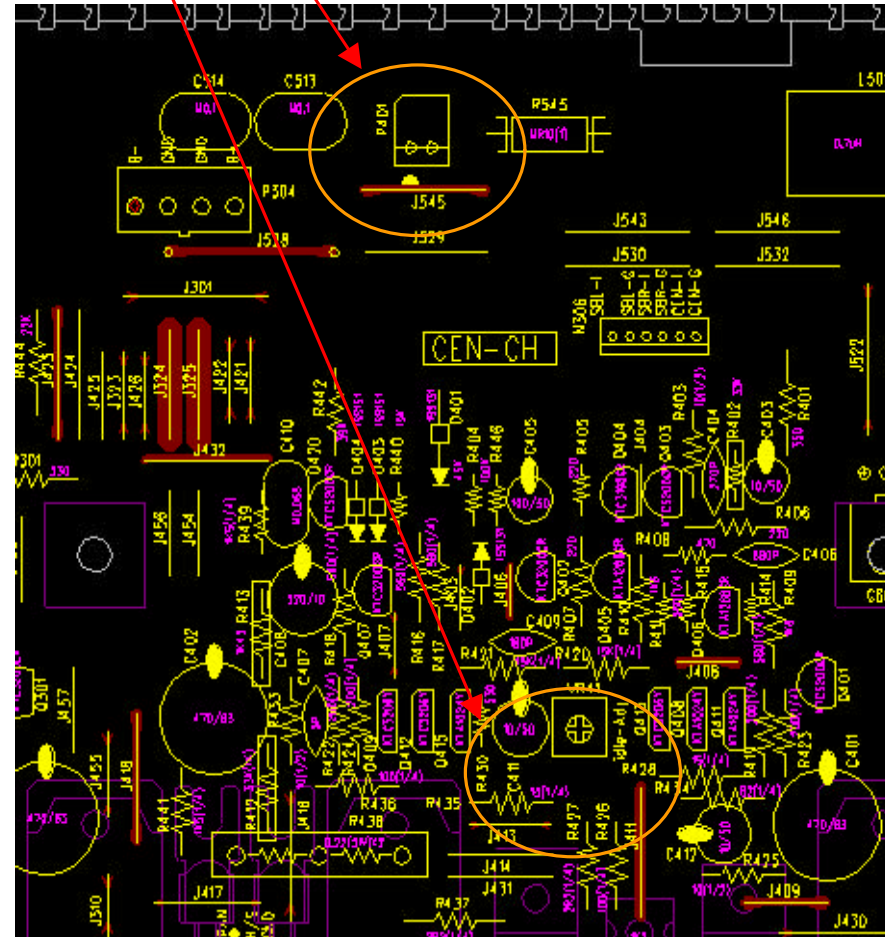

H/K AVR325/525 WIRING DIAGRAM

REVISION RECORD	
LTR	ECO NO: APPROVED DATE:

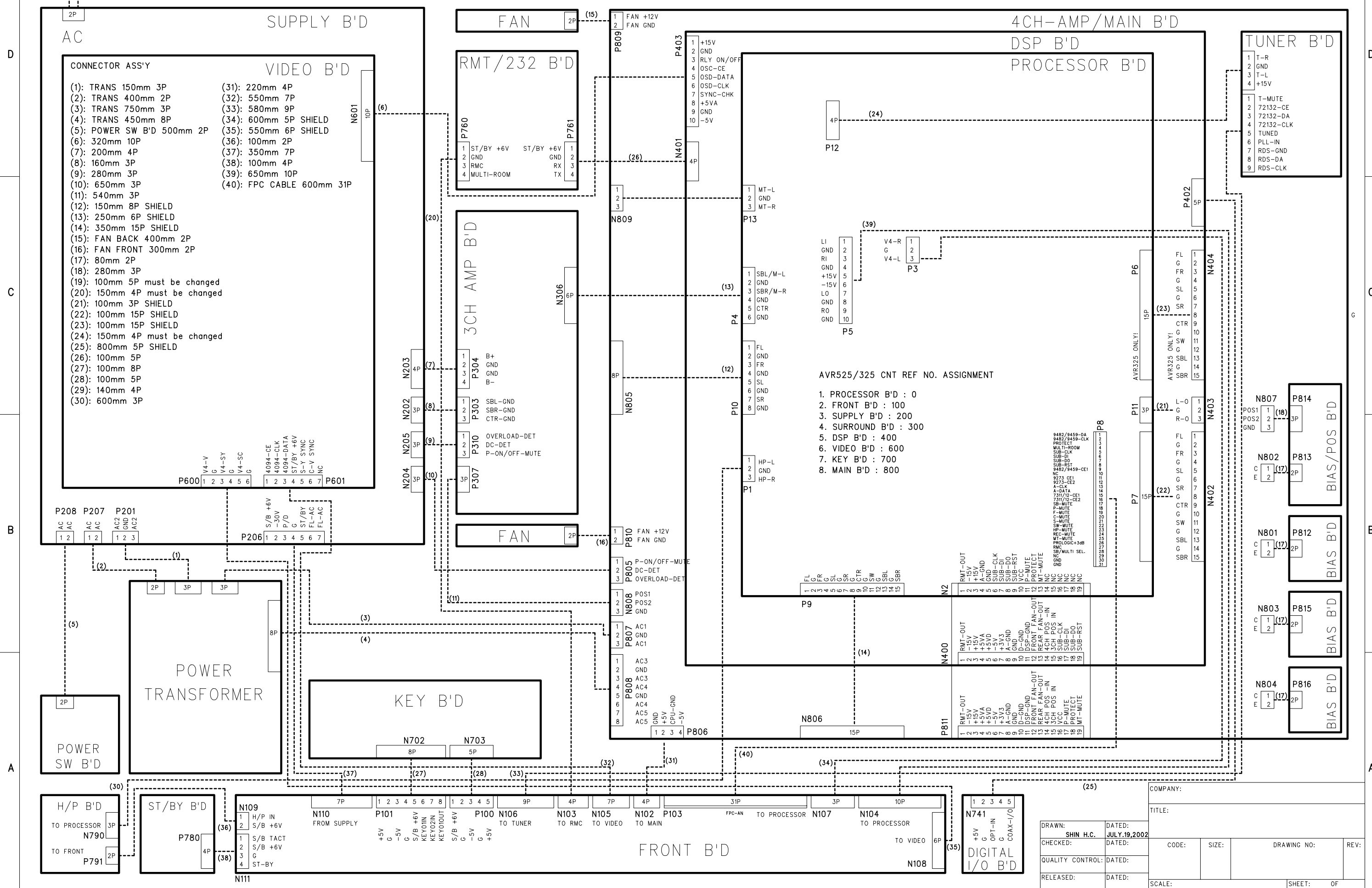

DRAWN: SHIN H.C.		DATED: JULY 19, 2002	
CHECKED:		DATED:	
QUALITY CONTROL:		DATED:	
RELEASED:		DATED:	
COMPANY:		TITLE:	
CODE:	SIZE:	DRAWING NO:	REV:
SCALE:		SHEET: OF	

BLOCK DIAGRAM AVR R525/325

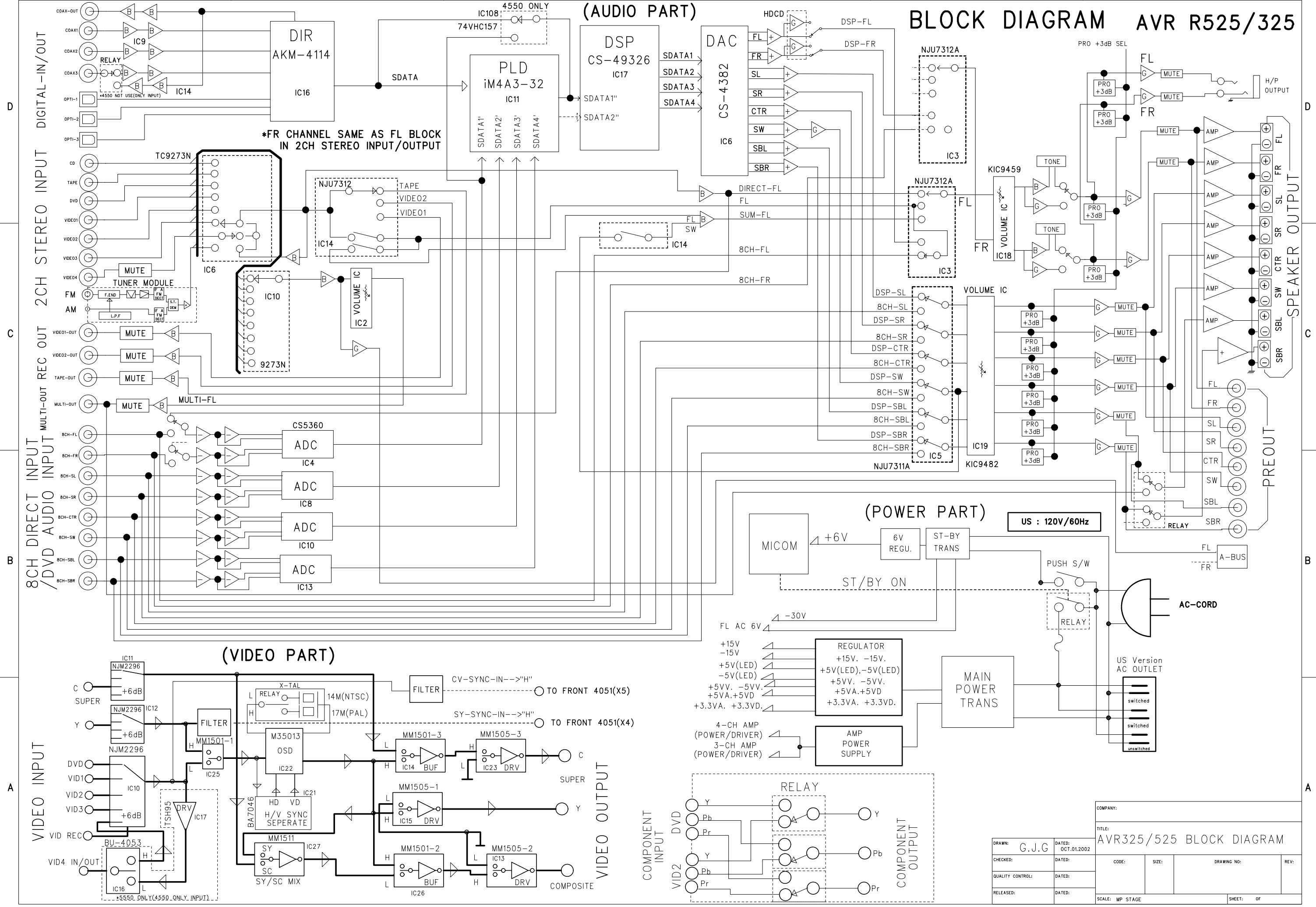

(VIDEO PART)

(AUDIO PART)

(POWER PART)

D

C

B

A

D

C

B

A

DRAWN: G.J.G		DATED: OCT.01.2002	
CHECKED:		DATED:	
QUALITY CONTROL:		DATED:	
RELEASED:		DATED:	
COMPANY: AVRR325/525 BLOCK DIAGRAM			
CODE:	SIZE:	DRAWING NO:	REV:
SCALE: MP STAGE		SHEET: OF	

6

5

4

3

2

1

REVISION RECORD			
LTR	ECD NO.	APPROVED:	DATE:

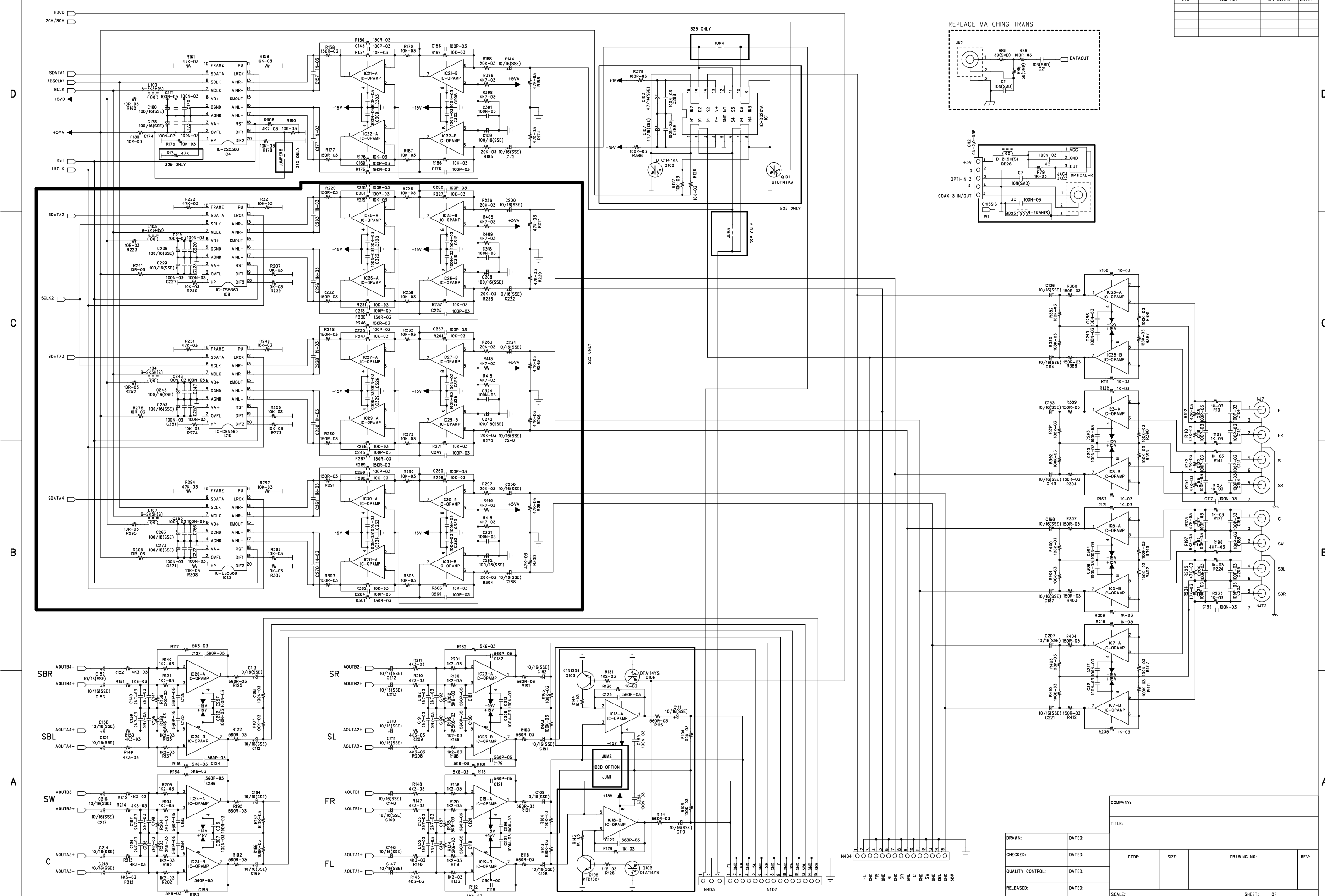

REPLACE MATCHING TRANS

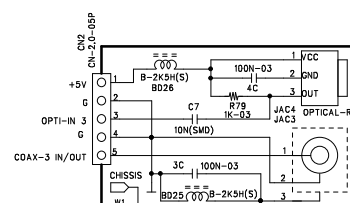
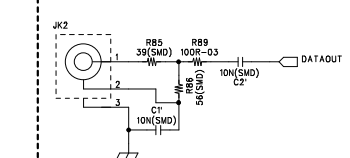

AVR 525/325 CENTER SB AMP SCHEMATIC DIAGRAM

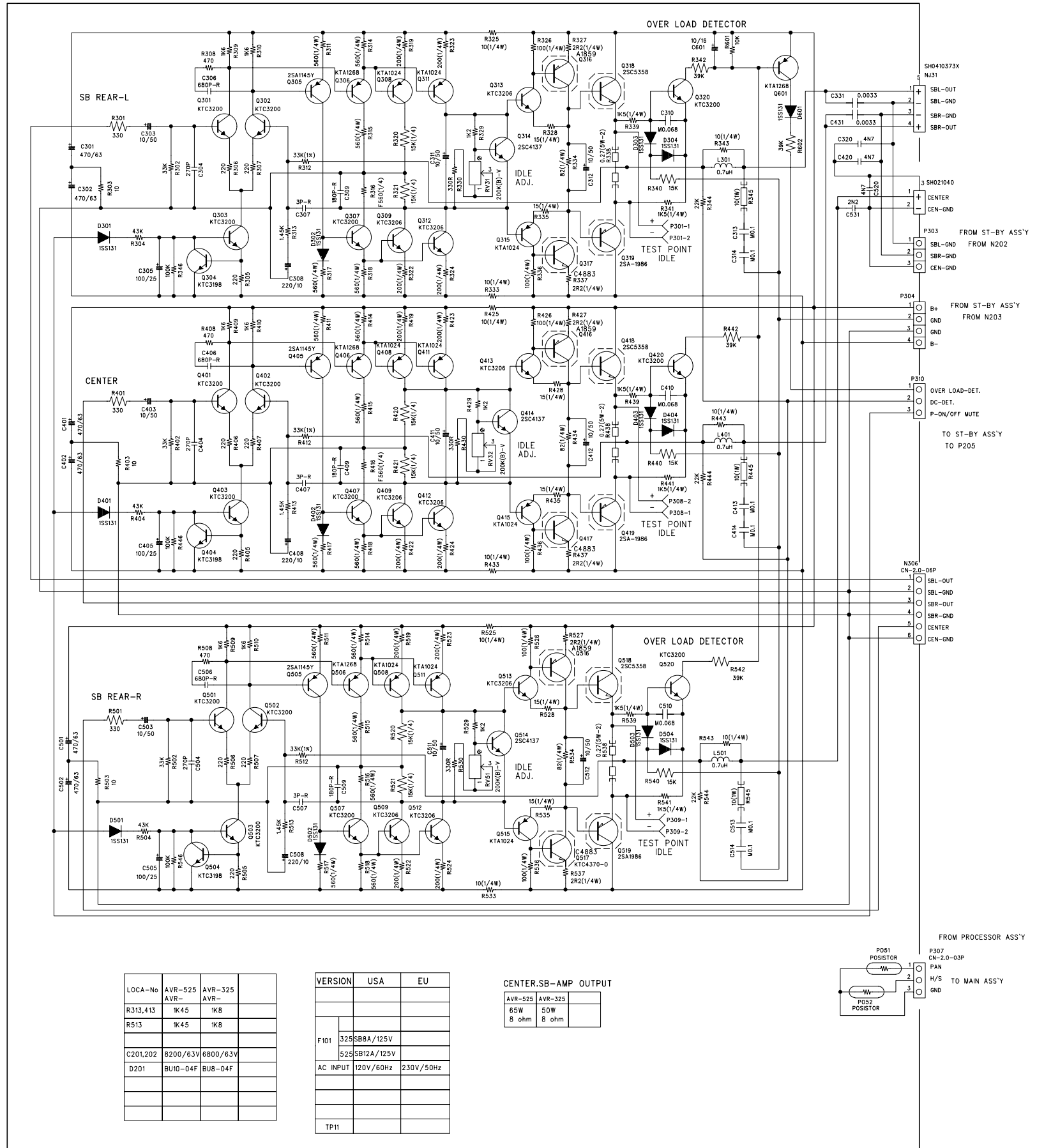

LOCA-No	AVR-525	AVR-325
R313,413	1K45	1K8
R513	1K45	1K8
C201,202	8200/63V	6800/63V
D201	BU10-04F	BU8-04F

VERSION	USA	EU
F101	325SB8A/125V	
	525SB12A/125V	
AC INPUT	120V/60Hz	230V/50Hz
TP11		

CENTER,SB-AMP OUTPUT	
AVR-525	AVR-325
65W	50W
8 ohm	8 ohm

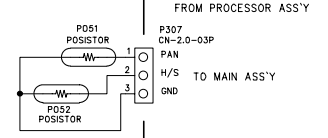

AVR 525/325 SUPPLY SCHEMATIC DIAGRAM

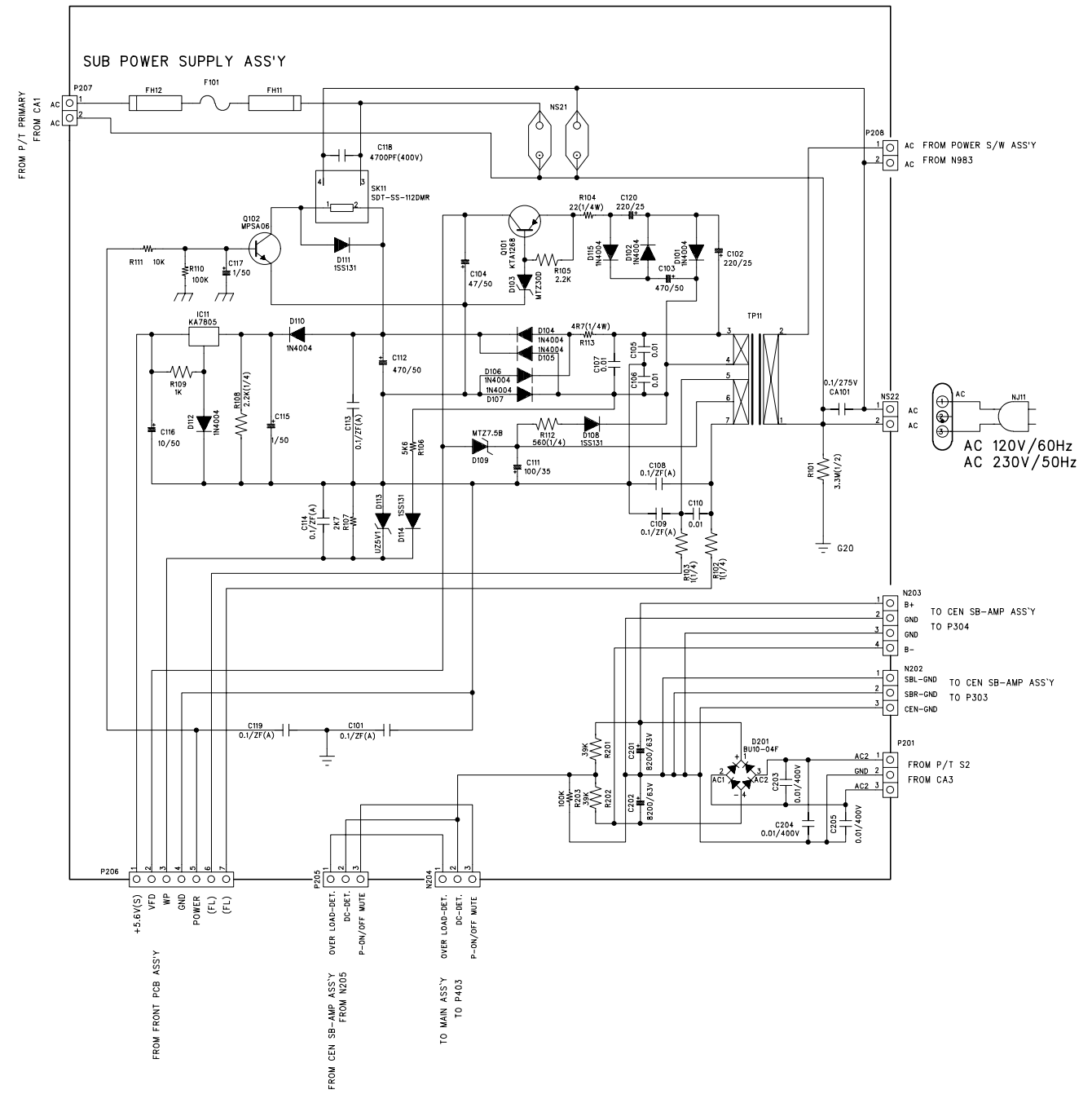

SCHEMATIC DIAGRAM AVR325/525

REVISION RECORD			
LTR	ECO NO.	APPROVED:	DATE:

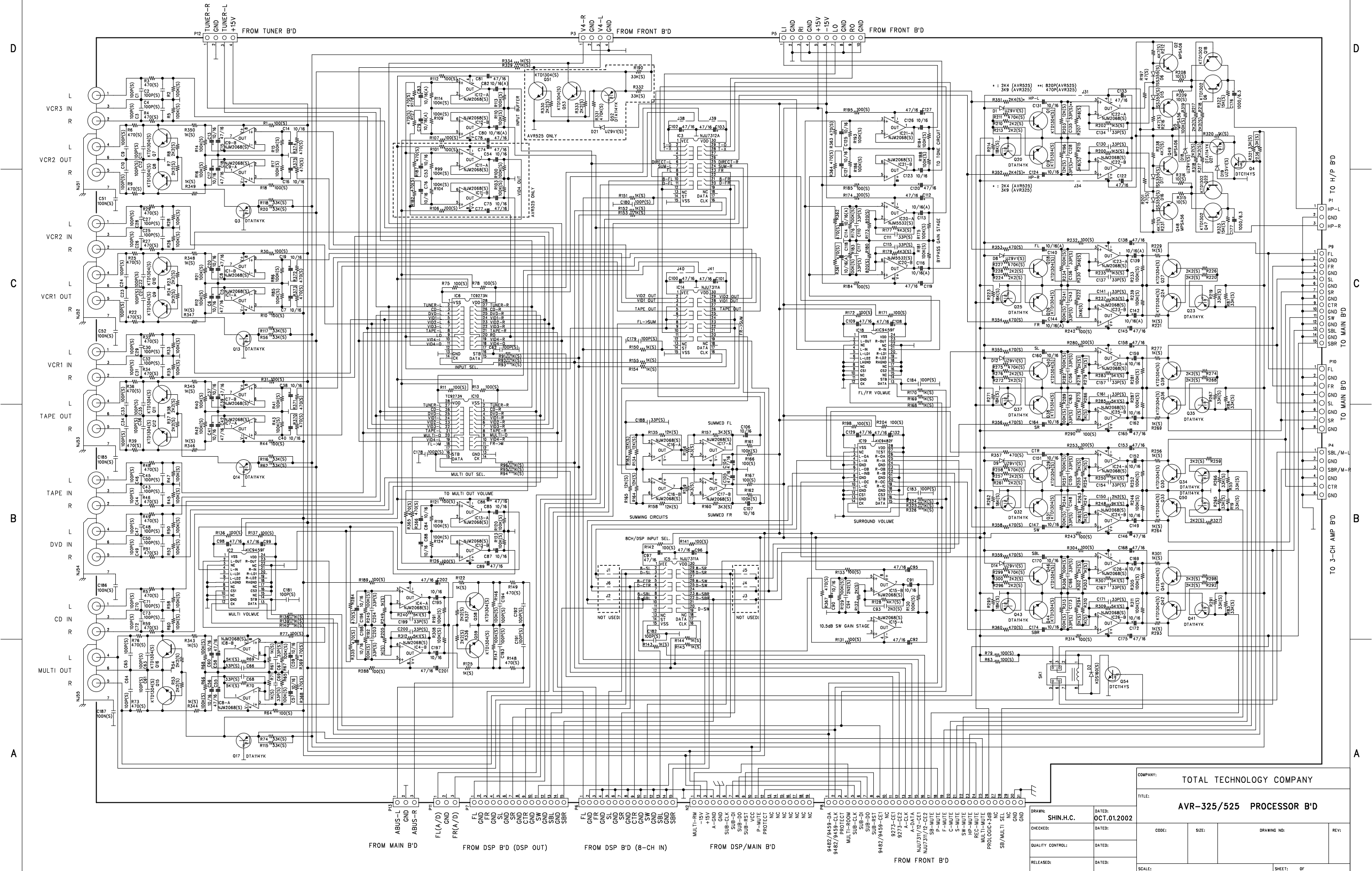

COMPANY: TOTAL TECHNOLOGY COMPANY		TITLE: AVR-325/525 PROCESSOR B'D	
DRAWN: SHIN.H.C.	DATED: OCT.01.2002	CODE:	DRAWING NO:
CHECKED:	DATED:	SIZE:	REV:
QUALITY CONTROL:	DATED:	SCALE:	SHEET: OF
RELEASED:	DATED:		

A

A

B

B

C

C

D

D

SCHEMATIC DIAGRAM

harman/kardon
AVR525/325

REVISION RECORD			
LTR	ECO NO:	APPROVED:	DATE:

COMPOSITE/SUPER VIDEO PART

COMPONENT VIDEO PART

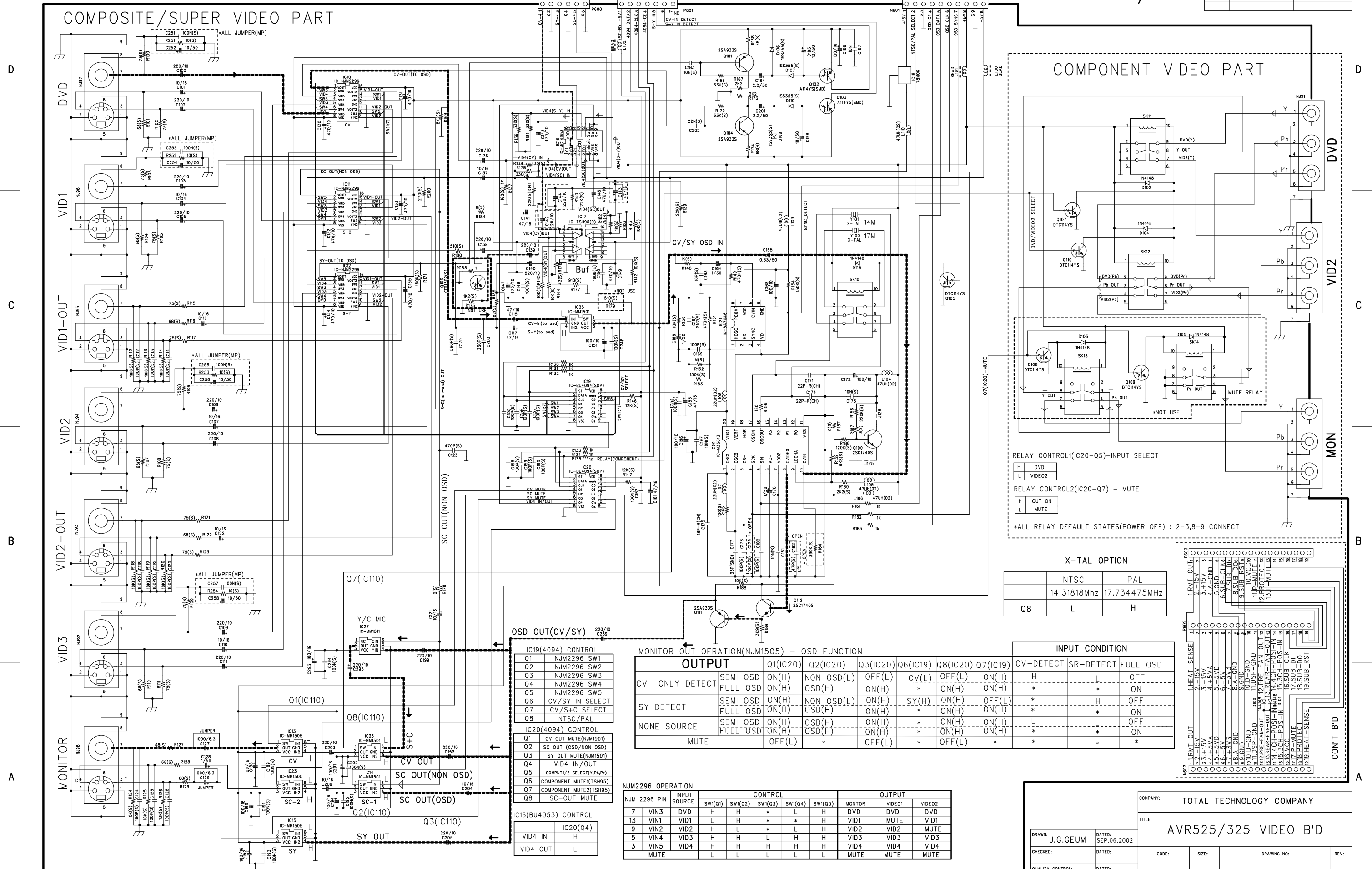

IC19(4094) CONTROL

Q1	NJM2296 SW1
Q2	NJM2296 SW2
Q3	NJM2296 SW3
Q4	NJM2296 SW4
Q5	NJM2296 SW5
Q6	CV/SY IN SELECT
Q7	CV/S+C SELECT
Q8	NTSC/PAL

IC20(4094) CONTROL

Q1	CV OUT MUTE(NJM1501)
Q2	SC OUT (OSD/NON OSD)
Q3	SY OUT MUTE(NJM1501)
Q4	VID4 IN/OUT
Q5	COMPNT1/2 SELECT(Y,Pb,Pr)
Q6	COMPONENT MUTE1(TSH95)
Q7	COMPONENT MUTE2(TSH95)
Q8	SC-OUT MUTE

IC16(BU4053) CONTROL

VID4 IN	H
VID4 OUT	L

MONITOR OUT OPERATION(NJM1505) - OSD FUNCTION

OUTPUT	Q1(IC20)	Q2(IC20)	Q3(IC20)	Q6(IC19)	Q8(IC20)	Q7(IC19)	CV-DETECT	SR-DETECT	FULL OSD
CV ONLY DETECT	SEMI OSD ON(H)	NON OSD(L)	OFF(L)	CV(L)	OFF(L)	ON(H)	H	L	OFF
FULL OSD	ON(H)	OSD(H)	ON(H)	*	ON(H)	ON(H)	*	*	ON
SY DETECT	SEMI OSD ON(H)	NON OSD(L)	ON(H)	SY(H)	ON(H)	OFF(L)	*	H	OFF
FULL OSD	ON(H)	OSD(H)	ON(H)	*	ON(H)	ON(H)	*	*	ON
NONE SOURCE	SEMI OSD ON(H)	OSD(H)	ON(H)	*	ON(H)	ON(H)	L	L	OFF
FULL OSD	ON(H)	OSD(H)	ON(H)	*	ON(H)	ON(H)	*	*	ON
MUTE	OFF(L)	*	OFF(L)	*	OFF(L)	*	*	*	*

NJM2296 OPERATION

NJM 2296 PIN	INPUT SOURCE	CONTROL	OUTPUT
7	VIN3 DVD	H H * L	DVD DVD DVD
13	VIN1 VID1	L H * L	VID1 MUTE VID1
9	VIN2 VID2	H L * L	VID2 VID2 MUTE
5	VIN4 VID3	H H L H	VID3 VID3 VID3
3	VIN5 VID4	H H H H	VID4 VID4 VID4
	MUTE	L L L L	MUTE MUTE MUTE

RELAY CONTROL1(IC20-Q5)-INPUT SELECT

H	DVD
L	VIDEO2

RELAY CONTROL2(IC20-Q7) - MUTE

H	OUT ON
L	MUTE

*ALL RELAY DEFAULT STATES(POWER OFF) : 2-3,8-9 CONNECT

X-TAL OPTION

	NTSC	PAL
Q8	14.31818Mhz	17.734475Mhz
	L	H

INPUT CONDITION

	CV-DETECT	SR-DETECT	FULL OSD
1 HEAT-SENSE	H	L	OFF
2 -15V	*	*	ON
3 +15V	*	*	ON
4 A-GND	*	*	ON
5 +5V	*	*	ON
6 SUB-D08	*	*	ON
7 +3V	*	*	ON
8 A-GND	*	*	ON
9 SUB-RS18	*	*	ON
10 GND	*	*	ON
11 GND	*	*	ON
12 POL-1	*	*	ON
13 POL-2	*	*	ON
14 CH-POS-N	*	*	ON
15 CH-POS-N	*	*	ON
16 SUB-CLK	*	*	ON
17 SUB-D0	*	*	ON
18 SUB-D1	*	*	ON
19 HEAT-SENSE	*	*	ON

COMPANY: TOTAL TECHNOLOGY COMPANY

TITLE: AVR525/325 VIDEO B'D

DRAWN: J.G.GEUM DATED: SEP.06.2002

CHECKED: DATED:

QUALITY CONTROL: DATED:

RELEASED: DATED:

STAGE: MP

CODE: SIZE: DRAWING NO: REV:

SHEET: 3 OF 5