

harman/kardon

# AVR435

7 X 65W 7.1 CHANNEL A/V RECEIVER

# AVR635

7 X 75W 7.1 CHANNEL A/V RECEIVER

## SERVICE MANUAL



## CONTENTS

PACKING.....	2	EXPLODED VIEW.....	27
ESD WARNING.....	3	MECHANICAL PARTS LIST.....	28
LEAKAGE TESTING.....	4	TECH TIP HKTT2003-01.....	30
AVR435 BASIC SPECIFICATIONS.....	5	IDLE ADJUSTMENT PROCEDURES.....	31
AVR635 BASIC SPECIFICATIONS.....	6	BLOCK DIAGRAMS.....	33
FRONT PANEL CONTROLS.....	7	AVR435 PARTS LISTS.....	35
REAR PANEL CONNECTIONS.....	10	AVR635 PARTS LISTS.....	54
REMOTE CONTROL FUNCTIONS.....	13	SEMICONDUCTOR PINOUTS.....	75
INSTALLATION/CONNECTIONS.....	17	PCB DRAWINGS.....	117
OPERATION.....	20	SCHEMATICS.....	128
TROUBLESHOOTING GUIDE.....	26	WIRING DIAGRAM.....	142
PROCESSOR RESET.....	26		

harman/kardon, Inc.  
250 Crossways Park Dr.  
Woodbury, New York 11797

Rev1 6/2004

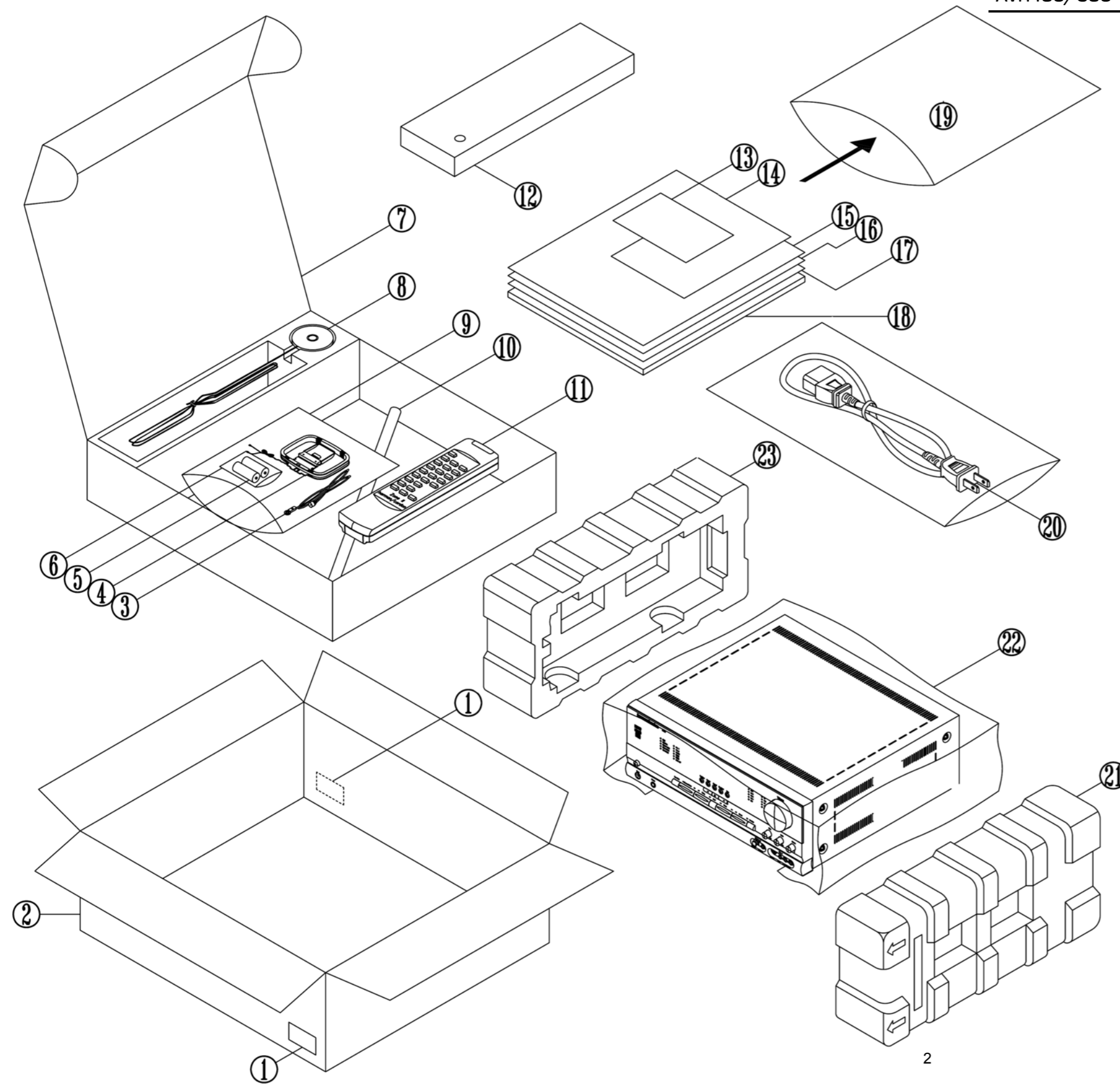

**AVR435/635 PACKING PART LIST**

Ref#	Part Number	Description	Qty
1		LABEL BARCODE	2
2	ZKD1204HA00-7	BOX CARTON AVR635 US	1
	ZKD1104HA00-2	BOX CARTON AVR435 US	1
3	H03-WAB01200203-4	ANTENNA WIRE 75 CT02-FM	1
4	H03-ATALF039ABK-5	ANTENNA WIRE ANTENNA LOOP CT01-AM	1
5		BATTERY ALKALINE 1.5V AAA	2
6		POLYBAG BATTERY	1
7	ZKD1202HA00-4	CARTON BOX MIC	1
8	H03-MCD12TWBKNN-8	AVR435/635 MICROPHONE ASSY	1
9		BAG PE 160X180MM	1
10	H03-ZPD1212INBK-5	MICROPHONE ASSY EXTENSION PIECE	1
11	H03-RYC1202HA00-0	REMOCON ZONE 2	1
12	RB18D01	REMOCON AVR635	1
	RB18D00	REMOCON AVR435	1
13	ZKC1113HA00-9	CARD WARRANTY	1
14	ZKC1263HA00	INSERT RS232 NOTE PAPER	1
15	ZKD1216HA00-5	QUICK SETUP GUIDE AVR635	1
	ZKD1116HA00-0	QUICK SETUP GUIDE AVR435	1
16	ZKC1214HA00	LABEL SAFETY LEAFLET	1
17	ZKD1263HA00	BROCHURE AVR US	1
18	ZKD1201HA00-8	OWNER'S MANUAL AVR635 US	1
	ZKD1101HA00-3	OWNER'S MANUAL AVR435 US	1
19		BAG PE 330 X 245 T0.05	1
20	H03-WAUSA2103BK-7	POWER CORD WS-004C+002E SJT#14*2C L=2M	1
21	ZQD1201HAWH-A	CUSHION POLY EPS RIGHT	1
22		FILM SHEET PE 920 X 1000 0.3~0.7T	1
23	ZQD1202HAWH-6	CUSHION POLY EPS LEFT	1

## ELECTROSTATICALLY SENSITIVE (ES) DEVICES

Some semiconductor (solid state) devices can be damaged easily by static electricity. Such components commonly are called Electrostatically Sensitive (ES) Devices. Examples of typical ES devices are integrated circuits and some field effect transistors and semiconductor "chip" components.

The following techniques should be used to help reduce the incidence of component damage caused by static electricity.



1. Immediately before handling any semiconductor component or semiconductor-equipped assembly, drain off any electrostatic charge on your body by touching a known earth ground. Alternatively, obtain and wear a commercially available discharging wrist strap device, which should be removed for potential shock reasons prior to applying power to the unit under test.
2. After removing an electrical assembly equipped with ES devices, place the assembly on a conductive surface such as aluminum foil, to prevent electrostatic charge build-up or exposure of the assembly.
3. Use only a grounded-tip soldering iron to solder or unsolder ES devices.
4. Use only an anti-static solder removal device. Some solder removal devices not classified as "anti-static" can generate electrical charges sufficient to damage ES devices.
5. Do not use freon-propelled chemicals. These can generate electrical charge sufficient to damage ES devices.
6. Do not remove a replacement ES device from its protective package until immediately before you are ready to install it. (Most replacement ES devices are packaged with leads electrically shorted together by conductive foam, aluminum foil or comparable conductive material.)
7. Immediately before removing the protective material from the leads of a replacement ES device, touch the protective material to the chassis or circuit assembly into which the device will be installed.

**CAUTION** : Be sure no power is applied to the chassis or circuit, and observe all other safety precautions.

8. Minimize bodily motions when handling unpackaged replacement ES devices. (Otherwise harmless motion such as the brushing together of your clothes fabric or the lifting of your foot from a carpeted floor can generate static electricity sufficient to damage an ES devices.

## PRODUCT SAFETY NOTICE

Each precaution in this manual should be followed during servicing.

Components identified with the IEC symbol  in the parts list are special significance to safety. When replacing a component identified with , use only the replacement parts designated, or parts with the same ratings or resistance, wattage, or voltage that are designated in the parts list in this manual. Leakage-current or resistance measurements must be made to determine that exposed parts are acceptably insulated from the supply circuit before returning the product to the customer.

## LEAKAGE TEST(FOR SERVICE ENGINEERS IN THE U.S.A)

Before returning the unit to the user, perform the following safety checks :

1. Inspect all lead dress to make certain that leads are not pinched or that hardware is not lodged between the chassis and other metal parts in the unit.
2. Be sure that any protective devices such as nonmetallic control knobs, insulating fish-papers, cabinet backs, adjustment and compartment covers or shields, isolation resistor-capacity networks, mechanical insulators, etc. Which were removed for the servicing are properly re-installed.
3. Be sure that no shock hazard exists ; check for leakage current using Simpson Model 229 Leakage Tester, standard equipment item No. 21641, RCA Model WT540A or use alternate method as follows : Plug the power cord directly into a 120 volt AC receptacle (do not use an Isolation Transformer for this test). Using two clip leads, connect a 1500 ohms, 10watt Resistor paralleled by a 0.15uF capacitor, in series with all exposed metal cabinet parts and a known earth ground, such as a water pipe or conduit. Use a VTVM or VOM with 1000 ohms per volt, or higher sensitivity to measure the AC voltage drop across the resistor. (See diagram) Move the resistor connection to each exposed metal part having a return path to the chassis (antenna, metal, cabinet, screw heads, knobs and control shafts, escutcheon, etc.) and measure the AC voltage drop across the resistor. (This test should be performed with the 0.35 volt RMS or more is excessive and indicates a potential shock hazard which must be corrected before returning the unit to the owner.

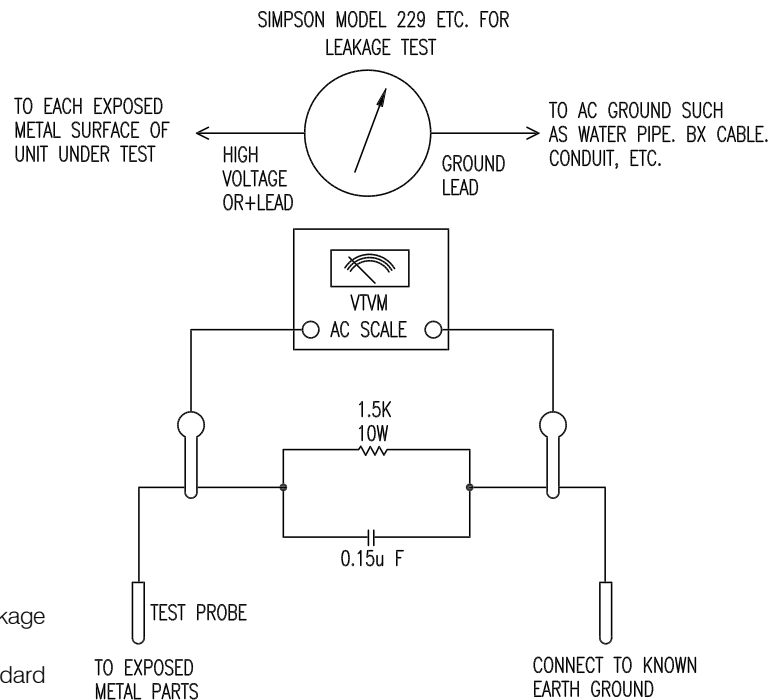

# AVR 435 TECHNICAL SPECIFICATIONS

## Audio Section

Stereo Mode  
 Continuous Average Power (FTC)  
 80 Watts per channel, 20Hz–20kHz,  
 @ <0.07% THD, both channels driven into 8 ohms

Seven-Channel Surround Modes  
 Power per Individual Channel

Front L&R channels:  
 65 Watts per channel  
 @ <0.07% THD, 20Hz–20kHz into 8 ohms

Center channel:  
 65 Watts @ <0.07% THD, 20Hz–20kHz into 8 ohms

Surround (L & R Side, L & R back) channels:  
 65 Watts per channel  
 @ <0.07% THD, 20Hz–20kHz into 8 ohms

Input Sensitivity/Impedance  
 Linear (High-Level) 200mV/47k ohms

Signal-to-Noise Ratio (IHF-A) 100dB

Surround System Adjacent Channel Separation

Pro Logic I/II	40dB
Dolby Digital (AC-3)	55dB
DTS	55dB

Frequency Response  
 @ 1W (+0dB, -3dB) 10Hz – 130kHz

High Instantaneous  
 Current Capability (HCC) ±40 Amps

Transient Intermodulation  
 Distortion (TIM) Unmeasurable

Slew Rate 40V/μsec

## FM Tuner Section

Frequency Range	87.5–108.0MHz
Usable Sensitivity	IHF 1.3μV/13.2dBf
Signal-to-Noise Ratio	Mono/Stereo 70/68dB
Distortion	Mono/Stereo 0.2/0.3%
Stereo Separation	40dB @ 1kHz
Selectivity	±400kHz, 70dB
Image Rejection	80dB
IF Rejection	90dB

## AM Tuner Section

Frequency Range	520–1720kHz
Signal-to-Noise Ratio	45dB
Usable Sensitivity	Loop 500μV
Distortion	1kHz, 50% Mod 0.8%
Selectivity	±10kHz, 30dB

## Video Section

Television Format	NTSC
Input Level/Impedance	1Vp-p/75 ohms
Output Level/Impedance	1Vp-p/75 ohms
Video Frequency Response (Composite and S-Video)	10Hz–8MHz (-3dB)
Video Frequency Response (Component Video)	10Hz–50MHz (-3dB)

## General

Power Requirement	AC 120V/60Hz	
Power Consumption	59W at Power On, idle; 1,000W at rated power output (7 channels driven)	
Dimensions	Product	Shipping
Width	17.3 inches (440mm)	20.1 inches (510mm)
Height	6.5 inches (165mm)	10 inches (254mm)
Depth	17.1 inches (435mm)	22.2 inches (565mm)
Weight	39 lb (18.6kg)	45 lb (21.4kg)

Depth measurement includes knobs, buttons and terminal connections.  
 Height measurement includes feet and chassis.  
 All features and specifications are subject to change without notice.

Harman Kardon, Power for the Digital Revolution and Logic 7 are registered trademarks of Harman International Industries, Incorporated.

|||||**Set/EQ**™ is a trademark of Harman International Industries, Incorporated.

\*Manufactured under license from Dolby Laboratories. "Dolby," "Pro Logic" and the Double-D symbol are trademarks of Dolby Laboratories.

DTS, DTS Surround, DTS-ES, DTS 96/24 and DTS Neo:6 are registered trademarks of Digital Theater Systems, Inc.

A-BUS and A-BUS Ready are registered trademarks of Leisure Tech Electronics Pty Ltd Australia.

SACD is a trademark of Sony Electronics Inc.

TiVo is a registered trademark of TiVo, Inc.

Replay TV is a registered trademark of Digital Networks North America, Inc.

## Supplied Accessories

The following accessory items are supplied with the AVR 435. If any of these items are missing, please contact Harman Kardon customer service at [www.harmankardon.com](http://www.harmankardon.com).

- A system remote control
- A Zone II remote control
- An |||||**Set/EQ** microphone
- Extender rod for microphone
- An AM loop antenna
- An FM wire antenna
- Six AAA batteries

# AVR 635 TECHNICAL SPECIFICATIONS

## Audio Section

Stereo Mode  
 Continuous Average Power (FTC)  
 90 Watts per channel, 20Hz–20kHz,  
 @ <0.07% THD, both channels driven into 8 ohms

Seven-Channel Surround Modes  
 Power per Individual Channel

Front L&R channels:  
 75 Watts per channel  
 @ <0.07% THD, 20Hz–20kHz into 8 ohms

Center channel:  
 75 Watts @ <0.07% THD, 20Hz–20kHz into 8 ohms

Surround (L & R Side, L & R back) channels:  
 75 Watts per channel  
 @ <0.07% THD, 20Hz–20kHz into 8 ohms

Input Sensitivity/Impedance  
 Linear (High-Level) 200mV/47k ohms

Signal-to-Noise Ratio (IHF-A) 100dB

Surround System Adjacent Channel Separation

Pro Logic I/II	40dB
Dolby Digital (AC-3)	55dB
DTS	55dB

Frequency Response  
 @ 1W (+0dB, -3dB) 10Hz – 130kHz

High Instantaneous  
 Current Capability (HCC) ±50 Amps

Transient Intermodulation  
 Distortion (TIM) Unmeasurable

Slew Rate 40V/μsec

## FM Tuner Section

Frequency Range	87.5–108.0MHz
Usable Sensitivity	IHF 1.3μV/13.2dBf
Signal-to-Noise Ratio	Mono/Stereo 70/68dB
Distortion	Mono/Stereo 0.2/0.3%
Stereo Separation	40dB @ 1kHz
Selectivity	±400kHz, 70dB
Image Rejection	80dB
IF Rejection	90dB

## AM Tuner Section

Frequency Range	520–1720kHz
Signal-to-Noise Ratio	45dB
Usable Sensitivity	Loop 500μV
Distortion	1kHz, 50% Mod 0.8%
Selectivity	±10kHz, 30dB

## Video Section

Television Format	NTSC
Input Level/Impedance	1Vp-p/75 ohms
Output Level/Impedance	1Vp-p/75 ohms
Video Frequency Response (Composite and S-Video)	10Hz–8MHz (-3dB)
Video Frequency Response (Component Video)	10Hz–50MHz (-3dB)

## General

Power Requirement	AC 120V/60Hz	
Power Consumption	59W at Power On, idle; 1,000W at rated power output (7 channels driven)	
Dimensions	Product	Shipping
Width	17.3 inches (440mm)	20.1 inches (510mm)
Height	6.5 inches (165mm)	10 inches (254mm)
Depth	17.1 inches (435mm)	22.2 inches (565mm)
Weight	41 lb (18.6kg)	47 lb (21.4kg)

Depth measurement includes knobs, buttons and terminal connections.  
 Height measurement includes feet and chassis.  
 All features and specifications are subject to change without notice.

Harman Kardon, Power for the Digital Revolution and Logic 7 are registered trademarks of Harman International Industries, Incorporated.

|||||**Set/EQ** is a trademark of Harman International Industries, Incorporated.

\*Manufactured under license from Dolby Laboratories. "Dolby," "Pro Logic" and the Double-D symbol are trademarks of Dolby Laboratories.

DTS, DTS Surround, DTS-ES, DTS 96/24 and DTS Neo:6 are registered trademarks of Digital Theater Systems, Inc.

HDCD system manufactured under license from Pacific Microsonics, Inc. This product is covered by one or more of the following: in the USA: 5,479,168; 5,638,074; 5,640,161; 5,808,574; 5,838,274; 5,854,600; 5,864,311; 5,872,531; and in Australia: 669114. Other patents pending.

A-BUS and A-BUS Ready are registered trademarks of Leisure Tech Electronics Pty Ltd Australia.

TiVo is a registered trademark of TiVo, Inc.

Replay TV is a registered trademark of Digital Networks North America, Inc.

## Supplied Accessories

The following accessory items are supplied with the AVR 635. If any of these items are missing, please contact Harman Kardon customer service at [www.harmankardon.com](http://www.harmankardon.com).

- A system remote control
- A Zone II remote control
- An |||||**Set/EQ** microphone
- Extender rod for microphone
- An AM loop antenna
- An FM wire antenna
- Six AAA batteries

FRONT - PANEL CONTROLS

  = AVR635 only

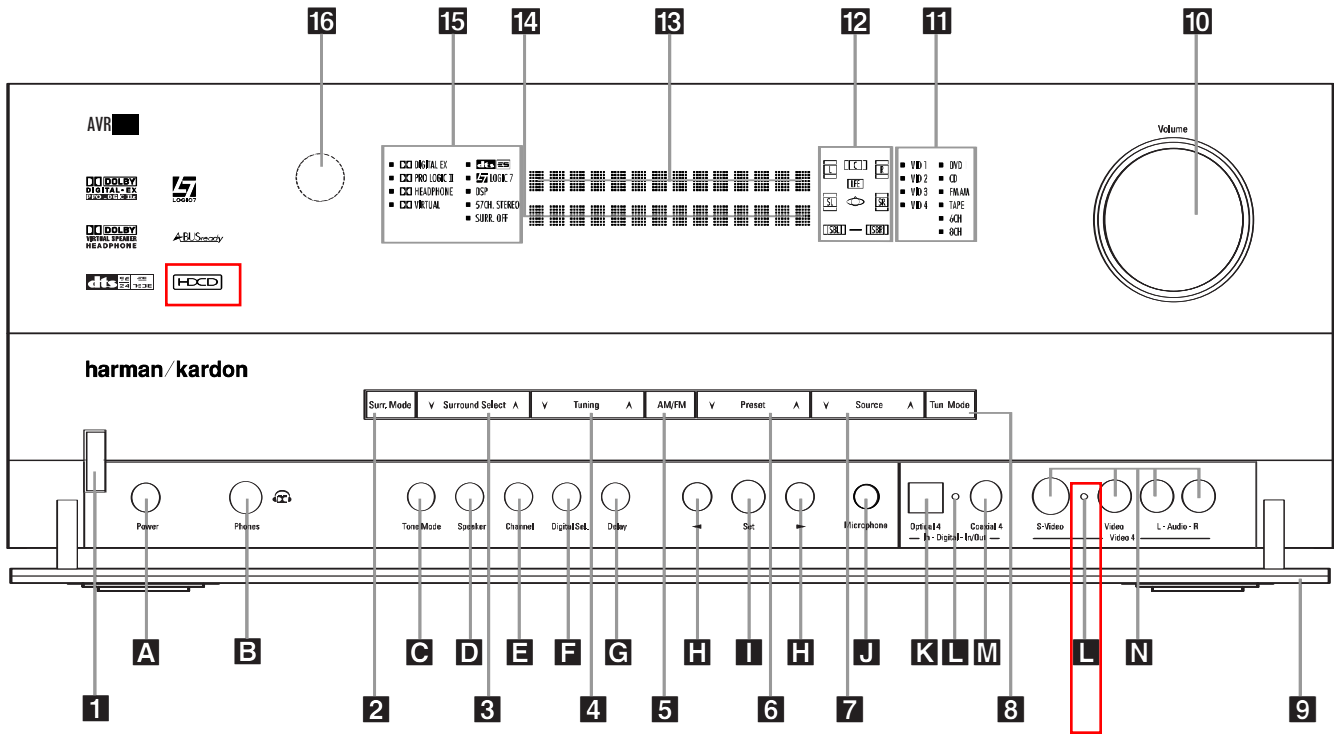

**NOTE:** To make it easier to follow the instructions that refer to this illustration, a larger copy may be downloaded from the Product Support section for this product at [www.harmankardon.com](http://www.harmankardon.com).

The following controls and indicators are available on the AVR's front panel:

- |                                       |  |                                    |
|---------------------------------------|--|------------------------------------|
| <b>1</b> Standby/On Switch            | <b>7</b> Input Source Selector             | <b>13</b> Upper Display Line       |
| <b>2</b> Surround Mode Group Selector | <b>8</b> Tuning Mode Selector              | <b>14</b> Lower Display Line       |
| <b>3</b> Surround Mode Selector       | <b>9</b> Front-Panel Control Door          | <b>15</b> Surround Mode Indicators |
| <b>4</b> Tuning Selector              | <b>10</b> Volume Control                   | <b>16</b> Remote Sensor Window     |
| <b>5</b> Tuner Band Selector          | <b>11</b> Input Indicators                 |                                    |
| <b>6</b> Preset Station Selector      | <b>12</b> Speaker/Channel Input Indicators |                                    |

The following controls and jacks are located behind the front-panel door. To open the door, place the edge of a finger on the left or right edge of the panel and gently swing the door down towards you.

- |                                  |                                    |
|----------------------------------|------------------------------------|
| <b>A</b> Main Power Switch       | <b>F</b> Digital Input Selector    |
| <b>B</b> Headphone Jack          | <b>G</b> Delay Adjust Selector     |
| <b>C</b> Tone Mode Button        | <b>H</b> ◀▶ Buttons                |
| <b>D</b> Speaker Selector Button | <b>I</b> Set Button                |
| <b>E</b> Channel Adjust Selector | <b>J</b> EzSet/EQ Microphone Jacks |

- AVR435**

  - K** Optical 4 Digital Input
  - L** Coaxial 4 Digital Input
  - M** Video 4 Audio/Video Jacks

- AVR635**

  - K** Optical 4 Digital Input
  - L** Input/Output Status Indicators
  - M** Coaxial 4 Digital Jack
  - N** Video 4 Audio/Video Jacks

**1 Standby/On Switch:** When the **Main Power Switch A** is "ON," press this button to turn on the AVR; press it again to turn the unit off. Note that the illumination surrounding the switch will turn blue when the unit is on.

**2 Surround Mode Group Selector:** Press this button to select the top-level group of surround modes. Each press of the button will select one of the surround mode categories. Once the button is pressed so

that the name of the desired surround mode category appears in the on-screen display and in the **Lower Display Line 14**, press the **Surround Mode Selector 3** to cycle through the individual modes available. For example, press this button to select Dolby modes, and then press the **Surround Mode Selector 3** to choose from the various mode options.

**3 Surround Mode Selector:** Press this button to select from among the available surround mode

options for the surround mode category selected. The specific modes will vary based on the number of speakers available, the surround mode category and whether the input source is digital or analog. For example, press the **Surround Mode Group Selector 2** to select a category such as Dolby or Logic 7, and then press this button to see the specific mode choices that are available.

# FRONT - PANEL CONTROLS

**4 Tuning Selector:** Press the left side of the button to tune lower-frequency stations and the right side of the button to tune higher-frequency stations. When the tuner is in the **MANUAL / MONO** mode, each tap of the Selector will increase or decrease the frequency by one increment. When the tuner receives a strong-enough signal for adequate reception, **MANUAL TUNED** will appear in the **Lower Display Line 14** and in the on-screen display. When the tuner is in the **AUTO / STEREO** mode, press the button once, and the tuner will scan for a station with acceptable signal strength. When the next higher- or lower-frequency station with a strong-enough signal is tuned, the frequency scan will stop and the **Lower Display Line 14** and the on-screen display will indicate **AUTO TUNED**. When an FM Stereo station is tuned, the display will read **AUTO ST TUNED**.

**5 Tuner Band Selector:** Pressing this button will automatically switch the AVR to the Tuner mode. Pressing it again will switch between the AM and FM frequency bands.

**6 Preset Station Selector:** Press this button to scroll up or down through the list of stations that have been entered into the preset memory.

**7 Input Source Selector:** Press this button to change the input by scrolling up or down through the list of input sources.

**8 Tuning Mode Selector:** Press this button to select Auto or Manual tuning. When the button is pressed so that **AUTO / STEREO** appears in the **Upper Display Line 13**, the tuner will search for the next station with an acceptable signal when the **Tuning Selector 4 23 E** is pressed. When the button is pressed so that **MANUAL / MONO** appears in the **Upper Display Line 13**, each press of the **Tuning Selector 4 23 E** will increase the frequency.

This button may also be used to switch between Stereo and Mono modes for FM radio reception. When weak

reception is encountered, select the Manual/Mono tuning mode. Press and hold again to switch back to Stereo mode.

**9 Front-Panel Control Door:** To open the door so that the front-panel jacks and controls behind this door may be accessed, gently pull the door down and towards you using either upper corner of the door.

**10 Volume Control:** Turn this knob clockwise to increase the volume, counterclockwise to decrease the volume. If the AVR is muted, adjusting the volume control will automatically release the unit from the silenced condition.

**11 Input Indicators:** One of these indicators will light to identify the currently selected input. Note that the entire list will light briefly each time the unit is turned on as a test.

**12 Speaker/Channel Input Indicators:** These indicators are multipurpose, indicating both the speaker type selected for each channel and the incoming data-signal configuration. The left, center, right, right surround and left surround speaker indicators are composed of three boxes, while the subwoofer is a single box. The center box lights when a "small" speaker is selected, and the two outer boxes light when "large" speakers are selected. When none of the boxes are lit for the center, surround or subwoofer channels, no speaker has been assigned that position.

The letters inside each box displays the active input channels. For standard analog inputs, only the L and R will light, indicating a stereo input. For a digital source, the indicators will light to display the channels being received at the digital input. When the letters flash, the digital input has been interrupted.

**13 Upper Display Line:** Depending on the unit's status, a variety of messages will appear here. In normal operation, this line will show the current input source and identify whether an analog or digital input is in use. When the tuner is selected as the input, this line will identify the station as AM or FM and show the frequency and preset number, if any.

**14 Lower Display Line:** Depending on the unit's status, a variety of messages will appear here. In normal operation, the current surround mode will appear on this line.

**15 Surround Mode Indicators:** One of these indicators will light to show the surround mode in use. Depending on the specific combination of input sources and surround mode selected, more than one indicator may light.

**16 Remote Sensor Window:** The sensor behind this window receives infrared signals from the remote control. Aim the remote at this area and do not block or cover it unless an external remote sensor is installed.



 = AVR635 Only

## FRONT - PANEL CONTROLS

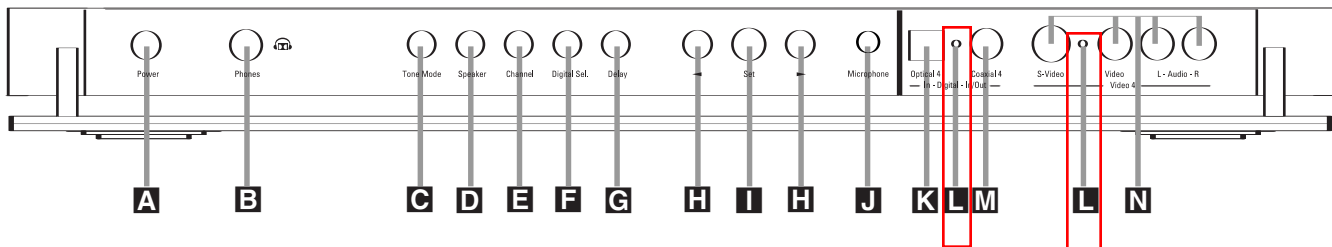

The following controls and jacks are located behind the front-panel door. To open the door, place the edge of a finger on the left or right edge of the panel and gently swing the door down towards you.

**A Main Power Switch:** Press this switch to apply power to the AVR . When the switch is pressed in, the unit is placed in a Standby mode, as indicated by the amber illumination surrounding the **Standby/On Switch 1**. This button MUST be pressed in to operate the unit. To turn the unit off and prevent the use of the remote control, this switch should be pressed until it pops out from the front panel so that the word "OFF" may be read at the top of the switch.

**NOTE:** This switch is normally left in the "ON" position.

**B Headphone Jack:** This jack may be used to listen to the AVR 's output through a pair of headphones. Be certain that the headphones have a standard 1/4" stereo phone plug, or that you use an adaptor, as needed, to convert the plug on your headphones to the 1/4" jack used on the AVR. When the headphone jack is in use, the main room speakers will automatically be turned off and the unit will output a standard stereo signal. You may also use one of the Dolby Headphone modes for an enhanced listening experience.

**C Tone Mode Button:** This button controls the tone mode settings, enabling adjustment of the bass and treble boost/cut. You may also use it to take the tone controls out of the signal path completely for "flat" response. The first press of the button displays a **TONE MODE** message in the **Lower Display Line 14** and in the on-screen display. To take the controls out of the signal path, press either of the **◀▶ Buttons H** until the display reads **TONE OUT**. To change the bass or treble settings, press the button again until the desired option appears in the **Lower Display Line 14** and in the on-screen display and then press either of the **◀▶ Buttons H** to enter the desired boost or cut setting.

**D Speaker Selector Button:** Press this button to begin the process of configuring the AVR 635 for the type of speakers it is being used with. For complete information on configuring the speaker settings, see page 27.

**E Channel Adjust Selector:** Press the button to begin the process of adjusting the channel level outputs using the source currently playing through your AVR.

**F Digital Input Selector:** Press this button to begin the process of selecting a digital source for use with the currently selected input. Once the button has been pressed, use the **◀▶ Buttons H** to choose the desired input and then press the **Set Button I** to enter the setting into the unit's memory.

**G Delay Adjust Selector:** Press this button to begin the process of adjusting the delay settings for Dolby surround modes.

**H ◀▶ Buttons:** When making system configuration changes using the front-panel controls, press these buttons to scroll through the available choices for the option being adjusted.

**I Set Button:** When making system configuration changes using the front-panel controls, press this button to enter a setting into the unit's memory.

**J EzSet/EQ Microphone Jack:** Before starting the EzSet/EQ automated setup process, plug the microphone into this jack. The microphone does not need to be plugged in at other times.

**K Optical 4 Digital Input:** Connect the optical digital output of an audio or video product to this jack.

**L Input/Output Status Indicators:** These LED indicators will normally light green to show that the front-panel **Coaxial 3 Digital Jack L** and **Video 4 Input/Output Jacks M** are operating as inputs. When these jacks are configured for use as an output, the appropriate indicator will turn red to show that the jack may be used as an output for recording. (See page 38 for more information on configuring the front-panel jacks as outputs, rather than inputs.)

**M Coaxial 4 Digital Jack:** Connect the coaxial digital input or output for a digital audio product such as a portable audio player or video game to this jack. The jack is normally an input, but may be switched to an output for recording using the menu system. **AVR635 Only**

**N Video 4 Input/Output Jacks:** These audio/video jacks may be used as either an input or output for temporary connection to video games or portable audio/video products such as camcorders and portable audio players.

# REAR-PANEL CONNECTIONS

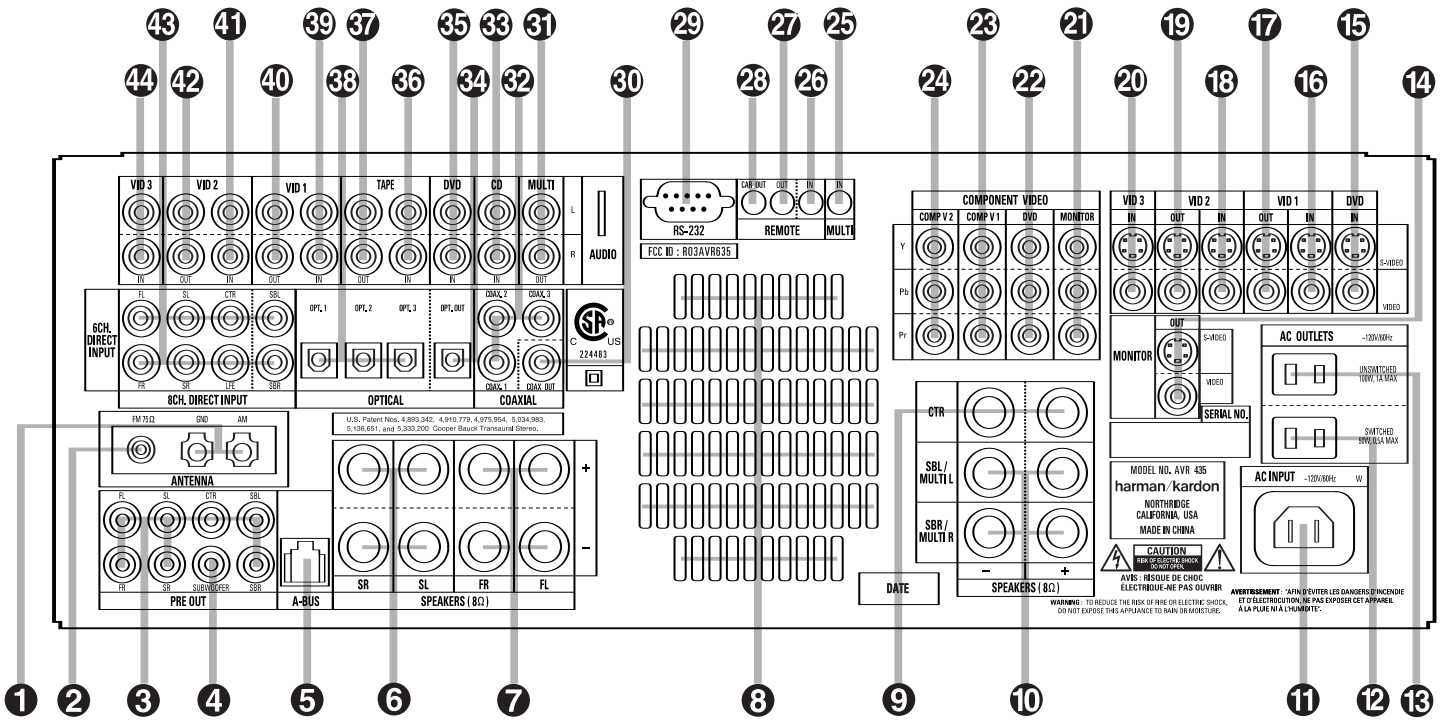

- 1 AM Antenna
- 2 FM Antenna
- 3 Preamp Outputs
- 4 Subwoofer Output
- 5 A-BUS Connector
- 6 Surround Speaker Outputs
- 7 Front Speaker Outputs
- 8 Fan Vents
- 9 Center Speaker Outputs
- 10 Surround Back/Multiroom Speaker Outputs
- 11 AC Power Cord
- 12 Switched AC Accessory Outlet
- 13 Unswitched AC Accessory Outlet
- 14 Video Monitor Outputs
- 15 DVD Video Inputs
- 16 Video 1 Video Inputs
- 17 Video 1 Video Outputs
- 18 Video 2 Video Inputs
- 19 Video 2 Video Outputs
- 20 Video 3 Video Inputs
- 21 Component Video Monitor Outputs
- 22 DVD Component Video Inputs
- 23 Component Video 1 Inputs
- 24 Component Video 2 Inputs
- 25 Multiroom IR Input
- 26 Remote IR Input
- 27 Remote IR Output
- 28 Remote IR Carrier Output
- 29 RS-232 Port
- 30 Coaxial Digital Audio Output
- 31 Multiroom Audio Outputs
- 32 Coaxial Digital Audio Inputs
- 33 CD Audio Inputs
- 34 Optical Digital Audio Output
- 35 DVD Audio Inputs
- 36 Tape Inputs
- 37 Tape Outputs
- 38 Optical Digital Audio Inputs
- 39 Video 1 Audio Inputs
- 40 Video 1 Audio Outputs
- 41 Video 2 Audio Inputs
- 42 Video 2 Audio Outputs
- 43 8-Channel Direct Inputs
- 44 Video 3 Audio Inputs

**NOTE:** To make it easier to follow the instructions that refer to this illustration, a larger copy may be downloaded from the Product Support section for this product at [www.harmankardon.com](http://www.harmankardon.com).

NOTE: To assist in making the correct connections for multichannel input, output and speaker connections, all connection jacks and terminals are color-coded as follows:		Surround Left: Blue	Component Video "Y": Green
Front Left: White	Surround Right: Gray	Surround Back Left: Brown	Component Video "Pr": Red
Front Right: Red	Surround Back Left: Brown	Surround Back Right: Tan	Component Video "Pb": Blue
Center: Green	Subwoofer: Purple	Coaxial Digital Audio: Orange	Optical Digital In: Black
	Coaxial Digital Audio: Orange	Composite Video: Yellow	Optical Digital Out: Gray

## REAR-PANEL CONNECTIONS

**1 AM Antenna:** Connect the AM loop antenna supplied with the receiver to these terminals. If an external AM antenna is used, make connections to the **AM** and **GND** terminals in accordance with the instructions supplied with the antenna.

**2 FM Antenna:** Connect the supplied indoor or an optional external FM antenna to this terminal.

**3 Preamp Outputs:** Connect these jacks to an optional, external power amplifier for applications where higher power is desired.

**4 Subwoofer Output:** Connect this jack to the line-level input of a powered subwoofer. If an external subwoofer amplifier is used, connect this jack to the subwoofer amplifier input.

**5 A-BUS Connector:** Connect this jack to an optional A-BUS®-certified remote room product to extend the multiroom capabilities of your AVR

**6 Surround Speaker Outputs:** Connect these outputs to the matching + and – terminals on your surround channel speakers. In conformance with the CEA color-code specification, the blue terminal is the positive (+) terminal that should be connected to the red (+) terminal on the Surround Left speaker with older color-coding, while the gray terminal should be connected to the red (+) terminal on the Surround Right speaker with the older color-coding. Connect the black (–) terminal on the AVR to the matching black negative (–) terminals for each surround speaker.

**7 Front Speaker Outputs:** Connect these outputs to the matching + or – terminals on your left and right speakers. When making speaker connections, always make certain to maintain correct polarity by connecting the color-coded (white for front left and red for front right) (+) terminals on the AVR to the red (+) terminals on the speakers and the black (–) terminals on the AVR to the black (–) terminals on the speakers.

**8 Fan Vents:** These ventilation holes are the output of the AVR's airflow system. To ensure proper operation of the unit and to avoid possible damage to delicate surfaces, make certain that these holes are not blocked and that there is at least 3 inches of open space between the vent holes and any wooden or fabric surface. It is normal for the fan to remain off at most normal volume levels. An automatic temperature sensor turns the fan on only when it is needed.

**9 Center Speaker Outputs:** Connect these outputs to the matching + and – terminals on your center channel speaker. In conformance with the CEA color-code specification, the green terminal is the positive (+) terminal that should be connected to the red (+) terminal on speakers with the older color-coding. Connect the black (–) terminal on the AVR to the black negative (–) terminal on your speaker.

**10 Surround Back/Multiroom Speaker Outputs:** These speaker terminals are normally used to power the surround back left/surround back right speakers in a 7.1-channel system. However, they may also be used to power the speakers in a second zone, which will receive the output selected for a multiroom system. To change the output fed to these terminals from the default of the Surround Back speakers to the Multiroom Output, you must change a setting in the Advanced Menu of the OSD system.

In normal surround system use, the brown and black terminals are the surround back left channel positive (+) and negative (–) connections and the tan and black terminals are the surround back right positive (+) and negative (–) terminals. For multiroom use, connect the brown and black SBL terminals to the red and black connections on the left remote zone speaker and connect the tan and black SBR terminals to the red and black terminals on the right remote zone speaker.

**11 AC Power Cord Jack:** Connect the AC power cord to this jack when the installation is complete. To ensure safe operation, use only the power cord supplied with the unit. If a replacement is required, it must be of the same type and capacity.

**12 Switched AC Accessory Outlet:** These outlets may be used to power any device you wish to have turned on when the AVR is turned on with the **Standby/On Switch 1**.

**13 Unswitched AC Accessory Outlet:** This outlet may be used to power any AC device. The power will remain on at this outlet, regardless of whether the AVR is on or off.

**NOTE:** The total power consumption of all devices connected to the accessory outlets should not exceed 100 watts.

**14 Video Monitor Outputs:** Connect these jacks to the composite or S-video input of a TV monitor or video projector to view the on-screen menus and the output of any standard video source selected by the receiver's video switcher.

**15 DVD Video Inputs:** Connect the composite or S-video outputs of a DVD player or other video source to these jacks.

**16 Video 1 Video Inputs:** Connect the composite or S-video PLAY/OUT jacks of a VCR or other video source to these jacks.

**17 Video 1 Video Outputs:** Connect the composite or S-video REC/IN jacks of a VCR or other video recording device such as a DVD recorder or PVR to these jacks.

**18 Video 2 Video Inputs:** Connect the composite or S-video PLAY/OUT jacks of a VCR or other video source to these jacks.

**19 Video 2 Video Outputs:** Connect the composite or S-video REC/IN jacks of a VCR or other video recording device such as a DVD recorder or PVR to these jacks.

**20 Video 3 Video Inputs:** Connect the composite or S-video PLAY/OUT jacks of a VCR or other video source to these jacks.

**21 Component Video Monitor Outputs:** Connect these outputs to the component video inputs of a video projector or monitor. When a source connected to one of the **Component Video Inputs 22/23** is selected, the signal will be sent to these jacks.

**22 DVD Component Video Inputs:** These inputs may be used with any source device equipped with analog Y/Pr/Pb or RGB component video outputs. The factory default is for these jacks to be linked to the DVD input, but you may change the setting at any time through the **INPUT SETUP** menu.

**23 Component Video 1 Inputs:** These inputs may be used with any source device equipped with analog Y/Pr/Pb or RGB component video outputs. The factory default is for these jacks to be linked to the DVD input, but you may change the setting at any time through the **INPUT SETUP** menu.

**24 Component Video 2 Inputs:** These inputs may be used with any video source device equipped with analog Y/Pr/Pb or RGB component video outputs. The factory default is for these jacks to be linked to the Video 2 input, but you may change the setting at any time through the **INPUT SETUP** menu.

**25 Multiroom IR Input:** Connect the output of an IR sensor in a remote room to this jack to operate the AVR's multiroom control system.

## REAR-PANEL CONNECTIONS

**26 Remote IR Input:** If the AVR's front-panel IR sensor is blocked due to cabinet doors or other obstructions, an external IR sensor may be used. Connect the output of the sensor to this jack.

**27 Remote IR Output:** This connection permits the IR sensor in the receiver to serve other remote controlled devices. Connect this jack to the "IR IN" jack on compatible Harman Kardon equipment.

**28 Remote IR Carrier Output:** The output of this jack is the full signal received at the **Remote Sensor Window 16** or input through the **Remote IR Input 26** including the carrier frequency that is removed from signals at the **Remote IR Output 27**. Use this output to extend IR remote signals to the input of compatible products by direct connection or through the use of optional, external IR "blasters". If you are in doubt as to which of the two IR Output jacks to use, we recommend that you consult with your dealer or installer, or check with the manufacturer of the external equipment you wish to control.

**29 RS-232 Port:** This jack may be used to control the AVR over a bi-directional RS-232 serial control link to a compatible computer or programmable remote control system. Due to the complexity of programming RS-232 commands, we strongly recommend that connections to this port for control purposes be made by a trained and qualified technician. This jack may also link to a compatible computer to upgrade the software and operating system of the AVR when upgrades are available.

**30 Coaxial Digital Audio Output:** Connect this jack to the coaxial digital input of a CD-R/RW, MiniDisc or other compatible digital recorder.

**31 Multiroom Audio Outputs:** Connect these jacks to the optional external audio power amplifier and video distribution system that delivers the source selected for multizone distribution.

**32 Coaxial Digital Audio Inputs:** Connect the coax digital output from a DVD player, HDTV receiver, the S/P-DIF output of a compatible computer sound card playing MP3 files or streams, LD player or CD player to these jacks. The signal may be a Dolby Digital signal, DTS signal or a standard PCM digital source. Do not connect the RF digital output of an LD player to these jacks.

**33 CD Audio Inputs:** Connect these jacks to the left/right analog audio output of a compact disc player or CD changer or other audio source.

**34 Optical Digital Audio Output:** Connect this jack to the optical digital input connector on a CD-R/RW, MiniDisc or other compatible digital recorder.

**35 DVD Audio Inputs:** Connect the left/right analog outputs of a DVD player or other audio source to these jacks.

**36 Tape Inputs:** Connect these jacks to the Play/Out jacks of an audio recorder.

**37 Tape Outputs:** Connect these jacks to the Record/Input jacks of an audio recorder.

**38 Optical Digital Audio Inputs:** Connect the optical digital output from a DVD player, HDTV receiver, the S/P-DIF output of a compatible computer sound card playing MP3 files or streams, LD player or CD player to these jacks. The signal may be a Dolby Digital signal, a DTS signal or a standard PCM digital source.

**39 Video 1 Audio Inputs:** Connect the left/right PLAY/OUT audio output jacks on a VCR or other video source to these jacks.

**40 Video 1 Audio Outputs:** Connect the left/right REC/IN audio input jacks on a VCR or other video source to these jacks.

**41 Video 2 Audio Inputs:** Connect the left/right PLAY/OUT audio output jacks on a VCR or other video source to these jacks.

**42 Video 2 Audio Outputs:** Connect the left/right REC/IN audio input jacks on a VCR or other video source to these jacks.

**43 8-Channel Direct Inputs:** These jacks are used for connection to source devices such as DVD-Audio or SACD players with discrete analog outputs. Depending on the source device in use, all eight jacks may be used, though in many cases only connections to the front left/right, center, surround left/right and LFE (subwoofer input) jacks will be used for standard 5.1 audio signals.

**44 Video 3 Audio Inputs:** Connect the left/right PLAY/OUT audio output jacks on a VCR, PVR, cable set-top, satellite receiver, HDTV receiver or other video source to these jacks.

# MAIN REMOTE CONTROL FUNCTIONS

- 1 Power Off Button
- 2 Power On Button
- 3 LCD Information Display
- 4 Input Selectors
- 5 AVR Selector
- 6 Test Button
- 7 DSP Surround Mode Selector
- 8 Logic 7 Mode Select Button
- 9 Direct Button
- 10 Clear Button
- 11 Numeric Keys
- 12 Tuning Mode Button
- 13 Dim Button
- 14 Channel Select Button
- 15 Navigation Button
- 16 Digital Select Button
- 17 Set Button
- 18 Volume Up/Down Selectors
- 19 Transport Fast-Play/Scan Buttons
- 20 Main Transport Controls
- 21 Track Skip Up/Down Buttons
- 22 Preset Up/Down Button
- 23 Video Input Button
- 24 Disc Skip Button
- 25 Program Button
- 26 Light Button
- 27 Multiroom Button
- 28 Macro Buttons
- 29 OSD Button
- 30 Night Mode Button
- 31 Tone Control Button
- 32 Sleep Button
- 33 AM/FM Button
- 34 Tuning Up/Down Button
- 35 Channel Up/Down Selector
- 36 Transport Play Buttons
- 37 Delay Select Button
- 38 Speaker Select Button
- 39 Memory Button
- 40 Stereo Mode Select Button
- 41 DTS Neo:6 Mode Select Button
- 42 DTS Digital Mode Select Button
- 43 Dolby Mode Select Button
- 44 6/8-Channel Input Select
- 45 Mute Button
- 46 Lens

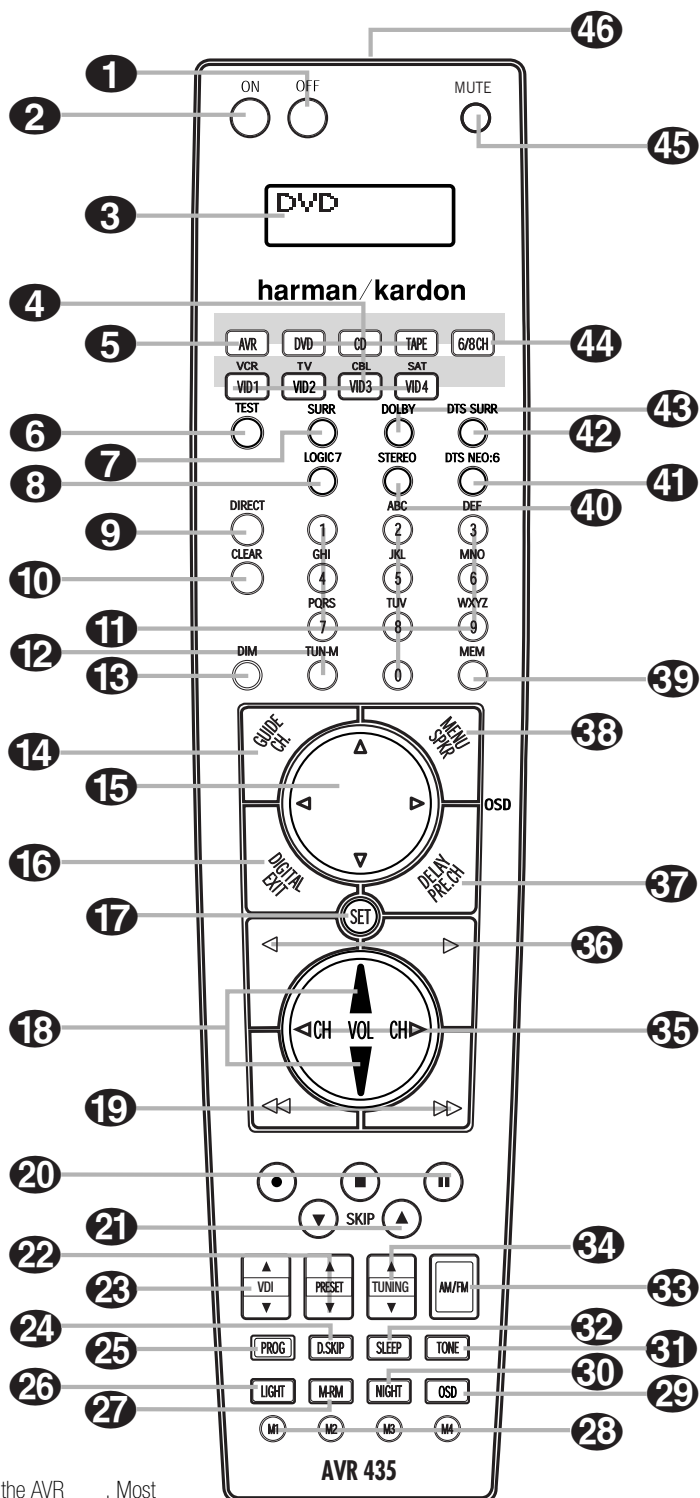

**NOTES:**

- The function names shown here are each button's feature when used with the AVR . Most buttons have additional functions when used with other devices. When a button is pressed, the function name will appear in the bottom line of the LCD Information Display 3.
- The jack on the upper right side of the remote is reserved for future use. Do not remove the plug provided or connect any device to the jack.
- To make it easier to follow the instructions that refer to this illustration, a larger copy may be downloaded from the Product Support section for this product at [www.harmankardon.com](http://www.harmankardon.com).

# MAIN REMOTE CONTROL FUNCTIONS

**IMPORTANT NOTE:** The AVR's remote may be programmed to control up to eight devices, including the AVR. Before using the remote, it is important to remember to press the **Input Selector Button 4** that corresponds to the unit you wish to operate. In addition, the AVR's remote is shipped from the factory to operate the AVR and most Harman Kardon CD or DVD players and cassette decks. The remote is also capable of operating a wide variety of other products using the control codes that are part of the remote. Before using the remote with other products, follow the instructions on pages 43 – 46 to program the proper codes for the products in your system.

It is also important to remember that many of the buttons on the remote take on different functions, depending on the product selected using the **Input Selectors 4**. The descriptions shown here primarily detail the functions of the remote when it is used to operate the AVR.

**1 Power Off Button:** Press this button to place the AVR or a selected device in the Standby mode. Note that this will turn off the main room functions, but if the Multiroom system is activated, it will continue to function.

**2 Power On Button:** Press this button to turn on the power to a device selected by first pressing one of the **Input Selectors 4**.

**3 LCD Information Display:** This two-line screen displays various information depending on the commands that have been entered into the remote.

**4 Input Selectors:** Pressing one of these buttons will perform three actions at the same time. First, if the AVR is not turned on, this will power up the unit. Next, it will select the source shown on the button as the input to the AVR. Finally, it will change the remote control so that it controls the device selected. In normal operation, the remote will revert to controlling the AVR when no button is pressed for 6 seconds.

This allows the remote to automatically return to control of important functions such as volume, mute and surround mode selection after you have used the remote to control another device. If you wish to change the length of time that the remote operates another device, or to have the remote remain active for control of the other device (such as a DVD player or set-top box) until you manually return control to the AVR by pressing the **AVR Selector 5**,

**5 AVR Selector:** Pressing this button will switch the remote so that it will operate the AVR 435's functions. If the AVR is in the Standby mode, it will also turn the AVR on.

**6 Test Button:** Press this button to begin the sequence used to manually calibrate the AVR's output levels.

**7 DSP Surround Mode Selector:** Press this button to select one of the DSP surround modes, such as VMaX, Hall 1, Hall 2 or Theater. Each press of the button selects another mode.

**8 Logic 7 Mode Select Button:** Press this button to select from among the available Logic 7 surround modes.

**9 Direct Button:** Press this button when the tuner is in use to start the sequence for direct entry of a station's frequency. After pressing the button, simply press the proper **Numeric Keys 11** to select a station.

**10 Clear Button:** When programming the remote or using the EzSet feature, press this button to cancel the current function. When using the remote to enter frequencies for direct tuner access, press this button to clear previous entries.

**11 Numeric Keys:** These buttons serve as a 10-button numeric keypad to enter tuner preset positions. They are also used to select channel numbers when TV, Cable or SAT has been selected on the remote, or to select track numbers on a CD, DVD or LD player, depending on how the remote has been programmed. These buttons are also used to enter letters and numbers when renaming devices in the LCD Information Display.

**12 Tuning Mode Button:** Press this button to change the tuner mode between manual and automatic. When the button is pressed so that **AUTO / STEREO** appears in the **Upper Display Line 13** and in the on-screen display, only stations with acceptable signal quality will be tuned, and the tuner will play FM stations in stereo, when available. In the **AUTO** mode, when the **Tuning Up/Down Buttons 4 34 E** are pressed, the unit will automatically search for the next available station with good signal strength. When this button is pressed so that **MANUAL / MONO** appears in the **Upper Display Line 13** and in the on-screen display, each press of the **Tuning Up/Down Buttons 4 34 E** will move the frequency up or down in single-step increments. When the FM band is in use, pressing the button so that the **MANUAL** mode is activated will enable you to tune stations with weak signals by changing to monaural reception.

**13 Dim Button:** Press this button to activate the Dimmer function, which reduces the brightness of the front-panel display, or turns it off entirely. Press the button once to change the display to reduce the brightness by 50%, and press it again within 5 seconds and the main display will go completely dark. Note that this setting is temporary; regardless of any changes, the display will always return to full brightness when the AVR is turned on. The blue illumination around the **Standby/On Switch 1** will always remain at full brightness regardless of the setting to remind you that the AVR is still turned on. The blue accent lighting inside the volume control will also remain at full brightness when the panel is at 50%, but go out when the panel lights are fully dimmed.

**14 Channel Select Button:** This button is used to start the process of setting the AVR's output levels to an external source. Once this button is pressed, press the **▲/▼** on the **Navigation Button 15** to select the channel being adjusted, then press the **Set Button 17**, followed by the **▲/▼** on the **Navigation Button 15** again, to change the level setting.

**15 Navigation Button:** This single disc-like button is used to navigate through the on-screen configuration menus, to scroll through the options list and to select choices for the various settings such as delay, speakers, surround modes, digital inputs, etc. To use the button, simply press it left, right, up or down in the direction indicated by the **▲/▼/◀/▶** icons printed on the button disc. Depending on the menu being used, pressing the button will either change a specific menu or configuration choice, or it will change the option shown in the on-screen or front-panel display. The sections in this manual describing the unit's individual features and configuration options contain specific information on how the navigation controls are used.

**16 Digital Select Button:** Press this button to assign one of the digital inputs **33 36 K L** to a source.

**17 Set Button:** This button is used to enter settings into the AVR's memory. It is also used in the setup procedures for delay time, speaker configuration and channel output level adjustment.

**18 Volume Up/Down Buttons:** These controls share the common disc in the lower third of the remote. To raise the volume, press the button marked **▲** by pressing towards the top of the remote. To lower the volume, press the button marked **▼** by pressing towards the bottom of the remote. The **◀/▶** buttons on the left and right sides of this disc change channels up or down when the TV, cable box or satellite **Input Selectors 4** have been pressed.

## MAIN REMOTE CONTROL FUNCTIONS

**19 Transport Fast-Play/Scan Buttons:** These buttons have no direct function on the AVR, but they are used when the remote is programmed for a compatible DVD, CD or tape player. Pressing these buttons will transmit a fast-play forward, fast-play reverse, or fast-forward or -reverse scan command, according to the capabilities of the player being controlled. In the factory default setting, these buttons are preprogrammed with the remote codes for Harman Kardon DVD players so that you may control a compatible player without having to switch devices.

**20 Main Transport Controls:** These buttons have no direct function on the AVR, but they are used when the remote is programmed for a compatible DVD, CD or tape player. Pressing these buttons will transmit a stop (■), record (●), or pause (⏸) command, according to the capabilities of the player being controlled. In the factory default setting, these buttons are programmed with the remote codes for Harman Kardon DVD players so that you may control a compatible player without having to switch devices.

**21 Track Skip Up/Down Buttons:** These buttons do not have a direct function with the AVR, but when used with a compatibly programmed CD or DVD changer will change the track or chapter currently being played. In the factory default setting, these buttons are programmed with the remote codes for Harman Kardon DVD players so that you may control a compatible player without having to switch devices.

**22 Preset Up/Down Button:** When the tuner is in use, press this button to scroll through the stations programmed into the AVR's memory.

**23 VDI Button:** This button does not have any function for the AVR, but is provided for your use in programming the codes that are used to scroll up or down through the available inputs on your video display. This allows you to switch video inputs that are directly connected to your video display. Alternatively, you may program any compatible remote code into the "up" and "down" portions of this button.

**24 Disc Skip Button:** This button has no direct function for the AVR, but may be used to change the disc in a CD or DVD changer when the remote is programmed for that type of device.

**25 Program Button:** This button is used to begin the process of programming the remote. Press and hold this button for 3 seconds to place the remote in the programming mode. Once the red LED under the **Set Button 17** lights, release the button. You may then select from the desired option.

**26 Light Button:** Press this button to activate the remote's backlight for ease of use in darkened rooms.

**27 Multiroom Button:** Press this button to begin the process of activating the multiroom system or to change the input or volume level for the second zone.

**28 Macro Buttons:** Press these buttons to store or recall a "Macro", which is a preprogrammed sequence of commands stored in the remote.

**29 OSD Button:** Press this button to activate or turn off the On-Screen Display (OSD) system used to set up or adjust the AVR's parameters.

**30 Night Mode Button:** Press this button to activate the Night mode. This mode is available in specially encoded Dolby Digital sources, and it preserves dialogue (center channel) intelligibility at low volume levels.

**31 Tone Control Button:** This button controls the tone mode settings, enabling adjustment of the bass and treble boost/cut. You may also use it to take the tone controls out of the signal path completely for "flat" response. The first press of the button displays a **TONE IN** message in the **Lower Display Line 14** and in the on-screen display. To take the controls out of the signal path, press either of the ▲/▼ **Navigation Buttons 15** until the display reads **TONE OUT**. To change the bass or treble settings, press the button again until the desired option appears in the **Lower Display Line 14** and in the on-screen display and then press either of the ▲/▼ **Navigation Buttons 15** to enter the desired boost or cut setting.

**32 Sleep Button:** Press this button to place the unit in the Sleep mode. After the time shown in the display, the AVR will automatically go into the Standby mode. Each press of the button changes the time until turn-off in the following order:

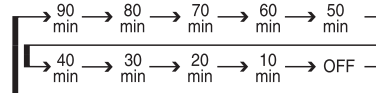

When the Sleep timer is in use, the front-panel display indicators will dim to half brightness.

**33 AM/FM Button:** Press this button to select the AVR's tuner as the listening choice. Pressing this button when the tuner is already in use will select between the AM and FM bands.

**34 Tuning Up/Down Button:** Press this button when the tuner is in use to change the station to one with a higher or lower frequency. When the tuner is in the **MANUAL / MONO** mode, each tap of the Selector will increase or decrease the frequency by one increment. When the tuner receives a strong-enough signal for adequate reception, **MANUAL TUNED** will appear in the **Lower Display Line 14** and in the on-screen display. When the tuner is in the **AUTO / STEREO** mode, press the button once, and the tuner will scan for a station with acceptable signal strength. When the next higher- or lower-frequency station with a strong-enough signal is tuned, the frequency scan will stop and the **Lower Display Line 14** and the on-screen display will indicate **AUTO TUNED**. When an FM Stereo station is tuned, the display will read **AUTO ST TUNED**.

**35 Channel Up/Down Selector:** This button has no function when the AVR is being controlled, but when programmed for use with a VCR, TV, cable box, satellite receiver or other similar product, it will change the channel up or down.

**36 Transport Play Buttons:** These buttons have no direct function on the AVR, but they are used when the remote is programmed for a compatible DVD, CD or tape player. Pressing these buttons will transmit a forward- or reverse-play command, according to the capabilities of the player being controlled. In the factory default setting, these buttons are programmed for Harman Kardon DVD players so that you may control a compatible player without having to switch devices.

**37 Delay Select Button:** This button selects adjustments to the A/V Sync Delay and the individual channel delays. The first press of the button displays an **A / V SYNC DELAY** message in the **Lower Display Line 14** and in the on-screen display, which means that you may change the amount of time that all channels are delayed together behind the video. This enables you to compensate for the loss of lip sync that may be caused by digital video processing in your display or by television stations. To change the A/V Sync Delay, press the **Set Button 17** while the **A / V SYNC DELAY** message is visible and then use the ▲/▼ **Navigation Button 15** to change the setting so that the sound and the video image are in sync. To change the delay for an individual output channel, press the ▲/▼ **Navigation Button 15** until the desired channel name is shown, and then press the **Set Button 17**. Use the ▲/▼ **Navigation Buttons 15** to change the delay amount.

# MAIN REMOTE CONTROL FUNCTIONS

**38 Speaker Select Button:** Press this button to begin the process of configuring the AVR's bass management system. Then press the ▲/▼ **Navigation Button 15** to select the channel you wish to set up. Press the **Set Button 17** and then select another channel to configure. When all adjustments have been completed, press the **Set Button 17** twice to exit the settings and return to normal operation.

**39 Memory Button:** Press this button to enter a radio station to the AVR's preset memory. First, tune the desired station, and then press this button. Within 5 seconds of when you see the station's frequency flash in the **Upper Display Line 13** and in the on-screen display, press the numeric keys for the preset number between 01 and 30 that you wish to assign to the station.

**40 Stereo Mode Select Button:** Press this button to select a stereo listening mode. When the button is pressed so that **SURROUND OFF** appears in the **Lower Display Line 14**, the AVR will operate in a bypass mode with true, fully analog, two-channel left/right stereo mode with no surround processing or bass management, as opposed to other modes where digital processing is used. When the button is pressed so that **SURROUND OFF** appears in the **Lower Display Line 14**, and the **DSP and Surround Off Surround Mode Indicators 15** are lit, you will enjoy a two-channel presentation of the sound, along with the benefits of bass management. Depending on whether your system is configured for 5.1 or 6.1/7.1 channels, the next press of the button will cause either **5 CH STEREO** or **7 CH STEREO** to appear, and the stereo signal will be routed to all five (or seven) speakers.

**41 DTS Neo:6 Mode Select Button:** Press this button to select a DTS Neo:6 mode.

**42 DTS Digital Mode Select Button:** When a DTS-encoded digital source is playing, each press of this button will scroll through the available DTS modes. The specific choice of modes will vary according to the type of encoding on the disc and your system's speaker configuration. When a DTS source is not in use, this button has no function.

**43 Dolby Mode Select Button:** This button is used to select from the available Dolby Surround modes. Each press of this button will select one of the Dolby Pro Logic II, Pro Logic IIx or Dolby Virtual Speaker modes, as available for the number of speakers in your system. When a Dolby Digital-encoded source is in use, the Dolby Digital mode may also be selected.

**44 6-Channel/8-Channel Input Select:** Press this button to select the device connected to the **6- or 8-Channel Direct Inputs 40**.

**45 Mute Button:** Press this button to momentarily silence the AVR or TV set being controlled, depending on which device has been selected.

**46 Lens:** The infrared emitters behind the plastic lens at the top of the remote communicate the remote codes to the AVR. Be certain that the lens is not covered when using the remote, and point the lens toward the AVR for best results. In learning mode, the remote receives IR codes to be learned through a sensor behind the lens.

**NOTE:** DO NOT remove the rubber plug that covers the jack on the upper right side of the remote. The jack is not active and is reserved for future use.



# INSTALLATION AND CONNECTIONS

## System Installation

After unpacking the unit, locating it in a place with adequate ventilation and placing it on a solid surface capable of supporting its weight, you will need to make the connections to your audio and video equipment.

**IMPORTANT NOTE:** For your personal safety and to avoid possible damage to your equipment and speakers, it is always good practice to turn off and unplug the AVR and ALL source equipment from the AC output before making any audio or video system connections.

### Audio Equipment Connections

We recommend that you use high-quality interconnect cables when making connections to source equipment and recorders to preserve the integrity of the signals.

1. Connect the analog output of a CD player to the **CD Audio Inputs 31**.

**NOTE:** If your CD player has both fixed and variable audio outputs, it is best to use the fixed output unless you find that the input to the receiver is so low that the sound is noisy, or so high that it is distorted.

2. Connect the analog Play/Out jacks of a cassette deck, MD, CD-R or other audio recorder to the **Tape Inputs 34**. Connect the analog Record/In jacks on the recorder to the **Tape Outputs 35** on the AVR.
3. Connect the output of any digital sources such as a CD or DVD changer or player, advanced video game, a digital satellite receiver, HDTV tuner or digital cable set-top box or the output of a compatible computer sound card to the **Optical and Coaxial Digital Audio Inputs 33 36 K L**.
4. Connect the coaxial or optical **Digital Audio Outputs 28 30** on the rear panel of the AVR to the matching digital input connections on a CD-R or MiniDisc recorder.
5. Assemble the AM loop antenna supplied with the unit so that the tabs at the bottom of the antenna loop snap into the holes in the base. Connect it to the **AM and GND Screw Terminals 1**.

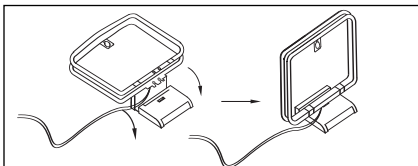

6. Connect the supplied FM antenna to the **FM (75-Ohm) Connection 2**. The FM antenna may be an external roof antenna, an inside powered or wire-lead antenna or a connection from a cable TV system. If the antenna or connection uses 300-ohm twin-lead cable, you must use an optional

300-ohm-to-75-ohm adaptor to make the connection.

7. Connect the front, center, surround and surround back speaker outputs **6 7 9 10** to the respective speakers.

To ensure that all the audio signals are carried to your speakers without loss of clarity or resolution, we suggest that you use high-quality speaker cable. Many brands of cable are available and the choice of cable may be influenced by the distance between your speakers and the receiver, the type of speakers you use, personal preferences and other factors. Your dealer or installer is a valuable resource to consult in selecting the proper cable.

Regardless of the brand of cable selected, we recommend that you use cable with a gauge of 14 or smaller. Remember that in specifying cable, the lower the number, the thicker the cable.

Cable with a gauge of 16 may be used for short runs of less than 10 feet. We do not recommend that you use cables with an AWG equivalent of 18 or higher, due to the power loss and degradation in performance that will occur.

Cables that are run inside walls should have the appropriate markings to indicate listing with UL, CSA or other appropriate testing agency standards. Questions about running cables inside walls should be referred to your installer or a licensed electrician who is familiar with the NEC and/or the applicable building codes in your area.

When connecting wires to the speakers, be certain to observe proper polarity. Note that the positive (+) terminal of each speaker connection has a specific color code, as noted on page 8. However, most speakers still use a red terminal for the positive (+) connection. Connect the "negative" or "black" wire to the same terminal on both the receiver and the speaker.

**NOTE:** While most speaker manufacturers adhere to an industry convention of using black terminals for negative and red ones for positive, some may vary from this configuration. To ensure proper phase and optimal performance, consult the identification plate on your speaker or the speaker's manual to verify polarity. If you do not know the polarity of your speaker, ask your dealer for advice before proceeding, or consult the speaker's manufacturer.

We also recommend that the length of cable used to connect speaker pairs be identical. For example, use the same length piece of cable to connect the front-left and front-right or surround-left and surround-right speakers, even if the speakers are a different distance from the AVR.

8. Connections to a subwoofer are normally made via a line-level audio connection from the **Subwoofer Output 4** to the line-level input of a subwoofer with a built-in amplifier. When a passive subwoofer is used, the connection first goes to a power amplifier, which will be connected to one or more subwoofer speakers. If you are using a powered subwoofer that does not have line-level input connections, follow the instructions furnished with the speaker for connection information.

9. If an external multichannel audio source with 5.1 outputs such as an external digital processor/decoder, DVD-Audio or SACD player is used, connect the outputs of that device to the **8-Channel Direct Inputs 40**.

### Video Equipment Connections

Video equipment is connected in the same manner as audio components. Again, the use of high-quality interconnect cables is recommended to preserve signal quality.

1. Connect a VCR's or other video source's audio and video Play/Out jacks to the **Video 1/Video 2 Audio and Video Input Jacks 16 18 37 39** on the rear panel. The Audio and Video Record/In jacks on the VCR should be connected to the **Video 1/Video 2 Audio and Video Output Jacks 17 19 38 41** on the AVR.
2. Connect the analog audio and video outputs of a satellite receiver, cable TV converter or television set or any other video source to the **Video 3 Audio and Video Input Jacks 20 42**.
3. Connect the analog audio and video outputs of a DVD or laser disc player to the **DVD Audio and Video Inputs 15 32**.
4. Connect the optical or coaxial digital audio outputs of a DVD player, satellite receiver, cable box, HDTV tuner or video game to any of the **Optical or Coaxial Digital Inputs 33 36 K L**. The recommended connection for a DVD player is to use a coaxial digital link connected to the Coaxial Digital Audio Input 1, but you may change the digital audio input assignment for any source using the **INPUT SETUP** menu.

**NOTE:** When connecting a device such as a digital cable box or other set-top tuner product with a digital audio output, we recommend that you connect both the digital and analog outputs of the product to your AVR. The audio input polling feature of the AVR will then be able to make certain that you have a constant audio feed, since it will automatically switch the audio input to the analog jacks if the digital feed is interrupted or not available for a particular channel.

# INSTALLATION AND CONNECTIONS

If your system requires direct connection of a video source to your display, we suggest that you consider programming the **VDI Buttons** **23** so that you may change the input used by your display from the AVR's remote. For information on "learning" remote codes into a button on the AVR remote,

5. Connect the **Video Monitor Output Jacks** **14** on the receiver to the composite or S-video input of your television monitor or video projector.
6. If your DVD player has Y/Pr/Pb analog component video outputs, connect them to the **Component Video 1 Inputs** **22**. Although this set of inputs may be assigned to any of the four video inputs on the AVR, the factory default is for this input to be assigned to the **DVD Audio Inputs** **32**. Remember to make a digital audio connection between the DVD player and the AVR, with the **Coaxial Digital Input 1** **36** being the factory default.
7. If you have other devices with Y/Pr/Pb or RGB component video outputs, connect the source device to the **Component Video 2 Inputs** **23**. The audio connections may be to any of the **Video Audio Inputs** **37** **39** **42** **M** or the **Optical** or **Coaxial Digital Inputs** **33** **36** **K** **L**. When using either of the Component Video Inputs, make certain that the audio and video inputs are properly configured in the **INPUT SETUP** menu.
8. If the component video inputs are used, connect the **Component Video Monitor Outputs** **21** to the component video inputs of your TV, projector or display device.
9. If you have a camcorder, video game or other audio/video device that is connected to the AVR on a temporary rather than permanent basis, connect the audio, video and digital audio outputs of that device to the **Front-Panel Inputs** **K** **L** **M**. A device connected here is selected as the Video 4 input, and the digital inputs must be assigned to the Video 4 input.

## System and Power Connections

The AVR is designed for flexible use with multi-room systems, external control components and power amplifiers.

### Main Room Remote Control Extension

If the receiver is placed behind a solid or smoked glass cabinet door, the obstruction may prevent the

remote sensor from receiving commands. In this event, an optional remote sensor may be used. Connect the output of the remote sensor to the **Remote IR Input Jack** **26**.

If other components are also prevented from receiving remote commands, only one sensor is needed. Simply use this unit's sensor or a remote eye by running a connection from the **Remote IR Output Jack** **27** to the Remote IR Input jack on Harman Kardon or other compatible equipment.

### Multiroom IR Link

The remote room IR receiver should be connected to the AVR via standard coaxial cable. Plug the IR connection cable into the **Multiroom IR Input Jack** **25** on the AVR's rear panel.

If other Harman Kardon-compatible source equipment is part of the main room installation, the **Remote IR Output Jack** **27** on the rear panel should be connected to the **IR IN** jack on source equipment. This will enable the remote room location to control source equipment functions.

When a remote IR sensor is used to control non-Harman Kardon source equipment, we recommend that you make a direct connection or use an optional, external IR "blaster" connected to the **Remote IR Carrier Output Jack** **28**. If you are in doubt as to which IR Output jack to use for the equipment in your system, contact your dealer or installer, or the manufacturer's support site and ask whether the unit to be controlled uses "full carrier" or "stripped" carrier IR commands. When "full carrier commands" are used, make the connection to the **Remote IR Carrier Output Jack** **28**. Otherwise, make the connection to the **Remote IR Output Jack** **27** as noted above.

**NOTE:** All remotely controlled components must be linked together in a "daisy chain." Connect the **IR OUT** jack of one unit to the **IR IN** of the next to establish this chain.

### Multiroom Connections

The AVR is equipped with multizone capabilities that allow it to send a separate audio source to the remote zone from the one selected for use in the main room.

Depending on your system's requirement, three options are available for audio connection:

**Option 1:** Use high-quality, shielded audio interconnect cable from the AVR's location to the remote room. In the remote room, connect the interconnect cable to a stereo power amplifier. The amplifier will be connected to the room's speakers. At the AVR, plug the audio interconnect cables into the **Multiroom Audio Outputs** **29** on the AVR's rear panel.

**Option 2:** Connect the **Multiroom Audio Outputs** **29** on the AVR to the inputs of an optional stereo power amplifier. Run high-quality speaker wire from the amplifier to the speakers in the remote room.

**Option 3:** Taking advantage of the AVR's built-in seven-channel amplifier, it is possible to use two of the amplifier channels to power speakers in the remote room. When using this option, you will not be able to use the full 7.1-channel capabilities of the AVR in the main listening room, but you will be able to add another listening room without external power amplifiers. To use the internal amplifiers to power a remote zone, connect the speakers for the remote room location to the **Surround Back/Multiroom Speaker Outputs** **10**. Before using the remote room, you will need to configure the amplifiers for surround operation by changing a setting in the **MULTIROOM** menu, following the instructions shown on page 41.

**NOTE:** For all options, you may connect an optional IR sensor in the remote room to the AVR via an appropriate cable. Connect the sensor's cable to the **Multiroom IR Input** **25** on the AVR and use the Zone II remote to control the room volume. Alternatively, you may install an optional volume control between the output of the amplifiers and the speakers.

### A-BUS® Installation Connections

The AVR is among the few receivers available that offer built-in A-BUS Ready operation. When used with an optional A-BUS product, you have all the benefits of remote zone operation without the need for an external power amplifier.

To use the AVR with an approved A-BUS product, simply connect it to the AVR using standard Category 5 wiring that is properly rated for the specific in-wall installation. Terminate the wiring at the receiver end to a standard RJ-45 connector in compliance with the instructions furnished with the A-BUS product.

You may connect a single A-BUS module to the AVR with no further equipment needed. If you wish to connect more than one A-BUS module, an optional, external A-BUS hub may be used to provide that capability. Contact your dealer or [www.harmankardon.com](http://www.harmankardon.com) for more information on other A-BUS products available from Harman Kardon.

No further installation or adjustment is needed, as the A-BUS jack on the AVR routes the signals to their proper destination for power, signal source and control. The output fed to the A-BUS jack is determined by the AVR's multiroom system and menus.

### RS-232 Connections

The AVR is equipped with an **RS-232 Serial Connection Port** **24** that may be used for two purposes. When the port is connected to a compatible,

# INSTALLATION AND CONNECTIONS

optional, external computer, keypad or control system, the AVR is capable of bi-directional communications that enable the external system to control the AVR, and for the AVR to report status and handshake data back to the controller. Use of the RS-232 port for this type of control requires specific technical knowledge, and we recommend that any connection and programming for control be made by a trained installer or technician familiar with the equipment being used.

The RS-232 port may also be used as an access point through which the AVR's operating system and surround mode memories may be updated via connection to a compatible computer. At the time that any upgrade is available, instructions for making the connection and installing the upgrade will be available through the Product Support area of the Harman Kardon Web site at [harmankardon.com](http://harmankardon.com).

The physical connection to the AVR's RS-232 port is a standard D-SUB 9 connection, but to ensure compatible and proper operation, specific software commands and pin wiring schemes may be required.

## AC Power Connections

This unit is equipped with two accessory AC outlets. They may be used to power accessory devices, but they should not be used with high-current draw equipment such as power amplifiers. The total power draw to each outlet may not exceed 100 watts.

The **Switched AC Accessory Outlet 1** is powered only when the unit is on. This is recommended for devices that have a mechanical power switch that may be left in the "ON" position.

**NOTE:** Many audio and video products go into a Standby mode when they are used with switched outlets. This type of product may not operate properly when used with the switched outlet.

The **Unswitched AC Accessory Outlet 1** is powered as long as the AVR is plugged into a powered AC outlet.

The AVR features a removable power cord that allows wires to be run in advance to a complex installation so that the unit itself need not be installed until it is ready for connection. When all needed connections have been made, connect the AC Power cord to the **AC Power Cord Jack 13**.

The AVR draws significantly more current than other household devices, such as computers, that use removable power cords. For that reason, it is important that only the cord supplied with the unit (or a direct replacement of identical capacity) be used.

Once the power cord is connected, you are almost ready to enjoy the AVR's incredible power and fidelity!

# OPERATION

## Basic Operation

Once you have completed the initial setup and configuration of the AVR, it is simple to operate and enjoy. The following instructions will help you maximize the enjoyment of your new receiver:

### Turning the AVR On or Off

- When using the AVR for the first time, you must press the **Main Power Switch A** to turn the unit on. This places the unit in a Standby mode, as indicated by the amber illumination surrounding the **Standby/On Switch 1**. Once the unit is in Standby, you may begin a listening session by pressing the **Standby/On Switch 1** on the front panel, or the **Power On Button 2** or **AVR Selector 5 B** on the remote. This will turn the unit on and return the AVR to the input source that was last used. The unit may also be turned on from Standby by pressing any of the **Input Selector Buttons 4 34 44 C D** on the remote or the **Input Source Selector Button 7** on the front panel.

Whenever the AVR is turned on, you will see all of the front-panel indicators light up for a few seconds. This is normal, and it is part of the unit's power-on self test procedure.

**NOTE:** After pressing one of the **Input Selector Buttons 4 34 44 C D** to turn the unit on, press the **AVR Selector 5 B** to set the remote control to the AVR functions.

To turn the unit off at the end of a listening session, simply press the **Standby/On Switch 1** on the front panel or the **Power Off Button 1 A** on the remote. Power will be shut off to any equipment plugged into the rear-panel **Switched AC Accessory Outlet 11** and the illumination around the **Standby/On Switch 1** will turn amber.

When the remote is used to turn the unit "off," it is actually placing the system in a Standby mode, as indicated by the amber lighting around the **Standby/On Switch 1**.

- To program the AVR for automatic turn-off, press the **Sleep Button 29** on the remote. Each press of the button will decrease the time before shut-down in the following sequence:

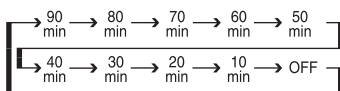

Once you have set the desired Sleep Time, the front panel display will automatically dim to half brightness and return. To check on the time remaining until the unit shuts off, press the **Sleep Button 29** once.

To cancel the Sleep function, press and hold the **Sleep Button 29** until the information display returns to normal brightness; and the words **SLEEP OFF** will appear in the **Lower Display Line 14**.

When you will be away from home for an extended period of time, it is always a good idea to completely turn the unit off with the front-panel **Main Power Switch A**.

**NOTE:** All preset memories are lost if the unit is left turned off by using the **Main Power Switch A** for more than four weeks.

## Source Selection

- To select a source, press any of the **Input Selector Buttons 4 34 44 C D** on the remote.
- The input source may also be changed by pressing the front-panel **Input Source Selector Button 7**. Each press of the button will move the input selection through the list of available inputs.
- When a new input is selected, the AVR will automatically switch to the digital input (if selected), surround mode, component video input, AV Sync Delay and Night Mode configurations that were in effect the last time that input was used. If the **LEVEL TRIM** line on the **CHANNEL ADJUST** menu (Fig. 20) was set to **INDEPENDENT**, the settings for channel output levels will also change to the preset values.
- The front-panel **Video 4 Inputs M**, **Optical Digital 3 Input K** or the **Coaxial Digital 3 Input L** may be used to connect a device such as a video game or camcorder to your home entertainment system on a temporary basis.
- As the input source is changed, the new input name will appear momentarily as an on-screen display in the lower third of the video display. The input name will also appear in the **Upper Display Line 13** and in the front-panel **Input Indicators 11**.
- When an audio only source is selected, the last video input used remains routed to the **Video 1/Video 2 Video Outputs 17 19** and **Video Monitor Outputs 14**. This permits simultaneous viewing and listening to different sources.
- When a composite or S-video source is selected, the video signal for that input will be routed to the **Video Monitor Output 14** and will be viewable on a TV monitor connected to the AVR.

## 6-Channel/8-Channel Direct Input

There are two input choices available for use with sources such as a DVD-Audio or SACD player that are connected to the **8-Channel Direct Inputs 40**. Select the appropriate input according to the way your system and source equipment is configured:

- The **6 CH DIRECT** input should be used when the SBR and SBL inputs are NOT in use and the input source device has its own internal bass management system. This input passes the input from the source directly through to the volume control without any analog to digital conversion and it mutes the unused input jacks to prevent unwanted noise from interfering with system performance.
- The **8 CH DIRECT** input should be used when an input is connected to all eight **8-Channel Direct Inputs 40** and when the input source device has its own internal bass management system. This input passes the input from the source directly through to the volume control without any analog to digital conversion and it mutes the unused input jacks to prevent unwanted noise from interfering with system performance.

## Volume and Tone Control

- Adjust the volume to a comfortable level using the front-panel **Volume Control 10** or remote **Volume Up/Down Buttons 18 19**.
- To temporarily silence all speaker outputs, press the **Mute Button 33 K**. This will interrupt the output to all speakers and the headphone jack, but it will not affect any recording or dubbing that may be in progress. When the system is muted, the word **MUTE** will flash in the on-screen display and **Upper Display Line 13**, press the **Mute Buttons 33 K** again to return to normal operation.
- The unit's tone controls may be taken out of the signal path by pressing the **Tone Mode Button** on the front panel **C** or the remote **32**. The first press of either button will show a message in the on-screen display and **Lower Display Line 14** with the current status of the tone controls. The system default is **TONE IN**, which indicates that the bass and treble controls are active. Press the **▲/▼ Navigation Button 15** on the remote or the **◀▶ Button H** on the front panel to change the setting to **TONE OUT**, which is "flat" response without the tone controls being active.
- When the tone controls are active, the amount of bass and treble boost/cut may be adjusted by first pressing the **Tone Mode Button** on the front panel **C** or the remote **32** two or three times until the desired setting (**BASS MODE** or **TREBLE MODE**) appears in the on-screen display and the **Lower Display Line 14**. Next, use the **▲/▼ Navigation Button 15** on the remote or the **◀▶ Button** on the front panel **H** to change the setting as desired. The unit will return to normal operation within 5 seconds after the setting is changed.

- For private listening, simply place a standard 1/4" stereo headphone plug or adaptor into the **Headphone Jack B** behind the door **9** on the front panel. The speakers will automatically mute and a two-channel stereo signal will be sent to the headphones. The **Lower Display Line 14** will read **DOLBY H: BP**, indicating that the headphone output is in the Bypass mode, and to confirm that no processing is being used.
- When the headphones are in use, you may take advantage of the Dolby Headphone modes to bring added spaciousness to headphone listening. Press the **Dolby Mode Select Button 43** or the **Surround Mode Selector 3** to cycle through the three Dolby Headphone modes to select the one that you prefer.

## Surround Mode Selection

One of the most important features of the AVR is its ability to reproduce a full multichannel surround sound field from digital sources, analog matrix surround-encoded programs and standard stereo programs.

Selection of a surround mode is based on personal taste, as well as the type of program source material being used. For example, motion pictures or TV programs bearing the logo of one of the major surround-encoding processes, such as Dolby Surround or DTS Stereo may be played in either the Dolby Digital, Dolby Pro Logic II Cinema, DTS Neo:6 Cinema, or Logic 7 Cinema surround modes, depending on the source material.

**NOTE:** Once a program has been encoded with matrix surround information, it retains the surround information as long as the program is broadcast in stereo. Thus, movies with surround sound may be decoded via any of the analog surround modes such as Pro Logic II Cinema, Logic 7 Cinema or DTS Neo:6 Cinema, when they are broadcast via conventional TV stations, cable, pay-TV and satellite transmission. In addition, a growing number of made-for-television programs, sports broadcasts, radio dramas and music CDs are also produced in surround sound. You may view a list of these programs at the Dolby Laboratories Web site at [www.dolby.com](http://www.dolby.com).

Even when a program is not listed as carrying intentional surround information, you may find that the Pro Logic II, Pro Logic Ix, Logic 7 or DTS Neo:6, and the Hall or Theater modes often deliver enveloping surround presentations through the use of the natural information present in all stereo recordings.

Surround modes may be changed at any time by using either the front panel or remote control. To

select a new surround mode from the front panel, first press the **Surround Mode Group Selector Button 2** until the desired major surround mode group such as Dolby, DTS or Logic 7 is selected. Next, press the **Surround Mode Selector Button 3** to choose the specific individual surround mode.

To select a surround mode using the remote, press the button for the major surround mode group that includes the mode you wish to choose from: **Dolby 43**, **DTS Digital 42**, **DTS Neo:6 41**, **Logic 7 8**, **Stereo 40** or **DSP Surround 7**. The first press of the button will show the current mode from that group if it is already in use, or the first available mode if you are currently using another mode. To cycle through the available modes in that group, press the button again until the desired mode appears in the **Lower Display Line 14** and the on-screen display and in the front-panel **Surround Mode Indicators 15**.

The Dolby Digital, Dolby Digital EX, DTS 5.1, DTS-ES Matrix and DTS-ES Discrete modes may only be selected when a digital input is in use. In addition, when a digital source is present, the AVR 435 will automatically select and switch to the correct mode, regardless of the mode that has been previously selected. For more information on selecting digital sources, see the Digital Audio Playback section below.

When the 6-Channel/8-Channel direct inputs are in use, there is no surround processing, as these inputs take the analog output signals from an optional, external DVD-Audio or SACD player, or another source device and carry them straight through to the volume control without any further digital processing.

To listen to a program in traditional two-channel stereo, using the front left and front right speakers only (plus the subwoofer, if installed and configured), press the **Stereo Mode Select Button 40** until **SURROUND OFF** appears in the **Lower Display Line 14**. From the front panel, press the **Surround Mode Group Selector 2** until the Stereo modes appear in the on-screen display and **Lower Display Line 14**. Next, press the **Surround Mode Selector Button 3** until **SURROUND OFF** appears in the on-screen display and **Lower Display Line 14**.

## Digital Audio Playback

Digital audio is a major advancement over older analog surround processing systems. It delivers up to six discrete channels, and each channel reproduces full frequency range (20Hz to 20kHz) and offers dramatically improved dynamic range and significant improvements to signal-to-noise ratios. In addition, digital systems have the capability to deliver an additional channel that is specifically devoted to low-frequency information. This is the

“.1” channel referred to when you see these systems described as “5.1,” “6.1” or “7.1.” The bass channel is separate from the other channels, but since it is intentionally bandwidth-limited, sound designers have given it that unique designation. When a Digital soundtrack is playing, the number of channels available will vary according to the way in which the program was recorded. Although most movies recorded with digital sound have 5.1 soundtracks, some have 6.1 or 7.1 sound, while others retain the original 2.0 or even monaural sound. When the program source is a broadcast, cable or satellite delivered digital program, only one type of soundtrack may be delivered at a time, while optical sources such as DVD may provide more than one audio option. In either case, the decision of what type of sound track and how many channels to offer is up to the program’s producer. With the AVR you are able to not only play back the original compatible digital format, but using the processing power of the Texas Instruments DSP processor it is possible to decode the basic digital track for 2.0 or 5.1 sound and then select an additional “post-processing” mode to deliver additional channels.

### Dolby Digital

Dolby Digital is a standard part of DVD, and is available on specially encoded LD discs and satellite broadcasts and it is a part of the high-definition television (HDTV) system.

An optional, external RF demodulator is required to use the AVR to listen to the Dolby Digital soundtracks available on laser discs. Connect the RF output of the LD player to the demodulator and then connect the digital output of the demodulator to the **Optical or Coaxial Inputs K M 39 36** of the AVR. No demodulator is required for use with DVD players or DTS-encoded laser discs.

In order to provide maximum playback compatibility with DVDs, the AVR receiver will always default first to the playback mode embedded in a disc’s digital “flag” information. For Dolby Digital discs, the following playback modes are initially selected after the AVR locks to the incoming digital audio data stream to identify the selected:

- When a 5.1 audio stream is detected, the Dolby Digital 5.1 format will be selected, regardless of the number of speakers in your system, in compliance with Dolby Laboratories licensing requirements.
- When a disc with the Dolby Digital EX format flag is played, your system will automatically switch to the EX mode when seven main channel speakers are available.

## OPERATION

- When a disc with Dolby Digital data, but only 2.0 audio is detected, the default mode is Dolby Digital with Pro Logic II post-processing when you have a 5.1 speaker system, or Dolby Digital with Pro Logic IIx post-processing when you have a 7.1 speaker system.
- Depending on the number of speaker channels available in your system, once the AVR locks to the digital signal, you may select any surround mode or post-processing option that is available, based on the incoming data stream's possible restrictions and the number of speakers in your system. For example, when a 5.1 or 2.0 audio stream is in use, you may select alternate post-processing such as Logic 7/7-Channel Movie Mode post-processing to create the rear surrounds in 7.1 speaker systems.

### DTS

DTS is another digital audio system that is capable of delivering 5.1 or 6.1 discrete or matrix sound field reproduction. Although both DTS and Dolby Digital are digital, they use different methods of encoding the signals, and thus they require different decoding circuits to convert the digital signals back to analog.

DTS-encoded soundtracks are available on select DVD and LD discs, as well as on special audio-only DTS discs. You may use any LD or CD player equipped with a digital output to play DTS-encoded discs with the AVR. All that is required is to connect the player's output to either an **Optical** or **Coaxial Input** on the rear panel **33 36** or front panel **K M**.

In order to listen to DVDs encoded with DTS soundtracks, the DVD player must be compatible with the DTS signal, which is indicated by a DTS logo on the player's front panel. Early DVD players may not be able to play DTS-encoded DVDs. This does not indicate a problem with the AVR, as some players cannot pass the DTS signal through to the digital outputs. If you are in doubt as to the capability of your DVD player to handle DTS discs, consult the player's owner's manual.

**NOTE:** Some DVD players have a default setting that does not pass through the DTS signal. Before playing DVDs with a DTS soundtrack, make certain that the settings in your DVD player have been properly adjusted so that DTS audio is passed through. Consult the owner's manual for your DVD player for more information on making these settings.

### Selecting a Digital Source

To utilize either digital mode, you must have properly connected a digital source to the AVR. Connect the digital outputs from DVD players, HDTV receivers, satellite systems or CD players to the **Optical** or

**Coaxial Inputs** **K M 33 36**. In order to provide a backup signal and a source for analog stereo recording, the analog outputs provided on digital source equipment should also be connected to their appropriate inputs on the AVR rear panel (e.g., connect the analog stereo audio output from a DVD to the **DVD Audio Inputs 32** on the rear panel when you connect the source's digital outputs).

If you have not already configured an input for a digital source using the on-screen menus

first select the input using the remote or front panel controls, as outlined in this manual. Next, select the digital source by pressing the **Digital Select Button 16 F** and then using the **▲/▼ Navigation Button 15** on the remote or the **◀▶ Button H** on the front panel to choose any of the **OPTICAL** or **COAXIAL** inputs, as they appear in the **Upper Display Line 13** or on-screen display. When the digital source is playing, the AVR will automatically detect which type of digital data stream is being decoded and display that information in the **Upper Display Line 13**.

When both a digital and an analog connection are made between a source device and the AVR, the digital input is the default. If the digital stream is not present or is interrupted, the unit will automatically switch over to the analog inputs for the selected source.

If you wish to disable the auto-polling feature, you may do so by following the instructions shown in the Advanced Features section

### Digital Bitstream and Surround Mode Indications

When a digital source is playing, the AVR senses the type of bitstream data that is present. Using this information, the correct surround mode will automatically be selected. For example, DTS bitstreams will cause the unit to switch to DTS decoding, and Dolby Digital bitstreams will enable Dolby Digital decoding. When the unit senses PCM data from CDs or LDs, you may select any of the standard Dolby or DTS surround modes or Logic 7. Since the range of available surround modes is dependent on the type of digital data that is present, the AVR shows you what type of signal is present to help you understand the choice of modes.

When a digital source is first detected, the AVR will display a message to indicate the type of bitstream being received. This message will appear shortly after an input or surround mode is changed, and will remain in the **Lower Display Line 14** for about five seconds before that portion of the display returns to the normal surround mode indication.

For Dolby Digital and DTS sources, a numerical indication (such as 3/2/2.1) will appear, showing the number of channels present in the data.

The first number in the display message indicates how many discrete front-channel signals are present.

- A "3" tells you that separate front left, center and front right signals are available. This will be displayed for Dolby Digital 5.1 and DTS 5.1 programs.
- A "2" tells you that separate front left and right signals are available, but there is no discrete center channel signal. This will be displayed for Dolby Digital bitstreams that have stereo program material.
- A "1" tells you that there is only a mono channel available in the Dolby Digital bitstream.

The middle number in the display message indicates how many discrete surround channel signals are present.

- A "3" tells you that separate, discrete left surround, center surround and right surround signals are present. This is available only on discs with DTS-ES digital audio.
- A "2" tells you that separate surround left and right signals are available. This will be displayed for Dolby Digital 5.1 and DTS 5.1 programs.
- A "1" tells you that there is only a single, surround-encoded surround channel. This will appear for Dolby Digital bitstreams that have matrix encoding.
- A "0" indicates that there is no surround channel information. This will be displayed for two-channel stereo programs.

The last number indicates whether there is a discrete low-frequency effects (LFE) channel. This is the ".1" in the common abbreviation of "5.1" sound and it is a special channel that contains only bass frequencies.

- A ".1" tells you that an LFE channel is present. This will be displayed for Dolby Digital 5.1 and DTS 5.1 programs, as available.
- A "0" indicates that there is no LFE channel information available. However, even when there is no dedicated LFE channel, low-frequency sound will be present at the subwoofer output when the speaker configuration is set to show the presence of a subwoofer.
- The information in the right side of the display will tell you if the digital audio data contains a special flag signal that will automatically activate the appropriate 6.1 or 7.1 mode. This will be shown as EX-ON or EX-OFF for Dolby Digital bitstreams and ES-ON or ES-OFF for DTS bitstreams.

When a 2.0 or 5.1 digital source is playing on a system configured for 5.1 operation, you may use Dolby Digital EX, DTS-ES, Logic 7/7 or Dolby Pro Logic IIx to add rear channels for full 7.1 sound fields. Note, however, that the availability of specific modes for post-processing is dependant on the format of the incoming source material. While some combinations

# OPERATION

(e.g., a Dolby Digital or DTS 5.1 source with Logic 7/7 or Dolby Pro Logic IIx post-processing) are allowable, others (e.g. A Dolby Digital 5.1 source with DTS Neo:6) are not. If you wish to add surround back channels to a 2.0 or 5.1 source we recommend that you experiment with the various options to see which may be available and which are best suited to your taste and listening environment.

It is always a good idea to check the readout for the channel data to make certain that it matches the audio logo information shown on the back of a DVD package. In some cases, you will see an indication for "2/0/0" even when the disc contains a full 5.1, or 3/2/.1, signal. When this happens, check the audio output settings for your DVD player or the audio menu selections for the specific disc being played to make certain that the player is sending the correct signal to the AVR.

## PCM Playback

PCM is the abbreviation for Pulse Code Modulation, the digital signal format used for standard CD playback, and other non-Dolby Digital and non-DTS digital sources such as Mini-Disc. When a PCM signal is detected, the **Lower Display Line 14** will briefly show a message with the letters PCM, in addition to a readout of the sampling frequency of the digital signal.

In most cases, this will be **PCM 44.1kHz** or **PCM 48kHz**, though in the case of specially mastered, high-resolution audio discs, you will see a **PCM 96kHz** indication. Note that the sampling rate displayed is that of the incoming digital signal, and not the upsampled rate that may be applied to PCM sources when Dolby Pro Logic or Pro Logic II processing is applied,

During PCM playback, you may select any surround mode except one of the Dolby Digital or DTS/DTS-ES modes.

## Speaker/Channel Indicators

In addition to the bitstream indicators, the AVR features a set of unique channel-input indicators that tell you how many channels of digital information are being received and/or whether the digital signal is interrupted (Figure 21).

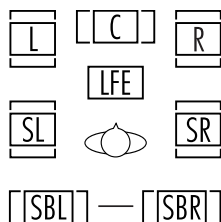

Figure 21

The letters inside the boxes tell you which channels are receiving an input signal. Since conventional analog audio is only two channels, the "L" and "R" letters will light with any analog source. When a digital source is in use you will see letters displayed that correspond to the number of channels in the incoming data stream, which may be just the L and R for two channel PCM or 2.0 Dolby Digital material. When a 5.1 signal is being received the L/C/R/SL/SR indicators will light, with the LFE indication also being shown when an LFE signal is present. All seven indicators, including the SBL/SBR letters will light for a 7.1 signal, and a horizontal line is shown to connect the SBL/SBR indicators when a 6.1 source is in use.

It is important to note that although Dolby Digital, for example, is referred to as a "5.1" system, not all Dolby Digital DVDs or programs are encoded for 5.1. Thus, it is sometimes normal for a DVD with a Dolby Digital soundtrack to trigger only the "L" and "R" indicators.

**NOTE:** Many DVD discs are recorded with both "5.1" and "2.0" versions of the same soundtrack. When playing a DVD, always be certain to check the type of material on the disc. Most discs show this information in the form of a listing or icon on the back of the disc jacket. When a disc does offer multiple soundtrack choices, you may have to make some adjustments to your DVD player (usually with the "Audio Select" button or in a menu screen on the disc) to send a full 5.1 feed to the AVR. It is also possible for the type of signal feed to change during the course of a DVD's playback. In some cases, the previews of special material will only be recorded in 2.0 audio, while the main feature is available in 5.1 audio. The AVR will automatically sense changes to the bitstream and channel count and reflect them in these indicators.

The letters used by the **Speaker/Channel Input Indicators 12** will flash to indicate when a bitstream has been interrupted. This will happen when a digital input source is selected before the playback starts, or when a digital source such as a DVD is paused. The flashing indicators remind you that the playback has stopped due to the absence of a digital signal and not through any fault of the AVR. This is normal, and the digital playback will resume once the playback is started again.

The boxes around the channel indication letters are used to show which speakers are configured in your system. A small box around the letter indicates that a "Small" speaker has been assigned to that position, while a larger, double box indicates a "Large" speaker assignment.

Note that in some cases, such as an analog stereo or 2.0 digital source you will see empty speaker position boxes, which indicates that the speaker is active and will receive sound, but that there is no discrete signal

for that channel. In other cases you may see letters with no speaker boxes. This indicates that there is a discrete signal for that channel, but due to the mode in use (e.g. Dolby VS with a 5.1 source) there is no signal being sent to the channel.

## Night Mode

A special feature of Dolby Digital is the Night mode, which enables specially encoded Dolby Digital input sources to be played back with full digital intelligibility while reducing the minimum peak level by 1/4 to 1/3. This prevents abruptly loud transitions from disturbing others, without reducing the impact of the digital source. The Night mode is available only when Dolby Digital signals with special data are being played.

The Night mode may be engaged when a Dolby Digital DVD is playing by pressing the **Night Mode Button 30** on the remote. Next, press the **▲/▼ Navigation Button 15** to select either the middle range or full compression versions of the Night mode. To turn the Night mode off, press the **▲/▼ Navigation Button 15** until the message in the lower third of the video display and in the **Lower Display Line 14** reads **D - RANGE OFF**.

The Night mode may also be selected to always be on at either level of compression using the options in the **DOLBY SURROUND** menu.

## MP3 Audio Playback

The AVR is one of the few receivers equipped for onboard decoding for the MP3 audio format used by computers and portable audio devices. By offering MP3 decoding, the AVR is able to deliver precise conversion of the digital signals to an analog output, along with the benefits of listening to the MP3 audio through the AVR's high-current amplifier and the speakers from your surround system, rather than the smaller speakers and low-powered amplifiers typically used with computers.

To take advantage of the AVR's MP3 capabilities, simply connect the S/P-DIF output of a computer's sound card or the S/P-DIF output of a portable digital audio device to either the rear panel **Digital Inputs 33 36** or the front-panel **Digital Inputs K/M**.

When the digital signal is available, the **Lower Display Line 14** will indicate that an MP3 bitstream is present, and the audio will begin playing.

## NOTES:

- The AVR is only capable of playing signals in the MP3 (MPEG 1/Layer 3) format. It is not compatible with other computer audio codecs.
- The digital audio input signal may be either optical or coaxial, but the signal must be in the S/P-DIF

format. Direct connection of USB or serial data outputs is not possible, even though the signals are in the MP3 format. If you have any questions about the data output format from your computer or a sound card, check with the device's owner's manual or contact the manufacturer's technical support area.

- If your computer or sound card's digital output is not capable of direct connection to the AVR, you may use an optional, external transcoder to convert the USB output of a computer to a format compatible with the AVR.
- Due to the wide variation in MP3 formats and encoding speeds, it is possible that the AVR may not be compatible with all MP3 input signals. Some may produce unacceptable results and some may not be decoded. This is not a fault of either the computer or the AVR, but rather a by-product of the unpredictable nature of MP3 playback.

#### IMPORTANT NOTES ON DIGITAL PLAYBACK:

- When playing DVDs, please note that even when you have selected a specific digital audio format for playback, an individual disc may change formats or the number of available channels during playback. For example, even if you select a DTS mode for the movie, you may see Dolby Digital in use when the trailers, menus or copyright warnings are playing. This is not a fault with either the AVR or your DVD player, as both are responding to the way the disc was created.
- When viewing digital television signals, note that the number of audio channels available may vary during the course of a program, depending on the content. For example, while a sports even may have 5.1 sound, the commercials or local station content may be in 2.0. In addition, not all local stations are currently equipped for carrying the 5.1 digital audio signals. This may mean that even though the actual program is produced with 5.1, it may be transmitted in a 2.0 configuration in some areas. Your AVR will automatically change to react to the proper type of audio stream if it is changed by the broadcast station.
- Although the AVR will decode virtually all current DVD movies, CDs and HDTV sources, it is possible that some future digital sources may not be compatible with the AVR.
- Not all digitally encoded programs contain full 5.1- or 6.1-channel audio. Consult the program guide that accompanies the DVD or laser disc to determine which type of audio has been recorded on the disc. The AVR will automatically sense the type of digital surround encoding used and adjust to accommodate it.

- When a digital source is playing, you may not be able to select some of the analog surround modes such as Dolby Pro Logic II, Dolby Pro Logic IIx, Stereo, Hall, Theater or Logic 7.
- When a Dolby Digital or DTS source is playing, it is not possible to make an analog recording using the **Tape Outputs** **35** and **Video 1** or **Video 2 Audio Outputs** **38** **41**. However, the digital signals will be passed through to the **Digital Audio Outputs** **23****30****M**.

#### Tuner Operation

The AVR's tuner is capable of tuning AM, FM and FM Stereo broadcast stations. Stations may be tuned manually, or they may be stored as favorite station presets and recalled from a 30-position memory.

#### Station Selection

1. Press the **AM/FM Tuner Selector Button** **34** on the remote to select the tuner as an input. The tuner may be selected from the front panel by either pressing the **Input Source Selector** **7** until the tuner is active or by pressing the **Tuner Band Selector** **5**.
2. Press the **AM/FM Tuner Select Button** **34** or **Tuner Band Selector** **5** again to switch between AM and FM so that the desired frequency band is selected.
3. Press the **Tuning Mode Selector** **8** **12** to select manual or automatic tuning.

When the button is pressed so that **AUTO / STEREO** appears in the **Upper Display Line** **13**, each press of the **Tuning Selectors** **4** **23** will put the tuner in a scan mode that seeks the next higher or lower frequency station with acceptable signal strength. An **AUTO ST TUNED** indication will momentarily appear when the station stops at a stereo FM station, and an **AUTO TUNED** indication will momentarily appear when an AM or monaural FM station is tuned. Press the Tuning buttons again to scan to the next receivable station.

When the button is pressed so that **MANUAL / MONO** appears in the **Upper Display Line** **13**, each tap of the Selector will increase or decrease the frequency by one increment. When the tuner receives a strong enough signal for adequate reception, **MANUAL TUNED** will appear in the **Lower Display Line** **14**.

4. Stations may also be tuned directly in either the automatic or manual mode. To enter a station's frequency directly, first select the AM or FM band as desired by pressing the **AM/FM Tuner Select**

**Button** **5** **34**. Next, press the **Direct Button** **9**. Within 5 seconds of when **DIRECT IN** scrolls in the **Upper Display Line** **13**, enter the station frequency by pressing the **Numeric Keys** **11**. If you press an incorrect button while entering a direct frequency, press the **Clear Button** **10** to start over.

**NOTE:** When the FM reception of a station is weak, audio quality will be increased by switching to Mono mode by pressing the **Tuning Mode Button** **8** **12** so that **MANUAL / MONO** appears momentarily in the **Upper Display Line** **13** and then goes out. This will also activate manual tuning mode.

#### Preset Tuning

Using the remote, up to 30 stations may be stored in the AVR's memory for easy recall using the front-panel controls or the remote.

To enter a station into the memory, first tune the station using the steps outlined above. Then:

1. Press the **Memory Button** **39** on the remote; the station's frequency will flash.
2. Within five seconds, press the **Numeric Keys** **11** corresponding to the location where you wish to store this station's frequency. Once entered, the preset number will appear in the **Upper Display Line** **13**.
3. Repeat the process after tuning any additional stations to be preset.

#### Recalling Preset Stations

- To manually select a station previously entered in the preset memory, press the **Numeric Keys** **11** that correspond to the desired station's memory location.
- To manually tune through the list of stored preset stations one by one, press the **Preset Stations Selector Buttons** **6** **22** on the front panel or remote.

#### Recording

In normal operation, the audio or video source selected for listening through the AVR is sent to the record outputs. This means that any program you are watching or listening to may be recorded simply by placing machines connected to the outputs for **Tape Outputs** **35** or **Video 1/Video 2 Audio and Video Outputs** **17** **19** **38** **41** in the record mode.

When a digital audio recorder is connected to the **Digital Audio Outputs** **23****30**, you are able to record the digital signal using a CD-R, MiniDisc or other digital recording system.



# OPERATION

## NOTES:

- The digital outputs are active only when a digital signal is present, and they do not convert an analog input to a digital signal, or change the format of the digital signal. In addition, the digital recorder must be compatible with the output signal. For example, the PCM digital input from a CD player may be recorded on a CD-R or MiniDisc, but Dolby Digital or DTS signals may not.
- Please make certain that you are aware of any copyright restrictions on any material you copy. Unauthorized duplication of copyrighted materials is prohibited by federal law.

## Output Level Trim Adjustment

Normal output level adjustment for the AVR is established using EzSet/EQ,

In some cases, however, it may be desirable to adjust the output levels using program material such as a test disc, or a selection you are familiar with. Additionally, the output level for the subwoofer can only be adjusted using this procedure.

To adjust the output levels using program material, first set the reference volume for the front left and front right channels using the **Volume Control** **10** **13** **1**.

Once the reference level has been set, press the **Channel Select Button** **14** and **FRONT LEVEL** will appear in the **Lower Display Line** **14**. To change the level, first press the **Set Button** **17**, and then use the **▲/▼ Navigation Button** **15** to raise or lower the level. DO NOT use the volume control, as this will alter the reference setting.

Once the change has been made, press the **Set Button** **17** and then press the **▲/▼ Navigation Button** **15** to select the next output-channel location that you wish to adjust. To adjust the subwoofer level, press the **▲/▼ Navigation Button** **15** until **SUBWOOFER LEVEL** appears in the **Lower Display Line** **14** or on-screen display.

Repeat the procedure as needed until all channels requiring adjustment have been set. When all adjustments have been made and no further adjustments are made for 5 seconds, the AVR will return to normal operation.

The output levels may also be adjusted using the on-screen menu system to either the internal test tone or an external test disc

## Dim Function

Since the AVR will often be used when movies or other video programming is viewed under low-light conditions, you may wish to lower the brightness of the front-panel displays and indicators so that they do not distract from the video presentation. You may dim the displays using the menu system, or you may control the brightness directly from the remote.

Simply press the **Dim Button** **13** once to dim the front panel to half the normal brightness level; press it again to turn the displays off. Note that when the displays are dimmed or turned off, the blue lighting around the **Standby/On Switch** **1** will continue to stay lit as a reminder that the AVR is still turned on. The accent lighting for the **Volume Control** **10** will remain at its normal level, rather than dim when the panel displays are at half brightness.

Note that all changes to the front-panel brightness level are temporary; the displays will return to full brightness after the AVR is turned off and then on again. To return the displays to full brightness without turning the unit off, press the **Dim Button** **13** as needed until the displays are on.

In addition to lowering the brightness of the displays or turning them off completely, you may wish to have them appear whenever a button on the remote or front panel is pushed, and then gradually fade out after a set time period. You may do this by making the appropriate settings in the **VFD FADE TIME OUT** line of the **ADVANCED SELECT** Menu,

## Memory Backup

This product is equipped with a memory backup system that preserves the system configuration information and tuner presets if the unit is accidentally unplugged or subjected to a power outage. This memory will last for at least four weeks, after which time all information must be reentered.

# TROUBLESHOOTING GUIDE

SYMPTOM	CAUSE	SOLUTION
Unit does not function when Main Power Switch is pushed	<ul style="list-style-type: none"> <li>No AC Power</li> </ul>	<ul style="list-style-type: none"> <li>Make certain AC power cord is plugged into a live outlet</li> <li>Check to see whether outlet is switch-controlled</li> </ul>
Display lights, but no sound or picture	<ul style="list-style-type: none"> <li>Intermittent input connections</li> <li><b>Mute</b> is on</li> <li>Volume control is down</li> </ul>	<ul style="list-style-type: none"> <li>Make certain that all input and speaker connections are secure</li> <li>Press <b>Mute Button</b> <b>33</b></li> <li>Turn up volume control</li> </ul>
Unit turns on, but front-panel display does not light up	<ul style="list-style-type: none"> <li>Display brightness is turned off</li> </ul>	<ul style="list-style-type: none"> <li>Follow the instructions in the Display Brightness section so that the display is set to <b>VFD FULL</b></li> </ul>
No sound from any speaker; light around power switch is red	<ul style="list-style-type: none"> <li>Amplifier is in protection mode due to possible short</li> <li>Amplifier is in protection mode due to internal problems</li> </ul>	<ul style="list-style-type: none"> <li>Check speaker wire connections for shorts at receiver and speaker ends</li> <li>Contact your local Harman Kardon service center</li> </ul>
No sound from surround or center speakers	<ul style="list-style-type: none"> <li>Incorrect surround mode</li> <li>Input is monaural</li> <li>Incorrect configuration</li> <li>Stereo or Mono program material</li> </ul>	<ul style="list-style-type: none"> <li>Select a mode other than Stereo</li> <li>There is no surround information from mono sources</li> <li>Check speaker mode configuration</li> <li>The surround decoder may not create center- or rear-channel information from non-encoded programs</li> </ul>
Unit does not respond to remote commands	<ul style="list-style-type: none"> <li>Weak batteries in remote</li> <li>Wrong device selected</li> <li>Remote sensor is obscured</li> </ul>	<ul style="list-style-type: none"> <li>Change remote batteries</li> <li>Press the AVR selector</li> <li>Make certain front-panel sensor is visible to remote or connect remote sensor</li> </ul>
Intermittent buzzing in tuner	<ul style="list-style-type: none"> <li>Local interference</li> </ul>	<ul style="list-style-type: none"> <li>Move unit or antenna away from computers, fluorescent lights, motors or other electrical appliances</li> </ul>
Letters flash in the channel indicator display and digital audio stops	<ul style="list-style-type: none"> <li>Digital audio feed paused</li> </ul>	<ul style="list-style-type: none"> <li>Resume play for DVD</li> <li>Check that Digital Input is selected</li> </ul>
Fan does not appear to operate	<ul style="list-style-type: none"> <li>Additional cooling may not be required</li> </ul>	<ul style="list-style-type: none"> <li>The fan is activated only when additional cooling is required due to high internal temperature. It is normal for the fan to be inactive at normal volume levels.</li> </ul>

In addition to the items shown above, additional information on troubleshooting possible problems with your AVR , or installation-related issues, may be found in the list of "Frequently Asked Questions" which is located in the Product Support section of our Web site at [www.harmankardon.com](http://www.harmankardon.com).

## Processor Reset

In the rare case where the unit's operation or the displays seem abnormal, the cause may involve the erratic operation of the system's memory or microprocessor.

To correct this problem, first unplug the unit from the AC wall outlet and wait at least 3 minutes. After the pause, reconnect the AC power cord and check the unit's operation. If the system still malfunctions, a system reset may clear the problem.

To clear the AVR 's entire system memory including tuner presets, output level settings, delay times and

speaker configuration data, first put the unit in Standby by pressing the **Standby/On Switch** **1**. Next, press and hold the **Surround Mode Group Selector** **2** and the **Tuning Mode Selector** **8** buttons for three seconds.

The unit will turn on automatically and display the **RESET** message in the **Upper Display Line** **13**.

**NOTE:** Resetting the processor will erase any configuration settings you have made for speakers, output levels, surround modes, digital input assignments as well as the tuner presets. After a reset the unit will be

returned to the factory presets, and all settings for these items must be reentered.

If the system is still operating incorrectly, there may have been an electronic discharge or severe AC line interference that has corrupted the memory or microprocessor.

If these steps do not solve the problem, consult an authorized Harman Kardon service center.

MRK	DATE	PNO	REVISION RECORD	DR.	DATE	PNO	REVISION RECORD	DR.
▲				▲				
▲				▲				
▲				▲				

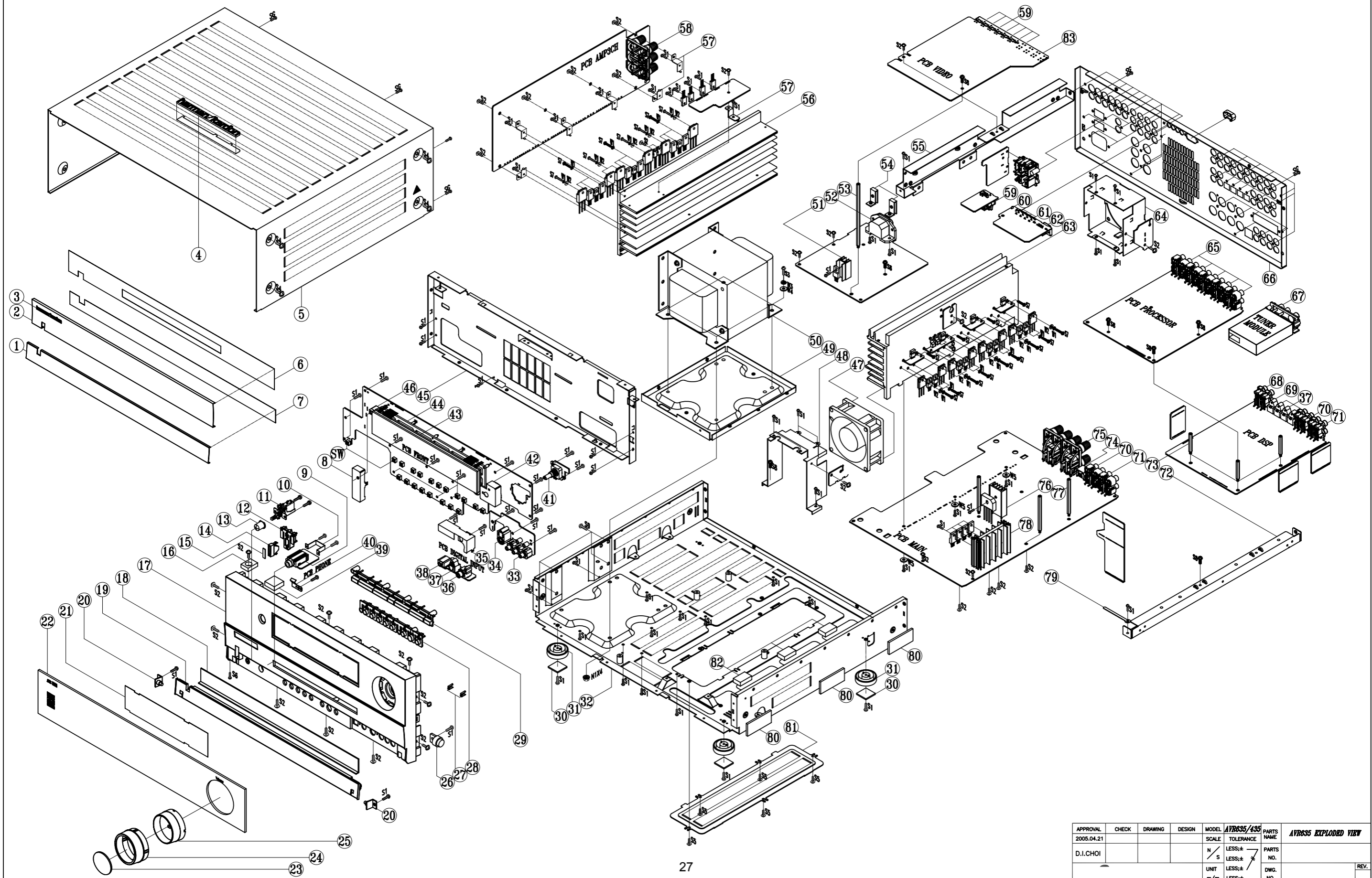

APPROVAL	CHECK	DRAWING	DESIGN	MODEL	SCALE	TOLERANCE	PARTS NAME	AVR435 EXPLODED VIEW
				AVR435/635				
					N/S	LESS:±	PARTS NO.	
						LESS:±	DWG. NO.	
					UNIT	LESS:±		
					m/m	LESS:±		

AVR 435/635 EXPLODED VIEW PART LIST				
NO	AVR435/635	AVR435 ONLY	DESCRIPTION	QTY
1	H03-ZMC11S00200-6		AL DOOR AVR	1
2	H03-ZMC11S00300-8		AL PANEL AVR	1
3	H03-ZMC12S20A00-8		BADGE AL HARMAN/KARDON SILVER	1
4	H03-ZMGEN00GAGY-6		AL LOGO BADGE TOP	1
5	H03-ZMC11S08A00-0		COVER TOP AVR	1
6	H03-ZVC11DWT200-0		TAPE PANEL	1
7	H03-ZVC11DWT100-9		TAPE DOOR	1
8	H03-ZMD12S01A00-9		SHIELD IR	1
9	H03-SOSS9CKX3NN-4		JACK PHONE 6.35 H70980110S 9P BK	1
10	H03-ZMB01S00100-0		BKT HEADPHONE JACK	1
11	H03-SWA2B21PDAA-2		SW PUSH POWER SDDL15700 5A 250V	1
12	ZPC1006GAWH-0		BUTTON STANDBY	1
13	ZPC1003GAGY-5		BUTTON POWER	1
14	ZPC1007GAMW-9		INDICATOR STAND-BY	1
15	H03-ZMC11S12A00-3		CAP BUTTON STAND-BY	1
16	ZFD122062SB-5		RUBBER TOP 20X15X6.2t	1
17	ZPD1201GAGY-4		PANEL FRONT	1
18	H03-ZMC11S14A00-5		BKT DOOR	1
19	ZPC1002GAGY-9		DOOR AVR	1
20	H03-ZMD05S16A00-9		BKT HINGE	2
21	H03-ZPC1018GART-2		FILTER VFD	1
22	H03-ZPD1219GABT-A	H03-ZPD1119GABT-1	WINDOW DISPLAY AVR435/635+BADGE NAME	1
23	H03-ZPD0317GACR-A		CAP KNOB VOLUME	1
24	H03-ZPD0316GASG-5		COVER KNOB	1
25	H03-ZPD0315GAMW-9		VOLUME KNOB	1
26	H03-ZVC11GEAR01-5		DAMPER GEAR DP120	1
27	ZPC1102GAMW-1		INDICATOR VIDEO 4	2
28	ZPC1005GAGY-8		BUTTON 8 KEY	1
29	H03-ZPC1004GASG-6		BUTTON 7 KEY	1
30	ZFNR19720SB-5		RUBBER FOOT 19.7X19.7X2T BK	4
31	ZPC1103GAGY-A		FOOT 50MM 15.8MM	4
32	H03-ZMC11S13A00-4		CHASSIS MAIN	1
33	H03-SORA3313PNN-9		JACK RCA 3P YWR	1
34	H03-SORA8OSC5N8-8		JACK S-VIDEO 1P C40160261N	1
35	H03-ZMC12S17A00-6		SHIELD DIGITAL	1
36	H03-SORA1JE01NN-6		JACK RCA 1P JE010003MN GND OR	1
37	H03-SOTOR179LBA-6		D-LEM TORX-179L	4
38	H03-SO3P5179NNN-A		JACK PHONE 3.5PI PJ0435179N	1
39	ZFD122072SB-2		RUBBER TOP 20X20X7.2t	1
40	H03-ZMC11S06A00-9		SPRING STOPPER	1
41	H03-SWE3A0505S1-4		SW ROT EC16B24204 5V 500U0A 10T 3P 0 0	1
42	H03-ZMD12S01B00-0		SHIELD MICROPHONE	1
43	H03-VDHCA18LL03-2		FL HCA-18LL03	1
44	ZPC1017GABK-6		HOLDER VFD	1
45	H03-ZMC11S07A00-A		CH FRONT	1
46	ZFNR1SENSOR-0		RUBBER SENSOR	1
47	H03-ZVC11FAN100-1		FAN JF0925S1L	1
48	H03-ZMC11S09A00-1		BKT FAN FRONT	1
49	H03-ZMC12S08B00-0		BKT TRANS BOTTOM	1
50	H03-TXPWMM635B0-9	H03-TXPWMM435B0-2	POWER TRANSFORMER	1
51	H03-ZMC12HS0100		HEATSINK 17*15*30	1
52	H03-SOPA21275BK-9		AC OUTLET 2P 110V FE 12.75MM 2 BK 0 0 A204D0043P	1
53	ZMC12S15AYE-6		STANDOFF HEX M4X0.7 6X111.2H	1
54	H03-ZMC12S19A00-8		BKT AC INLET	2
55	H03-ZMD12S04B00-3		BKT FRAME GUIDE	1
56	H03-ZMD12HS0100-5		HEATSINK H/SINK AMP	1
57	H03-ZMC12S09A00-A		BKT HEATSINK	7
58	H03-SOPA8SH0612-5		JACK SPEAKER 6P SH0612707P	1
59	H03-SORA11Y00NN-0		JACK RCA+S VIDEO C5016031DN	7
60	H03-ZMC12S16A00-5		BKT GROUND	1



**harman/kardon****TECH TIPS****Troubleshooting tips and solutions to common service problems**

For models:

TIP# HKTT2003-01 Rev4

AVR7000/7200/7300/8000

AVR10

AVR100/200/300/500

DPR1001

AVR110/210/310/510

DPR1005

AVR120/220/320/520

DPR2005

AVR125/225/325/525

HK3370/3470/3375/3475

AVR130/230/330/430/630

HK3250

AVR135/235/335/435/635

**Subject:** Backup Memory on AVR/DPR/HK series receivers**In the event of the complaint: “the receiver is losing its memory (any programmed system settings) when the unit is turned off, or after the unit is unplugged (briefly\*)”:**

Check and replace:

Model	Designator	Location	Description	Part number
AVR10	C712 D709	Front PCB	0.047 Farad 5.5v capacitor and 1N4148 diode	#3439247315 #2058322101
AVR7000	C730	Front PCB	0.047 Farad 5.5v capacitor	# 55134360 or # J3432147324X
AVR7200	C106	Front PCB	0.047 Farad 5.5v capacitor	# 55134360
AVR7300	C657	DSP PCB	0.047 Farad 5.5v capacitor	# H01-CEZXA0479MN-5
AVR8000	C726	Front PCB	0.047 Farad 5.5v capacitor	# 55230310NR or # 55134360
AVR100/200	C412	Front PCB	0.047 Farad 5.5v capacitor	# CEGT-B473J-0J0
AVR300	C906	Front PCB	0.1Farad 5.5v capacitor	# J4433210421X or # P10791-ND
AVR500	C906	Front PCB	0.1Farad 5.5v capacitor	# J4433210421X or # P10791-ND
AVR110/210/310/510 AVR120/220/320/520	C216	Front PCB	0.047 Farad 5.5v capacitor	# 55134360
AVR125/225	C734,C885	Front PCB	two 0.1F capacitors in parallel	# BCESOHD104
AVR325/525	C106	Front PCB	0.047 Farad 5.5v capacitor	# 55134360
AVR130/230/330	BAT1	Front PCB	3.6v Battery	# HABGP40BVH3A3H
AVR135/235/335	BAT1	Front PCB	3.6v Battery	# HGP15BNH3A3H
AVR430/630	C657	DSP PCB	0.047 Farad 5.5v capacitor	# CEZXA0479MN-5
AVR435/635	C557	DSP PCB	0.047 Farad 5.5v capacitor	# H03-CEZXA0479MN-0
DPR1001	BC601	Main PCB	0.1Farad 5.5v capacitor	# CEGT-B104J-0J0
DPR1005/2005	C437	Processor PCB	0.047 Farad 5.5v capacitor	# CEZXA0479MN-5
HK3370/3470	C301	Front PCB	0.1Farad 5.5v capacitor	# CEGT-B104J-0J0
HK3375/3475	C301	Front PCB	0.1Farad 5.5v capacitor	# CEGT-B104J-0J0
HK3250	C712 D709	Front PCB	0.047 Farad 5.5v capacitor and 1N4148 diode	#3439247315 #2058322101

\* After approximately two weeks of being disconnected from AC supply, even a normally functioning receiver may lose any programmed settings and switch to default settings. (Four weeks for the DPR1005 & 2005)

## AVR435/635 IDLE ADJUSTMENT PROCEDURES

NO Signal/No Load

AC Line Voltage:120V/60Hz.230V/50Hz

### 1. MAIN AMP idle Adjustment

MAIN:VR71.VR72

SURROUND:VR73.VR74

- 1) After turning the unit ON wait at least 25 minutes before adjustment (to achieve normal power/Driver TR temperature)
- 2) Adjust the voltage value of primary&secondary of wafer to be 23mV by rotating the Potentiometer of each channel

CHANNEL	ADJUSTMENT	MEASUREMENT	VOLTAGE
FRONT-L CH	VR71	P801	23+/-2mV
FRONT-R CH	VR72	P802	23+/-2mV
SURROUND-L CH	VR73	P803	23+/-2mV
SURROUND-R CH	VR74	P804	23+/-2mV

The corresponding channels should be adjusted again following the above procedure, when these Transistors are replaced:

FRONT AMP: Q433.Q434.Q435.Q436.Q337.Q338.Q339.Q340

SURROUND AMP: Q329.Q330.Q331.Q332.Q333.Q334.Q335.Q336

### 2. CENTER/SURROUND BACK AMP idle Adjustment

CENTER:VR501

SURROUND BACK:VR201.VR301

- 1) After turning the unit ON wait at least 25 minutes before adjustment (to achieve normal power/Driver TR temperature)
- 2) Adjust the voltage value of primary&secondary of wafer to be 23mV by rotating the Potentiometer of each channel

CHANNEL	ADJUSTMENT	MEASUREMENT	VOLTAGE
CENTER	VR501	P501	23+/-2mV
SUR BACK-L CH	VR201	P201	23+/-2mV
SUR BACK-R CH	VR301	P301	23+/-2mV

The corresponding channels should be adjusted again following the above procedure, when these Transistors are replaced:

CENTER AMP: Q516.Q517.Q518.Q519

SUR BACK AMP: Q216.Q217.Q218.Q219.Q316.Q317.Q318.Q319

### CAUTION

When POWER TR or DRIVER TR need replacement,

On the MAIN & SUPPLY BOARD, the following capacitors should be discharged for 30 seconds with a 4.7 Ohm 10W resistor after turning unit OFF, to preventing possible damage from an electrical spark.

MAIN BOARD	C504.C505	AVR435 12000/63V
	C571.C572	AVR635 15000/63V
SUPPLY BOARD	C201.C202	AVR435 8200/63V
	C201.C202	AVR635 10000/63V

REVISION RECORD		
No.	Date	Contents

Alignment and test Position(SURROUND B'D,3ch AMP)

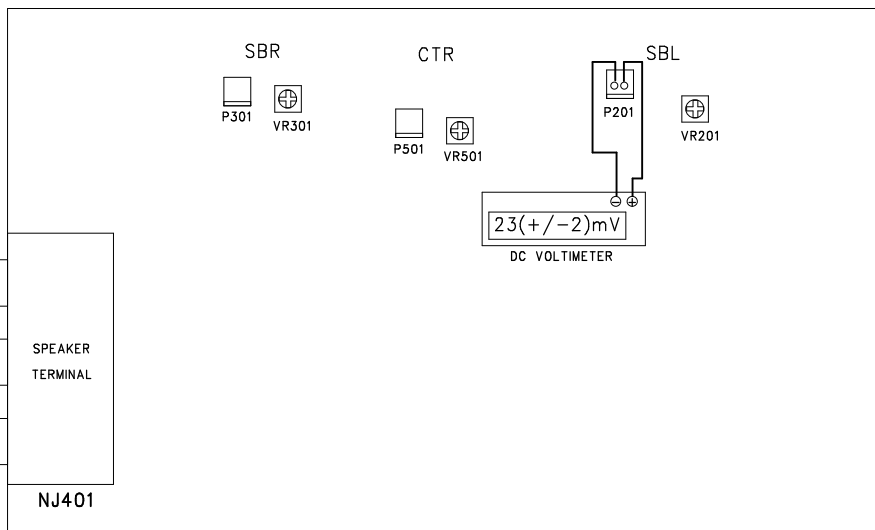

← REAR

→ FRONT

Alignment and test Position(MAIN B'D,4ch AMP)

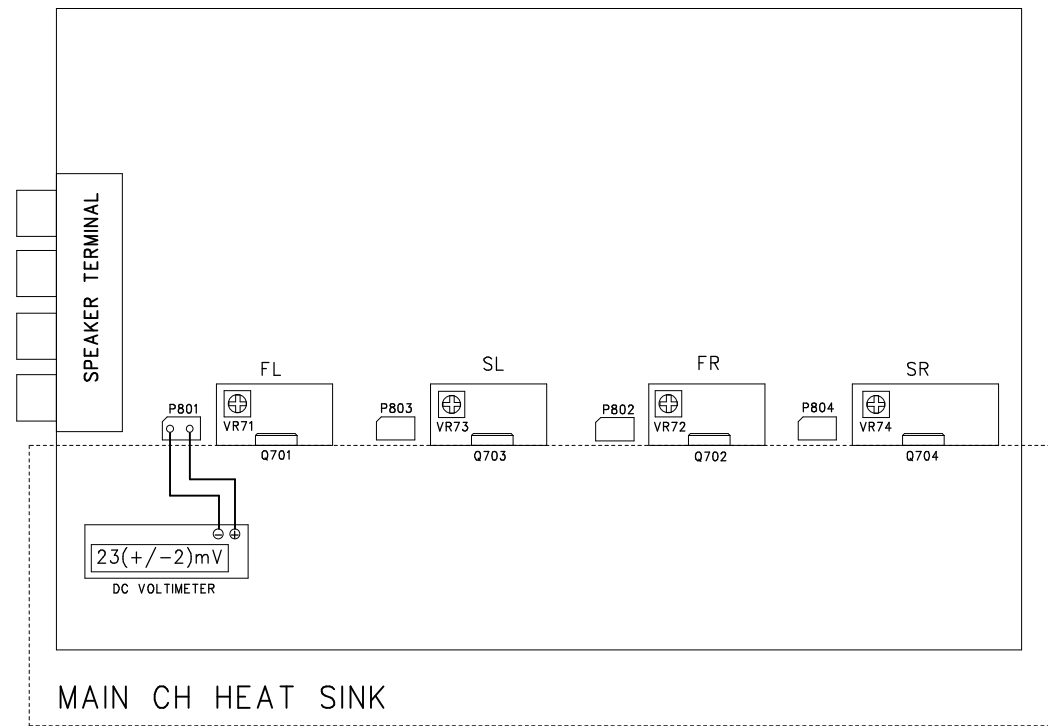

← REAR

→ FRONT

Category	DVD RECEIVER	Model	AVR635/435
Stage	Ver.	Sheet	B'D name
MP	VLO	/	SURROUND/MAIN
Draw	Approved	Date	Drawing No



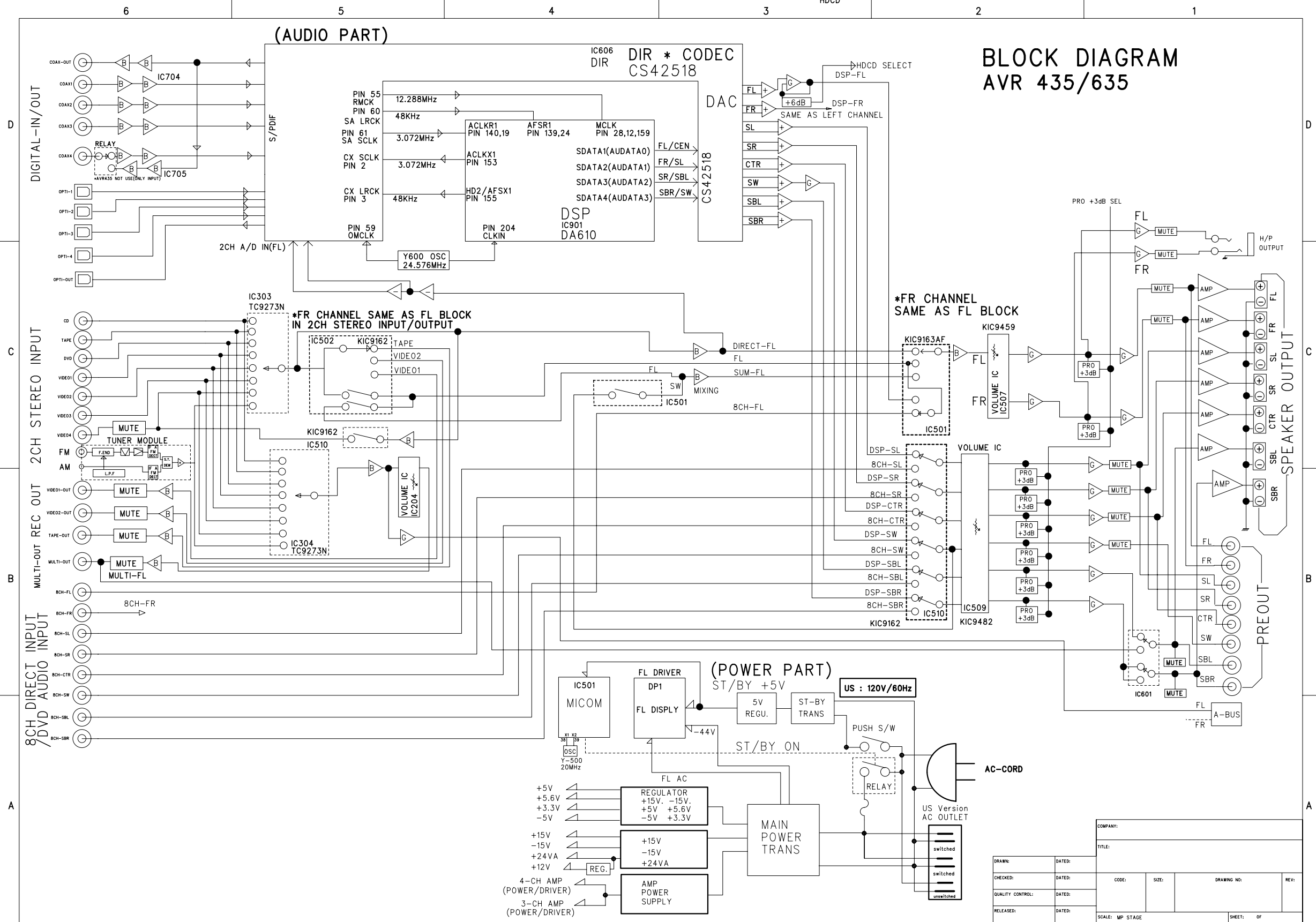

# BLOCK DIAGRAM AVR 435/635

## (AUDIO PART)

## (POWER PART)

DIGITAL -IN/OUT

2CH STEREO INPUT

REC OUT

8CH DIRECT INPUT / DVD AUDIO INPUT

SPEAKER OUTPUT

PREOUT

DRAWN:		DATED:		COMPANY:	
CHECKED:		DATED:		TITLE:	
QUALITY CONTROL:		DATED:		CODE:	SIZE:
RELEASED:		DATED:		DRAWING NO:	REV:
SCALE: MP STAGE				SHEET: of	

# AVR 635/435 VIDEO BLOCK DIAGRAM

REVISION RECORD		
No.	Date	Contents

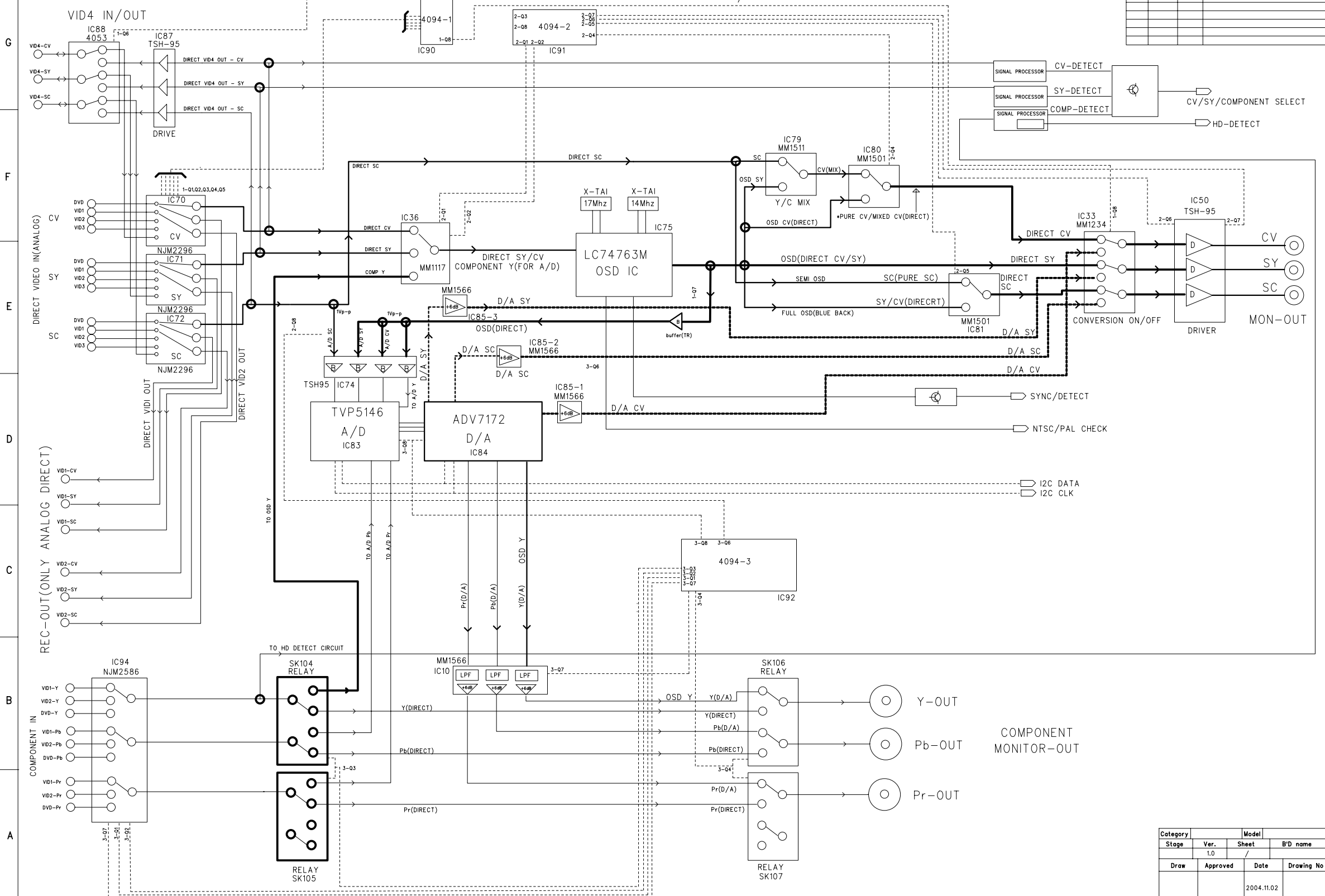

Category	Model
Stage	Ver. / Sheet / B'D name
Draw	Approved / Date / Drawing No

REF NO.	PART NO.	DESCRIPTION	REMARKS
	3SA-4120US-BC00-1-7	MECH BOM AVR435US HARMAN KARDON	
	H03-SWA2B21PDA&-2	SW PUSH POWER SDDL15700 5A 250V	
	H03-TXPWMM435B0-2	TRANS MN X'FORMER 120V AVR435US	
	H03-WF15S2605FU-6	WIRE FFC (CARD CABLE) DHCDF-15/260-P1.25-AT	
	H03-WF27S2705FU-5	WIRE FFC (CARD CABLE)DHCDF-27/270-P1.25-AT	
	H03-ZMB01S00100-0	BKT HEADPHONE JACK	
	H03-ZMB01S02200-4	SPRING PLATE GND C5212 0.2T	
	H03-ZMC11HS0200-2	H/SINK MAIN AVR630	
	H03-ZMC11S00200-6	AL DOOR AVR430/630	
	H03-ZMC11S00300-8	AL PANEL AVR430/630	
	H03-ZMD12S04B00-3	BKT FRAME GUIDE AVR635	
	H03-ZMC11S06A00-9	SPRING STOPPER AVR430/630	
	H03-ZMC11S07A00-A	CHASSIS FRONT AVR430/630	
	H03-ZMC11S08A00-0	COVER TOP AVR430/630	
	H03-ZMC11S09A00-1	BKT FAN FRONT AVR430/630	
	H03-ZMC11S10A00-1	BKT FAN REAR AVR430/630	
	H03-ZMC11S12A00-3	CAP BUTTON STAND-BY AVR430/630	
	H03-ZMC11S13A00-4	CHASSIS MAIN AVR430/630	
	H03-ZMC11S14A00-5	BRACKET DOOR	
	H03-ZMC12S07A00-8	COVER BOTTOM	
	H03-ZMC12S08B00-0	BKT TRANS BOTTOM	
	H03-ZMC12S09A00-A	BKT HEATSINK	
	H03-ZMC12S19A00-8	BKT AC INLET	
	H03-ZMC12S20A00-8	BADGE AL HARMAN/KARDON SILVER	
	H03-ZMD05S16A00-9	BKT HINGE AVR7300	
	H03-ZMC11S04B00-9	BKT FRAME GUIDE	
	H03-ZMD11HS0100-7	HEATSINK H/SINK AMP AVR435	
	H03-ZMD11S02A00-1	PANEL REAR AVR435US	
	H03-ZMGEN00GAGY-6	AL LOGO BADGE TOP	
	H03-ZPC1004GASG-6	BUTTON 7 KEY	
	H03-ZPC1018GART-2	FILTER VFD	
	H03-ZPD0315GAMW-9	VOLUMN KNOB	
	H03-ZPD0316GASG-5	COVER KNOB	
	H03-ZPD0317GACR-A	CAP KNOB VOLUMN	
	H03-ZPD1119GABT-1	WINOW DISPLAY AVR435+BADGE NAME AVR435	
	H03-ZVC11DWT100-9	TAPE DOOR	
	H03-ZVC11DWT200-0	TAPE PANEL	
	H03-ZVC11FAN100-1	FAN JF0925S1L	
	H03-ZVC11GEAR01-5	DAMPER GEAR DP120	
	H03-ZVC11TUNE01-2	TUNER MODULE KST-MB011MW0-81 US	
	ZFD122062SB-5	RUBBER TOP AVR635	
	ZFD122072SB-2	RUBBER TOP AVR635	
	ZFNR13830SB-6	RUBBER SIDE	
	ZFNR19720SB-5	RUBBER FOOT 19.7X19.7X2T BK	
	ZTB017030AA-4	CABLE TIE 100MM NYLON 6	
	ZKC1095HA00-0	LABEL LICENSE AVR430	
	ZKC1222HA00-2	LABEL RISK	
	ZKC1229HA00-7	LABEL DATE	
	ZKGEN29HA00-8	LABEL DATE BLANK	
	ZKC1281HA00-9	LABEL QC CHECK	
	ZKD1130HA00-3	LABEL SERIAL AVR435US	
	ZKGEN30HA00-6	LABEL SERIAL BLANK	
	ZKD1173HA00-4	LABEL BARCODE AVR435US	
	ZKGEN73HA00-7	LABEL BARCODE BLANK	
	ZKGEN97HA00-3	LABEL MAIN POWER REMIND	
	ZMC12S13AYE-1	STANDOFF HEX M4X0.7 6X31.9H	
	ZMC12S14AYE-9	STANDOFF HEX M4X0.7 6X61.9H	
	ZMC12S15AYE-6	STANDOFF HEX M4X0.7 6X111.2H	
	ZNSSM4045HZ-4	NUT M4 HEXAGON CIRCULAR EXTERNAL	
	ZPC1002GAGY-9	DOOR AVR430/630	
	ZPC1003GAGY-5	BUTTON POWER	

REF NO.	PART NO.	DESCRIPTION	REMARKS
	ZPC1005GAGY-8	BUTTON 8 KEY	
	ZPC1006GAWH-0	BUTTON STANDBY	
	ZPC1007GAMW-9	INDICATOR STAND-BY	
	ZPC1017GABK-6	HOLDER VFD AVR430/630	
	ZPC1103GAGY-A	FOOT 50MM 15.8MM	
	ZPD1101GAGY-A	PANEL FRONT AVR435	
	ZVC11FILM0A-A	PROTECTION FILM	
	ZSMCM4008BY-1	SCREW BM 4X8	
	ZSMCM4010BB-5	SCREW BM 4X10	
	ZSTBM3008BY-1	SCREW ST BH 3X8	
	ZSTBM3010BB-5	SCREW ST BH 3X10	
	ZSTBM3012BY-A	SCREW ST BH 3X12 PIVOT	
	ZSTGM3010BB-3	SCREW ST BH 3X10 GROUND	
	ZSTWM3006BB-3	SCREW ST WPH 3X6	
	ZSTWM3008BY-8	SCREW ST WPH 3X8	
	ZSTWM3A08BY-6	SCREW ST W7.5PH 3X8	
	ZSTWM4008BC-3	SCREW ST WPH 4X8 SILVER CHROM	
	ZUC1201AABK-7	SPONGE 30X30X10T BK	
	ZV4P00030TH-3	HEAT SHRINK TUBE L30MM*D4.0MM*T0.5MM	
	ZWF793008PO-5	WASHER FIBER 3 0.8T	
	ZWM623108SZ-2	WASHER SPRING 3	
	ZWM763109SZ-2	AC SPRING WASHER RT2250(PAV5005)	
	ZWM803305PZ-1	WASHER PLAIN 3	
	ZWMC04810PZ-5	WASHER PLAIN 4	
	H03-WF09SB81300-3	WIRE ASS'Y UL1007#26 STR 130MM 2.0MM 9P WHT	
	H03-WF4261805BN-7	WIRECONASY DL 2.0MM 4P 180MM UL 1007 RIBBON 26 1	
	H03-WG02SG8532A-4	WIRECONASY UNIQUE 2P 530MM UL1617 PVC DOUBLE INSULATED 20 1	
	H03-FBB0102AA00-2	FCORE FERRIT MAGNET SRH9. 9X20. 0X5. 3	
	H03-FBD0480BR00-8	FCORE CLAMP FILTER LF80BR W5 SRH 16X28X9	
	H03-ZUD0301AABK-5	SPONGE-UL 30X30X12T BK DPR2005	
	ZMC1221AA00-9	CLAMP WIRE-FIX UL 55212250	
	XY81204K4YW-5	GLUE, YELLOW, N.W=4.4KG #8120 @KG	
	XY1N218M3SW-4	GLUE FURROW W=12MML=18.3M SS WHITE @ROLL	
	XY501110CRD-2	GLUE, RED #AK-501 F/SCREW V=110CC @BOTTL	
	XY2N450M0DW-6	GLUE,TAPE,#9070,W=24MM,L=50,DOUBLE-SIDE,WHITE. @METER	
	XY1N055M0DW-7	GLUE TAPE , W=10MM L=55M DOUBLE-SIDE ,WHITE,#3M9495LE. @M	
	XYEM501K000-2	SPECIALTY LUBRICANTS GREASE,#EM-50L,W=1KG @G	
	H03-RYC1202HA00-0	REMOCON ZONE 2	
	H03-RYD1101HA00-0	REMOCON AVR435US	
	H03-WAUSA2103BK-7	POWER CORD WS-004C+002E SJT#14*2C L=2M	
	H03-ATALF039ABK-5	ANTENNA WIRE AM LOOP CT01-AM 0 0	
	H03-WAB01200203-4	FM ANTENNA WIRE 75 CT02-FM 0 0	
	ZKC1113HA00-9	CARD WARRANTY	
	ZKD1116HA00-0	QUICK SETUP GUIDE AVR435	
	ZKC1214HA00-A	LABEL SAFETY LEAFLET	
	ZKC1263HA00-0	INSERT RS232 NOTE PAPER	
	ZKD1101HA00-3	OWNER'S MANUAL AVR435US	
	ZKD1104HA00-2	BOX CARTON AVR435US	
	ZQD1201HAWH-A	CUSHION POLY EPS RIGHT AVR635	
	ZQD1202HAWH-6	CUSHION POLY EPS LEFT AVR435/635	
	H03-MCD12TWBKNN-8	AVR435/635 MICROPHONE ASSY	
	H03-ZPD1212INBK-5	MICROPHONE ASSY EXTENSION PIECE	
	ZKD1202HA00-4	CARTON BOX MIC	
	ZKD1263HA00-3	BROCHURE AVR US	

REF NO.	PART NO.	DESCRIPTION	REMARKS
	3SA-4120US-DGMI-1-6	IMA DSP BD AVR435US	
C557	H03-CEZXA0479MN-0	CM 47MI0F +80%-20% 5.5V 70C SCDA5R5473V	
IC851	H03-ICPC17T10B1-8	IC PHOTOCOUPLER PC-17T1 DIP4 KODENSHI	
T701	H03-LF11030A2NA-A	TFPULSE TRANSFORMER 110UH FP-110 FERRIT MAGNET	
Y600	H03-OSCEM24M5RU-5	VCXO 24M576 HZ +50 PPM -50 PPM 0 OHM 3.3V	
Y500	H03-OSCN120MOCU-1	CSTLS20MOX51-B0	
NJ705	H03-SOJB04013HN-0	JACK RCA 4P OR ,OR, OR, OR JB040131HN	
NJ802	H03-SORA40RSANN-1	JACK RCA 4P JB040131ZN GN BN PP TA	
NJ801	H03-SORA40RSCNN-5	JACK RCA 4P JB040131QN WH BU RD GY	
NJ701 702 703	H03-SOTOR179LBA-6	D-LEM TORX-179L	
NJ704	H03-SOTOT179LBA-2	D-LEM TOTX-179L	
N803	H03-WG06SB82800-7	WIRE ASS'Y UL1007#26 STR 280MM 2.0MM 6P WHT	
N501	H03-WG09SB81000-3	WIRECONASY DL 2.0MM 09P 100MM UL1007 RIBBON 26 1	
N701	H03-WN05SB00000-6	CONN 2.0MM 5 MA ST NAT GT201-5P-TS	
N504	H03-WN06AB00001-A	CNT PLUG BD'BD SOCKET 2.0mm 35237-0610 6P	
N506	H03-WN09SB00000-5	CONN 2.0MM 9 MA ST NAT GT201-9P-TS	
N503	H03-WN11SB00000-3	CONN 2.0MM 11P MA ST NAT MOLEX 35336-1110 0 0	
N802	H03-WN19AB00000-4	CONN 2.0MM 19 MA R NAT SOCKET MOLEX 35237-1910 0 0	
N407 801	H03-WN19SB00000-1	CONN 2.0MM 19 MA ST NAT MOLEX 35336-1910 0 0	
N502	H03-WN27AI00000-A	CONNECT 1.25mm 27P GF120-27S-LS	
IC507	H03-ICKA78R08I2-A	IC-KIA78R08API TO-220IS-4PIN	
L501	H03-LAINB047ACR-9	LF 4U7H +10% 1.7 OHM 190.0A	
R521	RC3DI010AIN-1	RCF 1R0 OHM +5% 250MI0W	
L702 703 704 705	H03-LAINB0470CR-8	LF 47U0H +10% 5.8 OHM 500MI0A	
N805	H03-WG01S022018-5	WIRE ASS'Y UL1007#18 220MM 1P BLK TERMINAL	
REWORK	H03-WC1201005C1-4	WIRE ASS'Y UL1007 #20 TS 100MM 1P BLK	
	XY0P523K000-A	WIRE,IRON,D=0.5MM,N.W=23KG @KG	
	XY0P801K000-A	WIRE TIN D=0.8MM N.W=1.0KG @KG	
	XY1N209M0DW-4	GLUE TAPE W=12MM L=9.0M DS WHITE @ROLL	
	XY1N218M3SW-4	GLUE FURROW W=12MML=18.3M SS WHITE @ROLL	
	XY1P202K000-1	WIRE, TIN, D=1.2MM N.W=2.0KG @KG	
	XY30155G00-0	TCE,CLEANER,-301#,V=55GALLON,TYPELESS @GALLON	
	XY4N836M5CL-9	GLUE TRANSPARENT W=48MM L=36.5M @ROLL	
	XY6R301K000-0	BAR,TIN,63/37,N.W=1.0KG @KG	
	XYALC01G000-2	ALCOHOL V=1.0GALLON @GALLON	
	XYGLU00K5RD-7	GLUE, RED, W=0.5KG TYPELESS FOR SMT @KG	
	XYJU100K5GY-5	JUICE TIN N=0.5KG GREY @KG	
	XYRF801G000-7	FLUX #RF-800 V=1.0 GALLON @ GALLON	
	XYWAX10K000-6	ANTI-OXIDATION,WAX,W-1#,N.W=10KG,@KG	
	3SA-4120US-DGAR-1-6	IAR DSP BD RADIAL AVR435US	
C411 431 432 433	CCKIC0471NC-9	CAP CERAMIC 470PF 50V K X7R TAP	
C412 415 434 435 454 458 475 476 487 488 489 495	CCKIC0561NC-8	CAP CERAMIC 560PF 50V K X7R TAP	

REF NO.	PART NO.	DESCRIPTION	REMARKS
C400 401 402 403 421 422 423 424 425 426 427 428 436 440 441 451 453 456 457 459 461 462 496 497 519 520 521 530 629 631 633 635 902	CEHFC01062S-0	CE 10UF +20% 16V D4XL7 P2.5MM 2000hours 85C	
C514	CEHFC04762S-0	CE 47UF +20% 16V D5XL7 P2.5MM 2000hours 85C	
C525	CEHIC01042S-5	CE 100NF +20% 50V SSE TYPE D4XL7 P2.5MM 85C	
C416 417 418 419 429 430 438 439 450 460 470 471 481 482 483 484	CCKIC0272NC-4	CAPACITOR CERAMIC 2N7F 50V K X7R TAP	
C258 259 265 267 527 744 745	CEMFC01072E-8	CE 100UF 16V +/-20% 5X11 P2.5MM ELIET	
C625	CEHIC01055E-6	CE 1UF +20% 50V D5XL11 P5MM 85C	
C958	CEHIC04755E-6	CE 4U7F +20% 50.0V 85C P5MM	
Q851	H03-TRKTA107MNA-2	TR-SLPSWA KRA107M P	
Q511	H03-TRMPSA06NNA-A	TR-SLPLF MPSA06 N 500MIOA TO-92	
	PBD11KDGB20-5	PCB DUALA VR435/635 DSP 209x170x1.6t FR-4 1OZ	
C823 824 825	CEHDC0108NN-3	CE 1MIOF +20% 6.3V 8X11.5 85C ELITE P5MM	
C601 959	CEHEC0477MN-A	CE 470U0F +20% 10.0V 6.3X11 85C ELITE P5MM	
C264 508 515 623 821 822 904 912	CEHFC01072S-9	CE 100UF +20% 16V D6.3XL7 P2.5MM 2000hours 85C	
	3SA-4120US-DGSB-1-7	BOTTOM SMD DSP BD AVR435US	
C501 502 504 505 506 801 802 803 804 805 806 807 808 809 810 811 812 813 814 815 816	CZJII0101BE-2	CAP CHIP 100P0F +5% -5% 50.0V NP0 0603	
C700 702 720 743	CZJII0220BE-5	CCCFMIC 22P0F +5% -5% 50.0V NP0 0603	
C444 492	CZJII0470BE-4	CAP CHIP 47P0F +5% -5% 50.0V NPO 0603	
C251 252 646	CZKII0102BC-7	CAP CHIP 1N0F +10% -10% 50.0V X7R 0603	
C603 604 647 648 701 703 706 717	CZKII0103BC-5	CAP CHIP 10N0F +10% -10% 50.0V X7R 0603	
C257 263 292 503 507 513 516 517 518 522 528 614 615 622 624 628 630 632 634 705 708 710 714 721 817 818 903 910 913 922 925 926 927 930 945 947 961 980 981 982 984 985 986 988 989 990 991 929 946 960 987	CZZFI0104BF-8	CAP CHIP 100N0F +80% -20% 16.0V Y5V 0603	
C619	CZZII0104CF-8	CAP CHIP 100N0F +80% -20% 50.0V Y5V 0805	
D503 504 505 507 851	H03-DS1S50094NB-5	D-SLP 1SS355 35.0V 225MIOA	
L504 604 610 700 901 904 905	H03-FB2K52012NN-0	FBEAD SURFACE MT 2500OHM FCM2012H-252T02	
L601 602 605 606 607	H03-FB3012012CN-8	FBEAD SURFACE MT FCM2012C-301T04 0805	
L706	RS3BB0000NA-5	RES CHIP 0 OHM +5% 100MIOW 0805	
E901	H03-FYACF333TNN-A	FILTER ACF451832-333-T	
IC502	H03-IC74HC4094D-1	IC CD74HC4094D(R-PDSO-G16) SOP16	
IC608	H03-IC74LV1G125-9	IC SN74LVC1G125DVB SOT23	
Q601	H03-TRDTC114YNI-0	TR-SSD DTC114YKA N 10K0 OHM 47K0 OHM	
U906 908 909 910	RN3AY0220NA-4	RES NETWORK RCA 22OHM 1/16W 5% CN34JT220	
JUM1 2 R601	RS3AD0000NA-0	RES CHIP 0 OHM +0% 62MI5W 0603	
R708	RS3AD0100NA-7	RES CHIP 10R0 OHM +5% 62MI5W 0603	
R531 607 608 646 711 715 C709 711 722	RS3AD0101NA-5	RES CHIP 100R0 OHM +5% 62MI5W 0603	
R528 529 530 532 803 804 807 808 811 815 816	RS3AD0102NA-3	RES CHIP 1K0 OHM +5% 62MI5W 0603	
R257 258 523 534 535 561 923	RS3AD0103NA-1	RES CHIP 10K0 OHM +5% 62MI5W 0603	
R265 266 414 415 448 449 480 491 492 499 556 702 706 724 730	RS3AD0104NA-A	RES CHIP 100K0 OHM +5% 62MI5W 0603	

REF NO.	PART NO.	DESCRIPTION	REMARKS
R405 416 417 418 419 425 426 429 430 431 445 446 483 484 485 486 609 612	RS3AD0122NA-8	RES CHIP 1K2 OHM +5% 62MI5W 0603	
R132 251 252 253 256 R913 914	RS3AD0151NA-1 RS3AD0182NA-1	RES CHIP 150R0 OHM +5% 62MI5W 0603 RES CHIP, 1.8K, 1/16W, +/-5%, 0603.	
R812 R736 738 741	RS3AD0332NA-8 RS3AD0222NA-4	RES CHIP 3K3 OHM +5% 62MI5W 0603 RES CHIP 2K2 OHM +5% 62MI5W 0603	
R801 802 805 806 809 813 814	RS3AD0223NA-2	RES CHIP 22K0 OHM +5% 62MI5W 0603	
R658 R263	RS3AD027ANA-3 RS3AD0512NA-6	RES, CHIP, 2.7, 1/16W, +/-5%, 0603 RES CHIP 5K1 OHM +5% 62MI5W 0603	
R853 915 921 922 924	RS3AD0392NA-1	RES CHIP 3K9 OHM +5% 62MI5W 0603	
R262 400 401 402 403 411 412 444 452 459 460 474 475 476 477 478 479	RS3AD0432NA-4	RES CHIP 4K3 OHM +5% 62MI5W 0603	
R852 R518 851	RS3AD0471NA-5 RS3AD0472NA-3	RES CHIP 470R0 OHM +5% 62MI5W 0603 RES CHIP 4K7 OHM +5% 1/16W 0603	
R522 555 737 739 740	RS3AD0473NA-1	RES CHIP 47K0 OHM +5% 62MI5W 0603	
R439 440 447 454 456 457 489 490 703 704 709 726 743	RS3AD0561NA-4	RES CHIP 560R0 OHM +5% 62MI5W 0603	
R406 427 428 432 433 434 435 438 443 450 453 458 481 482 487 488	RS3AD0562NA-2	RES CHIP 5K6 OHM +5% 62MI5W 0603	
R710 R810	RS3AD0621NA-1 RS3AD0682NA-3	RES CHIP 620R0 OHM +5% 62MI5W 0603 RES CHIP 6K8 OHM +5% 62MI5W 0603	
R700 701 705 723	RS3AD0750NA-1	RES CHIP 75R0 OHM +5% 62MI5W 0603	
	3SA-4120US-DGST-1-2	TOP SMD DSP BD AVR435US	
C253 254 255 256 510 542 543	CZJII0101BE-2	CAP CHIP 100P0F +5% -5% 50.0V NP0 0603	
C621	CZJII0102CC-3	CAP CHIP 1nF 50V X7R J 0805	
C443 491 541 544	CZJII0470BE-4	CAP CHIP 47P0F +5% -5% 50.0V NPO 0603	
C645	CZKII0103BC-5	CAP CHIP 10N0F +10% -10% 50.0V X7R 0603	
C602	CZKII0223CC-5	CAP CHIP 22NF 50V B K X7R 0805	
C260 261 413 414 447 448 449 455 490 493 509 526 723 742 901 918 919 920 921 928 948 949 950 951 952 953 954 955 956 957 962 963 964 965 966 967 968 969 970 971 972 973 974 975 976 977 978 983 992 620	CZZFI0104BF-8	CAP CHIP 100N0F +80% -20% 16.0V Y5V 0603	
C627	CZZII0104CF-8	CAP CHIP 100N0F +80% -20% 50.0V Y5V 0805	
D501 502 506 508	H03-DS1S50094NB-5	D-SLP 1SS355 35.0V 225MIOA	
L903	H03-FB2K52012NN-0	FBEAD SURFACE MT 2500OHM FCM2012H-252T02	
L508	H03-FB3012012CN-8	FBEAD SURFACE MT FCM2012C-301T04 0805	
IC904	H03-ICM317TO252-1	IC 3-TERMINAL POS VOL REG NJM317DL1 TO-252	
IC504	H03-IC74VC244G5-1	IC-LOGIC 74VHC244A INVERTER CMOS	
IC902	H03-ICAT49BV162-8	IC FLASH MEMORY AT49BV162AT-70TI 48T	
IC606	H03-ICCS42518E6-8	IC LOGIC CS42518CQ QFP64	
IC501	H03-ICD703033E1-0	IC-MICOM FLASH NEC UPD70F3033BGF 0228KK001 JAPAN QFP100	
IC903	H03-ICK4S1616M6-4	IC-SDRAM K4S161622H-TC60 OR TC80	
IC251 252 401 402 404 406	H03-ICLM02068D2-5	IC-OPERAMP NJM2068M-TE1 DUAL SOP8	
IC503	H03-ICM24C04WD2-7	IC-EEPROM M24C04WMN6T	
IC704 705	H03-ICSN74HCU04-6	IC SN74HCU04D	
IC505 506 607	H03-IC74LV1G125-9	IC SN74LVC1G125DVB SOT23	
IC901	H03-ICTMS320DA6-0	IC FLOATING-POINT DSP TMS320D610A PQFP208	
Q501 502 503 504 505 506 507 508 509 510 602	H03-TRDTC114YNI-0	TR-SSD DTC114YKA N 10K0 OHM 47K0 OHM	
R717 817 818 819 820 821 822 823 824 901 546 C716	RS3AD0000NA-0	RES CHIP 0 OHM +0% 62MI5W 0603	

REF NO.	PART NO.	DESCRIPTION	REMARKS
R503 504 505 506 507 508 631 633 634	RS3AD0100NA-7	RES CHIP 10R0 OHM +5% 62MI5W 0603	
R267 268 630 632 645 981 982 983 984 985 986	RS3AD0101NA-5	RES CHIP 100R0 OHM +5% 62MI5W 0603	
R509 510 511 512 513 514 515 604 967 968 659	RS3AD0102NA-3	RES CHIP 1K0 OHM +5% 62MI5W 0603	
R254 255 259 260 501 502 519 520 533 551 552 559 969	RS3AD0103NA-1	RES CHIP 10K0 OHM +5% 62MI5W 0603	
R916 917 918 919	RS3AD0182NA-1	RES CHIP,1.8K,1/16W,+5%,0603.	
R261 264	RS3AD0203NA-8	RES CHIP 20K0 OHM +5% 62MI5W 0603	
R544 629 524 525	RS3AD0221NA-6	RES CHIP 220R0 OHM +5% 62MI5W 0603	
R553 554 725	RS3AD0222NA-4	RES CHIP 2K2 OHM +5% 62MI5W 0603	
R920	RS3AD0392NA-1	RES CHIP 3K9 OHM +5% 62MI5W 0603	
R541 542 543	RS3AD0471NA-5	RES CHIP 470R0 OHM +5% 62MI5W 0603	
R516 517 557	RS3AD0472NA-3	RES CHIP 4K7 OHM +5% 1/16W 0603	
R727	RS3AD0473NA-1	RES CHIP 47K0 OHM +5% 62MI5W 0603	
U902 903 904 905 907	RN3AY0220NA-4	RES NETWORK RCA 22OHM 1/16W 5% CN34JT220	
R657	RS3BB0200NA-8	RES,CHIP,20R 1/10W +/-5%,0805	
R644	RS3BB0332NA-2	RES,CHIP, 3.3K OHM 1/10W +/-5%, 0805	

**3SA-4120US-FCMI-1-0 IMA FRONT BD AVR435US**

	ZFNR1SENSOR-0	RUBBER SENSOR	
D853 854 855 856	H03-DL30B2015AA-5	D-LEM 30B3-20-15 GaN SUPER BLUE WATER CLEAR 15	
D831	H03-DL3BA05V0BA-8	D-LEM BLUE/AMBER 3PIE RD RND CL L-3VYMBC	
RM71	H03-ICRPM6938NN-9	IC-REMOTE RPM6938-RSIP-A3 RECEIVER 38KHZ	
VR100	H03-SWE3A0505S1-4	SWIROT EC16B24204 5V 500U0A 10T 3P 0 0	
DP1	H03-VDHCA18LL03-2	FL HCA-18LL03	
N201	H03-WG03AB80900-8	WIRECONASY DL 2.0MM 03P 90MM ANG-DOWN UL1007 RIBBON 26 1 B2011HR2	
N203	H03-WG07SB82000-A	WIRE ASS'Y UL1007#26STR 200mm 2.0mm 7P WHT	
N202	H03-WG08SD84000-7	WIRE ASS'Y UL1007#24 STR 400mm 2.5mm 8P WHT	
P604	H03-WN06SB01000-4	CNT PLUG BD'BD PLUG 2.0mm 35336-0610 6P	
P234	H03-WN11AB00000-6	CONN 2.0MM 11 MA R NAT SOCKET MOLEX 35237-1110 0 0	
P233	H03-WN11SB00000-3	CONN 2.0MM 11P MA ST NAT MOLEX 35336-1110 0 0	
P201	H03-WN15AI00001-2	CONNECT GF120-15S-LS 1.25mm 15P	
N602	H03-WN19AB00000-4	CONN 2.0MM 19 MA R NAT SOCKET MOLEX 35237-1910 0 0	
P602 603	H03-WN19SB00000-1	CONN 2.0MM 19 MA ST NAT MOLEX 35336-1910 0 0	
P211	H03-WN27AI00000-A	CONNECT 1.25mm 27P GF120-27S-LS	
N204	H03-WS4261005FN-3	WIRE ASS'Y UL2547/1007#26 100MM 4P 2.0MM WHT	
N222	H03-WS7260805EN-6	WIRE ASS'Y UL1533/1007#26 80MM 2.0MM 7P WHT SHILED	
S2 4 5 6 7	H03-ZMB01S02200-4	SPRING PLATE GND C5212 0.2T	
SH11	H03-ZMD12S01A00-9	SHIELD IR	
SH12	H03-ZMC12S16A00-5	BKT GROUND	
RM72	H03-DPLP200LNNN-2	PIN PHOTODIODE LP-200L	
C127	CEHFC01075E-1	CE 100UF +-20% 16.0V D5XL11 P5MM 85C	
SH22	H03-ZMD12S01B00-0	SHIELD MICROPHONE	
	XY0N211N5WH-4	CABLE TIE W=0.2MM L=11.5CM WHITE @ STRIP	
	XY0N618M3SW-A	GLUE FURROW W=6MM L=18.3M SS WHITE @ROLL	
	XY0P523K000-A	WIRE,IRON,D=0.5MM,N.W=23KG @KG	
	XY0P801K000-A	WIRE TIN D=0.8MM N.W=1.0KG @KG	
	XY1N127N0WH-5	ADHESIVE WHITE D=1.1CM L=27CM @KG	
	XY1N209M0DW-4	GLUE TAPE W=12MM L=9.0M DS WHITE @ROLL	
	XY1N218M3CL-9	GLUE TRANSPARENT W=12MM L=18.3M @ROLL	
	XY1N218M3SW-4	GLUE FURROW W=12MML=18.3M SS WHITE @ROLL	
	XY1N250M0DW-4	GLUE,TAPE,#9070,W=12MM,L=50,DOUBLE-SIDE,WHITE. @METER	
	XY1P202K000-1	WIRE, TIN, D=1.2MM N.W=2.0KG @KG	
	XY30155G00-0	TCE,CLEANER,-301#,V=55GALLON,TYPELESS @GALLON	
	XY4N836M5CL-9	GLUE TRANSPARENT W=48MM L=36.5M @ROLL	
	XY6R301K000-0	BAR,TIN,63/37,N.W=1.0KG @KG	
	XYALC01G000-2	ALCOHOL V=1.0GALLON @GALLON	
	XYGLU00K5RD-7	GLUE, RED, W=0.5KG TYPELESS FOR SMT @KG	
	XYRF801G000-7	FLUX #RF-800 V=1.0 GALLON @ GALLON	



REF NO.	PART NO.	DESCRIPTION	REMARKS
	XYWAX10K000-6	ANTI-OXIDATION,WAX,W-1#,N.W=10KG,@KG	
	<b>3SA-4120US-FCAA-1-9</b>	<b>IAA FRONT BD AXIAL AVR435US</b>	
C128	CCZID0104NA-2	CC 100N0F +80% -20% 50.0V F	
D101 301	H03-DG1N04148NB-A	D-SLP 1N4148 100.0V 150E-3A	
L121	H03-LAINB0470CR-8	LF 47U0H +10% 5.8 OHM 500MIOA	
L120	H03-LAINB047ACR-9	LF 4U7H +10% 1.7 OHM 190.0A	
	PBD11KFC120-6	PCB SINGLE AVR435/635 FRONT PCB 400x163x1.6t FR-1 1OZ	
R105 122 123 501 502	RC3DI0101IN-0	RCF 100R0 OHM +5% 250MIOW	
R104	RC3DI0102IN-9	RCF 1K0 OHM +5% 250MIOW	
R111 112 113	RC3DI0103IN-7	RCF 10K0 OHM +5% 250MIOW	
R831	RC3DI0151IN-7	RCF 150 OHM 5% 1/4W	
R120 121	RC3DI0471IN-0	RCF 470R0 OHM +5% 250MIOW	
R832	RC3DI0331IN-5	RCF 330R0 OHM +5% 250MIOW	
R518	RC3DI0182IN-7	RCF 1K8 OHM 5% 1/4W	
R851 852	RC3DI0561IN-A	RCF 560R0 OHM +5% 250MIOW	
	<b>3SA-4120US-FCAR-1-0</b>	<b>IAR FRONT BD RADIAL AVR435US</b>	
C517	CEHEC02275E-9	CE 220UF +20% 10.0V D6.3XL11 P5MM 85C	
C101 718	H03-CEMGC0476AH-0	CAP ELEC 47uF 25v M 5x11 SHL P5MM	
C125 126	H03-CFHKA0473NN-9	CAP POLYESTER METAL 47NF 100V 20% CPM	
S201 202 203 204 205 206 207 208 209 210 211 212 213 214 215 216 217 218 219 220	H03-SWC2A112FS1-3	SWITACT VERTICAL SKQNADD010 12V 50MA	
Q821	H03-TRMPSA06NNA-A	TR-SLPLF MPSA06 N 500MIOA TO-92	
Q823	H03-TRMPSA56YNA-0	TR-SLPLF MPSA56 Y P -500MIOA -300V	
C503 504	H03-CEMFC01062R-8	CAP ELEC 10UF 16V M 3.5X5 SRE P2.5MM	
C501 502 708	H03-CEMGC04762R-6	CAP ELEC 47UF 25V M 6.3X5 SRE P2.5MM	
	<b>3SA-4120US-FCST-1-7</b>	<b>SMD FRONT BD AVR435US</b>	
C709	CZKII0104CC-2	CAP CHIP 100NF 50.0V X7R K 0805	
C120 121 122 404 717 900	CZJII0101BE-2	CAP CHIP 100P0F +5% -5% 50.0V NP0 0603	
Q701 702	H03-TRKTC3875ND-A	TRANSISTOR NPN KTC3875S SOT23	
C703 705 707	CZJII0122CC-8	CAP CHIP 1n2F 50V SL J X7R 0805	
C701 704 706	CZDII0100CE-7	CAP CERAMIC/CHIP 10PF 50V CH D N 0805	
D110	H03-DSUDZ05V1NB-A	DIODE ZENER UDZ5.1B 5.1V 200MIOW	
C300 301	CZJII0821CE-0	CAP CHIP 820pF 50V SL J NP0 0805	
C505 506	CZKII0221BA-3	CAP CHIP 220PF 50V K SL 0603	
C201 211	CZKII0223BC-6	CAP CHIP 22N0F +10% -10% 50.0V X7R 0603	
C102 124 521	CZZFI0104BF-8	CAP CHIP 100N0F +80% -20% 16.0V Y5V 0603	
D701 702 715	H03-DS1S50094NB-5	D-SLP 1SS355 35.0V 225MIOA	
IC101	H03-IC74HC4094D-1	IC CD74HC4094D(R-PDSO-G16) SOP16	
IC50	H03-ICLMO2068D2-5	IC-OPERAMP NJM2068M-TE1 DUAL SOP8	
Q824 831 832 833	H03-TRDTA114YNI-4	TR-SSD DTA114YKA P 10K0 OHM 47K0 OHM	
Q820 822	H03-TRDTC114YNI-0	TR-SSD DTC114YKA N 10K0 OHM 47K0 OHM	
Q703 704 705	H03-TRKTA1504ND-2	TRANSISTOR PNP KTA1504Y(S)SOT-23	
C702	CZJII0101CE-1	CAP CERAMIC/CHIP 100PF 50V CH J NPO 0805	
R746	RS3AD0101NA-5	RES CHIP 100R0 OHM +5% 62MI5W 0603	
R101 102 103 201 211 503 515 824	RS3AD0102NA-3	RES CHIP 1K0 OHM +5% 62MI5W 0603	
R505 822	RS3AD0103NA-1	RES CHIP 10K0 OHM +5% 62MI5W 0603	
R516	RS3AD0104NA-A	RES CHIP 100K0 OHM +5% 62MI5W 0603	
R202 212	RS3AD0122NA-8	RES CHIP 1K2 OHM +5% 62MI5W 0603	
R203 213	RS3AD0152NA-A	RES CHIP 1K5 OHM +5% 62MI5W 0603	
R209 219	RS3AD0183NA-A	RES CHIP 18K0 OHM +5% 62MI5W 0603	
R823	RS3AD0221NA-6	RES CHIP 220R0 OHM +5% 62MI5W 0603	
R204 214 510 519	RS3AD0222NA-4	RES CHIP 2K2 OHM +5% 62MI5W 0603	
R205 215	RS3AD0272NA-0	RES CHIP 2K7 OHM +5% 62MI5W 0603	
R206 216 506	RS3AD0332NA-8	RES CHIP 3K3 OHM +5% 62MI5W 0603	
R509	RS3AD0472NA-3	RES CHIP 4K7 OHM +5% 1/16W 0603	
R520	RS3AD0473NA-1	RES CHIP 47K0 OHM +5% 62MI5W 0603	
R207 217	RS3AD0562NA-2	RES CHIP 5K6 OHM +5% 62MI5W 0603	
R821	RS3AD0563NA-0	RES CHIP, 56K 1/16W +/-5%, 0603.	
R301 302	RS3AD0683NA-1	RES CHIP 68K0 OHM +5% 62MI5W 0603	

REF NO.	PART NO.	DESCRIPTION	REMARKS
R208 218	RS3AD0822NA-2	RES CHIP 8K2 OHM +5% 62MI5W 0603	
R508	RS3AD0911NA-3	RES CHIP 910 OHM +5% 62MI5W 0603	
R702 704 709 710	RS3BB0103NA-6	RES,CHIP,10K 1/10W +/-5%,0805	
R706 707	RS3BB0105NA-2	RES,CHIP,1M 1/10W +/-5%,0805	
R703	RS3BB0272NA-5	RES,CHIP,2.7K 1/10W +/-5%,0805	
R708	RS3BB0511NA-2	RES,CHIP,510 1/10W +/-5%,0805	
R701	RS3BB0683NA-6	RES,CHIP,68K 1/10W +/-5%,0805	
R711 715	RS3CB0102NN-8	RES,CHIP,1K,1/8W,+/-5%,0805	
R714	RS3BB0471NA-A	RES, CHIP 470 OHM 1/10W +/-5%, 0805	
R705	RS3BB0564NA-3	RES,CHIP,560K OHM,1/10W +/-5%,0805	
R712 713	RS3BB0221NA-0	RES,CHIP,220R 1/10W +/-5%,0805	

**3SA-4120US-FCMI-1-0 V4-DIG BD AVR435US**

C400 401 403	CZJII0101BE-2	CAP CHIP 100P0F +5% -5% 50.0V NP0 0603
C411	CZZII0104CF-8	CAP CHIP 100NOF +80% -20% 50.0V Y5V 0805
D401 411 412	H03-DS1S50094NB-5	D-SLP 1SS355 35.0V 225MIOA
N220	H03-WS4264822EN-A	WIRECONASY DL 2.0MM 04P 480MM UL1533 SHIELD 26 1 2/2
N221	H03-WS6265105EN-8	WIRECONASY DL 2.0MM 6P 510MM UL1533 SHIELD 26 1
NJ20	H03-SORA3313PNN-9	CON PHONO SCKT RCA-313P 3 PINS
NJ21	H03-SORA8OSC5N8-8	JACK S-VIDEO 1P C40160261N
P222	H03-WN07AB00000-3	CONNECT 2.0MM 7P GIL-S-07P-S2L2-EF
Q401 800 801 802 803	H03-TRDTC114YNI-0	TR-SSD DTC114YKA N 10K0 OHM 47K0 OHM
R841 842 843 844	RS3AD0000NA-0	RES CHIP 0 OHM +0% 62MI5W 0603
SK40	H03-RLV23079A10-6	RELAY V23079-A1001
SK40	H03-RLTX25VNAIS-2	RELAY TX2-5V STANDARD PC BOARD TERMINAL

**3SA-4120US-FCMI-1-0 HP BD AVR435US**

C1 4	CZZFI0104BF-8	CAP CHIP 100NOF +80% -20% 16.0V Y5V 0603
D1 2	H03-DS1S50094NB-5	D-SLP 1SS355 35.0V 225MIOA
L1	H03-LAINB0470CR-8	LF 47U0H +10% 5.8 OHM 500MIOA
N240	H03-WS4265913FN-0	CNT ASSY 2.0MM 4P 590MM SHIELD 26AWG UL2547 1/3
NJ88	H03-SOSS9CKX3NN-4	JACK PHONE 6.35 H70980110S 9P BK
R1 2	RC3DI022AIN-2	RCF 2R2 OHM +5% 250MIOW
S1	H03-ZMB01S02200-4	SPRING PLATE GND C5212 0.2T

**3SA-4120US-FCMI-1-0 RMT/RS232 BD AVR435US**

BD11	H03-FB3012012CN-8	FBEAD SURFACE MT FCM2012C-301T04 0805
C601	CPIKC0473NN-0	CPF 47N0F +10% 100.0V
C602 603 604	H03-CEMIC0334AH-A	CAP ELEC 0.33UF M 5X11 SHL 50V SAMYOUNG P5MM
C605	RS3AD0000NA-0	RES CHIP 0 OHM +0% 62MI5W 0603
C606 611 622	CZZFI0104BF-8	CAP CHIP 100NOF +80% -20% 16.0V Y5V 0603
C610	CEHFC01075E-1	CE 100UF +-20% 16.0V D5XL11 P5MM 85C
C612	RS3AD0000NA-0	RES CHIP 0 OHM +0% 62MI5W 0603
C9	CEMIC01045E-1	CAP ELEC 0.1uF 50v M 5x11 SHL P5MM
D602 603 604 605	RS3AD0000NA-0	RES CHIP 0 OHM +0% 62MI5W 0603
D606 607 651 652 653	H03-DS1S50094NB-5	D-SLP 1SS355 35.0V 225MIOA
IC61	H03-ICMAX322316-7	IC RS-232 LINE DIRVER MAX3223CDWR SOIC16P
IC651 652	H03-ICPC17T10B1-8	IC PHOTOCOUPLER PC-17T1 DIP4 KODENSHI
L600 601 602 603	H03-FB2K52012NN-0	FBEAD SURFACE MT 2500OHM FCM2012H-252T02
NJ60	SOPA96063NN-0	JACK D-SUB 9P 87204-6063 W/DUST COVER BK
NJ611 612 613 614	H03-SOJW2350SNN-5	JACK PHONE 3.6 EP-1401A 1P BK
P260	H03-WN09AB00000-8	CONNECT 2.0MM 9P GIL-S-09P-S2L2-EF
Q651 652	H03-TRKTA107MNA-2	TR-SLPSWA KRA107M P
R600 601 602	RS3AD0472NA-3	RES CHIP 4K7 OHM +5% 1/16W 0603
R651	RS3AD0471NA-5	RES CHIP 470R0 OHM +5% 62MI5W 0603
R652	RS3AD0271NA-2	RES CHIP 270R0 OHM +5% 62MI5W 0603
R653 654	RS3AD0473NA-1	RES CHIP 47K0 OHM +5% 62MI5W 0603
R655 656	RS3AD0470NA-7	RES CHIP 47R0 OHM +5% 62MI5W 0603
R657	RS3AD0392NA-1	RES CHIP 3K9 OHM +5% 62MI5W 0603

REF NO.	PART NO.	DESCRIPTION	REMARKS
R658	RC3DI0104IN-5	RCF 100K0 OHM +5% 250MI0W	
R659	RC3DI0471IN-0	RCF 470R0 OHM +5% 250MI0W	
	3SA-4120US-MAMI-1-3	IMA MAIN BD AVR435US	
C509 510	CEHHC0228MN-A	CE 2MI2F +20% 35.0V 85C ELITE	
C517	CEHIA0228MN-4	CE 2MI2F +20% 50.0V 85C ELITE	
C504 505	H03-CEMJA0129KB-8	CAP ELEC 12000uF 63V M 35x45 LSW123M1JQ45M	
D501	H03-DRBU10040BA-1	D-BRDLC BRIDGE BU10-04	
HS11	H03-ZMC11HS0400-6	AC HEATSINK DIODE 47X26X12 AVR630 -- ME	
HS12	H03-ZMD11HS0400-2	HEATSINK REG. TR 68X20X50	
P806	H03-WN07SB00001-4	CONN 2.0MM 7P GIL-S-7P-S2T2-EF	
D502 505	H03-DRW204F00BA-5	DIODE BRIDGE W2-04F FRONTIER	
IC59	H03-ICKIA7812I2-8	IC-REGPOSFXD KIA7812API NORMAL	
IC54	H03-ICKIA7824I2-2	IC-REGPOSFXD KIA7824API TO-220IS NORMAL	
IC51	H03-ICLM07815BD-6	IC-REGPOSFXD KIA7815API NORMAL	
IC52	H03-ICLM07915BD-4	IC-REGNEGFXD KIA7915API NORMAL TO-220AB	
L301 302 401 402	H03-LCNNNA050NA-7	LFA 1MM 10MM 5 LEFT 0.0MM NONE	
R378 379 471 472	H03-RI3IC022BEN-3	RW 220MI0 OHM +5% 5.0W 100PPM/C -100PPM/C	
R392 393 475 476	RM3FC0100BN-7	RMOF 10R0 OHM +5% 1.0W	
R505	H03-RM3GC0100CN-2	RESISTOR METAL OXIDE 10R0 OHM +5% 2.0W	
R514	H03-RM3GC022ACN-3	RESISTOR METAL OXIDE 2R2 OHM +5% 2.0W	
R504 507 510	H03-RM3GC033ACN-2	RESISTOR METAL OXIDE 3R3 OHM +5% 2.0W	
NJ12	H03-SORA40RSANN-1	JACK RCA 4P JB040131ZN GN BN PP TA	
NJ11	H03-SORA40RSCNN-5	JACK RCA 4P JB040131QN WH BU RD GY	
NJ14	H03-SOPA81900NN-3	CONN-SPE TERMINAL SPKR 8P SH081136JP FE 19MM 8 -- 0 0	
Q335 336 439 440	H03-TR2SB1647B0-6	TRANSISTOR PNP 2SB1647 MT-100	
Q333 334 437 438	H03-TR2SD2560B0-2	TRANSISTOR NPN 2SD2560 MT-100	
Q319 320 421 422	H03-TRKTA1360BE-5	TRANSISTOR PNP KTA1360 TO-126	
Q321 322 423 424	H03-TRKTC3423BE-A	TRANSISTOR NPN KTC3423 TO-126	
	ZSMBM3014BZ-5	SCREW M.S M3X14 ZN PLATED	
P801 802 803 804 809	H03-WN02SD00000-2	CONN 2.5MM 2 MA ST NAT 5267-02A 0 0	
	ZNSSM3023HZ-8	NUT M3 ZN PLATED	
P807	H03-WN03SE00000-9	CON 3.96MM PITCH MOLEX 35313-0310	
P808	H03-WN05SD100WH-6	CONN WAFER 2.5MM 5P 5267-05A WHT	
P811	H03-WN19SB00000-1	CONN 2.0MM 19 MA ST NAT MOLEX 35336-1910 0 0	
NJ13	SO0A18P8CNN-7	JACK-TELE SNAP-IN GOLDEN TELECOM GDL1-8P8C 8T BK 0 0	
IC22	H03-ICLM02068D2-5	IC-OPERAMP NJM2068M-TE1 DUAL SOP8	
N801 802 803 804	H03-WG02SB808AA-4	WIRECONASY UNIQUE 2P 80MM UL1007 PVC DISCRETE 26 BOTH	
N805	H03-WS8262505EN-6	WIRE ASS'Y UL1533#26 250MM 2.0MM 8P WHT SHIELD	
N806	H03-WSE263905EN-0	WIRECONASY DL 2.0MM 15P 390MM UL1533 SHIELD 26 1	
N807	H03-WG03SB821AA-0	WIRECONASY DL 2.0MM 3P 210MM UL1007 RIBBON 26 12 BOTH	
N808	H03-WG05SB84000-7	WIRE ASS'Y UL1007#26STR 400MM 2.0MM 5P WHT	
N809	H03-WG03SB82200-4	WIRE ASS'Y UL1007#26STR 220mm 2.0mm 3P WHT	
W311	H03-WG116S500BK-0	WIRE ASS'Y UL1007#16 500MM 1P BLK TERMINAL	
W401-2	H03-WC1180905H1-0	WIRE ASS'Y WCL 1P 90MM UL1015#18(TD) BLK HOOK-UP 090-05-05	
	ZWM803305PZ-1	WASHER PLAIN 3	
W301	H03-WC1180175H1-1	WIRE ASS'Y 1P 175MM UL1015#18(TD) BLK	
R494 REWORK	RC3DI0822IN-8	RCF 8K2 OHM +5% 250MI0W	
	XY0N211N5WH-4	CABLE TIE W=0.2MM L=11.5CM WHITE @ STRIP	
	XY0P523K000-A	WIRE,IRON,D=0.5MM,N.W=23KG @KG	
	XY0P801K000-A	WIRE TIN D=0.8MM N.W=1.0KG @KG	
	XY1N127N0WH-5	ADHESIVE WHITE D=1.1CM L=27CM @KG	
	XY1N218M3SW-4	GLUE FURROW W=12MML=18.3M SS WHITE @ROLL	
	XY1P202K000-1	WIRE, TIN, D=1.2MM N.W=2.0KG @KG	
	XY2N418M3SW-6	GLUE FURROW W=24MML=18.3M SS WHITE @ROLL	
	XY57501K0YW-0	GLUE, YELLOW, N.W=1.0KG #575 @KG	
	XY6R301K000-0	BAR,TIN,63/37,N.W=1.0KG @KG	
	XY74601K0WH-9	OINTMENT HTC #SDL-746 NW=1.0KG WHITE @KG	
	XYALC01G000-2	ALCOHOL V=1.0GALLON @GALLON	

REF NO.	PART NO.	DESCRIPTION	REMARKS
	XYRF801G000-7	FLUX #RF-800 V=1.0 GALLON @ GALLON	
	XYWAX10K000-6	ANTI-OXIDATION,WAX,W-1#,N,W=10KG,@KG	
	3SA-4120US-MAAA-1-1	IAA MAIN BD AXIAL AVR435US	
C101 102 107 108 111 112 114 115 116 209	CCKID0101NA-7	CC 100P0F +10% -10% 50.0V Y5P	
C313 314 569 570	CCKID0271NN-0	CC 270P0F +10% -10% 50.0V 2B4	
C433 601 602	CCMFD0103NN-4	CC 10N0F +20% -20% 16.0V Y5S	
C333 434	CCMFD0472NN-6	CC 4N7F +20% -20% 16.0V Y5R	
C119 120 212 214 527	CCZID0104NA-2	CC 100N0F +80% -20% 50.0V F	
D205 206 301 302 303 304 305 306 307 308 401 402 403 404 405 406 407 408 409 410 411 412	H03-DG1N04148NB-A	D-SLP 1N4148 100.0V 150E-3A	
D101 507 508 509	H03-DR1N04004NA-7	D-SR 1N4004 400.0V 1.0A	
D207	H03-DZMTZ05V1NB-3	DIODE ZENER MTZ J 5.1B 5.1V 500MW DO-34	
D204	H03-DZMTZ12V0NB-6	D-ZENER MTZJ 12.0V 500MIOW	
R351 352 367 368 445 446 447 448	H03-RM3EG0180LN-2	RMOF 18R0 OHM +5% 500MIOW	
	PBD11KMAI21-4	PCB SINGLE AVR435/635 MAIN 330x247x1.6t FR-1 1OZ	
R303 304 388 389 473 474 477 478	RC3DI0100IN-2	RCF 10R0 OHM +5% 250MIOW	
R213 215 221 609 614	RC3DI0101IN-0	RCF 100R0 OHM +5% 250MIOW	
R211 601	RC3DI0102IN-9	RCF 1K0 OHM +5% 250MIOW	
R485 516 605 606 608 610 611 613	RC3DI0103IN-7	RCF 10K0 OHM +5% 250MIOW	
R207 214 216 217 218 219 220 309 310 479 480 602	RC3DI0104IN-5	RCF 100K0 OHM +5% 250MIOW	
R311 312 313 314 380 381 386 387 405 406 407 408 481 483 488 490	RC3DI0152IN-5	RCF 1K5 OHM +5% 250MIOW	
R384 385 482 489 503	RC3DI0153IN-3	RCF 15K0 OHM +5% 250MIOW	
R331 332 419 420	RM1DI1651IN-7	RMF 1K65 OHM +-1% 250MIOW	
R317 318 319 320 409 410 411 412	RC3DI0221IN-1	RCF 220R0 OHM +5% 250MIOW	
R341 342 343 344 390 391 437 438 439 440 486 492	RC3DI0223IN-8	RCF 22K0 OHM +5% 250MIOW	
R616	RC3DI022AIN-2	RCF 2R2 OHM +5% 250MIOW	
R321 322 413 414 497	RC3DI0271IN-8	RCF 270R0 OHM +5% 250MIOW	
R209 498	RC3DI0273IN-4	RCF 27K0 OHM +5% 250MIOW	
R224	RC3DI0274IN-2	RCF 270K0 OHM +5% 250MIOW	
R301 302 401 402	RC3DI0331IN-5	RCF 330R0 OHM +5% 250MIOW	
R363 364 365 366 461 462 463 464	RC3DI033AIN-6	RCF 3R3 OHM +5% 250MIOW	
R382 383 484 487 491 493 501 502	RC3DI0393IN-5	RCF 39K0 OHM +5% 250MIOW	
R307 308 415 416	RC3DI0433IN-8	RCF 43K0 OHM +5% 250MIOW	
R223	RC3DI0513IN-A	RCF 51K0 OHM +5% 250MIOW	
R323 324 325 326 329 330 333 334 335 336 337 338 421 422 423 424 425 426 427 428 429 430 431 432	RC3DI0561IN-A	RCF 560R0 OHM +5% 250MIOW	
R347 348 349 350 441 442 443 444	RC3DI0750IN-7	RES FILM 75 OHM 1/4W 5%	
C103 104 109 110 113 117 118	CCKID0470NA-9	CC 47PF +10% -10% 50.0V Y5P	
R327 328 417 418	RM1DI0333IN-4	RMF 33K0 OHM +1% 250MIOW	
R101 102 105 106 109 110 113 114 315 316 593 594	RC3DI0471IN-0	RCF 470R0 OHM +5% 250MIOW	
R607 612	RC3DI0123IN-1	RCF 12K0 OHM +5% 250MIOW	

REF NO.	PART NO.	DESCRIPTION	REMARKS
R225 305 306 403 404	RC3DI0333IN-1	RCF 33K0 OHM +5% 250MI0W	
C307 308 403 404	CCKID0680NN-5	CC 68PF +10% -10% 50.0V 2B4	
	<b>3SA-4120US-MAAR-1-3</b>	<b>IAR MAIN BD RADIAL AVR435US</b>	
C315 316 409 410	CCJIC0120NN-2	CAP CERAMIC 12PF 50V J CH TAP	
C317 318 411 412	CCJIC0330NE-9	CAP CERAMIC 33PF 50V +-5% NPO	
C329 330 425 426	CCKIC0222NA-1	CC 2N2F +10% -10% 50.0V Y5P	
C331 332 407 408	CEHEC02275E-9	CE 220UF +20% 10.0V D6.3XL11 P5MM 85C	
C432	CEMGC04775E-9	CE 470U0F +/-20% 25.0V 10X13 85C	
C206 208 213 309 310 405 406 526	CEHGC01075E-5	CE 100U0F +20% 25.0V 6.3X11 85C P5MM	
C210	CEHIC01055E-6	CE 1UF +20% 50V D5XL11 P5MM 85C	
C301 302 401 402 429 518 519 521	CEHIC01065E-4	CE 10U0F +20% 50.0V 85C P5MM 5X11	
C501 502 503	CFIOC0104NN-5	CPM 100N0F +10% 250.0V	
C323 324 430 431	CFLJC0683NN-7	CPM 68N0F +5% 63.0V	
C506 507 508 516 528 529	CPIKC0473NN-0	CPF 47N0F +10% 100.0V	
Q443	H03-TRKRC107MNA-4	TR-SLPSWA KRC107M N	
C207	H03-CEMIC0475AH-3	CE 4.7UF 50V M 5X11 SHL SAMYOUNG P5MM	
C303 304 305 306 421 422 423 424	CEMJC02275E-0	CAP ELEC 220UF 63V M 10X16 85C 120HZ ELITE P5MM	
C211 319 320 413 414	H03-CEMKC0106AH-9	CAP ELEC 10UF 100V M 6.3X11 SHL	
C325 326 327 328 417 418 419 420	H03-CPKJC0104NN-2	CAP POLY NON METAL 0.1UF 63V K TAP PCMT365 75104	
F501 502 505 506	H03-FURN2200663-8	FUSE 663 SERIES 0663 002. 250V 2.0A TIMELUG	
G101 102	H03-ZNMSA4004SN-A	TERMLUG GND	
Q442	H03-TRKTA1024NA-2	TR-SLPLF KTA1024 Y P 50MI0A -150V	
Q605 607	H03-TRKTA1266NA-6	TR-SLPLF KTA1266 Y P 150MI0A	
Q311 312 410 413 414	H03-TRKTA1268NA-A	TR-SHPLF KTA1268BL P 100MI0A 120V	
Q307 308 407 408 426 441 606 608	H03-TRKTC3198NA-9	TR-SLPLF KTC3198BL N 150MI0A	
Q301 302 303 304 305 306 313 314 337 338 401 402 403 404 405 406 409 415 416 425	H03-TRKTC3200NA-4	TR-SHPLF KTC3200BL N 100MI0A 120V	
Q601	H03-TRKTD1302NA-6	TR-SLPLF KTD1302 B N 300MI0A 20V	
Q309 310 411 412	H03-TR2SA1145NA-8	TR-SLPLF 2SA1145Y TO-92MOD P -50MI0A -150V	
	<b>3SA-4120US-MAMI-1-3</b>	<b>FRONT L - BIAS BD AVR435US</b>	
R705	RC3DI0821IN-A	RCF 820R0 OHM +5% 250MI0W	
R707	RC3DI0282IN-3	RCF 2K8 OHM +5% 250MI0W	
VR71	RT6BA0201NB-A	PR 200R0 OHM +30% 100MI0W	
Q701	H03-TRKTC3114NE-9	TRANSISTOR NPN KTC3114 TO-126	
	<b>3SA-4120US-MAMI-1-3</b>	<b>FRONT R - BIAS BD AVR435US</b>	
R710	RC3DI0282IN-3	RCF 2K8 OHM +5% 250MI0W	
R708	RC3DI0821IN-A	RCF 820R0 OHM +5% 250MI0W	
VR74	RT6BA0201NB-A	PR 200R0 OHM +30% 100MI0W	
Q704	H03-TRKTC3114NE-9	TRANSISTOR NPN KTC3114 TO-126	
	<b>3SA-4120US-MAMI-1-3</b>	<b>SURROUND L - BIAS BD AVR435US</b>	
R711	RC3DI0282IN-3	RCF 2K8 OHM +5% 250MI0W	
R709	RC3DI0821IN-A	RCF 820R0 OHM +5% 250MI0W	
VR73	RT6BA0201NB-A	PR 200R0 OHM +30% 100MI0W	
Q703	H03-TRKTC3114NE-9	TRANSISTOR NPN KTC3114 TO-126	
	<b>3SA-4120US-MAMI-1-3</b>	<b>SURROUND - R BIAS BD AVR435US</b>	
R701	RC3DI0282IN-3	RCF 2K8 OHM +5% 250MI0W	
R702	RC3DI0821IN-A	RCF 820R0 OHM +5% 250MI0W	
PO71	H03-RP3NA0101NN-5	POS 100R0 OHM 16.0V	
PO72	H03-RP3NA0101HJ-4	THERMISTOR ASS'Y RP3NA-0101-NZ	
Q702	H03-TRKTC3114NE-9	TRANSISTOR NPN KTC3114 TO-126	
VR72	RT6BA0201NB-A	PR 200R0 OHM +30% 100MI0W	

REF NO.	PART NO.	DESCRIPTION	REMARKS
<b>3SA-4120US-POMI-1-1 IMA PROCESSOR BD AVR435US</b>			
NJ101 102 103 104 105	H03-SORA40GNDNN-2	JACK RCA 4P JB040131PN WWRR	
P101	H03-WN03SB00000-1	CONN 2.0MM 3 MA ST NAT GT201-3P-TS	
P103 104 113	H03-WN04SB00000-9	CONN 2.0MM 4 MA ST NAT GT201-4P-TS	
P110	H03-WN06SB00000-3	CONN 2.0MM 6 MA ST NAT GT201-6P-TS	
P111	H03-WN08SB00000-8	CONN 2.0MM 8 MA ST NAT GT201-8P-TS	
P108	H03-WN11AB00000-6	CONN 2.0MM 11 MA R NAT SOCKET MOLEX 35237-1110 0 0	
P112	H03-WN15SB00000-2	CONN 2.0MM 15 MA ST NAT GT201-15P-TS	
P106 107 109	H03-WN19AB00000-4	CONN 2.0MM 19 MA R NAT SOCKET MOLEX 35237-1910 0 0	
D601 602 603 604	H03-DZMTZ09V1NB-6	D-ZENER MTZJ 9.1V 500MI0W	
R691 692	RC3DI0331IN-5	RCF 330R0 OHM +5% 250MI0W	
C588 589 REWORK	CCKID0101NA-7	CC 100P0F +10% -10% 50.0V Y5P	
	XY0P523K000-A	WIRE,IRON,D=0.5MM,N.W=23KG @KG	
	XY0P801K000-A	WIRE TIN D=0.8MM N.W=1.0KG @KG	
	XY1N209M0DW-4	GLUE TAPE W=12MM L=9.0M DS WHITE @ROLL	
	XY1N218M3CL-9	GLUE TRANSPARENT W=12MM L=18.3M @ROLL	
	XY1N218M3SW-4	GLUE FURROW W=12MML=18.3M SS WHITE @ROLL	
	XY1P202K000-1	WIRE, TIN, D=1.2MM N.W=2.0KG @KG	
	XY30155G00-0	TCE,CLEANER,-301#,V=55GALLON,TYPELESS @GALLON	
	XY4N836M5CL-9	GLUE TRANSPARENT W=48MM L=36.5M @ROLL	
	XY6R301K000-0	BAR,TIN,63/37,N.W=1.0KG @KG	
	XYALC01G000-2	ALCOHOL V=1.0GALLON @GALLON	
	XYGLU00K5RD-7	GLUE, RED, W=0.5KG TYPELESS FOR SMT @KG	
	XYJU100K5GY-5	JUICE TIN N=0.5KG GREY @KG	
	XYRF801G000-7	FLUX #RF-800 V=1.0 GALLON @ GALLON	
	XYWAX10K000-6	ANTI-OXIDATION,WAX,W-1#,N.W=10KG,@KG	
<b>3SA-4120US-POAR-1-1 IAR PROCESSOR BD RADIAL AVR435US</b>			
C109 110 113 114 125 126 127			
128 141 143 144 146 206 207			
212 213 220 221 226 227 230			
231 232 233 301 302 303 304			
508 510 511 515 517 518 521	CEHIC01065E-4	CE 10U0F +20% 50.0V 85C P5MM 5X11	
522 528 529 534 535 601 602			
611 612 617 618 621 622 627			
628 631 632 637 638 641 642			
647 648 651 652			
C607 608	CEHGC0337NN-0	CE 330UI0F +20% 25V 85C ELITE P5MM	
C111 112 129 130 142 145 214			
215 228 229 234 235 236 237			
305 306 313 314 501 502 504			
505 507 509 514 516 523 524	CEMGC04765E-0	CAP ELEC 47UF 25V 85C 5X11 P5MM	
525 526 536 537 538 539 541			
542 609 610 619 620 629 630			
639 640 649 650 653 654			
	PBD11KPOB21-8	PCB DUAL AVR435/635 PROCESSOR 209x170x1.6t FR-4 1OZ	
<b>3SA-4120US-POSB-1-2 BOT SMD PROCESSOR BD AVR435US</b>			
C101 102 103 104 105 106 107			
108 116 117 118 119 121 122			
123 124 131 132 133 134 136			
137 138 139 147 148 149 150			
152 153 154 155 156 157 158			
159 201 202 204 205 216 217	CZJII0101BE-2	CAP CHIP 100P0F +5% -5% 50.0V NP0 0603	
218 219 224 225 238 315 503			
506 519 520 527 530 531 540			
543 603 604 613 614 623 624			
633 643 644			
C208 209 222 223	CZJII0330BE-9	CAP CHIP 33P0F +5% -5% 50.0V NP0 0603	
C605 606	CZJII0331BE-7	CAP CHIP 330P0F +5% -5% 50.0V NP0 0603	
C512 513 634	CZKII0222BC-8	CAP CHIP 2N2F +10% -10% 50.0V X7R 0603	
C120 135 151 160 203	CZZFI0104BF-8	CAP CHIP 100N0F +80% -20% 16.0V Y5V 0603	

REF NO.	PART NO.	DESCRIPTION	REMARKS
IC304	H03-ICTC9273NDA-6	IC-SWITCH TC9273F-004 SOP28 ANALOG SWITCH	
Q620 623 626 629	H03-TRDTA114YNI-4	TR-SSD DTA114YKA P 10K0 OHM 47K0 OHM	
Q1	H03-TRDTC114YNI-0	TR-SSD DTC114YKA N 10K0 OHM 47K0 OHM	
Q616 617 621 622 624 625 627 628 630 631	H03-TRKTD1304ND-0	TR-SLPSWA KTD1304 N 20V 300MIOA SOT-23	
R512 520 550 551	RS3AD0103NA-1	RES CHIP 10K0 OHM +5% 62MI5W 0603	
R113 114 137 138 157 158 217 218 237 238 239 240 245 246 307 308 324 325 501 502 507 508 513 519 526 532 539 540 541 542 556 557 558 559 567 568 619 620 635 636 651 652 669 670 685 686	RS3AD0101NA-5	RES CHIP 100R0 OHM +5% 62MI5W 0603	
R101 102 107 108 121 122 127 128 141 142 147 148 161 162 165 166 169 170 203 204 211 212 223 224 247 248 249 322 323 329 330 331 503 504 505 509 510 511 543 544 545 560 561 562 569 570 571 631 632 643 644 649 650 659 660 665 666 679 680 687 688	RS3AD0102NA-3	RES CHIP 1K0 OHM +5% 62MI5W 0603	
R103 104 109 110 115 116 123 124 129 131 132 136 143 144 151 152 153 154 163 164 167 168 171 172 207 208 227 228 233 234 241 242 303 304 305 306 518 524 528 531 535 536 537 538 548 549 554 555 603 604 609 610 625 626 629 630 641 642 647 648 657 658 663 664 677 678 689 690	RS3AD0104NA-A	RES CHIP 100K0 OHM +5% 62MI5W 0603	
R514 521	RS3AD0123NA-6	RES CHIP 12K0 OHM +5% 62MI5W 0603	
R4	RS3AD0153NA-8	RES CHIP,15K 1/16W,+/-5%,0603.	
R704 710 716 722	RS3AD0183NA-A	RES CHIP 18K0 OHM +5% 62MI5W 0603	
R529 552 553	RS3AD0202NA-A	RES CHIP 2K0 OHM +5% 62MI5W 0603	
R611 612 613 614	RS3AD0221NA-6	RES CHIP 220R0 OHM +5% 62MI5W 0603	
R225 226 615 616 617 618 633 634 667 668 693 694 697 698 701 702 707 708 713 714 719 720	RS3AD0222NA-4	RES CHIP 2K2 OHM +5% 62MI5W 0603	
R607 608	RS3AD0242NA-9	RES CHIP 2K4 OHM +5% 62MI5W 0603	
R516 523	RS3AD0332NA-8	RES CHIP 3K3 OHM +5% 62MI5W 0603	
R119 120 139 140 159 160 219 220 621 622 637 638 653 654 671 672 673 674 695 696 723 724 725 726 727 728	RS3AD0333NA-6	RES CHIP 33K0 OHM +5% 62MI5W 0603	
R2 3	RS3AD0122NA-8	RES CHIP 1K2 OHM +5% 62MI5W 0603	
R105 106 117 118 125 126 133 134 145 146 155 156 201 202 215 216 221 222 235 236 243 244 301 302 527 533 534 546 547 601 602 623 624 639 640 655 656 675 676	RS3AD0471NA-5	RES CHIP 470R0 OHM +5% 62MI5W 0603	
R530	RS3AD0472NA-3	RES CHIP 4K7 OHM +5% 1/16W 0603	
R703 709 715 721	RS3AD0474NA-A	RES CHIP 470K0 OHM +5% 62MI5W 0603	
R209 210 229 230	RS3AD0512NA-6	RES CHIP 5K1 OHM +5% 62MI5W 0603	
R605 606	RS3AD0911NA-3	RES CHIP 910 OHM +5% 62MI5W 0603	
R5 6	RS3AD0430NA-8	RES CHIP 43R0 OHM +5% 62MI5W 0603	
R231 232	RS3AD0272NA-0	RES CHIP 2K7 OHM +5% 62MI5W 0603	
R730 731	RS3AD0511NA-8	RES CHIP 510R0 OHM +5% 62MI5W 0603	

REF NO.	PART NO.	DESCRIPTION	REMARKS
C532 533	CZEII0100BE-0	CAP CHIP 10P0F +0P5F -0P5F 50.0V NP0 0603	
	<b>3SA-4120US-POST-1-8</b>	<b>TOP SMD PROCESSOR BD AVR435US</b>	
C210 211 316	CZJII0101BE-2	CAP CHIP 100P0F +5% -5% 50.0V NP0 0603	
C615 616 625 626 635 645 646	CZJII0330BE-9	CAP CHIP 33P0F +5% -5% 50.0V NP0 0603	
C636	CZKII0222BC-8	CAP CHIP 2N2F +10% -10% 50.0V X7R 0603	
IC606	H03-ICBU4053BB4-2	IC BU4053BCF SOP16 ANALOG MPX/DEMPX	
IC502 510	H03-ICKIC9162DA-0	IC-SWITCH KIC9162AF SOP28 ANALOG SWITCH	
IC501	H03-ICKIC9163DA-2	IC-SWITCH KIC9163AF SOP28 ANALOG SWITCH	
IC204 507	H03-ICKIC9459D5-3	IC-LOWFREQ KIC9459F SOP24 TONE/VOL/BAL/MUTE	
IC101 102 103 201 202 203 301 503 504 505 506 508 602 603 604 605	H03-ICLMO2068D2-5	IC-OPERAMP NJM2068M-TE1 DUAL SOP8	
IC509	H03-ICLMO9482DA-0	IC-LOWFREQ KIC9482F/TC9482F SOP28 TONE/VOL/BAL/MUTE	
IC303	H03-ICTC9273NDA-6	IC-SWITCH TC9273F-004 SOP28 ANALOG SWITCH	
Q103 106 109 203 605 608 611 614 615 618	H03-TRDTA114YNI-4	TR-SSD DTA114YKA P 10K0 OHM 47K0 OHM	
Q101 102 104 105 107 108 201 202 204 205 601 602 603 604 606 607 609 610 612 613	H03-TRKTD1304ND-0	TR-SLPSWA KTD1304 N 20V 300MIOA SOT-23	
R326 327 328	RS3AD0102NA-3	RES CHIP 1K0 OHM +5% 62MI5W 0603	
R213 214 683 684	RS3AD0104NA-A	RES CHIP 100K0 OHM +5% 62MI5W 0603	
R515 522	RS3AD0123NA-6	RES CHIP 12K0 OHM +5% 62MI5W 0603	
R627 628	RS3AD0152NA-A	RES CHIP 1K5 OHM +5% 62MI5W 0603	
R705 706 711 717 718	RS3AD0202NA-A	RES CHIP 2K0 OHM +5% 62MI5W 0603	
R111 112 130 135 149 150 205 206	RS3AD0222NA-4	RES CHIP 2K2 OHM +5% 62MI5W 0603	
R517 525	RS3AD0332NA-8	RES CHIP 3K3 OHM +5% 62MI5W 0603	
R699 700	RS3AD0362NA-A	RES CHIP 3K6 OHM +5% 62MI5W 0603	
R645 646 661 681 682	RS3AD0562NA-2	RES CHIP 5K6 OHM +5% 62MI5W 0603	
R662	RS3AD0912NA-1	RES CHIP 9K1 OHM +5% 62MI5W 0603	
D1 2	H03-DSUDZ09V1NB-2	D-ZENER UDZS 9.1B 9.1V 200MIOW	
R7	RS3AD0221NA-6	RES CHIP 220R0 OHM +5% 62MI5W 0603	
R712	RS3AD0242NA-9	RES CHIP 2K4 OHM +5% 62MI5W 0603	
IC601	H03-ICNJM4556B2-2	IC OP AMP NJM4556AD DIP8	
	<b>3SA-4120US-SRMI-1-A</b>	<b>IMA SURROUND BD AVR435US</b>	
C604	CEMFA02285E-5	CE 2200UF 16V M 12.5X20 P5MM	
C605	CEMFA0828BK-0	CAP ELEC 8200UF 16V M 18X25 P7.5MM ELITE	
C606	CEMFA0688BK-1	CAP ELEC 6800UF 16V M 16X25 85C 120HZ ELITE	
D601	H03-DRBU604F0NA-4	DIODE BRIDGE BU6-04F FRONTIER	
L201 301 501	H03-LCNNNA050NA-7	LFA 1MM 10MM 5 LEFT 0.0MM NONE	
R238 338 538	H03-RI3IC022BEN-3	RW 220MIO OHM +5% 5.0W 100PPM/C -100PPM/C	
R245 345 545	RM3FC0100BN-7	RMOF 10R0 OHM +5% 1.0W	
PO11	H03-RP3NA0101NN-5	POS 100R0 OHM 16.0V	
PO10	H03-RP3NA0101HJ-4	THERMISTOR ASS'Y RP3NA-0101-NZ	
VR301 501	H03-RT7EA0201NB-1	PR 200R0 OHM +20% 500MIOW	
NJ401	H03-SOPA8SH0612-5	JACK SPEAKER 8P SH0612707P	
Q219 319 519	H03-TR2SB1647B0-6	TRANSISTOR PNP 2SB1647 MT-100	
Q218 318 518	H03-TR2SD2560B0-2	TRANSISTOR NPN 2SD2560 MT-100	
Q211 311 511	H03-TRKTA1360BE-5	TRANSISTOR PNP KTA1360 TO-126	
Q214 314 514	H03-TRKTC3114NE-9	TRANSISTOR NPN KTC3114 TO-126	
Q212 312 512	H03-TRKTC3423BE-A	TRANSISTOR NPN KTC3423 TO-126	
P405	H03-WH800012P36-6	PIN HEADER YFW-800-01 2.36PI	
P201 301 501	H03-WN02AD00000-5	CONNECT WAFER 2.5mm 2P 5268-02A WHT ANGLE	
N403	H03-WN03SD100WH-1	CONN WAFER 2.5MM 3P 5267-03A WHT	
N404	H03-WG06SE81200-2	WIRE ASS'Y UL1007#16 120mm 3.96mm 6P RED	
N402	H03-WN10SB00000-6	CONNECT 2.0MM 10P GIL-S-10P-S2T2-EF	
N401	H03-WS6262605EN-1	WIRECONASY DL 2.0MM 6P 260MM UL1533 SHIELD 26 1	
VR201	RT6BA0201NB-A	PR 200R0 OHM +30% 100MIOW	
REWORK	H03-WC1201005C1-4	WIRE ASS'Y UL1007 #20 TS 100MM 1P BLK	



REF NO.	PART NO.	DESCRIPTION	REMARKS
	XY0P523K000-A	WIRE,IRON,D=0.5MM,N.W=23KG @KG	
	XY0P801K000-A	WIRE TIN D=0.8MM N.W=1.0KG @KG	
	XY1N218M3SW-4	GLUE FURROW W=12MML=18.3M SS WHITE @ROLL	
	XY1P00000TH-7	TUBE,HEAT SHRINKABLE,D=1.0MM VW1 L200M	
	XY1P202K000-1	WIRE, TIN, D=1.2MM N.W=2.0KG @KG	
	XY57501K0YW-0	GLUE, YELLOW, N.W=1.0KG #575 @KG	
	XY6R301K000-0	BAR,TIN,63/37,N.W=1.0KG @KG	
	XY74601K0WH-9	OINTMENT HTC #SDL-746 NW=1.0KG WHITE @KG	
	XYALC01G000-2	ALCOHOL V=1.0GALLON @GALLON	
	XYRF801G000-7	FLUX #RF-800 V=1.0 GALLON @ GALLON	
	XYWAX10K000-6	ANTI-OXIDATION,WAX,W-1#,N.W=10KG,@KG	
	<b>3SA-4120US-SRAA-1-8</b>	<b>IAA SURROUND BD AXIAL AVR435US</b>	
	PBD11KSRI21-6	PCB SINGLE AVR435/635 SURROUND 330x247x1.6t FR-1 1OZ	
C206 306 506	CCKID0271NN-0	CC 270P0F +10% -10% 50.0V 2B4	
D101 201 202 203 204 301 302 303 304 501 502 503 504	H03-DG1N04148NB-A	D-SLP 1N4148 100.0V 150E-3A	
R101	RC3DI0103IN-7	RCF 10K0 OHM +5% 250MI0W	
R102 242 342 542	RC3DI0393IN-5	RCF 39K0 OHM +5% 250MI0W	
R246 346 546	RC3DI0104IN-5	RCF 100K0 OHM +5% 250MI0W	
R201 301 501	RC3DI0331IN-5	RCF 330R0 OHM +5% 250MI0W	
R203 243 303 343 503 543	RC3DI0100IN-2	RCF 10R0 OHM +5% 250MI0W	
R204 304 504	RC3DI0433IN-8	RCF 43K0 OHM +5% 250MI0W	
R205 305 505	RC3DI0271IN-8	RCF 270R0 OHM +5% 250MI0W	
R206 207 306 307 506 507	RC3DI0221IN-1	RCF 220R0 OHM +5% 250MI0W	
R209 210 239 241 309 310 339 341 509 510 539 541	RC3DI0152IN-5	RCF 1K5 OHM +5% 250MI0W	
R211 214 215 216 217 218 311 314 315 316 317 318 511 514 515 516 517 518	RC3DI0561IN-A	RCF 560R0 OHM +5% 250MI0W	
R202 212 302 312 502 512	RM1DI0333IN-4	RMF 33K0 OHM +1% 250MI0W	
R213 313 513	RM1DI1651IN-7	RMF 1K65 OHM +-1% 250MI0W	
R220 221 244 320 321 344 520 521 544	RC3DI0223IN-8	RCF 22K0 OHM +5% 250MI0W	
R223 224 323 324 523 524	RC3DI0750IN-7	RES FILM 75 OHM 1/4W 5%	
R225 233 325 333 525 533	H03-RM3EG0180LN-2	RMOF 18R0 OHM +5% 500MI0W	
R228 235 328 335 528 535	RC3DI033AIN-6	RCF 3R3 OHM +5% 250MI0W	
R208 308 508	RC3DI0471IN-0	RCF 470R0 OHM +5% 250MI0W	
R229 329 529	RC3DI0282IN-3	RCF 2K8 OHM +5% 250MI0W	
R230 330 530	RC3DI0821IN-A	RCF 820R0 OHM +5% 250MI0W	
R240 340 540	RC3DI0153IN-3	RCF 15K0 OHM +5% 250MI0W	
C204 304 504	CCKID0680NN-5	CC 68PF +10% -10% 50.0V 2B4	
	<b>3SA-4120US-SRAR-1-A</b>	<b>IAR SURROUND BD RADIAL AVR435US</b>	
C207 307 507	CCJIC0120NN-2	CAP CERAMIC 12PF 50V J CH TAP	
C209 309 509	CCJIC0330NE-9	CAP CERAMIC 33PF 50V +-5% NPO	
C215 315 517	CCKIC0332NA-5	CC 3N3F +10% -10% 50.0V Y5P	
C216 316 516	CCKIC0472NA-0	CC 4N7F +10% -10% 50.0V Y5P	
C208 308 508	CEHEC02275E-9	CE 220UF +20% 10.0V D6.3XL11 P5MM 85C	
C205 305 505	CEHGC01075E-5	CE 100U0F +20% 25.0V 6.3X11 85C P5MM	
C601 602 603	CPIKC0473NN-0	CPF 47N0F +10% 100.0V	
C210 310 510	CPJJC0683NN-A	CAP POLY NON METAL 68NF 63V J TAP	
C201 202 301 302 501 502	CEMJC02275E-0	CAP ELEC 220UF 63V M 10X16 85C 120HZ ELITE P5MM	
C101 203 303 503	H03-CEMIC01065H-1	CAP ELEC 10UF 50V M 5X11 SHL P5MM	
C211 311 511	H03-CEMKC0106AH-9	CAP ELEC 10UF 100V M 6.3X11 SHL	
C213 214 313 314 513 514	H03-CPKJC0104NN-2	CAP POLY NON METAL 0.1UF 63V K TAP PCMT365 75104	
F601 602	H03-FURN23A1563-5	FUSE 663 SERIES 3.15 250V 3.15A LT-5 TIMELUG	
Q205 305 505	H03-TR2SA1145NA-8	TR-SLPLF 2SA1145Y TO-92MOD P -50M0A -150V	
G101 102 103 105	H03-ZNMSA4004SN-A	TERMLUG GND	
Q101 206 306 506	H03-TRKTA1268NA-A	TR-SHPLF KTA1268BL P 100M0A 120V	
Q204 304 504	H03-TRKTC3198NA-9	TR-SLPLF KTC3198BL N 150M0A	

REF NO.	PART NO.	DESCRIPTION	REMARKS
Q201 202 203 207 220 301 302 303 307 320 501 502 503 507 520	H03-TRKTC3200NA-4	TR-SHPLF KTC3200BL N 100MIOA 120V	
	3SA-4120US-SUMI-1-5	IMA SUPPLY BD AVR435US	
C201 202	H03-CEMJA0828KA-A	CAP ELEC 8200UF 63V M 30X40 LSW822M1JP40M	
R108	H03-RM3GC0330CN-1 XY0N211N5WH-4	RESISTOR METAL OXIDE 33 OHM +5% 2.0W CABLE TIE W=0.2MM L=11.5CM WHITE @ STRIP	
C100	CFMVA0104NN-2	CPPMX 100N0F +20% -20% P15MM	
F101	H03-FUGF210A065-2	FUSE 65TS SERIES 65 TS 250V 10A	
IC301	H03-ICKIA278R33-2 XY0N618M3SW-A	IC VOLTAGE REGULATOR KIA278R33PI TO-220IS-4 GLUE FURROW W=6MM L=18.3M SS WHITE @ROLL	
R113	RM3FC0100BN-7	RMOF 10R0 OHM +5% 1.0W	
IC11 302 304	H03-ICKIA7805I2-2	IC-REGPOSFXD KIA7805API NORMAL TO-220IS	
IC303	H03-ICKIA7905I2-0	IC-REGNEGFXD KIA7905PI NORMAL	
SK11	H03-RLL1227111K-7	RELAYPWR 12.0V 270.0OHM 10.0A	
R114	H03-RM3FC047ABN-4	RESISTOR METAL OXIDE 4R7 1W 5%	
NJ71	H03-SO3P5179NNN-A	JACK PHONE 3.5PI PJ0435179N	
HK11	H03-ZMC12HS0100-9	AC HEATSINK 17*15*30 AVR520 -- ME	
NJ79	H03-SOTOR179LBA-6	D-LEM TORX-179L	
NS19	H03-SOXA27014NN-4	CON MAINS INLET A/C INLET 7014-NGP AC05-4S020A	
TP11	H03-TXPWSUB635A-4	POWER TRANSFORMER AVR635 SUB	
P305 306	H03-WN02SE00000-1	CON 3.96MM PITCH HEADER 2 POS MOLEX 35328-0210	
P301	H03-WN03SE00000-9	CON 3.96MM PITCH MOLEX 35313-0310	
P307	H03-WN05SD100WH-6	CONN WAFER 2.5MM 5P 5267-05A WHT	
P308	H03-WN08SD00000-6	CONN 2.5MM 8 MA ST NAT 0 0	
N301	H03-WS5268505CN-6	CNT ASSY 2.0MM 5P 850MM SHIELD 26AWG UL1007	
P303	H03-WN19AB00000-4	CONN 2.0MM 19 MA R NAT SOCKET MOLEX 35237-1910 0 0	
P304	H03-WN19SB00000-1	CONN 2.0MM 19 MA ST NAT MOLEX 35336-1910 0 0	
P310	H03-WN06SE00000-0	CONNECT 6P 3.96MM 35313-0610	
N304	H03-WG03SE8122A-8	WIRE ASS'Y UL1617#22 120mm 3.96mm 3P WHT	
N311	H03-WG10SB81100-6	WIRE ASS'Y UL1007#26 STR 110mm 2.0mm 10P WHT	
SH11	H03-ZMC12S17A00-6	AC PUN SHIELD DIGITAL ET	
D201	H03-DRBU10040BA-1	D-BRDLC BRIDGE BU10-04	
C101	CCMOC0472NF-9 XY0P523K000-A XY0P801K000-A XY1N209M0DW-4 XY1N218M3CL-9 XY1N218M3SW-4 XY1P202K000-1 XY30155G00-0 XY4N836M5CL-9 XY501110CRD-2 XY57501K0YW-0 XY6R301K000-0 XYALC01G000-2 XYGLU00K5RD-7 XYRF801G000-7 XYWAX10K000-6	CC 4N7F +20% -20% 250.0V Y5V WIRE,IRON,D=0.5MM,N.W=23KG @KG WIRE TIN D=0.8MM N.W=1.0KG @KG GLUE TAPE W=12MM L=9.0M DS WHITE @ROLL GLUE TRANSPARENT W=12MM L=18.3M @ROLL GLUE FURROW W=12MML=18.3M SS WHITE @ROLL WIRE, TIN, D=1.2MM N.W=2.0KG @KG TCE,CLEANER,-301#,V=55GALLON,TYPELESS @GALLON GLUE TRANSPARENT W=48MM L=36.5M @ROLL GLUE, RED #AK-501 F/SCREW V=110CC @BOTTL GLUE, YELLOW, N.W=1.0KG #575 @KG BAR,TIN,63/37,N.W=1.0KG @KG ALCOHOL V=1.0GALLON @GALLON GLUE, RED, W=0.5KG TYPELESS FOR SMT @KG FLUX #RF-800 V=1.0 GALLON @ GALLON ANTI-OXIDATION,WAX,W-1#,N.W=10KG,@KG	
	3SA-4121US-SUAA-1-0	IAA SUPPLY BD AXIAL AVR635US	
C113 115	CCZID0104NA-2	CC 100N0F +80% -20% 50.0V F	
D101 111 D1	H03-DG1N04148NB-A	D-SLP 1N4148 100.0V 150E-3A	
D102 103 105 106 107 108 109 110 112 113 115 117 118	H03-DR1N04004NA-7	D-SR 1N4004 400.0V 1.0A	
D116	H03-DZMTZ05V1NB-3	DIODE ZENER MTZ J 5.1B 5.1V 500MW DO-34	
D104	H03-DZMTZ09V1NB-6	D-ZENER MTZJ 9.1V 500MIOW	
D119 120	H03-DZMTZJ22BNB-3	DIODE ZENER MTZ J 22B 22V 0.5W DO-34	
R310	RC3DI0392IN-7 PBD11KSUI20-A	RCF 3K9 OHM 1/4W 5% 250MIOW PCB SINGLE AVR435/635 SUPPLY 197x197x1.6T FR-1 1OZ	
R309	RC3DI0102IN-9	RCF 1K0 OHM +5% 250MIOW	

REF NO.	PART NO.	DESCRIPTION	REMARKS
R102 109	RC3DI0103IN-7	RCF 10K0 OHM +5% 250MI0W	
R110	RC3DI0104IN-5	RCF 100K0 OHM +5% 250MI0W	
R104	RC3DI0153IN-3	RCF 15K0 OHM +5% 250MI0W	
R105	RC3DI0222IN-A	RCF 2K2 OHM +5% 250MI0W	
R112	RC3DI0272IN-6	RCF 2K7 OHM +5% 250MI0W	
R106 107	RC3DI010AIN-1	RCF 1R0 OHM +5% 250MI0W	
R111	RC3DI0562IN-8	RCF 5K6 OHM +5% 250MI0W	
<b>3SA-4121US-SUAR-1-2</b>			<b>IAR SUPPLY BD RADIAL AVR635US</b>
C102 103 104 108 109 110	CCKIC0103NA-9	CC 10N0F +10% -10% 50.0V Y5P	
C107	CEMGC04775E-9	CE 470U0F +/-20% 25.0V 10X13 85C	
C111 114	CEHIC01055E-6	CE 1UF +20% 50V D5XL11 P5MM 85C	
C112	CEHIC01065E-4	CE 10U0F +20% 50.0V 85C P5MM 5X11	
C106	H03-CEHIC0107AH-4	CE 100U0F +20% 50.0V 85C SHL P5MM	
C203 204 205	H03-CFH0A0104NN-9	CAP POLY METAL CPM 100NF 250V 20% TAE YANG	
C125	CEHGC0687NN-6	CE 680U0F +20% 25.0V 85C ELITE P5MM	
C116 C1	H03-CEMHC0227AH-9	CAP ELEC 220UF 35V M 8X11.5 SHL SAMYOUNG	
C105	CEMJC02275E-0	CAP ELEC 220UF 63V M 10X16 85C 120HZ ELITE P5MM	
FH10 11	H03-SOPS1FEHDNN-4	TERMFUSEHLDR FUSE-HOLDER J4210020001X	
Q101 102	H03-TRMPSA06NNA-A	TR-SLPLF MPSA06 N 500MIOA TO-92	
G101 103	H03-ZNMSA4004SN-A	TERMLUG GND	
<b>3SA-4120US-SUMI-1-5</b>			<b>REG BD AVR435US</b>
C301 303 305 308	CCZID0104NA-2	CC 100N0F +80% -20% 50.0V F	
C302 304 306 307	CEHIC01065E-4	CE 10U0F +20% 50.0V 85C P5MM 5X11	
D301 302	H03-DR1N04004NA-7	D-SR 1N4004 400.0V 1.0A	
P311	H03-WN06SB00000-3	CONNECT 2.0mm 6P GIL-S-6P-S2T2-EF	
P312	H03-WN03SB00000-1	CONNECT 2.0mm 3P GIL-S-3P-S2T2-EF	
P313	H03-WN05SB00000-6	CONNECT 2.0mm 5P GIL-S-5P-S2T2-EF	
R301 302 303 304	H03-RM3GC022ACN-3	RESISTOR METAL OXIDE 2R2 OHM +5% 2.0W	
R305	H03-RM3GC047ACN-4	RESISTOR METAL OXIDE 4R7 +5% 2.0W	
R306	RC3DI0103IN-7	RCF 10K0 OHM +5% 250MI0W	
R307 308	H03-RM3GC033ACN-2	RESISTOR METAL OXIDE 3R3 OHM +5% 2.0W	
R309	RC3DI0102IN-9	RCF 1K0 OHM +5% 250MI0W	
<b>3SA-4121US-SUST-1-9</b>			<b>DIG/MIC BD AVR435US</b>
C701 702	CZZFI0104BF-8	CAP CHIP 100N0F +80% -20% 16.0V Y5V 0603	
C703 704 705	CZJII0101BE-2	CAP CHIP 100P0F +5% -5% 50.0V NPO 0603	
C721	RS3AD0101NA-5	RES CHIP 100R0 OHM +5% 62MI5W 0603	
D701 702	H03-DS1S50094NB-5	D-SLP 1SS355 35.0V 225MIOA	
L701	H03-FB2K52012NN-0	FBEAD SURFACE MT 2500OHM FCM2012H-252T02	
L700	H03-LS1502012NN-3	INDUCTOR COIL FCI2012-150K 15UH 0805	
N302	H03-WN04SB00000-9	CONN 2.0MM 4 MA ST NAT GT201-4P-TS	
NJ70	H03-SORA1JE01NN-6	JACK RCA 1P JE010003MN GND OR	
<b>3SA-4120US-SUMI-1-5</b>			<b>OUTLET BD AVR435US</b>
F201202	H03-FUGF23000XX-5	FUSE 239 SERIES 003 250V 3A	
FH21 22 23 24	H03-SOPS1FEHDNN-4	TERMFUSEHLDR FUSE-HOLDER J4210020001X	
NS21	H03-SOPA21275BK-9	CONN-SPE AC OUTLET 2P 110V FE 12.75MM 2 BK 0 0 A204D0043P	
P309	H03-WN03SG00000-7	CONNECT WAFER 7.92MM 3P 35328-0310 WHT	
<b>3SA-4120US-VDMI-1-7</b>			<b>IMA VIDEO BD AVR435US</b>
P901	H03-WN19SB00000-1	CONN 2.0MM 19 MA ST NAT MOLEX 35336-1910 0 0	
IC18	H03-ICKIA7806I2-4	IC KIA7806AP VOLTQAGE REGULATOR TO-220AB	
Y100	H03-OSXBE14M39S-3	CRYSTAL 14.31818MHZ HC-49/S WOOIN	
Y101	H03-OSXBE17M79S-5	CRYSTAL 17.734475MHZ HC-49/S WOOIN	
NJ91	H03-SOR12BJ12NN-9	JACK RCA 12P BJ120154JN	
NJ92 93 94 95 96 97 98	H03-SORA11Y00NN-0	JACK RCA+S VIDEO C5016031DN	
N601	H03-WG10SB82200-9	WIRE ASS'Y UL1007#26STR 220mm 2.0mm 10P WHT	
P603	H03-WN06AB00000-6	CONN 2.0MM 6 MA R NAT GT201-6P-LS	
P602	H03-WN10AB00000-9	CONN 2.0MM GIL-S-10P-S2L2-EF 10P	
N902	H03-WN19AB00000-4	CONN 2.0MM 19 MA R NAT SOCKET MOLEX 35237-1910 0 0	

REF NO.	PART NO.	DESCRIPTION	REMARKS
P601	H03-WN15AI00001-2	CONNECT GF120-15S-LS 1.25mm 15P	
N602	H03-WG03SB82200-4	WIRE ASS'Y UL1007#26STR 220mm 2.0mm 3P WHT	
R1	H03-RM3FC033ABN-2	RESISTOR METAL OXIDE 3R3 1W 5%	
	XY0N618M3SW-A	GLUE FURROW W=6MM L=18.3M SS WHITE @ROLL	
	XY0P523K000-A	WIRE,IRON,D=0.5MM,N.W=23KG @KG	
	XY0P801K000-A	WIRE TIN D=0.8MM N.W=1.0KG @KG	
	XY1N209M0DW-4	GLUE TAPE W=12MM L=9.0M DS WHITE @ROLL	
	XY1N218M3CL-9	GLUE TRANSPARENT W=12MM L=18.3M @ROLL	
	XY1N218M3SW-4	GLUE FURROW W=12MML=18.3M SS WHITE @ROLL	
	XY1P202K000-1	WIRE, TIN, D=1.2MM N.W=2.0KG @KG	
	XY30155G000-0	TCE,CLEANER,-301#,V=55GALLON,TYPELESS @GALLON	
	XY4N836M5CL-9	GLUE TRANSPARENT W=48MM L=36.5M @ROLL	
	XY6R301K000-0	BAR,TIN,63/37,N.W=1.0KG @KG	
	XYALCO01G000-2	ALCOHOL V=1.0GALLON @GALLON	
	XYGLU00K5RD-7	GLUE, RED, W=0.5KG TYPELESS FOR SMT @KG	
	XYRF801G000-7	FLUX #RF-800 V=1.0 GALLON @ GALLON	
	XYWAX10K000-6	ANTI-OXIDATION,WAX,W-1#,N.W=10KG,@KG	
	<b>3SA-4120US-VDAA-1-5</b>	<b>IAA VIDEO AXIAL AVR435US</b>	
D108	H03-DZMTZ09V1NB-6	D-ZENER MTZJ 9.1V 500M10W	
L100 101 102 109	H03-FB05B3580NN-7	BEAD AXIAL/TAP,HC3580 80.5ohm	
L104 105 106 108 110	H03-LAINB0470CR-8	LF 47U0H +10% 5.8 OHM 500M10A	
L107	H03-LALNB056ACR-5	INDUCTOR COIL AL02TB5R6J 5.6UH 1.9OHM +5%	
	PBD11KVDI20-5	PCB SINGLE AVR435 VIDEO 197x197x1.6t FR-1 1OZ	
R203 204	RC3DI0471IN-0	RCF 470R0 OHM +5% 250M10W	
C202	CCZID0104NA-2	CC 100N0F +80% -20% 50.0V F	
R299	RC3DI0152IN-5	RCF 1K5 OHM +5% 250M10W	
C222	CCKID0101NA-7	CC 100P0F +10% -10% 50.0V Y5P	
	3SA-4120US-VDAR-1-7	IAR VIDEO BD RADIAL AVR435US	
C142 143 171 174	CCJIC0390NE-2	CC 39P0F +5% -5% 50.0V NP0	
C183	CCKIC0103NA-9	CC 10N0F +10% -10% 50.0V Y5P	
C172 186 196	CEHEC01075E-8	CE 100U0F +20% 10.0V 5X11 85C P5MM	
C100 102 103 105 106 108 109 111 136 138 152 199 203 205 289 295	CEHEC02275E-9	CE 220UF +20% 10.0V D6.3XL11 P5MM 85C	
C130 131 132 133 134 135 188 190 420 422	CEHEC0477MN-A	CE 470U0F +20% 10.0V 6.3X11 85C ELITE P5MM	
C151 194 291 293	CEHFC01075E-1	CE 100UF +20% 16.0V D5XL11 P5MM 85C	
C115 117 153 161	CEHFC04765E-3	CE47UF +20% 16.0V D5XL11 P5MM 85C	
C164 167 169 220	CEHIC01055E-6	CE 1UF +20% 50V D5XL11 P5MM 85C	
C184 201	CEHIC02255E-7	CE 2U2F +20% 50V D5XL11 P5MM 85C	
C176	CEHIC0474NN-9	CE 470N0F +20% 50.0V 85C 5X11 ELITE P5MM	
C101 104 107 110 116 121 122 137 204 206 213 299	CEHFC0106NN-4	CE 10U0F +20% 16.0V 85C 5X11 ELITE P5MM	
C144	CPIIC0223NN-4	CPF 22N0F +10% 50.0V	
C168	CPIIC0682NN-5	CPF 6N8F +10% 50.0V	
C185 198	H03-CEMIC01065H-1	CAP ELEC 10UF 50V M 5X11 SHL P5MM	
C165	H03-CEMIC0334AH-A	CAP ELEC 0.33UF M 5X11 SHL 50V SAMYOUNG P5MM	
Q101 104 111	H03-TR2SA933ANW-8	TR-SLPLF 2SA933ASR P -3.0A -20V	
Q100 112 114 299	H03-TR2SC1740NW-4	TR-SLPLF 2SC1740S R N 150M10A 50V	
	<b>3SA-4120US-VDST-1-3</b>	<b>SMD VIDEO BD AVR435US</b>	
C163	CZDII0100BE-8	CAP CHIP 10PF 50V CH D NP0 0603 +/-0.25P	
C112 113 114 118 119 120 124 125 126 155 156 157 158 159 160 178 180 412 413 414	CZJII0101BE-2	CAP CHIP 100P0F +5% -5% 50.0V NP0 0603	
C123	CZJII0220BE-5	CCCFMIC 22P0F +5% -5% 50.0V NP0 0603	
C175	CZJII0270BE-1	CAP CHIP 27P0F +5% -5% 50.0V NP0 0603	
C177	CSJIE0300BG-2	CAP,CHIP FORM 30P +/-5% 50V COG 0603	
C200	CZJII0331BE-7	CAP CHIP 330P0F +5% -5% 50.0V NP0 0603	
IC22	H03-ICLC7476314-7	IC OSD LC74763M-9602 SOP30	
C173 181 187 197	CZKII0103BC-5	CAP CHIP 10N0F +10% -10% 50.0V X7R 0603	
C170	CZKII0561BC-8	CAP CHIP 560P0F +10% -10% 50.0V X7R 0603	

REF NO.	PART NO.	DESCRIPTION	REMARKS
C154 162 189 191 195 248 292 294 421 423	CZZFI0104BF-8	CAP CHIP 100N0F +80% -20% 16.0V Y5V 0603	
D101 106 107 109 110	H03-DS1S50094NB-5	D-SLP 1SS355 35.0V 225MIOA	
IC19 20	H03-IC74HC4094D-1	IC CD74HC4094D(R-PDSO-G16) SOP16	
IC14 25 26	H03-ICMM1501XDL-5	IC-VIDEO SW MM1501XNRE SOT-26B	
IC27	H03-ICMM1511XDL-3	IC-VIDEO SW MM1511XNRE SOT-26B	
IC10 11 12	H03-ICNJM2296D3-2	IC-LINEAR NJM2296	
IC40	H03-ICNJM2586MN-9	IC VIDEO AMP NJM2586M DMP24	
IC30	H03-ICTSH95IDB4-1	IC-VIDEOPROC TSH95ID VIDEO AMPLIFIER	
Q102 103	H03-TRDTA114YNI-4	TR-SSD DTA114YKA P 10K0 OHM 47K0 OHM	
Q105 106 113	H03-TRDTC114YNI-0	TR-SSD DTC114YKA N 10K0 OHM 47K0 OHM	
D120 121 122 123 124 125 126 127 128 129 1 2 3 4 5 6	H03-DS05GBUSCNB-5	DIODE PG05GBUSC	
R180 198 300 301 302 303 304 305 316 322	RS3AD0000NA-0	RES CHIP 0 OHM +0% 62MI5W 0603	
R190	RS3AD0101NA-5	RES CHIP 100R0 OHM +5% 62MI5W 0603	
R130 131 132 133 134 135 148 149 161 162 163	RS3AD0102NA-3	RES CHIP 1K0 OHM +5% 62MI5W 0603	
R112 113 114 118 119 120 124 125 126 159 160 165 175 188 191 199 205 206 207 208 220 221 222 412 413 414	RS3AD0103NA-1	RES CHIP 10K0 OHM +5% 62MI5W 0603	
R150 154 156	RS3AD0121NA-A	RES CHIP 120R0 OHM +5% 62MI5W 0603	
R146 147	RS3AD0123NA-6	RES CHIP 12K0 OHM +5% 62MI5W 0603	
R186	RS3AD0124NA-4	RES CHIP 120K0 OHM +5% 62MI5W 0603	
R152	RS3AD0152NA-A	RES CHIP 1K5 OHM +5% 62MI5W 0603	
R171	RS3AD0154NA-6	RES CHIP 150K0 OHM +5% 62MI5W 0603	
R170	RS3AD0200NA-3	RES,CHIP 20 OHM 1/16W +/-5% 0603	
R167 173	RS3AD0222NA-4	RES CHIP 2K2 OHM +5% 62MI5W 0603	
R187	RS3AD0224NA-0	RES CHIP 220K0 OHM +5% 62MI5W 0603	
R219	RS3AD036ANA-2	RES CHIP 3R6 OHM 1/16W 5% 0603	
R192	RS3AD0243NA-7	RES CHIP 24K0 OHM +5% 62MI5W 0603	
R200	RS3AD0910NA-5	RES CHIP 91OHM 1/16W 5% 0603	
R193	RS3AD0272NA-0	RES CHIP 2K7 OHM +5% 62MI5W 0603	
R217	RS3AD027ANA-3	RES, CHIP, 2.7, 1/16W, +/-5%, 0603	
R166 172	RS3AD0333NA-6	RES CHIP 33K0 OHM +5% 62MI5W 0603	
R189	RS3AD0392NA-1	RES CHIP 3K9 OHM +5% 62MI5W 0603	
R197	RS3AD0513NA-4	RES CHIP 51K0 OHM +5% 62MI5W 0603	
R101 104 107 110 116 122 127 129 168 174 178	RS3AD0680NA-7	RES CHIP 68R0 OHM +5% 62MI5W 0603	
R151	RS3AD0682NA-3	RES CHIP 6K8 OHM +5% 62MI5W 0603	
R100 102 103 105 106 108 109 111 115 117 121 123 136 137 400 401 402 403 404 405 406 407 408 409 410 411	RS3AD0750NA-1	RES CHIP 75R0 OHM +5% 62MI5W 0603	
R169	RS3AD0822NA-2	RES CHIP 8K2 OHM +5% 62MI5W 0603	
R315 317 321 323	RS3AD043ANA-7	RESISTOR CHIP 4R3 OHM 1/16W 5% 0603	
R153 155	RS3AD0105NA-8	RES CHIP 1M 1/16W +5% 0603	
R419 420 421	RS3AD020ANA-2	RES CHIP 2 OHM 1/16W 5% 0603	
R218 278	RS3AD030ANA-9	RES CHIP 3 OHM 1/16W 5% 0603	
R128	RS1AD0620NA-8	RES CHIP,62 OHM,1/16W,+/-1%,0603	

REF NO.	PART NO.	DESCRIPTION	REMARKS
	3SA-4121US-BC00-1-4	MECH BOM AVR635US HARMAN KARDON	
	H03-SWA2B21PDA&-2	SW PUSH POWER SDDL15700 5A 250V	
	H03-TXPWMM635B0-9	TRANS MN X'FORMER AVR635 120V	
	H03-WF15S2605FU-6	WIRE FFC (CARD CABLE) DHCDF-15/260-P1.25-AT	
	H03-WF27S2705FU-5	WIRE FFC (CARD CABLE)DHCDF-27/270-P1.25-AT	
	H03-ZMB01S00100-0	BKT HEADPHONE JACK	
	H03-ZMB01S02200-4	SPRING PLATE GND C5212 0.2T	
	H03-ZMC11HS0200-2	H/SINK MAIN AVR630	
	H03-ZMC11S00200-6	AL DOOR AVR430/630	
	H03-ZMC11S00300-8	AL PANEL AVR430/630	
	H03-ZMD12S04B00-3	BKT FRAME GUIDE AVR635	
	H03-ZMC11S06A00-9	SPRING STOPPER AVR430/630	
	H03-ZMC11S07A00-A	CHASSIS FRONT AVR430/630	
	H03-ZMC11S08A00-0	COVER TOP AVR430/630	
	H03-ZMC11S09A00-1	BKT FAN FRONT AVR430/630	
	H03-ZMC11S10A00-1	BKT FAN REAR AVR430/630	
	H03-ZMC11S12A00-3	CAP BUTTON STAND-BY AVR430/630	
	H03-ZMC11S13A00-4	CHASSIS MAIN AVR430/630	
	H03-ZMC11S14A00-5	BRACKET DOOR	
	H03-ZMC12S07A00-8	COVER BOTTOM	
	H03-ZMC12S08B00-0	BKT TRANS BOTTOM	
	H03-ZMC12S09A00-A	BKT HEATSINK	
	H03-ZMC12S19A00-8	BKT AC INLET	
	H03-ZMC12S20A00-8	BADGE AL HARMAN/KARDON SILVER	
	H03-ZMD05S16A00-9	BKT HINGE AVR7300	
	H03-ZUD0301AABK-5	SPONGE-UL 30X30X12T BK DPR2005	
	H03-ZMD12HS0100-5	HEATSINK H/SINK AMP AVR635	
	H03-ZMD12S02A00-A	PANEL REAR AVR635 US	
	H03-ZMGEN00GAGY-6	AL LOGO BADGE TOP	
	H03-ZPC1004GASG-6	BUTTON 7 KEY	
	H03-ZPC1018GART-2	FILTER VFD	
	H03-ZPD0315GAMW-9	VOLUMN KNOB	
	H03-ZPD0316GASG-5	COVER KNOB	
	H03-ZPD0317GACR-A	CAP KNOB VOLUMN	
	H03-ZPD1219GABT-A	WINDOW DISPLAY AVR635+BADGE NAME AVR635	
	H03-ZVC11DWT100-9	TAPE DOOR	
	H03-ZVC11DWT200-0	TAPE PANEL	
	H03-ZVC11FAN100-1	FAN JF0925S1L	
	H03-ZVC11GEAR01-5	DAMPER GEAR DP120	
	H03-ZVC11TUNE01-2	TUNER MODULE KST-MB011MW0-81 US	
	ZFD122062SB-5	RUBBER TOP AVR635	
	ZFD122072SB-2	RUBBER TOP AVR635	
	ZFNR13830SB-6	RUBBER SIDE	
	ZFNR19720SB-5	RUBBER FOOT 19.7X19.7X2T BK	
	ZVC11FILM0A-A	PROTECTION FILM	
	ZKC1195HA00-5	LABEL LICENSE AVR630	
	ZKC1222HA00-2	LABEL RISK	
	ZKC1229HA00-7	LABEL DATE	
	ZKGEN29HA00-8	LABEL DATE BLANK	
	ZKC1281HA00-9	LABEL QC CHECK	
	ZKD1230HA00-8	LABEL SERIAL AVR635 US	
	ZKGEN30HA00-6	LABEL SERIAL BLANK	
	ZKD1273HA00-9	LABEL BARCODE AVR635 US	
	ZKGEN73HA00-7	LABEL BARCODE BLANK	
	ZKGEN97HA00-3	LABEL MAIN POWER REMIND	
	ZMC12S13AYE-1	STANDOFF HEX M4X0.7 6X31.9H	
	ZMC12S14AYE-9	STANDOFF HEX M4X0.7 6X61.9H	
	ZMC12S15AYE-6	STANDOFF HEX M4X0.7 6X111.2H	
	ZNSSM4045HZ-4	NUT M4 HEXAGON CIRCULAR EXTERNAL	
	ZPC1002GAGY-9	DOOR AVR430/630	
	ZPC1003GAGY-5	BUTTON POWER	
	ZPC1005GAGY-8	BUTTON 8 KEY	
	ZPC1006GAWH-0	BUTTON STANDBY	

REF NO.	PART NO.	DESCRIPTION	REMARKS
	ZPC1007GAMW-9	INDICATOR STAND-BY	
	ZPC1017GABK-6	HOLDER VFD AVR430/630	
	ZPC1102GAMW-1	INDICATOR VIDEO 4	
	ZPC1103GAGY-A	FOOT 50MM 15.8MM	
	ZMC1221AA00-9	CLAMP WIRE-FIX UL 55212250	
	ZPD1201GAGY-4	PANEL FRONT AVR635	
	ZSMCM4008BY-1	SCREW BM 4X8	
	ZSMCM4010BB-5	SCREW BM 4X10	
	ZSTBM3008BY-1	SCREW ST BH 3X8	
	ZSTBM3010BB-5	SCREW ST BH 3X10	
	ZSTBM3012BY-A	SCREW ST BH 3X12 PIVOT	
	ZSTGM3010BB-3	SCREW ST BH 3X10 GROUND	
	ZSTWM3006BB-3	SCREW ST WPH 3X6	
	ZSTWM3008BY-8	SCREW ST WPH 3X8	
	ZSTWM3A08BY-6	SCREW ST W7.5PH 3X8	
	ZSTWM4008BC-3	SCREW ST WPH 4X8 SILVER CHROM	
	ZUC1201AABK-7	SPONGE 30X30X10T BK	
	ZV4P00030TH-3	HEAT SHRINK TUBE L30MM*D4.0MM*T0.5MM	
	ZWF793008PO-5	WASHER FIBER 3 0.8T	
	ZWM623108SZ-2	WASHER SPRING 3	
	ZWM763109SZ-2	AC SPRING WASHER RT2250(PAV5005)	
	ZWM803305PZ-1	WASHER PLAIN 3	
	ZWMC04810PZ-5	WASHER PLAIN 4	
	H03-WF09SB81300-3	WIRE ASS'Y UL1007#26 STR 130MM 2.0MM 9P WHT	
	H03-WF4261805BN-7	WIRECONASY DL 2.0MM 4P 180MM UL 1007 RIBBON 26 1	
	H03-WG02SG8532A-4	WIRECONASY UNIQUE 2P 530MM UL1617 PVC DOUBLE INSULATED 20 1	
	ZTB017030AA-4	CABLE TIE 100MM NYLON 6	
	H03-FBB0102AA00-2	FCORE FERRIT MAGNET SRH9. 9X20. 0X5. 3	
	H03-ZMC11S04B00-9	BKT FRAME GUIDE	
	H03-FBD0480BR00-8	FCORE CLAMP FILTER LF80BR W5 SRH 16X28X9	
	XYEM501K000-2	SPECIALTY LUBRICANTS GREASE,#EM-50L,W=1KG @G	
	XY1P202K000-1	WIRE, TIN, D=1.2MM N.W=2.0KG @K	
	3SA-4121US-PA00-1-3	PKG BOM AVR635US	
	H03-ATALF039ABK-5	ANTENNA WIRE ANTENNA LOOP CT01-AM 0 0	
	H03-RYC1202HA00-0	REMOCON ZONE 2	
	H03-RYD1201HA00-9	REMOCON AVR635	
	H03-WAB01200203-4	ANTENNA WIRE 75 CT02-FM 0 0	
	H03-WAUSA2103BK-7	POWER CORD WS-004C+002E SJT#14*2C L=2M	
	ZKC1113HA00-9	CARD WARRANTY	
	ZKD1216HA00-5	QUICK SETUP GUIDE AVR635	
	ZKC1263HA00-0	INSERT RS232 NOTE PAPER	
	ZKD1201HA00-8	OWNER'S MANUAL AVR635 US	
	ZKD1204HA00-7	BOX CARTON AVR635 US	
	ZQD1201HAWH-A	CUSHION POLY EPS RIGHT AVR635	
	ZQD1202HAWH-6	CUSHION POLY EPS LEFT AVR635	
	H03-MCD12TWBKNN-8	AVR635 MICROPHONE ASSY	
	H03-ZPD1212INBK-5	MICROPHONE ASSY EXTENSION PIECE	
	ZKD1202HA00-4	CARTON BOX MIC	
	ZKD1263HA00-3	BROCHURE AVR US	

REF NO.	PART NO.	DESCRIPTION	REMARKS
	3SA-4121US-DGMI-1-3	IMA DSP BD AVR635US	
K700	H03-RLL0516632B-5	RELAYPWR 5.0V 166.0OHM 1.0A 24.0V	
C557	H03-CEZXA0479MN-0	CM 47MIOF +80%-20% 5.5V 70C SCDA5R5473V	
IC507	H03-ICKA78R08I2-A	IC-KIA78R08API TO-220IS-4PIN	
IC851	H03-ICPC17T10B1-8	IC PHOTOCOUPLER PC-17T1 DIP4 KODENSHI	
T700 701	H03-LF11030A2NA-A	TFPULSE TRANSFORMER 110UH FP-110 FERRIT MAGNET	
Y600	H03-OSCEM24M5RU-5	VCXO 24M576 HZ +50 PPM -50 PPM 0 OHM 3.3V	
Y500	H03-OSCNI20MOCU-1	CSTLS20MOX51-B0	
N803	H03-WG06SB82800-7	WIRE ASS'Y UL1007#26 STR 280MM 2.0MM 6P WHT	
NJ705	H03-SOJB04013HN-0	JACK RCA 4P OR ,OR, OR, OR JB040131HN	
NJ802	H03-SORA40RSANN-1	JACK RCA 4P JB040131ZN GN BN PP TA	
NJ801	H03-SORA40RSCNN-5	JACK RCA 4P JB040131QN WH BU RD GY	
NJ701 702 703	H03-SOTOR179LBA-6	D-LEM TORX-179L	
NJ704	H03-SOTOT179LBA-2	D-LEM TOTX-179L	
N501	H03-WG09SB81000-3	WIRECONASY DL 2.0MM 09P 100MM UL1007 RIBBON 26 1	
N701	H03-WN05SB00000-6	CONNECT 2.0mm 5P GIL-S-5P-S2T2-EF	
N504	H03-WN06AB00001-A	CNT PLUG BD'BD SOCKET 2.0mm 35237-0610 6P	
N506	H03-WN09SB00000-5	CONNECT 2.0mm 9P GIL-S-9P-S2T2-EF	
N503	H03-WN11SB00000-3	CONN 2.0MM 11P MA ST NAT MOLEX 35336-1110 0 0	
N802	H03-WN19AB00000-4	CONN 2.0MM 19 MA R NAT SOCKET MOLEX 35237-1910 0 0	
N407 801	H03-WN19SB00000-1	CONN 2.0MM 19 MA ST NAT MOLEX 35336-1910 0 0	
N502	H03-WN27AI00000-A	CONNECT 1.25mm 27P GF120-27S-LS	
L501	H03-LAINB047ACR-9	LF 4U7H +10% 1.7 OHM 190.0A	
R521	RC3DI010AIN-1	RCF 1R0 OHM +5% 250MIOW	
L702 703 704 705	H03-LAINB047OCR-8	LF 47U0H +10% 5.8 OHM 500MIOA	
N805	H03-WG01S022018-5	WIRE ASS'Y UL1007#18 220MM 1P BLK TERMINAL	
	XY0P523K000-A	WIRE,IRON,D=0.5MM,N.W=23KG @KG	
	XY0P801K000-A	WIRE TIN D=0.8MM N.W=1.0KG @KG	
	XY1N209MODW-4	GLUE TAPE W=12MM L=9.0M DS WHITE @ROLL	
	XY1N218M3SW-4	GLUE FURROW W=12MML=18.3M SS WHITE @ROLL	
	XY1P202K000-1	WIRE, TIN, D=1.2MM N.W=2.0KG @KG	
	XY30155G00-0	TCE,CLEANER,-301#,V=55GALLON,TYPELESS @GALLON	
	XY4N836M5CL-9	GLUE TRANSPARENT W=48MM L=36.5M @ROLL	
	XY6R301K000-0	BAR,TIN,63/37,N.W=1.0KG @KG	
	XYALC01G000-2	ALCOHOL V=1.0GALLON @GALLON	
	XYGLU00K5RD-7	GLUE, RED, W=0.5KG TYPELESS FOR SMT @KG	
	XYJU100K5GY-5	JUICE TIN N=0.5KG GREY @KG	
	XYRF801G000-7	FLUX #RF-800 V=1.0 GALLON @ GALLON	
	XYWAX10K000-6	ANTI-OXIDATION,WAX,W-1#,N.W=10KG,@KG	
REWORK	H03-WC1201005C1-4	WIRE ASS'Y UL1007 #20 TS 100MM 1P BLK	
	XY0N618M3SW-A	GLUE FURROW W=6MM L=18.3M SS WHITE @ROLL	
	3SA-4121US-DGAR-1-3	IAR DSP BD RADIAL AVR635US	
C411 431 432 433	CCKIC0471NC-9	CAP CERAMIC 470PF 50V K X7R TAP	
C412 415 434 435 454 458 475 476 487 488 489 495	CCKIC0561NC-8	CAP CERAMIC 560PF 50V K X7R TAP	
C400 401 402 403 421 422 423 424 425 426 427 428 436 440 441 451 453 456 457 459 461 462 464 465 496 497 519 520 521 530 629 631 633 635 902	CEHFC01062S-0	CE 10UF +20% 16V D4XL7 P2.5MM 2000hours 85C	
C514	CEHFC04762S-0	CE 47UF +20% 16V D5XL7 P2.5MM 2000hours 85C	



REF NO.	PART NO.	DESCRIPTION	REMARKS
C525	CEHIC01042S-5	CE 100NF +20% 50V SSE TYPE D4XL7 P2.5MM 85C	
C416 417 418 419 429 430 438			
439 450 460 470 471 481 482	CCKIC0272NC-4	CAPACITOR CERAMIC 2N7F 50V K X7R TAP	
483 484			
C258 259 265 267 527 744 745	CEMFC01072E-8	CE 100UF 16V +/-20% 5X11 P2.5MM ELIET	
C625	CEHIC01055E-6	CE 1UF +20% 50V D5XL11 P5MM 85C	
C958	CEHIC04755E-6	CE 4U7F +20% 50.0V 85C P5MM	
Q851	H03-TRKTA107MNA-2	TR-SLPSWA KRA107M P	
Q511	H03-TRMPA06NNA-A	TR-SLPLF MPSA06 N 500M0A TO-92	
	PBD11KDBG20-5	PCB DUALA VR435/635 DSP 209x170x1.6t FR-4 1OZ	
C823 824 825	CEHDC0108NN-3	CE 1M10F +20% 6.3V 8X11.5 85C ELITE P5MM	
C601 959	CEHEC0477MN-A	CE 470U0F +20% 10.0V 6.3X11 85C ELITE P5MM	
C264 508 515 623 821 822 904 912	CEHFC01072S-9	CE 100UF +20% 16V D6.3XL7 P2.5MM 2000hours 85C	
	3SA-4121US-DGSB-1-4	BOTTOM SMD DSP BD AVR635US	
C501 502 504 505 506 801 802			
803 804 805 806 807 808 809	CZJII0101BE-2	CAP CHIP 100P0F +5% -5% 50.0V NP0 0603	
810 811 812 813 814 815 816			
C700 702 720 743	CZJII0220BE-5	CCCFMIC 22P0F +5% -5% 50.0V NP0 0603	
C444 492	CZJII0470BE-4	CAP CHIP 47P0F +5% -5% 50.0V NPO 0603	
C251 252 646	CZKII0102BC-7	CAP CHIP 1N0F +10% -10% 50.0V X7R 0603	
C604 647 648 701 703 706 717 603	CZKII0103BC-5	CAP CHIP 10N0F +10% -10% 50.0V X7R 0603	
C257 263 292 469 503 507 513			
516 517 518 522 528 614 615			
622 624 628 630 632 634 705			
708 710 714 721 817 818 903			
910 913 922 925 926 927 929	CZZFI0104BF-8	CAP CHIP 100N0F +80% -20% 16.0V Y5V 0603	
930 945 946 947 960 961 980			
981 982 984 985 986 987 988			
989 990 991			
C619	CZZII0104CF-8	CAP CHIP 100N0F +80% -20% 50.0V Y5V 0805	
D503 504 505 507 700 851	H03-DS1S50094NB-5	D-SLP 1SS355 35.0V 225M0A	
L504 604 610 700 901 904 905	H03-FB2K52012NN-0	FBEAD SURFACE MT 2500OHM FCM2012H-252T02	
L601 602 605 606 607	H03-FB3012012CN-8	FBEAD SURFACE MT FCM2012C-301T04 0805	
L706	RS3BB0000NA-5	RES CHIP 0 OHM +5% 100M0W 0805	
E901	H03-FYACF333TNN-A	FILTER ACF451832-333-T	
IC502	H03-IC74HC4094D-1	IC CD74HC4094D(R-PDSO-G16) SOP16	
Q402 403	H03-TRDTA114YNI-4	TR-SSD DTA114YKA P 10K0 OHM 47K0 OHM	
Q601 700	H03-TRDTC114YNI-0	TR-SSD DTC114YKA N 10K0 OHM 47K0 OHM	
Q400 401	H03-TRKTD1304ND-0	TR-SLPSWA KTD1304 N 20V 300M0A SOT-23	
R812	RS3AD0332NA-8	RES CHIP 3K3 OHM +5% 62MI5W 0603	
R708 719	RS3AD0100NA-7	RES CHIP 10R0 OHM +5% 62MI5W 0603	
R531 607 608 646 711 715	RS3AD0101NA-5	RES CHIP 100R0 OHM +5% 62MI5W 0603	
C709 711 722			
R528 529 530 532 803 804 807	RS3AD0102NA-3	RES CHIP 1K0 OHM +5% 62MI5W 0603	
808 811 815 816			
R257 258 523 534 535 561 923	RS3AD0103NA-1	RES CHIP 10K0 OHM +5% 62MI5W 0603	
R265 266 414 415 448 449 470			
471 480 491 492 499 556 702	RS3AD0104NA-A	RES CHIP 100K0 OHM +5% 62MI5W 0603	
706 724 730 801 802 805 806			
809 813 814			
R609 612 405 416 417 418 419			
425 426 429 430 431 445 446	RS3AD0122NA-8	RES CHIP 1K2 OHM +5% 62MI5W 0603	
464 465 483 484 485 486			
R132 251 252 253 256	RS3AD0151NA-1	RES CHIP 150R0 OHM +5% 62MI5W 0603	
R913 914	RS3AD0182NA-1	RES CHIP,1.8K,1/16W,+5%,0603.	

REF NO.	PART NO.	DESCRIPTION	REMARKS
R716	RS3AD0220NA-8	RES CHIP 22R0 OHM +5% 62MI5W 0603	
R736 738 741	RS3AD0222NA-4	RES CHIP 2K2 OHM +5% 62MI5W 0603	
R601	RS3AD0000NA-0	RES CHIP 0 OHM +0% 62MI5W 0603	
R853 915 921 922 924	RS3AD0392NA-1	RES CHIP 3K9 OHM +5% 62MI5W 0603	
R262 400 401 402 403 411 412 444 452 459 460 474 475 476 477 478 479	RS3AD0432NA-4	RES CHIP 4K3 OHM +5% 62MI5W 0603	
R852	RS3AD0471NA-5	RES CHIP 470R0 OHM +5% 62MI5W 0603	
R518 851	RS3AD0472NA-3	RES CHIP 4K7 OHM +5% 1/16W 0603	
R522 555 737 739 740	RS3AD0473NA-1	RES CHIP 47K0 OHM +5% 62MI5W 0603	
R439 440 447 454 456 457 489 490 703 704 709 726 743	RS3AD0561NA-4	RES CHIP 560R0 OHM +5% 62MI5W 0603	
R406 427 428 432 433 434 435 438 443 450 453 458 481 482 487 488	RS3AD0562NA-2	RES CHIP 5K6 OHM +5% 62MI5W 0603	
R710	RS3AD0621NA-1	RES CHIP 620R0 OHM +5% 62MI5W 0603	
R263	RS3AD0512NA-6	RES CHIP 5K1 OHM +5% 62MI5W 0603	
R810	RS3AD0682NA-3	RES CHIP 6K8 OHM +5% 62MI5W 0603	
R700 701 705 723	RS3AD0750NA-1	RES CHIP 75R0 OHM +5% 62MI5W 0603	
IC608	H03-IC74LV1G125-9	IC SN74LVC1G125DVB SOT23	
R658	RS3AD027ANA-3	RES, CHIP, 2.7, 1/16W, +/-5%, 0603	
U906 908 909 910	RN3AY0220NA-4	RES NETWORK RCA 22OHM 1/16W 5% CN34JT220	
	<b>3SA-4121US-DGST-1-A</b>	<b>TOP SMD DSP BD AVR635US</b>	
C253 254 255 256 510 542 543	CZJII0101BE-2	CAP CHIP 100P0F +5% -5% 50.0V NP0 0603	
C621	CZJII0102CC-3	CAP CHIP 1nF 50V X7R J 0805	
C443 491 541 544	CZJII0470BE-4	CAP CHIP 47P0F +5% -5% 50.0V NPO 0603	
C645	CZKII0103BC-5	CAP CHIP 10N0F +10% -10% 50.0V X7R 0603	
C602	CZKII0223CC-5	CAP CHIP 22NF 50V B K X7R 0805	
C466 467	CZKII0561BC-8	CAP CHIP 560P0F +10% -10% 50.0V X7R 0603	
C260 261 413 414 447 448 449 455 468 490 493 509 526 723 742 901 918 919 920 921 928 948 949 950 951 952 953 954 955 956 957 962 963 964 965 966 967 968 969 970 971 972 973 974 975 976 977 978 983 992 620	CZZFI0104BF-8	CAP CHIP 100N0F +80% -20% 16.0V Y5V 0603	
C627	CZZII0104CF-8	CAP CHIP 100N0F +80% -20% 50.0V Y5V 0805	
D501 502 506 508	H03-DS1S50094NB-5	D-SLP 1SS355 35.0V 225MI0A	
L903	H03-FB2K52012NN-0	FBEAD SURFACE MT 2500OHM FCM2012H-252T02	
L508	H03-FB3012012CN-8	FBEAD SURFACE MT FCM2012C-301T04 0805	
IC904	H03-ICM317TO252-1	IC 3-TERMINAL POS VOL REG NJM317DL1 TO-252	
IC504	H03-IC74VC244G5-1	IC-LOGIC 74VHC244A INVERTER CMOS	
IC902	H03-ICAT49BV162-8	IC FLASH MEMORY AT49BV162AT-70TI 48T	
IC606	H03-ICCS42518E6-8	IC LOGIC CS42518CQ QFP64	
IC501	H03-ICD703033E1-0	IC-MICOM FLASH NEC UPD70F3033BGF 0228KK001 JAPAN QFP100	
IC903	H03-ICK4S1616M6-4	IC-SDRAM K4S161622H-TC60 OR TC80	
IC251 252 401 402 403 404 406	H03-ICLM02068D2-5	IC-OPERAMP NJM2068M-TE1 DUAL SOP8	
IC503	H03-IC24LC256D2-3	IC CMOS SERIAL EEPROM 24LC256T-I/SN SOIC-8P(150MIL)	
IC704 705	H03-ICSN74HCU04-6	IC SN74HCU04D	
IC505 506 607	H03-IC74LV1G125-9	IC SN74LVC1G125DVB SOT23	
IC901	H03-ICTMS320DA6-0	IC FLOATING-POINT DSP TMS320D610A PQFP208	
Q501 502 503 504 505 506 507 508 509 510 602	H03-TRDTC114YNI-0	TR-SSD DTC114YKA N 10K0 OHM 47K0 OHM	
R817 818 819 820 821 822 823 824 901 546 C716	RS3AD0000NA-0	RES CHIP 0 OHM +0% 62MI5W 0603	
R503 504 505 506 507 508 631 633 634	RS3AD0100NA-7	RES CHIP 10R0 OHM +5% 62MI5W 0603	

REF NO.	PART NO.	DESCRIPTION	REMARKS
R267 268 630 632 645 720 981 982 983 984 985 986	RS3AD0101NA-5	RES CHIP 100R0 OHM +5% 62MI5W 0603	
R466 467 472 473 509 510 511 512 513 514 515 604 967 968 659	RS3AD0102NA-3	RES CHIP 1K0 OHM +5% 62MI5W 0603	
R254 255 259 260 501 502 519 520 533 551 552 559 969	RS3AD0103NA-1	RES CHIP 10K0 OHM +5% 62MI5W 0603	
R916 917 918 919	RS3AD0182NA-1	RES CHIP, 1.8K, 1/16W, +5%, 0603.	
R261 264	RS3AD0203NA-8	RES CHIP 20K0 OHM +5% 62MI5W 0603	
R544 629 524 525	RS3AD0221NA-6	RES CHIP 220R0 OHM +5% 62MI5W 0603	
R553 554 725	RS3AD0222NA-4	RES CHIP 2K2 OHM +5% 62MI5W 0603	
R920	RS3AD0392NA-1	RES CHIP 3K9 OHM +5% 62MI5W 0603	
R541 542 543	RS3AD0471NA-5	RES CHIP 470R0 OHM +5% 62MI5W 0603	
R516 517 557	RS3AD0472NA-3	RES CHIP 4K7 OHM +5% 1/16W 0603	
R727	RS3AD0473NA-1	RES CHIP 47K0 OHM +5% 62MI5W 0603	
R468 469 721 722	RS3AD0561NA-4	RES CHIP 560R0 OHM +5% 62MI5W 0603	
R657	RS3BB0200NA-8	RES,CHIP,20R 1/10W +/-5%,0805	
R644	RS3BB0332NA-2	RES,CHIP, 3.3K OHM 1/10W +/-5%., 0805	
U902 903 904 905 907	RN3AY0220NA-4	RES NETWORK RCA 22OHM 1/16W 5% CN34JT220	

3SA-4121US-FCMI-1-8			IMA FRONT BD AVR635US
	ZFNR1SENSOR-0	RUBBER SENSOR	
D853 854 855 856	H03-DL30B2015AA-5	D-LEM 30B3-20-15 GaN SUPER BLUE WATER CLEAR 15	
D831	H03-DL3BA05V0BA-8	D-LEM BLUE/AMBER 3PIE RD RND CL L-3VYMBC	
RM71	H03-ICRPM6938NN-9	IC-REMOTE RPM6938-RSIP-A3 RECEIVER 38KHZ	
VR100	H03-SWE3A0505S1-4	SWIROT EC16B24204 5V 500U0A 10T 3P 0 0	
DP1	H03-VDHCA18LL03-2	FL HCA-18LL03	
N201	H03-WG03AB80900-8	WIRECONASY DL 2.0MM 03P 90MM ANG-DOWN UL1007 RIBBON 26 1 B2011HR2	
N203	H03-WG07SB82000-A	WIRE ASS'Y UL1007#26STR 200mm 2.0mm 7P WHT	
N202	H03-WG08SD84000-7	WIRE ASS'Y UL1007#24 STR 400mm 2.5mm 8P WHT	
P604	H03-WN06SB01000-4	CNT PLUG BD'BD PLUG 2.0mm 35336-0610 6P	
P234	H03-WN11AB00000-6	CONN 2.0MM 11 MA R NAT SOCKET MOLEX 35237-1110 0 0	
P233	H03-WN11SB00000-3	CONN 2.0MM 11P MA ST NAT MOLEX 35336-1110 0 0	
N602	H03-WN19AB00000-4	CONN 2.0MM 19 MA R NAT SOCKET MOLEX 35237-1910 0 0	
P201	H03-WN15AI00001-2	CONNECT GF120-15S-LS 1.25mm 15P	
P602 603	H03-WN19SB00000-1	CONN 2.0MM 19 MA ST NAT MOLEX 35336-1910 0 0	
P211	H03-WN27AI00000-A	CONNECT 1.25mm 27P GF120-27S-LS	
N204	H03-WS4261005FN-3	WIRE ASS'Y UL2547/1007#26 100MM 4P 2.0MM WHT	
N222	H03-WS7260805EN-6	WIRE ASS'Y UL1533/1007#26 80MM 2.0MM 7P WHT SHILED	
S2 4 5 6 7	H03-ZMB01S02200-4	SPRING PLATE GND C5212 0.2T	
SH11	H03-ZMD12S01A00-9	SHIELD IR	
SH12	H03-ZMC12S16A00-5	BKT GROUND	
RM72	H03-DPLP200LNNN-2	PIN PHOTODIODE LP-200L	
SH22	H03-ZMD12S01B00-0	SHIELD MICROPHONE	
C127	CEHFC01075E-1	CE 100UF +-20% 16.0V D5XL11 P5MM 85C	
	XY0N211N5WH-4	CABLE TIE W=0.2MM L=11.5CM WHITE @ STRIP	
	XY0N618M3SW-A	GLUE FURROW W=6MM L=18.3M SS WHITE @ROLL	
	XY0P523K000-A	WIRE,IRON,D=0.5MM,N.W=23KG @KG	
	XY0P801K000-A	WIRE TIN D=0.8MM N.W=1.0KG @KG	
	XY1N127N0WH-5	ADHESIVE WHITE D=1.1CM L=27CM @KG	
	XY1N209M0DW-4	GLUE TAPE W=12MM L=9.0M DS WHITE @ROLL	
	XY1N218M3CL-9	GLUE TRANSPARENT W=12MM L=18.3M @ROLL	
	XY1N218M3SW-4	GLUE FURROW W=12MML=18.3M SS WHITE @ROLL	
	XY1N250M0DW-4	GLUE,TAPE,#9070,W=12MM,L=50,DOUBLE-SIDE,WHITE. @METER	
	XY1P202K000-1	WIRE, TIN, D=1.2MM N.W=2.0KG @KG	
	XY30155G00-0	TCE,CLEANER,-301#,V=55GALLON,TYPELESS @GALLON	
	XY4N836M5CL-9	GLUE TRANSPARENT W=48MM L=36.5M @ROLL	
	XY6R301K000-0	BAR,TIN,63/37,N.W=1.0KG @KG	
	XYALC01G000-2	ALCOHOL V=1.0GALLON @GALLON	
	XYGLU00K5RD-7	GLUE, RED, W=0.5KG TYPELESS FOR SMT @KG	
	XYRF801G000-7	FLUX #RF-800 V=1.0 GALLON @ GALLON	
	XYWAX10K000-6	ANTI-OXIDATION,WAX,W-1#,N.W=10KG,@KG	

REF NO.	PART NO.	DESCRIPTION	REMARKS
	<b>3SA-4121US-FCAA-1-6</b>	<b>IAA FRONT BD AXIAL AVR635US</b>	
C128	CCZID0104NA-2	CC 100N0F +80% -20% 50.0V F	
D101 301	H03-DG1N04148NB-A	D-SLP 1N4148 100.0V 150E-3A	
L121	H03-LAINB0470CR-8	LF 47U0H +10% 5.8 OHM 500MIOA	
L120	H03-LAINB047ACR-9	LF 4U7H +10% 1.7 OHM 190.0A	
	PBD11KFCI20-6	PCB SINGLE AVR435/635 FRONT PCB 400x163x1.6t FR-1 1OZ	
R105 122 123 501 502	RC3DI0101IN-0	RCF 100R0 OHM +5% 250MIOW	
R104	RC3DI0102IN-9	RCF 1K0 OHM +5% 250MIOW	
R111 112 113	RC3DI0103IN-7	RCF 10K0 OHM +5% 250MIOW	
R831	RC3DI0151IN-7	RCF 150 OHM 5% 1/4W	
R832	RC3DI0331IN-5	RCF 330R0 OHM +5% 250MIOW	
R518	RC3DI0182IN-7	RCF 1K8 OHM 5% 1/4W	
R851 852	RC3DI0561IN-A	RCF 560R0 OHM +5% 250MIOW	
R120 121	RC3DI0471IN-0	RCF 470R0 OHM +5% 250MIOW	
	<b>3SA-4121US-FCAR-1-8</b>	<b>IAR FRONT BD RADIAL AVR635US</b>	
C517	CEHEC02275E-9	CE 220UF +20% 10.0V D6.3XL11 P5MM 85C	
C501 502 708	H03-CEMGC04762R-6	CAP ELEC 47UF 25V M 6.3X5 SRE P2.5MM	
C503 504	H03-CEMFC01062R-8	CAP ELEC 10UF 16V M 3.5X5 SRE P2.5MM	
C101 718	H03-CEMGC0476AH-0	CAP ELEC 47uF 25v M 5x11 SHL P5MM	
C125 126	H03-CFHKA0473NN-9	CAP POLYESTER METAL 47NF 100V 20% CPM	
S201 202 203 204 205 206 207 208 209 210 211 212 213 214 215 216 217 218 219 220	H03-SWC2A112FS1-3	SWITACT VERTICAL SKQNADD010 12V 50MA	
Q821	H03-TRMPSA06NNA-A	TR-SLPLF MPSA06 N 500MIOA TO-92	
Q823	H03-TRMPSA56YNA-0	TR-SLPLF MPSA56 Y P -500MIOA -300V	
	<b>3SA-4121US-FCST-1-4</b>	<b>SMD FRONT BD AVR635US</b>	
C709	CZKII0104CC-2	CAP CHIP 100NF 50.0V X7R K 0805	
C120 121 122 404 717 900	CZJII0101BE-2	CAP CHIP 100P0F +5% -5% 50.0V NPO 0603	
D110	H03-DSUDZ05V1NB-A	DIODE ZENER UDZ5.1B 5.1V 200MIOW	
C703 705 707	CZJII0122CC-8	CAP CHIP 1n2F 50V SL J X7R 0805	
C701 704 706	CZDII0100CE-7	CAP CERAMIC/CHIP 10PF 50V CH D N 0805	
C702	CZJII0101CE-1	CAP CERAMIC/CHIP 100PF 50V CH J NPO 0805	
C300 301	CZJII0821CE-0	CAP CHIP 820pF 50V SL J NPO 0805	
C505 506	CZKII0221BA-3	CAP CHIP 220PF 50V K SL 0603	
C201 211	CZKII0223BC-6	CAP CHIP 22N0F +10% -10% 50.0V X7R 0603	
C124 521	CZZFI0104BF-8	CAP CHIP 100N0F +80% -20% 16.0V Y5V 0603	
D701 702 715	H03-DS1S50094NB-5	D-SLP 1SS355 35.0V 225MIOA	
IC101	H03-IC74HC4094D-1	IC CD74HC4094D(R-PDSO-G16) SOP16	
IC50	H03-ICLM02068D2-5	IC-OPERAMP NJM2068M-TE1 DUAL SOP8	
Q824 831 832 833	H03-TRDTA114YNI-4	TR-SSD DTA114YKA P 10K0 OHM 47K0 OHM	
Q820 822	H03-TRDTC114YNI-0	TR-SSD DTC114YKA N 10K0 OHM 47K0 OHM	
Q703 704 705	H03-TRKTA1504ND-2	TRANSISTOR PNP KTA1504Y(S)SOT-23	
R746	RS3AD0101NA-5	RES CHIP 100R0 OHM +5% 62MI5W 0603	
R101 102 103 201 211 503 515 824	RS3AD0102NA-3	RES CHIP 1K0 OHM +5% 62MI5W 0603	
R505 822	RS3AD0103NA-1	RES CHIP 10K0 OHM +5% 62MI5W 0603	
R516	RS3AD0104NA-A	RES CHIP 100K0 OHM +5% 62MI5W 0603	
R202 212	RS3AD0122NA-8	RES CHIP 1K2 OHM +5% 62MI5W 0603	
R203 213	RS3AD0152NA-A	RES CHIP 1K5 OHM +5% 62MI5W 0603	
R209 219	RS3AD0183NA-A	RES CHIP 18K0 OHM +5% 62MI5W 0603	
R823	RS3AD0221NA-6	RES CHIP 220R0 OHM +5% 62MI5W 0603	
R204 214 510 519	RS3AD0222NA-4	RES CHIP 2K2 OHM +5% 62MI5W 0603	
R205 215	RS3AD0272NA-0	RES CHIP 2K7 OHM +5% 62MI5W 0603	
R206 216 506	RS3AD0332NA-8	RES CHIP 3K3 OHM +5% 62MI5W 0603	
R509 600 601 602	RS3AD0472NA-3	RES CHIP 4K7 OHM +5% 1/16W 0603	
R520	RS3AD0473NA-1	RES CHIP 47K0 OHM +5% 62MI5W 0603	
R207 217	RS3AD0562NA-2	RES CHIP 5K6 OHM +5% 62MI5W 0603	
R821	RS3AD0563NA-0	RES CHIP, 56K 1/16W +/-5%, 0603.	
R301 302	RS3AD0683NA-1	RES CHIP 68K0 OHM +5% 62MI5W 0603	
R208 218	RS3AD0822NA-2	RES CHIP 8K2 OHM +5% 62MI5W 0603	
R508	RS3AD0911NA-3	RES CHIP 910 OHM +5% 62MI5W 0603	
R702 704 709 710	RS3BB0103NA-6	RES,CHIP,10K 1/10W +/-5%,0805	

REF NO.	PART NO.	DESCRIPTION	REMARKS
R706 707	RS3BB0105NA-2	RES,CHIP,1M 1/10W +/-5%,0805	
R703	RS3BB0272NA-5	RES,CHIP,2.7K 1/10W +/-5%,0805	
R708	RS3BB0511NA-2	RES,CHIP,510 1/10W +/-5%,0805	
R701	RS3BB0683NA-6	RES,CHIP,68K 1/10W +/-5%,0805	
R711 715	RS3CB0102NN-8	RES,CHIP,1K,1/8W,+/-5%,0805	
Q701 702	H03-TRKTC3875ND-A	TRANSISTOR NPN KTC3875S SOT23	
R705	RS3BB0564NA-3	RES,CHIP,560K OHM,1/10W +/-5%,0805	
R712 713	RS3BB0221NA-0	RES,CHIP,220R 1/10W +/-5%,0805	
R714	RS3BB0471NA-A	RES,CHIP 470 OHM 1/10W +/-5%, 0805	
<b>3SA-4121US-FCMI-1-8</b>			<b>V4-DIG BD AVR635US</b>
C400 401 403	CZJII0101BE-2	CAP CHIP 100P0F +5% -5% 50.0V NP0 0603	
C411	CZZII0104CF-8	CAP CHIP 100N0F +80% -20% 50.0V Y5V 0805	
D401 411 412	H03-DS1S50094NB-5	D-SLP 1SS355 35.0V 225MIOA	
D800 801	H03-DLRED3FRDBA-0	D-LEM RED/GREEN 3F RD RND CL	
N220	H03-WS4264822EN-A	WIRECONASY DL 2.0MM 04P 480MM UL1533 SHIELD 26 1 2/2	
N221	H03-WS6265105EN-8	WIRECONASY DL 2.0MM 6P 510MM UL1533 SHIELD 26 1	
NJ20	H03-SORA3313PNN-9	CON PHONO SCKT RCA-313P 3 PINS	
NJ21	H03-SORA8OSC5N8-8	JACK S-VIDEO 1P C40160261N	
P222	H03-WN07AB00000-3	CONNECT 2.0MM 7P GIL-S-07P-S2L2-EF	
Q401 800 801 802 803	H03-TRDTC114YNI-0	TR-SSD DTC114YKA N 10K0 OHM 47K0 OHM	
R800 802	RC3DI0271IN-8	RCF 270R0 OHM +5% 250MIOW	
R801 803	RC3DI0201IN-7	RCF 200R0 OHM +5% 250MIOW	
R841 842 843 844	RS3AD0000NA-0	RES CHIP 0 OHM +0% 62M5W 0603	
SK40	H03-RLV23079A10-6	RELAY V23079-A1001	
SK40	H03-RLTX25VNAIS-2	RELAY TX2-5V STANDARD PC BOARD TERMINAL	
<b>3SA-4121US-FCMI-1-8</b>			<b>HP BD AVR635US</b>
C1 4	CZZFI0104BF-8	CAP CHIP 100N0F +80% -20% 16.0V Y5V 0603	
D1 2	H03-DS1S50094NB-5	D-SLP 1SS355 35.0V 225MIOA	
L1	H03-LAINB0470CR-8	LF 47U0H +10% 5.8 OHM 500MIOA	
N240	H03-WS4265913FN-0	CNT ASSY 2.0MM 4P 590MM SHIELD 26AWG UL2547 1/3	
NJ88	H03-SOSS9CKX3NN-4	JACK PHONE 6.35 H70980110S 9P BK	
R1 2	RC3DI022AIN-2	RCF 2R2 OHM +5% 250MIOW	
S1	H03-ZMB01S02200-4	SPRING PLATE GND C5212 0.2T	
<b>3SA-4121US-FCMI-1-8</b>			<b>RMT/RS232 BD AVR635US</b>
BD11	H03-FB3012012CN-8	FBEAD SURFACE MT FCM2012C-301T04 0805	
C601	CPIKC0473NN-0	CPF 47N0F +10% 100.0V	
C602 603 604	H03-CEMIC0334AH-A	CAP ELEC 0.33UF M 5X11 SHL 50V SAMYOUNG P5MM	
C605	RS3AD0000NA-0	RES CHIP 0 OHM +0% 62M5W 0603	
C606 611 622	CZZFI0104BF-8	CAP CHIP 100N0F +80% -20% 16.0V Y5V 0603	
C610	CEHFC01075E-1	CE 100UF +-20% 16.0V D5XL11 P5MM 85C	
C612	RS3AD0000NA-0	RES CHIP 0 OHM +0% 62M5W 0603	
C9	CEMIC01045E-1	CAP ELEC 0.1uF 50v M 5x11 SHL P5MM	
D602 603 604 605	RS3AD0000NA-0	RES CHIP 0 OHM +0% 62M5W 0603	
D606 607 651 652 653	H03-DS1S50094NB-5	D-SLP 1SS355 35.0V 225MIOA	
IC61	H03-ICMAX322316-7	IC RS-232 LINE DIRVER MAX3223CDWR SOIC16P	
IC651 652	H03-ICPC17T10B1-8	IC PHOTOCOUPLER PC-17T1 DIP4 KODENSHI	
L600 601 602 603	H03-FB2K52012NN-0	FBEAD SURFACE MT 2500OHM FCM2012H-252T02	
NJ60	SOPA96063NN-0	JACK D-SUB 9P 87204-6063 W/DUST COVER BK	
NJ611 612 613 614	H03-SOJW2350SNN-5	JACK PHONE 3.6 EP-1401A 1P BK	
P260	H03-WN09AB00000-8	CONNECT 2.0MM 9P GIL-S-09P-S2L2-EF	
Q651 652	H03-TRKTA107MNA-2	TR-SLPSWA KRA107M P	
R600 601 602	RS3AD0472NA-3	RES CHIP 4K7 OHM +5% 1/16W 0603	
R651	RS3AD0471NA-5	RES CHIP 470R0 OHM +5% 62M5W 0603	
R652	RS3AD0271NA-2	RES CHIP 270R0 OHM +5% 62M5W 0603	
R653 654	RS3AD0473NA-1	RES CHIP 47K0 OHM +5% 62M5W 0603	
R655 656	RS3AD0470NA-7	RES CHIP 47R0 OHM +5% 62M5W 0603	
R657	RS3AD0392NA-1	RES CHIP 3K9 OHM +5% 62M5W 0603	
R658	RC3DI0104IN-5	RCF 100K0 OHM +5% 250MIOW	
R659	RC3DI0471IN-0	RCF 470R0 OHM +5% 250MIOW	

REF NO.	PART NO.	DESCRIPTION	REMARKS
	3SA-4121US-MAMI-1-0	IMA MAIN BD AVR635US	
C509 510	CEHHC0228MN-A	CE 2MI2F +20% 35.0V 85C ELITE	
C517	CEHIA0228MN-4	CE 2MI2F +20% 50.0V 85C ELITE	
C571 572	H03-CEMJA0159KA-7	CAP ELEC 15000uF 63V M 35x50 LSW153M1JQ50M	
D502 505	H03-DRW204F00BA-5	DIODE BRIDGE W2-04F FRONTIER	
HS11	H03-ZMC11HS0400-6	AC HEATSINK DIODE 47X26X12 AVR630 -- ME	
HS12	H03-ZMD11HS0400-2	HEATSINK REG. TR 68X20X50	
IC59	H03-ICKIA7812I2-8	IC-REGPOSFXD KIA7812API NORMAL	
IC54	H03-ICKIA7824I2-2	IC-REGPOSFXD KIA7824API TO-220IS NORMAL	
IC51	H03-ICLM07815BD-6	IC-REGPOSFXD KIA7815API NORMAL	
IC52	H03-ICLM07915BD-4	IC-REGNEGFXD KIA7915API NORMAL TO-220AB	
L301 302 401 402	H03-LCENNNA050NA-7	LFA 1MM 10MM 5 LEFT 0.0MM NONE	
Q329 330 433 434	H03-TR2SA1859BC-8	TR-SHPLF 2SA1859A P -2.0A	
R378 379 471 472	H03-RI3IC022BEN-3	RW 220MIO OHM +5% 5.0W 100PPM/C -100PPM/C	
R392 393 475 476	RM3FC0100BN-7	RMOF 10R0 OHM +5% 1.0W	
R505	H03-RM3GC0100CN-2	RESISTOR METAL OXIDE 10R0 OHM +5% 2.0W	
R514	H03-RM3GC022ACN-3	RESISTOR METAL OXIDE 2R2 OHM +5% 2.0W	
R504 507 510	H03-RM3GC033ACN-2	RESISTOR METAL OXIDE 3R3 OHM +5% 2.0W	
NJ12	H03-SORA40RSANN-1	JACK RCA 4P JB040131ZN GN BN PP TA	
NJ11	H03-SORA40RSCNN-5	JACK RCA 4P JB040131QN WH BU RD GY	
NJ14	H03-SOPA81900NN-3	CONN-SPE TERMINAL SPKR 8P SH081136JP FE 19MM 8 -- 0 0	
W311	H03-WG116S500BK-0	WIRE ASS'Y UL1007#16 500MM 1P BLK TERMINAL	
Q335 336 439 440	H03-TR2SA1986BE-0	TR-SHPLF 2SA1986-R P -15.0A	
Q333 334 437 438	H03-TR2SC5358BO-1	TR-SHPLF 2SC5358-R N 15.0A	
Q327 328 431 432	H03-TRKTA1360BE-5	TRANSISTOR PNP KTA1360 TO-126	
Q323 324 429 430	H03-TRKTC3423BE-A	TRANSISTOR NPN KTC3423 TO-126	
Q331 332 435 436	H03-TR2SC4883BC-3	TR-SHPLF 2SC4883A N 2.0A	
	ZSMBM3014BZ-5	SCREW M.S M3X14 ZN PLATED	
P801 802 803 804 809	H03-WN02SD00000-2	CONN 2.5MM 2 MA ST NAT 5267-02A 0 0	
	ZNSSM3023HZ-8	NUT M3 ZN PLATED	
P807	H03-WN03SE00000-9	CON 3.96MM PITCH MOLEX 35313-0310	
P808	H03-WN05SD100WH-6	CONN WAFER 2.5MM 5P 5267-05A WHT	
P806	H03-WN07SB00001-4	CONN 2.0MM 7P GIL-S-7P-S2T2-EF	
P811	H03-WN19SB00000-1	CONN 2.0MM 19 MA ST NAT MOLEX 35336-1910 0 0	
NJ13	SO0A18P8CNN-7	JACK-TELE SNAP-IN GOLDEN TELECOM GDL1-8P8C 8T BK 0 0	
IC22	H03-ICLM02068D2-5	IC-OPERAMP NJM2068M-TE1 DUAL SOP8	
D501	H03-DRBU10040BA-1	D-BRDLC BRIDGE BU10-04	
N801 802 803 804	H03-WG02SB808AA-4	WIRECONASY UNIQUE 2P 80MM UL1007 PVC DISCRETE 26 BOTH	
N806	H03-WSE263905EN-0	WIRECONASY DL 2.0MM 15P 390MM UL1533 SHIELD 26 1	
N809	H03-WG03SB82200-4	WIRE ASS'Y UL1007#26STR 220mm 2.0mm 3P WHT	
W401-2	H03-WC1180905H1-0	WIRE ASS'Y WCL 1P 90MM UL1015#18(TD) BLK HOOK-UP 090-05-05	
N805	H03-WS8262505EN-6	WIRE ASS'Y UL1533#26 250MM 2.0MM 8P WHT SHIELD	
N808	H03-WG05SB84000-7	WIRE ASS'Y UL1007#26STR 400MM 2.0MM 5P WHT	
C303 304 305 306 421 422 423 424	CEHJA0477MN-9	CE 470U0F +20% 63.0V 85C ELITE	
W301	H03-WC1180175H1-1	WIRE ASS'Y 1P 175MM UL1015#18(TD) BLK	
N807	H03-WG03SB821AA-0	WIRECONASY DL 2.0MM 3P 210MM UL1007 RIBBON 26 12 BOTH	
	ZWM803305PZ-1	WASHER PLAIN 3	
R494 REWORK	RC3DI0822IN-8	RCF 8K2 OHM +5% 250MIOW	
	XY0N211N5WH-4	CABLE TIE W=0.2MM L=11.5CM WHITE @ STRIP	
	XY0P523K000-A	WIRE,IRON,D=0.5MM,N.W=23KG @KG	
	XY0P801K000-A	WIRE TIN D=0.8MM N.W=1.0KG @KG	
	XY1N127N0WH-5	ADHESIVE WHITE D=1.1CM L=27CM @KG	
	XY1N218M3SW-4	GLUE FURROW W=12MML=18.3M SS WHITE @ROLL	
	XY1P202K000-1	WIRE, TIN, D=1.2MM N.W=2.0KG @KG	
	XY2N418M3SW-6	GLUE FURROW W=24MML=18.3M SS WHITE @ROLL	
	XY57501K0YW-0	GLUE, YELLOW, N.W=1.0KG #575 @KG	
	XY6R301K000-0	BAR,TIN,63/37,N.W=1.0KG @KG	
	XY74601K0WH-9	OINTMENT HTC #SDL-746 NW=1.0KG WHITE @KG	
	XYALC01G000-2	ALCOHOL V=1.0GALLON @GALLON	
	XYRF801G000-7	FLUX #RF-800 V=1.0 GALLON @ GALLON	
	XYWAX10K000-6	ANTI-OXIDATION,WAX,W-1#,N.W=10KG,@KG	

REF NO.	PART NO.	DESCRIPTION	REMARKS
	3SA-4121US-MAAA-1-9	IAA MAIN BD AXIAL AVR635US	
C101 102 103 104 107 108 109 110 111 112 113 114 115 116 117 118 209	CCKID0101NA-7	CC 100P0F +10% -10% 50.0V Y5P	
C307 308 313 314 403 404 569 570	CCKID0271NN-0	CC 270P0F +10% -10% 50.0V 2B4	
C433 601 602	CCMFD0103NN-4	CC 10N0F +20% -20% 16.0V Y5S	
C333 434	CCMFD0472NN-6	CC 4N7F +20% -20% 16.0V Y5R	
C119 120 212 214 527	CCZID0104NA-2	CC 100N0F +80% -20% 50.0V F	
D205 206 301 302 303 304 305 306 307 308 401 402 403 404 405 406 407 408 409 410 411 412	H03-DG1N04148NB-A	D-SLP 1N4148 100.0V 150E-3A	
D101 507 508 509	H03-DR1N04004NA-7	D-SR 1N4004 400.0V 1.0A	
D207	H03-DZMTZ05V1NB-3	DIODE ZENER MTZ J 5.1B 5.1V 500MW DO-34	
D204	H03-DZMTZ12V0NB-6	D-ZENER MTZJ 12.0V 500MI0W	
R351 352 367 368 445 446 447 448	H03-RM3EG0100LN-5  PBD11KMAI21-4	RMF 10R0 OHM +5% 500MI0W  PCB SINGLE AVR435/635 MAIN 330x247x1.6t FR-1 1OZ	
R363 364 365 366 461 462 463 464	RC3DI0150IN-9	RCF 15R0 OHM +5% 250MI0W	
R303 304 388 389 473 474 477 478	RC3DI0100IN-2	RCF 10R0 OHM +5% 250MI0W	
R213 215 221 353 354 369 370 457 458 459 460 609 614	RC3DI0101IN-0	RCF 100R0 OHM +5% 250MI0W	
R211 601	RC3DI0102IN-9	RCF 1K0 OHM +5% 250MI0W	
R485 516 605 606 608 610 611 613	RC3DI0103IN-7	RCF 10K0 OHM +5% 250MI0W	
R207 214 216 217 218 219 220 309 310 479 480 602	RC3DI0104IN-5	RCF 100K0 OHM +5% 250MI0W	
R339 340 345 346 347 348 349 350 433 434 435 436 441 442 443 444	RC3DI0201IN-7	RCF 200R0 OHM +5% 250MI0W	
R380 381 386 387 481 483 488 490	RC3DI0152IN-5	RCF 1K5 OHM +5% 250MI0W	
R341 342 343 344 384 385 437 438 439 440 482 489	RC3DI0153IN-3	RCF 15K0 OHM +5% 250MI0W	
R311 312 313 314 405 406 407 408	RC3DI0162IN-2	RCF 1K6 OHM +5% 250MI0W	
R317 318 319 320 321 322 409 410 411 412 413 414	RC3DI0221IN-1	RCF 220R0 OHM +5% 250MI0W	
R390 391 486 492	RC3DI0223IN-8	RCF 22K0 OHM +5% 250MI0W	
R371 372 373 374 465 466 467 468 616	RC3DI022AIN-2	RCF 2R2 OHM +5% 250MI0W	
R375 376 469 470	RC3DI0820IN-1	RCF 82R0 OHM +5% 250MI0W	
R209 498	RC3DI0273IN-4	RCF 27K0 OHM +5% 250MI0W	
R224	RC3DI0274IN-2	RCF 270K0 OHM +5% 250MI0W	
R301 302 401 402	RC3DI0331IN-5	RCF 330R0 OHM +5% 250MI0W	
R331 332 419 420	RM1DI1451IN-4	RMF 1K45 OHM +1% 250MI0W	
R382 383 484 487 491 493 501 502	RC3DI0393IN-5	RCF 39K0 OHM +5% 250MI0W	
R307 308 415 416	RC3DI0433IN-8	RCF 43K0 OHM +5% 250MI0W	
R101 102 105 106 109 110 113 114 315 316 593 594	RC3DI0471IN-0	RCF 470R0 OHM +5% 250MI0W	
R223	RC3DI0513IN-A	RCF 51K0 OHM +5% 250MI0W	
R323 324 325 326 329 330 333 334 335 336 337 338 421 422 423 424 425 426 427 428 429 430 431 432	RC3DI0561IN-A	RCF 560R0 OHM +5% 250MI0W	
R497	RC3DI0271IN-8	RCF 270R0 OHM +5% 250MI0W	
R327 328 417 418	RM1DI0333IN-4	RMF 33K0 OHM +1% 250MI0W	
R503 607 612	RC3DI0123IN-1	RCF 12K0 OHM +5% 250MI0W	

REF NO.	PART NO.	DESCRIPTION	REMARKS
R225 305 306 403 404	RC3DI0333IN-1	RCF 33K0 OHM +5% 250MI0W	
	3SA-4121US-MAAR-1-0	IAR MAIN BD RADIAL AVR635US	
C315 316 409 410	CCCIC0030NN-4	CAP CERAMIC 3PF 50V C CH TAP	
C317 318 411 412	CCKIC0181NA-0	CC 180P0F +10% -10% 50.0V Y5P	
C329 330 425 426	CCKIC0222NA-1	CC 2N2F +10% -10% 50.0V Y5P	
C331 332 407 408	CEHEC02275E-9	CE 220UF +20% 10.0V D6.3XL11 P5MM 85C	
C432	CEMGC04775E-9	CE 470U0F +/-20% 25.0V 10X13 85C	
C206 208 213 309 310 405 406 526	CEHGC01075E-5	CE 100U0F +20% 25.0V 6.3X11 85C P5MM	
C210	CEHIC01055E-6	CE 1UF +20% 50V D5XL11 P5MM 85C	
C301 302 401 402 518 519 521	CEHIC01065E-4	CE 10U0F +20% 50.0V 85C P5MM 5X11	
C501 502 503	CFIOC0104NN-5	CPM 100N0F +10% 250.0V	
C323 324 430 431	CFLJC0683NN-7	CPM 68N0F +5% 63.0V	
C506 507 508 516 528 529	CPIKC0473NN-0	CPF 47N0F +10% 100.0V	
C207	H03-CEMIC0475AH-3	CE 4.7UF 50V M 5X11 SHL SAMYOUNG P5MM	
C211 319 320 321 322 415 416 413 414	H03-CEMKC0106AH-9	CAP ELEC 10UF 100V M 6.3X11 SHL	
C325 326 327 328 417 418 419 420	H03-CPKJC0104NN-2	CAP POLY NON METAL 0.1UF 63V K TAP PCMT365 75104	
F501 502 505 506	H03-FURN2200663-8	FUSE 663 SERIES 0663 002. 250V 2.0A TIMELUG	
C429	H03-CEMIC01065H-1	CAP ELEC 10UF 50V M 5X11 SHL P5MM	
Q315 316 319 320 417 418 421 422 442	H03-TRKTA1024NA-2	TR-SLPLF KTA1024 Y P 50MI0A -150V	
Q317 318 321 322 419 420 423 424	H03-TRKTC3206NA-5	TR-SLPLF KTC3206 Y N 50MI0A 150V	
Q605 607	H03-TRKTA1266NA-6	TR-SLPLF KTA1266 Y P 150MI0A	
Q311 312 410 413 414	H03-TRKTA1268NA-A	TR-SHPLF KTA1268BL P 100MI0A 120V	
Q307 308 407 408 426 441 606 608	H03-TRKTC3198NA-9	TR-SLPLF KTC3198BL N 150MI0A	
Q301 302 303 304 305 306 313 314 337 338 401 402 403 404 405 406 409 415 416 425	H03-TRKTC3200NA-4	TR-SHPLF KTC3200BL N 100MI0A 120V	
Q601	H03-TRKTD1302NA-6	TR-SLPLF KTD1302 B N 300MI0A 20V	
G101 102	H03-ZNMSA4004SN-A	TERMLUG GND	
Q309 310 411 412	H03-TR2SA1145NA-8	TR-SLPLF 2SA1145Y TO-92MOD P -50MI0A -150V	
Q443	H03-TRKRC107MNA-4	TR-SLPSWA KRC107M N	
	3SA-4121US-MAMI-1-0	FRONT L - BIAS BD AVR635US	
R705	RC3DI0821IN-A	RCF 820R0 OHM +5% 250MI0W	
R707	RC3DI0282IN-3	RCF 2K8 OHM +5% 250MI0W	
VR71	RT6BA0201NB-A	PR 200R0 OHM +30% 100MI0W	
Q701	H03-TRKTC3114NE-9	TRANSISTOR NPN KTC3114 TO-126	
	3SA-4121US-MAMI-1-0	FRONT R - BIAS BD AVR635US	
R710	RC3DI0282IN-3	RCF 2K8 OHM +5% 250MI0W	
R708	RC3DI0821IN-A	RCF 820R0 OHM +5% 250MI0W	
VR74	RT6BA0201NB-A	PR 200R0 OHM +30% 100MI0W	
Q704	H03-TRKTC3114NE-9	TRANSISTOR NPN KTC3114 TO-126	
	3SA-4121US-MAMI-1-0	SURROUND L - BIAS BD AVR635US	
R711	RC3DI0282IN-3	RCF 2K8 OHM +5% 250MI0W	
R709	RC3DI0821IN-A	RCF 820R0 OHM +5% 250MI0W	
VR73	RT6BA0201NB-A	PR 200R0 OHM +30% 100MI0W	
Q703	H03-TRKTC3114NE-9	TRANSISTOR NPN KTC3114 TO-126	
	3SA-4121US-MAMI-1-0	SURROUND - R BIAS BD AVR635US	
R701	RC3DI0282IN-3	RCF 2K8 OHM +5% 250MI0W	
R702	RC3DI0821IN-A	RCF 820R0 OHM +5% 250MI0W	
PO71	H03-RP3NA0101NN-5	POS 100R0 OHM 16.0V	
PO72	H03-RP3NA0101HJ-4	THERMISTOR ASS'Y RP3NA-0101-NZ	
Q702	H03-TRKTC3114NE-9	TRANSISTOR NPN KTC3114 TO-126	



REF NO.	PART NO.	DESCRIPTION	REMARKS
VR72	RT6BA0201NB-A	PR 200R0 OHM +30% 100MI0W	
	3SA-4121US-POMI-1-9	IMA PROCESSOR BD AVR635US	
NJ101 102 103 104 105	H03-SORA40GNDNN-2	JACK RCA 4P JB040131PN WWRR	
P101	H03-WN03SB00000-1	CONNECT 2.0mm 3P GIL-S-3P-S2T2-EF	
P103 104 113	H03-WN04SB00000-9	CONNECT 2.0mm 4P GIL-S-4P-S2T2-EF	
P110	H03-WN06SB00000-3	CONNECT 2.0mm 6P GIL-S-6P-S2T2-EF	
P111	H03-WN08SB00000-8	CONNECT 2.0mm 8P GIL-S-8P-S2T2-EF	
P108	H03-WN11AB00000-6	CONN 2.0MM 11 MA R NAT SOCKET MOLEX 35237-1110 0 0	
P112	H03-WN15SB00000-2	CONNECT 2.0mm 15P GIL-S-15P-S2T2-EF	
P106 107 109	H03-WN19AB00000-4	CONN 2.0MM 19 MA R NAT SOCKET MOLEX 35237-1910 0 0	
D301 601 602 603 604	H03-DZMTZ09V1NB-6	D-ZENER MTZJ 9.1V 500MI0W	
R691 692	RC3DI0331IN-5	RCF 330R0 OHM +5% 250MI0W	
	XY0P523K000-A	WIRE,IRON,D=0.5MM,N.W=23KG @KG	
	XY0P801K000-A	WIRE TIN D=0.8MM N.W=1.0KG @KG	
	XY1N209MODW-4	GLUE TAPE W=12MM L=9.0M DS WHITE @ROLL	
	XY1N218M3CL-9	GLUE TRANSPARENT W=12MM L=18.3M @ROLL	
	XY1N218M3SW-4	GLUE FURROW W=12MML=18.3M SS WHITE @ROLL	
	XY1P202K000-1	WIRE, TIN, D=1.2MM N.W=2.0KG @KG	
	XY30155G00-0	TCE,CLEANER,-301#,V=55GALLON,TYPELESS @GALLON	
	XY4N836M5CL-9	GLUE TRANSPARENT W=48MM L=36.5M @ROLL	
	XY6R301K000-0	BAR,TIN,63/37,N.W=1.0KG @KG	
	XYALC01G000-2	ALCOHOL V=1.0GALLON @GALLON	
	XYGLU00K5RD-7	GLUE, RED, W=0.5KG TYPELESS FOR SMT @KG	
	XYJU100K5GY-5	JUICE TIN N=0.5KG GREY @KG	
	XYRF801G000-7	FLUX #RF-800 V=1.0 GALLON @ GALLON	
	XYWAX10K000-6	ANTI-OXIDATION,WAX,W-1#,N.W=10KG,@KG	
	XY0N618M3SW-A	GLUE FURROW W=6MM L=18.3M SS WHITE @ROLL	
	3SA-4121US-POAR-1-9	IAR PROCESSOR BD RADIAL AVR635US	
C109 110 113 114 125 126 127			
128 141 143 144 146 206 207			
212 213 220 221 226 227 230			
231 232 233 307 308 309 310	CEHIC01065E-4	CE 10U0F +20% 50.0V 85C P5MM 5X11	
508 510 511 515 621 622 627			
628 631 632 637 638 641 642			
647 648 651 652			
C607 608	H03-CEMGC0337AH-0	CAP ELEC 330UF 25V M 8X11.5 AHS P5MM	
C311 312	H03-CEMGC0476AH-0	CAP ELEC 47uF 25v M 5x11 SHL P5MM	
	PBD11KPOB21-8	PCB DUAL AVR435/635 PROCESSOR 209x170x1.6t FR-4 1OZ	
C301 302 303 304 517 518 521			
522 528 529 534 535 601 602	H03-CEMIC0106AH-4	CAP ELEC 10UF 50V 85C 5X11 P5MM AHS	
611 612 617 618			
C111 112 129 130 142 145 214			
215 228 229 234 235 236 237			
305 306 313 314 501 502 504			
505 507 509 514 516 523 524	CEMGC04765E-0	CAP ELEC 47UF 25V 85C 5X11 P5MM	
525 526 536 537 538 539 541			
542 609 610 619 620 629 630			
639 640 649 650 653 654			
	3SA-4121US-POSB-1-A	BOT SMD PROCESSOR BD AVR635US	
C101 102 103 104 105 106 107			
108 116 117 118 119 121 122			
123 124 131 132 133 134 136			
137 138 139 147 148 149 150			
152 153 154 155 156 157 158			
159 201 202 204 205 216 217	CZJII0101BE-2	CAP CHIP 100POF +5% -5% 50.0V NP0 0603	
218 219 224 225 238 315 503			
506 519 520 527 530 531 540			
543 603 604 613 614 623 624			
633 643 644			

REF NO.	PART NO.	DESCRIPTION	REMARKS
C208 209 222 223	CZJII0330BE-9	CAP CHIP 33P0F +5% -5% 50.0V NP0 0603	
C605 606	CZJII0331BE-7	CAP CHIP 330P0F +5% -5% 50.0V NP0 0603	
C512 513 634	CZKII0222BC-8	CAP CHIP 2N2F +10% -10% 50.0V X7R 0603	
C120 135 151 160 203	CZZFI0104BF-8	CAP CHIP 100N0F +80% -20% 16.0V Y5V 0603	
IC304	H03-ICTC9273NDA-6	IC-SWITCH TC9273F-004 SOP28 ANALOG SWITCH	
Q620 623 626 629	H03-TRDTA114YNI-4	TR-SSD DTA114YKA P 10K0 OHM 47K0 OHM	
Q1	H03-TRDTC114YNI-0	TR-SSD DTC114YKA N 10K0 OHM 47K0 OHM	
Q616 617 621 622 624 625 627 628 630 631	H03-TRKTD1304ND-0	TR-SLPSWA KTD1304 N 20V 300MIOA SOT-23	
R2 3	RS3AD0122NA-8	RES CHIP 1K2 OHM +5% 62MI5W 0603	
R113 114 137 138 157 158 217 218 237 238 239 240 245 246 307 308 315 316 324 325 501 502 507 508 513 519 526 532 539 540 541 542 556 557 558 559 567 568 619 620 635 636 651 652 669 670 685 686	RS3AD0101NA-5	RES CHIP 100R0 OHM +5% 62MI5W 0603	
R101 102 107 108 121 122 127 128 141 142 147 148 161 162 165 166 169 170 203 204 211 212 223 224 247 248 249 322 323 329 330 331 503 504 505 509 510 511 543 544 545 560 561 562 569 570 571 631 632 643 644 649 650 659 660 665 666 679 680 687 688	RS3AD0102NA-3	RES CHIP 1K0 OHM +5% 62MI5W 0603	
R103 104 109 110 115 116 123 124 129 131 132 136 143 144 151 152 153 154 163 164 167 168 171 172 207 208 227 228 233 234 241 242 303 304 305 306 311 312 313 314 518 524 528 531 535 536 537 538 548 549 554 555 603 604 609 610 625 626 629 630 641 642 647 648 657 658 663 664 677 678 689 690	RS3AD0104NA-A	RES CHIP 100K0 OHM +5% 62MI5W 0603	
R514 521	RS3AD0123NA-6	RES CHIP 12K0 OHM +5% 62MI5W 0603	
R4	RS3AD0153NA-8	RES CHIP,15K 1/16W,+5%,0603.	
R704 710 716 722	RS3AD0183NA-A	RES CHIP 18K0 OHM +5% 62MI5W 0603	
R529 552 553	RS3AD0202NA-A	RES CHIP 2K0 OHM +5% 62MI5W 0603	
R611 612 613 614	RS3AD0221NA-6	RES CHIP 220R0 OHM +5% 62MI5W 0603	
R225 226 320 321 615 616 617 618 633 634 667 668 693 694 697 698 701 702 707 708 713 714 719 720	RS3AD0222NA-4	RES CHIP 2K2 OHM +5% 62MI5W 0603	
R607 608	RS3AD0242NA-9	RES CHIP 2K4 OHM +5% 62MI5W 0603	
R516 523	RS3AD0332NA-8	RES CHIP 3K3 OHM +5% 62MI5W 0603	
R119 120 139 140 159 160 219 220 318 319 621 622 637 638 653 654 671 672 673 674 695 696 723 724 725 726 727 728	RS3AD0333NA-6	RES CHIP 33K0 OHM +5% 62MI5W 0603	
R512 520 550 551	RS3AD0103NA-1	RES CHIP 10K0 OHM +5% 62MI5W 0603	

REF NO.	PART NO.	DESCRIPTION	REMARKS
R105 106 117 118 125 126 133 134 145 146 155 156 201 202 215 216 221 222 235 236 243 244 301 302 309 310 527 533 534 546 547 601 602 623 624 639 640 655 656 675 676	RS3AD0471NA-5	RES CHIP 470R0 OHM +5% 62MI5W 0603	
R530	RS3AD0472NA-3	RES CHIP 4K7 OHM +5% 1/16W 0603	
R317 703 709 715 721	RS3AD0474NA-A	RES CHIP 470K0 OHM +5% 62MI5W 0603	
R209 210 229 230	RS3AD0512NA-6	RES CHIP 5K1 OHM +5% 62MI5W 0603	
R605 606	RS3AD0821NA-4	RES CHIP 820R0 OHM +5% 62MI5W 0603	
R5 6	RS3AD0430NA-8	RES CHIP 43R0 OHM +5% 62MI5W 0603	
R231 232	RS3AD0272NA-0	RES CHIP 2K7 OHM +5% 62MI5W 0603	
R730 731	RS3AD0511NA-8	RES CHIP 510R0 OHM +5% 62MI5W 0603	
C532 533	CZEII0100BE-0	CAP CHIP 10P0F +0P5F -0P5F 50.0V NP0 0603	
	<b>3SA-4121US-POST-1-5</b>	<b>TOP SMD PROCESSOR BD AVR635US</b>	
C210 211 316	CZJII0101BE-2	CAP CHIP 100P0F +5% -5% 50.0V NP0 0603	
C615 616 625 626 635 645 646	CZJII0330BE-9	CAP CHIP 33P0F +5% -5% 50.0V NP0 0603	
C636	CZKII0222BC-8	CAP CHIP 2N2F +10% -10% 50.0V X7R 0603	
IC606	H03-ICBU4053BB4-2	IC BU4053BCF SOP16 ANALOG MPX/DEMPX	
IC502 510	H03-ICKIC9162DA-0	IC-SWITCH KIC9162AF SOP28 ANALOG SWITCH	
IC501	H03-ICKIC9163DA-2	IC-SWITCH KIC9163AF SOP28 ANALOG SWITCH	
IC204 507	H03-ICKIC9459D5-3	IC-LOWFREQ KIC9459F SOP24 TONE/VOL/BAL/MUTE	
IC101 102 103 201 202 203 301 302 503 504 505 506 508 602 603 604 605	H03-ICLMO2068D2-5	IC-OPERAMP NJM2068M-TE1 DUAL SOP8	
IC509	H03-ICLMO9482DA-0	IC-LOWFREQ KIC9482F/TC9482F SOP28 TONE/VOL/BAL/MUTE	
IC303	H03-ICTC9273NDA-6	IC-SWITCH TC9273F-004 SOP28 ANALOG SWITCH	
Q103 106 109 203 301 605 608 611 614 615 618	H03-TRDTA114YNI-4	TR-SSD DTA114YKA P 10K0 OHM 47K0 OHM	
Q101 102 104 105 107 108 201 202 204 205 302 303 601 602 603 604 606 607 609 610 612 613	H03-TRKTD1304ND-0	TR-SLPSWA KTD1304 N 20V 300MIOA SOT-23	
R326 327 328	RS3AD0102NA-3	RES CHIP 1K0 OHM +5% 62MI5W 0603	
R213 214 683 684	RS3AD0104NA-A	RES CHIP 100K0 OHM +5% 62MI5W 0603	
R515 522	RS3AD0123NA-6	RES CHIP 12K0 OHM +5% 62MI5W 0603	
R627 628	RS3AD0152NA-A	RES CHIP 1K5 OHM +5% 62MI5W 0603	
R705 706 711 717 718	RS3AD0202NA-A	RES CHIP 2K0 OHM +5% 62MI5W 0603	
R111 112 130 135 149 150 205 206	RS3AD0222NA-4	RES CHIP 2K2 OHM +5% 62MI5W 0603	
R517 525	RS3AD0332NA-8	RES CHIP 3K3 OHM +5% 62MI5W 0603	
R699 700	RS3AD0362NA-A	RES CHIP 3K6 OHM +5% 62MI5W 0603	
R645 646 661 681 682	RS3AD0562NA-2	RES CHIP 5K6 OHM +5% 62MI5W 0603	
R662	RS3AD0912NA-1	RES CHIP 9K1 OHM +5% 62MI5W 0603	
D1 2	H03-DSUDZ09V1NB-2	D-ZENER UDZS 9.1B 9.1V 200MIOW	
R7	RS3AD0221NA-6	RES CHIP 220R0 OHM +5% 62MI5W 0603	
R712	RS3AD0242NA-9	RES CHIP 2K4 OHM +5% 62MI5W 0603	
IC601	H03-ICNJM4556B2-2	IC OP AMP NJM4556AD DIP8	
	<b>3SA-4121US-SRMI-1-7</b>	<b>IMA SURROUND BD AVR635US</b>	
C605	CEMFA0828BK-0	CAP ELEC 8200UF 16V M 18X25 P7.5MM ELITE	
C201 202 301 302 501 502	CEHJA0477MN-9	CE 470U0F +20% 63.0V 85C ELITE	
C606	CEMFA0688BK-1	CAP ELEC 6800UF 16V M 16X25 85C 120HZ ELITE	
D601	H03-DRBU604FONA-4	DIODE BRIDGE BU6-04F FRONTIER	
L201 301 501	H03-LCNNNA050NA-7	LFA 1MM 10MM 5 LEFT 0.0MM NONE	
R238 338 538	H03-RI3IC022BEN-3	RW 220MIO OHM +5% 5.0W 100PPM/C -100PPM/C	
R245 345 545	RM3FC0100BN-7	RMOF 10R0 OHM +5% 1.0W	
PO11	H03-RP3NA0101NN-5	POS 100R0 OHM 16.0V	
PO10	H03-RP3NA0101HJ-4	THERMISTOR ASS'Y RP3NA-0101-NZ	
VR301 501	H03-RT7EA0201NB-1	PR 200R0 OHM +20% 500MIOW	
NJ401	H03-SOPA8SH0612-5	JACK SPEAKER 8P SH0612707P	

REF NO.	PART NO.	DESCRIPTION	REMARKS
C604	CEMFA02285E-5	CE 2200UF 16V M 12.5X20 P5MM	
Q216 316 516	H03-TR2SA1859BC-8	TR-SHPLF 2SA1859A P -2.0A	
Q219 319 519	H03-TR2SA1986BE-0	TR-SHPLF 2SA1986-R P -15.0A	
Q217 317 517	H03-TR2SC4883BC-3	TR-SHPLF 2SC4883A N 2.0A	
Q218 318 518	H03-TR2SC5358BO-1	TR-SHPLF 2SC5358-R N 15.0A	
Q215 315 515	H03-TRKTA1360BE-5	TRANSISTOR PNP KTA1360 TO-126	
Q214 314 514	H03-TRKTC3114NE-9	TRANSISTOR NPN KTC3114 TO-126	
Q213 313 513	H03-TRKTC3423BE-A	TRANSISTOR NPN KTC3423 TO-126	
N402	H03-WN10SB00000-6	CONNECT 2.0MM 10P GIL-S-10P-S2T2-EF	
P201 301 501	H03-WN02AD00000-5	CONNECT WAFER 2.5mm 2P 5268-02A WHT ANGLE	
N403	H03-WN03SD100WH-1	CONN WAFER 2.5MM 3P 5267-03A WHT	
N404	H03-WG06SE81200-2	WIRE ASS'Y UL1007#16 120mm 3.96mm 6P RED	
N401	H03-WS6262605EN-1	WIRECONASY DL 2.0MM 6P 260MM UL1533 SHIELD 26 1	
VR201	RT6BA0201NB-A	PR 200R0 OHM +30% 100MIOW	
P405	H03-WH800012P36-6	PIN HEADER YFW-800-01 2.36PI	
	XY0P523K000-A	WIRE,IRON,D=0.5MM,N.W=23KG @KG	
	XY0P801K000-A	WIRE TIN D=0.8MM N.W=1.0KG @KG	
	XY1N218M3SW-4	GLUE FURROW W=12MML=18.3M SS WHITE @ROLL	
	XY1P00000TH-7	TUBE,HEAT SHRINKABLE,D=1.0MM VW1 L200M	
	XY1P202K000-1	WIRE, TIN, D=1.2MM N.W=2.0KG @KG	
	XY57501K0YW-0	GLUE, YELLOW, N.W=1.0KG #575 @KG	
	XY6R301K000-0	BAR,TIN,63/37,N.W=1.0KG @KG	
	XY74601K0WH-9	OINTMENT HTC #SDL-746 NW=1.0KG WHITE @KG	
	XYALC01G000-2	ALCOHOL V=1.0GALLON @GALLON	
	XYRF801G000-7	FLUX #RF-800 V=1.0 GALLON @ GALLON	
	XYWAX10K000-6	ANTI-OXIDATION,WAX,W-1#,N.W=10KG,@KG	
	<b>3SA-4121US-SRAA-1-5</b>	<b>IAA SURROUND BD AXIAL AVR635US</b>	
C204 206 304 306 504 506	CCKID0271NN-0	CC 270P0F +10% -10% 50.0V 2B4	
D101 201 202 203 204 301 302 303 304 501 502 503 504	H03-DG1N04148NB-A	D-SLP 1N4148 100.0V 150E-3A	
R225 233 325 333 525 533	H03-RM3EG0100LN-5 PBD11KSRI21-6	RMF 10R0 OHM +5% 500MIOW PCB SINGLE AVR435/635 SURROUND 330x247x1.6t FR-1 1OZ	
R203 243 303 343 503 543	RC3DI0100IN-2	RCF 10R0 OHM +5% 250MIOW	
R226 236 326 336 526 536	RC3DI0101IN-0	RCF 100R0 OHM +5% 250MIOW	
R101	RC3DI0103IN-7	RCF 10K0 OHM +5% 250MIOW	
R246 346 546	RC3DI0104IN-5	RCF 100K0 OHM +5% 250MIOW	
R228 235 328 335 528 535	RC3DI0150IN-9	RCF 15R0 OHM +5% 250MIOW	
R239 241 339 341 539 541	RC3DI0152IN-5	RCF 1K5 OHM +5% 250MIOW	
R220 221 240 320 321 340 520 521 540	RC3DI0153IN-3	RCF 15K0 OHM +5% 250MIOW	
R209 210 309 310 509 510	RC3DI0162IN-2	RCF 1K6 OHM +5% 250MIOW	
R219 222 223 224 319 322 323 324 519 522 523 524	RC3DI0201IN-7	RCF 200R0 OHM +5% 250MIOW	
R205 206 207 305 306 307 505 506 507	RC3DI0221IN-1	RCF 220R0 OHM +5% 250MIOW	
R244 344 544	RC3DI0223IN-8	RCF 22K0 OHM +5% 250MIOW	
R227 237 327 337 527 537	RC3DI022AIN-2	RCF 2R2 OHM +5% 250MIOW	
R229 329 529	RC3DI0282IN-3	RCF 2K8 OHM +5% 250MIOW	
R201 301 501	RC3DI0331IN-5	RCF 330R0 OHM +5% 250MIOW	
R102 242 342 542	RC3DI0393IN-5	RCF 39K0 OHM +5% 250MIOW	
R204 304 504	RC3DI0433IN-8	RCF 43K0 OHM +5% 250MIOW	
R211 214 215 216 217 218 311 314 315 316 317 318 511 514 515 516 517 518	RC3DI0561IN-A	RCF 560R0 OHM +5% 250MIOW	
R234 334 534	RC3DI0820IN-1	RCF 82R0 OHM +5% 250MIOW	
R230 330 530	RC3DI0821IN-A	RCF 820R0 OHM +5% 250MIOW	
R202 212 302 502 312 512	RM1DI0333IN-4	RMF 33K0 OHM +1% 250MIOW	
R213 313 513	RM1DI1451IN-4	RMF 1K45 OHM +1% 250MIOW	
R208 308 508	RC3DI0471IN-0	RCF 470R0 OHM +5% 250MIOW	
	<b>3SA-4121US-SRAR-1-7</b>	<b>IAR SURROUND BD RADIAL AVR635US</b>	
C207 307 507	CCCIC0030NN-4	CAP CERAMIC 3PF 50V C CH TAP	
C209 309 509	CCKIC0181NA-0	CC 180P0F +10% -10% 50.0V Y5P	

REF NO.	PART NO.	DESCRIPTION	REMARKS
C215 315 517	CCKIC0332NA-5	CC 3N3F +10% -10% 50.0V Y5P	
C216 316 516	CCKIC0472NA-0	CC 4N7F +10% -10% 50.0V Y5P	
C208 308 508	CEHEC02275E-9	CE 220UF +20% 10.0V D6.3XL11 P5MM 85C	
C205 305 505	CEHGC01075E-5	CE 100U0F +20% 25.0V 6.3X11 85C P5MM	
C601 602 603	CPIKC0473NN-0	CPF 47N0F +10% 100.0V	
C210 310 510	CPJJC0683NN-A	CAP POLY NON METAL 68NF 63V J TAP	
C101 203 303 503	H03-CEMIC01065H-1	CAP ELEC 10UF 50V M 5X11 SHL P5MM	
C211 212 311 312 511 512	H03-CEMKC0106AH-9	CAP ELEC 10UF 100V M 6.3X11 SHL	
C213 214 313 314 513 514	H03-CPKJC0104NN-2	CAP POLY NON METAL 0.1UF 63V K TAP PCMT365 75104	
F601 602	H03-FURN23A1563-5	FUSE 663 SERIES 3.15 250V 3.15A LT-5 TIMELUG	
Q208 211 308 311 508 511	H03-TRKTA1024NA-2	TR-SLPLF KTA1024 Y P 50MIOA -150V	
Q101 206 306 506	H03-TRKTA1268NA-A	TR-SHPLF KTA1268BL P 100MIOA 120V	
Q204 304 504	H03-TRKTC3198NA-9	TR-SLPLF KTC3198BL N 150MIOA	
Q201 202 203 207 220 301 302			
303 307 320 501 502 503 507 520	H03-TRKTC3200NA-4	TR-SHPLF KTC3200BL N 100MIOA 120V	
Q209 212 309 312 509 512	H03-TRKTC3206NA-5	TR-SLPLF KTC3206 Y N 50MIOA 150V	
G101 102 103 105	H03-ZNMSA4004SN-A	TERMLUG GND	
Q205 305 505	H03-TR2SA1145NA-8	TR-SLPLF 2SA1145Y TO-92MOD P -50MIOA -150V	

**3SA-4121US-SUMI-1-2 IMA SUPPLY BD AVR635US**

C201 202	H03-CEMJA0109KB-6	CAP ELEC 10000UF 63V M 30X45 LSW103M1JP45M	
R108	H03-RM3GC0330CN-1	RESISTOR METAL OXIDE 33 OHM +5% 2.0W	
	XY0N211N5WH-4	CABLE TIE W=0.2MM L=11.5CM WHITE @ STRIP	
C100	CFMVA0104NN-2	CPPMX 100N0F +20% -20% P15MM	
F101	H03-FUGF212A065-9	FUSE 65TS SERIES 250V 12A	
IC301	H03-ICKIA278R33-2	IC VOLTAGE REGULATOR KIA278R33PI TO-220IS-4	
	XY0N618M3SW-A	GLUE FURROW W=6MM L=18.3M SS WHITE @ROLL	
IC11 302 304	H03-ICKIA7805I2-2	IC-REGPOFXD KIA7805API NORMAL TO-220IS	
IC303	H03-ICKIA7905I2-0	IC-REGNEGFXD KIA7905PI NORMAL	
SK11	H03-RLL1227111K-7	RELAYPWR 12.0V 270.0OHM 10.0A	
R114	H03-RM3FC047ABN-4	RESISTOR METAL OXIDE 4R7 1W 5%	
NJ71	H03-SO3P5179NNN-A	JACK PHONE 3.5PI PJ0435179N	
HK11	H03-ZMC12HS0100-9	AC HEATSINK 17*15*30 AVR520 -- ME	
NJ70	H03-SORA1JE01NN-6	JACK RCA 1P JE010003MN GND OR	
NJ79	H03-SOTOR179LBA-6	D-LEM TORX-179L	
NS19	H03-SOXA27014NN-4	CON MAINS INLET A/C INLET 7014-NGP AC05-4S020A	
TP11	H03-TXPWSUB635A-4	POWER TRANSFORMER AVR635 SUB	
P305 306	H03-WN02SE00000-1	CON 3.96MM PITCH HEADER 2 POS MOLEX 35328-0210	
P301	H03-WN03SE00000-9	CON 3.96MM PITCH MOLEX 35313-0310	
P307	H03-WN05SD100WH-6	CONN WAFER 2.5MM 5P 5267-05A WHT	
P308	H03-WN08SD00000-6	CONN 2.5MM 8 MA ST NAT 0 0	
P303	H03-WN19AB00000-4	CONN 2.0MM 19 MA R NAT SOCKET MOLEX 35237-1910 0 0	
P304	H03-WN19SB00000-1	CONN 2.0MM 19 MA ST NAT MOLEX 35336-1910 0 0	
N301	H03-WS5268505CN-6	CNT ASSY 2.0MM 5P 850MM SHIELD 26AWG UL1007	
P310	H03-WN06SE00000-0	CONNECT 6P 3.96MM 35313-0610	
N304	H03-WG03SE8122A-8	WIRE ASS'Y UL1617#22 120mm 3.96mm 3P WHT	
N311	H03-WG10SB81100-6	WIRE ASS'Y UL1007#26 STR 110mm 2.0mm 10P WHT	
SH11	H03-ZMC12S17A00-6	AC PUN SHIELD DIGITAL ET	
D201	H03-DRBU10040BA-1	D-BRDLC BRIDGE BU10-04	
	XY0P523K000-A	WIRE,IRON,D=0.5MM,N.W=23KG @KG	
C101	CCMOC0472NF-9	CC 4N7F +20% -20% 250.0V Y5V	
R113	RM3FC0100BN-7	RMOF 10R0 OHM +5% 1.0W	
N302	H03-WN04SB00000-9	CONNECT 2.0mm 4P GIL-S-4P-S2T2-EF	
	XY0P801K000-A	WIRE TIN D=0.8MM N.W=1.0KG @KG	
	XY1N209M0DW-4	GLUE TAPE W=12MM L=9.0M DS WHITE @ROLL	
	XY1N218M3CL-9	GLUE TRANSPARENT W=12MM L=18.3M @ROLL	
	XY1N218M3SW-4	GLUE FURROW W=12MML=18.3M SS WHITE @ROLL	
	XY1P202K000-1	WIRE, TIN, D=1.2MM N.W=2.0KG @KG	
	XY30155G00-0	TCE,CLEANER,-301#,V=55GALLON,TYPELESS @GALLON	
	XY4N836M5CL-9	GLUE TRANSPARENT W=48MM L=36.5M @ROLL	
	XY501110CRD-2	GLUE, RED #AK-501 F/SCREW V=110CC @BOTTL	
	XY57501K0YW-0	GLUE, YELLOW, N.W=1.0KG #575 @KG	

REF NO.	PART NO.	DESCRIPTION	REMARKS
	XY6R301K000-0	BAR,TIN,63/37,N.W=1.0KG @KG	
	XYALC01G000-2	ALCOHOL V=1.0GALLON @GALLON	
	XYGLU00K5RD-7	GLUE, RED, W=0.5KG TYPELESS FOR SMT @KG	
	XYRF801G000-7	FLUX #RF-800 V=1.0 GALLON @ GALLON	
	XYWAX10K000-6	ANTI-OXIDATION,WAX,W-1#,N.W=10KG,@KG	
	<b>3SA-4121US-SUAA-1-0</b>	<b>IAA SUPPLY BD AXIAL AVR635US</b>	
C113 115	CCZID0104NA-2	CC 100N0F +80% -20% 50.0V F	
D101 111	H03-DG1N04148NB-A	D-SLP 1N4148 100.0V 150E-3A	
D102 103 105 106 107 108 109 110 112 113 115 117 118	H03-DR1N04004NA-7	D-SR 1N4004 400.0V 1.0A	
D116	H03-DZMTZ05V1NB-3	DIODE ZENER MTZ J 5.1B 5.1V 500MW DO-34	
D104	H03-DZMTZ09V1NB-6	D-ZENER MTZJ 9.1V 500MI0W	
D119 120	H03-DZMTZJ22BNB-3	DIODE ZENER MTZ J 22B 22V 0.5W DO-34	
	PBD11KSUI20-A	PCB SINGLE AVR435/635 SUPPLY 197x197x1.6T FR-1 1OZ	
R103 118	RC3DI0102IN-9	RCF 1K0 OHM +5% 250MI0W	
R102 109	RC3DI0103IN-7	RCF 10K0 OHM +5% 250MI0W	
R110	RC3DI0104IN-5	RCF 100K0 OHM +5% 250MI0W	
R104	RC3DI0153IN-3	RCF 15K0 OHM +5% 250MI0W	
R105	RC3DI0222IN-A	RCF 2K2 OHM +5% 250MI0W	
R112	RC3DI0272IN-6	RCF 2K7 OHM +5% 250MI0W	
R106 107	RC3DI010AIN-1	RCF 1R0 OHM +5% 250MI0W	
R111	RC3DI0562IN-8	RCF 5K6 OHM +5% 250MI0W	
	<b>3SA-4121US-SUAR-1-2</b>	<b>IAR SUPPLY BD RADIAL AVR635US</b>	
C102 103 104 108 109 110	CCKIC0103NA-9	CC 10N0F +10% -10% 50.0V Y5P	
C107	CEMGC04775E-9	CE 470U0F +/-20% 25.0V 10X13 85C	
C111 114	CEHIC01055E-6	CE 1UF +20% 50V D5XL11 P5MM 85C	
C112	CEHIC01065E-4	CE 10U0F +20% 50.0V 85C P5MM 5X11	
C106	H03-CEHIC0107AH-4	CE 100U0F +20% 50.0V 85C SHL P5MM	
C203 204 205	H03-CFH0A0104NN-9	CAP POLY METAL CPM 100NF 250V 20% TAE YANG	
C125	CEHGC0687NN-6	CE 680U0F +20% 25.0V 85C ELITE P5MM	
C116	H03-CEMHC0227AH-9	CAP ELEC 220UF 35V M 8X11.5 SHL SAMYOUNG	
C105	CEMJC02275E-0	CAP ELEC 220UF 63V M 10X16 85C 120HZ ELITE P5MM	
FH10 11	H03-SOPS1FEHDNN-4	TERMFUSEHLDR FUSE-HOLDER J4210020001X	
Q101 102	H03-TRMPSA06NNA-A	TR-SLPLF MPSA06 N 500MI0A TO-92	
G101 103	H03-ZNMSA4004SN-A	TERMLUG GND	
	<b>3SA-4121US-SUMI-1-2</b>	<b>REG BD AVR635US</b>	
C301 303 305 308	CCZID0104NA-2	CC 100N0F +80% -20% 50.0V F	
C302 304 306 307	CEHIC01065E-4	CE 10U0F +20% 50.0V 85C P5MM 5X11	
D301 302	H03-DR1N04004NA-7	D-SR 1N4004 400.0V 1.0A	
P311	H03-WN06SB00000-3	CONNECT 2.0mm 6P GIL-S-6P-S2T2-EF	
P312	H03-WN03SB00000-1	CONNECT 2.0mm 3P GIL-S-3P-S2T2-EF	
P313	H03-WN05SB00000-6	CONNECT 2.0mm 5P GIL-S-5P-S2T2-EF	
R301 302 303 304	H03-RM3GC022ACN-3	RESISTOR METAL OXIDE 2R2 OHM +5% 2.0W	
R305	H03-RM3GC047ACN-4	RESISTOR METAL OXIDE 4R7 +5% 2.0W	
R306	RC3DI0103IN-7	RCF 10K0 OHM +5% 250MI0W	
R307 308	H03-RM3GC033ACN-2	RESISTOR METAL OXIDE 3R3 OHM +5% 2.0W	
R309	RC3DI0102IN-9	RCF 1K0 OHM +5% 250MI0W	
	<b>3SA-4121US-SUST-1-9</b>	<b>DIG/MIC BD AVR635US</b>	
C701 702	CZZFI0104BF-8	CAP CHIP 100N0F +80% -20% 16.0V Y5V 0603	
C703 704 705	CZJII0101BE-2	CAP CHIP 100P0F +5% -5% 50.0V NP0 0603	
C721	RS3AD0101NA-5	RES CHIP 100R0 OHM +5% 62MI5W 0603	
D701 702	H03-DS1S50094NB-5	D-SLP 1SS355 35.0V 225MI0A	
L701	H03-FB2K52012NN-0	FBEAD SURFACE MT 2500OHM FCM2012H-252T02	
L700	H03-LS1502012NN-3	INDUCTOR COIL FCI2012-150K 15UH 0805	
N302	H03-WN04SB00000-9	CONN 2.0MM 4 MA ST NAT GT201-4P-TS	
NJ70	H03-SORA1JE01NN-6	JACK RCA 1P JE010003MN GND OR	
	<b>3SA-4121US-SUMI-1-2</b>	<b>OUTLET BD AVR635US</b>	
F201 202	H03-FUGF23000XX-5	FUSE 239 SERIES 003 250V 3A	
FH21 22 23 24	H03-SOPS1FEHDNN-4	TERMFUSEHLDR FUSE-HOLDER J4210020001X	

REF NO.	PART NO.	DESCRIPTION	REMARKS
NS21	H03-SOPA21275BK-9	CONN-SPE AC OUTLET 2P 110V FE 12.75MM 2 BK 0 0 A204D0043P	
P309	H03-WN03SG00000-7	CONNECT WAFER 7.92MM 3P 35328-0310 WHT	
	<b>3SA-4121US-VDMI-1-4</b>	<b>IMA VIDEO BD AVR635US</b>	
L705	H03-FY0100101N8-0	FILTER MPX 01011-101	
P901	H03-WN19SB00000-1	CONN 2.0MM 19 MA ST NAT MOLEX 35336-1910 0 0	
IC89	H03-ICKIA7806I2-4	IC KIA7806AP VOLTQAGE REGULATOR TO-220AB	
Y700 702	H03-OSXBE14M39S-3	CRYSTAL 14.31818MHZ HC-49/S WOOIN	
Y701	H03-OSXBE17M79S-5	CRYSTAL 17.734475MHZ HC-49/S WOOIN	
NJ90	H03-SOR12BJ12NN-9	JACK RCA 12P BJ120154JN	
NJ50 70 71 72 73 74 75	H03-SORA11Y00NN-0	JACK RCA+S VIDEO C5016031DN	
N601	H03-WG10SB82200-9	WIRE ASS'Y UL1007#26STR 220mm 2.0mm 10P WHT	
P603	H03-WN06AB00000-6	CONNECT 2.0mm 6P GIL-S-6P-S2L2-EF	
P602	H03-WN10AB00000-9	CONN 2.0MM GIL-S-10P-S2L2-EF 10P	
P601	H03-WN15AI00001-2	CONNECT GF120-15S-LS 1.25mm 15P	
N902	H03-WN19AB00000-4	CONN 2.0MM 19 MA R NAT SOCKET MOLEX 35237-1910 0 0	
N602	H03-WG03SB81600-0	WIRE ASS'Y UL1007#26 STR 160MM 2.0MM 3P WHT	
SK104 105 106 107	H03-RLV23079A10-6	RELAY V23079-A1001	
SK104 105 106 107	H03-RLTX25VNAIS-2	RELAY TX2-5V STANDARD PC BOARD TERMINAL	
R724	H03-RM3FC010ABN-3	RESISTOR METAL OXIDE 1 OHM 1W 5%	
	XY0N618M3SW-A	GLUE FURROW W=6MM L=18.3M SS WHITE @ROLL	
	XY0P523K000-A	WIRE,IRON,D=0.5MM,N.W=23KG @KG	
	XY0P801K000-A	WIRE TIN D=0.8MM N.W=1.0KG @KG	
	XY1N209M0DW-4	GLUE TAPE W=12MM L=9.0M DS WHITE @ROLL	
	XY1N218M3CL-9	GLUE TRANSPARENT W=12MM L=18.3M @ROLL	
	XY1N218M3SW-4	GLUE FURROW W=12MML=18.3M SS WHITE @ROLL	
	XY1P202K000-1	WIRE, TIN, D=1.2MM N.W=2.0KG @KG	
	XY30155G00-0	TCE,CLEANER,-301#,V=55GALLON,TYPELESS @GALLON	
	XY4N836M5CL-9	GLUE TRANSPARENT W=48MM L=36.5M @ROLL	
	XY6R301K000-0	BAR,TIN,63/37,N.W=1.0KG @KG	
	XYALC01G000-2	ALCOHOL V=1.0GALLON @GALLON	
	XYGLU00K5RD-7	GLUE, RED, W=0.5KG TYPELESS FOR SMT @KG	
	XYJU100K5GY-5	JUICE TIN N=0.5KG GREY @KG	
	XYRF801G000-7	FLUX #RF-800 V=1.0 GALLON @ GALLON	
	XYWAX10K000-6	ANTI-OXIDATION,WAX,W-1#,N.W=10KG,@KG	
	<b>3SA-4121US-VDAA-1-2</b>	<b>IAA VIDEO AXIAL AVR635US</b>	
D709	H03-DZMTZ09V1NB-6	D-ZENER MTZJ 9.1V 500MI0W	
L700 701 702 703 723	H03-FB05B3580NN-7	BEAD AXIAL/TAP,HC3580 80.5ohm	
L704 707 708 709 710	H03-LAINB0470CR-8	LF 47U0H +10% 5.8 OHM 500M10A	
L706	H03-LALNB056ACR-5	INDUCTOR COIL AL02TB5R6J 5.6UH 1.9OHM +5%	
	PBD12KVDB20-2	PCB DUAL AVR635 VIDEO 194x194x1.6t FR-4	
R765	RC3DI0121IN-5	RCF 120R0 OHM +5% 250MI0W	
R766	RC3DI0471IN-0	RCF 470R0 OHM +5% 250MI0W	
C956	CCKID0102NN-1	CAP CERAMIC AXIAL 1NF 50V +10%-10% 2B4	
C831	CCZID0104NA-2	CC 100N0F +80% -20% 50.0V F	
	3SA-4121US-VDAR-1-4	IAR VIDEO BD RADIAL AVR635US	
C954	H03-CEMEC0337AH-6	CE 330UF 10V M 6.3X11 SHL	
C834	CCKIC0223NN-6	CC 22N0F +10% -10% 50.0V Z5R	
C112	CEHDC0108NN-3	CE 1MI0F +20% 6.3V 8X11.5 85C ELITE P5MM	
C346 753 761 829 837	CEHEC01075E-8	CE 100U0F +20% 10.0V 5X11 85C P5MM	
C330 332 391 700 702 703 705 706 708 709 711 777 780 781 784 790 821 822 825 826 953 955	CEHEC02275E-9	CE 220UF +20% 10.0V D6.3XL11 P5MM 85C	
C324 500 501 724 725 726 727 728 729 816 817 823 824 925 926 949 950	CEHEC0477MN-A	CE 470U0F +20% 10.0V 6.3X11 85C ELITE P5MM	
C103 109 110 331 338 779 782 787 873 899	CEHFC01075E-1	CE 100UF +-20% 16.0V D5XL11 P5MM 85C	
C333 334 747 802 807 811 820	CEHFC04765E-3	CE47UF +20% 16.0V D5XL11 P5MM 85C	
C105 106 505 745 757 767 789	CEHIC01055E-6	CE 1UF +20% 50V D5XL11 P5MM 85C	

REF NO.	PART NO.	DESCRIPTION	REMARKS
C833 836 841 845	CEHIC01065E-4	CE 10U0F +20% 50.0V 85C P5MM 5X11	
C762	CEHIC0474NN-9	CE 470N0F +20% 50.0V 85C 5X11 ELITE P5MM	
C108 111 118 387 874 875	CEMFC0226NN-9	CAP ELEC 22UF 16V M ELITE P5MM	
C504 506 730	H03-CEMDC0108NN-9	CE 1000UF 6.3V M 8X11.5 SHL	
C756	CPHIC0223NN-4	CPF 22N0F +10% 50.0V	
C758	CPHIC0682NN-5	CPF 6N8F +10% 50.0V	
C701 704 707 710 713 716 776			
785 786 798 799 800 827 860	CEHFC0106NN-4	CE 10U0F +20% 16.0V 85C 5X11 ELITE P5MM	
861 905 910 915 919			
C832 835 840 844	CEHIC02255E-7	CE 2U2F +20% 50V D5XL11 P5MM 85C	
C743	H03-CEMIC0334AH-A	CAP ELEC 0.33UF M 5X11 SHL 50V SAMYOUNG P5MM	
Q704 705 706 707 708	H03-TR2SA933ANW-8	TR-SLPLF 2SA933ASR P -3.0A -20V	
Q300 700 702 703	H03-TR2SC1740NW-4	TR-SLPLF 2SC1740S R N 150MIOA 50V	
	3SA-4121US-VDSB-1-5	BOT SMD VIDEO BD AVR635US	
C339 502 503 778 783 788 801			
806 812 818 819 838 859 862			
863 864 865 866 870 927 928	CZZFI0104BF-8	CAP CHIP 100N0F +80% -20% 16.0V Y5V 0603	
951 952 900 901 902 903 904			
906 907 908 909 911 912 913			
914 916 917 918			
C803 804 805 808 809 810 813	CZJII0101BE-2	CAP CHIP 100P0F +5% -5% 50.0V NP0 0603	
814 815 828			
C104 752 760 830 898	CZKII0103BC-5	CAP CHIP 10N0F +10% -10% 50.0V X7R 0603	
C744	CZDII0100BE-8	CAP CHIP 10PF 50V CH D NP0 0603 +/-0.25P	
C736	CZKII0221BA-3	CAP CHIP 220PF 50V K SL 0603	
C839	CZKII0223BC-6	CAP CHIP 22N0F +10% -10% 50.0V X7R 0603	
C351	CZJII0331BE-7	CAP CHIP 330P0F +5% -5% 50.0V NP0 0603	
C854 855	CZJII0330BE-9	CAP CHIP 33P0F +5% -5% 50.0V NP0 0603	
C763 764 765 766	CZJII0390BE-2	CAP CHIP 39PF 50V CH J NP0 0603	
R994 995 996	RS3AD043ANA-7	RESISTOR CHIP 4R3 OHM 1/16W 5% 0603	
C350	CZKII0561BC-8	CAP CHIP 560P0F +10% -10% 50.0V X7R 0603	
D104 105 106 107	H03-DS1S50094NB-5	D-SLP 1SS355 35.0V 225MIOA	
D501 502 718 719 721 722 723	H03-DS05GBUSCNB-5	DIODE PG05GBUSC	
724			
L715	H03-FB121201208-8	FERRITE BEADS FCM2012K-121T08 120OHM 2012	
R302 310 311 312 314 315 320	RS3AD0000NA-0	RES CHIP 0 OHM +0% 62MI5W 0603	
323 730 880			
R873	RS3AD0101NA-5	RES CHIP 100R0 OHM +5% 62MI5W 0603	
R860	RS3AD0104NA-A	RES CHIP 100K0 OHM +5% 62MI5W 0603	
R500 501 502 745 828 874	RS3AD0103NA-1	RES CHIP 10K0 OHM +5% 62MI5W 0603	
R735 750 751	RS3AD0121NA-A	RES CHIP 120R0 OHM +5% 62MI5W 0603	
R741	RS3AD0124NA-4	RES CHIP 120K0 OHM +5% 62MI5W 0603	
R776 780 784	RS3AD0123NA-6	RES CHIP 12K0 OHM +5% 62MI5W 0603	
R327 744 851 853 858 866	RS3AD0154NA-6	RES CHIP 150K0 OHM +5% 62MI5W 0603	
R797	RS1AD1470NA-7	RES CHIP 147 OHM 1/16W 1% 0603	
R2 733 734 754 755 756 757			
773 774 775 777 778 779 781	RS3AD0102NA-3	RES CHIP 1K0 OHM +5% 62MI5W 0603	
783 782 850 857 865			
R937	RS1AD162ANA-2	RES CHIP 16.2 OHM 1/16W 1% 0603	
R321 737	RS3AD0152NA-A	RES CHIP 1K5 OHM +5% 62MI5W 0603	
R752 811	RS3AD0105NA-8	RES CHIP 1M 1/16W +5% 0603	
R740	RS3AD0224NA-0	RES CHIP 220K0 OHM +5% 62MI5W 0603	
R794 795 796	RS3AD0223NA-2	RES CHIP 22K0 OHM +5% 62MI5W 0603	
R747	RS3AD0243NA-7	RES CHIP 24K0 OHM +5% 62MI5W 0603	
R729 798	RS3AD0271NA-2	RES CHIP 270R0 OHM +5% 62MI5W 0603	
R848 855 863	RS3AD0222NA-4	RES CHIP 2K2 OHM +5% 62MI5W 0603	
R746	RS3AD0272NA-0	RES CHIP 2K7 OHM +5% 62MI5W 0603	
R799 800	RS3AD0331NA-A	RES CHIP 330R0 OHM +5% 62MI5W 0603	
R847 854 862	RS3AD0333NA-6	RES CHIP 33K0 OHM +5% 62MI5W 0603	
R861	RS3AD0392NA-1	RES CHIP 3K9 OHM +5% 62MI5W 0603	



REF NO.	PART NO.	DESCRIPTION	REMARKS
R743	RS3AD0513NA-4	RES CHIP 51K0 OHM +5% 62MI5W 0603	
C2	CZJII0181BE-0	CCCFMIC 180P0F +5% -5% 50.0V NP0 0603	
R504 505 849 856 864	RS3AD0680NA-7	RES CHIP 68R0 OHM +5% 62MI5W 0603	
R736	RS3AD0682NA-3	RES CHIP 6K8 OHM +5% 62MI5W 0603	
R102 103 104 375 885 886 887 888 889 890 891 892 893 894 895 896	RS3AD0750NA-1	RES CHIP 75R0 OHM +5% 62MI5W 0603	
R852 859	RS3AD0753NA-6	RES CHIP 75K 1/16W +-5% 0603.	
R328	RS3AD0822NA-2	RES CHIP 8K2 OHM +5% 62MI5W 0603	
Q104 105 106 107 713 714 715	H03-TRDTC114YNI-0	TR-SSD DTC114YKA N 10K0 OHM 47K0 OHM	
Q709 710 711	H03-TRDTA114YNI-4	TR-SSD DTA114YKA P 10K0 OHM 47K0 OHM	
C1	CZJII0680BE-4	CAPACITOR CERAMIC CHIP 68PF 50V CH J NPO 0603	
R5	RS3AD0911NA-3	RES CHIP 910 OHM +5% 62MI5W 0603	
R3	RS3AD0122NA-8	RES CHIP 1K2 OHM +5% 62MI5W 0603	
R4	RS3AD0221NA-6	RES CHIP 220R0 OHM +5% 62MI5W 0603	
R503	RS1AD0750NA-6	RES CHIP 75OHM 1% 1/16W 0603	
	3SA-4121US-VDST-1-0	TOP SMD VIDEO BD AVR635US	
C507 508 509 718 719 720 721 722 723 768 769 770 856 893 895 897	CZJII0101BE-2	CAP CHIP 100P0F +5% -5% 50.0V NP0 0603	
C755	CZJII0270BE-1	CAP CHIP 27P0F +5% -5% 50.0V NP0 0603	
C754	CSJIE0300BG-2	CAP,CHIP FORM 30P +/-5% 50V C0G 0603	
C342 849 850	CZJII0331BE-7	CAP CHIP 330P0F +5% -5% 50.0V NP0 0603	
C892 894 896	CZJII0680BE-4	CAPACITOR CERAMIC CHIP 68PF 50V CH J NPO 0603	
C759	CZKII0103BC-5	CAP CHIP 10N0F +10% -10% 50.0V X7R 0603	
C842	CZKII0153BC-1	CAP CHIP 15N0F +10% -10% 50.0V X7R 0603	
C848	CZKII0221BA-3	CAP CHIP 220PF 50V K SL 0603	
C843	CZKII0822BC-6	CAP CHIP 8N2F +10% -10% 50.0V X7R 0603	
C107 857 858 867 868 869	CZZFI0104BF-8	CAP CHIP 100N0F +80% -20% 16.0V Y5V 0603	
C851 852 853 920 921 922	CZZFI0224BF-9	CAP CHIP 220NF 16V Y5V +80%-20% 0603	
D710 711 712 713 714 715 716 717	H03-DS05GBUSCNB-5	DIODE PG05GBUSC	
D700 701 702 703 704 705 706 707 708 720	H03-DS1S50094NB-5	D-SLP 1SS355 35.0V 225MI0A	
L711 712 713 714	H03-FB121201208-8	FERRITE BEADS FCM2012K-121T08 120OHM 2012	
L719 720 721	H03-FB1R52012CN-5	INDUCTOR COIL FCI2012-1R5K 1.5UH 0805	
L716 717 718	H03-FB3R92012CN-0	INDUCTOR COIL FCI2012-3R9K 3.9UH 0805	
IC10 85	H03-IC3MM1566D2-1	IC 3CH VIDEO DRIVER MM1566AFBE SOP8 REGISTERED NO.R59-8387	
IC84	H03-ICADV717248-2	IC DIGITAL PAL/NTSC ADV7172 LQFP48	
IC88	H03-ICBU4053BB4-2	IC BU4053BCF SOP16 ANALOG MPX/DEMPX	
IC90 91 92	H03-IC74HC4094D-1	IC CD74HC4094D(R-PDSO-G16) SOP16	
IC75	H03-ICLC74763R1-0	IC OSD LC74763M-9655 SOP30	
IC36	H03-ICMM1117NDG-6	IC VIDEO SWITCH MM1117XFBE SOP-8C REGISTERED NO.R59-2186	
IC80 81	H03-ICMM1501XDL-5	IC-VIDEO SW MM1501XNRE SOT-26B REGISTERED NO.R59-4164	
IC79	H03-ICMM1511XDL-3	IC-VIDEO SW MM1511XNRE SOT-26B REGISTERED NO.R59-4174	
IC70 71 72	H03-ICNJM2296D3-2	IC-LINEAR NJM2296	
IC94	H03-ICNJM2586MN-9	IC VIDEO AMP NJM2586M DMP24	
IC50 74 87	H03-ICTSH95IDB4-1	IC-VIDEOPROC TSH95ID VIDEO AMPLIFIER	
IC83	H03-ICTVP514680-3	IC HPA DIGITAL A/V TVP5146PFP S-PQFP-G80	
Q712	H03-TRDTA114YNI-4	TR-SSD DTA114YKA P 10K0 OHM 47K0 OHM	
Q701 716	H03-TRDTC114YNI-0	TR-SSD DTC114YKA N 10K0 OHM 47K0 OHM	
R830 831	RS1AD0604NA-6	RES CHIP 604 OHM 1/16W 1% 0603	
R313 513 841 881 882 935	RS3AD0000NA-0	RES CHIP 0 OHM +0% 62MI5W 0603	
R803 804	RS3AD0101NA-5	RES CHIP 100R0 OHM +5% 62MI5W 0603	
R758 759 760 791 793 805 806 807 808 814	RS3AD0102NA-3	RES CHIP 1K0 OHM +5% 62MI5W 0603	
R507 508 509 718 719 720 721 722 723 738 742 748 785 786 787 812 824 825 826 827 829 903	RS3AD0103NA-1	RES CHIP 10K0 OHM +5% 62MI5W 0603	
R753	RS3AD0105NA-8	RES CHIP 1M 1/16W +5% 0603	
R842 876 877	RS3AD0151NA-1	RES CHIP 150R0 OHM +5% 62MI5W 0603	

REF NO.	PART NO.	DESCRIPTION	REMARKS
R788	RS3AD0152NA-A	RES CHIP 1K5 OHM +5% 62MI5W 0603	
R809 810	RS3AD0222NA-4	RES CHIP 2K2 OHM +5% 62MI5W 0603	
R790	RS3AD0330NA-1	RES CHIP 33R0 OHM +5% 62MI5W 0603	
R749	RS3AD0392NA-1	RES CHIP 3K9 OHM +5% 62MI5W 0603	
R332	RS3AD0394NA-8	RES.CHIP 390K 1/16W +-5% 0603	
R789	RS3AD0430NA-8	RES CHIP 43R0 OHM +5% 62MI5W 0603	
R813 815 816 817 818 819 820 821 822 823	RS3AD0470NA-7	RES CHIP 47R0 OHM +5% 62MI5W 0603	
R300 324 325 326 340 367 700 701 702 703 705 706 707 708 709 710 711 712 713 714 715 716 717 792 867 869 870 871 872	RS3AD0750NA-1	RES CHIP 75R0 OHM +5% 62MI5W 0603	
IC33	H03-ICMM1234S16-4	IC VIDEO SW MM1234XFBE SOP16 REGISTERED NO.R59-2542	
IC93	H03-ICPJCW1X8DG-6	IC VOLTAGE REGULATOR PJ1117CW-1.8 1.8V SOT-223	
R832 833	RS1AD0101NA-A	RES CHIP 100 OHM 1/16W 1% 0603	
R868	RS3AD020ANA-2	RES CHIP 2 OHM 1/16W 5% 0603	
R514 515	RS3AD030ANA-9	RES CHIP 3 OHM 1/16W 5% 0603	
R912 913 915 917	RS3AD043ANA-7	RESISTOR CHIP 4R3 OHM 1/16W 5% 0603	
R932	RS1AD453ANA-A	RES CHIP 45.3 OHM 1/16W 1% 0603	
R801	RS3AD0511NA-8	RES CHIP 510R0 OHM +5% 62MI5W 0603	
R704	RS1AD787ANA-4	RES CHIP 78.7 ohm 1/16W 1% 0603	
R933	RS1AD442ANA-6	RES CHIP 44.2 OHM 1/16W 1% 0603	
R936	RS1AD191ANA-4	RES CHIP 19.1 OHM 1/16W 1% 0606	
R834 835 836 837	RS1AD1470NA-7	RES CHIP 147 OHM 1/16W 1% 0603	
R914 916	RS3AD010ANA-6	RES, CHIP, 1, 1/16W, +/-5%, 0603	
R934	RS1AD0100NA-1	RES CHIP 10 OHM 1/16W 1% 0603	
R1	RS3AD0122NA-8	RES CHIP 1K2 OHM +5% 62MI5W 0603	

# Integrated Circuits

## 1. 24LC256(DSP:IC503)-AVR635 ONLY

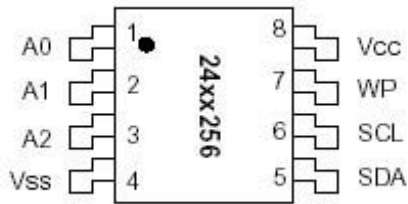

### BLOCK DIAGRAM

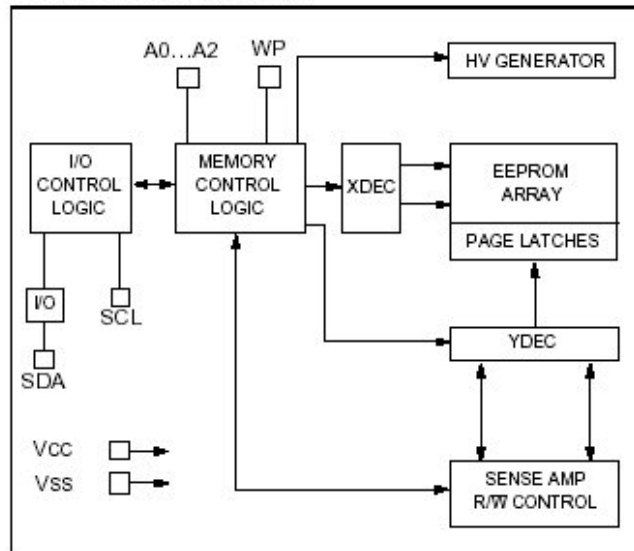

### PIN FUNCTION TABLE

Name	Function
A0, A1, A2	User Configurable Chip Selects
Vss	Ground
SDA	Serial Data
SCL	Serial Clock
WP	Write Protect Input
Vcc	+1.8 to 5.5V (24AA256) +2.5 to 5.5V (24LC256)

## 2. CD74HC4094D(FRONT:IC101,DSP:IC502, VIDEO:IC90,91,92(AVR435:IC19,20))

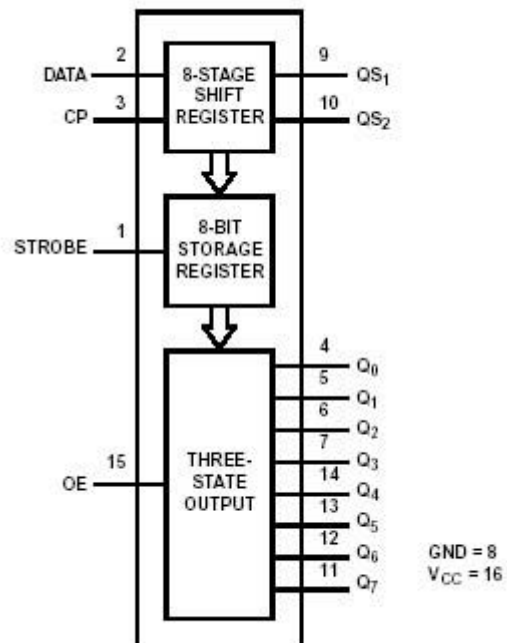
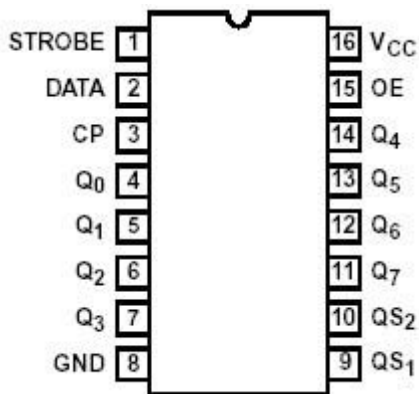

# Monolithic IC MM1566 Video Signal Driver for DVD Player

## Block diagram 3. MM1566AFBE(VIDEO:IC10,85)-AVR635 ONLY

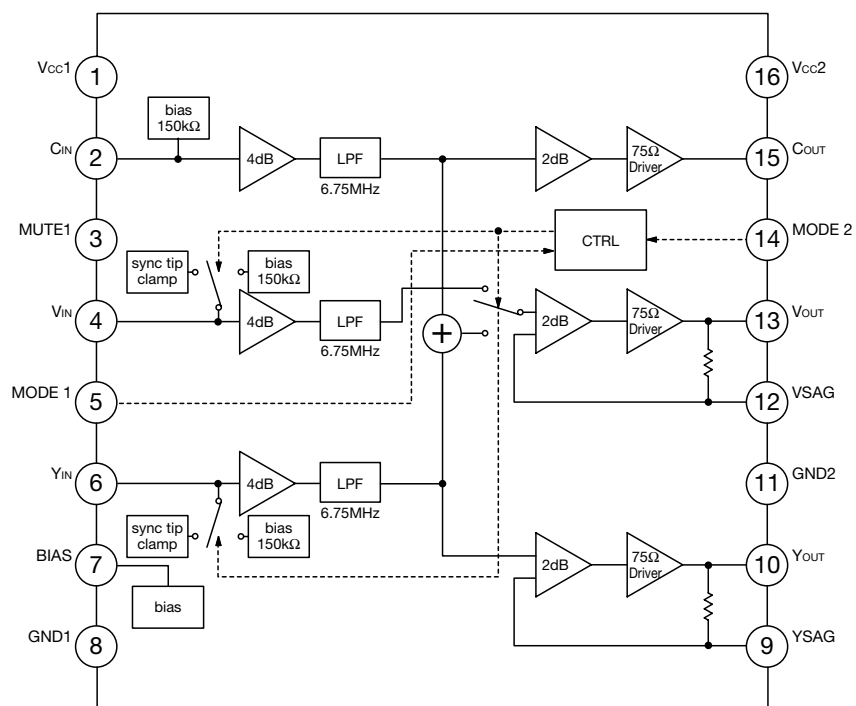

## Pin Assignment

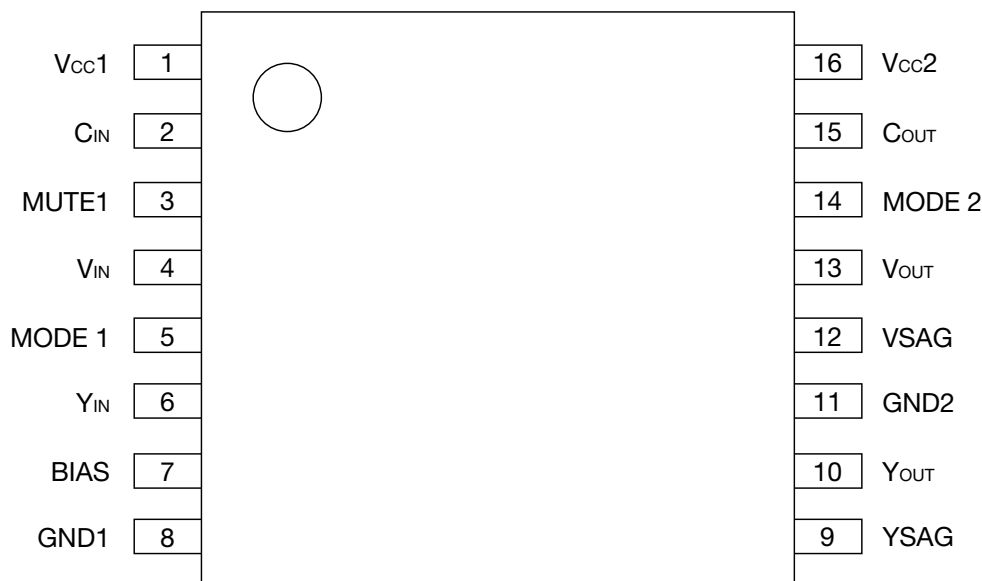

SOP-16C

1	Vcc1	9	YSAG
2	CIN	10	YOUT
3	MUTE1	11	GND2
4	VIN	12	VSAG
5	MODE 1	13	VOUT
6	YIN	14	MODE 2
7	BIAS	15	COUT
8	GND1	16	Vcc2

**Pin Description**

Pin No.	Pin name	Function	Internal equivalent circuit diagram
1 16	V <sub>cc1</sub> V <sub>cc2</sub>	V <sub>cc</sub>	
2	C <sub>IN</sub>	Croma input	
3	MUTE1	Mute select  Using of MUTE and POWER-SAVING.	
4 6	V <sub>IN</sub> Y <sub>IN</sub>	Video input  The input can select Sync tip clamp or Bias	
5 14	MODE1 MODE2	Mode select	

Pin Description

Pin No.	Pin name	Function	Internal equivalent circuit diagram
7	BIAS	Bias	
8 11	GND1 GND2	GND	
10 13  9 12		Signal output  SAG correction	
15	Cout	Croma output	

# 4. TMS320D610A(DSP:IC901) AUREUS™ TMS320DA610, TMS320DA601 FLOATING-POINT DIGITAL SIGNAL PROCESSORS

SPRS002F – SEPTEMBER 2001 – REVISED MAY 2003

## PYP PowerPAD™ QFP package (top view)

### PYP 208-PIN PowerPAD™ PLASTIC QUAD FLATPACK (PQFP) (TOP VIEW)

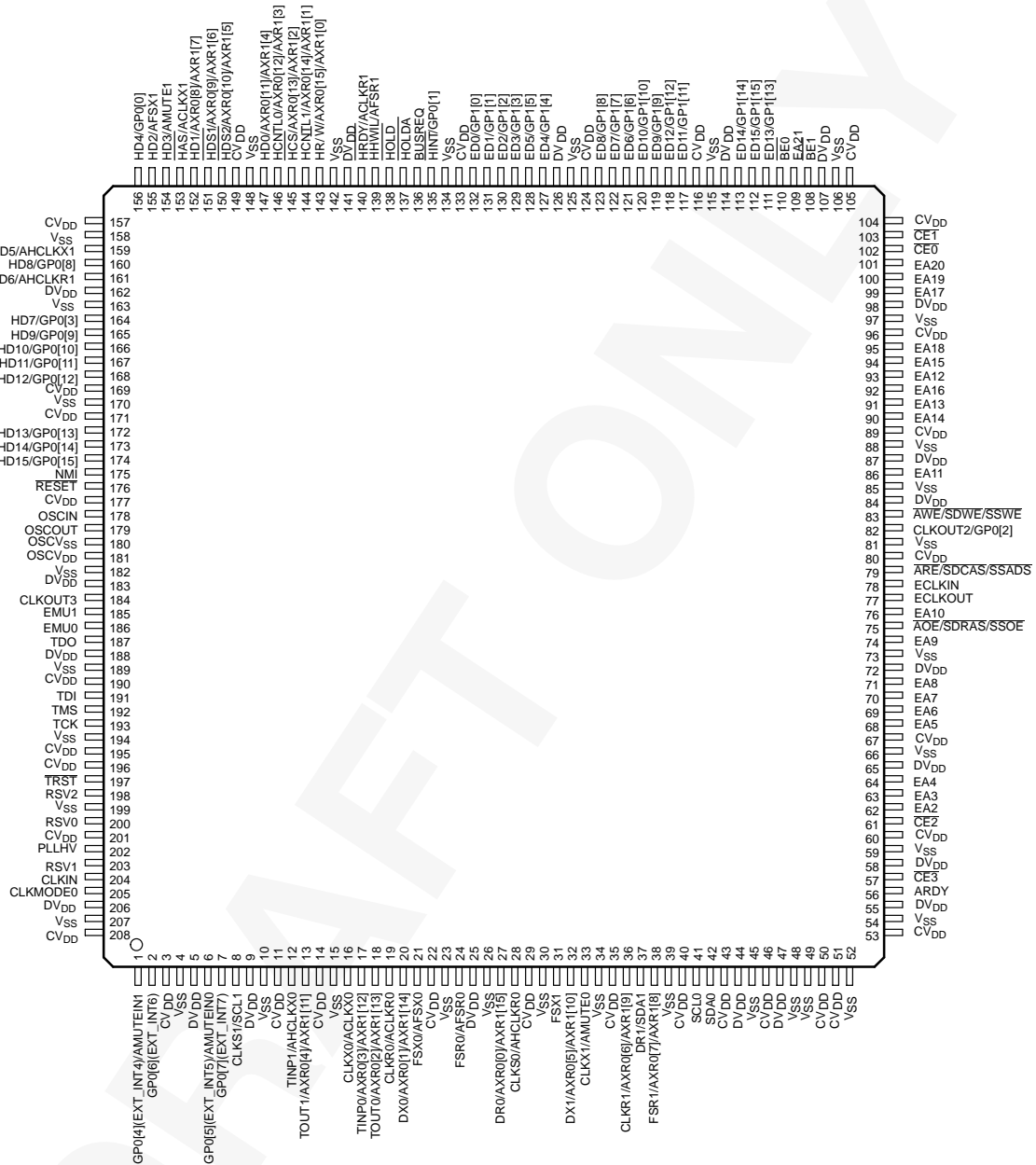

functional block and CPU (DSP core) diagram

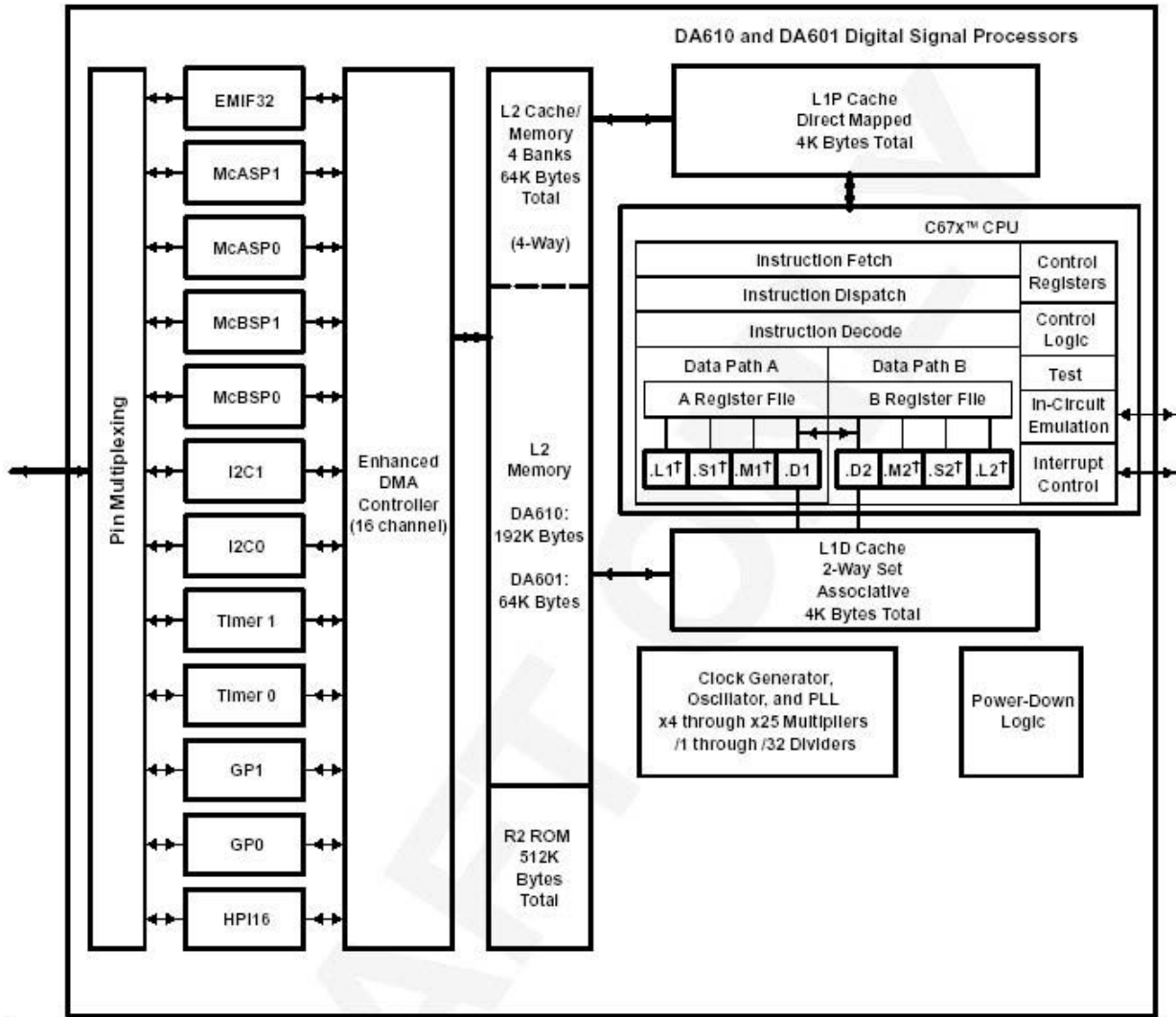



5. SN74LVC1G125DVB(DSP:IC505,506,607,608)

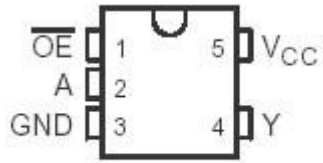

FUNCTION TABLE

INPUTS		OUTPUT
OE	A	Y
L	H	H
L	L	L
H	X	Z

logic symbol†



logic diagram (positive logic)

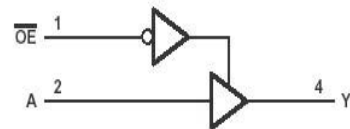

## 6. 74VHC244M(DSP:IC504)



PIN CONNECTION AND IEC LOGIC SYMBOLS

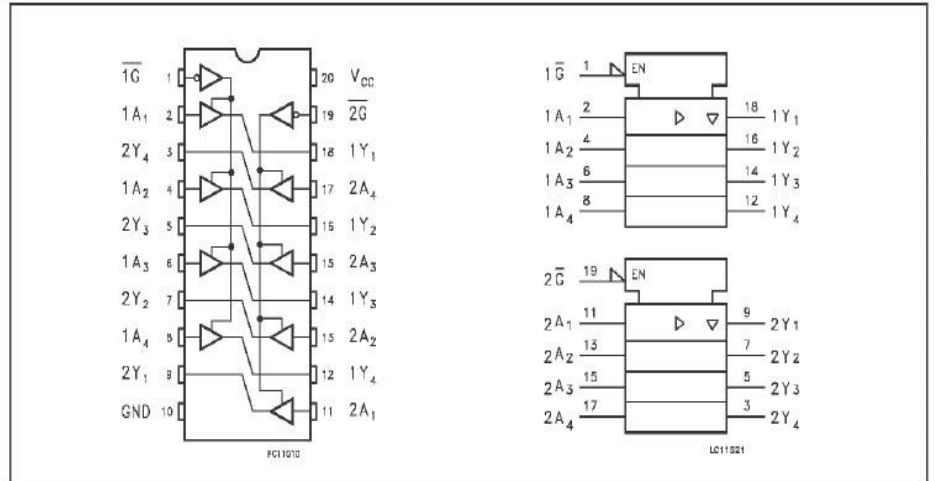

## 7. ADV7172(VIDEO:IC84)-AVR635 ONLY

PIN CONFIGURATION

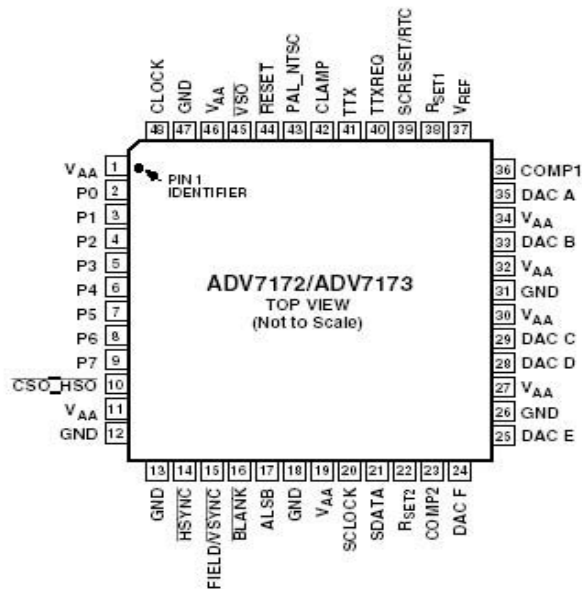

FUNCTIONAL BLOCK DIAGRAM

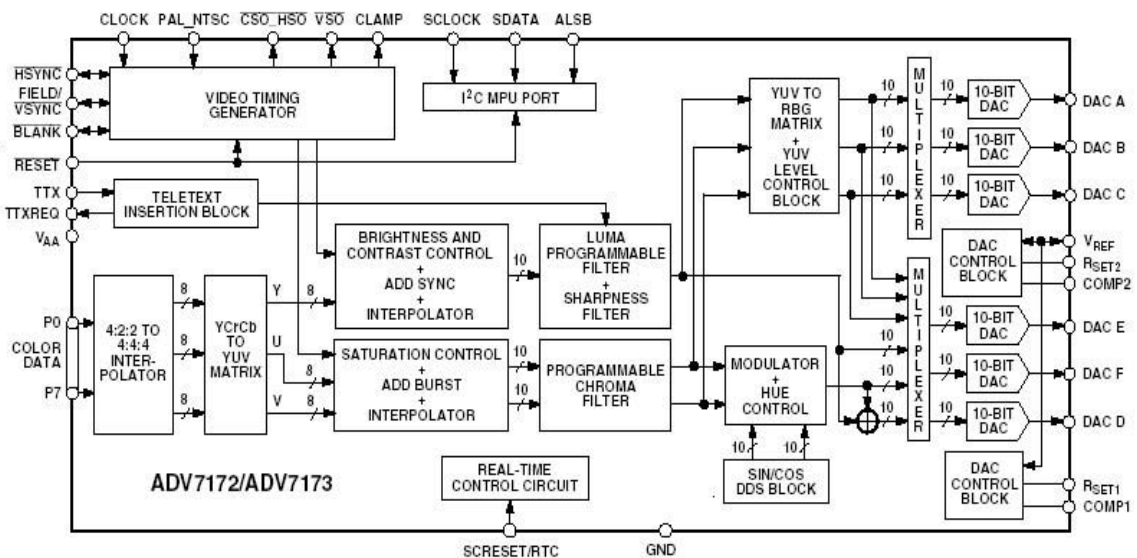

Digital PAL/NTSC Video Encoder with Six DACs (10 Bits), Color Control and Enhanced Power Management

**ADV7172/ADV7173**

**FUNCTIONAL BLOCK DIAGRAM**

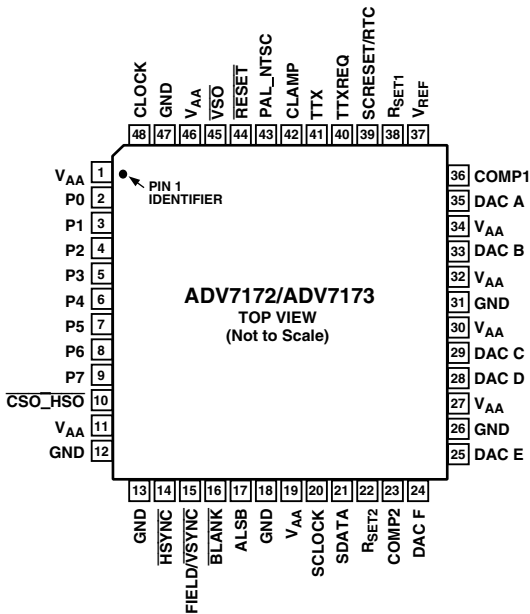
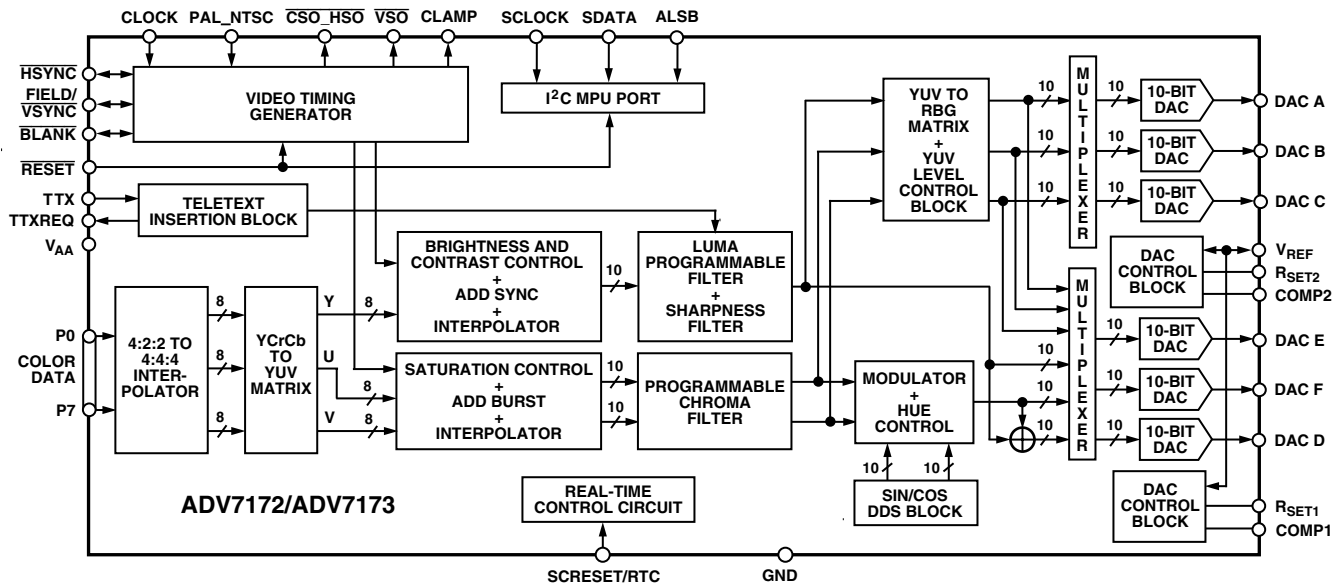

**CAUTION**

ESD (electrostatic discharge) sensitive device. Electrostatic charges as high as 4000 V readily accumulate on the human body and test equipment and can discharge without detection. Although the ADV7172/ADV7173 features proprietary ESD protection circuitry, permanent damage may occur on devices subjected to high-energy electrostatic discharges. Therefore, proper ESD precautions are recommended to avoid performance degradation or loss of functionality.



## ADV7172/ADV7173

## PIN FUNCTION DESCRIPTION

Mnemonic	Input/Output	Function
P7–P0	I	8-Bit 4:2:2 Multiplexed YCrCb Pixel Port (P7–P0) P0 represents the LSB.
CLOCK	I	TTL Clock Input. Requires a stable 27 MHz reference clock for standard operation. Alternatively, a 24.5454 MHz (NTSC) or 29.5 MHz (PAL) can be used for square pixel operation.
$\overline{\text{HSYNC}}$	I/O	$\overline{\text{HSYNC}}$ (Modes 1 and 2) Control Signal. This pin may be configured to output (Master Mode) or as an input and accept (Slave Mode) Sync signals.
FIELD/ $\overline{\text{VSYNC}}$	I/O	Dual Function FIELD (Mode 1) and $\overline{\text{VSYNC}}$ (Mode 2) Control Signal. This pin may be configured to output (Master Mode) or as an input (Slave Mode) and accept these control signals.
$\overline{\text{BLANK}}$	I/O	Video Blanking Control Signal. The pixel inputs are ignored when this is Logic Level “0.” This signal is optional.
SCRESET/RTC	I	This pin can be configured as an input by setting MR42 and MR41 of Mode Register 4. It can be configured as a subcarrier reset pin, in which case a low-to-high transition on this pin will reset the subcarrier phase to Field 0. Alternatively it may be configured as a Real-Time Control (RTC) Input.
V <sub>REF</sub>	I/O	Voltage Reference Input for DACs or Voltage Reference Output (1.235 V).
R <sub>SET1</sub>	I	A 150 $\Omega$ resistor connected from this pin to GND is used to control full-scale amplitudes of the Video Signals from DACs A, B, and C (the “large” DACs).
R <sub>SET2</sub>	I	A 600 $\Omega$ resistor connected from this pin to GND is used to control full-scale amplitudes of the Video Signals from DACs D, E, and F (the “small” DACs).
COMP1	O	Compensation Pin for DACs A, B, and C. Connect a 0.1 $\mu\text{F}$ Capacitor from COMP to V <sub>AA</sub> . For Optimum Dynamic Performance in Low Power Mode, the value of the COMP1 capacitor can be lowered to as low as 2.2 nF.
COMP2	O	Compensation Pin for DACs D, E, and F. Connect a 0.1 $\mu\text{F}$ Capacitor from COMP to V <sub>AA</sub> .
DAC A	O	GREEN/Composite/Y Analog Output. This DAC is capable of providing 34.66 mA output.
DAC B	O	BLUE/S-Video Y/U Analog Output. This DAC is capable of providing 34.66 mA output.
DAC C	O	RED/S-Video C/V Analog Output. This DAC is capable of providing 34.66 mA output.
DAC D	O	GREEN/Composite/Y Analog Output. This DAC is capable of providing 8.66 mA output.
DAC E	O	BLUE/S-Video Y/U Analog Output. This DAC is capable of providing 8.66 mA output.
DAC F	O	RED/S-Video C/V Analog Output. This DAC is capable of providing 8.66 mA output.
SCLOCK	I	MPU Port Serial Interface Clock Input.
SDATA	I/O	MPU Port Serial Data Input/Output.
CLAMP	O	TTL Output Signal to external circuitry to enable clamping of all video signals.
PAL_NTSC	I	Input signal to select PAL or NTSC mode of operation, pin set to Logic “1” selects PAL.
$\overline{\text{VSO}}$	O	$\overline{\text{VSO}}$ TTL Output Sync Signal.
$\overline{\text{CSO\_HSO}}$	O	Dual Function $\overline{\text{CSO}}$ or $\overline{\text{HSO}}$ TTL Output Sync Signal.
ALSB	I	TTL Address Input. This signal sets up the LSB of the MPU address.
$\overline{\text{RESET}}$	I	The input resets the on-chip timing generator and sets the ADV7172/ADV7173 into default mode. This is NTSC operation, Timing Slave Mode 0, DACs A, B, and C powered OFF, DACs D, E, and F powered ON, Composite and S-Video out.
TTX	I	Teletext Data Input Pin.
TTXREQ	O	Teletext Data Request output signal used to control teletext data transfer.
V <sub>AA</sub>	P	Power Supply (3 V to 5 V).
GND	G	Ground Pin.

8. AT49BV162AT-70TI(DSP:IC902)

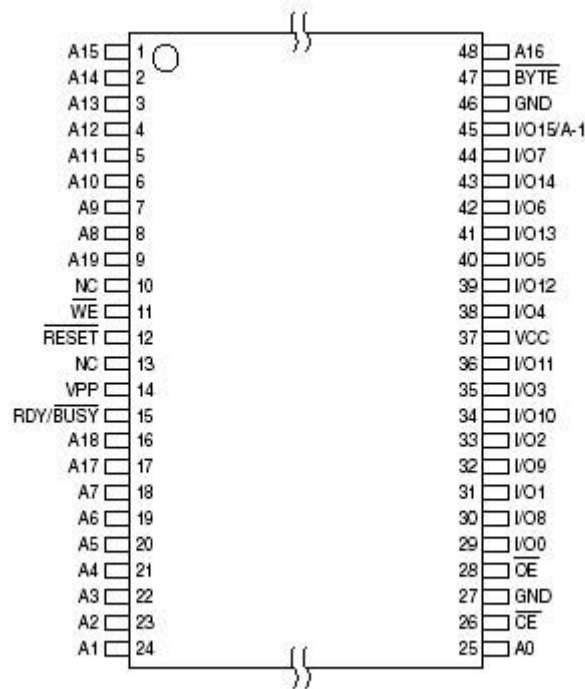

Block Diagram

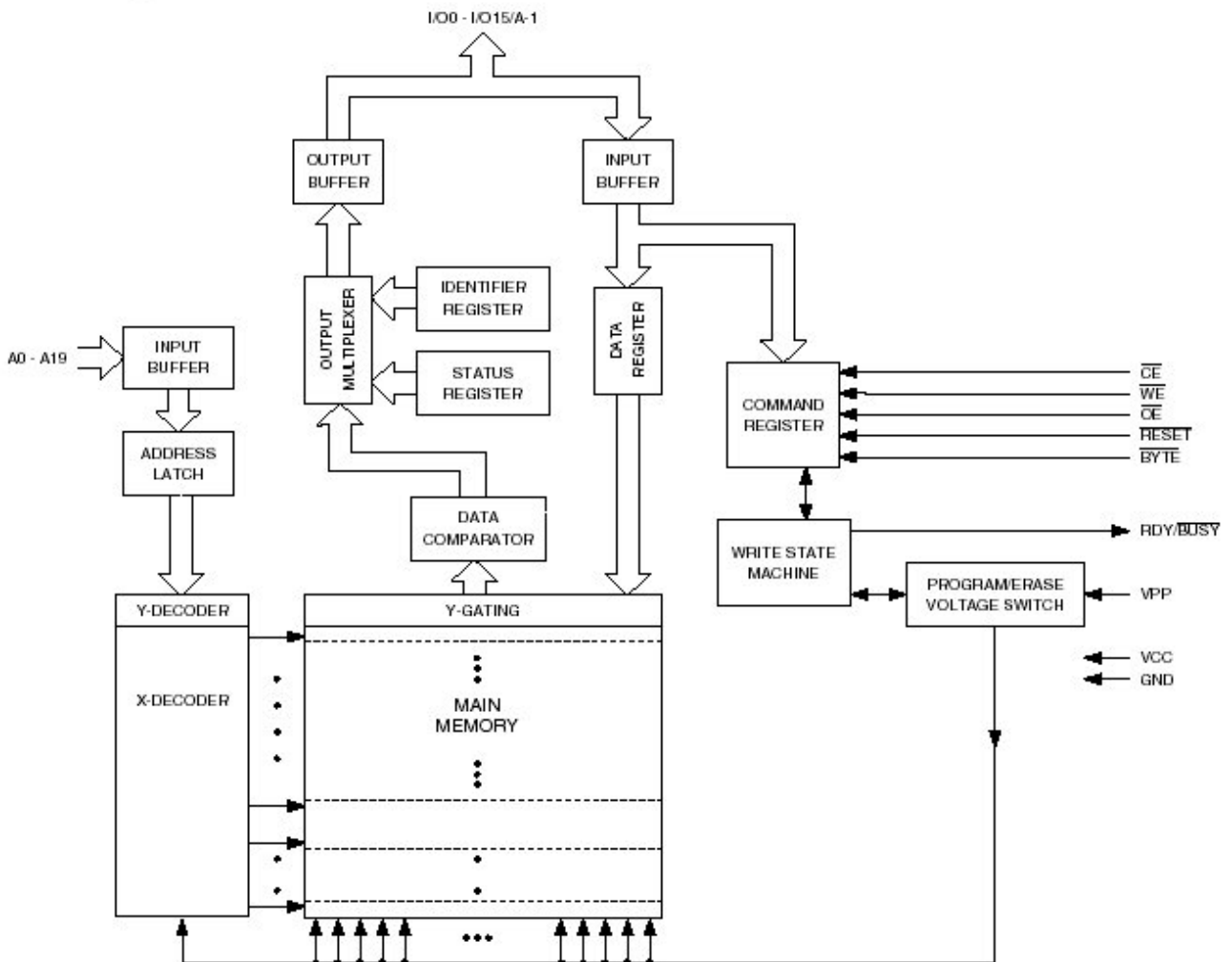

## 9. BU4053BCF(PROCESSOR:IC606, VIDEO:IC88(AVR635 ONLY))

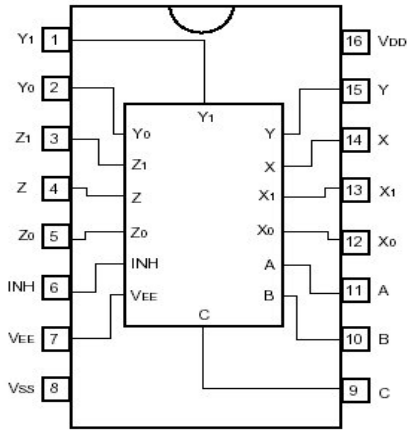

●Logic circuit diagram

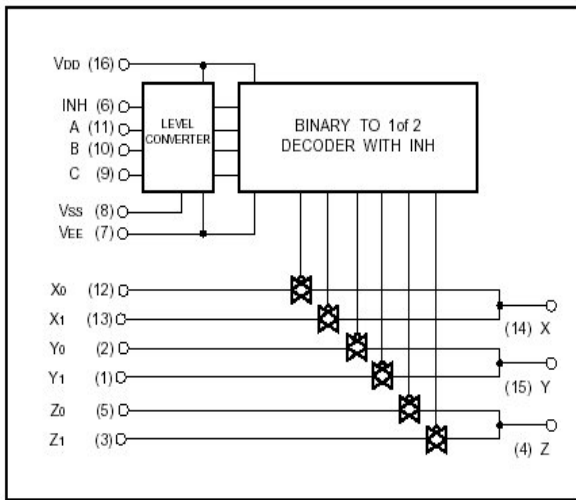

●Truth table

INH	A	B	C	ON SWITCH
L	L	L	L	X <sub>0</sub> Y <sub>0</sub> Z <sub>0</sub>
L	H	L	L	X <sub>1</sub> Y <sub>0</sub> Z <sub>0</sub>
L	L	H	L	X <sub>0</sub> Y <sub>1</sub> Z <sub>0</sub>
L	H	H	L	X <sub>1</sub> Y <sub>1</sub> Z <sub>0</sub>
L	L	L	H	X <sub>0</sub> Y <sub>0</sub> Z <sub>1</sub>
L	H	L	H	X <sub>1</sub> Y <sub>0</sub> Z <sub>1</sub>
L	L	H	H	X <sub>0</sub> Y <sub>1</sub> Z <sub>1</sub>
L	H	H	H	X <sub>1</sub> Y <sub>1</sub> Z <sub>1</sub>
H	X	X	X	NONE

X: Irrelevant

## 10. CS42518CQ(DSP:IC606)

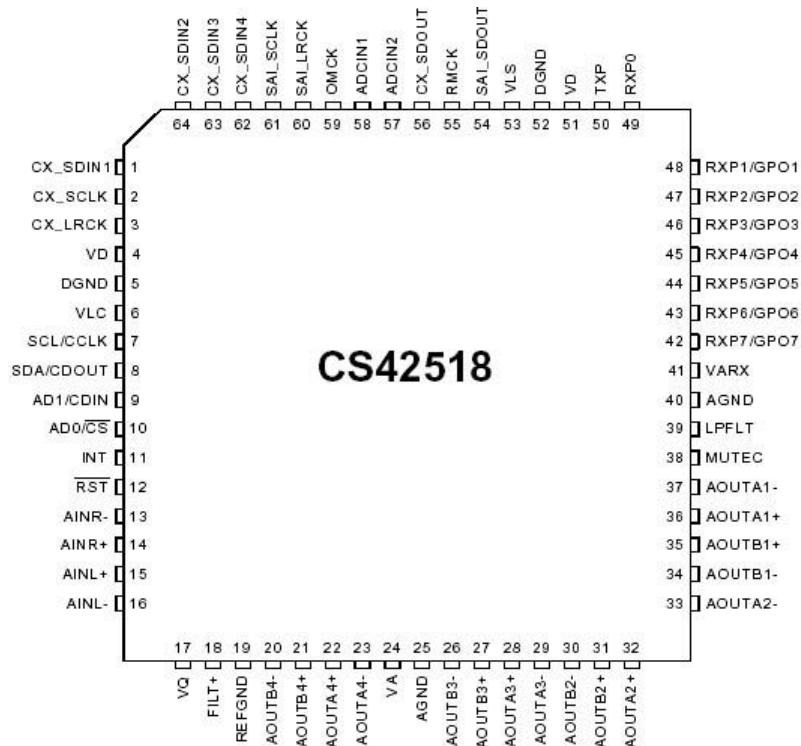

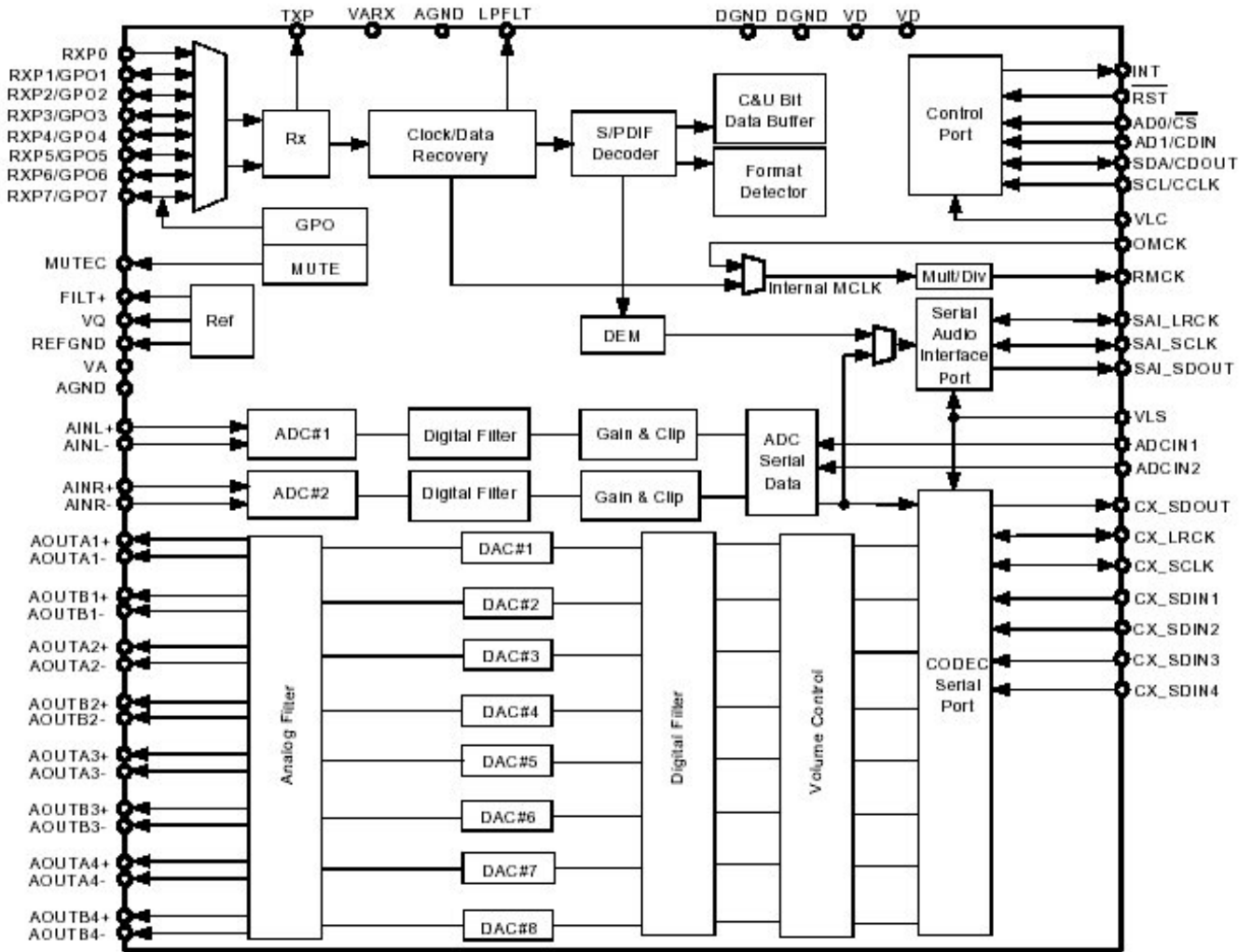

11. K4S161622H-TC60(DSP:IC903)

VDD	1	50	Vss
DQ0	2	49	DQ15
DQ1	3	48	DQ14
VssQ	4	47	VssQ
DQ2	5	46	DQ13
DQ3	6	45	DQ12
VDDQ	7	44	VDDQ
DQ4	8	43	DQ11
DQ5	9	42	DQ10
VssQ	10	41	VssQ
DQ6	11	40	DQ9
DQ7	12	39	DQ8
VDDQ	13	38	VDDQ
LDQM	14	37	N.C/RFU
<u>WE</u>	15	36	UDQM
<u>CAS</u>	16	35	CLK
<u>RAS</u>	17	34	CKE
<u>CS</u>	18	33	N.C
BA	19	32	A9
A10/AP	20	31	A8
A0	21	30	A7
A1	22	29	A6
A2	23	28	A5
A3	24	27	A4
VDD	25	26	Vss

## FUNCTIONAL BLOCK DIAGRAM

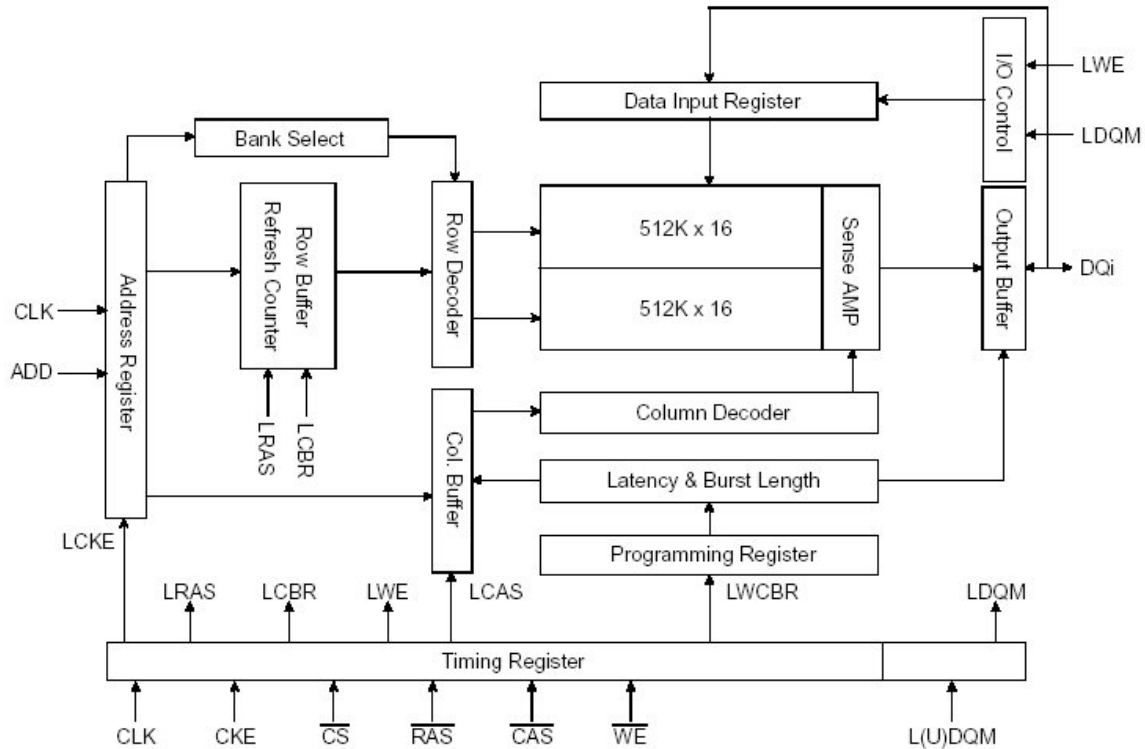

## PIN FUNCTION DESCRIPTION

Pin	Name	Input Function
CLK	System Clock	Active on the positive going edge to sample all inputs.
$\overline{\text{CS}}$	Chip Select	Disables or enables device operation by masking or enabling all inputs except CLK, CKE and L(U)DQM
CKE	Clock Enable	Masks system clock to freeze operation from the next clock cycle. CKE should be enabled at least one cycle prior to new command. Disable input buffers for power down in standby.
A0 ~ A10/AP	Address	Row / column addresses are multiplexed on the same pins. Row address : RA0 ~ RA10, column address : CA0 ~ CA7
BA	Bank Select Address	Selects bank to be activated during row address latch time. Selects bank for read/write during column address latch time.
$\overline{\text{RAS}}$	Row Address Strobe	Latches row addresses on the positive going edge of the CLK with $\overline{\text{RAS}}$ low. Enables row access & precharge.
$\overline{\text{CAS}}$	Column Address Strobe	Latches column addresses on the positive going edge of the CLK with $\overline{\text{CAS}}$ low. Enables column access.
$\overline{\text{WE}}$	Write Enable	Enables write operation and row precharge. Latches data in starting from CAS, WE active.
L(U)DQM	Data Input/Output Mask	Makes data output Hi-Z, tSHZ after the clock and masks the output. Blocks data input when L(U)DQM active.
DQ0 ~ 15	Data Input/Output	Data inputs/outputs are multiplexed on the same pins.
VDD/VSS	Power Supply/Ground	Power and ground for the input buffers and the core logic.
VDDQ/VSSQ	Data Output Power/Ground	Isolated power supply and ground for the output buffers to provide improved noise immunity.
N.C/RFU	No Connection/ Reserved for Future Use	This pin is recommended to be left No Connection on the device.



## 12. UPD70F3033BGF(DSP:IC501)

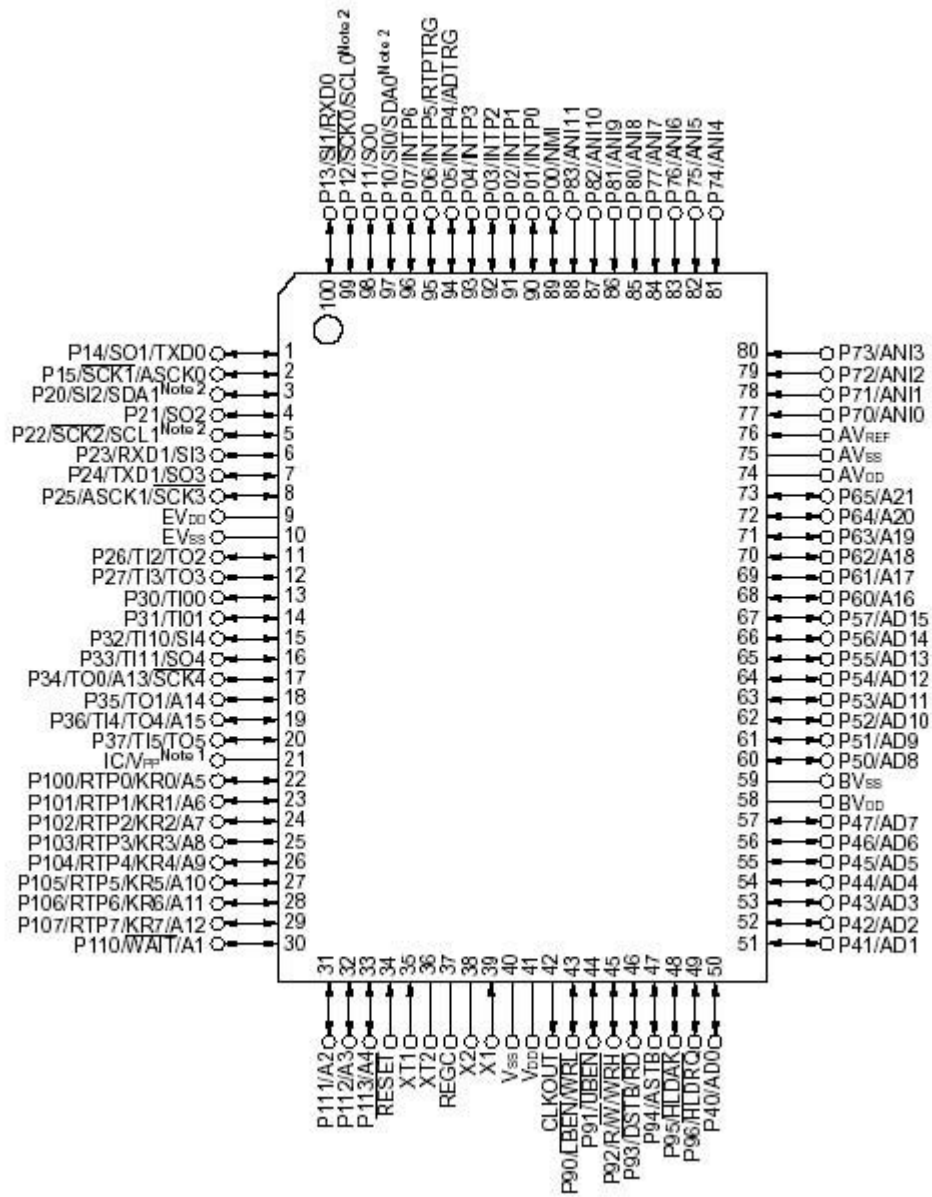

IC501 uPD70F3033B PORT ASSIGNMENT				
PIN	V850 NAME	RECEIVER NAME	IN/OUT	FUNCTION
1	P14/SO1/TXD0	RS-232 TX	TX	CPU FLASH UPGRADE UART TX PORT
2	P15/SCK1/ASCK0	VPP_CONTROL	OUT	Flash Upgrade VPP Control Pin
3	P20/SI2/SDA1	HDCD GAIN	OUT	HDCD GAIN (DSP)
4	P21/SO2	THX GAIN	OUT	THX GAIN (DSP)
5	P22/SCK2/SCL1	FIP_RST / FL STB	OUT	FIP DRIVER IC RESET / FL STROBE
6	P23/RXD1/SI3	FIP SI / FL BLK	SI	FIP DRIVER IC DATA IN / FL BLANK
7	P24/TXD1/SO3	FIP SO / FL DI	SO	FIP DRIVER IC DATA OUT / FL DI
8	P25/ASCK1/SCK3	FIP_CLK / FL_CLK	SCK	FIP DRIVER IC CLOCK OUT (NEC CPU MASTER) / FL_CLK
9	EVDD	EVDD	VDD	VDD
10	EVSS	EVSS	GND	GND
11	P26/TI2/TO2	ADC RESET	OUT	ADC RESET(DSP)
12	P27/TI3/TO3	CODEC_RESET	OUT	CODEC RESET(DSP)
13	P30/TI00	RMC_IN	CAPTURE	REMOCON IN
14	P31/TI01	CODEC_CE	OUT	CODEC CHIP ENABLE(DSP)
15	P32/T110/S14	RMC_MULTI	CAPTURE	MULTI ROOM REMOCON
16	P33/TI11/SO4	CODEC_CLK	OUT	CODEC CLK(DSP)
17	P34/TO0/SCK4	CODEC_DATA_OUT	OUT	CODEC DATA_OUT(DSP)
18	P35/TO1	CODEC_DATA_IN	IN	CODEC DSP_IN(DSP)
19	P36/TI4/TO4	CODEC_INT	IN	CODEC INT(DSP)
20	P37/TI5/TO5	FAN_OUT	OUT	FAN_OUT CONTROL(PWM)
21	IC/VPP	VPP	IN	47K Pull_Down, FLASH WRITE 7.8V
22	P100/RTP0/KR0	DSP_RESET	OUT	DA601 RESET(DSP)
23	P101/RTP1/KR1	DSP_DR1	IN	DA601 DX1(DSP)
24	P102/RTP2/KR2		IN	MIC- CHECK IN(HI)
25	P103/RTP3/KR3	DSP_CLK	OUT	DA601 CLKX1(DSP)
26	P104/RTP4/KR4	DSP_FSX1	OUT	DA601 FSX1(DSP)
27	P105/RTP5/KR5	DSP_DX1	OUT	DA601 DR1(DSP)
28	P106/RTP6/KR6	DSP_PIN1	IN/OUT	DA601 PIN1(DSP)
29	P107/RTP7/KR7	_INTERQ_	IN	VIDEO I2C DATA
30	P110/WAIT		OUT	VIDEO I2C CLK
31	P111	DA MODE	OUT	CS4391-M3
32	P112	DA MODE	OUT	CS4391-M2
33	P113	IN	IN/OUT	COMPO DETECT
34	/RESET	RESET	IN	LOW ACTIVE
35	XT1	XT1	IN	Pull_Down
36	XT2	XT2	OUT	OPEN
37	REGC	REGC	VDD	VDD
38	X2	Fx_OUT	OUT	20.00MHz RESONATOR
39	X1	Fx_IN	IN	20.00MHz RESONATOR
40	VSS	VSS	GND	GND
41	VDD	VDD	VDD	5V
42	CLKOUT	CLKOUT	OUT	OPEN (STOP MODE: LOW)
43	P90/LBEN/WRL	ADC MODE 0	OUT	ADC MODE 0(DSP)
44	P91/UBEN	ADC MODE 1	OUT	ADC MODE 1(DSP)
45	P92/RW/WRH	HP MUTE	OUT	HEADPHONE MUTE
46	P93/DSTB/RD	EEPROM DATA	OUT	EEPROM DATA
47	P94/ASTB	EEPROM_CLK	OUT	EEPROM_CLK
48	P95/HLDAK	VOL IC CE	OUT	TC9482/TC9459 CE
49	P96/HLDRQ	4094 CE	OUT	4094 CHIP ENABLE
50	P40	4094 CLK	OUT	4094 CLK
51	P41	4094 DATA	OUT	4094 DATA
52	P42	9482/59 DATA	OUT	9482/59 VOL IC DATA
53	P43	9482/59 CLK	OUT	9482/59 VOL IC CLK
54	P44	A DATA	OUT	9273_1, 9273_3, 9162, 9162_2, 9163 DATA
55	P45	A CLK	OUT	9273_1, 9273_3, 9162, 9162_2, 9163 CLK
56	P46	9273 CE1	OUT	9273_1, 9162, 9163 CHIP ENABLE
57	P47	9273_CE3	OUT	9273_3, 9162_2 CHIP ENABLE
58	BVDD	BVDD	VDD	VDD
59	BVSS	BVSS	GND	GND
60	P50	T_MUTE	OUT	TUNER MUTE OUT
61	P51	TUNED	IN	TUNED CHECK IN
62	P52	T_CE	OUT	TUNER PLL IC(LC72131) CHIP ENABLE

IC501 uPD70F3033B PORT ASSIGNMENT				
63	P53	T_CLOCK	OUT	TUNER PLL IC(LC72131) CLOCK
64	P54	T_DATA IN/STEREO	IN	TUNER PLL IC(LC72131) DATA IN / STEREO CHECK
65	P55	T_DATA OUT	OUT	TUNER PLL IC(LC72131) DATA OUT
66	P56	MMUTE	OUT	FRONT SPEAKER MUTE
67	P57	CMUTE	OUT	CENTER SPEAKER MUTE
68	P60	SMUTE	OUT	SURROUND SPAKER MUTE
69	P61	SBMUTE	OUT	SURR BACK SPEAKER MUTE
70	P62	SUBMUTE	OUT	SUB WOOFER MUTE
71	P63	PMUTE	OUT	POWER MUTE
72	P64	RECMUTE	OUT	REC MUTE
73	P65	MULTI MUTE	OUT	MULTI ROOM MUTE
74	AVDD	AVDD	VDD	VDD
75	AVSS	AVSS	GND	GND
76	AVREF	AVREF	VDD	VDD
77	P70/ANI0	AD KEY1	ADIN	A/D KEY INPUT1
78	P71/ANI1	AD KEY2	ADIN	A/D KEY INPUT2
79	P72/ANI2	FAN IN1	ADIN	TEMPERATURE SENSOR
80	P73/ANI3	FAN IN2	ADIN	DC LEVEL SENSOR
81	P74/ANI4	ENCODE1	IN	VOLUME ENCODER INPUT 1
82	P75/ANI5	ENCODE2	IN	VOLUME ENCODER INPUT 2
83	P76/ANI6	yc/comp check	ADIN	Y/C,COMPO jack check in
84	P77/ANI7	HP_IN	IN	HEADPHONE INPUT
85	P80/ANI8	STEP	IN	TUNER FREQ OPTION
86	P81/ANI9	NTSC/PAL SEL	IN	NC
87	P82/ANI10	PROTECTION	IN	PROTECTION IN
88	P83/ANI11	MODEL	IN	NC
89	P00/NMI	STANDBY	OUT	MAIN POWER ON/OFF
90	P01/INTP0	POWER DOWN	INTP0	POWER DOWN CHECK & WAKE UP : RISING EDGE
91	P02/INTP1	RDS_CLOCK	INTP1	RDS_CLOCK (INTERRUPT) : FALLING EDGE
92	P03/INTP2	RDS_DATA	IN	RDS_DATA
93	P04/INTP3	CODEC_MUTE	OUT	CODEC_MUTE(DSP)
94	P05/INTP4/ADTRG	SYNC pluse check	IN	SYNC PLUSE CHECK(OSD IC 7)
95	P06/INTP5/RTPTRG	SYNC CHECK	IN	SYNC CHECK(OSD IC29 PIN)
96	P07/INTP6		OUT	
97	P10/SI0	OSD CE	OUT	OSD CHIP ENABLE
98	P11/SO0	OSD CLK	OUT	OSD CLK
99	P12/SCK0	OSD DATA	OUT	OSD DATA
100	P13/SI1/RXD0	RS-232 RX	RX	CPU FLASH UPGRADE UART RX PORT

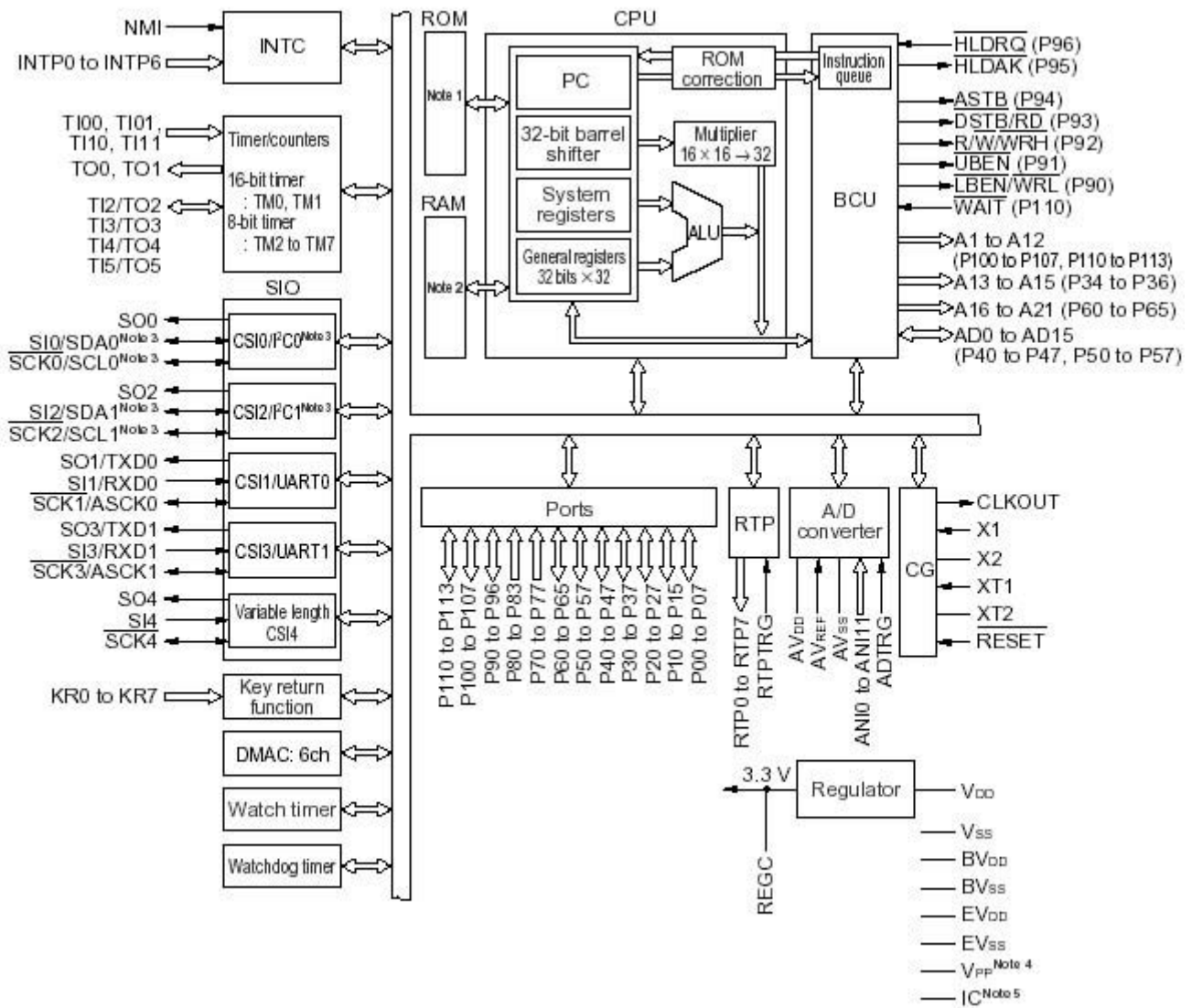

**13. KIC9162AF(PROCESSOR:IC502,510,501)**

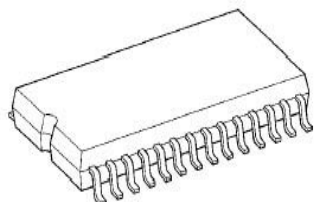

VSS	1	28	VDD
L-S <sub>1</sub>	2	27	R-S <sub>1</sub>
L-S <sub>2</sub>	3	26	R-S <sub>2</sub>
L-COM <sub>1</sub>	4	25	R-COM <sub>1</sub>
L-S <sub>3</sub>	5	24	R-S <sub>3</sub>
L-S <sub>4</sub>	6	23	R-S <sub>4</sub>
L-COM <sub>2</sub>	7	22	R-COM <sub>2</sub>
L-S <sub>5</sub>	8	21	R-S <sub>5</sub>
L-S <sub>6</sub>	9	20	R-S <sub>6</sub>
L-COM <sub>3</sub>	10	19	R-COM <sub>3</sub>
L-S <sub>7</sub>	11	18	R-S <sub>7</sub>
L-COM <sub>4</sub>	12	17	R-COM <sub>4</sub>
ST	13	16	DATA
GND	14	15	CK

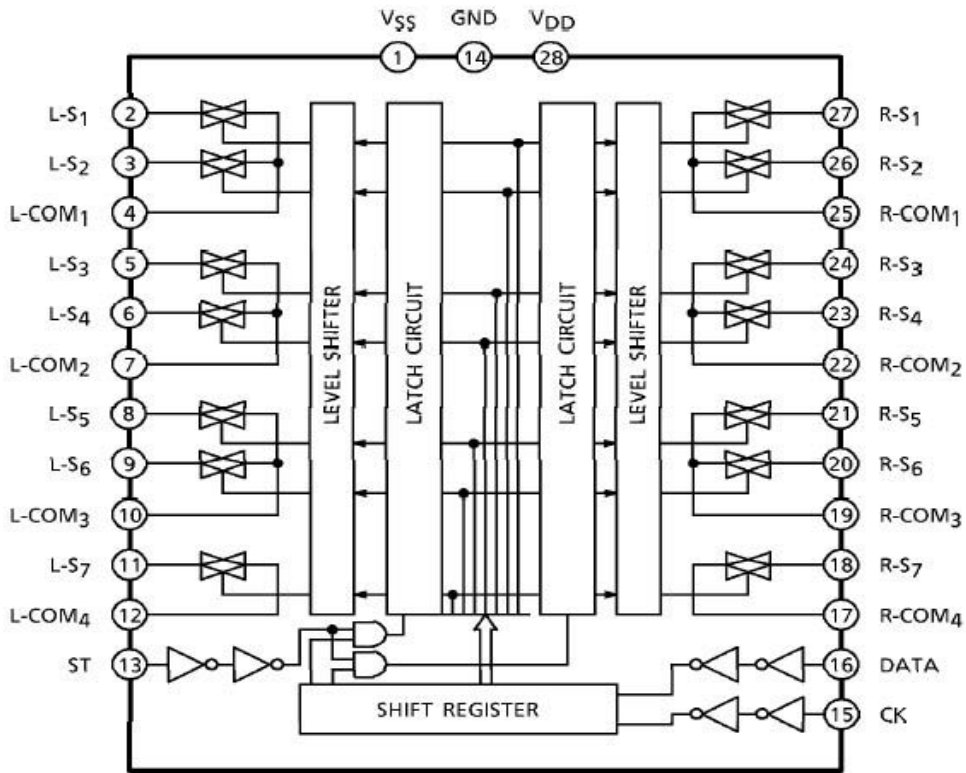

14. KIC9459F(PROCESSOR:IC204 507 )

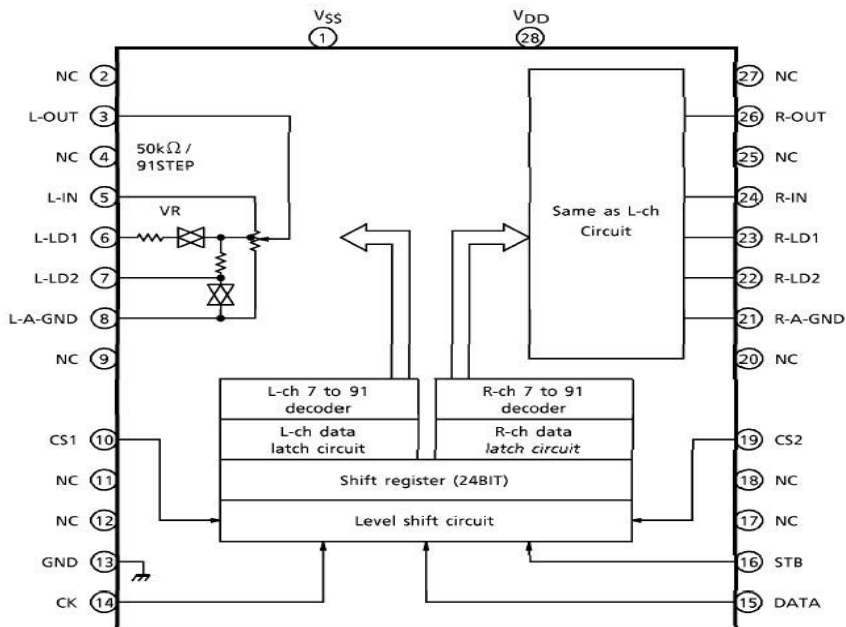
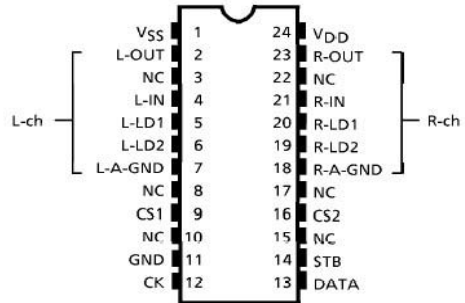
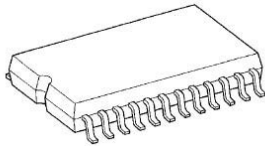

15. LC74763M(VIDEO:IC75(AVR435:IC22))

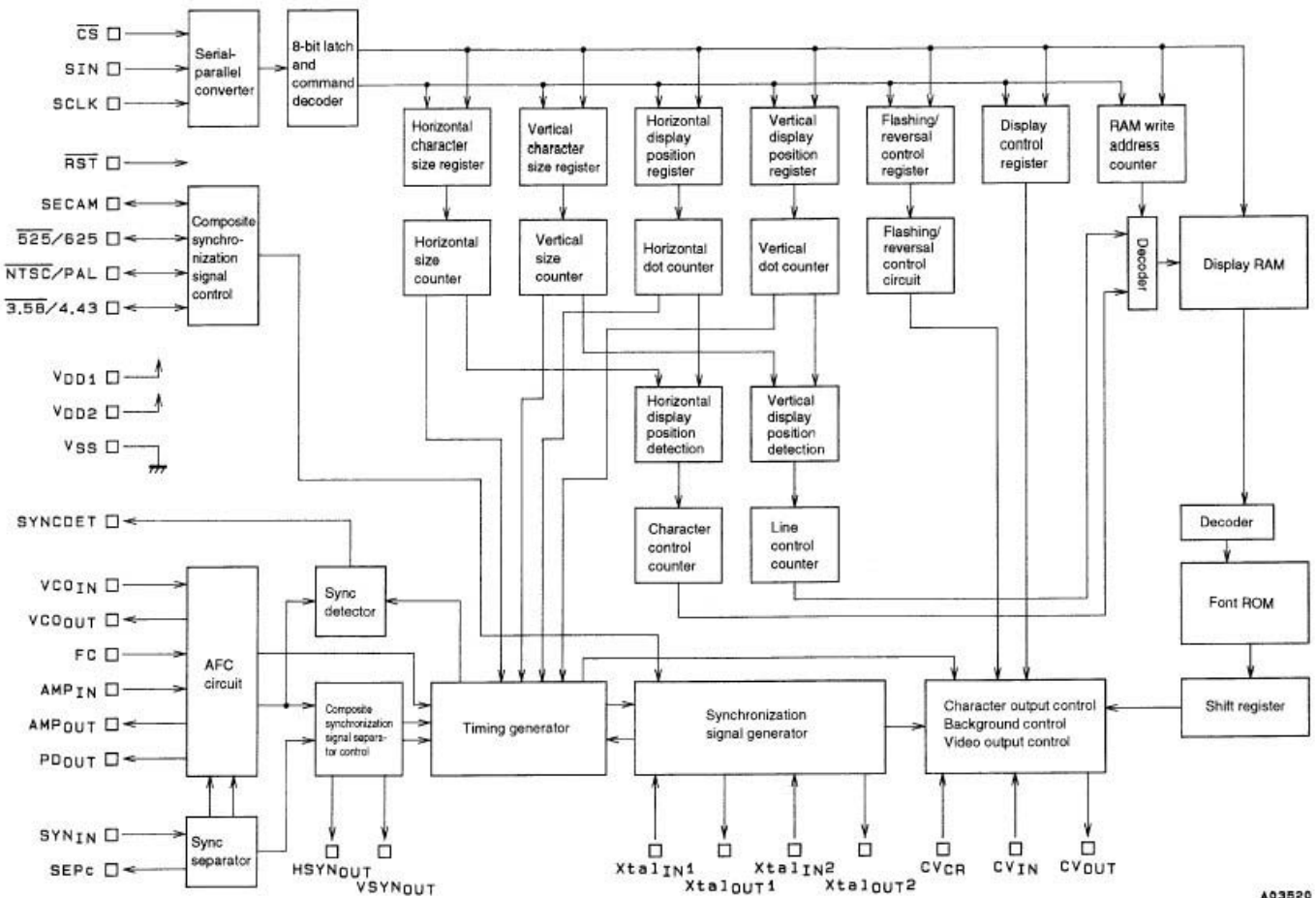
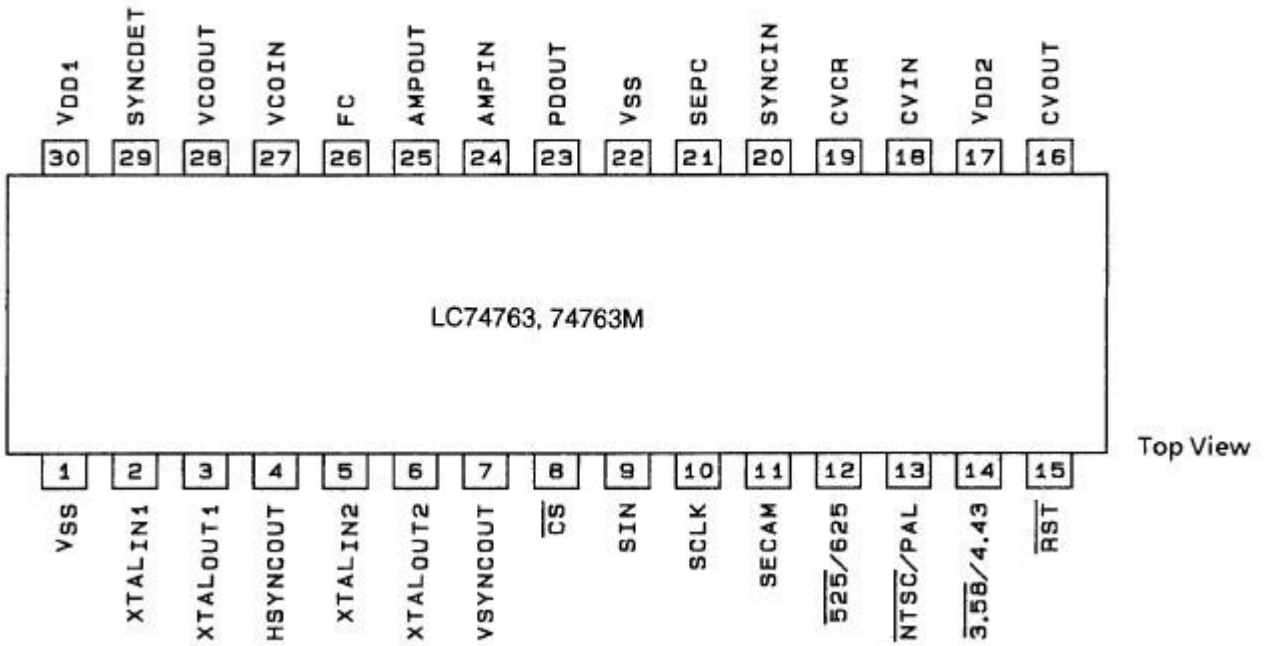

A03520

16. NJM2068M(PROCESSOR:IC101,102,103,201,202,203,301,302,503,504,505,506,508, 602, 603,604,605, MAIN:IC22,DSP:IC251,252,401,402,403,404,406, FRONT:IC50)

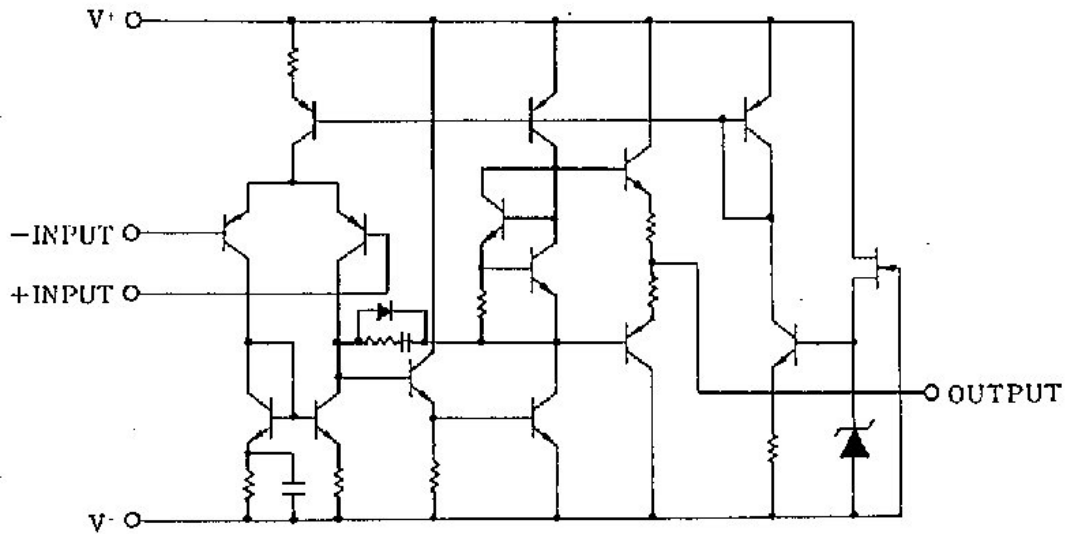
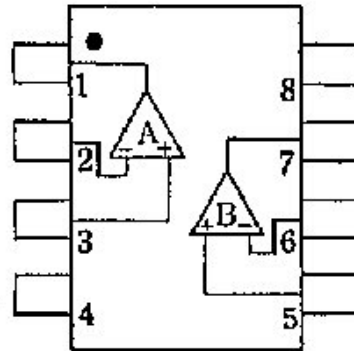

17. TC9482F(PROCESSOR:IC509)

TC9482F

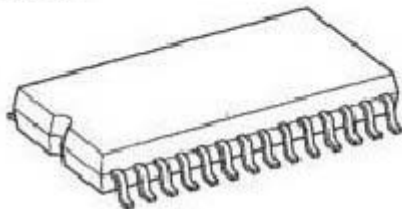

SOP28-P-450-1.27

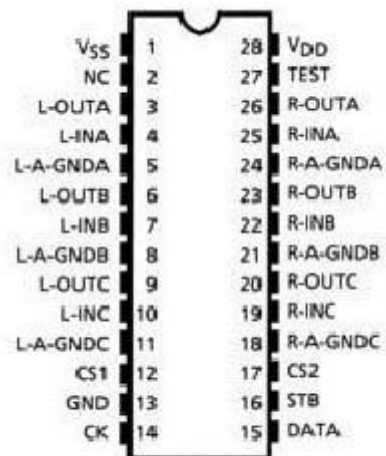

18. NJM317DL1(RMT/232:IC904)

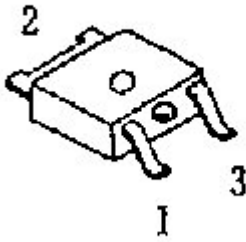

1. Adjustment
2. Output
3. Input

19. MAX3223CDWR(RMT/RS232:IC61)

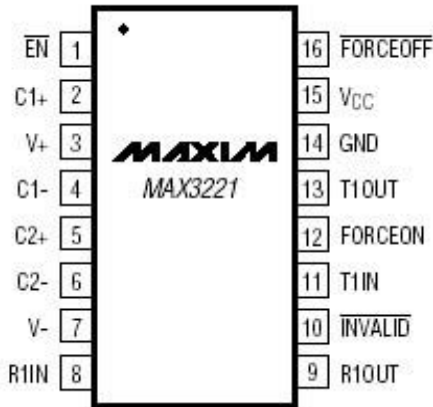

PIN			NAME	FUNCTION
MAX3221	MAX3223	MAX3243		
1	1	—	$\overline{\text{EN}}$	Receiver Enable Control. Drive low for normal operation. Drive high to force the receiver outputs into a high-Z state.
5	5	1	C2+	Positive terminal of inverting charge-pump capacitor
6	6	2	C2-	Negative terminal of inverting charge-pump capacitor
7	7	3	V-	-5.5V generated by the charge pump
8	9, 16	4-8	R_IN	RS-232 Receiver Inputs
13	8, 17	9, 10, 11	T_OUT	RS-232 Transmitter Outputs
11	12, 13	12, 13, 14	T_IN	TTL/CMOS Transmitter Inputs
9	10, 15	15-19	R_OUT	TTL/CMOS Receiver Outputs
—	—	20	R2OUTB	Noninverting Receiver Output—active in shutdown
10	11	21	$\overline{\text{INVALID}}$	Output of the valid signal detector. Indicates if a valid RS-232 level is present on receiver inputs logic "1".
16	20	22	$\overline{\text{FORCEOFF}}$	Drive low to shut down transmitters and on-board power supply. This overrides all automatic circuitry and FORCEON (Table 1).
12	14	23	FORCEON	Drive high to override automatic circuitry keeping transmitters on (FORCEOFF must be high) (Table 1).
4	4	24	C1-	Negative terminal of the voltage doubler charge-pump capacitor
14	18	25	GND	Ground
15	19	26	VCC	+3.0V to +5.5V Supply Voltage
3	3	27	V+	+5.5V generated by the charge pump
2	2	28	C1+	Positive terminal of the voltage doubler charge-pump capacitor



20. MM1117XFBE(VIDEO:IC36)-AVR635 ONLY

2-Input 1-Output Video Switch / 3-Input 1-Output Video Switch

IC VIDEO SWITCH MM1117

MM1117

SOP-8C

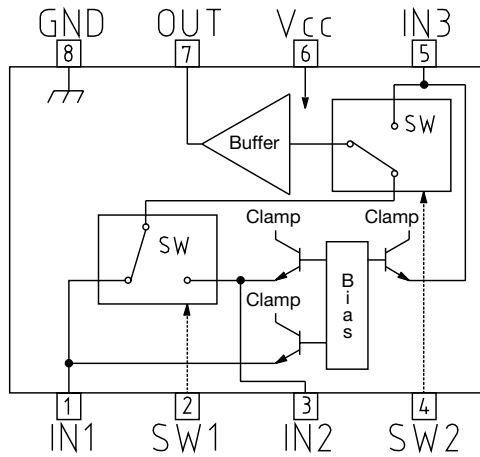

SIP-8A

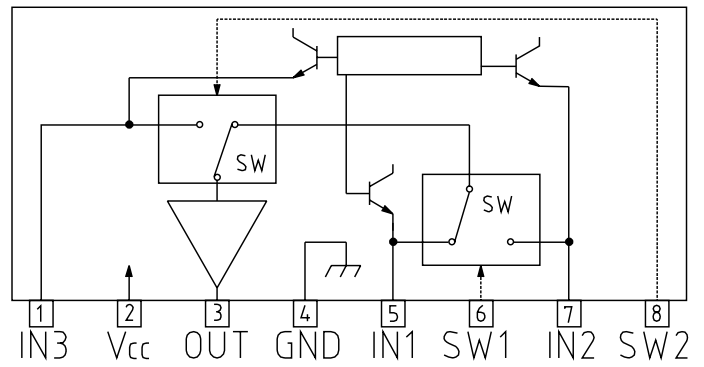

Control input truth table

SW1	SW2	OUT
L	L	IN1
H	L	IN2
-	H	IN3

21. MM1234XFBE(VIDEO:IC33)-AVR635 ONLY

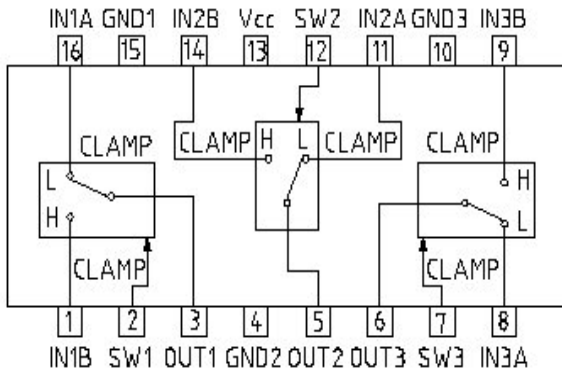

Control input truth table

SW	OUT
L	IN1A
	IN2A
	IN3A
H	IN1B
	IN2B
	IN3B

22. MM1501XNRE(VIDEO:IC80,81(AVR435: IC14,25,26))

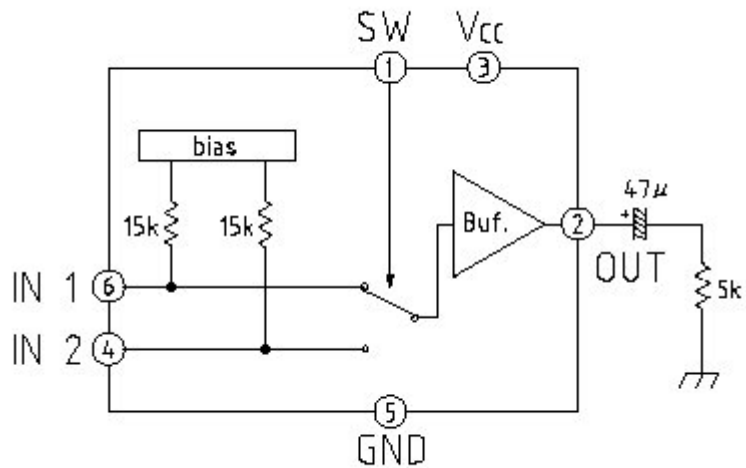

23. MM1511XNRE(VIDEO:IC79(AVR435:IC27))

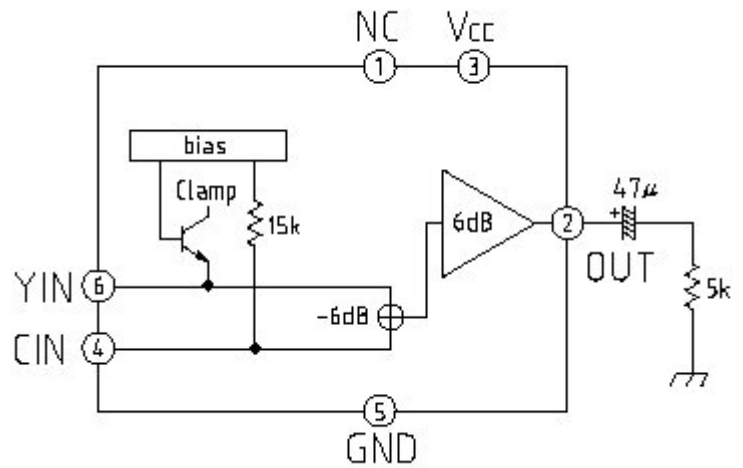
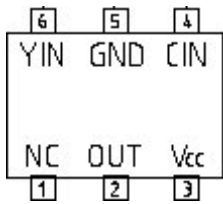

24.

NJM2296(VIDEO:IC70,71,72(AVR435: IC10,11,12))

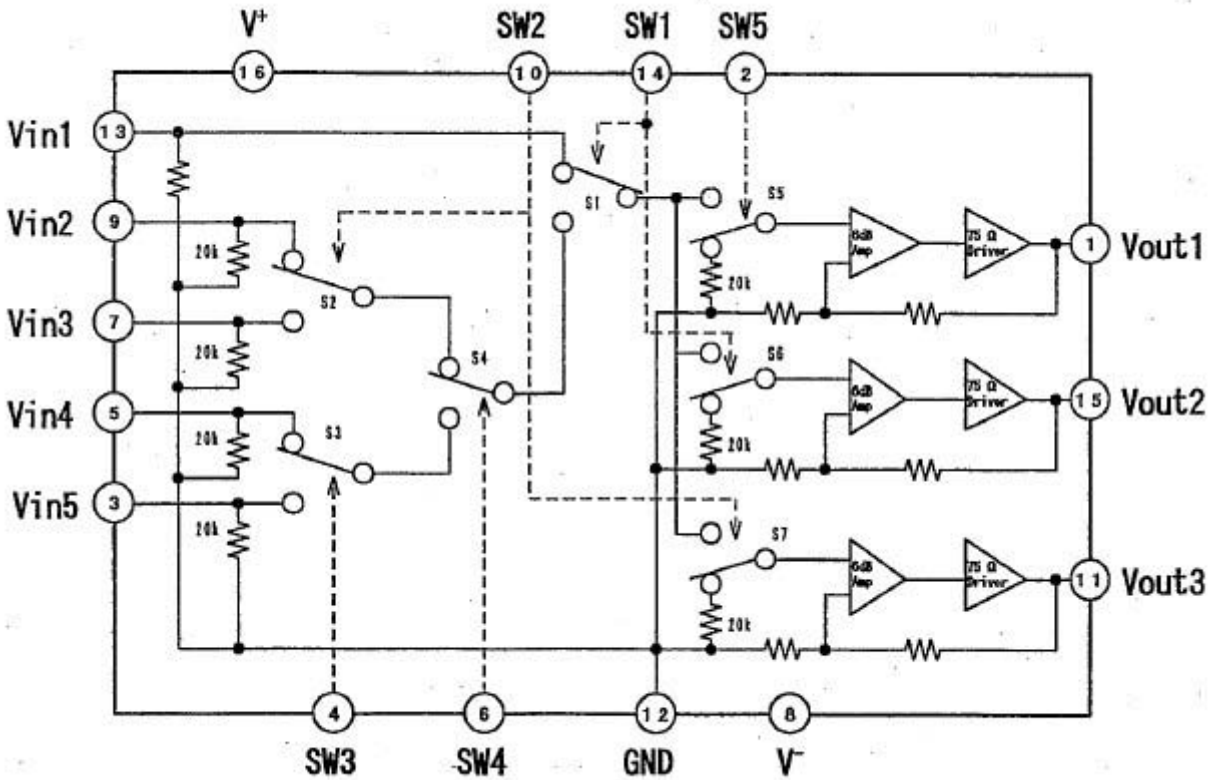
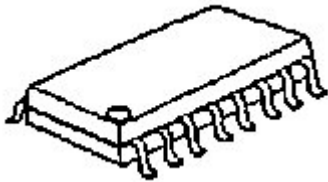

25. NJM2586M(VIDEO:IC94(AVR435:IC40))

# NJM2586A

## WIDE BAND 3-INPUT 1-OUTPUT 3-CIRCUIT VIDEO AMPLIFIER

### GENERAL DESCRIPTION

The **NJM2586A** is a wide band 3-input 1-output 3-circuit video amplifier. It is suitable for Y, Pb, and Pr signal because frequency range is 50MHz. The **NJM2586A** is suitable for AV receiver, STB, and other high quality AV systems.

### FEATURES

- Operating Voltage ±4.5 to ±5.5V
- Wide frequency range 0dB at 50MHz typ.
- Internal 3 input-1output 3-circuit video switch
- Internal 6dB Amplifier
- Internal 75Ω Driver Circuit
- Power Save Circuit
- Bipolar Technology
- Package Outline DMP24, SDIP22

### PACKAGE OUTLINE



NJM2586AM

NJM2586AL

### BLOCK DIAGRAM

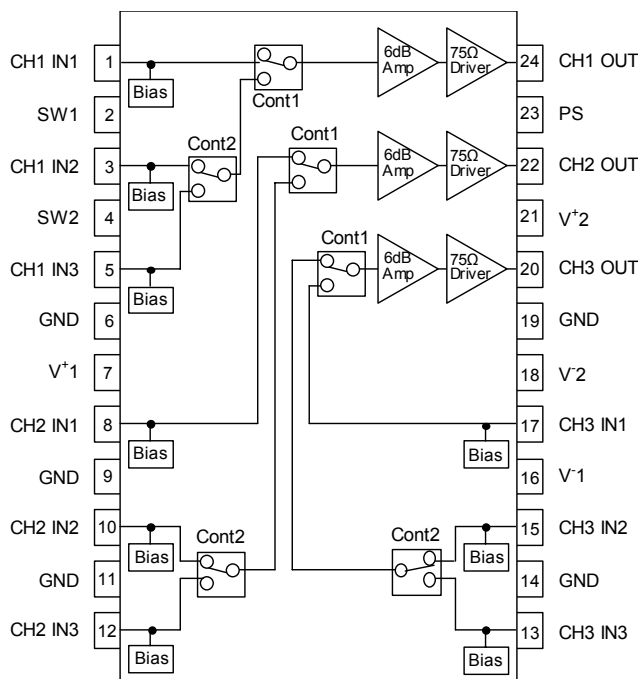

DMP24

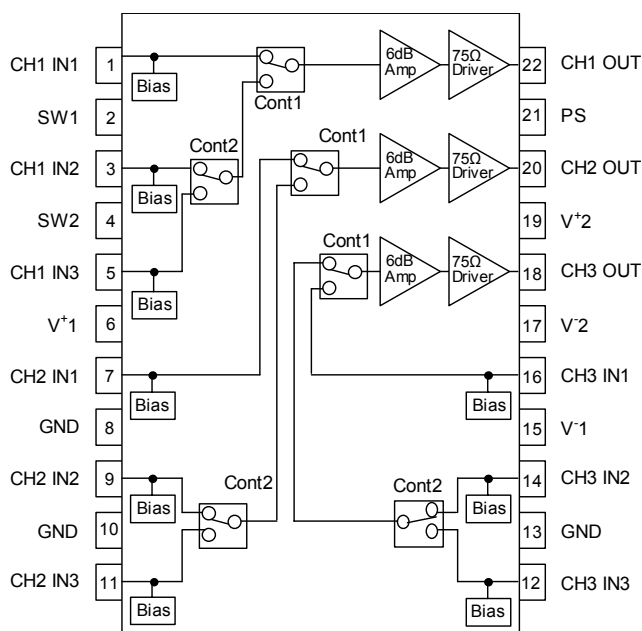

SDIP22

26. NJM4556AD(PROCESSOR:IC601)

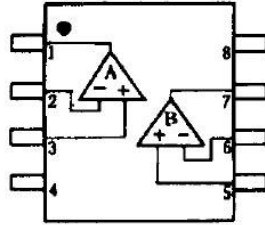
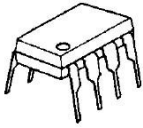

- PIN FUNCTION**  
 1.A OUTPUT  
 2.A -INPUT  
 3.A +INPUT  
 4.V<sup>-</sup>  
 5.B +INPUT  
 6.B -INPUT  
 7.B OUTPUT  
 8.V<sup>+</sup>

27. PC-17T1(RMT/RS232:IC651,652, DSP:IC851)

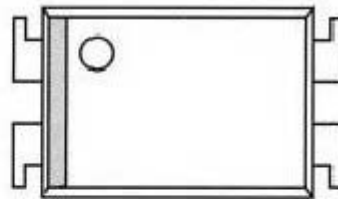
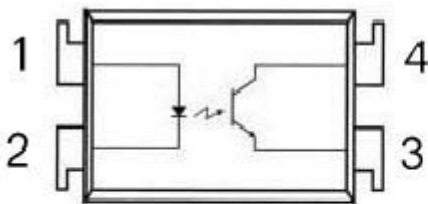

- PIN Connections**  
 1.Anode  
 2.C athode  
 3.E mitter  
 4.C ollector

28. SN74HCU04D(DSP:IC704 705)

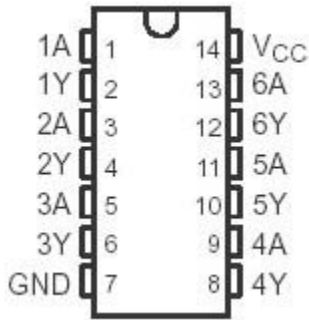

FUNCTION TABLE  
(each inverter)

INPUT A	OUTPUT Y
H	L
L	H

logic symbol†

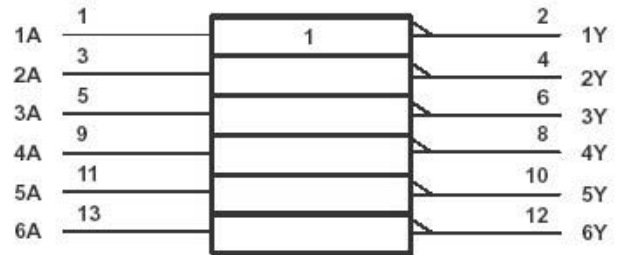

29. TC9273F-004(PROCESSOR:IC303,304 )

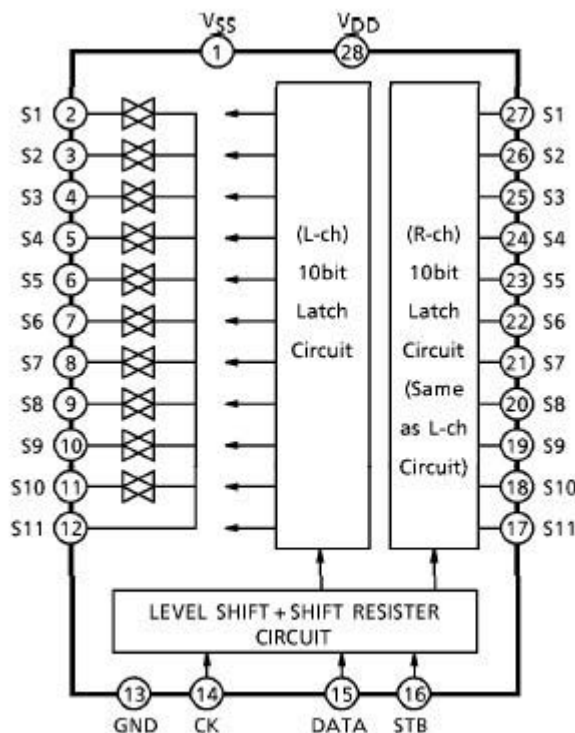
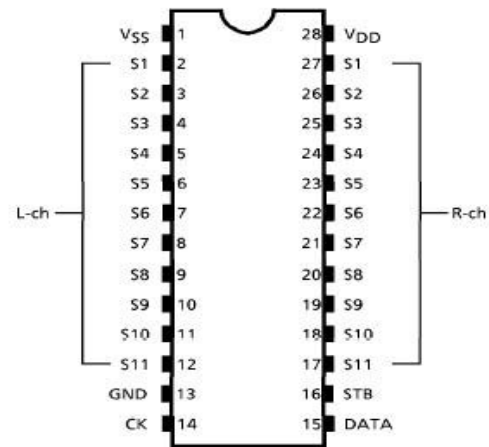
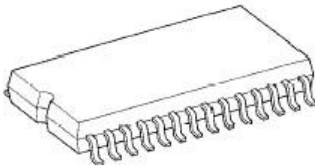

30. TSH95ID(VIDEO:IC50,74,87(AVR435:IC30)



TSH95

HIGH SPEED LOW POWER QUAD OPERATIONAL AMPLIFIER WITH DUAL **STANDBY** POSITION

- **2 SEPARATE STANDBY** : REDUCED CONSUMPTION AND HIGH IMPEDANCE OUTPUTS
- LOW SUPPLY CURRENT : 4.5mA/amp. typ.
- HIGH SPEED : 150MHz - 110V/μs
- UNITY GAIN STABILITY
- LOW OFFSET VOLTAGE : 4mV
- LOW NOISE 4.2 nV/√Hz
- LOW COST
- SPECIFIED FOR **600Ω** AND **150Ω** LOADS
- HIGH VIDEO PERFORMANCES :  
Differential Gain : 0.03%  
Differential Phase : 0.07°  
Gain Flatness : 6MHz, 0.1dB max. @ 10dB gain
- HIGH AUDIO PERFORMANCES
- ESD TOLERANCE : 2kV
- **SPICE MACROMODEL** INCLUDED IN THIS SPECIFICATION

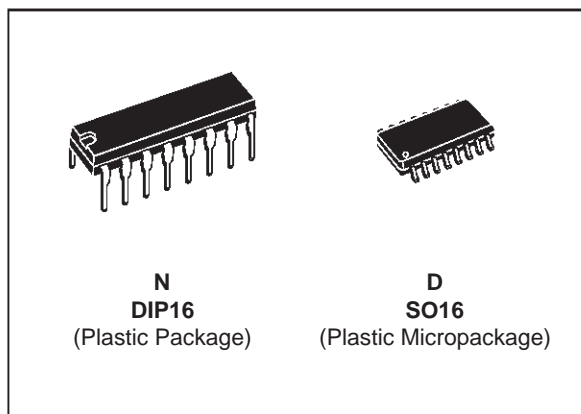

ORDER CODES

Part Number	Temperature Range	Package	
		N	D
TSH95I	-40, +125°C	•	•

PIN CONNECTIONS (top view)

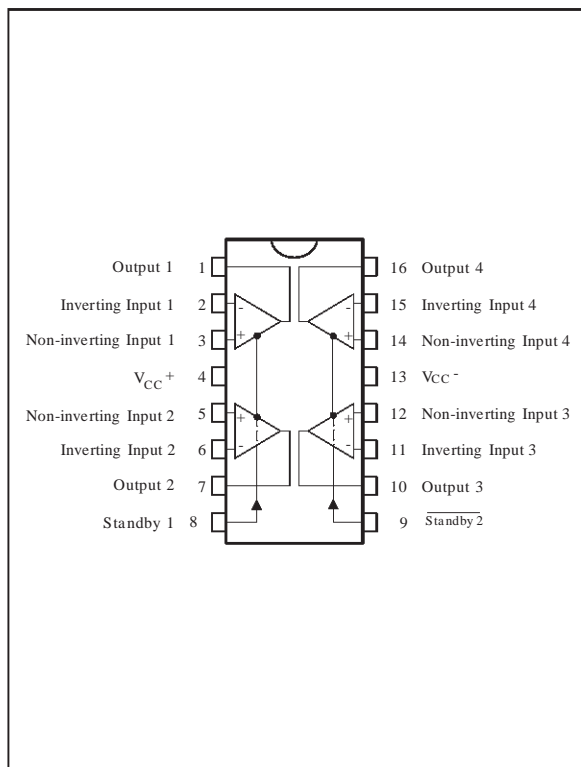

DESCRIPTION

The TSH95 is a quad low power high frequency op-amp, designed for high quality video processing. The device offers an excellent speed consumption ratio with 4.5mA per operator for 150MHz bandwidth.

High slew rate and low noise make it suitable for high quality audio applications.

The TSH95 offers 2 separate complementary **STANDBY** pins :

- STANDBY 1 acting on both n° 1 & 2 operators
  - STANDBY 2 acting on both n° 3 & 4 operators
- They reduce the consumption of the corresponding operators and put their output in a high impedance state.

# TVP5146PFP NTSC/PAL/SECAM 4 X 10 Bit Digital Video Decoder

## 31. TVP5146PFP(VIDEO:IC83) –AVR635 ONLY

### 1.5 Functional Block Diagram

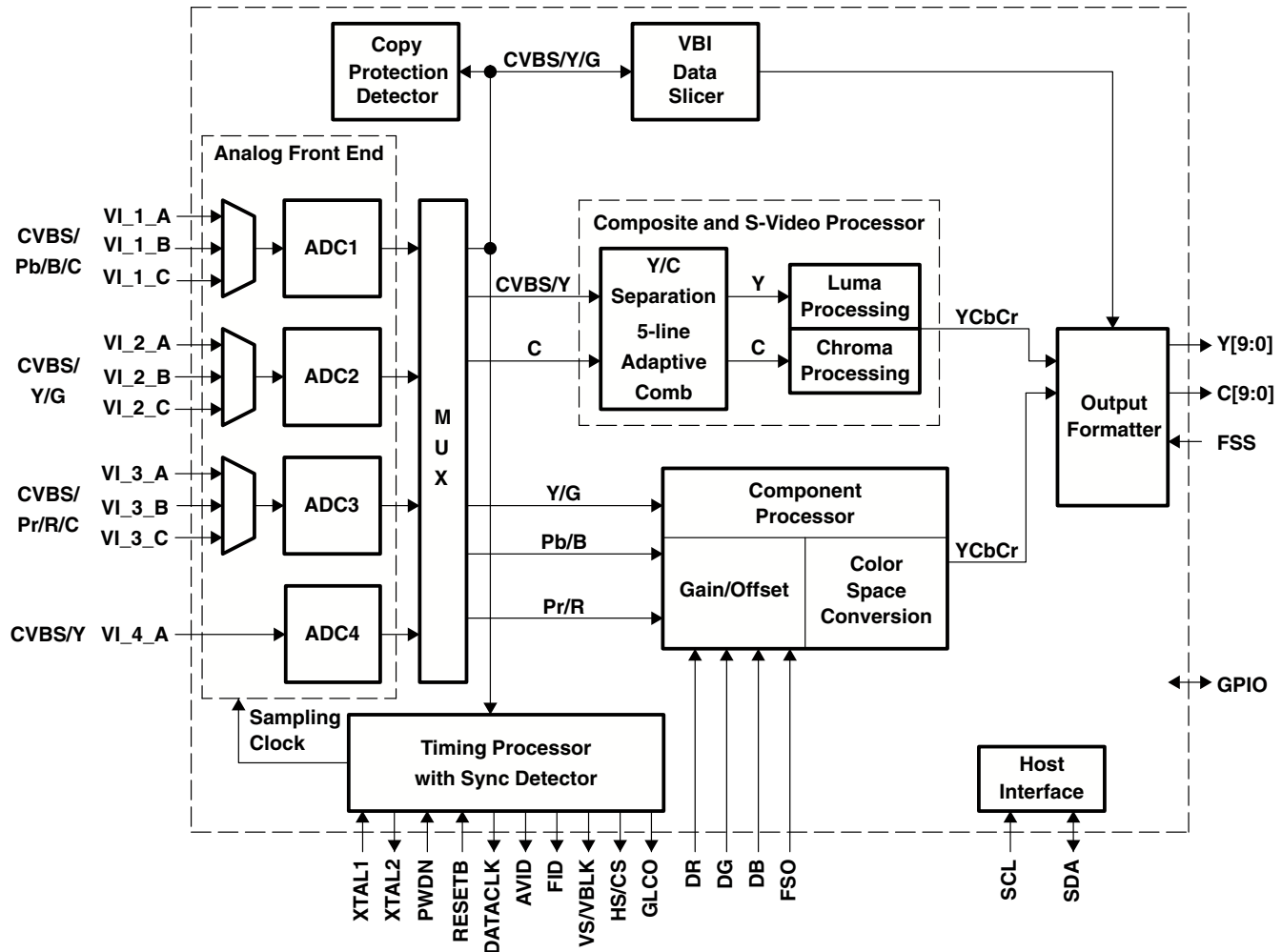

Figure 1–1. Functional Block Diagram



# TVP5146PFP NTSC/PAL/SECAM 4 X 10 Bit Digital Video Decoder

## 1.6 Terminal Assignments

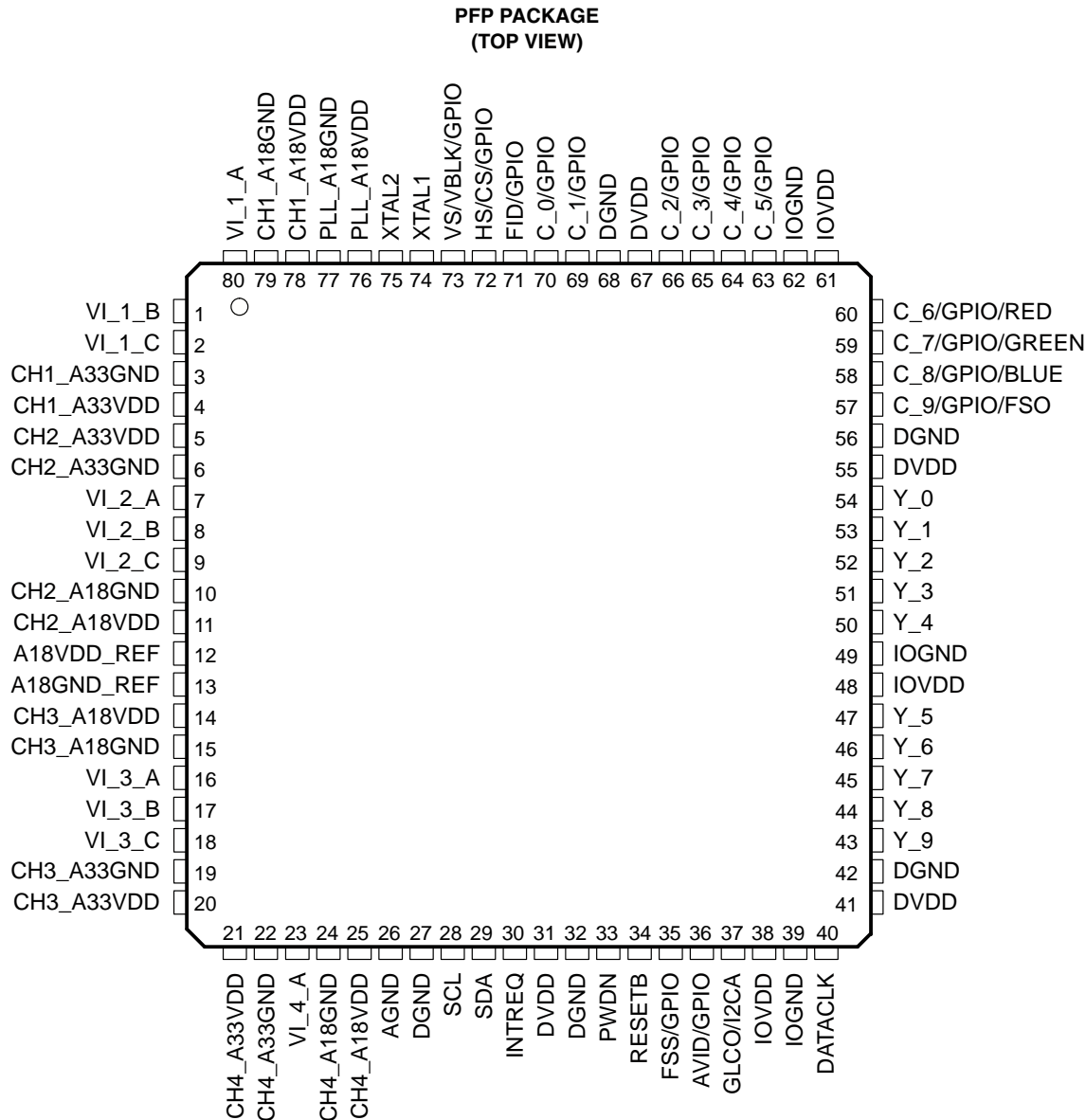

Figure 1–2. Terminal Assignments Diagram

## TVP5146PFP NTSC/PAL/SECAM 4 X 10 Bit Digital Video Decoder

## 1.7 Terminal Functions

Table 1–1. Terminal Functions

TERMINAL NAME	NUMBER	I/O	DESCRIPTION
<b>Analog Video</b>			
VI_1_A	80	I	VI_1_x: Analog video input for CVBS/Pb/B/C VI_2_x: Analog video input for CVBS/Y/G VI_3_x: Analog video input for CVBS/Pr/R/C VI_4_A: Analog video input for CVBS/Y Up to 10 composite, 4 S-video, and 2 composite or 3 component video inputs (or a combination thereof) can be supported. The inputs must be ac-coupled. The recommended coupling capacitor is 47 nF. The possible input configurations are listed in the input select register at I <sup>2</sup> C subaddress 00h (see Section 2.10.1).
VI_1_B	1		
VI_1_C	2		
VI_2_A	7		
VI_2_B	8		
VI_2_C	9		
VI_3_A	16		
VI_3_B	17		
VI_3_C	18		
VI_4_A	23		
<b>Clock Signals</b>			
DATACLK	40	O	Line-locked data output clock.
XTAL1	74	I	External clock reference input. It may connected to an external oscillator with a 1.8-V compatible clock signal or a 14.31818-MHz crystal oscillator.
XTAL2	75	O	External clock reference output. Not connected if XTAL1 is driven by an external single-ended oscillator.
<b>Digital Video</b>			
C[9:0]/GPIO[9:0]	57, 58, 59, 60, 63, 64, 65, 66, 69, 70	O	Digital video output of CbCr, C[9] is MSB and C[0] is LSB. Unused outputs can be left unconnected. Also, these terminals can be programmable general-purpose I/O. For the 8-bit mode, the two LSBs are ignored.
D_BLUE	58	I	Digital BLUE input from overlay device
D_GREEN	59	I	Digital GREEN input from overlay device
D_RED	60	I	Digital RED input from overlay device
FSO	57	I	Fast-switch overlay between digital RGB and any video
Y[9:0]	43, 44, 45, 46, 47, 50, 51, 52, 53, 54	O	Digital video output of Y/YCbCr, Y[9] is MSB and Y[0] is LSB. For the 8-bit mode, the two LSBs are ignored. Unused outputs can be left unconnected.
<b>Miscellaneous Signals</b>			
FSS/GPIO	35	I/O	Fast-switch (blanking) input. Switching signal between the synchronous component video (YPbPr/RGB) and the composite video input. Programmable general-purpose I/O
GLCO/I2CA	37	I/O	Genlock control output (GLCO). Two Genlock data formats are available: TI format and real time control (RTC) format. During reset, this terminal is an input used to program the I <sup>2</sup> C address LSB.
INTREQ	30	O	Interrupt request
PWDN	33	I	Power down input: 1 = Power down 0 = Normal mode
RESETB	34	I	Reset input, active low

## TVP5146PFP NTSC/PAL/SECAM 4 X 10 Bit Digital Video Decoder

Table 1–1. Terminal Functions (Continued)

TERMINAL NAME	NUMBER	I/O	DESCRIPTION
<b>Host Interface</b>			
SCL	28	I	I <sup>2</sup> C clock input
SDA	29	I/O	I <sup>2</sup> C data bus
<b>Power Supplies</b>			
AGND	26	I	Analog ground. Connect to analog ground.
A18GND_REF	13	I	Analog 1.8-V return
A18VDD_REF	12	I	Analog power for reference 1.8 V
CH1_A18GND	79	I	Analog 1.8-V return
CH2_A18GND	10		
CH3_A18GND	15		
CH4_A18GND	24		
CH1_A18VDD	78	I	Analog power. Connect to 1.8 V.
CH2_A18VDD	11		
CH3_A18VDD	14		
CH4_A18VDD	25		
CH1_A33GND	3	I	Analog 3.3-V return
CH2_A33GND	6		
CH3_A33GND	19		
CH4_A33GND	22		
CH1_A33VDD	4	I	Analog power. Connect to 3.3 V.
CH2_A33VDD	5		
CH3_A33VDD	20		
CH4_A33VDD	21		
DGND	27, 32, 42, 56, 68	I	Digital return
DVDD	31, 41, 55, 67	I	Digital power. Connect to 1.8 V.
IOGND	39, 49, 62	I	Digital power return
IOVDD	38, 48, 61	I	Digital power. Connect to 3.3 V or less for reduced noise.
PLL_A18GND	77	I	Analog power return
PLL_A18VDD	76	I	Analog power. Connect to 1.8 V.
<b>Sync Signals</b>			
HS/CS/GPIO	72	I/O	Horizontal sync output or digital composite sync output Programmable general-purpose I/O
VS/VBLK/GPIO	73	I/O	Vertical sync output (for modes with dedicated VSYNC) or VBLK output Programmable general-purpose I/O
FID/GPIO	71	I/O	Odd/even field indicator output. This terminal needs a pulldown resistor. Programmable general-purpose I/O
AVID/GPIO	36	I/O	Active video indicator output Programmable general-purpose I/O

**32. PJ1117CW-1.8(VIDEO:IC93)-AVR635 ONLY**

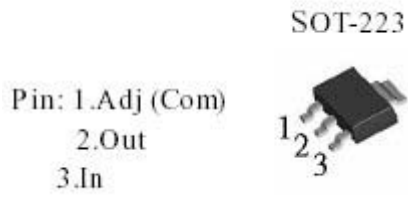

**33. KIA78R08API(DSP:IC507)  
KIA278R33API(SUPPLY:IC301)**

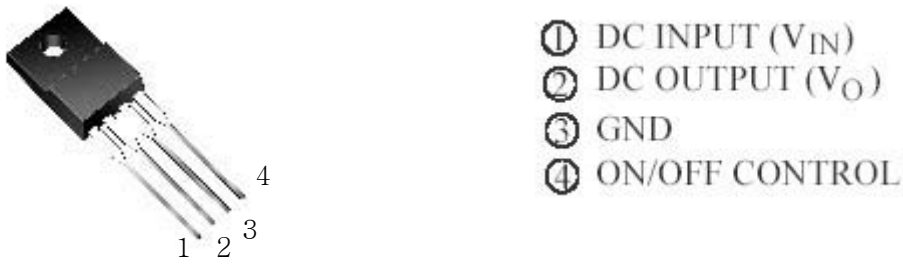

34. KIA7805API (SUPPLY:IC11,302,304)  
 KIA7812API (MAIN:IC59 )  
 KIA7815API (MAIN:IC51)  
 KIA7915API (MAIN:IC52)  
 KIA7824API (MAIN:IC54)  
 KIA7905PI (SUPPLY:IC303)  
 KIA7806AP (VIDEO:IC89)



**POSITIVE REGULATORS**  
 1. INPUT  
 2. COMMON  
 3. OUTPUT

**NEGATIVE REGULATORS**  
 1. COMMON  
 2. INPUT  
 3. OUTPUT

35. M24C04 (DSP:IC503)-AVR435 ONLY

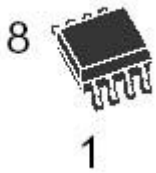

M24Cxx

16Kb/8Kb/4Kb/2Kb/1Kb

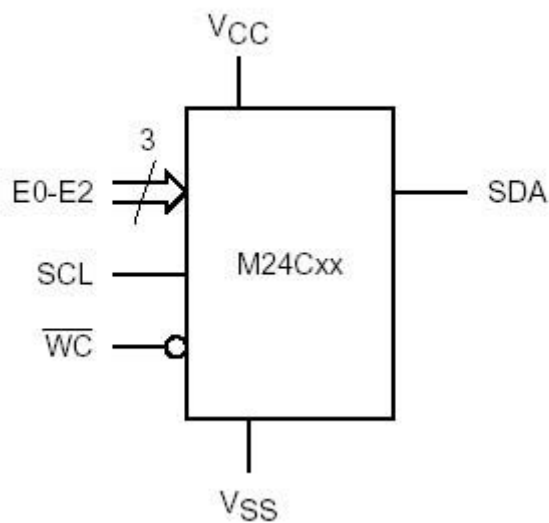
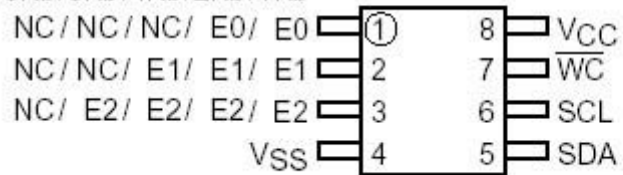

# TRANSISTORS

## 1. DTA114YKA

(PROCESSOR:Q103,106,109,203,301,605,608,611,614,615,618,Q620,623,626,  
 DSP:Q402,403, VIDEO:Q709,710,711,Q712(AVR435:Q102,103),  
 FRONT:Q824,831,832,833)

629,

### EQUIVALENT CIRCUIT

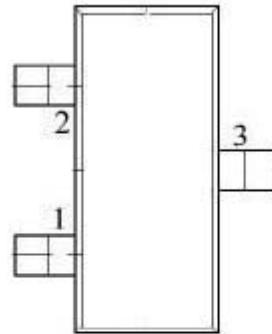
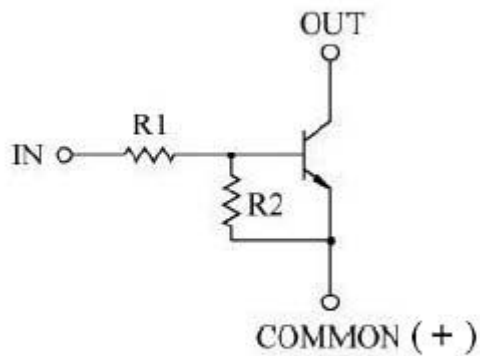

- 1. COMMON (EMITTER)
- 2. IN (BASE)
- 3. OUT (COLLECTOR)

## 2. DTC114YKA

(PROCESSOR:Q1,DSP:Q501,502,503,504,505,506,507,508,509,510,Q601,700,  
 VIDEO:Q104,105,106,107,713,714,715,Q701,716, FRONT:Q820,822,(AVR435:Q105,106,113)  
 VID4 DIG:Q501,502,503,504,505,506,507,508,509,510,602)

### EQUIVALENT CIRCUIT

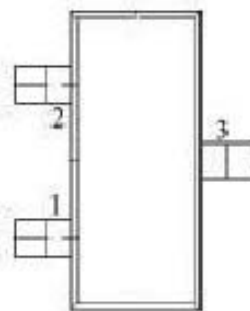
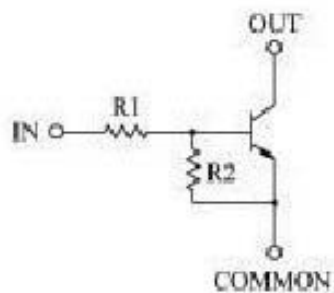

- 1. COMMON (EMITTER)
- 2. IN (BASE)
- 3. OUT (COLLECTOR)

**3. 2SA933ASR**

(VIDEO:Q704,705,706,707,708(AVR435:Q101,104,111))

2SC1740S (VIDEO:Q300,700,702,703(AVR435:Q100,112,114,299))

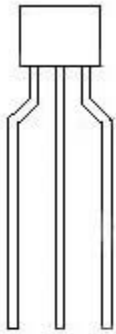

- (1) Emitter
- (2) Collector
- (3) Base

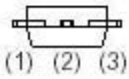

**4. KTA1504Y (FRONT:Q703,704,705)**

**KTC3875S (FRONT:Q701,702)**

**KTD1304 (PROCESSOR:Q101,102,104,105,107,108,201,202,204,205,302,303,601,602,603,604,606,607,609,610,612,613,Q616,617,621,622,624,625,627,628,630,631 DSP:Q400 401)**

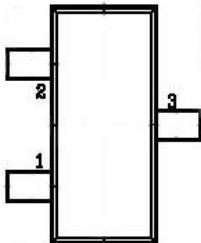

- 1. EMITTER**
- 2. BASE**
- 3. COLLECTOR**

**5. KTA1360(SURROUND:Q215,315,515, MAIN:Q327,328,431,432)**

**KTC3114(SURROUND:Q214,315,514, FRONT L - BIAS:Q701, SURROUND - R BIAS:Q702, SURROUND L - BIAS:Q703, FRONT R - BIAS:Q704)**

**KTC3423(SURROUND:Q213,313,513 MAIN:Q323,324,429,430)**



- 1. EMITTER
- 2. COLLECTOR
- 3. BASE

6. 2SA1859A(SURROUND:Q216,316,516, MAIN:Q329,330,433,434)  
2SC4883A(SURROUND:Q217,317,517, MAIN:Q331,332,435,436)

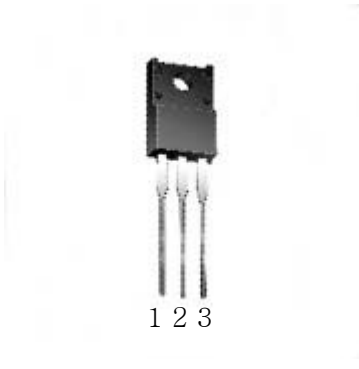

1.BASE  
2.COLLECTOR  
3.EMITTOR

7. KTA1266(MAIN:Q605,607)  
KTA1268BL(SURROUND:Q101,206,306,506, MAIN:Q311,312,410,413,414)  
KTC3198BL(SURROUND:Q204,304,504, MAIN:Q307,308,407,408,426,441,606,608)  
KTC3200BL(SURROUND:Q201,202,203,207,220,301,302,303,307,320,501,502,503,507,520,  
MAIN:Q301,302,303,304,305,306,313,314,337,338,401,402,403,404,405,406,  
409,415,416,425)  
KTD1302(MAIN:Q601)  
MPSA06(SUPPLY:Q101,102, DSP:Q511, FRONT:Q821)  
MPSA56(FRONT:Q823)

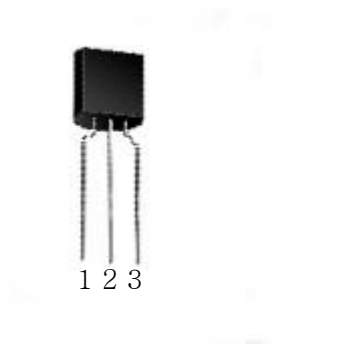

1. EMITTER  
2. COLLECTOR  
3. BASE

8. KTA1024Y(SURROUND:Q208,211,308,311,508,511,  
MAIN:Q315,316,319,320,417,418,421,422,442)  
KTC3206(SURROUND:Q209,212,309,312,509,512  
MAIN:Q317,318,321,322,419,420,423,424)

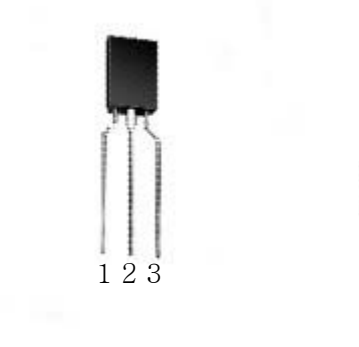

1. EMITTER  
2. COLLECTOR  
3. BASE



9. KRA107M(RMT/RS232:Q651,652 ,DSP:Q851)  
KRC107M(MAIN:Q443)



1. EMITTER
2. COLLECTOR
3. BASE

10. 2SA1145Y(SURROUND:Q205,305,505, MAIN:Q309,310,411,412)

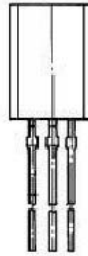
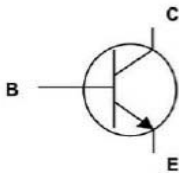

1. EMITTER
2. COLLECTOR
3. BASE

11. 2SA1986(SURROUND:Q219,319,519, MAIN:Q335,336,439,440)-AVR635 ONLY  
2SC5358-R(SURROUND:Q218,318,518, MAIN:Q333,334,437,438)-AVR635 ONLY  
2SD2560(MAIN:Q333,334,437,438, SURROUND:Q218,318,518)-AVR435 ONLY  
2SB1647(MAIN:Q335,336,439,440, SURROUND:Q219,319,519)- AVR435 ONLY



- 1.BASE
- 2.COLLECTOR
- 3.EMITTOR

**2SD2560**

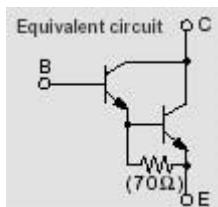

**2SB1647**

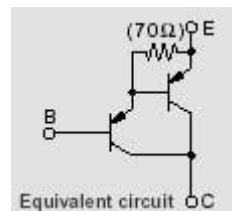

MISC.

1. FL HCA-18LL03 (FRONT DP1)

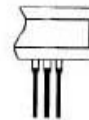
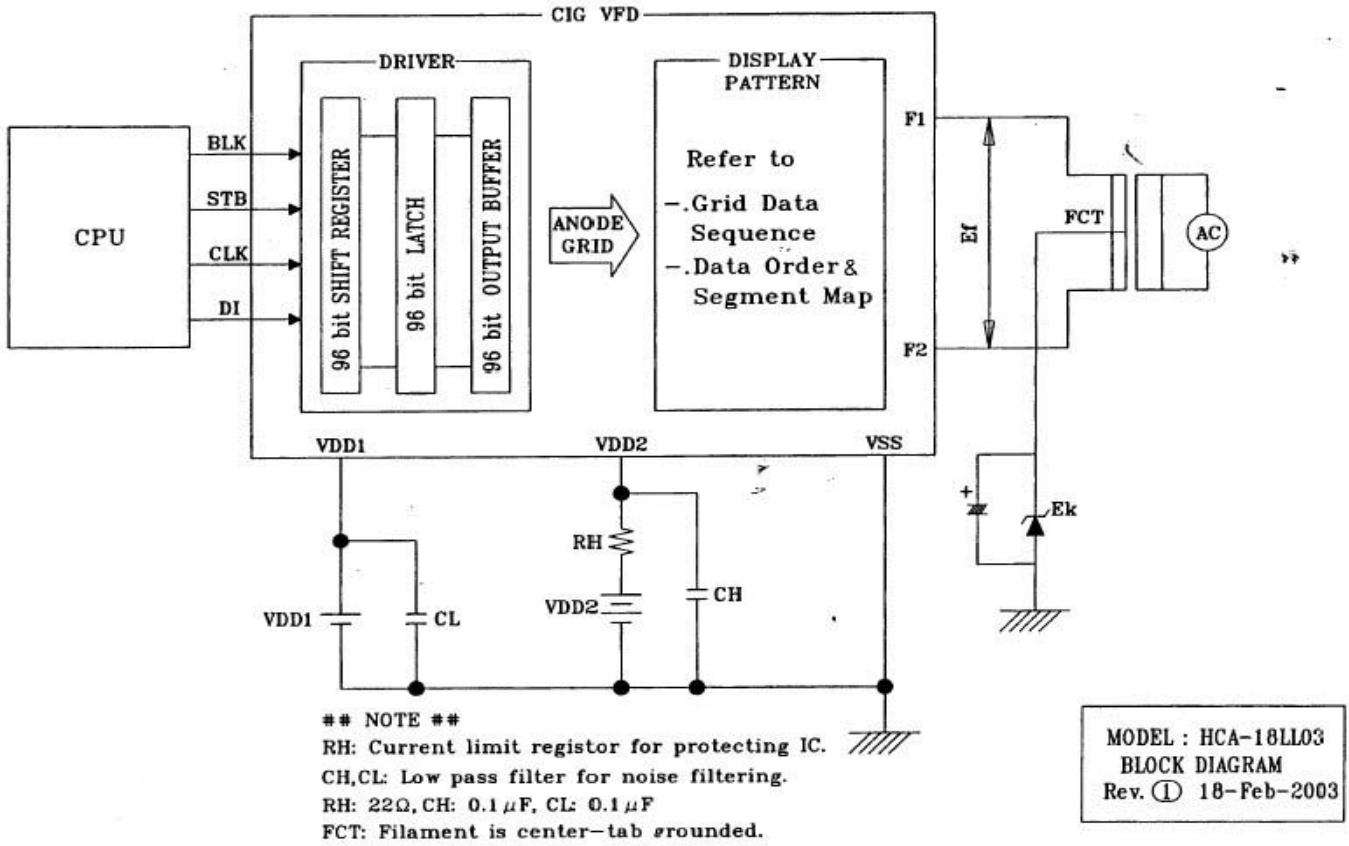

2.  
2.

PIN CONNECTION

PIN NO.	104	103	102	101	100	99	98	97	96	95	94	93	92	91	90~16	14~8	5	4	3	2	1
CONNECTION	F2	F2	F2	NP	NP	VDD2	VSS	VSS	CLK	DO	DI	BLK	STB	VDD1	NP	NC	NP	NP	F1	F1	F1

\*Notes

Fn : Filament Pin      \* DO(Serial data output) : Be left open if not used.  
 NP : No Pin  
 NC : No Connection Pin

MODEL : HCA-18LL03  
 OUTER DIMENSIONS  
 Rev. ① 18-Feb-2003

### VCXO 24M576HZ(DSP Y600)

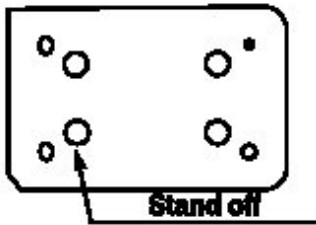
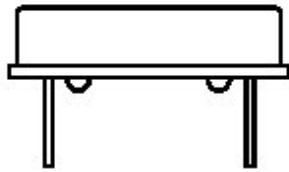

<14 PIN DIP>

PIN	CONNECTION
# 1	INH or No Connection
# 7	Ground
# 8	Output
# 14	Vdc

### 3. TORX-179L(DSP: NJ701,702,703)

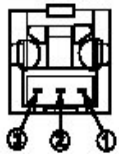

- Pin connection
1. GND
  2. Vcc
  3. Input

Fiber optic connector insertion side

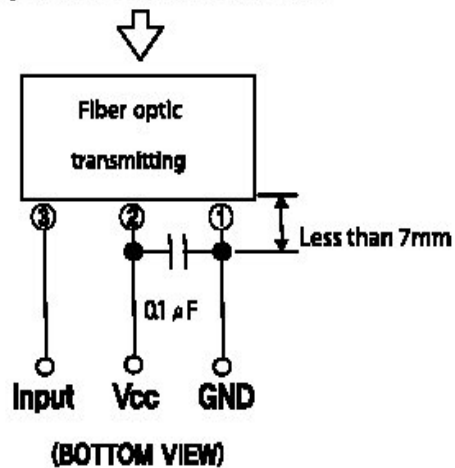

### 4. TOTX-179L(DSP: NJ704)

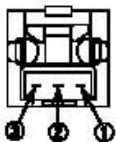

- Pin connection
1. Output
  2. GND
  3. Vcc

Fiber optic connector insertion side

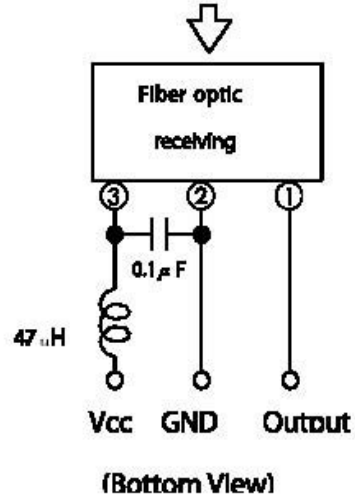

5. RPM6938-RSIP-A3(FRONT:RM71)

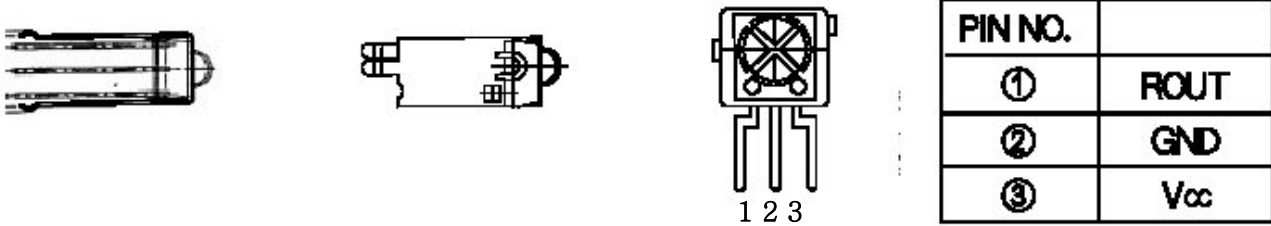

PIN NO.	
①	ROUT
②	GND
③	Vcc

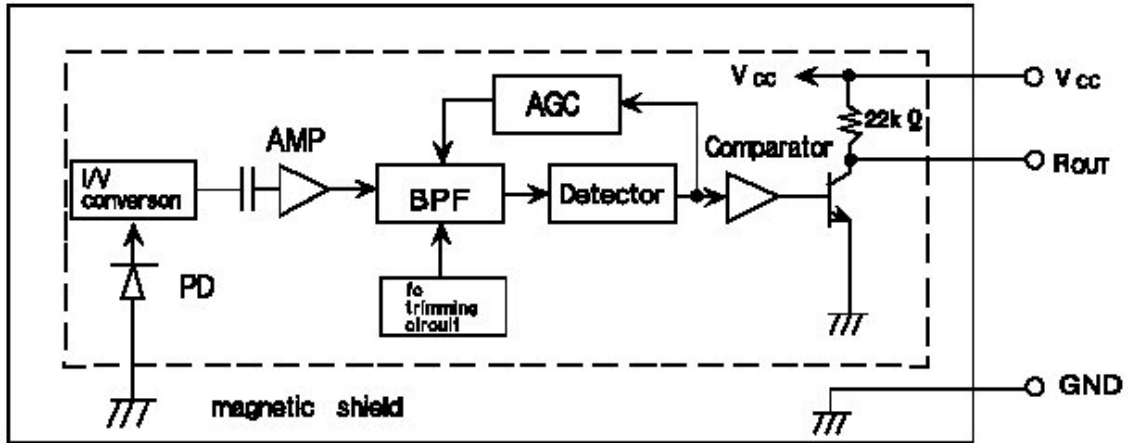

6. LP-200TL(FRONT:RM72)

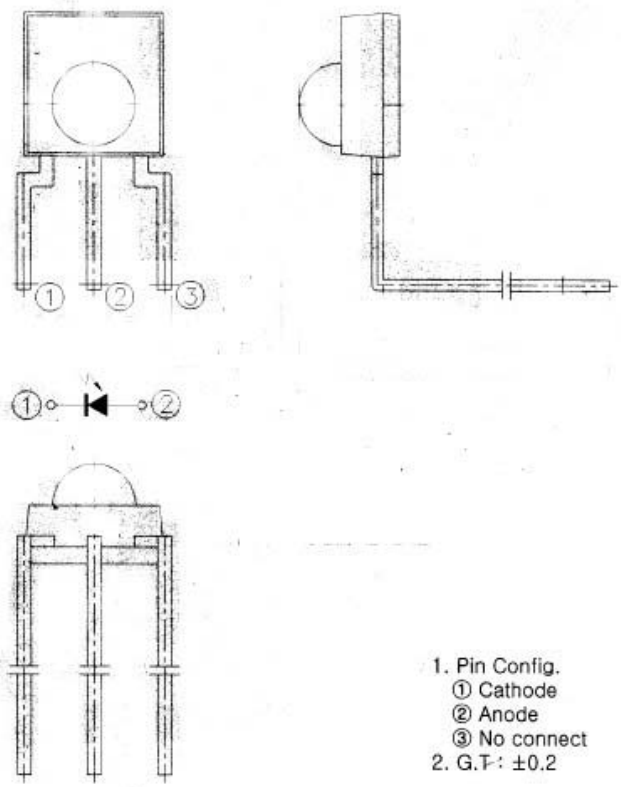

1. Pin Config.
  - ① Cathode
  - ② Anode
  - ③ No connect
2. G.T: ±0.2

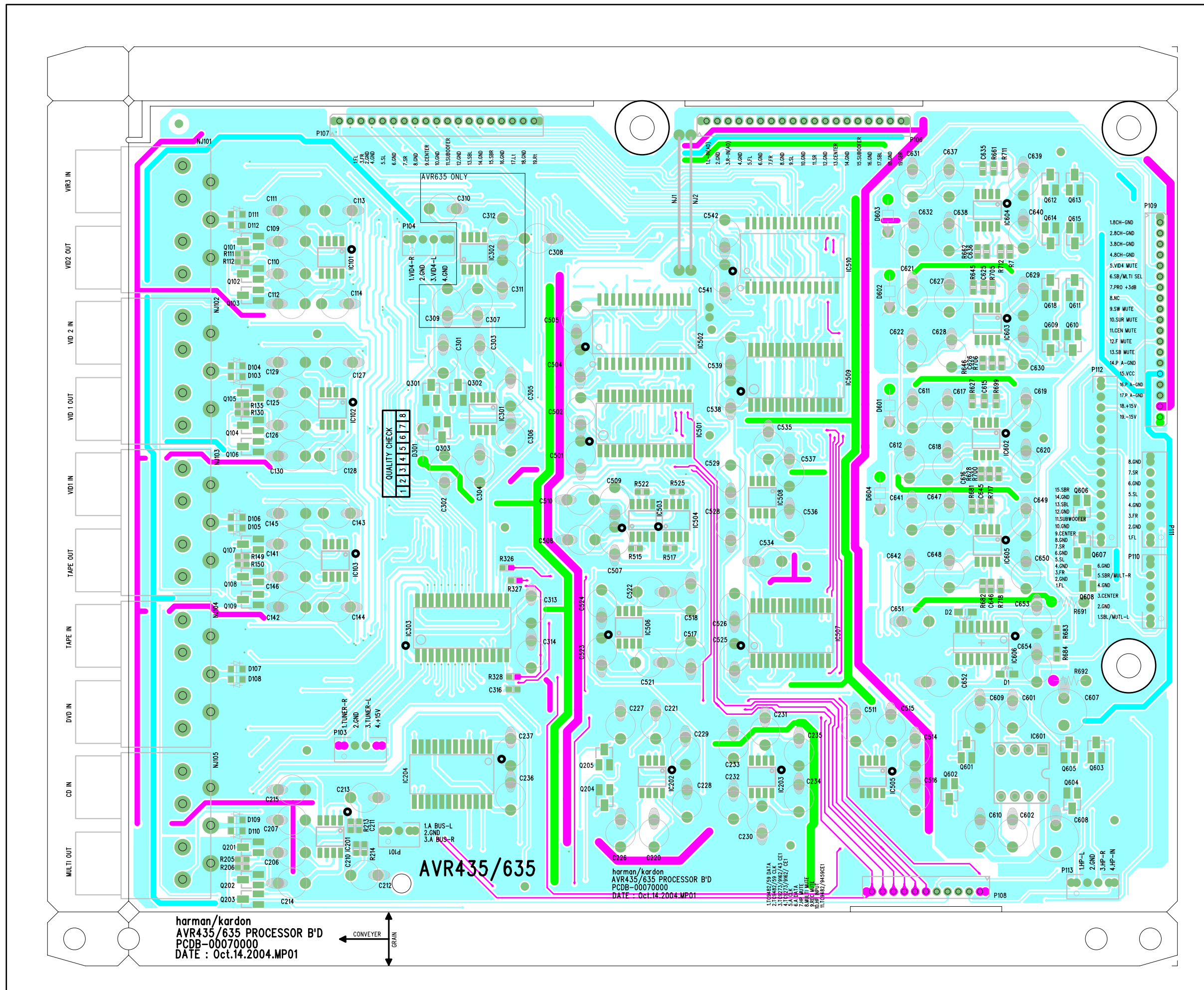

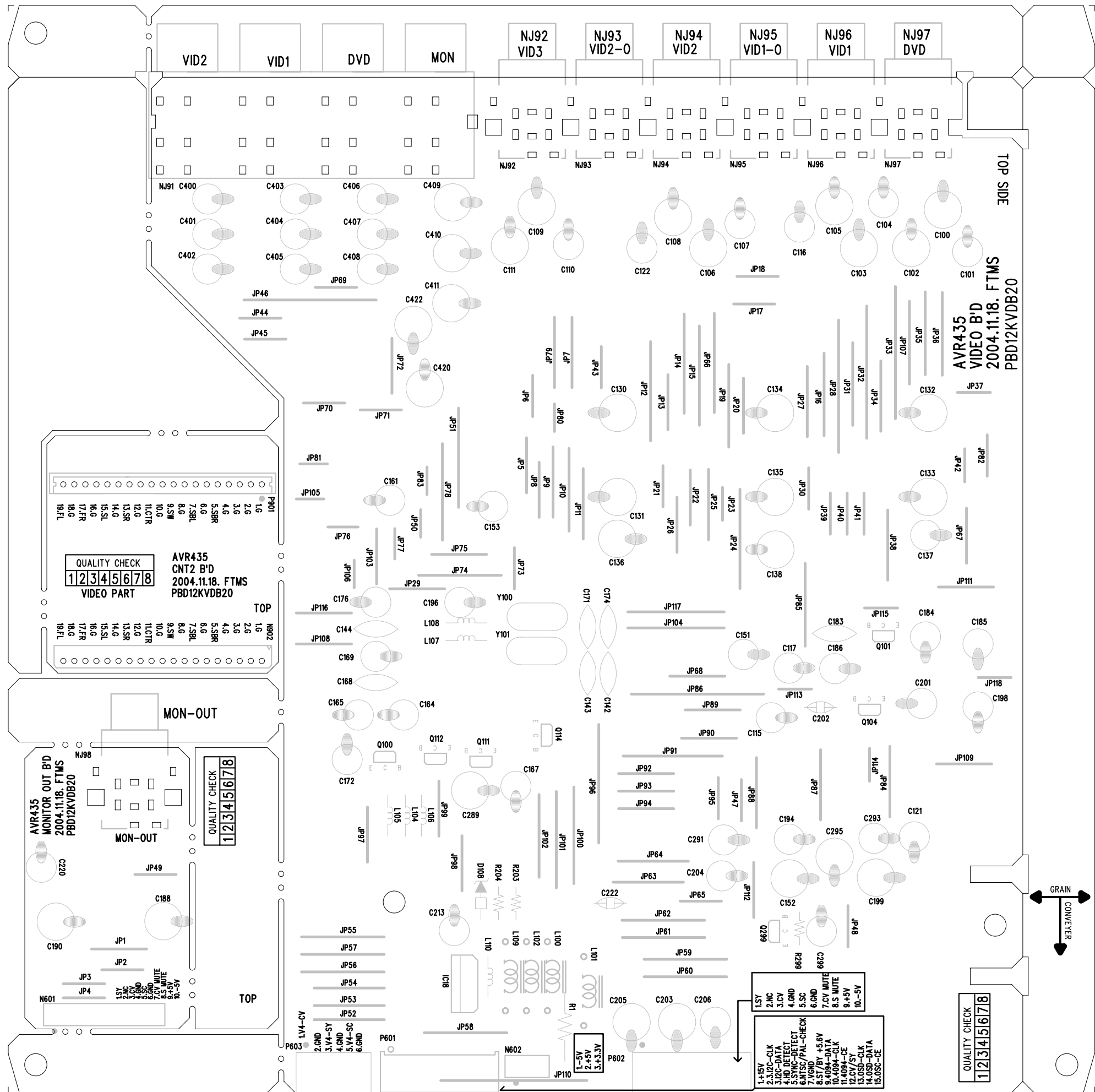

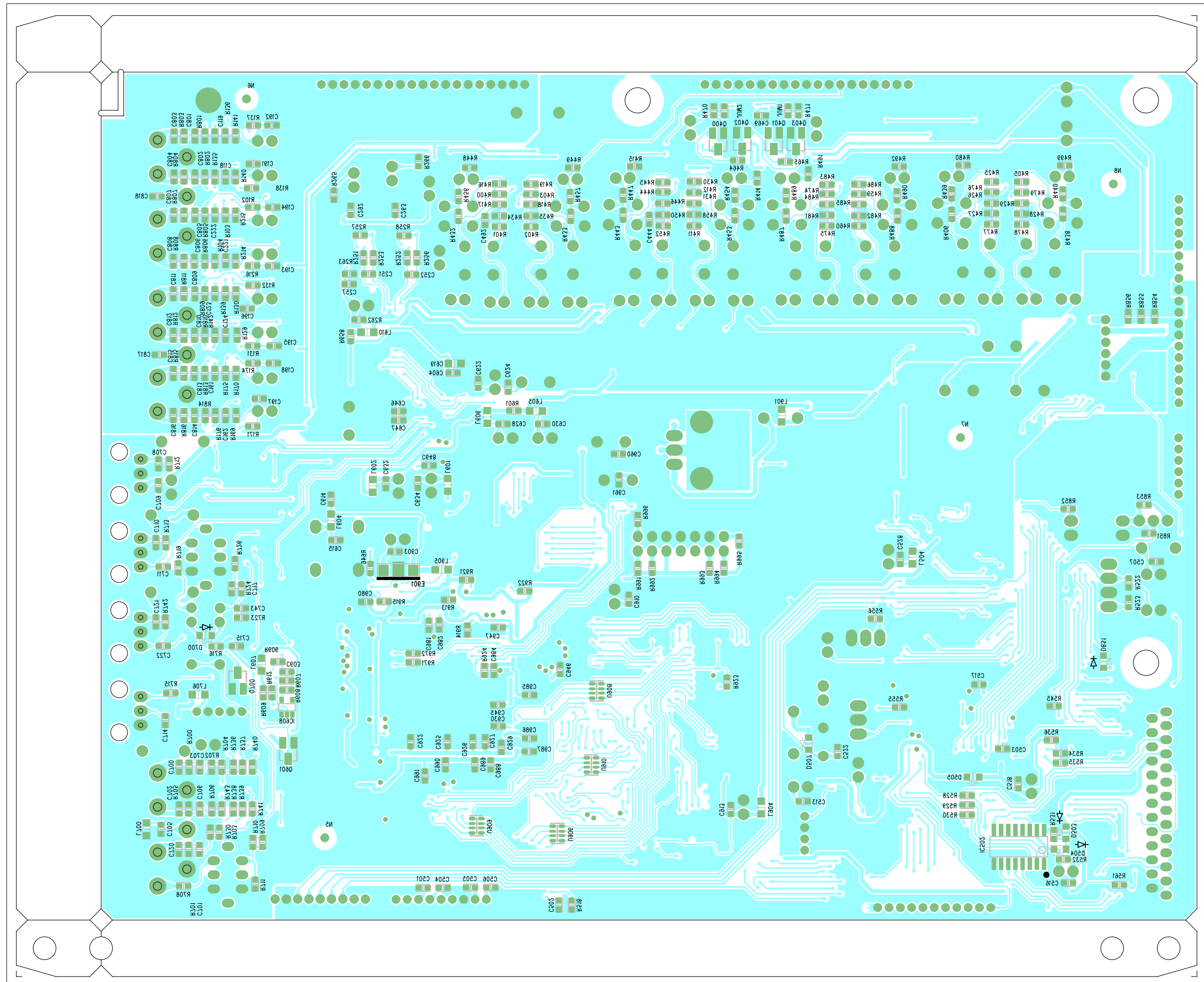

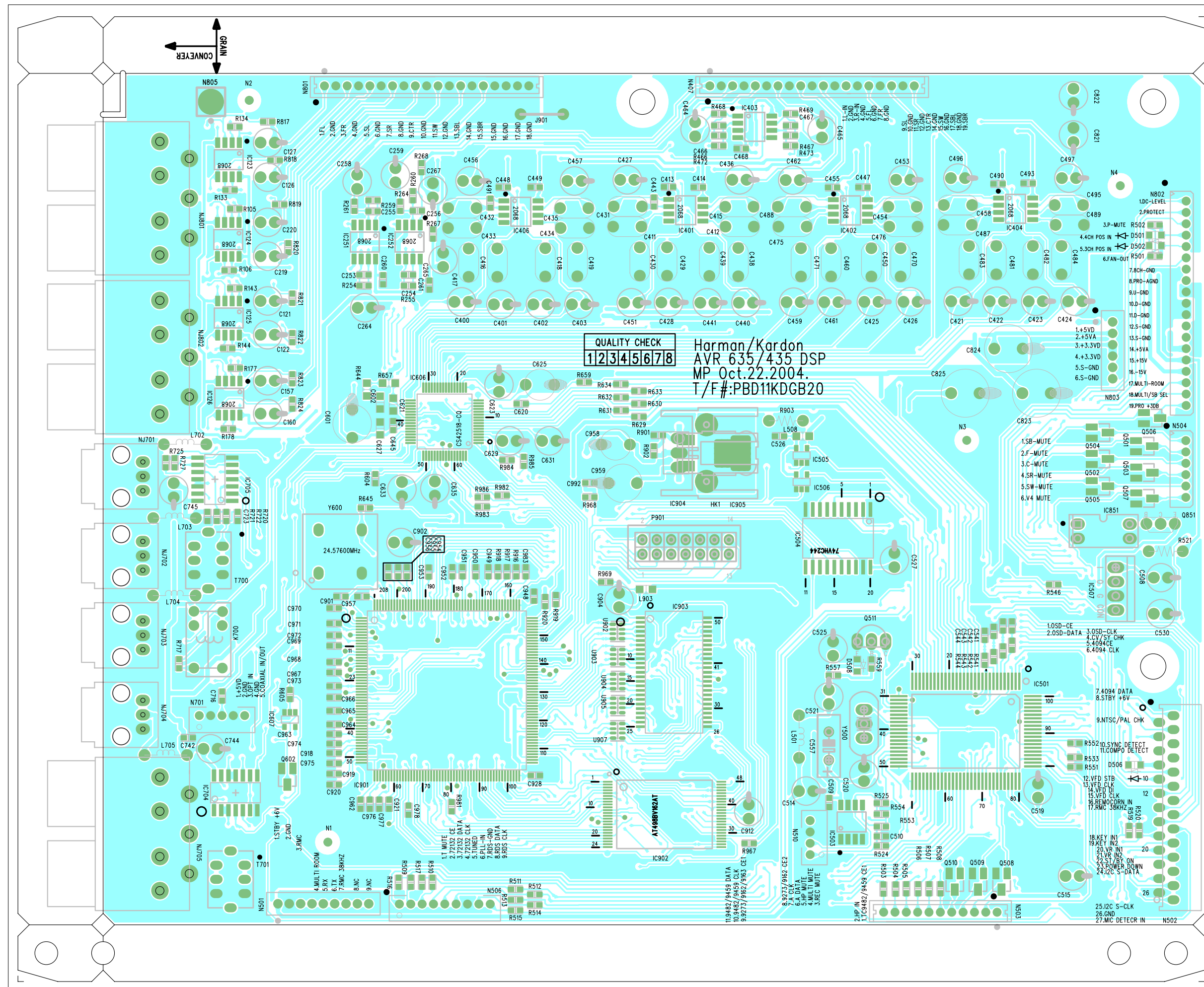

QUALITY CHECK  

1	2	3	4	5	6	7	8
---	---	---	---	---	---	---	---

Harman/Kardon  
 AVR 635/435 DSP  
 MP Oct.22.2004.  
 T/F#:PBD11KDGB20







Harman/Kardon  
AVR-635/435 MAIN B'D  
14.DEC.2004 MP1  
T/F NO:PBD11KMA121

- 1.DC LEVEL
- 2.PROTECT
- 3.P-MUTE
- 4.VCC
- 5.ACH
- 6.3CH THERMAL IN
- 7.3CH THERMAL IN

- 1.H.DSP GND
- 2.D-GND
- 3.D-GND
- 4.D-GND
- 5.D-GND
- 6.D-GND
- 7.D-GND
- 8.D-GND
- 9.D-GND
- 10.D-GND
- 11.D-GND
- 12.D-GND
- 13.D-GND
- 14.+5V GND
- 15.+5V GND
- 16.+5V GND
- 17.+5V GND
- 18.+5V GND
- 19.+5V GND
- 20.MULTI ROOM(A-BUS)

- 1.THER DET
- 2.POS IN
- 3.GND
- 4.GND
- 5.GND
- 6.GND
- 7.GND
- 8.GND
- 9.GND
- 10.GND
- 11.GND
- 12.GND
- 13.GND
- 14.GND
- 15.GND
- 16.GND
- 17.GND
- 18.GND
- 19.GND
- 20.GND

"ATTENTION"  
-UTILISER UN FUSIBLE DE RECHANGE  
DE MEME TYPE ET PUISSANCE"

"CAUTION"  
-FOR CONTINUED PROTECTION AGAINST  
REPLACE ONLY WITH SAME TYPE AND RATINGS OF  
FUSE(S)"

7.FRONT FAN OUT  
8.NC  
9.ACH GND  
10.PROCESSOR-G

1.+15V  
2.-15V  
3.+5V  
4.LED-G

5.AC3  
6.AC4  
7.AC5  
8.AC6  
9.AC7  
10.AC8

1.THER DET  
2.POS IN  
3.GND

1.SL-BIAS  
2.FR-BIAS  
3.FL-BIAS  
4.SR-BIAS

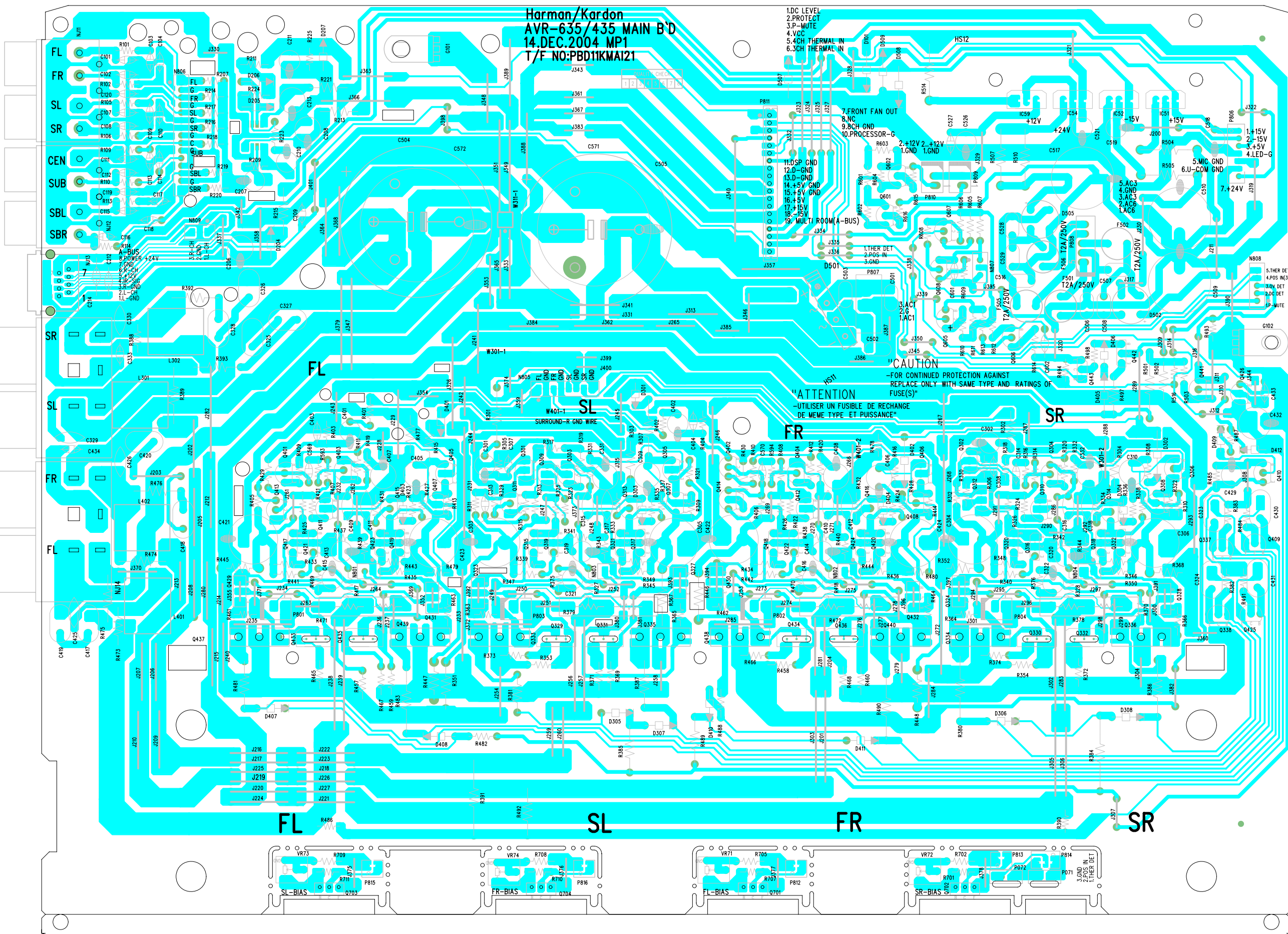

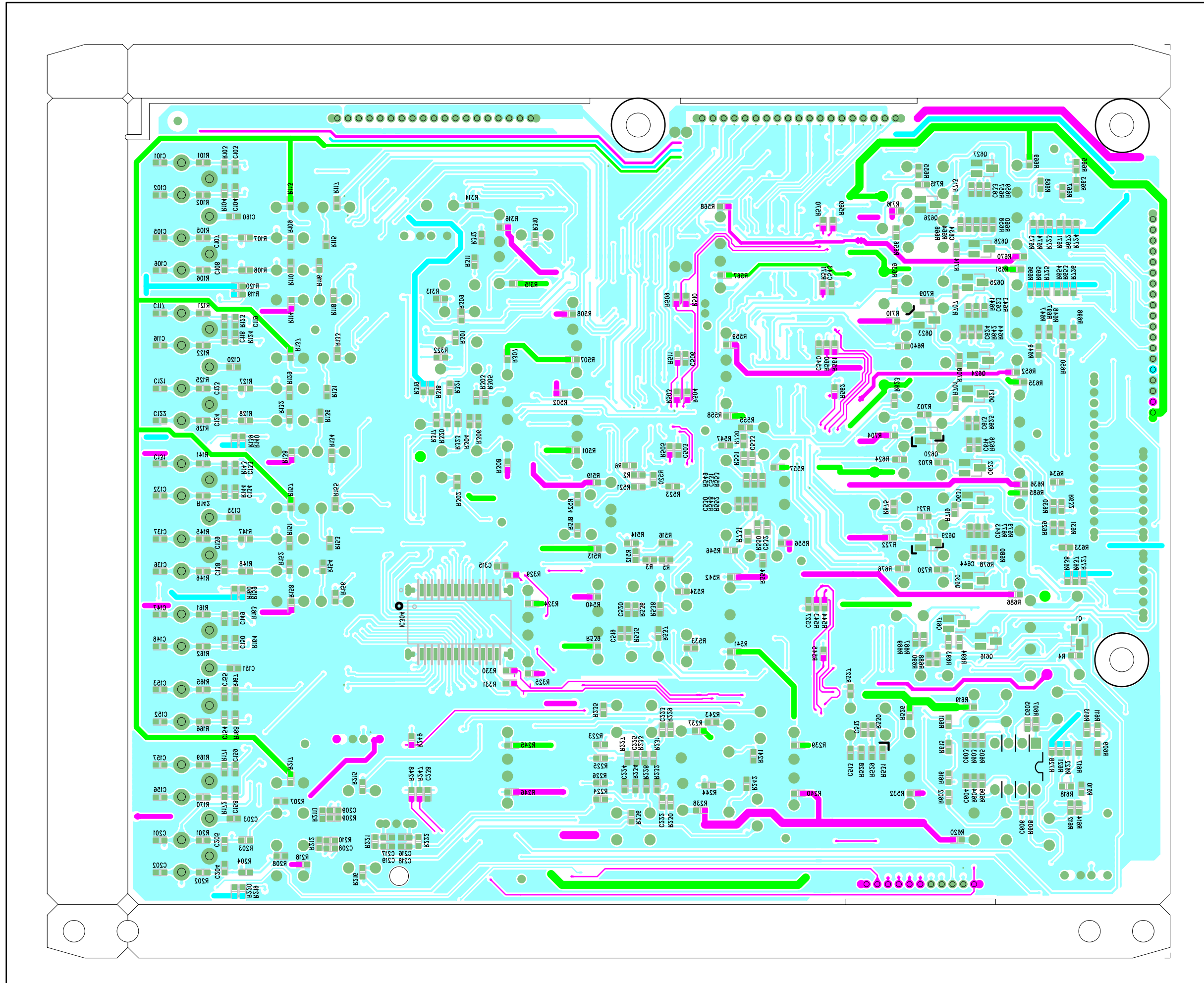



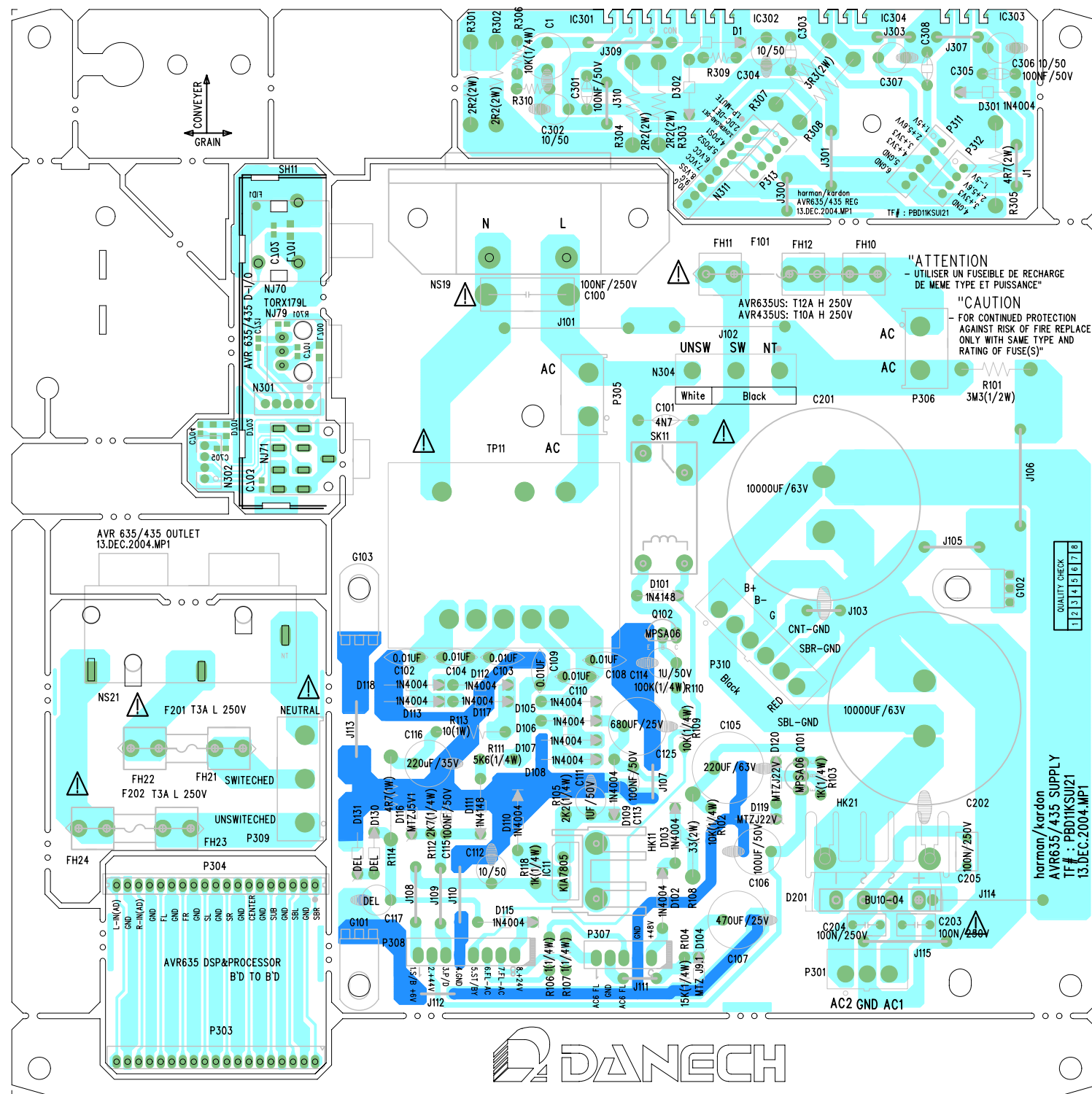

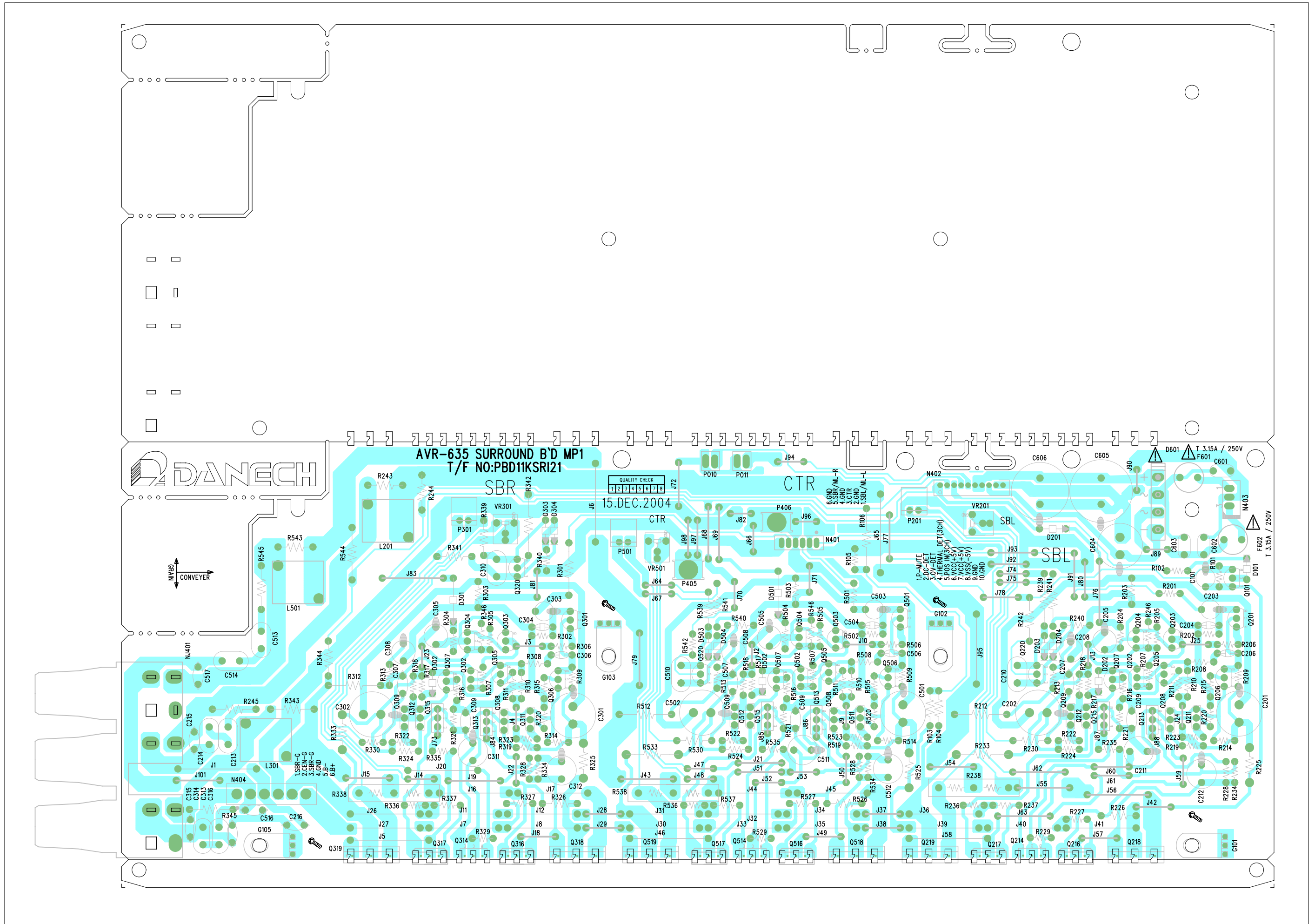

# SCHEMATIC DIAGRAM

harman/kardon  
AVR435 VIDEO

REVISION RECORD		
NO.	Date	Contents

... THE UNIT OF RESISTANCE IS OHM.  
... K=1000 OHM, M=1000 K OHM.  
... THE UNIT OF CAPACITANCE IS MICROFARAD (UF)  
... THE SCHEMATIC DIAGRAM MAY MODIFIED AT ANYTIME WITH THE IMPROVEMENT OF PERFORMANCE.

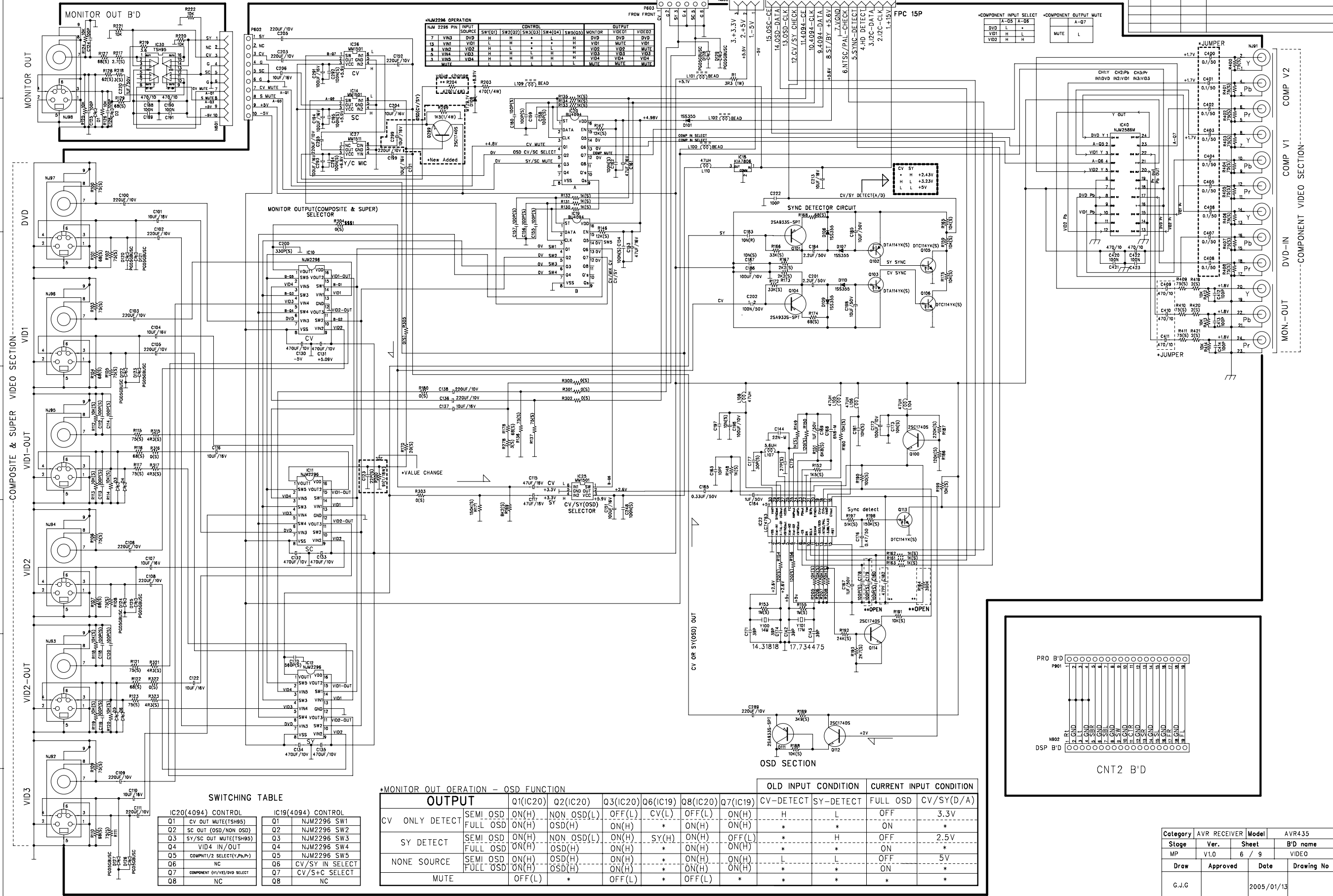

NJM 2296 PIN	INPUT SOURCE	CONTROL	MONITOR	OUTPUT
7	VNS	DVD	H	H
8	VN1	VID1	L	H
9	VN2	VID2	L	H
10	VN3	VID3	L	H
11	VN4	VID4	L	H
12	VN5	VID5	L	H
13	VN1	VID1	L	MUTE
14	VN2	VID2	L	MUTE
15	VN3	VID3	L	MUTE
16	VN4	VID4	L	MUTE
17	VN5	VID5	L	MUTE

SWITCHING TABLE	
IC20(4094) CONTROL	IC19(4094) CONTROL
Q1 CV OUT MUTE(TSH95)	Q1 NJM2296 SW1
Q2 SC OUT (OSD/NON OSD)	Q2 NJM2296 SW2
Q3 SY/SC OUT MUTE(TSH95)	Q3 NJM2296 SW3
Q4 VID4 IN/OUT	Q4 NJM2296 SW4
Q5 COMPNT1/2 SELECT(Y,Pb,Pr)	Q5 NJM2296 SW5
Q6 NC	Q6 CV/SY IN SELECT
Q7 NC	Q7 CV/S+C SELECT
Q8 NC	Q8 NC

\*MONITOR OUT OPERATION - OSD FUNCTION

OUTPUT	OLD INPUT CONDITION						CURRENT INPUT CONDITION			
	Q1(IC20)	Q2(IC20)	Q3(IC20)	Q6(IC19)	Q8(IC20)	Q7(IC19)	CV-DETECT	SY-DETECT	FULL OSD	CV/SY(D/A)
CV ONLY DETECT	SEMI OSD	ON(H)	NON OSD(L)	OFF(L)	CV(L)	OFF(L)	ON(H)	*	OFF	3.3V
FULL OSD	FULL OSD	ON(H)	OSD(H)	ON(H)	*	ON(H)	ON(H)	*	ON	*
SY DETECT	SEMI OSD	ON(H)	NON OSD(L)	ON(H)	SY(H)	ON(H)	OFF(L)	*	OFF	2.5V
FULL OSD	FULL OSD	ON(H)	OSD(H)	ON(H)	*	ON(H)	ON(H)	*	ON	*
NONE SOURCE	SEMI OSD	ON(H)	OSD(H)	ON(H)	*	ON(H)	ON(H)	*	OFF	5V
FULL OSD	FULL OSD	ON(H)	OSD(H)	ON(H)	*	ON(H)	ON(H)	*	ON	*
MUTE	OFF(L)	*	OFF(L)	*	OFF(L)	*	*	*	*	*

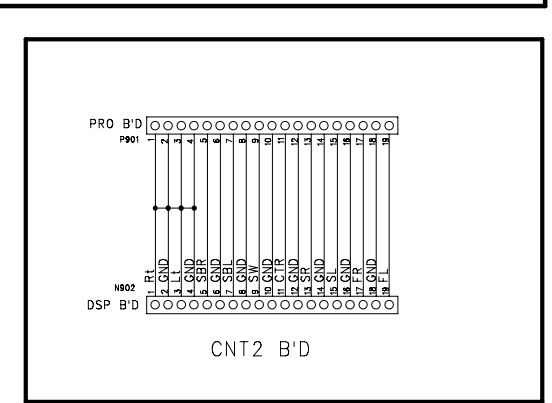

Category	AVR RECEIVER	Model	AVR435
Stage	Ver.	Sheet	B'D name
MP	V1.0	6 / 9	VIDEO
Draw	Approved	Date	Drawing No
G.J.C		2005/01/13	



# AVR635 VIDEO B'D

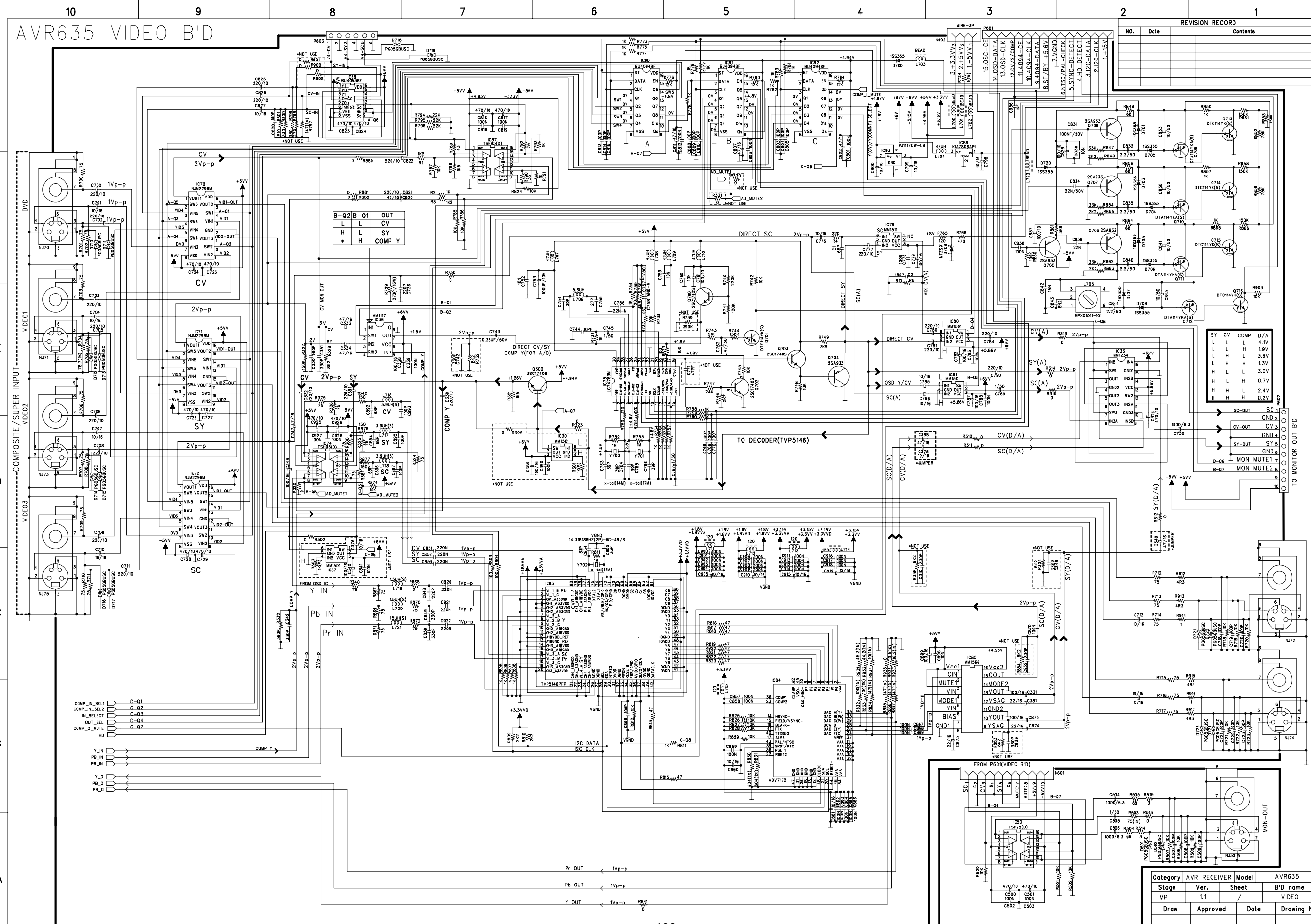

REVISION RECORD		
NO.	Date	Contents

Category	AVR RECEIVER	Model	AVR635
Stage	Ver.	Sheet	B'D name
MP	1.1		VIDEO
Draw	Approved	Date	Drawing No
GEUM .J.C		2004.10.22	

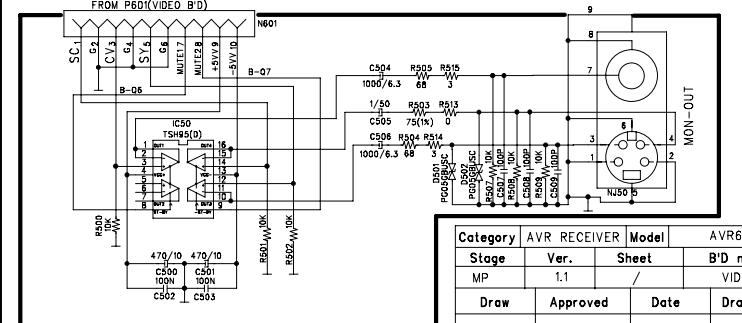

REVISION RECORD		
NO.	Date	Contents

COMPONENT B'D

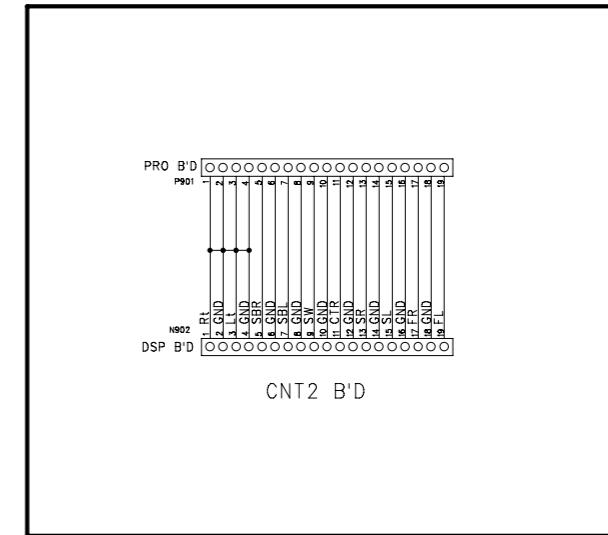
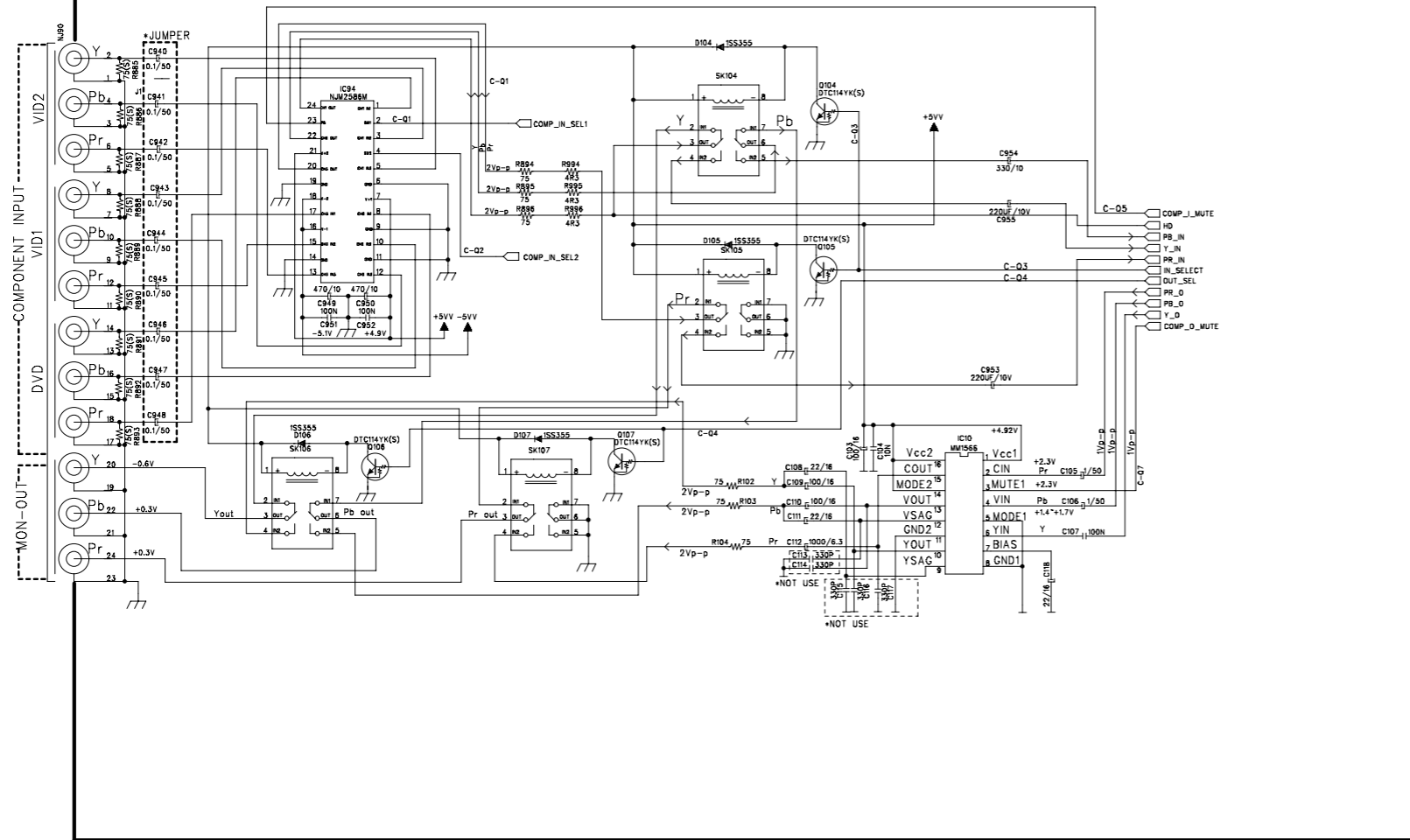

CNT2 B'D

Category	AVR RECEIVER	Model	AVR635
Stage	Ver.	Sheet	B'D name
MP	1.1	/	VIDEO
Draw	Approved	Date	Drawing No
GEUM.J.G		2004.10.22	

# AVR 435 CENTER SB AMP SCHEMATIC DIAGRAM

REVISION RECORD		
NO.	Date	Contents

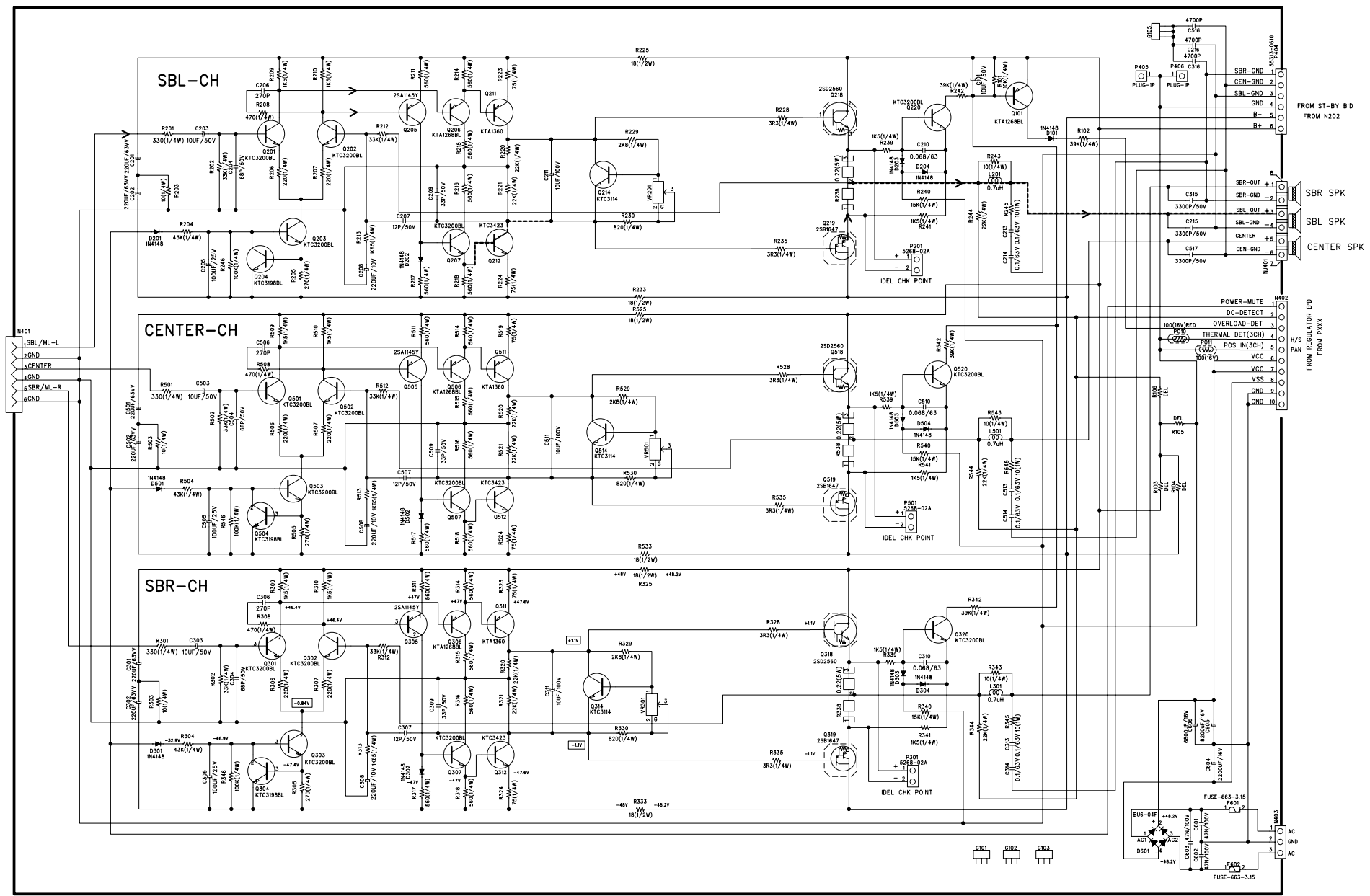

Category	AVR RECEIVER	Model	AVR435
Stage	Ver.	Sheet	B'D name
HMS		/	SURROUND
Draw	Approved	Date	Drawing No
KIM.S.Y		2005.1.05	

# AVR 635 CENTER SB AMP SCHEMATIC DIAGRAM

REVISION RECORD		
No.	Date	Contents

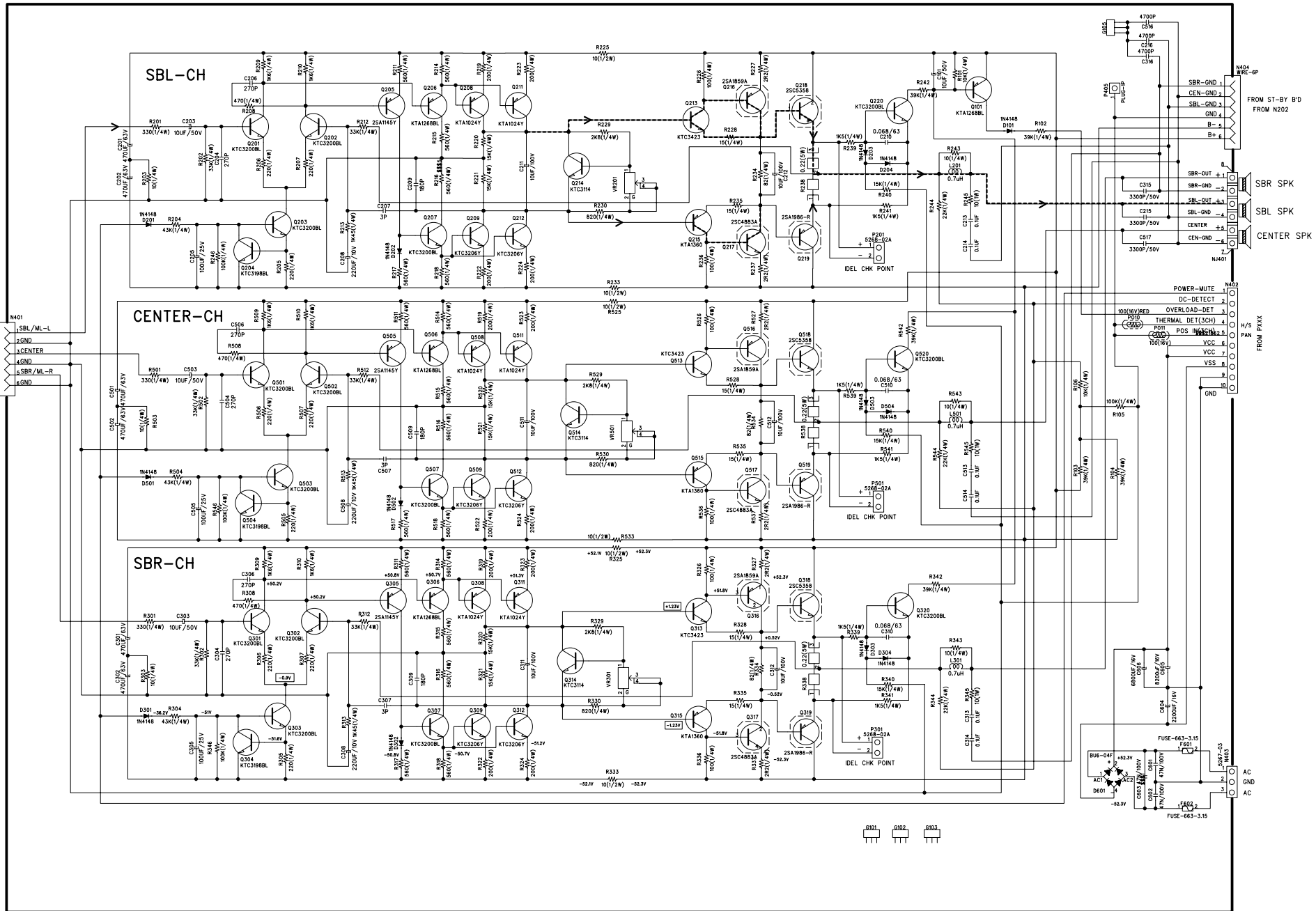

Category	AVR RECEIVER	Model	AVR635
Stage	Ver.	Sheet	B'D name
MP		/	SURROUND
Draw	Approved	Date	Drawing No
KIM.S.Y		2004.10.19	

# AVR 435 MAIN AMP SCHEMATIC DIAGRAM

REVISION RECORD		
NO.	Date	Contents

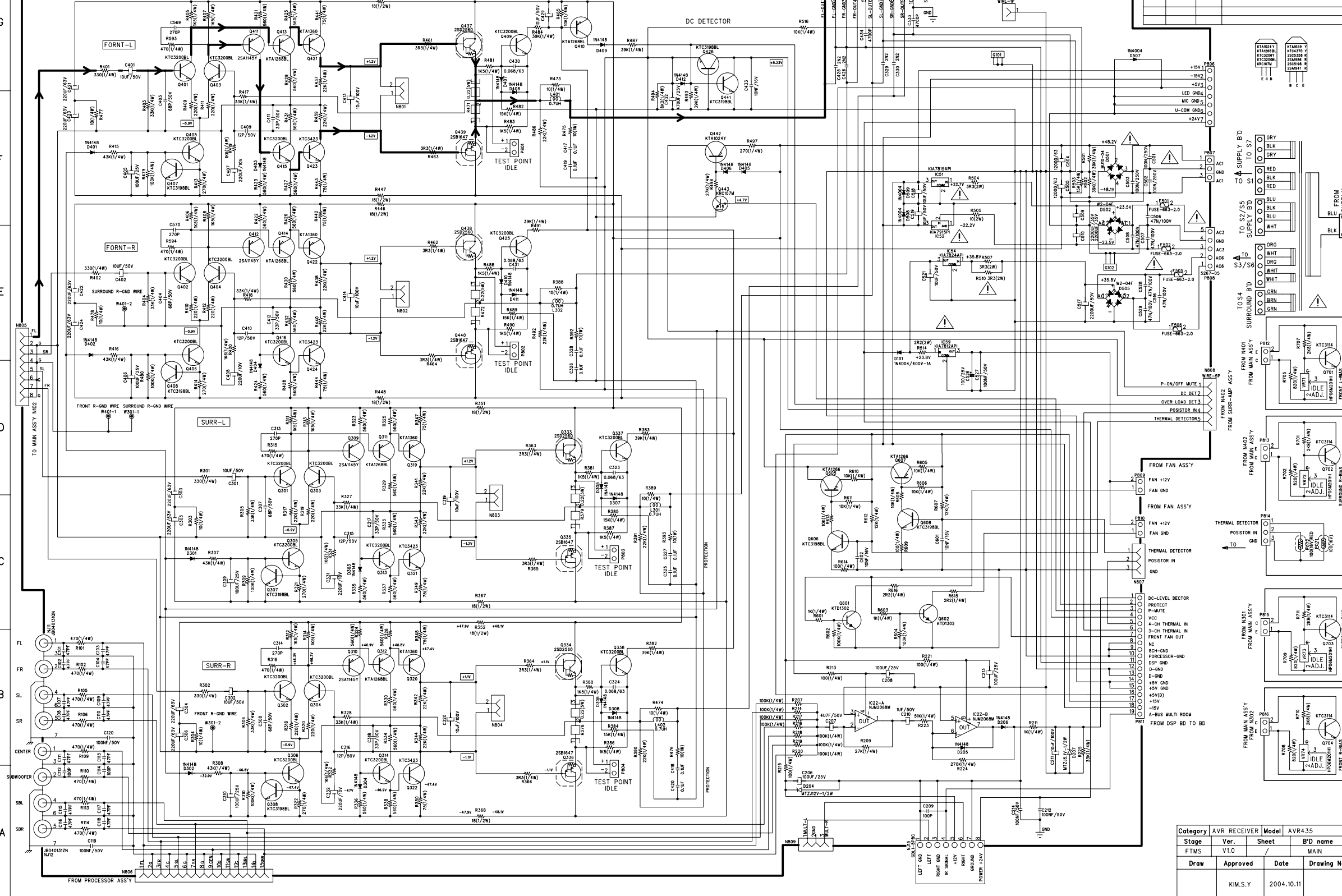

Category	AVR RECEIVER	Model	AVR435
Stage	Ver.	Sheet	B'D name
FTMS	V1.0	MAIN	MAIN
Draw	Approved	Date	Drawing No
		2004.10.11	

# AVR 635 MAIN AMP SCHEMATIC DIAGRAM

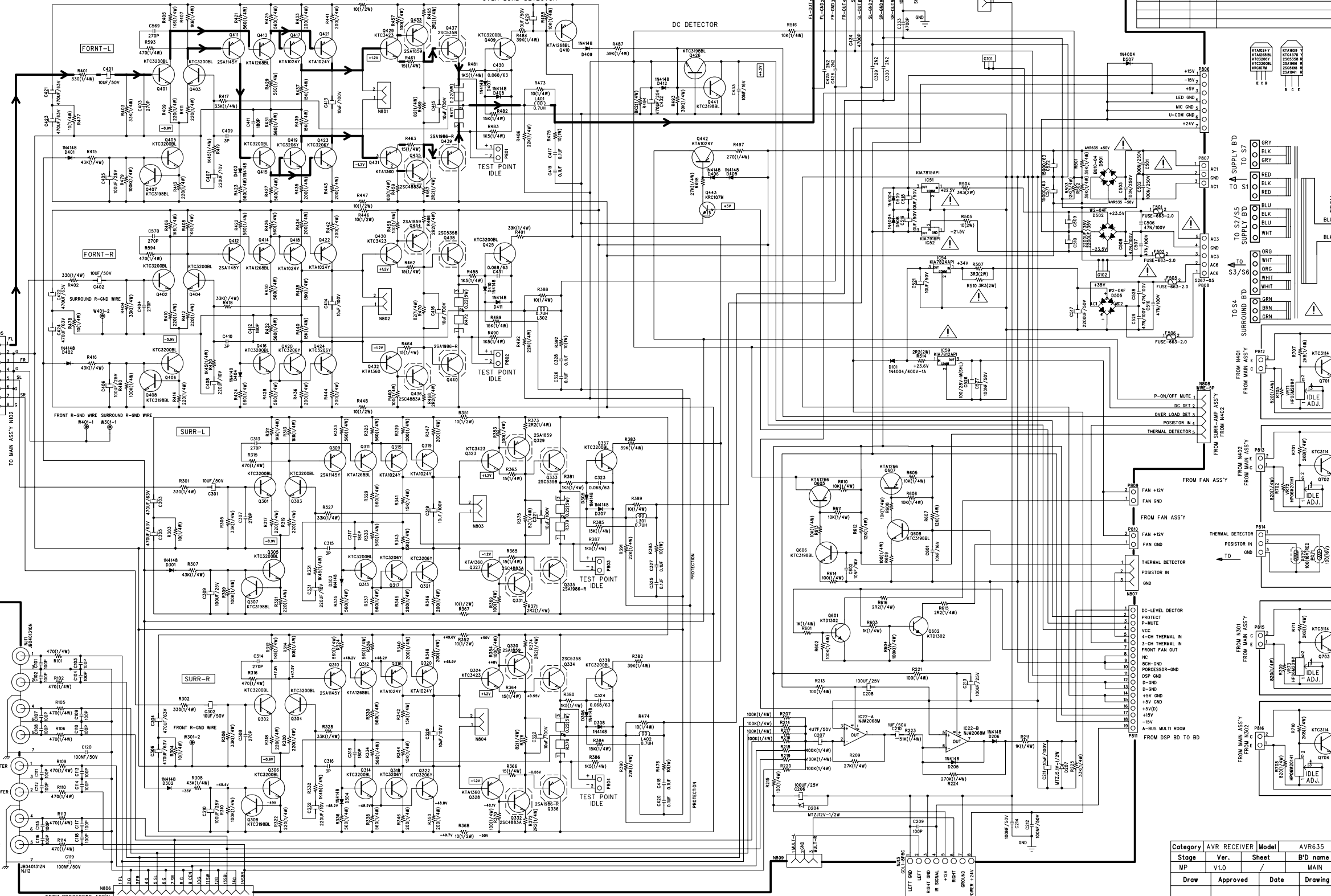

REVISION RECORD		
NO.	Date	Contents

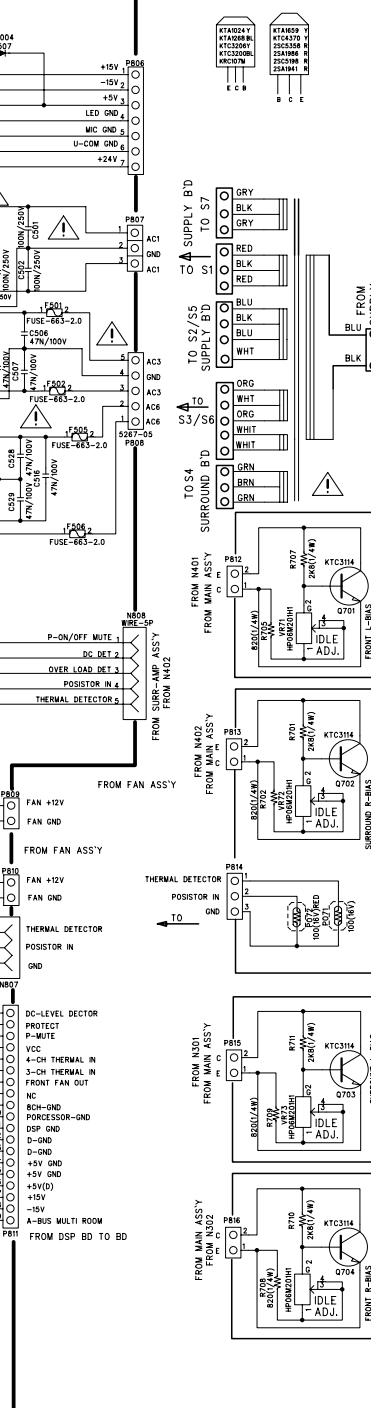

Category	AVR RECEIVER	Model	AVR635
Stage	Ver.	Sheet	B'D name
MP	V1.0		MAIN
Draw	Approved	Date	Drawing No
		2004.10.19	

REVISION RECORD		
NO.	Date	Contents

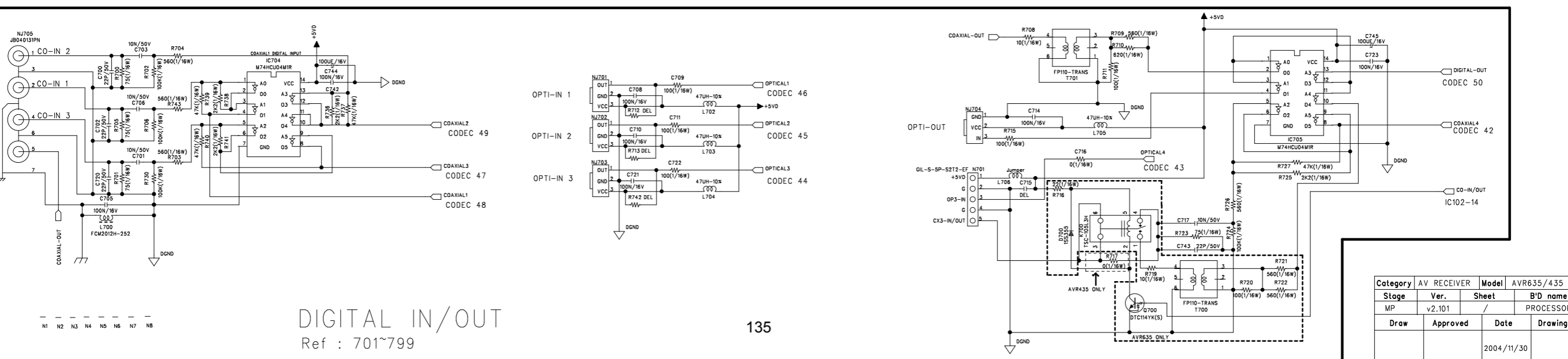
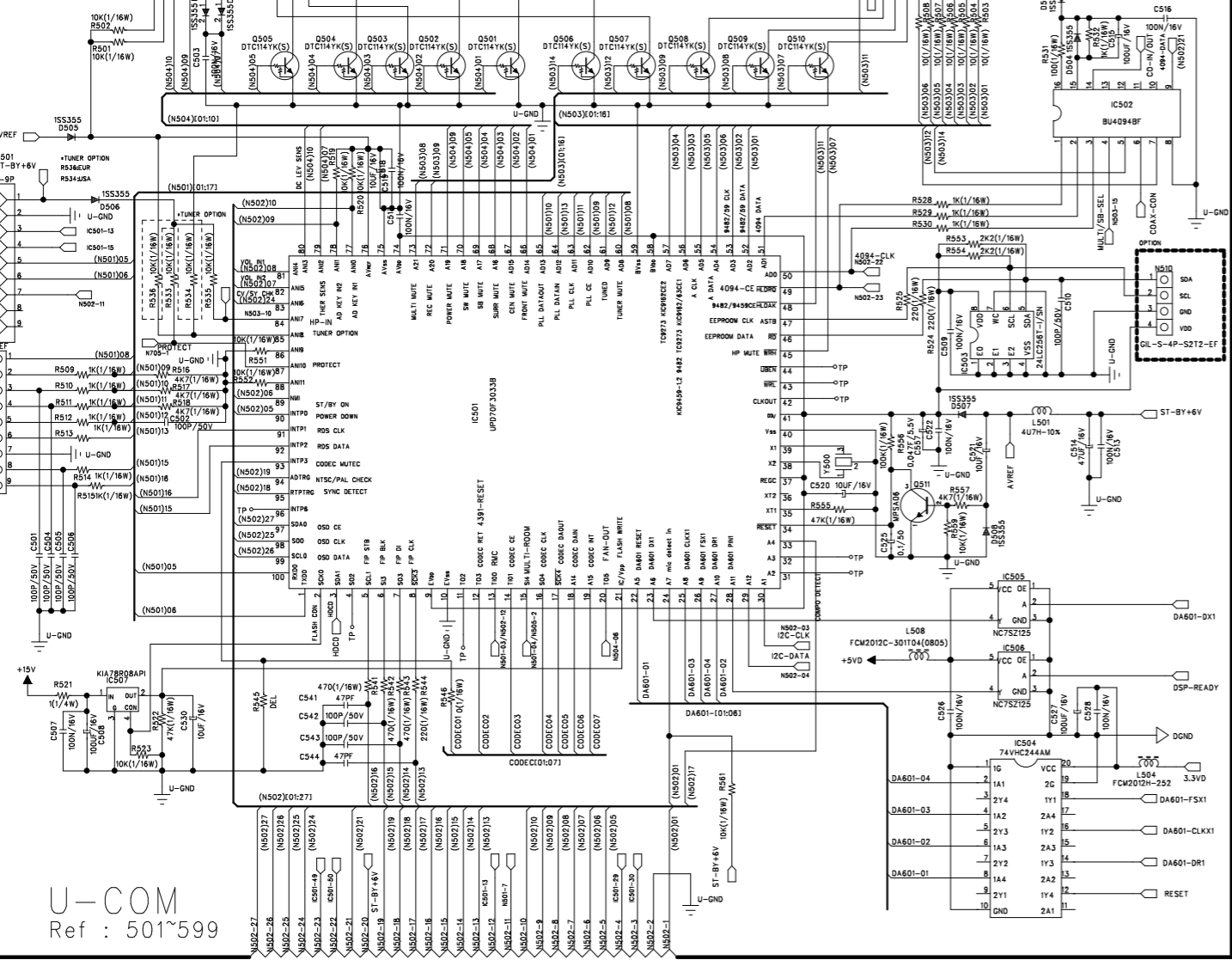
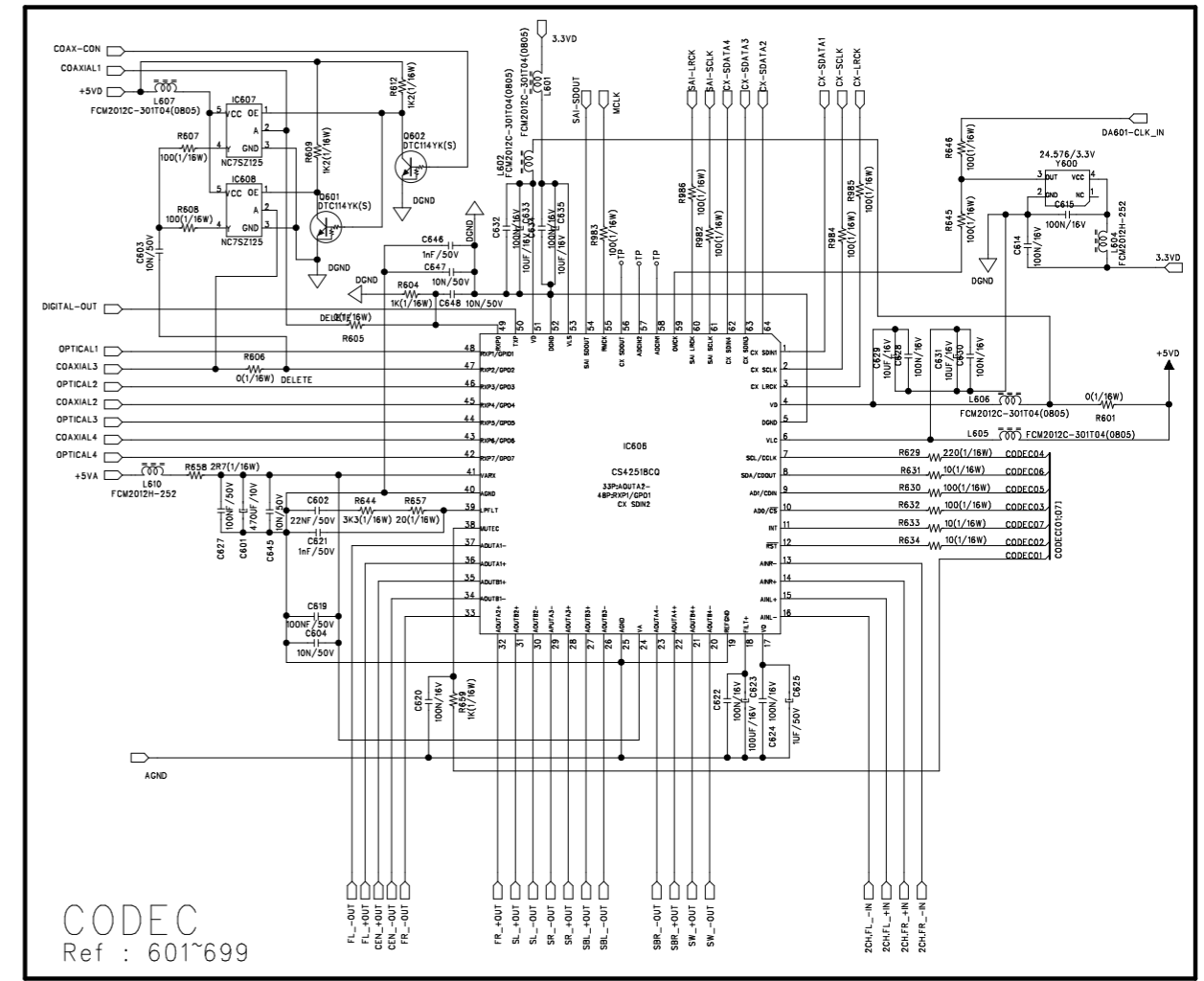

Category	AV RECEIVER	Model	AVR635/435
Stage	Ver.	Sheet	B'D name
MP	v2.101	/	PROCESSOR
Draw	Approved	Date	Drawing No
		2004/11/30	

REVISION RECORD		
NO.	Date	Contents

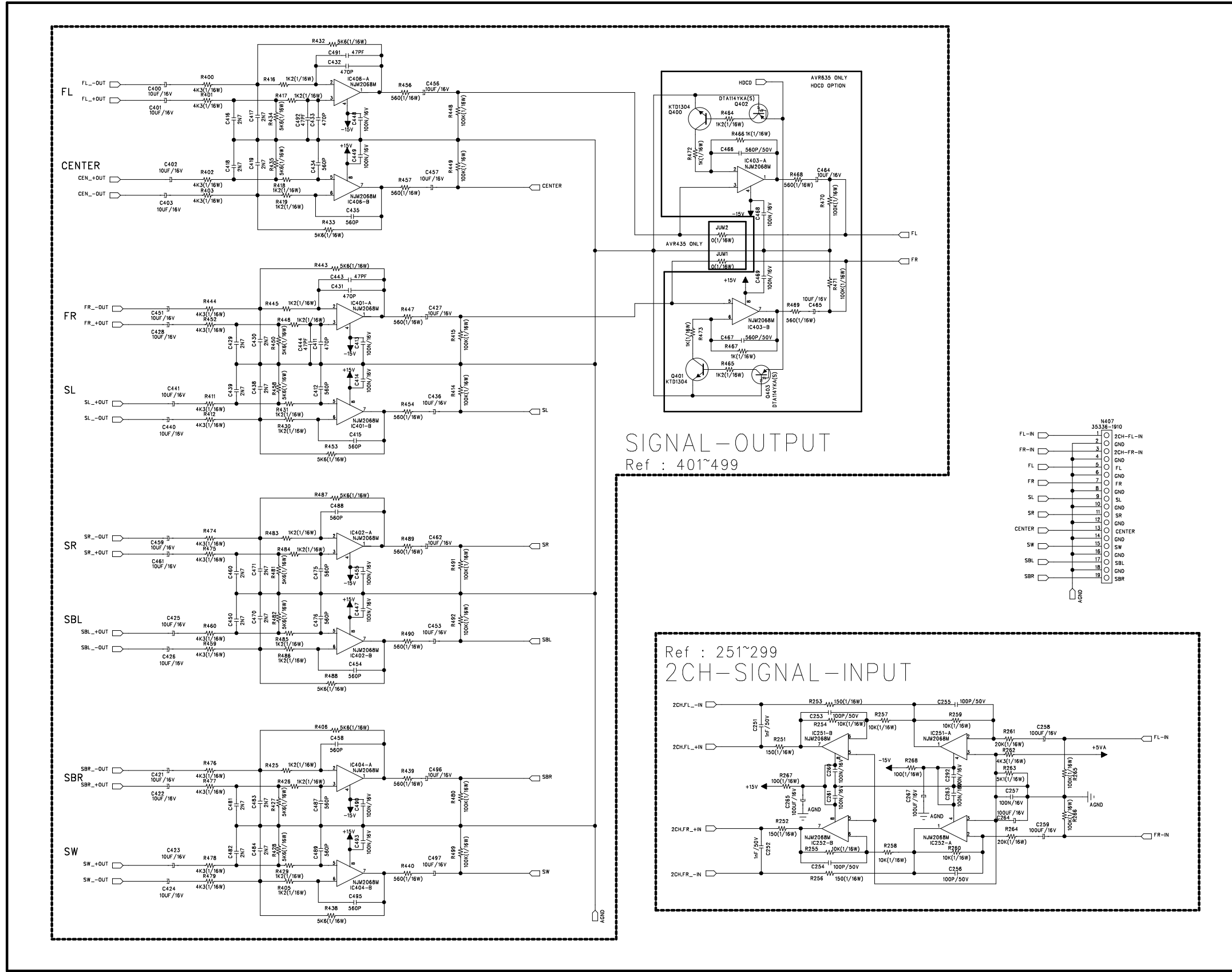

SIGNAL-OUTPUT  
Ref : 401~499

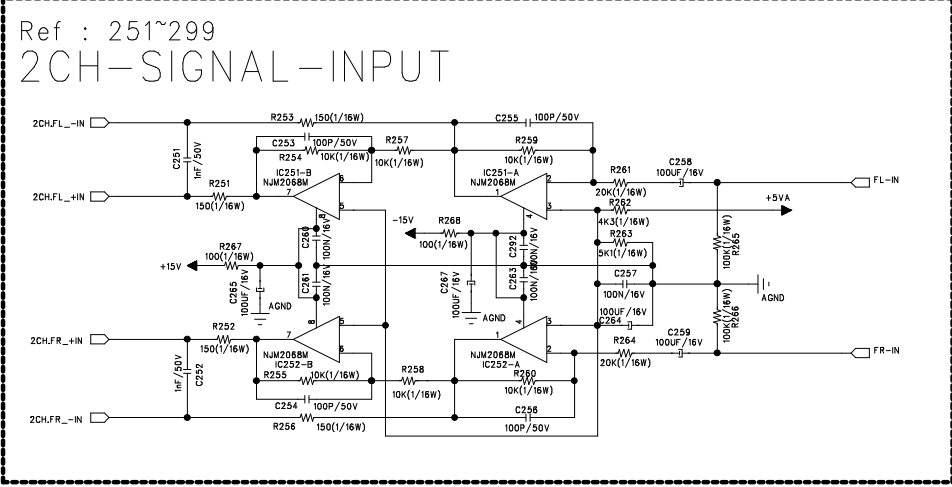
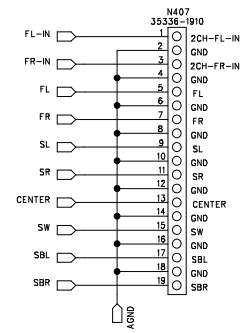

Ref : 251~299  
2CH-SIGNAL-INPUT

Category	AV RECEIVER	Model	AVR635/435
Stage	Ver.	Sheet	B'D name
MP	v2.101	/	PROCESSOR
Draw	Approved	Date	Drawing No
		2004/11/30	



REVISION RECORD		
NO.	Date	Contents

8ch-D

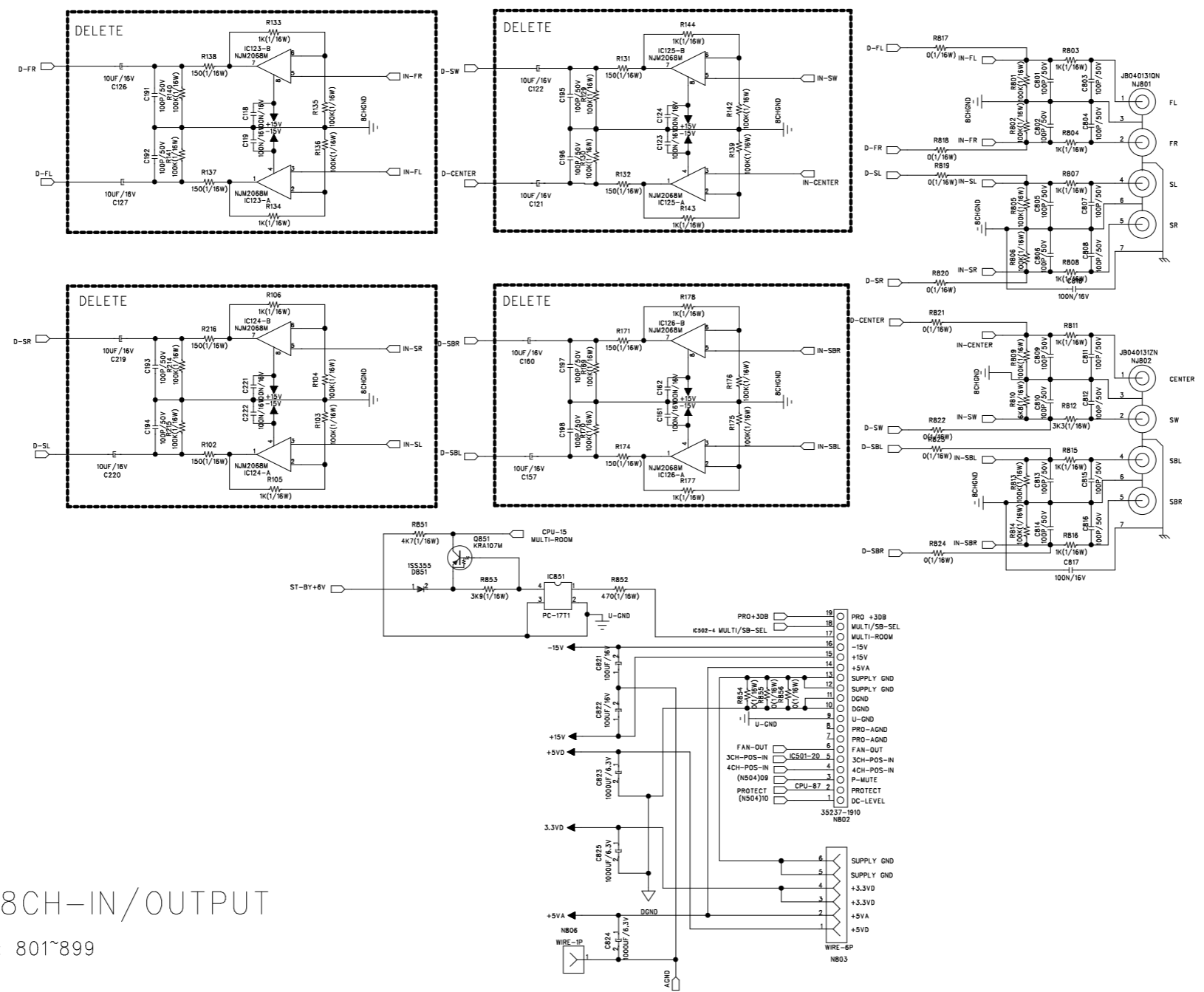
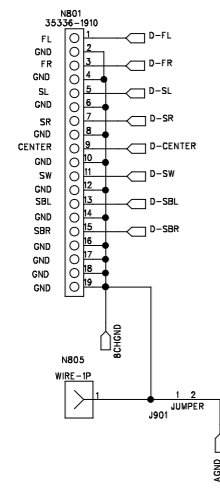

POWER/GND/8CH-IN/OUTPUT  
 Ref : 101~251    Ref : 801~899

Category	AV RECEIVER	Model	AVR635/435
Stage	Ver.	Sheet	B'D name
MP	v2.101	/	PROCESSOR
Draw	Approved	Date	Drawing No
		2004/11/30	

REVISION RECORD		
NO.	Date	Contents

# DSP

Ref : 901~999

**\*BOOT CONFIGURATIONS**  
 HD8: 1  
 HD13: 1 HD[4:3]: 1 0  
 HD[11:9]: X X X  
 CLKMODE0 : 1  
 HD14: 0

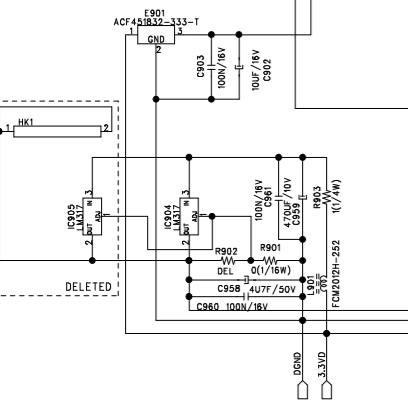
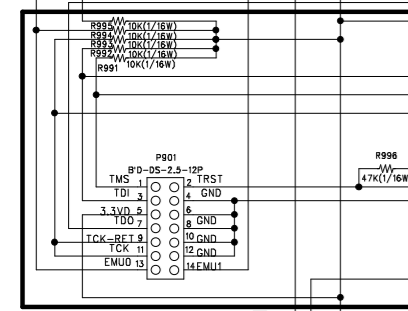
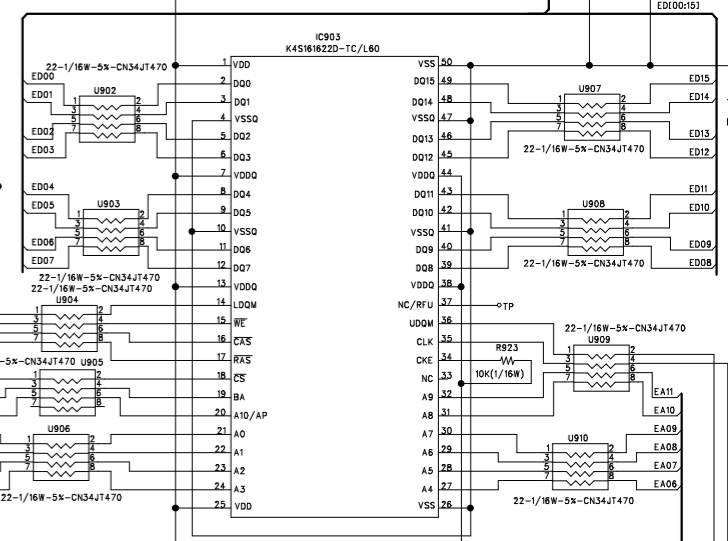
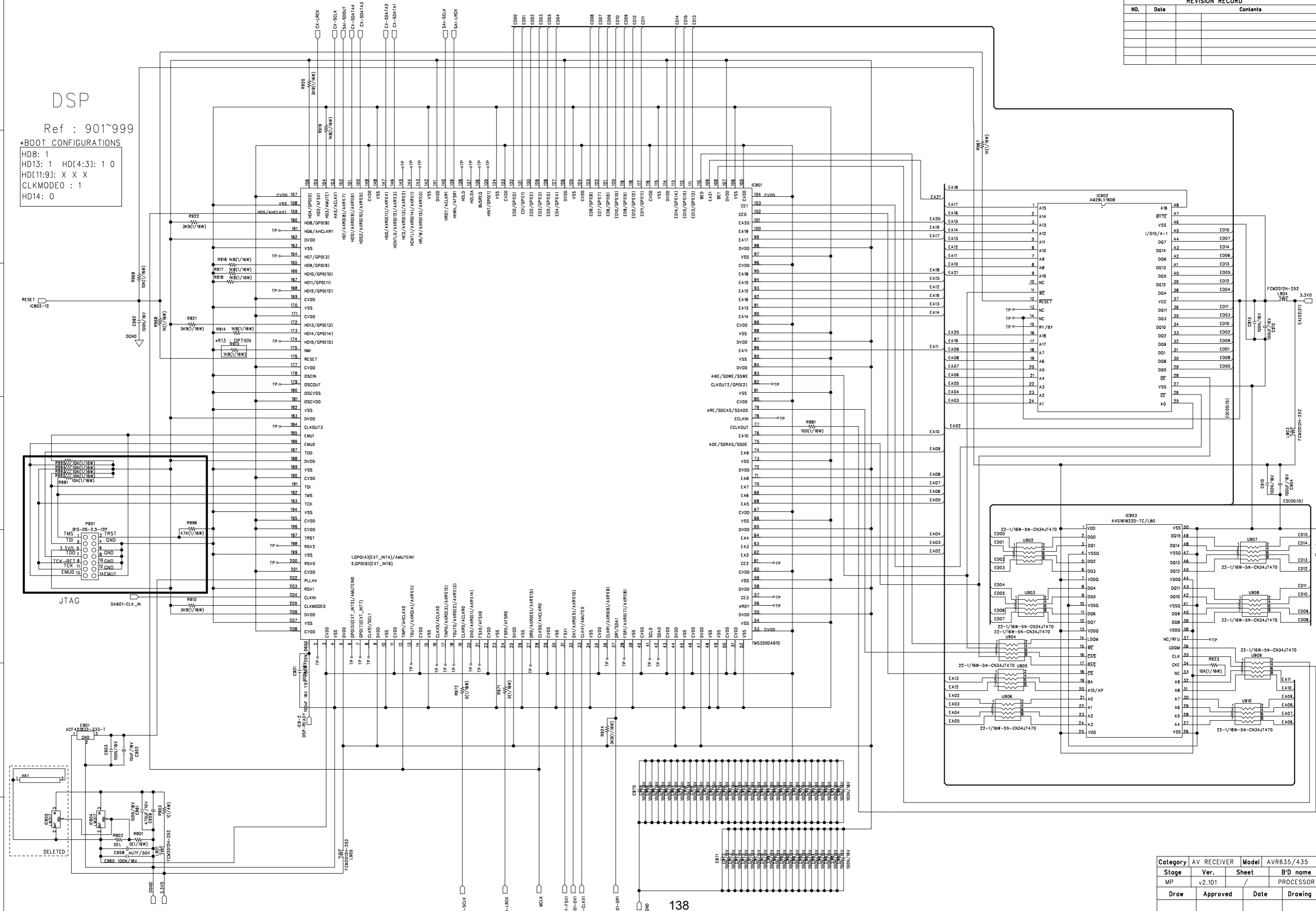

Category	AV RECEIVER	Model	AVR635/435
Stage	MP	Ver.	v2.101
Sheet	/	PROCESSOR	B'D name
Draw	Approved	Date	2004/11/30
		Drawing No	

REVISION RECORD		
NO.	Date	Contents

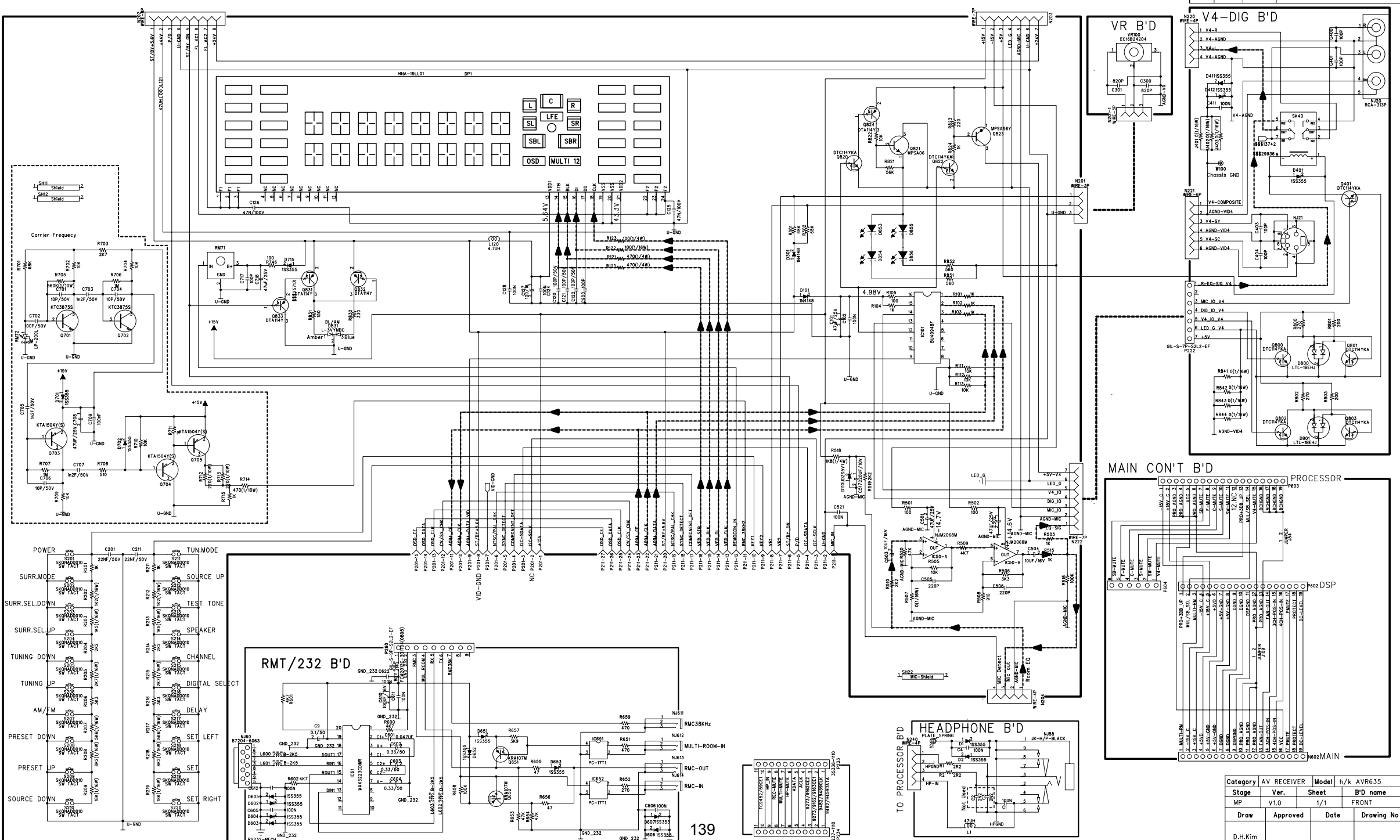

Category	AV RECEIVER	Model	h/k AVR635
Stage	Ver.	Sheet	B'D name
MP	V1.0	1/1	FRONT
Draw	Approved	Date	Drawing No
D.H.Kim			

REVISION RECORD		
NO.	Date	Contents

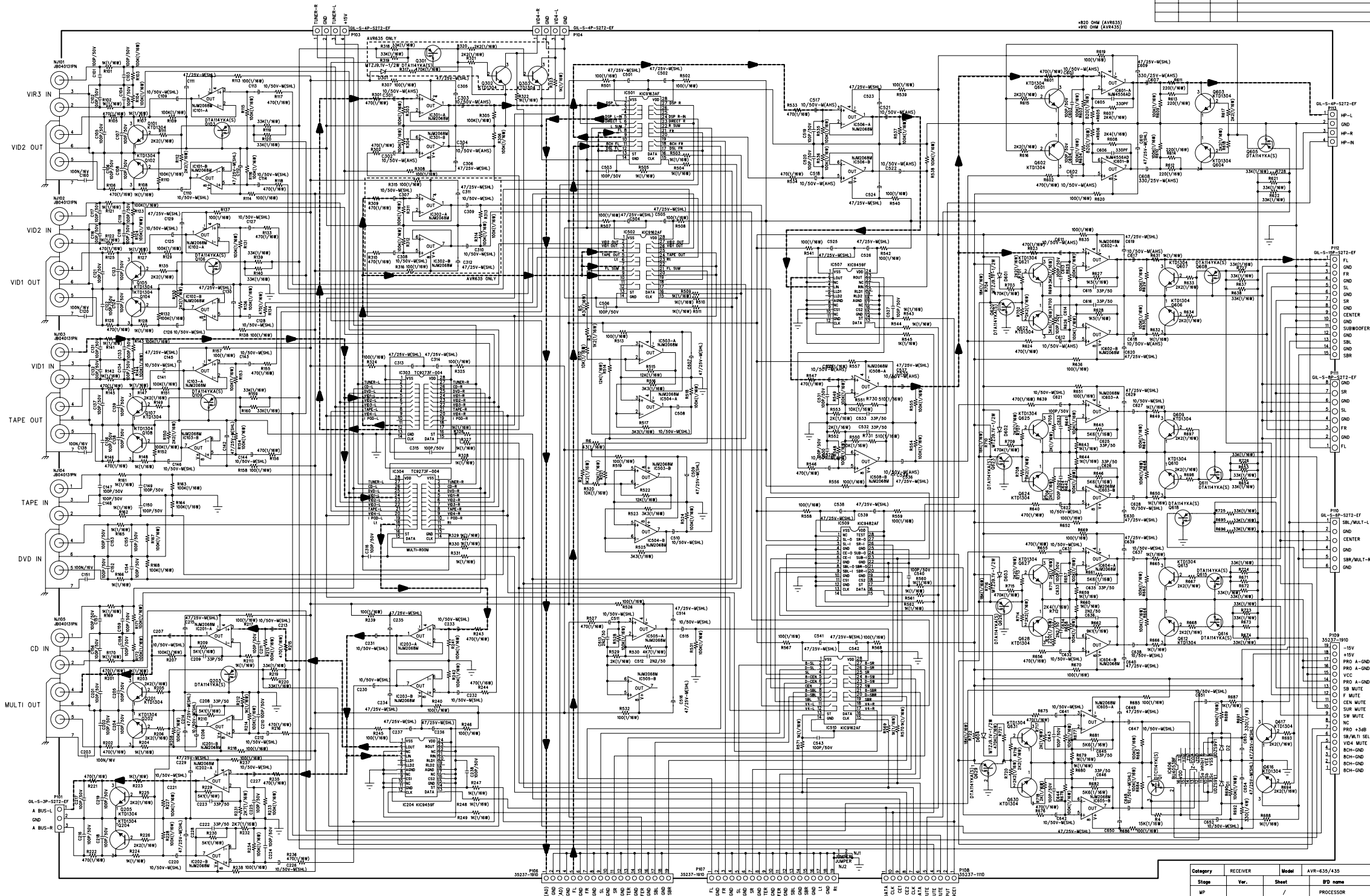

- 1 GND
- 2 FL
- 3 FR
- 4 SL
- 5 SR
- 6 CENTER
- 7 SUBWOOFER
- 8 SBL
- 9 SBR
- 10 GND
- 11 GND
- 12 GND
- 13 GND
- 14 FL
- 15 FR
- 16 SL
- 17 SR
- 18 CENTER
- 19 SUBWOOFER
- 20 GND
- 21 GND
- 22 GND
- 23 GND
- 24 FL
- 25 FR
- 26 SL
- 27 SR
- 28 CENTER
- 29 SUBWOOFER
- 30 GND
- 31 GND
- 32 GND
- 33 GND
- 34 FL
- 35 FR
- 36 SL
- 37 SR
- 38 CENTER
- 39 SUBWOOFER
- 40 GND
- 41 GND
- 42 GND
- 43 GND
- 44 FL
- 45 FR
- 46 SL
- 47 SR
- 48 CENTER
- 49 SUBWOOFER
- 50 GND

Category	RECEIVER	Model	AVR-635/435
Stage	Ver.	Sheet	BD name
MP	PROCESSOR		
Draw	Approved	Date	Drawing No

# AVR 635 SUPPLY & REG SCHEMATIC DIAGRAM

REVISION RECORD		
NO.	Date	Contents

G  
F  
E  
D  
C  
B  
A

## SUPPLY B'D

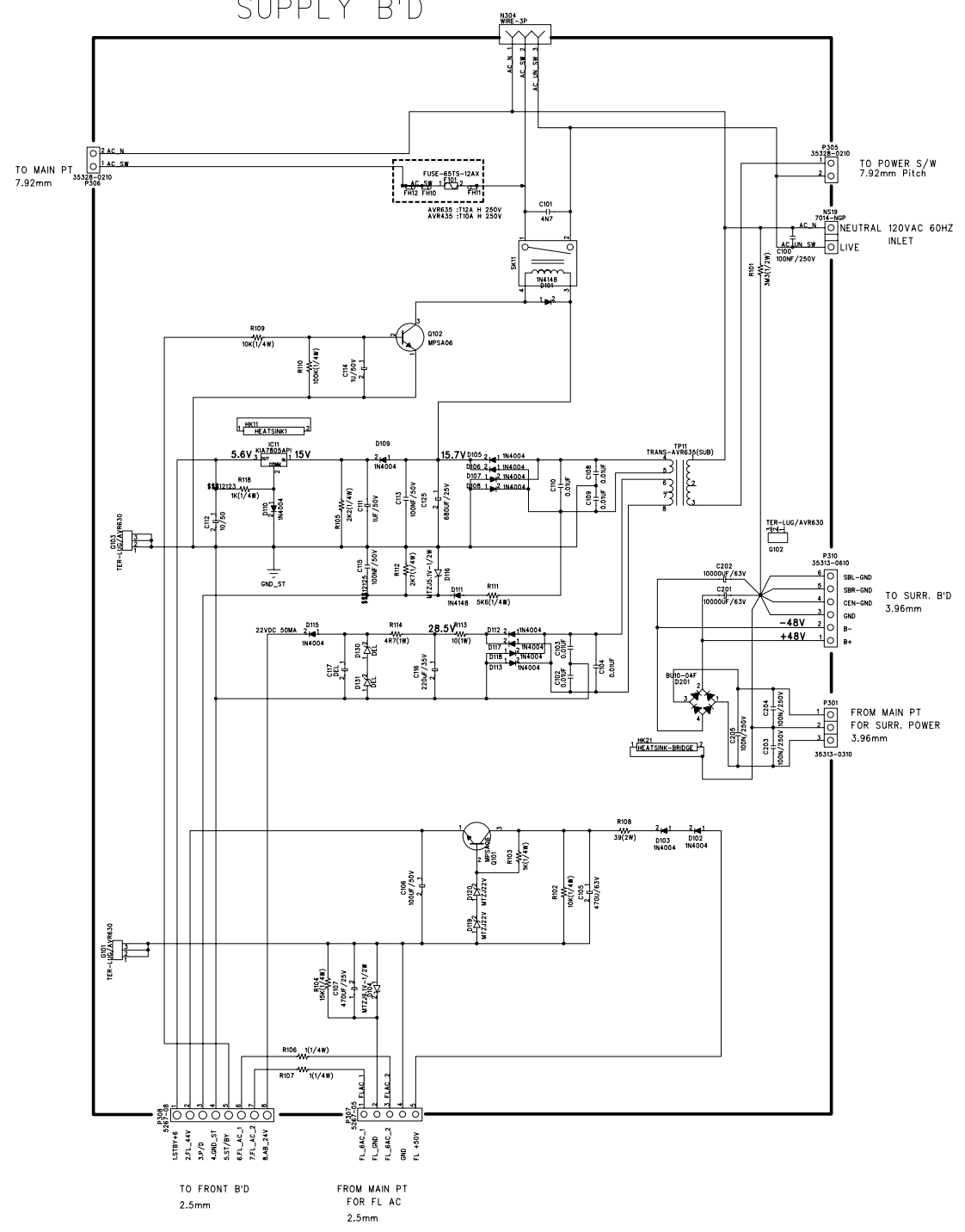

## AVR435/635

## harman/kardon

## REG B'D

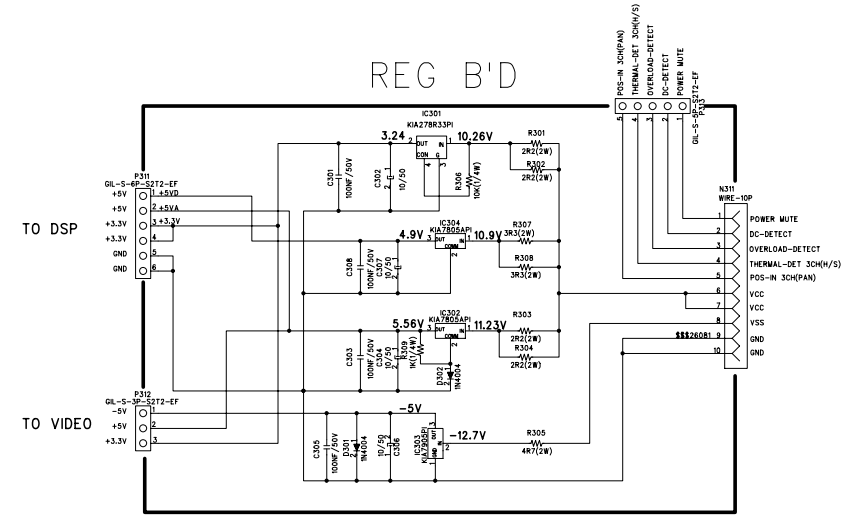

## DIG/MIC B'D

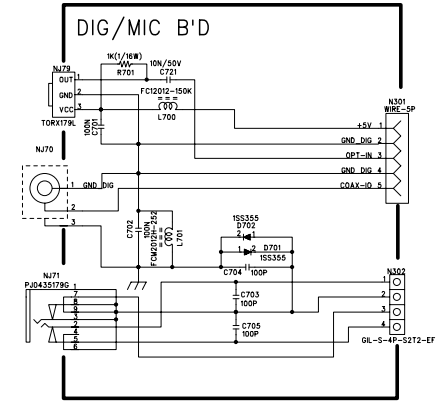

## PROCESSOR B'D

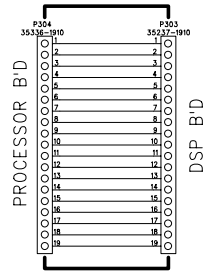

## DSP B'D

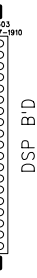

## Outlet B'D

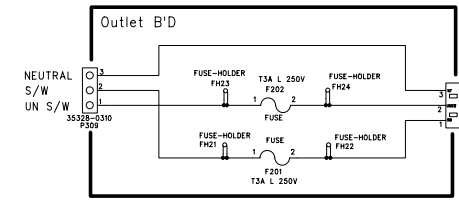

Category	A/V RECEIVER	Model	AVR635
Stage	Ver.	Sheet	B'D name
MP	v0.0	/	SUPP/REGU
Draw	Approved	Date	Drawing No
S.Y. .KIM		18/OCT/04	

# H/K AVR435/635 WIRING DIAGRAM

REVISION RECORD		
NO.	Date	Contents

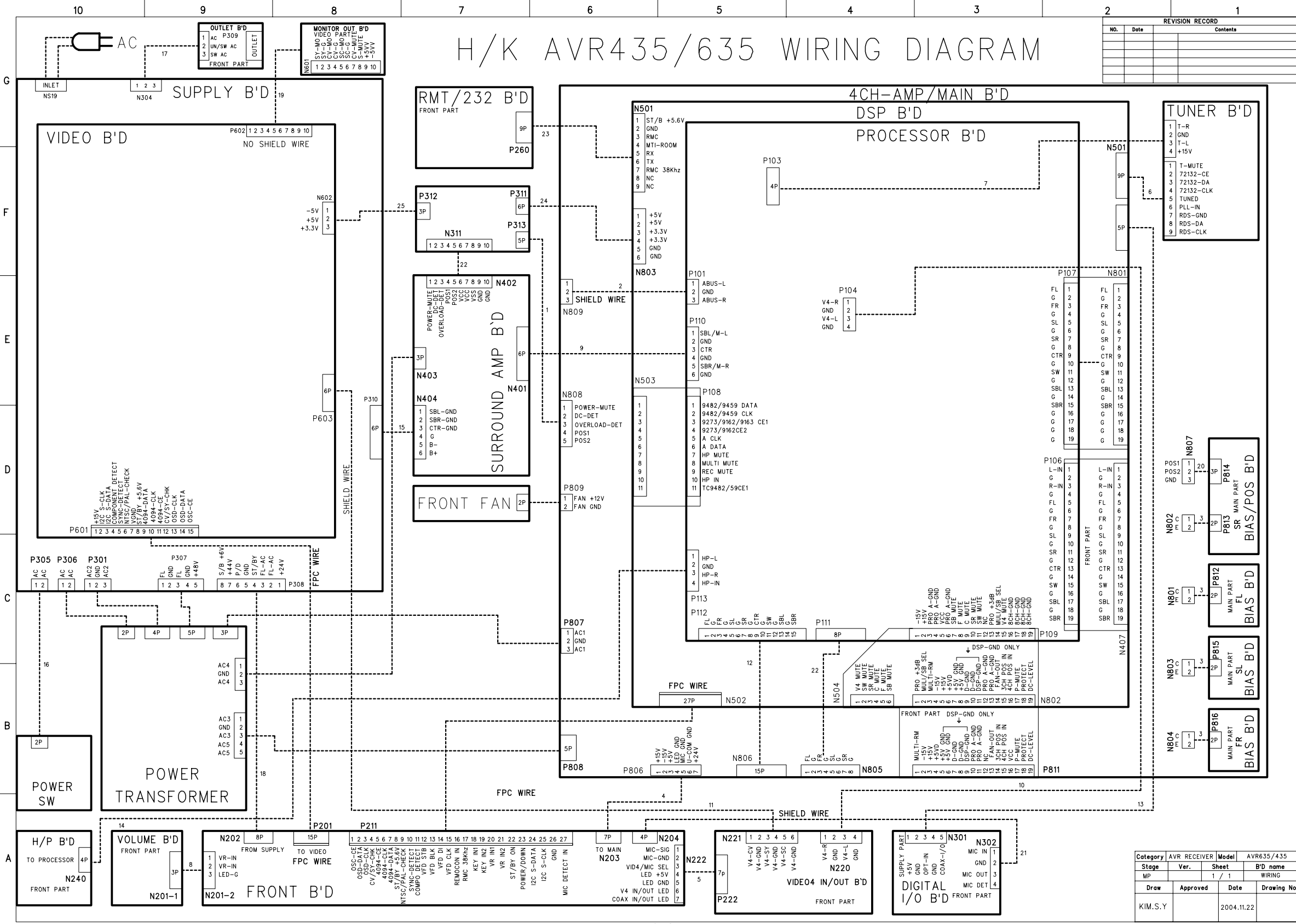

Category	AVR RECEIVER	Model	AVR635/435
Stage	Ver.	Sheet	B'D name
MP		1 / 1	WIRING
Draw	Approved	Date	Drawing No
KIM.S.Y		2004.11.22	