

## AVR 70/230

5x75W 5.1 CHANNEL A/V RECEIVER



## CONTENTS

ESD WARNING	2	SEMICONDUCTOR PINOUTS	46
OWNER'S MANUAL	3	PCB DRAWINGS	63
EXPLODED VIEW AND PARTS	29	BLOCK DIAGRAMS	74
TROUBLESHOOTING	30	WIRING DIAGRAM	78
PARTS LIST	33	SCHEMATIC DIAGRAMS	79

## ELECTROSTATICALLY SENSITIVE (ES) DEVICES

Some semiconductor (solid state) devices can be damaged easily by static electricity. Such components commonly are called Electrostatically Sensitive (ES) Devices. Examples of typical ES devices are integrated circuits and some field effect transistors and semiconductor "chip" components.

The following techniques should be used to help reduce the incidence of component damage caused by static electricity.



1. Immediately before handling any semiconductor component or semiconductor-equipped assembly, drain off any electrostatic charge on your body by touching a known earth ground. Alternatively, obtain and wear a commercially available discharging wrist strap device, which should be removed for potential shock reasons prior to applying power to the unit under test.
2. After removing an electrical assembly equipped with ES devices, place the assembly on a conductive surface such as aluminum foil, to prevent electrostatic charge build-up or exposure of the assembly.
3. Use only a grounded-tip soldering iron to solder or unsolder ES devices.
4. Use only an anti-static solder removal device. Some solder removal devices not classified as "anti-static" can generate electrical charges sufficient to damage ES devices.
5. Do not use freon-propelled chemicals. These can generate electrical charge sufficient to damage ES devices.
6. Do not remove a replacement ES device from its protective package until immediately before you are ready to install it. (Most replacement ES devices are packaged with leads electrically shorted together by conductive foam, aluminum foil or comparable conductive material.)
7. Immediately before removing the protective material from the leads of a replacement ES device, touch the protective material to the chassis or circuit assembly into which the device will be installed.

**CAUTION** : Be sure no power is applied to the chassis or circuit, and observe all other safety precautions.

8. Minimize bodily motions when handling unpackaged replacement ES devices. (Otherwise harmless motion such as the brushing together of your clothes fabric or the lifting of your foot from a carpeted floor can generate static electricity sufficient to damage an ES devices.

## PRODUCT SAFETY NOTICE

Each precaution in this manual should be followed during servicing.

Components identified with the IEC symbol  in the parts list are special significance to safety. When replacing a component identified with , use only the replacement parts designated, or parts with the same ratings or resistance, wattage, or voltage that are designated in the parts list in this manual. Leakage-current or resistance measurements must be made to determine that exposed parts are acceptably insulated from the supply circuit before returning the product to the customer.

# AVR 700/AVR 70/AVR 70C

Audio/video receiver

Owner's Manual



**harman/kardon**<sup>®</sup>  
by HARMAN

INTRODUCTION	3	OPERATING YOUR AVR	16
SUPPLIED ACCESSORIES	3	CONTROLLING THE VOLUME	16
IMPORTANT SAFETY INFORMATION	3	MUTING THE SOUND	16
PLACE THE AVR	3	LISTENING THROUGH HEADPHONES	16
FRONT-PANEL CONTROLS	4	SELECTING A SOURCE	16
REAR-PANEL CONNECTORS	5	VIDEO TROUBLESHOOTING TIPS	16
SYSTEM REMOTE CONTROL FUNCTIONS	6	LISTENING TO FM AND AM RADIO	16
INTRODUCTION TO HOME THEATER	8	LISTENING TO MEDIA ON A USB DEVICE	16
TYPICAL HOME THEATER SYSTEM	8	SELECTING A SURROUND MODE	17
MULTICHANNEL AUDIO	8	ADVANCED FUNCTIONS	17
SURROUND MODES	8	AUDIO PROCESSING AND SURROUND SOUND	17
PLACE YOUR SPEAKERS	8	ADJUSTING THE CHANNEL VOLUMES	17
PLACING THE LEFT, CENTER AND RIGHT SPEAKERS	8	RECORDING	17
PLACING THE SURROUND SPEAKERS	8	SLEEP TIMER	18
PLACING THE SUBWOOFER	8	PROCESSOR RESET	18
TYPES OF HOME THEATER SYSTEM CONNECTIONS	9	MEMORY	18
SPEAKER CONNECTIONS	9	TROUBLESHOOTING	19
SUBWOOFER CONNECTIONS	9	SPECIFICATIONS	20
SOURCE DEVICE CONNECTIONS	9	APPENDIX	21
VIDEO CONNECTIONS	10		
RADIO CONNECTIONS	10		
USB PORT	10		
MAKING CONNECTIONS	11		
CONNECT YOUR SPEAKERS	11		
CONNECT YOUR SUBWOOFER	11		
CONNECT YOUR TV OR VIDEO DISPLAY	11		
CONNECT YOUR SOURCE DEVICES	11		
CONNECT THE RADIO ANTENNAS	13		
CONNECT TO AC POWER	13		
INSTALL BATTERIES IN THE REMOTE CONTROL	13		
SET UP THE AVR	14		
TURN ON THE AVR	14		
USING THE ON-SCREEN MENU SYSTEM	14		
CONFIGURE THE AVR FOR YOUR SPEAKERS	15		
ADDITIONAL SETUP MENU ITEMS	15		

# AVR 700/AVR 70/AVR 70C

## Introduction, Supplied Accessories, Important Safety Information and Place the AVR

### Introduction

#### Thank you for choosing this Harman Kardon product!

For more than fifty years, the Harman Kardon mission has been to share a passion for music and entertainment, using leading-edge technology to achieve premium performance. Sidney Harman and Bernard Kardon invented the receiver, a single component designed to simplify home entertainment without compromising performance. Over the years, Harman Kardon products have become easier to use while offering more features and sounding better than ever.

The AVR 70, AVR 700 and AVR 70C 5.1-channel digital audio/video receivers (AVRs) continue this tradition with some of the most advanced audio and video processing capabilities yet and a wealth of listening and viewing options.

To obtain the maximum enjoyment from your new AVR, please read this manual and refer back to it as you become more familiar with its features and their operation.

If you have any questions about this product, its installation or its operation, please contact your Harman Kardon retailer or custom installer, or visit our Web site at [www.harmankardon.com](http://www.harmankardon.com).

### Supplied Accessories

The following accessory items are supplied with your AVR. If any of these items are missing, please contact your Harman Kardon dealer, or Harman Kardon customer service at [www.harmankardon.com](http://www.harmankardon.com).

- IR remote control
- AM loop antenna
- FM wire antenna
- Three AAA batteries
- AC power cord

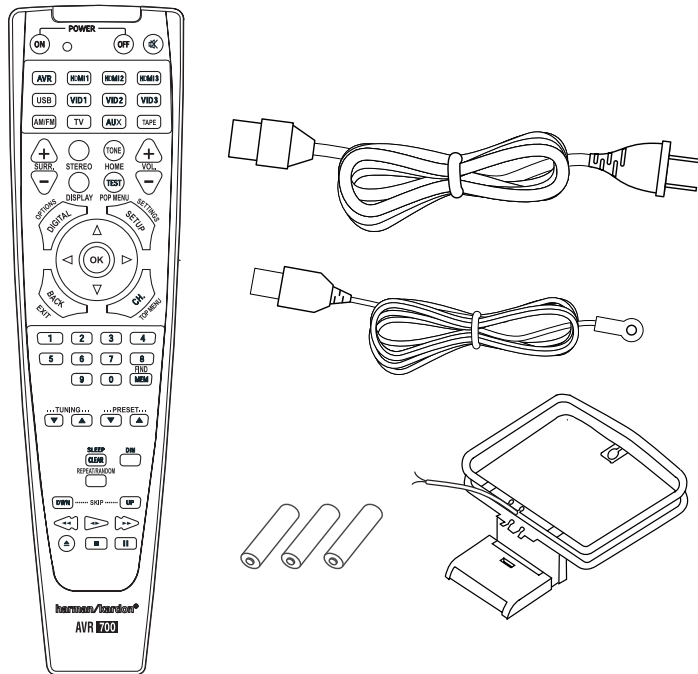

### IMPORTANT SAFETY INFORMATION

#### Verify Line Voltage Before Use

The AVR 700 has been designed for use with 120-volt alternating current (AC). The AVR 70 and AVR 70C have been designed for use with 220 – 240-volt AC. Connection to a line voltage other than that for which your AVR is intended can create a safety and fire hazard, and may damage the unit. If you have any questions about the voltage requirements for your specific model or about the line voltage in your area, contact your selling dealer before plugging the unit into a wall outlet.

#### Do Not Use Extension Cords

To avoid safety hazards, use only the power cord supplied with your unit. We do not recommend that extension cords be used with this product. As with all electrical devices, do not run power cords under rugs or carpets, or place heavy objects on them. Damaged power cords should be replaced immediately by an authorized service center with a cord meeting factory specifications.

#### Handle the AC Power Cord Gently

When disconnecting the power cord from an AC outlet, always pull the plug; never pull the cord. If you do not intend to use your AVR for any considerable length of time, disconnect the plug from the AC outlet.

#### Do Not Open the Cabinet

There are no user-serviceable components inside this product. Opening the cabinet may present a shock hazard, and any modification to the product will void your warranty. If water or any metal object such as a paper clip, wire or staple accidentally falls inside the unit, disconnect it from the AC power source immediately, and consult an authorized service center.

#### CATV or Antenna Grounding (AVR 700)

If an outside antenna or cable system is connected to this product, be certain that it is grounded so as to provide some protection against voltage surges and static charges. Section 810 of the United States National Electrical Code, ANSI/NFPA No. 70-1984, provides information with respect to proper grounding of the mast and supporting structure, grounding of the lead-in wire to an antenna discharge unit, size of grounding conductors, location of antenna discharge unit, connection to grounding electrodes and requirements of the grounding electrode.

**NOTE TO CATV SYSTEM INSTALLER:** This reminder is provided to call the CATV (cable TV) system installer's attention to article 820-40 of the NEC, which provides guidelines for proper grounding and, in particular, specifies that the cable ground shall be connected to the grounding system of the building, as close to the point of cable entry as possible.

#### Place the AVR

- Place the AVR on a firm and level surface. Be certain that the surface and any mounting hardware can support the AVR's weight.
- Provide proper space above and below the AVR for ventilation. Recommended clearance distances are 30cm above the unit, 10cm behind the unit and 20cm on each side of the unit.
- If you install the AVR in a cabinet or other enclosed area, provide cooling air within the cabinet. Under some circumstances, a fan may be required.
- Do not obstruct the ventilation slots on the top of the AVR or place objects directly over them.
- Do not place the AVR directly on a carpeted surface.
- Do not place the AVR in moist or humid locations, in extremely hot or cold locations, in areas near heaters or heat registers, or in direct sunlight.

### Front-Panel Controls

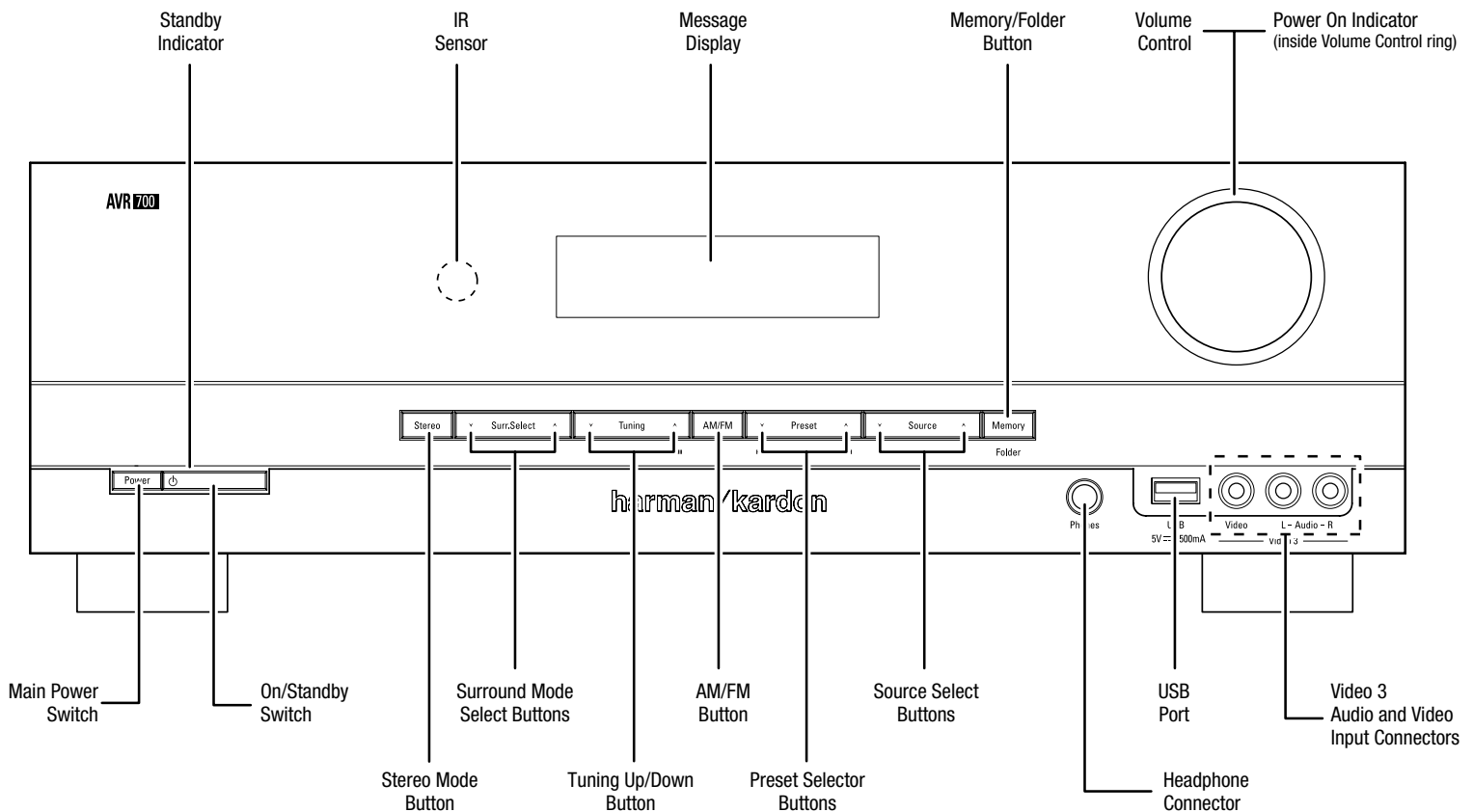

**Main Power switch:** This mechanical switch turns the AVR's power supply on or off. It is usually left on and cannot be turned on or off using the remote control.

**Standby indicator:** This LED glows amber to indicate that the AVR is in the Standby mode.

**Power On/Standby button:** Press this button to turn the AVR on and put it into the Standby mode. When the AVR is on the Power On indicator glows blue and the Standby indicator turns off.

**Stereo Mode button:** Places the AVR in the stereo listening mode.

**IR Sensor:** This sensor receives infrared (IR) commands from the remote control. It is important to ensure that the sensor is not blocked.

**Surround Mode Select buttons:** Press these buttons to select a surround listening mode. Surround-mode availability depends on the nature of the source input signal, i.e., digital versus analog, and the number of channels encoded within the signal.

**Tuning Up/Down buttons:** Use these buttons to tune radio stations according to the setting of the AM/FM button (see below).

**AM/FM button:** Press this button to listen to the radio. Pressing this button when the radio is in use will select among the FM Stereo, FM Mono and AM bands. See *Listening to FM and AM Radio*, on page 16, for more information.

**Message display:** Various messages appear in this display in response to commands and changes in the incoming signal. In normal operation, the current source device name, surround mode and active input appear. When the on-screen display menu system (OSD) is in use, the current menu settings appear.

**IMPORTANT NOTE:** If the PROTECT message ever appears on the Message Display, turn off the AVR and unplug it from the AC outlet. Check all speaker wires for a possible short circuit (the "+" and "-" conductors touching each other or both touching the same piece of metal). If a short circuit is not found, bring the unit to an authorized Harman Kardon service center for inspection and repair before using it again.

**Preset Selector buttons:** When the radio is in use, press these buttons to cycle through your preset radio stations. (See *Listening to FM and AM Radio*, on page 16, for more information.) NOTE: When you're listening to files on a USB device, the Tuning Up/Down buttons and the Preset Selector buttons serve as the USB device's transport control buttons. (See *Playing Files on a USB Device*, on page 16, for more information.)

**Source Select buttons:** Press these buttons to select the active source device.

**Memory/Folder button:** When the radio is in use, press this button to set the current station as a preset. See *Listening to FM and AM Radio*, on page 16, for more information. When a USB device is the active source device, press this button to display the contents of the current folder or to display all of the folders in the current directory level. See *Playing files on a USB Device*, on page 16, for more information.

**Headphone connector:** Connect a 1/4" stereo headphone plug to this jack for private listening.

**USB Port:** Insert a flash drive or HDD disk drive with a USB Standard-A cable to this port.

**Volume control:** Turn this knob to raise or lower the volume.

**Video 3 Audio and Video Input connectors:** Connect an auxiliary audio/video source component that will be used only temporarily, such as a camcorder, portable music player or game console, here.

### Rear-Panel Connectors

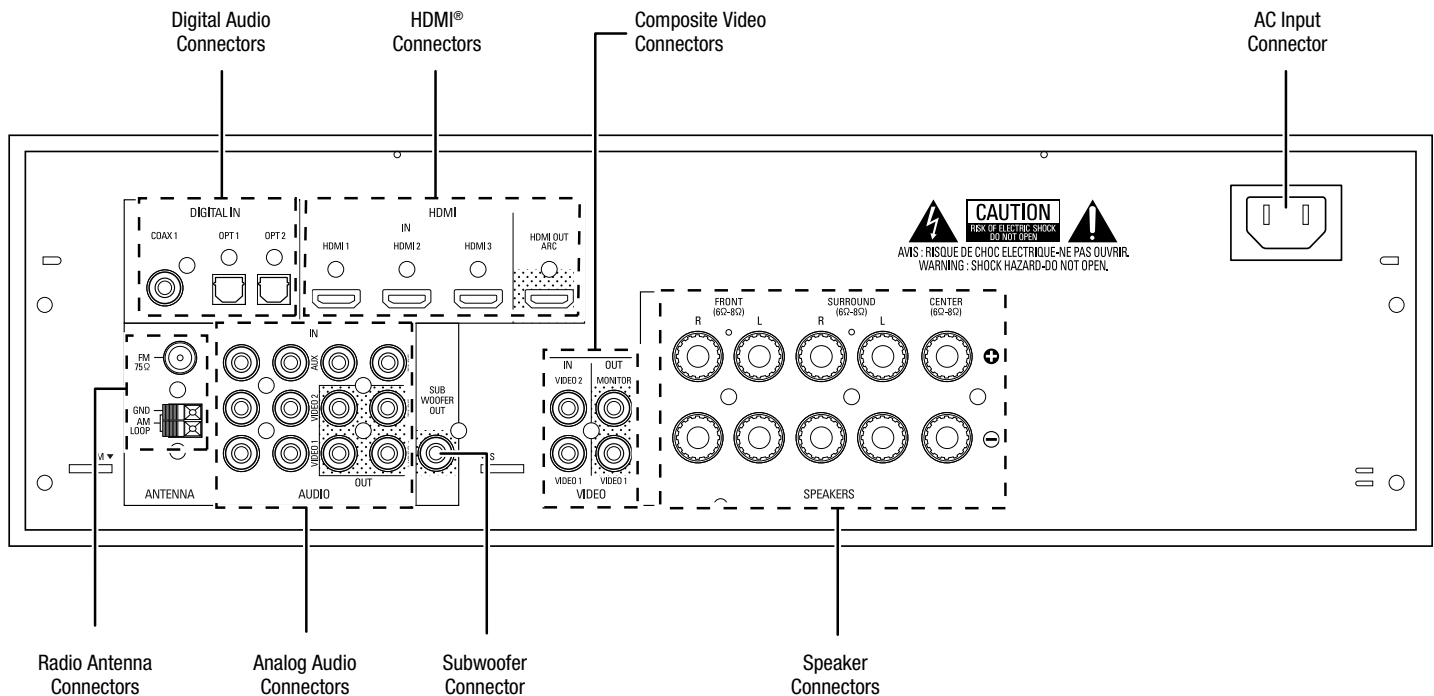

**Radio Antenna connectors:** Connect the included AM and FM antennas to their respective terminals for radio reception. See *Connect the Radio Antennas*, on page 13, for more information.

**Digital Audio connectors:** If your non-HDMI source devices have digital outputs, connect them to the AVR's digital audio connectors. See *Connect Your Source Devices*, on page 11, for more information.

**Analog Audio connectors:** Use the AVR's Analog Audio connectors for source devices that don't have HDMI or digital audio connectors. Use the Video 1 Out, Video 2 Out and Tape Out connectors to connect to the audio inputs of VCRs, tape decks or other analog recorders. See *Connect Your Source Devices*, on page 11, for more information.

**HDMI connectors:** The HDMI (High-Definition Multimedia Interface®) feature is a connection for transmitting digital audio and video signals between devices. If your source devices and TV have HDMI connectors, using them will provide the best possible video and audio performance quality. Since the HDMI cable carries both digital video and audio signals, you do not have to make any additional audio connections for devices you connect via HDMI connections. See *Connect Your Source Devices*, on page 11, for more information.

#### Notes on using the HDMI Out connector:

- When connecting a DVI-equipped display to the HDMI Monitor Out connector, use an HDMI-to-DVI adapter and make a separate audio connection.
- Make sure the HDMI-equipped display is HDCP-compliant. If it isn't, do not connect it via HDMI; use an analog video connection instead and make a separate audio connection.

**Subwoofer connector:** Connect this jack to a powered subwoofer that has a line-level input connector. See *Connect Your Subwoofer*, on page 11, for more information.

**Composite Video connectors:** Use composite video connectors for video source devices and a TV that don't have HDMI connectors. You will also need to make audio connections from the source devices to the AVR. See *Connect Your Source Devices*, on page 11, for more information.

**IMPORTANT:** The AVR's on-screen display (OSD) only appears through the Composite Monitor Out connector. If you want to use the AVR's OSD menus you need to connect its Composite Monitor Out connector to your TV even if you are not connecting any composite video source devices to the AVR.

**Speaker connectors:** Use two-conductor speaker wire to connect each set of terminals to the correct speaker. See *Connect Your Speakers*, on page 11, for more information.

**AC Input connector:** After you have made all other connections, plug the supplied AC power cord into this receptacle and into an unswitched wall outlet.

## Remote Control Functions

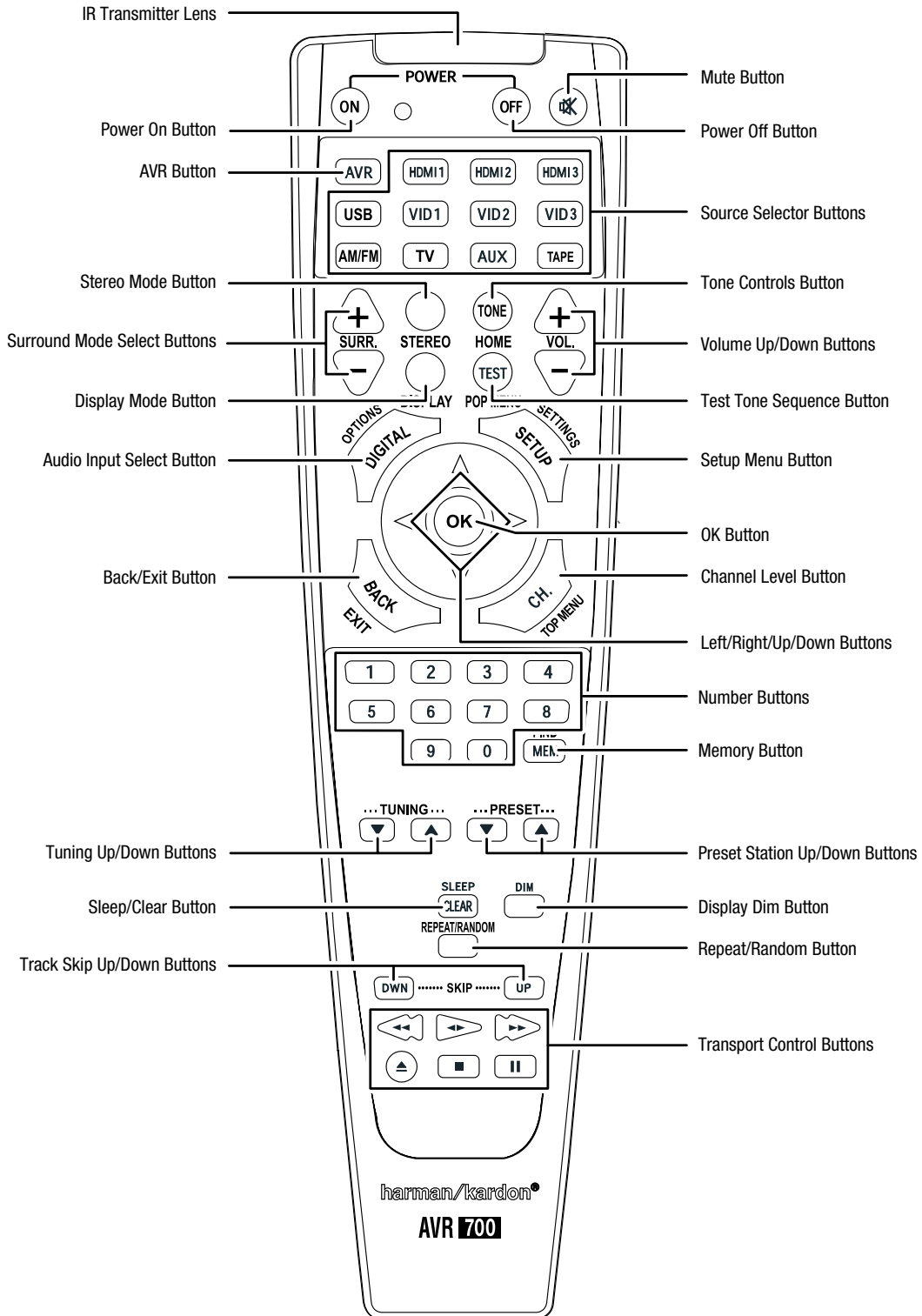



## Remote Control Functions, continued

In addition to controlling the AVR, the AVR remote can also control a Harman Kardon Blu-ray Disc® or DVD player that is connected to the HDMI 1 connector. The remote control buttons will have different functions depending on if the remote is controlling the AVR or a Blu-ray Disc or DVD player. Appendix A5, *Remote Control Function List*, on page 25, provides a list of the different remote control button functions when controlling a Blu-ray Disc or DVD player.

**IR Transmitter lens:** As buttons are pressed on the remote, infrared codes are emitted through this lens.

**Power On/Off buttons:** Press these buttons to turn the AVR on and off. The Main Power switch on the AVR's front panel must be on for these buttons to turn the AVR on and off.

**Mute button:** Press this button to mute the AVR's speaker-output connectors and Headphone jack. To restore the sound, press this button or adjust the volume.

**AVR button:** Press this button to switch the remote's control mode to operate the AVR. Pressing this button when the AVR is in the Standby mode will turn it on.

**Source Selector buttons:** Press one of these buttons to select a source device. This action will also turn on the AVR and switch the AVR to the selected input.

- Pressing the TV Source Selector button plays the sound from the HDMI Audio Return Channel, so you can listen to sources connected directly to the TV or to the TV itself through the AVR. See *Additional Setup Menu Items: HDMI Set*, on page 15, for more information.
- The first press of the Radio Source Selector button switches the AVR to the last-used tuner band (AM or FM). Successive presses cycle through AM, FM stereo and FM mono.

**Stereo Mode button:** Press this button to switch to the stereo listening mode.

**Tone Controls button:** Press this button to activate or bypass the bass and treble controls. When the tone controls are set to "ON", use the up, down, left and right arrow buttons to vary the tone quality by adjusting the bass and treble.

**Surround Mode Select buttons:** Press these buttons to select a surround listening mode. Surround-mode availability depends on the nature of the source input signal, i.e., digital versus analog, and the number of channels encoded within the signal. See *Selecting a Surround Mode and Audio Processing and Surround Sound*, on page 17, for more information.

**Volume Up/Down buttons:** Press these buttons to raise or lower the volume.

**Display Mode button:** Press this button to display the active surround mode and current volume control setting on the AVR's Message Display. After five seconds the display will revert back to showing the currently-active source.

**Test Tone sequence button:** Press this button to activate the test tone for calibrating channel volume levels by ear.

**Audio Input Select button:** Press this button to select the specific digital audio input (or analog audio input) to which the current source is connected. Each press of the button advances through the following inputs: Optical Digital 1, Optical Digital 2, Coaxial Digital, HDMI (for HDMI 1 – HDMI 3 only) and Analog. This button does not function for the AM/FM and USB sources.

**Setup Menu button:** Press this button to activate the setup menus. See *Set Up the AVR*, on page 14, for more information.

**OK button:** This button is used to select items from the menu system.

**Back button:** When you're using the setup menus, press this button to return to the previous menu screen.

**Channel Level button:** Press this button to activate the individual channel-level adjustment. It lets you easily change the channel balance while you're listening to suit different programs or seating arrangements. See *Set Up the AVR*, on page 14, for more information.

**Left/Right/Up/Down buttons:** These buttons are used to navigate the menu system.

**Number buttons:** Use these buttons to enter numbers for radio-station frequencies or to select station presets.

**Memory button:** To save the currently tuned radio station as a preset, press this button, then a Number button.

**Tuning Up/Down buttons:** Press these buttons to tune a radio station. When you're listening to an FM station, each press will either change one tuning frequency increment at a time or seek the next higher or lower station with acceptable signal strength, depending on whether you are listening in FM mono or FM stereo.

**Preset Station Up/Down buttons:** Press these buttons to cycle through your preset radio stations.

**Sleep/Clear button:** Press this button to activate the Sleep Timer function. See *Sleep Timer*, on page 18, for more information. When controlling a Harman/Kardon Blu-ray Disc or DVD player, press this button to clear an entry.

**Display Dimmer button:** Press this button to dim the AVR's front-panel display partially or fully.

**Repeat/Random button:** This button has no effect on the AVR but can be used to activate the repeat function when you're listening to media on a device inserted into the AVR's USB port and the repeat and random functions on a Harman Kardon Blu-ray Disc or DVD player. See *Listening to Media on a USB Device*, on page 16, for more information.

**Track Skip Up/Down buttons:** These buttons have no effect on the AVR but are used to change tracks or chapters when you're listening to media on a device inserted into the AVR's USB port, or on a Harman Kardon Blu-ray Disc or DVD player.

**Transport Control buttons:** These buttons have no effect on the AVR but are used to control a Harman Kardon Blu-ray Disc player or DVD player or a device inserted in the AVR's USB port.

## Introduction to Home Theater

This introductory section will help you to familiarize yourself with some basic concepts unique to multichannel surround-sound AVRs, which will make it easier for you to set up and operate your AVR.

### Typical Home Theater System

A home theater typically includes an audio/video receiver (AVR), which controls the system and supplies amplification for the loudspeakers; a disc player; a source component for television broadcasts (cable box, satellite dish AVR, HDTV tuner or antenna connected to the TV); a TV or video display; and multiple loudspeakers.

### Multichannel Audio

The main benefit of a home theater system is its ability to produce “surround sound.” Surround sound uses multiple speakers and amplifier channels to immerse you in the audio/video presentation for a dramatically increased sense of realism.

Your AVR can have up to five main speakers connected directly to it, plus a subwoofer. Each main speaker is powered by its own amplifier channel inside the AVR. A system with more than two speakers is called a multichannel system. The different main speaker types in a home theater system are:

- **Front Left and Right:** The front left and right speakers are used as in a 2-channel system. In many surround-sound modes, these speakers are secondary, while the main action, especially dialogue, is reproduced by the center speaker.
- **Center:** When you are watching movies and television programs, the center speaker reproduces most of the dialogue and other soundtrack information that occurs on the screen, anchoring it with the picture. When you are listening to a musical program, the center speaker helps to create a seamless front soundstage, creating a more realistic “you-are-there” listening experience.
- **Surround Left and Right:** The surround left and right speakers produce ambient sounds that help create a realistic and immersive surround-sound environment. They also help recreate directional sound effects such as aircraft flyovers.  
  
Many people expect the surround speakers to play as loudly as the front speakers. Although you will calibrate all of the speakers in your system to sound equally loud at the listening position, most artists use the surround speakers for ambient effects only, and they create their programs to steer relatively little sound to these speakers.
- **Subwoofer:** A subwoofer is designed to play only the lowest frequencies (the deep bass). It augments smaller, limited-range main speakers that are usually used for the other channels. Many digital-format programs, such as movies recorded in Dolby Digital, contain a low-frequency effects (LFE) channel that is directed to the subwoofer. The LFE channel packs the punch of a rumbling train or airplane, or the power of an explosion, adding realism and excitement to your home theater. Some people use two subwoofers for additional power and for even distribution of the sound.

### Surround Modes

There are different theories as to the best way to present surround sound and to distribute the individual channel information to the surround-sound system’s speakers. A variety of algorithms have been developed in an effort to recreate the way we hear sounds in the real world, resulting in a rich variety of options. Several companies have developed different surround-sound technologies, all of which can be accurately reproduced by your AVR:

- **Dolby Laboratories:** Dolby TrueHD, Dolby Digital Plus, Dolby Digital, Dolby Pro Logic II, Dolby Pro Logic.
- **DTS:** DTS-HD™ High Resolution Audio, DTS-HD Master Audio™, DTS, DTS 96/24™, DTS Neo: 6.
- **HARMAN International:** Analog Surround Modes (Theater Hall, Stadium, Club, Arena).
- **Stereo Modes:** 2-channel stereo and 5-channel stereo.

Appendix Table A4, on page 22, contains detailed explanations of the different surround-sound options available on your AVR. Digital surround-sound modes, such as Dolby Digital and DTS systems, are available only with specially encoded programs, such as those available via HDTV, DVD and Blu-ray Disc media and digital cable or satellite television. Other surround modes may be used with digital and analog signals to create a different surround presentation or to use a different number of speakers. Surround-mode selection depends upon the number of speakers in your system, the programs you are watching or listening to, and your personal tastes.

## Place Your Speakers

Determine the locations for your system’s speakers according to their manufacturer’s directions and the layout of your listening room. Use the illustration below as a guide for 5.1-channel systems.

To create the most realistic surround-sound environment possible, you should place your speakers in a circle with the listening position at its center. You should angle each speaker so it directly faces the listening position. Use the diagram below as a guide.

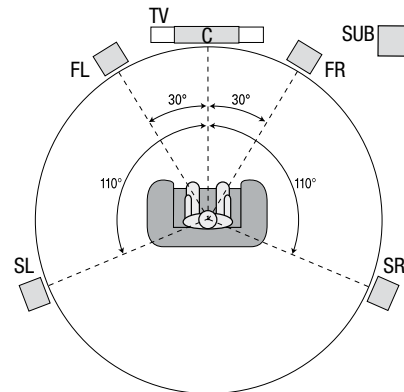

### Placing the Left, Center and Right Speakers

Place the center speaker either on top of, below or mounted on the wall above or below the TV or video-display screen. Place the front left and right speakers along the circle, about 30 degrees from the center speaker and angled toward the listener.

Place the front left, front right and center speakers at the same height, preferably at about the same height as the listener’s ears. The center speaker should be no more than 2 feet (0.6m) above or below the left/right speakers. If you’re using only two speakers with your AVR, place them in the front left and front right positions.

### Placing the Surround Speakers

You should place the left and right surround speakers approximately 110 degrees from the center speaker, slightly behind and angled toward the listener. Alternatively, you can place them behind the listener, with each surround speaker facing the opposite-side front speaker. You should place the surround speakers 2 feet – 6 feet (0.6m – 1.8m) higher than the listener’s ears.

**NOTE: Your AVR will sound its best when the same model or brand of loudspeaker is used for all positions.**

### Placing the Subwoofer

Because a room’s shape and volume can have a dramatic effect on a subwoofer’s performance, it is best to experiment with placement so that you will find the location that produces the best results in your particular listening room. With that in mind, these rules will help you get started:

- Placing the subwoofer next to a wall generally will increase the amount of bass in the room.
- Placing the subwoofer in a corner generally will maximize the amount of bass in the room.
- In many rooms, placing the subwoofer along the same plane as the left and right speakers can produce the best integration between the sound of the subwoofer and that of the left and right speakers.
- In some rooms, the best performance could even result from placing the subwoofer behind the listening position.

A good way to determine the best location for the subwoofer is by temporarily placing it in the listening position and playing music with strong bass content. Move around to various locations in the room while the system is playing (putting your ears where the subwoofer would be placed), and listen until you find the location where the bass performance is best. Place the subwoofer in that location.

## Types of Home Theater System Connections

There are different types of audio and video connections used to connect the AVR to your speakers, your TV or video display, and your source devices. The Consumer Electronics Association has established the CEA® color-coding standard.

### Connection Color Guide Table

Analog Audio Connection	Color
Front Left/Right	White/Red
Center	Green
Surround Left/Right	Blue/Gray
Subwoofer	Purple
Digital Audio Connection	Color
Coaxial (input or output)	Orange
Optical Input	Black
Analog Video Connection	Color
Composite Video	Yellow

## Speaker Connections

Speaker cables carry an amplified signal from the AVR's speaker terminals to each loudspeaker. Each cable contains two wire conductors, or leads, that are differentiated in some way, such as with colors or stripes.

The differentiation helps you maintain proper polarity, without which your system's low-frequency performance can suffer. Each speaker is connected to the AVR's speaker-output terminals using two wires, one positive (+) and one negative (-). Always connect the positive terminal on the speaker, which is usually colored red, to the positive terminal on the AVR, which is colored as indicated in the Connection Color Guide Table, above. The negative terminals on the speakers and the AVR are black.

Your AVR uses binding-post speaker terminals that can accept bare-wire cables or banana plugs. Bare-wire cables are installed as shown below:

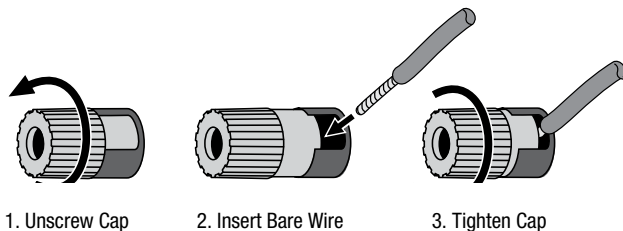

Banana plugs are inserted into the hole in the middle of the terminal cap, as shown below:

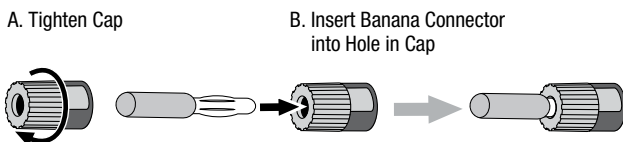

Always connect the colored (+) terminal on the AVR to the (+) terminal on the speaker (usually red), and the black (-) terminal on the AVR to the (-) terminal on the speaker (usually black).

**IMPORTANT: Make sure the (+) and (-) bare wires do not touch each other or the other terminal. Touching wires can cause a short circuit that can damage your AVR or amplifier.**

## Subwoofer Connections

The subwoofer is a speaker dedicated to reproducing only the low (bass) frequencies, which require more power. To obtain the best results, most speaker manufacturers offer powered subwoofers that contain their own amplifiers. Use a single RCA audio cable (not included) to make a line-level (non-amplified) connection from the AVR's Subwoofer connector to a corresponding input jack on the subwoofer.

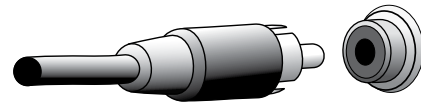

Although the AVR's purple subwoofer output looks similar to a full-range analog audio jack, it is filtered so that only the low frequencies pass through it. Don't connect this output to any device other than a subwoofer.

## Source Device Connections

Audio and video signals originate in source devices (components where a playback signal originates) such as your Blu-ray Disc or DVD player, CD player, DVR (digital video recorder) or other recorder, tape deck, game console, cable or satellite television tuner, MP3 player or a device docked in the AVR's USB port. The AVR's FM/AM tuner also counts as a source, even though no external connectors are needed other than the AVR's FM and AM antennas. Separate connectors are required for the audio and video portions of the source device's signal, except for digital HDMI connectors. The types of connectors you use will depend upon the capabilities of the source device and of your TV or video display.

### Digital Audio Connections – HDMI

There are two types of audio connections – digital and analog. Digital audio signals are required for listening to sources encoded with digital surround modes, such as Dolby Digital and DTS, or for uncompressed PCM digital audio. Your AVR has three types of digital audio connectors: HDMI, coaxial and optical. Do not use more than one type of digital audio connector for each source device. However, it's okay to make both analog and digital audio connections to the same source.

Your AVR is equipped with four rear-panel HDMI input connectors and one HDMI monitor output connector. HDMI technology enables digital audio and video information to be carried using a single cable, delivering the highest quality picture and sound. If your TV or video-display device has an HDMI input connector, make a single HDMI connection from each source device to the AVR. Usually, a separate digital audio connection is not required.

The AVR's HDMI Monitor Output connector contains an Audio Return Channel (ARC) that carries a digital audio signal from your TV or video display back to the AVR. It allows you to listen to HDMI devices that are connected directly to your TV (such as an Internet connection) without making an additional connection from the device to the AVR. The ARC signal is active when the TV source is selected. See *Additional Setup Menu Items*, on page 15, for more information.

The HDMI connector is shaped for easy plug-in (see illustration, below), and HDMI cable runs are limited to about 10 feet (3m). If your video display has a DVI input and is HDCP-compliant, use an HDMI-to-DVI adapter (not included), and make a separate audio connection.

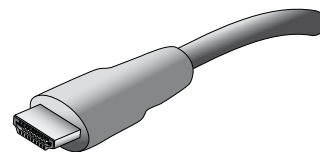

### Digital Audio Connections – Coaxial

Coaxial digital audio jacks are usually color-coded orange. Although they look like standard RCA-type analog jacks, you should not connect coaxial digital audio outputs to analog inputs or vice versa.

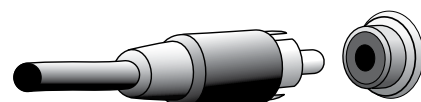

### Digital Audio Connections – Optical

Optical digital audio connectors are normally covered by a shutter to protect them from dust. The shutter opens as the cable is inserted. Optical input connectors are color-coded using a black shutter.

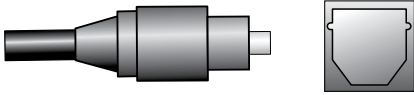

### Analog Audio Connections

Two-channel analog connections require a stereo audio cable, with one connector for the left channel (white) and one for the right channel (red). These two connectors are attached to each other.

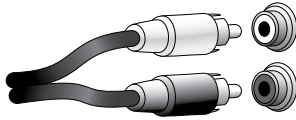

For source devices that have both digital and analog audio outputs, you may make both connections.

The analog connections also feed the Analog Record Output connectors. You may record materials from Blu-ray Disc recordings, DVDs or other copy-protected sources using only analog connections. Remember to comply with all copyright laws if you choose to make a copy for your own personal use.

### Video Connections

Many source devices output both audio and video signals (e.g., Blu-ray Disc, DVD player, cable television box, HDTV tuner, satellite box, VCR, DVR). In addition to an audio connection as described above, make a video connection for each of these source devices. Make only one type of video connection for each device.

#### Digital Video Connections

If you have already connected a source device to one of the AVR's HDMI input connectors, you have automatically made a video connection for that device, since the HDMI cable carries both digital audio and digital video signals.

#### Analog Video Connections – Composite Video

Composite video is the basic connection most commonly available. Both the chrominance (color) and the luminance (intensity) components of the video signal are transmitted using a single cable. The jack is usually color-coded yellow and looks like an analog audio jack. Do not connect a composite video jack to an analog audio or coaxial digital audio jack, or vice versa.

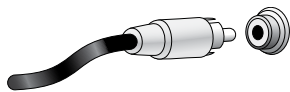

### Radio Connections

Your AVR uses separate terminals for the included FM and AM antennas. The FM antenna uses a 75-ohm F-connector.

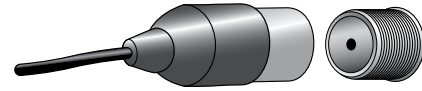

The AM antenna connector uses spring-clip terminals. After assembling the antenna as shown below, press the levers to open the connectors, insert the bare wires into the openings, and release the levers to secure the wires.



### USB Port

The AVR can play MP3 and WMA audio files from a USB device inserted into the USB port. Insert the device into the USB port oriented so it fits all the way into the port. You may insert or remove the device at any time – there is no installation or ejection procedure.

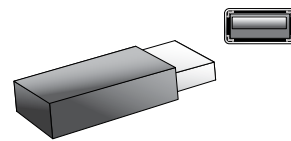

**IMPORTANT: Do not connect a PC or other USB host/controller to the AVR's USB port, or you may damage both the AVR and the other device.**

### Making Connections

**CAUTION:** Before making any connections to the AVR, ensure that the AVR's AC power cord is unplugged from the AVR and the AC outlet. Making connections with the AVR plugged in and turned on could damage the speakers.

#### Connect Your Speakers

After you have placed your loudspeakers in the room as explained in *Place Your Speakers*, on page 8, connect each speaker to its color-coded terminal on the AVR as explained in *Speaker Connections*, on page 9. Connect the speakers as shown in the illustration.

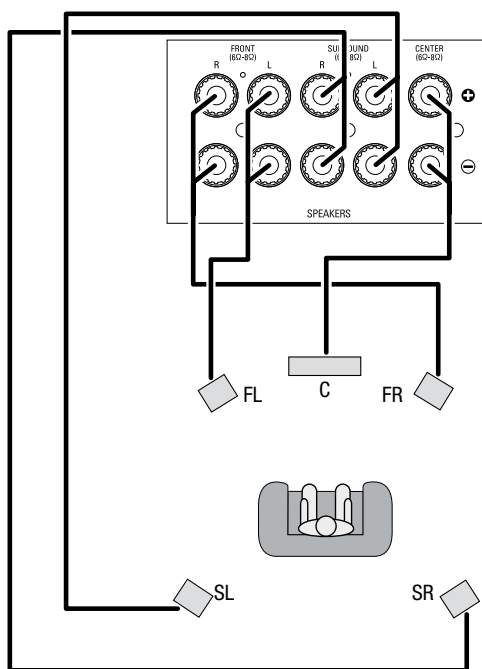

#### Connect Your Subwoofer

Use a single RCA audio cable to connect the AVR's Subwoofer Out connector to your subwoofer. Consult your subwoofer's user manual for specific information about making connections to it.

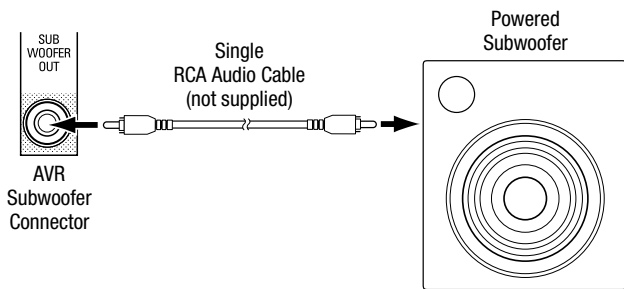

#### Connect Your TV or Video Display

##### HDMI Monitor Out connector

If your TV has an HDMI connector and you have HDMI or component video source devices, use an HDMI cable (not included) to connect your TV to the AVR's HDMI Monitor Out connector. It will provide the best possible picture quality.

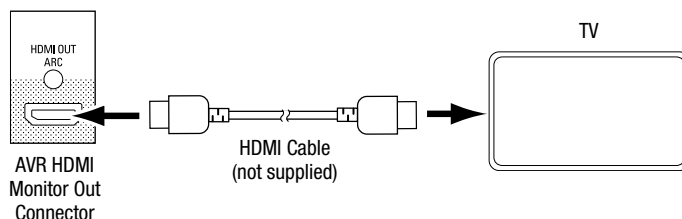

##### Composite Video Monitor Out connector

If your TV does not have an HDMI connector, or if your TV does have an HDMI connector but you are connecting some source devices with only composite video connectors, use a composite video cable (not included) to connect the AVR's Composite Monitor Out connector to your TV's composite video connector.

**IMPORTANT:** The AVR's on-screen display (OSD) only appears through the Composite Monitor Out connector. If you want to use the AVR's OSD menus you need to connect its Composite Monitor Out connector to your TV even if you are not connecting any composite video source devices to the AVR.

##### AVR Composite Monitor Out Connector

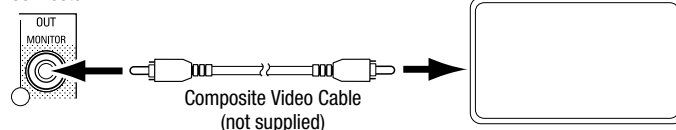

#### Connect Your Source Devices

Source devices are components where a playback signal originates, such as a Blu-ray Disc or DVD player, or a cable, satellite or HDTV tuner. Your AVR has several different types of input connectors for your audio and video source devices: HDMI, composite video, optical digital audio, coaxial digital audio and analog audio.

Each of your AVR's source buttons is assigned to an HDMI connector or an analog audio input connector (listed in the "AVR Source Button/Analog Audio Connector" column of the table below). The digital inputs are not assigned to any specific sets of analog inputs. Once you select a source device you can use the remote control's Audio Input Select (DIGITAL) button to select the specific audio input connection (HDMI, coaxial digital, optical digital, analog) that you want to listen to. (Note: You cannot select an audio input connection for the FM/AM or USB source buttons.)

As you connect your various source components, fill out the "Source Device Connected" and "Digital Audio Input Connector Used" columns in the following table – it will make it easy to keep track of which devices you have connected to which connectors. Note: The AVR remote is pre-programmed to control a Harman/Kardon Blu-ray Disc or DVD player connected to HDMI 1.

AVR Source Button/ Analog Audio Connector	Source Device Connected	Digital Audio Input Connector Used
Video 1		
Video 2		
Video 2		
Tape		
Aux		
AVR Source Button/ HDMI Connector	Source Device Connected	Digital Audio Input Connector Used
*HDMI 1		
HDMI 2		
HDMI 3		

\*The AVR remote is pre-programmed to control a Harman/Kardon Blu-ray Disc or DVD player connected to HDMI 1.

### HDMI devices

If any of your source devices have HDMI connectors, using those connectors will provide the best possible video and audio performance quality. Since the HDMI cable carries both digital video and digital audio signals, you do not have to make any additional audio connections for devices you connect via HDMI cables.

- The AVR remote control is pre-programmed to control a Harman/Kardon Blu-ray Disc or DVD player when the HDMI 1 Source Selector button is pressed.

If you have a TV equipped with the HDMI Audio Return Channel function, its sound is fed to the AVR via the HDMI Out connector's Audio Return Channel, and it will not require additional audio connections to the AVR.

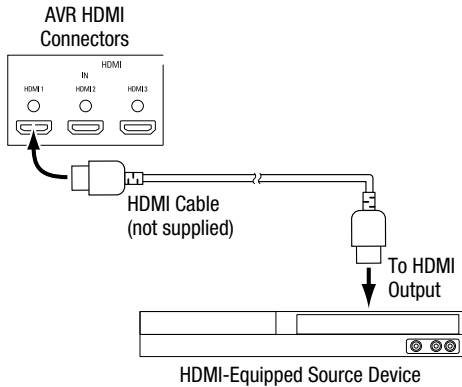

### Composite video devices

You will need to make composite video connections from your source devices that do not have HDMI connectors. You will also need to make an audio connection from the device to the AVR.

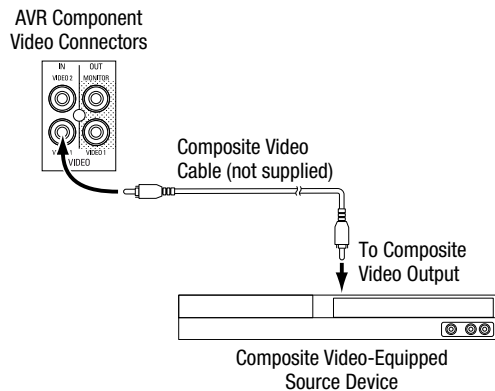

### Optical digital audio devices

If your source devices have optical digital outputs, connect them to the AVR's Optical Digital Audio connectors. NOTE: Make only one type of digital connection (HDMI, optical or coaxial) from each device.

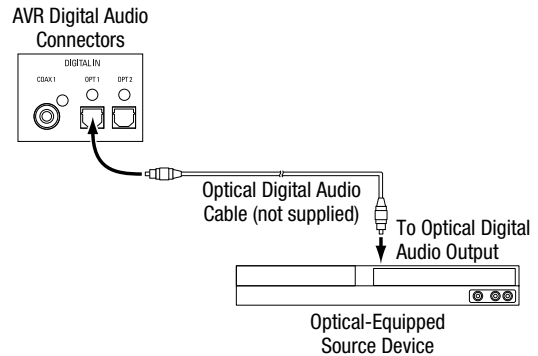

### Coaxial digital audio devices

If your source devices have coaxial digital outputs, connect them to the AVR's Coaxial Digital Audio connectors. NOTE: Make only one type of digital connection (HDMI, optical or coaxial) from each device.

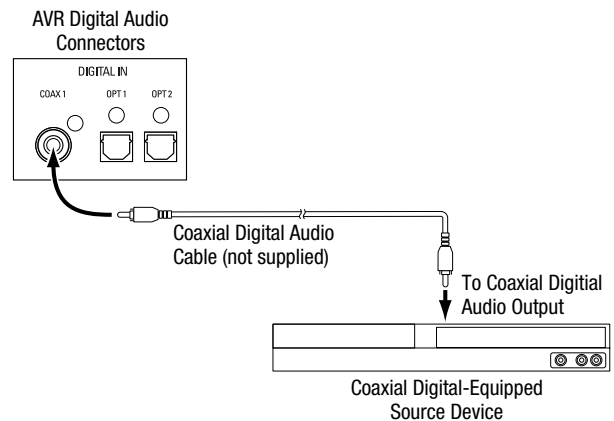

### Analog audio devices

Make analog audio connections from your source devices that do not have HDMI or digital audio connectors. If you're connecting video sources to the Video 1, Video 2 or Video 3 audio inputs, you must also connect the source device's composite video output to the corresponding composite video connector.

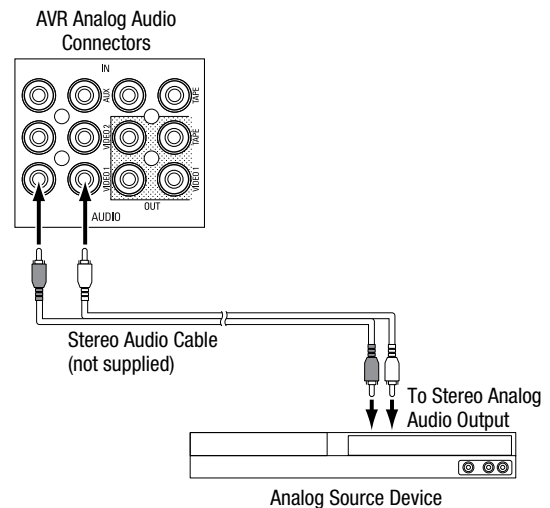

### Audio recorders

Connect an analog audio recorder's inputs to the AVR's analog audio Tape Out connectors. You can record any analog audio input signal except for the Tape 1 input.

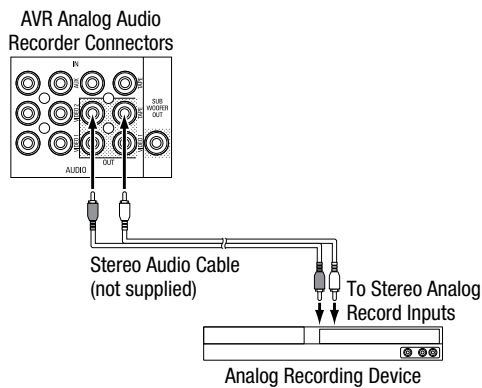

### Connect to AC Power

Connect the AC power cord to the AVR's AC Input connector and then to a working AC power outlet.

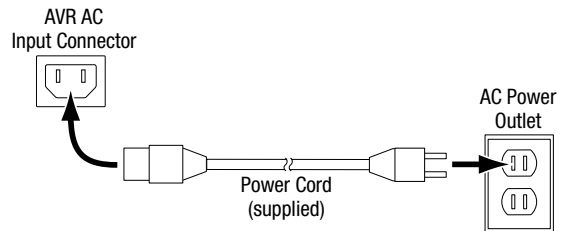

### Install the Batteries in the Remote Control

Remove the remote control's battery cover, insert the three supplied AAA batteries as shown in the illustration, and replace the battery cover.

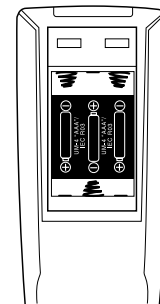

**NOTE:** Remove the protective plastic from the AVR's front panel to keep it from reducing the remote control's effectiveness.

### Video recorders

Connect an analog video recorder's video input connector to the AVR's Video 1 Out Composite Video connector, and its audio input connectors to the AVR's Video 1 Out Analog Audio connectors. You can record the Video 2 or Video 3 composite video input signals.

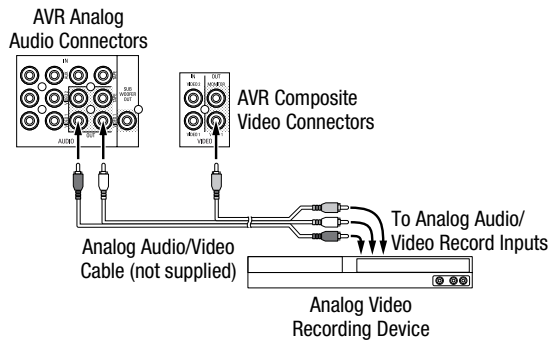

### Connect the Radio Antennas

- Connect the supplied FM antenna to the AVR's FM 75Ω Radio Antenna connector. For the best reception, extend the FM antenna as far as possible.
- Bend and fold the base of the supplied AM antenna as shown and connect the antenna wires to the AVR's AM and Gnd connectors. Rotate the antenna as necessary to minimize background noise.

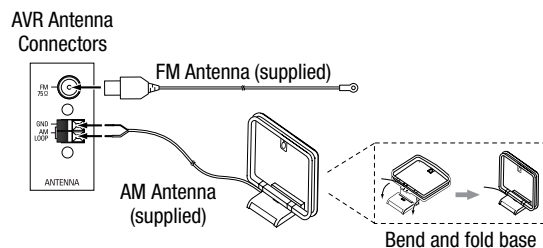

## Set Up the AVR

### Turn On the AVR

1. Set the front-panel Main Power switch to "On." (The front-panel Standby indicator will glow amber.)
2. Press the front-panel On/Standby switch.

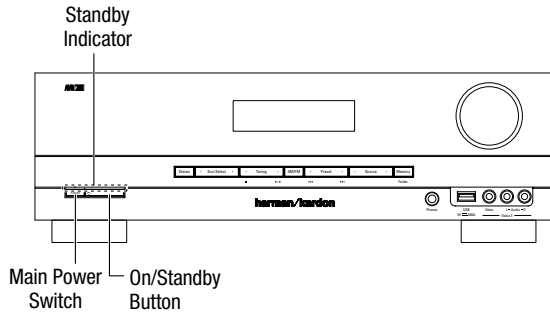

Unless you will not be using the AVR for an extended period of time, leave the Main Power switch set to "On." When the Main Power switch is turned off, any settings you have programmed will be preserved for up to two weeks.

**IMPORTANT NOTE:** If the PROTECT message ever appears in the Message display, turn off the AVR and unplug it. Check all speaker wires for a short circuit ("+" and "-" wires touching). If none is found, bring the unit to an authorized Harman Kardon service center for inspection and repair before using it again.

### Using the On-Screen Menu System

Although it's possible to configure the AVR using only the remote and the front-panel Message display, it is easier to use the on-screen menu system.

To access the menu system, turn on your TV and select the TV's composite video input where you connected the AVR in *Connect Your TV or Video Display*, on page 11.

Press the remote control's SETUP button. The AVR's on-screen display (OSD) System Setup menu will appear on the TV.

#### System Setup

1. Speaker Setup
2. HDMI Setup
3. Audio Settings
4. Audio Power Control
5. Speaker On/Off

The System Setup menu consists of five submenus: Speaker Set, HDMI Set, Parameter, Auto Power Control and Speaker On/Off.

Use the Up/Down/Left/Right buttons on the remote to navigate the menu system, and press the OK button to select a menu or setting line, or to enter a new setting.

The current menu, setting line or setting will appear in the front-panel Message display, as well as on screen.

To return to the previous menu, press the remote's BACK button. To exit the menu system, press the SETUP button.

Follow the instructions in this *Set Up the AVR* section to configure your home theater system. You may return to these menus at any time to make additional adjustments.

Before you begin initial setup, all loudspeakers, a video display and all source devices should be connected to the AVR. You should be able to turn on the AVR and view the System Setup menu when you press the SETUP button. If necessary, reread the *Making Connections* section and the beginning of this section before continuing.

### Configure the AVR for Your Speakers

1. Turn on your TV and select the TV's composite video input where you connected the AVR in *Connect Your TV or Video Display*, on page 11.
2. Press the remote control's SETUP button. The AVR's on-screen display (OSD) System Setup menu will appear on the TV.

#### System Setup

1. Speaker Setup
2. HDMI Setup
3. Audio Settings
4. Audio Power Control
5. Speaker On/Off

3. Use the remote's arrow and OK buttons to select "Speaker Setup." The *Speaker Setup* menu will appear.

#### 1. Speaker Setup

- a. Speaker Settings
- b. Crossover
- c. Channel Level
- d. Speaker Distance

4. Select "Speaker Settings." The Speaker Settings menu will appear.

#### 1a. Speaker Settings

```

Front      < [ LARGE ] >
Center     [  LARGE  ]
Surround L/R [  LARGE  ]
Subwoofer  [  YES  ]
    
```

5. Use the remote's left and right arrow buttons to select OFF, SMALL or LARGE for the Front, Center and Surround speaker positions, depending on the speakers you have connected to the receiver.

OFF: Select this setting if you have not connected a speaker in that position (not available for the Front speakers).

SMALL: Select this setting if the speaker is not capable of producing clean, deep bass energy at output levels that match those produced by a powered subwoofer. All bass below the crossover frequency (see Step 6, below) in that channel is removed from that speaker and is sent to the subwoofer (or to the Front speakers if Subwoofer is set to NO). Most speakers (unless they are large and powerful) should be considered SMALL.

LARGE: Select this setting if the speaker is capable of producing clean, deep bass energy at output levels that match those produced by a powered subwoofer. All bass in that channel is sent to that speaker.

NOTE: If your system has a subwoofer and you set the Front speakers to LARGE, the subwoofer may not output audio except for Dolby Digital- and DTS-encoded program material that contains LFE channel information. If you set your Front speakers to LARGE and you want your subwoofer to reproduce bass from all program material, set the Subwoofer to PLUS (see below).

For Subwoofer, select YES (if your system has a subwoofer), NO (if your system does not have a subwoofer), or PLUS (if your system has a subwoofer, you set your Front speakers to LARGE and you want your subwoofer to reproduce bass from all program material).

When you're finished, record your settings in Table A2 of the Appendix, on page 21, then press the remote control's BACK button to return to the Speaker Setting menu.

6. (Note: If your system does not have a subwoofer, skip to step 7.) Press the BACK button and select "Crossover." The Crossover menu will appear

#### 2b. Crossover

```

Frequency  < [ 100Hz ] >
    
```



Consult the technical specifications for your system's main left and right speakers and locate the frequency response, usually given as a range, e.g., 80Hz – 20kHz ( $\pm 3$ dB). Note the lowest frequency that the speakers are capable of playing (80Hz in the above example). NOTE: This frequency is not the same as the crossover frequency that may also be listed in the specifications.

Use the remote's left and right arrow buttons to select the crossover frequency that most closely matches the low frequency specification that you noted above. The AVR will divide the source signal at this crossover point, will send all information above the crossover point to your system's speakers, and all information below the crossover point to the subwoofer. This way, each loudspeaker in your system will perform at its best, delivering a more powerful and enjoyable sound experience. Record the setting in Table A2 of the Appendix, on page 21.

- Press the BACK button and select "Speaker Distance." The Speaker Distance menu will appear.

#### 2d. Speaker Distance

```

Front L   < 10.0ft >
Center   [ 10.0ft ]
Front R   [ 10.0ft ]
Surround R [ 10.0ft ]
Surround L [ 10.0ft ]
Subwoofer [ 10.0ft ]

```

- Measure the distance from each speaker in your system to the listening position. Record the distances in Table A3 of the Appendix, on page 21.
- Use the remote's left and right arrow buttons to change the distance setting for each speaker so it matches the distance you wrote down in step 8. When you're finished, press the remote control's BACK button to return to the Speaker Setting menu.
- Select "Channel Level." The Channel Level menu will appear. Use the remote's left and right arrow buttons to set Test Tone to "Manual" and press the remote's OK button. After the on-screen countdown you will hear test noise through the front left speaker.

#### 2c. Channel Level

```

Test Tone < Manual >

```

- Sit in the main listening position and adjust the AVR's volume control so the test noise is moderately loud. Note the volume of the test noise through the first speaker. Press the remote's down arrow button to advance the test noise to each of your system's speakers and note the volume level of the noise in each speaker.
- As you advance the test noise through the speakers, use the remote's left and right arrow buttons to adjust the volumes of the channels until all of them play at the same volume.

#### Notes on Setting Speaker Volumes in Home Theater Systems:

While setting your system's individual speaker volume levels is ultimately up to your personal taste, here are some ideas you may find helpful:

- For films and video-music programs, your overall goal should be to create an enveloping, realistic sound field that draws you into the film or music program without drawing your attention away from the action on the screen.
- For multichannel music recordings, some music producers will create a sound field that places the musicians all around you; others will create a sound field that places the musicians in front of you, with more subtle ambience in the surround speakers (as you would experience in a concert hall).
- In most 5.1-channel film soundtracks, the surround speakers are not intended to be as loud or as active as the front speakers. Adjusting the surround speakers so they are always as loud as the front speakers could make dialogue difficult to understand and will make some sound effects sound unrealistically loud.

#### Notes on Setting Subwoofer Volume:

- Sometimes the ideal subwoofer volume setting for music is too loud for films, while the ideal setting for films is too quiet for music. When setting the subwoofer volume, listen to both music and films with strong bass content and find a "middle ground" volume level that works for both.
  - If your subwoofer always seems too loud or too quiet, you may want to place it in a different location. Placing the subwoofer in a corner will always tend to increase its bass output, while placing it away from any walls or corners will always tend to lessen its bass output.
- When you're finished, record the settings in Table A3 of the Appendix, on page 21, then press the remote's SETUP button to turn off the on-screen menus.

#### Additional Setup Menu Items

You can also adjust the following settings:

**HDMI Set:** Selecting ARC/CEC On will send audio from the TV to the AVR via the HDMI Audio Return Channel (ARC) connection (which is in the HDMI cable connecting the AVR to the TV). This way, whenever you're watching a source that is connected directly to your TV (such as an Internet connection), you can listen to the sound through the AVR by selecting TV as the AVR source device. Selecting On also allows the communication of control information among the HDMI devices in your system (CEC).

**Audio Settings:** Selecting Audio Settings allows you to adjust the following audio settings:

- Night Mode works with specially encoded Dolby® Digital discs or broadcasts, compressing the audio so that louder passages are reduced in volume to avoid disturbing others, while dialogue remains intelligible. Press the left/right arrow buttons to advance through the following DRC (Dynamic Range Control) settings:

**Off:** No compression is applied. Loud passages in the program remain as they were recorded.

**Mid:** Loud passages in the program are reduced moderately in volume.

**Max:** Loud passages in the program are reduced more in volume.

**Auto:** Automatically compresses the audio a specific amount in response to instructions encoded in the Dolby Digital program.

- PLII Music: Additional adjustments are available that allow you to fine-tune the Dolby Pro Logic II Music surround mode's performance for your listening room and personal taste:

**Panorama:** With the Panorama mode turned on, some of the sound from the front speakers is moved to the surround speakers, creating an enveloping "wraparound" effect. Each press of the left or right arrow buttons toggles the setting On or Off.

**Center Width:** This setting affects how vocals sound through the three front speakers. A lower number focuses the vocal information tightly on the center channel. Higher numbers (up to 7) broaden the vocal soundstage. Use the left/right arrow buttons to adjust this setting.

**Dimension:** This setting affects the depth of the surround presentation, allowing you to "move" the sound toward the front or rear of the room. The setting of "0" is a neutral default. "+" settings move the sound toward the front of the room, while "-" settings move the sound toward the rear. Use the left/right arrow buttons to adjust it.

See *Audio Processing and Surround Sound*, on page 17, for more information about Dolby Pro Logic II.

**Auto Power Control:** This setting allows you to set the AVR to automatically enter the Standby mode after a period of inactivity, saving energy. The available settings are Off (default), 2 hours, 4 hours and 6 hours.

**Speaker On/Off:** Use this setting to turn the speakers off when you are listening through headphones.

## Operating Your AVR

Now that you have installed your components and completed a basic configuration, you are ready to begin enjoying your home theater system.

### Controlling the Volume

Adjust the volume either by turning the front-panel Volume knob (clockwise to increase volume or counterclockwise to decrease volume) or by pressing the Volume Up/Down buttons on the remote.

### Muting the Sound

To mute all speakers and the headphones, press the Mute button on the remote. Any recording in progress will not be affected. The MUTE message will appear in the front-panel display as a reminder. To restore the sound, press the Mute button again, or adjust the volume.

### Listening Through Headphones

Plug the 1/4-inch stereo plug on a pair of headphones into the front-panel Phones jack for private listening. Note: For information about turning off the speakers during headphone listening, see *Additional Setup Menu Items – Speaker On/Off*, on page 15.

### Selecting a Source

There are two different ways to select a source:

- Press the front-panel Source Select buttons.
- Directly select any source by pressing its Source Selector button on the remote.

The AVR selects the analog audio and video inputs assigned to the source and any other settings you made during setup.

The digital audio inputs are not assigned to any specific sets of analog inputs. Once you select a source device you can use the remote control's Audio Input Select (DIGITAL) button to select the specific audio input connection (HDMI, coaxial digital, optical digital, analog) that you want to listen to. (Note: You cannot select an audio input connection for the FM/AM or USB source buttons.)

The source name, the selected audio input and the surround mode will appear on the front panel.

### Video Troubleshooting Tips

#### If there is no picture:

- Check the source selection.
- Check all connections for a loose or incorrect connection.
- Check the video-input selection on the TV/display device.

#### Additional Tips for Troubleshooting HDMI Connections

- Turn off all devices (including the TV, the AVR and any source components).
- Unplug the HDMI cables, starting with the cable between the AVR and the TV, and continuing with the cables between the AVR and each source device.
- Carefully reconnect the cables from the source devices to the AVR. Connect the cable from the AVR to the TV last.
- Turn on the devices in this order: TV, AVR, source devices.

**NOTE: Depending upon the particular components involved, the complexity of the required communication between HDMI components may cause delays of up to a minute in the completion of some actions, such as input switching or switching between SD and HD channels.**

### Listening to FM and AM Radio

Select the AM/FM source. Use the Tuning Up/Down buttons to tune a station, which will be shown on the front-panel display and the TV screen.

In the FM Stereo mode, the radio uses automatic tuning, meaning each press of the Tuning Up/Down buttons scans until a station with acceptable signal strength is found. In the FM Mono mode, the radio uses manual tuning, in which each press of a Tuning button steps through a single frequency increment. (Using the FM Mono mode may improve the reception of weaker stations.)

### Preset Stations

A total of 30 stations (AM and FM combined) may be stored as presets. When the desired station has been tuned in, press the Memory button and the preset number will flash on the front-panel Message display. Use the remote's Number buttons to enter the desired preset number.

To tune a preset station, press the Preset Up/Down buttons or enter the preset number using the remote's Number buttons.

### Listening to Media on a USB Device

Your AVR is compatible with USB 2.0 or USB 1.1 media in the FAT 16 or FAT 32 file format and is compatible with the following MP3 and WMA media:

- MP3: Bit rates between 96 – 320kbps. Fixed bit-rates at 44.1kHz sampling is recommended. Variable bit-rates (VBR) are playable, but playing time may be displayed incorrectly. Files must have a “.mp3” file extension.
- WMA: Bit rates of 64kbps or higher. NOTE: Bit rates of 80kbps and 256kbps are not compatible. Files must have a “.wma” file extension.

A maximum number of 65,536 folders and files can be supported.

### Playing files on a USB device

1. Insert the USB drive into the AVR's front-panel USB port. **IMPORTANT:** Do not connect a personal computer or peripheral to the USB port. USB hubs are not supported.
2. Select USB as the source device. “USB” will appear on the front-panel display, and after the AVR loads the contents of the current folder the USB playback screen will appear on the OSD.

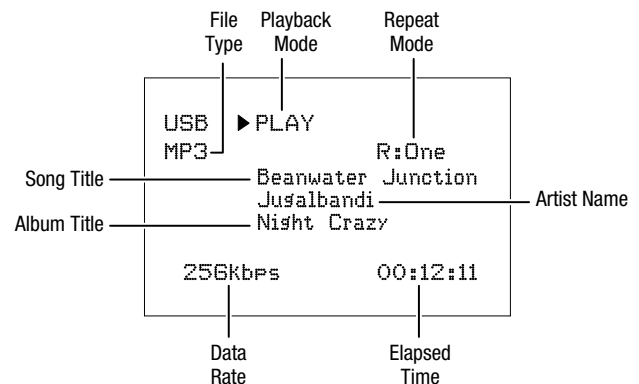

Use the remote's Transport Control buttons to control playback.

To browse the contents of the current folder, press the remote's BACK button. The USB folder screen will appear on the OSD for 20 seconds.

```

USB
  ▲ Last 002/010
[Ants Ate My Silkworms.mP3 ]
[Night Crazy.mP3           ]
[Beanwater Junction, Part 1]
[Yarmishun Jim.mP3        ]
[Successfully Assimilated, P]
[The Lost Transit Center.mP]
[Successfully Assimilated, P]
[Beanwater Junction, Part 2]
ENTER ▼ Next
    
```

Use the remote's up, down and OK buttons to highlight and select tracks.

**IMPORTANT:** To prevent damage or malfunction, press the remote's Stop (■) Transport Control button before removing the USB device from the AVR's USB port.

### Selecting a Surround Mode

Selecting a surround mode can be as simple or sophisticated as your individual system and tastes. Feel free to experiment, and you may find a few favorites for certain sources or program types. You can find more detailed information on surround modes in *Audio Processing and Surround Sound*, below.

To select a surround mode, press the Surround Mode Select buttons. Each press advances to the next available surround mode.

Digital surround-sound modes, such as Dolby Digital and DTS systems, are available only with specially encoded programs, such as those available via HDTV, DVD and Blu-ray Disc media and digital cable or satellite television. Other surround modes such as Dolby Pro Logic II may be used with digital or analog signals to create a different surround presentation or to use a different number of speakers.

Surround mode selection depends upon the number of speakers in your system, the programs you are watching or listening to, and your personal tastes.

### Advanced Functions

Much of the adjusting and configuration your AVR requires is handled automatically, with little intervention required on your part. You can also customize your AVR to suit your system and your tastes. In this section, we will describe some of the more advanced adjustments available to you.

#### Audio Processing and Surround Sound

Audio signals can be encoded in a variety of formats that affect not only the quality of the sound but also the number of speaker channels and the surround mode. You may also manually select a different surround mode, when available.

##### Analog Audio Signals

Analog audio signals usually consist of two channels – left and right. Your AVR offers several options for analog playback:

- **Stereo:** When you want conventional 2-channel playback, press the STEREO button. Sound will be output from the front left and right speakers.
- **5-Ch Stereo:** When you want to hear stereo sound through all of the system's speakers (such as during a party), select 5CH STEREO via the Surround Mode Select buttons. This plays the left-channel signal through the front left and surround left speakers, the right-channel signal through the front right and surround right speakers, and a summed mono signal through the center speaker.
- **Analog Surround Modes:** Your AVR is able to process 2-channel audio signals to produce multi-channel surround sound, even when no surround sound has been encoded in the recording. Among the available modes are Dolby Pro Logic II, Dolby Pro Logic, DTS Neo: 6, Theater, Hall, Stadium, Club and Arena modes. Use the Surround Mode Select buttons to select one of these modes. See Table A5 in the Appendix, on page 25, for brief explanations of each of these surround modes.

##### Digital Audio Signals

Digital audio signals offer greater flexibility and capacity than analog signals and allow the encoding of up to 5.1 channels of discrete channel information directly into the signal. The result is improved sound quality and startling directionality, since each channel's information is transmitted independently of the other channels. High-resolution recordings sound extraordinarily distortion-free, especially in the high frequencies.

Digital surround-sound formats include Dolby Digital 2.0 (two channels only), Dolby Digital 5.1, Dolby Digital EX (6.1), Dolby Digital Plus (7.1), Dolby TrueHD (7.1), DTS-HD High-Resolution Audio (7.1), DTS-HD Master Audio (7.1), DTS 5.1, DTS 96/24 (5.1), 2-channel PCM modes in 44.1kHz, 48kHz, 88.1kHz, 96kHz or 176.4kHz, and 5.1 or 7.1 multichannel PCM. (Your AVR will downmix the discrete surround back-channel information in 6.1-channel and 7.1-channel recordings into your system's surround left and surround right channels.)

#### Surround Mode Selection

Surround-mode selection depends upon the format of the incoming audio signal as well as your personal taste. Although there is never a time when all of the AVR's surround modes are available, the table below indicates which surround modes are available for a given input.

Input Signal Format	Available Surround Modes
Dolby True HD, Dolby Digital Plus, Dolby Digital (7.1-channel/5.1-channel)	Corresponding Dolby True HD or Dolby Digital mode (Theater, Hall, Stadium, Club, Arena and 5-Ch Stereo are also available for 5.1-channel programs)
Dolby Digital (2.0-channel)	Dolby Pro Logic II Movie, Dolby Pro Logic II Music, Dolby Pro Logic II Game, Dolby Pro Logic
DTS HD Master Audio, DTS, DTS 96/24	Corresponding DTS Mode (Theater, Hall, Stadium, Club, Arena and 5-Ch Stereo are also available for 5.1-channel programs)
PCM (2-channel), Analog (2-channel)	Dolby Pro Logic II Movie, Dolby Pro Logic II Music, Dolby Pro Logic II Game, Dolby Pro Logic, DTS Neo:6 Cinema, DTS Neo:6 Music, Theater, Hall, Stadium, Club, Arena, 5-Ch Stereo
MP3/WMA	Dolby Pro Logic II Movie, Dolby Pro Logic II Music, Dolby Pro Logic II Game, Dolby Pro Logic, DTS Neo:6 Cinema, DTS Neo:6 Music, Theater, Hall, Stadium, Club, Arena, 5-Ch Stereo

When in doubt, check the broadcast or the jacket of your disc for more information on which surround modes are available. Usually, nonessential sections of a disc, such as trailers, extra materials or the disc menu, are available only in Dolby Digital 2.0 (2-channel) or PCM 2-channel mode. Look for an audio setup section in the disc's menu. Also, make sure your disc player's audio output is set to the original bitstream rather than 2-channel PCM. Stop play and check the player's output setting.

#### Adjusting the Channel Volumes

In addition to using the AVR's built-in test noise to configure the AVR for your speakers as explained in *Configure the AVR for Your Speakers*, you can also adjust the volume of any channel at any time to compensate for individual program sources or your personal taste.

1. Press the remote's Channel Level button. The Message Display will show the left channel volume level.
2. Use the remote's up and down arrow buttons to display the channel you want to adjust.
3. Use the remote's left and right arrow buttons to adjust the channel's volume.

Press the BACK button when you're finished.

#### Recording

Two-channel analog audio signals, as well as composite video signals, are normally available at the appropriate recording output connectors. To make a recording, connect your audio or video recorder to the appropriate AVR output connectors as described in the *Making Connections* section, insert blank media in the recorder and make sure the recorder is turned on and recording while the source is playing. Refer to the recording device's instructions for complete information about making recordings.

##### NOTES:

1. The AVR does not convert digital signals to analog. Only devices connected to the analog audio and composite video input connections can be recorded.
2. HDMI video sources are not available for recording.
3. Please make certain that you are aware of any copyright restrictions on any material you record. Unauthorized duplication of copyrighted materials is prohibited by law.

**Sleep Timer**

The sleep timer sets the AVR to play for up to 90 minutes and then turn off automatically.

Press the Sleep button on the remote, and the time until turn-off will be displayed on the front-panel Message display. The available settings are 30 min., 60 min., 90 min. and OFF.

When the sleep timer has been set, a small crescent-moon icon will appear on the front-panel display.

If you press the Sleep button after the timer has been set, the remaining play time will be displayed. Press the Sleep button again to change the play time.

**Processor Reset**

If the AVR behaves erratically after a power surge, first turn off the front-panel Main Power switch and unplug the AC power cord for at least 3 minutes. Plug the cord back in and turn the AVR on. If this procedure doesn't help, reset the AVR's processor as described below.

**NOTE:** Resetting the processor will erase all user configurations, including speaker and level settings, and tuner presets. After a reset, reenter all of these settings from your notes in the Appendix worksheets.

**To reset the AVR's processor:**

1. Press the front-panel Standby/On switch to place the unit in the Standby mode (the Standby Indicator LED will turn amber).
2. Press and hold the front-panel Standby and Memory/Folder buttons until the RESET message appears on the front-panel Message display.
3. Press the Memory/Folder button again to reset the AVR's processor.

If the AVR does not function correctly after a processor reset, contact an authorized Harman Kardon service center for assistance. To locate an authorized service center, visit our Web site at [www.harmankardon.com](http://www.harmankardon.com).

**Memory**

If the AVR is unplugged or experiences a power outage, it will retain your user settings for up to two weeks.

## Troubleshooting

Symptom	Cause	Solution
Unit does not function when Main Power switch is turned on	<ul style="list-style-type: none"> <li>No AC power</li> </ul>	<ul style="list-style-type: none"> <li>Ensure that the power cord is plugged into a live AC power outlet</li> <li>Check if the AC outlet is switch-controlled</li> </ul>
Front-panel Message display lights, but there's no sound or picture	<ul style="list-style-type: none"> <li>Intermittent input connection</li> <li>Mute is on</li> <li>Volume control is turned down</li> </ul>	<ul style="list-style-type: none"> <li>Secure all input and speaker connections</li> <li>Press Mute button</li> <li>Turn up Volume control</li> </ul>
No sound from any speaker	<ul style="list-style-type: none"> <li>Speakers set to "Off" in System Setup menu</li> </ul>	<ul style="list-style-type: none"> <li>Set speakers to "On" in System Setup menu. See <i>Additional Setup Menu Items: Speaker On/Off</i>, on page 15, for more information.</li> </ul>
No sound from any speaker; PROTECT message appears on Message display	<ul style="list-style-type: none"> <li>Amplifier is in protection mode due to possible short circuit</li> <li>Amplifier is in protection mode due to internal problems</li> </ul>	<ul style="list-style-type: none"> <li>Check all speaker wires at speaker and AVR connections for crossed wires</li> <li>Contact your local Harman Kardon service center</li> </ul>
No sound from center or surround speakers	<ul style="list-style-type: none"> <li>Incorrect surround mode</li> <li>Program material is monophonic</li> <li>Incorrect speaker configuration</li> <li>Program material is stereo</li> </ul>	<ul style="list-style-type: none"> <li>Select a surround mode other than stereo</li> <li>Mono programs contain no surround information</li> <li>Check the speaker configuration in the setup menu</li> <li>The surround decoder may not create center- or surround-channel information from nonencoded stereo programs</li> </ul>
Unit does not respond to remote control commands	<ul style="list-style-type: none"> <li>Weak batteries in remote</li> <li>AVR not selected</li> <li>Remote sensor is obscured</li> </ul>	<ul style="list-style-type: none"> <li>Change batteries in remote</li> <li>Press the Setup/AVR button</li> <li>Ensure that the AVR's front-panel remote sensor is in the line of sight of the remote</li> </ul>
Intermittent buzzing in tuner	<ul style="list-style-type: none"> <li>Local interference</li> </ul>	<ul style="list-style-type: none"> <li>Move the AVR or antenna away from computers, fluorescent lights, motors or other electrical appliances</li> </ul>

Additional information on troubleshooting possible problems with your AVR and installation-related issues may be found in the list of "Frequently Asked Questions," which is located in the Product Support section of our Web site: [www.harmankardon.com](http://www.harmankardon.com)

## Specifications

### Audio Section

Multichannel power:	75W per channel, two channels driven @ 6 ohms, 20Hz – 20kHz, <0.1% THD; 100W per channel, two channels driven @ 6 ohms, 1kHz, <1% THD
Input sensitivity/impedance:	200mV/47k ohms
Signal-to-noise ratio (IHF-A):	95dB
Surround system adjacent-channel separation:	Dolby Pro Logic/PLII: 40dB Dolby Digital: 55dB DTS: 55dB
Frequency response:	10Hz – 100kHz
High instantaneous-current capability (HCC):	±25 amps

### FM Tuner Section

Frequency range:	87.5 – 108.0MHz
Usable sensitivity IHF:	1.3µV/13.2dBf
Signal-to-noise ratio (mono/stereo):	65dB/62dB
Distortion (mono/stereo):	0.2%/0.3%
Stereo separation:	35dB @ 1kHz
Image rejection:	80dB
IF rejection:	80dB

### AM Tuner Section

Frequency range:	520 – 1720kHz
Signal-to-noise ratio:	45dB
Usable sensitivity (loop):	500µV
Selectivity (±10kHz):	30dB

### Video Section

Television format:	NTSC (AVR 700); PAL (AVR 70/AVR 70C)
Input level/impedance:	1Vp-p/75 ohms
Output level/impedance:	1Vp-p/75 ohms
Video frequency response (composite video):	10Hz – 8MHz (–3dB)
HDMI:	With 3D and Deep Color

### General Specifications

Power requirement:	120V AC/60Hz (AVR 700) 220V AC/50Hz (AVR 70) 230V AC/50Hz (AVR 70C)
Power consumption:	<0.5W (standby); 280W maximum
Dimensions (W x H x D):	17-5/16" x 4-5/16" x 13" (440mm x 125mm x 330mm)
Weight	20 lb (9.1kg)

## Appendix – Default settings, worksheets, remote product codes

**Table A1 – Recommended Source Component Connections**

Device Type	AVR Source	Audio Connections	Video Connections
VCR, DVR, PVR, or other audio/video recorder	Video 1	<ul style="list-style-type: none"> <li>Video 1 Analog (inputs and outputs)</li> </ul>	<ul style="list-style-type: none"> <li>Composite Video 1 Input</li> <li>For recording, use Composite Video 1 Output</li> </ul>
Cable TV, Satellite, HDTV or other device that delivers television programs	Video 2	<ul style="list-style-type: none"> <li>Video 2 Analog inputs</li> <li>Optical 1 Input (if not in use)</li> </ul>	Composite Video 2 Input
Blu-ray Disc player	HDMI 1	<ul style="list-style-type: none"> <li>HDMI 1 Input</li> </ul>	<ul style="list-style-type: none"> <li>HDMI 1 Input</li> </ul>
HDMI-capable disc player, game console or other audio/video device	HDMI 2	<ul style="list-style-type: none"> <li>HDMI 2 Input</li> </ul>	<ul style="list-style-type: none"> <li>HDMI 2 Input</li> </ul>
HDMI-capable disc player, game console or other audio/video device	HDMI 3	<ul style="list-style-type: none"> <li>HDMI 3 Input</li> </ul>	<ul style="list-style-type: none"> <li>HDMI 3 Input</li> </ul>
Portable audio device, camcorder, game console	Video 3	<ul style="list-style-type: none"> <li>Video 3 Analog Audio Input on front panel</li> </ul>	<ul style="list-style-type: none"> <li>Video 3 Coaxial Video Input on front panel</li> </ul>
CD player	Aux	<ul style="list-style-type: none"> <li>Aux Analog Inputs</li> <li>Any one available coaxial or optical digital audio input</li> </ul>	<ul style="list-style-type: none"> <li>Not required</li> </ul>
CD-R, MiniDisc, cassette	Tape	<ul style="list-style-type: none"> <li>Tape Analog (inputs and outputs)</li> </ul>	<ul style="list-style-type: none"> <li>Not required</li> </ul>

Note: Table A1 is a guideline; you may need to make adjustments to fit your system.

**Table A2 – Speaker/Channel Settings**

Source	Speaker Setting
Left/Right Speaker	
Center Speaker	
Surround Speakers	
Subwoofer	
Crossover	

**Table A3 – Speaker Volume and Distance Settings**

Speaker Positions	Channel Volume Setting	Your Distance From Speaker to Listening Position
Front Left		
Center		
Front Right		
Surround Right		
Surround Left		
Subwoofer		

**Table A4 – Surround Modes**

Surround Mode	Description	Incoming Bitstream or Signal
Dolby Digital	Provides up to five separate main audio channels and a dedicated low-frequency effects (LFE) channel.	<ul style="list-style-type: none"> <li>• Dolby Digital 1/0/.0 or .1, 2/0/.0 or .1, 3/0/.0 or .1, 2/1/.0 or .1, 2/2/.0 or .1, 3/2/.0 or .1</li> <li>• Dolby Digital EX (played as 5.1)</li> <li>• Dolby Digital Plus decoded and delivered via coaxial or optical connection</li> </ul>
Dolby Digital Plus	An enhanced version of Dolby Digital encoded more efficiently, Dolby Digital Plus has the capacity for additional discrete channels and for streaming audio from the Internet, all with enhanced audio quality. Source material may be delivered via an HDMI connection or decoded to Dolby Digital or PCM and transmitted via coaxial or optical digital audio.	<ul style="list-style-type: none"> <li>• Dolby Digital Plus via HDMI connection (source device decodes to Dolby Digital when a coaxial or optical connection is used)</li> </ul>
Dolby TrueHD	Dolby TrueHD is an expansion of MLP Lossless™ audio, the same format used on DVD-Audio discs. Dolby TrueHD adds the features found in Dolby Digital, such as night mode settings, while delivering fully lossless audio that is a true reproduction of studio master recordings.	<ul style="list-style-type: none"> <li>• Blu-ray Disc or HD-DVD encoded with Dolby TrueHD, delivered via HDMI</li> </ul>
Dolby Digital Stereo	Delivers a 2-channel downmix of Dolby Digital materials.	<ul style="list-style-type: none"> <li>• Dolby Digital 1/0/.0 or .1, 2/0/.0 or .1, 3/0/.0 or .1, 2/1/.0 or .1, 2/2/.0 or .1, 3/2/.0 or .1</li> <li>• Dolby Digital EX</li> </ul>
Dolby Pro Logic II Mode Group	Analog decoder that derives five full-range, discrete main audio channels from matrix surround-encoded or 2-channel analog sources. Four variants are available.	See below
Dolby Pro Logic II Movie	Variant of Dolby Pro Logic II that is optimized for movie and television programs.	<ul style="list-style-type: none"> <li>• Dolby Digital 2.0 or 2.1</li> <li>• Analog (two-channel)</li> <li>• Tuner</li> <li>• PCM (32kHz, 44.1kHz, 48kHz, 96kHz)</li> <li>• MP3/WMA</li> </ul>
Dolby Pro Logic II Music	Variant of Dolby Pro Logic II that is optimized for music selections. Allows adjustment of sound-field presentation in three dimensions: <ul style="list-style-type: none"> <li>• Center Width (adjusts width of vocal soundstage)</li> <li>• Dimension (adjusts depth of soundstage)</li> <li>• Panorama (adjusts wraparound surround effect)</li> </ul>	<ul style="list-style-type: none"> <li>• Dolby Digital 2.0 or 2.1</li> <li>• Analog (two-channel)</li> <li>• Tuner</li> <li>• PCM (32kHz, 44.1kHz, 48kHz, 96kHz)</li> <li>• MP3/WMA</li> </ul>
Dolby Pro Logic II Game	Variant of Dolby Pro Logic II that emphasizes use of the surround channels and subwoofer for total immersion in the video gaming experience.	<ul style="list-style-type: none"> <li>• Dolby Digital 2.0 or 2.1</li> <li>• Analog (two-channel)</li> <li>• Tuner</li> <li>• PCM (32kHz, 44.1kHz, 48kHz, 96kHz)</li> <li>• MP3/WMA</li> </ul>
Dolby Pro Logic	Original version of Dolby Pro Logic that steered a mono signal containing information below 7kHz to the surround channels.	<ul style="list-style-type: none"> <li>• Dolby Digital 2.0 or 2.1</li> <li>• Analog (two-channel)</li> <li>• Tuner</li> <li>• PCM (32kHz, 44.1kHz, 48kHz, 96kHz)</li> <li>• MP3/WMA</li> </ul>
DTS Digital	Using a different encoding/decoding method from Dolby Digital, DTS Digital also provides up to five discrete main channels, plus an LFE channel.	<ul style="list-style-type: none"> <li>• DTS 1/0/.0 or .1, 2/0/.0 or .1, 3/0/.0 or .1, 3/1/.0 or .1, 2/2/.0 or .1, 3/2/.0 or .1</li> <li>• DTS-ES Matrix (played as 5.1)</li> <li>• DTS-ES Discrete (played as 5.1)</li> </ul>
DTS-HD	DTS-HD is a high-definition audio format that complements the high-definition video found on Blu-ray Disc and HD-DVD discs. It is transmitted using a DTS core with high-resolution extensions. Even when only DTS 5.1 surround sound is desired (or available, if the multizone system is in use), the higher capacity of high-resolution discs serves up DTS at twice the bit rate used on DVD-Video discs.	<ul style="list-style-type: none"> <li>• Blu-ray Disc or HD-DVD discs encoded with DTS-HD modes, delivered via HDMI connection</li> </ul>
DTS-HD Master Audio	DTS-HD Master Audio technology delivers bit-for-bit reproductions of studio master recordings for an incredibly accurate performance.	<ul style="list-style-type: none"> <li>• Blu-ray Disc or HD-DVD discs encoded with DTS-HD Master Audio technology, delivered via HDMI connection</li> </ul>



**Table A4 – Surround Modes (cont.)**

Surround Mode	Description	Incoming Bitstream or Signal
DTS Stereo	Delivers a 2-channel downmix of DTS Digital materials or presents a matrix-encoded surround presentation.	<ul style="list-style-type: none"> <li>• DTS 1/0/.0 or .1, 2/0/.0 or .1, 3/0/.0 or .1, 3/1/.0 or .1, 2/2/.0 or .1, 3/2/.0 or .1</li> <li>• DTS 96/24</li> <li>• DTS-ES Matrix</li> </ul>
DTS Neo:6 Cinema	Delivers an enhanced 5.1-channel surround-sound experience for movies	<ul style="list-style-type: none"> <li>• Analog (two-channel)</li> <li>• AM/FM radio</li> <li>• PCM (32kHz, 44.1kHz, 48kHz, 96kHz)</li> <li>• MP3/WMA</li> </ul>
DTS Neo:6 Music	Delivers an enhanced 5.1-channel surround-sound experience for music	<ul style="list-style-type: none"> <li>• Analog (two-channel)</li> <li>• AM/FM radio</li> <li>• PCM (32kHz, 44.1kHz, 48kHz, 96kHz)</li> <li>• MP3/WMA</li> </ul>
Theater	Creates the effect of being in a large movie theater. Works well with movies.	<ul style="list-style-type: none"> <li>• Analog (two-channel)</li> <li>• AM/FM radio</li> <li>• PCM (32kHz, 44.1kHz, 48kHz, 96kHz)</li> <li>• MP3/WMA</li> </ul>
Hall	Creates the ambience of a concert hall. Good when listening to classical music sources such as orchestral music, chamber music or instrumental soloists.	<ul style="list-style-type: none"> <li>• Analog (two-channel)</li> <li>• AM/FM radio</li> <li>• PCM (32kHz, 44.1kHz, 48kHz, 96kHz)</li> <li>• MP3/WMA</li> </ul>
Stadium	Creates an expansive soundfield as heard in stadiums. Good for watching sporting events like baseball or soccer.	<ul style="list-style-type: none"> <li>• Analog (two-channel)</li> <li>• AM/FM radio</li> <li>• PCM (32kHz, 44.1kHz, 48kHz, 96kHz)</li> <li>• MP3/WMA</li> </ul>
Club	Creates the ambience of a club with a low ceiling and hard wall surfaces. Good for listening to jazz or other intimate musical ensembles.	<ul style="list-style-type: none"> <li>• Analog (two-channel)</li> <li>• AM/FM radio</li> <li>• PCM (32kHz, 44.1kHz, 48kHz, 96kHz)</li> <li>• MP3/WMA</li> </ul>
Arena	Creates a dynamic and broad soundspace that heightens the impact of film soundtracks and musical performances.	<ul style="list-style-type: none"> <li>• Analog (two-channel)</li> <li>• AM/FM radio</li> <li>• PCM (32kHz, 44.1kHz, 48kHz, 96kHz)</li> <li>• MP3/WMA</li> </ul>
5-Channel Stereo	Useful for parties, the left- and right-channel information is played through both the front and surround speakers on each side, while the center speaker plays a summed mono mix.	<ul style="list-style-type: none"> <li>• Analog (two-channel)</li> <li>• Tuner</li> <li>• PCM (32kHz, 44.1kHz, 48kHz, 96kHz)</li> <li>• MP3/WMA</li> </ul>
2-Channel Stereo	Turns off all surround processing and plays a pure 2-channel signal or a downmix of a multichannel signal. The signal is digitized and bass management settings are applied, making it appropriate when a subwoofer is used.	<ul style="list-style-type: none"> <li>• Analog (two-channel; DSP downmix available for multichannel)</li> <li>• Tuner</li> <li>• PCM (32kHz, 44.1kHz, 48kHz, 96kHz)</li> <li>• MP3/WMA</li> </ul>

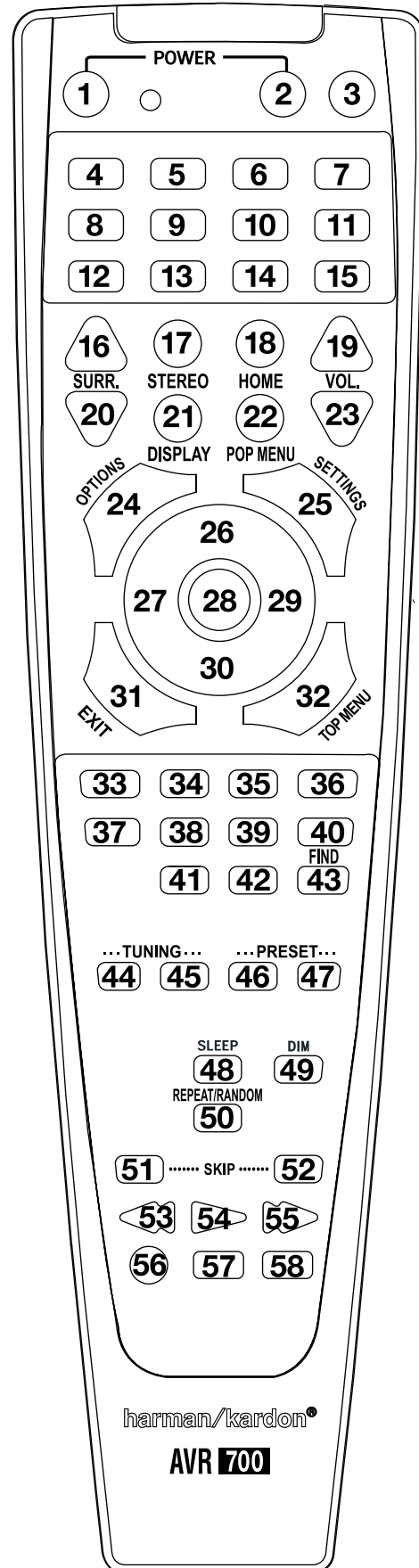

Refer to the numbered buttons when using the Remote Control Function List

**Table A5 – Remote Control Function List**

No.	Button Name	AVR Function	Blu-ray/DVD
01	Power On	Power On	Power On
02	Power Off	Power Off	Power Off
03	Mute	Mute	Mute
04	AVR	AVR Select	AVR Select
05	HDMI 1	HDMI 1 Select	HDMI 1 Select
06	HDMI 2	HDMI 2 Select	HDMI 2 Select
07	HDMI 3	HDMI 3 Select	HDMI 3 Select
08	USB	USB Select	USB Select
09	VID 1	Video 1 Select	Video 2 Select
10	VID 2	Video 2 Select	Video 2 Select
11	VID 3	Video 3 Select	Video 3 Select
12	AM/FM	Radio Select	Radio Select
13	TV	HDMI ARC Select	HDMI ARC Select
14	AUX	Aux	Stereo Mode Select
15	Tape	Tape Select	Tape Select
16	SURR+	Surr Mode Select +	Surr Mode Select +
17	STEREO	Stereo Mode Select	Stereo Mode Select
18	TONE	Tone Controls	Home (BD)
19	VOL +	Volume Up	Volume Up
20	SURR-	Surr Mode Select -	Surr Mode Select -
21	DISPLAY	Display Mode Select	Display Mode Select
22	TEST	Test Tone On/Off	Pop-Up Menu
23	VOL-	Volume Down	Volume Down
24	DIGITAL	Input Type Select	Options Menu
25	SETUP	Setup Menu On/Off	Settings (BD) Setup (DVD)
26	Up	Move/Adust Up	Up
27	Left	Move/Adjust Left	Left
28	OK	OK	Enter
29	Right	Move/Adjust Right	Right
30	Down	Move/Adjust Down	Down
31	BACK	Previous Menu	Exit (BD)
32	CHANNEL	Channel Level Adjust	Top Menu Display (BD)

No.	Button Name	AVR Function	Blu-ray/DVD
33	1	1	1
34	2	2	2
35	3	3	3
36	4	4	4
37	5	5	5
38	6	6	6
39	7	7	7
40	8	8	8
41	9	9	9
42	0	0	0
43	MEMORY	Preset Memory	Find
44	Tuning Down	Tuning Down	Program/Red (BD)
45	Tuning Up	Tuning Up	Bookmark/Green (BD)
46	Preset Down	Preset Tune Down	Thumbnail/Yellow (BD)
47	Preset Up	Preset Tune Down	Zoom/Blue (BD)
48	SLEEP/CLEAR	Sleep Timer	Clear
49	Dim	Display Dimmer	Display Dimmer
50	Repeat/Random	USB Repeat/Ramdon	Repeat
51	Skip Down	----	Previous
52	Skip Up	----	Next
53	Reverse ◀◀	----	Reverse Search
54	Play ▶▶	----	Play/Reverse
55	Forward ▶▶	----	Forward Search
56	Open/Close	----	Open/Close
57	Stop	----	Stop
58	Pause	----	Pause



## HARMAN

HARMAN International Industries, Incorporated  
8500 Balboa Boulevard, Northridge, CA 91329 USA

© 2012 HARMAN International Industries, Incorporated. All rights reserved.

Harman Kardon is a trademark of HARMAN International Industries, Incorporated, registered in the United States and/or other countries.

Blu-ray Disc is a trademark of the Blu-ray Disc Association.

CEA is a registered trademark of the Consumer Electronics Association.

Manufactured under license from Dolby Laboratories. Dolby, the double-D symbol and Pro Logic are registered trademarks of Dolby Laboratories. MLP Lossless is a trademark of Dolby Laboratories.

Manufactured under license under U.S. Patent Nos: 5,956,674; 5,974,380; 6,226,616; 6,487,535; 7,212,872; 7,333,929; 7,392,195; 7,272,567 & other U.S. and worldwide patents issued & pending. DTS-HD, the Symbol, & DTS-HD and the Symbol together are registered trademarks of DTS, Inc. © DTS, Inc. All Rights Reserved.

HDMI, the HDMI logo and High-Definition Multimedia Interface are registered trademarks of HDMI Licensing LLC in the United States and other countries.

Features, specifications and appearance are subject to change without notice.

HKP4078 Rev. 1

**harman/kardon**  
by HARMAN

[www.harmankardon.com](http://www.harmankardon.com)

	.12101	AVR70 HK112102	AVR70C HK112103
	Q	PART NUMBER	Q
		5077-21254-302-0S	1
2 BADGE MODEL	1	5630-21078-810-0S	1
3 FILTER FLT	1	5200-21026-200-0S	1
4 PANEL FRDNT	1	3067-21397-110-0S	1
5 FELT	1	2690-04005-701-0S	1
6 LENS STANDBY	1	3710-21079-300-0S	1
7 BUTTON STANDBY	1	5097-21364-110-0S	1
8 BUTTON POWER SWITCH	1	5097-21363-111-0S	1
9 PCB STANDBY SW	1	7028-06685-801-0	1
10 BRACKET POWER SWITCH	1	4010-21354-600-0S	1
11 PCB POWER SW	1	7028-06685-701-0	1
12 PCB FRONT	1	1	1
13 HEAT SINK MAIN	1	2120-21053-810-0S	1
14 PCB GUIDE L	1	7028-07209-301-0	1
15 BRACKET HEAT SINK	3	4010-05690-601-0S	3
16 CABINET TOP COVER	1	3007-04123-606-1S	1
17 PCB AMP	1	7028-06684-101-0	1
18 CUSHION SIDE	6	4050-21373-500-0S	6
19 FOOT/TITANO	2	4007-04020-106-0S	2
20 CHASSIS MAIN	1	3200-20002-602-0S	1
21 TRANS MAIN	1	8200-85863-023-0S	1
22	2	8200-85863-024-0S	2
23 CUSHION STANDBY	1	4050	1
24 PCB STANDBY	1	7028-07212-101-0	1
25 CUSHION FELT	3	4050-21138-500-0S	3
26 SOCKET POWER AC	1	6430-04059-000-0S	1
27 CHASSIS BACK	1	3207-21429-601-0S	1
28 FOOT	2	4000-04020-101-0S	2
29 PCB MAIN	1	7028-07209-101-0	1
30 PCB HDMI	1	7028-07208-302-0	1
31 PCB CNT SIDE	1	7028-07210-101-0	1
32 PCB CNT FRONT	1	7028-07210-201-0	1
33 PCB GUIDE R	1	7028-07209-501-0	1
34 PCB GUIDE C	1	7028-07209-301-0	1
35 PLATE VIDEO	1	3070-21046-600-0S	1
36 BUTTON FUNCTION	1	5097-21365-110-0S	1
37 PLATE USB	1	3070-21045-600-0S	1
38 PCB USB	1	7028-07209-201-0	1
39 PLATE PANEL	1	1	1
40 KNDB VOLUME	1	5080-21179-310-0S	1
41 BUSHING SHAFT	1	2410-21006-100-0S	1
42 KNDB CAP	1	1	1
43 PLATE KNDB	1	4470-21142-200-0S	1
44 PCB HEADPHONE	1	7028-06685-601-0	1
46 BADGE LOGO	1	5630-21077-800-0S	1
47 CLAMP(MTD)	1	4330-00031-000-0S	1

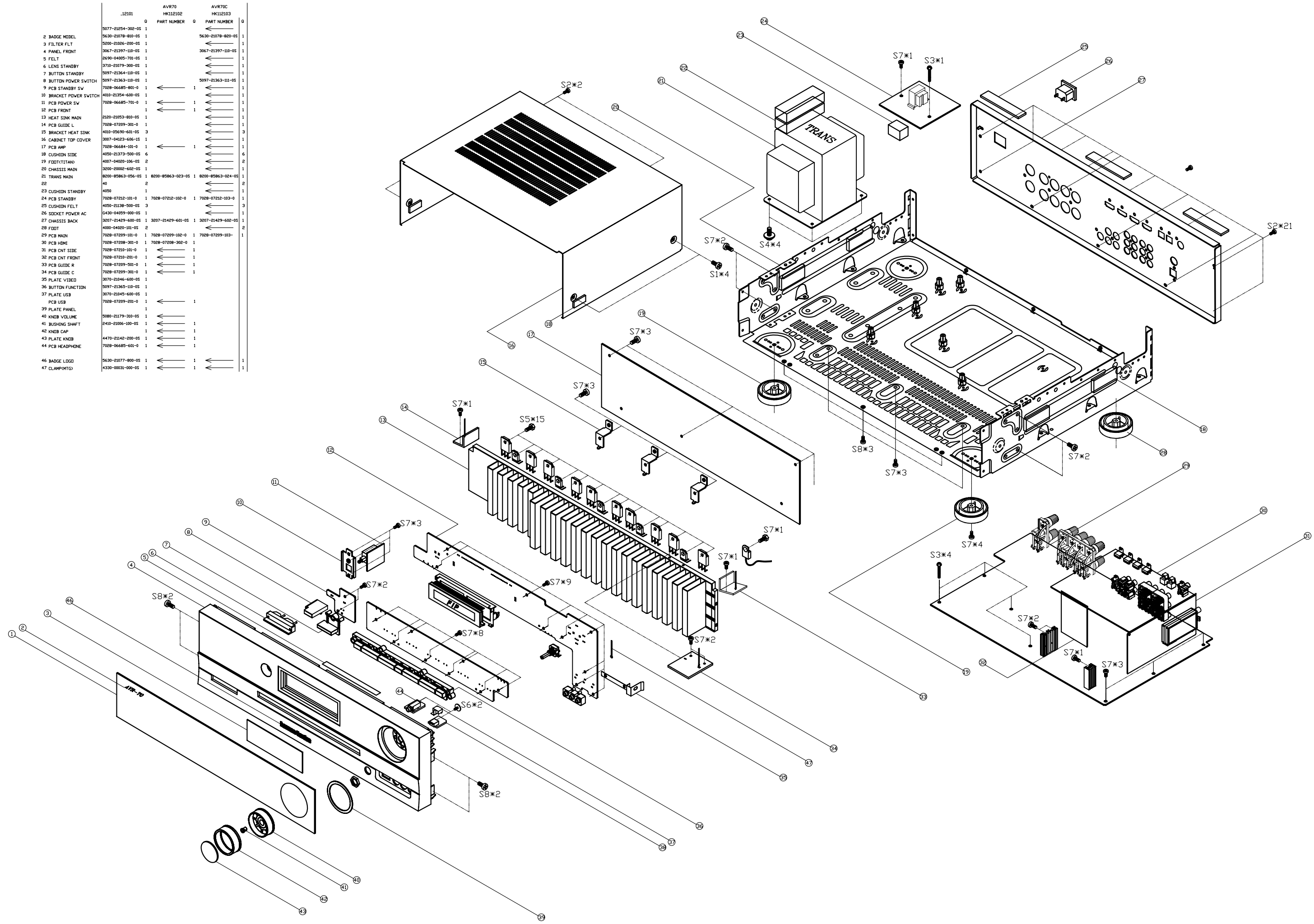

## AVR70/700/70C TROUBLESHOOTING

Symptom	Cause and Remedy	Ref No.
Power On Failure 1. FLT does not light up. 2. ST-BY LED does not light up.	A) AC-Cord check. B) Power Trans (Main/ST-BY) check. C) Fuse's disconnection check. D) Connector's disconnection or disjunction. Change or close insertion of the connector. E) Inferior ST-By switch. F) VFD Driver I.C & Resonator check. 1. VFD Driver I.C VCC(+3.3)V check. 2. VFD Driver clock pulse check.	F300(STANDBY)  CP704,FPC100(FRONT) SW(700)(FRONT) I.C701 SC16315(FORNT) I.C701 Pin No13(FRONT) I.C701 Pin No5(FRONT)
Fuse Disconnection. (Power On)	A) Inferior transformer. B) AMP drive TR out. (POWER TR) C) AMP drive TR out. ( POWER TR ) D) voltage check. 1. B+ ( 47 )V, B- ( 47 ) V	Q206( FL, FR, C, SL, SR )(AMP) Q205 ( FL, FR, C, SL, SR ) (AMP)
Key Disorder.	A) Key's being pushed check. B) Key signal input components inferior. C) Key PORT check. D) $\mu$ -COM I.C inferior. 1. $\mu$ -COM IC VCC +3.3V check.	I.C119 Pin No. (91,92 )(DMAIN)  I.C119 Pin No. ( 16,62 )(DMAIN)
Power Off in 2~3 sec. after Power On.	A) Regulator I.C out. 1. Signal IN/OUT check. B) Drive transistor out. ( POWER TR )  C) Protection circuit check. 1. Output DC check. 2. $\mu$ -COM I.C protection terminal check. D) Connector's disconnection or disjunction E) SLEEP MODE cancellation.	I.C 300 (IL1117S_3.3V)(STANDBY)  Q205 ( FL, FR, C, SL, SR ) (AMP) Q206( FL, FR, C, SL, SR )(AMP)  $\mu$ -COM Pin No. ( 85 )(DMAIN) CP (111)(MAIN)
Bump Sound (During input-select switch's change.)	A) FRONT Mute transistor's out and inferior. $\mu$ -Com front mute control PORT check. B) CENTER Mute transistor's out and inferior. $\mu$ -Com center mute control PORT check. D) SURROUND Mute transistor's out and inferior. $\mu$ -Com surround mute control PORT check.	Q (105 ) (MAIN) I.C119 Pin No. ( 2 )(DMAIN) Q ( 107 )(MAIN) I.C119 Pin No. ( 97 )(DMAIN) Q ( 109 )(MAIN) I.C119 Pin No. ( 1 )(DMAIN)

To check software version: Switch AVR 70 into Standby (LED lights amber), Keep "Standby" and "Preset Down" buttons pressed at the same time until display shows software version (such as "70 E0.65").

Symptom	Cause and Remedy	Ref No.
Sounds from Speaker when Headphone's connected.	A) NOT Supported Headphone Detect. Push the Speaker On/Off Button(Speaker off).	
Bass / Treble Control Failure.	A) Volume IC check. 1. Resister/Capacitor correction figure check.(Bass) 2. Resister/Capacitor correction figure check.(Treble)	I.C109(MAIN) I.C109 PIN No. ( 26,27,32,33)(MAIN) I.C109 PIN No. ( 28,34)(MAIN)
AMP Sound Dead. 1. "LEFT" Channel dead. 2. "RIGHT" Channel dead. 3. "CENTER" Channel dead. 4. "REAR" Channel dead.	A) Signal Mute TR's inferior. B) Connector disconnection & disjunction. Change or close insertion of the connector. C) Speaker wire's disjunction. Close insertion of the speaker wire. D) Volume IC check. 1. I.C voltage check ( +7.5 )V, ( -7.5 )V 2. I.C control data check. 3. I.C signal IN/OUT check.	Q 105,107,109(MAIN) CP111(MAIN)  I.C No. ( 109 )(MAIN) I.C Pin No. ( 30,52)(MAIN) I.C PIN No. (49,50)(MAIN)
AC-3/DTS Failure. (DSP Sound Mode)	A) I.C Regulator check. DSP I/O + (3.3)V,DSP CORE + (1.2)V CODEC + ( 5)V B) DIR check. 1. OSC check. 2. BICK, LRCK, RDATA Check. 3. Micom Interface Port Check. C) DSP Check. 1. BICK, LRCK Check. 2. Micom Interface Port Check. 3. SDATA 1, 2, 3,4 Check. D) D/A Check. 1. LRCK/BCK/SDATA check. 2. Signal out check.	I.C110, I.C111(DMAIN) I.C111 (MAIN) I.C109(DMAIN) X-TAL 102(DMAIN) I.C Pin No. ( 15, 16, 14)(DMAIN ) I.C Pin No. ( 21,22,31 )(DMAIN) I.C117(DMAIN) I.C Pin No. ( 162, 163 )(DMAIN) I.C Pin No.(7, 8, 13, 14, 146)(DMAIN) I.C Pin No. (1, 174, 175, 176)(DMAIN) I.C109 I.C Pin No. ( 17,18,19)(DMAIN) I.C Pin No. (39, 41, 43, 45, 47, 49)(DMAIN)

Symptom	Cause and Remedy	Ref No.
Video Output Dead.	A) Video Regulator voltage check. 1. DC voltage check. + ( 12 )V B) Video Mute(MONTOR,V1 OUT) port check.(IC101)	I.C110 (MAIN) I.C119 ( 23 )(DMAIN)

Remote Controller Failure.	A) Battery check. B) RMC I.C & Resonator inferior. 1. $\mu$ -COM I.C B+( 3.3 )V check. 2. REMOCON data check.	I.C119 Pin No. ( 16,62 )(DMAIN) RMC701(1) (FRONT)
FM Failure.	A) FM MUTE adjustment inferior. B) FRONT-END inferior. C) FM DET COIL inferior. D) PLL&MPX IC check. 1. PLL&MPX I.C B+( 5 )Vcheck. 2. PLL control data check. (Data/CE/Clock) E) TUNER B+ voltage inferior. F) $\mu$ -COM I.C & Resonator inferior. 1. $\mu$ -COM I.C B+( 3.3 )V check. 2. Micom control data check.	PACK102( 6 )(MAIN) pack102(3, 4, 5)(MAIN)  I.C119 Pin No. ( 16,62 )(DMAIN) I.C Pin No. ( 18, 40, 42, 43, 44)(DMAIN)
AM Failure.	A) PLL&MPX IC check. 1. PLL&MPX I.C B+( 5 )Vcheck. 2. PLL control data check (Data/CE/Clock) B) TUNER B+ voltage inferior. C) AM OSC COIL inferior. D) $\mu$ -COM I.C & Resonator inferior. 1. $\mu$ -COM I.C B+( 3.3)V check. 2. Micom control data check.	PACK102( 6 )(MAIN) pack102(3, 4, 5)(MAIN)  I.C119 Pin No. ( 16,62 )(DMAIN) I.C Pin No. ( 18, 40, 42, 43, 44)(DMAIN)
Stereo Effect Failure. Stereo does not light up.	A) FM DET COIL Inferior. B) PLL&MPX IC check. 1. PLL&MPX I.C B+( 5 )V,B+( 3.3 )V check. 2. MPX control data check. C) $\mu$ -COM I.C & Resonator inferior. 1. $\mu$ -COM IC B+( 3.3)V check 2. Micom control data check.	I.C119 Pin No. ( 16,62 )(DMAIN) I.C Pin No. ( 18, 40, 42, 43, 44)(DMAIN)
Tuner Sound Dead. 1. "L / R" Channel dead. 2. "LEFT" Channel dead. 3. "RIGHT" Channel dead.	A) Connector's disconnection or disjunction. Change or Close insertion of the connector. B) FM DET COIL inferior. C) AM IFT COIL inferior. D) PLL&MPX IC check. 1. Signal IN/OUT terminal. 2. I.C driving voltage check. ( +5V)	PACK102( 6 )(MAIN)



<b>PRIMARY AVR 70 PARTS LIST</b>	
Please order the below parts using these numbers, not the numbers in the long parts list	
Part number	Description
7025HK1121020	AVR70(HARMAN)/MAIN
7025HK1121021	AVR70(HARMAN)/HDMI
7025HK1121022	AVR70(HARMAN)/AMP
7025HK1121023	AVR70(HARMAN)/FRONT
7025HK1121024	AVR70(HARMAN)/STANDBY
7025HK1121025	AVR70(HARMAN)/CNT
8200858630570S	POWER TRANSFORMER AVR 70/230
8200280150410S	STAND-BY TRANSFORMER AVR 70/230V
8300880000010S	REMOTE CONTROL AVR 70/230
30070412360H0S	TOP COVER AVR70/230
3067213971110S	FRONT (PLASTIC) PANEL AVR 70/230
5630210828000S	LOGO BADGE 'AVR 70'
5630210818000S	LOGO BADGE 'Harman /kardon' AVR 70
5097213641100S	STBY BUTTON AVR133/134
3207214296010S	REAR PANEL AVR 70/230
3710210793000S	STANDBY LENS AVR 70 /230
4000040201010S	FOOT RUBBER
4007040201060S	FOOT
5080211793000S	PLATE KNOB VOLUME BK
5077212543020S	FRONT WINDOW ACRY AVR70
5080211793000S	KNOB VOLUME MILKY
5087211781100S	KNOB VOLUME CAP AVR 70
5097213651100S	FUNCTION BUTTON (7)
5200210262000S	FILTER FIP, WINE COLOR
6007212260010S	GIFT BOX BEAUTY CARTON AVR 70/230

AVR 70 amplifier board parts list				
REF NO.	DESCRIPTION		QTY	PART NO.
PCB	P.C.B TOTAL ASSY	AMP	1	7025-HK112-101-2
PCB	P.C.B SUB ASSY	AMP	1	7028-06684-101-0
PCB	P.C.B	AMP	1	7020-06684-000-05
PCB	P.C.B INS ASSY	AVR133(HARMAN)/AMP-AXIAL	1	7027-06684-1A1-0
PCB	P.C.B INS ASSY	AVR133(HARMAN)/AMP-MANUAL	1	7027-06684-1M1-0
PCB	P.C.B INS ASSY	AVR133(HARMAN)/AMP-RADIAL	1	7027-06684-1R1-0
COILS				
L201C/FL/FR/SL/SR	COIL,FILTER-INDUCTOR	SP-2507 1.0 PI*21UEW TURNS=7T SPRING COIL	5	D3309000013305
CONNECTOR				
CN101	CN,WIRE 2MM	100MM/10P 20010HS-10=CKM2002HV-10 WH1007#26 연결	1	L002-10110-006-05
CN102	CN,WIRE	80MM/12P 5264-12=CKM2509H-12 WH1007#26 연결	1	L000-80012-005-05
CAPACITOR				
C211C/FL/FR/SL/SR	C,CERAMIC HIK AXIAL	UP025 F223Z-B-BZ	5	D005-22359-452-15
C206C/FL/FR/SL/SR	C,CERAMIC HIK AXIAL	UP025 B102K-B-BZ	5	D005-10217-753-15
C202C/FL/FR/SL/SR	C,CERAMIC HIK AXIAL	UP025 B681K-B-BZ	5	D005-68117-752-15
C204C/FL/FR/SL/SR	C,CERAMIC T.C DISC	SL33PF-J/500V-5RE CC1-L5N7505B330JTPW	5	D000-33006-D05-15
C209C/FL/FR/SL/SR	C,CERAMIC HIK DISC	B100PF-K/500V-5RE CT1-L5S2L5B101KTP	5	D004-10107-D05-15
C210C/FL/FR/SL/SR	C,CERAMIC HIK DISC	B100PF-K/500V-5RE CT1-L5S2L5B101KTP	5	D004-10107-D05-15
C203C/FL/FR/SL/SR	C,CERAMIC-UNKNOWN	CAP C 220PF 500V-5RE	5	D009-09221-250-05
C201C/FL/FR/SL/SR	C,ELECT GE 85C	10UF-M/50V,5*11-5RE.SMS SY	5	D040-10008-707-05
C208C/FL/FR/SL/SR	C,ELECT GE 85C	10UF-M/50V,5*11-5RE.SMS SY	5	D040-10008-707-05
C212	C,ELECT GE 85C	10UF-M/100V,6.3*11-5RE,SMS SY	1	D040-10008-C05-05
C205C/FL/FR/SL/SR	C,ELECT GE 85C	100UF-M/10V,5*11-5RE.SMS SY	5	D040-10108-209-05
C207C/FL/FR/SL/SR	C,ELECT GE 85C	47UF-M/50V,6.3*11-5RE.SMS SY (Pb Free)	5	D040-47008-707-05
DIODES				
D201C/FL/FR/SL/SR	D,SWITCHING	1SS133T-72-52MM	5	K0000133005205
TRANSISTOR				
Q201C/FL/FR/SL/SR	SEMI,TR/GE PNP 2SA	KSA992F,0.5W/T092-REEL	5	J5000992F00505
Q202C/FL/FR/SL/SR	SEMI,TR/GE PNP 2SA	KSA992F,0.5W/T092-REEL	5	J5000992F00505
Q203C/FL/FR/SL/SR	SEMI,TR/GE NPN 2SC	KTC3200BL,0.6W/T092-REEL	5	J5023200B00505
Q207C/FL/FR/SL/SR	SEMI,TR/GE NPN 2SC	KTC3200BL,0.6W/T092-REEL	5	J5023200B00505
RESISTOR				
R209C/FL/FR/SL/SR	R,CARBON FILM	1.2K-J, 1/5W	5	C000-01226-P52-05
R207C/FL/FR/SL/SR	R,CARBON FILM	1.5K-J, 1/5W	5	C000-01526-P52-05
R201C/FL/FR/SL/SR	R,CARBON FILM	220-J, 1/5W	5	C000-02216-P52-05
R227C/FL/FR/SL/SR	R,CARBON FILM	2.2K-J, 1/5W	5	C000-02226-P52-05
R224C/FL/FR/SL/SR	R,CARBON FILM	27K-J, 1/5W	5	C000-02736-P52-05
R214C/FL/FR/SL/SR	R,CARBON FILM	3K-J, 1/5W	5	C000-03026-P52-05
R206C/FL/FR/SL/SR	R,CARBON FILM	33K-J, 1/5W	5	C000-03336-P52-05
R225C/FL/FR/SL/SR	R,CARBON FILM	330K-J, 1/5W	5	C000-03346-P52-05
R204C/FL/FR/SL/SR	R,CARBON FILM	39K-J, 1/5W	5	C000-03936-P52-05
R210C/FL/FR/SL/SR	R,CARBON FILM	470-J, 1/5W	5	C000-04716-P52-05
R208C/FL/FR/SL/SR	R,CARBON FILM	47K-J, 1/5W	5	C000-04736-P52-05
R205C/FL/FR/SL/SR	R,CARBON FILM	470K-J, 1/5W	5	C000-04746-P52-05
R213C/FL/FR/SL/SR	R,CARBON FILM	56-J, 1/5W	5	C000-05606-P52-05
R203C/FL/FR/SL/SR	R,CARBON FILM	7.5K-J, 1/5W	5	C000-07526-P52-05
R226C/FL/FR/SL/SR	R,CARBON FILM	75K-J, 1/5W	5	C000-07536-P52-05
R212C/FL/FR/SL/SR	R,CARBON FILM	910-J, 1/5W	5	C000-09116-P52-05
R228C/FL/FR/SL/SR	R,METAL FILM 100PPM	RES MF 10 OHM 1W	5	C060-01006-552-05
R229	R,METAL FILM 100PPM	10-J, 1W	1	C060-01006-505-05
R211C/FL/FR/SL/SR	R,METAL FILM 100PPM	47-J, 1/4W	5	C060-04706-305-05
R216C/FL/FR/SL/SR	R,METAL FILM 100PPM	5.6K-J, 1W	5	C0600562650505
R217C/FL/FR/SL/SR	R,METAL FILM 100PPM	5.6K-J, 1W	5	C060-05626-505-05
R218C/FL/FR/SL/SR	R,METAL FILM 100PPM	4.7-J, 1/4W	5	C060-4R706-305-05
R219C/FL/FR/SL/SR	R,METAL FILM 100PPM	4.7-J, 1/4W	5	C060-4R706-305-05
R220C/FL/FR/SL/SR	R,METAL FILM 100PPM	0.47-J, 2W	5	C060R470660505
R221C/FL/FR/SL/SR	R,METAL FILM 100PPM	0.47-J, 2W	5	C060-R4706-605-05
R222C/FL/FR/SL/SR	R,METAL FILM 100PPM	0.47-J, 2W	5	C060-R4706-605-05
R223C/FL/FR/SL/SR	R,METAL FILM 100PPM	0.47-J, 2W	5	C060-R4706-605-05
J204/J206/J208	CN,WIRE 1P	0.6/52MM	3	L045-08400-604-05
J210-J214	CN,WIRE 1P	0.6/52MM	5	L045-08400-604-05
J216/J218	CN,WIRE 1P	0.6/52MM	2	L045-08400-604-05
J222-J231	CN,WIRE 1P	0.6/52MM	10	L045-08400-604-05
J233/J234/J238	CN,WIRE 1P	0.6/52MM	3	L045-08400-604-05
J241/J242	CN,WIRE 1P	0.6/52MM	2	L045-08400-604-05
J246-J253	CN,WIRE 1P	0.6/52MM	8	L045-08400-604-05
J255-J266	CN,WIRE 1P	0.6/52MM	12	L045-08400-604-05
J268/J269	CN,WIRE 1P	0.6/52MM	2	L045-08400-604-05
J271-J308	CN,WIRE 1P	0.6/52MM	38	L045-08400-604-05
J314/J315	CN,WIRE 1P	0.6/52MM	2	L045-08400-604-05

AVR 70 control board parts list				
REF NO.	DESCRIPTION		QTY	PART NO.
PCB	P.C.B TOTAL ASSY	CNT	1	7025-HK112-101-5
PCB	P.C.B SUB ASSY	CNT	1	7028-07210-101-0
PCB	P.C.B	CNT	1	7020-07210-000-05
PCB	P.C.B INS ASSY	CNT-AXIAL	1	7027-07210-1A1-0
PCB	P.C.B INS ASSY	CNT-MANUAL	1	7027-07210-1M1-0
PCB	P.C.B INS ASSY	CNT-RADIAL	1	7027-07210-1R1-0
PCB	P.C.B INS ASSY	CNT-SMD	1	7027-07210-1S1-0
CN101/CN102	CN,WAFER	C12521-19 19P BtoB HEADER(MALE) P=1.25MM	2	L109-01251-191-05
CN105/CN106	CN,WAFER	C12522-19 19P BtoB SOCKET(FEMALE) P=1.25MM	2	L109-01252-191-05
CN100	CN,WAFER	C12521-25 25P BtoB HEADER(MALE) P=1.25MM	1	L109-01251-251-05
CN104	CN,WAFER	C12522-25 25P BtoB SOCKET(FEMALE) P=1.25MM	1	L109-01252-251-05
C653/C667	C,ELECT GE 85C	10UF-M/50V,5*11-5RE.SMS SY (Pb Free)	2	D040-01008-715-05
C678/C683	C,ELECT GE 85C	10UF-M/16V,3*5-5RE SY	2	D040-10008-305-05
C650/C652	C,ELECT GE 85C	10UF-M/50V,5*11-5RE.SMS SY	2	D040-10008-707-05
C647	C,CERAMIC CHIP T.C	X7R 0.01UF-K/50V-1608REEL	1	D010-10377-716-05
C665/C668/C669	C,CERAMIC CHIP T.C	X7R 0.01UF-K/50V-1608REEL	3	D010-10377-716-05
C680/C682	C,CERAMIC CHIP T.C	X7R 0.01UF-K/50V-1608REEL	2	D010-10377-716-05
C672/C679/C681/C684	C,CERAMIC CHIP T.C	COG33PF-J/50V-1608REEL	4	D010-33016-716-05
C658	C,CERAMIC CHIP T.C	COG 680PF-J 50V-1608REEL	1	D010-68116-716-05
C657	C,CERAMIC CHIP HIK	X7R3300PF-K/50V-1608REEL	1	D011-33277-716-05
D566/D567	D,SWITCHING CHIP	1N4148WS FAST SWITCHING DOIDE Trr=4ns SOD-323	2	K005-04148-323-05
IC558/IC560/IC561	IC,LINEAR OP	UTC4580E SOP8 DUAL OP AMP	3	J121-45800-101-05
Q583	SEMI,CHIP TR/PNP 2SA	RT1P141C 0.2W/SC-59 ISAHAYA	1	J520-10141-121-05
Q580	SEMI,CHIP TR/NPN 2SC	RT1N441C 0.2W/SC-59 ISAHAYA	1	J522-10441-121-05
Q581/Q582	SEMI,FET/2SN	2SK492C N-CH FET SC-59 ISAHAYA	2	J544-04920-121-05
R692/R702	R,CARBON FILM	10K-J,1/5W-52RE-AX	2	C000-01036-P52-05
R676	R,CARBON FILM	100K-J,1/5W-52RE-AX	1	C000-01046-P52-05
R707	R,CARBON FILM	2.2K-J,1/5W-52RE-AX	1	C000-02226-P52-05
R705/R710	R,CARBON FILM	9.1K-J,1/5W-52RE-AX	2	C000-09126-P52-05
R701/R703/R706/R709	R,CHIP THICK	10K-J,1/16W-1608REEL	4	C200-01036-M16-05
R711/R712	R,CHIP THICK	10K-J,1/16W-1608REEL	2	C200-01036-M16-05
R680	R,CHIP THICK	100K-J,1/16W-1608REEL	1	C200-01046-M16-05
R669/R671	R,CHIP THICK	4.7K-J,1/16W-1608REEL	2	C200-04726-M16-05
R708	R,CHIP THICK	470K-J,1/16W-1608REEL	1	C200-04746-M16-05
R677	R,CHIP THICK	5.6K-J,1/16W-1608REEL	1	C200-05626-M16-05
R689/R704	R,CHIP THICK	91K-J,1/16W-1608REEL	2	C200-09136-M16-05
J107	R,CHIP THICK	0-J,1/8W-3216REEL	1	C200-00006-130-05
R672	R,CHIP THICK	1K-J,1/16W-1608REEL	1	C200-01026-M16-05
R679	R,CHIP THICK	1.8K-J,1/16W-1608REEL	1	C200-01826-M16-05
J101-J104/J106	CN,WIRE 1P	JUMPER (0.6/52MM)	5	L045-08400-604-05
PCB	P.C.B SUB ASSY	AVR700(HARMAN)/CNT2	1	7028-07210-201-0
PCB	P.C.B INS ASSY	AVR700(HARMAN)/CNT2-MANUAL	1	7027-07210-2M1-0
CN103	CN.WAFER	C12521-29 29P BtoB HEADER(MALE) P=1.25MM	1	L109-01251-291-05
CN107	CN.WAFER	C12522-29 29P BtoB SOCKET(FEMALE) P=1.25MM	1	L109-01252-291-05
AVR 70 front board parts list				
REF NO.	DESCRIPTION		QTY	PART NO.
PCB	P.C.B TOTAL ASSY	FRONT	1	7025-HK112-101-3
PCB	P.C.B SUB ASSY	FRONT	1	7028-06685-501-0
PCB	P.C.B	AVR133(HARMAN) 330*247 1.6T FR1 ARRY(2)/FRONT	1	7020-06685-000-2S
PCB	P.C.B INS ASSY	FRONT-AXIAL	1	7027-06685-5A1-0
PCB	P.C.B INS ASSY	FRONT-MANUAL	1	7027-06685-5M1-0
PCB	P.C.B INS ASSY	FRONT-RADIAL	1	7027-06685-5R1-0
PCB	P.C.B INS ASSY	FRONT-SMD	1	7027-06685-5S1-0
CB701-CB704	COIL,BEAD	CBW160808U121T 120ohm SMD1608 TYPE	4	D340-16081-121-05
L702	COIL,FILTER-INDUCTOR	10UH-Q40/24M-R2.5-52RE 02TB	1	D330-10070-052-05
L700	COIL,FILTER-INDUCTOR	100UH-Q40/9M-R12-52RE 02TB	1	D330-10100-102-05
L703/L704	COIL,FILTER-INDUCTOR	2.2UH-Q50/110M-R1.2 52RE-AXIAL LAL03TB	2	D330-2R200-052-05
C707/C710	C,FILM POLYESTER	ST-0.047UF-J/100V-5RE	2	D02047306C060S
C708/C709/C731	C,ELECT GE 85C	10UF-M/50V,5*11-5RE.SMS SY	3	D040-10008-707-05
C735L/R	C,ELECT GE 85C	10UF-M/50V,5*11-5RE.SMS SY	2	D040-10008-707-05
C721	C,ELECT GE 85C	100UF-M/10V,5*11-5RE.SMS SY	1	D040-10108-207-05
C703/C717	C,ELECT GE 85C	47UF-M/16V,5*7-5RE SRA SY	2	D040-47008-306-05
C728	C,CERAMIC HIK AXIAL	UPO25 B103K-B-BZ	1	D005-10377-353-1S
C743-C745	C,CERAMIC CHIP T.C	COG100PF-J/50V-1608REEL	3	D010-10116-716-05
C734/C726/C727	C,CERAMIC CHIP T.C	X7R 0.01UF-K/50V-1608REEL	3	D010-10377-716-05
C718/C719	C,CERAMIC CHIP HIK	X7R0.1UF-K/50V-1608REEL	2	D011-10457-716-05
C714-716	C,CERAMIC CHIP HIK	X7R0.1UF-K/50V-1608REEL	3	D011-10457-716-05
C713L/R	C,CERAMIC CHIP HIK	X7R470PF-K/50V-1608REEL	2	D011-47176-716-05
C704-C706	C,CERAMIC CHIP HIK	X7R820PF-K/50V-1608REEL	3	D011-82177-716-05

REF NO.	AVR 70 front board parts list	DESCRIPTION	QTY	PART NO.
CN707	CN,WIRE 2MM	250/5P 20010HS-05=CKM2002H-05 WH2547,1533#265HLD	1	L002-25105-007-05
J700-J714	CN,WIRE 1P	JUMPER (0.6/52MM)	15	L045-08400-604-05
CP704	CN.WAFER 2.5MM	5268-03A 3P ANGLE	1	L102-52680-301-05
CP701	CN.WAFER 2.0MM	20010WS-04A00 DIP4P STRAIGHT	1	L101-20010-041-05
FPC701	CN.FPC 1.25MM	1.25-25-17PW 17P AN DIP	1	L131-12502-172-05
DZ705	D,ZENER	MTZJ7.5B-0.5W/5MA-52MM	1	K06007R5445205
D701-D704	D,SWITCHING CHIP	1N4148WS FAST SWITCHING DOIDE Trr=4ns SOD-323	4	K005-04148-323-05
Q703	SEMI,CHIP TR/PNP 25A	KRA105S(PE) 0.2W/SOT-23 REEL	1	J520-01050-021-05
Q701/Q704	SEMI,CHIP TR/NPN 25C	KRC105S (NE) 0.2W/SOT-23 REEL	2	J522-01050-021-05
IC701	IC,LINEAR-DRIVER	SC16315 VFD DRIVER CONTROLLER IC QFP44P	1	J1271631500105
R755/R757	R,CHIP THICK	1K-J,1/16W-1608REEL	2	C200-01026-M16-05
R752/R754	R,CHIP THICK	1.5K-J,1/16W-1608REEL	2	C200-01526-M16-05
R749/R751	R,CHIP THICK	2.2K-J,1/16W-1608REEL	2	C200-02226-M16-05
R782L/R	R,CHIP THICK	100K-J,1/16W-1608REEL	2	C200-01046-M16-05
R744/R747	R,CHIP THICK	3.3K-J,1/16W-1608REEL	2	C200-03326-M16-05
R784L/R	R,CHIP THICK	470-J,1/16W-1608REEL	2	C200-04716-M16-05
R742/R760	R,CHIP THICK	4.7K-J,1/16W-1608REEL	2	C200-04726-M16-05
R704-R731	R,CHIP THICK	56K-J,1/16W-1608REEL	28	C200-05636-M16-05
R702/R703	R,CHIP THICK	68K-J,1/16W-1608REEL	2	C200-06836-M16-05
R732/R733	R,CHIP THICK	68K-J,1/16W-1608REEL	2	C200-06836-M16-05
R743	R,CHIP THICK	75-J,1/16W-1608REEL	1	C200-07506-M16-05
R748/R758/R759	R,CHIP THICK	200-J,1/16W-1608REEL	3	C200-02016-M16-05
R737	R,CHIP THICK	82K-J,1/16W-1608REEL	1	C200-08236-M16-05
R771	R,CARBON FILM	15K-J,1/5W-52RE-AX	1	C000-01536-P52-05
R739/R471/R774	R,CARBON FILM	470-J,1/5W-52RE-AX	3	C000-04716-P52-05
J713	R,CHIP THICK	0-J,1/8W-3216REEL	1	C200-00006-130-05
R745	R,CHIP THICK	0-J,1/16W-1608REEL	1	C200-00006-M16-05
FLT701	DISPLAY,FLT	SPC08.03.13-02 12G*16A 110*29 GREEN/AVR133	1	K530-08030-001-05
RMC701	MODULE,REMOCON	R34F59A 38KHZ IR REMOCON MODULE P=2.54MM H=15MM	1	E940-34900-381-05
VR701	SW,ENCODER	REB12307PV25FINB1-2-24E 24PULSES	1	G1211230700205
JACK700	TER,RCA 3PIN	RCA-326H-02(YL,WH,RD)	1	G606-326H0-200-YS
HOLDER	HOLDER	() HOLDER FL(P/C)HK-3250	1	4320-04078-301-AS
LED701/LED703/LED704	LED,ROUND	WEJ51BWW-C53 5PI WHITE P=2.54 BULK	3	K500-05900-111-05
SW705/SW706	SW,TACT	SKHV10920A,5MM/260G-REEL	2	G1800002700105
SW708/SW709	SW,TACT	SKHV10920A,5MM/260G-REEL	2	G1800002700105
SW711/SW712	SW,TACT	SKHV10920A,5MM/260G-REEL	2	G1800002700105
SW714/SW715	SW,TACT	SKHV10920A,5MM/260G-REEL	2	G1800002700105
SW718-SW720	SW,TACT	SKHV10920A,5MM/260G-REEL	2	G1800002700105
PCB	P.C.B SUB ASSY	AVR700(HARMAN)/HEADPHONE	1	7028-06685-601-0
PCB	P.C.B INS ASSY	AVR700(HARMAN)/HEADPHONE-MANUAL	1	7027-06685-6M1-0
PCB	P.C.B INS ASSY	AVR700(HARMAN)/HEADPHONE-SMD	1	7027-06685-651-0
JACK701	JACK,D6.5	PHONE (YUQU) D6.5 SILVER	1	G402PJ619A01YS
CN702	CN,WIRE 2MM	330MM/4P 20010HS-04=CKM2002HV-04 WH2547#26 SHIELD	1	L002-33104-001-05
LUG703	RING,TER WIRE	190MM/1P 61640BS(3.2PI)=B1813TOP BK1007#18	1	8410-19101-003-05
C712L/R	C,CERAMIC CHIP T.C	X7R 0.01UF-K/50V-1608REEL	2	D010-10377-716-05
CB707-CB709	COIL,BEAD	CBW160808U121T 120ohm SMD1608 TYPE	3	D340-16081-121-05
C711	C,CERAMIC CHIP HIK	X7R0.1UF-K/50V-1608REEL	1	D011-10457-716-05
C712	C,CERAMIC CHIP HIK	X7R470PF-K/50V-1608REEL	1	D011-47176-716-05
C713	C,CERAMIC CHIP T.C	X7R 0.01UF-K/50V-1608REEL	1	D010-10377-716-05
PCB	P.C.B SUB ASSY	AVR700(HARMAN)/POWER SW	1	7028-06685-701-0
PCB	P.C.B INS ASSY	AVR700(HARMAN)/POWER SW-MANUAL	1	7027-06685-7M1-0
SW701	SW,PUSH	SDDL-005-S(C-UL)	1	G0001220060605
CN705	CN,WIRE	420MM/2P 35191-02=CKM99050101-03 BK/RD1617#22	1	L000-42102-003-05
PCB	P.C.B SUB ASSY	AVR700(HARMAN)/STANDBY SW	1	7028-06685-801-0
PCB	P.C.B INS ASSY	AVR700(HARMAN)/STANDBY-MANUAL	1	7027-06685-8M1-0
PCB	P.C.B INS ASSY	AVR700(HARMAN)/STANDBY-RADIAL	1	7027-06685-8R1-0
PCB	P.C.B INS ASSY	AVR700(HARMAN)/STANDBY-SMD	1	7027-06685-851-0
CN701	CN,WIRE 2MM	60MM/4P 20010HS-04=CKM2002HV-04 WH1007#26 연결	1	L002-60004-006-05
LED702/LED705	LED,ROUND	SLI-343D8UT32X3 3PI AMBER P=2.5	3	K5000330000405
SW700	SW,TACT	SKHV10920A,5MM/260G-REEL	1	G180-00027-001-05
R746/R750	R,CHIP THICK	120-J,1/16W-1608REEL	2	C200-01216-M16-05
Q702	SEMI,CHIP TR/NPN 25C	KRC105S (NE) 0.2W/SOT-23 REEL	1	J522-01050-021-05

AVR 70 HDMI board parts list				
REF NO.	DESCRIPTION		QTY	PART NO.
PCB	P.C.B TOTAL ASSY	HDMI	1	7025-HK112-101-1
PCB	P.C.B SUB ASSY	HDMI	1	7028-07208-301-0
PCB	P.C.B	HDMI	1	7020-07208-020-0
PCB	P.C.B INS ASSY	HDMI-MANUAL	1	7027-07208-3M1-0
PCB	P.C.B INS ASSY	HDMI-SMD	1	7027-07208-351-0
COILS				
L100-L114	COIL,BEAD	220ohm	15	D340-20120-221-05
L117-119	COIL,BEAD	220ohm	3	D340-20120-221-05
L124/L129/L131/L133	COIL,BEAD	220ohm	4	D340-20120-221-05
L136/L137/L139/L140	COIL,BEAD	220ohm	4	D340-20120-221-05
L142-L144	COIL,BEAD	220ohm	3	D340-20120-221-05
L200-L206/L215	COIL,BEAD	120ohm	8	D340-16081-121-05
L122/L125/L132/L134	COIL,INDUCTOR	LB C2012T4R7M 4.7UH INDUCTOR	4	D310-4R701-020-05
L135	COIL,CHIP	DLP11SN1215L2L CHIP COMMON MODE CHOKE COIL	1	D311-12101-121-05
L128/L130	COIL,CHIP	FI-B1608-222KIT 2.2UH SMD(1608)-REEL	2	D311-16080-222-05
L141	COIL,BEAD	BKP2125 HS101-T 100ohm SMD2125 TYPE BEAD FOR POWER	1	D340-21256-101-05
CAPACITOR				
C269/C286/C348	C,CERAMIC CHIP HIK	COG)10PF-D/50V-1005REEL	3	D011-10011-710-1S
C213/C215/C249	C,CERAMIC CHIP HIK	COG)100PF-J/50V-1005REEL	3	D011-10116-710-1S
C102/C143/C235/C237	C,CERAMIC CHIP HIK	X7R)1000PF-K/50V-1005REEL	4	D011-10217-710-1S
C243/C245/C252/C257	C,CERAMIC CHIP HIK	X7R)1000PF-K/50V-1005REEL	4	D011-10217-710-1S
C260/C264/C266/C270	C,CERAMIC CHIP HIK	X7R)1000PF-K/50V-1005REEL	4	D011-10217-710-1S
C271/C276/C278/C280	C,CERAMIC CHIP HIK	X7R)1000PF-K/50V-1005REEL	4	D011-10217-710-1S
C287/C293/C299	C,CERAMIC CHIP HIK	X7R)1000PF-K/50V-1005REEL	3	D011-10217-710-1S
C307/C310/C325/C329	C,CERAMIC CHIP HIK	X7R)1000PF-K/50V-1005REEL	4	D011-10217-710-1S
C347/C349/C352	C,CERAMIC CHIP HIK	X7R)1000PF-K/50V-1005REEL	3	D011-10217-710-1S
C361-C365/C380	C,CERAMIC CHIP HIK	X7R)1000PF-K/50V-1005REEL	6	D011-10217-710-1S
C145/C149/C152	C,CERAMIC CHIP HIK	X7R)0.01UF-K/16V-1005REEL	3	D011-10317-710-1S
C161/C164/C169	C,CERAMIC CHIP HIK	X7R)0.01UF-K/16V-1005REEL	3	D011-10317-710-1S
C175/C177/C185/C187	C,CERAMIC CHIP HIK	X7R)0.01UF-K/16V-1005REEL	4	D011-10317-710-1S
C192/C195/C206/C209	C,CERAMIC CHIP HIK	X7R)0.01UF-K/16V-1005REEL	4	D011-10317-710-1S
C214/C218/C220/C226	C,CERAMIC CHIP HIK	X7R)0.01UF-K/16V-1005REEL	4	D011-10317-710-1S
C227/C229/C231/C313	C,CERAMIC CHIP HIK	X7R)0.01UF-K/16V-1005REEL	4	D011-10317-710-1S
C340/C343/C346	C,CERAMIC CHIP HIK	X7R)0.01UF-K/16V-1005REEL	3	D011-10317-710-1S
C355/C357/C359	C,CERAMIC CHIP HIK	X7R)0.01UF-K/16V-1005REEL	3	D011-10317-710-1S
C368/C369	C,CERAMIC CHIP HIK	X7R)0.01UF-K/16V-1005REEL	2	D011-10317-710-1S
C104-C107	C,CERAMIC CHIP HIK	X7R)0.1UF-K/16V-1005REEL	1	D011-10417-710-1S
C109/C111-C114	C,CERAMIC CHIP HIK	X7R)0.1UF-K/16V-1005REEL	1	D011-10417-710-1S
C116/C117	C,CERAMIC CHIP HIK	X7R)0.1UF-K/16V-1005REEL	1	D011-10417-710-1S
C120-C126	C,CERAMIC CHIP HIK	X7R)0.1UF-K/16V-1005REEL	7	D011-10417-710-1S
C128/C130	C,CERAMIC CHIP HIK	X7R)0.1UF-K/16V-1005REEL	2	D011-10417-710-1S
C132-C137	C,CERAMIC CHIP HIK	X7R)0.1UF-K/16V-1005REEL	6	D011-10417-710-1S
C139/C141	C,CERAMIC CHIP HIK	X7R)0.1UF-K/16V-1005REEL	2	D011-10417-710-1S
C146-C148	C,CERAMIC CHIP HIK	X7R)0.1UF-K/16V-1005REEL	3	D011-10417-710-1S
C150/C154/C155/C157	C,CERAMIC CHIP HIK	X7R)0.1UF-K/16V-1005REEL	4	D011-10417-710-1S
C159/C160/C166	C,CERAMIC CHIP HIK	X7R)0.1UF-K/16V-1005REEL	3	D011-10417-710-1S
C182/C189/C199	C,CERAMIC CHIP HIK	X7R)0.1UF-K/16V-1005REEL	3	D011-10417-710-1S
C201/C216/C225/C228	C,CERAMIC CHIP HIK	X7R)0.1UF-K/16V-1005REEL	4	D011-10417-710-1S
C236/C244/C248/C250	C,CERAMIC CHIP HIK	X7R)0.1UF-K/16V-1005REEL	4	D011-10417-710-1S
C253-C256	C,CERAMIC CHIP HIK	X7R)0.1UF-K/16V-1005REEL	4	D011-10417-710-1S
C258/C259/C261/C262	C,CERAMIC CHIP HIK	X7R)0.1UF-K/16V-1005REEL	4	D011-10417-710-1S
C265/C267/C268	C,CERAMIC CHIP HIK	X7R)0.1UF-K/16V-1005REEL	3	D011-10417-710-1S
C273-C275	C,CERAMIC CHIP HIK	X7R)0.1UF-K/16V-1005REEL	3	D011-10417-710-1S
C279/C281/C282	C,CERAMIC CHIP HIK	X7R)0.1UF-K/16V-1005REEL	3	D011-10417-710-1S
C285/C288-C290	C,CERAMIC CHIP HIK	X7R)0.1UF-K/16V-1005REEL	4	D011-10417-710-1S
C295-C297	C,CERAMIC CHIP HIK	X7R)0.1UF-K/16V-1005REEL	3	D011-10417-710-1S
C300-C306	C,CERAMIC CHIP HIK	X7R)0.1UF-K/16V-1005REEL	7	D011-10417-710-1S
C308/C309/C314	C,CERAMIC CHIP HIK	X7R)0.1UF-K/16V-1005REEL	3	D011-10417-710-1S
C316/C317/C319	C,CERAMIC CHIP HIK	X7R)0.1UF-K/16V-1005REEL	3	D011-10417-710-1S
C321-C323	C,CERAMIC CHIP HIK	X7R)0.1UF-K/16V-1005REEL	3	D011-10417-710-1S
C326-C328	C,CERAMIC CHIP HIK	X7R)0.1UF-K/16V-1005REEL	3	D011-10417-710-1S
C330/C332/C333	C,CERAMIC CHIP HIK	X7R)0.1UF-K/16V-1005REEL	3	D011-10417-710-1S
C335/C337-C339	C,CERAMIC CHIP HIK	X7R)0.1UF-K/16V-1005REEL	4	D011-10417-710-1S
C353/C377-C379	C,CERAMIC CHIP HIK	X7R)0.1UF-K/16V-1005REEL	4	D011-10417-710-1S
C158	C,CERAMIC CHIP HIK	X7R)1UF-K/16V-1608REEL	1	D011-10517-316-1S
C188/C190/C205/C263/C284	C,CERAMIC CHIP HIK	X5R)10UF-K/10V-2012REEL GRM21BR61A106K19L	5	D011-10657-220-05
C101/C103/C165/C167	C,CERAMIC CHIP HIK	COG)15PF-J/50V-1005REEL	4	D011-15016-710-1S
C292/C294	C,CERAMIC CHIP HIK	COG)18PF-J/50V-1005REEL	2	D011-18016-710-1S
C351	C,CERAMIC CHIP HIK	COG)20PF-J/50V-1005REEL	1	D011-20016-710-1S
C171/C179/C184/C186	C,CERAMIC CHIP HIK	COG)22PF-J/50V-1005REEL	4	D011-22016-710-1S
C207/C208/C350	C,CERAMIC CHIP HIK	COG)22PF-J/50V-1005REEL	3	D011-22016-710-1S
C272/C311	C,CERAMIC CHIP HIK	X7R)0.22UF-K/25V-1608REEL TDK	2	D011-22477-416-2S
C174/C196/C197	C,CERAMIC CHIP HIK	COG)330PF-J/50V-1005REEL	3	D011-33116-710-1S
C200/C204/C251	C,CERAMIC CHIP HIK	COG)330PF-J/50V-1005REEL	3	D011-33116-710-1S
C291/C298	C,CERAMIC CHIP HIK	COG)330PF-J/50V-1005REEL	2	D011-33116-710-1S
C303/C318/C331/C342	C,CERAMIC CHIP HIK	COG)330PF-J/50V-1005REEL	4	D011-33116-710-1S
C172/C173	C,CERAMIC CHIP HIK	COG)47PF-J/50V-1005REEL	2	D011-47016-710-1S
C108/C127/C163/C238	C,ELECT CHIP(GE)	1UF-MVG/50V,4.3*5.1*5.3 REEL (Z8155) SY	4	D050-01008-720-05

AVR 70 HDMI board parts list				
REF NO.		DESCRIPTION	QTY	PART NO.
C110/C118/C129/C131	C,ELECT CHIP(GE)	10UF-MVG/16V,3.3*3.7*5.2 REEL (Z8154) SY	4	D050-10008-347-0S
C180/C232/C356/C360	C,ELECT CHIP(GE)	10UF-MVG/16V,3.3*3.7*5.2 REEL (Z8154) SY	4	D050-10008-347-0S
C370-C374	C,ELECT CHIP(GE)	10UF-MVG/16V,3.3*3.7*5.2 REEL (Z8154) SY	5	D050-10008-347-0S
C162/C191/C193/C198	C,ELECT CHIP(GE)	100UF-MVG/6.3V,5.3*5.9*5.3 3REEL (Z8156) SY	4	D050101081650S
C203/C277/C312/C324/C354	C,ELECT CHIP(GE)	100UF-MVG/6.3V,5.3*5.9*5.3 3REEL (Z8156) SY	5	D050101081650S
C210/C230/C241/C246	C,ELECT CHIP(GE)	220UF-M/6.3V,6.6*7.2*5.7 REEL (Z8157) (F55) SY	4	D050221081200S
C358/C382	C,ELECT CHIP(GE)	220UF-M/6.3V,6.6*7.2*5.7 REEL (Z8157) (F55) SY	2	D050221081200S
C144/C153/C240	C,ELECT CHIP(GE)	220UF-M/6.3V,6.6*7.2*5.7 REEL (Z8157) (F55) SY	1	D050221081200S
C100	C,ELECT CHIP(GE)	2.2UF-MVG/50V,3.3*3.7*5.2 REEL (Z8154) SY	1	D0502R2083200S
C119/C140/C142	C,ELECT CHIP(GE)	47UF-MVG/16V,5.3*5.9*5.3 REEL (Z8156) SY	3	D050470083200S
C151/C156/C168	C,ELECT CHIP(GE)	47UF-MVG/16V,5.3*5.9*5.3 REEL (Z8156) SY	3	D050470083200S
C176/C217/C219	C,ELECT CHIP(GE)	47UF-MVG/16V,5.3*5.9*5.3 REEL (Z8156) SY	3	D050470083200S
C183	C,ELECT CHIP(GE)	0.1UF-MVG/50V,3.3*3.7*5.2 REEL (Z8154) SY	1	D050R10080010S
C500	C,CERAMIC CHIP HIK	X7R)0.22UF-K/25V-1608REEL TDK	1	D011224774162S
C221/C222	C,CERAMIC CHIP HIK	COG)20PF-/50V-1005REEL	2	D011200167101S
C202	C,CERAMIC CHIP HIK	X7R2200PF-K/50V-1608REEL	1	D011222777160S
CONNECTOR				
CP100	CN.WAFER 2.0MM	20022WS-04C 4P STRAIGHT SMT	1	L101200220410S
CN102-CN104	CN,WAFER	C12522-19 19P BtoB SOCKET(FEMALE) P=1.25MM	3	L109-01252-191-0S
CN105	CN,WAFER	C12522-25 25P BtoB SOCKET(FEMALE) P=1.25MM	1	L109-01252-251-0S
JACK100-JACK103	CN.WAFER	AD3PB19GO-REV_B 3ROW 19P DIP HDMICON R/A W/FLANGE	4	L109-10019-016-0S
FPC100	CN.FPC 1.25MM	1.25-9-17PB 17P VERTICAL SMT	1	L131-12509-173-0S
CP100	CN.WAFER 2.0MM	20022WS-04C 4P STRAIGHT SMT	1	L101-20022-041-0S
DIODES				
D137-D139/D153	D,ZENER CHIP	0.2W 5.1V UDZ S SERIES (UMD2 TYPE)	4	K06605R14P400S
ZD106	D,ZENER CHIP	0.2W 2.4V UDZS B SERIES (UMD2 TYPE)	1	K066-02R44-P40-0S
D100-D136	D,ESD CHIP	CDS2C05HDMI1 CERADIODE ESD FOR HDMI 1005REEL	37	K067-02050-00-10S
D140-D151	D,ESD CHIP	CDS2C05HDMI1 CERADIODE ESD FOR HDMI 1005REEL	12	K067-02050-00-10S
C223/C224/R28/R269	D,ESD CHIP	CDS2C05HDMI1 CERADIODE ESD FOR HDMI 1005REEL	4	K067-02050-00-10S
D155/D156	D,SCHOTTKY	RS501V-40 VF=0.43V AT100MA SOD-323	2	K120-50100-001-0S
D152/D154	D,SWITCHING CHIP	KDS4148U FAST SWITCHING SOD-323(USC)	2	K005041480030S
D157-D162	D,SWITCHING CHIP	KDS4148U FAST SWITCHING SOD-323(USC)	6	K005041480030S
INTEGRATED CIRCUITS				
IC120	IC,MEMORY-EEPROM	CW24C16DR/ADR 16kbit 1.8V TO 5.5V SOP8P	1	J000-24160-017-0S
IC113	IC,MEMORY-RAM	W9864G6JH-6 1M*4BANKS*16BIT(64MB) TSOP54	1	J001-98646-601-0S
IC119	IC,CPU MICRO PROCESS	M3030RFGPFP FLASH(256K,12K)QFP100	1	J020-30302-004-0S
IC108	IC,LOGIC	74VHC04MTCX HEX INVERTER TSSOP14P	1	J040-74040-027-0S
IC115	IC,LOGIC	74LCX257MTC TSSOP-16P QUAD 2-INPUT MULTIPLEXER	1	J040-74257-004-0S
IC100	IC,LOGIC-INTERFACE	EP94A1 HDMI 1.3 4TO1 REPEATER LQFP128	1	J046-94100-001-0S
IC117	IC,ANALOG	TMS320DA808K013BTP400 DSP S-PQFP-G176	1	J080-32080-801-0S
IC106	IC,LINER-REGULATOR	NJM2831F33 3.3V 0.13A LDO WITH ON/OFF SOT-23-5P	1	J126-28313-301-0S
IC105	IC,LINER-DRIVER	EPF011C GENERIC MCU 64K EMBEDDED FLASH SSOP24	1	J127-01100-001-0S
IC103	IC,LINER-DRIVER	EPF021A KEYBOARD CONTROLLER LQFP64	1	J127-02100-001-0S
IC116	IC,MEMORY FLASH	W25Q32BVSSIG 32M-BIT SERIAL FLASH SOIC8	1	J005-25320-002-0S
IC123	IC,LOGIC-INTERFACE	TPS2557DRB CURRENT LIMIT LOAD SW SONS	1	J046-25570-001-0S
IC109	IC,ANALOG	AK4588 AUDIO CODEC WITH DIR LQFP80P (Pb Free)	1	J080458800010S
IC122	IC,LOGIC	TC74VHC157FK-TBB VSSOP16 QUAD 2CH MULTIPLEXER	1	J040-74157-039-0S
JACKS				
JACK100-JACK103	CN.WAFER	AD3PB19GO-REV_B 3ROW 19P DIP HDMICON R/A W/FLANGE	4	L109-10019-016-0S
JACK104/JACK105	MODULE	JSR1165/OPTICAL RECEIVER 96K SHUTTER	2	E100116500040S
JACK106	TER,RCA 1PIN	RCA-107A(O)ORANGE)	1	G600-107A0-001-YS
TRANSISTOR				
Q100/Q102/Q104/Q138	SEMI,CHIP TR/NPN 25C	KRC102S (NB) 0.2W/SOT-23 REEL	4	J522-01020-021-0S
Q107/Q111	SEMI,CHIP TR/NPN 25C	RT1N141C 0.2W/SC-59 ISAHAYA	2	J522-10141-121-0S
Q101/Q103/Q105	SEMI,CHIP TR/NPN 25C	KRC104S (ND)/SOT-23 REEL	3	J522-10141-121-0S
Q139	SEMI,CHIP TR/NPN 25C	KTC2875B(MB) 0.15W/LOW-ON-RES SOT23(RTK)-REEL	1	J522-2875B-001-0S
Q106/Q110	SEMI,FET CHIP	FDC608PZ P-CH 2.5V MOSFET SOT6	2	J543-60800-001-0S
RESISTOR				
FU100	R,CHIP THICK	0-J, 1/10W	1	C200-00006-020-1S
R221/R260/R2626/R270	R,CHIP THICK	0-J, 1/10W	4	C200-00006-020-1S
R295/R389/R450	R,CHIP THICK	0-J, 1/10W	3	C200-00006-020-1S
L126/L127	R,CHIP THICK	0-J, 1/10W	2	C200-00006-020-1S
L138/C145	R,CHIP THICK	0-J, 1/10W	2	C200-00006-020-1S
R104	R,CHIP THICK	0-J, 1/16W	1	C200-00006-M10-1S
R1050/R1051	R,CHIP THICK	0-J, 1/16W	2	C200-00006-M10-1S
R243/R264/R265/R300	R,CHIP THICK	0-J, 1/16W	4	C200-00006-M10-1S
R336/R338/R340	R,CHIP THICK	0-J, 1/16W	3	C200-00006-M10-1S
R343/R344/R347	R,CHIP THICK	0-J, 1/16W	3	C200-00006-M10-1S
R381/R385/R395	R,CHIP THICK	0-J, 1/16W	3	C200-00006-M10-1S
R405/R406	R,CHIP THICK	0-J, 1/16W	2	C200-00006-M10-1S
R419	R,CHIP THICK	0-J, 1/16W	1	C200-00006-M10-1S
R123	R,CHIP THICK	0-J, 1/16W	1	C200-00006-M10-1S
R1052	R,CHIP THICK	0-J, 1/16W	1	C200-00006-M10-1S
R125-R128	R,CHIP THICK	0-J, 1/16W	4	C200-00006-M10-1S

REF NO.	AVR 70 HDMI board parts list		DESCRIPTION	QTY	PART NO.
R133-R137	R,CHIP THICK	0-J, 1/16W		5	C200-00006-M10-1S
R140/R156/R169/R176	R,CHIP THICK	0-J, 1/16W		4	C200-00006-M10-1S
R190/R200-R202	R,CHIP THICK	0-J, 1/16W		4	C200-00006-M10-1S
R421/R459-R463/R482	R,CHIP THICK	0-J, 1/16W		7	C200-00006-M10-1S
R526/R527	R,CHIP THICK	0-J, 1/16W		1	C200-00006-M10-1S
R532-R535/R537	R,CHIP THICK	0-J, 1/16W		1	C200-00006-M10-1S
R311/R331/R349	R,CHIP THICK	0-J, 1/16W		3	C20000006M160S
L207-L214	R,CHIP THICK	0-J, 1/16W		8	C200-00006-M16-0S
R551/R554/R559/R562	R,CHIP THICK	0-J, 1/16W		4	C200-00006-M16-0S
R541-R544	R,CHIP THICK	0-J, 1/16W		4	C200-00006-M16-0S
R545	R,CHIP THICK	0-J, 1/8W		1	C200-00006-130-0S
R173/R174/R192	R,CHIP THICK	10-J, 1/16W		3	C200-01006-M10-1S
R253-R256	R,CHIP THICK	10-J, 1/16W		4	C200-01006-M10-1S
R212/R216/R228-R233	R,CHIP THICK	100-J, 1/16W		8	C200-01016-M10-1S
R236/R239	R,CHIP THICK	100-J, 1/16W		4	C200-01016-M10-1S
R242/R247/R337	R,CHIP THICK	100-J, 1/16W		3	C200-01016-M10-1S
R346/R350-R352	R,CHIP THICK	100-J, 1/16W		4	C200-01016-M10-1S
R354/R355/R433/R437	R,CHIP THICK	100-J, 1/16W		4	C200-01016-M10-1S
R485/R486	R,CHIP THICK	100-J, 1/16W		2	C200-01016-M10-1S
R546/R553/R557/R394	R,CHIP THICK	100-J, 1/16W		4	C200-01016-M10-1S
R100/R129/R152	R,CHIP THICK	1K-J, 1/16W		3	C200-01026-M10-1S
R191/R195/R199	R,CHIP THICK	1K-J, 1/16W		3	C200-01026-M10-1S
R272/R277	R,CHIP THICK	1K-J, 1/16W		2	C200-01026-M10-1S
R357/R358/R360	R,CHIP THICK	1K-J, 1/16W		3	C200-01026-M10-1S
R1053	R,CHIP THICK	1K-J, 1/16W		1	C200-01026-M10-1S
R101/R103/R106	R,CHIP THICK	10K-J, 1/16W		3	C200-01036-M11-1S
R130/R132/R153/R155	R,CHIP THICK	10K-J, 1/16W		4	C200-01036-M11-1S
R163/R164/R168	R,CHIP THICK	10K-J, 1/16W		3	C200-01036-M11-1S
R170/R172	R,CHIP THICK	10K-J, 1/16W		2	C200-01036-M11-1S
R217/R223-R225	R,CHIP THICK	10K-J, 1/16W		4	C200-01036-M11-1S
R246/R275/R278	R,CHIP THICK	10K-J, 1/16W		3	C200-01036-M11-1S
R356/R374/R375/R379	R,CHIP THICK	10K-J, 1/16W		4	C200-01036-M11-1S
R411/R422/R445/R448	R,CHIP THICK	10K-J, 1/16W		4	C200-01036-M11-1S
R455/R457/R481	R,CHIP THICK	10K-J, 1/16W		3	C200-01036-M11-1S
R548/R549/R556	R,CHIP THICK	10K-J, 1/16W		3	C200-01036-M11-1S
R210/R219/R276/R520	R,CHIP THICK	100K-J, 1/16W		4	C200-01046-M10-1S
R309	R,CHIP THICK	1M-J, 1/16W		1	C200-01056-M10-1S
R109/R197	R,CHIP THICK	10M-J, 1/16W		2	C200-01066-M10-1S
R222	R,CHIP THICK	12K-J, 1/16W		1	C200-01236-M10-1S
R499-R503	R,CHIP THICK	1.5K-J, 1/16W		1	C200-01526-M10-1S
R116/R117	R,CHIP THICK	1.8K-J, 1/16W		2	C200-01826-M10-1S
R110/R111	R,CHIP THICK	2K-J, 1/16W		2	C200-02026-M10-1S
R161/R162/R184/R185	R,CHIP THICK	2K-J, 1/16W		4	C200-02026-M10-1S
R160/R384/R388	R,CHIP THICK	22-J, 1/16W		3	C200-02206-M10-1S
R397-R402	R,CHIP THICK	22-J, 1/16W		6	C200-02206-M10-1S
R407/R410/R412	R,CHIP THICK	22-J, 1/16W		3	C200-02206-M10-1S
R423/R424	R,CHIP THICK	22-J, 1/16W		2	C200-02206-M10-1S
R426-R430	R,CHIP THICK	22-J, 1/16W		5	C200-02206-M10-1S
R432/R436	R,CHIP THICK	22-J, 1/16W		2	C200-02206-M10-1S
R441/R443/R446	R,CHIP THICK	22-J, 1/16W		3	C200-02206-M10-1S
R447/R449	R,CHIP THICK	22-J, 1/16W		2	C200-02206-M10-1S
R452-R454/R458	R,CHIP THICK	22-J, 1/16W		4	C200-02206-M10-1S
R466-R473	R,CHIP THICK	22-J, 1/16W		8	C200-02206-M10-1S
R487/R488	R,CHIP THICK	22-J, 1/16W		2	C200-02206-M10-1S
R491-R497	R,CHIP THICK	22-J, 1/16W		7	C200-02206-M10-1S
R514-R518	R,CHIP THICK	22-J, 1/16W		5	C200-02206-M10-1S
R530/R531/R538	R,CHIP THICK	22-J, 1/16W		1	C200-02206-M10-1S
R105/R208/R220	R,CHIP THICK	2.2K-J, 1/16W		3	C200-02226-M10-1S
R145	R,CHIP THICK	270-J, 1/16W		1	C200-02716-M10-1S
R189	R,CHIP THICK	27K-J, 1/16W		1	C200-02736-M10-1S
R209	R,CHIP THICK	300K-J, 1/16W		1	C200-03046-M10-1S
R213-R215/R237/R328	R,CHIP THICK	33-J, 1/16W		5	C200-03306-M10-1S
R252/R258/R341/R431	R,CHIP THICK	33-J, 1/16W		4	C200-03306-M10-1S
R226/R312	R,CHIP THICK	33-J, 1/16W		2	C200-03306-M10-1S
R157	R,CHIP THICK	330-J, 1/16W		1	C200-03316-M10-1S
R386/R403/R404	R,CHIP THICK	33K-J, 1/16W		3	C200-03336-M10-1S
R474-R476/R479	R,CHIP THICK	33K-J, 1/16W		4	C200-03336-M10-1S
R188	R,CHIP THICK	4.7-J, 1/16W		1	C200-4R706-M10-1S
R259	R,CHIP THICK	47-J, 1/16W		1	C200-04706-M10-1S
R279-R294	R,CHIP THICK	47-J, 1/16W		16	C200-04706-M10-1S
R296-R298	R,CHIP THICK	47-J, 1/16W		3	C200-04706-M10-1S
R301-R308	R,CHIP THICK	47-J, 1/16W		8	C200-04706-M10-1S
R310/R313/R315/R316	R,CHIP THICK	47-J, 1/16W		4	C200-04706-M10-1S
R318-R329	R,CHIP THICK	47-J, 1/16W		12	C200-04706-M10-1S
R332/R333/R335/R339	R,CHIP THICK	47-J, 1/16W		4	C200-04706-M10-1S
R342/R345/R348/R353	R,CHIP THICK	47-J, 1/16W		4	C200-04706-M10-1S
R362-R370	R,CHIP THICK	47-J, 1/16W		9	C200-04706-M10-1S
R382/R383/R387	R,CHIP THICK	47-J, 1/16W		3	C200-04706-M10-1S
R442/R444	R,CHIP THICK	47-J, 1/16W		2	C200-04706-M10-1S
R489/R490/R529	R,CHIP THICK	47-J, 1/16W		3	C200-04706-M10-1S

AVR 70 HDMI board parts list				
REF NO.	DESCRIPTION		QTY	PART NO.
R148/R314	R,CHIP THICK	470-J, 1/16W	2	C200-04716-M10-1S
R207/R211/R244/R245	R,CHIP THICK	4.7K-J, 1/16W	4	C200-04726-M10-1S
R248/R250/R267/R271	R,CHIP THICK	4.7K-J, 1/16W	4	C200-04726-M10-1S
R376/R377/R483/R484	R,CHIP THICK	4.7K-J, 1/16W	3	C200-04726-M10-1S
R513/R525	R,CHIP THICK	4.7K-J, 1/16W	2	C200-04726-M10-1S
R102/R131/R154/R187	R,CHIP THICK	47K-J, 1/16W	4	C200-04736-M10-1S
R196/R198/R249/R261	R,CHIP THICK	47K-J, 1/16W	4	C200-04736-M10-1S
R274/R299/R317/R330	R,CHIP THICK	47K-J, 1/16W	4	C200-04736-M10-1S
R372/R380/R408/R439	R,CHIP THICK	47K-J, 1/16W	4	C200-04736-M10-1S
R477/R478/R552	R,CHIP THICK	47K-J, 1/16W	3	C200-04736-M10-1S
R205/R528	R,CHIP THICK	47K-J, 1/16W	2	C200-04736-M10-1S
R506-R510	R,CHIP THICK	470K-J, 1/16W	5	C200-04746-M10-1S
R182/R183	R,CHIP THICK	51-J, 1/16W	2	C200-05106-M10-1S
R440	R,CHIP THICK	51K-J, 1/16W	1	C200-05136-M10-1S
R113-R115	R,CHIP THICK	5.6-J, 1/16W	3	C200-5R606-M10-1S
R118/R119	R,CHIP THICK	5.6-J, 1/16W	2	C200-5R606-M10-1S
R121/R122/R124/R124	R,CHIP THICK	5.6-J, 1/16W	4	C200-5R606-M10-1S
R142-R144	R,CHIP THICK	5.6-J, 1/16W	3	C200-5R606-M10-1S
R146/R147	R,CHIP THICK	5.6-J, 1/16W	2	C200-5R606-M10-1S
R149-R151	R,CHIP THICK	5.6-J, 1/16W	3	C200-5R606-M10-1S
R167/R171/R175	R,CHIP THICK	5.6-J, 1/16W	3	C200-5R606-M10-1S
R177/R178	R,CHIP THICK	5.6-J, 1/16W	2	C200-5R606-M10-1S
R180/R181/R186	R,CHIP THICK	5.6-J, 1/16W	3	C200-5R606-M10-1S
R234/R235/R240/R241	R,CHIP THICK	56-J, 1/16W	4	C200-05606-M10-1S
R334	R,CHIP THICK	56-J, 1/16W	1	C200-05606-M10-1S
R112/R141/R165	R,CHIP THICK	5.6K-J, 1/16W	3	C200-05626-M10-1S
R561	R,CHIP THICK	68K-J, 1/16W	1	C200-06836-M10-1S
R480	R,CHIP THICK	680K-J, 1/16W	1	C200-06846-M10-1S
R218	R,CHIP THICK	75-J, 1/16W	1	C200-07506-M10-1S
R560	R,CHIP THICK	75K-J, 1/16W	1	C200-07536-M10-1S
ETC				
XTAL105	CRYSTAL CHIP	FCX-04(16MHz) CL=7PF SMD3225 RIVER	1	E805-16R00-008-0S
XTAL100	CRYSTAL CHIP	18.432MHz CL=15PF HCX-5FA/SMD5032	1	E805-18R43-201-0S
XTAL101/XTAL104	CRYSTAL CHIP	24.000MHz CL=15PF HCX-5FA/SMD5032	2	E805-24R00-004-0S
XTAL102	CRYSTAL CHIP	FCX-04(24.576MHz) CL=10PF SMD3225 RIVER	1	E805-24R57-608-0S
IC104/IC110	IC,LINEAR-REGULATOR	IL1117-3.3 SOT-223 3.3V 1A LOW DROPOUT	2	J126111700041S
IC102/IC114	IC,LINEAR-REGULATOR	IL1117_1.8 SOT-223 1.8V 1A LOW DROPOUT	2	J12611171-001-1S
IC111	IC,LINEAR-REGULATOR	IL1117_1.2 SOT-223 1.2V 1A LOW DROPOUT	1	J126111712040S
AVR 70 main board parts list				
REF NO.	DESCRIPTION		QTY	PART NO.
PCB	P.C.B TOTAL ASSY	MAIN	1	7025-HK112-101-0
PCB	P.C.B SUB ASSY	MAIN	1	7028-07209-101-0
PCB	P.C.B	MAIN	1	7020-07209-000-0S
PCB	P.C.B INS ASSY	MAIN-AXIAL	1	7027-07209-1A1-0
PCB	P.C.B INS ASSY	MAIN-MANUAL	1	7027-07209-1M1-0
PCB	P.C.B INS ASSY	MAIN-RADIAL	1	7027-07209-1R1-0
PCB	P.C.B INS ASSY	MAIN-SMD	1	7027-07209-1S1-0
COILS				
BD101/BD103/BD104	COIL,BEAD	120ohm	3	D340-16081-121-0S
BD106-BD110	COIL,BEAD	120ohm	5	D340-16081-121-0S
BD120	COIL,BEAD	120ohm	1	D340-16081-121-0S
L1201	COIL,FILTER-INDUCTOR	33UH-Q40/14M-R4.7-52RE	1	D330-33070-052-0S
CAPACITOR				
C207R/L	C,ELECT GE 85C	4.7UF-M/50V,5*11-5RE.SMS SY	2	D040-4R708-725-0S
C170/C171	C,ELECT GE 85C	4.7UF-M/50V,5*11-5RE.SMS SY	2	D040-4R708-725-0S
C212/C213	C,ELECT GE 85C	10UF-M/16V,5*11-5RE.SHL SY	2	D040-10008-310-0S
C356/C357	C,CERAMIC SEMI DISC	F0.1UF-Z/50V-5RE P16	2	D006-10459-705-0S
C161C/L/R/SL/SR	C,FILM POLYESTER	ST-0.01UF-J/100V-5RE PEFAM103J100 PEF TYPE	5	D02010306C060S
C162C/L/R/SL/SR	C,FILM POLYESTER	ST-0.01UF-J/100V-5RE PEFAM103J100 PEF TYPE	5	D020-10306-C06-0S
C160C/L/R/SL/SR	C,FILM POLYESTER	ST-0.1UF-J/100V-5RE PEFAM104J100 PEF TYPE	5	D020-10306-C06-0S
C201-C203	C,FILM POLYESTER	ST-0.1UF-J/100V-5RE PEFAM104J100 PEF TYPE	3	D020-10306-C06-0S
C208-C210	C,FILM POLYESTER	ST-0.1UF-J/100V-5RE PEFAM104J100 PEF TYPE	3	D020-10306-C06-0S
C182-C186	C,FILM POLYESTER	RED-0.1UF-K/250V-5RE PCMT365	5	D02010407H080S
C187/C188	C,ELECT GE 85C	1UF-M/50V,5*11-5RE.SMS SY (Pb Free)	2	D040-01008-715-0S
C204/C205	C,ELECT GE 85C	1UF-M/50V,5*11-5RE.SMS SY (Pb Free)	2	D040-01008-715-0S
C604/C608/C620	C,ELECT GE 85C	10UF-M/16V,5*11-5RE.SHL SY	3	D040-10008-310-0S
C623	C,ELECT GE 85C	10UF-M/16V,5*11-5RE.SHL SY	1	D040-10008-310-0S
C106L/R	C,ELECT GE 85C	10UF-M/50V,5*11-5RE.SMS SY	2	D040-10008-707-0S
C108L/R	C,ELECT GE 85C	10UF-M/50V,5*11-5RE.SMS SY	2	D040-10008-707-0S
C110L/R	C,ELECT GE 85C	10UF-M/50V,5*11-5RE.SMS SY	2	D040-10008-707-0S
C112L/R	C,ELECT GE 85C	10UF-M/50V,5*11-5RE.SMS SY	2	D040-10008-707-0S
C140SW	C,ELECT GE 85C	10UF-M/50V,5*11-5RE.SMS SY	1	D040-10008-707-0S
C158SW	C,ELECT GE 85C	10UF-M/50V,5*11-5RE.SMS SY	1	D040-10008-707-0S
C176/C178	C,ELECT GE 85C	10UF-M/50V,5*11-5RE.SMS SY	2	D040-10008-707-0S
C191	C,ELECT GE 85C	10UF-M/50V,5*11-5RE.SMS SY	1	D040-10008-707-0S
C123-C128	C,ELECT GE 85C	100UF-M/10V,5*11-5RE.SMS SY	6	D040-10108-209-0S
C197	C,ELECT GE 85C	100UF-M/10V,5*11-5RE.SMS SY	1	D040-10108-209-0S
C1235/C1263/C1270	C,ELECT GE 85C	100UF-M/16V,6.3*11-5RE.SMS SY	3	D040-10108-307-0S



AVR 70 main board parts list				
REF NO.		DESCRIPTION	Q'TY	PART NO.
C264	C,ELECT GE 85C	100UF-M/16V,6.3*11-5RE,SMS SY	1	D040-10108-307-05
C167	C,ELECT GE 85C	2.2UF-M/50V,5*11-5RE SMS SY (Pb Free)	1	D040-2R208-716-05
C193/C195	C,ELECT GE 85C	330UF-M/10V,6.3*11-5RE,SHL-SY	2	D040-33108-207-05
C131/C139	C,ELECT GE 85C	47UF-M/16V,5*11-5RE,SMS SY	2	D040-47008-308-05
C145SW/C146SW	C,ELECT GE 85C	47UF-M/16V,5*11-5RE,SMS SY	2	D040-47008-308-05
C252/C254	C,ELECT GE 85C	47UF-M/16V,5*11-5RE,SMS SY	2	D040-47008-308-05
C257/C258	C,ELECT GE 85C	470UF-M/10V,6.3*11-5RE,SHL SY	2	D040-47108-206-05
C158C/L/R/SL/SR	C,ELECT GE 85C	4.7UF-M/50V,5*11-5RE,SMS SY	5	D040-4R708-725-05
C219/C222/C223	C,ELECT GE 85C	4.7UF-M/50V,5*11-5RE,SMS SY	3	D040-4R708-725-05
C190	C,ELECT GE 85C	4.7UF-M/100V,5*11-5RE,SMS SY	1	D040-4R708-C06-05
C179/C180	C,ELECT GE 85C	1000UF-M/63V,30*50 DL-BLK SY	2	D0401030883805
C189	C,ELECT GE 85C	330UF-M/63V,12.5*20 SY	1	D0403310882305
C207	C,ELECT GE 85C	220UF-M/25V,12.5*25 SHL SY	1	D040-22208-400-05
C206	C,ELECT GE 85C	4700UF-M/25V,16*31.5L.BLK SY	1	D0404720840205
C200	C,ELECT GE 85C	SHL 1000UF 16V M 18*35 P=7.5MM SY	1	D040-10308-302-05
C1254	C,CERAMIC CHIP T.C	COG10PF-D/50V-1608REEL	1	D010-10011-716-05
C1261/1266/C1267	C,CERAMIC CHIP T.C	COG100PF-J/50V-1608REEL	3	D010-10116-716-05
C137/C138	C,CERAMIC CHIP T.C	COG100PF-J/50V-1608REEL	2	D010-10116-716-05
C164SW	C,CERAMIC CHIP T.C	COG100PF-J/50V-1608REEL	1	D010-10116-716-05
C615/C617/C618	C,CERAMIC CHIP T.C	COG100PF-J/50V-1608REEL	3	D010-10116-716-05
C621	C,CERAMIC CHIP T.C	COG100PF-J/50V-1608REEL	1	D010-10116-716-05
C1234/C1253	C,CERAMIC CHIP T.C	X7R 0.01UF-K/50V-1608REEL	2	D010-10377-716-05
C1259/C1260	C,CERAMIC CHIP T.C	X7R 0.01UF-K/50V-1608REEL	2	D010-10377-716-05
C135/C1366	C,CERAMIC CHIP T.C	X7R 0.01UF-K/50V-1608REEL	2	D010-10377-716-05
C141SW/C144SW	C,CERAMIC CHIP T.C	X7R 0.01UF-K/50V-1608REEL	2	D010-10377-716-05
C159C/F/S/SW	C,CERAMIC CHIP T.C	X7R 0.01UF-K/50V-1608REEL	1	D010-10377-716-05
C168C/169	C,CERAMIC CHIP T.C	X7R 0.01UF-K/50V-1608REEL	4	D010-10377-716-05
C231-C234	C,CERAMIC CHIP T.C	X7R 0.01UF-K/50V-1608REEL	4	D010-10377-716-05
C467/C468	C,CERAMIC CHIP T.C	X7R 0.01UF-K/50V-1608REEL	2	D010-10377-716-05
C1258/C1269	C,CERAMIC CHIP T.C	COG15PF-J/50V-1608REEL	2	D010-15016-716-05
C105L/R	C,CERAMIC CHIP T.C	COG220PF-J/50V-1608REEL	2	D010-22116-716-05
C107L/R	C,CERAMIC CHIP T.C	COG220PF-J/50V-1608REEL	2	D010-22116-716-05
C109L/R	C,CERAMIC CHIP T.C	COG220PF-J/50V-1608REEL	2	D010-22116-716-05
C111L/R	C,CERAMIC CHIP T.C	COG220PF-J/50V-1608REEL	2	D010-22116-716-05
C251/C253	C,CERAMIC CHIP T.C	COG220PF-J/50V-1608REEL	2	D010-22116-716-05
C1265/C1268	C,CERAMIC CHIP T.C	COG24PF-J/50V-1608REEL	2	D010-24016-716-05
C143SW	C,CERAMIC CHIP T.C	COG47PF-J/50V-1608REEL	1	D010-47016-716-05
C142SW	C,CERAMIC CHIP HIK	X7R1000PF-K/50V-1608REEL	1	D011-10277-716-05
C1257	C,CERAMIC CHIP HIK	X7R0.1UF-K/50V-1608REEL	1	D011-10457-716-05
C192/C194/C196	C,CERAMIC CHIP HIK	X7R0.1UF-K/50V-1608REEL	3	D011-10457-716-05
C227/C228	C,CERAMIC CHIP HIK	X7R0.1UF-K/50V-1608REEL	2	D011-10457-716-05
C414/C685	C,CERAMIC CHIP HIK	X7R0.1UF-K/50V-1608REEL	2	D011-10457-716-05
C122/C132	C,CERAMIC CHIP HIK	Y5V 0.15uF-Z/10V-1608REEL	2	D011-15479-216-05
C120/C134	C,CERAMIC CHIP HIK	X7R0.022UF-K/25V-1608REEL	2	D011-22377-716-05
C121/C133/C260	C,CERAMIC CHIP HIK	X7R0.047UF-K/16V-1608REEL	3	D011-47377-316-05
C229	C,CERAMIC CHIP HIK	X7R0.1UF-K/50V-1608REEL	1	D011-10457-716-05
C1271	C,CERAMIC CHIP T.C	COG100PF-J/50V-1608REEL	1	D010-10116-716-05
C206R/L	C,CERAMIC CHIP HIK	X7R4700PF-K/50V-1608REEL	2	D011-47277-716-05
C205R1/L	C,CERAMIC CHIP HIK	X7R4700PF-K/50V-1608REEL	2	D011-47277-716-05
C419/C420/C422	C,CERAMIC CHIP HIK	X7R0.1UF-K/50V-1608REEL	3	D011-10457-716-05
C423	C,CERAMIC CHIP HIK	X7R1000PF-K/50V-1608REEL	1	D011-10277-716-05
C322	C,CERAMIC CHIP HIK	X7R0.1UF-K/50V-1608REEL	1	D011-10457-716-05
CONNECTOR				
CP102	CN.WAFER 2.5MM	5267-06A 6P	1	L1025267006005
CP111	CN.WAFER 2.5MM	5267-12A 12P	1	L102-52670-120-05
CP101	CN.WAFER 7.92MM	35328-0360, 7.92MM HEADER,VER,3CKT	1	L108-35328-036-05
CN101/CN107	CN.WAFER	C125Z1-19 19P BtoB HEADER(MALE) P=1.25MM	2	L109-01251-191-05
CN106	CN.WAFER	C125Z1-29 29P BtoB HEADER(MALE) P=1.25MM	1	L109-01251-291-05
FPC103/FPC104	CN.FPC 1.0MM	1.0-11S-10PW 10P AN DIP TOP CONTACT	2	L130-10011-105-05
CP103	CN.FPC 1.25MM	127301107K2 BLK ST 7P	1	L1310071000105
CP117	CN.WAFER 2.0MM	20010WS-02A00 DIP2P STRAIGHT	1	L101-20010-021-05
CP116	CN.WAFER 2.0MM	20010WS-04A00 DIP4P STRAIGHT	1	L101-20010-041-05
CP104	CN.WAFER 2.0MM	20010WS-05A00 DIP5P STRAIGHT	1	L101-20010-051-05
CP112	CN.WAFER 2.0MM	20010WS-10A00 DIP10P STRAIGHT	1	L1012001010105
CN105	CN.WAFER	C125Z1-25 25P BtoB HEADER(MALE) P=1.25MM	1	L109-01251-251-05
DIODE				
D101-D110	D,SWITCHING CHIP	1N4148WS FAST SWITCHING DOIDE Trr=4ns SOD-323	10	K005-04148-323-05
D126-D128	D,SWITCHING CHIP	1N4148WS FAST SWITCHING DOIDE Trr=4ns SOD-323	3	K005-04148-323-05
D120/D121/D123	D,SWITCHING CHIP	1N4148WS FAST SWITCHING DOIDE Trr=4ns SOD-323	3	K005-04148-323-05
D142/D139	D,SWITCHING CHIP	1N4148WS FAST SWITCHING DOIDE Trr=4ns SOD-323	2	K005-04148-323-05
D201/D202	D,SWITCHING CHIP	1N4148WS FAST SWITCHING DOIDE Trr=4ns SOD-323	2	K005-04148-323-05
D116-D119	D,SWITCHING	1SS133T-72-52MM	4	K0000133005205
D124	D,SWITCHING	1SS133T-72-52MM	1	K0000133005205
D122	D,SWITCHING	1N4007 52REEL 1000V 1A	1	K000-40070-001-05
D129-D134	D,SWITCHING	1N4007 52REEL 1000V 1A	6	K000-40070-001-05
ZD109	D,ZENER CHIP	0.2W 5.1V UDZ S SERIES (UMD2 TYPE)	1	K06605R14P4005
ZD105/ZD107	D,ZENER CHIP	0.2W 3.3V UDZ S SERIES (UMD2 TYPE)	2	K06603R34P4005
ZD101/ZD102	D,ZENER CHIP	0.2W 7.5V UDZ S SERIES (UMD2 TYPE)	2	K06607R54P4005
ZD103/ZD104	D,ZENER CHIP	0.2W 16V UDZ S SERIES (UMD2 TYPE)	1	K06616R04P4005

REF NO.	AVR 70 main board parts list	DESCRIPTION	Q'TY	PART NO.
D137	D,SWITCHING	1N4148M-52RE 75V 150MA	1	K000-41480-252-0S
D111/D112	D,RECTIFIER BRIDGE	KBPC604 6A	2	K047604000020S
INTEGRATED CIRCUIT				
IC105	IC,LINEAR OP	UTC4580E SOP8 DUAL OP AMP	1	J121-45800-101-0S
IC106	IC,MONITOR SW	IC LA7956 VIDEO SWITCH FOR TV/VCR USE SIP9P	1	J171795600010S
IC109	IC,ELECT VR	R2A15218FP-U00R 8CH-VOL WITH 11 INPUT QFP100P	1	J084152180010S
IC1204	IC,MONITOR	LC74781M-9017-E OSD CONTROL LSI MFP-24	1	J170-74781-002-0S
IC105	IC,LINEAR OP	UTC4580E SOP8 DUAL OP AMP	1	J121-45800-101-0S
IC113	IC,LOGIC	SN74AHCT08PWR-EL2 QUADRUPLE 2-INPUT REEL TSSOP14	1	J040-74080-024-0S
JACK				
JACK104	TER,RCA 1PIN	JACK RCA-107A(PURPLE)-YUQIU	1	G600-107A0-000-0S
JACK105	TER,RCA	RCA-1201A-01-20(RD,W,RD,W/RD,W,RD,W,RD,W)	1	G6081201A120YS
JACK103	TER,RCA 4PIN	RCA-405BE-31(YL,YL,YL,YL)-YUQIU	1	G602-405BE-310-YS
JACK102	TER,BOARD SCREW 8P	MST-108V1-06 (RD,WH,GY,BL,BK,BK,BK)	1	G614-108V1-060-MS
JACK101	TER,BOARD SCREW 2P	JB-201A-07(GN,BK)	1	G611-201A0-700-YS
TRANSISTOR				
Q105/Q107/Q109	SEMI,CHIP TR/PNP 2SA	KRA105S(PE) 0.2W/SOT-23 REEL	3	J520-01050-021-0S
Q111	SEMI,CHIP TR/PNP 2SA	KRA105S(PE) 0.2W/SOT-23 REEL	1	J520-01050-021-0S
Q1211	SEMI,CHIP TR/PNP 2SA	ISA1530AC1 0.2W/SC-59 ISAHAYA	1	J520-01050-021-0S
Q116-Q118/Q120	SEMI,CHIP TR/NPN 2SC	KRC105S (NE) 0.2W/SOT-23 REEL	4	J520-01050-021-0S
Q103/Q104/Q106	SEMI,CHIP TR/NPN 2SC	KTC2875B	3	J522-2875B-001-0S
Q108/Q110	SEMI,CHIP TR/NPN 2SC	KTC2875B	2	J522-2875B-001-0S
Q114/Q115	SEMI,CHIP TR/NPN 2SC	KTC2875B	2	J522-2875B-001-0S
Q1214	SEMI,CHIP TR/NPN 2SC	2SC3052 0.15W/SC-59 REEL ISAHAYA	1	J522-30520-005-0S
Q125	SEMI,TR/GE PNP 2SA	KSA916Y,0.9W/TO92L-REEL	1	J5000916Y0050S
Q121	SEMI,TR/GE PNP 2SA	KTA1268BL	1	J5001268B0050S
Q123/Q124	SEMI,TR/GE PNP 2SA	KTA1268BL	2	J5001268B0050S
Q126/Q128	SEMI,TR/GE PNP 2SA	KTA1268BL	2	J5001268B0050S
Q131/Q134	SEMI,TR/GE PNP 2SA	KTA1268BL	2	J5001268B0050S
Q122/Q127	SEMI,TR/GE NPN 2SC	KTC3198Y	2	J5023198Y0000S
Q129/Q130	SEMI,TR/GE NPN 2SC	KTC3198Y	2	J5023198Y0000S
Q132/Q133	SEMI,TR/GE NPN 2SC	KTC3198Y	2	J5023198Y0000S
Q135/Q136	SEMI,TR/GE NPN 2SC	KTC3198Y	2	J5023198Y0000S
Q201/Q202	SEMI,TR/GE NPN 2SC	KTC3198Y	2	J5023198Y0000S
Q205-Q208	SEMI,CHIP TR/NPN 2SC	KRC111S (NM) 0.2W/SOT-23 REEL	4	J522-01110-021-0S
RESISTOR				
J137/J139/J140	R,CHIP THICK	0-J, 1/8W	3	C200-00006-130-0S
J163/347-J350/J356	R,CHIP THICK	0-J, 1/8W	6	C200-00006-130-0S
R1257/R1259	R,CHIP THICK	0-J, 1/16W	2	C200-00006-M16-0S
R1252	R,CHIP THICK	0-J, 1/16W	1	C200-00006-M16-0S
R224/R607/R611	R,CHIP THICK	100-J, 1/16W	3	C200-01016-M16-0S
R618/R620/R625	R,CHIP THICK	100-J, 1/16W	3	C200-01016-M16-0S
R639/R643	R,CHIP THICK	100-J, 1/16W	2	C200-01016-M16-0S
R125SW/R152SW	R,CHIP THICK	1K-J, 1/16W	2	C200-01026-M16-0S
R185	R,CHIP THICK	10K-J, 1/16W	1	C200-01036-M16-0S
R1262	R,CHIP THICK	10M-J, 1/16W	1	C200-01056-M16-0S
R216	R,CHIP THICK	20K-J, 1/16W	1	C200-02036-M16-0S
R159SW/R164	R,CHIP THICK	220-J, 1/16W	2	C200-02216-M16-0S
R1253	R,CHIP THICK	2.2K-J, 1/16W	1	C200-02226-M16-0S
R140SW/R141SW	R,CHIP THICK	2.2K-J, 1/16W	2	C200-02226-M16-0S
R151R/SR	R,CHIP THICK	2.2K-J, 1/16W	2	C200-02226-M16-0S
R167	R,CHIP THICK	2.2K-J, 1/16W	1	C200-02226-M16-0S
R255/R258	R,CHIP THICK	22K-J, 1/16W	2	C200-02236-M16-0S
R202	R,CHIP THICK	27K-J, 1/16W	1	C200-02736-M16-0S
R105L/R	R,CHIP THICK	330-J, 1/16W	2	C200-03316-M16-0S
R107L/R	R,CHIP THICK	330-J, 1/16W	2	C200-03316-M16-0S
R109L/R	R,CHIP THICK	330-J, 1/16W	2	C200-03316-M16-0S
R111L/R	R,CHIP THICK	330-J, 1/16W	2	C200-03316-M16-0S
R261/R262	R,CHIP THICK	330-J, 1/16W	2	C200-03316-M16-0S
R127SW	R,CHIP THICK	3.3K-J, 1/16W	1	C200-03326-M16-0S
R260/R275	R,CHIP THICK	3.3K-J, 1/16W	2	C200-03326-M16-0S
R165/R196/R225	R,CHIP THICK	3.3K-J, 1/16W	3	C200-03326-M16-0S
R163	R,CHIP THICK	3.6K-J, 1/16W	1	C200-03326-M16-0S
R256/R259	R,CHIP THICK	390-J, 1/16W	2	C200-03916-M16-0S
R1263	R,CHIP THICK	3.9K-J, 1/16W	1	C200-03926-M16-0S
R192	R,CHIP THICK	43K-J, 1/16W	1	C200-04336-M16-0S
R194	R,CHIP THICK	43K-J 1/16W	1	C200-04336-M16-0S
R217/R218	R,CHIP THICK	47-J, 1/16W	2	C200-04706-M16-0S
R149C/L/R/SL/SR	R,CHIP THICK	470-J, 1/16W	5	C200-04716-M16-0S
R613/R622/R640	R,CHIP THICK	470-J, 1/16W	3	C200-04716-M16-0S
R644	R,CHIP THICK	470-J, 1/16W	1	C200-04716-M16-0S
R117/R123	R,CHIP THICK	4.7K-J, 1/16W	2	C200-04726-M16-0S
R128SW	R,CHIP THICK	4.7K-J, 1/16W	1	C200-04726-M16-0S
R166	R,CHIP THICK	4.7K-J, 1/16W	1	C200-04726-M16-0S
R126SW	R,CHIP THICK	47K-J, 1/16W	1	C200-04736-M16-0S
R188/R189	R,CHIP THICK	47K-J, 1/16W	2	C200-04736-M16-0S
R150C/F/S/SW	R,CHIP THICK	470K-J, 1/16W	4	C200-04746-M16-0S
R1258/R1260	R,CHIP THICK	560-J, 1/16W	2	C200-05616-M16-0S
R162/R182	R,CHIP THICK	560K-J, 1/16W	2	C200-05646-M16-0S
R251/R252	R,CHIP THICK	75-J, 1/16W	2	C200-07506-M16-0S

REF NO.	AVR 70 main board parts list	DESCRIPTION	Q'TY	PART NO.
R254/R257	R,CHIP THICK	75-J , 1/16W	2	C200-07506-M16-05
R187	R,CHIP THICK	15K-J , 1/16W	1	C200-01536-M16-05
R243	R,CHIP THICK	100-J , 1/16W	1	C200-01016-M16-05
R205L/R	R,CHIP THICK	1K-J , 1/16W	2	C200-01026-M16-05
R198	R,CHIP THICK	51K-J , 1/16W	1	C200-05136-M16-05
J363-J371	R,CHIP THICK	0-J , 1/8W	9	C200-00006-130-05
J465/J466	R,CHIP THICK	0-J , 1/8W	2	C200-00006-130-05
J141/J373	R,CHIP THICK	0-J , 1/8W	2	C200-00006-130-05
J359/J1202	R,CHIP THICK	0-J , 1/8W	2	C200-00006-130-05
J445/J467/J512	R,CHIP THICK	0-J , 1/8W	3	C200-00006-130-05
R106L/R	R,CHIP THICK	100K-J , 1/16W	2	C200-01046-M16-05
R108L/R	R,CHIP THICK	100K-J , 1/16W	2	C200-01046-M16-05
R110L/R	R,CHIP THICK	100K-J , 1/16W	2	C200-01046-M16-05
R112L/R	R,CHIP THICK	100K-J , 1/16W	2	C200-01046-M16-05
R120-R122	R,CHIP THICK	100K-J , 1/16W	13	C200-01046-M16-05
R154C/L/R/SL/SR/SW	R,CHIP THICK	100K-J , 1/16W	6	C200-01046-M16-05
R191/R193/R195	R,CHIP THICK	100K-J , 1/16W	3	C200-01046-M16-05
R206L/R	R,CHIP THICK	100K-J , 1/16W	2	C200-01046-M16-05
R126/R127	R,CHIP THICK	100-J , 1/16W	2	C200-01016-M16-05
R264-R265	R,CHIP THICK	3.3K-J , 1/16W	12	C200-03326-M16-05
R236	R,CHIP THICK	33-J,1/16W-1608REEL	1	C200-03306-M16-05
R651/R655	R,CHIP THICK	1K-J , 1/16W	2	C200-01026-M16-05
R631/R638/R642/R650	R,CHIP THICK	470K-J , 1/16W	4	C200-04746-M16-05
R615	R,CARBON FILM	100-J , 1/5W	1	C000-01016-P52-05
R148C/L/R/SL/SR/SW	R,CARBON FILM	1K-J , 1/5W	6	C000-01026-P52-05
R180	R,CARBON FILM	1K-J , 1/5W	1	C000-01026-P52-05
R151SL	R,CARBON FILM	2.2K-J , 1/5W	1	C000-02226-P52-05
R197/R177/R201	R,CARBON FILM	2.2K-J , 1/5W	3	C000-02226-P52-05
R203	R,CARBON FILM	27K-J , 1/5W	1	C000-02736-P52-05
R124/R125	R,CARBON FILM	470-J , 1/5W	2	C000-04716-P52-05
R199/R200	R,CARBON FILM	51K-J , 1/5W	2	C000-05136-P52-05
R157/R158	R,METAL FILM 100PPM	470-J , 2W	2	C0600471665205
R152F/S/C	R,CARBON FILM	1K-J , 1/5W	3	C000-01026-P52-05
R153S/F/C/SW	R,CARBON FILM	470K-J , 1/5W	4	C000-04746-P52-05
R1251/R1254/R1255	R,CARBON FILM	470-J , 1/5W	3	C000-04716-P52-05
R155C/L/R/SR/SL	R,CARBON FILM	22K-J , 1/5W	5	C000-02236-P52-05
R1261	R,CARBON FILM	1K-J , 1/5W	1	C000-01026-P52-05
R151L/C	R,CARBON FILM	2.2K-J , 1/5W	2	C000-02226-P52-05
R235	R,CARBON FILM	15K-J , 1/5W	1	C000-01536-P52-05
J102-J107	CN,WIRE 1P	0.6/52MM	6	L045-08400-604-05
J110/J113-J119	CN,WIRE 1P	0.6/52MM	3	L045-08400-604-05
J123/J131/J138	CN,WIRE 1P	0.6/52MM	3	L045-08400-604-05
J145-J147	CN,WIRE 1P	0.6/52MM	3	L045-08400-604-05
J152/J155/J159	CN,WIRE 1P	0.6/52MM	3	L045-08400-604-05
J164/J165	CN,WIRE 1P	0.6/52MM	2	L045-08400-604-05
J171-J174	CN,WIRE 1P	0.6/52MM	4	L045-08400-604-05
J207/J209/J217	CN,WIRE 1P	0.6/52MM	3	L045-08400-604-05
J309/J311	CN,WIRE 1P	0.6/52MM	2	L045-08400-604-05
J313-J316	CN,WIRE 1P	0.6/52MM	4	L045-08400-604-05
J351-J355	CN,WIRE 1P	0.6/52MM	5	L045-08400-604-05
J358/J360-J362	CN,WIRE 1P	0.6/52MM	4	L045-08400-604-05
J401-J403	CN,WIRE 1P	0.6/52MM	4	L045-08400-604-05
J405-J439	CN,WIRE 1P	0.6/52MM	35	L045-08400-604-05
J442-J444	CN,WIRE 1P	0.6/52MM	3	L045-08400-604-05
J446-J450	CN,WIRE 1P	0.6/52MM	5	L045-08400-604-05
J453-J464/J468	CN,WIRE 1P	0.6/52MM	13	L045-08400-604-05
J471/J472	CN,WIRE 1P	0.6/52MM	2	L045-08400-604-05
J475-J477/J479	CN,WIRE 1P	0.6/52MM	4	L045-08400-604-05
J482-J485	CN,WIRE 1P	0.6/52MM	4	L045-08400-604-05
J487-J508	CN,WIRE 1P	0.6/52MM	22	L045-08400-604-05
J510/J511/J513	CN,WIRE 1P	0.6/52MM	3	L045-08400-604-05
J519-J523	CN,WIRE 1P	0.6/52MM	5	L045-08400-604-05
J526/J568-J571	CN,WIRE 1P	0.6/52MM	5	L045-08400-604-05
R156C/L/R/SL/SR	R,METAL FILM 100PPM	10-J , 1W	5	C060-01006-505-05
R186	R,METAL FILM 100PPM	22-J , 1/4W	1	C060-02206-305-05
R174-R176	R,METAL FILM 100PPM	2.2K-J , 1W	3	C060-02226-505-05
R190	R,METAL FILM 100PPM	47K-J , 1/4W	1	C060-04736-305-05
R142/R143	R,METAL FILM 100PPM	68-J , 1W	2	C0600680650605
R184	R,METAL FILM 100PPM	4.7-J , 1W	1	C0604R70650505
R205-R208	R,METAL FILM 100PPM	0.22-J , 1W	4	C060R220650505
J509	R,CARBON FILM	180-J , 1/5W	1	C000-01816-P52-05
R178/R179/R204/R215	R,CEMENT RADIAL FORM	RES CE 0.1-J 5W 14*17 PITCH(10MM) ETC	4	C141R100690105
XTAL1203	CRYSTAL	14.31818MHZ, HC-49S CL;18PF STRIGHT LEAD (수삽)		E800-14R31-808-05
RLY101-RLY104	RELAY	G5PA-28-MC 12V 5A SPK 1회로 2접점	4	G6801205020505
IC103	IC,LINEAR-REGULATOR	KIA7812AP,20W-TO220IS MOLD	1	J126-78120-004-05
IC104	IC,LINEAR-REGULATOR	KIA7912PI,20W-TO220IS MOLD	1	J126-79120-006-05
IC107/IC110-IC112	IC,LINEAR-REGULATOR	KIA7805AP,20W-TO220IS MOLD	4	J126-78050-011-05
HSINK102	HEAT SINK	R945 ALL H=45/REG TR	1	21200435380305
HSINK101	HEAT SINK	HEAT SINK REG TR(24X45)	1	2120-04429-801-05

AVR 70 main board parts list				
REF NO.	DESCRIPTION		Q'TY	PART NO.
PACK102	TUNER,FM/AM	KST-MW004MV1-S63 FM/AM NA	1	E903-00410-002-0S
WIRE101	CN,WIRE	140,100MM/2P SOLDER(7MM) RD,YL1007#18 TWIST	1	L000-14102-015-0S
WIRE102	CN,WIRE	190MM/1P SOLDER(5MM),SOLDER(5MM) BK1007#18	1	L000-19101-007-0S
WIRE103	CN,WIRE	175MM/3P SOLDER(5MM),SOLDER(5MM) YW1007#18 TWIST	1	L000-17103-007-0S
GND101-GND104	TERMINAL	MET37-0002/TAPIG EARTH FITTING	4	3790-04088-600-0S
PCB	P.C.B SUB ASSY	AVR700(HARMAN)/USB	1	7028-07209-201-0
PCB	P.C.B INS ASSY	AVR700(HARMAN)/USB-AXIAL	1	7027-07209-2A1-0
PCB	P.C.B INS ASSY	AVR700(HARMAN)/USB-MANUAL	1	7027-07209-2M1-0
PCB	P.C.B INS ASSY	AVR700(HARMAN)/USB-RADIAL	1	7027-07209-2R1-0
PCB	P.C.B INS ASSY	AVR700(HARMAN)/USB-SMD	1	7027-07209-2S1-0
J514	CN,WIRE 1P	0.6/52MM	1	L045-08400-604-0S
CN109	CN,WIRE 2MM	330MM/4P 20010HS-04-CKM2002HV-04 RD2725#24/28 CORE	1	L002-33104-005-0S
C198/C211/C215/C216	C,CERAMIC CHIP HIK	X7R0.1UF-K/50V-1608REEL	4	D011-10457-716-0S
C217/C218	C,CERAMIC CHIP T.C	COG10PF-D/50V-1608REEL	2	D010-10011-716-0S
C358/C359	C,CERAMIC CHIP HIK	X7R0.1UF-K/50V-1608REEL	2	D011-10457-716-0S
C214	C,CERAMIC CHIP HIK	X7R1000PF-K/50V-1608REEL	1	D011-10277-716-0S
C199/C224	C,ELECT GE 85C	220UF-M/10V,5*11-5RE.SHL-SY	2	D040-22108-208-0S
D702/C703	D,SWITCHING CHIP	1N4148WS FAST SWITCHING DOIDE Trr=4ns SOD-323	2	K005-04148-323-0S
JACK106	CN,PLUG CONTACT	USB A TYPE FLAT DIP4P USBAS-00401BANB	1	G480040100010S
L121/L125	COIL,BEAD	CBW160808U121T 120ohm SMD1608 TYPE	2	D340-16081-121-0S
L127	R,CHIP THICK	0-J 1/16W	1	C200-00006-M16-0S
R240/R242	R,CHIP THICK	15K-J 1/16W	2	C200-01536-M16-0S
*	SHIELD	AVR133(HARMAN) SPT E.0.2T A4/PLATE USB-A	1	3070-21045-600-0S
PCB	P.C.B SUB ASSY	AVR700(HARMAN)/GUIDE_C	1	7028-07209-301-0
PCB	P.C.B INS ASSY	AVR700(HARMAN)/GUIDE_C-MANUAL	1	7027-07209-3M1-0
CLAMP101	CLAMP	HMX9800(ON)(HAITAI) (W=2.6,L=50)/WIRE(SOLDER)	1	4330-00012-000-0S
PCB	P.C.B SUB ASSY	AVR700(HARMAN)/GUIDE_L	1	7028-07209-401-0
PCB	P.C.B INS ASSY	AVR700(HARMAN)/GUIDE_L-AXIAL	1	7027-07209-4A1-0
PCB	P.C.B INS ASSY	AVR700(HARMAN)/GUIDE_L-MANUAL	1	7027-07209-4M1-0
J270-J273	CN,WIRE 1P	0.6/52MM	4	L045-08400-604-0S
J278-J281	CN,WIRE 1P	0.6/52MM	4	L045-08400-604-0S
CLAMP201	CLAMP	HMX9800(ON)(HAITAI) (W=2.6,L=50)/WIRE(SOLDER)	1	4330-00012-000-0S
PCB	P.C.B SUB ASSY	AVR700(HARMAN)/GUIDE_R	1	7028-07209-501-0
PCB	P.C.B INS ASSY	AVR700(HARMAN)/GUIDE_R-AXIAL	1	7027-07209-5A1-0
PCB	P.C.B INS ASSY	AVR700(HARMAN)/GUIDE_R-MANUAL	1	7027-07209-5M1-0
J286-J293	CN,WIRE 1P	0.6/52MM	8	L045-08400-604-0S
CLAMP301	CLAMP	HMX9800(ON)(HAITAI) (W=2.6,L=50)/WIRE(SOLDER)	1	4330-00012-000-0S
AVR 70 standby board parts list				
REF NO.	DESCRIPTION		Q'TY	PART NO.
PCB	P.C.B TOTAL ASSY	STANDBY	1	7025-HK112-101-4
PCB	P.C.B SUB ASSY	STANDBY	1	7028-07212-101-0
PCB	P.C.B	STANDBY	1	7020-07212-000-0S
PCB	P.C.B INS ASSY	STANDBY-AXIAL	1	7027-07212-1A1-0
PCB	P.C.B INS ASSY	STANDBY-MANUAL	1	7027-07212-1M1-0
PCB	P.C.B INS ASSY	STANDBY-RADIAL	1	7027-07212-1R1-0
PCB	P.C.B INS ASSY	STANDBY-SMD	1	7027-07212-1S1-0
CAPACITORS				
C300	C,ELECT GE 85C	10UF-M/50V,5*11-5RE.SMS SY	1	D040-10008-707-0S
C302/C315	C,ELECT GE 85C	1UF-M/50V,5*11-5RE.SMS SY (Pb Free)	2	D040-01008-715-0S
C304	C,CERAMIC AC(SAFETY)	SCF2E472M10FF7 0.0047UF 250VAC 7.5MM-REEL	1	D00847208H010S
C301	C,ELECT GE 85C	2200UF-M/16V,10*20-L.BLK SY	1	D040222083080S
CONNECTOR				
CP305	CN.WAFER 7.92MM	35328-0260, 7.92MM HEADER,VER,2CKT	1	L108-35328-026-0S
CP304	CN.WAFER 7.92MM	35328-0261, 7.92MM HEADER,VER,2CKT,BLK	1	L108-35328-027-0S
CP306	CN.WAFER 7.92MM	PLUG YW396-03AV 2P	1	L108-39603-001-0S
CN301	CN.FPC 1.25MM	TWG-P07P-A1 BLK ST 7P	1	L131007000010S
DIODES				
D302-D304	D,SWITCHING CHIP	1N4148WS FAST SWITCHING DOIDE Trr=4ns SOD-323	3	K005-04148-323-0S
D305-D308	D,SWITCHING	1N4007 52REEL 1000V 1A	4	K000-40070-001-0S
ZD301	D,ZENER	MTZJ4.7B-0.5W/5MA-52MM	1	K06004R744520S
ZD302	D,ZENER CHIP	0.2W 10V UDZ 5 SERIES (UMD2 TYPE)	1	K066-10R04-P40-0S
TRANSISTOR				
Q300/Q301	SEMI,CHIP TR/NPN 25C	KTC3875Y(ALY) 0.15W/SMT-REEL	2	J522-3875Y-021-0S
Q302	SEMI,CHIP TR/NPN 25C	KRC1075 (NH)/SOT-23 REEL	1	J522-10750-021-0S
RESISTOR				
R302	R,CARBON FILM	3.3K-J,1/5W-52RE-AX	1	C000-03326-P52-0S

AVR 70 standby board parts list				
REF NO.	DESCRIPTION		QTY	PART NO.
R304	R,METAL FILM 100PPM	10-J,1/4W-R.REEL	1	C060-01006-305-0S
R300	R,CHIP THICK	10K-J,1/16W-1608REEL	1	C200-01036-M16-0S
R301	R,CHIP THICK	20K-J,1/16W-1608REEL	1	C200-02036-M16-0S
R333	R,CHIP THICK	47K-J,1/16W-1608REEL	1	C200-04736-M16-0S
R303	R,CHIP THICK	2.2K-J,1/16W-1608REEL	1	C200-02226-M16-0S
J304	R,CHIP THICK	0-J,1/8W-3216REEL	1	C200-00006-130-0S
J301-J303	CN,WIRE 1P	JUMPER (0.6/52MM)	3	L045-08400-604-0S
ETC				
RLY301	RELAY	G5PA-1 DC6V 5A 1회로1접점	1	G680060502010S
F301	FUSE GLASS TUBE 20MM	T6.3A /250V-SVBRTC(K) 218	1	N751-22630-111-0S
IC300	IC,LINEAR-REGULATOR	IL1117-3.3 SOT-223 3.3V 1A LOW DROPOUT	1	J126111700041S
PT301	POWER TRANS	AVR1908 BKE3(DENON) STAND-BY 120V/60HZ 28*15	1	8200-28015-040-1S
F301A/F301B	HOLDER,FUSE CLIP	PI5.2-REEL	2	G645000050010S
GT301	TERMINAL	MET37-0002/TAPIG EARTH FITTING	1	3790-04088-600-0S

## 2.2 Pin Diagram

Figure 2-2 EPF011C Pin Diagram

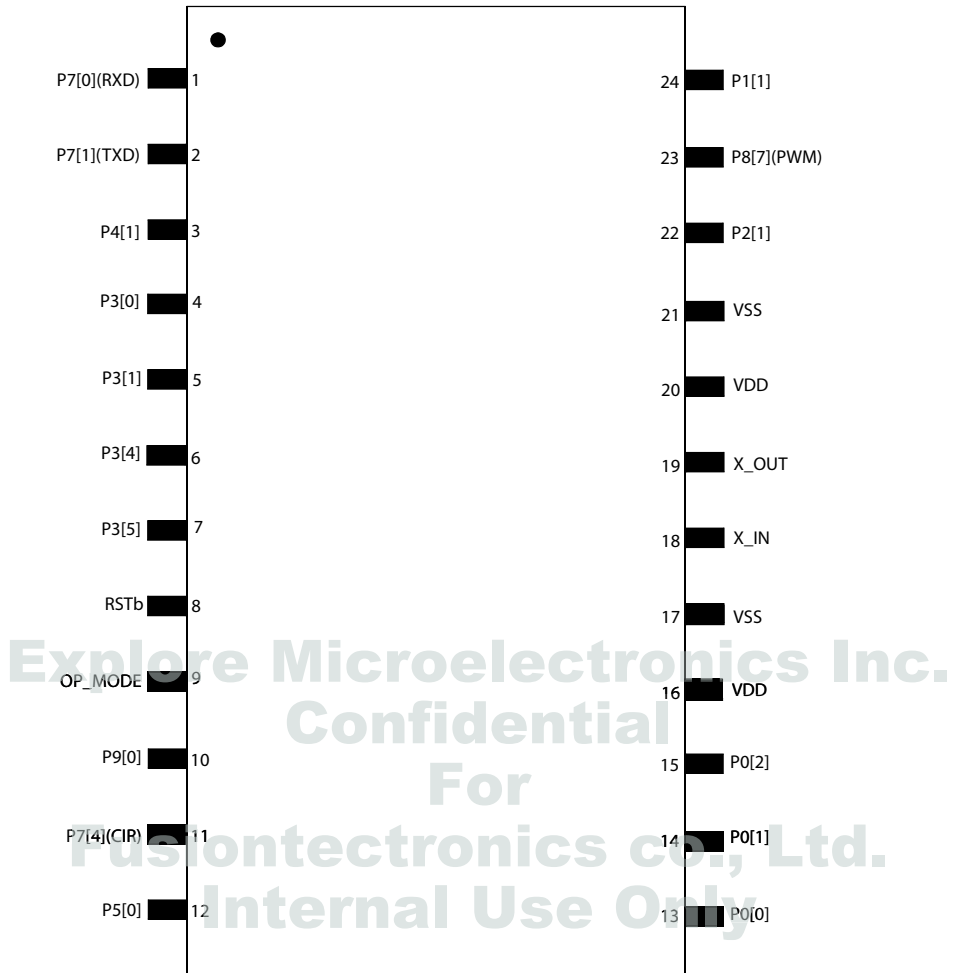

## 2.3 Pin Description

Unless otherwise stated, unused input pins must be tied to ground, and unused output pins left open.

**Table 2-1 Pin Description**

Name	In/Out	Buffer Type	Description
OP_MODE	IN	IXDXXP	Chip operation mode. 0: Normal mode 1: ICP (In Circuit Flash Programming) mode NOTE: The input crystal rate will be 24MHz if this ICP mode is used.
RSTb	IN	BDUX8P	External Reset (active low) with on-chip pull-up. When this pin is asserted low, the chip is totally reset.
X_IN	IN	XTL24P	crystal input
X_OUT	OUT	XTL24P	crystal output
P0[2:0]	IN/OUT	BRXX12P	GPIO port 0 with programmable Open Drain capability.
P11	IN/OUT	BRUX8P	GPIO port 1 or Keyboard Interrupt inputs with internal 20K $\Omega$ pull-up to VDD
P21	IN/OUT	BRXX8P	GPIO port 2 with programmable Open Drain capability.
P3[5:4, 1:0]	OD IN/OUT	BRXX8P	Open Drain I/O port 3. Shared with IIC.
P41	IN/OUT	BRXX8P	GPIO port 4 or External Interrupt inputs
P50	IN/OUT	BRXX24P	GPIO port 5 with programmable Open Drain capability. 20 mA drive
P7[4,1:0]	IN/OUT	BRXX8P	Open Drain I/O port 7. P7[1:0] shared with Serial Port. P7[4] share with CIR.
P87	IN/OUT	BRXX8P	GPIO port 8 with programmable Open Drain capability. Share with PWM
P90	IN/OUT	BRXX8P	GPIO port 9 with programmable Open Drain capability.
VDD	PWR	-	Digital VDD (3.3V)
VSS	PWR	-	Digital Ground

Fig 1. BLOCKDIAGRAM AND PIN CONFIGURATION(TOP VIEW)

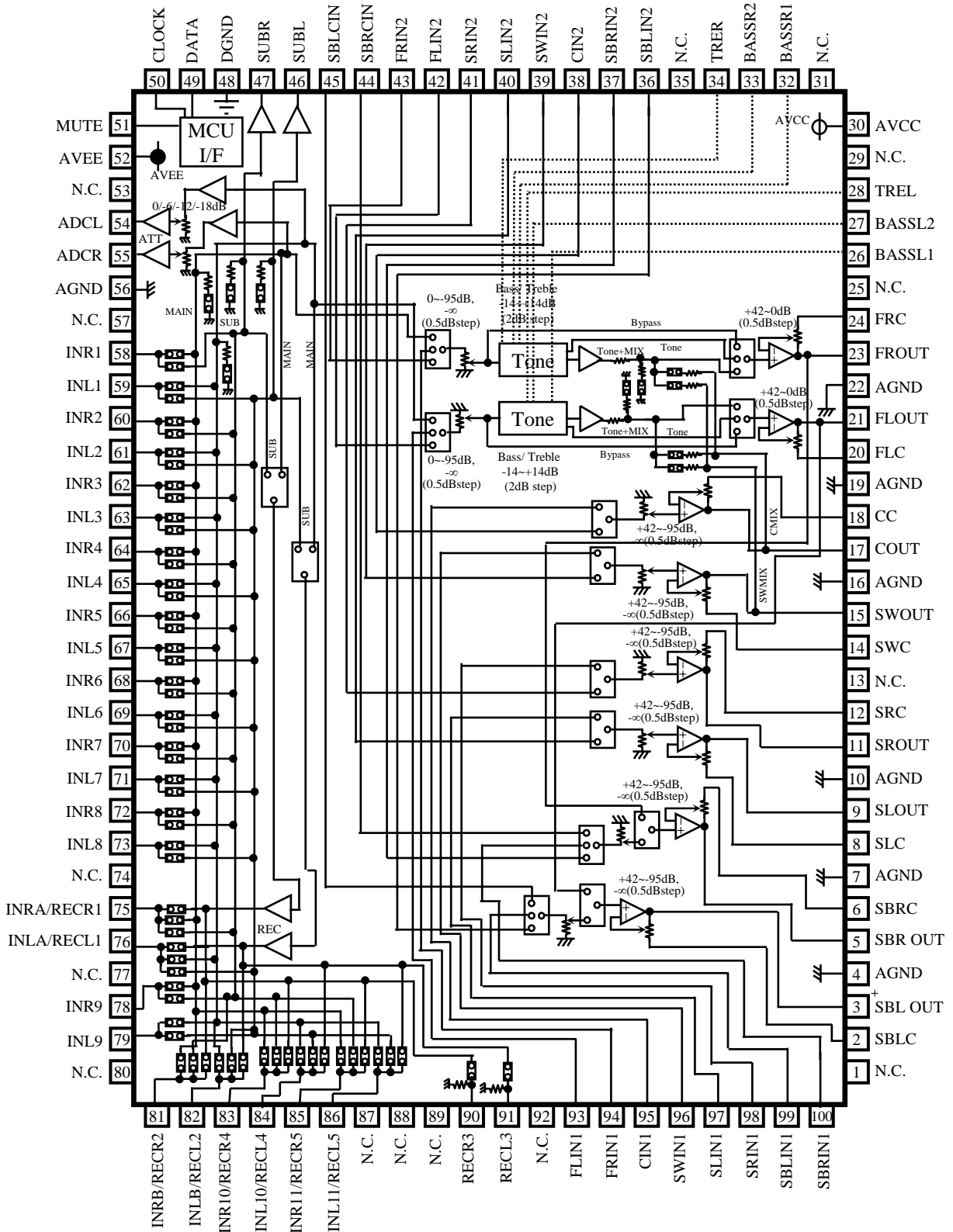
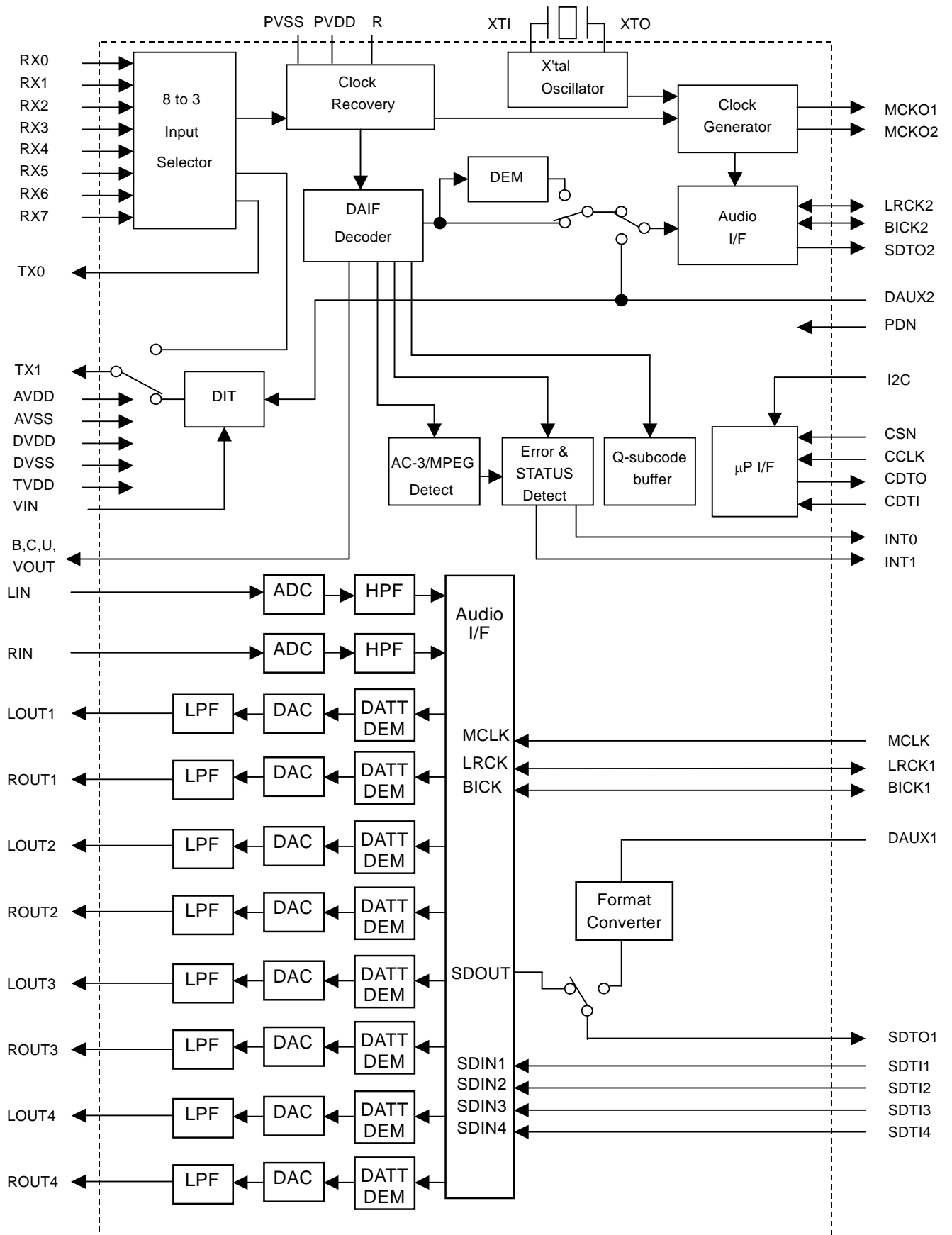



Fig 2. PIN DESCRIPTION

PIN No.	Name	Function
23,21, 17,15, 11,9, 5,3	FROUT,FLOUT, COUT,SWOUT, SROUT, SLOUT, SBROUT,SBLOUT	Output pin of FL/FR/C/SW/SL/SR/SBL/SBR channel
24,20, 18,14, 12,8, 6,2	FRC,FLC, CC,SWC, SRC,SLC, SBRC,SBLC	Connects capacitor for reducing click noise of L/R/C/SW/SL/SR/SBL/SBR channel volume
4,7,10,16, 19,22,56	AGND	Analog ground of internal circuit
28,34	TREL, TRER	Frequency characteristic setting pin of L/R channel tone control (Treble)
26,27, 32,33	BASSL1,BASSL2 BASSR1,BASSR2	Frequency characteristic setting pin of L/R channel tone control (Bass)
30	AVCC	Positive power supply to internal circuit
43,42, 41,40, 39,38, 37,36	FRIN2, FLIN2, SRN2,SLIN2, SWIN2,CIN2, SBRIN2,SBLIN2	Input pin of L/R/C/SW/SL/SR/SBL/SBR channel (Multi IN 1/2)
93,94, 95,96, 97,98, 99,100	FLIN1, FRIN1, CIN1,SWIN1, SLIN1,SRIN1, SBLIN1,SBRIN1	
48	DGND	Digital ground of internal circuit
49	DATA	Input pin of control data
50	CLOCK	Input pin of control clock
52	AVEE	Negative power supply to internal circuit
59,61,63, 65,67,69, 71,73,79	INL1,INL2, INL3, INL4,INL5,INL6, INL7,INL8,INL9	Input pin of L/R channel (Input Selector)
58,60,62, 64,66,68, 70,72,78	INR1,INR2, INR3, INR4,INR5,INR6, INR7,INR8,INR9	
51	MUTE	Outside Mute Control PIN
44,45	SBRCIN,SBLCIN	Input pin for SBL/SBR channel Volume
46,47	SUBL,SUBR	Output pin for L/R channel SUB Output
54,55	ADCL, ADCR	Output pin for L/R channel ADC
90,91	RECR3,RECL3	Output pin for L/R channel REC Output
75,76, 81,82, 83,84, 85,86	INRA/RECR1,INLA/RECL1, INRB/RECR2,INLB/RECL2, INR10/RECR4,INL10/RECL4, INR11/RECR5,INL11/RECL5	Input pin of L/R channel (Input Selector)/ Output pin for L/R channel REC Output
1,13,25,29,31, 35,53, 57,74,77,80, 87,88,89,92	N.C.	No Connected PIN

■ ブロック図



■ オーダリングガイド

AK4588VQ  
AKD4588

-40 ~ +85°C  
評価ボード

80pin LQFP(0.5mm pitch)

■ ピン配置

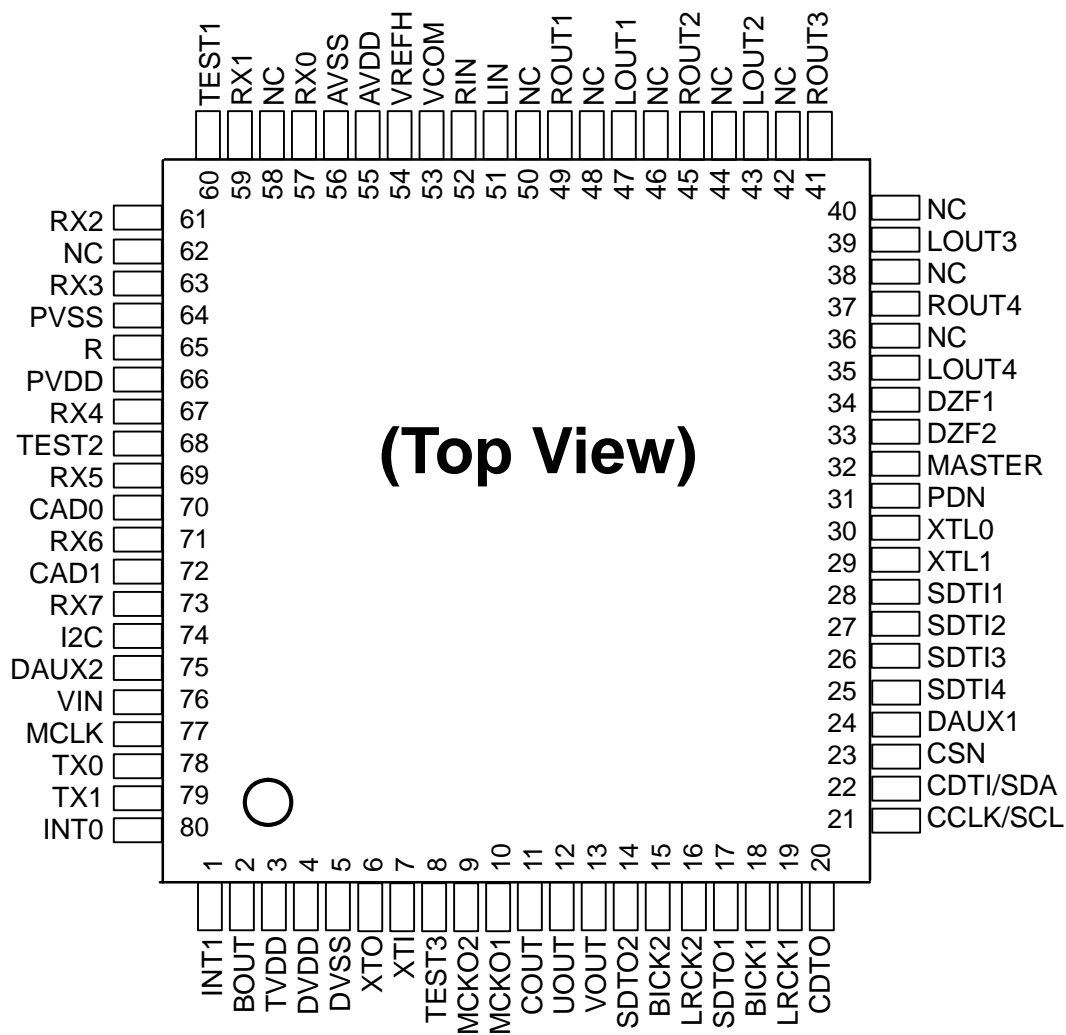

## ピン / 機能

No.	Pin Name	I/O	Function
1	INT1	O	Interrupt 1 Pin
2	BOUT	O	Block-Start Output Pin for Receiver Input “H” during first 40 frames.
3	TVDD	-	Output Buffer Power Supply Pin, 2.7V~5.5V
4	DVDD	-	Digital Power Supply Pin, 4.5V~5.5V
5	DVSS	-	Digital Ground Pin
6	XTO	O	X'tal clock Output Pin
7	XTI	I	X'tal / External clock Input Pin
8	TEST3	I	Test 3 Pin This pin should be connected to DVSS.
9	MCKO2	O	Master Clock Output 2 Pin
10	MCKO1	O	Master Clock Output 1 Pin
11	COUT	O	C-bit Output Pin for Receiver Input
12	UOUT	O	U-bit Output Pin for Receiver Input
13	VOUT	O	V-bit Output Pin for Receiver Input
14	SDTO2	O	Audio Serial Data Output Pin (DIR/DIT part)
15	BICK2	I/O	Audio Serial Data Clock Pin (DIR/DIT part)
16	LRCK2	I/O	Channel Clock Pin (DIR/DIT part)
17	SDTO1	O	Audio Serial Data Output Pin (ADC/DAC part)
18	BICK1	I/O	Audio Serial Data Clock Pin (ADC/DAC part)
19	LRCK1	I/O	Input Channel Clock Pin
20	CDTO	O	Control Data Output Pin in Serial Mode, I2C pin= “L”.
21	CCLK	I	Control Data Clock Pin in Serial Mode, I2C pin= “L”
	SCL	I	Control Data Clock Pin in Serial Mode, I2C pin= “H”
22	CDTI	I	Control Data Input Pin in Serial Mode, I2C pin= “L”.
	SDA	I/O	Control Data Pin in Serial Mode, I2C pin= “H”.
23	CSN	I	Chip Select Pin in Serial Mode, I2C pin=“L”.
		I	This pin should be connected to DVSS, I2C pin=“H”.
24	DAUX1	I	AUX Audio Serial Data Input Pin (ADC/DAC part)
25	SDTI4	I	DAC4 Audio Serial Data Input Pin
26	SDTI3	I	DAC3 Audio Serial Data Input Pin
27	SDTI2	I	DAC2 Audio Serial Data Input Pin
28	SDTI1	I	DAC1 Audio Serial Data Input Pin
29	XTL1	I	X'tal Frequency Select 0 Pin
30	XTL0	I	X'tal Frequency Select 1 Pin

No.	Pin Name	I/O	Function
31	PDN	I	Power-Down Mode Pin When “L”, the AK4588 is powered-down, all output pin goes “L”, all registers are reset. When CAD1-0 pins are changed, the AK4588 should be reset by the PDN pin.
32	MASTER	I	Master Mode Select Pin “H”: Master mode, “L”: Slave mode
33	DZF2	O	Zero Input Detect 2 Pin (Table 13) When the input data of the group 1 follow total 8192 LRCK cycles with “0” input data, this pin goes to “H”. When RSTN1 bit is “0” or PWDAN bit is “0”, this pin goes to “H”.
	OVF	O	Analog Input Overflow Detect Pin This pin goes to “H” if the analog input of Lch or Rch overflows. This pin becomes OVF pin if OVFE bit is set to 1.
34	DZF1	O	Zero Input Detect 1 Pin (Table 13) When the input data of the group 1 follow total 8192 LRCK cycles with “0” input data, this pin goes to “H”. When RSTN1 bit is “0” or PWDAN bit is “0”, this pin goes to “H”.
35	LOUT4	O	DAC4 Lch Analog Output Pin
36	NC	-	No Connect pin No internal bonding. This pin should be opened.
37	ROUT4	O	DAC4 Rch Analog Output Pin
38	NC	-	No Connect pin No internal bonding. This pin should be opened.
39	LOUT3	O	DAC3 Lch Analog Output Pin
40	NC	-	No Connect pin No internal bonding. This pin should be opened.
41	ROUT3	O	DAC3 Rch Analog Output Pin
42	NC	-	No Connect pin No internal bonding. This pin should be opened.
43	LOUT2	O	DAC2 Lch Analog Output Pin
44	NC	-	No Connect pin No internal bonding. This pin should be opened.
45	ROUT2	O	DAC2 Rch Analog Output Pin
46	NC	-	No Connect pin No internal bonding. This pin should be opened.
47	LOUT1	O	DAC1 Lch Analog Output Pin
48	NC	-	No Connect pin No internal bonding. This pin should be opened.
49	ROUT1	O	DAC1 Rch Analog Output Pin
50	NC	-	No Connect pin No internal bonding. This pin should be opened.
51	LIN	I	Lch Analog Input Pin
52	RIN	I	Rch Analog Input Pin
53	VCOM	-	Common Voltage Output Pin 2.2 $\mu$ F capacitor should be connected to AVSS externally.
54	VREFH	-	Positive Voltage Reference Input Pin, AVDD

No.	Pin Name	I/O	Function
55	AVDD	-	Analog Power Supply Pin, 4.5V~5.5V
56	AVSS	-	Analog Ground Pin, 0V
57	RX0	I	Receiver Channel 0 Pin (Internal biased pin. Internally biased at PVDD/2)
58	NC	-	No Connect pin No internal bonding. This pin should be connected to PVSS.
59	RX1	I	Receiver Channel 1 Pin (Internal biased pin. Internally biased at PVDD/2)
60	TEST1	I	Test 1 Pin This pin should be connected to PVSS.
61	RX2	I	Receiver Channel 2 Pin (Internal biased pin. Internally biased at PVDD/2)
62	NC	-	No Connect pin No internal bonding. This pin should be connected to PVSS.
63	RX3	I	Receiver Channel 3 Pin (Internal biased pin. Internally biased at PVDD/2)
64	PVSS	-	PLL Ground pin
65	R	-	External Resistor Pin 12k $\Omega$ +/-1% resistor should be connected to PVSS externally.
66	PVDD	-	PLL Power supply Pin, 4.5V~5.5V
67	RX4	I	Receiver Channel 4 Pin (Internal biased pin. Internally biased at PVDD/2)
68	TEST2	I	Test 2 Pin This pin should be connected to PVSS.
69	RX5	I	Receiver Channel 5 Pin (Internal biased pin. Internally biased at PVDD/2)
70	CAD0	I	Chip Address 0 Pin (ADC/DAC part)
71	RX6	I	Receiver Channel 6 Pin (Internal biased pin. Internally biased at PVDD/2)
72	CAD1	I	Chip Address 1 Pin (ADC/DAC part)
73	RX7	I	Receiver Channel 7 Pin (Internal biased pin. Internally biased at PVDD/2)
74	I2C	I	Control Mode Select Pin. “L”: 4-wire Serial, “H”: I <sup>2</sup> C Bus
75	DAUX2	I	Auxiliary Audio Data Input Pin (DIR/DIT part)
76	VIN	I	V-bit Input Pin for Transmitter Output
77	MCLK	I	Master Clock Input Pin
78	TX0	O	Transmit Channel (Through Data) Output 0 Pin
79	TX1	O	Transmit Channel Output1 pin When TX bit = “0”, Transmit Channel (Through Data) Output 1 Pin. When TX bit = “1”, Transmit Channel (DAUX2 Data) Output Pin (default).
80	INT0	O	Interrupt 0 Pin

Note: 内部バイアスピンを除くすべてのデジタル入力ピンはフローティングにしないで下さい。

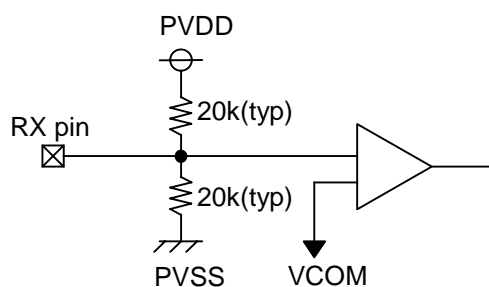

Internal biased pin Circuit

### 3.5 Pin Assignments

Extensive use of pin multiplexing is used to accommodate the largest number of peripheral functions in the smallest possible package. Pin multiplexing is controlled using a combination of hardware configuration at device reset and software programmable register settings.

#### 3.5.1 Pin Map (Bottom View)

Figure 3-3 and Figure 3-4 show the pin assignments for ZKB package and PTP package respectively.

	1	2	3	4	5	6	7	8	9	10	11	12	13	14	15	16	
T	V <sub>SS</sub>	V <sub>SS</sub>	AXR1[0]/ GP4[0]	AXR1[11]/ GP5[11]	SPID_CLK/ EQEP1/ GP5[2]/ BOOT[2]	SPID_CLK/ EQEP1S/ GP5[7]/ BOOT[7]	EMA_CS[3]/ AMUTE2/ GP2[6]	EMA_CS[0]/ UHPT_HAS/ GP2[4]	EMA_A[0]/ GP1[0]	EMA_A[4]/ GP1[4]	EMA_A[8]/ GP1[8]	EMA_SDCKE/ GP2[0]	EMA_D[0]/ MMCS_DAT[0]/ UHPT_HD[0]/ GP0[0]/ BOOT[12]	EMA_D[9]/ UHPT_HD[9]/ GP0[9]	V <sub>SS</sub>	V <sub>SS</sub>	T
R	DV <sub>DD</sub>	AXR1[1]/ GP4[1]	UART0_RXD/ E0_SDA/ TMS4P0_N12/ GP5[8]/ BOOT[8]	SPID_ENA/ UART2_RXD/ GP5[12]	SPID_ENA/ UART0_CTS/ EQEP0A/ GP5[3]/ BOOT[3]	SPID_SOM[0]/ EQEP0/ GP5[0]/ BOOT[0]	EMA_OE/ UHPT_HDS1/ AXR0[13]/ GP2[7]	EMA_BA[0]/ GP1[14]	EMA_A[1]/ MMCS_CLK/ UHPT_HCNTL[0]/ GP1[1]	EMA_A[5]/ GP1[5]	EMA_A[9]/ GP1[9]	EMA_CLK/ OBSCLK/ AHCLKR2/ GP1[5]	EMA_D[2]/ MMCS_DAT[2]/ UHPT_HD[2]/ GP0[2]	EMA_D[10]/ UHPT_HD[10]/ GP0[10]	EMA_D[1]/ MMCS_DAT[1]/ UHPT_HD[1]/ GP0[1]	DV <sub>DD</sub>	R
P	AXR1[3]/ EQEP1A/ GP4[3]	AXR1[2]/ GP4[2]	UART0_TXD/ E0_SCL/ TMS4P0_OUT12/ GP5[9]/ BOOT[9]	SPID_SC[0]/ UART2_TXD/ GP5[13]	SPID_SOM[0]/ E0_SCL/ EQEP0S/ GP5[1]/ BOOT[5]	SPID_SOM[0]/ EQEP0S/ GP5[1]/ BOOT[1]	EMA_CS[2]/ UHPT_HCS/ GP2[5]	EMA_BA[1]/ UHPT_HHWL/ GP1[3]	EMA_A[2]/ MMCS_CMD/ UHPT_HCNTL1/ GP1[2]	EMA_A[6]/ GP1[6]	EMA_A[11]/ GP1[11]	EMA_WE/ DQM[1]/ UHPT_HDS2/ AXR0[14]/ GP2[8]	EMA_D[4]/ MMCS_DAT[4]/ UHPT_HD[4]/ GP0[4]	EMA_D[12]/ UHPT_HD[12]/ GP0[12]	EMA_D[3]/ MMCS_DAT[3]/ UHPT_HD[3]/ GP0[3]	EMA_D[11]/ UHPT_HD[11]/ GP0[11]	P
N	AXR1[5]/ EPWM2B/ GP4[5]	AXR1[4]/ EQEP1B/ GP4[4]	AXR1[10]/ GP5[10]	SPID_SC[0]/ UART0_RTS/ EQEP0B/ GP5[4]/ BOOT[4]	SPID_SOM[0]/ E0_SDA/ EQEP0/ GP5[6]/ BOOT[6]	EMA_WAIT[0]/ UHPT_HRDY/ GP2[10]	EMA_RAS/ EMA_CS[5]/ GP2[2]	EMA_A[10]/ GP1[10]	EMA_A[3]/ GP1[3]	EMA_A[7]/ GP1[7]	EMA_A[12]/ GP1[12]	EMA_D[8]/ UHPT_HD[8]/ GP0[8]	EMA_D[6]/ MMCS_DAT[6]/ UHPT_HD[6]/ GP0[6]	EMA_D[14]/ UHPT_HD[14]/ GP0[14]	EMA_D[5]/ MMCS_DAT[5]/ UHPT_HD[5]/ GP0[5]	EMA_D[13]/ UHPT_HD[13]/ GP0[13]	N
M	AXR1[9]/ GP4[9]	AXR1[8]/ EPWMI A/ GP4[8]	AXR1[7]/ EPWMI B/ GP4[7]	AXR1[6]/ EPWMI A/ GP4[6]	DV <sub>DD</sub>	V <sub>SS</sub>	V <sub>SS</sub>	DV <sub>DD</sub>	DV <sub>DD</sub>	V <sub>SS</sub>	V <sub>SS</sub>	DV <sub>DD</sub>	EMA_WE/ UHPT_HRW/ UHPT_HD[7]/ GP2[3]/ BOOT[14]	EMA_WE/ DQM[0]/ UHPT_HINT/ AXR0[15]/ GP2[9]	EMA_D[7]/ MMCS_DAT[7]/ UHPT_HD[7]/ GP0[7]	EMA_D[15]/ UHPT_HD[15]/ GP0[15]	M
L	AHCLKR1/ GP4[11]	ACLKX1/ ECAP2/ APWM2/ GP4[12]	AFSR1/ GP4[13]	AMUTE0/ RESETOUT	DV <sub>DD</sub>	CV <sub>DD</sub>	V <sub>SS</sub>	V <sub>SS</sub>	V <sub>SS</sub>	V <sub>SS</sub>	DV <sub>DD</sub>	DV <sub>DD</sub>	EMB_CAS	EMB_D[22]	EMB_D[23]	EMB_CAS/ EMA_CS[4]/ GP2[1]	L
K	GP7[14]	AHCLKX1/ EPWMI B/ GP3[14]	ACLKX1/ EPWMI A/ GP3[15]	AFSX1/ EPWMSYNCI/ GP4[10]	DV <sub>DD</sub>	CV <sub>DD</sub>	CV <sub>DD</sub>	V <sub>SS</sub>	V <sub>SS</sub>	CV <sub>DD</sub>	CV <sub>DD</sub>	DV <sub>DD</sub>	EMB_D[20]	EMB_WE/ DQM[0]/ GP5[15]	EMB_WE	EMB_D[21]	K
J	TMS	TDI	TDO	TRST	EMU[0]/GP7[15]	CV <sub>DD</sub>	CV <sub>DD</sub>	V <sub>SS</sub>	V <sub>SS</sub>	CV <sub>DD</sub>	CV <sub>DD</sub>	CV <sub>DD</sub>	EMB_D[5]/ GP6[5]	EMB_D[19]	EMB_D[6]/ GP6[6]	EMB_D[7]/ GP6[7]	J
H	RTC_XI	RTC_XO	TCK	NC	USB0_VDDA33	CV <sub>DD</sub>	CV <sub>DD</sub>	V <sub>SS</sub>	V <sub>SS</sub>	CV <sub>DD</sub>	CV <sub>DD</sub>	CV <sub>DD</sub>	EMB_D[3]/ GP6[3]	EMB_D[17]	EMB_D[18]	EMB_D[4]/ GP6[4]	H
G	RTC_CV <sub>DD</sub>	RTC_V <sub>SS</sub>	RESET	USB0_DM	DV <sub>DD</sub>	CV <sub>DD</sub>	CV <sub>DD</sub>	V <sub>SS</sub>	V <sub>SS</sub>	CV <sub>DD</sub>	CV <sub>DD</sub>	DV <sub>DD</sub>	EMB_D[1]/ GP6[1]	EMB_D[31]	EMB_D[16]	EMB_D[2]/ GP6[2]	G
F	OSCO	OSCI	NC	USB0_DP	DV <sub>DD</sub>	CV <sub>DD</sub>	RSV1	V <sub>SS</sub>	V <sub>SS</sub>	V <sub>SS</sub>	DV <sub>DD</sub>	DV <sub>DD</sub>	EMB_D[15]/ GP6[15]	EMB_D[29]	EMB_D[30]	EMB_D[0]/ GP6[0]	F
E	PLL0_VSSA	OSCVSS	USB0_VDDA18	USB0_DRVVBUS/ GP4[15]	DV <sub>DD</sub>	V <sub>SS</sub>	V <sub>SS</sub>	DV <sub>DD</sub>	DV <sub>DD</sub>	V <sub>SS</sub>	V <sub>SS</sub>	DV <sub>DD</sub>	EMB_D[13]/ GP6[13]	EMB_D[27]	EMB_D[28]	EMB_D[14]/ GP6[14]	E
D	PLL0_VDDA	USB0_ID	USB0_VBUS	AMUTE1/ EHRPWMIZ/ GP4[14]	AFSX0/ GP2[13]/ BOOT[10]	UART1_TXD/ AXR0[10]/ GP3[10]	AXR0[6]/ ACLKX2/ GP3[6]	AXR0[2]/ AXR2[3]/ GP3[2]	EMB_CS[0]	EMB_A[0]/ GP7[2]	EMB_A[4]/ GP7[6]	EMB_A[8]/ GP7[10]	EMB_D[9]/ GP6[9]	EMB_D[10]/ GP6[10]	EMB_D[11]/ GP6[11]	EMB_D[12]/ GP6[12]	D
C	NC	NC	USB0_VDDA12	AFSR0/ GP3[12]	ACLKX0/ ECAP0/ APWM0/ GP2[12]	UART1_RXD/ AXR0[9]/ GP3[9]	AXR0[5]/ AFSX2/ GP3[5]	AXR0[1]/ ACLKX2/ GP3[1]	EMB_BA[0]/ GP7[1]	EMB_A[11]/ GP7[3]	EMB_A[5]/ GP7[7]	EMB_A[9]/ GP7[11]	EMB_SDCKE	EMB_CLK	EMB_WE/ DQM[1]/ GP5[14]	EMB_D[8]/ GP6[8]	C
B	RSV2	V <sub>SS</sub>	V <sub>SS</sub>	ACLKX0/ ECAP1/ APWM1/ GP2[15]	AHCLKX2/ USB_REFCLKIN/ GP2[11]	AXR0[8]/ GP3[8]	AXR0[4]/ AXR2[1]/ GP3[4]	AXR0[0]/ AFSR2/ GP3[0]	EMB_BA[1]/ GP7[0]	EMB_A[2]/ GP7[4]	EMB_A[6]/ GP7[8]	EMB_A[11]/ GP7[13]	EMB_WE/ DQM[2]	EMB_D[25]	EMB_A[12]/ GP3[13]	DV <sub>DD</sub>	B
A	V <sub>SS</sub>	V <sub>SS</sub>	V <sub>SS</sub>	AHCLKX0/ GP2[14]/ BOOT[11]	AXR0[11]/ AXR2[0]/ GP3[11]	AXR0[7]/ GP3[7]	AXR0[3]/ AXR2[2]/ GP3[3]	EMB_RAS	EMB_A[10]/ GP7[12]	EMB_A[3]/ GP7[5]	EMB_A[7]/ GP7[9]	EMB_WE/ DQM[3]	EMB_D[24]	EMB_D[26]	V <sub>SS</sub>	V <sub>SS</sub>	A

Figure 3-3. Pin Map (ZKB)

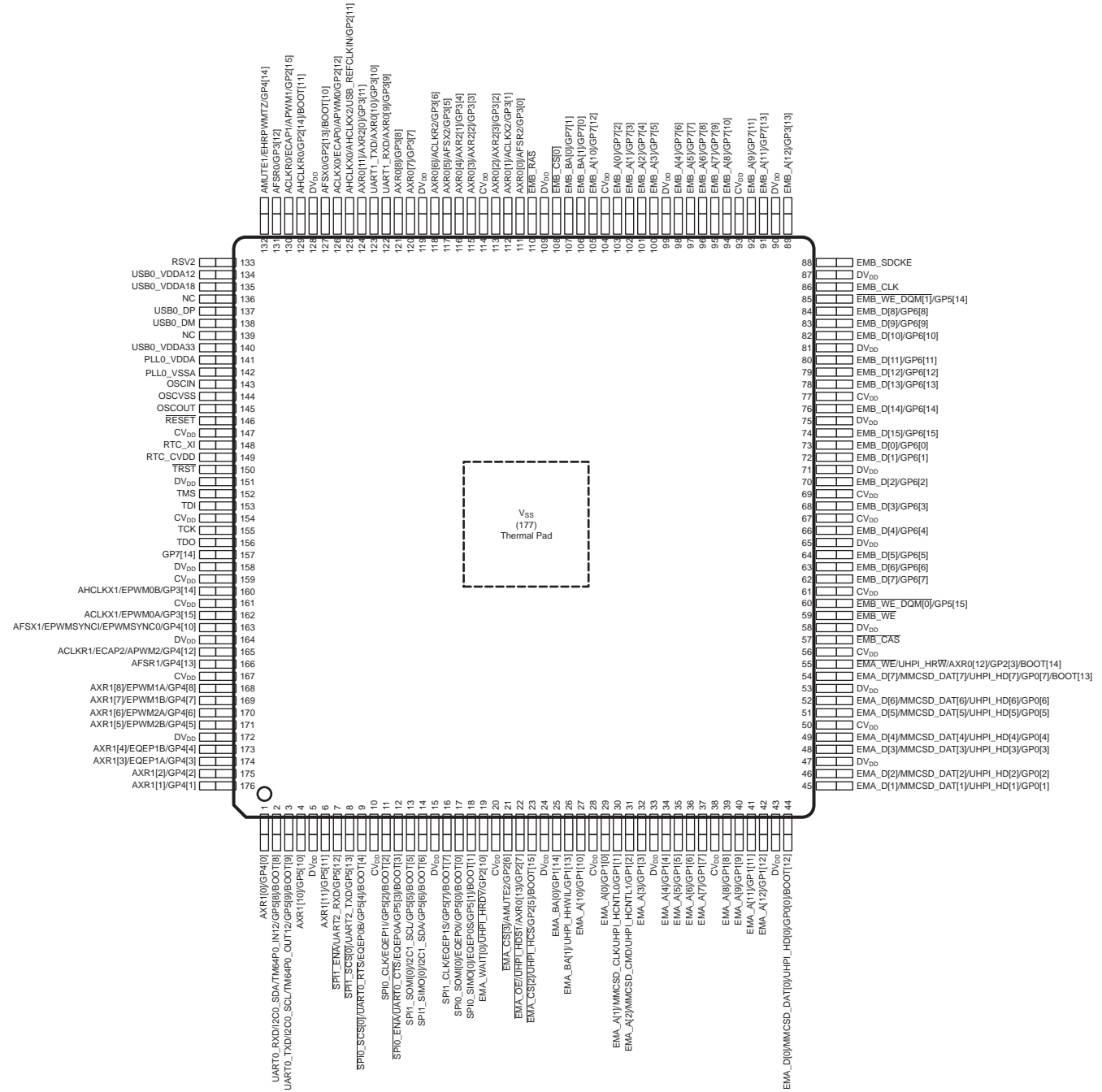
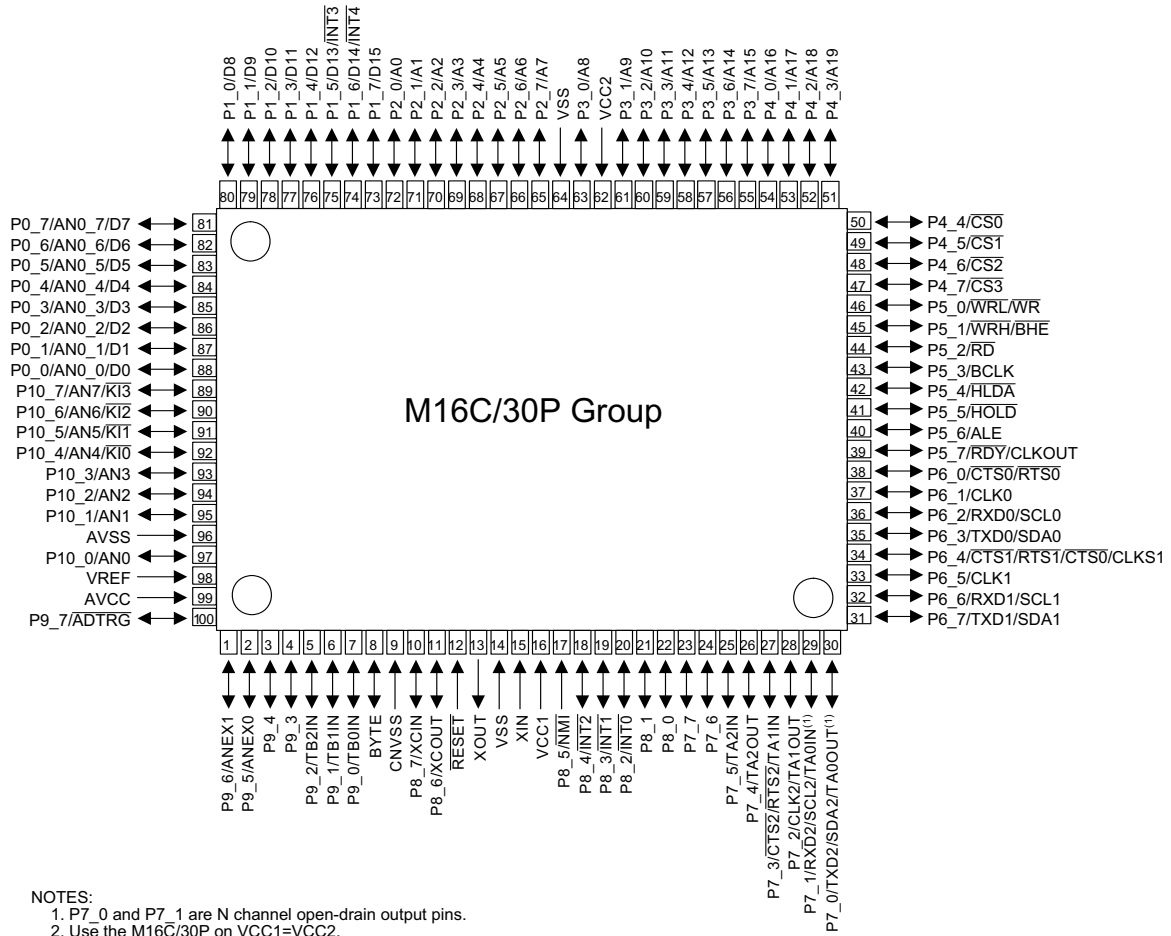

Figure 3-4. Pin Map (PTP)



PIN CONFIGURATION (top view)



Package : PRQP0100JB-A (100P6S-A)

Figure 1.2 Pin Configuration (Top View)

## 1.2 Performance Outline

Table 1.1 lists Performance Outline of M16C/30P Group.

**Table 1.1 Performance Outline of M16C/30P Group**

Item		Performance
CPU	Number of Basic Instructions	91 instructions
	Minimum Instruction Execution Time	62.5ns(f(XIN)=16MHz, VCC1=VCC2=3.0 to 5.5V, no wait) 100ns(f(XIN)=10MHz, VCC1=VCC2=2.7 to 5.5V, no wait)
	Operation Mode	Single-chip, memory expansion and microprocessor mode
	Memory Space	1 Mbyte
	Memory Capacity	See <b>Table 1.2 Product List</b>
Peripheral Function	Port	Input/Output : 87 pins, Input : 1 pin
	Multifunction Timer	Timer A : 16 bits x 3 channels, Timer B : 16 bits x 3 channels
	Serial Interface	1 channels Clock synchronous, UART, I <sup>2</sup> C Bus, IEBus (1)
		2 channels Clock synchronous, UART, I <sup>2</sup> C Bus (1)
	A/D Converter	10-bit A/D converter: 1 circuit, 18 channels
	DMAC	2 channels
	CRC Calculation Circuit	CCITT-CRC
	Watchdog Timer	15 bits x 1 channel (with prescaler)
Interrupt	Internal: 20 sources, External: 7 sources, Software: 4 sources, Priority level: 7 levels	
Electric Characteristics	Supply Voltage (2)	VCC1=VCC2=3.0 to 5.5 V (f(XIN)=16MHz) VCC1=VCC2=2.7 to 5.5 V (f(XIN)=10MHz, no wait)
	Power Consumption	10 mA (VCC1=VCC2=5V, f(XIN)=16MHz) 8 mA (VCC1=VCC2=3V, f(XIN)=10MHz) 1.8 μA (VCC1=VCC2=3V, f(XCIN)=32kHz, wait mode) 0.7 μA (VCC1=VCC2=3V, stop mode)
One time flash version	Program Supply Voltage	3.3±0.3 V or 5.0±0.5 V
Flash memory version	Program/Erase Supply Voltage	3.3±0.3 V or 5.0±0.5 V
	Program and Erase Endurance	100 times (all area)
Lite flash memory version	Program/Erase Supply Voltage	3.3±0.3 V or 5.0±0.5 V
	Program and Erase Endurance	100 times (all area)
Operating Ambient Temperature		-20 to 85°C, -40 to 85°C
Package		100-pin plastic mold QFP, LQFP

**NOTES:**

- IEBus is a registered trademark of NEC Electronics Corporation.
- Use the M16C/30P on VCC1 = VCC2.

# PRELIMINARY W9864G6JH



## 3. AVAILABLE PART NUMBER

PART NUMBER	SPEED	SELF REFRESH CURRENT (MAX.)	OPERATING TEMPERATURE
W9864G6JH-5	200MHz/CL3	2 mA	0°C ~ 70°C
W9864G6JH-6	166MHz/CL3	2 mA	0°C ~ 70°C
W9864G6JH-6I	166MHz/CL3	2 mA	-40°C ~ 85°C
W9864G6JH-7	143MHz/CL3	2 mA	0°C ~ 70°C
W9864G6JH-7S	143MHz/CL3	2 mA	0°C ~ 70°C

## 4. PIN CONFIGURATION

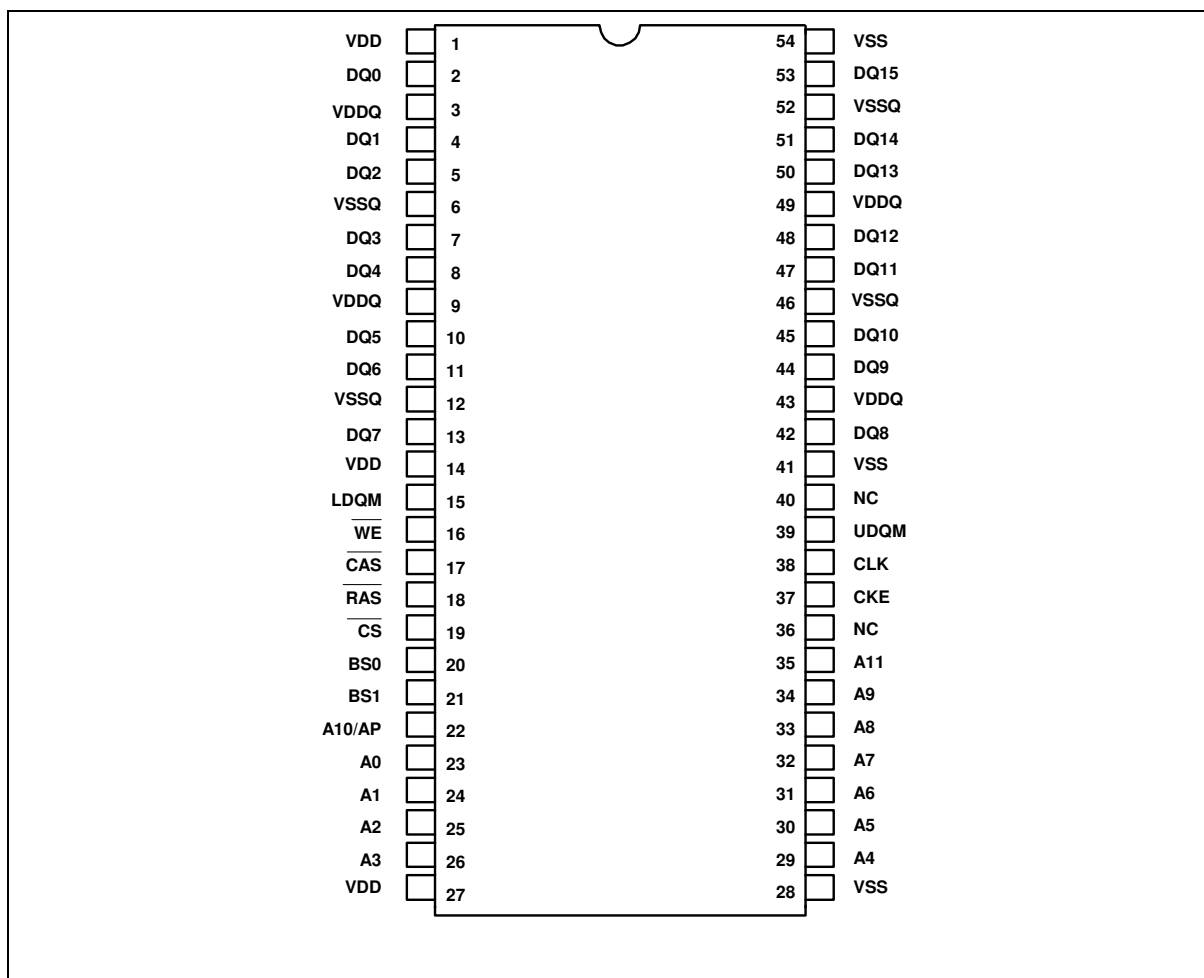

# PRELIMINARY W9864G6JH



## 5. PIN DESCRIPTION

PIN NUMBER	PIN NAME	FUNCTION	DESCRIPTION
23 ~ 26, 22, 29 ~ 35	A0–A11	Address	Multiplexed pins for row and column address. Row address: A0–A11. Column address: A0–A7. A10 is sampled during a precharge command to determine if all banks are to be precharged or bank selected by BS0, BS1.
20, 21	BS0, BS1	Bank Select	Select bank to activate during row address latch time, or bank to read/write during address latch time.
2, 4, 5, 7, 8, 10, 11, 13, 42, 44, 45, 47, 48, 50, 51, 53	DQ0–DQ15	Data Input/ Output	Multiplexed pins for data output and input.
19	$\overline{\text{CS}}$	Chip Select	Disable or enable the command decoder. When command decoder is disabled, new command is ignored and previous operation continues.
18	$\overline{\text{RAS}}$	Row Address Strobe	Command input. When sampled at the rising edge of the clock $\overline{\text{RAS}}$ , $\overline{\text{CAS}}$ and $\overline{\text{WE}}$ define the operation to be executed.
17	$\overline{\text{CAS}}$	Column Address Strobe	Referred to $\overline{\text{RAS}}$
16	$\overline{\text{WE}}$	Write Enable	Referred to $\overline{\text{RAS}}$
39, 15	UDQM LDQM	Input/output mask	The output buffer is placed at Hi-Z (with latency of 2) when DQM is sampled high in read cycle. In write cycle, sampling DQM high will block the write operation with zero latency.
38	CLK	Clock Inputs	System clock used to sample inputs on the rising edge of clock.
37	CKE	Clock Enable	CKE controls the clock activation and deactivation. When CKE is low, Power Down mode, Suspend mode, or Self Refresh mode is entered.
1, 14, 27	VDD	Power	Power for input buffers and logic circuit inside DRAM.
28, 41, 54	VSS	Ground	Ground for input buffers and logic circuit inside DRAM.
3, 9, 43, 49	VDDQ	Power for I/O buffer	Separated power from VDD, to improve DQ noise immunity.
6, 12, 46, 52	VSSQ	Ground for I/O buffer	Separated ground from VSS, to improve DQ noise immunity.
36, 40	NC	No Connection	No connection.

PIN CONFIGURATIONS

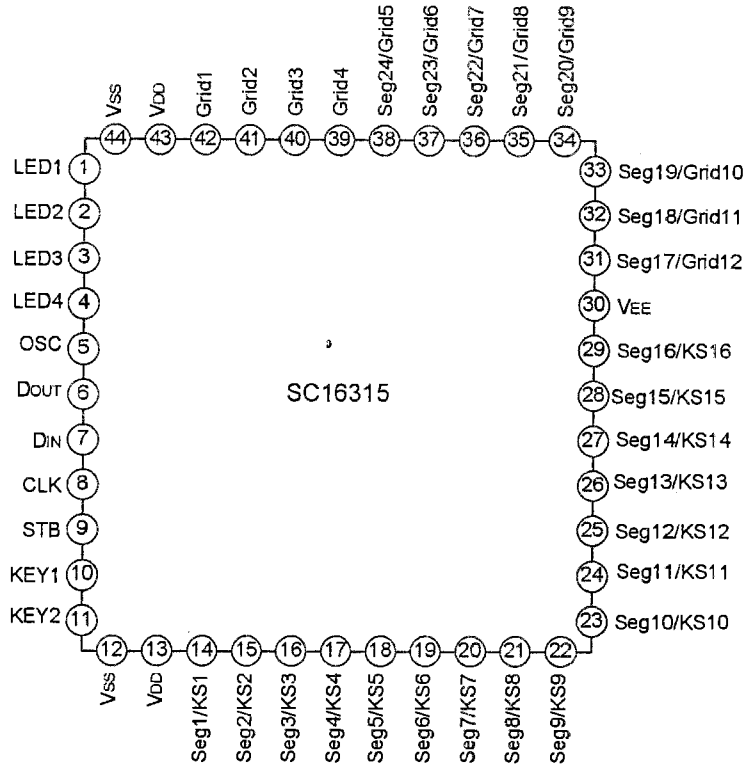

PIN DESCRIPTION

Pin No.	Pin Name	Description
7	DIN	Data input pin. Input serial data at rising edge of shift clock, starting from the low order bit.
6	DOUT	Data output pin. Output serial data at the falling edge of the shift clock, starting from low order bit. This is N-ch open-drain output pin.
9	STB	Strobe pin. Initializes serial interface at the rising or falling edge of the SC16315. It then waits for reception of a command. Data input after STB has fallen is processed as a command. While command data is processed, current processing is stopped, and the serial interface is initialized. While STB is high, CLK is ignored.
8	CLK	Clock input pin. Reads serial data at the rising edge, and outputs data at the falling edge.
5	OSC	Oscillator pin. Determine the oscillation frequency by the resistor connecting this pin and GND (Vss).
14 ~ 29	Seg1/KS1 to Seg16/KS16	High-voltage output (segment). Segment output pins (Dual function as key source).

(To be continued)

(Continued)

Pin No	Pin Name	Description
39~42	Grid1 to Grid4	High-voltage output (grid). Grid output pins.
31~38	Seg17/Grid12 to Seg24/Grid5	High-voltage output (segment/grid). Segment or grid driving.
1 ~4	LED1 to LED4	LED output pin. CMOS output. +20mA max.
10 ~ 11	KEY1 to KEY2	Key data input. Data input to these pins is latched at the end of the display cycle.
13, 43	VDD	Logic power pin. 5V±10%
12, 44	VSS	Logic ground. Connect this pin to system GND.
30	VEE	Pull-down level. VDD-35V max.

## FUNCTIONAL DESCRIPTION

### 1. DISPLAY RAM ADDRESS AND DISPLAY MODE

The display RAM stores the data transmitted from an external device to the SC16315 through the serial interface, and is assigned addresses as follows, in 8 bits unit:

Seq1	Seq4	Seq8	Seq12	Seq16	Seq20	Seq24	
00HL	00Hu	01HL	01Hu	02HL	02Hu		DIG1
03HL	03Hu	04HL	04Hu	05HL	05Hu		DIG2
06HL	06Hu	07HL	07Hu	08HL	08Hu		DIG3
09HL	09Hu	0AHL	0AHu	0BHL	0BHu		DIG4
0CHL	0CHu	0DHL	0DHu	0EHL	0EHu		DIG5
0FHL	0FHu	10HL	10Hu	11HL	11Hu		DIG6
12HL	12Hu	13HL	13Hu	14HL	14Hu		DIG7
15HL	15Hu	16HL	16Hu	17HL	17Hu		DIG8
18HL	18Hu	19HL	19Hu	1AHL	1AHu		DIG9
1BHL	1BHU	1CHL	1CHu	1DHL	1DHu		DIG10
1EHL	1EHu	1FHL	1FHu	20HL	20Hu		DIG11
21HL	21Hu	22HL	22Hu	23HL	23Hu		DIG12

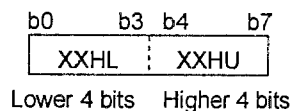

### 2. KEY MATRIX AND KEY-INPUT DATA STORAGE RAM

The key matrix is made up of a 16 x 2 matrix, as shown below.

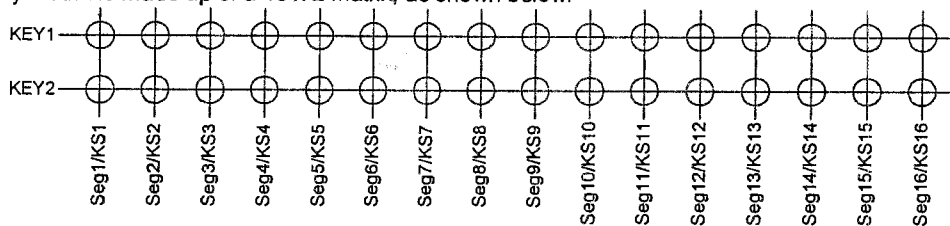

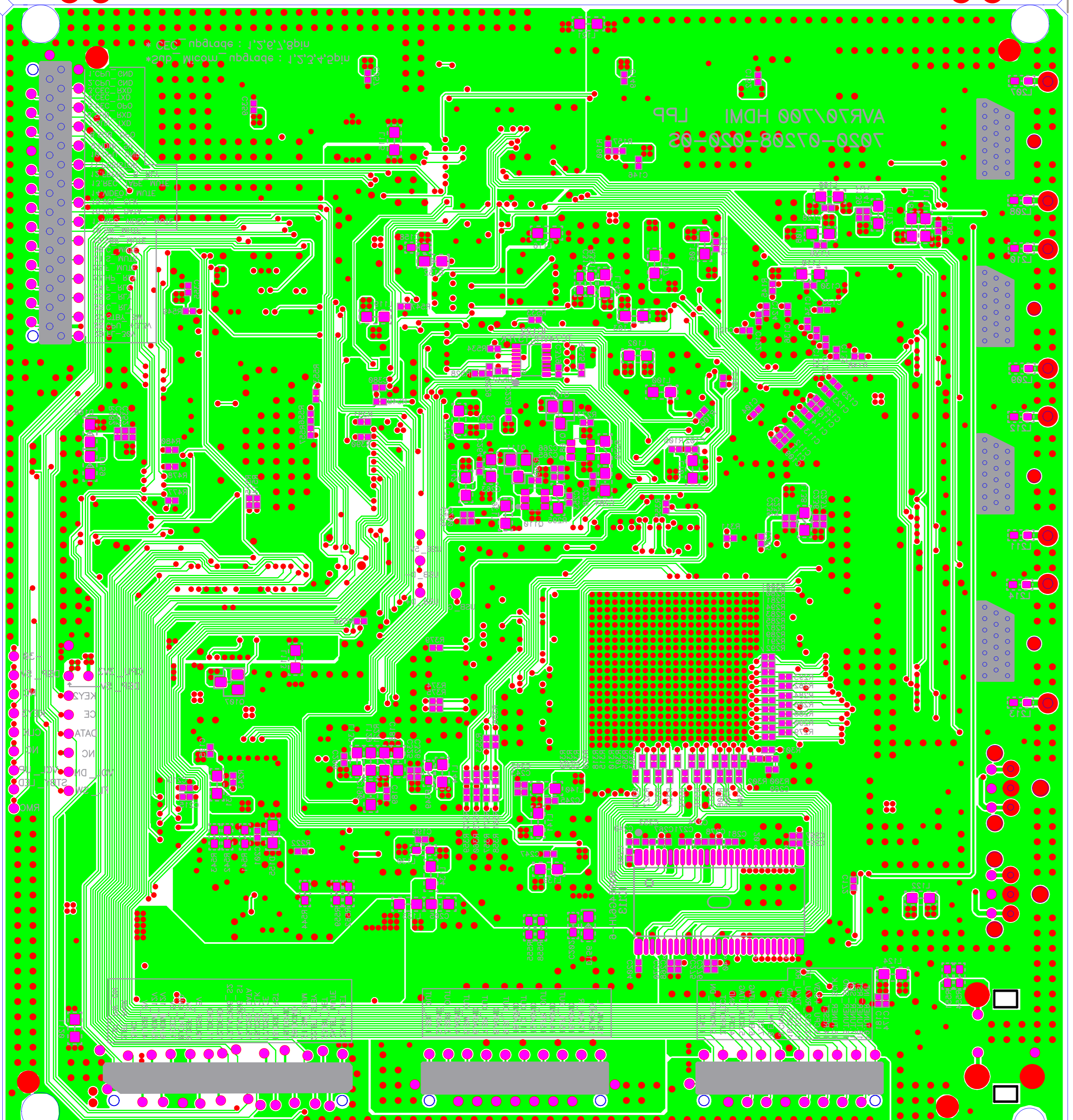

\*CEC - package : 1, 2, 3, 4, 5, 6, 7, 8, 9, 10, 11, 12, 13, 14, 15, 16, 17, 18, 19, 20, 21, 22, 23, 24, 25, 26, 27, 28, 29, 30, 31, 32, 33, 34, 35, 36, 37, 38, 39, 40, 41, 42, 43, 44, 45, 46, 47, 48, 49, 50, 51, 52, 53, 54, 55, 56, 57, 58, 59, 60, 61, 62, 63, 64, 65, 66, 67, 68, 69, 70, 71, 72, 73, 74, 75, 76, 77, 78, 79, 80, 81, 82, 83, 84, 85, 86, 87, 88, 89, 90, 91, 92, 93, 94, 95, 96, 97, 98, 99, 100

\*CEC - package : 1, 2, 3, 4, 5, 6, 7, 8, 9, 10, 11, 12, 13, 14, 15, 16, 17, 18, 19, 20, 21, 22, 23, 24, 25, 26, 27, 28, 29, 30, 31, 32, 33, 34, 35, 36, 37, 38, 39, 40, 41, 42, 43, 44, 45, 46, 47, 48, 49, 50, 51, 52, 53, 54, 55, 56, 57, 58, 59, 60, 61, 62, 63, 64, 65, 66, 67, 68, 69, 70, 71, 72, 73, 74, 75, 76, 77, 78, 79, 80, 81, 82, 83, 84, 85, 86, 87, 88, 89, 90, 91, 92, 93, 94, 95, 96, 97, 98, 99, 100

AVR0700 HDMI LPP  
 7020-07208-050-02

1. CEM  
 2. CEM  
 3. CEM  
 4. CEM  
 5. CEM  
 6. CEM  
 7. CEM  
 8. CEM  
 9. CEM  
 10. CEM  
 11. CEM  
 12. CEM  
 13. CEM  
 14. CEM  
 15. CEM  
 16. CEM  
 17. CEM  
 18. CEM  
 19. CEM  
 20. CEM  
 21. CEM  
 22. CEM  
 23. CEM  
 24. CEM  
 25. CEM  
 26. CEM  
 27. CEM  
 28. CEM  
 29. CEM  
 30. CEM  
 31. CEM  
 32. CEM  
 33. CEM  
 34. CEM  
 35. CEM  
 36. CEM  
 37. CEM  
 38. CEM  
 39. CEM  
 40. CEM  
 41. CEM  
 42. CEM  
 43. CEM  
 44. CEM  
 45. CEM  
 46. CEM  
 47. CEM  
 48. CEM  
 49. CEM  
 50. CEM  
 51. CEM  
 52. CEM  
 53. CEM  
 54. CEM  
 55. CEM  
 56. CEM  
 57. CEM  
 58. CEM  
 59. CEM  
 60. CEM  
 61. CEM  
 62. CEM  
 63. CEM  
 64. CEM  
 65. CEM  
 66. CEM  
 67. CEM  
 68. CEM  
 69. CEM  
 70. CEM  
 71. CEM  
 72. CEM  
 73. CEM  
 74. CEM  
 75. CEM  
 76. CEM  
 77. CEM  
 78. CEM  
 79. CEM  
 80. CEM  
 81. CEM  
 82. CEM  
 83. CEM  
 84. CEM  
 85. CEM  
 86. CEM  
 87. CEM  
 88. CEM  
 89. CEM  
 90. CEM  
 91. CEM  
 92. CEM  
 93. CEM  
 94. CEM  
 95. CEM  
 96. CEM  
 97. CEM  
 98. CEM  
 99. CEM  
 100. CEM

1. CEM  
 2. CEM  
 3. CEM  
 4. CEM  
 5. CEM  
 6. CEM  
 7. CEM  
 8. CEM  
 9. CEM  
 10. CEM  
 11. CEM  
 12. CEM  
 13. CEM  
 14. CEM  
 15. CEM  
 16. CEM  
 17. CEM  
 18. CEM  
 19. CEM  
 20. CEM  
 21. CEM  
 22. CEM  
 23. CEM  
 24. CEM  
 25. CEM  
 26. CEM  
 27. CEM  
 28. CEM  
 29. CEM  
 30. CEM  
 31. CEM  
 32. CEM  
 33. CEM  
 34. CEM  
 35. CEM  
 36. CEM  
 37. CEM  
 38. CEM  
 39. CEM  
 40. CEM  
 41. CEM  
 42. CEM  
 43. CEM  
 44. CEM  
 45. CEM  
 46. CEM  
 47. CEM  
 48. CEM  
 49. CEM  
 50. CEM  
 51. CEM  
 52. CEM  
 53. CEM  
 54. CEM  
 55. CEM  
 56. CEM  
 57. CEM  
 58. CEM  
 59. CEM  
 60. CEM  
 61. CEM  
 62. CEM  
 63. CEM  
 64. CEM  
 65. CEM  
 66. CEM  
 67. CEM  
 68. CEM  
 69. CEM  
 70. CEM  
 71. CEM  
 72. CEM  
 73. CEM  
 74. CEM  
 75. CEM  
 76. CEM  
 77. CEM  
 78. CEM  
 79. CEM  
 80. CEM  
 81. CEM  
 82. CEM  
 83. CEM  
 84. CEM  
 85. CEM  
 86. CEM  
 87. CEM  
 88. CEM  
 89. CEM  
 90. CEM  
 91. CEM  
 92. CEM  
 93. CEM  
 94. CEM  
 95. CEM  
 96. CEM  
 97. CEM  
 98. CEM  
 99. CEM  
 100. CEM

1. CEM  
 2. CEM  
 3. CEM  
 4. CEM  
 5. CEM  
 6. CEM  
 7. CEM  
 8. CEM  
 9. CEM  
 10. CEM  
 11. CEM  
 12. CEM  
 13. CEM  
 14. CEM  
 15. CEM  
 16. CEM  
 17. CEM  
 18. CEM  
 19. CEM  
 20. CEM  
 21. CEM  
 22. CEM  
 23. CEM  
 24. CEM  
 25. CEM  
 26. CEM  
 27. CEM  
 28. CEM  
 29. CEM  
 30. CEM  
 31. CEM  
 32. CEM  
 33. CEM  
 34. CEM  
 35. CEM  
 36. CEM  
 37. CEM  
 38. CEM  
 39. CEM  
 40. CEM  
 41. CEM  
 42. CEM  
 43. CEM  
 44. CEM  
 45. CEM  
 46. CEM  
 47. CEM  
 48. CEM  
 49. CEM  
 50. CEM  
 51. CEM  
 52. CEM  
 53. CEM  
 54. CEM  
 55. CEM  
 56. CEM  
 57. CEM  
 58. CEM  
 59. CEM  
 60. CEM  
 61. CEM  
 62. CEM  
 63. CEM  
 64. CEM  
 65. CEM  
 66. CEM  
 67. CEM  
 68. CEM  
 69. CEM  
 70. CEM  
 71. CEM  
 72. CEM  
 73. CEM  
 74. CEM  
 75. CEM  
 76. CEM  
 77. CEM  
 78. CEM  
 79. CEM  
 80. CEM  
 81. CEM  
 82. CEM  
 83. CEM  
 84. CEM  
 85. CEM  
 86. CEM  
 87. CEM  
 88. CEM  
 89. CEM  
 90. CEM  
 91. CEM  
 92. CEM  
 93. CEM  
 94. CEM  
 95. CEM  
 96. CEM  
 97. CEM  
 98. CEM  
 99. CEM  
 100. CEM

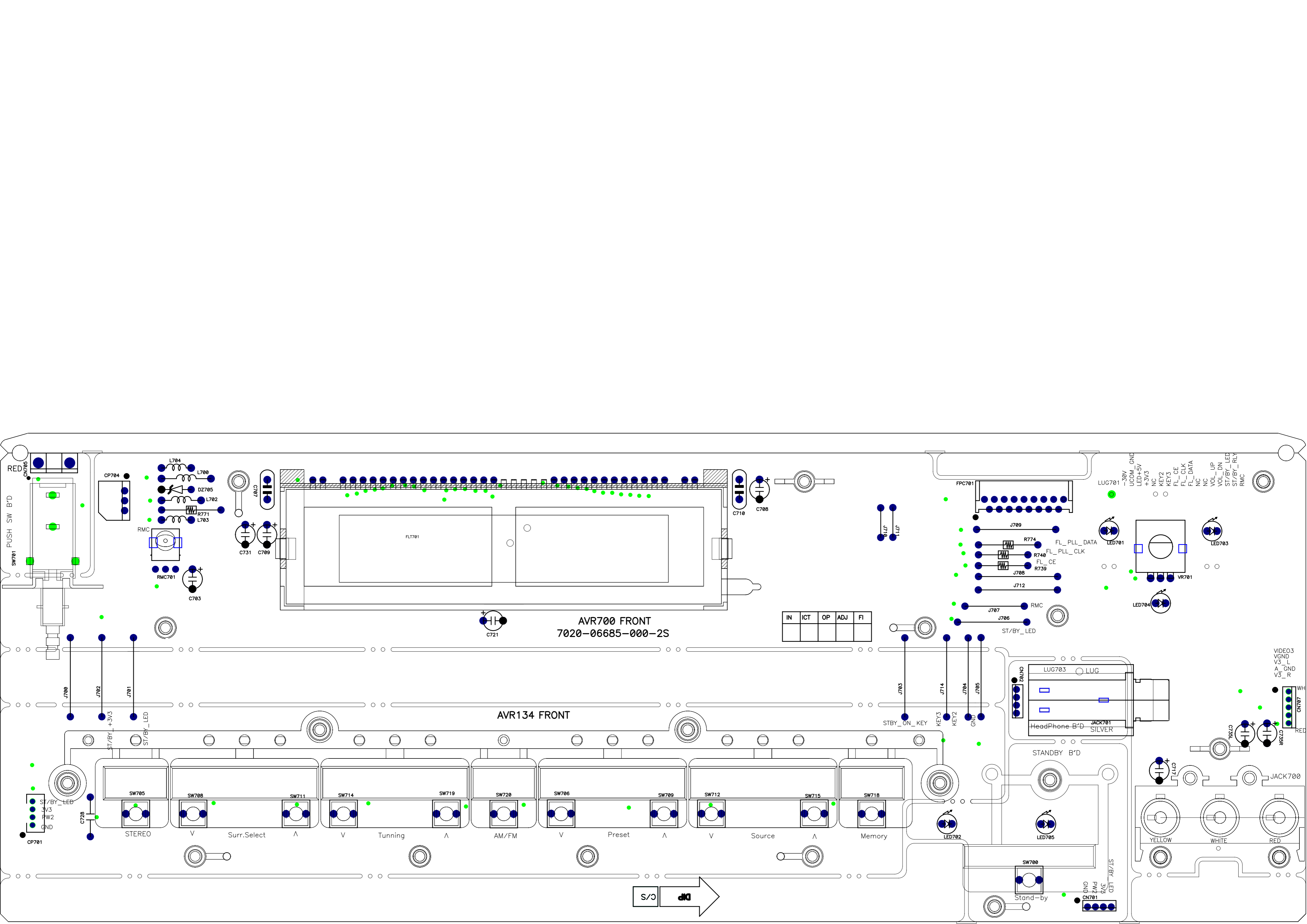

AVR700 FRONT  
7020-06685-000-2S

AVR134 FRONT

IN	ICT	OP	ADJ	FI

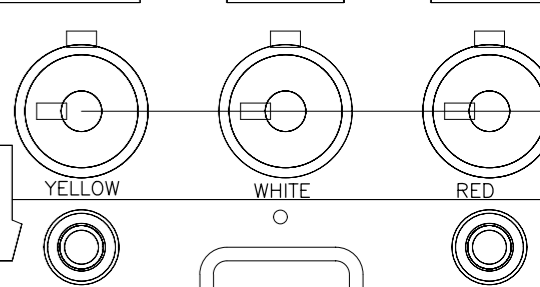
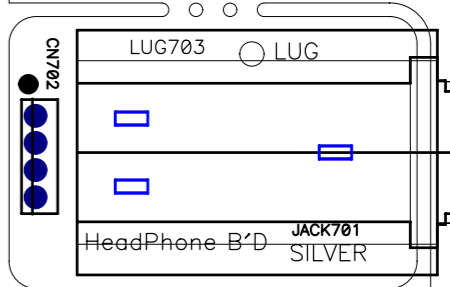
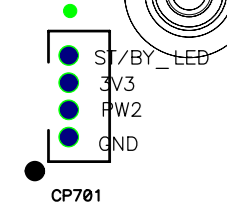
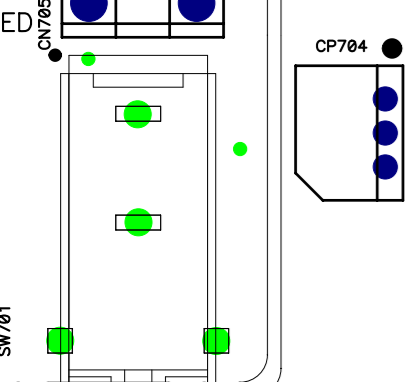

VIDEO3  
VGND  
V3\_L  
A\_GND  
V3\_R



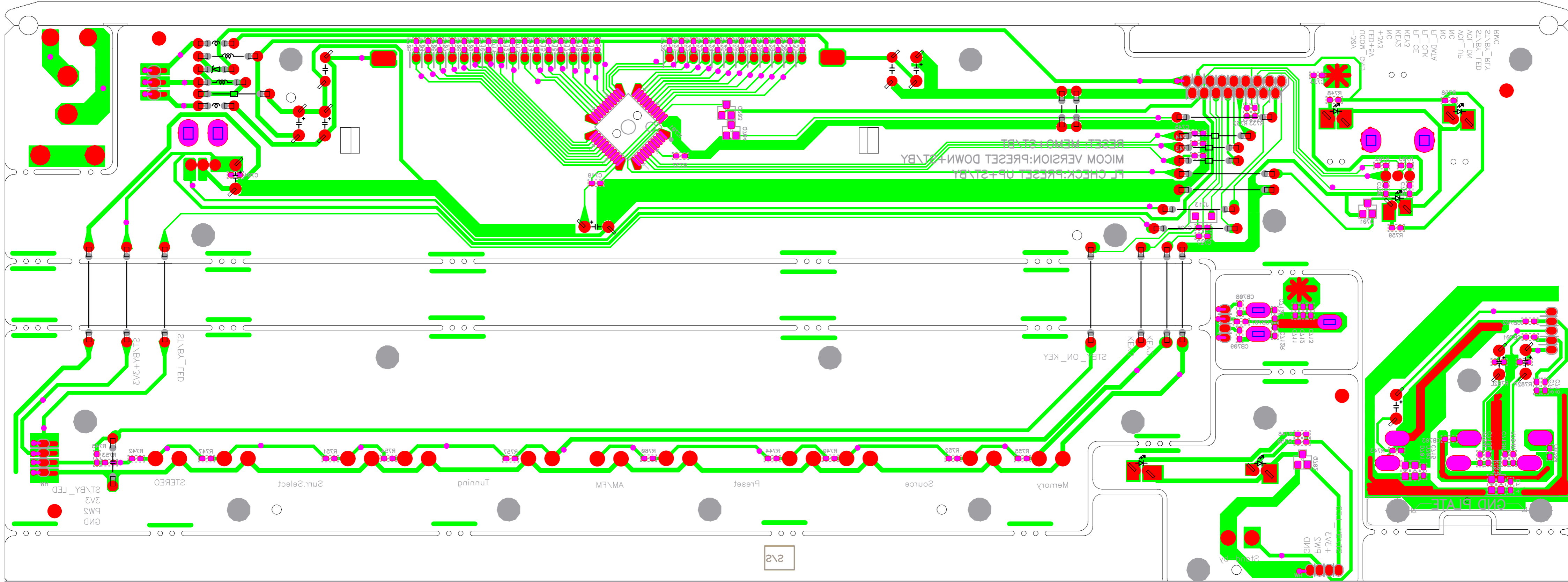

RMC 21VBY\_RFLA  
21VBY\_FLBD  
AOI\_Np  
NC  
NC  
LF\_DPA1A  
LF\_OTK  
LF\_CE  
KEYA2  
KEYA3  
KEYA4  
+2V3  
+2V3  
NC  
NC  
LED+2V  
NCOM\_GND  
-20V

MCOM VERSION:PRESET DOWN+STBY  
FL CHECK:PRESET UP+STBY  
RESET MEMO+STBY

21VBY\_LED  
21VBY\_LED+2V3

KEYA1  
KEYA2  
KEYA3  
KEYA4  
STBY\_ON\_KEY

21VBY\_LED  
3V3  
PW3  
GND

2urr.Select

Tuning

AM/FM

Preset

Source

Memory

GND  
BWS  
+2V3

GND PLATE

2V3

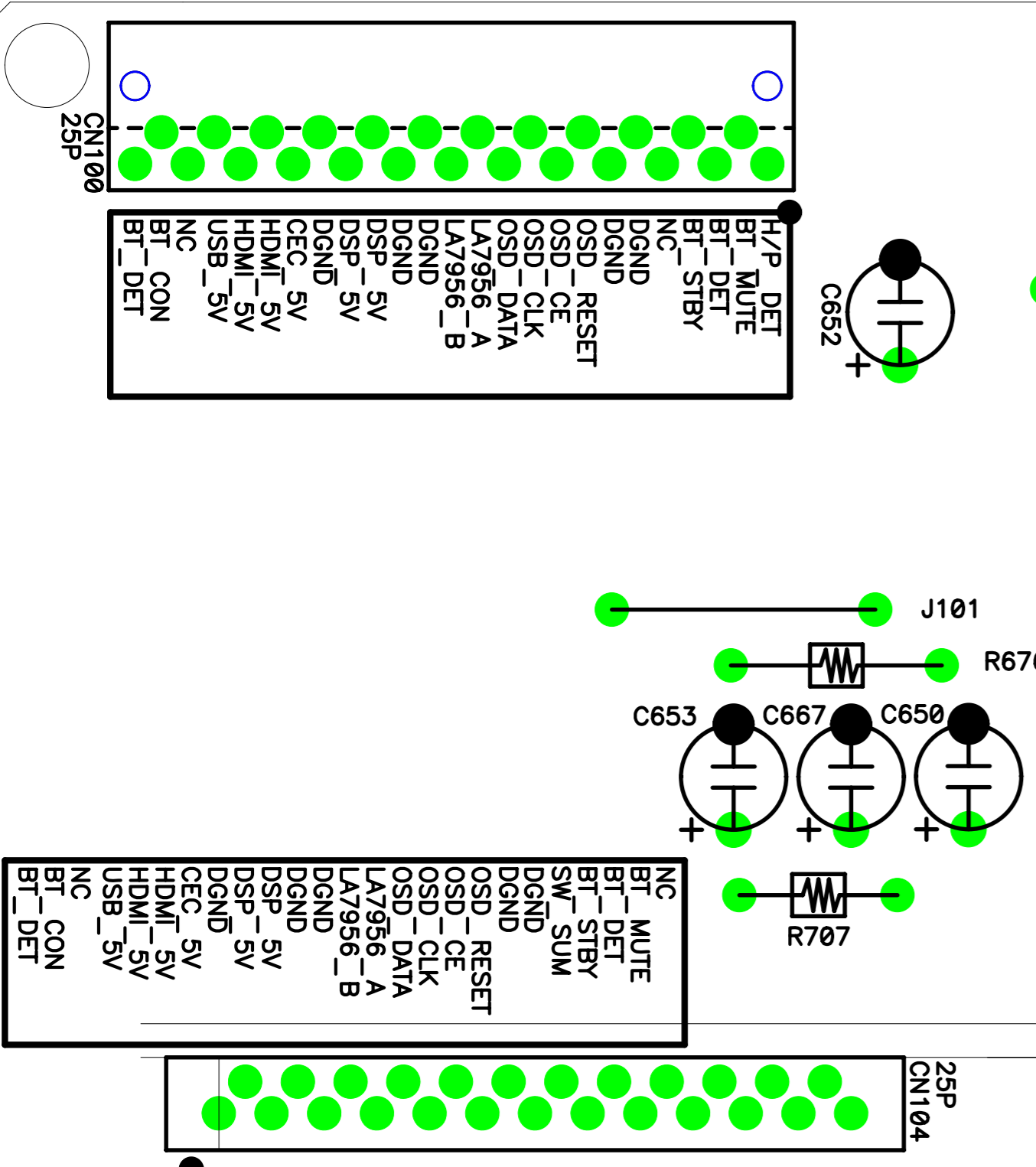
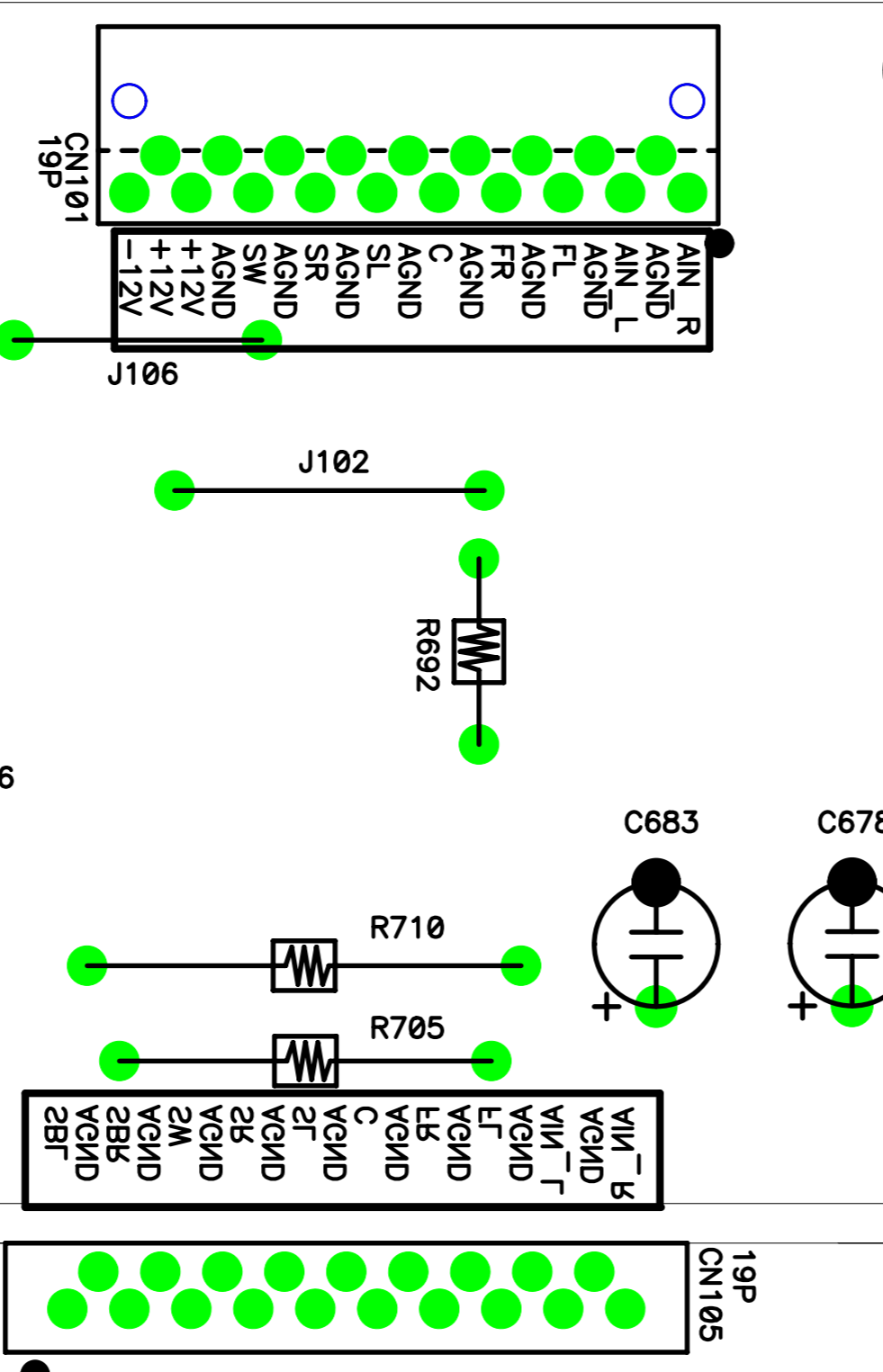
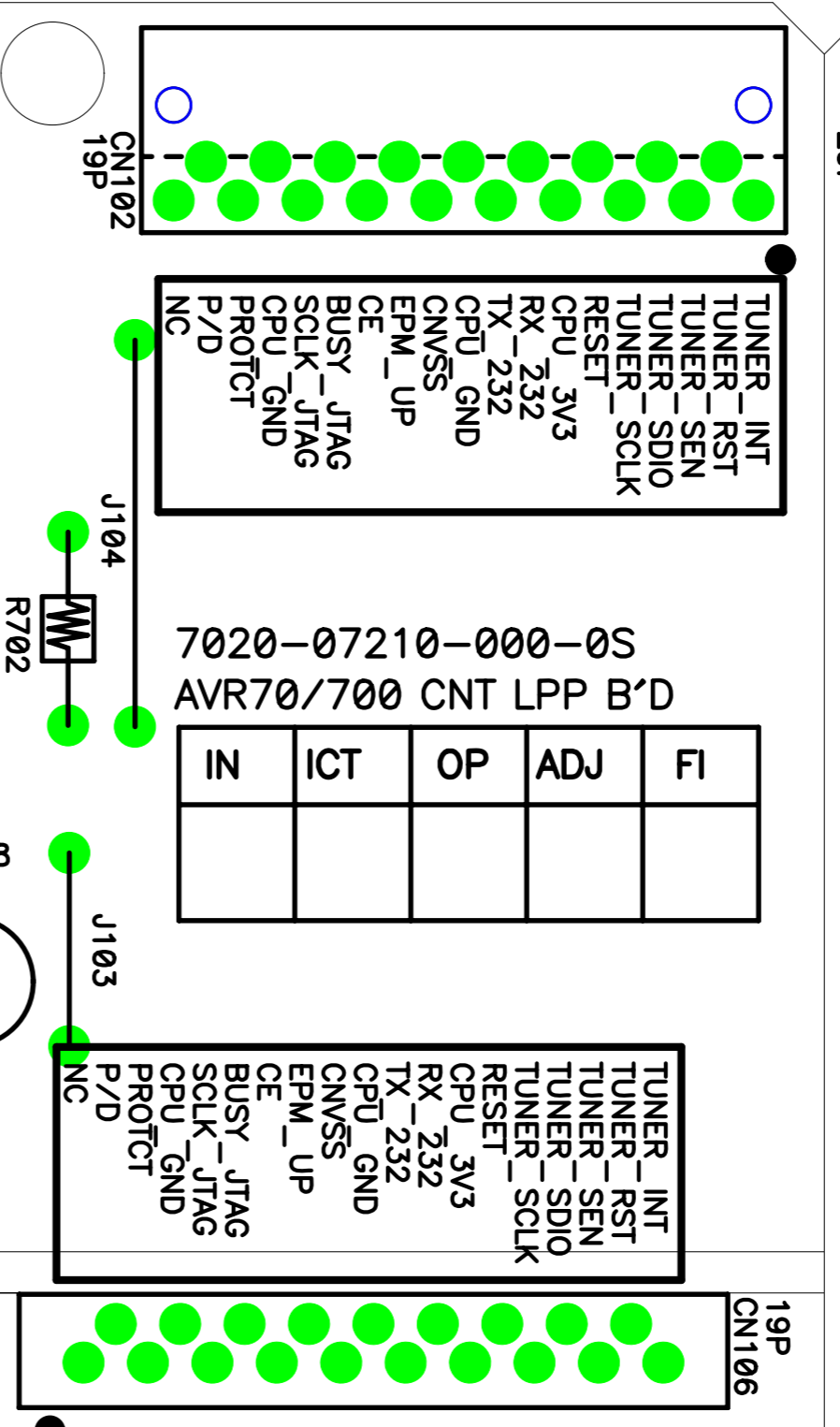
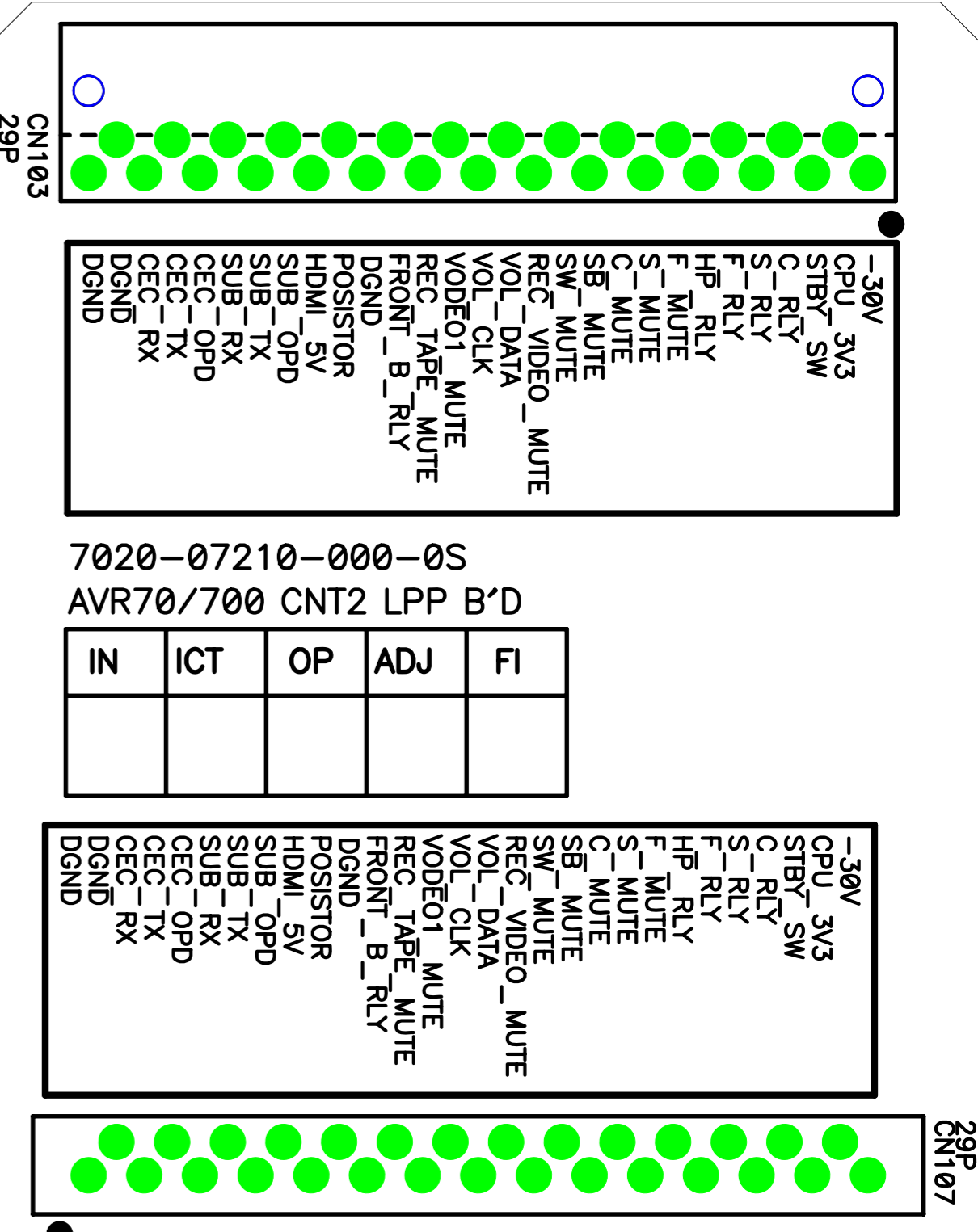

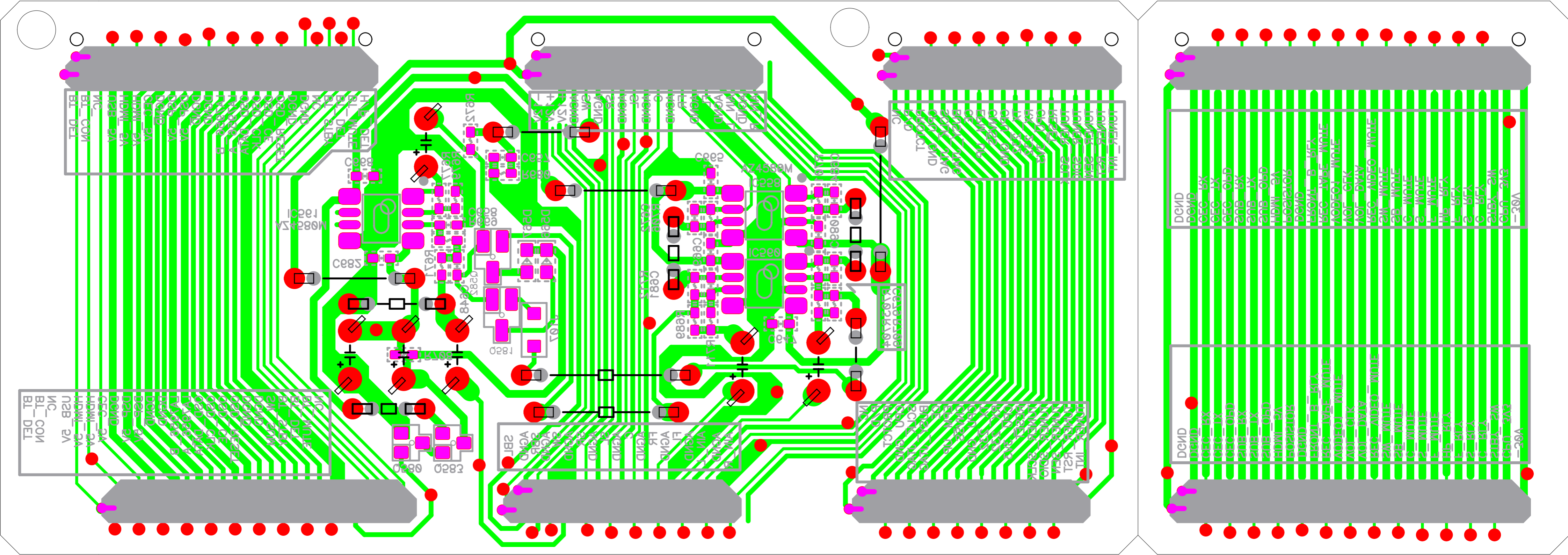

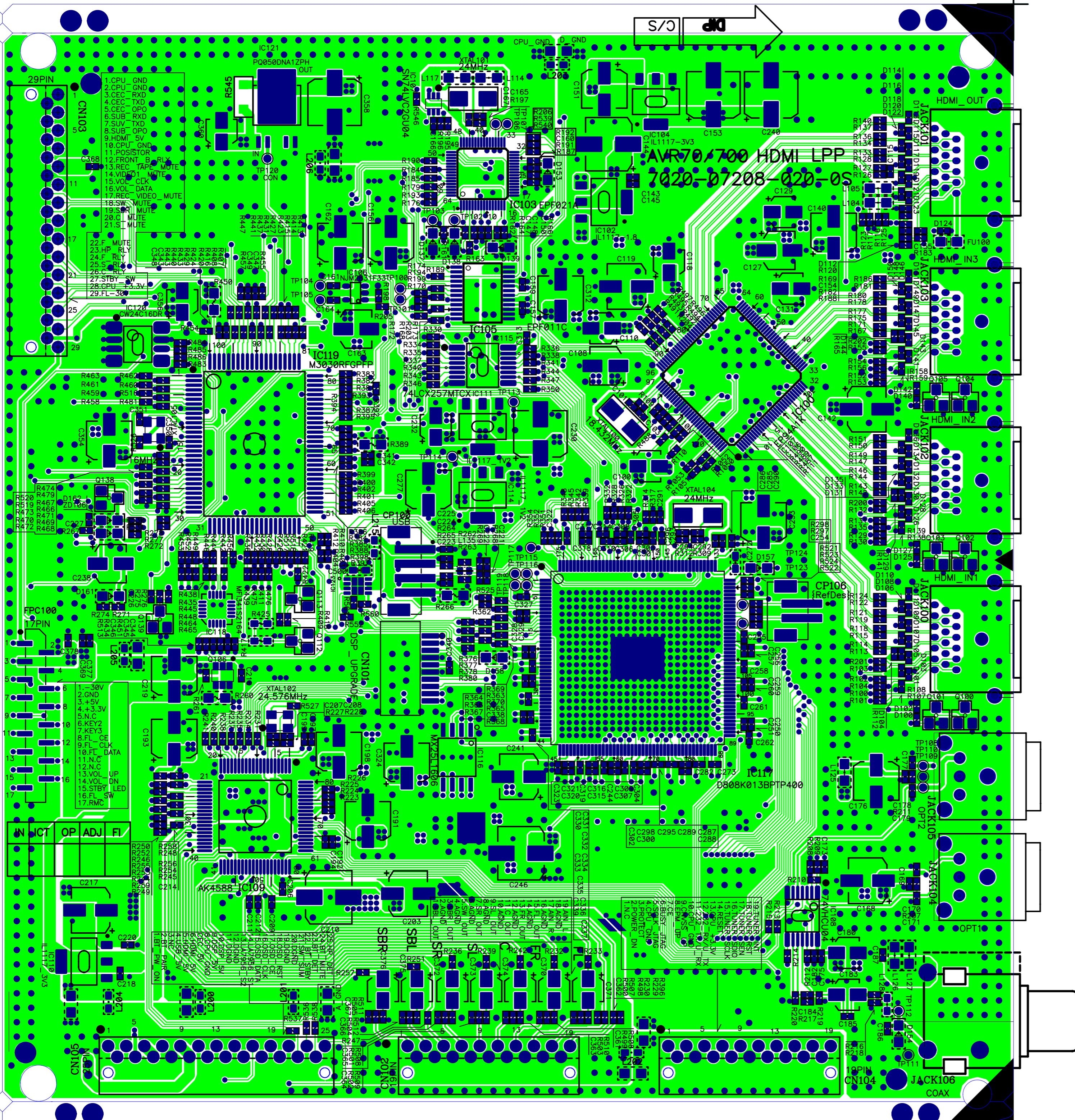

AVR70/700 HDMI LPP  
7020-07208-020-0S

0808K013BTP400

IC109  
M3030R OPTO

IC110  
M3030R OPTO

IC111  
M3030R OPTO

IC112  
M3030R OPTO

IC113  
M3030R OPTO

IC114  
M3030R OPTO

S/C

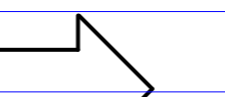

- 1.CPU\_GND
- 2.CPU\_GND
- 3.CEC\_RXD
- 4.CEC\_TXD
- 5.CEC\_OPO
- 6.SUB\_RXD
- 7.SUB\_TXD
- 8.SUB\_OPO
- 9.HDMI\_5V
- 10.CPU\_GND
- 11.POSISTOR
- 12.FRONT\_B\_RLY
- 13.REC\_TAPE\_MUTE
- 14.VID\_O1\_MUTE
- 15.VOL\_CLK
- 16.VOL\_DATA
- 17.REC\_VIDEO\_MUTE
- 18.SW\_MUTE
- 19.SPR\_MUTE
- 20.C\_MUTE
- 21.ST\_MUTE
- 22.F\_MUTE
- 23.HP\_RLY
- 24.F\_RLY
- 25.F\_RLY
- 26.C\_RLY
- 27.STBY\_SW
- 28.CPU\_F\_3.3V
- 29.FL\_30V

- 1.-30V
- 2.GND
- 3.+5V
- 4.+3.3V
- 5.DN
- 6.CN2
- 7.KEY3
- 8.FL\_CX
- 9.FL\_CLK
- 10.FL\_DATA
- 11.N.C
- 12.N.C
- 13.VOL\_UP
- 14.VOL\_DN
- 15.STBY\_LED
- 16.FL\_SW
- 17.RMC

- IN
- ICT
- OP
- ADJ
- FL

- 1
- 2
- 3
- 4
- 5
- 6
- 7
- 8
- 9
- 10
- 11
- 12
- 13
- 14
- 15
- 16
- 17
- 18
- 19
- 20
- 21
- 22
- 23
- 24
- 25
- 26
- 27
- 28
- 29
- 30
- 31
- 32
- 33
- 34
- 35
- 36
- 37
- 38
- 39
- 40

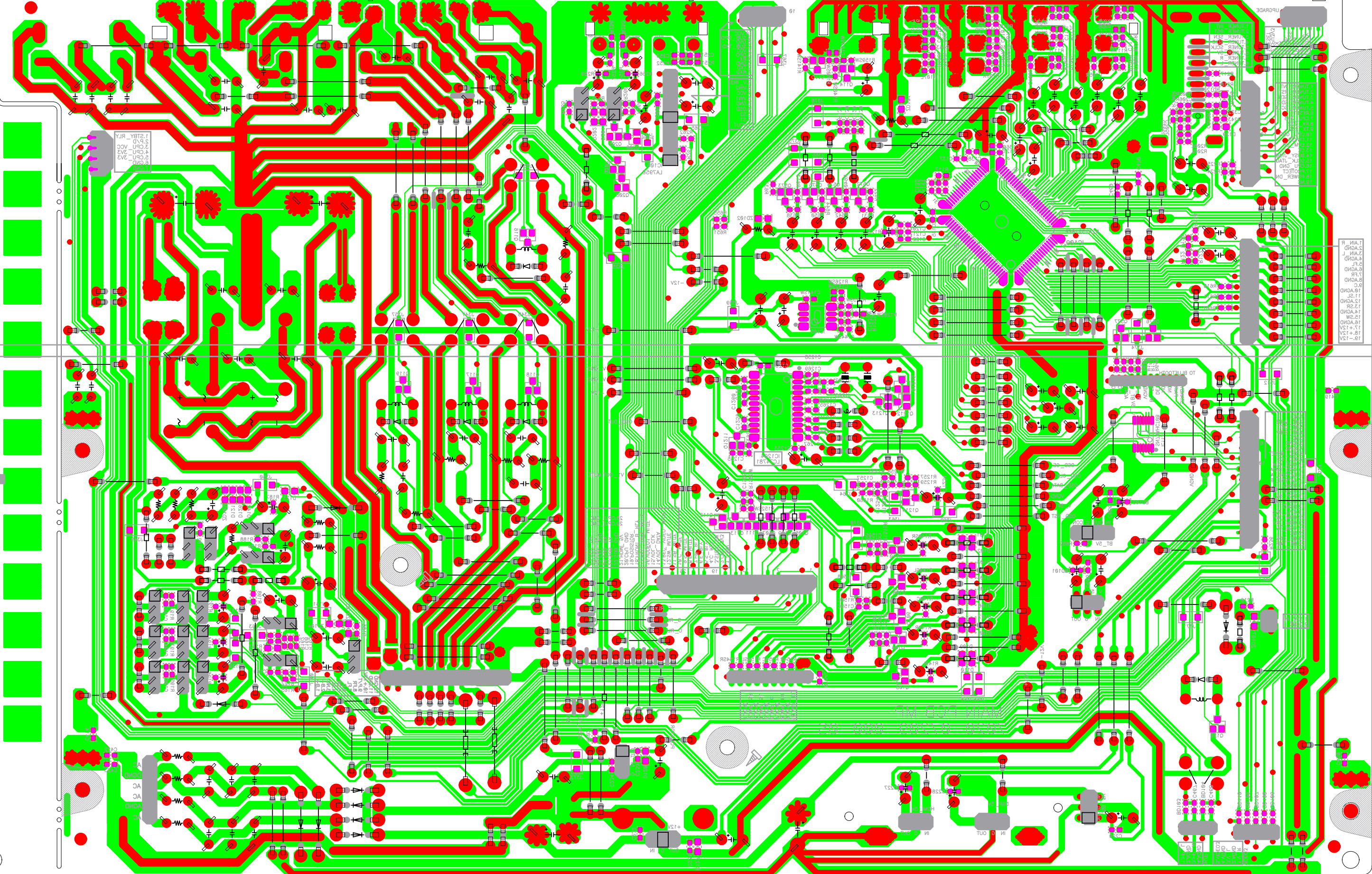

7050-02509-201-02  
GUIDE-C B.D

C

7050-02509-401-02  
GUIDE-L B.D

L

7050-02509-201-02  
GUIDE-R B.D

R

1. VIA R  
2. GND  
3. VIA  
4. GND  
5. 2.7F  
6. GND  
7. R  
8. GND  
9. 1.2F  
10. GND  
11. 1.2F  
12. GND  
13. 1.2F  
14. GND  
15. 1.2F  
16. GND  
17. 1.2F  
18. GND  
19. 1.2F  
20. GND

1. STBY\_RLY  
2. CPU\_VCC  
3. CPU\_VCC  
4. CPU\_VCC  
5. GND

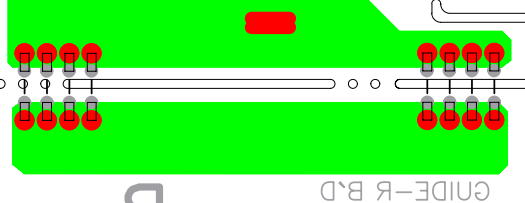
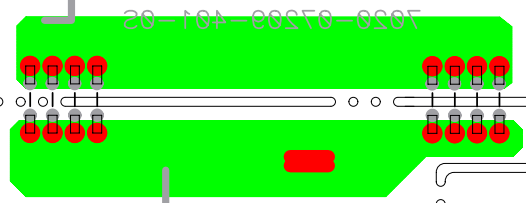
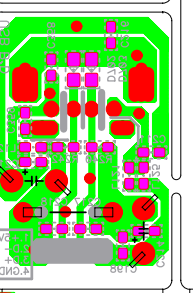

GUIDE-C B'D  
7020-07209-301-0S

GUIDE-L B'D  
7020-07209-401-0S

GUIDE-R B'D  
7020-07209-501-0S

USB B'D  
7020-07209-201-0S

MAIN PCB MP  
7020-07209-000-0S

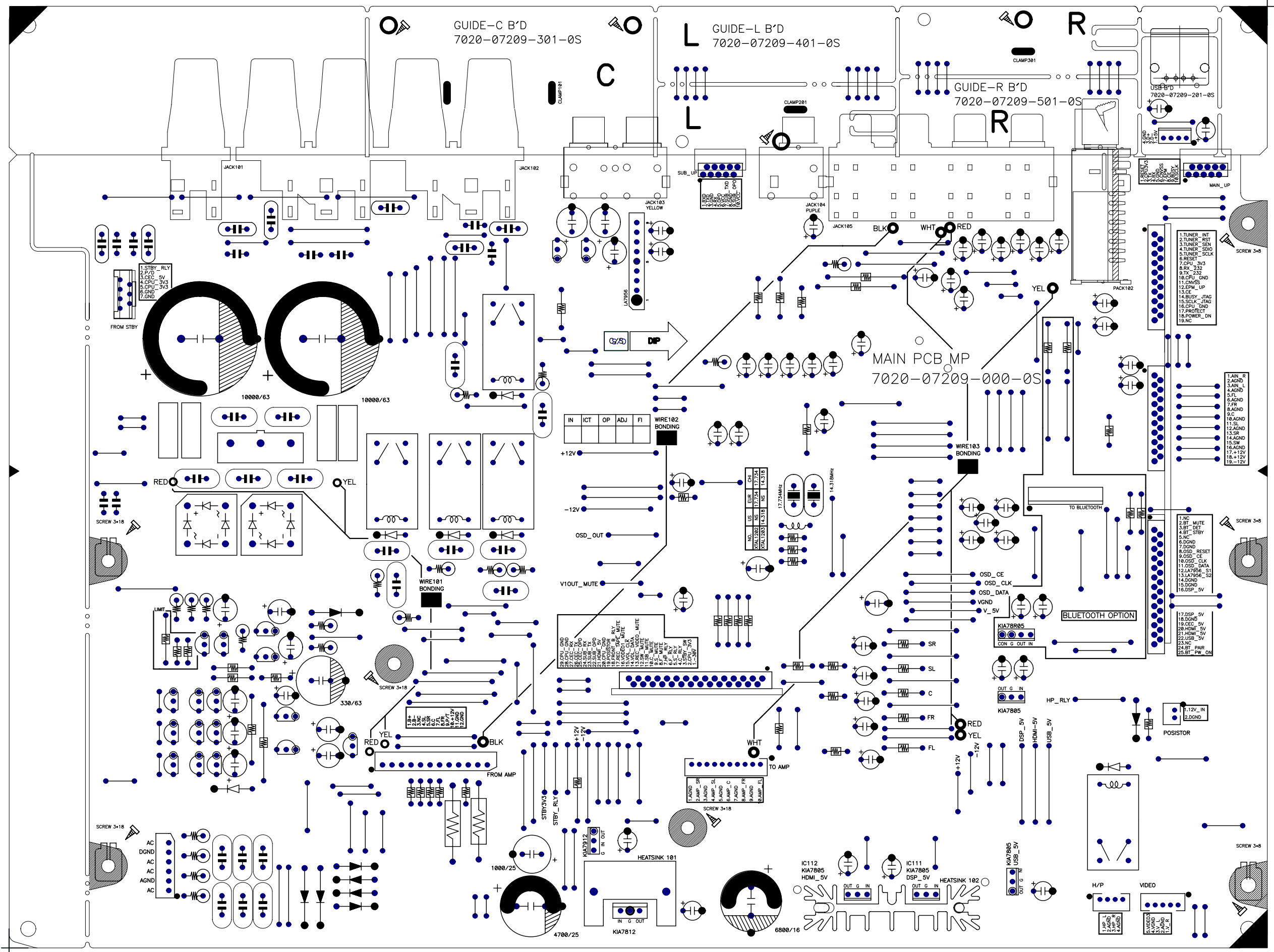

- 1.TUNER\_INT
- 2.TUNER\_RST
- 3.TUNER\_SEN
- 4.TUNER\_SND
- 5.TUNER\_SCLK
- 6.RESET
- 7.CPU\_3V3
- 8.KU\_232
- 9.TX\_232
- 10.CPU\_GND
- 11.CNV5V
- 12.EPM\_UP
- 13.CE
- 14.BUSY\_ITAG
- 15.SCLK\_ITAG
- 16.CPU\_GND
- 17.PROTECT
- 18.POWER\_DN
- 19.NC

- 1.AIN\_R
- 2.AGND
- 3.AIN\_L
- 4.AGND
- 5.FL
- 6.AGND
- 7.FR
- 8.AGND
- 9.C
- 10.AGND
- 11.SL
- 12.AGND
- 13.SR
- 14.AGND
- 15.SW
- 16.AGND
- 17.+12V
- 18.+12V
- 19.-12V

- 1.NC
- 2.MUTE
- 3.BT\_DET
- 4.BT\_STBY
- 5.NC
- 6.DGND
- 7.DGND
- 8.DGND
- 9.RESET
- 10.OSD\_CE
- 11.OSD\_CLK
- 12.OSD\_DATA
- 13.LA7956\_S1
- 14.LA7956\_S2
- 15.DGND
- 16.DSP\_5V

- 17.DSP\_5V
- 18.DGND
- 19.CEC\_5V
- 20.HDMI\_5V
- 21.HDMI\_5V
- 22.USB\_5V
- 23.NC
- 24.BT\_PAIR
- 25.BT\_PW\_ON

- 1.+12V\_IN
- 2.DGND

- 1.H/P
- 2.AGND
- 3.AGND
- 4.AGND
- 5.AGND

- 1.VIDEO
- 2.VIDEO
- 3.VIDEO
- 4.VIDEO
- 5.VIDEO

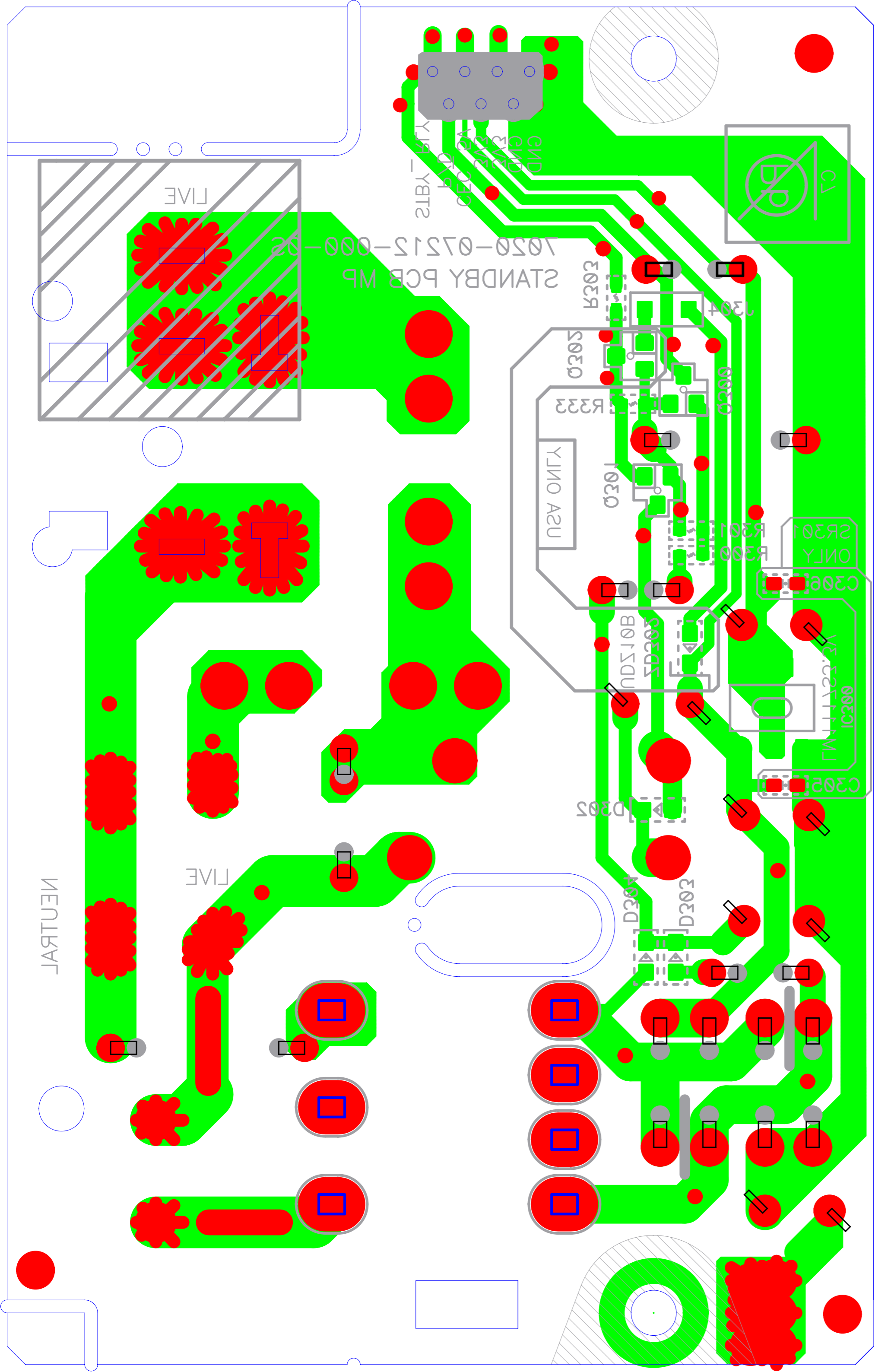

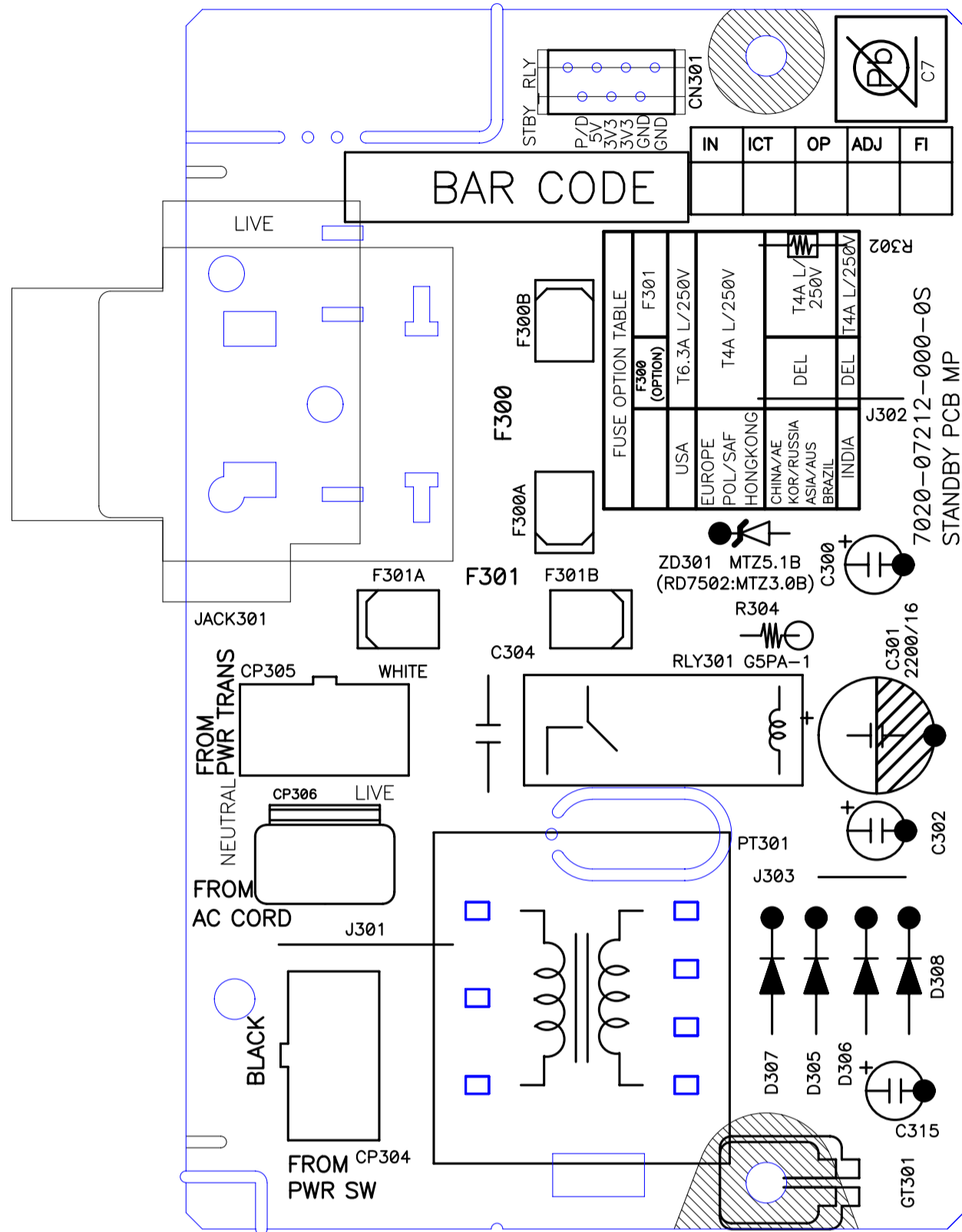



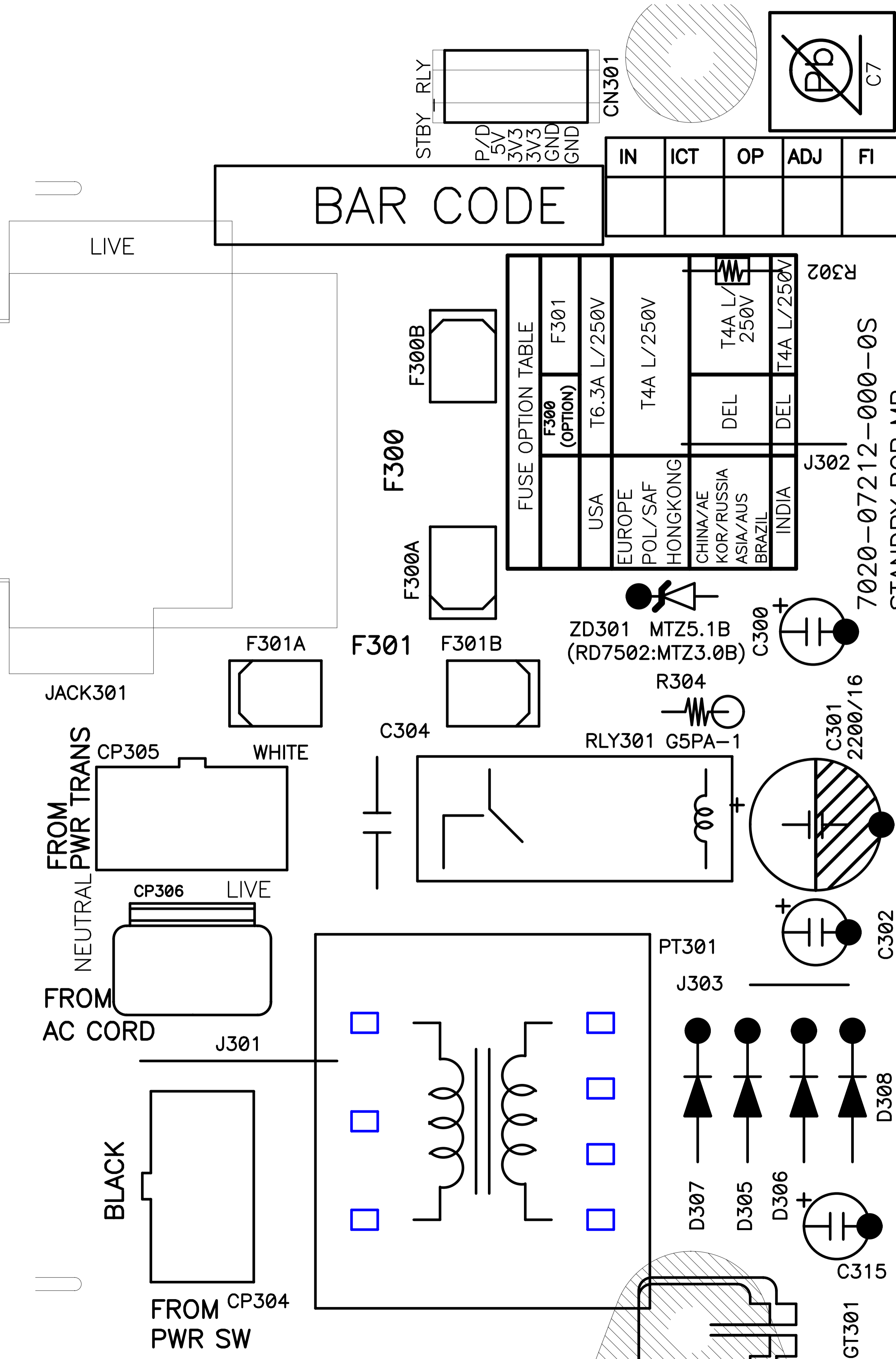

BAR CODE

IN	ICT	OP	ADJ	FI

FUSE OPTION TABLE	
F300 (OPTION)	F301
USA	T6.3A L/250V
EUROPE POL/SAF HONGKONG	T4A L/250V
CHINA/AE KOR/RUSSIA ASIA/AUS BRAZIL	DEL
INDIA	DEL
	T4A L/250V

7020-07212-000-0S  
STANDBY PCB MP

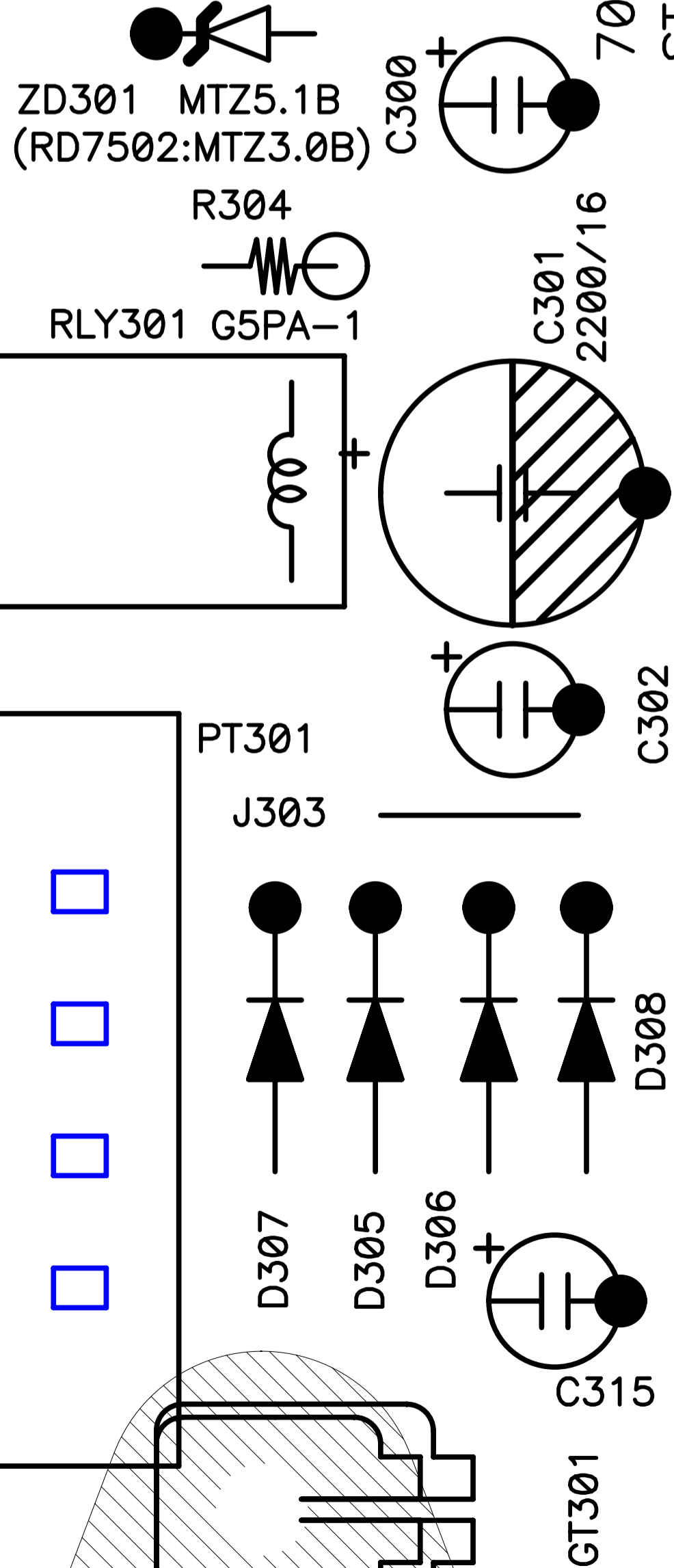
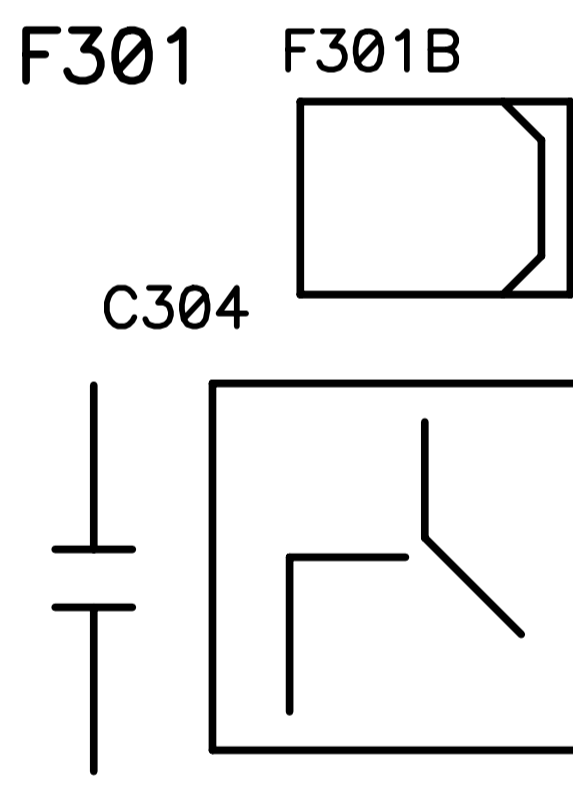
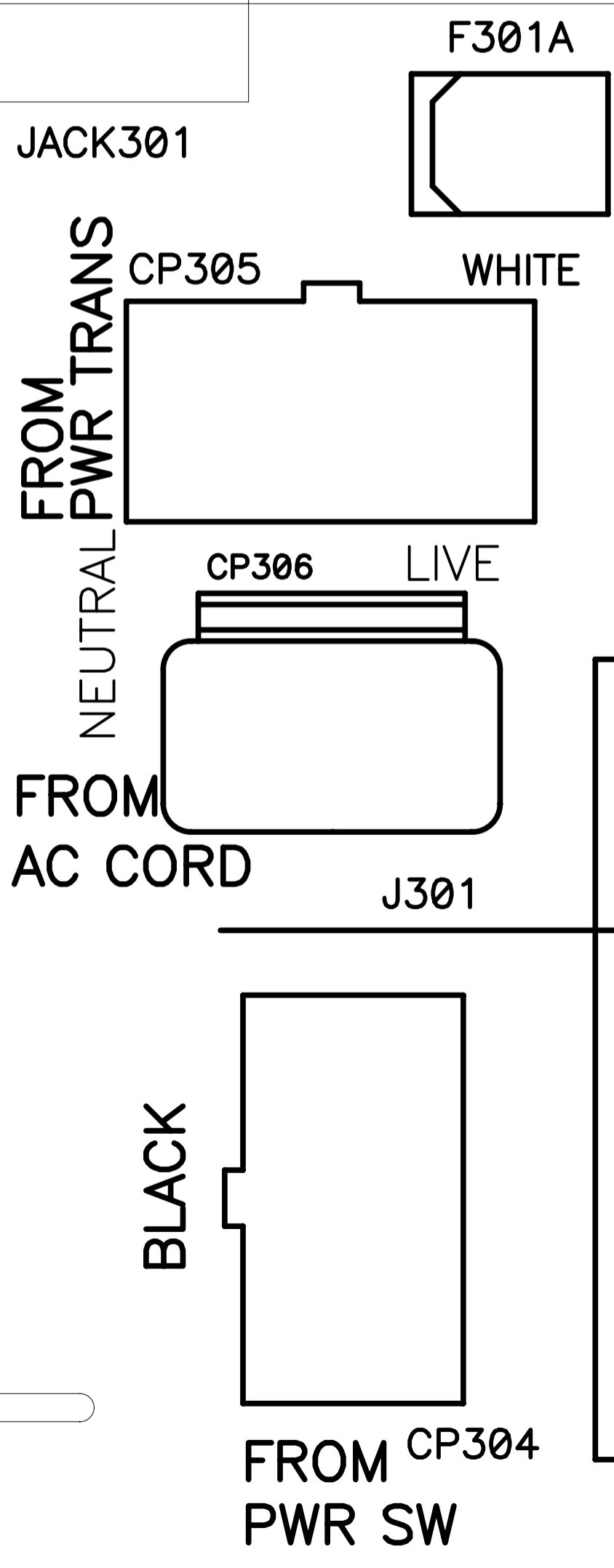
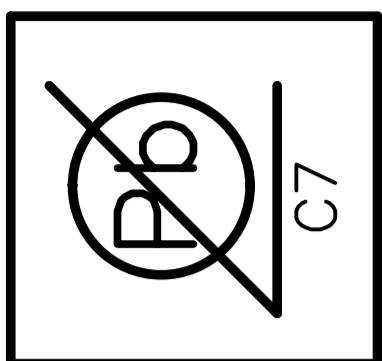
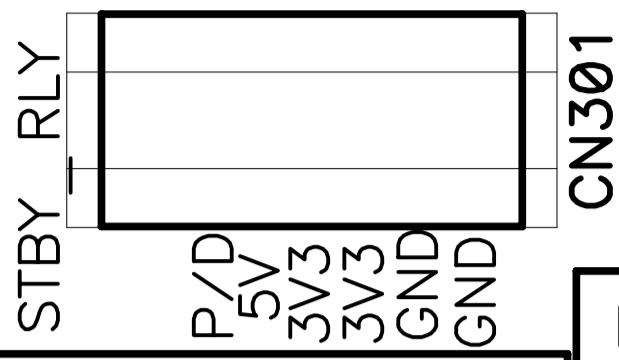

BLACK

FROM CP304  
PWR SW

FROM  
AC CORD

NEUTRAL  
FROM  
PWR TRANS

WHITE  
FROM  
PWR TRANS

JACK301

F301A

F301

F301B

C304

ZD301 MTZ5.1B  
(RD7502:MTZ3.0B)

R304  
RLY301 G5PA-1

C300

C301  
2200/16

C302

PT301

J303

D307

D305

D306

GT301

C315

D308

F300A

F300

F300B

J302

R302

STBY\_RLY

P/D  
5V  
3V3  
3V3  
GND  
GND

CN301

# AVR70/700/70C BLOCK DIAGRAM(VIDEO PART)

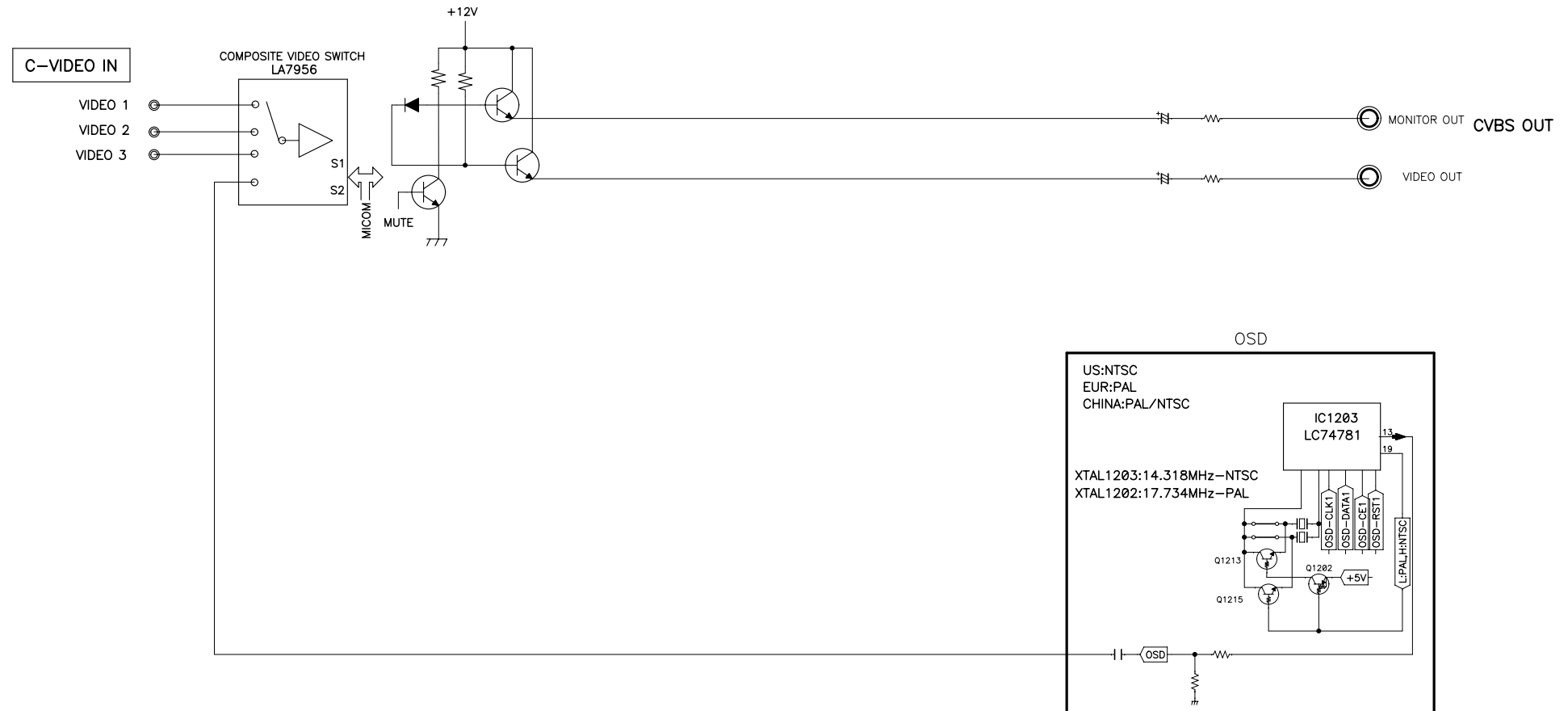

# AVR70/700/70C BLOCK DIAGRAM(AUDIO PART)

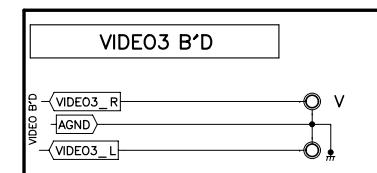
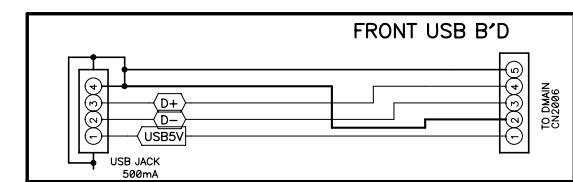
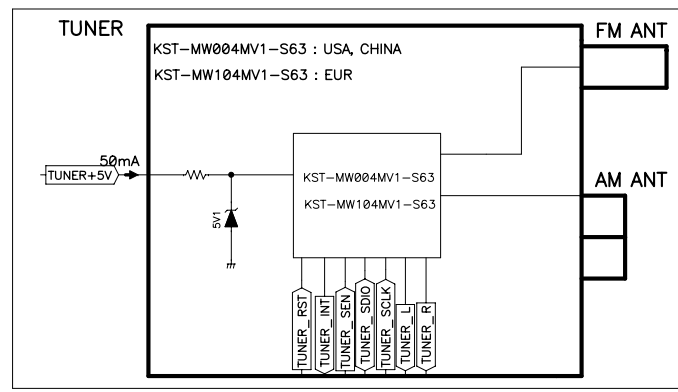
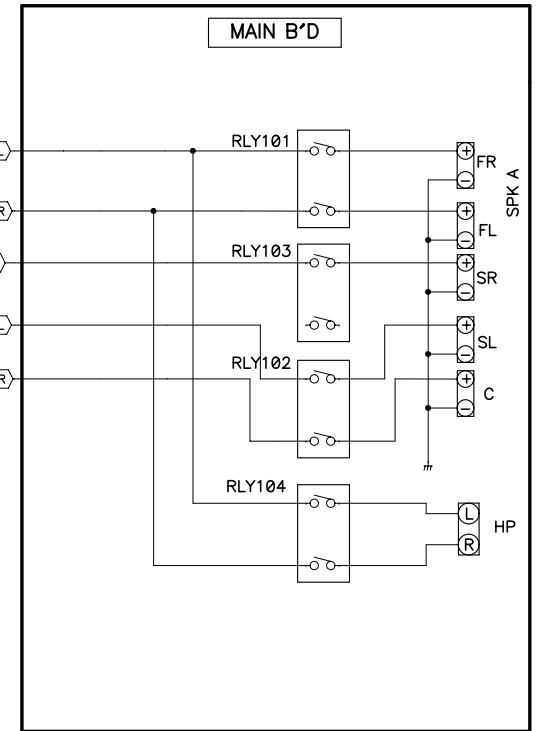
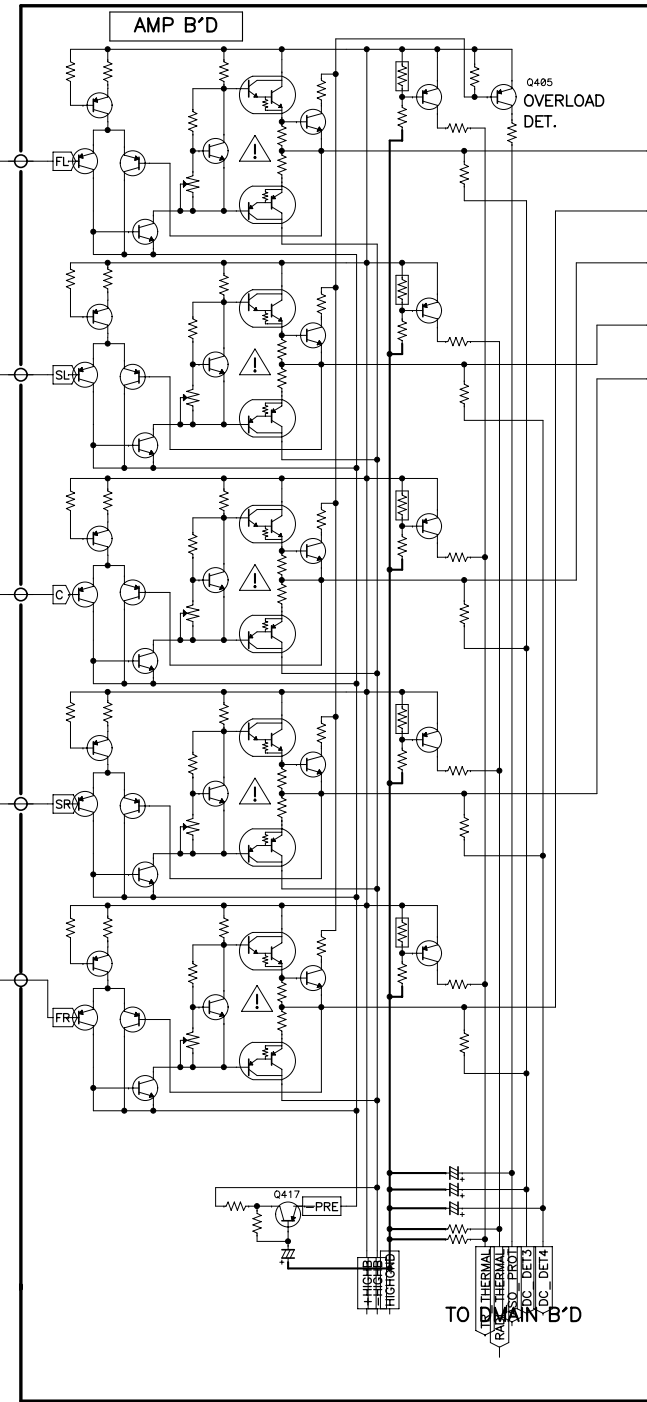
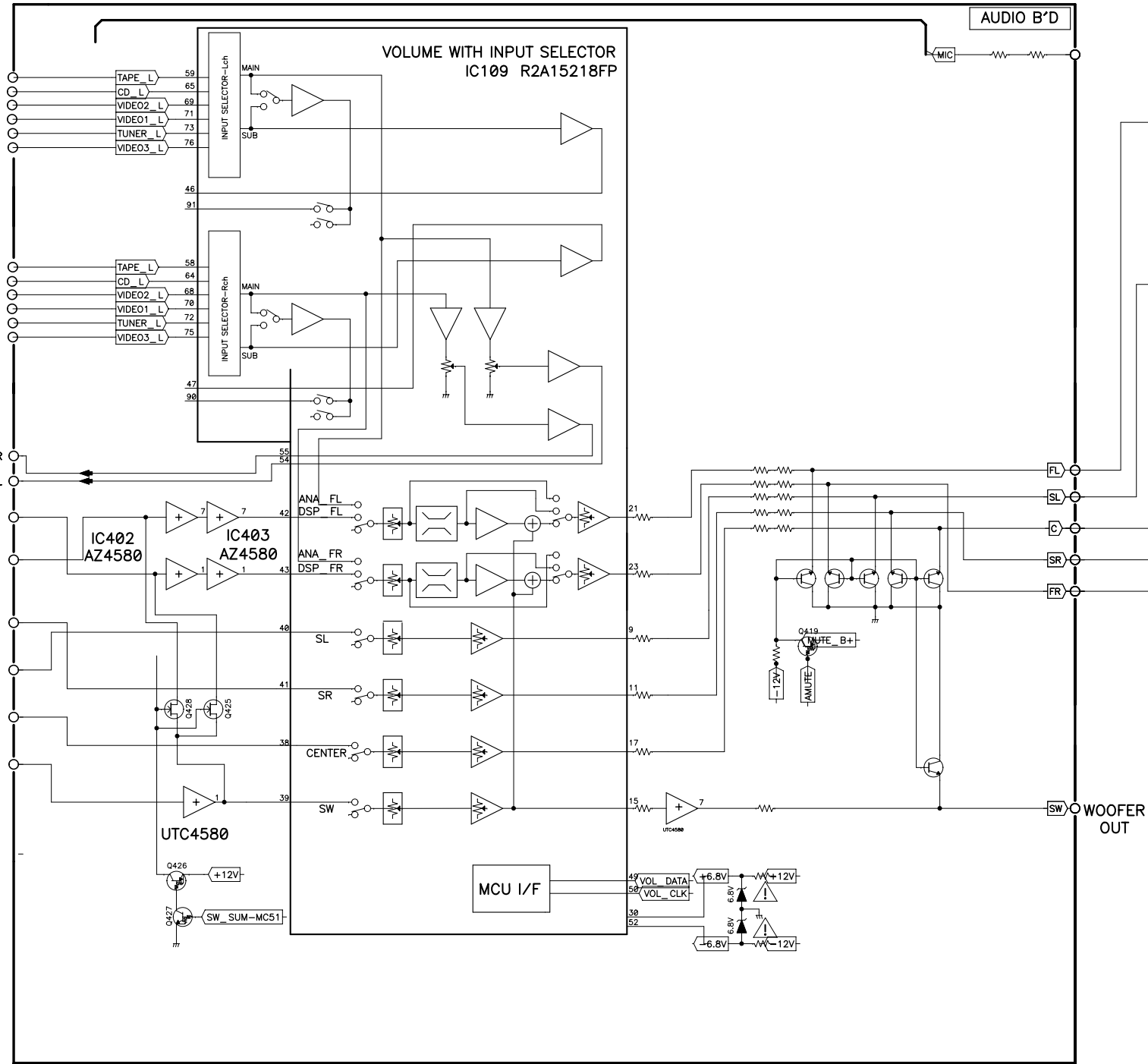

# AVR70/700/70C BLOCK DIAGRAM(HDMI & DSP PART)

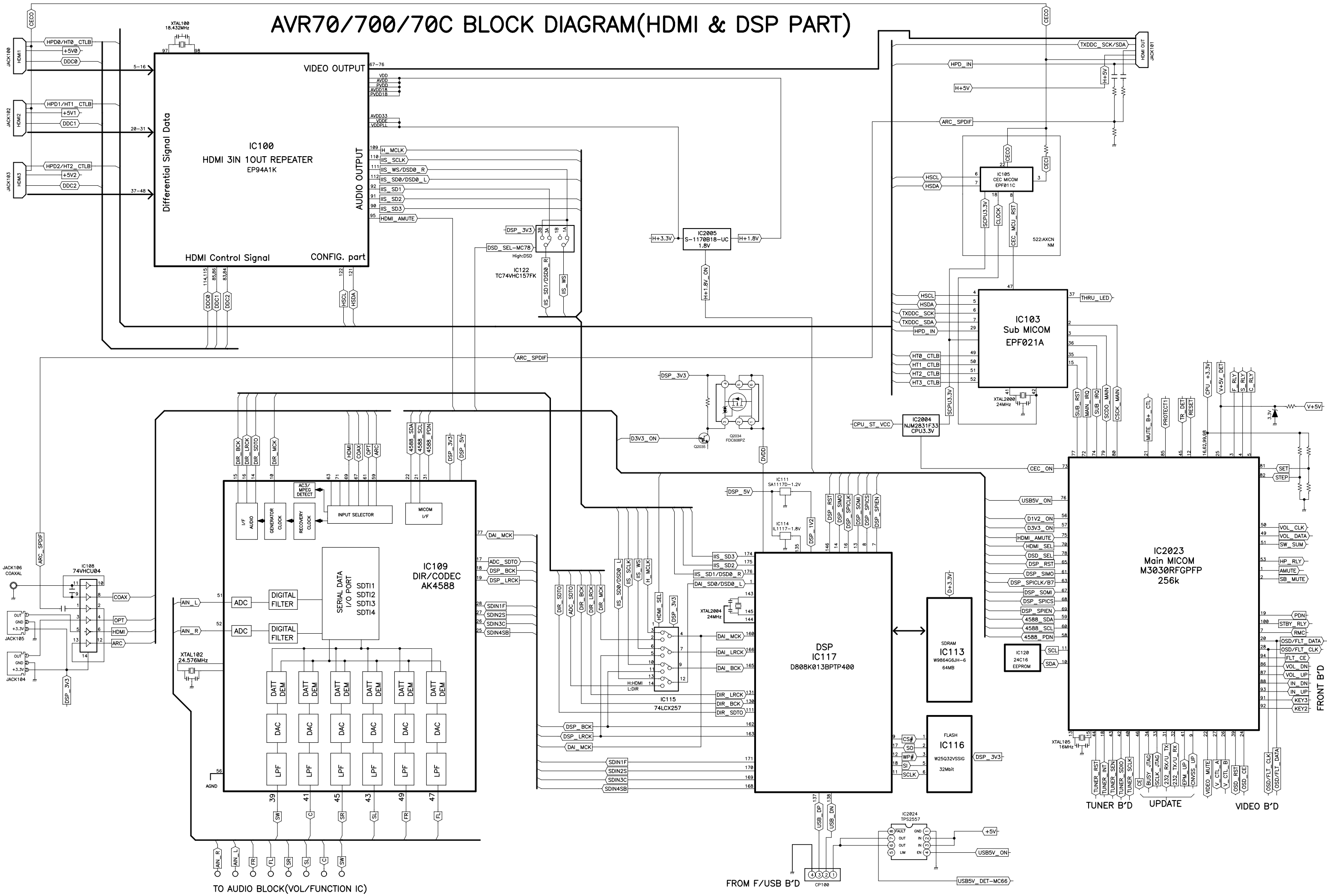

TO AUDIO BLOCK (VOL/FUNCTION IC)

FROM F/USB B'D

TUNER B'D UPDATE VIDEO B'D

FRONT B'D

# AVR70/700/70C BLOCK DIAGRAM(POWER PART)

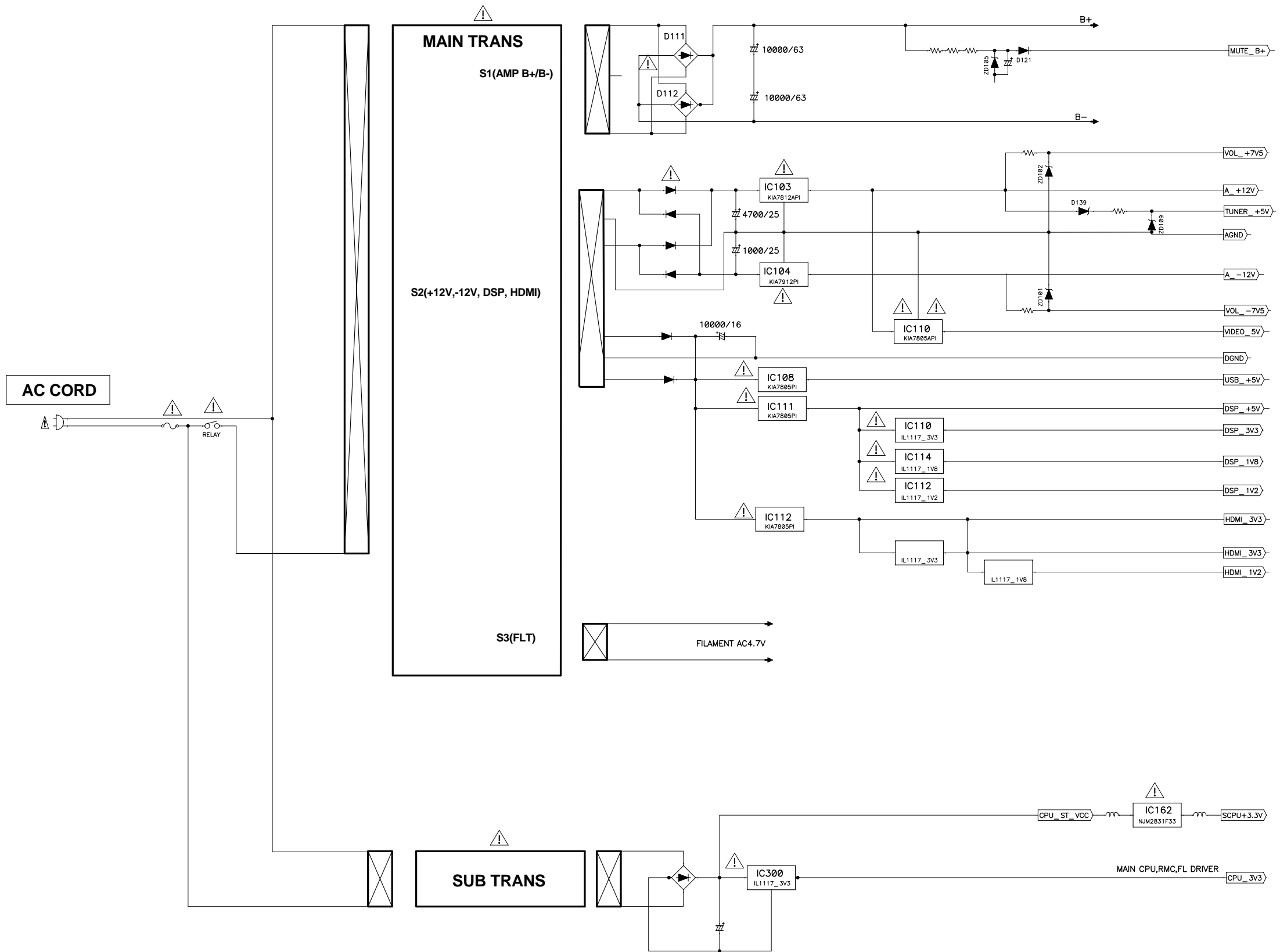

# AVR700/70/70C WIRING DIAGRAM

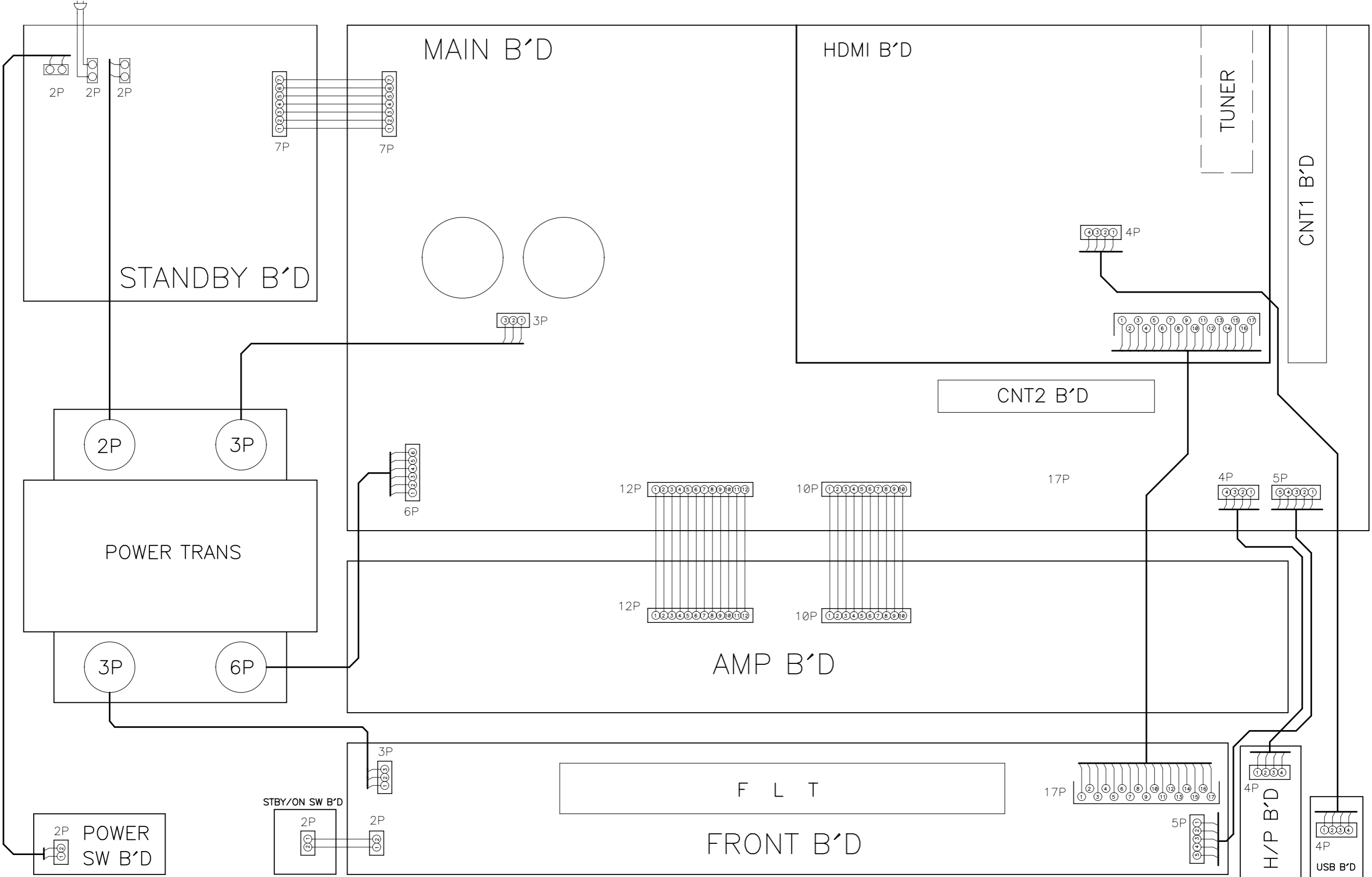

# AVR700 AMP

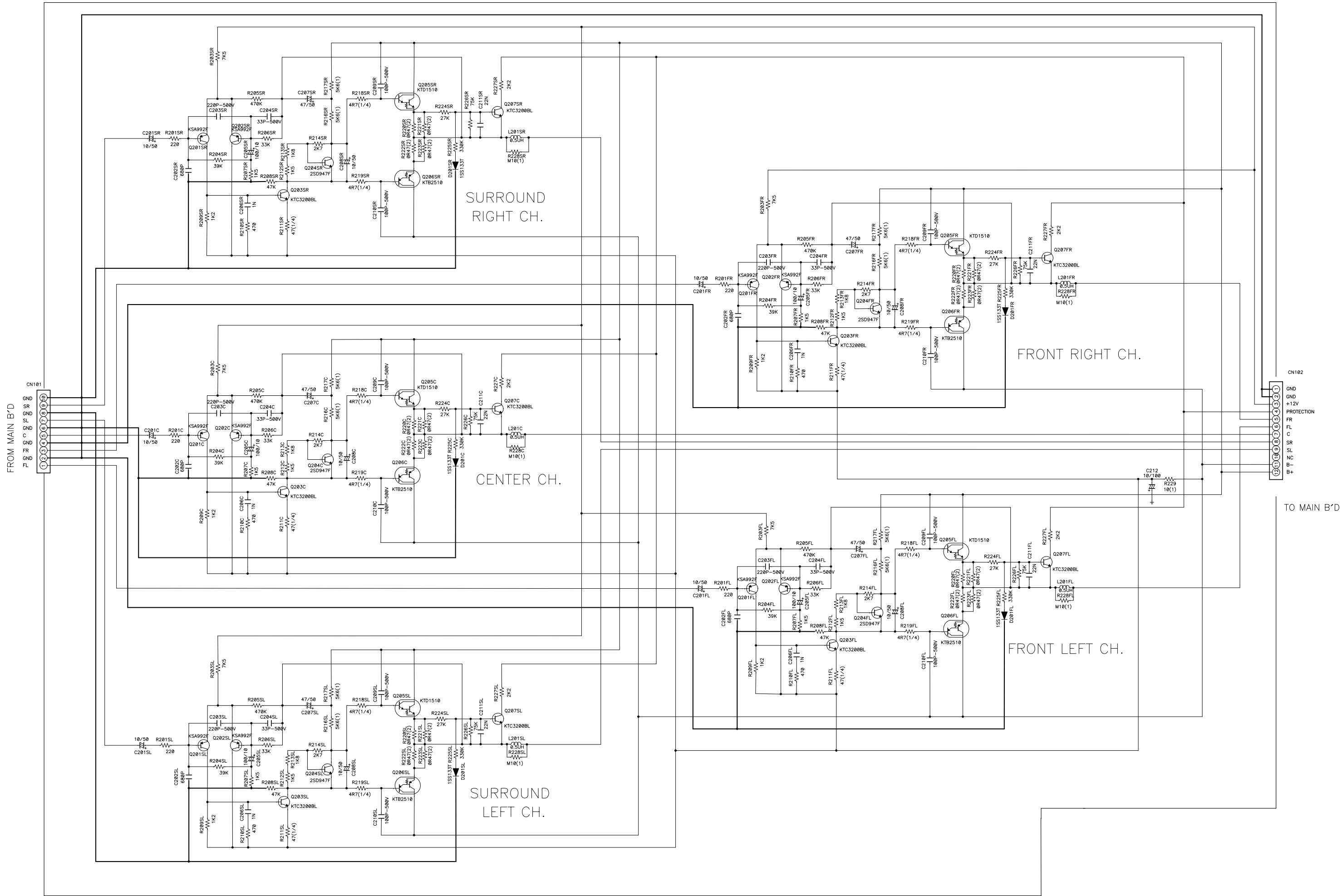

SURROUND  
RIGHT CH.

FRONT RIGHT CH.

CENTER CH.

FRONT LEFT CH.

SURROUND  
LEFT CH.

# AVR700 CNT

## CNT1

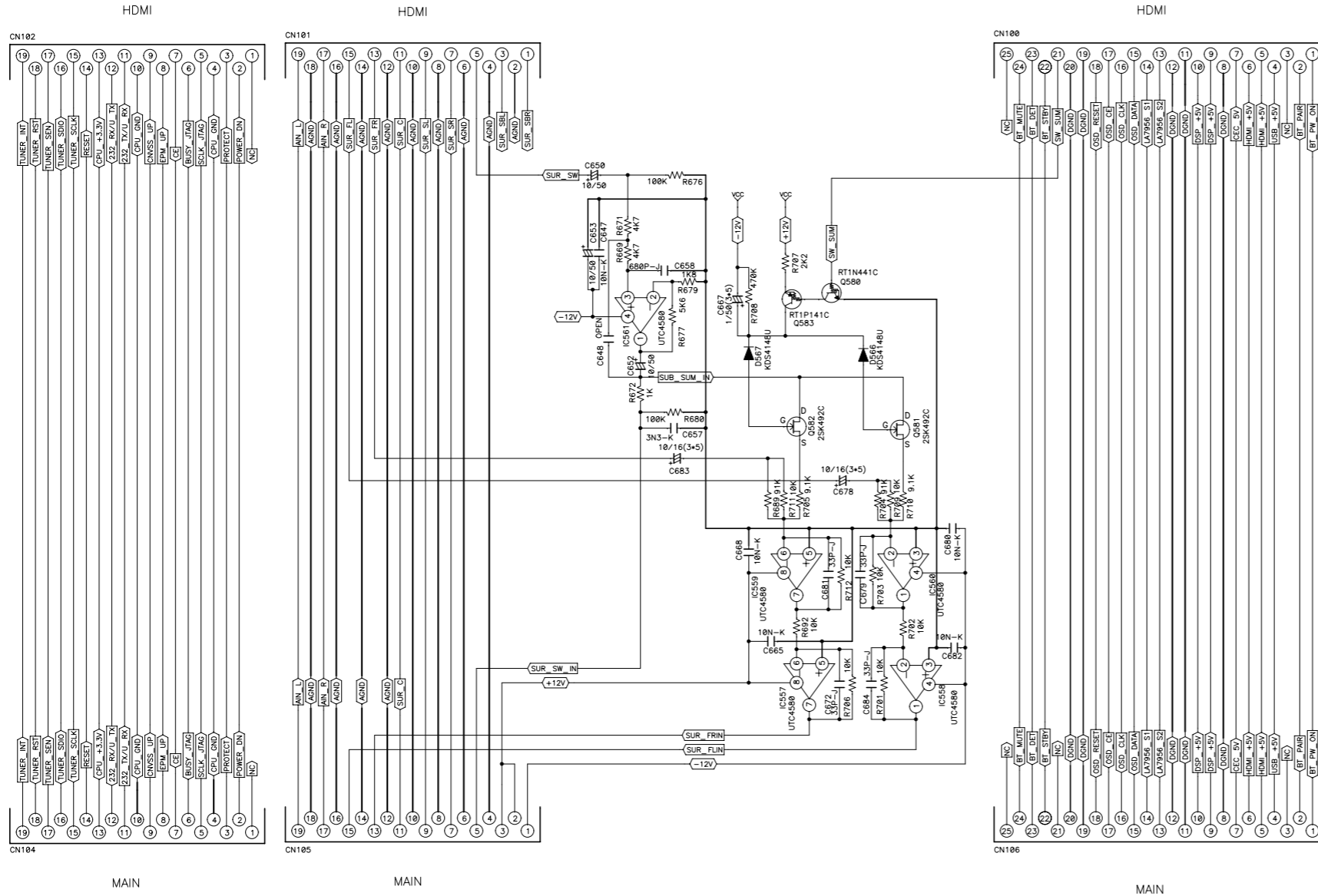

## CNT2

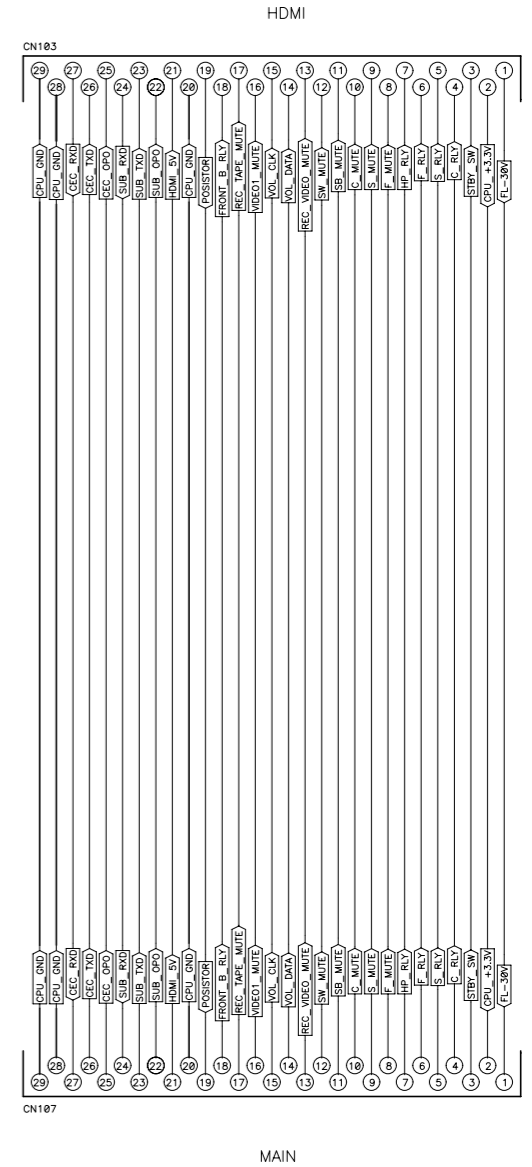



# AVR700 FRONT

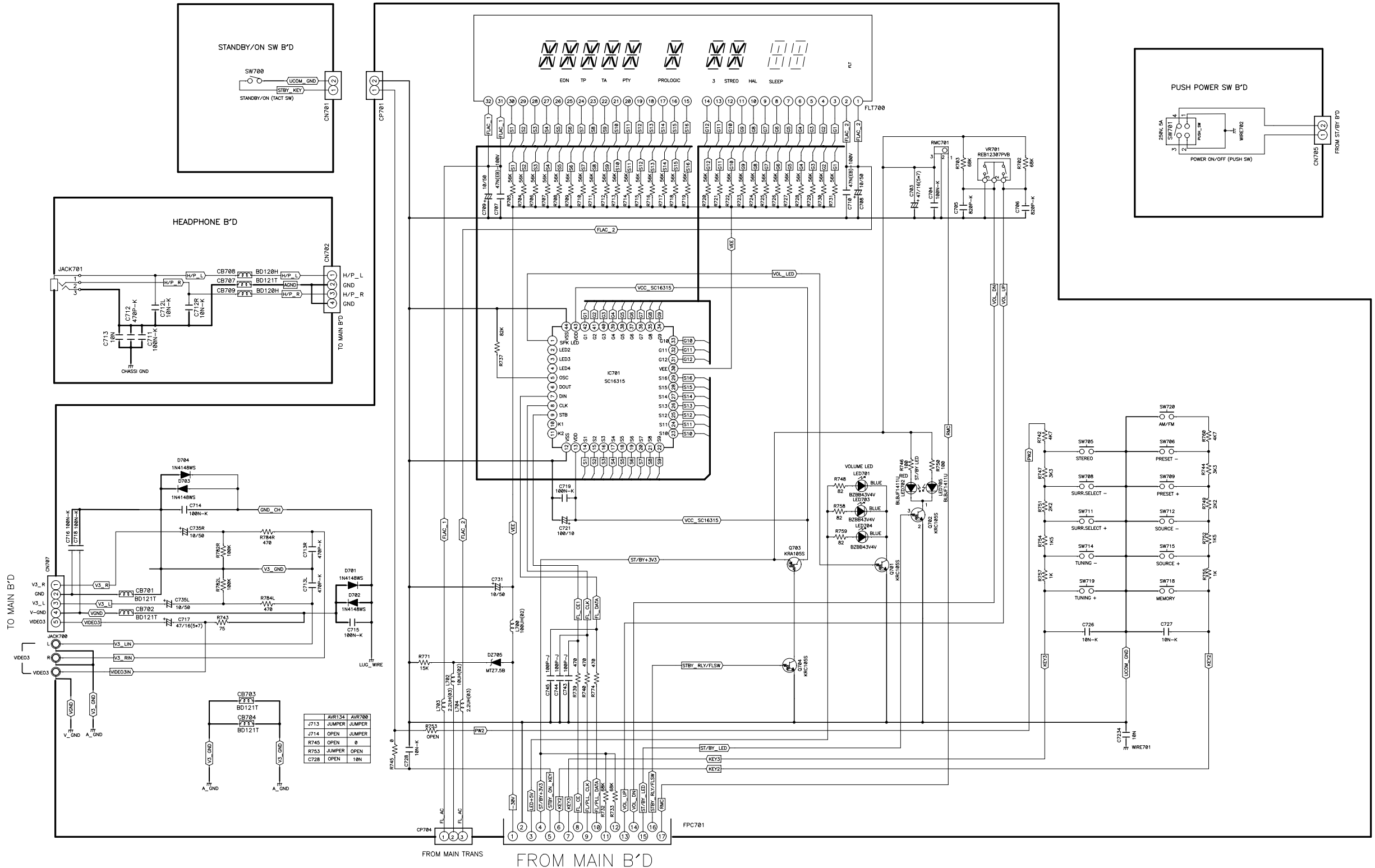

# AVR700 STBY

## ST-BY B'D

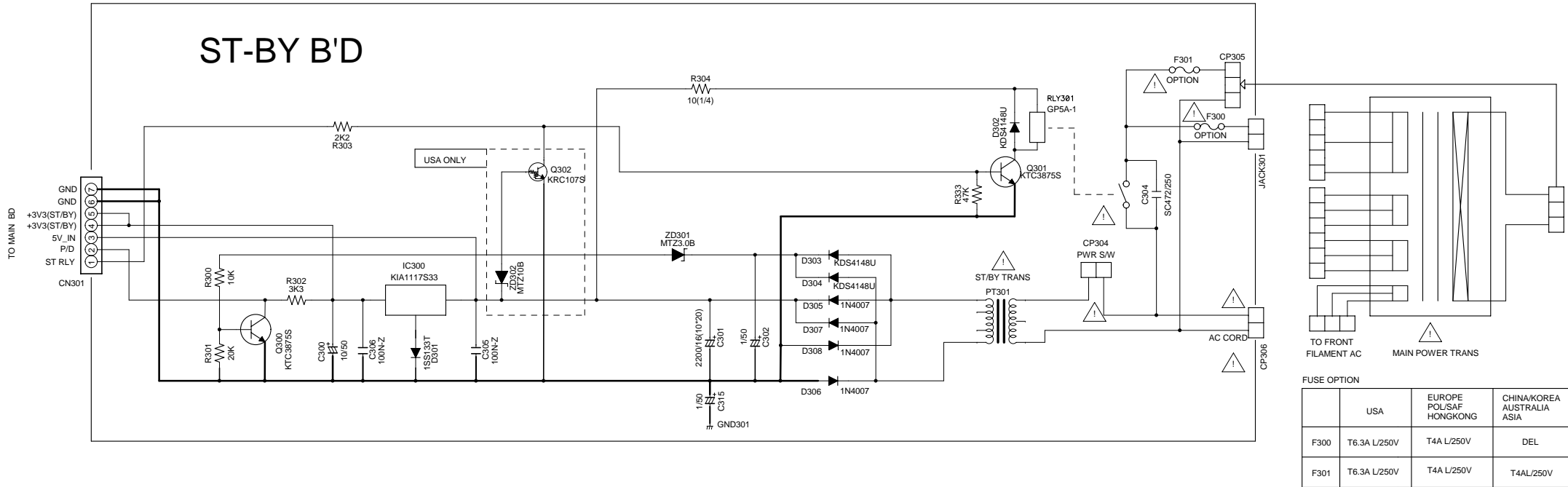

### FUSE OPTION

	USA	EUROPE POL/SAF HONGKONG	CHINA/KOREA AUSTRALIA ASIA
F300	T6.3A L/250V	T4A L/250V	DEL
F301	T6.3A L/250V	T4A L/250V	T4AL/250V

\* F300 : AVR700/70/70C NOT USE

# AVR700 MAIN(1/2)

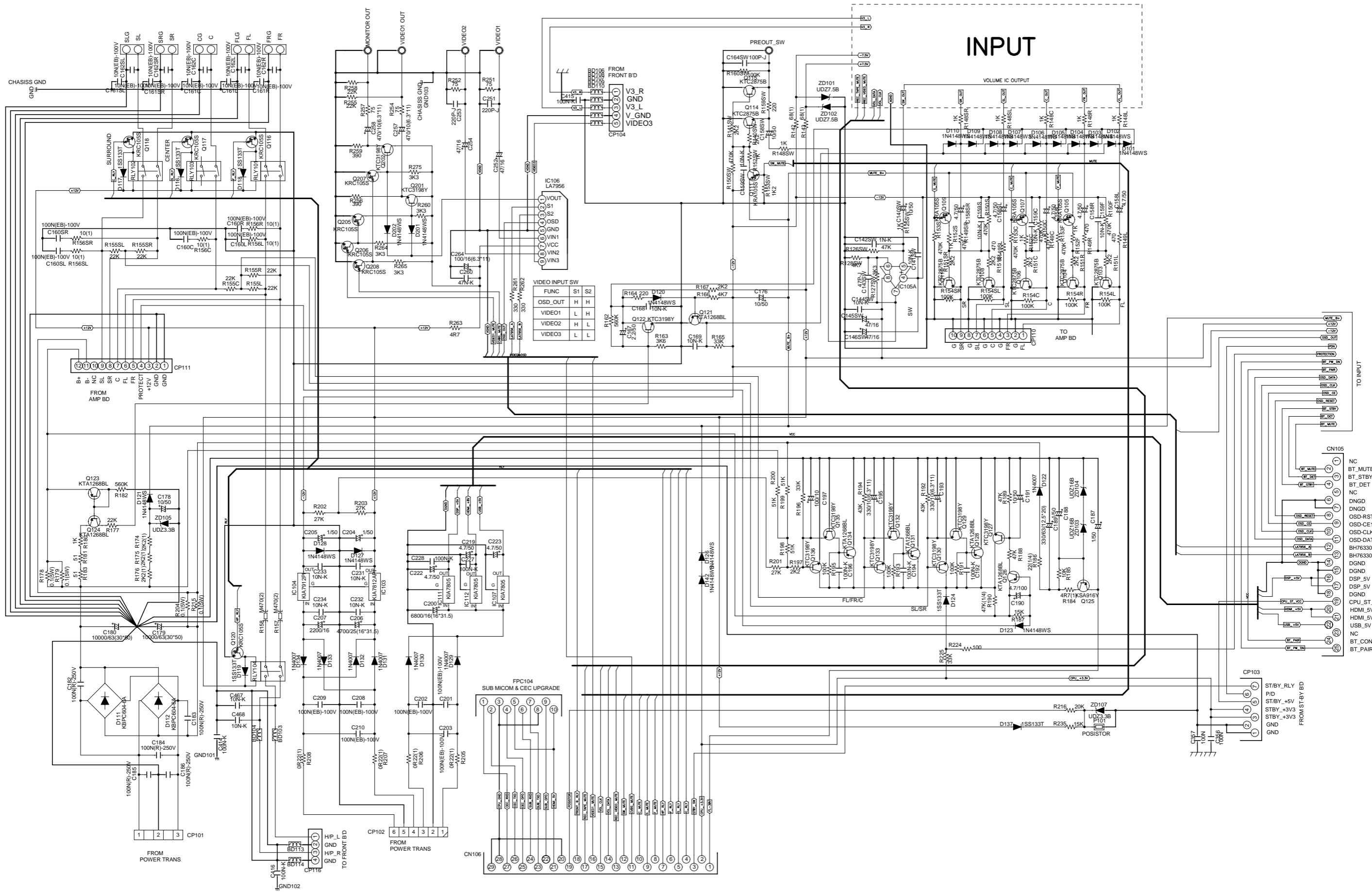

# AVR700 INPUT(2/2)

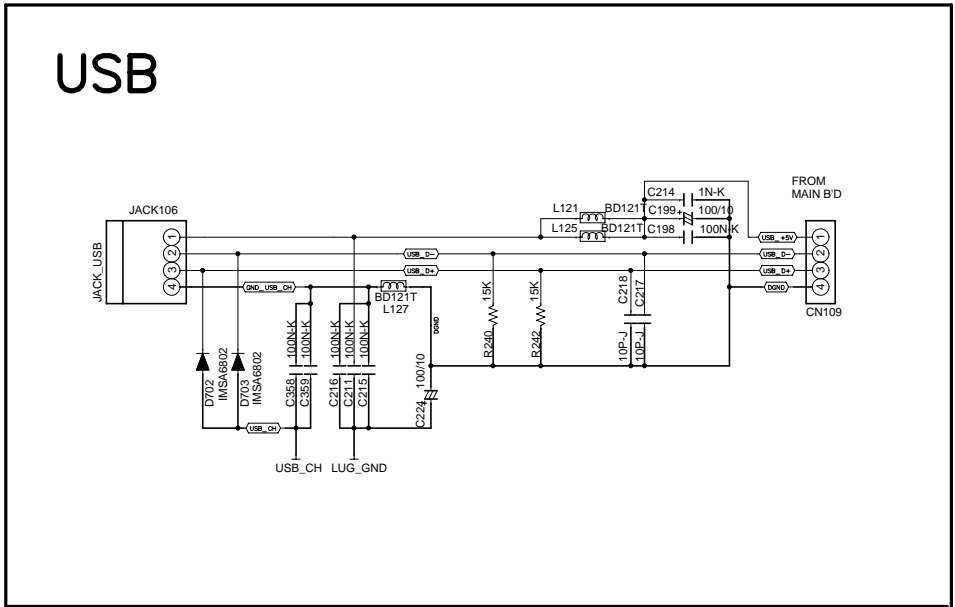
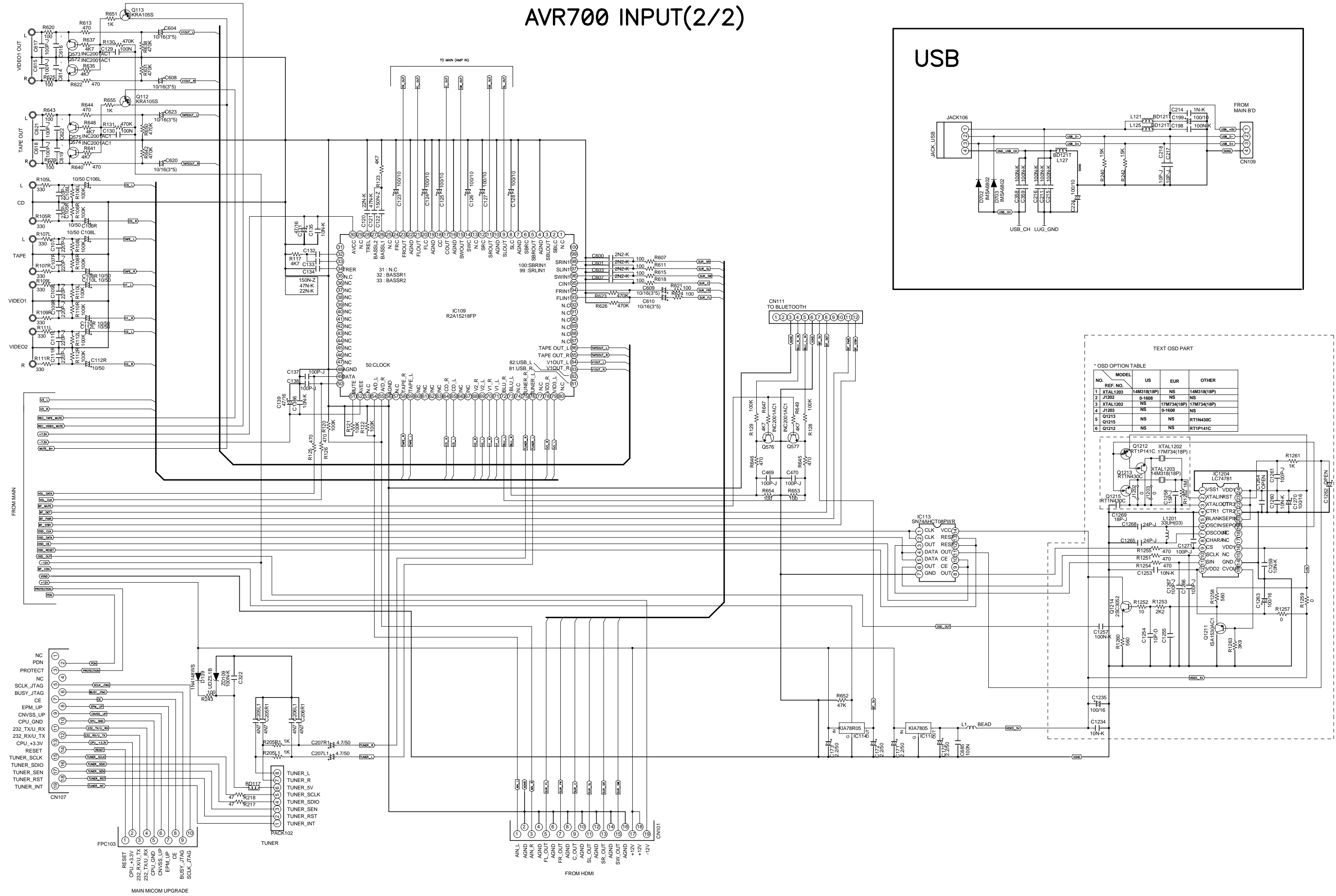

TEXT OSD PART

\* OSD OPTION TABLE

NO.	MODEL	US	EUR	OTHER
1	XTAL1203	14M318(18P)	NS	14M318(18P)
2	J1202	0-1608	NS	NS
3	XTAL1202	NS	17M734(18P)	17M734(18P)
4	J1203	NS	0-1608	NS
5	Q1213	NS	NS	RT1N430C
6	Q1212	NS	NS	RT1P141C

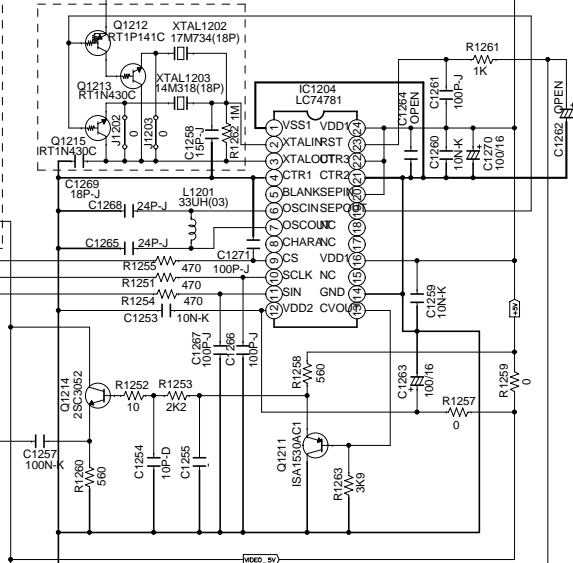

# AVR70/700 HDMI SHEET(1/5)

HDMI\_IN\_DVR  
JACK205

HDMI\_IN\_CD  
JACK201

HDMI\_IN2  
JACK202

HDMI\_OUT  
JACK203

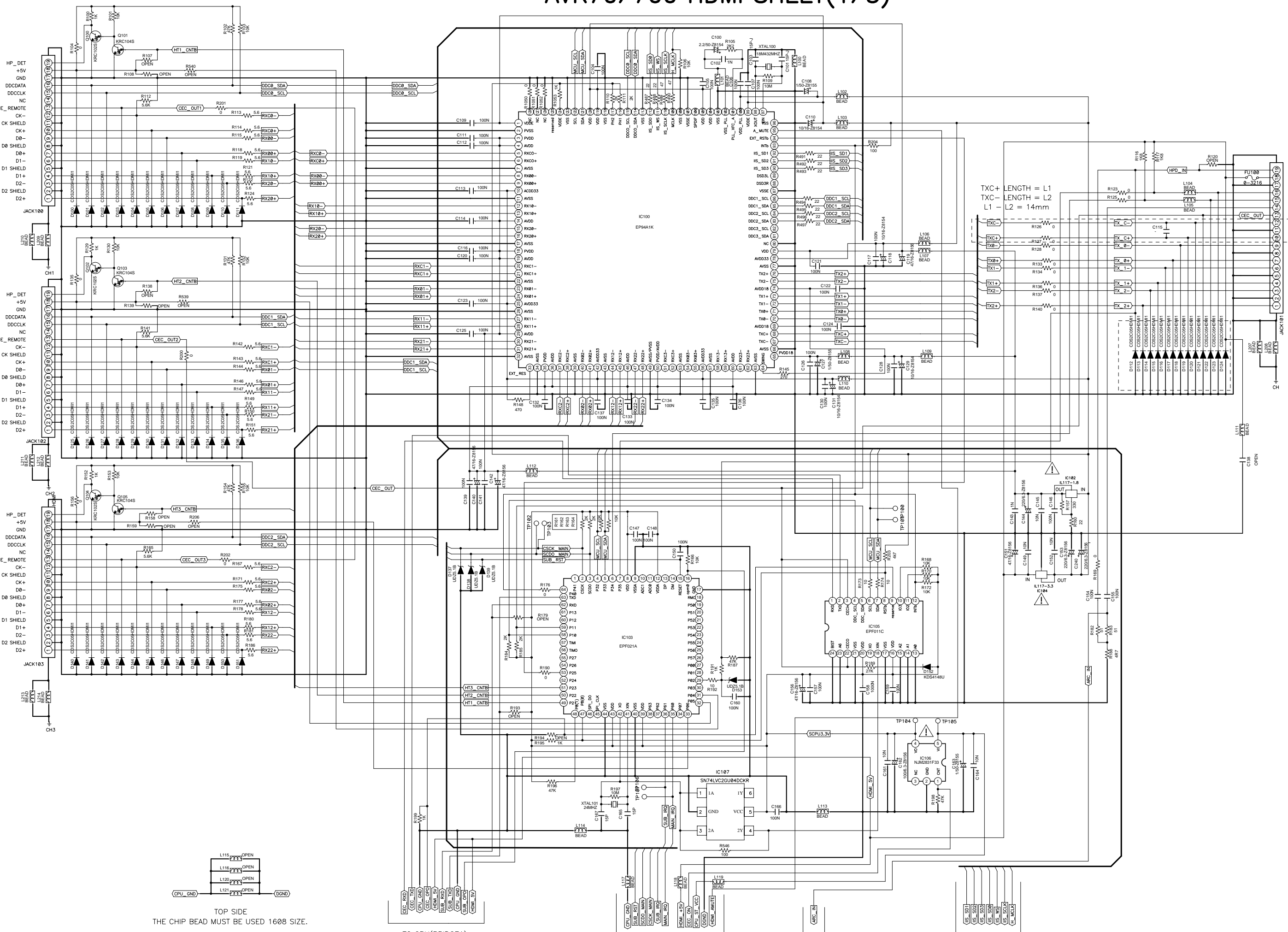

TOP SIDE  
THE CHIP BEAD MUST BE USED 1608 SIZE.

TO CPU(BRIDGE1)

TO CPU

DIGITAL\_IN

TO DSP

# AVR70/700 DIGITAL\_IN SHEET(2/5)

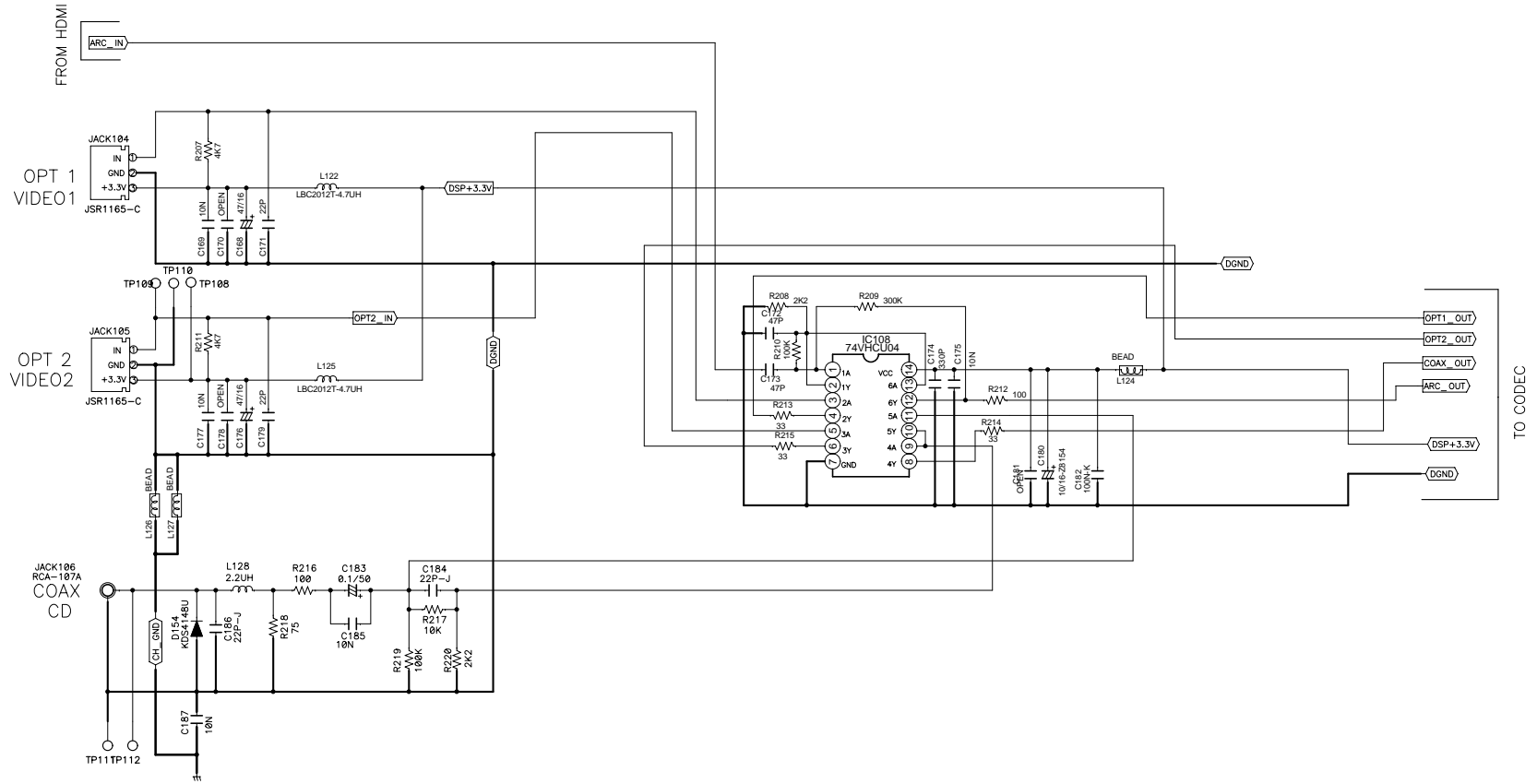

# AVR70/700 CODEC SHEET(3/5)

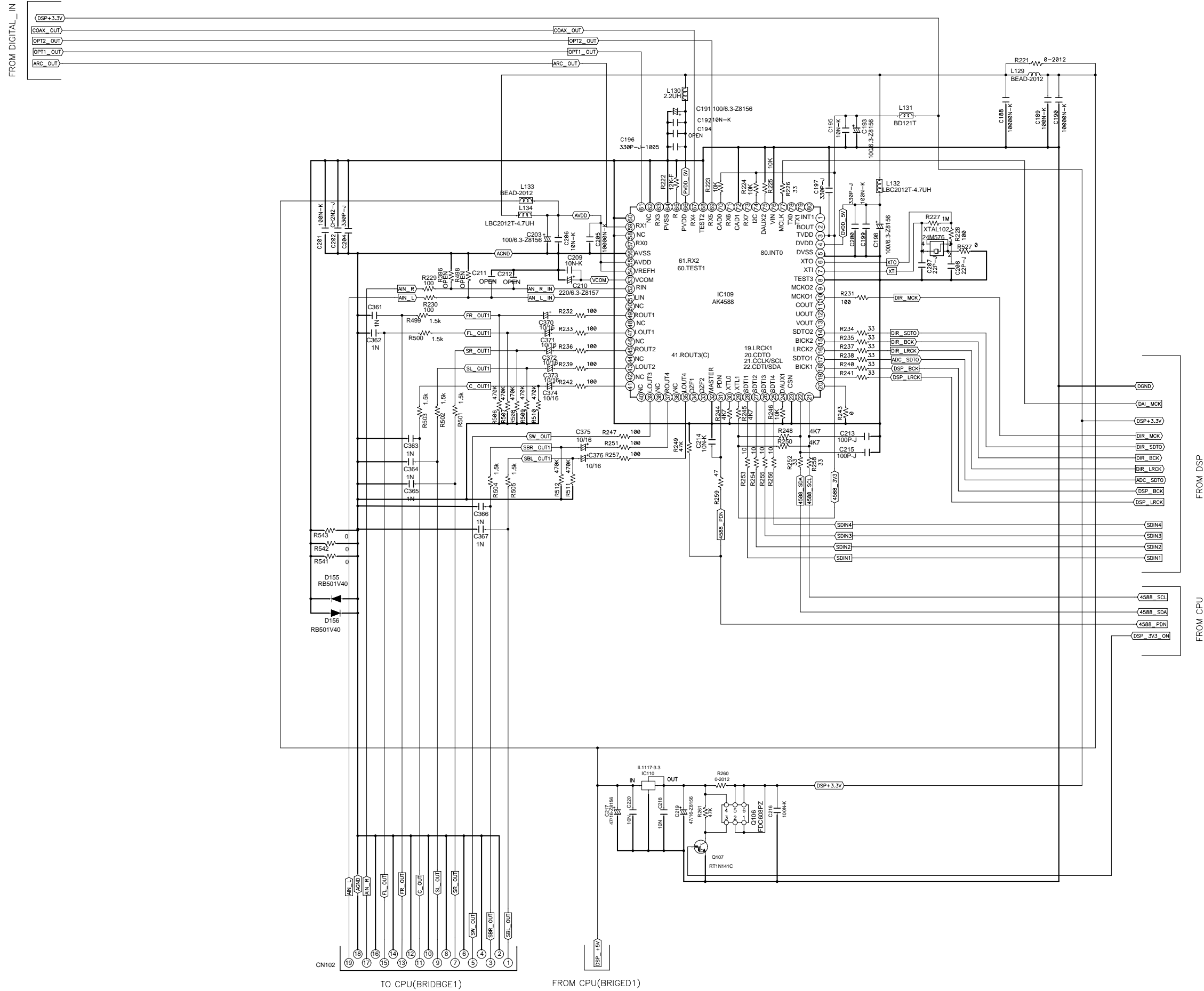

# AVR70/700 DSP SHEET(4/5)

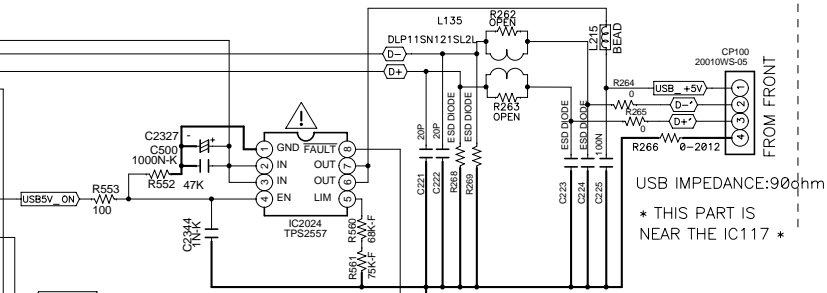
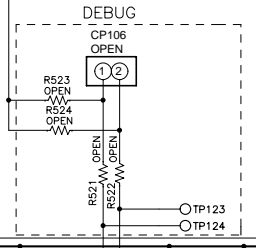
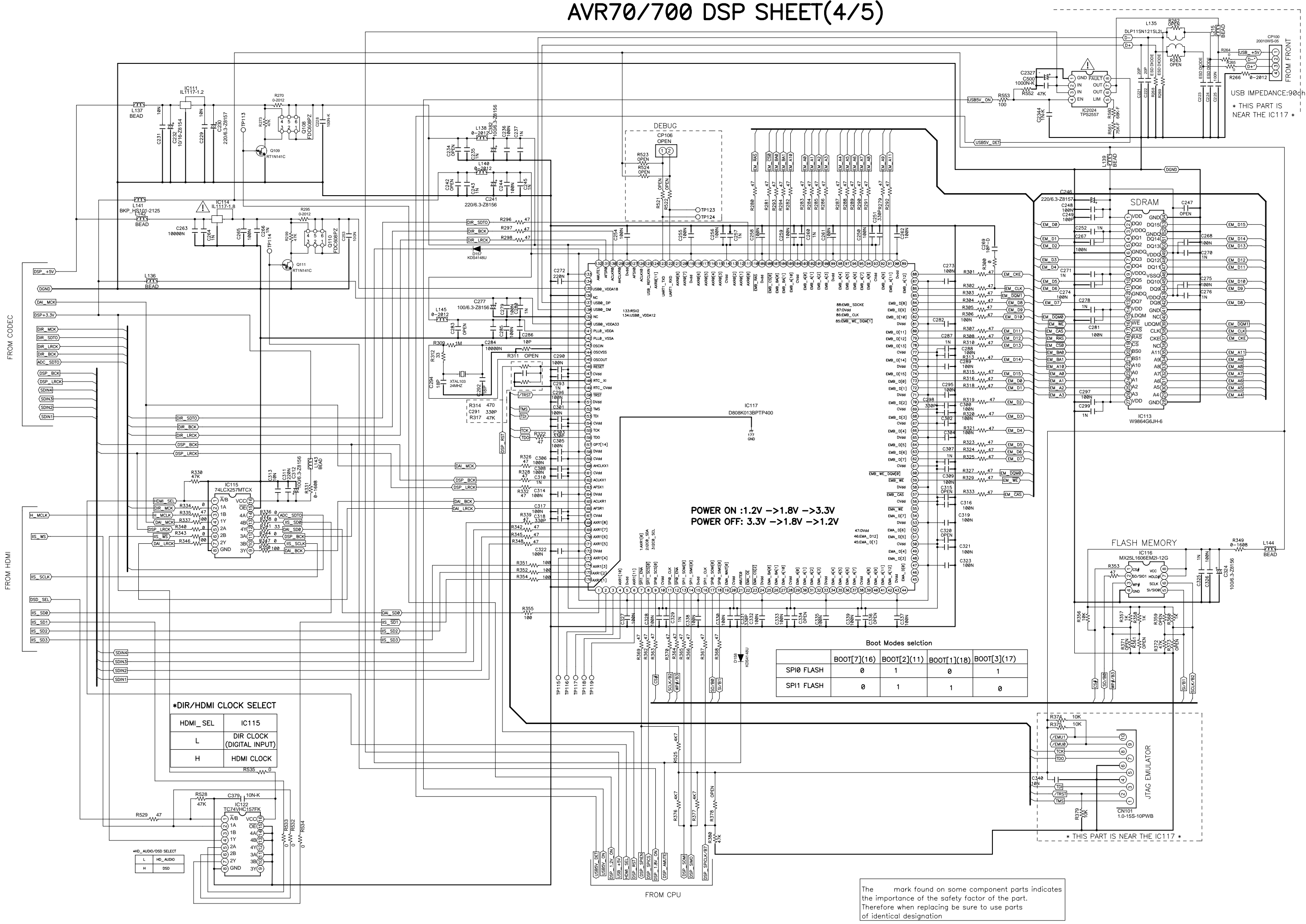

POWER ON : 1.2V -> 1.8V -> 3.3V  
 POWER OFF : 3.3V -> 1.8V -> 1.2V

Boot Modes selection

	BOOT[7](16)	BOOT[2](11)	BOOT[1](18)	BOOT[3](17)
SPI0 FLASH	0	1	0	1
SPI1 FLASH	0	1	1	0

\*DIR/HDMI CLOCK SELECT

HDMI_SEL	IC115
L	DIR CLOCK (DIGITAL INPUT)
H	HDMI CLOCK

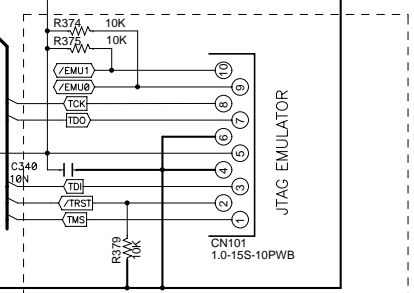

The mark found on some component parts indicates the importance of the safety factor of the part. Therefore when replacing be sure to use parts of identical designation



# AVR70/700 CPU SHEET(5/5)

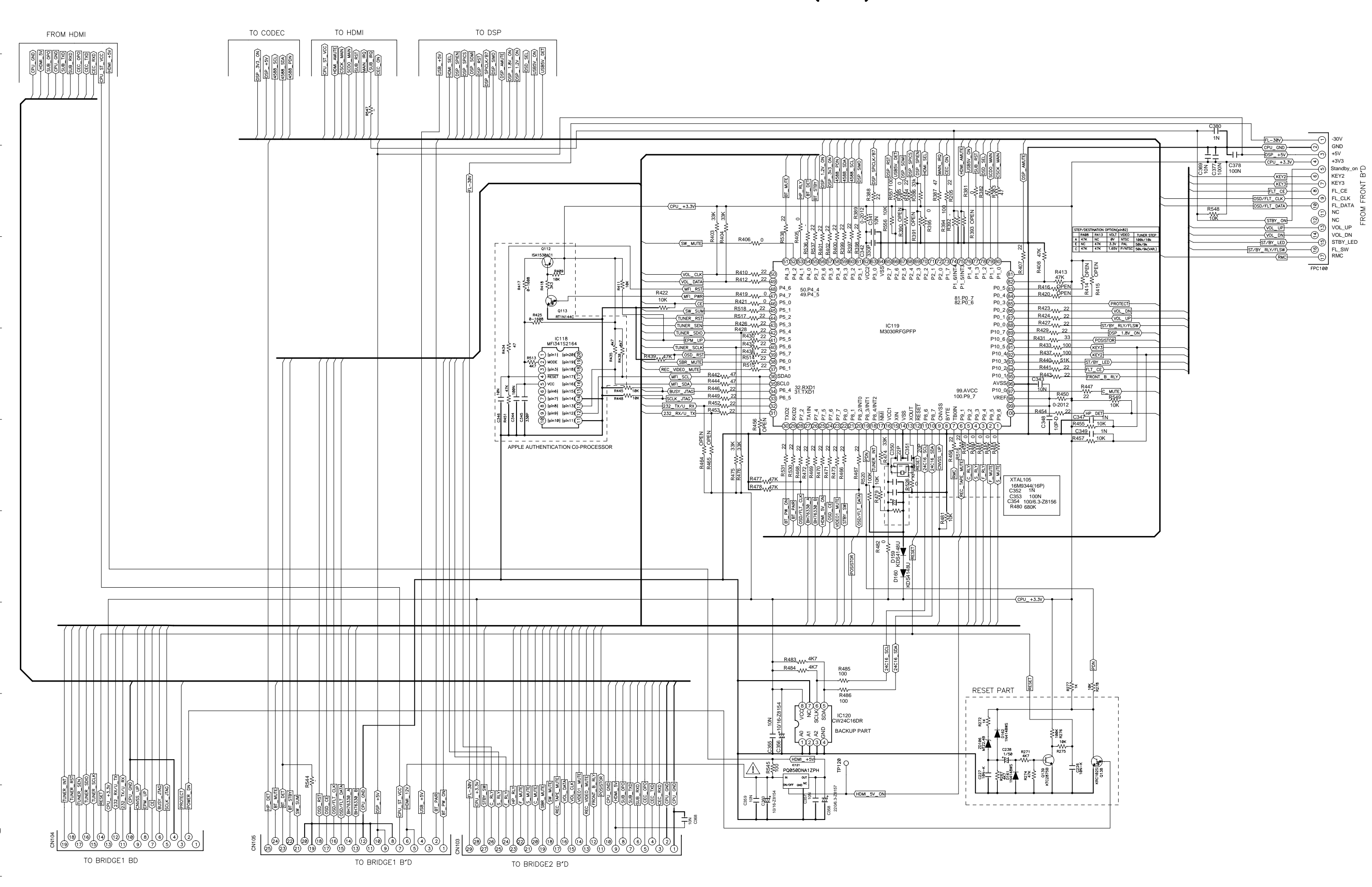

STEP	DESTINATION	OPTION	pin
A	47K	47K	1800/18k
E	47K	47K	3.3V
C	47K	47K	1.65V

XTAL105  
16M0344(16P)  
C352 1N  
C353 100N  
C354 100K 3-Z8156  
R480 680K

