

harman/kardon

AVR75/85

Dolby Digital Audio/Video Receiver

TECHNICAL MANUAL



Harman Consumer Group
250 Crossways Park Drive
Woodbury, N.Y. 11797
1-800 422-8026 in the USA

H A Harman International Company

Rev A 12/99

TABLE OF CONTENTS

ELECTROSTATICALLY SENSITIVE (ES) DEVICES4	AVR78 & AVR85 PACKING EXPLODED VIEW.....52
LEAKAGE TEST4	VOLTAGE AMP PCB - P714.....53
AVR75 & AVR85 FRONT PANEL CONTROLS.....5	AC3/DAC PCB - P60454
AVR75 & AVR85 FRONT PANEL DISPLAY INFORMATION.....7	MAIN PCB -P704.....55
AVR75 & AVR85 REMOTE CONTROL INFO9	AUDIO FUNCTION PCB - PS04, AUDIO/VIDEO PCB - PS54, ELECTRONIC VOLUME CONTROL PCB - PE04, AC-3 CROSSOVER PCB - PC04.....56
AVR75 & AVR85 REAR PANEL CONNECTIONS12	SPEAKER TERMINAL PCB - P754, VIDEO SELECTOR PCB - PL04, CONNECT PCB - PY04.....57
Service Bulletin #9705 for AVR85.....14	S-VIDEO PCB - PL54, 120V TUNER PCB - P104, 120V STANDBY PCB - PB04, 120V SURROUND AMP PCB - PP04, 120V.....58
SERVICE AND ADJUSTMENT16	S-VIDEO PCB - PL54, 230V TUNER PCB - P104, 230V STANDBY PCB - PB04, 230 SURROUND AMP PCB - PP04, 230V.....59
ALIGNMENT AND TEST POINTS.....20	FRONT PCB - PU04, S-VIDEO PCB - PL54, <i>AVR85 ONLY</i> MASTER VOLUME PCB - PU54, SPEAKER PROTECT PCB - PN54, TONE CONTROL PCB - PF04, AUX IN PCB - PL94, POWER SWITCH PCB - PU94, HEADPHONE PCB - PW04.....60
AVR75/85 BLOCK DIAGRAM.....22	INTEGRATED CIRCUIT DIAGRAMS61-71
SPECIFICATIONS.....23	AVR75/85 WIRING DIAGRAM (120V & 230V).....72
AVR75 MECHANICAL EXPLODED VIEW (120V AND 230V).....32	AVR75 (120V) SCHEMATIC DIAGRAM 1 of 8 (FRONT PCB PU04, MASTER VOLUME PCB PU54, AUX IN PL94)73
AVR75 MECHANICAL PARTS LIST (120V & 230V) ...33	AVR75 (120V) SCHEMATIC DIAGRAM 2 of 8 (TUNER PCB P104)74
AVR85 MECHANICAL EXPLODED VIEW (120V AND 230V).....35	AVR75 (120V) SCHEMATIC DIAGRAM 3 of 8 (AUDIO SELECTOR PCB PS04, AUDIO/VIDEO PCB PS54)75
AVR85 MECHANICAL PARTS LIST (120V & 230V) ...36	AVR75 (120V) SCHEMATIC DIAGRAM 4 of 8 (AC-3 CROSSOVER PCB PC04, TONE CONTROL PCB PF04, VIDEO SELECTOR PCB PL04, S-VIDEO PCB PL54)76
AVR75/85 ELECTRICAL PARTS LISTS38	AVR75 (120V) SCHEMATIC DIAGRAM 5 of 8 (CONNECT PCB PY04).....77
GENERAL MISCELLANEOUS.....38	
PCB - PB04, Standby.....38	
PCB - PC04, AC-3 Crossover.....38	
PCB - PW04, Headphone39	
PCB PU04, Front.....39	
PCB - PL94, Aux In.....40	
PCB -PU54, Master Volume40	
PCB - P72440	
PCB - P73441	
PCB - P74441	
PCB - P714, Voltage Amp41	
PCB - PP04, Surround Amp42	
PCB - PN54, Speaker Protect.....42	
PCB - P604 AC-3/DAC43	
PCB - PU94, Power Switch.....44	
PCB - P704, Main.....44	
PCB - PS04, Audio Funtion46	
PCB - P754, Speaker Terminal.....46	
PCB - PS54, Audio Video46	
PCB - PY04, Connect47	
PCB - PF04, Tone Control.....48	
PCB - P104, Tuner48	
PCB - P104 Tuner (230v) Discrepancy List49	
PCB - PE04, Electronic Volume Control.....50	
PCB - PL54, S-Video51	
PCB - PL04, Video Selector.....51	

AVR75 (120V) SCHEMATIC DIAGRAM 6 of 8 (VOLTAGE AMP PCB - P714, MAIN PCB - P704, SURROUND AMP PCB - PP04, SPEAKER TERMINAL PCB - P754, HEADPHONE PCB - PW04, SPEAKER PROTECT PCB - PN54, STANDBY PCB - PB04, POWER SWITCH PCB - PU94).....	78	TONE CONTROL PCB - PF04, VIDEO SELECTOR PCB - PL04, S-VIDEO PCB - PL54).....	91
AVR75 (120V) SCHEMATIC DIAGRAM 7 of 8 (ELECTRONIC VOLUME PCB - PE04)	79	AVR85 (120V) SCHEMATIC DIAGRAM 5 of 8 (CONNECT PCB - PY04)	92
AVR75 (120V/230V) SCHEMATIC DIAGRAM 8 of 8 (AC-3/DSP PCB - P604).....	80	AVR85 (120V) SCHEMATIC DIAGRAM 6 of 8 (VOLTAGE AMP PCB - P714, MAIN PCB - P704, SURROUND AMP PCB - PP04, SPEAKER TERMINAL - P754, HEADPHONE PCB - PW04, SPEAKER PROTECT PCB - PN54, STANDBY PCB - PB04, POWER SWITCH PCB - PU94)	93
AVR75 (230V) SCHEMATIC DIAGRAM 1 of 7 (FRONT PCB - PU04, MASTER VOLUME PCB - PU54, AUX IN - PL94)	81	AVR85 (120V) SCHEMATIC DIAGRAM 7 of 8 (ELECTRONIC VOLUME PCB - PE04)	94
AVR75 (230V) SCHEMATIC DIAGRAM 2 of 7 (TUNER PCB - P104).....	82	AVR85 (120V & 230v) SCHEMATIC DIAGRAM 8 of 8 (AVR85 DSP BOARD - P604).....	95
AVR75 (230V) SCHEMATIC DIAGRAM 3 of 7 (AUDIO SELECTOR PCB - PS04, AUDIO/VIDEO PCB - PS54).....	83	AVR85 (230V) SCHEMATIC DIAGRAM 1 of 8 (FRONT PCB - PU04, MASTER VOLUME PCB - PU54, AUX IN - PL94)	96
AVR75 (230V) SCHEMATIC DIAGRAM 4 of 7 (AC-3 CROSSOVER PCB - PC04, TONE CONTROL PCB - PF04, VIDEO SELECTOR PCB - PL04, S-VIDEO PCB - PL54).....	84	AVR85 (230V) SCHEMATIC DIAGRAM 2 of 8 (TUNER PCB - P104).....	97
AVR75 (230V) SCHEMATIC DIAGRAM 5 of 7 (CONNECT PCB PY04).....	85	AVR85 (230V) SCHEMATIC DIAGRAM 3 of 8 (AUDIO SELECTOR PCB - PS04, AUDIO/VIDEO PCB PS54)	98
AVR75 (230V) SCHEMATIC DIAGRAM 6 of 7 (VOLTAGE AMP PCB - P714, MAIN PCB - P704, SURROUND AMP PCB - PP04, SPEAKER TERMINAL - P754, HEADPHONE PCB - PW04, SPEAKER PROTECT PCB - PN54, STANDBY PCB - PB04, POWER SWITCH PCB - PU94)	86	AVR85 (230V) SCHEMATIC DIAGRAM 4 of 8 (AC-3 CROSSOVER PCB - PC04, TONE CONTROL PCB - PF04, VIDEO SELECTOR PCB - PL04, S-VIDEO PCB PL54)	99
AVR75 (230V) SCHEMATIC DIAGRAM 7 of 7 ELECTRONIC VOLUME CONTROL PCB, PE04.....	87	AVR85 (230V) SCHEMATIC DIAGRAM 5 of 8 (CONNECT PCB PY04).....	100
AVR85 (120V) SCHEMATIC DIAGRAM 1 of 8 (FRONT PCB - PU04, MASTER VOLUME PCB - PU54, AUX IN - PL94).....	88	AVR85 (230V) SCHEMATIC DIAGRAM 6 of 8 (VOLTAGE AMP PCB - P714, MAIN PCB - P704, SURROUND AMP PCB - PP04, SPEAKER TERMINAL - P754, HEADPHONE PCB - PW04, SPEAKER PROTECT PCB - PN54, STANDBY PCB - PB04, POWER SWITCH PCB - PU94).....	101
AVR85 (120V) SCHEMATIC DIAGRAM 2 of 8 (TUNER PCB - P104).....	89	AVR85 (230V) SCHEMATIC DIAGRAM 7 of 8 (ELECTRONIC VOLUME PCB PE04)	102
AVR85 (120V) SCHEMATIC DIAGRAM 3 of 8 (AUDIO SELECTOR PCB - PS04, AUDIO/VIDEO PCB - PS54).....	90		
AVR85 (120V) SCHEMATIC DIAGRAM 4 of 8 (AC-3 CROSSOVER PCB - PC04,			

ELECTROSTATICALLY SENSITIVE (ES) DEVICES

Some semiconductor (solid state) devices can be damaged easily by static electricity. Such components commonly are called Electrostatically Sensitive (ES) Devices. Examples of typical ES devices are integrated circuits and some field effect transistors and semiconductor "chip" components. The following techniques should be used to help reduce the incidence of component damage caused by static electricity.

1. Immediately before handling and semiconductor component or semiconductor-equipped assembly, drain off any electrostatic charge on your body by touching a known earth ground. Alternatively, obtain and wear a commercially available discharging wrist strap device, which should be removed for potential shock reasons prior to applying power to the unit under test.

2. After removing an electrical assembly equipped with ES devices, place the assembly on a conductive surface such as aluminum foil, to prevent electrostatic charge buildup or exposure of the assembly.

3. Use only a grounded-tip soldering iron to solder or unsolder ES devices.

4. Use only an anti-static solder removal device. Some solder removal devices not classified as "anti-static" can generate electrical charges sufficient to damage ES devices.

5. Do not use freon-propelled chemicals. These can generate electrical charge sufficient to damage ES devices.

6. Do not remove a replacement ES device from its protective package until immediately before you are ready to install it. (Most replacement ES devices are packaged with leads electrically shorted together by conductive foam, aluminum foil or comparable conductive material.)

7. Immediately before removing the protective material from the leads of a replacement ES device, touch the protective material to the chassis or circuit assembly into which the device will be installed.

CAUTION: Be sure no power is applied to the chassis or circuit, and observe all other safety precautions.

8. Minimize bodily motions when handling unpackaged replacement ES devices. (Otherwise harmless motion such as the brushing together of your clothes fabric or the lifting of your foot from a carpeted floor can generate static electricity sufficient to damage an ES device.)

LEAKAGE TEST (FOR SERVICE ENGINEERS IN THE U.S.A.)

Before returning the unit to the user, perform the following safety checks:

1. Inspect all lead dress to make certain that leads are not pinched or that hardware is not lodged between parts in the unit.

2. Be sure that any protective devices such as nonmetallic control knobs, insulating fishpapers, cabinet backs, adjustment and compartment covers or shields, isolation resistor-capacity networks, mechanical insulators, etc. which were removed for servicing are properly reinstalled.

3. Be sure that no shock hazard exists; check for leakage current using Simpson Model 229 Leakage Tester, standard equipment item No. 21641, RCA Model WT540A or use alternate method as follows: Plug the power cord directly into a 120-volt AC receptacle (do not use an Isolation Transformer for this test). Using two clip leads, connect a 1500 Ohm, 10-watt resistor parallel by a 0.15 F capacitor, in series with all exposed metal cabinet parts and a known earth ground, such as a water pipe or conduit. Use a VTVM or VOM with 1000 Ohms per volt, or higher sensitivity to measure the AC voltage drop across the resistor. (See Diagram.) Move the resistor connection to each exposed metal part having a return path to the chassis (antenna, metal, cabinet, screw heads, knobs and control shafts, escutcheon, etc.) and measure the AC voltage drop across the resistor. (This test should be performed with the power switch in both the On and Off positions.)

A reading of 0.35 volt RMS or more is excessive and indicates a potential shock hazard which must be corrected before returning the unit to the owner.

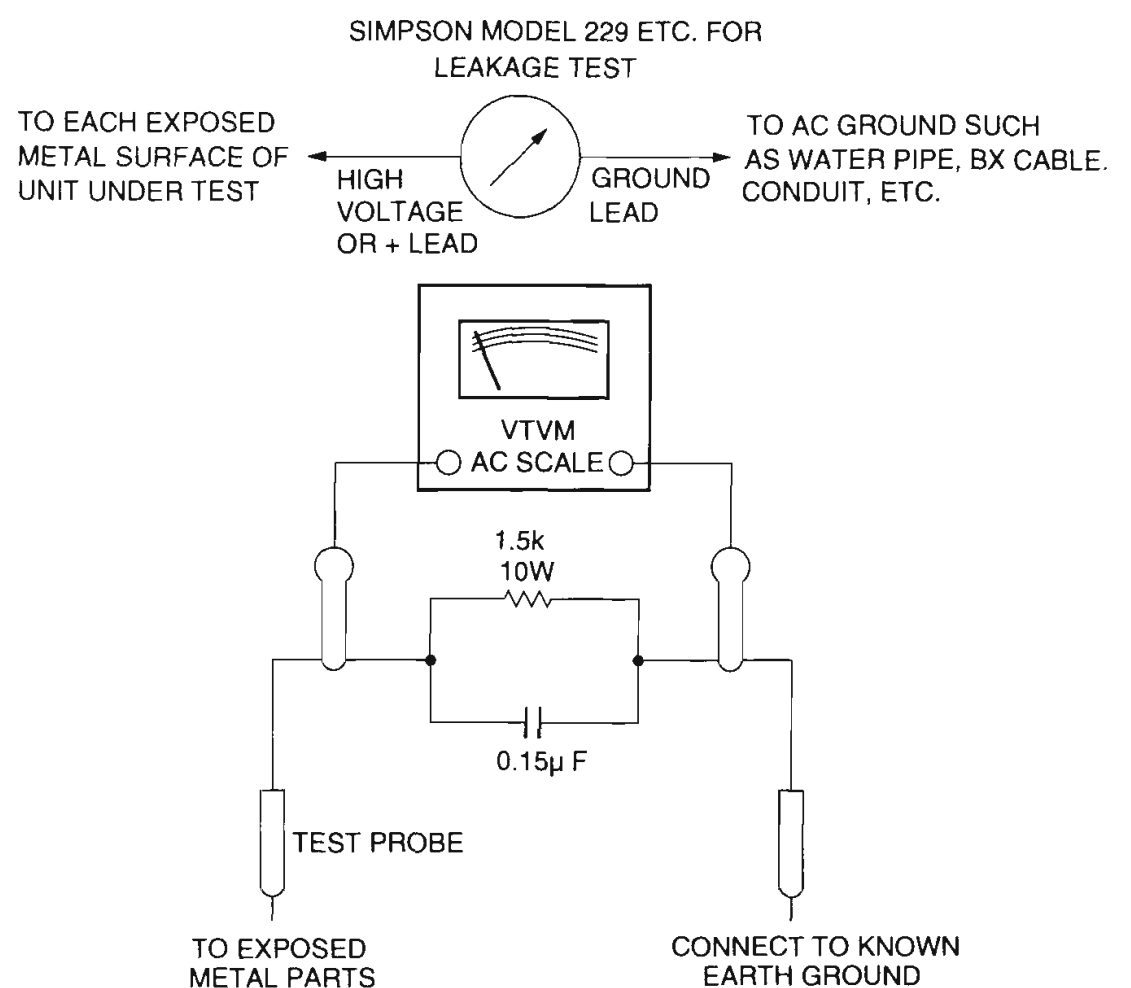

AVR75 & AVR85 FRONT PANEL CONTROLS

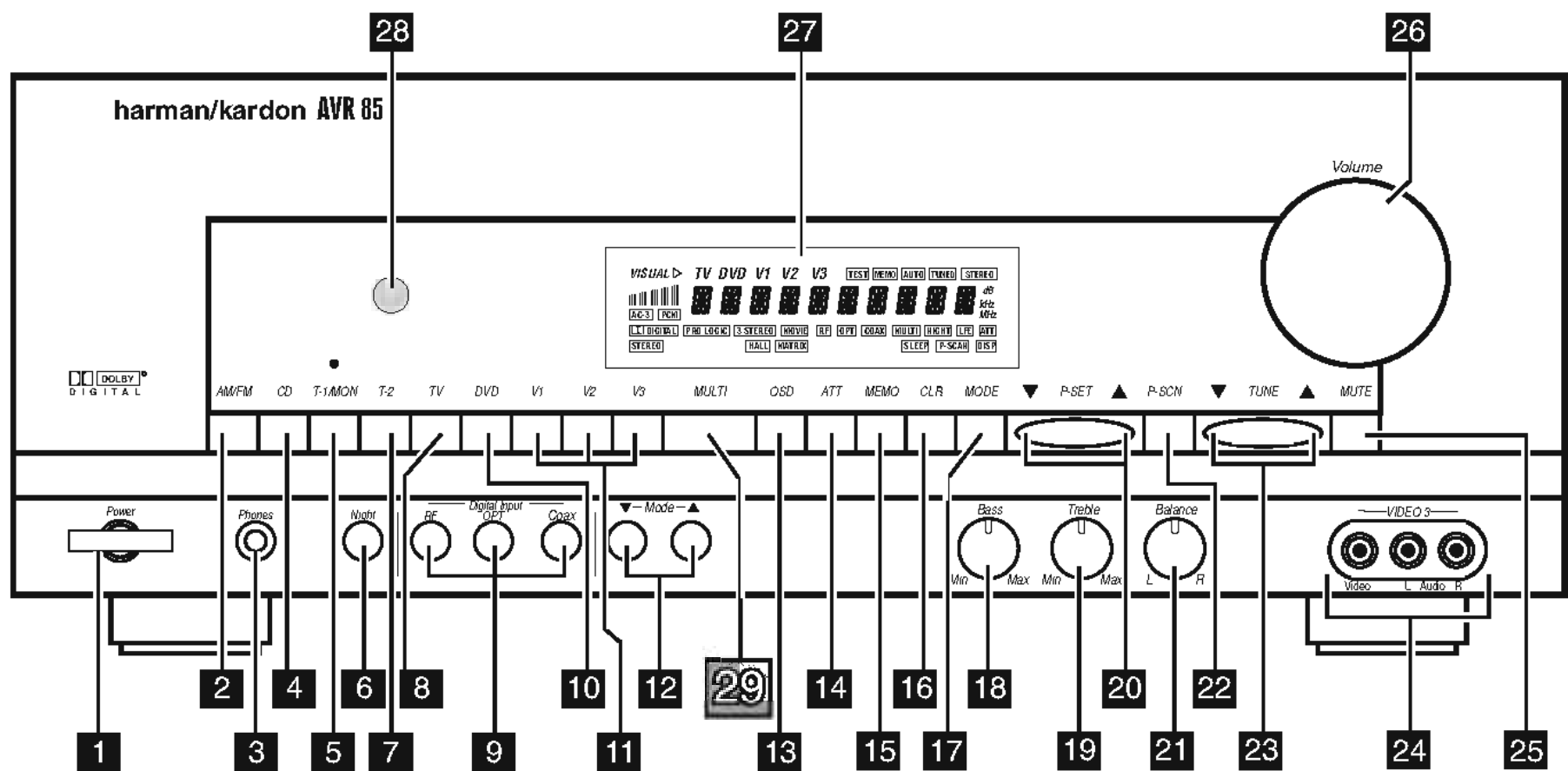
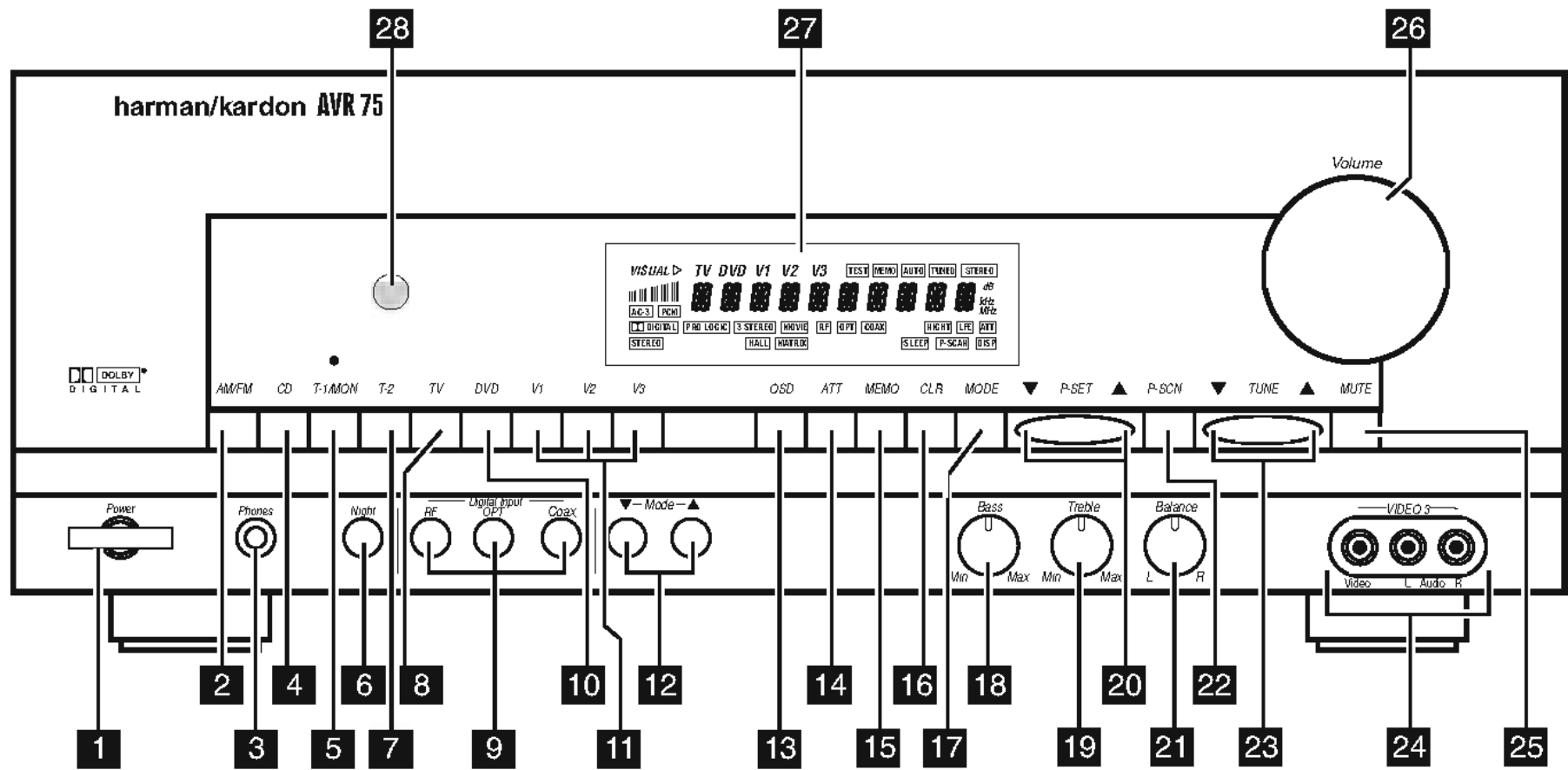

1. Power: Press this button once to turn the unit on and off. Once the unit is turned on, it may be turned off and then on again from the remote, if desired.

NOTE: When the remote is used to turn the unit off the LED surrounding the Power Switch will turn amber, indicating that the AVR75/85 is in a Standby mode. In this condition the unit is NOT disconnected from the AC main power supply.

2. AM/FM Tuner Selector: Press this button once to select the tuner. Press it again to switch between AM and FM.

3. Headphone Jack: Plug standard stereo headphones into this jack for private listening.

NOTE: When the headphones are in use the output to the speakers is muted and the surround mode is automatically switched to STEREO. When the headphones are removed from the jack, sound to the speakers is restored and the unit returns to the previous sound mode.

- 4. CD:** Press this button to select the CD player.
- 5. Tape 1/Monitor:** Press this button to select Tape One as the input source. A red LED above the button will illuminate to indicate that the Tape Monitor has been selected.
- 6. Night Mode:** Press this button to activate the "Night" mode, preventing loud playback when the digital modes are in use.
- 7. Tape 2:** Press this button to select tape 2 input.
- 8. TV Input:** Press this button to select the source connected to the **TV Input (38)**.
- 9. Digital input Selectors:** Press one of these buttons to select a digital input source. The digital audio source may be the same as, or different from, the analog audio of the selected video source.
- 10. DVD Input:** Press this button to select the source connected to the **DVD Input (37)**. Note that the DVD or LV player's digital audio output is used, it must be selected separately using the **Digital Input Selectors (9)**.
- 11. Video Sources:** Press any of these buttons to select a video input source.
- 12. Mode:** Press these buttons to scroll up or down through the list of available surround modes.
- 13. OSD (On-Screen Display):** Press this button to activate the Attenuation mode which cuts the analog input signal by 50% to compensate for high-level input sources.
- 14. ATT Attenuation Mode Select:** Press this button to activate the Attenuation Mode which cuts the analog input signal by 50% to compensate for high-level input sources.
- 15. Memo:** The memo button is used to enter stations to the tuner's preset memory in either the manual or automatic modes.
- 16. Clear:** The clear button is used to cancel tuning, memory input or when cleaning the unit's memories.
- 17. FM Mode:** Press this button to select the tuning mode for FM stations.
- 18. Bass:** This knob adjusts the tone of low-frequency sounds. Turn it to the right to boost bass frequencies or to the left to cut bass frequencies.
- 19. Treble:** This knob adjusts the tone of high-frequency sounds. Turn it to the right to boost high frequencies or to the left to cut high frequencies.
- 20. P-Set:** Press this button to manually scroll up or down through the FM or AM stations programmed into the receiver's preset memory.
- 21. Balance:** This knob adjusts the balance between the front left and right speakers.
- 22. P-Scan:** Press this button to automatically scan through the FM or AM stations preset into the receiver's memory. Press the button again to stop the scan when the tuner is at the desired station.
- 23. Tune:** Press this button to manually scan up or down through the FM or AM bands.
- 24. Video 3 Input:** Audio or Video sources connected to these jacks may be selected by pressing the **Video Source** button (**11**).
- 25. Mute:** Press this button to cut the output to the speakers. Press it again to return to the previous volume level.
- 26. Volume Control:** Turn the knob clockwise to increase volume, counterclockwise to decrease the volume. Note that approximately two revolutions of the knob are required to go from no output to maximum volume.
- 27. Information Display:** This display delivers messages and status indications to help you operate the receiver. Refer to the separate diagram for complete explanation of the FL display.
- 28. Remote Sensor Window:** The sensor behind this window receives infrared signals from the remote control. Aim the remote at this area and do not block or cover it unless an external remote sensor is installed.
- 29. Multiroom Control:** **NOTE: this feature differentiates the AVR85 from the AVR75. The AVR75 does not have this feature.** Press this button to turn the remote room feed On or Off. The MULTI indicator (D) will light or flash when the remote feed is On. Note that the remote feed will remain On after the main room power is turned Off until it is switched Off by pressing this button again.

AVR75 & AVR85 FRONT PANEL DISPLAY

AVR75 DISPLAY

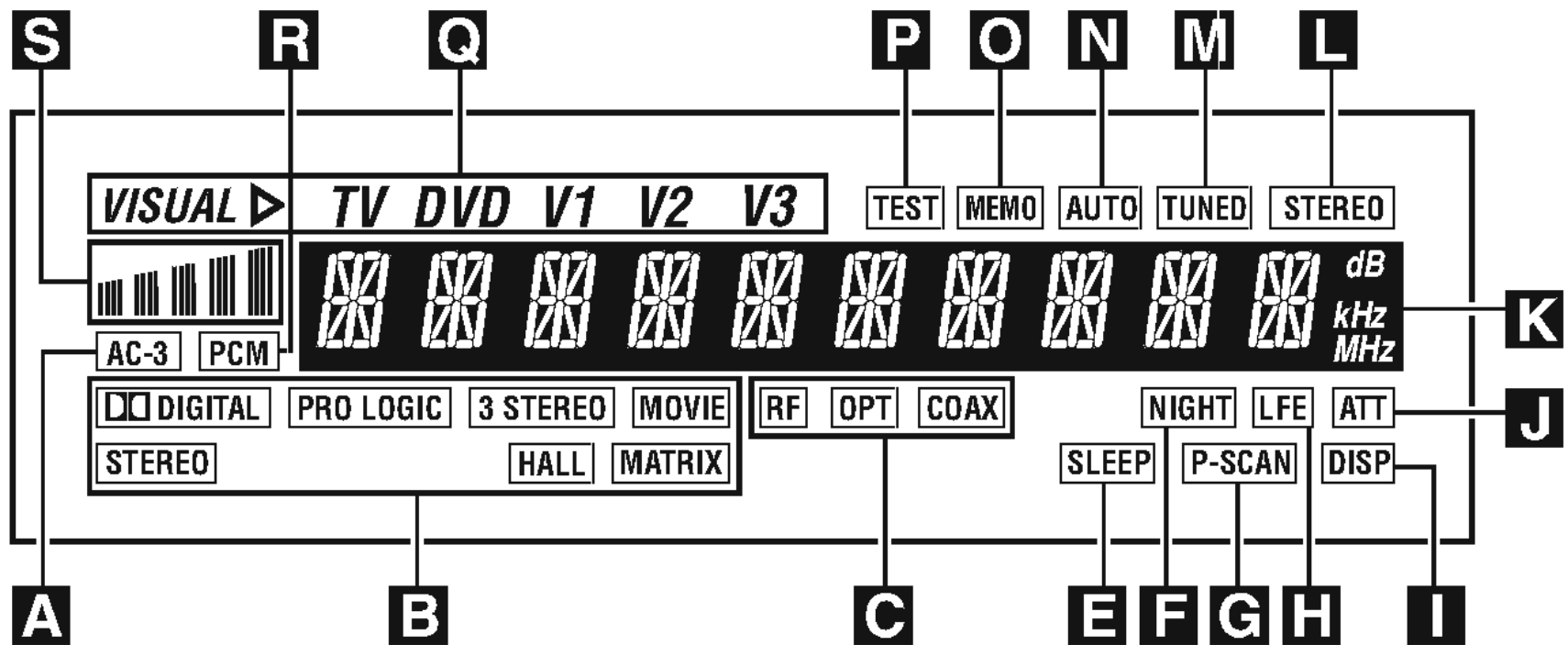

AVR85 DISPLAY

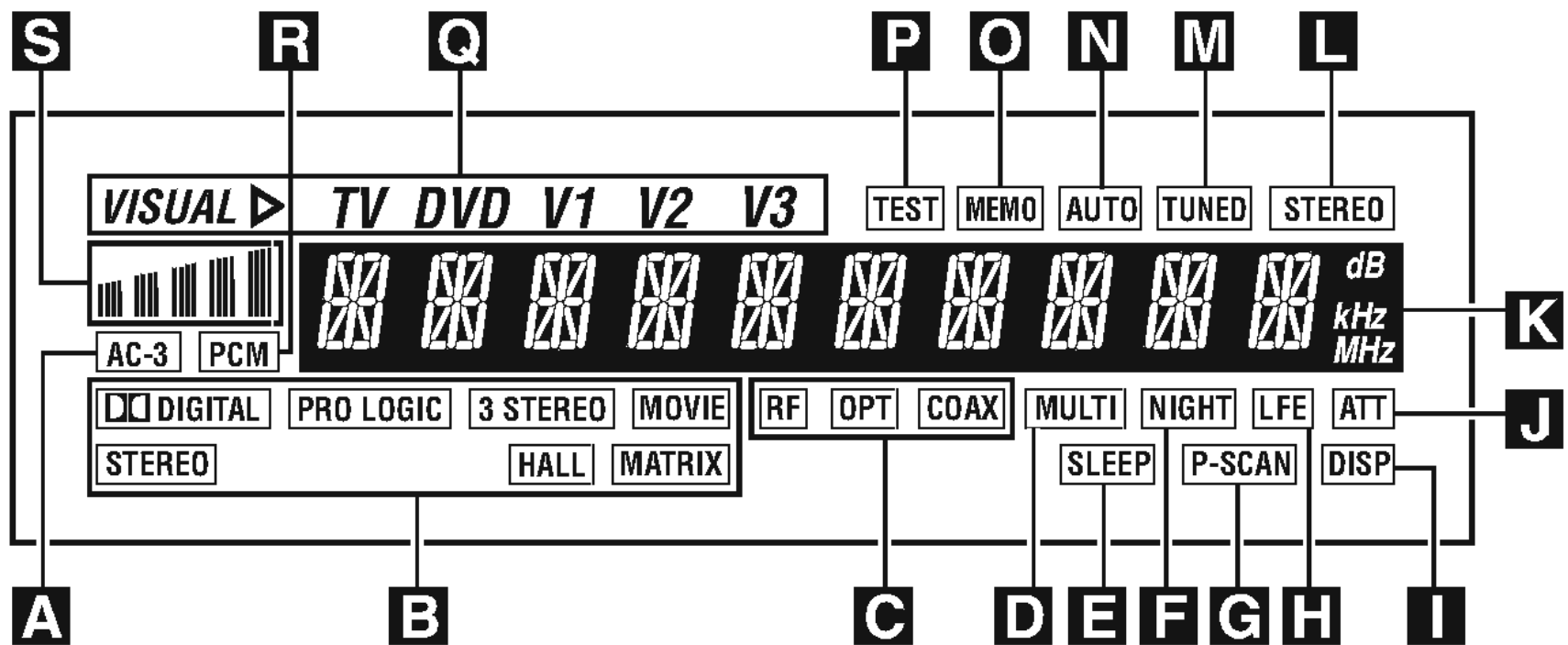

A. AC-3 Indicator: This indicator illuminates when the AVR75 is decoding a Dolby Digital input source.

B. Surround Mode Status: These indicators display the currently selected surround mode.

C. Digital Mode Indicators: These indicators show which digital input is in use.

D. Multi: This indicator signifies that the AVR85 is sending a program source to a remote room location. Note that it may be illuminated even when the unit is "off" in the main listening room, signifying that operation continues at

another location. When a remote command is being received via the **Multi IR connection (59)**, this indicator will flash. **NOTE: this feature differentiates the AVR85 from the AVR75. The AVR75 does not have this feature.**

E. Sleep Indicator: This indicator lights when the AVR75/85 is in the Sleep mode.

F. Night Indicator: This indicator lights when the AVR75/85 is in Night mode, which prevents the AVR75/85 from loud playback when digital sources are in use.

G. P-Scan: This indicator flashes when the stations programmed into the tuner memory are being automatically reviewed.

H. LFE Indicator: This indicator will illuminate when the Low-Frequency Effects (LFE) option has been turned on through the controls in **SETUP MENU 3**.

I. DISP: This indicator lights when the FL display has been turned off using the Display button (16) to remind you that the unit is still turned on.

J. ATT Indicator: This indicator lights when the Attenuation function has been engaged to cut the input from analog sources by approximately 50%.

K. Main Information Display: This ten-digit display shows messages relating to the status, input source, surround mode, tuner, volume level or other aspects of unit's operation.

L. Stereo: This indicator lights when an FM station is broadcasting in stereo.

M. Tuned: This indicator lights when an AM or FM station is properly tuned and locked.

N. Auto: This indicator signifies that the Automatic Tuning mode is in use for FM broadcasts.

O. Memo: This indicator flashes when the **Memo** button is pressed when entering presets and other information into the tuner's memory.

P. Test: This indicator flashes when the output levels are being set using the built-in test signal generator.

Q. "Visual" Indicator: These indicators display which input source is being fed to the video monitor output.

R. PCM Indicator: This indicator illuminates to show that a standard PCM (S/P-DIF) digital audio signal is being decoded by the digital-to-analog converter.





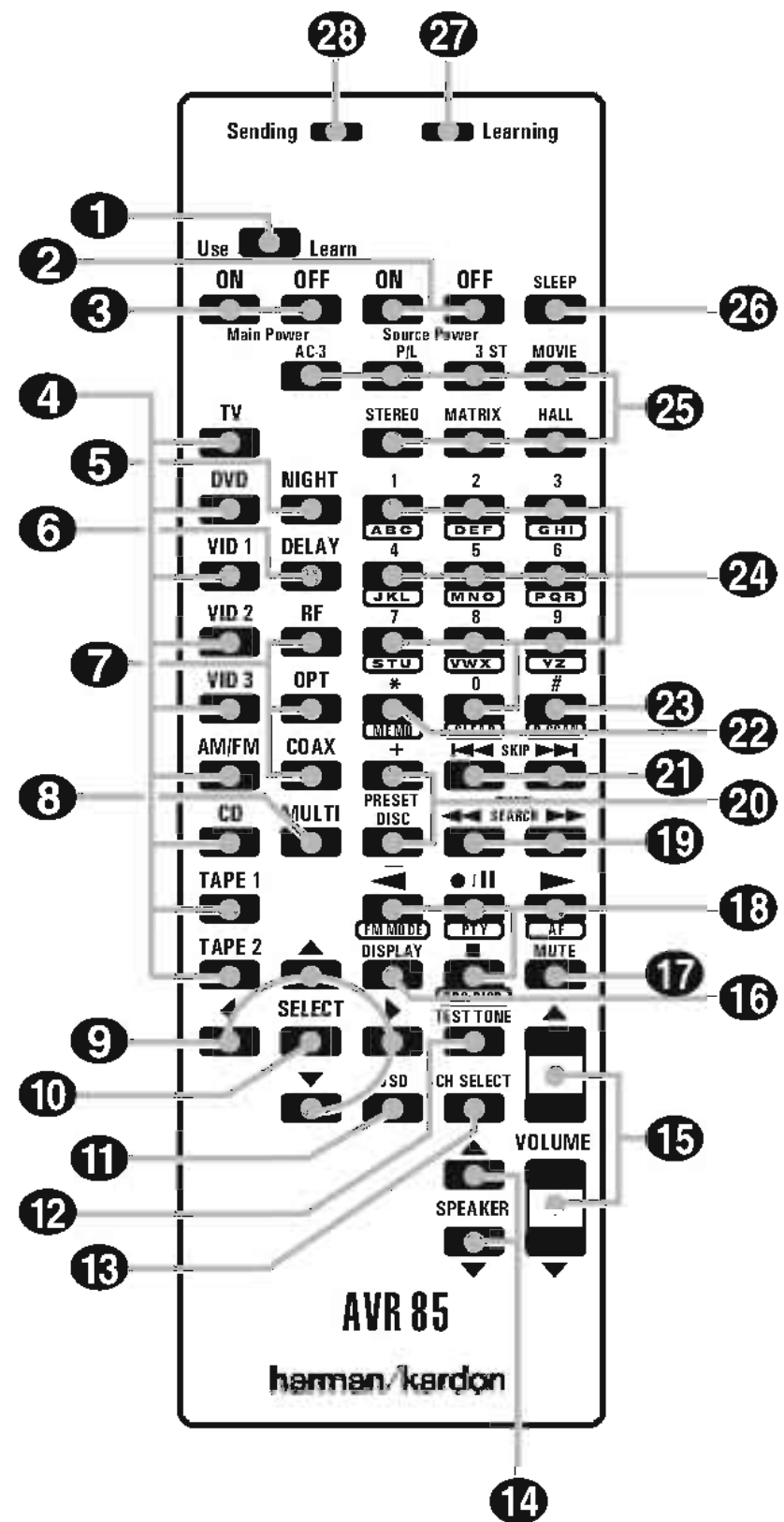
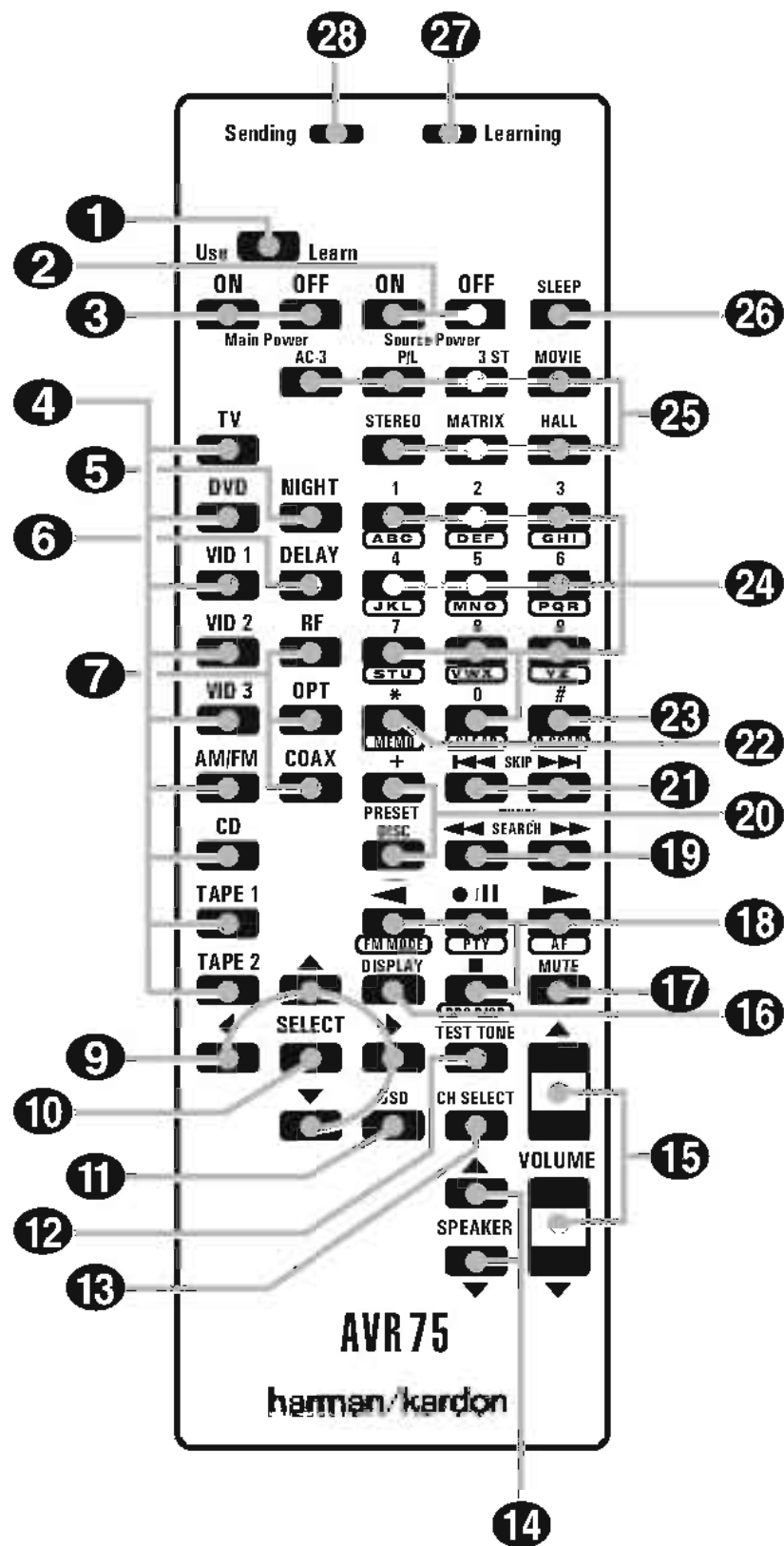





S. Signal Level Indication: This is a visual indication of the strength of a radio station signal. The more bars visible, the stronger the station.

AVR75 & AVR85 REMOTE CONTROL







- | | |
|---------------------------------|---------------------------------|
| 1 Use/Learn | 15 Main Volume |
| 2 Source Power | 16 Display |
| 3 Main Power | 17 Mute |
| 4 Source Selection | 18 Transport Controls |
| 5 Night Mode | 19 Tune/Search and Fast Forward |
| 6 Delay | 20 Preset/Disc |
| 7 Digital Audio Input Selectors | 21 Channel/Skip |
| 8 Multiroom Control | 22 Memo |
| 9 Menu Controls | 23 P-Scan |
| 10 Select | 24 Number Keys |
| 11 OSD | 25 Surround Mode Selection |
| 12 Test Tone | 26 Sleep |
| 13 Channel Select | 27 Learn LED |
| 14 Speaker Level Adjust | 28 Sending LED |





AVR75 & AVR85 REMOTE CONTROL INFORMATION ...continued

- 1. Use/Learn:** This switch selects the operation mode of the remote control. Slide it to the left for normal operation. Slide it to the right when the remote is being programmed.
- 2. Source Power:** When power on/off commands have been programmed into the remote's memory, press these buttons to control power for the last source device selected.
- 3. Main Power:** Press these buttons to turn the unit on or off (to Standby Mode).
- 4. Source Selection:** Pressing one of these buttons selects the input source that will be listened to through the receiver. When a source is selected the remote's transport and numeric number buttons will also transmit the commands needed to control that machine.
- 5. Night Mode:** Press this button to activate the "Night" mode, preventing loud playback when the digital modes are in use without altering the dynamic range of the output signal.
- 6. Delay:** Press this button to change the delay for the surround channels when the Surround Mode Menu is on the screen.
- 7. Digital Audio Input Selectors:** Press one of these buttons to select a digital input source. The digital audio source may be the same as, or different analog audio of the selected video source.
- 8. Multiroom Control:** Press this button to turn the remote room feed on or off. The **Multi** indicator  will light or flash when the remote feed is on. Note that the remote zone feed will remain on after the main room power is turned off until it is switched off by pressing this button again.
- 9. Menu Controls:** These buttons control the action of the cursor or the selection of menu items when the receiver is being configured using the setup menus.
- 10. Select:** This button enters settings to the receiver's memory during system configuration.
- 11. OSD:** Press this button to activate the on-screen menu system.
- 12. Test Tone:** Press this button to begin calibration of the output level for each channel. A test signal will immediately be heard from the left front speaker and the Test indicator  will flash.
- 13. Channel Select:** Press this button to view a status report of the output level for each channel. When the Test Tone is audible and the system output levels are being set, pressing this button will advance the channel being adjusted in a clockwise direction to the next channel.
- 14. Speaker Level Adjust:** When setting the system output levels, press these buttons to increase or decrease the output level.
- 15. Main Volume:** These buttons control the unit's volume. Note that all channels are controlled simultaneously.
- 16. Display:** Press this button to turn off all displays and indicators in the Information Display except for a small Disp indication in the lower right corner of the display . Press the button again to turn the display back on.
- 17. Mute:** Press this button to temporarily cut the audio output of the receiver. Press it again to return to the previous volume level.
- 18. Transport Controls:** These buttons may be programmed to control the tape or disc motion of the last playback source selected with the Source Selection buttons . Use them as you would the Play, Stop, Pause, Record, Reverse Play and Forward Play buttons on any **VCR**, **CD**, cassette, **DVD** or **LD** remote control. The Reverse Play button  also operates the FM Mode function of the AVR75/85's tuner.
NOTE: The /II,  and  buttons are also used to control the PTY, AF and RDS Display functions of the tuner.
- 19. Tune/Search & Fast Forward:** These buttons may be programmed to have multiple functions, which vary according to the input device selected.
 - a. When the TUNER has been selected, these buttons are used to tune stations.
 - b. When **CD**, **Tape**, **DVD**, **LD** or **VCR** is the input source, these buttons act as the Fast Scan Forward  or Fast Scan Reverse  controls.

20. Preset/Disc: These buttons have multiple functions, which may vary according to the input device codes programmed.

- a. When the TUNER has been selected, these buttons will scroll up  or down  through the stations that have been programmed in the preset memory.
- b. When CD is selected and the unit is a CD changer, these buttons will change to the next disc  or previous disc .
- c. When Tape 1 or Tape 2 is the input source, and the tape machine is a compatible Harman Kardon dual cassette deck, these buttons will switch between the "A" and "B" sides.

21. Channel/Skip: These buttons have multiple functions, which vary according to the input device selected and the codes programmed from another remote.

- a. When TV, Vid 1 or Vid 2 are selected, they may function as the channel up  or channel down  tuning buttons when programmed with the codes from another unit's remote.
- b. When CD is selected these buttons act as forward and reverse "Skip" buttons to move to the next track or chapter on the disc.
- c. When a compatible Harman Kardon cassette player has been selected as Tape 1 or Tape 2, these buttons move the tape forward  or backwards  to the next selection using the Music Scan feature.





22. Memo: The memo button is used to enter stations to the tuner's preset memory in either the manual or automatic modes. It is also used in the process of clearing the memory. This button also performs the functions of the "*" symbol on compatible equipment.

23. P-Scan: Press this button to automatically scan through the stations preset into the tuner memory. Press the button again to end the scan when the tuner stops at the desired station. This button also performs the functions of the "#" symbol on compatible equipment.

24. Number Keys: These buttons serve as a ten button numeric keypad to enter tuner preset positions. They are also to be used to select channel numbers when TV has been selected on the remote, or to select track numbers on a CD, DVD or LD player, depending on how the remote has been programmed. The letters below the buttons are used to enter information for tuner station names.



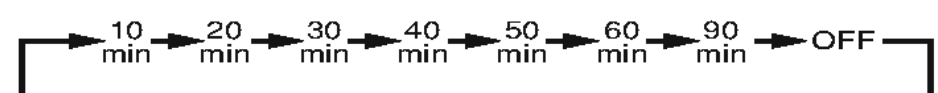

NOTE: The 0 button has a dual function. It also serves as the CLEAR button for use in programming the tuner or clearing the system memory.

25. Surround Mode Selection: Press one of these buttons to select a surround mode for the current listening session.

26. Sleep (AVR75): Press this button when the Sleep timer has previously been activated to view the time remaining before the unit turns off to the Standby Mode. To activate the Sleep function, first put the unit in the Tuner Mode by pressing the AM/FM button . Next, press the Sleep button  and note that the Sleep and Memo indicators   will blink. Within that blinking time press the Memo button  and then press the Sleep button again to set the sleep time in the following order:



When the desired time is shown in the display, press the Memo button  to enter the time. The unit will go into the Standby Mode when the time entered has elapsed.

26. Sleep (AVR85): Pressing this button when the Sleep timer has previously been activated allows you to view the time remaining before the timer function turns the unit off. When the remote is in the AM/FM mode , the Sleep function may also be changed or set by pressing this button so that the Sleep and Memo indicators   blink (timer not yet set) or Sleep time is indicated (timer set already). Within that time press the Memo button  so that both indicators blink slowly. Now press the Sleep button  again to set the desired sleep time in the following order:

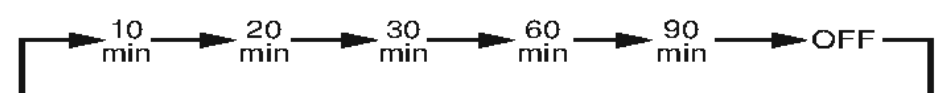

When the desired time is shown in the display, press the Memo button  to enter the time. The unit will go into the Standby Mode when the time entered has elapsed.

27. Learn LED: This indicator will illuminate when a button on the remote is being programmed with signals from another remote during the "learning" mode. The light will go out when the signal is received and memorized.

28. Sending LED: This indicator should flash any time a button is pressed to confirm that a command is being sent to the receiver or another unit. If the light is dim or does not illuminate when a button is pressed the batteries in the remote should be replaced.

AVR75 & AVR85 REAR PANEL CONNECTIONS

AVR75 REAR CONNECTIONS

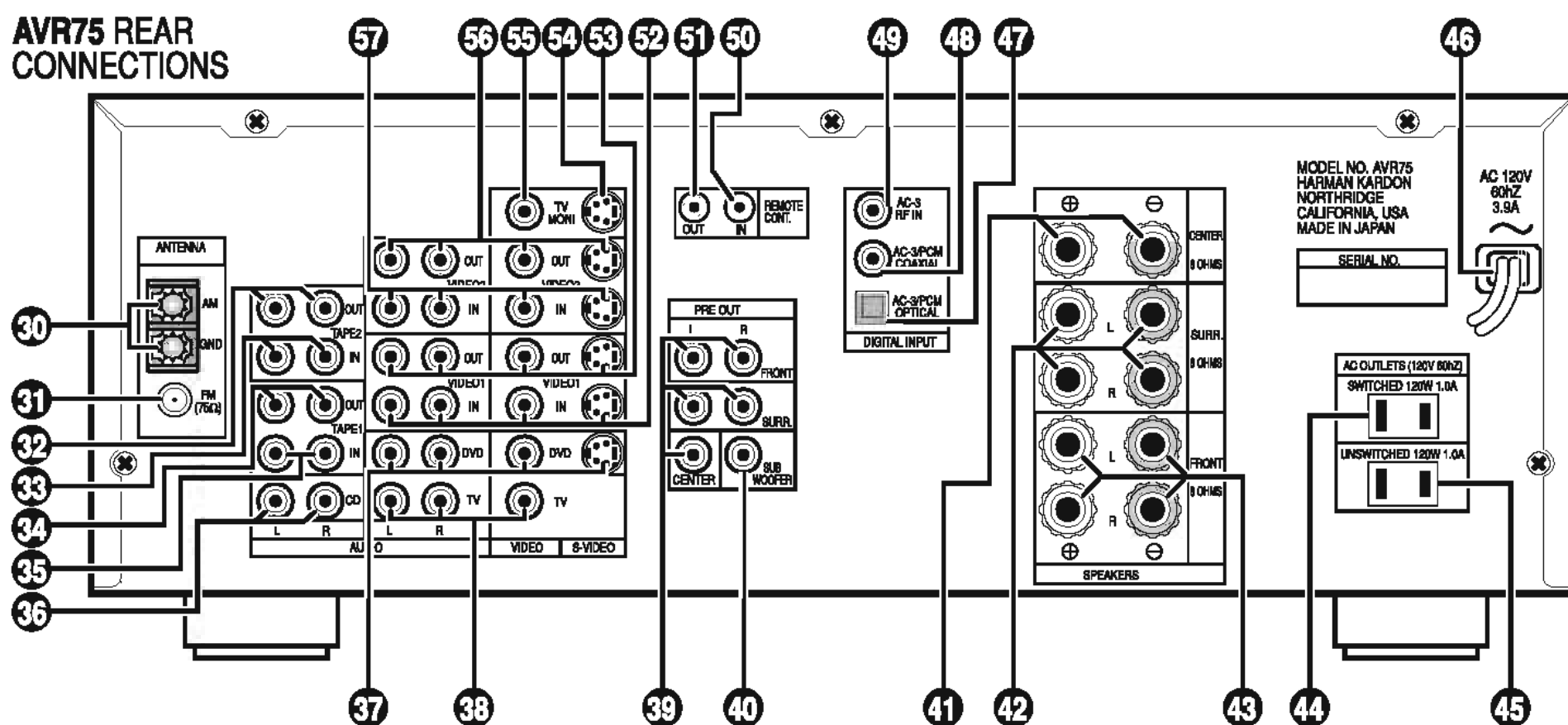

AVR85 REAR CONNECTIONS

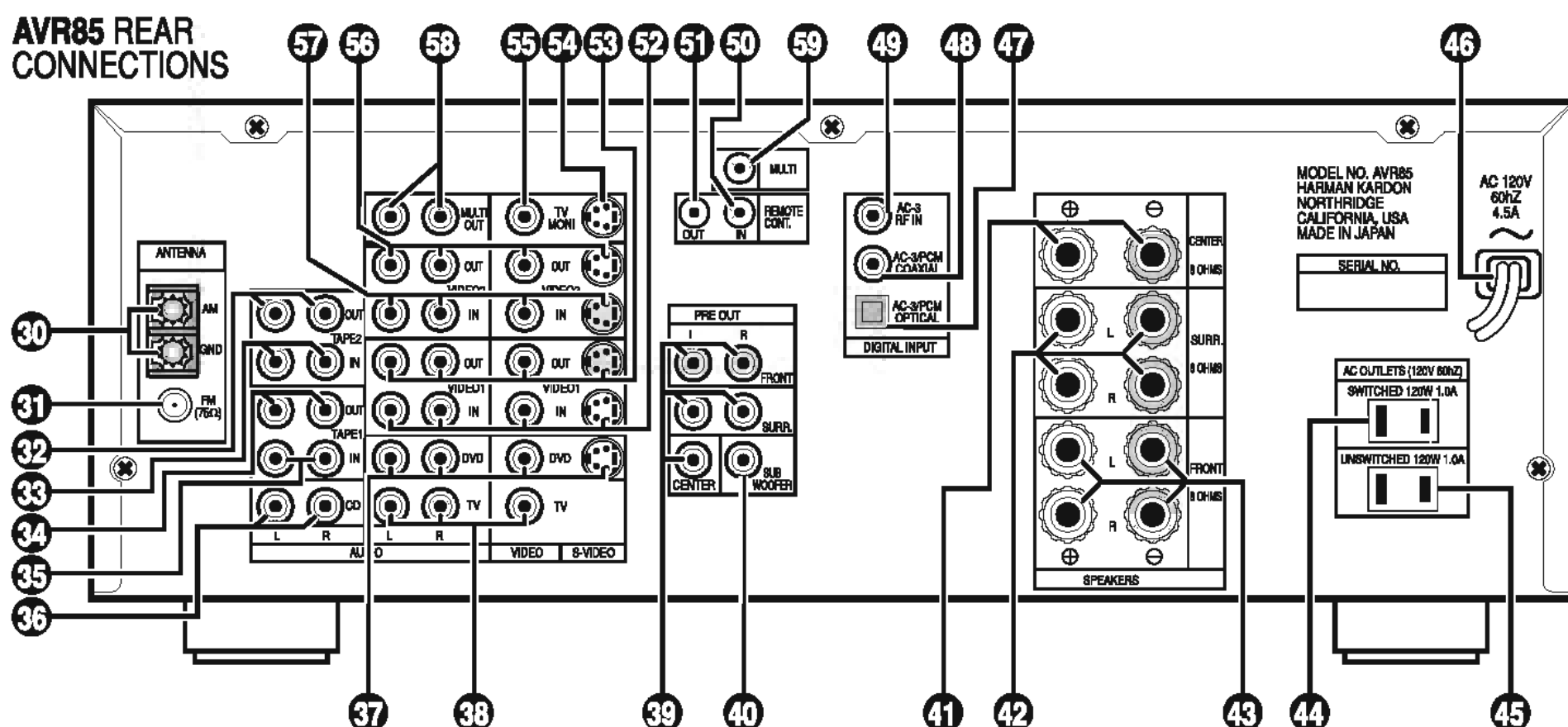

30. AM Antenna: Connect the AM loop antenna supplied with the receiver to these terminals. If an external AM antenna is used, make connections to the **AM** and **GND** terminals in accordance with the instructions supplied with the antenna.

31. FM Antenna: Connect an indoor or external FM antenna to this terminal.

32. Tape 2 Out: Connect these jacks to the RECORD/INPUT jacks of a second audio recorder.

33. Tape 2 In: Connect these jacks to the PLAY/OUT jacks of a second audio recorder.

34. Tape 1 Out: Connect these jacks to the RECORD/INPUT jacks of an audio recorder.

35. Tape 1 In: Connect these jacks to the PLAY/OUT jacks of an audio recorder.

36. CD IN: Connect these jacks to the output of a compact disk player or CD changer.

37. DVD Inputs: Connect the analog audio outputs and composite or S-Video output of a DVD or LV player to these jacks.

38. TV Inputs: Connect these jacks to the audio and video outputs of a TV Tuner, Cable TV converter box, satellite receiver, or any other audio/video source.

39. Pre-Outs: If external power amplifiers are used for any channels, connect them to these jacks.

40. Subwoofer Pre-Out: Connect this jack to the line level input of a powered subwoofer. If an external subwoofer amplifier is used, connect this jack to the subwoofer amplifier input.

41. Center: Connect these terminals to the center speaker.

42. Surround: Connect these terminals to the surround speakers.

43. Front: Connect these terminals to the front speakers.

44. Switched AC Outlet: This outlet may be used to power any device that you wish to have on when the unit is turned on.

45. Unswitched AC Outlet: This outlet, may be used to power any AC device. The power will remain on at this outlet regardless of whether the AVR75/85 is on or off.

NOTE: The power consumption of the device plugged into each of these outlets should not exceed 120 watts.

46. Power Cable: Connect the AC plug to a non-switched AC wall output.

47. AC-3/PCM Optical Input: Connect the optical digital output from a DVD player, HDTV receiver, LV player or CD player to this jack. The signal may be either a Dolby Digital (AC-3) signal or a standard PCM digital source.

48. AC-3/PCM Coaxial Input: Connect the coax digital output from a DVD player, HDTV receiver, LV player or CD player to this jack. The signal may be either a Dolby Digital (AC-3) signal or a standard PCM digital source.

49. AC-3 RF Input: Connect the AC-3 RF output of an LV player equipped for digital audio to this jack.

NOTE: Do not connect standard analog sources to these jacks (48)(49).

50. Remote IR In: If the AVR75/85's front panel IR sensor is blocked due to cabinet doors or other obstructions, an external IR sensor may be used. Connect the output of the sensor to this jack.

51. Remote IR Out: This connection permits the IR sensor in the receiver to serve other remote controlled devices. Connect this jack to the "IR IN" jack on Harman Kardon or other compatible equipment.

52. VCR 1 Inputs: Connect these jacks to the audio, video and S-Video PLAY/OUT jacks of a VCR.

53. VCR 1 Outputs: Connect these jacks to the audio, video and S-Video RECORD/IN jacks of a VCR.

54. TV Monitor S-Video Output: Connect this jack to the S-Video input of the TV monitor or video projector to view S-Video sources selected by the receiver's video switcher.

NOTE: Standard (composite) video and S-Video signals will appear only at their respective output. The AVR75/85 does not convert one video format to another.

55. TV Monitor Video Output: Connect this jack to the standard (composite) video input of a TV monitor or video projector to view the on-screen menus and the output of any standard video source selected by the receiver's video switch.

56. VCR 2 Outputs: Connect these jacks to the audio, video and S-Video RECORD/IN jacks of a second VCR.

57. VCR 2 Inputs: Connect these jacks to the audio, video and S-Video PLAY/OUT jacks of a second VCR.

58. Multiroom Audio Outputs: Connect these jacks to the optional audio power amplifier that powers remote room speakers with the input selected by the multiroom control system. This feature is found only on the AVR85.

59. Multi IR: Connect the output of an IR sensor in a remote room to this jack to operate the AVR85's multiroom control system. This feature is found only on the AVR85.

Service Bulletin #9705 for AVR85

Service bulletin # 9705 August 1997
To: All harman/kardon Service Centers
Models: **AVR85**
Subject: **No audio output**

In the event you receive an AVR85 with the complaint "no audio output" (even though the display is lit up normally), perform the necessary steps listed below:

PROCEDURE:

- 1) Make sure the receiver is OFF and unplugged; remove the top cover of the unit.
- 2) Position the unit on its side, facing it so you are looking at the bottom cover, with the front of the receiver facing left. The power transformer should be down, or nearest the work bench.
- 3) Remove the front right "foot" of the unit; then with a sharp pair of dikes or wire cutters cut the (16) metal connections on the bottom screen attaching it to the bottom cover. Remove bottom screen from unit; for safety continue to cut all the remaining severed metal tabs from the bottom cover.
- 4) Locate and discharge main power supply electrolytic capacitors C802 & C803 with a 10 ohm, 10 watt resistor. At this point, C802 & 803 are at the top of the main PCB; The two leads to C803 can be identified by the marking "-B" on the PCB; C802 is just above it. After discharge, check with voltmeter that capacitors have less than 1 volt DC across leads to confirm that discharge is complete.
- 5) See drawing; locate two areas of a poor solder connection due to an unintended mask, or dark-colored dot that is partially covering the solder pad(s) where the leads come through. Unsolder the connection(s) with solder wick. Clean & scrape, if necessary, with a small screwdriver the foil/pad area thoroughly and remove any excess mask residue. Re-solder the connection(s) carefully to assure good connections.
- 6) Turn the unit upright; locate PCB P714, the small vertical circuit board nearest the main heatsink. Unplug and remove small molex connector J701 at the top of the board; then remove the four mounting screws and metal tabs holding the top of the board in place.
- 7) Remove the two locks to the two sockets, J714 and J716. Take care not to damage the lock or connector while attempting to unlatch the PCB; then unplug and remove the entire PCB P714.
- 8) Locate 10 ohm, 1/4 watt resistors RH23, RH24, R745, R746, R747, R748; test with multimeter to assure they are still 10 ohms +/- 5%. If values are different (indicating damage), replace as necessary.
- 9) Return PCB P714 to unit; re-attach molex connector; replace 4 screws and mounting tabs. Replace top cover of receiver.
- 10) Re-attach the bottom screen to the bottom cover using 12 screws, (H/K# 51260306MO); the screen will be upside-down compared to its former position when attached; replace the unit's "foot".
- 11) **TO TEST:**
 - a) Plug in the unit; connect speakers to left, right, and center output terminals.
 - b) Turn the unit on; switch the unit to "Prologic" mode by use of the mode buttons on the front panel.
 - c) Press the button "TEST TONE" on the remote control. The display should read "FRONT L" and "TEST" should flash.
 - d) Adjust the master volume, and verify test noise is heard from front left channel.
 - e) Press the button "CH SELECT" on the remote control to change to the right and center speakers, and verify test noise is heard from each one.
 - f) Press the button "TEST TONE" on the remote control again to exit the test.

Model	Serial number 120V	Serial number 230V	Status	Action
AVR85	MJ0011-01001 to MJ0011-02500	MJ0012-01001 to MJ0012-01500	Poor connections in two areas on main PCB	Clean & re-solder connections, check or replace RH23,RH24,R745.R746, R747, R748 if necessary
AVR85	MJ0011-02501 and above	MJ0011-01501 and above	Modified by factory	NONE REQUIRED

View is upper left-hand corner of PCB
Bottom (trace) side

CONNECTION #1

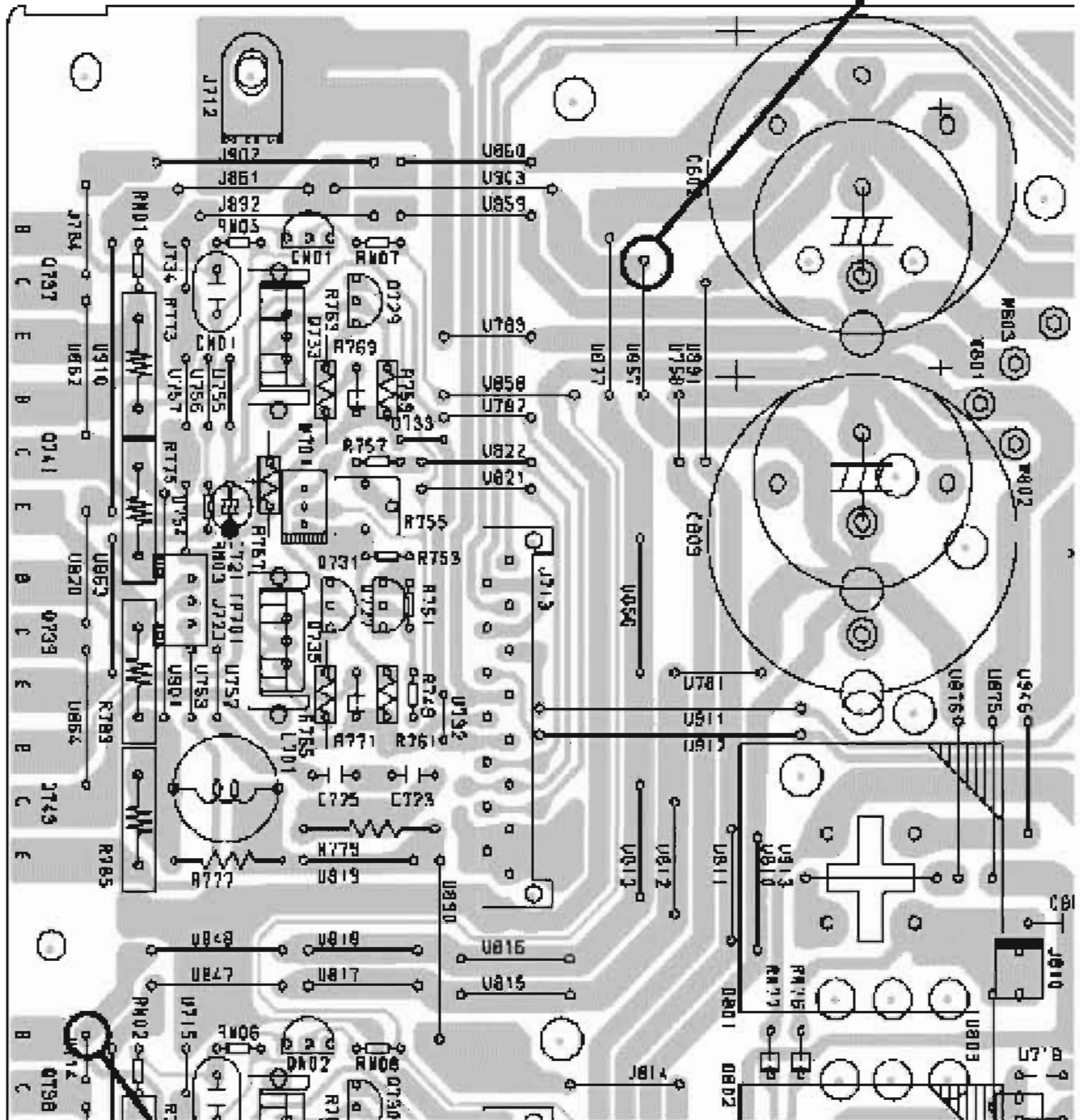

CONNECTION #2

SERVICE AND ADJUSTMENT

I. SERVICE PROCEDURE

1. Tracking Point Memory

This service procedure can be used for measurement of the tuner circuit. With the **POWER ON**, press the “**PRESET UP**” button while pressing the “**MEMO**” button for at least 3 seconds or more. FLD will display “**TRACKING**”. Frequencies to be memorized are as follows:

	VERSION	P1	P2	P3	P4
FM	US, Europe.	90.0	98.0	106.0	87.5

	SCAN STEP	P5	P6	P7	P8	P9	P10	P11	P12~P30
AM	10 KHz	600.0	1000.0	1400.0	520.0	←	←	←	←
	9 KHz	603.0	999.0	1404.0	531.0	←	←	←	←
	MW/LW	↑	↑	↑	171.0	207.0	270.0	152.0	531.0

2. FLD Segment Illumination

This service procedure will illuminate all segments by the following step: With the **POWER ON**, press the “**FM/AM (TUNER)**” button while pressing the “**MODE**” button for at least 3 seconds or more. This procedure takes 1 minute and 40 seconds to finish; at this point the procedure is complete.

Sequence

- All segments will be illuminated for 5 seconds.
- At the grid “**1G**”, segments are illuminated in the following order:
- At the grid “**2G**” to “**11G**”, each segment is illuminated individually:

① KHz → ② MHz → ③ ATT → ④ LFE → ⑤ NIGHT → ⑥ MULTI → ⑦ COAX → ⑧ OPT →
⑨ RF → ⑩ MOVIE → ⑪ TAPE1 → ⑫ COPY → ⑬ VID1 → ⑭ SLEEP → ⑮ P-SCAN → ⑯ DISP

- At the grid “**12G**”, segments are illuminated in the following order:

① VISUAL → ② SIGNAL BAR (LEFT SIDE) → ③ SIGNAL BAR (2nd LEFT) → ④ SIGNAL BAR (CENTER) →
⑤ SIGNAL BAR (2nd RIGHT) → ⑥ SIGNAL BAR (RIGHT SIDE) → ⑦ AC-3 → ⑧ PCM → ⑨  DIGITAL →
⑩ PRO-LOGIC → ⑪ 3 - STEREO → ⑫ MATRIX → ⑬ HALL → ⑭ THX CINEMA → ⑮ STEREO

3. All Clear

This service program can clear all memorized operations and functions. With the **POWER ON**, press the “**CD**” button while pressing the “**MODE▲**” button for more than 3 seconds. FLD shows “**CLEAR MEMO**” and power will be **OFF**.

II. ELECTRICAL ADJUSTMENT

1. Main amp idling current adjustment.

- 1) With the power **OFF**, set variable resistor **R755** (Lch), **R756** (Rch) **RH28** (Center ch) on the PC board (**P704**) to the center position.
- 2) Locate test points J723 (Lchan) J724 (Rchan) and J725 (Centerchan). These are 3 pin female molex connectors on the MAIN PCB. Attach a DC voltmeter (set to a low range) to the two outer pins on each test point. This is best accomplished by making up a “test plug” using a male molex connector that fits into the one in the unit, with wires attached, for connection to the voltmeter. An alternate method is to use two “mini-grabbers” to attach to the two outer pins on each connection. The middle pin has no connection.
- 3) After the above, adjust the idling current as follows: Turn the power **ON** and adjust variable resistor **R755** (Lch), **R756** (Rch), **RH28** (Center ch) while observing the reading on the voltmeter.

*The target value is **11mV** (25 mA).

NOTE:

When a unit whose idling current has been adjusted is switched on after 1 minute it reaches about 4.7~5.5mV. After 30 minutes, it reaches a balanced state and stabilizes at **8.9-11mV** (target). Therefore, if the adjustment is made 30 seconds after the power is switched on, adjust to 3.5 ~ 4.0mV. In the same way, if 1 minute has passed since the power was switched on, adjust to 4.7 ~ 5.5mV. From 1 to 2 minutes, adjust to 6.2 ~ 6.4mV. From 2 to 4 minutes, adjust to 7.1 ~ 7.6mV. From 4 to 7 minutes, adjust to 7.9 ~ 9.0mV. After more than 7 minutes since the power was switched on, adjust to the setting of 10.5 ~ 11.2mV. Here is a reference table for the adjustment values:

Time since power switched on	Idling current adjustment
30 seconds	3.5 ~ 4.0mV
1 minute	4.7 ~ 5.5 mV
1 - 2 minutes	6.2 ~ 6.4mV
2 - 4 minutes	7.1 ~ 7.6mV
4 - 7 minutes	7.9 ~ 9.0mV
More than 7 minutes	10.5 ~ 11.2mV

III. ALIGNMENT PROCEDURES

Test Equipment Required

- 1) AM/FM Signal Generator
- 2) Video Signal Generator
- 3) Digital Multimeter
- 4) Distortion level meter

1. AM IF Adjustment

Step	Input Signal Source Connection	Signal Frequency	Source Signal Output Level and Modulation	Reception Frequency	Adjustment Point	Adjustment Value
1	Signal generator output to transmission loop antenna. (:Standard required loop)	999 KHz (Europe) 1000 KHz (USA)	Level 300 V/m (50dB/m) Mod. 400 Hz 30%	Tuning point	LA06	Output level (L or R) Maximum at TAPE-OUT

REMARK: For receiving antenna, the one supplied with the unit is adequate.

This adjustment is not normally necessary, because the coil LA06 is preset by the original supplier.

2. AM Tracking Adjustment

Step	Input Signal Source Connection	Signal Frequency	Source Signal Output Level and Modulation	Reception Frequency	Adjustment Point	Adjustment Value
1	Signal generator output to transmission loop antenna. (:Standard required loop)	603 kHz (Europe) 600 kHz (USA)	Level 300 - 400 V/m Mod. 400 Hz 30%	603 kHz (Europe) 600 kHz (USA)	LA01	Output level (L or R) Maximum at TAPE-OUT
2		1404 kHz (Europe) 1400 kHz (USA)	Level 300 - 400 V/m Mod. 400 Hz 30%	1404 KHz (Europe) 1400 KHz (USA)	CA01	Output level (L or R) Maximum at TAPE-OUT
3	Repeat steps 1 and 2 until sensitivity is maximized.					

3. AM Tracking Adjustment (LW)

Step	Input Signal Source Connection	Signal Frequency	Source Signal Output Level and Modulation	Reception Frequency	Adjustment Point	Adjustment Value
1	Signal generator output to transmission loop antenna. (:Standard required loop)	171 kHz	Level 300 - 400 μ V/m Mod. 400 Hz 30%	171 kHz	LA03	Output level (L or R) Maximum at TAPE-OUT
2		270 kHz	Level 300 - 400 μ V/m Mod. 400 Hz 30%	270 kHz	CA08	Output level (L or R) Maximum at TAPE-OUT
3	Repeat step 1 and 2 until sensitivity is maximized.					

4. AM Auto Stop Adjustment

Step	Input Signal Source Connection	Signal Frequency	Source Signal Output Level and Modulation	Reception Frequency	Adjustment Point	Adjustment Valve
1	Signal generator output to transmission loop antenna. (:Standard required loop)	999 kHz (Europe)	500 V/m (54 dB/m)	999 kHz (Europe)	RA11	"TUNED" indicate on FLD
2		1000 kHz (USA)	1000 V/m (60 dB/m)	AUTO SCAN	Only Confirm	"TUNED" indicate on FLD

REMARK: This adjustment is related to the FM muting Level Adjustment. The FM muting Level re-adjustment is necessary after this adjustment.

5. FM MONO. Distortion Adjustment

Step	Input Signal Source Connection	Signal Frequency	Source Signal Output Level and Modulation	Reception Frequency	Adjustment Point	Adjustment Value
1	Signal generator output to FM antenna terminal. (75)	98 MHz	500 V (54 dB) MONO 1 KHz/ Dev. 40 KHz 53.3% (Europe) MONO 1 KHz/ Dev. 75 KHz 100% (USA)	98 MHz (P2)	L201	Distortion level Minimum at TAPE-OUT

6. FM Muting Level Adjustment

Turn the variable resistor **R212** until the word **TUNED** is not shown in the display. Then adjust the resistor **R212** in the opposite direction until **TUNED** is shown in the display.

Step	Input Signal Source Connection	Signal Frequency	Source Signal Output Level and Modulation	Reception Frequency	Adjustment Point	Adjustment Value
1	Signal generator output to FM antenna terminal. (75)	98 MHz	6.3 V (16 dB) MONO 1 KHz/ Dev. 40 KHz 53.3% (Europe) MONO 1 KHz/ Dev. 75 KHz 100% (USA)	98 MHz (P2)	R212	"TUNED" indicate on FLD
2			Over mentioned level +3 dB	AUTO SCAN	Only Confirm	"TUNED" indicate on FLD

7. FM STEREO Distortion Adjustment

Adjust the **L channel** with the RF signal modulated only **L channel** first and confirm the **R channel** with the RF signal modulated only **R channel**.

Step	Input Signal Source Connection	Signal Frequency	Source Signal Output Level and Modulation	Reception Frequency	Adjustment Point	Adjustment Valve
1	Signal generator output to FM antenna terminal. (75)	98 MHz	500 V (54 dB) L or R 1 kHz/ Dev. 40 kHz 53.3% PILOT 19 kHz/ Dev. 6 kHz 8% (Europe)	98 MHz (P2)	IF COIL in FRONT END	Distortion level Minimum at TAPE-OUT
2			L or R 1 kHz/ Dev. 67.5 kHz 90% PILOT 19 kHz/ Dev. 6.75 kHz 9% (USA)		R218	Distortion level Minimum at TAPE-OUT

REMARK: Adjustment with **R218** is not necessary when the distortion level is less than 0.5% with adjusting IF coil.

8. FM STEREO Separation Adjustment

Step	Input Signal Source Connection	Signal Frequency	Source Signal Output Level and Modulation	Reception Frequency	Adjustment Point	Adjustment Value
1	Signal generator output to FM antenna terminal. (75)	98 MHz	Same specification as FM STEREO distortion adjustment. Input only L channel	98 MHz (P2)	R211	Output level Minimum at TAPE-OUT channel R
2		98 MHz	Same specification as FM STEREO distortion adjustment. Input only R channel	98 MHz (P2)	R211	Output level Similar as Rch at TAPE-OUT channel L

9. On Screen Display VCO Adjustment

Step	Input Signal Source and Connection	Measuring Position	Measuring Equipment	Input Selector	Adjustment Point	Adjustment Value
1	Color bar or other standard video signal. Video signal generator output to LD video input.	IC QX60 26pin and GND	DC voltmeter (Impedance > 10k /V)	LD	CX67	2.5V 0.1V

REMARK: Connect the TV monitor to the monitor output terminal of the product.

ALIGNMENT AND TEST POINTS

ALIGNMENT AND TEST POINTS

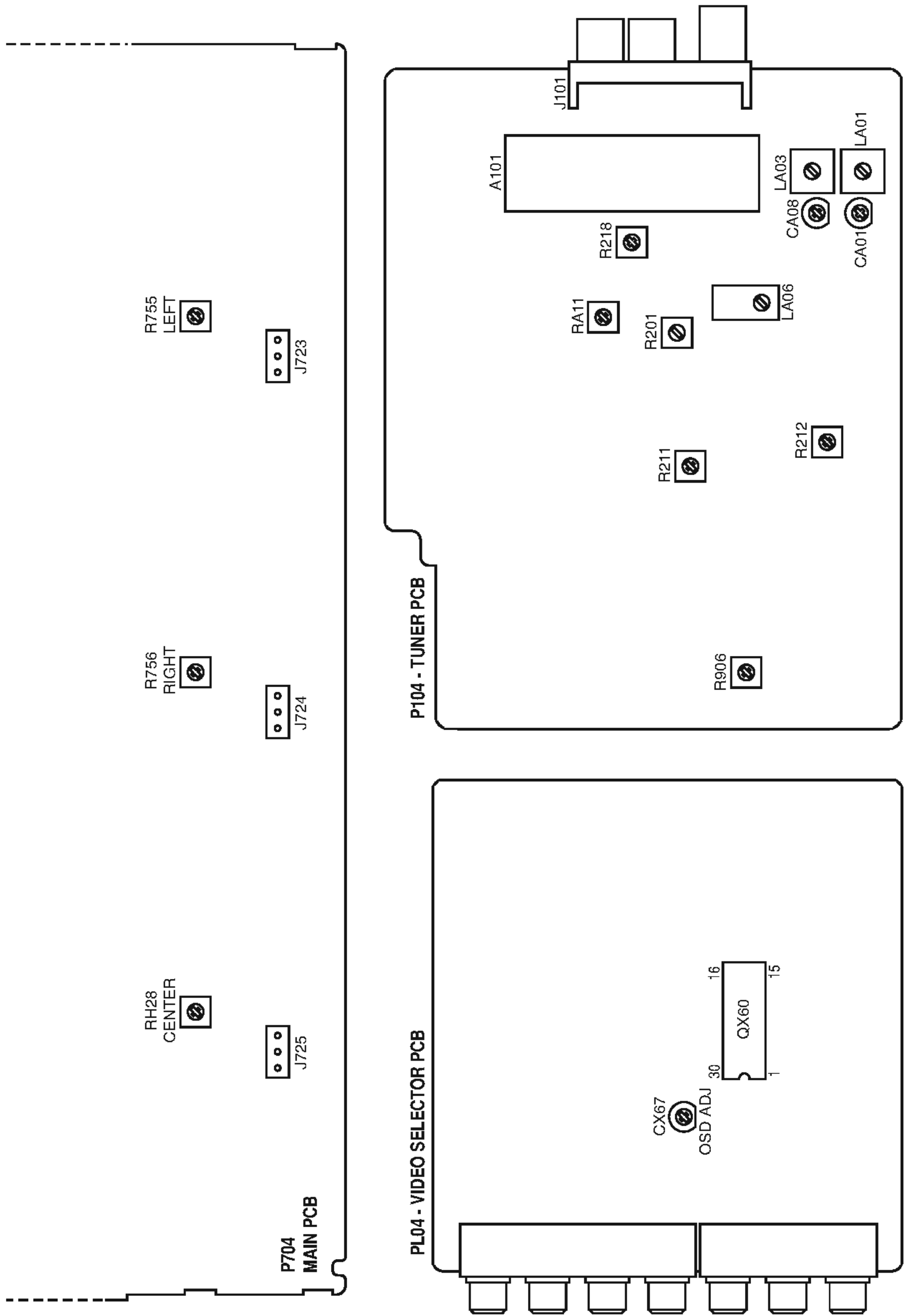

IV. TECHNICAL DESCRIPTION

This product is a “Dolby Digital (AC-3)” decoder. By connecting this product with a Dolby digital compatible component such as a DVD player or DBS tuner, it will be capable of 5.1 CH (Front L/R, Rear L/R, Center and Sub-woofer) play.

This product is composed of approximately of 5 blocks including the AC-3 decoder & DAC block (**P604**), crossover block (**PC04**), power supply block (**P704**), volume control block (**PE04**) and front key input block (**PU04**).

V. SIGNAL AND CIRCUIT DESCRIPTION

OPT/COAX (AC-3/PCM input)

This signal is based on an additional format for transmitting the AC-3 data through the conventional digital audio interface (SPDIF). This SPDIF contains the compressed data for AC-3, instead of PCM Audio data. Similarly to the case of ROM data, whether the data is audio or non-audio is identified according to the status in the signal. This signal can be output from a DVD player, etc.

DAI (Digital Audio Interface) Receiver

This circuit extracts various clock and data signals from the signal input in the SPDIF format.

AC-3 Decoder DSP

This circuit generates the 6-channel data (Front L/R, Rear L/R, Center and LFE) based on the data output from the DAI, and outputs the 6-channel data to the DAC as 3 sets of 2-channel data.

Crossover

This circuit consists of 100Hz HPF for each channel, 100Hz LPF for sub-woofer channel, and mixing for sub-woofer output. Depending on the speaker mode setting, frequencies of this circuit will be changed.

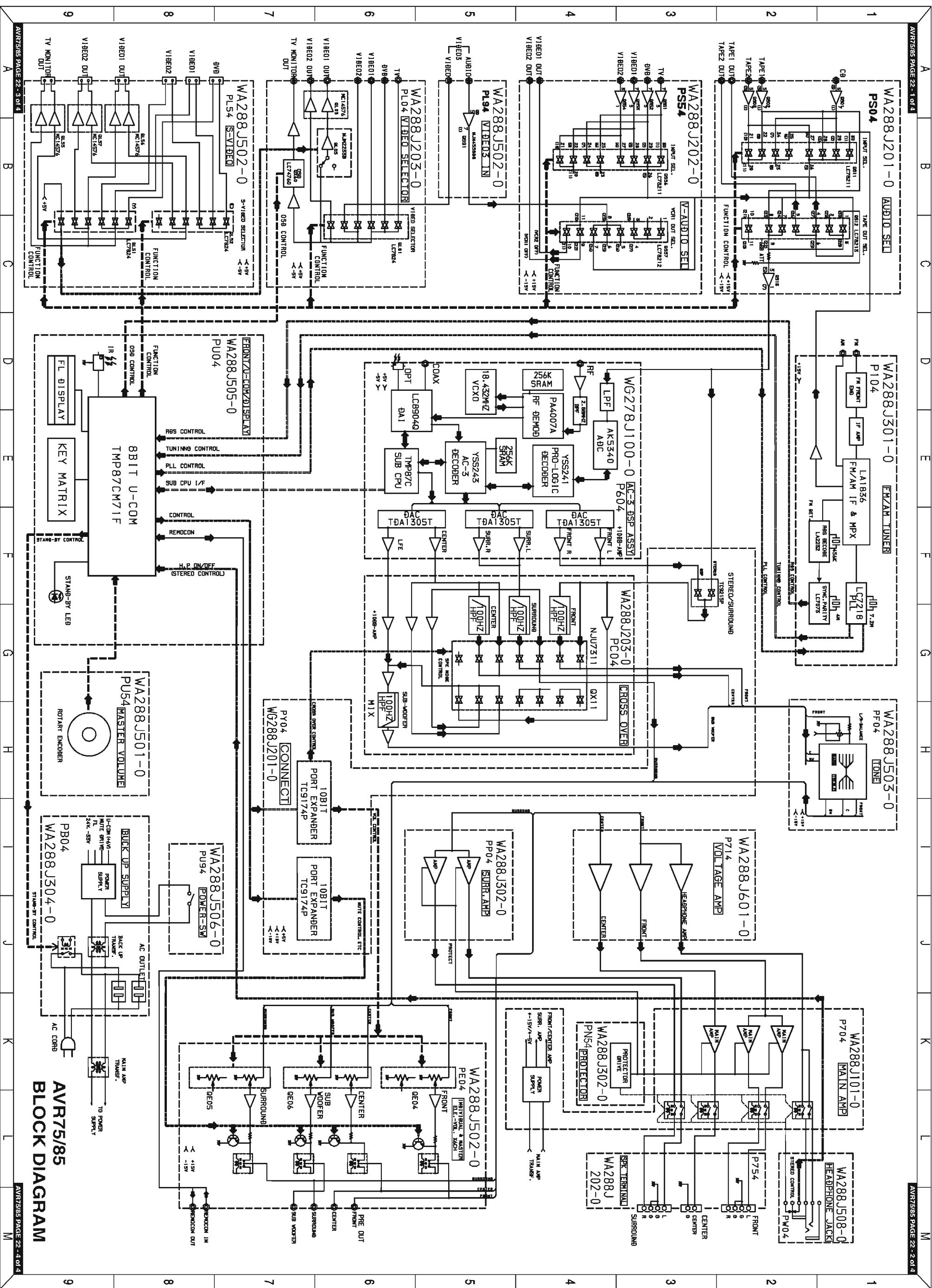

AVR75/85
BLOCK DIAGRAM

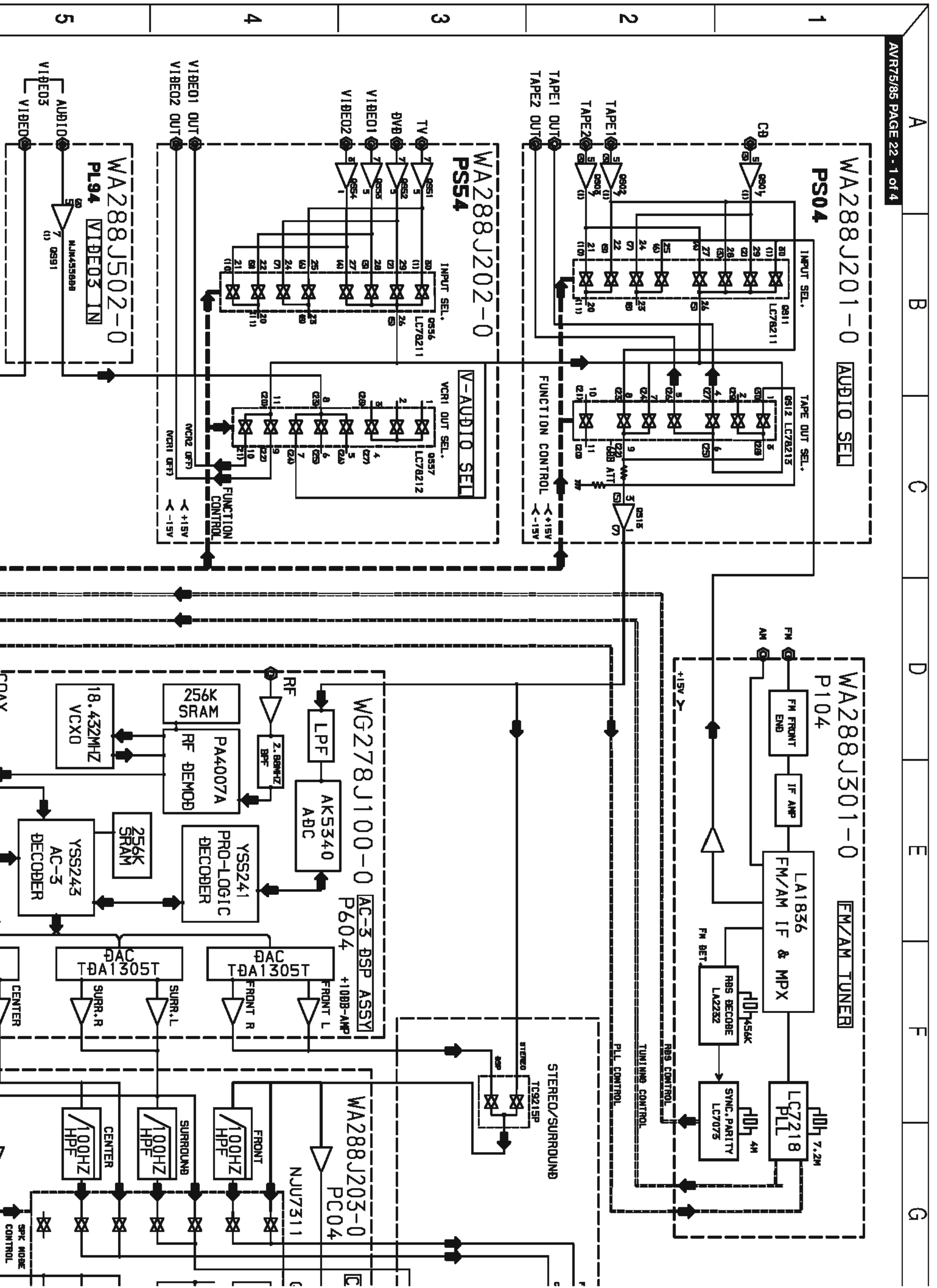

5/85 BLOCK DIAGRAM

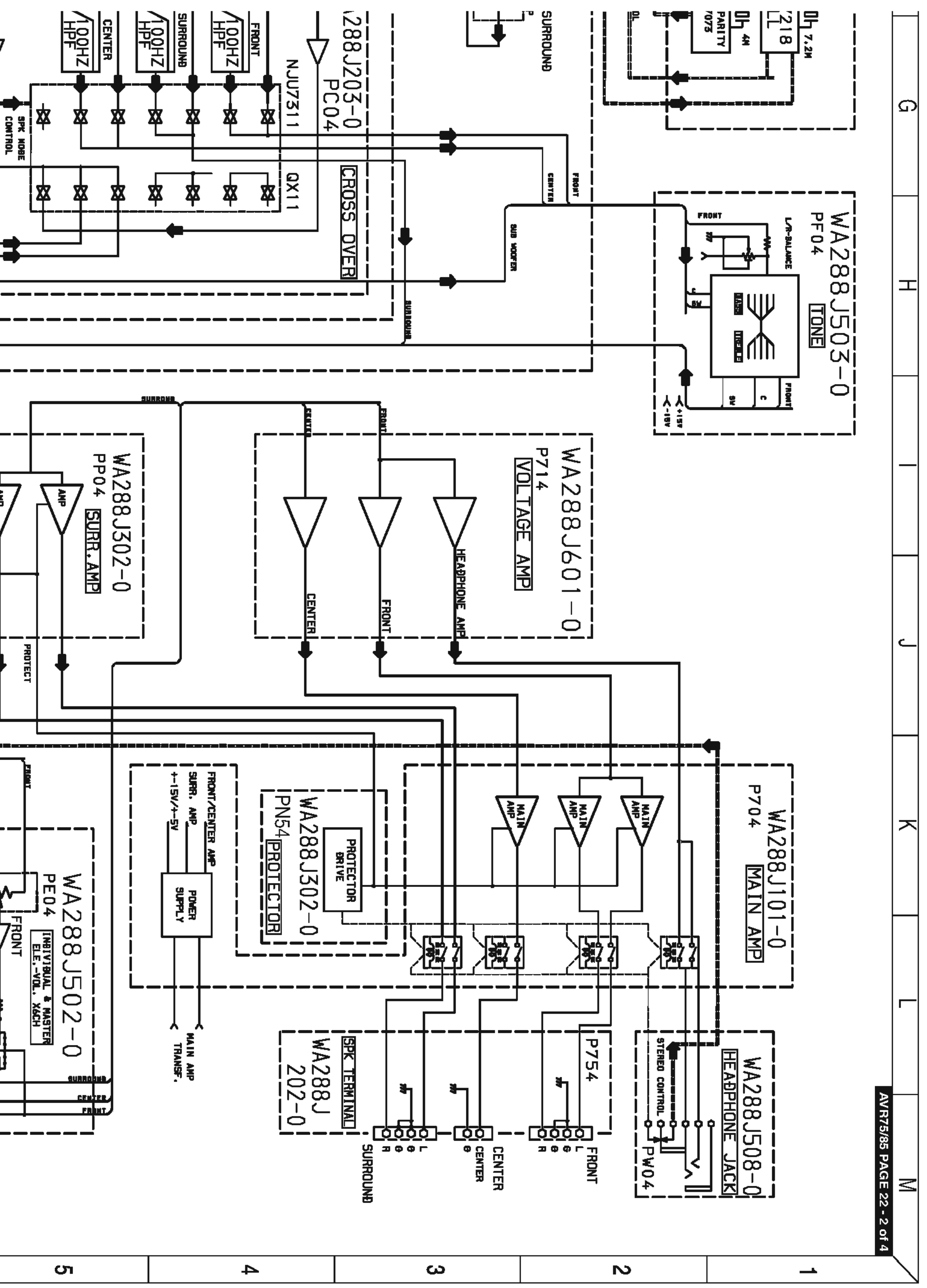

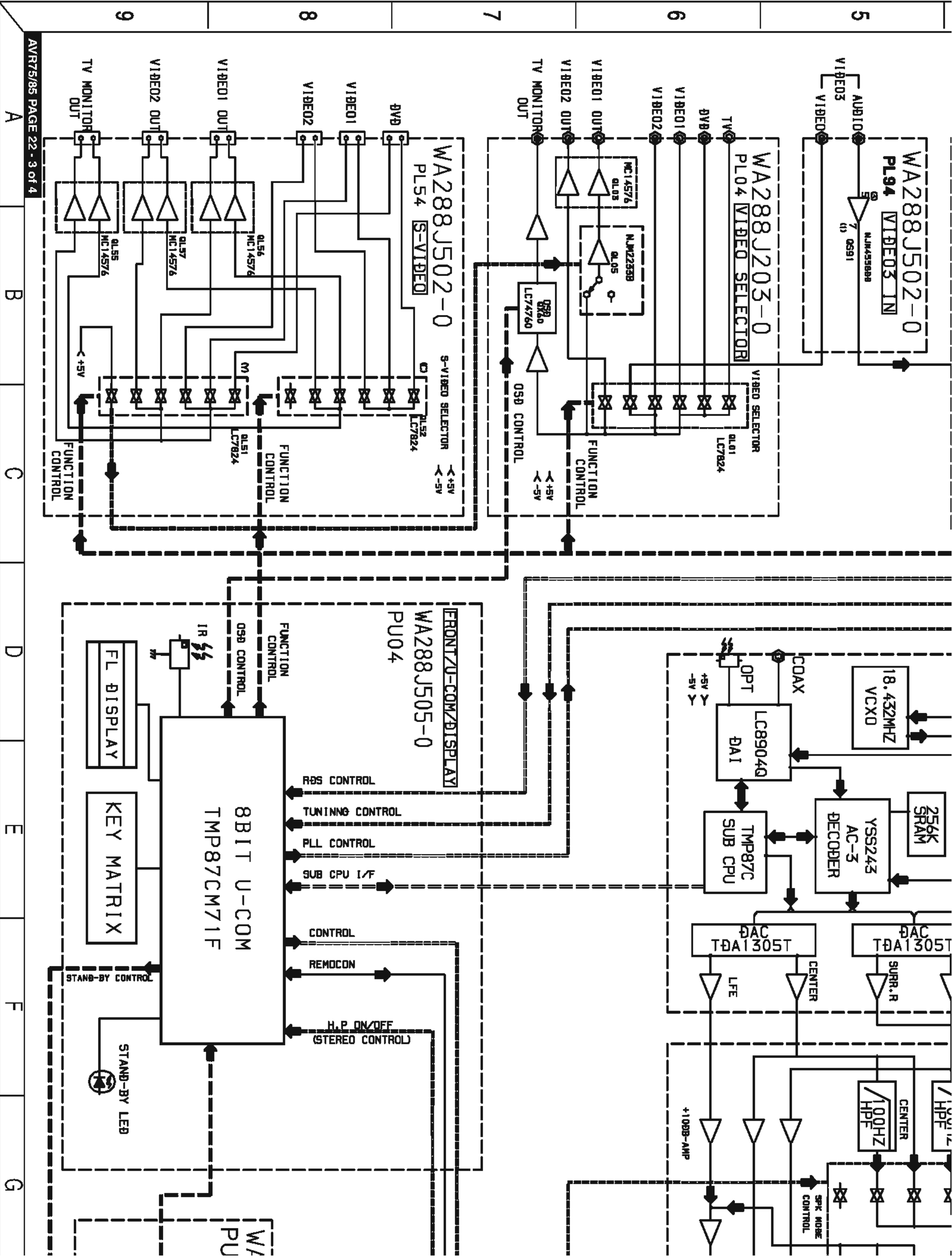

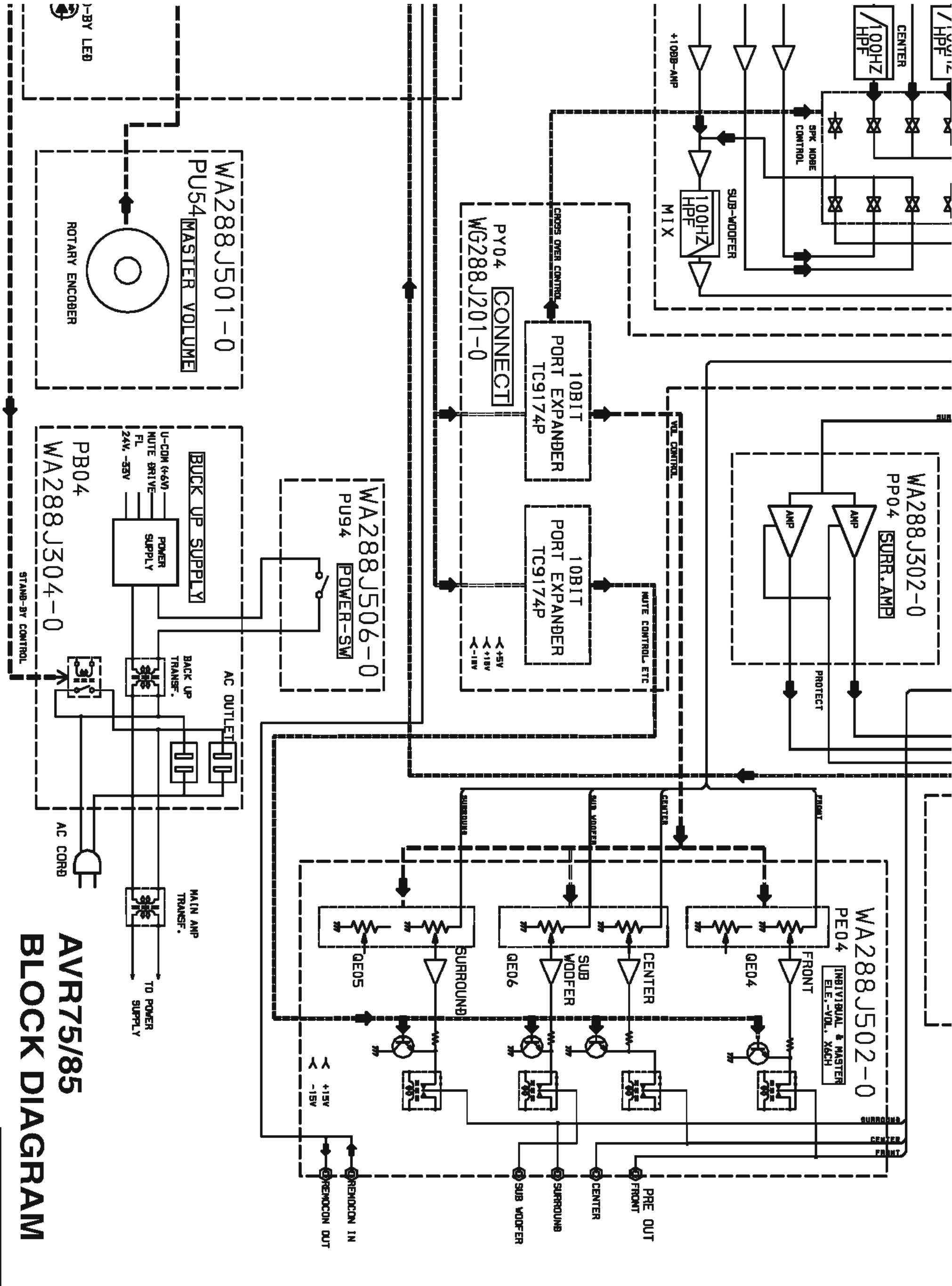

AVR75/85 BLOCK DIAGRAM

G H J K L M

SPECIFICATIONS

Power Supplies

USA/Canada AC 120V, 60Hz
Europe AC 230V, 50Hz

Dimensions (W x H x D)

Inches: 17 1/2 x 6 3/8 x 18"
mm 444 x 162 x 457mm

Weight (lbs/kgs) 34/15.4

These specifications are service target specs. Specifications and components are subject to change without notice. Overall performance will be maintained or improved.

General Test Conditions

1	Test Methods	Test methods for Tuners and Amplifier. CP-2101, C6102, C6104	
2	Power Source	The amplifier shall be tested at the (Primary power supply) conditions shown in table below.	
		Destination	Power Source
		U	120 Volts RMS 1% 60 Hz 2%
		N	230 Volts RMS 1% 50 Hz 2%
3	Tuner Measurements	The FM signal shall be 500uV (65dBf) with 75kHz Deviation at 1000Hz and 50mV/m Loop injected with 30% modulation at 400Hz for AM, unless otherwise specified. TAPE OUT terminated with 47kohms load unless otherwise specified.	
4	Audio Measurements	All audio measurement shall be made with test signals injected into CD. Inputs and output measured at SPEAKER outputs with 8ohms 1% non-inductive resistor load, or at TAPE OUT with 10kohms 5%/1nF 5% loads, unless otherwise specified.	
5	Control Settings	Tone control : Mechanical center position Balance control : Mechanical center position Volume control : According to CP-2101 SPK SETT : ALL Large ATT : off unless otherwise specified AC-3 Section Setting Night Mode : off SPK SETT NO. 1 Front: Small, Center: Small, Surround: Small, Subw: ON SPK SETT NO. 2 Front: Large, Center: Large, Surround: Large, Subw: ON SPK SETT NO. 3 Front: Large, Center: Large, Surround: Small, Subw: OFF	
6	Used Test Disc	Dolby AC-3 Demonstration & Test Laser Disc Ver. 1.0 (for AC-3 RF)	

Audio Section Performance Specifications

Seq #	Test	Reference	Unit	Nominal	Limits	
1	Continuous Power Output THD 0.09% (L/C/R) Front L/R both, Center Ch. <input type="checkbox"/> FTC <input type="checkbox"/> CP-2101 <input checked="" type="checkbox"/> CD Input <input checked="" type="checkbox"/> Volume Max.	8	20Hz	W	80	≥65
		8	1kHz		80	≥65
		8	20kHz		80	≥65
	Surr. Ch.	8			—	—
		8	1kHz		75	≥65
		8			—	—
DIN 1% Power Output Front Ch. <input checked="" type="checkbox"/> CD In	8	1kHz	85	≥75		
Dynamic Power Output Front Ch. <input type="checkbox"/> CP-2101 <input type="checkbox"/> CD IN	8	1kHz	—	—		
	4/2	1kHz	—	—		
2	Power Bandwidth THD 0.09% Front Ch. <input type="checkbox"/> CP-2101 <input checked="" type="checkbox"/> Volume: Max. <input checked="" type="checkbox"/> CD IN	8	32.5W	Hz	5~70k	10~60k
			W			
3	Total Harmonics Distortion at 65W Output Front Ch. <input checked="" type="checkbox"/> THD <input type="checkbox"/> FTC <input type="checkbox"/> CP-2101 <input type="checkbox"/> Volume: Max. Front L/R both, Center Ch. <input checked="" type="checkbox"/> CD IN MODE: STEREO Surround L/R Ch. Mode: PCM STEREO Service SPK SETT NO. 2	FRONT Ch. L/R/C	20Hz	%	0.03	≤0.09
			1kHz		0.01	
			20kHz		0.05	
		Surr. Ch.	40Hz		0.5	≤0.7
			1kHz		0.5	
			20kHz		0.5	
Total Harmonics Distortion at 0.25W Output Front Ch. <input checked="" type="checkbox"/> THD <input type="checkbox"/> FTC <input type="checkbox"/> CP-2101 <input type="checkbox"/> Volume: Max. <input checked="" type="checkbox"/> CD IN MODE: STEREO	20Hz	0.05	≤0.09			
	1kHz	0.05				
	20kHz	0.05				
4	Intermodulation Distortion at 65W Output Front channel at STEREO Mode <input checked="" type="checkbox"/> CP-2101 (SMPTE Method) <input checked="" type="checkbox"/> Volume: Max.				0.03	≤0.09
		8				
	Input Sensitivity for 1.0V Pre-Output at CD IN Measured at 1kHz Vol: Max, Mode: STEREO	Front L/R	mV	240	200~280	
5	Difference of Input Sensitivity at each source ch., at CD IN 1KHz	Front L/R	dB	—	≤1	
6	Frequency Response at Output -3 dB Mode: Stereo ref: 1KHz	Front L/R	Hz	10~70k	15~50k	
7	Treble Action (L, C, R)	10KHz	Boost	dB	10	7.5~12.5
			Cut		10	
	Bass Action (L, C, R, SW)	100Hz (SW 40Hz)	Boost		10	7.5~12.5
			Cut		10	
8	Crosstalk (between Stereo Channels) terminated by 1k Ω <input checked="" type="checkbox"/> without Hum & Noise <input checked="" type="checkbox"/> CP-2101	Input: CD	100Hz		59	≥50
			1kHz		59	
		STEREO	10kHz		59	

Seq #	Test	Reference	Unit	Nominal	Limits	
9	Crosstalk (between Stereo Channels) Measured at TAPE IN terminated by 1k Ω ■ without Hum & Noise ■ CP-2101	Input: CD STEREO	dB	100Hz	$\cong 70$	
				1kHz	$\cong 70$	
				10kHz	$\cong 70$	
10	Output Impedance Referred to 1kHz (SUB-WOOFER 40HZ) Input CD			Preout Front	550	350~ 750
				Preout Center		
				Preout Surround		
				Preout Sub Woofer		
				Tape/Video1	1100	1000~1200
11	Input Impedance at 1KHz	CD		47k	$\cong 40k$	
12	ATT Level at 1kHz	CD	dB	6	4~8	
13	Minimum Volume Hum & Noise Output, CD Input Using 20kHz LPF	STEREO	mV	Front	0.5	$\cong 1.0$
				Front	0.5	$\cong 1.0$
		Surr. Mode Pro Logic (LARGE)		Center	0.5	$\cong 1.0$
				Surround	0.5	$\cong 1.0$
				Sub Woofer PreOut	15	$\cong 20$
14	Maximum Volume Hum & Noise SPK Output, CD Input Input shorted Using: 20kHz LPF A weighted (Except Subwoofer)	Front	mV	STEREO	1.5	$\cong 3.0$
				PRO LOGIC	8.0	$\cong 15$
		Center		LARGE	8.0	$\cong 15$
		Surround		LARGE	8.0	$\cong 15$
		Sub Woofer		PRO LOGIC	uV	150
15	Signal to Noise Ratio at 1kHz 1W Output A weighted at short circuit ■ CP-2101	DVD 0.5V Input		82	$\cong 78$	
16	Signal to Noise Ratio at DOLBY reference Level measured CCIR/ARM weighted referred to 1kHz Input shorted Measured at Preout terminal PRO LOGIC/LARGE Master Vol.: 0dB	350mV Input Front	dB	70	$\cong 65$	
				350mV Input Center	70	$\cong 65$
				350mV Input Surround	70	$\cong 65$
17	Dolby overload CD input Level at PREOUT terminal, THD 1% (PRO LOGIC) Vol. 0dB	1kHz	V	2	$\cong 1.9$	
18	Damping Factor at 32.5W (8 Ω) Output CD input, Front channel Surround MODE:STEREO	100Hz		—	—	
		1kHz		60	$\cong 50$	
		10kHz		—	—	

19	DC offset of Speaker output Volume Min. No Load	Front	mV	—	≦60
		Center		—	≦60
		Surround		—	≦60
20	Idling Power Consumption at Minimum Volume Control	AC Line	W	85	70~100
21	Power Consumption at Rated Power L/R channel Driven	AC Line		290	245~335
22	Power Consumption at STANDBY	AC Line		7	≦10

Video Section Performance Specifications for Model AVR75

Seq #	Test	Reference	Units	Nominal	Limit
1	Output Level for CVBS 1VP-p (100%) White CVBS) Input * at Monitor Output * Output terminated by 75Ω			1.0	0.9~1.1
	Output Level Difference between each source		%	+/-3%	+/-5%
2	Output Level for Y/C 1Vp-p(Y), 0.28Vp-p(C) Input * Measured S-Terminal * at Monitor Output * Output Terminated by 75Ω			1.0	0.9~1.1
				0.28	0.25~0.31
	Output Level Difference between each source		%	+/-3%	+/-5%
			%	+/-3%	+/-5%
3	Input Impedance * 1MHz, 1VP-p Sine Wave Input * Output terminated by 75Ω		Ω	75	—
		TV		75	—
		Video1		75	—
		Video2		75	—
		Video3		75	—
4	Output Impedance at 1Vp-p Output * LD Input * 1MHz, Sine Wave	Monitor		75	—
		Video1		75	—
		Video2		75	—
5	Frequency Response at -3dB Referred to 1MHz measured at 1Vp-p output * Input LD * Terminated by 75Ω * Measured by Composite output	Monitor	Hz	8M	≧6M
		Video1		8M	≧6M
		Video2		8M	≧6M

FM Tuner Section Performance Specifications for Model AVR75/85

Seq #	Test	Measured	Unit	Nominal	Limits				
1	Frequency Range	50K	MHz	87.50~ 108.00	—				
2	(MONO) Usable Sensitivity at 75Ω	U Version	90MHz	13.5	1.3	≦2.5			
					98MHz	1.3	≦2.5		
					106MHz	1.3	≦2.5		
		N Version			90MHz	13.5	≦3.0	≦20.8	
					98MHz	13.5	≦3.0	≦20.8	
					106MHz	13.5	≦3.0	≦20.8	
		U, N, Version			OTHERS	2.6	19.5	≦6.0	≦26.8
		3			3 dB Limiting Sensitivity	98MHz		0.8	≦1.3
								9.3	≦13.5
4	MONO Quieting Sensitivity	U Version 50 dB	90MHz	16.8	1.9	≦3.3			
					98MHz	1.9	≦3.3		
					106MHz	1.9	≦3.3		
		N Version 50 dB			90MHz	16.8	≦4.5	≦24.3	
					98MHz	16.8	≦4.5	≦24.3	
					106MHz	16.8	≦4.5	≦24.3	
5	MONO S/N Ratio at 98MHz	500uV (65dBf)	dB	76	≧71				
	MONO Hum & Noise at 98MHz			70	≧65				
6	Muting Threshold		UV (dBf)	6.3	4~11				
				27.2	23.2-32.0				
7	Muting Window width at 98MHz		kHz	± 70	±30~± 150				
8	Frequency Response referred to 30Hz-15kHz De-Emphasis	75uS:U 50uS:U	dB	+0.5 -2.0	+1.0 -4.0				
9	Mono Distortion	1kHz	%	0.2	≦0.5				
10	Overload Brake up	98MHz	V (dBf)	1.0	≧0.5				
				71	≧65				

Seq #	Test	Measured	Unit	Nominal	Limits	
11	Capture Ratio at 98MHz U: 75kHz Dev. N: 40kHz Dev.	45dBf 100uV	dB	—	—	
		65dBf 500uV		1.5	≧2.5	
12	A.C.S. U: ± 400kHz N: ± 300kHz	98MHz		55	≧50	
13	Intermediate Frequency	MHz		10.7	—	
14	IF Rejection	90MHz		—	—	
		98MHz		70	≧60	
		106MHz		—	—	
15	Image Rejection	U Version		90MHz	—	—
				98MHz	50	≧40
				106MHz	—	—
		N Version		90MHz	—	—
				98MHz	70	≧60
				106MHz	—	—
16	Signal +1/2 IF Rejection	98MHz		75	≧65	
17	Other Spurious Response Range 10MHz to 200MHz	98MHz		75	≧65	
18	AM Suppression at 98MHz	100uV (45dBf)		—	—	
		500uV (65dBf)		55	≧45	
19	Signal Strength Meter Deflection	500uV (65dBf)		Point	5	≧4
20	Tape Out Level U:75kHz Dev. N:40kHz Dev.	98MHz		mV	800	600~1300

FM Tuner Section Performance Specifications for Model AVR75/85

Seq #	Test	Measured	Unit	Nominal	Limits
1	1-a (STEREO) 50dB Quieting Sensitivity at 75Ω	90MHz	Uv (dBf)	25.2 39.2	≦40.0 ≦43.3
		98MHz		25.0 39.2	≦40.0 ≦43.3
		106MHz		25.0 39.2	≦40.0 ≦43.3
	1-b (STEREO) Quieting Slope at 98MHz	17uV (30dBf)	dB	—	—
		55uv (40dBf)		—	—
		170uV (50dBf)		—	—
		1mV (65dBf)		—	—
		100mV (105dBf)		—	—
	2	2-a (STEREO) S/N Ratio at 98MHz	500uV (65dBf)		68
2-b (STEREO) Hum & Noise at 98MHz		500uV (65dBf)	63		≧58
3	3-a (STEREO) Switching Level at 98MHz	Input Level	UV (dBf)	6.3 27.2	≦11.0 ≦32.1
		Pilot Level		500uV 65dBf)	5
4	4-a (STEREO) Distortion at 50dB Quieting Sensitivity	98MHz	%	—	—
	4-b (STEREO) Distortion at 98MHz 500uV(65dBf) Input U: 67.kHz+6.75kHz Dev. N: 40.0kHz+6.00kHz Dev.	100MHz		—	—
		1kHz		0.4	≦1.0
		6kHz		—	—
5	Separation at 98MHz 500uV(65dBf) Input U: 67.5kHz+6.75kHz Dev. N: 40.0kHz+6.00kHz Dev.	100Hz	dB	—	—
		1kHz		40	≧30
		10kHz		—	—
	Separation at 98MHz 500uV(65dBf) Input 67.5kHz+6.75kHz	100Hz		—	—
		1kHz		—	—
		NR ON 10kHz		—	—
6	Sub Carrier Rejection	98MHz		70	≧60
7	RDS Sensitivity 67.kHz + 6.0kHz + RDS Dev.	98MHz 65dBf 500uV	kHz Dev.	0.5	≦1.2

AM Tuner Section Performance Specifications for Model AVR75/85

Seq #	Test	Measured	Unit	Nominal	Limits
1	Frequency Range(MW)	U: 10k others: 9k	10kHz STEP 9kHz STEP	520~1710 531~1602	—
	Frequency Range(LW)		1kHz	152~282	—
2	2-a Usable Sensitivity of MW Band Loop ANT.		603kHz 600kHz	700	≧
			999kHz 1000kHz	500	≧
			1404kHz 1400kHz	500	≧
	2-b Usable Sensitivity of LW Band Loop ANT. N Version		171kHz	2000	≧
			207kHz	1500	≧
			270kHz	1500	≧
3	IF Rejection Referred to #2-a		999kHz 1000kHz	60	≧50
4	Image Rejection Referred to #2-a		999kHz 1000kHz	40	≧35
5	Spurious Rejection Referred to #2-a		999kHz 1000kHz	65	≧55
6	AUTO STOP Sensitivity		999kHz 1000kHz	500	≧1000
7	Selectivity Referred to #2-a at 999/1000kHz		9kHz 10kHz	30	≧20
			18kHz 20kHz	70	≧60
8	S/N Ratio at 50mV/m Input (Loop)		999kHz 1000kHz	50	≧45
9	Frequency Response at -3dB (Loop)		999kHz 1000kHz	100~2.2K	150~1.8K
10	Distortion 50mV/m Input at 999kHz/1000kHz (Loop)		30% mod.	1.0	≧2.0
			90%	—	—
11	AGC Figure of Merit Referred to 100mV/m Input (Loop)		999kHz 1000kHz	55	≧48
12	Overload Break up at 999kHz/1000kHz		T.H.D 10%	1000	≧500
13	Signal Strength Meter Deflection at 999/1000kHz (Loop)		50mV/m	POINT	5 ≧4
14	TAPE Output Level at 50mV/m Input (LOOP)		999kHz 1000kHz	240	150~340

AC-3 Section Performance Specifications for Model AVR75/85

Seq #	Test	LD No.	Ref.	Unit	Nominal	Limits	
1	Output Level at Preout Input Level 0dB fs Master Volume: 0 dB SPK SETT NO. 1	Front	38	1kHz	V	1.40	1.10~1.70
		Surround				1.40	1.10~1.70
		Center				1.40	1.10~1.70
		Subw	18	30kHz	4.4	3.60~5.10	
2	S/N Ratio at Preout Input Level -20dB & silence A weight +20k LPF (except Subw) SubW: 20k LPF Master Volume: Max SPK SETT NO. 1	Front	6	1kHz	dB	80	≧74
		Surround				80	≧74
		Center				80	≧74
		Subw	24	30Hz	74	≧68	
3	T.H.D at Preout Input Level -20dB fs 20k LPF Master Volume: Max SPK SETT NO.1	Front	6	1kHz	%	0.01	≦0.02
		Surround				0.01	≦0.02
		Center				0.01	≦0.02
		Subw	24	30Hz	0.07	≦0.14	
4	Channel Separation at SPK Output (SW:Preout) Input Level 0dB fs Input f=1kHz (except Subw) f=30Hz (Subw) Master Volume; -5 dB SPK SETT NO. 1 between each CH	Front	8, 12	1kHz	dB	—	≧57
		Surround	14, 16			—	≧57
		Center	10			—	≧57
		Subw	18	30Hz	—	≧57	
5	30Hz Output Level at Preout for Crossover Master Volume: 0dB Delay Time 0ms	Front SPK SETT No. 3	20	30Hz	V	2.70	2.0-3.5
		Subw SPK SETT No. 1				6.50	5.5-7.5
6	Frequency Response at 20-20kHz (subw: 500Hz) INPUT 0dB fs Master Volume: -10 dB Mode: PCM STEREO Service SPK SETT NO. 2	Front		1kHz	dB	-1	0~3
		Surround				-1	0~3
		Center				-1	0~3
		Subw		31.5Hz	-55	≦-50	
		Front		1kHz	-29	≦-18	
		Surround			-29	≦-18	
		Center			-29	≦-18	
7	PCM OUTPUT INPUT -20dB fs (L, R) 20kHz LPF Master Volume: Max fs: 32K, 44.1K, 48K	LEVEL		1kHz	V	0.75	0.6-0.9
		THD			%	0.01	≦0.02
		S/N			dB	80	≧74

AVR75 MECHANICAL EXPLODED VIEW (120V AND 230V)

EXPLODED VIEW FOR MODEL AVR75

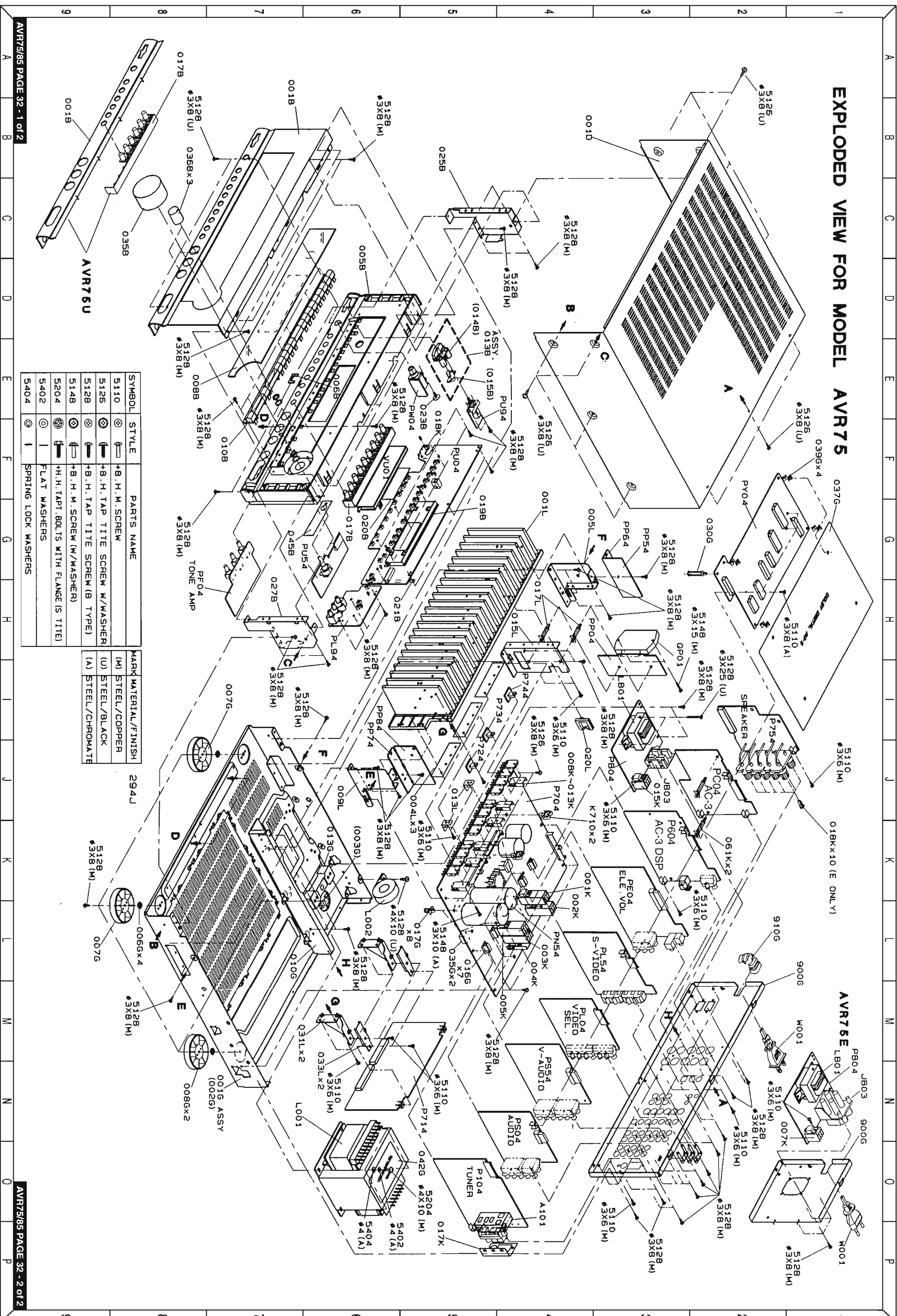

SYMBOL	STYLE	PARTS NAME	MARK MATERIAL/FINISH
5110	⊗	+B. H. M. SCREW	(M) STEEL/COPPER
5125	⊗	+B. H. TAP TITE SCREW W/WASHER	(U) STEEL/BLACK
5128	⊗	+B. H. TAP TITE SCREW (B TYPE)	(A) STEEL/CHROMATE
5148	⊗	+B. H. M. SCREW (W/WASHER)	
5204	⊗	+H. H. TAPT. BOLTS WITH FLANGE (S TITE)	
5402	⊗	FLAT WASHERS	
5404	⊗	SPRING LOCK WASHERS	



AVR75 MECHANICAL EXPLODED VIEW (12)

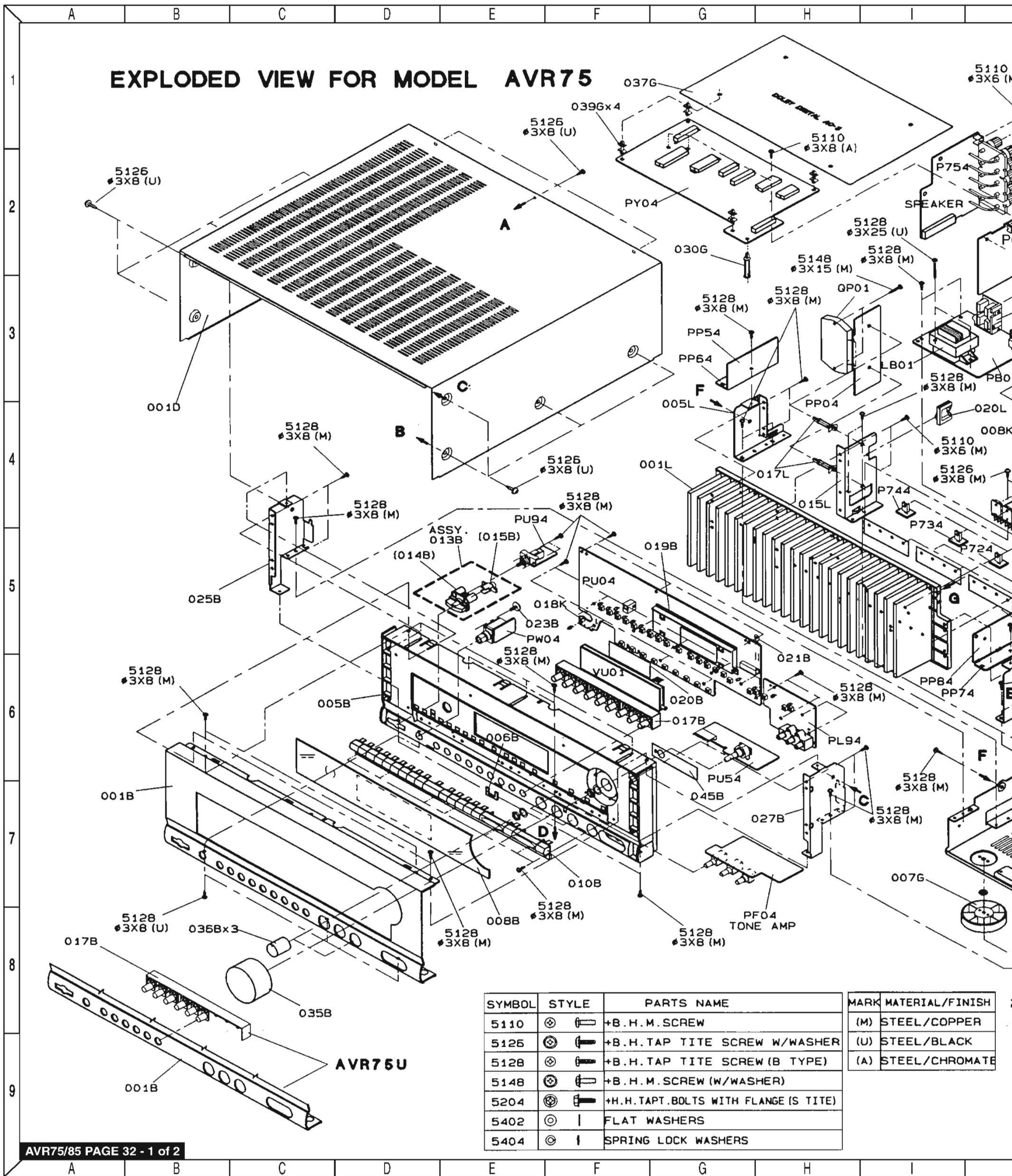

AVR75 MECHANICAL PARTS LIST (120V & 230V)

Ref.#	Part #	Description	Qty.	Ref.#	Part #	Description	Qty.
001B	260J248360	FRONT ALMI PANEL (BLACK) N	1	002G	264J105010	MAIN CHASSIS	1
001B	260J248350	FRONT ALMI PANEL (BLACK) U	1	003G	030J114010	STOPPER	1
005B	260J105015	FRONT MOLD CHASSIS	1	006G	227J056010	BUFFER PEPU SHEET	4
006B	259J118010	SPACER FOR HINGE BUTTON	1	007G	183J057010	LEG (FRONT)	2
008B	260J158350	WINDOW	1	008G	183J057110	LEG (REAR)	2
010B	260J270010	FUNCTION HINGE BUTTON	1	009G	51280308M0	B.H. TAP. SCREW LEG	4
011B	51280308M0	B.H. TAP. SCREW FUNCTION HINGE BUTTON	7	010G	264J160010	TRANSF. BRACKET	1
013B	260J270520	BUTTON POWER BUTTON KIT	1	011G	51280308M0	B.H. TAP. SCREW TRANSF. BRACKET	2
014B	260J270050	POWER BUTTON	1	012G	52040410M0	H.HEAD BOLT S.F. TRANSF.	4
015B	260J355020	POWER BUTTON LENS	1	013G	260J271010	HOLDER SUB TRANSF BASE	1
017B	260J270020	MODE HINGE BUTTON (N)	1	014G	51280325U0	B.H. TAP. SCREW SUB TRANSF	2
017B	260J270120	MODE HINGE BUTTON (U)	1	015G	51280308M0	B.H. TAP. SCREW DENGEN PCB	2
019B	183J271022	FL HOLDER	1	016G	2218271020	HOLDER VERTICAL PCB SUPPORT	7
020B	056J122010	STICKER ADHESIVE FOR FL	1	017G	054J101020	MAIN PCB SUPPORT	8
021B	4220005040	CLAMPER FOR FLAT CABLE	1	018G	278J861010	FUSE LABEL T1.6A 250V	4
022B	51280308M0	B.H. TAP. SCREW FUNCTION PCB	16	020G	54040402A0	SPRING WASHER FOR TRANSF FIX	4
023B	183J010010	SCREW PHONE PCB	1	021G	54020401A0	FLAT WASHER P. FOR TRANSF. FIX	4
024B	51280308M0	B.H. TAP. SCREW FOR POWER SWITCH PCB	2	030G	136J101020	SUPPORT FOR CONNECTOR PCB	1
025B	264J160040	FRONT LEFT SIDE BRACKET	1	031G	51280410U0	B.H. TAP. SCREW FOR EMC PART LOCK	1
026B	51280308M0	B.H. TAP. SCREW FRONT LEFT SIDE BRACKET	4	031G	51280410U0	B.H. TAP. SCREW FOR EMC PART LOCK	1
027B	264J160050	BRACKET FRONT RIGHT SIDE BRACKET	1	035G	140S056040	BUFFER FOR MAIN PCB	2
028B	51280308M0	B.H. TAP. SCREW FRONT RIGHT SIDE BRACKET	4	037G	288J053012	COVER	1
030B	51280308U0	B.H. TAP. SCREW ALMI PANEL DOWN SIDE	3	039G	329K101010	SUPPORT FOR COVER	4
031B	51280308M0	B.H. TAP. SCREW ALMI PANEL UP CENTER	1	041G	51100306M9	B.H.M. SCREW MAIN PCB+SUB PCB	2
033B	51280308M0	B.H. TAP. SCREW FRONT PANEL ASSEMBLY	4	042G	288J861013	TRANS LABEL	1
035B	063J154180	MAIN VOL KNOB	1	900G	294J250020	REAR PANEL (N)	1
036B	042J154180	TONE VOL KNOB	3	900G	294J250010	REAR PANEL (U)	1
041B	51280308M0	B.H. TAP. SCREW FOR CLAMPER	1	901G	51280308M0	B.H. TAP. SCREW RCA	19
045B	288J123010	CONTACTOR	1	902G	51100306M9	B.H.M. SCREW FOR CONTRACTOR	5
001D	264J257110	LID TOP COVER BLACK	1	903G	51100308A9	B.H.M. SCREW CONNECT PCB	5
005D	51260308U0	B.T.SCREW(W/W) TOP COVER REAR	3	905G	51280308M0	B.H. TAP. SCREW REAR PANEL	6
006D	5126030SU0	B.T.SCREW(W/W) TOP COVER SIDE	8	906G	51280308M0	B.H. TAP. SCREW SPEAKER TERMINAL	3
001G	264J105500	MAIN CHASSIS ASSY	1	907G	51280308M0	B.H. TAP. SCREW AC OUTLET	2
				907G	51280308M0	B.H. TAP. SCREW AC OUTLET	2
				910G	450H259010	BUSHING AC CODE BUSH 2271	1
				915G	260J861010	"UL, CUL LABEL"	1

AVR75 MECHANICAL PARTS LIST (120V &230V) continued

Ref.#	Part #	Description	Qty.	Ref.#	Part #	Description	Qty.
920G	95109111D0	FACTORY ID TSK LABEL	1	Printed Circuit Boards			
001L	288J267010	MAIN HEATSINK	1	Part #	PCB Type		
002L	51480310A9	F.WASHER SCREW POWER TR	12	P714	VOLTAGE AMP PCB		
003L	51480310A9	F.WASHER SCREW REGULATOR TR	3	P604	AC-3/DAC PCB		
004L	288J107010	SHEET FOR POWER TR	3	P704	MAIN PCB		
005L	264J160020	HEAT SINK LEFT SIDE BRACKET	1	PS04	AUDIO FUNCTION PCB		
006L	51280308M0	B.H. TAP. SCREW LEFT SIDE BRACKET	2	PS54	AUDIO/VIDEO PCB		
009L	264J160030	HEAT SINK RIGHT SIDE BRACKET	1	PE04	ELECTRONIC VOLUME CONTROL PCB		
010L	51280308M0	B.H. TAP. SCREW RIGHT SIDE BRACKET	2	PC04	AC-3 CROSSOVER PCB		
013L	261J104010	MAIN PCB RETAINER	2	PU94	POWER SWITCH PCB		
014L	51100306M9	B.H.M. SCREW MAIN PCB RETAINER	2	P754	SPEAKER TERMINAL PCB		
015L	264J160060	HEATSINK CENTER BRACKET	1	PL04	VIDEO SELECTOR PCB		
016L	51100306M9	B.H.M. SCREW CENTER BRACKET	2	PY04	CONNECT PCB		
017L	090J101010	SURROUND PCB SUPPORT	2	PL54	S-VIDEO PCB		
018L	51480315M9	F.WASHER SCREW SURROUND PACK	2	P104	TUNER PCB		
020L	287S005010	CLAMPER FOR CORD	1	PB04	STANDBY PCB		
025L	51260308M0	B.T.SCREW(W/W) MAIN PCB KARI	4	PP04	SURROUND AMP PCB		
026L	51260308M0	B.T.SCREW(W/W) MAIN PCB ASSEMBLY	2	PU04	FRONT PCB		
027L	51280308M0	B.H. TAP. SCREW HEAT SINK ASSEMBLY	8	PU54	MASTER VOLUME PCB		
028L	51280308M0	B.H. TAP. SCREW SIDE PCB	2	PN54	SPEAKER PROTECT PCB		
030L	51280308M0	B.H. TAP. SCREW MAIN PCB ASSEMBLY	2	PF04	TONE CONTROL PCB		
031L	288J160010	BRACKET FOR SUB PCB(1)	2	PL94	AUX IN		
032L	51100306M9	B.H.M. SCREW BRACKET FOR SUB PCB(1)	4	PW04	HEADPHONE PCB		
033E	288J160020	BRACKET FOR SUB PCB(2)	2				
034L	51100306M9	B.H.M. SCREW BRACKET FOR SUB PCB(2)	2				
QP01	HC10386030	STK401 IC	1				

AVR85 MECHANICAL EXPLODED VIEW (120V AND 230V)

EXPLODED VIEW FOR MODEL AVR85

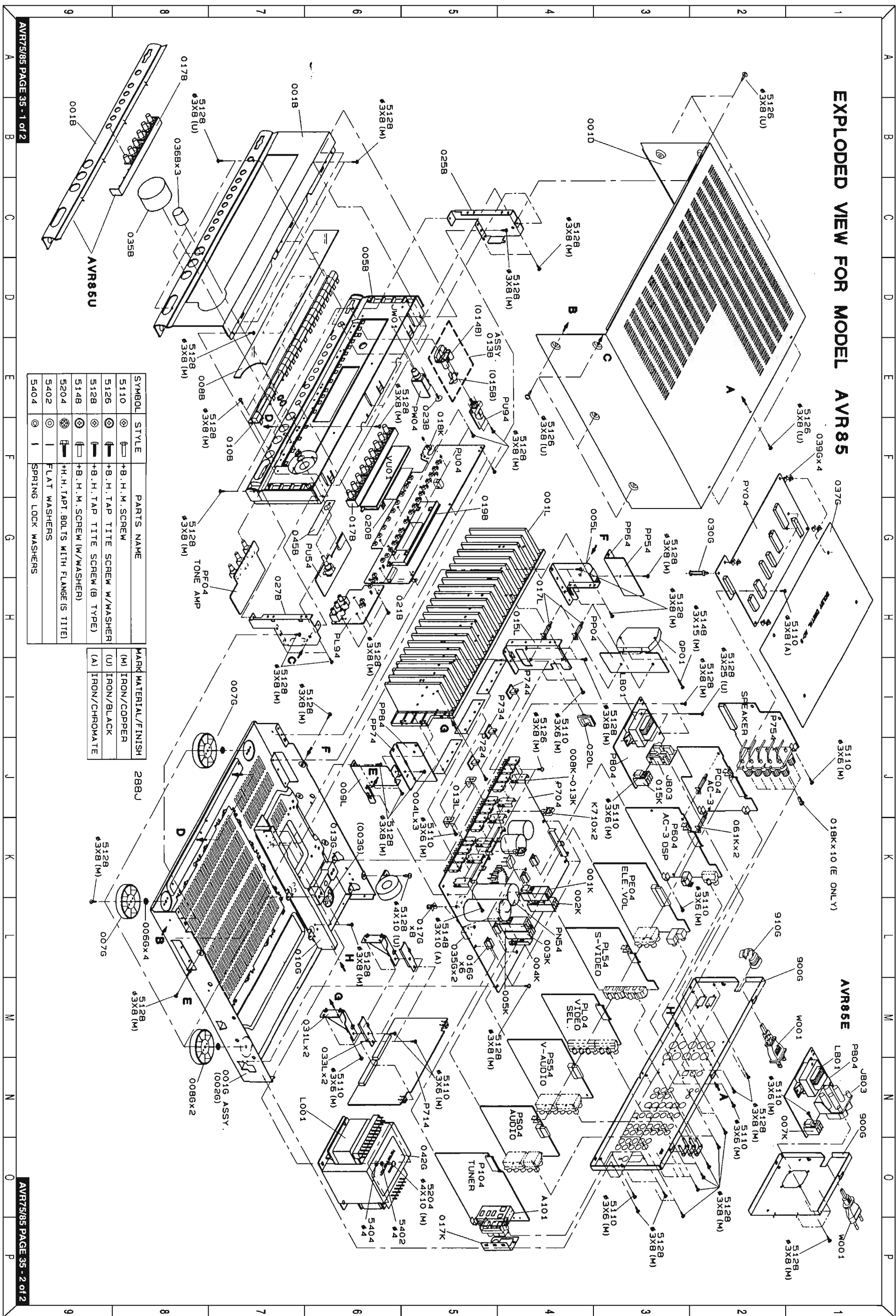

SYMBOL	STYLE	PARTS NAME	MARK MATERIAL/FINISH
5110	⊗	+B.H.M. SCREW	288J
5126	⊗	+B.H. TAP TITE SCREW W/WASHER	(M) IRON/COPPER
5128	⊗	+B.H. TAP TITE SCREW (B TYPE)	(U) IRON/BLACK
5148	⊗	+B.H.M. SCREW (W/WASHER)	(A) IRON/CHROMATE
5204	⊗	+H.H. TAPT. BOLTS WITH FLANGE (S TITE)	
5402	⊗	FLAT WASHERS	
5404	⊗	SPRING LOCK WASHERS	

AVR85 MECHANICAL EXPLODED VIEW (1)

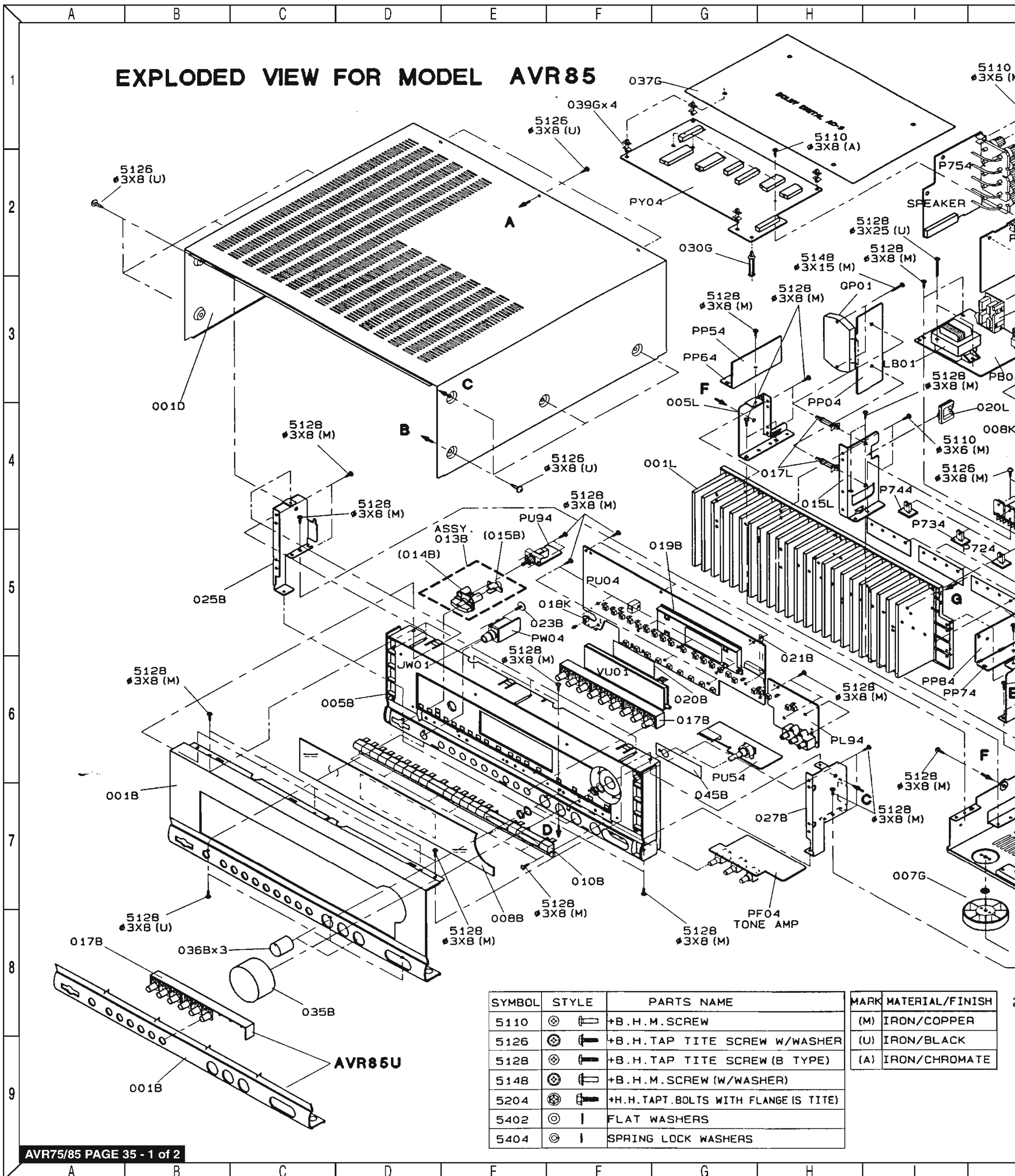

MECHANICAL EXPLODED VIEW (120V AND 230V)

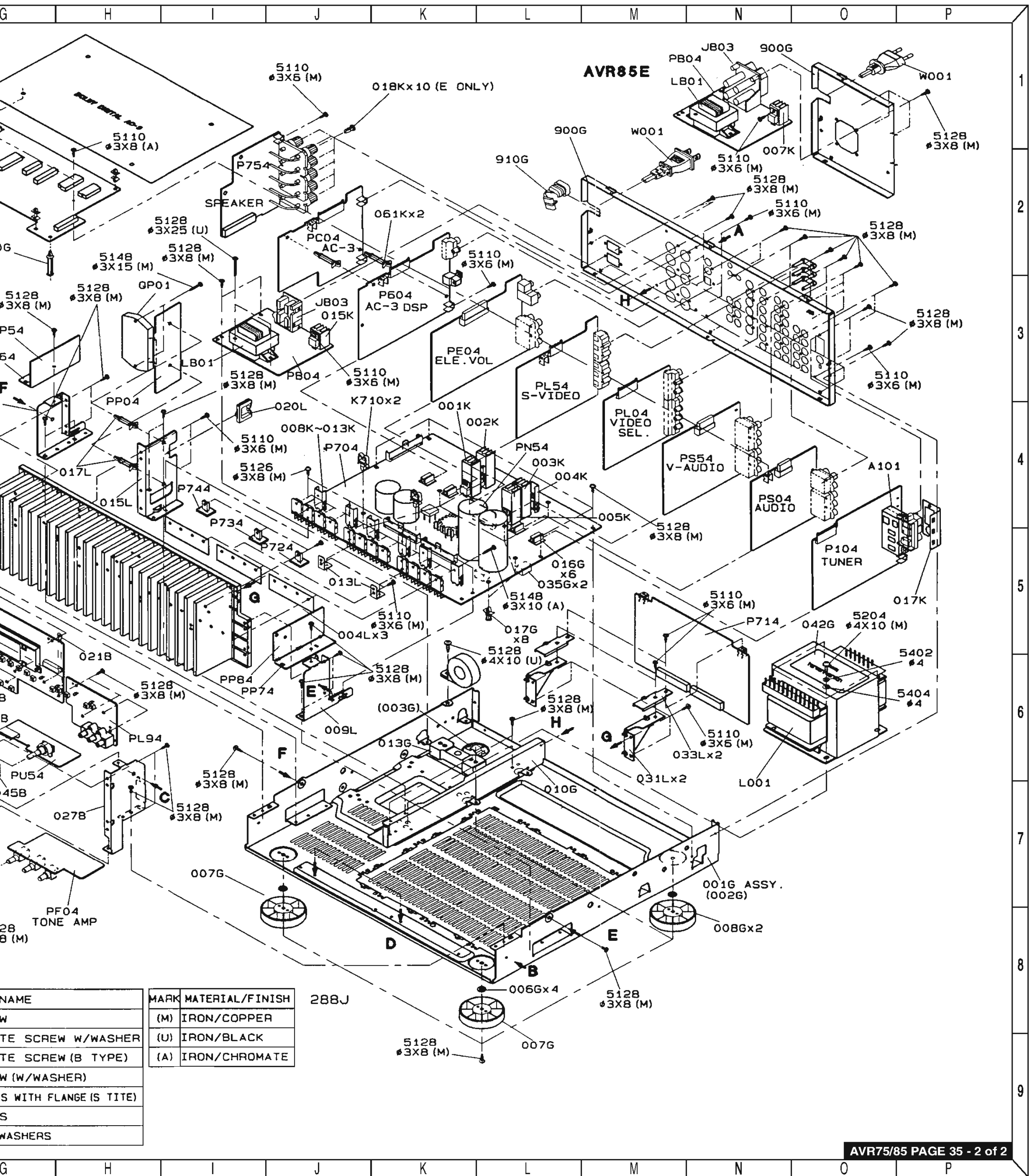

AVR85 MECHANICAL PARTS LIST (120V & 230V)

Ref.#	Part #	Description	Qty.	Ref.#	Part #	Description	Qty.
001B	260J248320	FRONT PANEL BLACK 120V	1	006G	227J056010	BUFFER, PEFU SHEET	4
	260J248310	FRONT PANEL BLACK 230V	1	007G	183J057010	LEG, FRONT	2
0058	260J105015	CHASSIS, FRONT MOLD	1	008G	183J057110	LEG, REAR	2
008B	260J158312	WINDOW	1	009G	51280308M0	SCREW, B.H. TAP. LEG	4
010B	260J270010	BUTTON, FUNCTION HINGE	1	010G	264J160010	BRACKET, TRANSFORMER	1
011B	51280308M0	SCREW, B.H. TAP. FUNCTION HINGE BUTTON	7	011G	51280308M0	SCREW, B.H. TAP. TRANSFORMER BRACKET	2
013B	260J270520	BUTTON, POWER BUTTON KIT	1	012G	5204010M0	BOLT, H. HEAD S.F. TRANSFORMER	4
014B	260J270050	BUTTON, POWER BUTTON	1	013G	260J271010	HOLDER, SUB TRANSFORMER BASE	1
015B	260J355020	LENS, POWER BUTTON LENS	1	014G	51280325U0	SCREW, B.H. TAP. SUB SUB TRANSFORMER	2
017B	260J270020	BUTTON, MODE HINGE BLACK 120V	1	015G	51280308M0	SCREW, B.H. TAP. DENGEN PCB	2
	260J270120	BUTTON, MODE HINGE BLACK 230V	1	016G	2218271020	HOLDER, VERTICAL PCB SUPPORT	7
019B	183J271022	HOLDER, FL HOLDER	1	017G	054J101020	SUPPORT, MAIN PCB SUPPORT	8
020B	056J122010	STICKER ADHESIVE FOR FL	1	018G	278L861010	LABEL, FUSE LABEL T1.6A 250V	4
021B	4220005040	CLAMPER FOR FLAT CABLE	1	020G	54040402A0	SPRING WASHER, FOR TRANSFORMER FIX	4
022B	51280308M0	SCREW, B.H. TAP. FUNCTION PCB	16	021G	54020401A0	FLAT WASHER P. WASHER FOR TRANSFORMER FIX	4
023B	183J010010	SCREW, PHONE PCB	1	030G	136J101020	SUPPORT, FOR CONNECTOR PCB	1
024B	51280308M0	SCREW, B.H. TAP. FOR POWER SWITCH	2	013G	51280410U0	SCREW, B.H. TAP. FOR EMC PART LOCK 120V & 230V	1
025B	264J160040	BRACKET, FRONT LEFT SIDE	1	035G	140S056040	BUFFER, FOR MAIN PCB	2
026B	51280308M0	SCREW, B.H. TAP FRONT LEFT SIDE	4	037G	288J053012	COVER	1
027B	264J160050	BRACKET, FRONT RIGHT SIDE	1	039G	329K101010	SUPPORT FOR COVER	4
028B	51280308M0	SCREW, B.H. TAP FRONT RIGHT SIDE BRACKET	4	041G	51100306M9	SCREW, MAIN PCB+SUB	2
030B	51280308U0	SCREW, B.H. TAP. ALUMINUM PANEL DOWN SIDE	3	042G	288J861013	LABEL, TRANSFORMER LABEL	1
031B	51280308M0	SCREW, B.H. TAP. ALUMINUM PANEL UP CENTER	1	900G	278J250222	REAR PANEL 120V	1
033B	51280308M0	SCREW, B.H. TAP. FRONT PANEL ASSEMBLY	4		278J250212	REAR PANEL 230V	1
035B	063J154180	KNOB, MAIN BLACK KNOB	1	901G	51280308M0	SCREW, B.H. TAP. RCA	20
036B	04J154022	KNOB, VOLUME KNOB	3	902G	51100306M9	SCREW, B.H.M. FOR CONTACTOR	5
041B	51280308M0	SCREW, B.H. TAP. FOR CLAMPER	1	903G	51100308A9	SCREW, B.H.M. CONNECT PCB	5
045B	288J123010	CONTACTOR	1	905G	51280308M0	SCREW, B.H. TAP. REAR PANEL	6
001D	264J257110	LID, TOP COVER BLACK	1	906G	51280308M0	SCREW, B.H. TAP. SPEAKER TERMINAL	3
005D	51260308U0	SCREW, B.T. (W/W) TOP COVER REAR	3	907G	51280308M0	SCREW, B.H. TAP. (120V) AC OUTLET	4
006D	51260308U0	SCREW, B.T. (W/W) TOP COVER SIDE	8			SCREW, B.H. TAP. (230V) AC OUTLET	2
001G	264J105500	CHASSIS, MAIN CHASSIS ASSEMBLY	1	910G	450H259010	BUSHING AC CODE BUSH 2271	1
002G	264J105010	CHASSIS, MAIN CHASSIS	1				
003G	030J114010	STOPPER	1				

AVR85 MECHANICAL PARTS LIST (120V & 230V) continued

Ref.#	Part #	Description	Qty.	Ref.#	Part #	Description	Qty.
915G	260J861010	LABEL, UL, CUL LABEL	1	L001	TS60513110	POWER TRANSFORMER (120V)	1
920G	95109111D0	LABEL, FACTORY ID TSK LABEL	1		TS60513120	POWER TRANSFORMER (230V)	1
001L	288J267010	HEATSINK, MAIN HEATSINK	1	LB01	TS14823240	STANDBY TRANSFORMER (230V)	1
002L	51480310A9	SCREW, F. WASHER POWER TRANSFORMER	12		TS14823230	STANDBY TRANSFORMER (120V)	1
003L	51480310A9	SCREW, F. WASHER REGULATOR TRANSFORMER	3	W001	YC01900260	AC POWER CORD (120V)	1
004L	288J107010	SHEET FOR POWER TRANSISTORS	3		YC01800790	AC POWER CORD (230V)	1
005L	264J160020	BRACKET, HEAT SINK LEFT SIDE BRACKET	1	JB03	YJ04002040	AC ACCESSORY JACK (120V)	1
006L	51280308M0	SCREW, B.H. TAP. LEFT SIDE BRACKET	2		YJ04002080	AC ACCESSORY JACK (230V)	1
009L	264J160030	BRACKET, HEAT SINK RIGHT SIDE BRACKET	1	L002	FC50380010	FERRITE CHOKE	1
010L	51280308M0	SCREW, B.H. TAP. RIGHT SIDE BRACKET	2	015K	009D267010	HEATSINK FOR QB01	1
013L	261J104010	RETAINER MAIN PCB RETAINER	2	Printed Circuit Boards			
014L	51100306M9	SCREW, B.H.M. MAIN PCB RETAINER	2	Part #	PCB Type		
015L	264J160060	BRACKET HEATSINK CENTER BRACKET	1	P714	VOLTAGE AMP PCB		
016L	51100306M9	SCREW, B.H.M. CENTER BRACKET	2	P604	AC-3/DAC PCB		
017L	090J101010	SUPPORT SURROUND PCB SUPPORT	2	P704	MAIN PCB		
018L	51480315M9	SCREW, F. WASHER SURROUND PACK	2	PS04	AUDIO FUNCTION PCB		
020L	287S005010	CLAMPER CLAMPER FOR CORD	1	PS54	AUDIO/VIDEO PCB		
025L	51260308M0	SCREW (W/W) B.T. MAIN PCB KARI	4	PE04	ELECTRONIC VOLUME CONTROL PCB		
026L	51260308M0	SCREW (W/W) B.T. MAIN PCB ASSEMBLY	2	PC04	AC-3 CROSSOVER PCB		
027L	51280308M0	SCREW, B.H. TAP. HEAT SINK ASSEMBLY	8	PU94	POWER SWITCH PCB		
028L	51280308M0	SCRWE, B.H. TAP. SIDE PCB	2	P754	SPEAKER TERMINAL PCB		
030L	51280308M0	SCREW, B.H. TAP. MAIN PCB ASSEMBLY	2	PL04	VIDEO SELECTOR PCB		
031L	288J160010	BRACKET BRACKET FOR SUB PCB(1)	2	PY04	CONNECT PCB		
032L	51100306M9	SCREW, B.H.M. BRACKET FOR PCB(1)	4	PL54	S-VIDEO PCB		
033L	288J160020	BRACKET BRACKET FOR SUB PCB(2)	2	P104	TUNER PCB		
034L	51100306M9	SCREW, B.H.M. BRACKET FOR SUB PCB(2)	2	PB04	STANDBY PCB		
QP01	HC10386030	STK401 IC	1	PP04	SURROUND AMP PCB		
				PU04	FRONT PCB		
				PU54	MASTER VOLUME PCB		
				PN54	SPEAKER PROTECT PCB		
				PF04	TONE CONTROL PCB		
				PL94	AUX IN		
				PW04	HEADPHONE PCB		

AVR75/85 ELECTRICAL PARTS LISTS

REF. NO.	Part No.	Description	Qty.	REF. NO.	Part No.	Description	Qty.
General Miscellaneous				Transistor			
WB01	YB00182170	CONNECTIVE CORD EHR-3P JB09(PB04)-JY11(PY04)	1	RB08	GD05103161	RESISTOR 10K OHM +- 5% 1/6W	1
WF01	YB00620140	"CONNECTIVE CORD 12P JF01(PF04)-JY15(PY04), JC02"	1	QB02	HT420331E1	! 2SD2033(E) 120V 1.8W ROHM	1
WP01	YB00331070	CONNECTIVE CORD UP-3P JP01(PP04)-JV57(PE04)	1	Miscellaneous			
WU02	YB00480330	CONNECTIVE CORD UP-7P JU02(PU04)-JB04(PB04)	1	JB01	YJ08000581	JACK ! FUSE CLIP 20MM	1
WU91	YB00501450	CONNECTIVE CORD JB10-JU92-JN82-JY14	1	JB01, 02	YJ08000170	JACK ! FUSE CLIP 20MM	2
WU92	YB00071960	CONNECTIVE CORD UP-3P JU91(PU94)-JU06(PU04)	1	JB02	YJ08000591	JACK ! FUSE CLIP 20MM	1
WV51	YB00331180	CONNECTIVE CORD JY16(PY04)- J701(P714)XJ804	1	JB03	YJ04002080	JACK ! AC OUTLET 2P (N)	1
WW02	YB00550780	CONNECTIVE CORD EHR-5P JW02(PW04)-J706(P704)	1	JB03	YJ04002040	JACK ! 2P AC OUTLET (CCT1304-0212)	1
WY01	YB00451340	CONNECTIVE CORD 8P JY10(PY04)-JL92(PL94)	1	JB04	YP06006670	PLUG 2MM PITCH UP CONNECTOR 7PIN	1
W602	YB00451350	CONNECTIVE CORD UP-7P J601(P604)-JU05(PU04)	1	JB05, 06	YP04000760	PLUG CONNECTOR 2P B3P-VH	2
W760	YB00122870	CONNECTIVE CORD VHR-5P J761(P754)-J803(P704)	1	JB07	YL01010241	GND TERMINAL FOR PCB	1
				JB09	YP0600383X	PLUG B3B-EH 3P RADIAL TAPING	1
				JB10	YP06006931	PLUG UP-3P CONNECTOR	1
				LB01	TS14823240	# POWER TRANSF. STANDBY EU 230V	1
				LB01	TS14823230	# POWER TRANSF. STANDBY USA 120V	1
				LB02	LY10240240	RELAY # VS24MB-NR TV-8 SEMKO LISTED	1
				015K	009D267010	HEATSINK FOR QB01	1
				016K	51100306M9	B.H.M. SCREW FOR QB01+015K	1

PCB - PB04, Standby

Capacitors

CB01	EA47703516	ELECTROLY CAP 470UF 35V	1
CB02	EA10606311	ELECT. CAP. 10UF M 63V	1
CB03	EA47603511	ELECT. CAP. 47UF M 35V	1
CB05	EA47705016	ELECT. CAP. 470UF/50V	1
CB06	EA47603511	ELECTROLY CAP. 47UF 35V	1
CB07, 08	DK18103311	CERAMIC CAP. 0.01UF Z 50V	2
CB09	DK17103847	CERAMIC CAP. # 0.01UF	1
CB10	EA10606311	ELECT. CAP. 10UF M 63V	1

Diodes

DB01, 02, 03, 04	HD20002711	DIODE 1D3 1A/200V	4
DB05	HD33301001	ZENER DIODE MTZJ33D 33V	1
DB06	HD30821001	ZENER DIODE NTJ8.2C 8.2V	1
DB07, 08	HD20002711	DIODE 1D3 1A/200V	2

Fuses

FB01	FS10400860	FUSE # 8A 250V (218004) SLO-BLO EU 230V	1
FB01	FS10630540	FUSE # 6.3A 250V SM6.3 SLO-BLO USA 120V	1
FB02, 03	FS20250201	FUSE # T2.5A/250V SLO-BLO EU 230V	2

Integrated Circuit

QB01	HC38905320	IC ! PQ05RR1 5V 1A REGULATOR	1
------	------------	------------------------------	---

Resistors

RB01	GG0510014X	RESISTOR ! 10 OHM +- 5% 1/4W	1
RB03	GA05471010	RESISTOR 470 OHM 1W	1
RB04, 05	GD05101161	RESISTOR 100 OHM J 1/6W	2
RB07	RC10225820	RESISTOR ! 2.2M OHMS K 1/2W	1

PCB - PC04, AC-3 Crossover

Capacitors

CC01, 02, 03, 04	DF15104351	FILM CAP. 0.1UF J 50V	4
CC05, 06	DA15220111	CERAMIC CAP. 22PF	2
CC07, 08, 09, 10, 11, 12	EJ10601611	ELECTROLY CAP 10UF 16V	6
CC13, 14, 15, 16	DF15104351	FILM CAP 0.1UF J 50V	4
CC17, 18, 19, 20, 21, 22	EJ10601611	ELECTROLY CAP 10UF 16V	6
CC23, 24	DA15220111	CERAMIC CAP 22PF 50V	2
CC25, 26	EJ10601611	CAP 10UF 16V	2
CC27, 28	DA15220111	CERAMIC CAP 22PF 50V	2
CC29, 30, 33, 34, 35, 36	EJ10601611	ELECTROLY CAP 10UF 16V	6
CC31, 32	DF15104351	FILM CAP 0.1UF J 50V	2
CC37	DA15220111	CERAMIC CAP 22PF 50V	1
CC38	DA15100121	CERAMIC CAP 10PF	1
CC39, 42, 45, 47, 49	EJ10601611	CAP 10UF 16V	5
CC40	DF15104351	FILM CAP 0.1UF J 50V	1
CC41	DF15823311	FILM CAP 0.082 J 50V	1
CC43	DF15223351	"FILM CAP 0.022UF, J, M, 50V"	1
CC44	DF15154351	"FILM CAP 0.15UF, J, T, 50V"	1
CC46	DA15100121	CERAMIC CAP 10PF	1
CC48	DA15220111	CERAMIC CAP 22PF 50V	1
CC52, 53	EA10701611	CAP 100UF 16V	2
CC54, 55, 56, 57, 58, 59, 62, 63, 64, 65, 66, 67, 70, 71, 75, 76, 77	DK18103311	CERAMIC CAP 0.01UF Z 50V	17

REF. NO.	Part No.	Description	Qty.
CC79	EA10601611	CAP 10UF 16V	1
CC80	EJ10601611	CAP 10UF 16V	1

Integrated Circuits

QC01, 02, 03 04, 05, 06, 07, 08, 09, 10	HC10008090	IC NJM4558DD DUAL OP-AMP	10
QC11	HC10123090	IC NJU7311L ANALOG SWITCH	1
QC12	HC10008090	IC NJM4558DD DUAL OP-AMP	1

Resistors

RC01, 02, 03, 04	GD05223161	RESISTOR 22K OHM +- 5% 1/6W	4
RC05, 06	GD05102161	RESISTOR 1K OHM 5% 1/6W	2
RC07, 08, 09, 10	GD05104161	RESISTOR 100K OHM J 1/6W	4
RC11, 12	GD05103161	RESISTOR 10K OHM J 1/6W	2
RC13, 14	GD05102161	RESISTOR 1K OHM J 1/6W	2
RC15, 16	GD05223161	RESISTOR 22K OHM J 1/6W	2
RC17, 18, 19, 20, 21, 22	GD05104161	RESISTOR 100K OHM J 1/6W	6
RC23, 24, 25, 26, 27, 28, 29, 30, 31, 32, 36	GD05103161	RESISTOR 10K OHM J 1/6W	11
RC33, 34, 38, 39, 40	GD05104161	RESISTOR 100K OHM J 1/6W	5
RC35	GD05223161	RESISTOR 22K OHM J 1/6W	1
RC37	GD05102161	RESISTOR 1K OHM J 1/6W	1
RC41	GD05103161	RESISTOR 10K OHM J 1/6W	1
RC42	GD05822161	RESISTOR 8.2K OHM 5% 1/6W	1
RC43, 47, 48	GD05183161	RESISTOR 18K OHM 5% 1/6W	3
RC44	GD05562161	RESISTOR 5.6K OHM J 1/6W	1
RC45	GD05331161	RESISTOR 330 OHM J 1/6W	1
RC46, 49, 52, 55, 58	GD05104161	RESISTOR 100K OHM J 1/6W	5
RC50, 51	GD05273161	RESISTOR 27K OHM 5% 1/6W	2
RC53, 56, 57, 62, 63, 64	GD05103161	RESISTOR 10K OHM J 1/6W	6
RC54	GD05682161	RESISTOR 6.8K OHM J 1/6W	1

Miscellaneous

JC01	YP06020870	PLUG 17P A1	1
JC02	YP06007150	PLUG 2MM PITCH SIDE CONNECTOR 5P	1
JC03, 04, 05	YL01010140	TERMINAL M1698 GND TERMINAL WITH M3	3

PCB - PW04, Headphone

Capacitors

CW09, 10, 11	DA17103111	CERAMIC CAP. 0.01UF M 16V	3
--------------	------------	---------------------------	---

Miscellaneous

JW01	YJ01004240	H.P. JACK HLJ2307-01-3160	1
JW02	YP0601045X	PLUG B5B-EH 5P RADIAL TAPING	1
WW01	YB00152110	CONNECTIVE CORD 1P 150 MM	1

PCB PU04, Front

Capacitors

CU01, 09	DA17223111	CERAMIC CAP. 0.022UF TP050F223Z TAIYO YUDEN	2
CU02	EX22300531	BIG ELECT. CAP 0.022 F 5.5V SUPER CAPACITOR	1
CU03	EJ47601011	ELECT. CAP. 47UF/10V	1
CU04	DA17223111	CERAMIC CAP. 0.022UF TP050F223Z TAIYO YUDEN	1
CU05, 08	DD38104011	CERAMIC CAP. 0.1 UF Z 50V	2
CU10	EJ22700611	ELECT. CAP. 220UF/6.3V	1
CU14, 15	DA16102111	CERAMIC CAP. 1000PF K 50V B	2

Diodes/LEDs

DU01, 02, 03	HD20029211	DIODE 1SS132	3
DU07, 08, 09 10, 11, 12, 13, 14, 15, 16, 17, 18	HD20002001	"DIODE 1SS176, MA165, 1SS254 30V 0.1A"	12
DU19	HI10062321	L.E.D. LT3D8B RED 30	1
DU20	HI10099320	L.E.D. GL3ED8 SHARP	1
DU21, 22	HD20002000	"DIODE 1SS176, MA165, 1SS245 30V 0.1A"	2
DU30, 31, 32, 33, 34, 35, 36, 37, 38	HI10095321	L.E.D. LT3K44B GREEN 30MA	9
DU40, 41, 42, 43, 45, 46, 47	HI10095321	L.E.D. LT3K44B GREEN 30MA	7

Integrated Circuits

QU01	HU288JT00F	MICROPROCESSOR TMP87CP71F-6630 8BIT U-COM	1
QU05	HC754100B0	IC 74HC541 DIP 3 STATE BUFFER/ LINE DRIVER	1

Resistors

DU39	GD05151161	RESISTOR 150 OHM +- 5%	1
RU01, 02, 03, 04, 05	GD05152161	RESISTOR 1.5K OHM +- 5% 1/6W	5
RU06, 07, 08, 09, 10	GD05222161	RESISTOR 2.2K OHM +- 5% 1/6W	5
RU11, 12, 13, 14, 15	GD05332161	RESISTOR 3.3K OHM +- 5% 1/6W	5
RU16, 17, 18, 19, 20	GD05332161	RESISTOR 6.8K OHM +- 5% 1/6W	5
RU21, 22, 23, 24, 25, 26, 27, 28, 29, 30	GD05103161	RESISTOR 10K OHM +- 5% 1/6W	10
RU36, 37	GD05151161	RESISTOR 150 OHM +- 5% 1/6W	2
RU39	GD05101161	RESISTOR 100 OHM +- 5% 1/6W	1
RU40, 43, 44, 45, 48, 51, 53, 54, 59, 64, 65	GD05103161	RESISTOR 10K OHM +- 5% 1/6W	11
RU41, 49, 50, 52, 55, 60, 67	GD05473161	RESISTOR 47K OHM +- 5% 1/6W	7
RU42	GD05183161	RESISTOR 18K OHM +- 5% 1/6W	1
RU46	GD05471161	RESISTOR 470 OHM +- 5% 1/6W	1
RU47	GD05221161	RESISTOR 220 OHM +- 5% 1/6W	1
RU56, 57, 58	GD05182161	RESISTOR 1.8K OHM +- 5% 1/6W	3
RU63	GD05100161	RESISTOR 10 OHM +- 5% 1/6W	1
RU66	GD05303161	RESISTOR 330 OHM +- 5% 1/6W	1
RU68	GG0501014X	RESISTOR 1 OHM +- 5% 1/4W	1

**Harman Kardon
Dolby Digital Audio/Video Receiver**

AVR75/85

REF. NO.	Part No.	Description	Qty.
RU69	GD05104161	RESISTOR 100K OHM +- 5% 1/6W	1

Switches

SU01, 02, 03, 04, 06, 07, 08, 09, 10, 11, 12, 13, 14, 15, 17, 18, 19, 20, 22, 23, 24, 25, 26, 28, 29, 30	SP0101128X	PUSH SWITCH TACK SWITCH ALPS-SKHVAE	26
--	------------	--	----

Transistors

QU02	BA20001001	"SEMICON.COMP DTC114ES/UN4211 10K, 10K"	1
QU03	BA10001001	"SEMICON.COMP DTA114ES/UN4111 10K, 10K"	1
QU04, 08, 14	BA20002001	"SEMICON.COMP DTC144ES/UN4213 47K, 47K"	3
QU06, 07, 10 12	HT30001001	"TRANSISTOR C536SP, C2458, C3311, C1740S"	4
QU09	HT10001001	"TRANSISTOR A608SP, A1048, A1309, A933S"	1
QU11, 15	BA10002001	"SEMICON.COMP DTA144ES/ UN4113 47K, 47K"	2
QU13	BA10003211	SEMICON.COMP DIGITAL TRANSISTOR DTA114TS	1

Miscellaneous

JU01	YJ07011160	JACK 9604S-23P	1
JU02	YP06007170	PLUG W-P7907	1
JU03	YJ06030640	JACK TSK-B04X-A1	1
JU04	YP06006290	PLUG S6B-XH-A	1
JU05	YP06001260	PLUG 2MM PITCH UP CONNECTOR 8PIN	1
JU06	YP06006931	PLUG UP-3P CONNECTOR	1
PU04	WA288J5010	PWB INSERT+CHIP ! UCOM/ FUNCTION-SW PCB	1
QU16	HW10001210	PHOTO UNIT IR RECEIVER RPM-670CBR H-15MM	1
VU01	HQ31210060	DISPLAY UNIT FIP12DM8R NEC 12WGIT 16SEG	1
XU01	FQ08004011	CERAMIC VIB.CST8.0MHZ (MT) TAPING	1
018K	152J118030	SPACER FOR DU20 LED SPACER	1

PCB - PL94, Aux In

Capacitor

CL91, 93, 94	EJ10601611	ELECT. CAP. 10UF/16V	3
CL92	EJ22601611	ELECT. CAP. 22UF/16V	1
CL97, 98	DA16681111	CERAMIC CAP. 680PF K 50V	2

LEDs

DU48	HI10095321	L.E.D. LT3K44B GREEN 30MA	1
DU49	HI10095321	L.E.D. LT3K44B GREEN 30MA	1

Miscellaneous

JL91	YT02030390	TERMINAL AUX YKC21-XXXX	1
JL92	YP06007260	PLUG UP-8P	1
JU52	YJ06008860	JACK 06JQ-ST	1
PL94	WA288J5040	INSERT+CHIP ! AUX IN PCB	1

REF. NO.	Part No.	Description	Qty.
----------	----------	-------------	------

Integrated Circuit

QL91	HC10008090	IC NJM4558DD DUAL OP-AMP	1
------	------------	--------------------------	---

Resistors

RL91	GD05100161	RESISTOR 10 OHM +- 5% 1/6W	1
RL92	GD05750161	RESISTOR 75 OHM +- 5% 1/6W	1
RL93, 94	GD05473161	RESISTOR 47K OHM +- 5% 1/6W	2
RL95, 96	GD05151161	RESISTOR 150 OHM +- 5% 1/6W	2
RU38	GD05100161	RESISTOR 10 OHM +- 5% 1/6W	1

Switches

SU05, 06, 21	SP0101128X	PUSH SWITCH TACK SWITCH ALPS-SKHVAE	3
--------------	------------	--	---

Miscellaneous

WL91	SP0101128X	CONNECTIVE CORD BOARD IN/#18 OFC	1
------	------------	----------------------------------	---

PCB -PU54, Master Volume

Capacitors

CU71	DA16102111	CERAMIC CAP. 1000PF K 50V B	1
CU72	DA16102111	CERAMIC CAP. 1000PF K 50V B	1

Diode

DU71	HD20002000	"DIODE 1SS176, MA165, 1SS254 30V 0.1A"	1
------	------------	--	---

Miscellaneous

JU51	YP06020740	PLUG TSK-B04P-A1	1
------	------------	------------------	---

Transistors

QU71, 72	HT30001001	"TRANSISTOR C536SP, C2458, C3311, C1740S"	2
----------	------------	--	---

Resistors

RU71, 72	GD05104161	RESISTOR 100K OHM +- 5% 1/6W	2
RU73, 74	GD05104161	RESISTOR 220K OHM +- 5% 1/6W	2

Switch

SU75	SR02010040	ROTARY SWITCH ENCODER EC16B40B0	1
------	------------	---------------------------------	---

Miscellaneous

WU71	YB00152520	CONNECTIVE CORD 1P CORD RUG-NON	1
------	------------	---------------------------------	---

PCB - P724

Miscellaneous

J717	YP06006931	CONNECTIVE PLUG UP 3P	1
Q725	HT33423100	TRANSISTOR 2SC3423 O	1

REF. NO. Part No. Description Qty.

PCB - P734

Miscellaneous

718	YP06006931	CONNECTIVE PLUG UP 3P	1
Q726	HT33423100	TRANSISTOR 2SC3423 O	1

PCB - P744

Miscellaneous

719	YP06006931	CONNECTIVE PLUG UP 3P	1
QH13	HT33423100	TRANSISTOR 2SC3423 O	1

PCB - P714, Voltage Amp

Capacitors

CH01	EA476016Q1	ELECT. CAP. 47UF/16V MATSUSHITA	1
CH02	DK16681301	CERAMIC CAP. 680PF K 50V	1
CH02, C703 C704	DD15680301	CERAMIC CAP. 68PF J CH 50V BLK	3
CH03	DF15102351	FILM CAP. J, M, 1000 PF 50V	1
CH04, 05	EA477063Q6	ELECT. CAP. 470UF/63V MATSUSHITA	2
CH06	DD10030301	CERAMIC CAP. 3PF C CJ 50V BLK	1
CH07	DK16101301	CERAMIC CAP. 100PF K 50V	1
CH08	EA108006Q1	ELECT. CAP. 1000UF/6.3V MATSUSHITA	1
CH09, 11	EA106100Q1	ELECT. CAP. 10UF/100V MATSUSHITA	2
CH12, 13	DF15104351	"FILM CAP. 0.1UF, J, N, 50V"	2
CH15, 16	DD15220550	CERAMIC CAP. 22PF J 500V CH	2
C701, 702	EA476016Q1	ELECT. CAP. 47UF/16V MATSUSHITA	2
C703, 704	DK16681301	CERAMIC CAP. 680PF K 50V	2
C705, 706	DF15102351	"FILM CAP. 0.001UF, J, M, 50V"	2
C707, 708, 709, 710	EA477063Q6	ELECT. CAP. 470UF/63V MATSUSHITA	4
C711, 712	DD10030301	CERAMIC CAP. 3PF C CJ 50V BLK	2
C713, 714	DK16101301	CERAMIC CAP. 100PF K 50V	2
C715, 716	EA108006Q1	ELECT. CAP. 1000UF/6.3V MATSUSHITA	2
C717, 718, 721, 722	EA106100Q1	ELECT. CAP. 10UF/100V MATSUSHITA	4
C723, 724, 725, 726	DF15104351	"FILM CAP. 0.1UF, J, N, 50V"	4
C740, 741, 742, 743	DD15220550	CERAMIC CAP. 22PF J 500V CH	4
CN73	EJ10601611	ELECT. CAP. 10 F M 16V	1
CN74	EJ22700611	ELECT. CAP. 220 F M 6.3V	1
CN75	DK16102300	CERAMIC CAP. 1000PF K 50V	1
CW01, 02	EA105050Q1	ELECT. CAP. 1UF/50V	2
CW03, 04	EA475050Q1	ELECT. CAP. 4.7UF/50V	2
CW05, 06	EA106050Q1	ELECT. CAP. 10UF/50V	2
CW07, 08	EA227016Q1	ELECT. CAP. 220UF/16V	2

Diodes

D701, 702	HD20029051	DIODE S5688G 400V 1A	2
D703, 704	HD20002001	"DIODE 1S1555/2473/2076, DS448, MA150"	2
DH01	HD20029051	DIODE S5688G 400V 1A	1
DH02, DN74	HD20002001	"DIODE 1S1555/2473/2076, DS448, MA150"	2

REF. NO. Part No. Description Qty.

Integrated Circuit

QW01	HC10016090	IC NJM4458D DUAL OP-AMP	1
------	------------	-------------------------	---

Resistors

RH01	GD05331141	RESISTOR 330 OHM +- 5% 1/4W	1
RH02	GD05333141	RESISTOR 33K OHM +- 5% 1/4W	1
RH03, 04	GD05152141	RESISTOR 1.5K OHM +- 5% 1/4W	2
RH05, 06	GD05331141	RESISTOR 330 OHM +- 5% 1/4W	2
RH07	GD05271161	RESISTOR 270 OHM +- 5% 1/6W	1
RH08	NH0510214X	FUSIBLE RESIST 1K OHM J 1/4W	1
RH09	GD05122141	RESISTOR 1.2K OHM +- 5% 1/4W	1
RH10	GD05333141	RESISTOR 33K OHM +- 5% 1/4W	1
RH11, 12, 13, 14, 15, 16, 17, 18	NF0256114X	FUSE RESISTOR 560 OHM G 1/4W	8
RH19, 20	GD05153141	RESISTOR 15K OHM +- 5% 1/4W	2
RH21, 22	NF0215114X	FUSE RESISTOR 150 OHM G 1/4W	2
RH23, 24	NH05100142	FUSIBLE RESIST 10 OHM J 1/4W	2
R701, 702	GD05331141	RESISTOR 330 OHM +- 5% 1/4W	2
R703, 704	GD05333141	RESISTOR 33K OHM +- 5% 1/4W	2
R705	GD05152141	RESISTOR 1.5K OHM +- 5% 1/4W	1
R706, 707, 708	GD05152141	RESISTOR 1.5K OHM +- 5% 1/4W	3
R709, 710, 711, 712	GD05331141	RESISTOR 330 OHM +- 5% 1/4W	4
R713, 14	GD05271161	RESISTOR 270 OHM +- 5% 1/6W	2
R715, 716	NH0510214X	FUSIBLE RESIST 1K OHM J 1/4W	2
R717, 18	GD05122141	RESISTOR 1.2K OHM +- 5% 1/4W	2
R719, 20	GD05333141	RESISTOR 33K OHM +- 5% 1/4W	2
R721, 722, 723, 724, 725, 726, 727, 728, 729, 730, 731, 732	NF0256114X	FUSE RESISTOR 560 OHM G 1/4W	12
R733, 734, 735, 736	NF0215114X	FUSE RESISTOR 150 OHM G 1/4W	4
R737, 738, 739, 740	GD05153141	RESISTOR 15K OHM +- 5% 1/4W	4
R741, 742, 743, 744	NF0215114X	FUSE RESISTOR 150 OHM G 1/4W	4
R745, 746, 747, 748	NH05100142	FUSIBLE RESIST 10 OHM J 1/4W	4
RN78, 79	GD05102161	RESISTOR 1K OHM +- 5% 1/6W	2
RW01, 02	GD05103161	RESISTOR 10K OHM +- 5% 1/6W	2
RW03, 04	GD05224161	RESISTOR 220K OHM +- 5% 1/6W	2
RW05, 06	GD05563161	RESISTOR 56K OHM +- 5% 1/6W	2
RW07, 08	GD05224161	RESISTOR 220K OHM +- 5% 1/6W	2
RW09, 10	GD05820161	RESISTOR 82 OHM +- 5% 1/6W	2
RW11, 12	GD05102161	RESISTOR 1K OHM +- 5% 1/6W	2
RW13, 14	NH05100142	FUSIBLE RESIST 10 OHM J 1/4W	2

Transistors

QH01, 02, 03 Q701, 702, 703, 704, 705, 706	HT317751E1	TRANSISTOR 2SC1775A E RANK	9
QH04, Q707, Q708	HT317401L1	TRANSISTOR 2SC1740S(R)	3
QH05, Q709, 710	HF203731Y1	F.E.T. 2SK373-Y TPE2	3
QH06, 07, Q711, 712, 713, 714	HT109701B1	TRANSISTOR 2SA970 (BL) TOSHIBA	6

**Harman Kardon
Dolby Digital Audio/Video Receiver**

AVR75/85

REF. NO.	Part No.	Description	Qty.
QH08, Q715, 716	HT322401B1	TRANSISTOR 2SC2240 (BL) TPE2 TOSHIBA	3
QH09, 11, Q717, 718, 721, 722,	HT111242R0	"TRANSISTOR 2SA1124 (R,S)"	6
QH10, 12, Q719, 720, 723, 724	HT326322R0	"TRANSISTOR 2SC2632 (R,S)"	6
QN71	BA20001001	"SEMICON.COMP DTC114ES/ UN4211 10K, 10K"	1
QN72	HT109331Q1	TRANSISTOR 2SA933S(Q)	1
QN73	HT317401L1	TRANSISTOR 2SC1740S(R)	1
QN74, 75	HT109331Q1	TRANSISTOR 2SA933S(Q)	2
QN76	BA10009211	SEMICON.COMP DTA144TS	1

Miscellaneous

J701, 706	YP0601045X	PLUG 85B-EH	2
J702	YP06019700	PLUG TAC-P20P-A1	1
J707	YL0101241X	TERMINAL GND TERMINAL FOR PCB	1
J708, 709, 710, 712	YL01010241	TERMINAL GND TERMINAL FOR PCB	4
J713	YP06019650	PLUG TAC-P15P-A1	1
J715	YP06019650	PLUG TAC-P15P-A1	1
J714, 716	YJ06020750	JACK TAC-P15X-A1	2
J720, 721	YL01010140	TERMINAL M1698 PWB GND	2

PCB - PP04, Surround Amp

Capacitors

CP01, 02	DK16222301	CERAMIC CAP. 2200PF K 50V	1
CP03, 04	EQ10606391	ELECT. CAP. 10UF M 63V	2
CP05, 06	EA10701611	ELECT. CAP. 100UF/16V	2
CP07, 08,	DD11100301	CERAMIC CAP. 10PF D CH 50V	2
CP09, 10, 11, 12	EJ22405011	ELECT. CAP. 0.22UF/50V	4
CP13, 15	EA10706311	ELECT. CAP. 100UF/63V	2
CP14	EA10706311	ELECT. CAP. 10UF M 63V	1
CP16	EA10606311	ELECT. CAP. 10UF M 63V	1
CP17	EJ22601011	ELECT. CAP. 22UF/10V	1
CP21, 22	DD15470301	CERAMIC CAP. 47PF J CH 50V BLK	2

Diodes

DP01, 02	HD20027011	DIODE HSS81TD 150V 150MA AXIAL TAPG.	2
----------	------------	--------------------------------------	---

Integrated Circuit

QP01	HC10386030	IC ! STK401-120 (70WX70W) POWER AMP	1
------	------------	-------------------------------------	---

Resistors

RP01, 02, 16	GD05102161	RESISTOR 1K OHM +- 5% 1/6W	3
RP01, 02	GD05471161	RESISTOR 470 OHM +- 5% 1/6W	2
RP03, 04	GD05473161	RESISTOR 47K OHM +- 5% 1/6W	2
RP05, 06	GD05563161	RESISTOR 56K OHM +- 5% 1/6W	2
RP07, 08	GD05222161	RESISTOR 2.2K OHM +- 5% 1/6W	2
RP09, 10	GD05513161	RESISTOR 51K OHM +- 5% 1/6W	2
RP11, 12	GD10222050	RESISTOR 0.22 OHM +- 10% 5W	2
RP13, 14, 15	GG0510216X	RESISTOR 1K OHM +- 5% 1/6W	3

REF. NO.	Part No.	Description	Qty.
RP17, 18	GD05273161	RESISTOR 27K OHM +- 5% 1/6W	2
RP19, 20	GD05223161	RESISTOR 22K OHM +- 5% 1/6W	2
RP21, 22	GA05100010	RESISTOR 10 OHM +- 5% 1W	2
RP23, 24	GD05221161	RESISTOR 220 OHM +- 5% 1/6W (AVR75/85 230V)	2
RP23, 23	GD05181161	RESISTOR 180 OHM +- 5% 1/6W (AVR75/85 120V)	2
RP25, 26	GG0510116X	RESISTOR 100 OHM +- 5% 1/6W	2
RP27	GD05682161	RESISTOR 6.8K OHM +- 5% 1/6W	1
RP28	GD05333161	RESISTOR 33K OHM +- 5% 1/6W	1
RP29	GD05100161	RESISTOR 10 OHM +- 5% 1/6W	1
RP99	GG0510014X	RESISTOR 10 OHM J 1/4W	1

Transistors

QP02, 03	HT322402A1	TRANSISTOR 2SC2240 GR OR BL TOSHIBA	2
QP04	HT109702A1	TRANSISTOR 2SA970 (GR) OR (BL) TOSHIBA	1

Miscellaneous

JP01	YP06006931	PLUG CONNECTIVE PLUG UP 3P	1
LP01	ML08010030	AIR COIL SPK CHOCK COIL VERTICAL TYPE	1
LP02	ML08010030	AIR COIL SPK CHOCK COIL VERTICAL TYPE	1
WP02	YB00170880	CONNECTIVE CORD VHR-6P/SDN-6P TO J802(P704)	1
WP03	YB00170870	CONNECTIVE CORD 1P 170MM	1

PCB - PN54, Speaker Protect

Capacitors

CN81, 82	EJ10505011	ELECT. CAP. 1 F M 50V	2
CN83	DD38104011	CERAMIC CAP. 0.1 50V	1

Diodes

DN81, 82	HD20002001	DIODE 1SS176	2
----------	------------	--------------	---

Resistors

RN84, 87	GD05473161	RESISTOR 47K OHM J 1/6W	2
RN85	GD05104161	RESISTOR 100K OHM J 1/6W	1
RN86	GD05103161	RESISTOR 10K OHM +- 5% 1/6W	1
RN88	GD05101161	RESISTOR 100 OHM J 1/6W	1

Transistors

QN81	BA10001001	"SEMICON.COMP DTA114ES/ UN4111 10K, 10K"	1
QN82, 83	HT322402A1	TRANSISTOR 2SC2240 GR OR BL	2

Miscellaneous

JN81	YJ06019130	JACK	1
JN82	YP06007130	3P PLUG	1
QN84	HC10042050	IC TA7317P OVERLOAD PROTECTOR	1

REF. NO. Part No. Description Qty.
PCB - P604 AC-3/DAC

Capacitors

C601, 605, 606, 609, 610, 612, 623, 633, 635, 636, 637, 638, 654, 655, 656	DK9810420Y	CERAMIC CAP. GRM39F104Z16 0.1UF	15
C602, 613	EA10700611	ELECT. CAP. 100UF/6.3V	2
C603, 604	DK9610420Y	CERAMIC CAP. 0.1 +- 10% B 10V	2
C607, 608, 631, 634, 651, 653	DD9510130Y	CERAMIC CAP. 100 PF +- 5% CG 50V GR39	6
C652	DK9622230Y	CERAMIC CAP. 2200 PF +- 10% B 25V GR39	1
CD59, 60	EJ10601611	ELECT. CAP. 10UF/16V	2
CD61, 62	DF15121551	FILM CAP. 120PF 100V	2
CD63	DF15561351	FILM CAP. 560PF J 50V	1
CD64	DF15561351	FILM CAP. 560PF J 50V	1
CD65, 66	EJ10601611	ELECT. CAP. 10UF/16V	2
CD67, 68	DK9810420Y	CERAMIC CAP. GRM39F104Z16 0.1UF	2
CK01, 02, 03, 13	EJ10601611	ELECT. CAP. 10UF/16V	4
CK04, 05, 06, 14	DK9810420Y	CERAMIC CAP. GRM39F104Z16 0.1UF MURATA	4
CK09, 10	DK9615230Y	CERAMIC CAP. 1500PF (GR39)	2
CK11, 12	DK9810420Y	CERAMIC CAP. GRM39F104Z16 0.1UF MURATA	2
CK15, 17, 19, 20	EA10700611	ELECT. CAP. 100UF/6.3V	4
CK16, 18	DK9810420Y	CERAMIC CAP. GRM39F104Z16 0.1UF MURATA	2
CM01	DK9622320Y	CERAMIC CAP. 0.022 UF +- 10% XTR 16V	1
CM02, 04	EA10700611	ELECT. CAP. 100UF/6.3V	2
CM03, 05, 11, 13	DK9810420Y	CERAMIC CAP. GRM39F104Z16 0.1UF	4
CM06	DK9610230Y	CERAMIC CAP. 1000 PF +- 10% B 50V	1
CM14, 15	DD9515130Y	CERAMIC CAP. 150 PF +- 5% CG 50V	2
CM18	DK9610420Y	CERAMIC CAP. 0.1 UF +- 10% B 10V	1
CM19	DK9610330Y	CERAMIC CAP. 0.01UF +- 10% 50V	1
CM31, 32	DF15105351	FILM CAP. 1 UF J 50V	2
CM33, 35	EA10700611	ELECT. CAP. 100UF/6.3V	2
CM34, 36, 37, 45, 51, 53, 54, 56, 57, 58, 59, 60, 63	DK9810420Y	CERAMIC CAP. GRM39F104Z16 0.1UF	13
CM39	EQ47601631	ELECT. CAP. 47UF/16V	1
CM41	DF15104351	"FILM CAP. 0.1UF, J, N, 50V"	1
CM42, 43	DK9610330Y	CERAMIC CAP. 0.01UF +- 10% 50V	2
CM44, 46	DD9518030Y	CERAMIC CAP. 18PF GR39	2
CM52	DD9510130Y	CERAMIC CAP. 100 PF +- 5% CG 50V GR39	1
CM61, 62	EA10700611	ELECT. CAP. 100UF/6.3V	2
CR01	DK9810420Y	CERAMIC CAP. GRM39F104Z16 0.1UF MURATA	1
CR02	EA10700611	ELECT. CAP. 100UF/6.3V	1
CR03	DK9610420Y	CERAMIC CAP. 0.1 UF +- 10% B 10V	1
CR04, 05	DK9610230Y	CERAMIC CAP. 1000 PF +- 10% B 50V GR36	2
CR05	DD9510130Y	CERAMIC CAP. 100 PF +- 5% CG 50V GR39	1
CR06, 08, 09, 11, 15, 16	DK9810420Y	CERAMIC CAP. GRM39F194Z16 0.1UF MURATA	6
CR07	EA10700611	ELECT. CAP. 100UF/6.3V	1

REF. NO.	Part No.	Description	Qty.
CR10	DK9610320Y	CERAMIC CAP. 0.01 UF +- 10% B 25V GR39	1
CR13, 14	DD9515030Y	CERAMIC CAP. 15 PF +- 5% CG 50V GR39	2

Diode

DM01	HZ4000342Z	CHIP DIODE KV1851-TL00 (TAPING)	1
------	------------	---------------------------------	---

Integrated Circuits

Q601	HC10013640	IC YSS243 (AC-3 DECODER)	1
Q602	HC10012640	IC YSS241F (PRO LOGIC DECODER)	1
Q603	HC1007600Z	IC 8X32K #NS High Speed Static RAM	1
Q604	HC715705ZY	IC TC74HC157A QUAD MULTIPLEXER	1
Q605	HC707400ZY	IC 74HC74 FLAT DUAL D TYPE FLIP-FLOP	1
Q606	HC700405WY	IC TC7W04F INVERTER X 3	1
Q607, 608	HC716400ZY	IC 74HC164F TAPING 8 Bit Shift Register	2
Q609	HC1040905Y	IC TCW125FU DUAL BUS BUFFER	1
Q651	HU278JT50F	MICROPROCESSOR TMP87CH40F (FOR AC-3 DECODE)	1
Q652	HC754100RZ	IC 74HC541 3 State Buffer/Line Driver	1
Q653	HC700000ZY	IC CMOS 74HCOO QUAD 2 INPUT NAND GATE	1
Q654	HC10075531	IC V-SENSOR IC S-806C 4.55V	1
QD01, 31	HC1012249Z	IC TDA1305T DAC	2
QD02, 32, 52	HC1002909Y	IC NJM4560M DUAL OP-AMP	3
QD51	HC1012249Z	IC TDA1305T DAC	1
QK01	HC1001748Y	IC 2CH 18BIT ADC AK5340	1
QK02, 03	HC1017209Y	IC NJM2115M DUAL OP-AMP	2
QM04	HC1006517Z	IC MC14577C VIDEO AMP	1
QM08	HC1002909Y	IC NJM4560M DUAL OP-AMP	1
QM09	HC10016660	IC PM4007A(AC-3) RF DEMODULATOR)	1
QM10	HC1007600Z	IC 8X32K SRAM #NS	1
QR01	HC10372030	IC LC8904Q DIGITAL AUDIO I/F	1
QR02	HC700000ZY	IC CMOS 74HC00 QUAD 2 INPUT NAND GATE	1

Transistors

QC53	HT328782A1	TRANSISTOR 2SC2878 A/B	1
QD54	BA10001001	.COMP TRANSISTOR DTA114ES/ETC	1
QM01, 02, 03	HX300012AY	"CHIP TR. (2SC) 2SC4081 (Q,R) 2SC4116 (Y,GR)"	3
QM05	HX300012AY	"CHIP TR. (2SC) 2SC4081 (Q,R) 2SC4116 (Y,GR)"	1
QM06, 07	HX100012AY	"CHIP TR. (2SA) 2SA1586 (Y,GR) 2SA1576A (Q,R)"	2

Resistors

L651, 652, 653, 654, 655, 656, 657, 658, 659, 671, 672, 673, 674, 675, 676	NN0500061Y	CHIP RESISTOR 0 OHM +- 5% 1/16W	15
L660	NN0522161Y	CHIP RESISTOR 220 OHM +- 5% 1/16W	1
R601, 607, 608, 621, 640	NN0510161Y	CHIP RESISTOR 100 OHM +- 5% 1/16W	5
R602	NN0512361Y	CHIP RESISTOR 12K OHM +- 5% 1/16W	1
R603	NN0582161Y	CHIP RESISTOR 820 OHM +- 5% 1/16W	1
R604, 605, 606, 609, 610, 611, 613	NN0547061Y	CHIP RESISTOR 47 OHM 1/16W	7
R631, 632, RG633, 634, 635, 636, 637, 638, 639	NN0547061Y	CHIP RESISTOR 47 OHM 1/16W	9

**Harman Kardon
Dolby Digital Audio/Video Receiver**

AVR75/85

REF. NO.	Part No.	Description	Qty.	REF. NO.	Part No.	Description	Qty.
R651, 654	NN0547261Y	CHIP RESISTOR 4.7K OHM 1/16W	2	RR07	NN0533361Y	CHIP RESISTOR 33K OHM 1/16W	1
R652	NN0510361Y	CHIP RESISTOR 10K OHM 1/16W	1	RR08	NN0510161Y	CHIP RESISTOR 100 OHM 1/16W	1
R653	NN0510361Y	CHIP RESISTOR 2.2K OHM 1/16W	1	RR09	NN0510361Y	CHIP RESISTOR 10K OHM 1/16W	1
R655, 656, 657, 658	NN0522261Y	CHIP RESISTOR 2.2K OHM 1/16W	4	RR10, 11	NN0512361Y	CHIP RESISTOR 12K OHM 1/16W	2
R659, 661	NN0500061Y	CHIP RESISTOR 0 OHM 1/16W	2	RR12, 13	NN0556261Y	CHIP RESISTOR 5.6K OHM 1/16W	2
R693	NN0510361Y	CHIP RESISTOR 10K OHM 1/16W	1	RR14	NN0512161Y	CHIP RESISTOR 120 OHM 1/16W	1
RD01, 02, 07, 08, 31, 32, 37, 38, 51, 52, 57, 58	NN0547361Y	CHIP RESISTOR 47K OHM 1/16W	12	RR15	NN0522461Y	CHIP RESISTOR 220K OHM 1/16W	1
RD03, 04, 05 06, 09, 10, 33, 34, 35, 36, 39, 40, 53, 54, 55, 56, 62, 63, 64	NN0510361Y	CHIP RESISTOR 10K OHM +- 5% 1/16W	19	RR16	NN0500061Y	CHIP RESISTOR 0 OHM 1/16W	1
RD59	NN0510261Y	CHIP RESISTOR 1K OHM +- 5% 1/16W	1	RR17, 18, 19, 20	NN0533061Y	CHIP RESISTOR 33 OHM 1/16W	4
RD60	NN0547161Y	CHIP RESISTOR 470 OHM +- 5% 1/16W	1	RR21, 23, 24	NN0500061Y	CHIP RESISTOR 0 OHM +- 5% 1/16W	3
RD61	NN0510561Y	CHIP RESISTOR 1.0M OHM 1/16W	1	Miscellaneous			
RK01, 02	NN0515361Y	CHIP RESISTOR 15K OHM 1/16W	2	J601	YP06020640	PLUG	1
RK03, 04	NN0510361Y	CHIP RESISTOR 10K OHM 1/16W	2	J602, 603	YL01010140	TERMINAL M1698 GND TERMINAL WITH M3	2
RK05, 06, 07, 08	NN0547261Y	CHIP RESISTOR 4.7K OHM 1/16W	4	J651	YJ0700677Y	JACK 53261-0790(1.25MM-7PIN)	1
RK09, 10 11, 12	NN0510361Y	CHIP RESISTOR 10K OHM 1/16W	4	JR01	YT02021400	TERMINAL YKC21-3211	1
RK13, 14 15, 16	NN0533161Y	CHIP RESISTOR 330 OHM 1/16W	4	JR02	YJ15000150	OPT. CONNECTOR GP1F32R OPTICAL RECEIVER	1
RM01	NN0556161Y	CHIP RESISTOR 560 OHM 1/16W	1	L601, 602, 603, 604	FM12223011	FILTER 0.022UF	4
RM02	NN0510161Y	CHIP RESISTOR 100 OHM 1/16W	1	L605	FC90090011	FERRITE CORE ZBF503D-00TA (NATIONAL)	1
RM03, 10, 12	NN0510261Y	CHIP RESISTOR 1K OHM 1/16W	3	L606	FM12223011	FILTER 0.022UF	1
RM04	NN0518261Y	CHIP RESISTOR 1.8K OHM 1/16W	1	LK01	FC90090011	FERRITE CORE ZBF503D-00TA (NATIONAL)	1
RM05, 06, 19 35	NN0510361Y	CHIP RESISTOR 10K OHM 1/16W	4	LM01	LU1268301Y	CHIP INDUCTANCE CHIP INDUCTOR 68UH	1
RM07, 32	NN0547261Y	CHIP RESISTOR 4.7K OHM 1/16W	2	LM02	FF30288010	L.C. FILTER SBP-4930 2.88MHZ B.P.F	1
RM08	NN0500061Y	CHIP RESISTOR 0 OHM 1/16W	1	W601	NN0510361Y	CONNECTIVE CORD 1P SIN-01T1.2 BLK	1
RM11	NN0547281Y	CHIP RESISTOR 4.7K OHM 1/16W	1	X651	FQ0800403Y	CERAMIC VIB. 8.0MHZ TYPE(EF0 V) TAPING	1
RM13	NN0515161Y	CHIP RESISTOR 150 OHM 1/16W	1	XM01	JX1800138Y	CRYSTAL 18.432MHZ	1
RM14	NN0522261Y	CHIP RESISTOR 2.2K OHM 1/16W	1	XR01	JX2400138Y	CRYSTAL CX-5F 24.576MHZ	1
RM15, 16, 17, 18, 20, 21, 23	NN0510261Y	CHIP RESISTOR 1K OHM 1/16W	7	PCB - PU94, Power Switch			
RM22	NN0547261Y	CHIP RESISTOR 4.7K OHM 1/16W	1	JU91	YP06006391	PLUG CONNECTIVE PLUG UP 3P	1
RM24	NN0533261Y	CHIP RESISTOR 3.3K OHM 1/16W	1	JU92	YP06006391	PLUG CONNECTIVE PLUG UP 3P	1
RM25	NN0582261Y	CHIP RESISTOR 8.2K OHM 1/16W	1	SU91	SP02011573	PUSH SWITCH ALPS LOCK TYPE	1
RM31	NN0539261Y	CHIP RESISTOR 3.9K OHM 1/16W	1	PCB - P704, Main			
RM33	NN0510461Y	CHIP RESISTOR 100K OHM 1/16W	1	Capacitors			
RM34, 41	NN0522361Y	CHIP RESISTOR 22K OHM 1/16W	2	C801, 804	DK18103566	CERAMIC CAP. 0.01 Z E 500V	2
RM42	NN0568361Y	CHIP RESISTOR 68K OHM 1/16W	1	C802, 03	EB18906310	ELECT. CAP. 18000UF 63V D35XL80 LH6	2
RM43	NN0512161Y	CHIP RESISTOR 120 OHM 1/16W	1	C805, 806	EB68806370	ELECT. CAP. 6800UF M 63V D25XL45 LP5	2
RM44	NN0547361Y	CHIP RESISTOR 47K OHM 1/16W	1	C807, 808	DK18103311	CERAMIC CAP. 0.01UF Z 50V	2
RM45, 46	NN0510361Y	CHIP RESISTOR 10K OHM 1/16W	2	C809, 810	EA33802516	ELECT. CAP. 3300UF/25V	2
RM47, 48, 49	NN0547361Y	CHIP RESISTOR 47K OHM 1/16W	3	C811, 812	DK18103311	CERAMIC CAP. 0.01UF Z 50V	2
RM50	NN0522061Y	CHIP RESISTOR 22 OHM +- 5% 1/16W	1	C813, 814, 821, 822, 823	EA10701611	ELECT. CAP. 100UF/16V	5
RM61	NN0510161Y	CHIP RESISTOR 100 OHM 1/16W	1	C815, 816, 824	DK18103311	CERAMIC CAP. 0.01UF Z 50V	3
RM62	NN0510261Y	CHIP RESISTOR 1K OHM 1/16W	1	C817	EA33801616	ELECT. CAP. 3300UF M 16V	1
RM63	NN0510361Y	CHIP RESISTOR 10K OHM 1/16W	1	C818	EA22801616	ELECT. CAP. 2200UF/16V	1
RM64	NN0510381Y	CHIP RESISTOR 10K OHM 1/16W	1	C819	EA68801686	ELECT. CAP. 6800UF/16V +-20%	1
RM65, 66	NN0500061Y	CHIP RESISTOR 0 OHM 1/16W	2				
RR01, 02, 03	NN0575061Y	CHIP RESISTOR 75 OHM 1/16W	3				
RR04, 06	NN0556361Y	CHIP RESISTOR 56K OHM 1/16W	1				
RR05	NN0533461Y	CHIP RESISTOR 330K OHM 1/16W	1				

**Harman Kardon
Dolby Digital Audio/Video Receiver**

AVR75/85

REF. NO.	Part No.	Description	Qty.	REF. NO.	Part No.	Description	Qty.
C820	DA17103111	CERAMIC CAP. 10000PF	1	RH25	GD05102161	RESISTOR 1K OHM +- 5% 1/6W	1
C825, 826, 827, 828, 829	EA10701611	ELECT. CAP. 100UF/16V	5	RH26	GD05472161	RESISTOR 4.7K OHM +- 5% 1/6W	1
C831, 832	EA22701611	ELECT. CAP. 220UF/16V	2	RH27	GD05562161	RESISTOR 5.6K OHM +- 5% 1/6W	1
CN01, 02	DF15683311	FILM CAP. 0.068 J 50V	2	RH28	RA01020781	TRIMMING RESIST 1K OHM RH0638CJ3R TYPE ALPS	1
CN03	EA10601611	ELECT. CAP. 10UF M 16V	1	RH29	GD05561161	RESISTOR 560 OHM +- 5% 1/6W	1
CN04	EJ33505011	ELECT. CAP. 3.3UF 50V	1	RH30, 31	NF0210114X	FUSE RESISTOR 100 OHM G 1/4W	2
CN04	EJ22505011	ELECT. CAP. 2.2UF 50V	1	RH32, 33	NF0215014X	FUSE RESISTOR 15 OHM G 1/4W	2
CN05	DD38104011	CERAMIC CAP. 50V DC 0.1UF +80-20%	1	RH34	NF0282014X	FUSE RESISTOR ! 82 OHM G 1/4W	1
CN06, 07	EJ47601611	ELECT. CAP. 47UF/16V	2	RH35, 36	NH0502214X	FUSIBLE RESIST 2.2 OHM G 1/4W	2
CN08	EJ10505011	ELECT. CAP. 1UF/50V	1	RH37, 38	GW10222050	RESISTOR 0.22 OHM 5W	2
CN09	EJ10701611	ELECT. CAP. 100UF/16V	1	RH39	NK05100010	METAL RESISTOR 10 OHM +- 5% 1W	1
CN10, 12	DD38104011	CERAMIC CAP. 0.1 Z 50V	2	RH40	NK05150020	METAL RESISTOR 15 OHM +- 5% 2W	1
CN51	DF15683311	FILM CAP. 0.068 J 50V	1	RH41	GD05100161	RESISTOR 10 OHM J 1/6W	1
CN71	EJ10505011	ELECT. CAP. 1UF/50V	1	RH42	GD05224141	RESISTOR 220K OHM +- 5% 1/4W	1
CN72	EJ10605011	ELECT. CAP. 50V	1	RH43, 44	GW10222050	RESISTOR 0.22 OHM 5W	2
Diodes				RN01, 02, 03, 04, 05, 06	GD05152161	RESISTOR 1.5K OHM +- 5% 1/6W	6
D801, 802	HE20012290	DIODE ! D5FB20 200V 5A W/FIN	2	RN07, 08	GD05393161	RESISTOR 39K OHM +- 5% 1/6W	2
D803, 804	HE20011290	DIODE ! S2VB20	1	RN10, 11, 12	GD05472161	RESISTOR 4.7K OHM +- 5% 1/6W	3
D805, 806, 807, 808, 809	HD20002711	DIODE 1D3 1A/200V	5	RN13, 14, 21	GD05473161	RESISTOR 47K OHM +- 5% 1/6W	3
DN01, 02, 03, 04, 09, 51, 72, 73	HD20002711	DIODE 1D3 1A/200V	8	RN15	GD05104161	RESISTOR 100K OHM +- 5% 1/6W	1
DN71	HD30511001	DIODE 5.1V ZENER	1	RN16	GD05822161	RESISTOR 8.2K OHM +- 5% 1/6W	1
Integrated Circuits				RN20	GG0522214X	RESISTOR 2.2K OHM +- 5% 1/4W	1
Q801	HC3891509F	IC ! NJM7815FA +15V 1A REGULATOR	1	RN22, 72	GD05333161	RESISTOR 33K OHM +- 5% 1/6W	2
Q802	HC3991509F	IC ! NJM7915FA -15V 1A REGULATOR	1	RN23, 24, 25, 26, 55	GD05683161	RESISTOR 68K OHM +- 5% 1/6W	5
Q803	HC3890509F	IC ! NJM7805FA +5V 1A REGULATOR	1	RN27, 32	GD05223161	RESISTOR 22K OHM +- 5% 1/6W	2
Q804	HC3990509F	IC ! NJM7905FA -5V 1A REGULATOR	1	RN30, 31, 33 75	GD05103161	RESISTOR 10K OHM +- 5% 1/6W	4
Plugs				RN35	GG0510018X	RESISTOR ! 10 OHM +- 5% 1/6W	1
J801	YP06010950	PLUG B5P-VH 5P BASE POST 7A	1	RN36, 71, 74	GD05222161	RESISTOR 2.2K OHM J 1/6W	3
J802	YP06003690	PLUG B6P-VH 6P BASE POST 7A	1	RN51, 52, 53	GD05152161	RESISTOR 1.5K OHM +- 5% 1/6W	3
J803	YP06010950	PLUG B5P-VH 5P BASE POST 7A	1	RN54	GD05393161	RESISTOR 39K OHM +- 5% 1/6W	1
J804	YP06006680	PLUG W-UP7508	1	RN61, 62	GD05472161	RESISTOR 4.7K OHM +- 5% 1/6W	2
Resistors				RN73	GD05153161	RESISTOR 15K OHM +- 5% 1/6W	1
R749, 750	GD05102161	RESISTOR 1K OHM +- 5% 1/6W	2	RN76, 77	NF0568114X	FUSE RESISTOR 680 OHM G 1/4W (AVR75/85 230V)	2
R751, 752	GD05472161	RESISTOR 4.7K OHM +- 5% 1/6W	2	RN76, 77	NH0568114X	FUSIBLE RESIST 680 OHM J 1/4W (AVR75/85 120V)	2
R753, 754	GD05562161	RESISTOR 5.6K OHM +- 5% 1/6W	2	Q805, 806	GG05022120	RESISTOR 2.2 OHM +- 5% 1/2W	2
R755, 756	RA01020781	TRIMMING RESIST 1K OHM RH0638CJ3R TYPE ALPS	2	Transistors			
R757, 758	GD05561161	RESISTOR 560 OHM +- 5% 1/6W	2	Q727, 728	HT322401B1	TRANSISTOR 2SC2240 (BL) TPE2 TOSHIBA	2
R759, 760, 761, 762	NF0210114X	FUSE RESISTOR 100 OHM G 1/4W	4	Q729, 730	HT326322R0	"TRANSISTOR 2SC2632 (R,S)"	2
R763, 764 765, 766	NF0215014X	FUSE RESISTOR 15 OHM G 1/4W	4	Q731, 732	HT111242R0	"TRANSISTOR 2SA1124 (R,S)"	2
R767, 768 769, 770, 771, 772	NF0282014X	FUSE RESISTOR ! 820HM G 1/4W	6	Q733, 734	HT11930000	TRANSISTOR 2SA1930 (R) OR (O)	2
R773, 774 775, 776	GW10222050	RESISTOR 0.22 OHM 5W	4	Q735, 736	HT35171000	TRANSISTOR 2SC5171 (R) OR (O)	2
R777, 778	NK05100010	METAL RESISTOR 10 OHM +- 5% 1W	2	Q737, 738,	HT351982A0	TRANSISTOR ! 2SC5198	2
R779, 780	NK05150020	METAL RESISTOR 15 OHM +- 5% 2W	2	Q739, 740,	HT119412A0	TRANSISTOR ! 2SA1941	2
R781, 782	GD05100161	RESISTOR 10 OHM +- 5% 1/6W	2	Q741, 742	HT351982A0	TRANSISTOR ! 2SC5198	2
R783, 784 785, 786	GW10222050	RESISTOR 0.22 OHM 5W	4	Q743, 744	HT119412A0	TRANSISTOR ! 2SA1941	2
				QH14	HT322401B1	TRANSISTOR 2SC2240 (BL) TPE2 TOSHIBA	1
				QH15	HT326322R0	"TRANSISTOR 2SC2632 (R,S)"	1
				QH16	HT111242R0	"TRANSISTOR 2SA1124 (R,S)"	1
				QH17	HT11930000	TRANSISTOR 2SA1930 (R) OR (O)	1
				QH18	HT35171000	TRANSISTOR 2SC5171 (R) OR (O)	3
				QH19, 21	HT351982A0	TRANSISTOR ! 2SC5198	2
				QH20, 22	HT119412A0	TRANSISTOR ! 2SA1941	2

**Harman Kardon
Dolby Digital Audio/Video Receiver**

AVR75/85

REF. NO.	Part No.	Description	Qty.
QN01, 02, 51	HT322402A1	TRANSISTOR 2SC2240 OR BL	3
QN03	HT109702A1	TRANSISTOR 2SA970 () OR (BL) TOSHIBA	1
QN07	HT10001001	"TRANSISTOR A608SP, A1048, A1309, A933S"	1
QN08	HT316272B1	"TRANSISTOR 2SC1627 O,Y 80V 300MA 600MW TO"	1

Miscellaneous

001K	A009D267010	HEATSINK FOR Q801	1
002K	A009D267010	HEATSINK FOR Q802	1
003K	A009D267010	HEATSINK FOR Q803	1
004K	A009D267010	HEATSINK FOR Q804	1
005K	A009D267010	HEATSINK FOR Q805	1
006K	51280308M0	B.H. TAP. SCREW FOR Q804+004K	1
007K	51100306M9	"B.H.M. SCREW FOR 001K, 002K, 003K, 005K"	4
008K	A001J267050	HEATSINK FOR Q733	1
009K	A001J267050	HEATSINK FOR Q735	1
010K	A001J267050	HEATSINK FOR Q734	1
011K	A001J267050	HEATSINK FOR Q736	1
012K	A001J267050	HEATSINK FOR QH17	1
013K	A001J267050	HEATSINK FOR QH18	1
014K	51280308M0	B.H. TAP. SCREW FOR 008K-013K	6
017K	2886005050	CLAMPER NIFCO CLAMPER #175	2
019K	288J152010	"GLASS TUBE 70MM TO W701, 702, 703"	3
J723, 724, 725	YP0600383X	PLUG B3B-EH 3P RADIAL TAPING	3
JN01	YP06013130	PLUG	1
LH01, L701 L702	ML08010030	AIR COIL SPK CHOCK COIL VERTICAL TYPE 3	3
LN01, 02, 51	LY20180020	RELAY 5A AC240V	3
LN03	LY20240410	RELAY ! MR62-24SR 24V RELAY	1
W701	YB00105440	CONNECTIVE CORD CONNECTIVE PLUG UP 3P	1
W702	YB00105440	CONNECTIVE CORD CONNECTIVE PLUG UP 3P	1
W703	YB00105440	CONNECTIVE CORD CONNECTIVE PLUG UP 3P	1
W801	YB00230470	CONNECTIVE CORD 1P 230 MM	1
W802, 803, 804	YB00430310	CONNECTIVE CORD SIN-21T-1.8 AWG18	3

PCB - PS04, Audio Function

Capacitors

CS01, 02, 03, 04, 05, 06	EJ47601611	ELECT. CAP. 47UF/16V	6
CS09, 10, 13, 14	EA10701611	ELECT. CAP. 100UF/16V	4
CS15, 16	EJ47502511	ELECT. CAP. 4.7UF/25V	2
CS17, 18	EJ10601611	ELECT. CAP. 10UF/16V	2
CS19, 21, 22	DD38104011	CERAMIC CAP. 50V DC 0.1UF +80 -20%	3
CS23, 24, 25, 26, 30	DK16151301	CERAMIC CAP. 150PF K 50V	5
CS27, 28	DK16221301	CERAMIC CAP. 220PF K 50V	2
CS29	DK16151011	CERAMIC CAP. 150PF K 50V	1
CS31, 32	DK16221301	CERAMIC CAP. 220PF K 50V	2
CS34, 35, 36, 37, 38	DK16221301	CERAMIC CAP. 220PF K 50V	5

REF. NO.	Part No.	Description	Qty.
Integrated Circuits			
QS01, 02, 03	HC10008090	IC NJM4558D-D DUAL OP-AMP	3
QS11	HC10308030	IC LC78211ANALOG SWITCH	1
QS12	HC10310030	IC LC78213ANALOG SWITCH	1
QS13	HC10008090	IC NJM4558DD DUAL OP-AMP	1

Resistors

RS01, 02, 03, 04, 05, 06	GD05473161	RESISTOR 47K OHM J 1/6W	6
RS07, 08, 09, 10, 11, 12	GD05102161	RESISTOR 1K OHM J 1/6W	6
RS13, 14, 15, 16, 17, 18	GD05473161	RESISTOR 47K OHM +- 5% 1/6W	6
RS21, 22, 27, 28	GD05102161	RESISTOR 1K OHM J 1/6W	4
RS29, 30, 31, 32, 33, 34	GD05104161	RESISTOR 100K OHM J 1/6W	6
RS43, 44, 45, 46	GD05222161	RESISTOR 2.2K OHM J 1/6W	4

Miscellaneous

JS01	YT02060460	TERMINAL 14X14 RA 2L6P NI	1
JS02	YT02040940	TERMINAL RCA PIN JACK RA2L4P	1
JS03	YJ06030570	JACK 16P	1
JS04	YL01010140	TERMINAL GROUND TERMINAL FOR PCB	1

PCB - P754, Speaker Terminal

Capacitors

C727, 728, 729, 730, 731, 732, 733, 734, 764, 765	DK16221551	CERAMIC CAP. 220PF K B 500V	10
---	------------	-----------------------------	----

Miscellaneous

J703	YJ06020800	JACK TAC-P20X-A1	1
J704	YT01040790	TERMINAL LTS0410-1002	1
J751	YT01060020	TERMINAL LTS0610-3001	1
J752	YL01010140	TERMINAL M1698 PWB GND TERMINAL WITH M3	1
J760, 61	YP06011050	PLUG B5PS-VH	2
J762, 64, 66, 768	YJ08000591	JACK CLIP FOR 20MM FUSE ON PCB	4
J763, 65, 67, 69	YJ08000581	JACK CLIP FOR 20MM FUSE ON PCB	4

PCB - PS54, Audio Video

Capacitors

C731, 732	DK18222311	CERAMIC CAP. 0.022UF Z 50V	2
CG51, 52, 55, 56, 57, 58, 59, 60	EJ47502511	ELECTROLYTIC CAP. 4.7UF 25V	8
CG61, 62	DK16101391	CERAMIC CAP. 100PF K 50V	2
CG63, 64	EJ47502511	ELECTROLYTIC CAP. 4.7UF 25V	2
CS51, 52, 53, 54, 55, 56, 57, 58	EJ47601611	ELECT. CAP. 47UF/16V	8
CS61, 68, 91	DD38104011	CERAMIC CAP. 50V DC 0.1UF +80 -20%	3

**Harman Kardon
Dolby Digital Audio/Video Receiver**

AVR75/85

REF. NO.	Part No.	Description	Qty.
CS62, 63, 65, 66	EA10701611	ELECT. CAP. 100UF/16V	4
CS71, 72, 73, 74, 75, 76, 77, 78	DK16151301	CERAMIC CAP. 150PF K 50V	8
CS79, 80, 81, 82, 83, 84, 85, 86, 87, 88, 89, 90	DK16221301	CERAMIC CAP. 220PF K 50V	12
CS93, 94	EJ47601611	ELECT. CAP. 47UF/16V	2

Diodes

DG51	HD20002001	DIODE 1SS176, MA165, 1SS254 30V 0.1A	1
------	------------	--------------------------------------	---

Fuses

F760, 761, 762, 763	FS10160850	FUSE ! 1.6 A 250V BS LISTED (AVR75/85 230V)	4
F760, 761, 762, 763	FS10200350	FUSE ! 2A 125V UL, CSA, MITI TYPE FBT (AVR75/85 120V)	4

Integrated Circuit

QG55, 56	HC10008090	IC NJM4558DD DUAL OP-AMP	2
QG57	HC10304050	IC TC9213P ELEC. VOLUME CONTROL	1
QS51, 52, 53, 54	HC10008090	IC NJM4558DD DUAL OP-AMP	4
QS56	HC10308030	IC LC78211 ANALOG SWITCH	1
QS57	HC10309030	IC LC78212 ANALOG SWITCH	1

Resistors

RG51, 52, 55, 56	GD05473161	RESISTOR 47 OHM J 1/6W	4
RG53, 54	GD05471161	RESISTOR 470 OHM J 1/6W	2
RG57, 58	GD05104161	RESISTOR 100K OHM J 1/6W	2
RG59, 60	GD05334161	RESISTOR 330K OHM J 1/6W	2
RG61, 62	GD05152161	RESISTOR 1.5K OHM J 1/6W	2
RG63, 64	GD05472161	RESISTOR 4.7K OHM J 1/6W	2
RG65, 66	GD05331161	RESISTOR 330 OHM J 1/6W	2
RG67, 68	GD05473161	RESISTOR 47K OHM +- 5% 1/6W	2
RG69, 70	GD05103161	RESISTOR 10K OHM J 1/6W	2
RG71, 72	GD05471161	RESISTOR 470 OHM J 1/6W	2
RG73	NF0222114X	FUSE RESISTOR 220 OHM J 1/4W	1
RG74, 75	GD05103161	RESISTOR 10K OHM +- 5% 1/6W	2
RG76, 77	GD05101161	RESISTOR 100 OHM +- 5% 1/6W	2
RS51, 52, 53, 54, 55, 56, 57, 58, 67, 68, 69, 70, 71, 72, 73, 74, 94	GD05473161	RESISTOR 47K OHM J 1/6W	17
RS59, 60, 61, 62, 63, 64, 65, 66, 77, 78, 83, 84	GD05102161	RESISTOR 1K OHM J 1/6W	8
RS85, 86	GD05104161	RESISTOR 100K OHM J 1/6W	2
RS93	GD05473161	RESISTOR 47K OHM +- 5% 1/6W	1

Transistors

QG51, 52	HT421442A1	TRANSISTOR 2SD2144S/U/V	2
QG59, 60	HT421442A1	TRANSISTOR 2SD2144 S/U/V	2
QG61	HT321201A1	TRANSISTOR 2SC2120 O	1

Miscellaneous

JS51, 52	YT02060460	TERMINAL 14X14 RA 2L6P W/R NI FLM-GND	2
----------	------------	---------------------------------------	---

REF. NO.	Part No.	Description	Qty.
JS54	YJ06030580	JACK 20P TKC-V20X-A1	1
LG01	LV20240410	RELAY MR62-24SR 24V AVR85 ONLY	1

PCB - PY04, Connect

Capacitor

CY02, 04, 14	DD38104011	CERAMIC CAP. 0.1UF 50V +80 -20%	3
CY06, 13	DD15470301	CERAMIC CAP. 47PF J CH 50V BLK	2
CY11, 94	DK18103311	CERAMIC CAP. 0.01UF Z 50V	1
CY15	DK16121301	CERAMIC CAP. 120PF K 50V	1
CY16, 17	DD15560301	CERAMIC CAP. 56PF J CH 50V	2

Diodes

DY01, 02, 03, 04, 05, 06, 07, 08, 10, 11	HD20002001	"DIODE 1SS176, MA165, 1SS254 30V 0.1A"	10
DY09	HD20002711	DIODE 1D3 1A/200V	1

Integrated Circuit

QY10	HC10370050	IC TC9173P PORT EXPANDER	1
QY11	HC10250050	IC TC9174P PORT EXPANDER	1
QY12	HC10262050	IC ANALOGUE SWITCH -TC9215P	1

Resistors

RY01, 02, 03, 04, 05, 06, 07, 08, 09, 10, 11, 12, 13, 14, 15, 22, 24, 25, 26, 27	GD05103161	RESISTOR 10K OHM J +- 5% 1/6W	20
RY23	GD05332161	3.3K OHM 1/6W	1
RY28, 29	GD05472161	RESISTOR 4.7K OHM +- 5% 1/6W	2
RY30, 31, 32	GD05101161	RESISTOR 100 OHM +- 5% 1/6W	3

Transistor

QY01, 03, 05, 07, 13	BA10001001	COMP TRANSISTOR DTA114ES/ETC	5
QY02, 04, 06, 08, 15	BA20002001	COMP DTC144ES/UN4213 47K, 47K	5
QY13	BA10001001	DTA114ES	1

Miscellaneous

JY01	YJ06030140	JACK TKC-A14X-B1	1
JY02, 03	YP06020670	PLUG TKC-V16P-A1	1
JY04	YJ06030140	JACK TKC-A14X-B1	1
JY05	YJ06030100	JACK	1
JY06	YP06020700	PLUG TKC-V30P-A1	1
JY09	YJ07011160	JACK 9604S-23F 23P FFC CONNECTOR	1
JY10	YP06006931	PLUG 2MM PITCH UP CONNECTOR 8PIN	1
JY11	YP0600383X	PLUG B3B-EH 3P	1
JY12	YJ06030140	JACK TKC-A14X-B1	1
JY13	YJ06030770	JACK TSK-B17X-A1	1
JY14	YP06006931	PLUG CONNECTIVE PLUG UP 3P	1
JY15	YP06006670	PLUG 2MM PITCH UP CONNECTOR 7PIN	1
JY16	YP06004570	PLUG CONNECTOR 13P (UP)	1

REF. NO. Part No. Description Qty.

PCB - PF04, Tone Control

Capacitors

CF01, 02, 03	OA10601621	ELECT. CAP. 10UF M 16V RA-2	3
CF04	EJ47601611	ELECT. CAP. 47UF/16	1
CF05, 06, 07	DK16222301	CERAMIC CAP. 2200PF K 50V	3
CF09, 10, 11	DD15101301	CERAMIC CAP. 100PF J CH 50V	3
CF13, 14, 15 17, 18, 19	DF15153351	"FILM CAP. 0.015UF, J, M, 50V"	6
CF16, 20	DF15473311	FILM CAP. 0.047 J 50V	2
CF21, 22, 23	OA47601621	ELECT. CAP. 47UF M 16V RA-2	3
CF25, 26, 27	EJ22601611	ELECT. CAP. 22UF/16V	3
CF28	OA22601621	ELECT. CAP. 22UF M 16V RA-2	1
CF29, 30, 31	DK16101301	CERAMIC CAP. 100PF K 50V (AVR75/85 230V)	3
CF29, 30, 31 32	DD15470301	CERAMIC CAP. 47PF J CH 50V (AVR75/85 120V)	4
CF40, 41	OA10701621	ELECT. CAP. 100UF M 16V RA-2	2
CF43, 44, 45, 46, 47, 48,	DA17223111	CERAMIC CAP. 0.022UF TP050F223Z TAIYO	6

Integrated Circuits

QF01	HC10031090	IC QUAD OP. AMP NJM2058D	1
QF02, 03	HC10008090	IC NJM4558D-D DUAL OP-AMP	2

Resistors

RF01, 02, 03, 04, 05, 06, 07, 08	GD05473161	RESISTOR 47K OHM +- 5% 1/6W	8
RF09	GD05103161	RESISTOR 10K OHM +- 5% 1/6W	1
RF10, 11, 13, 14, 15, 17, 18, 19, 20	GD05103161	RESISTOR 10K OHM +- 5% 1/6W	9
RF21, 22, 23 24, 29, 30, 31, 32	GD05223161	RESISTOR 22K OHM +- 5% 1/6W	8
RF41, 42	RG01040150	VARIABLE RESIST 100K(B)X4	2
RF43	RK01040622	VARIABLE RESIST 100K OHM 0.5W	1
RF45, 46	GD05102161	RESISTOR 1K OHM +- 5% 1/6W	2
RF81, 82, 83, 84	GD05473161	RESISTOR 47K OHM +- 5% 1/6W	4

Miscellaneous

JF01	YP06006720	PLUG W-P7512*XX UP PLUG 12P	1
------	------------	-----------------------------	---

PCB - P104, Tuner

Capacitors

CA01	CT12000201	TRIMMING CAP. VCT51E 20PF TRIMMING	1
CA02, 203, 204, 208	DK18473311	CERAMIC CAP. 0.047UF Z 50V	4
CA03, 09	DD15150301	CERAMIC CAP. 15PF J CH 50V	2
CA04	DF15391551	FILM CAP. 390PF 100V	1
CA05	DD15470301	CERAMIC CAP. 47PF J CH 50V	1
CA06, 07, 13 14, 201, 202, 210, 218, 223, 224, 225, 226, 233, 234	DK18103311	CERAMIC CAP. 0.01UF Z 50V	14

REF. NO. Part No. Description Qty.

CA08	CT12000201	TRIMMING CAP. VCT51E 20PF TRIMMING	1
CA11	DD15680301	CERAMIC CAP. 68PF J CH 50V	1
CA12	DD15151301	CERAMIC CAP. 150PF J CH 50V	1
CA18	EJ47502511	ELECT. CAP. 4.7UF/25V	1
C205, 209, 212	EJ10505011	ELECT. CAP. 1UF/50V	3
C206	EJ10601611	ELECT. CAP. 10UF/16V	1
C207	EA10701611	ELECT. CAP. 100UF/16V	1
C211	EJ22505011	ELECT. CAP. 2.2 M 50V	1
C213	EJ47405011	ELECT. CAP. 0.47UF/50V	1
C214	EA47603511	ELECT. CAP. 47UF M 35V	1
C215	DK18473311	CERAMIC CAP. 0.047UF Z 50V	1
C216	EA10701611	ELECT. CAP. 100UF/16V	1
C217	DF15562351	FILM CAP. 5600PF J 50V	1
C217, 227	DF15822351	"FILM CAP. 0.0082UF, J, M, 50V, D=9.5	1
C219	EJ10601611	ELECT. CAP. 10UF/16V	1
C220	DK16222301	CERAMIC CAP. 2200PF K 50V	1
C222	DK16152301	CERAMIC CAP. 1500PF K 50V	1
C223, 224, 225, 226	DK16472301	CERAMIC CAP. 4700PF K 50V	4
C227	DF15391551	FILM CAP. 390 PF J (AVR75/85 230V)	1
C227	DF15822351	FILM CAP. 8200 PF J 50V (AVR75/85 120V)	1
C233, 234	DK18103311	CERAMIC CAP. 0.01UF Z 50V	2
C301, 302	DF15333311	FILM CAP. 0.033UF J 50V	2
C301, 302	DF15473311	FILM CAP. 0.047UF J 50V	2
C303, 304	EJ10601611	ELECT. CAP. 10UF/16V	2
C305, 306	EJ47502511	ELECT. CAP. 4.7UF/25V	2
C307, 308	EJ10601611	ELECT. CAP. 10UF/16V	2
C311, 312	EJ22601611	ELECT. CAP. 22UF/16V	2
C313	EJ10601611	ELECT. CAP. 10UF/16V	1
C314	EA47603511	ELECT. CAP. 47UF M 35V	1
C315, 316	DK16151301	CERAMIC CAP. 150PF K 50V	2
C317, 318	DK16101301	CERAMIC CAP. 100PF K 50V	2
C501, 502	DD15470301	CERAMIC CAP. 47PF J CH 50V BLK	2
C503, 508	EA10700611	ELECT. CAP. 100UF/6.3V	2
C504, 507, 511	DK18103311	CERAMIC CAP. 0.01UF Z 50V	3
C505	EJ10505011	ELECT. CAP. 1UF/50V	1
C506	EJ10405011	ELECT. CAP. 0.1UF/50V	1
C509, 510	DK16101301	CERAMIC CAP. 100PF K 50V	2

Diode

D202	HD30681001	DIODE 6.8V EQUIVALENT	1
D501	HD30511001	ZENER DIODE 5.1V ZENER EQUIVALENT	1
DA01	HD4000903X	SVC342-L TAPING TYPE	1
DA02	HD20017211	DIODE 1SS135	1
DA03	HD4000903X	SVC342-L TAPING TYPE	1
DA04	HD20017211	DIODE 1SS135	1
DA05, 06, 201	HD20002001	"DIODE 1SS176, MA165, 1SS254 30V 0.1A"	3

Integrated Circuits

Q201	HC10342030	IC LA1836 FM/AM IF, MPX IC	1
Q301	HC10008090	IC NJM4558D-D DUAL OP-AMP	1
Q501	HC10221032	IC LC7218 PLL	1

**Harman Kardon
Dolby Digital Audio/Video Receiver**

AVR75/85

REF. NO.	Part No.	Description	Qty.
Resistors			
RA01	GD05103161	RESISTOR 10K OHM +- 5% 1/6W	1
RA02, 04, 08 06, 209	GD05104161	RESISTOR 100K OHM +- 5% 1/6W	4
RA03, 07, 102 103	GD05103161	RESISTOR 10K OHM +- 5% 1/6W	4
RA09, 203	GD05222161	RESISTOR 2.2K OHM +- 5% 1/6W	2
RA11	RA02230781	TRIMMING RESIST 22K OHM RH0638CJ4R TYPE ALPS	1
R201	GD05101161	RESISTOR 100 OHM J 1/6W	1
R202, 204	GD05471161	RESISTOR 470 OHM J 1/6W	2
R202	GD05391161	RESISTOR 390 OHM J 1/6W	1
R205	GD05331161	RESISTOR 330 OHM +- 5% 1/6W	1
R206	GD05153161	RESISTOR 15K OHM +- 5% 1/6W	1
R207	GG0518114X	RESISTOR ! 180 OHM J 1/4W	1
R208	GD05392161	RESISTOR 3.9K OHM +- 5% 1/6W	1
R210	GD05332161	RESISTOR 3.3K OHM +- 5% 1/6W	1
R211	RA02230781	TRIMMING RESIST 22K OHM B	1
R211	RA04720781	TRIMMING RESIST 4.7K OHM B	1
R212	RA02230781	TRIMMING RESIST 22K OHM B	1
R213	GD05220161	RESISTOR 22 OHM +- 5% 1/6W	1
R214	GD05473161	RESISTOR 47K OHM +- 5% 1/6W	1
R215	GD05104161	RESISTOR 100K OHM J 1/6W	1
R215	GD05223161	RESISTOR 22K OHM J 1/6W	1
R216	GD05103161	RESISTOR 10K OHM J 1/6W	1
R217	GG0518114X	RESISTOR ! 180 OHM J 1/4W	1
R217	GG0522114X	RESISTOR ! 220 OHM J 1/4W	1
R218	RA04720781	TRIMMING RESIST 4.7K OHM B	1
R219	GD05334161	RESISTOR 330K OHM +- 5% 1/6W	1
R301, 302	GD05104161	RESISTOR 100K OHM +- 5% 1/6W	2
R303, 304, 305, 306	GD05103161	RESISTOR 10K OHM +- 5% 1/6W	4
R307, 308	GD05221161	RESISTOR 220 OHM +- 5% 1/6W	2
R309, 310, 311, 312	GD05473161	RESISTOR 47K OHM +- 5% 1/6W	4
R313	GG0522114X	RESISTOR 220 OHM +- 5% 1/4W	1
R501, 503 506, 510, 511	GD05102161	RESISTOR 1K OHM +- 5% 1/6W	5
R502, 507	GD05332161	RESISTOR 3.3K OHM +- 5% 1/6W	2
R504, 513	GD05103161	RESISTOR 10K OHM +- 5% 1/6W	2
R508, 516, 517	GD05473161	RESISTOR 47K OHM +- 5% 1/6W	3
R512	GA05271010	RESISTOR ! 270 OHM J 1/6W	1
R514	GG0547016X	RESISTOR ! 47 OHM J 1/6W	1
R515	GD05683161	RESISTOR 68K OHM +- 5% 1/6W	1
Transistor			
Q203	BA10001001	SEMICON.COMP DTA114ES/ UN4111 10K, 10K	1
Q204	BA20002001	SEMICON.COMP DTC144ES/ UN4213 47K, 47K	1
Q502	HF200300B1	F.E.T. 2SK30ATM Y1	1
Q503	HT30001001	TRANSISTOR C536SP, C2458, C3311, C1740S	1
QA01, 02	HT30001001	TRANSISTOR C536SP, C2458, C3311, C1740S	2
QA03	HT421442A1	TRANSISTOR 2SD2144S/U/V	1
QA04, 05	BA10002001	COMP DTA144ES/UN4113 47K, 47K	2
Q202	HT318091P1	TRANSISTOR 2SC1809S P	1

REF. NO.	Part No.	Description	Qty.
Miscellaneous			
A101	AV01202210	VHF TUNER FM FRONT END FE415-G09 (AVR75/85 230V)	1
A101	AV01202220	VHF TUNER FM FRONT END FE337-A05 (AVR75/85 120V)	1
A017K	260J123010	ROUND SHEET	1
F201	FF11070610	CERAMIC FILTER SFF10, 7MA8-A (AVR75/85 120V)	1
F201	FF11070620	CERAMIC FILTER SFE10, 7MS3-A (AVR75/85 230V)	2
F202	FF11070620	CERAMIC FILTER SFE10, 7MS3-A (AVR75/85 BOTH 120V & 230V)	1
J101	YT03030020	FM/AM ANT TERM.PAL TYPE EU 230V	1
J101	YT01010140	FM/AM ANT TERM.F TYPE USA 120V	1
J102	YL01010141	TERMINAL GROUND TERMINAL FOR TUNER PCB	1
J301	YP06020640	PLUG	1
LA01	LA10295170	ANT COIL MW ANT COIL 280UH	1
LA02	LO70013010	. COIL MW OSC	1
LA03	LA10295160	ANT COIL LW ANT COIL FOR LA1267	1
LA04	LO70013020	. COIL LW OSC COIL	1
LA05	LC23960711	CHOKO COIL 39MH J	1
LA06	FF10045330	CERAMIC FILTER SFL450J3	1
L201	LI70376010	"I.F.T. COIL FM COIL, M292BEAS-5968Z"	1
L301, 302	LS10293022	"M.P.X. COIL 19,38KHZ "	2
L501, 502, 503, 504	LC14733801	CHOKO COIL LAL02TA470J 47UH	4
X201	FQ04563040	CERAMIC . CSB456F33	1
X501	JX07001261	CRYSTAL AD0618CTB 7.2MHZ	1

**PCB - P104 Tuner
(230V) Discrepancy List**

Capacitors			
C901	EA10700611	ELECT. CAP. 100UF/6.3V	1
C902, 910	EJ10601611	ELECT. CAP. 10UF/16V	2
C903, 904	DK16332301	CERAMIC CAP. 3300PF K 50V	2
C905, 906	DK18103311	CERAMIC CAP. 0.01UF Z 50V	2
C907, 908	EJ10601611	ELECT. CAP. 10UF/16V	2
C909	EJ47502511	ELECT. CAP. 4.7UF/25V	1
C910	EJ10601611	ELECT. CAP. 10UF/16V	1
C911	DK18223311	CERAMIC CAP. 0.022UF Z 50V	1
C912, 913	DF15333311	FILM CAP. 0.033UF J 50V	2
C914	DF15682351	"FILM CAP. 0.0068UF, J, M, 50V"	1
C915	DK18103311	CERAMIC CAP. 0.01UF Z 50V	1
Diode			
D901	HD30511001	ZENER DIODE 5.1V ZENER EQUIVALENT	1
Integrated Circuits			
Q901	HC10315050	IC LA2232 RDS DEMODULATOR	1
902	HC10333030	IC LC7073 RDS ERROR CORRECTION	1
Transistors			
Q903	HT30001001	"TRANSISTOR C536P C2458, C3311, C1740S"	1

**Harman Kardon
Dolby Digital Audio/Video Receiver**

AVR75/85

REF. NO.	Part No.	Description	Qty.
Resistors			
R901	GD05333161	RESISTOR 33K OHM +- 5% 1/6W	1
R902, 909, 911	GD05103161	RESISTOR 10K OHM +- 5% 1/6W	3
R903	GD05223161	RESISTOR 22K OHM +- 5% 1/6W	1
R904, 907	GD05102161	RESISTOR 1K OHM +- 5% 1/6W	2
R905	GD05682161	RESISTOR 6.8K OHM +- 5% 1/6W	1
R906	RA04720781	TRIMMING RESIST 4.7K OHM RH0638CS3R TYPE ALPS	1
R908	GD05332161	RESISTOR 3.3K +- OHM 5% 1/6W	1
R910	GA05221010	RESISTOR ! 220 OHM J 1W	1
X901	FQ04563040	CERAMIC VIB. CSB456F33	1
X902	FQ04004031	CERAMIC VIB. CERALOCK CST4.00MGW	1

PCB - PE04, Electronic Volume Control

Capacitors

CE01, 02	OA10601621	ELECT. CAP. 10UF M 16V RA-2	2
CE03, 04, 05, 06	EJ10601611	ELECT. CAP. 10UF/16V	4
CE07, 08, 09, 10, 11, 12, 13, 14, 15, 16, 17, 18	EJ47502511	CAP 4.7UF 25V	12
CE19, 20	OA47505021	ELECT. CAP. 4.7UF M 50V RA-2	2
CE21, 22, 23, 24	EJ47502511	CAP 4.7UF 25V	4
CE25, 26	OA47505021	ELECT. CAP. 4.7UF M 50V RA-2	2
CE27, 28, 29, 30	EJ47502511	CAP 4.7UF 25V	4
CE31, 32	OA47505021	ELECT. CAP. 4.7UF M 50V RA-2	2
CE33, 34, 35	EJ47502511	CAP 4.7UF 25V	3
CE36	EJ22601611	ELECT. CAP. 22UF M 16V	1
CE37, 38	EJ10505010	ELECT. CAP. 1UF M 50V	2
CE41, 42	OA10601621	ELECT. CAP. 10UF M 16V RA-2	2
CE43, 44, 45, 46	EJ10601611	ELECT. CAP. 10UF/16V	4
CT01	DD38104011	CERAMIC CAP. 50V DC 0.1UF +80 -20%	1
CT02	EJ10601611	ELECT. CAP. 10UF/16V	1
CT04	DK18103311	CERAMIC CAP. 0.01UF Z 50V	1
CV80, 81, 82, 83, 84, 85	DK16681301	CERAMIC CAP. 680PF K 50V	6
CV94, 96, 97, 98	DK18103311	CERAMIC CAP. 0.01UF Z 50V	4

Diodes

DV01, 02, 03	HD20002001	"DIODE 1SS176, MA165, 1SS254 30V 0.1A"	3
--------------	------------	--	---

Integrated Circuits

QE01, 02, 03	HC10008090	IC NJM4558DD DUAL OP-AMP	3
QE04, 05, 06	HC10304050	IC TC9213P ELECTRIC VOLUME CONTROL	3
QE07, 08, 09, 10, 11, 12	HC10008090	IC NJM4558DD DUAL OP-AMP	6
QT02	HW10006320	PHOTO UNIT ! PC-817 PHOTO CUPLER 1PAIR	1
QT04	HC713200A0	IC 74LS132 QUAD NAND SCHMITT	1

REF. NO.	Part No.	Description	Qty.
Resistors			
RE01, 02, 03, 04, 05, 06	GD05104161	RESISTOR 100K OHM J 1/6W	6
RE07, 08, 09, 10, 11, 12	GD05332161	RESISTOR 3.3K OHM +- 5% 1/6W	6
RE13, 14, 15, 16, 17, 18	GD05152161	RESISTOR 1.5K OHM J 1/6W	6
RE19, 20, 21, 22, 23, 24	GD05104161	RESISTOR 100K OHM J 1/6W	6
RE25, 26, 27, 28, 29, 30	GD05331161	RESISTOR 330 OHM J 1/6W	6
RE31, 32, 33, 34, 35, 36	GD05152161	RESISTOR 1.5K OHM J 1/6W	6
RE37, 38, 39, 40, 41, 42	GD05334161	RESISTOR 330K OHM J 1/6W	6
RE43, 44, 45, 46, 47, 48	GD05152161	RESISTOR 1.5K OHM J 1/6W	6
RE49, 50, 51, 52, 53, 54	GD05104161	RESISTOR 100K OHM J 1/6W	6
RE55, 56, 57, 58, 59, 60	GD05182161	RESISTOR 1.8K OHM +- 5% 1/6W	6
RE61, 62, 63, 64, 65, 66	GD05152161	RESISTOR 1.5K OHM J 1/6W	6
RE65, 66	GD05152161	RESISTOR 1.5K OHM J 1/6W	2
RE73, 74, 75, 76	GD05105161	RESISTOR 1M OHM J 1/6W	4
RT02	GD05102161	RESISTOR 1K OHM +- 5% 1/6W	1
RT03	GD05103160	RESISTOR 10K OHM +- 5% 1/6W	1
RT05	GD05271161	RESISTOR 270 OHM +- 5% 1/6W	1
RT07	GD05222161	RESISTOR 2.2K OHM +- 5% 1/6W	1
RT20	GD05220161	RESISTOR 22 OHM 5% 1/6W	1
RV69, 70, 71, 72, 73	GD05471161	RESISTOR 470 OHM +- 5% 1/6W	5
RV74	GD05221161	RESISTOR 220 OHM +- 5% 1/6W	1
RV75, 76, 77, 78, 79, 80	GD05473161	RESISTOR 47K OHM J 1/6W	6
RV81, 82, 83, 84, 85, 86, 87	GD05103161	RESISTOR 10K OHM J 1/6W +-5%	7
RV88	GD05271161	RESISTOR 270 OHM +- 5% 1/6W	1
RV89, 90, 91	NF0222114X	FUSE RESISTOR 220 OHM G 1/4W	3
RV92, 93	GD05103161	RESISTOR 10K OHM +- 5% 1/6W	2
RV94, 95, 96, 97, 98, 99	GD05101161	RESISTOR 100 OHM +- 5% 1/6W	6

Transistors

QT05	BA10001001	SEMICON.COMP DTA114ES/ UN4111 10K, 10K	1
QV51, 52, 53, 54, 55, 56, 60	HT328782A1	TRANSISTOR 2SC2878 A/B	7
QV57	HT321201A1	TRANSISTOR 2SC2120 O	1

Miscellaneous

JV53	YT02060540	TERMINAL YKC21-3324	1
JV54	YJ06030600	JACK 30P TKC-V30X-A1	1
JV55	YL01010140	TERMINAL M1698 PWB GND TERMINAL WITH M3	1
JV57	YP06006931	PLUG CONNECTIVE PLUG UP 3P	1
JT03	YJ01004230	JACK HSJ1002-01-1020	1
KA04	LC14733801	CHOKE COIL LAL02TA470J 47UH	1
LV04, 05, 06	LY20240410	RELAY MR62-24SR 24V RELAY	3
UV03, 05	LC14733801	CHOKE COIL LAL02TA470J 47UH	2

**Harman Kardon
Dolby Digital Audio/Video Receiver**

AVR75/85

REF. NO. Part No. Description Qty.

PCB - PL54, S-Video

Capacitors

CL52, 53, 54, 57, 58, 59, 60, 61, 62	EJ10601611	ELECT. CAP. 10UF/16V	9
CL65, 66, 67 68	DD38104011	CERAMIC CAP. 50V DC 0.1UF +80 -20%	4
CL71	EA10700611	ELECT. CAP. 100UF/6.3V	1
CL72, 73	DK18103311	CERAMIC CAP. 0.01UF Z 50V	2
CL74, 75, 78	EA10700611	ELECT. CAP. 100UF/6.3V	3
CL76, 77, 79	DK18103311	CERAMIC CAP. 0.01UF Z 50V	3

Integrated Circuits

QL51, 52, 53, 54, 58	HC10275030	IC LC7824 ANALOG SWITCH	5
QL55, 56, 57	HC10046170	IC MC 14576 VIDEO AMP	3

Resistors

RL52, 53, 54	GD05100161	RESISTOR 10 OHM +- 5% 1/6W	3
RL57, 58, 59 60, 61, 62	GD05820161	RESISTOR 82 OHM +- 5% 1/6W	6
RL63, 64, 65, 66, 67, 68	GD05750161	RESISTOR 75 OHM +- 5% 1/6W	6
RL69, 70, 71, 72, 73, 74	GD05104161	RESISTOR 100K OHM +- 5% 1/6W	6

Miscellaneous

JL52, 53	YT02030350	3P S TERMINAL	2
JL54	YP06020600	PLUG TKC-A10P-L1	1
JL55	YL01010140	GND TERMINAL	1

PCB - PL04, Video Selector

Capacitors

CL01, 03, 05, 09	EQ22600671	ELECT. CAP. 22UF 6.3V NON-POLE	4
CL02, 04, 06 10	EJ10601611	ELECT. CAP. 10UF/16V	4
CL14, 15, 31	DD38104011	CERAMIC CAP. 50V DC 0.1UF +80 -20%	3
CL16, 17, 22 CX52, CX54	DK18103311	CERAMIC CAP. 0.01UF Z 50V	5
CL18, CL19, CX51, CX53	EA22700611	ELECT. CAP. 220UF/6.3V	2
CL20, 24	EJ22601011	ELECT. CAP. 22UF/10V	2
CL21	EA10701011	ELECT. CAP. 100UF/10V	1
CL23	EQ22600671	ELECT. CAP. 22UF 6.3V NON-POLE	1
CL25	EJ10601611	ELECT. CAP. 10UF M 16V	1
CX49	EA10601611	ELECT. CAP. 10UF 16V +- 20%	1
CX50	EA10601611	ELECT. CAP. 47UF/10V	1
CX55, 56, 57, 58	DD15220301	CERAMIC CAP. 22PF J CH 50V	4
CX59	EJ47405011	ELECT. CAP. 0.47UF/50V	1
CA60	DD15560301	CERAMIC CAP. 56PF J CH 50V	1
CX61, 63	EJ10505011	ELECT. CAP. 1UF/50V	2
CX62	DK16122301	CERAMIC CAP. 1200PF K 50V	1
CX64, 65	DF15682351	"FILM CAP. 0.0068UF, J, M, 50V"	2
CX66	DD15470301	CERAMIC CAP. 47PF J CH 50V	1
CX67	CT12000201	TRIMMING CAP. VCT51E 20PF TRIMMING	1

REF. NO. Part No. Description Qty.

CX69	EA47601011	ELECT. CAP. 47UF/10V	1
CX70	EJ47502511	ELECT. CAP. 4.7UF/25V	1
CX72	DA17103111	CERAMIC CAP. 0.01UF M 16V	1
CX73	EA22700611	ELECT. CAP. 220UF/6.3V	1
CX74	EJ10505011	ELECT. CAP. 1UF/50V	1
CX75	EJ22601011	ELECT. CAP. 22UF/10V	1
CX76	EA10701011	ELECT. CAP. 100UF/10V	1

Diodes

DL01, 02, 03, 04, 05, 06, 07, 08, 09, 10, DX61	HD20002001	"DIODE 1SS176, MA165, 1SS254, 30V 0.1A"	11
---	------------	---	----

Integrated Circuits

QL01	HC10275030	IC LC7824 ANALOG SW	1
QL03	HC10046170	IC MC 14576 VIDEO AMP	1
QL04, 05	HC12233090	IC NJM2233D VIDEO AMP	2
QX60	HC10328030	IC LC74760-9004 LSI	1
QX63	HC10141090	IC NJM2267D(DIP)VIDEO AMP	1

Resistors

RL01, 03, 05, 09	GD05820161	RESISTOR 82 OHM +- 5% 1/6W	4
RL02, 04, 06, 10	GD05100161	RESISTOR 10 OHM +- 5% 1/6W	4
RL07, 11, 15	GD05750161	RESISTOR 75 OHM +- 5% 1/6W	3
RL18, RX67	GD05104161	RESISTOR 100K OHM +- 5% 1/6W	2
RL19	GD05472161	RESISTOR 4.7K OHM +- 5% 1/6W	1
RX51	GD05333161	RESISTOR 33K OHM +- 5% 1/6W	1
RX52, 59	GD05221161	RESISTOR 220 OHM +- 5% 1/6W	2
RX53, 54	GD05105161	RESISTOR 1M OHM +- 5% 1/6W	2
RX55, 56, 57	GD05103161	RESISTOR 10K OHM +- 5% 1/6W	3
RX60	GD05152161	RESISTOR 1.5K OHM +- 5% 1/6W	1
RX61	GD05682161	RESISTOR 6.8K OHM +- 5% 1/6W	1
RX62, 65, 66	GD05102161	RESISTOR 1K OHM +- 5% 1/6W	3
RX68	GDO5223161	RESISTOR 22K OHM +- 5% 1/6W	1
RX69	GD05471161	RESISTOR 470 OHM +- 5% 1/6W	1

Transistors

QX61	HT30001001	"TRANSISTOR C536SP, C2458, C3311, C1740S"	1
QX62	BA20002001	".COMP DTC144ES/UN4213 47K, 47K"	1
QX64	HT30001001	"TRANSISTOR C536SP, C2458, C3311, C1740S"	1

Miscellaneous

JL01	YT02041130	TERMINAL YKC21-3235	1
JL02	YT02030370	TERMINAL YKC21-3111	1
JL03	YP06020640	PLUG	1
LX51	LC12233801	CHOKE COIL LAL02TA220J 22UH	1
LX52	LC15623801	CHOKE COIL LAL02TA5R6J 5.6UH	1
LX53	FM12223011	FILTER DSS306-91-F-223Z	1
XX51	JX14001261	CRYSTAL AT49/14.31818MHZ(TP)	1
XX52	JX17001261	CRYSTAL AT49 17.7MHZ	1

AVR78 & AVR85 PACKING EXPLODED VIEW

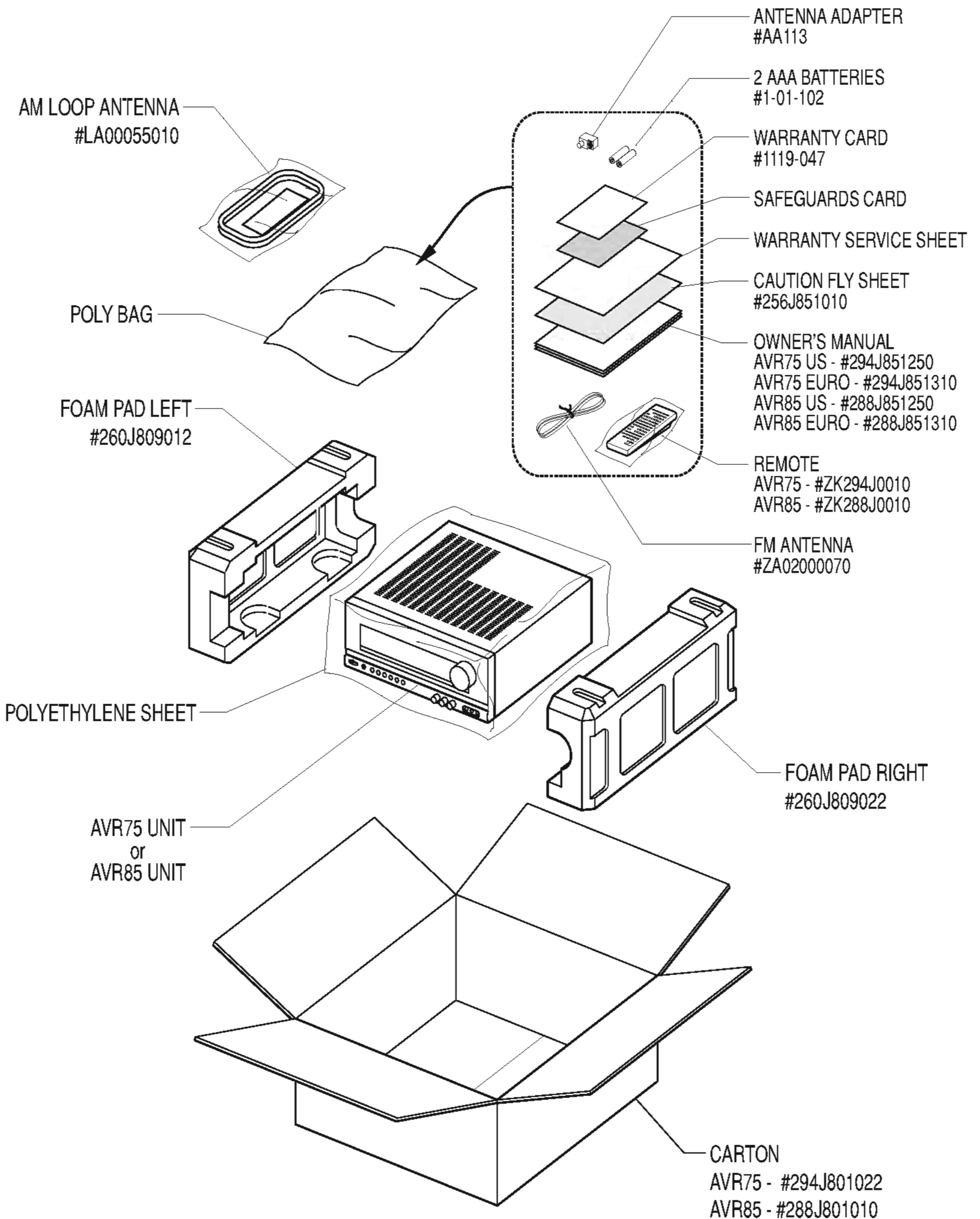

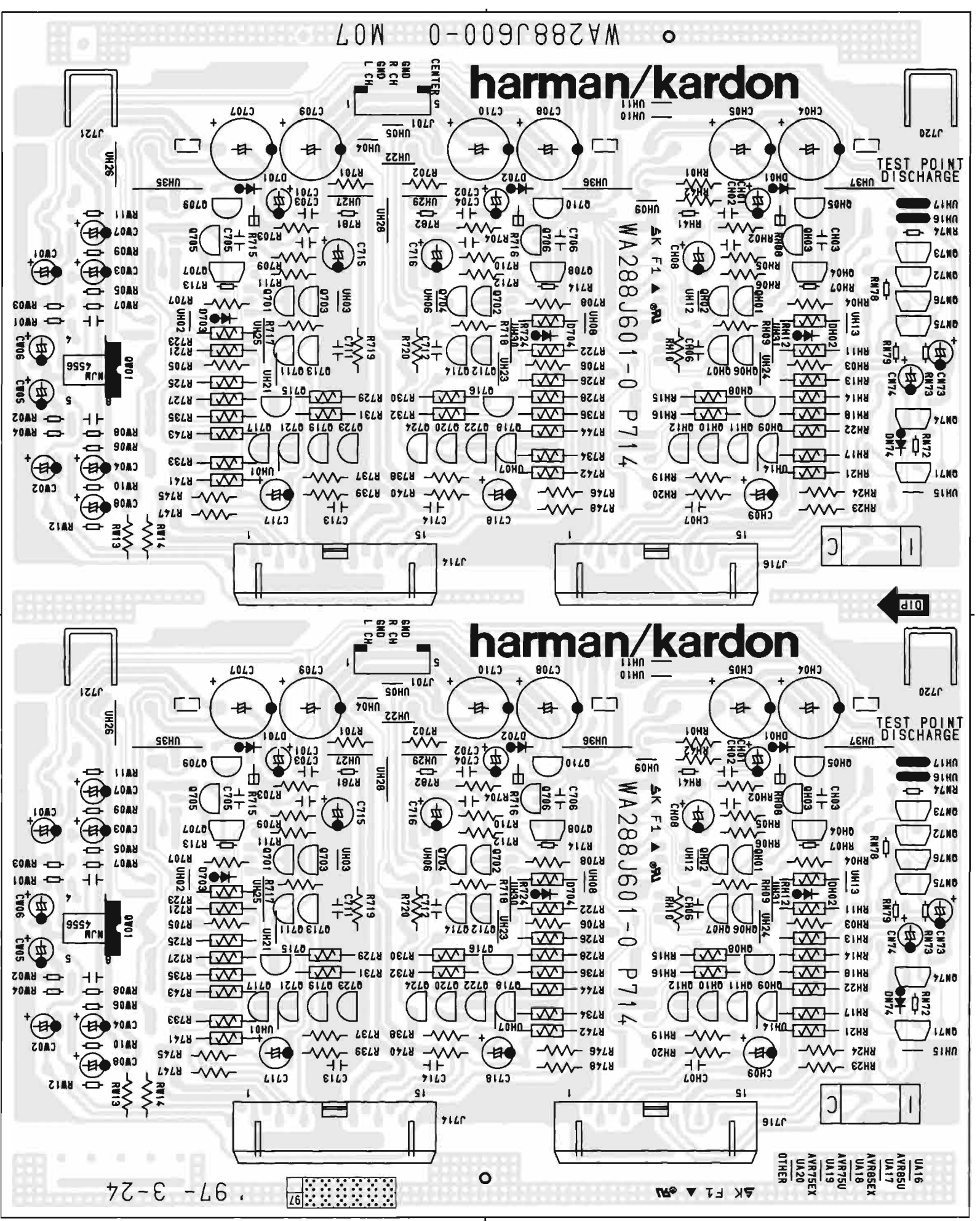

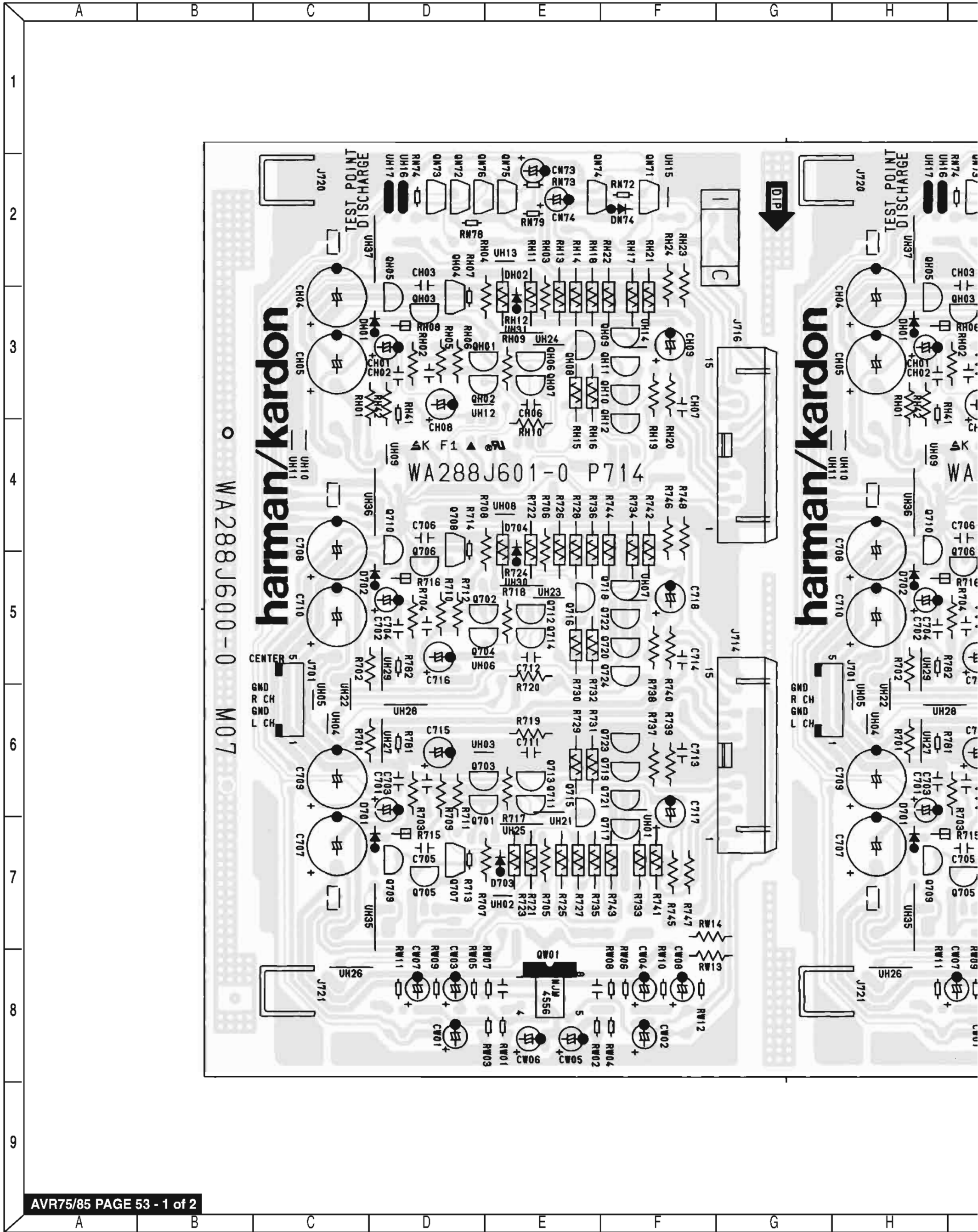

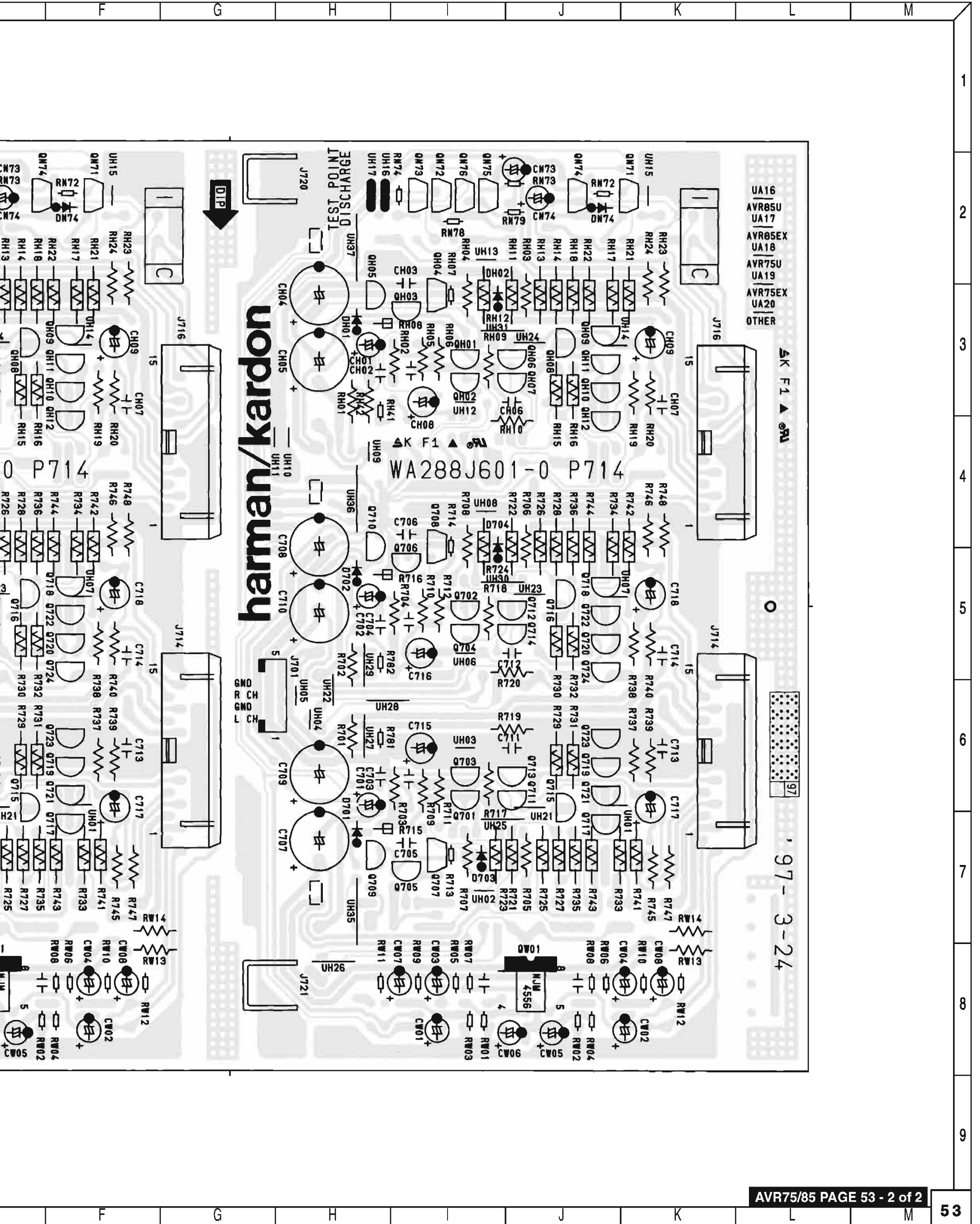

Component Side Shown Here
at 140% for added clarity

Solder Side Shown Here
at 140% for added clarity

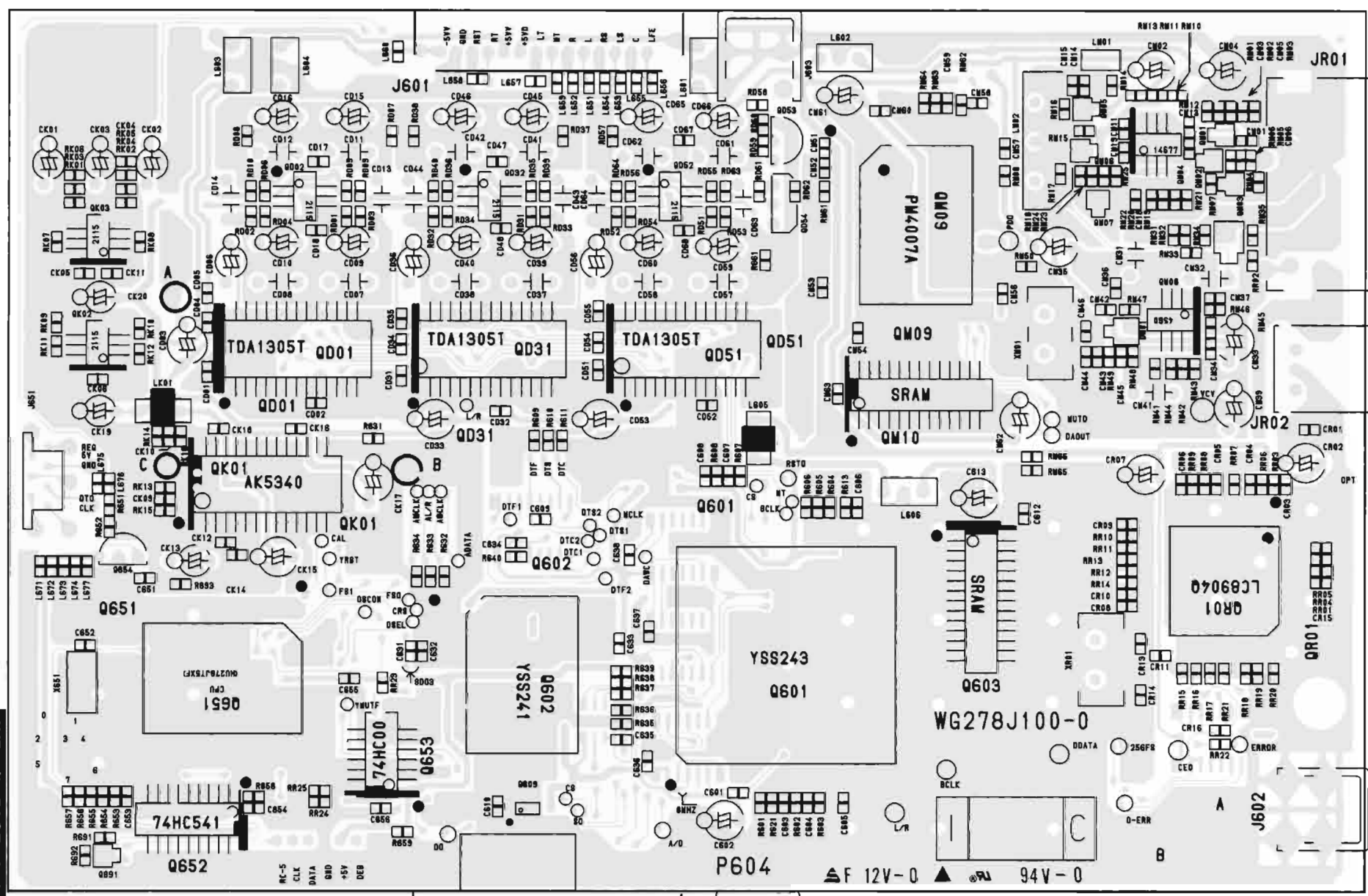
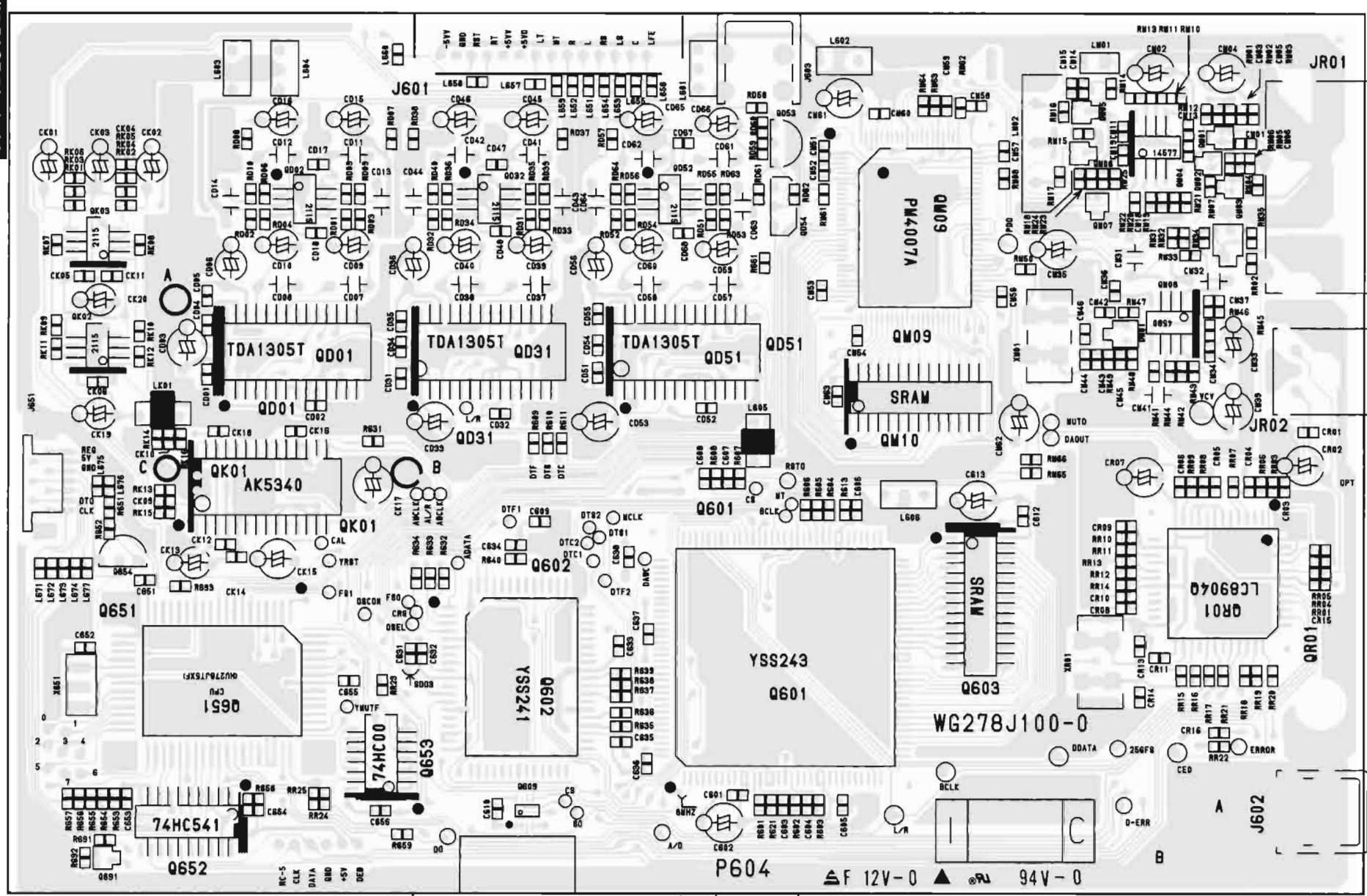

Component Side Shown Here
at 140% for added clarity

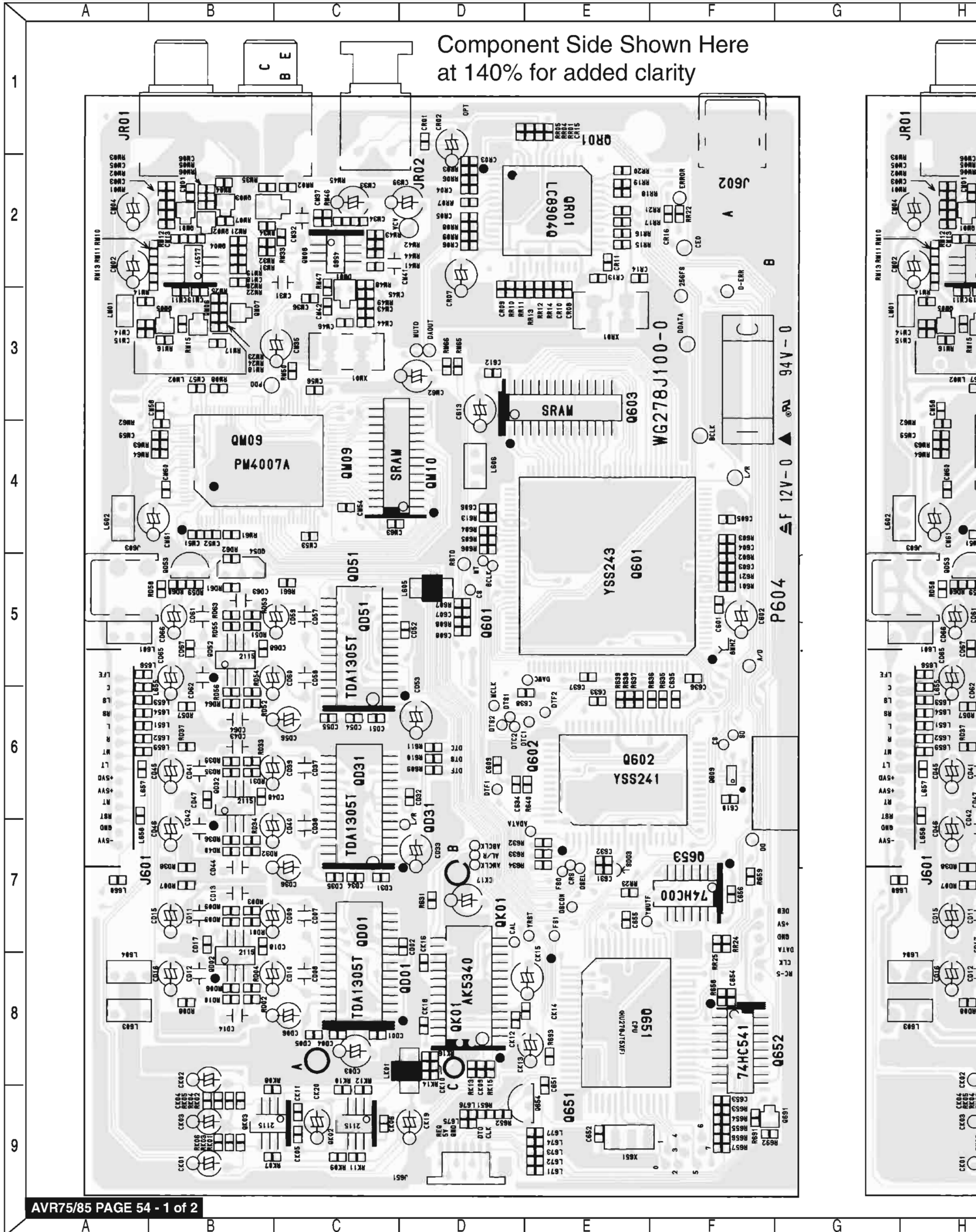

own Here
rity

Solder Side Shown Here
at 140% for added clarity

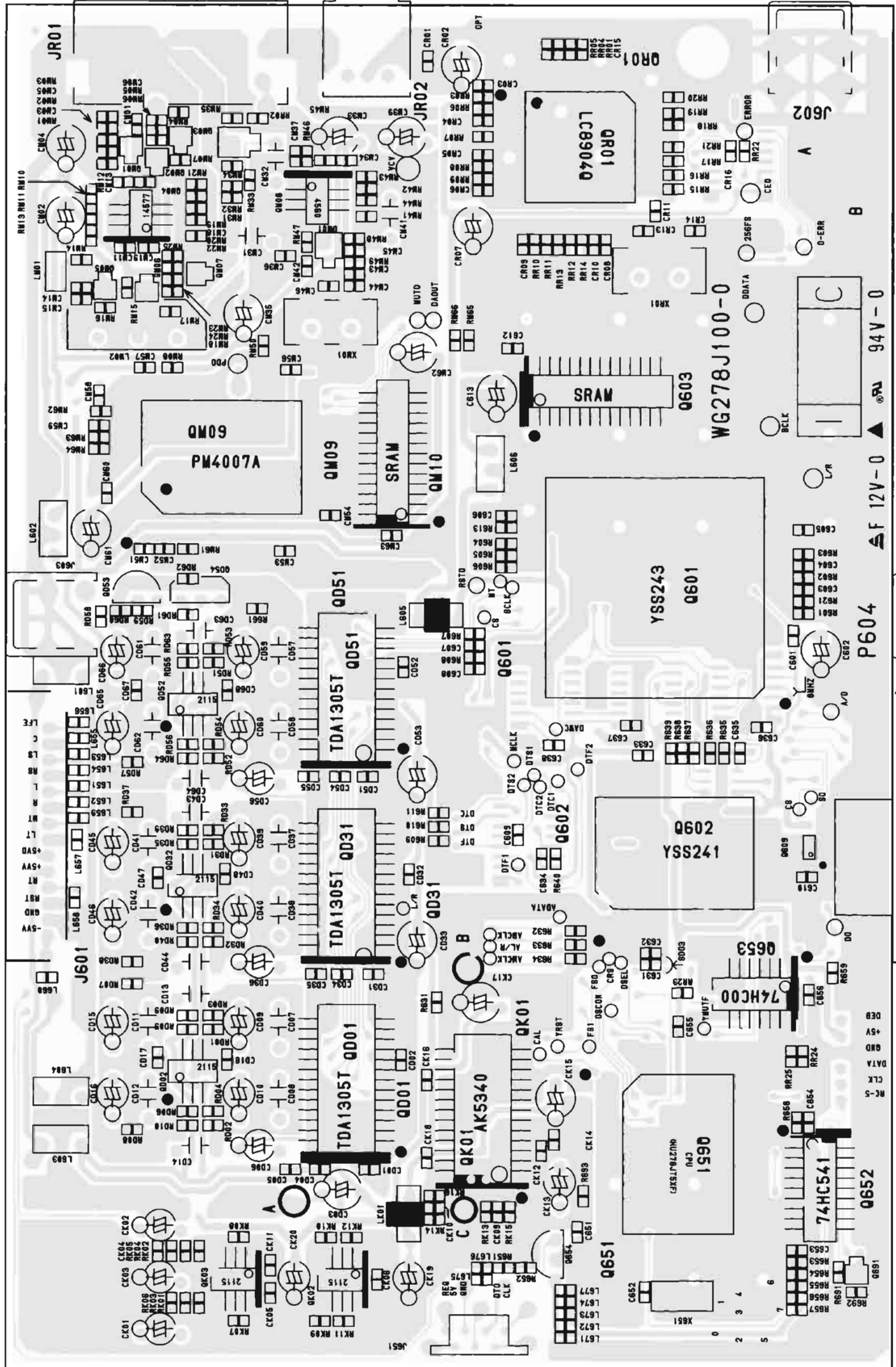
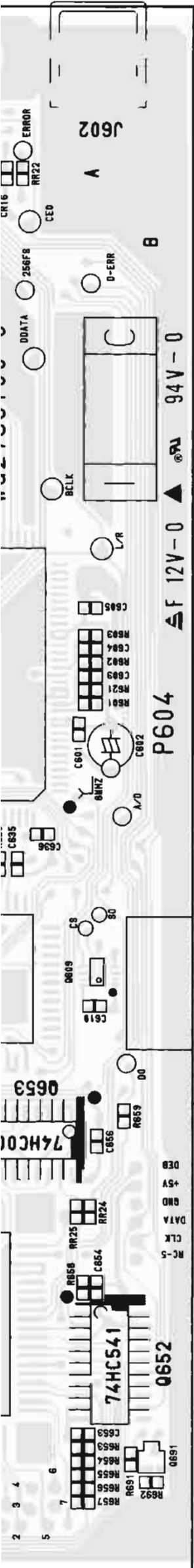

WA288J100-2 • M01

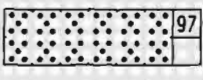

WA288J101-2
P704

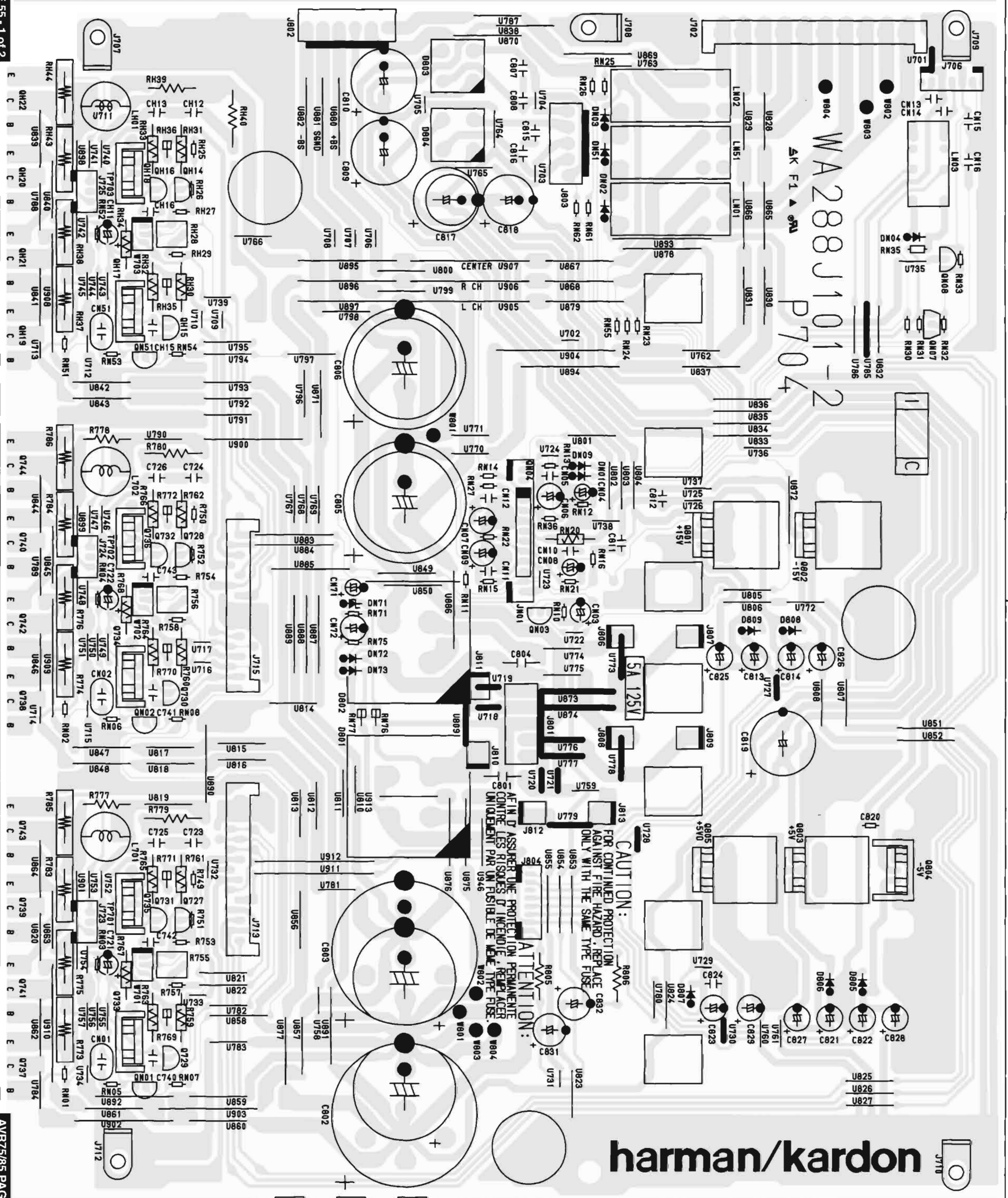

harman/kardon



- AVR95U
- UA01
- AVR95EX
- UA02
- AVR75U
- UA03
- AVR75EX
- UA04
- OTHER
- UA05

97-3-24

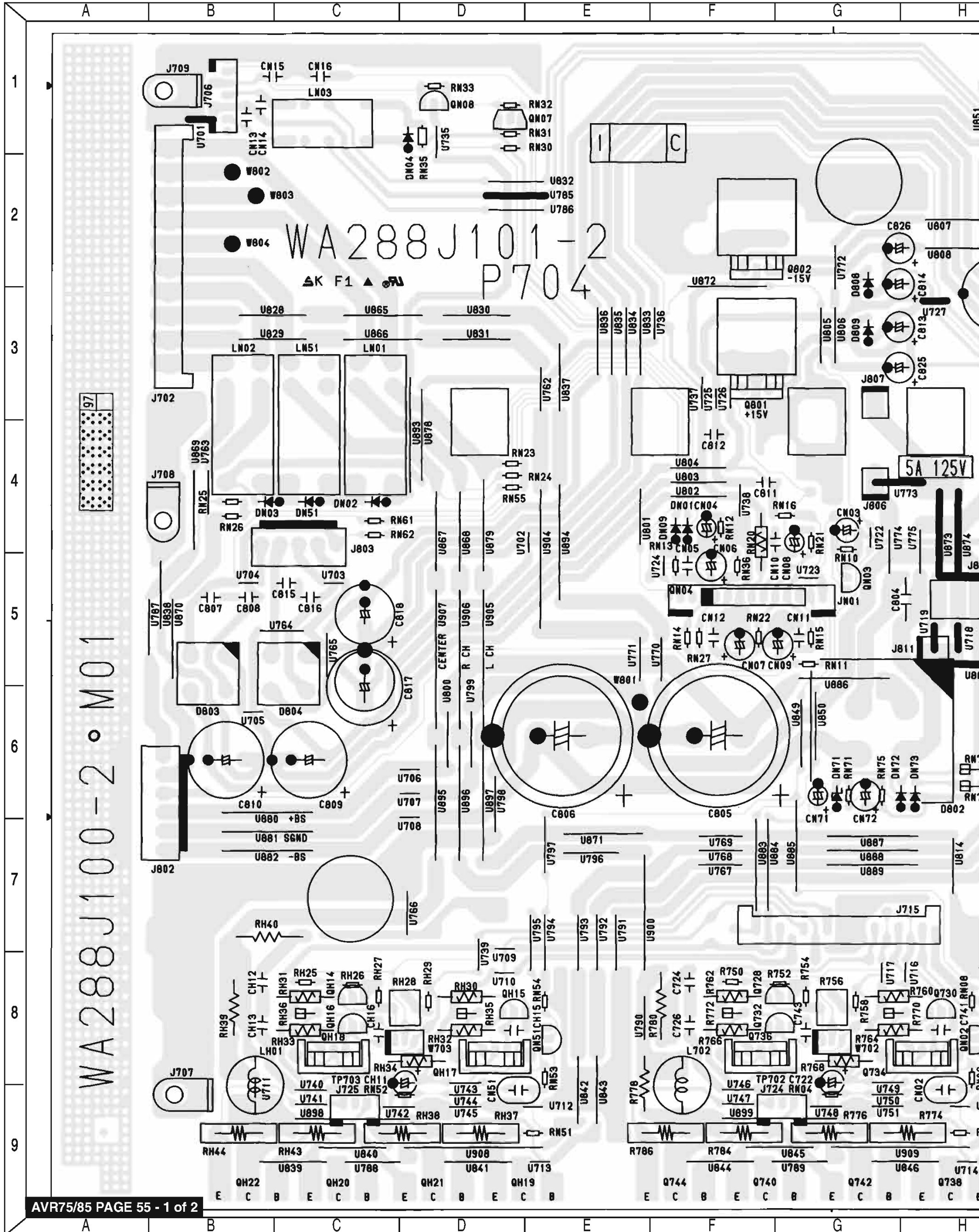

WA288J100-2 M01

WA288J101-2
P704

5A 125V

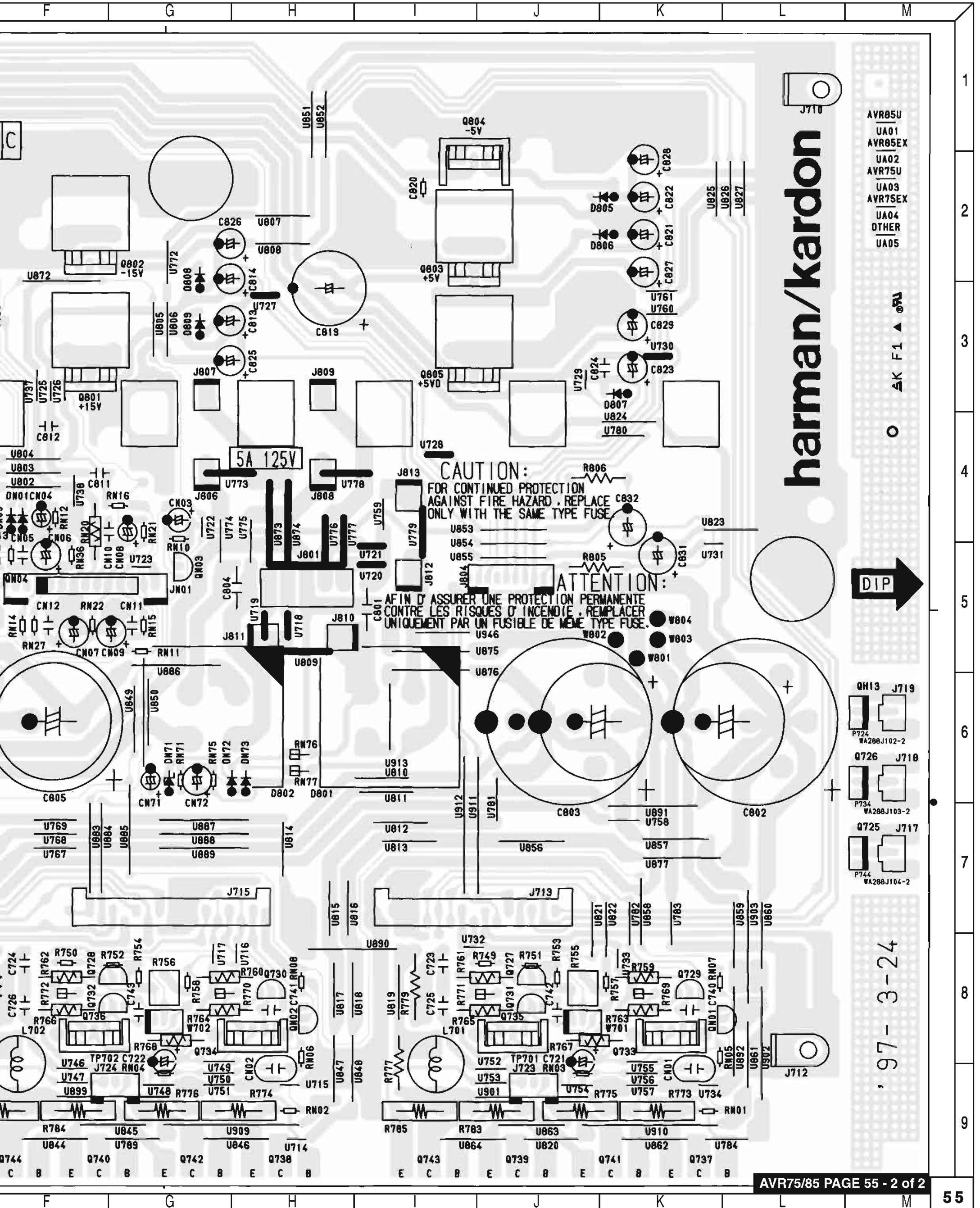

harman/kardon

CAUTION:
 FOR CONTINUED PROTECTION
 AGAINST FIRE HAZARD, REPLACE
 ONLY WITH THE SAME TYPE FUSE

ATTENTION:
 AFIN D'ASSURER UNE PROTECTION PERMANENTE
 CONTRE LES RISQUES D'INCENDIE, REMPLACER
 UNIQUEMENT PAR UN FUSIBLE DE MEME TYPE FUSE.

DIP

- AVR85U
- UA01
- AVR85EX
- UA02
- AVR75U
- UA03
- AVR75EX
- UA04
- OTHER
- UA05

- QH13 J719
- P724 WA288J102-2
- Q726 J718
- P734 WA288J103-2
- Q725 J717
- P744 WA288J104-2

97-3-24

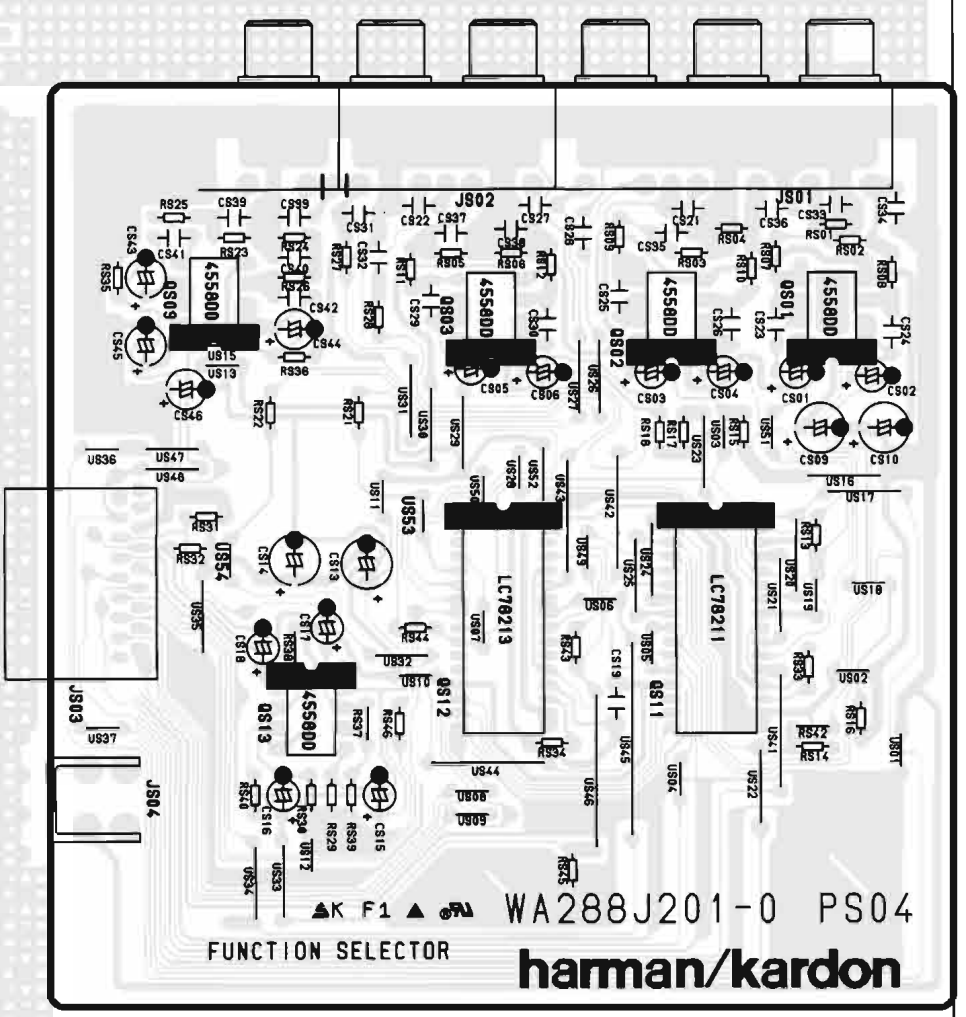

**AUDIO
FUNCTION
PCB - PS04**

**AUDIO/VIDEO
PCB - PS54**

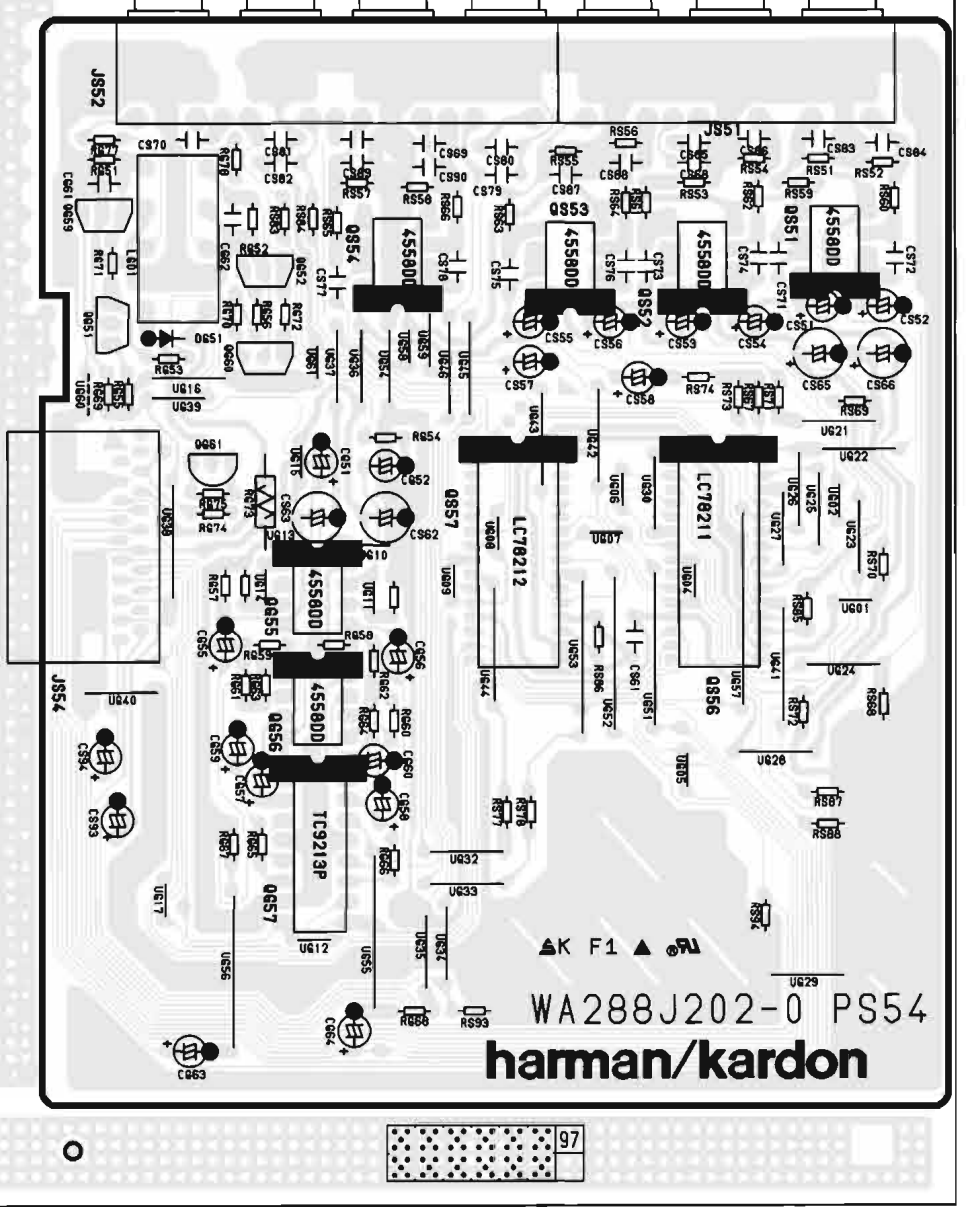

**WA288J202-0 PS54
harman/kardon**

**AC-3 CROSSOVER
PCB - PC04**

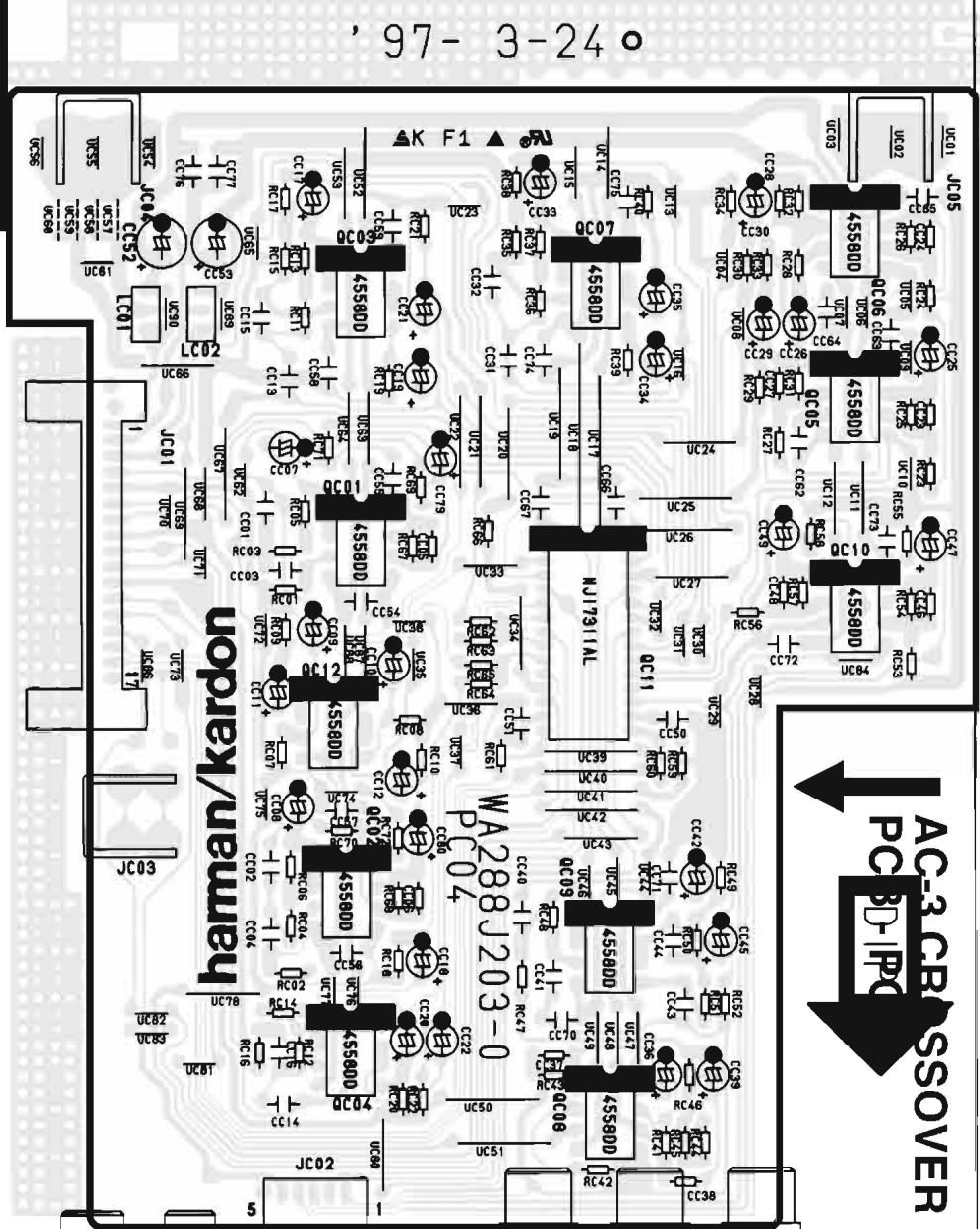

uprexy/newway

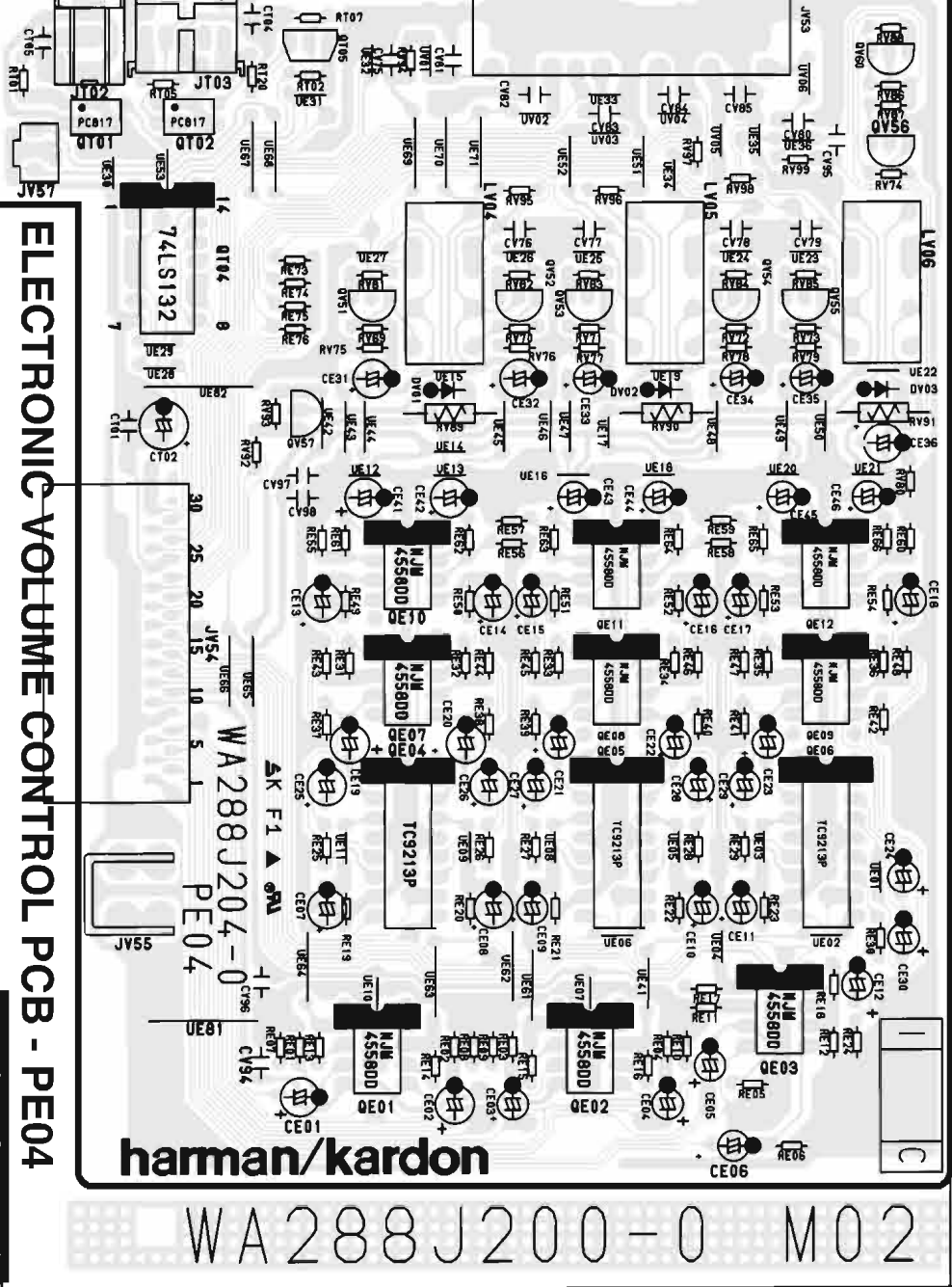

ELECTRONIC VOLUME CONTROL PCB - PE04

harman/kardon

WA288J200-0 M02

97-3-24

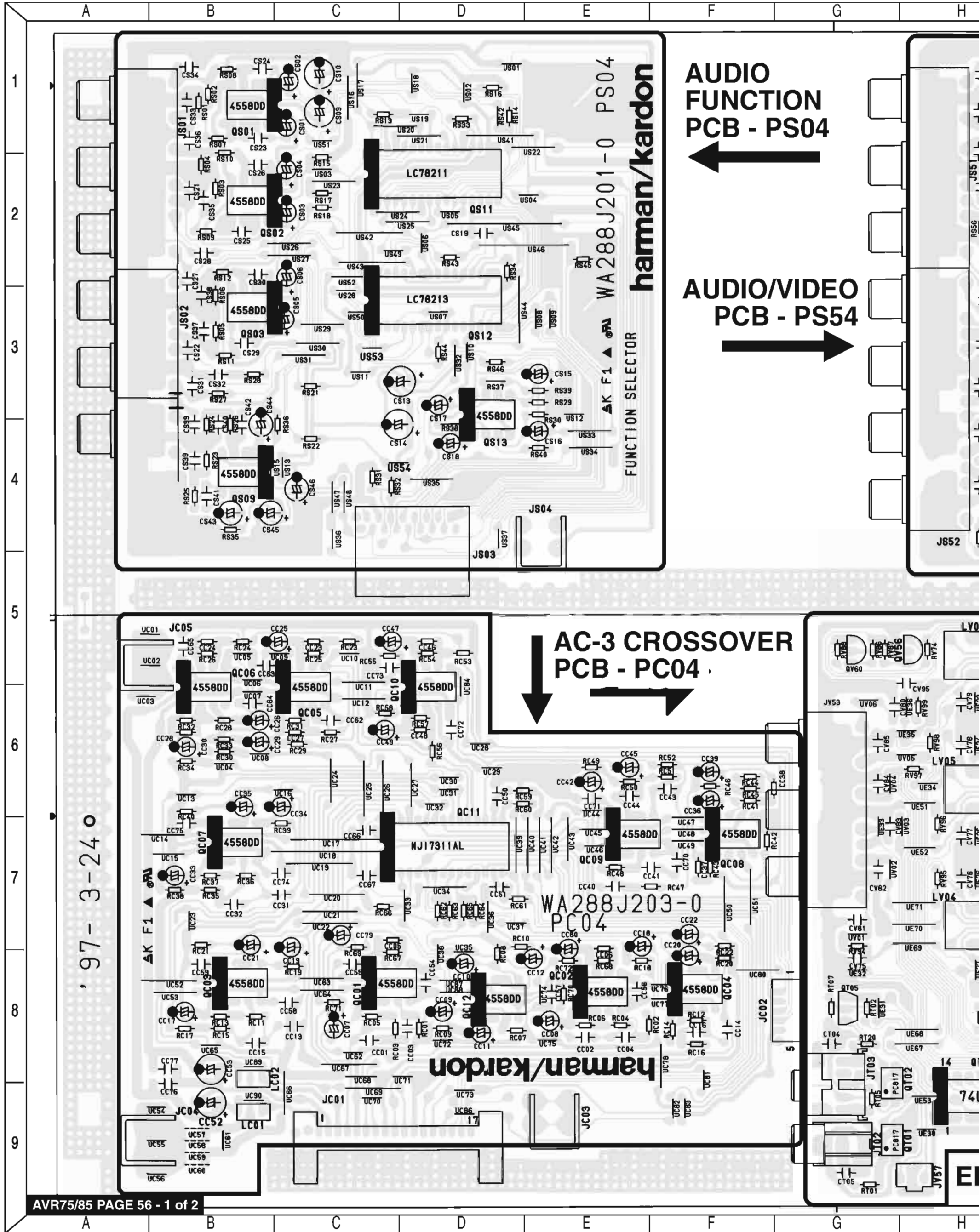

AUDIO
FUNCTION
PCB - PS04

AUDIO/VIDEO
PCB - PS54

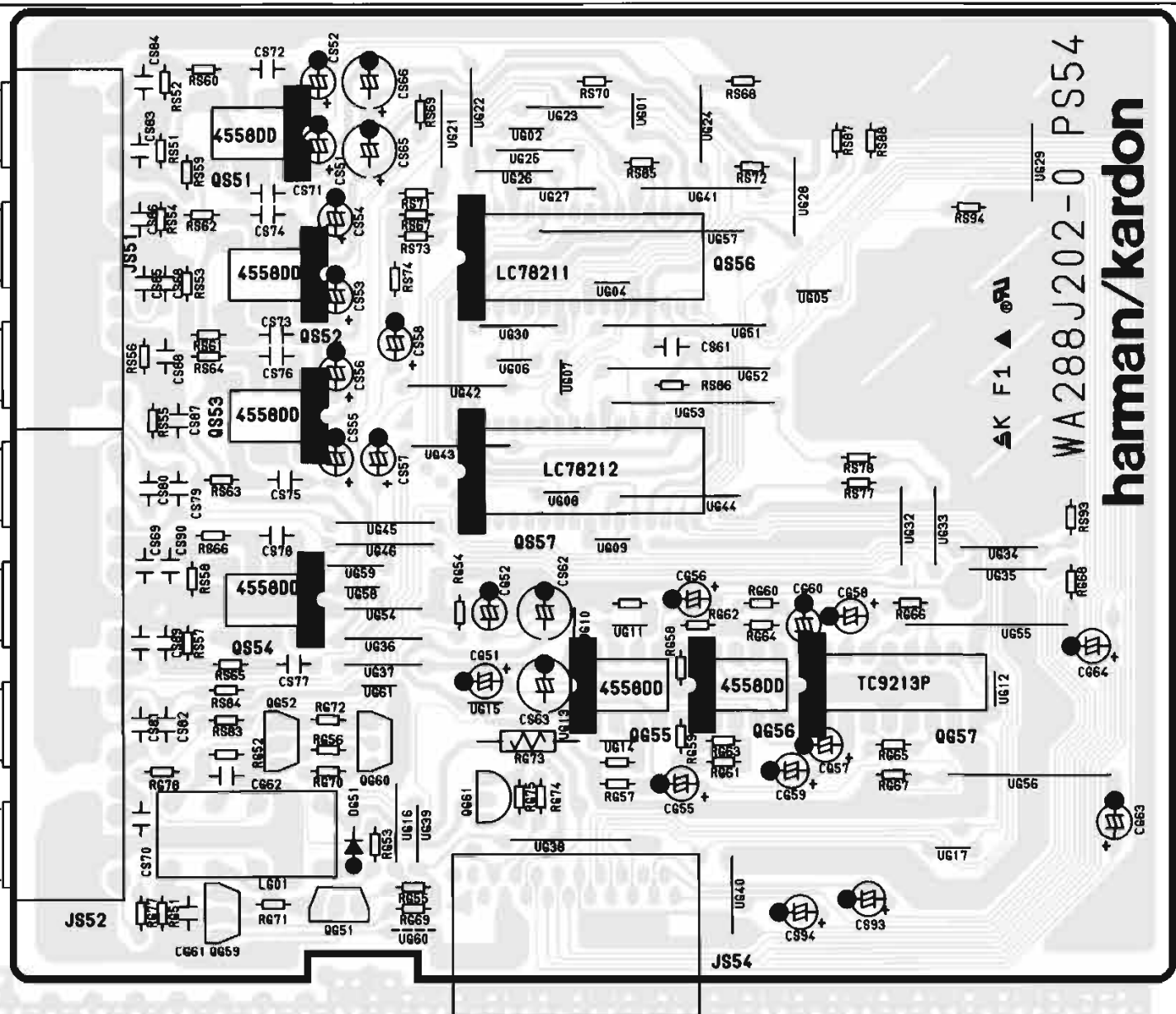

CROSSOVER
PCB - PC04

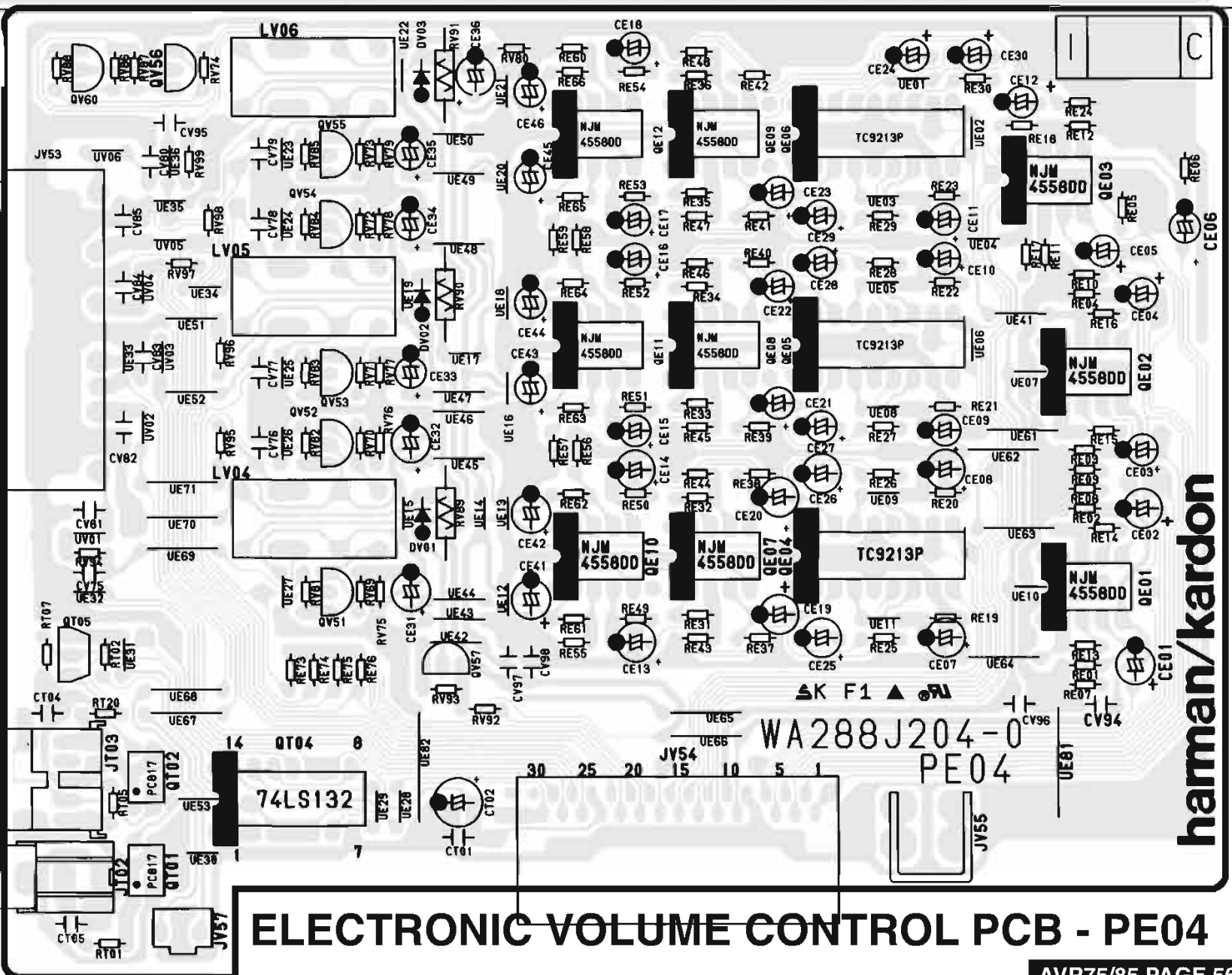

ELECTRONIC VOLUME CONTROL PCB - PE04

WA288J200-0 M02

AVR75/85 PAGE 57 - 1 of 2

CONNECT PCB - PY04

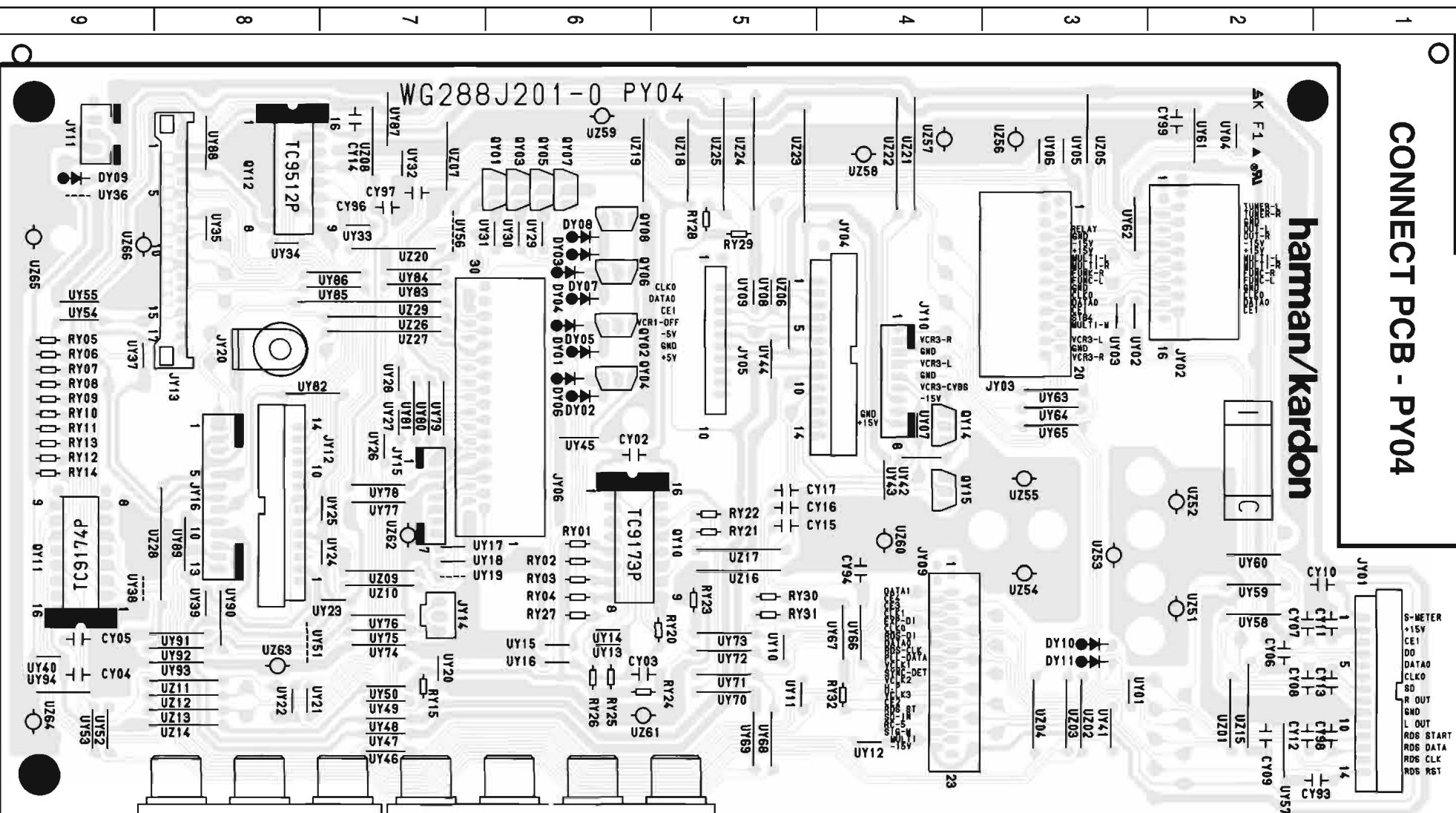

SPEAKER TERMINAL PCB - P754

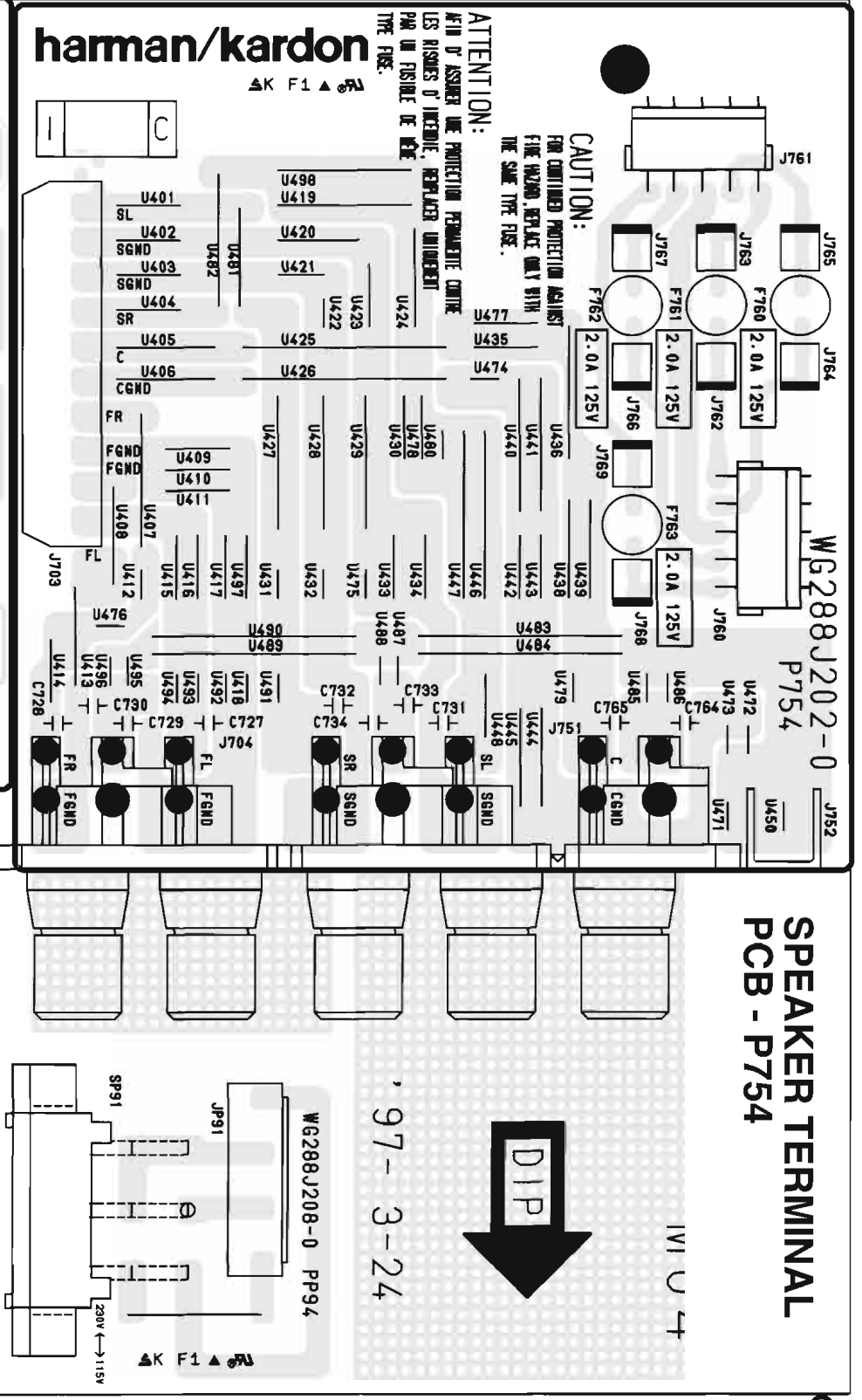

97-3-24

VIDEO SELECTOR PCB - PL04

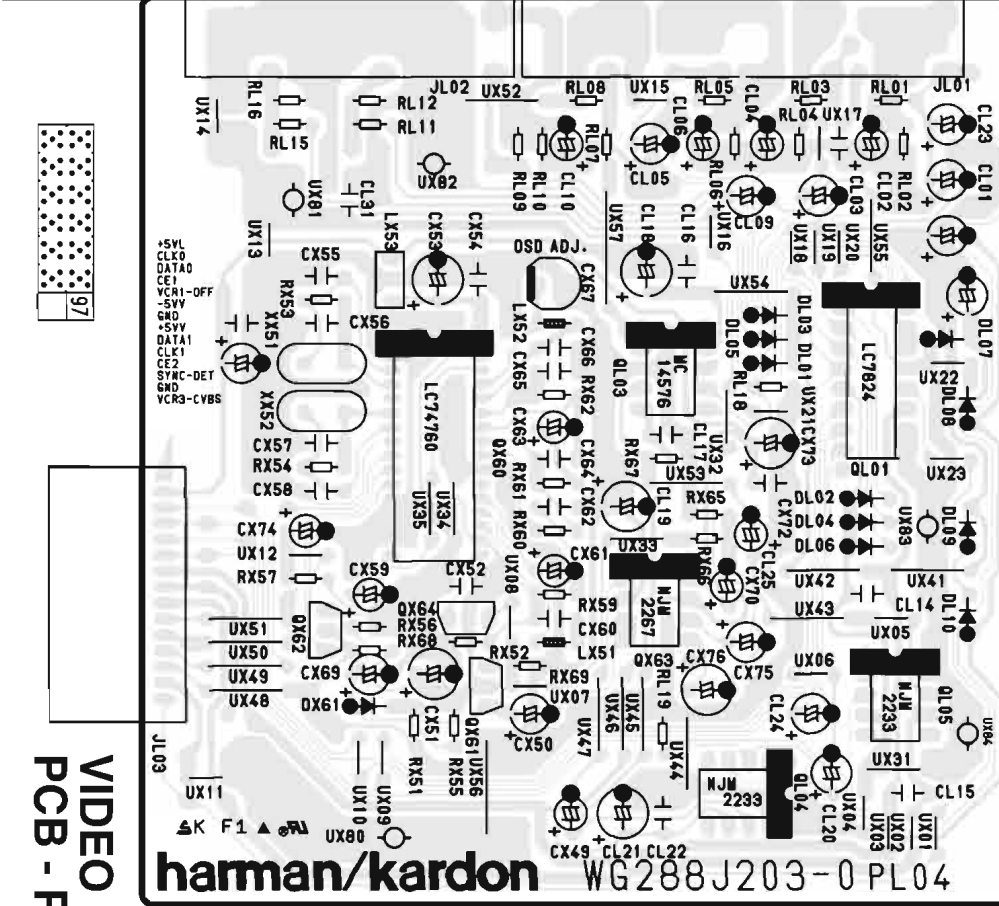

upkardn/wawmuy

78DD
0-702F882GM

harman/kardon

WG288J204-0
PP54

79DD
0-502F882GM

WG288J206-0
PP74

CONNECT PCB - PY04

harman/kardon

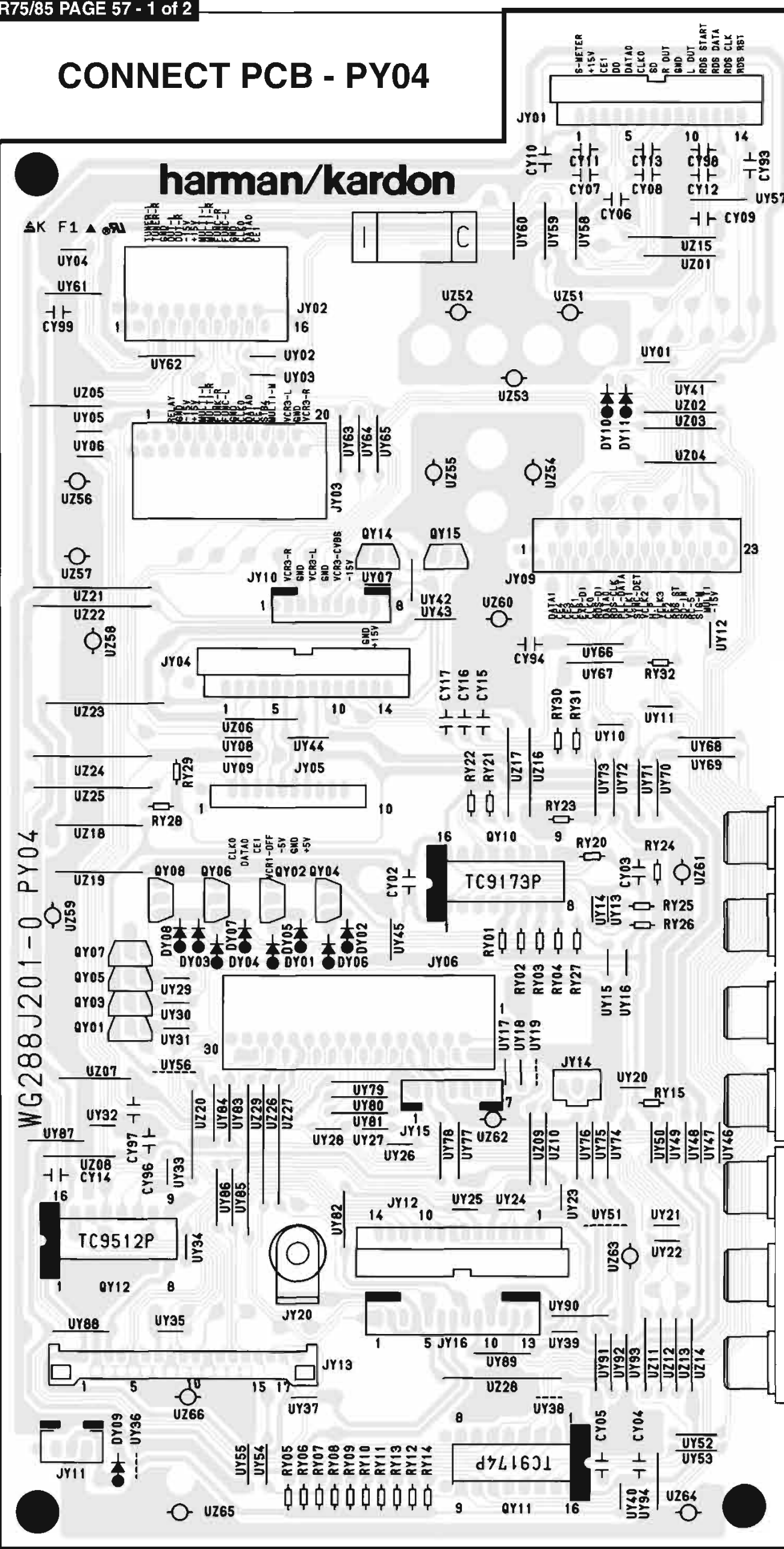

WG288J201-0 PY04

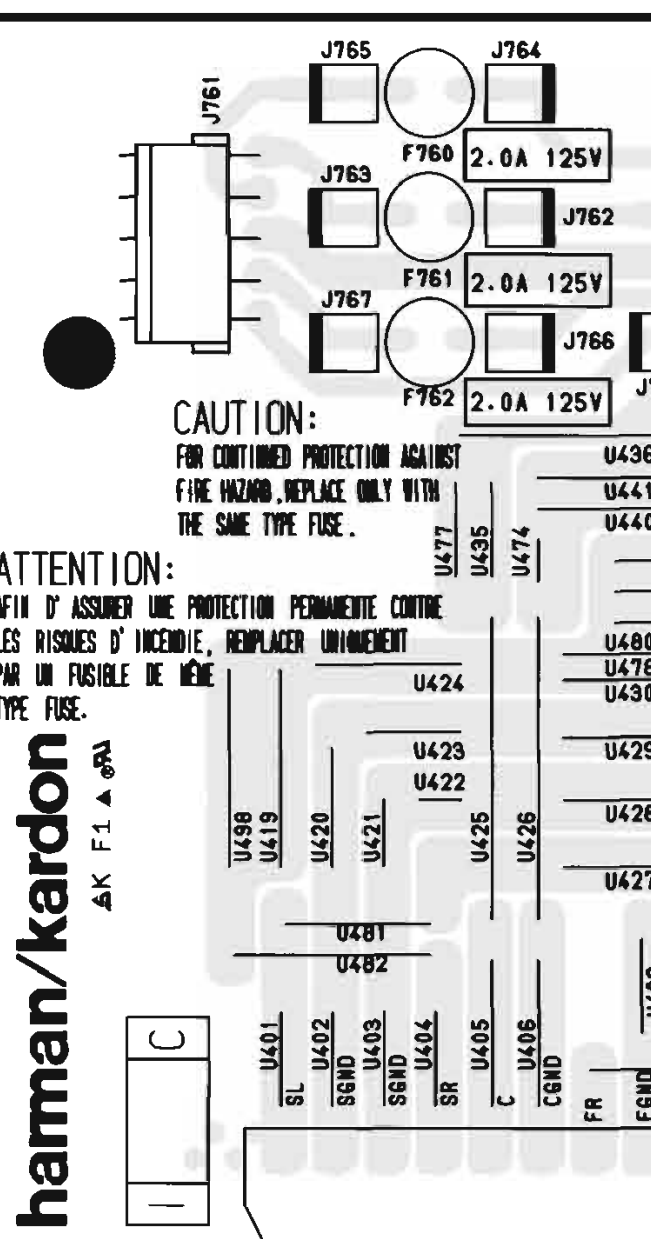

CAUTION:
FOR CONTINUED PROTECTION AGAINST
FIRE HAZARD, REPLACE ONLY WITH
THE SAME TYPE FUSE.

ATTENTION:
AFIN D'ASSURER UNE PROTECTION PERMANENTE CONTRE
LES RISQUES D'INCENDIE, REMPLACER UNIQUEMENT
PAR UN FUSIBLE DE MEME
TYPE FUSE.

harman/kardon

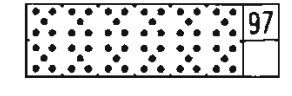
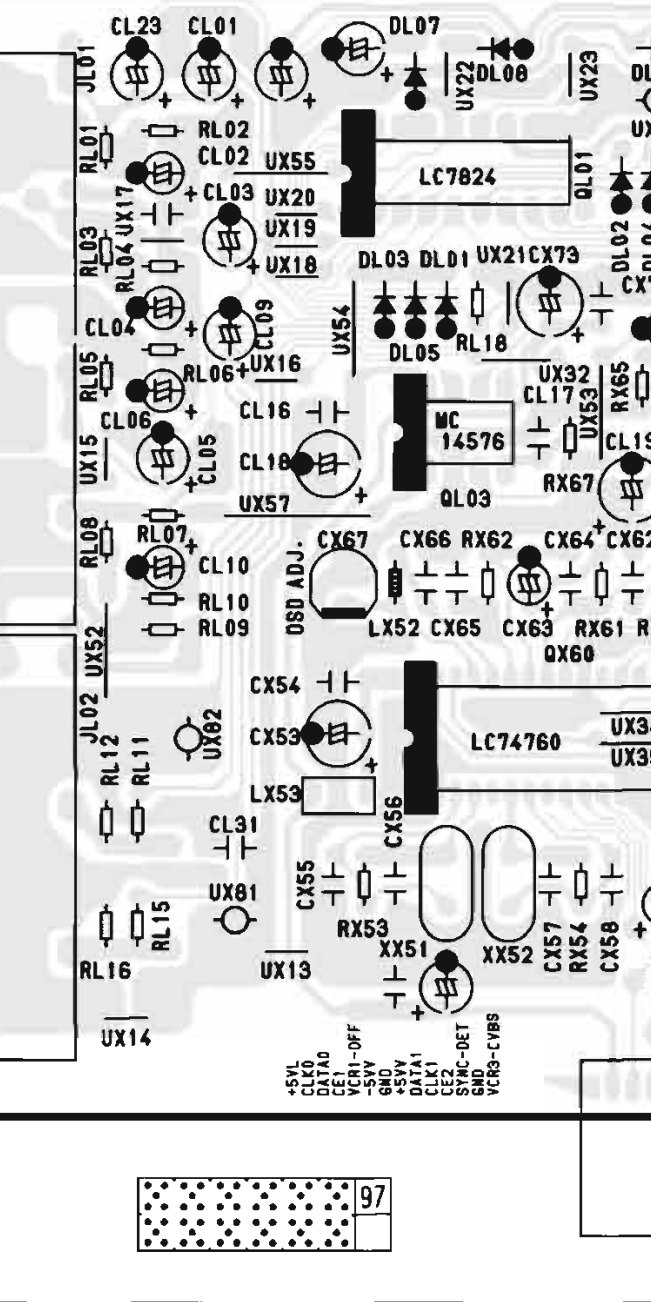

F	G	H	I	J	K	L	M
---	---	---	---	---	---	---	---

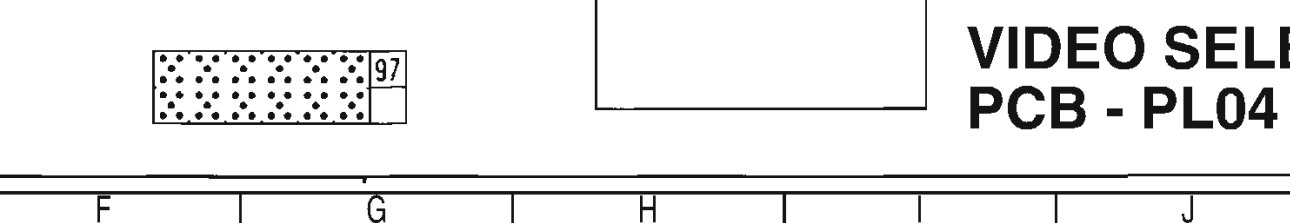
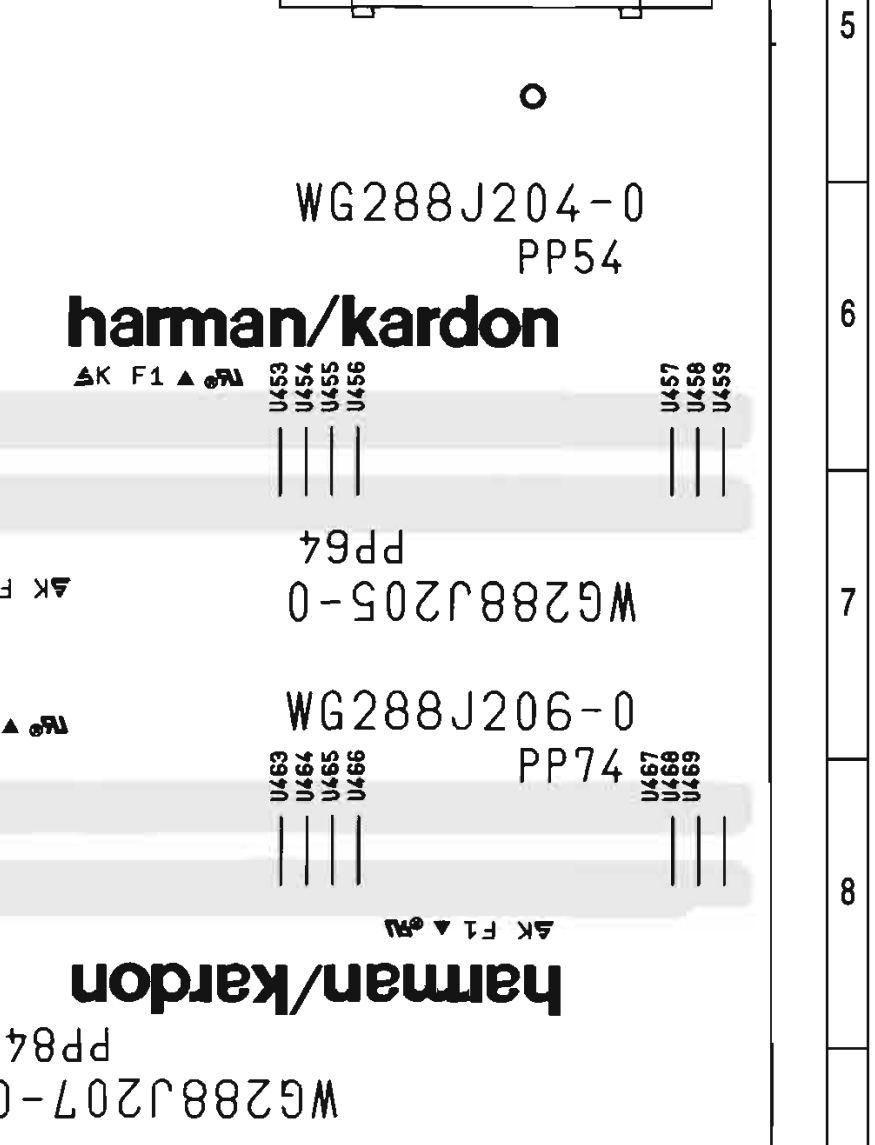
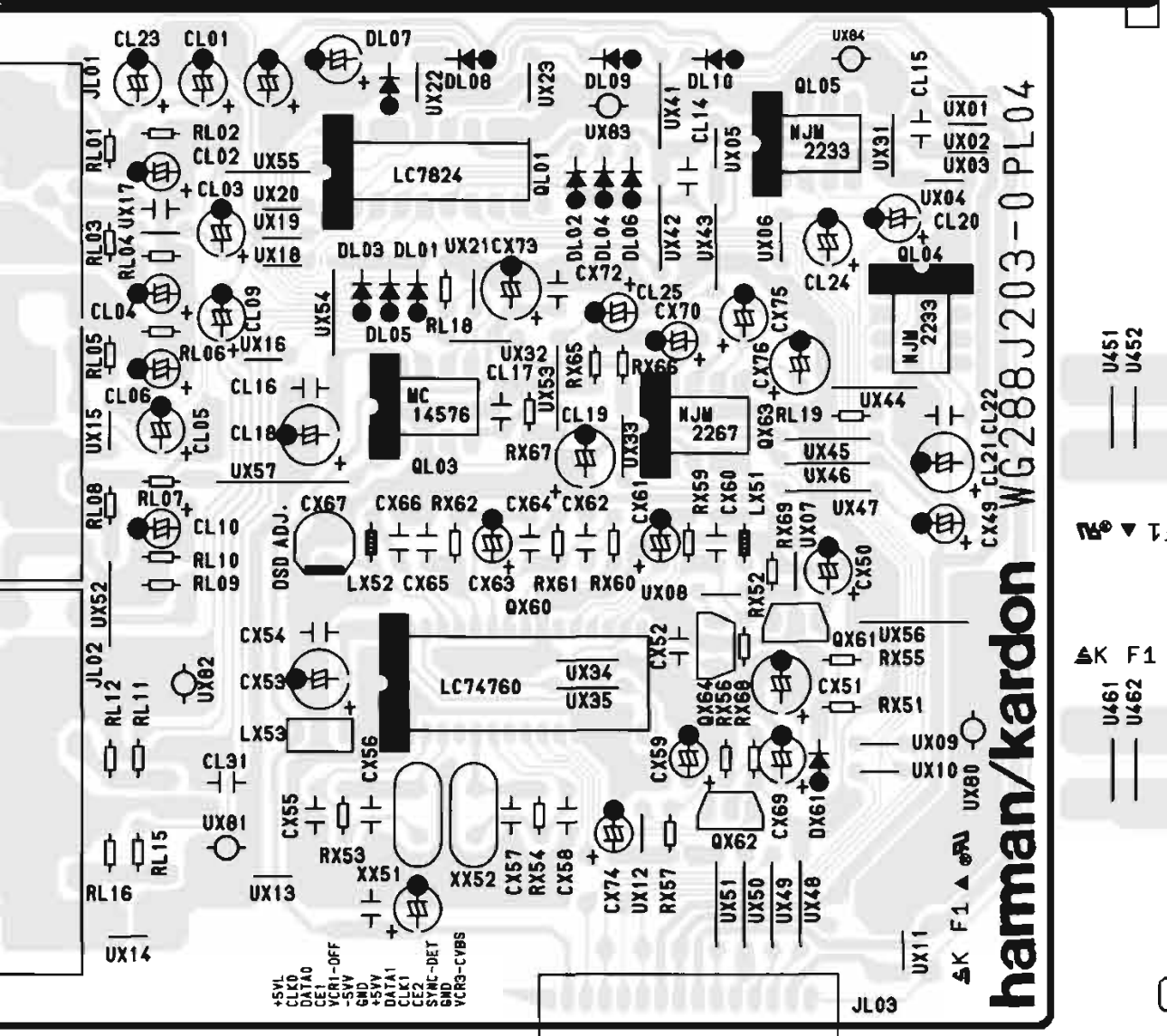
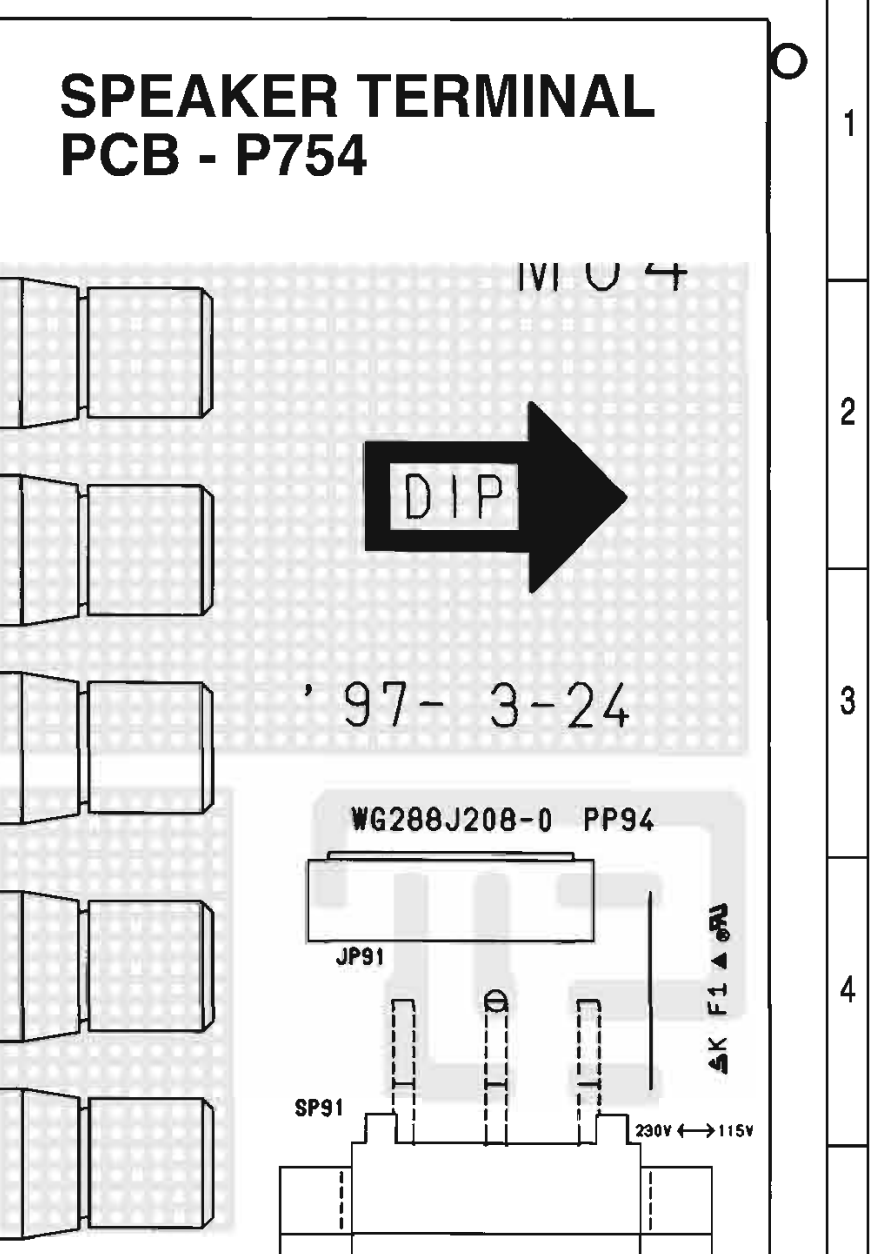
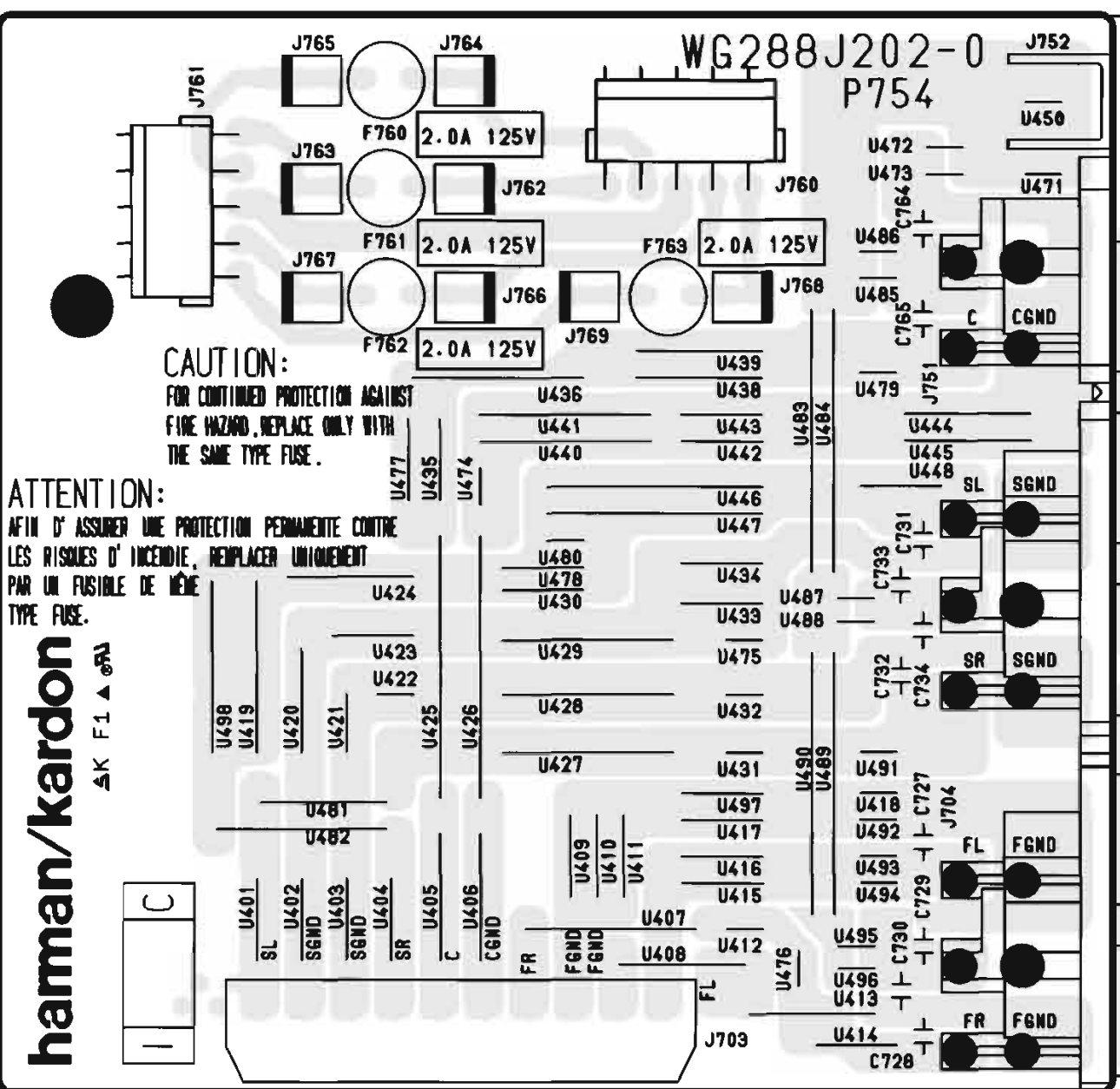

VIDEO SELECTOR PCB - PL04

SPEAKER TERMINAL PCB - P754

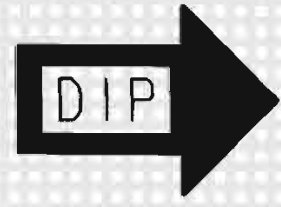

97-3-24

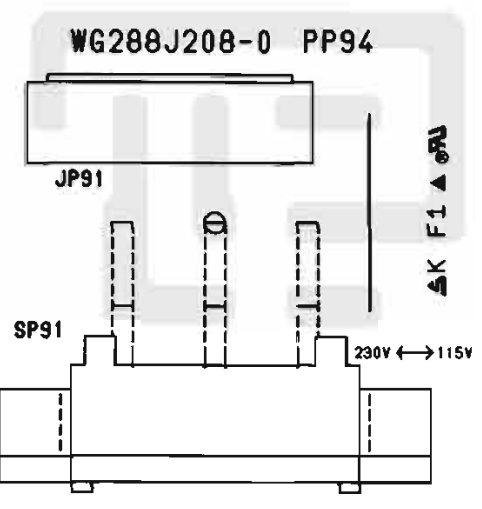

WG288J204-0 PP54

haman/kardon



F	G	H	I	J	K	L	M
---	---	---	---	---	---	---	---

**S-VIDEO
 PCB - PL54**
 for 120V
 AVR85 ONLY

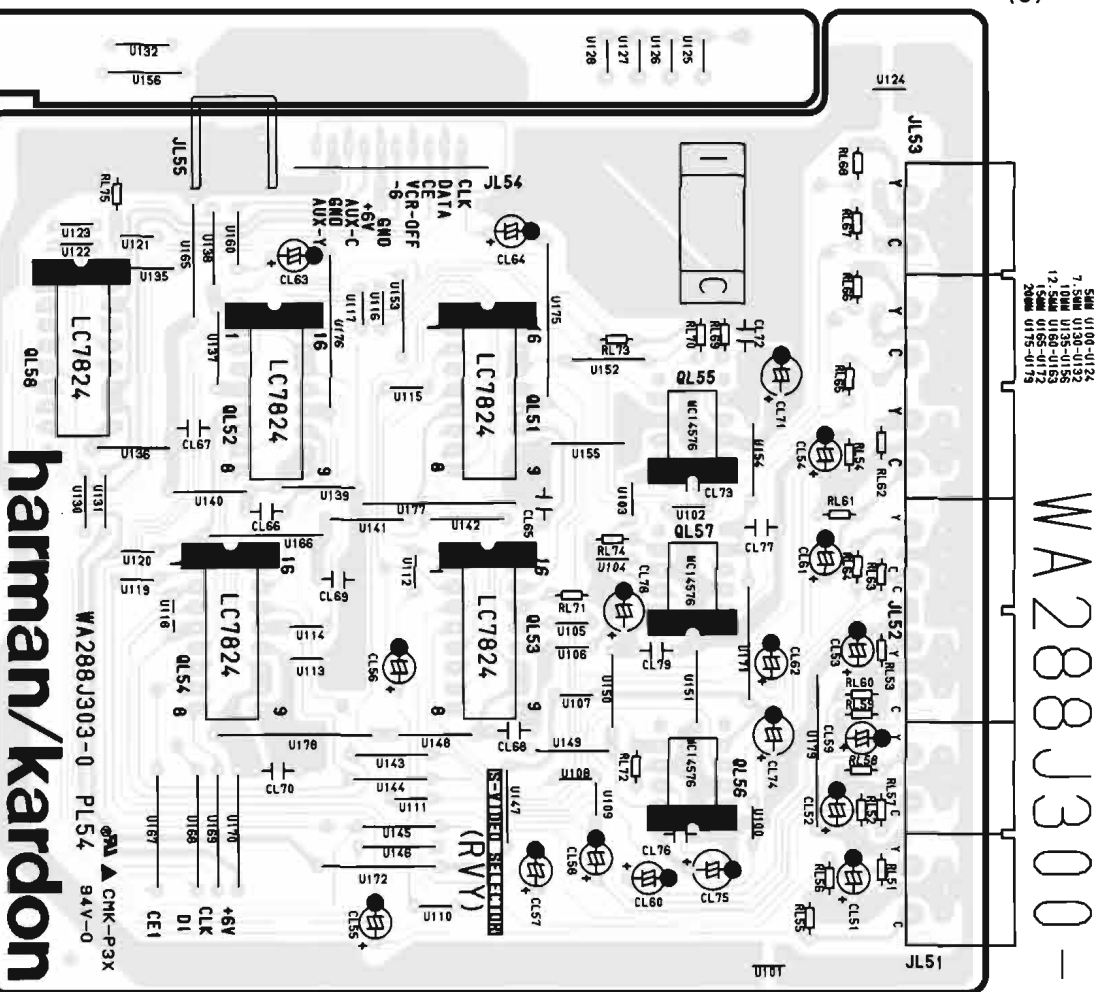

WA288J300-0 M03

**STANDBY
 PCB - PB04**
 for 120V

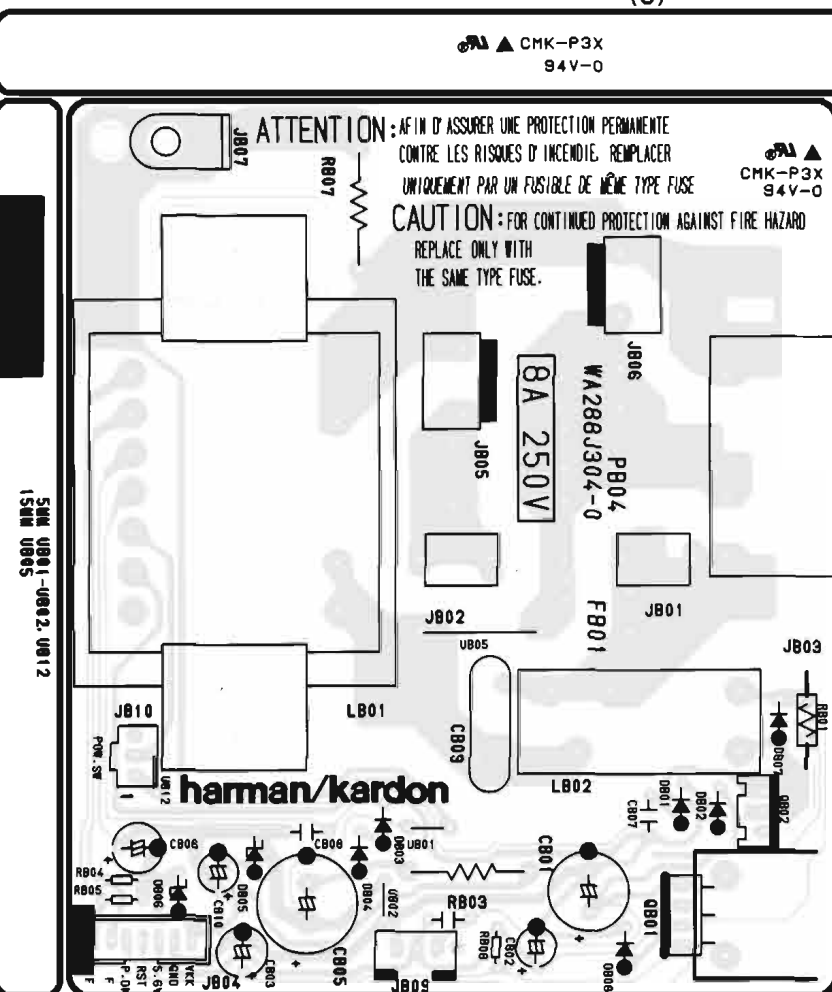

**TUNER
 PCB - P104**
 for 120V

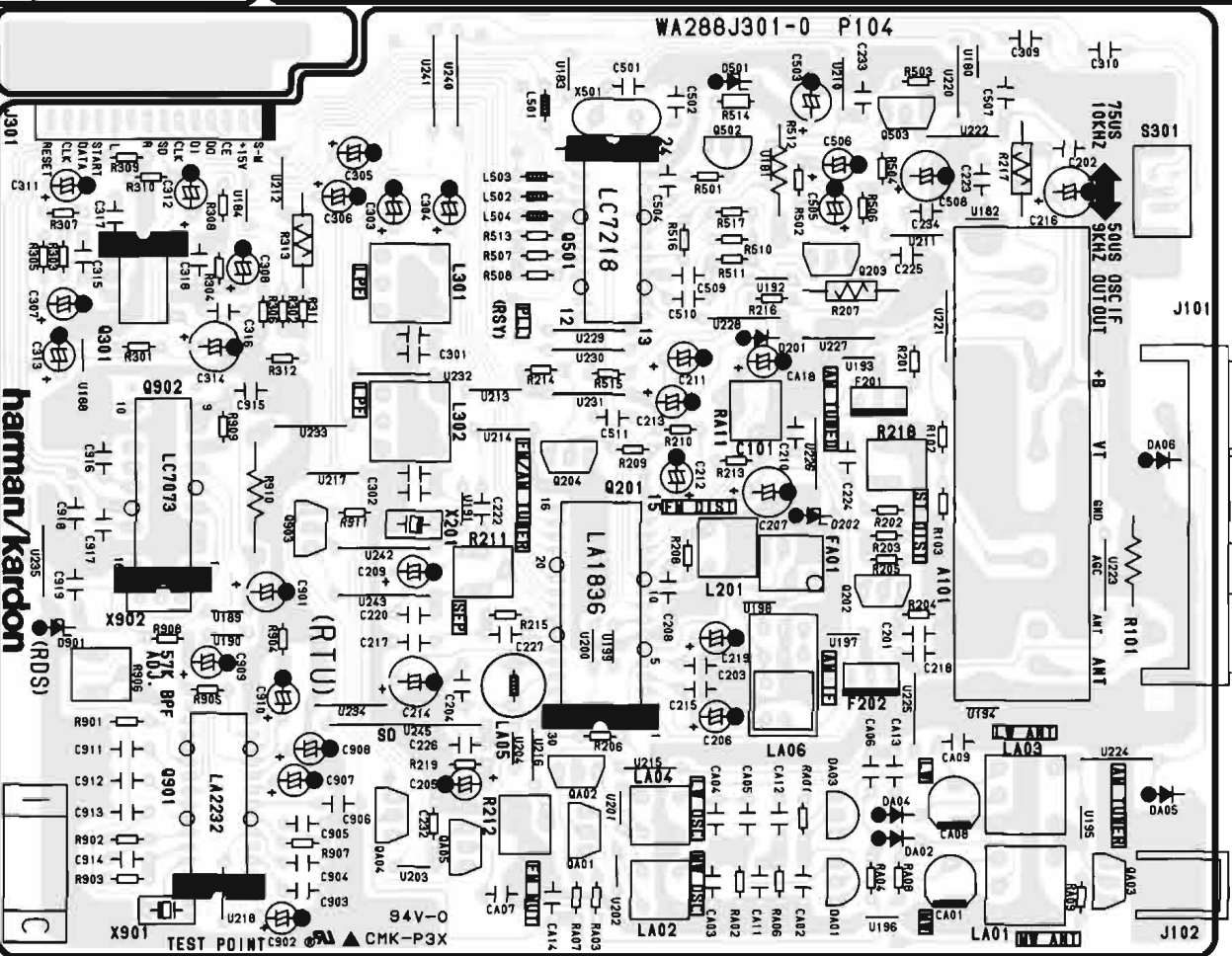

**SURROUND
 AMP
 PCB - PP04**
 for 120V

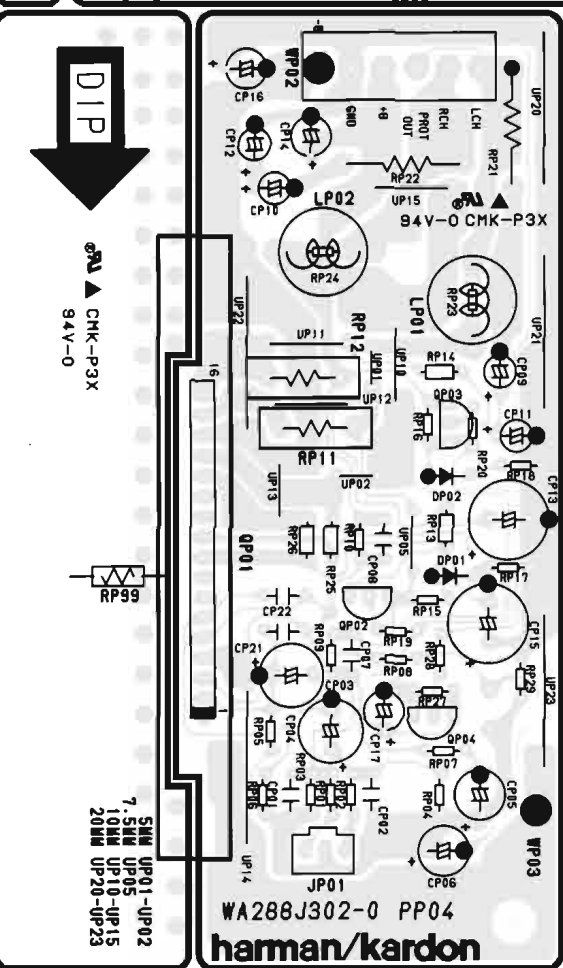

WA288J300-0 MO

S-VIDEO
 PCB - PL54

for 120V
 AVR85 ONLY



1

2

3

4

5

6

7

8

9

(01)

(01)

5MM U100-U124
 7.5MM U130-U132
 10MM U135-U156
 12.5MM U158-U166
 15MM U165-U172
 20MM U175-U179

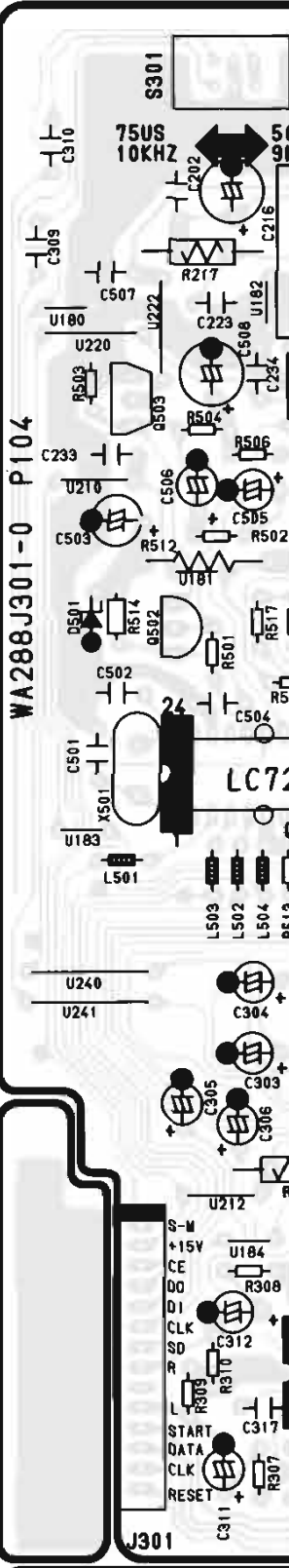
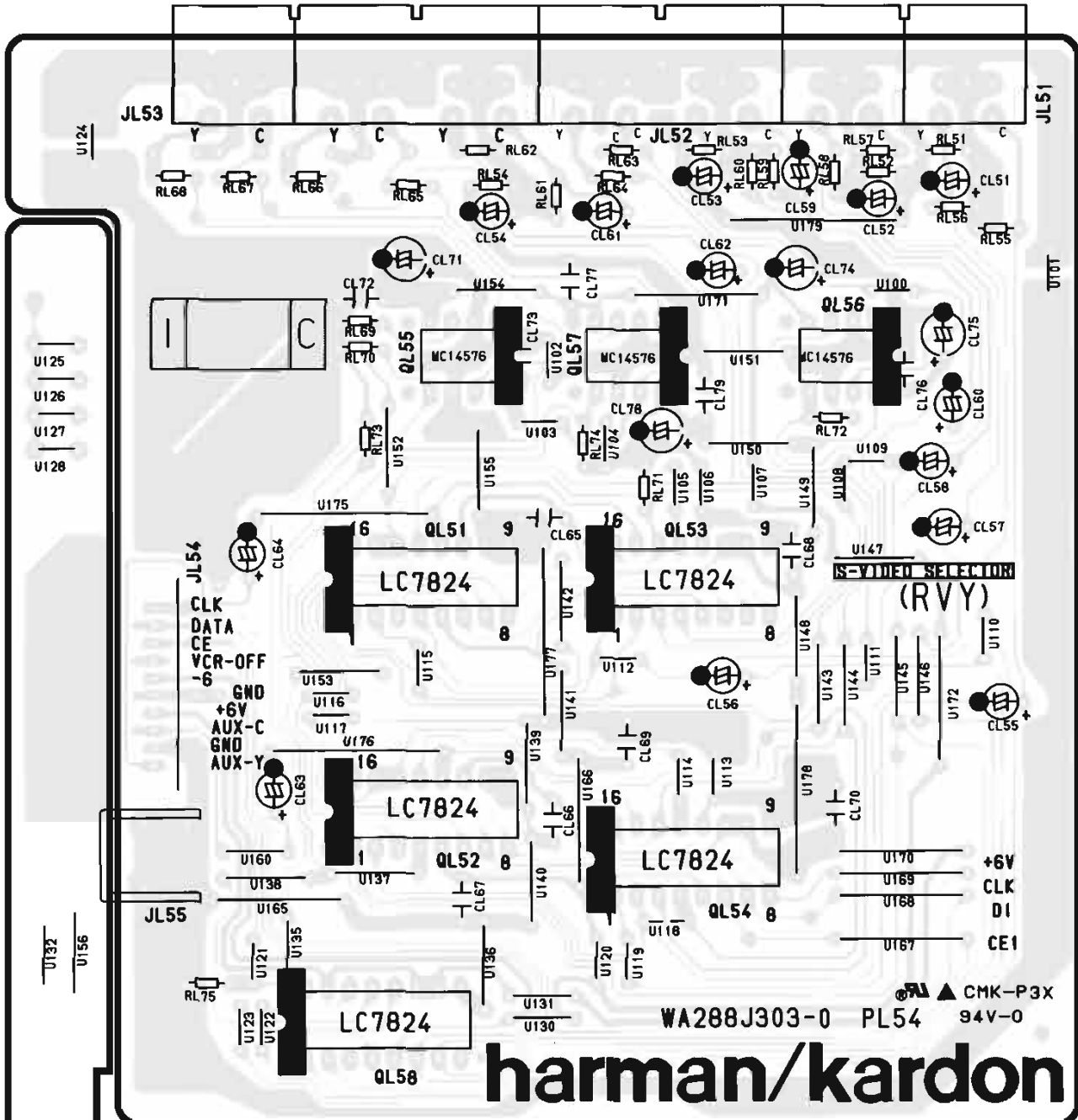

STANDBY
 PCB - PB04



for 120V

CMK-P3X
 94V-0

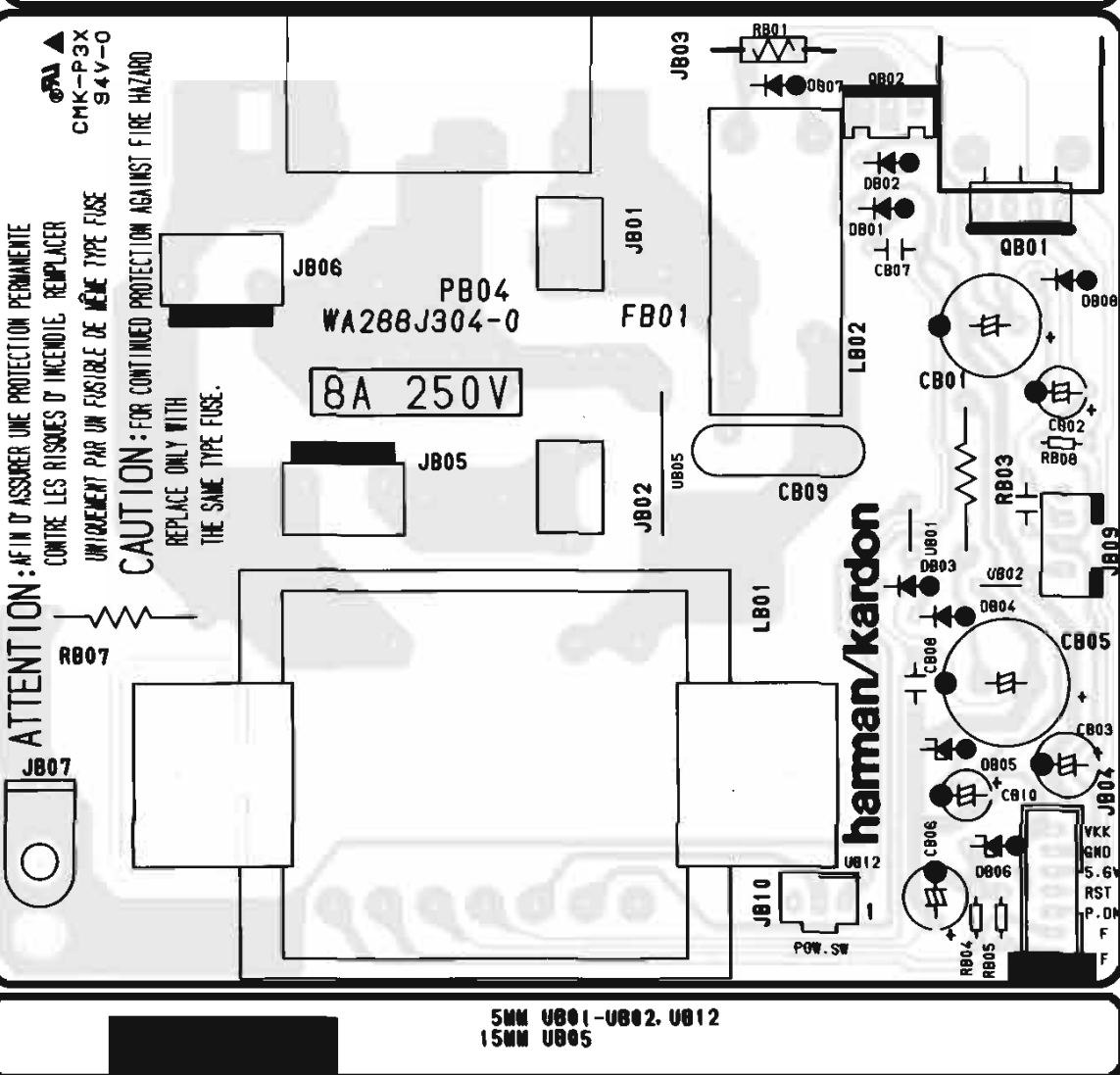

A B C D E F G H

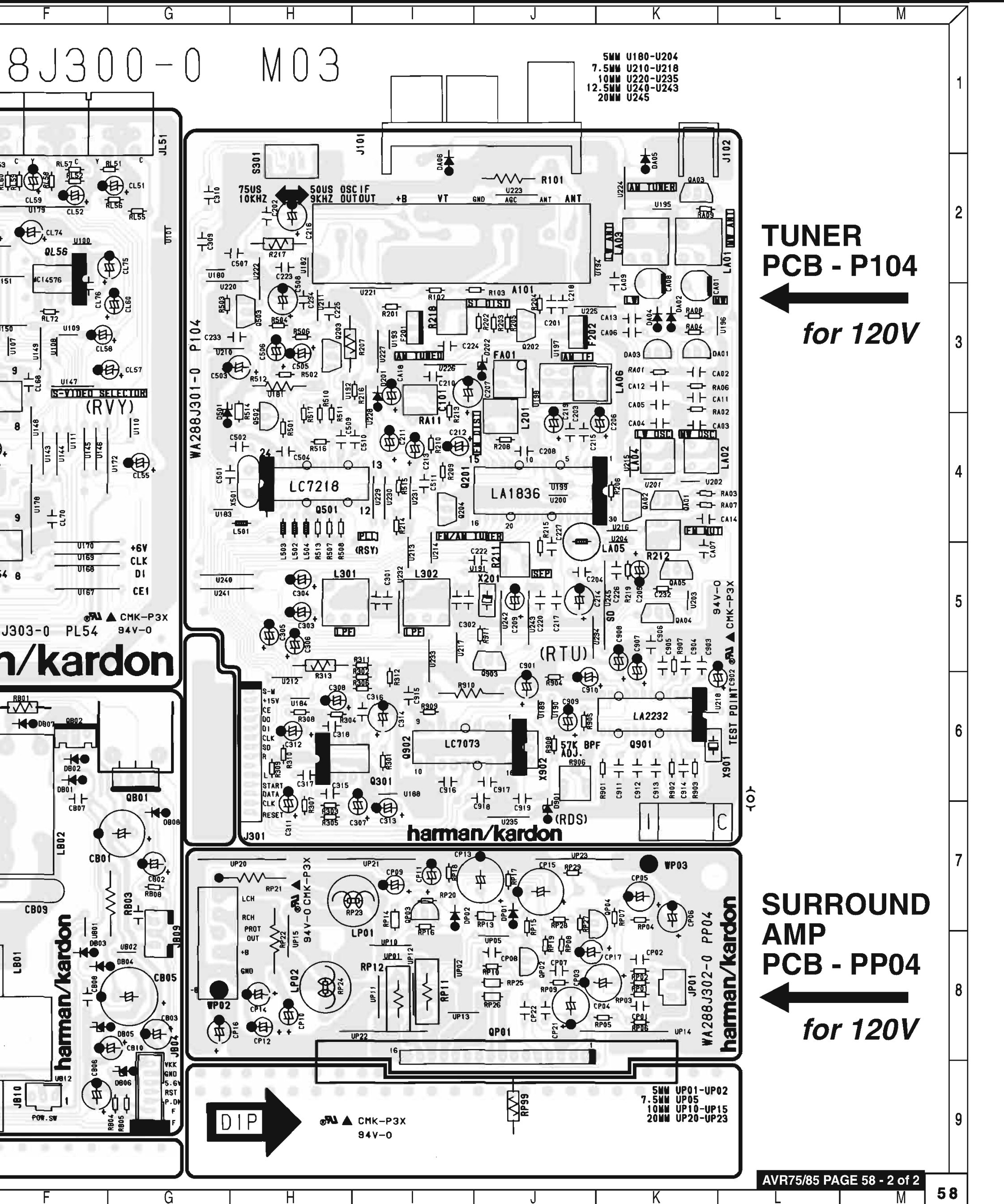

TUNER PCB - P104
← for 120V

SURROUND AMP PCB - PP04
← for 120V

S-VIDEO
PCB - PL54
for 230V
AVR85 ONLY

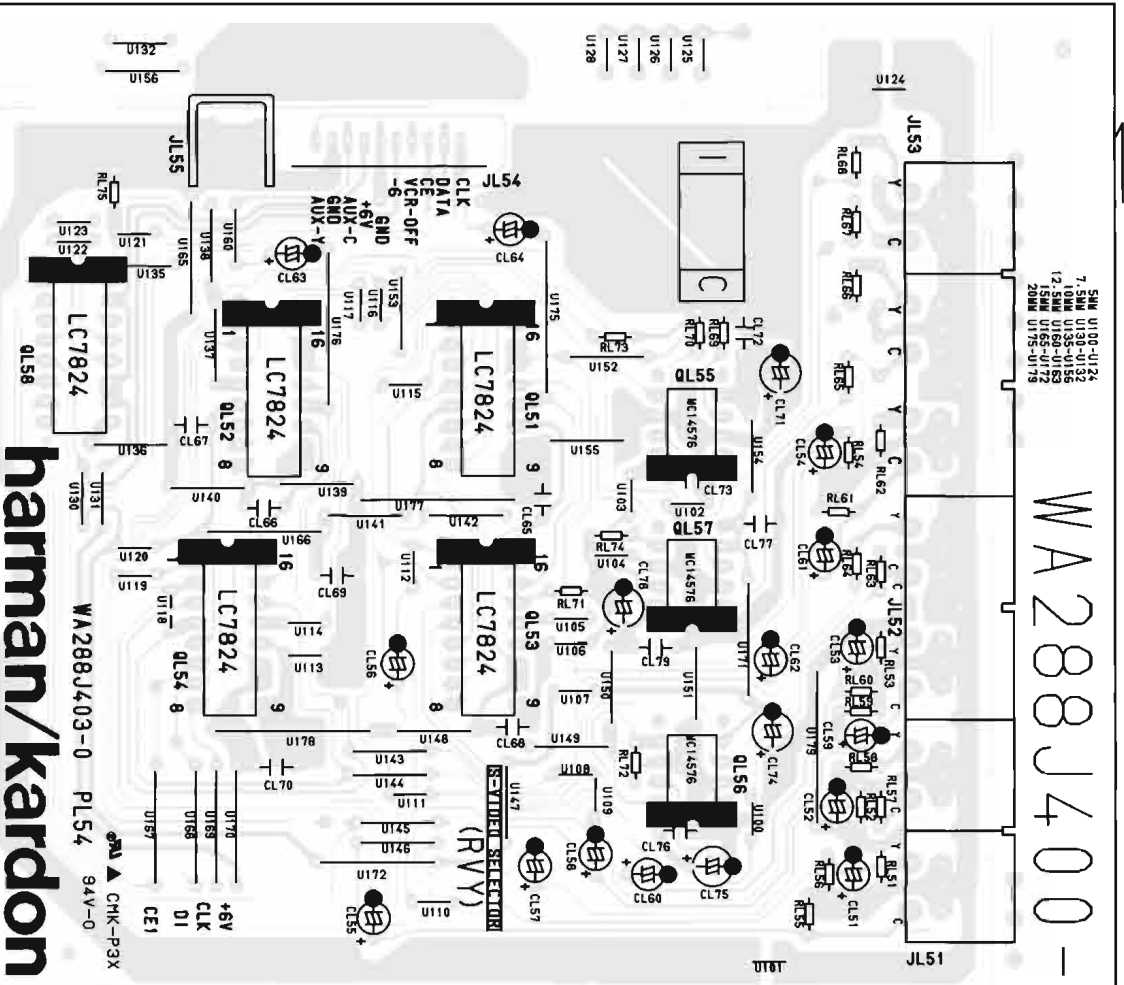

WA288J403-0 PL54
94V-0
CNK-P3X
harman/kardon

STANDBY
PCB - PB04
for 230V

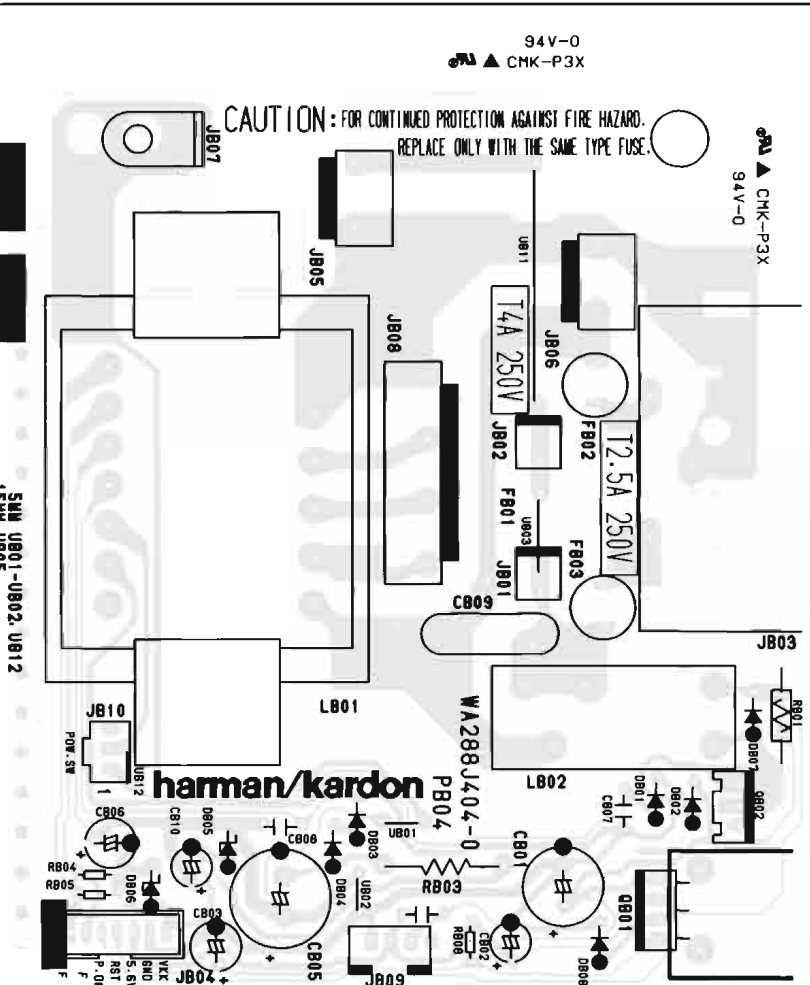

CAUTION: FOR CONTINUED PROTECTION AGAINST FIRE HAZARD,
REPLACE ONLY WITH THE SAME TYPE FUSE.
94V-0
CNK-P3X
WA288J404-0
PB04
94V-0
CNK-P3X
harman/kardon

TUNER
PCB - P104
for 230V

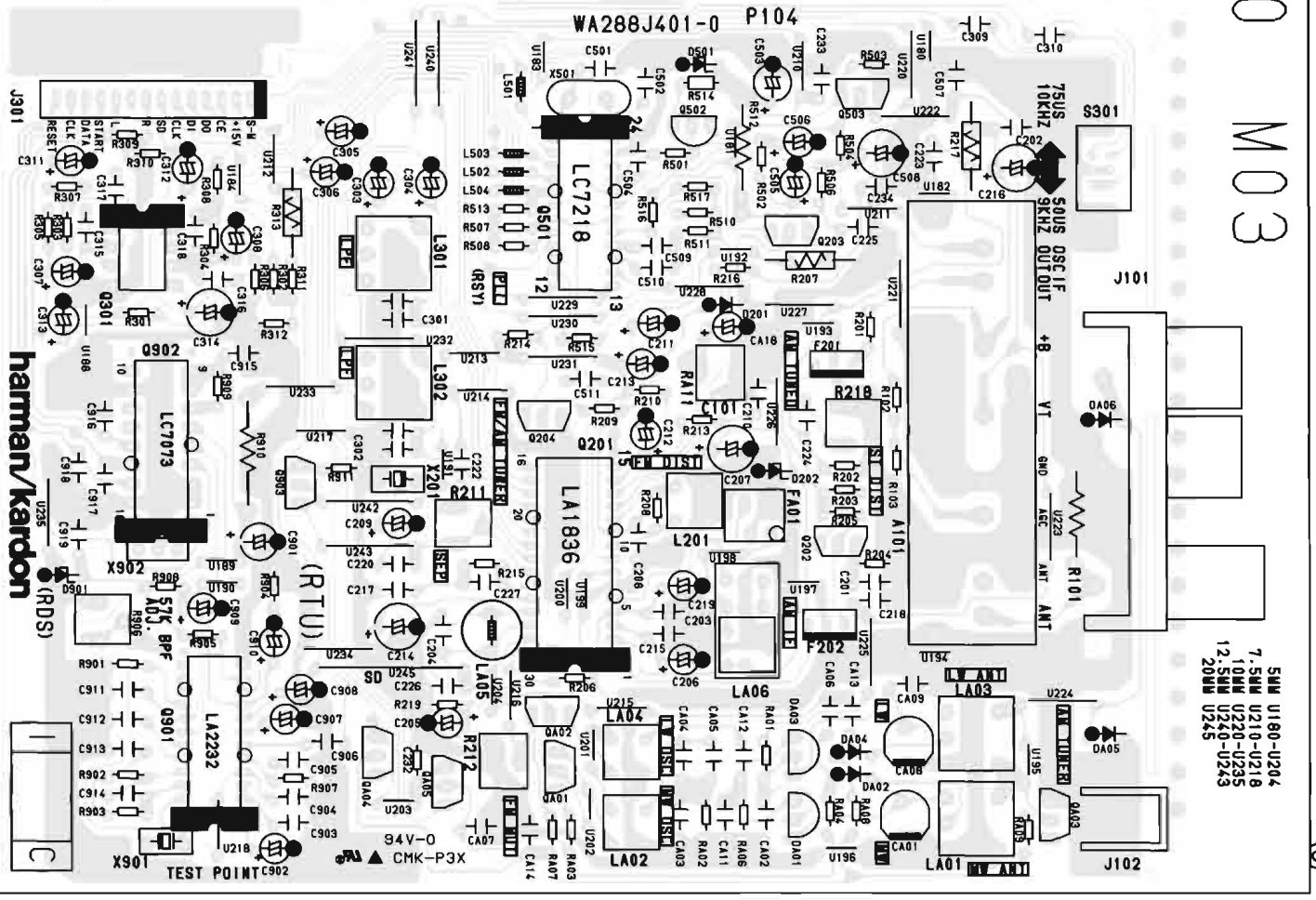

WA288J401-0 P104
94V-0
CNK-P3X
harman/kardon

SURROUND
AMP
PCB - PP04
for 230V

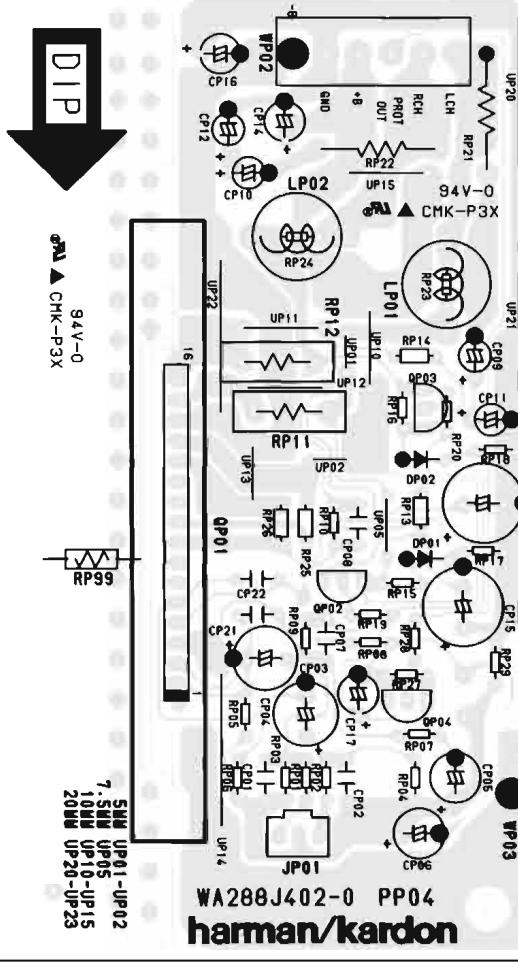

WA288J402-0 PP04
94V-0
CNK-P3X
harman/kardon

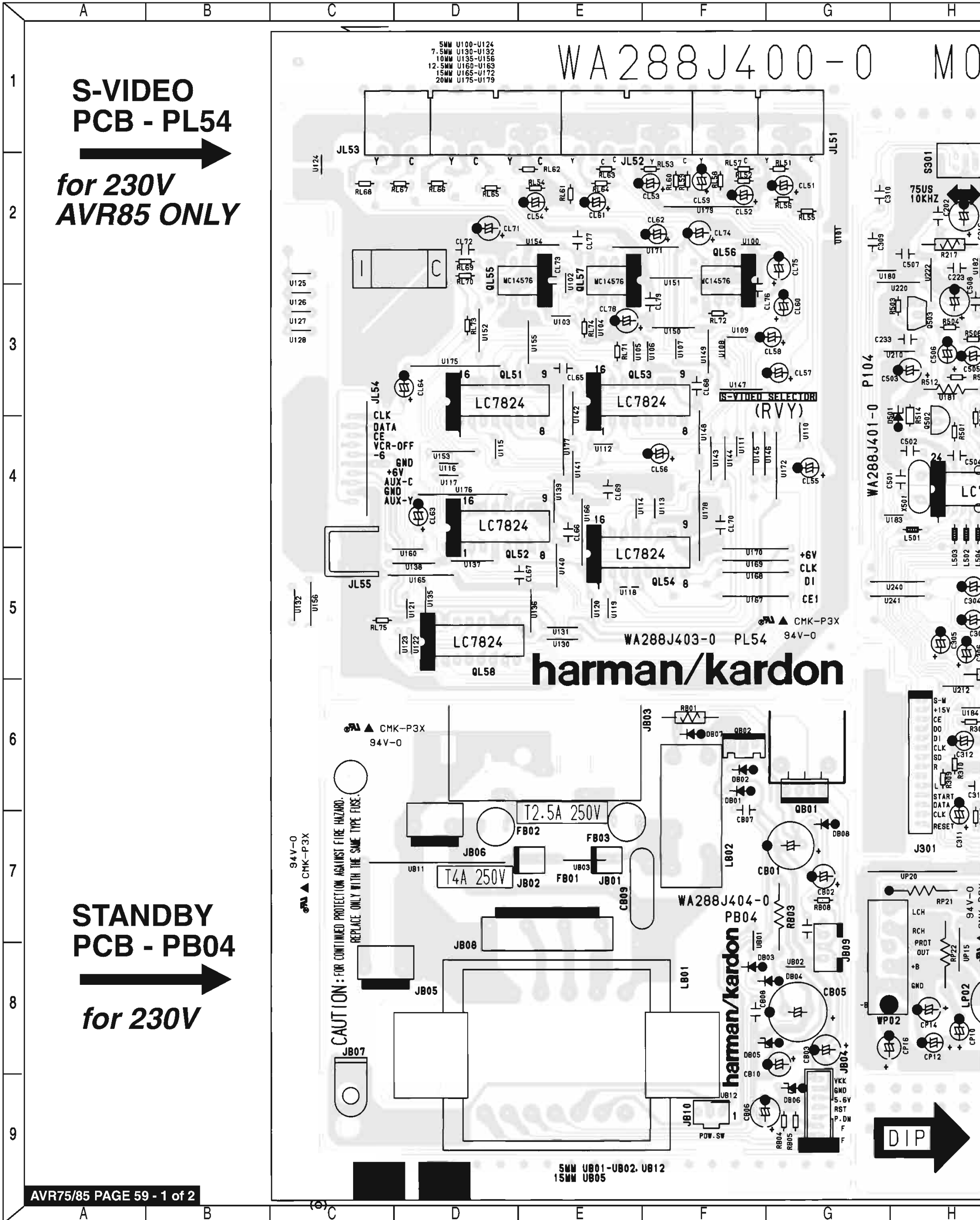

38J400-0 M03

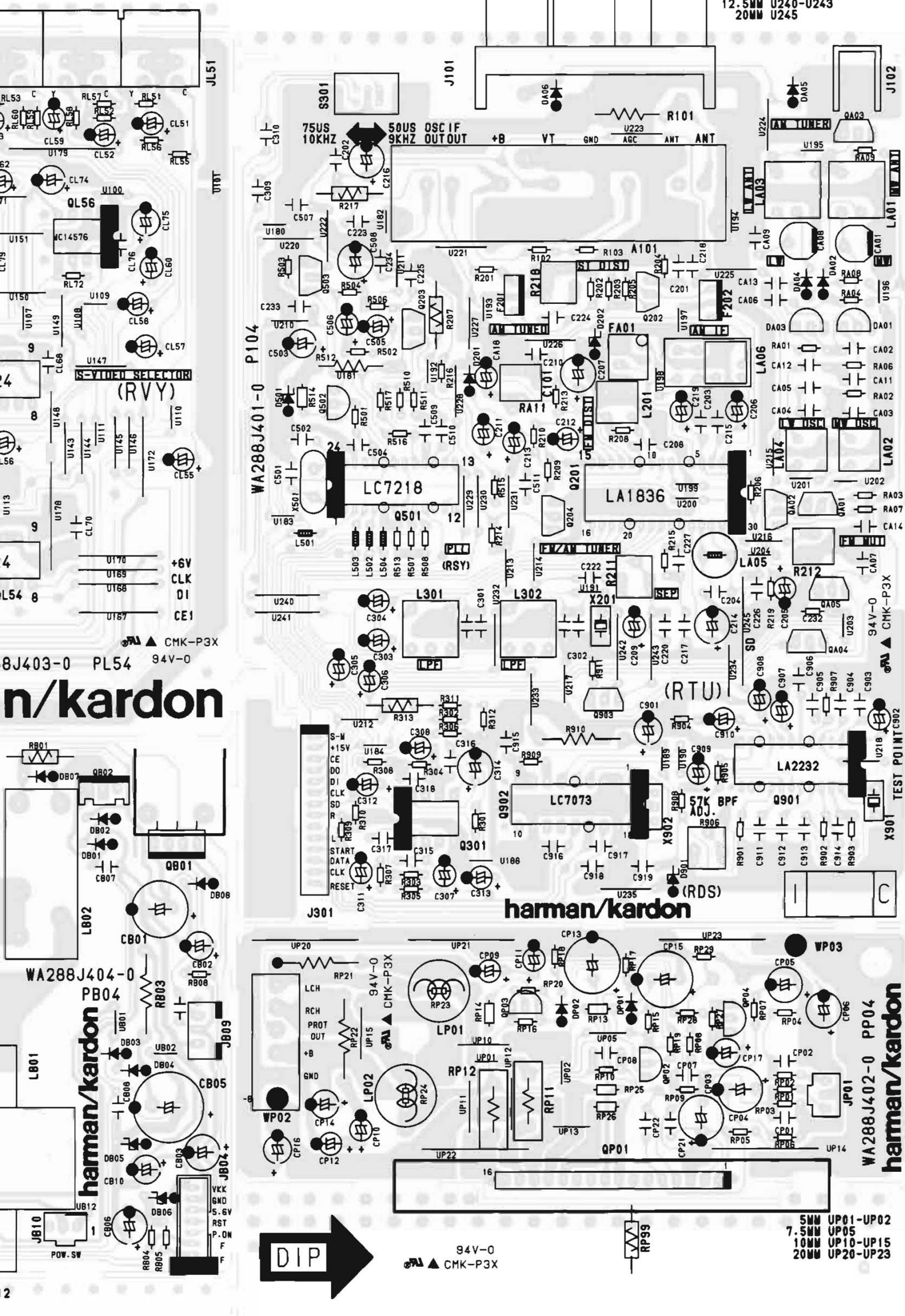

- 5MM U180-U204
- 7.5MM U210-U218
- 10MM U220-U235
- 12.5MM U240-U243
- 20MM U245

**TUNER
PCB - P104**
←
for 230V

**SURROUND
AMP
PCB - PP04**
←
for 230V



- 5MM UP01-UP02
- 7.5MM UP05
- 10MM UP10-UP15
- 20MM UP20-UP23

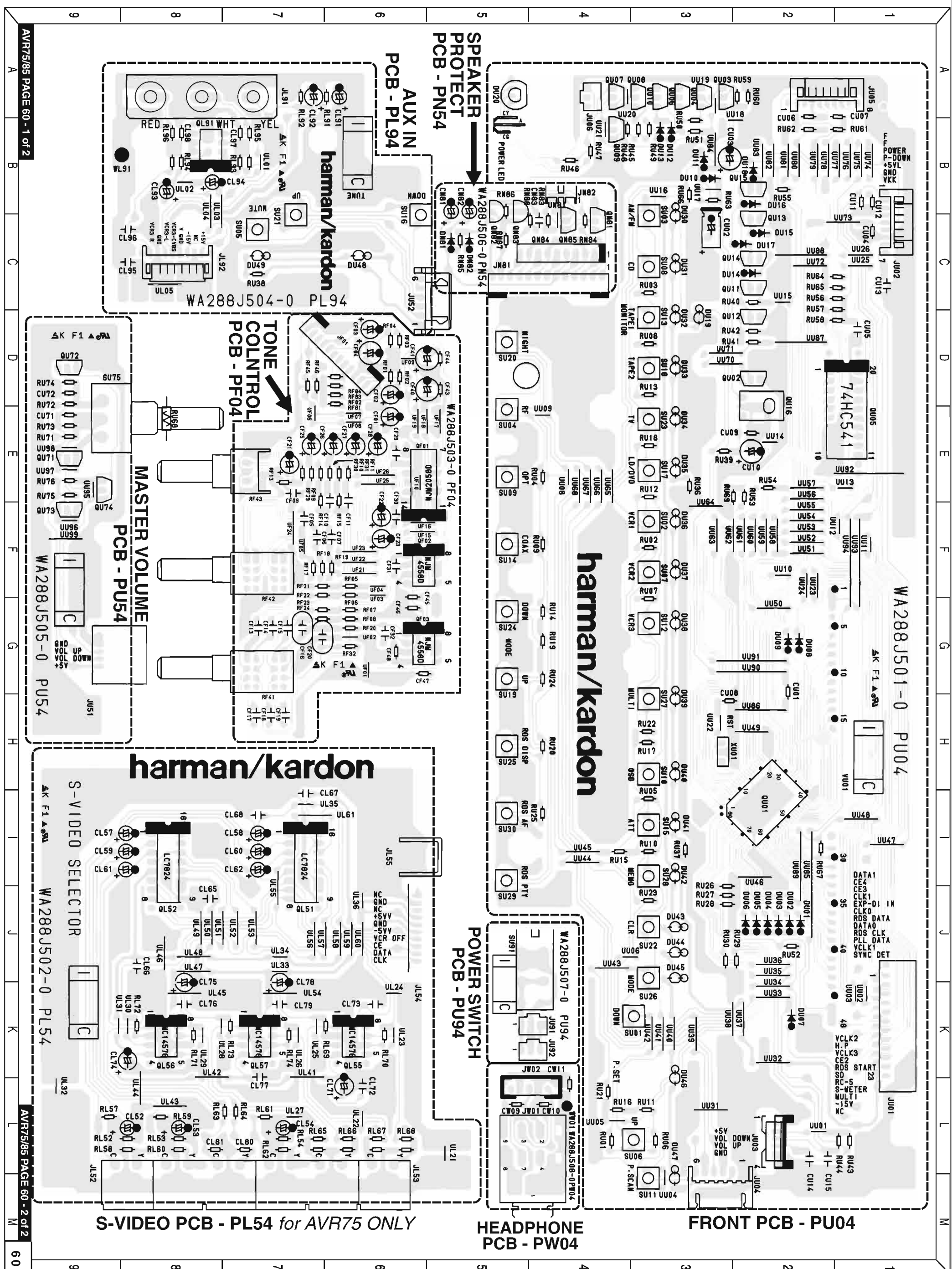

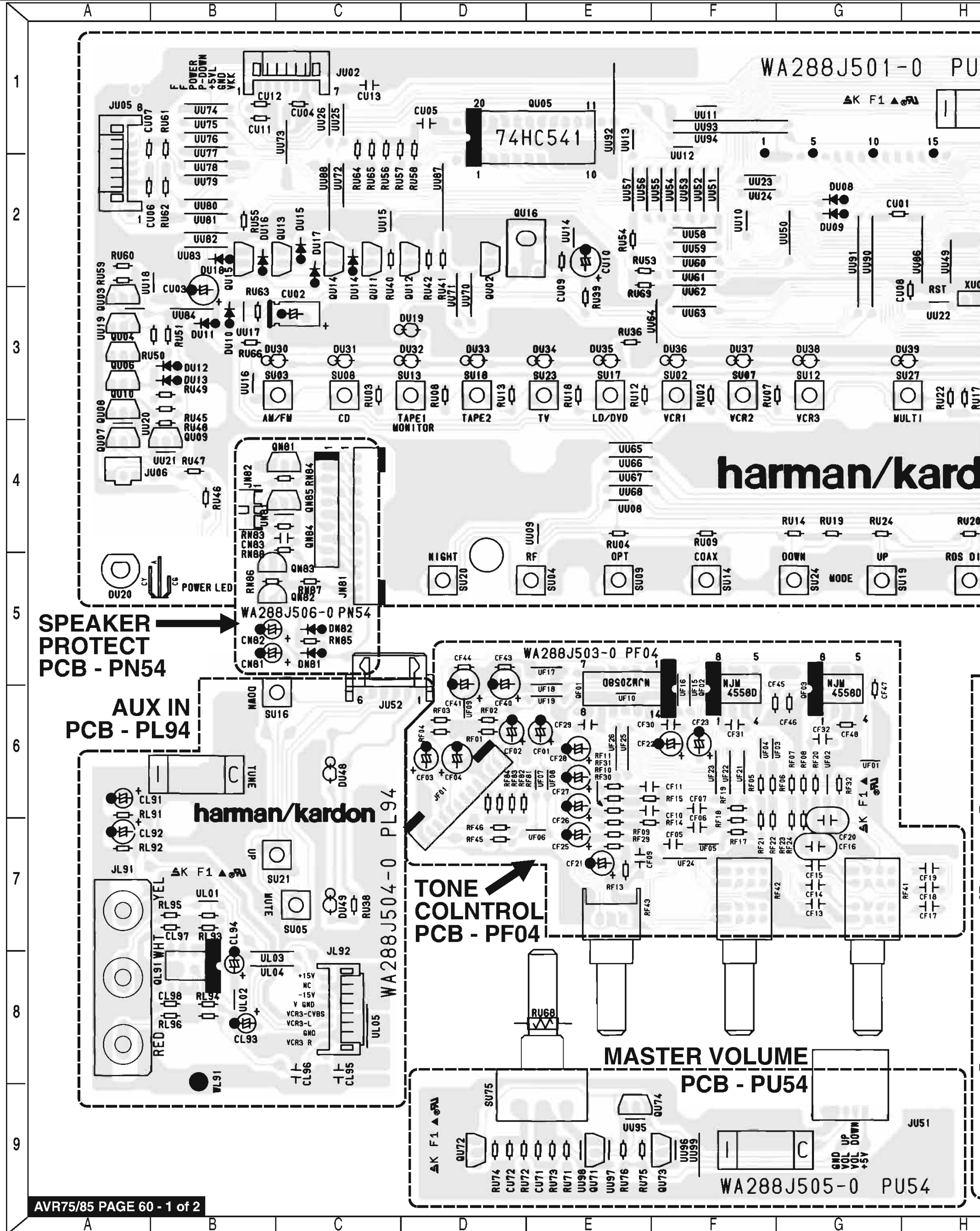

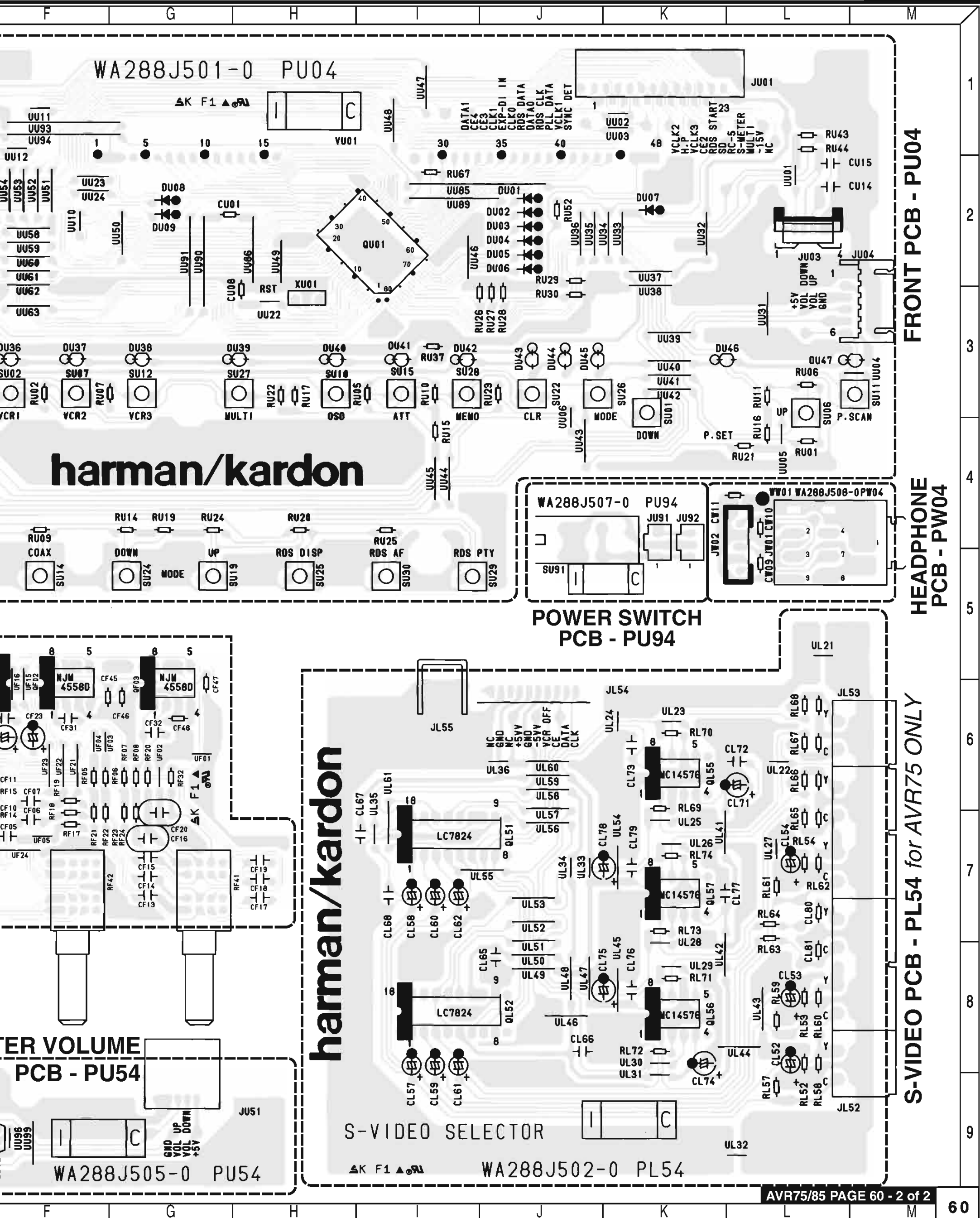

INTEGRATED CIRCUIT DIAGRAMS 1

QX60: LC74760
LSI

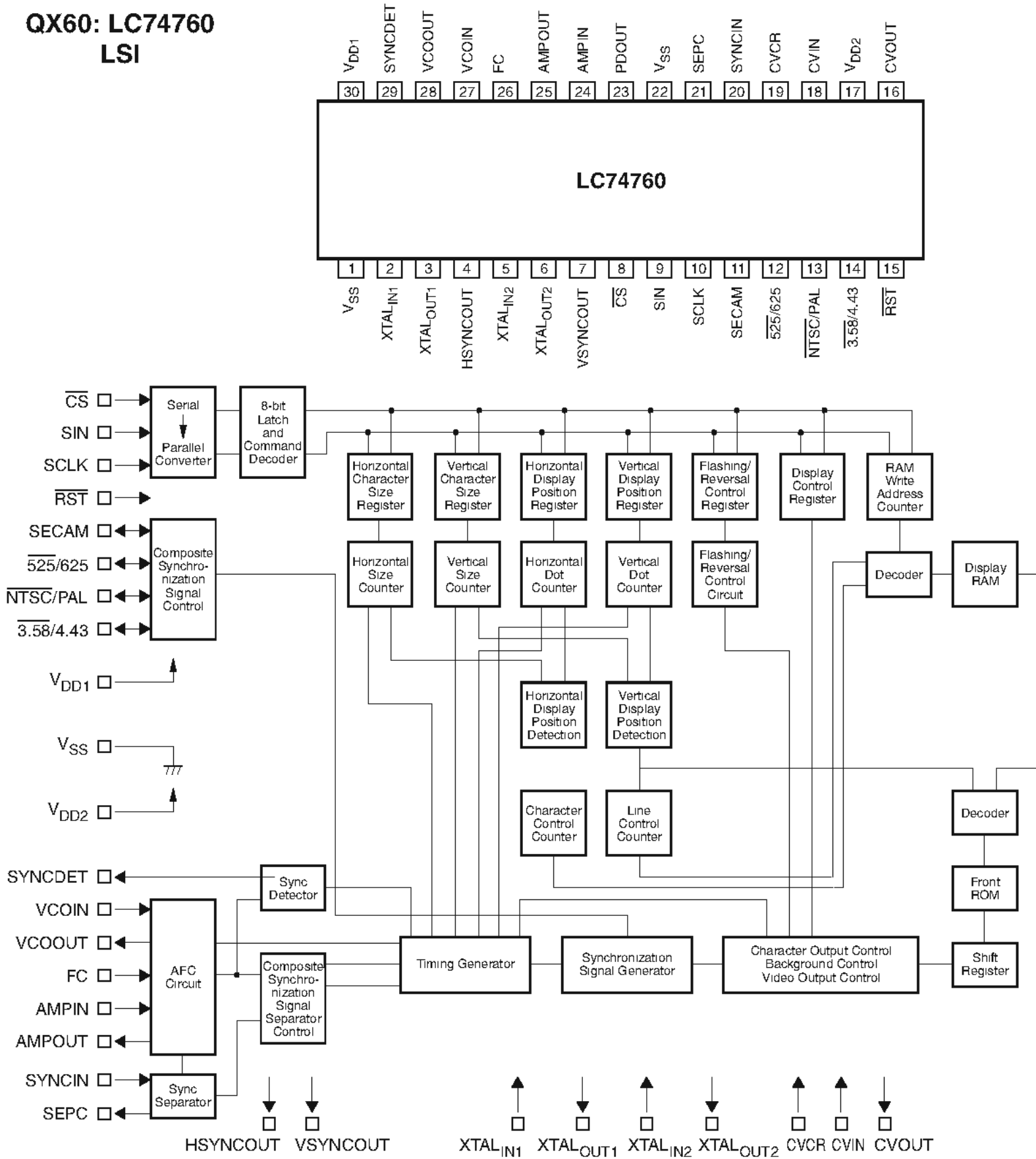

QR01: LC8904Q
DIGITAL AUDIO I/F

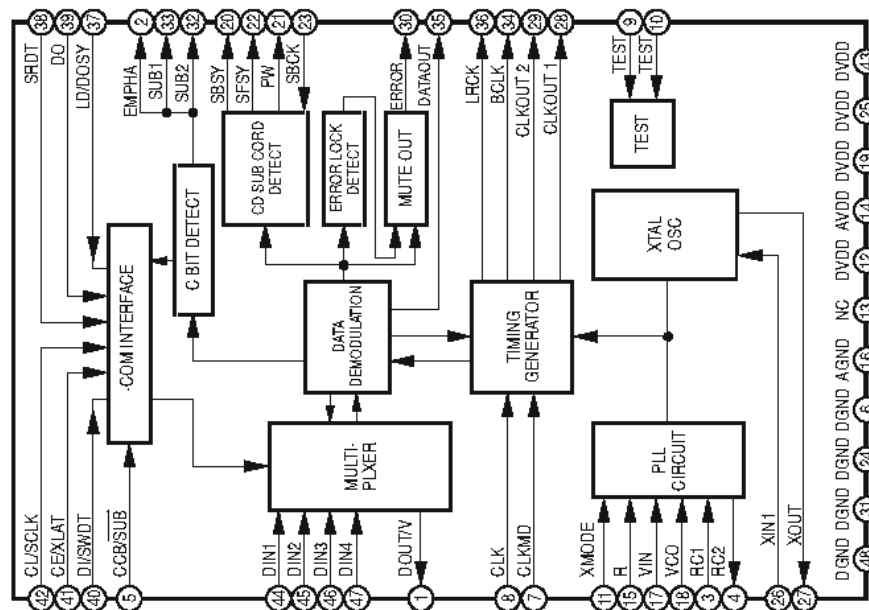

INTEGRATED CIRCUIT DIAGRAMS 2

Q601: YSS243 AC-3 DECODER

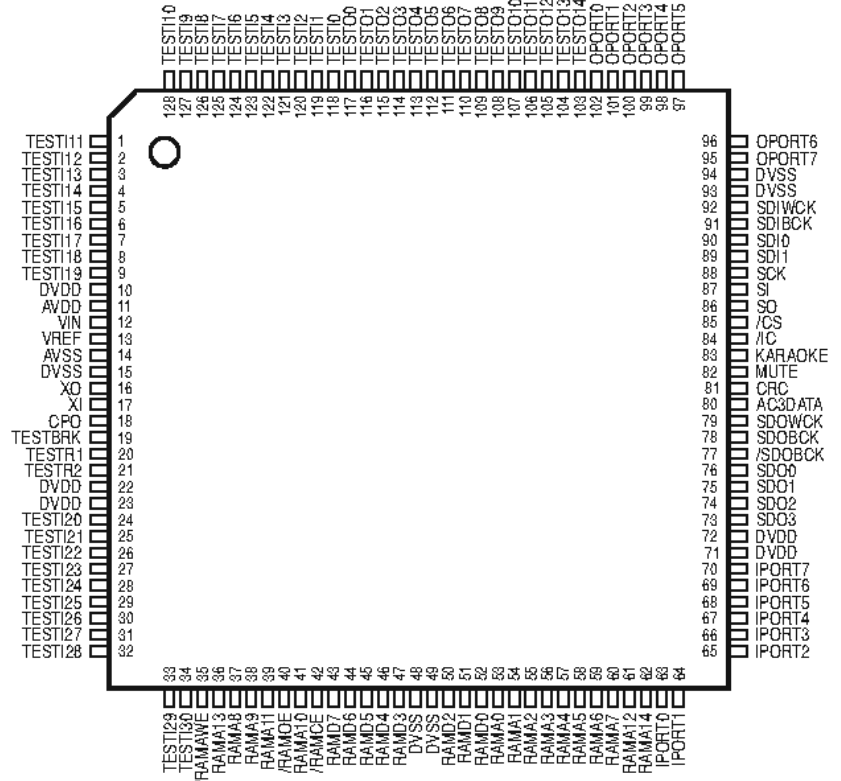
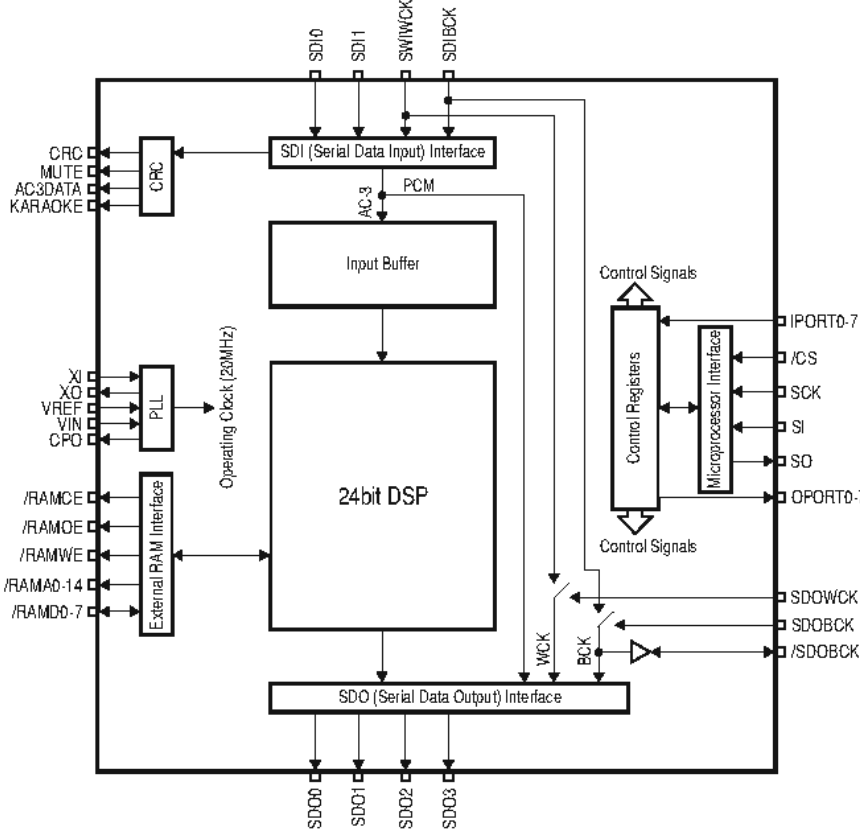

No.	Name	I/O	Function
1	TEST11	I	N.C.
2	TEST12	I	N.C.
3	TEST13	I	N.C.
4	TEST14	I	N.C.
5	TEST15	I	N.C.
6	TEST16	I	N.C.
7	TEST17	I	N.C.
8	TEST18	I	N.C.
9	TEST19	I	N.C.
10	DVDD	-	+5VD
11	AVDD	-	+5VD
12	VIN	AI	PLL input
13	VREF	AI	PLL input
14	AVSS	-	GND
15	DVSS	-	GND
16	XO	O	N.C.
17	XI	I	External clock input
18	CPO	AO	PLL output
19	TESTBRK	I	N.C.
20	TESTR1	I	N.C.
21	TESTR2	I	N.C.
22	DVDD	-	+5VD
23	DVDD	-	+5VD
24	TEST20	I	N.C.
25	TEST21	I	N.C.
26	TEST22	I	N.C.
27	TEST23	I	N.C.
28	TEST24	I	N.C.
29	TEST25	I	N.C.
30	TEST26	I	N.C.
31	TEST27	I	N.C.
32	TEST28	I	N.C.
33	TEST29	I	N.C.
34	TEST30	I	N.C.
35	/RAMWE	O	SRAM /WE
36	RAMA13	O	SRAM A13
37	RAMA8	O	SRAM A8
38	RAMA9	O	SRAM A9
39	RAMA11	O	SRAM A11
40	/RAMOE	O	SRAM /OE
41	RAMA10	O	SRAM A10
42	/RAMCE	O	SRAM /CE
43	RAMD7	VO	SRAM D7
44	RAMD6	VO	SRAM D6
45	RAMD5	VO	SRAM D5
46	RAMD4	VO	SRAM D4
47	RAMD3	VO	SRAM D3
48	DVSS	-	GND
49	DVSS	-	GND
50	RAMD2	VO	SRAM D2
51	RAMD1	VO	SRAM D1
52	RAMD0	VO	SRAM D0
53	RAMA0	O	SRAM A0
54	RAMA1	O	SRAM A1
55	RAMA2	O	SRAM A2
56	RAMA3	O	SRAM A3
57	RAMA4	O	SRAM A4
58	RAMA5	O	SRAM A5
59	RAMA6	O	SRAM A6
60	RAMA7	O	SRAM A7
61	RAMA12	O	SRAM A12
62	RAMA14	O	SRAM A14
63	IPORT0	I	N.C.
64	IPORT1	I	N.C.

No.	Name	I/O	Function
65	IPORT2	I	N.C.
66	IPORT3	I	N.C.
67	IPORT4	I	N.C.
68	IPORT5	I	N.C.
69	IPORT6	I	N.C.
70	IPORT7	I	N.C.
71	DVDD	-	+5VD
72	DVDD	-	+5VD
73	SDO3	O	PCM MDX0, MDX1 output
74	SDO2	O	PCM C, LFE output
75	SDO1	O	PCM LS, RS output
76	SDO0	O	PCM L, R output
77	/SDOBCK	O	N.C.
78	SDOBCK	I	SDO bit clock input
79	SDOWCK	I	SDO work clock input
80	AC3DATA	O	N.C.
81	CRC	O	N.C.
82	MUTE	O	Set to 1 if error data is detected when auto muting function triggered
83	KARAOKE	O	N.C.
84	/IC	I	Initial clear
85	/CS	I	m-com interface chip select input
86	SO	O	m-com interface data output
87	SI	I	m-com interface data input
88	SCK	I	m-com interface clock input
89	SDI1	I	N.C.
90	SDI0	I	AC-3 bit stream (or PCM) data input
91	SDIBCK	I	SDI bit clock input
92	SDIWCK	I	SDI work clock input
93	DVSS	-	GND
94	DVSS	-	GND
95	OPORT7	O	N.C.
96	OPORT6	O	N.C.
97	OPORT5	O	N.C.
98	OPORT4	O	N.C.
99	OPORT3	O	N.C.
100	OPORT2	O	N.C.
101	OPORT1	O	N.C.
102	OPORT0	O	N.C.
103	TESTO14	O	N.C.
104	TESTO13	O	N.C.
105	TESTO12	O	N.C.
106	TESTO11	O	N.C.
107	TESTO10	O	N.C.
108	TESTO9	O	N.C.
109	TESTO8	O	N.C.
110	TESTO7	O	N.C.
111	TESTO6	O	N.C.
112	TESTO5	O	N.C.
113	TESTO4	O	N.C.
114	TESTO3	O	N.C.
115	TESTO2	O	N.C.
116	TESTO1	O	N.C.
117	TESTO0	O	N.C.
118	TESTI0	I	N.C.
119	TESTI1	I	N.C.
120	TESTI2	I	N.C.
121	TESTI3	I	N.C.
122	TESTI4	I	N.C.
123	TESTI5	I	N.C.
124	TESTI6	I	N.C.
125	TESTI7	I	N.C.
126	TESTI8	I	N.C.
127	TESTI9	I	N.C.
128	TESTI10	I	N.C.

INTEGRATED CIRCUIT DIAGRAMS 3

**Q651: SUB CPU (AC-3 DSP)
TMP87CH40F MICROPROCESSOR**

PORT No.	PORT NAME	I/O	SIGNAL NAME	FUNCTION	NOTES
1	P76	O	CAL	RESET&CALIBRATE FOR ADC	H:RESET&CAL,L:NORMAL
2	P77	O	RSTO	RESET OUT FOR DAI&DEMURATOR	L:RESET,H:NORMAL
3	P00	O	CS	SPI CHIP SELECT FOR YSS243	
4	P01	O	CRS	SPI CPU I/F RESET FOR YSS241	
5	P02	O	FS0	Fs SET FOR YSS241	
6	P03	O	FS1	Fs SET FOR YSS241	
7	P04	O	MUTE-S	DAC MUTE CONT. OUT	L:MUTE H:NORMAL
8	P05	O	EMP-1	DAC EMP.CONT.1	
9	P06	O	EMP-2	DAC EMP.CONT.2	
10	P07	O	YRST	RESET OUTPUT FOR YSS241&243	L:RESET H:NORMAL
11	P10/INT0			N.C.	
12	P11/INT1			N.C.	
13	P12/INT2	I	(DEBUG)	FIXED+5V	
14	P13/DVO			N.C.	
15	P14/PPG			N.C.	
16	P15/TC2			N.C.	
17	P16			N.C.	
18	P17			N.C.	
19	P20/INT5	I/O	IFREQ	REQUEST SIGNAL FOR MAIN CPU I/F	
20	TEST			GND	
21	P21/XTIN			N.C.	
22	P22/XTO			N.C.	
23	RESET	I	RSTI	RESET INPUT FROM MAIN CPU	L:RESET
24	XIN	I	XIN	FOR CPU OSC	
25	XOUT	O	XOUT	FOR CPU OSC	
26	VSS			GND	
27	P30			N.C.	
28	P31			N.C.	
29	P32			N.C.	
30	P33			N.C.	
31	P34			N.C.	
32	P35			N.C.	
33	P36			N.C.	
34	P37			N.C.	
35	P40	O	CEO	CHIP ENABLE OUT FOR I/F TO DAI(LC8904Q)	
36	P41	I/O	IFACK	ACKNOWLEDGE SIGNAL FOR MAIN CPU I/F	
37	P42/SCK1	O	CL/SCK	SPI CLOCK OUT TO DAI(LC8904Q)&YSS241,243	
38	P43/SI1	I	DO/SO	SPI DATA IN FROM DAI&DSP(YSS243)	
39	P44/SO1	O	DI/SI	SPI DATA OUT TO DAI&DSP(YSS241&243)	
40	P45/SCK2	O	IFCLK	I/F CLOCK OUT TO MAIN CPU	
41	P46/SI2	I	IFDATAI	I/F DATA IN FROM MAIN CPU	
42	P47/SO2	O	IFDATAO	I/F DATA OUT TO MAIN CPU	
43	P50/INT3	I	C1F0	DEMURATOR ERROR INPUT(FOR DEBUG USE ONLY)	
44	P51/INT4	I	ERROR	DAI ERROR INPUT L:Error H:OK	
45	P52/PDO			N.C.	
46	P53			N.C.	
47	P54			N.C.	
48	VASS			GND	
49	VAREF			GND	
50	P60/AIN0	O	DEBO	CHIP ENABLE OUT FOR DEBUG USE ONLY	
51	P61/AIN1			N.C.	
52	P62/AIN2	I	YMUTE	YSS241 ERROR MUTE INPUT(H:MUTEON,L:MUTEOFF)	
53	P63/AIN3			N.C.	
54	P64/AIN4			N.C.	
55	P65/AIN5			N.C.	
56	P66/AIN6			N.C.	
57	P67/AIN7			N.C.	
58	VDD			+5V	
59	P70	O	OSCON	PM4007A OSC CONTROL	H:ONL:STOP
60	P71	O	DSEL	DATA SELECT(YSS243or241)	H:241L:243
61	P72	O	LFE-ATT	LFEATT.CONT.	H:0dB L:-10dB,OFF
62	P73	O	A/D	ADC/DAI SELECT	H:DAI L:ADC
63	P74	O	RF/OTH	RF/OTHER SELECT	H:RF L:THER
64	P75	O	MUTE-1	MUTE CONTROLLED BY SUB CPU	H:NORMAL L:MUTE

**QD01, QD31, QD51: TDA1305T
D/A CONVERTER**

PINNING

SYMBOL	PIN	DESCRIPTION
V _{DDA}	1	analog supply voltage
V _{SSA}	2	analog ground
TEST1	3	test input, pin should be connected to ground (internal pull-down resistor)
BCK	4	bit clock input
WS	5	word select input
DATA	6	data input
CLKS1	7	clock selection 1 input
CLKS2	8	clock selection 2 input
V _{SSO}	9	digital ground
V _{DDO}	10	digital supply voltage
TEST2	11	test input, pin should be connected to ground (internal pull-down resistor)
SYCLKI	12	system clock input
n.c.	13	not connected (this pin should be left open-circuit)
n.c.	14	not connected (this pin should be left open-circuit)
V _{SSO}	15	digital ground
SYCLKO	16	system clock output
DEEM1	17	de-emphasis on/off, f _{DEEM} 32 kHz, 44 kHz and 48 kHz
DEEM2	18	de-emphasis on/off, f _{DEEM} 32 kHz, 44 kHz and 48 kHz
MUSB	19	mute input (active LOW)
DSMB	20	double-speed mode input (active LOW)
ATSB	21	12 dB attenuation input (active LOW)
VOL	22	left channel output
FILTCL	23	capacitor for left channel 1st order filter function should be connected between pins 22 and 23
FILTCR	24	capacitor for right channel 1st order filter function should be connected between pins 25 and 24
VOR	25	right channel output
V _{ref}	26	internal reference voltage for output channels (0.5V _{DDO})
V _{SSO}	27	operational amplifier ground
V _{DDO}	28	operational amplifier supply voltage

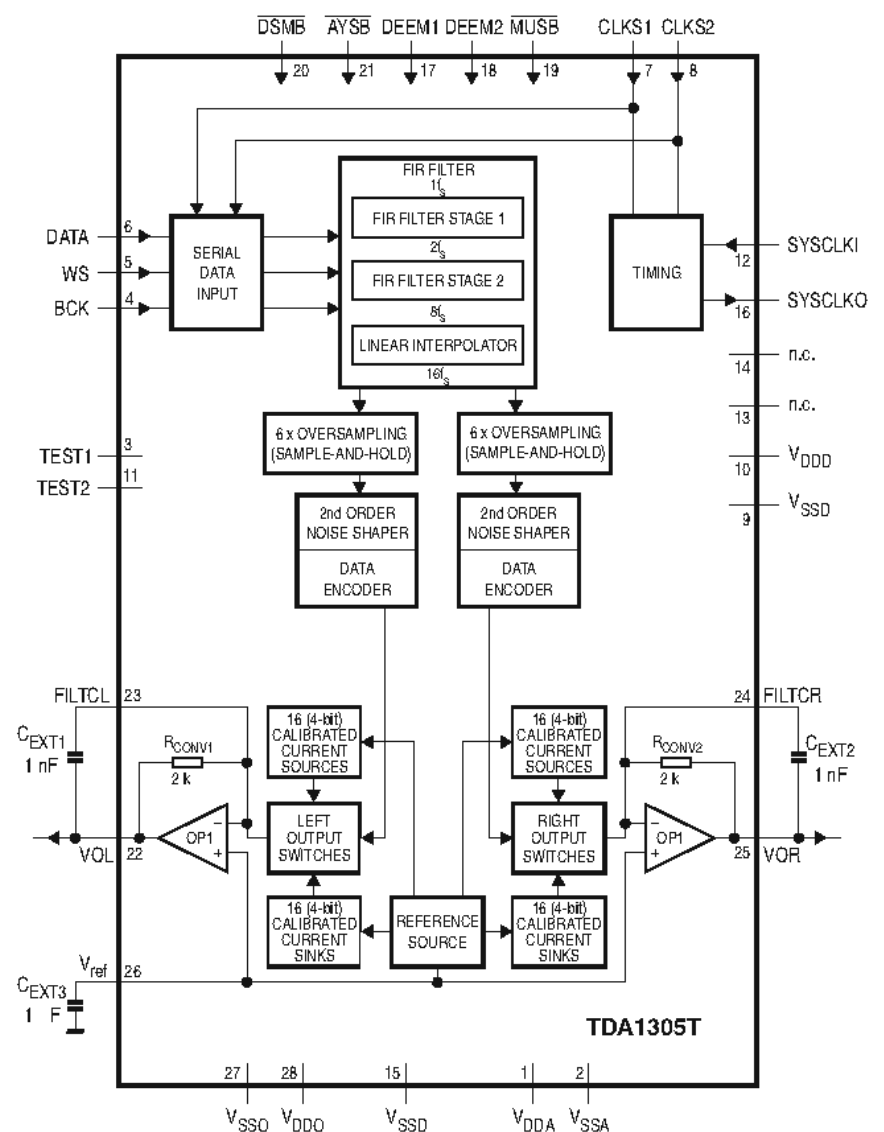

INTEGRATED CIRCUIT DIAGRAMS 4

Q602: YSS241 PRO LOGIC DECODER

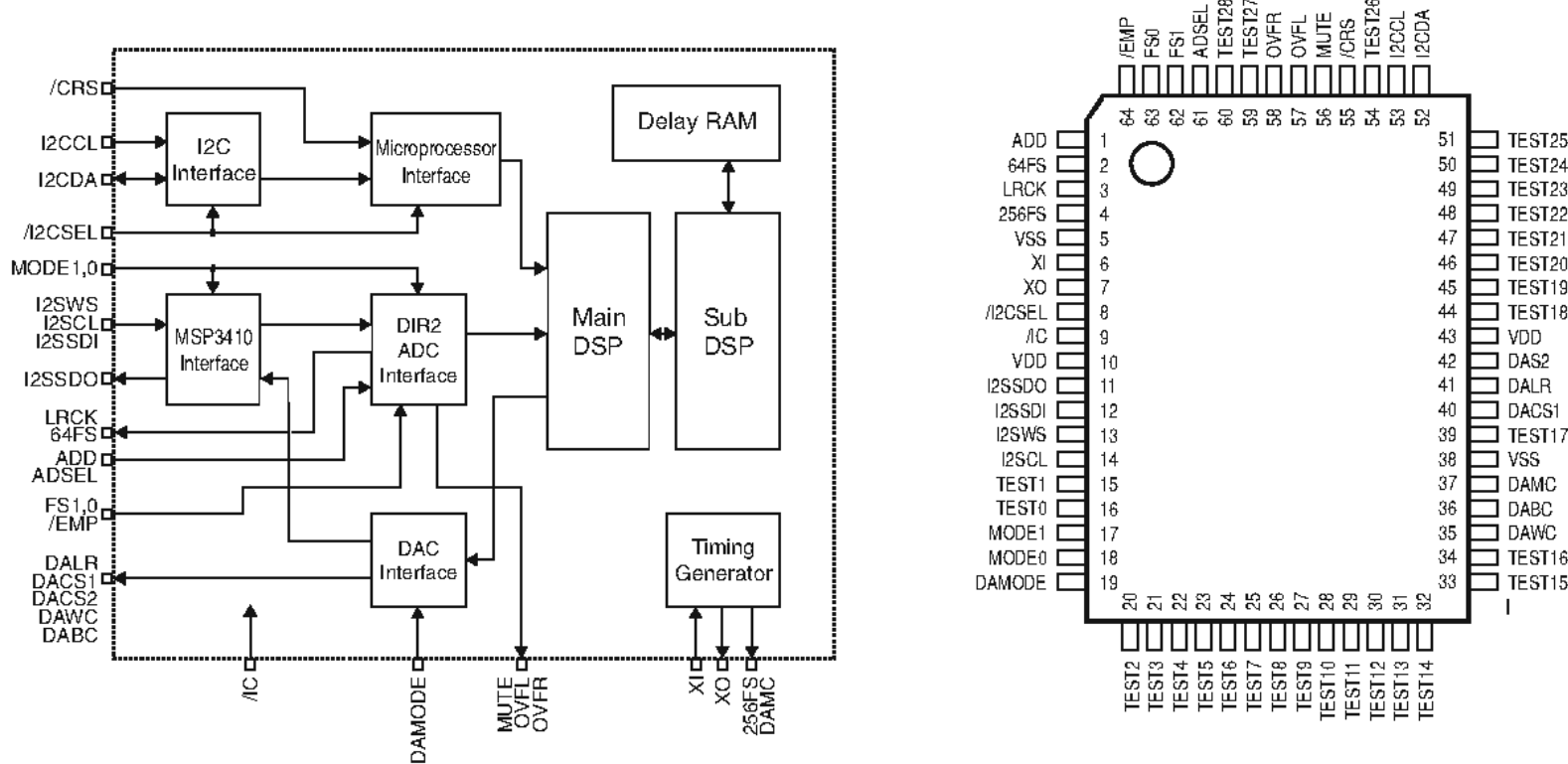

No	Name	I/O	Function
1	ADD	I	A/D CONVERTER SOUND DATA INPUT
2	64FS	O	ADC BIT CLOCK OUTPUT
3	LRCK	O	ADC L/R CLOCK OUTPUT
4	256FS	O	ADC MASTER CLOCK OUTPUT
5	VSS	-	GND
6	XI	I	EXTERNAL CLOCK OUTPUT
7	XO	O	N.C.
8	/I2CSEL	I	SELECTS CPU INTERFACE ("H": SERIAL 3-WIRE TYPE, "L": 12C BUS TYPE)
9	/IC	I	INITIAL CLEAR INPUT
10	VDD	-	+5VD
11	I2SSDO	O	INVALID
12	I2SSDI	I	DIR2 SOUND DATA INPUT
13	I2SWS	I	DIR2 L/R CLOCK INPUT
14	I2SCL	I	GND
15	TEST1	I	N.C.
16	TEST0	I	N.C.
17	MODE1	I	N.C.
18	MODE0	I	N.C.
19	DAMODE	I	SELECTS AUDIO DATA OUTPUT FORMAT
20	TEST2	I	N.C.
21	TEST3	I	N.C.
22	TEST4	I	N.C.
23	TEST5	I	N.C.
24	TEST6	I	N.C.
25	TEST7	I	N.C.
26	TEST8	I	N.C.
27	TEST9	I	N.C.
28	TEST10	I	N.C.
29	TEST11	I	N.C.
30	TEST12	I	N.C.
31	TEST13	I	N.C.
32	TEST14	I	N.C.

No	Name	I/O	Function
33	TEST15	I	N.C.
34	TEST16	I	N.C.
35	DAWC	O	DAC L/R CLOCK OUTPUT
36	DABC	O	DAC BIT CLOCK OUTPUT
37	DAMC	O	DAC MASTER CLOCK
38	VSS	-	GND
39	TEST17	I	N.C.
40	DACS1	O	DAC AUDIO DATA OUTPUT
41	DALR	O	DAC AUDIO DATA OUTPUT
42	DAS2	O	DAC AUDIO DATA OUTPUT
43	VDD	-	+5V
44	TEST18	O	N.C.
45	TEST19	O	N.C.
46	TEST20	I	N.C.
47	TEST21	O	N.C.
48	TEST22	I	N.C.
49	TEST23	I	N.C.
50	TEST24	I	N.C.
51	TEST25	I	N.C.
52	I2CDA	I/O	CPU/I2C BUS INTERFACE SERIAL DATA INPUT
53	I2CCLD	I	CPU/I2C BUS INTERFACE BIT CLOCK INPUT
54	TEST26	O	N.C.
55	/CRS	I	SERIAL 3-WIRE TYPE (/I2CSEL = "H"):CPU INTERFACE RESET INPUT
56	MUTE	O	SYSTEM MUTE DETECTION
57	OVFL	O	N.C.
58	OVFR	O	N.C.
59	TEST27	O	N.C.
60	TEST28	O	N.C.
61	ADSEL	I	AUDIO DATA INPUT SWITCH ("H":ADD INPUT, "L":I2SSDI INPUT)
62	FS1	I	SAMPLING FREQUENCY SWITCHER (VALID ONLY WHEN ADSEL = "L")
63	FS0	I	SAMPLING FREQUENCY SWITCHER (VALID ONLY WHEN ADSEL = "L")
64	/EMP	I	DE-EMPHASIS PROCESSING ("L":ON)

QK01: AK5340 A/D CONVERTER

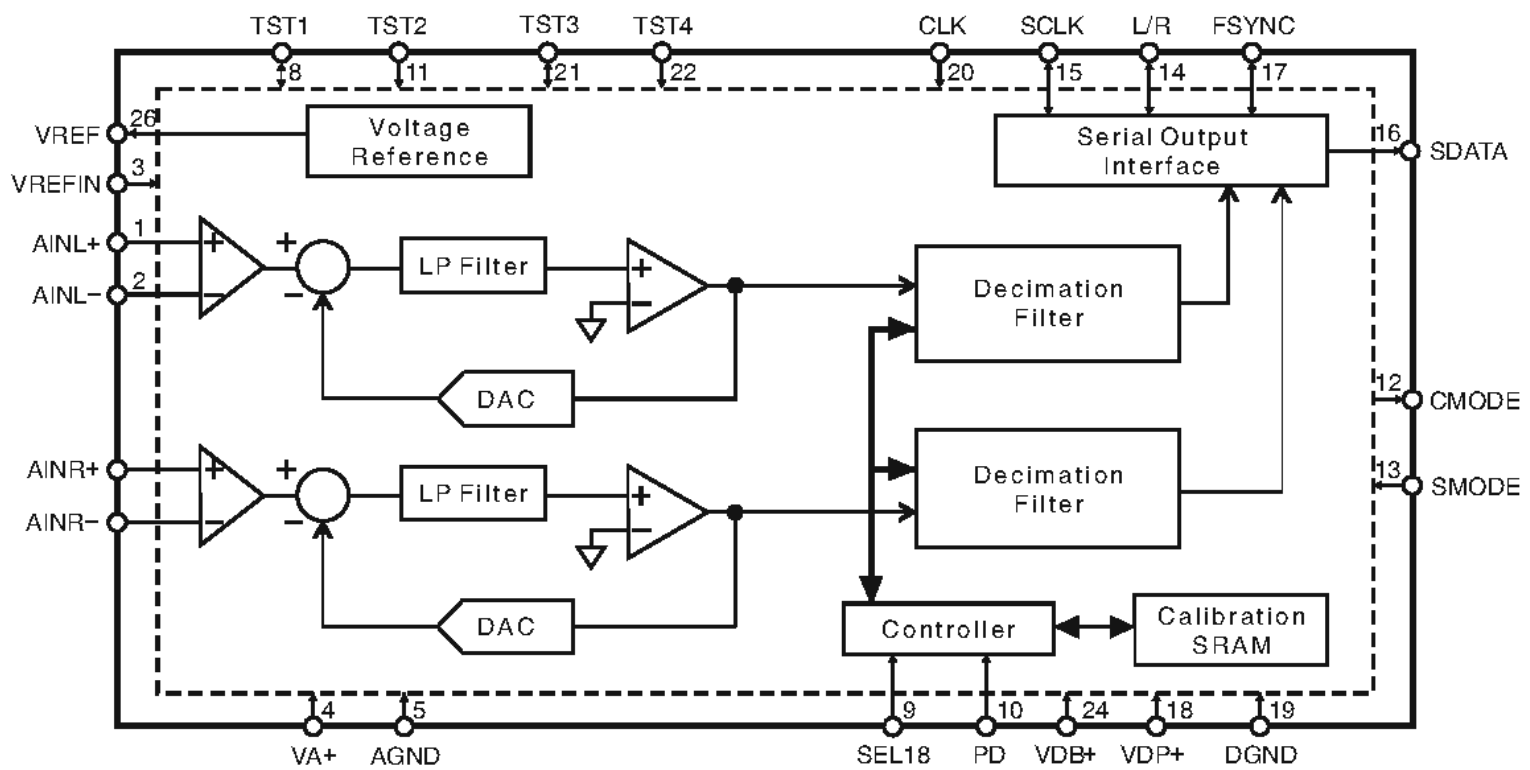

INTEGRATED CIRCUIT DIAGRAMS 5

QM09: PM4007A
RF DEMODULATOR

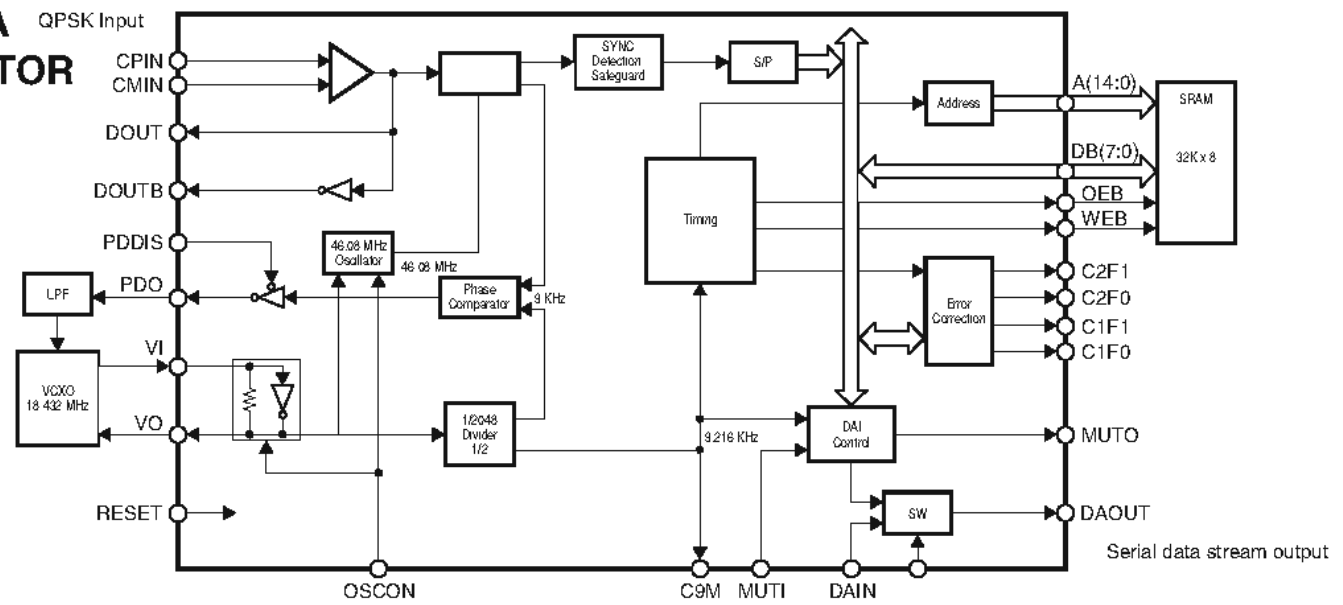

No.	Name	I/O	Function
1	GND	-	GND
2	VDD	-	+5VDD
3	RESET	I	System Reset At "L" reset
4	OSCON	I	Oscillator Control At "H" during normal operation At "L" during standby
5	DATA	I	TEST
6	MCK	I	TEST
7	MLTB	I	TEST
8	IDST	O	TEST
9	IDCK	O	TEST
10	IDO	O	TEST
11	TM0	I	TEST
12	ECCK	O	TEST
13	DEN	O	TEST
14	DRY	O	TEST
15	MSYC	O	TEST
16	TM1	I	TEST
17	A0	O	RAM A0
18	A1	O	RAM A1
19	A2	O	RAM A2
20	A3	O	RAM A3
21	A4	O	RAM A4
22	A5	O	RAM A5
23	TM2	I	TEST
24	TM3	I	TEST
25	XOUT	O	TEST
26	XIN	I	TEST
27	XENT	I	TEST
28	GND	-	GND
29	VDD	-	+5VDD
30	A6	O	RAM A6
31	A7	O	RAM A7
32	GND	-	GND
33	VDD	-	+5VDD
34	A12	O	RAM A12
35	A14	O	RAM A14
36	WEB	O	RAM WEB
37	A13	O	RAM A13
38	A8	O	RAM A8
39	A9	O	RAM A9
40	GND	-	GND
41	A11	O	RAM A11
42	OEB	O	RAM OE
43	A10	O	RAM A10
44	DB7	B	RAM D7
45	DB6	B	RAM D6
46	DB5	B	RAM D5
47	DB4	B	RAM D4
48	DB3	B	RAM D3
49	DB2	B	RAM D2
50	DB1	B	RAM D1

No.	Name	I/O	Function
51	DB0	B	RAM D0
52	VDD	-	+5VDD
53	GND	-	GND
54	TI1	I	TEST
55	VIN	I	VCXO input
56	VOUT	O	VCXO output
57	TI2	I	TEST
58	TI3	I	TEST
59	TLDB	I	TEST
60	TCK	I	TEST
61	TRP	O	TEST
62	TDO	O	TEST
63	PDO	O	Phase comparator output (3-state)
64	TI4	I	TEST
65	PDDIS	I	Control input for PDO out At "L" Output ON
66	MUTO	O	Muting output. Mutes at "H." Sets to "H" when MUTI = H or the AC-3 period cannot be received.
67	TI5	I	TEST
68	VLDY	O	TEST
69	DASYO	O	TEST
70	DAOUT	O	Digital OUT (serial data stream output)
71	DAIN	I	Digital external input: Sets to DAOUT when DASEL is "H"
72	DASEL	I	Selects digital OUT
73	TI8	I	TEST
74	C2F1	O	N.C.
75	C2F0	O	N.C.
76	C1F1	O	N.C.
77	C1F0	O	Displays C1 correction error status. Outputs error count at C1.
78	MUTI	I	Muting input. Mutes at "H."
79	VDD	-	+5VDD
80	GND	-	GND
81	AVDD	-	+5VDD
82	CPIN	I	Analog converter inverted input
83	CMIN	I	Analog converter inverted input
84	AGND	-	GND
85	TM4	I	TEST
86	VDD	-	+5VDD
87	DIN	I	TEST
88	DOUT	O	Analog converter inverted input
89	DOUTB	O	Analog converter inverted reverse output
90	C9M	O	N.C.
91	GND	-	GND
92	WINGT	O	TEST
93	SYST0	O	TEST
94	SYST1	O	TEST
95	ADST0	O	TEST
96	ADST1	O	TEST
97	TM5	I	TEST
98	BUNRI	I	TEST
99	AGND	-	GND
100	AVDD	-	+5VDD

Q201: LA1836
FM/AM IF, MPX

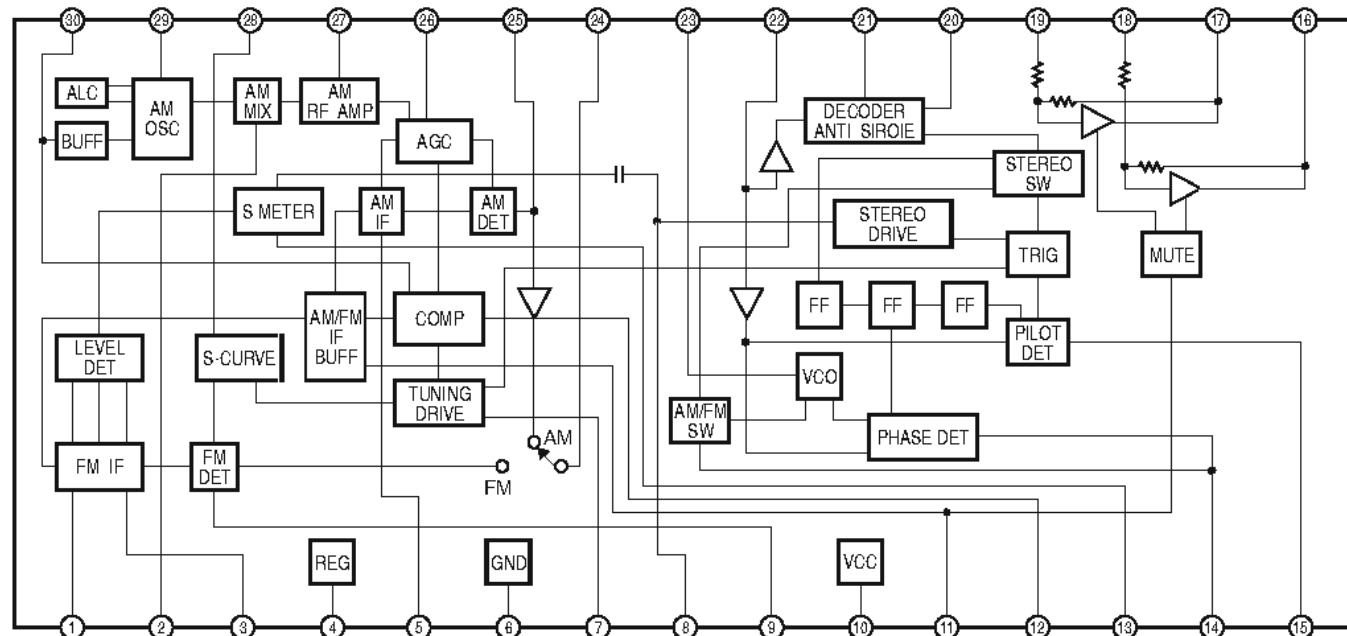

INTEGRATED CIRCUIT DIAGRAMS 6

**QU01: TMP87CP71F
MICROPROCESSOR**

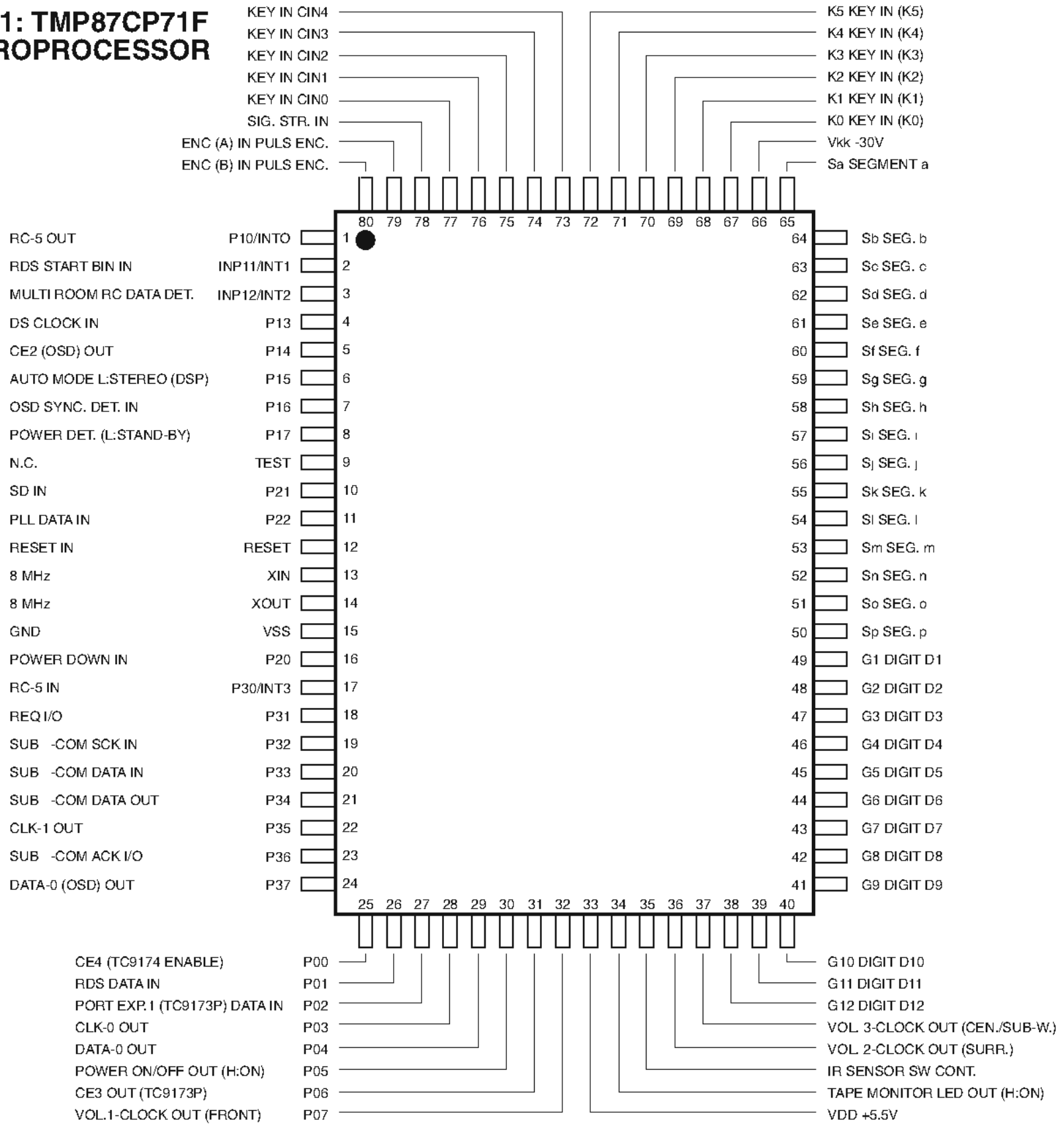

Q501: LC7218 PPL

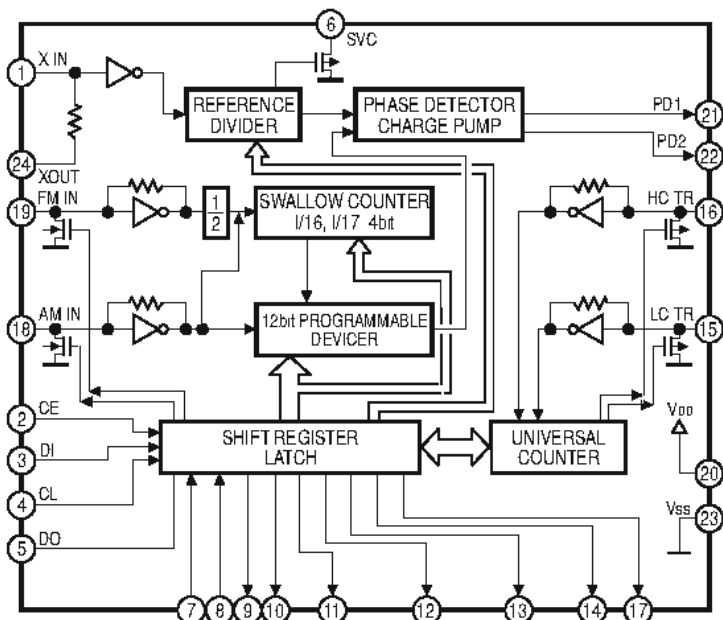

INTEGRATED CIRCUIT DIAGRAMS 7

QS57 - LC78212 ANALOG SWITCH

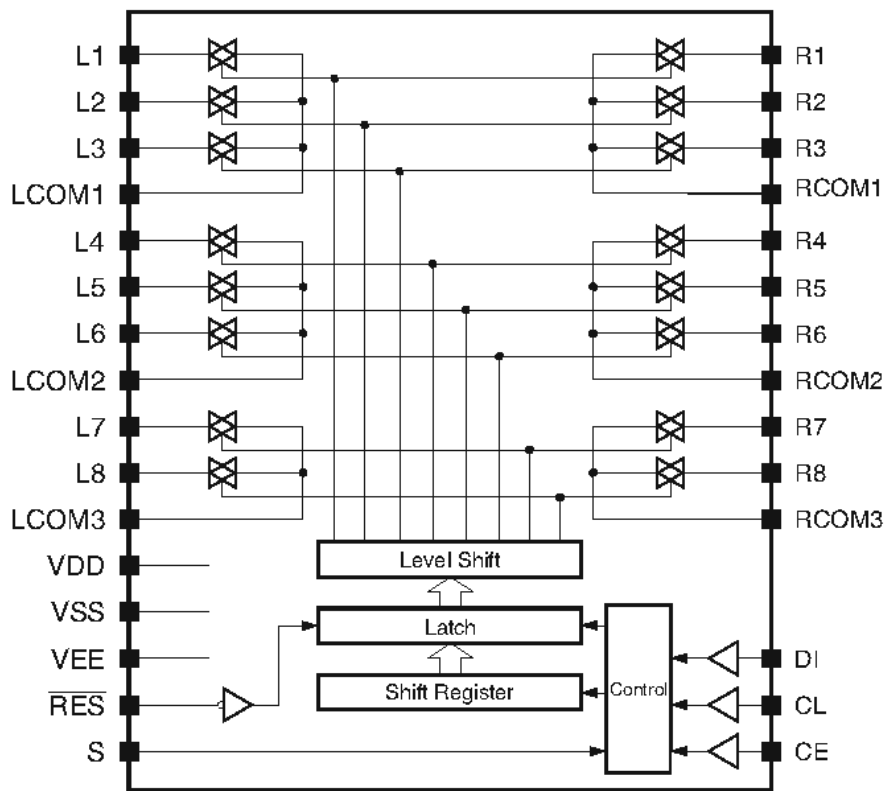

Q511, Q556 - LC78211 ANALOG SWITCH

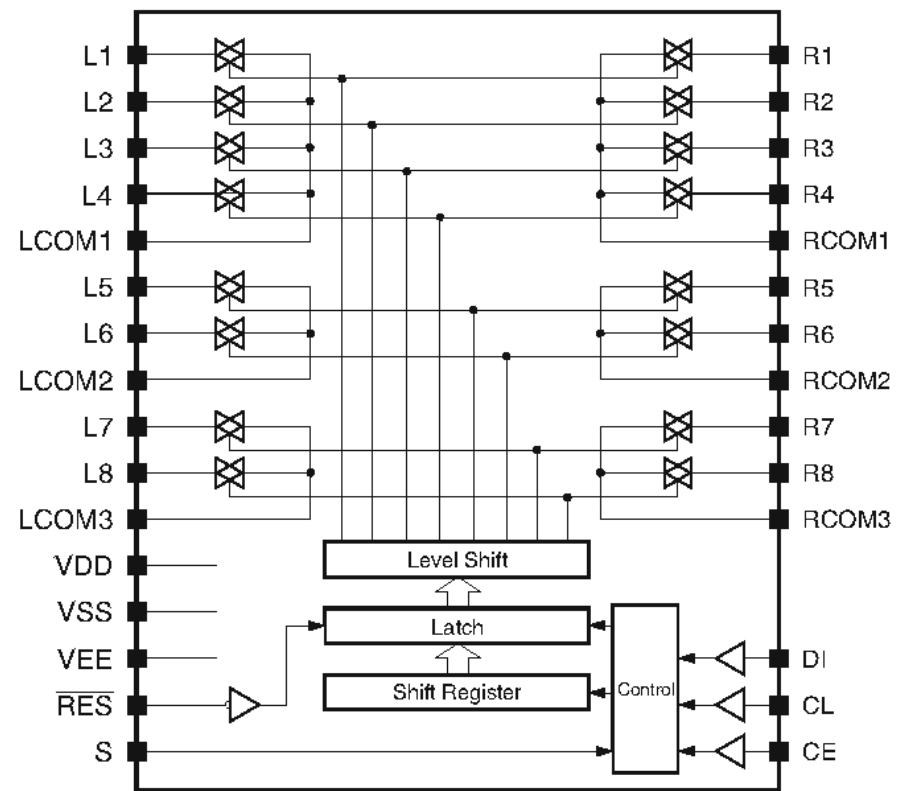

Q512 - LC78213 ANALOG SWITCH

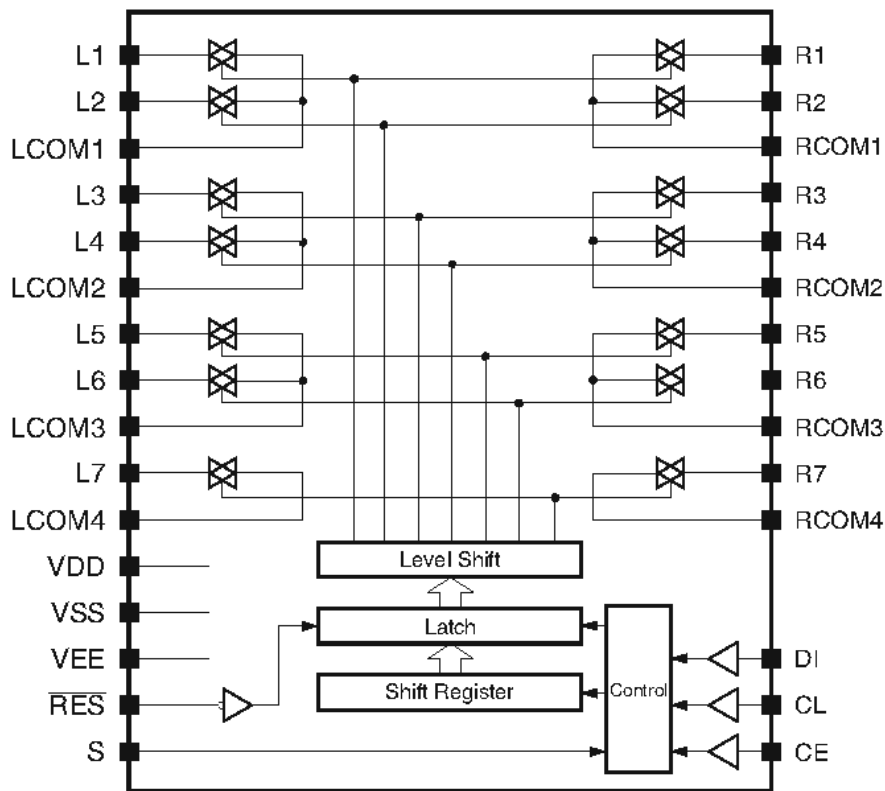

QY12 - TC9215 ANALOG SWITCH

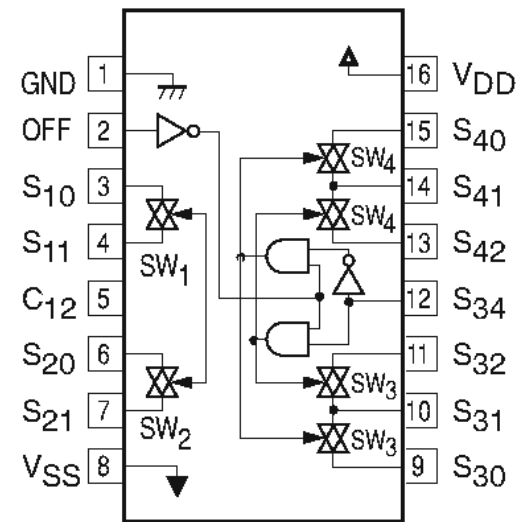

QE04, 05, 06, QG04-07, QG57 - TC9213P
ELECTRIC VOLUME CONTROL

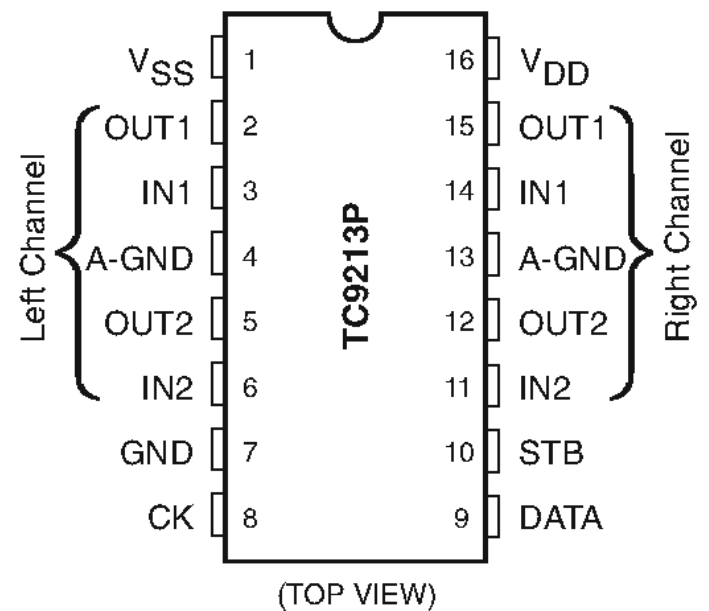

+5, +15V REGULATORS
Q801 - NJM7815
Q803 - NJM7805

-5, -15V REGULATORS
Q802 - NJM7915
Q804 - NJM7905

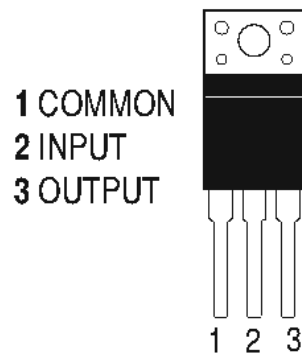
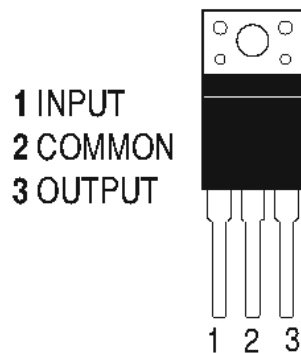

INTEGRATED CIRCUIT DIAGRAMS 8

Q652 - 74HC541
**3-STATE BUFFER/
LINE DRIVER**

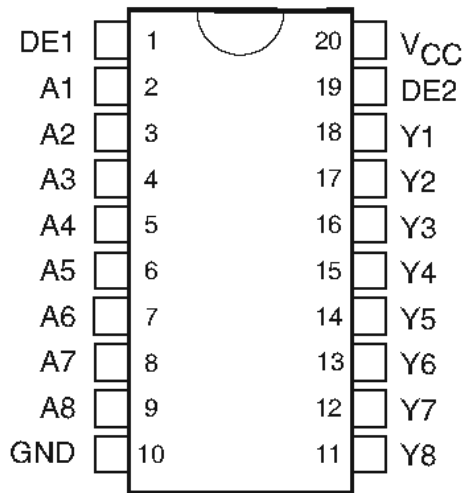

QC11 - NJU7311L
ANALOG SWITCH

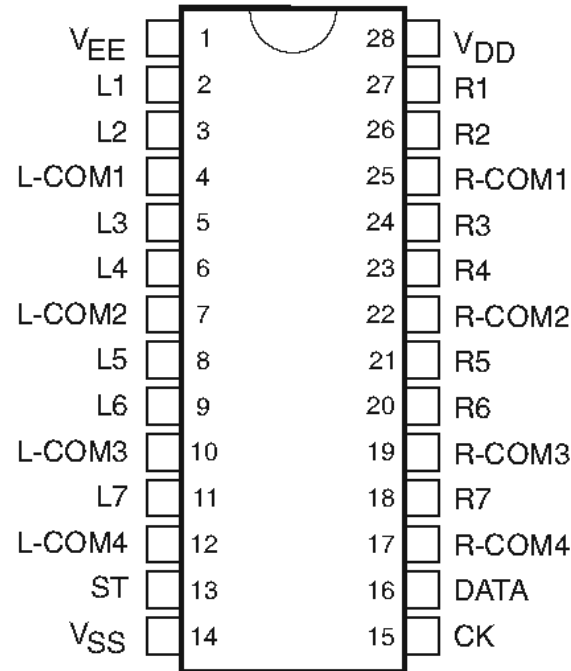

QM10 - 8X32 SRAM

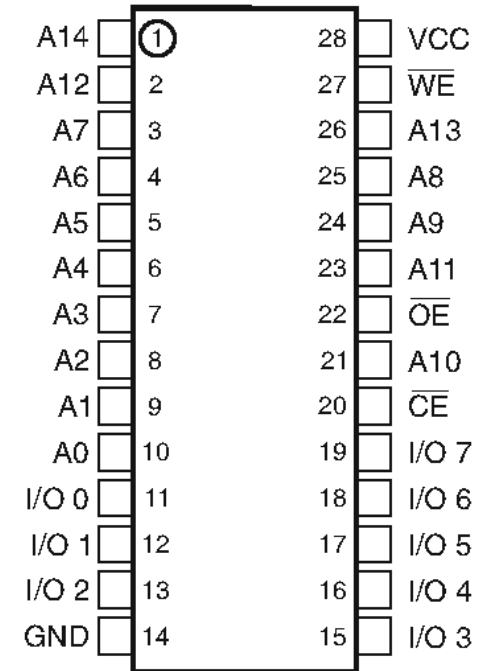

QF01 - NJM2058
QUAD OP-AMP

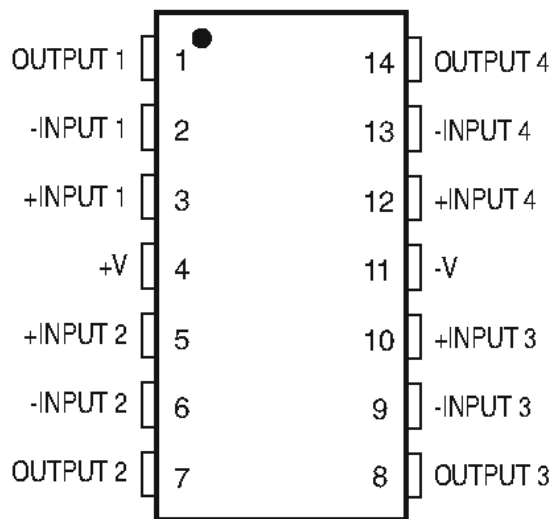

QR02 - TC74CH00AP
QUAD 2-INPUT NAND GATE

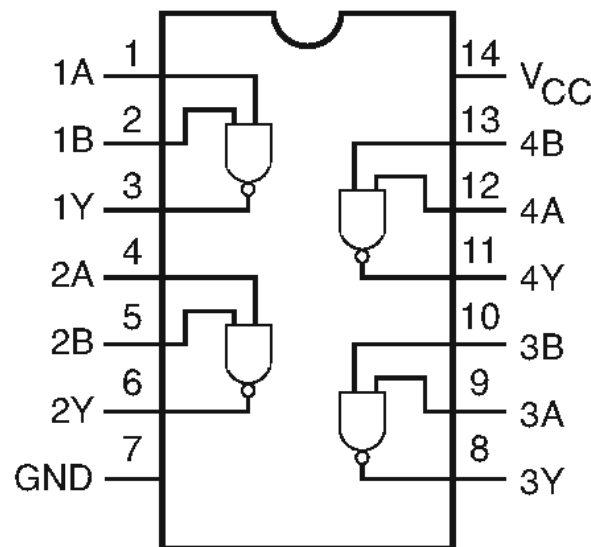

QT04 - 74LS132
**QUAD 2-INPUT NAND
SCHMITT TRIGGER**

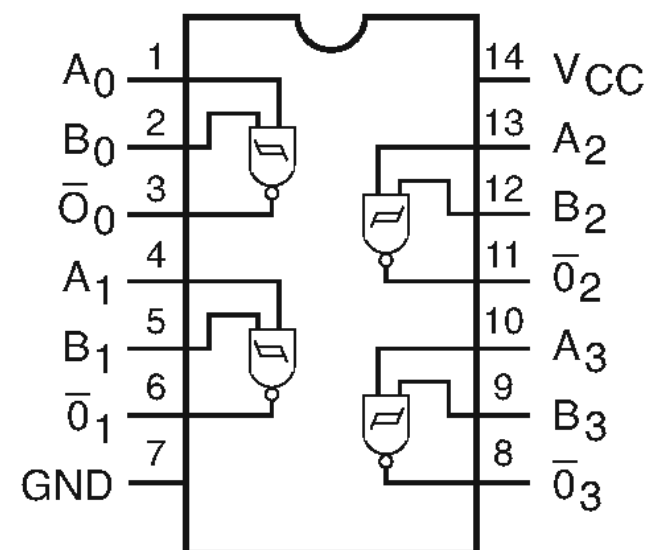

Q604 - 74HC157A
QUAD 2-INPUT MULTIPLEXER

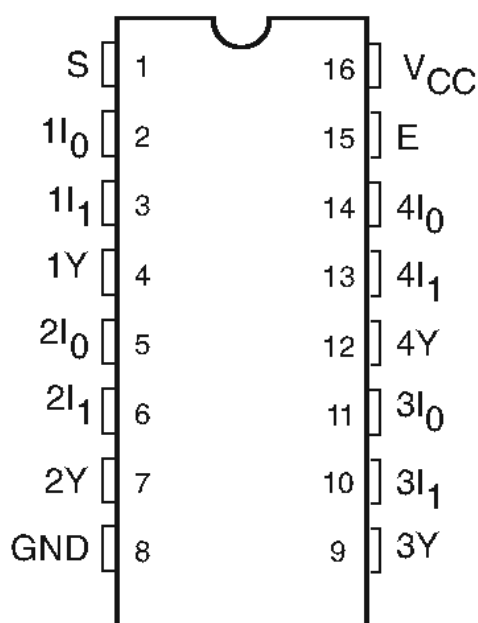

Q607, 608 - 74HC164E
**8-BIT SERIAL-IN/PARALLEL-OUT
SHIFT REGISTER**

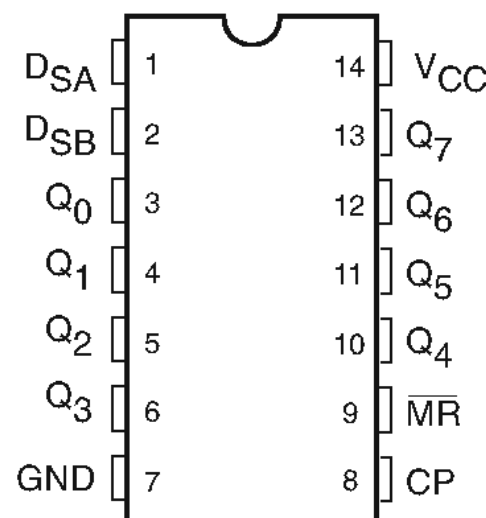

Q605 - 74HC74
DUAL D-TYPE FLIP-FLOP

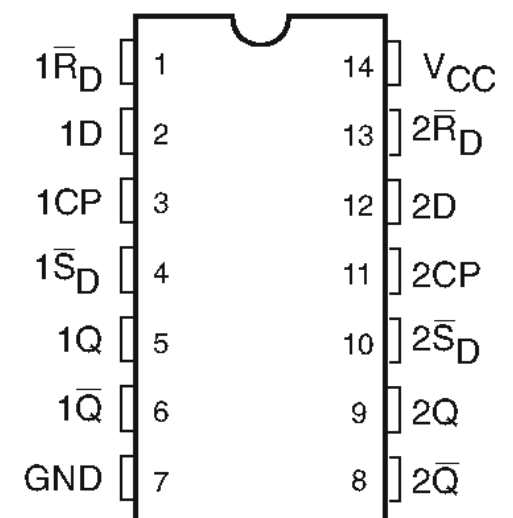

INTEGRATED CIRCUIT DIAGRAMS 9

QL01, QL51, QL52 - LC7824
ANALOG SWITCH

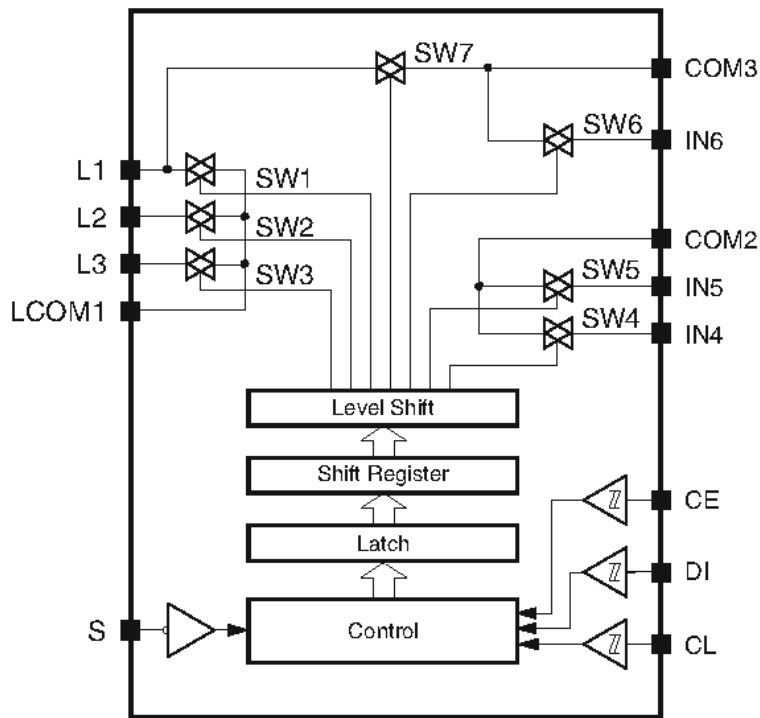

QN84 - TA7317P OVERLOAD PROTECTOR

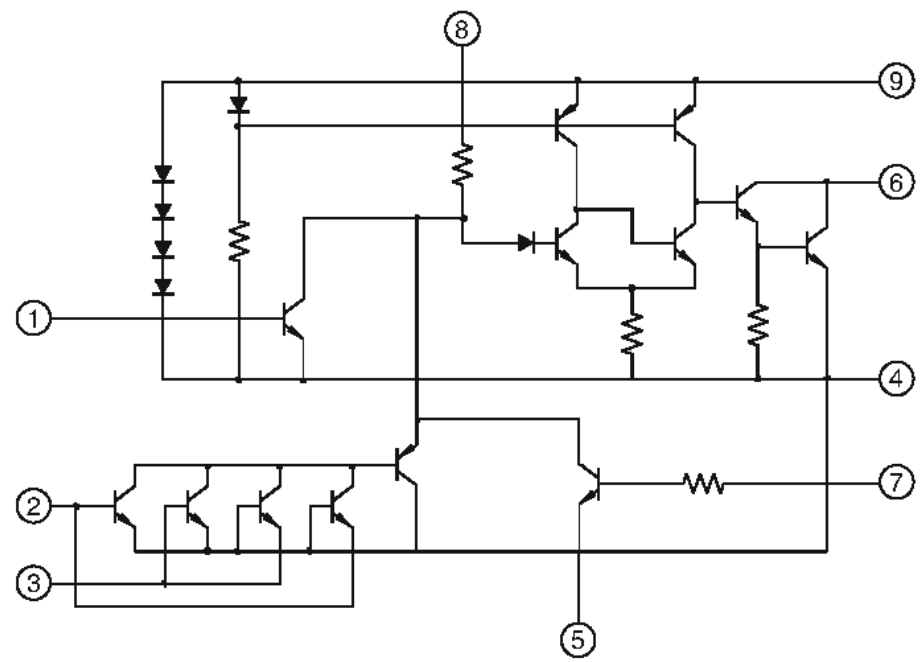

Q902 - LC7073 RDS ERROR MODULATOR

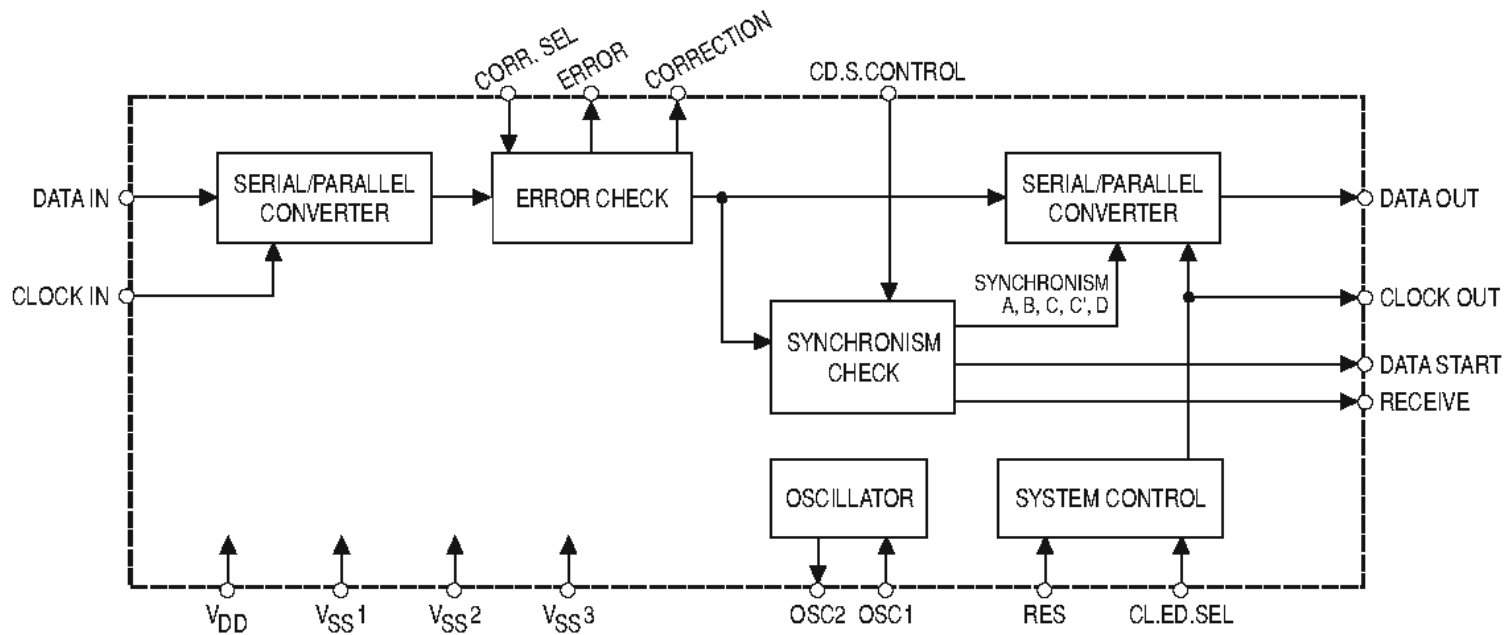

QY10 - TC9173
PORT EXPANDER

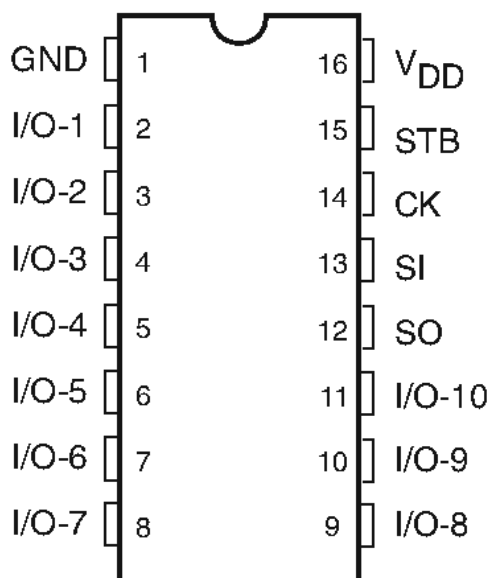

QY11 - TC9174P
PORT EXPANDER

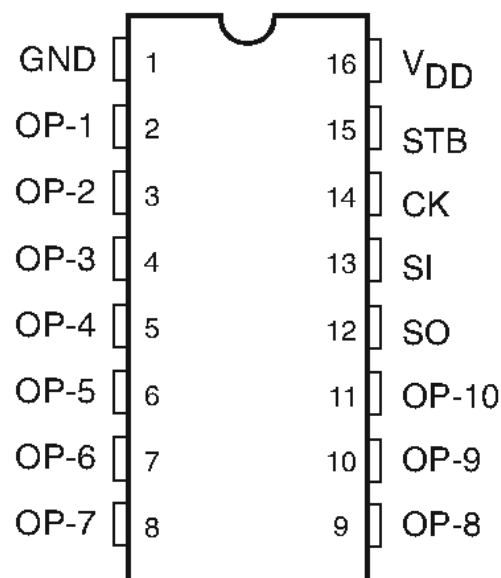

QL04, QL05 - NJM2233D
VIDEO AMP

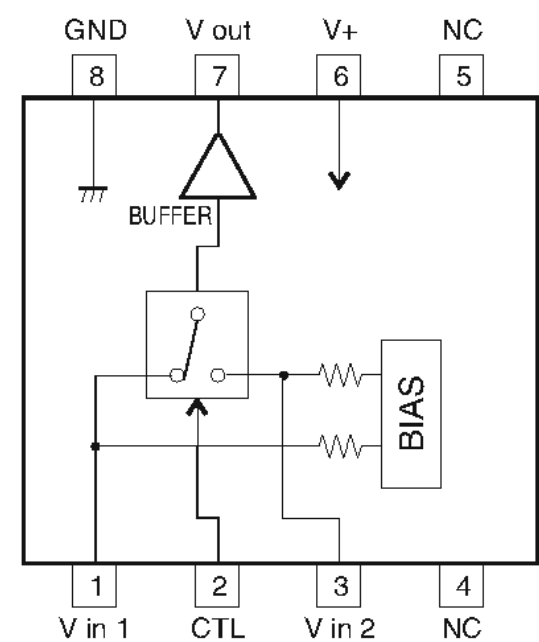

INTEGRATED CIRCUIT DIAGRAMS 10

QX63 - NJM2267D VIDEO AMP

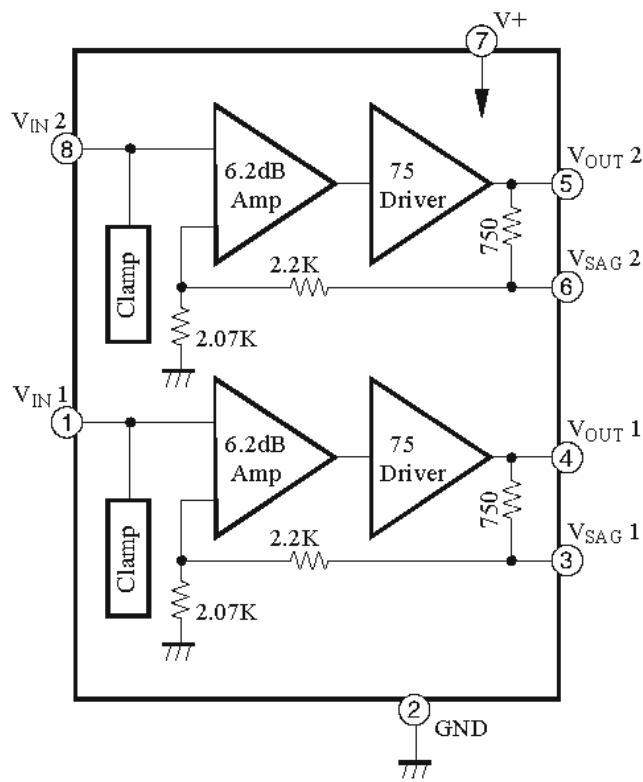

Q603 - HM62H256AJ-15T 32Kx8
HIGH SPEED CMOS STATIC RAM

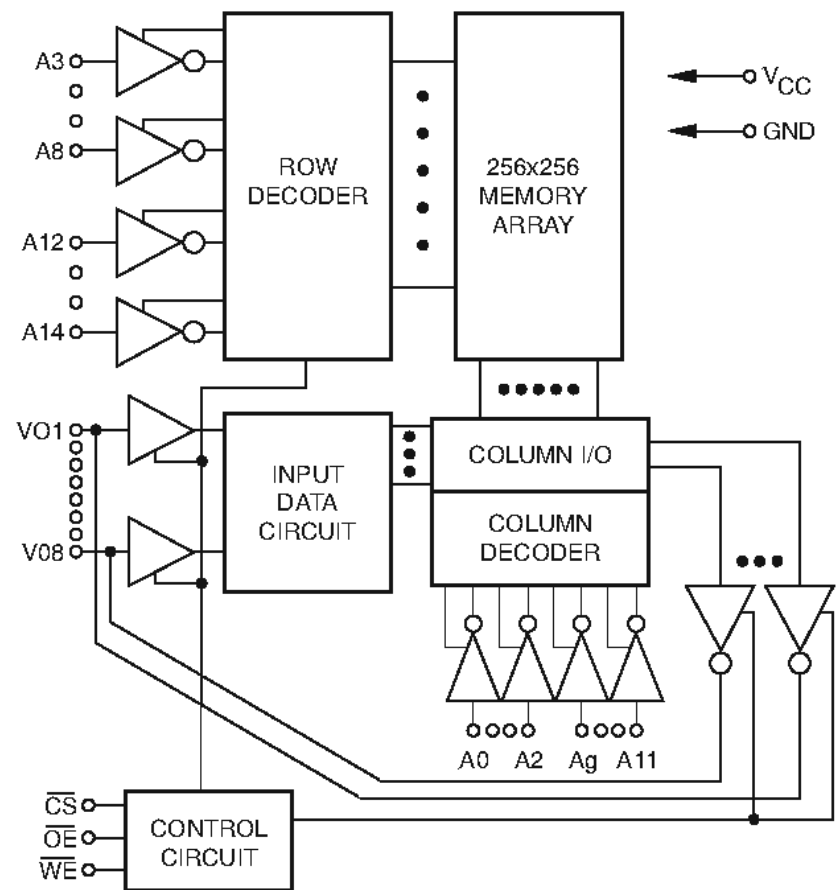

QL03, QL55-57 - MC14576S, MC14577A
VIDEO AMP

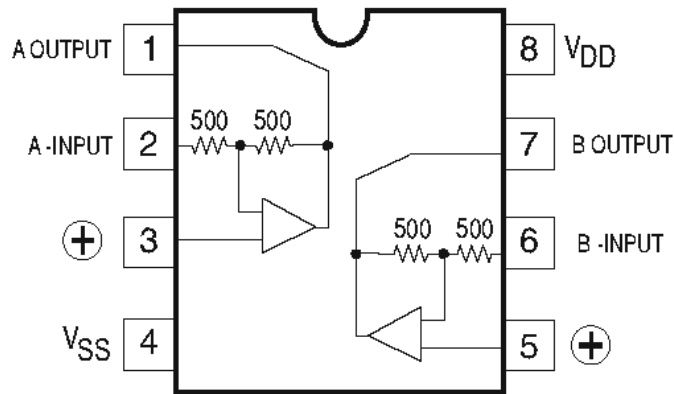

QP01 - STK401
STEREO POWER AMP

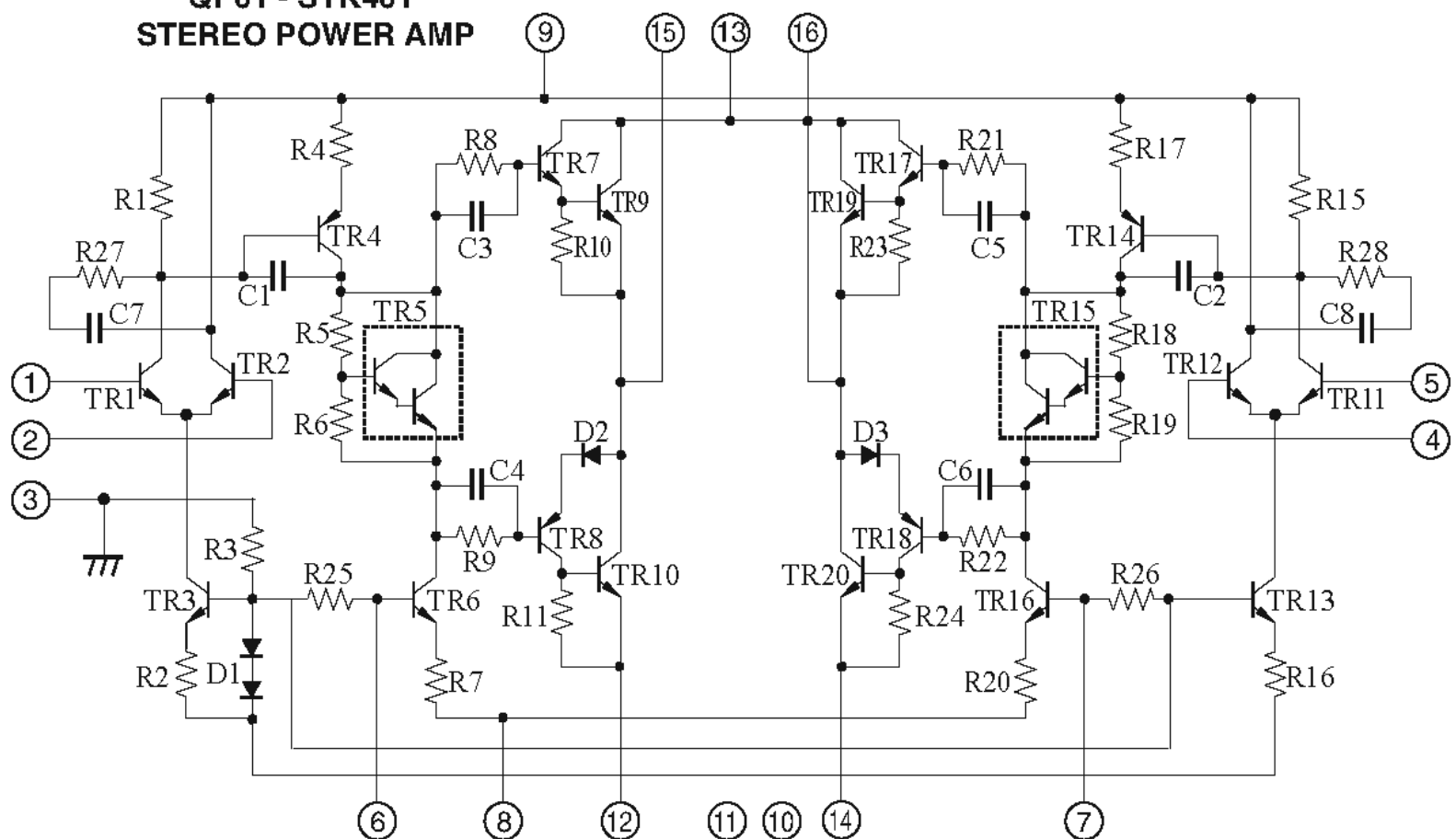

INTEGRATED CIRCUIT DIAGRAMS 11

Q901 - LA2232 RDS MODULATOR

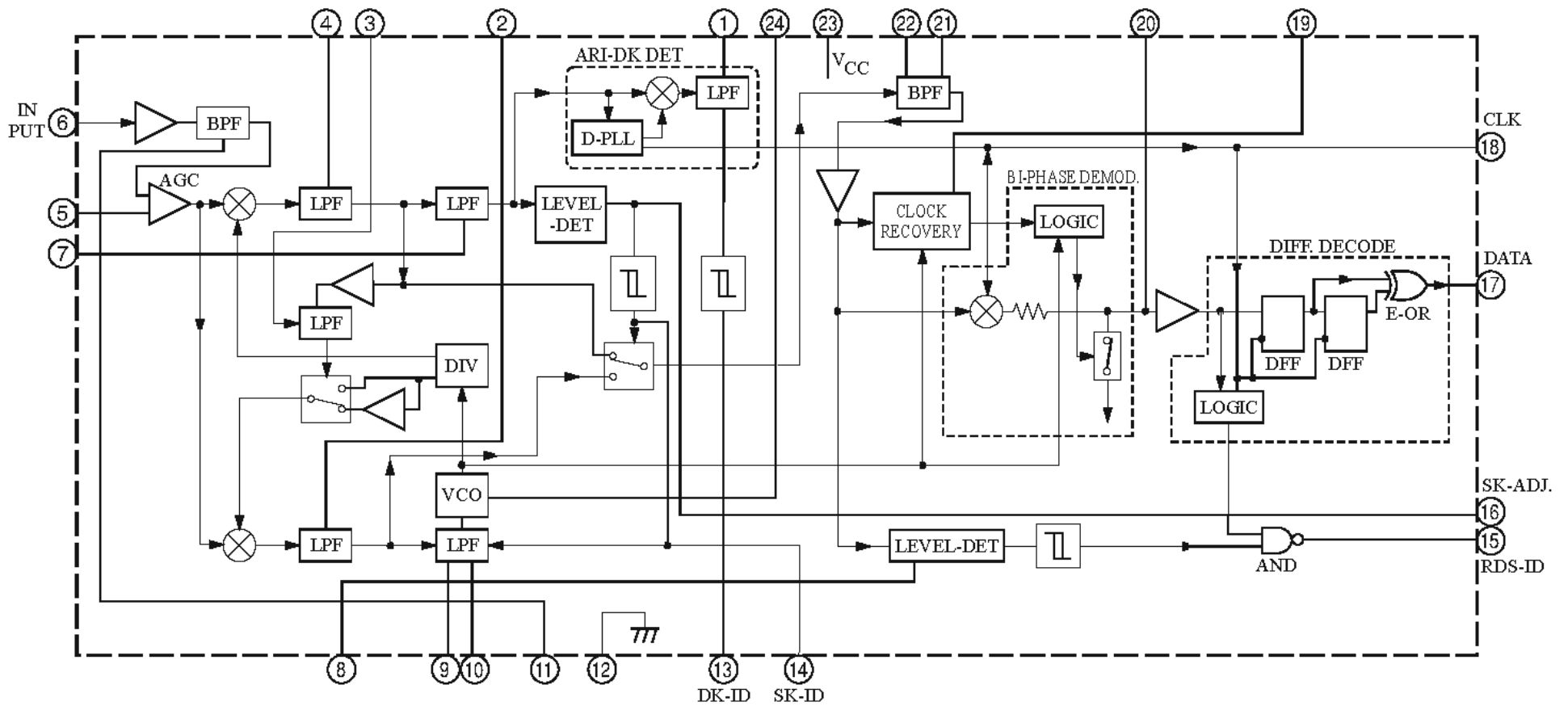

- QD02, 32, 52, QM08 - NJM4560M OP-AMP
 Q301, QE01-03, QC01-10, QE07-12, QC12, QL91, QS01-03,
 QW01, QS13, QS51-54, QF02, 03, QG55, 56 NJM4558DD - OP-AMP

QM04 - MC14577C
VIDEO AMP

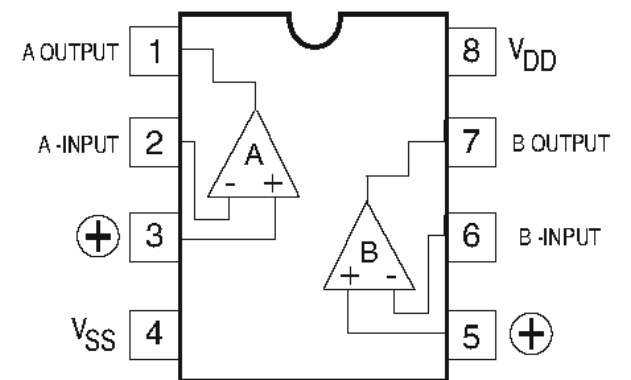
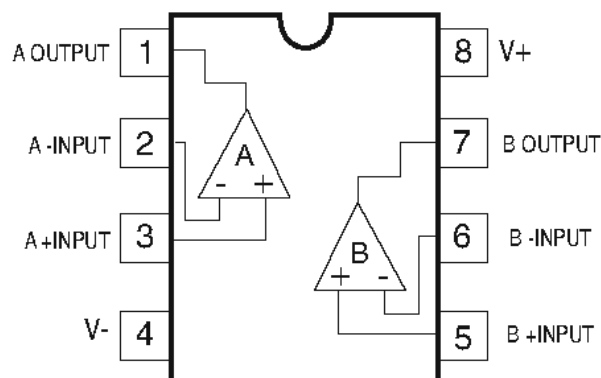
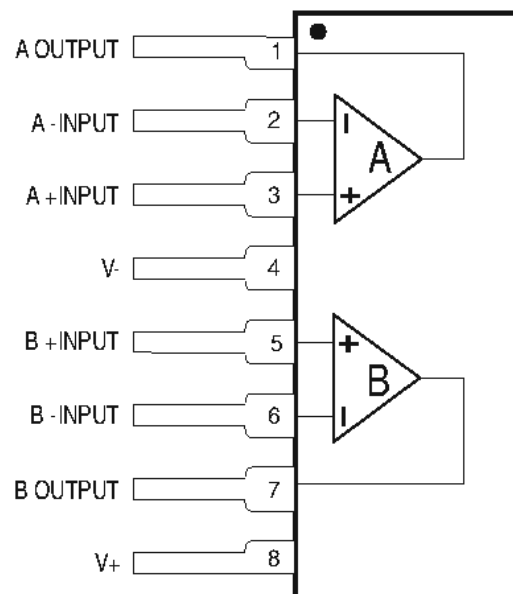

QK02, QK03 - NJM2115M
OP-AMP

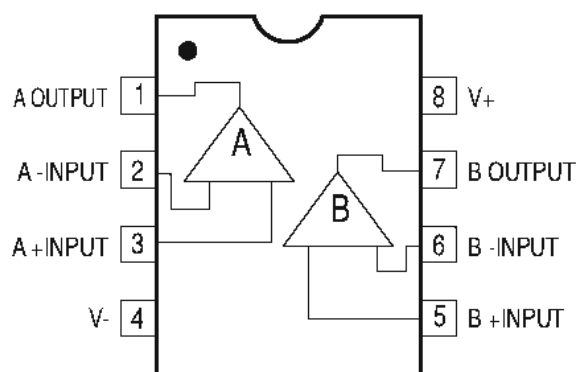

QW01 - NJM2115M
DUAL OP-AMP

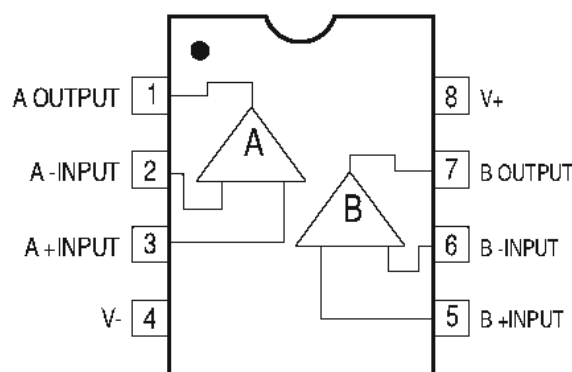

Q609 - TCW125FU
DUAL BUS BUFFER

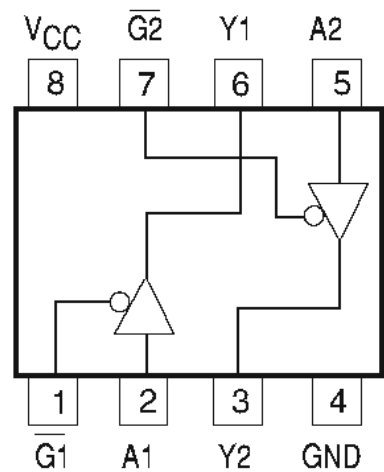

AVR75/85 WIRING DIAGRAM (120V & 230V)

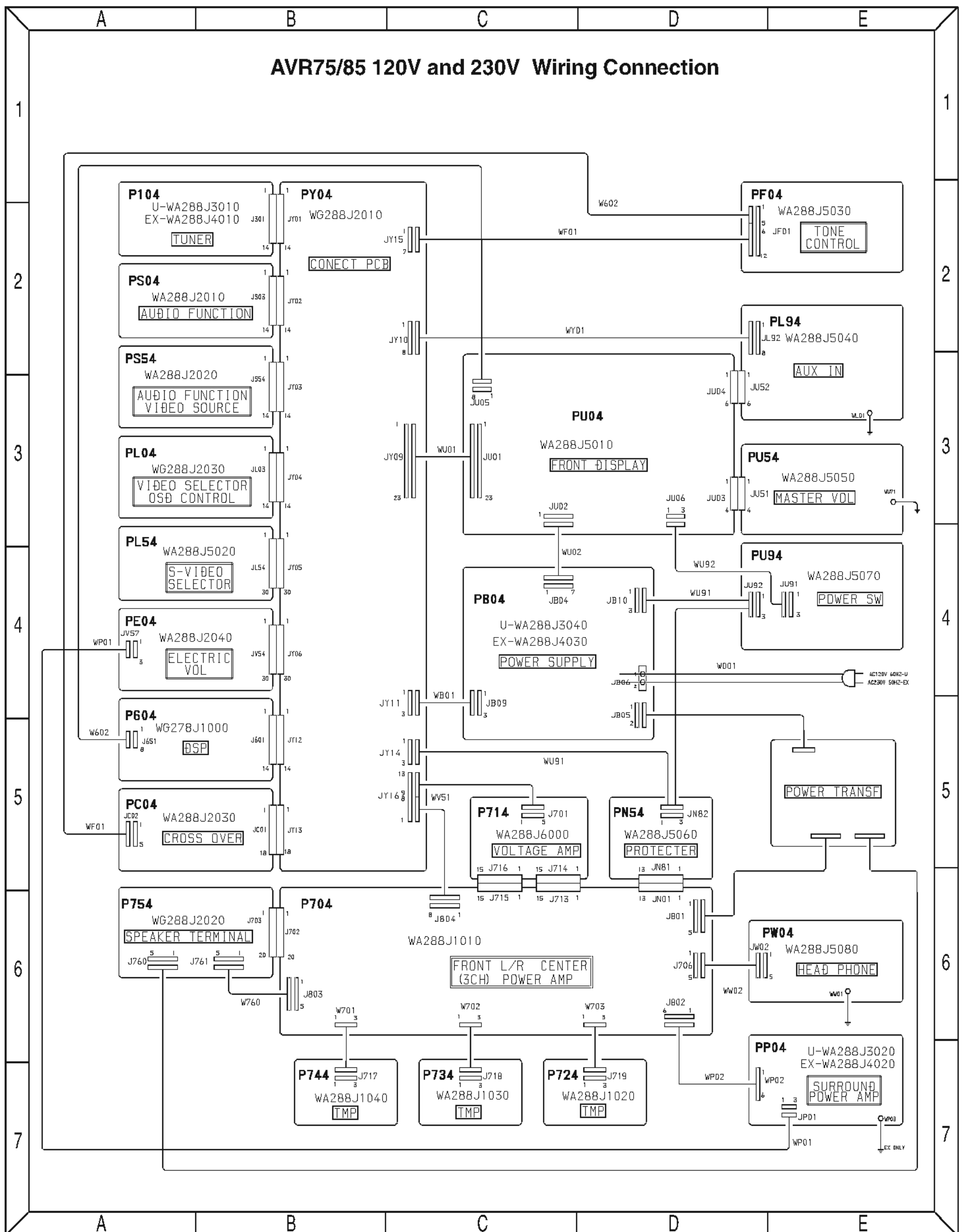

AVR75 (120V) SCHEMATIC DIAGRAM 1 of 8 (FRONT PCB PU04, MASTER VOLUME PCB PU54, AUX IN PL94)

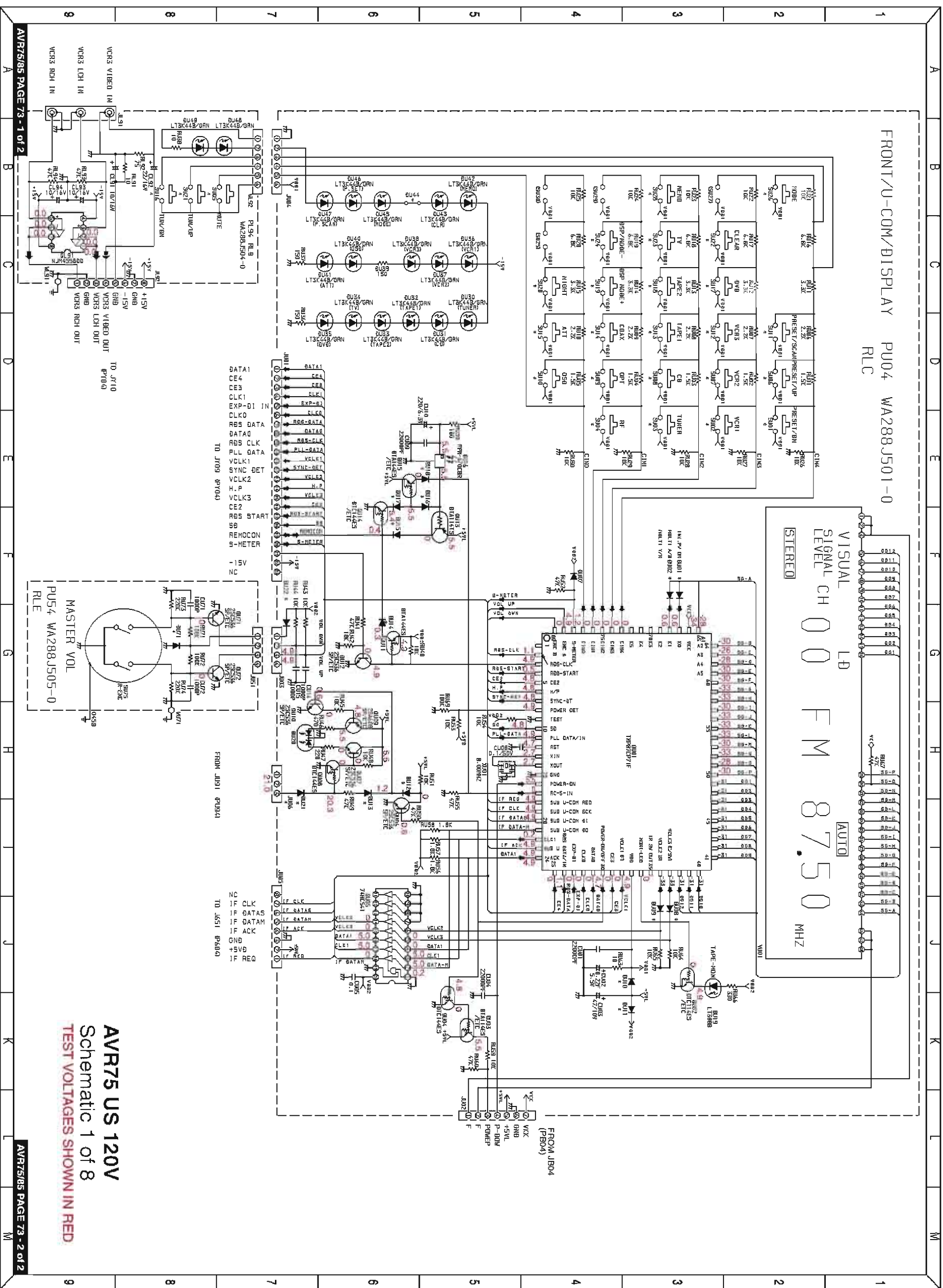

AVR75 US 120V
Schematic 1 of 8
TEST VOLTAGES SHOWN IN RED

AVR75 (120V) SCHEMATIC DIAGRAM 1 of 8 (FRONT PCB PU04, MASTER V

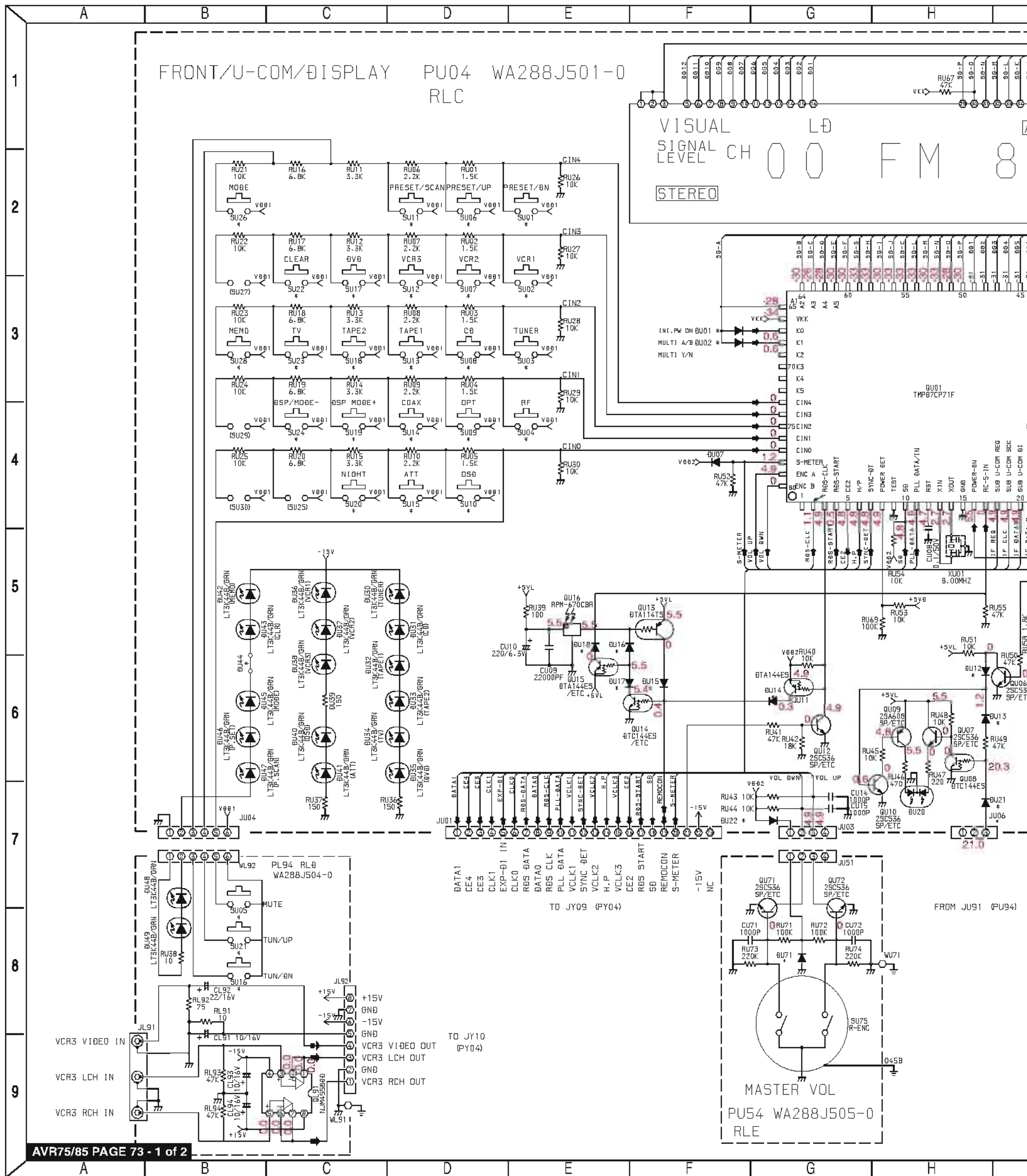

RAM 1 of 8 (FRONT PCB PU04, MASTER VOLUME PCB PU54, AUX IN PL94)

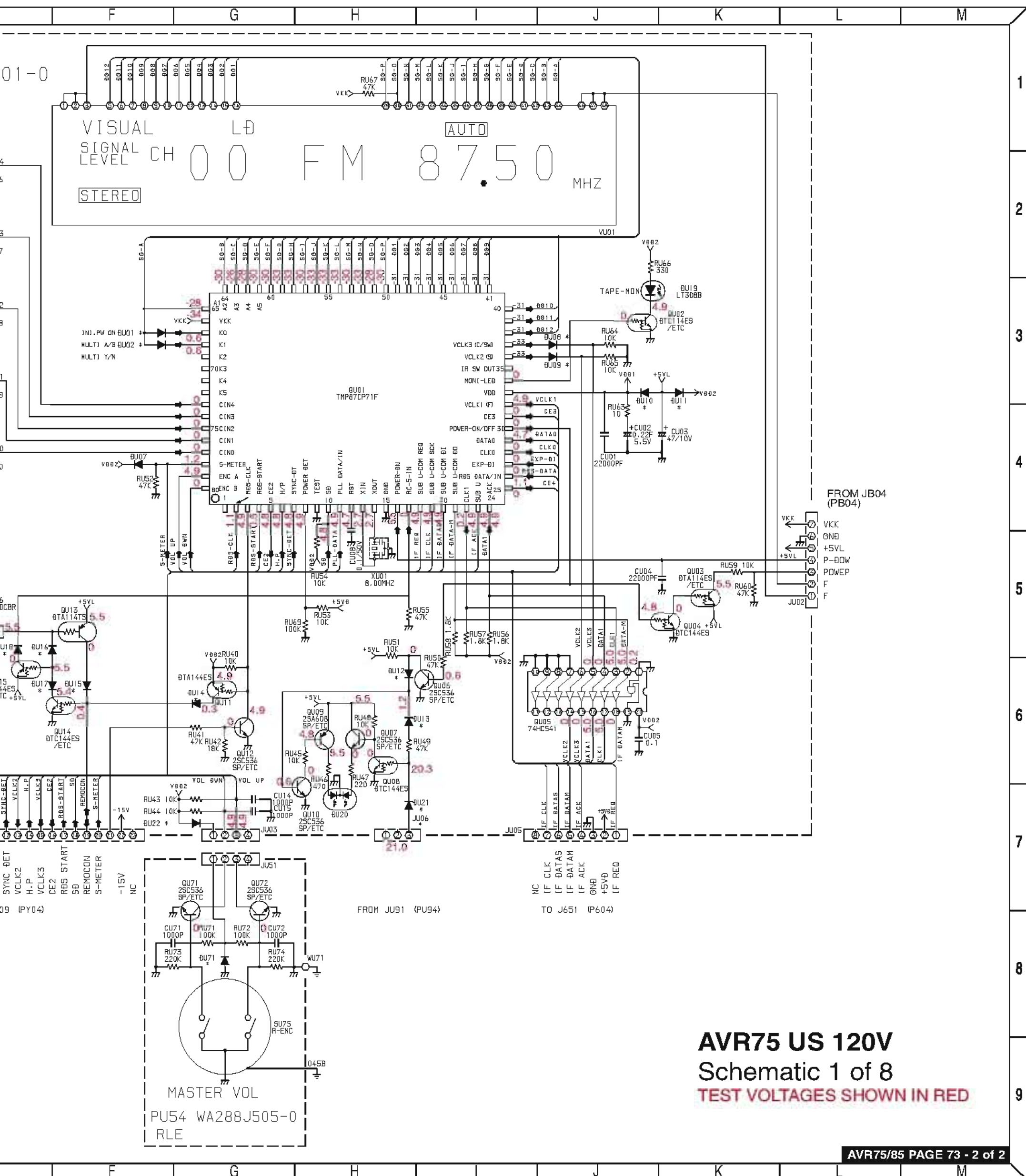

AVR75 US 120V
Schematic 1 of 8
TEST VOLTAGES SHOWN IN RED

AVR75 (120V) SCHEMATIC DIAGRAM 2 of 8 (TUNER PCB P104)

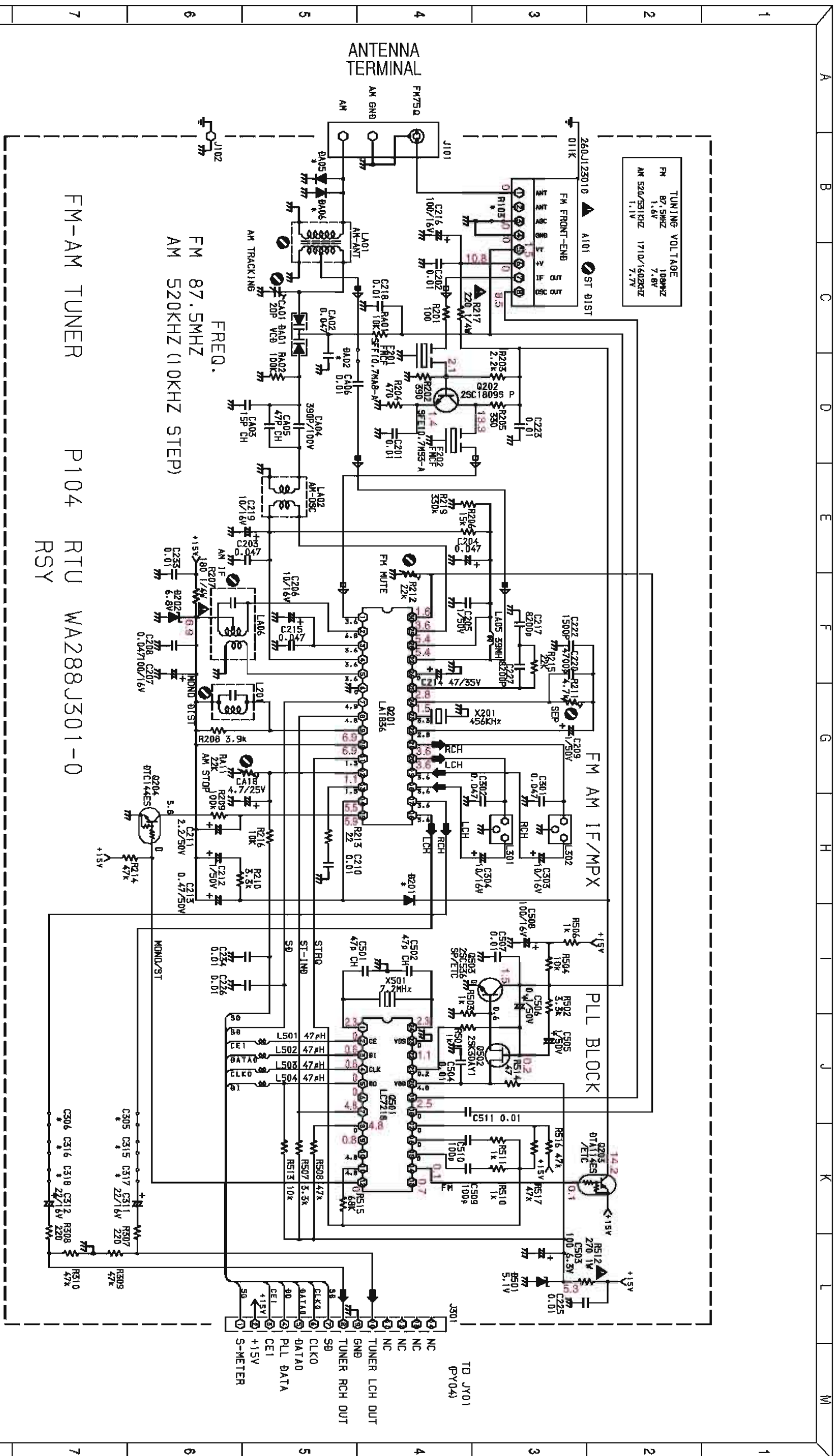

AVR75 US 120V
Schematic 2 of 8
TEST VOLTAGES SHOWN IN RED

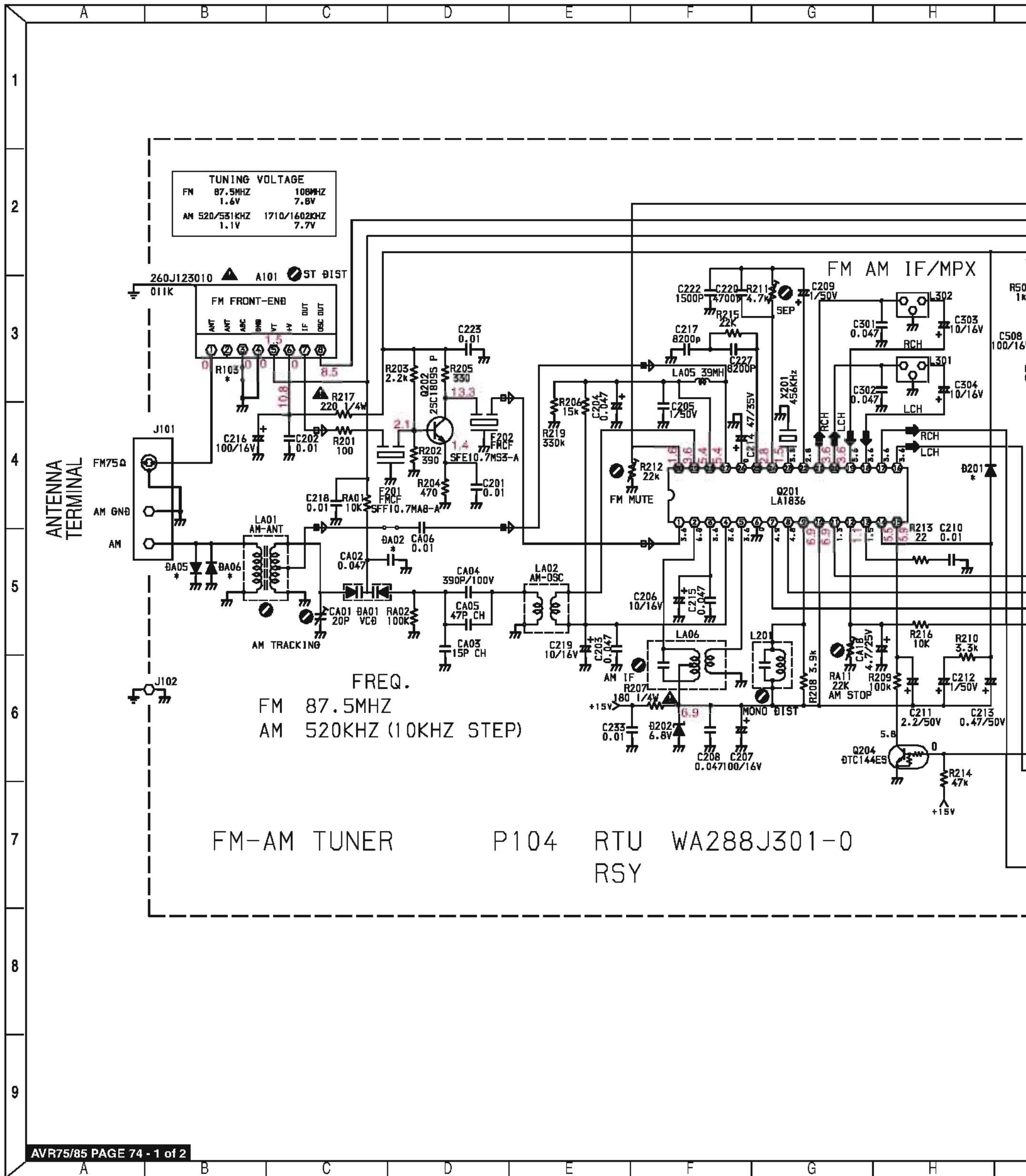

120V) SCHEMATIC DIAGRAM 2 of 8 (TUNER PCB P104)

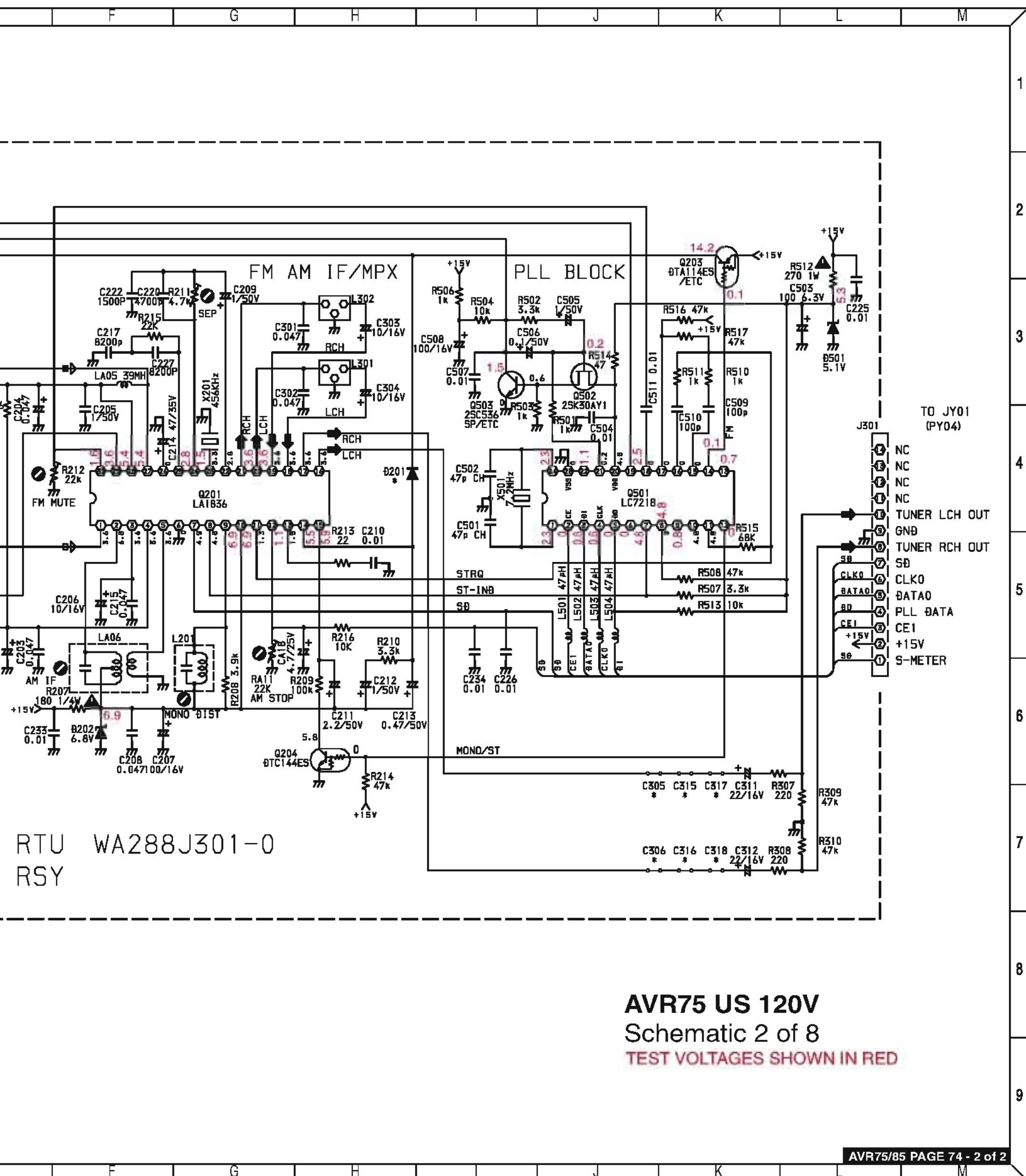

RTU WA288J301-0
RSY

AVR75 US 120V
Schematic 2 of 8
TEST VOLTAGES SHOWN IN RED

AVR75 (120V) SCHEMATIC DIAGRAM 3 of 8 (AUDIO SELECTOR PCB PS04, AUDIO/VIDEO PCB PS54)

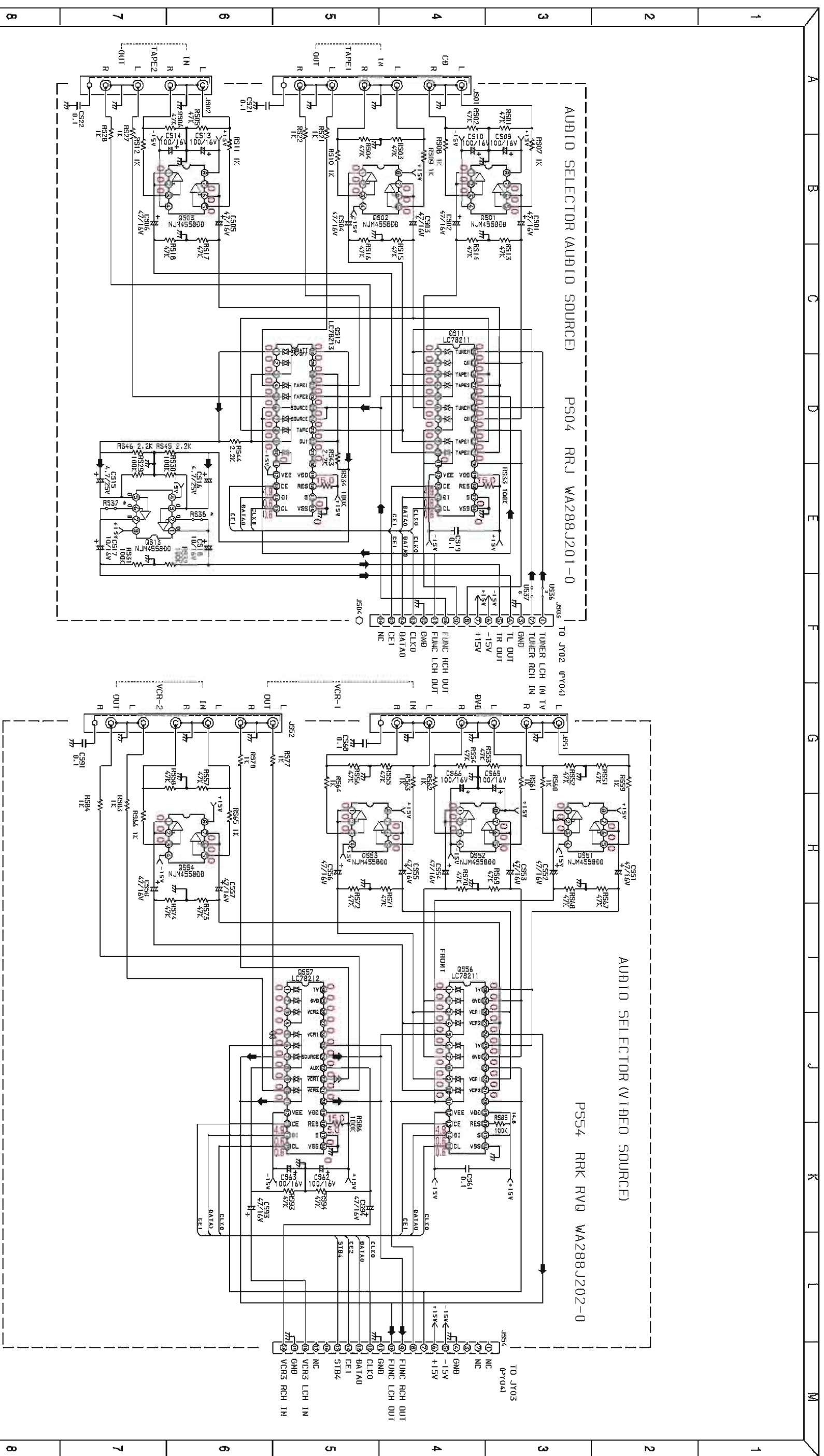

AVR75 US 120V
Schematic 3 of 8
TEST VOLTAGES SHOWN IN RED

AVR75 (120V) SCHEMATIC DIAGRAM 3 of 8 (AUDIO SELECTOR P

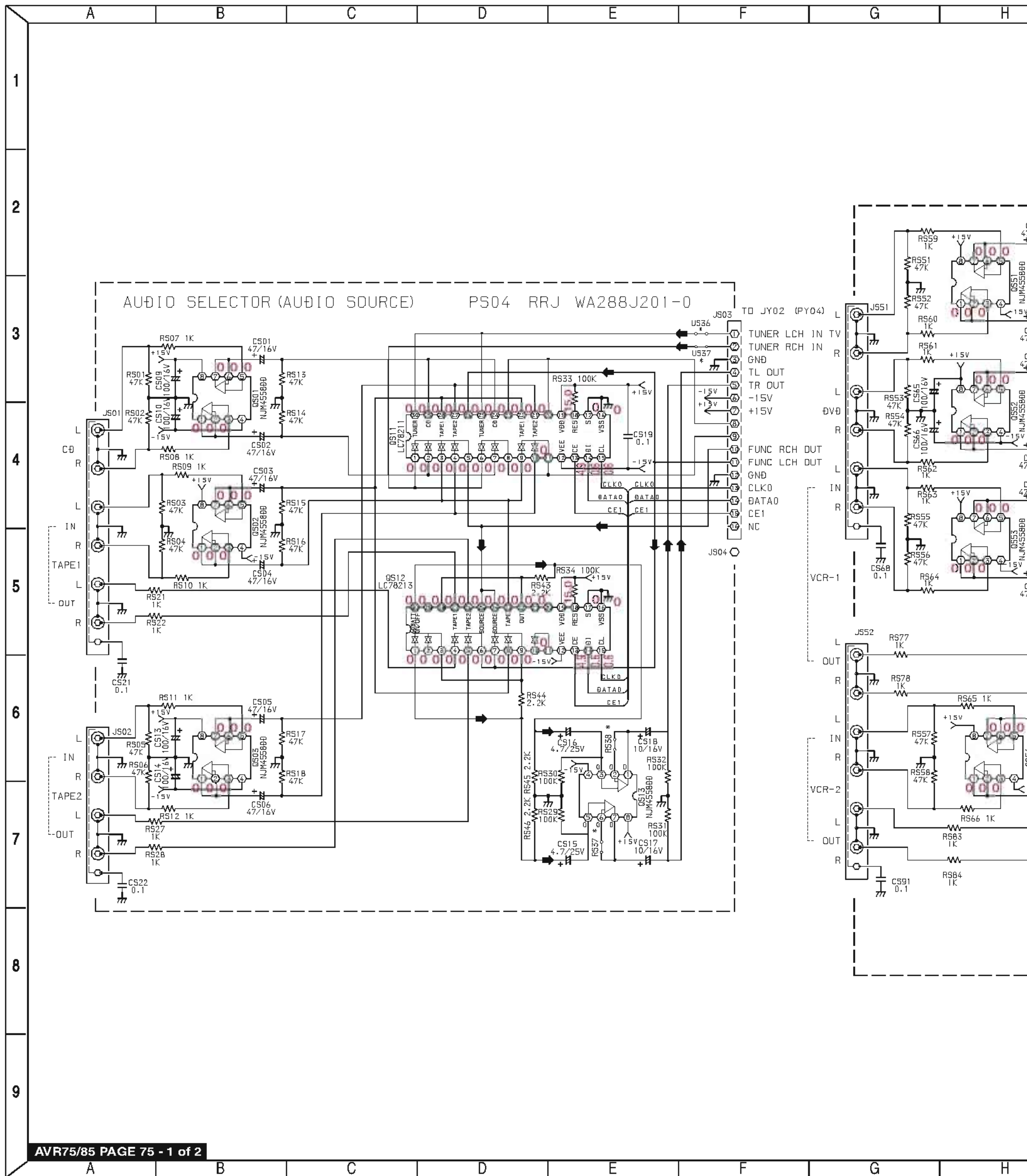

AVR75 US 120V
Schematic 4 of 8
TEST VOLTAGES SHOWN IN RED

CROSSOVER
PC04 RCR WA288J203-0

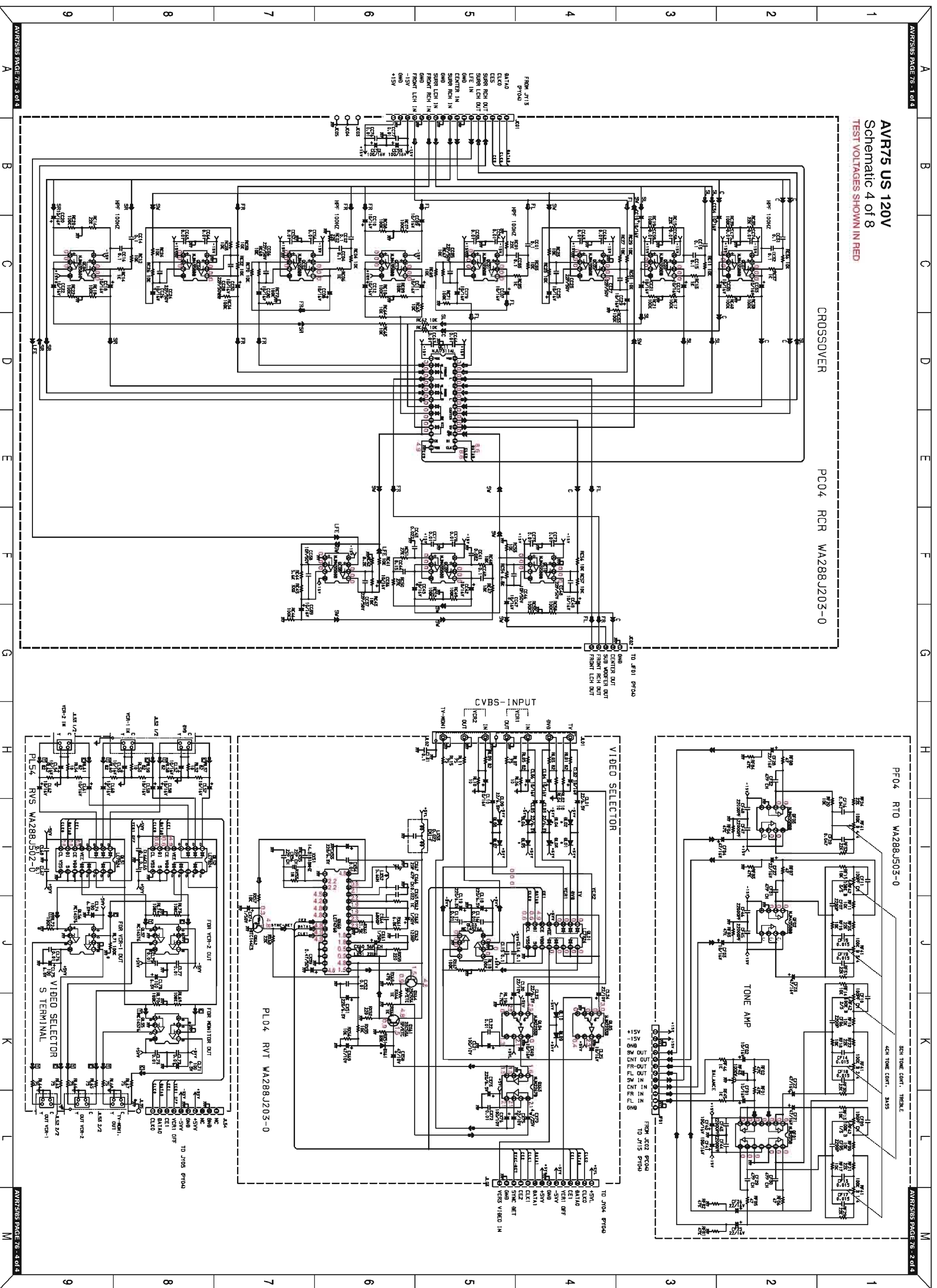
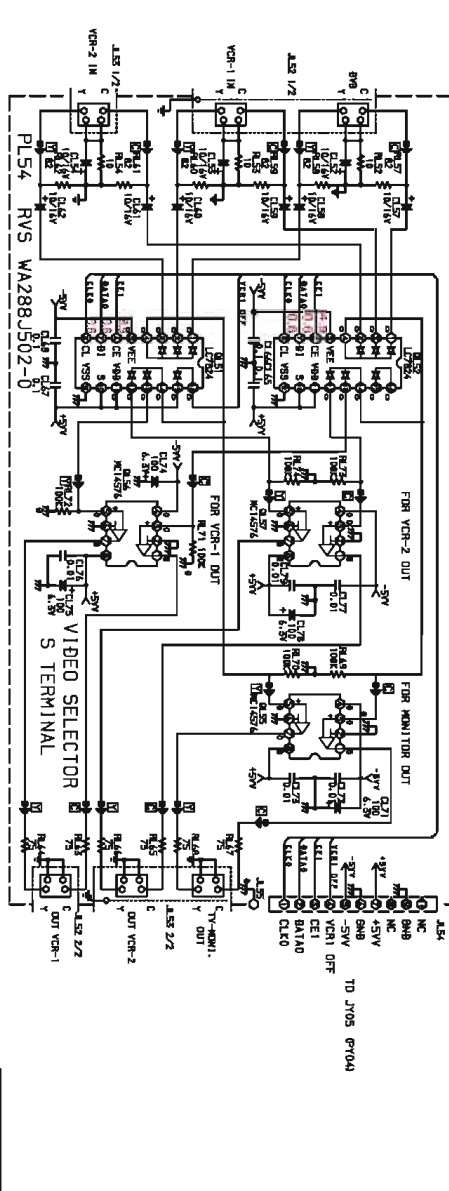
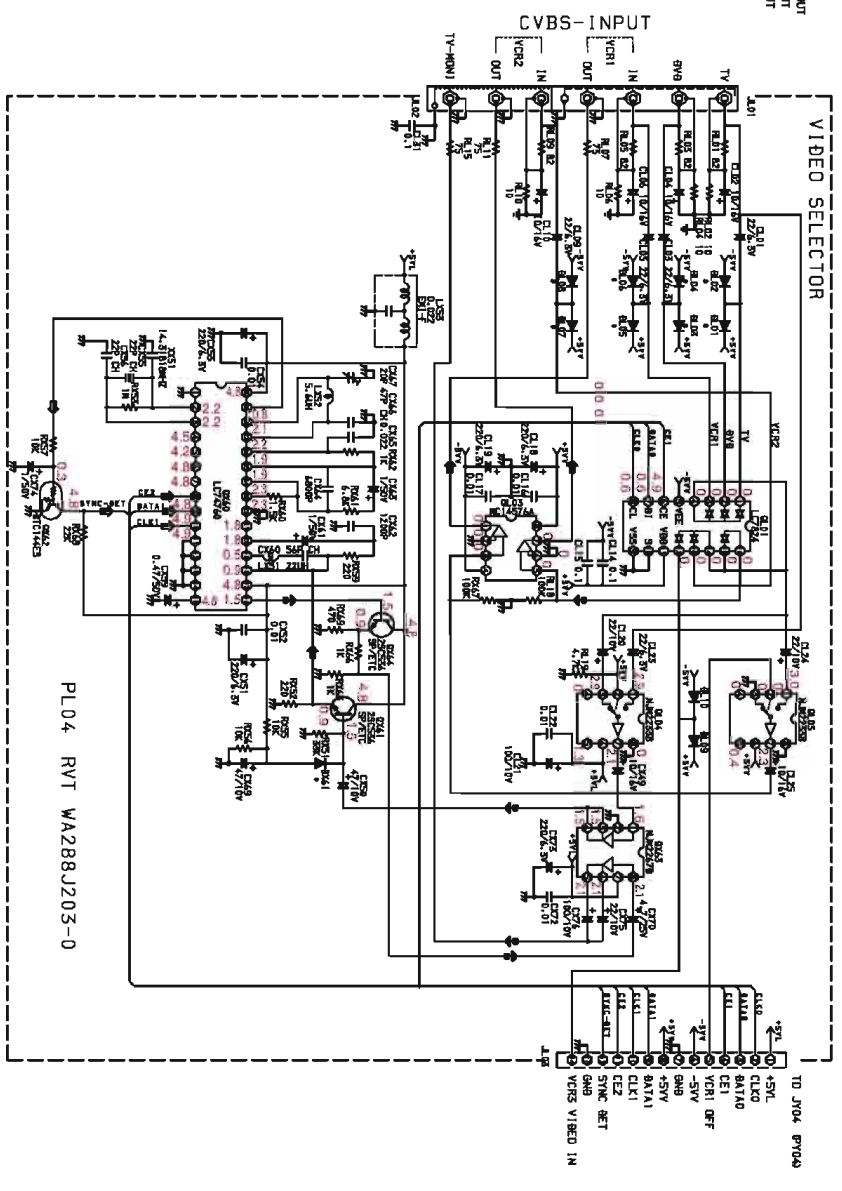
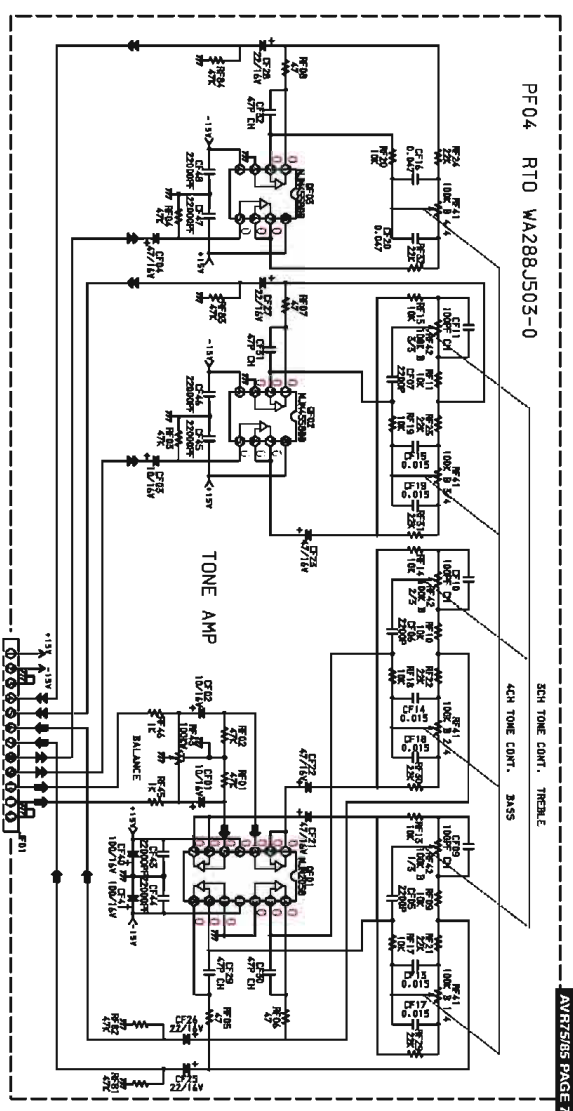
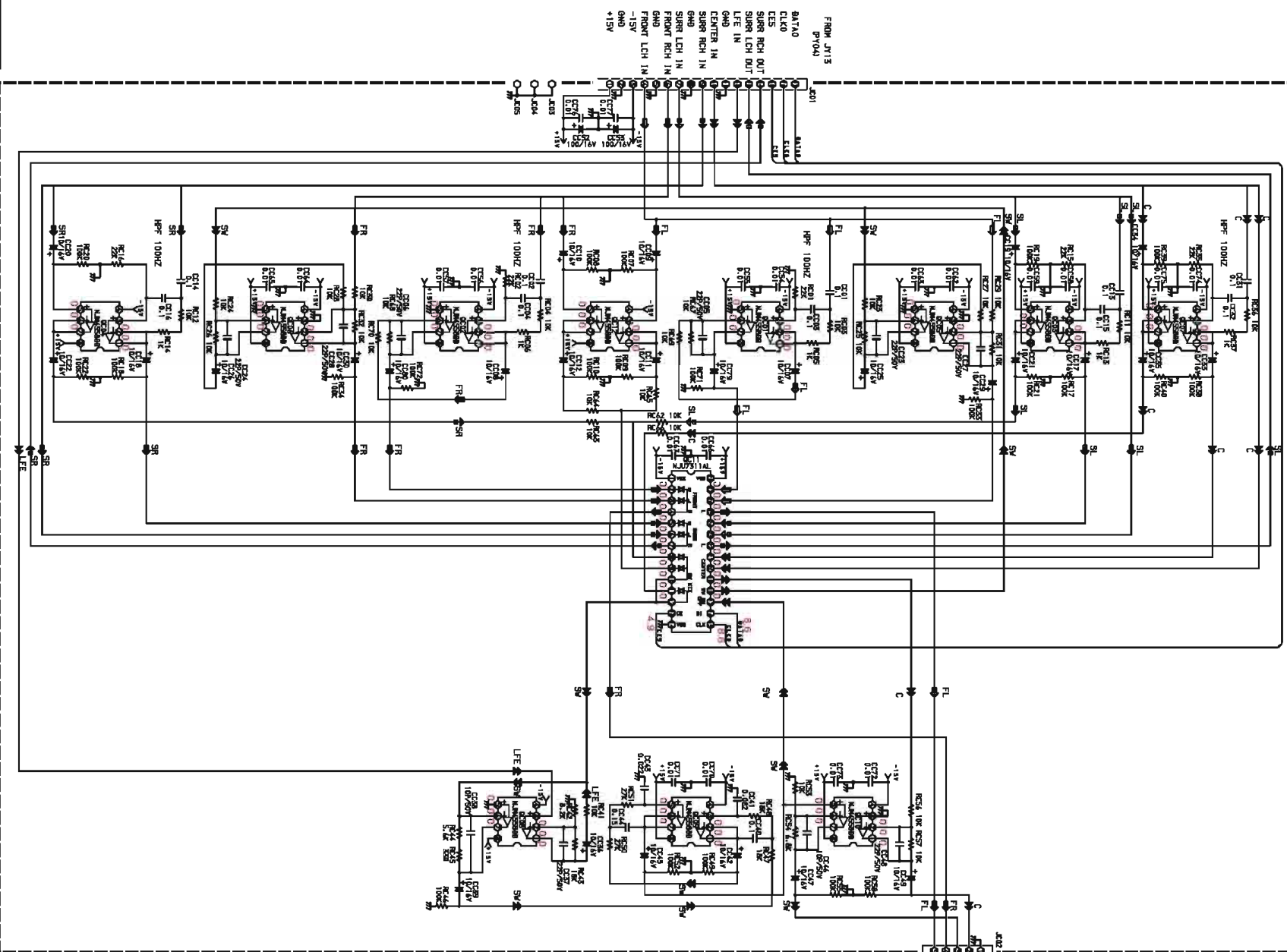

AVR75 (120V) SCHEMATIC DIAGRAM 4 of 8 (AC-3 CROSSOVER PCB PC04, TONE CON

AVR75/85 PAGE 76 - 1 of 4

AVR75 US 120V
Schematic 4 of 8
TEST VOLTAGES SHOWN IN RED

CROSSOVER PC04 RCR WA288J203-0

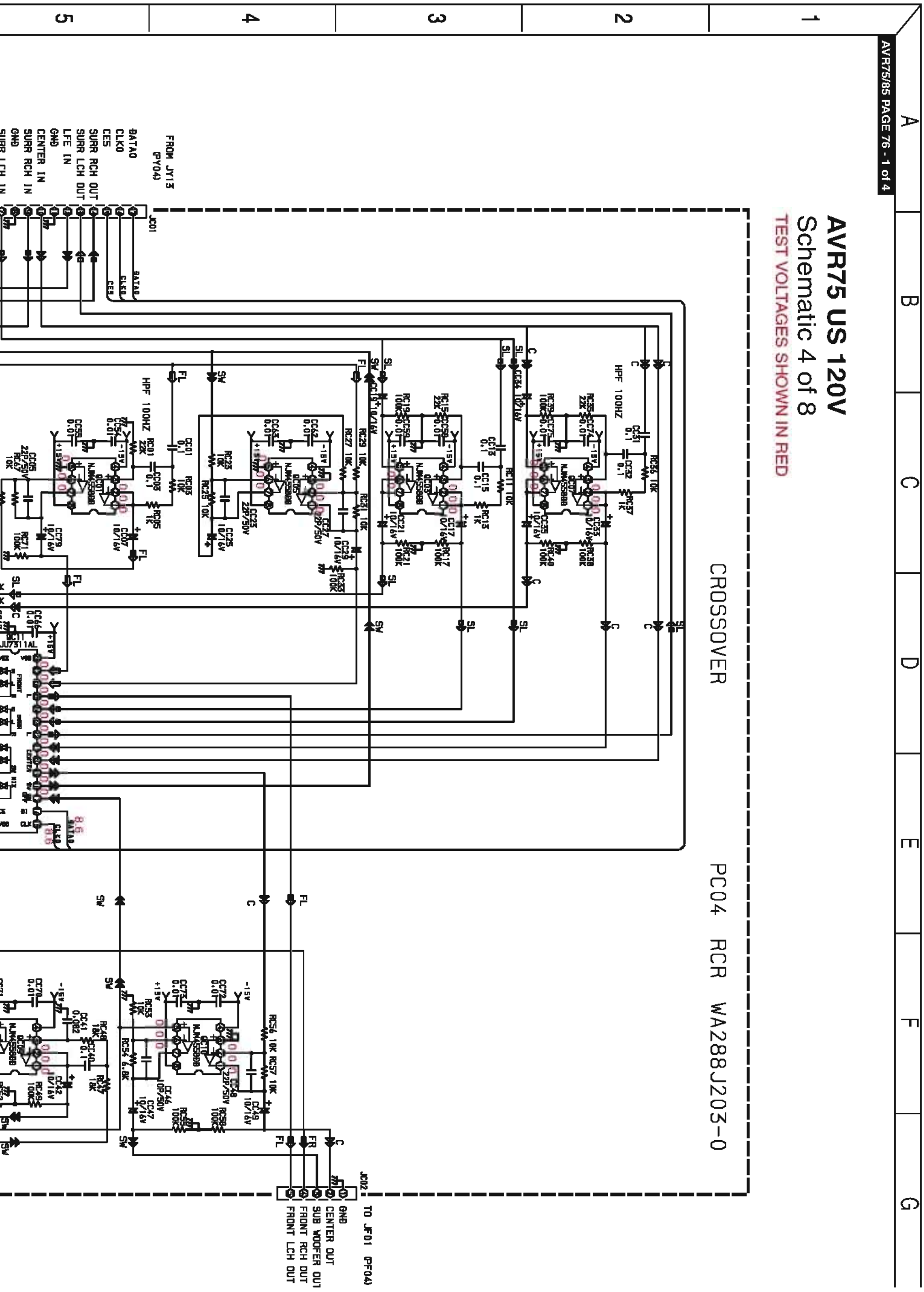

FROM JY13
(PY04)

BATA0
CLK0
CES
SURR RCH OUT
SURR LCH OUT
LFE IN
GND
CENTER IN
SURR RCH IN
SURR LCH IN

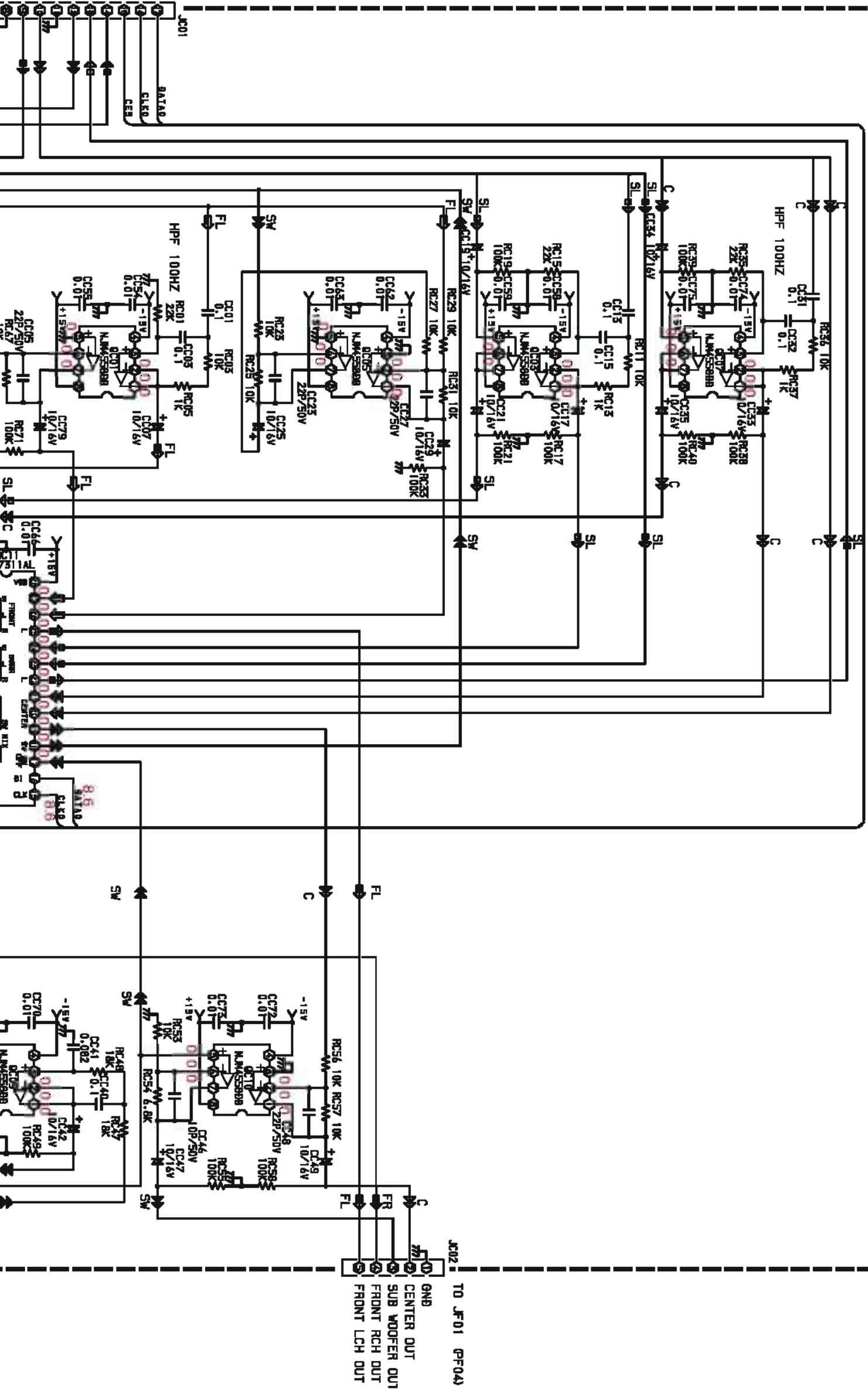

TO JF01 (PF04)

GND
CENTER OUT
SUB WOOFER OUT
FRONT RCH OUT
FRONT LCH OUT

3 PC04, TONE CONTROL PCB PF04, VIDEO SELECTOR PCB PL04, S-VIDEO PCB PL54

G H J K L M

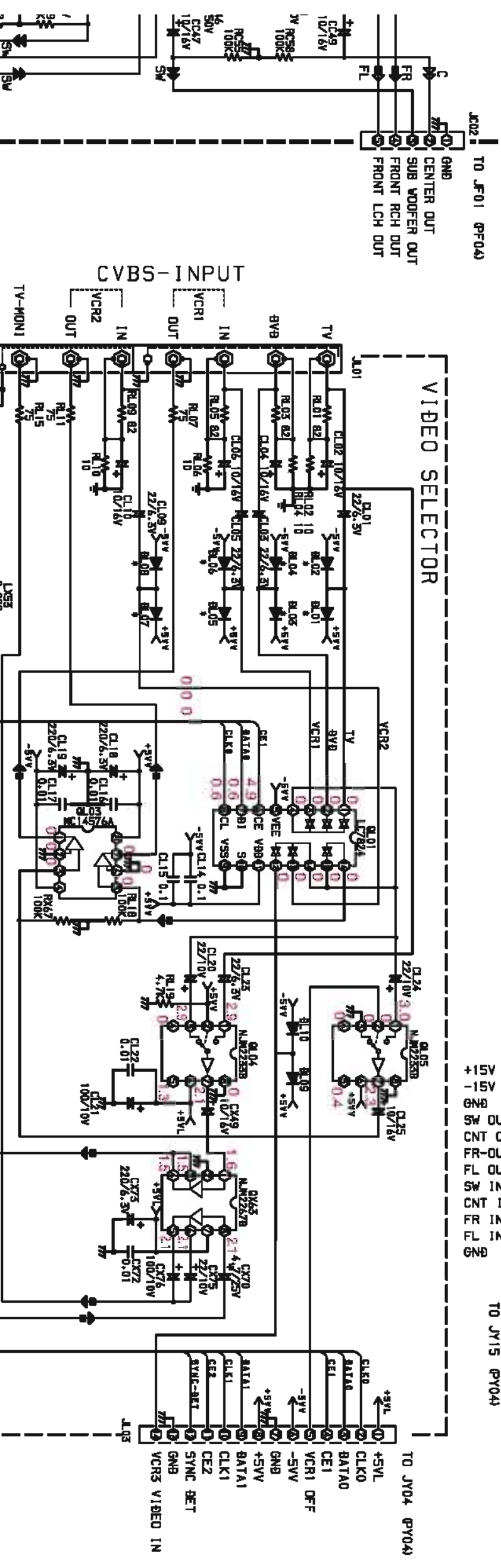
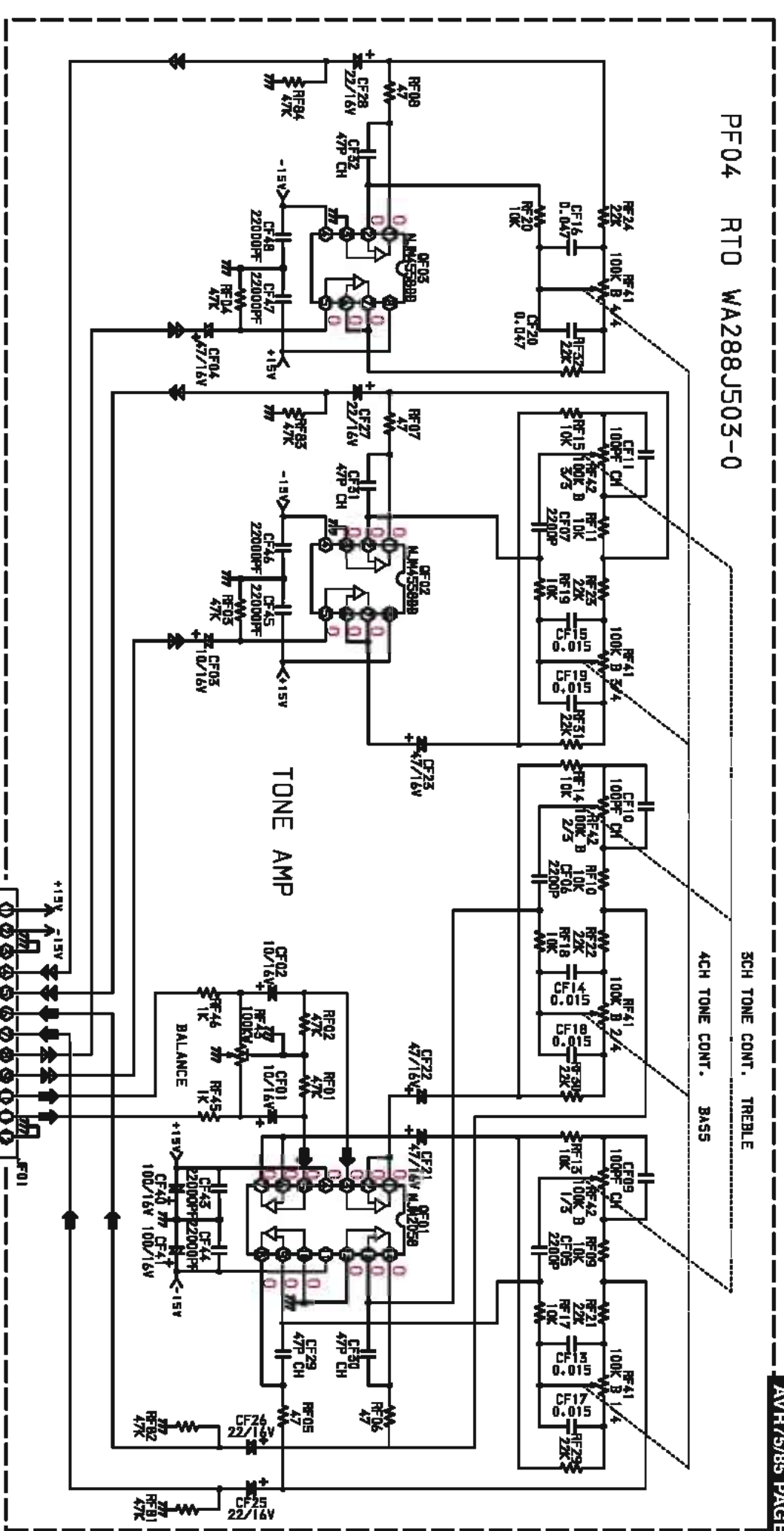

03-0

JC02 TO JF01 (PF04)

GROUND CENTER OUT SUB WOOFER OUT FRONT RCH OUT FRONT LCH OUT

CVBS-INPUT

VIDEO SELECTOR

TONE AMP

SCH TONE CONT. TREBLE ACH TONE CONT. BASS

FROM JC02 (PC04) TO JY15 (PY04)

TO JY04 (PY04)

1 2 3 4 5

BATAO
 CLKO
 CES
 SURR RCH OUT
 SURR LCH OUT
 LFE IN
 GNB
 CENTER IN
 SURR RCH IN
 SURR LCH IN
 FRONT RCH IN
 FRONT LCH IN
 GNB
 FRONT LCH IN
 -15V
 GNB
 +15V

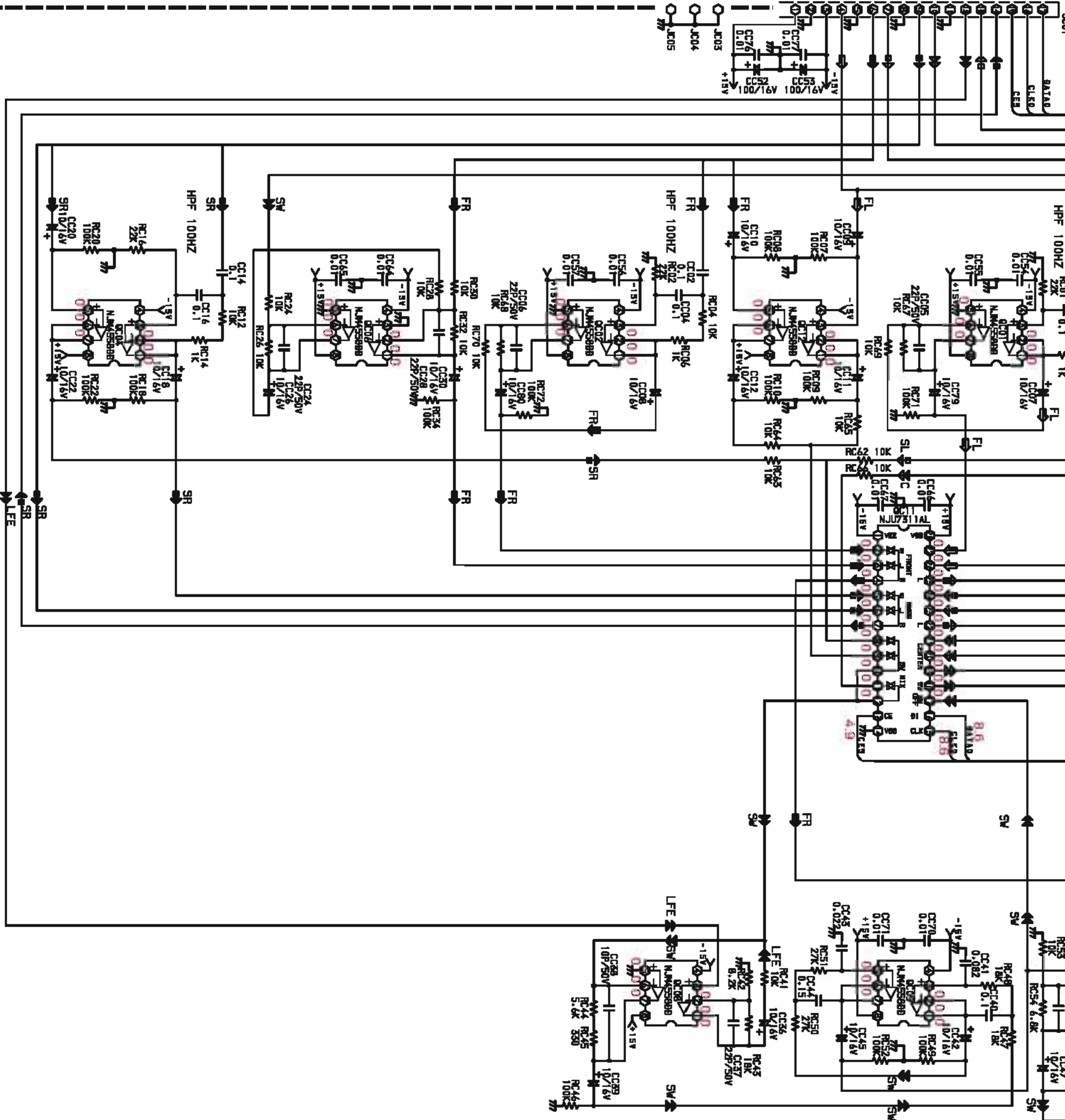

A

B

C

D

E

F

G

9

8

7

6

5

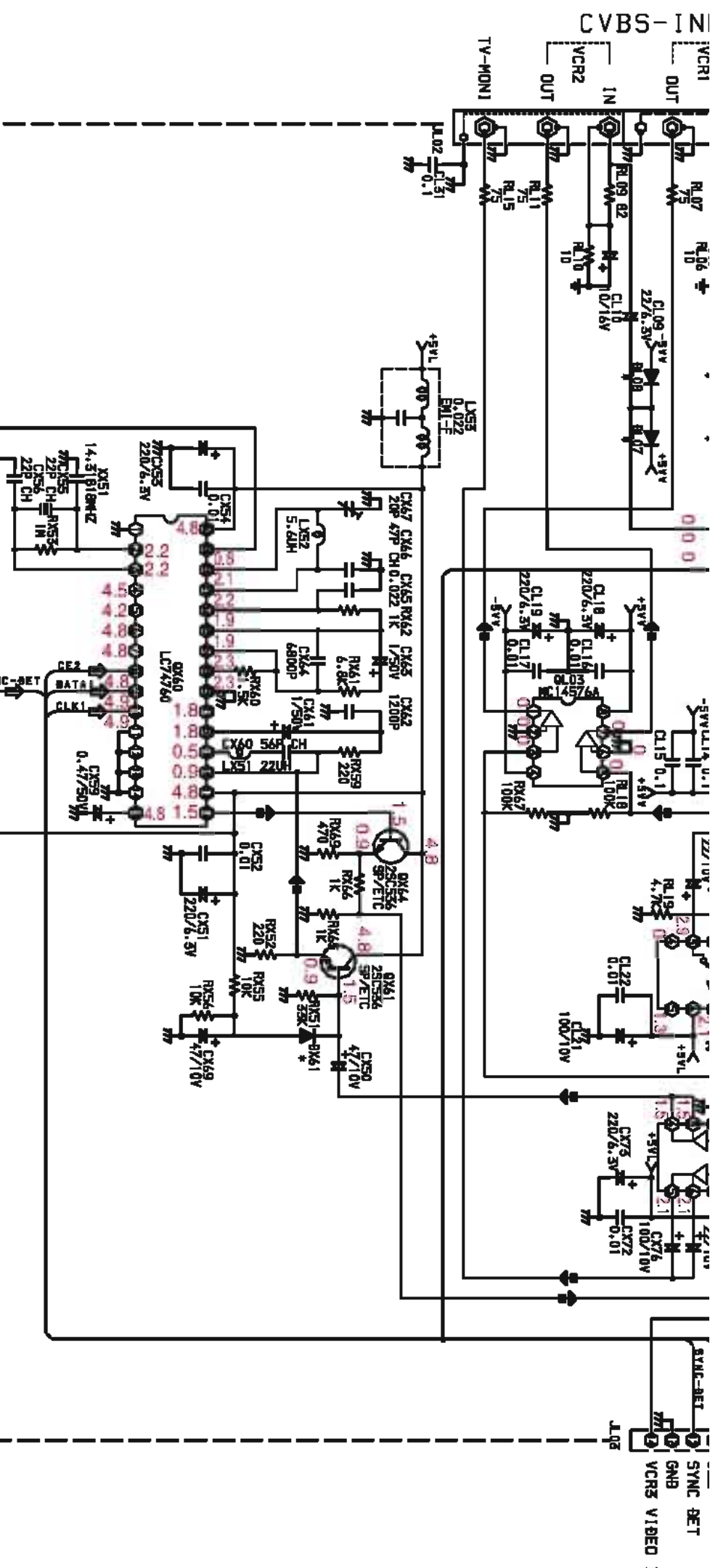
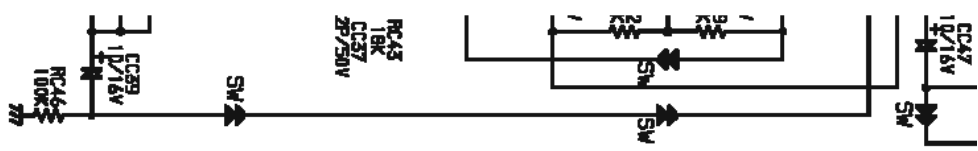

PL04 RVT WA288J203-0

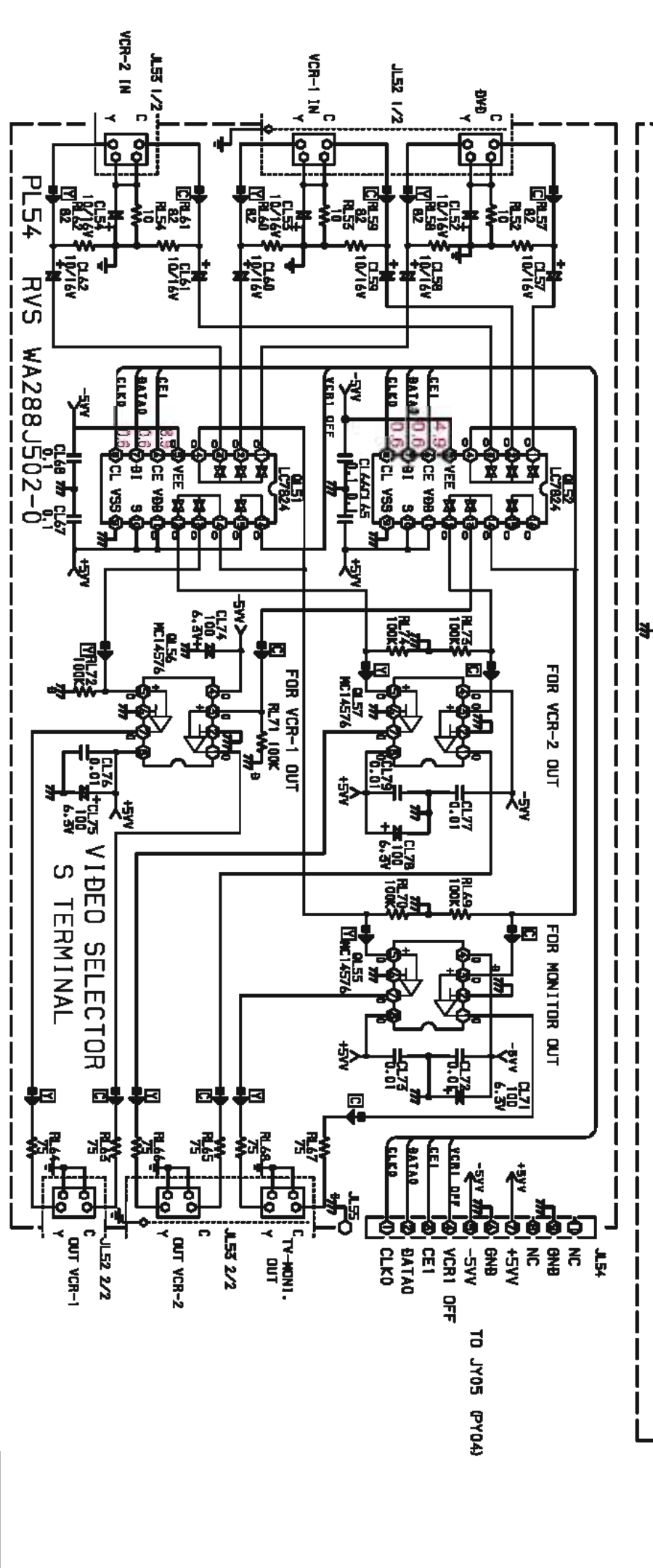

PLS4 RVS WA288J502-0

VIDEO SELECTOR
S TERMINAL

G H J K L M

AVR75 (120V) SCHEMATIC DIAGRAM 5 of 8 (CONNECT PCB PY04)

AVR75 US 120V
Schematic 5 of 8
TEST VOLTAGES ARE SHOWN IN RED

BACKUP SUPPLY
FROM JB09 (P904)

FRONT/UP-CONV/81SP/PLAY
FROM JU01 (P104)

CROSS OVER
TO JC01 (P104)

DSP
FROM J601 (P604)

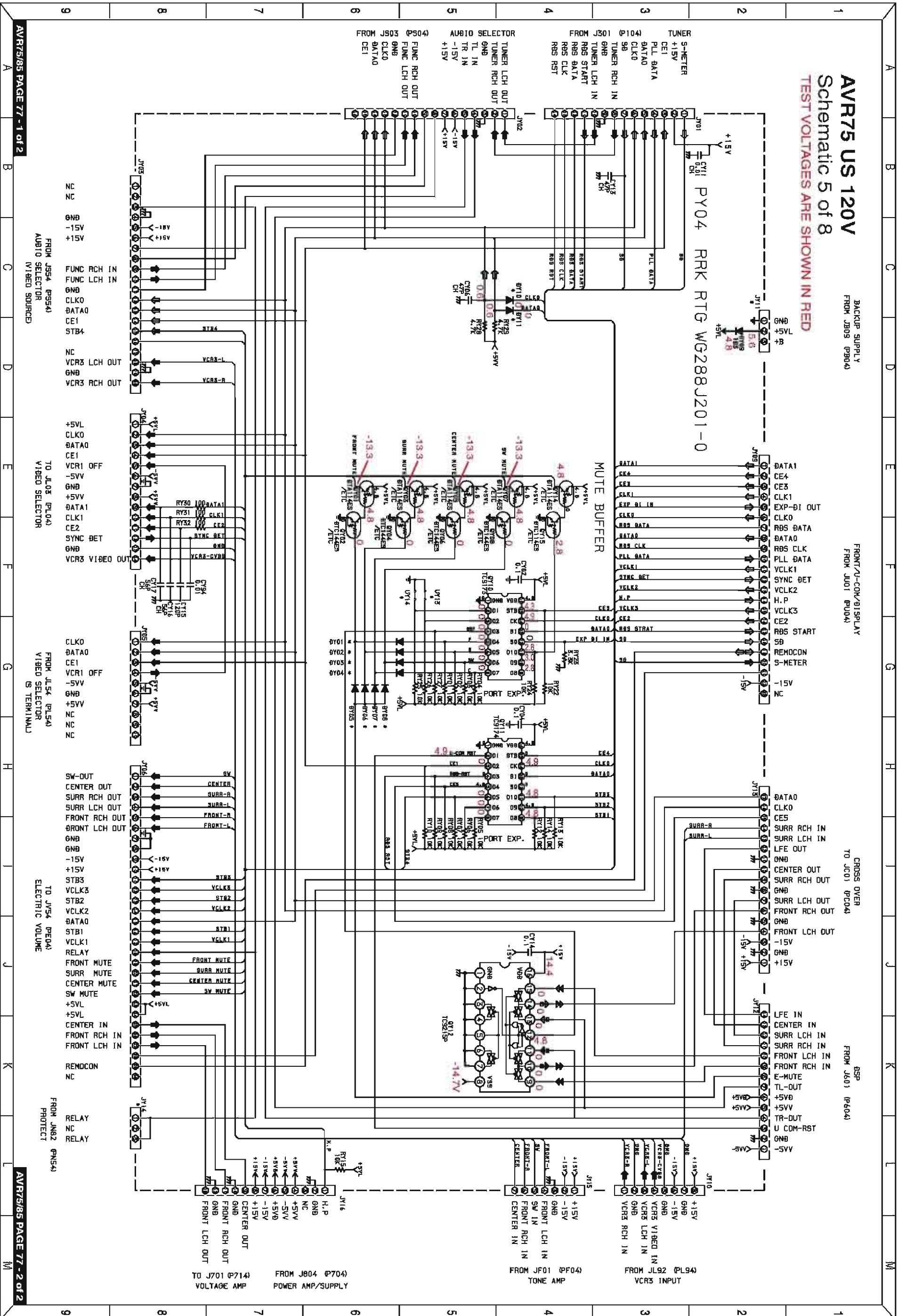

TO J701 (P714)
VOLTAGE AMP

FROM J804 (P704)
POWER AMP/SUPPLY

FROM JF01 (P704)
TONE AMP

FROM JL92 (P194)
VCR3 INPUT

SCHEMATIC DIAGRAM 5 of 8 (CONNECT PCB PY04)

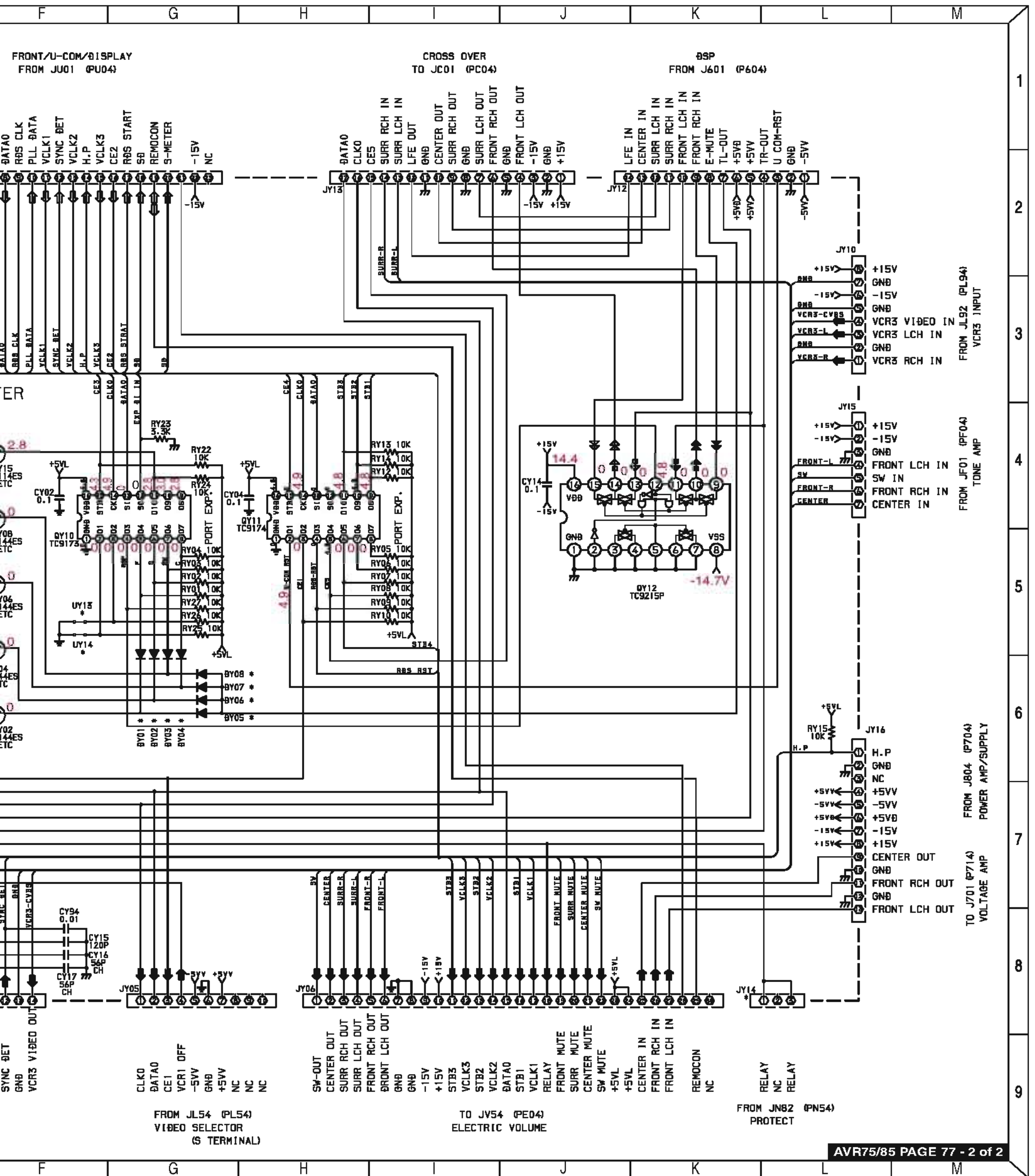

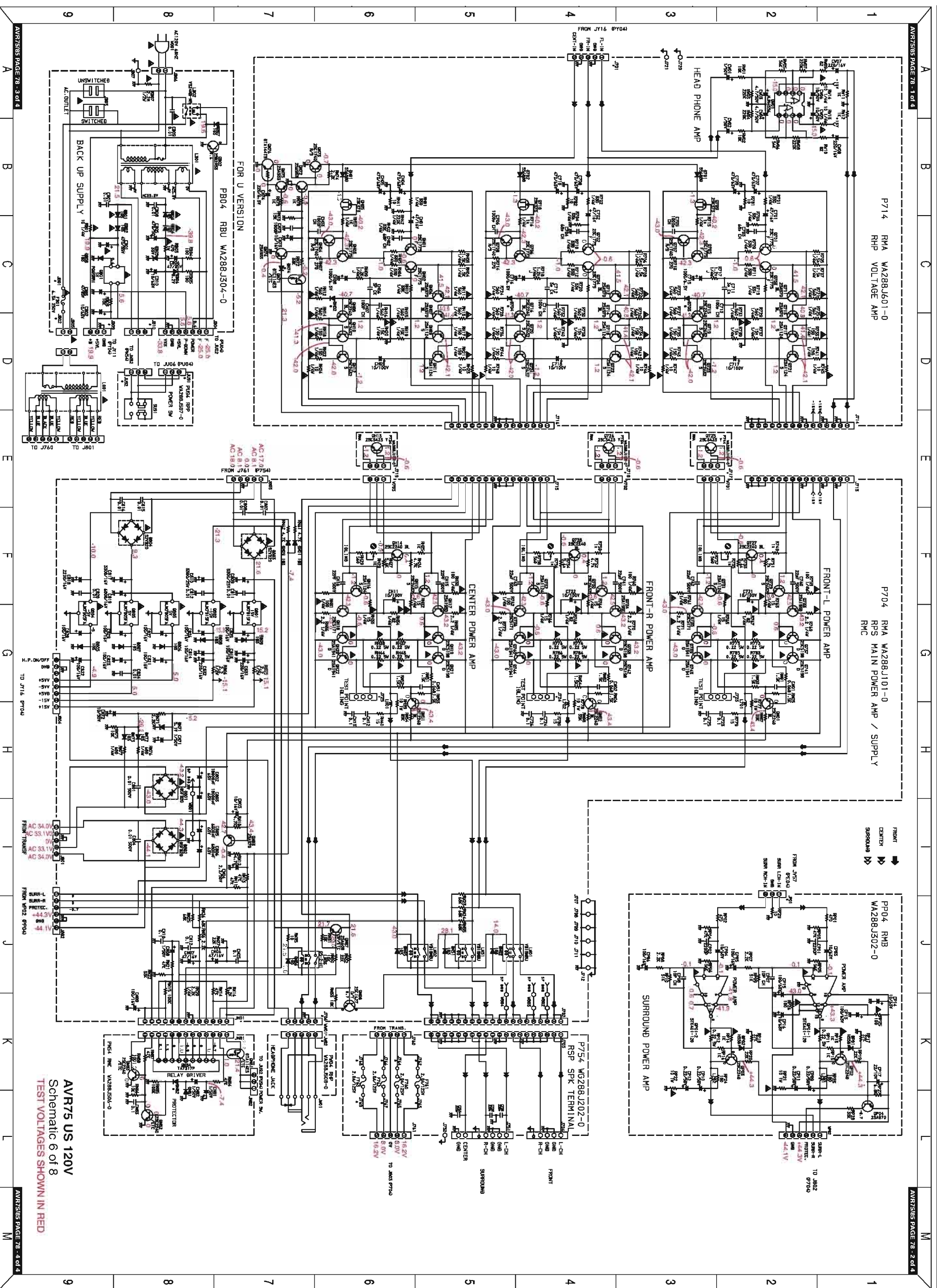

AVR75 US 120V
Schematic 6 of 8
TEST VOLTAGES SHOWN IN RED

AVR75 (120V) SCHEMATIC DIAGRAM 6 of 8 (VOLTAGE AMP PCB - P714
SPEAKER TERMINAL PCB - P754, HEADPHONE PCB - PW04, SPEAKER PROTECT PC

AVR75/85 PAGE 78 - 1 of 4

A B C D E F G

P714 RMA WA288J601-0
RHP VOLTAGE AMP

P704 RMA WA288J101-
RPS MAIN POWER
RMC

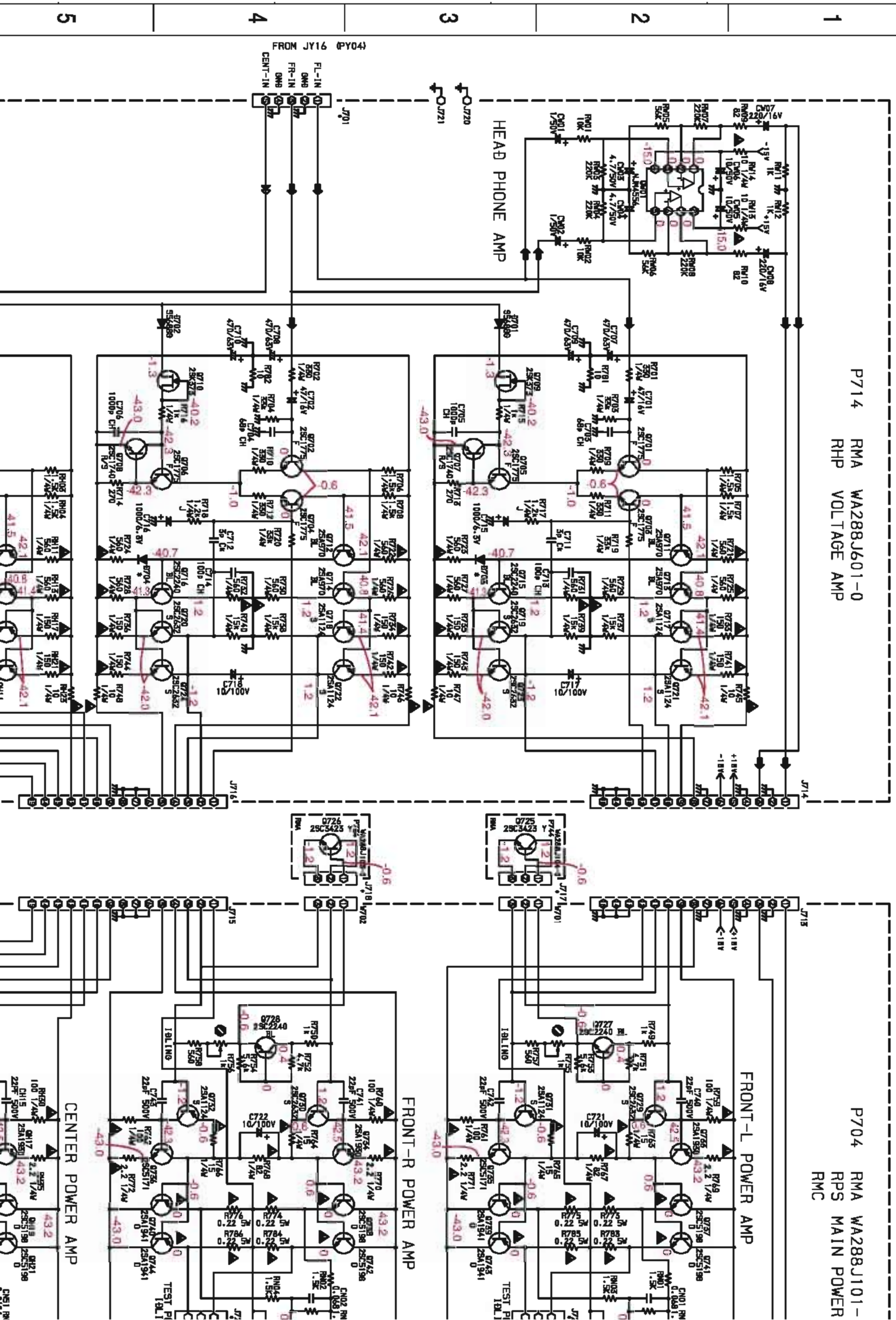

TAGE AMP PCB - P714, MAIN PCB - P704, SURROUND AMP PCB - PP04,
 PEAKER PROTECT PCB - PN54, STANDBY PCB - PB04, POWER SWITCH PCB - PU94)

G

H

J

K

M

704 RMA WA288J101-0
 RPS MAIN POWER AMP / SUPPLY
 RMC

FRONT
 CENTER
 SURROUND

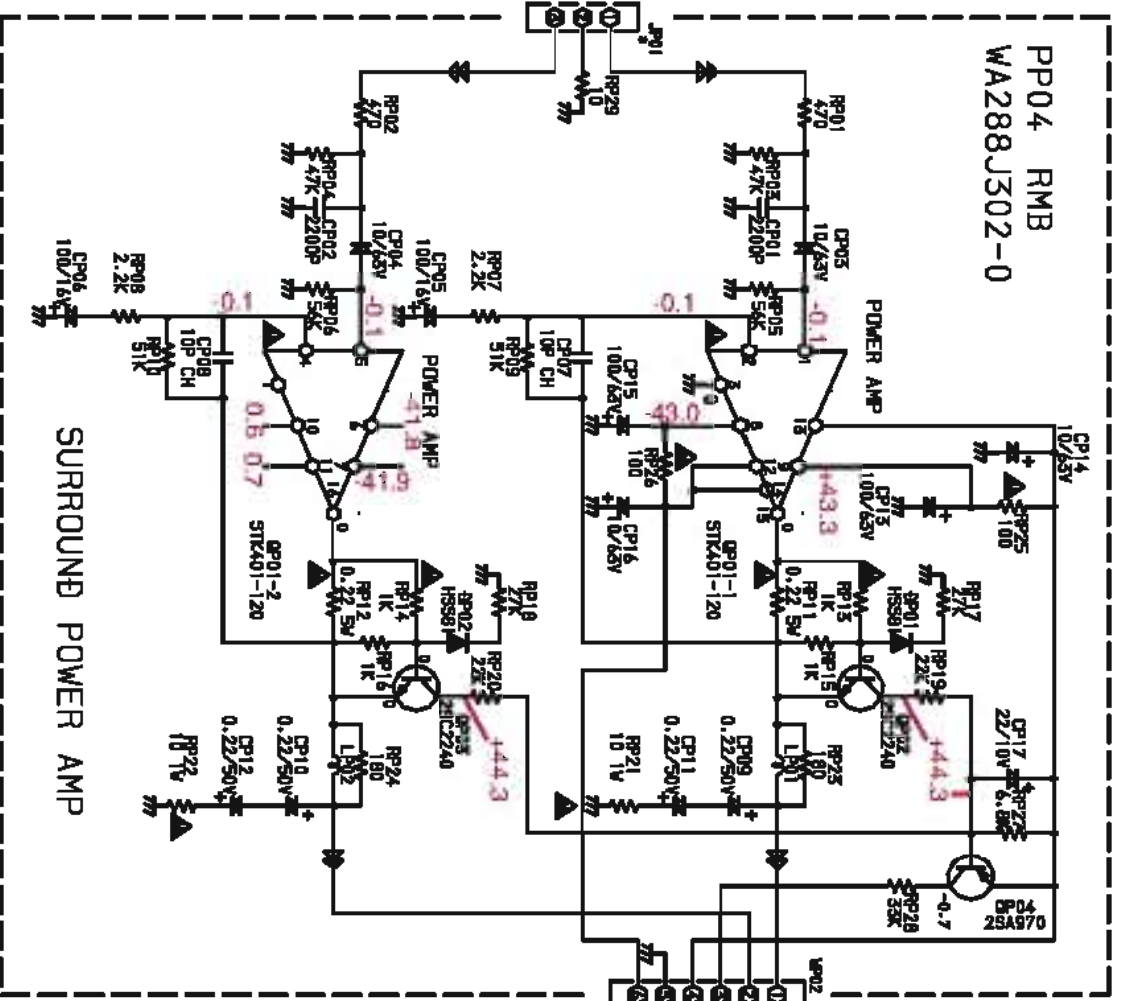
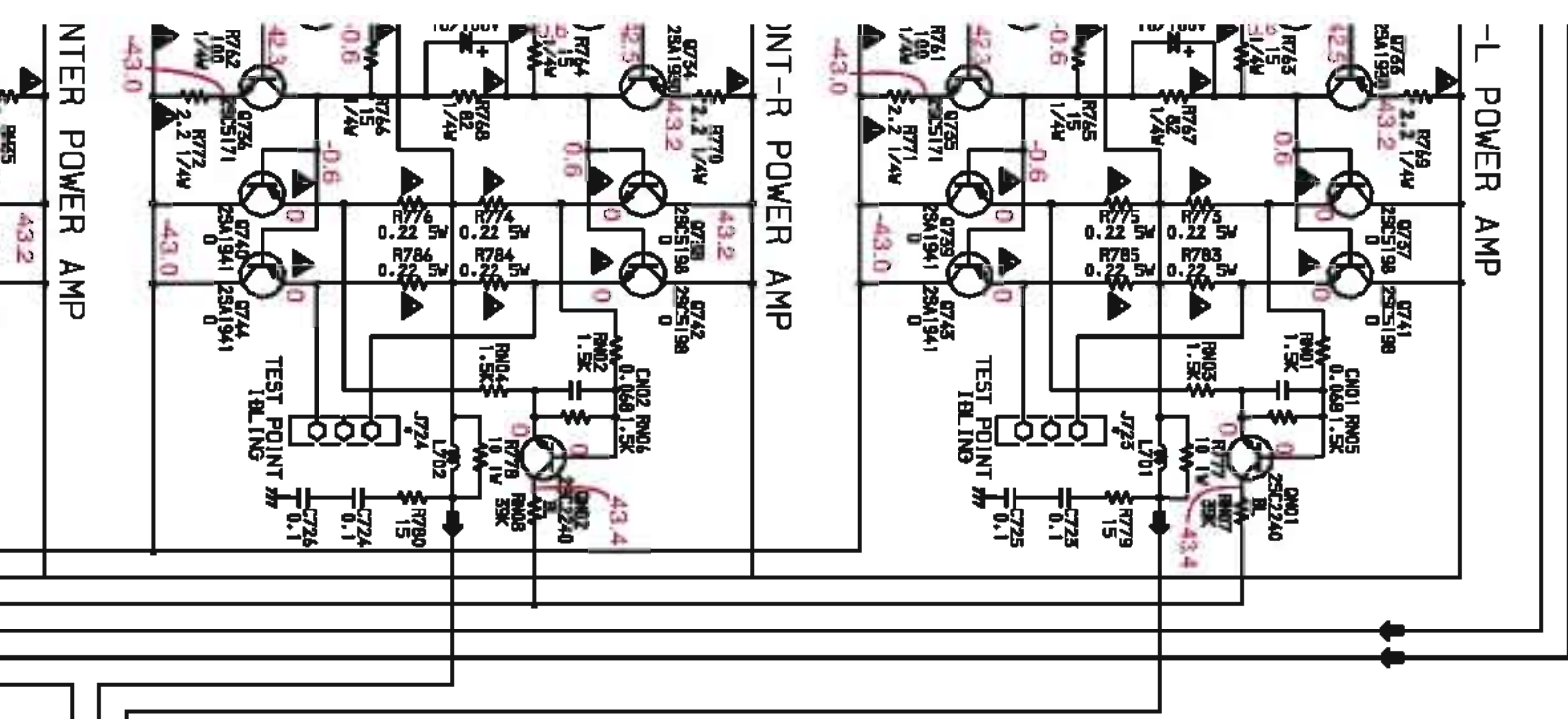

TO J802
 SURR-L
 SURR-R
 PROTCT.
 GND

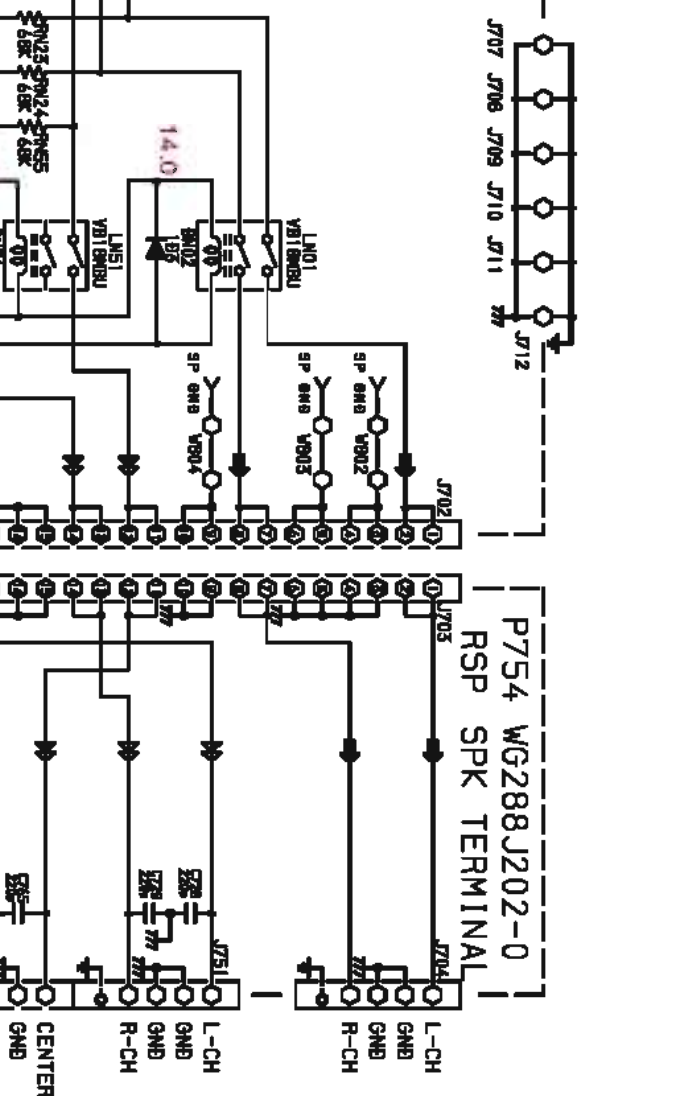

FRONT
 SURROUND

A B C D E F G

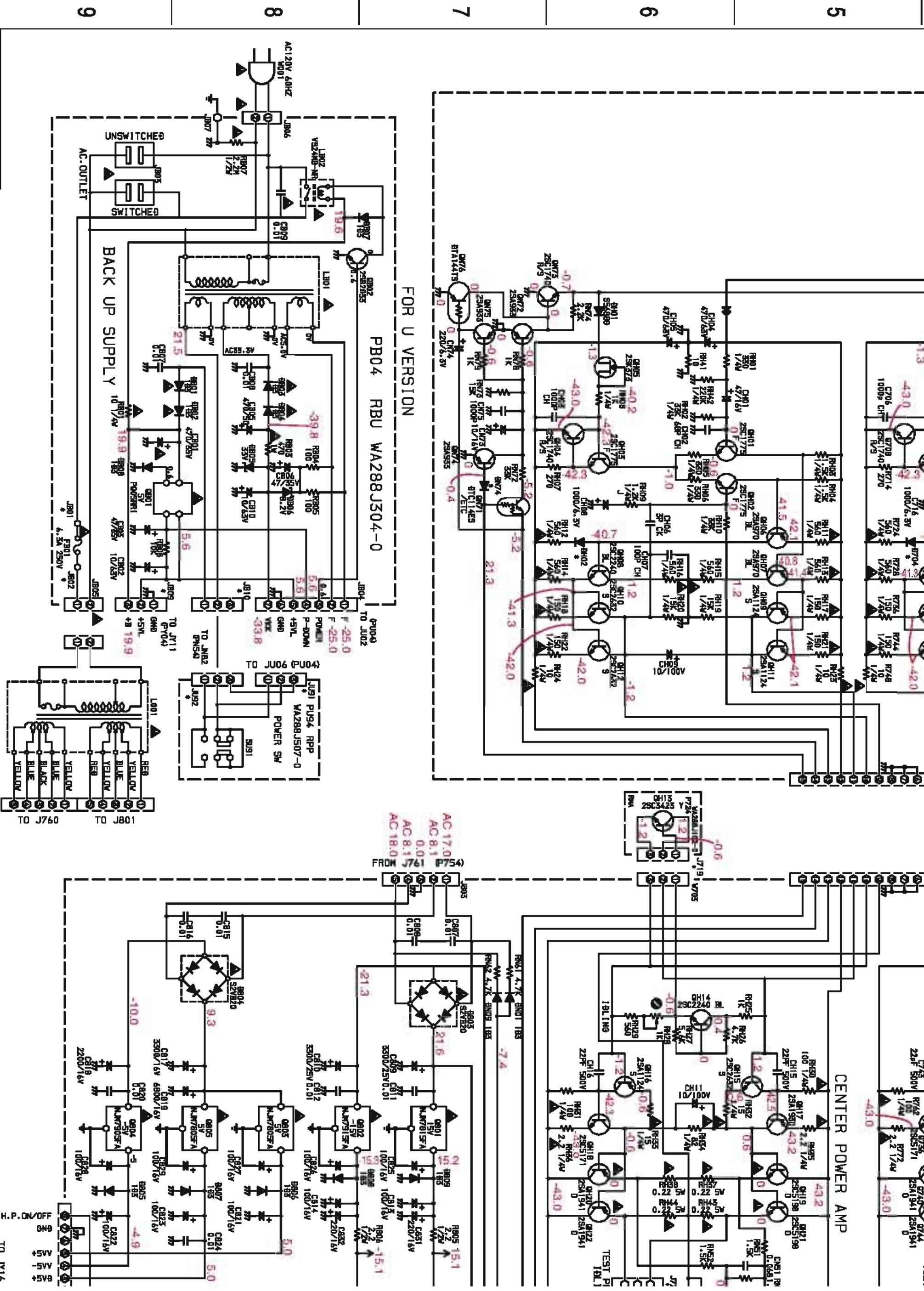

5
6
7
8
9

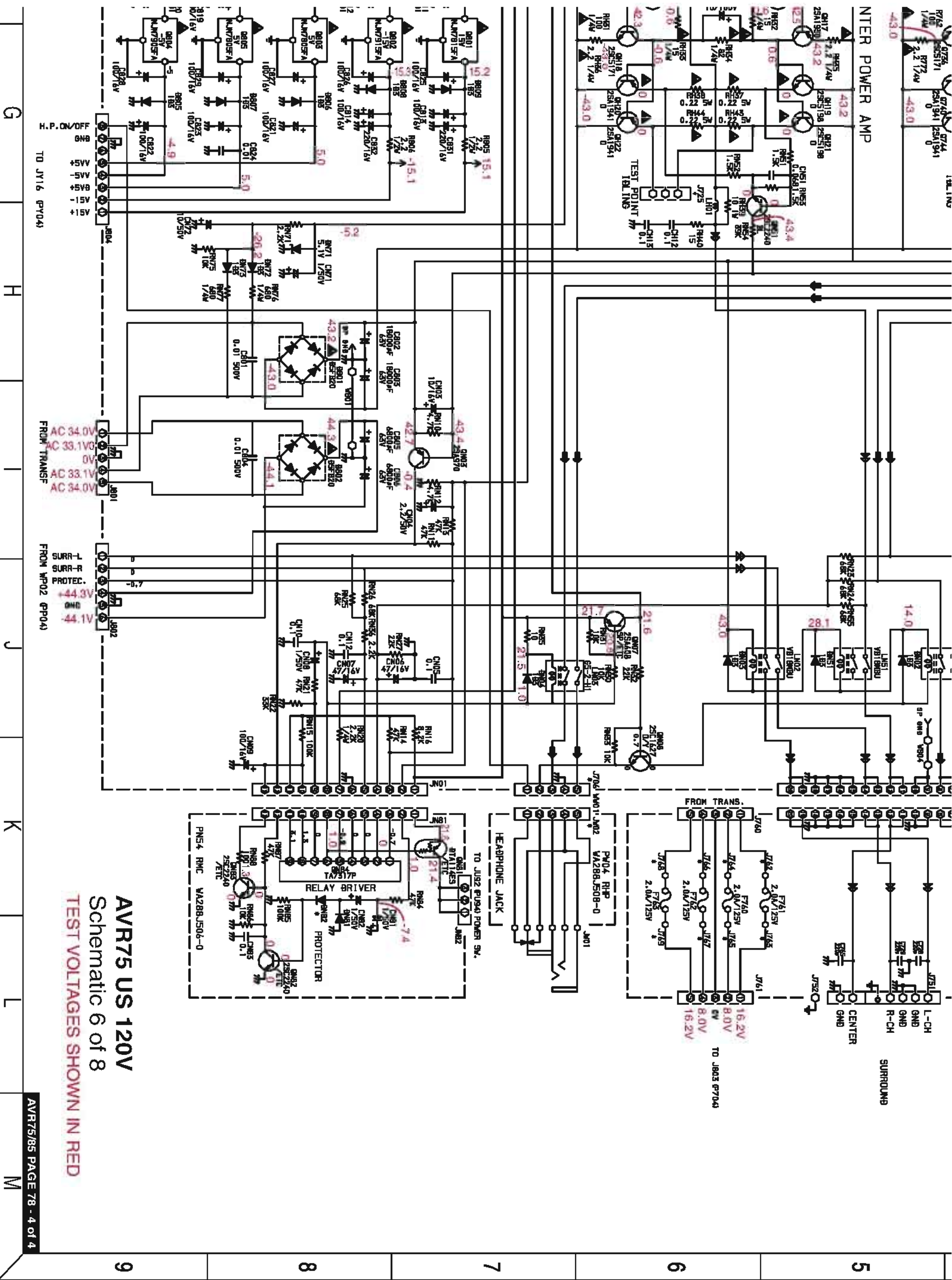

AVR75 US 120V
 Schematic 6 of 8
 TEST VOLTAGES SHOWN IN RED

AVR75 (120V) SCHEMATIC DIAGRAM 7 of 8 (ELECTRONIC VOLUME PCB - PE04)

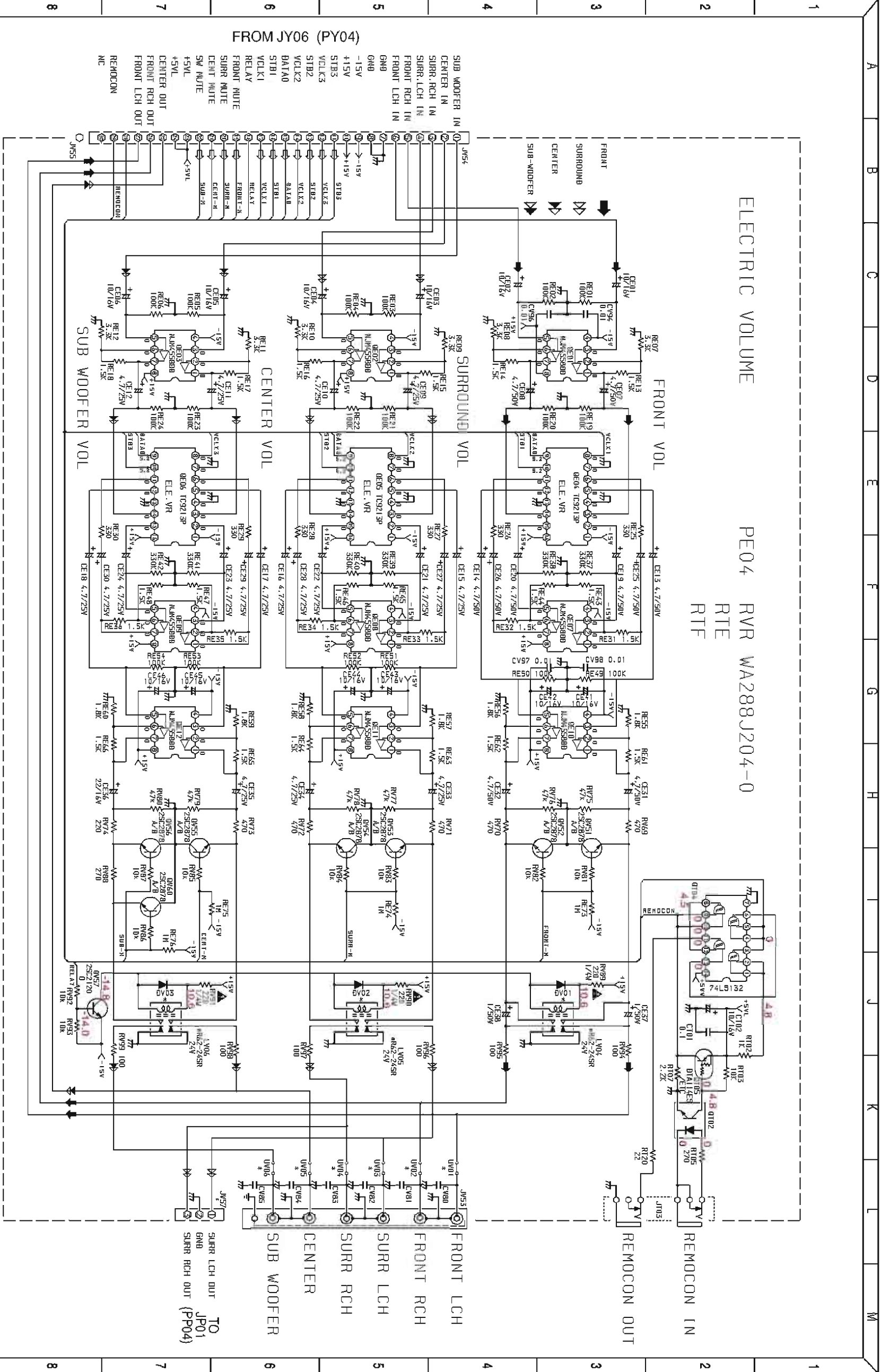

ELECTRIC VOLUME

PE04 RVR WA288J204-0

RTE
RTF

FROM JY06 (PY04)

SUB WOOFER IN
CENTER IN
SURR. RCH IN
SURR. LCH IN
FRONT RCH IN
FRONT LCH IN
GND
-15V
+15V
S1B3
VCLK3
S1B2
VCLK2
BATA0
S1B1
VCLK1
RELAY
FRONT MUTE
SURR MUTE
CENT MUTE
SM MUTE
+5VL
FRONT RCH OUT
FRONT LCH OUT
REMOCON
NC

SUB WOOFER

CENTER

SURROUND

FRONT

VOL

VOL

VOL

VOL

SUB WOOFER

CENTER

SURROUND

FRONT

VOL

VOL

VOL

VOL

SUB WOOFER

CENTER

SURROUND

FRONT

VOL

VOL

VOL

VOL

AVR75 US 120V
Schematic 7 of 8
TEST VOLTAGES SHOWN IN RED

AVR75 (120V) SCHEMATIC DIAGRAM 7 of 8 (ELECTRONIC VO...

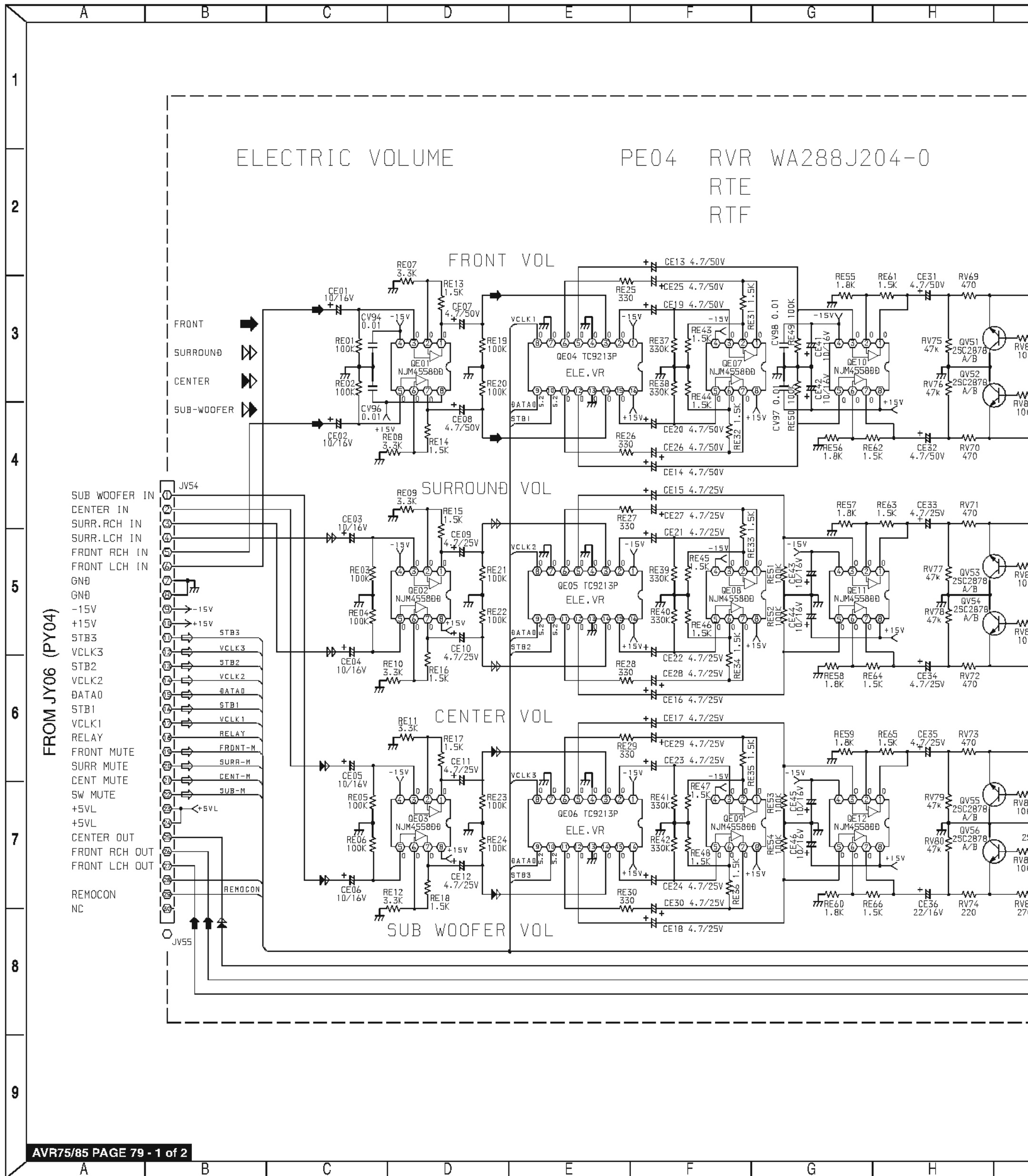

SCHEMATIC DIAGRAM 7 of 8 (ELECTRONIC VOLUME PCB - PE04)

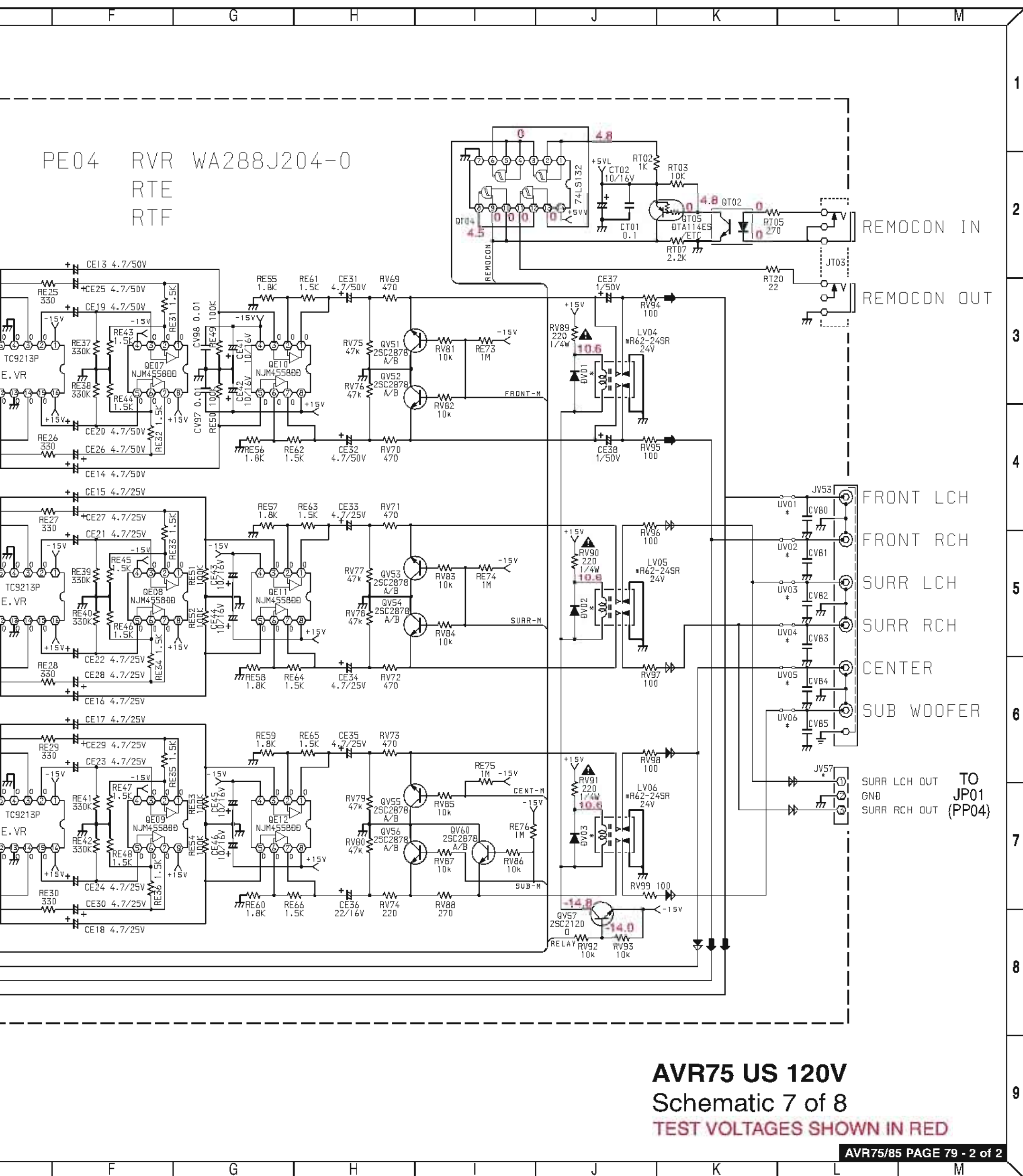

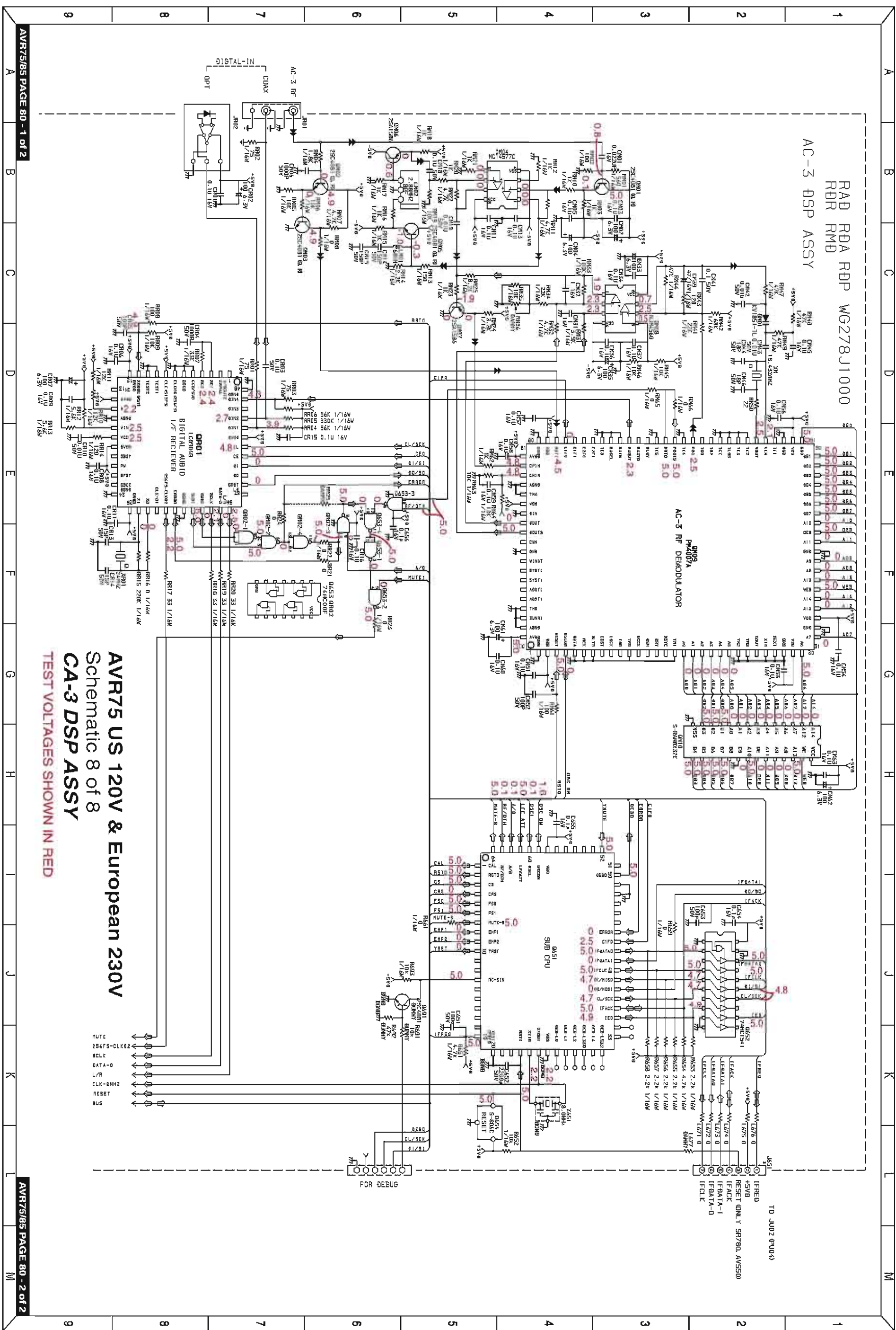

AVR75 US 120V & European 230V
Schematic 8 of 8
CA-3 DSP ASSY
TEST VOLTAGES SHOWN IN RED

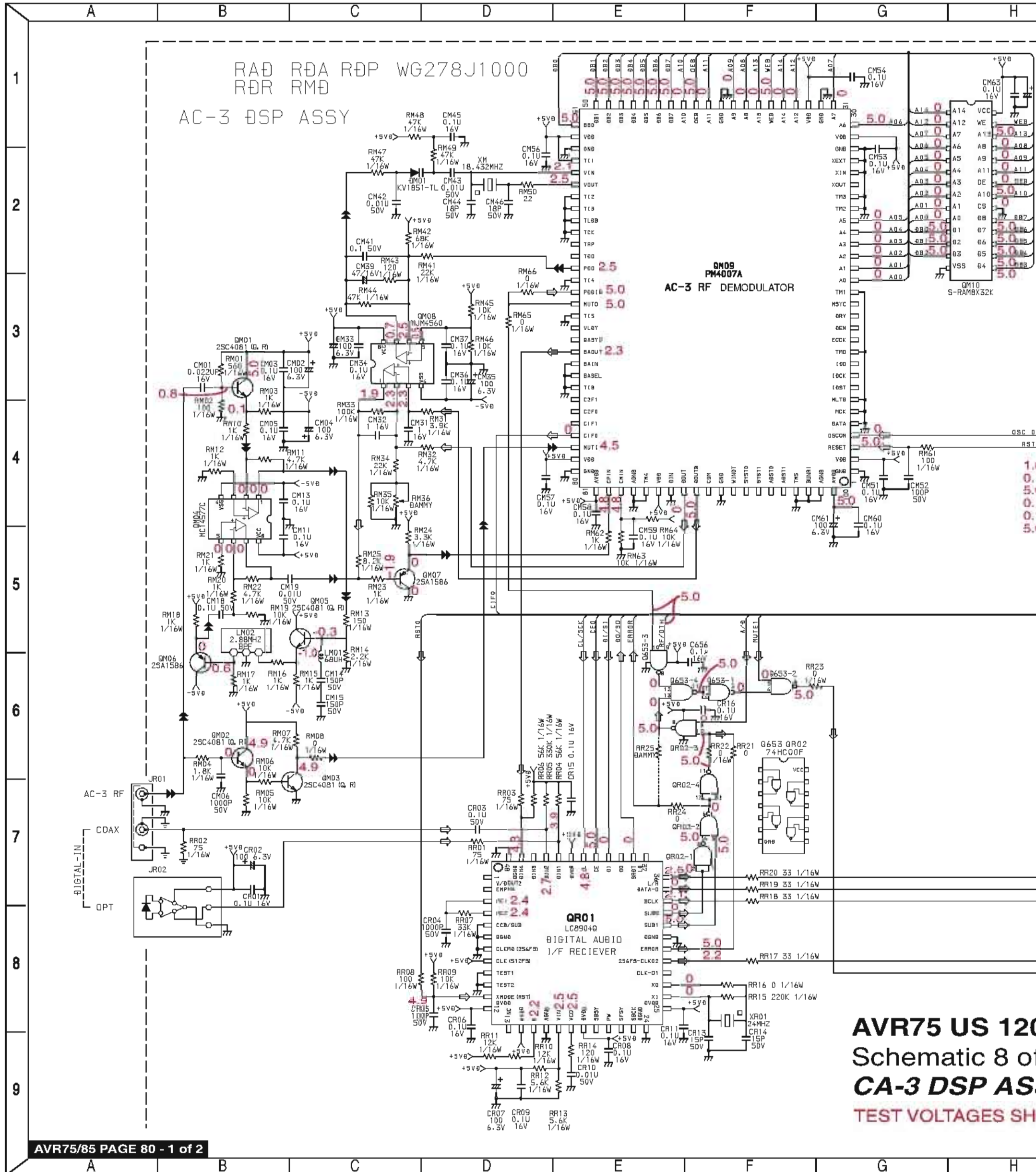

AVR75 US 120
Schematic 8 of 8
CA-3 DSP AS
TEST VOLTAGES SH

SCHEMATIC DIAGRAM 8 of 8 (AC-3/DSP PCB - P604)

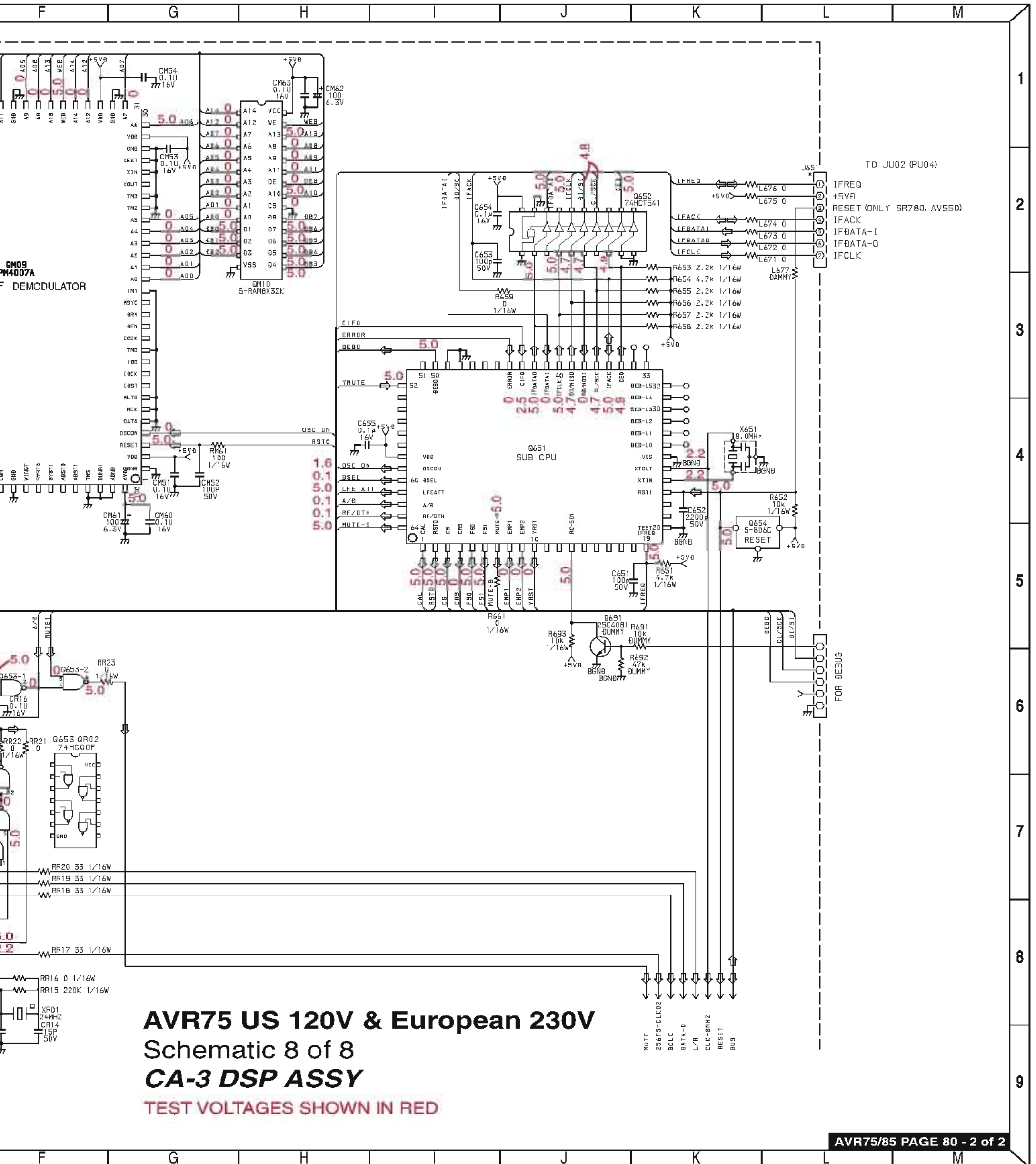

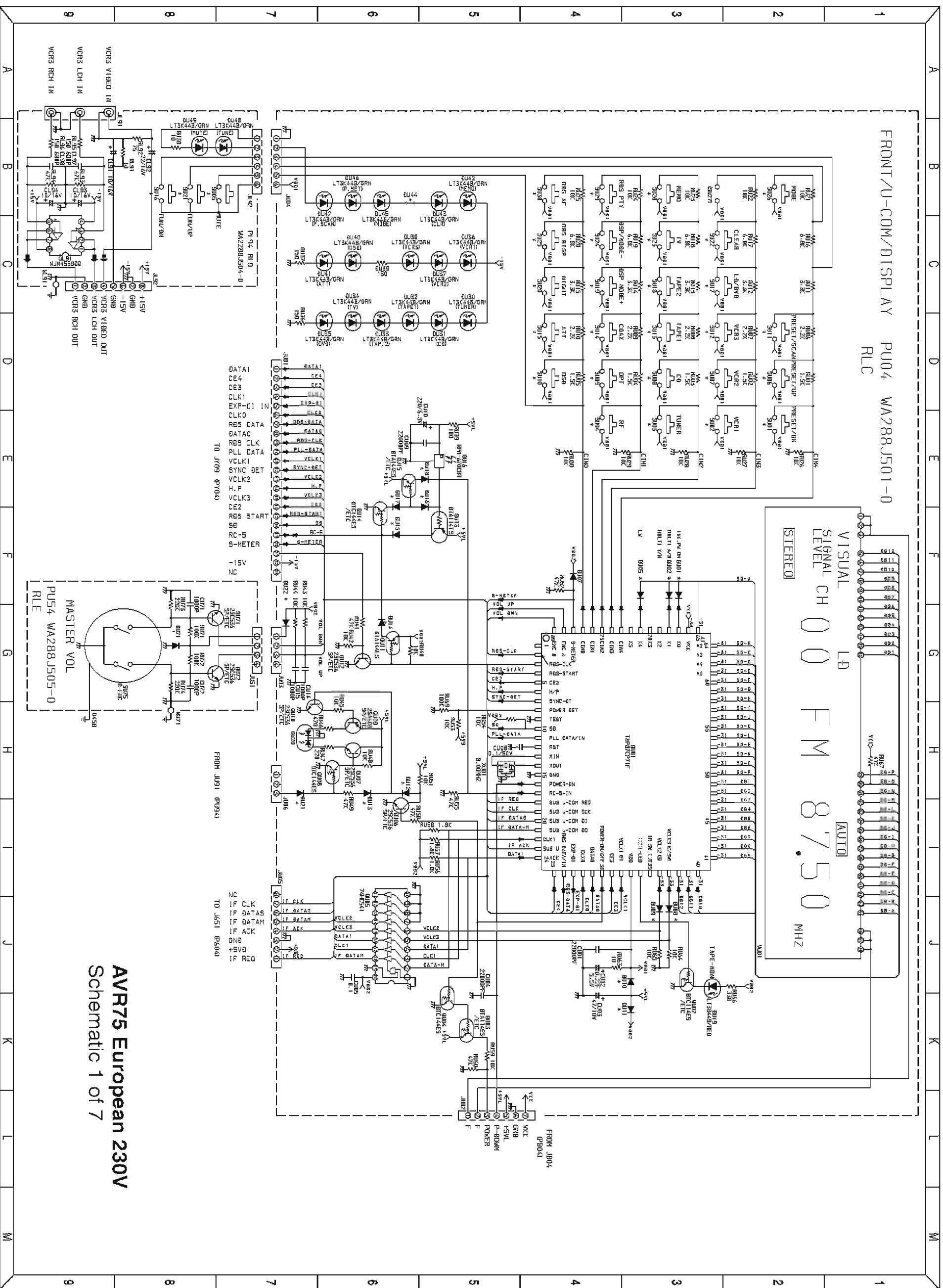

AVR75 (230V) SCHEMATIC DIAGRAM 1 of 7 (FRONT PCB - PU04, MASTER VOL)

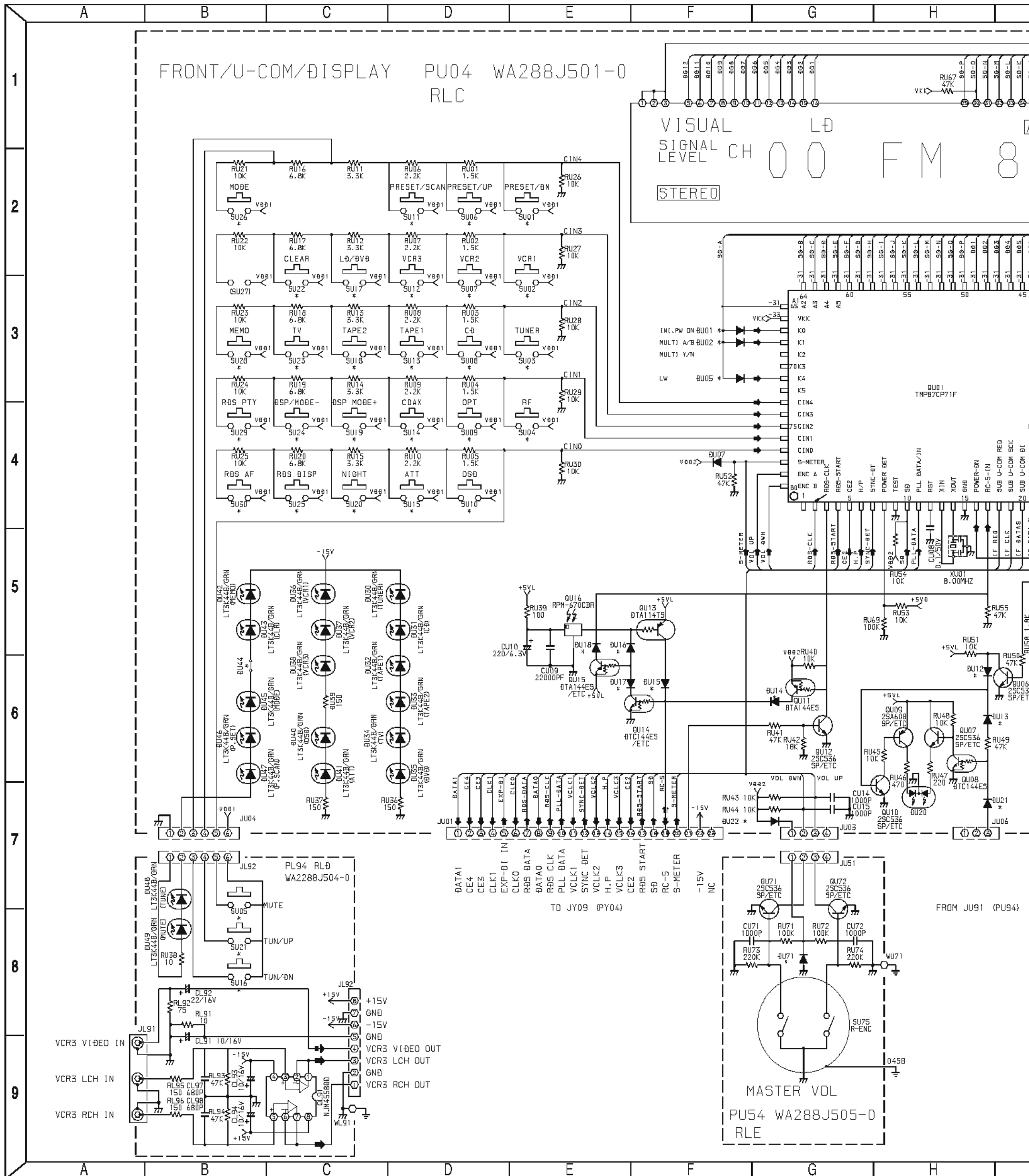

1 of 7 (FRONT PCB - PU04, MASTER VOLUME PCB - PU54, AUX IN - PL94)

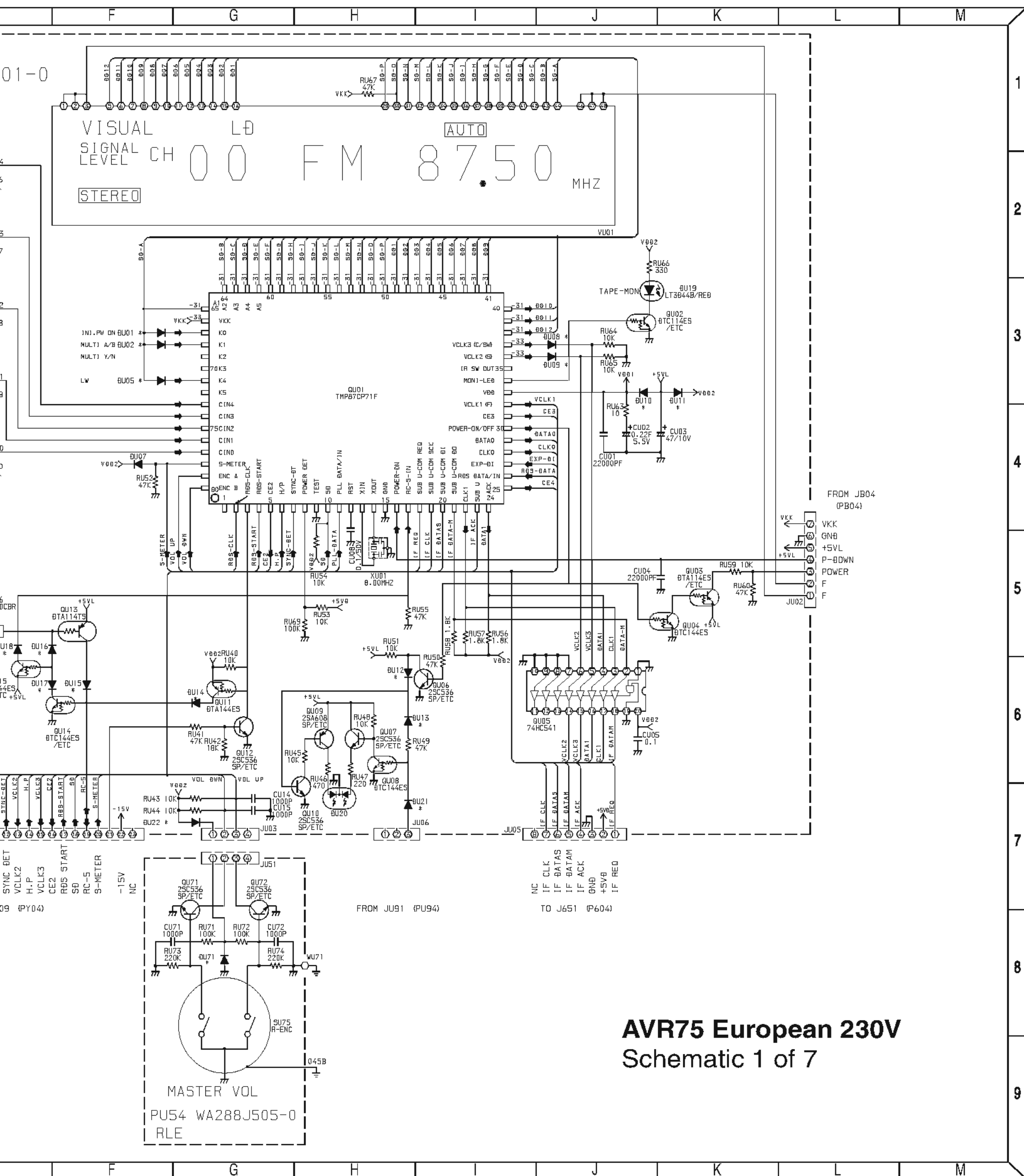

AVR75 European 230V
Schematic 1 of 7

AVR75 (230V) SCHEMATIC DIAGRAM 2 of 7 (TUNER PCB - P104)

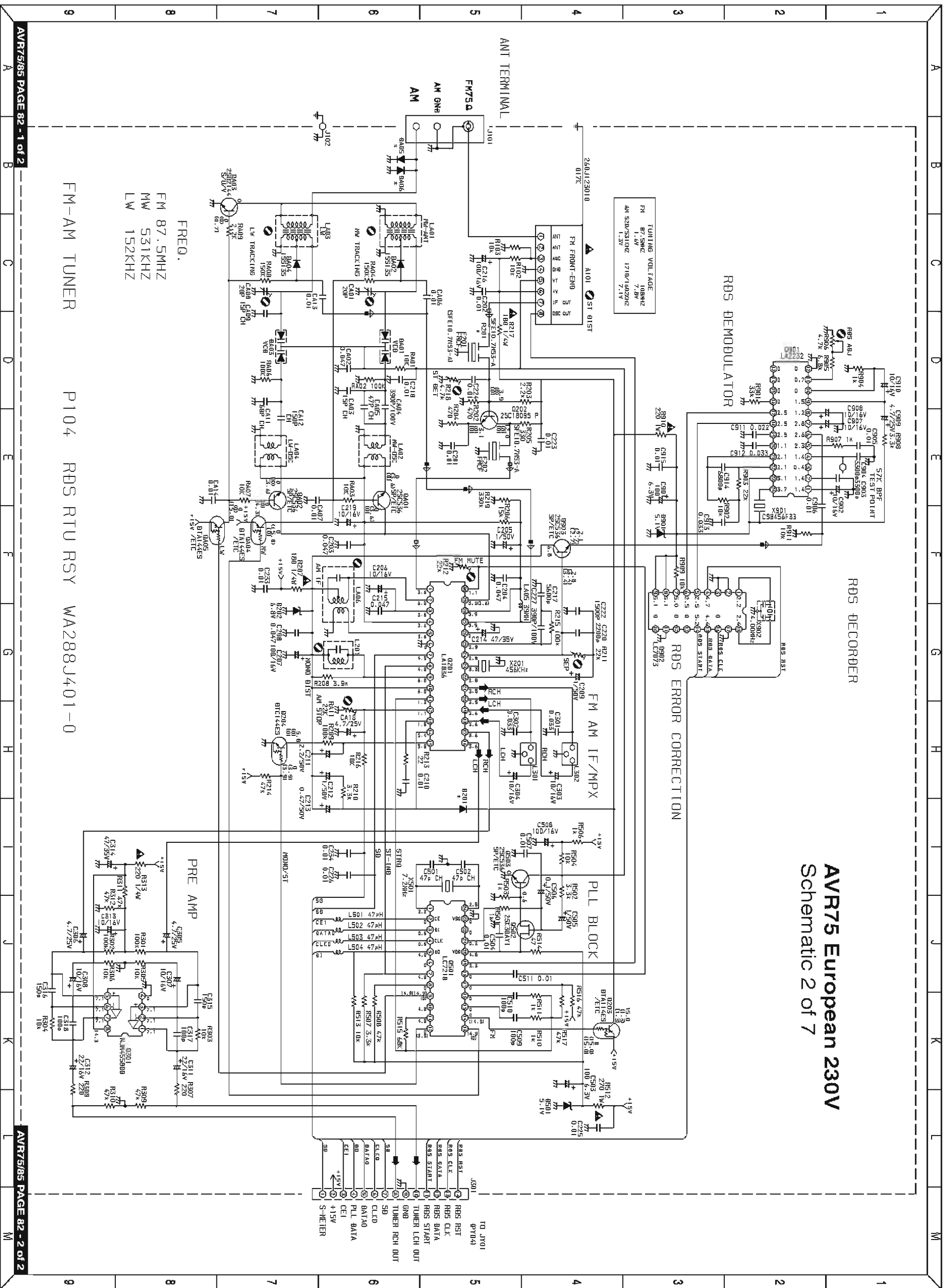

AVR75 European 230V
Schematic 2 of 7

AVR75 (230V) SCHEMATIC DIAGRAM 2 of 7 (TUNER P

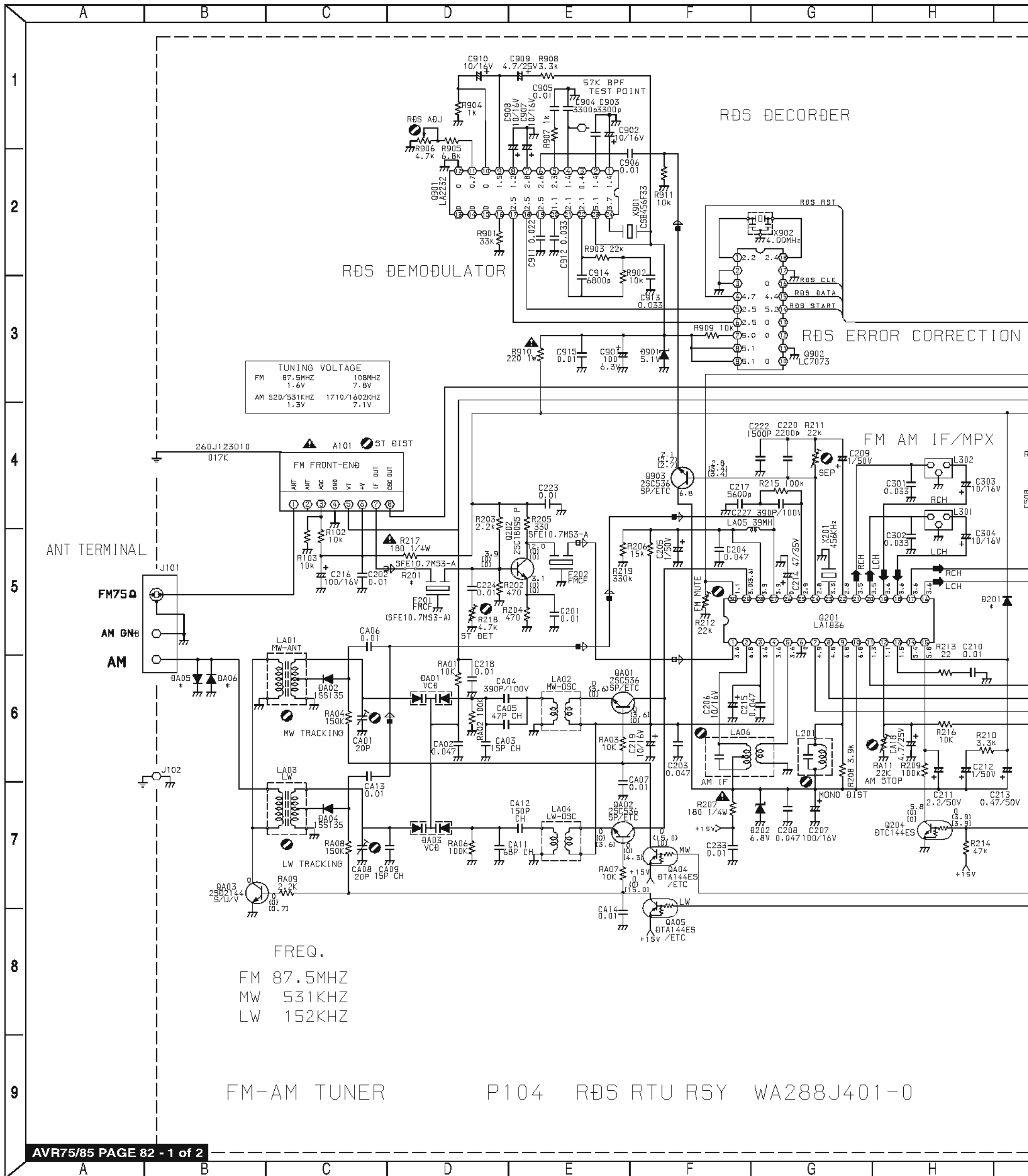

AVR75/85 SCHEMATIC DIAGRAM 2 of 7 (TUNER PCB - P104)

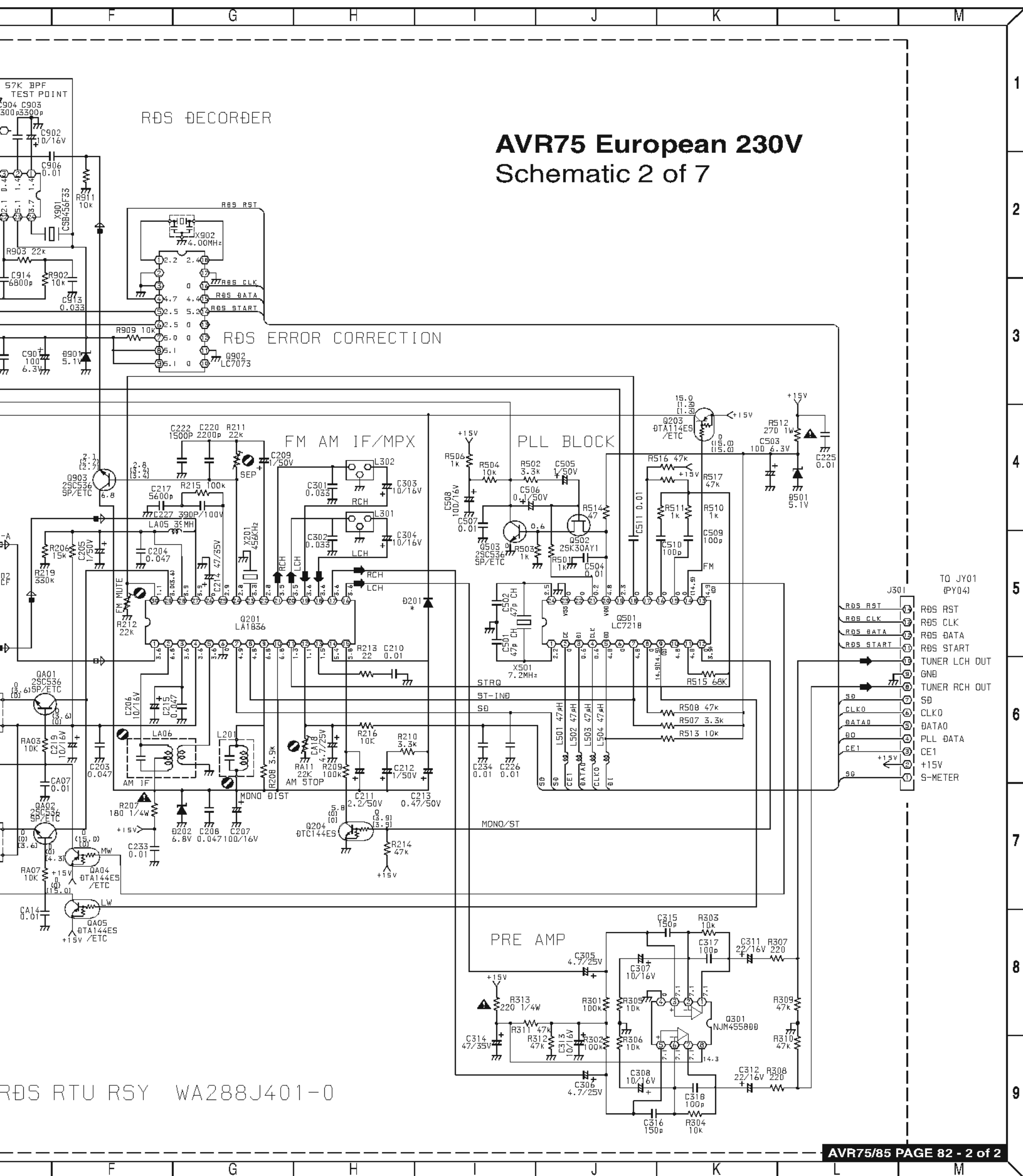

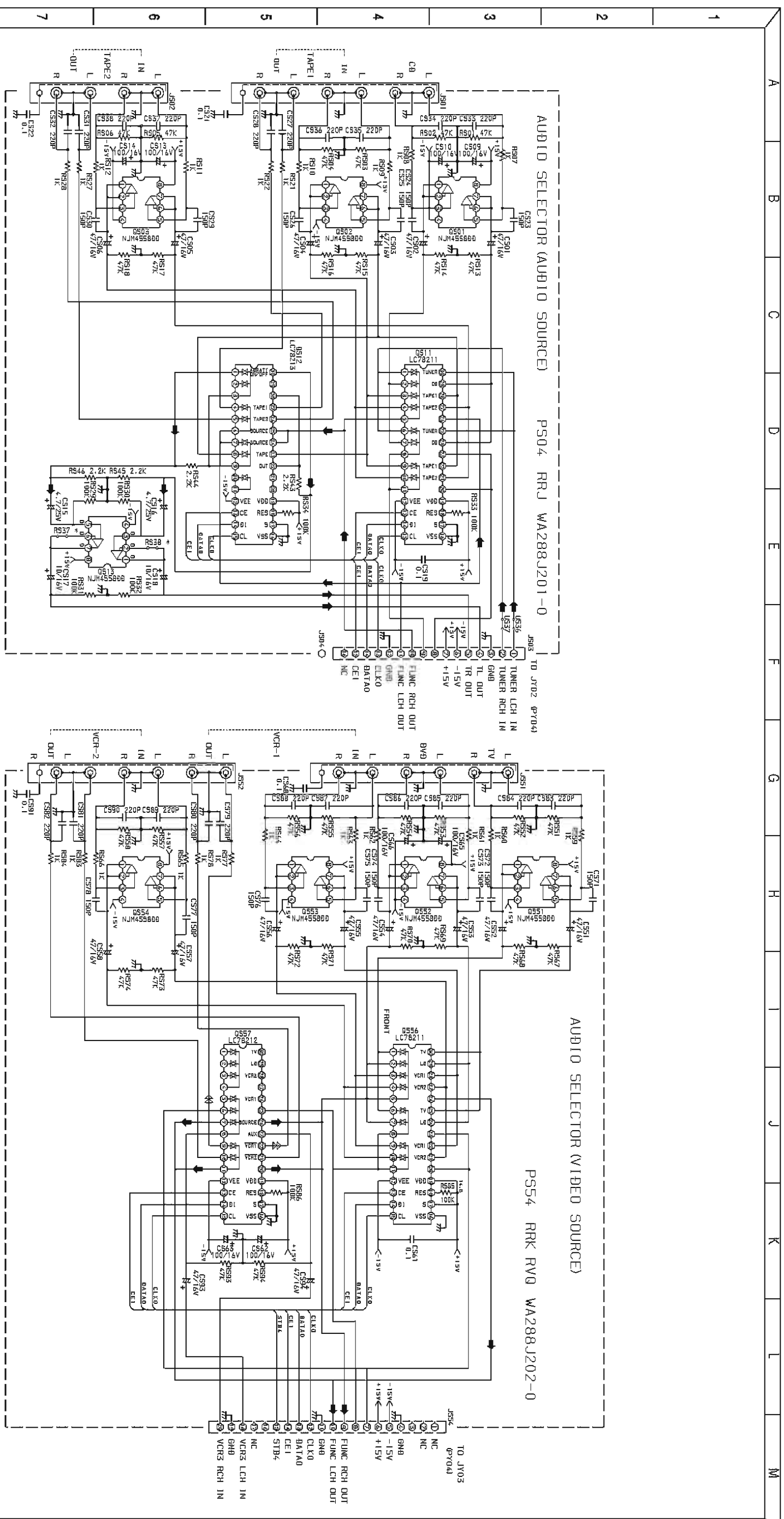

AVR75 European 230V
Schematic 3 of 7

AVR75 (230V) SCHEMATIC DIAGRAM 3 of 7 (AUDIO SELECTOR PC

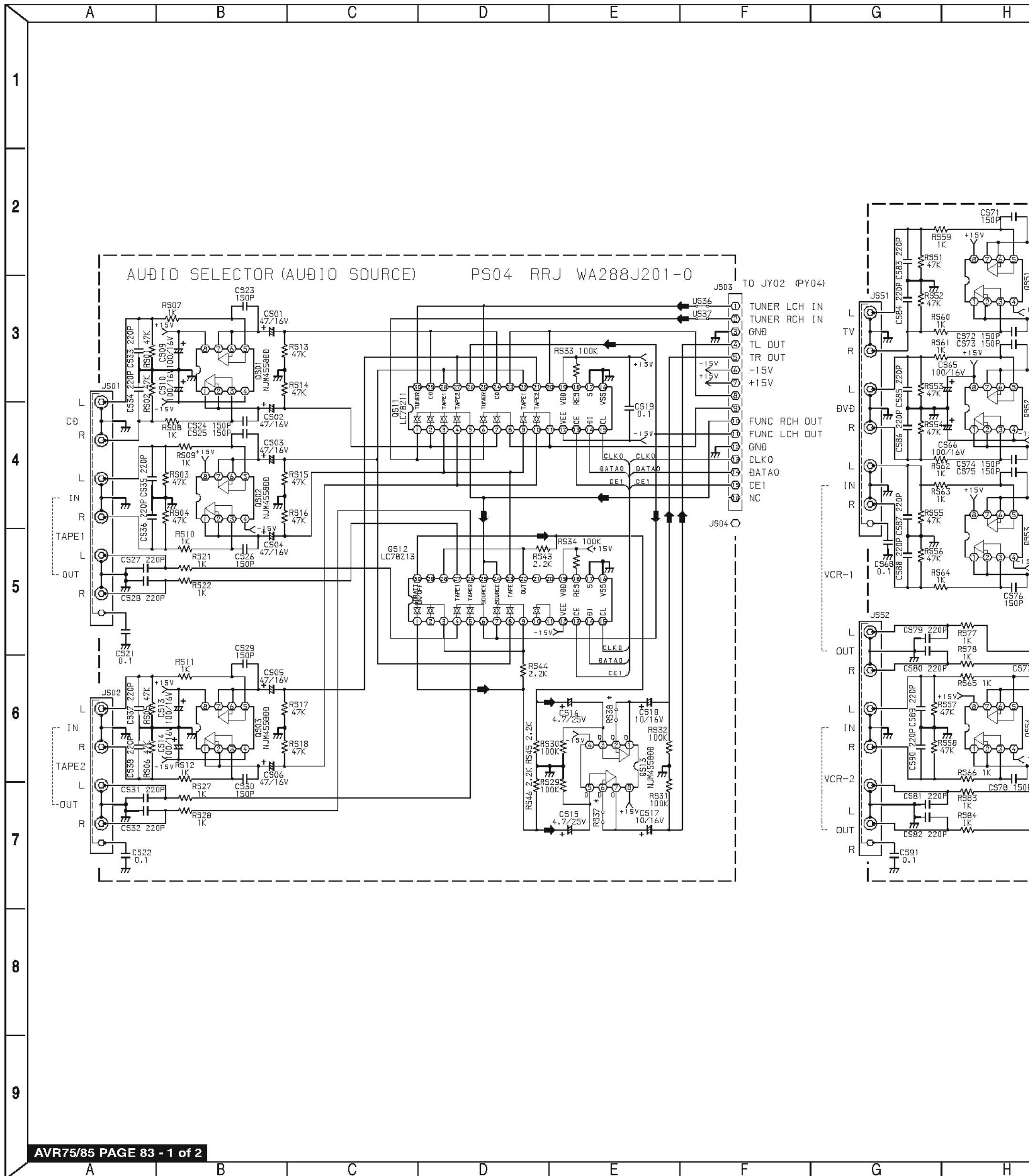

Schematic 3 of 7 (AUDIO SELECTOR PCB - PS04, AUDIO/VIDEO PCB - PS54)

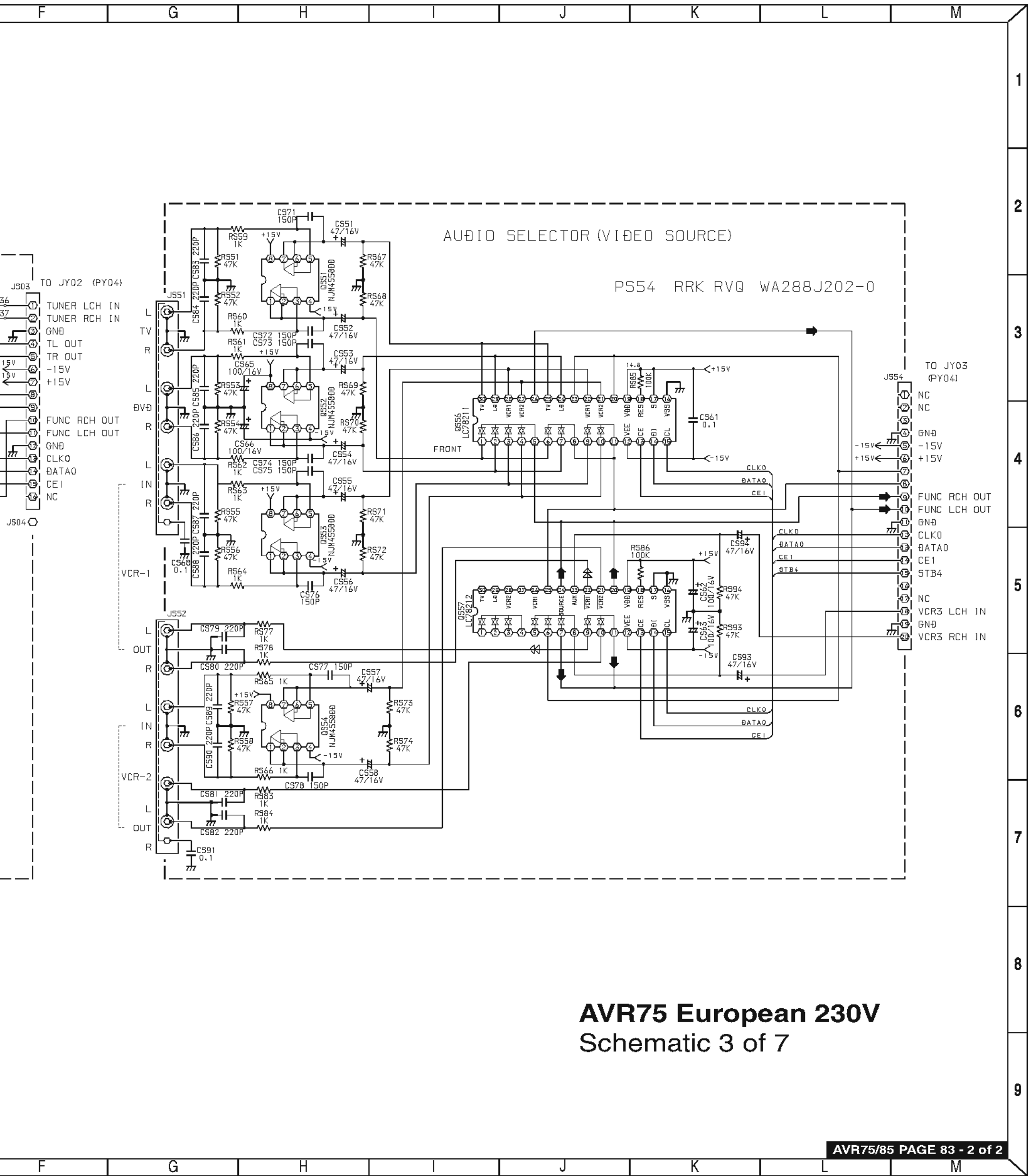

AVR75 European 230V Schematic 3 of 7

AVR75/85 PAGE 84 - 1 of 4

AVR75 European 230V
Schematic 4 of 7

CROSSOVER
PC04 RCR WA288J203-0

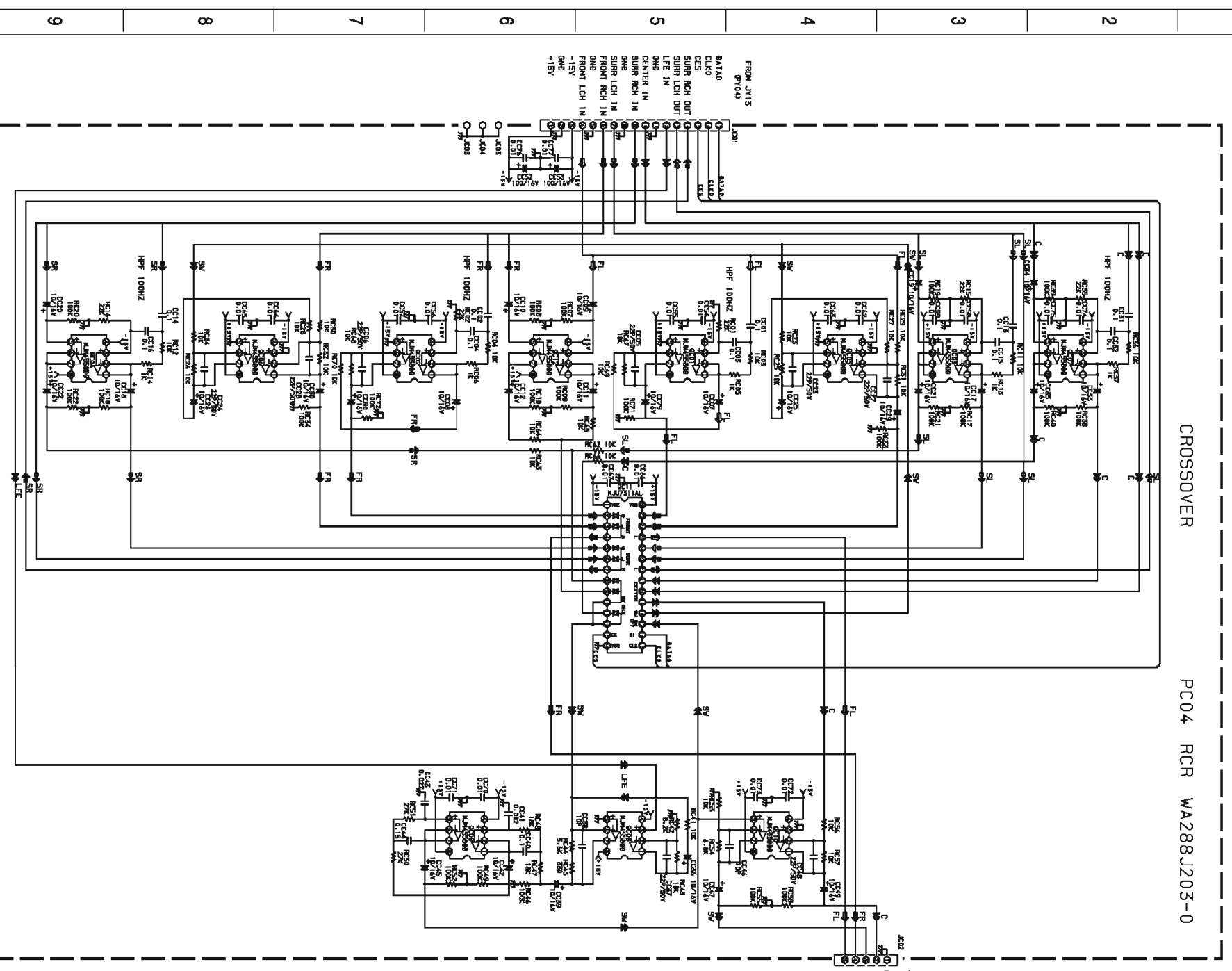

AVR75/85 PAGE 84 - 2 of 4

PF04 RTD WA288J503-0

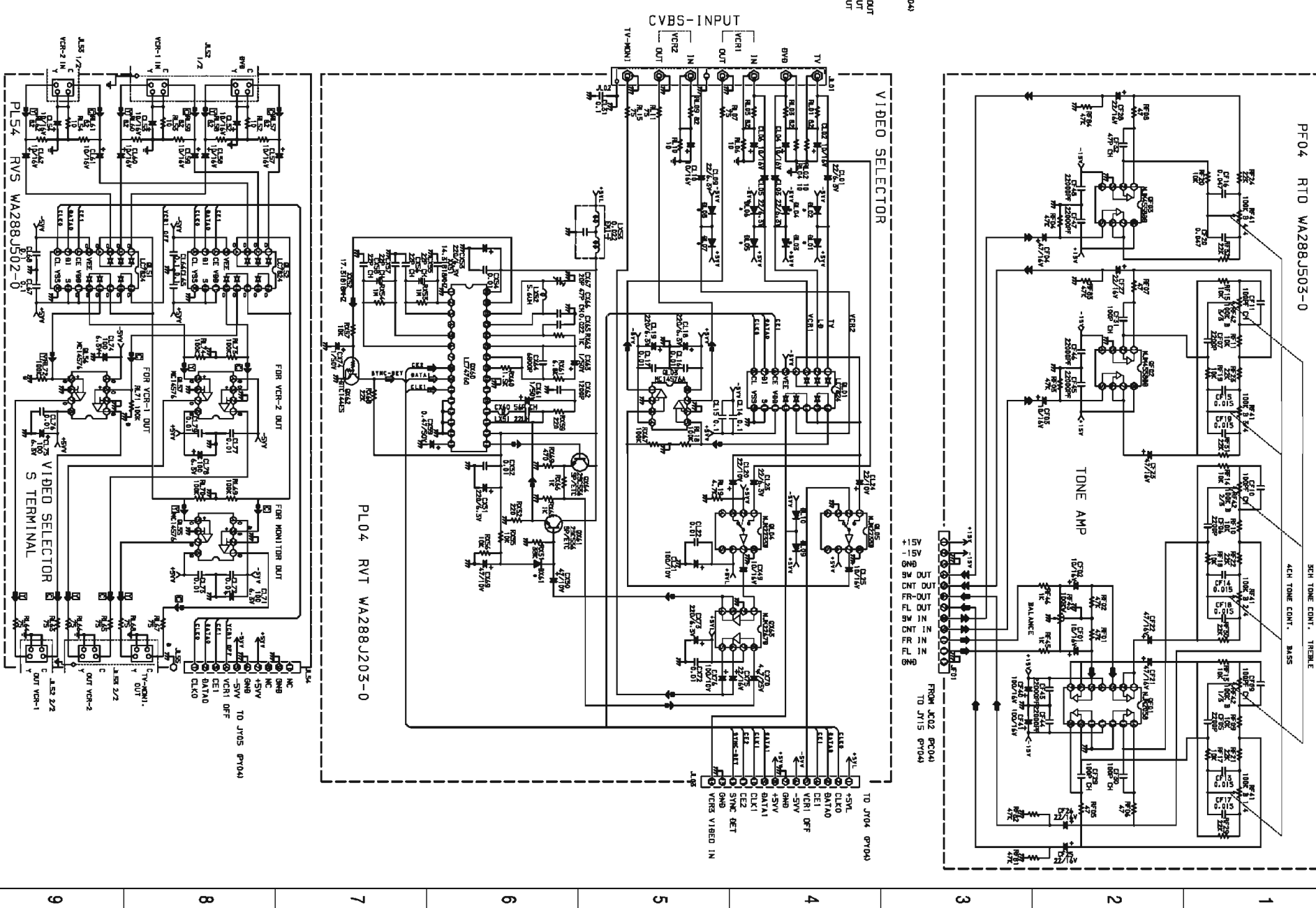

AVR75/85 PAGE 84 - 3 of 4

PL04 RVT WA288J203-0

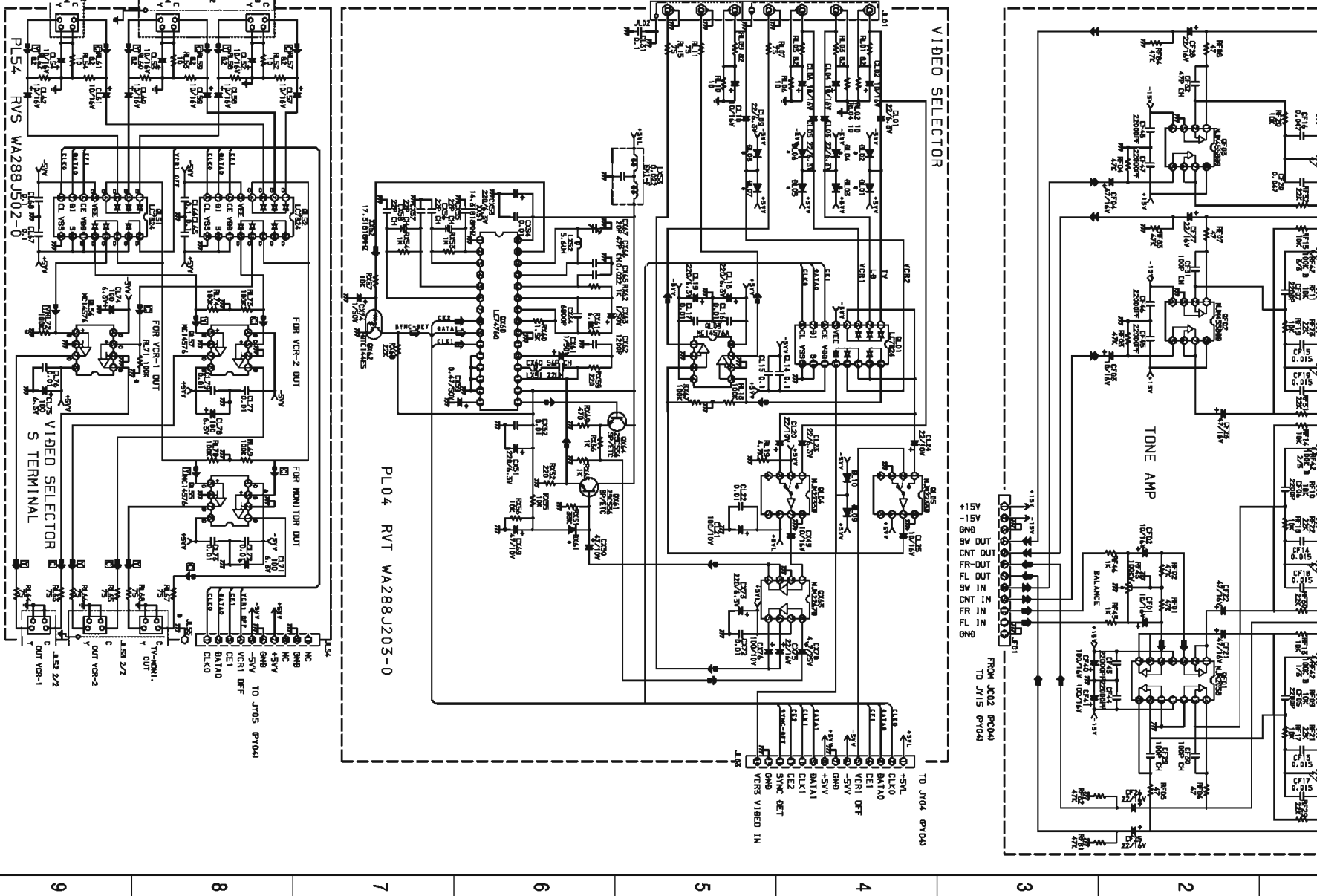

AVR75 (230V) SCHEMATIC DIAGRAM 4 of 7 (AC-3 CROSSOVER PCB - PC04, TONE CONT

AVR75/85 PAGE 84 - 1 of 4

AVR75 European 230V
Schematic 4 of 7

CROSSOVER

PC04 RCR WA288J203-0

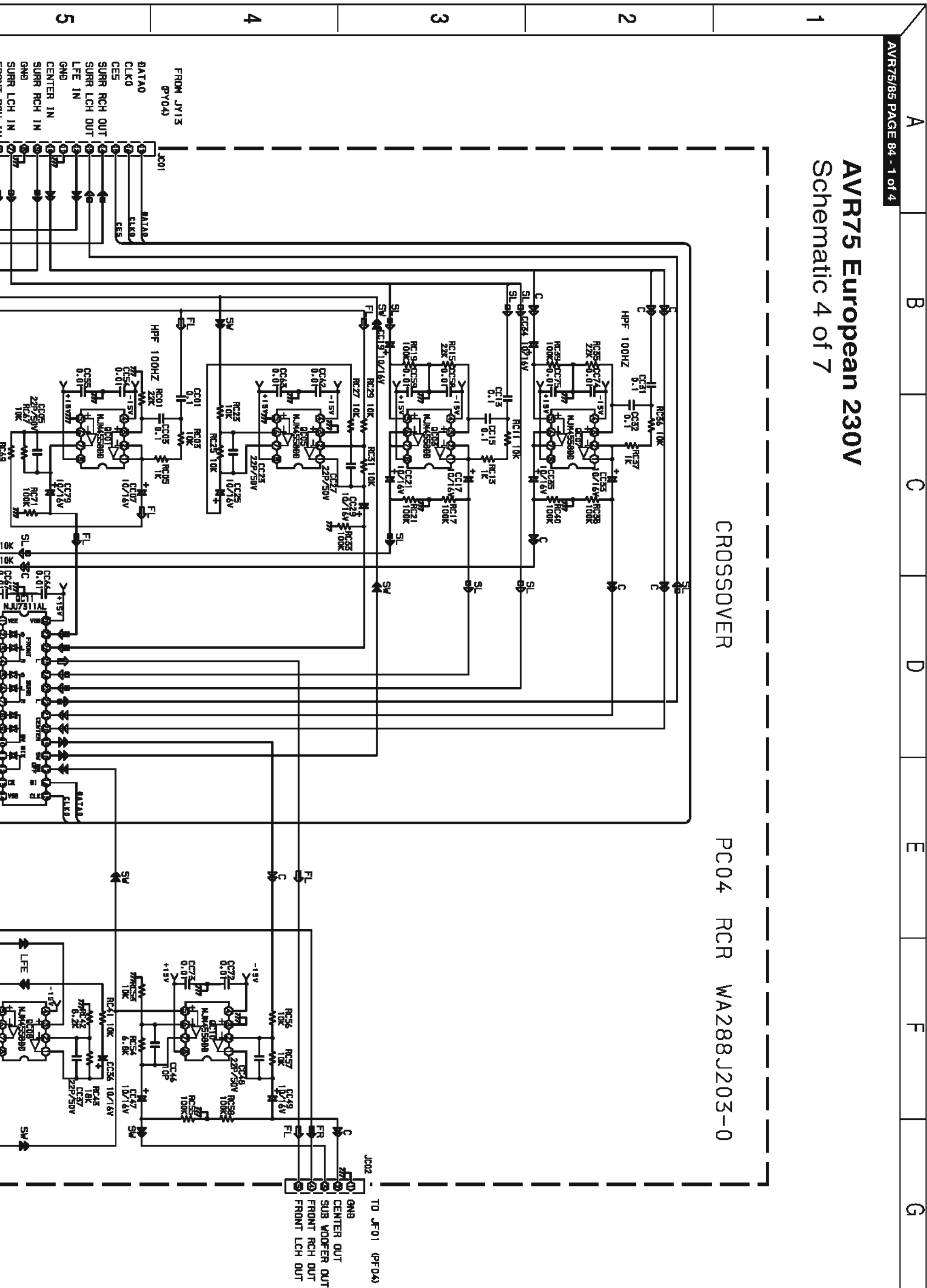

PC04, TONE CONTROL PCB - PF04, VIDEO SELECTOR PCB - PL04, S-VIDEO PCB - PL54)

G H J K L M

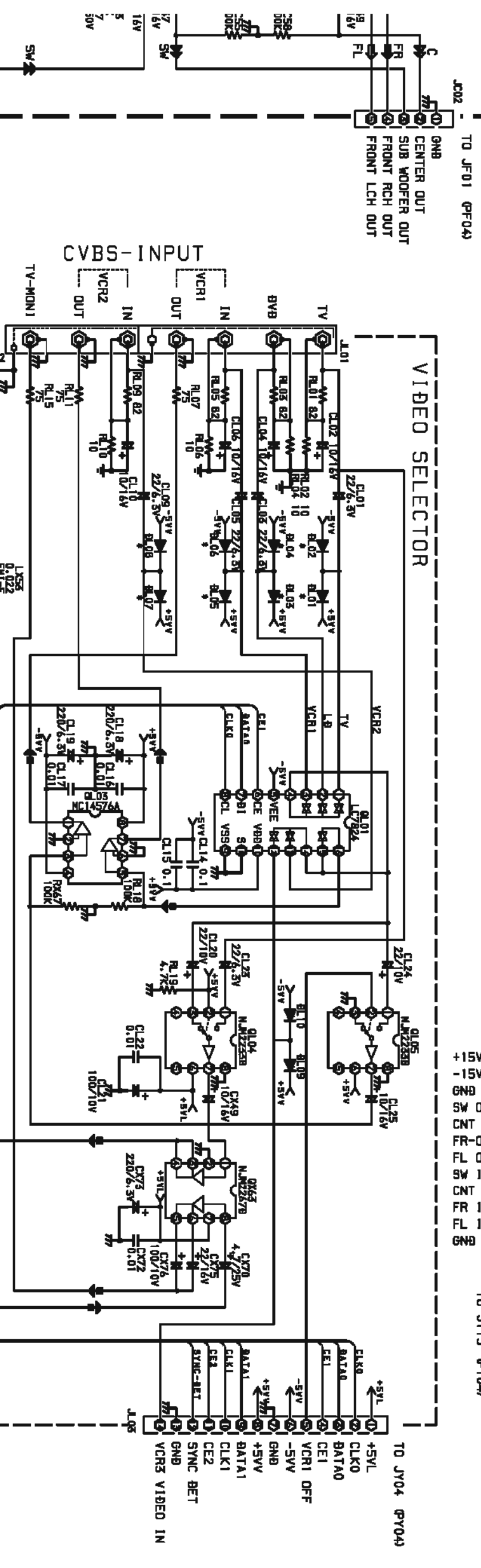
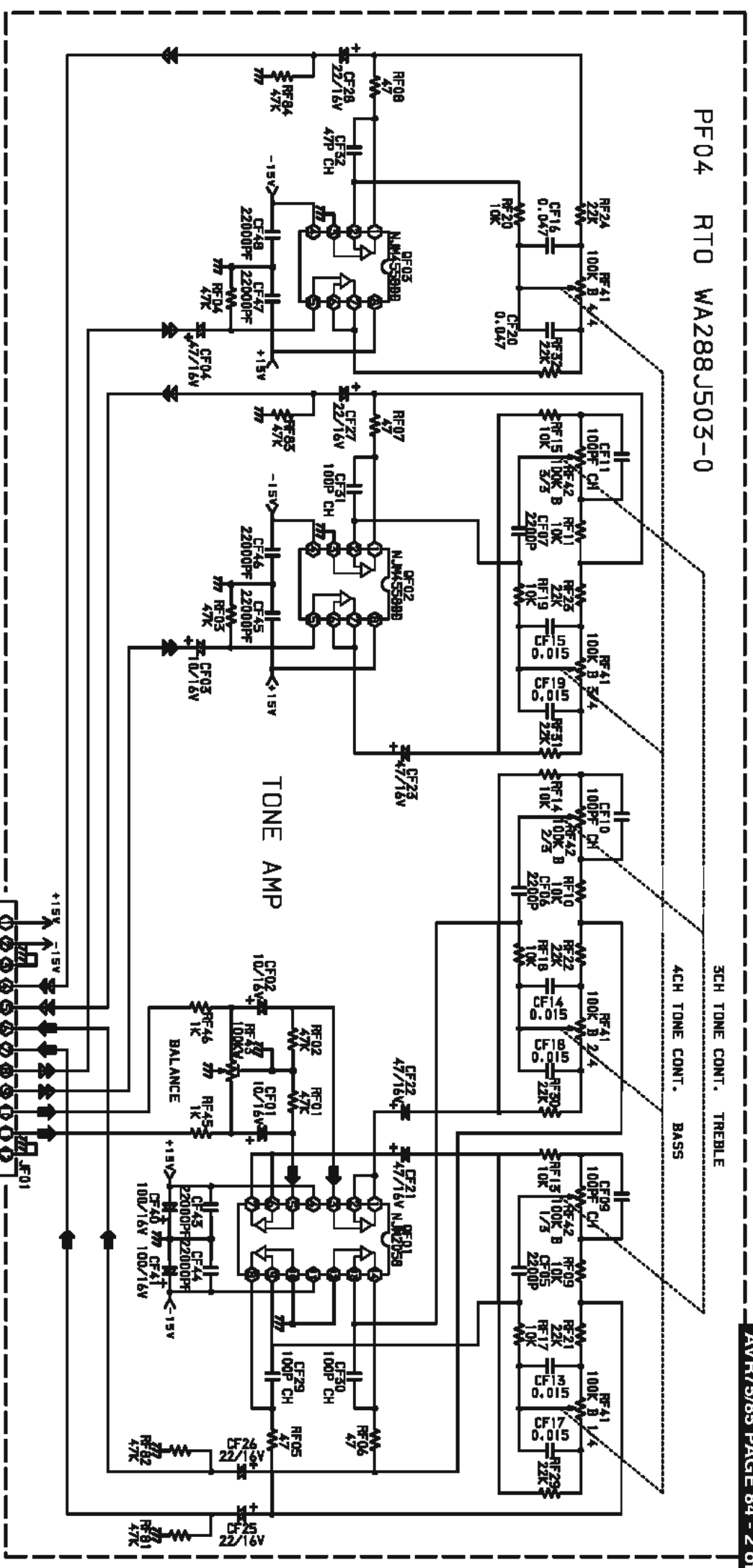

1 2 3 4 5

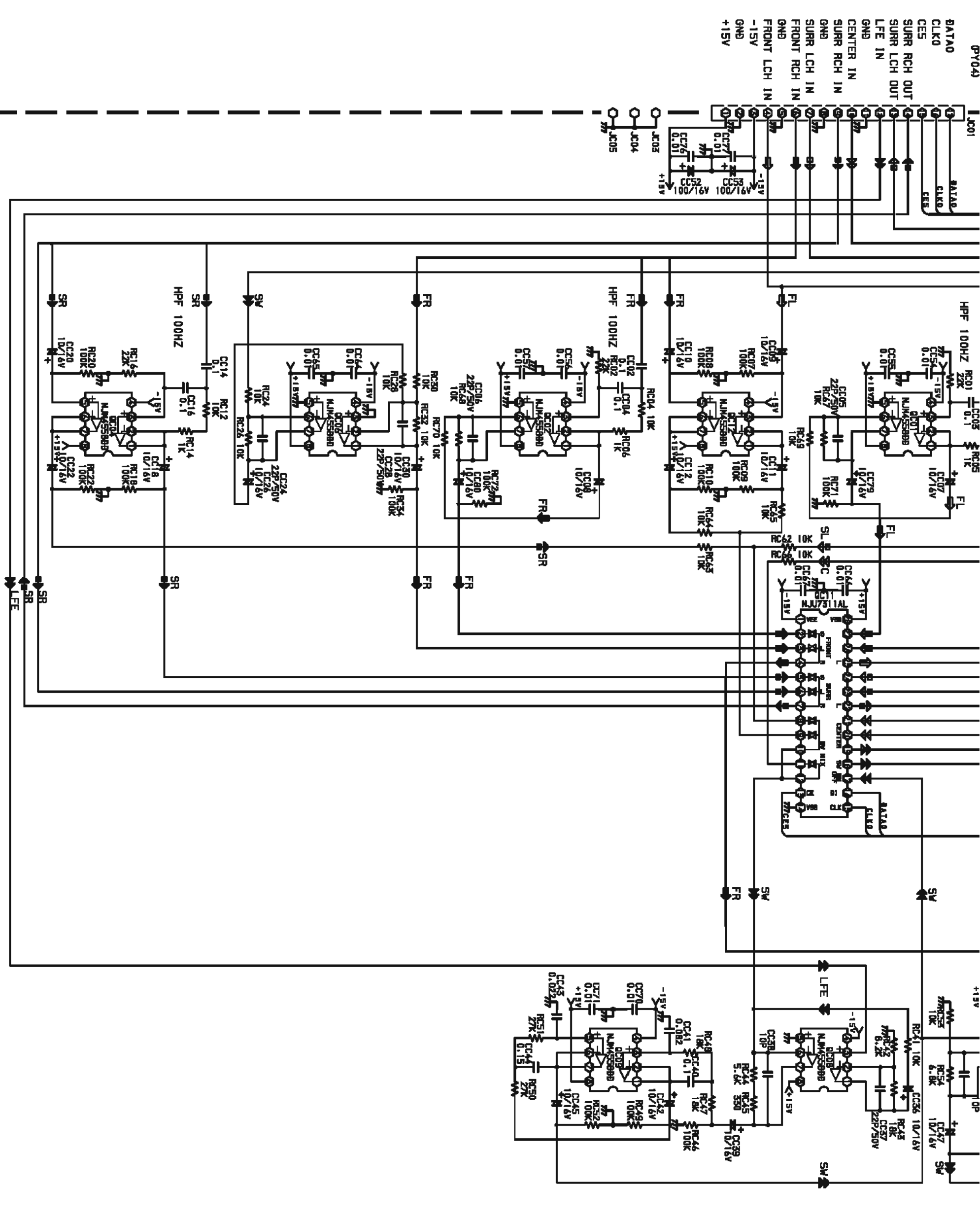

- BATAO
- CLKO
- CE5
- SURR RCH OUT
- SURR LCH OUT
- LFE IN
- GND
- CENTER IN
- SURR RCH IN
- GND
- SURR LCH IN
- FRONT RCH IN
- GND
- FRONT LCH IN
- 15V
- GND
- +15V

- JC01
- JC02
- JC03
- JC04
- JC05

9
8
7
6
5

A B C D E F G

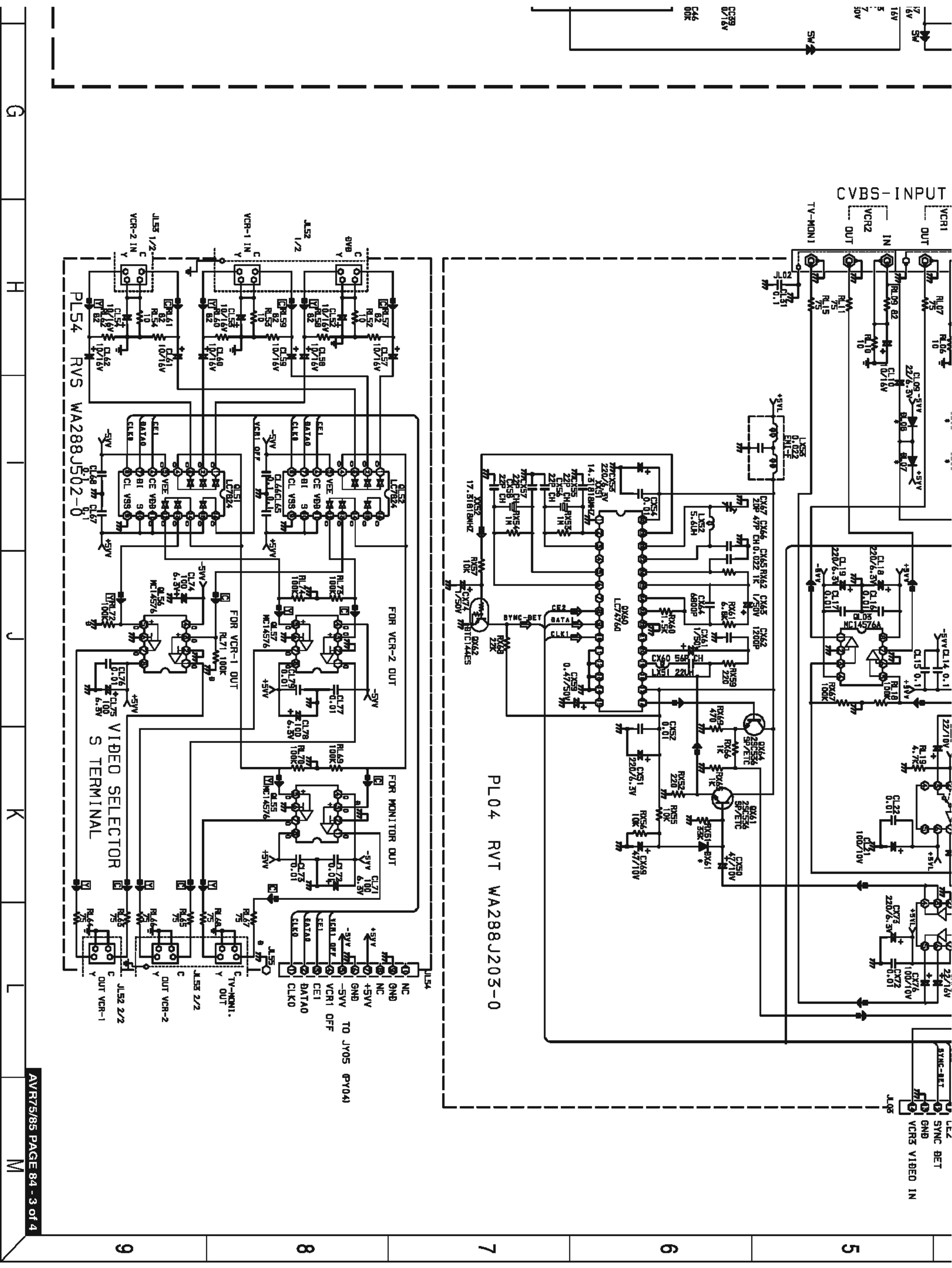

CVBS-INPUT

VCR1 IN
VCR2 IN
TV-MON1

PL04 RVT WA288J203-0

PL54 RVS WA288J502-0

G

H

J

K

M

AVR75 (230V) SCHEMATIC DIAGRAM 5 of 7 (CONNECT PCB PY04)

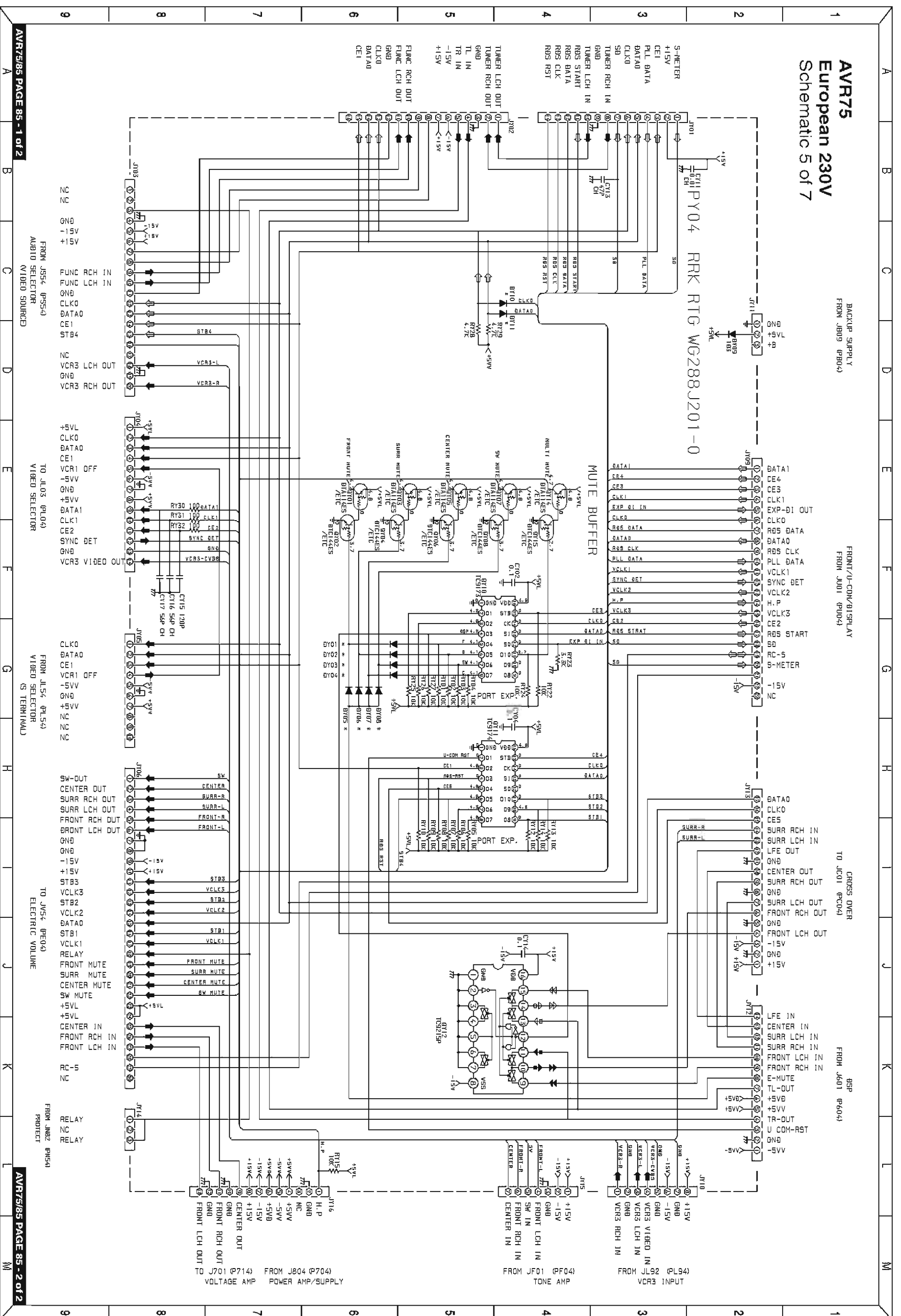

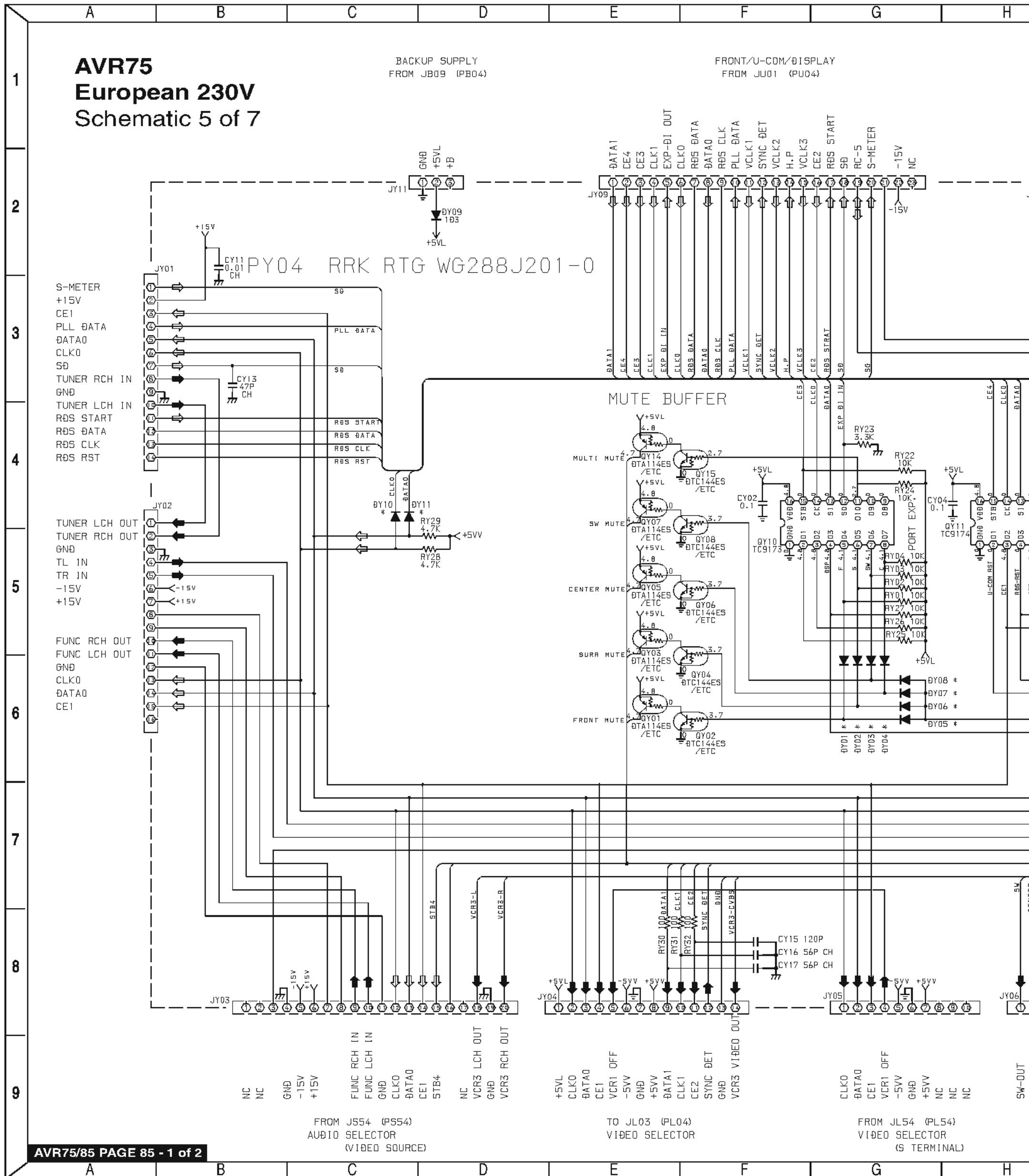

SCHEMATIC DIAGRAM 5 of 7 (CONNECT PCB PY04)

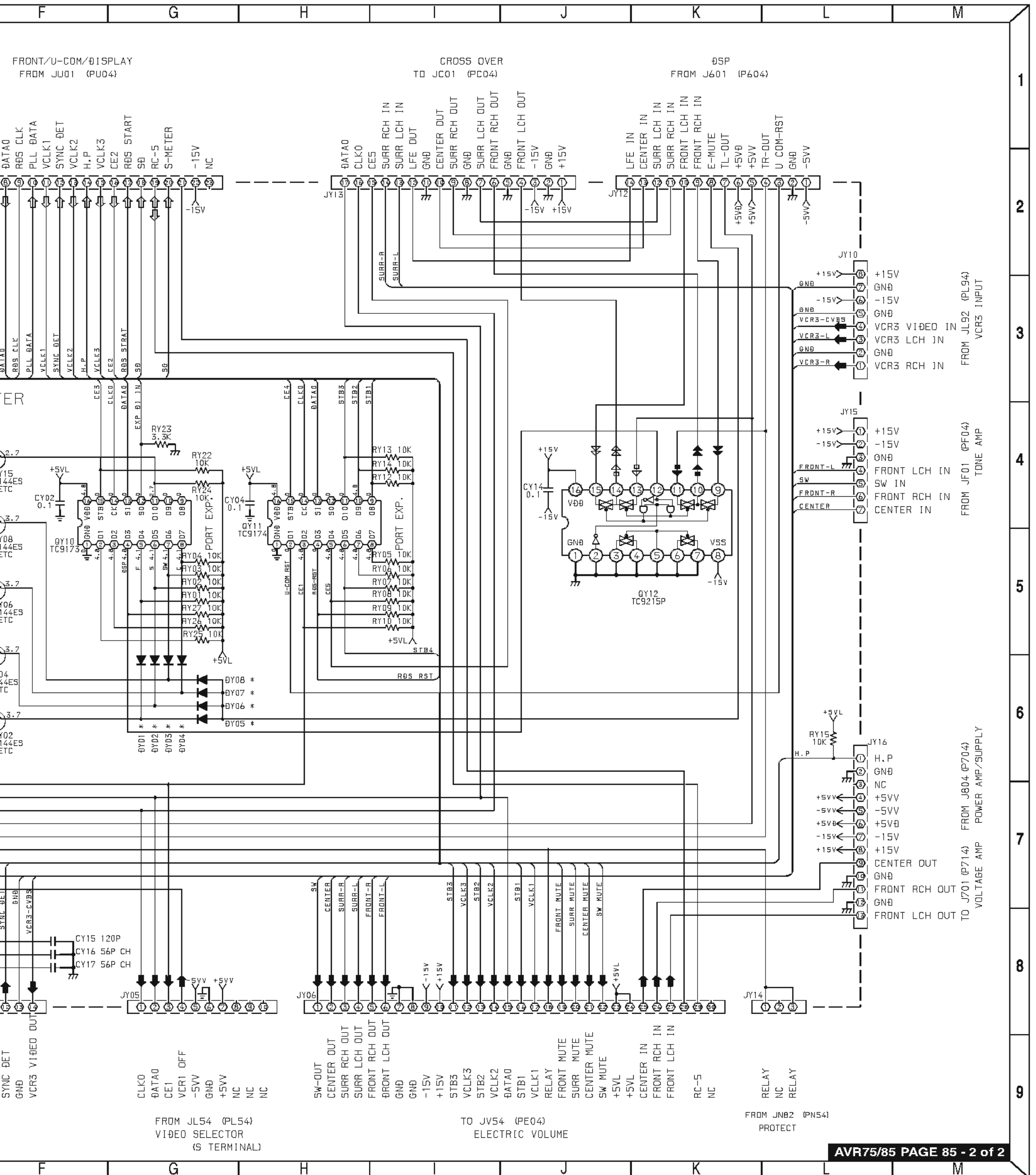

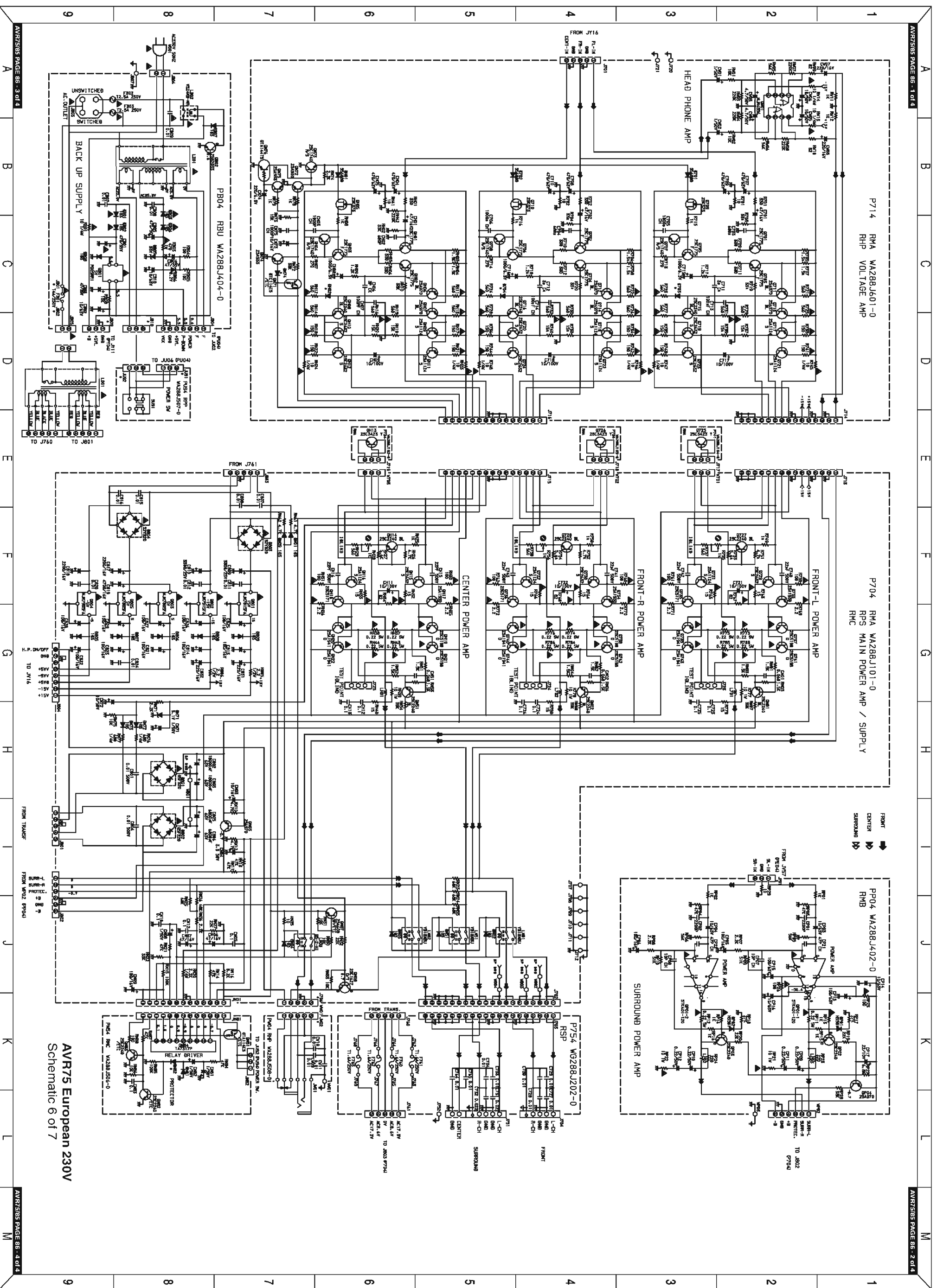

AVR75 European 230V
Schematic 6 of 7

AVR75 (230V) SCHEMATIC DIAGRAM 6 of 7 (VOLTAGE AMP PCB - P714, MAIN PCB - P704, SURROUND AMP PCB - PP04, SPEAKER TERMINAL

AVR75/85 PAGE 86 - 1 of 4

A B C D E F G

P714 RMA WA288J601-0
RHP VOLTAGE AMP

P704 RMA WA288J101-0
RPS MAIN POWER AM
RMC

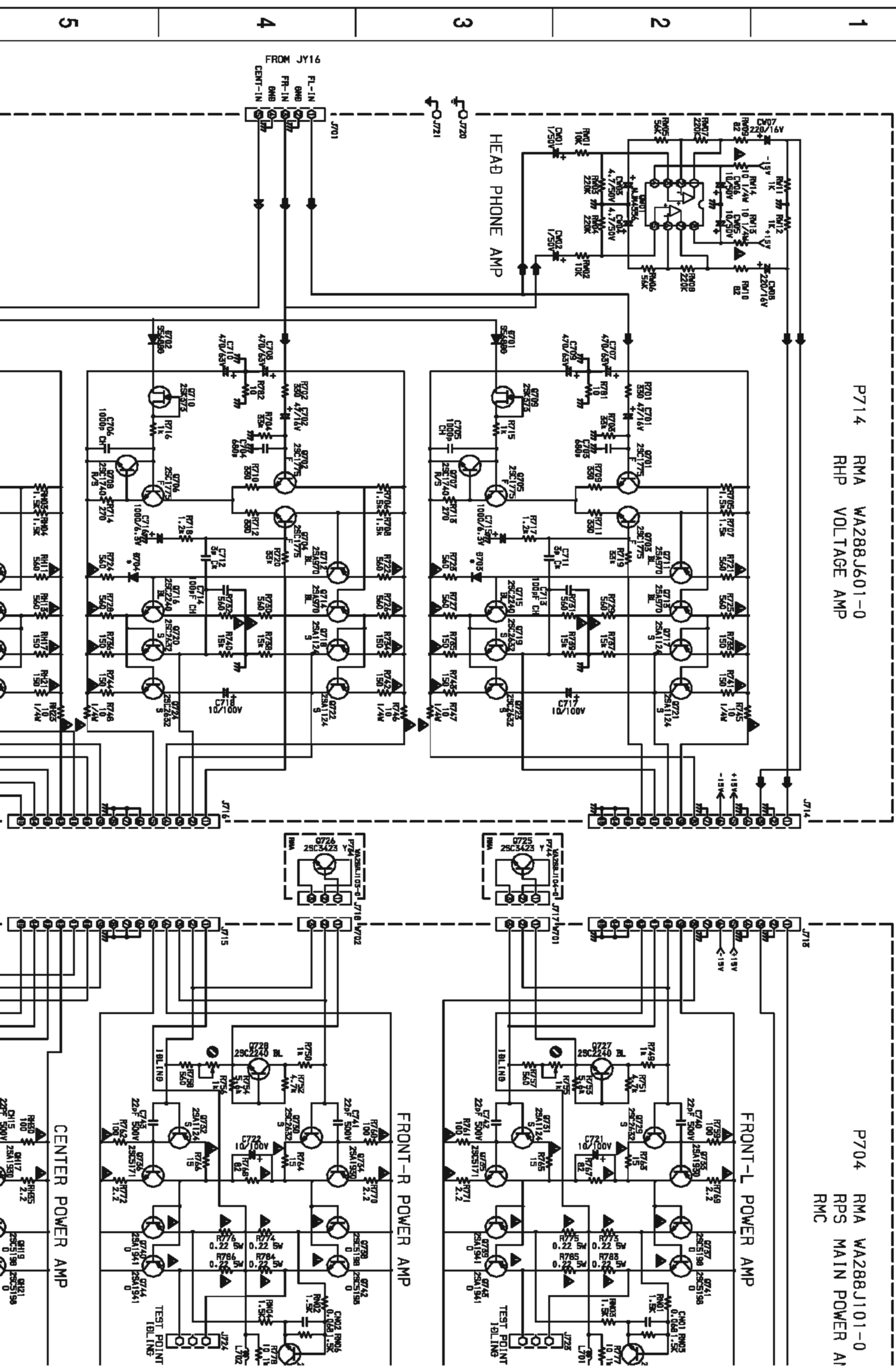

SPEAKER TERMINAL - P754, HEADPHONE PCB - PW04, SPEAKER PROTECT PCB - PN54, STANDBY PCB - PB04, POWER SWITCH PCB - PU94)

	G	H	J	K	L	M
--	---	---	---	---	---	---

- 4 RMA WA288J101-0
- RPS MAIN POWER AMP / SUPPLY
- RMC

FRONT →
 CENTER →→
 SURROUND ⇨⇨

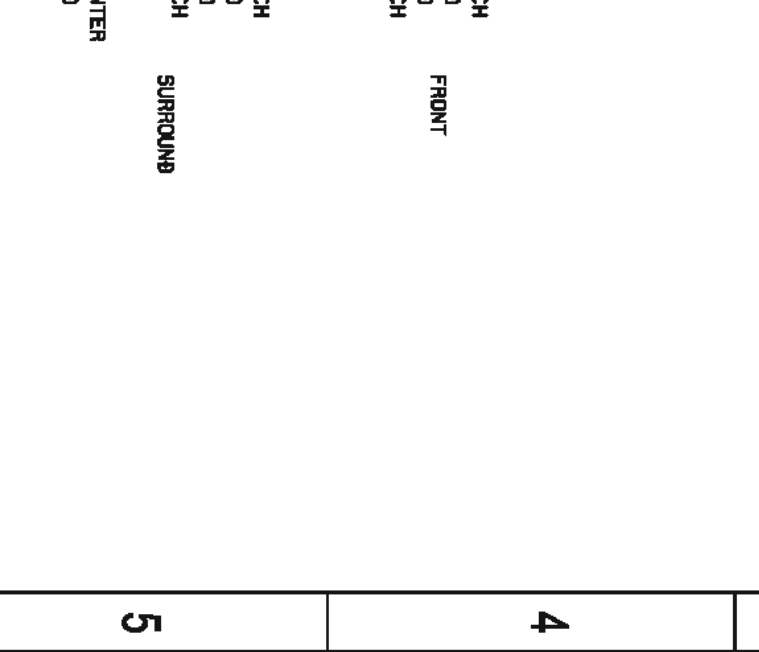
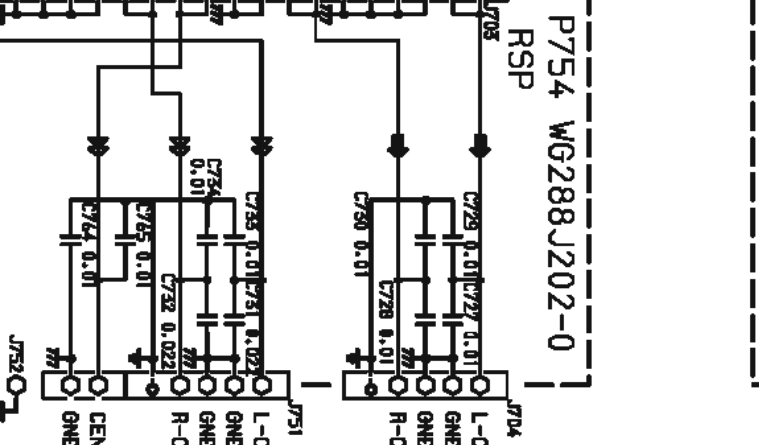
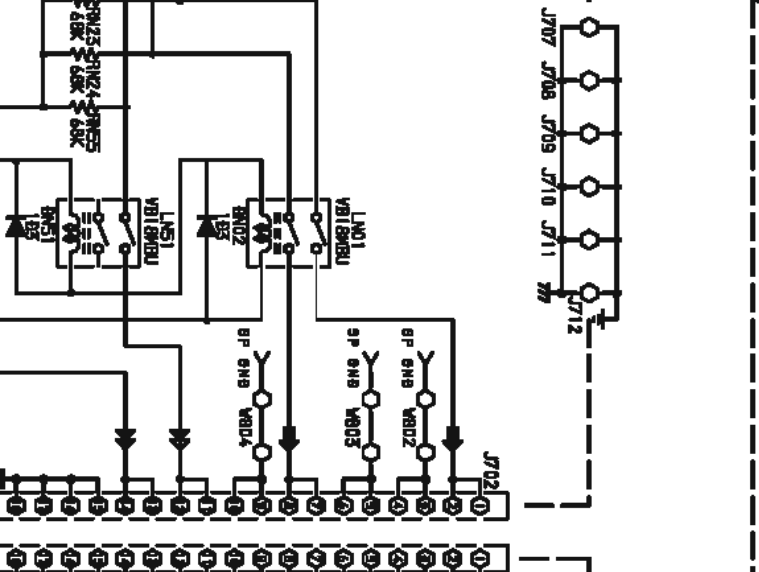
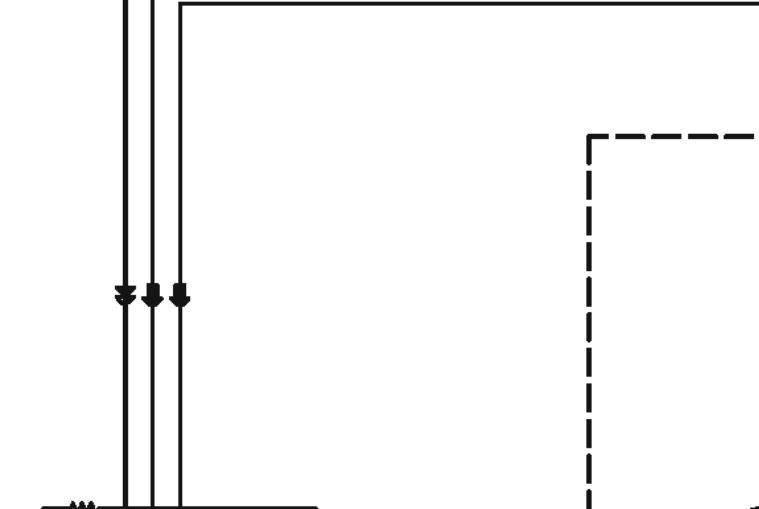
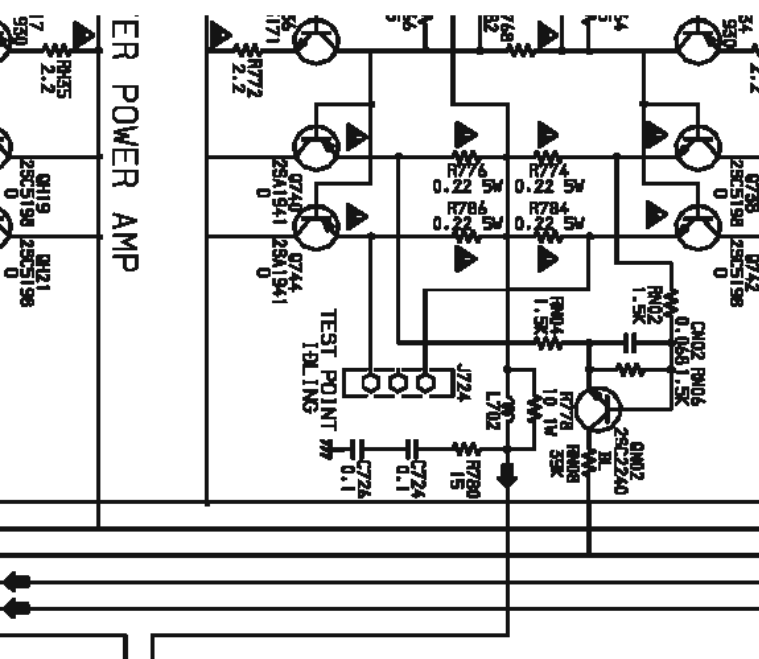
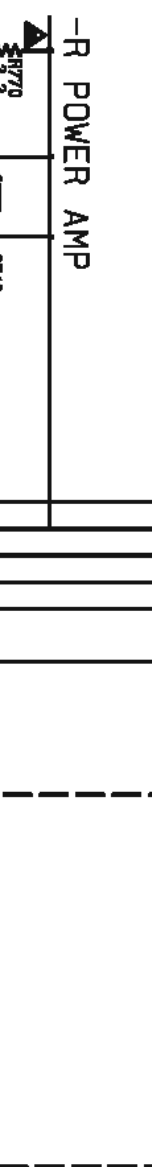
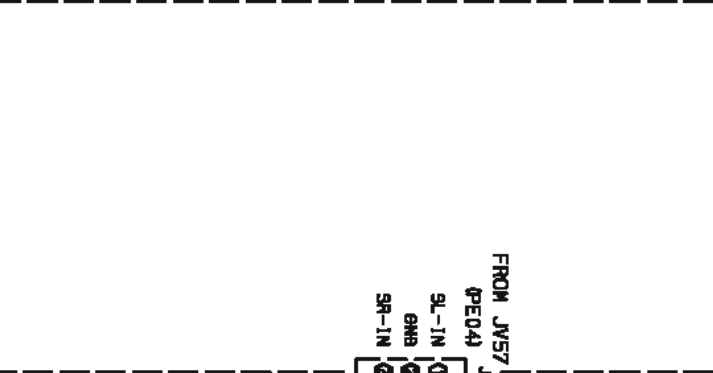
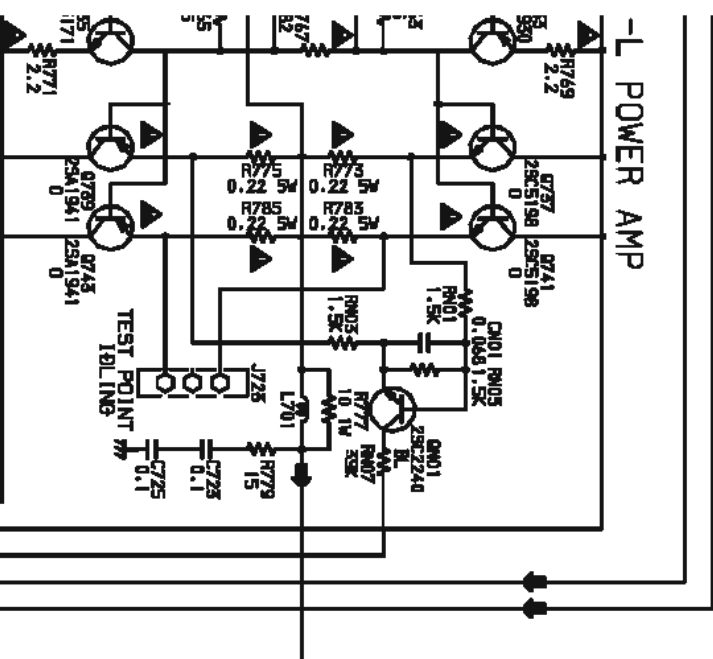

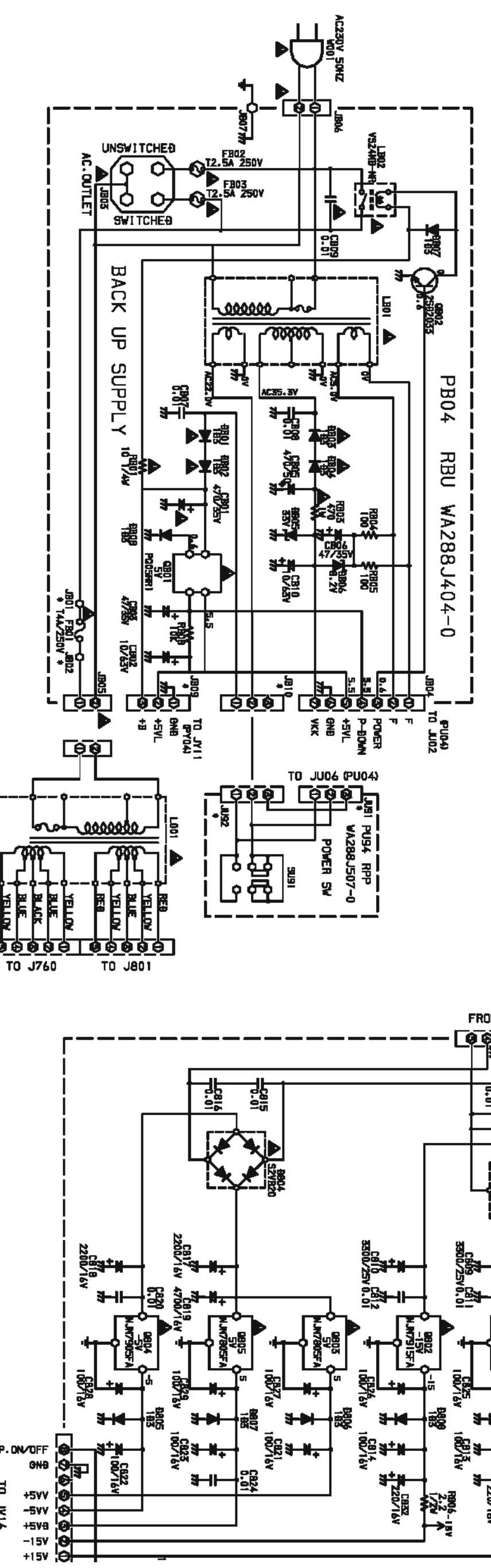
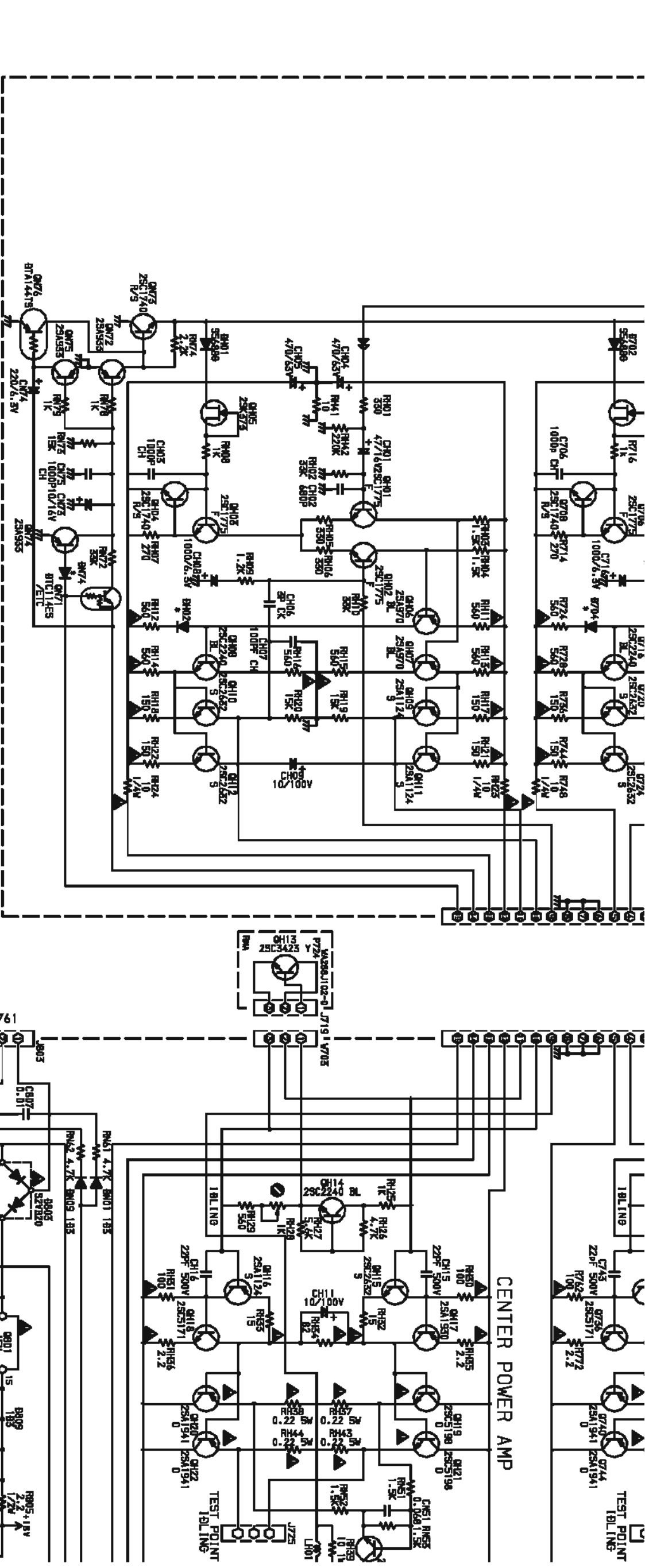

A B C D E F G

5 6 7 8 9

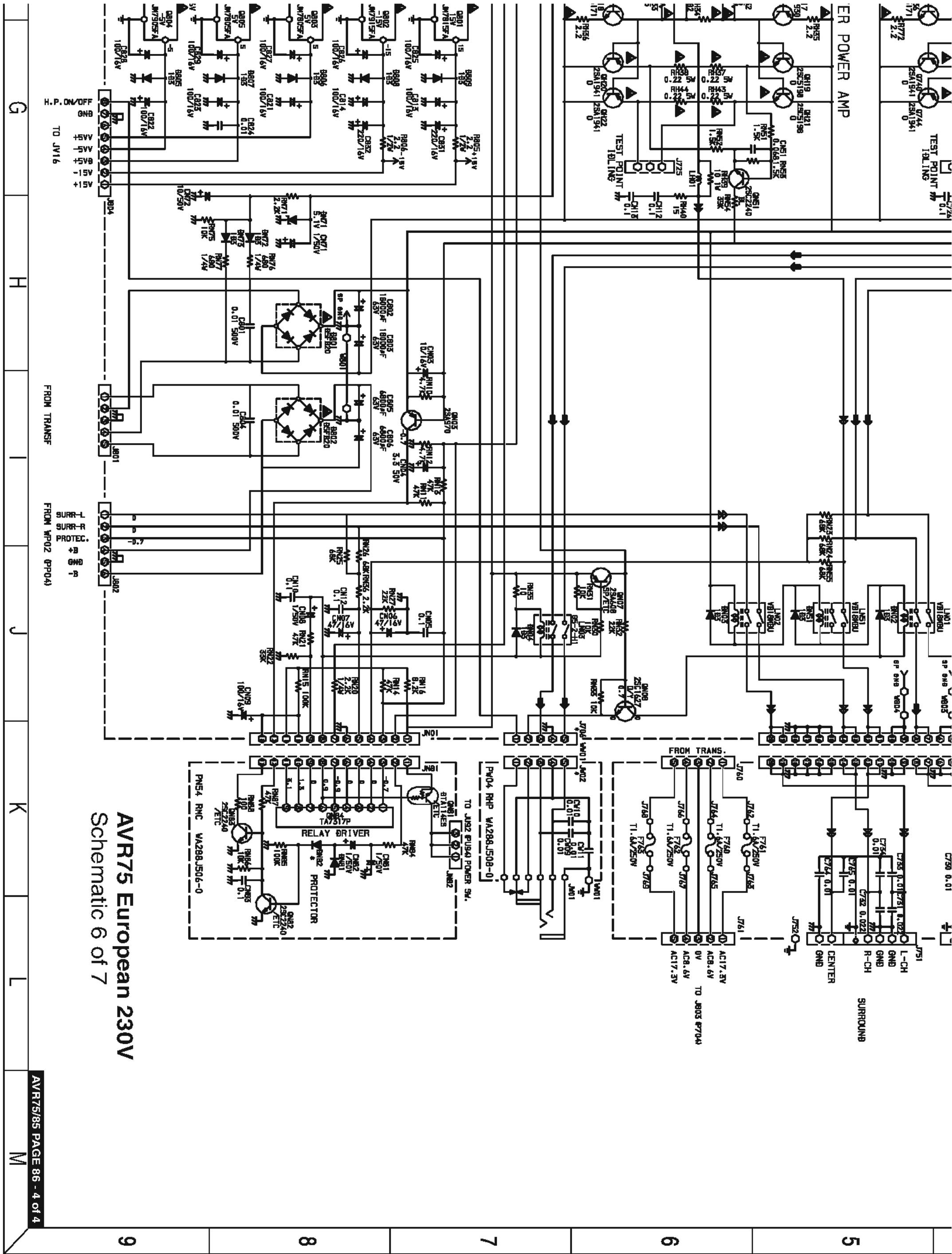

AVR75 European 230V
Schematic 6 of 7

AVR75 (230V) SCHEMATIC DIAGRAM 7 of 7 ELECTRONIC VOLUME CONTROL PCB, PE04

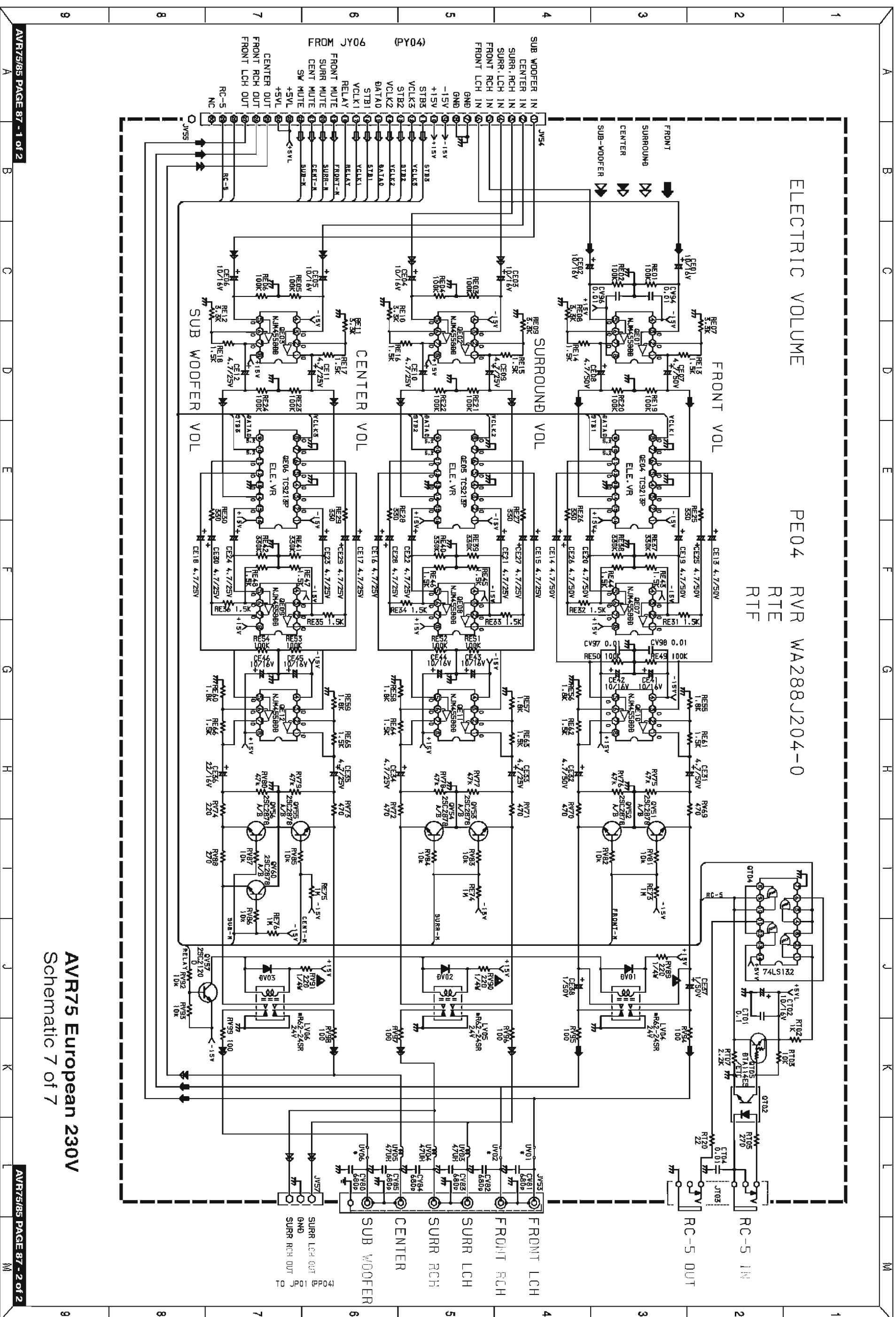

AVR75 European 230V
Schematic 7 of 7

AVR75 (230V) SCHEMATIC DIAGRAM 7 of 7 ELECTRONIC V

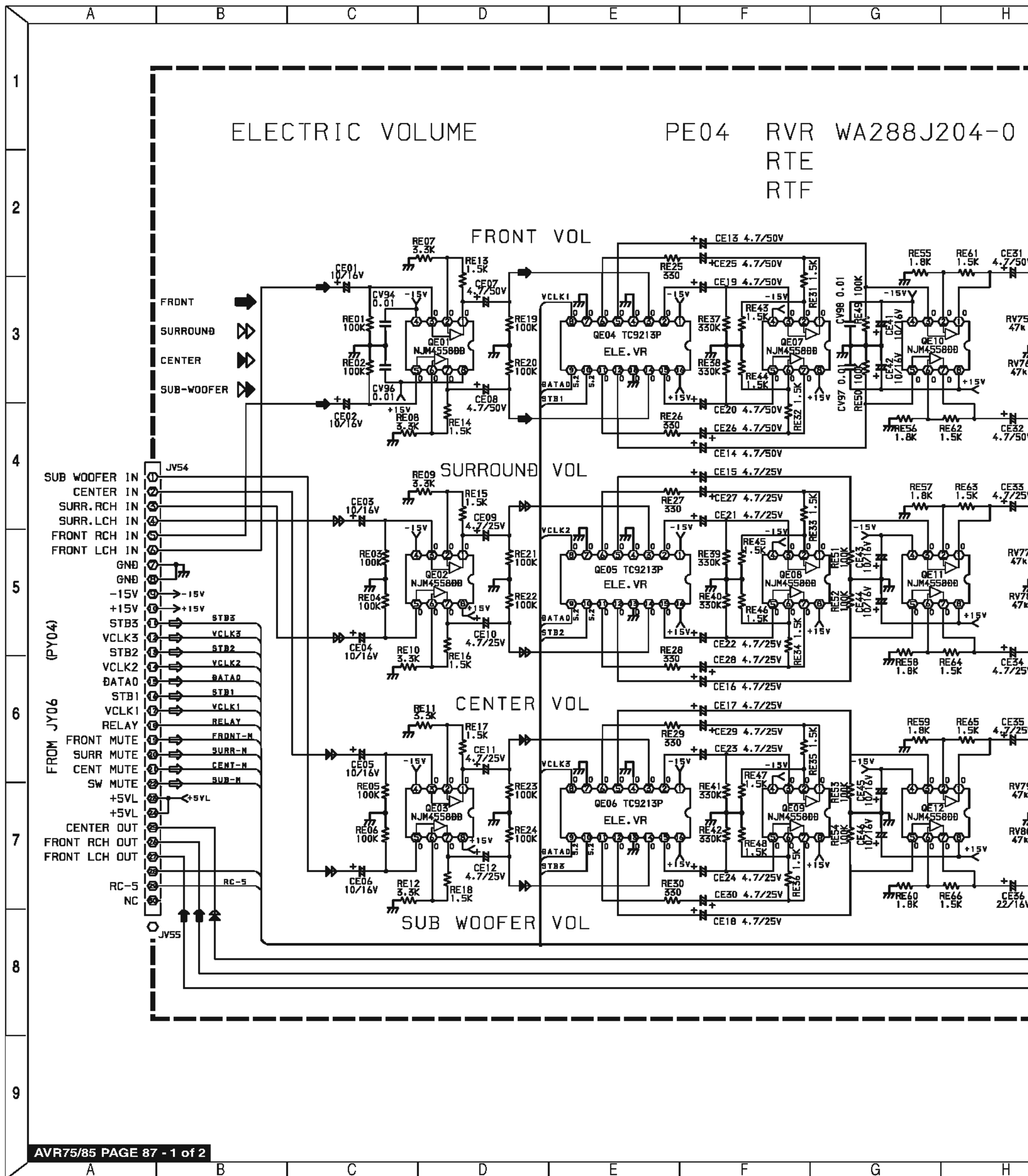
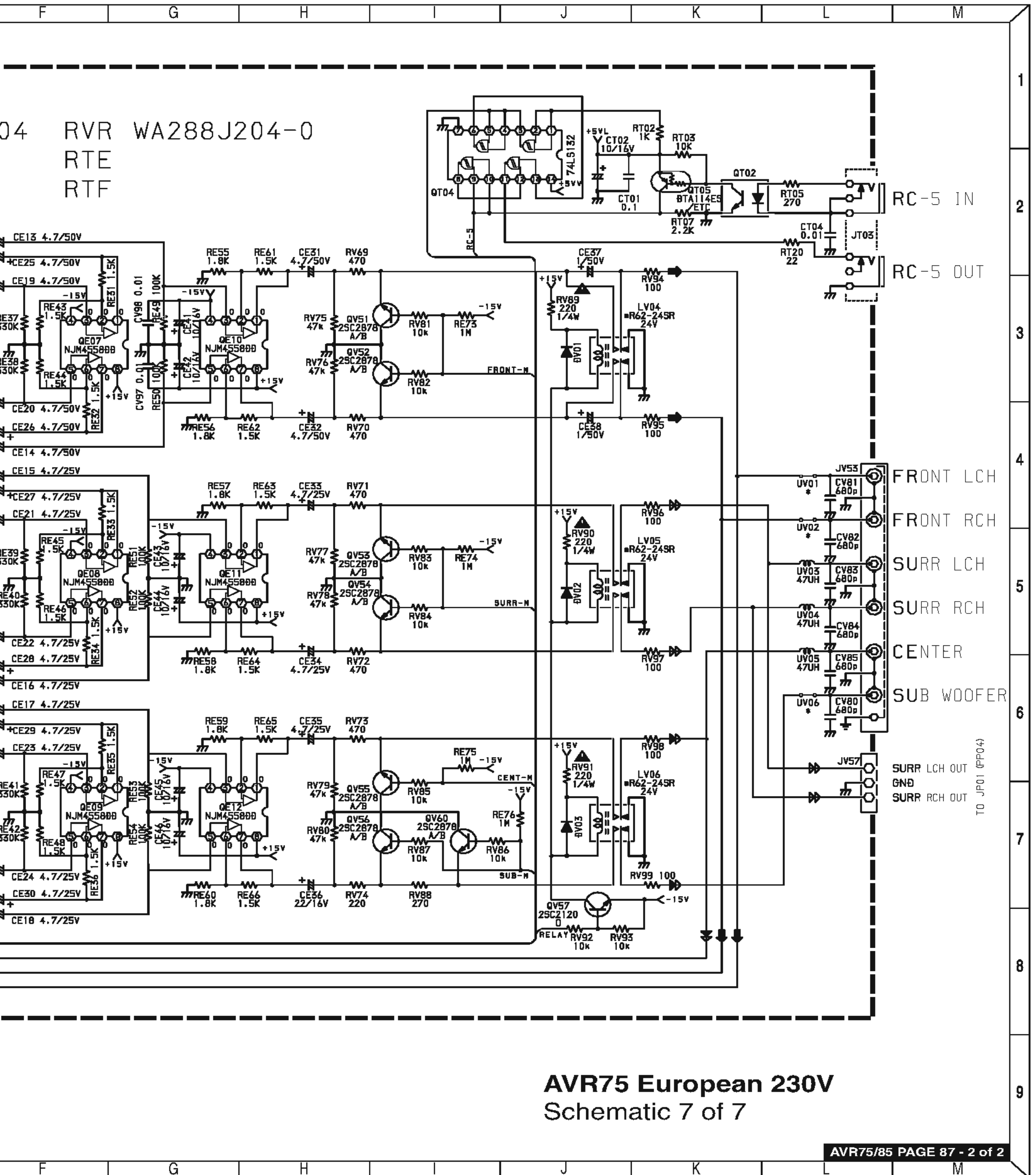
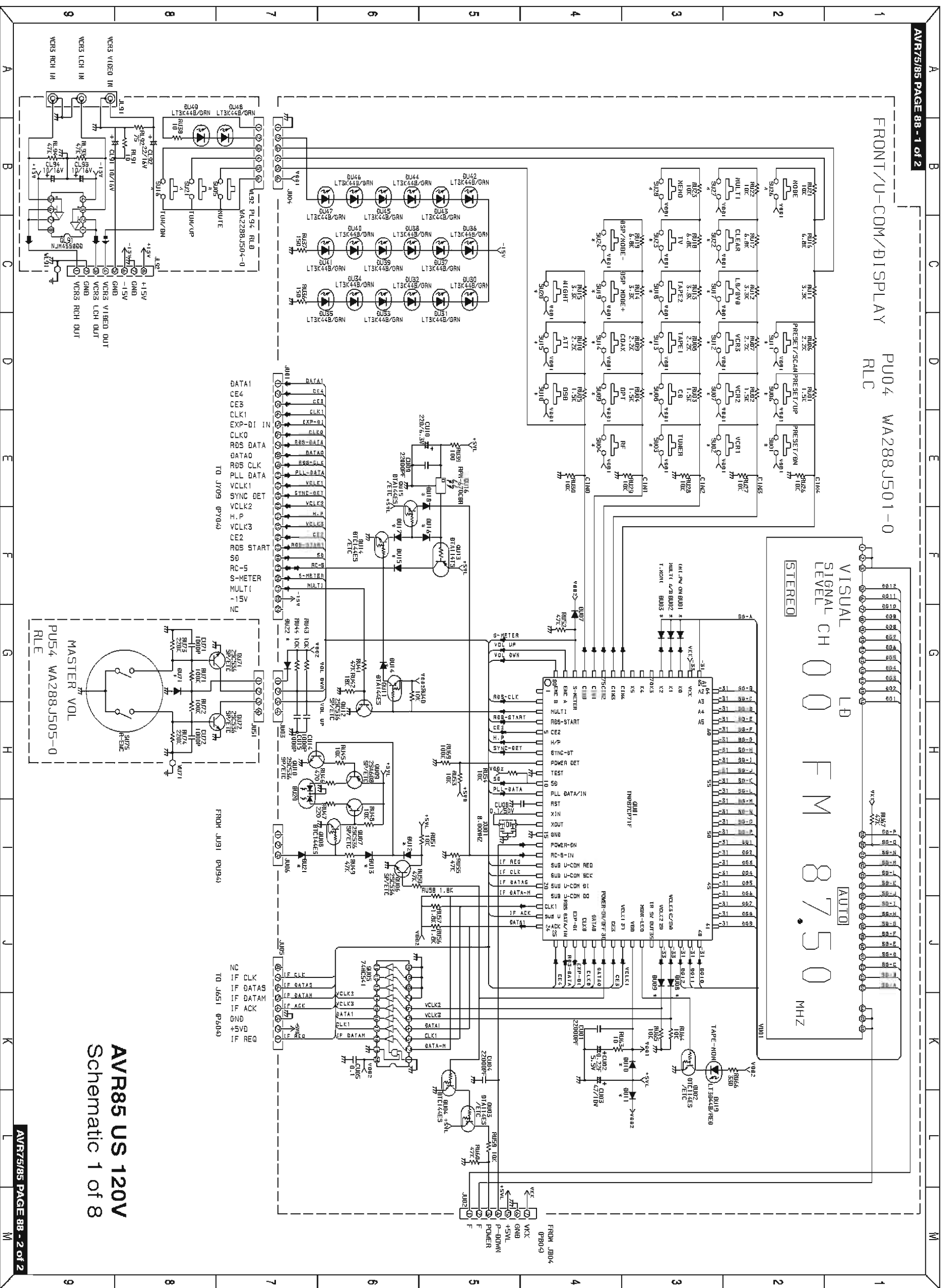
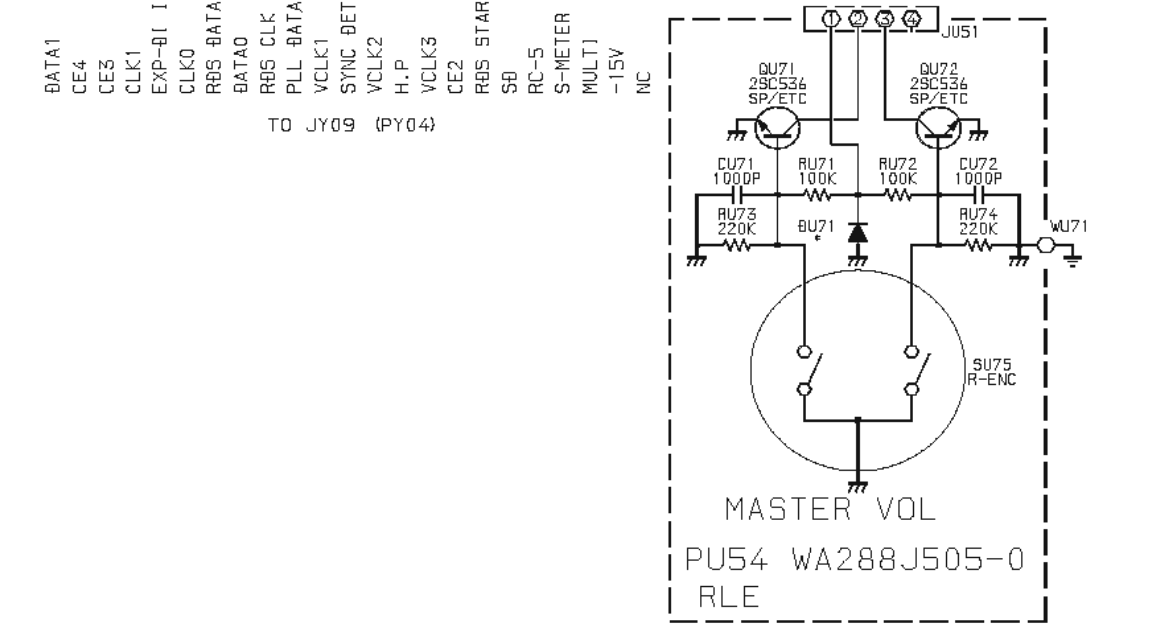
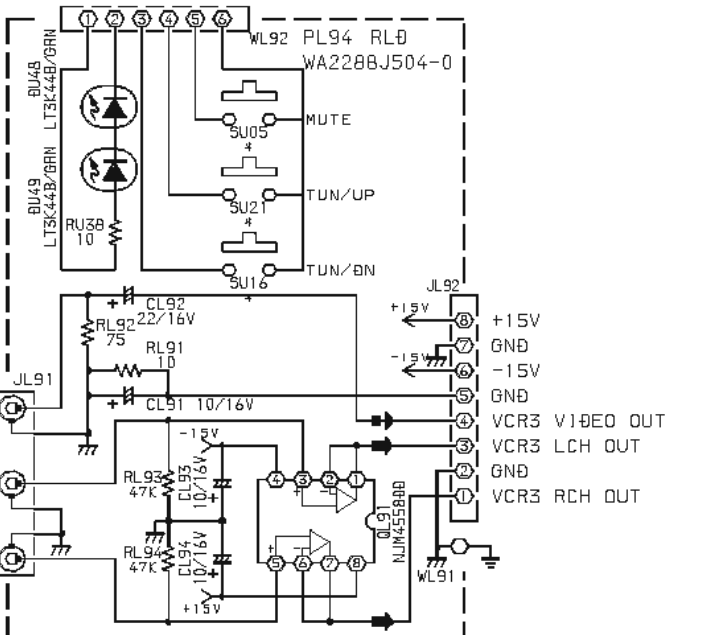
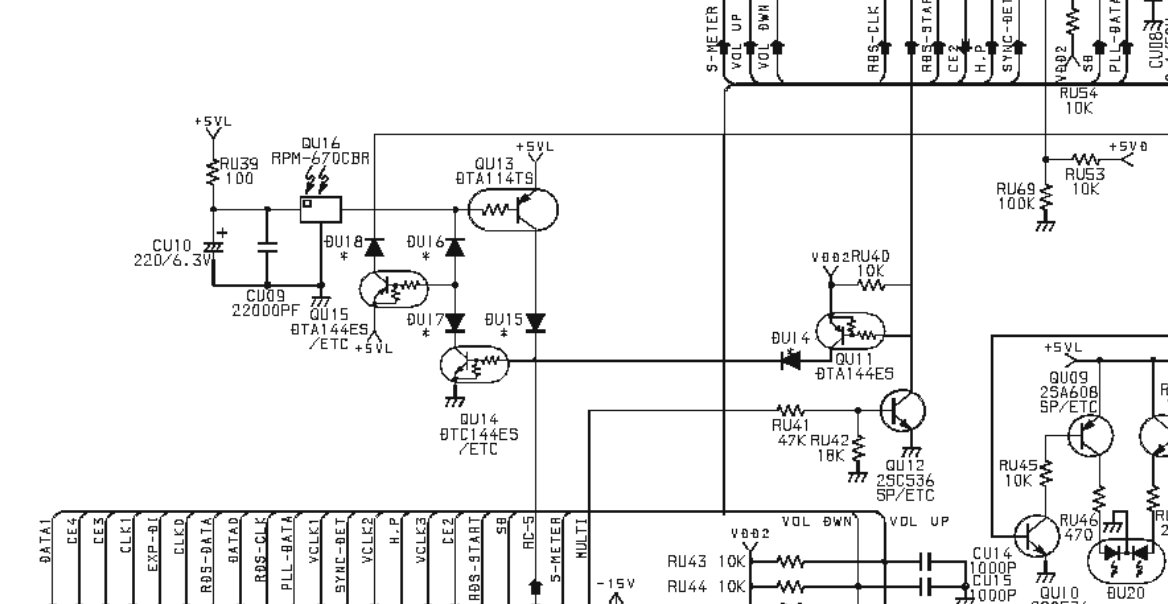
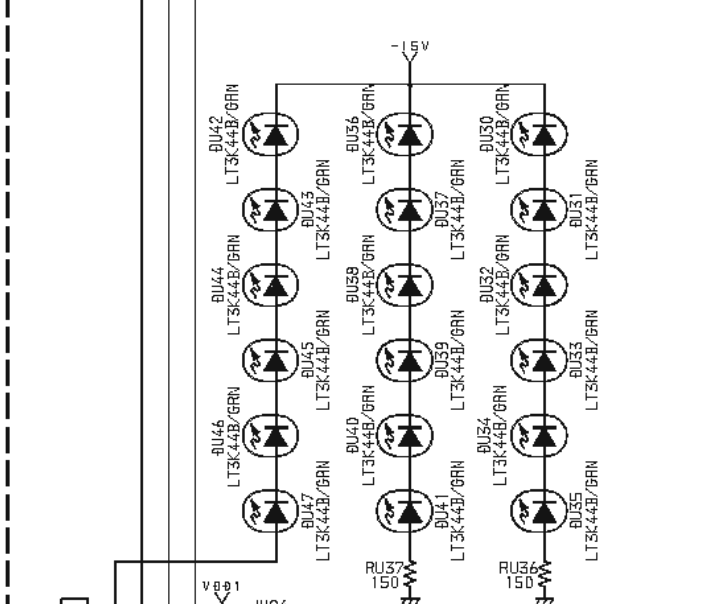
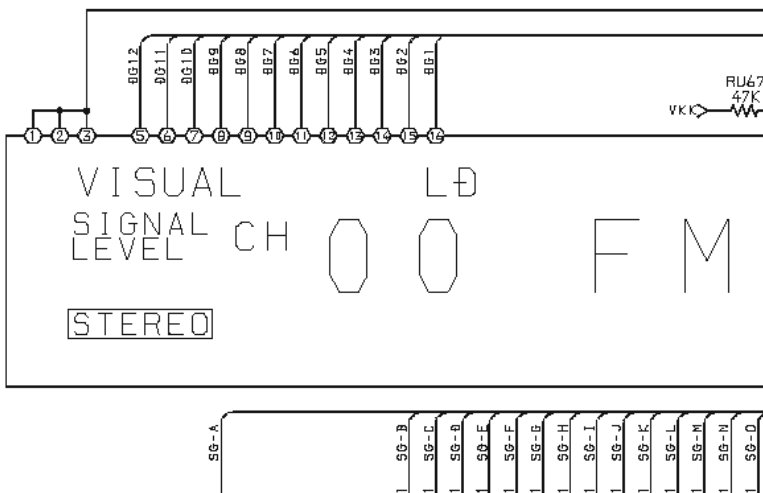
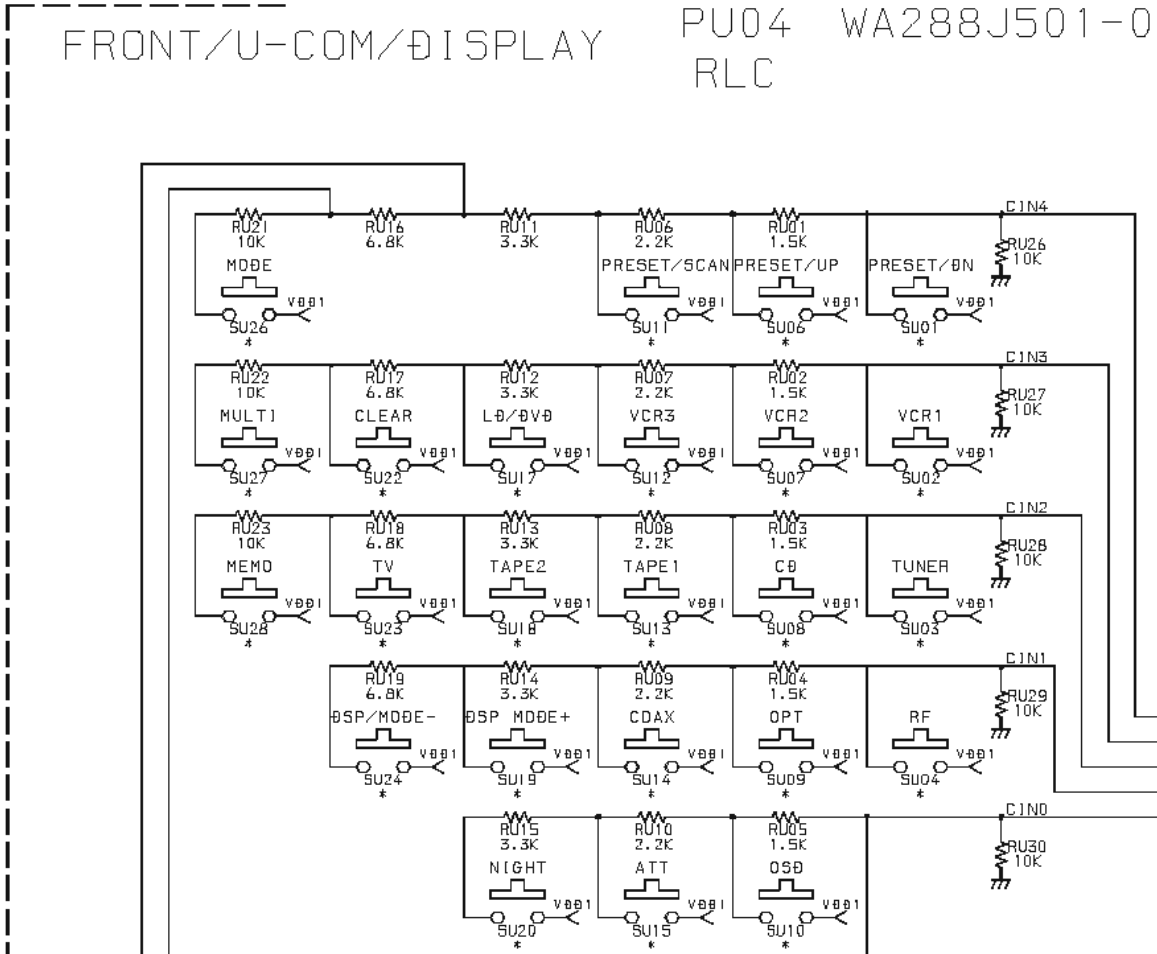
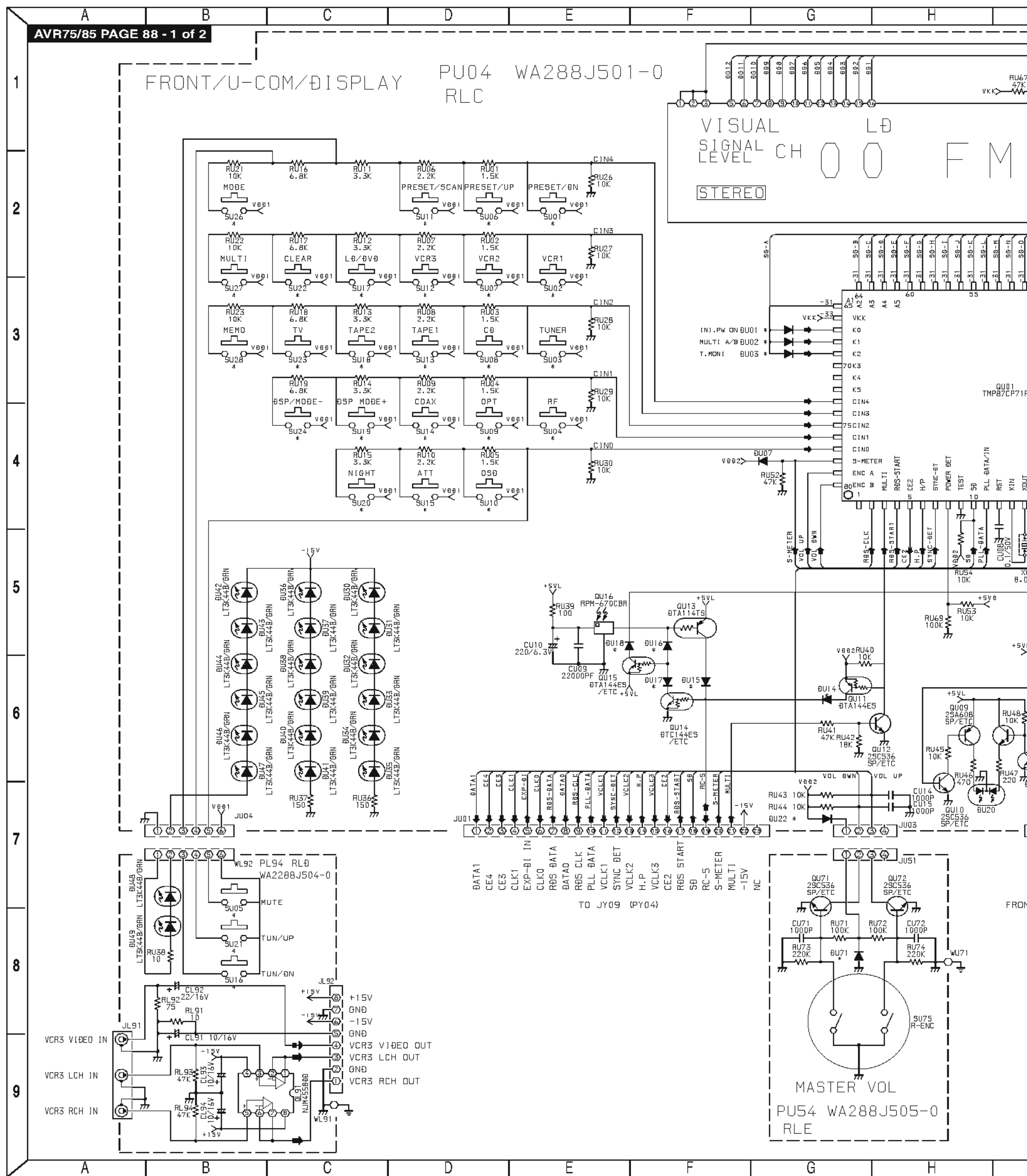

DIAGRAM 7 of 7 ELECTRONIC VOLUME CONTROL PCB, PE04





AVR85 (120V) SCHEMATIC DIAGRAM 1 of 8 (FRONT PCB - PU04, MASTER VOL)



AM 1 of 8 (FRONT PCB - PU04, MASTER VOLUME PCB - PU54, AUX IN - PL94)

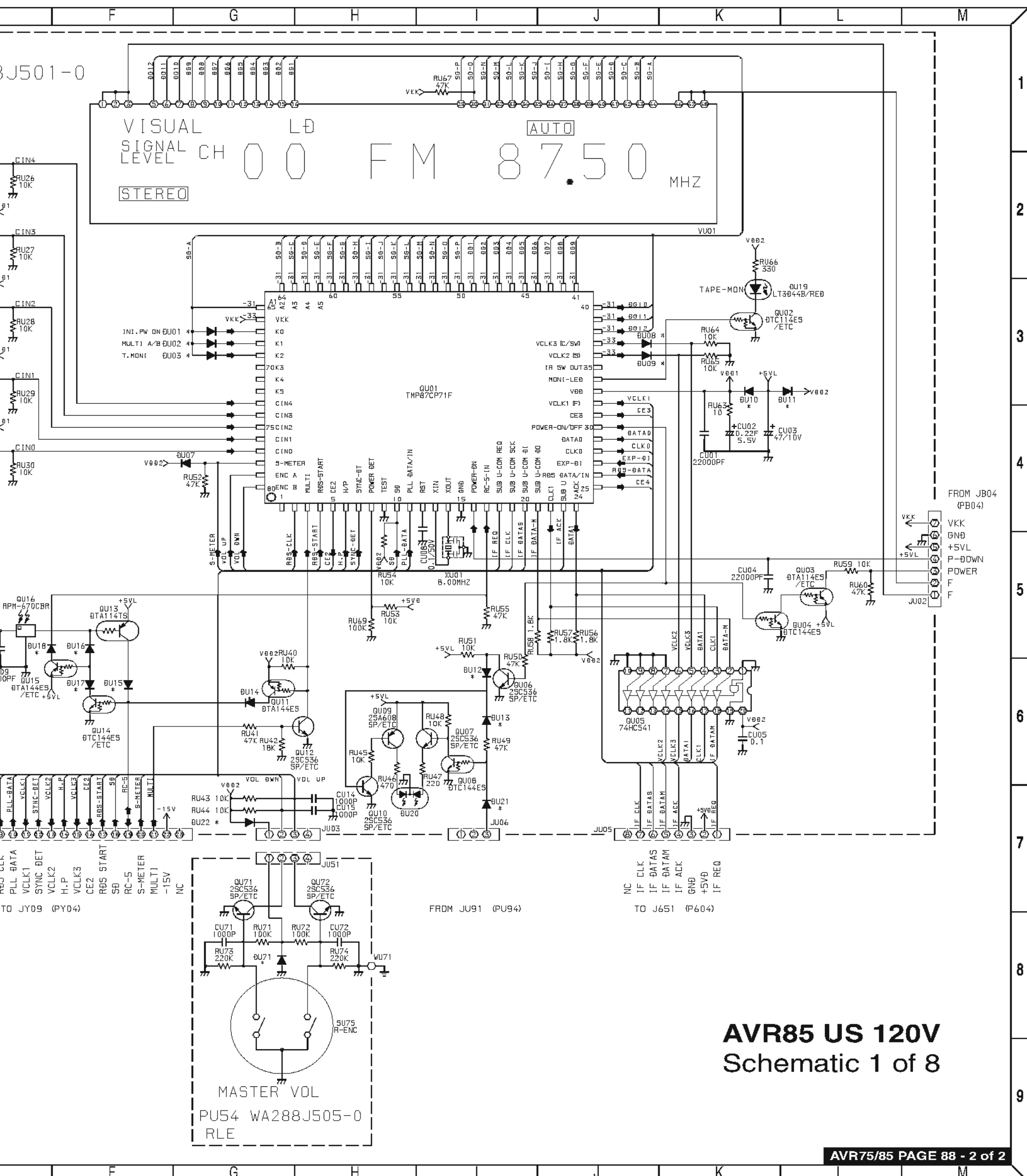

AVR85 US 120V
Schematic 1 of 8

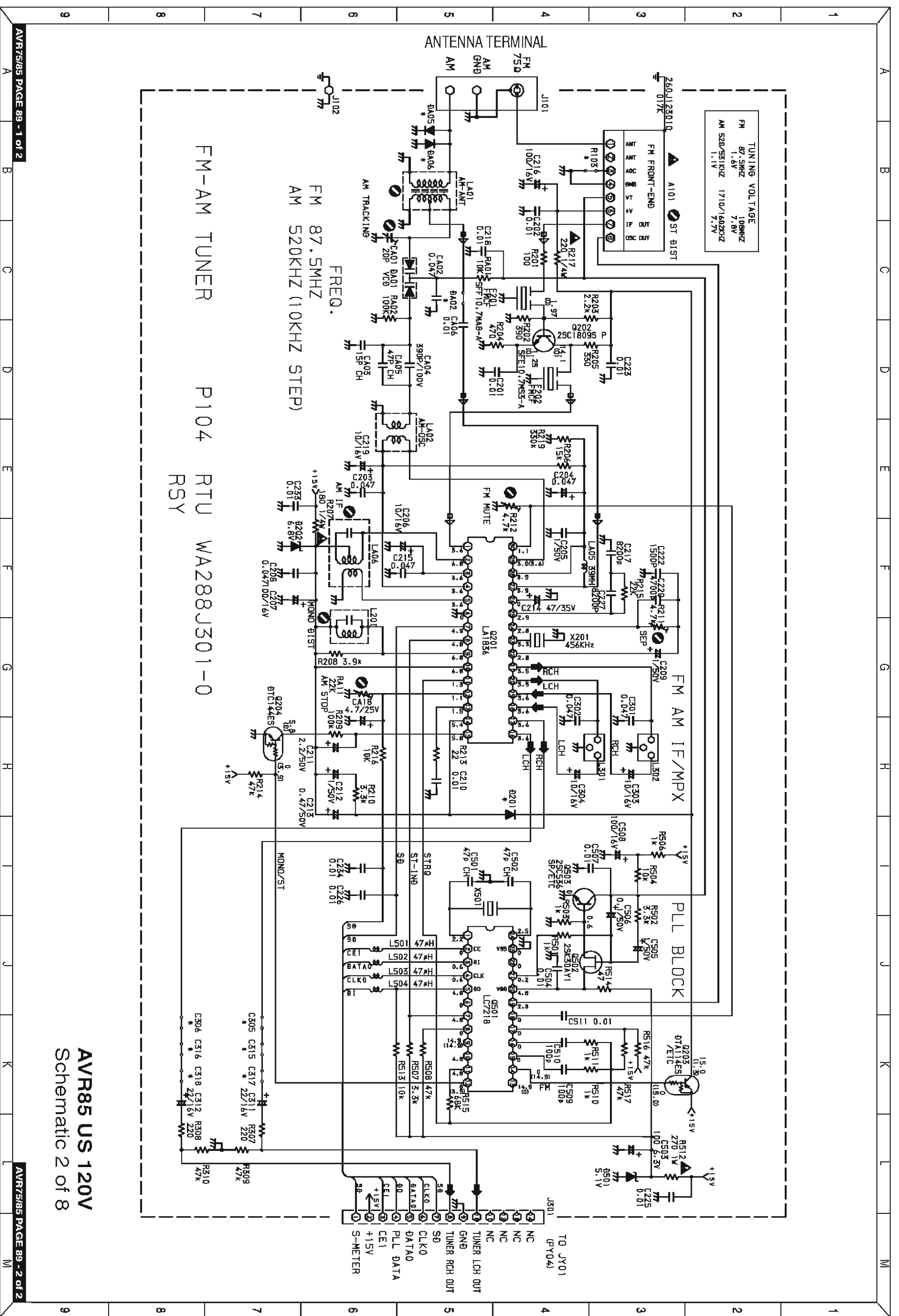

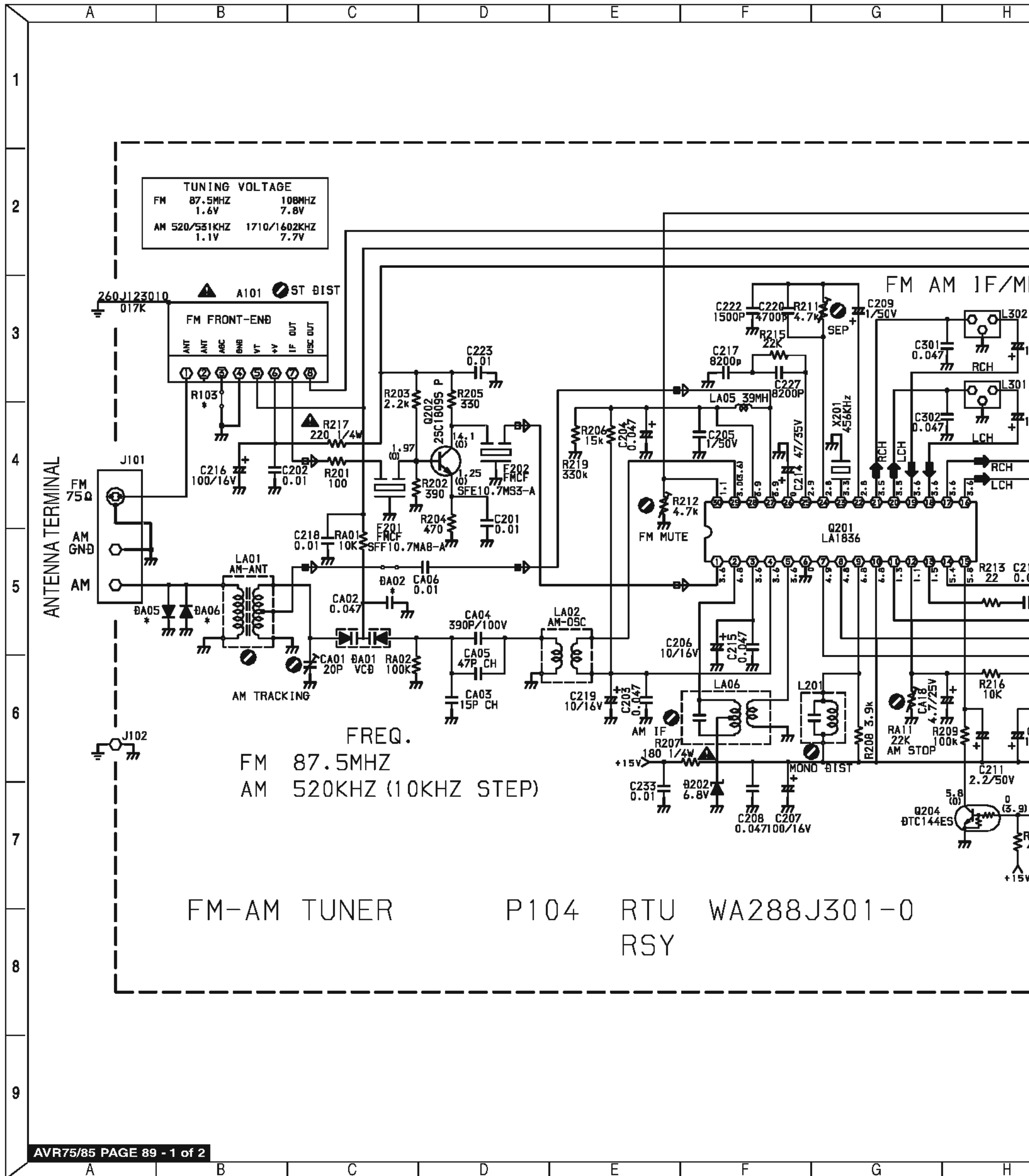

SCHEMATIC DIAGRAM 2 of 8 (TUNER PCB - P104)

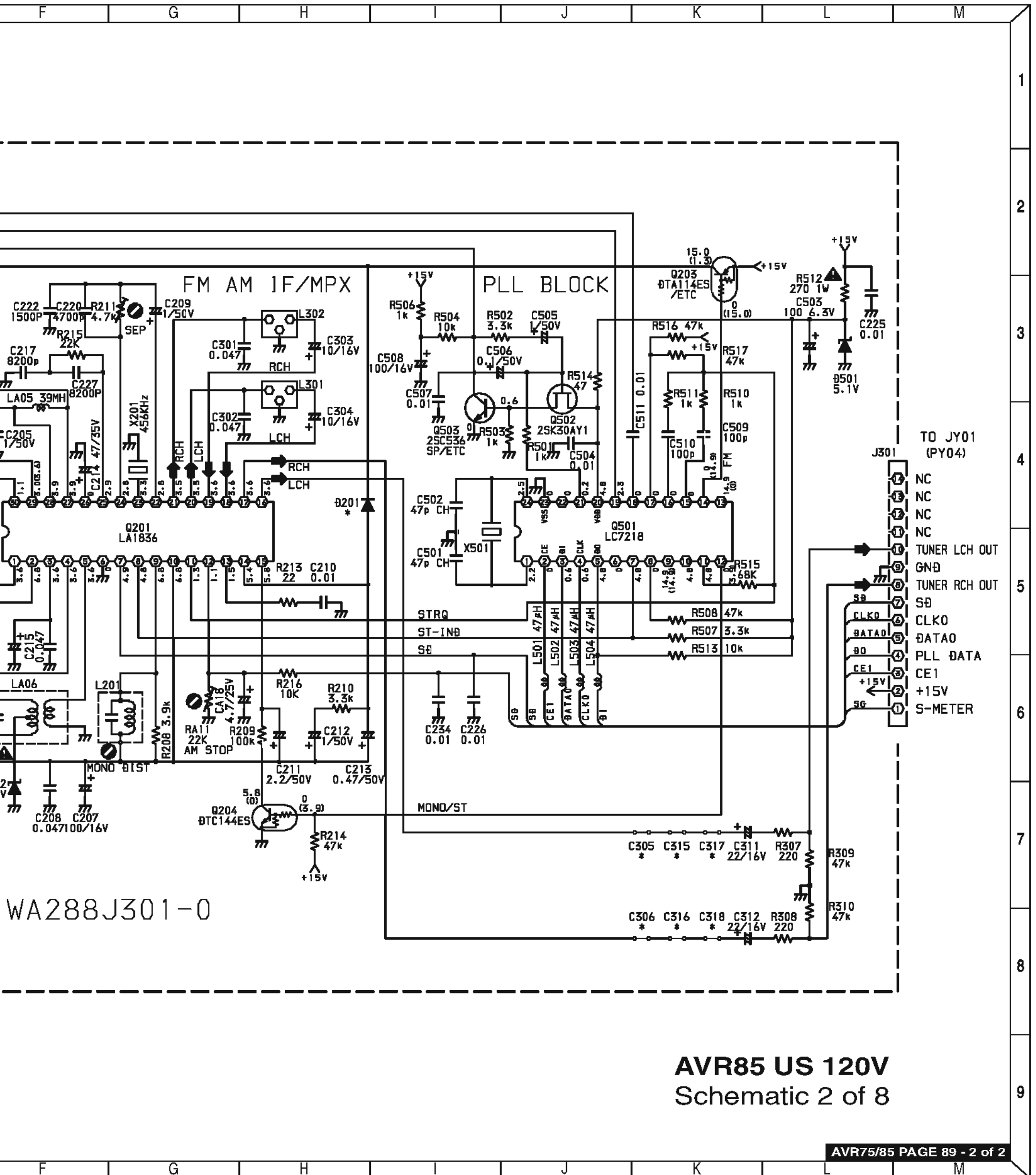

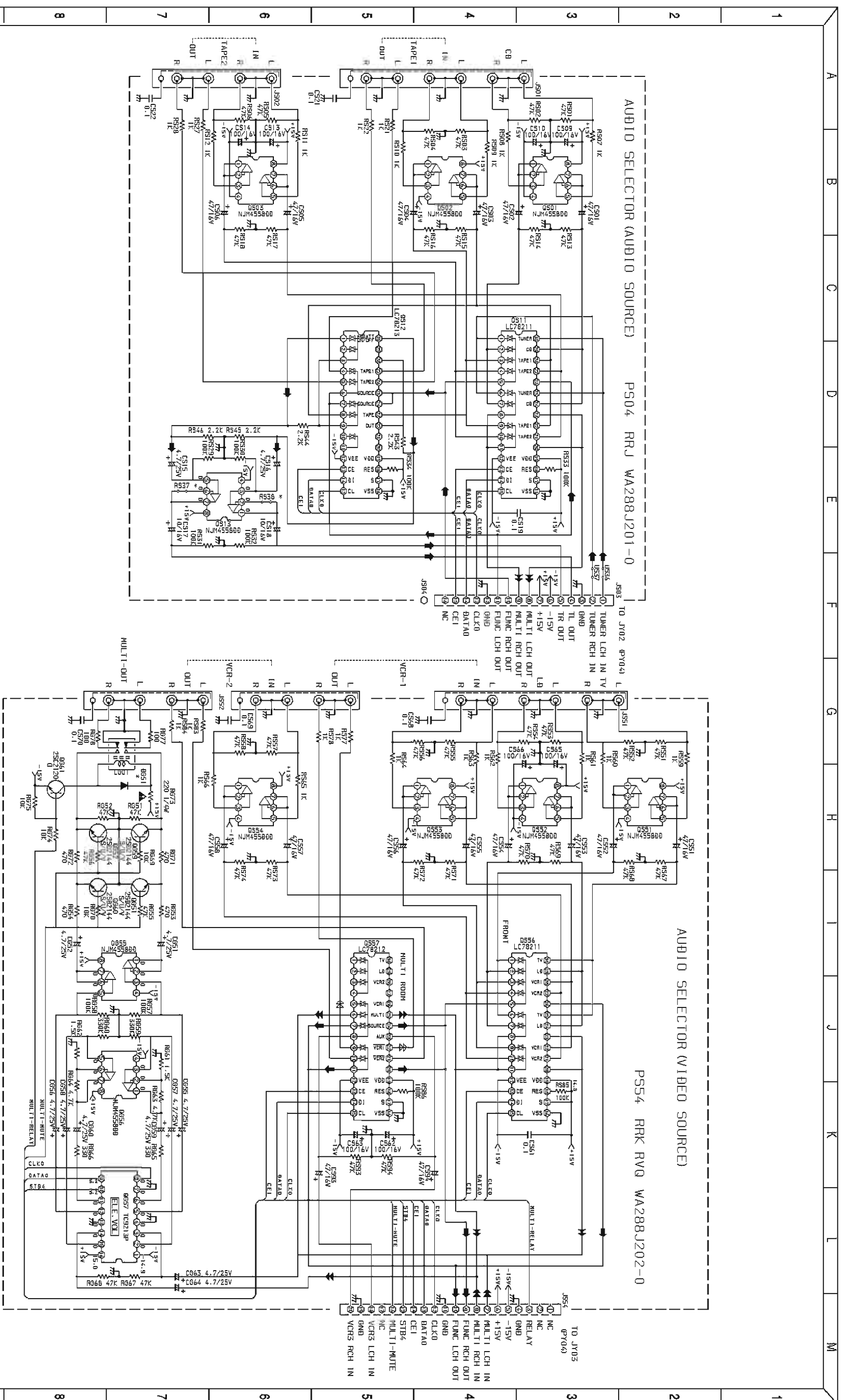

AVR85 US 120V
Schematic 3 of 8

AVR85 (120V) SCHEMATIC DIAGRAM 3 of 8 (AUDIO SELECTOR PC

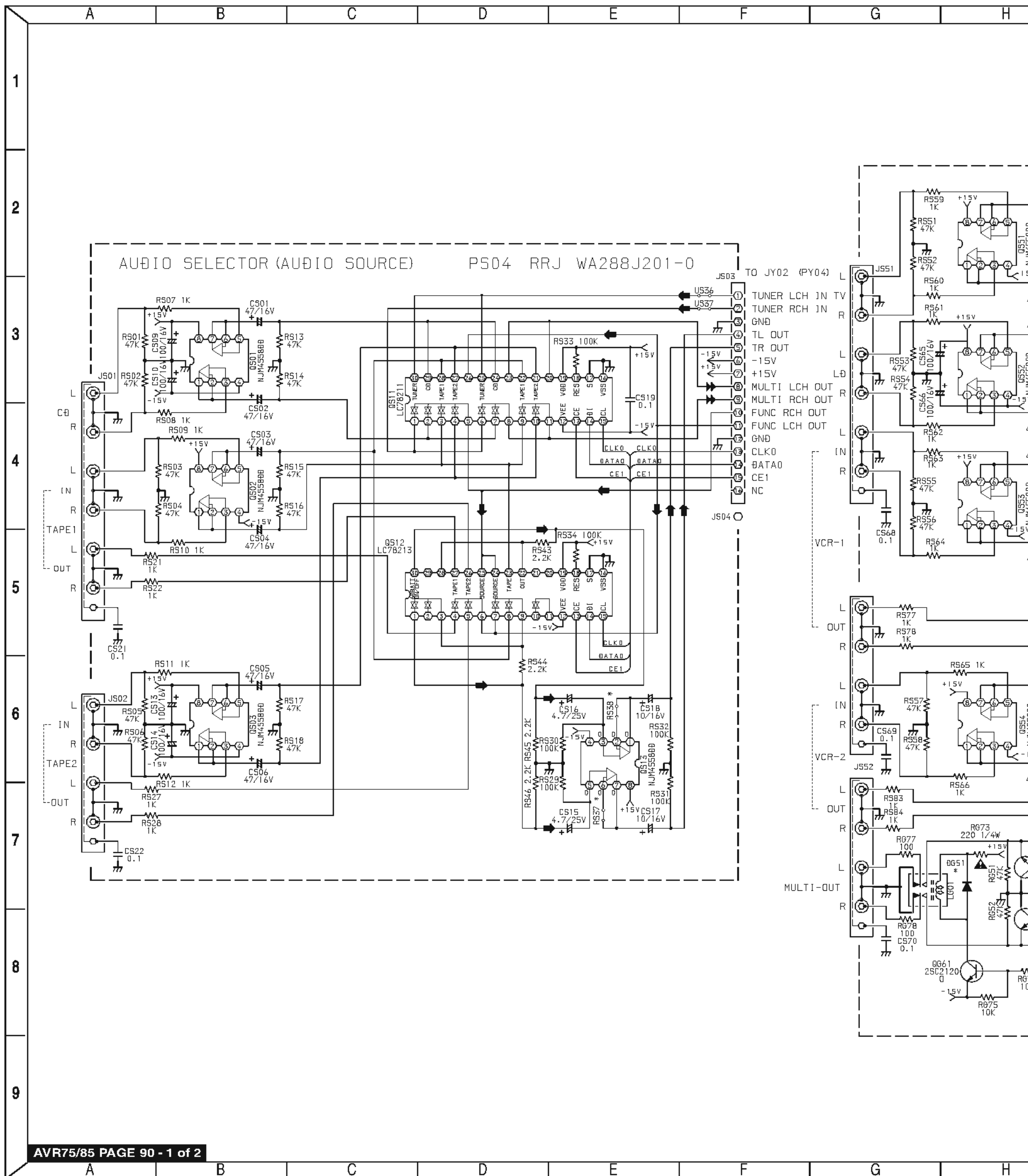

Schematic 3 of 8 (AUDIO SELECTOR PCB - PS04, AUDIO/VIDEO PCB - PS54)

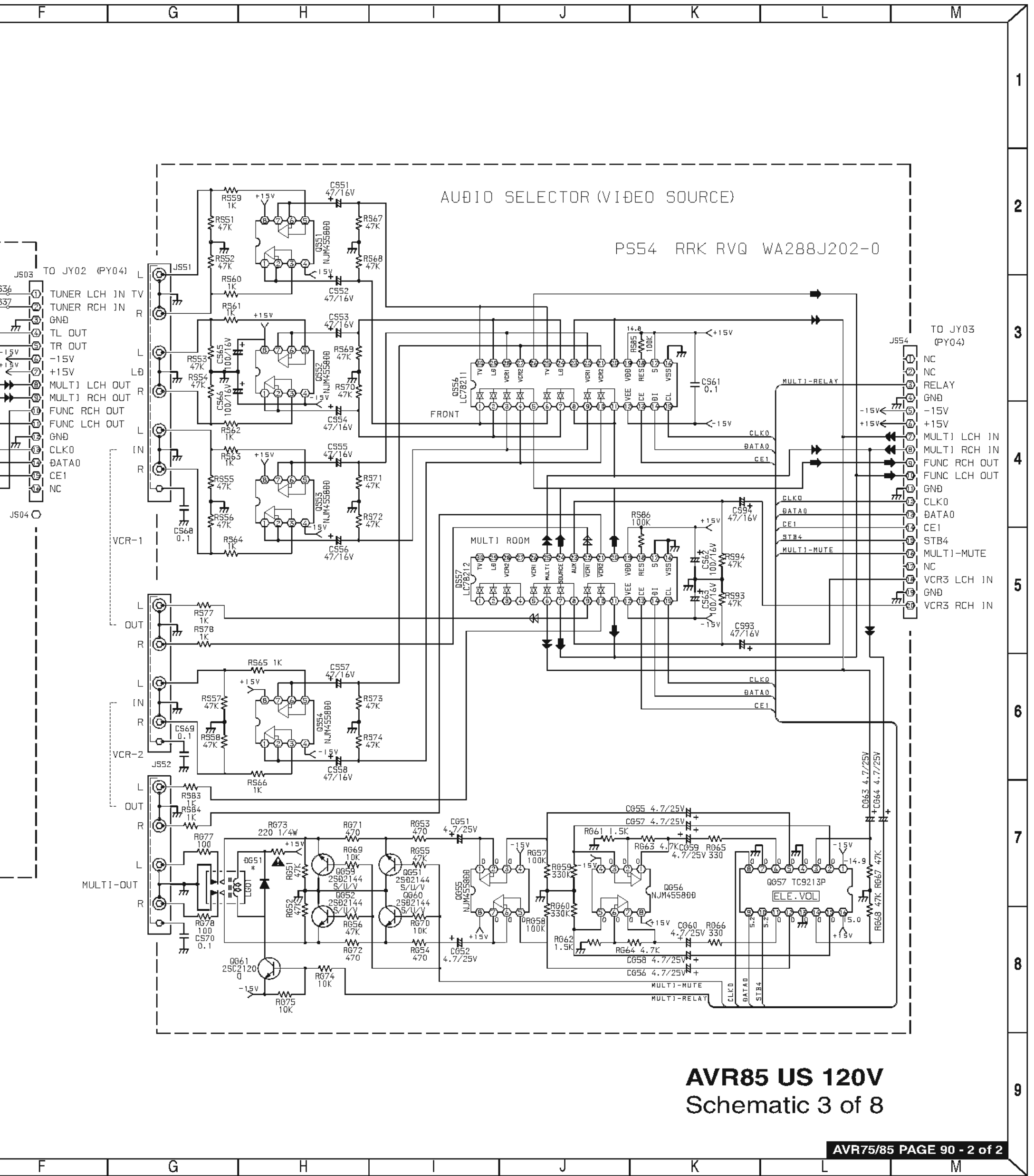

AVR85 US 120V
Schematic 3 of 8

AVR85 US 120V
Schematic 4 of 8

CROSSOVER
PC04 RCR WA288J203-0

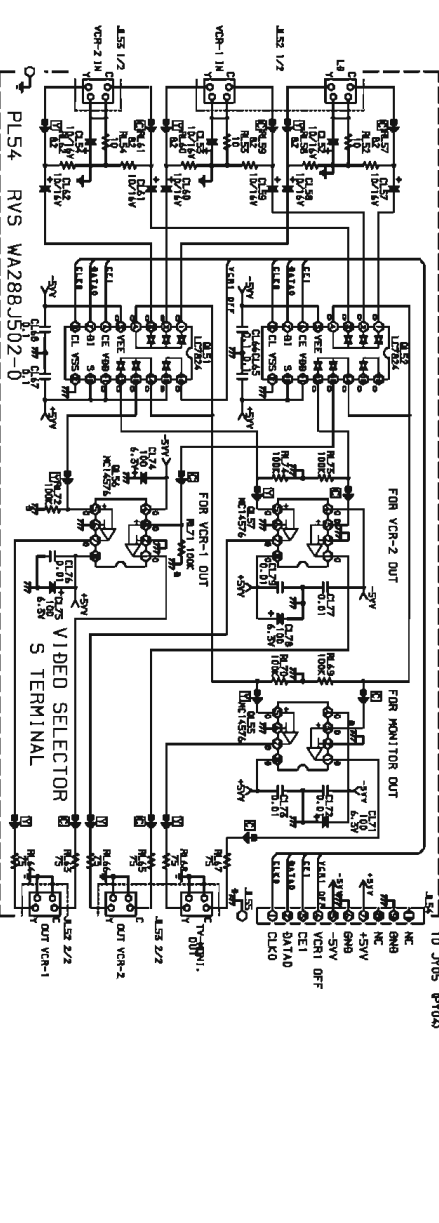
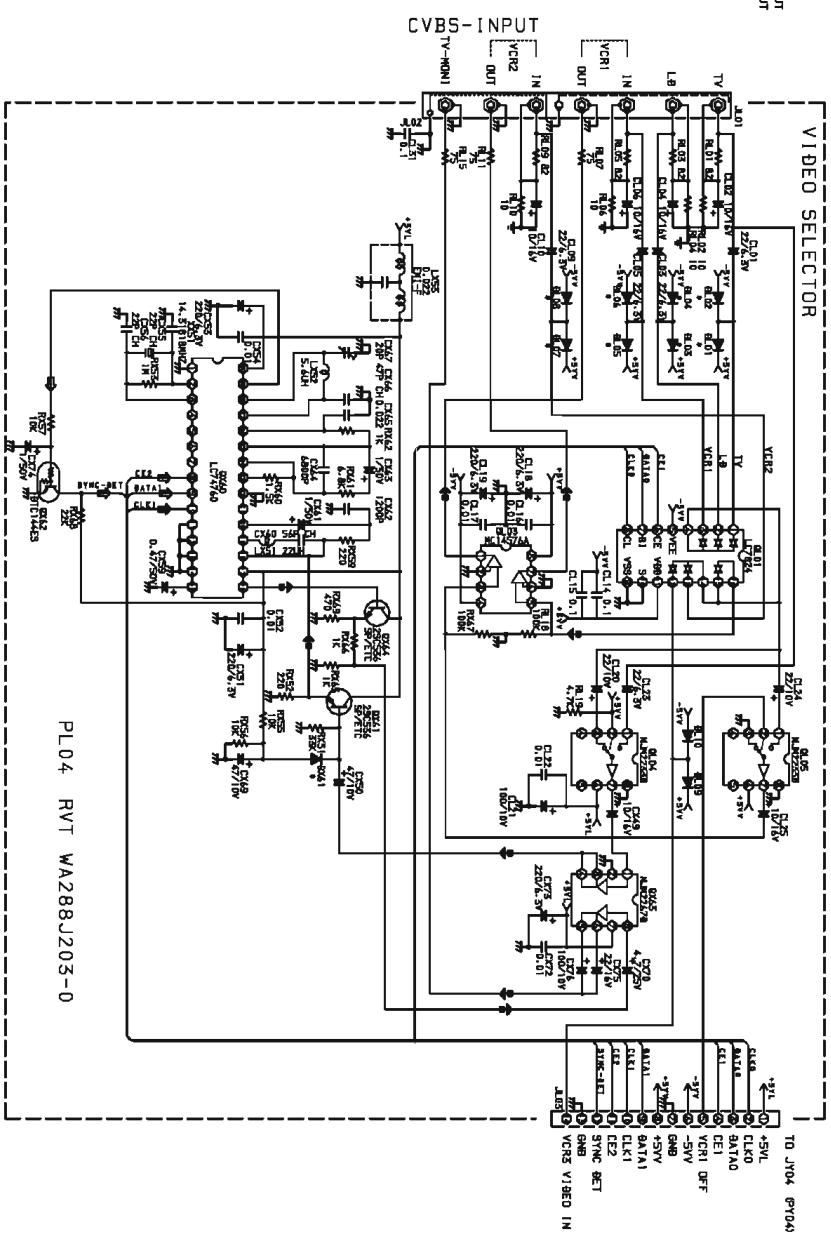
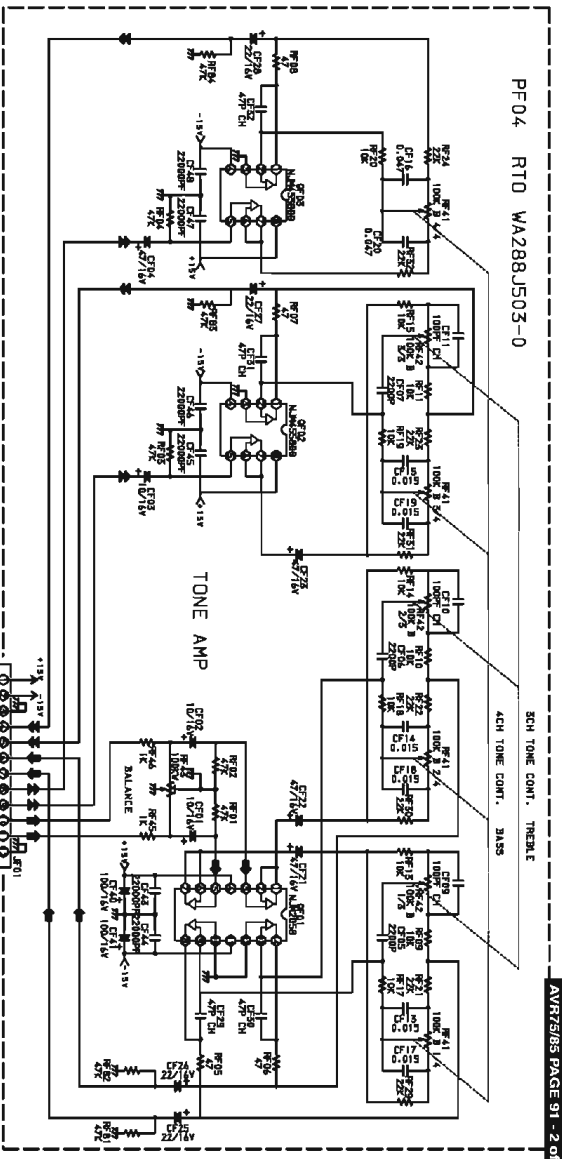
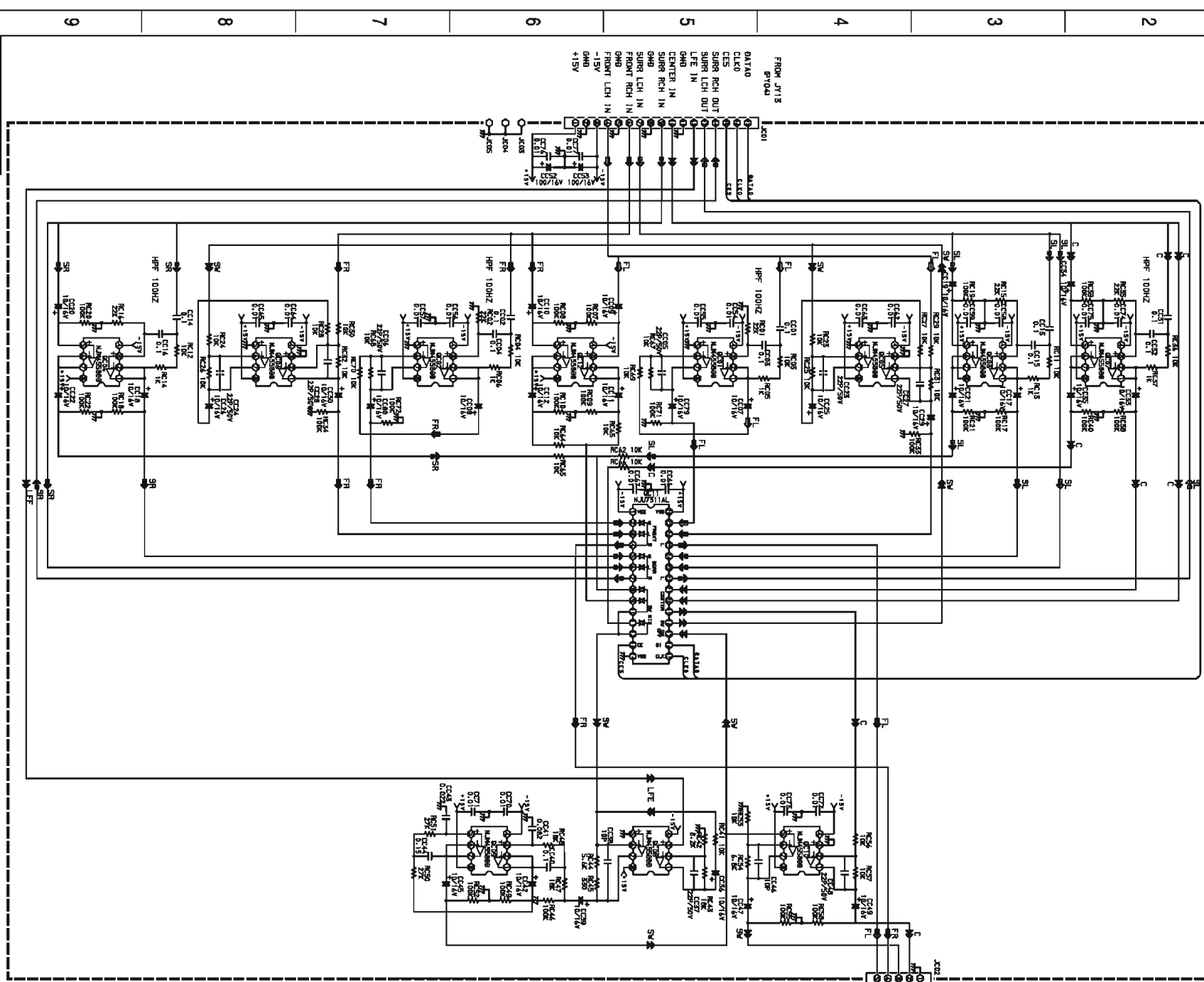

AVR85 (120V) SCHEMATIC DIAGRAM 4 of 8 (AC-3 CROSSOVER PCB - PC04, TONE CONT

AVR75/85 PAGE 91 - 1 of 4

AVR85 US 120V
Schematic 4 of 8

CROSSOVER

PC04 RCR WA288J203-0

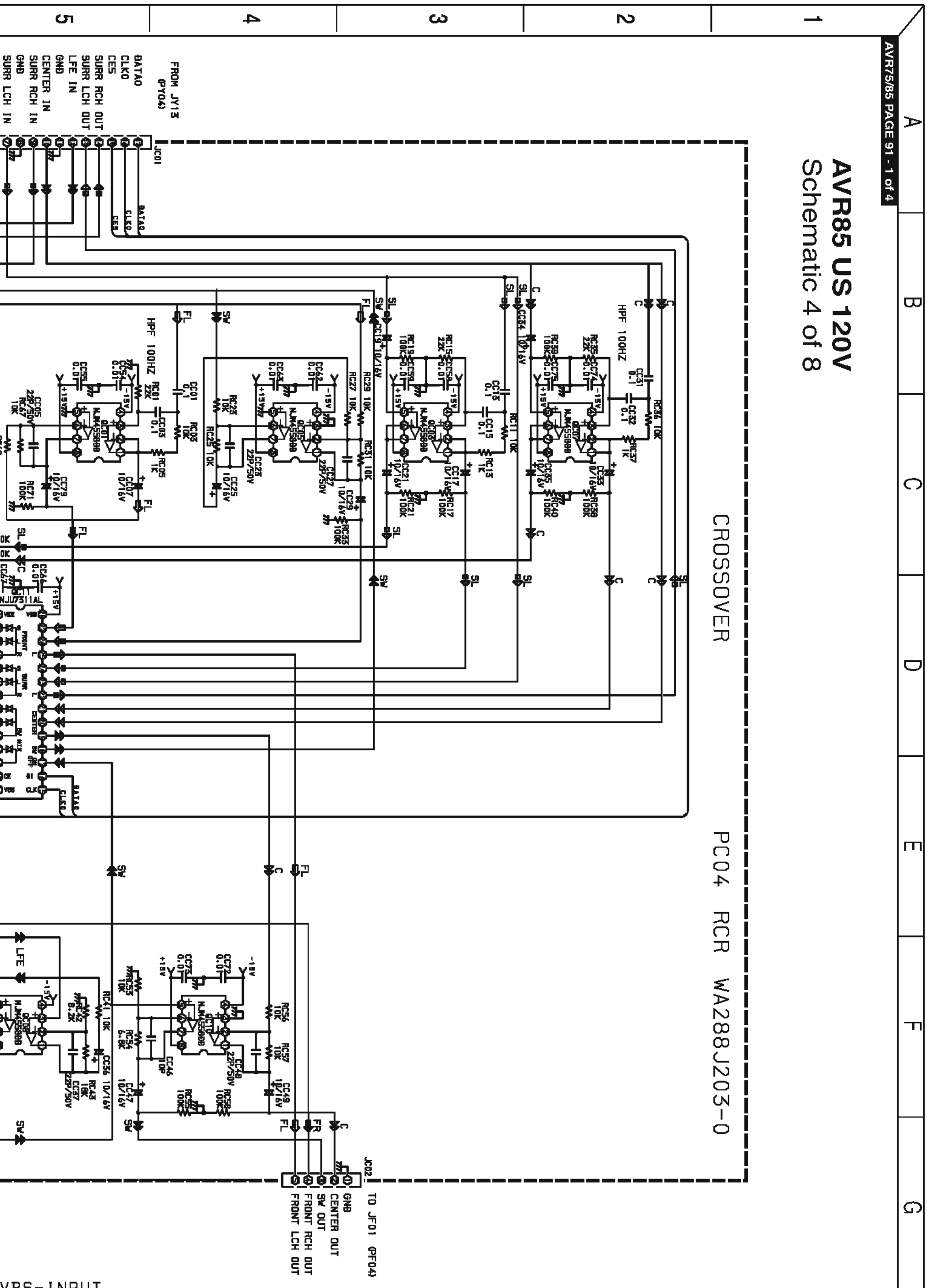

PC04, TONE CONTROL PCB - PF04, VIDEO SELECTOR PCB - PL04, S-VIDEO PCB - PL54)

G

H

J

K

M

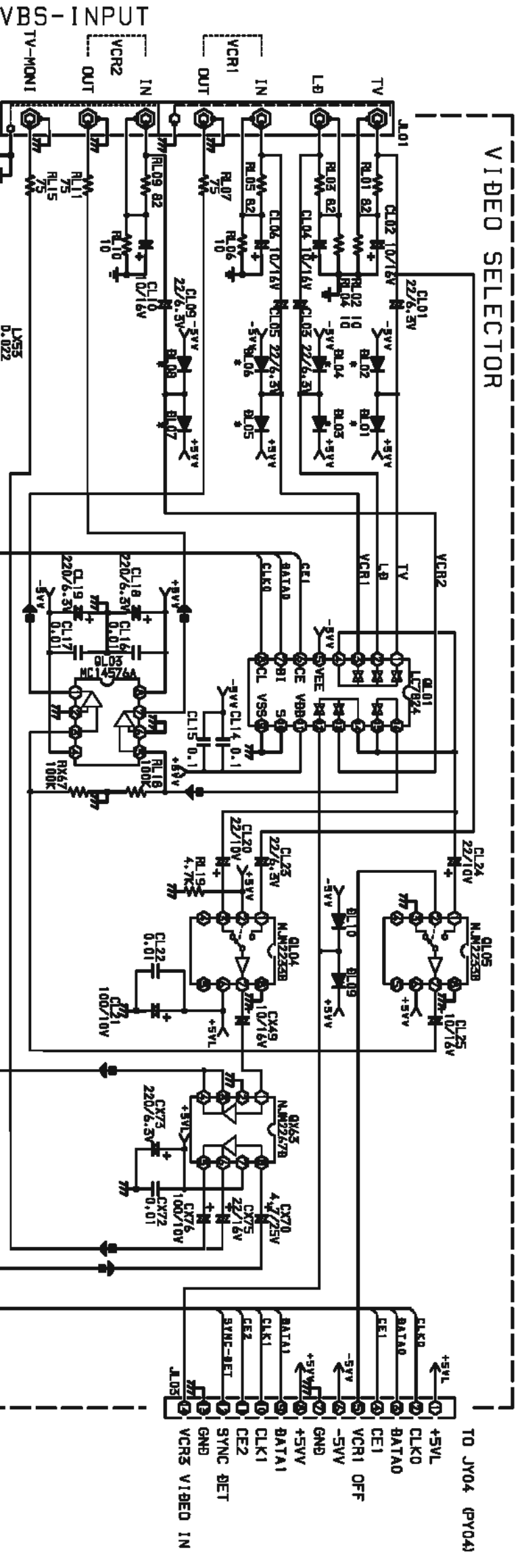
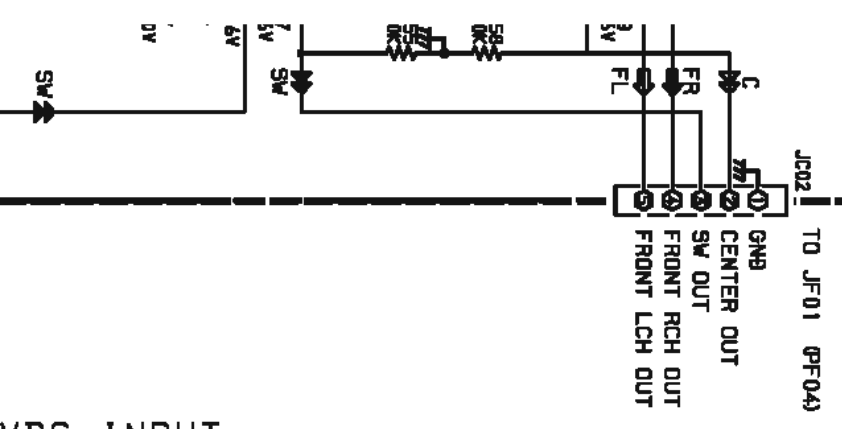
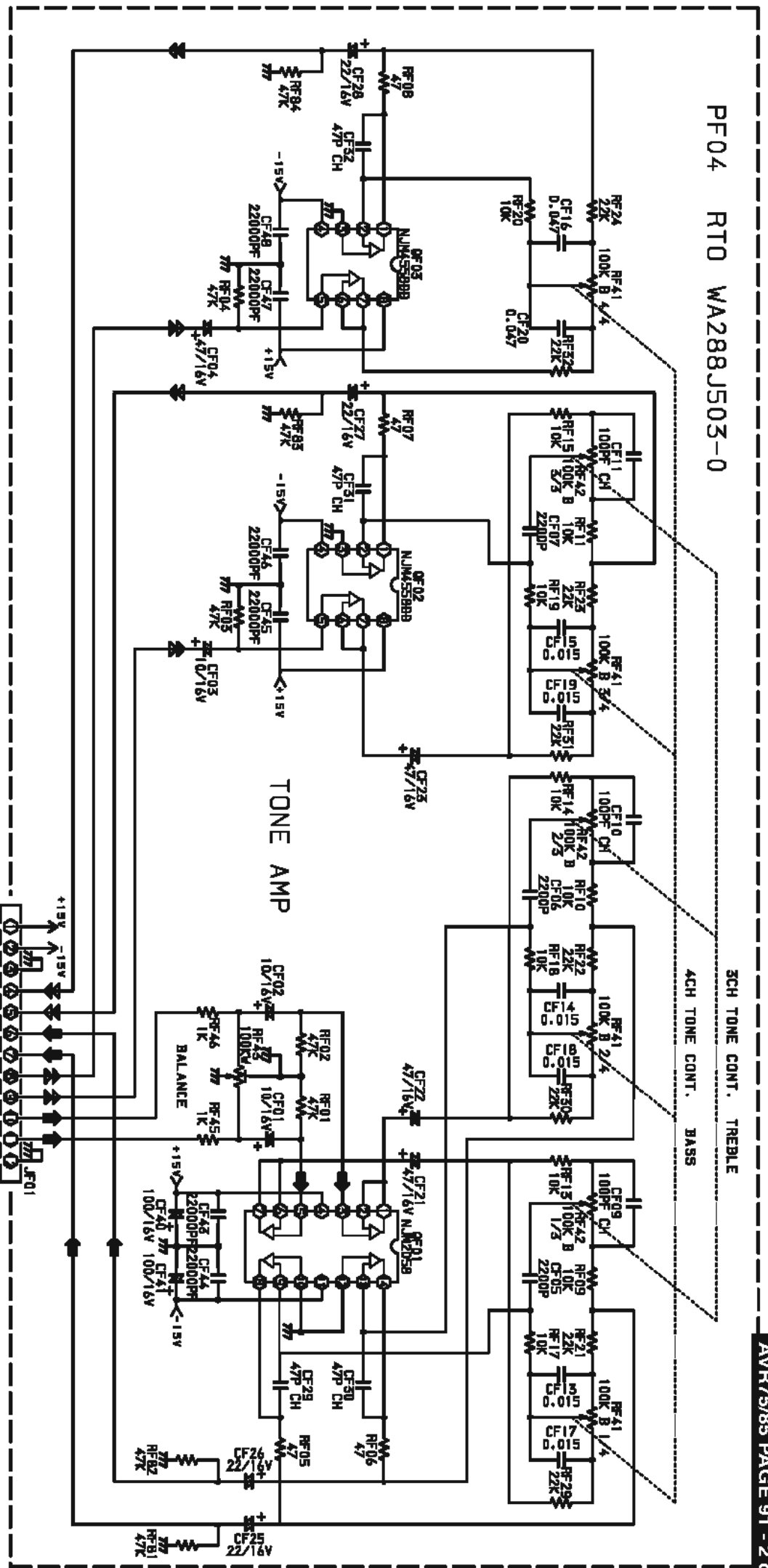

3

2

1

4

5

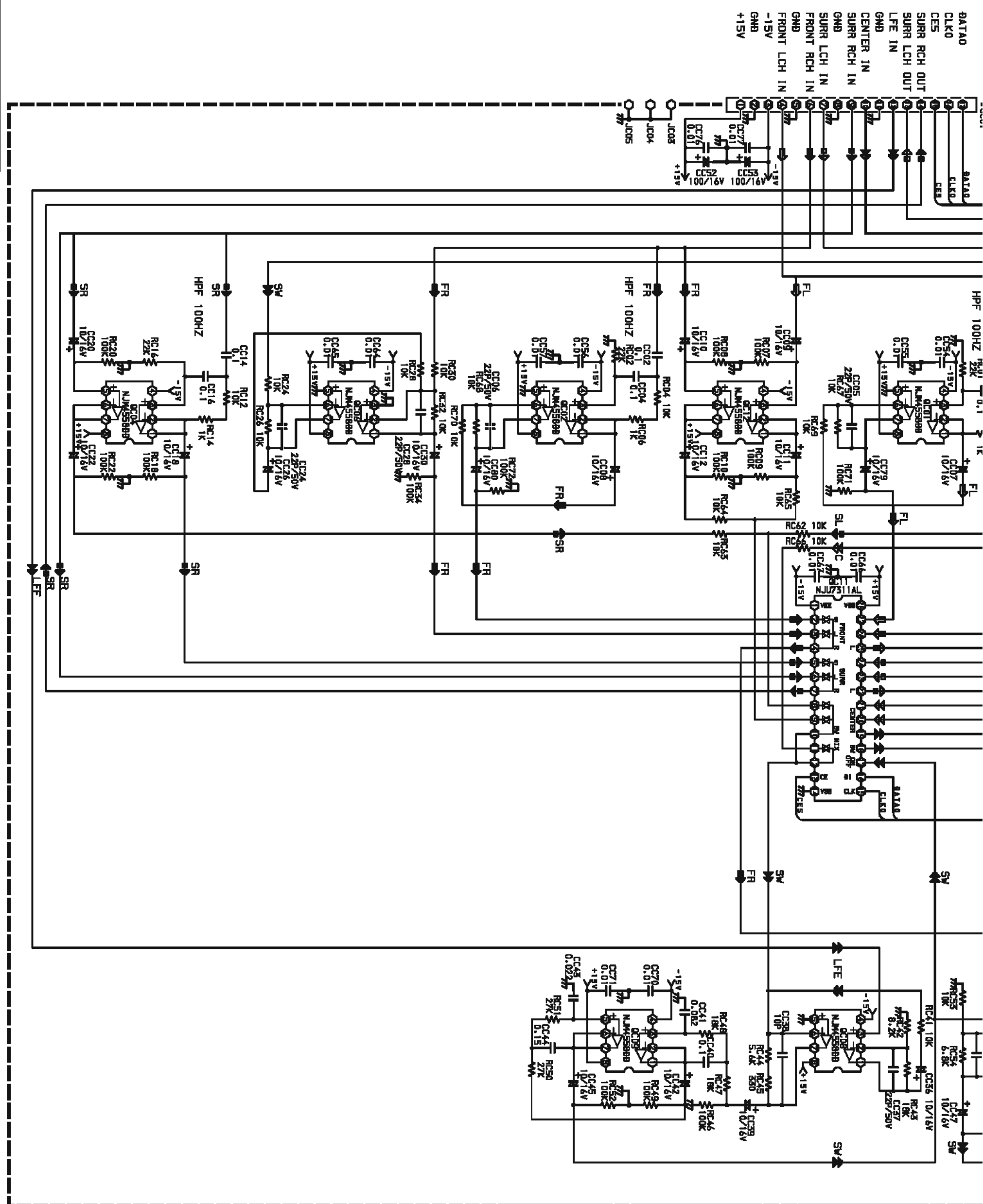

BATAO
CLK0
CES
SURR RCH OUT
SURR LCH OUT
LFE IN
GND
SURR RCH IN
CENTER IN
SURR LCH IN
FRONT RCH IN
FRONT LCH IN
GND
-15V
+15V

A B C D E F G

9

8

7

6

5

CVBS-INPUT

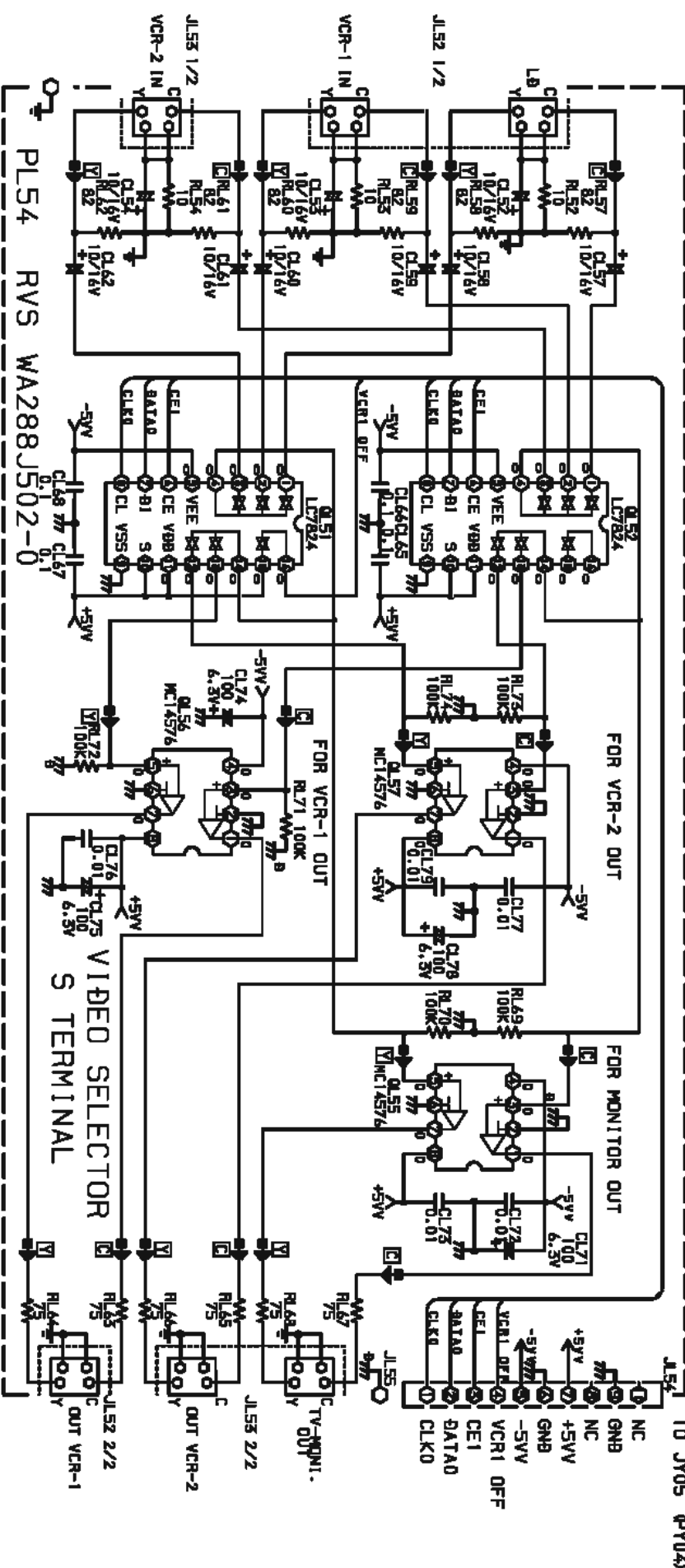
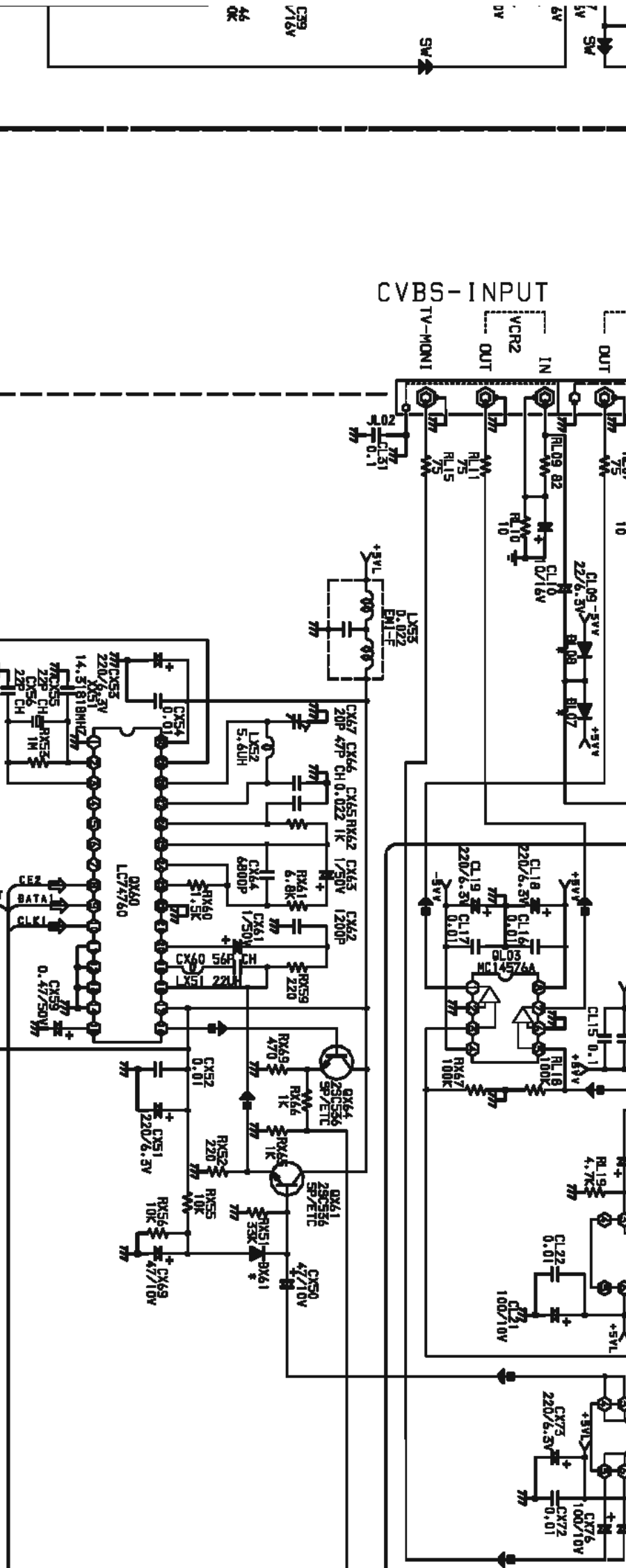

AVR85 (120V) SCHEMATIC DIAGRAM 5 of 8 (CONNECT PCB - PY04)

AVR85 US 120V
Schematic 5 of 8

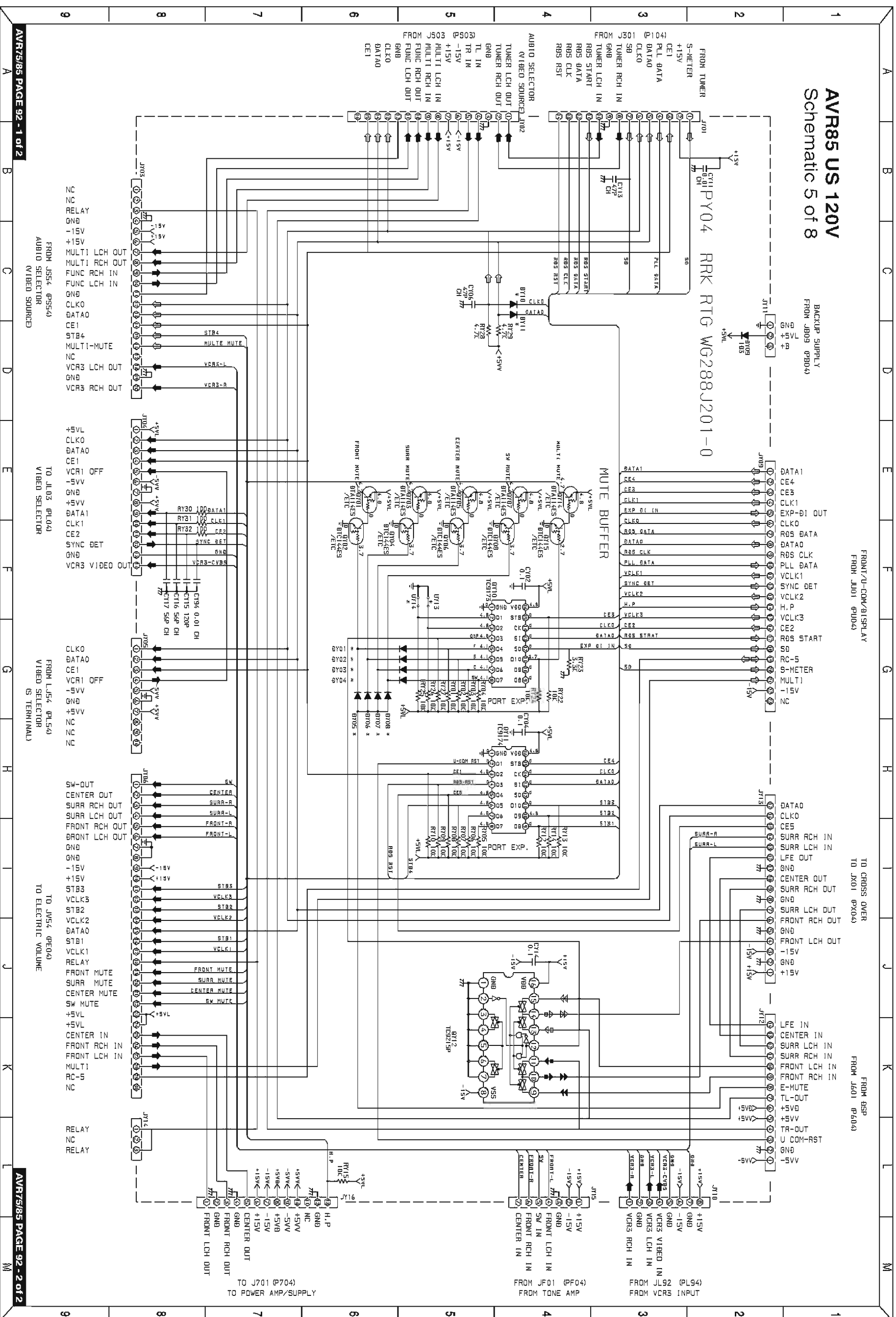

AVR75/85 PAGE 92 - 1 of 2

AVR75/85 PAGE 92 - 2 of 2

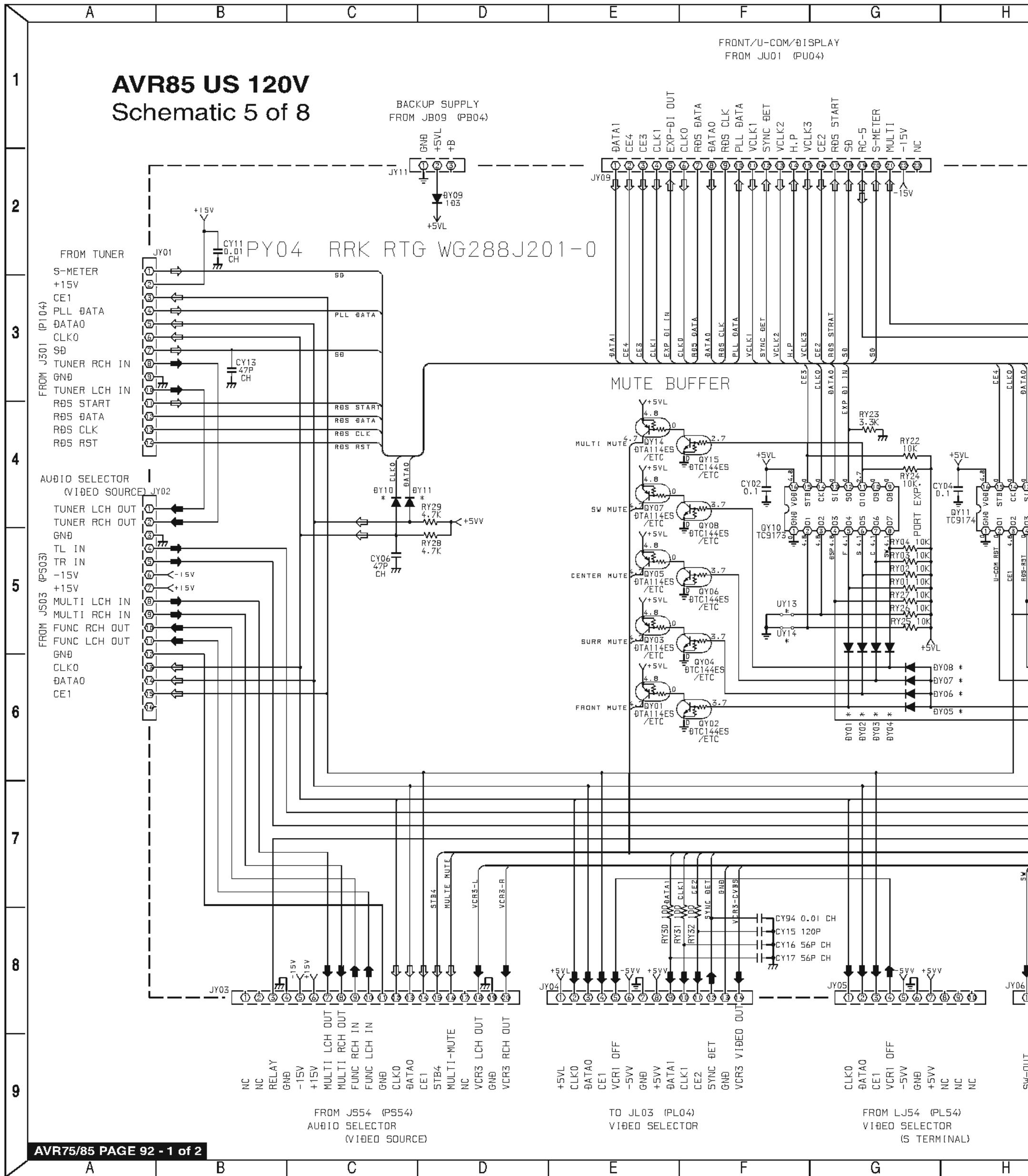

SCHEMATIC DIAGRAM 5 of 8 (CONNECT PCB - PY04)

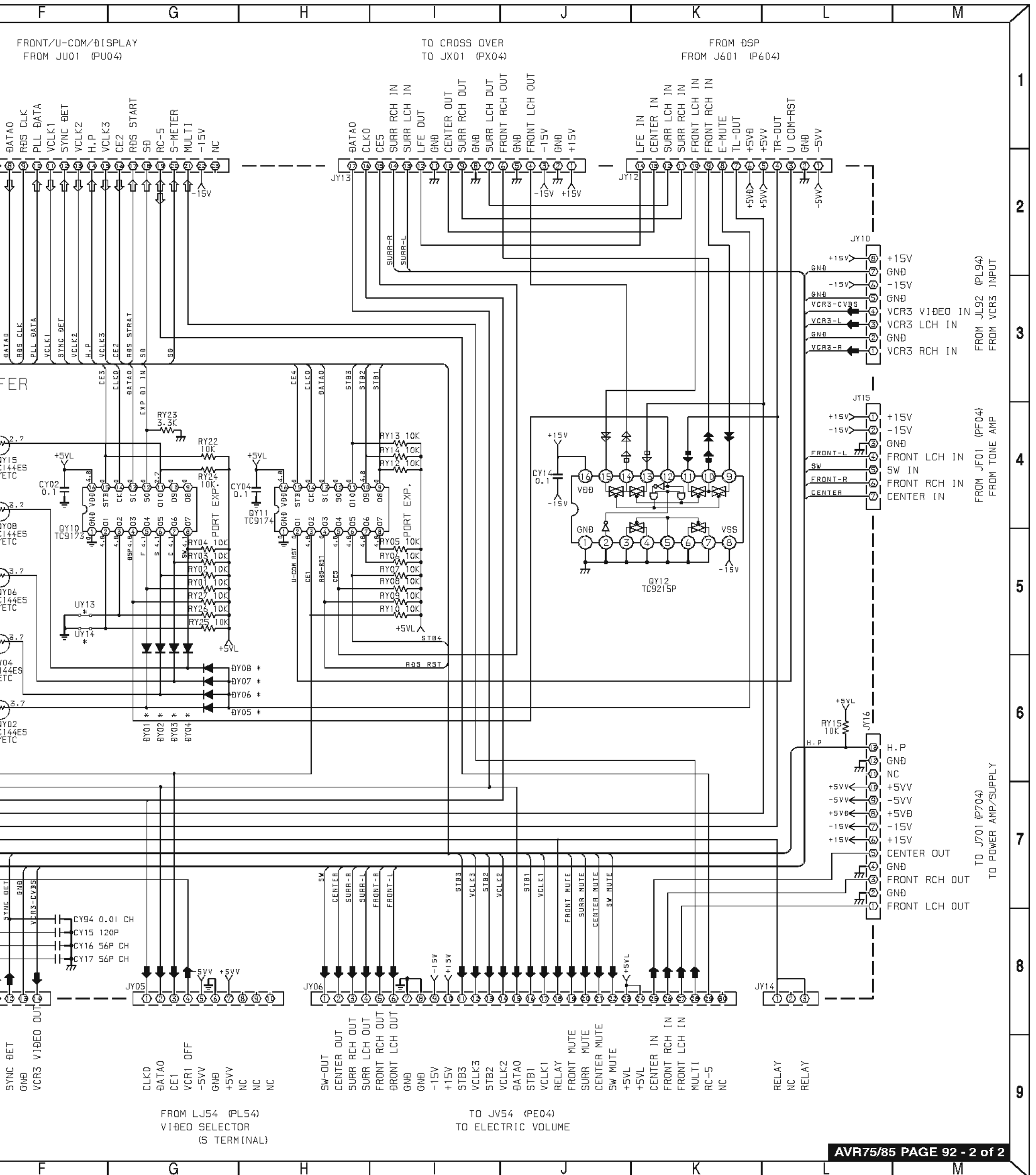

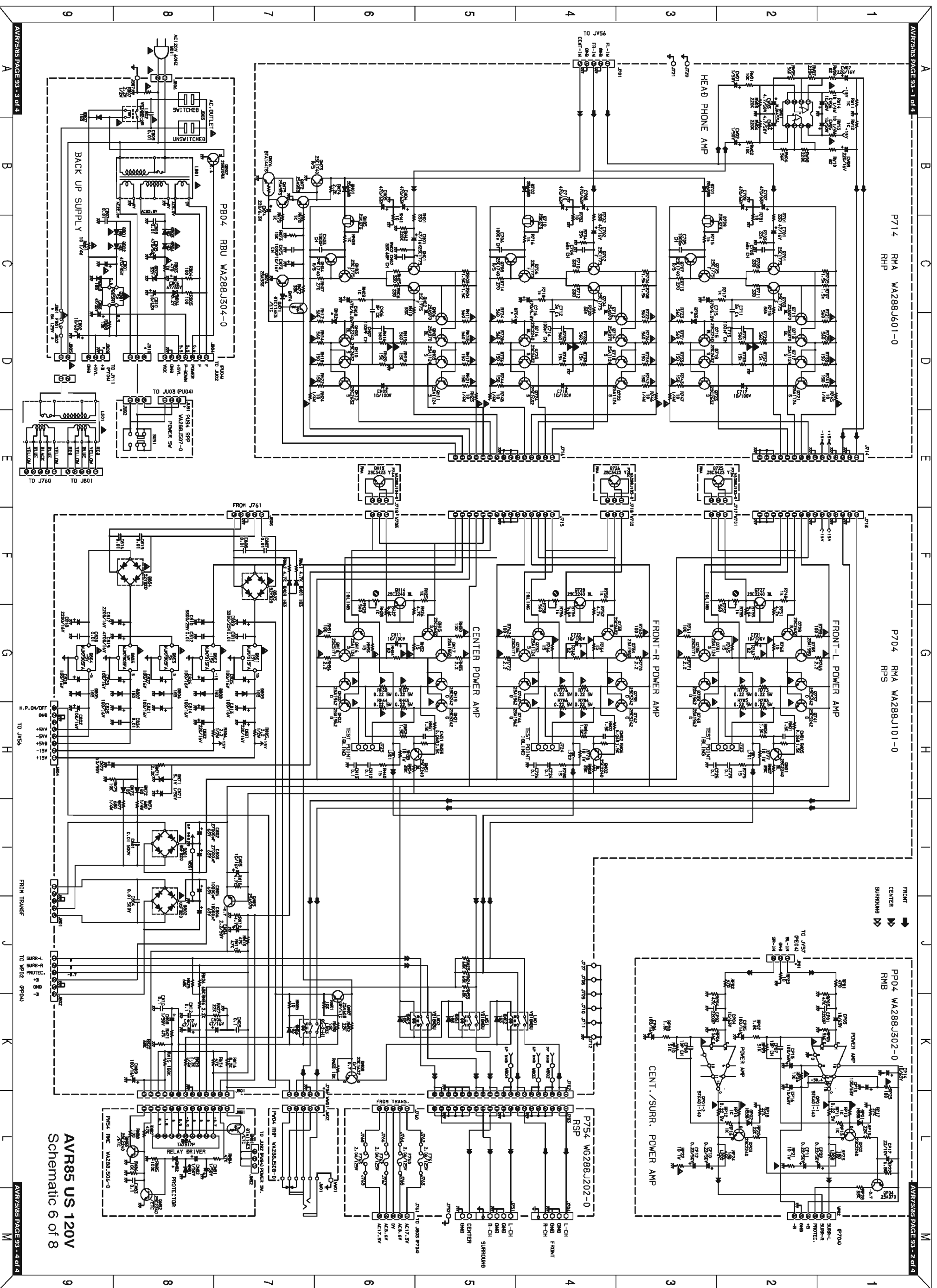

AVR85 US 120V
Schematic 6 of 8

AVR85 (120V) SCHEMATIC DIAGRAM 6 of 8 (VOLTAGE AMP PCB - P714, MAIN PCB -
HEADPHONE PCB - PW04, SPEAKER PROTECT PCB - PN54, STAN

AVR75/85 PAGE 93 - 1 of 4

P714 RMA WA288J601-0
RHP

P704 RMA W/
RPS

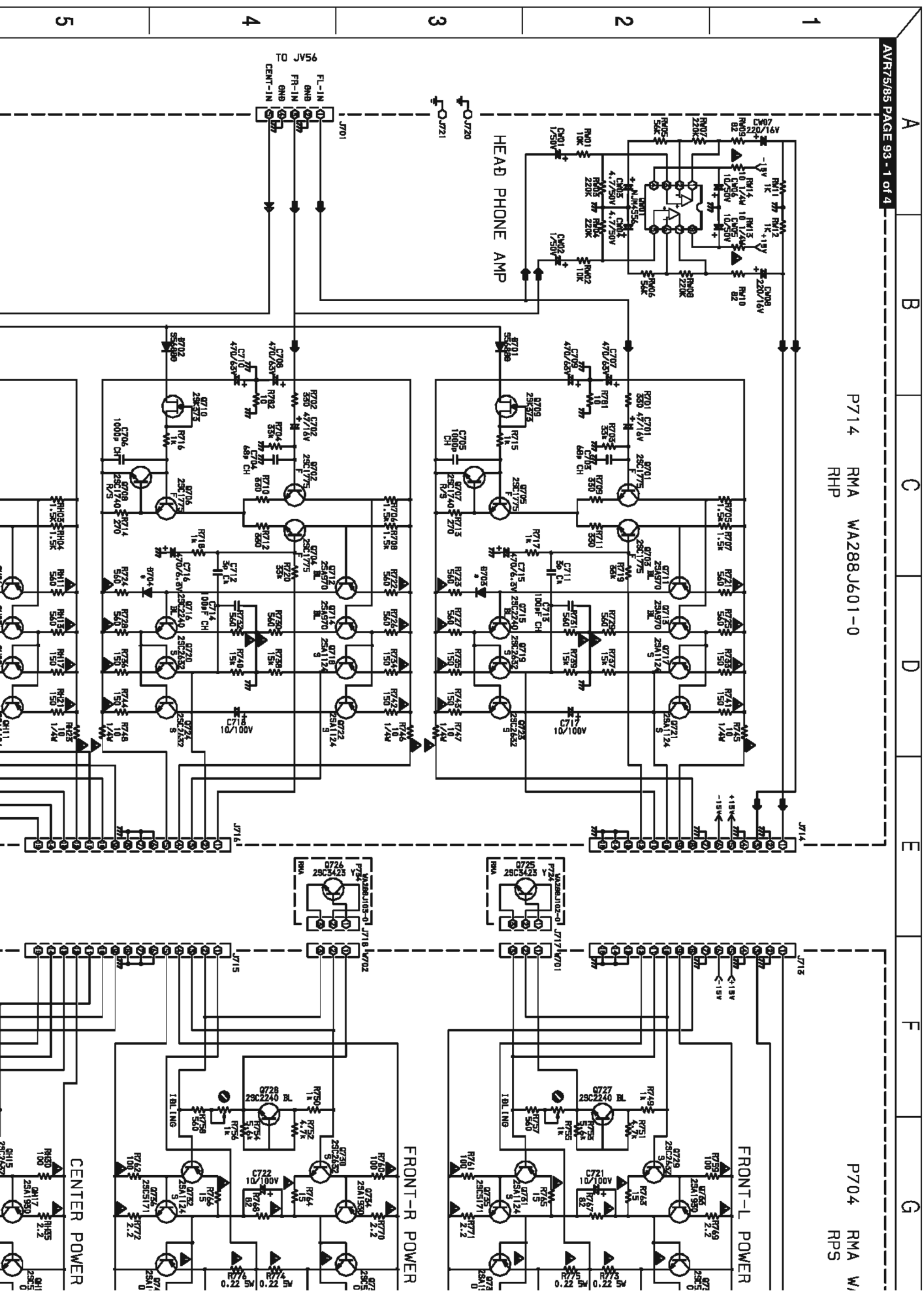

. P714, MAIN PCB - P704, SURROUND AMP PCB - PP04, SPEAKER TERMINAL - P754,
PCB - PN54, STANDBY PCB - PB04, POWER SWITCH PCB - PU94)

G H J K L M

P704 RMA WA288J101-0
RPS

FRONT-L POWER AMP

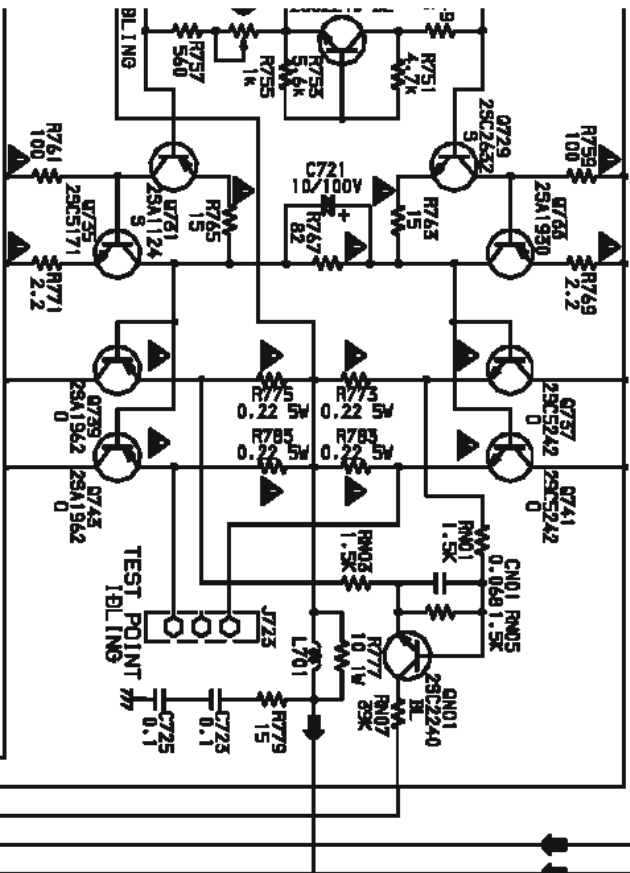

FRONT-R POWER AMP

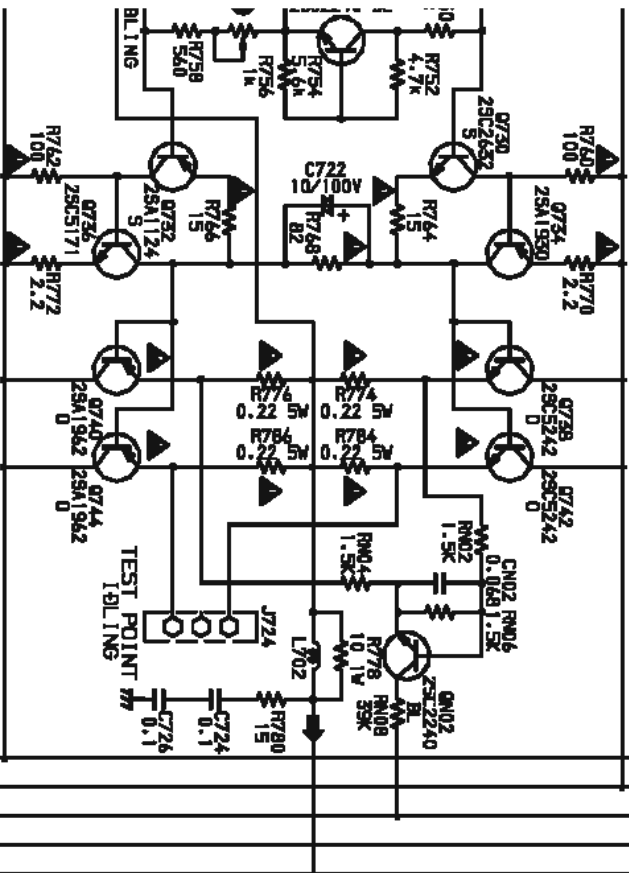

CENTER POWER AMP

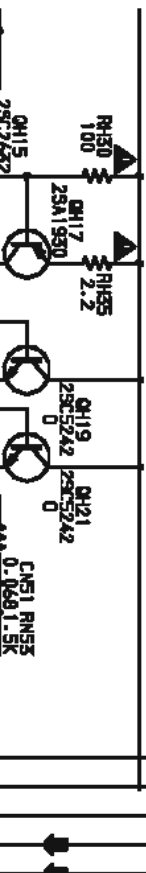

FRONT →
CENTER →
SURROUND →

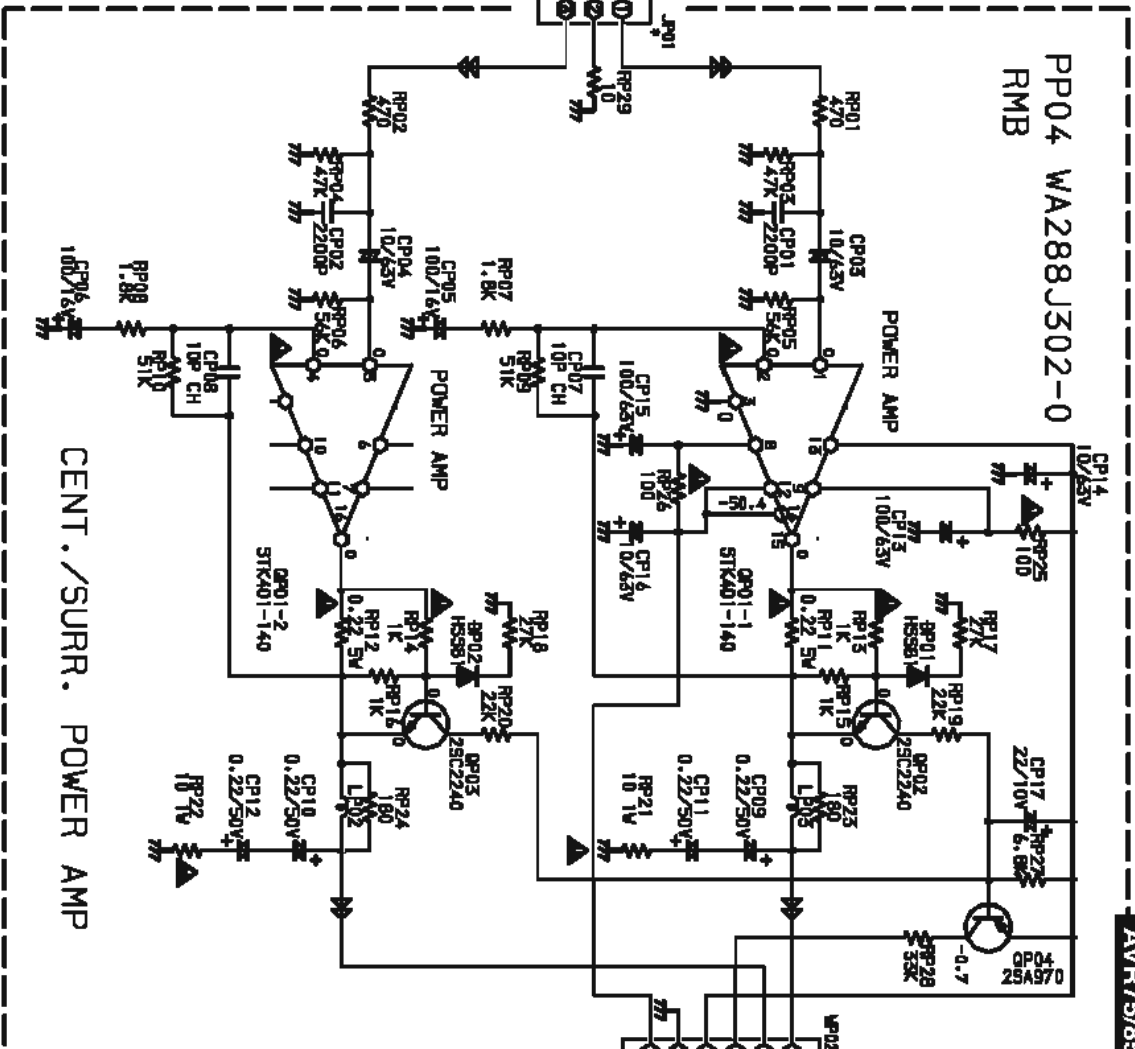

CENT./SURR. POWER AMP

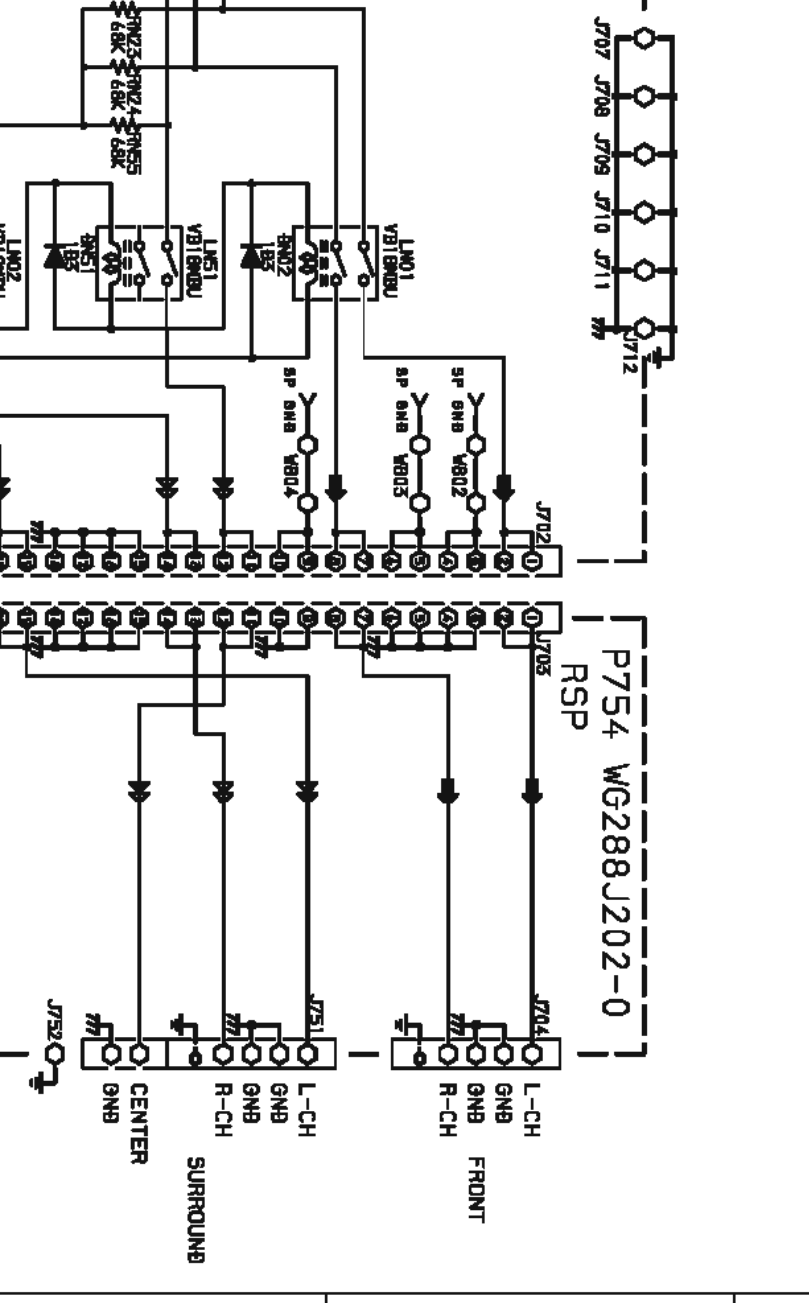

1
2
3
4
5

A B C D E F G

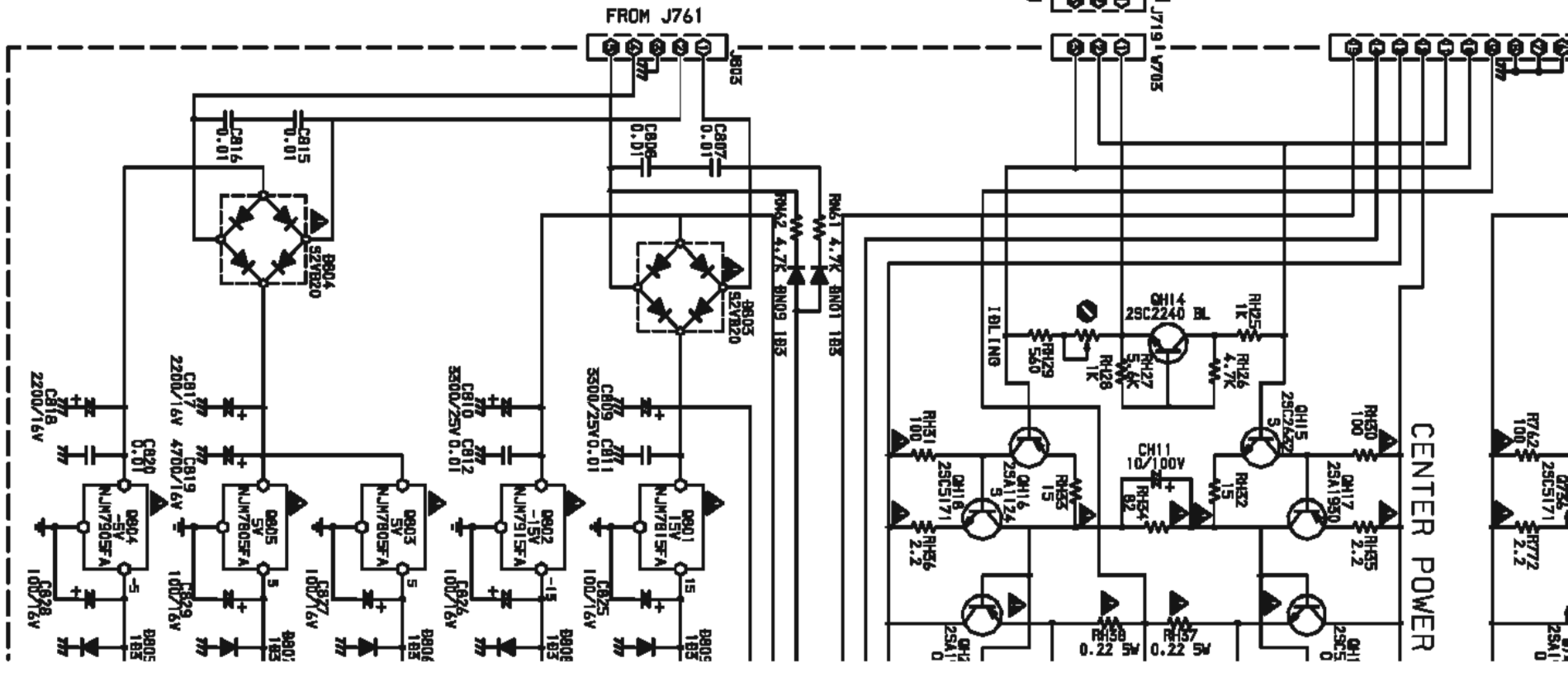
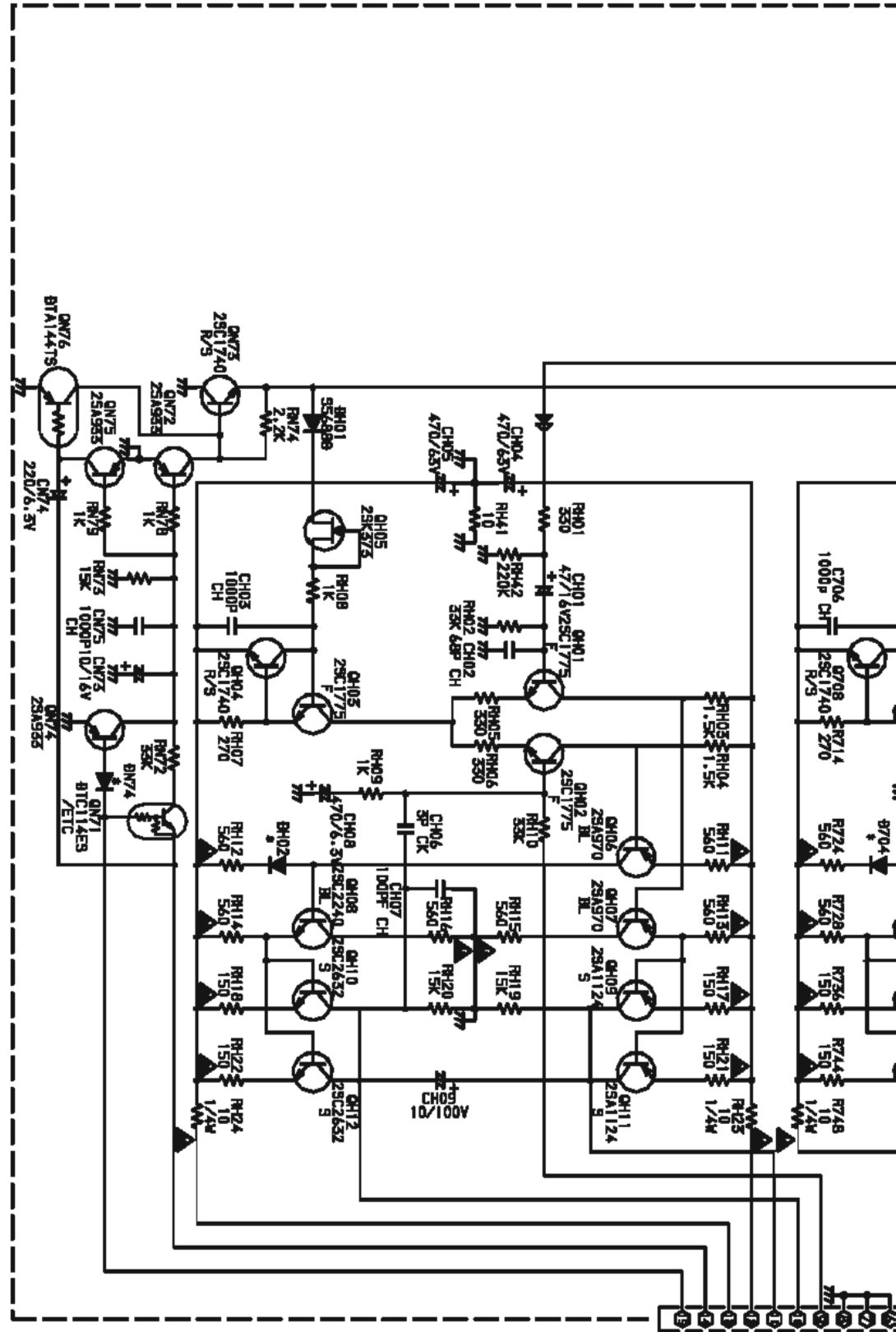
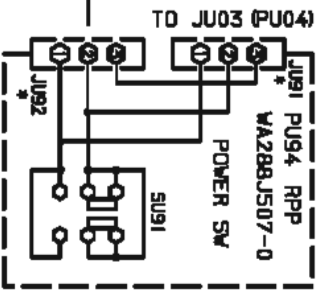
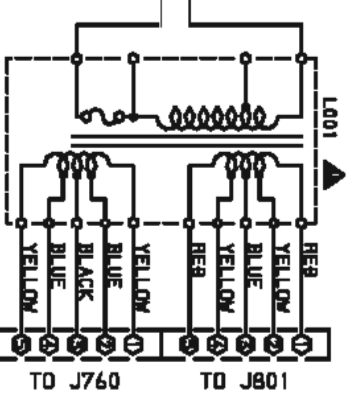
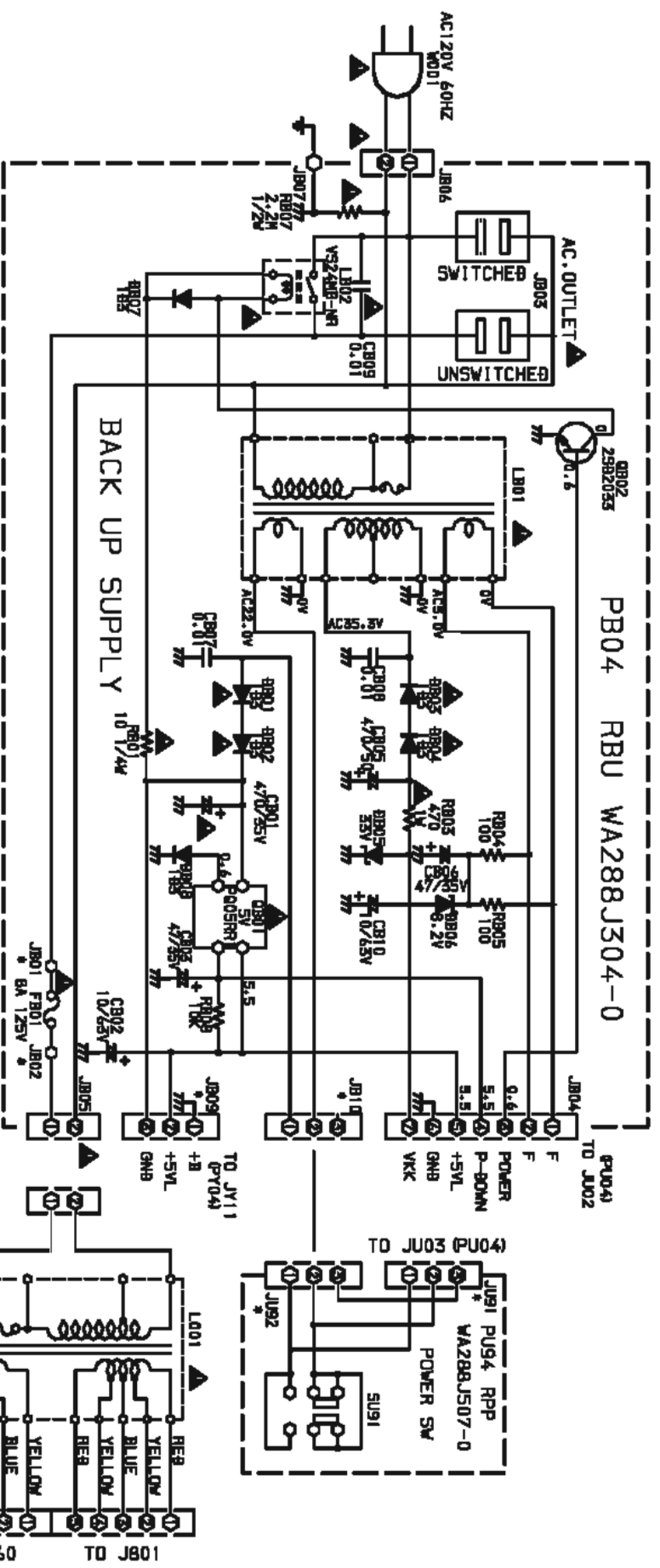

CENTER POWER AMP

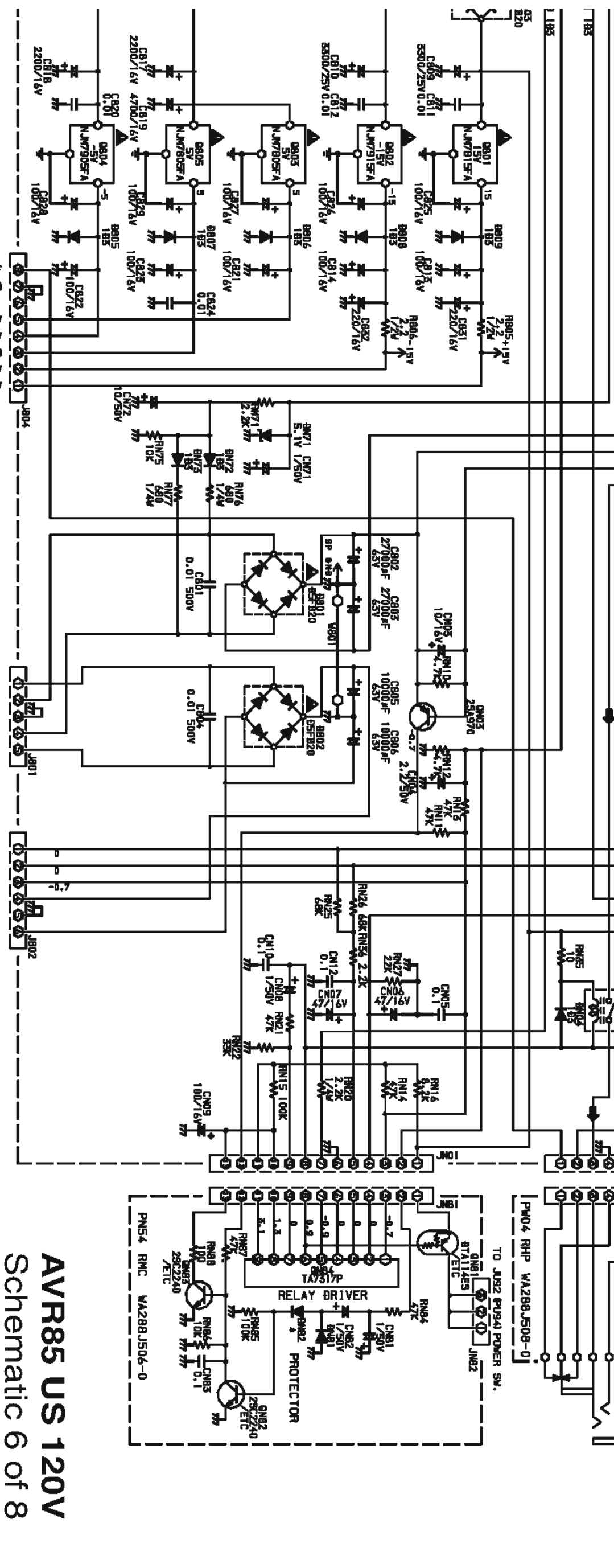
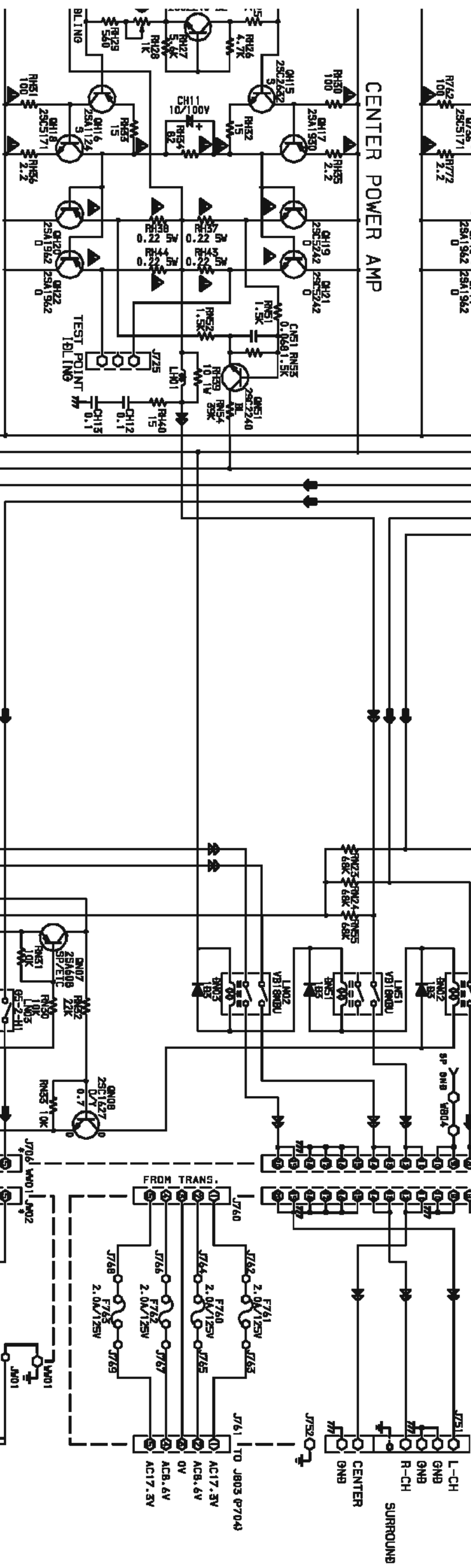

AVR85 US 120V
Schematic 6 of 8

AVR85 US 120V Schematic 7 of 8

ELECTRIC VOLUME PE04 RVR WA288J204-0 RTE

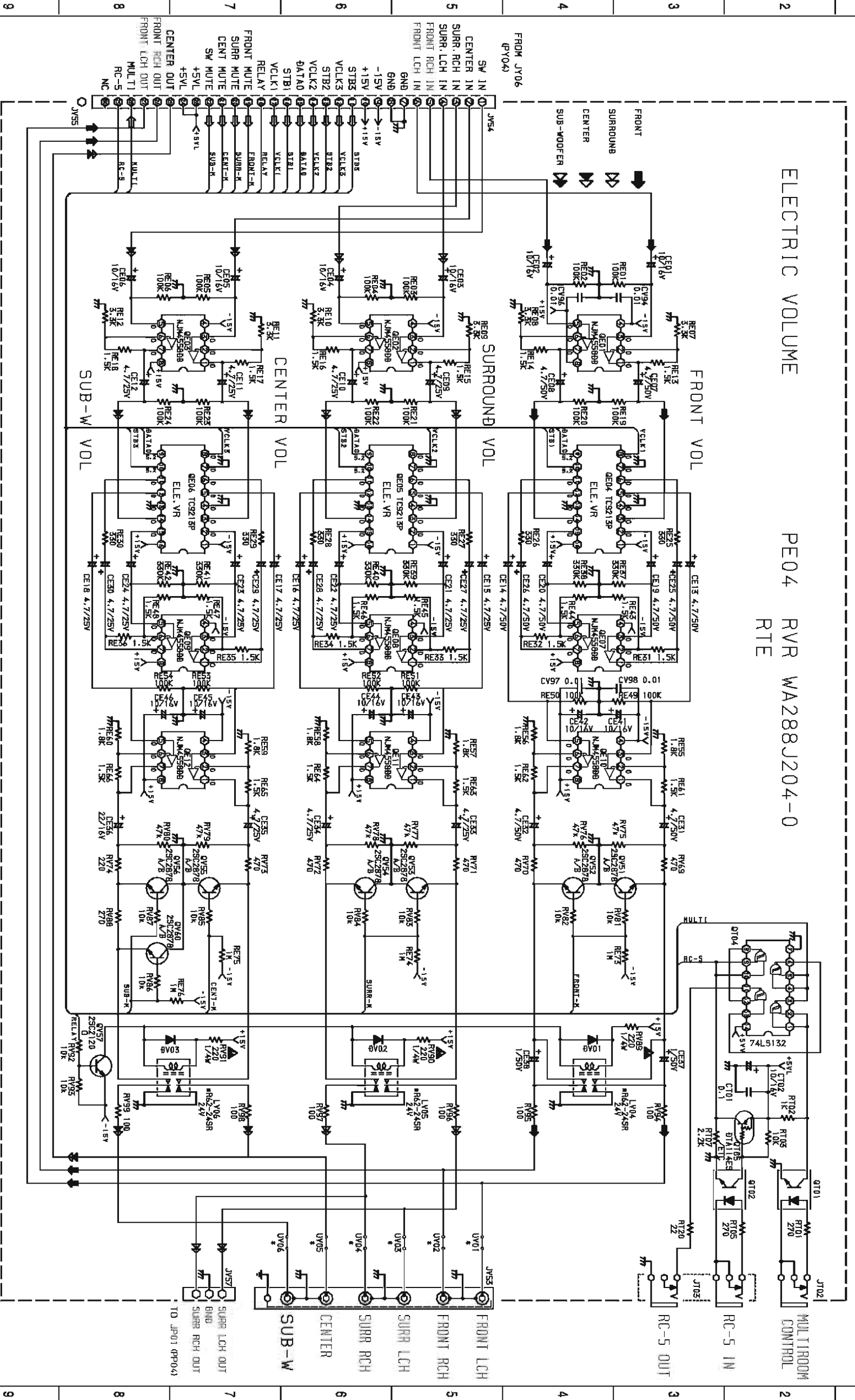

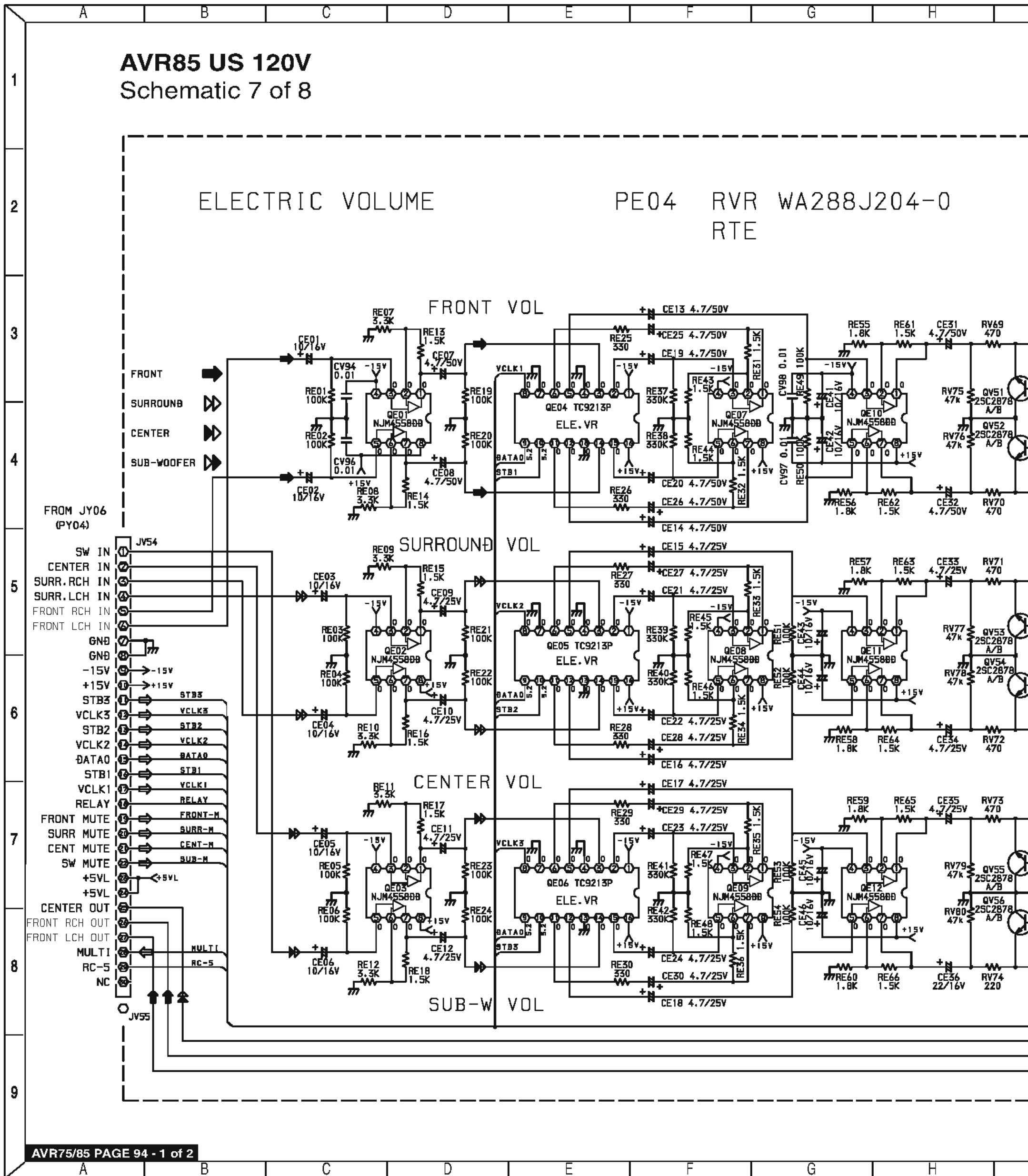

SCHEMATIC DIAGRAM 7 of 8 (ELECTRONIC VOLUME PCB - PE04)

PE04 RVR WA288J204-0
RTE

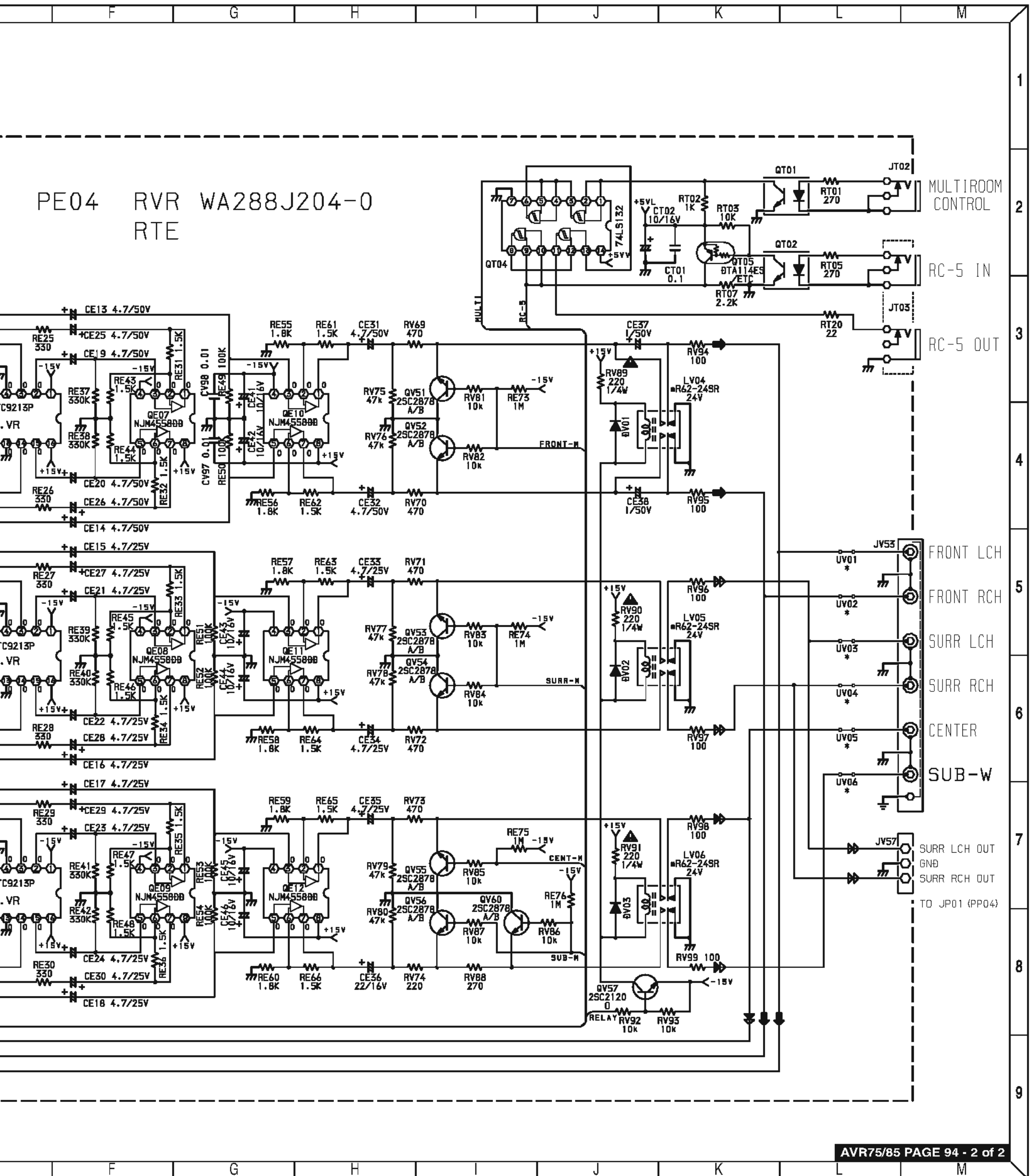

AVR85 (120V & 230V) SCHEMATIC DIAGRAM 8 of 8 (AVR85 DSP BOARD - P604)

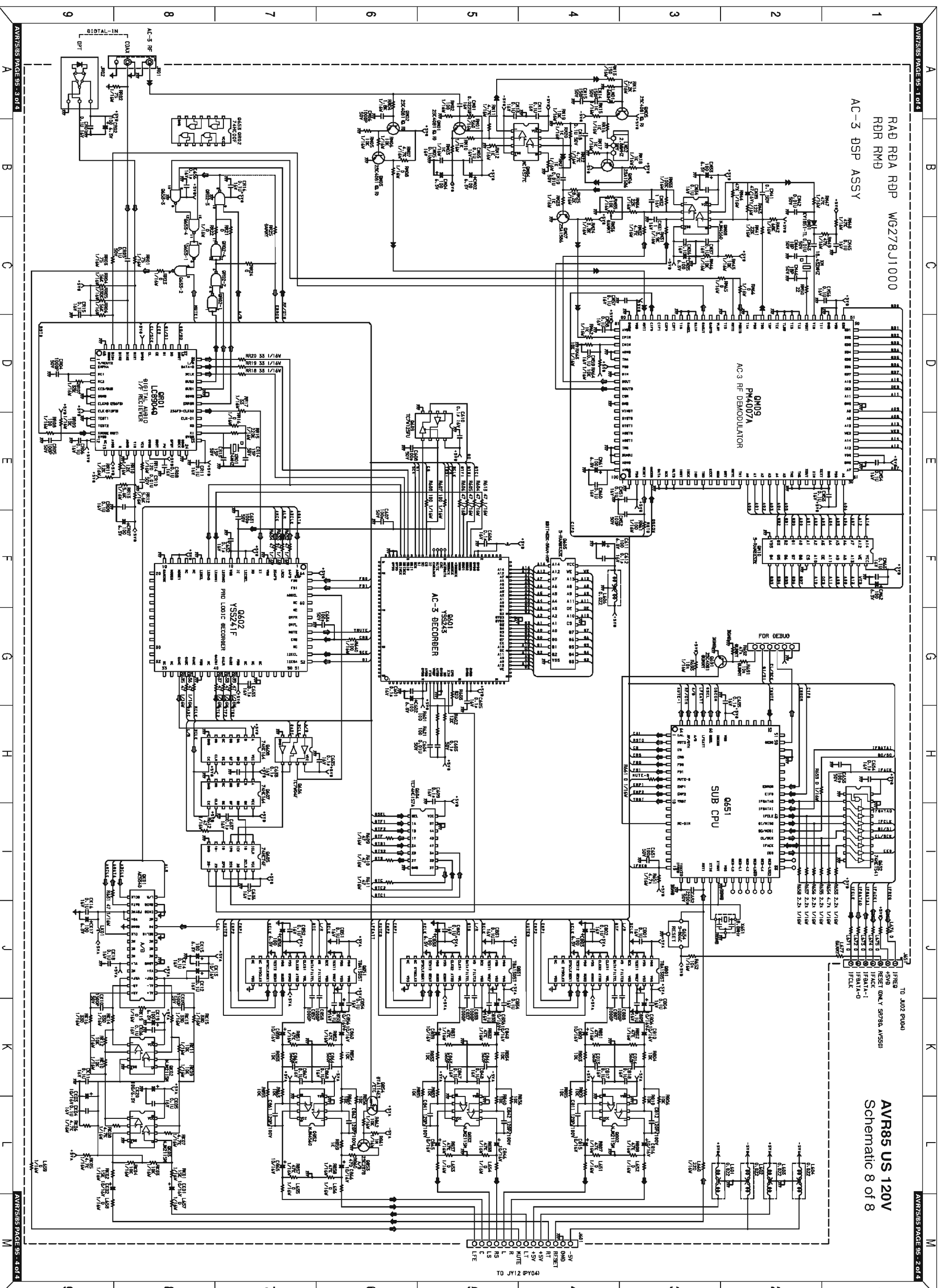

AVR85 US 120V
Schematic 8 of 8

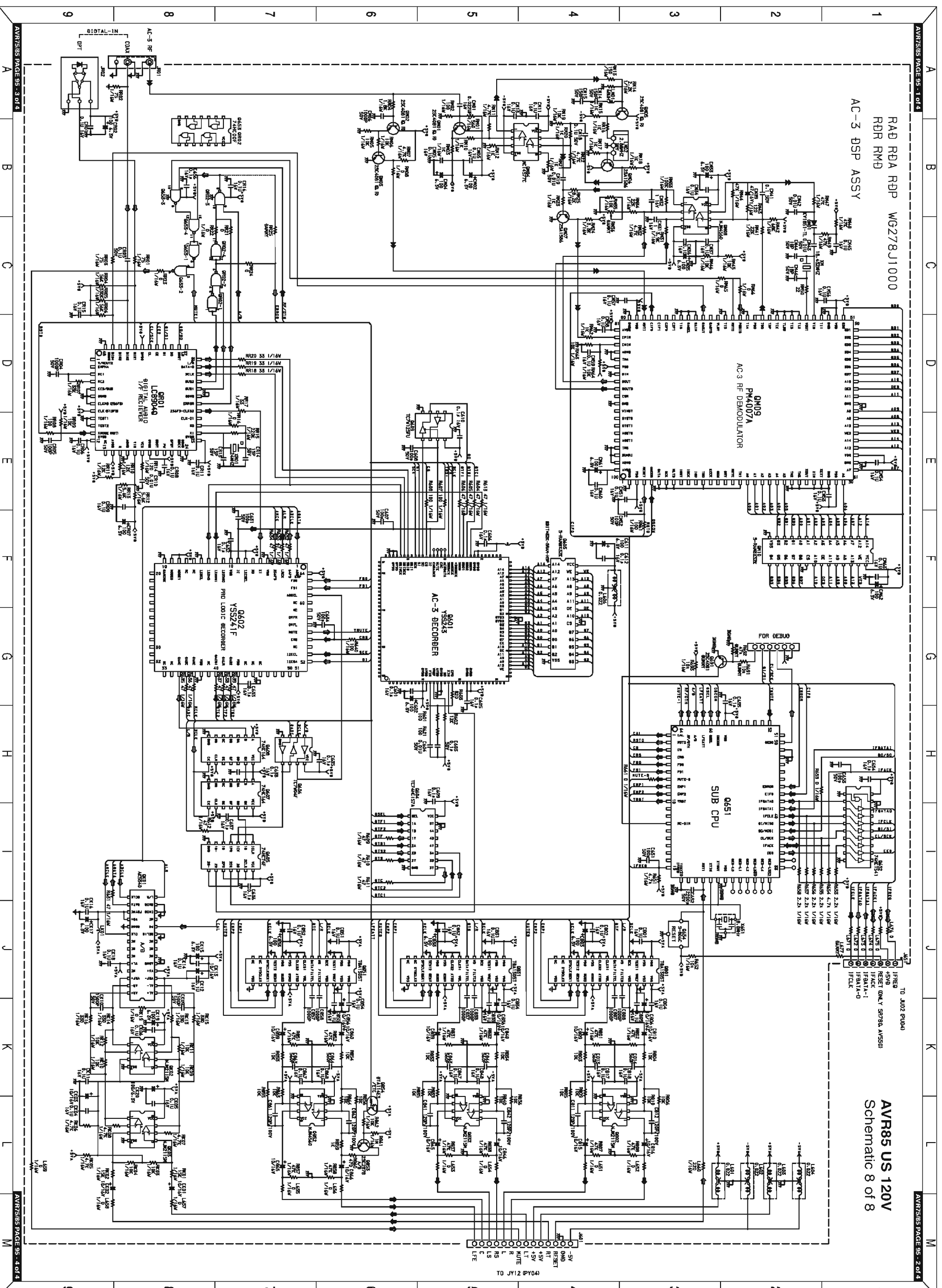

AVR85 US 120V
Schematic 8 of 8

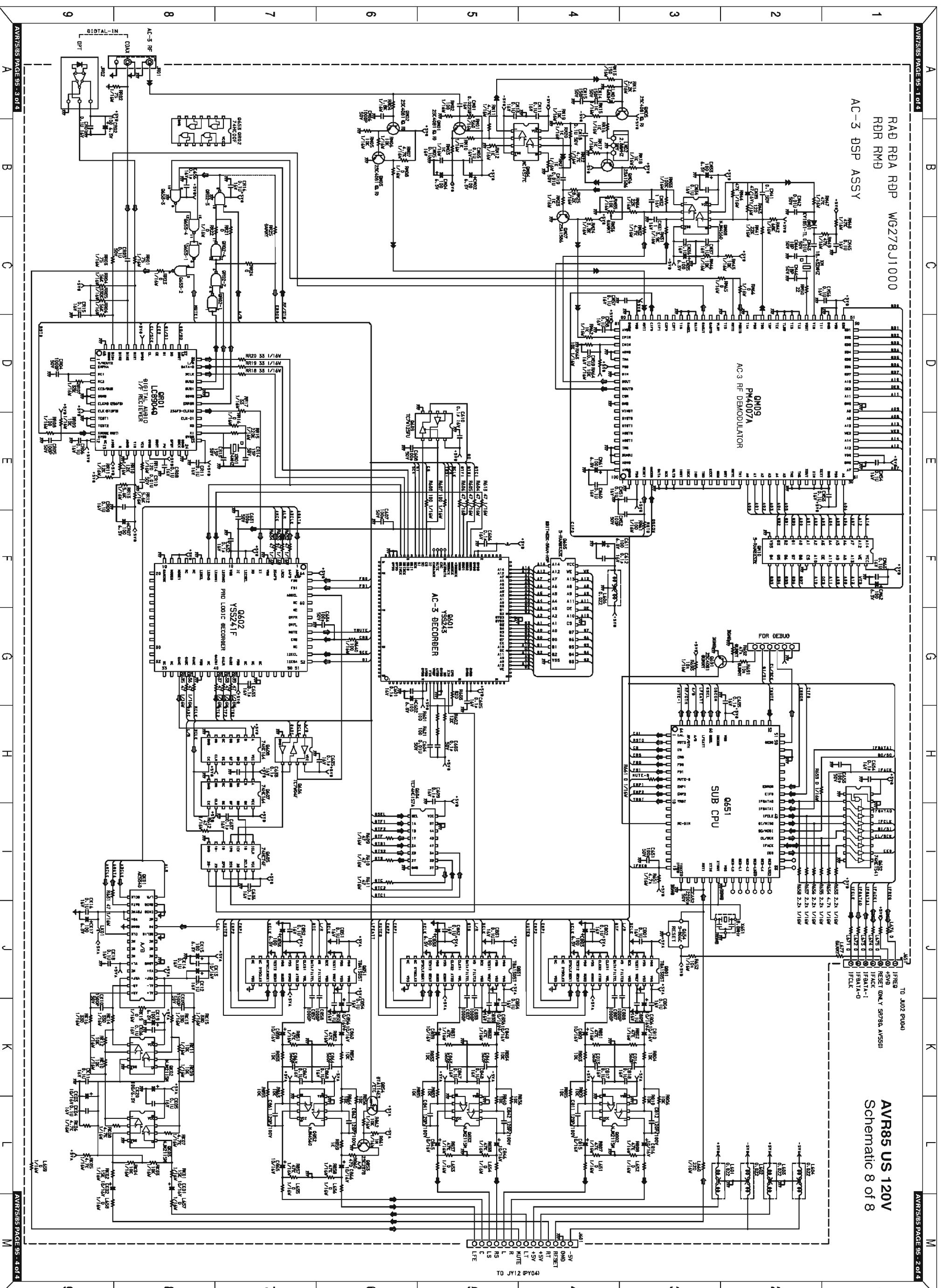

AVR85 US 120V
Schematic 8 of 8

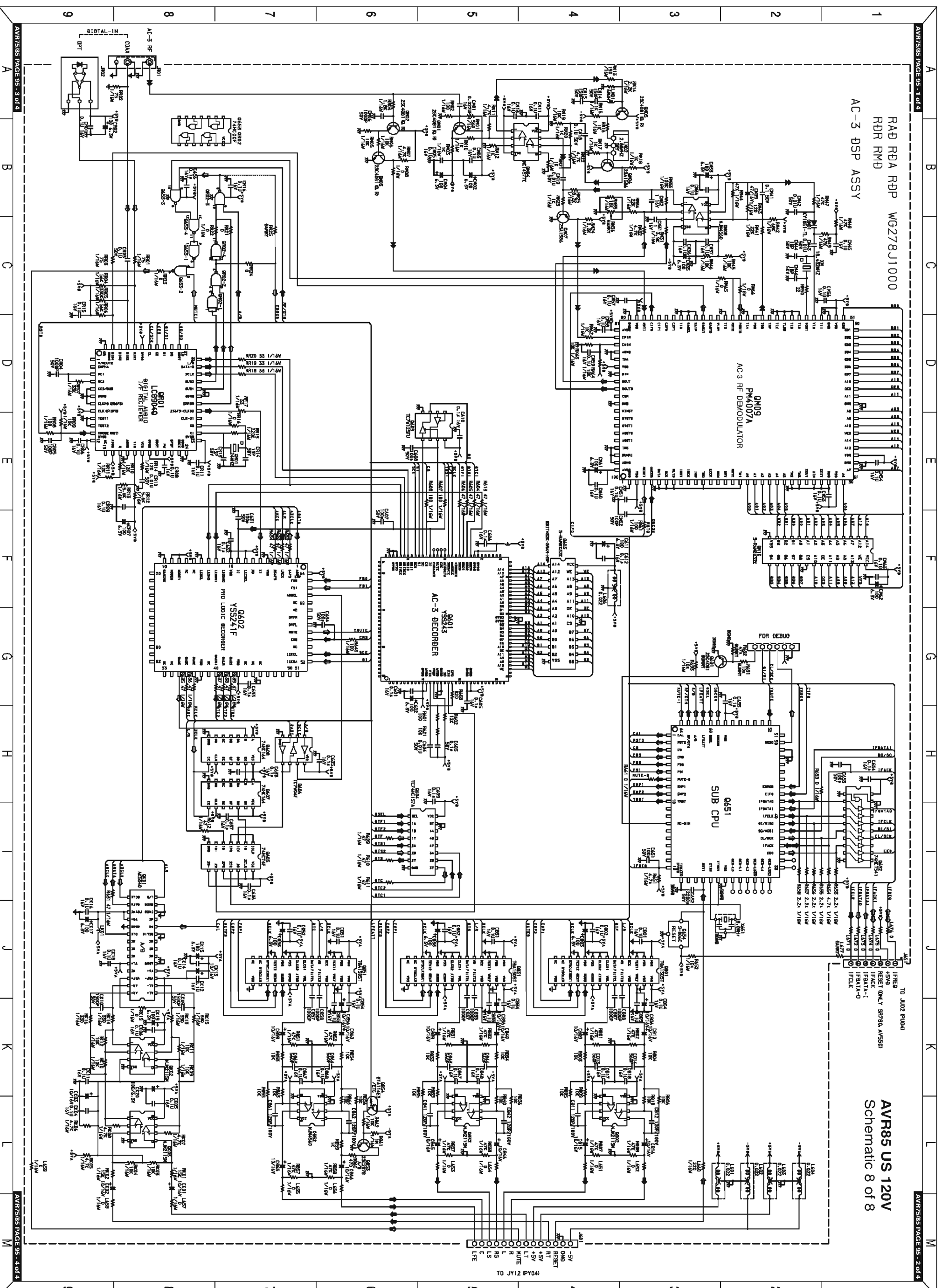

AVR85 US 120V
Schematic 8 of 8

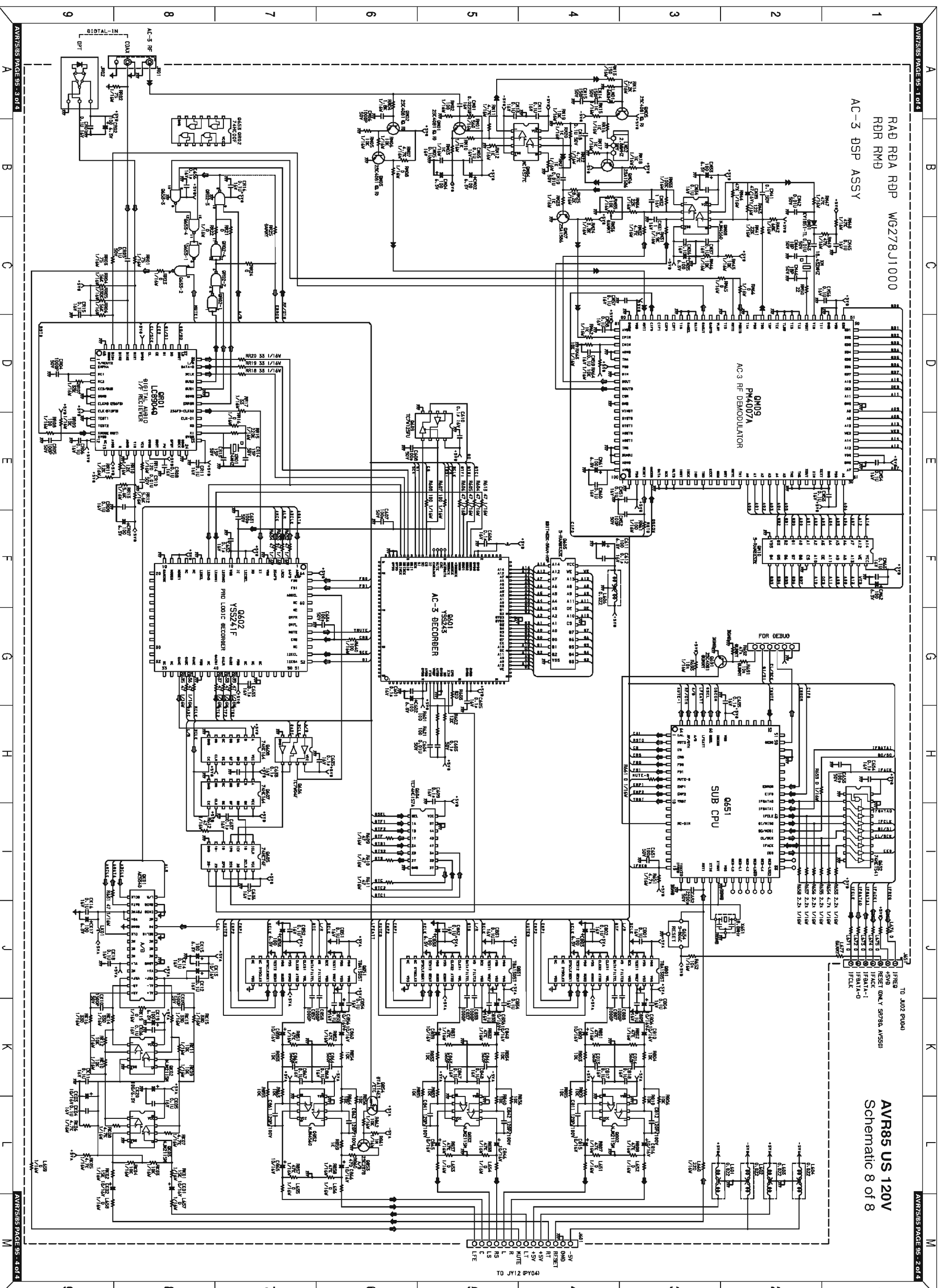

AVR85 US 120V
Schematic 8 of 8

AVR75/85 PAGE 95 - 1 of 4

A B C D E F G

RAD RDA RDP WG278J1000
RDR RMD
AC-3 DSP ASSY

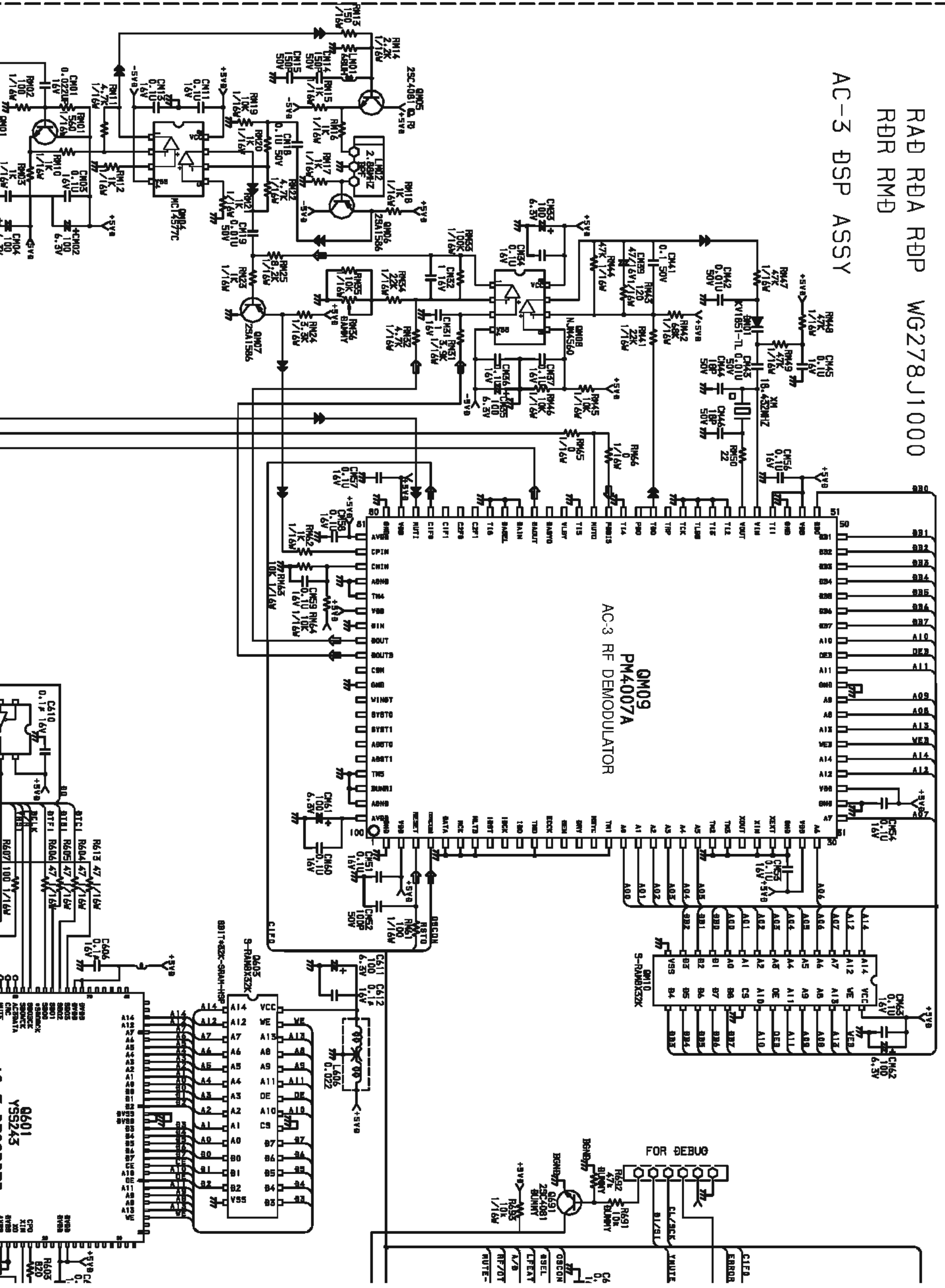

1
2
3
4
5

AVR85 DSP BOARD - P604

G H J K L M

AVR85 US 120V
Schematic 8 of 8

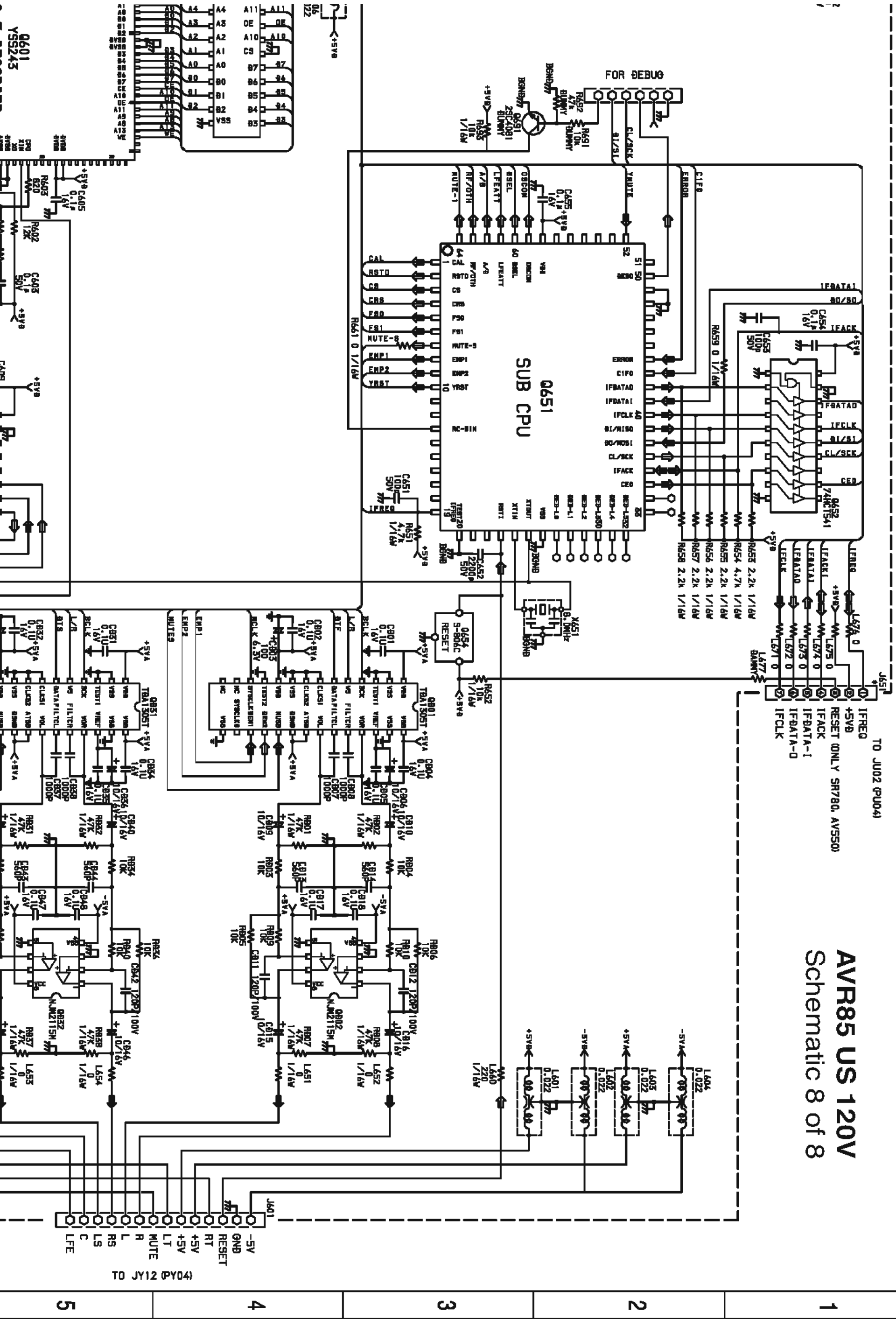

TO JY12 (PY04)

1
2
3
4
5

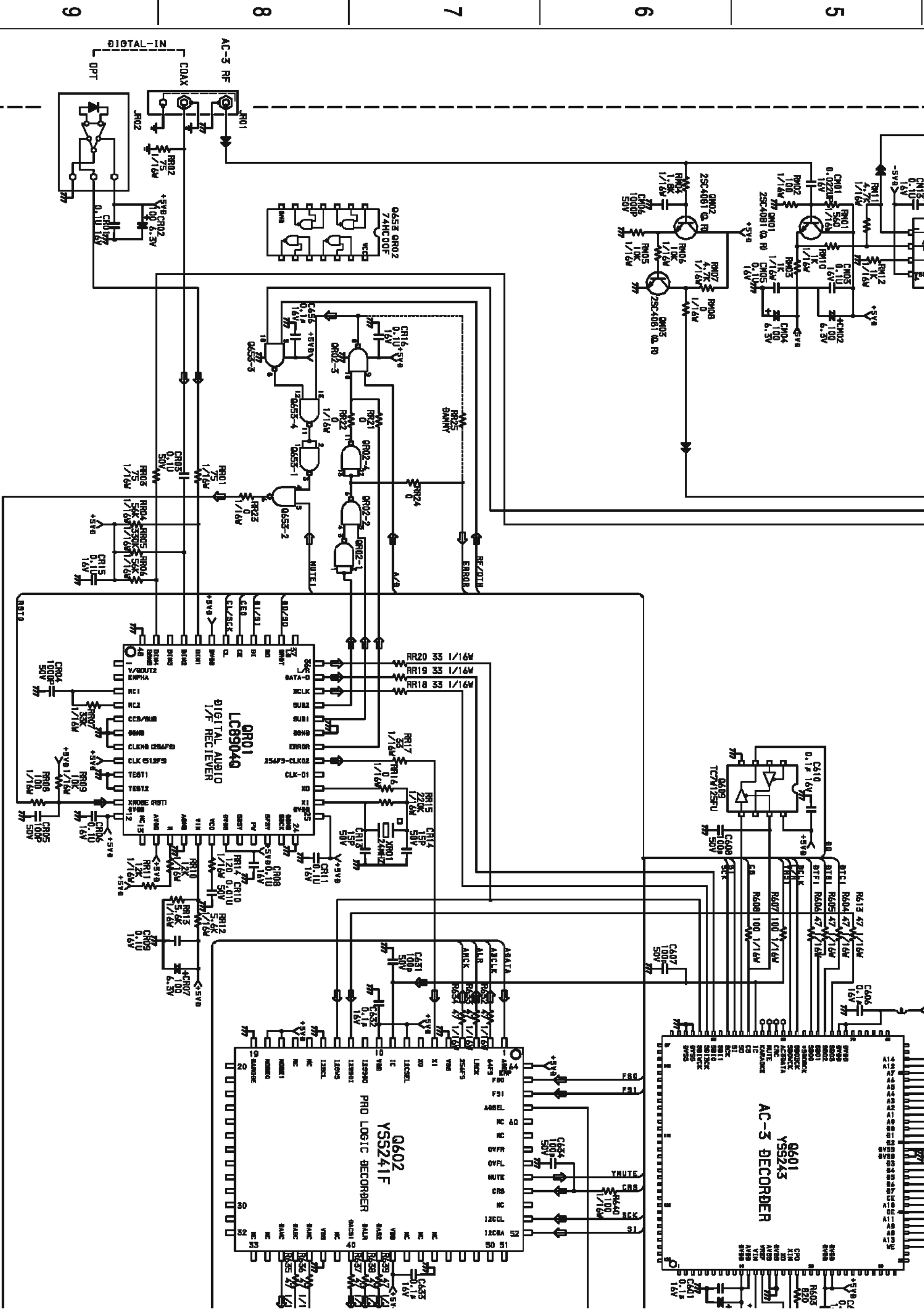

A B C D E F G

9

8

7

6

5

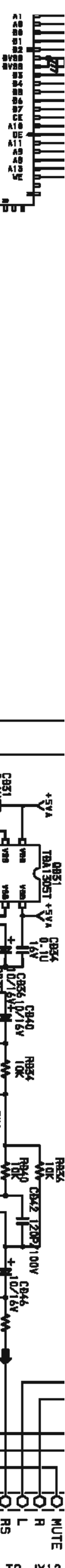

**Q601
YSS243
C-3 RECORDER**

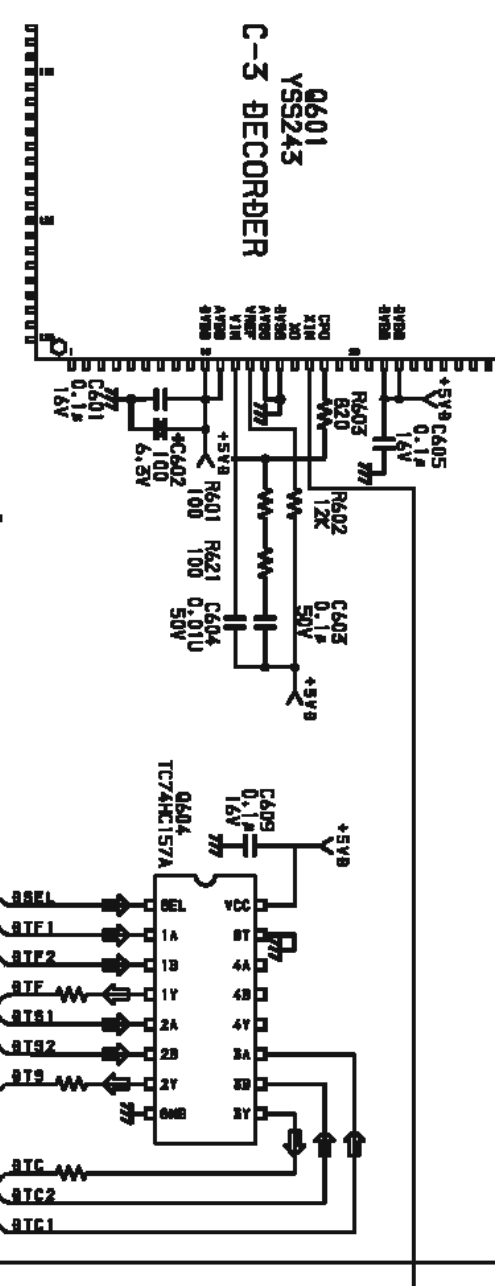

**Q602
YSS241F
LOGIC RECORDER**

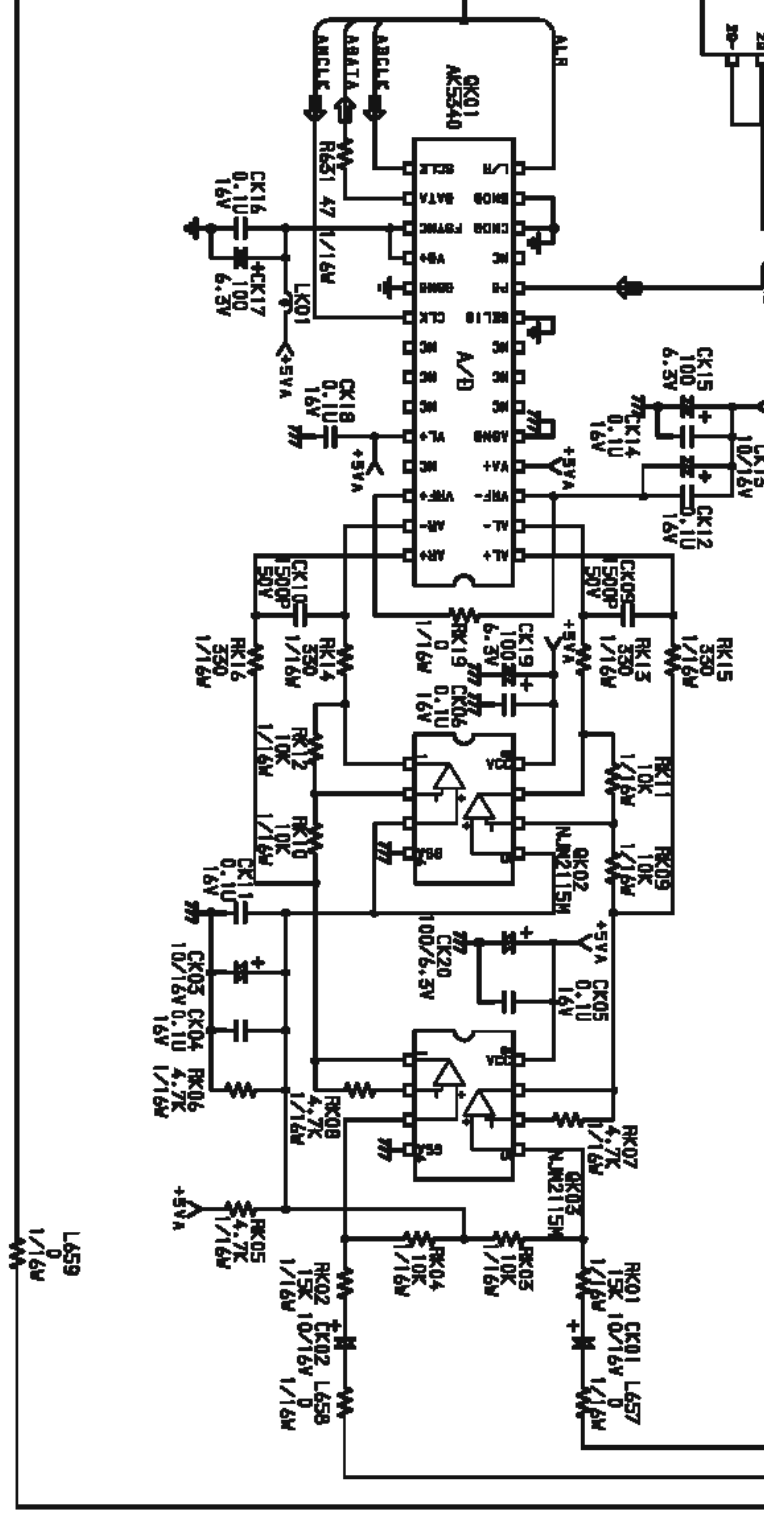
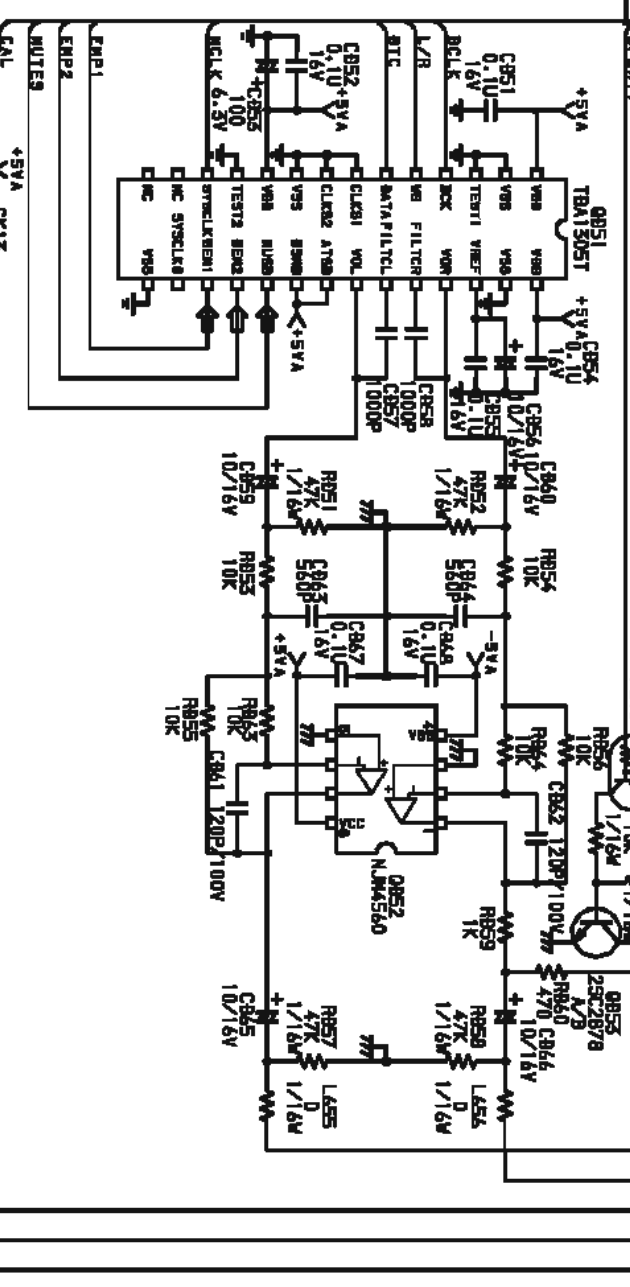
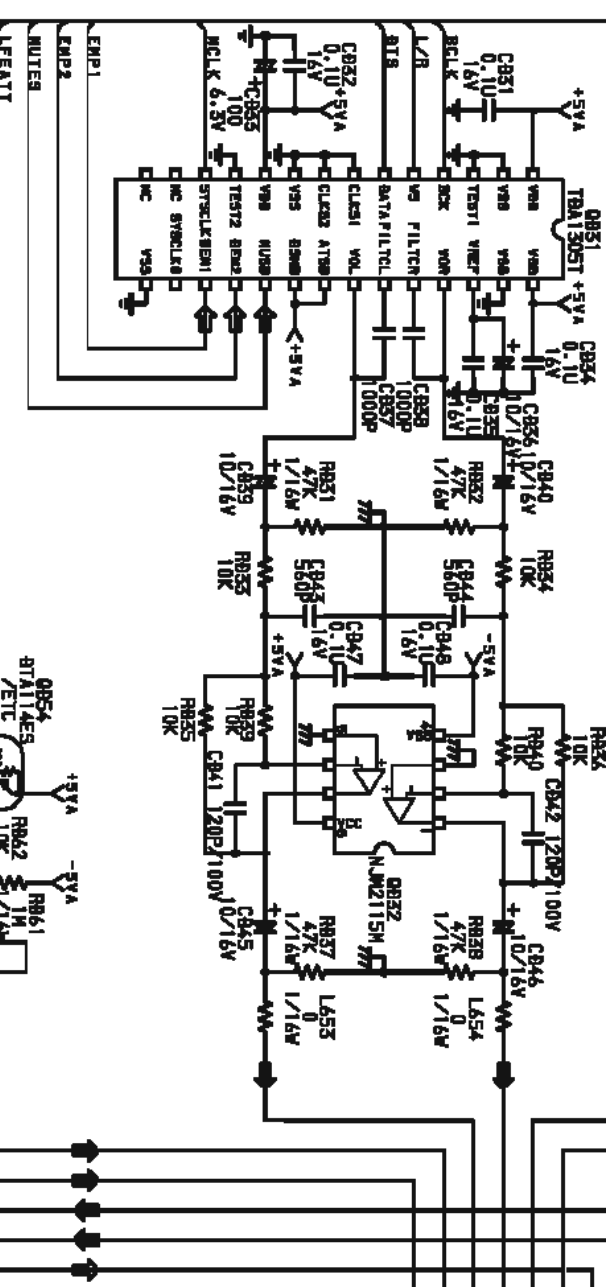
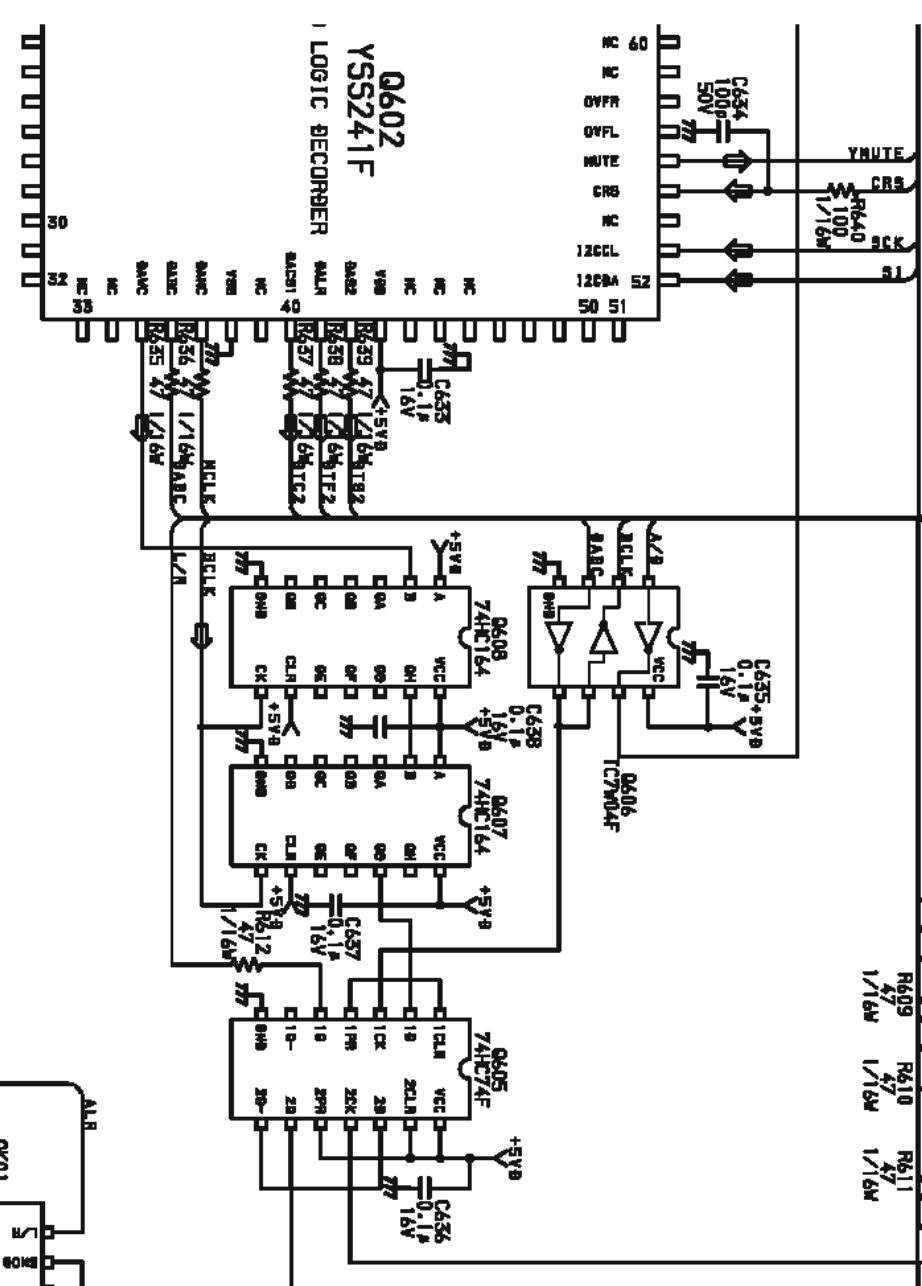

G H J K L M

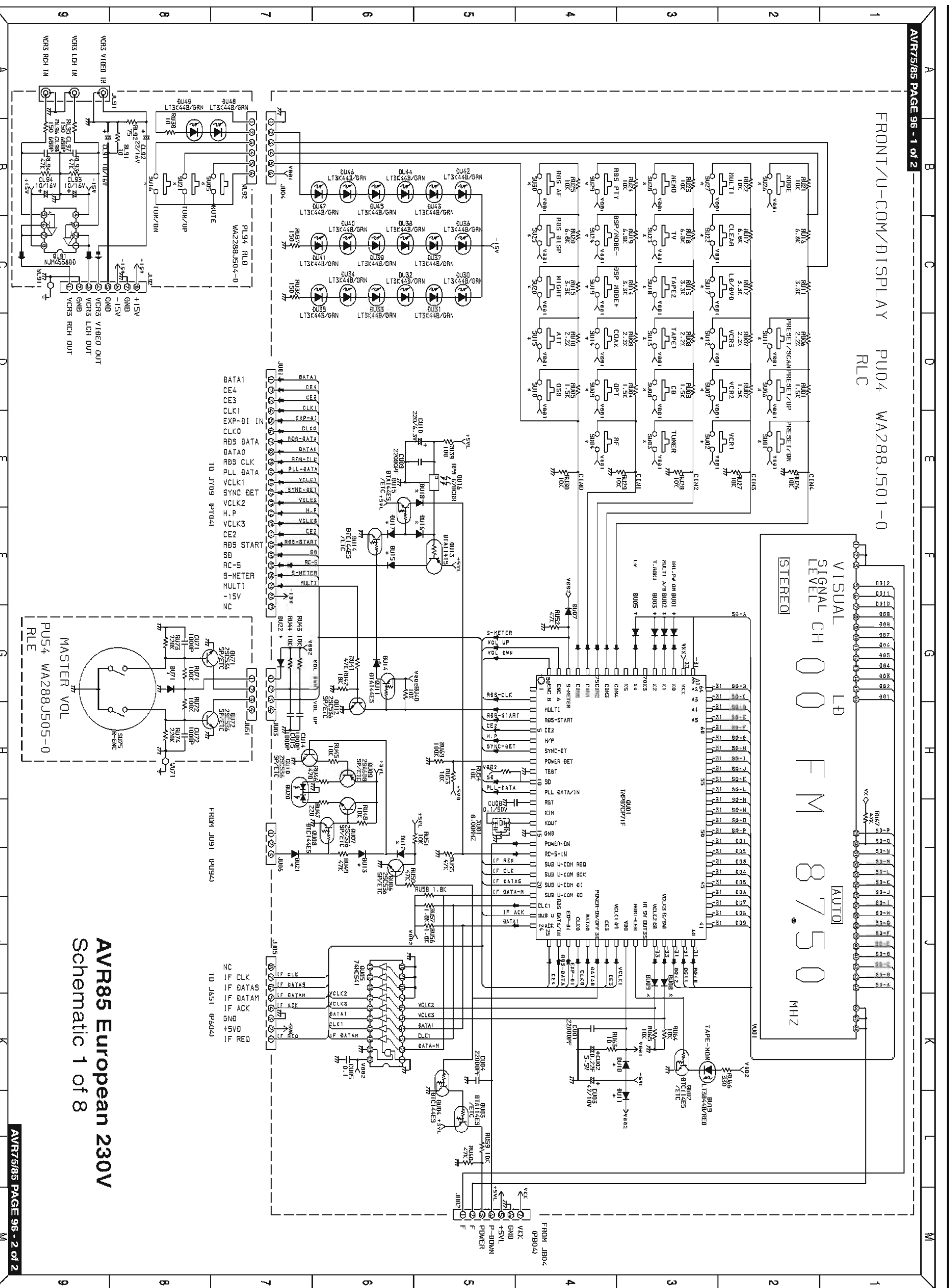

AVR85 European 230V
Schematic 1 of 8

AVR85 (230V) SCHEMATIC DIAGRAM 1 of 8 (FRONT PCB - PU04, MASTER VOL)

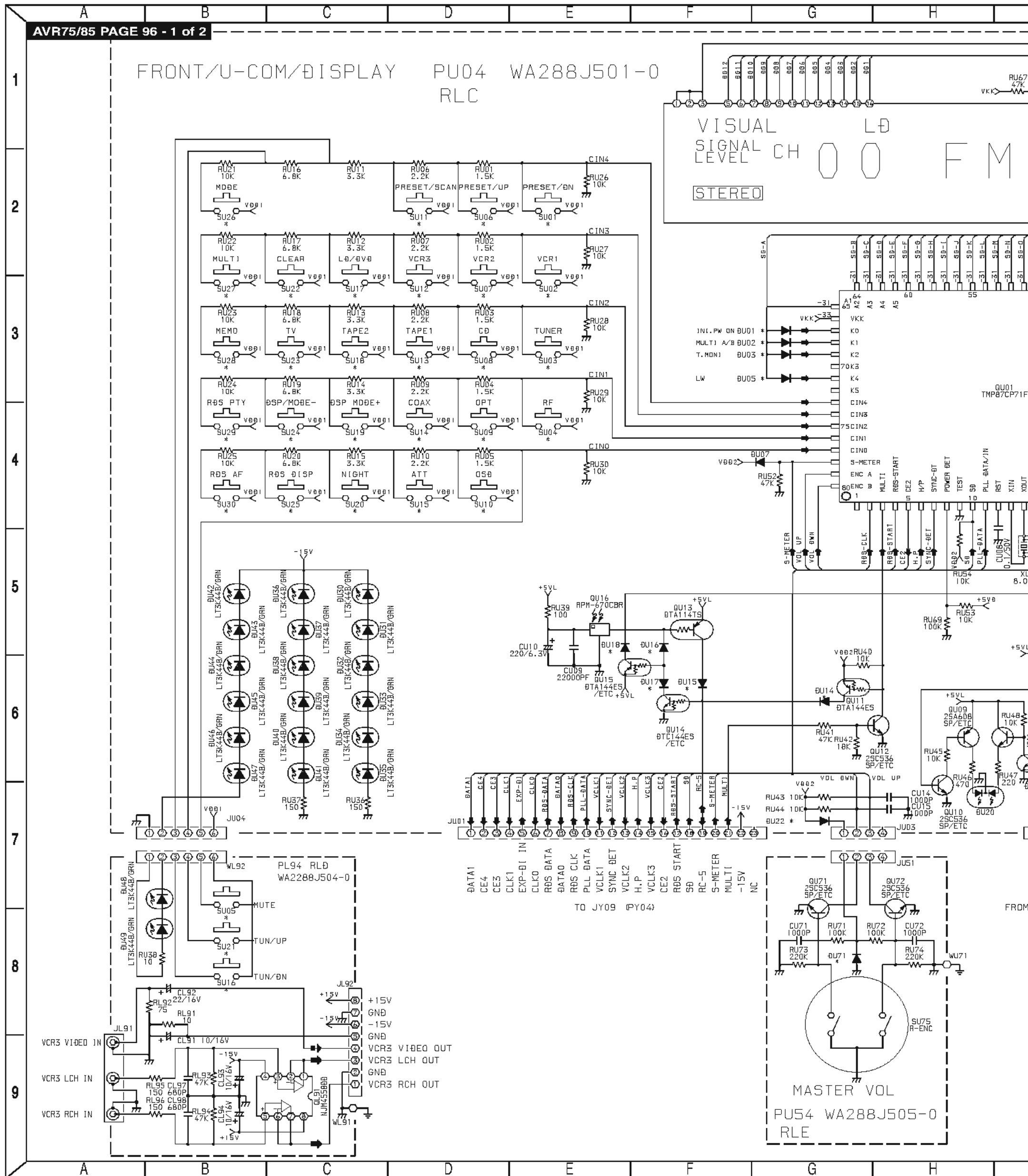

AM 1 of 8 (FRONT PCB - PU04, MASTER VOLUME PCB - PU54, AUX IN - PL94)

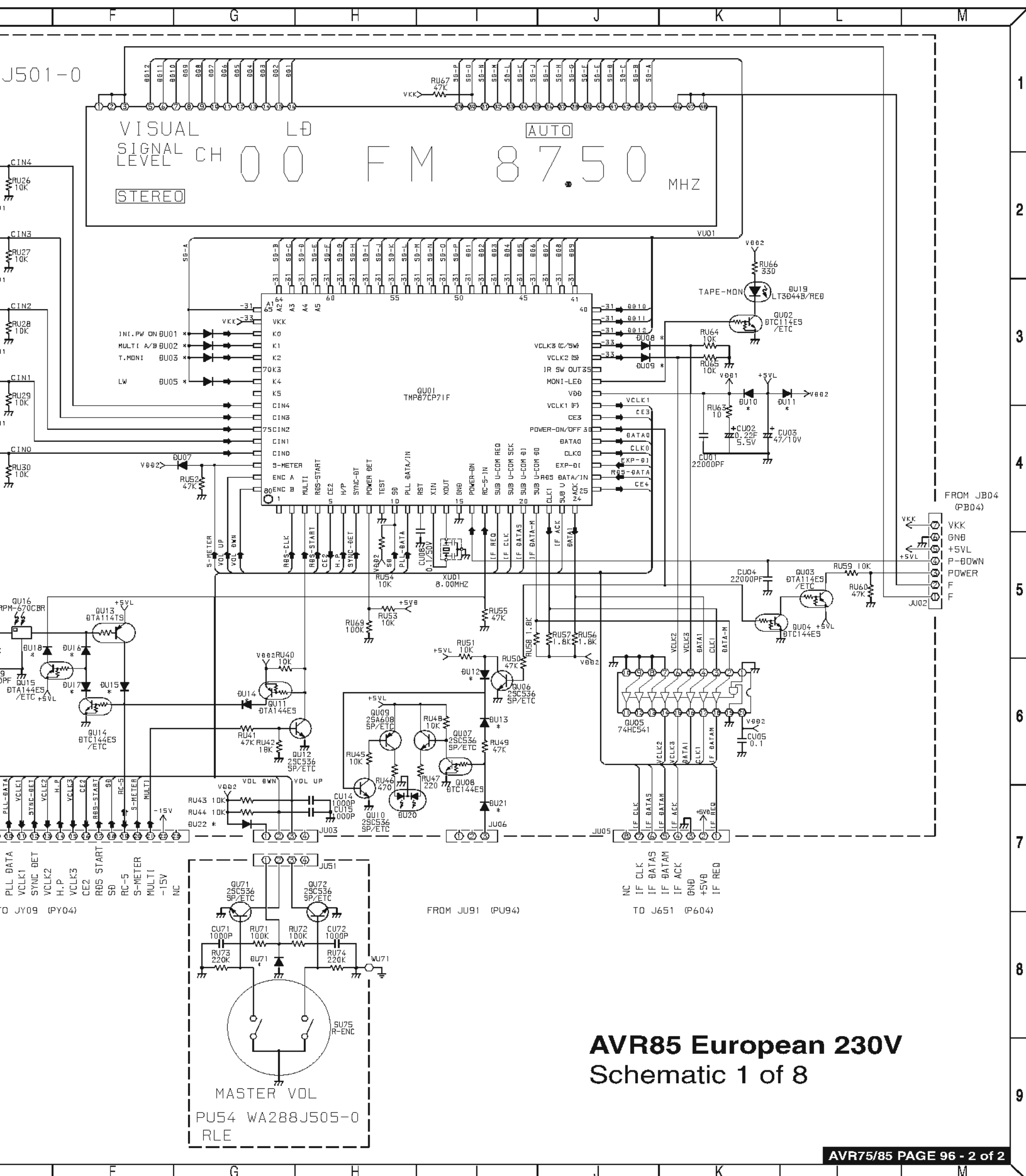

AVR85 European 230V Schematic 1 of 8

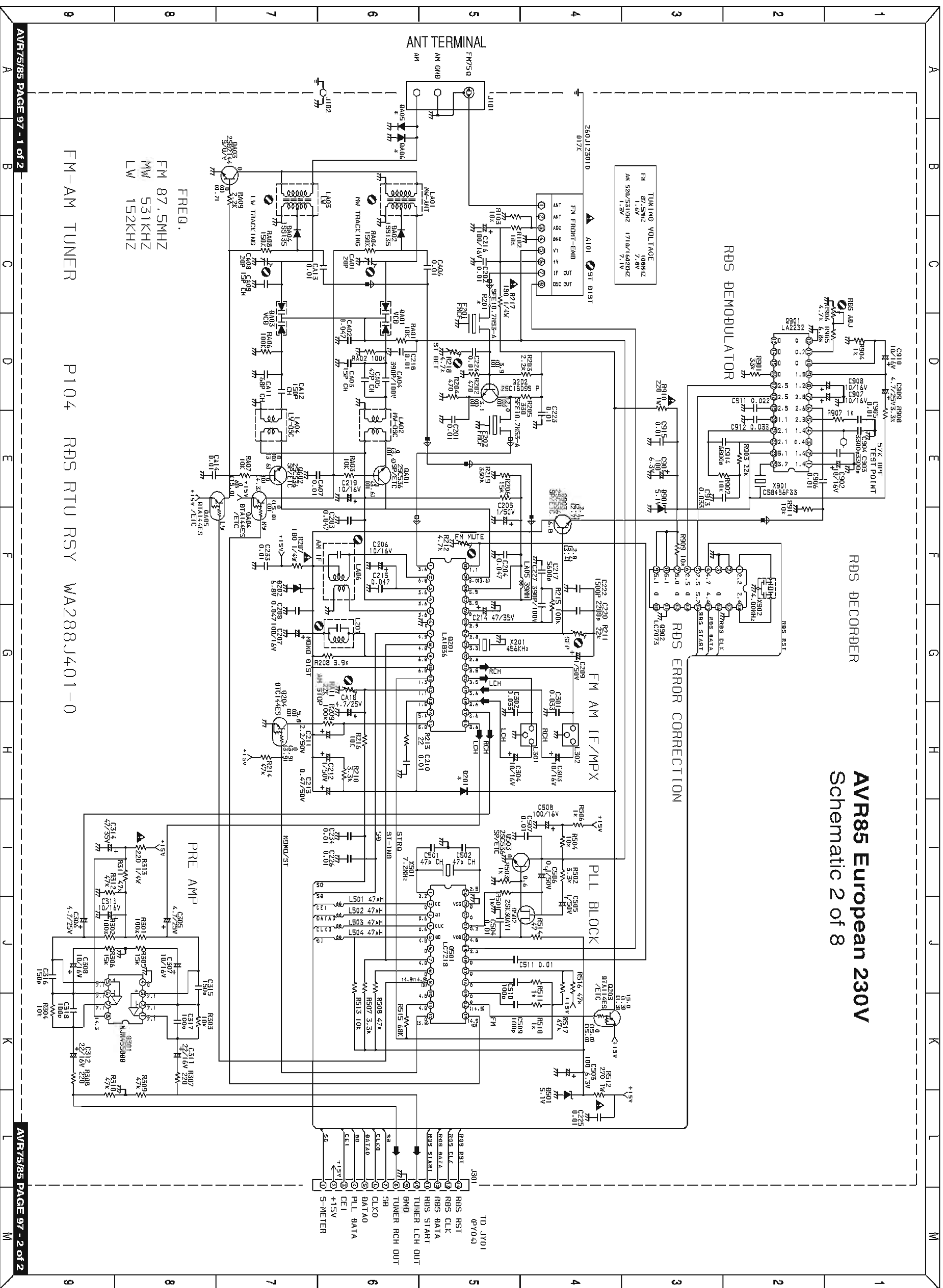

AVR85 European 230V Schematic 2 of 8 (TUNER PCB - P104)

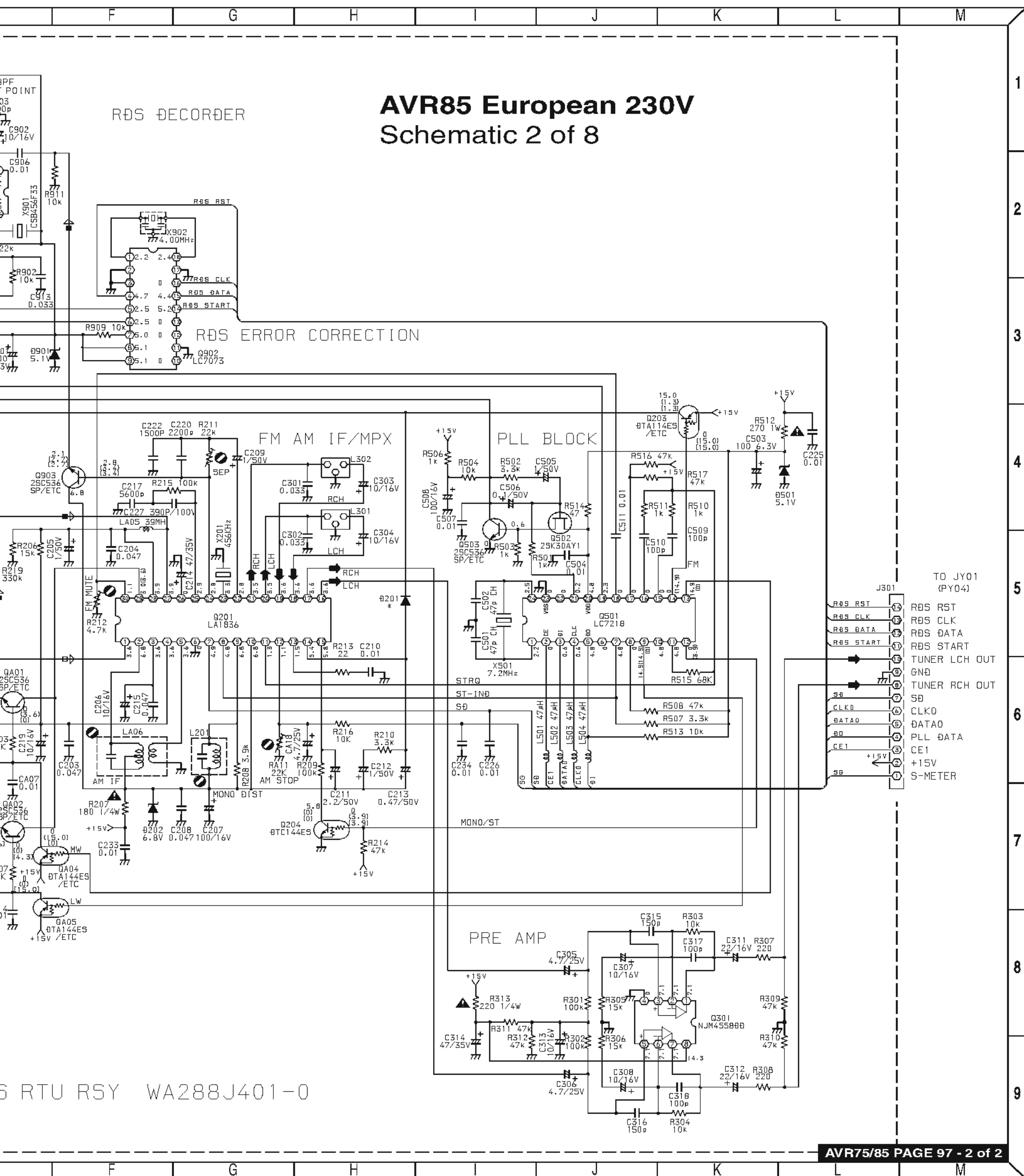

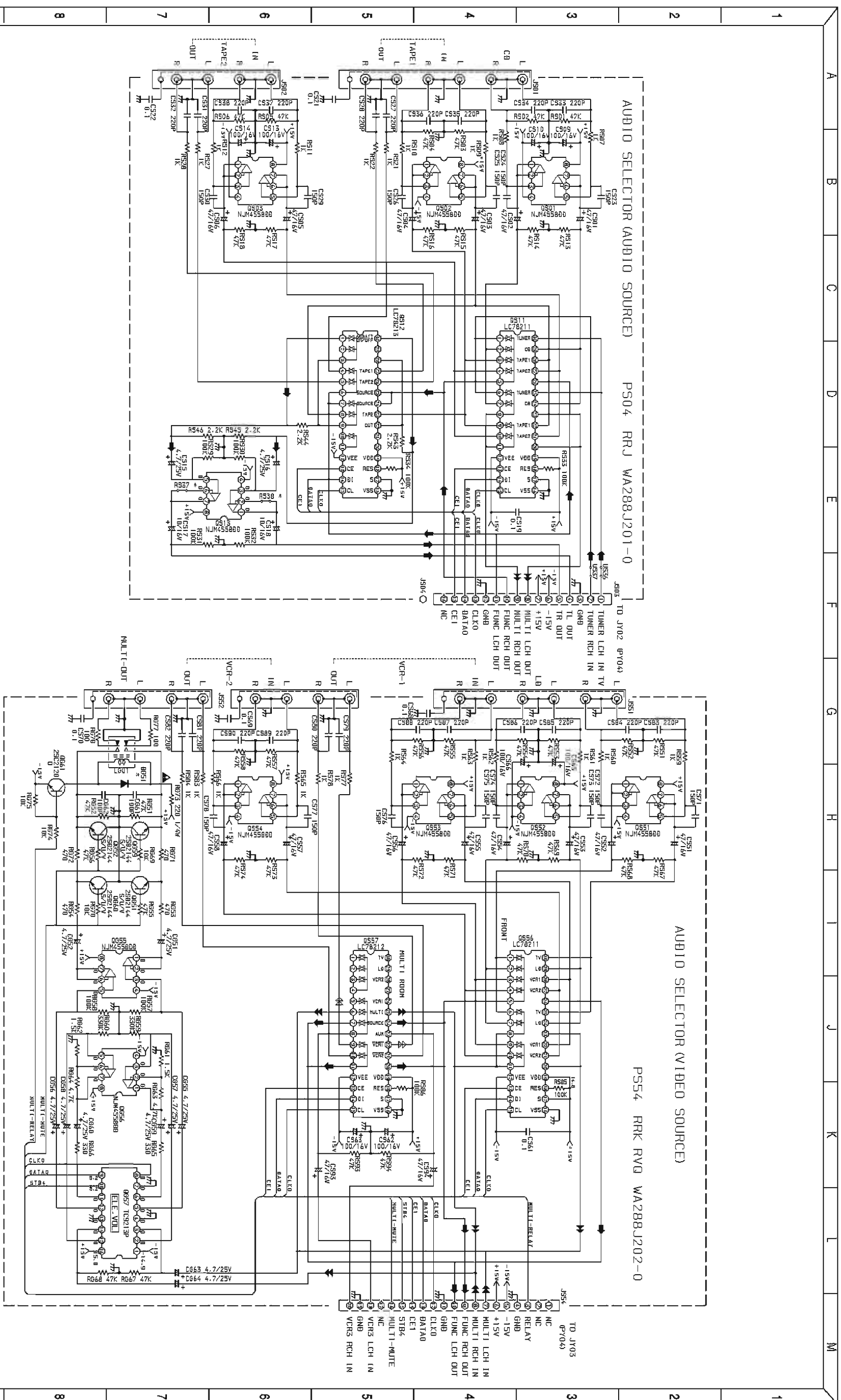

AVR85 European 230V
Schematic 3 of 8

AVR85 (230V) SCHEMATIC DIAGRAM 3 of 8 (AUDIO SELECTOR PC

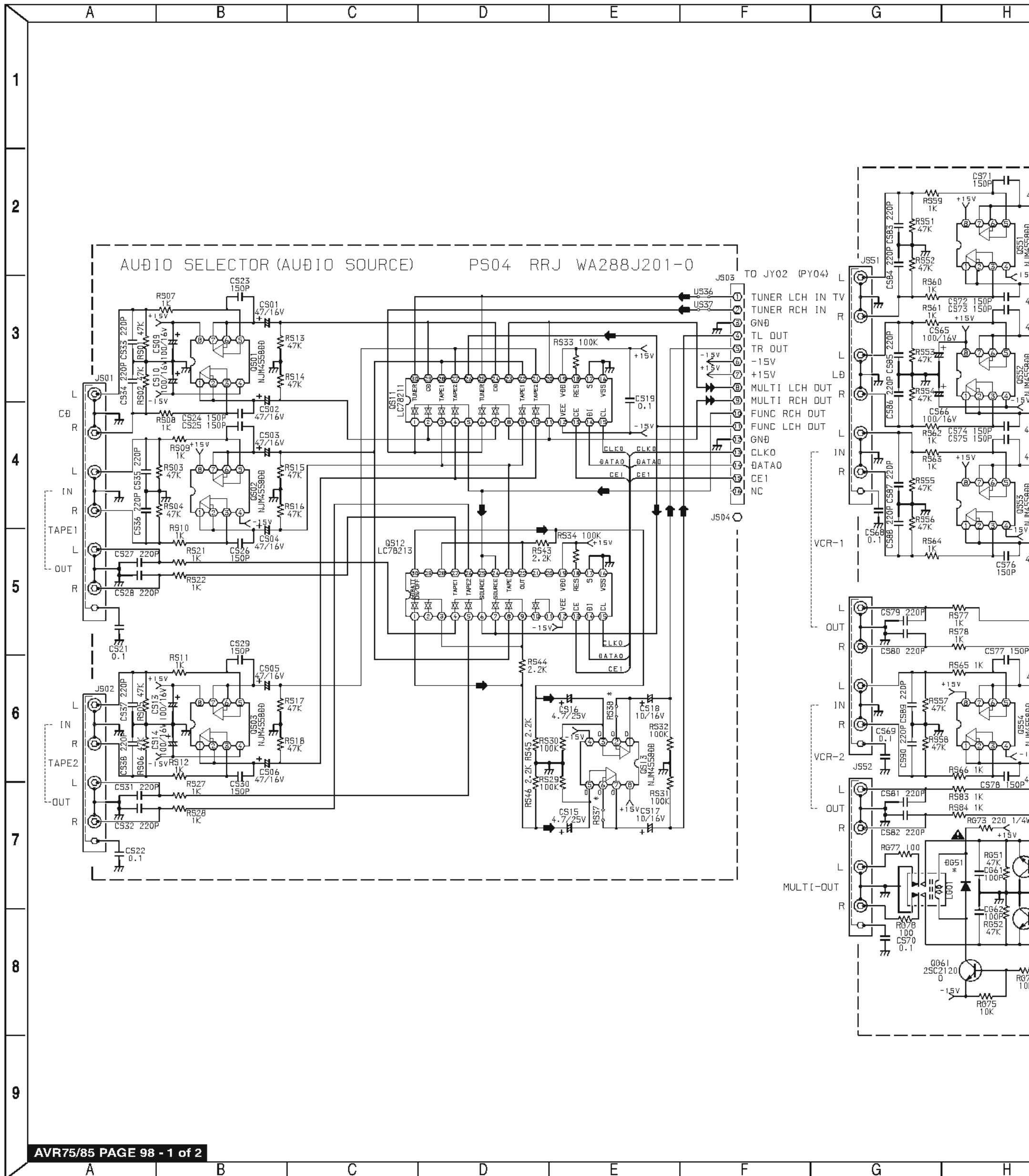

Schematic 3 of 8 (AUDIO SELECTOR PCB - PS04, AUDIO/VIDEO PCB PS54)

F G H I J K L M

1
2
3
4
5
6
7
8
9

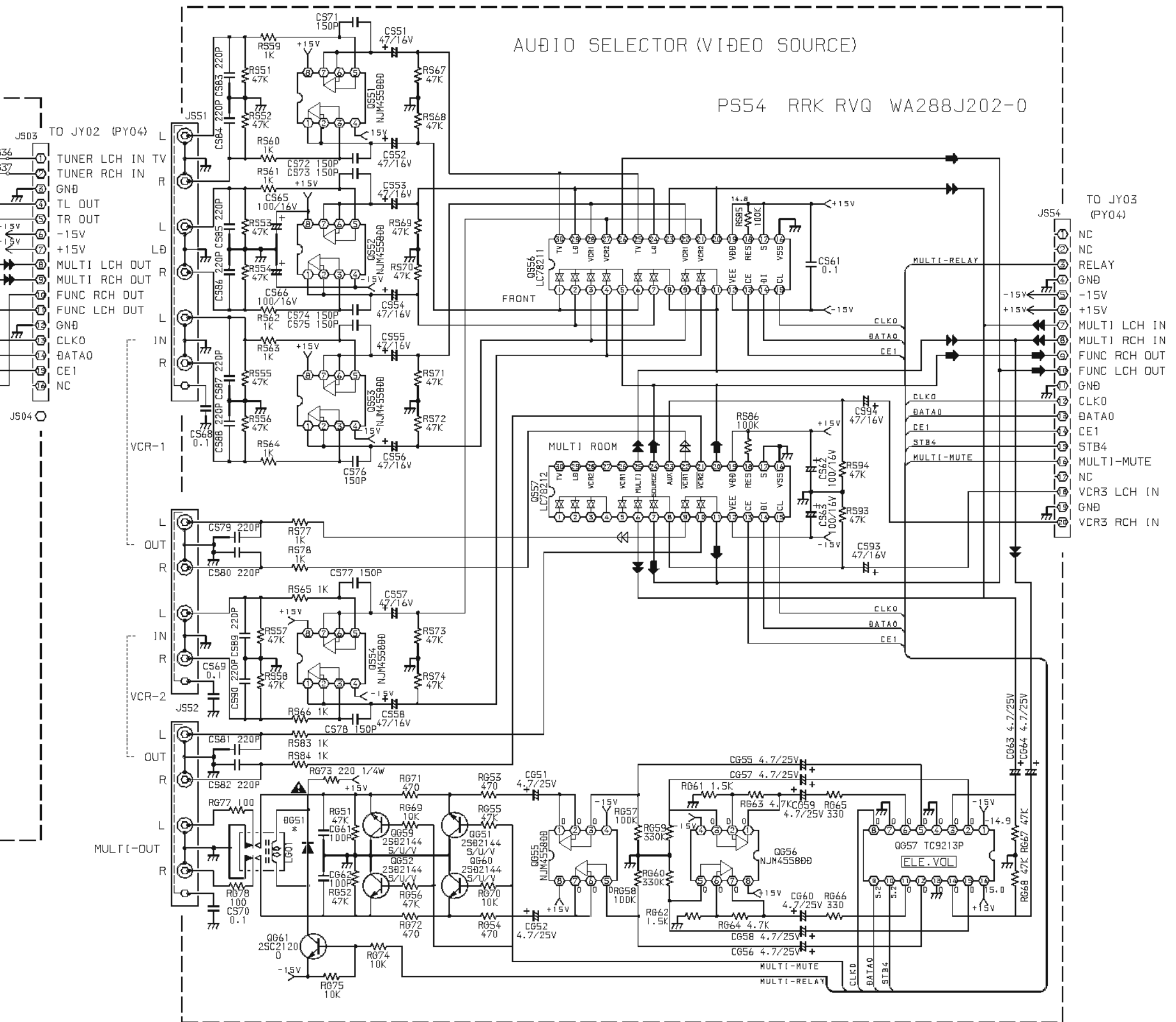

AVR85 European 230V Schematic 3 of 8

F G H I J K L M

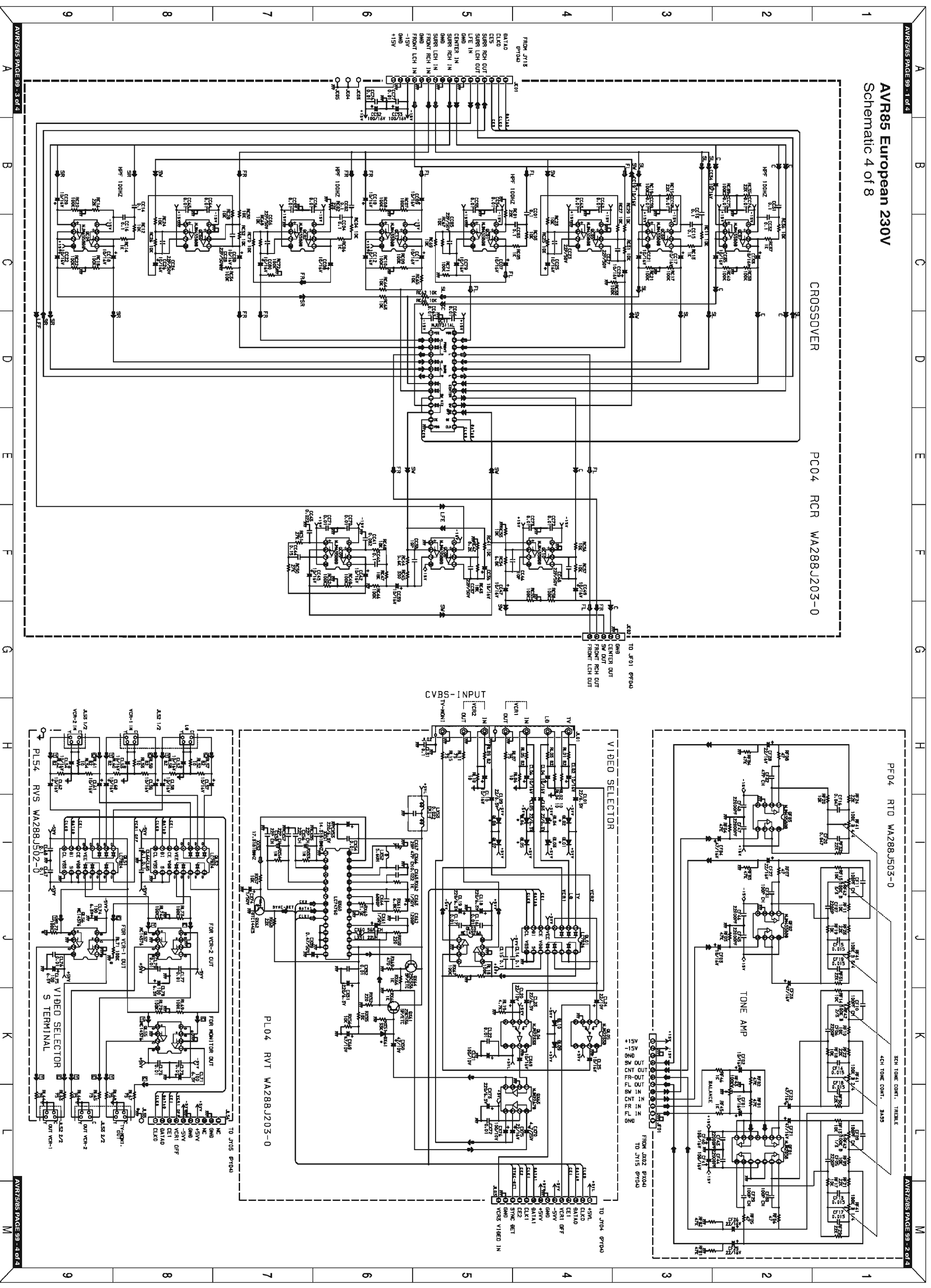

AVR75/85 PAGE 99 - 1 of 4

AVR75/85 PAGE 99 - 2 of 4

A B C D E F G

AVR85 European 230V
Schematic 4 of 8

CROSSOVER

PC04 RCR WA288J203-0

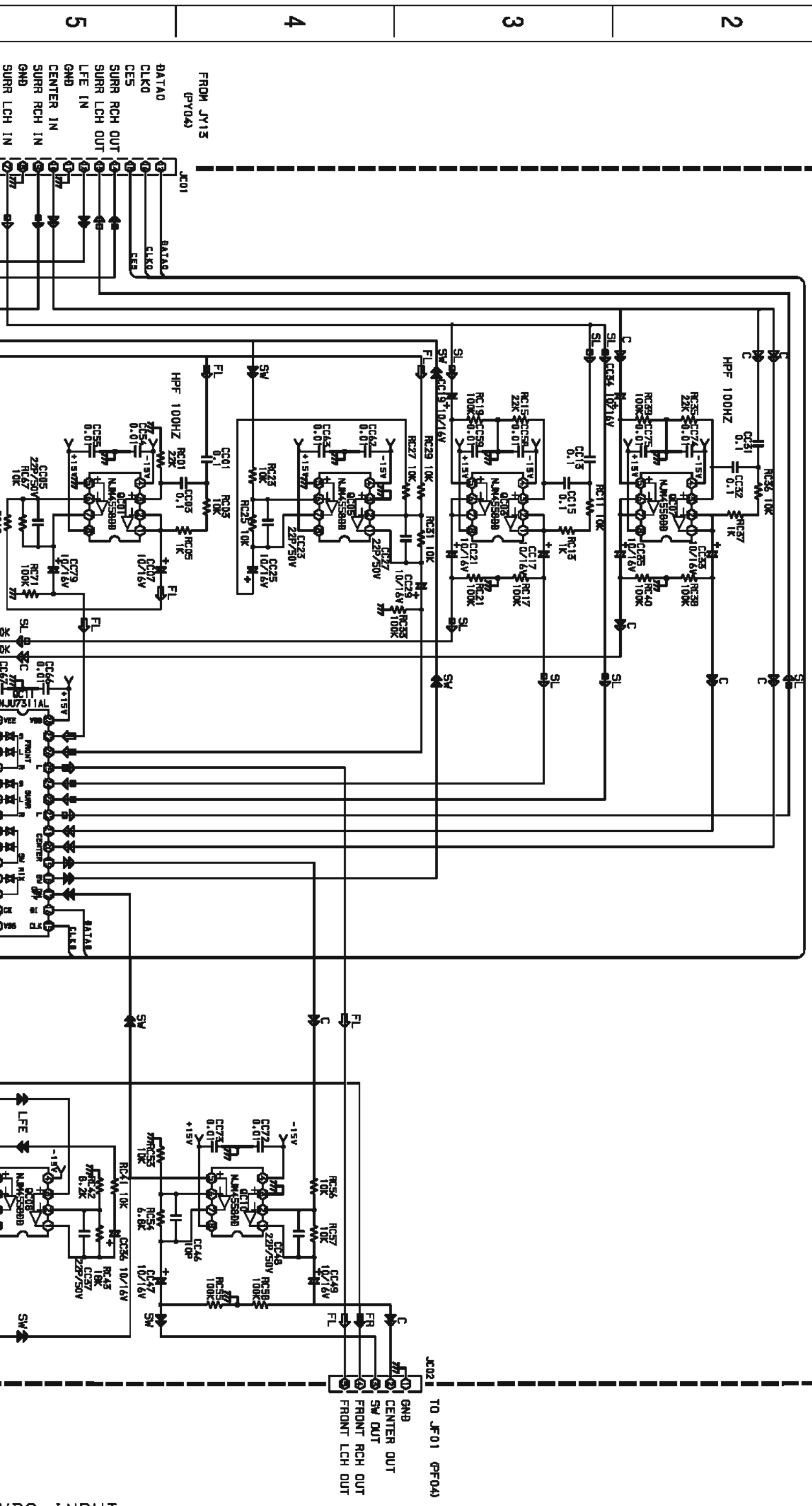

1
2
3
4
5

PC04, TONE CONTROL PCB - PF04, VIDEO SELECTOR PCB - PL04, S-VIDEO PCB PL54

G

H

J

K

M

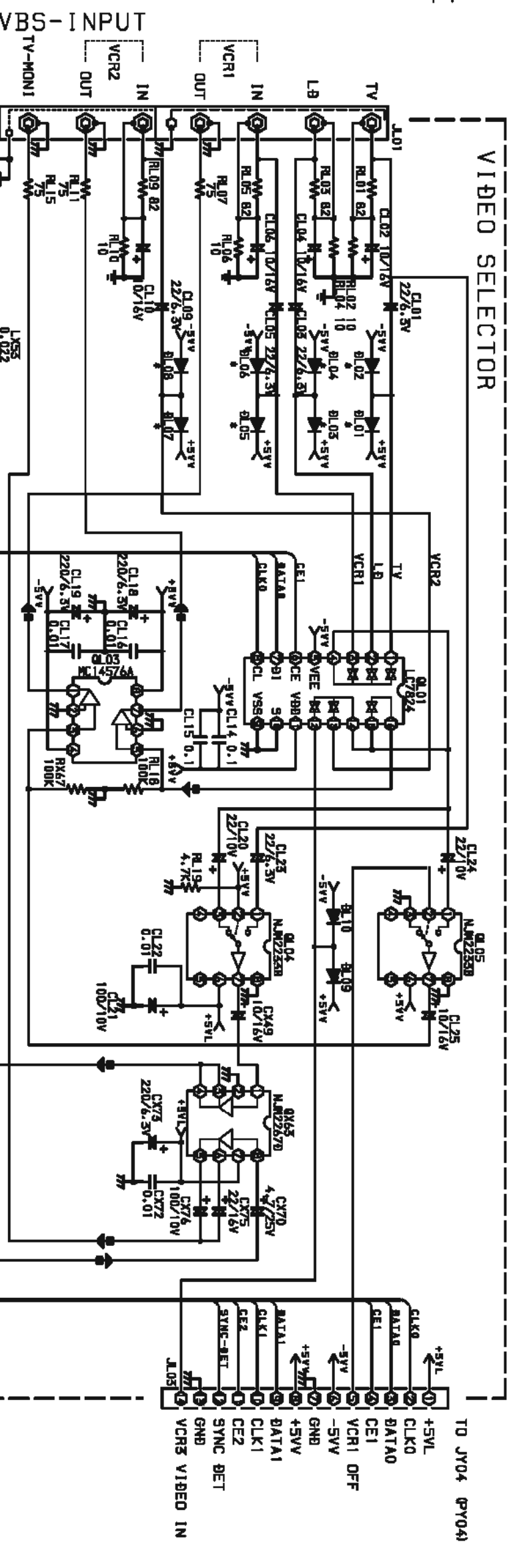
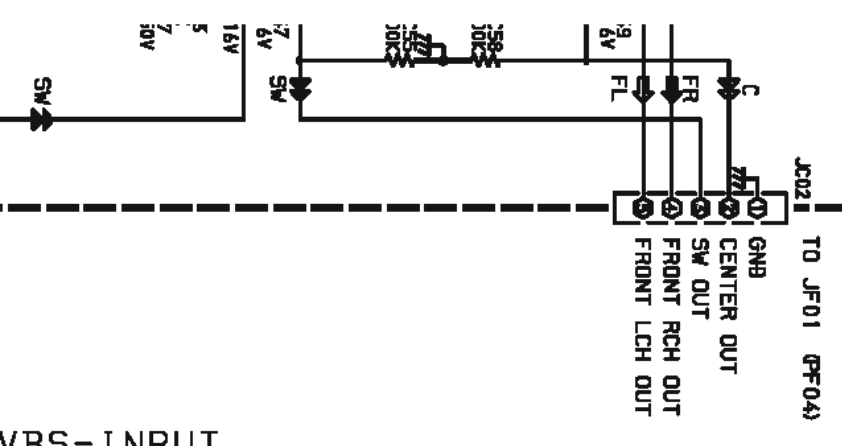
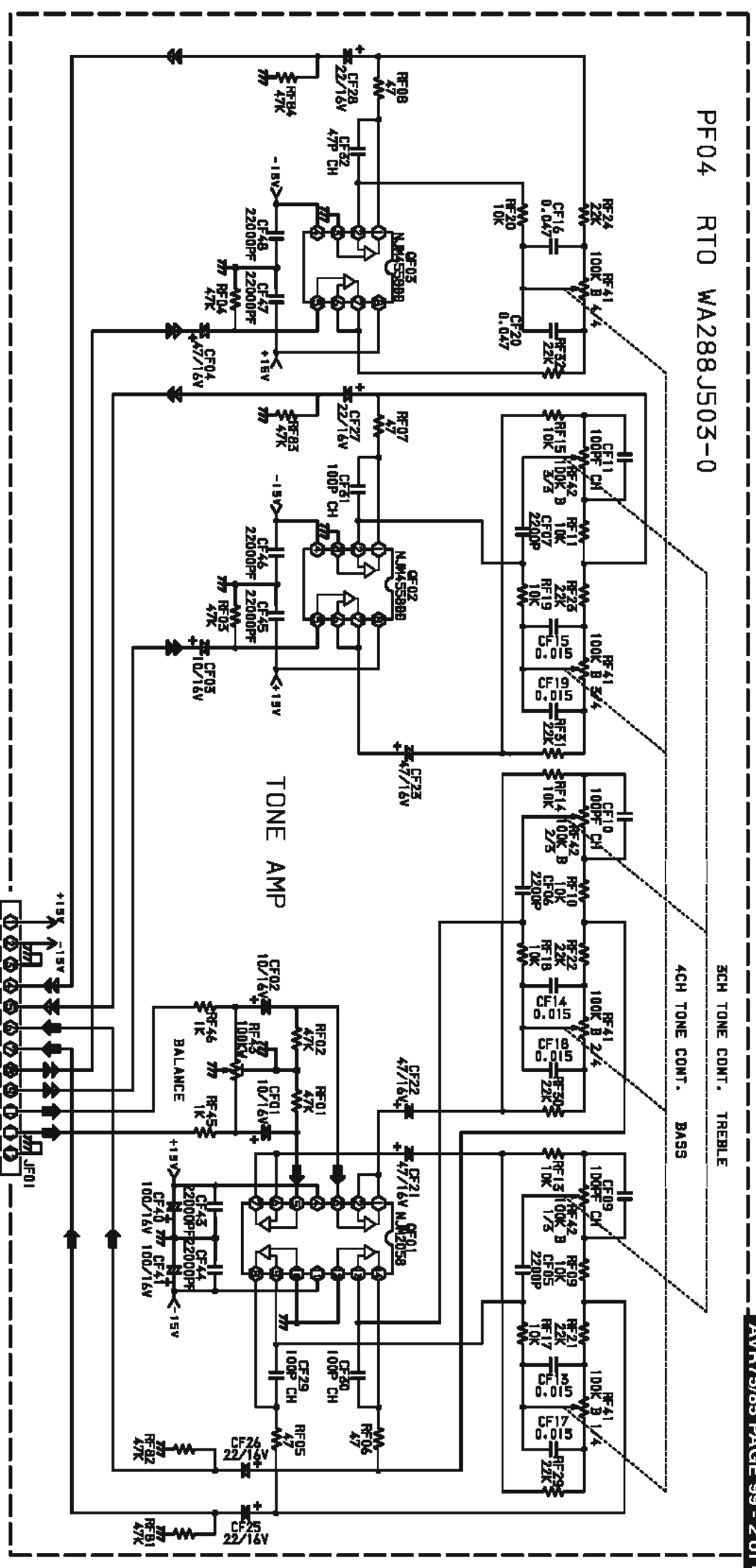

3-0

3

2

1

4

5

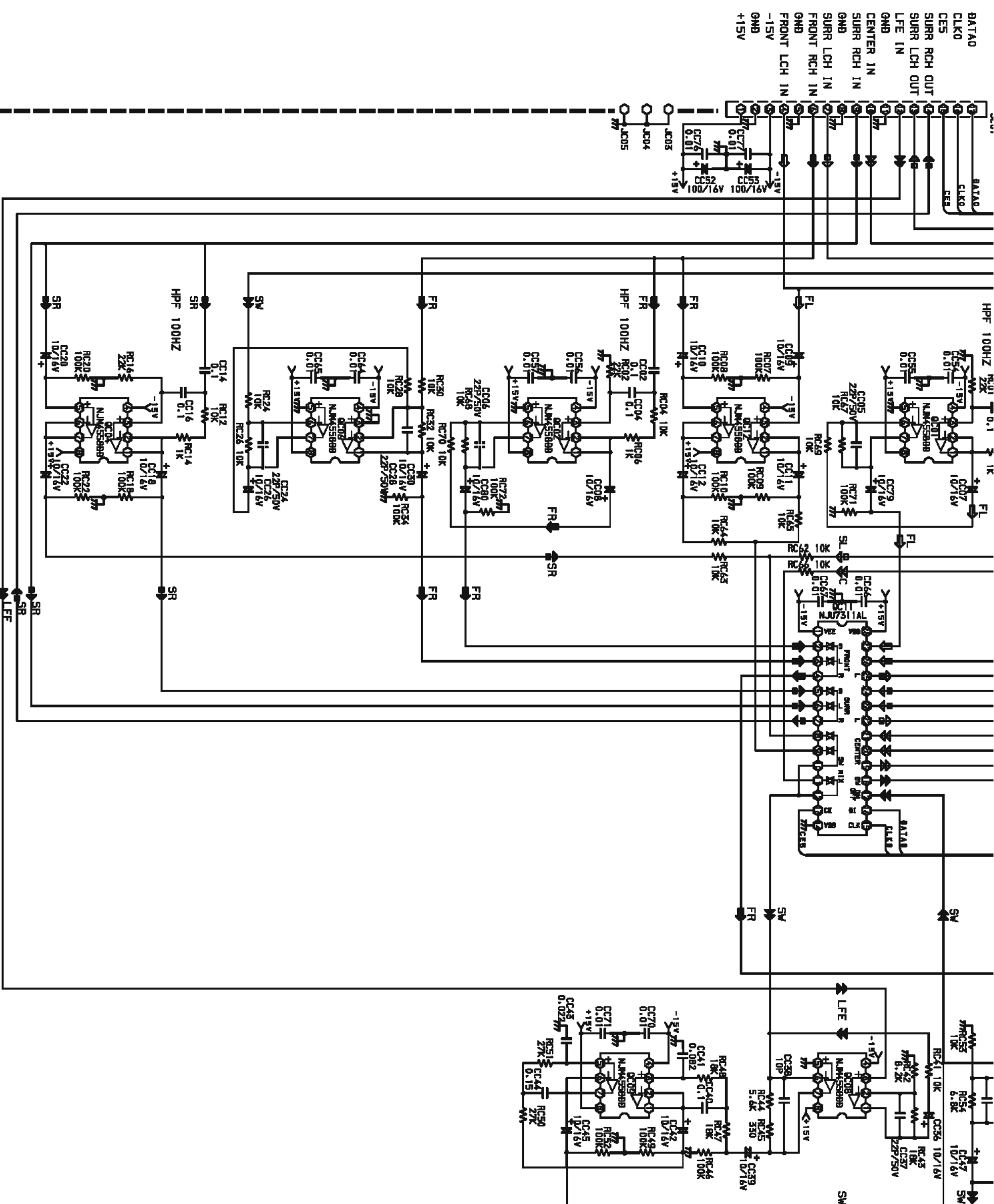

A B C D E F G

5 6 7 8 9

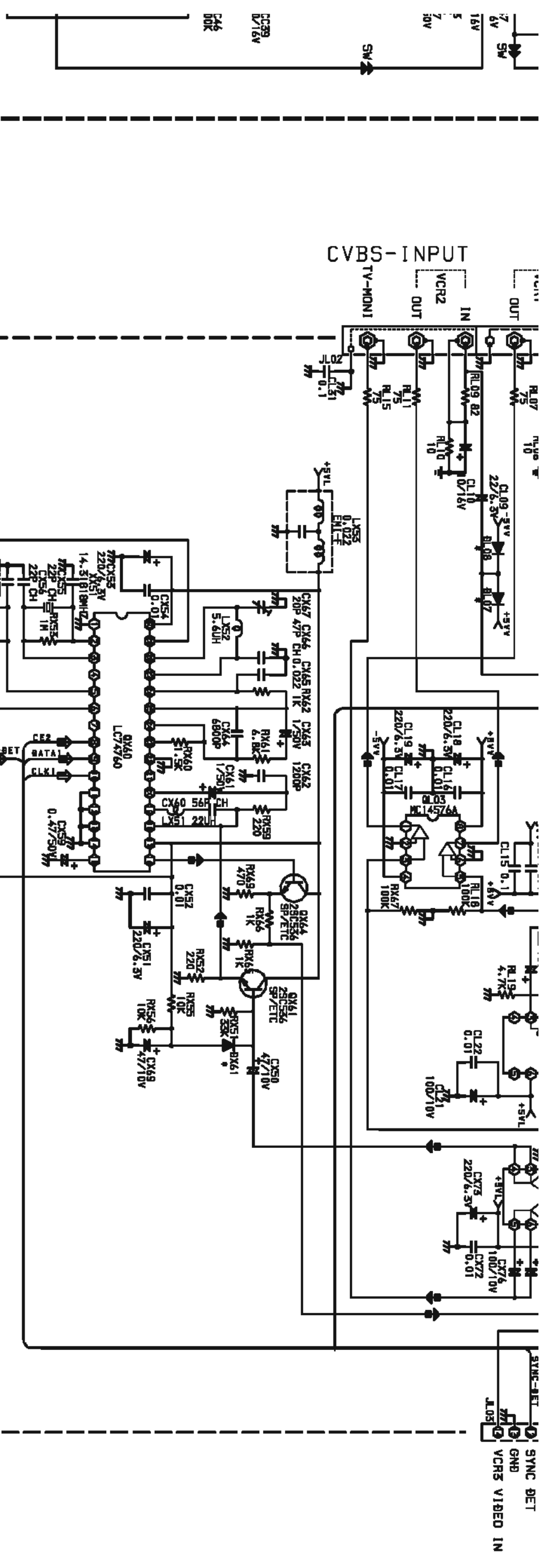

PL04 RVT WA288J203-0

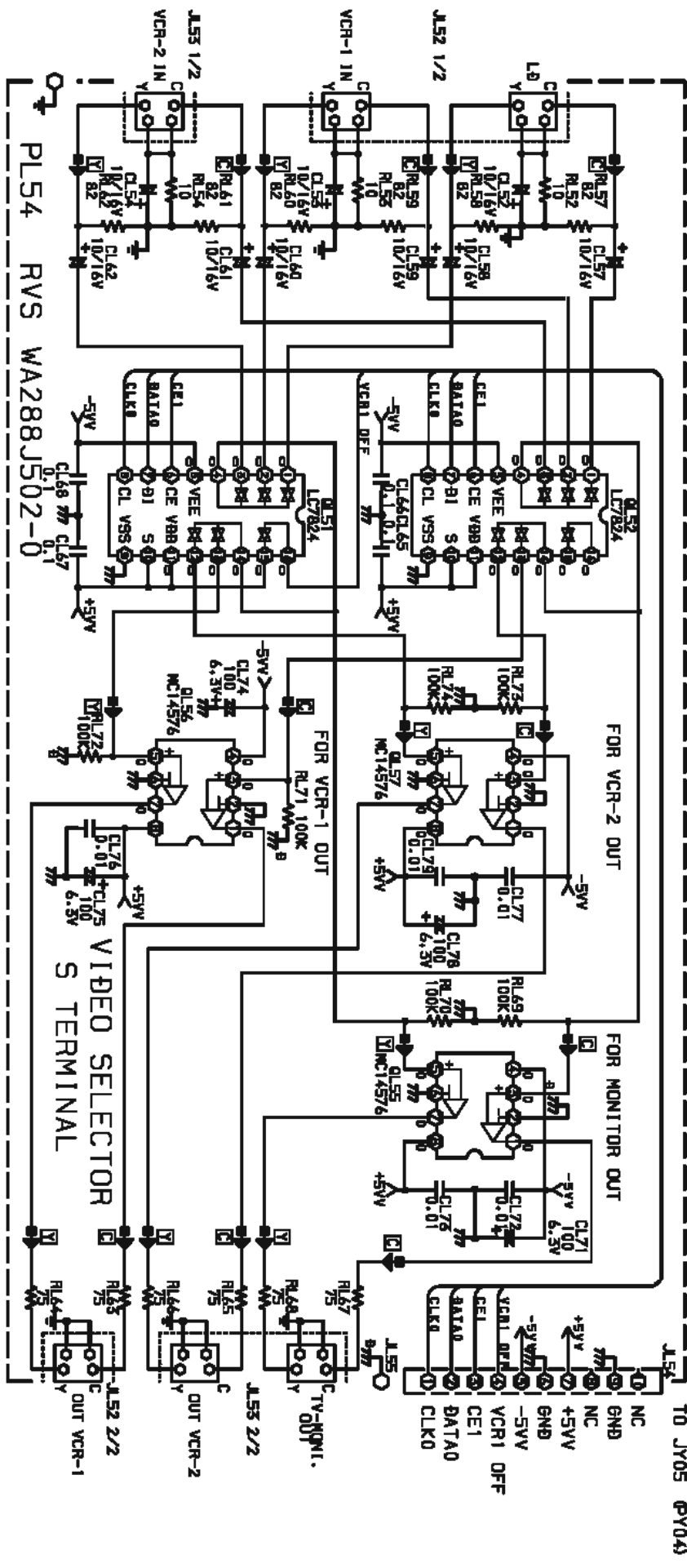

G H J K L M

AVR85 European 230V

Schematic 5 of 8

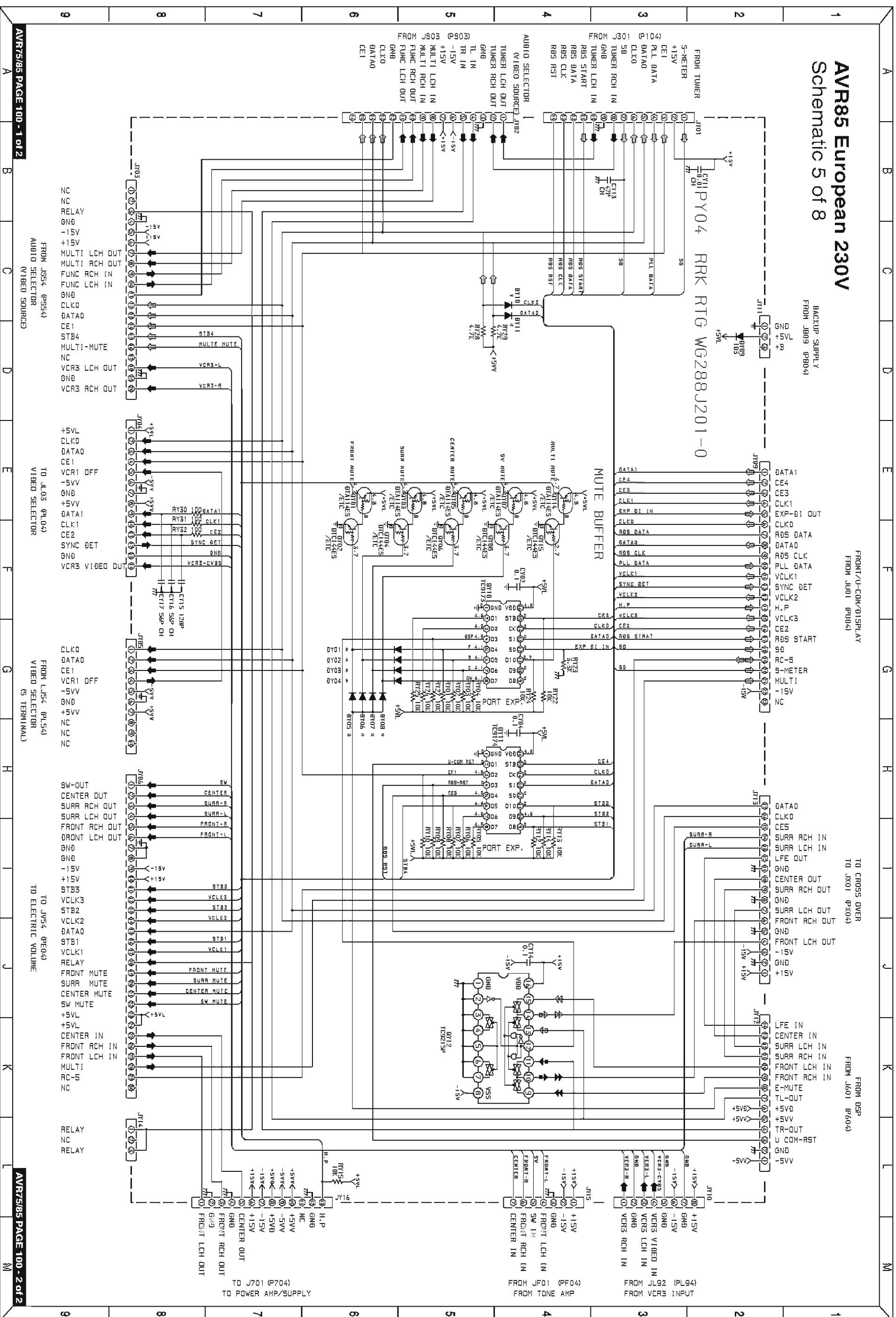

AVR75/85 PAGE 100-1 of 2

AVR75/85 PAGE 100-2 of 2

AVR85 European 230V
Schematic 5 of 8

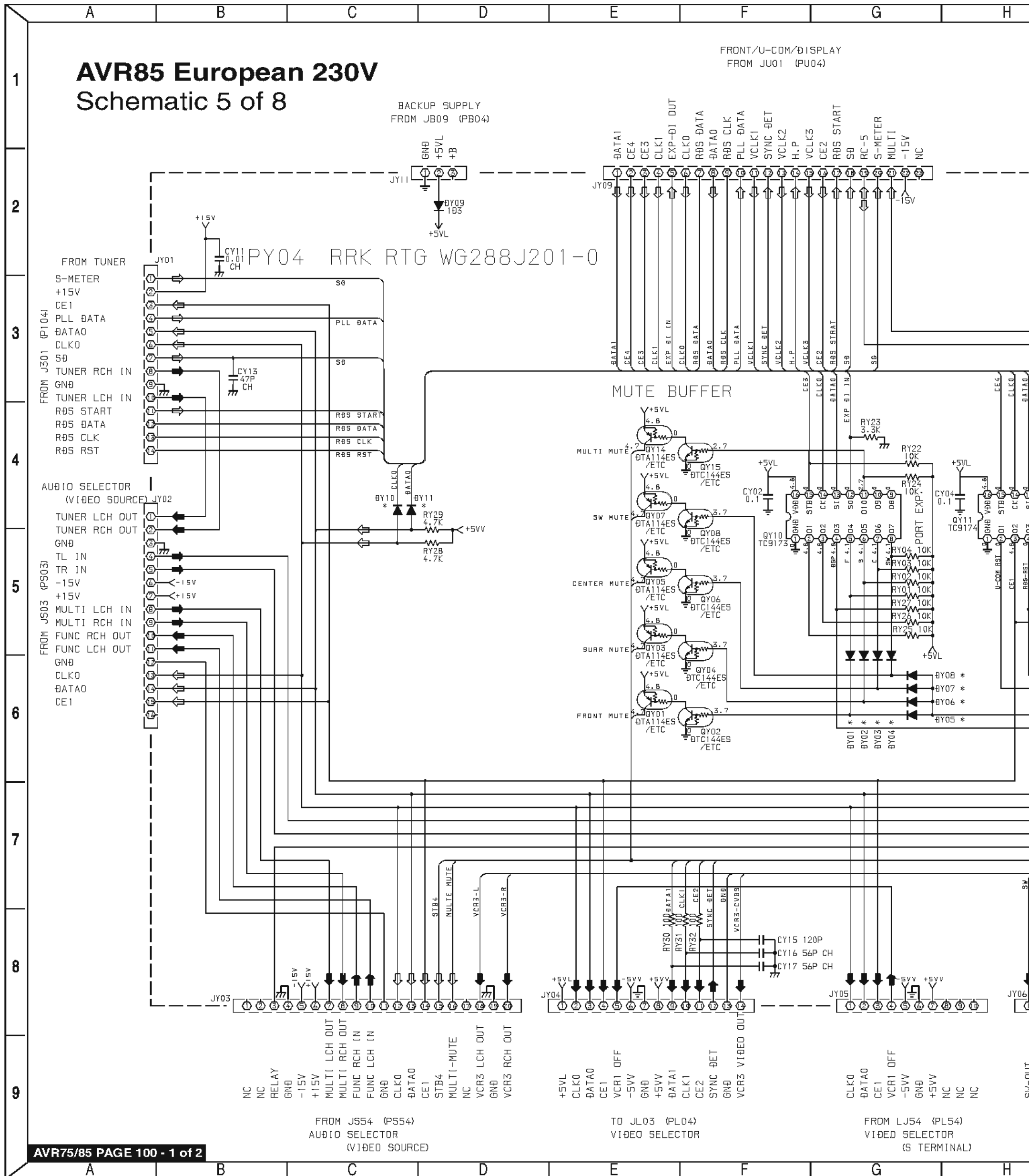

SCHEMATIC DIAGRAM 5 of 8 (CONNECT PCB PY04)

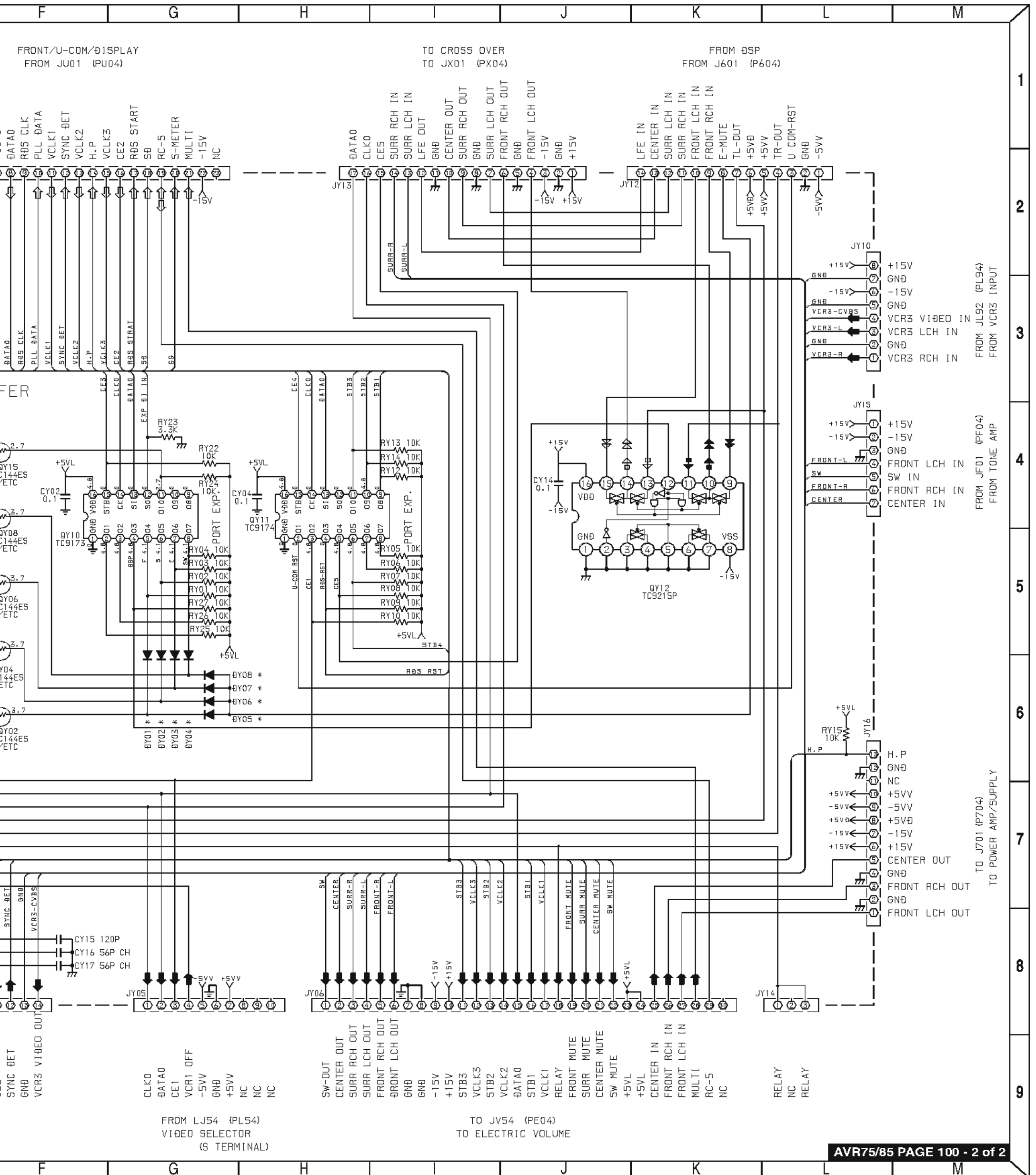

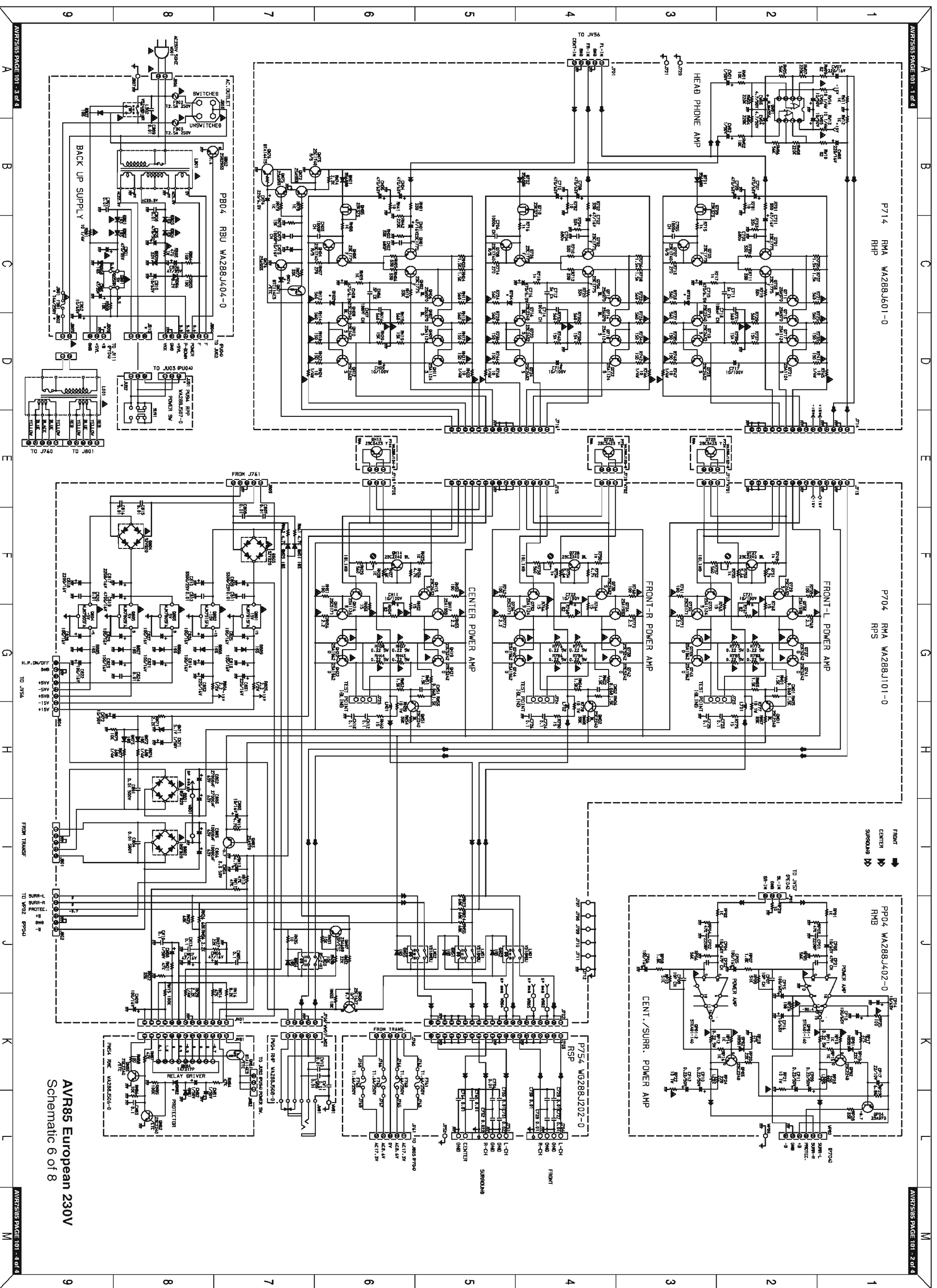

AVR85 European 230V
Schematic 6 of 8

AVR85 (230V) SCHEMATIC DIAGRAM 6 of 8 (VOLTAGE AMP PCB - P714, MAIN PCB -
HEADPHONE PCB - PW04, SPEAKER PROTECT PCB - PN54, STAI

AVR75/85 PAGE 101 - 1 of 4

A B C D E F G

P714 RMA WA288J601-0
RHP

P704 RMA WA288J101-
RPS

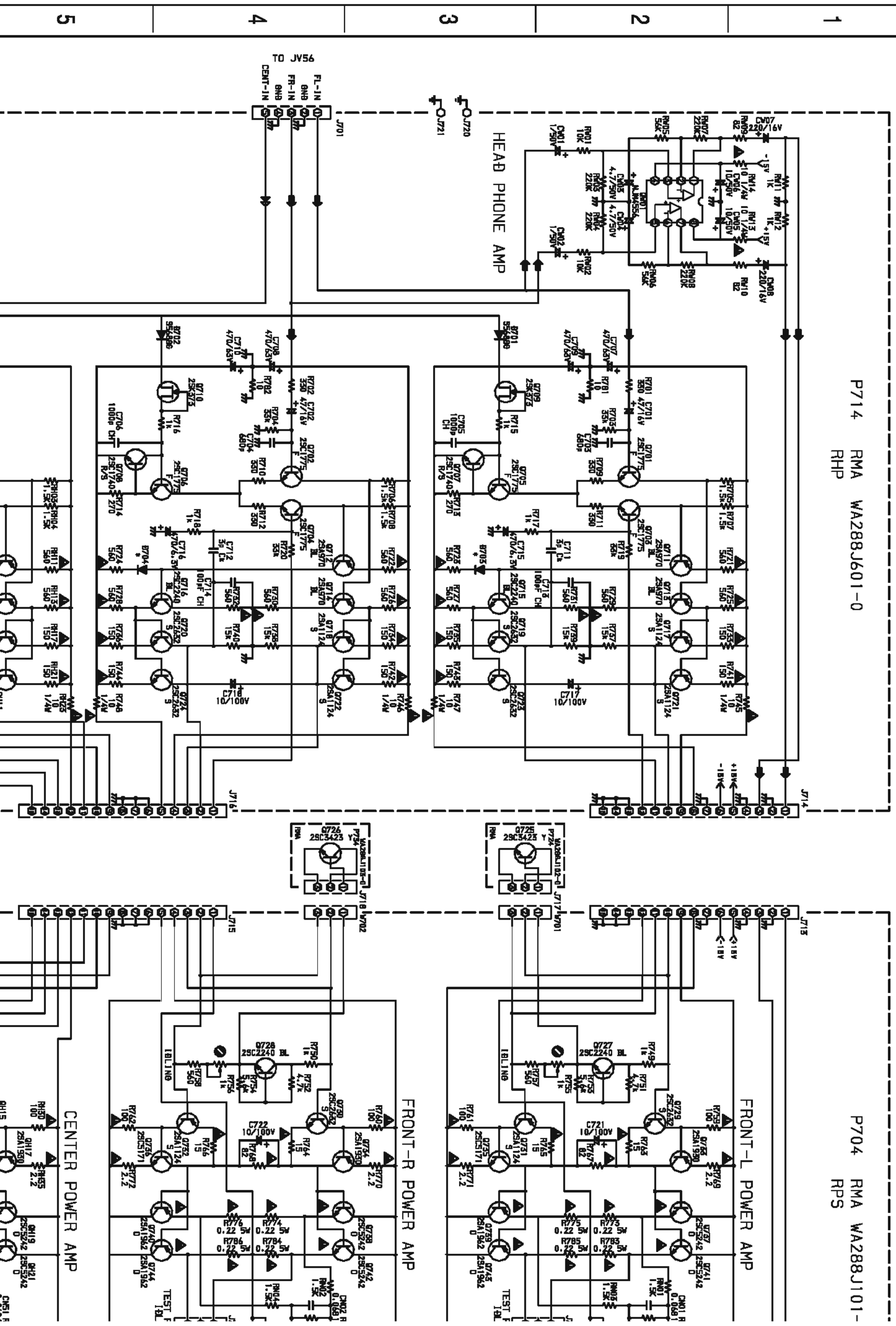

- P714, MAIN PCB - P704, SURROUND AMP PCB - PP04, SPEAKER TERMINAL - P754,
- PCB - PN54, STANDBY PCB - PB04, POWER SWITCH PCB - PU94)

G

H

J

K

M

704 RMA WA288J101-0
RPS

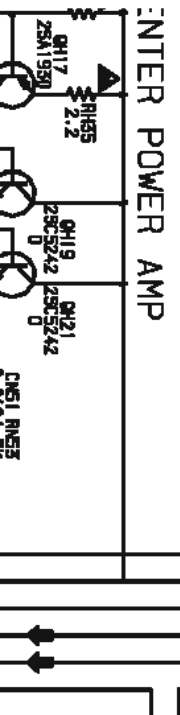
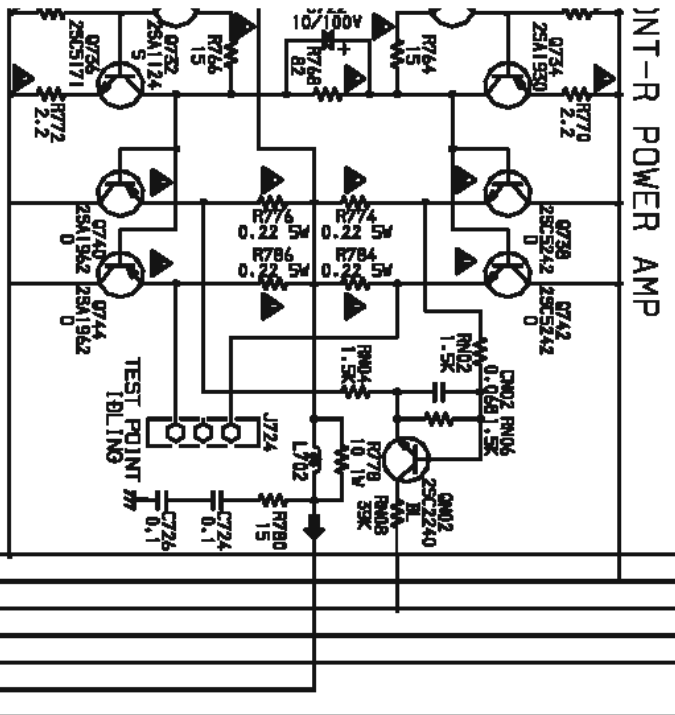
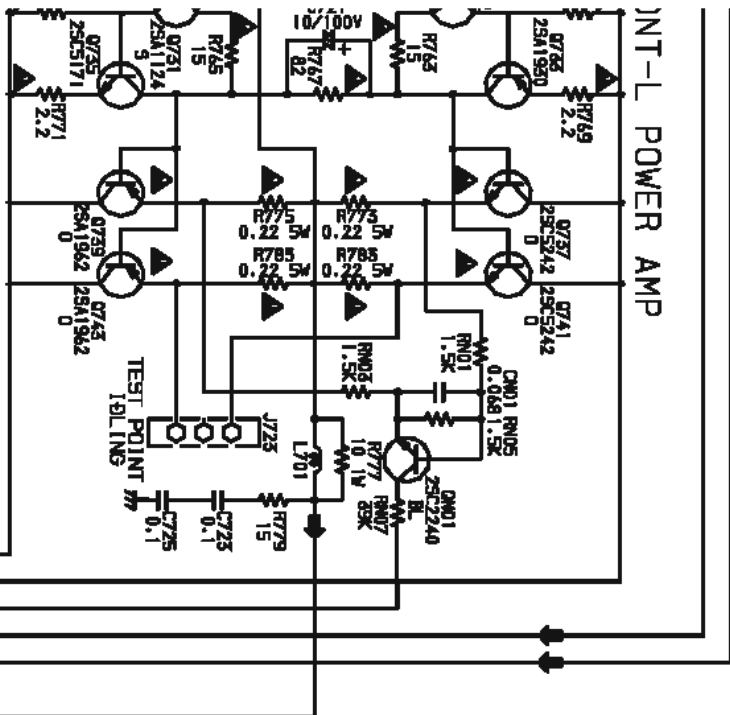

FRONT →
CENTER →
SURROUND →

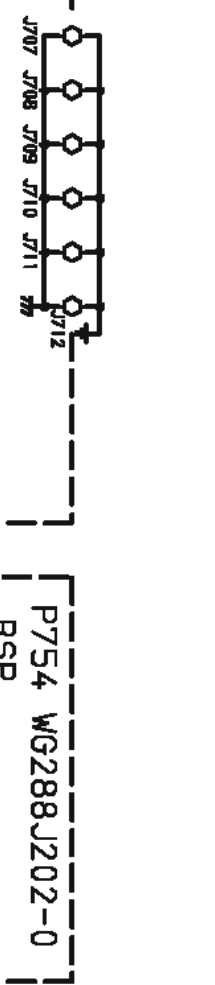
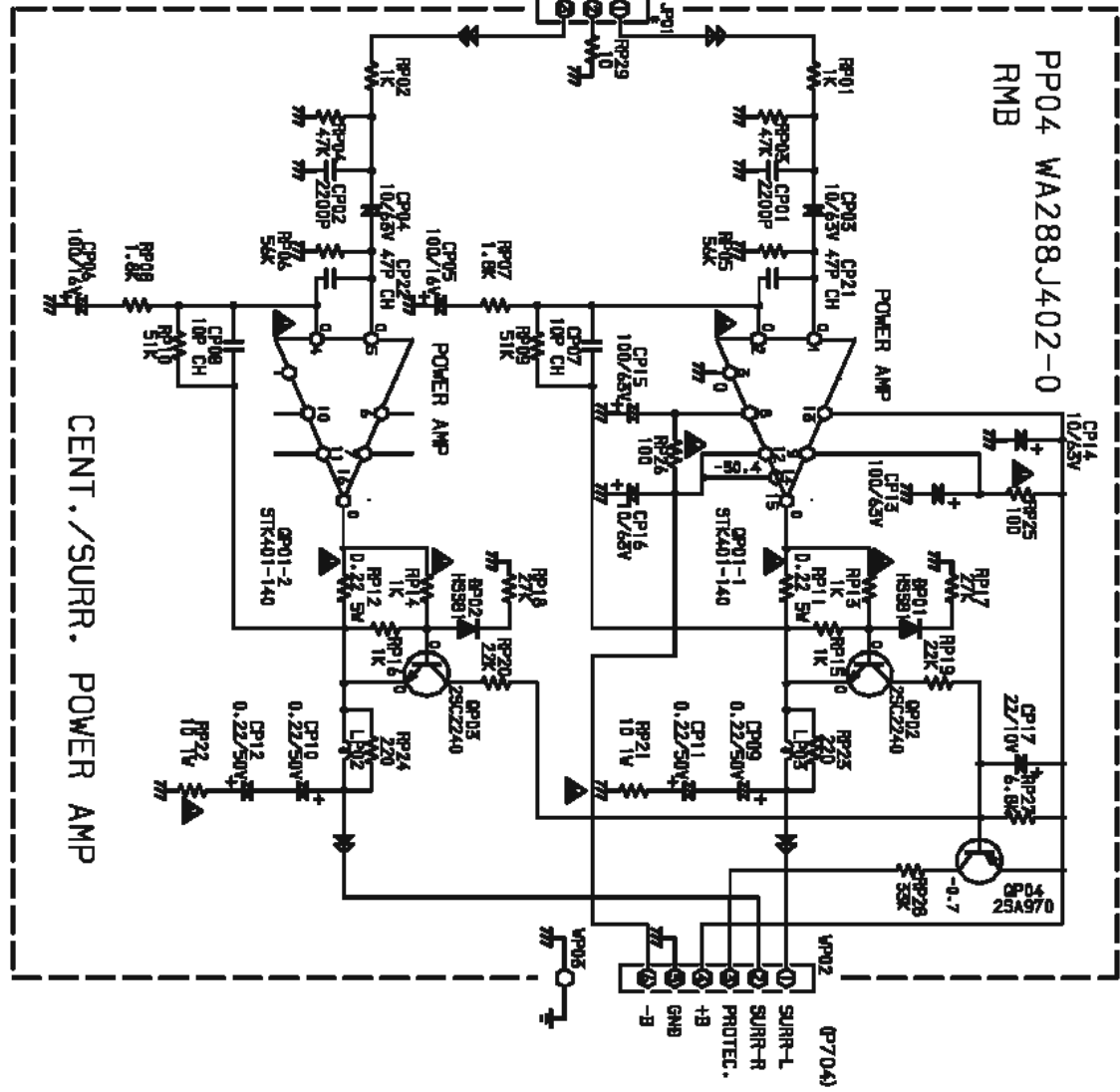

P754 WG288J202-0
RSP

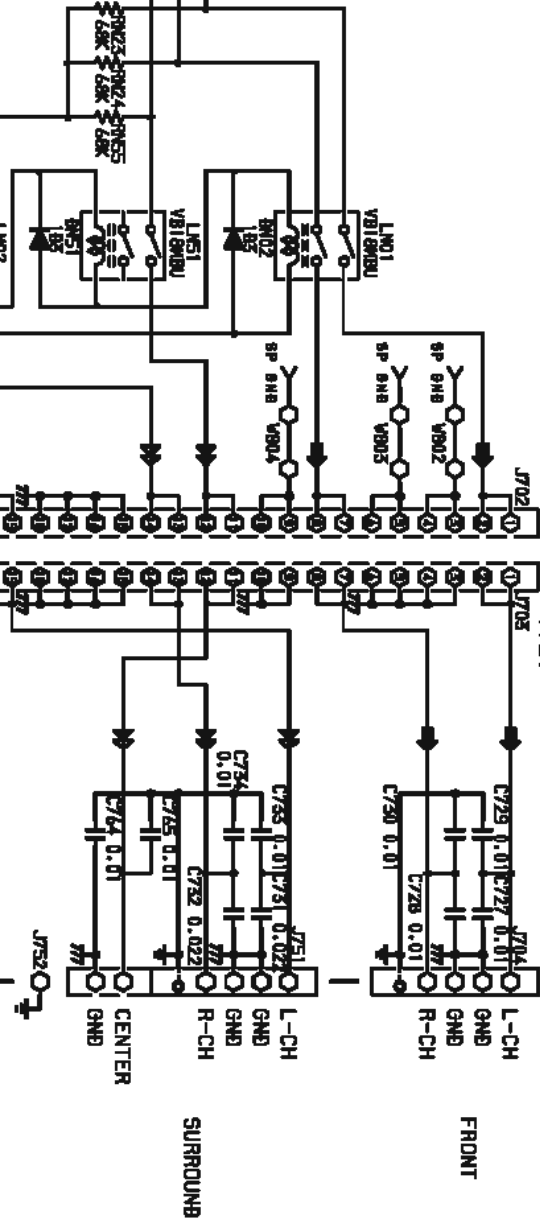

1

2

3

4

5

A B C D E F G

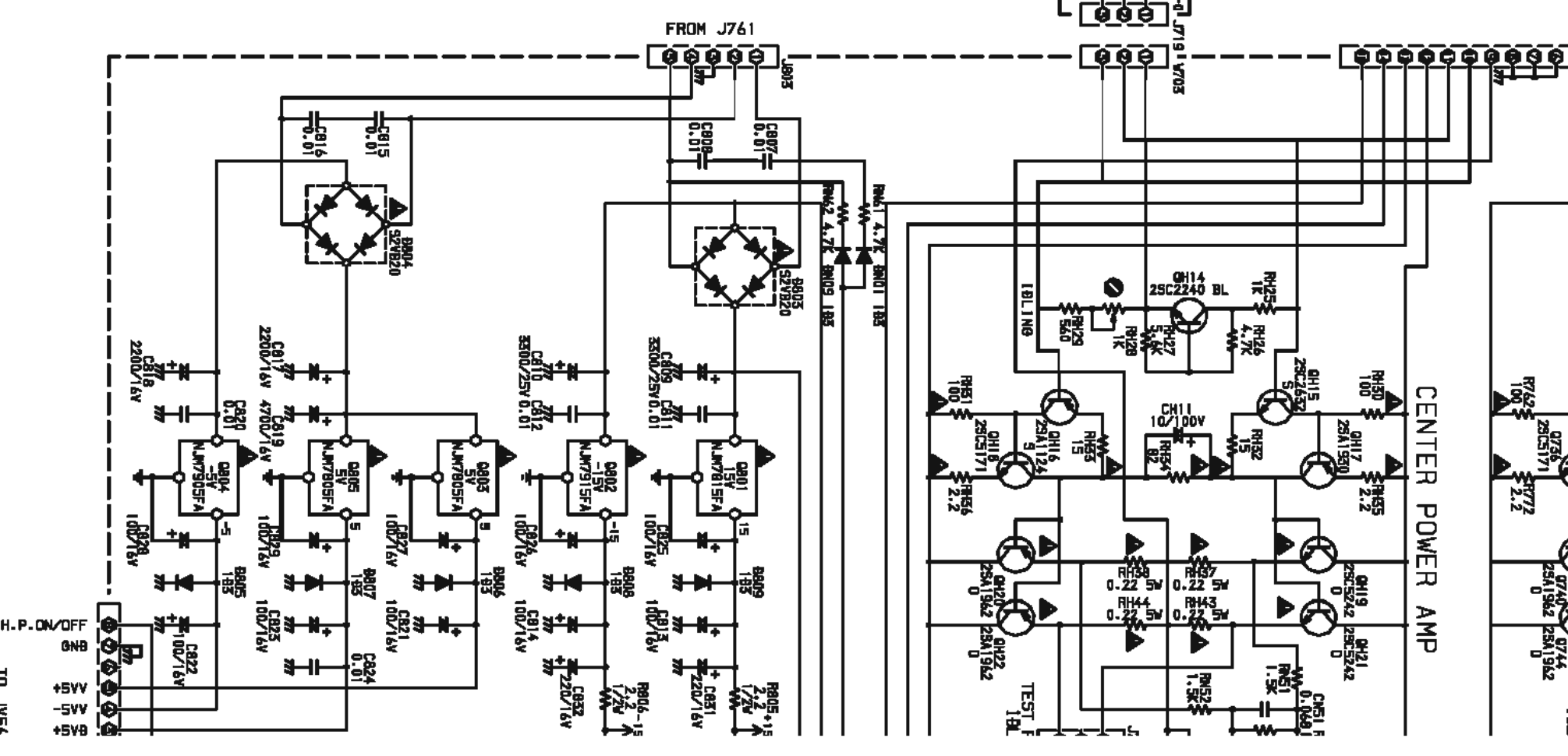
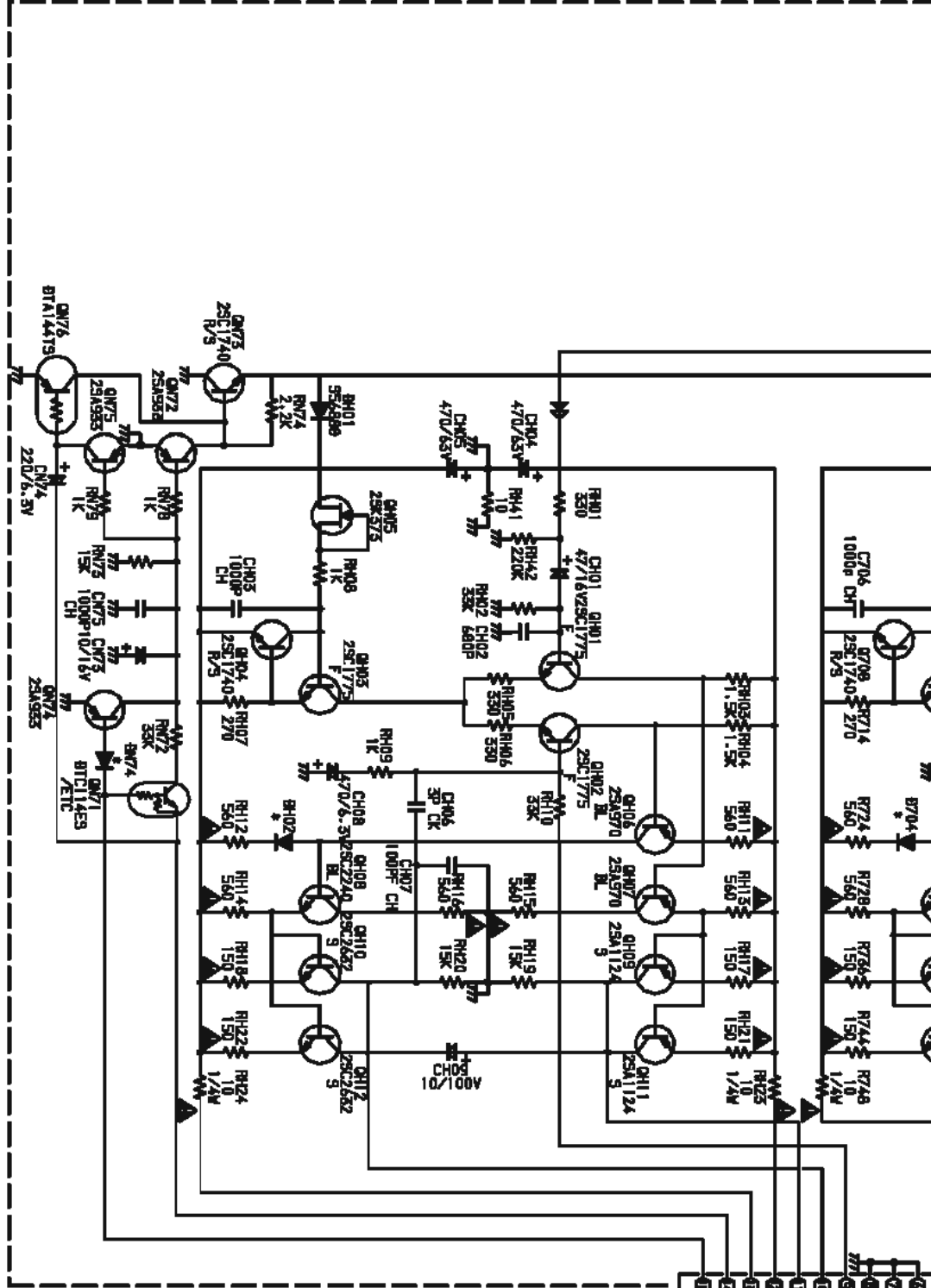
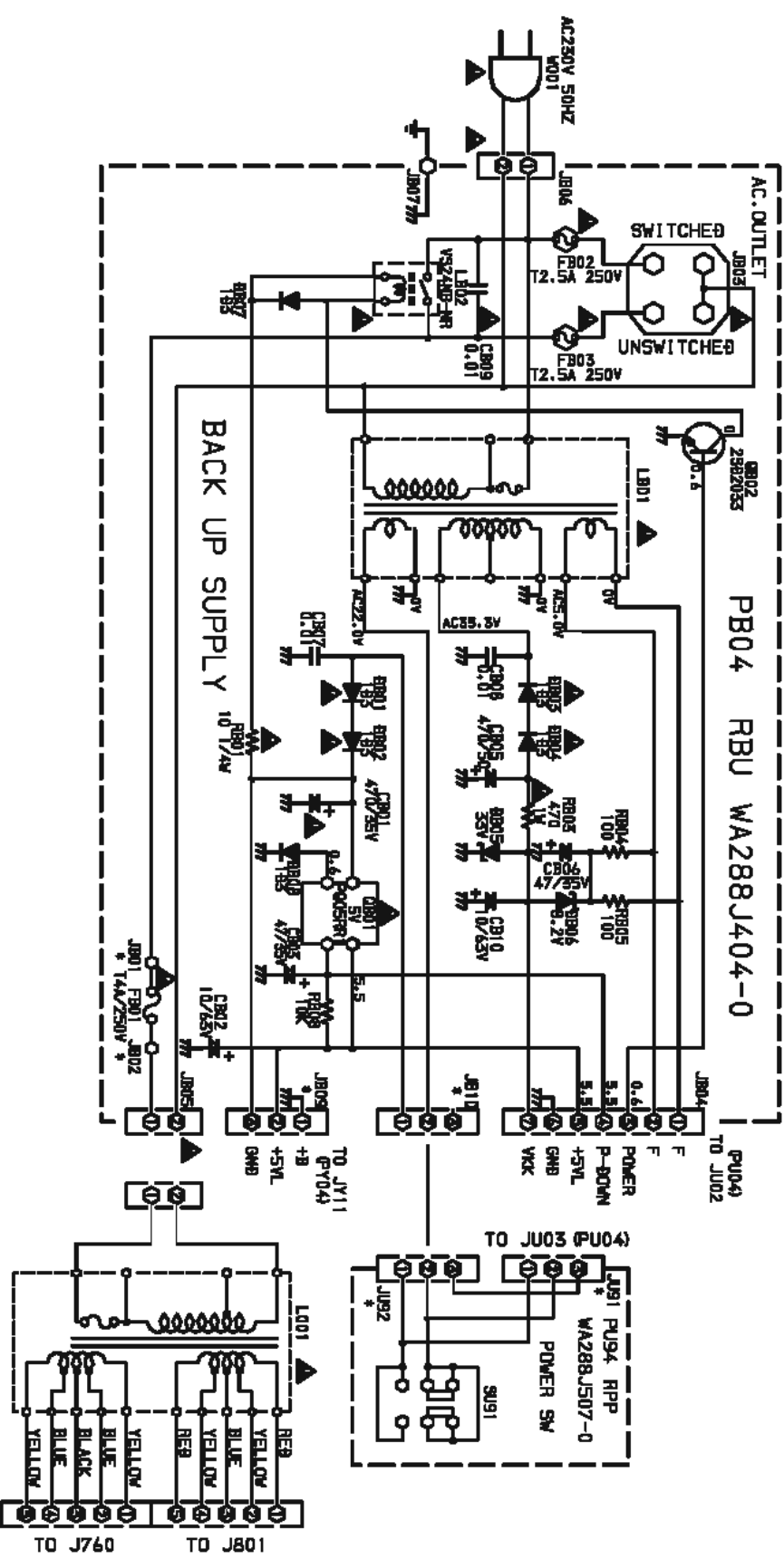

TO JVS6

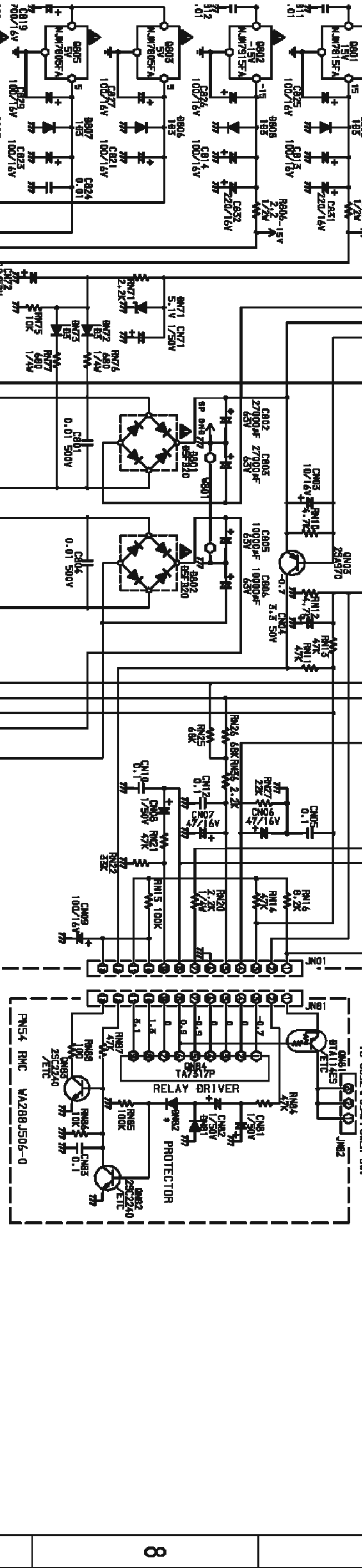
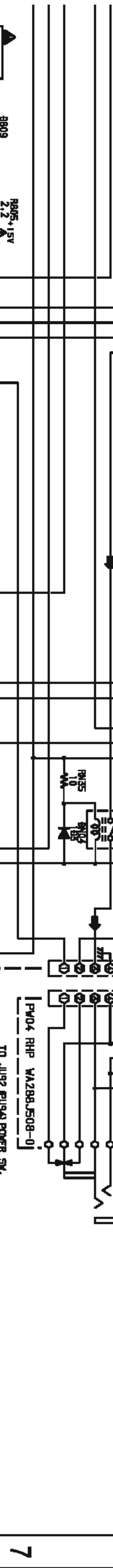
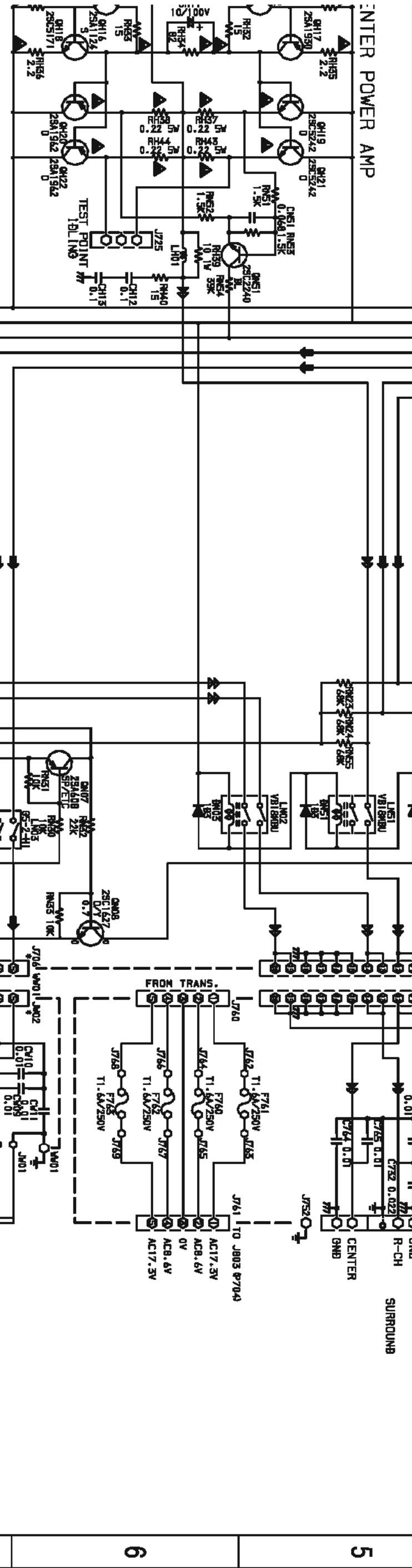

AVR85 European 230V
Schematic 6 of 8

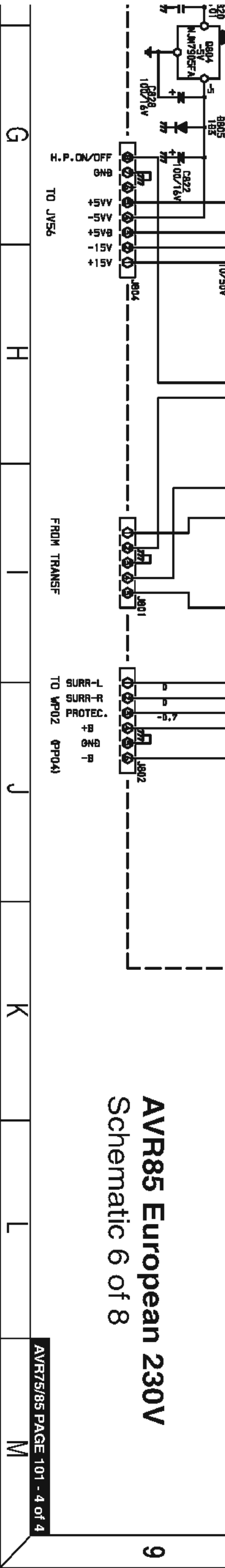

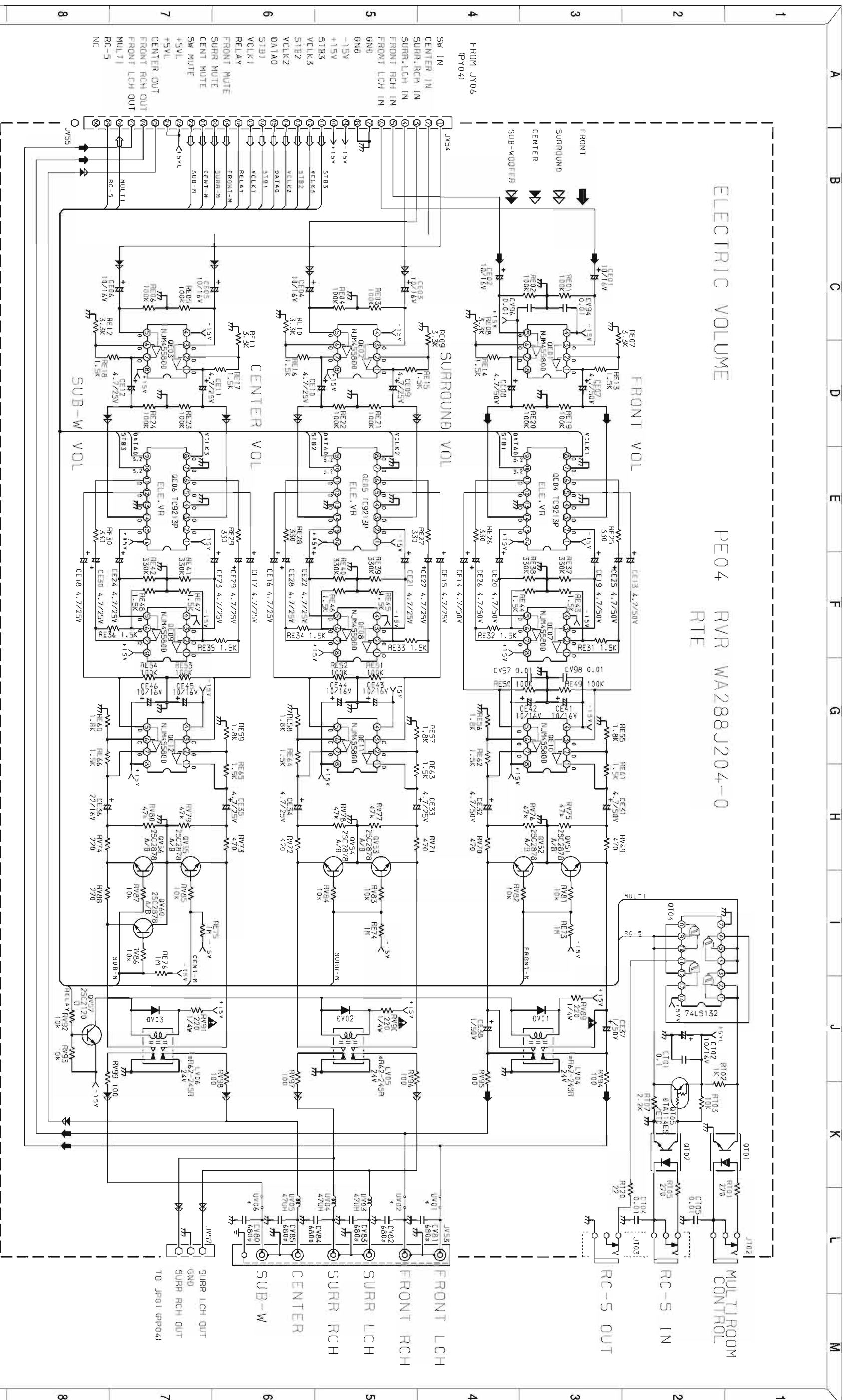

AVR85 European 230V
Schematic 7 of 8

