

The Harman Kardon Model CA205

Manual 89A

HIGH FIDELITY CAR AMPLIFIER

Technical Manual

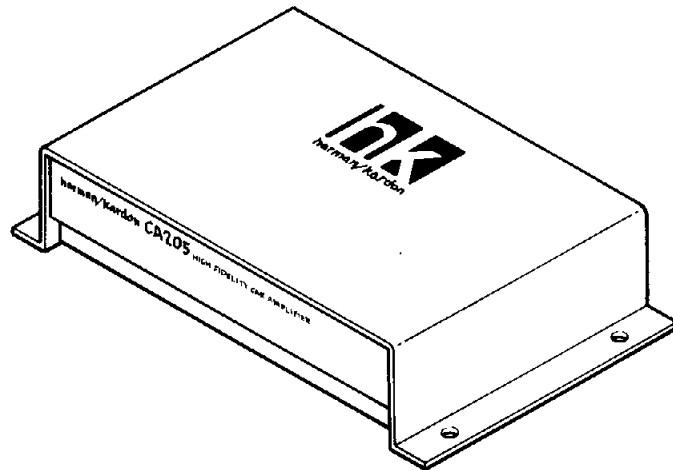

harman/kardon

240 Crossways Park West, Woodbury, N.Y., 11797
1112 H15289A3 P 088504 1850 Printed in Japan

SPECIFICATIONS

Power Output, RMS : 3.5 watts per channel into 4 Ohms, 20 ~ 20,000Hz
HCC (High Instantaneous Current Capability) : ±5A
THD (4 ohms) : No more than 0.2%
Negative Feedback : 25dB
Power Bandwidth : 10Hz to 100,000Hz
Frequency Response : 10Hz to 100,000Hz +0, -3dB
Signal-to-Noise Ratio : 90dB
Input Sensitivity/Impedance : 0.1V/22k Ohms
Power Supply : DC +13.8V (11 ~ 16V usable), negative ground

Typical Input Current Requirements
At Idle : 0.2A
Full Power Music Signal : 0.4A (4 Ohms/ch.)
Full Power Sine Wave : 1.2A (4 Ohms/ch.)
Dimensions (W×H×D) : 6-3/4" × 1-1/2" × 4-1/8" (172 × 38 × 105 mm)
Weight : 1lbs. 5oz. (0.6kg)

Specifications and components subject to change without notice. Overall performance will be maintained or improved.

ALIGNMENT PROCEDURES

■ Idling current adjustment

Conditions:

- Connect a 13.8V power supply to the Power Supply Lead.
- After the power on, wait for 15 minutes before measuring to be sure of the most stable operation.
- Connect the DC voltmeter between TP1 and TP2 and between TP3 and TP4.

Inspection:

- Check that the voltage is between 5mV and 30mV. If it is higher than the specified range, adjust it according to the procedure described at the right.

Adjustment:

Note: When disconnecting a resistor, disconnect the power supply first.

Voltage	Procedure
30mV ~ 53mV	Cut out R135 and R136.
54mV ~ 77mV	Cut out R137 and R138.

After the adjustment is complete, let the unit settle down for 15 minutes, then double-check that the idling current is set properly.

DISASSEMBLY PROCEDURES

① CABINET TOP (131) REMOVAL

Remove 4 screws ④ and remove the Cabinet Top (131).

② MAIN P.C.BOARD REMOVAL

1. Remove the Cabinet Top (131). (Refer to step ①.)
2. Remove 4 screws ⑤ and Loosen screw ⑥, then remove the Main P.C.Board with Insulator (138).

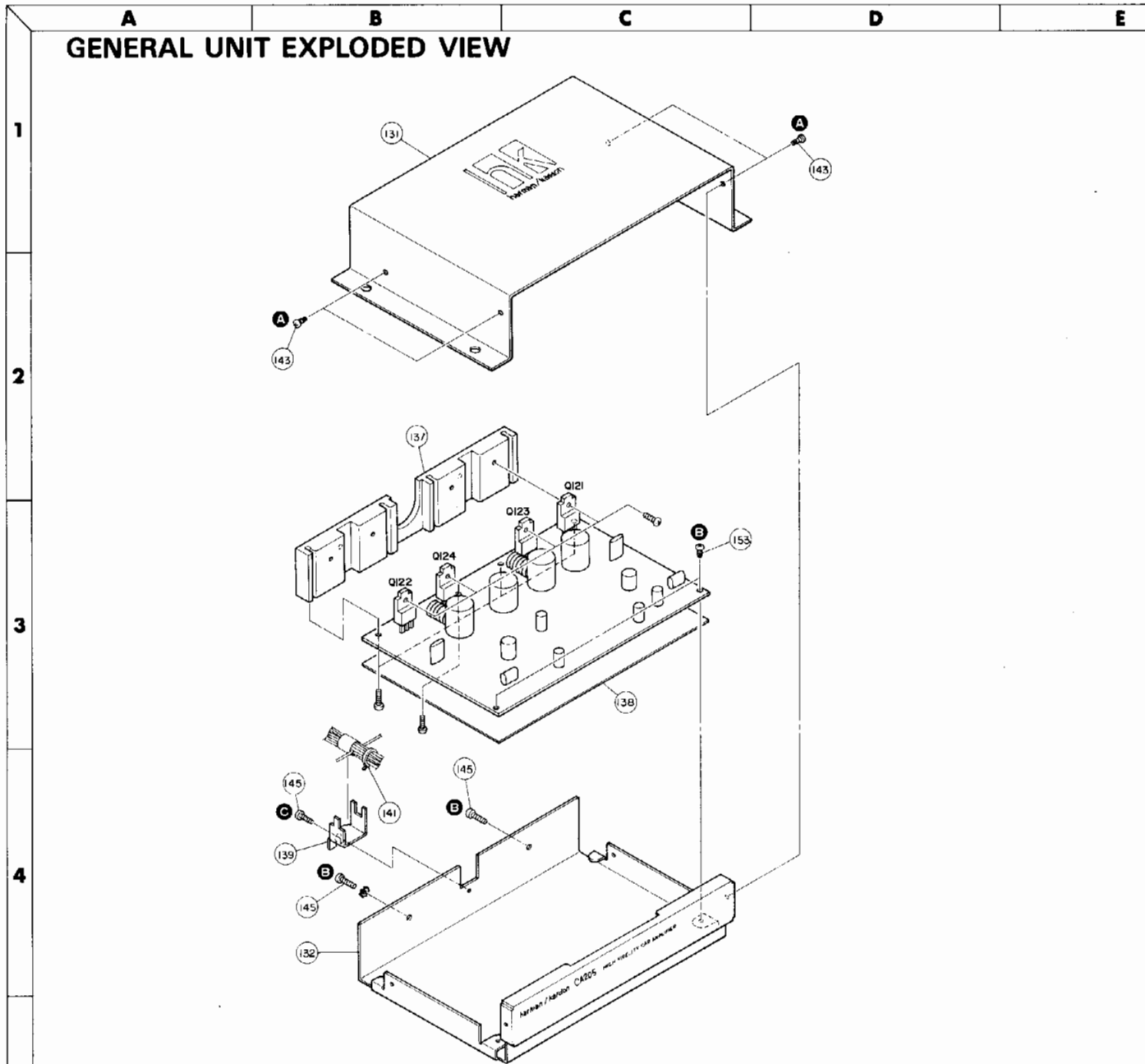

Ref. No.	Part No.	Description
131	1414-05701	Cabinet Top
132	1424-15401	Cabinet Bottom
137	2222-7184	Heat Sink
138	2224-7109	Insulator
139	2219-8047	Bracket
141	2240-7120	Holder
143	2327-2605K9	Self-tapping Screw (+) (2.6×5mm)
145	2340-7003	Special Screw
153	2347-300627	Self-tapping Screw (+) (3×6mm)
	1111-J30211	Owner Guide (for U.S.A. model)
	1111-J30212	Owner Guide (for General model)
	2310-7034	Mounting Screws and Washers (Set)(Accessory)
	1221-717180	Packing Box
	1222-7283	Packing Cushion

ELECTRICAL PARTS LIST

Ref. No.	Part No.	Description
CHASSIS MISCELLANEOUS		
F1	5732-202029	Fuse, 2A, 125V
J1/2	4163-705118	Plug with Lead Wire, Line Input
J3	4163-703118	Connector with Lead Wire, Red
LUG1	4163-704118	Lug with Lead Wire, Black
L1	4163-708118	Filter with Fuse Holder (includes: Fuse)
MAIN P.C.BOARD		
RESISTORS		
R131,132	5165-470J50P	47 Ω , \pm 5%, 1/2W, Solid
CAPACITORS		
C1,2	5345-228C041	2200 μ F, \pm 20%, 16V, Electrolytic
C3	5345-226C041	22 μ F, \pm 20%, 16V, Electrolytic
C4	5345-477C045	470 μ F, \pm 20%, 16V, Electrolytic
C101,102	5345-335F0951	3.3 μ F, \pm 20%, 50V, Electrolytic
C103,104	5359-4715851	470pF, \pm 5%, 100V, Polypropylene
C105,106	5345-107C041	100 μ F, \pm 20%, 16V, Electrolytic
C109,110	5359-1015851	100pF, \pm 5%, 100V, Polypropylene
C111,112	5345-227C045	220 μ F, \pm 20%, 16V, Electrolytic
C113,114	5345-478B045	4700 μ F, \pm 20%, 10V, Electrolytic
TRANSISTORS		
Q1,109,110,111,112	5611-1115(E)	2SA1115(E) or 2SA1115(F)
Q2,105,106,107,108, 113,114	5613-2603(E)	2SC2603(E) or 2SC2603(F)
Q101,102,103,104	5613-2603(F)	2SC2603(F)
Q115,116	5613-945(K)	2SC945(K) or 2SC945(P)
Q117,118	5613-2320(F)	2SA2320(F)
Q119,120	5611-999(F)	2SA999(F)
Q121,122	5611-1305(Y)	2SA1305(Y)
Q123,124	5613-3297(Y)	2SC3297(Y)
DIODES		
D101,102	5631-1S2473	1S2473
COILS		
L2,101,102	5991-7165	

SCHEMATIC DIAGRAM

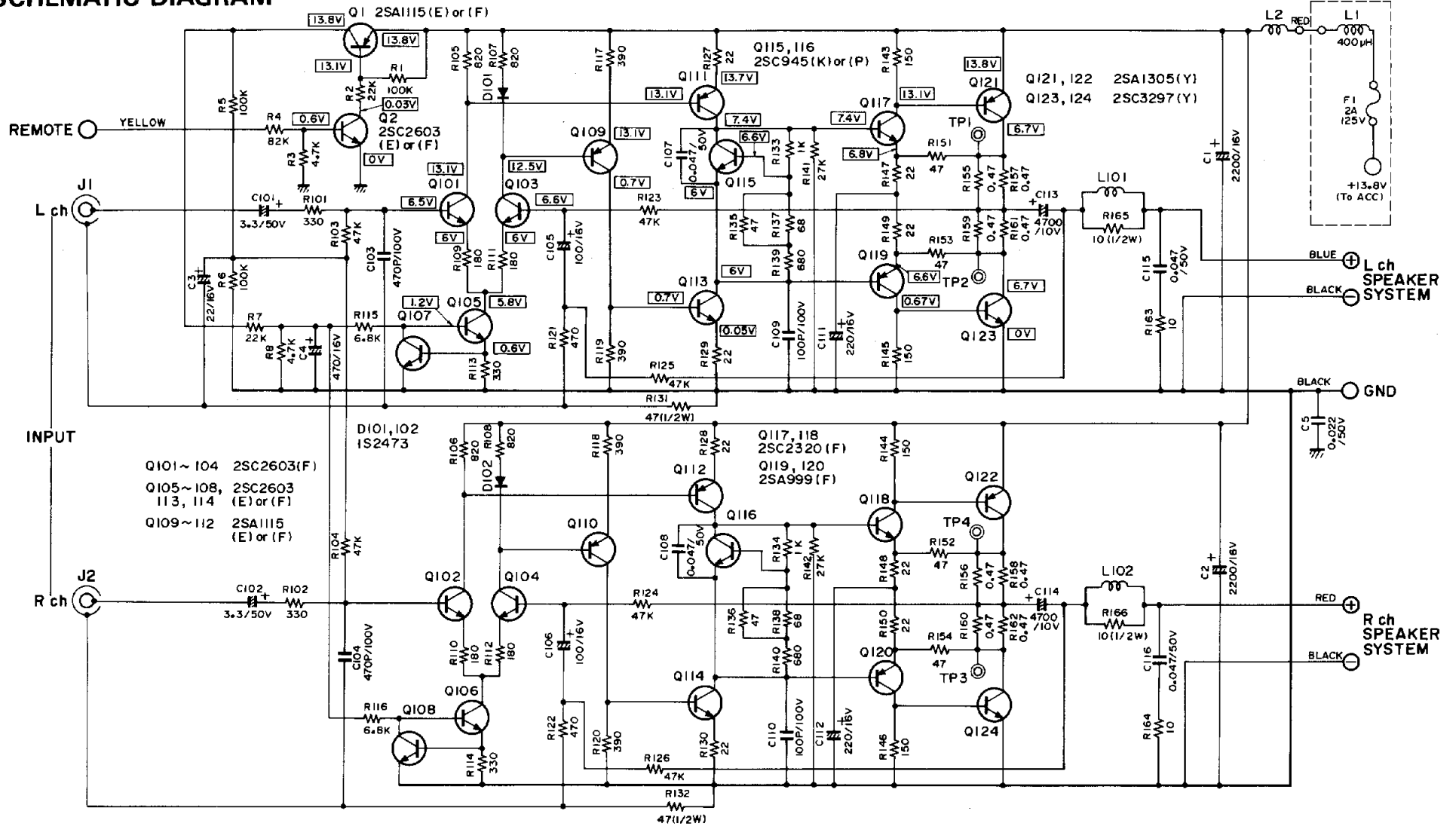

Q101~104 2SC2603(F)
 Q105~108, 2SC2603
 113, 114 (E) or (F)
 Q109~112 2SA1115
 (E) or (F)

1. ALL RESISTANCES VALUES ARE IN Ω.
 KΩ=1000Ω, MΩ=1000KΩ.
2. THE WATTAGE OF RESISTORS IS 1/4W UNLESS OTHERWISE NOTED.
3. ALL CAPACITANCES VALUES ARE IN μF UNLESS OTHERWISE NOTED. P=μF
4. [... V] : DC VOLTAGE AT NO SIGNAL

WIRING DIAGRAM

To Left Channel Speaker System

To Chassis(GND)

LUG1

To Remote Lead
BLK

J3

L1 Filter

F1 Fuse

To ACC(+12V)

To Right Channel Speaker System

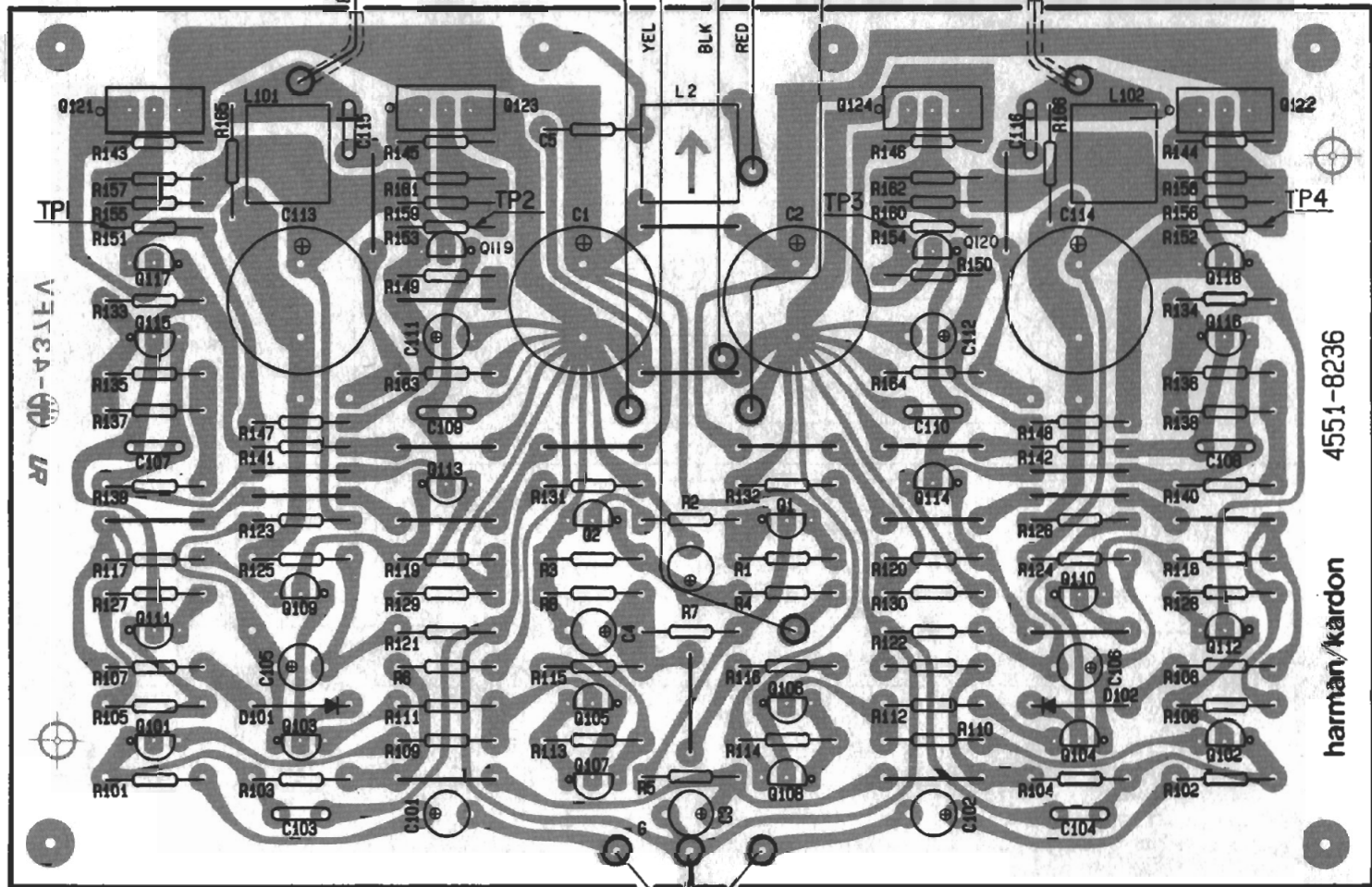

PIN CONNECTION DIAGRAM OF TRANSISTORS AND DIODES.

2SA1115
2SC2803

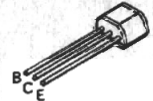

2SC945
2SA2320
2SA999

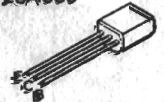

2SA1305
2SC3297

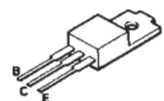

1S2473

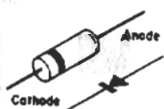

• WIRE COLOR ABBREVIATIONS

- RED : Red
- ORG : Orange
- BLU : Blue
- WHT : White
- BLK : Black
- YEL : Yellow

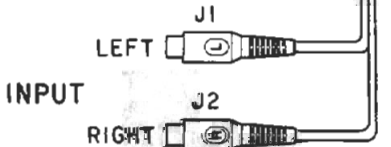

TRANSISTORS

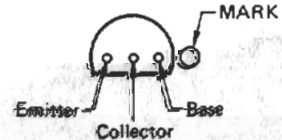
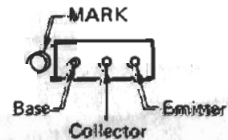

4551-8236 hamman/kardon

1

2

3

4

5