

The Harman Kardon Model CA260

3786

Manual No.74A

HIGH FIDELITY CAR AMPLIFIER

Technical Manual

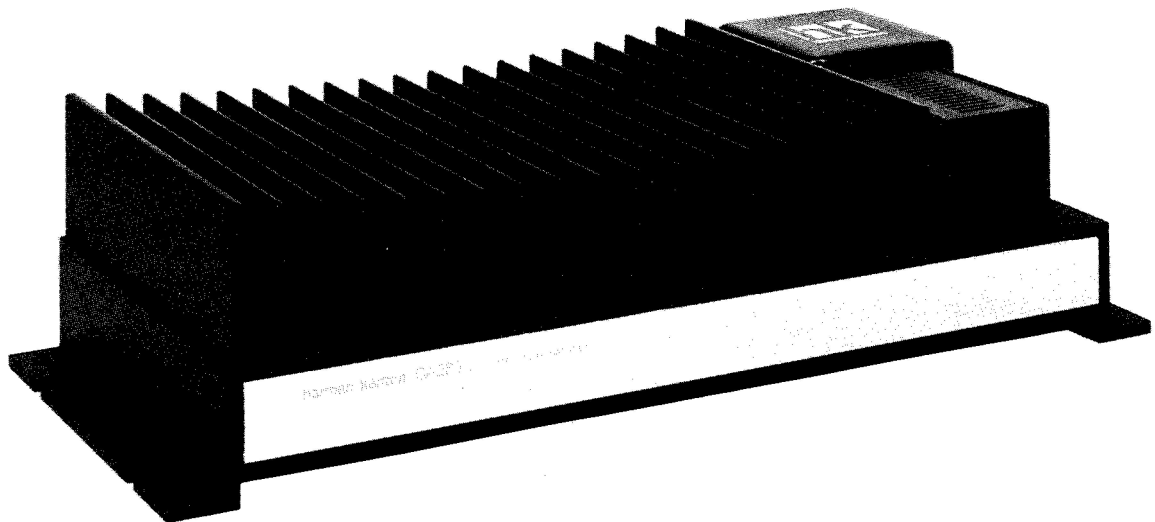

harman/kardon

240 CROSSWAYS PARK WEST, WOODBURY, N.Y. 11797
1112-H15274A8 P-08846 1650 PRINTED IN JAPAN



Power Output, RMS	: 60 watts per channel into 4 Ohms, 20 ~ 20,000Hz
	: 90 watts per channel into 2 Ohms, 20 ~ 20,000Hz
	: 180 watts bridged mono into 4 Ohms, 20 ~ 20,000Hz
HCC (High Instantaneous: Current Capability)	: $\pm 30A$
THD	: No more than 0.1%
Negative Feedback	: 25dB
Power Bandwidth	: 10Hz to 100,000Hz
Frequency Response	: 10Hz to 100,000Hz + 0, - 3dB
Signal-to-Noise Ratio	: 80dB
Input Sensitivity	
Line Level	: 0.25V/0.8V (switchable)
High Level	: 3V

Active Crossover Characteristics

High Pass	: 200Hz, 12dB/Octave
Low Pass	: 200Hz, 6dB/Octave
Power Supply	: DC + 13.8V (11 ~ 16V usable), negative ground

Typical Input Current Requirements

At Idle	: 2.5A
Full Power Music Signal	: 6.7A (4 Ohms/ch.) : 10A (2 Ohms/ch.)
Full Power Sine Wave	: 20A (4 Ohms/ch.) : 30A (2 Ohms/ch.)
Dimensions (W x H x D)	: 15-5/8" x 3-7/8" x 7-1/8" (396 x 98 x 180 mm)
Weight	: 10lbs. 2oz (4.6kg)

All specifications and features subject to change without notice.

DISASSEMBLY PROCEDURES (REFER TO PAGES 4 AND 10)

Note: When replacing parts, discharge by shorting between terminals of the capacitor (C51, C52) at the power source with 8 Ω 100W resistor as it may have charge accumulated.

1 CABINET BOTTOM ASSEMBLY (101) REMOVAL

Remove 7 screws **A** and remove the Cabinet Bottom Assembly (101).

2 MAIN P.C. BOARD (PCB-1) REMOVAL

1. Remove the Cabinet Bottom Assembly (101). (Refer to step 1.)
2. Remove 9 screws **B** and remove the Main P.C. Board (PCB-1) with Cabinet Back (142), Line Input P.C. Board (PCB-2), Bridged-Mono Switch P.C. Board (PCB-3) and terminals (TE1 and TE2).
3. Unsolder the lead wires from the Line Input P.C. Board (PCB-2) and Bridged-Mono Switch P.C. Board (PCB-3) and remove the terminals (TE1 and TE2) by unsoldering.
4. Remove 2 screws **C** and remove the Cabinet Back (142) with the Line Input P.C. Board (PCB-2), Bridged-Mono Switch P.C. Board (PCB-3) and terminals (TE1 and TE2).

3 POWER SUPPLY P.C. BOARD (PCB-4) REMOVAL

1. Remove the Cabinet Bottom Assembly (101). (Refer to step 1.)
2. Unsolder the lead wires from the Power Transformer (T1).
3. Remove 7 screws **D** and remove the Power Supply P.C. Board (PCB-4) with the Cabinet Back (143), Fuse with Holder (F1), Insulator (186) and terminal (TE3).
4. Remove the terminal (TE3) by unsoldering.
5. Remove screw **E** and remove the Cabinet Back (143) with Fuse with Holder (F1), Insulator (186) and terminal (TE3). At this time, disconnect the connector from Fuse with Holder (F1).

4 POWER TRANSFORMER (T1) REMOVAL

1. Remove the Power Supply P.C. Board (PCB-4). (Refer to step 3.)
2. Remove 4 screws **F** and remove the Power Transformer (T1).

PROTECTION CIRCUIT

If the temperature inside the CA260 rises above 80°C, the protection circuit comes into operation, decreasing output. At this time the protect indicator blinks. If the temperature comes back below 80°C by natural cooling, output returns as it was.

If the temperature rises above 100°C, the power supply circuit is shut off. Not only does the output stop, but also the protect indicator goes out. If this happens, it is possible that the CA260 is broken. However, even in this state, it cannot be always said that it is broken because the unit may operate when the temperature comes back below 80°C by natural cooling.

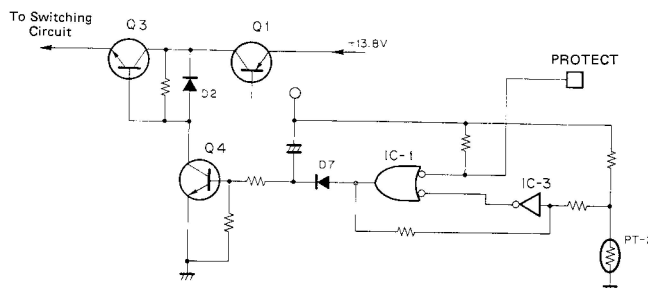

ALIGNMENT PROCEDURES (REFER TO PAGES 9 AND 10)

■ Idling current adjustment

Conditions:

- Connect the DC voltmeter between TP1 and TP2 and between TP3 and TP4.
- Connect a 13.8V power supply to the 12V Battery Power In terminal.
- After the power on, wait for 5 minutes before measuring to be sure of the most stable operation.

Inspection:

- Confirm that the idling current is $50\text{mA} \pm 20\text{mA}$ (voltage: $33\text{mV} \pm 13\text{mV}$).
If the current measured does not fall within the range specified, adjust it with the procedure below.

Adjustment

Note: When replacing or disconnecting a resistor, disconnect the power supply first.

Current	Voltage	Procedure
less than 29mA	less than 19mV	Add R481 and R482 between TP5 and TP6 and between TP7 and TP8.
71mA ~ 100mA	46mV ~ 66mV	After cutting out R477 and R478, add R481 and R482 between TP5 and TP6 and between TP7 and TP8.
101mA ~ 200mA	67mV ~ 132mV	After cutting out R479 and R480, add R481 and R482 between TP5 and TP6 and between TP7 and TP8.
201mA ~ 250mA	133mV ~ 165mV	Cut out R477 and R478.
more than 251mA	more than 166mV	Cut out R479 and R480.

After the adjustment is complete, let the unit settle down for 10 minutes, then double-check that the idling current is set properly.

BLOCK DIAGRAM

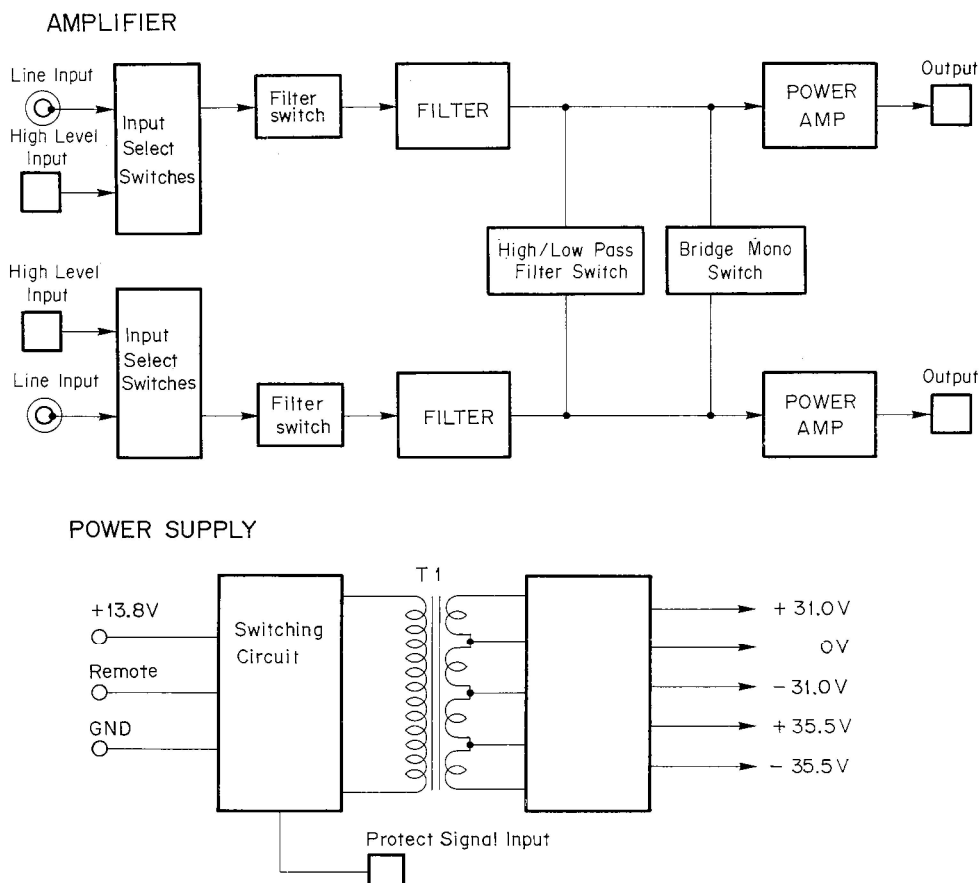

GENERAL UNIT EXPLODED VIEW

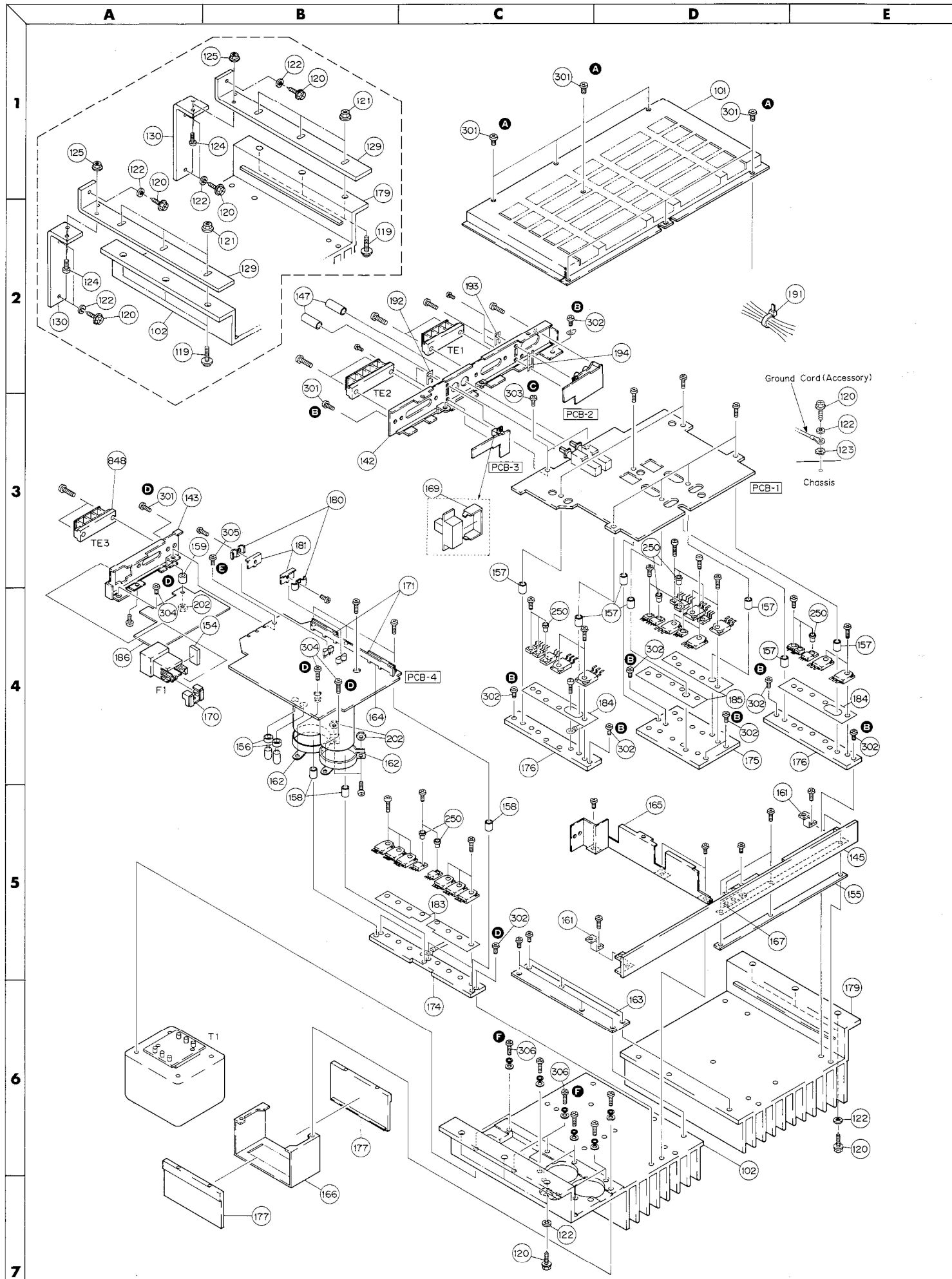

GENERAL UNIT PARTS LIST

Ref. No.	Part No.	Description
101	A424-CA260A	Cabinet Bottom Assembly
102	B222-CA260A	Heat Sink Assembly, Right
119	2310-7028	Hexagon-Head Bolt
120	2346-501641	Hexagon-Head Tapping Screw
121	2440-7018	Hexagon Nut
122	2412-5042	Spring Washer
123	2414-504	Toothed Lock Washer
124	2557-401649	Bolt
125	2440-7019	Hexagon Nut
129	2218-7035	Bracket
130	2218-7036	Bracket
142	1424-12101	Cabinet Back
143	1424-12201	Cabinet Back
145	1443-07701	Front Panel
147	1662-05002	Push Button, Filter Switches
154	2112-11768	Sponge
155	2132-7118	Spacer
156	2132-7119	Spacer
157	2132-7120	Spacer
158	2132-7123	Spacer
159	2132-7124	Spacer
161	2219-7965	Bracket
162	2219-7966	Bracket
163	2219-7967	Bracket
164	2219-7968	Bracket
165	2219-7969	Bracket
166	2219-7971	Bracket
167	2219-7972	Bracket
169	2219-7994	Bracket
170	2219-7995	Bracket
171	2219-7998	Bracket
174	2222-7158	Heat Sink
175	2222-7159	Heat Sink
176	2222-7160	Heat Sink
177	2222-7161	Heat Sink
179	2222-7163	Heat Sink
180	2222-7106	Heat Sink
181	2222-7168	Heat Sink
183	2224-7092	Insulator
184	2224-7093	Insulator
185	2224-7094	Insulator
186	2224-7098	Insulator
191	2240-7120	Holder
192	2240-7220	Holder
193	2240-7224	Holder
194	2240-7225	Holder
202	2440-7016	Special Nut
250	2114-YC40B	Bushing
301	2347-3006K7	Self-Tapping Screw (+) (3 x 6mm)
302	2347-301026	Self-Tapping Screw (+) (3 x 10mm)
303	2347-300627	Self-Tapping Screw (+) (3 x 6mm)
304	2347-300626	Self-Tapping Screw (+) (3 x 6mm)
305	2347-301227	Self-Tapping Screw (+) (3 x 12mm)
306	2557-301229	Screw with Washer (+) (3 x 12mm)
	1111-J30179	Owner Guide (for U.S.A. model)
	1111-J30180	Owner Guide (for General & Canada models)
	1756-09901	Installation Template (Accessory)
	1221-717169	Packing Box
	1222-7267	Packing Cushion, Left
	1222-7268	Packing Cushion, Right

ELECTRICAL PARTS LIST

Ref. No.	Part No.	Description
CHASSIS MISCELLANEOUS		
△ T1	5584-701464	Power Transformer
C429	5369-104144	Capacitor, 0.1 μ F, \pm 10%, 25V, Semiconductor
△ F1	4472-7935	Fuse with Holder, 30A (Spare Fuse Inclusive)
PT1, 2	5192-090TS1	Posistor, ME2
TE1, 3	4214-148	Terminal, High Level Input, 12V Battery Power In
TE2	4214-147	Terminal, Speaker System
△ J3	4163-701107	Connector with Lead Wire
LUG1	4211-4	Lug Terminal
	4162-726	Power Cord, Red (Accessory)
	4162-736	Ground Cord, Black (Accessory)
	4211-31	Spade Lug (w/Tube) (Accessory)
PCB-1 MAIN P.C. BOARD		
RESISTORS		
△ R97, 98, 441, 442, 443, 444	5102-1014713	100 Ω , \pm 2%, 1/4W, Fuse
R417, 418	5174-562381	5.6k Ω , \pm 1%, 1/4W, Metal
R419, 420	5174-243381	24k Ω , \pm 1%, 1/4W, Metal
R421, 422	5174-301381	300 Ω , \pm 1%, 1/4W, Metal
R449, 450	5174-561381	560 Ω , \pm 1%, 1/4W, Metal
R459, 460	5174-470381	47 Ω , \pm 1%, 1/4W, Metal
R465A/B, 466A/B, 467A/B, 468A/B	5275-R33671	0.33 Ω , \pm 10%, 5W x 2, Cement
R469, 470, 471, 472	5171-220572	22 Ω , \pm 5%, 1W, Metal
R473, 474, 475, 476	5171-470572	47 Ω , \pm 5%, 1W, Metal
R477, 478	5174-151381	150 Ω , \pm 1%, 1/4W, Metal
R479, 480	5174-131381	130 Ω , \pm 1%, 1/4W, Metal
R483, 484, 485, 486	5174-100381	10 Ω , \pm 1%, 1/4W, Metal
R513, 514	5174-243381	24k Ω , \pm 1%, 1/4W, Metal
CAPACITORS		
C76	5345-226B041	22 μ F, \pm 20%, 10V, Electrolytic
C77, 78	5345-476D041	47 μ F, \pm 20%, 25V, Electrolytic
C79, 80	5345-227D041	220 μ F, \pm 20%, 25V, Electrolytic
C81	5345-225F041	2.2 μ F, \pm 20%, 50V, Electrolytic
C401, 402	5345-684F0951	0.68 μ F, \pm 20%, 50V, Electrolytic
C405, 406	5345-337B0226	330 μ F, \pm 20%, 10V, Electrolytic
C407, 408	5345-476C0952	47 μ F, \pm 20%, 16V, Electrolytic
△ C409, 410, 411, 412	5345-226F041	22 μ F, \pm 20%, 50V, Electrolytic
C413, 414	5359-1015851	100pF, \pm 5%, 100V, Polypropylene
C415, 416	5345-476C041	47 μ F, \pm 20%, 16V, Electrolytic
C417, 418	5353-050934	5pF, \pm 0.5pF, 500V, Mica
△ C425, 426, 427, 428	5345-476F041	47 μ F, \pm 20%, 50V, Electrolytic
C501, 502	5345-106C0952	10 μ F, \pm 20%, 16V, Electrolytic
C503, 504, 505, 506	5345-106D0952	10 μ F, \pm 20%, 25V, Electrolytic
C523, 524	5345-226D041	22 μ F, \pm 20%, 25V, Electrolytic
DIODES		
D61, 401, 402, 413, 414	5631-1S2473	1S2473
D62, 65	5641-MV104V	Varistor, MV104V
D63, 64	5635-HZ15-2L	Zener, HZ15-2L
D403, 404, 405, 406	5632-10DF2	10DF2
D407, 408	5635-HZ12B2L	Zener, HZ12B2L
D409, 410, 411, 412	5636-1S2471	1S2471

Ref. No.	Part No.	Description
TRANSISTORS		
Q31, 32, 33, 413, 414	5613-2240(BL)	2SC2240(BL) or 2SC2240(GR)
Q34, 409, 410, 415, 416, 417, 418	5611-970(BL)	2SA970(BL)
Q35, 36, 38, 405, 406, 407, 408	5613-2603(E)	2SC2603(E) or 2SC2603(F)
Q37, 39	5611-1115(E)	2SA1115(E) or 2SA1115(F)
Q40	5613-2877(O)	2SC2877(O) or 2SC2877(Y)
Q41	5611-1217(O)	2SA1217(O) or 2SC1217(Y)
Q401, 402, 403, 404	5613-1775(F)	2SC1775(F)
Q411, 412	5613-2240(BL)	2SC2240(BL)
Q419, 420	5612-646(C)	2SB646(C)
Q421, 422	5614-666(C)	2SD666(C)
Q423, 424	5614-669(B)	2SD669(B) or 2SD669(C)
Q425, 426	5612-649(B)	2SB649(B) or 2SB649(C)
Q427, 428	5614-669(C)	2SD669(C)
Q429, 430	5612-649(C)	2SB649(C)
Q431, 432	5613-2591(Q)	2SC2591(Q) or 2SC2591(R) or 2SC2591(S)
Q433, 434	5611-1111(Q)	2SA1111(Q) or 2SA1111(R) or 2SA1111(S)
Q435, 436, 437, 438	5613-3182(O)	2SC3182(O) or 2SC3182(R)
Q439, 440, 441, 442	5611-1265(O)	2SA1265(O) or 2SA1265(R)
Q501, 502	5611-999L(F)	2SA999L(F)
Q503, 504	5613-2320L(F)	2SC2320L(F)
COILES		
L405, 406	5991-7165	
MISCELLANEOUS		
SW1, 2	4431-A04727	Push Switch, Filter ON/OFF, High Pass/Low Pass Filter
PCB-2 LINE INPUT P.C. BOARD		
CAPACITORS		
C519, 520	5359-2715851	270pF, $\pm 5\%$, 100V, Polypropylene
C521, 522	5359-1515851	150pF, $\pm 5\%$, 100V, Polypropylene
MISCELLANEOUS		
SW4	4421-0427126	Slide Switch, Line Input Sensitivity
J1, 2	4482-7117	2-Pin Jack, Line Input
PCB-3 BRIDGED-MONO SWITCH P.C. BOARD		
CAPACITORS		
C507	5345-475D0952	4.7 μ F, $\pm 20\%$, 25V, Electrolytic
C508	5345-106D0952	10 μ F, $\pm 20\%$, 25V, Electrolytic
TRANSISTOR		
Q505	5613-2603(E)	2SC2603(E) or 2SC2603(F)
MISCELLANEOUS		
SW3	4421-0227123	Slide Switch, Bridge Mono

Ref. No.	Part No.	Description
PCB-4 POWER SUPPLY P.C. BOARD		
RESISTOR		
R24	5174-184381	180k Ω , \pm 10%, 1/4W, Metal
CAPACITORS		
Δ C1, 29, 30, 31, 32, 33	5345-227D0921	220 μ F, \pm 20%, 25V, Electrolytic
C2, 4, 5, 6	5345-107-25	100 μ F, \pm 20%, 25V, Electrolytic
C3, 15	5345-227A041	220 μ F, \pm 20%, 6.3V, Electrolytic
C7, 8, 34, 35	5345-225F041	2.2 μ F, \pm 20%, 50V, Electrolytic
C9, 10	5359-3315851	330pF, \pm 5%, 100V, Polypropylene
C12	5359-2015851	200pF, \pm 5%, 100V, Polypropylene
C13	5345-106-16	10 μ F, \pm 20%, 16V, Electrolytic
C18	5345-105-50	1 μ F, \pm 20%, 50V, Electrolytic
Δ C51, 52	5341-109F0960	10000 μ F, \pm 20%, 50V, Electrolytic
Δ C53, 54	5345-476F041	47 μ F, \pm 20%, 50V, Electrolytic
Δ C55, 56, 57, 58	5345-226F041	22 μ F, \pm 20%, 50V, Electrolytic
INTEGRATED CIRCUITS		
IC1, 2	5654-MN4011B	MN4011B
IC3	5654-MN4069UB	MN4069UB
IC4	5654-MN4027B	MN4027B
IC5	5652-M5223P	M5223P
TRANSISTORS		
Q1, 13, 14	5611-1286(H)	2SA1286(H)
Q2, 4, 6, 7, 8, 9, 10, 11	5613-2603(E)	2SC2603(E) or 2SC2603(F)
Q3, 12, 15	5613-3246(H)	2SC3246(H)
Q16, 17	5613-3345(O)	2SC3345(O) or 2SC3345(Y)
Q18, 19, 20, 21, 22, 23	5613-2626	2SC2626
DIODES		
D1	5632-ERC0102F	ERC0102F
D2, 7, 9, 10, 11, 13	5631-1S2473	1S2473
Δ D3, 4, 5, 6, 52, 53, 54, 55	5632-10DF2	10DF2
D8	5635-HZ6A-2L	Zener, HZ6A-2L
D12	5635-HZ9B-2L	Zener, HZ9B-2L
D14	5637-GL5HD10	L.E.D., GL5HD10, Power Indicator, Red
D15	5637-GL5HY10	L.E.D., GL5HY10, Protect Indicator, Amber
Δ D51	5685-PB101F	Bridge Silicon, PB101F
COILS		
L51, 52	5991-7175	

SCHEMATIC DIAGRAM

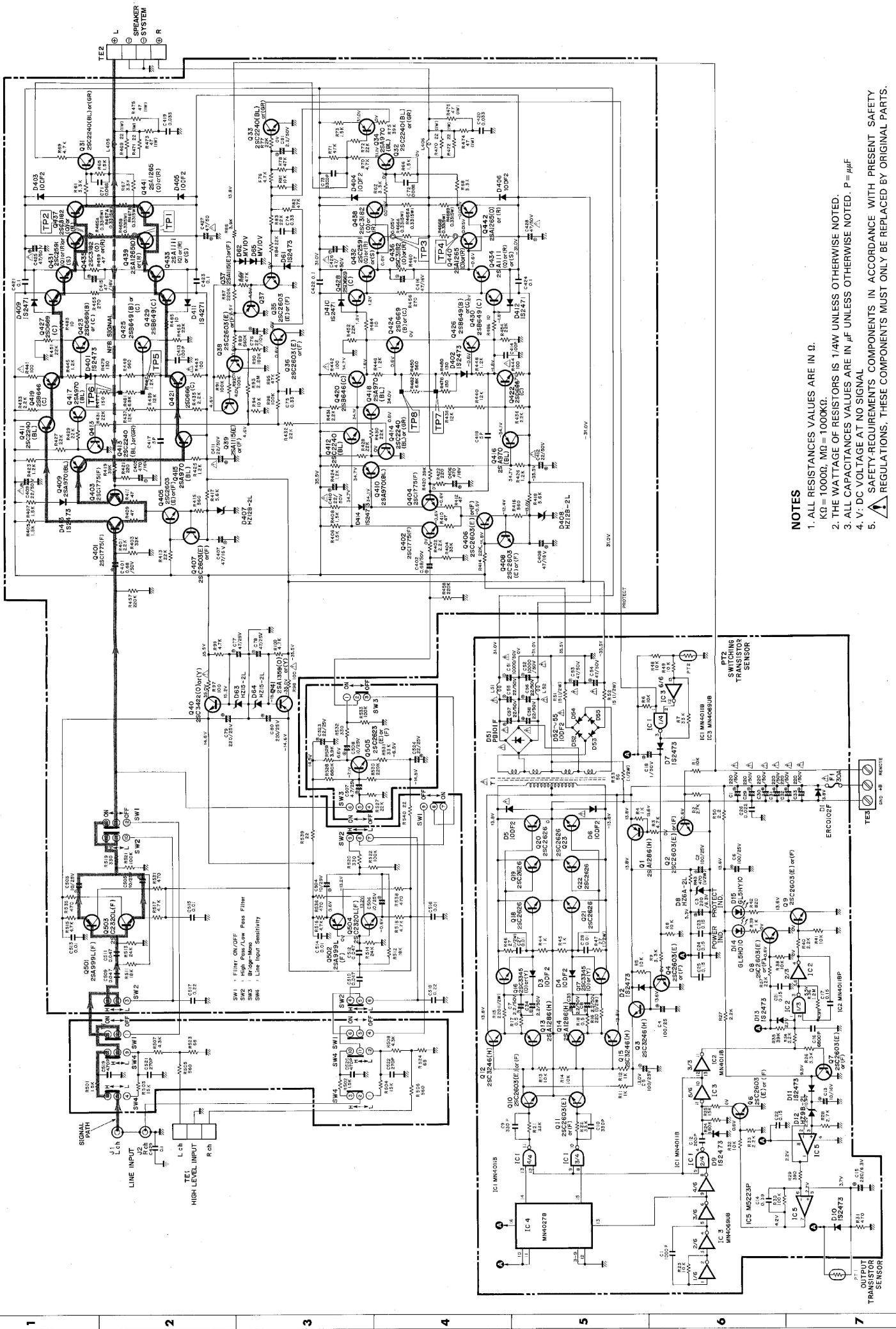

NOTES

1. ALL RESISTANCE VALUES ARE IN Ω .
2. THE WATTAGE OF RESISTORS IS 1/4W UNLESS OTHERWISE NOTED.
3. ALL CAPACITANCE VALUES ARE IN μF UNLESS OTHERWISE NOTED. P = μF
4. V: DC VOLTAGE AT NO SIGNAL
5. Δ : REGULATIONS. THESE COMPONENTS MUST ONLY BE REPLACED BY ORIGINAL PARTS.

The Harman Kardon Model CA260

Manual 74C

HIGH FIDELITY CAR AMPLIFIER SUPPLEMENTARY MANUAL

MODIFICATIONS WERE MADE AT SERIAL NUMBER 9008201 TO IMPROVE PERFORMANCE. EXCEPT FOR THE CHANGES AS NOTED IN THIS SUPPLEMENT, REFER TO MANUAL 74A AND 74B FOR ALL OTHER PARTS AND SERVICE INFORMATION.

SPECIFICATIONS

Power Output, RMS	: 60 watts per channel into 4 Ohms, 20-20,000Hz : 90 watts per channel into 2 Ohms, 20-20,000Hz : 180 watts bridged mono into 4 Ohms, 20-20,000Hz	Active Crossover Characteristics	: 200Hz, 12dB/Octave : 200Hz, 6dB/Octave : DC +13.8V (11-18V usable), negative ground
HCC (High Instantaneous Current Capability)	: ±30A	Typical Input Current Requirements	: 2.5A
THD (4 Ohms/2 Ohms)	: No more than 0.1%/0.2%	At Idle	: 6.7A (4 Ohms/ch.) : 10A (2 Ohms/ch.)
Negative Feedback	: 25dB	Full Power Music Signal	: 20A (4 Ohms/ch.) : 30A (2 Ohms/ch.)
Power Bandwidth	: 10Hz to 100,000Hz	Full Power Sine Wave	: 15-5/8" x 3-7/8" x 7-1/8" (395 x 98 x 180 mm)
Frequency Response	: 10Hz to 100,000Hz +0, -3dB	Dimensions (W x H x D)	: 10lbs. 2oz. (4.6kg)
Signal-to-Noise Ratio	: 80dB	Weight	
Input Sensitivity	: 0.1V/O.5V (switchable)	Specifications and components subject to change without notice.	
Line Level	: 1V	Overall performance will be maintained or improved.	
High Level			

ELECTRICAL PARTS LIST

Ref. No.	Part No.	Description
PCB-1 MAIN P. C. BOARD		
RESISTORS		
R419, 420	5174-393381	39K Ω , \pm 1%, 1/4W, Metal
R421, 422	5174-221381	220 Ω , \pm 1%, 1/4W, Metal
CAPACITORS		
C405, 406	5345-477C0952	470 μ F, \pm 20%, 16V, Electrolytic
TRANSISTORS		
O40	5613-3422(O)	2SC3422(O) or 2SC3422(Y)
O41	5611-1359(O)	2SA1359(O) or 2SA1359(Y)
PCB-2 LINE INPUT P. C. BOARD		
CAPACITORS		
C519, 520	5359-4715851	470 μ F, \pm 5%, 100V, Polypropylene
C521, 522	5359-2715851	270 μ F, \pm 5%, 100V, Polypropylene

WIRING DIAGRAM

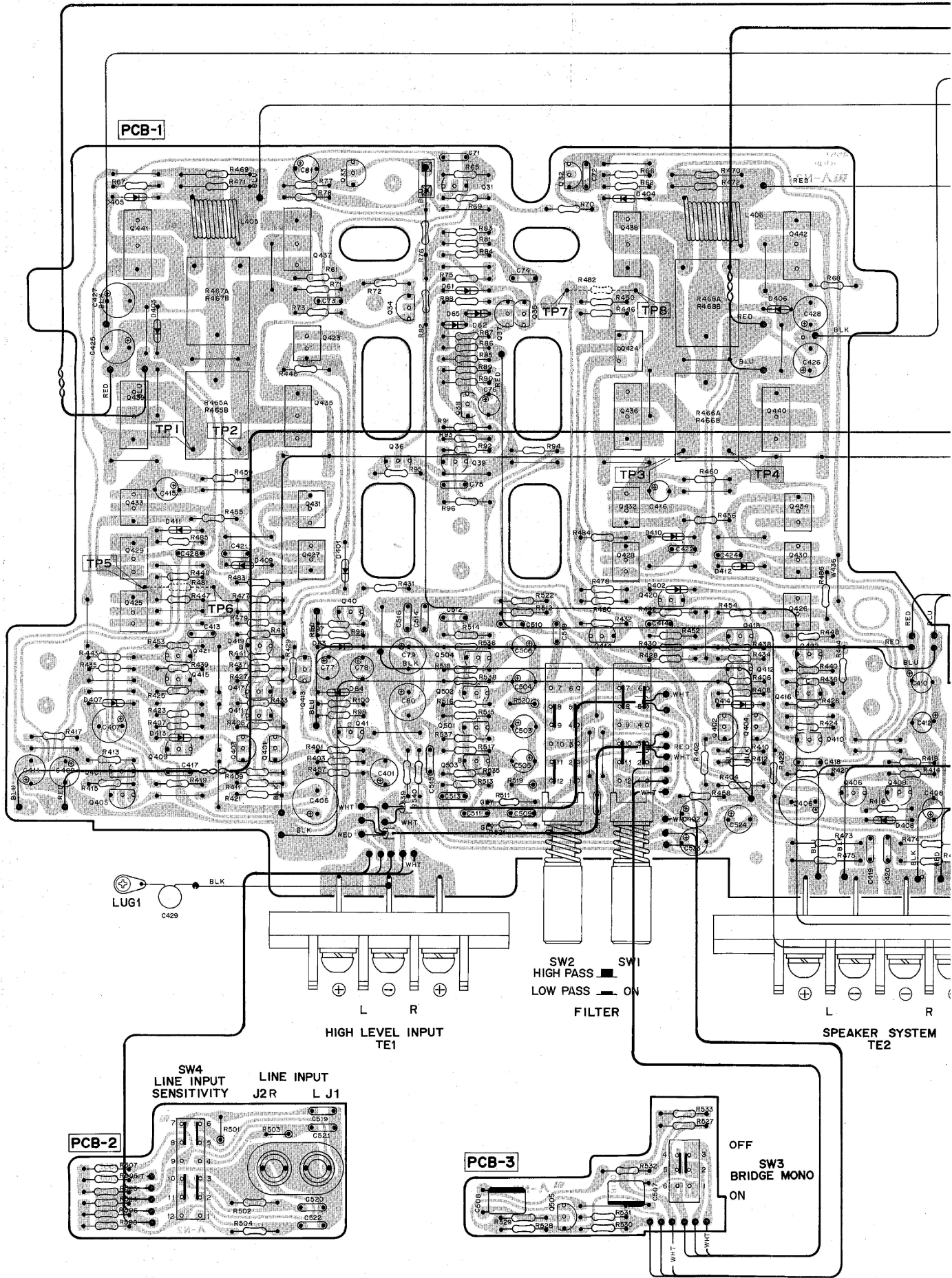

PIN CONNECTION DIAGRAM OF TRANSISTORS, DIODES AND ICs.

<p>2SC2240 2SA970 2SC1775 2SA999L 2SC2320L</p>	<p>2SC2603 2SA1115</p>	<p>2SC2877 2SA1217 2SD669 2SB649</p>	<p>2SB646 2SD666 2SA1286 2SC3246</p>	<p>2SC3345 2SC2591 2SA1111</p>	<p>2SC2626 2SC3182 2SA1265</p>	<p>1S2473 HZ15-2L 10DF2 HZ12B2L</p>	<p>MV104V</p>	<p>GL5HD10 GL5HY10</p>	<p>PB101</p>
--	----------------------------	--	--	--	--	---	---------------	----------------------------	--------------

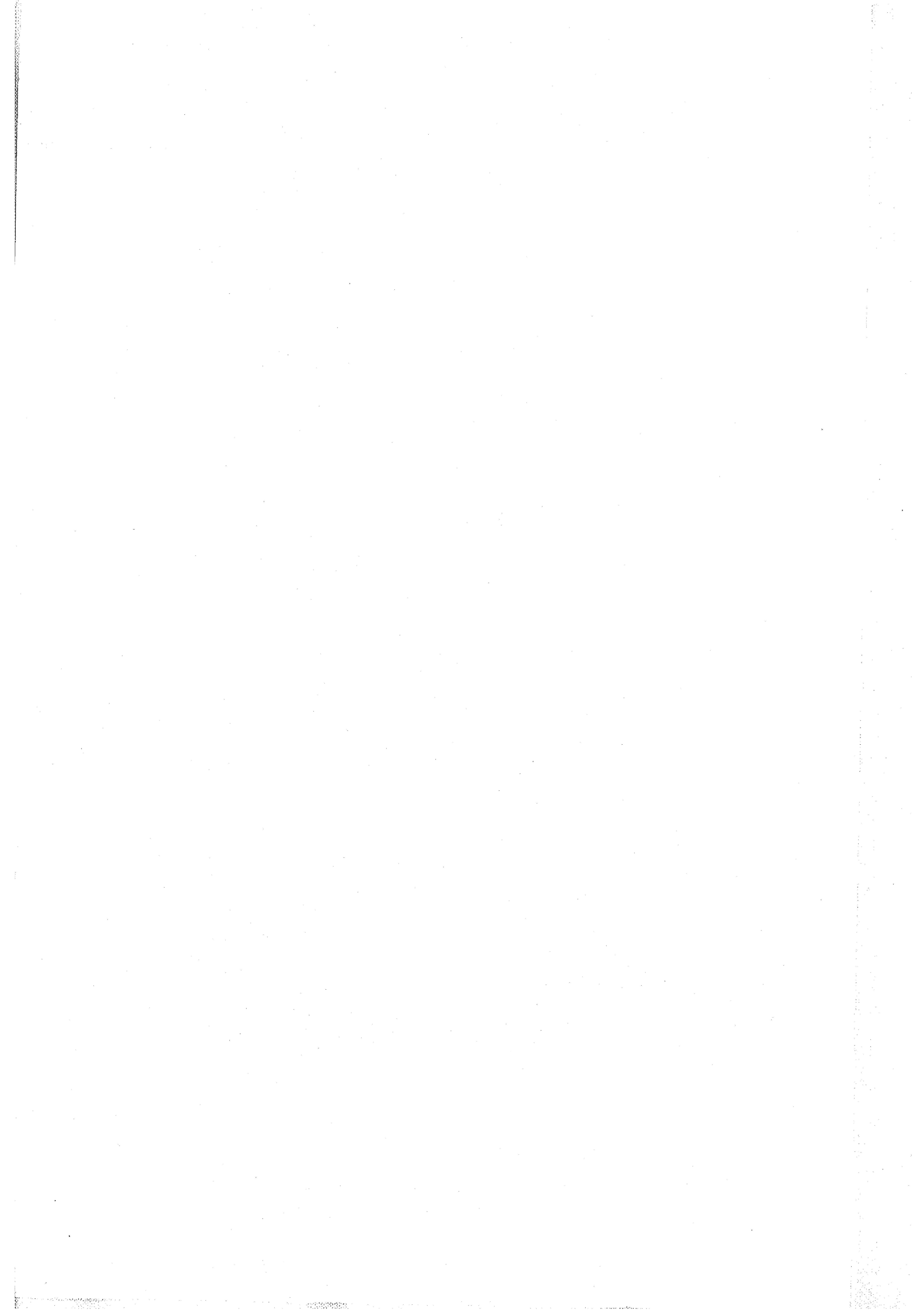

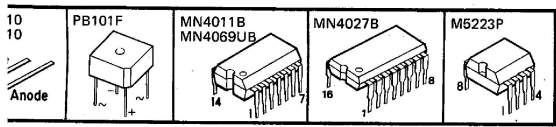
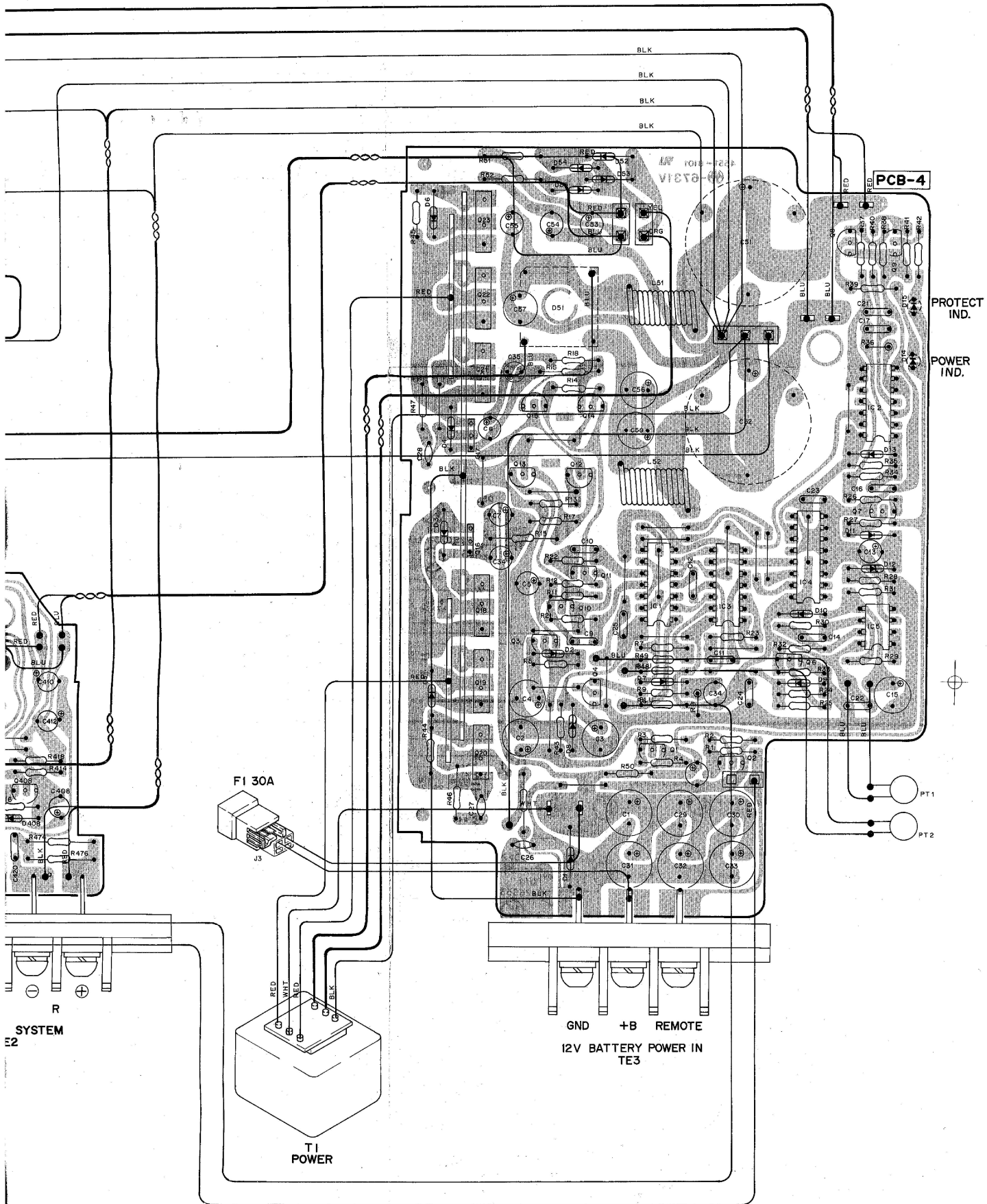

• WIRE COLOR ABBREVIATIONS

- RED : Red
- ORG : Orange
- BLU : Blue
- WHT : White
- GRN : Green
- BLK : Black
- YEL : Yellow
- PUP : Purple
- PIK : Pink

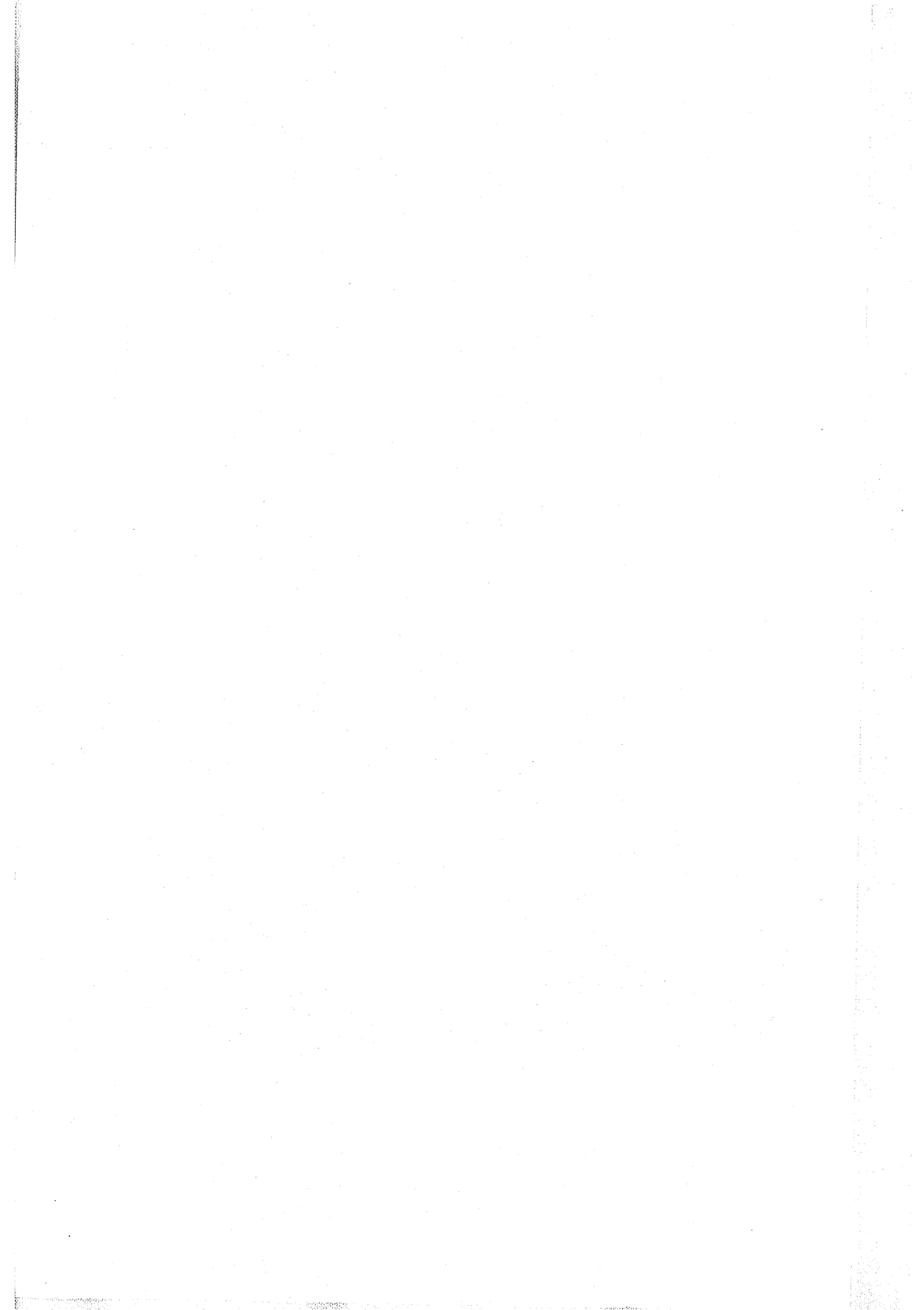

1. ALL RESISTANCE VALUES ARE IN Ω .
2. THE WATTAGE OF RESISTORS IS 1/4W UNLESS OTHERWISE NOTED.
3. ALL CAPACITANCE VALUES ARE IN μF UNLESS OTHERWISE NOTED. P= μF F.
4. V: DC VOLTAGE AT NO SIGNAL.
5. SAFETY REQUIREMENTS COMPONENTS IN ACCORDANCE WITH PRESENT SAFETY REGULATIONS, THESE COMPONENTS MUST ONLY BE REPLACED BY ORIGINAL PARTS.

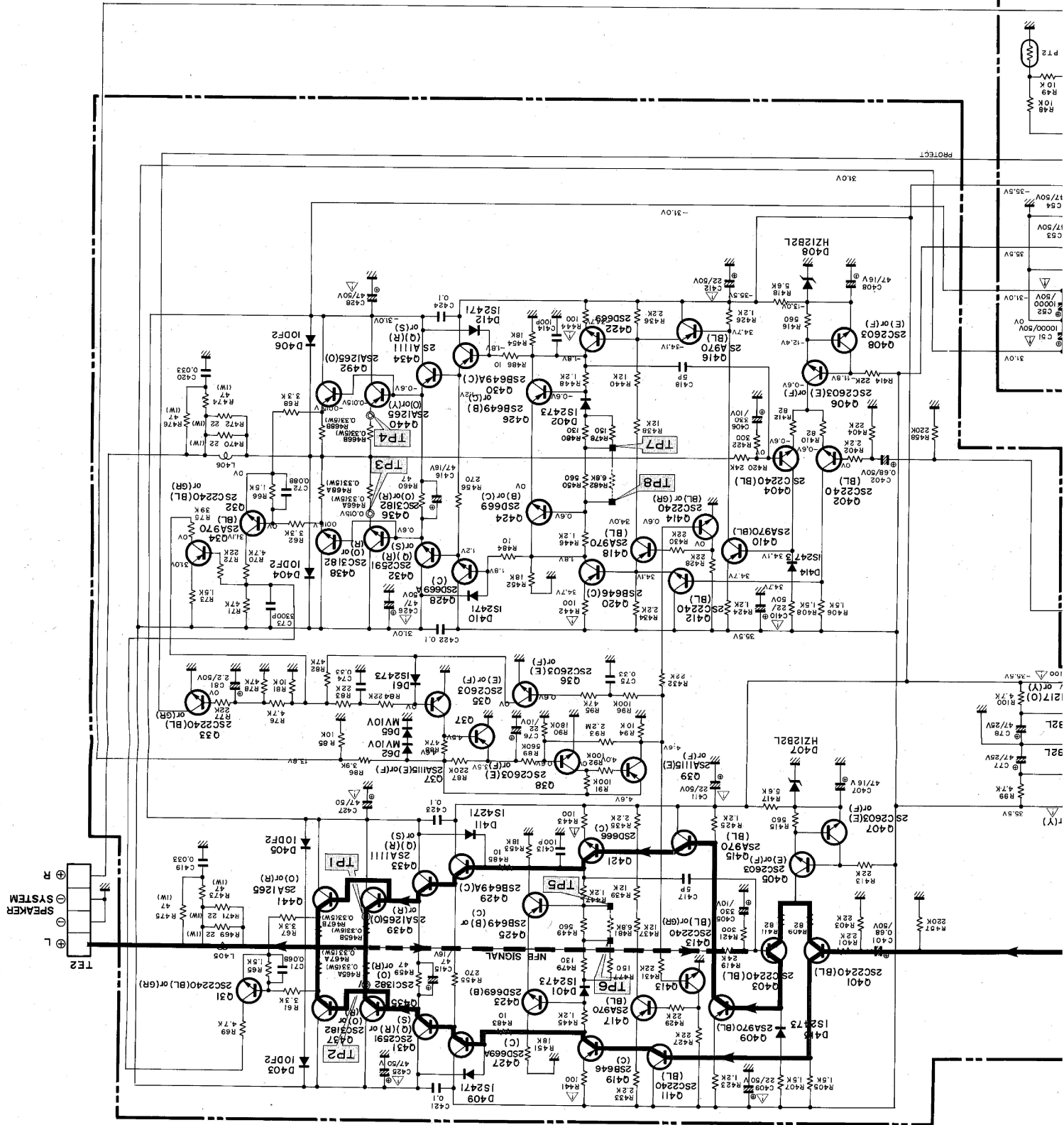

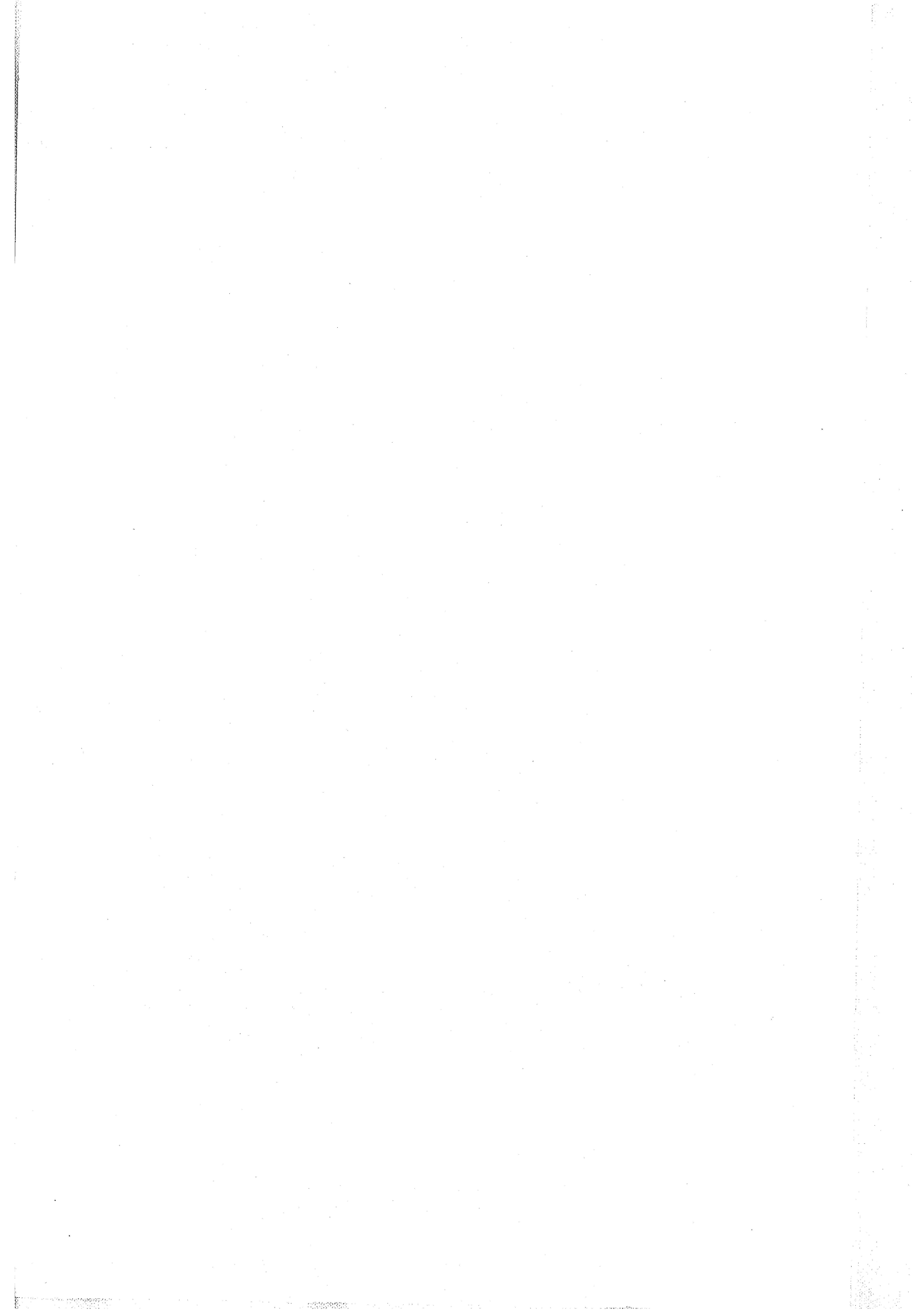

SCHMATIC DIAGRAM

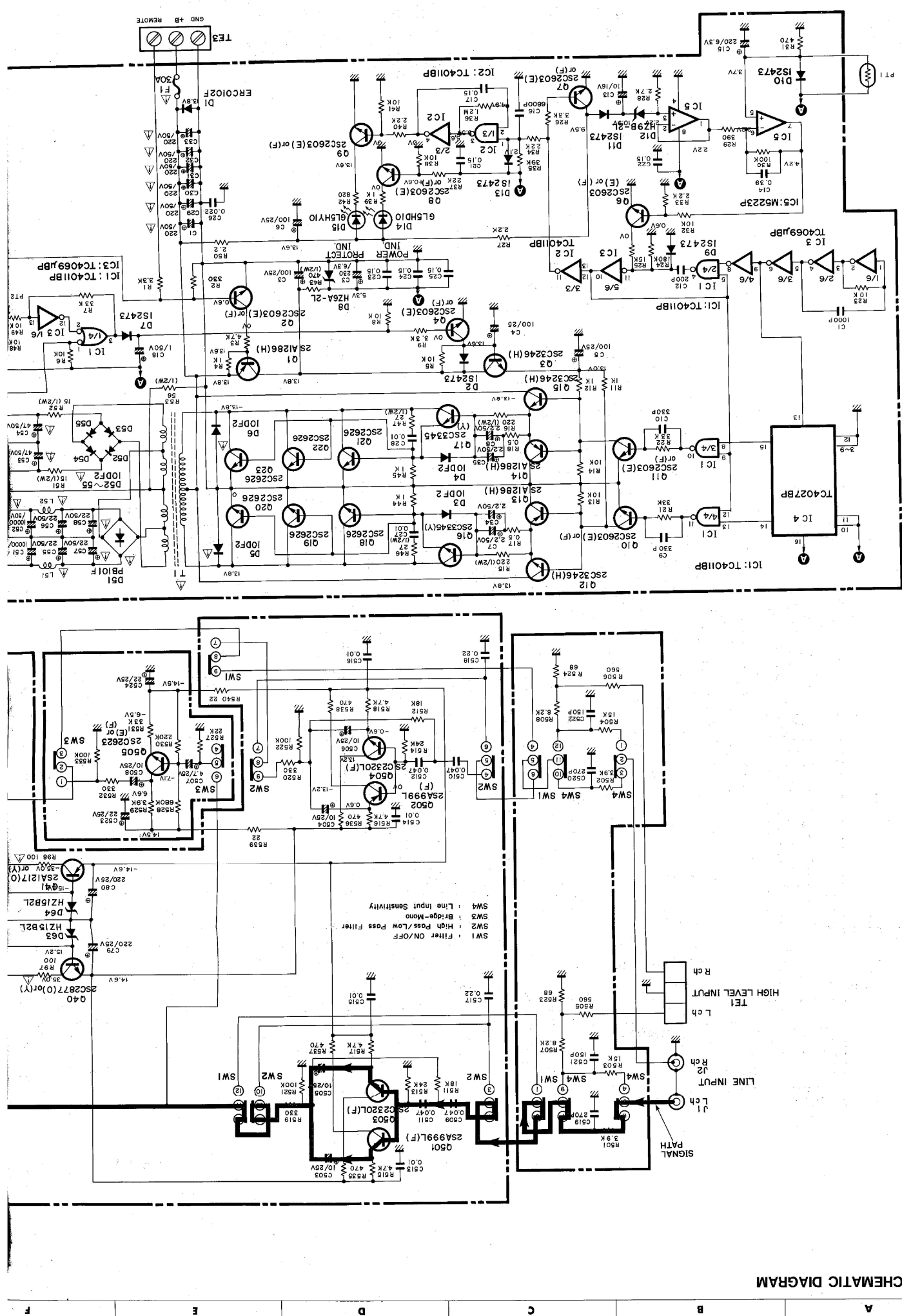

SW1 : Filter ON/OFF
 SW2 : High Pass/Low Pass Filter
 SW3 : Bridge-Mono
 SW4 : Line Input Sensitivity