

The Harman Kardon Model CD191

Manual No. 55C

ULTRAWIDEBAND LINEAR PHASE CASSETTE DECK

CD191

Technical Manual



SUPPLEMENTARY MANUAL

THE CASSETTE MECHANISM WAS REVISED AT SERIAL NUMBER 14301. FOLLOWING IS THE COMPLETE PARTS LIST AND ASSEMBLY DRAWINGS OF THE REVISED CASSETTE MECHANISM. ALSO, SOME REVISIONS IN THE CIRCUITRY ARE INCORPORATE. REFER TO TECHNICAL MANUAL NO. 55A FOR ALL OTHER REPLACEMENT PARTS AND SERVICE INFORMATION EXCEPT FOR THE CHANGES AS NOTED IN THIS SUPPLEMENT.

harman/kardon

240 CROSSWAYS PARK WEST, WOODBURY, N.Y. 11797
1112-H15256C2 P-088412 1650 PRINTED IN JAPAN

CASSETTE MECHANISM EXPLODED VIEW

CD191

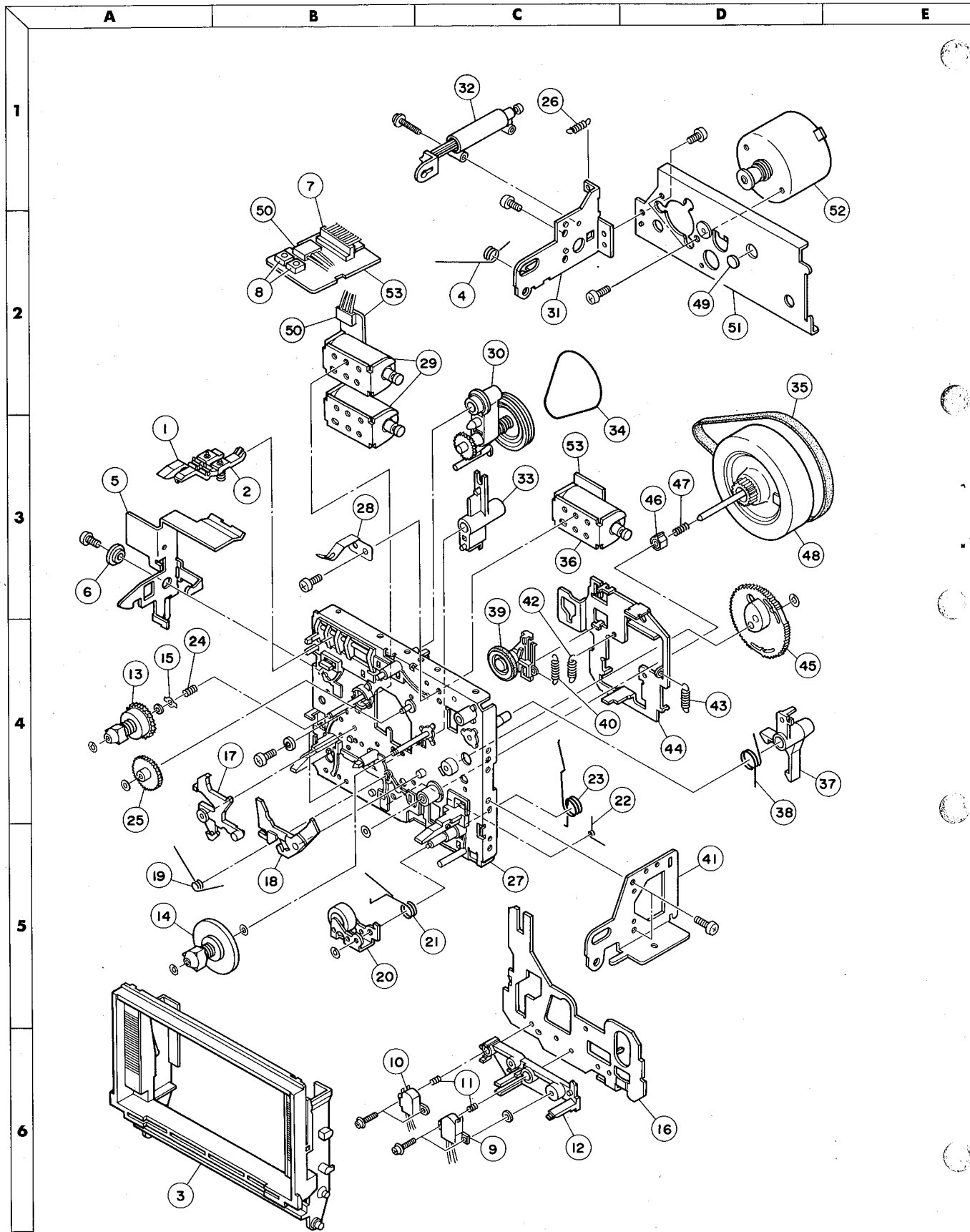

CASSETTE MECHANISM PARTS LIST

Ref. No.	Part No.	Description
1	F245-011	Record Arm
2	F244-011	Switch Arm
3	FD28S-14	Cassette Support
4	FK568-11	Spring, Door
5	FC30K-11	Eject Lock Arm
6	FM296-11	Spacer
7	KY130-11	Connector, 8-Pin
8	UE13K-11	Switch
9	FU161-13	Head, Record/Playback
10	FU192-11	Head, Erase
11	FK572-11	Spring, Azimuth
12	FD23C-13	Spacer, Head
13	F105-020	Supply Reel Assembly
14	F123-026	Take-up Reel Assembly
15	FC29K-11	Spring Holder
16	FC29N-13	Head Base
17	FD24H-12	Brake Arm (L)
18	FD24K-12	Brake Arm (R)
19	FK18U-11	Spring, Brake
20	F014-075	Pinch Roller
21	FK18S-11	Spring, Pinch Roller
22	FK18V-11	Spring, Solenoid Arm
23	FK18T-14	Spring, Assist
24	FK11F-47	Spring, Back Tension
25	FN14B-12	Idler Gear
26	FK18M-11	Spring, Eject Lock Arm
27	F011-163	Chassis Assembly
28	FC29E-11	Spring, Cassette
29	PKA16112	Solenoid, F. FWD, REW.
30	FR17M-13	Clutch Assembly
31	FC29F-11	Bracket, Dumper
32	FP472-11	Dumper Assembly
33	FD23B-12	F. FWD/REW. Solenoid Arm
34	FP463-11	Sub-Belt
35	FF14A-11	Main Belt
36	PKA16113	Solenoid, Play
37	FD23E-12	Play Arm
38	FK18W-12	Spring, Play Arm
39	FR17N-11	Idler Assembly
40	FK18R-11	Spring, Idler
41	FC29G-11	Bracket, Door
42	FK18N-11	Spring, Head Base
43	FK18P-11	Spring, Assist Base
44	FC29M-12	Assist Base
45	FN14C-12	Play Gear
46	FD24G-12	Collar
47	FK11F-51	Spring, Flywheel
48	FR17E-11	Flywheel Assembly
49	UJ11S-11	Spacer
50	WH20C-01	Connector with Lead Wire, 4-Pin
51	FC29H-15	Bracket, Motor
52	F064-129	Motor
53	FP12T-12	Connector Panel

GENERAL UNIT EXPLODED VIEW

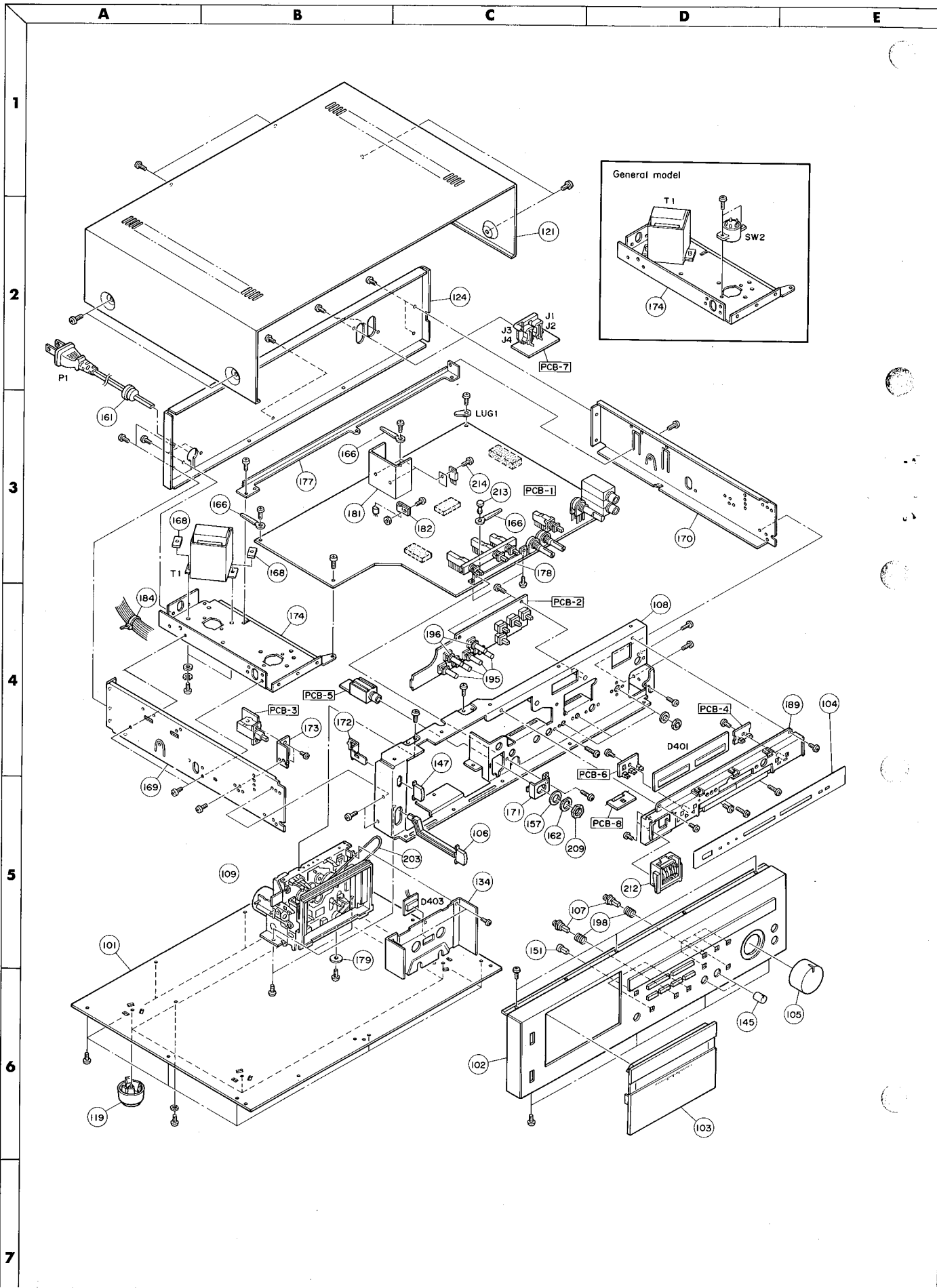

GENERAL UNIT PARTS LIST

Ref. No.	Part No.	Description
104	A514-CD191C	Plate Assembly, LED Level Display
109	3112-12801	Cassette Tape Recorder Mechanical Assembly
121	1414-03601	Cabinet Top
134	1514-15401	Dressing Plate
172	2219-7985	Bracket, Eject
179	2219-7755	Bracket, Cassette Mechanism
189	2240-7181	Holder, LED Level Display
213	2459-3003511	Rivet, Holding Bracket

ELECTRICAL PARTS LIST

Ref. No.	Part No.	Description
CHASSIS MISCELLANEOUS		
J403	4163-71265	Connector with Lead Wire, 3-Pin
J802	4163-70996	Connector with Lead Wire, 8-Pin
PCB-1 MAIN P.C. BOARD		
RESISTOR		
R733	5102-2204715	22 Ω , \pm 2%, 1/4W, Fuse
CAPACITORS		
C54	5345-225F041	2.2 μ F, \pm 20%, 50V, Electrolytic
C55	5342-335F0951	3.3 μ F, \pm 20%, 50V, Electrolytic
C103, 104	5345-226C0951	22 μ F, \pm 20%, 16V, Electrolytic
C111, 112	5345-106C0951	10 μ F, \pm 20%, 16V, Electrolytic
C201, 202	5359-8215851	820pF, \pm 5%, 100V, Polypropylene
C207, 208	5359-5615851	560pF, \pm 5%, 100V, Polypropylene
C213, 214	5345-684F0952	0.68 μ F, \pm 20%, 50V, Electrolytic
C219, 220	5342-225F0951	2.2 μ F, \pm 20%, 50V, Electrolytic
C515, 516	5345-107B0951	100 μ F, \pm 20%, 10V, Electrolytic
C567, 568	5345-477C041	470 μ F, \pm 20%, 16V, Electrolytic
C702	5345-107C041	100 μ F, \pm 20%, 16V, Electrolytic
INTEGRATED CIRCUITS		
IC161	5652- μ PC4558C	μ PC4558C
IC201	5652-M5219P	M5219P
TRANSISTORS		
Q105, 106	5613-2320L(F)	2SC2320L (F)
Q107, 108	5611-999L(F)	2SA999L (F)
Q817	5613-2603 (F)	2SC2603 (F)
DIODES		
D2, 3, 7, 51, 52, 53, 54, 55, 56, 57, 251, 252, 253, 254, 255, 701, 702, 703, 704, 706, 707, 801, 802, 803, 808, 813	5636-1S2473	1S2473
COILS		
L101, 102	5995-363368	36mH
L201, 202	5932-70423	3.9mH
PCB-2 CONTROL SWITCHES P.C. BOARD		
MISCELLANEOUS		
P403	4443-034116	Connector, 3-Pin

SCHEMATIC DIAGRAM

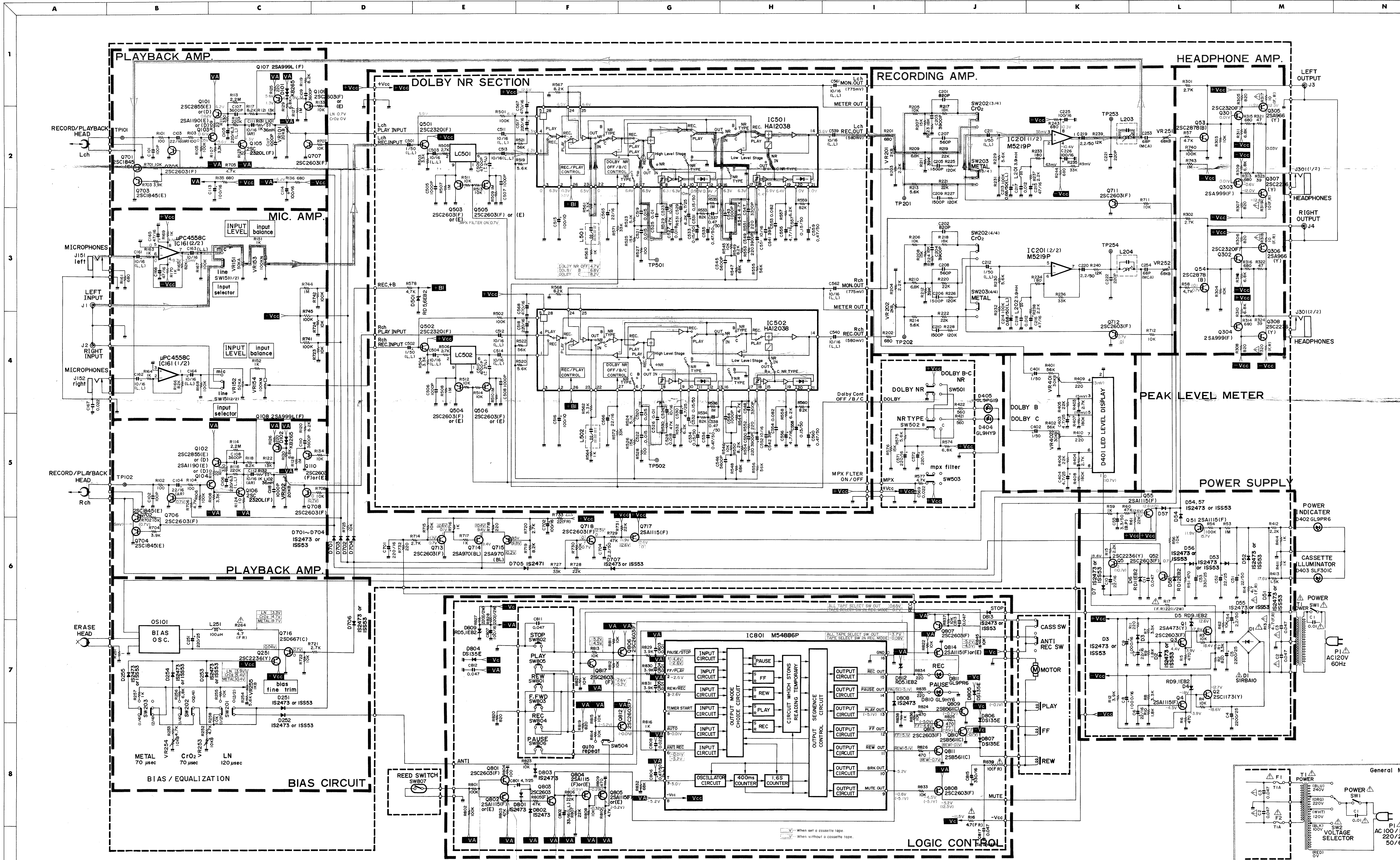

- RECORDING SIGNAL (Lch)
 PLAYBACK SIGNAL (Rch)
1. ALL RESISTANCES VALUES ARE IN Ω .
 $k\Omega = 1000\Omega$, $M\Omega = 1000k\Omega$
 2. THE WATTAGE OF RESISTORS IS 1/4W UNLESS OTHERWISE NOTED.
 3. ALL CAPACITANCES VALUES ARE IN μF UNLESS OTHERWISE NOTED. $P = \mu\mu F$
 4. V: DC VOLTAGE AT NO SIGNAL.
 (...) V STOP MODE
 (...) V PLAYBACK MODE
 (...) V RECORDING MODE
 5. SAFETY REQUIREMENTS COMPONENTS IN ACCORDANCE WITH PRESENT SAFETY REGULATIONS. THESE COMPONENTS MUST ONLY BE REPLACED BY ORIGINAL PARTS.

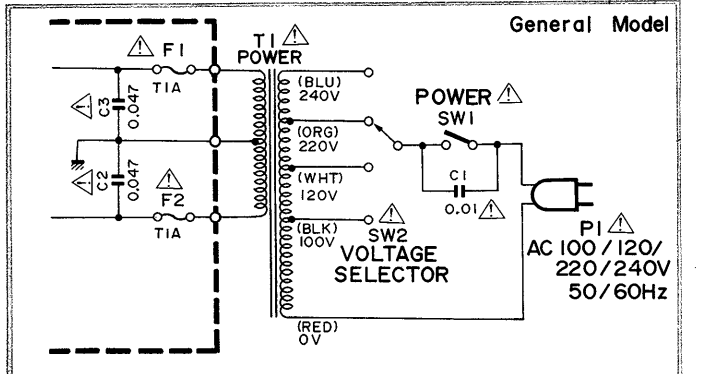

SCHEMATIC DIAGRAM

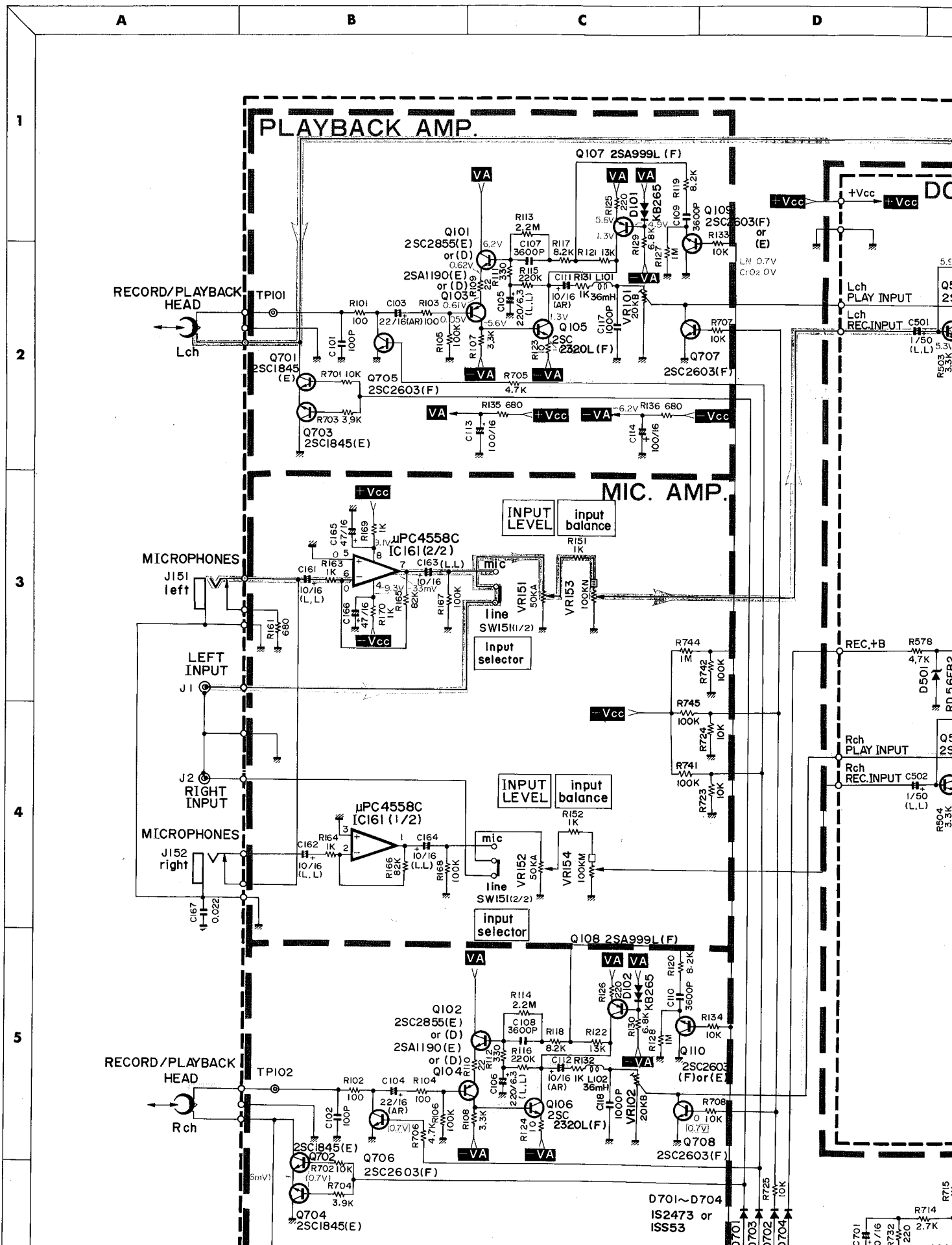

E

F

G

H

DOLBY NR SECTION

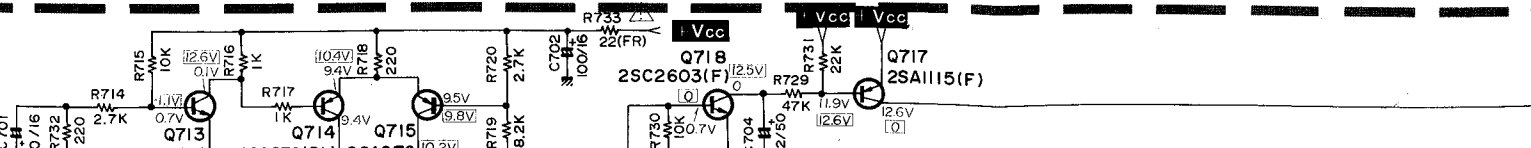
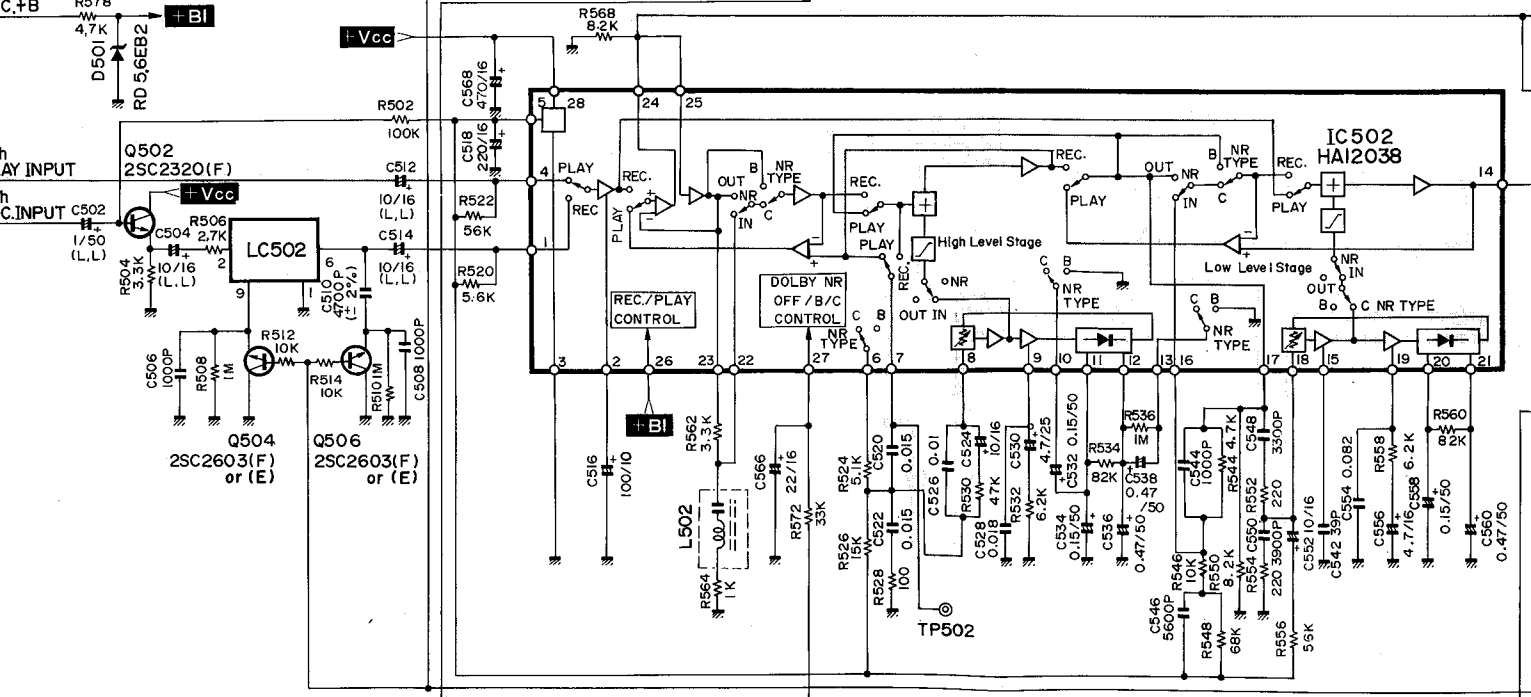
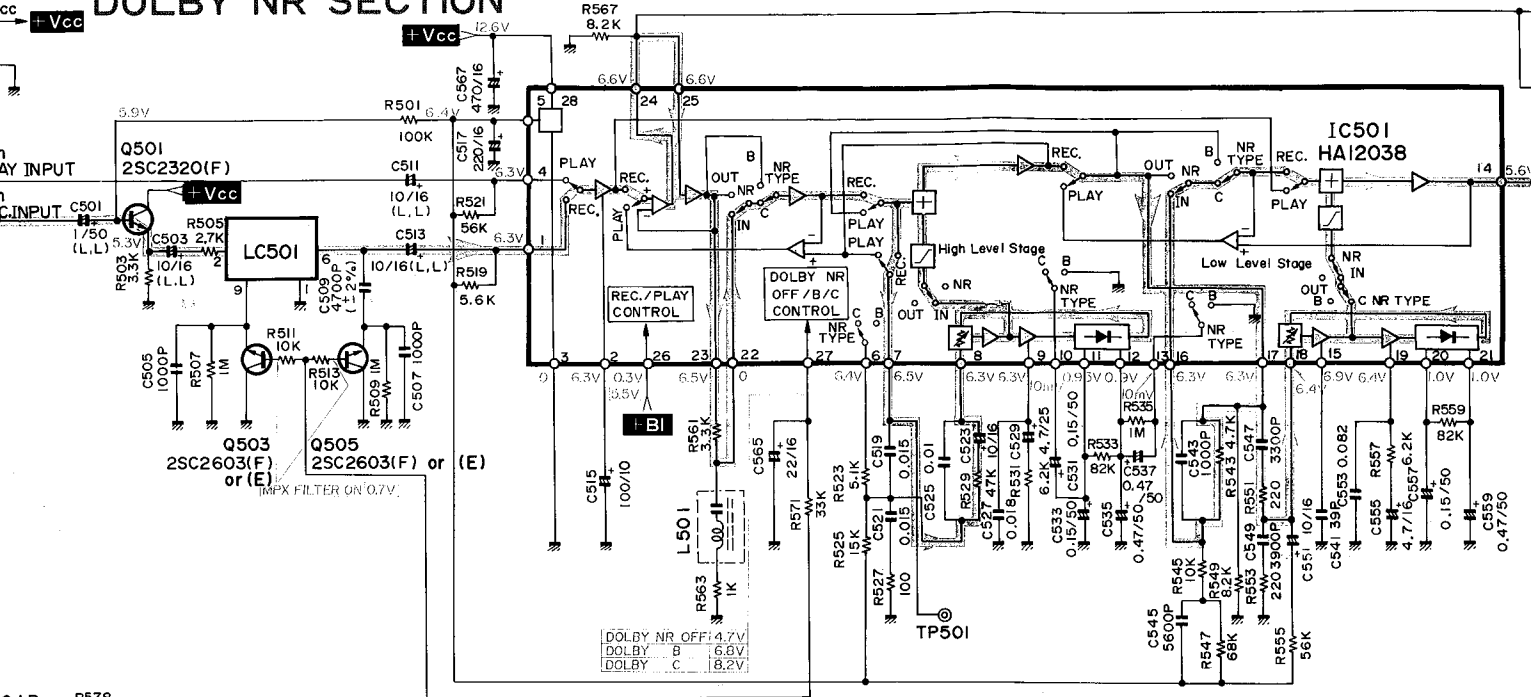

H

I

J

K

RECORDING AMP.

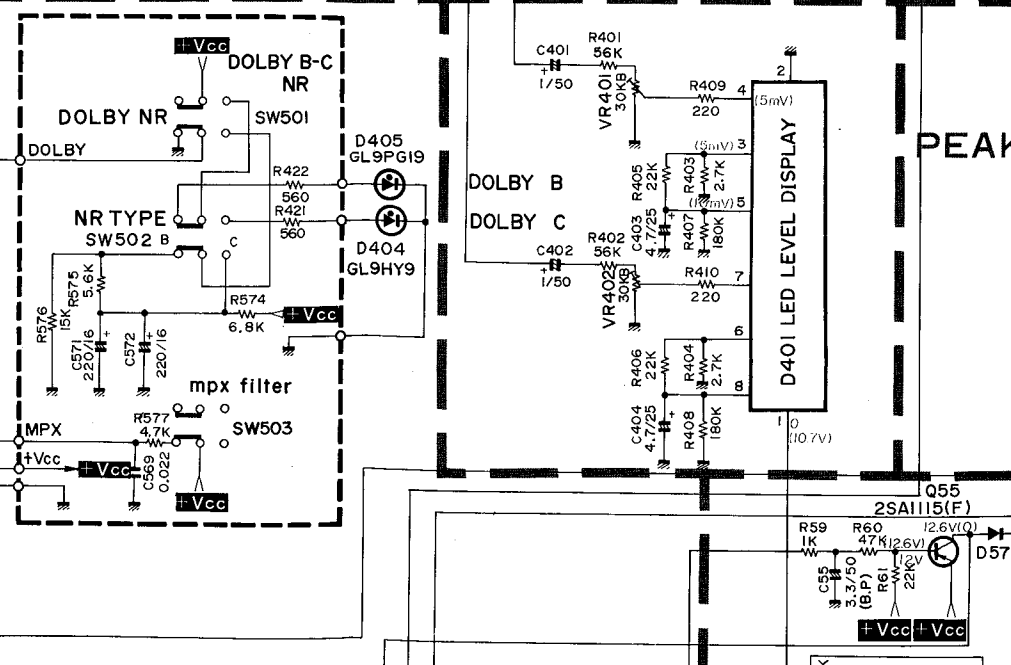
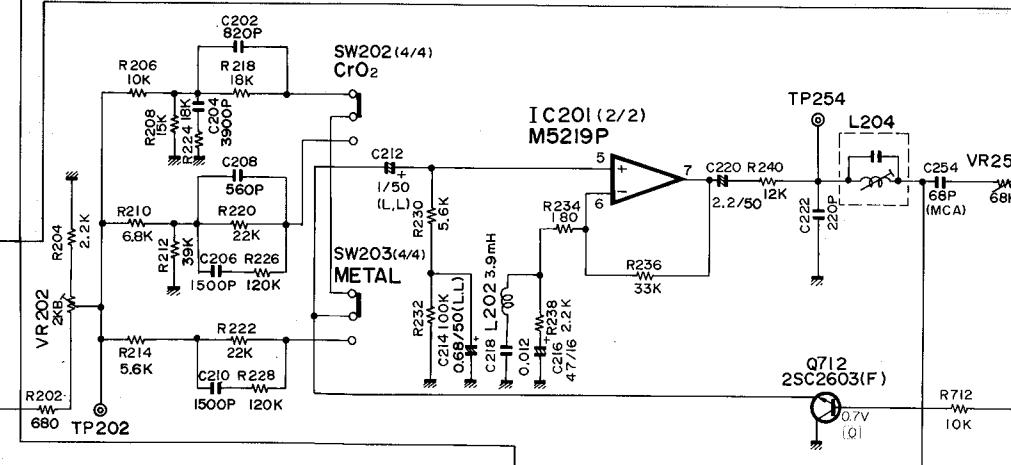
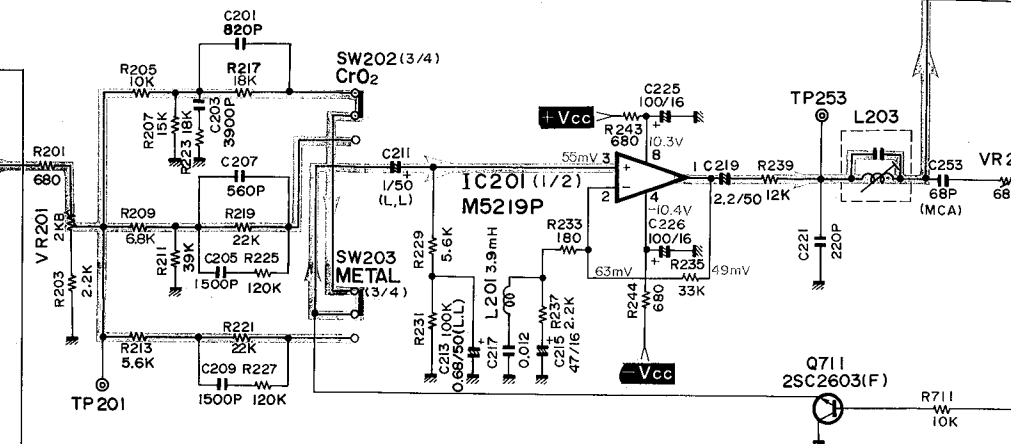
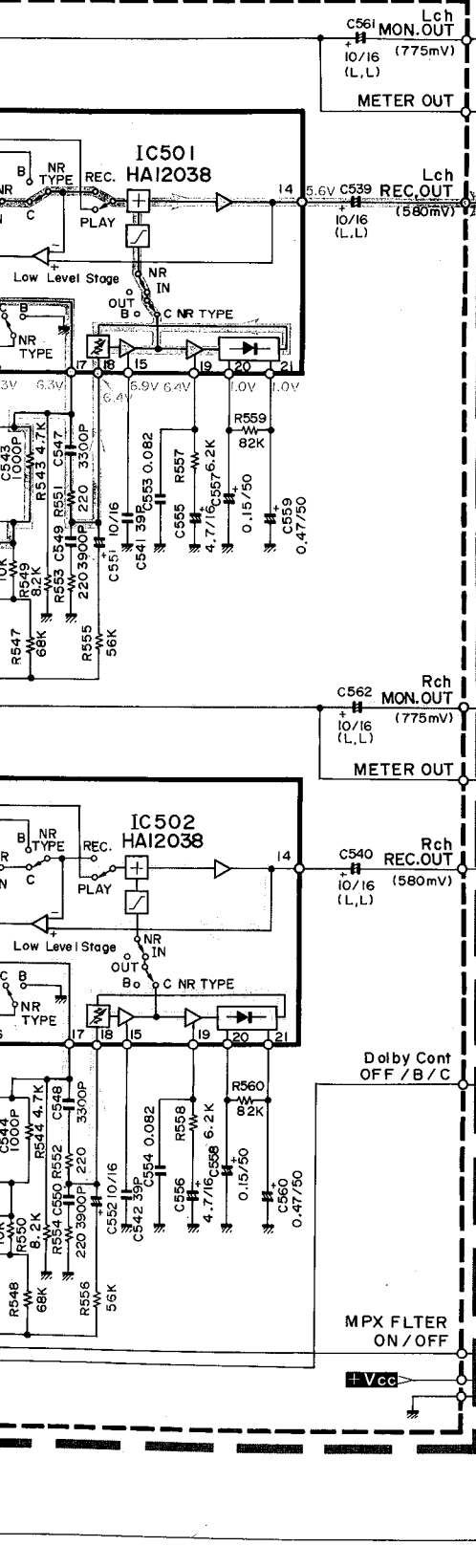

K

L

M

N

HEADPHONE AMP.

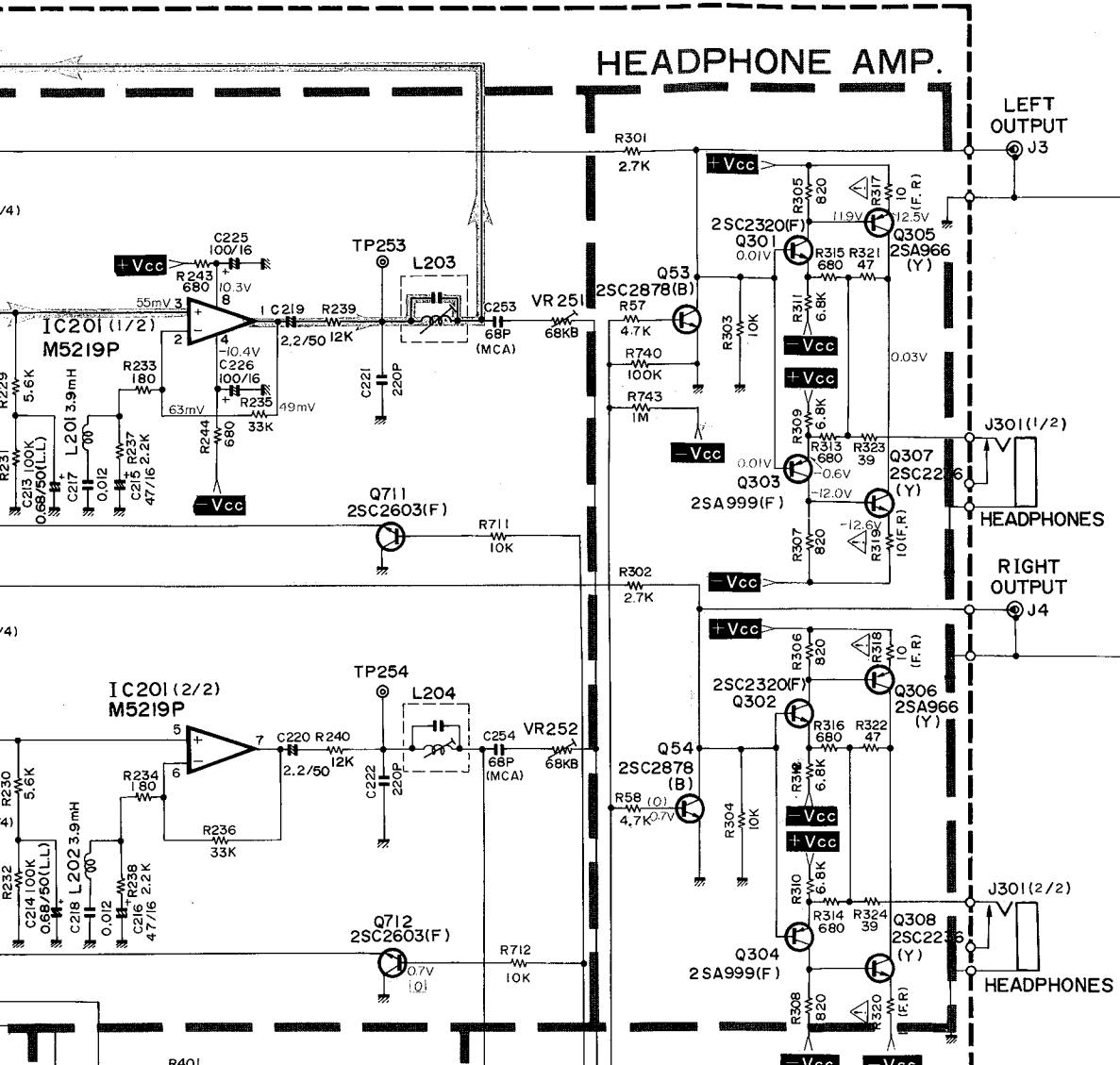

PEAK LEVEL METER

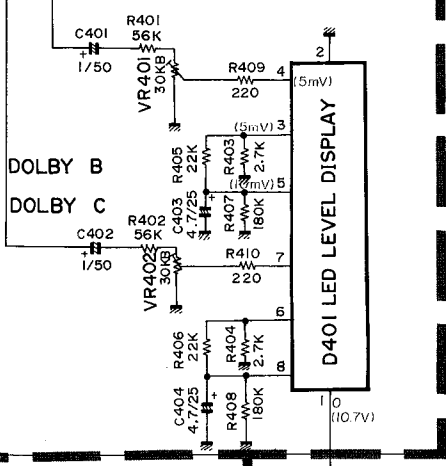

POWER SUPPLY

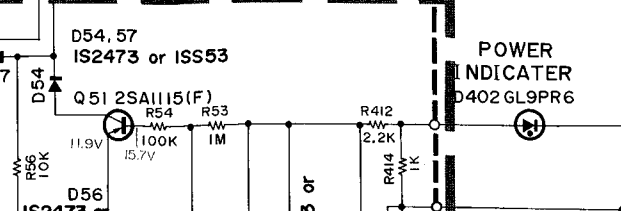

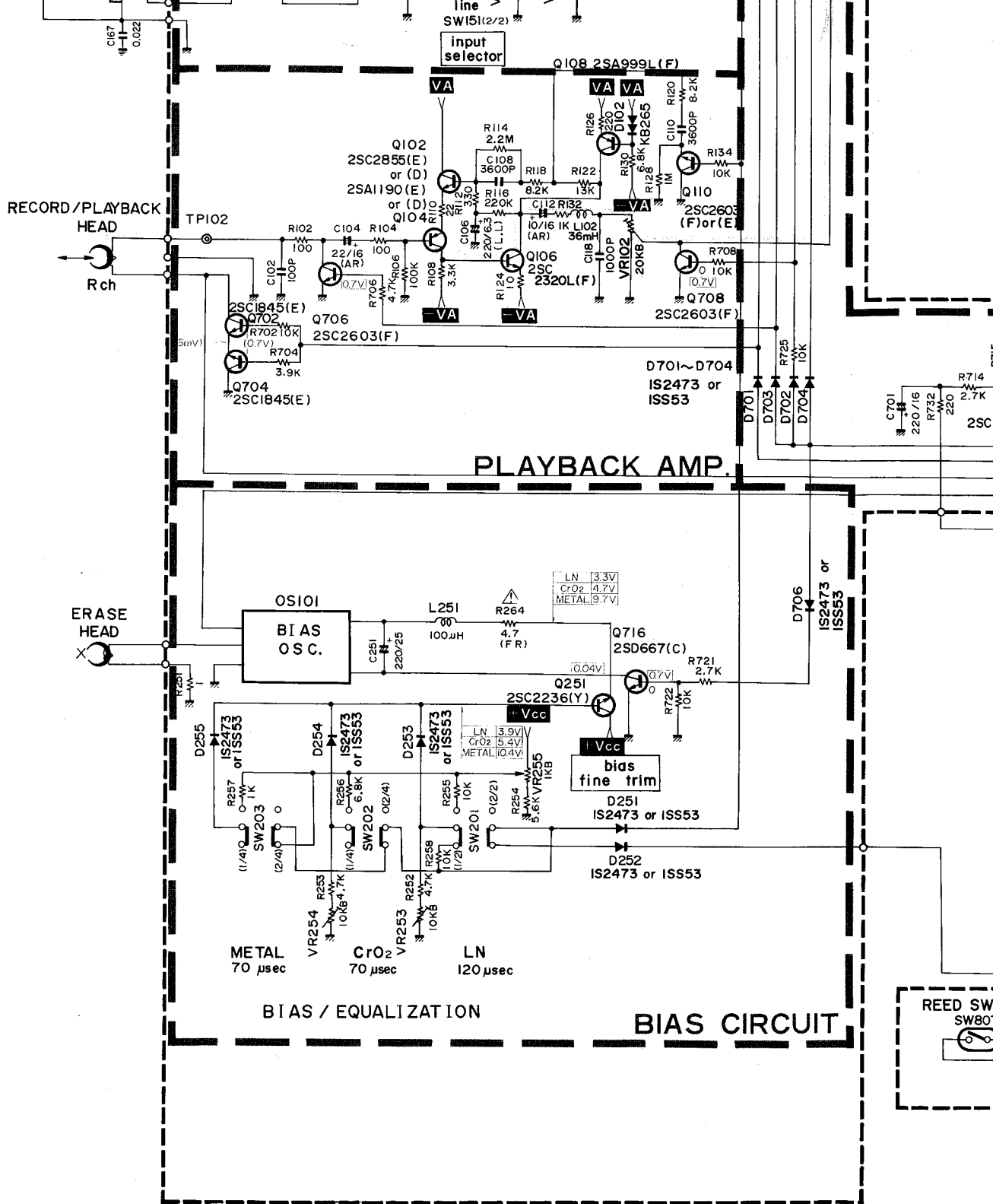

..... RECORDING SIGNAL (Lch)
 PLAYBACK SIGNAL (Rch)

1. ALL RESISTANCES VALUES ARE IN Ω .
 $k\Omega = 1000\Omega$, $M\Omega = 1000 k\Omega$
2. THE WATTAGE OF RESISTORS IS 1/4W UNLESS OTHERWISE NOTED.
3. ALL CAPACITANCES VALUES ARE IN μF UNLESS OTHERWISE NOTED. $P = \mu\mu F$
4. V: DC VOLTAGE AT NO SIGNAL.
 ... V STOP MODE
 (... V) PLAYBACK MODE
 (... V) RECORDING MODE
5. Δ SAFETY-REQUIREMENTS COMPONENTS IN ACCORDANCE WITH PRESENT SAFETY REGULATIONS. THESE COMPONENTS MUST ONLY BE REPLACED BY ORIGINAL PARTS.

5
6
7
8
9
10

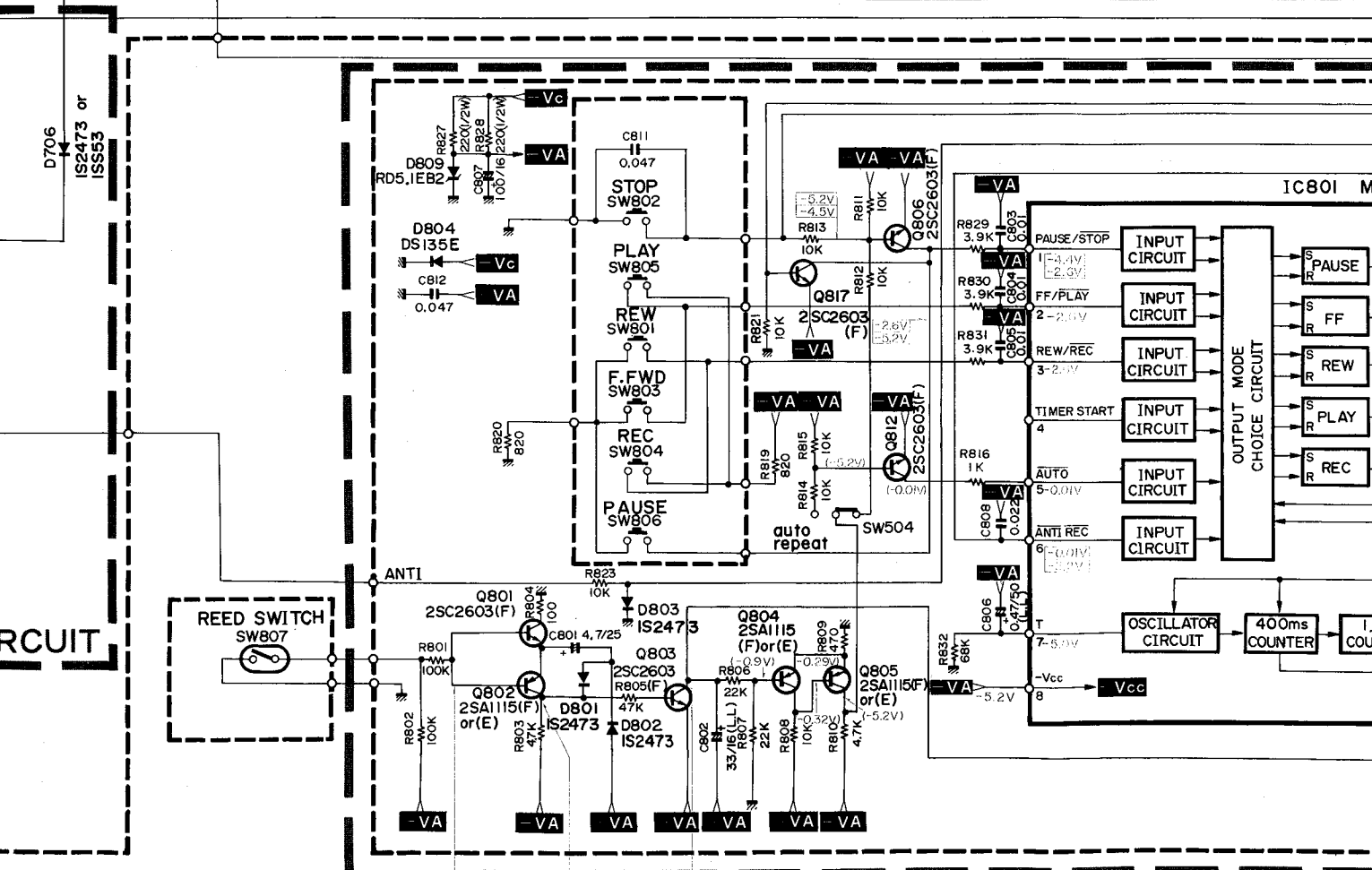
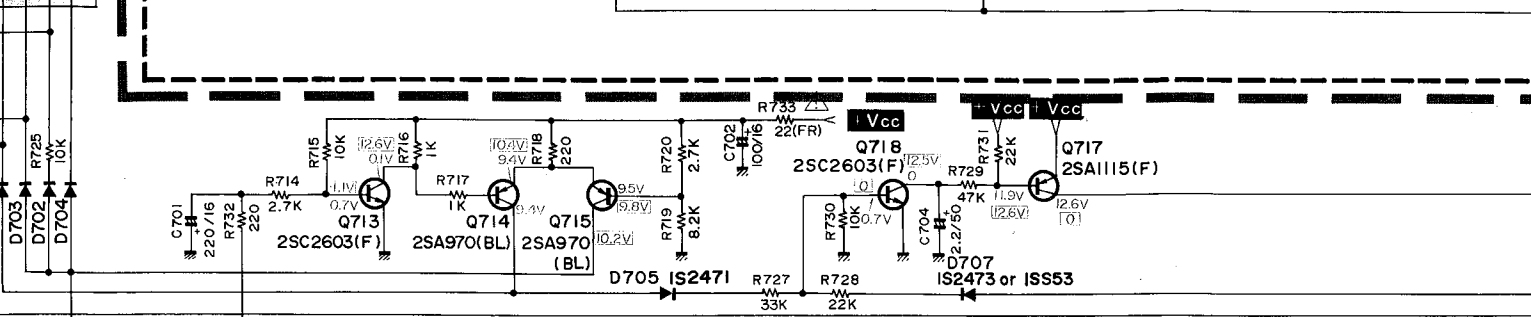
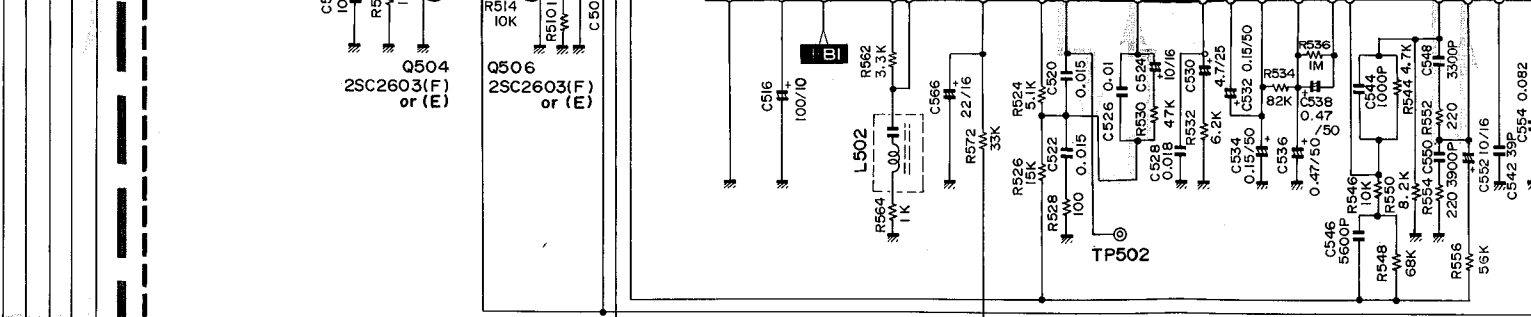

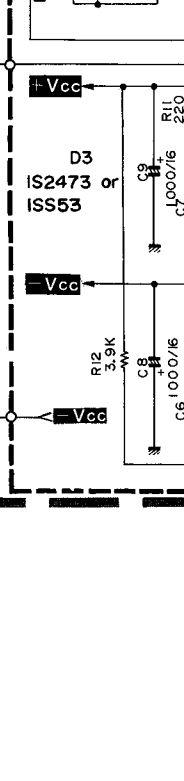
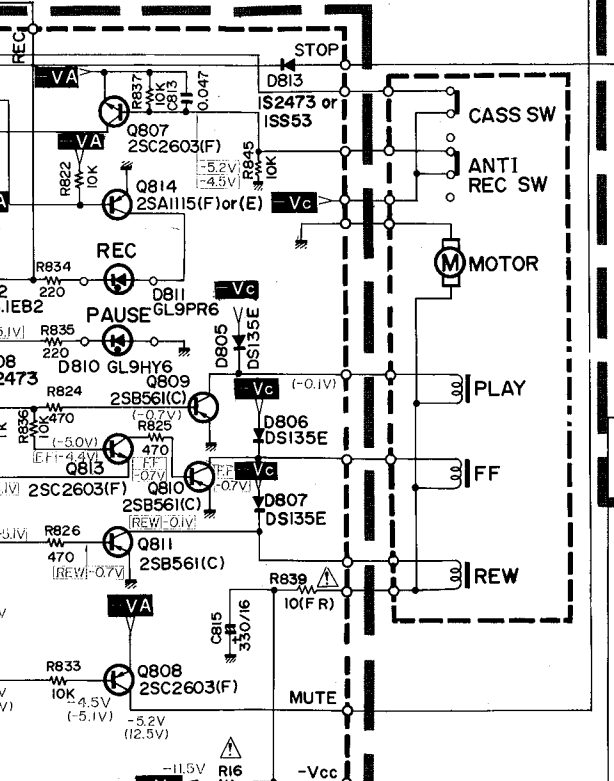
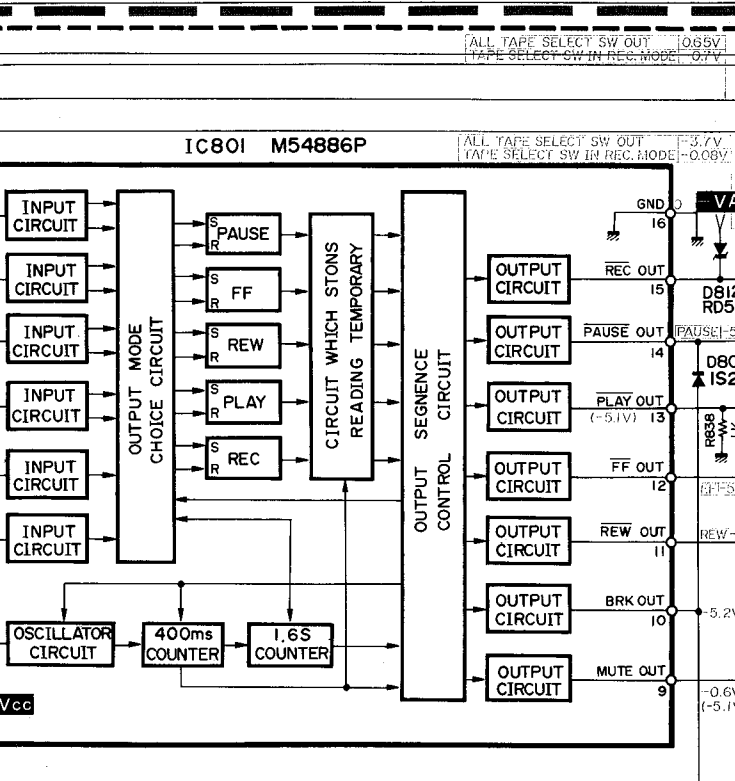
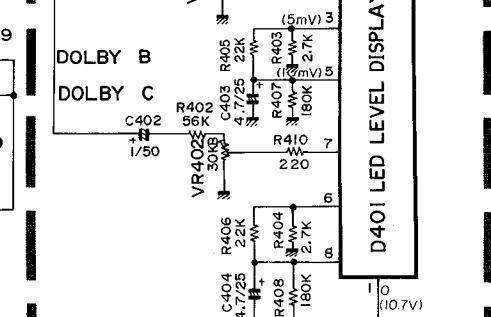
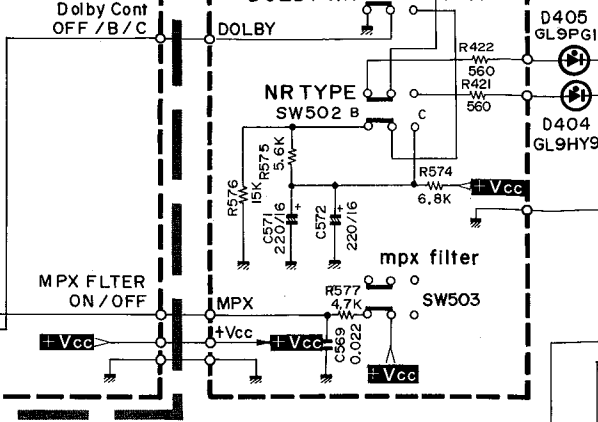
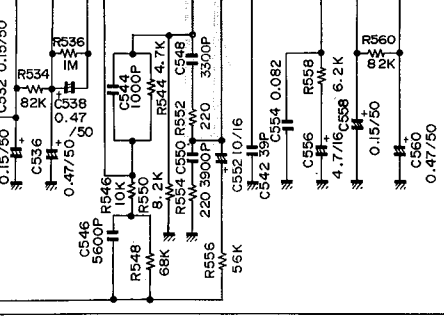

When set a cassette tape.
 When without a cassette tape.

LOGIC CONTROL

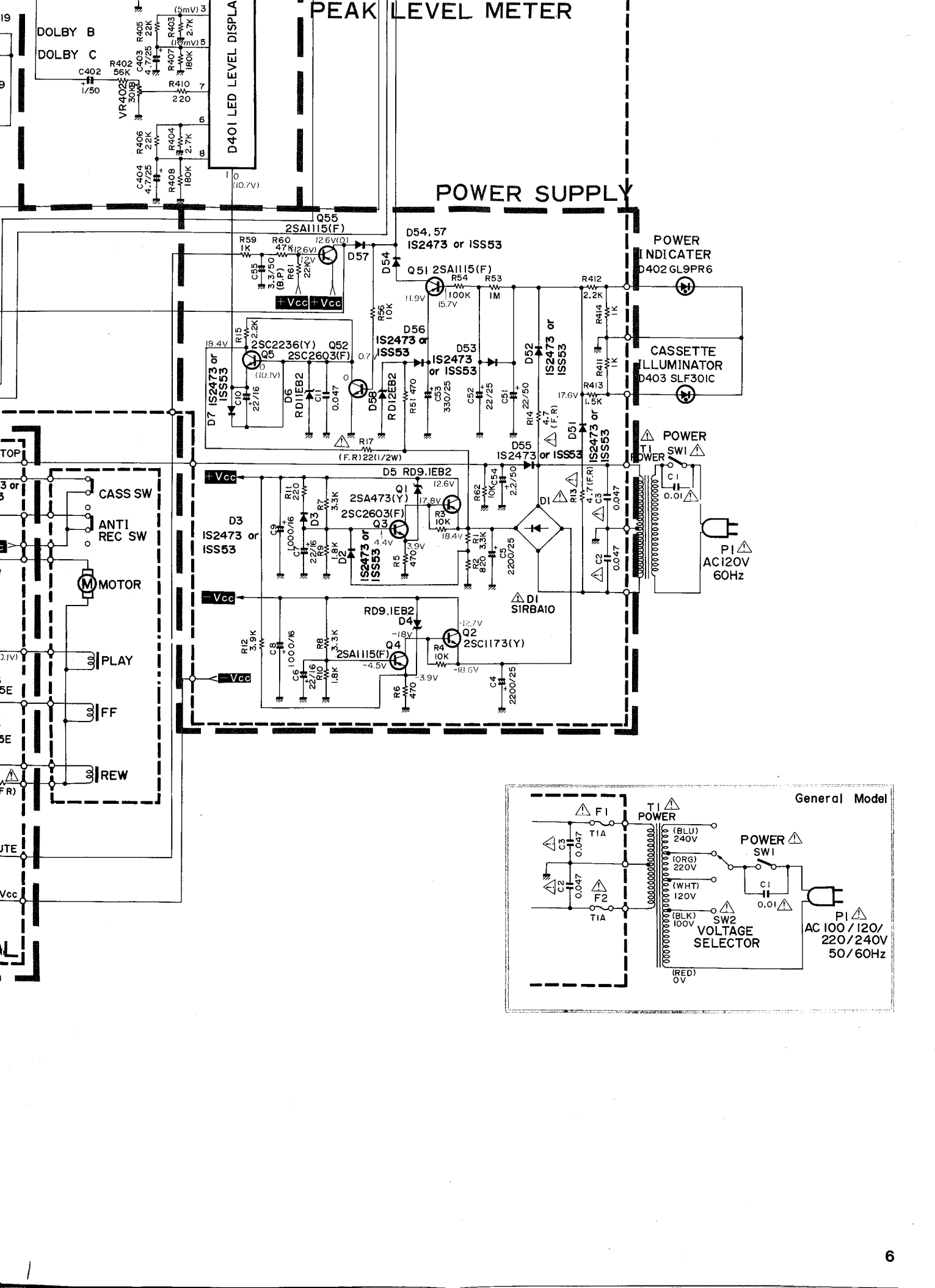

POWER SUPPLY

POWER INDICATOR
D402 GL9PR6

CASSETTE ILLUMINATOR
D403 SLF301C

POWER SW
SW1

PI
AC120V
60Hz

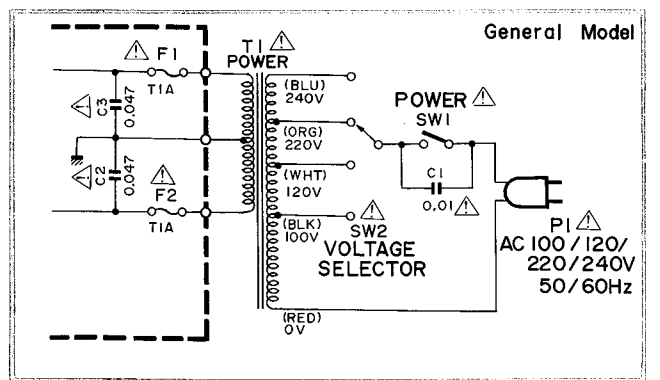

WIRING DIAGRAM

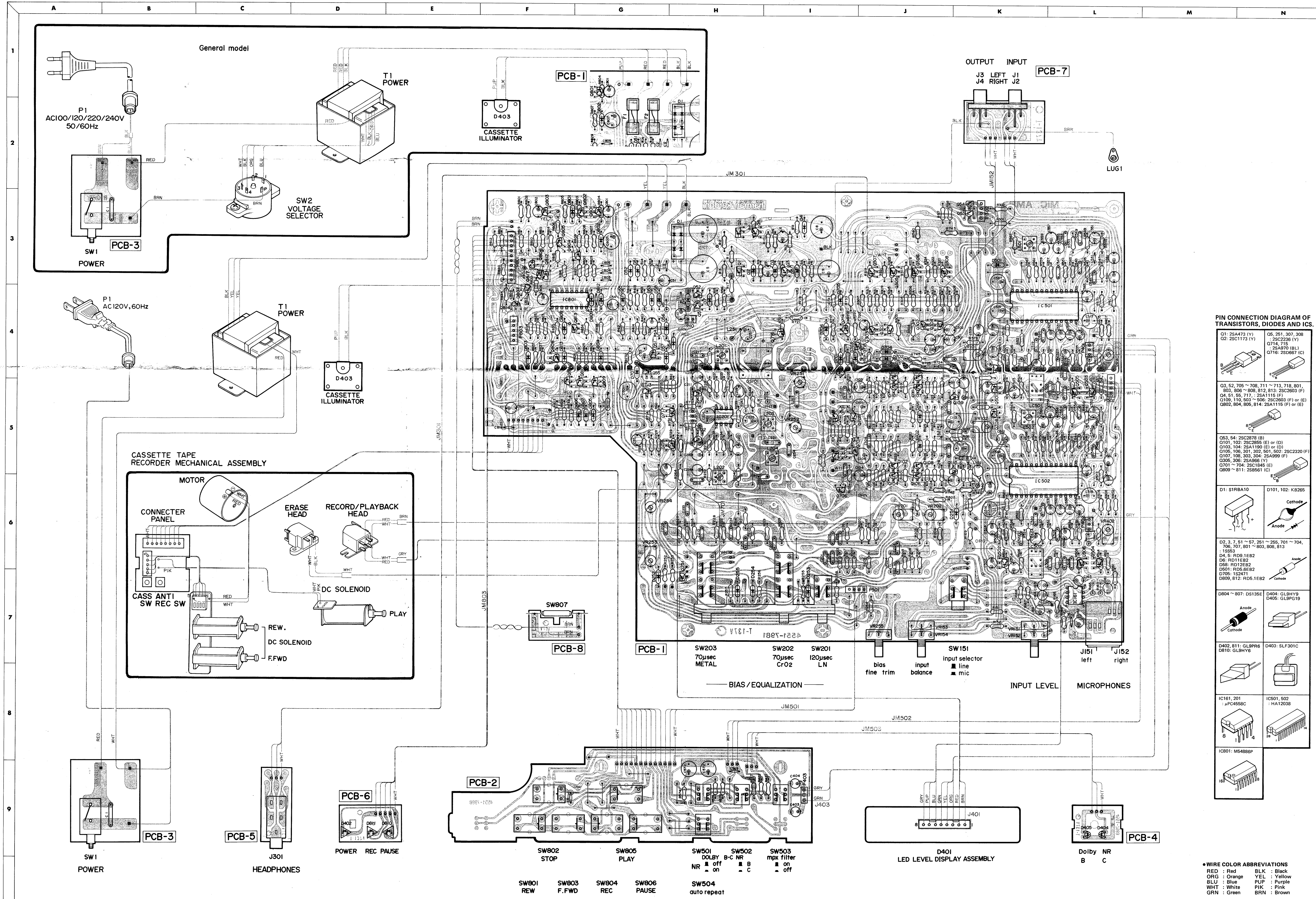

PIN CONNECTION DIAGRAM OF TRANSISTORS, DIODES AND ICs.

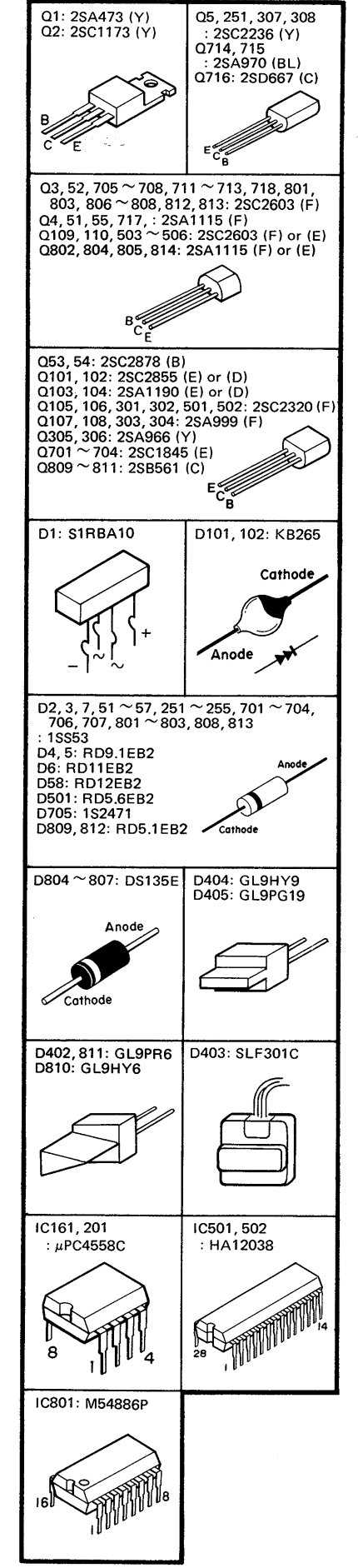

WIRE COLOR ABBREVIATIONS
 RED : Red BLK : Black
 BLU : Blue PUP : Purple
 WHT : White PK : Pink
 GRN : Green BRN : Brown

WIRING DIAGRAM

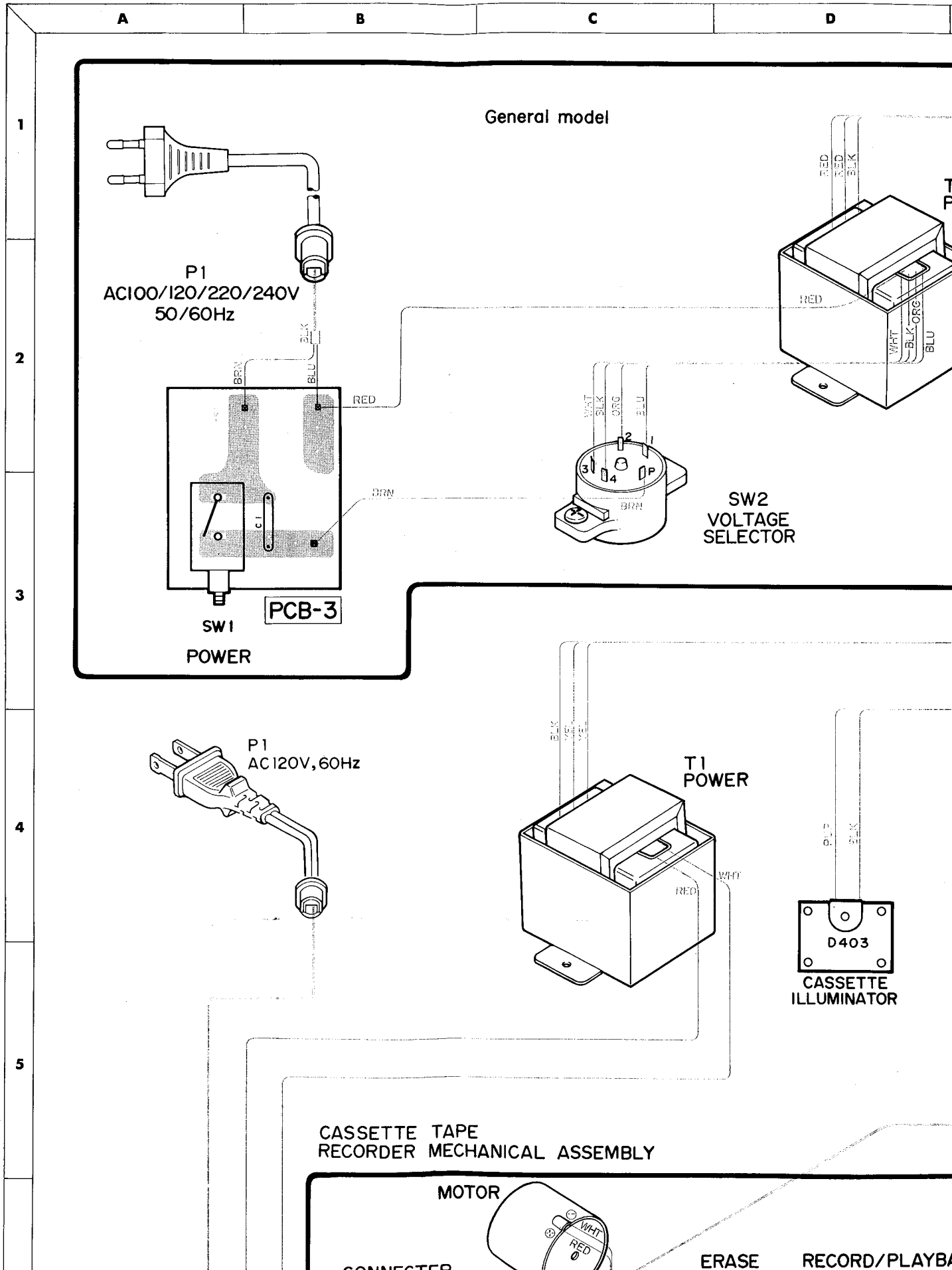

T1
POWER

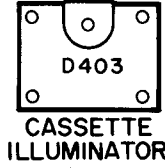
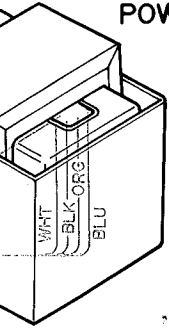

PCB-1

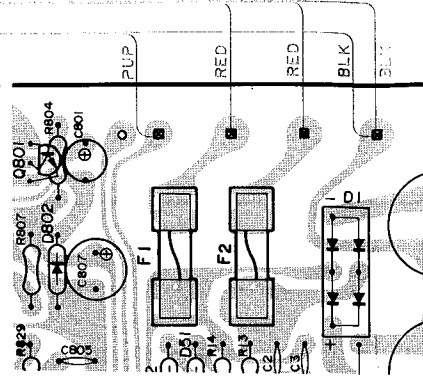

JM301

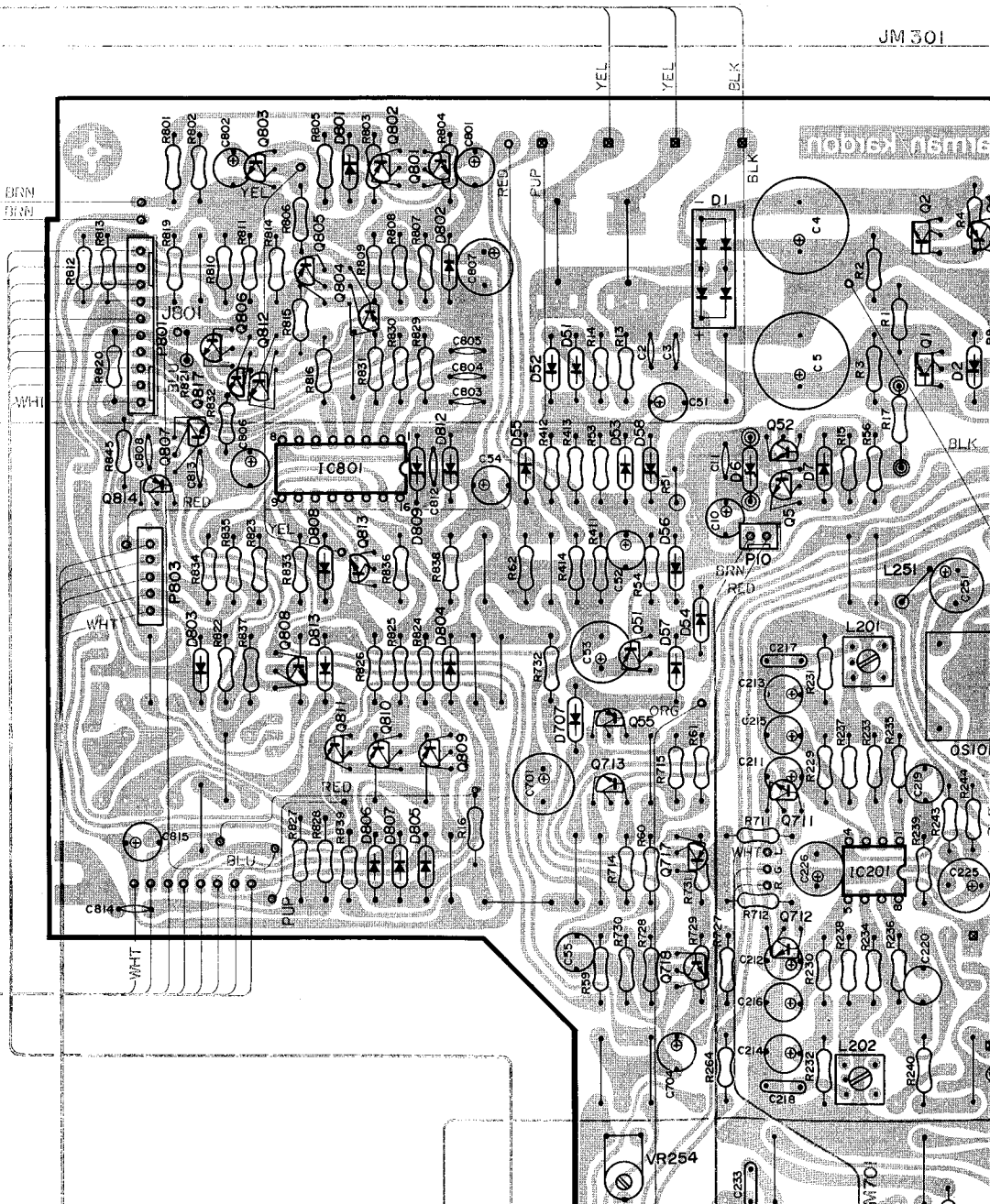

JM301

3
TE
ATOR

RD/PLAYBACK
HEAD

OUTPUT INPUT

J3 LEFT J1
J4 RIGHT J2

PCB-7

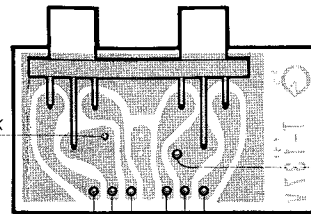

BLK

JMI52

WHT

WHT

BRN

JM301

robbery nsmm

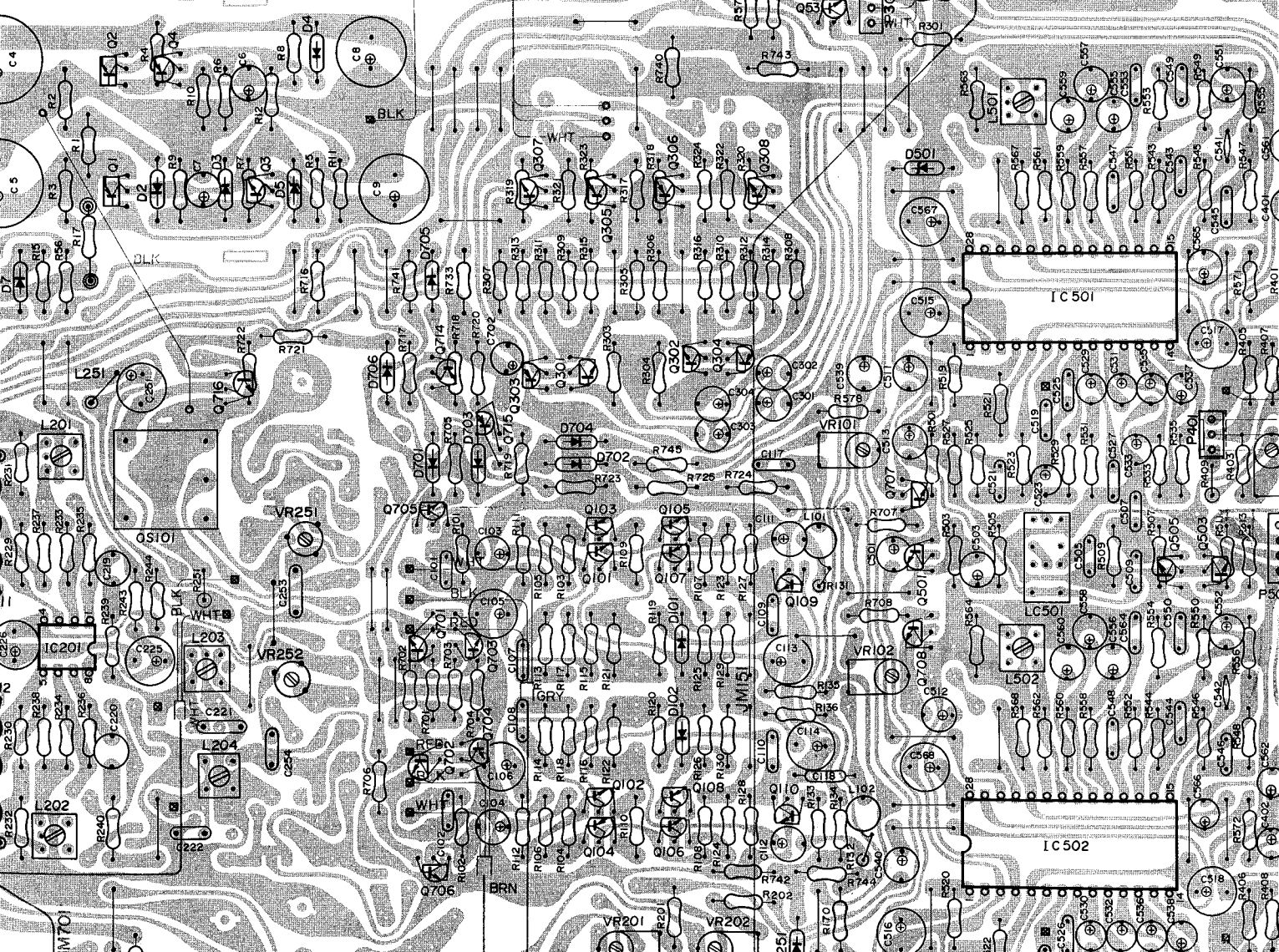

AM701

K

L

M

N

OUTPUT INPUT

J3 LEFT J1
J4 RIGHT J2

PCB-7

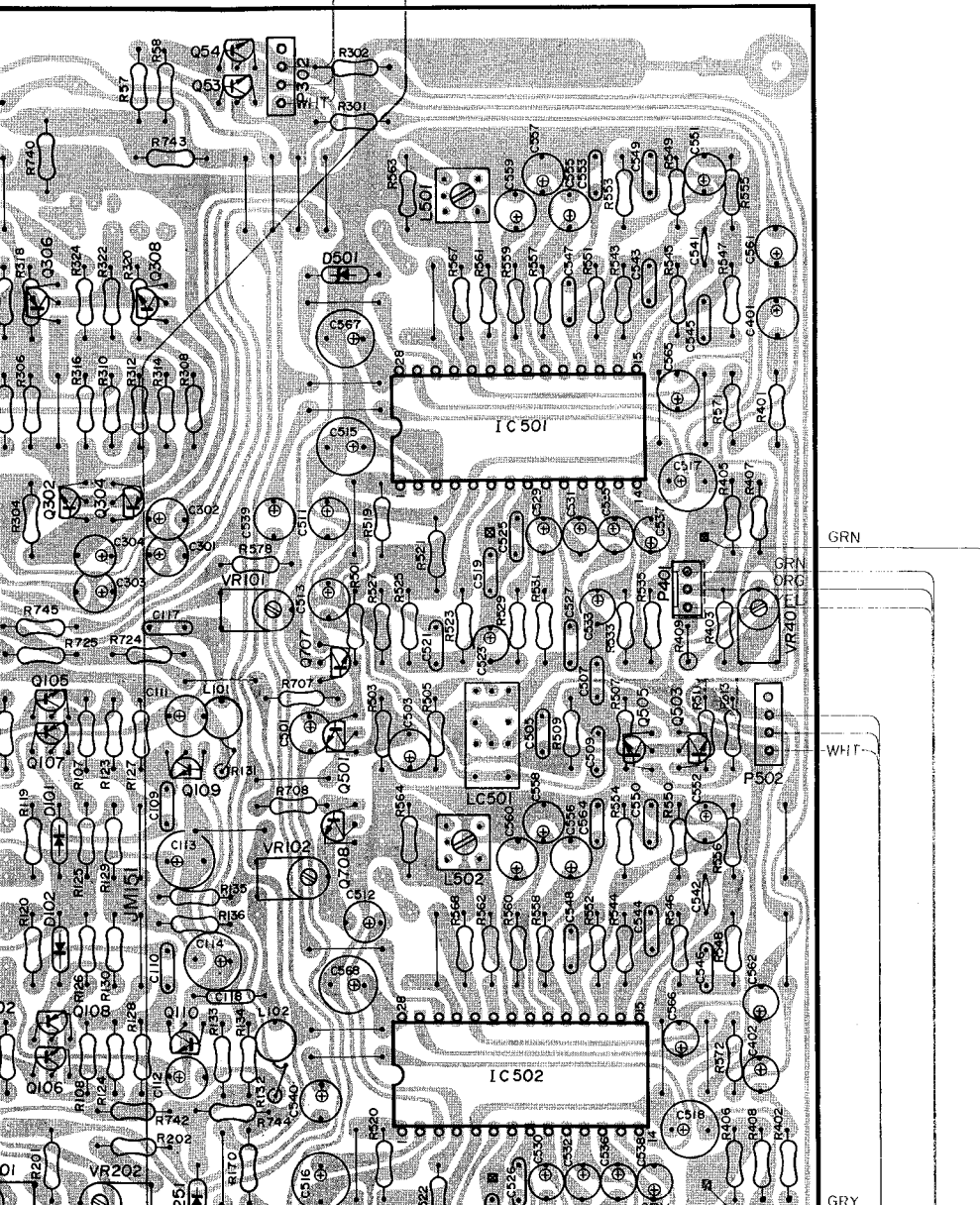
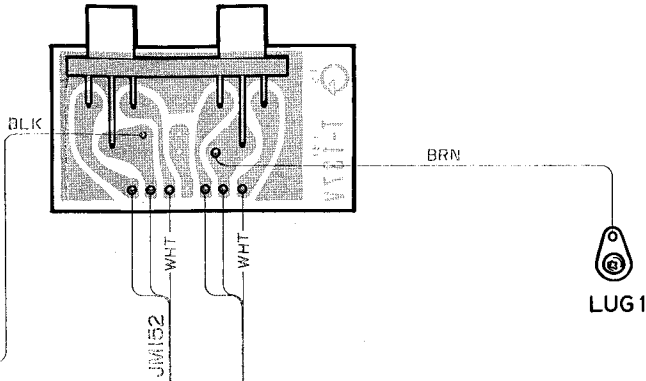

PIN CONNECTION DIAGRAM OF TRANSISTORS, DIODES AND ICs

Q1: 2SA473 (Y)
Q2: 2SC1173 (Y)

Q5, 251, 307, 308 : 2SC2236 (Y)
Q714, 715 : 2SA970 (BL)
Q716: 2SD667 (C)

B
C
E

E
C
B

Q3, 52, 705 ~ 708, 711 ~ 713, 718, 801, 803, 806 ~ 808, 812, 813: 2SC2603 (F)
Q4, 51, 55, 717, : 2SA1115 (F)
Q109, 110, 503 ~ 506: 2SC2603 (F) or (E)
Q802, 804, 805, 814: 2SA1115 (F) or (E)

B
C
E

Q53, 54: 2SC2878 (B)
Q101, 102: 2SC2855 (E) or (D)
Q103, 104: 2SA1190 (E) or (D)
Q105, 106, 301, 302, 501, 502: 2SC2320 (F)
Q107, 108, 303, 304: 2SA999 (F)
Q305, 306: 2SA966 (Y)
Q701 ~ 704: 2SC1845 (E)
Q809 ~ 811: 2SB561 (C)

B
C
E

E
C
B

D1: 1RBA10
D101, 102: KB265

Cathode

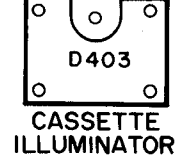

CASSETTE TAPE RECORDER MECHANICAL ASSEMBLY

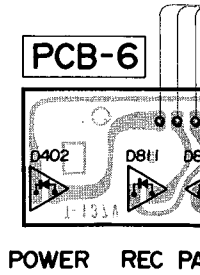
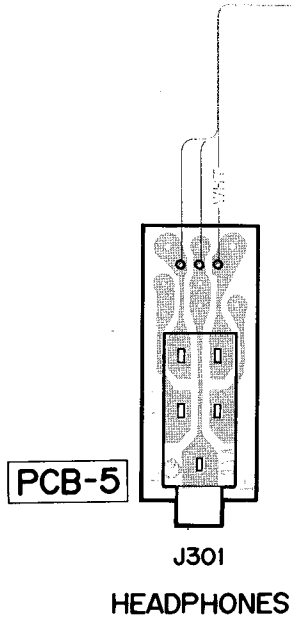
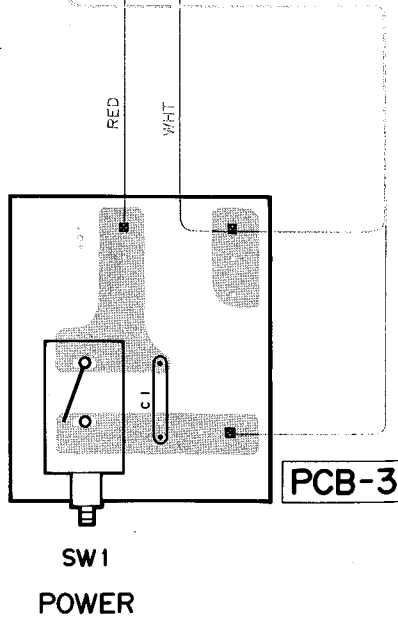
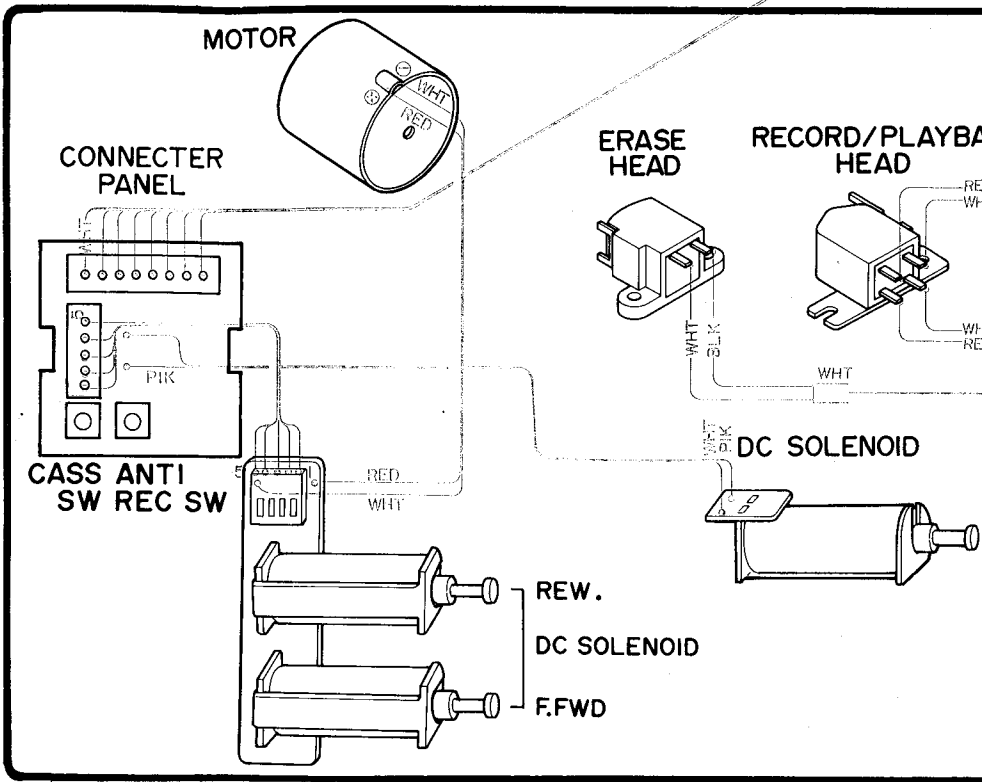

5

6

7

8

9

10

D403
CASSETTE
ILLUMINATOR

RECORD/PLAYBACK
HEAD

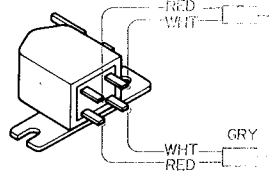

SOLENOID

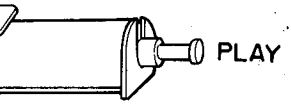

JM501

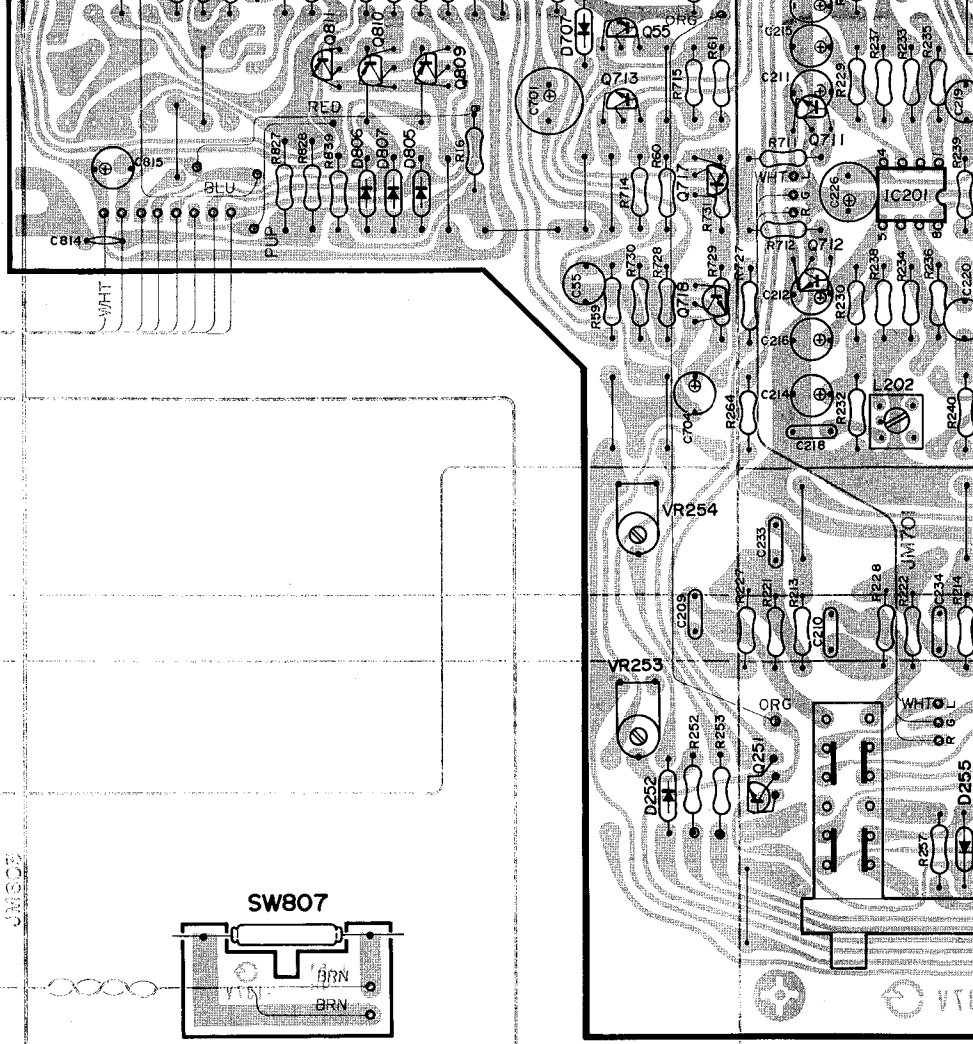

JM502

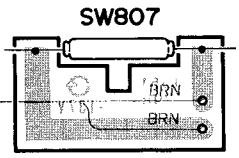

PCB-8

PCB-1

SW203
70µsec
METAL

BIA

PCB-6

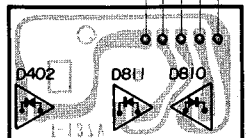

POWER REC PAUSE

PCB-2

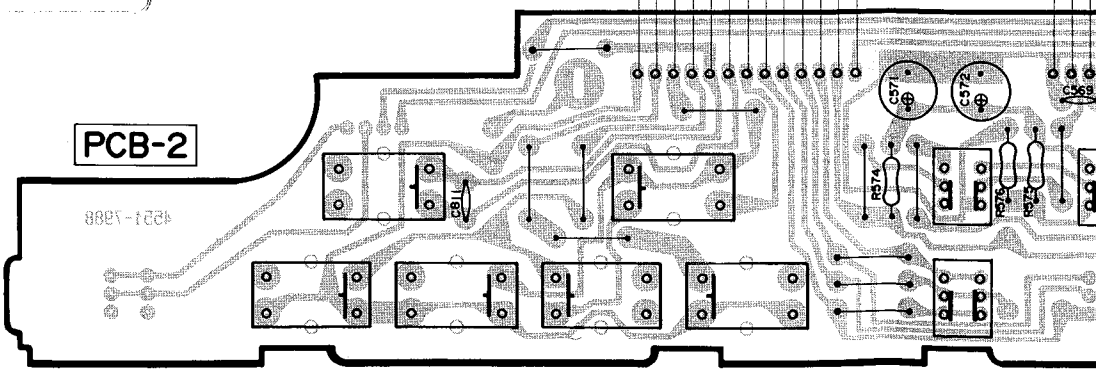

SW802
STOP

SW805
PLAY

SW501
DOLBY B-C NR

NR off
 on

SW801
REW

SW803
F.FWD

SW804
REC

SW806
PAUSE

SW504
auto repeat

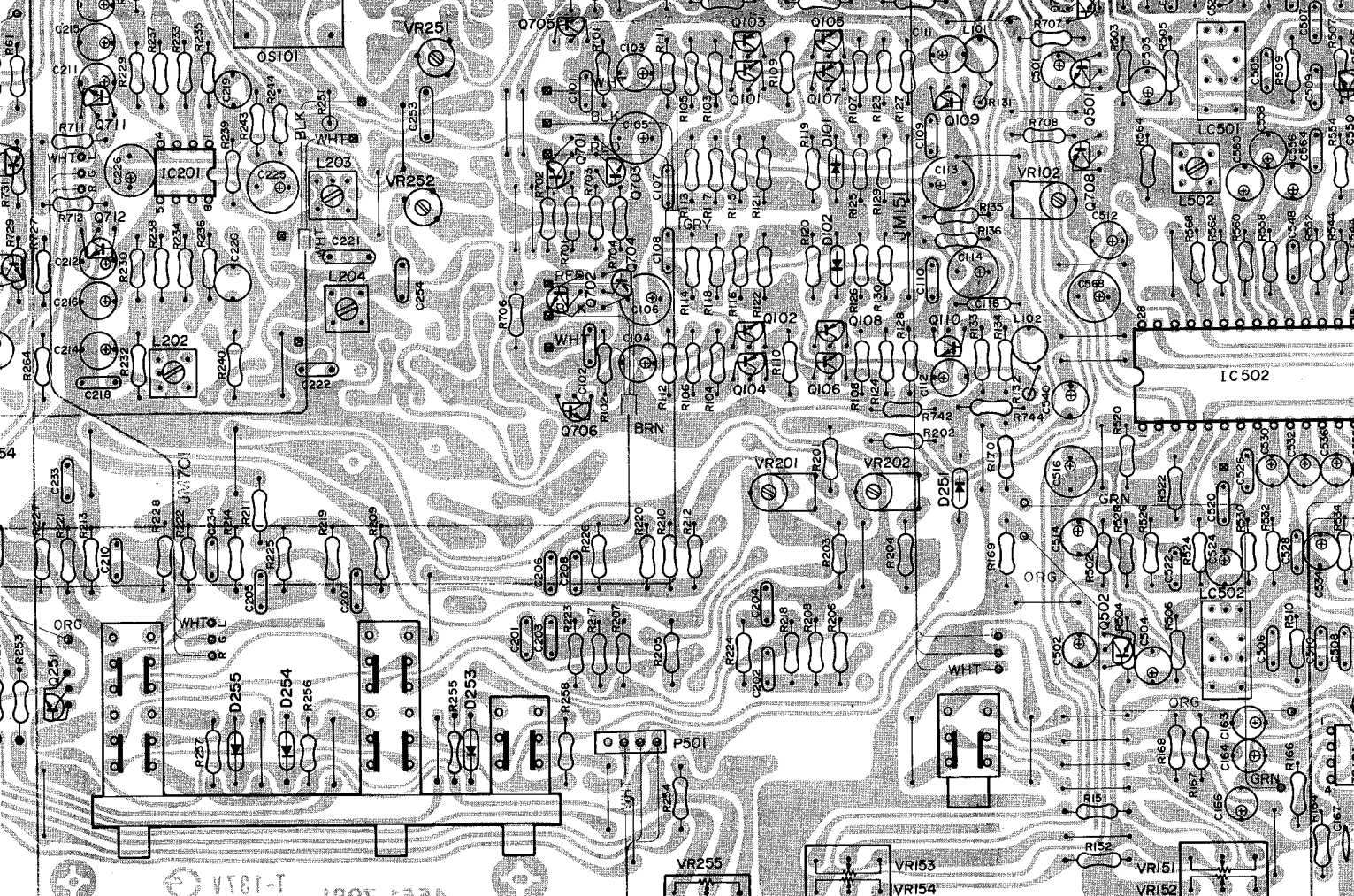

SW203
70µsec
METAL

SW202
70µsec
CrO2

SW201
120µsec
LN

VR255
bias
fine trim

VR201
VR202
input
balance

SW151
input selector
■ line
■ mic

INPUT LEVEL

BIAS / EQUALIZATION

JM501

JM502

JM503

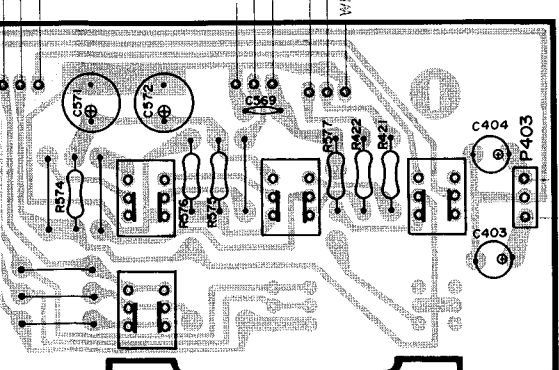

SW501
DOLBY
NR ■ off
■ on

SW502
B-C NR
■ B
■ C

SW503
mpx filter
■ on
■ off

SW504
auto repeat

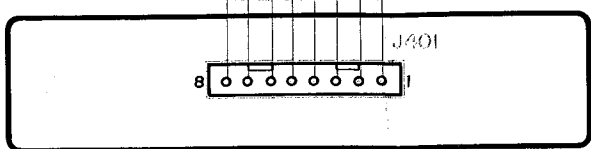

D401
LED LEVEL
DISPLAY ASSEMBLY

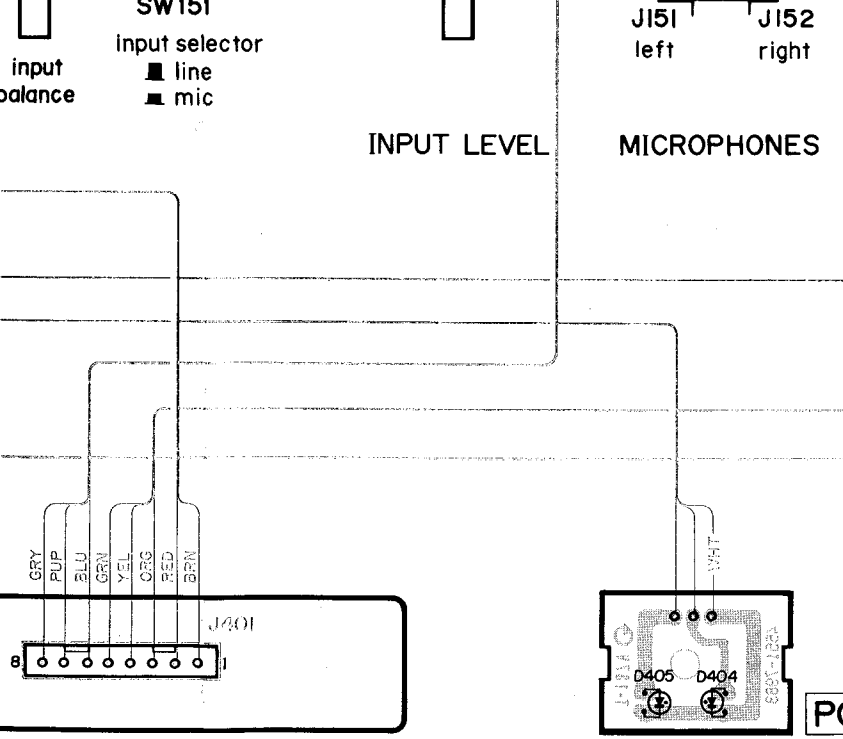
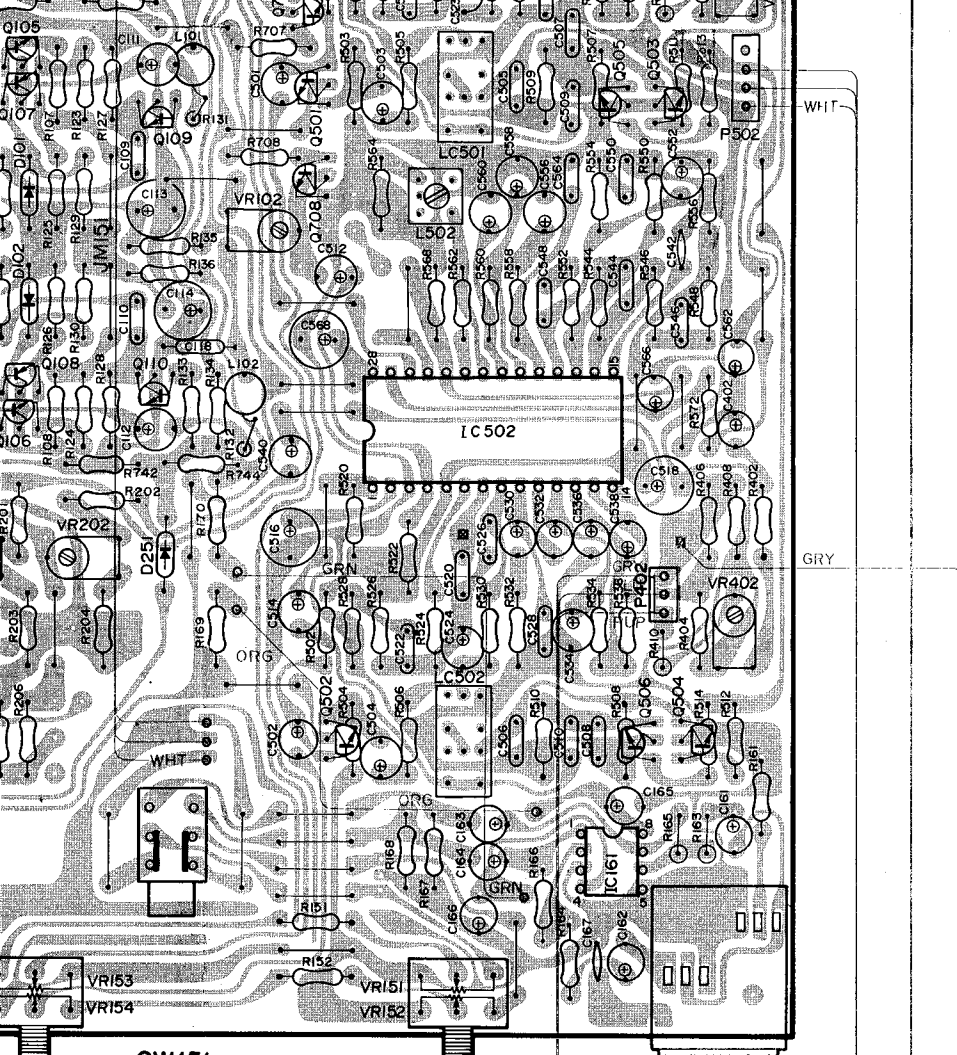

D401
LEVEL DISPLAY ASSEMBLY

Dolby NR
B C

PCB-4

Q3, 52, 705 ~ 708, 711 ~ 713, 718, 801, 803, 806 ~ 808, 812, 813: 2SC2603 (F) Q4, 51, 55, 717, ~ 2SA1115 (F) Q109, 110, 503 ~ 506: 2SC2603 (F) or (E) Q802, 804, 805, 814: 2SA1115 (F) or (E)	
Q53, 54: 2SC2878 (B) Q101, 102: 2SC2855 (E) or (D) Q103, 104: 2SA1190 (E) or (D) Q105, 106, 301, 302, 501, 502: 2SC2320 (F) Q107, 108, 303, 304: 2SA999 (F) Q305, 306: 2SA966 (Y) Q701 ~ 704: 2SC1845 (E) Q809 ~ 811: 2SB561 (C)	
D1: S1RBA10	D101, 102: KB265
D2, 3, 7, 51 ~ 57, 51 ~ 255, 701 ~ 704, 706, 707, 801 ~ 803, 808, 813 : 1SS53 D4, 5: RD9.1EB2 D6: RD11EB2 D58: RD12EB2 D501: RD5.6EB2 D705: 1S2471 D809, 812: RD5.1EB2	
D804 ~ 807: DS135E	D404: GL9HY9 D405: GL9PG19
D402, 811: GL9PR6 D810: GL9HY6	D403: SLF301C
IC161, 201 : μ PC4558C	IC501, 502 : HA12038
IC801: M54886P	

- WIRE COLOR ABBREVIATIONS
- | | |
|--------------|--------------|
| RED : Red | BLK : Black |
| ORG : Orange | YEL : Yellow |
| BLU : Blue | PUP : Purple |
| WHT : White | PIK : Pink |
| GRN : Green | BRN : Brown |