

The Harman Kardon Model CD391

Manual No. 68A

ULTRAWIDEBAND LINEAR PHASE CASSETTE DECK

Technical Manual

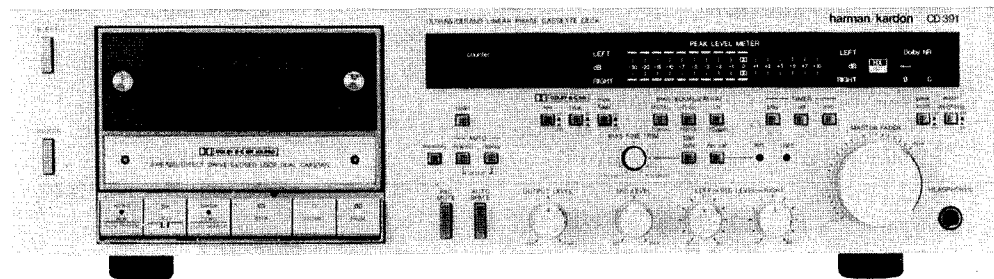

harman/kardon

240 CROSSWAYS PARK WEST, WOODBURY, N. Y. 11797
1112-H15268A3 P-08836 1650 PRINTED IN JAPAN

CD391

SPECIFICATIONS

Track Configuration 4-track 2 channel Stereo

Cassette Deck
Nominal Limit

●MECHANICAL SECTION

Record/Playback Tape Speed		
Deviation 4.75cm/sec.	0.3%	+1.0% -0.5%
Drift 4.75cm/sec.	0.2%	≤ 0.5%
Wow and Flutter	0.025% (NAB)	≤ 0.038%
	0.033% (CCIR)	≤ 0.1%
Take Up Torque	55gcm	35 ~ 70gcm
Back Tension	6gcm	4.5 ~ 8gcm
F.FWD Torque	120gcm	90 ~ 150gcm
REW. Torque	110gcm	90 ~ 150gcm
F.FWD/REW. Time for C-60 Cassette		72 sec. ≤ 85 sec.
Motor	Direct Drive motor (Capstan) 2 Flat Torque DC motors (Reel & Assist)	

●AMPLIFIRE SECTION

Bias Frequency	105kHz ± 5kHz	
Playback Output	420mV ± 1dB	
Signal-to-Noise Ratio at LINE input (Input 1kHz, 100mV) IHF-A WTD at Dolby Level		
Dolby NR OFF	LN	52dB
	CrO ₂	55dB
	Metal	55dB
Dolby NR B to ON	LN	61dB
	CrO ₂	63dB ≥ 60dB
	Metal	63dB ≥ 60dB
Dolby NR C to ON	LN	68dB
	CrO ₂	70dB ≥ 66dB
	Metal	70dB ≥ 66dB

Signal-to-Noise Ratio
at MIC input (Input 1kHz, 1.5mV)

Dolby NR B to ON (LN)	52dB ≥ 46dB
Dolby NR C to ON (LN)	60dB

Channel Separation		Nominal	Limit
		45dB	≥ 35dB
Crosstalk		72dB	≥ 60dB
Record/Playback Distortion (Input 1kHz)	LN	1.3%	≤ 2.0%
	CrO ₂	1.6%	≤ 3.0%
	Metal	0.9%	≤ 1.6%
MPX Filter Attenuation			
at 15kHz		0.5dB	≤ 1dB
at 19kHz		35dB	≥ 30dB
Erase Ratio (Input 80Hz)	LN	70dB	≥ 60dB
	Metal	65dB	≥ 60dB
Input Sensitivity (Input 1kHz)			
at MIC input		0.65mV	
		0.2(min) ~ 1.0(max)	mV
at LINE input		33mV	
		25(min) ~ 50(max)	mV
Input Impedance (Input 1kHz)			
at MIC input		1kΩ	
		0.8(min) ~ 2(max)	kΩ
at LINE input		22kΩ	
		19(min) ~ 30(max)	kΩ
Overload at MIC input (Input 1kHz)		90mV	≥ 20mV
●DIMENSIONS (WxHxD)	17-7/16" x 4-13/16" x 13-9/16" (443 x 123 x 345mm)		
●WEIGHT	15 lbs. 14 oz. (7.2 kg)		
●POWER SUPPLY			
U.S.A. & Canada models	AC120V, 60Hz		
General model	AC100/120/220/240V, 50/60Hz		
●POWER CONSUMPTION	55W		

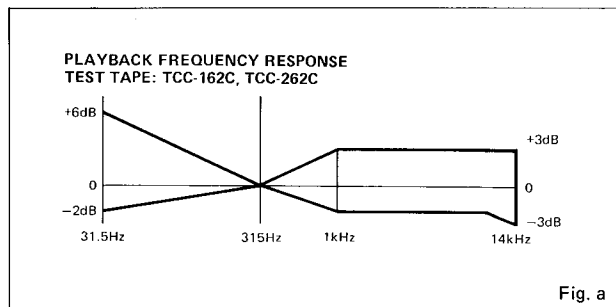

Fig. a

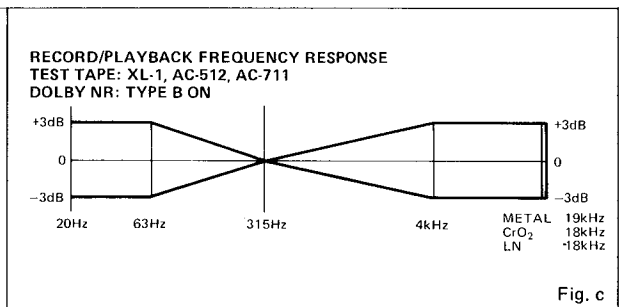

Fig. c

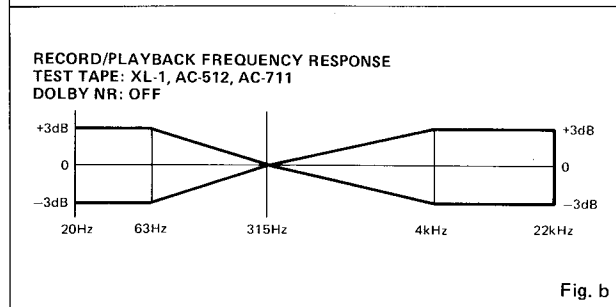

Fig. b

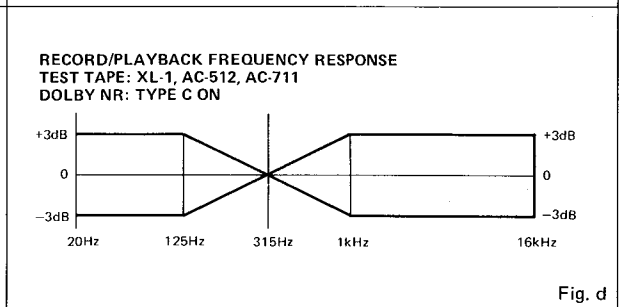

Fig. d

Specifications and components subject to change without notice. Overall performance will be maintained or improved.

This specification is the target of servicing. But, there is a case that the specification is not applicable to the measurement condition and instrument.

LEAKAGE TEST

Before returning the unit to the user, perform the following safety checks:

1. Inspect all lead dress to make certain that leads are not pinched or that hardware is not lodged between the chassis and other metal parts in the unit.
2. Be sure that any protective devices such as nonmetallic control knobs, insulating fishpapers, cabinet backs, adjustment and compartment covers or shields, isolation resistor-capacity networks, mechanical insulators, etc. which were removed for servicing are properly reinstalled.
3. Be sure that no shock hazard exists; check for leakage current using Simpson Model 229 Leakage Tester, standard equipment item No. 21641, RCA Model WT540A or use alternate method as follows:
 Plug the AC line cord directly into a 120-volt AC receptacle (do not use an Isolation Transformer for this test). Using two clip leads, connect a 1500 ohm, 10-watt resistor paralleled by a 0.15mf capacitor, in series with all exposed metal cabinet parts and a known earth ground, such as a water pipe or conduit. Use a VTVM or VOM with 1000 ohms per volt, or higher, sensitivity to measure the AC voltage drop across the resistor. (See Diagram.) Move the resistor connection to each exposed metal part having a return path to the chassis (antenna, metal, cabinet, screw heads, knobs and control shafts, escutcheon, etc.) and measure the AC voltage drop across the resistor. (This test should be performed with the power switch in both the On and Off positions.)
 A reading of 0.35 volt RMS or more is excessive and indicates a potential shock hazard which must be corrected before returning the unit to the owner.

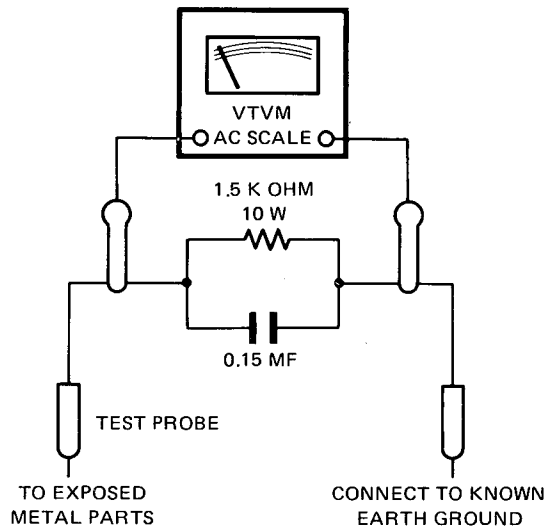
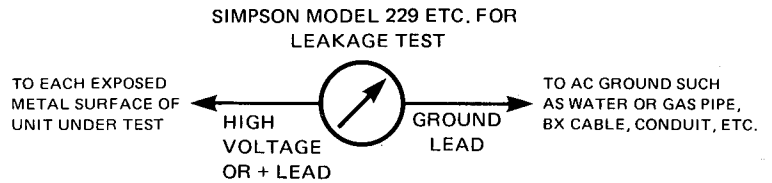

Dolby* HX-Professional Headroom Extension (HX-PRO) System

The CD391 is equipped with the Dolby HX-Professional Headroom Extension system (HX-PRO). It operates only during the record mode and does not require the user to "turn it on" or make adjustments. It is compatible with any low noise (standard), chromium dioxide (CrO₂), or metal audio cassette tape.

The effect of HX-PRO is that it extends the high frequency saturation (overload) level of the tape being recorded. Therefore, many of the high level, high frequency music signals that would be compressed or distorted with a conventional cassette deck will be recorded accurately by the CD391.

The advantages of HX-PRO are:

1. The performance of low noise and chromium dioxide tapes almost equals that of the more expensive metal tapes.
2. A major improvement is made in high frequency dynamic range.
3. The higher record levels result in an increased signal-to-noise ratio.
4. No decoding is necessary. The improved recording accuracy can be appreciated with any high quality tape player, including a portable or car stereo unit.
5. It can be used with or without Dolby B and C noise reduction circuitry.

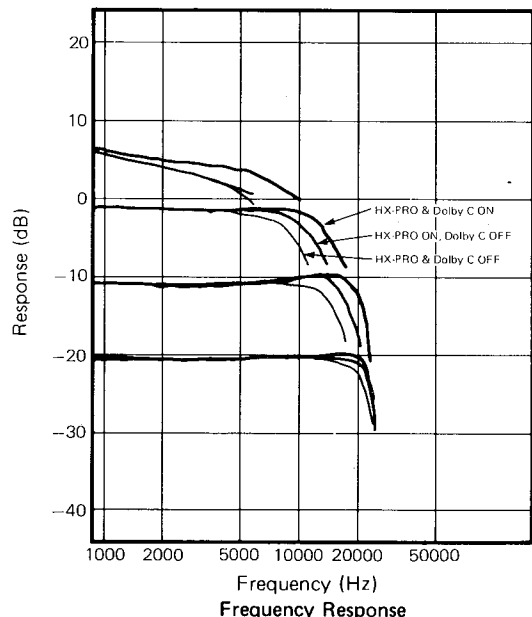

*Noise reduction and headroom extension manufactured under license from Dolby Laboratories Licensing Corporation. HX Professional originated by Bang and Olufsen. "Dolby" and the double-D symbol are trademarks of Dolby Laboratories Licensing Corporation.

DISASSEMBLY PROCEDURES (REFER TO PAGES 17, 18, 19 AND 31)

- ① **CABINET TOP REMOVAL**
Remove 6 screws **A** and remove the cabinet top.
- ② **FRONT PANEL ASSEMBLY (103) REMOVAL**
 1. Remove the cabinet top. (Refer to step ①.)
 2. Pull off Master Fader, Output Level, Mic. Level and Rec. Level knobs (105 and 152).
 3. Remove 6 screws **B** and remove the front panel assembly (103).
- ③ **LOGIC CONTROL P.C.BOARD(PCB-2) REMOVAL**
 1. Remove the cabinet top. (Refer to step ①.)
 2. Disconnect J801, J802, J803, J807 and J808 from P801, P802, P803, P807 and P808 on the logic control P.C. board (PCB-2).
 3. Open the lid of connectors (P804, P805 and P806) on the logic control P.C. board (PCB-2) and disconnect the lead wires.
 4. Unsolder the lead wires connected to the logic control P.C. board (PCB-2).
 5. Remove 4 screws **C** and remove the logic control P.C. board (PCB-2) with heat sink (275).
- ④ **PUSH SWITCHES P.C.BOARD(PCB-4) REMOVAL**
 1. Remove the cabinet top. (Refer to step ①.)
 2. Disconnect J803 and J601 from P803 and P601 on the logic control and push switches P.C. boards (PCB-2 and PCB-4).
 3. Open the lid of connectors P451, P804 and P401 on the main, logic control and VR P.C. boards (PCB-1, PCB-2 and PCB-3) and disconnect the lead wires.
 4. Remove 3 screws **D** and remove the push switches P.C. board (PCB-4) with rec. cal P.C. board (PCB-9). If necessary, unsolder the lead wires.
- ⑤ **MAIN P.C. BOARD (PCB-1) REMOVAL**
 1. Remove the front panel assembly, logic control P.C. board (PCB-2) and push switches P.C. board (PCB-4). (Refer to steps ② through ④.)
 2. Disconnect J301, J452, J501, J502, J503 and J504 from P301, P452, P501, P502, P503 and J504 on the main P.C. board (PCB-1).
 3. Open the lid of connectors (P201, P202, P251 and P451) on the main P.C. board (PCB-1) and disconnect the lead wires.
 4. Unsolder lead wires connected to the main P.C. board (PCB-1).
 5. Remove 8 screws **F** and remove the main P.C. board (PCB-1).
- ⑥ **VR P.C. BOARD (PCB-3) REMOVAL**
 1. Remove the front panel assembly. (Refer to step ②.)
 2. Remove 6 screws **G** and remove the cabinet bottom assembly (102).
 3. Remove 4 hexagon nuts **H** mounting the VR P.C. board (PCB-3) and remove it. If necessary, unsolder the lead wires.
- ⑦ **CASSETTE TAPE RECORDER MECHANICAL ASSEMBLY (112) REMOVAL**
 1. Remove the front panel assembly and logic control P.C. board (PCB-2). (Refer to steps ② and ③.)
 2. Remove 4 screws **I** and remove the cassette tape recorder mechanical assembly (112) with plate assembly (104) backward. At this time, remove the belt (213).
- ⑧ **PLATE ASSEMBLY (104) REMOVAL**
 1. Remove the cassette tape recorder mechanical assembly. (Refer to step ⑦.)
 2. Remove 2 screws **J** and remove the plate assembly (104).
- ⑨ **DIRECT DRIVE MOTOR (506) REMOVAL**
 1. Remove the plate assembly. (Refer to step ⑧.)
 2. Remove 2 hexagon nuts **K** and remove the direct drive motor. If necessary, unsolder the lead wires.
- ⑩ **PAD ASSEMBLY (505) REMOVAL**
 1. Remove the plate assembly. (Refer to step ⑧.)
 2. Remove 2 screws **L** and remove PAD assembly. If necessary, unsolder the lead wires.
- ⑪ **IDLER MOTOR ASSEMBLY (503) REMOVAL**
 1. Remove the direct drive motor. (Refer to step ⑨.)
 2. Remove 2 lock washers **M** and remove supply and take-up reel spindle assembly (508 and 509). At this time, remove the belt (511) and spring (507).
 3. Remove 3 screws **N** and remove the idler motor assembly.
- ⑫ **HEAD BASE ASSEMBLY (502) REMOVAL**
 1. Remove the direct drive motor. (Refer to step ⑨.)
 2. Remove 2 E-stop rings **O** and remove supply and take-up pinch roller assembly (516 and 513).
 3. Remove the lamp holder assembly (519) and bracket (526).
 4. Remove 2 E-stop ring **P** and remove head base assembly with record/playback and erase heads.

CIRCUIT DESCRIPTION

• MPX/DOLBY NR CIRCUIT

The MPX filter circuit is turned on and off by the MPX filter switch. When it is off, the signals bypass the circuit. The dolby circuit is turned on and off by the dolby NR switch, and selected B and C types by the dolby NR type selector. When the circuit is on and type selector is B position, B-type dolby equalization is applied so that the signal is compressed during recording and expanded during playback.

• MUTING

1. PLAYBACK MODE

At stop mode, the muting signal from 2 pin of IC851 is turned on and Q81, Q83 (left channel) and Q82, Q84 (right channel) are turned on. So the output signal is cut. When play button is pressed, the muting signal from 2 pin of IC851 is turned off. So Q81, Q83 (left channel) and Q82, Q84 (right channel) are turned off. So the muting mode is absolved and playback signal is activated.

2. RECORDING MODE

When rec and pause or rec and play buttons are pressed, the signal changing recording/playback mode turns Q709, Q710 and Q711 on. At the same time Q705, Q707 (left channel) and Q706, Q708 (right channel) changes to recording mode and Q703 (left channel) and Q704 (right channel) are turned on. So the set becomes recording mode.

3. LINE MUTE (POWER SWITCH ON/OFF)

When the power is turned on, Q51 is turned on for a few seconds. At the same time Q93 and Q94 go on. ④ pin of the 4 bit micro computer IC851 becomes high level. The computer is reset. At the same time Q81 (left channel) and Q82 (right channel) are turned on. Thus, no shock noise is output to the OUTPUT terminals.

BLOCK DIAGRAM

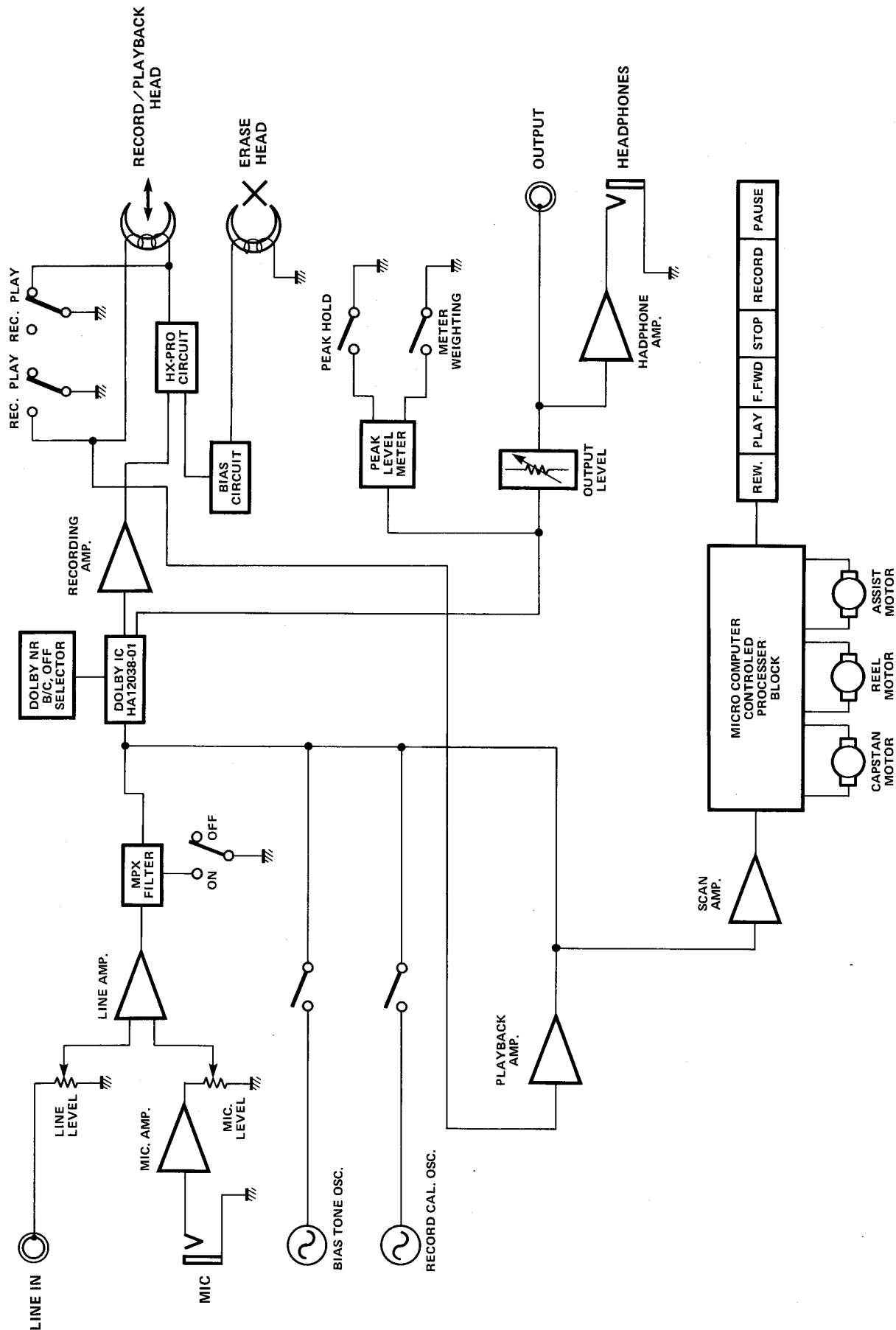

Bias Fine Trim Feature

The optimal amount of recording bias varies from tape to tape. The bias fine trim feature is provided to enable precise adjustment for such variations.

The high frequency range tends to be attenuated if the bias current is higher than the optimum value while it tends to be boosted if the bias current is less than the optimum value. Less than optimum bias also increases the amount of distortion in a recording.

This unit assists the user in determining the precise amount of bias, and therefore in obtaining the widest and flattest frequency response.

Operate as follows:

1. Insert a cassette tape in the CASSETTE COMPARTMENT and press the TAPE SELECTOR button corresponding to the type of tape being used.
2. Press the RECORD and PLAY buttons together to start recording.
3. Hold the BIAS TONE button in. A 400Hz signal and a 12.5kHz signal are recorded in the left and right channels, respectively.
4. Rewind the tape and press the PLAY button to start playback. With hold the BIAS TONE button in, compare the left and right channel PEAK LEVEL METER readings.
5. If the amount of bias is optimum, the left and right channels will have the same reading. Turn the BIAS FINE TRIM knob counterclockwise (toward the direction marked as HI CUT) if the right channel reading exceeds the left channel reading or clockwise (toward the direction marked as HI BOOST) if the left channel reading exceeds the right channel reading.

If the right channel reading exceeds the left channel reading.



Turn the knob counterclockwise.

If the left channel reading exceeds the right channel reading.



Turn the knob clockwise.

6. Repeat steps 2 through 5 until the left and right channels have the same reading.

Record Calibration Feature

Each tape has different sensitivity. As a result, a tape that is recorded at a 0dB level may have a playback level that is either higher or lower than 0dB. The record calibration feature enables the user to precisely adjust the record/playback level so that both modes correlate. This is especially important when making Dolby NR encoded recordings.

Operate as follows:

1. Insert the cassette tape to be recorded into the CASSETTE COMPARTMENT. Press the TAPE SELECTOR button according to the tape type.
2. Press the RECORD and PLAY buttons together to start recording.
3. Hold in the RECORD CALIBRATION button. A 400Hz signal is recorded on each channel.
4. Rewind the tape and press the PLAY button to start playback. If the PEAK LEVEL METERS show 0dB, no adjustment is required.
5. If the indicated level is above or below 0dB, adjust the RECORD CALIBRATION control(s) of the left and right channels using the screwdriver provided with your unit. If the indication of the PEAK LEVEL METER is below 0dB, turn the RECORD CALIBRATION control clockwise. If the PEAK LEVEL METER reads above 0dB, turn the RECORD CALIBRATION control counterclockwise.

If the indication is below 0dB.

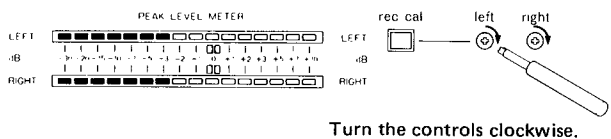

Turn the controls clockwise.

If the indication is above 0dB.

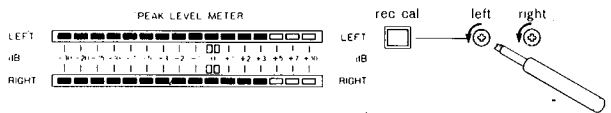

Turn the controls counterclockwise.

6. Repeat steps 2 through 5 until the PEAK LEVEL METERS shows 0dB.

NOTE: Adjustment to 0dB may be impossible if the tape used is old or of poor quality.

ALIGNMENT PROCEDURES (REFER TO PAGES 30 AND 31)

ELECTRICAL ADJUSTMENT

1. Before adjustment

- After the power switch is pushed on, wait for 10 minutes before measuring to be sure of the most stable operation.
- Since head magnetization, dust accumulations, etc. are likely to introduce errors in the various characteristics, it is very important that the heads are properly demagnetized and cleaned before commencing any adjustment, particularly frequency response and head azimuth adjustment.

2. INSTRUMENTS REQUIRED

- Low frequency oscillator
- AC VTVM or dual channel AC VTVM
- Oscilloscope
- Wow/flutter meter
- Frequency counter

3. TEST TAPE

- Azimuth adjustment MTT-114
 - Tape speed adjustment . . . MTT-111 or MTT-111D
 - Playback amp. level adjustment MTT-150 or TCC-130
 - Playback frequency characteristic confirmation TCC-162C and TCC-262C
 - Auto search adjustment MTT-150
 - Auto search confirmation MTT-250B
- Reference tapes
 LN XL-1
 CrO₂ AC-512
 Metal AC-711

Note:

C-90 differs with C-60 in the thickness and bias is unequal, so adjust with the tape whose bias is of specified value.

• **General conditions (unless otherwise noted).**

CONTROLS AND SWITCHES	SETTINGS
Dolby NR	off
MPX Filter	off
Bias Fine Trim	center
Timer	off
Output Level	max
Mic. Level	off
Rec. Level	max
Master Fader	max

STEP	ADJUSTMENT ITEM	INSTRUMENT REQUIRED	MODE	INPUT SIGNAL	POINT TO BE CONNECTED	ADJUST POINT	RATING	REMARKS
1	Azimuth	VTVM Test tape (MTT-114)	PB		TP501 or TP502	Azimuth screw	Maximum output	Refer to "Azimuth adjustment" on page 12.
2	Tape speed	Frequency counter Test tape (MTT-111 or MTT-111D)	PB		TP501 or TP502	VR built in motor	3kHz ⁺³⁰ / ₋₁₅ Hz	
3	Playback amp. level	VTVM Test tape (MTT-150 or TCC-130)	PB		TP501 TP502	VR101 VR102	580mV	
4	Playback frequency characteristic confirmation	VTVM Test tape (TCC-162C and TCC-262C)	PB		LINE OUTPUT		Confirm that frequency response is within the range in Fig. a.	
5	Auto search	VTVM Test tape (MTT-150)	PB		TP751	VR751	90 ~ 100mV	Set the auto search mode. Tape selector is CrO ₂ position.
6	Auto search confirmation	Test tape (MTT-250B)						Refer to "Auto-search operation confirmation" on page 9.
7	Step up trans.	VTVM	REC-PAUSE		TP203 TP204	L651 L203 L652 L204	Maximum output	Tape selector is metal position. Set the bias fine trim to hi cut position. Set VR256 and VR257 all the way to counterclockwise.
8	Bias trap	VTVM	REC-PAUSE		TP201 TP202	L205 L206	Minimum output	Tape selector is metal position. Set the bias fine trim to hi cut position. Set VR256 and VR257 all the way to counterclockwise.
9	Bias level (Pre-adjustment)	VTVM	REC-PAUSE		TP203 TP204	VR257 VR256	110mV	Tape selector is metal position.
					TP203 TP204	VR253 VR252	58mV	Tape selector is CrO ₂ position.
					TP203 TP204	VR255 VR254	38mV	Tape selector is LN position.
10	Bias frequency confirmation	Frequency counter	REC-PAUSE		TP251		105kHz ± 5kHz	Tape selector is metal position.
11	Record level (Pre-adjustment)	VTVM Blank tape (AC-512)	REC/PB	Apply 400Hz signal to LINE INPUT. Set REC LEVEL knob so that TP501 and TP502 voltage is 580mV in REC-PAUSE mode.	TP501 TP502	VR201 VR202	580mV	Tape selector is CrO ₂ position.
12	Peaking coil (Pre-adjustment)	VTVM	REC/PB	Apply 24kHz signal to LINE INPUT. Set REC LEVEL knob so that TP501 and TP502 voltage is 580mV -25dB in REC mode.	TP201 TP202	L201 L202	Maximum output	Short the TP251 and TP252. Tape selector is metal position.
13	Record/Playback equalizer frequency characteristic	VTVM Blank tapes metal AC-711 CrO ₂ AC-512 LN XL-1	REC/PB	Apply 400Hz signal to LINE INPUT. Set REC LEVEL knob so that TP501 and TP502 voltage is 580mV -25dB in REC-PAUSE mode. Then adjust with a 20Hz to 30kHz sweep signal.	LINE OUTPUT	VR257 L201	So that the record/playback frequency response is flat (at least within the range in Fig. b.)	Tape selector is metal position.
					LINE OUTPUT	VR256 L202		
					LINE OUTPUT	VR253 L201	So that the record/playback frequency response is flat (at least within the range in Fig. b.)	Tape selector is CrO ₂ position.
					LINE OUTPUT	VR252 L202		
					LINE OUTPUT	VR255 VR254	So that the record/playback frequency response is flat (at least within the range in Fig. b.)	Tape selector is LN position.

ALIGNMENT PROCEDURES (REFER TO PAGES 30 AND 31)

ELECTRICAL ADJUSTMENT

1. Before adjustment

- After the power switch is pushed on, wait for 10 minutes before measuring to be sure of the most stable operation.
- Since head magnetization, dust accumulations, etc. are likely to introduce errors in the various characteristics, it is very important that the heads are properly demagnetized and cleaned before commencing any adjustment, particularly frequency response and head azimuth adjustment.

2. INSTRUMENTS REQUIRED

- Low frequency oscillator
- AC VTVM or dual channel AC VTVM
- Oscilloscope
- Wow/flutter meter
- Frequency counter

3. TEST TAPE

- Azimuth adjustment MTT-114
 - Tape speed adjustment . . MTT-111 or MTT-111D
 - Playback amp. level adjustment MTT-150 or TCC-130
 - Playback frequency characteristic confirmation TCC-162C and TCC-262C
 - Auto search adjustment MTT-150
 - Auto search confirmation MTT-250B
- Reference tapes
 LN XL-1
 CrO₂ AC-512
 Metal AC-711

Note:

C-90 differs with C-60 in the thickness and bias is unequal, so adjust with the tape whose bias is of specified value.

STEP	ADJUSTMENT ITEM	INSTRUMENT REQUIRED	MODE	INPUT SIGNAL	POINT TO BE CONNECTED
1	Azimuth	VTVM Test tape (MTT-114)	PB		TP501 or TP502
2	Tape speed	Frequency counter Test tape (MTT-111 or MTT-111D)	PB		TP501 or TP502
3	Playback amp. level	VTVM Test tape (MTT-150 or TCC-130)	PB		TP501 TP502
4	Playback frequency characteristic confirmation	VTVM Test tape (TCC-162C and TCC-262C)	PB		LINE OUTPUT
5	Auto search	VTVM Test tape (MTT-150)	PB		TP751
6	Auto search confirmation	Test tape (MTT-250B)			
7	Step up trans.	VTVM	REC-PAUSE		TP203 TP204
8	Bias trap	VTVM	REC-PAUSE		TP201 TP202
9	Bias level (Pre-adjustment)	VTVM	REC-PAUSE		TP203 TP204
					TP203 TP204
					TP203 TP204
10	Bias frequency confirmation	Frequency counter	REC-PAUSE		TP251
11	Record level (Pre-adjustment)	VTVM Blank tape (AC-512)	REC/PB	Apply 400Hz signal to LINE INPUT. Set REC LEVEL knob so that TP501 and TP502 voltage is 580mV in REC-PAUSE mode.	TP501 TP502
12	Peaking coil (Pre-adjustment)	VTVM	REC/PB	Apply 24kHz signal to LINE INPUT. Set REC LEVEL knob so that TP501 and TP502 voltage is 580mV -25dB in REC mode.	TP201 TP202
13	Record/Playback equalizer frequency characteristic	VTVM Blank tapes (metal AC-711 CrO ₂ AC-512 LN XL-1)	REC/PB	Apply 400Hz signal to LINE INPUT. Set REC LEVEL knob so that TP501 and TP502 voltage is 580mV -25dB in REC-PAUSE mode. Then adjust with a 20Hz to 30kHz sweep signal.	LINE OUTPUT
					LINE OUTPUT
					LINE OUTPUT
					LINE OUTPUT
					LINE OUTPUT

● General conditions (unless otherwise noted).

CONTROLS AND SWITCHES	SETTINGS
Dolby NR	off
MPX Filter	off
Bias Fine Trim	center
Timer	off
Output Level	max
Mic. Level	off
Rec. Level	max
Master Fader	max

TTT-114
TT-111D
CC-130
ation
CC-262C
TTT-150
TT-250B

d bias is
as is of

	POINT TO BE CONNECTED	ADJUST POINT	RATING	REMARKS
	TP501 or TP502	Azimuth screw	Maximum output	Refer to "Azimuth adjustment" on page 12.
	TP501 or TP502	VR built in motor	3kHz $\begin{matrix} +30 \\ -15 \end{matrix}$ Hz	
	TP501 TP502	VR101 VR102	580mV	
	LINE OUTPUT		Confirm that frequency response is within the range in Fig. a.	
	TP751	VR751	90 ~ 100mV	Set the auto search mode. Tape selector is CrO2 position.
				Refer to "Auto-search operation confirmation" on page 9.
	TP203 TP204	L651 L203 L652 L204	Maximum output	Tape selector is metal position. Set the bias fine trim to hi cut position. Set VR256 and VR257 all the way to counterclockwise.
	TP201 TP202	L205 L206	Minimum output	Tape selector is metal position. Set the bias fine trim to hi cut position. Set VR256 and VR257 all the way to counterclockwise.
	TP203 TP204	VR257 VR256	110mV	Tape selector is metal position.
	TP203 TP204	VR253 VR252	58mV	Tape selector is CrO2 position.
	TP203 TP204	VR255 VR254	38mV	Tape selector is LN position.
	TP251		105kHz \pm 5kHz	Tape selector is metal position.
C age	TP501 TP502	VR201 VR202	580mV	Tape selector is CrO2 position.
C age	TP201 TP202	L201 L202	Maximum output	Short the TP251 and TP252. Tape selector is metal position.
	LINE OUTPUT	VR257 L201 VR256 L202	So that the record/playback frequency response is flat (at least within the range in Fig. b.)	Tape selector is metal position.
	LINE OUTPUT	VR253 L201 VR252 L202	So that the record/playback frequency response is flat (at least within the range in Fig. b.)	Tape selector is CrO2 position.
C age	LINE OUTPUT	VR255 VR254	So that the record/playback frequency response is flat (at least within the range in Fig. b.)	Tape selector is LN position.

STEP	ADJUSTMENT ITEM	INSTRUMENT REQUIRED	MODE	INPUT SIGNAL	POINT TO BE CONNECTED	ADJUST POINT	RATING	REMARKS
14	Record level	VTVM Blank tape (AC-512)	REC/PB	Apply 400Hz signal to LINE INPUT. Set REC LEVEL knob so that TP501 and TP502 voltage is 580mV in REC-PAUSE mode.	TP501 TP502	VR201 VR202	580mV	Tape selector is CrO2 position.
15	Record level confirmation	VTVM Blank tapes metal AC-711 LN XL-1	REC/PB	Apply 400Hz signal to LINE INPUT. Set REC LEVEL knob so that TP501 and TP502 voltage is 580mV in REC-PAUSE mode.	TP501 TP502		580mV \pm 0.5dB	This confirmation should be done at each tape selector position.
16	Rec. input trap	VTVM Blank tape (AC-711)	REC-PAUSE		TP501 TP502	L501 L502	Minimum output	Tape selector is metal position.
17	Record/playback equalizer frequency characteristic confirmation	VTVM Blank tapes metal AC-711 CrO2 AC-512 LN XL-1	REC/PB	Apply 400Hz signal to LINE INPUT. Set REC LEVEL knob so that TP501 and TP502 voltage is 25dB below 580mV in REC-PAUSE mode. Then adjust with a 20Hz to 30kHz sweep signal.	LINE OUTPUT		Confirm that record/playback frequency response is within the range in Fig. c and Fig. d. If it is not within the specification, redo the adjustment and confirmation on steps 13, 15 and 16.	This confirmation should be done at each tape selector position under each of the following conditions, Dolby B and Dolby C on.
18	Meter level	VTVM	REC-PAUSE	Apply 400Hz signal to LINE INPUT. Set REC LEVEL knob so that TP501 and TP502 voltage is 0.5dB below 580mV in REC-PAUSE mode.		VR401 VR402	Adjust to the point where the 0VU LED of the LED display lights.	
19	Record calibration tone level	VTVM	REC-PAUSE		TP501 TP502	VR453	580mV	Keep pressing the REC CAL button. Adjust balance if there is a difference in output between the R and L channels.
20	Bias tone	VTVM	REC-PAUSE		TP501 TP502	VR451 VR452	580mV -20dB	Keep pressing the BIAS TONE button.
21	LED display lighting level of record calibration tone confirmation		REC-PAUSE					Refer to "LED display light level confirmation" on page 9.
22	LED display lighting level of bias tone confirmation		REC-PAUSE					Same as above.
23	MPX filter characteristic confirmation		REC-PAUSE	Apply 15kHz and 19kHz signal to LINE INPUT. Set REC LEVEL knob so that TP501 and TP502 voltage is 580mV in REC-PAUSE mode.	LINE OUTPUT		Confirm that attenuation of 15kHz and 19kHz is within the specification.	MPX filter switch is on position.
24	Anti skwing level confirmation	VTVM	REC-PAUSE	Apply 400Hz signal to LINE INPUT. Set REC LEVEL knob so that TP501 and TP502 voltage is 580mV - 25dB in REC-PAUSE mode.	TP201 TP202		Confirm that attenuation of 19.9kHz \pm 100Hz is maximum.	Dolby NR C is on.

STEP	ADJUSTMENT ITEM	INSTRUMENT REQUIRED	MODE	INPUT SIGNAL	POINT TO BE CONNECTED	ADJ. POINT
14	Record level	VTVM Blank tape (AC-512)	REC/PB	Apply 400Hz signal to LINE INPUT. Set REC LEVEL knob so that TP501 and TP502 voltage is 580mV in REC-PAUSE mode.	TP501 TP502	VR1 VR2
15	Record level confirmation	VTVM Blank tapes [metal AC-711 LN XL-1]	REC/PB	Apply 400Hz signal to LINE INPUT. Set REC LEVEL knob so that TP501 and TP502 voltage is 580mV in REC-PAUSE mode.	TP501 TP502	
16	Rec. input trap	VTVM Blank tape (AC-711)	REC-PAUSE		TP501 TP502	L5 L5
17	Record/playback equalizer frequency characteristic confirmation	VTVM Blank tapes [metal AC-711 CrO ₂ AC-512 LN XL-1]	REC/PB	Apply 400Hz signal to LINE INPUT. Set REC LEVEL knob so that TP501 and TP502 voltage is 25dB below 580mV in REC-PAUSE mode. Then adjust with a 20Hz to 30kHz sweep signal.	LINE OUTPUT	
18	Meter level	VTVM	REC-PAUSE	Apply 400Hz signal to LINE INPUT. Set REC LEVEL knob so that TP501 and TP502 voltage is 0.5dB below 580mV in REC-PAUSE mode.		VR VR
19	Record calibration tone level	VTVM	REC-PAUSE		TP501 TP502	VR
20	Bias tone	VTVM	REC-PAUSE		TP501 TP502	VR VR
21	LED display lighting level of record calibration tone confirmation		REC-PAUSE			
22	LED display lighting level of bias tone confirmation		REC-PAUSE			
23	MPX filter characteristic confirmation		REC-PAUSE	Apply 15kHz and 19kHz signal to LINE INPUT. Set REC LEVEL knob so that TP501 and TP502 voltage is 580mV in REC-PAUSE mode.	LINE OUTPUT	
24	Anti skwing level confirmation	VTVM	REC-PAUSE	Apply 400Hz signal to LINE INPUT. Set REC LEVEL knob so that TP501 and TP502 voltage is 580mV - 25dB in REC-PAUSE mode.	TP201 TP202	

POINT TO BE CONNECTED	ADJUST POINT	RATING	REMARKS
TP501 TP502	VR201 VR202	580mV	Tape selector is CrO2 position.
TP501 TP502		580mV \pm 0.5dB	This confirmation should be done at each tape selector position.
TP501 TP502	L501 L502	Minimum output	Tape selector is metal position.
LINE OUTPUT		Confirm that record/play-back frequency response is within the range in Fig. c and Fig. d. If it is not within the specification, redo the adjustment and confirmation on steps 13, 15 and 16.	This confirmation should be done at each tape selector position under each of the following conditions, Dolby B and Dolby C on.
	VR401 VR402	Adjust to the point where the 0VU LED of the LED display lights.	
TP501 TP502	VR453	580mV	Keep pressing the REC CAL button. Adjust balance if there is a difference in output between the R and L channels.
TP501 TP502	VR451 VR452	580mV -20dB	Keep pressing the BIAS TONE button.
			Refer to "LED display light level confirmation" on page 9.
			Same as above.
LINE OUTPUT		Confirm that attenuation of 15kHz and 19kHz is within the specification.	MPX filter switch is on position.
TP201 TP202		Confirm that attenuation of 19.9kHz \pm 100Hz is maximum.	Dolby NR C is on.

■ **AUTO-SEARCH OPERATION CONFIRMATION**

● **Conditions**

Test tape MTT-250B
 Tape Selector CrO₂
 Dolby NR off

1. Wind the test tape to its end and reset the counter to "000".
2. Press the REW key to rewind the tape until the counter indicates around "950".
3. Check for the following operation by pressing the F.FWD key and the PLAY key simultaneously.

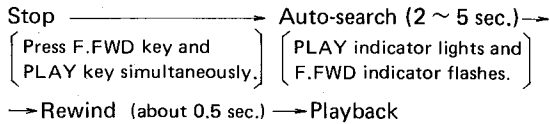

4. Repeat the same check as in step 3 a few times by pressing the F.FWD key and the PLAY key simultaneously.

5. With the test tape rewound fully, reset the counter to "000".
6. Wind the tape on quickly until the counter indicates around "005" by pressing the F.FWD key.
7. Check for the following operation by pressing the REW. key and the PLAY key simultaneously.

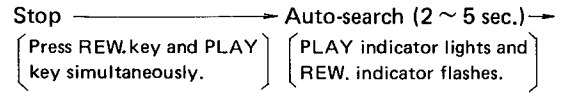

→ Rewind (about 0.5 sec.) → Playback

8. Repeat the same check as in step 7 a few times by pressing the REW. key and the PLAY key simultaneously.

■ **LED DISPLAY LIGHTING LEVEL CONFIRMATION**

● **Conditions (unless otherwise noted)**

Output Level Center
 Mic. Level Off
 Bias Fine Trim Center
 Dolby NR Off
 MPX Filter Off
 Connect a 10kΩ load resistors to LINE OUTPUT.

● **Test tape** MTT-150

● **Reference tapes**

LN XL-1
 CrO₂ AC-512
 Metal AC-711

1. Dolby NR light level confirmation

Play back the test tape (MTT-150) and confirm that the LED display lights to 0VU with the tape selector at both the LN position and the CrO₂ position. If the display does not operate as described above, make a readjustment by repeating steps 3 and 18 of Electrical Adjustment.

2. REC. CAL. TONE and BIAS TONE light level confirmation

1) With the tape selector at the CrO₂ position, set the unit in the REC-PAUSE state. Then confirm that the LED display lights to 0VU when the REC CAL button is pressed.

If the display does not operate as described above, make a readjustment by repeating step 19 of Electrical Adjustment.

2) Check to ensure that the LED display lights to 0VU when the BIAS TONE button is pressed.

If the display does not operate as described above, make a readjustment by repeating step 20 of Electrical Adjustment.

3) With the tape selector at the LN and then the Metal position, check to ensure that the LED display reading does not change when the buttons are pressed as in steps 1) and 2).

3. Playback level and playback frequency response confirmation of REC. CAL. TONE and BIAS TONE

- 1) With the tape selector set at the LN position, record the REC. CAL. TONE by pressing the REC. CAL. button and play it back. During playback, check to ensure that one of -1VU, 0VU and +1VU on the Lch of the LED display lights. If the display does not operate as described above, make a readjustment by repeating step 14 of Electrical Adjustment.

Repeat the same check with the tape selector set to the CrO₂ position and then the Metal position. The level difference with the Rch must be within 1VU.

- 2) As in step 1), record the BIAS TONE by pressing the BIAS TONE button and play it back. During playback, keep the BIAS TONE button depressed and check to ensure that one of -1VU, 0VU and +1VU on the Lch of the LED display lights. If the display does not operate as described above, make a readjustment by repeating steps 13 and 14 of Electrical Adjustment. The level difference with the Rch must be within 1VU.

4. Recording/playback frequency response correction confirmation by means of BIAS FINE TRIM

- 1) With the 2ch VTVM connected to the LINE OUTPUT terminals and the tape selector set to the CrO₂ position, record the BIAS TONE by pressing the BIAS TONE button and play it back. Note the output level of Lch and Rch when playing back and suppose it as 0dB.
- 2) With the 2ch VTVM connected to the LINE OUTPUT terminals and the tape selector set to the CrO₂ position, record the BIAS TONE by pressing the BIAS TONE button and play it back. Turn the BIAS FINE TRIM all the way to the BOOST side and confirm that the output level changes more than +2dB. Then turn it all the way to the CUT side and confirm that the output level changes less than -2dB.
- 3) Repeat the same confirmation procedure as in steps 1) and 2) with the tape selector set to the LN position and the Metal position respectively. The amount of the output level change should be more than +2dB on the BOOST side and less than -2dB on the CUT side.

5. MEMORY, AUTO REWIND, AUTO REPLAY operation confirmation

- 1) With the AUTO REWIND and AUTO REPLAY switches in the OFF state, load the tape and wind it up to the end by pressing the F.FWD key. Then confirm that the AUTO STOP operation. The unit must stop automatically about 2 seconds after the tape was wound fully and the reel stopped.
- 2) With the AUTO REWIND switch ON, rewind the tape (for any length) by pressing the REW. key and then play it back to the end. Then confirm that the AUTO STOP operates about 2 seconds after the tape was fully wound up and the reel stopped and at the same time the REWIND operates automatically.
- 3) With the MEMORY switch ON, wind the tape approximately half way, press the RESET button to make the counter indication "000" and wind the tape quickly by pressing the F.FWD key (for any length). Then press the REW. key to rewind the tape and confirm that the tape automatically stops somewhere between "000" and "999" on the counter.
- 4) With the AUTO REPLAY switch ON, press the F.FWD key to wind the tape quickly (for any length). Then press the REW. key to rewind the tape and confirm that the tape stops automatically somewhere between "000" and "999" on the counter and at the same time the REPLAY operates.
- 5) Furthermore, press the REW. key to rewind to the end of the tape and confirm that about 2 seconds after the tape was fully rewound and the tape stopped, the AUTO STOP operates and at the same time the REPLAY operates.

CASSETTE MECHANISM ADJUSTMENT AND CONFIRMATION

1. Pinch roller contact timing

- 1) Run the capstans by placing the POWER switch in the ON position.
- 2) Lift the head base slowly until the take-up pinch roller starts rotating. Then confirm that there is a clearance of 0.05 ~ 0.5mm between the supply pinch roller and the capstan.

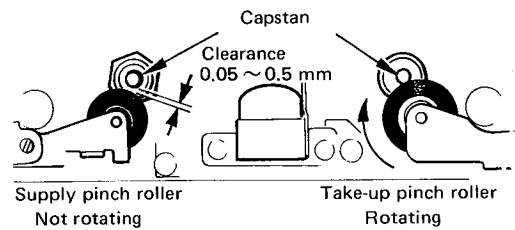

Fig. 1

- 3) If the pinch roller contact timing is simultaneous or reverse, advance the pinch roller contact timing of the take-up pinch roller by bending the A section in the below Fig. 2 in the arrow direction or replace the supply pinch roller assembly.

Note: If the contact timing has been adjusted by bending the A section of the head base, be sure to confirm after the adjustment that the capstan and the take-up pinch roller are not in contact while the deck is in the PAUSE mode.

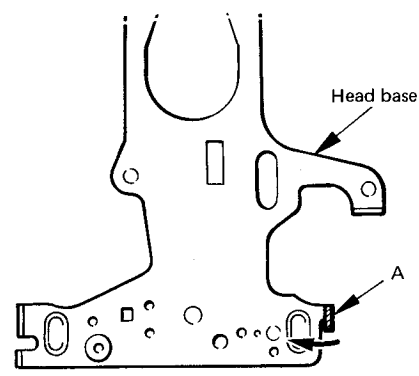

Fig. 2

2. Pinch roller parallelism confirmation

- 1) Push up the head base until right before the capstan and pinch roller contact and visually confirm for parallelism of each capstan and the pinch roller.

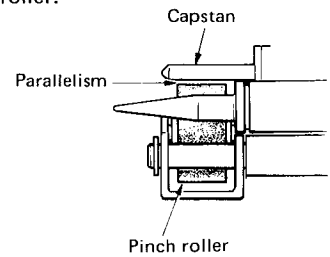

Fig. 3

- 2) If out of parallelism, check the pinch arm spindle for bend and if not bent, replace the pinch roller assembly.

3. Specification confirmation

- Check for the following specifications.
- 1) Back tension 6gcm (4.5 ~ 8gcm)
 - 2) Pinch roller pressure Tape-up 360g ± 40g
Supply 260g ± 40g

4. Head height adjustment

- 1) Install the M-300 head gauge plate.
- 2) With the unit in the PLAY state, apply the adjustment chip to the head gauge plate and make an adjustment with the adjusting screws A and B in the below Fig. 4 so that the chip doesn't contact the tape guide.

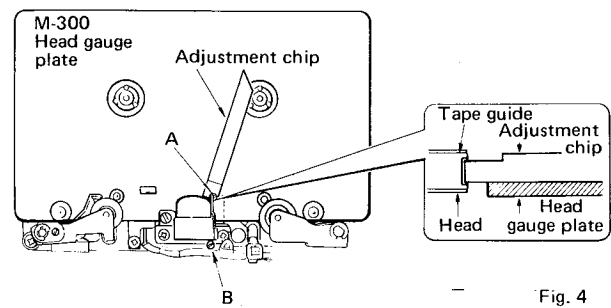

Fig. 4

5. Head penetration adjustment

- 1) Install the M-300 head gauge plate.
- 2) Apply the adjustment chip to the head and check for the chip to head clearance. If there is a clearance, make an adjustment with the adjusting screw C so that no clearance remains.

Note:

1. There should be no clearance at record/playback head.
2. If there is a clearance at record/playback head, adjust so that the clearance will be at the lower side as shown in the Fig. 5.
3. After the flapping adjustment, re-check the head height.

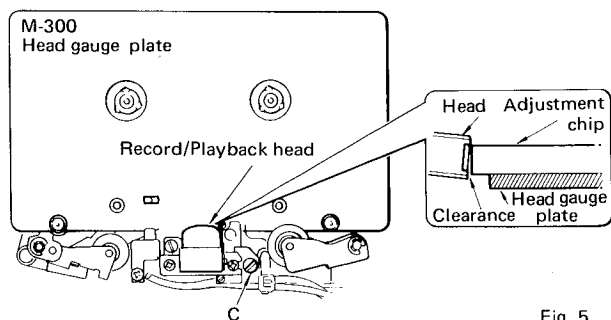

Fig. 5

6. Supply pinch roller height adjustment

- 1) Install the M-300 head gauge plate.
- 2) Set the unit in the PLAY state. With the adjustment chip applied to the tape guide of the supply pinch roller, check the tape guide to chip clearance. Make an adjustment with the adjusting screw D in the below Fig. 6 so that the upper and lower clearances become equal.
- 3) After the adjustment, repeat STOP-PLAY and re-check the height.

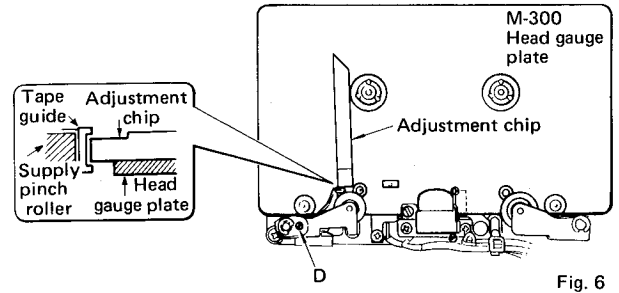

Fig. 6

7. Erase head flapping confirmation

As in step 5, visually check the erase head flapping. If the clearance is large, make an adjustment by inserting a spacer or replace the erase head.

8. Azimuth adjustment

When the maximum level point of R channel does not equal that of L channel, connect the oscilloscope as shown in Fig. 7 and proceed with azimuth adjustment so that L and R channels are in phase.

- a) Connect L channel tape out to "X(or V)" and R channel to "Y(or H)". Observe the lissajous waveform.
- b) Set L and R channels to monaural. Adjust vertical and horizontal gain so that the waveform becomes 45 degree.
- c) Adjust azimuth so that the measurement of "a" becomes maximum and the measurement of "b" becomes minimum against 45 degree line.

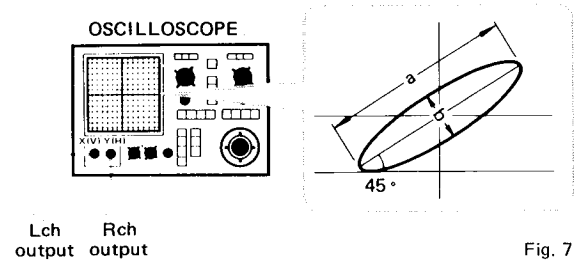

Fig. 7

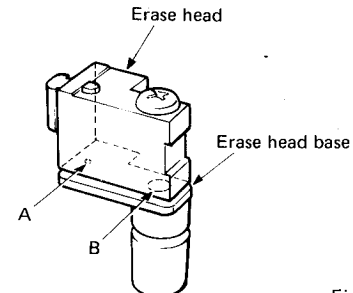

Fig. 8

9. Tape pass confirmation

- 1) With the mirror cassette (MC-109C without pad) in the PLAY state, check the tape for snaking or curling at the side.
- 2) Confirm by repeating PLAY-STOP more than twice.

- Contact or curling at the tape guide
Curling must be corrected but contact is acceptable.

- Watch carefully between the tape guide of the pinch roller and the erase head as flapping tends to occur there.

- If flapping exists, perform checking as described in the following 3) and on.

- 3) When the tape transport is unstable;
 - a. Re-adjust the supply pinch roller height as in step 6. Then perform the azimuth adjustment as in step 10 and check the tape transit. If the tape transit is satisfactory, check to ensure that the erase head height is proper.
 - b. If the pinch roller height adjustment can not correct the unstable tape transport, check each part for parallelism.

- ① Check the capstan spindle for tilt. If it has a tilt, try tilting the record/playback head in the same direction.

- ② If the tape flapping exists right before the erase head, eliminate it by tilting the erase head with a spacer inserted A or B between the erase head and erase head base as shown in the Fig. 8.

- ③ Check for parallelism of the tape guide of the supply pinch roller and the capstan. If they are not parallel, replace the supply pinch roller assembly.

- ④ Check for parallelism of the take-up pinch roller and the capstan. If they are not parallel, replace the take-up pinch roller assembly.

Note: Make sure to perform the azimuth adjustment after each adjustment and then check the head height and flapping.

■ CASSETTE MECHANISM ADJUSTMENT AND CONFIRMATION

1. Pinch roller contact timing

- 1) Run the capstans by placing the POWER switch in the ON position.
- 2) Lift the head base slowly until the take-up pinch roller starts rotating. Then confirm that there is a clearance of 0.05 ~ 0.5mm between the supply pinch roller and the capstan.

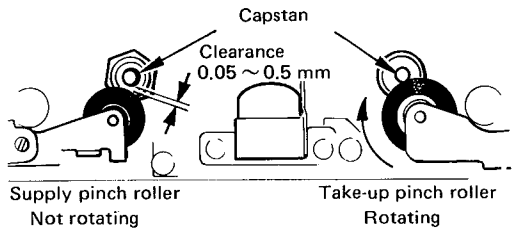

Fig. 1

- 3) If the pinch roller contact timing is simultaneous or reverse, advance the pinch roller contact timing of the take-up pinch roller by bending the A section in the below Fig. 2 in the arrow direction or replace the supply pinch roller assembly.

Note: If the contact timing has been adjusted by bending the A section of the head base, be sure to confirm after the adjustment that the capstan and the take-up pinch roller are not in contact while the deck is in the PAUSE mode.

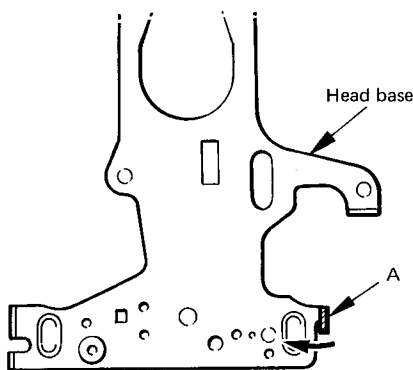

Fig. 2

2. Pinch roller parallelism confirmation

- 1) Push up the head base until right before the capstan and pinch roller contact and visually confirm for parallelism of each capstan and the pinch roller.

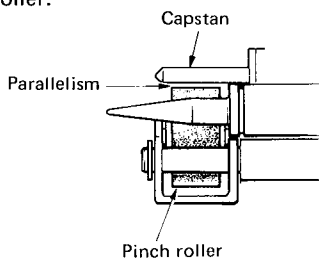

Fig. 3

- 2) If out of parallelism, check the pinch arm spindle for bend and if not bent, replace the pinch roller assembly.

3. Specification confirmation

Check for the following specifications.

- 1) Back tension 6gcm (4.5 ~ 8gcm)
- 2) Pinch roller pressure Tape-up 360g ± 40g
Supply 260g ± 40g

4. Head height adjustment

- 1) Install the M-300 head gauge plate.
- 2) With the unit in the PLAY state, apply the adjustment chip to the head gauge plate and make an adjustment with the adjusting screws A and B in the below Fig. 4 so that the chip doesn't contact the tape guide.

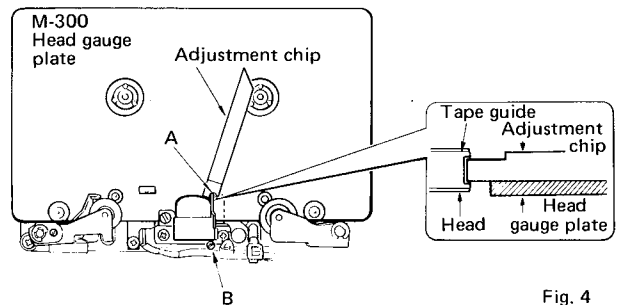

Fig. 4

5. Head penetration adjustment

- 1) Install the M-300 head gauge plate.
- 2) Apply the adjustment chip to the head and check for the chip to head clearance. If there is a clearance, make an adjustment with the adjusting screw C so that no clearance remains.

- Note:**
1. There should be no clearance at record/playback head.
 2. If there is a clearance at record/playback head, adjust so that the clearance will be at the lower side as shown in the Fig. 5.
 3. After the flapping adjustment, re-check the head height.

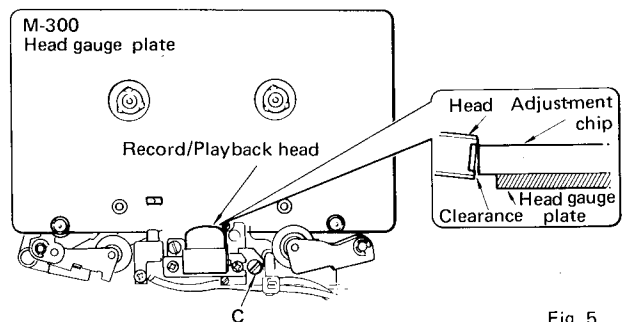

Fig. 5

6. Supply pinch roller height adjustment

- 1) Install the M-300 head gauge plate.
- 2) Set the unit in the PLAY state. With the adjustment chip applied to the tape guide of the supply pinch roller, check the tape guide to chip clearance. Make an adjustment with the adjusting screw D in the below Fig. 6 so that the upper and lower clearances become equal.
- 3) After the adjustment, repeat STOP-PLAY and re-check the height.

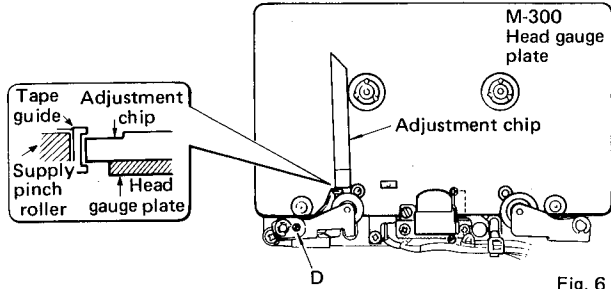

Fig. 6

7. Erase head flapping confirmation

As in step 5, visually check the erase head flapping. If the clearance is large, make an adjustment by inserting a spacer or replace the erase head.

8. Azimuth adjustment

When the maximum level point of R channel does not equal that of L channel, connect the oscilloscope as shown in Fig. 7 and proceed with azimuth adjustment so that L and R channels are in phase.

- a) Connect L channel tape out to "X(or V)" and R channel to "Y(or H)". Observe the lissajous waveform.
- b) Set L and R channels to monaural. Adjust vertical and horizontal gain so that the waveform becomes 45 degree.
- c) Adjust azimuth so that the measurement of "a" becomes maximum and the measurement of "b" becomes minimum against 45 degree line.

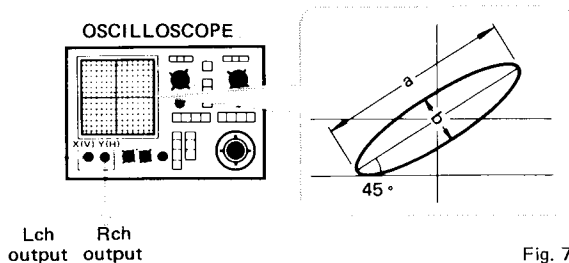

Fig. 7

9. Tape pass confirmation

- 1) With the mirror cassette (MC-109C without pad) in the PLAY state, check the tape for snaking or curling at the side.
- 2) Confirm by repeating PLAY-STOP more than twice.
 - Contact or curling at the tape guide
 - Curling must be corrected but contact is acceptable.
 - Watch carefully between the tape guide of the pinch roller and the erase head as flapping tends to occur there.
 - If flapping exists, perform checking as described in the following 3) and on.
- 3) When the tape transport is unstable;
 - a. Re-adjust the supply pinch roller height as in step 6. Then perform the azimuth adjustment as in step 10 and check the tape transit. If the tape transit is satisfactory, check to ensure that the erase head height is proper.
 - b. If the pinch roller height adjustment can not correct the unstable tape transport, check each part for parallelism.

- ① Check the capstan spindle for tilt. If it has a tilt, try tilting the record/playback head in the same direction.
- ② If the tape flapping exists right before the erase head, eliminate it by tilting the erase head with a spacer inserted A or B between the erase head and erase head base as shown in the Fig. 8.
- ③ Check for parallelism of the tape guide of the supply pinch roller and the capstan. If they are not parallel, replace the supply pinch roller assembly.
- ④ Check for parallelism of the take-up pinch roller and the capstan. If they are not parallel, replace the take-up pinch roller assembly.

Note: Make sure to perform the azimuth adjustment after each adjustment and then check the head height and flapping.

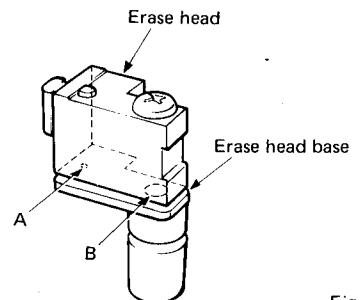

Fig. 8

9
9
ply the
and make
A and B
doesn't

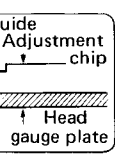

Fig. 4

and check
there is a
adjusting
at record/
/playback
ce will be
e Fig. 5.
re-check

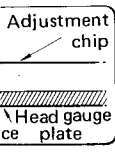
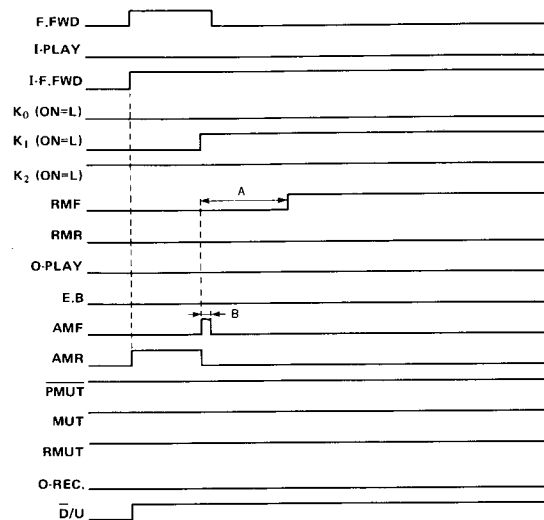

Fig. 5

TIMING CHART

A = 130 msec.
B = 30 msec.

1. STOP → F.FWD



Cautions: 1. After AMR rises, the computer performs puls check and auto stop processing at F.FWD.
2. It performs auto stop and auto playback processing.

2. STOP → REW.

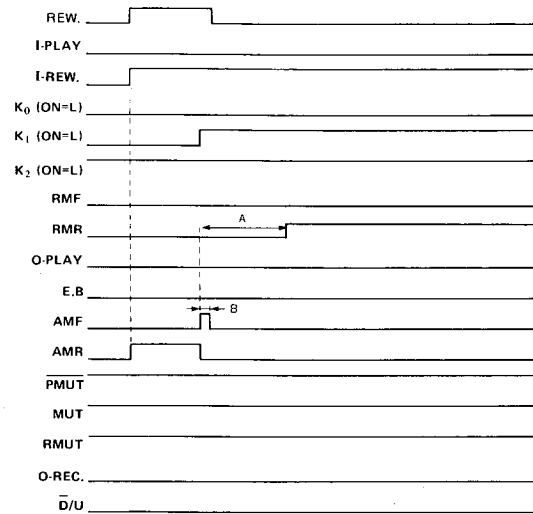

Cautions: 1. After AMR rises, the computer performs puls check and auto stop processing at REW.
2. It performs auto stop and auto playback processing.

5. STOP → RECORD & PLAYBACK

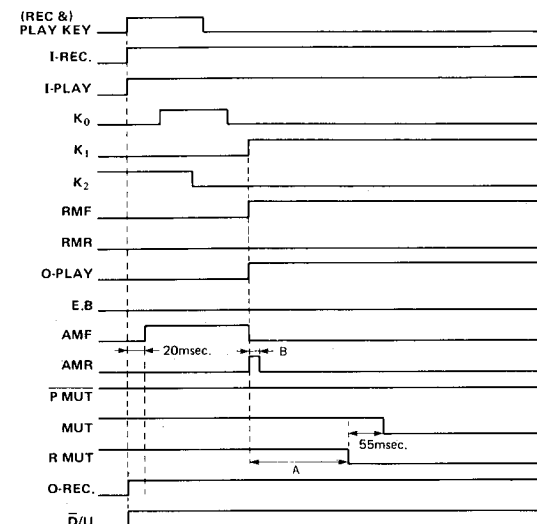

Cautions: 1. After RMF rises, the computer performs puls signal check, auto stop and auto rewind processing.
2. At timer play mode or immediately after attaching the cassette half, it performs correcting the slack of a tape.

6. STOP → RECORD-PAUSE

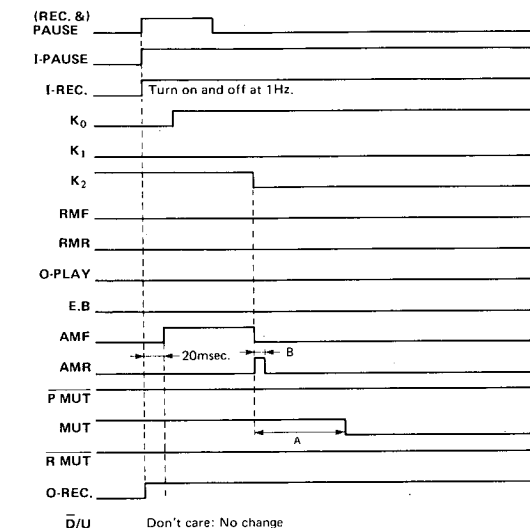

Cautions: 1. At recording pause, when play or pause key are depressed, the set switches over to recording mode.
2. Immediately after attaching a cassette half, when pause key performs correcting the slack of a tape.

3. STOP → SCAN F.FWD

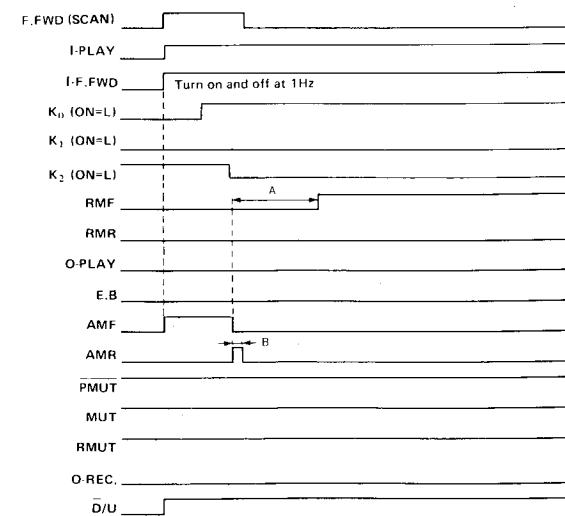

Cautions: 1. After AMR rises, the computer performs puls check and auto stop processing at F.FWD.
2. After AMR rises, if the set is in scan F.FWD, the computer checks scan signal and performs queuing processing.

4. STOP → SCAN REW.

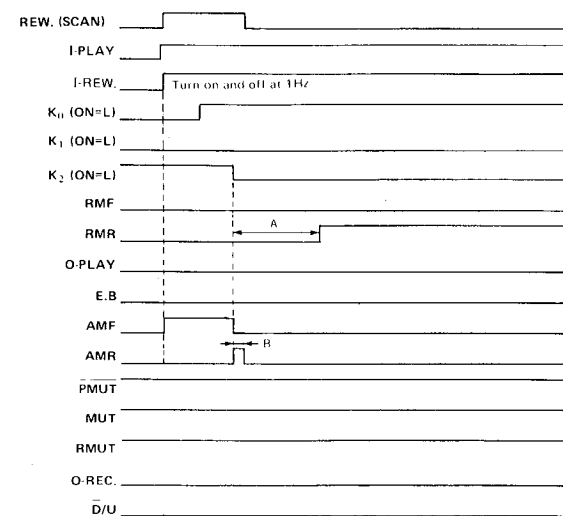

Cautions: 1. After AMR rises, the computer performs puls check and auto stop processing at F.FWD.
2. After AMR rises, if the set is in scan REW., the computer checks scan signal and performs queuing processing.

7. F.FWD → STOP

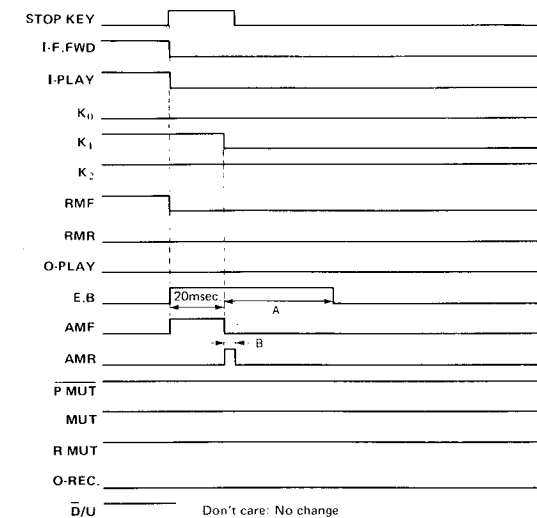

8. REW. → STOP

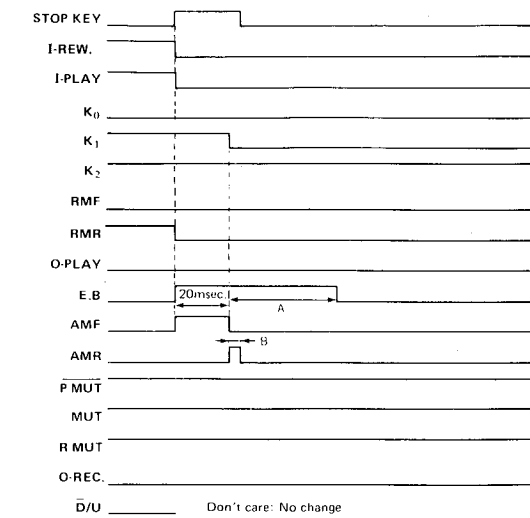

TIMING CHART

A = 130 msec.
B = 30 msec.

1. STOP → F.FWD

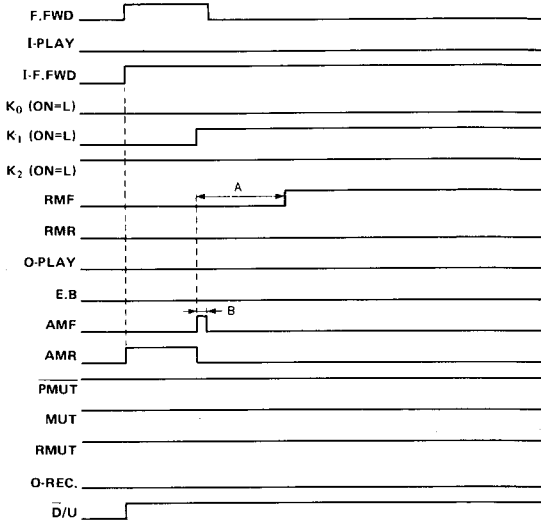

- Cautions:**
1. After AMR rises, the computer performs puls check and auto stop processing at F.FWD.
 2. It performs auto stop and auto playback processing.

2. STOP → REW.

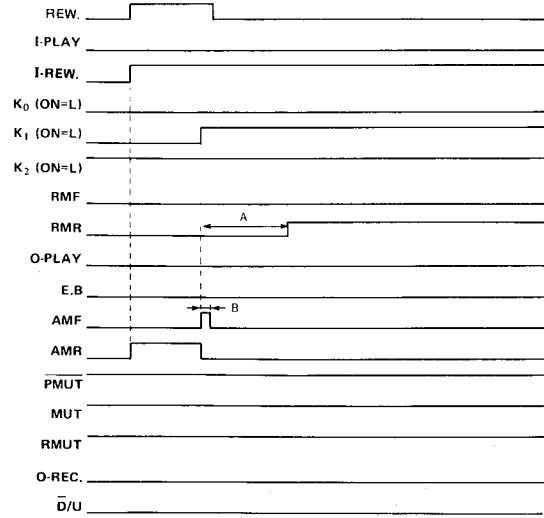

- Cautions:**
1. After AMR rises, the computer performs puls check and auto stop processing at REW.
 2. It performs auto stop and auto playback processing.

3. STOP → SCAN F.FWD

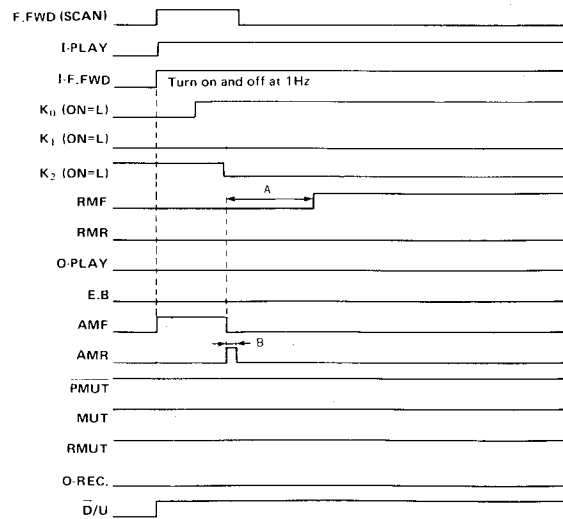

- Cautions:**
1. After AMR rises, the computer performs puls check and auto stop processing at F.FWD.
 2. After AMR rises, if the set is in scan F.FWD, the computer checks scan signal and performs queing processing.

4. STOP → SCAN REW.

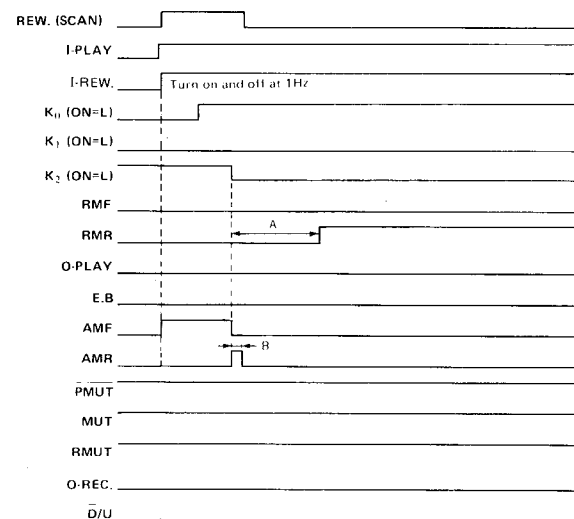

- Cautions:**
1. After AMR rises, the computer performs puls check and auto stop processing at F.FWD.
 2. After AMR rises, if the set is in scan REW, the computer checks scan signal and performs queing processing.

5. STO



Caution

7. F.F

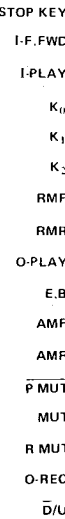

5. STOP → RECORD & PLAYBACK

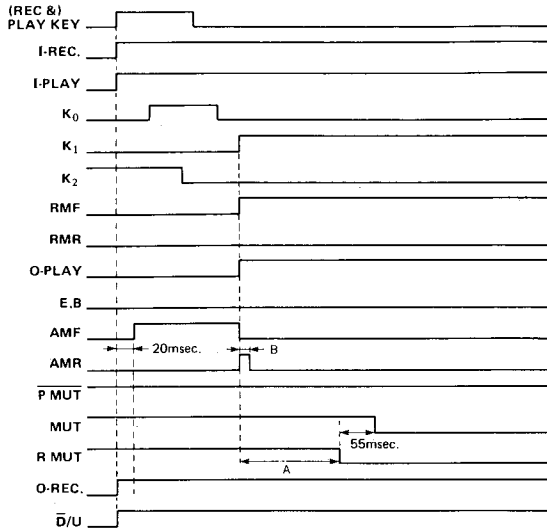

- Cautions:**
1. After RMF rises, the computer performs puls signal check, auto stop and auto rewind processing.
 2. At timer play mode or immediately after attaching the cassette half, it performs correcting the slack of a tape.

6. STOP → RECORD-PAUSE

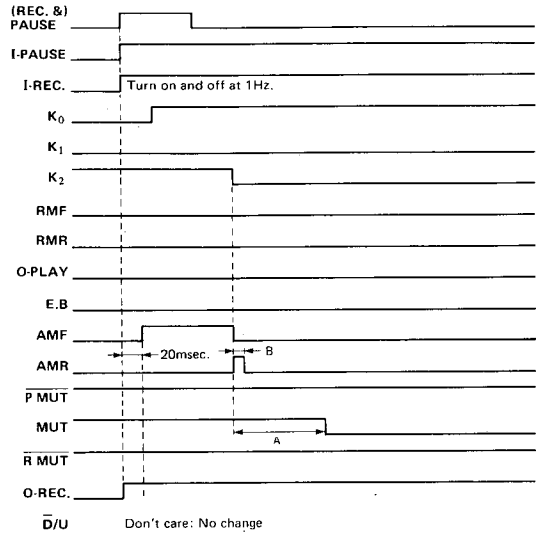

- Cautions:**
1. At recording pause, when play or pause key are depressed, the set switches over to recording mode.
 2. Immediately after attaching a cassette half, when pause key performs correcting the slack of a tape.

7. F.FWD → STOP

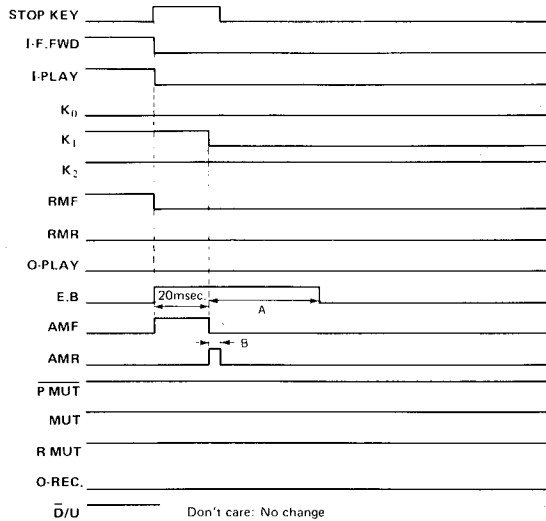

8. REW. → STOP

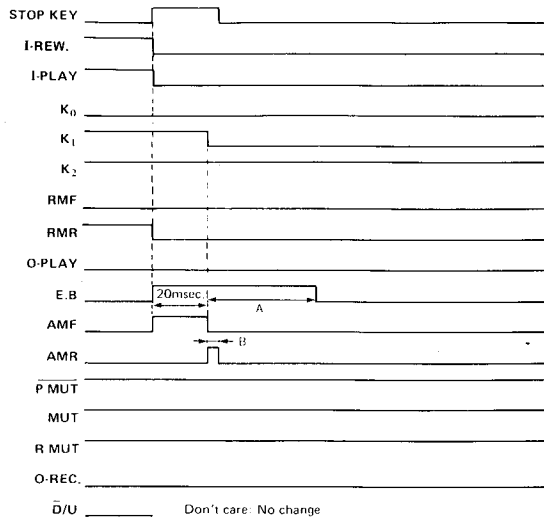

9. SCAN F.FWD → STOP

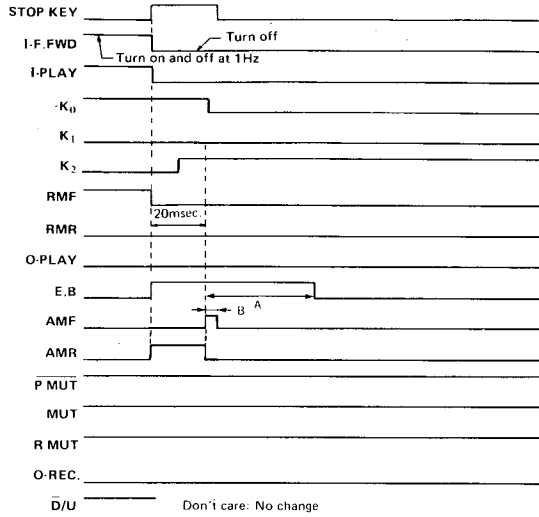

10. SCAN REW. → STOP

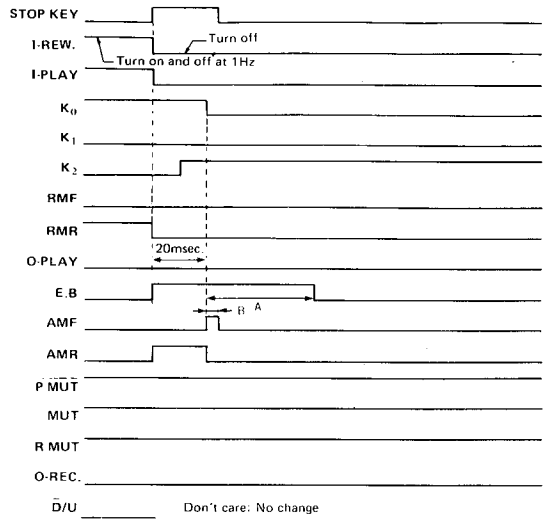

11. RECORD → STOP

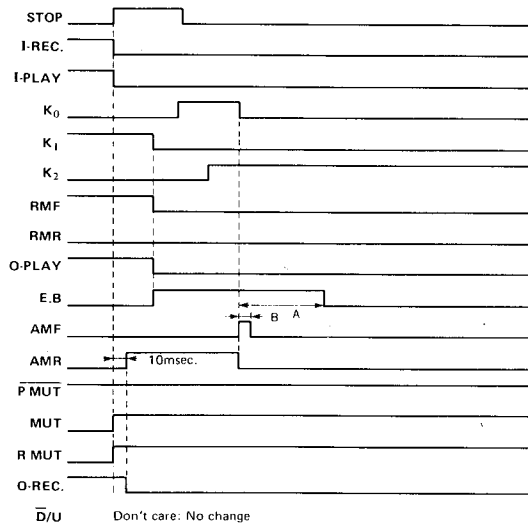

12. RECORD-PAUSE → STOP

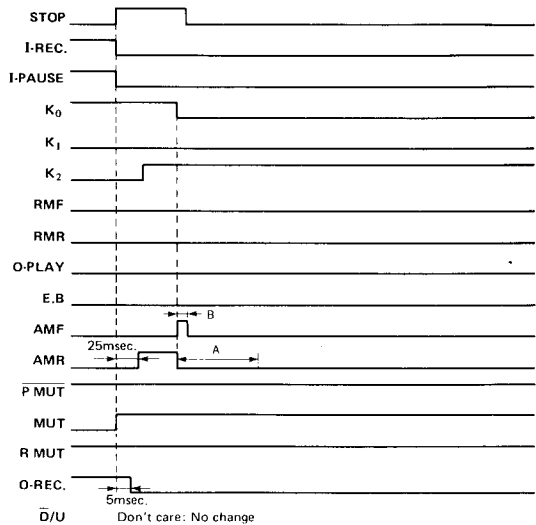

13. RECORD-PAUSE → RECORD

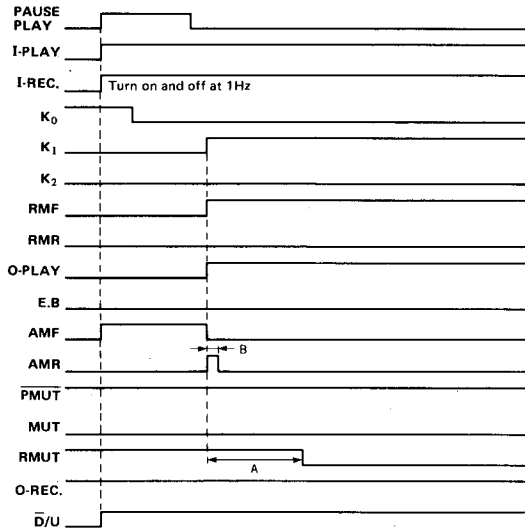

14. RECORD → RECORD-PAUSE

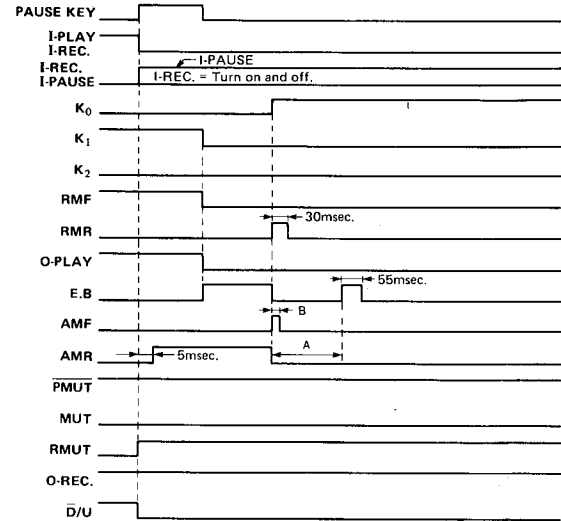

Caution: After RMF rises, the computer performs puls check, auto stop and auto rewind processing.

- All sorts of operating mode and conditions of output signals (steady states)

OUTPUT MODE	I-REW.	I-PLAY	I-F.FWD	I-REC	I-PAUSE	RMF	RMR	O-PLAY	MUT	R MUT	O-REC.	D/U
REWIND	H	L	L	L	L	L	H	L	H	H	L	L
PLAYBACK	L	H	L	L	L	H	L	H	L	H	L	H
F.FWD	L	L	H	L	L	H	L	L	H	H	L	H
STOP	L	L	L	L	L	L	L	L	H	H	L	-
PAUSE	L	L	L	L	H	L	L	L	H	H	L	-
RECORD	L	L	L	H	L	H	L	H	L	L	H	H
RECORD PAUSE	L	L	L	H/L	H	L	L	L	L	H	H	-
SCAN (F.FWD)	L	H	H/L	L	L	H	L	L	H	H	L	H
SCAN (REW.)	H/L	H	L	L	L	L	H	L	H	H	L	L
AUTO SPACE	L	H/L	L	H	L	H	L	H	L	H	H	H

H; high level output transistor on

L; low level output transistor off

H/L; on/off at 1Hz 50% duty

• When it turns on and off from L, it starts from H.

• When it turns on and off from H, it starts from L.

-; Holds the before state.

GENERAL UNIT EXPLODED VIEW

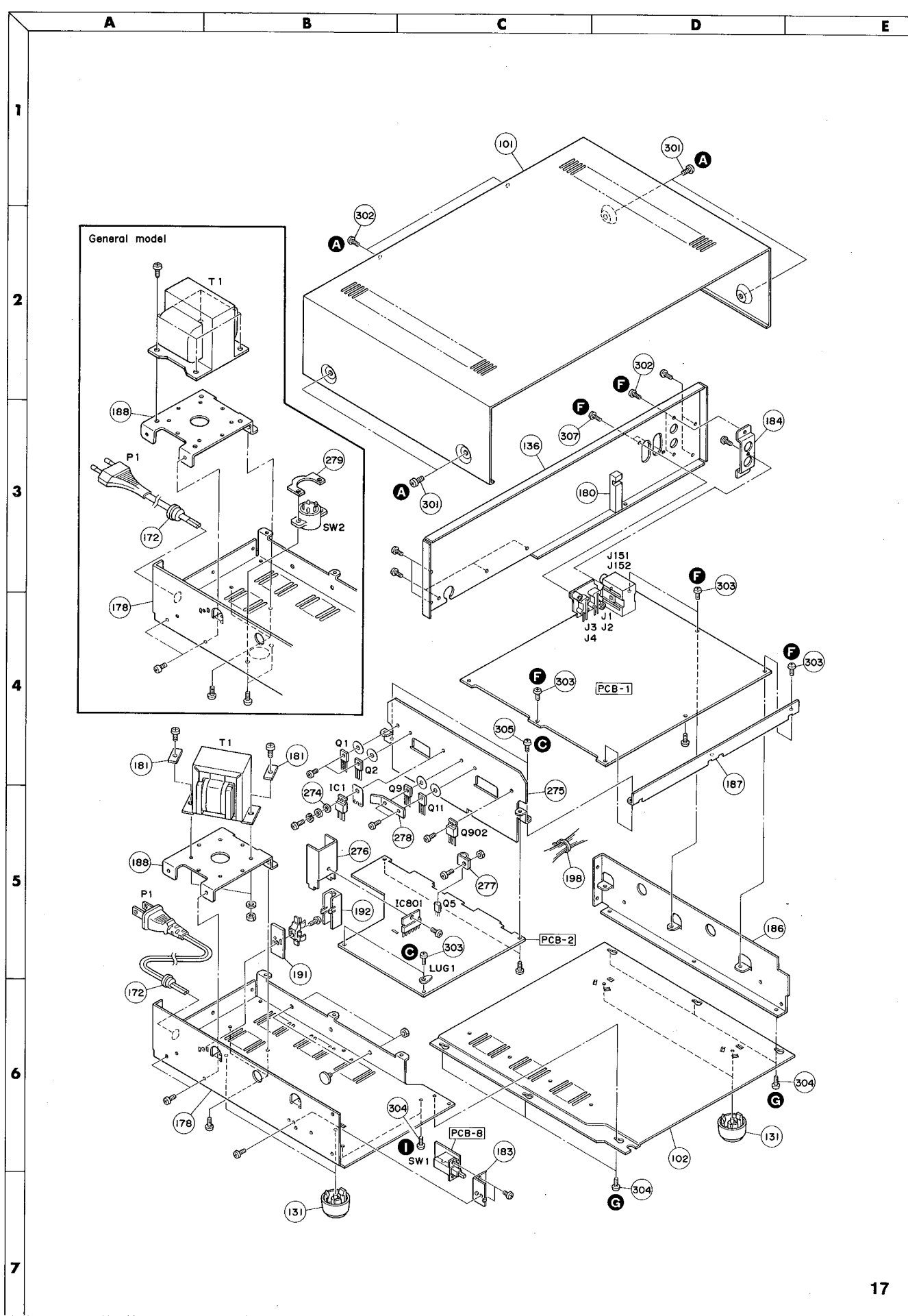

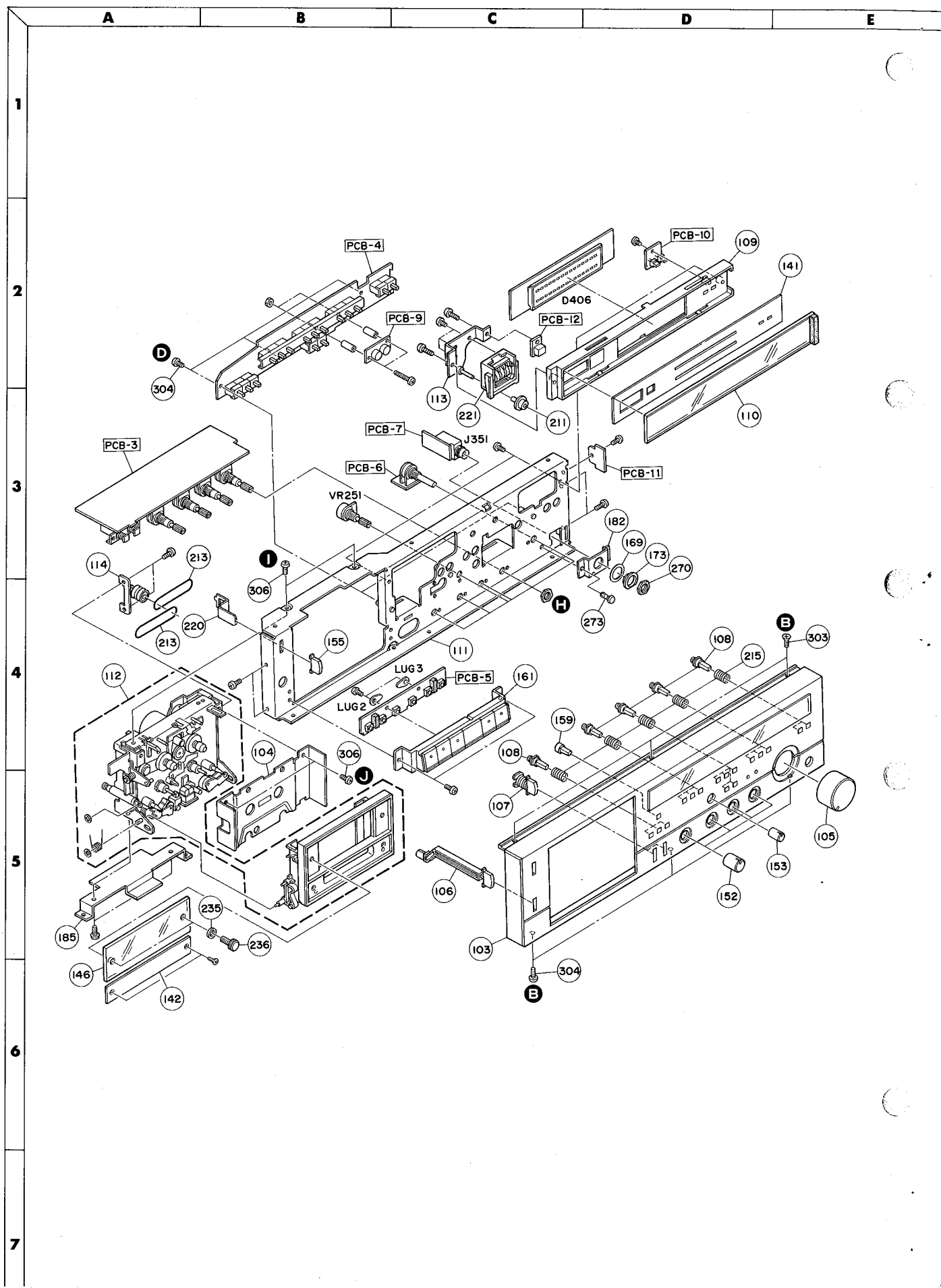

CASSETTE MECHANISM EXPLODED VIEW

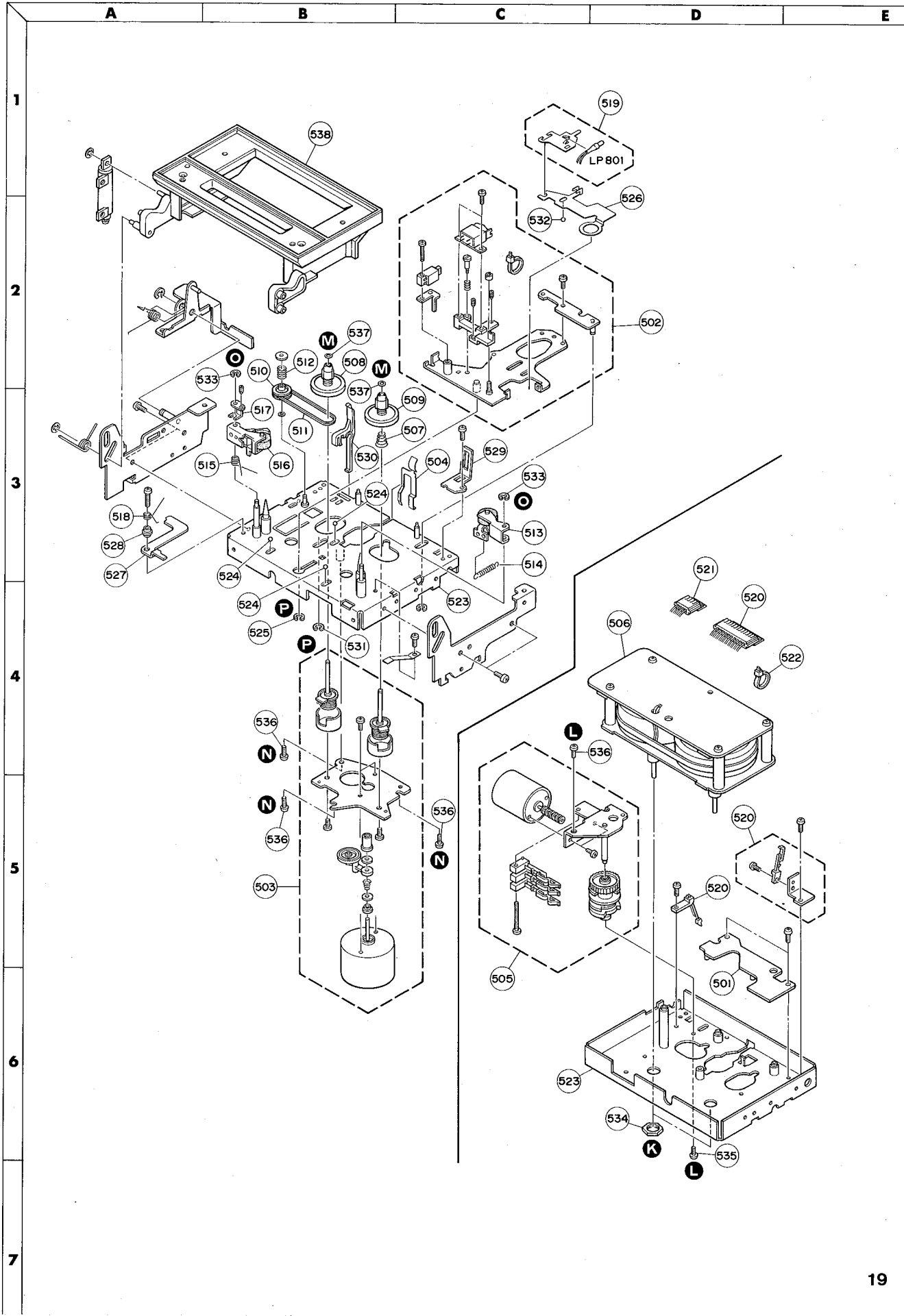

GENERAL UNIT PARTS LIST

Ref. No.	Part No.	Description
101	A414-CD391A	Cabinet Top Assembly
102	A424-CD391A	Cabinet Bottom Assembly
103	A443-CD391A	Front Panel Assembly
104	A514-CD391A	Plate Assembly
105	A630-CD391A	Knob Assembly, Master Fader
106	A662-CD391A	Push Button Assembly, Power
107	A662-CD391B	Push Button Assembly, Rec. Mute, Auto Space
108	A662-CD391C	Push Button Assembly, Memory, Auto rewind/replay, Dolby NR, NR Type, MPX Filter, Bias Equalization (METAL, CrO ₂ , LN), Bias Tone, Rec. Cal, Timer (Play, Off, Rec.), Peak Hold, Meter Weighting
109	A731-CD391A	Indicator Holder Assembly
110	A443-CD391B	Indicator Panel Assembly
111	B211-CD391A	Chassis Assembly, Front
112	C112-CD391A	Cassette Tape Recorder Mechanical Assembly
113	B219-CD391A	Bracket Assembly, Counter
114	B219-CD391B	Bracket Assembly, Counter Wheel
131	1319-0139	Foot
136	1424-09303	Cabinet Back (U.S.A. & Canada models)
"	1424-09304	Cabinet Back (General model)
141	1513-05001	Plate
142	1513-05102	Dressing Plate
146	1531-05601	Cassette Compartment Cover
152	1630-01901	Knob, Output Level, Mic. Level, Rec. Level
153	1634-02701	Knob, Bias Fine Trim
155	1662-05501VN	Push Button, Eject
159	1662-05401VN	Push Button, Reset
161	3351-015	Push Button Assembly, Cassette Mechanism Control
169	2111-1356	Felt
172	2114-415027	Bushing, P1
173	2114-72167	Bushing, Headphone
178	2211-7238	Chassis (U.S.A. & Canada models)
"	2211-7245	Chassis (General model)
180	2114-71254	Bushing
181	2219-7093	Bracket, T1 (for U.S.A. & Canada models)
182	2219-7809	Bracket, Headphone Jack
183	2219-7811	Bracket, SW1
184	2219-7909	Bracket, Microphone Jack
185	2219-7910	Bracket, Cassette Mechanism Bottom
186	2219-7911	Bracket, Right
187	2219-7924	Bracket, PCB-1 Mounting
188	2219-7937	Bracket, T1 (U.S.A. & Canada models)
"	2219-7963	Bracket, T1 (General model)
191	2224-7061	Insulator (for U.S.A. & Canada models)
192	2240-7118	Holder (for U.S.A. & Canada models)
198	2240-7120	Holder, Lead Wires
211	2603-7007	Sleeve
213	2642-01458	Belt
215	2651-2101705	Spring
220	2674-7013	Slider
221	3131-025014	Tape Counter
235	2114-01224	Bushing
236	2310-7025	Special Screw
270	2440-61	Special Nut
273	2459-3003511	Rivet
274	2114-71278	Bushing
275	2222-7147	Heat Sink
276	2222-7151	Heat Sink
277	2222-7067	Heat Sink
278	2652-00309	Leaf Spring
279	2440-7017	Special Nut (for General model)
301	2347-400647	Bind Head Tapping Screw
302	2347-300647	Bind Head Tapping Screw
303	2343-300627	Self-Tapping Screw
304	2347-300627	Bind Head Tapping Screw
306	2347-260547	Bind Head Tapping Screw
307	2347-300842	Bind Head Tapping Screw
	1111-J30145	Owner Guide (U.S.A. model)
	1111-J30146	Owner Guide (Canada & General models)
	1221-907130	Packing Box
	1222-7184	Packing Cushion (2 Used)
	4474-29	AC Adaptor (for General model)
	1192-1	Screw Driver, Rec. Cal. Tone Level ADJ.

CASSETTE MECHANISM PARTS LIST

Ref. No.	Part No.	Description
501	SIE08008-07	Rotation Sensor P.C. board
502	SIE02016-10	Head Base Assembly
503	SID05001-08	Idler Motor Assembly
504	SIE25017-01	Cassette Hold Spring
505	SIE09048-03	PAD Assembly
506	30A2NLB-51	Direct Drive Motor
507	SIE24010-03	Spindle Spring, Take-up Reel
508	SIE04006-02	Supply Reel Spindle Assembly
509	SIE04018-03	Take-up Reel Spindle Assembly
510	SIE14004-01	Pulley
511	SIE18001-07	Belt
512	SIE24034-01	Spring
513	SIE99017-02	Take-up Pinch Roller Assembly
514	SIE24017-01	Spring
515	SIE24068-02	Spring
516	SIE99018-02	Supply Pinch Roller Assembly
517	SIE12004-01	Adjustment Bracket, Supply Pinch Roller
518	SIE24007-01	Spring
519	SIE09025-01	Lamp Holder Assembly
520	SIE09129-01	Switch & Connector Assembly
521	SIE67065-01	Connector with Lead Wires, 6 Pos.
522	SIE33014-01	Holder, Lead Wires
523	SID01007-14	Chassis Assembly
524	SIE36002-01	Steel Ball
525	SIE36001-02	E-Stop Ring
526	SIE25010-01	Bracket, Head Base Hold
527	SIE21018-02	Lock Lever
528	SIE23004-01	Collar
529	SIE21015-02	Bracket, Cassette Detect Switch
530	SIE20006-01	Lever, Mis-Erase Protect Switch
531	SIE36001-01	E-Stop Ring
532	SIE36002-03	Steel Ball
533	22145	E-Stop Ring
534	SIE36014-01	Hexagon Nut
535	SEE30545-01	Pan Head Screw
536	SEE30535-01	Pan Head Screw
537	SEE10228-02	Washer
538	A614-CD391A	Cassette Compartment Slot Assembly

ELECTRICAL PARTS LIST

Ref. No.	Part No.	Description
CHASSIS MISCELLANEOUS		
P1	4161-0487	Power Cord (U.S.A. & Canada models)
"	4161-7256	Power Cord (General model)
T1	5584-703434	Power Transformer (U.S.A. & Canada models)
"	5584-702434	Power Transformer (General model)
VR251	5113-2028221	Control, 2k Ω B, Bias Fine Trim
D406	5623-LT1107	L.E.D. Display, Peak Level Meter
SW2	4411-104736	Rotary Switch, Voltage Selector (for General model)
F1	5732-402031	Fuse, 4A, 125V (for U.S.A. & Canada models)
LUG1	4211-4	Lug Terminal
LUG2, 3	4211-6	Lug Terminal
	4472-0125	Fuse Holder (for U.S.A. & Canada models)
PCB-1 MAIN P.C. BOARD		
RESISTORS		
R101, 102	5174-104381	100k Ω , \pm 1%, 1/4W, Metal
R113, 114, 117, 118	5174-822381	8.2k Ω , \pm 1%, 1/4W, Metal
R115, 116	5174-133381	13k Ω , \pm 1%, 1/4W, Metal
R273, 274	5102-8204715	82 Ω , \pm 2%, 1/4W, Fuse
R365, 366, 367, 368, 671, 672	5102-1004715	10 Ω , \pm 2%, 1/4W, Fuse
R465, 466, 761	5102-1014715	100 Ω , \pm 2%, 1/4W, Fuse
R505, 506	5174-512381	5.1k Ω , \pm 1%, 1/4W, Metal
R507, 508	5174-153381	15k Ω , \pm 1%, 1/4W, Metal
R531, 532	5174-563381	56k Ω , \pm 1%, 1/4W, Metal
R552	5102-1204715	12 Ω , \pm 2%, 1/4W, Fuse
R651, 652	5174-154381	150k Ω , \pm 1%, 1/4W, Metal
R667, 668	5102-5604713	56 Ω , \pm 2%, 1/4W, Fuse
R718	5102-4704715	47 Ω , \pm 2%, 1/4W, Fuse
CONTROLS		
VR101, 102, 256, 257	5101-20371920	20k Ω B
VR252, 253	5101-10371920	10k Ω B
VR254, 255	5101-50271920	5k Ω B
VR451, 452, 751	5101-50371920	50k Ω B
VR453	5101-50171920	500 Ω B
CAPACITORS		
C81	5352-224571	0.22 μ F, \pm 5%, 63V, Metalized Polyester
C101, 102	5353-270534	27pF, \pm 5%, 500V, Mica
C103, 104	5345-226C0226	22 μ F, \pm 20%, 16V, Electrolytic
C105, 106	5345-337A0952	330 μ F, \pm 20%, 6.3V, Electrolytic
C107, 108, 109, 110	5359-3627851	3600pF, \pm 2%, 100V, Polypropylene
C111, 112	5345-106C0226	10 μ F, \pm 20%, 16V, Electrolytic
C115, 116, 219, 220	5345-107C041	100 μ F, \pm 20%, 16V, Electrolytic
C151, 152, 155, 156, 511, 512, 539, 540	5345-106C0952	10 μ F, \pm 20%, 16V, Electrolytic
C153, 154, 251, 457, 458, 559, 667, 668	5345-476C041	47 μ F, \pm 20%, 16V, Electrolytic
C207, 208	5345-105F0951	1 μ F, \pm 20%, 50V, Electrolytic
C209, 210	5345-226C0952	22 μ F, \pm 20%, 16V, Electrolytic
C211, 212	5352-184571	0.18 μ F, \pm 5%, 63V, Metalized Polyester
C215, 216	5342-225F0951	2.2 μ F, \pm 20%, 50V, Electrolytic
C217, 218	5359-8215851	820pF, \pm 5%, 100V, Polypropylene
C223, 224, 661, 662	5359-4715851	470pF, \pm 5%, 100V, Polypropylene
C252	5342-476C0951	47 μ F, \pm 20%, 16V, Electrolytic
C351, 352, 353, 354, 551, 552	5345-226C041	22 μ F, \pm 20%, 16V, Electrolytic
C455, 456	5345-105F041	1 μ F, \pm 20%, 50V, Electrolytic
C501, 502, 555, 556, 557, 558	5345-106C0951	10 μ F, \pm 20%, 16V, Electrolytic
C503, 504	5345-107C0952	100 μ F, \pm 20%, 16V, Electrolytic
C505, 506, 561, 701	5345-477C041	470 μ F, \pm 20%, 16V, Electrolytic
C507, 508, 509, 510	5359-153771	0.015 μ F, \pm 2%, 50V, Polypropylene
C517, 518, 543, 544	5345-475D0952	4.7 μ F, \pm 20%, 25V, Electrolytic

Ref. No.	Part No.	Description
C519, 520, 521, 522, 545, 546	5345-154F0952	0.15 μ F, \pm 20%, 50V, Electrolytic
C523, 524, 525, 526, 547, 548	5345-474F0952	0.47 μ F, \pm 20%, 50V, Electrolytic
C527, 528	5345-226C0951	22 μ F, \pm 20%, 16V, Electrolytic
C535, 536	5359-3327851	3300pF, \pm 2%, 100V, Polypropylene
C537, 538	5359-3927851	3900pF, \pm 2%, 100V, Polypropylene
C553, 554	5345-228C0962	2200 μ F, \pm 20%, 16V, Electrolytic
C651, 652	5359-2715851	270pF, \pm 5%, 100V, Polypropylene
C665, 666	5353-101534	100pF, \pm 5%, 500V, Mica
C756	5345-L224M50	0.22 μ F, \pm 20%, 50V, Electrolytic
C757, 758, 759	5345-476-16	47 μ F, +50% -10%, 16V, Electrolytic
INTEGRATED CIRCUITS		
IC151, 451, 653, 751	5652-M5218P	M5218P
IC201	5652-M5220P	M5220P
IC501, 502	5652-HA12038	HA12038
IC651, 652	5652-HA17082P	HA17082PS
IC752	5652-BA335	BA335
TRANSISTORS		
Q83, 84, 109, 110, 201, 202, 203, 204, 205, 206, 251, 252, 253, 254, 455, 456, 457, 701, 702, 703, 704, 709	5613-2603(F)	2SC2603(F) or 2SC2603(E)
Q101, 102	5613-2855(E)	2SC2855(E) or 2SC2855(D)
Q103, 104	5611-1190(E)	2SA1190(E) or 2SA1190(D)
Q105, 106	5613-2320L(F)	2SC2320L(F)
Q107, 108	5611-999L(F)	2SA999L(F)
Q111, 255, 355, 356, 501	5611-966(Y)	2SA966(Y)
Q112, 357, 358, 502	5613-2236(Y)	2SC2236(Y)
Q351, 352	5613-2603(F)	2SC2603(F)
Q353, 354	5611-1115(F)	2SA1115(F)
Q451, 452, 453, 454	5616-245(GR)	F.E.T., 2SK246(GR)
Q458, 459	5613-945L(K)	2SC945L(K) or 2SC945L(P)
Q651, 652	5613-3246(H)	2SC3246(H)
Q705, 706, 707, 708	5613-1845(E)	2SC1845(E)
Q710, 711	5611-970(BL)	2SA970(BL)
DIODES		
D81, 252, 254, 455, 456, 457, 651, 652, 653, 654, 701, 702, 703, 704, 705, 706	5631-1S2473	1S2473
D101, 102, 502, 503	5635-HZ11B2L	Zener, HZ11B2L
D103, 104	5641-KB265	Varistor, KB265
D207, 208, 252, 253	5636-MC921	MC921
D451, 452, 453, 454	5635-RD5R1EB2	Zener, RD5.1EB2
D501	5635-RD5R6JB2	Zener, RD5.6JB2
D761	5635-RD11JB2	Zener, RD11JB2
COILS		
L101, 102	5995-363156	
L201, 202	5932-70223	3.3mH
L203, 204	5932-70116	
L205, 206, 501, 502	5932-70115	
L561, 562	5932-70215	
L651, 652	5933-70223	
L751	5597-35502	Ferrite Bead
MISCELLANEOUS		
OS101	6171-0103	Complex, Record Bias Osc.
J1/2/3/4	4484-24	4-Pin Jack, Line Input, Line Output
J151/152	4452-0110	Jack, Microphones
P201	4443-040185	Connector, 4 Pos.
P202, 251	4443-030185	Connector, 3 Pos.

Ref. No.	Part No.	Description
P451	4443-090185	Connector, 9 Pos.
P301, 452, 501, 502, 503, 504	4443-037114	Connector, 3 Pos.
J808	4163-071002 2132-5049	Connector with Lead Wire, 7 Pos. Spacer, D502
PCB-2 LOGIC CONTROL P.C. BOARD		
RESISTORS		
R26	5102-4R74713	4.7Ω, ±2%, 1/4W, Fuse
CAPACITORS		
C3	5345-478D0962	4700μF, ±20%, 25V, Electrolytic
C4	5345-228D041	2200μF, ±20%, 25V, Electrolytic
C5, 6, 11, 13, 51	5345-477C041	470μF, ±20%, 16V, Electrolytic
C7	5341-109D0958	10000μF, ±20%, 25V, Electrolytic
C8, 9	5352-684571	0.68μF, ±5%, 63V, Metalized Polyester
C14	5345-107C041	100μF, ±20%, 16V, Electrolytic
C18, 52	5345-475D041	4.7μF, ±20%, 25V, Electrolytic
C53	5345-476D041	47μF, ±20%, 25V, Electrolytic
C54	5345-106D041	10μF, ±20%, 25V, Electrolytic
C802	5342-475D0951	4.7μF, ±20%, 25V, Electrolytic
C803, 804	5342-476C0951	47μF, ±20%, 16V, Electrolytic
C863	5345-226C0951	22μF, ±20%, 16V, Electrolytic
INTEGRATED CIRCUITS		
IC1	5653-T78012AP	TA78012AP
IC801	5653-BA6109	BA6109
IC851	5654-58846-41	M58846-641SP
IC852	5654-TD62503P	TD62503P
TRANSISTORS		
Q1, 9	5611-1217(Y)	2SA1217(Y)
Q2, 11	5613-2877(Y)	2SC2877(Y)
Q3	5616-2SK381(D)	F.E.T., 2SK381(D)
Q4, 10, 807, 851, 852, 853, 854, 855, 856	5611-1115(F)	2SA1115(F) or 2SA1115(E)
Q5, 801, 802, 803, 808, 809	5613-3246(H)	2SC3246(H)
Q6, 812, 813	5611-1286(H)	2SA1286(H)
Q7, 8, 12, 13, 804, 805, 806, 810, 811, 857	5613-2603(F)	2SC2603(F) or 2SC2603(E)
Q51, 91, 94	5611-1115(E)	2SA1115(E) or 2SA1115(F)
Q52, 92, 93	5613-2603(E)	2SC2603(E) or 2SC2603(F)
DIODES		
D1, 2	5632-SIB01-02	1SR35-10 or S1B01-02
D3	5685-1F	Bridge Silicon, S1RBA
D4, 5	5635-RD9R1JB2	Zener RD9.1JB2
D6	5635-RD8R2JB1	Zener, RD8.2JB1
D8, 9	5641-KB265	Varistor, KB265 or MV-12
D10	5635-RD12JB1	Zener, RD12JB1
D11, 51, 55, 56, 57, 58, 59, 91, 92, 93, 95, 96, 97, 98, 801, 802, 805, 806, 808, 809, 810, 856, 859, 860, 861, 862, 863, 864, 865, 866, 873	5631-1S2473	1S2473
D52	5635-RD13EB2	Zener, RD13EB2
D53, 54	5631-1S2471	1S2471
D803	5635-RD8R2JB3	Zener, RD8.2JB3
D804	5635-RD6R2JB2	Zener, RD6.2JB2
D807	5635-RD4R7JB2	Zener, RD4.7JB2
COIL		
L851	5597-35502	Ferrite Bead

Ref. No.	Part No.	Description
MISCELLANEOUS		
X851	5693-CSB457	Crystal, Osc.
F2, 3	5732-402031	Fuse, 4A, 125V (U.S.A. & Canada models)
"	5732-40202	Fuse, 4A, 250V (General model)
P801	4443-067114	Connector, 6 Pos.
P802	4443-107114	Connector, 10 Pos.
P803	4443-097114	Connector, 9 Pos.
P804	4443-080185	Connector, 8 Pos.
P805	4443-050185	Connector, 6 Pos.
P806	4443-060185	Connector, 6 Pos.
P807	4443-034116	Connector, 3 Pos.
P808	4443-074116	Connector, 7 Pos.
	4472-414	Fuse Holder (x4)
	2132-7048	Spacer, R13, 810, 811, 832, 835, D1, 2, 6
	2132-7049	Spacer, R20, 836, 837
	2132-5049	Spacer, R833, 834
PCB-3 VR P.C. BOARD		
RESISTORS		
R191, 192	5102-1814715	180 Ω , \pm 2%, 1/4W, Fuse
R428	5173-270571	27 Ω , \pm 5%, 2W, Metal
CONTROLS		
VR151/152	5113-50272140	5k Ω A, Mic. Level
VR161, 162	5113-2038321	20k Ω A, Rec Level Left/Right
VR301/302	5113-50271150	5k Ω A, Output Level
VR401, 402	5101-20371920	20k Ω B
CAPACITORS		
C161, 162	5345-106C0952	10 μ F, \pm 20%, 16V, Electrolytic
C163, 164	5359-2215851	220pF, \pm 5%, 100V, Polypropylene
C165, 166	5345-106C0951	10 μ F, \pm 20%, 16V, Electrolytic
C167, 168	5359-1015851	100pF, \pm 5%, 100V, Polypropylene
C169, 170	5345-226C0951	22 μ F, \pm 20%, 16V, Electrolytic
C171, 172	5359-1025851	1000pF, \pm 5%, 100V, Polypropylene
C177, 178	5345-476C041	47 μ F, \pm 20%, 16V, Electrolytic
C403, 404	5345-475D041	4.7 μ F, \pm 20%, 25V, Electrolytic
C405, 406	5345-335F041	3.3 μ F, \pm 20%, 50V, Electrolytic
C411, 412	5345-226C041	22 μ F, \pm 20%, 16V, Electrolytic
C413, 414	5345-476C041	47 μ F, \pm 20%, 16V, Electrolytic
C415	5345-227C041	220 μ F, \pm 20%, 16V, Electrolytic
INTEGRATED CIRCUIT		
IC401	5652-M5218P	M5218P
TRANSISTORS		
Q81, 82	5613-945L(K)	2SC945L(K) or 2SC945L(P)
Q161, 162, 165, 166	5613-2320L(F)	2SC2320L(F)
Q163, 164	5611-999L(F)	2SA999L(F)
Q167, 168, 169, 170, 401, 402, 403, 404, 405, 406	5613-2603(F)	2SC2603(F)
Q407	5613-2236(Y)	2SC2236(Y)
DIODES		
D161, 162	5635-RD10JB2	Zener, RD10JB2
D401, 402, 403, 404	5631-1K34A	1K34A
D405	5635-RD7R5JB2	Zener, RD7.5JB2
MISCELLANEOUS		
LC161, 162	5214-51	LC Components
SW301/302	4431-02047364	Push Switch, Rec. Mute, Auto Space
P401	4443-070185	Connector, 7 Pos.
J402	4163-072002	Connector with Lead Wire, 7 Pos.
J501	4163-70296	Connector with Lead Wire, 3 Pos.
J502	4163-70696	Connector with Lead Wire, 3 Pos.
J503	4163-70396	Connector with Lead Wire, 3 Pos.
J504	4163-70796	Connector with Lead Wire, 3 Pos.
	2132-5049	Spacer, R425, 428

Ref. No.	Part No.	Description
PCB-4 PUSH SWITCHES P.C. BOARD		
DIODES		
D201, 202, 203, 204, 205, 206, 411, 867, 868, 869, 870, 871	5631-1S2473	1S2473
MISCELLANEOUS		
SW201, 202, 203, 401, 402, 403, 801, 802, 803	4431-0918716	Push Switch, Bias/Equalization, Dolby NR/Type, MPX Filter, Timer
SW204, 205, 901, 902, 903	4431-A027136	Push Switch, Peak Hold, Meter Weighting, Memory, Auto Rewind/Replay
SW404, 405	4431-A027236	Push Switch, Bias Tone, Rec Cal
P601	4443-0241116	Connector, 2 Pos.
J803	4163-094502	Connector with Lead Wire, 9 Pos.
J601	4163-022003	Connector with Lead Wire, 2 Pos.
PCB-5 KEY SWITCHES P.C. BOARD		
DIODES		
D851	5637-SY406TK	L.E.D., SY406TK, Yellow, Pause
D852	5637-TLR122	L.E.D., TLR122, Red, Record
D853, 854, 855	5637-TLG121	L.E.D., TLG121, Green, F.FWD, Play, Rew.
D857, 858	5631-1S2473	1S2473
MISCELLANEOUS		
SW101, 102, 103, 104, 105, 106	4431-A017140	Push Switch, Rew., Play, F.FWD, Stop, Record, Pause
PCB-6 MASTER FADER P.C. BOARD		
VR163/164	5113-10371141	Control, 10k Ω A, Master Fader
J452	4163-70496	Connector with Lead Wire, 3 Pos.
PCB-7 HEADPHONES JACK P.C. BOARD		
J351	4451-00141	Jack, Headphones
J301	4163-70596	Connector with Lead Wire, 3 Pos.
PCB-8 POWER SWITCH P.C. BOARD		
C1	5361-1030419	Capacitor, 0.01 μ F, +100% -0%, AC125V, Ceramic (U.S.A. & Canada models)
"	5352-1030958	Capacitor, 0.01 μ F, \pm 20%, AC250V, Metalized Polyester (General model)
SW1	4431-A01056	Push Switch, Power
PCB-9 REC. CAL P.C. BOARD		
VR201, 202	5101-2228074	Control, 2.2k Ω , Rec. Cal Left/Right
PCB-10 DOLBY NR INDICATORS P.C. BOARD		
D407	5637-GL9PG19	L.E.D., GL9PG19, Green, Dolby B
D408	5637-GL9HY9	L.E.D., GL9HY9, Yellow, Dolby C
PCB-11 LAMP P.C. BOARD		
LP802	5731-0807445	Lamp, Illumination
PCB-12 WAIT INDICATOR P.C. BOARD		
D905	5637-LT9002D	L.E.D., LT9002D, Red, Wait
J807	4163-032503	Connector with Lead Wire, 3 Pos.

IC FUNCTIONAL BLOCK DIAGRAM

TA78012AP: IC1

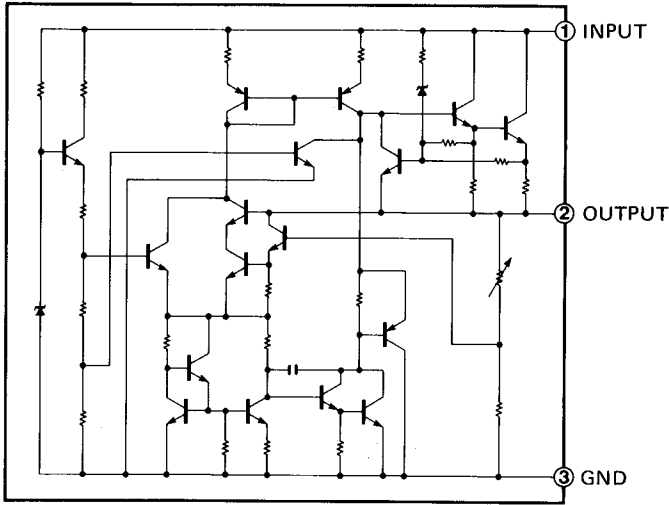

M5218L: IC151

M5220P: IC201

M5218P: IC401, 451, 653, 751

HA17082PS: IC651, 652

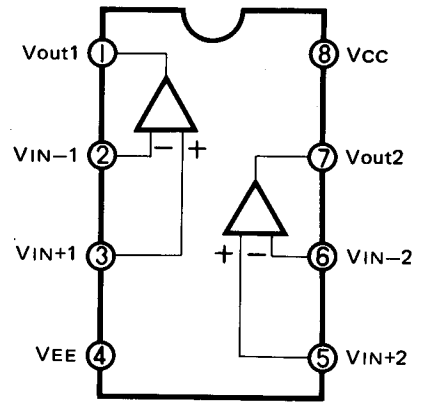

HA12038: IC501, 502

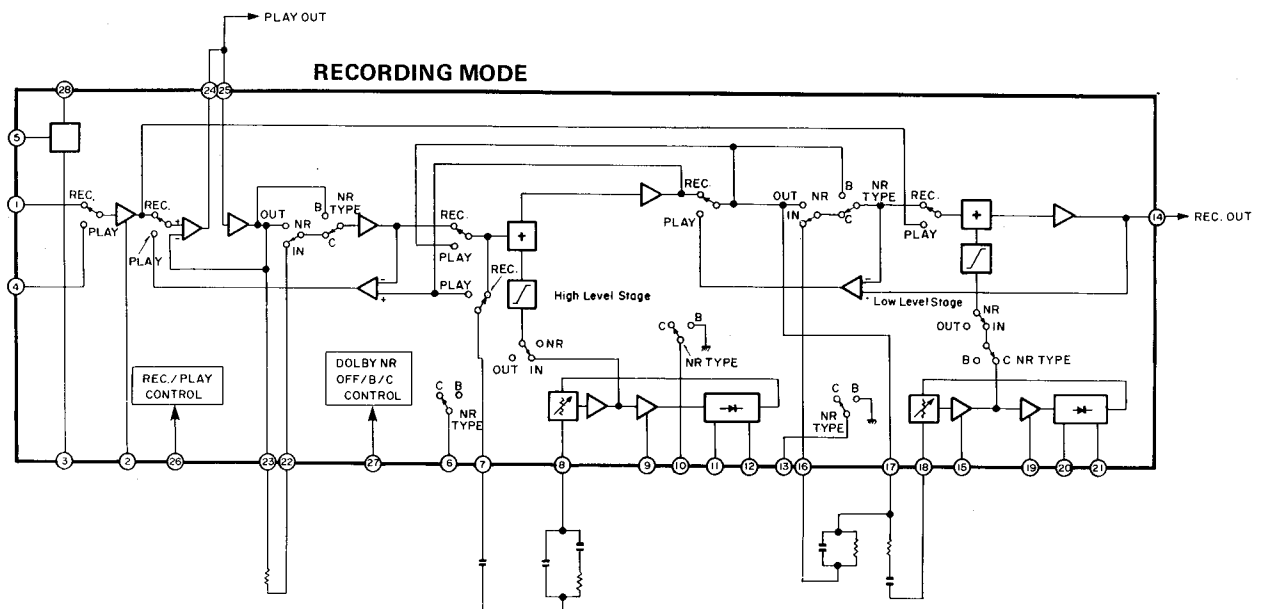
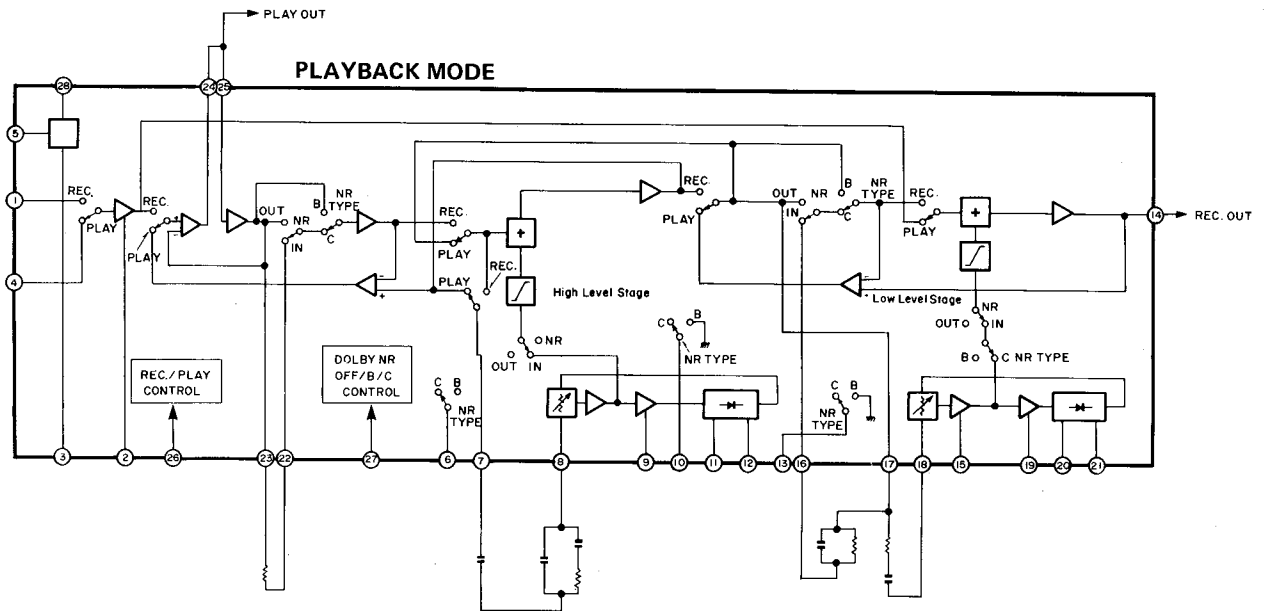

BA335: IC752

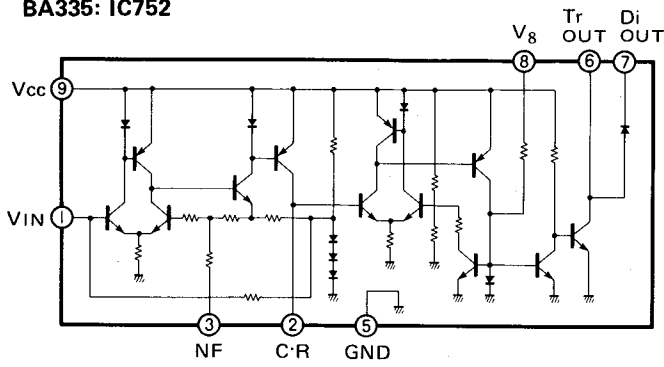

BA6109: IC801

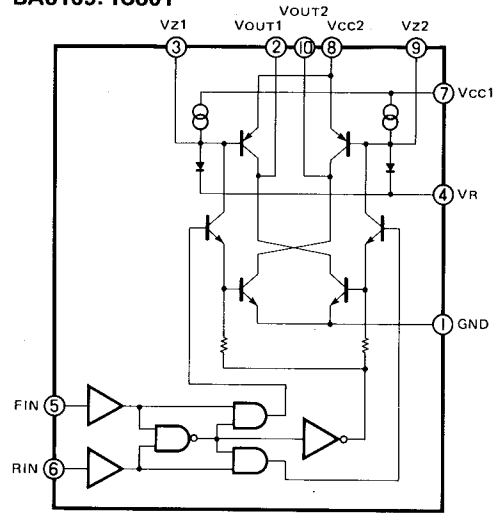

M58846-641SP: IC851

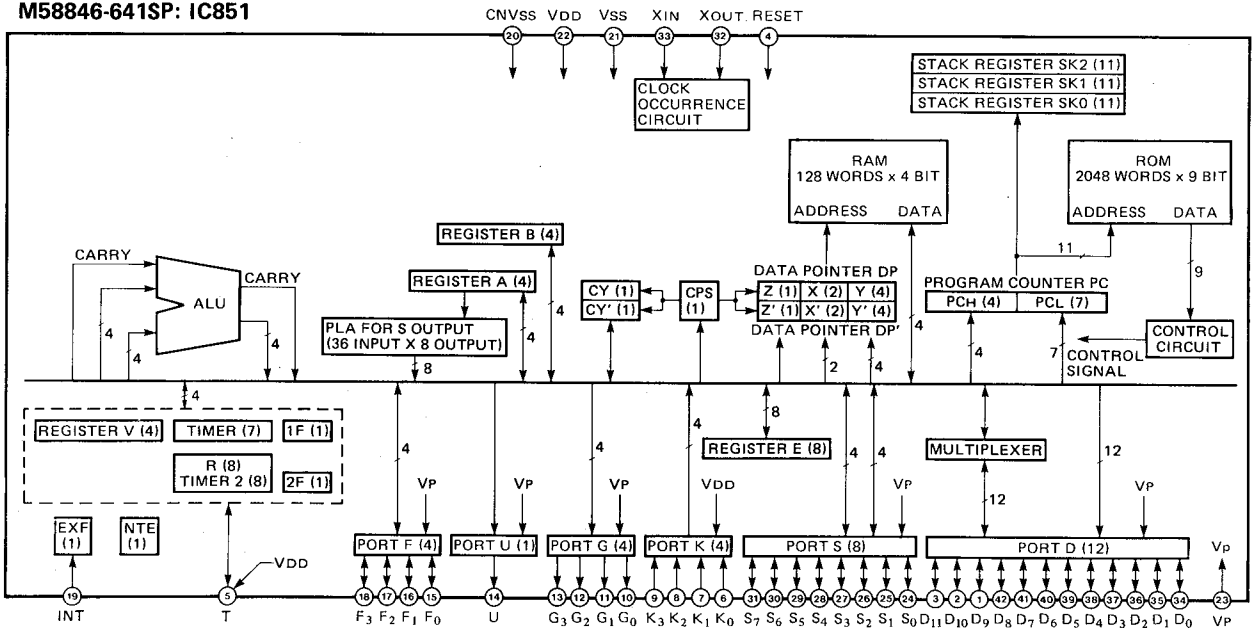

TD62503P: IC852

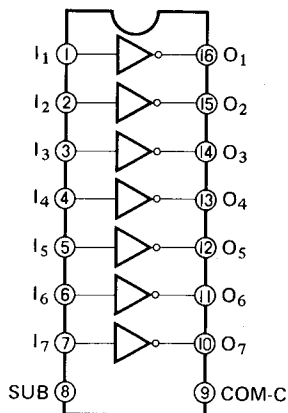

POWER CORD REPLACEMENT (FOR SERVICE ENGINEERS IN OTHER THAN NORTH AMERICA)

In order to prevent fire or shock hazard when replacing the power cord, follow the procedure below to replace the parts with the standard supply parts.

