

# The Harman Kardon Model HK3450/HK3550 STEREO RECEIVER

Manual 194A

## Technical Manual

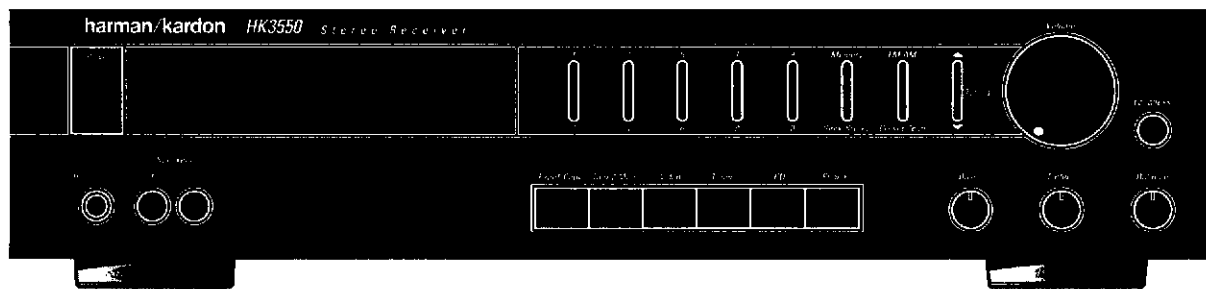

The following marks found in the parts list of this manual identify the models as follows:

- HK3550 **BK** : North America area model Black version
- HK3450/HK3550 **IB** : International model Black version
- HK3450/HK3550 **I** : International model

### CONTENTS

SPECIFICATIONS .....	2	GENERAL UNIT EXPLODED VIEW .....	9
LEAKAGE TEST .....	2	P.C. BOARDS .....	10
DISASSEMBLY PROCEDURES .....	3	ELECTRICAL PARTS LIST .....	13
CIRCUIT DESCRIPTION .....	4	IC BLOCK DIAGRAMS .....	21
BLOCK DIAGRAM .....	5	IC TERMINAL FUNCTION .....	23
TIMING CHART .....	5	SCHEMATIC DIAGRAMS .....	24
ALIGNMENT PROCEDURES .....	6	WIRING DIAGRAM .....	30
GENERAL UNIT PARTS LIST .....	8		

**harman/kardon**

Parts and Service Office  
80 Crossways Park West, Woodbury, N.Y. 11797  
1112-0600A152 K9404 1500 Printed in Japan

## SPECIFICATIONS

### FM SECTION

	Nominal	Limit
Tuning Range	87.5MHz - 108.0MHz	
50dB Quieting Sensitivity		
Mono	14.2dBf	19.0dBf <b>(BK)</b>
Stereo	24.5dBf	27.0dBf <b>(IB)</b>
Usable Sensitivity		
Mono	37.2dBf	41.0dBf <b>(BK)</b>
Stereo	47.0dBf	50.0dBf <b>(IB)</b>
Image Ratio	12.0dBf	15.0dBf <b>(BK)</b>
IF Rejection	14.0dBf	17.0dBf <b>(IB)</b>
Spurious Response Rejection	85.0dB	40.0dB
Capture Ratio (at 45dBf)	105.0dB	80.0dB
Alternate Channel Selectivity (+400kHz, -400kHz 45dBf input)	110.0dB	
AM Rejection (at 45 dBf)	1.5dB	2.0dB
Signal to Noise Ratio (at 65dBf)	77.0dB	60.0dB
Mono	80.0dB	76.0dB <b>(BK)</b>
Stereo	73.5dB	70.0dB <b>(IB)</b>
Stereo	70.5dB	68.0dB <b>(BK)</b>
Stereo	64.5dB	62.0dB <b>(IB)</b>

### Total Harmonic Distortion (at 65dBf 1kHz input)

Mono	0.05%	0.3%
Stereo	0.1%	0.4%
Stereo Separation (at 1kHz)	48.5dB	42.0dB <b>(BK)</b>
Stereo	47.0dB	35.0dB <b>(IB)</b>

### AM SECTION

Tuning Range	530kHz - 1710kHz	<b>(BK)</b>
Stereo	531kHz - 1602kHz	<b>(IB)</b>
20dB S/N Usable Sensitivity	400µV/m	700µV/m
Selectivity (+10kHz, -10kHz)	35.0dB	25.0dB
Signal to Noise Ratio	52.0dB	47.0dB
Image Rejection	39.0dB	30.0dB
IF Rejection	63.0dB	50.0dB

### AUDIO SECTION

Usable Sensitivity		
Video/CD (at 30W output)	135.0mV ± 25mV/26kohm	(HK3450)
Video/CD (at 50W output)	135.0mV ± 25mV/26kohm	(HK3550)
Phono(MM) (at 30W output)	2.2mV + 0.4mV-0.2mV/48kohm	(HK3450)
Phono(MM) (at 50W output)	2.2mV + 0.4mV-0.2mV/48kohm	(HK3550)
Signal to Noise Ratio		
Video/CD	84.0dB	≥ 75.0dB
Phono(MM)	81.0dB	≥ 73.0dB
Frequency Response (at -3dB down)	0.4Hz-175kHz <1Hz- ≥150kHz	

	Nominal	Limit
Channel Separation (at 10kHz)		
Video/CD	73.0dB	45.0dB (HK3450)
Video/CD	53.0dB	45.0dB (HK3550)
Phono(MM)	63.0dB	40.0dB
IM Distortion Ratio (at 15W)	0.047%	0.1%
RMS Output Power		
8Ω, 1kHz, THD 0.1%	38.0W	30W (HK3450)
8Ω, 1kHz, THD 0.1%	48.0W	50W (HK3550) <b>(BK)</b>
8Ω, 1kHz, THD 0.1%	48.0W	40W (HK3550) <b>(IB)</b>
4Ω, 1kHz, THD 0.3%	55.0W	35W (HK3450)
4Ω, 1kHz, THD 0.3%	71.0W	55W (HK3550) <b>(BK)</b>
4Ω, 1kHz, THD 0.3%	71.0W	50W (HK3550) <b>(IB)</b>
High-instantaneous Current Capability (HCC)	30.0A	≥ 20.0A (HK3450)
HCC	38.0A	≥ 30.0A (HK3550)
Damping Factor (at 1kHz)	44.0	≥ 30.0
Tone Control Characteristics		
Bass at 50Hz		
Boost	10dB ± 2dB	
Cut	10dB ± 2dB	
Treble (at 10kHz)		
Boost	10dB ± 2dB	
Cut	10dB ± 2dB	
Loudness Control (at 50Hz)	10dB ± 2dB	
DC Output Voltage		
L channel	34mV ± 60mV	
R channel	24mV ± 60mV	
Idling Current		
L channel	32.4mV ± 5mV	
R channel	32.4mV ± 5mV	
Phono Overload (at 1kHz)	123.0mV	≥ 110mV
RIAA Equalization		
20Hz-20kHz	0.2dB	0.2dB ± 0.5dB
● DIMENSIONS (W x H x D)	17-3/8" x 4-1/8" x 13-3/4" (443 x 105 x 349 mm)	
● WEIGHT	16.3lbs./ (7.4kg) (HK3450)	
	17.8lbs./ (8.1kg) (HK3550)	
● POWER SUPPLY	AC120V, 60Hz <b>(BK)</b>	
	AC230V/240V, 50Hz/60Hz <b>(IB)</b>	
● POWER CONSUMPTION	170W (HK3450) <b>(IB)</b>	
	235W (270VA) (HK3550) <b>(BK)</b>	
	190W (HK3550) <b>(IB)</b>	

These specifications are service target specs.

Specifications and components subject to change without notice. Overall performance will be maintained or improved.

## LEAKAGE TEST (FOR SERVICE ENGINEERS IN THE U.S.A)

Before returning the unit to the user, perform the following safety checks:

1. Inspect all lead dress to make certain that leads are not pinched or that hardware is not lodged between the chassis and other metal parts in the unit.
2. Be sure that any protective devices such as nonmetallic control knobs, insulating fishpapers, cabinet backs, adjustment and compartment covers or shields, isolation resistor-capacity networks, mechanical insulators, etc. which were removed for servicing are properly reinstalled.
3. Be sure that no shock hazard exists; check for leakage current using Simpson Model 229 Leakage Tester, standard equipment item No. 21641, RCA Model WT540A or use alternate method as follows: Plug the power cord directly into a 120-volt AC receptacle (do not use an Isolation Transformer for this test). Using two clip leads, connect a 1500 Ohm, 10-watt resistor paralleled by a 0.15 µF capacitor, in series with all exposed metal cabinet parts and a known earth ground, such as a water pipe or conduit. Use a VTVM or VOM with 1000 Ohms per volt, or higher sensitivity to measure the AC voltage drop across the resistor. (See Diagram.) Move the resistor connection to each exposed metal part having a return path to the chassis (antenna, metal, cabinet, screw heads, knobs and control shafts, escutcheon, etc.) and measure the AC voltage drop across the resistor. (This test should be performed with the power switch in both the On and Off positions.)

SIMPSON MODEL 229 ETC. FOR LEAKAGE TEST

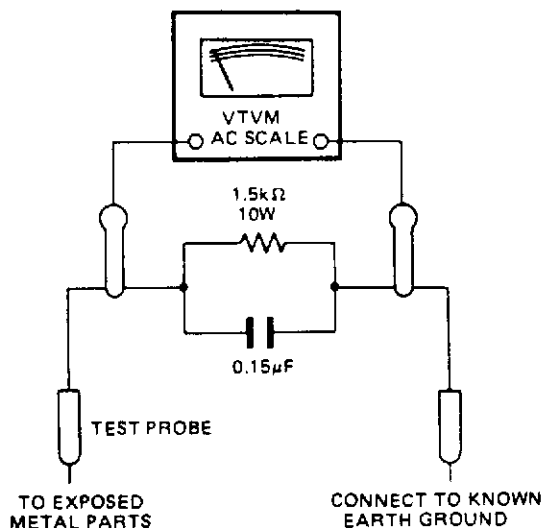
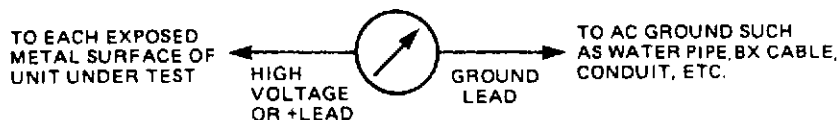

A reading of 0.35 volt RMS or more is excessive and indicates a potential shock hazard which must be corrected before returning the unit to the owner.

**DISASSEMBLY PROCEDURES** (REFER TO PAGES 9 and 30)**1 CABINET TOP (124) REMOVAL**

Remove 6 screws (A) and then remove the Cabinet Top (124).

**2 FRONT PANEL ASSEMBLY (AA) REMOVAL**

1. Remove the Cabinet Top (124), referring to the previous step [1](#).
2. Disconnect the 1 connector (LCN22) from 1 connector (CN22) on the Volume P.C. Board (PCB3).
3. Pull out the Volume knob (131) with the Volume Indicator P.C. Board (PCB6).
4. Disconnect the 1 Jumper lead (JW701) from 1 connector (CN701B) on the Tuner P.C. Board (PCB1).
5. If necessary, unsolder the lead wire.
6. Remove 6 screws (B) and then remove the Front Panel Assembly (AA) with Front P.C. Board (PCB102).

**3 FRONT P.C. BOARD (PCB102) REMOVAL**

1. Remove the Front Panel Assembly (AA), referring to the previous step [2](#).
2. Remove 12 screws (C) and then remove the Front P.C. Board (PCB102).

**4 SPEAKER SWITCH P.C. BOARD (PCB103) REMOVAL**

1. Remove the Front Panel Assembly (AA), referring to the previous step [2](#).
2. Pull out the 2 push buttons (134).
3. Remove 3 screws (D) and then remove Speaker Switch P.C. Board (PCB103).
4. If necessary, unsolder the lead wires.

**5 VOLUME P.C. BOARD (PCB3) REMOVAL**

1. Remove the Front Panel Assembly (AA), referring to the previous step [2](#).
2. Disconnect the 1 connector (LCN23) from 1 connector (CN23) on the Tuner P.C. Board (PCB1).
3. Pull out the 1 push button (134).
4. Remove the 1 nut (E) and 2 screws (F) and then remove the Volume P.C. Board (PCB3) with Loudness P.C. Board (PCB4).
5. If necessary, unsolder the lead wires.

**6 TONE CONTROL P.C. BOARD (PCB2) REMOVAL**

1. Remove the Volume P.C. Board (PCB3), referring to the previous step [5](#).
2. Pull out the 3 Knobs (132).
3. Disconnect the 2 connectors (LCN601 and LCN603) from 2 connectors (CN601 and CN603) on the Tuner P.C. Board (PCB1).
4. Open the lid of connector (CN602) on the Tuner P.C. Board (PCB1) and then disconnect the Shield wire (W602).
5. Remove the 3 nuts (G) and 1 screw (H) and then remove the Tone Control P.C. Board (PCB2).
6. If necessary, unsolder the lead wires.

**7 EQ P.C. BOARD (PCB8) REMOVAL**

1. Remove the Cabinet Top (124), referring to the previous step [1](#).
2. Open the lid of connector (CN604) on the Tuner P.C. Board (PCB1) and then disconnect the Shield wire (W601).
3. Disconnect the 1 connector (LCN605) from 1 connector (CN605) on the EQ P.C. Board (PCB8).
4. Remove 4 screws (I) and then remove the EQ P.C. Board (PCB8) with Shield case (144).
5. If necessary, unsolder the lead wires.

**8 MAIN P.C. BOARD (PCB101) REMOVAL**

1. Remove the Cabinet Top (124), referring to the previous step [2](#).
2. Disconnect the 1 connector (LCN406) from 1 connector (CN406) on the Tone Control P.C. Board (PCB2).
3. Disconnect the 1 connector (LCN25) from 1 connector (CN25) on the Tuner P.C. Board (PCB1).
4. Disconnect the 1 connector (LCN605) from 1 connector (CN605) on the EQ P.C. Board (PCB8).
5. Remove 4 screws (J) and then remove the Main P.C. Board (PCB101) with 3 Metal Fittings (208, 209 and 210) and Heat Sink (206).
6. If necessary, unsolder the lead wires.

**9 TUNER P.C. BOARD (PCB1) REMOVAL**

1. Remove the Main P.C. Board (PCB1), referring to the previous step [8](#).
2. Open the lid of 1 connector (CN604) on the Tuner P.C. Board (PCB1) and then disconnect the Shield wire (W601).
3. Remove 4 screws (I) and then remove the EQ P.C. Board (PCB8) with Shield Case (144).
4. Disconnect the 4 connectors (LCN26, LCN23, LCN601 and LCN603) from 4 connectors (CN26, CN23, CN601 and CN603) on the Tuner P.C. Board (PCB1).
5. Open the lid of 2 connectors (CN6 and CN602) on the Tuner P.C. Board (PCB1) and then disconnect the lead wire.
6. Remove 14 screws (K) and then remove the Tuner P.C. Board (PCB1).
7. If necessary, unsolder the lead wires.

**10 SPEAKER TERMINAL P.C. BOARD (PCB107) REMOVAL**

1. Remove the cabinet Top (124), referring to the previous step [1](#).
2. Remove 2 screws (L) and then remove the Speaker Terminal P.C. Board (PCB107).

## CIRCUIT DESCRIPTION

### ■ FM TUNER SECTION

The FM signal which has entered through the antenna is high-frequency amplified in the front end. Then it is mixed with the output of the local oscillators and converted into the 10.7MHz intermediate-frequency.

The 10.7MHz signal is amplified in the intermediate frequency amplifying section which consists of CF201, Q201, CF202, Q202 and CF203 and fed to pin 1 of IC201. In IC201, the signal is sent through the IF amplifier and after being detected in the quadrature, it is sent through the post amplifier to pin 12 and then input to pin 2 of IC301. In IC301, the pilot signal is detected out of the signal which has been fed and 38kHz signal is produced. Then by this signal, stereo signal is demodulated, output from pin 4 for the left channel and from pin 7 for the right channel and transmitted to the input selector section.

### ■ AM TUNER SECTION

The AM signal which has entered through the antenna passes through the tuning circuit consisting of T241 and is inputted to pin 21 of IC201. In IC201, it undergoes radio-frequency amplification and local oscillation and is output from pin 20, and passed through the transformer (T251) and ceramic filter (CF252) and enters pin 18 of IC201. It is then passed through the IF amplification and detection and is output from pin 15. This signal is fed to IC301.

### ■ AUDIO AMPLIFIER SECTION

The signal which has entered from each input terminal is selected by the input selector, passes through the balance circuit, volume and loudness circuit and is fed into the pre-amplifier.

Then it is fed into the power amplifier through the tone control circuit, power is amplified and transmitted to the speaker terminal.

The power amplifier has an over-output protective circuit. If current exceeding the specification flows to Q423, Q425 (L ch), Q424, Q426 (R ch), it is detected at Q51 (L ch) and Q52 (R ch) and the protective circuit consisting of Q53 and Q12 draws in Q55 and Q54, and thus the input signal is cut to protect the circuit.

### ■ MUTING CIRCUIT

If FM or AM is received out of tuning or in a very weak field intensity, pin 6 of IC701 becomes high level. This is fed to the base of Q757, whose collector then becomes low level and the collector of Q756 high level. As a result, Q301 (L ch) and Q302 (R ch) are conducted to mute the output.

### ■ SYNTHESIZER SECTION

#### ● FM

The local oscillation output at the front end is fed to pin 14 of the prescaler IC751 and after being frequency divided into 30 or 32, control output signal is fed from IC701, compared with the divided local oscillation output and output to pin 18. This voltage is level converted at Q751 and Q752, and fed to the front end.

#### ● AM

The local oscillation output is fed from pin 24 of IC201 to pin 13 of IC751.

In IC751, control output signal is fed from IC701, compared with the local oscillation output and output to pin 18. This voltage is level converted at Q751 and Q752, and fed to the AM local oscillation section.

### ■ INDICATOR SECTION

#### ● Frequency display

The indicator tube is turned ON by the output decoded in IC701.

#### ● Tuning

When broadcast is received, pin 2 of IC701 turns ON by the control signal in IC301 and "Tuned" of the indicator tube is turned ON. When FM or stereo broadcast is received, pin 9 of IC301 becomes low level, pin 5 of IC701 turns ON and "Stereo" of the indicator tube is turned ON.

# BLOCK DIAGRAM

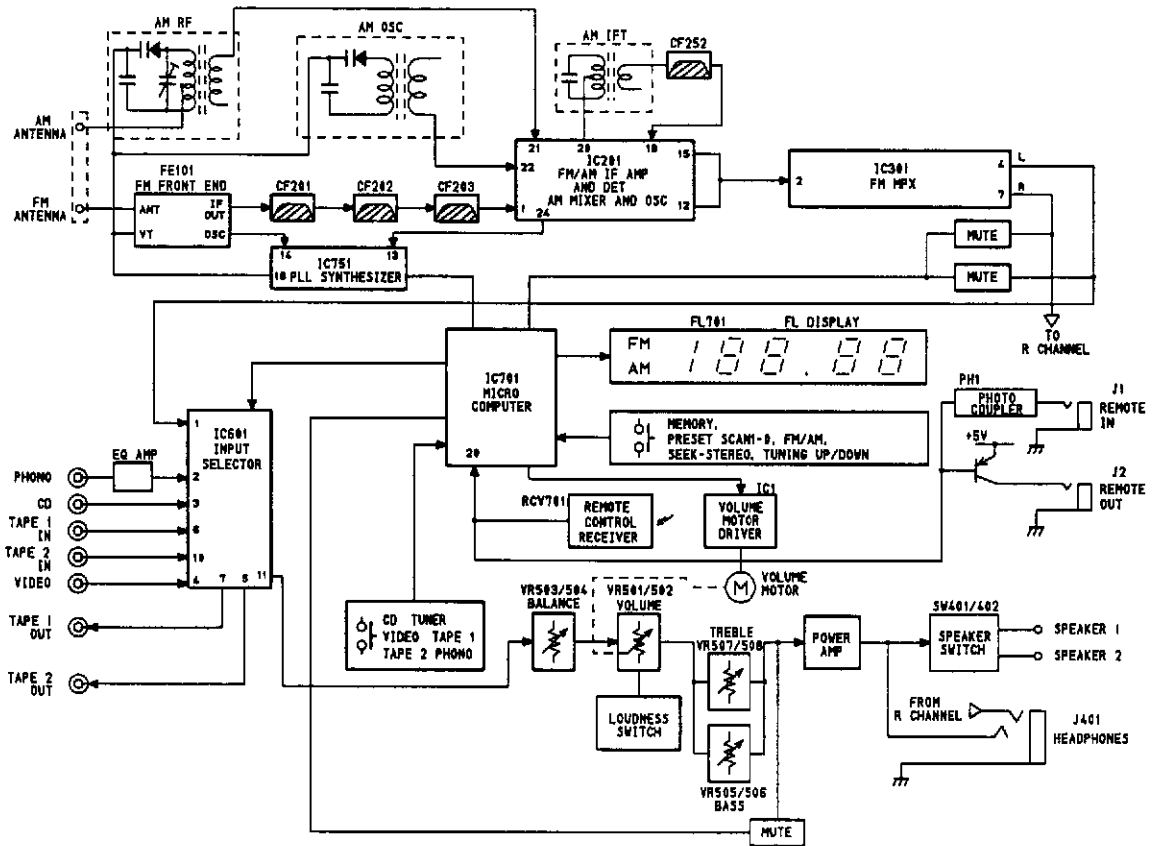

# TIMING CHART

Serial Data input timing chart of IC601 (LC7821)

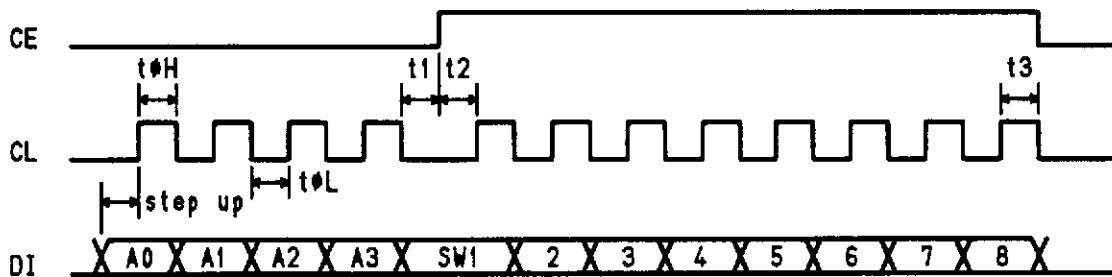

Serial Data input timing chart of IC751 (LM7000)

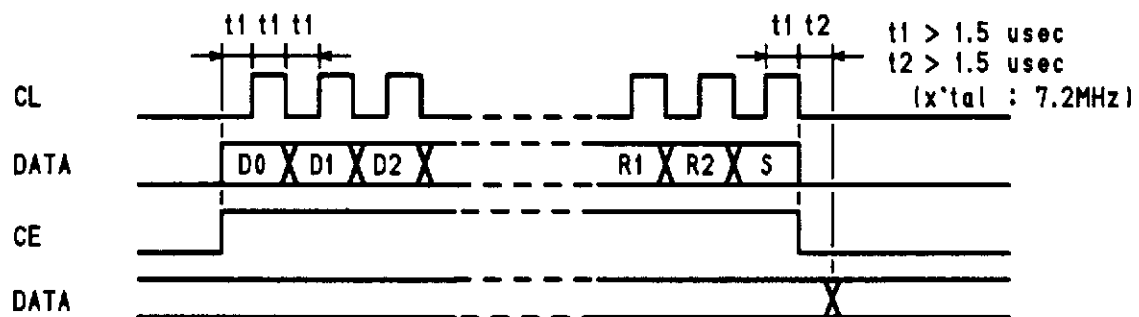

## ALIGNMENT PROCEDURES (REFER TO PAGES 10, 11, 26 AND 29)

- Conditions:
- Make the adjustment at a room temperature of 77°F (25°C).
  - After the Power switch is pushed on, wait for 30 minutes before measuring to be sure of the most stable operation.
  - Set the Volume control to minimum.
  - Set the Speakers switch to 1 position.

### ■ AM ADJUSTMENT

- Conditions:
- Set the AM mode by pressing the "FM/AM" button.
  - Set the Seek-Stereo switch to off (put out seek indicator) position.
  - Standard modulation of the AM Signal Generator is 400Hz at 30%.

Step	Alignment	Terminal to be connected	Measurement Frequency	Station Display	Adjustment	For
1	IF	<ul style="list-style-type: none"> <li>• Connect the AM Test Loop Antenna cable into the output jack of AM Signal Generator. (80 dBμV input signal) Place AM Test Loop Antenna close enough to couple signal into the AM Loop Antenna.</li> <li>• Connect the VTVM and oscilloscope to the out jacks of Tape 1 or 2.</li> </ul>	1400kHz *1404kHz	1400kHz *1404kHz	T251	Maximum output level and symmetrical curve on scope.
2	Tracking		1400kHz *1404kHz	1400kHz *1404kHz	TR241	Maximum output
3			600kHz *603kHz	600kHz *603kHz	T241	Maximum output
4			Repeat steps 2 and 3 for optimum sensitivity.			

\* International model

### ■ FM ADJUSTMENT

- Conditions:
- Set the FM mode by pressing the "FM/AM" button.
  - Set the Seek-Stereo switch to on (seek indicator lights) position.

<b>FM Signal Generator</b>	1kHz, 75kHz modulation 1kHz, 40kHz modulation*
<b>Stereo Modulator</b>	L + R = 45.5%, L - R = 45.5%, 19kHz = 9% L + R = 22.5%, L - R = 22.5%, 19kHz = 8%*

Step	Alignment	Terminal to be connected	Measurement Frequency	Station Display	Adjustment	For
1	Discriminator	<ul style="list-style-type: none"> <li>• Connect the FM Signal Generator to FM 300Ω BAL Antenna terminals through the 300Ω balanced dummy. (1mV (65dBf) input signal)</li> <li>• Connect the Oscilloscope and Distortion meter to the out jacks of Tape 1 or 2.</li> </ul>	97.9MHz	97.9MHz	T201(A)	Adjust so that the TUNED indicator lights in the same range on both plus (+) and minus (-) sides of 97.9MHz.
2			97.9MHz	97.9MHz	T201(B)	Minimum distortion.
3			Repeat steps 1 and 2 for optimum sensitivity.			
4	Muting level		97.9MHz	97.9MHz	VR201	Adjust VR201 so that the waveform is muted at 35 dBf input.
5	Separation	<ul style="list-style-type: none"> <li>• Connect the Stereo Modulator to FM Signal Generator. Connect the FM Signal Generator to FM 300Ω BAL Antenna terminals through the 300Ω balanced dummy. (1mV (65dBf) input signal)</li> <li>• Connect the VTVM and Oscilloscope to the out jacks of Tape 1 or 2.</li> </ul>	97.9MHz	97.9MHz	VR301	Adjust so that the left (or right) channel output becomes minimum when only the right (or left) channel of the Stereo Modulator is modulated.

## ALIGNMENT PROCEDURES (POWER AMP SECTION)

- Conditions:
- Set the Source selector to the "CD" position.
  - Set the Volume control to minimum.
  - Set the Speaker selector to the "off" position.
  - Make the adjustment at a room temperature of 77°F (25°C).

### ■ DC BALANCE ADJUSTMENT

Step	Connection Equipments	Adjustment	For
1	Connect the Digital Volt Meter to TP401 and center pin of TM404.	VR403	0±10mV
2	Connect the Digital Volt Meter to TP402 and center pin of TM404.	VR404	0±10mV

### ■ IDLING CURRENT ADJUSTMENT

Step	Connection Equipments	Adjustment	For
1	Connect the Digital Volt Meter to TP403 and TP405.	VR401	33mV±6mV
2	Connect the Digital Volt Meter to TP404 and TP406.	VR402	33mV±6mV

- After the above adjustment, leave the unit with its power on for longer than 15 minutes and then repeat the same adjustment.

## GENERAL UNIT PARTS LIST

Ref.No.	Part No.	Description	Ref.No.	Part No.	Description
AA	A442-HK3450A	PANEL ASS'Y (Model:HK3450) <b>IB</b>	138	2224-7143	INSULATOR, FRONT PANEL
AA	A442-HK3450B	PANEL ASS'Y (Model:HK3450) <b>I</b>	139	2216-7209	SHIELD PLATE, VOLUME
AA	A442-HK3550A	PANEL ASS'Y (Model:HK3550) <b>BK IB</b>	140	2224-7144	INSULATOR, TRANS PCB (Model:HK3550)
AA	A442-HK3550B	PANEL ASS'Y (Model:HK3550) <b>I</b>			<b>IB I</b>
AB	A319-HK3450A	LEG ASS'Y (x4) (Model:HK3450)	141	2211-7329	CHASSIS, FRONT
AB	A319-HK3550A	LEG ASS'Y (x4) (Model:HK3550)	142	2219-7945	METAL FITTG, TUNER P.C. BOARD GND
025	1756-CSA	LABEL, CSA LABEL (Model:HK3550) <b>BK</b>	143	2219-8412	METAL FITTG, TONE CONTROL P.C. BOARD
026	1756-05910	LABEL, FUSE CAUTION (Model:HK3550) <b>BK</b>	144	2217-7020	SHIELD CASE, PHONO PCB
		<b>IB</b>	145	2224-7141	INSULATOR, FRONT PCB
027	2459-3004511	RIVET, PLASTIC (Model:HK3550) <b>BK</b>	146	2240-R0101	HOLDER, WIRING (x20)
030	2224-7145	INSULATOR, TRANS PCB (Model:HK3550) <b>BK</b>	148	2360-7022	SPECIAL BOSS (x5) (Model:HK3450/3550)
		<b>IB I</b>			<b>IB I</b>
119	1756-23902	LABEL, FTZ (Model:HK3450) <b>IB I</b>	148	2360-7022	SPECIAL BOSS (x4) (Model:HK3550) <b>BK</b>
119	1756-23903	LABEL, FTZ (Model:HK3550) <b>IB I</b>	149	2360-7066	SPECIAL BOSS
120	1117-78	SERIAL LABEL	151	2327-R0130062	SCREW, BND+ (3x6 mm) (x4)
122	1319-04302	LEG, BASE (x4)	152	2347-R0126082	SCREW, BND T+ (2.6x8 mm) (x13)
123	1319-04601	LEG (x4)	153	2347-R0130082	SCREW, BND T+ (3x8 mm) (x13)
124	1414-17004	CABINET TOP (Model:HK3450)	154	2347-R0130104	SCREW, BND T+ (3x10 mm) (x19)
124	1414-17002	CABINET TOP (Model:HK3550)			(Model:HK3550) <b>BK</b>
125	1424-37901	CABINET BACK, BOTTOM	154	2347-R0130104	SCREW, BND T+ (3x10 mm) (x17)
126	1424-38102	CABINET BACK, REAR (Model:HK3450)			(Model:HK3450/3550) <b>IB I</b>
126	1424-38002	CABINET BACK, REAR (Model:HK3550) <b>BK</b>	155	2347-R0130062	SCREW, BND T+ (3x6 mm) (x2)
126	1424-38103	CABINET BACK, REAR (Model:HK3550) <b>IB I</b>			(Model:HK3450/3550) <b>IB I</b>
		<b>IB I</b>	155	2347-R0130062	SCREW, BND T+ (3x6 mm) (Model:HK3550)
127	1442-29704	FRONT PANEL (Model:HK3450) <b>IB</b>			<b>BK</b>
127	1442-29703	FRONT PANEL (Model:HK3450) <b>I</b>	157	2347-R0140062	SCREW, BND T+ (4x6 mm) (x4)
127	1442-29708	FRONT PANEL (Model:HK3550) <b>BK IB</b>	158	2347-R0140064	SCREW, BND T+ (4x6 mm) (x4)
127	1442-29707	FRONT PANEL (Model:HK3550) <b>I</b>	159	2651-110519	SPRING, VOLUME
128	1511-19811	PLATE, FL	203	2240-7370	HOLDER, FL701 (x2)
129	1532-17504	WINDOW, DISPLAY	206	2222-7332	HEAT SINK, MAIN AMP P.C. BOARD
130	2111-1389	FELT, CABINET BOTTOM (x4)			(Model:HK3450)
131	1630-04602	ROTARY KNOB, VOLUME (Model:HK3450) <b>IB</b>	206	2222-7333	HEAT SINK, MAIN AMP P.C. BOARD
		(Model:HK3550) <b>BK IB</b>			(Model:HK3550) <b>BK</b>
131	1630-04601	ROTARY KNOB, VOLUME (Model:HK3450/3550) <b>I</b>	206	2222-7340	HEAT SINK, MAIN AMP P.C. BOARD
		<b>IB</b>			(Model:HK3550) <b>IB I</b>
132	1632-20401	ROTARY KNOB, BASS TREBLE BALANCE (x3) (Model:HK3450) <b>IB</b>	207	2224-7134	INSULATOR, Q423-Q426 (x4)
		(Model:HK3550) <b>BK IB</b>	208	2219-8408	METAL FITTG, HEAT SINK FRONT
		<b>IB</b>	209	2219-8409	METAL FITTG, HEAT SINK REAR
132	1632-20402	ROTARY KNOB, BASS TREBLE BALANCE (x3) (Model:HK3450/3550) <b>I</b>	210	2219-8410	METAL FITTG, HEAT SINK CENTER
		<b>IB</b>	211	2347-R0130082	SCREW, BND T+ (3x8 mm) (x12)
133	1662-52001	PUSH BUTTON, POWER (Model:HK3450) <b>IB</b>	212	2557-301429	SCREW, B SPW+ (3x14 mm)(X5)
		(Model:HK3550) <b>BK IB</b>	215	1756-R01TL122	LABEL, FUSE LABEL F1 (Model:HK3450)
133	1662-52003	PUSH BUTTON, POWER (Model:HK3450/3550) <b>I</b>	215	1756-R01TL162	LABEL, FUSE LABEL F1 (Model:HK3550)
134	1662-62902	PUSH BUTTON, SPEAKERS, LOUDNESS (x3) (Model:HK3450) <b>IB</b>			<b>IB I</b>
		(Model:HK3550) <b>BK IB</b>	303	2222-7319	HEAT SINK, Q1, Q4
134	1662-62901	PUSH BUTTON, SPEAKERS, LOUDNESS (x3) (Model:HK3450/3550) <b>I</b>	304	2327-R0130062	SCREW, BND+ (3x6 mm) (x2)
		<b>IB</b>	307	2219-2411	METAL FITTG, TUNER P.C. BOARD
135	1662-70402	PUSH BUTTON, FUNCTION (Model:HK3450) <b>IB</b>	308	2347-R0130062	SCREW, BND T+ (3x6 mm)
		(Model:HK3550) <b>BK IB</b>	311	1756-R01TL202	LABEL, FUSE LABEL F2, 3 (x2)
135	1662-70401	PUSH BUTTON, FUNCTION (Model:HK3450/3550) <b>I</b>			(Model:HK3450/3550) <b>IB I</b>
136	1662-70502	PUSH BUTTON, PRESET, MEMORY, FM/AM, TUNING (x8) (Model:HK3450) <b>IB</b>	330	2347-R0130102	SCREW, BND T+ (3x10 mm) (X14)
		(Model:HK3550) <b>BK IB</b>			(Model:HK3450/3550) <b>IB I</b>
136	1662-70501	PUSH BUTTON, PRESET, MEMORY, FM/AM, TUNING (x8) (Model:HK3450/3550) <b>I</b>	330	2347-R0130102	SCREW, BND T+ (3x10 mm) (X12)
		<b>IB</b>			(Model:HK3550) <b>BK</b>
		<b>IB</b>	331	2114-91143	BUSHING, TRANS TOP (Model:HK3550)
		<b>IB</b>	332	2340-7009	SCREW, SPE T+ (x3)
		<b>IB</b>	333	2218-R0130	BRACKET, FIX
		<b>IB</b>	334	4214-168	TERMINAL, PHONO GND
		<b>IB</b>	335	2111-11189	FELT, CABINET BACK BOTTOM (x3)
		<b>IB</b>	406	2440-62	NUT, SPECIAL (X4)



A

B

C

D

E

# GENERAL UNIT EXPLODED VIEW

1

2

3

4

5

6

7

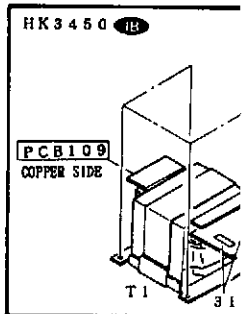
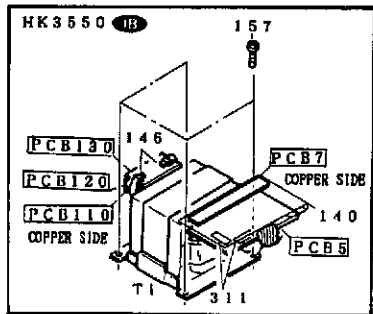
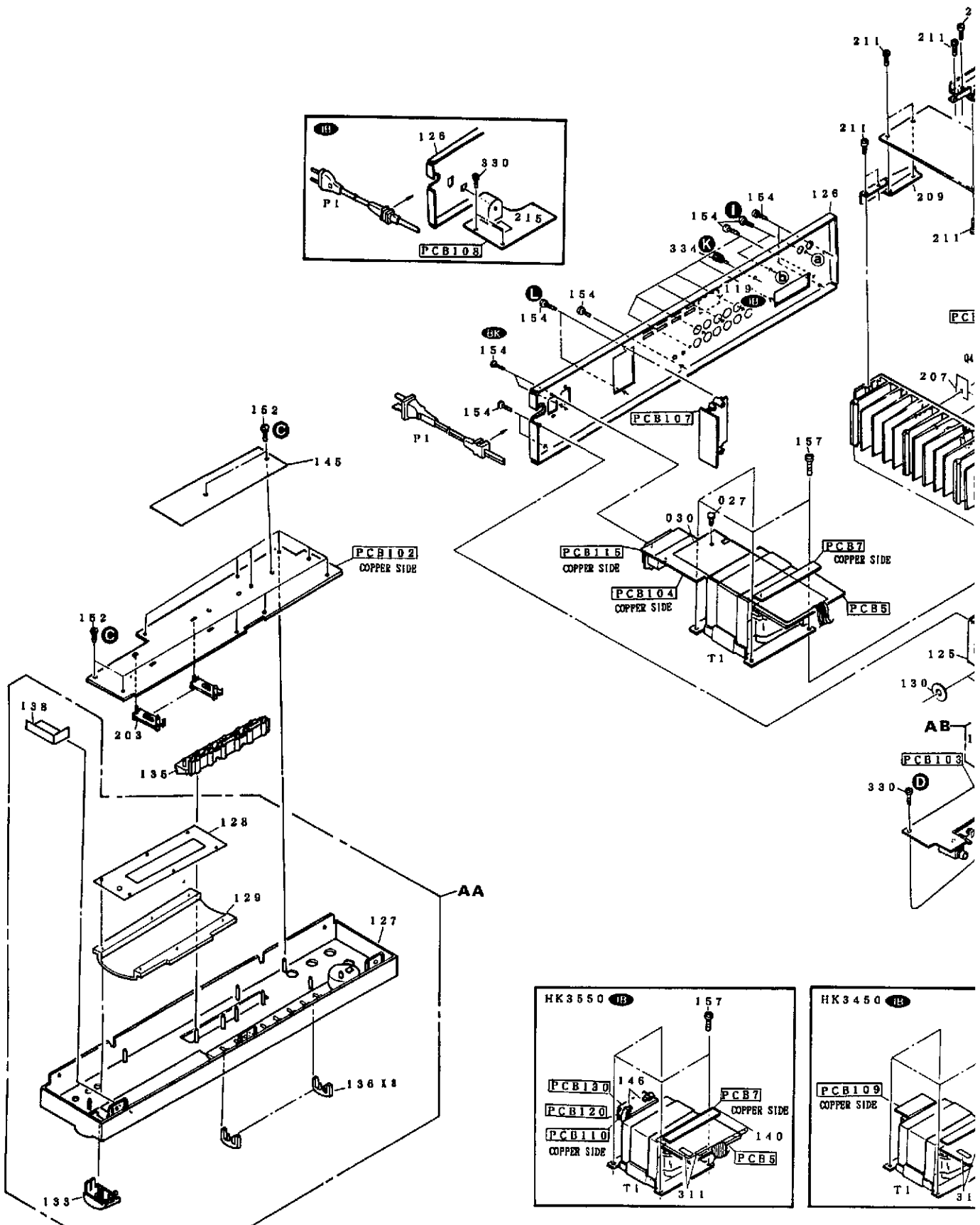
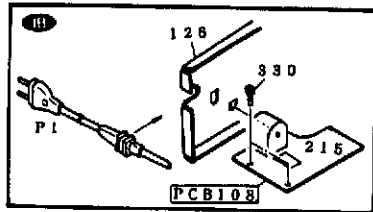

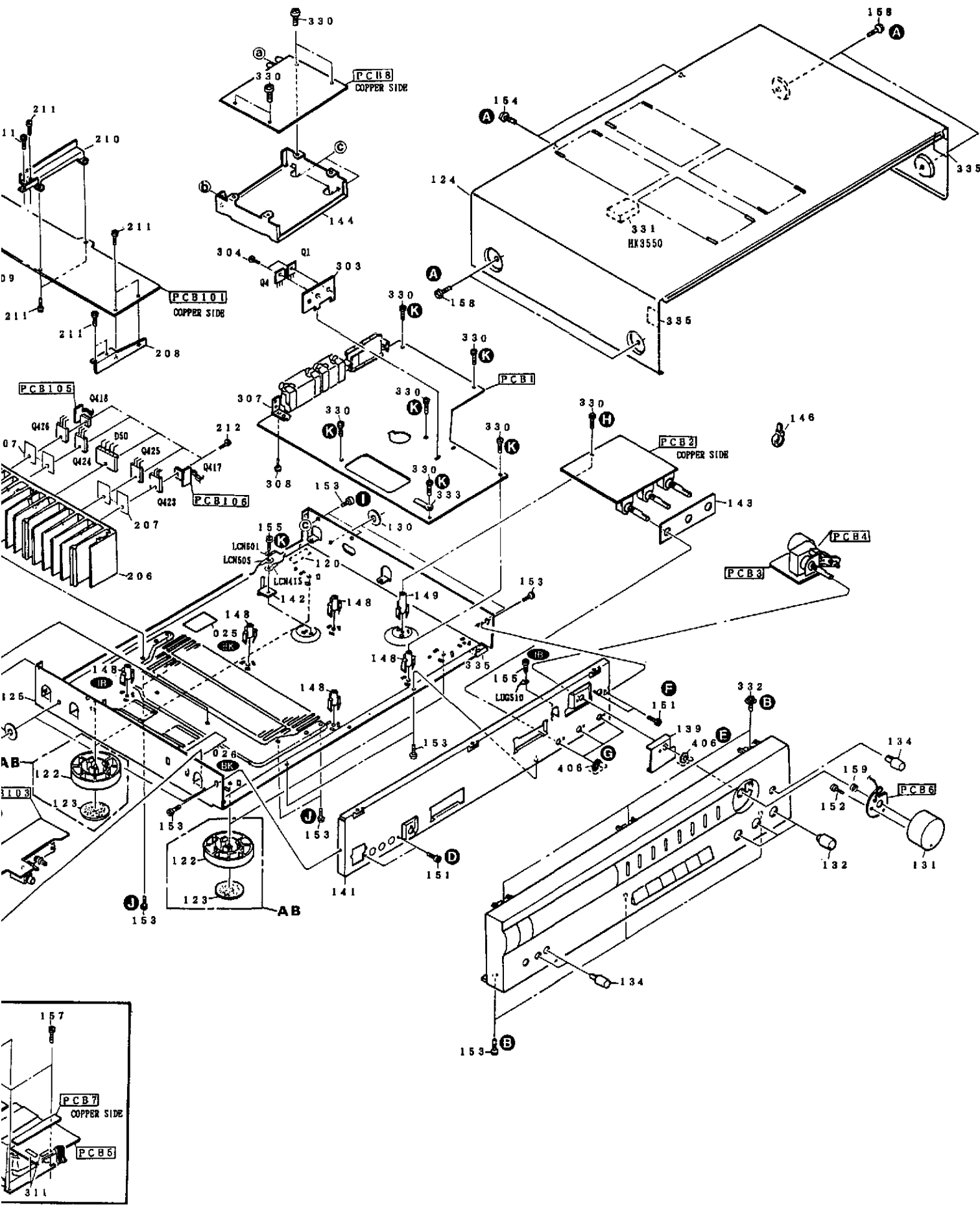



### PCB 2 TONE CONTROL P.C. BOARD

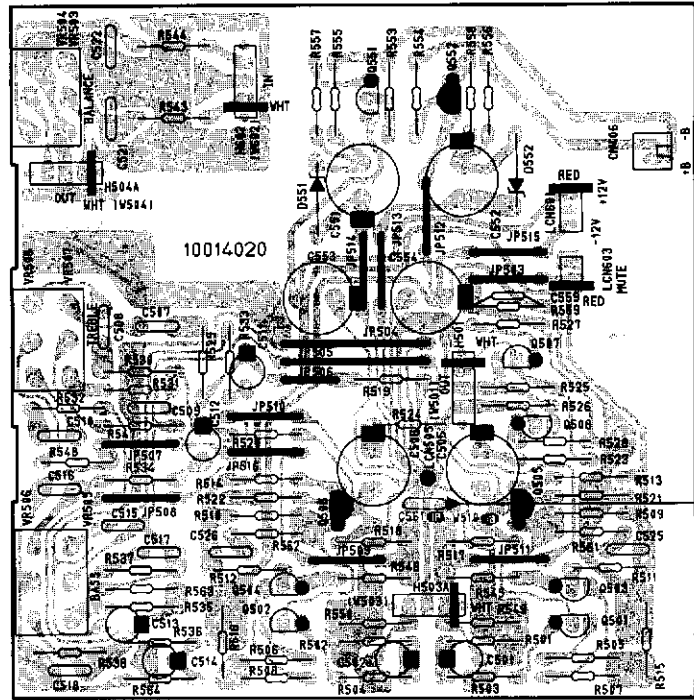

### PCB 6 VOLUME INDICATOR P.C. BOARD

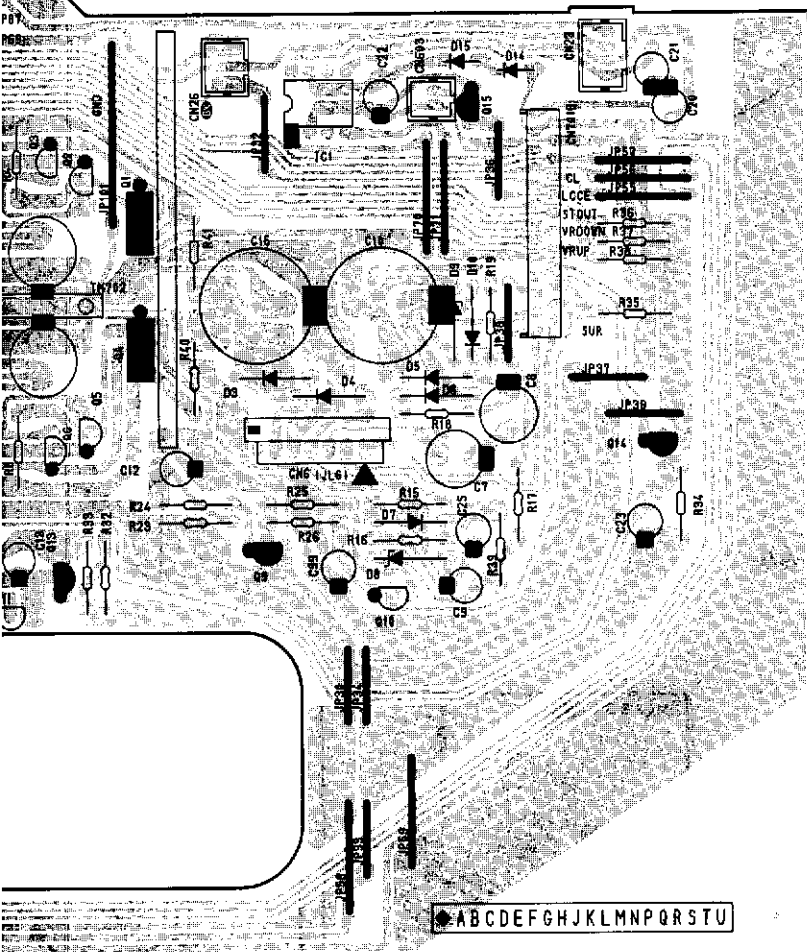
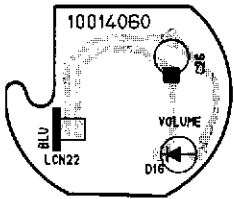

### PCB 3 VOLUME P.C. BOARD

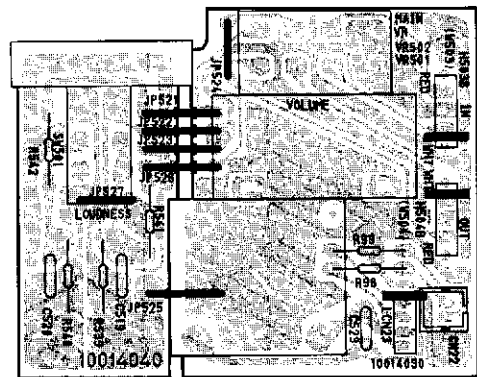

### PCB 4 LOUDNESS P.C. BOARD

A

B

C

D

E

1

2

3

### PCB 101 MAIN AMP P.C. BOARD

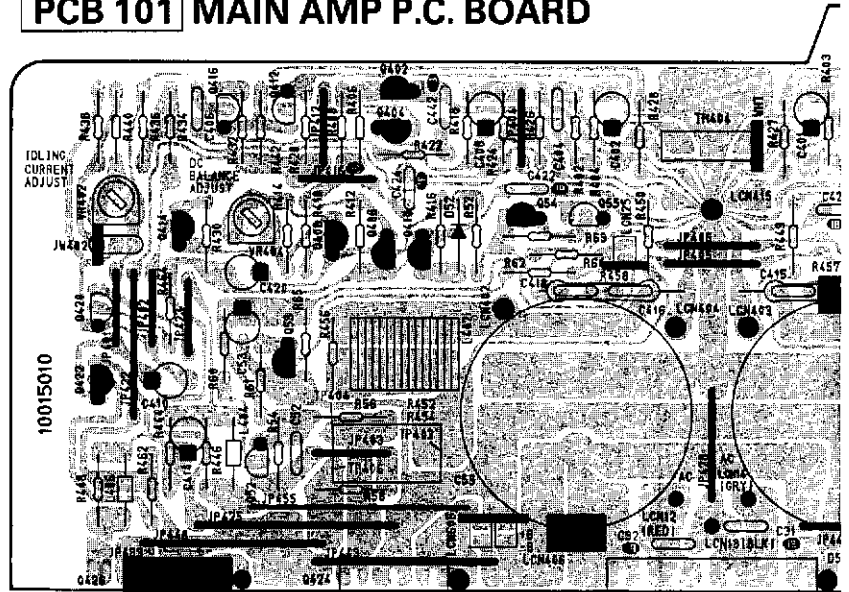

### PCB 105

### BIAS 1 P.C. BOARD



4

### PCB 102 FRONT P.C. BOARD

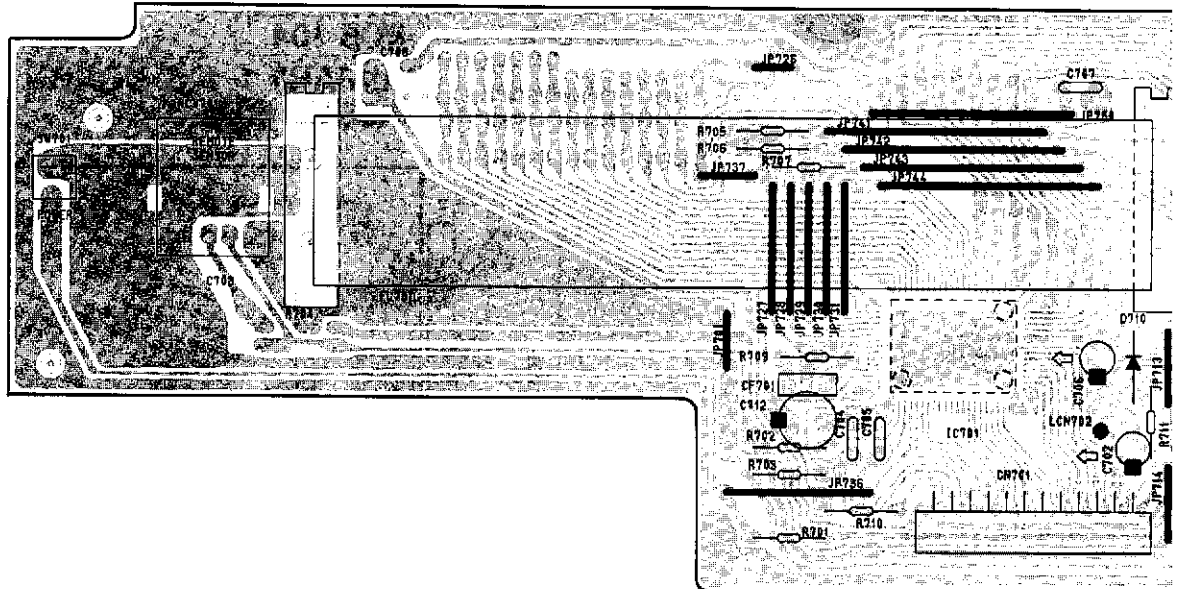

5

6

7

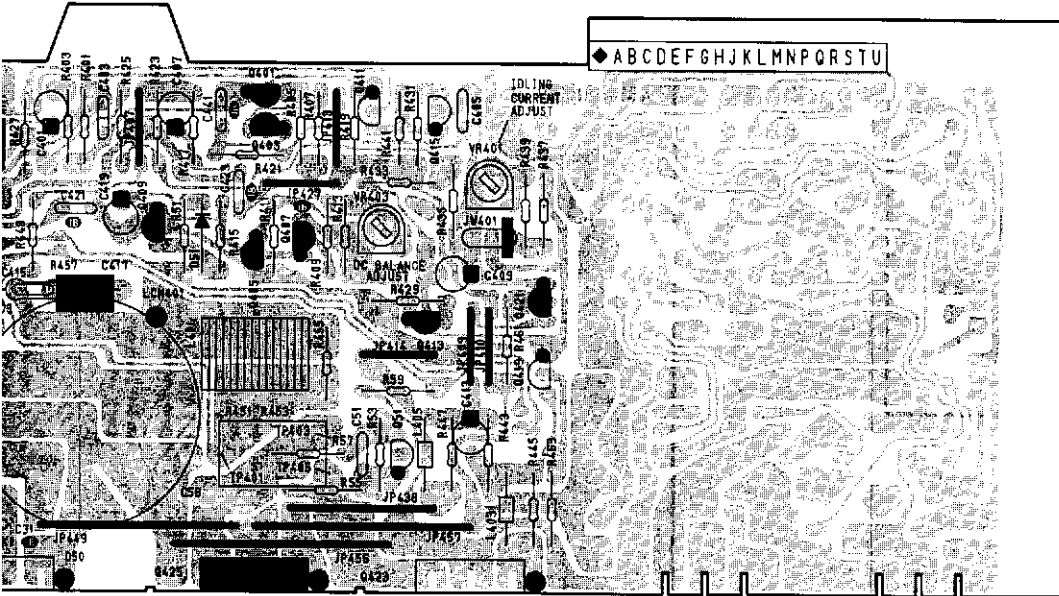

**PCB 106**  
**BIAS 2 P.C. BOARD**

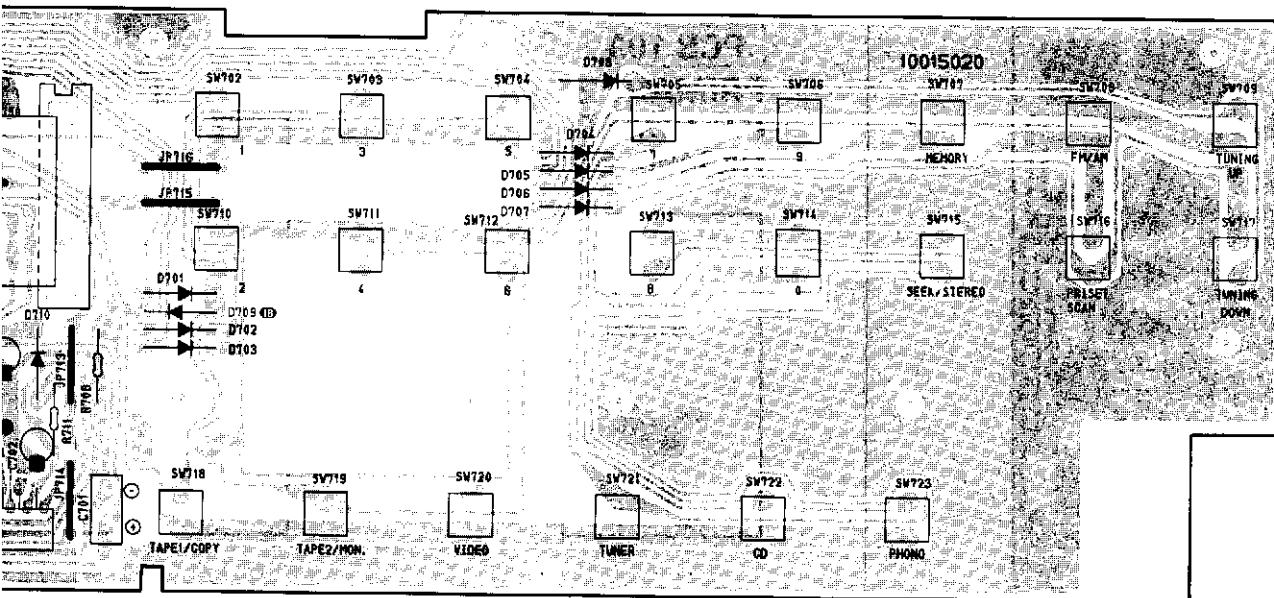



**PCB 103**  
**SPEAKER SWITCH P.C. BOARD**

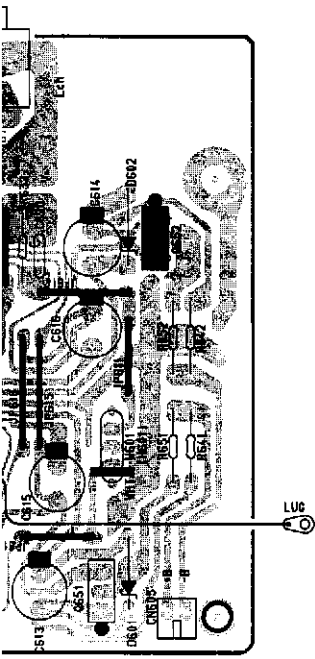
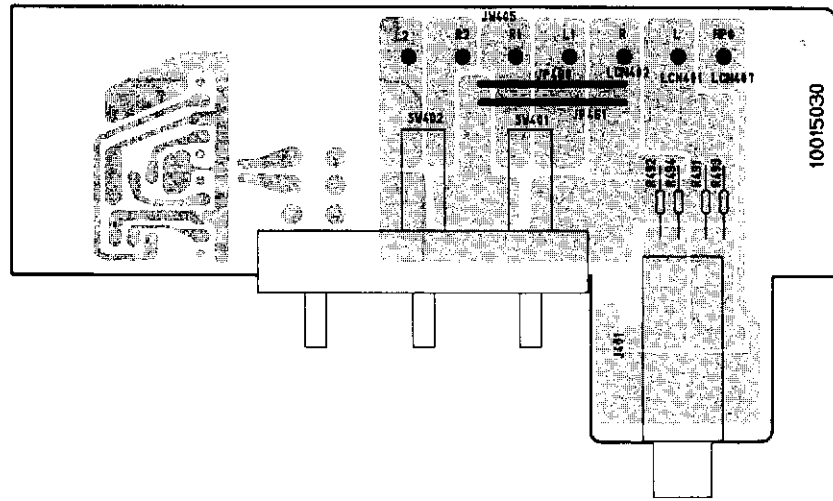

**PCB 107**  
**SPEAKER TERMINAL P.C. BOARD**

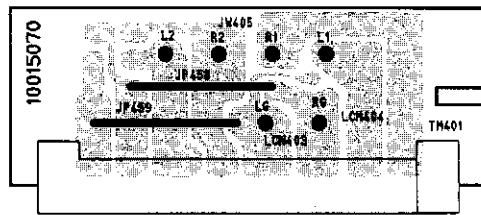

**PCB 110**  
**SHEET 3 P.C. BOARD**  
**HK3550 (B)**

**C. BOARD**  
**(B)**

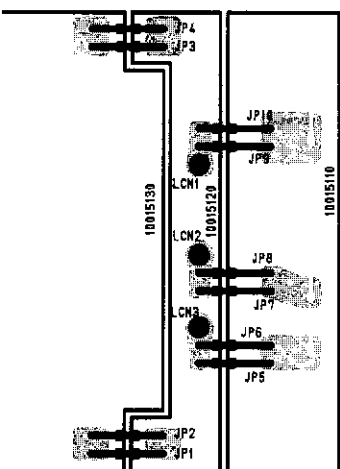

**PCB 120**  
**SHEET 2 P.C. BOARD**  
**HK3550 (B)**

**PCB 104**  
**PRIMARY 1 P.C. BOARD**  
**HK3550 (BK)**

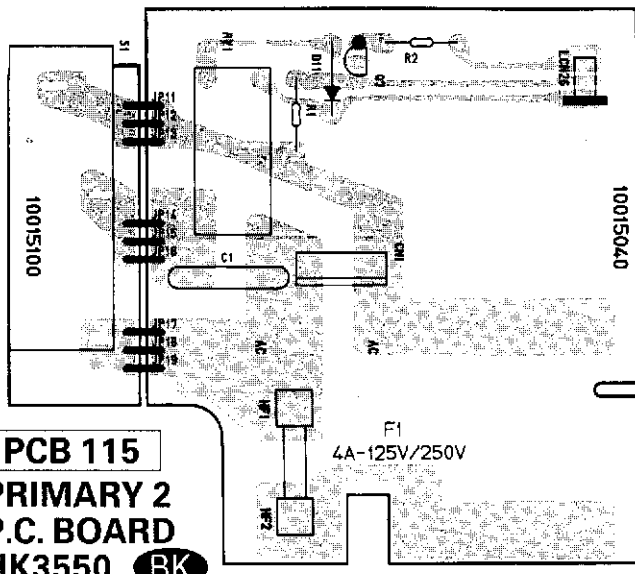

**PCB 115**  
**PRIMARY 2 P.C. BOARD**  
**HK3550 (BK)**



# ELECTRICAL PARTS LIST

Ser. No.	Ref. No.	Part No.	Description
<b>PCB TUNER P.C. BOARD</b>			
<b>CAPACITORS</b>			
448	C7	5345-476F0962	CAP, MINI ELE 47U/50V
448	C8	5345-476F0962	CAP, MINI ELE 47U/50V
449	C9	5345-106F0962	CAP, MINI ELE 10U/50V
450	C10	5345-337E0962	CAP, MINI ELE 330U/35V
451	C11	5345-476D0962	CAP, MINI ELE 47U/25V
452	C12	5345-107B0962	CAP, MINI ELE 100U/10V
452	C13	5345-107B0962	CAP, MINI ELE 100U/10V
453	C15	5345-228D0962	CAP, MINI ELE 2200U/25V
454	C16	5345-227D0962	CAP, MINI ELE 220U/25V
455	C17	5345-477C0962	CAP, MINI ELE 470U/16V
456	C18	5345-227C0962	CAP, MINI ELE 220U/16V
457	C19	5345-477B0962	CAP, MINI ELE 470U/10V
458	C20	5345-476F0962	CAP, MINI ELE 4.7U/50V
458	C21	5345-475F0962	CAP, MINI ELE 4.7U/50V
452	C22	5345-107B0962	CAP, MINI ELE 100U/10V
459	C23	5345-106F0962	CAP, MINI ELE 10U/50V
459	C24	5345-105F0962	CAP, MINI ELE 1U/50V
458	C25	5345-475F0962	CAP, MINI ELE 4.7U/50V
446	C99	5345-105F0962	CAP, MINI ELE 1U/50V
205	C101	5361-223ZF	CAP, CER .022U
208	C102	5345-227C0962	CAP, MINI ELE 220U/16V
206	C103	5361-150KSL	CAP, CER 15P
207	C104	5361-220KSL	CAP, CER 22P (Model:HK3450/3550)
229	C201	5361-103ZF	CAP, CER .01U
228	C202	5361-223ZF	CAP, CER .022U
229	C203	5361-103ZF	CAP, CER .01U
228	C206	5361-223ZF	CAP, CER .022U
228	C207	5361-223ZF	CAP, CER .022U
228	C208	5361-223ZF	CAP, CER .022U
233B	C211	5345-226C0962	CAP, MINI ELE 22U/16V (Model:HK3550) <b>BK</b>
233	C212	5345-226C0962	CAP, MINI ELE 22U/16V (Model:HK3450/3550) <b>IB I</b>
231	C214	5345-106F0962	CAP, MINI ELE 10U/50V
232	C215	5345-105F0962	CAP, MINI ELE 1U/50V
230	C216	5361-101KB	CAP, CER 100P
233	C218	5345-226C0962	CAP, MINI ELE 22U/16V
227	C221	5361-221KB	CAP, CER 220P (Model:HK3450/3550)
227	C222	5361-221KB	CAP, CER 220P (Model:HK3450/3550)
264	C241	5361-223ZF	CAP, CER .022U
264	C242	5361-223ZF	CAP, CER .022U
265	C244	5359-3915851	CAP, PPP 390P
264	C245	5361-223ZF	CAP, CER .022U
266	C246	5361-150JCH	CAP, CER 15P
268	C247	5345-106F0962	CAP, MINI ELE 10U/50V
271	C252	5345-224F0962	CAP, MINI ELE .22U/50V
264	C253	5361-223ZF	CAP, CER .022U
267	C254	5361-472KB	CAP, CER 4700P
269	C255	5345-475F0962	CAP, MINI ELE 4.7U/50V
269	C256	5345-475F0962	CAP, MINI ELE 4.7U/50V
270	C257	5345-105F0962	CAP, MINI ELE 1U/50V
271	C258	5345-224F0962	CAP, MINI ELE .22U/50V
299	C301	5345-226C0962	CAP, MINI ELE 22U/16V
300	C302	5345-476C0962	CAP, MINI ELE 47U/16V
296	C303	5359-1815851	CAP, PPP 180P (Model:HK3450/3550)
296D	C303	5359-3915851	CAP, PPP 390P (Model:HK3550) <b>EK</b>
296	C304	5359-1815851	CAP, PPP 180P (Model:HK3450/3550)
296D	C304	5359-3915851	CAP, PPP 390P (Model:HK3550) <b>BK</b>
301	C305	5345-225F0962	CAP, MINI ELE 2.2U/50V
301	C306	5345-225F0962	CAP, MINI ELE 2.2U/50V
298	C308	5354-S100J473	CAP, MYL .047U
302	C309	5345-474F0962	CAP, MINI ELE .47U/50V
303	C310	5345-106F0962	CAP, MINI ELE 10U/50V
304	C311	5345-224F0962	CAP, MINI ELE .22U/50V

Ser. No.	Ref. No.	Part No.	Description
305	C312	5345-225F0962	CAP, MINI ELE 2.2U/50V
297	C315	5361-101KB	CAP, CER 100P
419	C601	5361-221KB	CAP, CER 220P
419	C602	5361-221KB	CAP, CER 220P
419	C603	5361-221KB	CAP, CER 220P
420	C605	5345-106F0962	CAP, MINI ELE 10U/50V
420	C606	5345-106F0962	CAP, MINI ELE 10U/50V
336	C751	5345-227C0962	CAP, MINI ELE 220U/16V
334	C752	5345-224F0951	CAP, MINI ELE .22U/50V
335	C754	5345-684F0951	CAP, MINI ELE .68U/50V
337	C757	5345-337A0962	CAP, MINI ELE 330U/6.3V
332	C758	5361-300JCH	CAP, CER 30P
332	C759	5361-300JCH	CAP, CER 30P
330	C761	5361-101KB	CAP, CER 100P
330	C762	5361-101KB	CAP, CER 100P
331	C763	5361-223ZF	CAP, CER .022U
338	C764	5345-334F0962	CAP, MINI ELE .33U/50V

Ser. No.	Ref. No.	Part No.	Description
<b>RESISTORS</b>			
466	R3	5134-152J25P	RES, CBN 1/4P 1.5K
467	R4	5134-391J25P	RES, CBN 1/4P 390
468	R5	5134-101J25P	RES, CBN 1/4P 100
470	R6	5134-3R9J25P	RES, CBN 1/4P 3.9
466	R7	5134-152J25P	RES, CBN 1/4P 1.5K
467	R8	5134-391J25P	RES, CBN 1/4P 390
468	R9	5134-101J25P	RES, CBN 1/4P 100
469	R10	5134-2R2J25P	RES, CBN 1/4P 2.2
471	R11	5134-103J25P	RES, CBN 1/4P 10K
464	R12	5134-222J25P	RES, CBN 1/4P 2.2K
472	R13	5134-470J25P	RES, CBN 1/4P 47
473	R14	5134-473J25P	RES, CBN 1/4P 47K
465	R15	5134-102J25P	RES, CBN 1/4P 1K
481	R16	5134-272J25P	RES, CBN 1/4P 2.7K
471	R17	5134-103J25P	RES, CBN 1/4P 10K
468	R18	5134-101J25P	RES, CBN 1/4P 100
475	R19	5134-223J25P	RES, CBN 1/4P 22K
476	R20	5134-392J25P	RES, CBN 1/4P 3.9K
472	R21	5134-470J25P	RES, CBN 1/4P 47
477	R22	5134-271J25P	RES, CBN 1/4P 270
465	R23	5134-102J25P	RES, CBN 1/4P 1K
471	R24	5134-103J25P	RES, CBN 1/4P 10K
471	R25	5134-103J25P	RES, CBN 1/4P 10K
465	R26	5134-102J25P	RES, CBN 1/4P 1K
478	R27	5134-104J25P	RES, CBN 1/4P 100K
471	R28	5134-103J25P	RES, CBN 1/4P 10K
479	R29	5134-393J25P	RES, CBN 1/4P 39K
480	R30	5134-683J25P	RES, CBN 1/4P 68K
474	R31	5134-472J25P	RES, CBN 1/4P 4.7K
474	R32	5134-472J25P	RES, CBN 1/4P 4.7K
478	R33	5134-104J25P	RES, CBN 1/4P 100K
476	R34	5134-392J25P	RES, CBN 1/4P 3.9K
473	R35	5134-473J25P	RES, CBN 1/4P 47K
471	R36	5134-103J25P	RES, CBN 1/4P 10K
471	R37	5134-103J25P	RES, CBN 1/4P 10K
471	R38	5134-103J25P	RES, CBN 1/4P 10K
483	R39	5134-332J25P	RES, CBN 1/4P 3.3K
482	△ R40	5102-4R75116	RES, FUSE 4.7
482	△ R41	5102-4R75116	RES, FUSE 4.7
211	R101	5232-102J16P	RES, CBN 1/6P 1K
238	R202	5232-391J16P	RES, CBN 1/6P 390
236	R203	5232-102J16P	RES, CBN 1/6P 1K
237	R204	5232-154J16P	RES, CBN 1/6P 150K
239	R205	5232-220J16P	RES, CBN 1/6P 22
240	R206	5232-101J16P	RES, CBN 1/6P 100
238	R207	5232-391J16P	RES, CBN 1/6P 390
238	R208	5232-391J16P	RES, CBN 1/6P 390
236	R209	5232-102J16P	RES, CBN 1/6P 1K
237	R210	5232-154J16P	RES, CBN 1/6P 150K
239	R211	5232-220J16P	RES, CBN 1/6P 22
240	R212	5232-101J16P	RES, CBN 1/6P 100
238	R213	5232-391J16P	RES, CBN 1/6P 390
241	R214	5232-822J16P	RES, CBN 1/6P 8.2K
242	R215	5232-332J16P	RES, CBN 1/6P 3.3K
243	R216	5232-472J16P	RES, CBN 1/6P 4.7K

Ser. No.	Ref. No.	Part No.	Description	Ser. No.	Ref. No.	Part No.	Description
244	R217	5232-273J16P	RES, CBN 1/6P 27K (Model:HK3450/3550) <b>IB I</b>	421	R613	5134-122J25P	RES, CBN 1/4P 1.2K
244B	R217	5232-153J16P	RES, CBN 1/6P 15K (Model:HK3550) <b>BK</b>	421	R614	5134-122J25P	RES, CBN 1/4P 1.2K
246	R218	5134-220J25P	RES, CBN 1/4P 22	421	R615	5134-122J25P	RES, CBN 1/4P 1.2K
245	R224	5134-222J25P	RES, CBN 1/4P 2.2K (Model:HK3450/3550) <b>IB I</b>	421	R616	5134-122J25P	RES, CBN 1/4P 1.2K
245B	R224	5134-822J25P	RES, CBN 1/4P 8.2K (Model:HK3550) <b>BK</b>	421	R617	5134-122J25P	RES, CBN 1/4P 1.2K
248	R225	5232-224J16P	RES, CBN 1/6P 220K	346	R751	5134-103J25P	RES, CBN 1/4P 10K
247	R226	5134-103J25P	RES, CBN 1/4P 10K	343	R752	5232-103J16P	RES, CBN 1/6P 10K
274	R241	5232-153J16P	RES, CBN 1/6P 15K	340	R753	5232-473J16P	RES, CBN 1/6P 47K
274	R242	5232-153J16P	RES, CBN 1/6P 15K	345	R754	5232-222J16P	RES, CBN 1/6P 2.2K
275	R243	5232-470J16P	RES, CBN 1/6P 47	341	R758	5134-102J25P	RES, CBN 1/4P 1K
276	R244	5232-104J16P	RES, CBN 1/6P 100K	342	R761	5232-102J16P	RES, CBN 1/6P 1K
277	R245	5134-180J25P	RES, CBN 1/4P 18	342	R762	5232-102J16P	RES, CBN 1/6P 1K
278	R252	5232-563J16P	RES, CBN 1/6P 56K	342	R763	5232-102J16P	RES, CBN 1/6P 1K
279	R253	5232-103J16P	RES, CBN 1/6P 10K	342	R764	5232-102J16P	RES, CBN 1/6P 1K
282	R254	5134-102J25P	RES, CBN 1/4P 1K	342	R765	5232-102J16P	RES, CBN 1/6P 1K
279	R255	5232-103J16P	RES, CBN 1/6P 10K	344	R766	5232-472J16P	RES, CBN 1/6P 4.7K
280	R256	5232-223J16P	RES, CBN 1/6P 22K	347	R767	5232-472J16P	RES, CBN 1/6P 4.7K
281	R257	5232-820J16P	RES, CBN 1/6P 82	347	R768	5232-472J16P	RES, CBN 1/6P 4.7K
283	R259	5232-473J16P	RES, CBN 1/6P 47K	348	R770	5134-220J25P	RES, CBN 1/4P 22
284	R260	5232-223J16P	RES, CBN 1/6P 22K (Model:HK3450/3550) <b>IB I</b>	<b>INTEGRATED CIRCUITS</b>			
284B	R260	5232-183J16P	RES, CBN 1/6P 18K (Model:HK3550) <b>BK</b>	427	IC1	5653-LB1639	IC, LINEAR
276	R261	5232-104J16P	RES, CBN 1/6P 100K	217	IC201	5653-LA1266	IC, LINEAR
276	R262	232-104J16P	RES, CBN 1/6P 100K	287	IC301	5653-LA3410	IC, LINEAR
308	R301	5232-334J16P	RES, CBN 1/6P 330K (Model:HK3450/3550) <b>IB I</b>	418	IC601	5654-LC7821	IC, DIGITAL
308D	R301	5232-274J16P	RES, CBN 1/6P 270K (Model:HK3550) <b>BK</b>	321	IC751	5654-LM7000	IC, DIGITAL
308	R302	5232-334J16P	RES, CBN 1/6P 330K (Model:HK3450/3550) <b>IB I</b>	<b>TRANSISTORS</b>			
308D	R302	5232-274J16P	RES, CBN 1/6P 270K (Model:HK3550) <b>BK</b>	428	Q1	5612-941(P)	XISTOR, PNP A
309	R303	5232-274J16P	RES, CBN 1/6P 270K (Model:HK3450/3550) <b>IB I</b>	429	Q2	5613-1740(R)	XISTOR, NPN R
309D	R303	5232-184J16P	RES, CBN 1/6P 180K (Model:HK3550) <b>BK</b>	429	Q3	5613-1740(R)	XISTOR, NPN R
309	R304	5232-274J16P	RES, CBN 1/6P 270K (Model:HK3450/3550) <b>IB I</b>	428	Q4	5612-941(P)	XISTOR, PNP A
309D	R304	5232-184J16P	RES, CBN 1/6P 180K (Model:HK3550) <b>BK</b>	429	Q5	5613-1740(R)	XISTOR, NPN R
314	R305	5232-272J16P	RES, CBN 1/6P 2.7K	429	Q6	5613-1740(R)	XISTOR, NPN R
314	R306	5232-272J16P	RES, CBN 1/6P 2.7K	430	Q8	5611-A143ES	XISTOR, PNP R
310	R307	5232-102J16P	RES, CBN 1/6P 1K	431	Q9	5611-933(R)	XISTOR, PNP R
311	R308	5232-103J16P	RES, CBN 1/6P 10K	429	Q10	5613-1740(R)	XISTOR, NPN R
312	R309	5134-222J25P	RES, CBN 1/4P 2.2K	429	Q11	5613-1740(R)	XISTOR, NPN R
312	R310	5134-222J25P	RES, CBN 1/4P 2.2K	429	Q12	5613-1740(R)	XISTOR, NPN R
311	R311	5232-103J16P	RES, CBN 1/6P 10K	431	Q13	5611-933(R)	XISTOR, PNP R
311	R312	5232-103J16P	RES, CBN 1/6P 10K	432	Q14	5611-A114ES	XISTOR, PNP R
315	R315	5232-822J16P	RES, CBN 1/6P 8.2K	432	Q15	5611-A114ES	XISTOR, PNP R
315	R316	5232-822J16P	RES, CBN 1/6P 8.2K	433	Q16	5613-C114ES	XISTOR, NPN R
313D	R317	5232-123J16P	RES, CBN 1/6P 12K (Model:HK3550) <b>BK</b>	434	Q17	5612-647(C)	XISTOR, PNP A
313	R317	5232-682J16P	RES, CBN 1/6P 6.8K (Model:HK3450/3550) <b>IB I</b>	218	Q201	5613-1923(Y)	XISTOR, NPN R
313D	R318	5232-123J16P	RES, CBN 1/6P 12K (Model:HK3550) <b>BK</b>	218	Q202	5613-1923(Y)	XISTOR, NPN R
313	R318	5232-682J16P	RES, CBN 1/6P 6.8K (Model:HK3450/3550) <b>IB I</b>	219	Q211	5614-1450(T)	XISTOR, NPN A
316	R321	5134-220J25P	RES, CBN 1/4P 22 (Model:HK3450/3550) <b>IB I</b>	226	Q212	5611-A144ES	XISTOR, PNP R
421	R603	5134-122J25P	RES, CBN 1/4P 1.2K	288	Q301	5614-1450(T)	XISTOR, NPN A
421	R604	5134-122J25P	RES, CBN 1/4P 1.2K	288	Q302	5614-1450(T)	XISTOR, NPN A
421	R605	5134-122J25P	RES, CBN 1/4P 1.2K	323	Q751	5613-2240(BL)	XISTOR, NPN R
421	R606	5134-122J25P	RES, CBN 1/4P 1.2K	322	Q752	5613-1740(R)	XISTOR, NPN R
421	R607	5134-122J25P	RES, CBN 1/4P 1.2K	326	Q753	5611-A143ES	XISTOR, PNP R
421	R608	5134-122J25P	RES, CBN 1/4P 1.2K	326	Q754	5611-A143ES	XISTOR, PNP R
421	R609	5134-122J25P	RES, CBN 1/4P 1.2K	326	Q755	5611-A143ES	XISTOR, PNP R
421	R610	5134-122J25P	RES, CBN 1/4P 1.2K	325	Q756	5611-A124ES	XISTOR, PNP R
421	R611	5134-122J25P	RES, CBN 1/4P 1.2K	324	Q757	5613-C124ES	XISTOR, NPN R
421	R612	5134-122J25P	RES, CBN 1/4P 1.2K	<b>DIODES</b>			
				437	$\Delta$ D3	5632-S5566B	DIODE, RECT
				437	$\Delta$ D4	5632-S5566B	DIODE, RECT
				437	$\Delta$ D5	5632-S5566B	DIODE, RECT
				437	$\Delta$ D6	5632-S5566B	DIODE, RECT
				435	D7	5631-1S2473	DIODE, DET
				438	D8	5635-HZ5C1	DIODE, ZENER
				439	D9	5635-HZ24-1L	DIODE, ZENER
				440	D10	5635-HZ6C1	DIODE, ZENER
				441	D12	5635-HZ12C1	DIODE, ZENER
				442	D13	5635-HZ7A1	DIODE, ZENER
				436	D14	5636-1SS133	DIODE, SWITCH
				436	D15	5636-1SS133	DIODE, SWITCH
				253	D241	5633-321SP(B)	DIODE, CAP
				253	D242	5633-321SP(B)	DIODE, CAP
				254	D251	5631-1S2473	DIODE, DET
				255	D252	5636-1SS133	DIODE, SWITCH



Ser. No.	Ref. No.	Part No.	Description
401	R562	5134-221J25P	RES, CBN 1/4P 220
402	R563	5134-393J25P	RES, CBN 1/4P 39K
402	R564	5134-393J25P	RES, CBN 1/4P 39K
<b>TRANSISTORS</b>			
356	Q501	5613-2320L(F)	XISTOR, NPN R
356	Q502	5613-2320L(F)	XISTOR, NPN R
356	Q503	5613-2320L(F)	XISTOR, NPN R
356	Q504	5613-2320L(F)	XISTOR, NPN R
357	Q505	5611-1115(F)	XISTOR, PNP R
357	Q506	5611-1115(F)	XISTOR, PNP R
358	Q507	5614-1450(T)	XISTOR, NPN A
358	Q508	5614-1450(T)	XISTOR, NPN A
359	Q551	5614-667(C)	XISTOR, NPN A
360	Q552	5612-647(C)	XISTOR, PNP A
<b>DIODES</b>			
361	D551	5635-HZ12C1	DIODE, ZENER
361	D552	5635-HZ12C1	DIODE, ZENER
<b>CONTROLS</b>			
407	VR503/ 504	5113-S2001503	RES, V CBN 16 50K, BALANCE
409	VR505/ 506	5113-S2003104	RES, V CBN 16 100K, BASS
411	VR507/ 508	5113-S2002503	RES, V CBN 16 50K, TREBLE
<b>MISCELLANEOUS</b>			
510	CN406	4443-0201141	CONNECTOR, 2 PIN
520	LCN505	4162-01201251	LUG W/WIRE
519	LCN601	4163-S5303301	CONNECTOR W/W, 2 PIN
516	LCN603	4163-S5302101	CONNECTOR W/W, 2 PIN
541	LUG510	4211-4	LUG, W-510 (Model:HK3450/3550)
526	W501	4142-00151351	SHLD WIRE, 2C
527	W503	4142-00151201	SHLD WIRE, 2C
528	W504	4142-00151171	SHLD WIRE, 2C
529	W602	4142-00151301	SHLD WIRE, 2C
502		2240-Z031	HOLDER

**PCB3 VOLUME P.C. BOARD**

Ser. No.	Ref. No.	Part No.	Description
375	C523	5352-S110J104	CAP, MTL .1U
<b>RESISTORS</b>			
403	R98	5134-331J25P	RES, CBN 1/4P 330
403	R99	5134-331J25P	RES, CBN 1/4P 330
<b>CONTROLS</b>			
405	VR501/ 502	6161-00703	VR BLOCK 100K, VOLUME
<b>MISCELLANEOUS</b>			
507	CN22	4443-0201140	CONNECTOR, 2 PIN
518	LCN23	4163-S5304101	CONNECTOR W/W, 4 PIN
503		2240-Z031	HOLDER

**PCB4 LOUDNESS P.C. BOARD**

Ser. No.	Ref. No.	Part No.	Description
374	C519	5352-S110J823	CAP, MTL .082U
374	C520	5352-S110J823	CAP, MTL .082U
<b>RESISTORS</b>			
395	R539	5134-273J25P	RES, CBN 1/4P 27K
395	R540	5134-273J25P	RES, CBN 1/4P 27K
396	R541	5134-472J25P	RES, CBN 1/4P 4.7K
396	R542	5134-472J25P	RES, CBN 1/4P 4.7K

Ser. No.	Ref. No.	Part No.	Description
488	SW501	4431-A027610	SWITCH, PUSH, LOUDNESS

**PCB5 SECONDARY P.C. BOARD**

Ser. No.	Ref. No.	Part No.	Description
<b>CAPACITORS</b>			
460	C2	5352-S181K104	CAP, MTL .1U
460	C3	5352-S181K104	CAP, MTL .1U
460	C4	5352-S181K104	CAP, MTL .1U
460	C5	5352-S181K104	CAP, MTL .1U
460	C6	5352-S181K104	CAP, MTL .1U
<b>MISCELLANEOUS</b>			
491	△ F2	5732-01601202	FUSE, T2A/T2AL 250V (Model:HK3450/3550) <b>IB I</b>
491B	△ F2	5732-01501202	FUSE, 2A-125V/250V (Model:HK3550) <b>BK</b>
491	△ F3	5732-01601202	FUSE, T2A/T2AL 250V (Model:HK3450/3550) <b>IB I</b>
491B	△ F3	5732-01501202	FUSE, 2A-125V/250V (Model:HK3550) <b>BK</b>
492	△ HF3	4472-04901	HOLDER, FUSE, F2
492	△ HF4	4472-04901	HOLDER, FUSE, F2
492	△ HF5	4472-04901	HOLDER, FUSE, F3
492	△ HF6	4472-04901	HOLDER, FUSE, F3
523	JL6	4242-R0506301	JUMPER LEAD
501		2240-Z062	HOLDER, JL6

**PCB6 VOLUME INDICATOR P.C. BOARD**

Ser. No.	Ref. No.	Part No.	Description
<b>CAPACITOR</b>			
447	C26	5345-106F0962	CAP, MINI ELE 10U/50V
<b>DIODE</b>			
443	D16	5637-S2410E1	LED, VOLUME
<b>MISCELLANEOUS</b>			
517	LCN22	4163-01524002	CONNECTOR W/W, 2 PIN

**PCB7 EQ P.C. BOARD**

Ser. No.	Ref. No.	Part No.	Description
<b>CAPACITORS</b>			
352	C601	5345-336C0951	CAP, MINI ELE 33U/16V
352	C602	5345-336C0951	CAP, MINI ELE 33U/16V
357	C603	5359-1215851	CAP, PPP 120P
357	C604	5359-1215851	CAP, PPP 120P
351	C605	5345-227B0962	CAP, MINI ELE 220U/10V
351	C606	5345-227B0962	CAP, MINI ELE 220U/10V
358	C607	5359-5625851	CAP, PPP 5600P
358	C608	5359-5625851	CAP, PPP 5600P
359	C609	5359-2025851	CAP, PPP 2000P
359	C610	5359-2025851	CAP, PPP 2000P
353	C611	5345-106F0962	CAP, MINI ELE 10U/50V
353	C612	5345-106F0962	CAP, MINI ELE 10U/50V
354	C613	5345-227D0962	CAP, MINI ELE 220U/25V
354	C614	5345-227D0962	CAP, MINI ELE 220U/25V
354	C615	5345-227D0962	CAP, MINI ELE 220U/25V
354	C616	5345-227D0962	CAP, MINI ELE 220U/25V
356	C617	5353-040933	CAP, MCA 4P
356	C618	5353-040933	CAP, MCA 4P
360	C619	5359-6825851	CAP, PPP 6800P
360	C620	5359-6825851	CAP, PPP 6800P
361	C621	5359-2215851	CAP, PPP 220P (Model:HK3450/3550) <b>IB I</b>
361	C622	5359-2215851	CAP, PPP 220P (Model:HK3450/3550) <b>IB I</b>

Ser. No.	Ref. No.	Part No.	Description	Ser. No.	Ref. No.	Part No.	Description
<b>RESISTORS</b>				<b>DIODES</b>			
377	R601	5134-823J25P	RES, CBN 1/4P 82K	344	D601	5635-HZ15-2L	DIODE, ZENER
377	R602	5134-823J25P	RES, CBN 1/4P 82K	344	D602	5635-HZ15-2L	DIODE, ZENER
378	R603	5134-124J25P	RES, CBN 1/4P 120K	<b>MISCELLANEOUS</b>			
378	R604	5134-124J25P	RES, CBN 1/4P 120K	350	CN605	4443-0201141	CONNECTOR
368	R605	5134-102J25P	RES, CBN 1/4P 1K	348	J601	4489-04006002	PIN JACK, MLT, PHONO
			(Model:HK3450/3550)	346	LCN601	4162-01201201	LUG W/WIRE
042A	R605	5134-221J25P	RES, CBN 1/4P 220 (Model:HK3550)	336	W601	4142-00151201	SHLD WIRE, 2C
				349		2240-Z031	HOLDER, CN601
368	R606	5134-102J25P	RES, CBN 1/4P 1K	<b>PCB101 MAIN AMP P.C BOARD</b>			
			(Model:HK3450/3550)	<b>CAPACITORS</b>			
042A	R606	5134-221J25P	RES, CBN 1/4P 220 (Model:HK3550)	277	C31	5352-S181K104	CAP, MTL .1U (Model:HK3450/3550)
369	R607	5134-122J25P	RES, CBN 1/4P 1.2K	277	C32	5352-S181K104	CAP, MTL .1U (Model:HK3450/3550)
369	R608	5134-122J25P	RES, CBN 1/4P 1.2K				
363	R609	5134-220J25P	RES, CBN 1/4P 22	259	C51	5352-S110J683	CAP, MTL .068U
363	R610	5134-220J25P	RES, CBN 1/4P 22	259	C52	5352-S110J683	CAP, MTL .068U
369	R611	5134-122J25P	RES, CBN 1/4P 1.2K	260	C53	5345-105F0962	CAP, MINI ELE 1U/50V
369	R612	5134-122J25P	RES, CBN 1/4P 1.2K	275	C55	5341-S38FM688	CAP, ELE 6800U/50V (Model:HK3450)
376	R613	5134-473J25P	RES, CBN 1/4P 47K	275D	C55	5341-S38FM828	CAP, ELE 8200U/50V (Model:HK3550)
376	R614	5134-473J25P	RES, CBN 1/4P 47K	275	C56	5341-S38FM688	CAP, ELE 6800U/50V (Model:HK3450)
364	R615	5134-820J25P	RES, CBN 1/4P 82	275D	C56	5341-S38FM828	CAP, ELE 8200U/50V (Model:HK3550)
364	R616	5134-820J25P	RES, CBN 1/4P 82	220	C401	5345-107B0962	CAP, MINI ELE 100U/10V
364	R617	5134-820J25P	RES, CBN 1/4P 82	220	C402	5345-107B0962	CAP, MINI ELE 100U/10V
364	R618	5134-820J25P	RES, CBN 1/4P 82	221	C403	5359-6805851	CAP, PPP 68P
367	R621	5134-911J25P	RES, CBN 1/4P 910	221	C404	5359-6805851	CAP, PPP 68P
367	R622	5134-911J25P	RES, CBN 1/4P 910	222	C405	5353-050933	CAP, MCA 5P (Model:HK3450/3550)
375	R623	5134-393J25P	RES, CBN 1/4P 39K				
375	R624	5134-393J25P	RES, CBN 1/4P 39K	222E	C405	5353-030933	CAP, MCA 3P (Model:HK3550)
380	R625	5134-564J25P	RES, CBN 1/4P 560K	222	C406	5353-050933	CAP, MCA 5P (Model:HK3450/3550)
380	R626	5134-564J25P	RES, CBN 1/4P 560K				
379	R627	5134-334J25P	RES, CBN 1/4P 330K	222E	C406	5353-030933	CAP, MCA 3P (Model:HK3550)
379	R628	5134-334J25P	RES, CBN 1/4P 330K	223	C407	5345-105F0962	CAP, MINI ELE 1U/50V
368	R629	5134-102J25P	RES, CBN 1/4P 1K	223	C408	5345-105F0962	CAP, MINI ELE 1U/50V
368	R630	5134-102J25P	RES, CBN 1/4P 1K	224	C409	5345-106F0962	CAP, MINI ELE 10U/50V
374	R631	5134-333J25P	RES, CBN 1/4P 33K	224	C410	5345-106F0962	CAP, MINI ELE 10U/50V
374	R632	5134-333J25P	RES, CBN 1/4P 33K	226	C413	5345-475F0962	CAP, MINI ELE 4.7U/50V
371	R633	5134-331J25P	RES, CBN 1/4P 330	226	C414	5345-475F0962	CAP, MINI ELE 4.7U/50V
371	R634	5134-331J25P	RES, CBN 1/4P 330	227	C415	5354-104593	CAP, MYL .1U
370	R635	5134-222J25P	RES, CBN 1/4P 2.2K	227	C416	5354-104593	CAP, MYL .1U
370	R636	5134-222J25P	RES, CBN 1/4P 2.2K	227	C417	5354-104593	CAP, MYL .1U
362	R637	5134-105J25P	RES, CBN 1/4P 1M	227	C418	5354-104593	CAP, MYL .1U
362	R638	5134-105J25P	RES, CBN 1/4P 1M	228	C419	5345-104F0962	CAP, MINI ELE .1U/50V
372	R641	5134-822J25P	RES, CBN 1/4P 8.2K	228	C420	5345-104F0962	CAP, MINI ELE .1U/50V
372	R642	5134-822J25P	RES, CBN 1/4P 8.2K	227	C421	5354-104593	CAP, MYL .1U (Model:HK3450/3550)
368	R643	5134-102J25P	RES, CBN 1/4P 1K				
			(Model:HK3450/3550)	227	C422	5354-104593	CAP, MYL .1U (Model:HK3450/3550)
041A	R643	5134-471J25P	RES, CBN 1/4P 470 (Model:HK3550)	227	C423	5354-104593	CAP, MYL .1U (Model:HK3450/3550)
368	R644	5134-102J25P	RES, CBN 1/4P 1K	227	C424	5354-104593	CAP, MYL .1U (Model:HK3450/3550)
			(Model:HK3450/3550)	291	C441	5359-3905851	CAP, PPP 39P (Model:HK3450/3550)
041A	R644	5134-471J25P	RES, CBN 1/4P 470 (Model:HK3550)				
				291	C442	5359-3905851	CAP, PPP 39P (Model:HK3450/3550)
345	△ R651	5102-8205116	RES, FUSE 82	<b>RESISTORS</b>			
345	△ R652	5102-8205116	RES, FUSE 82	262	R51	5134-123J25P	RES, CBN 1/4P 12K
370	R681	5134-222J25P	RES, CBN 1/4P 2.2K	262	R52	5134-123J25P	RES, CBN 1/4P 12K
370	R682	5134-222J25P	RES, CBN 1/4P 2.2K	263	R53	5134-331J25P	RES, CBN 1/4P 330
				263	R54	5134-331J25P	RES, CBN 1/4P 330
				264	R55	5134-152J25P	RES, CBN 1/4P 1.5K
				264	R56	5134-152J25P	RES, CBN 1/4P 1.5K
				264	R57	5134-152J25P	RES, CBN 1/4P 1.5K
				264	R58	5134-152J25P	RES, CBN 1/4P 1.5K
				265	R59	5134-682J25P	RES, CBN 1/4P 6.8K
				265	R60	5134-682J25P	RES, CBN 1/4P 6.8K
				266	R61	5134-683J25P	RES, CBN 1/4P 68K



Ser. No.	Ref. No.	Part No.	Description
331	LCN406	4163-S5302351	CONNECTOR W/W, 2 PIN
332	LCN415	4162-01201151	LUG W/WIR
041C	LCN605	4163-S5302351	CONNECTOR W/W, 2 PIN
309	TM404	4214-11032	TERMINAL

Ser. No.	Ref. No.	Part No.	Description
317	SW721	4437-01202	SWITCH, PU-TC, TUNER
317	SW722	4437-01202	SWITCH, PU-TC, CD
317	SW723	4437-01202	SWITCH, PU-TC, PHONO

**PCB102 FRONT P.C. BOARD**

CAPACITORS			
295	C701	5350-S051Z473	CAP, SPE .047F/5.5V
296	C702	5345-106F0962	CAP, MINI ELE 100U/50V
297	C703	5345-107B0962	CAP, MINI ELE 100U/10V
299	C704	5354-104593	CAP, MYL .1U
298	C705	5354-103J1HM	CAP, MYL .01U
297	C706	5345-107B0962	CAP, MINI ELE 100U/10V
299	C707	5354-104593	CAP, MYL .1U
299	C708	5352-104593	CAP, MYL .1U
294	C712	5345-107D0962	CAP, MINI ELE 100U/25V

RESISTORS			
300	R701	5134-103J25P	RES, CBN 1/4P 10K
301	R702	5134-102J25P	RES, CBN 1/4P 1K
302	R703	5134-123J25P	RES, CBN 1/4P 12K
303	R704	5134-470J25P	RES, CBN 1/4P 47
300	R705	5134-103J25P	RES, CBN 1/4P 10K
300	R706	5134-103J25P	RES, CBN 1/4P 10K
300	R707	5134-103J25P	RES, CBN 1/4P 10K
300	R708	5134-103J25P	RES, CBN 1/4P 10K
304	R709	5134-105J25P	RES, CBN 1/4P 1M
305	R710	5134-100J25P	RES, CBN 1/4P 10
305	R711	5134-100J25P	RES, CBN 1/4P 10

INTEGRATED CIRCUIT			
287	IC701	5654-37421-2F	IC, DIGITAL

DIODES			
288	D701	5631-1S2473	DIODE, DET
288	D702	5631-1S2473	DIODE, DET
288	D703	5631-1S2473	DIODE, DET
288	D704	5631-1S2473	DIODE, DET
288	D705	5631-1S2473	DIODE, DET
288	D706	5631-1S2473	DIODE, DET
288	D707	5631-1S2473	DIODE, DET
288	D708	5631-1S2473	DIODE, DET
288	D709	5631-1S2473	DIODE, DET (Model:HK3450/3550)

289	D710	5632-S5566B	DIODE, RECT
-----	------	-------------	-------------

MISCELLANEOUS			
292	CF701	5693-FC4004A4	OSC, CER
322	CN701A	4443-05401025	CONNECTOR, 25 PIN
291	FL701	5722-064	TUBE DISPLAY
325	LCN702	4163-0135020	CONNECTOR W/W, 1 PIN
293	RCV701	6143-00802	RECEIV UNIT, REMOTE SENSOR
316	SW701	4437-01201	SWITCH, PU-TC, POWER
317	SW702	4437-01202	SWITCH, PU-TC, MEMORY 1
317	SW703	4437-01202	SWITCH, PU-TC, MEMORY 3
317	SW704	4437-01202	SWITCH, PU-TC, MEMORY 5
317	SW705	4437-01202	SWITCH, PU-TC, MEMORY 7
317	SW706	4437-01202	SWITCH, PU-TC, MEMORY 9
317	SW707	4437-01202	SWITCH, PU-TC, MEMORY
317	SW708	4437-01202	SWITCH, PU-TC, FM/AM
317	SW709	4437-01202	SWITCH, PU-TC, TUNING UP
317	SW710	4437-01202	SWITCH, PU-TC, MEMORY 2
317	SW711	4437-01202	SWITCH, PU-TC, MEMORY 4
317	SW712	4437-01202	SWITCH, PU-TC, MEMORY 6
317	SW713	4437-01202	SWITCH, PU-TC, MEMORY 8
317	SW714	4437-01202	SWITCH, PU-TC, MEMORY 0
317	SW715	4437-01202	SWITCH, PU-TC, SEEK-STEREO
317	SW716	4437-01202	SWITCH, PU-TC, PRESET SCAN
317	SW717	4437-01202	SWITCH, PU-TC, TUNING DOWN
317	SW718	4437-01202	SWITCH, PU-TC, TAPE 1/COPY
317	SW719	4437-01202	SWITCH, PU-TC, TAPE 2/MONITOR
317	SW720	4437-01202	SWITCH, PU-TC, VIDEO

**PCB103 SPEAKER SWITCH P.C. BOARD**

RESISTORS			
249	R491	5134-102J25P	RES, CBN 1/4P 1K
249	R492	5134-102J25P	RES, CBN 1/4P 1K
249	R493	5134-102J25P	RES, CBN 1/4P 1K
249	R494	5134-102J25P	RES, CBN 1/4P 1K

MISCELLANEOUS			
311	△ J401	4451-00158	JACK, 1P, HEADPHONES
336	JW405	4163-S5404401	CONNECTOR W/W, 4 PIN
337	LCN407	4163-0136039	CONNECTOR W/W, 1 PIN
315	SW401/	4431-S0317204	SWITCH, PUSH, SPEAKERS 1/2
		402	

**PCB104 PRIMARY 1 P.C. BOARD**

CAPACITOR			
043B	△ C1	5352-S010M103	CAP, MTL .01U (Model:HK3550) <b>BK</b>

RESISTORS			
044B	△ R1	5135-335J50P	RES, CBN 1/2P 3.3M (Model:HK3550) <b>BK</b>
045B	R2	5134-102J25P	RES, CBN 1/4P 1K (Model:HK3550) <b>BK</b>

TRANSISTOR			
041B	Q7	5613-2603(F)	XISTOR, NPN R (Model:HK3550) <b>BK</b>

DIODE			
042B	D11	5631-1S2473	DIODE, DET (Model:HK3550) <b>BK</b>

MISCELLANEOUS			
057B	△ CN1	4443-09501002	CONNECTOR, 2 PIN (Model:HK3550) <b>BK</b>
058B	△ F1	5732-01301402	FUSE, 4A-125V/250V (Model:HK3550) <b>BK</b>
059B	△ HF1	4472-04901	HOLDER, FUSE, F1 (Model:HK3550) <b>BK</b>
059B	△ HF2	4472-04901	HOLDER, FUSE, F1 (Model:HK3550) <b>BK</b>
048B	LCN26	4163-S5303551	CONNECTOR W/W, 3 PIN (Model:HK3550) <b>BK</b>
046B	△ RY1	4331-01702	RELAY, DC (Model:HK3550) <b>BK</b>

**PCB105 BIAS 1 P.C. BOARD**

TRANSISTOR			
206	Q418	5613-3423(Y)	XISTOR, NPN R

**PCB106 BIAS 2 P.C. BOARD**

TRANSISTOR			
207	Q417	5613-3423(Y)	XISTOR, NPN R

**PCB107 SPEAKER TERMINAL P.C. BOARD**

MISCELLANEOUS			
308	△ TM401	4214-254	TERMINAL, SPEAKERS

Ser. No.	Ref. No.	Part No.	Description
<b>PCB108 PRIMARY 1 P.C. BOARD</b>			
<b>MISCELLANEOUS</b>			
323	△ CN1	4443-09501002	CONNECTOR, 2 PIN (Model:HK3450/3550) <b>IB</b> <b>I</b>
319	△ F1	5732-01601122	FUSE, T1.25A/1.25AL 250V (Model:HK3450)
319D	△ F1	5732-01601162	FUSE, T1.25A/1.25AL 250V (Model:HK3550) <b>IS</b> <b>I</b>
320	△ HF1	4472-04901	HOLDER, FUSE, F1 (Model:HK3450/3550) <b>B</b> <b>I</b>
320	△ HF2	4472-04901	HOLDER, FUSE, F1 (Model:HK3450/3550) <b>IB</b> <b>I</b>
318	△ SW1	4411-00501102	SWITCH, ROTARY, VOLTAGE SELECTOR (Model:HK3450/3550) <b>IB</b> <b>I</b>

Ser. No.	Ref. No.	Part No.	Description
<b>PCB109 PRIMARY 2 P.C. BOARD</b>			
<b>MISCELLANEOUS</b>			
333	△ LCN1	4163-S5101120	CONNECTOR W/W, 1 PIN (Model:HK3450)
334	△ LCN2	4163-S5201120	CONNECTOR W/W, 1 PIN (Model:HK3450)
334	△ LCN3	4163-S5201120	CONNECTOR W/W, 1 PIN (Model:HK3450)

Ser. No.	Ref. No.	Part No.	Description
<b>PCB115 PRIMARY 2 P.C. BOARD</b>			
<b>MISCELLANEOUS</b>			
047B	△ S1	4474-02901	SOCKET, AC OUTLET (Model:HK3550) <b>BK</b>

Ser. No.	Ref. No.	Part No.	Description
<b>PCB120 SHEET 2 P.C. BOARD</b>			
<b>MISCELLANEOUS</b>			
052D	△ LCN1	4163-S5101120	CONNECTOR W/W, 1PIN (Model:HK3550) <b>IB</b> <b>I</b>
053D	△ LCN2	4163-S5201120	CONNECTOR W/W, 1PIN (Model:HK3550) <b>IB</b> <b>I</b>
053D	△ LCN3	4163-S5201120	CONNECTOR W/W, 1PIN (Model:HK3550) <b>IB</b> <b>I</b>

Ser. No.	Ref. No.	Part No.	Description
<b>CHASSIS MISCELLANEOUS</b>			
<b>TRANSFORMERS</b>			
321	△ T1	5584-T3202	XFORMER, POWER (Model:HK3450)
321A	△ T1	5584-T3602	XFORMER, POWER (Model:HK3550) <b>BK</b>
321	△ T1	5584-T3601	XFORMER, POWER (Model:HK3550) <b>B</b> <b>I</b>
<b>MISCELLANEOUS</b>			
328	JW701	4242-S0325301	JUMPER LEAD, 25 WIRE
327	△ P1	4161-10201202	CORD W/PLUG (Model:HK3450/3550) <b>IB</b> <b>I</b>
327A	△ P1	4161-09401202	CORD W/PLUG (Model:HK3550) <b>BK</b>
538	PCB7	4551-10014070	P.C. BOARD, SECONDARY 2 P.C. BOARD
051D	PCB110	4551-10015110	P.C. BOARD, SHEET 3 P.C. BOARD (Model:HK3550) <b>IB</b> <b>I</b>
051D	PCB130	4551-10015130	P.C. BOARD, SHEET 1 P.C. BOARD (Model:HK3550) <b>IB</b> <b>I</b>

Ser. No.	Ref. No.	Part No.	Description
<b>PACKING PARTS LIST</b>			
021A		1113-02501	OWNER CARD (Model:HK3550) <b>BK</b>
022A		1116-03802	GUARANTY CARD, WARRANTY CARD (Model:HK3550) <b>BK</b>
023A		1119-05301	ATTACH SHEET, IMPORTANT (Model:HK3550) <b>BK</b>
024A		1119-04502	ATTACH SHEET, SERVICE STATION (Model:HK3550) <b>BK</b>
026B		1756-23601	LABEL, (CH)LABEL (Model:HK3450/3550) <b>I</b>
107		1221-34003	CARTON BOX (Model:HK3450)
107		1221-34005	CARTON BOX (Model:HK3550)
108		1222-7409	CUSHION, L
109		1222-7410	CUSHION, R
110		1756-03108	LABEL, (I) LABEL, CARTON BOX (X2) (Model:HK3450/3550) <b>IB</b> <b>I</b>
111		1223-R0420055	SOFT SHEET, SET FRONT
112		1241-R0123351	POLYETHY BAG, IB
113		1241-R0160601	POLYETHY BAG, SET
115		1111-1310M152	OWNER GUIDE (Model:HK3450/3550) <b>IB</b> <b>I</b>
115A		1111-1320M152	OWNER GUIDE (Model:HK3550) <b>BK</b>
322		6142-07805	REMOTE CONTROL ASS'Y
323		4163-F03186	CONNECTOR W/W, FM ANT (Model:HK3450/3550) <b>IB</b> <b>I</b>
323A		1397-017	T FEEDER ANT, FM ANT (Model:HK3550) <b>BK</b>
324		5911-278	ANT COIL, AM LOOP
325		4191-0355	BATTERY, DRY
326		4161-08201102	CORD W/PLUG, REMOTE CONTROL (x2)

**ABBREVIATIONS IN PARTS LIST**

<b>CAPACITORS</b>	<b>RESISTORS</b>
CAP, MINI ELE : Electrolytic	RES, CBN 1/6P : Carbon 1/6W
CAP, CER : Ceramic	RES, FUSE : Fuse
CAP, PPP : Polypropylene	RES, CEM 5P : Cement 5W
CAP, MYL : Mylar	RES, MTL 1P : Metal 1W
CAP, MCA : Mica	2.2K : 2.2kΩ
CAP, MINI BP : Bipolar	220 : 220Ω
CAP, ELE BP : Electrolytic Bipolar	
CAP, STY : Polystyrene Film	<b>TRANSISTORS</b>
CAP, SPE : Special	XISTOR : Transistor
CAP, TAN : Tantalum	FET : Field Effect Transistor
470U : 470μF	
6800P : 6800pF	<b>CONTROLS</b>
.047U : 0.047μF	RES, V CBN : Variable Carbon Resis- tor
	RES, SEMI FIX : Semi-fixed Resistor

**NOTE**  
 SAFETY RELATED COMPONENT. USE ONLY EXACT REPLACEMENT PART AS SPECIFIED.



IC BLOCK DIAGRAMS

IC201: LA1266 FM/AM IF Amp. and Det., AM Mixer and OSC.

IC1: LB1639 Volume Motor Driver

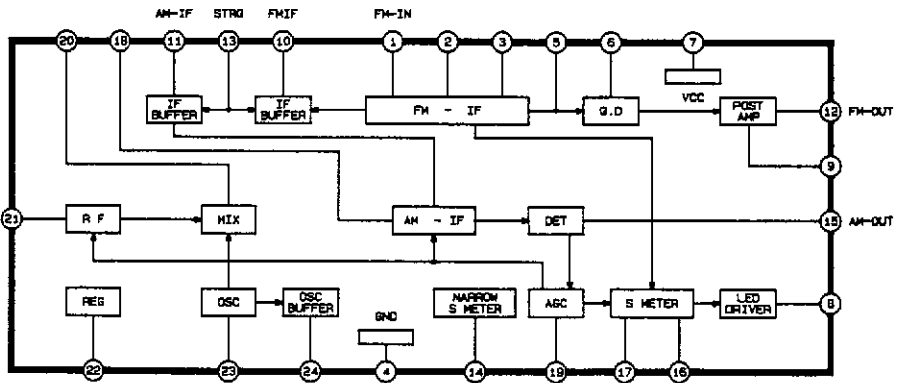
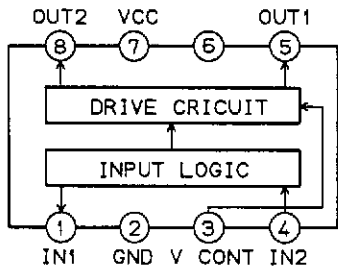

IC301: LA3410 FM MPX

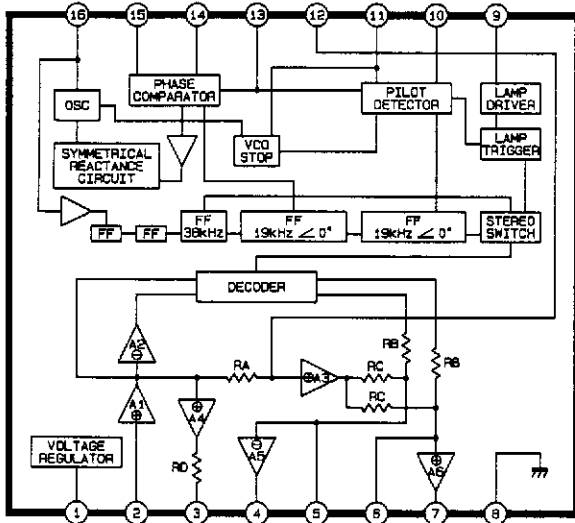

IC601: LC7821 Input Selector

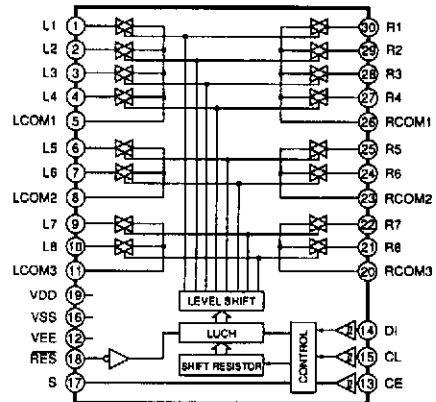

IC751: LM7000 PLL Synthesizer

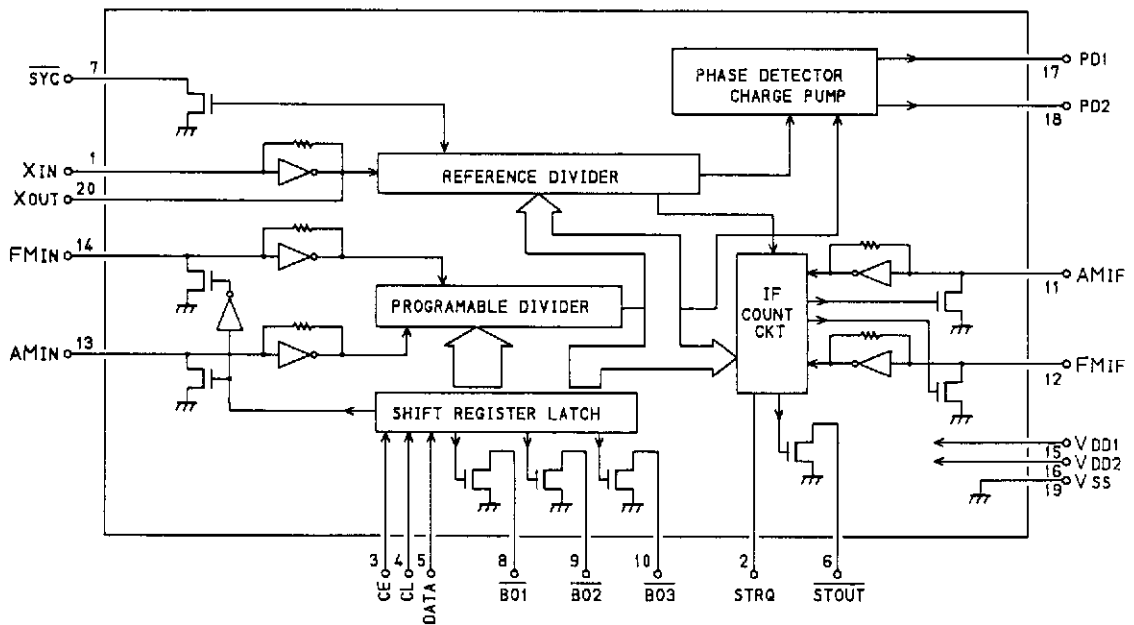

IC701: M37421M6-351FP Micro Computer

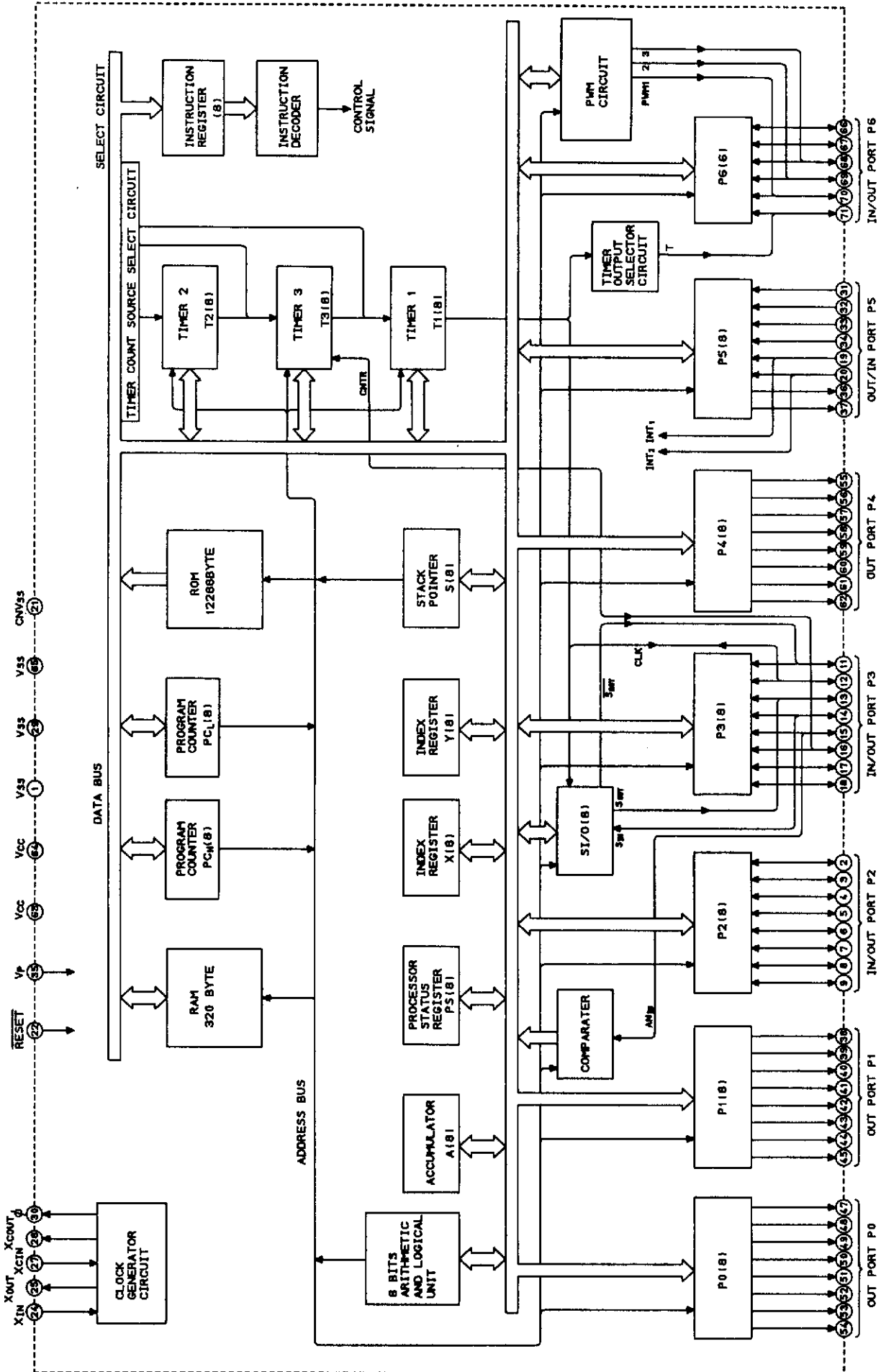

## IC TERMINAL FUNCTION

IC701:M37421M6-351FP

Pin No.	Pin Name	I/O	Function
1	Supply voltage		Power supply inputs 4.5 ~ 5.5V to Vcc, and 0V to Vss.
2	I/O port P27	I/O	Port P27 is an 8-bit I/O port.
3	I/O port P26	I/O	Port P26 is an 8-bit I/O port.
4	I/O port P25	I/O	Port P25 is an 8-bit I/O port.
5	I/O port P24	I/O	Port P24 is an 8-bit I/O port.
6	I/O port P23	I/O	Port P23 is an 8-bit I/O port.
7	I/O port P22	I/O	Port P22 is an 8-bit I/O port.
8	I/O port P21	I/O	Port P21 is an 8-bit I/O port.
9	I/O port P20	I/O	Port P20 is an 8-bit I/O port.
10	NC		
11	I/O port P37	I/O	Port P37 is an 8-bit output port and has basically the same functions as port P2.
12	I/O port P36	I/O	Port P36 is an 8-bit output port and has basically the same functions as port P2.
13	I/O port P35	I/O	Port P35 is an 8-bit output port and has basically the same functions as port P2.
14	I/O port P34	I/O	Port P34 is an 8-bit output port and has basically the same functions as port P2.
15	I/O port P33	I/O	Port P33 is an 8-bit output port and has basically the same functions as port P2.
16	I/O port P32	I/O	Port P32 is an 8-bit output port and has basically the same functions as port P2.
17	I/O port P31	I/O	Port P31 is an 8-bit output port and has basically the same functions as port P2.
18	I/O port P30	I/O	Port P30 is an 8-bit output port and has basically the same functions as port P2.
19	Input port P53	I	Port P53 is an 2-bit input port.
20	Input port P52	I	Port P52 is an 2-bit input port.
21	CNVss		This is usually connected to Vss.
22	Reset input	I	To enter the reset state, the reset input pin must be kept at a "L" for more than 2 $\mu$ s (under normal Vcc conditions).
23	NC		
24	Clock input	I	This chip has an internal clock generating circuit. To control generating frequency, a ceramic or crystal is connected between the Xin and Xouts or the Xoutf pins.
25	Clock output	O	This is output pin from internal clock generating circuit. The generating frequency can be controlled by connecting a ceramic or crystal between this pin and Xin pin.
26	NC		
27	Clock I/O for timer	I	These are I/O pins of the clock oscillating circuit for timer. To control generating frequency, an external ceramic or quartz crystal oscillator is connected between the Xcin pin and Xcout pin.
28	Clock I/O for timer	O	These are I/O pins of the clock oscillating circuit for timer. To control generating frequency, an external ceramic or quartz crystal oscillator is connected between the Xcin pin and Xcout pin.
29	Supply voltage		Power supply inputs 4.5 ~ 5.5V to Vcc, and 0V to Vss.
30	Timing output	O	This is the timing output pin.
31	Input port P57	I	Port P57 is an 7-bit input port.
32	Input port P56	I	Port P56 is an 7-bit input port.
33	Input port P55	I	Port P55 is an 7-bit input port.
34	Input port P54	I	Port P54 is an 7-bit input port.

Pin No.	Pin Name	I/O	Function
35	Pull-down voltage	I	This is the input voltage pin for the pull-down transistor of ports P0, P1, P4, P5 and P51.
36	Output port P51	O	Port P51 is an 2-bit output port.
37	Output port P50	O	Port P50 is an 2-bit output port.
38	Output port P17	O	Port P17 is an 8-bit output port.
39	Output port P16	O	Port P16 is an 8-bit output port.
40	Output port P15	O	Port P15 is an 8-bit output port.
41	Output port P14	O	Port P14 is an 8-bit output port.
42	Output port P13	O	Port P13 is an 8-bit output port.
43	Output port P12	O	Port P12 is an 8-bit output port.
44	Output port P11	O	Port P11 is an 8-bit output port.
45	Output port P10	O	Port P10 is an 8-bit output port.
46	NC		
47	Output port P07	O	Port P07 is an 8-bit output port. At reset, this port is set to "L" level.
48	Output port P06	O	Port P06 is an 8-bit output port. At reset, this port is set to "L" level.
49	Output port P05	O	Port P05 is an 8-bit output port. At reset, this port is set to "L" level.
50	Output port P04	O	Port P04 is an 8-bit output port. At reset, this port is set to "L" level.
51	Output port P03	O	Port P03 is an 8-bit output port. At reset, this port is set to "L" level.
52	Output port P02	O	Port P02 is an 8-bit output port. At reset, this port is set to "L" level.
53	Output port P01	O	Port P01 is an 8-bit output port. At reset, this port is set to "L" level.
54	Output port P00	O	Port P00 is an 8-bit output port. At reset, this port is set to "L" level.
55	Output port P47	O	Port P47 is an 8-bit output port and has basically the same functions as port P0.
56	Output port P46	O	Port P46 is an 8-bit output port and has basically the same functions as port P0.
57	Output port P45	O	Port P45 is an 8-bit output port and has basically the same functions as port P0.
58	Output port P44	O	Port P44 is an 8-bit output port and has basically the same functions as port P0.
59	Output port P43	O	Port P43 is an 8-bit output port and has basically the same functions as port P0.
60	Output port P42	O	Port P42 is an 8-bit output port and has basically the same functions as port P0.
61	Output port P41	O	Port P41 is an 8-bit output port and has basically the same functions as port P0.
62	Output port P40	O	Port P40 is an 8-bit output port and has basically the same functions as port P0.
63	Supply voltage		Power supply inputs 4.5 ~ 5.5V to Vcc, and 0V to Vss.
64	Supply voltage		Power supply inputs 4.5 ~ 5.5V to Vcc, and 0V to Vss.
65	Supply voltage		Power supply inputs 4.5 ~ 5.5V to Vcc, and 0V to Vss.
66	I/O port P65	I/O	Port P65 is an 6-bit I/O port.
67	I/O port P64	I/O	Port P64 is an 6-bit I/O port.
68	I/O port P63	I/O	Port P63 is an 6-bit I/O port.
69	I/O port P62	I/O	Port P62 is an 6-bit I/O port.
70	I/O port P61	I/O	Port P61 is an 6-bit I/O port.
71	I/O port P60	I/O	Port P60 is an 6-bit I/O port.
72	NC		

**SCHEMATIC DIAGRAM**  
(INFRARED REMOTE CONTROL)

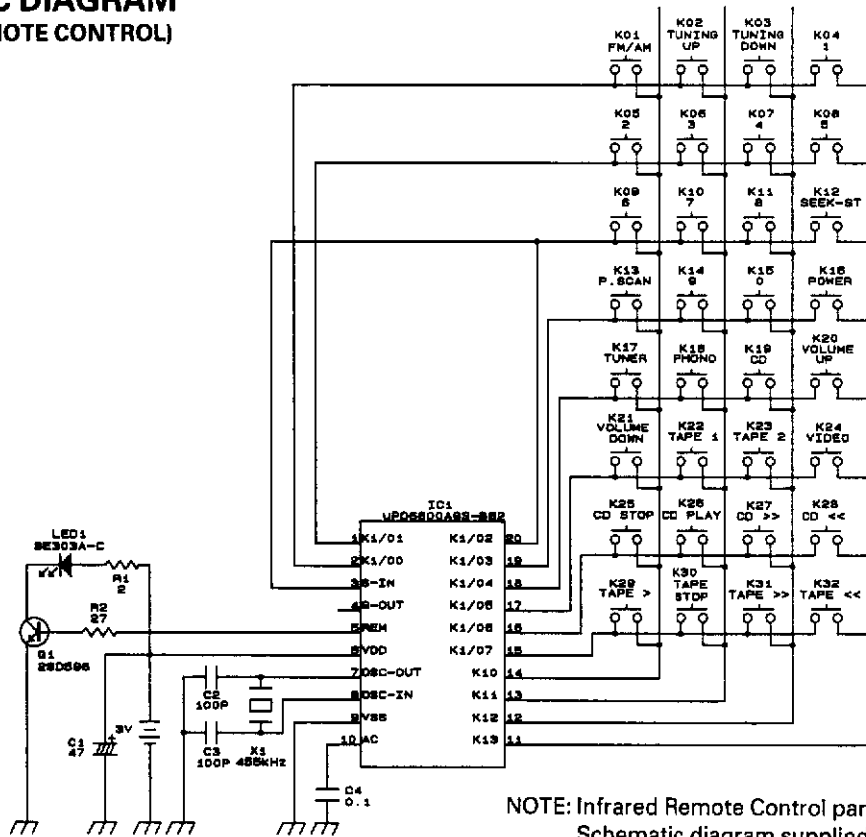

NOTE: Infrared Remote Control parts not available.  
Schematic diagram supplied for reference only.

**FL701: Display Pin Connection**

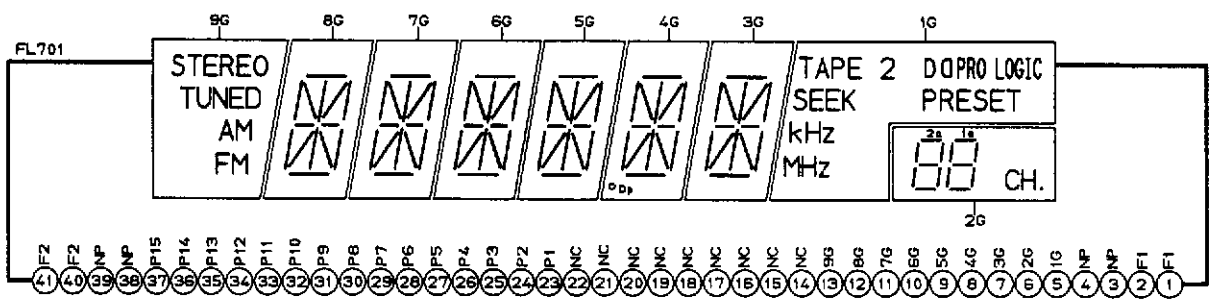

**ANODE CONNECTION**

	9G	8G	7G	6G	5G	4G	3G	2G	1G
P1	STEREO	a	a	a	a	a	a	2a	TAPE2
P2	TUNED	h	h	h	b	h	h	1a	SEEK
P3	AM	b	b	b	b	b	b	2b	kHz
P4	FM	j	j	j	j	j	j	1b	MHz
P5	-	k	k	k	k	k	k	1c	PROLOGIC
P6	-	f	f	f	f	f	f	2f	PRESET
P7	-	g	g	g	g	g	g	2g	-
P8	-	m	m	m	m	m	m	1d	-
P9	-	p	p	p	p	p	p	1f	-
P10	-	r	r	r	r	r	r	1g	-
P11	-	n	n	n	n	n	n	1e	-
P12	-	e	e	e	e	e	e	2e	-
P13	-	c	c	c	c	c	c	2c	-
P14	-	d	d	d	d	d	d	2d	-
P15	-	-	-	-	-	Dp	-	CH	-

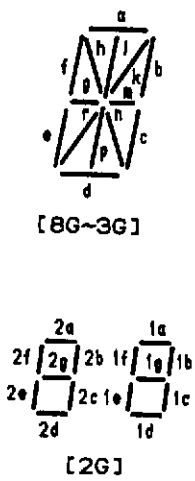





**SCHEMATIC DIAGRAM**  
(TUNER SECTION)

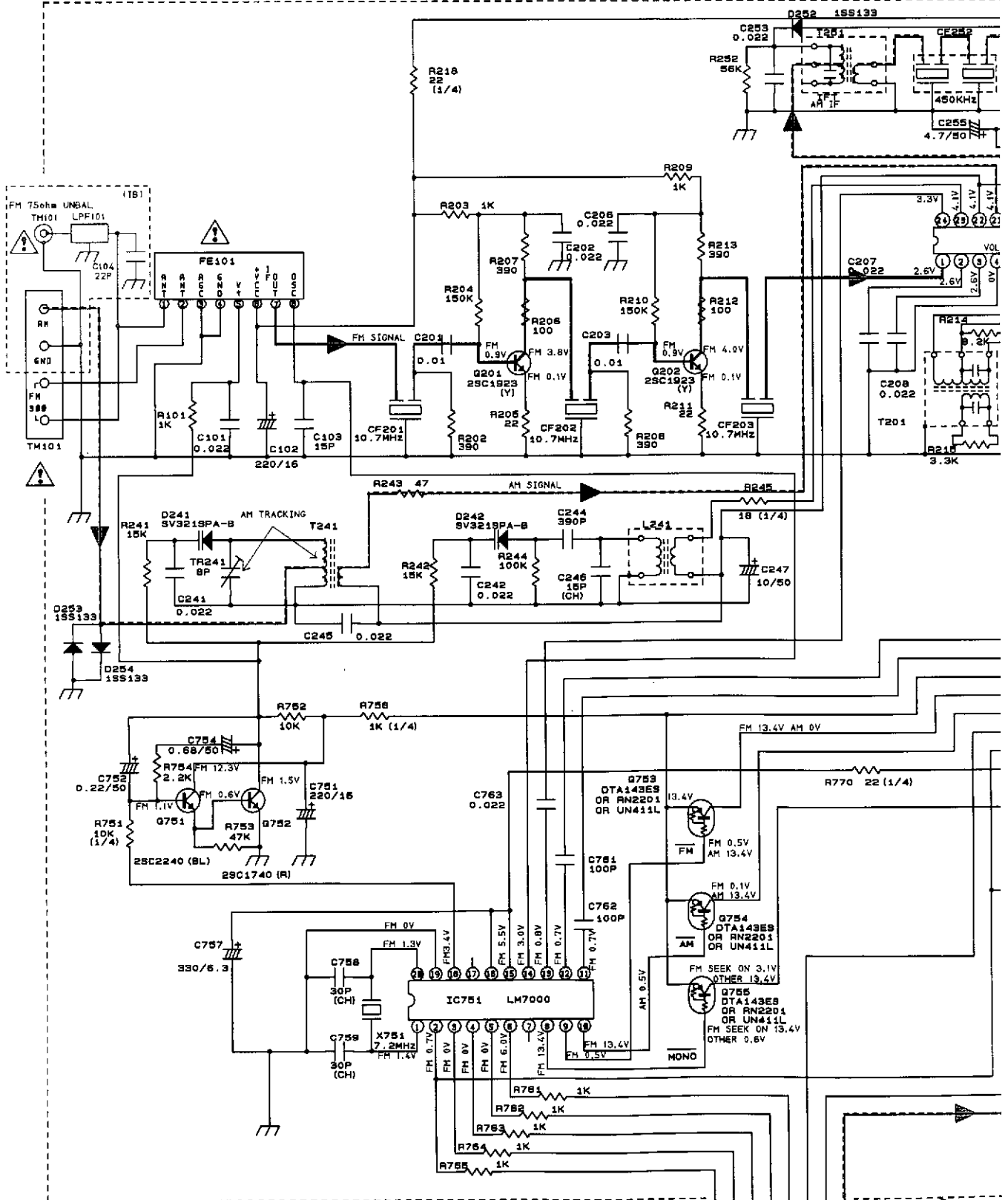

NOTE:

1. ALL RESISTANCES VALUES ARE IN (ohm).  
K=1000 (ohm), M=1000K (ohm).
2. THE WATTAGE OF RESISTANCES IS 1/8W UNLESS OTHERWISE NOTED.
3. ALL CAPACITANCES VALUES ARE IN uF UNLESS OTHERWISE NOTED.  
P=µUF
4. SAFETY REQUIREMENTS COMPONENTS IN ACCORDANCE WITH PRESENT SAFETY REGULATIONS.
5. THESE COMPONENTS MUST ONLY BE REPLACED BY ORIGINAL PARTS.



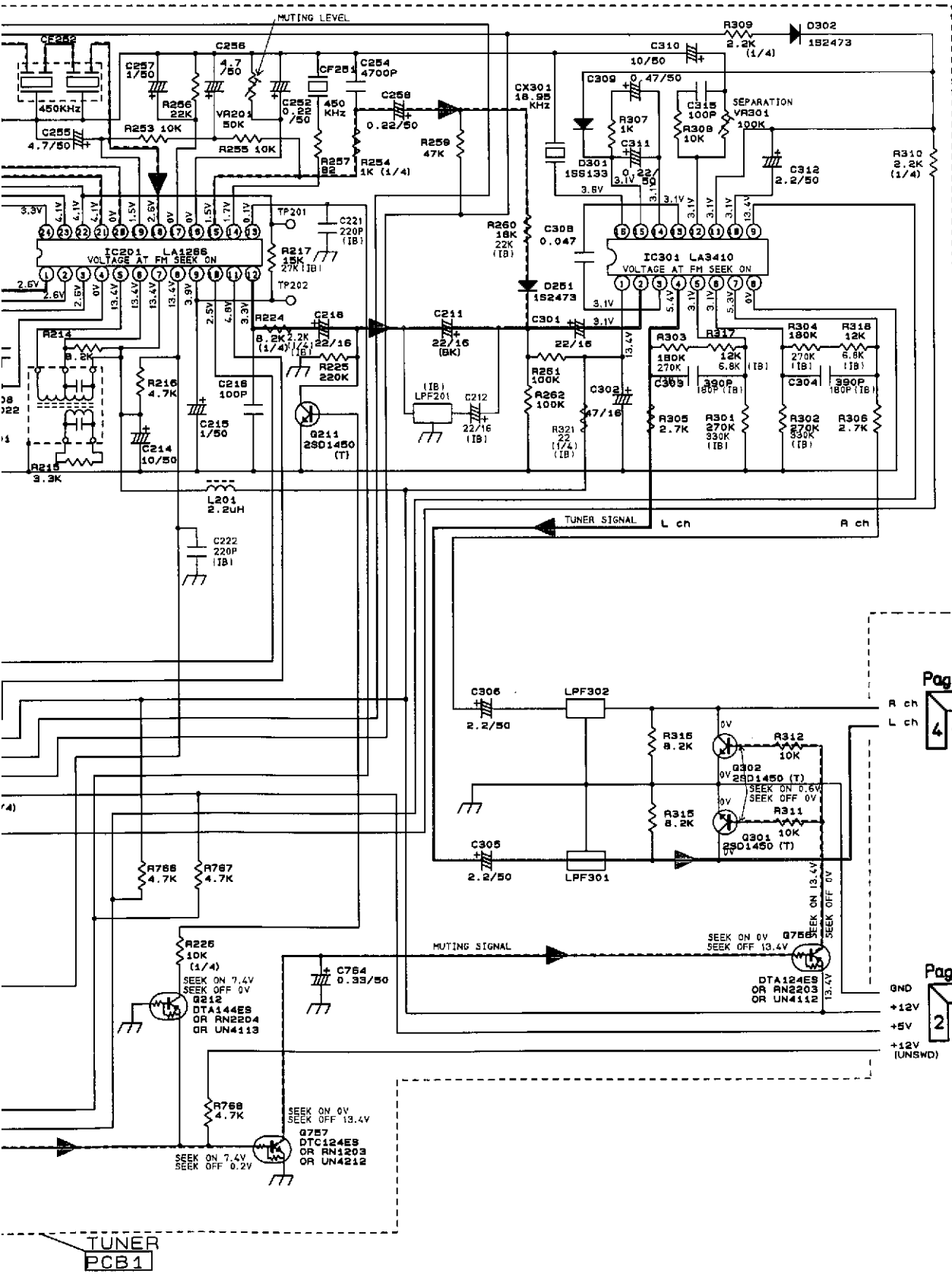

Page 29  
4 (A)

Page 26  
2 (B)

Page 28  
2 (C)



# SCHEMATIC DIAGRAM (FUNCTION SECTION)

FRONT  
PCB 102

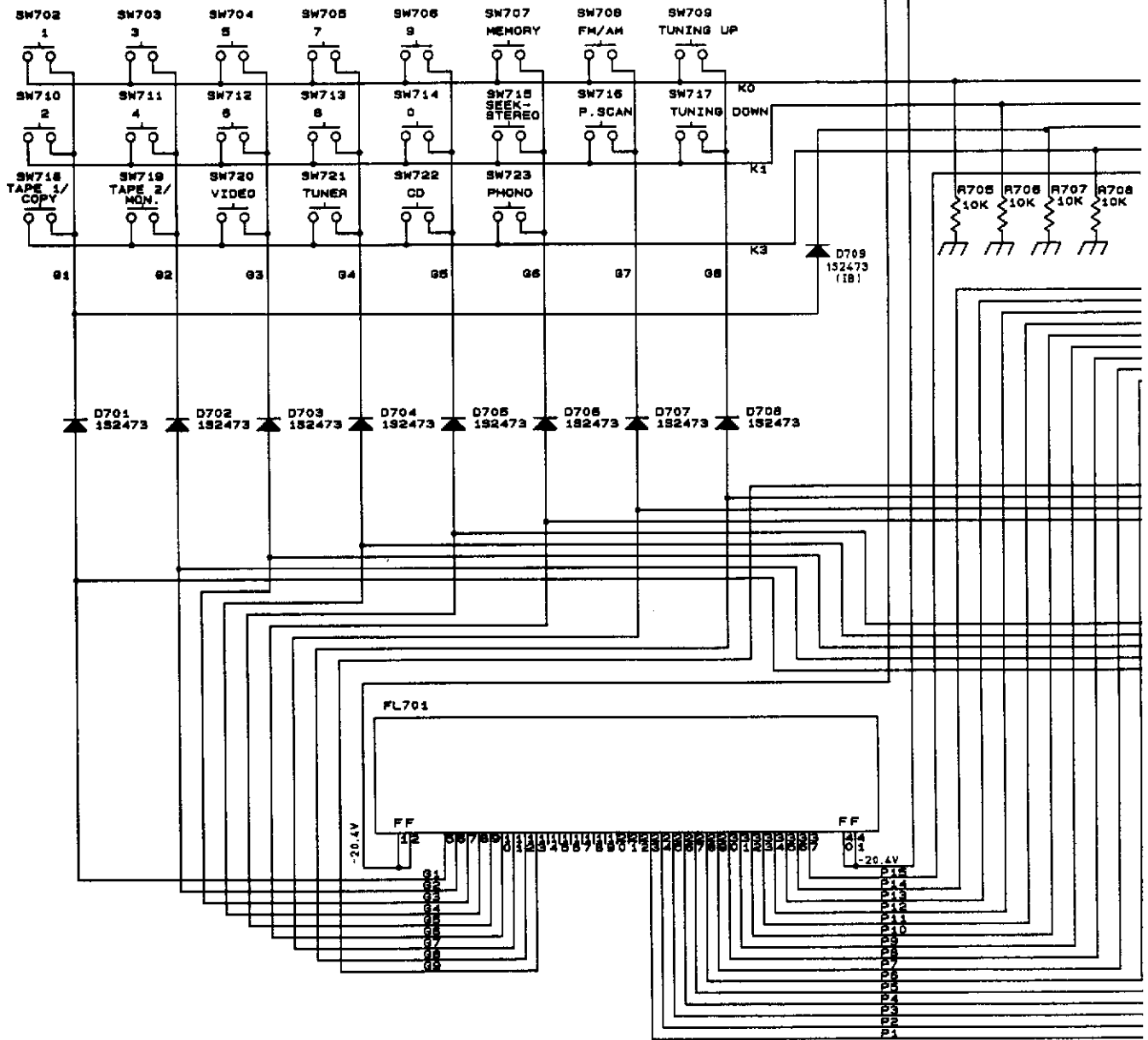

- NOTE:
1. ALL RESISTANCE VALUES ARE IN (ohm).  
K=1000 (ohm), M=1000K (ohm)
  2. THE WATTAGE OF RESISTANCES IS 1/4W UNLESS OTHERWISE NOTED.
  3. ALL CAPACITANCE VALUES ARE IN UF UNLESS OTHERWISE NOTED.  
P=uuF
  4. SAFETY REQUIREMENTS COMPONENTS IN ACCORDANCE WITH PRESENT SAFETY REGULATIONS.
  5. THESE COMPONENTS MUST ONLY BE REPLACED BY ORIGINAL PARTS.





# SCHEMATIC DIAGRAM (POWER SUPPLY SECTION)

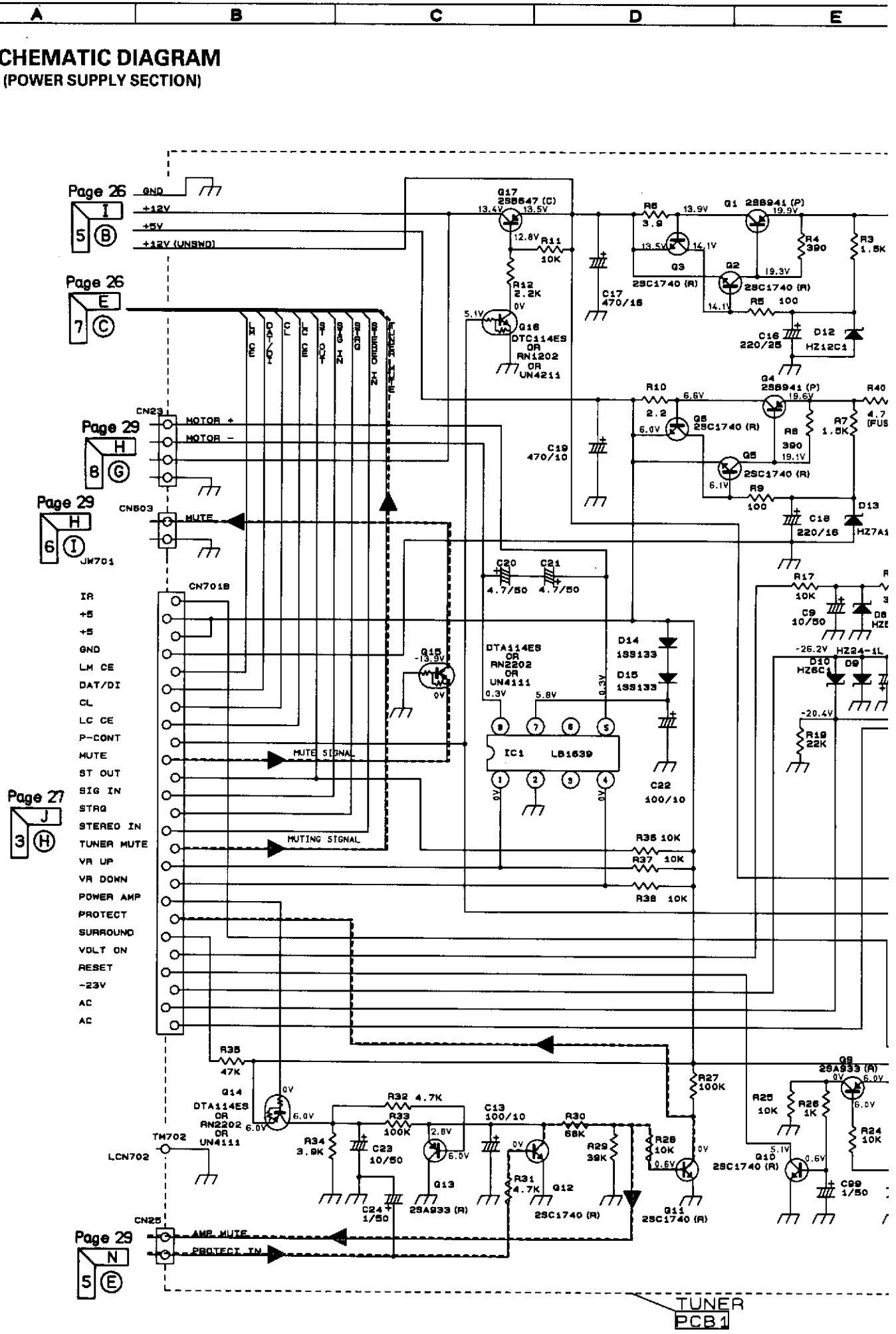

TUNER  
PCB 1

SECONDARY 1  
PCB5

PRIMARY 2  
PCB109

PRIMARY 1  
PCB108

Page 29

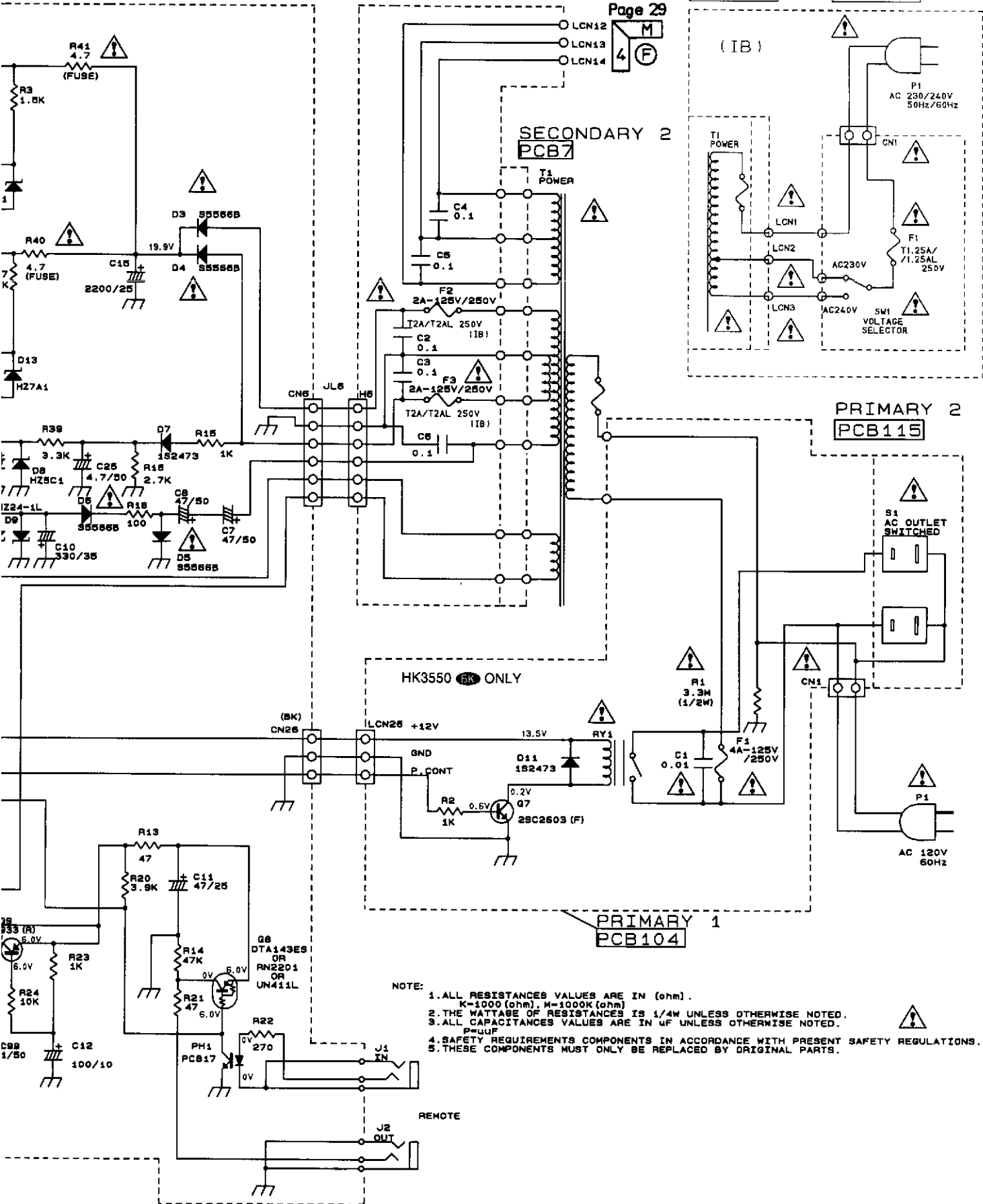

NOTE:

1. ALL RESISTANCES VALUES ARE IN (ohm).  
K=1000 (ohm), M=1000K (ohm)
2. THE WATTAGE OF RESISTANCES IS 1/4W UNLESS OTHERWISE NOTED.
3. ALL CAPACITANCES VALUES ARE IN uF UNLESS OTHERWISE NOTED.  
P=µF
4. SAFETY REQUIREMENTS COMPONENTS IN ACCORDANCE WITH PRESENT SAFETY REGULATIONS.
5. THESE COMPONENTS MUST ONLY BE REPLACED BY ORIGINAL PARTS.



A

B

C

D

E

F

G

# SCHEMATIC DIAGRAM (POWER AMP SECTION)

1

2

3

4

5

Page 26



Page 25



Page 25



Page 25



Page 25



TUNER SIGNAL

TUNER PCB1

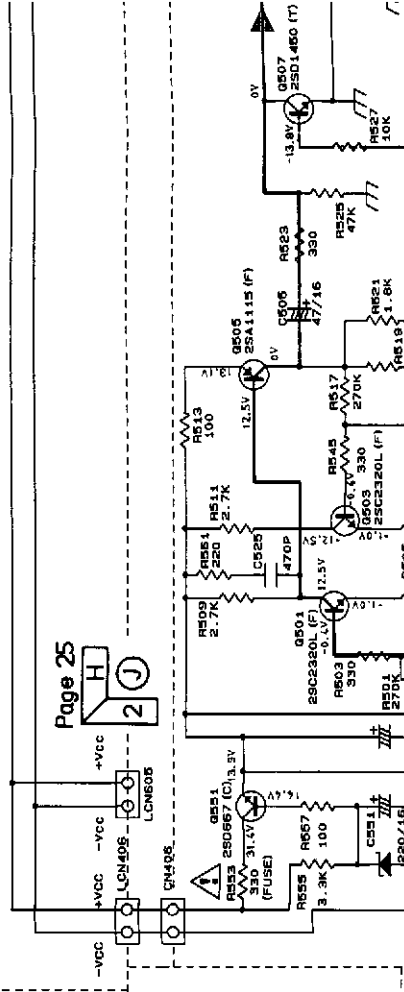
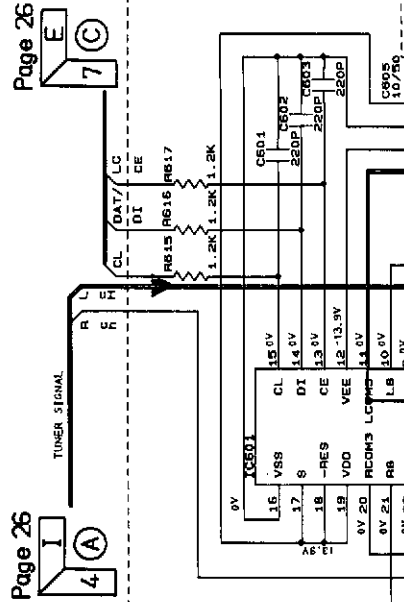

H I J K L M N

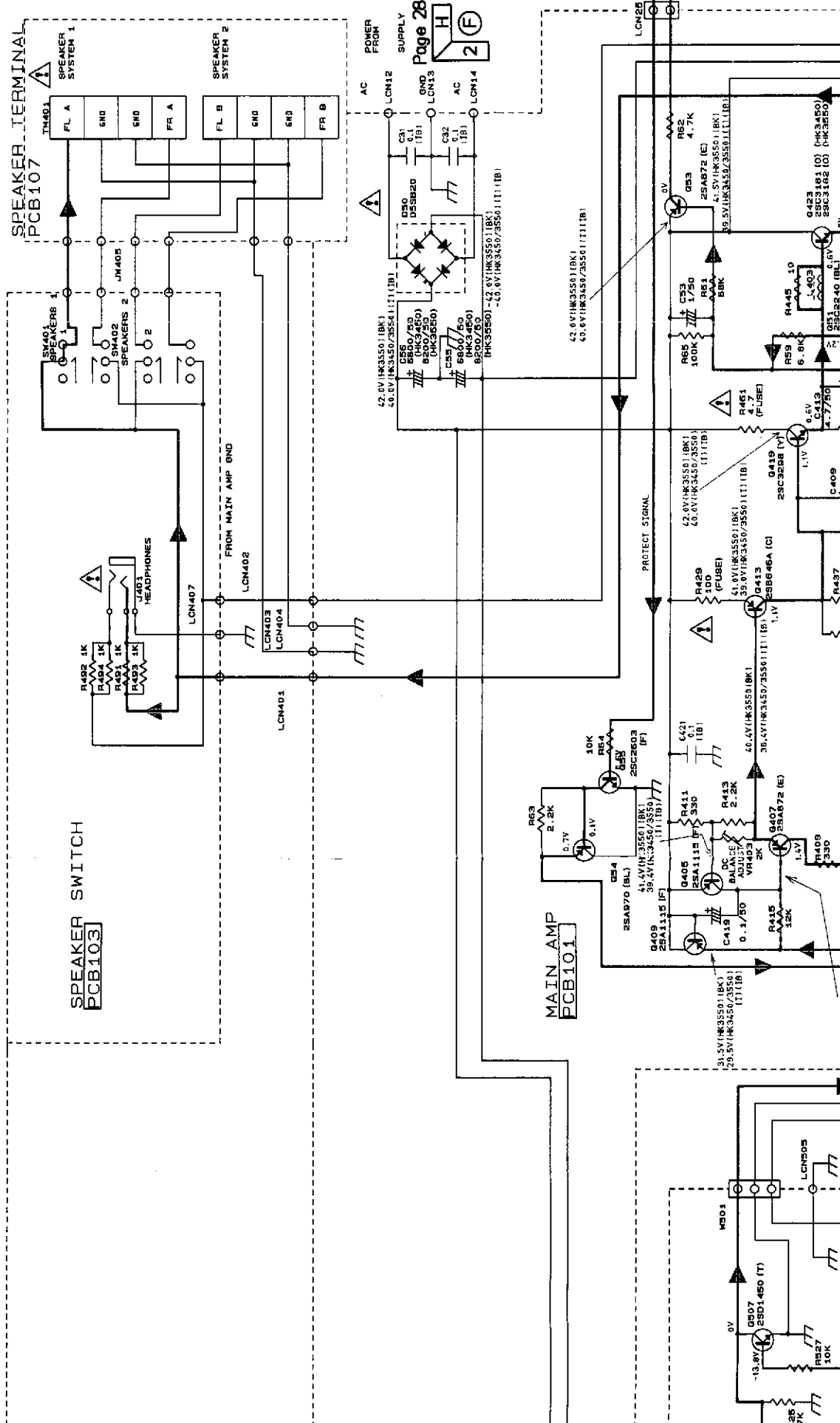



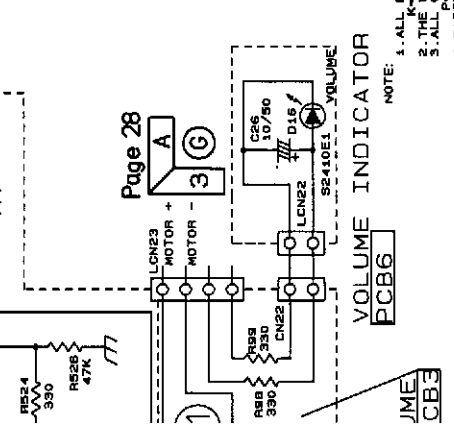
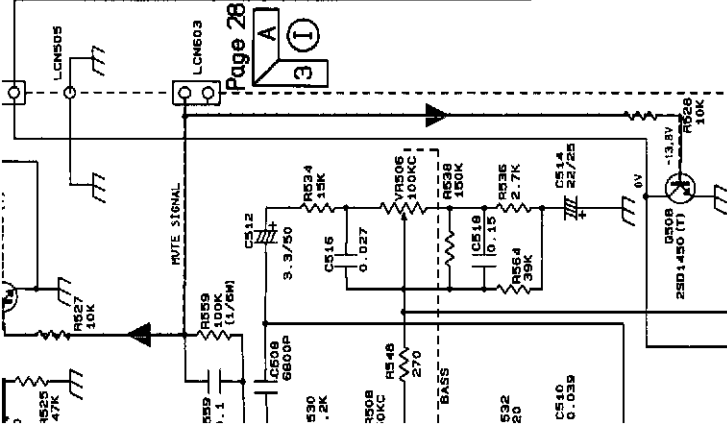
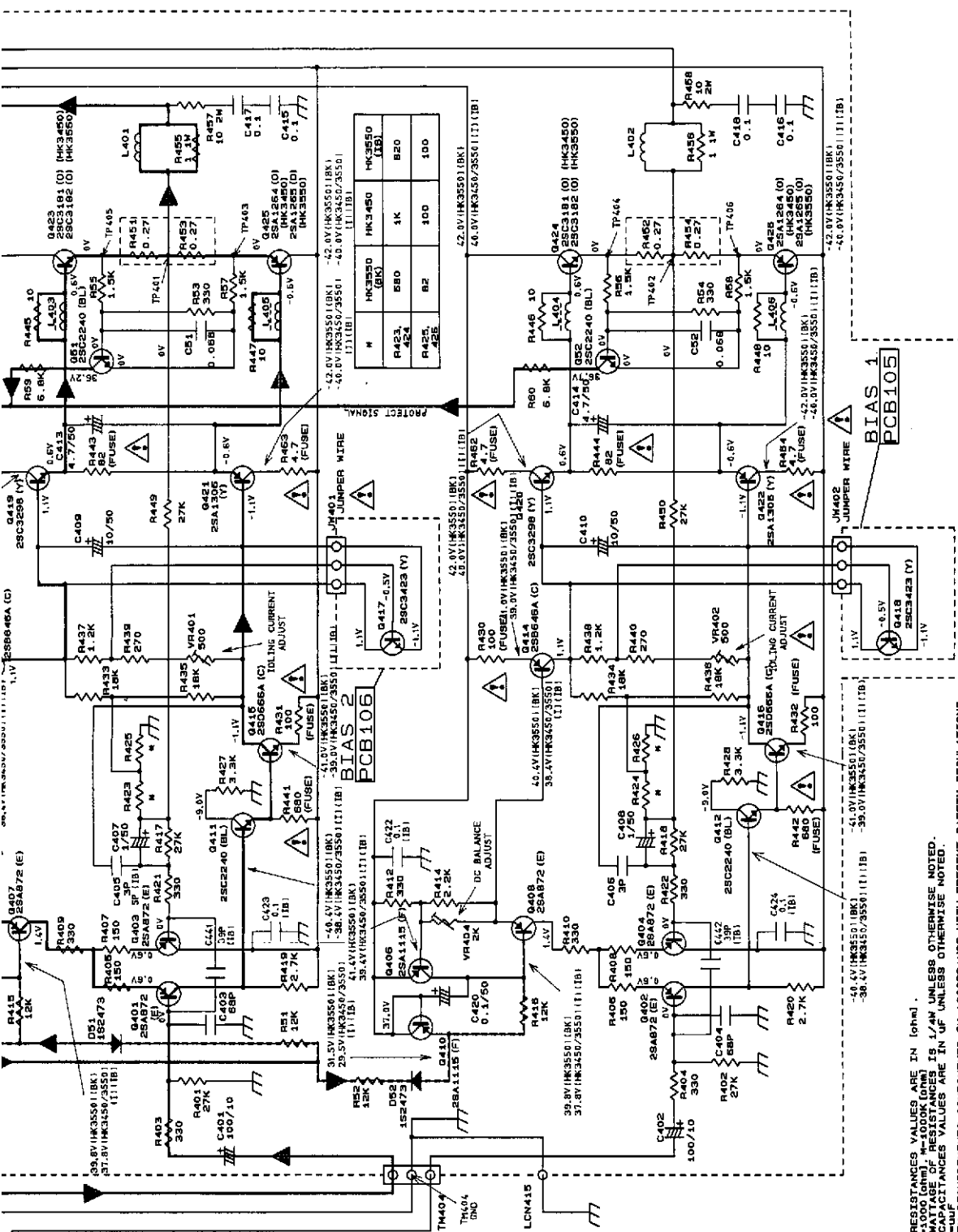

- NOTE:
1. ALL RESISTANCE VALUES ARE IN OHMS.
  2. THE WATTAGE OF RESISTANCES IS 1/4W UNLESS OTHERWISE NOTED.
  3. ALL CAPACITANCE VALUES ARE IN UF UNLESS OTHERWISE NOTED.
  4. SAFETY REQUIREMENTS COMPONENTS IN ACCORDANCE WITH PRESENT SAFETY REGULATIONS.
  5. THESE COMPONENTS MUST ONLY BE REPLACED BY ORIGINAL PARTS.



VOLUME INDICATOR  
PCB6

JME  
CB3



A B C D E F G

WIRING DIAGRAM

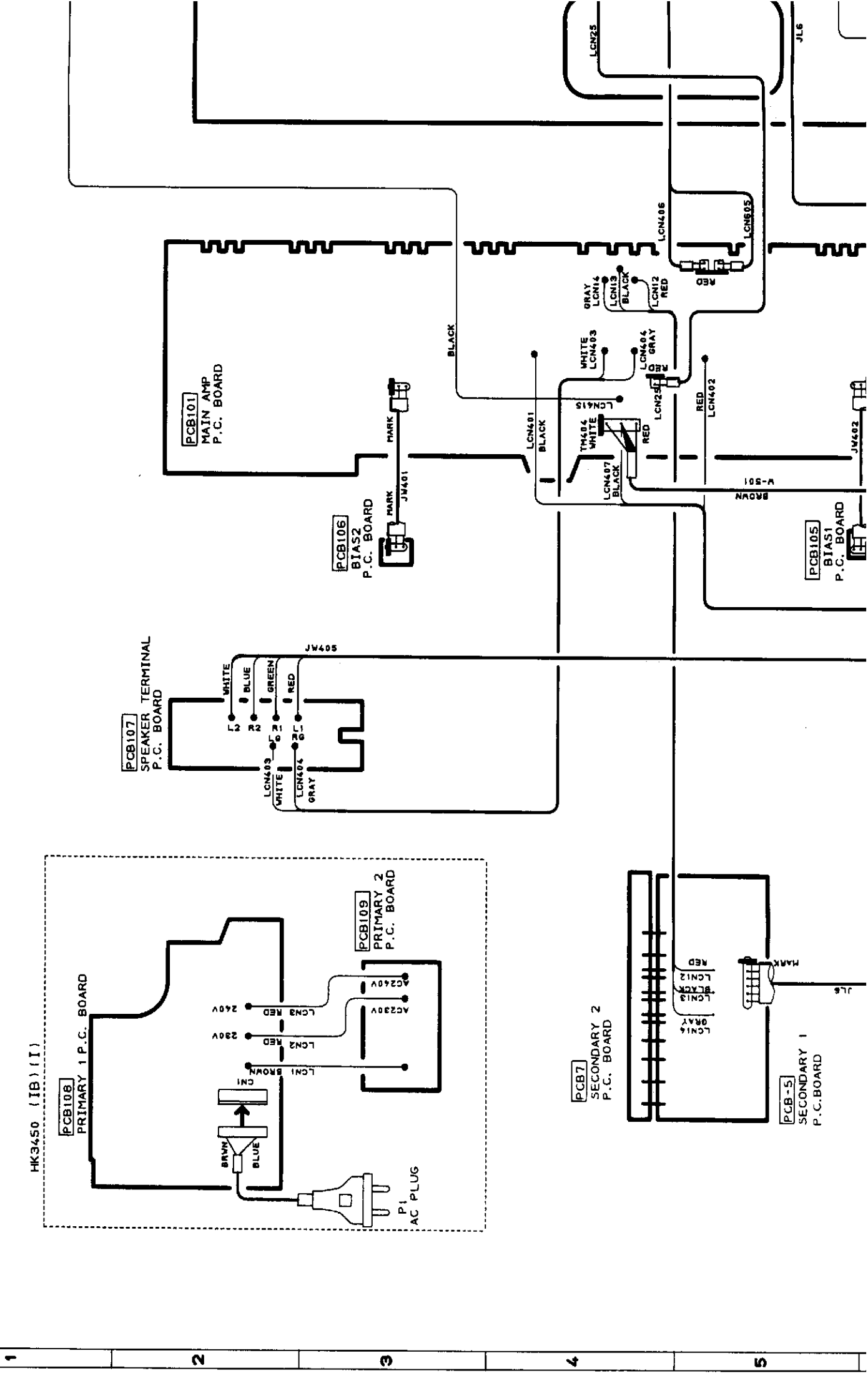

1 2 3 4 5

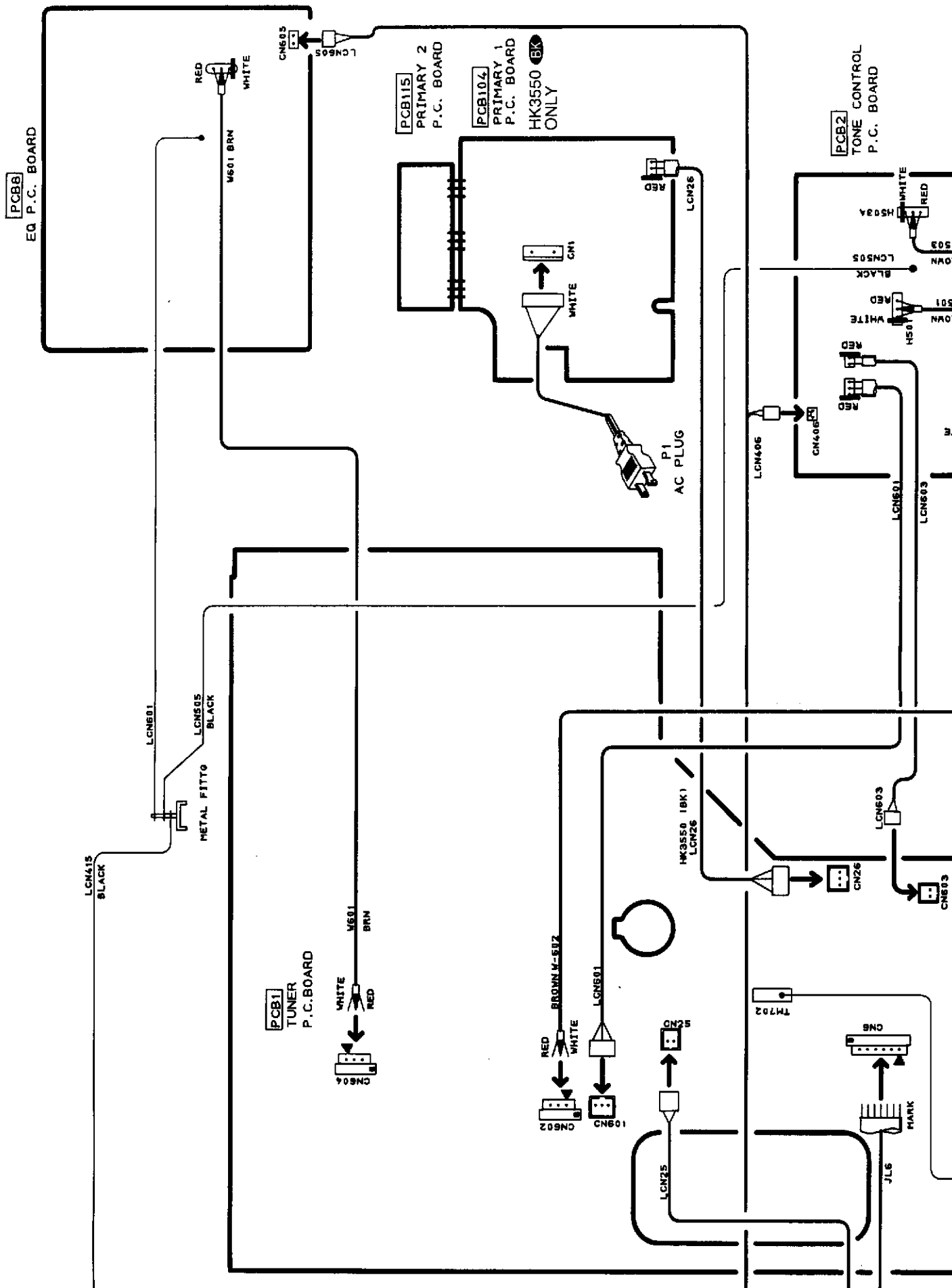

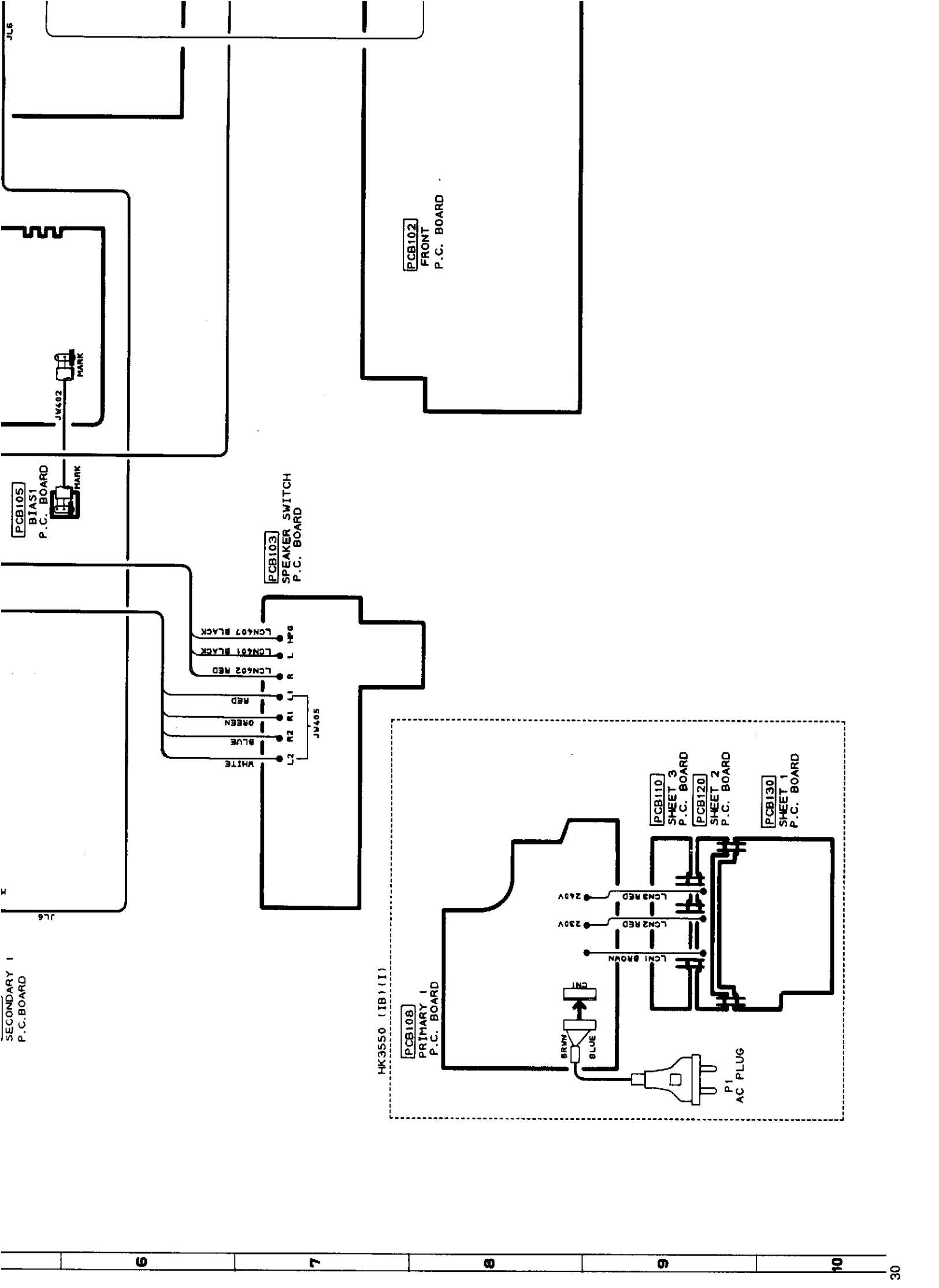

SECONDARY 1  
P.C. BOARD

K

JLE

PCB105  
BIAS1  
P.C. BOARD

JM402  
MARK

JLE

PCB103  
SPEAKER SWITCH  
P.C. BOARD

JM405  
L2 R2 R1 L1 R L HP6  
WHITE  
BLUE  
GREEN  
RED  
LCN402 RED  
LCN401 BLACK  
LCN407 BLACK

HK3550 (1B111)  
PCB108  
PRIMARY 1  
P.C. BOARD

PCB102  
FRONT  
P.C. BOARD

PCB110  
SHEET 3  
P.C. BOARD

PCB120  
SHEET 2  
P.C. BOARD

PCB130  
SHEET 1  
P.C. BOARD

LCN1 BROWN  
LCN2 RED  
LCN3 RED  
200V  
240V

BRWN  
BLUE

P1  
AC PLUG

6

7

8

9

10

