

harman/kardon

hk3370/3470

STEREO RECEIVER

PRELIMINARY SERVICE MANUAL

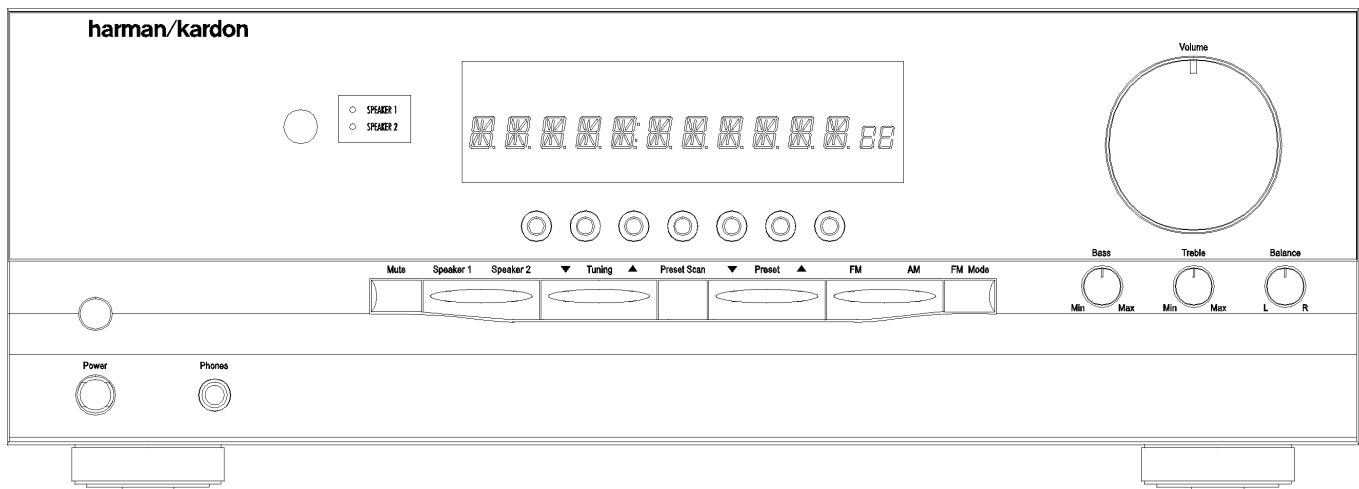

CONTENTS

ESD WARNING.....	2	BLOCK DIAGRAM.....	28
LEAKAGE TESTING.....	3	EXPLODED VIEW HK3370.....	29
BASIC SPECIFICATIONS hk3370.....	4	EXPLODED VIEW HK3470.....	30
BASIC SPECIFICATIONS hk3470.....	5	DISASSEMBLY PROCEDURES.....	31
FRONT PANEL CONTROLS hk3370.....	6	MECHANICAL PARTS LIST HK3370.....	39
REAR PANEL CONNECTIONS hk3370.....	8	ELECTRICAL PARTS LIST HK3370.....	40
REMOTE CONTROL FUNCTIONS HK3370..	10	MECHANICAL PARTS LIST HK3370.....	57
FRONT PANEL CONTROLS hk3470.....	12	ELECTRICAL PARTS LIST HK3370.....	58
REAR PANEL CONNECTIONS hk3470.....	15	IC DESCRIPTIONS.....	75
REMOTE CONTROL FUNCTIONS HK3470..	17	PCB DRAWINGS.....	86
TROUBLESHOOTING GUIDE.....	19	SCHEMATICS.....	92
ALIGNMENT PROCEDURES.....	20	WIRING DIAGRAM.....	103
WAVEFORMS.....	23	PACKAGE.....	104

harman/kardon, Inc.
250 Crossways Park Dr.
Woodbury, New York 11797

SCHEMATIC DIAGRAM MAIN

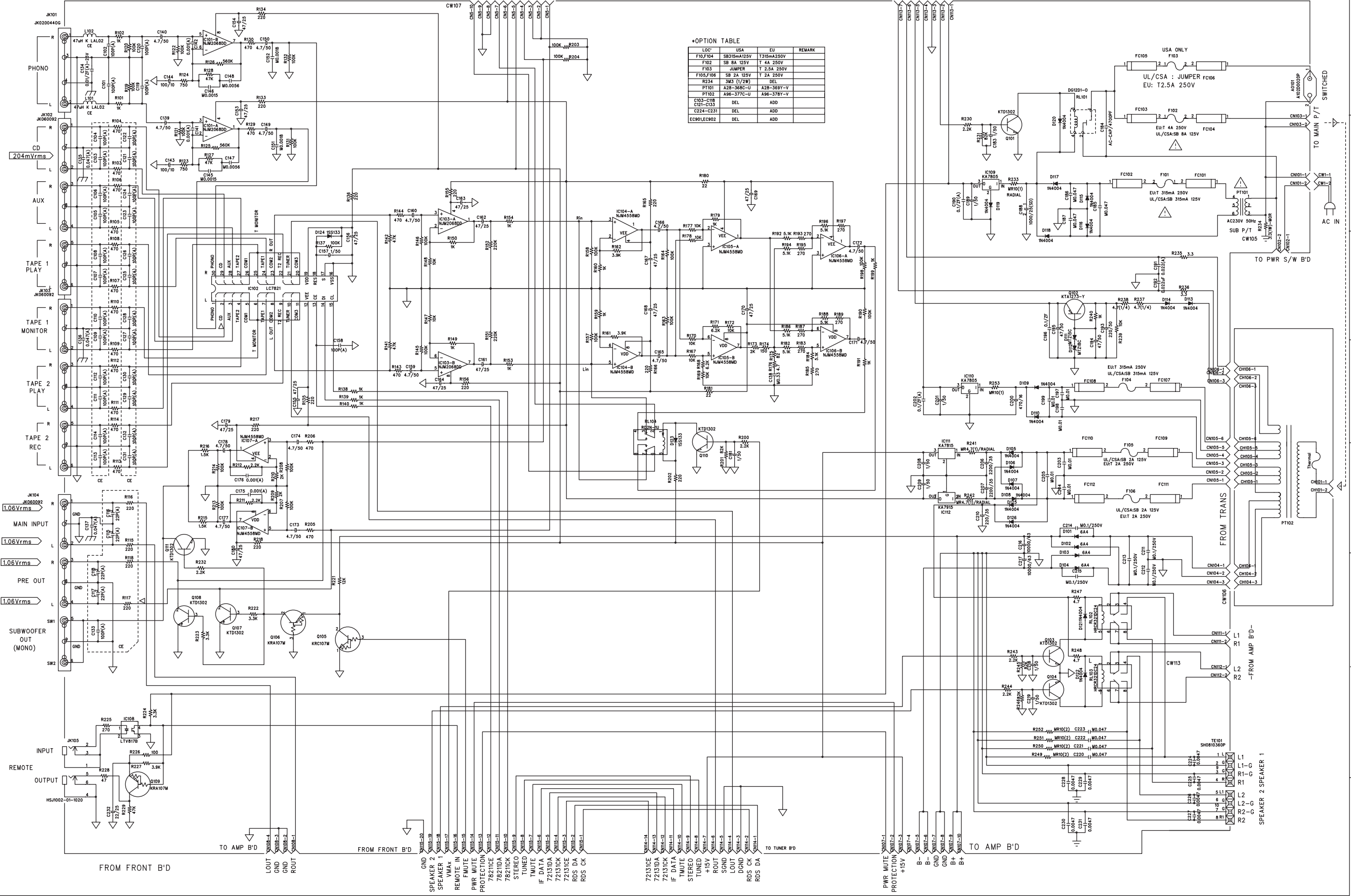

+OPTION TABLE

LOC	USA	EU	REMARK
F10,F104	SB315A125V	T315A250V	
F102	SB 8A 125V	T 4A 250V	
F103	JUMPER	T 2.5A 250V	
F105,F106	SB 2A 125V	T 2A 250V	
R234	3M3 (1/2W)	DEL	
PT101	A28-349C-U	A28-349T-V	
PT102	A36-377C-U	A36-378V-V	
C103-C118	DEL	ADD	
C121-C133	DEL	ADD	
C224-C231	DEL	ADD	
EC90LEC902	DEL	ADD	

SCHEMATIC DIAGRAM AMP/TONE/ETC.

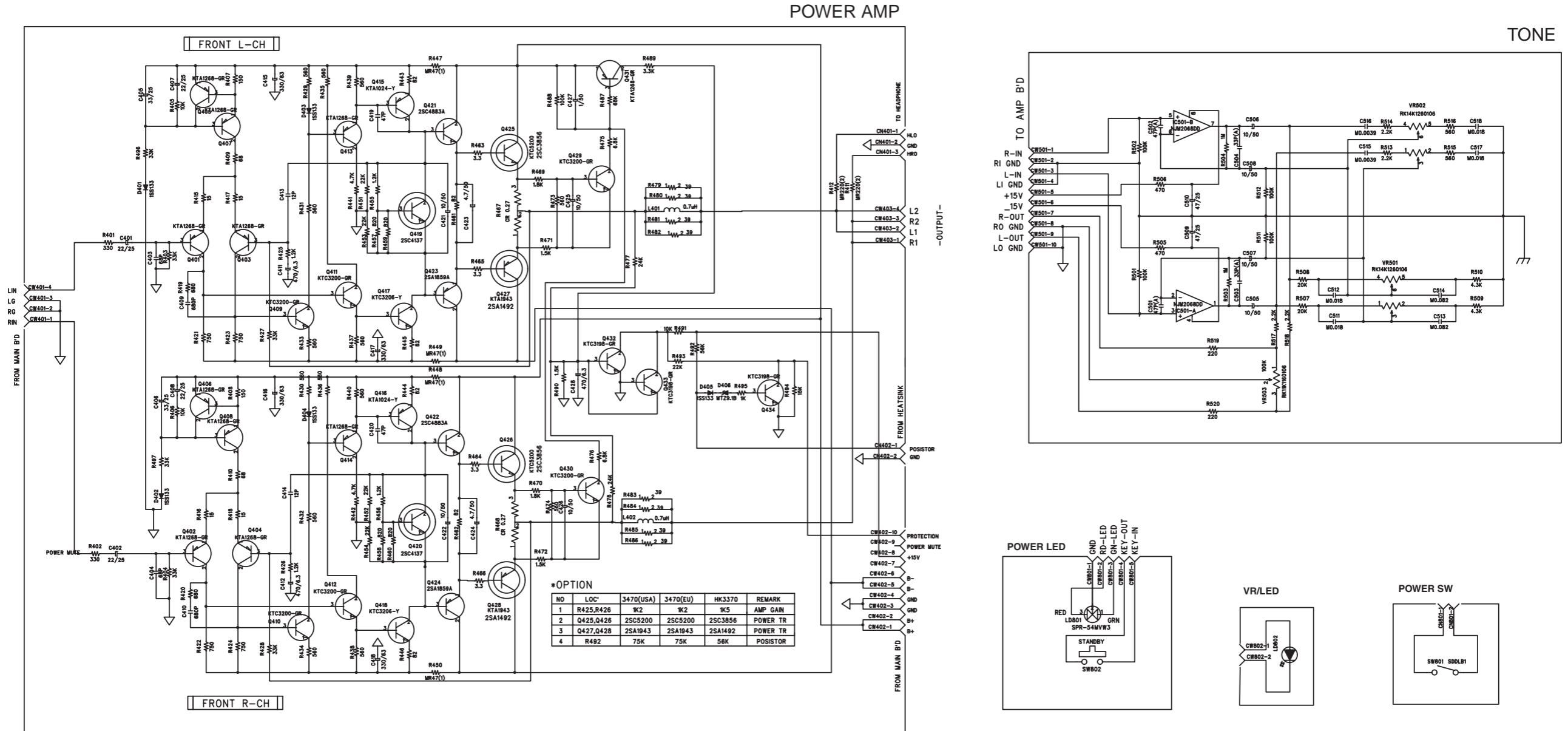

**SCHEMATIC DIAGRAM
FRONT**

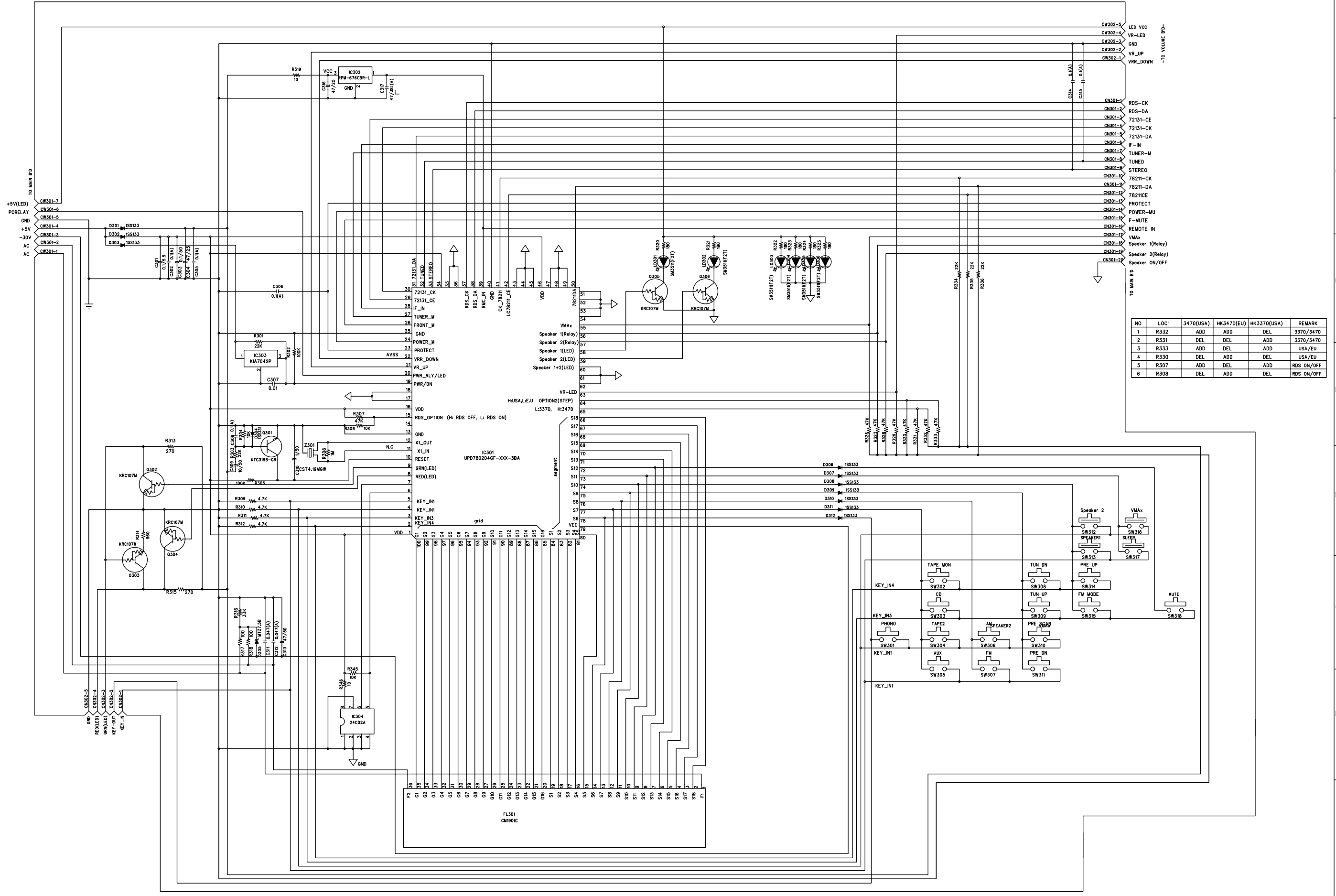

NO	LOC'	3470(USA)	HK3470(EU)	HK3370(USA)	REMARK
1	R332	ADD	DEL	ADD	3370/3470
2	R331	DEL	DEL	ADD	3370/3470
3	R333	ADD	DEL	ADD	USA/EU
4	R330	DEL	ADD	DEL	USA/EU
5	R307	ADD	DEL	ADD	RDS ON/OFF
6	R308	DEL	ADD	DEL	RDS ON/OFF

**SCHEMATIC DIAGRAM
TUNER/VR/HP**

TUNER

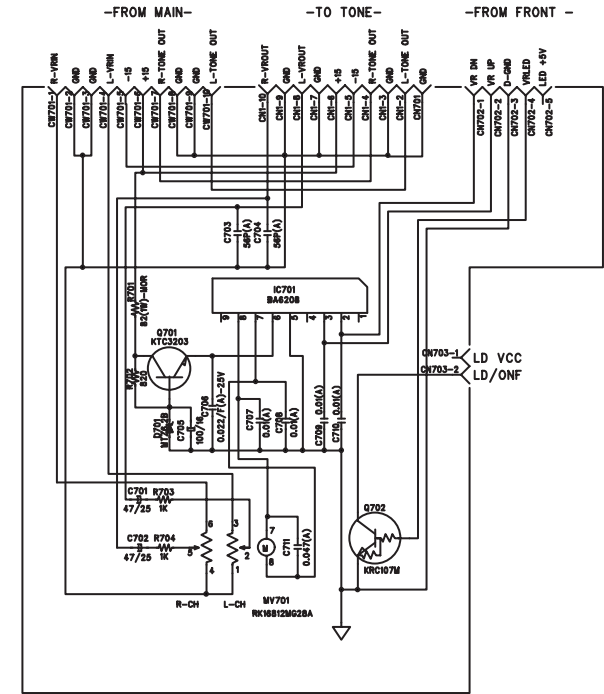
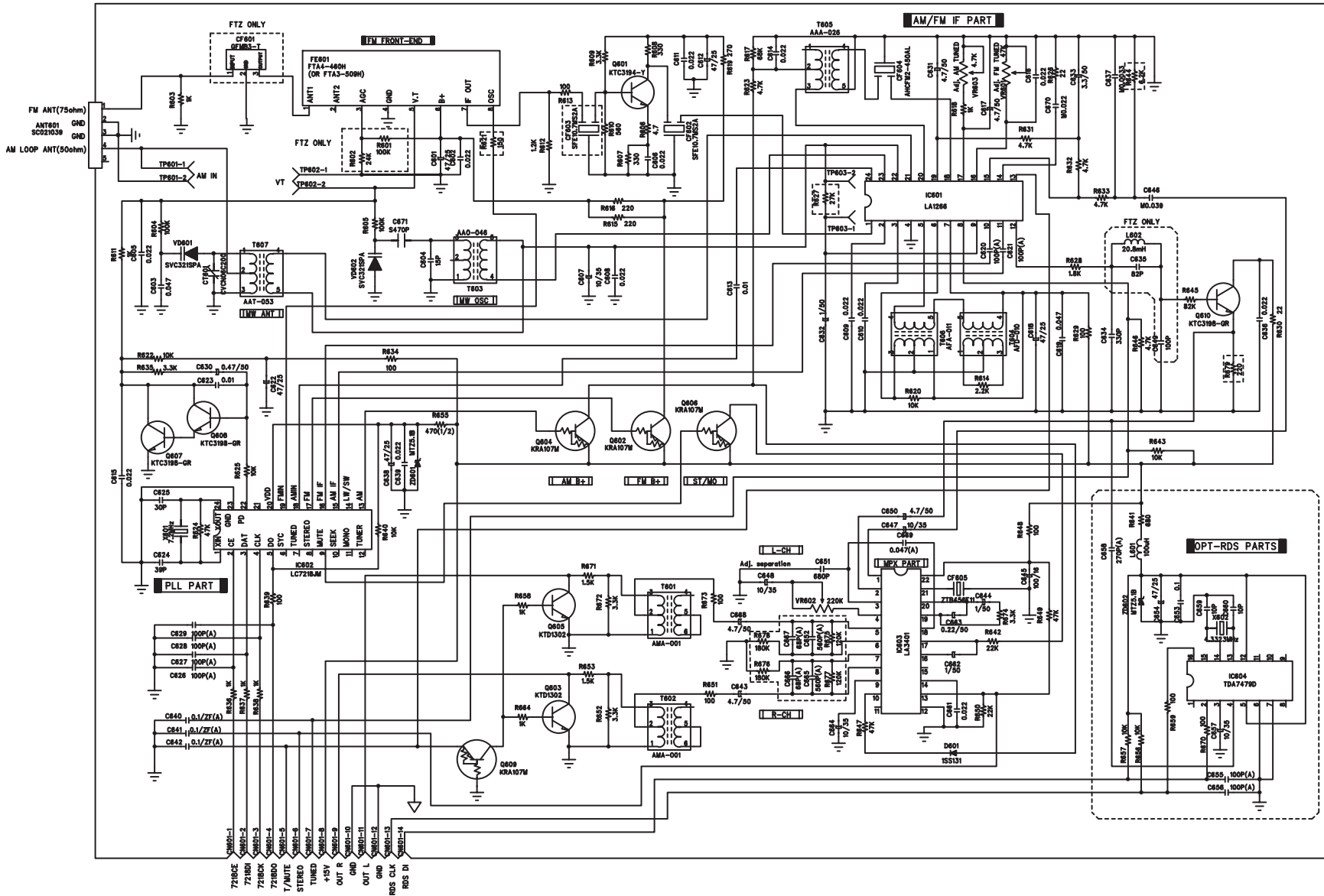

LOC NO	USA	EU
ANT801	SC0210	SC0210
CF601	X	O
JW16	O	X
FE601	FTA3-509HA	FTA4-460H
JW17	O	X
R602	X	O
R601		
C635	X	O
C649		
R644	6.2K	1.5K
L602	X	O
JW1	O	X
R675	120K	220K
R677		
C652	560P(A)	220P(A)
C665		
C666	68P(A)	10P(A)
R676	180K	270K
R678		
R627	27K	47K
R621	470	150
CF603	SFE 10.7MS2A	SFE 10.7MJA
RDS	X	O

HEAD PHONE

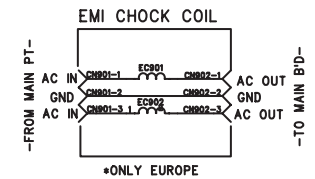
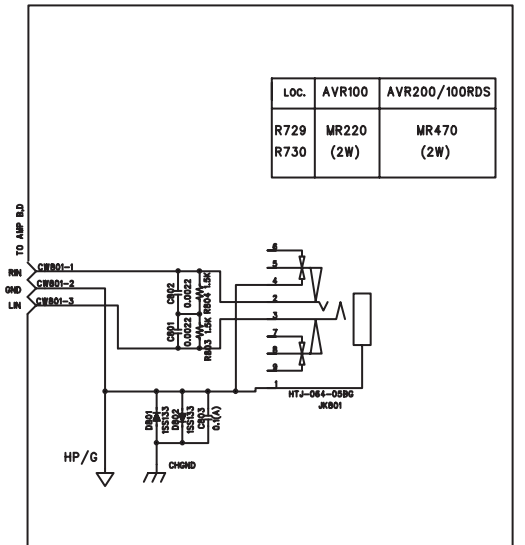

*ONLY EUROPE

1	2	3	4	5	6	7	8							
NO	PARTS NAME	PART NO	Q'TY	REMARK	NO	PARTS NAME	PART NO	Q'TY	REMARK	NO	PARTS NAME	PART NO	Q'TY	REMARK
1	KNOB-VOLUME	MJAF-16100-ZZ4	1	ABS	28	RADIATOR-TR	MEAC-08215-004	1	AL	g	STANDBY P.C.BOARD	***	1	***
2	LENS-VOLUME	MAAF-16130-ZZ3	1	ACRYL	29	HEAT-SINK(TR)	MEAC-12693-004	1	AL	h	AMP P.C.BOARD	***	1	***
3	NUT	***	4	***	30	PLUG-RCA	PLRC-00020-S30	2	***	i	MAIN P.C.BOARD	***	1	***
4	WASHER	***	1	***	31	JACK-CONNECT	MMAC-17070-004	2	***	j	TUNER P.C.BOARD	***	1	***
5	KNOB-BALANCE	MJAF-16070-ZZ4	3	ABS	32	CHASSIS-BOTTOM	MPAC-04812-002	1	US Co					
6	WINDOW-FL	MAAF-03600-ZZ2	1	ACRYL	33	CUSHION-A(SHEET-SIDE)	MRAG-13050-004	2	FELT					
7	BADGE-H/K	MLAG-13850-ZZ4	1	AL	34	CUSHION-A(SIDE)	MRAG-13250-004	2	EVA					
8	SHEET-WINDOW	MAAF-17070-004	1	PE	35	FOOT(A)	MJAF-15640-ZZ4	4	ABS					
9	DECO-CHOICE	MJAF-08880-ZZ3	1	ABS	36	SUPPORT-PCB	MJAF-16140-004	6	ABS					
10	FILTER-FL	MAAF-17040-ZZ4	1	PVC	37	CHASSIS-PANEL	MPAC-04760-003	1	US Co					
11	PANEL-FRONT	MJAF-06570-ZZ1	1	ABS	38	POWER-TRANS	***	1	***					
12	SHIELD-BALANCE	MPAC-16880-004	1	ET-HD	39	CORD-BUSH	MJAC-00280-003	1	***					
13	KNOB-CHOICE	MJAF-08870-ZZ3	1	ABS	40	CORD-AC ASS'y	***	1	***					
14	KNOB-FUNCTION	MJAF-03850-ZZ2	1	ABS	41	CHASSIS-BACK	MPAC-05040-ZZ2	1	SECC					
15	CUSHION-A(FL)	MRAG-13830-004	2	EVA	42	CUSHION-A(SHEET-TOP)	MRAG-13040-004	1	FELT					
16	CUSHION-A(REMOTE)	MRAG-13840-004	1	EVA	43	TERMINAL-GND	MMAC-12060-004	1	***					
17	GUIDE-LED	MJAF-17030-004	1	ABS	44	CHASSIS-TOP	MPAC-04950-ZZ2	1	VCM					
18	KNOB-STANDBY	MJAF-16950-ZZ4	1	ABS	a	VOLUME2 P.C.BOARD	***	1	***					
19	KNOB-POWER	MJAF-16980-ZZ4	1	ABS	b	VOLUME P.C.BOARD	***	1	***					
20	LENS-POWER	MAAF-16990-ZZ4	1	ACRYL	c	TONE P.C.BOARD	***	1	***					
21	RADIATOR-MAIN	MEAC-05060-002	1	AL	d	FRONT P.C.BOARD	***	1	***					
22	GUIDE-PCB	***	1	***	e	PHONE P.C.BOARD	***	1	***					
23	T/R	***	4	***	f	POWER P.C.BOARD	***	1	***					
24	T/R	***	2	***										
25	MICA	***	4	***										
26	BRACKET-RAD(S)	MPAC-16220-004	4	US Co										
27	RADIATOR	MEAC-08212-004	4	AL										

EXPLODED VIEW

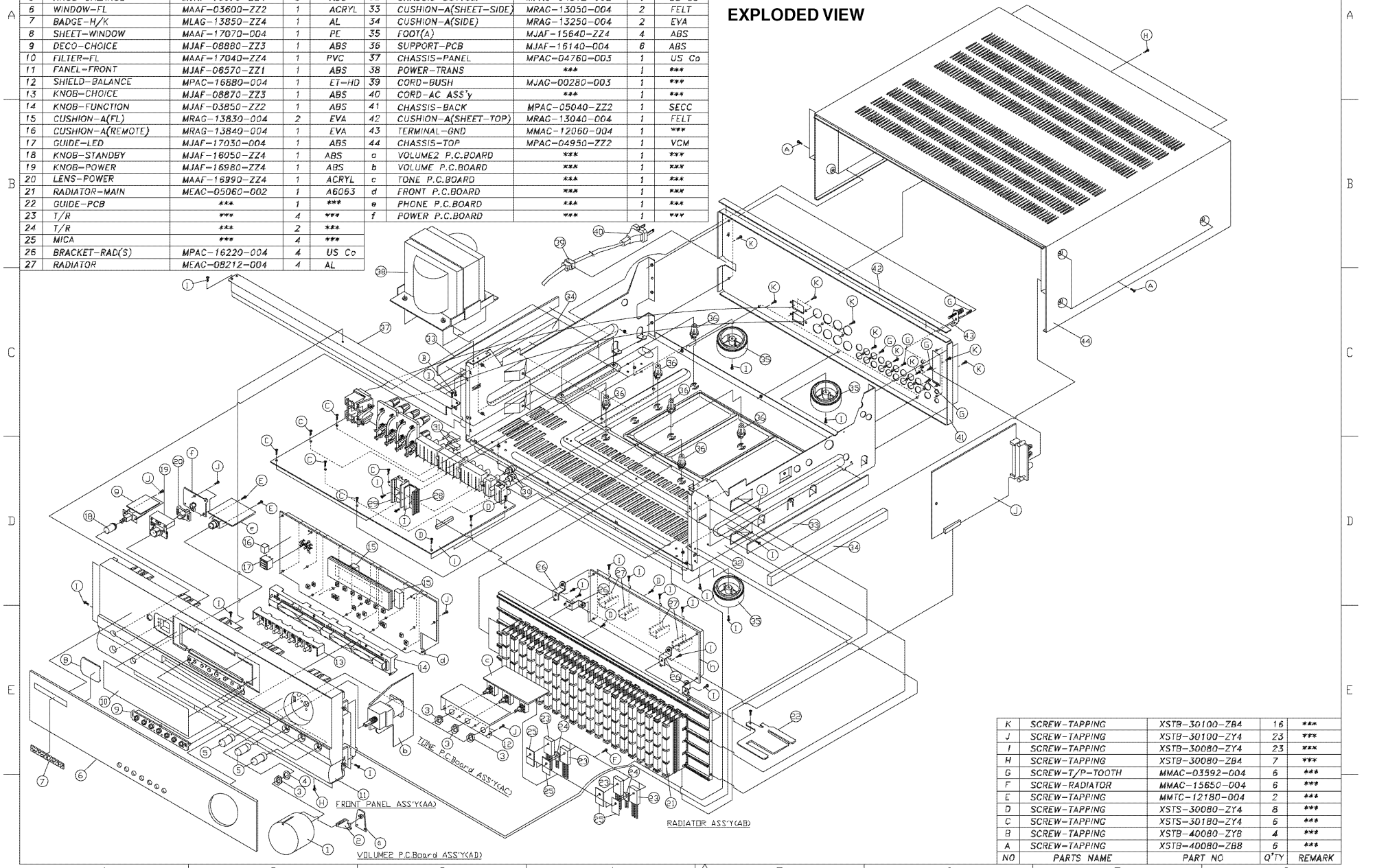

K	SCREW-TAPPING	XSTB-30100-ZB4	16	***
J	SCREW-TAPPING	XSTB-30100-ZY4	23	***
I	SCREW-TAPPING	XSTB-30080-ZY4	23	***
H	SCREW-TAPPING	XSTB-30080-ZB4	7	***
G	SCREW-T/P-TOOTH	MMAC-03592-004	6	***
F	SCREW-RADIATOR	MMAC-15650-004	6	***
E	SCREW-TAPPING	MMTC-12180-004	2	***
D	SCREW-TAPPING	XSTS-30080-ZY4	8	***
C	SCREW-TAPPING	XSTS-30180-ZY4	6	***
B	SCREW-TAPPING	XSTB-40080-ZYB	4	***
A	SCREW-TAPPING	XSTB-40080-ZBB	6	***
NO	PARTS NAME	PART NO	Q'TY	REMARK

3. Circuit Description

CPU(IC401) :uPD780204GF

1. Pin Configuration

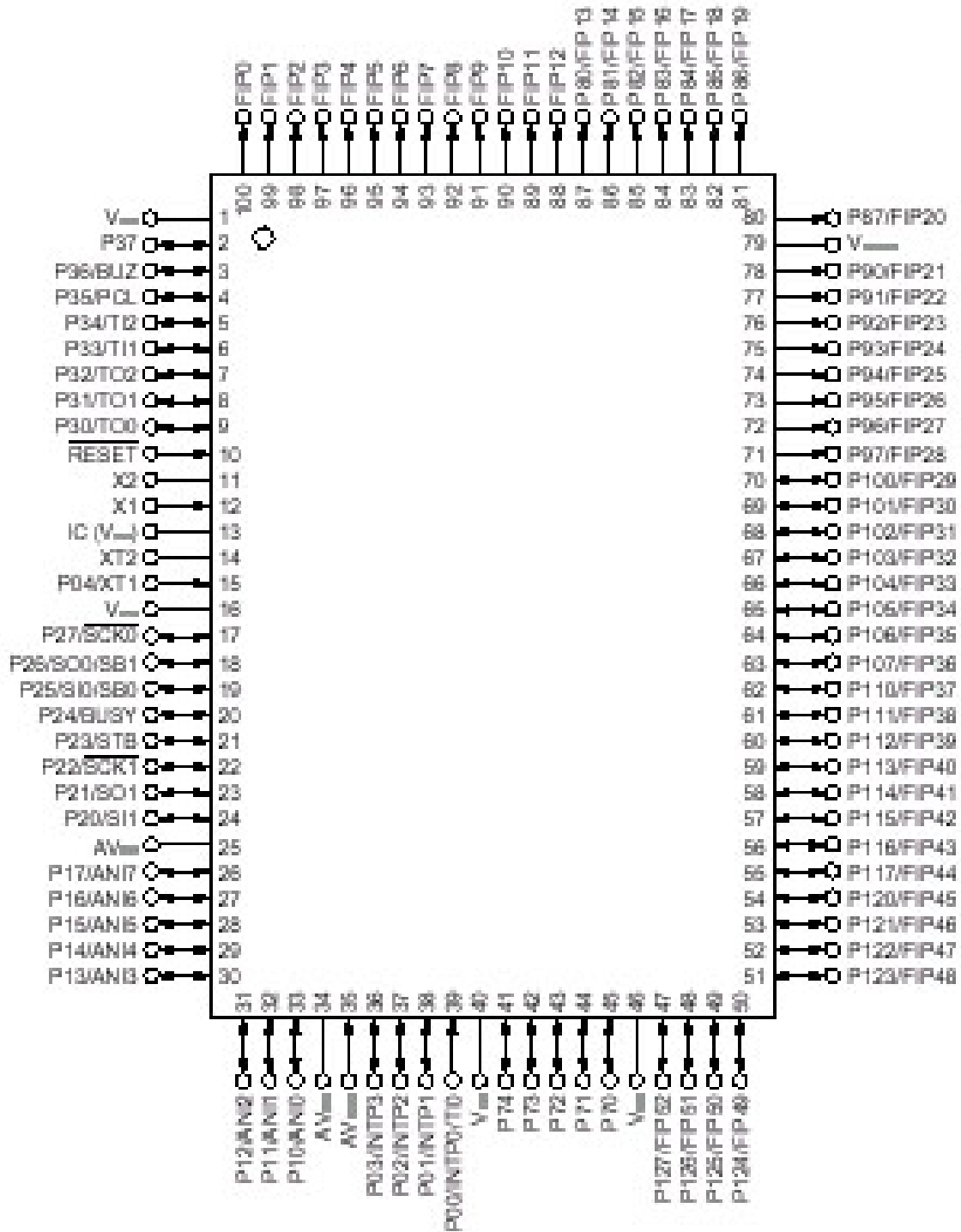

2. Pin Description

uPD780204GF QFP Type

Pin No.	Pin Name	I/O	ACTIVE	PORT NAME	REMARK
1	Vdd	-	H	+5V	System power supply
2	P37	I	H	KR4	Key read 4
3	P36	I	H	KR3	Key read 3
4	P35	I	H	KR2	Key read 2
5	P34	I	H	KR1	Key read 1
6	P33	-	-	-	Not used
7	P32	-	-	-	Not used
8	P31	O	H/L	PWR_LED(RED)	L:AMBER L:GREEN H:RED
9	P30	O	H/L	PWR_LED(GRN)	L:STBY H:OPER L:PROT
10	RESET	I	L	System reset	Low reset
11	X2	-	-	OSC	Main system osc.
12	X1	I	-	OSC	-
13	Vpp	-	-	Connected to Vss	
14	XT2	-	-	-	Not used
15	P04/XT1	I	H/L	OPT_RDS	Rds on/off
16	Vdd	-	H	+5V	System power supply
17	P27	-	-		Not used
18	P26	-	-		Not used
19	P25	I	L	PWR_DOWN	Detect power off
20	P24	O	H	PWR_RLY	Power Relay on/off
21	P23	O	H	VR_UP	Volume up
22	P22	O	H	VR_DOWN	Volume Down
23	P21	I	L	PROTECT	Detect protection
24	P20	O	H	PWR_MUTE	Power Mute
25	AVss	-	L	GND	Analog ground
26	P17	O	H	PRE_MUTE	Pre mute
27	P16	O	H	TUNER_MUTE	Tuner mute
28	P15	I	H/L	IF_IN	IF conter in
29	P15	O	H	PLL CE	
30	P13	O	H	PLL CLOCK	
31	P12	O	H/L	PLL DATA	
32	P11	I	L	TUNED	Tuned in on : L
33	P10	I	L	STEREO	Stereo in on : L
34	Avdd	-	H	+5V	Analog power supply
35	Avref	-	L	GND	
36	P03	-	-		Not used
37	INTP2	I	L	RDS CLK	Rds clock in
38	P01	I	H	RDS DATA	Rds data in
39	P00	I	L	REMOCON IN	Remocon data in
40	Vss	-	L	GND	Ground
41	P74	O	H/L	78211 CLK	
42	P73	O	H/L	78211 CE	
43	P72	-	-		Not used
44	P71	-	-		Not used
45	P70	-	-		Not used
46	Vdd	-	H	+5V	

Pin No.	Pin Name	I/O	ACTIVE	PORT NAME	REMARK
47	P127	-	-		Not used
48	P127	-	-		Not used
49	P125	-	-		Not used
50	P124	O	H/L	78211 DATA	
51	P123	-	-		Not used
52	P122	-	-		Not used
53	P121	-	-		Not used
54	P120	-	-		Not used
55	P117	O	H	VMAX	VMAx on/off
56	P116	O	H	SPK1_RLY	Speaker1 relay on/off
57	P115	O	H	SPK2_RLY	Speaker2 relay on/off
58	P114	O	H	SPK1_LED	Speaker1 led on/off
59	P113	O	H	SPK2_LED	Speaker2 led on/off
60	P112	O	H	SPK12_LED	Speaker1/2 led on/off
61	P111	-	-		
62	P110	-	-		
63	P107	O	H	VR_LED	Volume led on/off
64	P106	I	H/L	OPT_STEP	L:E.U. , H:USA
65	P105	I	H/L	OPT_3400/3700	L:3400, H:3370
66	FIP33	O	H	S18	FIP segment output
67	FIP32	O	H	S17	FIP segment output
68	FIP31	O	H	S16	FIP segment output
69	FIP30	O	H	S15	FIP segment output
70	FIP29	O	H	S14	FIP segment output
71	FIP28	O	H	S13	FIP segment output
72	FIP27	O	H	S12	FIP segment output
73	FIP26	O	H	S11	FIP segment output
74	FIP25	O	H	S10	FIP segment output
75	FIP24	O	H	S9	FIP segment output
76	FIP23	O	H	S8	FIP segment output
77	FIP22	O	H	S7	FIP segment output
78	FIP21	O	H	S6	FIP segment output
79	Vload	-	-	Vload	FIP DRIVER VOLTAGE
80	FIP20	O	H	S5	FIP segment output
81	FIP19	O	H	S4	FIP segment output
82	FIP18	O	H	S3	FIP segment output
83	FIP17	O	H	S2	FIP segment output
84	FIP16	O	H	S1	FIP segment output
85	FIP15	O	H	G16	FIP grid output
86	FIP14	O	H	G15	FIP grid output
87	FIP13	O	H	G14	FIP grid output
88	FIP12	O	H	G13	FIP grid output
89	FIP11	O	H	G12	FIP grid output
90	FIP10	O	H	G11	FIP grid output
91	FIP9	O	H	G10	FIP grid output
92	FIP8	O	H	G9	FIP grid output
93	FIP7	O	H	G8	FIP grid output
94	FIP6	O	H	G7	FIP grid output
95	FIP5	O	H	G6	FIP grid output

IC 701 : BA6208

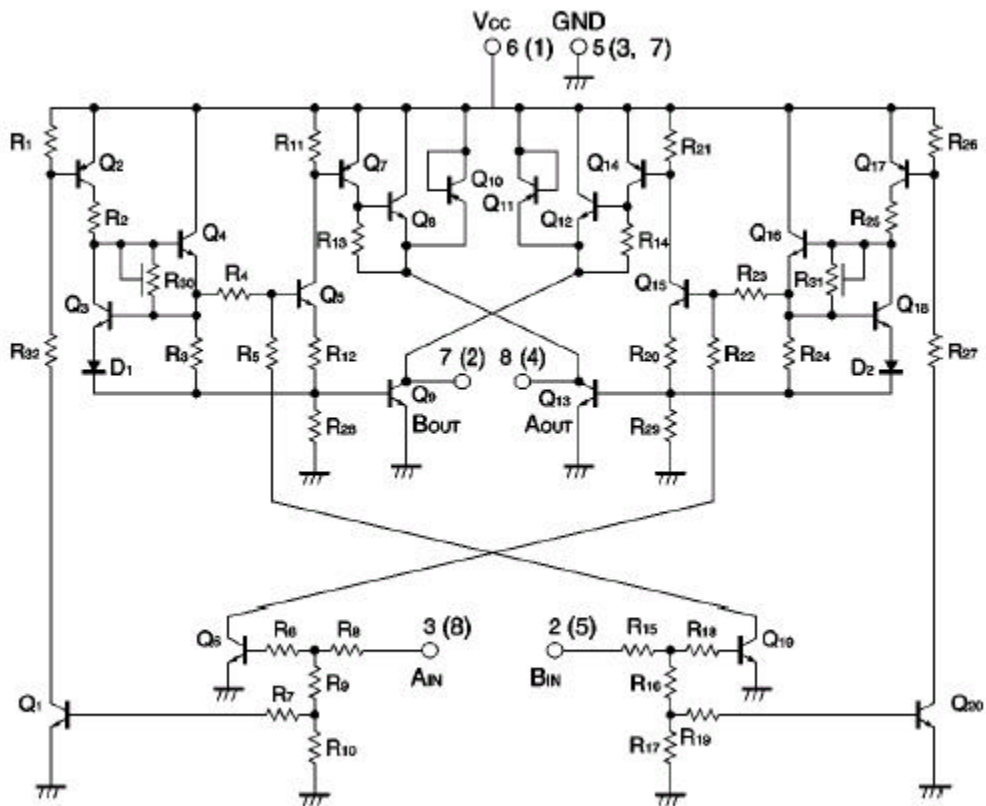

IC 302 : HI-M602HO

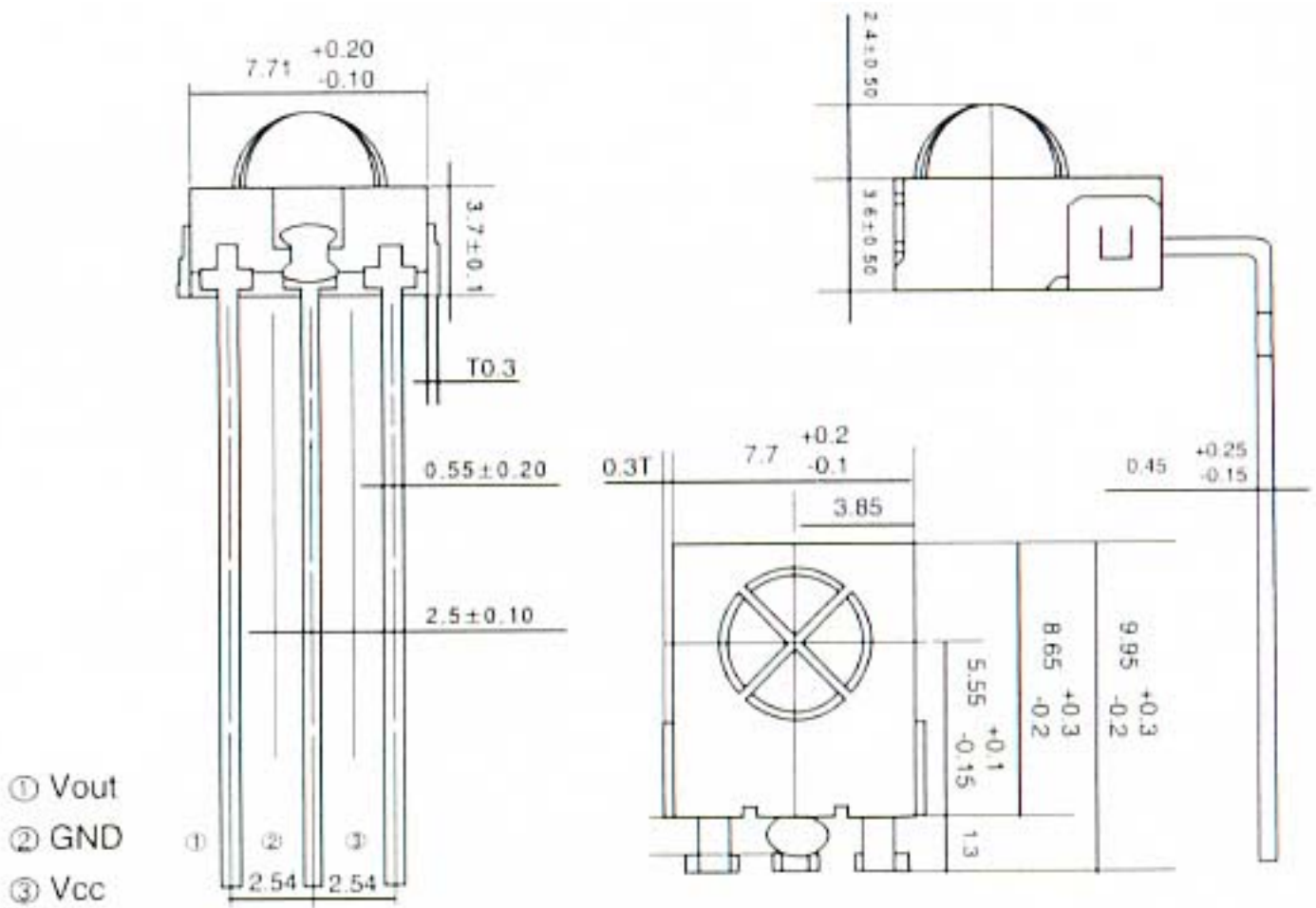

IC 303 : KIA7042AP

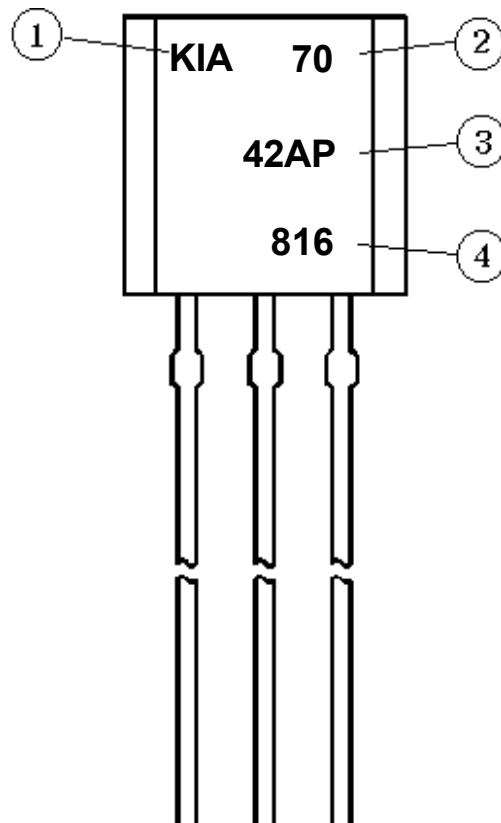

IC 111 : KA78XX

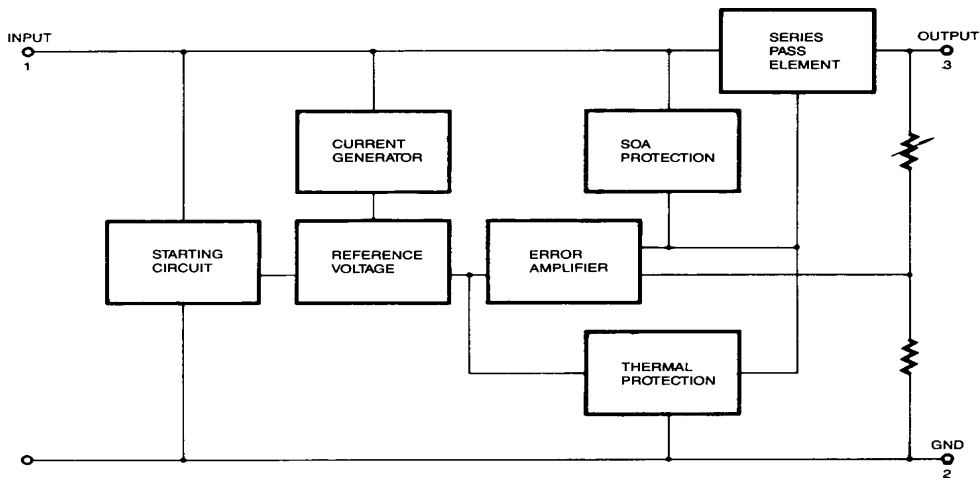

IC 112 : KA79XX

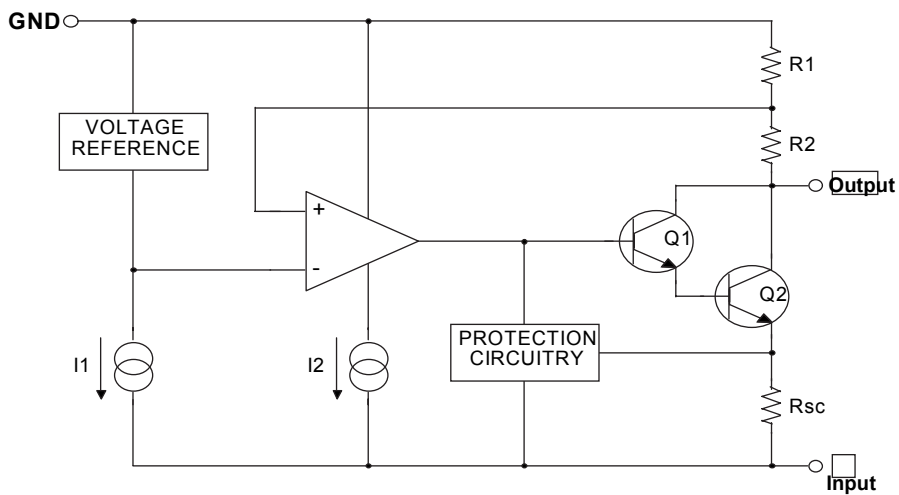

IC 603 : LA3401

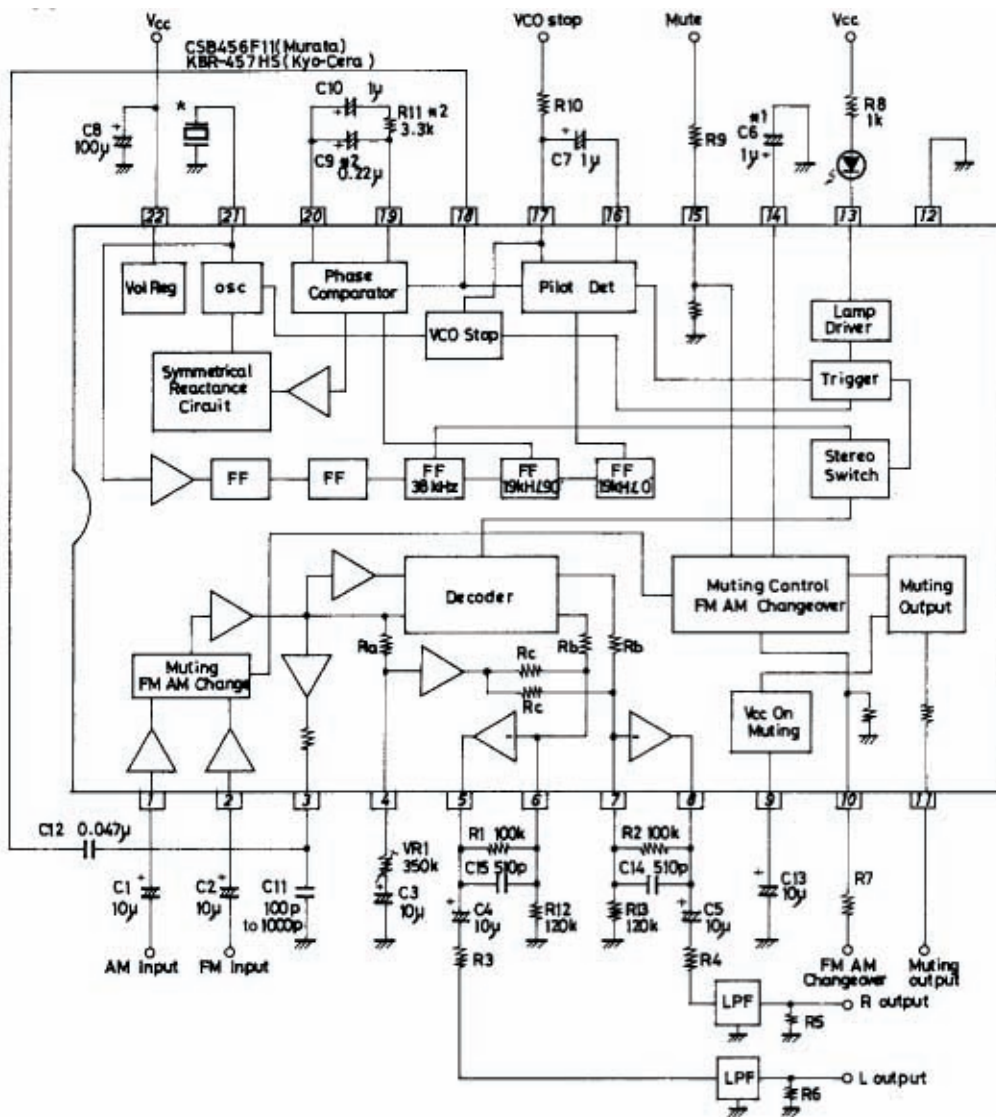

IC 102 : LC7821

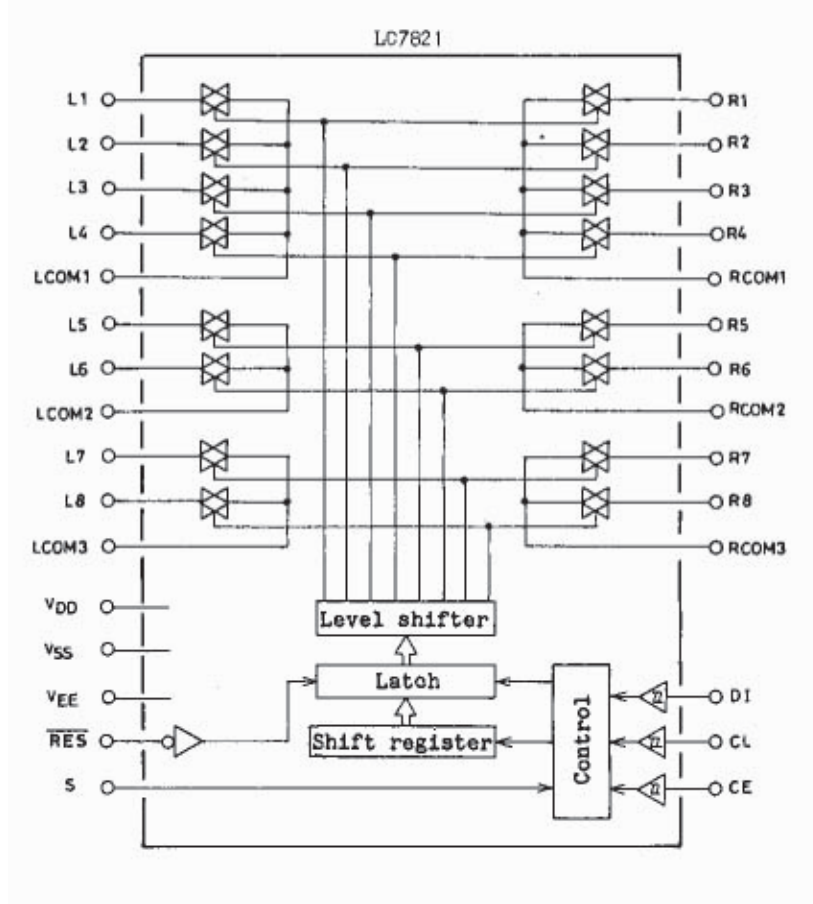

IC 602 : LC7218JM

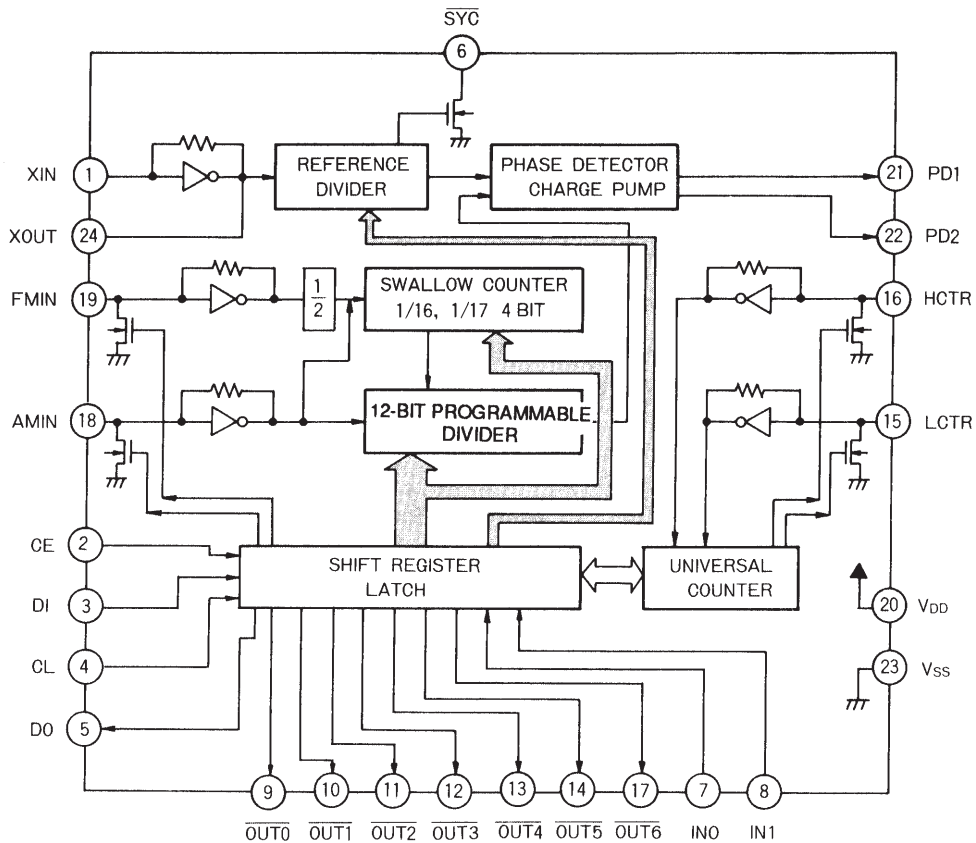

IC 108 : LTV817B

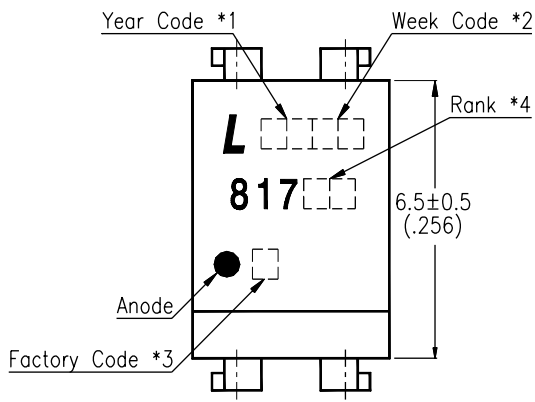

Pin No. and Internal connection diagram

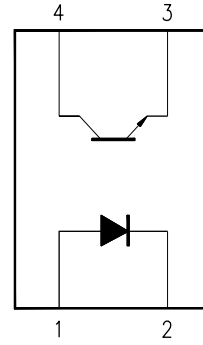

- 1. Anode
- 2. Cathode
- 3. Emitter
- 4. Collector

IC 304 : BR24C04

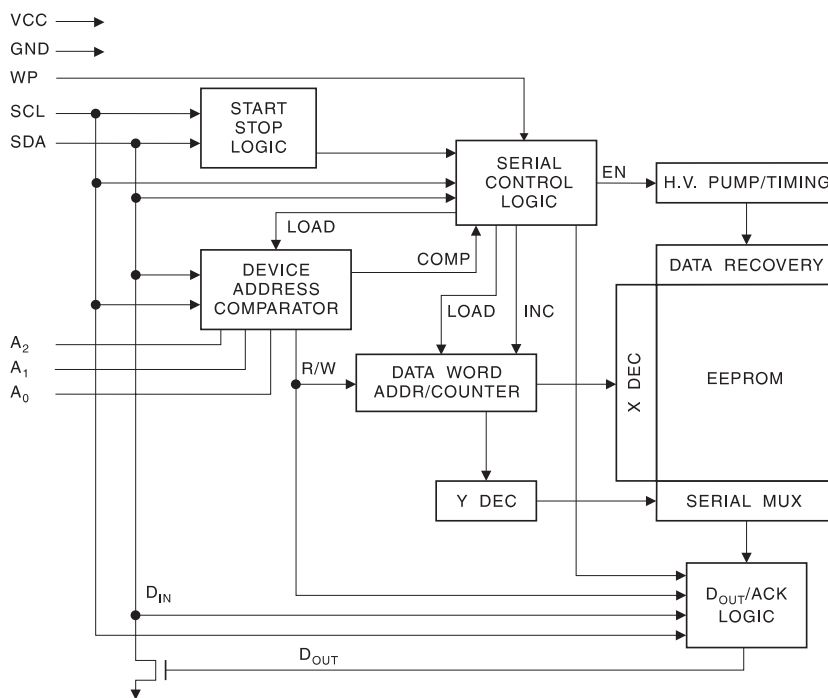

IC 604 : TDA7479D

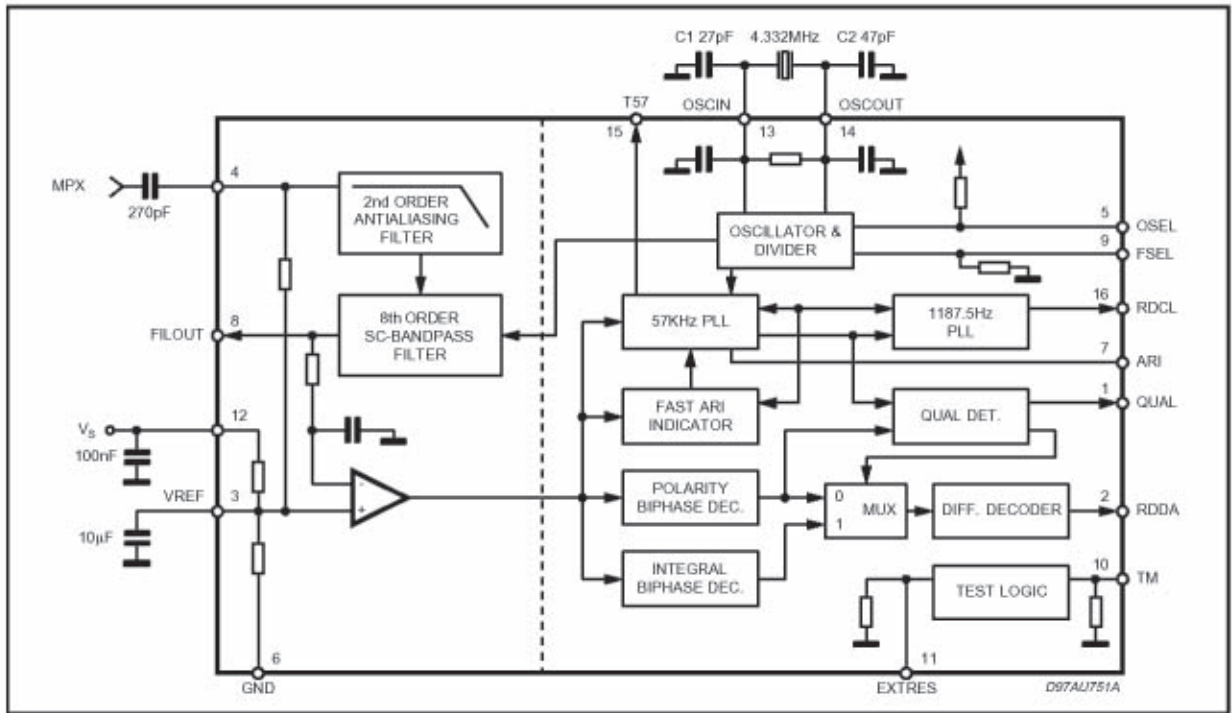

IC 601 : LA1266 AM/FM IF

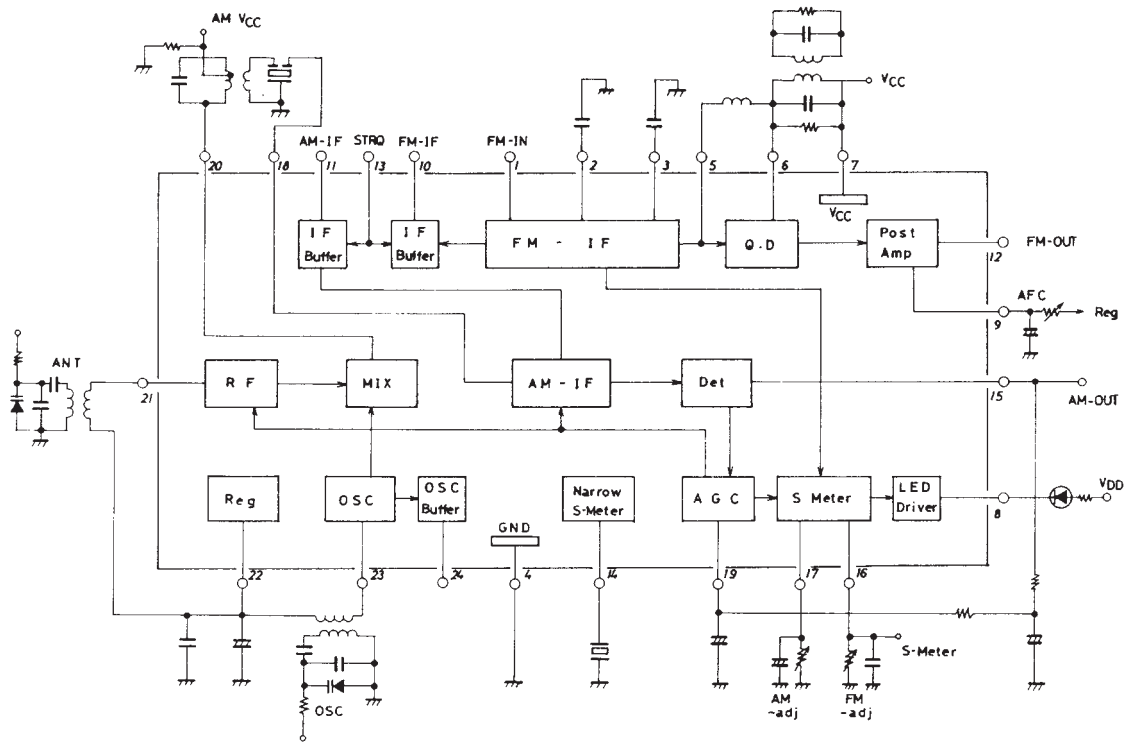

Front End : FE601 (FTA3-509HA) U.S.A. Version

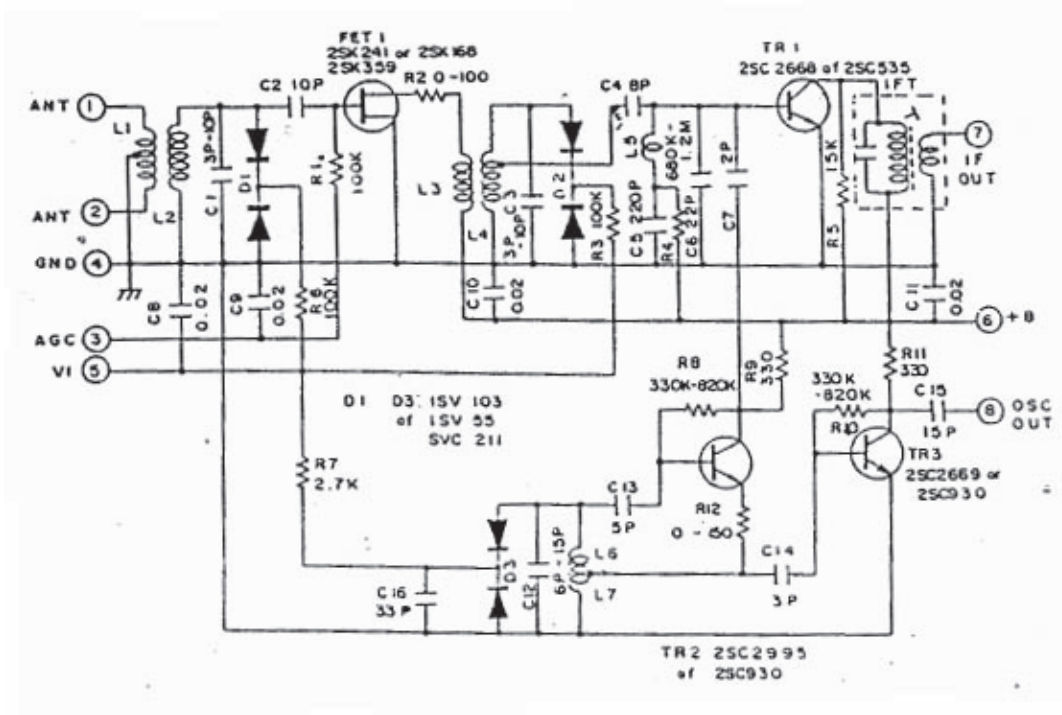

Front End : FE601 (FTA4-460H) E.U. Version

