

harman/kardon

HK3485 STEREO RECEIVER

SERVICE MANUAL



CONTENTS

ESD WARNING.....	2	PROCESSOR RESET.....	23
LEAKAGE TESTING.....	3	DISASSEMBLY PROCEDURES.....	24
SPECIFICATIONS	4	EXPLODED VIEW	25
PACKAGE.....	5	AMPLIFIER BIAS ADJUSTMENT.....	26
FRONT PANEL CONTROLS	6	BLOCK DIAGRAM.....	27
REAR PANEL CONNECTIONS	9	IC DESCRIPTIONS/PINOUTS.....	28
REMOTE CONTROL FUNCTIONS	11	ELECTRICAL PARTS LIST	42
CONNECTIONS/INSTALLATION.....	13	PCB DRAWINGS.....	47
OPERATION.....	19	SCHEMATICS.....	49
TROUBLESHOOTING GUIDE.....	23	WIRING DIAGRAM.....	51

harman/kardon, Inc.
250 Crossways Park Dr.
Woodbury, New York 11797

Released 2007
Discontinued XXXX

Rev0 7/2007

ELECTROSTATICALLY SENSITIVE (ES) DEVICES

Some semiconductor (solid state) devices can be damaged easily by static electricity. Such components commonly are called Electrostatically Sensitive (ES) Devices. Examples of typical ES devices are integrated circuits and some field effect transistors and semiconductor "chip" components.

The following techniques should be used to help reduce the incidence of component damage caused by static electricity.



1. Immediately before handling any semiconductor component or semiconductor-equipped assembly, drain off any electrostatic charge on your body by touching a known earth ground. Alternatively, obtain and wear a commercially available discharging wrist strap device, which should be removed for potential shock reasons prior to applying power to the unit under test.
2. After removing an electrical assembly equipped with ES devices, place the assembly on a conductive surface such as aluminum foil, to prevent electrostatic charge build-up or exposure of the assembly.
3. Use only a grounded-tip soldering iron to solder or unsolder ES devices.
4. Use only an anti-static solder removal device. Some solder removal devices not classified as "anti-static" can generate electrical charges sufficient to damage ES devices.
5. Do not use freon-propelled chemicals. These can generate electrical change sufficient to damage ES devices.
6. Do not remove a replacement ES device from its protective package until immediately before you are ready to install it. (Most replacement ES devices are packaged with leads electrically shorted together by conductive foam, aluminum foil or comparable conductive material.)
7. Immediately before removing the protective material from the leads of a replacement ES device, touch the protective material to the chassis or circuit assembly into which the device will be installed.

CAUTION : Be sure no power is applied to the chassis or circuit, and observe all other safety precautions.

8. Minimize bodily motions when handling unpackaged replacement ES devices. (Otherwise harmless motion such as the brushing together of your clothes fabric or the lifting of your foot from a carpeted floor can generate static electricity sufficient to damage an ES devices.

PRODUCT SAFETY NOTICE

Each precaution in this manual should be followed during servicing.

Components identified with the IEC symbol  in the parts list are special significance to safety. When replacing a component identified with , use only the replacement parts designated, or parts with the same ratings or resistance, wattage, or voltage that are designated in the parts list in this manual. Leakage-current or resistance measurements must be made to determine that exposed parts are acceptably insulated from the supply circuit before returning the product to the customer.

SAFETY PRECAUTIONS

The following check should be performed for the continued protection of the customer and service technician.

LEAKAGE CURRENT CHECK

Measure leakage current to a known earth ground (water pipe, conduit, etc.) by connecting a leakage current tester between the earth ground and all exposed metal parts of the appliance (input/output terminals, screwheads, metal overlays, control shaft, etc.). Plug the AC line cord of the appliance directly into a 120V AC 60Hz outlet and turn the AC power switch on. Any current measured must not exceed 0.5mA.

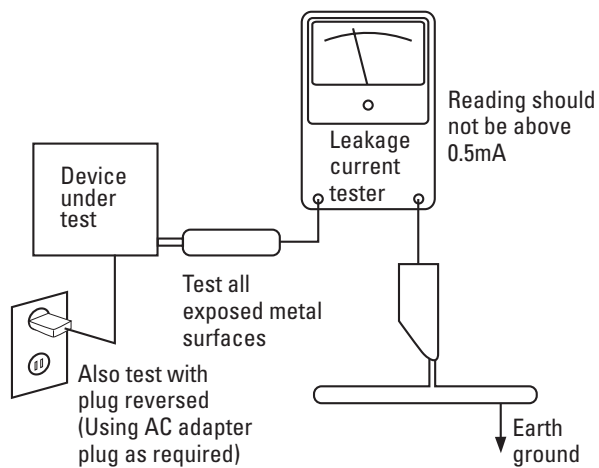

AC Leakage Test

ANY MEASUREMENTS NOT WITHIN THE LIMITS OUTLINED ABOVE ARE INDICATIVE OF A POTENTIAL SHOCK HAZARD AND MUST BE CORRECTED BEFORE RETURNING THE APPLIANCE TO THE CUSTOMER.

HK 3485 TECHNICAL SPECIFICATIONS

Audio Section

Stereo Mode:

Continuous Average Power (FTC):

- 120 Watts per channel, 20Hz – 20kHz,
@ <0.07% THD, both channels driven into 8 ohms
- 150 Watts per channel, 20Hz – 20kHz
@ <0.2% THD, both channels driven into 4 ohms

Input Sensitivity/Impedance

Linear (High-Level): 200mV/47k ohms

Signal-to-Noise Ratio (IHF-A): 95dB

Frequency Response @ 1W (+0dB, -3dB): 10Hz – 110kHz

High Instantaneous Current Capability (HCC): ±42 Amps

Transient Intermodulation

Distortion (TIM): Unmeasurable

Rise Time: 16 µsec

Slew Rate: 40V/µsec

FM Tuner Section

- Frequency Range: 87.5 – 108.0MHz
- Usable Sensitivity: IHF 1.12µV/13.5dB
- Signal-to-Noise Ratio: Mono/Stereo 73/72dB
- Distortion: Mono/Stereo 0.3/0.4%
- Stereo Separation: 40dB @ 1kHz
- Selectivity: ±400kHz, 65dB
- Image Rejection: >80dB
- IF Rejection: >100dB
- Tuner Output Level: 1kHz, ±100kHz, Dev 500mV

AM Tuner Section

- Frequency Range: 520 – 1710kHz
- Signal-to-Noise Ratio: >40dB
- Usable Sensitivity: Loop 500µV/M
- Distortion: 1kHz, 50% Mod 0.8%
- Selectivity: ±10kHz, >25dB

Video Section

- Television Format: NTSC/PAL/SECAM
- Signal Format: Composite
- Input Level: 1Vp-p
- Input Impedance: 75 Ohms, unbalanced
- Sync Polarity: Negative
- Output Level: 1Vp-p
- Output Impedance: 75 Ohms, unbalanced
- Video Frequency Response: 10Hz – 10MHz

General

- Power Requirement: AC 120V/60Hz
- Power Consumption: 3W standby, 280W maximum
(both channels driven)

- | | | |
|-------------|---------------|---------------|
| Dimensions: | (Product) | (Shipping) |
| Width: | 17.4" (442mm) | 21.5" (545mm) |
| Height: | 6.6" (168mm) | 9.9" (251mm) |
| Depth: | 15" (382mm) | 17.9" (455mm) |

- | | | |
|---------|-----------------|------------------|
| | (Product) | (Shipping) |
| Weight: | 20.9 lb (9.5kg) | 25.1 lb (11.4kg) |

Depth measurement includes knobs, buttons and terminal connections.

Height measurement includes feet and chassis.

All features and specifications are subject to change without notice.

Harman Kardon is a trademark of Harman International Industries, Incorporated, registered in the United States and/or other countries. Designed to Entertain is a trademark of Harman International Industries, Incorporated.

CEA is a registered trademark of the Consumer Electronics Association.

iPod is a trademark of Apple Inc., registered in the U.S. and other countries.

Instruction manual ass'y - Accessories

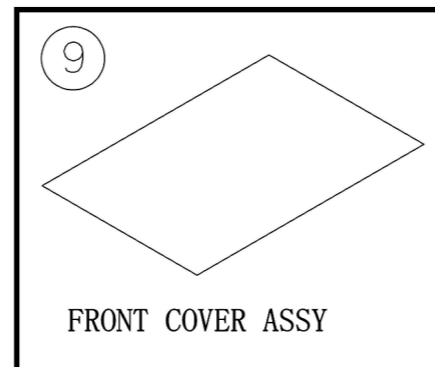
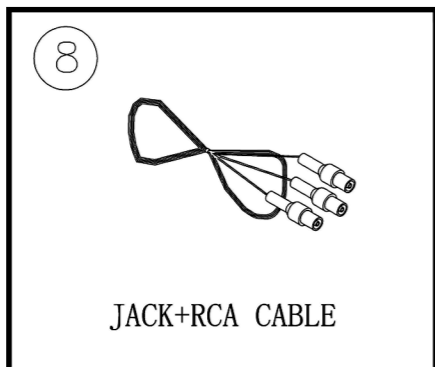
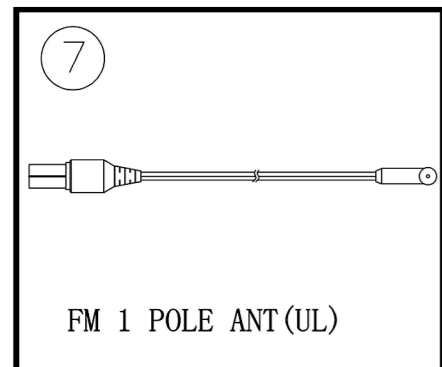
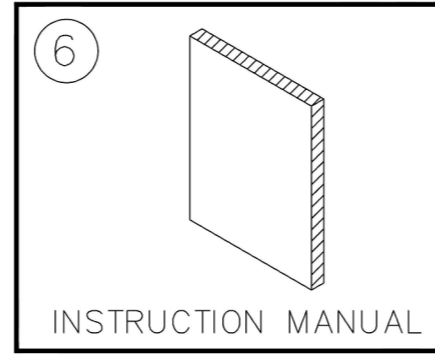
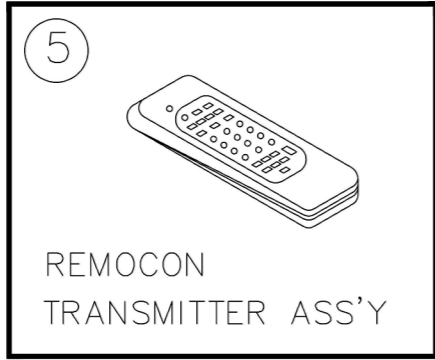
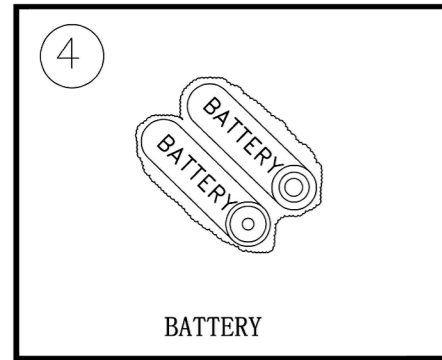
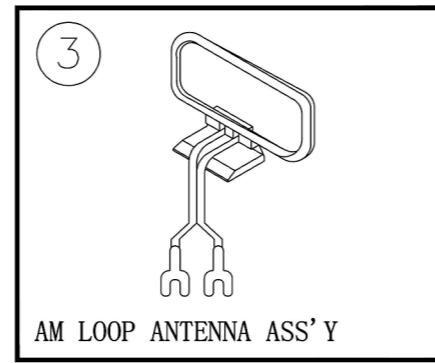
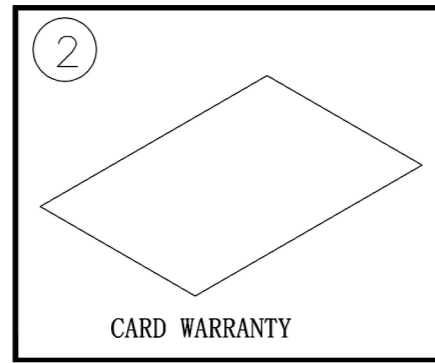
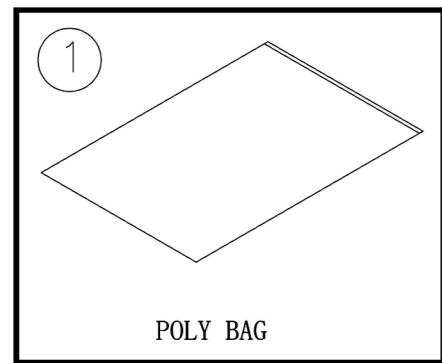

NO	DESCRIPTION	PARTS NO.	Qty
1	POLY BAG		1
2	CARD WARRANTY	CQE1A172X	1
3	AM LOOP ANTENNA ASS'Y	CSA3A012Z	1
4	BATTERY		2
5	REMOCON TRANSMITTER ASS'Y	CARTHK3485	1
6	INSTRUCTION MANUAL	Visit Website www.harmanardon.com	1
7	FM 1 POLE ANT (UL)	CSA1A019Z	1
8	JACK+RCA CABLE	CJS9L006Z	1
9	FRONT COVER ASSY		1

Package Drawing

HK3485

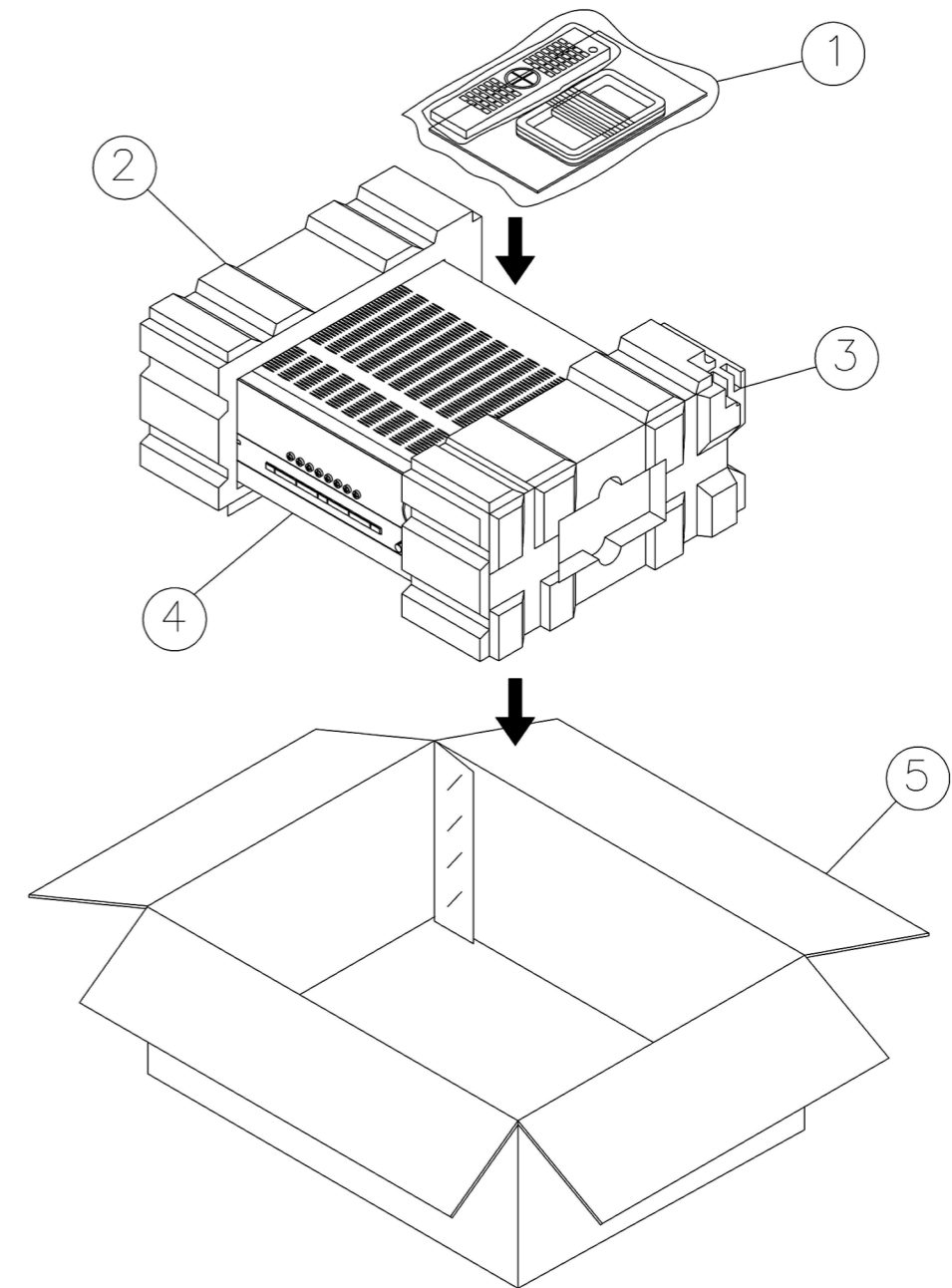

NO	DESCRIPTION	PART NO.	Qty
1	INSTRUCTION MANUAL ASS'Y		1
2	SNOW PAD (L)	CPS4A564	1
3	SNOW PAD (R)	CPS4A565	1
4	HK 3485 STEREO RECEIVER	HK 3485	1
5	OUTER CARTON	CPG1A743S	1

FRONT-PANEL CONTROLS

Power Switch: This electrical switch turns the receiver on for playback, or leaves it in Standby mode for quick turn-on using the remote control.

Power Indicator: This LED has two modes. When power is turned off, the LED is amber to indicate that the receiver is plugged in and ready to be turned on. When the receiver is turned on, the LED turns blue.

Headphone Jack: Plug a 1/4" headphone plug into this jack for private listening.

Mute: Press this button to mute the HK 3485's speaker and headphone outputs temporarily. To end the muting, press this button or adjust the volume. Muting is also canceled when the receiver is turned off.

Speaker 1/2: Press the left side of this button to enable the HK 3485 to output audio to the speakers connected to the Speaker 1 Outputs, and press the right side of the button to enable the Speaker 2 Outputs. You may enable or disable both sets of speaker outputs simultaneously. This feature is a convenient way of hearing audio in more than one room at a time, although the same source material will be played through both sets of speakers.

Tuning: Press either side of this button to tune a radio station. Tap the button briefly to tune one frequency step at a time, or press and hold the button to seek the next frequency with an acceptably strong signal.

Preset Scan: Press this button once to scan through the stations you have previously programmed as presets. Each station will play for five seconds before the tuner skips to the next preset station. Press the button a second time to select the current station. If no presets have been programmed, the 0 PRESET message will be displayed.

Preset Stations: Press this button to select a preset radio station. If no presets have been programmed, the 0 PRESET message will be displayed.

Tuner Band: Press this button to select the tuner as the source, or to select the AM (right side of button) or FM (left side of button) band.

FM Mode: This button toggles between Stereo and Mono modes when an FM station is tuned. Mono mode may improve reception of weaker signals.

Bass Control: Turn the knob clockwise to boost low-frequency output by up to 10dB, or counterclockwise to cut low-frequency output by up to 10dB. Set the control to suit your taste and room acoustics.

Video 3, Analog Audio and Video Inputs: Connect a source component that will only be used temporarily to these jacks, such as a camera or game console, or connect an iPod using the supplied audio/video cable.

Balance Control: Turn the knob to adjust the relative volume of the left and right channels, which affects imaging and can compensate for room characteristics.

Volume Control: Turn this knob to raise or lower the volume, which will be shown in decibels (dB) in the Message Display.

Treble Control: Turn the knob clockwise to boost high-frequency output by up to 10dB, or counterclockwise to cut high-frequency output by up to 10dB. Set the control to suit your taste and room acoustics.

Sleep: Press this button to activate the sleep timer, which shuts off the receiver after a programmed period of time up to 90 minutes.

Dimmer: Some people find the front-panel display distracting. Press this button once to dim the displays to half-brightness, and a second time to turn the displays completely off. The Power Indicator will always remain lit to remind you that the receiver is turned on. Press the button a third time to return the display to normal brightness. This setting is canceled when the unit is turned off.

Message Display: Various messages appear in this display in response to commands.

Video Source Selectors: Press any of these buttons to select the device connected to the corresponding Audio and Video Inputs for playback. Remember to turn on the source device, to connect the Video Monitor Output to your video display and to turn on your video display and select the correct Video Input.

NOTE: The Video 3 source device may be connected to either the front- or rear-panel connectors. To select the desired device, press the Video 3 Source Selector repeatedly until the dot to the left of the Video 3 Indicator in the Message Display lights steadily (rear-panel connections selected) or flashes (front-panel connections selected).

CD Source Selector: Press this button to select the device connected to the CD Inputs as the source.

Tape Source Selector: Press this button to select the device connected to the Tape/CDR Audio Inputs as the source. If you are making a recording using a three-head tape deck or another unit with off-head playback, the dot to the left of the Tape Monitor Indicator in the Message Display will flash when the recording is being monitored.

Phono Source Selector: Press this button to select a turntable connected to the Phono Inputs as the source.

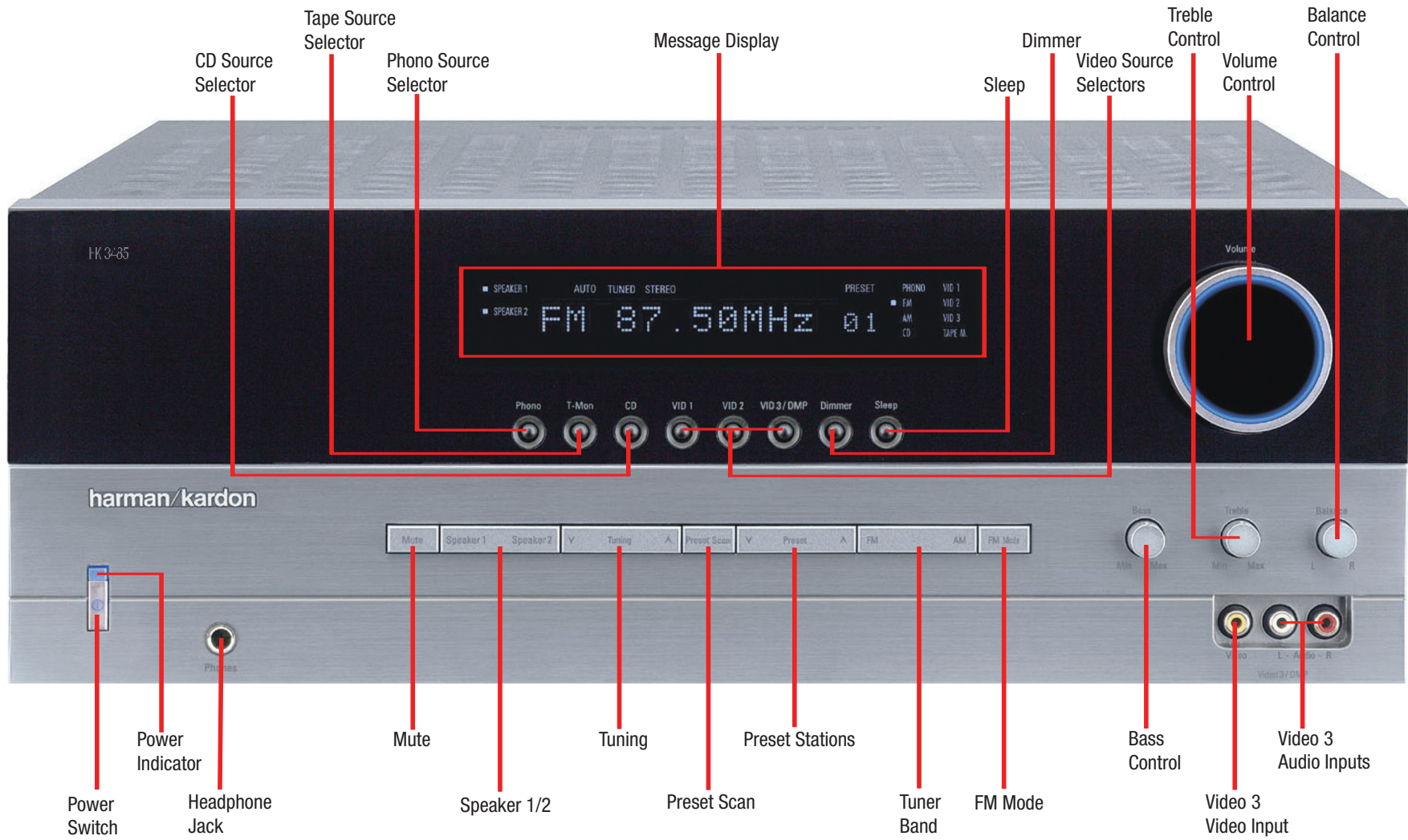

NOTE: To make it easier to follow the instructions throughout the manual that refer to this illustration, a copy of this page may be downloaded from the Product Support section at www.harmankardon.com.

FRONT-PANEL INFORMATION DISPLAY

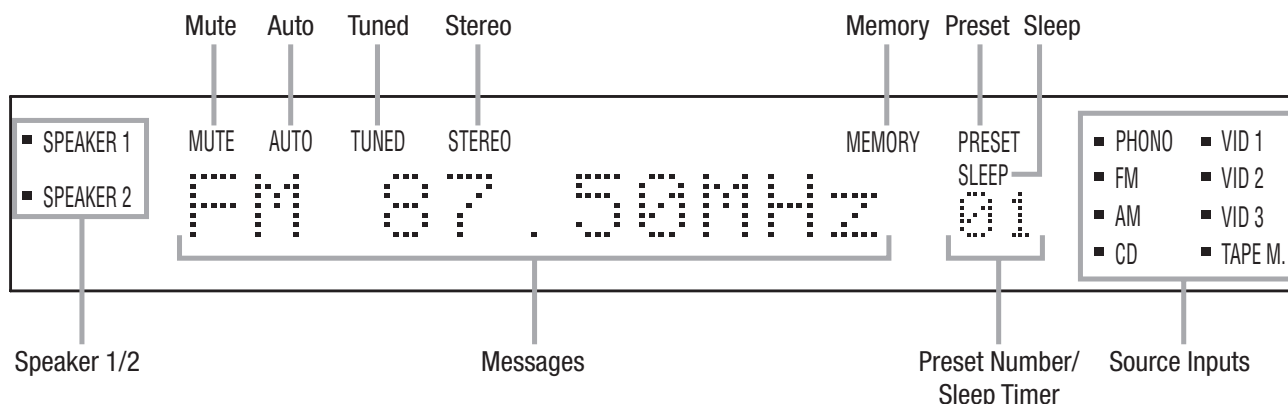

NOTE: To make it easier to follow the instructions that refer to this illustration, a larger copy may be downloaded from the Product Support section for this product at www.harmankardon.com.

Speaker 1/2: The dot to the left of the indicator for each speaker pair will light when that pair is active. Press the Speaker 1/2 Selectors to activate either or both pairs of speakers.

Messages: This display shows messages relating to the status, input source, tuner or other aspects of the HK 3485's operation.

Preset Number/Sleep Timer: When the tuner is in use, these numbers indicate the specific preset memory location in use. When the Sleep function is in use, these numbers show how many minutes remain before the unit turns off.

Source Inputs: The dot to the left of the name of the device that is currently the source input for the HK 3485 will light.

When the device connected to the Tape Monitor Inputs has been selected, the dot to the left of the Tape Monitor Input Indicator will flash to indicate that you are monitoring a recording being made on the device connected to the Tape Monitor Inputs, if the recorder has off-head playback. The dot to the left of the Input Indicator for the last-selected source input will remain lit.

Sleep Indicator: This indicator lights when the Sleep function is in use. The numbers in the Preset Number/Sleep Timer Indicators will show the minutes remaining before the HK 3485 turns off.

Preset Indicator: This indicator lights when the tuner is in use to show that the Preset Number/Sleep Timer is showing the station's preset memory number.

Memory Indicator: This indicator flashes when entering presets and other information into the tuner's memory.

Stereo Indicator: This indicator lights when an FM station is being tuned in stereo.

Tuned Indicator: This indicator lights when a station is being received with sufficient signal strength to provide acceptable listening quality.

Auto Indicator: This indicator lights when the tuner's Auto Stereo mode is in use.

Mute Indicator: This indicator flashes to remind you that the HK 3485's output has been silenced by pressing the Mute Button. Press the button again to end muting.

REAR-PANEL CONNECTIONS

AM and FM Antenna Terminals: Connect the included AM and FM antennas to their respective terminals for radio reception.

Video 1, Video 2 and Video 3 Audio/Video Inputs: These jacks may be used to connect your video-capable source components (e.g., VCR, DVD player, cable TV box) to the receiver.

NOTE: The Video 3 source has inputs on both the front and rear panels of the HK 3485, and you may connect different devices to each set of inputs. To select between the two sets of inputs, press the Video 3 Source Selector repeatedly. Observe the HK 3485's front panel. When the dot next to the Video 3 Input Indicator lights steadily, the device connected to the rear panel has been selected. When the dot flashes, the device connected to the front panel has been selected.

Video 1 Audio/Video Outputs: These jacks may be used to connect your VCR or another recorder.

Video Monitor Output: If some of your sources use video connections, then you will need to connect the Video Monitor Output to the corresponding input on your television or video display in order to view the sources. No video signal will be available when an audio-only source input, such as CD or Tape, is selected.

Remote Infrared (IR) Input and Output: When the remote IR receiver on the front panel is blocked, such as when the HK 3485 is placed inside a cabinet, connect an optional IR receiver to the Remote IR Input jack for use with the remote control. The Remote IR Output may be connected to the Remote IR Input of a compatible source device (or other product) to enable remote control through the HK 3485. When several source devices are used, connect them in "daisy chain" fashion.

AC Power Cord: After you have made all other connections, plug the AC power cord into an unswitched outlet.

Switched AC Accessory Outlets: You may plug the AC power cord of one source device into each of these outlets, and it will turn on whenever you turn on the receiver. Do not use sources that consume more than 100 watts of power per outlet.

Speaker 1 and 2 Outputs: Use two-conductor speaker wire to connect each set of terminals to the correct speaker. Remember to observe the correct polarity (positive and negative connections). Always connect the positive lead to the red terminal on the receiver and the red terminal on the speaker. Connect the negative lead to the black terminal on both the receiver and the speaker. Use the Speaker 1/2 Selector on the front panel or remote to select either or both pairs of speakers for playback.

Subwoofer Outputs: If you have a powered subwoofer, connect these jacks to the line-level inputs on the subwoofer. The same full-range signal is output through both jacks. Thus, you have the option of connecting each jack to the line-level input on a separate subwoofer. If you have only one subwoofer with a single line-level input, connect it to the right Subwoofer Output on the HK 3485.

Main-Amp Inputs and Preamp Outputs: These jacks are normally connected directly to each other with an included jumper. Some devices, such as equalizers and some loudspeaker systems, require connection between the Preamp Outputs and Main-Amp Inputs, in which case the jumpers should be removed and stored in a safe place for future use. You may also remove the jumpers if you wish to connect the Preamp Outputs to an external amplifier, or if you wish to connect another device's line-level output directly to the HK 3485's power amplifier for a special application.

Tape Outputs: These jacks may be used to connect your CDR or another audio-only recorder.

CD and Tape Audio Inputs: These jacks may be used to connect your audio-only source components (e.g., CD player, tape deck). Do not connect a turntable to these jacks unless you are using the turntable with a phono preamp. When your recorder features three-head or off-head playback, you may monitor a recording as it is being made.

Phono Inputs and Ground: Connect the outputs of your turntable or tonearm to these jacks, and connect the ground wire from the turntable to this Ground Connector to reduce system hum. Only moving-magnet (MM-type) cartridges are compatible with the Phono Inputs. If your turntable is equipped with its own onboard phono preamp, you may connect it to any of the HK 3485's audio inputs.

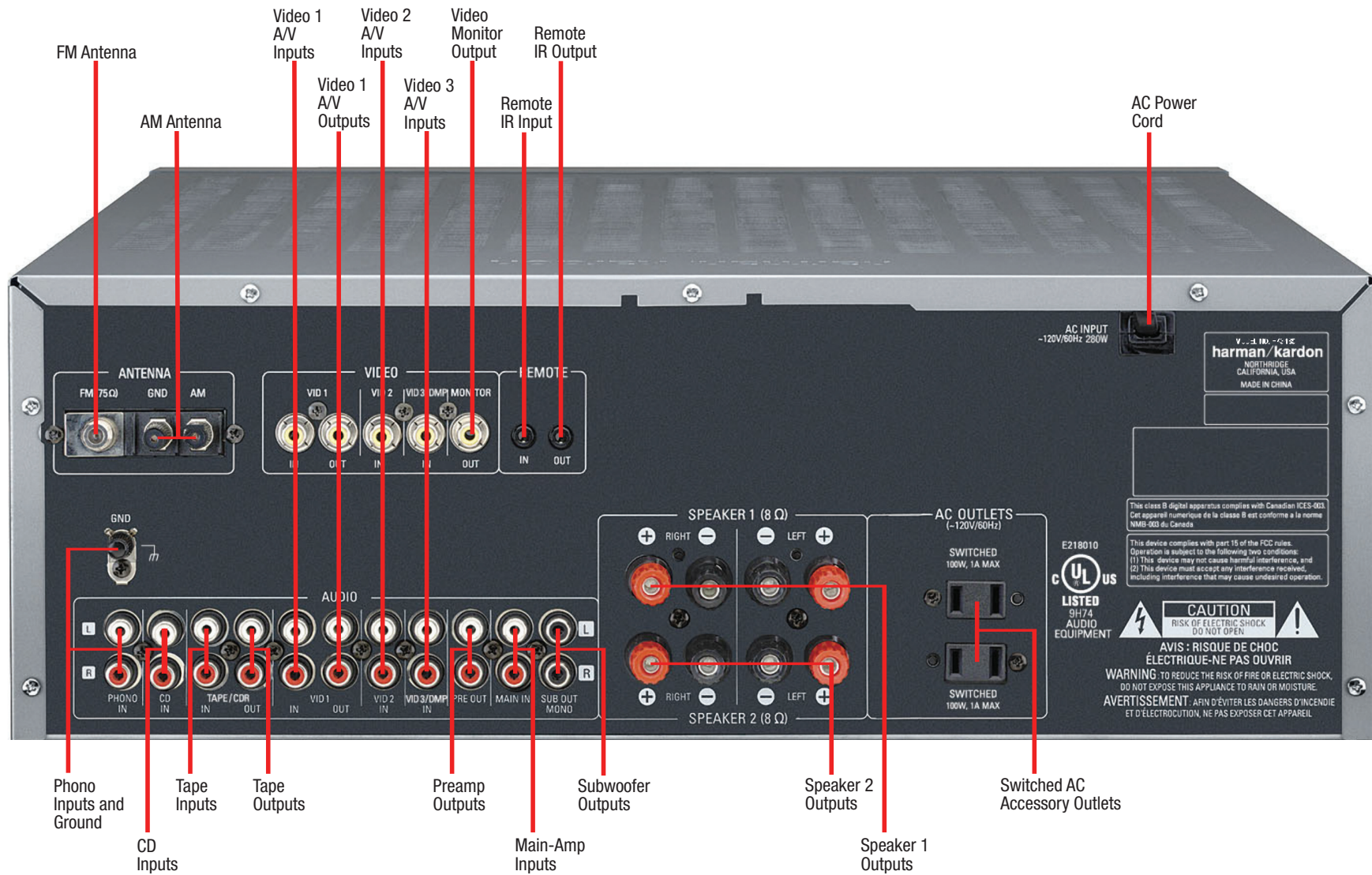

NOTE: To make it easier to follow the instructions throughout the manual that refer to this illustration, a copy of this page may be downloaded from the Product Support section at www.harmankardon.com.

REMOTE CONTROL FUNCTIONS

The HK 3485 remote is capable of controlling six devices, including the HK 3485 itself. The remote is preprogrammed at the factory to operate most Harman Kardon DVD, CD and CDR players. Each time you wish to use the codes for any component, you will need to first press the Selector Button for that component. This changes the button functions to the appropriate codes for that product.

Phono: Controls only the HK 3485 when a turntable is in use.

Video 1, 2 and 3: Controls DVD players.

Tape: Controls CD recorders.

CD: Controls CD players.

AM/FM: Controls the HK 3485 and its internal tuner only.

The functions specific to the HK 3485 are always available: Main Power On and Off, Speaker 1/2, source selection, Mute, Sleep, Dimmer and the Volume Controls.

Any given button may have different functions, depending on which component is being controlled. Some buttons are labeled with these functions. For example, the Track Skip and Fast Search Buttons are labeled with the transport control icons printed on the buttons themselves, and these functions are active when a CD or DVD player is in use. The Preset and Tuning indications appear above these buttons, and those commands are active when the HK 3485's tuner is in use. See the Appendix for listings of the different functions for each type of component.

IR Transmitter Lens: As buttons are pressed on the remote, infrared codes are emitted through this lens. Make sure it is pointing toward the component being operated.

Power Off Button: Press this button to turn off the HK 3485 or another device.

Power On Button: Press this button to turn on the HK 3485 or another device.

Speaker 1/2: Press the Speaker 1 Button to enable the HK 3485 to output audio to the speakers connected to the Speaker 1 Outputs, and press the Speaker 2 Button to enable the Speaker 2 Outputs. You may enable or disable both sets of speaker outputs simultaneously. This feature is a convenient way of hearing audio in more than one room at a time, although the same source material will be played through both sets of speakers.

Source Selectors: Press one of these buttons to select a source device, which is a component where a playback signal originates, e.g., DVD, CD or the tuner. This will also turn on the receiver and switch the remote to the codes that operate the source device.

NOTE: The Video 3 source device may be connected to either the front- or rear-panel connectors. To select the desired device, press the Video 3 Source Selector repeatedly until the dot to the left of the Video 3 Indicator in the Message Display lights steadily (rear-panel connections selected) or flashes (front-panel connections selected).

Preset Stations Selectors/Track Skip: Press these buttons to select a preset radio station, or to change tracks or chapters on compatible Harman Kardon DVD and CD players.

Tuning/Fast Search: Press these buttons to tune a radio station. Tap the button briefly to tune one frequency step at a time, or press and hold the button to seek the next frequency with an acceptably strong signal. The Fast Search function is available with compatible Harman Kardon DVD and CD players.

Stop, Record/Pause and Play: These transport controls have no effect on the receiver, but are used to control compatible Harman Kardon DVD and CD players.

Enter: This button has no effect on the HK 3485, but is used as the Enter key for compatible Harman Kardon DVD players, or the Random Play Button for compatible Harman Kardon CD players.

Disc Skip: These buttons have no effect on the receiver, but are used with compatible Harman Kardon optical disc changers to skip to the next disc.

FM Mode: This button toggles between Stereo and Mono modes when an FM station is tuned.

Preset Scan: Press this button once to scan through the stations you have previously programmed as presets. Each station will play for five seconds before the tuner skips to the next preset station. Press the button a second time to select the current station. If no presets have been programmed, the 0 PRESET message will be displayed.

Mute Button: Press this button to mute the HK 3485's speaker and headphone outputs temporarily. To end the muting, press this button or adjust the volume. Muting is also canceled when the receiver is turned off.

Sleep Button: Press this button to activate the sleep timer, which shuts off the receiver after a programmed period of time up to 90 minutes.

Dimmer: Press this button to partially or fully dim the front-panel display.

Tuning: The HK 3485 has two sets of Tuning Buttons for your convenience. Press these buttons to tune a radio station. Tap the button briefly to tune one frequency step at a time, or press and hold the button to seek the next frequency with an acceptably strong signal.

Volume Controls: Press these buttons to raise or lower the volume, which will be shown in decibels (dB) in the Message Display.

Direct: Press this button before using the Numeric Keys to directly enter a radio station frequency.

Memory: After you have tuned a particular radio station, press this button, then the Numeric Keys, to save that station as a radio preset.

Numeric Keys: Use these buttons to enter radio station frequencies when using the tuner (after pressing the Direct Button), or to select station presets.

REMOTE CONTROL FUNCTIONS

Auto Preset: The Auto Preset feature enables you to automatically set presets for all available FM radio stations in your area with a single button press. To start the process, make sure the FM tuner has been selected as the source. Press and hold this button. The Memory and Preset Indicators will flash as the HK 3485 tuner scans through all FM stations with acceptable signal quality and programs them into the presets. If there are fewer than 30 stations, the tuner will cycle through again, filling up the higher

preset slots with the same stations. The scan will stop when all 30 presets have been filled, or after three scans through the FM band.

Clear: Press this button to clear a radio station frequency you have started to enter.

Control Cover: This cover slides down when you gently press the recessed area down and toward the bottom of the remote, revealing the Numeric Keys and some additional controls.

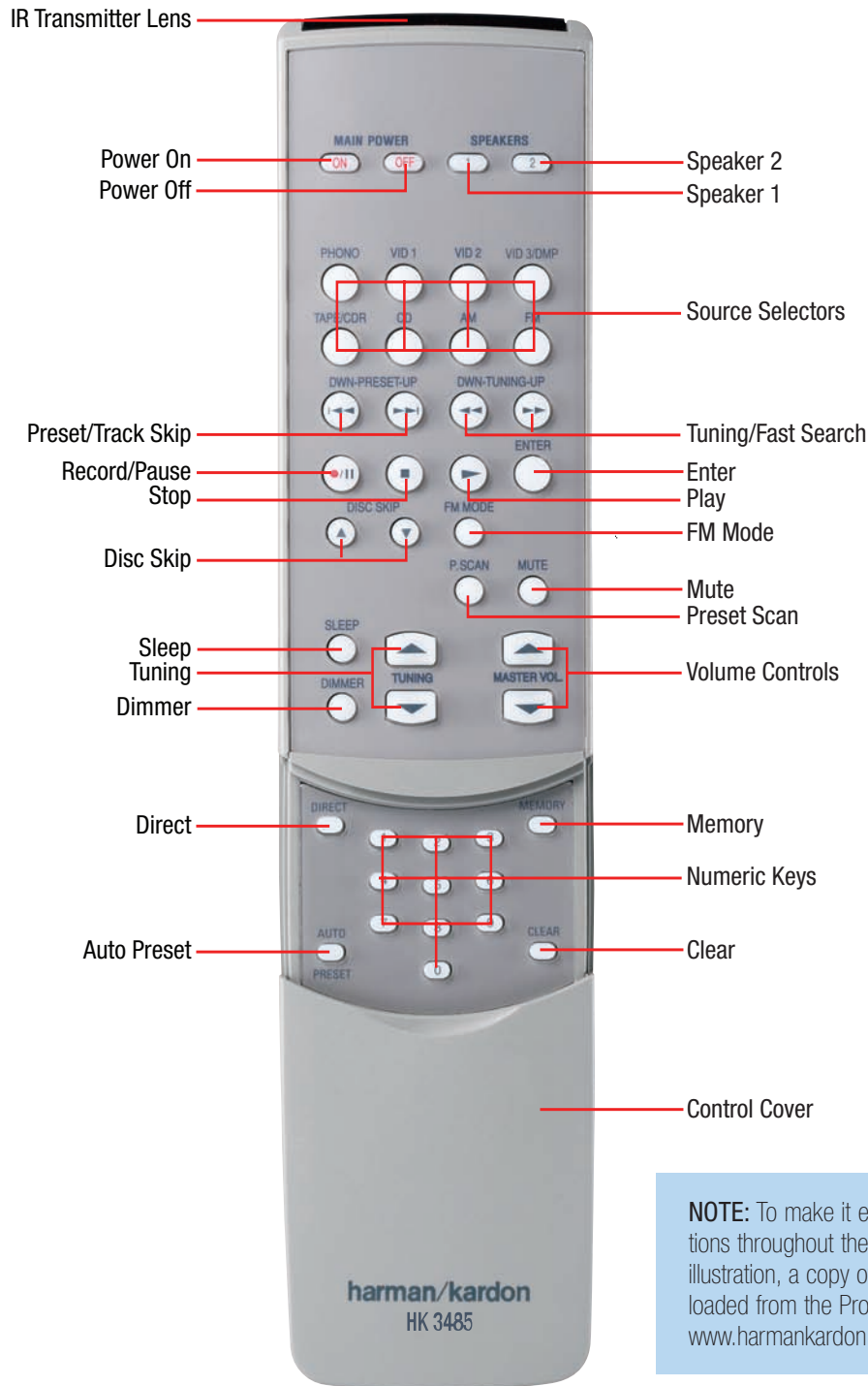

NOTE: To make it easier to follow the instructions throughout the manual that refer to this illustration, a copy of this page may be downloaded from the Product Support section at www.harmankardon.com.

CONNECTIONS

There are different types of audio and video connections used to connect the receiver to the speakers and video display, and to connect the source devices to the receiver. To make it easier to keep them all straight, the Consumer Electronics Association (CEA®) has established a color-coding standard. Table 1 may be helpful to you as a reference while you set up your system.

Table 1— Connection Color Guide

Audio Connections	
	Left Right
Front (FL/FR)	
Video Connections	
Composite	

Types of Connections

This section will briefly review different types of cables and connections that you may use to set up your system.

Speaker Connections

Speaker cables carry an amplified signal from the receiver's speaker terminals to each loudspeaker. Speaker cables contain two wire conductors, or leads, inside plastic insulation. The two conductors are usually differentiated in some way, by using different colors, or stripes, or even by adding a ridge to the insulation. Sometimes the actual wires are different, one being copper red and the other silver.

The differentiation is important because each speaker must be connected to the receiver's Speaker-Output terminals using two wires, one positive (+) and one negative (-). This is called speaker polarity. It's important to maintain the proper polarity for all speakers in the system. If some speakers have their negative terminals connected to the receiver's positive terminals, performance can suffer, especially for the low frequencies.

Always connect the positive terminal on the loudspeaker, which is usually colored red, to the positive terminal on the receiver, also colored red. Similarly, always connect the black negative terminal on the speaker to the black negative terminal on the receiver.

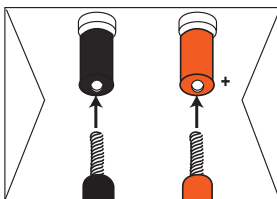

The HK 3485 uses binding-post speaker terminals that can accept banana plugs or bare-wire cables.

Banana plugs are simply plugged into the hole in the middle of the terminal cap. See Figure 1.

Figure 1 – Binding-Post Speaker Terminals With Banana Plugs

Bare-wire cables are installed as follows (see Figure 2):

1. Unscrew the terminal cap until the pass-through hole in the collar is revealed.
2. Insert the bare end of the wire into the hole.
3. Screw the cap back into place until the wire is held snugly.

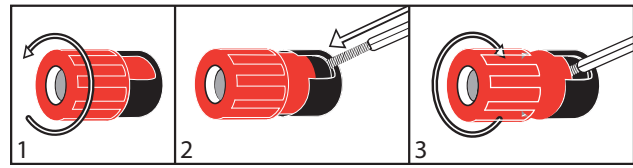

Figure 2 – Binding-Post Speaker Terminals With Bare Wires

Subwoofer

The subwoofer is a specialized type of loudspeaker that is usually connected in a different way. The subwoofer is used to play only the low frequencies (bass), which require much more power than the other speaker channels. In order to obtain the best results, most speaker manufacturers offer powered subwoofers, in which the speaker contains its own amplifier on board. Sometimes the subwoofer is connected to the receiver using the front left and right Speaker Outputs, and then the front left and right speakers are connected to terminals on the subwoofer. More often, line-level (nonamplified) connections are made from the receiver's Subwoofer Outputs to corresponding jacks on the subwoofer, as shown in Figure 3. The same full-range signal is output through both jacks. Thus, you have the option of connecting each jack to the line-level input on a separate subwoofer. If you have only one subwoofer with a single line-level input, connect it to the right Subwoofer Output on the HK 3485.

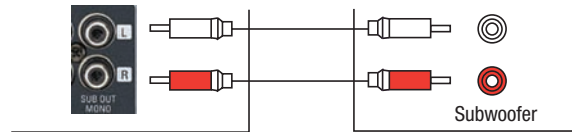

Figure 3 – Subwoofer

Connecting Source Devices to the HK 3485

The HK 3485 is designed to process audio and video input signals, playing back the audio and displaying the video on a television or monitor connected to it. These signals originate in what are known as "source devices," including your DVD player, CD player, DVR (digital video recorder) or other recorder, tape deck, game console, cable or satellite television box, or MP3 player. Although the tuner is built into the HK 3485, it also counts as a source, even though no external connections are needed, other than the FM and AM antennas.

Separate connections are required for the audio and video portions of the signal.

Analog Audio Connections

Analog audio connections require two cables, one for the left channel (white) and one for the right channel (red). These two cables are often attached to each other for most of their length. See Figure 4.

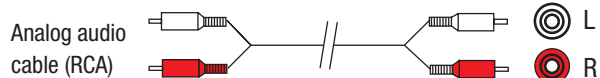

Figure 4 – Analog Audio

CONNECTIONS

Video Connections

Although some sources produce an audio signal only (e.g., CD player, tape deck), many sources output both audio and video signals (e.g., DVD player, cable television box, HDTV tuner, satellite box, VCR, DVR). In addition to the audio connection, you will need to make a video connection for each source.

Composite video is the basic connection most commonly available, and is the only type of video connection available with the HK 3485. The jack is usually color-coded yellow, and looks like an analog audio jack, although it is important never to confuse the two. Do not plug a composite video cable into an analog audio jack, and vice versa. Both the chrominance (color) and luminance (intensity) components of the video signal are transmitted using a single cable. See Figure 5.

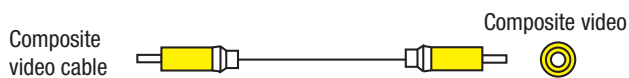

Figure 5 – Composite Video

Antennas

The HK 3485 uses separate terminals for the included FM and AM antennas that provide proper reception for the tuner.

The FM antenna uses a 75-ohm F-connector. See Figure 6.



Figure 6 – FM Antenna

The AM loop antenna needs to be assembled. Then connect the two leads to the screw terminals on the receiver. See Figure 7.

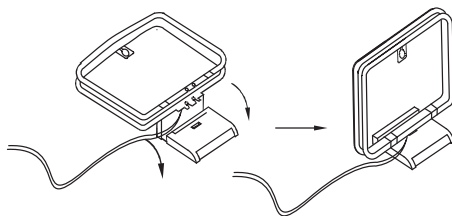

Figure 7 – AM Antenna

INSTALLATION

You are now ready to connect your various components to your receiver. Before beginning, make sure that all components, including the HK 3485, are turned completely off and their power cords are unplugged. **Don't plug any of the power cords back in until you have finished making all of your connections.**

Remember that your receiver generates heat while it is on. Select a location that leaves several inches of space on all sides of the receiver. It is preferable to avoid completely enclosing the receiver inside a cabinet. It is also preferable to place components on separate shelves rather than directly on top of the receiver. Some surface finishes are delicate. Try to select a location with a sturdy surface finish.

Step One – Connect the Speakers

If you have not yet done so, place your speakers in the listening room as described in the Speaker Placement section.

Connect the front left and right loudspeakers to the Speaker 1 speaker terminals on the HK 3485. Remember to maintain the proper polarity by always connecting the positive and negative terminals on each speaker to the positive and negative terminals on the receiver. If you wish to place a second pair of speakers in another room, or in the same room for additional sound power, connect those speakers to the Speaker 2 Outputs, again remembering to maintain polarity. You may use the Speaker 1/2 Selector on the front panel of the receiver. You may use the Speaker 1/2 Selector on the front panel or remote to activate either or both pairs of speakers simultaneously. See Figure 9.

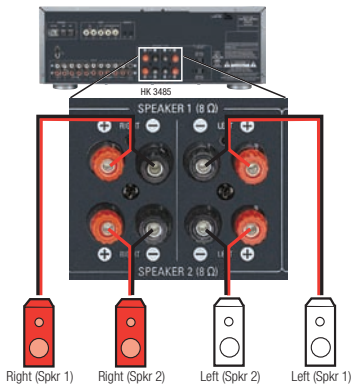

Figure 9 – Speaker Connections

Step Two – Connect the Subwoofer

Connect the Subwoofer Outputs on the HK 3485 to the line-level inputs on your subwoofer. The same full-range signal is output through both jacks. Thus, you have the option of connecting each jack to the line-level input on a separate subwoofer. If you have only one subwoofer with a single line-level input, connect it to the right Subwoofer Output on the HK 3485. See Figure 10. Consult the manufacturer's guide for the subwoofer for additional information.

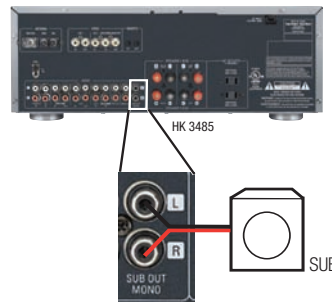

Figure 10 – Subwoofer Connection

Step Three – Connect the Antennas

Connect the FM and AM antennas to their terminals. See Figure 11.

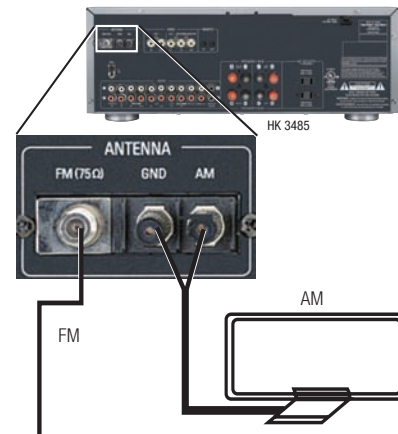

Figure 11 – Antenna Connections

Step Four – Connect the Source Components

Use the worksheets in the Appendix to note which connections you will use for each of your source devices.

For each source, select a source input (Video 1, Video 2, Video 3, etc.). In Table 2 we recommend connecting certain types of sources to certain source inputs to make it easier to use the remote control.

The remote is preprogrammed to operate certain Harman Kardon components, as shown in Table 2. However, you may connect any component with analog audio and/or composite video outputs to any source input on the HK 3485, with the exception of the Phono Inputs, and you may use the original remote control supplied with the component. It is not possible to reprogram the HK 3485 remote, or to change the device type associated with any source input.

INSTALLATION

Table 2 – Remote Control Device Types

Source Input	Remote Control Device Type
Phono	Operates HK 3485 only
Video 1	Harman Kardon DVD player
Video 2	Harman Kardon DVD player
Video 3	Harman Kardon DVD player
Tape/CDR	Harman Kardon CD recorder
CD	Harman Kardon CD player
AM/FM	Operates HK 3485 only

We recommend you follow the guidelines in Table 2 when connecting various source components to the HK 3485. However, due to the limitations in the design of the HK 3485 remote control, when using source components manufactured by other brands, you may need to use the device's original remote control to operate it. Alternatively, you may wish to consider purchasing the Harman Kardon TC 30 activity-based remote control, which is custom-programmed by accessing a vast Internet library of remote control codes for numerous brands and types of products.

For each audio-only source, such as a CD player, simply connect the left and right analog audio outputs of the source device to the corresponding inputs on the HK 3485. For audio/video devices, such as a cable television set-top box, in addition to the audio connections, connect the composite video output on the set-top box to the corresponding video input jack on the HK 3485.

Phono (Turntable)

Connect the audio outputs of your turntable or tone arm with a moving-magnet (MM-type) cartridge to the Phono Inputs, and connect the ground wire to the Ground Terminal immediately above the Phono Inputs (not the AM Antenna Ground Terminal). If the cartridge is a moving-coil (MC-type) cartridge, it requires a separate phono preamp (available at your local electronics store) before you connect it to the Phono Inputs. See Figure 12.



Figure 12 – Phono Inputs and Ground

If your turntable has an MM-type cartridge and a built-in phono preamp, *do not* connect it to the Phono Inputs. Use one of the other available audio input sources on the HK 3485.

Compact Disc (CD) Player

Connect the analog audio outputs of your CD player (or another audio-only device) to the CD Audio Inputs. See Figure 13.



Figure 13 – CD Audio Inputs

Tape

The Tape source is used for audio recorders, such as a CDR, MiniDisc or cassette deck.

Connect the output jacks on your recorder to the Tape Audio Input jacks on the HK 3485, and the input jacks on your recorder to the Tape Output jacks on the HK 3485. See Figure 14.



Figure 14 – Tape/CDR Audio Inputs and Outputs

If your tape deck is a three-head unit or has off-head playback capability, you may monitor recordings by repeatedly pressing the Tape Source Selector on the front panel or remote until the dot to the left of the Tape Input Indicator in the front-panel display flashes.

Video 1 Source

Since this source includes audio and video recording output jacks, it is best suited to a video recorder, such as your VCR or DVR, even though the remote codes are programmed to operate a DVD player. Simply use your video recorder's original remote or the Harman Kardon TC 30.

Connect your recorder to the Video 1 Audio Inputs and Outputs. Then connect the recorder to the Video 1 Composite Video Input and Output. See Figure 15.



Figure 15 – Video 1 AV Inputs and Outputs

Remember to connect the audio and video *output* jacks on your recorder to the Video 1 *Input* jacks on the HK 3485, and the audio and video *input* jacks on your recorder to the Video 1 *Output* jacks on the HK 3485.

INSTALLATION

Video 2 Source

The Video 2 source is used only for playback. Since the remote is preprogrammed to operate a Harman Kardon DVD player when the Video 2 source is selected, we recommend that you connect a DVD player to the Video 2 Inputs.

You may have observed that the HK 3485 is not equipped with digital audio inputs or surround sound decoding. If you prefer the complete home theater experience, you may wish to consider purchasing a full-featured Harman Kardon AVR Series audio/video receiver. However, we hope you will find that using a DVD player with the HK 3485 in smaller settings, such as a bedroom or den, surpasses the audio performance of most televisions, including those with onboard stereo speakers.

Connect the left and right analog audio outputs of the DVD player to the Video 2 Audio Inputs on the HK 3485. Then connect the composite video output of the DVD player, usually colored yellow, to the Video 2 Video Input. See Figure 16.



Figure 16 – Video 2 Audio and Video Inputs

NOTE: If you receive your television programming using your TV with an antenna or direct cable connection, then you will need to connect the analog audio (if available on your TV) outputs to the Video 2 Analog Audio Inputs. Do not connect any video output on the television set to any Video Input on the receiver. See Step Five for information on connecting the receiver's Video Monitor Outputs to the television.

Video 3 Source

The Video 3 source is used only for playback. The Video 3 source has two sets of input jacks, one located on the HK 3485's rear panel and one set on the front panel. If you wish to connect a video device more or less permanently, you may prefer to connect it to the rear-panel inputs for a neater appearance. You may prefer to reserve the front-panel inputs for devices connected on a temporary basis, such as a video-capable iPod (not included), a camcorder, a game console, or another type of media player with analog audio and/or video outputs.

You may connect devices to both the front- and rear-panel inputs simultaneously. To select either device, press the Video 3 Source Selector on the HK 3485's front panel or remote repeatedly. When the dot to the left of the Video 3 Input Indicator (on the front panel of the HK 3485) is lit steadily, the rear-panel inputs are active. When the dot flashes, the front-panel inputs are active.

Connect the left and right analog audio outputs of your device to the corresponding Video 3 Inputs on either the front or rear panel, and if available, connect the composite video output of the device to the Video 3 Video Input on the same panel. See Figure 17.

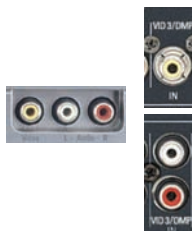

Figure 17 – Front- and Rear-Panel Video 3 A/V Inputs

To connect an iPod to the Video 3 Inputs, insert the 1/8" mini plug on the A/V cable included with the HK 3485 into the iPod's headphone jack. Insert the left and right analog audio plugs on the other end of the A/V cable into the Video 3 Audio Inputs on the front of the receiver. If the iPod is capable of playing videos or displaying images, insert the composite video plug of the A/V cable into the Video 3 Video Input.

Since the remote is preprogrammed to operate a Harman Kardon DVD player when the Video 3 source has been selected, use the original remote to control other components, or operate an iPod using its own controls.

Step Five – Connect the Video Display

Only video connections should be made between the receiver and your video display (TV), unless your TV is the source for your television programming (see note above).

To view video or images played by your source devices, connect the Video Monitor Output of the HK 3485 to a Composite Video Input on your television or video display. See Figure 18. Consult the manual for your TV so that you understand how to select and display the correct Video Input.



Figure 18 – Video Monitor Output

Step Six – Connect the Remote IR Input and Output (Optional)

The HK 3485 is equipped with a Remote IR Input and a Remote IR Output to facilitate use of your system with a remote control in a variety of situations.

When the HK 3485 is placed in such a way that aiming the remote at the front-panel IR sensor is difficult, such as inside a cabinet or facing away from the listener, you may connect an external IR receiver, such as the optional Harman Kardon HE 1000, to the Remote IR Input jack.

If any of your source devices are equipped with a compatible Remote IR Input, you may use a 1/8" mini-plug interconnect cable (not included) to

INSTALLATION

connect the HK 3485's Remote IR Output to the source device's Remote IR Input, which will pass any applicable remote signals transmitted through the HK 3485 to the source device. This enables you to control your sources even when the HK 3485 itself is controlled via an external IR receiver.

To control more than one source device using the Remote IR Output, connect all sources in "daisy chain" fashion, with the HK 3485's Remote IR Output connected to the first device's Remote IR Input, that device's Remote IR Output connected to the next device's Remote IR Input, and so forth. See Figure 19.



Figure 19 – Remote IR Input and Output

NOTE: Not all remote-controllable devices are equipped with compatible IR inputs and outputs. Check with the manufacturer of the source device for more information on the type of IR signal expected. The HK 3485 will output a "stripped carrier" IR signal.

Step Seven – Connect Optional External Equipment

If you wish to use the HK 3485 with an external power amplifier, remove the jumpers connecting the Preamp Outputs and Main-Amp Inputs. Store the jumpers in a safe place in case they are needed in the future. Connect the left and right Preamp Outputs of the HK 3485 to the analog audio inputs on the external power amplifier. See Figure 20.



Figure 20 – Preamp Outputs and Main-Amp Inputs

You may adjust the Volume and Tone Controls using the HK 3485's front panel or remote.

If you wish to connect an external processor, such as an equalizer, you may connect it to the Preamp Outputs and Main-Amp Inputs. Remove the jumpers and store them in a safe place. Connect the HK 3485's Preamp Outputs to the processor's analog audio inputs, and then connect the processor's analog audio outputs to the Main-Amp Inputs on the HK 3485.

Alternatively, you may connect the external processor to the HK 3485's Tape Monitor Loop. See Figure 14.

Step Eight – Plug In AC Power

Having made all of your wiring connections, it is now time to plug each component's AC power cord into a working outlet.

You may plug two devices into the AC Switched Accessory Outlets on the rear of the HK 3485. See Figure 21. Make sure each device draws no more than 100 watts. The devices should have their mechanical or master power switches turned on, and they will power on any time the HK 3485 is turned on.



Figure 21 – Switched AC Accessory Outlets

Step Nine – Insert Batteries in Remote

The HK 3485 remote control uses two AAA batteries, which are included.

To remove the battery cover located on the back of the remote, firmly press the ridged depression and slide the cover toward the bottom of the remote.

Insert the batteries as shown in the diagram, making sure to observe the correct polarity. See Figure 22.

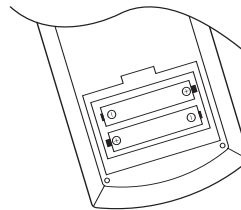

Figure 22 – Remote Battery Compartment

When using the remote, remember to point the lens toward the front panel of the HK 3485. Make sure no objects, such as furniture, are blocking the remote's path to the receiver. Bright lights, fluorescent lights and plasma video displays may interfere with the remote's functioning. The remote has a range of about 20 feet, depending on the lighting conditions. It may be used at an angle of up to 30 degrees to either side of the HK 3485.

If the remote seems to operate intermittently, then make sure the batteries have been inserted correctly, or replace the batteries with fresh ones.

Step Ten – Turn On the HK 3485

The HK 3485 may be turned on from Standby mode by pressing the Power Switch on either the front panel or the remote. See Figures 23 and 24.

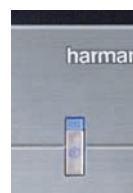

Figure 23 – Front-Panel Power Switch



Figure 24 – Remote Control Power Switch

OPERATION

Now that you have installed your system components, you are ready to begin enjoying your new audio system.

Turning On the HK 3485

After you plug the power cord into an AC outlet, the Power Indicator should light up in amber. This indicates that the HK 3485 is in Standby mode and is ready to be turned on. See Figure 23.

The HK 3485 may be turned on by pressing the Power Switch on the front panel or the remote. See Figure 24.

The Power Indicator will turn red briefly, and then blue to indicate that the HK 3485 is on. If it remains red, then unplug the receiver from AC power and check all of your wires and connections. Make sure no speaker wires are shorting out by touching each other, and that there are no breaks in the insulation covering any of the speaker wires, interconnects or the power cord. If the Power Indicator remains red when you plug in the HK 3485 and try to turn it on again, then bring the receiver to an authorized Harman Kardon service center for assistance.

To turn the receiver off, press the Power Switch on the front panel, or press the Power Off Button on the remote. When the HK 3485 is left unplugged, any settings you have programmed, including system configuration and preset radio stations, will be preserved indefinitely.

Sleep Timer

You may program the HK 3485 to play for up to 90 minutes and then turn off automatically using the sleep timer.

Press the Sleep Button on the front panel or remote, and the time until turn-off will be displayed. Each additional press of the Sleep Button will reduce the time until turn-off by 10 minutes, until the OFF setting is reached, which disables the sleep timer. See Figures 25 and 26.



Figure 25 – Front-Panel Sleep Button



Figure 26 – Remote Control Sleep Button

When the sleep timer has been set, the front-panel display will automatically dim to half-brightness. If you press any button on the remote or front panel, the display will return to full-brightness. The display will dim again several seconds after your last command.

If you press the Sleep Button after the timer has been set, the remaining time until turn-off will be displayed. You may press the Sleep Button to change the time until turn-off. Pressing and holding the Sleep Button will disable the sleep timer, and the SLEEP OFF message will appear.

Volume Control

The volume may be adjusted either by turning the knob on the front panel (clockwise to increase volume or counterclockwise to decrease volume), or by pressing the Volume Control Buttons on the remote. See Figure 27. The volume is displayed as a negative number of decibels (dB) below the 0dB reference point. Unlike some volume controls on

other products, 0dB is the maximum volume for the HK 3485. Although it's physically possible to turn the volume to a higher level, doing so may damage your hearing and your speakers. For certain more-dynamic audio materials, even 0dB may be too high, allowing for damage to equipment.



Figure 27 – Volume Controls

Remember that the HK 3485 is designed to reproduce audio with a minimum amount of distortion. This clarity may lead you to believe that your hearing and the equipment can handle higher volumes. We urge caution with regard to volume levels.

Mute Function

To temporarily mute all speakers and the headphones, press the Mute Button on the front panel or remote. See Figure 28. Any recording in progress will not be affected. The MUTE message will flash in the display as a reminder. To restore normal audio, either press the Mute Button again, or adjust the volume. Turning off the HK 3485 will also end muting.



Figure 28 – Mute Buttons

Tone Controls

You may boost or cut either the treble or the bass frequencies by up to 10dB.

The Bass and Treble Tone Controls may be adjusted by turning the knobs on the front panel. Turn either knob counterclockwise to reduce the levels of the low frequencies (Bass Control) or the high frequencies (Treble Control), and turn either knob clockwise to increase the levels for the low or high frequencies. See Figure 29.



Figure 29 – Tone Controls

You may also adjust the balance to compensate for speaker placement or the acoustic characteristics of your listening room. Ideally, the audio should be heard most clearly at a point exactly midway between the left and right speakers, unless the artist has mixed the recording in a way that pans sounds to one side or the other. If your speakers are not placed the same distance from the listening position, or if your room has other unusual characteristics, turn the Balance Control knob on the front panel counterclockwise to move the sound toward the left speaker or clockwise to move the sound toward the right speaker. See Figure 30.

OPERATION



Figure 30 – Balance Control

The Balance Control reduces the level of the speaker opposite the pointer. For example, turning the knob from the midpoint toward “R” reduces the level of the left speaker, leaving the right speaker unaffected. If two pairs of speakers are connected to the HK 3485, then both will be affected.

Headphones

Plug the 1/4" plug on a pair of headphones into the headphone jack on the front of the receiver for private listening. See Figure 31.

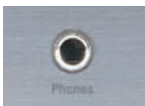

Figure 31 – Headphone Jack

Speaker 1/2

The HK 3485 may be used with up to two pairs of speakers for additional sound power in the main listening room, or if you wish to place the second pair of speakers in another room, or even outdoors (when you select weather-resistant loudspeakers). Select each pair of speakers by pressing its associated button on either the front panel or remote. See Figure 32.



Figure 32 – Speaker 1/2 Buttons

Press the button a second time to deactivate that pair of speakers. You may activate both speaker pairs simultaneously, or deactivate both pairs for private listening through the headphones.

Source Selection

Select a source device connected to the HK 3485 for playback by pressing its associated button on the front panel or remote control. See Figure 33.



Figure 33 – Source Selectors

To enjoy video sources, make sure to connect the device's composite video output to the correct Video Input on the HK 3485. In addition, connect the HK 3485's Video Monitor Output to an input on your television or video display.

NOTES:

- The HK 3485 is not an audio/video surround sound receiver. It is only capable of playing source programs in one- or two-channel formats, and any information encoded in additional channels will be lost. The HK 3485 is not equipped with digital audio inputs, and cannot decode digital surround sound programs. If you have connected the analog audio and composite video outputs of a DVD player to the HK 3485, remember to select two-channel audio in the DVD player and disc menus.
- The HK 3485 does not switch the last-selected video source when an audio-only source, such as Phono, CD or Tape/CDR, is selected subsequently. It is not possible to view video while listening to an audio-only source.
- You may select a device connected to either the front- or rear-panel Video 3 Inputs. Press the front-panel or remote Video 3 Source Selector repeatedly to toggle between the front- and rear-panel Video 3 Inputs, and observe the front-panel display indicators. When the dot to the left of the Video 3 Indicator is lit steadily, the rear-panel inputs have been selected. When the dot flashes, the front-panel inputs are active. When the front-panel inputs are not in use, you may snap the supplied cover over them. Remove the cover by pressing on the left side until it pivots outward.
- Similarly, if you have connected a three-head tape deck to the Tape/CDR Inputs, you may monitor a recording while it is being made so that you can confirm that the correct program material is being recorded and make any necessary adjustments to the recording level. When a recording is being made, the dot to the left of the source being recorded will be lit. Press the T-Mon Button on the front panel to hear playback from the tape deck's playback head. When the recording is being monitored, the dot to the left of the Tape Monitor Indicator will flash. Press the T-Mon Button again to hear the original source.

Using the Tuner

The HK 3485's built-in tuner may be selected in one of two ways (see Figure 34):

1. Press the front-panel AM or FM Button.
2. Press the AM or FM Button on the remote.



Figure 34 – Tuner Input Selection

Tuner operation requires some special keys, including the Numeric Keys, which are normally hidden behind a door in the lower half of the remote. To access these controls, hold the remote in one hand while grasping the ridged finger holds on the sides of the door with the other hand. Squeeze the door gently as you slide it toward you, revealing the additional controls. See Figure 35.

OPERATION



Figure 35 – Controls Behind Door

Radio stations may be selected in one of five ways (see Figure 36):

1. If you know the frequency number, enter it directly by first pressing the Direct Button on the remote, and then using the Numeric Keys.
2. After you have programmed preset stations (see below), either enter the preset number (1 through 30) using the remote or use the front-panel Preset Stations Button to scroll through the list of presets.
3. In Auto Tuning mode, press and hold the Tuning Buttons (front-panel or remote) to scan in the chosen direction until a station with acceptable signal strength is detected.
4. In Manual Tuning mode, with each press of the Tuning Buttons the HK 3485 will tune the next frequency increment (0.1MHz for FM, or 10kHz for AM) in the selected direction.
5. Press the Preset Scan (P. Scan) Button on the front panel or remote to scan through the previously programmed preset stations. The tuner will pause for five seconds at each frequency before tuning to the next preset. Press the Preset Scan Button again to select the current station and stop scanning.

When an FM station has been tuned, pressing the FM Mode Button will switch between stereo and mono tuning, which may improve reception of weaker stations. See Figure 36.



Figure 36 – Tuning a Station

To store a station in one of the 30 presets (see Figure 35):

1. Tune the desired station.
2. Press the Memory Button on the remote.
3. Use the Numeric Keys to enter the desired preset number.

To clear a station from the preset memory:

1. Tune the preset station using any of the methods described above.
2. Press the Memory Button.
3. Within five seconds, press the Clear Button.

Auto Preset

You may automatically program all FM radio stations in your area that are received with acceptable signal strength into the HK 3485's presets. Press and hold the Auto Preset Button until the Memory and Preset Indicators flash in the front-panel display. The tuner will automatically scan through the entire FM band, entering all stations with acceptable signal strength into the presets until either all 30 presets have been filled, or the tuner has scanned the band three times.

NOTE: If there are a large number of FM stations in your area, Auto Preset will overwrite any presets you programmed previously. Stations with exceptionally strong signals may be programmed into more than one preset.

Recording

Two-channel analog audio signals, as well as composite video signals, are normally available at the appropriate recording outputs. Thus, to make a recording, you need only make sure to connect your audio or video recorder to the appropriate output jacks, as described in the Installation section, insert blank media and make sure the recorder is turned on and recording while the source is playing.

You may monitor your recording if your recorder has separate record and playback heads. Press the front-panel T-Mon Button to monitor the recording using the playback head, indicated by the dot to the left of the Tape Monitor Indicator flashing. This will not affect the recording being made from the original source. To hear the original source again, press the T-Mon Button so that the dot to the left of the Tape Monitor Indicator stops flashing.

If your recorder does not have off-head playback, then you will not hear anything when you press the T-Mon Button.

NOTE: Please make certain that you are aware of any copyright restrictions on any material you record. Unauthorized duplication of copyrighted materials is prohibited by federal law.

OPERATION

Dim Function

Some people find the front-panel messages distracting and would prefer to dim them or turn them off altogether.

To dim the display, press the Dim Button on the front panel or remote. Each button press will cycle through the three settings of:

VFD FULL: Normal brightness

VFD HALF: Display is dimmed but still visible; the light inside the volume knob goes dark

VFD OFF: Display goes completely dark except for Power Indicator to remind you that the receiver is turned on

Processor Reset

If you wish to fully reset the HK 3485 to its factory defaults, or if it behaves erratically after a power surge, first turn the Master Power Switch off and unplug the AC power cord for at least three minutes. Plug the cord back in and turn the receiver back on. If this doesn't help, you may want to try a system reset.

NOTE: A system reset erases all user configurations, including tuner presets. After a reset, you will need to re-enter all of these settings.

Place the receiver in Standby mode by pressing the Power Switch so that the Power Indicator turns amber. Press and hold the front-panel Mute Button for at least five seconds until the RESET message appears in the display.

If the receiver still does not function correctly after a processor reset, contact an authorized Harman Kardon service center for assistance. Service centers may be located by visiting our Web site at www.harmankardon.com.

Memory

If the HK 3485 is unplugged or experiences a power outage, it will retain user settings indefinitely.

TROUBLESHOOTING GUIDE

SYMPTOM	CAUSE	SOLUTION
Unit does not function when Main Power Switch is pushed	<ul style="list-style-type: none"> No AC power 	<ul style="list-style-type: none"> Make certain AC power cord is plugged into a live outlet Check to see whether outlet is switch-controlled
Display lights, but there's no sound or picture	<ul style="list-style-type: none"> Intermittent input connections Mute is on Volume Control is down Desired source not selected Speakers deactivated Headphones are in use Jumper pins between Preamp Outputs and Main-Amp Inputs were removed 	<ul style="list-style-type: none"> Make certain that all input and speaker connections are secure Press Mute Button Turn up Volume Control Press correct Source Selector Press Speaker 1 or Speaker 2 Button Unplug headphones Replace jumper pins, or if external amplifier is in use, make sure it is turned on
No sound from any speaker; light around Power Switch is red	<ul style="list-style-type: none"> Amplifier is in Protection mode due to possible short Amplifier is in Protection mode due to internal problems 	<ul style="list-style-type: none"> Check speaker-wire connections for shorts at receiver and speaker ends Contact your local Harman Kardon service center
Unit does not respond to remote commands	<ul style="list-style-type: none"> Weak batteries in remote Remote sensor is obscured 	<ul style="list-style-type: none"> Change remote batteries Make certain front-panel sensor is visible to remote or connect an optional remote sensor
Intermittent buzzing in tuner	<ul style="list-style-type: none"> Local interference 	<ul style="list-style-type: none"> Move unit or antenna away from computers, fluorescent lights, motors or other electrical appliances
Audio sources sound distorted	<ul style="list-style-type: none"> CD player or other audio device incorrectly plugged into Phono Inputs Turntable not plugged into Phono Inputs 	<ul style="list-style-type: none"> Only plug a device into the Phono Inputs if it is a turntable with a moving-magnet cartridge, or if it is a turntable with a moving-coil cartridge with a phono preamp Do not use a turntable with any inputs other than the Phono Inputs, unless it has a moving-magnet-type cartridge and includes a phono preamp
No video image	<ul style="list-style-type: none"> Source device's video output not connected to HK 3485 Wrong source selected Video Monitor Output not connected to display Wrong video input on video display selected Audio-only source selected 	<ul style="list-style-type: none"> Connect the source's composite video output to the correct video input on the HK 3485 Press the correct Source Selector on the HK 3485 Connect the HK 3485's Video Monitor Output to a composite video input on your television or video display Consult the manual for your television for instructions on selecting the correct video input It is not possible to view video while listening to the Phono, Tape/CDR or CD sources

In addition to the items shown above, additional information on troubleshooting possible problems with your HK 3485, or on installation-related issues, may be found in the list of "Frequently Asked Questions," which is located in the Product Support section of our Web site at www.harmankardon.com.

Processor Reset

If you wish to fully reset the HR 3485 to its factory defaults, or if it behaves erratically after a power surge, first turn the Master Power Switch off and unplug the AC Power Cord for at least three minutes. Plug the cord back in and turn the receiver back on. If this doesn't help, you may want to try a system reset.

NOTE: A system reset erases all user configurations, including tuner presets. After a reset, you will need to re-enter all of these settings.

Place the receiver in Standby mode by pressing the Power Switch so that the Power Indicator turns amber. Press and hold the front-panel Mute Button for at least five seconds until the RESET message appears in the display.

DISASSEMBLY

1. Removing the Top Cabinet
Remove the Screws ①~⑬

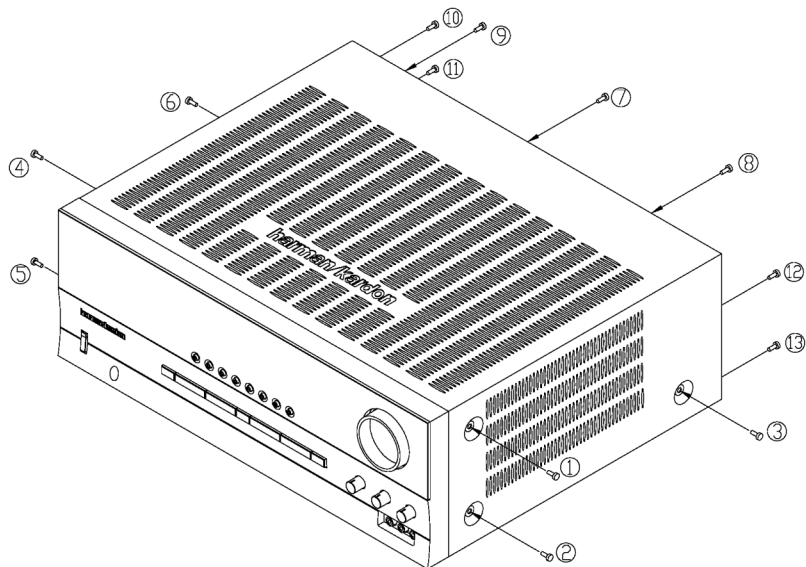

2. Removing the Front Panel
Remove the Screws ①~⑨

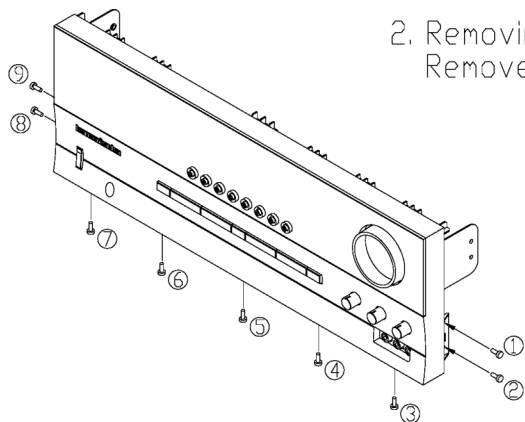

HK3385/HK3485

3. Removing the Rear Panel
Remove the Screws ①~⑱

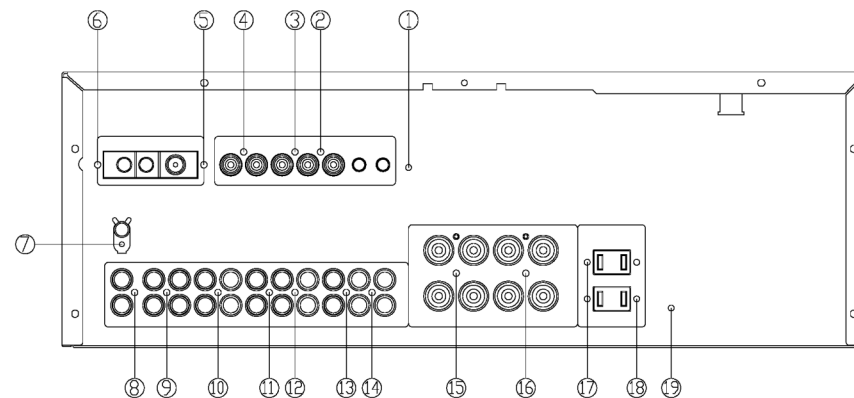

4. Removing the Main PCB
Remove the Screws ①~⑨

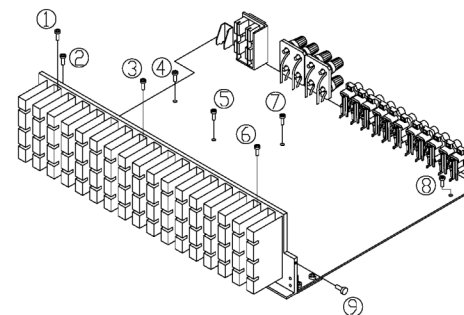

AMPLIFIER SECTION BIAS ADJUSTMENT

Measurement condition

; No input signal or volume position is minimum.

Standard value

; Ideal current = 48mA (±5%)

; Ideal DC Voltage = 21.12mV (±5%)

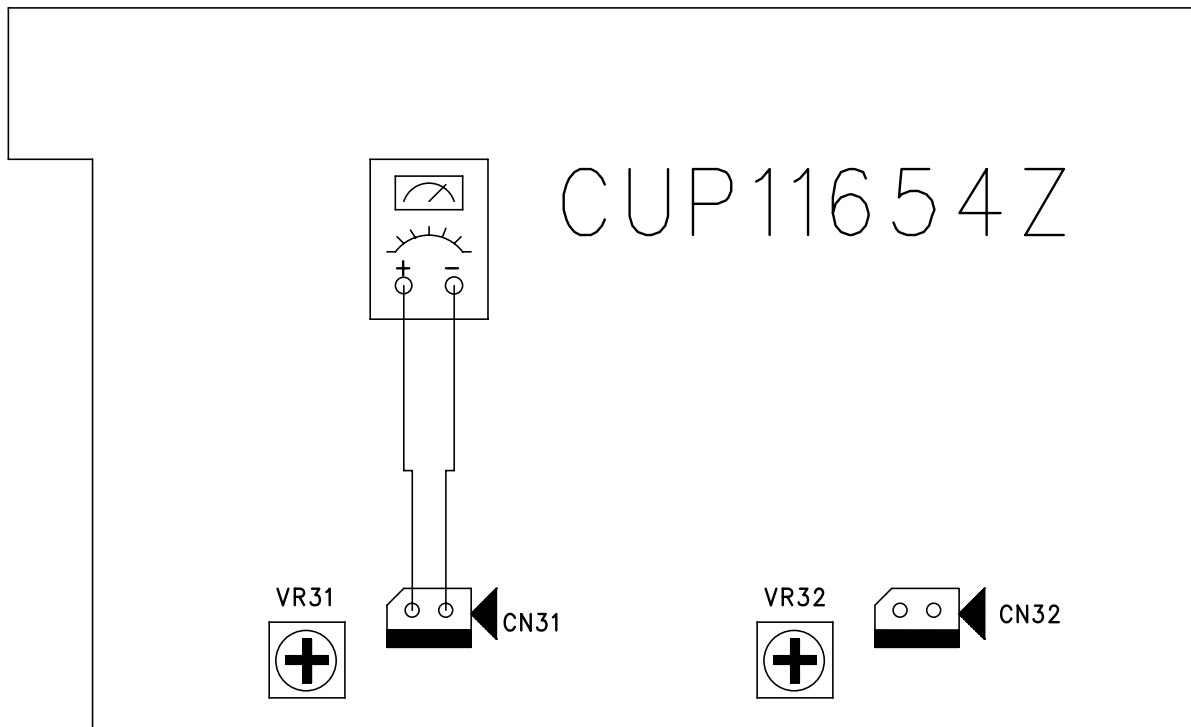

DC VOLTMETERConnect to CN31 , CN32

NO.	CHENNEL	ADJUST FOR	ADJUSTMENT
1	L CH	21.12mV (±5%)	VR31
2	R CH	21.12mV (±5%)	VR32

HK3385/HK3485/HK3380/HK3480 BLOCK DIAGRAM

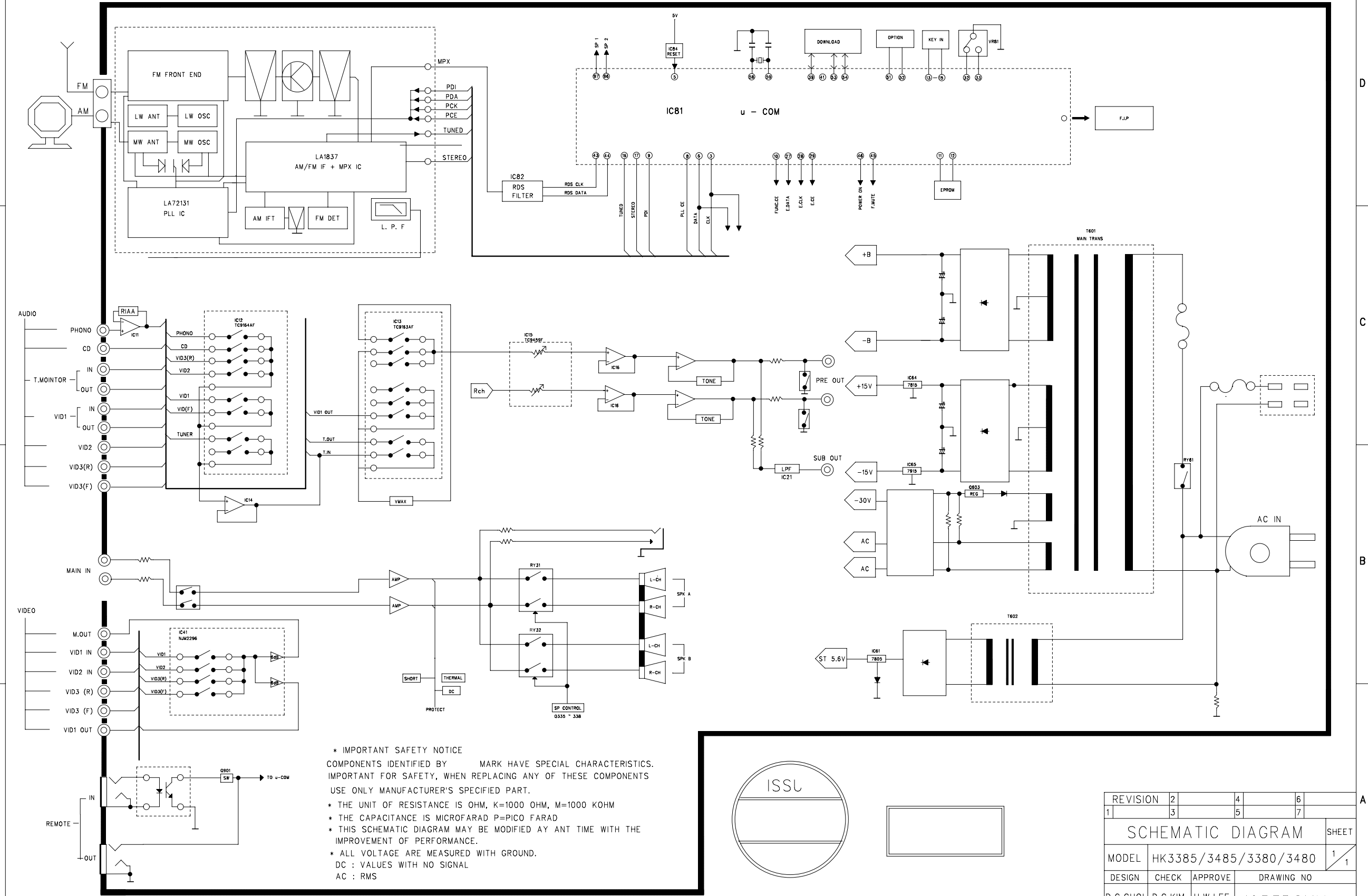

* IMPORTANT SAFETY NOTICE
 COMPONENTS IDENTIFIED BY MARK HAVE SPECIAL CHARACTERISTICS.
 IMPORTANT FOR SAFETY, WHEN REPLACING ANY OF THESE COMPONENTS
 USE ONLY MANUFACTURER'S SPECIFIED PART.
 * THE UNIT OF RESISTANCE IS OHM, K=1000 OHM, M=1000 KOHM
 * THE CAPACITANCE IS MICROFARAD P=PICO FARAD
 * THIS SCHEMATIC DIAGRAM MAY BE MODIFIED BY ANT TIME WITH THE
 IMPROVEMENT OF PERFORMANCE.
 * ALL VOLTAGE ARE MEASURED WITH GROUND.
 DC : VALUES WITH NO SIGNAL
 AC : RMS

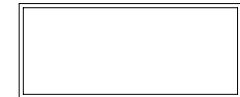
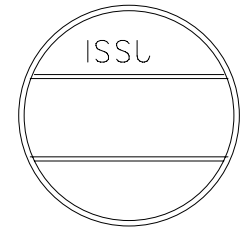

REVISION	2	4	6
1	3	5	7
SCHEMATIC DIAGRAM			
SHEET			
MODEL	HK3385/3485/3380/3480		
DESIGN	CHECK	APPROVE	DRAWING NO
D.C.CHOI	D.G.KIM	H.W.LEE	1653BCMY
03.08.01			

ST72F321R (U-COM) : IC81

Figure 1. Device Block Diagram

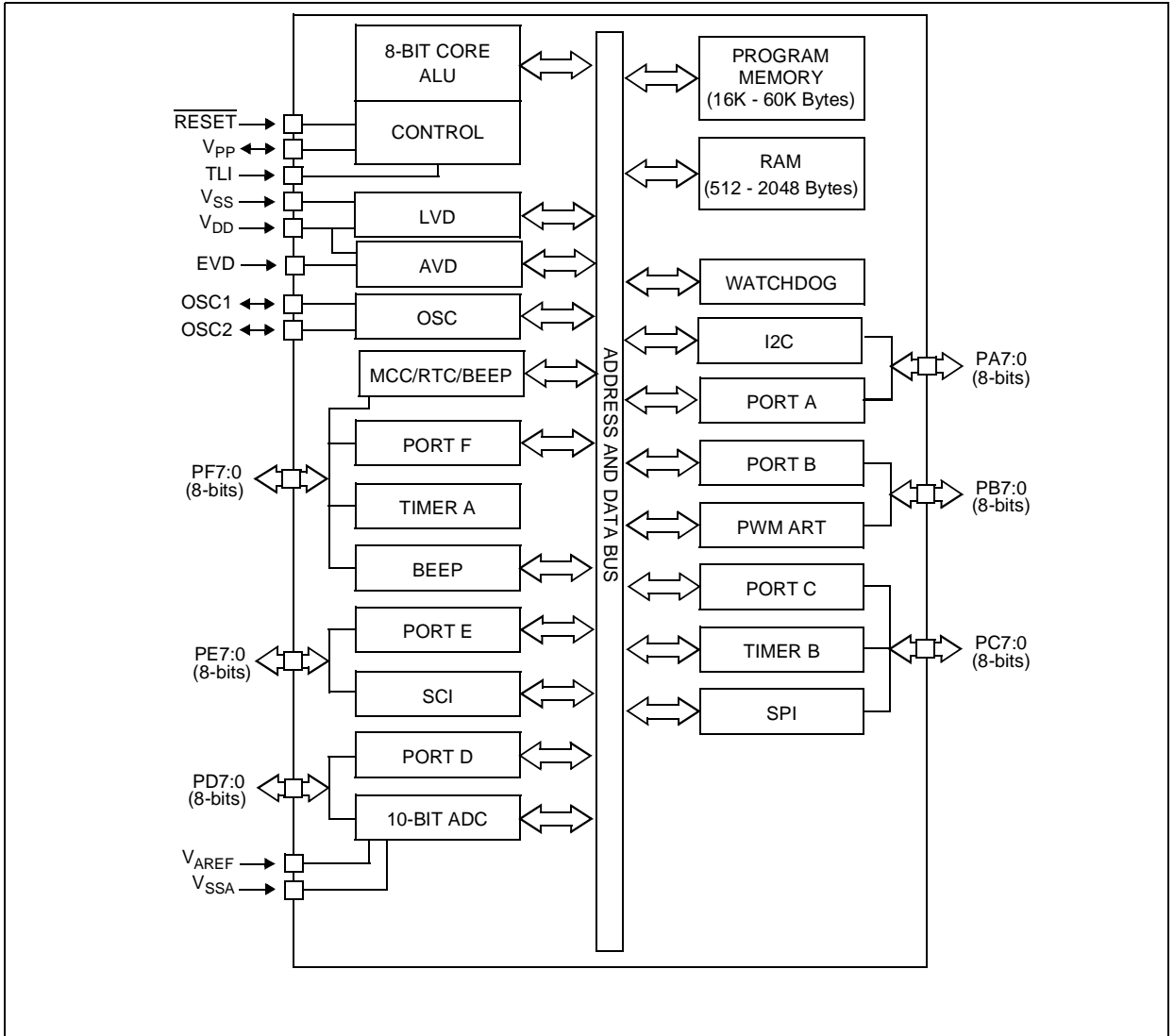

2 PIN DESCRIPTION

Figure 2. 64-Pin TQFP 14x14 and 10x10 Package Pinout

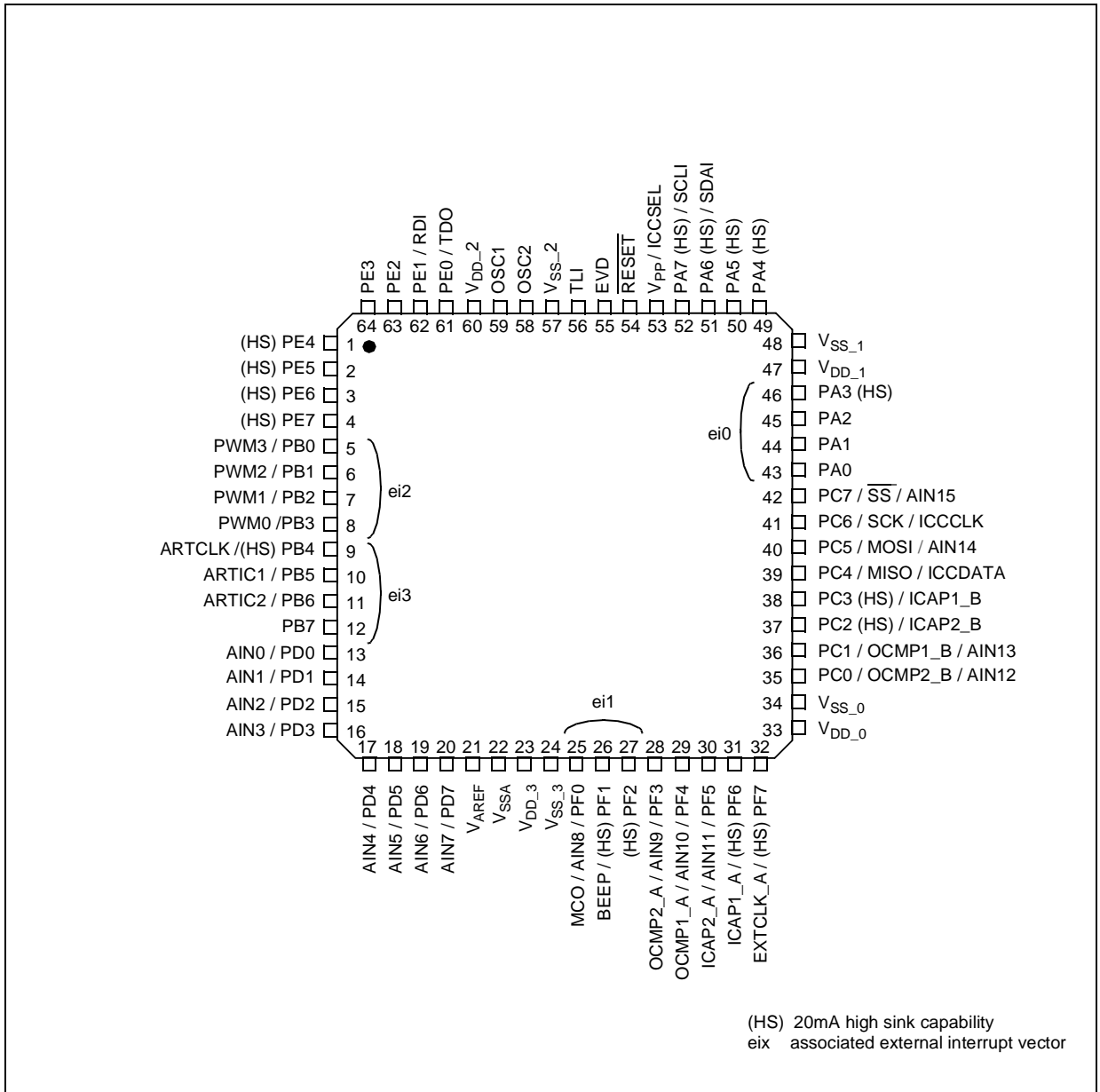

PIN DESCRIPTION (Cont'd)

For external pin connection guidelines, refer to See “ELECTRICAL CHARACTERISTICS” on page 135.

Legend / Abbreviations for Table 1:

Type: I = input, O = output, S = supply

Input level: A = Dedicated analog input

In/Output level: C = CMOS 0.3V_{DD}/0.7V_{DD}
 C_T= CMOS 0.3V_{DD}/0.7V_{DD} with input trigger
 T_T= TTL 0.8V / 2V with Schmitt trigger

Output level: HS = 20mA high sink (on N-buffer only)

Port and control configuration:

- Input: float = floating, wpu = weak pull-up, int = interrupt ¹⁾, ana = analog
- Output: OD = open drain ²⁾, PP = push-pull

Refer to “I/O PORTS” on page 45 for more details on the software configuration of the I/O ports.

The RESET configuration of each pin is shown in bold. This configuration is valid as long as the device is in reset state.

Table 1. Device Pin Description

Pin n°	Pin Name	Type	Level		Port						Main function (after reset)	Alternate function
			Input	Output	Input				Output			
					float	wpu	int	ana	OD	PP		
1	PE4 (HS)	I/O	C _T	HS	X	X			X	X	Port E4	
2	PE5 (HS)	I/O	C _T	HS	X	X			X	X	Port E5	
3	PE6 (HS)	I/O	C _T	HS	X	X			X	X	Port E6	
4	PE7 (HS)	I/O	C _T	HS	X	X			X	X	Port E7	
5	PB0/PWM3	I/O	C _T		X		ei2		X	X	Port B0	PWM Output 3
6	PB1/PWM2	I/O	C _T		X		ei2		X	X	Port B1	PWM Output 2
7	PB2/PWM1	I/O	C _T		X		ei2		X	X	Port B2	PWM Output 1
8	PB3/PWM0	I/O	C _T		X		ei2		X	X	Port B3	PWM Output 0
9	PB4 (HS)/ARTCLK	I/O	C _T	HS	X		ei3		X	X	Port B4	PWM-ART External Clock
10	PB5 / ARTIC1	I/O	C _T		X		ei3		X	X	Port B5	PWM-ART Input Capture 1
11	PB6 / ARTIC2	I/O	C _T		X		ei3		X	X	Port B6	PWM-ART Input Capture 2
12	PB7	I/O	C _T		X		ei3		X	X	Port B7	
13	PD0/AIN0	I/O	C _T		X	X		X	X	X	Port D0	ADC Analog Input 0
14	PD1/AIN1	I/O	C _T		X	X		X	X	X	Port D1	ADC Analog Input 1
15	PD2/AIN2	I/O	C _T		X	X		X	X	X	Port D2	ADC Analog Input 2
16	PD3/AIN3	I/O	C _T		X	X		X	X	X	Port D3	ADC Analog Input 3
17	PD4/AIN4	I/O	C _T		X	X		X	X	X	Port D4	ADC Analog Input 4
18	PD5/AIN5	I/O	C _T		X	X		X	X	X	Port D5	ADC Analog Input 5
19	PD6/AIN6	I/O	C _T		X	X		X	X	X	Port D6	ADC Analog Input 6
20	PD7/AIN7	I/O	C _T		X	X		X	X	X	Port D7	ADC Analog Input 7
21	V _{AREF}	I									Analog Reference Voltage for ADC	
22	V _{SSA}	S									Analog Ground Voltage	
23	V _{DD_3}	S									Digital Main Supply Voltage	



Pin n°	Pin Name	Type	Level		Port						Main function (after reset)	Alternate function	
			Input	Output	Input				Output				
					float	wpu	int	ana	OD	PP			
24	V _{SS_3}	S										Digital Ground Voltage	
25	PF0/MCO/AIN8	I/O	C _T		X	ei1	X	X	X	Port F0	Main clock out (f _{OSC} /2)	ADC Analog Input 8	
26	PF1 (HS)/BEEP	I/O	C _T	HS	X	ei1		X	X	Port F1	Beep signal output		
27	PF2 (HS)	I/O	C _T	HS	X		ei1		X	X	Port F2		
28	PF3/OCMP2_A/AIN9	I/O	C _T		X	X		X	X	Port F3	Timer A Output Compare 2	ADC Analog Input 9	
29	PF4/OCMP1_A/AIN10	I/O	C _T		X	X		X	X	Port F4	Timer A Output Compare 1	ADC Analog Input 10	
30	PF5/ICAP2_A/AIN11	I/O	C _T		X	X		X	X	Port F5	Timer A Input Capture 2	ADC Analog Input 11	
31	PF6 (HS)/ICAP1_A	I/O	C _T	HS	X	X		X	X	Port F6	Timer A Input Capture 1		
32	PF7 (HS)/EXTCLK_A	I/O	C _T	HS	X	X		X	X	Port F7	Timer A External Clock Source		
33	V _{DD_0}	S								Digital Main Supply Voltage			
34	V _{SS_0}	S								Digital Ground Voltage			
35	PC0/OCMP2_B/AIN12	I/O	C _T		X	X		X	X	Port C0	Timer B Output Compare 2	ADC Analog Input 12	
36	PC1/OCMP1_B/AIN13	I/O	C _T		X	X		X	X	Port C1	Timer B Output Compare 1	ADC Analog Input 13	
37	PC2 (HS)/ICAP2_B	I/O	C _T	HS	X	X		X	X	Port C2	Timer B Input Capture 2		
38	PC3 (HS)/ICAP1_B	I/O	C _T	HS	X	X		X	X	Port C3	Timer B Input Capture 1		
39	PC4/MISO/ICCDATA	I/O	C _T		X	X		X	X	Port C4	SPI Master In / Slave Out Data	ICC Data Input	
40	PC5/MOSI/AIN14	I/O	C _T		X	X		X	X	Port C5	SPI Master Out / Slave In Data	ADC Analog Input 14	
41	PC6/SCK/ICCCLK	I/O	C _T		X	X		X	X	Port C6	SPI Serial Clock	ICC Clock Output	
42	PC7/ \overline{SS} /AIN15	I/O	C _T		X	X		X	X	Port C7	SPI Slave Select (active low)	ADC Analog Input 15	
43	PA0	I/O	C _T		X	ei0		X	X	Port A0			
44	PA1	I/O	C _T		X	ei0		X	X	Port A1			
45	PA2	I/O	C _T		X	ei0		X	X	Port A2			
46	PA3 (HS)	I/O	C _T	HS	X		ei0	X	X	Port A3			
47	V _{DD_1}	S								Digital Main Supply Voltage			
48	V _{SS_1}	S								Digital Ground Voltage			
49	PA4 (HS)	I/O	C _T	HS	X	X		X	X	Port A4			
50	PA5 (HS)	I/O	C _T	HS	X	X		X	X	Port A5			
51	PA6 (HS)/SDAI	I/O	C _T	HS	X			T		Port A6	I ² C Data ¹⁾		
52	PA7 (HS)/SCLI	I/O	C _T	HS	X			T		Port A7	I ² C Clock ¹⁾		

Pin n°	Pin Name	Type	Level		Port						Main function (after reset)	Alternate function	
			Input	Output	Input				Output				
					float	wpu	int	ana	OD	PP			
53	V _{PP} / ICCSEL	I										Must be tied low. In flash programming mode, this pin acts as the programming voltage input V _{PP} . See Section 12.9.2 for more details. High voltage must not be applied to ROM devices	
54	RESET	I/O	C _T									Top priority non maskable interrupt.	
55	EVD											External voltage detector	
56	TLI	I	C _T				X					Top level interrupt input pin	
57	V _{SS_2}	S										Digital Ground Voltage	
58	OSC2 ³⁾	I/O										Resonator oscillator inverter output or capacitor input for RC oscillator	
59	OSC1 ³⁾	I										External clock input or Resonator oscillator inverter input or resistor input for RC oscillator	
60	V _{DD_2}	S										Digital Main Supply Voltage	
61	PE0/TDO	I/O	C _T		X	X			X	X	Port E0	SCI Transmit Data Out	
62	PE1/RDI	I/O	C _T		X	X			X	X	Port E1	SCI Receive Data In	
63	PE2	I/O	C _T			X					Port E2		
64	PE3	I/O	C _T		X	X			X	X	Port E3		

AT24C08N10SC (EEPROM) : IC83

BLOCK DIAGRAM

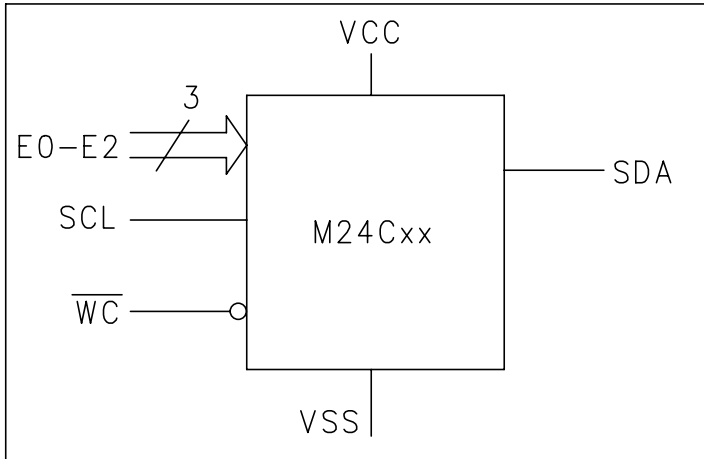

SIGNAL NAMES

E0,E1,E2	Chip Enable
SDA	Serial Data
SCL	Serial Clock
\overline{WC}	Write Control
Vcc	Supply Voltage
Vss	Ground

DIP, SO and TSSOP Connections

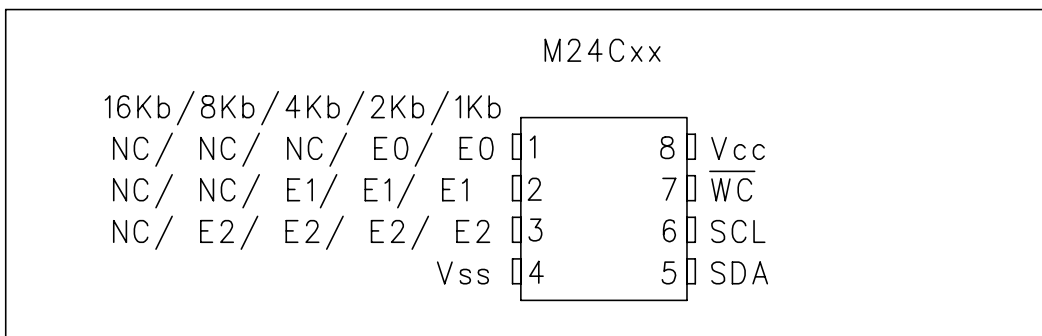



NJM2068

LOW-NOISE DUAL OPERATIONAL AMPLIFIER

GENERAL DESCRIPTION

The NJM2068 is a high performance, low noise dual operational amplifier. This amplifier features popular pin-out, superior noise performance, and superior total harmonic distortion. This amplifier also features guaranteed noise performance with substantially higher gain-bandwidth product and slew rate which far exceeds that of the 4558 type amplifier. The specially designed low noise input transistors allow the NJM2068 to be used in very low noise signal processing applications such as audio preamplifiers and servo error amplifier.

PACKAGE OUTLINE

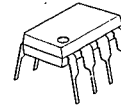

NJM2068D



NJM2068M



NJM2068V

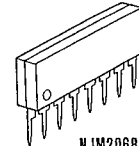

NJM2068L

FEATURES

- Operating Voltage ($\pm 4V \sim \pm 18V$)
- Low Total Harmonic Distortion (0.001% typ.)
- Low Noise Voltage (FLAT+JISA, $0.56 \mu V$ typ.)
- High Slew Rate ($6V/\mu s$ typ.)
- Unity Gain Bandwidth (27MHz @f=10kHz)
- Package Outline DIP8, DMP8, SIP8, SSOP8
- Bipolar Technology

4

PIN CONFIGURATION

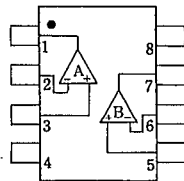

NJM2068D
NJM2068M
NJM2068V

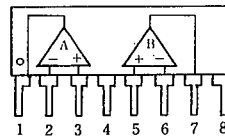

NJM2068L

PIN FUNCTION

1. A OUTPUT
2. A-INPUT
3. A+INPUT
4. V-
5. B+INPUT
6. B-INPUT
7. B OUTPUT
8. V+

EQUIVALENT CIRCUIT (1/2 Shown)

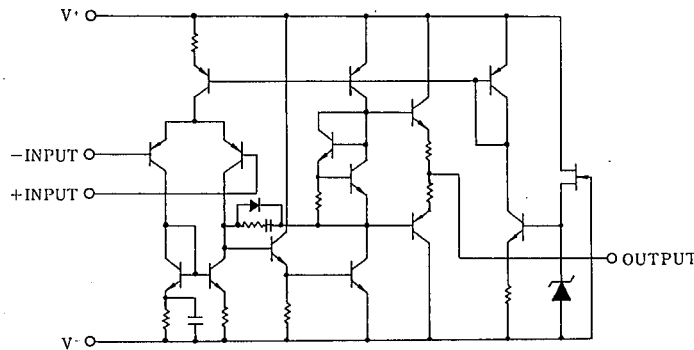

■ BLOCK DIAGAM (NJM2296M) : IC91

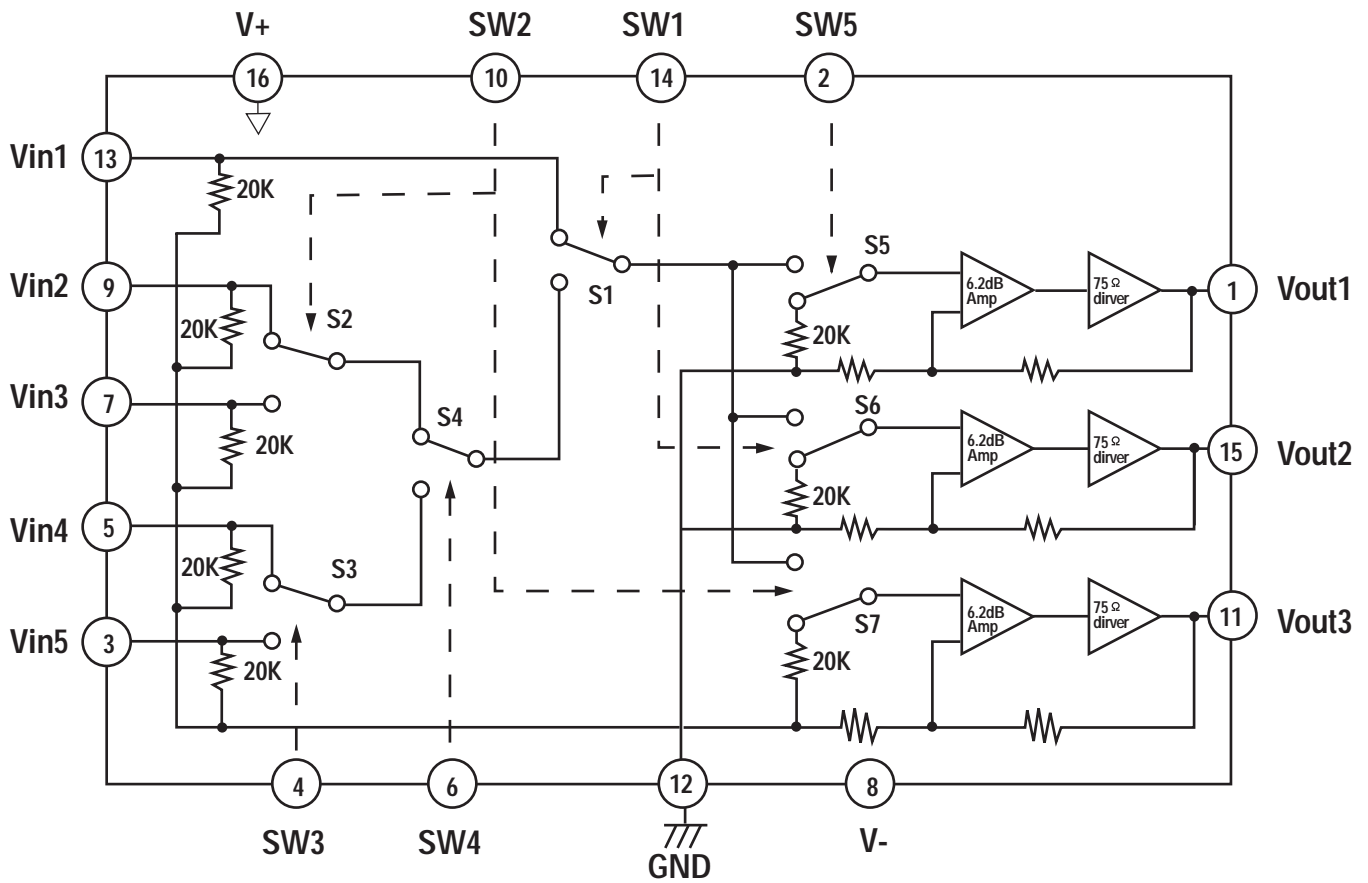

* Normally mute
 Above circuits show that the switches are set at low.

IC92

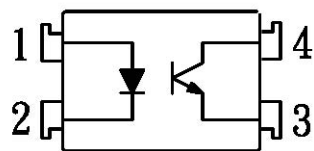

- 1. Anode
- 2. Cathode
- 3. Emitter
- 4. Collector

S-80145ALMC (RESET I.C) : IC84

PIN CONFIGURATION

*SOT-23-5

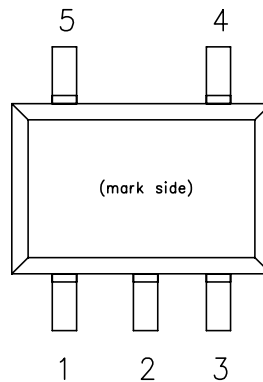

PIN DESCRIPTION

Pin No.	Symbol	Description
1	OUT	Output Pin
2	V _{DD}	Input and power source for device itself
3	GND	Ground Pin
4	NC	No Connection
5	C _D	Pin for external capacitor

BLOCK DIAGRAMS

*Nch Open Drain Output(RN5VDxxA)

*CMOS Output (RN5VDxxC)

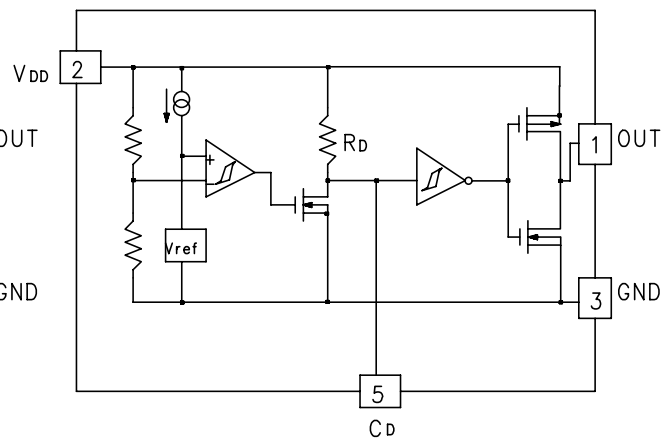
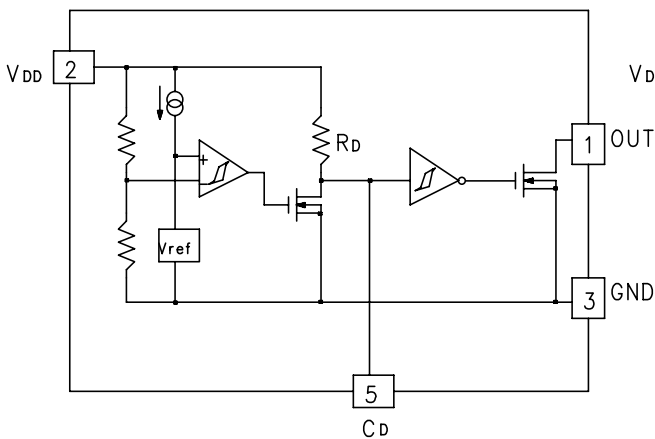

RE5VL28CATZ (VOLTAGE DETECTOR : IC85)

■ BLOCK DIAGRAM

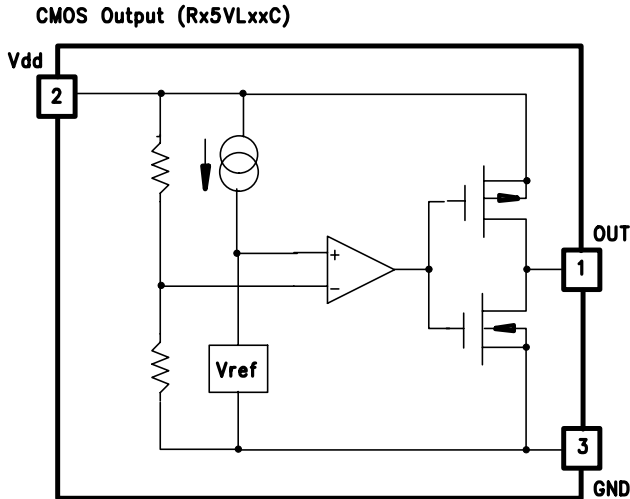

■ TIME CHART

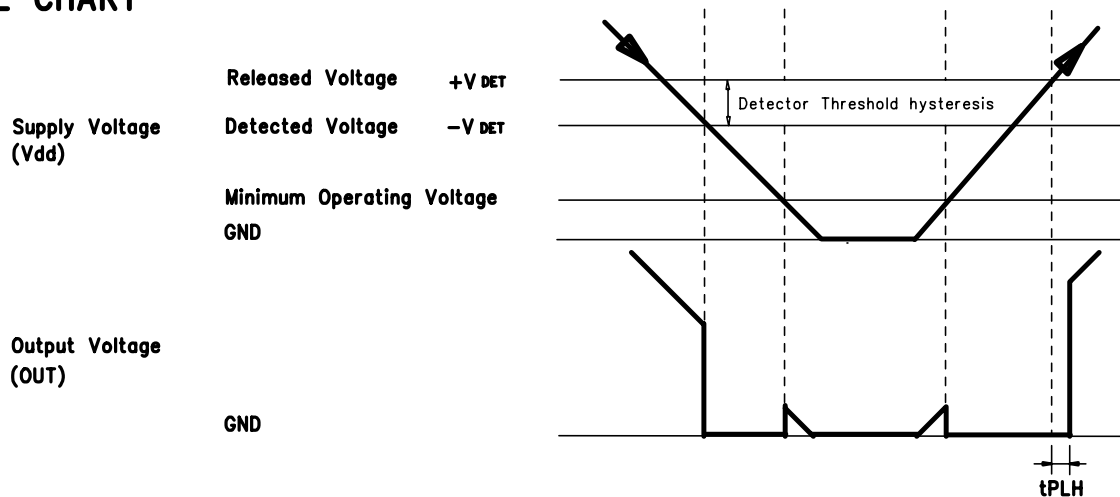

■ DEFINITION OF OUTPUT DELAY TIME tPLH

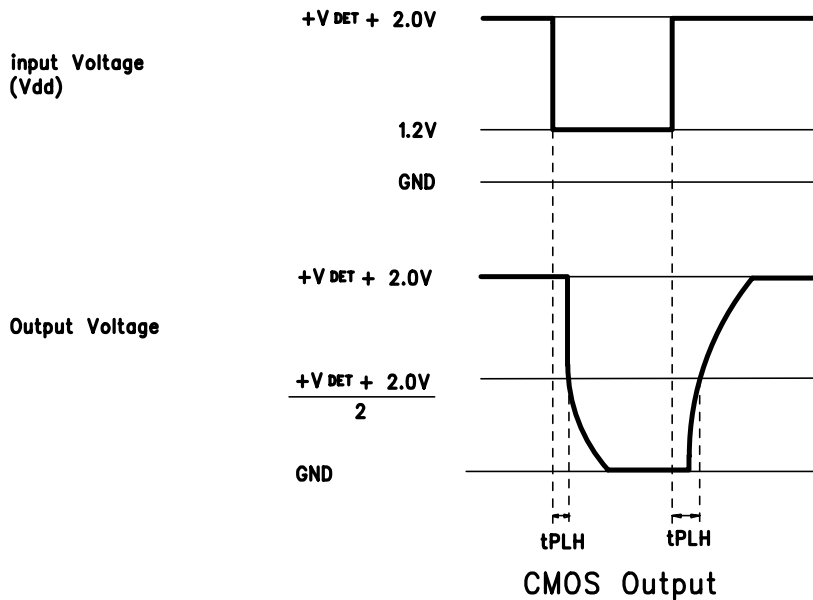

TC9164AF (FUNCTION/INPUT) : IC12

■ BLOCK DIAGRAM

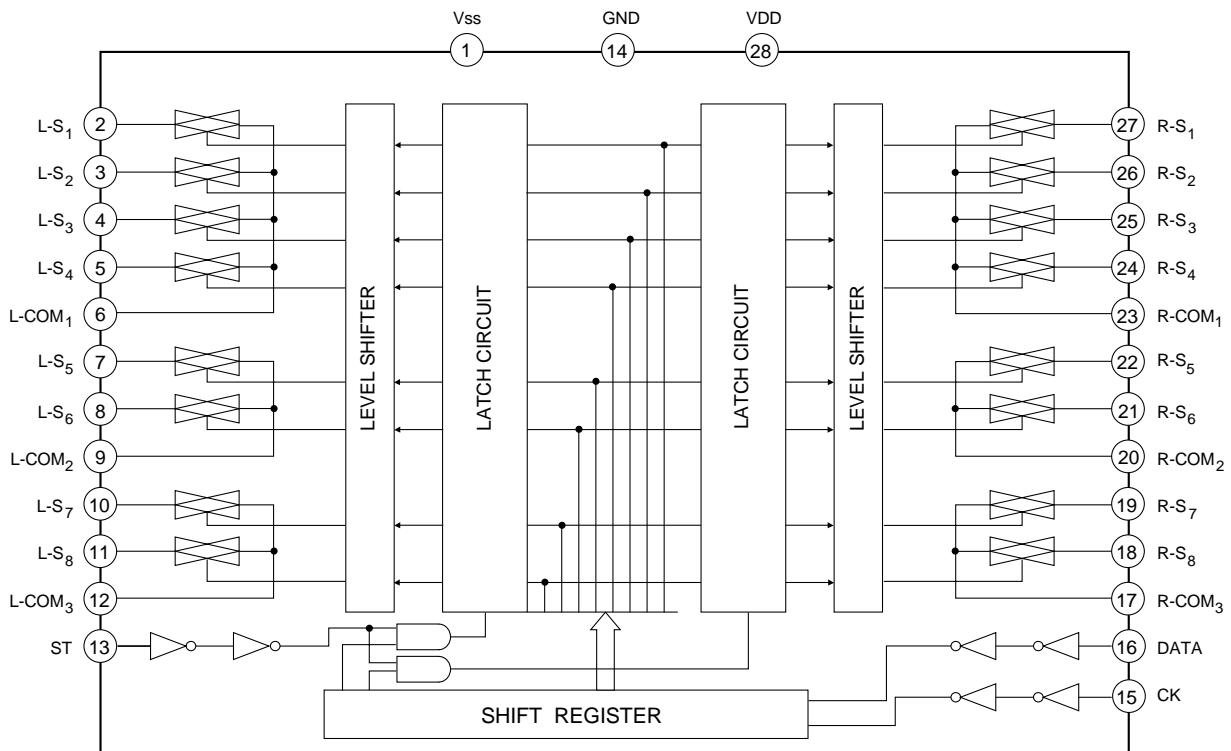

TC9163AF (FUNCTION/INPUT) : IC13

■ BLOCK DIAGRAM

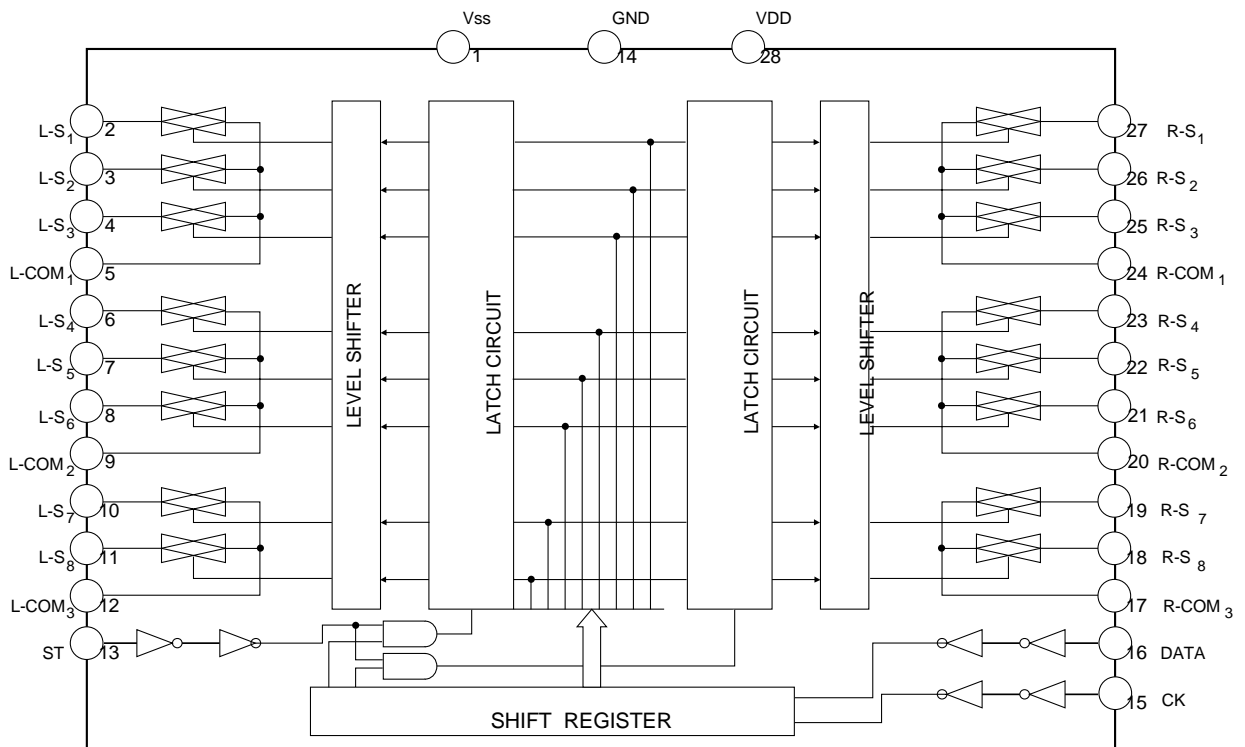

BLOCK DIAGRAM (TC9459F)

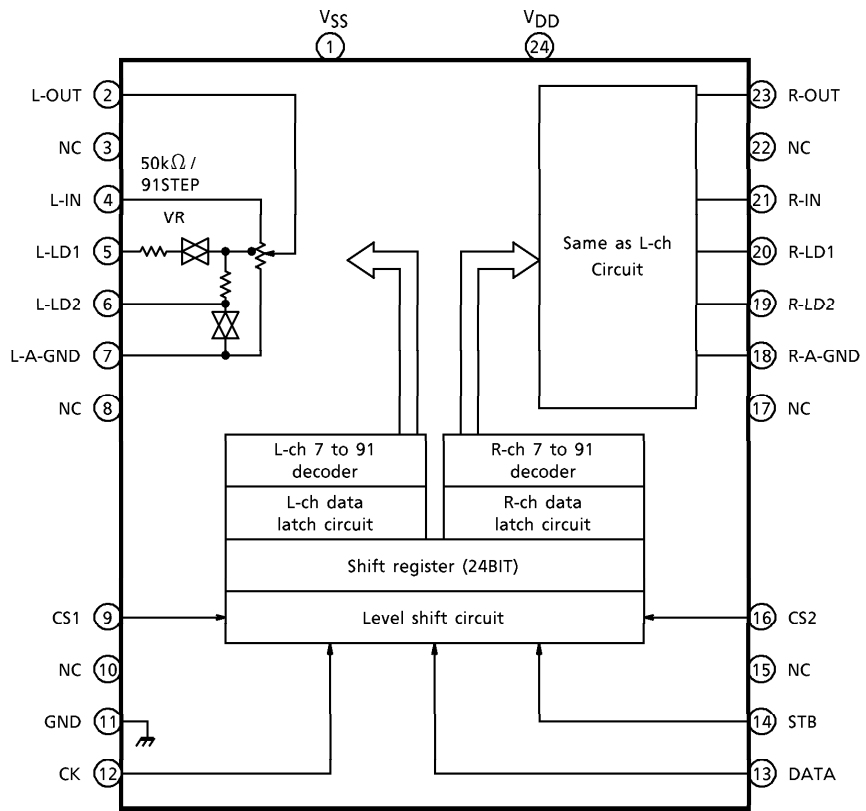

PIN DESCRIPTION

Numeral in () means the pin No. of TC9459F.

PIN No.	SYMBOL	PIN NAME	FUNCTION	REMARK										
1 (1)	V _{SS}	Negative power supply pin	When using dual power supplies $V_{DD} = 6.0 \sim 17V$ $GND = 0V$ $V_{SS} = -6.0 \sim -17V$ When using a single power supply $V_{DD} = 6.0 \sim 18V$ $GND = V_{SS} = 0V$	—										
28 (24)	V _{DD}	Positive power supply pin												
13 (11)	GND	Digital GND pin												
3 (2)	L-OUT	Volume output pin	• Volume circuit 	—										
26 (23)	R-OUT													
5 (4)	L-IN	Volume input pin												
24 (21)	R-IN													
6 (5)	L-LD1	Loudness tap output pin			<table border="1"> <tr> <td></td> <td>LA1</td> <td>LA2</td> </tr> <tr> <td>LOUDNESS "ON"</td> <td>ON</td> <td>OFF</td> </tr> <tr> <td>LOUDNESS "OFF"</td> <td>OFF</td> <td>ON</td> </tr> </table>		LA1	LA2	LOUDNESS "ON"	ON	OFF	LOUDNESS "OFF"	OFF	ON
	LA1					LA2								
LOUDNESS "ON"	ON					OFF								
LOUDNESS "OFF"	OFF					ON								
23 (20)	R-LD1													
7 (6)	L-LD2													
22 (19)	R-LD2													
8 (7)	L-A-GND	Analog GND pin												
21 (18)	R-A-GND													
10 (9)	CS1	Chip select input pin	Up to 4 chips on the same bus can be used by switching over chip select code.	—										
19 (16)	CS2													
14 (12)	CK	Clock input pin	Data transfer clock input	Low threshold value input pin										
15 (13)	DATA	Data input pin	Volume setup serial data input											
16 (14)	STB	Strobe input pin	Data write strobe input											
2 (3)	NC	No connection	—	—										
27 (22)														
4														
25														
9 (8)														
20 (17)														
11														
18														
12 (10)														
17 (15)														

TRANSISTOR , REGULATOR IC BLOCK DIAGRAM

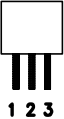
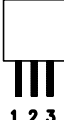
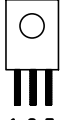
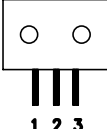
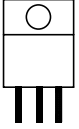
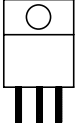
<p>T0-92M</p>  <p>1. Emitter 2. Collector 3. Base</p> <p>1 2 3</p> <p>KRA107M KRC107M KSA1175Y KSC2785Y KTC2874B</p>	<p>T0-92</p>  <p>1. Emitter 2. Collector 3. Base</p> <p>1 2 3</p> <p>KTA1271Y KSC945CY KTA1268GR KTC3200GR</p>	<p>T0-126</p>  <p>1. Emitter 2. Collector 3. Base</p> <p>1 2 3</p> <p>KTA1360Y KTC3423Y KTC3114A</p>
<p>T0-3P</p>  <p>1. Base 2. Collector 3. Emitter</p> <p>1 2 3</p> <p>2SB1570 2SD2401</p>	<p>T0-220</p>  <p>1. INPUT 2. GND 3. OUTPUT</p> <p>1 2 3</p> <p>L7805CP L7815CP</p>	<p>T0-220</p>  <p>1. GND 2. INPUT 3. OUTPUT</p> <p>1 2 3</p> <p>L7905CP L7915CP</p>

KP1010 photocoupler

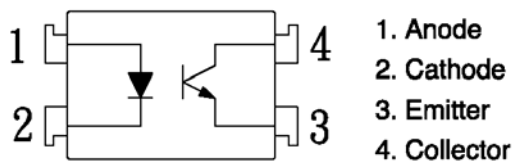

HK3485 ELECTRICAL PARTS LIST			
Ref. Designator	Part Number	Description	
PCB, FRONT/HEADPHONE/TONE/VIDEO			
<i>Capacitors</i>			
C603,604,605,606	HCQI1H473JZT	CAP , MYLAR	0.047UF 50V J
C701,702,711~714,C802,817	CCEA1HKS100T	CAP , ELECT	10UF 50V KS
C703,704,726	HCBS1H101KBT	CAP , CERAMIC	100PF 50V K
C707, 708	CCEA1CKS470T	CAP , ELECT	47UF/16V
C709,710,813,814	HCBS1H470JT	CAP , CERAMIC	47PF 50V J
C715,716,719,720	KCFE1J183JBT	CAP , FILM	0.018UF 63V J
C717,718	KCFE1J823JBT	CAP , FILM	0.082UF 63V J
C721,722	KCFE1J332JBT	CAP , FILM	0.0033UF 63V J
C723,724	HCBS1H221KBT	CAP , CERAMIC	220PF 50V K
C727,744,808,809,C819,838,839,914	HCBS1H104ZFT	CAP , CERAMIC	0.1UF 50V Z
C728,729,730,804,C811,815,816,818, C830,834,837,911,912	HCBS1H223ZFT	CAP , CERAMIC	0.022UF 50V Z
C741,742	HCQI1H122JZT	CAP , MYLAR	1200PF 50V J
C745	HCBS1H103ZFT	CAP , CERAMIC	0.01UF 50V Z
C801	CCFT1H104ZF	CAP , CERAMIC	0.1UF 50V Z
C803,812	CCEA1AH471T	CAP , ELECT	47UF 10V
C805,806	HCBS1H150JCT	CAP , CERAMIC	15PF 50V
C807,823,824,840	HCBS1H821KBT	CAP , CERAMIC	820PF 50V K
C810	CCEA1AKS101T	CAP. ELECT	100UF 10V
C820	CCEA1CH331T	CAP , ELECT	330UP 16V
C821	CCEA1CKS4R7T	CAP. ELECT	4.7UF 16V
C822	HCBS1H151KBT	CAP , CERAMIC	150PF 50V K
C832,833	HCBS1H102KBT	CAP , CERAMIC	1000PF 50V B
C835	CCEA0JH102T	CAP , ELECT	1000PF 6.3V
C904~908	CCKT1H101KB	CAP , CERAMIC	100PF 50V KB
C909,910,921,922	CCEA1CH101T	CAP , ELECT	100UF 16V
C913	CCEA1EH220T	CAP , ELECT	22UF/25V
<i>Semiconductors</i>			
D701~705	CVD52CSBBCEAB2	BLUE L.E.D	
D706	CVD50BOGDWGA	L.E.D , 2 COLOR	
D707,708,802~808,D901~903	CVD1SS133MT	DIODE	1SS133T-77
Q801,803,805,807,Q808,813	HVTKRC107MT	TRANSISTOR NPN	KRC107M
Q802,806,814,901	HVTKRA107MT	TRANSISTOR PNP	KRA107M
Q804	HVTKTA1271YT	TRANSISTOR PNP	KTA1271Y
Q809	KVTKSA1175YT	TRANSISTOR PNP	KSA1175Y
Q810	KVTKSC2785YT	TRANSISTOR NPN	KSC2785Y
Q811,812	HVTKSC945CYT	TRANSISTOR NPN	KSC945CY
IC71	HVINJM2068MDTE1	I.C , DUAL OP AMP	NJM2068MD-TE1
IC81	HVIST72F321R	IC , FLASH U-COM	
IC83	HVIAT24C08N10SC	I.C. EEPROM	AT24C08N10SC2.7
IC84	HVIS-80145ALMC	I.C RESET	S-80145ALMC
IC85	HVIRE5VL28CATZ	IC , RESET	
IC87	HVIL7805CP	I.C, REGULATOR +5v	
IC88	HVIL7905CP	I.C, REGULATOR -5v	
IC91	HVINJM2296M	I.C , VIDEO SW	NJM2296M
IC92	BVIKP1010B	IC, PHOTO COUPLER	
<i>Resistors</i>			
R705,706,829,830,R870,918	CRD20TJ101T	RES , CARBON	100 OHM 1/5W J
R701,702,707,708,R709,710,723,724	CRD20TJ104T	RES , CARBON	100K OHM 1/5W J
R711,712	CRD20TJ105T	RES , CARBON	1M OHM 1/5W J

Ref. Designator	Part Number	Description	
PCB, FRONT/HEADPHONE/TONE/VIDEO			
R713,714	CRD20TJ223T	RES , CARBON	22K OHM 1/5W J
R715,716,919	CRD20TJ392T	RES , CARBON	3.9K OHM 1/5W J
R717,718,824	CRD20TJ222T	RES , CARBON	2.2K OHM 1/5W J
R719,720	CRD20TJ681T	RES , CARBON	680 OHM 1/5W J
R721,722,745	CRD20TJ471T	RES , CARBON	470 OHM 1/5W J
R725,901~905	CRD20TJ750T	RES , CARBON	75 OHM 1/5W J
R726	CRD20TJ560T	RES , CARBON	56 OHM 1/5W J
R727,728,820,856,866	CRD20TJ272T	RES , CARBON	2.7K OHM 1/5W J
R729,809,825~827,R835,853,860,863,R 908,911,912,913	CRD20TJ102T	RES , CARBON	1K OHM 1/5W J
R733,734	CRD20TJ331T	RES , CARBON	330 OHM 1/5W J
R742,828,833,834,R836,909,910	CRD20TJ100T	RES , CARBON	10 OHM 1/5W J
R744	CRD20TJ181T	RES , CARBON	180 OHM 1/5W J
R801	CRD20TJ122T	RES , CARBON	1.2K OHM 1/5W J
R806,807,808,822,R823,837~839,841,R 842,845,847~852,R876	CRD20TJ103T	RES , CARBON	10K OHM 1/5W J
R831,832,844,846	CRD20TJ472T	RES , CARBON	4.7K OHM 1/5W J
R843,857,867,906,R907,917	CRD20TJ332T	RES , CARBON	3.3K OHM 1/5W J
R854,861,864	CRD20TJ152T	RES , CARBON	1.5K OHM 1/5W J
R855,862,865	CRD20TJ182T	RES , CARBON	1.8K OHM 1/5W J
R858,868	CRD20TJ562T	RES , CARBON	5.6K OHM 1/5W J
R859,869	CRD20TJ752T	RES , CARBON	7.5K OHM 1/5W J
R875	CRD20TJ820T	RES , CARBON	82 OHM 1/5W J
R878	CRD20TJ273T	RES , CARBON	27K OHM 1/5W J
R915	CRD20TJ271T	RES , CARBON	270 OHM 1/5W J
R916	CRD20TJ470T	RES , CARBON	47 OHM 1/5W J
R920	CRD20TJ473T	RES , CARBON	47K OHM 1/5W J
R921,922	CRG2ANJ470H	RES , METAL OXIDE FILM	47 OHM 2W J
VR71,72	CVV2X12C104Z	RES , VARIABLE(TONE)	
VR73	CVV2X13M104Z	RES , VARIABLE(BALANCE)	
<i>Miscellaneous</i>			
VR81	CSR2A037Z	VR , ENCODER	
FIP1	HFLHCA16ML08-1	F.I.P	
L801	HLQ02C100KT	COIL , AXAIL	
S701,801~819	HST1A020ZT	SW , TACT	
BN71	CWZHK3380BN71	WIRE ASS'Y	
BN72	CWZHK3380BN72	WIRE ASS'Y	
BN73	CWB2B903350EN	WIRE ASS'Y	
BN82	CWB2B907350EN	WIRE ASS'Y	
BN83,84	CWB2B904070EN	WIRE ASS'Y	
BN89	CWB2B907160EN	WIRE ASS'Y	
BN91	CWB2B909200EN	WIRE ASS'Y	
BN81	CWZHK3380BN81	WIRE ASS'Y	
CN62	CJP02GA89ZM	WAFER	MOLEX35328-02
CN63	CJP03GA90ZM	WAFER	MOLEX35313-0310
CN64	CJP06GA01ZY	WAFER	MOLEX 5267-06A
CN81	CJP20GB163ZW	WAFER	
CN83,84	CJP04GA19ZY	WAFER	
CN89	CJP07GA19ZY	WAFER	MOLEX53014-0710
CN90	CJP07HA37ZM	WAFER	
JK71	CJJ2E026Z	JACK , HEADPHONE(SILVER PLATE)	
JK72	CJJ4S023Y	JACK , BOARD	
JK91	CJJ4N043Z	JACK , BOARD	
JK92	CJJ4S010Z	JACK , BOARD	
JK93,94	CJJ2D008Z	JACK , STEREO	
JW72	CWE8202110RV	WIRE, ASS'Y	

Ref. Designator	Part Number	Description	
PCB, FRONT/HEADPHONE/TONE/VIDEO			
JW73	CWZAVR2550JW82	WIRE , ASS'Y	
RC81	HRVKSM603TH2	REMOCON SENSER	CN KSM-603TH2
X801	HOX04000E150C	CRYSTAL , 4MHZ	
PCB, MAIN			
CUP11654Y			
<i>Capacitors</i>			
C101,102,105,106	CCKT1H101KB	CAP , CERAMIC	100PF 50V KB
C103,104,117,118,C191~194,301,302	CCEA1VH100T	CAP , ELECT	10UF 35V
C107,108,111,112,C121,122,123,124, C175,176,181,182,C195,196,219,220, C305,306	CCEA1CH101T	CAP , ELECT	100UF 16V
C109,110,213,214,222	HCQI1H102JZT	CAP , MYLAR	1000PF 50V J
C113,114,331~336	HCQI1H562JZT	CAP , MYLAR	5600PF 50V J
C115,116	HCQI1H152JZT	CAP , MYLAR	1500PF 50V J
C119,120	HCQI1H183JZT	CAP , MYLAR	0.018UF 50V J
C125~130	HCBS1H471KBT	CAP , CERAMIC	470PF 50V K
C131~144	HCBS1H221KBT	CAP , CERAMIC	220PF 50V K
C145,146	HCBS1H104ZFT	CAP , CERAMIC	0.1UF 50V Z
C183~185,303,304	CCKT1H471KB	CAP , CERAMIC	470PF 50V KB
C197,198,342,615,C616,623,624,627	CCFT1H223ZF	CAP , CERAMIC	0.022UF 50V ZF
C201~204	HCBS1H101KBT	CAP , CERAMIC	100PF 50V K
C211,212,215,C216,341,620	CCEA1HH4R7T	CAP , ELECT	4.7UF 50V
C240	CCEA1HH1R0T	CAP , ELECT	1UF 50V
C311,312	HCBS1H120JCT	CAP , CERAMIC	12PF 50V J
C313,314	HCBS1H330JT	CAP , CERAMIC	33PF 50V
C315,316,317	CCEA1HH100TS	CAP , ELECT	10UF/50V 105°C
C318	CCEA1HH100T	CAP. ELECT	10UF/50V
C319,320,607~609	HCQI1H473JZT	CAP , MYLAR	0.047UF 50V J
C343	CCEA1AH471T	CAP , ELECT	47UF 10V
C351,352	HCBS1H681KBT	CAP , CERAMIC	680PF 50V K
C613,614,622	CCEA1EH101T	CAP , ELECT	100UF
C619,629	CCEA1HH470T	CAP , ELECT	47UF/50V
C626	CCEA1AH101T	CAP. ELECT	100UF 10V
C628,630	HCBS1H103ZFT	CAP , CERAMIC	0.01UF 50V Z
C307~310	CCEA1JH471E	CAP , ELECT	470UF/63V
C601,602	CCET63VKL5153NK	CAP , ELECT	15000/63V
C611	CCEA1EH332E	CAP , ELECT	3300UF 25V
C612	CCEA1EH222E	CAP. ELECT.	2200UF 25V
C621	KCKDKS472ME	CAP , CERAMIC(X1/Y2/SC)	0.0047UF/2.5KV
C625	CCEA1EH102E	CAP , ELECT	1000UF 25V
C631	HCQE2E104KDE	CAP , LINE ACROSS	0.1UF 250V KD
C632	CCEA1JH101E	CAP , ELECT	100UF
<i>Semiconductors</i>			
D101~110,112~115,D301~309,606, 612,D613,614	CVD1SS133MT	DIODE	1SS133T-77
D602~605,607,615,D616~618	CVD1N4003ST	DIODE	1N4003
D608,609	CVDZJ15BT	DIODE , ZENER	15V 1/2W
D611	CVDZJ6.2BT	DIODE , ZENER	6.2V 1/2W
D601	HVDGBJ806MF	DIODE , BRIDGE	
Q204~208	HVTKTC2874BT	TRANSISTOR , MUTE	KTC2874B
Q209,332,337,338,602	HVTKRA107MT	TRANSISTOR PNP	KRA107M
Q210,335,336	HVTKRC107MT	TRANSISTOR NPN	KRC107M
Q301~306,311,312	HVTKTC3200GRT	TRANSISTOR NPN	KTC3200GR
Q307~310	HVTKTA1268GRT	TRANSISTOR PNP	KTA1268GR

Ref. Designator	Part Number	Description	
PCB, MAIN	CUP11654Y		
Q323,324,333,334,601	HVTKSC2785YT	TRANSISTOR NPN	KSC2785Y
Q331	HKVTKSA1175YT	TRANSISTOR PNP	KSA1175Y
Q603	HVTKTA1271YT	TRANSISTOR PNP	KTA1271Y
Q313,314	HVTKTA1360Y	TRANSISTOR , PRE DRIVE, PNP	KTA1360Y
Q315,316	HVTKTC3423Y	TRANSISTOR , PRE DRIVE, PNP	KTC3423Y
Q317	HVTKTC3114A	TRANSISTOR , BIAS, NPN	KTC3114A
Q318	HVTKTC3114A	TRANSISTOR , BIAS, NPN	KTC3114A
Q319, 320	HVT2SD2401P	TRAN , POWER(DARINGTON), NPN	2SD2401P
Q321, 322	HVT2SB1570P	TRAN , POWER(DARINGTON), PNP	2SB1570P
IC11,14,16,21	HVINJM2068MDTE1	I.C , DUAL OP AMP	NJM2068MD-TE1
IC12	HVITC9164CFG	I.C , FUNCTION	TC9164CFG
IC13	HVITC9163CFG	I.C , FUNCTION	TC9163CFG
IC15	HVITC9459BFG	I.C , VOLUME	
IC61	HVIL7805CP	I.C, REGULATOR +5V	
IC64	CVIL7815CPVA	I.C, REGULATOR +15V	
IC65	CVIL7915CPVA	I.C, REGULATOR -15V	
<i>Resistors</i>			
R101,102,359,360,R363,364,386	CRD20TJ102T	RES , CARBON	1K OHM 1/5W J
R103~106,117,118,R213,214,221,222,R618	CRD20TJ104T	RES , CARBON	100K OHM 1/5W J
R107,108,121,123,R124,171,172,181, R182,195,196,201,R202~204,219,220	CRD20TJ101T	RES , CARBON	100 OHM 1/5W J
R109,110	CRD20TJ564T	RES , CARBON	560K OHM 1/5W J
R111,112,173,174,R367,368,385	CRD20TJ473T	RES , CARBON	47K OHM 1/5W J
R113,114	CRD20TJ751T	RES , CARBON	750 OHM 1/5W J
R115,116,125~144,R183~185,211, 305,306	CRD20TJ471T	RES , CARBON	470 OHM 1/5W J
R122	CRD25TJ101T	RES , CARBON	100 OHM 1/4W J
R151~164	CRD20TJ474T	RES , CARBON	470K OHM 1/5W J
R191~194,205~208	CRD20TJ184T	RES , CARBON	180K OHM 1/5W J
R212	CRD25TJ471T	RES , CARBON	470 OHM 1/4W J
R215,216	CRD20TJ202T	RES , CARBON	2K OHM 1/5W J
R217,218,617	CRD20TJ222T	RES , CARBON	2.2K OHM 1/5W J
R223,224,315~318,384	CRD20TJ152T	RES , CARBON	1.5K OHM 1/5W J
R234	CRD20TJ562T	RES , CARBON	5.6K OHM 1/5W J
R235~239	CRD20TJ332T	RES , CARBON	3.3K OHM 1/5W J
R240,365,366	CRD20TJ103T	RES , CARBON	10K OHM 1/5W J
R241	CRD20TJ822T	RES , CARBON	8.2K OHM 1/5W J
R255	CRD20TJ105T	RES , CARBON	1M OHM 1/5W J
R303,304,319,320	CRD20TJ333T	RES , CARBON	33K OHM 1/5W J
R383	CRD20TJ433T	RES , CARBON	43K OHM 1/5W J
R307,308	CRD20TJ100T	RES , CARBON	10 OHM 1/5W J
R309,310,357,358	CRD20TJ271T	RES , CARBON	270 OHM 1/5W J
R311~314	CRD20TJ221T	RES , CARBON	220 OHM 1/5W J
R321,322,343,344,611	CRD20TJ122T	RES , CARBON	1.2K OHM 1/5W J
R323~334	CRD20TJ561T	RES , CARBON	560 OHM 1/5W J
R335~338	CRD20TJ750T	RES , CARBON	75 OHM 1/5W J
R339~342	CRD20TJ223T	RES , CARBON	22K OHM 1/5W J
R345,346	CRD20TJ331T	RES , CARBON	330 OHM 1/5W J
R347~350	CRD25FJ3R3T	RES , CARBON	3.3 OHM 1/4W J
R351~354	CRD25FJ180T	RES , CARBON	18 OHM 1/4W J
R361,362,609,610,R619,620	CRD20TJ182T	RES , CARBON	1.8K OHM 1/5W J
R371~374	CRD25TJ470T	RES , CARBON	47 OHM 1/4W J
R381,382	CRD20TJ273T	RES , CARBON	27K OHM 1/5W J
R391~393	CRD20TJ470T	RES , CARBON	47 OHM 1/5W J
R601~604	CRD25TJ393T	RES , CARBON	39K OHM 1/4W J

Ref. Designator	Part Number	Description	
PCB, MAIN	CUP11654Y		
R607,608	CRD20TJ123T	RES , CARBON	12K OHM 1/5W J
R612,613	CRD20TJ560T	RES , CARBON	56 OHM 1/5W J
R614	CRD20TJ820T	RES , CARBON	82 OHM 1/5W J
R355,356	CRF5EKR22HX2	RES , CEMENT	0.22OHM(*2), 5W
R375,376	CRG1ANJ100H	RES , METAL OXIDE FILM	10 OHM 1W J
R377,378	CRG1ANJ221H	RES , METAL OXIDE FILM	220 OHM 1W J
R605,606,616	CRQ1AJR47H	RES , FUSE	0.47 OHM 1W J
R615	CRQ1AJ100H	RES , FUSE	10 OHM 1W J
R631	HRDERC12UGK335T	RES , CARBON JP	3.3M OHM 1/2W
VR31,32	HVN1RA221B01T	RES , SEMI FIXED(220 OHM)	RH0615C100221
<i>Miscellaneous</i>			
L101,102	HLQ02C470KT	COIL , AXAIL	
L301,302	CLEY0R5KAK	COIL , SPEAKER	0.5UH K
BN62	CWB4FA32120PU	WIRE ASS'Y	
BN63	CWB3FE03280UP	WIRE ASS'Y	
BN64	CWB1C906200BM	WIRE ASS'Y	
JW31	CWE7202050AA	WIRE ASS'Y	
JW32	CWE7202070AA	WIRE ASS'Y	
JW33	CWE7202060AA	WIRE ASS'Y	
JW34,35	CWE7202090AA	WIRE ASS'Y	
CN26	CJP13GA115ZY	WAFER , CARD CABLE	
CN31,32	CJP02GA01ZY	WAFER	
CN61	CJP02KA060ZY	WAFER	7.92MM(YUNHO)
CN71	CJP12GA19ZY	WAFER	
CN73,74	CJP03GA19ZY	WAFER	
CN75	CJP02GA19ZY	WAFER	
CN81	CJP20GA147ZW	20 DUAL WAFER	JWT
CN82	CJP07GA19ZY	WAFER	
CN91	CJP09GA19ZY	WAFER	
JK10	CJJ4N060Z	JACK , BOARD 2P (GOLD)	
JK11,12	CJJ4P014W	JACK , IN/OUT	
JK13	CJJ4R019W	TERMINAL , IN/OUT	
JK14	CJJ4R021W	JACK , IN/OUT	
JK15	CJJ5Q006Z	TERMINAL , SPEAKER	
OL61	KJJ7A015Z	OUTLET , AC(UL/2P/SEP)	A204D0041P
RY31,32	HSL4A004ZU	RELAY	OSA-SS-212DM3
RY61	HSL1A008ZE	RELAY	SDT-S-112DMR
TH31	KRTP42T7D330B	THERMAL SENSOR , POSISTOR	P42T7D330BW20
T602	CLT5J033ZU	TRANS , SUB	SR-68
T601	CLT5V036ZU	TRANS , POWER	
BN26	CWC4C4A13B170B	CARD , CABLE	
F601,603,604	KBA2C8000TLEY	FUSE 8A	
F602	KBA2D2500TLET	FUSE 2.5A	

HK3385/3485/3380/3480
MAIN BOARD

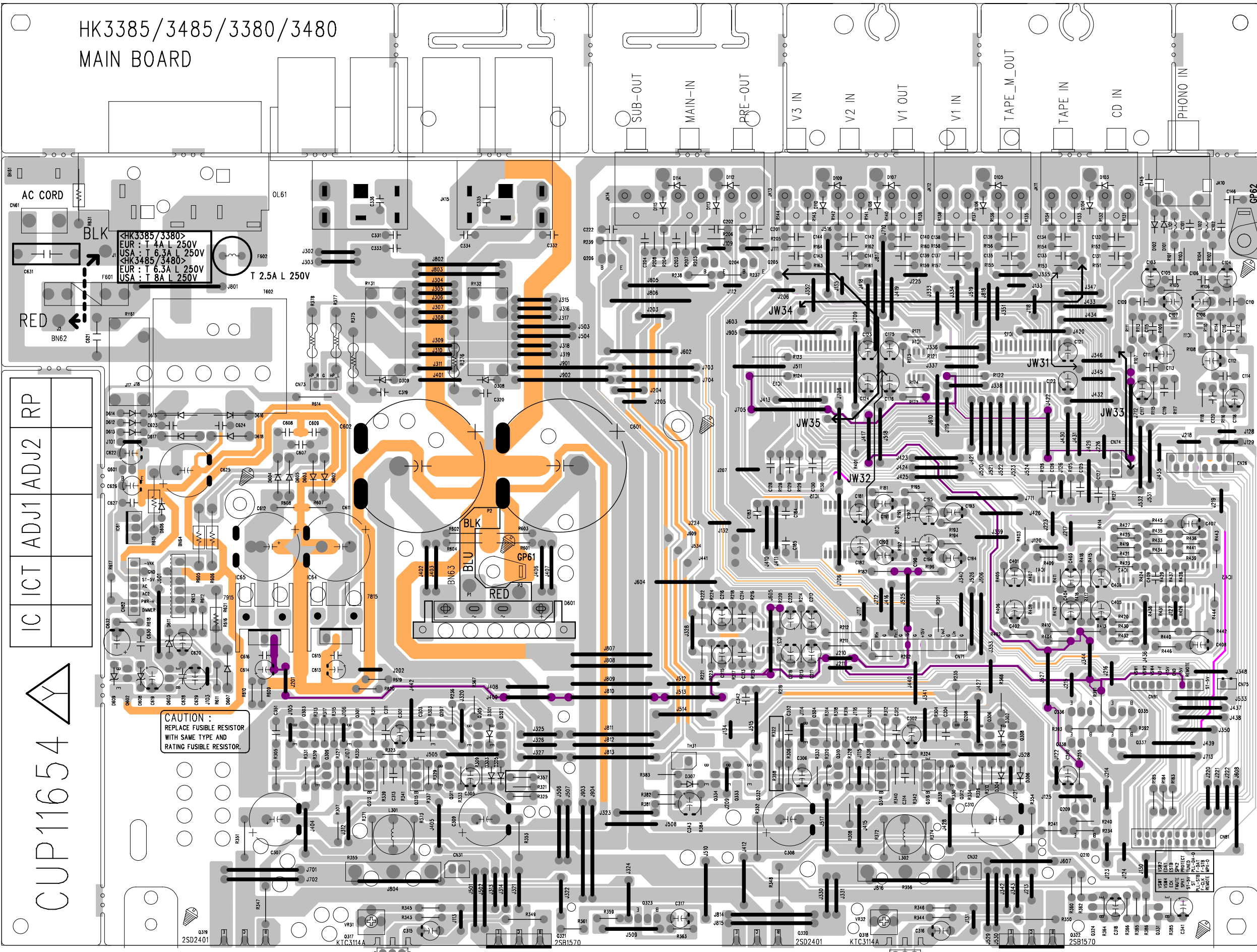

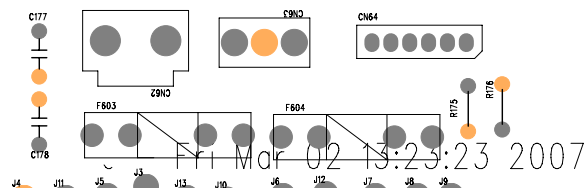

Mar 02 13:29:23 2007

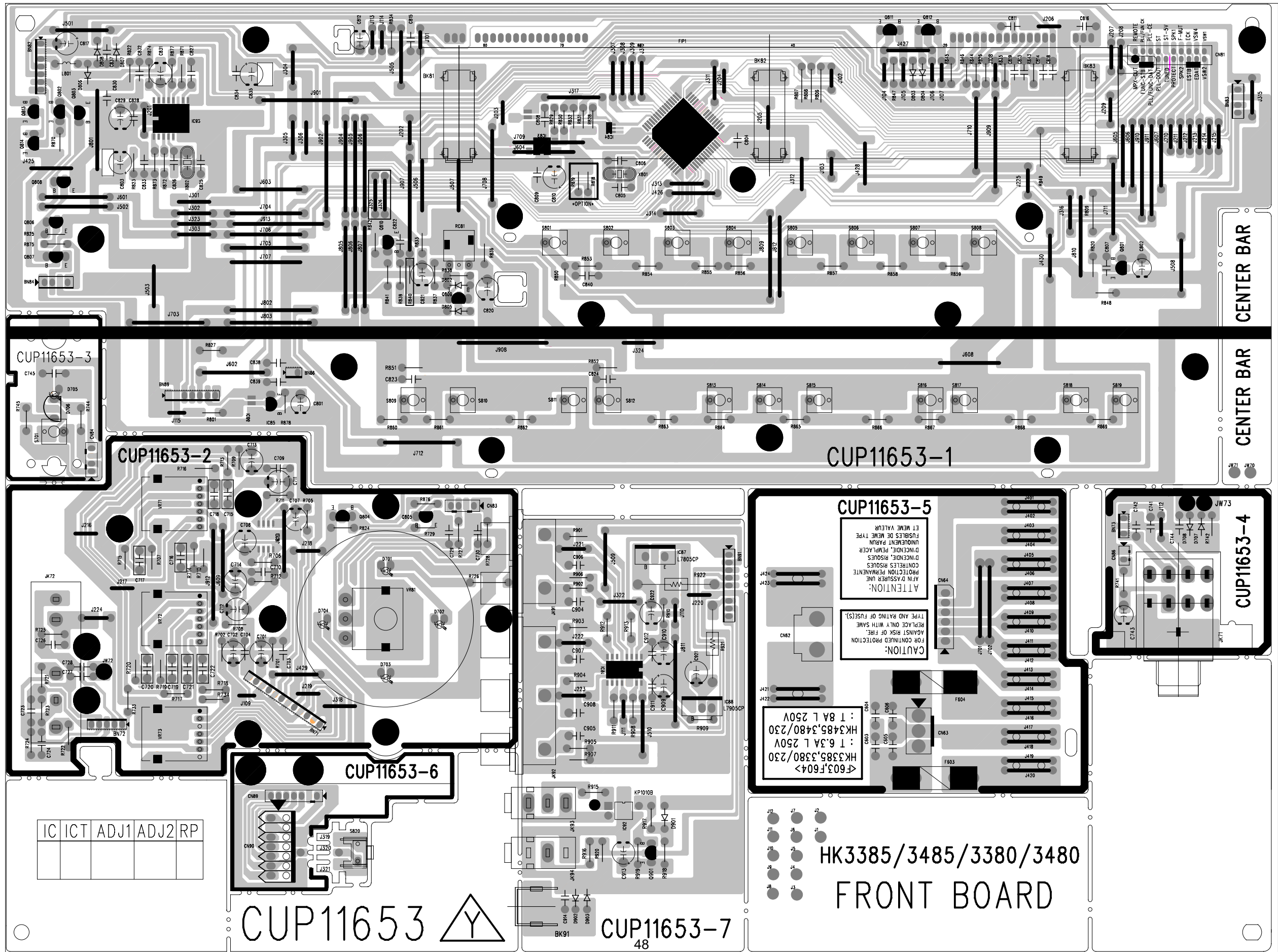

IC	ICT	ADJ1	ADJ2	RP

CUP11653

CUP11653-7

CUP11653-5

CAUTION:
 FOR CONTINUED PROTECTION AGAINST RISK OF FIRE, REPLACE ONLY WITH SAME TYPE AND RATING OF FUSE(S).

ATTENTION:
 Afin d'assurer une protection permanente contre les risques d'incendie, remplacez les fusibles de même type et même valeur.

HK3385,3380/230 <603JF604>
 : 1 6,3A L 250V
 HK3485,3480/230 : 1 8A L 250V

HK3385/3485/3380/3480 FRONT BOARD

CENTER BAR

CENTER BAR

CUP11653-4

6

5

4

3

2

1

D

D

C

C

B

B

A

A

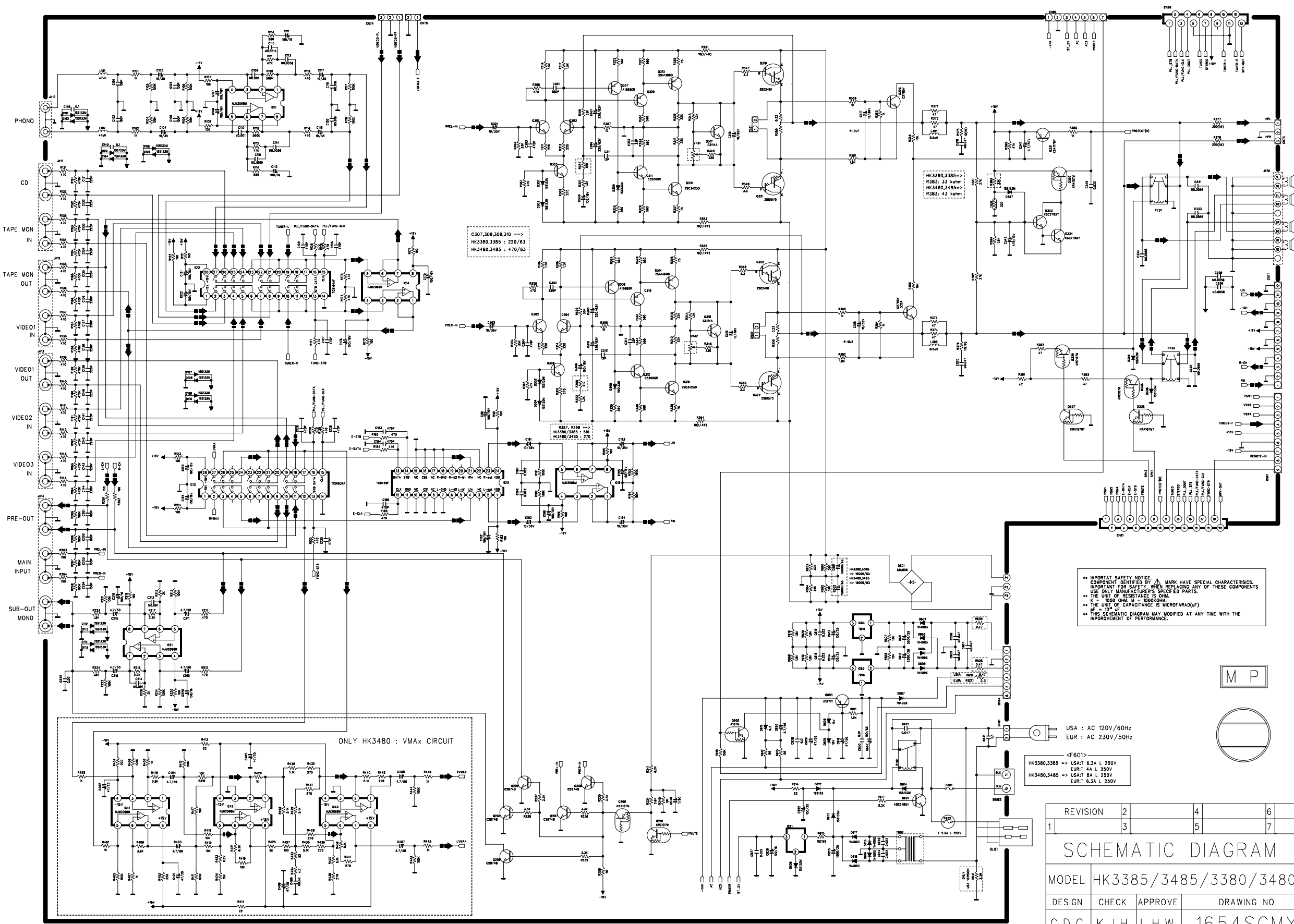

C307.308.309.310 =>
 HK3380.3385 : 220/63
 HK3480.3485 : 470/63

R337: 82kΩ
 HK3380.3385 : 810
 HK3480.3485 : 220

HK3380.3385 =>
 R383: 33 kΩ
 HK3480.3485 =>
 R383: 43 kΩ

IMPORTANT SAFETY NOTICE:
 COMPONENT IDENTIFIED BY THE MARK HAVE SPECIAL CHARACTERISTICS.
 IMPORTANT FOR SAFETY, WHEN REPLACING ANY OF THESE COMPONENTS
 USE ONLY MANUFACTURER'S SPECIFIED PARTS.
 THE UNIT OF RESISTANCE IS OHM.
 K = 1000 OHM, M = 10000 OHM, U = 100000 OHM.
 THE UNIT OF CAPACITANCE IS MICROFARAD (μF).
 μF = 10⁻⁶ F
 THIS SCHEMATIC DIAGRAM MAY MODIFIED AT ANY TIME WITH THE
 IMPROVEMENT OF PERFORMANCE.

M P



USA : AC 120V/60Hz
 EUR : AC 230V/50Hz

<F601>
 HK3380.3385 => USA: 6.3A L 250V
 EUR: 4A L 250V
 HK3480.3485 => USA: 8A L 250V
 EUR: 6.3A L 250V

REVISION	2	4	6
1	3	5	7
SCHEMATIC DIAGRAM			
SHEET			
MODEL	HK3385/3485/3380/3480		
DESIGN	CHECK	APPROVE	DRAWING NO
C.D.C	K.J.H	L.H.W	1654SCMY
06.12.08	06.12.08	06.12.08	(AMP)

6 5 4 3 2 1

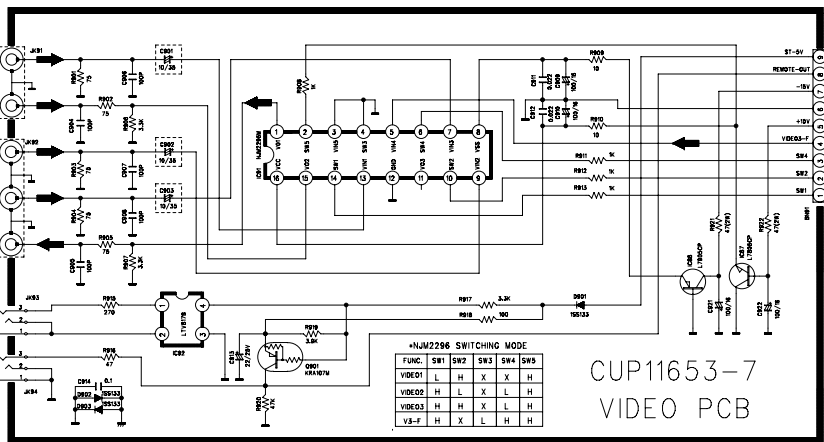
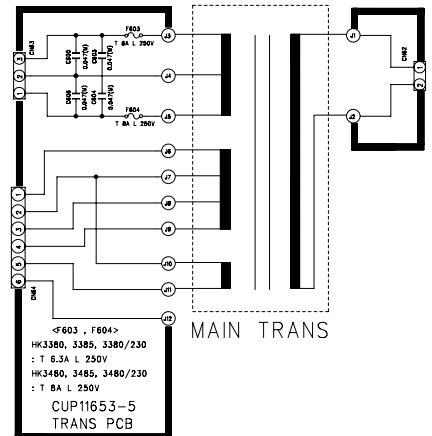
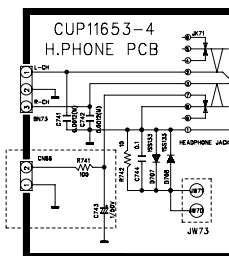
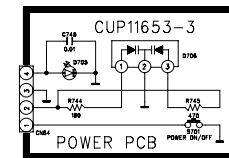
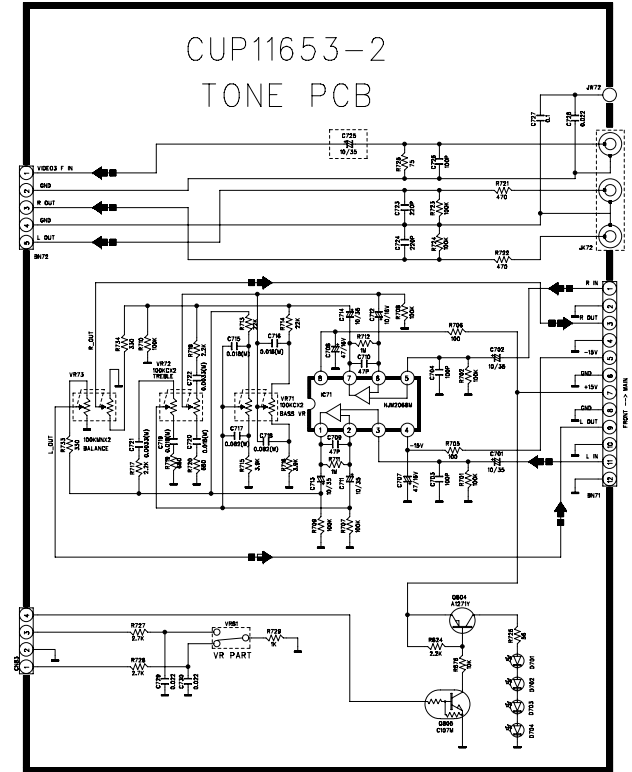
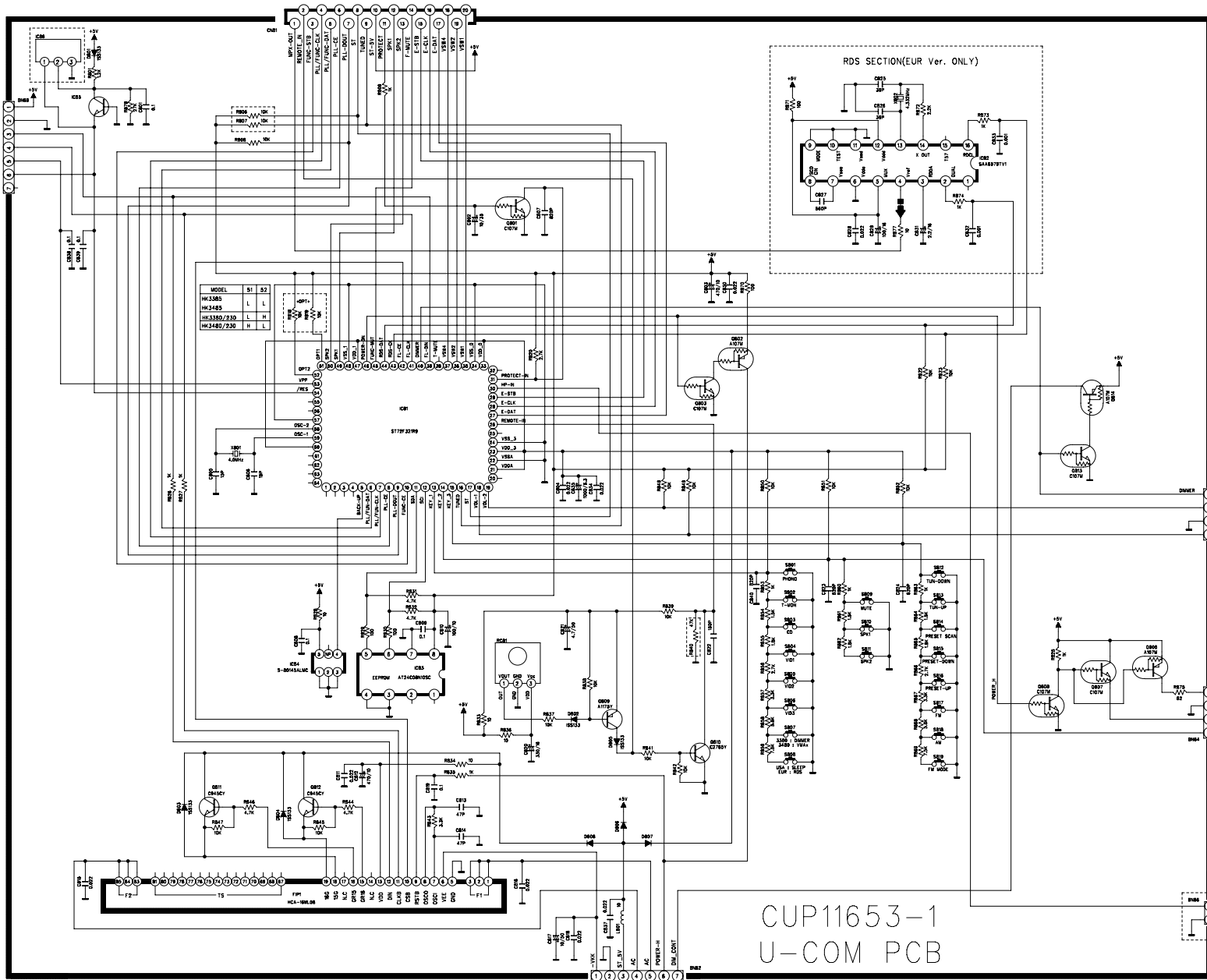
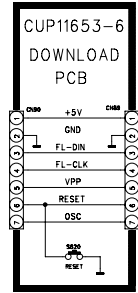

CUP11653-1
U-COM PCB

CUP11653-7
VIDEO PCB

RESISTOR VALUE CHART

100K 10K 1K 100 10 1 0.1 0.01 0.001

- IMPORTANT SAFETY NOTICE. COMPONENTS IDENTIFIED BY MARK SPECIAL CHARACTERISTICS. IMPORTANT FOR SAFETY. WHEN REPLACING ANY OF THESE COMPONENTS USE ONLY MANUFACTURER'S SPECIFIED PARTS.
- THE UNIT OF RESISTANCE IS OHM.
K=1000 OHM, M=1000 KOHM
- THE UNIT OF CAPACITANCE IS MICROFARAD. (uF)
pF=10 uF
- THIS SCHEMATIC DIAGRAM MAY MODIFIED AT ANY TIME WITH THE IMPROVEMENT OF PERFORMANCE.

M/P

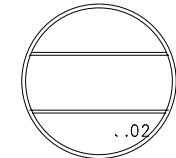

REVISION	2	4	6
1	3	5	7

SCHEMATIC DIAGRAM SHEET

MODEL	HK3385/3485/3380/3480			1/2
DESIGN	CHECK	APPROVE	DRAWING NO	
C.D.C	K.J.H	L.H.W	1653SCMY	
06.12.08			(FRONT)	

6

5

4

3

2

1

HK3385/3485/3380/HK3480 WIRING DIAGRAM

D

D

C

C

B

B

A

A

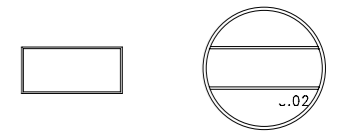
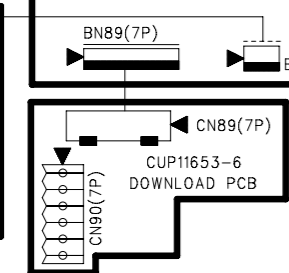
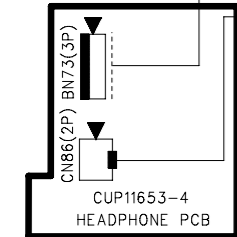
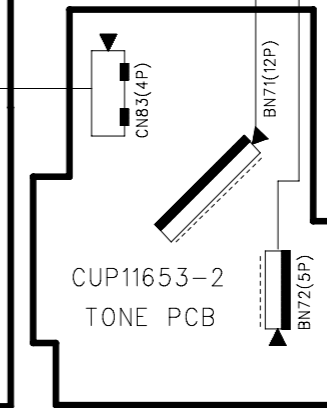
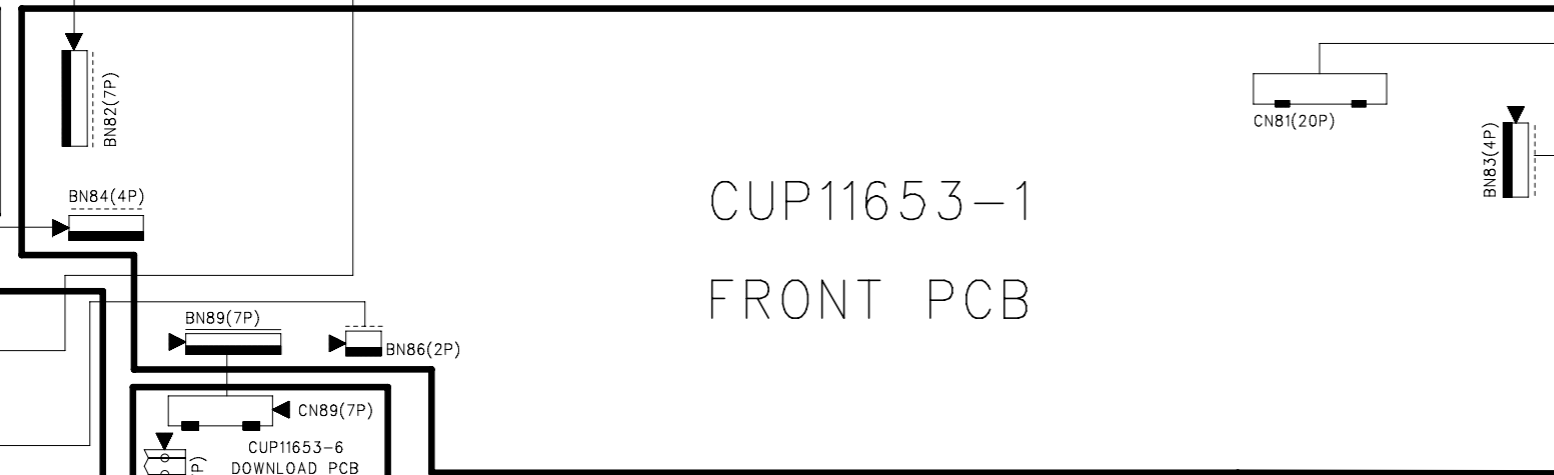
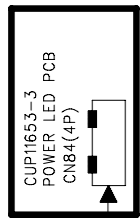
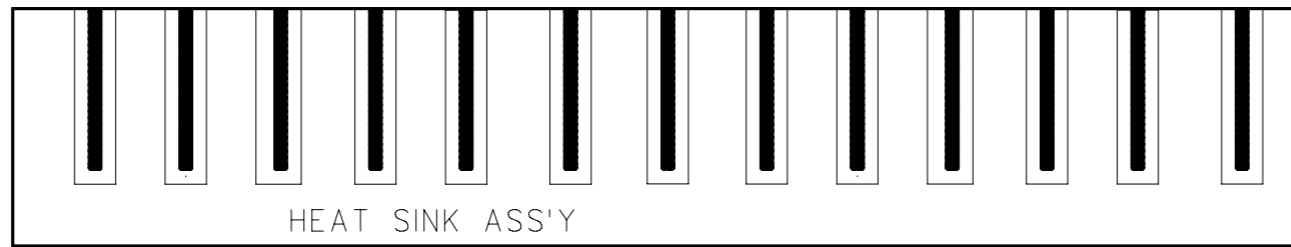
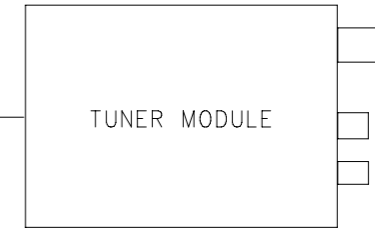
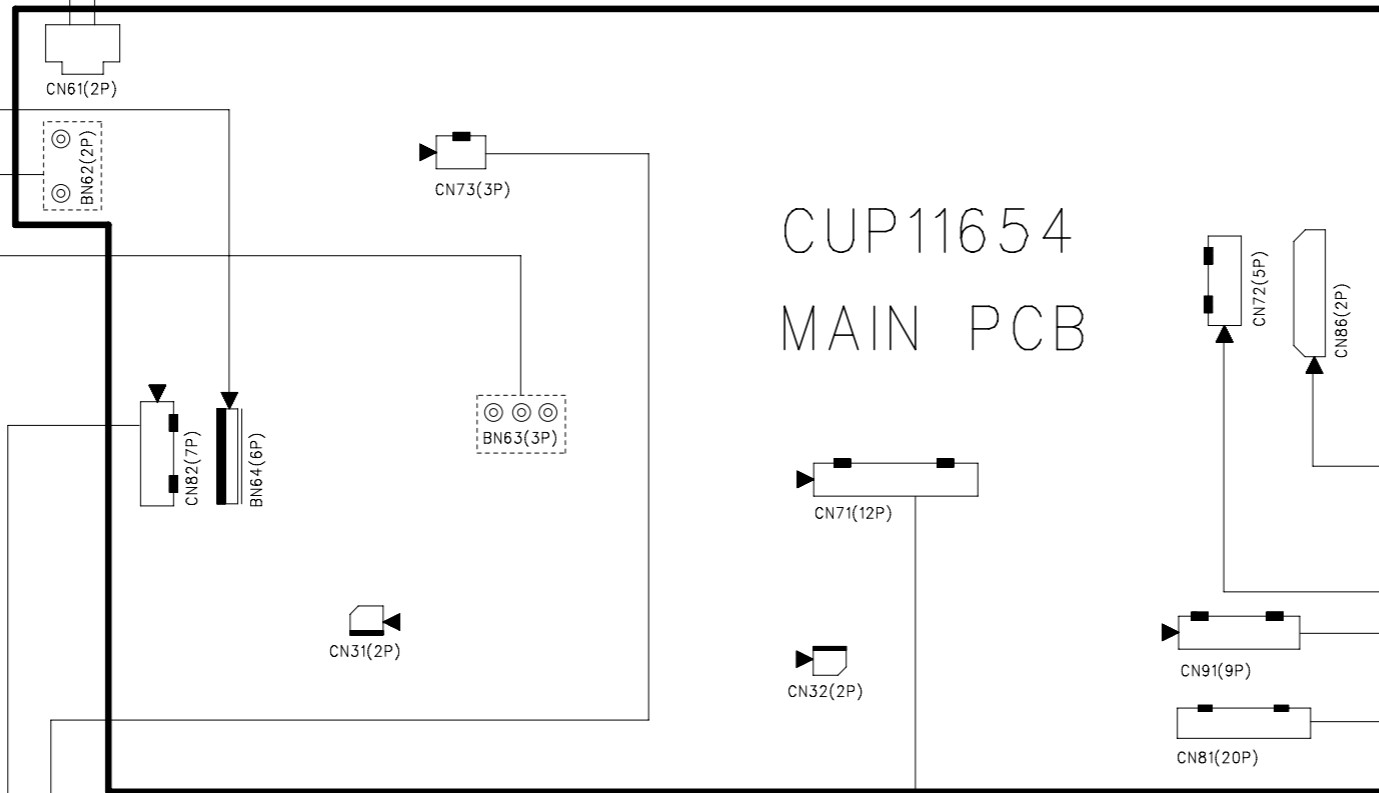
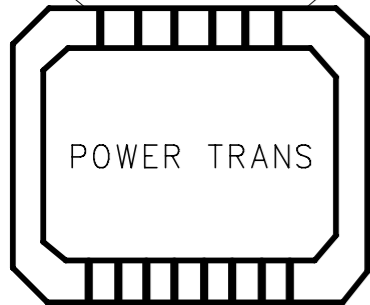
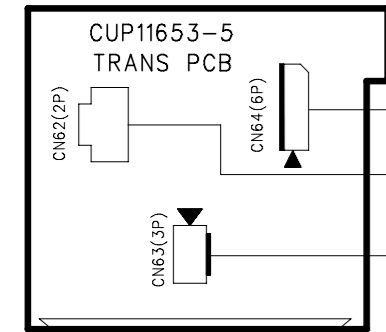

REVISION	2	4	6	
1	3	5	7	
SCHEMATIC DIAGRAM				SHEET
MODEL	HK3385/3485/3380/HK3480			1/1
DESIGN	CHECK	APPROVE	DRAWING NO	
C.D.CHOI	D.G.KIM	H.W.LEE	1653WCMY	
03.08.01				1/1