

**The Harman Kardon
Model hk 503**

Integrated Amplifier

Technical Manual

harman/kardon

PRECAUTIONS

1. Always disconnect the chassis from power line when soldering. Turning the power switch OFF is not enough. Power line leakage passing through the heating element may destroy the transistors.
2. Never attempt to do any work on the transistor amplifiers without first disconnecting the AC line cord and waiting until the power supply filter capacitors have discharged.
3. Replacement for output and driver transistors, if necessary, must be made from the same beta group as the original type.
4. If one output transistor burns out (open or short) always remove all the output transistors in that channel and check the bias adjustment, the control and other parts in the network with an ohmmeter before inserting a new transistor. All transistors in one channel will be destroyed if the base biasing circuit is open on the emitter end.
5. When mounting a replacement power transistor, be sure that the bottom of the flange, the mica insulators and the surface of the heat sink are free of foreign matter, for they may cause transistor failure.
6. Silicon grease must be applied between the transistor and the mica insulator, and between the mica insulator and the heat sink for better heat conduction.
7. Fuses must be replaced with size and type indicated. Use of other types can expose components to destructive current levels.

ALIGNMENT PROCEDURES

OUTPUT DC VOLTAGE ZERO ADJUSTMENT

INSTRUMENT

1. D. C. V. T. V. M.

NOTE

1. Set function selector switch to AUX position.
2. Set volume control to minimum position.
3. Activate speaker system 1

STEP	CONNECT OUTPUT METER TO	ADJUST	ADJUST FOR
1	D. C. V. T. V. M. to Rch terminal of speaker system 1	VR401	0 mV \pm 60 mV
2	D. C. V. T. V. M. to Lch terminal of speaker system 1	VR402	

POWER AMPLIFIER IDLING ADJUSTMENT

INSTRUMENT

1. D. C. V. T. V. M.

NOTE

1. Set function selector switch to AUX position.
2. Set volume control to minimum position.

STEP	CONNECT OUTPUT METER TO	ADJUST	ADJUST FOR
1	D. C. V. T. V. M. to Q421 (emitter) and Q423 (emitter)	VR403	33 mV \pm 1.6 mV
2	D. C. V. T. V. M. to Q422 (emitter) and Q424 (emitter)	VR404	

ALIGNMENT POINTS

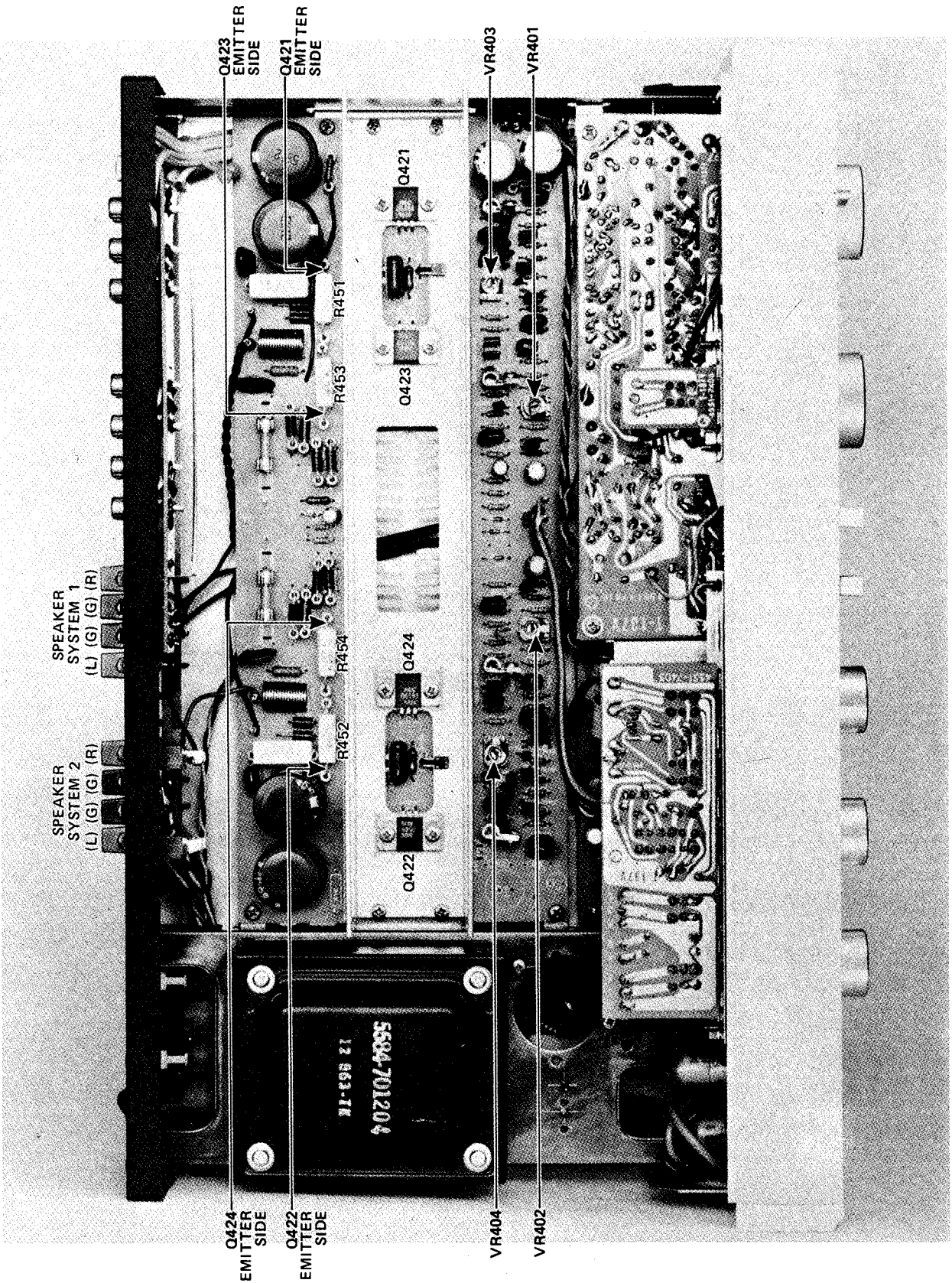

SCHEMATIC NOTES AND DIAGRAMS

NOTES: Unless otherwise noted.

1. All resistors are 1/4 watt, $\pm 5\%$. Values are in ohms. K = 1000 M = 1000K.
2. All capacitance values are in MF. PF = MMF.
3. Function selector switch (SW2) is in FM position.

VOLTAGE CHART

AC120V

No Signal

Chassis Ground

Volume Control at Minimum

Tone Controls at Mechanical Center

+B1	+40V	
+B2	+40V	-B1
+B3	+18V	-B2
+B4	+14.3V	-B3
B5	-8.5V	-B4
		-14.3V

	BASE	EMITTER	COLLECTOR
Q1	-0.64V	0V	-0.21V
Q21	-18.60V	-18.00V	-33.20V
Q22	+18.70V	+18.00V	+32.77V
Q25	-0.48V	0V	+17.70V
Q401, 402	-0.02V	-0.60V	+38.00V
Q403, 404	-0.02V	-0.60V	+38.00V
Q405, 406	-26.93V	-27.50V	-0.68V
Q407, 408	+38.00V	+38.60V	-10.35V
Q409, 410	+38.00V	+38.60V	+1.22V
Q411, 412	-38.00V	-38.75V	-38.00V
Q413, 414	-39.00V	-38.40V	-1.18V
Q415, 416	+0.06V	-1.18V	+1.21V
Q417, 418	+1.14V	+0.60V	+40.00V
Q419, 420	-1.12V	-0.60V	-40.00V
Q421, 422	+0.60V	+0.03V	+40.00V
Q423, 424	-0.60V	-0.03V	-40.00V
Q501, 502	-0.08V	-0.62V	+10.84V
Q503, 504	-0.09V	-0.62V	+14.30V
Q505, 506	-12.07V	-12.70V	-0.04V
Q507, 508	+10.84V	+11.48V	-0.04V
Q509, 510	-0.28V	-0.88V	+13.11V
Q511, 512	-0.73V	-1.35V	+13.11V
Q701, 702	-0.06V	-0.60V	+17.28V
Q703, 704	+17.28V	+17.88V	+2.52V
Q705, 706	+2.52V	+1.91V	+17.88V
Q707, 708	-16.87V	-17.46V	+1.78V

	GATE	SOURCE	DRAIN
Q23	-35.00V	-34.60V	-18.60V
Q24	+18.70V	+18.60V	+35.00V

SCHEMATIC DIAGRAM

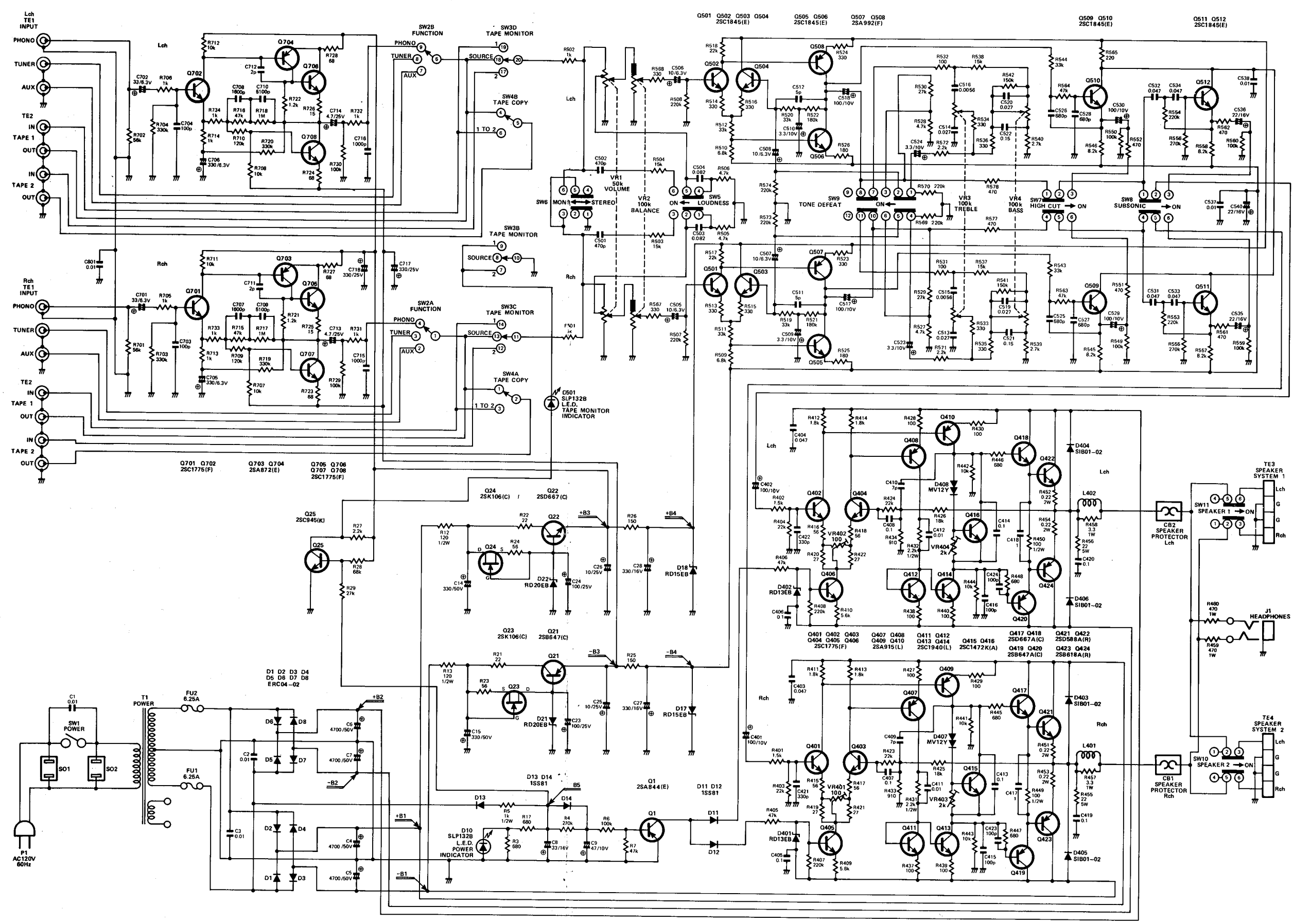

SCHEMATIC DIAGRAM

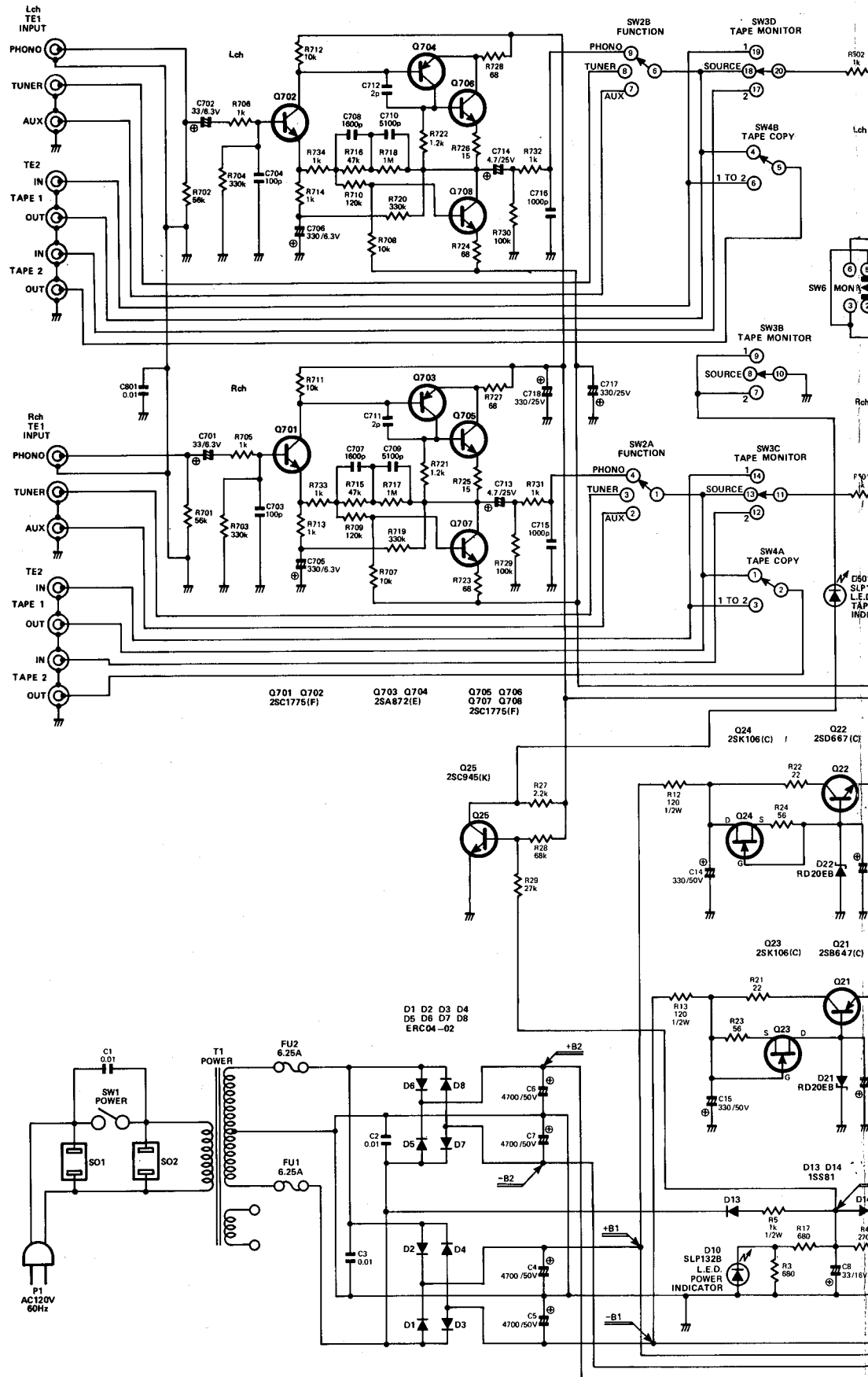

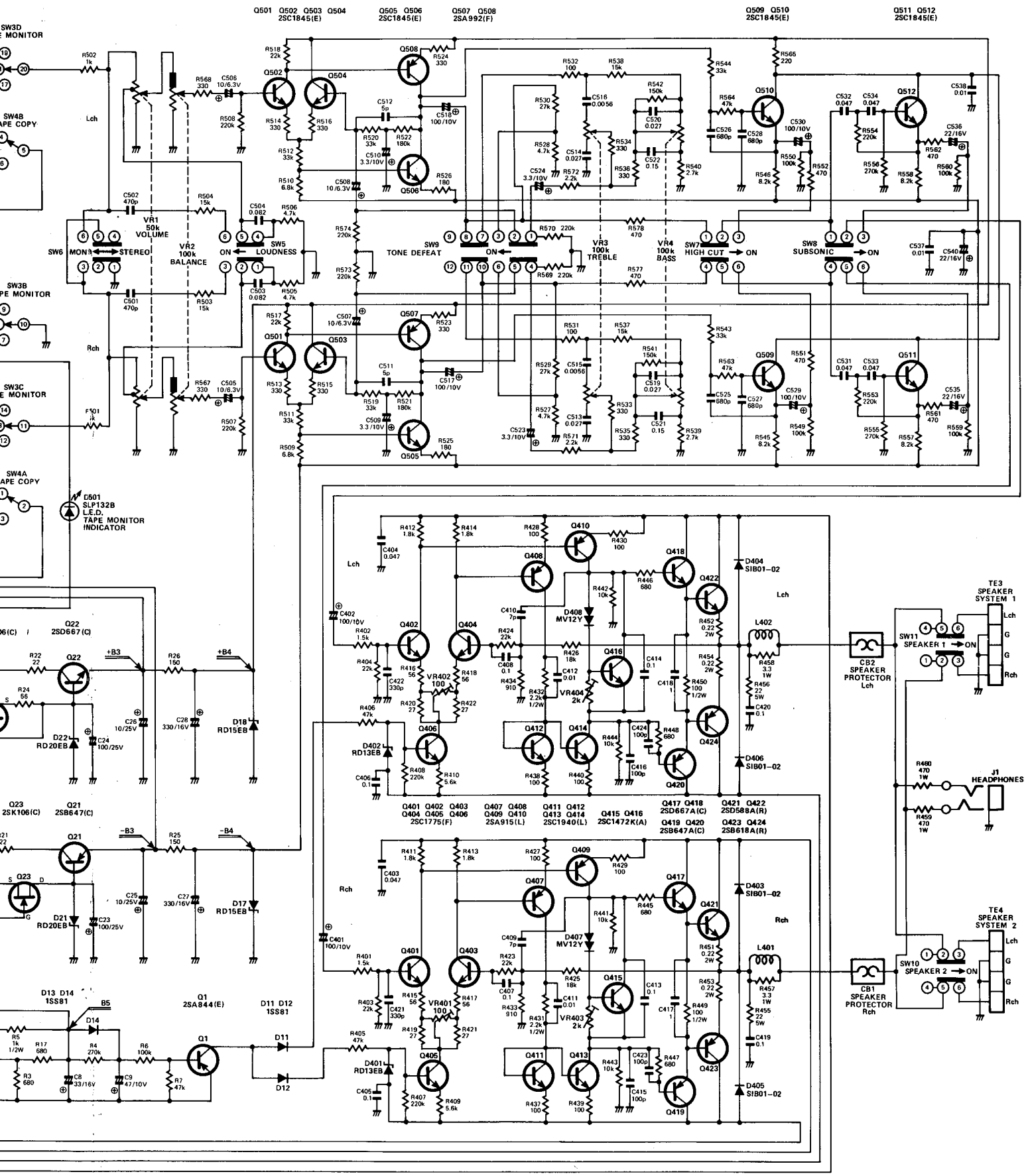

SCHEMATIC DIAGRAM – MULTI VOLTAGE

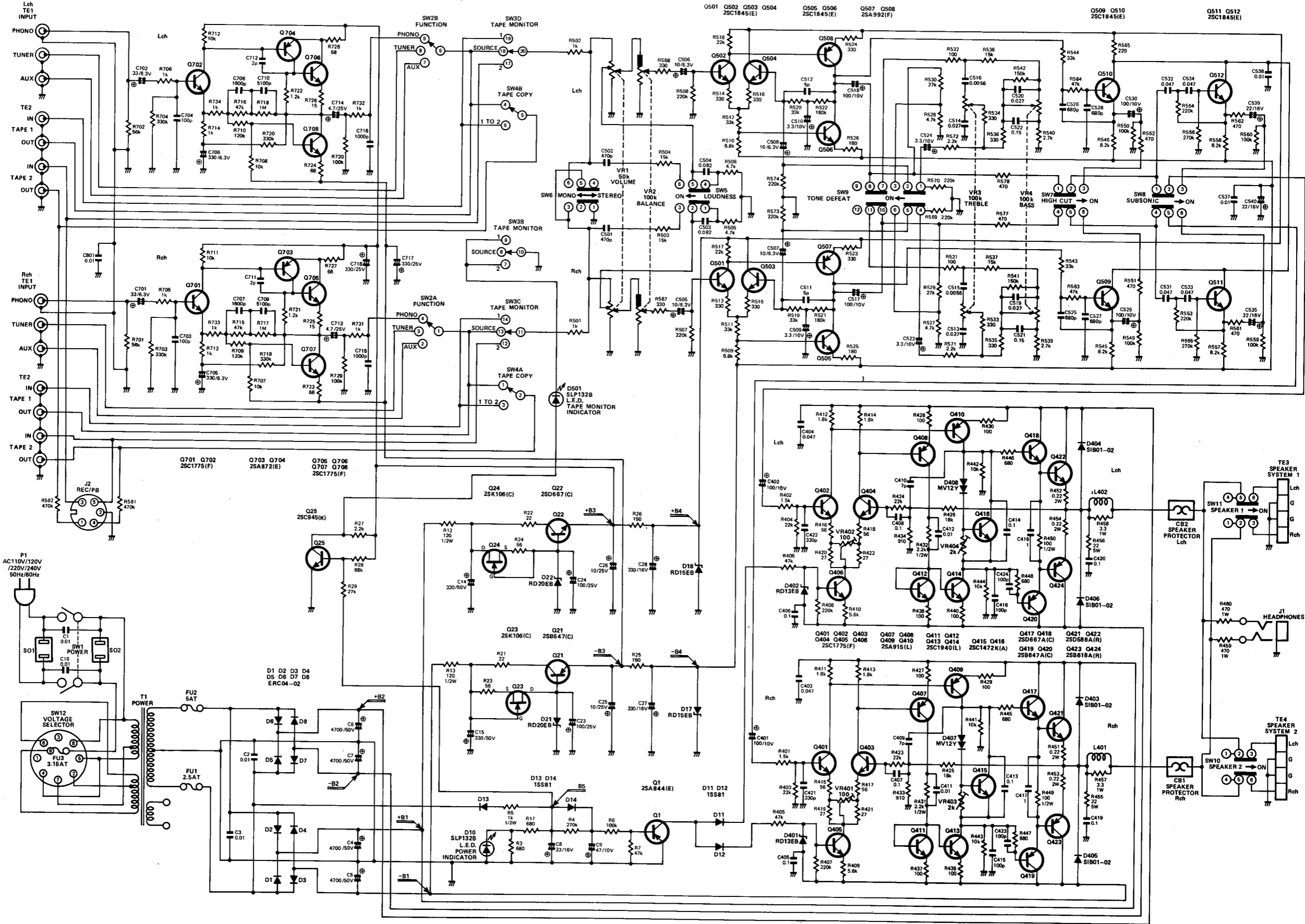

SCHEMATIC DIAGRAM – MULTI VOLTAGE

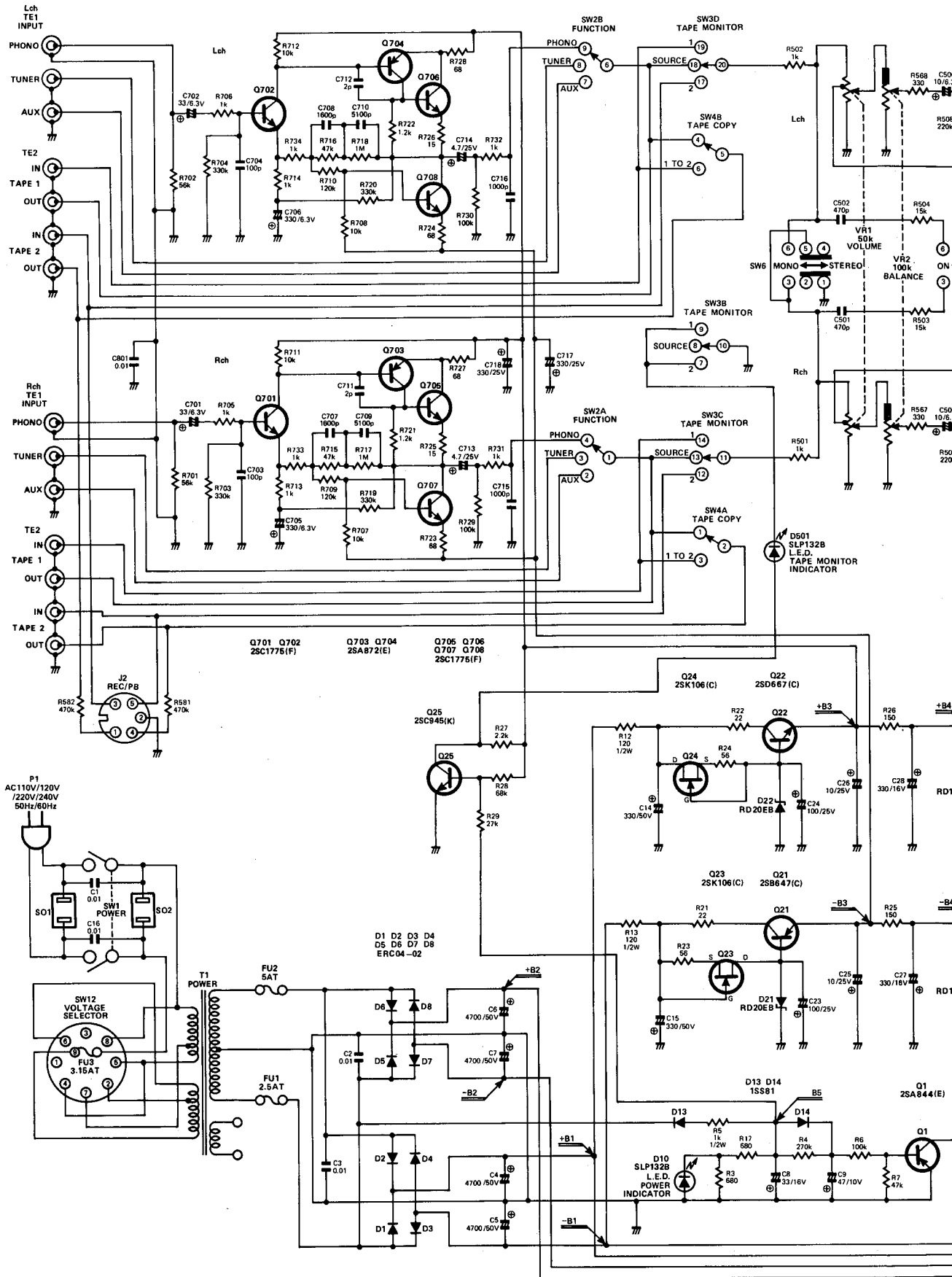

Q501 Q502 Q503 Q504
2SC1845(E)

Q505 Q506
2SC1845(E)

Q507 Q508
2SA992(F)

Q509 Q510
2SC1845(E)

Q511 Q512
2SC1845(E)

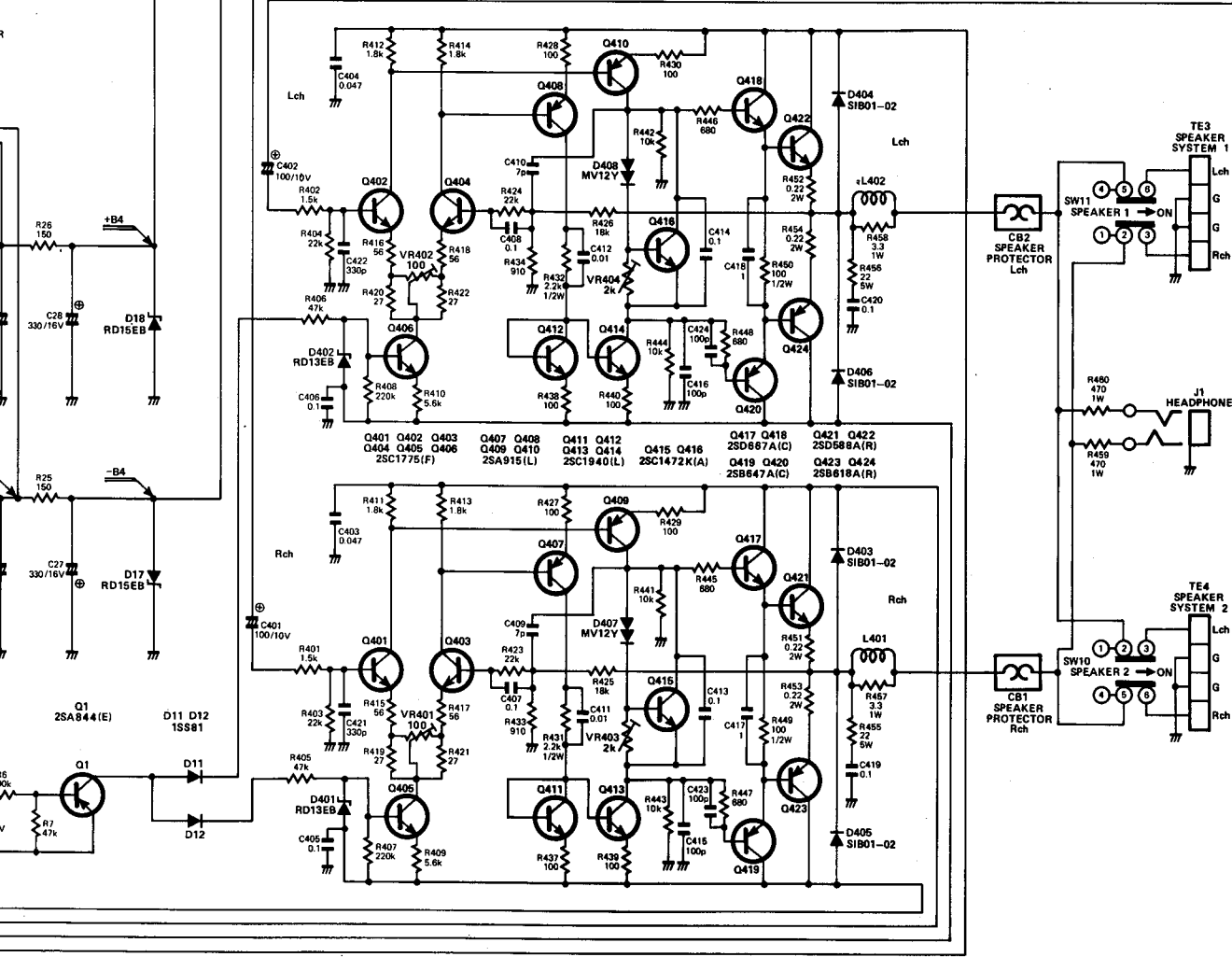
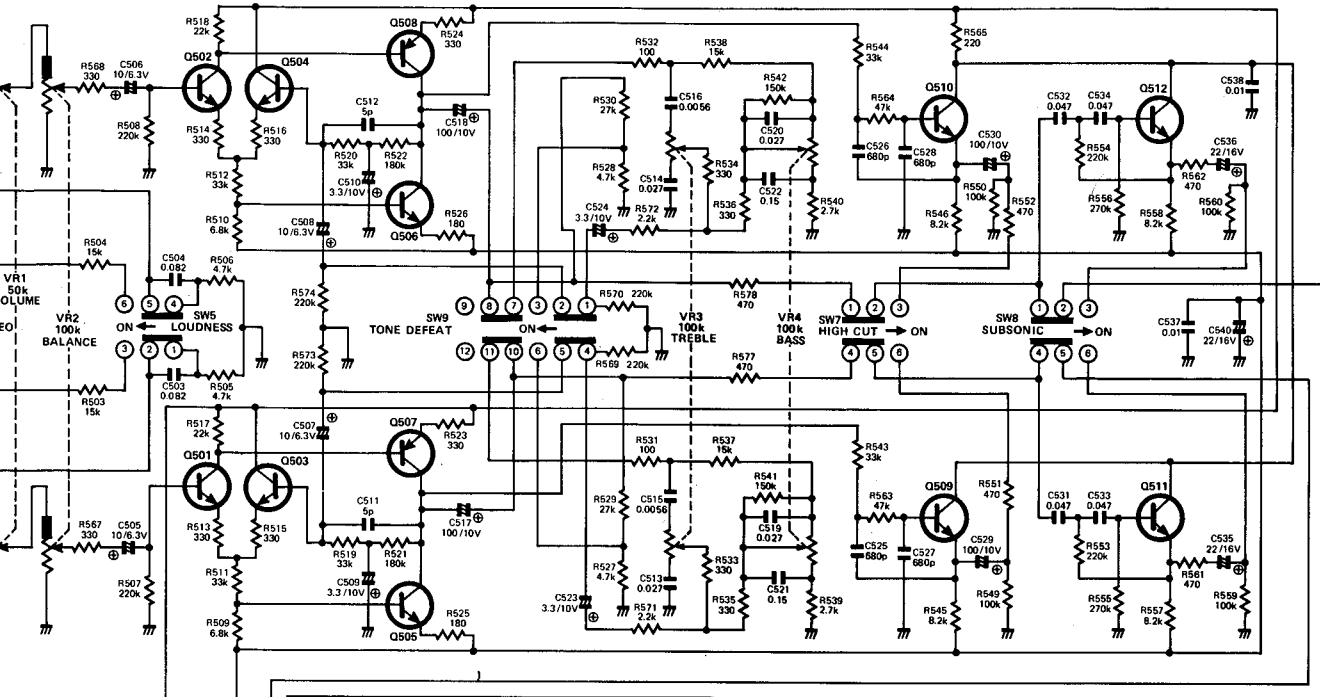

GENERAL UNIT EXPLODED VIEW

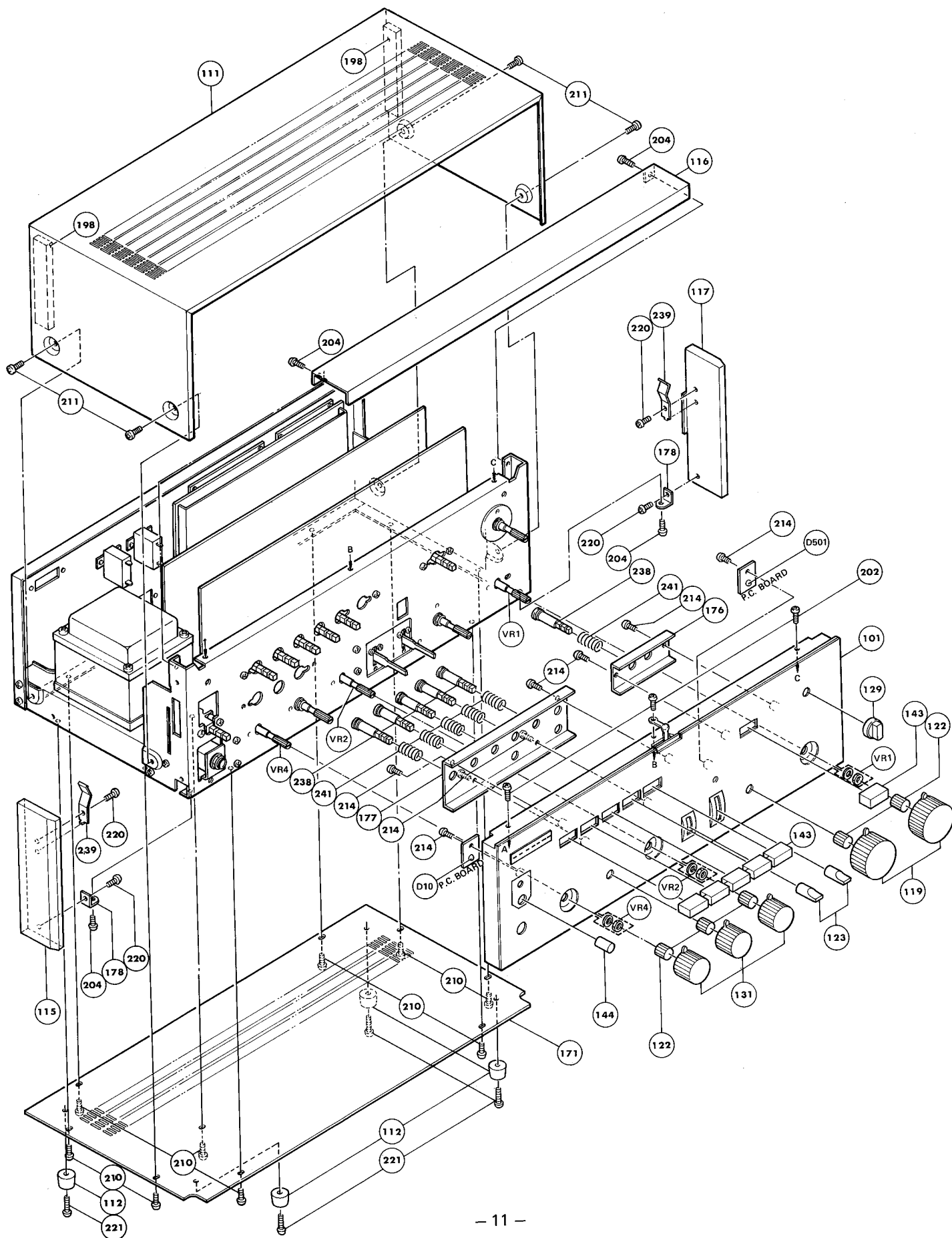

GENERAL UNIT EXPLODED VIEW

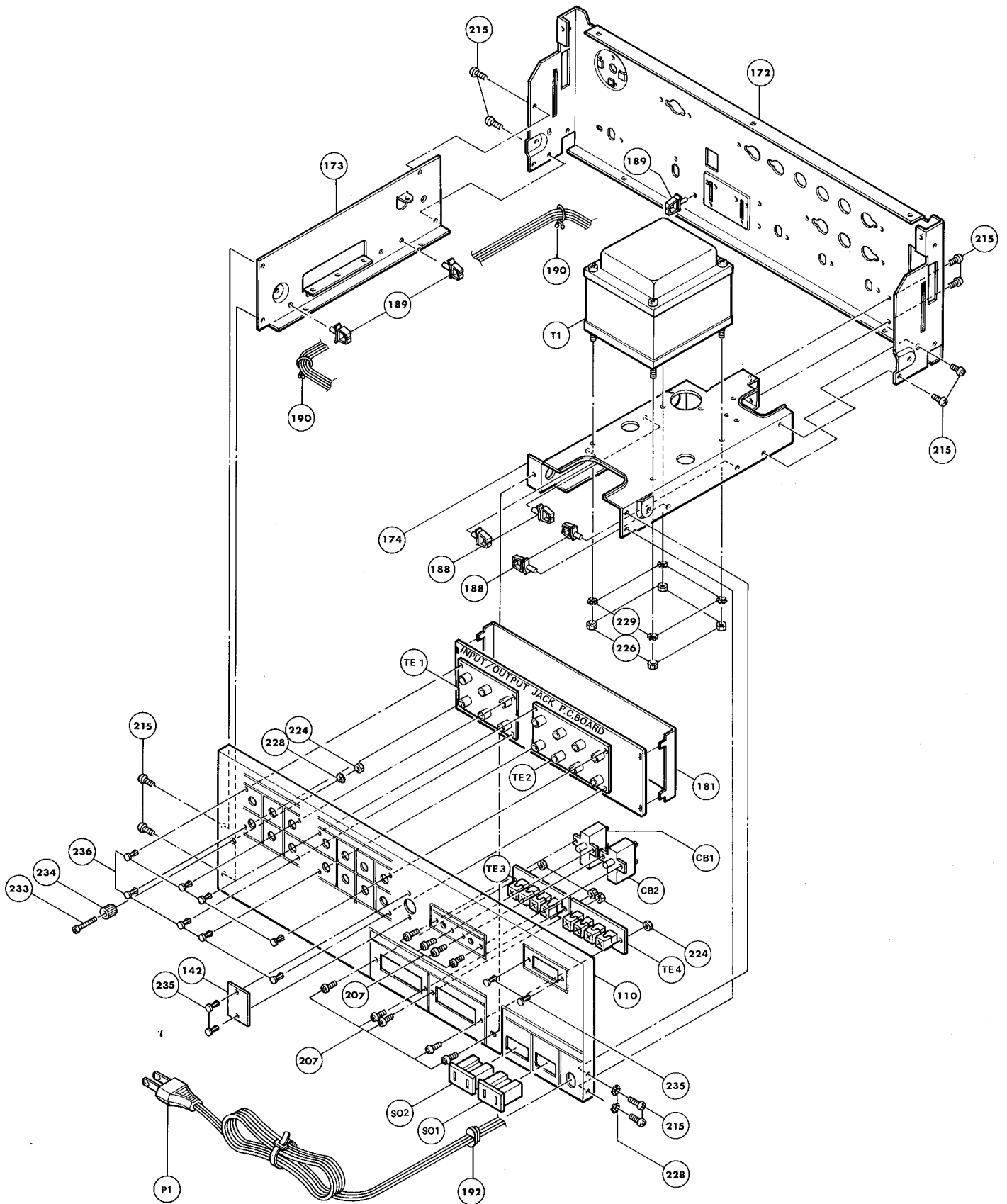

GENERAL UNIT EXPLODED VIEW

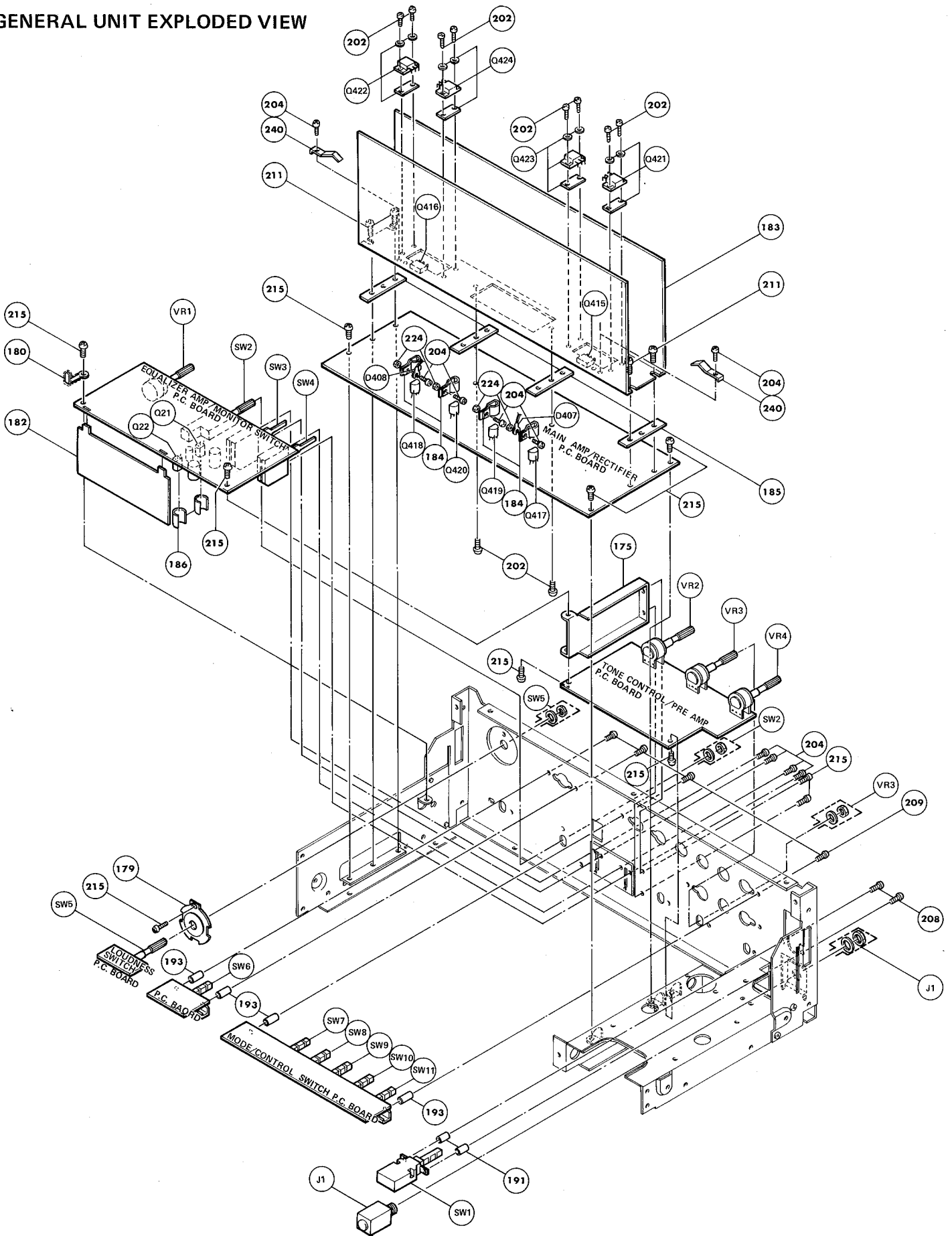

GENERAL UNIT EXPLODED VIEW
MULTI VOLTAGE

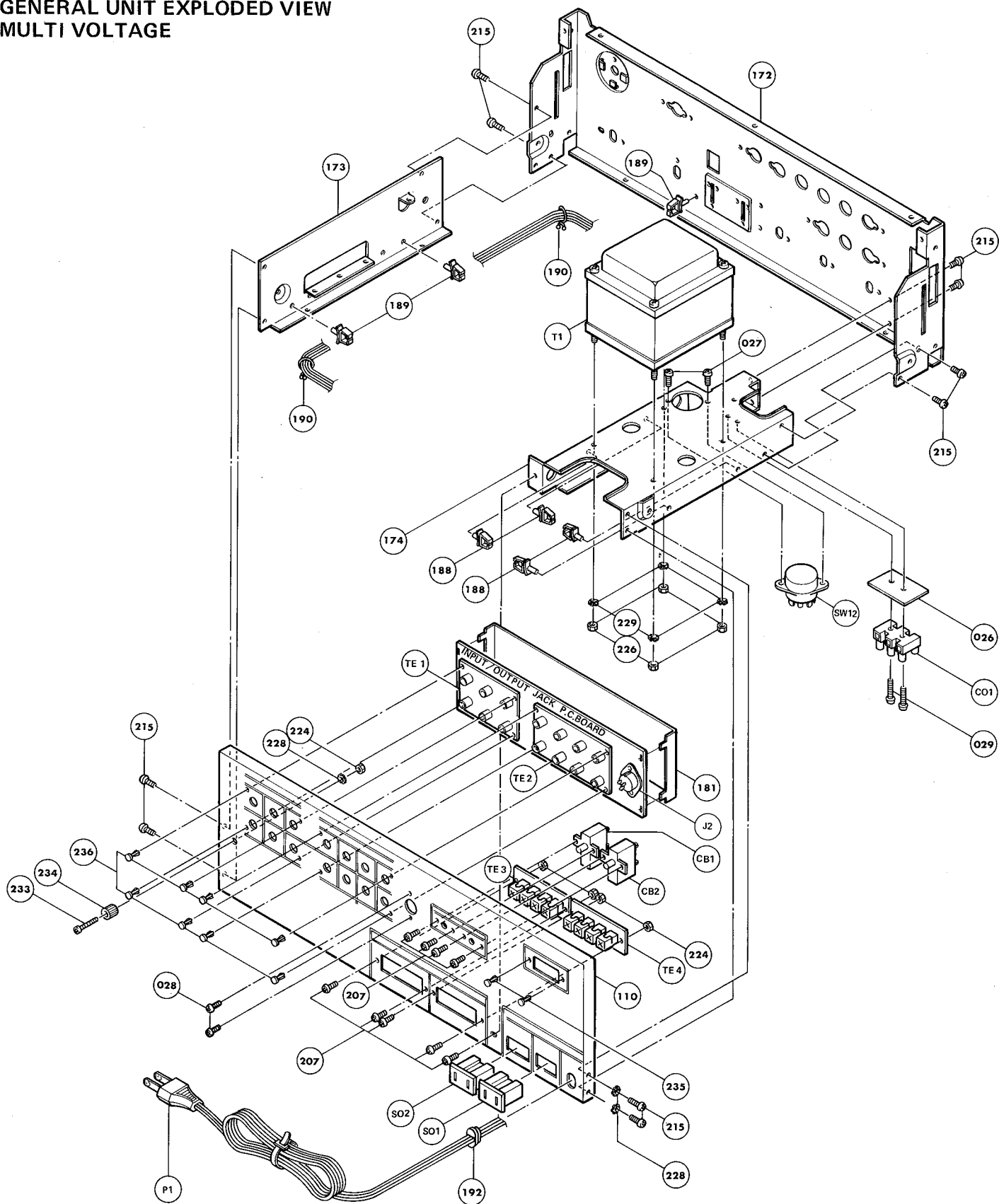

EQUALIZER AMP/MONITOR PC BOARD

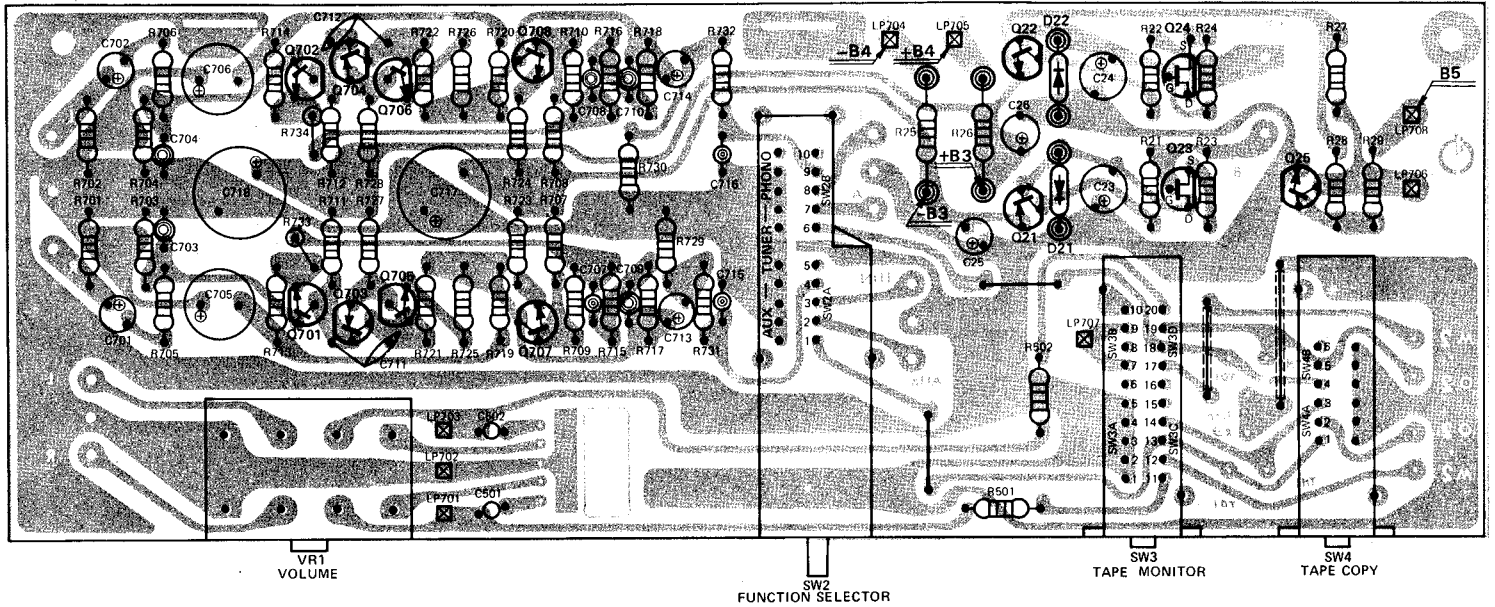

CIRCUIT REF.	H/K PART NO.	DESCRIPTION
RESISTORS (All resistors 1/4w, ±5% Carbon unless otherwise noted)		
VR1	23535871	Variable Resistor, 50 k ohm, Volume Control
CAPACITORS, ELECTROLYTIC		
C23, 24	31835770	100MF +50% -10% 25V
C25, 26	31835769	10MF +50% -10% 25V
C701, 702	31835586	33MF ±20% 6.3V Tantalum
C705, 706	31835587	330MF +50% -10% 6.3V
C713, 714	31835588	4.7MF ±20% 25V
C717, 718	31835655	330MF +50% -10% 25V
SEMICONDUCTORS		
Q21	43034850A	Transistor, 2SB647(C) Voltage Regulator
Q22	43034849A	Transistor, 2SD667(C) Voltage Regulator
Q23, 24	43035874	F. E. T. 2SK106(C) Current Regulator
Q25	43035875	Transistor, 2SC945(K) Switching
Q701, 702, 705 706, 707, 708	43035592	Transistor, 2SC1775(E) Equalizer Amp.
Q703, 704	43032151	Transistor, 2SA872(E) Equalizer Amp.
D21, 22	42035659	Zener Diode, RD20EB 20V ±1.2V
MISCELLANEOUS		
SW2	24035876	Rotary Slide Switch, Function Selector
SW3	26535669	Lever Switch, Tape Monitor
SW4	26535632	Lever Switch, Tape Copy

TONE CONTROL/PRE AMP PC BOARD

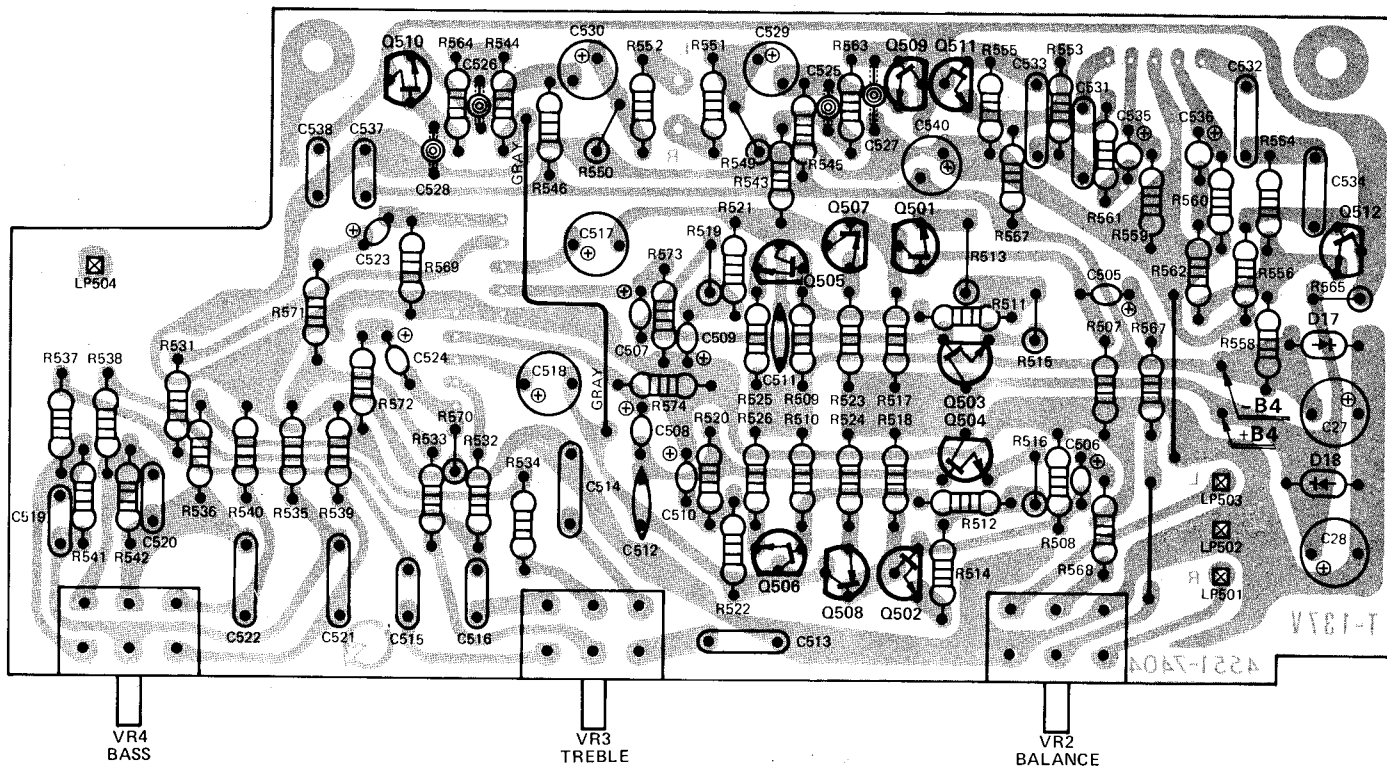

CIRCUIT REF.	H/K PART NO.	DESCRIPTION
CAPACITORS, ELECTROLYTIC		
C27, 28	31835877	330MF +50% -10% 16V
C505, 506	31835583	10MF ±20% 6.3V Tantalum
507, 508		
C509, 510	31835878	3.3MF ±20% 10V Tantalum
523, 524		
C517, 518	31835879	100MF ±20% 10V
C529, 530	31835879	100MF ±20% 10V
C535, 536, 540	31835880	22MF ±20% 16V
SEMICONDUCTORS		
Q501, 502, 503	43035883	Transistor, 2SC1345(E) Pre. Amp.
504, 505, 506		
C507, 508	43035882	Transistor, 2SA992(F) Pre. Amp.
Q509, 510, 511, 512	43035883	Transistor, 2SC1845(E) High-Cut Filter, Subsonic Filter
D17, 18	42032757	Zener Diode, RD15EB 14.7V ±0.9V

MODE/CONTROL SWITCH PC BOARD

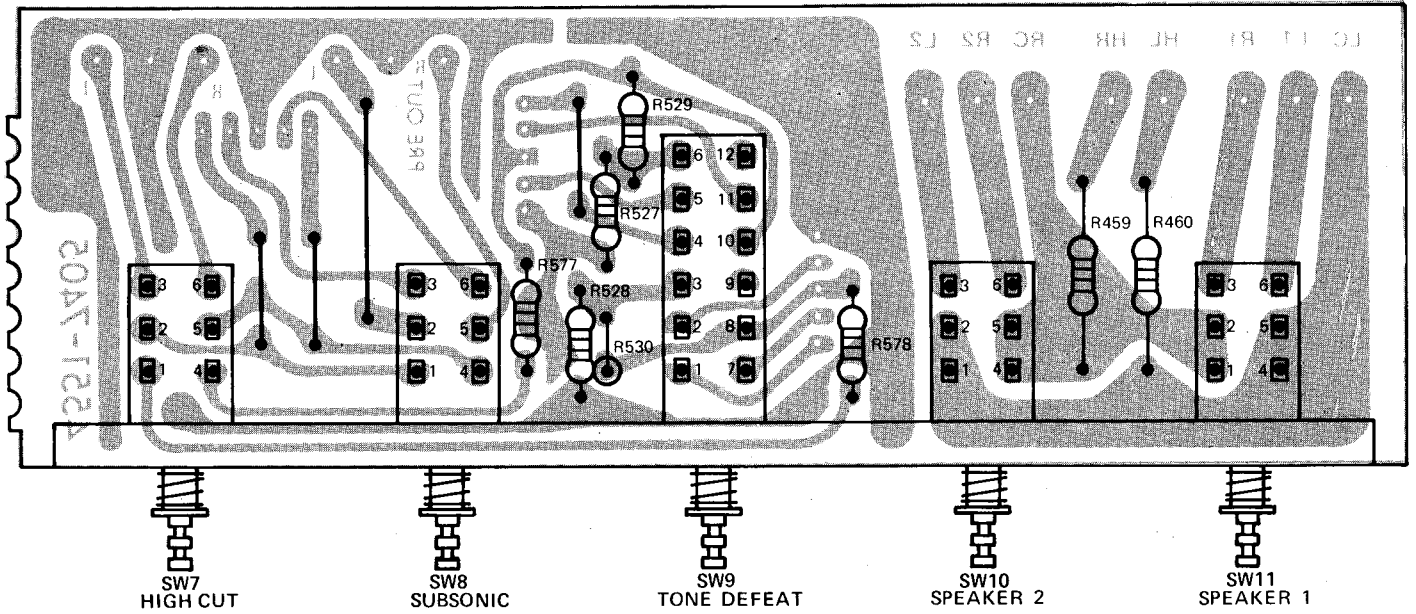

CIRCUIT REF.	H/K PART NO.	DESCRIPTION
SW7, 8, 9 10, 11	25035894	Push Switch, High Cut/Subsonic/Tone Defeat/Speaker 2/Speaker 1

LOUDNESS SWITCH PC BOARD

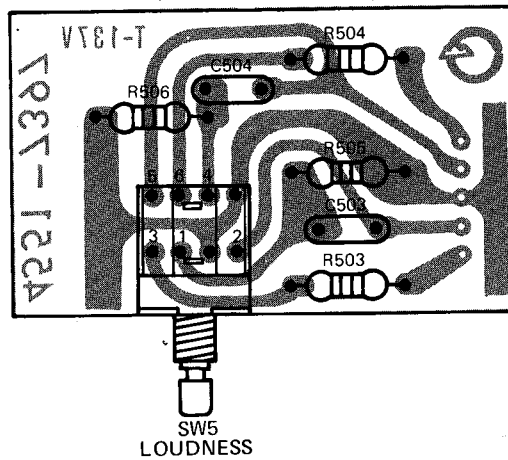

CIRCUIT REF.	H/K PART NO.	DESCRIPTION
SW5	24035884	Rotary Switch, Loudness

MAIN AMP/RECTIFIER PC BOARD

CIRCUIT REF.	H/K PART NO.	DESCRIPTION
RESISTORS (All resistors 1/4w, ±5% Carbon unless otherwise noted)		
VR401, 402	23535613	Variable Resistor, 100 ohm
VR403, 404	23535614	Variable Resistor, 2 k ohm
CAPACITORS, ELECTROLYTIC		
C4, 5, 6, 7	31535660	4700MF +30% -10% 50V
C8	31835886	33MF +50% -10% 16V
C9	31835887	47MF +50% -10% 10V
C14, 15	31835888	330MF +50% -10% 50V
C401, 402	31835879	100MF ±20% 10V
SEMICONDUCTORS		
Q1	43031312	Transistor, 2SA844(E) Audio Muting
Q401, 402, 403 404, 405, 406	43035592	Transistor, 2SC1775(F) Differential Amp., Current Regulator
Q407, 408, 409, 410	43035889	Transistor, 2SA915(L) Differential Amp.
Q411, 412, 413, 414	43035890	Transistor, 2SC1940(L) Current Regulator
Q415, 416	43035623	Transistor, 2SC1472K(A) Bias Stabilization
Q417, 418	43035624	Transistor, 2SD667A(C) Driver
Q419, 420	43035625	Transistor, 2SB647A(C) Driver
Q421, 422	43035663	Transistor, 2SD588A(R) Power Amp.
Q423, 424	43035891 47035664	Transistor, 2SB618A(R) Power Amp.
D1, 2, 3, 4 5, 6, 7, 8	41035892	Diode, ERC04-02
D11, 12, 13, 14	41035628	Diode, 1SS81
D401, 402	42032760	Zener Diode, RD13EB 13.2V ±0.8V
D403, 404, 405, 045	41631295	Diode, SIB01-02
D407, 408	41035666	Varistor, MV12Y
MISCELLANEOUS		
L401, 402	12035630	Coil, RF Choke
FU1, 2	45035649	Fuse, 6.25A 125V
	66035035	Fuse Holder (X4)

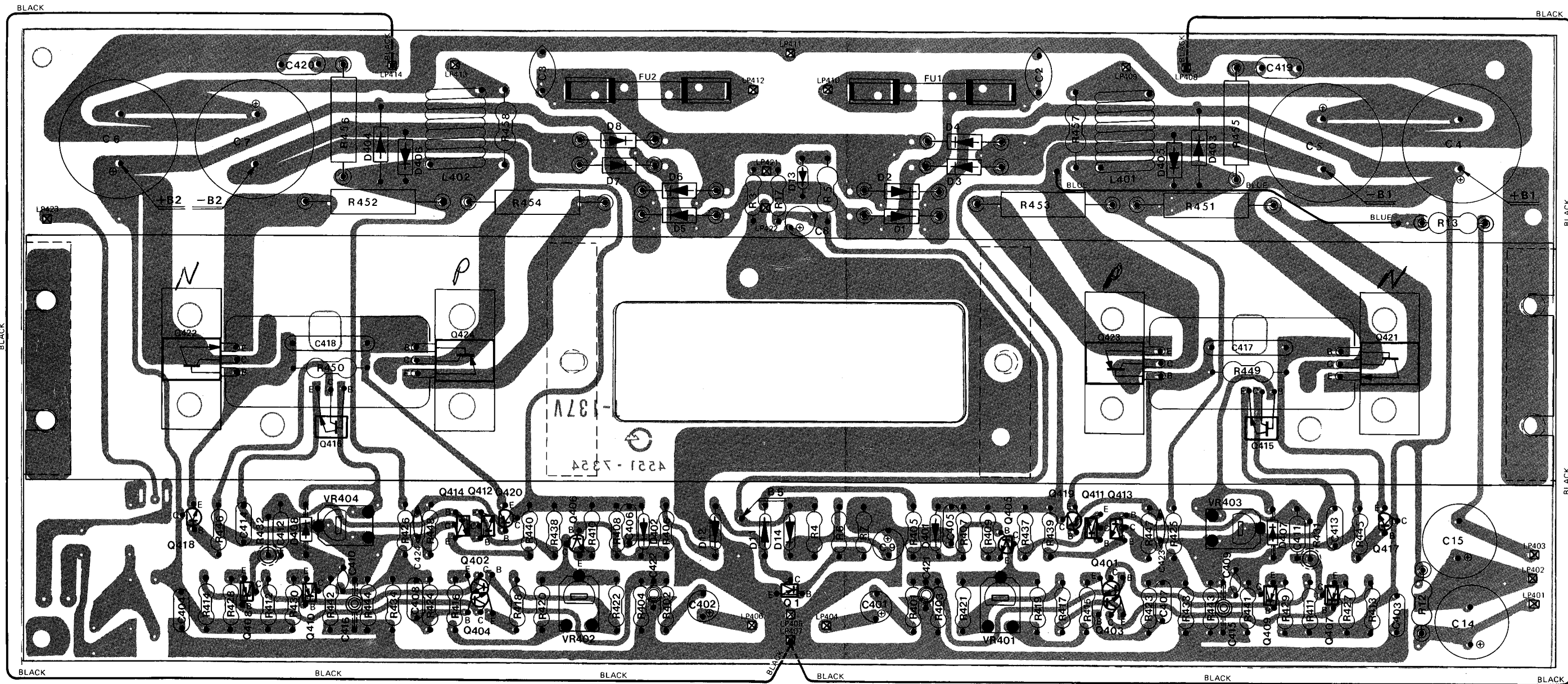

MAIN AMP/RECTIFIER PC BOARD

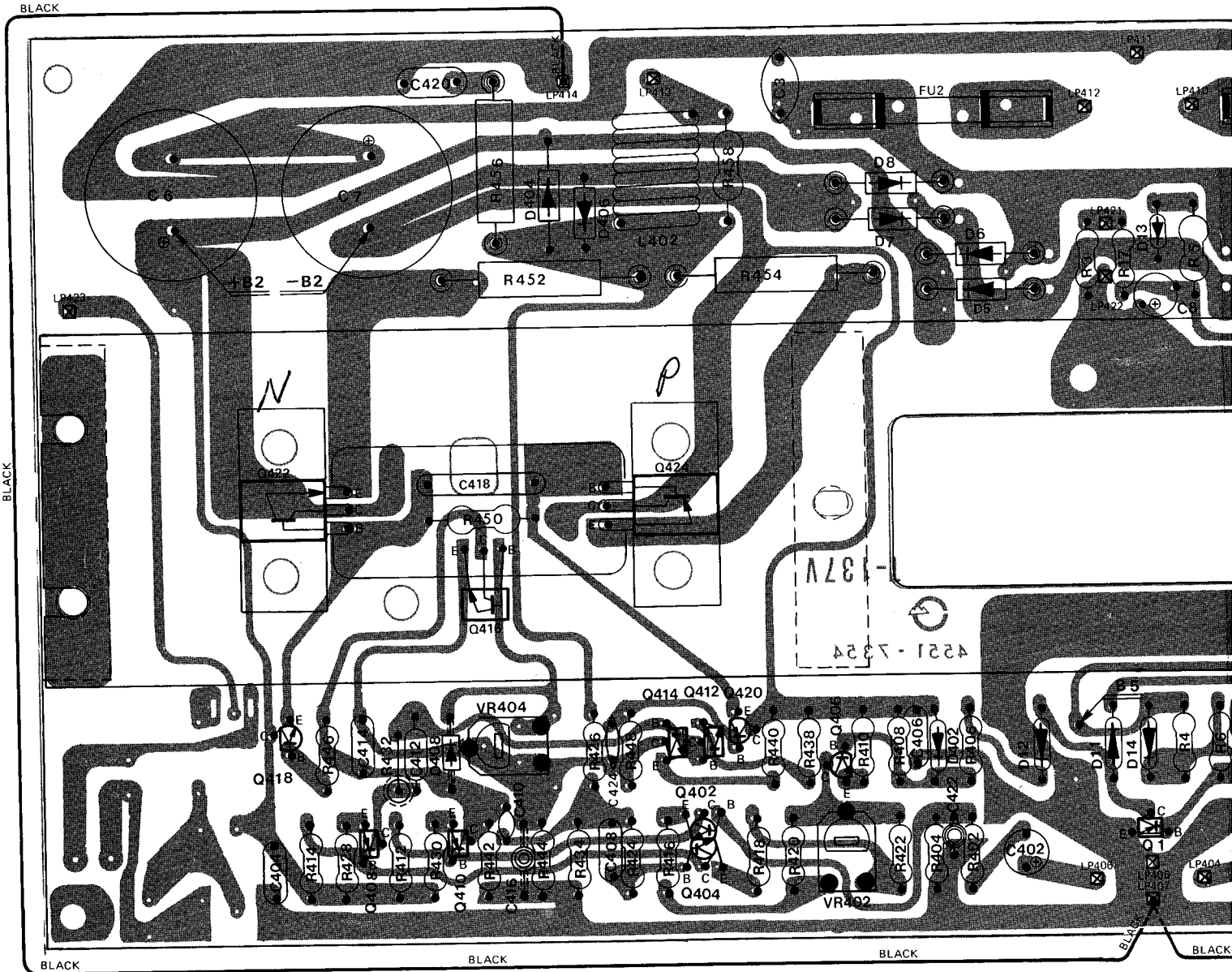

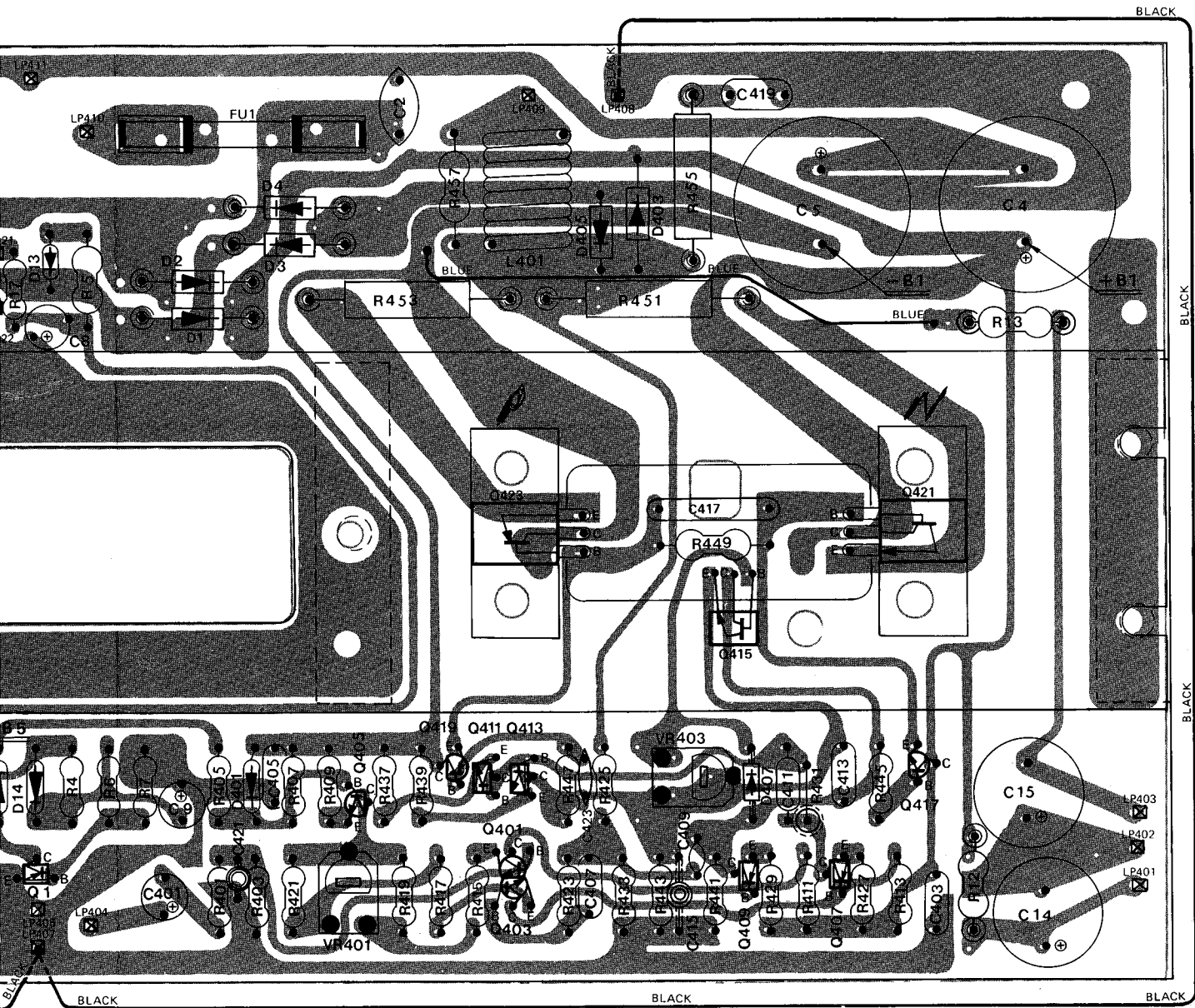

INPUT/OUTPUT JACK PC BOARD

MULTI VOLTAGE

WIRING DIAGRAM

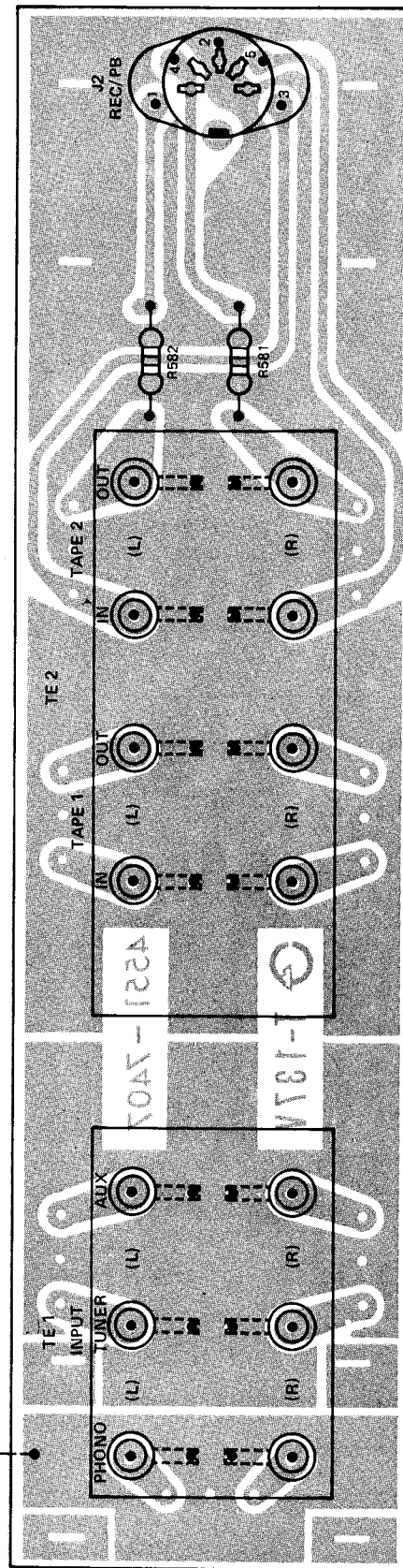
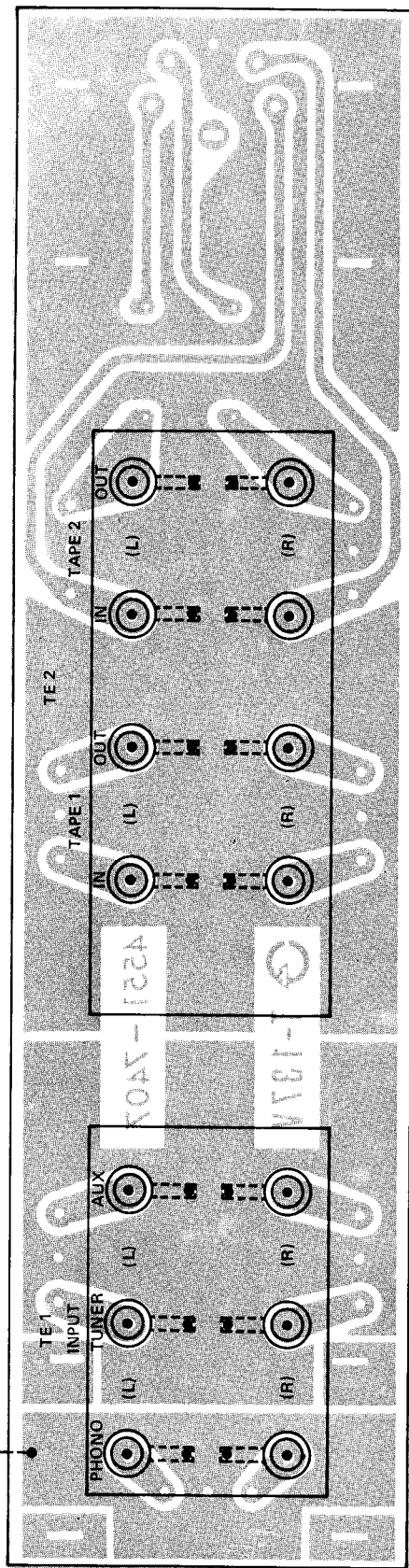

CIRCUIT REF.

H/K PART NO.

DESCRIPTION

- | | | |
|-----|----------|--|
| TE1 | 65435885 | 6-Pin Jack, Phono./Tuner/Aux. Input |
| TE2 | 65433652 | 8-Pin Jack, Tape 1 and Tape 2 Input/Output |

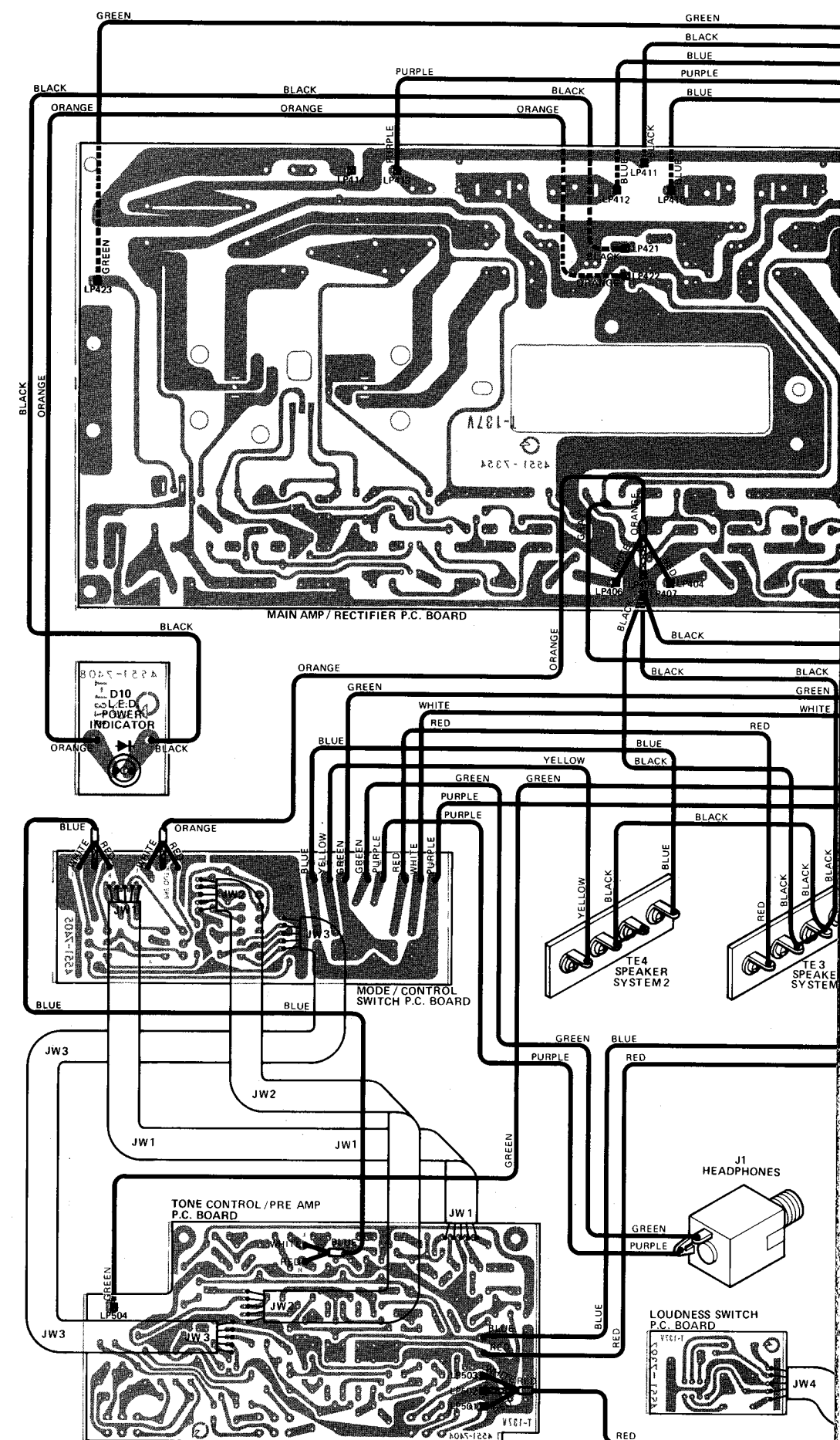

INPUT/OUTPUT JACK PC BOARD

MULTI VOLTAGE

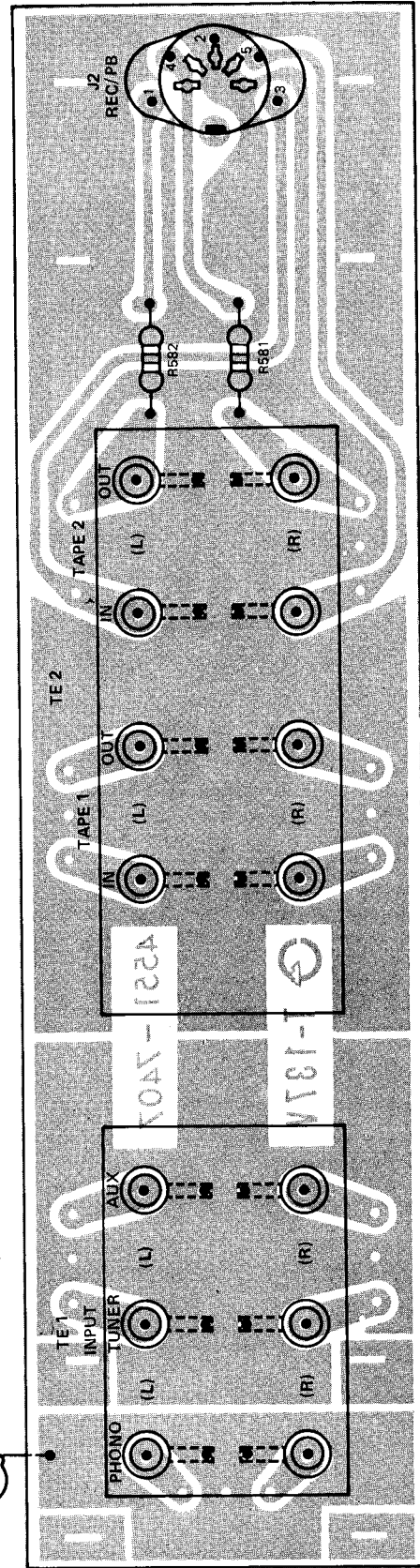
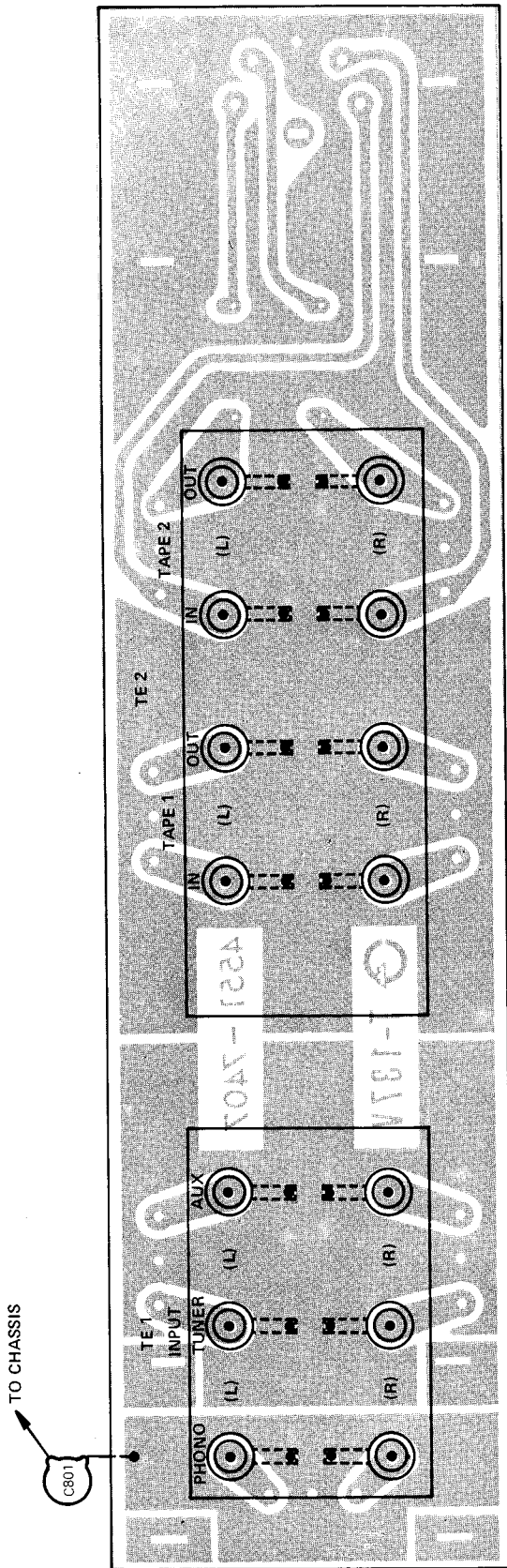

CIRCUIT REF.

H/K PART NO.

DESCRIPTION

TE1
TE2

65435885
65433652

6-Pin Jack, Phono./Tuner/Aux. Input
8-Pin Jack, Tape 1 and Tape 2 Input/Output

WIRING DIAGRAM

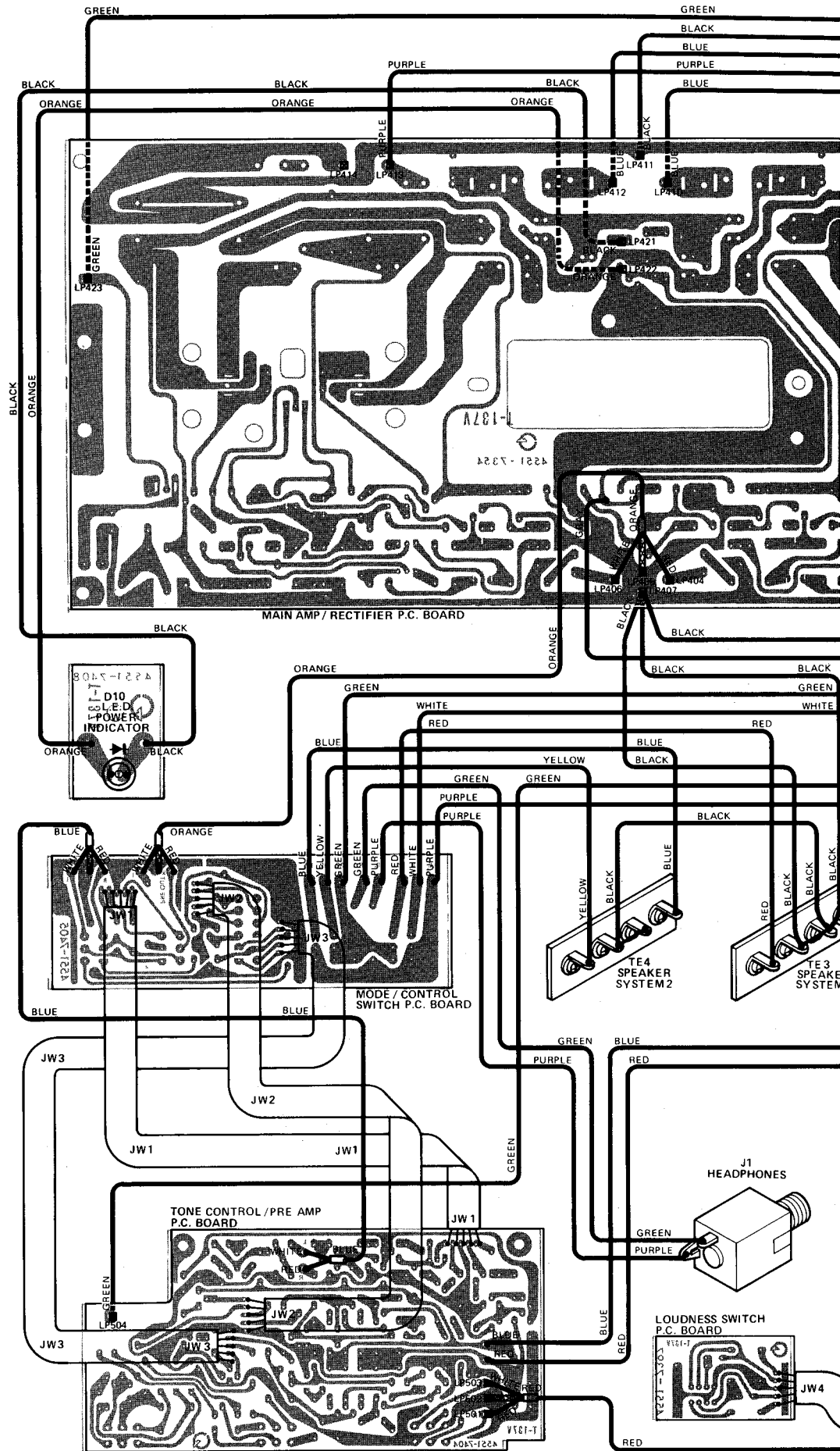

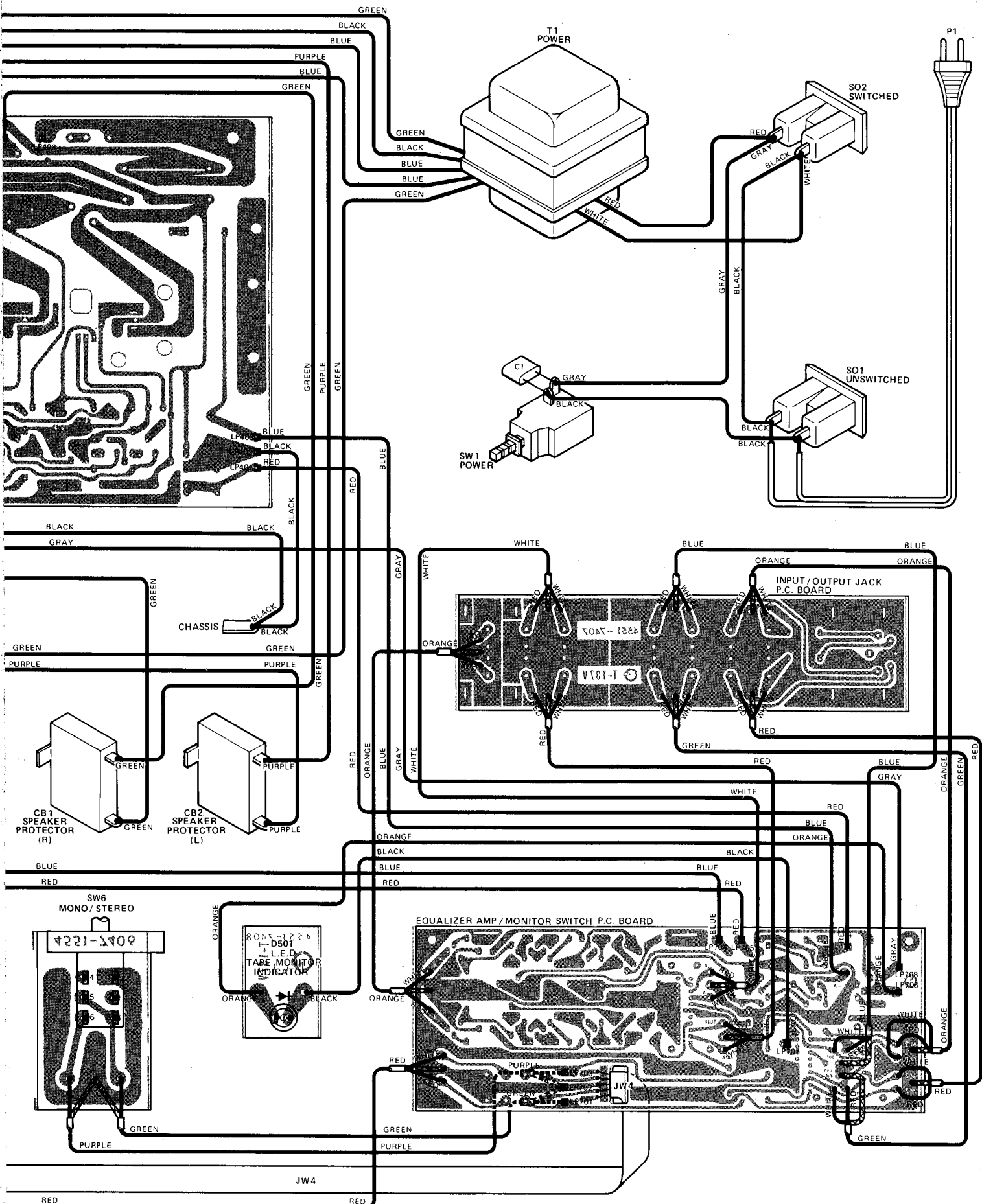

WIRING DIAGRAM - MULTI VOLTAGE

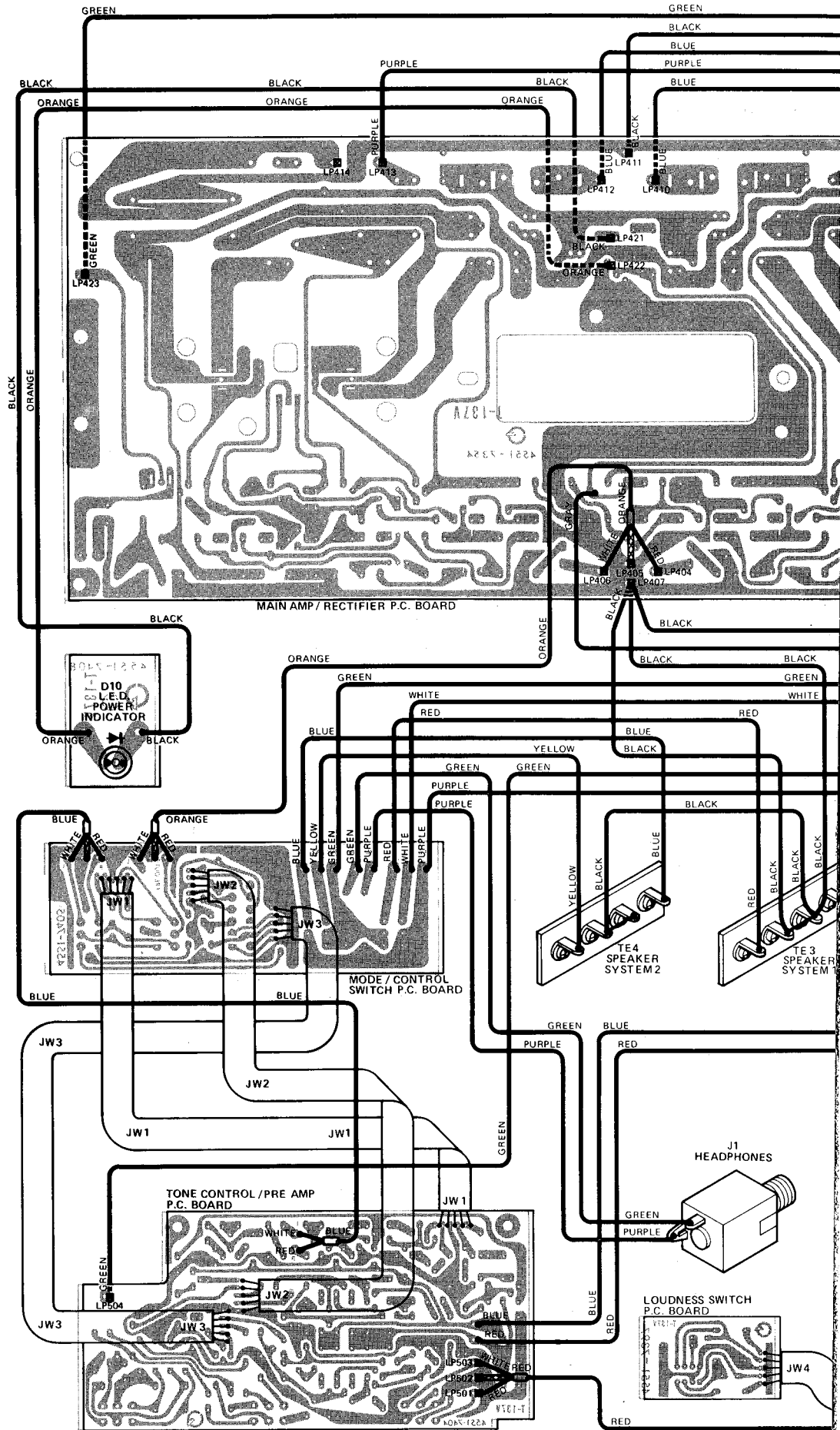

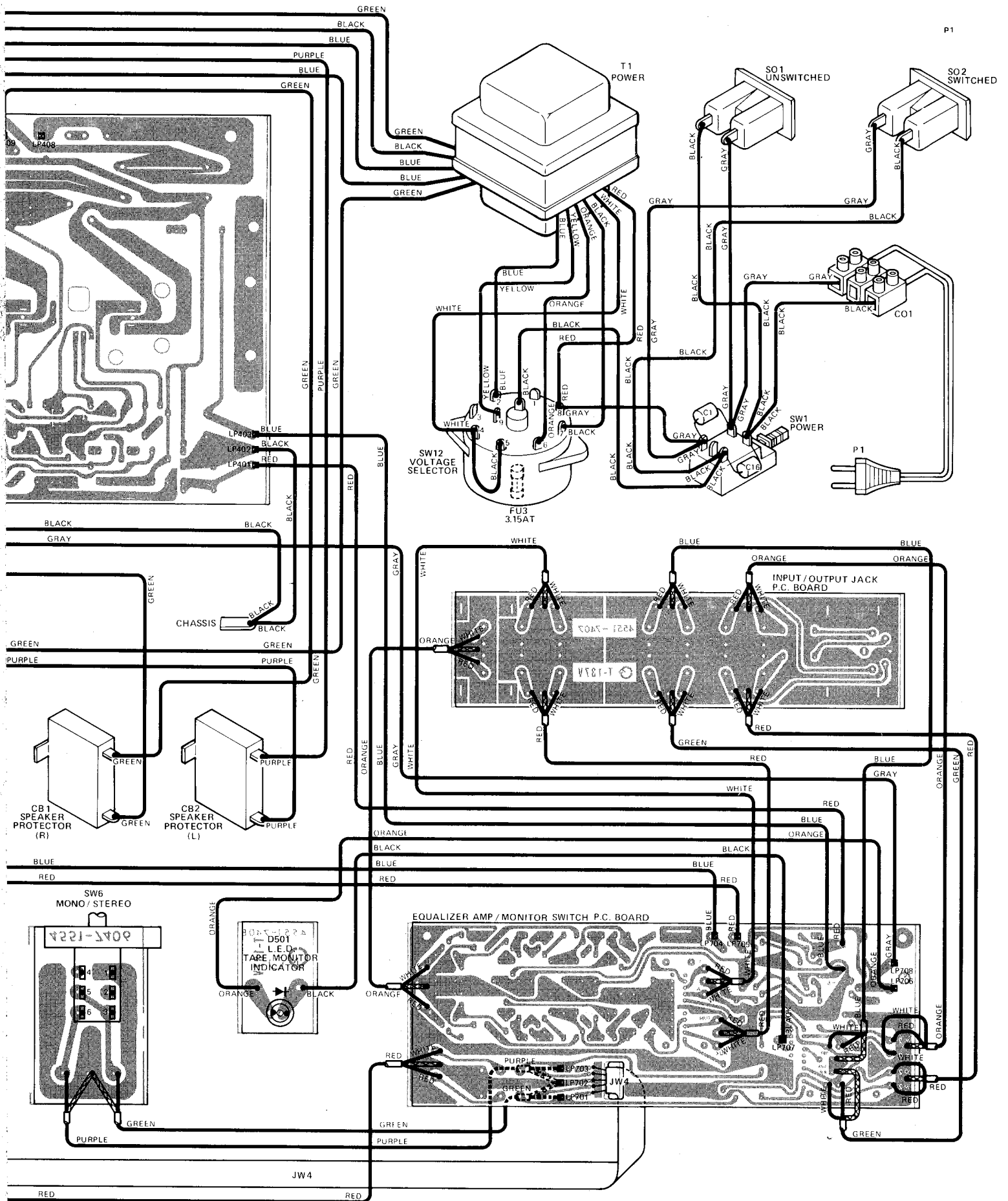

CHASSIS PARTS LIST

CIRCUIT REF.	H/K PART NO.	DESCRIPTION
GENERAL		
101	00235857	Front Panel Assembly
110	00235858	Cabinet Back
111	00235859	Cabinet Top
112	62035544	Feet, Cabinet Bottom (X4)
115	00235860	Bracket, Front Panel Right
116	00235861	Bracket, Front Panel Top
117	00235862	Bracket, Front Panel Left
119	63235758	Knob, Volume/Function (X2)
122	63235759	Knob Base, Volume/Balance/Treble/Bass/ Function (X5)
123	63235552	Knob, Tape Monitor/Tape Copy (X2)
129	63235863	Knob, Loudness
131	63235760	Knob, Balance/Treble/Bass (X3)
142	00235864	Dressing Plate, Cabinet Back
143	63235761	Push Button, Mono/High Cut/Subsonic/ Tone Defeat/Speaker 2/Speaker 1 (X6)
144	63233663	Push Button, Power

ELECTRICAL PARTS LIST

MISCELLANEOUS

T1	10135647	Power Transformer
SW1	25035554	Push Switch, Power
SW6	25035869	Push Switch, Mono/Stereo
J1	65432119	Headphones Jack
TE3, 4	65434823A	Speaker Output Terminal
CB1, 2	45535648	Speaker Protector
SO1, 2	65435870	External AC Socket, Unswitched and Switched
D10, 501	46735566	Light Emitting Diode, SLP132B Power Indicator, Tape Monitor Indicator

MULTI VOLTAGE AMPLIFIER

T1	10135671	Power Transformer
SW1	25035635	Push Switch, Power
FU1, 2	45035601	Fuse, 5AT 250V
	65435893	Fuse Holder (X4)
SW12	24035639	Power Source Voltage Selector
FU3	45035636	Fuse, 3.15AT 250V
J2	65432127	5-Pin DIN Jack, REC/PB