

The Harman Kardon Model hk590i

Manual No. 67A

DIGITAL SYNTHESIZED QUARTZ-LOCKED STEREO RECEIVER

hk590i

Technical Manual

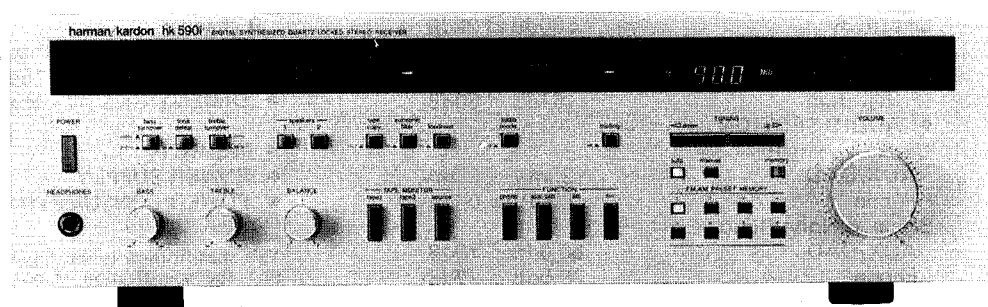

SPECIFICATIONS

• FM SECTION

	Nominal	Limit
Tuning Range	87.5 ~ 108.0MHz	
50dB Quieting Sensitivity		
Mono	14.9dBf	17dBf
Stereo	36.9dBf	38dBf
Usable Sensitivity	10.5dBf	12.5dBf
Image Ratio	76.5dB	60dB
IF Rejection	76dB	70dB
Spurious Response Rejection	101dB	80dB
Capture Ratio	1.5dB	2.5dB
Alternate Channel Selectivity	78dB	50dB
AM Rejection	54.5dB	45dB
Signal to Noise Ratio		
Mono	82dB	78dB
Stereo	74.5dB	72dB
Total Harmonic Distortion (65dBf 1kHz Input)		
Mono	0.09%	0.2%
Stereo	0.12%	0.3%
Stereo Separation at 1kHz	52.9dB	45dB

• AM SECTION

Tuning Range	520 ~ 1,710kHz	
Usable Sensitivity	14μV/m	20μV/m
Selectivity	30dB	22dB
Signal to Noise Ratio	53dB	50dB
Image Rejection	34dB	28dB
IF Rejection	61dB	50dB

• AUDIO SECTION

Usable Sensitivity		
AUX/DAD	135mV ± 25mV	
Phono	2.2mV ± 0.2mV	
Signal to Noise Ratio		
AUX/DAD	80.6dB	78dB
Phono	79.5dB	77dB
Channel Separation at 10kHz		
AUX/DAD	66dB	45dB
Phono	57.5dB	45dB

	Nominal	Limit
IM Distortion Ratio	0.13%	0.25%
RMS Output Power		
8Ω, 1kHz, THD 0.08%	50.9W	45W
4Ω, 1kHz, THD 0.08%	76.5W	60W
Damping Factor at 1kHz	44	40
Tone Control Characteristics		
Bass Turnover Frequency	400Hz/200Hz	
Treble Turnover Frequency	2kHz/6kHz	
Bass at 50Hz		
Boost	10dB ± 2dB	
Cut	-10dB ± 2dB	
Treble at 10kHz		
Boost	10dB ± 2dB	
Cut	-10dB ± 2dB	
Loudness Control		
at 10kHz	3dB ± 1dB	
at 50Hz	10dB ± 3dB	
Subsonic Control		
at 15Hz	3dB ± 1dB	
DC Output Voltage		
L channel	5.6mV ± 60mV	
R channel	6.2mV ± 60mV	
RIAA Equalization at Tape Out (20Hz/20kHz)	0.15dB ± 0.5dB/0.15dB ± 0.5dB	
• DIMENSIONS (W x H x D)	17-3/8" x 5-1/4" x 14-3/8"	
	(443 x 134 x 365 mm)	
• WEIGHT	17 lbs. 10 oz. (8.0 kg)	
• POWER SUPPLY	AC120V, 60Hz	
• POWER CONSUMPTION	310W (330VA)	

This specification is the target of servicing. But, there is a case that the specification is not applicable to the measurement condition and instrument.

Specifications and components subject to change without notice. Overall performance will be maintained or improved.

LEAKAGE TEST

Before returning the unit to the user, perform the following safety checks:

- Inspect all lead dress to make certain that leads are not pinched or that hardware is not lodged between the chassis and other metal parts in the unit.
- Be sure that any protective devices such as nonmetallic control knobs, insulating fishpapers, cabinet backs, adjustment and compartment covers or shields, isolation resistor-capacity networks, mechanical insulators, etc. which were removed for servicing are properly reinstalled.
- Be sure that no shock hazard exists; check for leakage current using Simpson Model 229 Leakage Tester, standard equipment item No. 21641, RCA Model WT540A or use alternate method as follows: Plug the AC line cord directly into a 120-volt AC receptacle (do not use an Isolation Transformer for this test). Using two clip leads, connect a 1500 ohm, 10-watt resistor paralleled by a 0.15mf capacitor, in series with all exposed metal cabinet parts and a known earth ground, such as a water pipe or conduit. Use a VTVM or VOM with 1000 ohms per volt, or higher, sensitivity to measure the AC voltage drop across the resistor. (See Diagram.) Move the resistor connection to each exposed metal part having a return path to the chassis (antenna, metal, cabinet, screw heads, knobs and control shafts, escutcheon, etc.) and measure the AC voltage drop across the resistor. (This test should be performed with the power switch in both the On and Off positions.) A reading of 0.35 volt RMS or more is excessive and indicates a potential shock hazard which must be corrected before returning the unit to the owner.

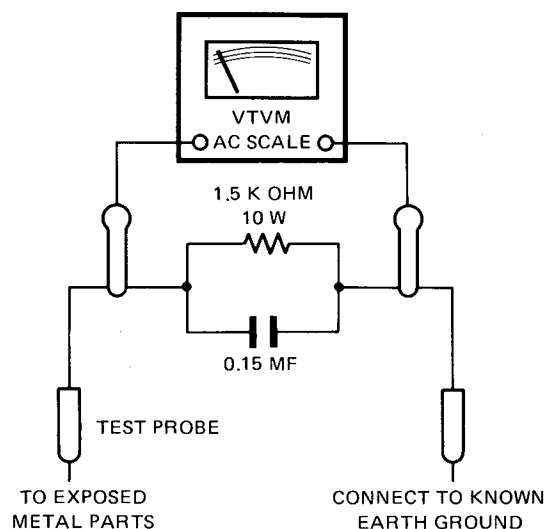
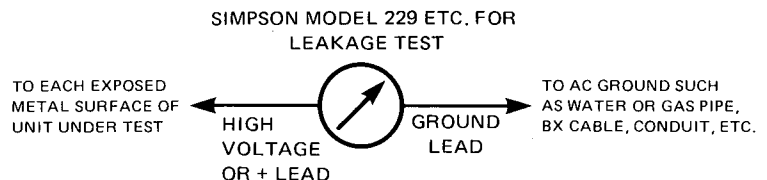

ALIGNMENT PROCEDURES

■ AMPLIFIER SECTION

● DC balance and idling adjustments

- Conditions:
- Set the function switch to aux/DAD.
 - Set the volume to minimum.
 - Set the speaker system switches 1 and 2 to OFF.
 - Make the adjustment at a room temperature of 25°C.

Step	Item	Connections required	Adjustment location	Correct value
1	DC balance adjustment	Connect the digital voltmeter between TP1 and ground.	VR403 (L channel)	0 ± 10mV
2		Connect the digital voltmeter between TP2 and ground.	VR404 (R channel)	0 ± 10mV
3	Idling adjustment	Connect the digital voltmeter to TP3 and TP4.	VR401 (L channel)	33mV
4		Connect the digital voltmeter to TP5 and TP6.	VR402 (R channel)	33mV
5	Repeat steps 1 through 4 after aging for 5 minutes.			

■ TUNER SECTION

1. STANDARD FREQUENCY CHECK

- Condition: ● Set the function switch to FM.

Step	Connections required	Measurement frequency	Station display	Adjustment location	Adjustment method
1	● Connect the frequency counter to TP7 (+) and ground (-).		98.3 MHz		109MHz ± 2kHz

2. AM ALIGNMENT

- Conditions:
- Set the function switch to AM.
 - Set the muting switch to off (—).

Step	Item	Connections required	Measurement frequency	Station display	Adjustment location	Adjustment method
1	Tuning voltage adjustment	● Connect the DC voltmeter to TP11 (+) and ground (-).		520kHz	L252	1.5V ± 0.05V
2				1710kHz	TC252	23V ± 0.5V
3	IF adjustment	● Radiate output of AM signal generator (400Hz 30% modulation) to AM loop antenna. ● Connect oscilloscope to TP8 (+) and ground (-).	450kHz	1600kHz	T251 T252	Adjust so that peak and good waveform.
4	Tracking adjustment	● Radiate output of AM signal generator (400Hz 30% modulation) to AM loop antenna. ● Connect oscilloscope and AC voltmeter to TAPE 1 OUT terminal.	600kHz	600kHz	L251	Maximize the output level.
5			1400kHz	1400kHz	TC251	
6			Repeat steps 4 and 5.			
7	Tuned indicator adjustment	● Radiate output of AM signal generator (400Hz 30% modulation) to AM loop antenna.	1000kHz	1000kHz	VR251	Adjust so that the tuned indicator lights at 54dB input.

3. FM ALIGNMENT

- Conditions:
- Set the function switch to FM.
 - Set the muting switch to off (—).

Step	Item	Connections required	Measurement frequency	Station display	Adjustment location	Adjustment method
1	Discriminator adjustment	● Connect the FM signal generator (1kHz 100% modulation) to FM 300Ω BAL ANT terminals through the 300Ω balanced dummy. ● Connect the oscilloscope and distortion meter to TAPE 1 OUT terminals.	98.14MHz	98.1MHz	T201 (A)	Adjust so that the waveforms in steps 1 and 2 become the same level. At this time tuned indicator lights.
2			98.06MHz	98.1MHz	T201 (A)	
3			98.1MHz	98.1MHz	T201 (B)	Adjust so that the distortion become minimum.
4	Repeat steps 1 through 3.					
5	Tuned indicator adjustment	● Same as above. ● Connect the DC voltmeter to TP9 (+) and ground (-).			VR202	Adjust so that the tuned indicator lights at 10μV input.
6	Signal indicator adjustment				VR201	Adjust so that the DC voltage becomes 11V at 1mV input. And then, confirm the five signal indicator lights.
7	MPX adjustment	● Connect the stereo modulator (L + R = 45.5%, L - R = 45.5%, 19kHz = 9%) to FM signal generator. ● Apply signal generator output to FM 300Ω BAL ANT terminals through the 300Ω balanced dummy. ● Connect the frequency counter to TP10 (+) and ground (-). ● Connect the oscilloscope and AC voltmeter to TAPE 1 OUT terminals.	98.1MHz (unmodulation)	98.1MHz	VR303	75.95kHz ± 0.05kHz
8			98.1MHz	98.1MHz	VR351 (MAX)	Confirm the stereo indicator lights at 30μV ± 2dB input.
9			98.1MHz	98.1MHz	VR301	Set the stereo modulator to 19kHz only. Adjust so that L and R output level becomes minimum.
10			98.1MHz	98.1MHz	VR302	Adjust so that the right channel output becomes minimum when only the left channel of the stereo modulator modulated and so that the left channel output becomes minimum when only the right channel modulated.

NOTE) Adjustment of step 8 should be done after setting the VR351 in the position as shown in the figure.

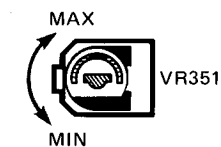

ALIGNMENT PROCEDURES

■ AMPLIFIER SECTION

● DC balance and idling adjustments

- Conditions:
- Set the function switch to aux/DAD.
 - Set the volume to minimum.
 - Set the speaker system switches 1 and 2 to OFF.
 - Make the adjustment at a room temperature of 25°C.

Step	Item	Connections required	Adjustment location	Correct value
1	DC balance adjustment	Connect the digital voltmeter between TP1 and ground.	VR403 (L channel)	0 ± 10mV
2		Connect the digital voltmeter between TP2 and ground.	VR404 (R channel)	0 ± 10mV
3	Idling adjustment	Connect the digital voltmeter to TP3 and TP4.	VR401 (L channel)	33mV
4		Connect the digital voltmeter to TP5 and TP6.	VR402 (R channel)	33mV
5	Repeat steps 1 through 4 after aging for 5 minutes.			

■ TUNER SECTION

1. STANDARD FREQUENCY CHECK

- Condition: ● Set the function switch to FM.

Step	Connections required	Measurement frequency	Station display	Adjustment location	Adjustment method
1	● Connect the frequency counter to TP7 (+) and ground (-).		98.3 MHz		109MHz ± 2kHz

2. AM ALIGNMENT

- Conditions: ● Set the function switch to AM.
● Set the muting switch to off (■).

Step	Item	Connections required	Measurement frequency	Station display	Adjustment location	Adjustment method
1	Tuning voltage adjustment	● Connect the DC voltmeter to TP11 (+) and ground (-).		520kHz	L252	1.5V ± 0.05V
2				1710kHz	TC252	23V ± 0.5V
3	IF adjustment	● Radiate output of AM signal generator (400Hz 30% modulation) to AM loop antenna. ● Connect oscilloscope to TP8 (+) and ground (-).	450kHz	1600kHz	T251 T252	Adjust so that peak and good waveform.
4	Tracking adjustment	● Radiate output of AM signal generator (400Hz 30% modulation) to AM loop antenna. ● Connect oscilloscope and AC voltmeter to TAPE 1 OUT terminal.	600kHz	600kHz	L251	Maximize the output level.
5			1400kHz	1400kHz	TC251	
6			Repeat steps 4 and 5.			
7	Tuned indicator adjustment	● Radiate output of AM signal generator (400Hz 30% modulation) to AM loop antenna.	1000kHz	1000kHz	VR251	Adjust so that the tuned indicator lights at 54dB input.

3. FM ALIGNMENT

- Conditions: • Set the function switch to FM.
 • Set the muting switch to off (—).

Step	Item	Connections required	Measurement frequency	Station display	Adjustment location	Adjustment method
1	Discriminator adjustment	<ul style="list-style-type: none"> Connect the FM signal generator (1kHz 100% modulation) to FM 300Ω BAL ANT terminals through the 300Ω balanced dummy. Connect the oscilloscope and distortion meter to TAPE 1 OUT terminals. 	98.14MHz	98.1MHz	T201 (A)	Adjust so that the waveforms in steps 1 and 2 become the same level. At this time tuned indicator lights.
2			98.06MHz	98.1MHz	T201 (A)	
3			98.1MHz	98.1MHz	T201 (B)	Adjust so that the distortion become minimum.
4	Repeat steps 1 through 3.					
5	Tuned indicator adjustment	<ul style="list-style-type: none"> Same as above. Connect the DC voltmeter to TP9 (+) and ground (-). 			VR202	Adjust so that the tuned indicator lights at 10μV input.
6	Signal indicator adjustment				VR201	Adjust so that the DC voltage becomes 11V at 1mV input. And then, confirm the five signal indicator lights.
7	MPX adjustment	<ul style="list-style-type: none"> Connect the stereo modulator (L + R = 45.5%, L - R = 45.5%, 19kHz = 9%) to FM signal generator. Apply signal generator output to FM 300Ω BAL ANT terminals through the 300Ω balanced dummy. Connect the frequency counter to TP10 (+) and ground (-). Connect the oscilloscope and AC voltmeter to TAPE 1 OUT terminals. 	98.1MHz (unmodulation)	98.1MHz	VR303	75.95kHz ± 0.05kHz
8			98.1MHz	98.1MHz	VR351 (MAX)	Confirm the stereo indicator lights at 30μV ± 2dB input.
9			98.1MHz	98.1MHz	VR301	Set the stereo modulator to 19kHz only. Adjust so that L and R output level becomes minimum.
10			98.1MHz	98.1MHz	VR302	Adjust so that the right channel output becomes minimum when only the left channel of the stereo modulator modulated and so that the left channel output becomes minimum when only the right channel modulated.

NOTE) Adjustment of step 8 should be done after setting the VR351 in the position as shown in the figure.

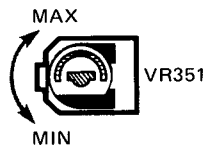

GENERAL UNIT EXPLODED VIEW

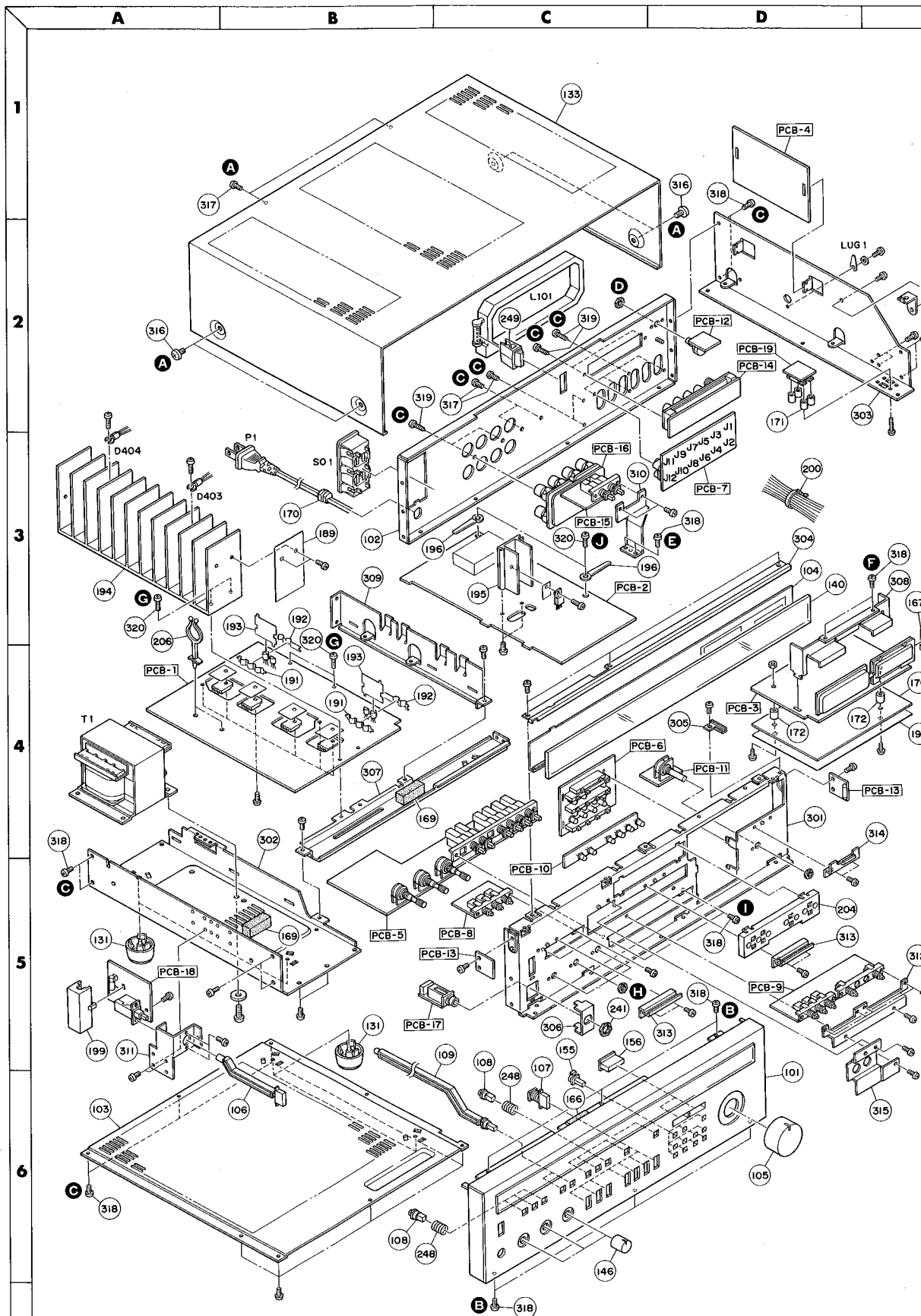

DISASSEMBLY PROCEDURES (REFER TO PAGES 5 AND 16)

1 CABINET TOP REMOVAL

Remove 6 screws **A** and then remove the cabinet top.

2 FRONT PANEL ASSEMBLY REMOVAL

1. Remove the cabinet top. (Refer to step **1**.)
2. Pull off Volume, Bass, Treble and Balance knobs (105 and 146).
3. Remove 6 screws **B** and then remove the front panel assembly.

3 SPEAKER SWITCH AND SPEAKER TERMINAL P.C. BOARDS (PCB-15 AND PCB-16) REMOVAL

1. Remove the front panel assembly. (Refer to step **2**.)
2. Pull off push button assembly (109).
3. Remove 19 screws **C** and a hexagonal nut **D**, and remove the cabinet back assembly (102) with AC outlet (SO1). If necessary, unsolder the leads.
4. Remove 2 screws **E** and then remove speaker switch and speaker terminal P.C. boards (PCB-15 and PCB-16). If necessary, unsolder the leads.

4 LOGIC CONTROL P.C. BOARD (PCB-3) REMOVAL

1. Remove the front panel assembly. (Refer to step **2**.)
2. Disconnect J701 and J706 from P701 and P706 on the logic control P.C. board (PCB-3).
3. Open the lid of connectors (P702, 703, 704, 705, 707, 708) on the logic control P.C. board (PCB-3) and then disconnect the lead wires.
4. Remove 2 screws **F** and then remove the logic control P.C. board (PCB-3).

5 MAIN AMP. P.C. BOARD (PCB-1) REMOVAL

1. Remove the speaker switch and speaker terminal P.C. boards (PCB-15 and PCB-16). (Refer to step **3**.)
2. Open the lid of connectors (P101, 102) on the main amp. P.C. board (PCB-1) and then disconnect the lead wires.
3. Open the lid of connector (P301) on the tuner P.C. board (PCB-2) and then disconnect the lead wire.
4. Remove 4 screws **G** and then remove the main P.C. board (PCB-1). If necessary, unsolder the leads.

6 TONE P.C. BOARD (PCB-5) REMOVAL

1. Remove the main P.C. board (PCB-1). (Refer to step **5**.)
2. Remove 3 hexagonal nuts **I** and 2 screws **H**, and remove tone P.C. board (PCB-5) backward. If necessary, unsolder the leads.

7 TUNER P.C. BOARD (PCB-2) REMOVAL

1. Remove the logic control P.C. board (PCB-3). (Refer to step **4**.)
2. Open the lid of connectors (P301, 351, 352) and then disconnect the lead wires.
3. Remove 2 screws **J** and then remove the tuner P.C. board (PCB-2). If necessary, unsolder the leads.

CIRCUIT DESCRIPTION

[1] MUTING CIRCUIT

The muting control voltage is taken out from ⑫ pin of IC201 and then fed to the base of Q203. At the weak station or detuned point the ⑫ pin becomes high level, Q203 becomes low, Q355 is turned off, Q357 and Q358 are turned to on, Q302 (Lch) and Q303 (Rch) are turned to ON and muting operation is completed.

[2] SYNTHESIZER SECTION**1) FM**

The output of local oscillator in the front-end is fed to ⑤ pin of the pre-scaler IC701 and then divided by 30 or 32 and fed to ②7 pin of the PLL synthesizer IC702. The standard quartz oscillator output (4.5MHz) is divided by 180 in IC702 and 25kHz standard signal is got. The divided local oscillator output is compared with the 25kHz standard signal in the phase comparator. When the divided local oscillator frequency is higher than standard frequency, ③5 pin of IC702 becomes high level but when it is lower, ③5 pin of IC702 becomes low level. When the both frequencies are equal, ③5 pin becomes floating.

③5 pin output of IC702 is fed to the vari-cap diode of the front-end through L.P.F. (Q702, Q703, Q712) and controls the frequency of VCO (local oscillator frequency).

2) AM

The local oscillator output of AM IC251 is fed to ③9 pin of the PLL synthesizer IC702 and divided. The standard quartz oscillator output (4.5MHz) is divided by 450 in IC702 and 10kHz standard signal is got. The divided local oscillator output is compared with the 10kHz standard signal in phase comparator.

[3] PRESET MEMORY**1) Memorizing**

When one of the preset keys, M1 to M8 is depressed, one of the ⑫ to ⑲ pins of IC702 becomes high level. The displayed frequency is memorized into the memory (RAM) with correspond to the depressed key.

2) Recalling

When one of the preset keys, M1 to M8 is depressed, the contents of the memory (frequency) is recalled.

[4] FM/AM STATION SCANNING**1) When tuning mode switch is set to AUTO**

When the UP key is depressed, the frequency rises at saw tooth wave mode and when DOWN key is depressed, the frequency falls. When the high level input is fed to stop, terminal (③3 pin of IC702), the scanning is stopped.

2) When tuning mode switch is set to MANUAL

Whenever UP or DOWN key is depressed once, the frequency rises or falls by one step (channel space).

[5] OVERLOAD PROTECTION

As soon as the current over rated power flows, the voltage between both emitters of Q421 and Q423 (Rch) rises and Q7, Q9 and Q4 are turned ON. So Q1 (Schmitt trigger circuit) is turned ON. The base of Q10 becomes 0V and Q405 is turned off. The operation of power amp. circuit stops and the circuit is protected.

DISASSEMBLY PROCEDURES (REFER TO PAGES 5 AND 16)

1 CABINET TOP REMOVAL

Remove 6 screws (A) and then remove the cabinet top.

2 FRONT PANEL ASSEMBLY REMOVAL

1. Remove the cabinet top. (Refer to step 1.)
2. Pull off Volume, Bass, Treble and Balance knobs (105 and 146).
3. Remove 6 screws (B) and then remove the front panel assembly.

3 SPEAKER SWITCH AND SPEAKER TERMINAL P.C. BOARDS (PCB-15 AND PCB-16) REMOVAL

1. Remove the front panel assembly. (Refer to step 2.)
2. Pull off push button assembly (109).
3. Remove 19 screws (C) and a hexagonal nut (D), and remove the cabinet back assembly (102) with AC outlet (SO1). If necessary, unsolder the leads.
4. Remove 2 screws (E) and then remove speaker switch and speaker terminal P.C. boards (PCB-15 and PCB-16). If necessary, unsolder the leads.

4 LOGIC CONTROL P.C. BOARD (PCB-3) REMOVAL

1. Remove the front panel assembly. (Refer to step 2.)
2. Disconnect J701 and J706 from P701 and P706 on the logic control P.C. board (PCB-3).
3. Open the lid of connectors (P702, 703, 704, 705, 707, 708) on the logic control P.C. board (PCB-3) and then disconnect the lead wires.
4. Remove 2 screws (F) and then remove the logic control P.C. board (PCB-3).

5 MAIN AMP. P.C. BOARD (PCB-1) REMOVAL

1. Remove the speaker switch and speaker terminal P.C. boards (PCB-15 and PCB-16). (Refer to step 3.)
2. Open the lid of connectors (P101, 102) on the main amp. P.C. board (PCB-1) and then disconnect the lead wires.
3. Open the lid of connector (P301) on the tuner P.C. board (PCB-2) and then disconnect the lead wire.
4. Remove 4 screws (G) and then remove the main P.C. board (PCB-1). If necessary, unsolder the leads.

6 TONE P.C. BOARD (PCB-5) REMOVAL

1. Remove the main P.C. board (PCB-1). (Refer to step 5.)
2. Remove 3 hexagonal nuts (H) and 2 screws (I), and remove tone P.C. board (PCB-5) backward. If necessary, unsolder the leads.

7 TUNER P.C. BOARD (PCB-2) REMOVAL

1. Remove the logic control P.C. board (PCB-3). (Refer to step 4.)
2. Open the lid of connectors (P301, 351, 352) and then disconnect the lead wires.
3. Remove 2 screws (J) and then remove the tuner P.C. board (PCB-2). If necessary, unsolder the leads.

CIRCUIT DESCRIPTION

[1] MUTING CIRCUIT

The muting control voltage is taken out from (12) pin of IC201 and then fed to the base of Q203. At the weak station or detuned point the (12) pin becomes high level, Q203 becomes low, Q355 is turned off, Q357 and Q358 are turned to on, Q302 (Lch) and Q303 (Rch) are turned to ON and muting operation is completed.

[2] SYNTHESIZER SECTION

1) FM

The output of local oscillator in the front-end is fed to (5) pin of the pre-scaler IC701 and then divided by 30 or 32 and fed to (27) pin of the PLL synthesizer IC702. The standard quartz oscillator output (4.5MHz) is divided by 180 in IC702 and 25kHz standard signal is got. The divided local oscillator output is compared with the 25kHz standard signal in the phase comparator.

When the divided local oscillator frequency is higher than standard frequency, (35) pin of IC702 becomes high level but when it is lower, (35) pin of IC702 becomes low level. When the both frequencies are equal, (35) pin becomes floating.

(35) pin output of IC702 is fed to the vari-cap diode of the front-end through L.P.F. (Q702, Q703, Q712) and controls the frequency of VCO (local oscillator frequency).

2) AM

The local oscillator output of AM IC251 is fed to (39) pin of the PLL synthesizer IC702 and divided. The standard quartz oscillator output (4.5MHz) is divided by 450 in IC702 and 10kHz standard signal is got. The divided local oscillator output is compared with the 10kHz standard signal in phase comparator.

[3] PRESET MEMORY

1) Memorizing

When one of the preset keys, M1 to M8 is depressed, one of the (12) to (19) pins of IC702 becomes high level. The displayed frequency is memorized into the memory (RAM) with correspond to the depressed key.

2) Recalling

When one of the preset keys, M1 to M8 is depressed, the contents of the memory (frequency) is recalled.

[4] FM/AM STATION SCANNING

1) When tuning mode switch is set to AUTO

When the UP key is depressed, the frequency rises at saw tooth wave mode and when DOWN key is depressed, the frequency falls. When the high level input is fed to stop, terminal (33) pin of IC702, the scanning is stopped.

2) When tuning mode switch is set to MANUAL

Whenever UP or DOWN key is depressed once, the frequency rises or falls by one step (channel space).

[5] OVERLOAD PROTECTION

As soon as the current over rated power flows, the voltage between both emitters of Q421 and Q423 (Rch) rises and Q7, Q9 and Q4 are turned ON. So Q1 (Schmit trigger circuit) is turned ON. The base of Q10 becomes 0V and Q405 is turned off. The operation of power amp. circuit stops and the circuit is protected.

BLOCK DIAGRAM

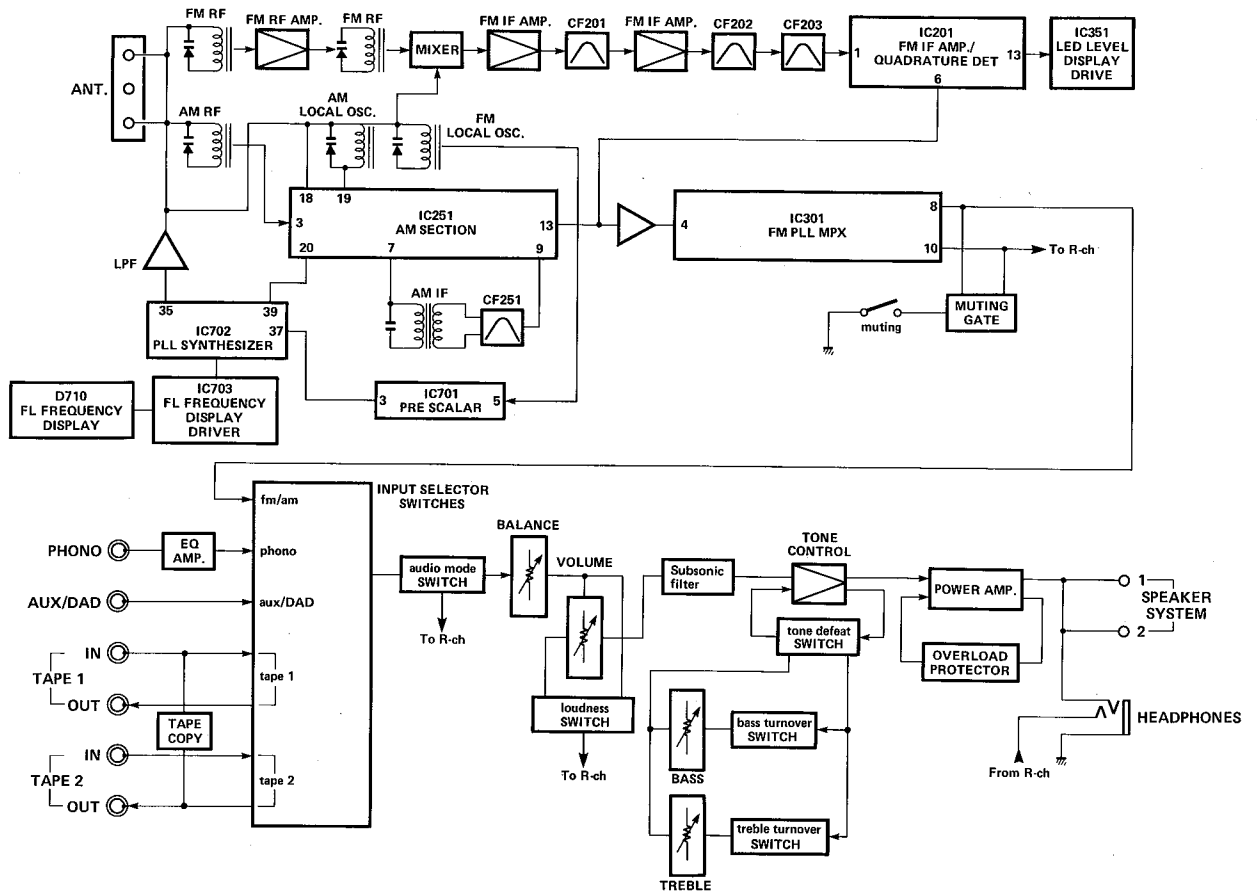

TIMING CHART

Frequency display timing chart of IC702 (TC9147AP)

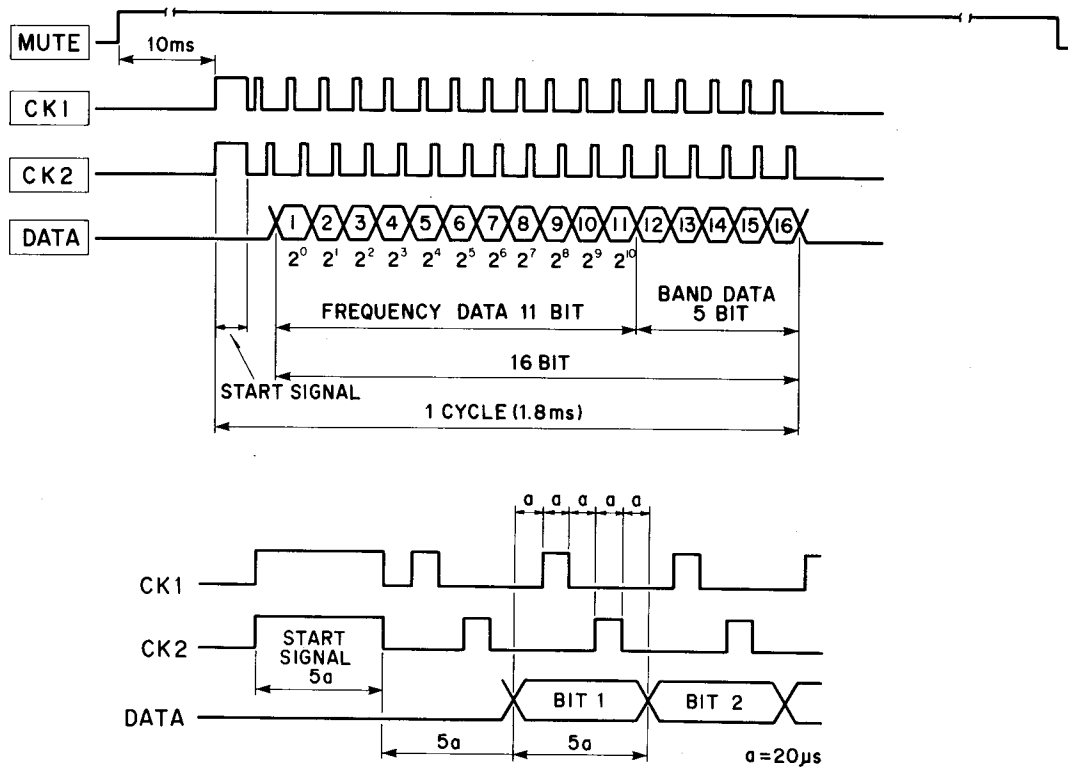

GENERAL UNIT PARTS LIST

Ref. No.	Part No.	Description
101	A443-HK590A	Front Panel Assembly
102	A424-HK590A	Cabinet Back Assembly
"	A424-HK590C	Cabinet Back Assembly (for Canada model)
103	A424-HK590B	Cabinet Bottom Assembly
104	A554-HK590A	Dial Back Assembly
105	A630-HK590A	Knob Assembly, Volume
106	A662-HK590A	Push Button Assembly, Power
107	A662-HK590B	Push Button Assembly, Tape Monitor, Function
108	A662-HK590C	Push Button Assembly, Bass Turnover, Tone Defeat, Treble Turnover, Tape Copy, Subsonic Filter, Loudness, Audio Mode, Muting
109	A662-HK590D	Push Button Assembly, Speakers
110	B211-HK590A	Chassis Assembly, T1
131	1319-0139	Foot
133	1414-03901	Cabinet Top
140	1541-02302	Dial Panel
146	1630-02501	Knob, Bass, Treble, Balance
155	1662-12701	Push Button, Auto, Manual, Memory, FM/AM Preset Memory
156	1662-12801VN	Push Button, Tuning
167	2111-11738	Felt
169	2112-11769	Sponge
170	2114-415027	Bushing
171	2132-01401	Spacer
172	2132-5052	Spacer
176	2216-7142	Shield Plate
189	2224-7085	Insulator
190	2216-7143	Shield Plate
191	2222-7100	Heat Sink
192	2222-7101	Heat Sink
193	2222-7103	Heat Sink
194	2222-7152	Heat Sink
195	2222-7149	Heat Sink
196	2218-7001	Holding Bracket
199	2240-7176	Holder
200	2240-7120	Holder
204	2240-7206	Holder
206	2240-7050	Holder
241	2440-61	Special Nut
248	2651-210189	Spring
249	2240-7208	Holder
301	2211-7250	Chassis, Front
302	2211-7241	Chassis, T1
303	2211-7242	Chassis, Right
304	2219-7645	Bracket, Dial Back Upper Side
305	2219-7671	Bracket, Dial Panel Right Side
306	2219-7879	Bracket, PCB-17
307	2219-7913	Bracket, Transverse Direction
308	2219-7914	Bracket, PCB-3
309	2219-7915	Bracket, Vertical Direction
310	2219-7916	Bracket, Speakers Switch
311	2219-7917	Bracket, Power Switch
312	2219-7919	Bracket, PCB-9
313	2219-7920	Bracket, Dial Back Hold (Left, Center)
314	2219-7921	Bracket, Dial Back Hold (Right)
315	2219-7946	Bracket, Speakers Switch Shaft
316	2347-400647	Bind Head Tapping Screw
317	2347-300647	Bind Head Tapping Screw
318	2347-300627	Bind Head Tapping Screw
319	2347-301041	Bind Head Tapping Screw
320	2347-300827	Bind Head Tapping Screw
	1111-J30137	Owner Guide
	1111-J30138	Owner Guide (for Canada model)
	1222-7263	Packing Cushion (2 Used)
	1221-727167	Packing Box
	1397-6	Dipole Antenna (Accessory)

ELECTRICAL PARTS LIST

Ref. No.	Part No.	Description
CHASSIS MISCELLANEOUS		
P1	4161-71151	Power Cord
T1	5584-701435	Power Transformer
SO1	4474-156	AC Outlet, Switched, Unswitched
R1	5135-335J50P	Resistor, 3.3M Ω , \pm 5%, 1/2W, Carbon
L101	5911-235	AM Loop Antenna
LUG1	4211-4	Lug Terminal
PCB-1 MAIN AMP. P.C. BOARD		
RESISTORS		
R61	5102-2214715	220 Ω , \pm 2%, 1/4W, Fuse
R417, 418	5174-562381	5.6k Ω , \pm 1%, 1/4W, Metal
R423, 424, 427, 428, 479, 480	5102-3314713	330 Ω , \pm 2%, 1/4W, Fuse
R425, 426, 429, 430	5102-3314715	330 Ω , \pm 2%, 1/4W, Fuse
R437, 438, 439, 440, 469, 470, 489, 490	5102-1014713	100 Ω , \pm 2%, 1/4W, Fuse
R455, 456, 457, 458	5102-1004713	10 Ω , \pm 2%, 1/4W, Fuse
R459, 460	5174-820381	82 Ω , \pm 1%, 1/4W, Metal
R461, 462	5273-R22672	0.22 Ω , \pm 10%, 3W x 2, Cement
R467, 468	5173-100571	10 Ω , \pm 5%, 2W, Metal
R477, 478, 483, 484	5102-2R2579	2.2 Ω , \pm 5%, 1/4W, Fuse
R485, 486	5102-2R25711	2.2 Ω , \pm 5%, 1W, Fuse
CONTROLS		
VR401, 402	5101-20271920	2k Ω B
VR403, 404	5101-10471920	100k Ω B
CAPACITORS		
C4, 12	5345-476F041	47 μ F, \pm 20%, 50V, Electrolytic
C5, 6, 7, 8	5341-478F0955	4700 μ F, \pm 20%, 50V, Electrolytic
C9	5345-107C041	100 μ F, \pm 20%, 16V, Electrolytic
C10	5345-476C041	47 μ F, \pm 20%, 16V, Electrolytic
C11	5345-106C041	10 μ F, \pm 20%, 16V, Electrolytic
C13	5345-477G041	470 μ F, \pm 20%, 63V, Electrolytic
C401, 402	5345-107B0951	100 μ F, \pm 20%, 10V, Electrolytic
C403, 404	5359-2215851	220pF, \pm 5%, 100V, Polypropylene
C405, 406	5345-106D041	10 μ F, \pm 20%, 25V, Electrolytic
C407, 408, 409, 410	5345-227F041	220 μ F, \pm 20%, 50V, Electrolytic
C411, 412	5359-1015851	100pF, \pm 5%, 100V, Polypropylene
C415, 416	5353-050934	5pF, \pm 0.5pF, 500V, Mica
C417, 418	5345-106F041	10 μ F, \pm 20%, 50V, Electrolytic
C423, 424	5345-475F041	4.7 μ F, \pm 20%, 50V, Electrolytic
TRANSISTORS		
Q1, 2, 4, 10	5611-1115(E)	2SA1115(E) or 2SA1115(F)
Q7, 8	5611-872A(E)	2SA872A(E)
Q9, 405, 406	5613-2603(E)	2SC2603(E) or 2SC2603(F)
Q401, 402, 403, 404	5613-2240(BL)	2SC2240(BL)
Q407, 408, 409, 410, 411, 412	5612-646A(C)	2SB646A(C)
Q413, 414	5614-666A(C)	2SD666A(C)
Q415, 416	5613-945(K)	2SC945(K) or 2SC945(P)
Q417, 418	5613-1627(Y)	2SC1627(Y)
Q419, 420	5611-817(Y)	2SA817(Y)
Q421, 422	5613-3182(O)	2SC3182(O) or 2SC3182(R)
Q423, 424	5611-1265(O)	2SA1265(O) or 2SA1265(R)
Q425, 426	5611-965(Y)	2SA965(Y)
Q427, 428	5613-2235(Y)	2SC2235(Y)
DIODES		
D1, 2, 3, 4, 17, 18, 19, 20	5632-ERC402FL	ERC402FL
D5, 6	5636-1S2471	1S2471
D7	5635-HZ11B2L	Zener, HZ11B2L
D8, 13, 14, 401, 402, 409, 410	5631-1S2473	1S2473

Ref. No.	Part No.	Description
D11, 12, 405, 406, 407, 408	5632-DS135E	DS135E
D403, 404	5641-MV12YM	Varistor, MV12YM
D411, 412	5635-HZ12C3L	Zener, HZ12C3L
COILS		
L401, 402	5991-7165	
MISCELLANEOUS		
P101, 102	4443-030185	Connector, 3 Pos.
PCB-2 TUNER P.C. BOARD		
RESISTORS		
R51	5102-3R3579	3.3 Ω , \pm 5%, 1/4W, Fuse
R305	5102-2204713	22 Ω , \pm 2%, 1/4W, Fuse
R323	5174-183381	18k Ω , \pm 1%, 1/4W, Metal
CONTROLS		
VR201, 202, 251	5101-50371920	50k Ω B
VR301, 302, 351	5101-10471920	100k Ω B
VR303	5101-1037187	10k Ω
CAPACITORS		
C51	5345-337-16	330 μ F, +50%–10%, 16V, Electrolytic
C52, 220	5345-108-16	1000 μ F, +50%–10%, 16V, Electrolytic
C201, 304	5345-476-16	47 μ F, +50%–10%, 16V, Electrolytic
C208, 217, 257, 351, 352	5345-106-16	10 μ F, +50%–10%, 16V, Electrolytic
C214	5359-1015851	100pF, \pm 5%, 100V, Polypropylene
C215	5345-105-50	1 μ F, +75%–10%, 50V, Electrolytic
C216	5345-226C0952	22 μ F, \pm 20%, 16V, Electrolytic
C218, 260	5345-L104M50	0.1 μ F, \pm 20%, 50V, Electrolytic
C263	5345-107-16	100 μ F, +50%–10%, 16V, Electrolytic
C266	5345-335-50	3.3 μ F, +75%–10%, 50V, Electrolytic
C267	5345-475-25	4.7 μ F, +75%–10%, 25V, Electrolytic
C269	5359-5115851	510pF, \pm 5%, 100V, Polypropylene
C271	5345-225-50	2.2 μ F, +75%–10%, 50V, Electrolytic
C301, 303	5345-L226M16	22 μ F, \pm 20%, 16V, Electrolytic
C302	5345-L107M10	100 μ F, \pm 20%, 10V, Electrolytic
C305	5345-227-16	220 μ F, +50%–10%, 16V, Electrolytic
C309, 310	5359-6815851	680pF, \pm 5%, 100V, Polypropylene
C311, 312	5345-L225M50	2.2 μ F, \pm 20%, 50V, Electrolytic
C315	5345-L106M16	10 μ F, \pm 20%, 16V, Electrolytic
C316	5345-L475M25	4.7 μ F, \pm 20%, 25V, Electrolytic
C317	5345-L474M50	0.47 μ F, \pm 20%, 50V, Electrolytic
C320	5359-8215851	820pF, \pm 5%, 100V, Polypropylene
C353	5345-474-50	0.47 μ F, +75%–10%, 50V, Electrolytic
C354	5345-226-16	22 μ F, +50%–10%, 16V, Electrolytic
TC251, 252	5371-93	Trimmer Capacitor
INTEGRATED CIRCUIT		
IC201	5652-HA11225	HA11225
IC251	5652-LA1245	LA1245
IC301	5652- μ PC1223C	μ PC1223C
IC352	5654-TC4049BP	TC4049BP
TRANSISTORS		
Q51	5614-880(GR)	2SD880(GR)
Q201, 202	5613-2058(N)	2SC2058(N) or 2SC2058(P)
Q203, 251, 252, 301, 302, 303, 352, 355, 356, 357	5613-2603(F)	2SC2603(F) or 2SC2603(E)
Q351, 353, 354, 358, 359, 360	5611-1115(F)	2SA1115(F) or 2SA1115(E)
DIODES		
D51	5635-HZ15-1L	Zener, HZ15-1L
D201, 202, 203, 253, 352, 353, 354, 355, 356, 357, 358, 359, 360, 361, 362, 363, 364	5636-1SS53	1SS53
D251, 252	5633-1SV102	Capacitor Diode, 1SV102
D351	5635-RD5R1EB2	Zener, RD5.1EB2

Ref. No.	Part No.	Description
	COILS	
L202	5995-2R2269	2.2 μ H
L251	5933-70127	
L252	5923-70133	
	TRANSFORMERS	
T201	5574-7024	
T251	5552-70113	
T252	5932-70123	
	MISCELLANEOUS	
	6114-7128	FM Tuner Assembly
CF201, 202, 203	5671-7117A	Ceramic Filter, MA8
CF251	5671-7138F	Ceramic Filter, SFZ450F
CF252	5671-7137C	Ceramic Filter, BFU450C4N
J701	4163-70196	Connector with Lead Wire, 5 Pos.
P301	4443-040185	Connector, 4 Pos.
P351	4443-030185	Connector, 3 Pos.
P352	4443-070185	Connector, 7 Pos.
PCB-3 LOGIC CONTROL P.C. BOARD		
	RESISTORS	
R712	5171-221581	220 Ω , \pm 5%, 1W, Metal
R752, 753	5171-680581	68 Ω , \pm 5%, 1W, Metal
	CAPACITORS	
C355	5345-106-16	10 μ F, +50%–10%, 16V, Electrolytic
C703	5345-476-10	47 μ F, +50%–10%, 10V, Electrolytic
C708	5345-336-35	33 μ F, +50%–10%, 35V, Electrolytic
C709	5345-334F0951	0.33 μ F, \pm 20%, 50V, Electrolytic
C712	5350-4730H651	47000 μ F, +80%–20%, 5V, Special
C715	5345-227-10	220 μ F, +50%–10%, 10V, Electrolytic
C716, 717	5345-L225M50	2.2 μ F, \pm 20%, 50V, Electrolytic
C721, 722	5345-225-50	2.2 μ F, +75%–10%, 50V, Electrolytic
	INTEGRATED CIRCUIT	
IC351	5652-AN6875	AN6875
IC701	5654-TD6104P	TD6104P
IC702	5654-TC9147AP	TC9147AP
IC703	5654-TD6301AP	TD6301AP
	TRANSISTORS	
Q701	5616-2SK362GR	F.E.T., 2SK362(GR)
Q702	5616-2SK117(Y)	F.E.T., 2SK117(Y)
Q703	5613-2320L(F)	2SC2320L(F) or 2SC2320L(G)
Q704, 705, 708, 709, 710, 711	5613-2603(F)	2SC2603(F) or 2SC2603(E)
Q707, 712	5611-1115(F)	2SA1115(F) or 2SA1115(E)
	DIODES	
D371/372/373/374/375/ 376/377	5623-LS007S	LED Display
D701	5635-HZ27-3L	Zener, HZ27-3L
D702, 703, 704, 705, 706	5636-1SS53	1SS53
D707	5635-RD5R6EB2	Zener, RD5.6EB2
D708	5635-RD10EB3	Zener, RD10EB3
D709	5635-RD9R1EB1	Zener, RD9.1EB1
D722, 723	5631-1S2473	1S2473
	COILS	
L701, 702	5995-2R2269	2.2 μ H
	MISCELLANEOUS	
	5722-10	Station Display, FIP7B8S
X701	5691-00720019	Crystal Osc.
F701, 702, 703	5212-3	R Components
P701	4443-057114	Connector, 5 Pos.
P702	4443-030185	Connector, 3 Pos.
P703	4443-080185	Connector, 8 Pos.
P704	4443-070185	Connector, 7 Pos.
P705, 707, 708	4443-050185	Connector, 5 Pos.
P706	4443-027114	Connector, 2 Pos.

Ref. No.	Part No.	Description
PCB-4 EQUALIZER P.C. BOARD		
RESISTORS		
R37, 38, 41, 42, 63, 64, 65, 66	5102-5604715	56 Ω , \pm 2%, 1/4W, Fuse
R649, 650	5174-Z549328	549k Ω , \pm 0.5%, 1/4W, Metal
R651, 652	5174-Z412228	41.2k Ω , \pm 1%, 1/4W, Metal
CAPACITORS		
C23, 24	5345-476D041	47 μ F, \pm 20%, 25V, Electrolytic
C27, 28	5345-227D041	220 μ F, \pm 20%, 25V, Electrolytic
C601, 602	5345-476B0951	47 μ F, \pm 20%, 10V, Electrolytic
C603, 604	5359-1215851	120pF, \pm 5%, 100V, Polypropylene
C605, 606	5345-337A0952	330 μ F, \pm 20%, 6.3V, Electrolytic
C607, 608	5359-2025851	2000pF, \pm 5%, 100V, Polypropylene
C609, 610	5359-5625851	5600pF, \pm 5%, 100V, Polypropylene
C611, 612, 613, 614	5345-226D0951	22 μ F, \pm 20%, 25V, Electrolytic
C615, 616	5359-8225851	8200pF, \pm 5%, 100V, Polypropylene
C617, 618	5345-226E041	22 μ F, \pm 20%, 35V, Electrolytic
C619, 620	5359-1015851	100pF, \pm 5%, 100V, Polypropylene
C625, 626	5359-1525851	1500pF, \pm 5%, 100V, Polypropylene
C627	5345-104F041	0.1 μ F, \pm 20%, 50V, Electrolytic
TRANSISTORS		
Q11	5613-2235(O)	2SC2235(O) or 2SC2235(Y)
Q12	5611-965(O)	2SA965(O) or 2SA965(Y)
Q601, 602, 603, 604, 605, 606, 609, 610, 615, 616	5613-2240(BL)	2SC2240(BL)
Q607, 608, 611, 612, 613, 614	5611-970(BL)	2SA970(BL)
Q617, 618	5613-2705(O)	2SC2705(O) or 2SC2705(Y)
Q619, 620	5611-1145(O)	2SA1145(O) or 2SA1145(Y)
Q621, 622	5616-2SK364(V)	F.E.T., 2SK364(V) or 2SK364 (BL)
Q623, 624, 629	5613-2603(E)	2SC2603(E) or 2SC2603(F)
Q627, 628	5611-1115(F)	2SA1115(F) or 2SA1115(E)
DIODES		
D15, 16	5635-HZ20-2L	Zener, HZ20-2L
D601, 603, 604	5631-1S2473	1S2473
MISCELLANEOUS		
P801, 802	4443-040185	Connector, 4 Pos.
PCB-5 TONE P.C. BOARD		
RESISTORS		
R19, 20, 21, 22	5174-181381	180 Ω , \pm 1%, 1/4W, Metal
CONTROLS		
VR501/502	5113-50385122	50k Ω MN, Balance
VR505/506	5113-50371148	50k Ω C, Treble
VR507/508	5113-10472148	100k Ω C, Bass
CAPACITORS		
C17, 18	5345-476C041	47 μ F, \pm 20%, 16V, Electrolytic
C21, 22	5345-227C041	220 μ F, \pm 20%, 16V, Electrolytic
C509, 510	5345-685D0951	6.8 μ F, \pm 20%, 25V, Electrolytic
C511, 512	5353-010934	1pF, \pm 0.5pF, 500V, Mica
C513, 514	5345-226D0951	22 μ F, \pm 20%, 25V, Electrolytic
C515, 516, 517, 518	5353-680534	68pF, \pm 0.5pF, 500V, Mica
C519, 520	5345-476C0951	47 μ F, \pm 20%, 16V, Electrolytic
C521, 522	5359-1015851	100pF, \pm 5%, 100V, Polypropylene
TRANSISTORS		
Q5	5613-2235(O)	2SC2235(O) or 2SC2235(Y)
Q6	5611-965(O)	2SA965(O) or 2SA965(Y)
Q14, 509, 510, 513, 514, 515, 516	5611-1115(E)	2SA1115(E) or 2SA1115(F)
Q501, 502, 503, 504	5613-2320L(F)	2SC2320L(F)

Ref. No.	Part No.	Description
Q505, 506, 507, 508, 511, 512, 517, 518 Q519, 520	5613-2603(E) 5616-2SK381(B)	2SC2603(E) or 2SC2603(F) F.E.T., 2SK381(B) or 2SK381(C)
D9, 10 D501, 502, 503, 504	DIODES 5635-HZ15-2L 5631-1S2473	Zener, HZ15-2L 1S2473
SW501, 502, 503, 504, 505, 506, 507	MISCELLANEOUS 4431-0728714	Push Switch, Tape Monitor, Function
PCB-6 LOGIC CONTROL SWITCHES P.C. BOARD		
D711, 712, 713, 714, 715, 716, 717, 718, 719, 720, 721	DIODES 5637-GL5NG6	L.E.D., GL5NG6, Green, Auto, Manual, Memory, FM/AM Preset Memory
SW701, 702 SW703, 704, 705 SW706, 707, 708, 709, 710, 711, 712, 713	MISCELLANEOUS 4431-02027167 4431-03037155 4431-04047165	Push Switch, Tuning Push Switch, Auto, Manual, Memory Push Switch, FM/AM Preset Memory
PCB-7 PIN JACK P.C. BOARD		
J1/2/3/4/5/6, 7/8/9/10/ 11/12	4486-8	6-Pin Jack, Phono, Aux/DAD, Tape 1, Tape 2
PCB-8 TONE SELECTOR P.C. BOARD		
SW508, 509, 510	4431-03127253	Push Switch, Bass Turnover, Tone Defeat, Treble Turnover
PCB-9 PUSH SWITCHES P.C. BOARD		
C503, 504 SW511, 512, 513 SW514, 515	5359-1815851 4431-03127253 4431-02047365	Capacitor, 180pF, $\pm 5\%$, 100V, Polypropylene Push Switch, Tape Copy, Subsonic Filter, Loudness Push Switch, Audio Mode, Muting
PCB-10 TAPE MONITOR & FUNCTION INDICATORS P.C. BOARD		
D21, 22 D25, 26, 27, 28	5637-GL5PR6 5637-GL5NG6	L.E.D., GL5PR6, Red, Tape Monitor L.E.D., GL5NG6, Green, Function
PCB-11 VOLUME P.C. BOARD		
VR503/504	5113-10471147	Control, 100k Ω B, Volume
PCB-12 MUTE ADJ. VR P.C. BOARD		
VR352 P301	5113-50372136 4443-030185	Control, 50k Ω B, Mute Adjust Connector, 3 Pos.
PCB-13 LAMP P.C. BOARD		
LP1, 2 J706	5731-1507245 4163-023503	Lamp, 15V, 100mA, Illuminator Connector with Lead Wire, 2 Pos.
PCB-14 ANTENNA TERMINAL P.C. BOARD		
TE1	4214-95	External Antenna Terminal
PCB-15 SPEAKER SWITCHES P.B. BOARD		
R475, 476 SW401, 402	5171-471572 4431-02047166	Resistor, 470 Ω , $\pm 5\%$, 1W, Metal Push Switch, Speaker 1, Speaker 2
PCB-16 SPEAKER TERMINAL P.C. BOARD		
TE2	4214-121	Terminal, Speaker System 1/2
PCB-17 HEADPHONE JACK P.C. BOARD		
J401 P401	4451-00139 4443-030185	Jack, Headphones Connector, 3 Pos.

Ref. No.	Part No.	Description
PCB-18 POWER SWITCH P.C. BOARD		
CAPACITORS		
C1	5352-1030959	0.01 μ F, \pm 20%, AC125V, Metalized Polyester
C30	5345-105F041	1 μ F, \pm 20%, 50V, Electrolytic
TRANSISTOR		
Q13	5613-2603(E)	2SC2603(E) or 2SC2603(F)
DIODES		
D23	5636-1S2472	1S2472
D24	5631-1S2473	1S2473
MISCELLANEOUS		
SW1	4431-A01716	Push Switch, Power
F1	5732-402031	Fuse, 4A, 125V
	4472-7122	Fuse Holder (x 2)
PCB-19 FREQUENCY STEP CONTROL SWITCHES P.C. BOARD		
SW714, 715	4421-012413	Slide Switch, AM 9kHz/10kHz, FM 50kHz/100kHz

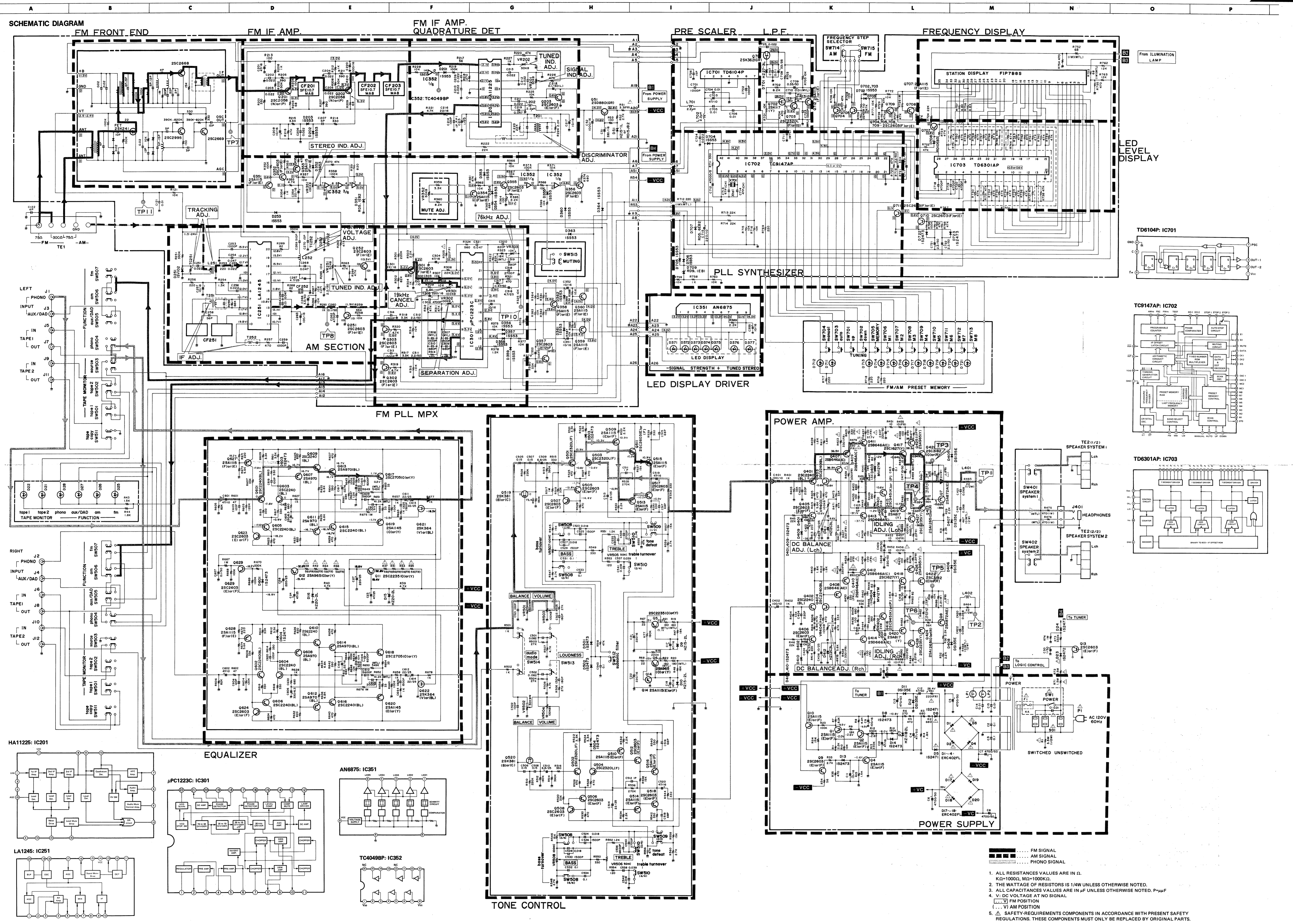

SCHEMATIC DIAGRAM

FM FRONT END

FM IF AMP.

FM IF AMP. QUADRATURE DET

PRE SCALER L.P.F.

FREQUENCY DISPLAY

LEFT INPUT

TAPE 1

TAPE 2

RIGHT INPUT

TAPE 1

TAPE 2

HA1225: IC201

LA1245: IC251

EQUALIZER

µPC1223C: IC301

AN6875: IC351

TC4048BP: IC352

LED DISPLAY DRIVER

POWER AMP.

POWER SUPPLY

LED LEVEL DISPLAY

LED DISPLAY DRIVER

FM/AM PRESET MEMORY

DC BALANCE ADJ. (Lch)

DC BALANCE ADJ. (Rch)

SWITCHED UNSWITCHED

FM SIGNAL
 AM SIGNAL
 PHONO SIGNAL

1. ALL RESISTANCE VALUES ARE IN Ω.
2. KΩ=1000Ω, MΩ=1000KΩ.
3. ALL CAPACITANCE VALUES ARE IN µF UNLESS OTHERWISE NOTED. P=µF.
4. V: DC VOLTAGE AT NO SIGNAL.
5. SAFETY-REQUIREMENTS COMPONENTS IN ACCORDANCE WITH PRESENT SAFETY REGULATIONS. THESE COMPONENTS MUST ONLY BE REPLACED BY ORIGINAL PARTS.

SCHEMATIC DIAGRAM

FM FRONT END

FM IF AMP.

1
2
3
4
5
6

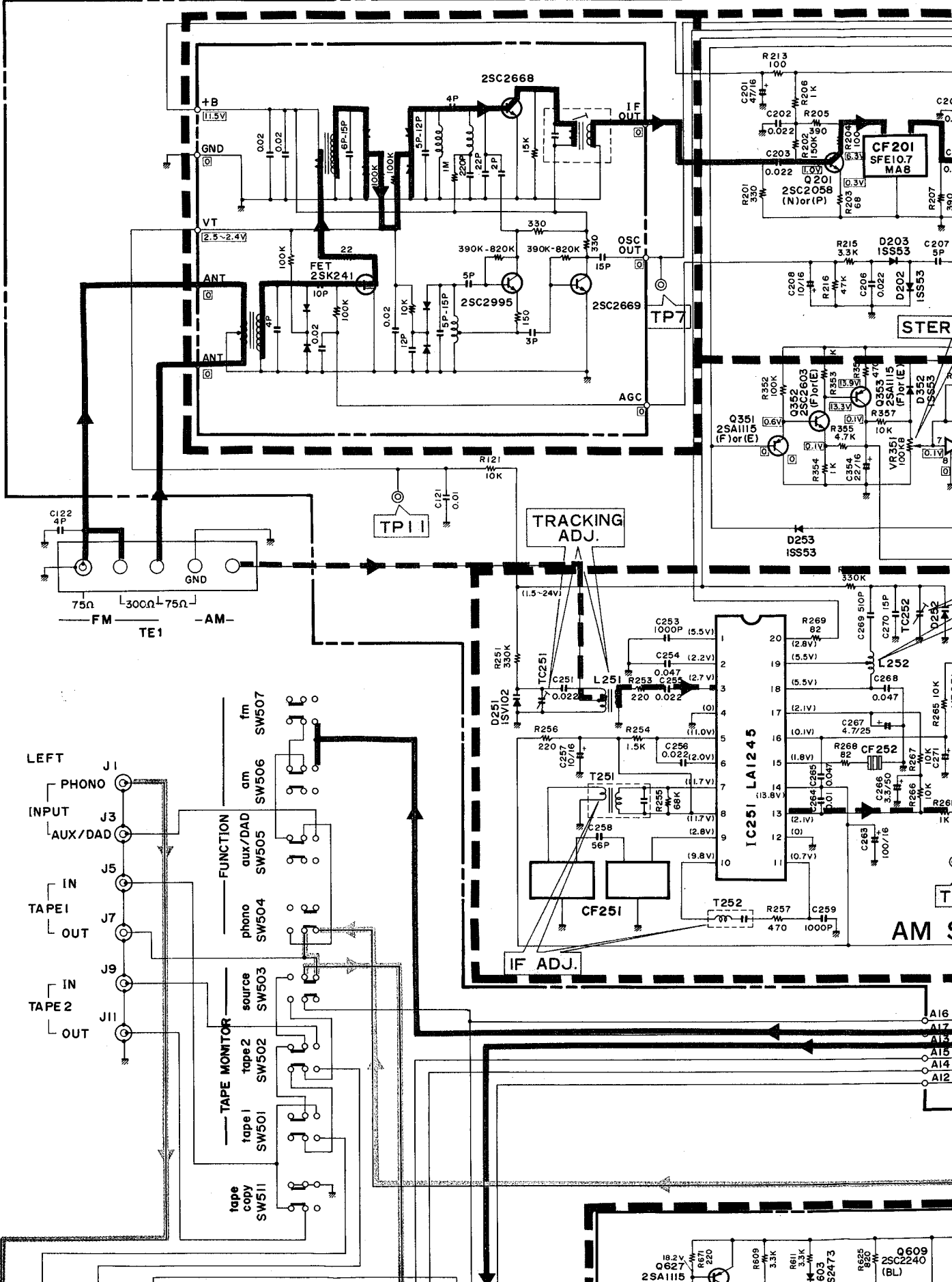

PRE SCALER L.P.F.

FREQUENCY STEP SELECTOR

FREQUENCY

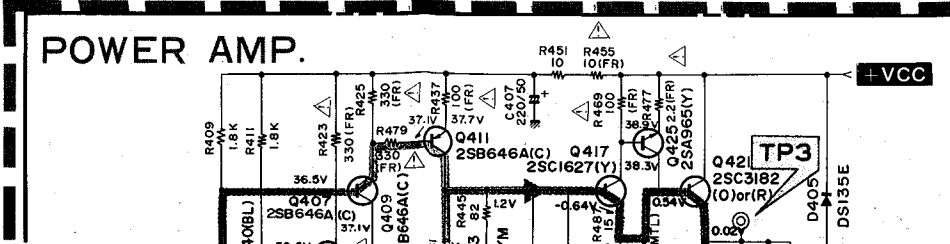
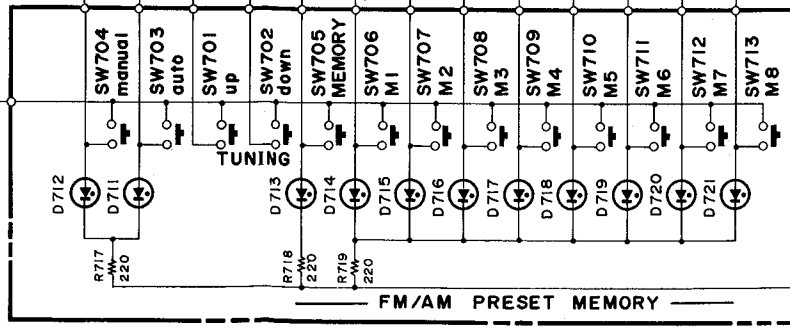
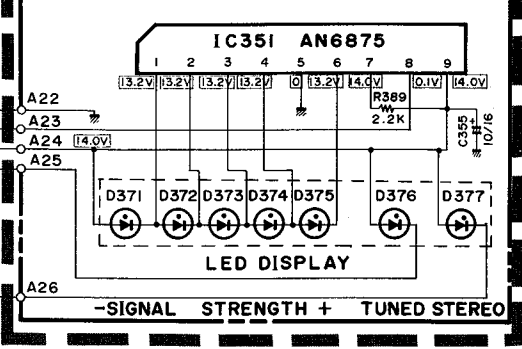
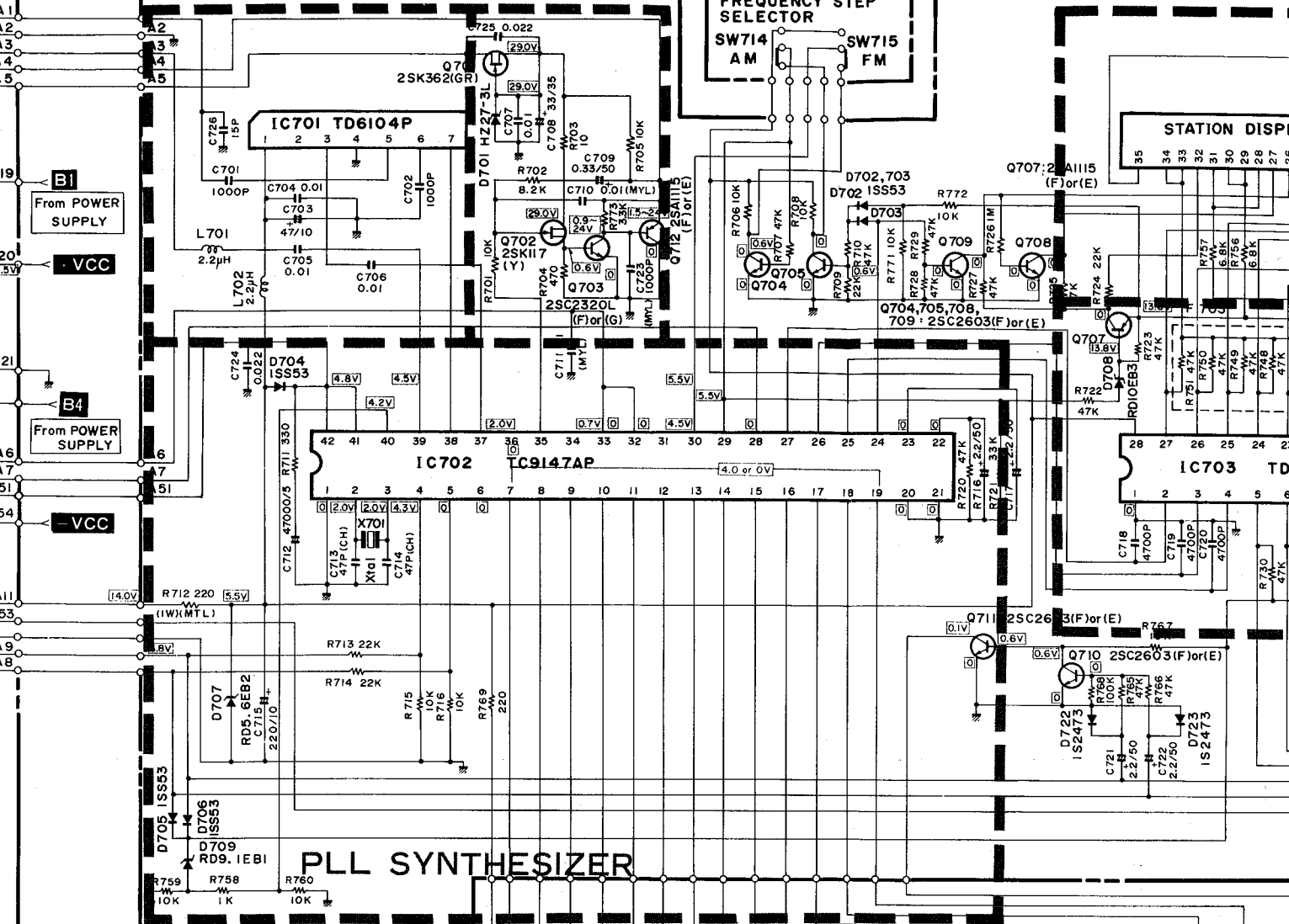

M

N

O

P

FREQUENCY DISPLAY

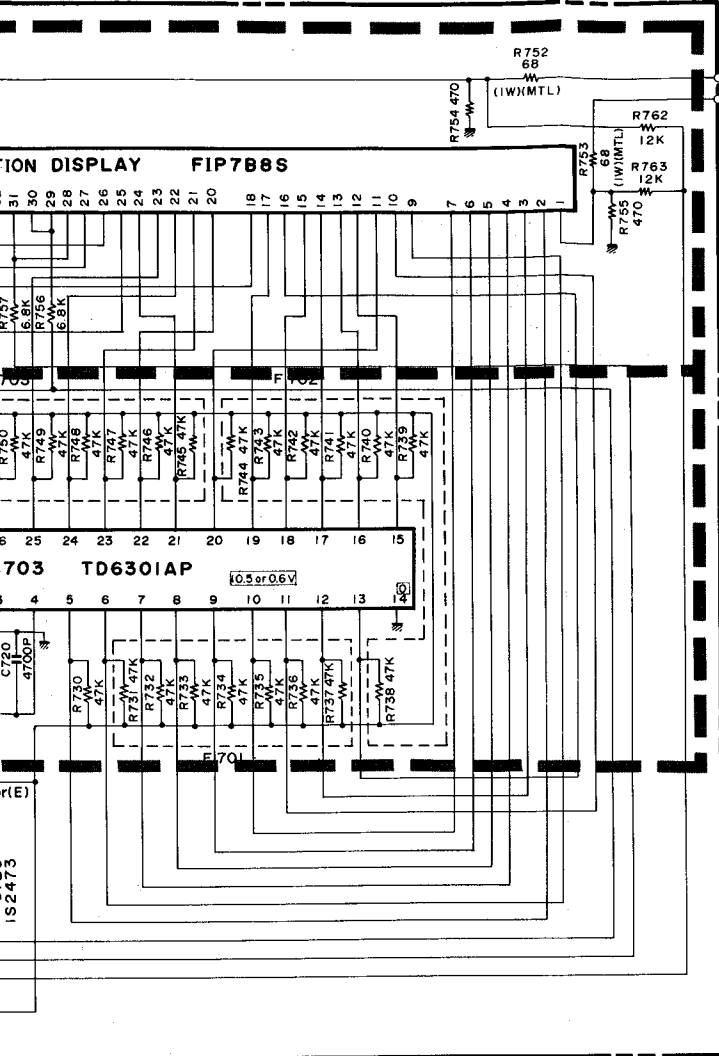

LED LEVEL DISPLAY

From ILLUMINATION LAMP

B2
B3

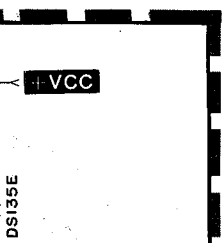
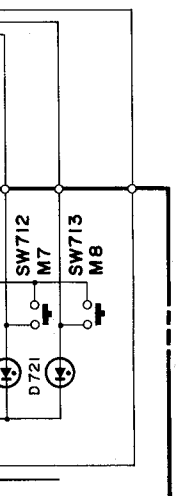

TE2 (1/2) SPEAKER SYSTEM I

TD6104P: IC701

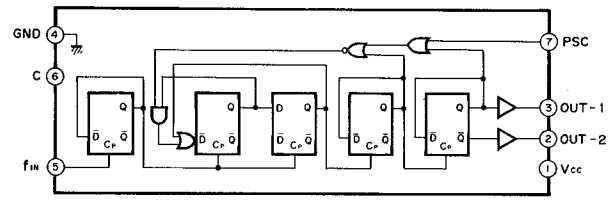

TC9147AP: IC702

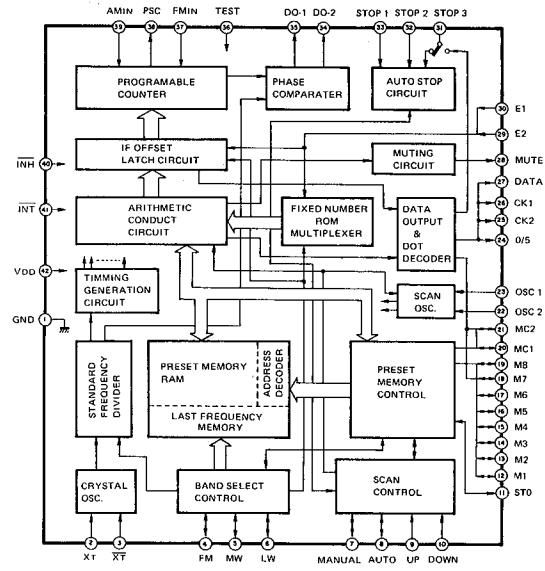

TD6301AP: IC703

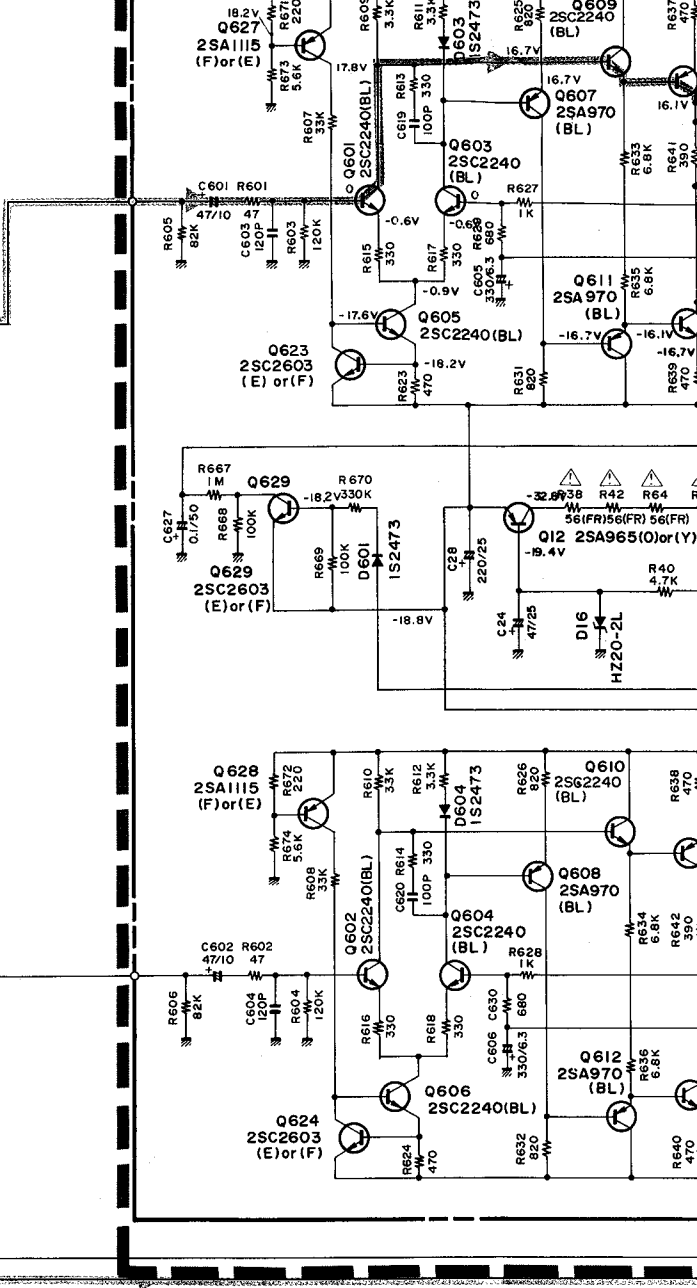
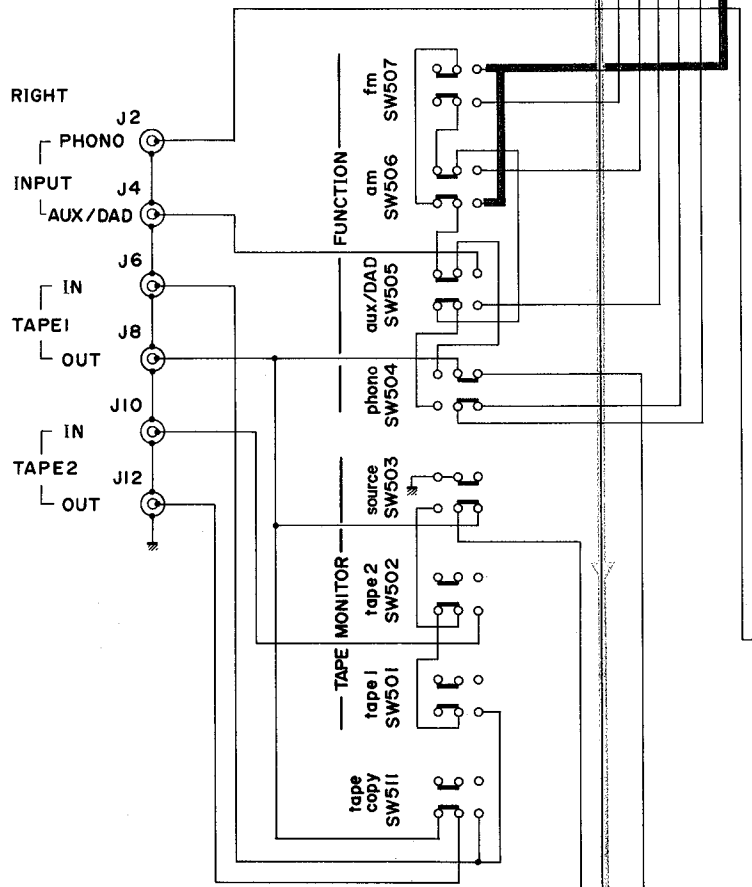
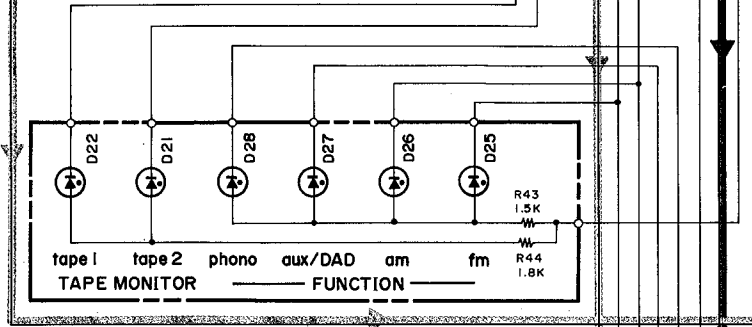

HA11225: IC201

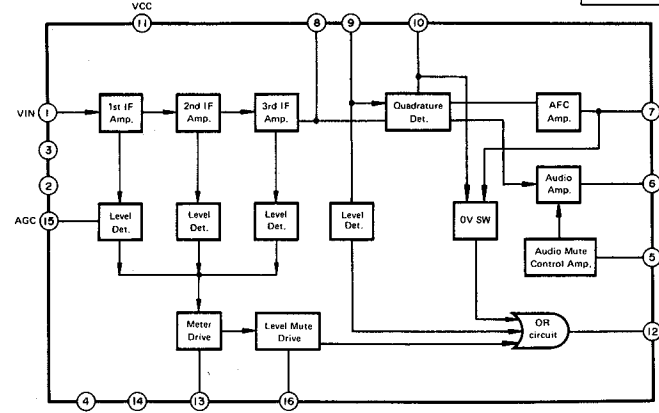

LA1245: IC251

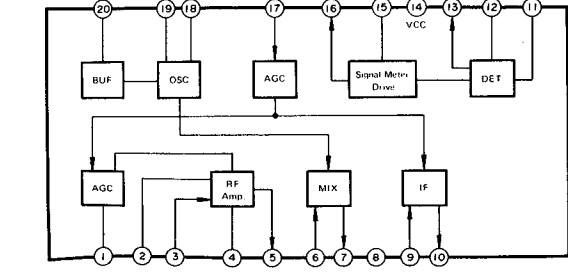

EQUALIZER

μPC1223C: IC301

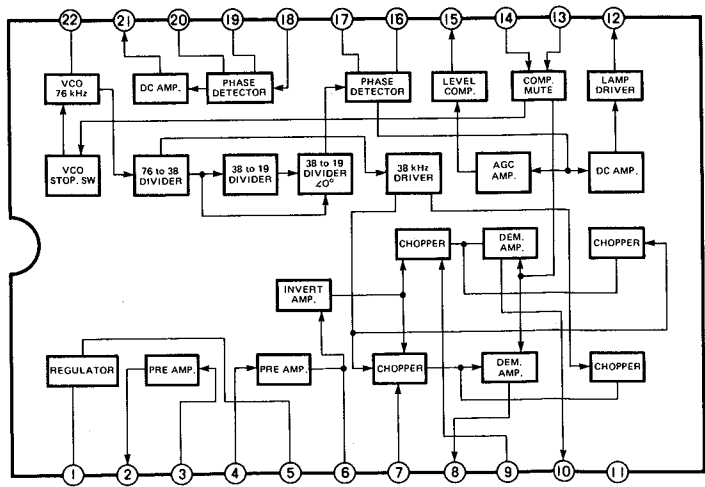

7

8

9

10

11

12

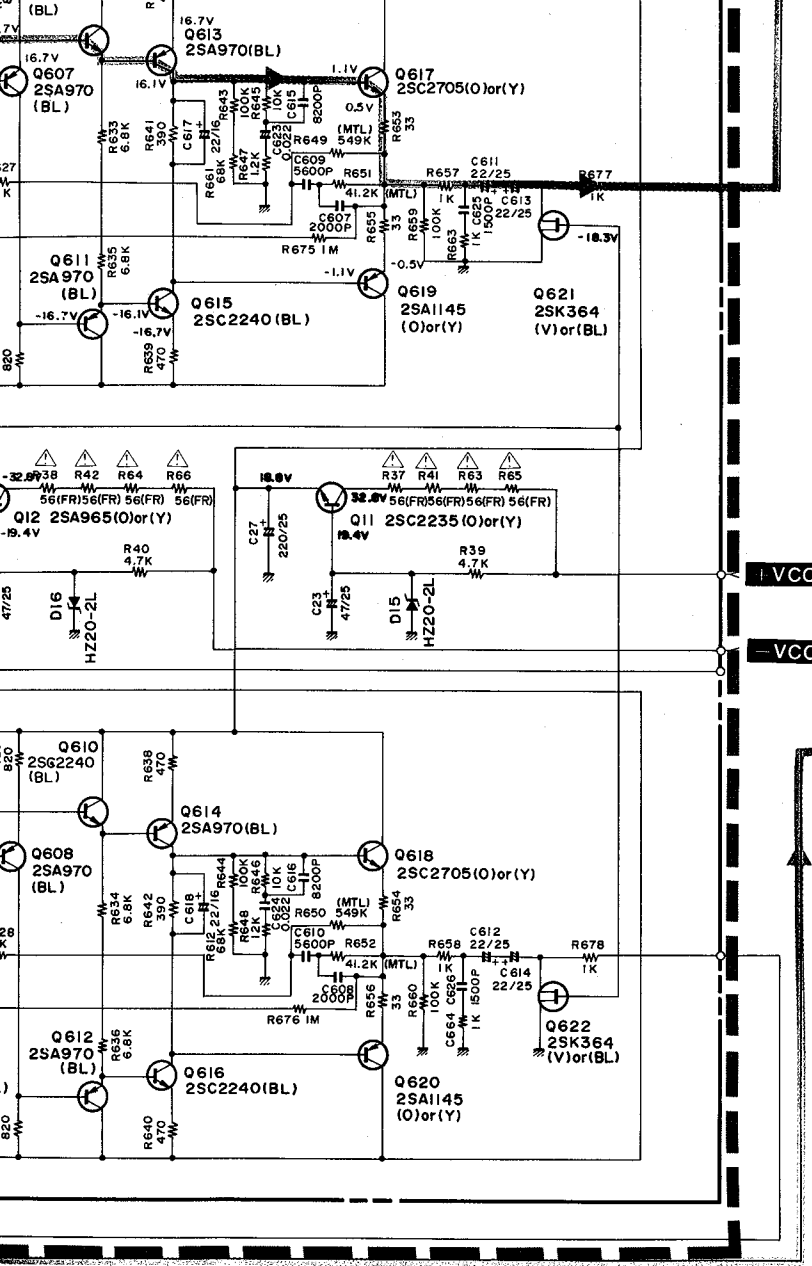

AN6875: IC351

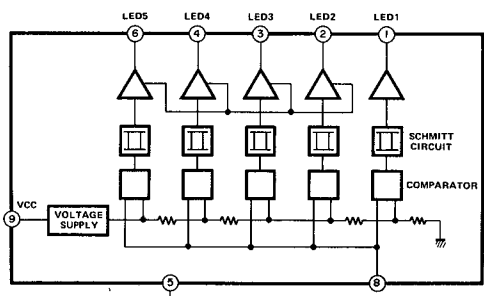

TC4049BP: IC352

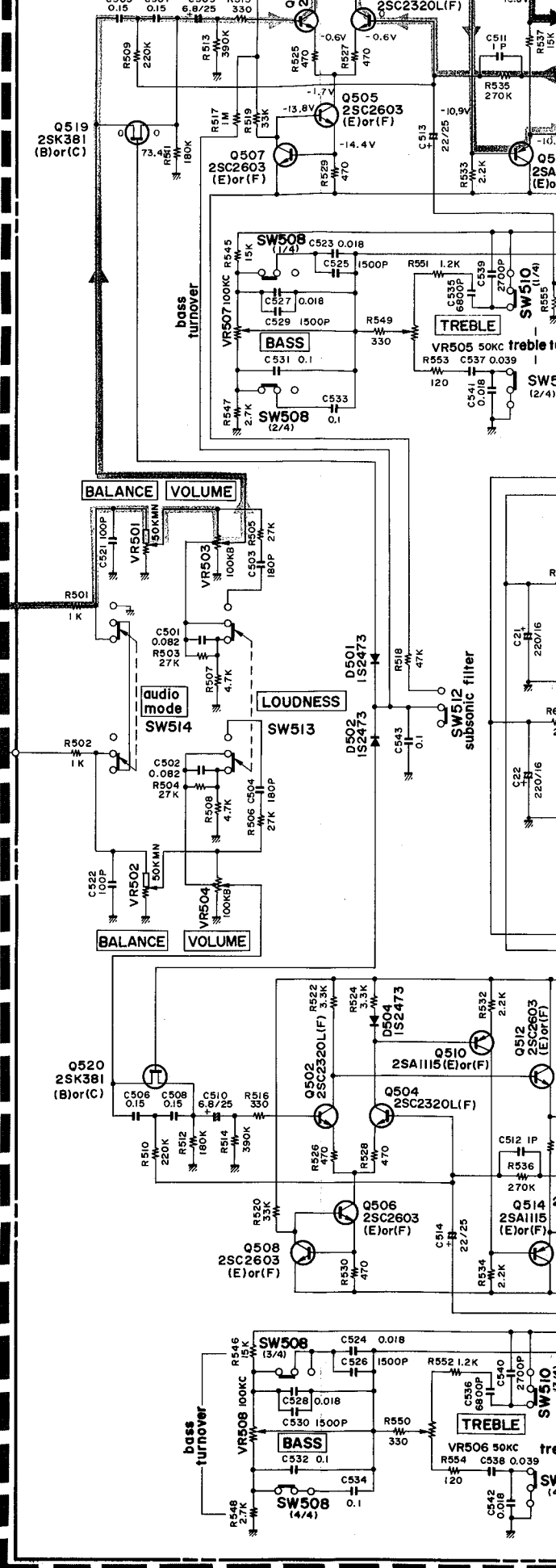
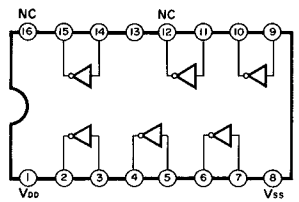

TONE CONTROL

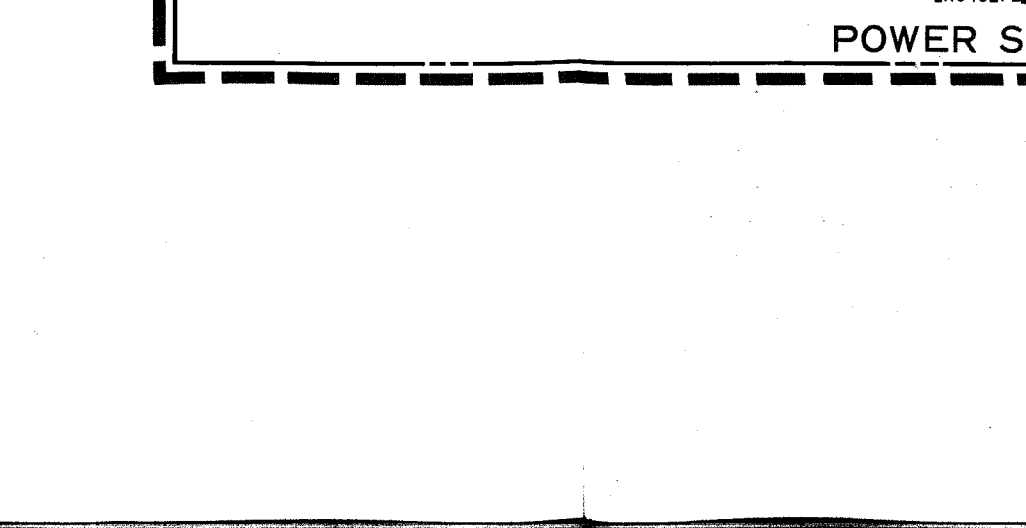
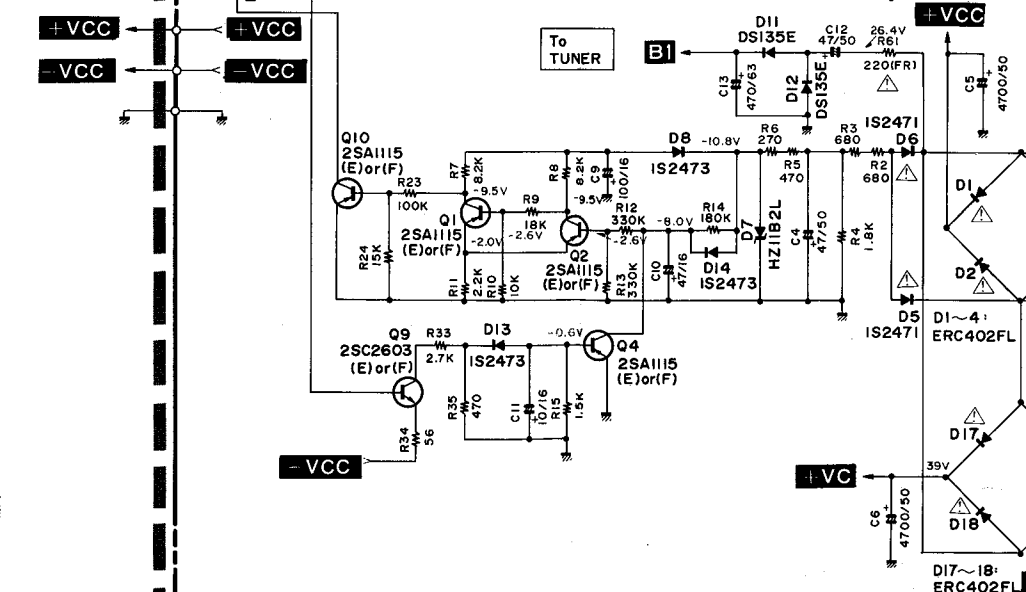
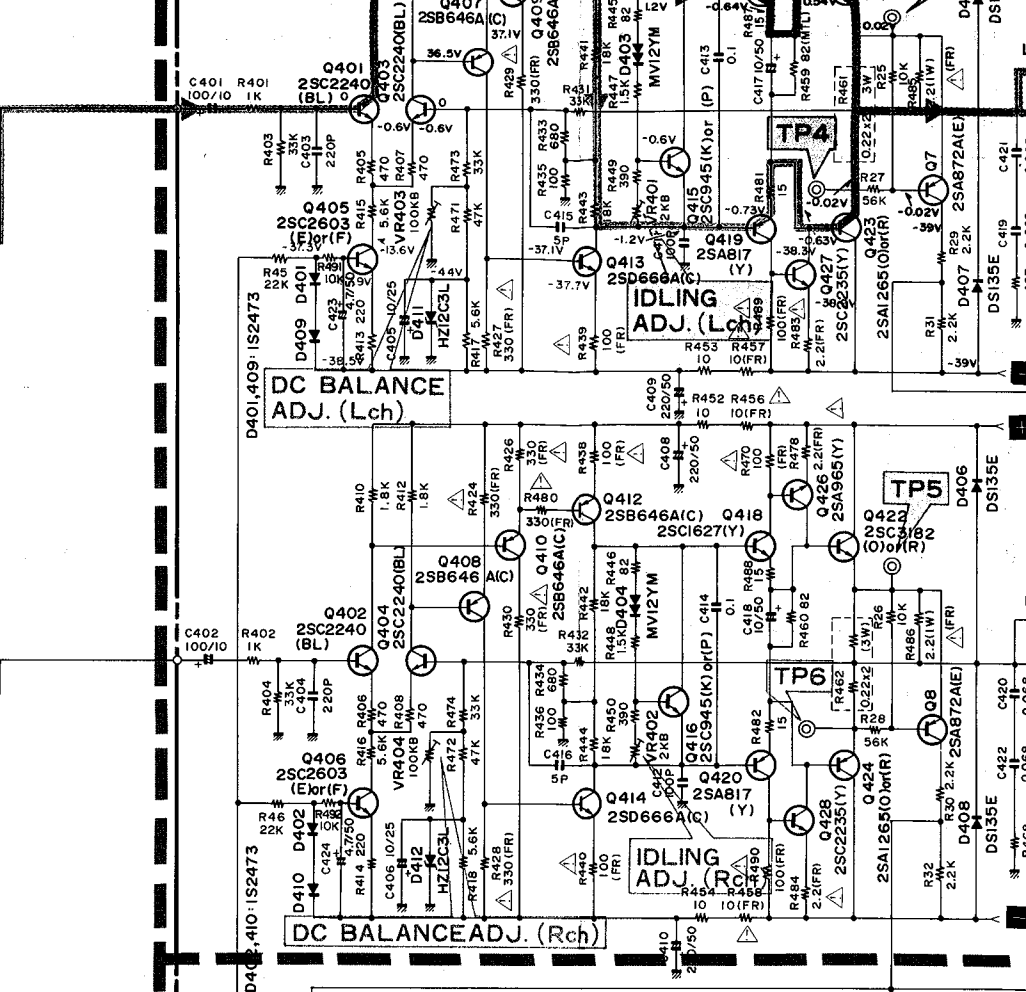
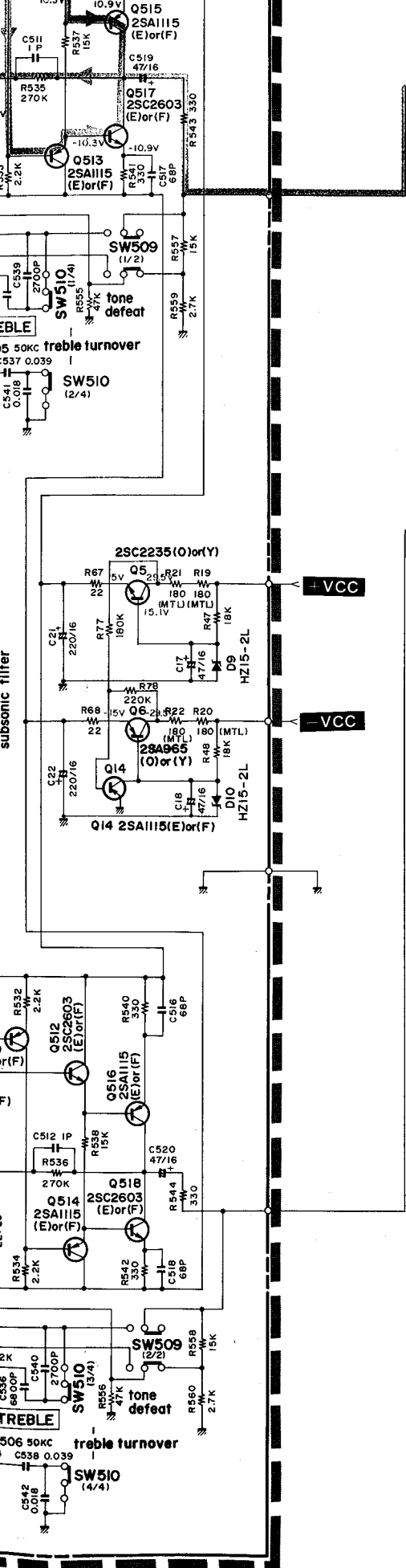

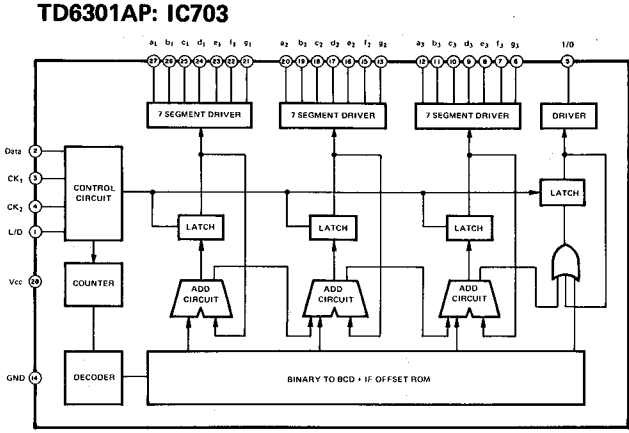
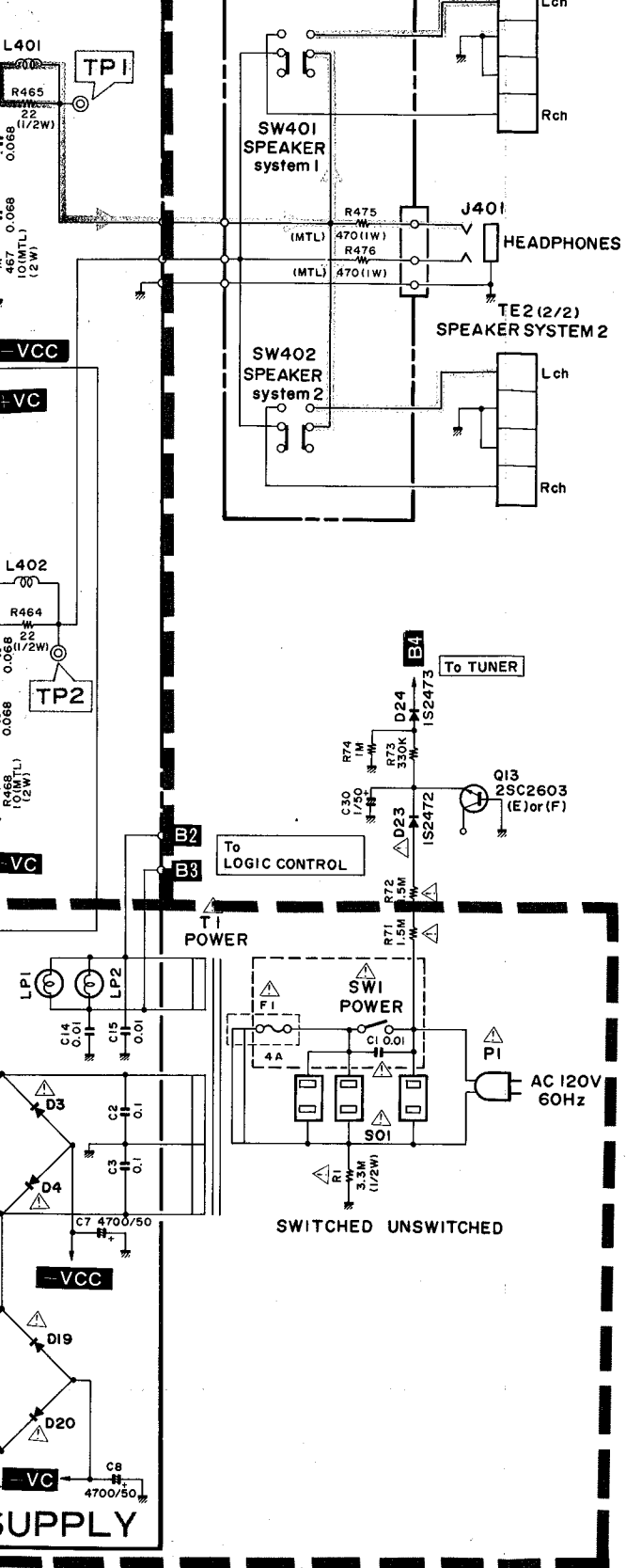

..... FM SIGNAL
 AM SIGNAL
 PHONO SIGNAL

1. ALL RESISTANCES VALUES ARE IN Ω .
 $K\Omega=1000\Omega$, $M\Omega=1000K\Omega$.
2. THE WATTAGE OF RESISTORS IS 1/4W UNLESS OTHERWISE NOTED.
3. ALL CAPACITANCES VALUES ARE IN μF UNLESS OTHERWISE NOTED. $P=\mu\mu F$
4. V: DC VOLTAGE AT NO SIGNAL
 FM POSITION
 AM POSITION
5. Δ SAFETY-REQUIREMENTS COMPONENTS IN ACCORDANCE WITH PRESENT SAFETY REGULATIONS. THESE COMPONENTS MUST ONLY BE REPLACED BY ORIGINAL PARTS.

WIRING DIAGRAM

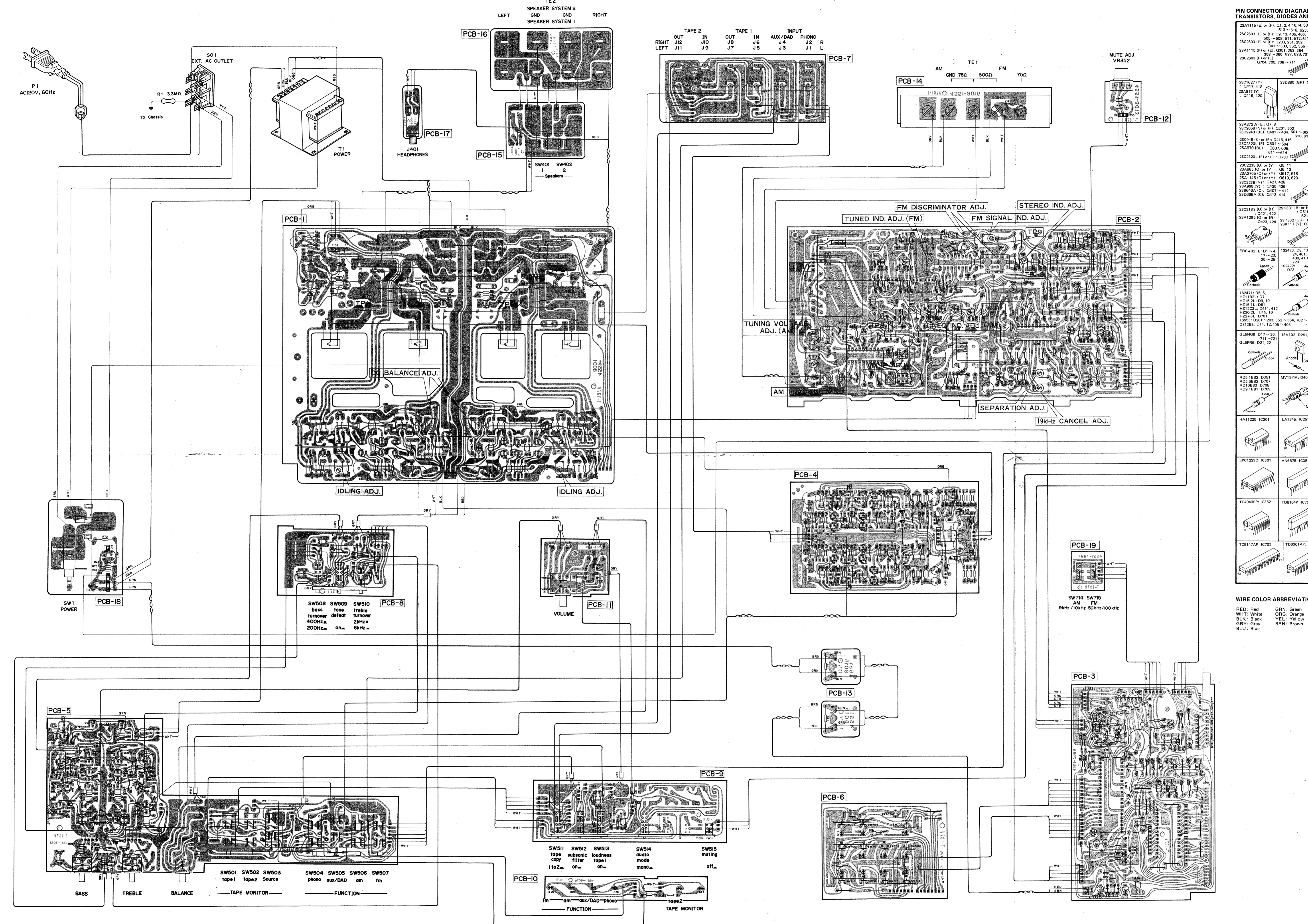

PIN CONNECTION DIAGRAM OF TRANSISTORS, DIODES AND ICs.

2SA1115 (E) or (F): Q1, 2, 4, 10, 14, 509, 510, 513-516, 825, 824	2SC2603 (E) or (F): Q5, 13, 405, 406, 805-808, 911, 912, 917, 618	2SC2603 (F) or (E): Q203, 251, 252, 301-303, 352, 355-357	2SA1116 (F) or (E): Q351, 353, 354, 358-360, 627, 628, 707, 712	2SC2603 (F) or (E): Q704, 705, 708-711
2SC1627 (Y): Q417, 418	2SA817 (Y): Q419, 420	2SD890 (GR): Q51	2SA872 A (E) or (F): Q201, 202	2SC2240 (BL): Q401-404, 601-606, 609, 610, 615, 616
2SC345 (K) or (Y): Q415, 416	2SC2220L (F): Q501-504	2SA970 (BL): Q507, 608, 611-614	2SC2230L (F) or (G): Q703	2SC2235 (O) or (Y): Q5, 11
2SC2235 (O) or (Y): Q6, 12	2SA1145 (O) or (Y): Q617, 618	2SC2235 (Y): Q423, 429	2SA965 (Y): Q425, 426	2SD666A (G): Q407-412
2SD666A (G): Q413, 414	2SC3182 (O) or (R): Q421, 422	2SK381 (B) or (C): Q519, 520, 621, 622	2SA1265 (O) or (R): Q423, 424	2SK362 (GR): Q701
2SK117 (Y): Q702	ERC402FL: D1-4, 17-20, 25-28	1S2473: D8, 13, 14, 24, 401, 402, 409, 410, 722, 723	1S2472: D23	1S2471: D5, 6
HZ181L: D7	HZ15-2L: D9, 10	HZ15-1L: D411, 412	HZ20-2L: D16, 16	1SS53: D201-203, 352-354, 702-706
D31355: D11, 12, 405-408	GL59G6: D17-20, 711-721	GL59PR: D21, 22	1S2472: D23	1S2471: D5, 6
RD5.1EB2: D351	RD5.6EB2: D707	RD19EB2: D709	RD9.1EB1: D709	HA11225: IC201
LA1246: IC261	IPC1223C: IC301	AN6875: IC351	TC4049BP: IC352	TD6104P: IC701
TC8147AP: IC702	TD6301AP: IC703	WIRE COLOR ABBREVIATIONS		

WIRE COLOR ABBREVIATIONS

RED: Red
 WHT: White
 BLK: Black
 GRN: Green
 YEL: Yellow
 GRY: Gray
 BLU: Blue

GRN: Green
 ORG: Orange
 YEL: Yellow
 BRN: Brown

WIRING DIAGRAM

1

2

3

4

5

6

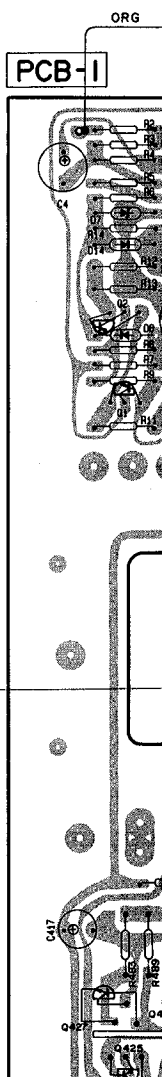
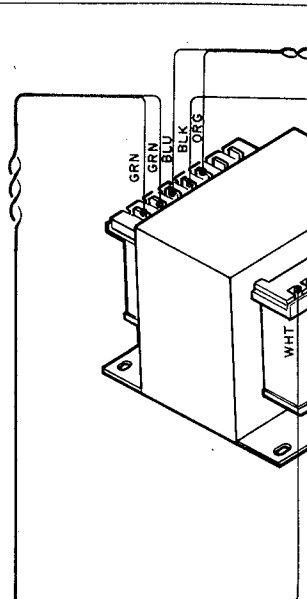
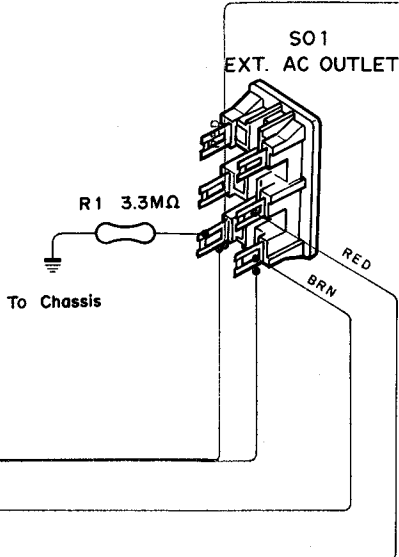
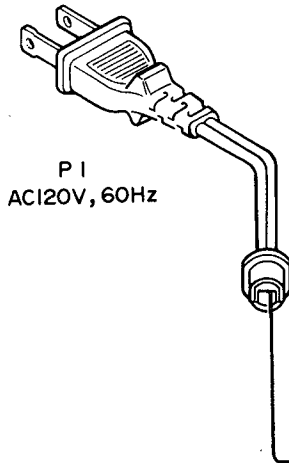

E

F

G

H

TE 2
SPEAKER SYSTEM 2
GND GND
SPEAKER SYSTEM 1

LEFT

RIGHT

PCB-16

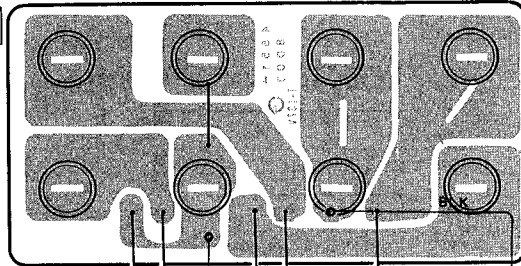

PCB-17



PCB-15

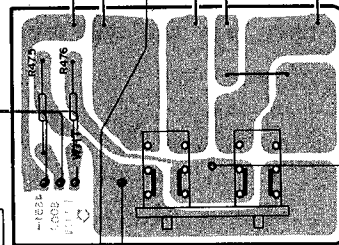

SW401 SW402
1 2
Speakers

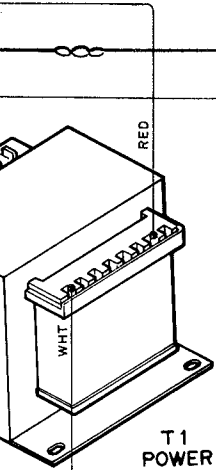

T1
POWER

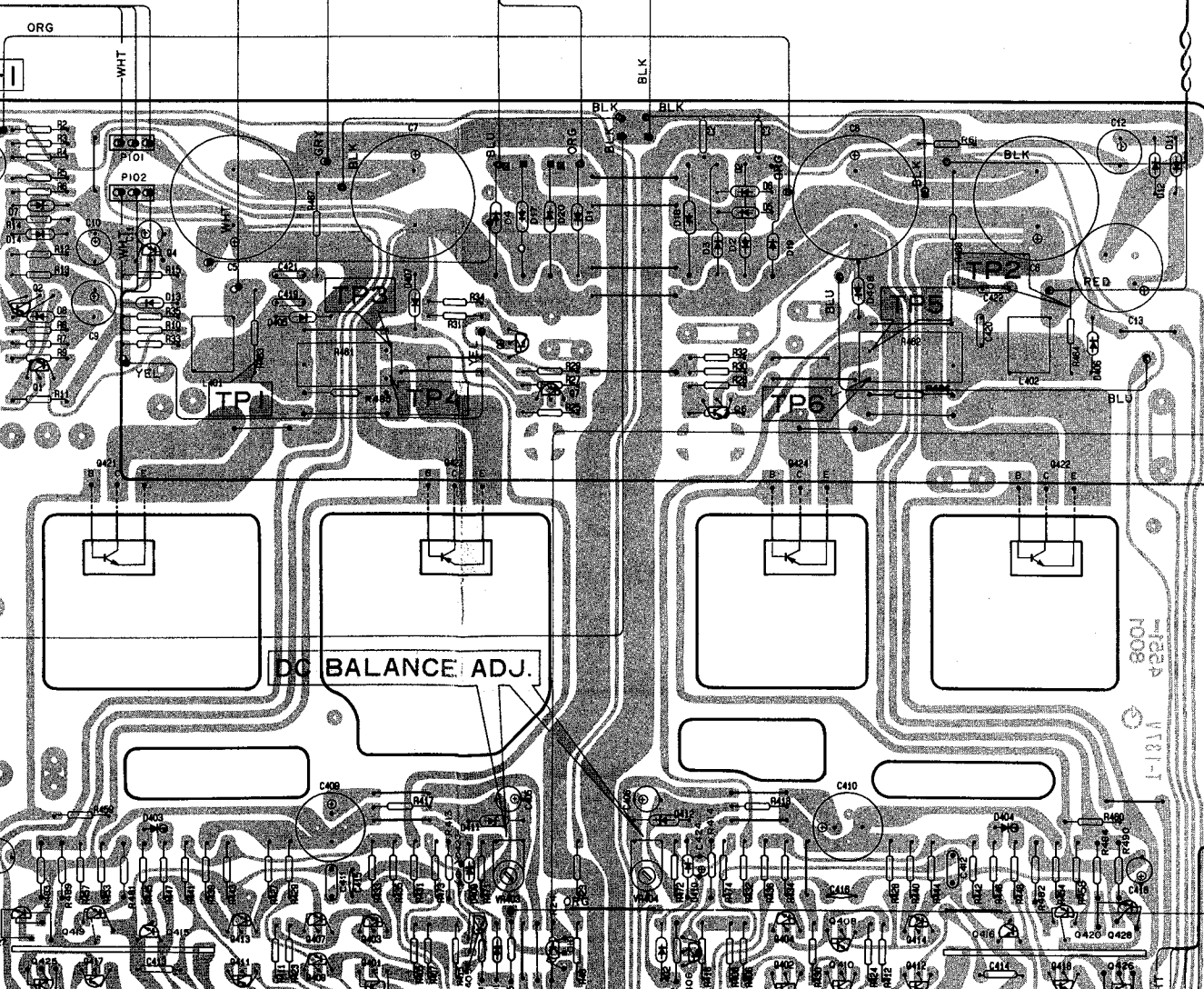

DC BALANCE ADJ.

1224
P008

V181-1

I

J

K

L

	TAPE 2		TAPE 1		INPUT		
	OUT	IN	OUT	IN	AUX/DAD	PHONO	
RIGHT	J12	J10	J8	J6	J4	J2	R
LEFT	J11	J9	J7	J5	J3	J1	L

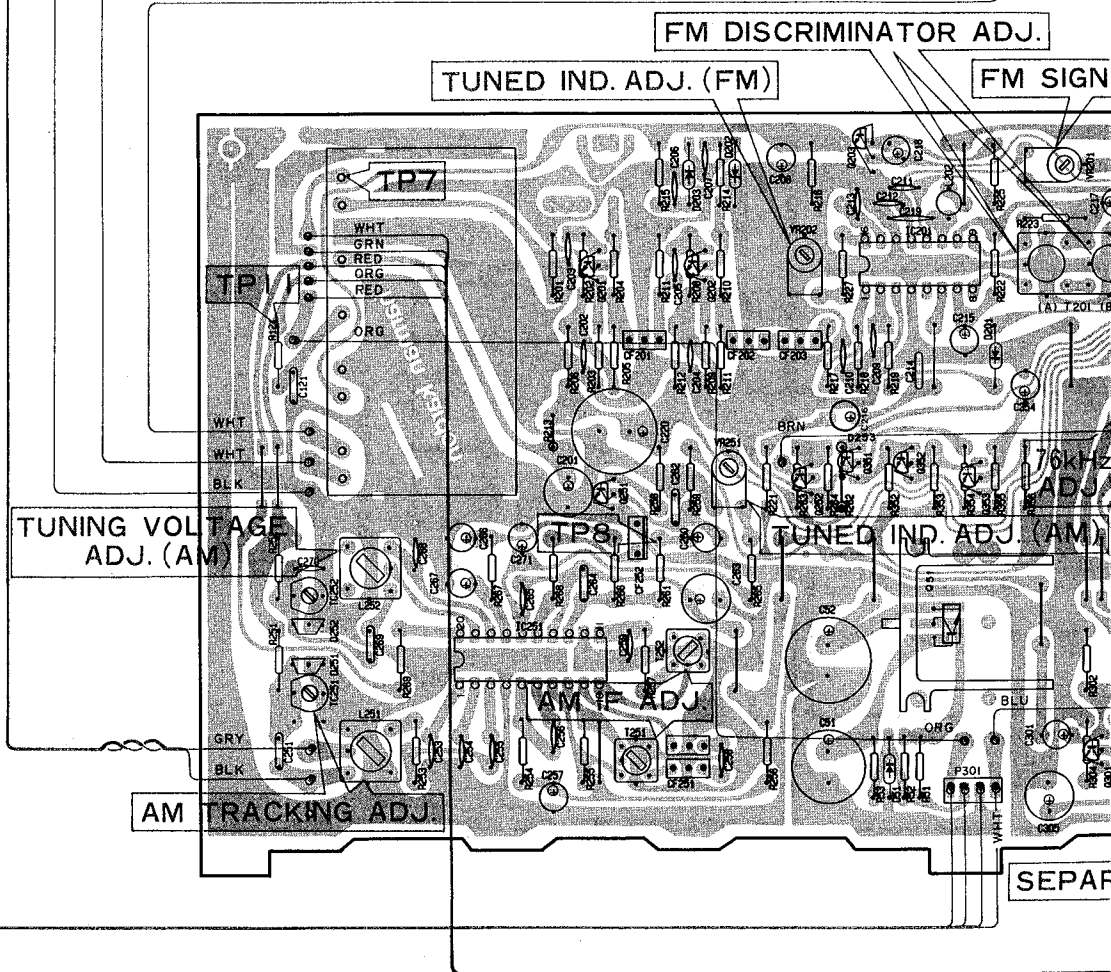
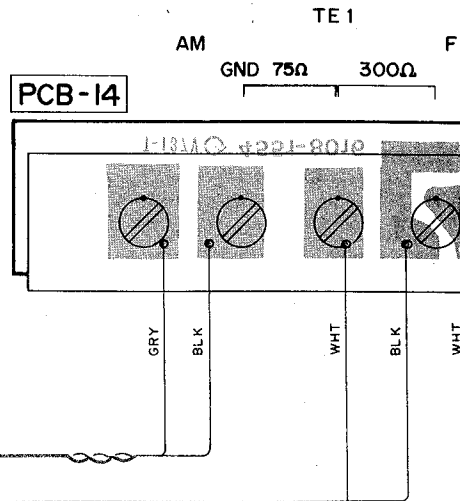
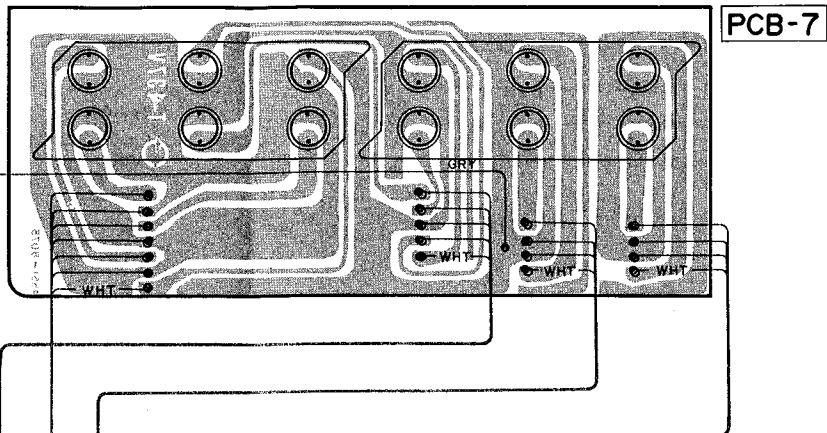

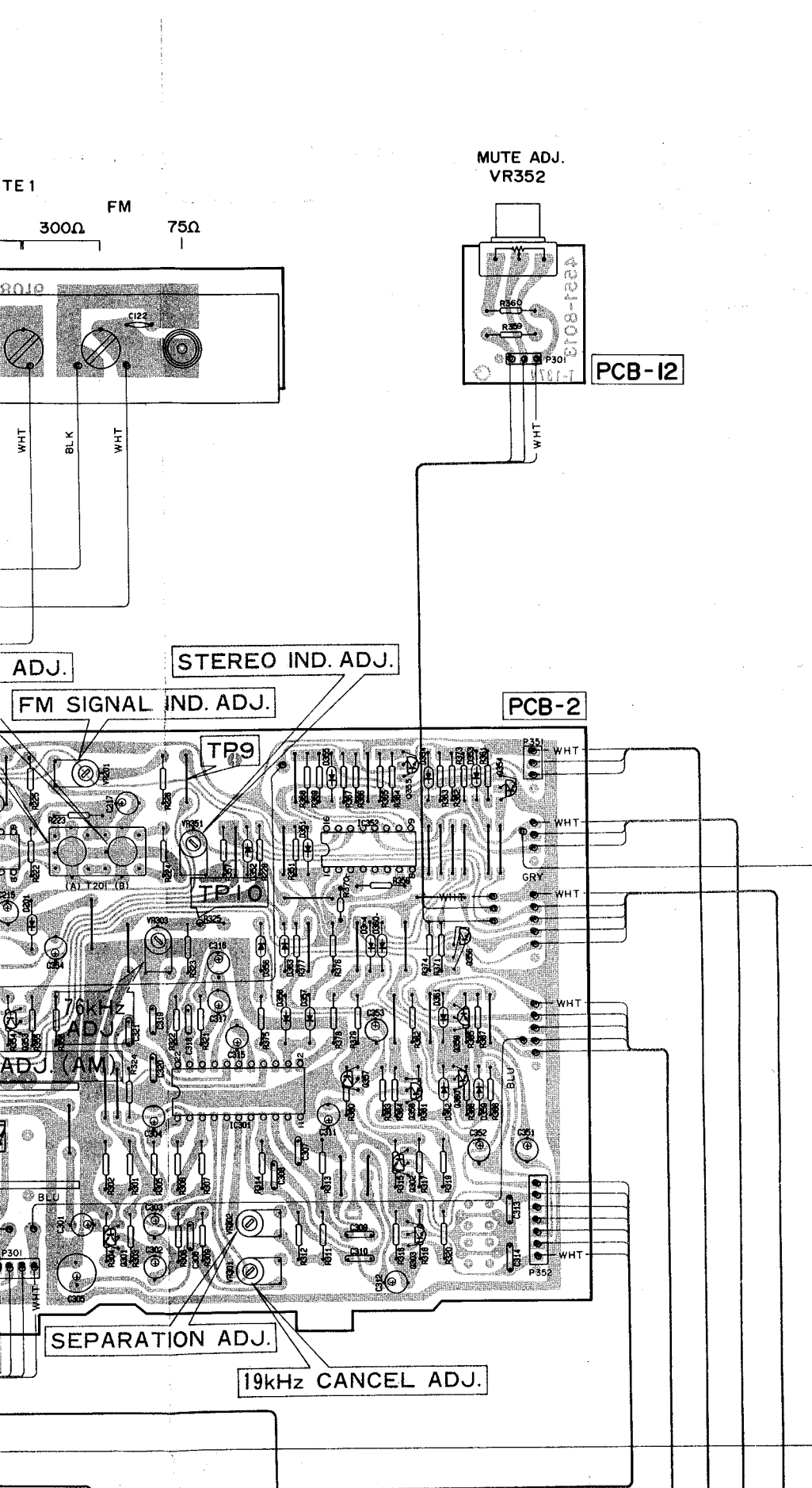

PIN CONNECTION DIAGRAM OF TRANSISTORS, DIODES AND ICs.

<p>2SA1115 (E) or (F): Q1, 2, 4, 10, 14, 509, 510, 513 ~ 516, 623, 624</p> <p>2SC2603 (E) or (F): Q9, 13, 405, 406, 505 ~ 508, 511, 512, 517, 518</p> <p>2SC2603 (F) or (E): Q203, 251, 252, 301 ~ 303, 352, 355 ~ 357</p> <p>2SA1115 (F) or (E): Q351, 353, 354, 358 ~ 360, 627, 628, 707, 712</p> <p>2SC2603 (F) or (E): Q704, 705, 708 ~ 711</p>	<p>2SC1627 (Y): Q417, 418</p> <p>2SA817 (Y): Q419, 420</p>	<p>2SD880 (GR): Q51</p>
<p>2SA872 A (E): Q7, 8</p> <p>2SC2058 (N) or (P): Q201, 202</p> <p>2SC2240 (BL): Q401 ~ 404, 601 ~ 606, 609, 610, 615, 616</p> <p>2SC945 (K) or (P): Q415, 416</p> <p>2SC2320L (F): Q501 ~ 504</p> <p>2SA970 (BL): Q607, 608, 611 ~ 614</p> <p>2SC2320L (F) or (G): Q703</p>	<p>2SC2235 (O) or (Y): Q5, 11</p> <p>2SA965 (O) or (Y): Q6, 12</p> <p>2SA2705 (O) or (Y): Q617, 618</p> <p>2SA1145 (O) or (Y): Q619, 620</p> <p>2SC2235 (Y): Q427, 428</p> <p>2SA965 (Y): Q425, 426</p> <p>2SB646A (C): Q407 ~ 412</p> <p>2SD666A (C): Q413, 414</p>	<p>2SC3182 (O) or (R): Q421, 422</p> <p>2SA1265 (O) or (R): Q423, 424</p> <p>2SK381 (B) or (C): Q519, 520, 621, 622</p> <p>2SK362 (GR): Q701</p> <p>2SK117 (Y): Q702</p>
<p>ERC 402FL: D1 ~ 4, 17 ~ 20, 25 ~ 28</p>	<p>1S2473: D8, 13, 14, 24, 401, 402, 409, 410, 722, 723</p> <p>1S2472: D23</p>	<p>1S2471: D5, 6</p> <p>HZ11B2L: D7</p> <p>HZ15-2L: D9, 10</p> <p>HZ15-1L: D51</p> <p>HZ12C3L: D411, 412</p> <p>HZ20-2L: D15, 16</p> <p>HZ27-3L: D701</p> <p>1S553: D201 ~ 203, 352 ~ 364, 702 ~ 706</p> <p>DS135E: D11, 12, 405 ~ 408</p>
<p>GL5NG6: D17 ~ 20, 711 ~ 721</p> <p>GL5PR6: D21, 22</p>	<p>1SV102: D251, 252</p>	<p>RD5.1EB2: D351</p> <p>RD5.6EB2: D707</p> <p>RD10EB3: D708</p> <p>RD9.1EB1: D709</p>
<p>HA11225: IC201</p>	<p>LA1245: IC251</p>	<p>MV12YM: D403, 404</p>

7

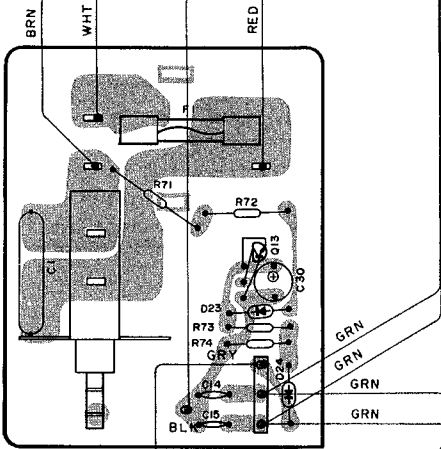

SW1
POWER

PCB-18

8

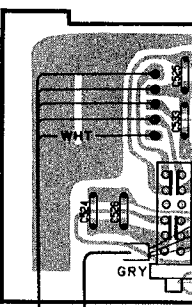

SW50
bass
turnover
400Hz
200Hz

9

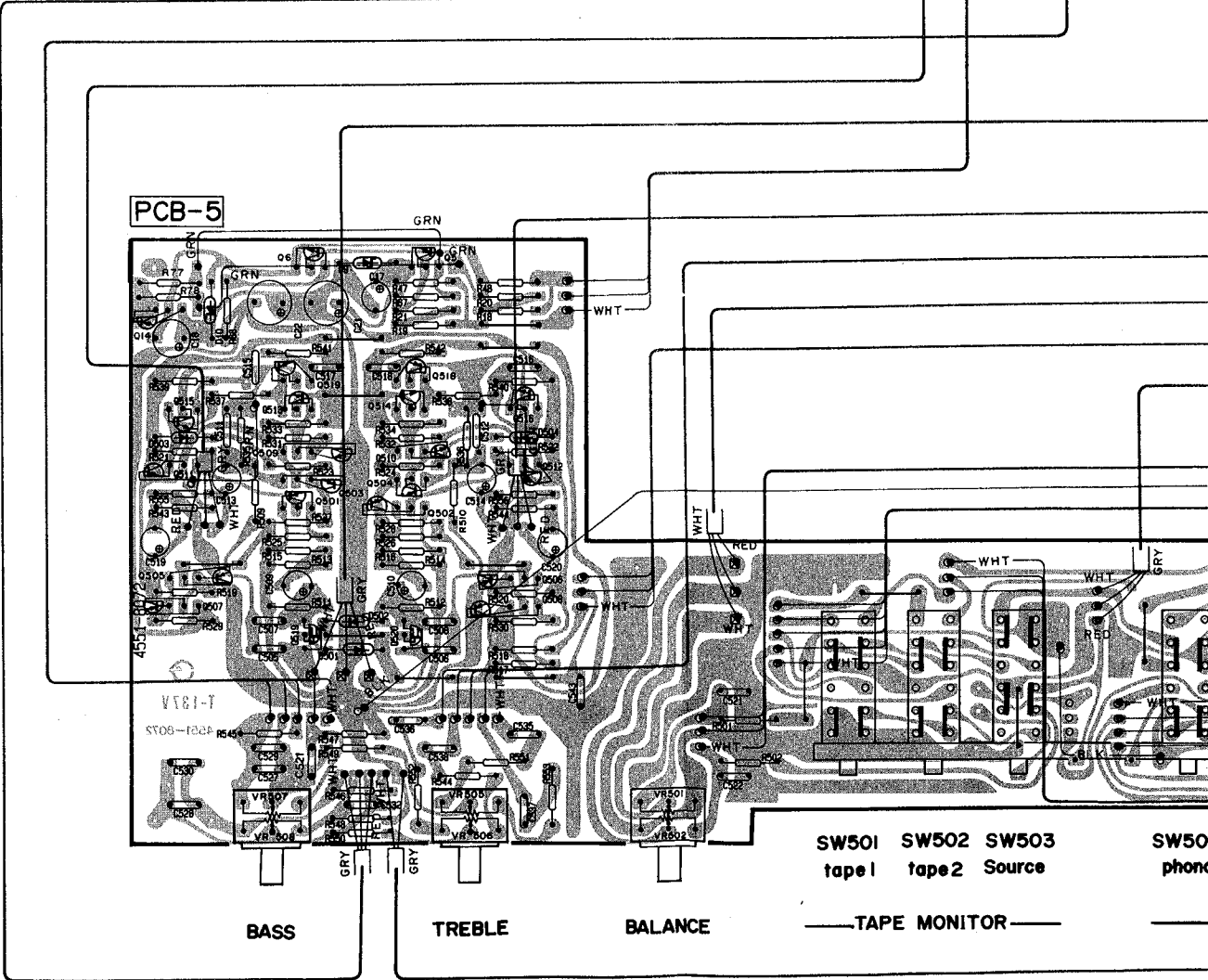

PCB-5

BASS

TREBLE

BALANCE

SW501 SW502 SW503
tape1 tape2 Source

TAPE MONITOR

SW504
phone

10

11

16

12

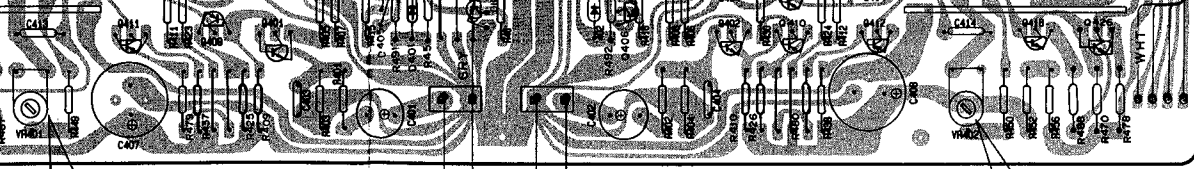

IDLING ADJ.

IDLING ADJ.

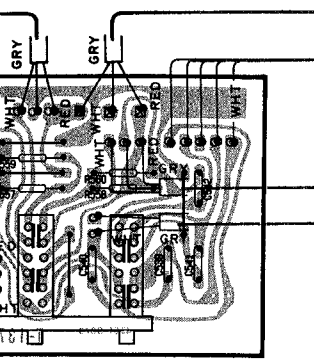

PCB-8

SW509 tone defeat on
SW510 treble turnover 2kHz 6kHz

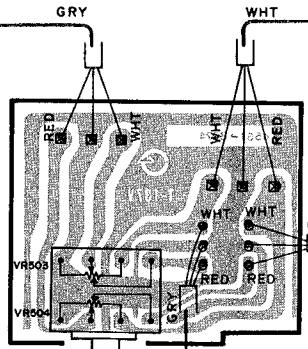

PCB-11

VOLUME

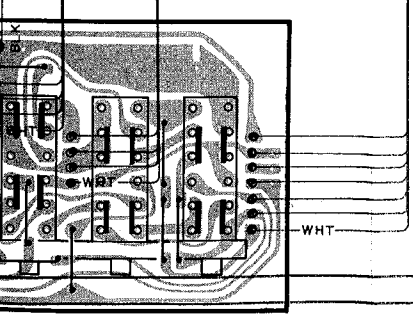

SW505 aux/DAD
SW506 am
SW507 fm

FUNCTION

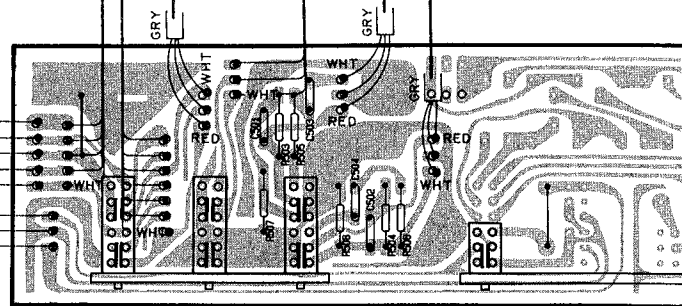

PCB-10

SW511 tape copy 1 to 2
SW512 subsonic filter on
SW513 loudness tapel on
SW514 audio mode mono

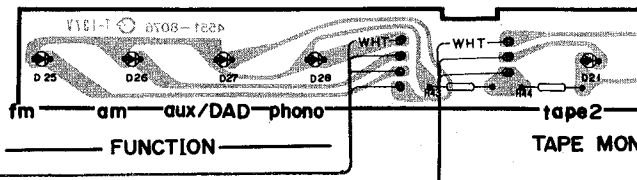

fm am aux/DAD phono tape2 TAPE MON

FUNCTION

PCB-4

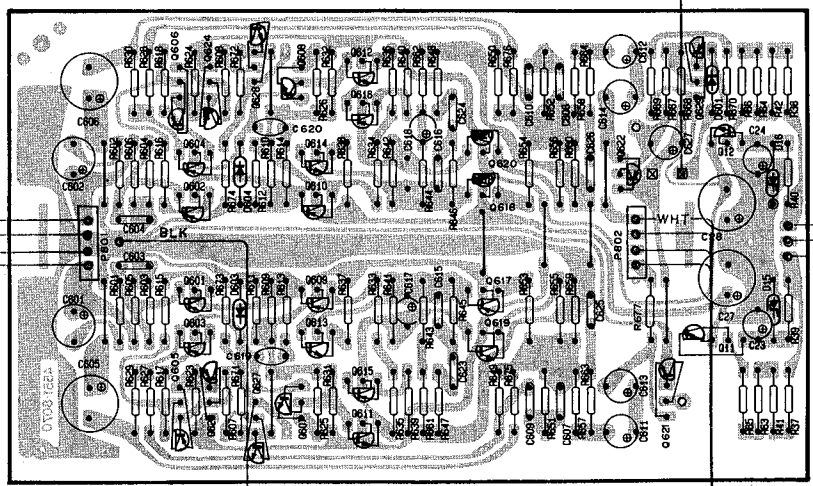

PCB-13

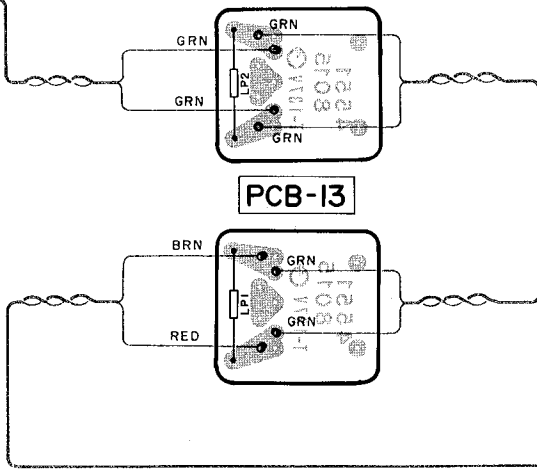

PCB-9

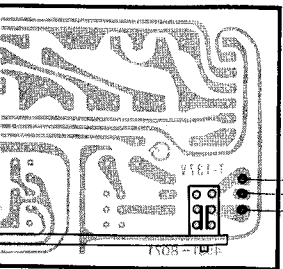

SW515 muting
off

PCB-6

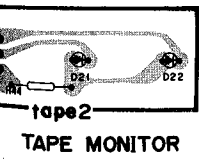
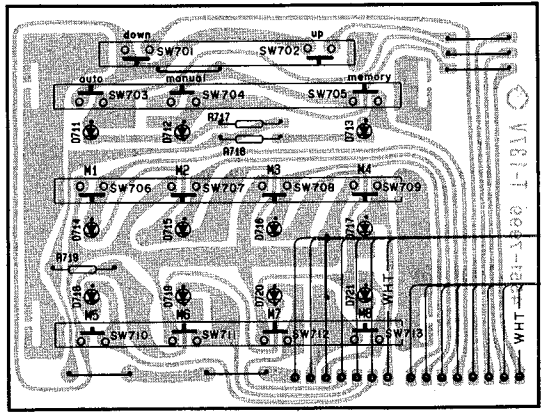

TAPE MONITOR

WHT

PCB-19

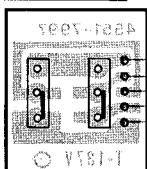

SW714 SW715
AM FM
9kHz / 10kHz 50kHz / 100kHz

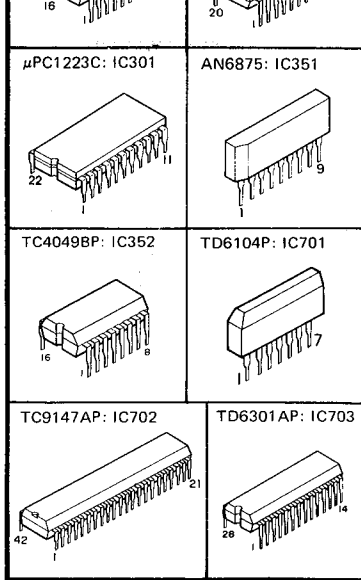

WIRE COLOR ABBREVIATIONS

- RED: Red
- WHT: White
- BLK: Black
- GRY: Gray
- BLU: Blue
- GRN: Green
- ORG: Orange
- YEL: Yellow
- BRN: Brown

PCB-3

