

# The Harman Kardon Model HK6100 INTEGRATED AMPLIFIER

Manual 144A

## Technical Manual

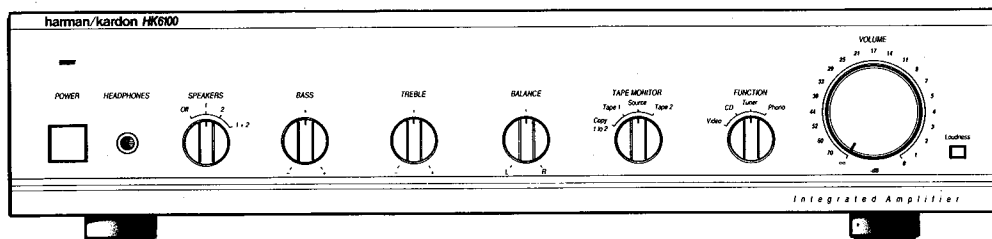

The following marks found in the parts list of this manual identify the models as follows.

- BK : North America area model Black version
- GB : German model Black version
- NB : Japan model Black version
- BB : Australian model Black version
- IE : International model Black version

**harman/kardon**

240 Crossways Park West, Woodbury, N.Y. 11797  
1112-3152144A7 P-088905 1500 Printed in Japan

**SPECIFICATIONS**

	Nominal	Limit
Continuous Average Power FTC, both channels driven, 20-20,000Hz	30Watts per channel	@ less than 0.09% THD into 8 Ohms
High Instantaneous Current Capability (HICC)	22A	
Half Power Bandwidth (8ohms)	10Hz ~ 100kHz	
Frequency Responce at -3dB	0.5Hz ~ 230kHz*	
Input Sensitivity		
Tuner	135mV ± 25mV	
Phono	2.2mV $\pm$ 0.4 -0.2mV	
Signal to Noise Ratio		
Tuner	87.3dB $\geq$ 77dB	
Phono	81.0dB $\geq$ 73dB	
Channel Separation at 10kHz		
Tuner	55dB $\geq$ 45dB	
Phono	55dB $\geq$ 45dB	
IM Distortion Ratio	0.04% $\leq$ 0.1%	
Damping Factor at 1kHz	70 $\geq$ 50	
Tone Control Characteristics		
Bass Turnover Frequency (200Hz/400Hz)		
Bass at 50Hz/100Hz		
Boost	$\pm$ 10dB $\pm$ 2dB	
Cut	$\pm$ 10dB $\pm$ 2dB	
Treble Turnover Frequency (2kHz/6kHz)		
Treble at 10kHz/30kHz		
Boost	$\pm$ 10dB $\pm$ 2dB	
Cut	$\pm$ 10dB $\pm$ 2dB	

	Nominal	Limit
Loudness Control (with Volume Control at -40dB)		
at 10kHz	3dB $\pm$ 1dB	
at 50Hz	10dB $\pm$ 2dB	
DC Output Voltage		
L channel	0mV $\pm$ 60mV	
R channel	0mV $\pm$ 60mV	
RIAA Equalization at Tape Out (20Hz/20kHz) (No load)	0.12dB + 0.5dB/0.12dB - 0.5dB	
Phono Over Load (No load)		
Phono (MM)	135mV $\geq$ 110mV	
Dimensions (W x H x D)	17-1/2" x 4-1/16" x 14-1/4" (443 x 103 x 361mm)	
Weight		
North America area model	14 lbs. 2oz. (6.4kg)	
Power Supplies		
North America area model	AC 120V, 60Hz	
International model	AC 220/240V, 50/60Hz	
Japan model	AC 100V, 50/60Hz	
Power Consumption		
North America area model	220W (242VA)	
International model	190W	
Japan model	98W	
* Frequency Responce at -3dB	0.5Hz ~ 170kHz	
International model		

These specifications are service target specs.

Specifications and components subject to change without notice. Overall performance will be maintained or improved.

**LEAKAGE TEST (FOR SERVICE ENGINEERS IN THE U.S.A.)**

Before returning the unit to the user, perform the following safety checks:

1. Inspect all lead dress to make certain that leads are not pinched or that hardware is not lodged between the chassis and other metal parts in the unit.
2. Be sure that any protective devices such as nonmetallic control knobs, insulating fishpapers, cabinet backs, adjustment and compartment covers or shields, isolation resistor-capacity networks, mechanical insulators, etc. which were removed for servicing are properly reinstalled.
3. Be sure that no shock hazard exists; check for leakage current using Simpson Model 229 Leakage Tester, standard equipment item No. 21641, RCA Model WT540A or use alternate method as follows: Plug the power cord directly into a 120-volt AC receptacle (do not use an Isolation Transformer for this test). Using two clip leads, connect a 1500 Ohm, 10-watt resistor paralleled by a 0.15  $\mu$ F capacitor, in series with all exposed metal cabinet parts and a known earth ground, such as a water pipe or conduit. Use a VTVM or VOM with 1000 Ohms per volt, or higher sensitivity to measure the AC voltage drop across the resistor. (See Diagram.) Move the resistor connection to each exposed metal part having a return path to the chassis (antenna, metal, cabinet, screw heads, knobs and control shafts, escutcheon, etc.) and measure the AC voltage drop across the resistor. (This test should be performed with the power switch in both the On and Off positions.) A reading of 0.35 volt RMS or more is excessive and indicates a potential shock hazard which must be corrected before returning the unit to the owner.

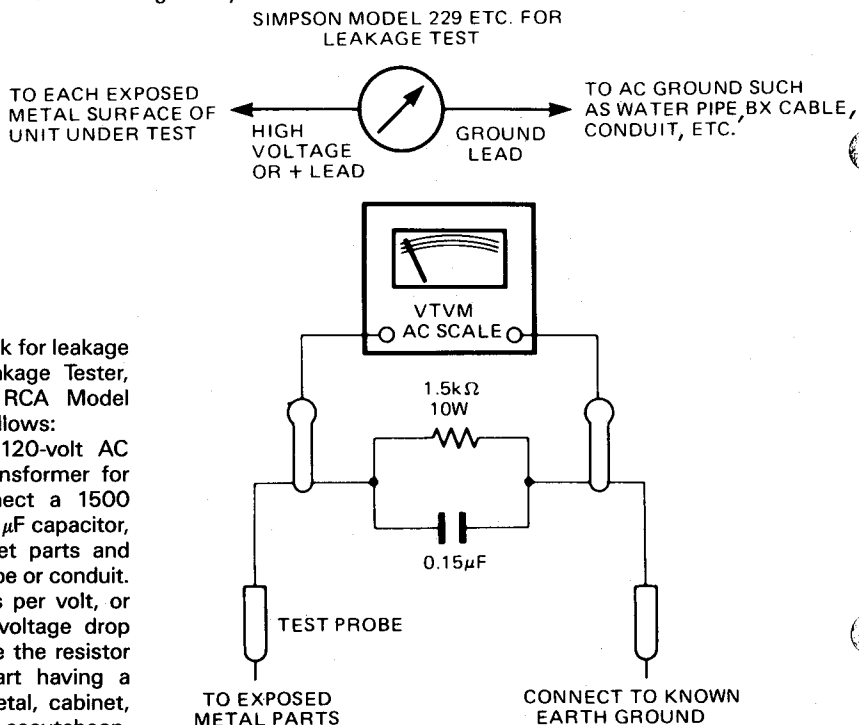

HK6100

**DISASSEMBLY PROCEDURES (REFER TO PAGES 5 AND 14)**

**1 CABINET TOP REMOVAL**

Remove 6 screws (A) and then remove the Cabinet Top (131).

**2 FRONT PANEL ASS'Y (AA) REMOVAL**

1. Remove the Cabinet Top (131), referring to the previous step 1.
2. Pull out 6 Rotary Knob (152) and Volume Rotary Knob (150).
3. Remove 5 screws (B) and then Front Panel Ass'y (AA).

**3 MAIN P. C. BOARD (PCB-1) REMOVAL**

1. Remove the Front Panel Ass'y (AA), referring to the previous step 2.
2. Open the lid of connector (CN106) on the Main P. C. Board (PCB-1).
3. Remove 6 hexagon nuts (C) and then remove the Speaker Switch, and Function P. C. Board (PCB-5 and PCB-9).

4. Remove 4 screws (D) and then remove the Main P. C. Board (PCB-1).  
If necessary, unsolder the lead wires.

**4 EQUALIZER P. C. BOARD (PCB-10) REMOVAL**

1. Remove the Cabinet Top (131), referring to the previous step 1.
2. Remove 4 screws (E) and then remove the Equalizer P. C. Board (PCB-10).  
If necessary, unsolder the lead wires.

**POWER CORD REPLACEMENT (FOR SERVICE ENGINEERS OTHER THAN NOTRH AMERICA)**

In order to prevent fire or shock hazard when replacing the power cord, follow the procedure below to replace the parts with the standard supply parts.

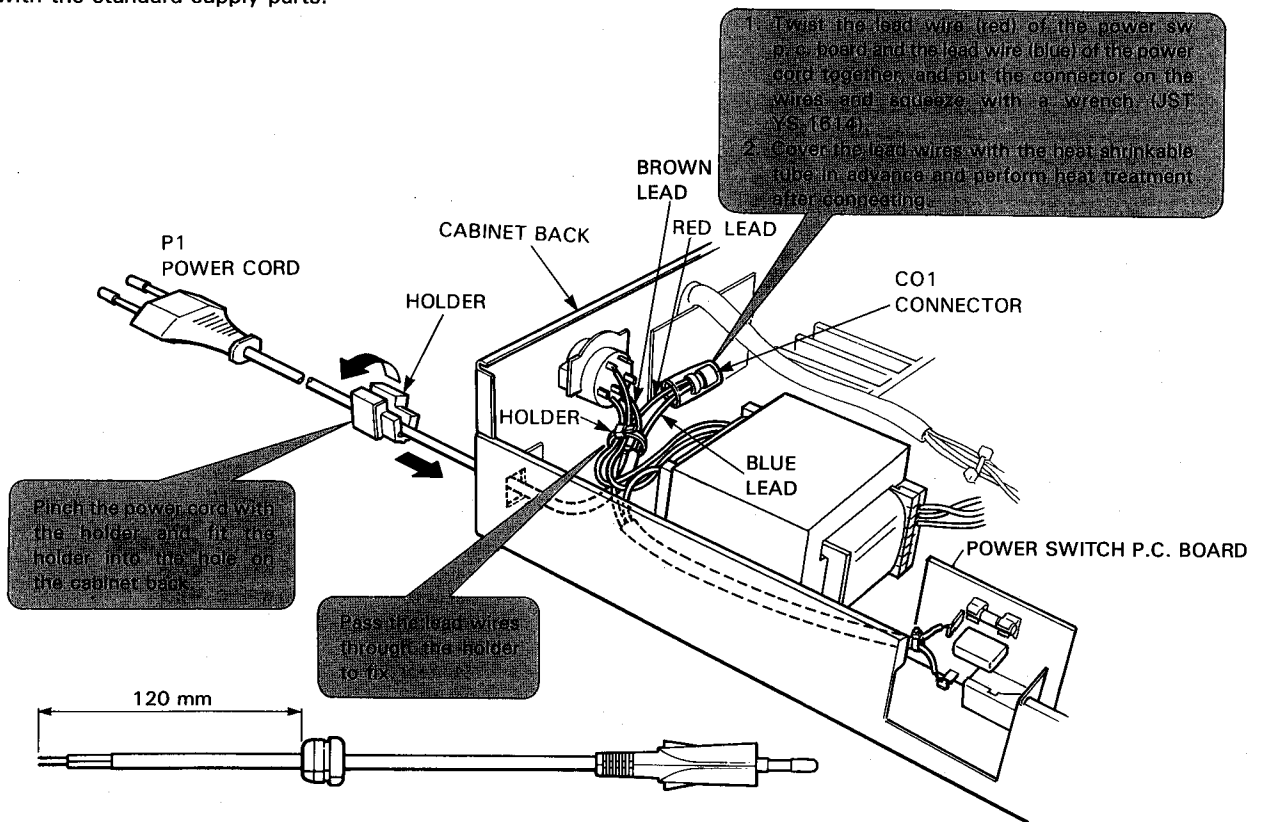

**BLOCK DIAGRAM**

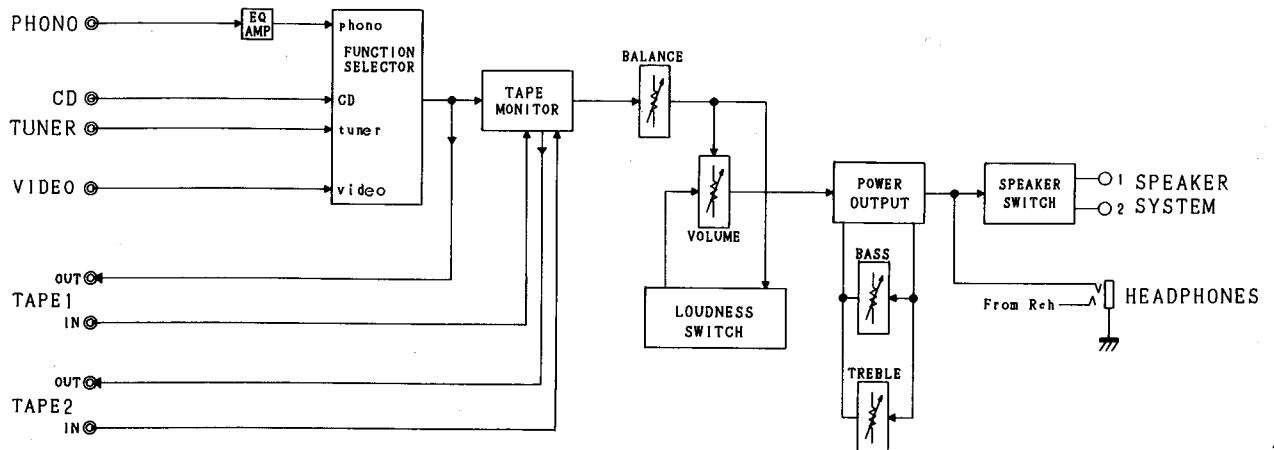

**ALIGNMENT PROCEDURES (REFER TO PAGES 6, 7 AND 13)**

- Conditions:**
- Set the Volume control to minimum.
  - Set the Speaker selector to "1 + 2" position.
  - Make the adjustment at a room temperature of 77°F (25°C).
  - After the Power switch is pushed on, wait for 30 minutes before measuring to be sure of the most stable operation.

**IDLING CURRENT ADJUSTMENT**

Step	Connection Equipments	Adjustment	For
1	Connect the Digital Volt Meter to TP1 and TP2.	VR401 (L ch)	40mV ± 2mV
2	Connect the Digital Volt Meter to TP3 and TP4.	VR402 (R ch)	40mV ± 2mV

**PARTS LIST**

Ref. No.	Part No.	Description	Ref. No.	Part No.	Description
AA	A443-HK6100B	FRONT PANEL ASS'Y <b>BK</b>	171	2224-7134	INSULATOR, MAIN
AA	A443-HK6100C	FRONT PANEL ASS'Y <b>GB</b>	172	2240-7320	HOLDER, POWER
AA	A443-HK6100D	FRONT PANEL ASS'Y <b>NB</b>	173	2240-7202	HOLDER, LOUDNESS
AA	A443-HK6100E	FRONT PANEL ASS'Y <b>BB</b>	174	2240-7209	HOLDER, POWER
AA	A443-HK6100F	FRONT PANEL ASS'Y <b>IB</b>	175	2240-7349	HOLDER, LED
AB	A424-HK6100A	CABINET BACK ASS'Y <b>BK</b>	176	2240-R0101	HOLDER, WIRING
AB	A424-HK6100C	CABINET BACK ASS'Y <b>GB</b>	177	2240-364	HOLDER, AC
AB	A424-HK6100E	CABINET BACK ASS'Y <b>NB</b>	182	2112-11771	SPONGE, REAR
AB	A424-HK6100G	CABINET BACK ASS'Y <b>BB</b>	183	2112-11744	SPONGE, PANEL
AB	A424-HK6100J	CABINET BACK ASS'Y <b>IB</b>	186	4214-168	TERMINAL (GND)
AC	A424-HK6100B	CABINET BOTTOM ASS'Y <b>BK</b>	188	2402-0374	WASHER, PLASTIC BOSS
AC	A424-HK6100D	CABINET BOTTOM ASS'Y <b>GB</b>	191	2672-7018	LEVER
AC	A424-HK6100F	CABINET BOTTOM ASS'Y <b>NB</b>	192	2601-7077	SHAFT, LOUDNESS
AC	A424-HK6100H	CABINET BOTTOM ASS'Y <b>BB</b>	195	2651-210189	SPRING
AC	A424-HK6100K	CABINET BOTTOM ASS'Y <b>IB</b>	198	2360-7015	BOSS, SPE, BOTTOM
AD	A662-HK6100B	PUSH BUTTON ASS'Y <b>BK</b>	201	2327-R0130064	SCREW, BND +
AD	A662-HK6100C	PUSH BUTTON ASS'Y <b>GB</b>	205	2347-R0130062	SCREW, BND T +
AD	A662-HK6100D	PUSH BUTTON ASS'Y <b>NB</b>	206	2347-R0130062	SCREW, BND T +
AD	A662-HK6100E	PUSH BUTTON ASS'Y <b>BB</b>	207	2347-R0130084	SCREW, BND T +
AD	A662-HK6100F	PUSH BUTTON ASS'Y <b>IB</b>	209	2347-R0130102	SCREW, BND T +, MAIN
023	2132-7116	SPACER <b>GB</b> <b>BB</b> <b>IB</b>	211	2347-R0140064	SCREW, BND T +, TOP
024	2327-R0130124	SCREW, BND + <b>GB</b> <b>BB</b> <b>IB</b>	212	2347-400827	SCREW, BND T +, TRANS
025	2440-7017	NUT, SPE <b>GB</b> <b>BB</b> <b>IB</b>	215	2557-301429	SCREW, B SPW +
028	1756-19301	LABEL, DBP No. <b>GB</b>	217	2401-0373	WASHER, METAL
063	2347-R0130084	SCREW, BND T + MAIN <b>GB</b>	△ P1	4161-71151	CORD W/PLUG <b>BK</b>
113	1117-78	SERIAL LABEL, BOTTOM	△ P1	4161-7256	CORD W/PLUG <b>GB</b> <b>IB</b>
116	1756-05910	LABEL <b>BK</b>	△ P1	4161-00401192	CORD W/PLUG <b>NB</b>
117	1756-01426	LABEL, FUSE (2.5A) <b>BK</b>	△ P1	4161-04100	CORD W/PLUG <b>BB</b>
117	1756-01402	LABEL, FUSE <b>GB</b> <b>BB</b> <b>IB</b>	△ T1	5584-701526	XFORMER, POWER <b>BK</b>
117	1756-01436	LABEL, FUSE <b>NB</b>	△ T1	5584-S2503	XFORMER, POWER <b>GB</b> <b>BB</b> <b>IB</b>
118	1756-CSA	LABEL, CSA <b>BK</b>	△ T1	5584-S2504	XFORMER, POWER <b>NB</b>
131	1414-11501	CABINET TOP <b>BK</b> <b>NB</b>	△ SO1	4474-227	SOCKET <b>BK</b> <b>NB</b>
131	1414-04901	CABINET TOP <b>GB</b> <b>BB</b> <b>IB</b>	LUG1	4211-4	LUG <b>GB</b>
133	1424-27101	CABI BACK, BOTTOM	LUG2	4211-4	LUG
134	1424-27006	CABI BACK, REAR <b>BK</b>	△ SW101	4411-102729	SWITCH, ROTARY <b>GB</b> <b>BB</b> <b>IB</b>
134	1424-27005	CABI BACK, REAR <b>GB</b> <b>BB</b> <b>IB</b>	Q431	5613-3181 (O)	XISTOR, NPN R
134	1424-27004	CABI BACK, REAR <b>NB</b>	Q432	5613-3181 (O)	XISTOR, NPN R
136	1443-13201	PANEL, FRONT	Q433	5611-1264 (O)	XISTOR, PNP R
141	1562-07302	FRAME, L-SIDE	Q434	5611-1264 (O)	XISTOR, PNP R
142	1562-07402	FRAME, L-SIDE	Q801(L)	5613-2682 (Q)	XISTOR, NPN R
146	1662-49502	PUSH BUTTON, POWER	Q801(R)	5613-2682 (Q)	XISTOR, NPN R
147	1662-05702	PUSH BUTTON, LOUDNESS			
150	1630-02603	ROTARY KNOB, VOLUME			
152	1632-17101	ROTARY KNOB, SPEAKER, TONE, BALANCE, FUNCTION, TAPE, MONITOR			
154	1732-05801	INDICATOR, LED			
157	1319-02201	LEG, BOTTOM			
161	2211-7295	CHASSIS, FRONT			
163	2219-8179	METAL FITTING			
164	2219-8207	METAL FITTING, BOTTOM			
165	2219-7879	METAL FITTING, H/P			
169	2222-7232	HEAT SINK, MAIN <b>BK</b> <b>NB</b>			
169	2222-7252	HEAT SINK, MAIN <b>GB</b> <b>BB</b> <b>IB</b>			

# GENERAL UNIT EXPLODED VIEW

1  
2  
3  
4  
5  
6  
7

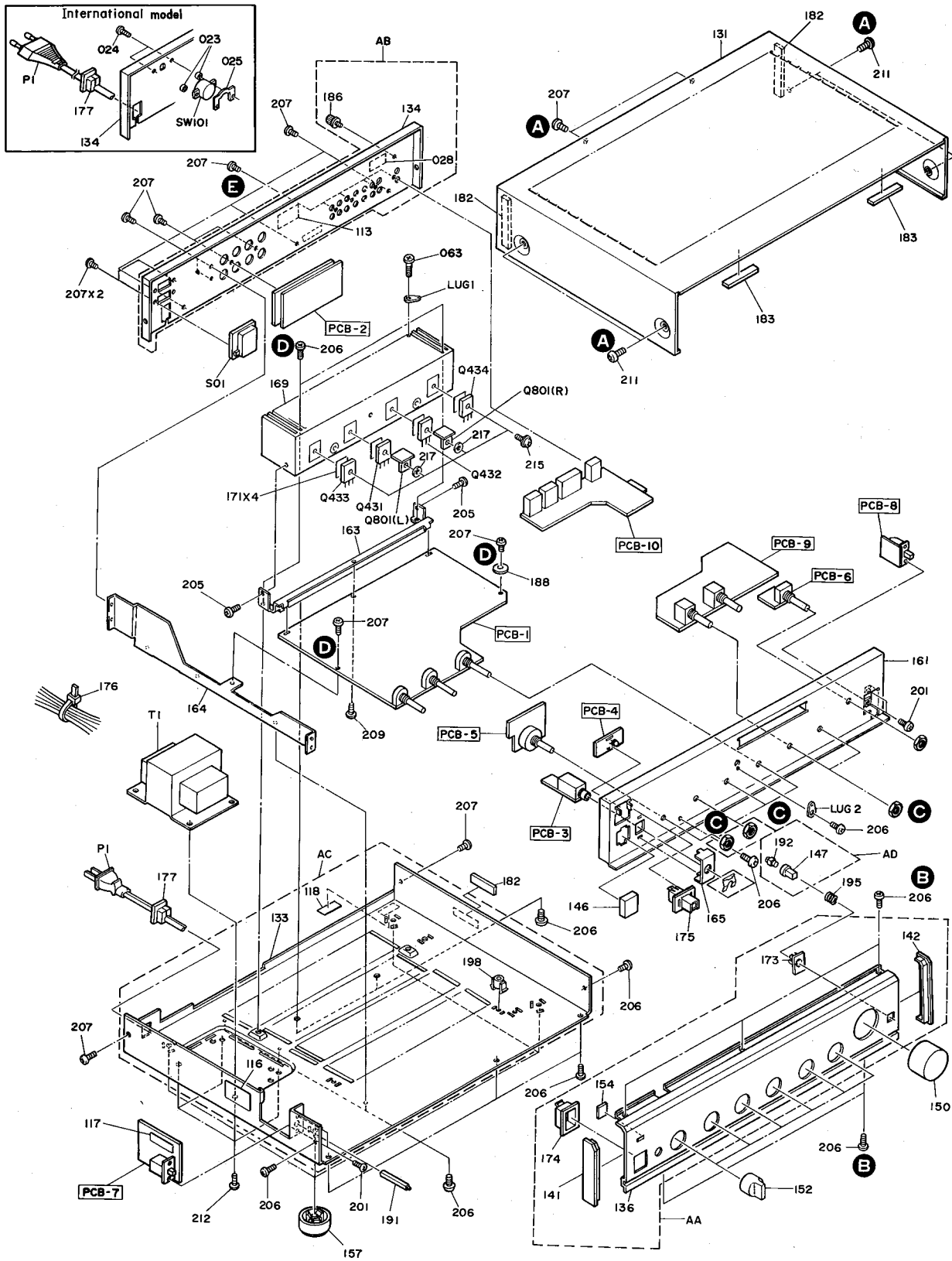
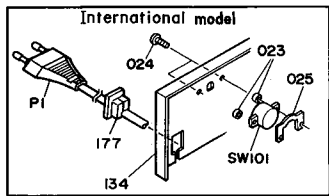

P. C. BOARDS

PCB-9 Function P. C. Board

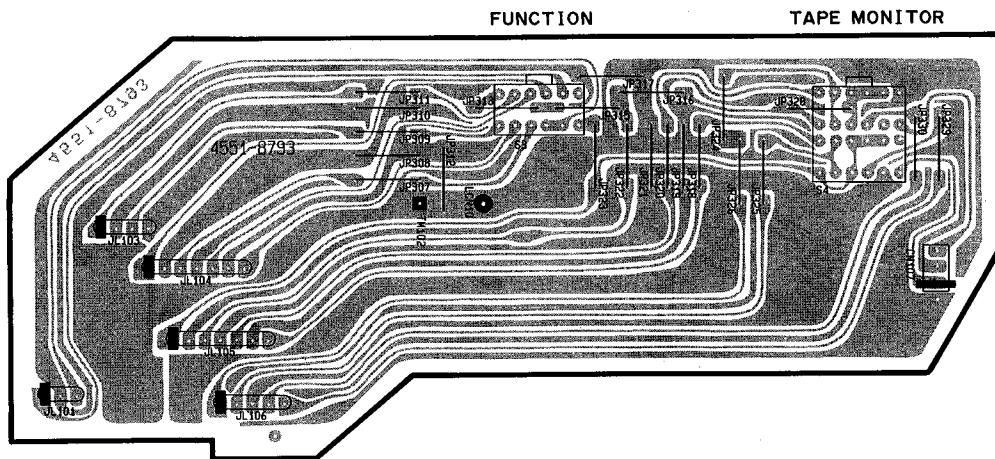

PCB-10 Equalizer P. C. Board

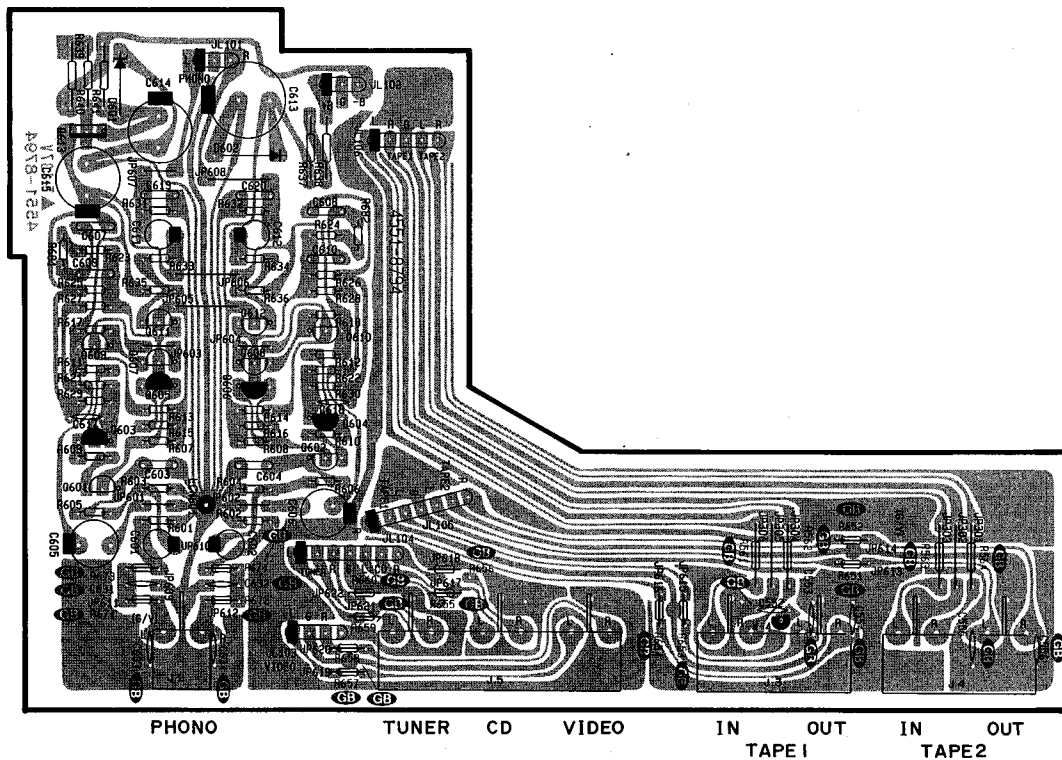

P. C. BOARDS

PCB-1 Main P. C. Board

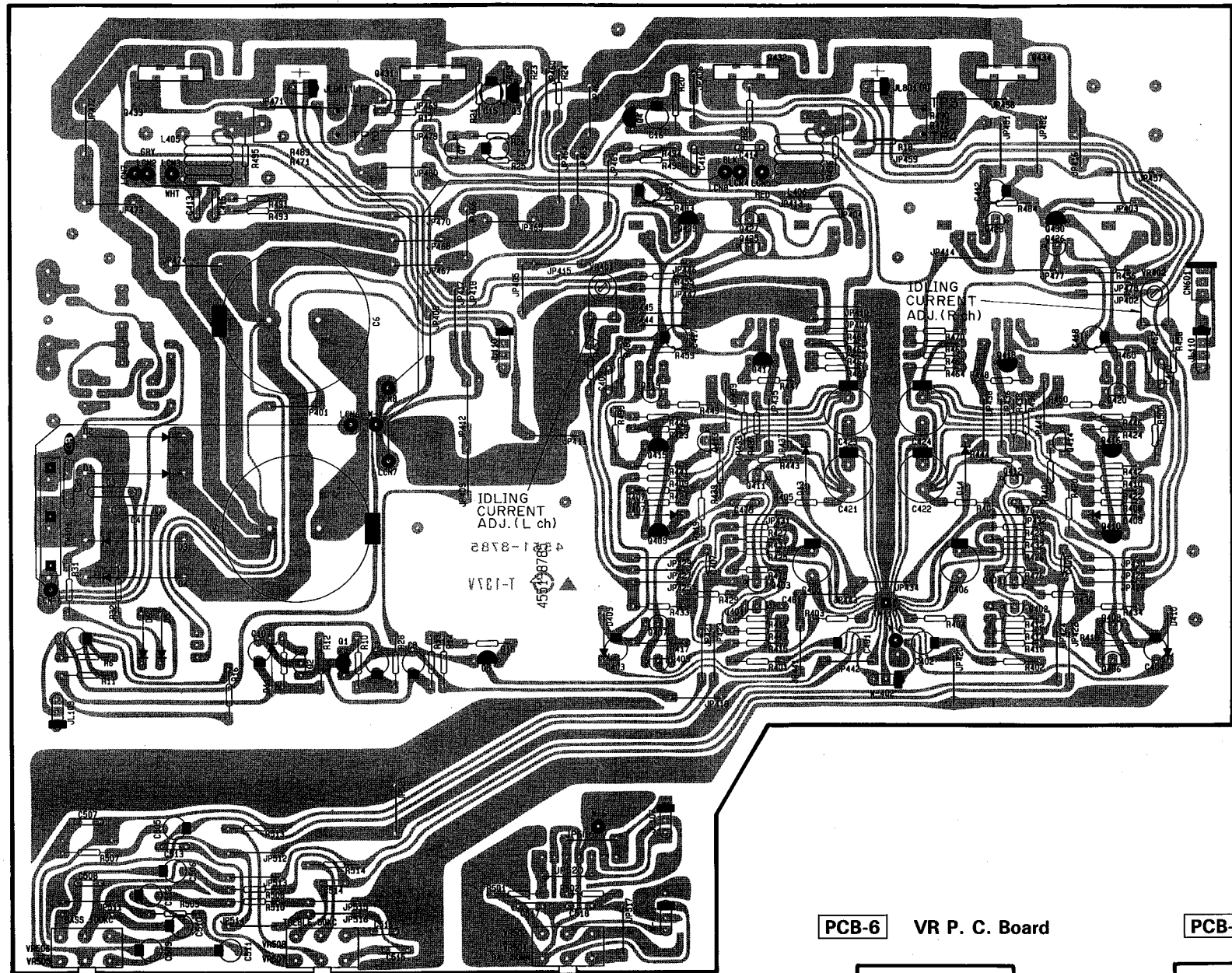

PCB-2 Speaker Terminal P. C. Board

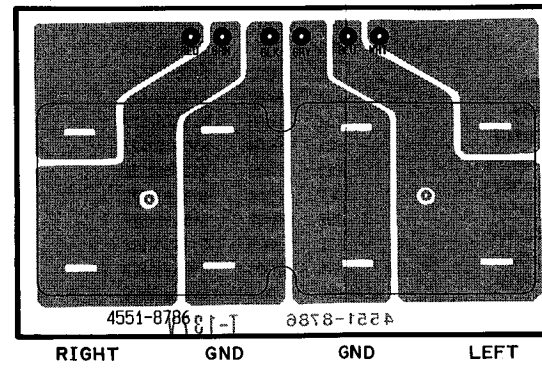

PCB-3 Headphones P. C. Board

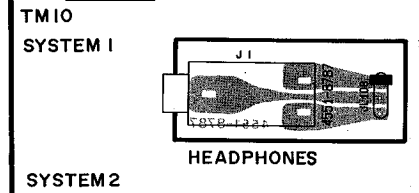

PCB-4 LED P. C. Board

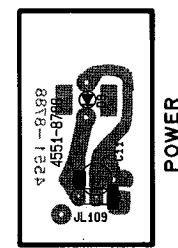

PCB-5 Speaker Switch P. C. Board

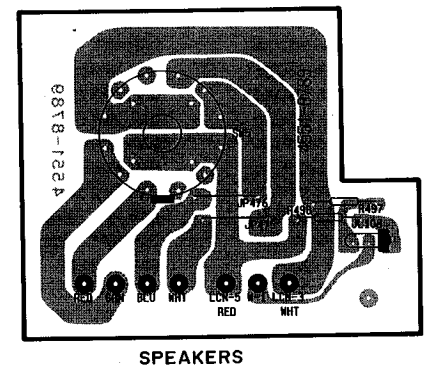

PCB-6 VR P. C. Board

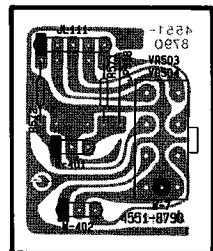

PCB-7 Power Switch P. C. Board

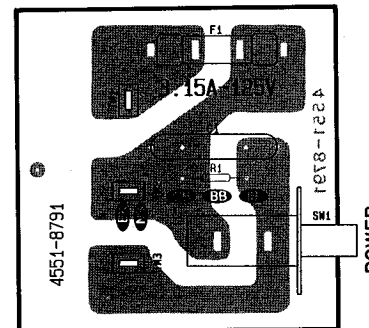

PCB-8 Loudness P. C. Board

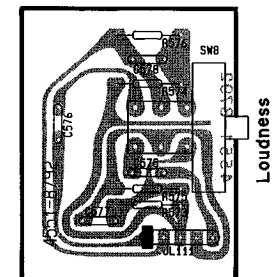

PCB-11 Bias P. C. Board

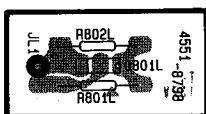

PCB-12 Bias P. C. Board

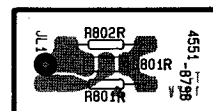

**P. C. BOARDS**

**PCB-1 Main P. C. Board**

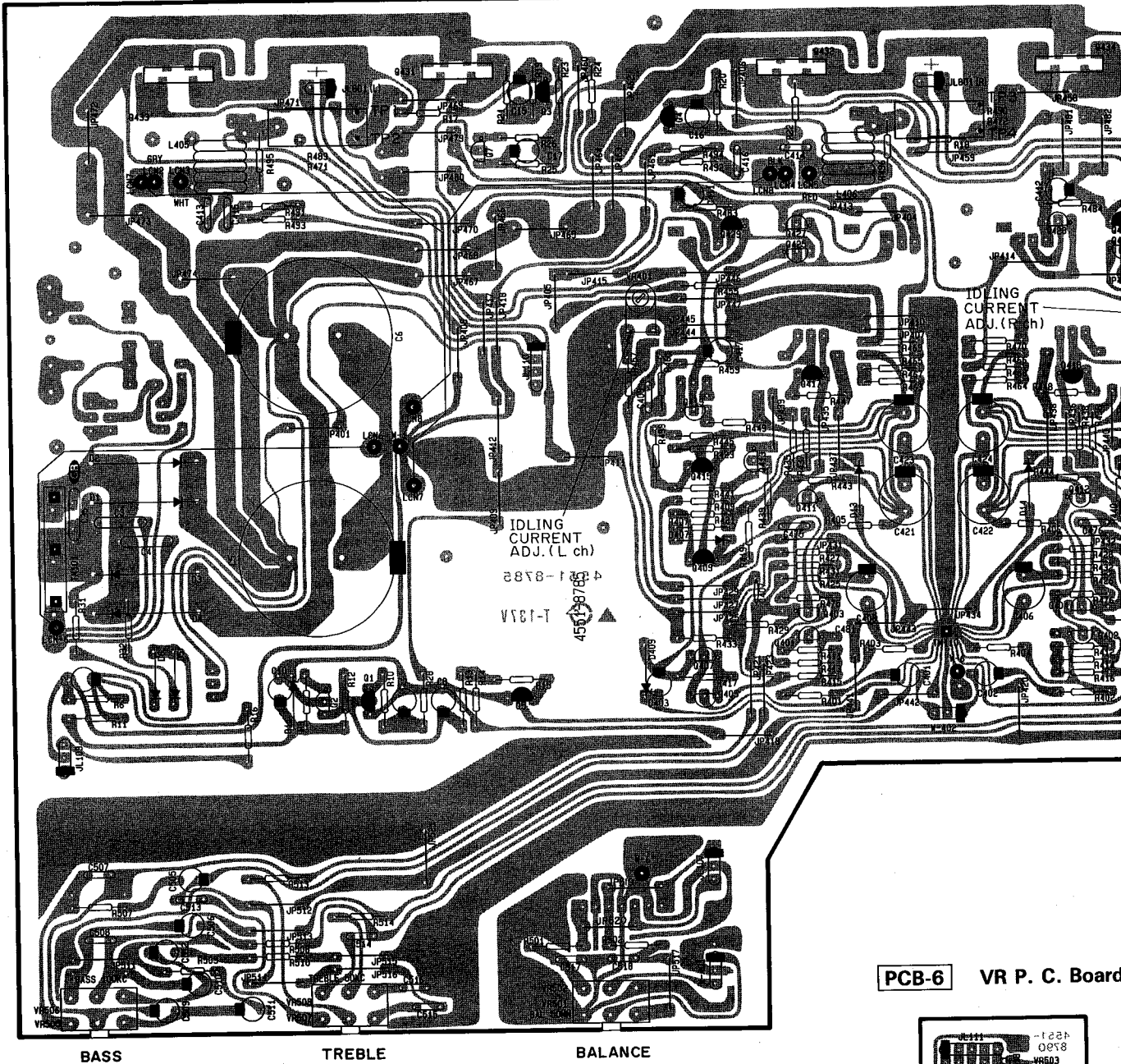

BASS

TREBLE

BALANCE

**PCB-6 VR P. C. Board**

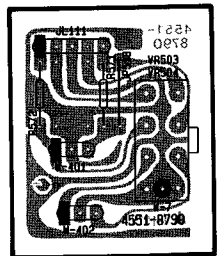

VOLUME

**PCB-11 Bias P. C. Board**

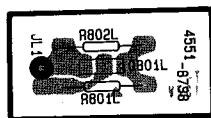

**PCB-12 Bias P. C. Board**

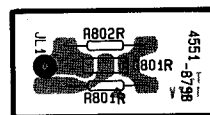

7



F

G

H

I

J

**PCB-2** Speaker Terminal P. C. Board

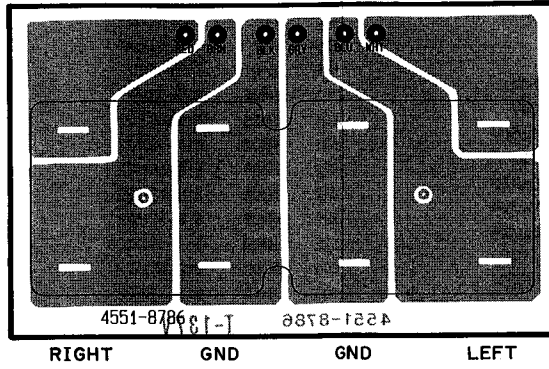

**PCB-3** Headphones P. C. Board

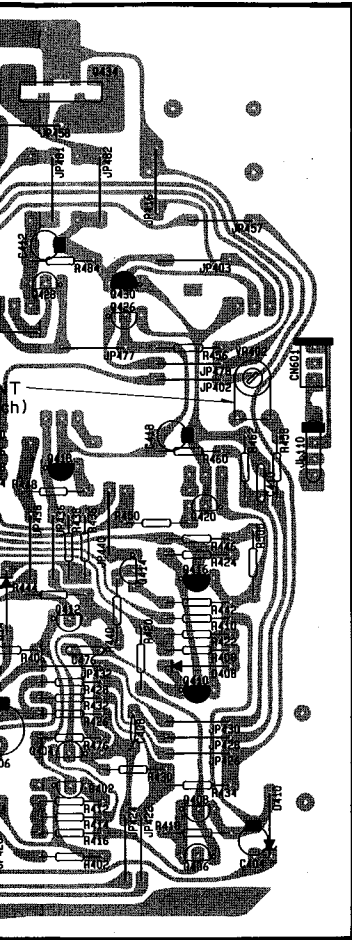
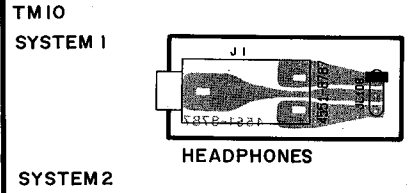

**PCB-4** LED P. C. Board

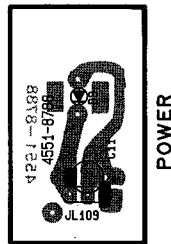

**PCB-5** Speaker Switch P. C. Board

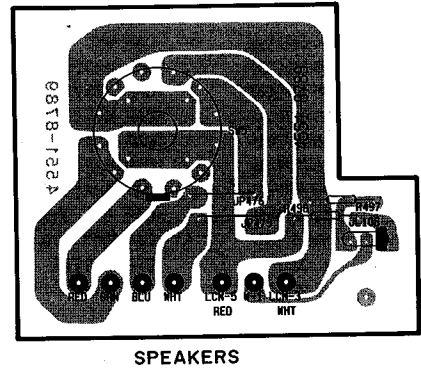

. C. Board



**PCB-7** Power Switch P. C. Board

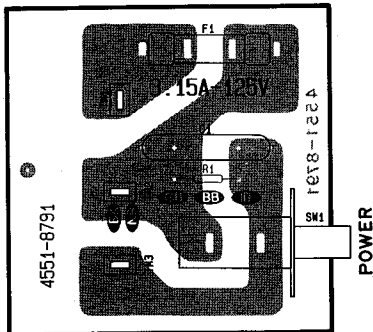

**PCB-8** Loudness P. C. Board

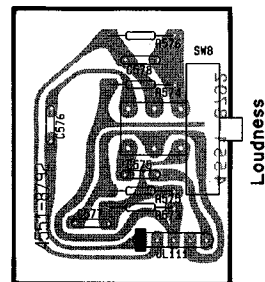

**ELECTRICAL PARTS LIST**

Ser.No	Ref. No.	Part No.	Description
<b>PCB-1 MAIN P.C. BOARD</b>			
<b>CAPACITORS</b>			
662	C2	5345-106F041	CAP, MINI ELE 10μ/50V
689	C3	5362-103048	CAP, CER .01μ
689	C4	5362-103048	CAP, CER .01μ
687	△C5	5341-S07FM822	CAP, ELE 8200μ/50V
687	△C6	5341-S07FM822	CAP, ELE 8200μ/50V
660	C7	5345-106F041	CAP, MINI ELE 10μ/50V
661	C8	5345-107B041	CAP, MINI ELE 100μ/10V
659	C10	5345-106C041	CAP, MINI ELE 10μ/16V
663	C15	5345-334F0951	CAP, MINI ELE .33μ/50V
663	C16	5345-334F0951	CAP, MINI ELE .33μ/50V
664	C17	5345-105F0951	CAP, MINI ELE 1μ/50V
057B	C35	5352-1041957	CAP, MTL 1μ <b>GB</b>
581	C401	5345-476B0951	CAP, MINI ELE 47μ/10V
581	C402	5345-476B0951	CAP, MINI ELE 47μ/10V
587	C403	5345-476C0951	CAP, MINI ELE 47μ/16V
587	C404	5345-476C0951	CAP, MINI ELE 47μ/16V
582	C405	5345-227A0951	CAP, MINI ELE 220μ/6.3V
582	C406	5345-227A0951	CAP, MINI ELE 220μ/6.3V
592	C407	5353-020934	CAP, MCA 2p
592	C408	5353-020934	CAP, MCA 2p
590	C409	5359-1015851	CAP, PPP 100p
590	C410	5359-1015851	CAP, PPP 100p
583	C411	5345-106C0951	CAP, MINI ELE 10μ/16V
583	C412	5345-106C0951	CAP, MINI ELE 10μ/16V
595	C413	5354-683J1HM	CAP, MYL .068μ
595	C414	5354-683J1HM	CAP, MYL .068μ
595	C415	5354-683J1HM	CAP, MYL .068μ
595	C416	5354-683J1HM	CAP, MYL .068μ
583	C417	5345-106C0951	CAP, MINI ELE 10μ/16V
583	C418	5345-106C0951	CAP, MINI ELE 10μ/16V
584	△C421	5345-337F041	CAP, MINI ELE 330μ/50V
584	△C422	5345-337F041	CAP, MINI ELE 330μ/50V
584	△C423	5345-337F041	CAP, MINI ELE 330μ/50V
584	△C424	5345-337F041	CAP, MINI ELE 330μ/50V
593	C475	5359-3315851	CAP, PPP 330p
593	C476	5359-3315851	CAP, PPP 330p
585	C505	5345-225F0951	CAP, MINI ELE 2.2μ/50V
585	C506	5345-225F0951	CAP, MINI ELE 2.2μ/50V
596	C507	5354-273J1HM	CAP, MYL .027μ
596	C508	5354-273J1HM	CAP, MYL .027μ
588	C509	5345-154F0951	CAP, MINI ELE .15μ/50V
588	C510	5345-154F0951	CAP, MINI ELE .15μ/50V
586	C511	5345-106C0951	CAP, MINI ELE 10μ/16V
586	C512	5345-106C0951	CAP, MINI ELE 10μ/16V
597	C513	5354-682J1HM	CAP, MYL 6800p
597	C514	5354-682J1HM	CAP, MYL 6800p
598	C515	5354-393J1HM	CAP, MYL .039μ
598	C516	5354-393J1HM	CAP, MYL .039μ
591	C517	5359-6805851	CAP, PPP 68p
591	C518	5359-6805851	CAP, PPP 68p
<b>RESISTORS</b>			
668	R6	5135-103522	RES, CBN 1/2P 10K
670	R9	5135-472522	RES, CBN 1/2P 4.7K
670	R10	5135-472522	RES, CBN 1/2P 4.7K
667	R11	5135-822522	RES, CBN 1/2P 8.2K
669	R12	5135-104522	RES, CBN 1/2P 100K
675	R13	5135-683522	RES, CBN 1/2P 68K
676	R14	5135-333522	RES, CBN 1/2P 33K
672	R15	5135-223522	RES, CBN 1/2P 22K
677	R16	5135-222522	RES, CBN 1/2P 2.2K
674	R17	5135-392522	RES, CBN 1/2P 3.9K
674	R18	5135-392522	RES, CBN 1/2P 3.9K
673	R19	5135-821522	RES, CBN 1/2P 820
673	R20	5135-821522	RES, CBN 1/2P 820
674	R21	5135-101522	RES, CBN 1/2P 100
674	R22	5135-101522	RES, CBN 1/2P 100
677	R23	5135-222522	RES, CBN 1/2P 2.2K

Ser.No	Ref. No.	Part No.	Description
677	R24	5135-222522	RES, CBN 1/2P 2.2K
671	R25	5135-104522	RES, CBN 1/2P 100K
672	R26	5135-683522	RES, CBN 1/2P 68K
671	R28	5135-822522	RES, CBN 1/2P 8.2K
666	R31	5135-681522	RES, CBN 1/2P 680
666	R32	5135-681522	RES, CBN 1/2P 680
603	R401	5135-331522	RES, CBN 1/2P 330
603	R402	5135-331522	RES, CBN 1/2P 330
604	R403	5135-683522	RES, CBN 1/2P 68K
604	R404	5135-683522	RES, CBN 1/2P 68K
622	R405	5135-681522	RES, CBN 1/2P 680
622	R406	5135-681522	RES, CBN 1/2P 680
622	R407	5135-681522	RES, CBN 1/2P 680
622	R408	5135-681522	RES, CBN 1/2P 680
606	R409	5135-682522	RES, CBN 1/2P 6.8K
606	R410	5135-682522	RES, CBN 1/2P 6.8K
608	R411	5135-390522	RES, CBN 1/2P 39
608	R412	5135-390522	RES, CBN 1/2P 39
608	R413	5135-390522	RES, CBN 1/2P 39
608	R414	5135-390522	RES, CBN 1/2P 39
623	R415	5135-222522	RES, CBN 1/2P 2.2K
623	R416	5135-222522	RES, CBN 1/2P 2.2K
609	R417	5135-331522	RES, CBN 1/2P 330
609	R418	5135-331522	RES, CBN 1/2P 330
604	R419	5135-683522	RES, CBN 1/2P 68K
604	R420	5135-683522	RES, CBN 1/2P 68K
638	△R421	5102-3315116	RES, FUSE 330
638	△R422	5102-3315116	RES, FUSE 330
638	△R423	5102-3315116	RES, FUSE 330
638	△R424	5102-3315116	RES, FUSE 330
610	R425	5135-473522	RES, CBN 1/2P 47K
610	R426	5135-473522	RES, CBN 1/2P 47K
610	R427	5135-473522	RES, CBN 1/2P 47K
610	R428	5135-473522	RES, CBN 1/2P 47K
611	R429	5135-224522	RES, CBN 1/2P 220K
611	R430	5135-224522	RES, CBN 1/2P 220K
618	R431	5135-121522	RES, CBN 1/2P 120
618	R432	5135-121522	RES, CBN 1/2P 120
612	R433	5135-222522	RES, CBN 1/2P 2.2K
612	R434	5135-222522	RES, CBN 1/2P 2.2K
613	R435	5135-223522	RES, CBN 1/2P 22K
613	R436	5135-223522	RES, CBN 1/2P 22K
613	R437	5135-223522	RES, CBN 1/2P 22K
613	R438	5135-223522	RES, CBN 1/2P 22K
624	R439	5135-153522	RES, CBN 1/2P 15K
624	R440	5135-153522	RES, CBN 1/2P 15K
614	R441	5135-123522	RES, CBN 1/2P 12K
614	R442	5135-123522	RES, CBN 1/2P 12K
633	R443	5174-222381	RES, MTL 1/4P 2.2K
633	R444	5174-222381	RES, MTL 1/4P 2.2K
633	R445	5174-222381	RES, MTL 1/4P 2.2K
633	R446	5174-222381	RES, MTL 1/4P 2.2K
636	△R447	5102-4705116	RES, FUSE 47
636	△R448	5102-4705116	RES, FUSE 47
636	△R449	5102-4705116	RES, FUSE 47
636	△R450	5102-4705116	RES, FUSE 47
609	R455	5135-331522	RES, CBN 1/2P 330
609	R456	5135-331522	RES, CBN 1/2P 330
615	R457	5135-391522	RES, CBN 1/2P 390
615	R458	5135-391522	RES, CBN 1/2P 390
625	R459	5135-183522	RES, CBN 1/2P 18K
625	R460	5135-183522	RES, CBN 1/2P 18K
625	R461	5135-183522	RES, CBN 1/2P 18K
625	R462	5135-183522	RES, CBN 1/2P 18K
617	R463	5135-100522	RES, CBN 1/2P 10
617	R464	5135-100522	RES, CBN 1/2P 10
617	R465	5135-100522	RES, CBN 1/2P 10
617	R466	5135-100522	RES, CBN 1/2P 10
637	△R467	5102-1005116	RES, FUSE 10
637	△R468	5102-1005116	RES, FUSE 10
637	△R469	5102-1005116	RES, FUSE 10
637	△R470	5102-1005116	RES, FUSE 10

Ser.No	Ref. No.	Part No.	Description
639	R471/	5273-R27672	RES, CEM 3P .27
	489		
639	R472/	5273-R27672	RES, CEM 3P .27
	490		
605	R475	5135-122522	RES, CBN 1/2P 1.2K
605	R476	5135-122522	RES, CBN 1/2P 1.2K
616	R483	5135-820522	RES, CBN 1/2P 82
616	R484	5135-820522	RES, CBN 1/2P 82
627	R491	5135-4R7522	RES, CBN 1/2P 4.7
627	R492	5135-4R7522	RES, CBN 1/2P 4.7
627	R493	5135-4R7522	RES, CBN 1/2P 4.7
627	R494	5135-4R7522	RES, CBN 1/2P 4.7
626	R495	5135-220522	RES, CBN 1/2P 22
626	R496	5135-220522	RES, CBN 1/2P 22
607	R499	5135-680522	RES, CBN 1/2P 68
607	R500	5135-680522	RES, CBN 1/2P 68
619	R501	5135-331522	RES, CBN 1/2P 330
619	R502	5135-331522	RES, CBN 1/2P 330
620	R507	5135-153522	RES, CBN 1/2P 15K
620	R508	5135-153522	RES, CBN 1/2P 15K
621	R509	5135-272522	RES, CBN 1/2P 2.7K
621	R510	5135-272522	RES, CBN 1/2P 2.7K
622	R513	5135-681522	RES, CBN 1/2P 680
622	R514	5135-681522	RES, CBN 1/2P 680
<b>TRANSISTORS</b>			
652	Q1	5611-933S(S)	XISTOR, PNP R
651	Q2	5613-1740S(S)	XISTOR, NPN R
655	Q3	5611-970(BL)	XISTOR, PNP R
653	Q4	5611-970(BL)	XISTOR, PNP R
653	Q5	5611-970(BL)	XISTOR, PNP R
651	Q7	5613-1740S(S)	XISTOR, NPN R
561	Q401	5613-2240(BL)	XISTOR, NPN R
561	Q402	5613-2240(BL)	XISTOR, NPN R
561	Q403	5613-2240(BL)	XISTOR, NPN R
561	Q404	5613-2240(BL)	XISTOR, NPN R
562	Q405	5613-2320L(F)	XISTOR, NPN R
562	Q406	5613-2320L(F)	XISTOR, NPN R
562	Q407	5613-2320L(F)	XISTOR, NPN R
562	Q408	5613-2320L(F)	XISTOR, NPN R
563	Q409	5611-970(BL)	XISTOR, NPN R
563	Q410	5611-970(BL)	XISTOR, PNP R
574	Q411	5613-2320L(F)	XISTOR, NPN R
574	Q412	5613-2320L(F)	XISTOR, NPN R
573	Q413	5613-2240(BL)	XISTOR, NPN R
573	Q414	5613-2240(BL)	XISTOR, NPN R
578	Q415	5611-999L(F)	XISTOR, PNP R
578	Q416	5611-999L(F)	XISTOR, PNP R
564	Q417	5612-646A(C)	XISTOR, PNP A
564	Q418	5612-646A(C)	XISTOR, PNP A
565	Q419	5614-666A(C)	XISTOR, NPN A
565	Q420	5614-666A(C)	XISTOR, NPN A
566	Q425	5613-945(P)	XISTOR, NPN R
566	Q426	5613-945(P)	XISTOR, NPN R
567	Q427	5614-667A(C)	XISTOR, NPN A
567	Q428	5614-667A(C)	XISTOR, NPN A
568	Q429	5612-647A(C)	XISTOR, PNP A
568	Q430	5612-647A(C)	XISTOR, PNP A
569	Q431	5613-3181(O)	XISTOR, NPN R
569	Q432	5613-3181(O)	XISTOR, NPN R
571	Q433	5611-1264(O)	XISTOR, PNP R
571	Q434	5611-1264(O)	XISTOR, PNP R
<b>DIODES</b>			
681	△D1	5632-ERC402FL	DIODE, RECT
681	△D2	5632-ERC402FL	DIODE, RECT
681	△D3	5632-ERC402FL	DIODE, RECT
681	△D4	5632-ERC402FL	DIODE, RECT
656	△D5</		

**ELECTRICAL PARTS LIST**

Ser.No	Ref. No.	Part No.	Description
<b>PCB-1 MAIN P.C BOARD</b>			

**CAPACITORS**

662	C2	5345-106F041	CAP, MINI ELE 10μ50V
689	C3	5362-103048	CAP, CER .01μ
689	C4	5362-103048	CAP, CER .01μ
687	△C5	5341-S07FM822	CAP, ELE 8200μ50V
687	△C6	5341-S07FM822	CAP, ELE 8200μ50V
660	C7	5345-106F041	CAP, MINI ELE 10μ50V
661	C8	5345-107B041	CAP, MINI ELE 100μ10V
659	C10	5345-106C041	CAP, MINI ELE 10μ16V
663	C15	5345-334F0951	CAP, MINI ELE .33μ50V
663	C16	5345-334F0951	CAP, MINI ELE .33μ50V
664	C17	5345-105F0951	CAP, MINI ELE 1μ50V
057B	C35	5352-1041957	CAP, MTL .1μ <b>GB</b>
581	C401	5345-476B0951	CAP, MINI ELE 47μ10V
581	C402	5345-476B0951	CAP, MINI ELE 47μ10V
587	C403	5345-476C0951	CAP, MINI ELE 47μ16V
587	C404	5345-476C0951	CAP, MINI ELE 47μ16V
582	C405	5345-227A0951	CAP, MINI ELE 220μ6.3V
582	C406	5345-227A0951	CAP, MINI ELE 220μ6.3V
592	C407	5353-020934	CAP, MCA 2p
592	C408	5353-020934	CAP, MCA 2p
590	C409	5359-1015851	CAP, PPP 100p
590	C410	5359-1015851	CAP, PPP 100p
583	C411	5345-106C0951	CAP, MINI ELE 10μ16V
583	C412	5345-106C0951	CAP, MINI ELE 10μ16V
595	C413	5354-683J1HM	CAP, MYL .068μ
595	C414	5354-683J1HM	CAP, MYL .068μ
595	C415	5354-683J1HM	CAP, MYL .068μ
595	C416	5354-683J1HM	CAP, MYL .068μ
583	C417	5345-106C0951	CAP, MINI ELE 10μ16V
583	C418	5345-106C0951	CAP, MINI ELE 10μ16V
584	△C421	5345-337F041	CAP, MINI ELE 330μ50V
584	△C422	5345-337F041	CAP, MINI ELE 330μ50V
584	△C423	5345-337F041	CAP, MINI ELE 330μ50V
584	△C424	5345-337F041	CAP, MINI ELE 330μ50V
593	C475	5359-3315851	CAP, PPP 330p
593	C476	5359-3315851	CAP, PPP 330p
585	C505	5345-225F0951	CAP, MINI ELE 2.2μ50V
585	C506	5345-225F0951	CAP, MINI ELE 2.2μ50V
596	C507	5354-273J1HM	CAP, MYL .027μ
596	C508	5354-273J1HM	CAP, MYL .027μ
588	C509	5345-154F0951	CAP, MINI ELE .15μ50V
588	C510	5345-154F0951	CAP, MINI ELE .15μ50V
586	C511	5345-106C0951	CAP, MINI ELE 10μ16V
586	C512	5345-106C0951	CAP, MINI ELE 10μ16V
597	C513	5354-682J1HM	CAP, MYL 6800p
597	C514	5354-682J1HM	CAP, MYL 6800p
598	C515	5354-393J1HM	CAP, MYL .039μ
598	C516	5354-393J1HM	CAP, MYL .039μ
591	C517	5359-6805851	CAP, PPP 68p
591	C518	5359-6805851	CAP, PPP 68p

**RESISTORS**

668	R6	5135-103522	RES, CBN 1/2P 10K
670	R9	5135-472522	RES, CBN 1/2P 4.7K
670	R10	5135-472522	RES, CBN 1/2P 4.7K
667	R11	5135-822522	RES, CBN 1/2P 8.2K
669	R12	5135-104522	RES, CBN 1/2P 100K
675	R13	5135-683522	RES, CBN 1/2P 68K
676	R14	5135-333522	RES, CBN 1/2P 33K
672	R15	5135-223522	RES, CBN 1/2P 22K
677	R16	5135-222522	RES, CBN 1/2P 2.2K
674	R17	5135-392522	RES, CBN 1/2P 3.9K
674	R18	5135-392522	RES, CBN 1/2P 3.9K
673	R19	5135-821522	RES, CBN 1/2P 820
673	R20	5135-821522	RES, CBN 1/2P 820
674	R21	5135-101522	RES, CBN 1/2P 100
674	R22	5135-101522	RES, CBN 1/2P 100
677	R23	5135-222522	RES, CBN 1/2P 2.2K

Ser.No	Ref. No.	Part No.	Description
677	R24	5135-222522	RES, CBN 1/2P 2.2K
671	R25	5135-104522	RES, CBN 1/2P 100K
672	R26	5135-683522	RES, CBN 1/2P 68K
671	R28	5135-822522	RES, CBN 1/2P 8.2K
666	R31	5135-681522	RES, CBN 1/2P 680
666	R32	5135-681522	RES, CBN 1/2P 680
603	R401	5135-331522	RES, CBN 1/2P 330
603	R402	5135-331522	RES, CBN 1/2P 330
604	R403	5135-683522	RES, CBN 1/2P 68K
604	R404	5135-683522	RES, CBN 1/2P 68K
622	R405	5135-681522	RES, CBN 1/2P 680
622	R406	5135-681522	RES, CBN 1/2P 680
622	R407	5135-681522	RES, CBN 1/2P 680
622	R408	5135-681522	RES, CBN 1/2P 680
606	R409	5135-682522	RES, CBN 1/2P 6.8K
606	R410	5135-682522	RES, CBN 1/2P 6.8K
608	R411	5135-390522	RES, CBN 1/2P 39
608	R412	5135-390522	RES, CBN 1/2P 39
608	R413	5135-390522	RES, CBN 1/2P 39
608	R414	5135-390522	RES, CBN 1/2P 39
623	R415	5135-222522	RES, CBN 1/2P 2.2K
623	R416	5135-222522	RES, CBN 1/2P 2.2K
609	R417	5135-331522	RES, CBN 1/2P 330
609	R418	5135-331522	RES, CBN 1/2P 330
604	R419	5135-683522	RES, CBN 1/2P 68K
604	R420	5135-683522	RES, CBN 1/2P 68K
638	△R421	5102-3315116	RES, FUSE 330
638	△R422	5102-3315116	RES, FUSE 330
638	△R423	5102-3315116	RES, FUSE 330
638	△R424	5102-3315116	RES, FUSE 330
610	R425	5135-473522	RES, CBN 1/2P 47K
610	R426	5135-473522	RES, CBN 1/2P 47K
610	R427	5135-473522	RES, CBN 1/2P 47K
610	R428	5135-473522	RES, CBN 1/2P 47K
611	R429	5135-224522	RES, CBN 1/2P 220K
611	R430	5135-224522	RES, CBN 1/2P 220K
618	R431	5135-121522	RES, CBN 1/2P 120
618	R432	5135-121522	RES, CBN 1/2P 120
612	R433	5135-222522	RES, CBN 1/2P 2.2K
612	R434	5135-222522	RES, CBN 1/2P 2.2K
613	R435	5135-223522	RES, CBN 1/2P 22K
613	R436	5135-223522	RES, CBN 1/2P 22K
613	R437	5135-223522	RES, CBN 1/2P 22K
613	R438	5135-223522	RES, CBN 1/2P 22K
624	R439	5135-153522	RES, CBN 1/2P 15K
624	R440	5135-153522	RES, CBN 1/2P 15K
614	R441	5135-123522	RES, CBN 1/2P 12K
614	R442	5135-123522	RES, CBN 1/2P 12K
633	R443	5174-222381	RES, MTL 1/4P 2.2K
633	R444	5174-222381	RES, MTL 1/4P 2.2K
633	R445	5174-222381	RES, MTL 1/4P 2.2K
633	R446	5174-222381	RES, MTL 1/4P 2.2K
636	△R447	5102-4705116	RES, FUSE 47
636	△R448	5102-4705116	RES, FUSE 47
636	△R449	5102-4705116	RES, FUSE 47
636	△R450	5102-4705116	RES, FUSE 47
609	R455	5135-331522	RES, CBN 1/2P 330
609	R456	5135-331522	RES, CBN 1/2P 330
615	R457	5135-391522	RES, CBN 1/2P 390
615	R458	5135-391522	RES, CBN 1/2P 390
625	R459	5135-183522	RES, CBN 1/2P 18K
625	R460	5135-183522	RES, CBN 1/2P 18K
625	R461	5135-183522	RES, CBN 1/2P 18K
625	R462	5135-183522	RES, CBN 1/2P 18K
617	R463	5135-100522	RES, CBN 1/2P 10
617	R464	5135-100522	RES, CBN 1/2P 10
617	R465	5135-100522	RES, CBN 1/2P 10
617	R466	5135-100522	RES, CBN 1/2P 10
637	△R467	5102-1005116	RES, FUSE 10
637	△R468	5102-1005116	RES, FUSE 10
637	△R469	5102-1005116	RES, FUSE 10
637	△R470	5102-1005116	RES, FUSE 10

Ser.No	Ref. No.	Part No.	Description
639	R471/489	5273-R27672	RES, CEM 3P 27
639	R472/490	5273-R27672	RES, CEM 3P 27
605	R475	5135-122522	RES, CBN 1/2P 1.2K
605	R476	5135-122522	RES, CBN 1/2P 1.2K
616	R483	5135-820522	RES, CBN 1/2P 82
616	R484	5135-820522	RES, CBN 1/2P 82
627	R491	5135-4R7522	RES, CBN 1/2P 4.7
627	R492	5135-4R7522	RES, CBN 1/2P 4.7
627	R493	5135-4R7522	RES, CBN 1/2P 4.7
627	R494	5135-4R7522	RES, CBN 1/2P 4.7
626	R495	5135-220522	RES, CBN 1/2P 22
626	R496	5135-220522	RES, CBN 1/2P 22
607	R499	5135-680522	RES, CBN 1/2P 68
607	R500	5135-680522	RES, CBN 1/2P 68
619	R501	5135-331522	RES, CBN 1/2P 330
619	R502	5135-331522	RES, CBN 1/2P 330
620	R507	5135-153522	RES, CBN 1/2P 15K
620	R508	5135-153522	RES, CBN 1/2P 15K
621	R509	5135-272522	RES, CBN 1/2P 2.7K
621	R510	5135-272522	RES, CBN 1/2P 2.7K
622	R513	5135-681522	RES, CBN 1/2P 680
622	R514	5135-681522	RES, CBN 1/2P 680

#### TRANSISTORS

652	Q1	5611-933S(S)	XISTOR, PNP R
651	Q2	5613-1740S(S)	XISTOR, NPN R
655	Q3	5611-970(BL)	XISTOR, PNP R
653	Q4	5611-970(BL)	XISTOR, PNP R
653	Q5	5611-970(BL)	XISTOR, PNP R
651	Q7	5613-1740S(S)	XISTOR, NPN R
561	Q401	5613-2240(BL)	XISTOR, NPN R
561	Q402	5613-2240(BL)	XISTOR, NPN R
561	Q403	5613-2240(BL)	XISTOR, NPN R
561	Q404	5613-2240(BL)	XISTOR, NPN R
562	Q405	5613-2320L(F)	XISTOR, NPN R
562	Q406	5613-2320L(F)	XISTOR, NPN R
562	Q407	5613-2320L(F)	XISTOR, NPN R
562	Q408	5613-2320L(F)	XISTOR, NPN R
563	Q409	5611-970(BL)	XISTOR, PNP R
563	Q410	5611-970(BL)	XISTOR, PNP R
574	Q411	5613-2320L(F)	XISTOR, NPN R
574	Q412	5613-2320L(F)	XISTOR, NPN R
573	Q413	5613-2240(BL)	XISTOR, NPN R
573	Q414	5613-2240(BL)	XISTOR, NPN R
578	Q415	5611-999L(F)	XISTOR, PNP R
578	Q416	5611-999L(F)	XISTOR, PNP R
564	Q417	5612-646A(C)	XISTOR, PNP A
564	Q418	5612-646A(C)	XISTOR, PNP A
565	Q419	5614-666A(C)	XISTOR, NPN A
565	Q420	5614-666A(C)	XISTOR, NPN A
566	Q425	5613-945(P)	XISTOR, NPN R
566	Q426	5613-945(P)	XISTOR, NPN R
567	Q427	5614-667A(C)	XISTOR, NPN A
567	Q428	5614-667A(C)	XISTOR, NPN A
568	Q429	5612-647A(C)	XISTOR, PNP A
568	Q430	5612-647A(C)	XISTOR, PNP A
569	Q431	5613-3181(O)	XISTOR, NPN R
569	Q432	5613-3181(O)	XISTOR, NPN R
571	Q433	5611-1264(O)	XISTOR, PNP R
571	Q434	5611-1264(O)	XISTOR, PNP R

#### DIODES

681	△ D1	5632-ERC402FL	DIODE, RECT
681	△ D2	5632-ERC402FL	DIODE, RECT
681	△ D3	5632-ERC402FL	DIODE, RECT
681	△ D4	5632-ERC402FL	DIODE, RECT
656	△ D5	5636-1S2471	DIODE, SWITCH
656	△ D6	5636-1S2471	DIODE, SWITCH
657	D11	5635-HZ6B-1L	DIODE, ZENER

Ser.No	Ref. No.	Part No.	Description
658	D13	5631-1S2473	DIODE, DET
658	D14	5631-1S2473	DIODE, DET
575	D407	5631-1S2473	DIODE, DET
575	D408	5631-1S2473	DIODE, DET
576	D409	5635-HZ12B2L	DIODE, ZENER
576	D410	5635-HZ12B2L	DIODE, ZENER
<b>COILS</b>			
644	L405	5991-7165	SPRING COIL
644	L406	5991-7165	SPRING COIL
<b>CONTROLS</b>			
641	VR401	5101-50171913	RES, SEMI FIX 500
641	VR402	5101-50171913	RES, SEMI FIX 500
720	VR501/502	5113-50399122	RES, V CBN 16 50K
714	VR505/506	5113-10441122	RES, V CBN 16 100K
717	VR507/508	5113-50342122	RES, V CBN 16 50K
<b>MISCELLANEOUS</b>			
699	CN601	4443-030185	CONNECTOR
764	JL107	4242-R0203600	JUMPER LEAD
763	JL109	4242-R0103201	JUMPER LEAD
762	JL110	4242-R0104181	JUMPER LEAD
755	JL801(L)	4132-R0202800	CORD, 2C
755	JL801(R)	4132-R0202800	CORD, 2C
747	LCN2	4163-0140026	CONNECTOR W/W
748	LCN3	4163-0140027	CONNECTOR W/W
749	LCN4	4163-0140024	CONNECTOR W/W
750	LCN5	4163-0140025	CONNECTOR W/W
751	LCN6	4163-0112024	CONNECTOR W/W
751	LCN7	4163-0112024	CONNECTOR W/W
751	LCN8	4163-0112024	CONNECTOR W/W
694	TM101	4214-11033	TERMINAL
646	TM110	4214-11013	TERMINAL

#### PCB-2 SPEAKER TERMINAL P.C. BOARD

MISCELLANEOUS			
761	JL120	4242-043805	JUMPER LEAD
743	TM10	4214-156	TERMINAL

#### PCB-3 HEADPHONE P.C. BOARD

MISCELLANEOUS			
736	J1	4451-00159	JACK, 1P

#### PCB-4 LED P.C. BOARD

CAPACITOR			
665	C11	5345-106C0951	CAP, MINI ELE 10μ/16V
DIODE			
741	D9	5637-GL5EG41	LED

#### PCB-5 SPEAKER SWITCH P.C. BOARD

RESISTORS			
632	R497	5135-471522	RES, CBN 1/2P 470
632	R498	5135-471522	RES, CBN 1/2P 470

#### MISCELLANEOUS

765	JL108	4242-R0103101	JUMPER LEAD
729	SW5	4411-00301104	SWITCH, ROTARY

Ser.No	Ref. No.	Part No.	Description
<b>PCB-6 VR P.C. BOARD</b>			
<b>RESISTORS</b>			
631	R571	5135-273522	RES, CBN 1/2P 27K
631	R572	5135-273522	RES, CBN 1/2P 27K
<b>CONTROLS</b>			
711	VR503/504	5113-10419122	RES, V CBN 16 100K

Ser.No	Ref. No.	Part No.	Description
<b>PCB-7 POWER SWITCH P.C. BOARD</b>			
<b>CAPACITORS</b>			
688	△C1	5352-S010M103	CAP, MTL .01μ <b>BK NB</b>
688B	△C1	5352-1030958	CAP, MTL .01μ <b>GB BB IB</b>
<b>RESISTOR</b>			
054B	△R1	5135-335522	RES, CBN 1/2P 3.3M <b>GB BB IB</b>
<b>MISCELLANEOUS</b>			
684	△HF1	4472-0131	HOLDER, FUSE
684	△HF2	4472-0131	HOLDER, FUSE
732	△SW1	4433-00401	SWITCH, PUSH
696	TM1	4214-122	TERMINAL
696	TM2	4214-122	TERMINAL <b>BK BB</b>
696	TM3	4214-122	TERMINAL

Ser.No	Ref. No.	Part No.	Description
<b>PCB-8 LOUDNESS P.C. BOARD</b>			
<b>CAPACITORS</b>			
589	C575	5359-1815851	CAP, PPP 180p
589	C576	5359-1815851	CAP, PPP 180p
594	C577	5354-823JIHM	CAP, MYL .082μ
594	C578	5354-823JIHM	CAP, MYL .082μ
<b>RESISTORS</b>			
629	R573	5135-472522	RES, CBN 1/2P 4.7K
629	R574	5135-472522	RES, CBN 1/2P 4.7K
630	R575	5135-273522	RES, CBN 1/2P 27K
630	R576	5135-273522	RES, CBN 1/2P 27K
<b>MISCELLANEOUS</b>			
766	JL111	4242-R0105800	JUMPER LEAD
733	SW8	4431-A027610	SWITCH, PUSH

Ser.No	Ref. No.	Part No.	Description
<b>PCB-9 FUNCTION P.C. BOARD</b>			
<b>MISCELLANEOUS</b>			
700	CN107	4443-030185	CONNECTOR
768	JL101	4242-R0103181	JUMPER LEAD
769	JL103	4242-R0104301	JUMPER LEAD
772	JL104	4242-R0107301	JUMPER LEAD
771	JL105	4242-R0107251	JUMPER LEAD
770	JL106	4242-R0105181	JUMPER LEAD
753	LCN10	4163-0112039	CONNECTOR W/W
723	SW3	4411-00203104	SWITCH, ROTARY
726	SW4	4411-00204204	SWITCH, ROTARY
695	TM102	4214-11013	TERMINAL

Ser.No	Ref. No.	Part No.	Description
<b>PCB-10 EQUALIZER P.C. BOARD</b>			
<b>CAPACITORS</b>			
066B	C552	5361-103ZF	CAP, CER .01μ <b>GB</b>
069B	C553	5361-101KSL	CAP, CER 100p <b>GB</b>
069B	C554	5361-101KSL	CAP, CER 100p <b>GB</b>
070B	C555	5361-101KSL	CAP, CER 100p <b>GB</b>
070B	C556	5361-101KSL	CAP, CER 100p <b>GB</b>
513	C601	5345-336C0951	CAP, MINI ELE 33μ/16V
513	C602	5345-336C0951	CAP, MINI ELE 33μ/16V
520	C603	5359-1215851	CAP, PPP 120p
520	C604	5359-1215851	CAP, PPP 120p

Ser.No	Ref. No.	Part No.	Description
514	C605	5345-227A0951	CAP, MINI ELE 220μ/6.3V
514	C606	5345-227A0951	CAP, MINI ELE 220μ/6.3V
521	C607	5359-5625851	CAP, PPP 5600p
521	C608	5359-5625851	CAP, PPP 5600p
522	C609	5359-2025851	CAP, PPP 2000p
522	C610	5359-2025851	CAP, PPP 2000p
515	C611	5345-106C0951	CAP, MINI ELE 10μ/16V
515	C612	5345-106C0951	CAP, MINI ELE 10μ/16V
517	C613	5345-337F041	CAP, MINI ELE 330μ/50V
516	C614	5345-227D041	CAP, MINI ELE 220μ/25V
516	C615	5345-227D041	CAP, MINI ELE 220μ/25V
523	C617	5353-040934	CAP, MCA 4p
523	C618	5353-040934	CAP, MCA 4p
519	C619	5359-8215851	CAP, PPP 820p
519	C620	5359-8215851	CAP, PPP 820p
056B	C631	5353-101534	CAP, MCA 100p <b>GB</b>
056B	C632	5353-101534	CAP, MCA 100p <b>GB</b>
069B	C633	5361-101KSL	CAP, CER 100p <b>GB</b>
069B	C634	5361-101KSL	CAP, CER 100p <b>GB</b>

Ser.No	Ref. No.	Part No.	Description
<b>RESISTORS</b>			
064B	R561	5135-102522	RES, CBN 1/2P 1K <b>GB</b>
064B	R562	5135-102522	RES, CBN 1/2P 1K <b>GB</b>
064B	R563	5135-102522	RES, CBN 1/2P 1K <b>GB</b>
064B	R564	5135-102522	RES, CBN 1/2P 1K <b>GB</b>
526	R601	5232-823J16P	RES, CBN 1/6P 82K
526	R602	5232-823J16P	RES, CBN 1/6P 82K
527	R603	5232-124J16P	RES, CBN 1/6P 120K
527	R604	5232-124J16P	RES, CBN 1/6P 120K
528	R605	5232-221J16P	RES, CBN 1/6P 220
528	R606	5232-221J16P	RES, CBN 1/6P 220
529	R607	5154-122J25R	RES, CBN 1/4P 1.2K
529	R608	5154-122J25R	RES, CBN 1/4P 1.2K
530	R609	5178-220381	RES, MTL 1/6P 22
530	R610	5178-220381	RES, MTL 1/6P 22
531	R611	5154-122J25R	RES, CBN 1/4P 1.2K
531	R612	5154-122J25R	RES, CBN 1/4P 1.2K
532	R613	5232-223J16P	RES, CBN 1/6P 22K
532	R614	5232-223J16P	RES, CBN 1/6P 22K
541	R615	5232-820J16P	RES, CBN 1/6P 82
541	R616	5232-820J16P	RES, CBN 1/6P 82
533	R617	5232-121J16P	RES, CBN 1/6P 120
533	R618	5232-121J16P	RES, CBN 1/6P 120
534	R621	5232-821J16P	RES, CBN 1/6P 820
534	R622	5232-821J16P	RES, CBN 1/6P 820
535	R623	5232-393J16P	RES, CBN 1/6P 39K
535	R624	5232-393J16P	RES, CBN 1/6P 39K
536	R625	5232-564J16P	RES, CBN 1/6P 560K
536	R626	5232-564J16P	RES, CBN 1/6P 560K
537	R627	5232-334J16P	RES, CBN 1/6P 330K
537	R628	5232-334J16P	RES, CBN 1/6P 330K
538	R629	5232-102J16P	RES, CBN 1/6P 1K
538	R630	5232-102J16P	RES, CBN 1/6P 1K
539	R631	5232-104J16P	RES, CBN 1/6P 100K
539	R632	5232-104J16P	RES, CBN 1/6P 100K
538	R633	5232-102J16P	RES, CBN 1/6P 1K
538	R634	5232-102J16P	RES, CBN 1/6P 1K
540	R635	5232-222J16P	RES, CBN 1/6P 2.2K
540	R636	5232-222J16P	RES, CBN 1/6P 2.2K
546	R637	5176-S010J471	RES, MTL 1/2P 470
550	△R638	5102-2215116	RES, FUSE 220
551	△R639	5102-1815116	RES, FUSE 180
545	R640	5176-S010J331	RES, MTL 1/2P 330
544	R641	5135-123522	RES, CBN 1/2P 12K
055B	R651	5232-102J16P	RES, CBN 1/6P 1K <b>GB</b>
055B	R652	5232-102J16P	RES, CBN 1/6P 1K <b>GB</b>
055B	R653	5232-102J16P	RES, CBN 1/6P 1K <b>GB</b>
055B	R654	5232-102J16P	RES, CBN 1/6P 1K <b>GB</b>
055B	R655	5232-102J16P	RES, CBN 1/6P 1K <b>GB</b>
055B	R656	5232-102J16P	RES, CBN 1/6P 1K <b>GB</b>
055B	R657	5232-102J16P	RES, CBN 1/6P 1K <b>GB</b>
055B	R658	5232-102J16P	RES, CBN 1/6P 1K <b>GB</b>

Ser.No	Ref. No.	Part No.	Description
055B	R659	5232-102J16P	RES, CBN 1/6P 1K <b>GB</b>
055B	R660	5232-102J16P	RES, CBN 1/6P 1K <b>GB</b>
055B	R671	5232-102J16P	RES, CBN 1/6P 1K <b>GB</b>
055B	R672	5232-102J16P	RES, CBN 1/6P 1K <b>GB</b>
055B	R673	5232-102J16P	RES, CBN 1/6P 1K <b>GB</b>
055B	R674	5232-102J16P	RES, CBN 1/6P 1K <b>GB</b>
540	R681	5232-222J16P	RES, CBN 1/6P 2.2K
540	R682	5232-222J16P	RES, CBN 1/6P 2.2K

Ser.No	Ref. No.	Part No.	Description
<b>TRANSISTORS</b>			
501	Q601	5613-2320L(F)	XISTOR, NPN R
501	Q602	5613-2320L(F)	XISTOR, NPN R
503	Q603	5611-999L(F)	XISTOR, PNP R
503	Q604	5611-999L(F)	XISTOR, PNP R
504	Q605	5611-999L(F)	XISTOR, PNP R
504	Q606	5611-999L(F)	XISTOR, PNP R
501	Q607	5613-2320L(F)	XISTOR, NPN R
501	Q608	5613-2320L(F)	XISTOR, NPN R
501	Q609	5613-2320L(F)	XISTOR, NPN R
501	Q610	5613-2320L(F)	XISTOR, NPN R
501	Q611	5613-2320L(F)	XISTOR, NPN R
501	Q612	5613-2320L(F)	XISTOR, NPN R
505	Q613	5612-647A(C)	XISTOR, PNP A

Ser.No	Ref. No.	Part No.	Description
<b>DIODES</b>			
509	D601	5635-HZ18-2L	DIODE, ZENER
510	D602	5632-S5566B	DIODE, RECT
<b>MISCELLANEOUS</b>			
737	J2	4482-0133	PIN JACK, 2P
738	J3	4484-46	PIN JACK, 4P
738	J4	4484-46	PIN JACK, 4P
739	J5	4486-15	PIN JACK, 6P
767	JL102	4242-R0203101	JUMPER LEAD
752	LCN601	4163-0140039	CONNECTOR W/W

**PCB-11 BIAS P.C. BOARD (Lch)**

Ser.No	Ref. No.	Part No.	Description
<b>RESISTORS</b>			
634	R801(L)	5135-152522	RES, CBN 1/2P 1.5K
635	R802(L)	5135-122522	RES, CBN 1/2P 1.2K
<b>TRANSISTOR</b>			
579	Q801(L)	5613-2682(Q)	XISTOR, NPN R

**PCB-12 BIAS P.C. BOARD (Rch)**

Ser.No	Ref. No.	Part No.	Description
<b>RESISTORS</b>			
634	R801(R)	5135-152522	RES, CBN 1/2P 1.5K
635	R802(R)	5135-122522	RES, CBN 1/2P 1.2K
<b>TRANSISTOR</b>			
579	Q801(R)	5613-2682(Q)	XISTOR, NPN R

Ser.No	Ref. No.	Part No.	Description
<b>CHASSIS MISCELLANEOUS</b>			
<b>MISCELLANEOUS</b>			
052B	△CO1	4443-712	CONNECTOR <b>GB BB IB</b>
685	△F1	5732-252031	FUSE <b>BK</b>
685B	△F1	5732-122052	FUSE <b>GB BB IB</b>
685C	△F1	5732-312036	FUSE <b>NB</b>
062B	LUG1	4211-4	LUG <b>GB</b>
062B	LUG2	4211-4	LUG
745	△P1	4161-71151	CORD W/PLUG <b>BK</b>
745B	△P1	4161-7256	CORD W/PLUG <b>GB IB</b>
745C	△P1	4161-00401192	CORD W/PLUG <b>NB</b>
745D	△P1	4161-04100	CORD W/PLUG <b>BB</b>
744	△SO1	4474-227	SOCKET, AC OUTLET <b>BK NB</b>
051B	△SW101	4411-102729	SWITCH, ROTARY <b>GB BB IB</b>
683	△T1	5584-701526	XFORMER, POWER <b>BK</b>
683B	△T1	5584-82503	XFORMER, POWER <b>GB BB IB</b>
683C	△T1	5584-S2504	XFORMER, POWER <b>NB</b>
053B		4150-8	TUBING, SPE <b>GB BB IB</b>

**PACKAGE PARTS LIST**

Ser.No	Ref. No.	Part No.	Description
021		1756-06303	LABEL <b>GB BB IB</b>
021		1756-03113	LABEL <b>NB</b>
022		1756-03124	LABEL <b>GB</b>
022		1756-03111	LABEL <b>BB</b>
022		1756-03108	LABEL <b>IB</b>
023		1241-PB	POLYETHYLENE BAG <b>NB</b>
026		1119-0135	ATTACH SHEET <b>GB</b>
027		1756-08501	LABEL <b>BB</b>
029		1111-J30319	

Ser.No	Ref. No.	Part No.	Description
<b>PCB-6 VR P.C. BOARD</b>			
<b>RESISTORS</b>			
631	R571	5135-273522	RES, CBN 1/2P 27K
631	R572	5135-273522	RES, CBN 1/2P 27K
<b>CONTROLS</b>			
711	VR503/ 504	5113-10419122	RES, V CBN 16 100K

Ser.No	Ref. No.	Part No.	Description
<b>PCB-7 POWER SWITCH P.C. BOARD</b>			
<b>CAPACITORS</b>			
688	△C1	5352-S010M103	CAP, MTL .01μ <b>BK NB</b>
688B	△C1	5352-1030958	CAP, MTL .01μ <b>GB BB IB</b>
<b>RESISTOR</b>			
054B	△R1	5135-335522	RES, CBN 1/2P 3.3M <b>GB BB IB</b>
<b>MISCELLANEOUS</b>			
684	△HF1	4472-0131	HOLDER, FUSE
684	△HF2	4472-0131	HOLDER, FUSE
732	△SW1	4433-00401	SWITCH, PUSH
696	TM1	4214-122	TERMINAL
696	TM2	4214-122	TERMINAL <b>BK BB</b>
696	TM3	4214-122	TERMINAL

Ser.No	Ref. No.	Part No.	Description
<b>PCB-8 LOUDNESS P.C. BOARD</b>			
<b>CAPACITORS</b>			
589	C575	5359-1815851	CAP, PPP 180p
589	C576	5359-1815851	CAP, PPP 180p
594	C577	5354-823JIHM	CAP, MYL .082μ
594	C578	5354-823JIHM	CAP, MYL .082μ
<b>RESISTORS</b>			
629	R573	5135-472522	RES, CBN 1/2P 4.7K
629	R574	5135-472522	RES, CBN 1/2P 4.7K
630	R575	5135-273522	RES, CBN 1/2P 27K
630	R576	5135-273522	RES, CBN 1/2P 27K
<b>MISCELLANEOUS</b>			
766	JL111	4242-R0105800	JUMPER LEAD
733	SW8	4431-A027610	SWITCH, PUSH

Ser.No	Ref. No.	Part No.	Description
<b>PCB-9 FUNCTION P.C. BOARD</b>			
<b>MISCELLANEOUS</b>			
700	CN107	4443-030185	CONNECTOR
768	JL101	4242-R0103181	JUMPER LEAD
769	JL103	4242-R0104301	JUMPER LEAD
772	JL104	4242-R0107301	JUMPER LEAD
771	JL105	4242-R0107251	JUMPER LEAD
770	JL106	4242-R0105181	JUMPER LEAD
753	LCN10	4163-0112039	CONNECTOR W/W
723	SW3	4411-00203104	SWITCH, ROTARY
726	SW4	4411-00204204	SWITCH, ROTARY
695	TM102	4214-11013	TERMINAL

Ser.No	Ref. No.	Part No.	Description
<b>PCB-10 EQUALIZER P.C. BOARD</b>			
<b>CAPACITORS</b>			
066B	C552	5361-103ZF	CAP, CER .01μ <b>GB</b>
069B	C553	5361-101KSL	CAP, CER 100p <b>GB</b>
069B	C554	5361-101KSL	CAP, CER 100p <b>GB</b>
070B	C555	5361-101KSL	CAP, CER 100p <b>GB</b>
070B	C556	5361-101KSL	CAP, CER 100p <b>GB</b>
513	C601	5345-336C0951	CAP, MINI ELE 33μ/16V
513	C602	5345-336C0951	CAP, MINI ELE 33μ/16V
520	C603	5359-1215851	CAP, PPP 120p
520	C604	5359-1215851	CAP, PPP 120p

Ser.No	Ref. No.	Part No.	Description
514	C605	5345-227A0951	CAP, MINI ELE 220μ/6.3V
514	C606	5345-227A0951	CAP, MINI ELE 220μ/6.3V
521	C607	5359-5625851	CAP, PPP 5600p
521	C608	5359-5625851	CAP, PPP 5600p
522	C609	5359-2025851	CAP, PPP 2000p
522	C610	5359-2025851	CAP, PPP 2000p
515	C611	5345-106C0951	CAP, MINI ELE 10μ/16V
515	C612	5345-106C0951	CAP, MINI ELE 10μ/16V
517	C613	5345-337F041	CAP, MINI ELE 330μ/50V
516	C614	5345-227D041	CAP, MINI ELE 220μ/25V
516	C615	5345-227D041	CAP, MINI ELE 220μ/25V
523	C617	5353-040934	CAP, MCA 4p
523	C618	5353-040934	CAP, MCA 4p
519	C619	5359-8215851	CAP, PPP 820p
519	C620	5359-8215851	CAP, PPP 820p
056B	C631	5353-101534	CAP, MCA 100p <b>GB</b>
056B	C632	5353-101534	CAP, MCA 100p <b>GB</b>
069B	C633	5361-101KSL	CAP, CER 100p <b>GB</b>
069B	C634	5361-101KSL	CAP, CER 100p <b>GB</b>

Ser.No	Ref. No.	Part No.	Description
<b>RESISTORS</b>			
064B	R561	5135-102522	RES, CBN 1/2P 1K <b>GB</b>
064B	R562	5135-102522	RES, CBN 1/2P 1K <b>GB</b>
064B	R563	5135-102522	RES, CBN 1/2P 1K <b>GB</b>
064B	R564	5135-102522	RES, CBN 1/2P 1K <b>GB</b>
526	R601	5232-823J16P	RES, CBN 1/6P 82K
526	R602	5232-823J16P	RES, CBN 1/6P 82K
527	R603	5232-124J16P	RES, CBN 1/6P 120K
527	R604	5232-124J16P	RES, CBN 1/6P 120K
528	R605	5232-221J16P	RES, CBN 1/6P 220
528	R606	5232-221J16P	RES, CBN 1/6P 220
529	R607	5154-122J25R	RES, CBN 1/4P 1.2K
529	R608	5154-122J25R	RES, CBN 1/4P 1.2K
530	R609	5178-220381	RES, MTL 1/6P 22
530	R610	5178-220381	RES, MTL 1/6P 22
531	R611	5154-122J25R	RES, CBN 1/4P 1.2K
531	R612	5154-122J25R	RES, CBN 1/4P 1.2K
532	R613	5232-223J16P	RES, CBN 1/6P 22K
532	R614	5232-223J16P	RES, CBN 1/6P 22K
541	R615	5232-820J16P	RES, CBN 1/6P 82
541	R616	5232-820J16P	RES, CBN 1/6P 82
533	R617	5232-121J16P	RES, CBN 1/6P 120
533	R618	5232-121J16P	RES, CBN 1/6P 120
534	R621	5232-821J16P	RES, CBN 1/6P 820
534	R622	5232-821J16P	RES, CBN 1/6P 820
535	R623	5232-393J16P	RES, CBN 1/6P 39K
535	R624	5232-393J16P	RES, CBN 1/6P 39K
536	R625	5232-564J16P	RES, CBN 1/6P 560K
536	R626	5232-564J16P	RES, CBN 1/6P 560K
537	R627	5232-334J16P	RES, CBN 1/6P 330K
537	R628	5232-334J16P	RES, CBN 1/6P 330K
538	R629	5232-102J16P	RES, CBN 1/6P 1K
538	R630	5232-102J16P	RES, CBN 1/6P 1K
539	R631	5232-104J16P	RES, CBN 1/6P 100K
539	R632	5232-104J16P	RES, CBN 1/6P 100K
538	R633	5232-102J16P	RES, CBN 1/6P 1K
538	R634	5232-102J16P	RES, CBN 1/6P 1K
540	R635	5232-222J16P	RES, CBN 1/6P 2.2K
540	R636	5232-222J16P	RES, CBN 1/6P 2.2K
546	R637	5176-S010J471	RES, MTL 1/2P 470
550	△R638	5102-2215116	RES, FUSE 220
551	△R639	5102-1815116	RES, FUSE 180
545	R640	5176-S010J331	RES, MTL 1/2P 330
544	R641	5135-123522	RES, CBN 1/2P 12K
055B	R651	5232-102J16P	RES, CBN 1/6P 1K <b>GB</b>
055B	R652	5232-102J16P	RES, CBN 1/6P 1K <b>GB</b>
055B	R653	5232-102J16P	RES, CBN 1/6P 1K <b>GB</b>
055B	R654	5232-102J16P	RES, CBN 1/6P 1K <b>GB</b>
055B	R655	5232-102J16P	RES, CBN 1/6P 1K <b>GB</b>
055B	R656	5232-102J16P	RES, CBN 1/6P 1K <b>GB</b>
055B	R657	5232-102J16P	RES, CBN 1/6P 1K <b>GB</b>
055B	R658	5232-102J16P	RES, CBN 1/6P 1K <b>GB</b>

Ser.No	Ref. No.	Part No.	Description
055B	R659	5232-102J16P	RES, CBN 1/6P 1K <b>GB</b>
055B	R660	5232-102J16P	RES, CBN 1/6P 1K <b>GB</b>
055B	R671	5232-102J16P	RES, CBN 1/6P 1K <b>GB</b>
055B	R672	5232-102J16P	RES, CBN 1/6P 1K <b>GB</b>
055B	R673	5232-102J16P	RES, CBN 1/6P 1K <b>GB</b>
055B	R674	5232-102J16P	RES, CBN 1/6P 1K <b>GB</b>
540	R681	5232-222J16P	RES, CBN 1/6P 2.2K
540	R682	5232-222J16P	RES, CBN 1/6P 2.2K

**TRANSISTORS**

501	Q601	5613-2320L(F)	XISTOR, NPN R
501	Q602	5613-2320L(F)	XISTOR, NPN R
503	Q603	5611-999L(F)	XISTOR, PNP R
503	Q604	5611-999L(F)	XISTOR, PNP R
504	Q605	5611-999L(F)	XISTOR, PNP R
504	Q606	5611-999L(F)	XISTOR, PNP R
501	Q607	5613-2320L(F)	XISTOR, NPN R
501	Q608	5613-2320L(F)	XISTOR, NPN R
501	Q609	5613-2320L(F)	XISTOR, NPN R
501	Q610	5613-2320L(F)	XISTOR, NPN R
501	Q611	5613-2320L(F)	XISTOR, NPN R
501	Q612	5613-2320L(F)	XISTOR, NPN R
505	Q613	5612-647A(C)	XISTOR, PNP A

**DIODES**

509	D601	5635-HZ18-2L	DIODE, ZENER
510	D602	5632-S5566B	DIODE, RECT

**MISCELLANEOUS**

737	J2	4482-0133	PIN JACK, 2P
738	J3	4484-46	PIN JACK, 4P
738	J4	4484-46	PIN JACK, 4P
739	J5	4486-15	PIN JACK, 6P
767	JL102	4242-R0203101	JUMPER LEAD
752	LCN601	4163-0140039	CONNECTOR W/W

**PCB-11 BIAS P.C. BOARD (Lch)**

**RESISTORS**

634	R801(L)	5135-152522	RES, CBN 1/2P 1.5K
635	R802(L)	5135-122522	RES, CBN 1/2P 1.2K

**TRANSISTOR**

579	Q801(L)	5613-2682(Q)	XISTOR, NPN R
-----	---------	--------------	---------------

**PCB-12 BIAS P.C. BOARD (Rch)**

**RESISTORS**

634	R801(R)	5135-152522	RES, CBN 1/2P 1.5K
635	R802(R)	5135-122522	RES, CBN 1/2P 1.2K

**TRANSISTOR**

579	Q801(R)	5613-2682(Q)	XISTOR, NPN R
-----	---------	--------------	---------------

**Ser.No Ref. No. Part No. Description**

**CHASSIS MISCELLANEOUS**

**MISCELLANEOUS**

052B	△CO1	4443-712	CONNECTOR <b>GB</b> <b>BB</b> <b>IB</b>
685	△F1	5732-252031	FUSE <b>BK</b>
685B	△F1	5732-122052	FUSE <b>GB</b> <b>BB</b> <b>IB</b>
685C	△F1	5732-312036	FUSE <b>NB</b>
062B	LUG1	4211-4	LUG <b>GB</b>
062B	LUG2	4211-4	LUG
745	△P1	4161-71151	CORD W/PLUG <b>BK</b>
745B	△P1	4161-7256	CORD W/PLUG <b>GB</b> <b>IB</b>
745C	△P1	4161-00401192	CORD W/PLUG <b>NB</b>
745D	△P1	4161-04100	CORD W/PLUG <b>BB</b>
744	△SO1	4474-227	SOCKET, AC OUTLET <b>BK</b> <b>NB</b>
051B	△SW101	4411-102729	SWITCH, ROTARY <b>GB</b> <b>BB</b> <b>IB</b>
683	△T1	5584-701526	XFORMER, POWER <b>BK</b>
683B	△T1	5584-S2503	XFORMER, POWER <b>GB</b> <b>BB</b> <b>IB</b>
683C	△T1	5584-S2504	XFORMER, POWER <b>NB</b>
053B		4150-8	TUBING, SPE <b>GB</b> <b>BB</b> <b>IB</b>

**PACKAGE PARTS LIST**

021	1756-06303	LABEL <b>GB</b> <b>BB</b> <b>IB</b>
021	1756-03113	LABEL <b>NB</b>
022	1756-03124	LABEL <b>GB</b>
022	1756-03111	LABEL <b>BB</b>
022	1756-03108	LABEL <b>IB</b>
023	1241-PB	POLYETHYLENE BAG <b>NB</b>
026	1119-0135	ATTACH SHEET <b>GB</b>
027	1756-08501	LABEL <b>BB</b>
029	1111-J30319	OWNER GUIDE <b>BB</b>
107	1111-J30311	OWNER GUIDE <b>BK</b>
107	1111-J30312	OWNER GUIDE <b>GB</b> <b>IB</b>
107	1111-J2050	OWNER GUIDE <b>NB</b>
108	1113-717004	OWNER CARD <b>BK</b>
108	1113-OC	OWNER CARD <b>NB</b>
109	1119-047	ATTACH SHEET <b>BK</b>
109	1116-GC	GUARANT CARD <b>NB</b>
110	1119-0137	ATTACH SHEET <b>BK</b>
111	1119-01201	ATTACH SHEET <b>BK</b>
121	1241-C12732	POLYETHYLENE BAG
122	1241-C1491	POLYETHYLENE BAG
124	1221-957144	CARTON BOX
125	1222-7216	CUSHION
127	1223-11729	SOFT SHEET

**ABBREVIATIONS IN PARTS LIST**

**CAPACITORS**

CAP, MINI ELE	: Electrolytic
CAP, CER	: Ceramic
CAP, PPP	: Polypropylene
CAP, MYL	: Mylar
CAP, MCA	: Mica
CAP, MINI BP	: Bipolar
CAP, ELE BP	: Electrolytic Bipolar
CAP, STY	: Polystyrene Film
CAP, SPE	: Special
CAP, TAN	: Tantalum

470μ	: 470μF
6800p	: 6800pF
.047μ	: 0.047μF

**RESISTORS**

RES, CBN 1/6P	: Carbon 1/6W
RES, FUSE	: Fuse
RES, CEM 5P	: Cement 5W
RES, MTL 1P	: Metal 1W
2.2K	: 2.2KΩ
220	: 220Ω

**TRANSISTORS**

XISTOR	: Transistor
FET	: Field Effect Transistor

**CONTROLS**

RES, V CBN	: Variable Carbon Resistor
RES, SEMI FIX	: Semi-fixed Resistor

**NOTE**



SAFETY RELATED COMPONENT. USE ONLY EXACT REPLACEMENT PART AS SPECIFIED.

SCHEMATIC DIAGRAM (PHONO AMP SECTION)

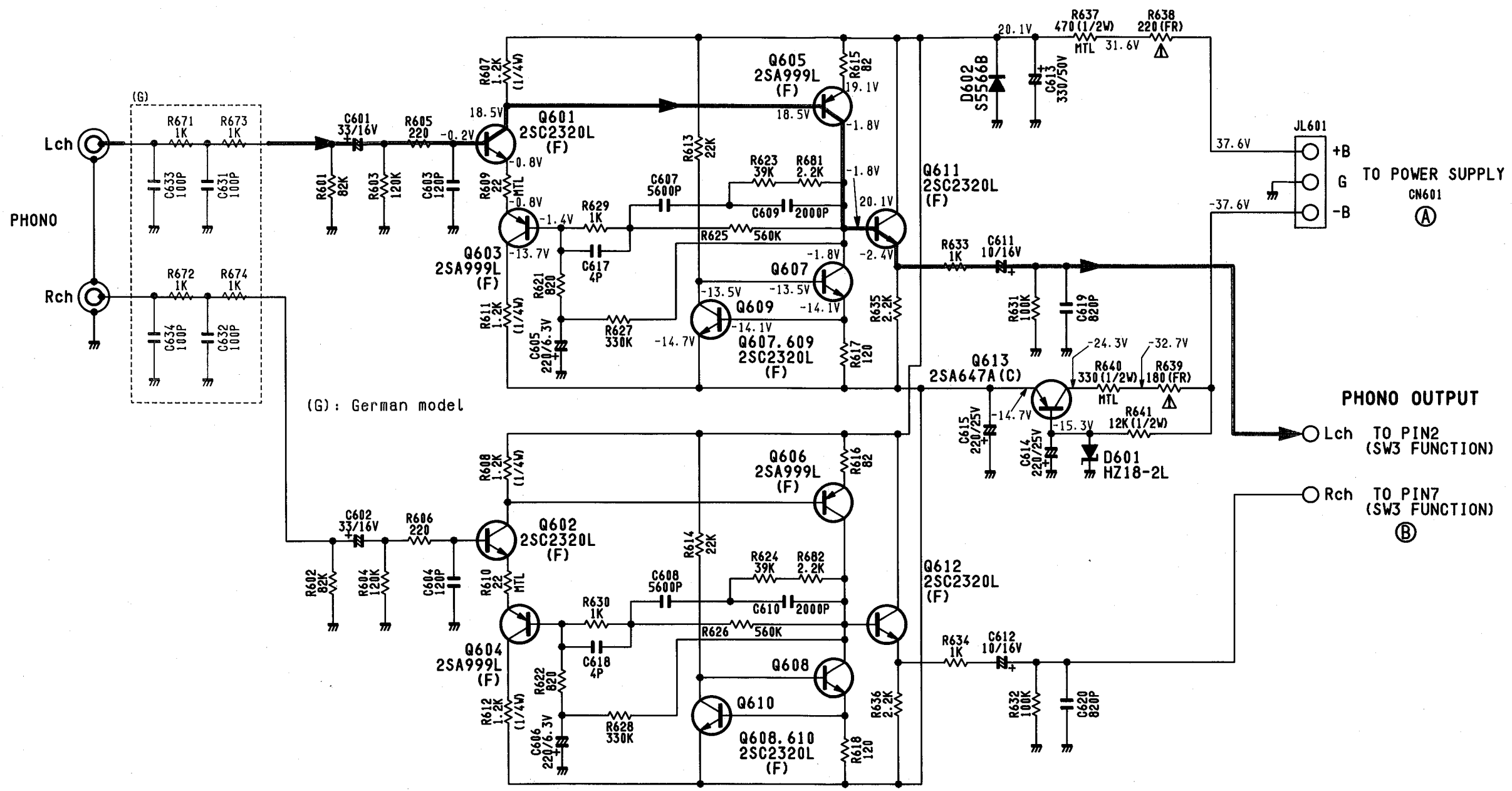

(G): German model

TO POWER SUPPLY  
CN601  
(A)

PHONO OUTPUT  
Lch TO PIN2 (SW3 FUNCTION)  
Rch TO PIN7 (SW3 FUNCTION)  
(B)

NOTE:

1. ALL RESISTANCES VALUES ARE IN  $\Omega$ .  
 $K\Omega=1000\Omega$ .  $M\Omega=1000K\Omega$ .
2. THE WATTAGE OF RESISTORS IS 1/6W UNLESS OTHERWISE NOTED.
3. ALL CAPACITANCES VALUES ARE IN  $\mu F$  UNLESS OTHERWISE NOTED. P=# $\mu F$ .
4. ...V:DC VOLTAGE AT NO SIGNAL UNLESS OTHERWISE NOTED.
5. SAFETY REQUIREMENTS COMPONENTS IN ACCORDANCE WITH PRESENT SAFETY REGULATIONS. THESE COMPONENTS MUST ONLY BE REPLACED BY ORIGINAL PARTS.





**SCHEMATIC DIAGRAM (PHONO AMP SECTION)**

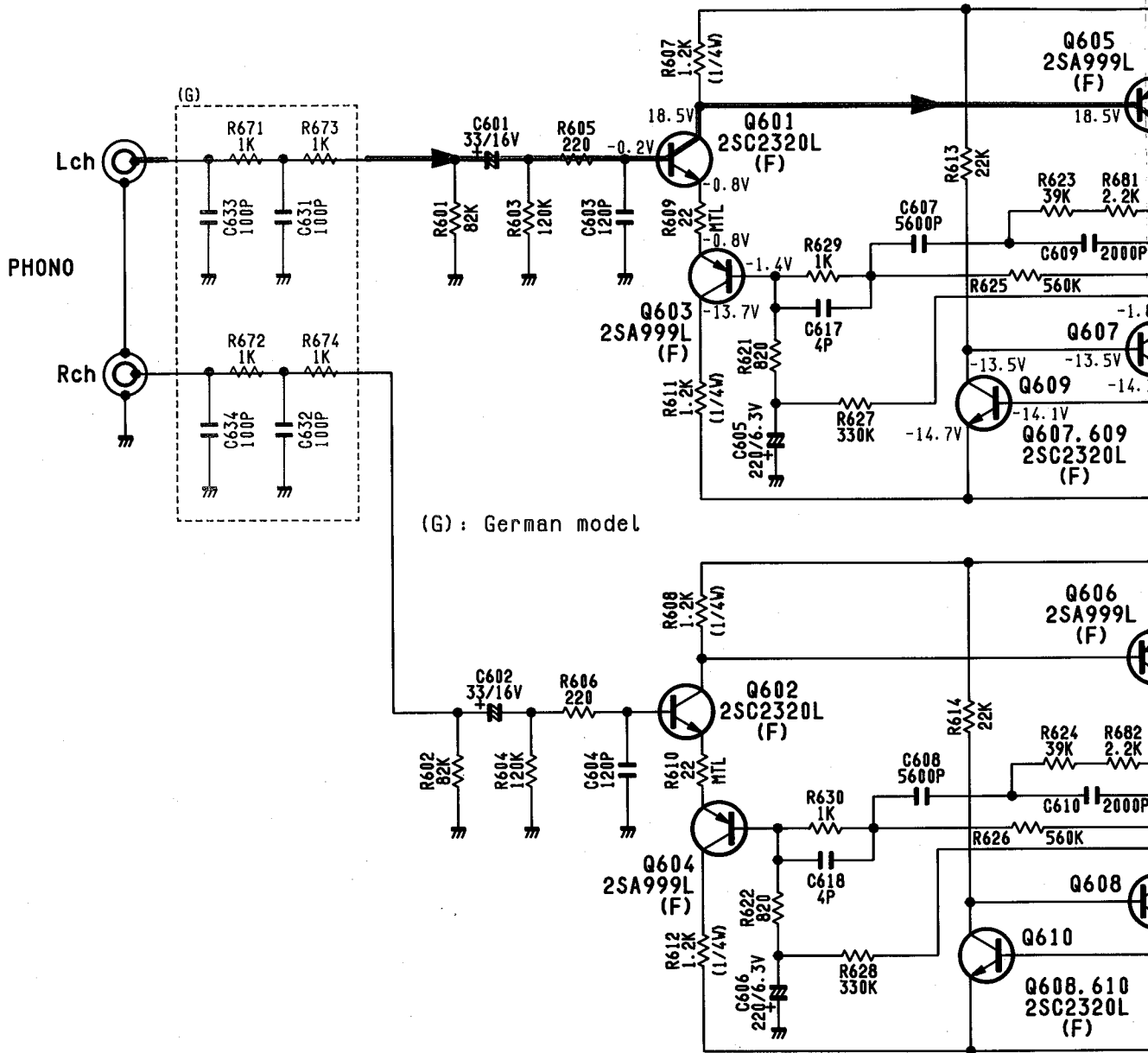

(G): German model

**NOTE:**

1. ALL RESISTANCES VALUES ARE IN  $\Omega$ .  
K $\Omega$ =1000 $\Omega$ , M $\Omega$ =1000K $\Omega$ .
2. THE WATTAGE OF RESISTORS IS 1/6W UNLESS OTHERWISE NOTED.
3. ALL CAPACITANCES VALUES ARE IN  $\mu$ F UNLESS OTHERWISE NOTED. P= $\mu$ MF.
4. ...V:DC VOLTAGE AT NO SIGNAL UNLESS OTHERWISE NOTED.
5. SAFETY REQUIREMENTS COMPONENTS IN ACCORDANCE WITH PRESENT SAFETY REGULATIONS. THESE COMPONENTS MUST ONLY BE REPLACED BY ORIGINAL PARTS.



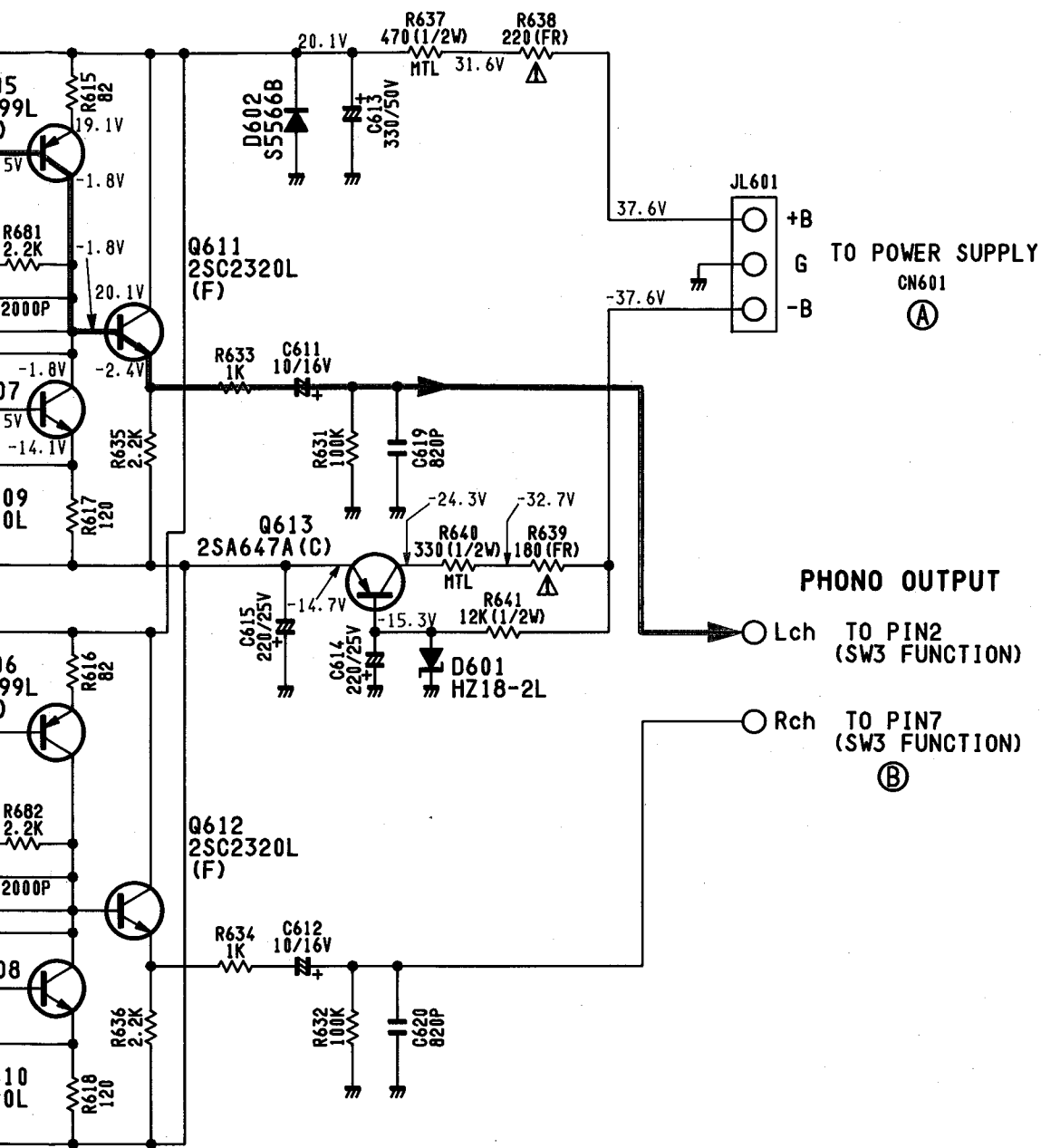

PHONO OUTPUT

- Lch TO PIN2 (SW3 FUNCTION)
- Rch TO PIN7 (SW3 FUNCTION)

TO POWER SUPPLY  
CN601  
Ⓐ

SCHEMATIC DIAGRAM

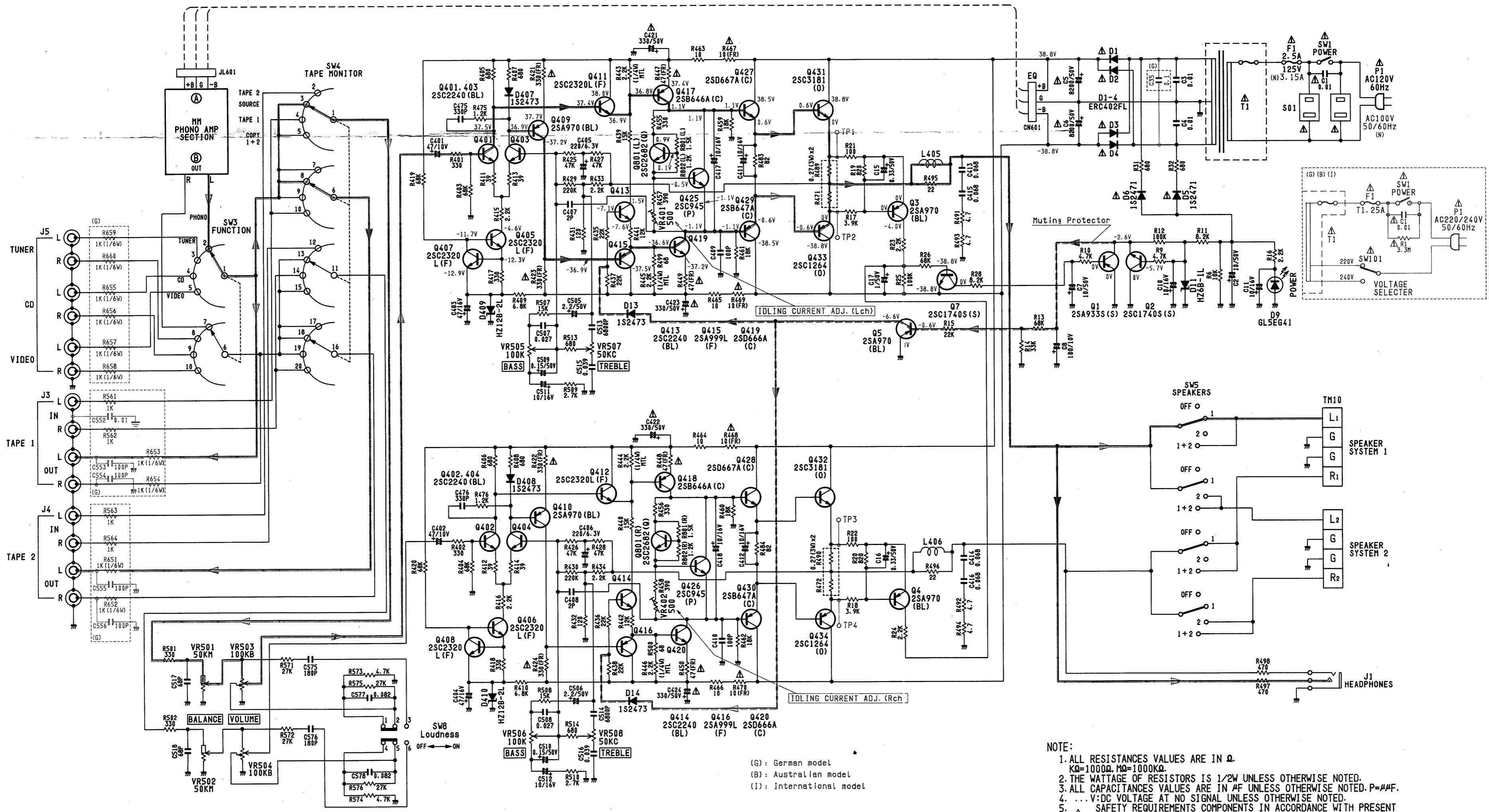

NOTE:

1. ALL RESISTANCES VALUES ARE IN  $\Omega$ .  
K $\Omega$ =1000 $\Omega$ , M $\Omega$ =1000K $\Omega$ .
2. THE WATTAGE OF RESISTORS IS 1/2W UNLESS OTHERWISE NOTED.
3. ALL CAPACITANCES VALUES ARE IN  $\mu$ F UNLESS OTHERWISE NOTED. P= $\mu$ F.
4. ...V:DC VOLTAGE AT NO SIGNAL UNLESS OTHERWISE NOTED.
5. SAFETY REQUIREMENTS COMPONENTS IN ACCORDANCE WITH PRESENT SAFETY REGULATIONS. THESE COMPONENTS MUST ONLY BE REPLACED BY ORIGINAL PARTS.

(G): German model  
(B): Australian model  
(I): International model



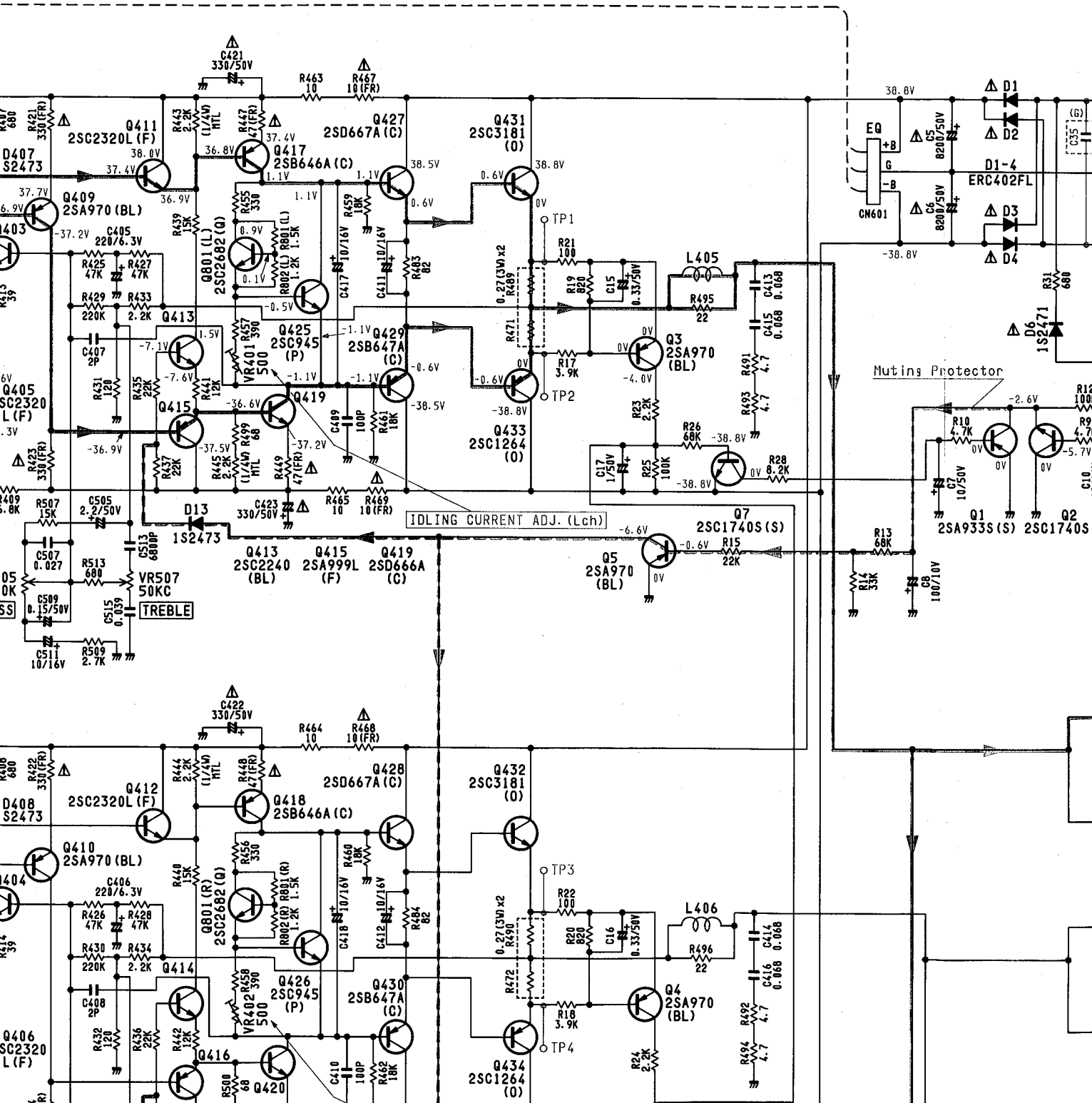

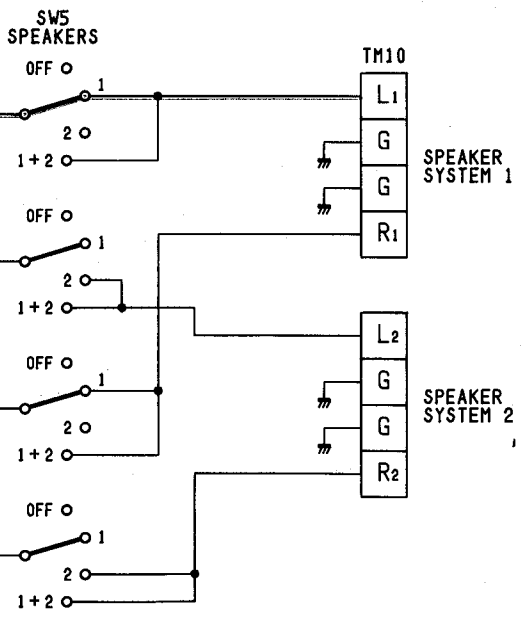
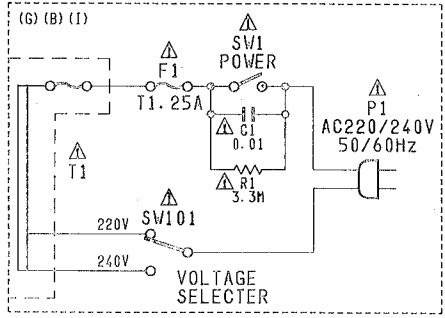
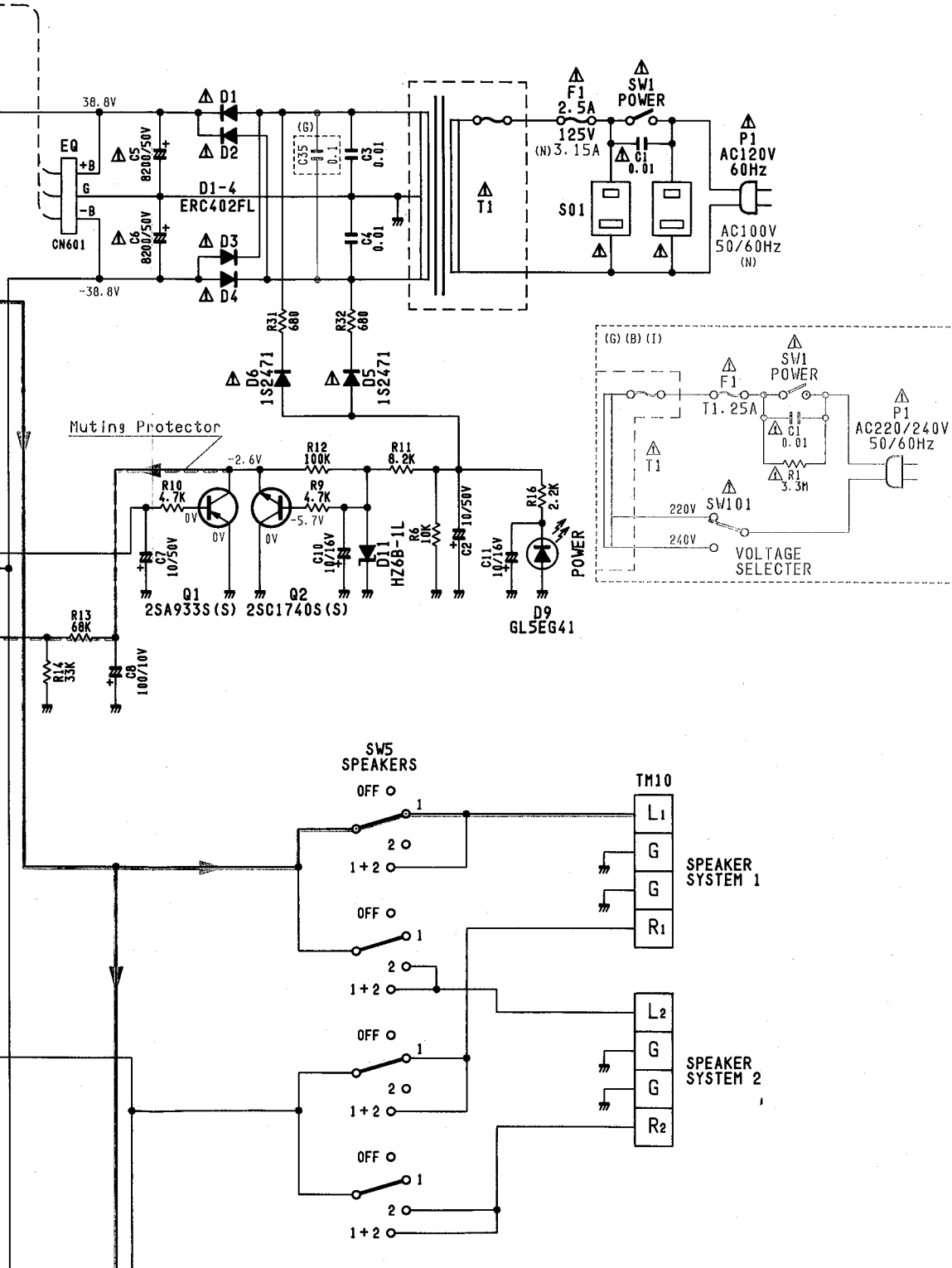



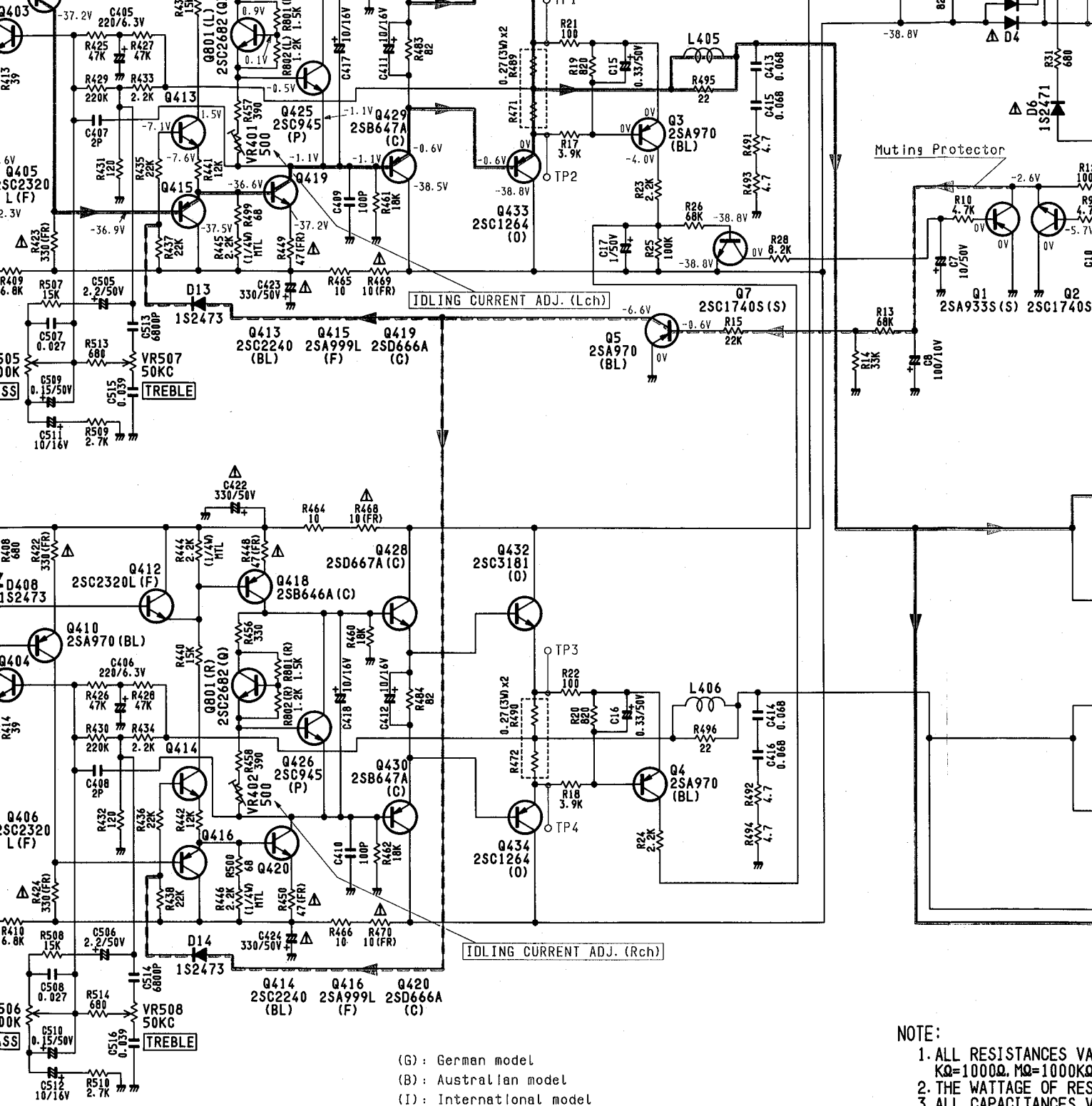

**NOTE:**

1. ALL RESISTANCES VA  
KΩ=1000Ω, MΩ=1000KΩ
2. THE WATTAGE OF RES
3. ALL CAPACITANCES V
4. ...V:DC VOLTAGE A
5. SAFETY REQUIR  
SAFETY REGULA  
BY ORIGINAL P





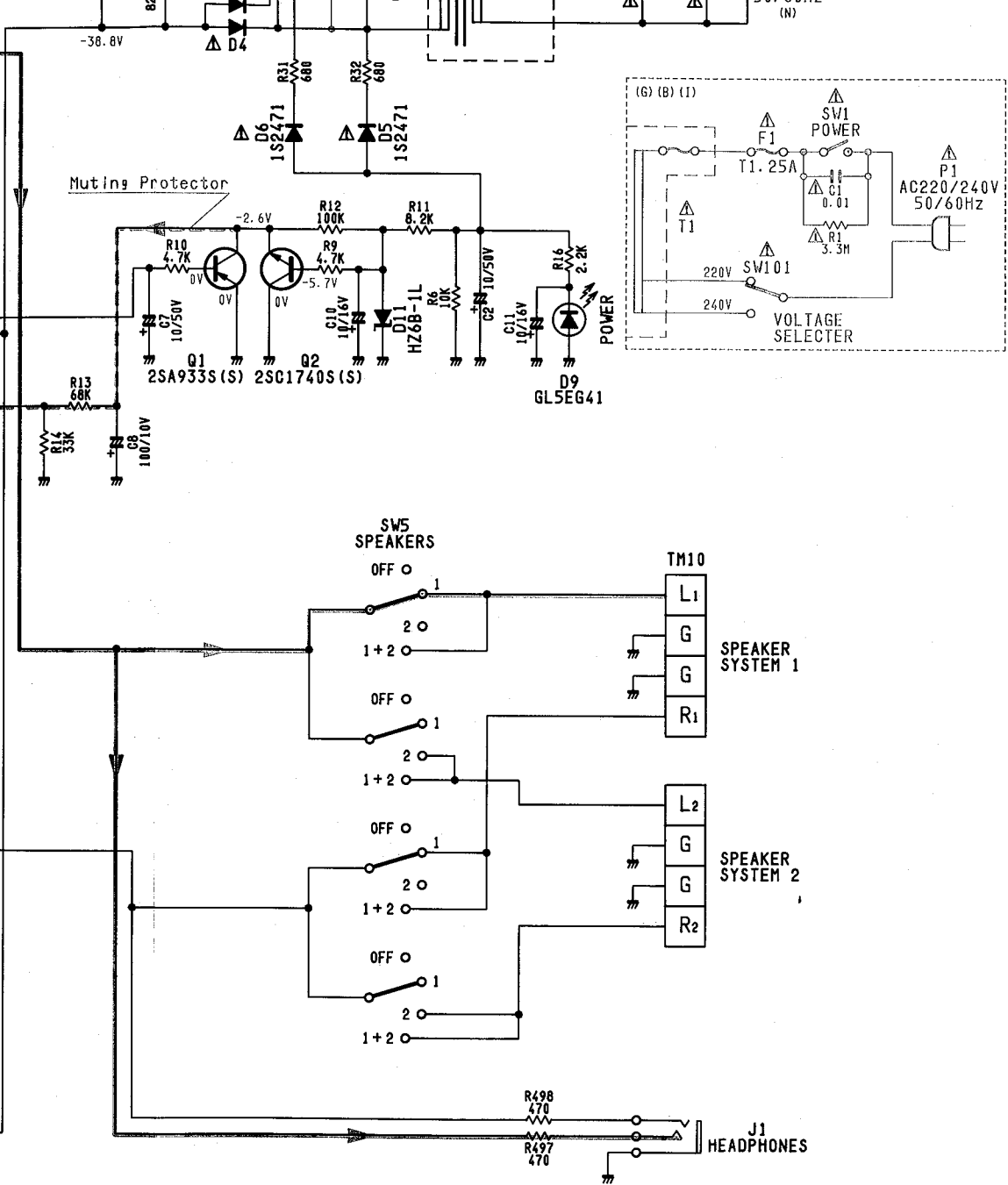

**NOTE:**

1. ALL RESISTANCES VALUES ARE IN  $\Omega$ .  
K $\Omega$ =1000 $\Omega$ , M $\Omega$ =1000K $\Omega$ .
2. THE WATTAGE OF RESISTORS IS 1/2W UNLESS OTHERWISE NOTED.
3. ALL CAPACITANCES VALUES ARE IN  $\mu$ F UNLESS OTHERWISE NOTED. P= $\mu$ F.
4. ...V:DC VOLTAGE AT NO SIGNAL UNLESS OTHERWISE NOTED.
5. SAFETY REQUIREMENTS COMPONENTS IN ACCORDANCE WITH PRESENT SAFETY REGULATIONS. THESE COMPONENTS MUST ONLY BE REPLACED BY ORIGINAL PARTS.

A B C D E F G H I J K L M N

WIRING DIAGRAM

1  
2  
3  
4  
5  
6  
7  
8  
9  
10

WIRE COLOR ABBREVIATIONS

RED	: Red	YEL	: Yellow
ORG	: Orange	PUR	: Purple
BLU	: Blue	PIK	: Pink
WHT	: White	GRY	: Gray
GRN	: Green	BRN	: Brown
BLK	: Black		

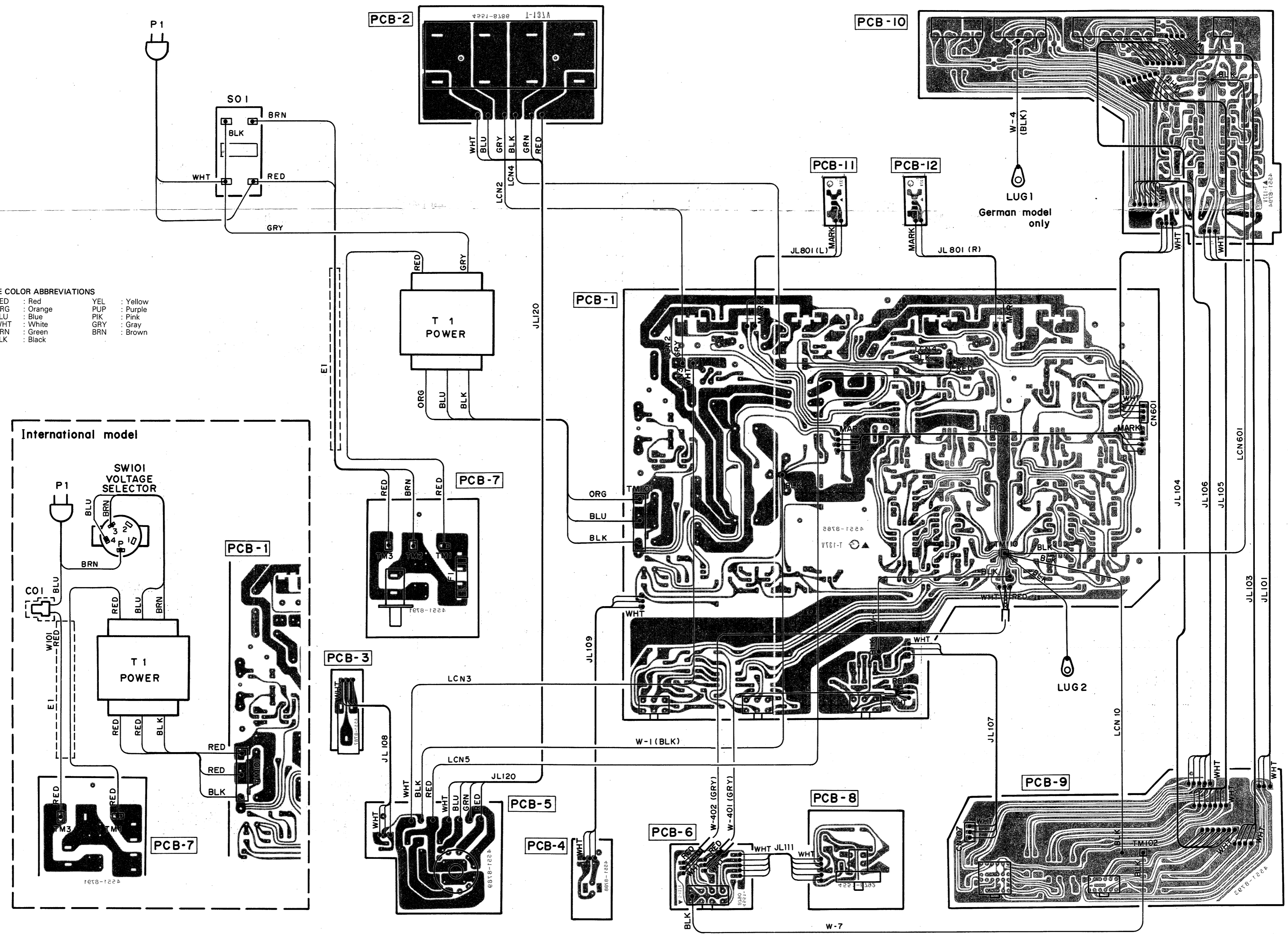

WIRING DIAGRAM

1  
2  
3  
4  
5  
6  
7

WIRE COLOR ABBREVIATIONS

RED	: Red	YEL	: Yellow
ORG	: Orange	PUP	: Purple
BLU	: Blue	PIK	: Pink
WHT	: White	GRY	: Gray
GRN	: Green	BRN	: Brown
BLK	: Black		

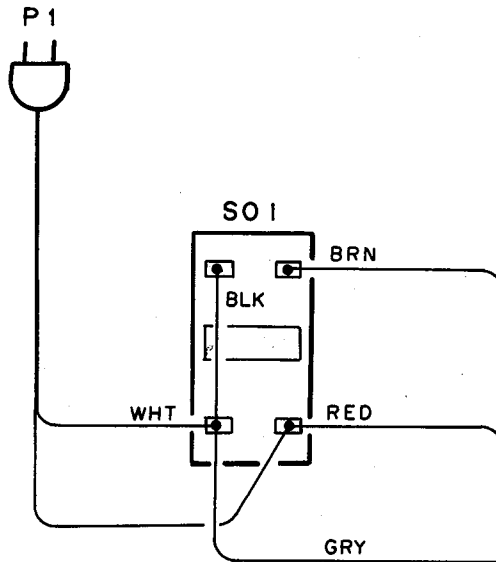

PCB-2

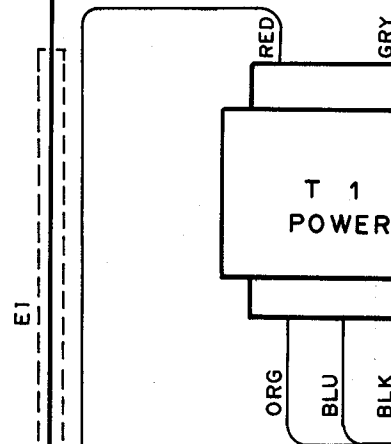
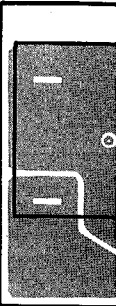

T 1 POWER

International model

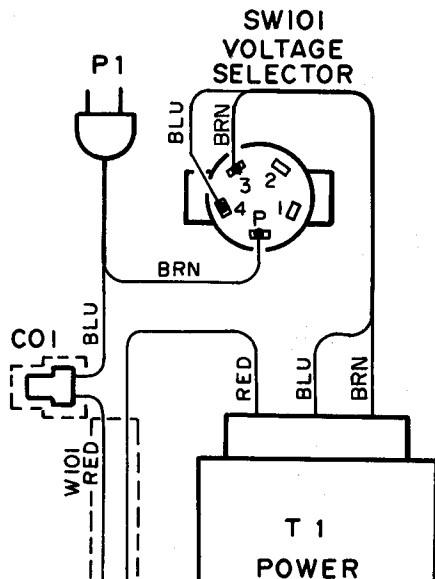

PCB-1

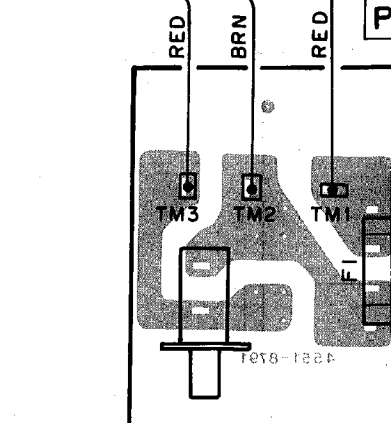
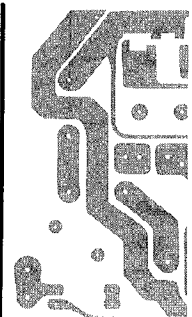

PCB-3

1978-1224

F

G

H

I

J

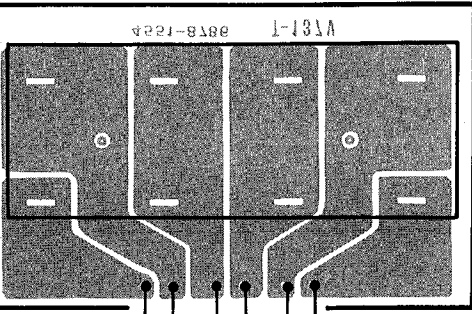

PCB-10

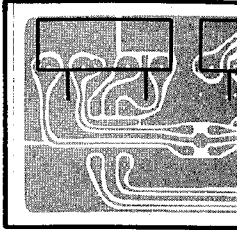

WHT  
BLU  
GRY  
BLK  
GRN  
RED

LCN2  
LCN4

PCB-11

PCB-12

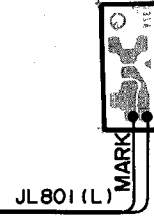

JL801 (L)



JL801 (R)

Germa

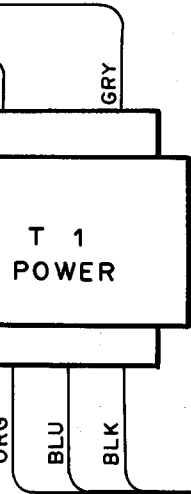

T 1  
POWER

GRY

JLI20

PCB-1

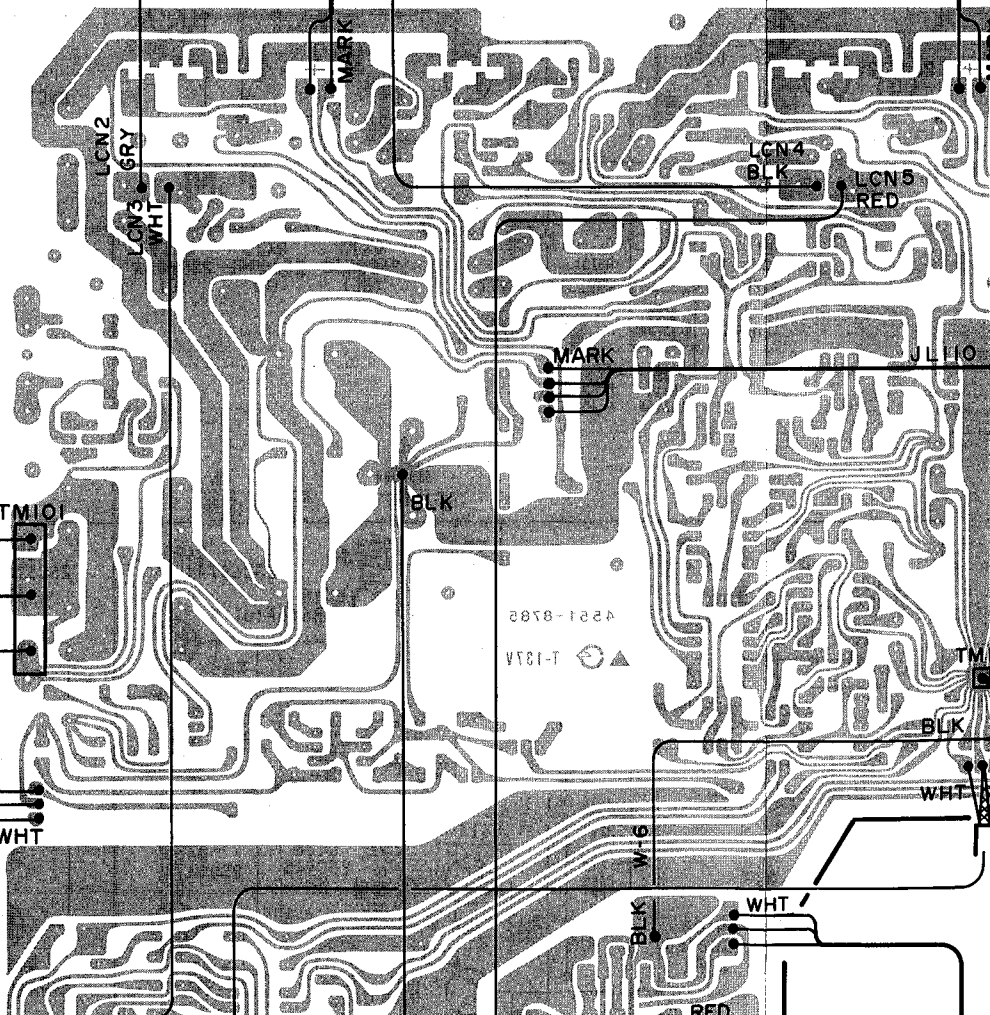

LCN2  
GRY  
LCN3  
WHT

LCN4  
BLK

LCN5  
RED

MARK

MARK

JLI10

BLK

ORG  
TMIO  
BLU  
BLK

4221-8282  
1-183A

TM

BLK

WHT

WHT

WHT

BLK

WHT

RED

JL109

PCB-7

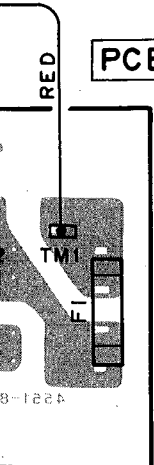

RED

TM

FI

LCN3



4  
5  
6  
7  
8  
9  
10

**WIRE COLOR ABBREVIATIONS**

RED	: Red	YEL	: Yellow
ORG	: Orange	PUP	: Purple
BLU	: Blue	PIK	: Pink
WHT	: White	GRY	: Gray
GRN	: Green	BRN	: Brown
BLK	: Black		

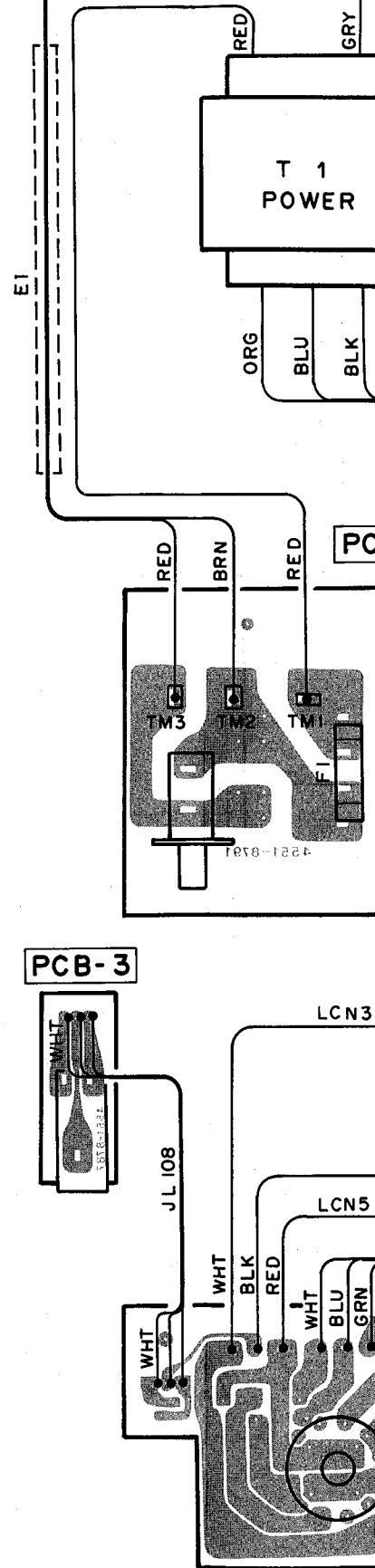
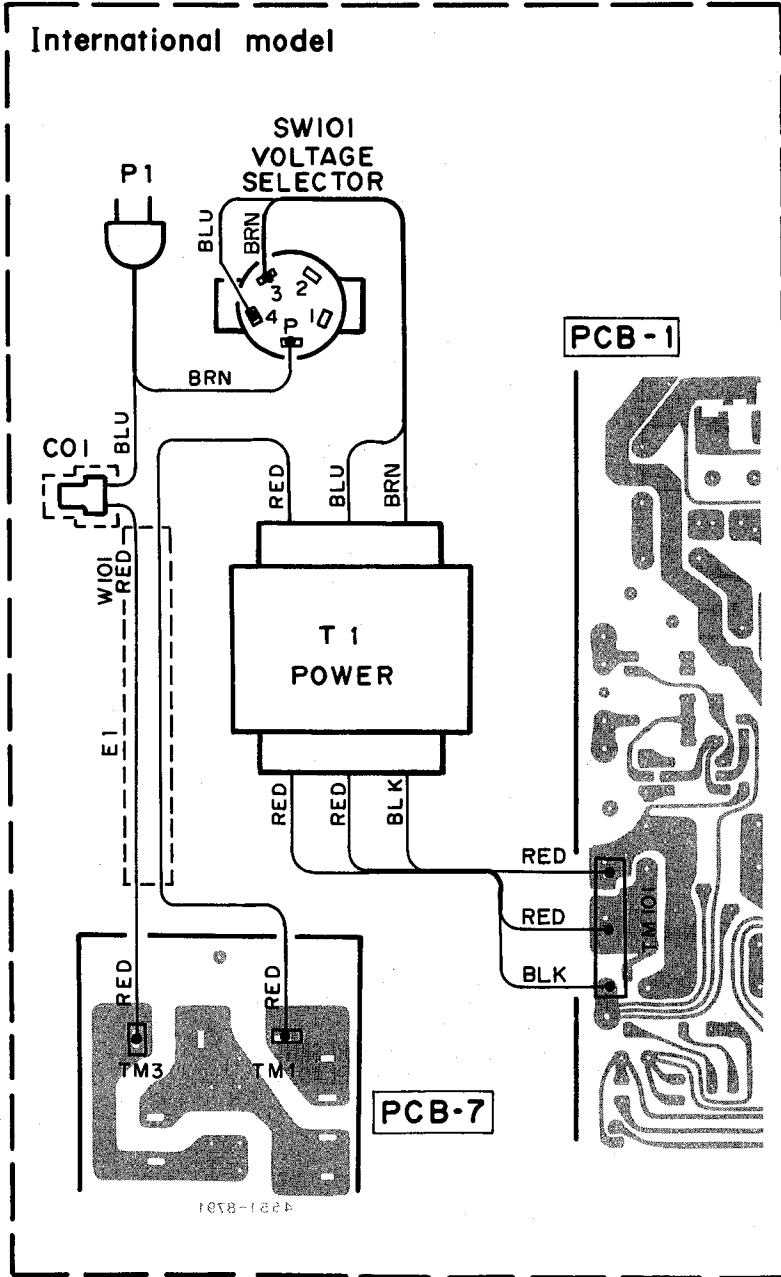



terminal model only

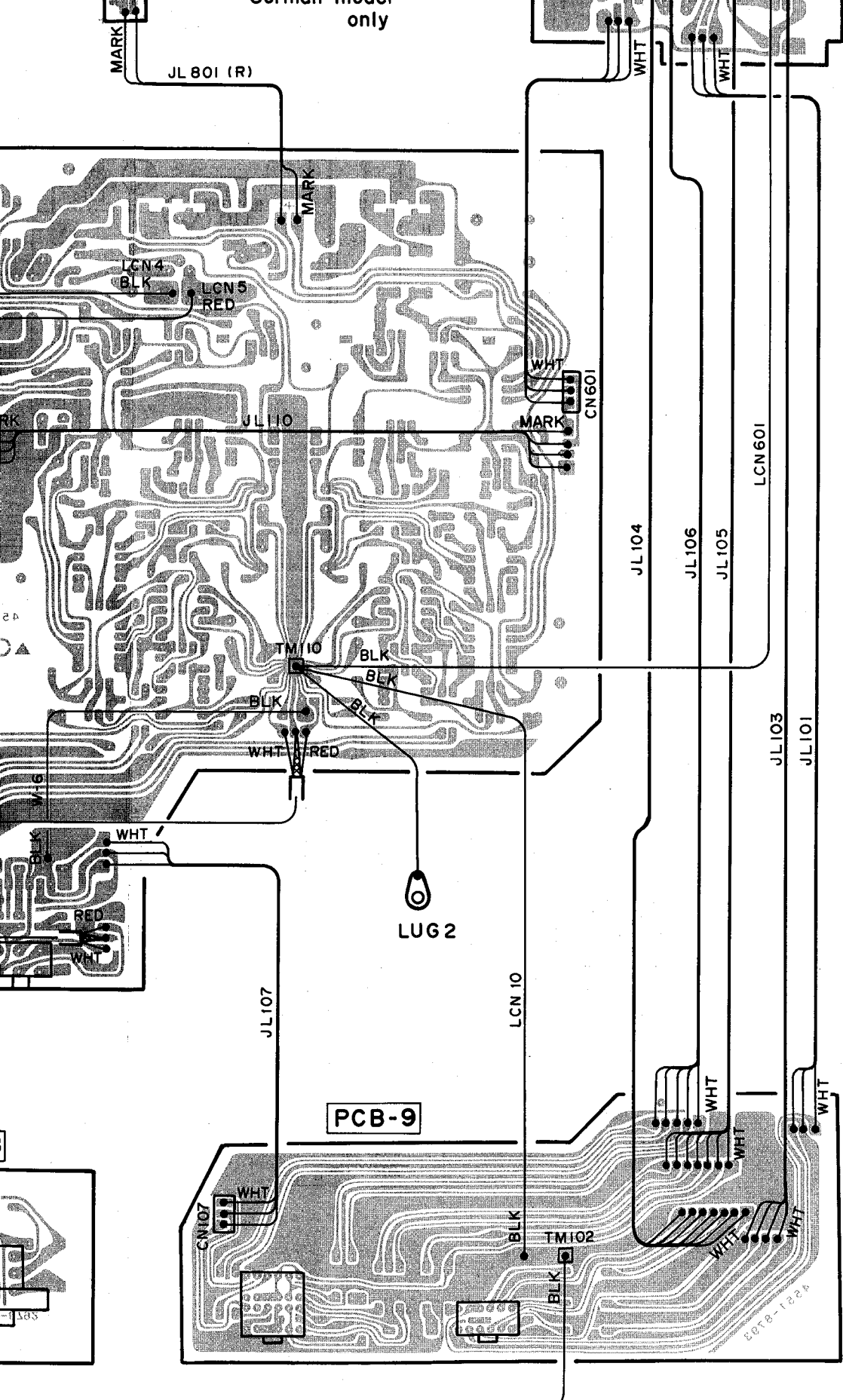

PCB-9

207B-1226