

**The Harman Kardon
Model hk680i**

**Digital Synthesized Quartz-Locked
Stereo Receiver**

Technical Manual

PRECAUTIONS

1. Always disconnect the chassis from power line when soldering. Turning the power switch OFF is not enough. Power line leakage passing through the heating element may destroy the transistors.
2. Never attempt to do any work on the transistor amplifiers without first disconnecting the AC line cord and waiting until the power supply filter capacitors have discharged.
3. Replacement for output and driver transistors, if necessary, must be made from the same beta group as the original type.
4. If one output transistor burns out (open or short) always remove all the output transistors in that channel and check the bias adjustment, the control and other parts in the network with an ohmmeter before inserting a new transistor. All transistors in one channel will be destroyed if the base biasing circuit is open on the emitter end.
5. When mounting a replacement power transistor, be sure that the bottom of the flange, the mica insulators and the surface of the heat sink are free of foreign matter, for they may cause transistor failure.
6. Silicon grease must be applied between the transistor and the mica insulator, and between the mica insulator and the heat sink for better heat conduction.
7. Fuses must be replaced with size and type indicated. Use of other types can expose components to destructive current levels.

ALIGNMENT PROCEDURES

AM ALIGNMENT

- Instruments:**
1. AM Signal Generator modulated with 400Hz at 30%.
 2. Oscilloscope
 3. AC V.T.V.M.
 4. DC Voltmeter

- Notes:**
1. Set function selector switch to AM position.
 2. Connect signal source to a loop placed to radiate signals into AM antenna loop stick (L251).

Step	Signal Source	Connect Output Meter To	Station Display Setting	Adjust	Adjust For
1	450kHz	VTVM and oscilloscope to TP1 and ground	1610kHz	T251, T252	Maximum output on VTVM and at the same time clean wave form on oscilloscope
2	450kHz	VTVM and oscilloscope to TP2 and ground	1610kHz	T253	Same as above
3	—	DC voltmeter to TP3 and ground	530kHz	L252	1.6V on DC voltmeter
4	—	Same as above	1610kHz	TC252	22.5V on DC voltmeter
5	600kHz	VTVM to Tape 1 Out jack	600kHz	L251	Maximum output on VTVM
6	1400kHz	Same as above	1400kHz	TC251	Same as above
7	Repeat steps 5 and 6 for optimum sensitivity.				
8	1000kHz 40dB/m(100 μ V/m)	Oscilloscope to Tape 1 Out jack	1000kHz	VR251	Clean wave form on oscilloscope

ALIGNMENT PROCEDURES

FM ALIGNMENT

- Instruments:**
1. FM Signal Generator modulated with 1000Hz at 100% (75kHz).
 2. Oscilloscope
 3. Frequency Counter
 4. Distortion Meter
 5. AC V.T.V.M.
 6. DC Voltmeter

- Notes:**
1. Set function selector switch to FM position.
 2. Set muting switch to OFF (button in) position.
 3. Connect signal source to FM antenna terminals.

Step	Signal Source	Connect Output Meter To	Station Display Setting	Adjust	Adjust For
1	—	DC voltmeter to TP4 and ground	88.1MHz	Lo	3V on DC voltmeter
2	—	Same as above	107.9MHz	TC _o	21V on DC voltmeter
3	90.1MHz 65dBf (970 μ V)	VTVM to Tape 1 Out jack	90.1MHz	L _A , L _{R1} , L _{R2}	Maximum output on VTVM
4	106.1MHz 65dBf (970 μ V)	Same as above	106.1MHz	T _{CA} , T _{CR1} , T _{CR2}	Same as above
5	Repeat steps 3 and 4 for optimum sensitivity.				
6	—	Frequency counter to TP5 and ground	98.3MHz	TC801	109MHz on frequency counter
7	Set Muting switch to ON position.				
8	98.15MHz 65dBf (970 μ V)	Oscilloscope to Tape 1 Out jack	98.1MHz	T201(A)	Clean wave on oscilloscope
9	98.05MHz 65dBf (970 μ V)	Same as above	98.1MHz	T202(A)	Same as above
10	Repeat steps 8 and 9 for optimum sensitivity.				
11	98.1MHz 65dBf (970 μ V)	Distortion meter to Tape 1 Out jack	98.1MHz	T201(B)	Minimum reading on distortion meter
12	Repeat steps 8, 9 and 11 for optimum alignment point of T201(A) and (B).				

QUARTZ LOCK INDICATOR ADJUSTMENT

Instrument: FM Signal Generator modulated with 1000Hz at 100% (75kHz).

- Notes:**
1. Set function selector switch to FM position.
 2. Set muting switch to OFF (button in) position.
 3. Connect signal source to FM antenna terminals.
 4. Turn the VR202 and VR352 to the center.

Signal Source	Station Display Setting	Adjust	Adjust For
98.1MHz 12dBf (2 μ V)	98.1MHz	VR201	Quartz indicator LED lights

ALIGNMENT PROCEDURES

MUTING SENSITIVITY AND SIGNAL STRENGTH DISPLAY ADJUSTMENT

- Instruments:**
1. FM Signal Generator modulated with 1000Hz at 100% (75kHz).
 2. Oscilloscope
 3. AC V.T.V.M.

- Notes:**
1. Set function selector switch to FM position.
 2. Set muting switch to ON (button out) position.
 3. Connect signal source to FM antenna terminals.

Step	Signal Source	Connect Output Meter To	Station Display Setting	Adjust	Adjust For
1	98.1MHz 12dBf (2 μ V)	VTVM and oscilloscope to Tape 1 Out jack	98.1MHz	VR352	Clean wave on oscilloscope and 1 of signal strength display LEDs lights
2	98.1MHz 65dBf (970 μ V)	—	98.1MHz	VR202	10 of signal strength display LEDs lights
3	Repeat steps 1 and 2 for optimum sensitivity.				

MPX ADJUSTMENT

- Instruments:**
1. FM Signal Generator modulated with 1000Hz at 100% (75kHz).
 2. Frequency Counter

- Notes:**
1. Set function selector switch to AUTO FM position.
 2. Connect signal source to FM antenna terminals.

Signal Source	Connect Output Meter To	Station Display Setting	Adjust	Adjust For
98.1MHz 65dBf (970 μ V)	Frequency Counter to TP6 and ground	98.1MHz	VR301	76kHz on frequency counter

STEREO FM INDICATOR ADJUSTMENT

- Instrument:** FM Stereo Signal Generator modulated with 1000Hz at 100% (75kHz).
(L + R = 45% L - R = 45% 19kHz = 9%)

- Notes:**
1. Set function selector switch to AUTO FM position.
 2. Connect signal source to FM antenna terminals.

Signal Source	Station Display Setting	Adjust	Adjust For
98.1MHz 36dBf (30 μ V)	98.1MHz	VR351	Stereo FM indicator LED lights

ALIGNMENT PROCEDURES

SEPARATION ADJUSTMENT

- Instruments:** 1. FM Stereo Signal Generator modulated with 1000Hz at 100% (75kHz).
(L+R=45% L-R=45% 19kHz=9%)
2. AC V.T.V.M.

- Notes:** 1. Set function selector switch to AUTO FM position.
2. Set blend control to STEREO position.
3. Connect signal source to FM antenna terminals.

Step	Signal Source	Connect Output Meter To	Station Display Setting	Adjust	Adjust For
1	Set Lch signal ON at FM stereo signal generator.				
2	98.1MHz 65dBf (970 μ V)	VTVM to Rch Tape 1 Out jack	98.1MHz	VR302, VR303	Minimum output on VTVM
3	Set Rch signal ON at FM stereo signal generator.				
4	98.1MHz 65dBf (970 μ V)	VTVM to Lch Tape 1 Out jack	98.1MHz	VR302, VR303	Minimum output on VTVM
5	Repeat steps 2 and 4 to obtain same level at left and right channels.				

IDLING CURRENT ADJUSTMENT

Instrument: DC Voltmeter

- Notes:** 1. Set function selector switch to AUX position.
2. Set volume control to minimum position.

Step	Connect Output Meter To	Adjust	Adjust For
1	DC voltmeter to TP7 (+) and TP8 (-)	VR403	33mV on DC voltmeter
2	DC voltmeter to TP9 (+) and TP10 (-)	VR404	Same as above

DC VOLTAGE BALANCE ADJUSTMENT

Instrument: DC Voltmeter

- Notes:** 1. Set function selector switch to AUX position.
2. Set volume control to minimum position.
3. Press in speakers 1 push button to ON (button in) position.

Step	Connect Output Meter To	Adjust	Adjust For
1	DC voltmeter to Lch terminal of Speaker System 1	VR401	0V \pm 50mV on DC voltmeter
2	DC voltmeter to Rch terminal of Speaker System 1	VR402	Same as above

ALIGNMENT PROCEDURES

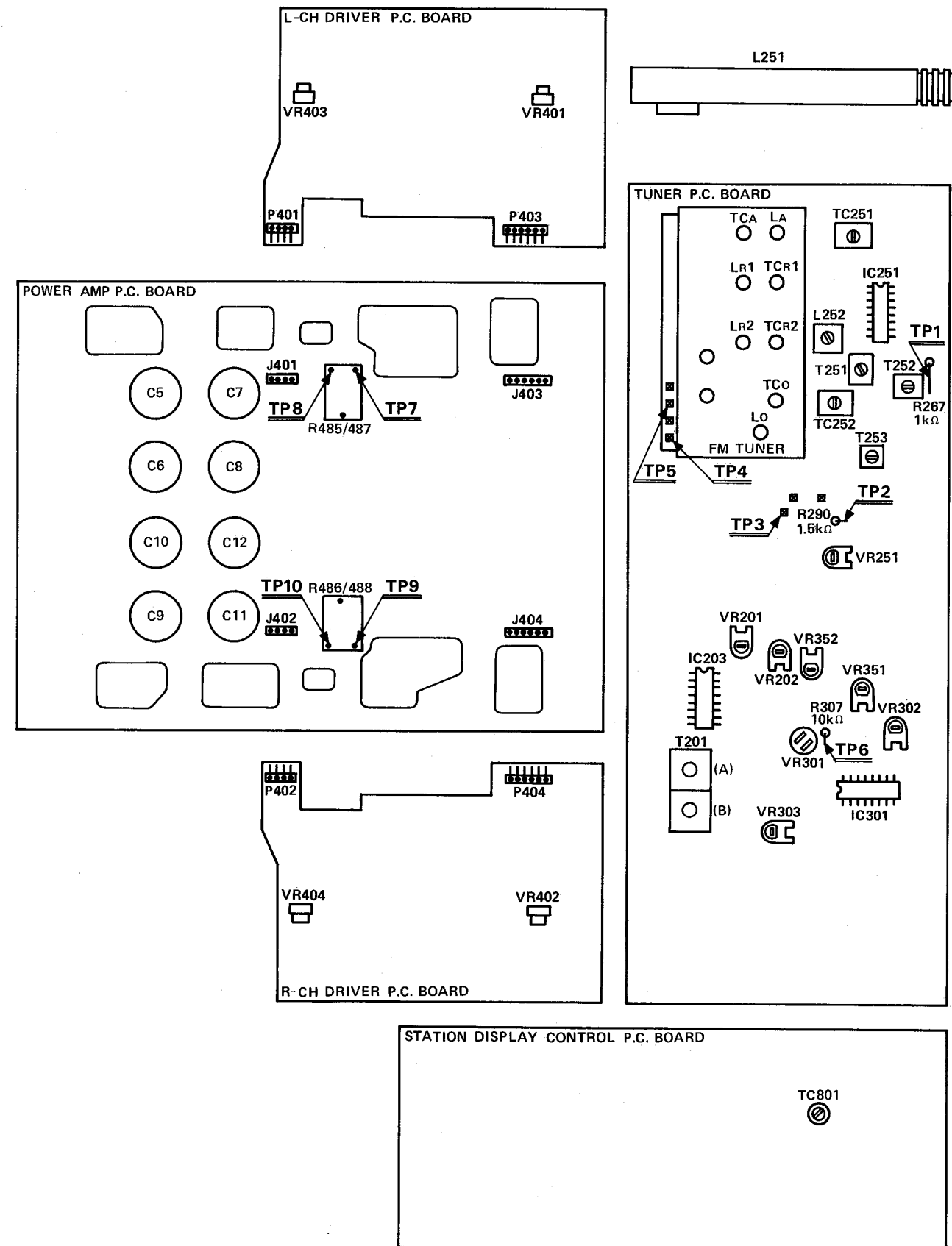

Fig. 1—Alignment Points Location

ALIGNMENT PROCEDURES

SEPARATION ADJUSTMENT

- Instruments:** 1. FM Stereo Signal Generator modulated with 1000Hz at 100% (75kHz).
(L+R=45% L-R=45% 19kHz=9%)
2. AC V.T.V.M.

- Notes:** 1. Set function selector switch to AUTO FM position.
2. Set blend control to STEREO position.
3. Connect signal source to FM antenna terminals.

Step	Signal Source	Connect Output Meter To	Station Display Setting	Adjust	Adjust For
1	Set Lch signal ON at FM stereo signal generator.				
2	98.1MHz 65dBf (970 μ V)	VTVM to Rch Tape 1 Out jack	98.1MHz	VR302, VR303	Minimum output on VTVM
3	Set Rch signal ON at FM stereo signal generator.				
4	98.1MHz 65dBf (970 μ V)	VTVM to Lch Tape 1 Out jack	98.1MHz	VR302, VR303	Minimum output on VTVM
5	Repeat steps 2 and 4 to obtain same level at left and right channels.				

IDLING CURRENT ADJUSTMENT

Instrument: DC Voltmeter

- Notes:** 1. Set function selector switch to AUX position.
2. Set volume control to minimum position.

Step	Connect Output Meter To	Adjust	Adjust For
1	DC voltmeter to TP7 (+) and TP8 (-)	VR403	33mV on DC voltmeter
2	DC voltmeter to TP9 (+) and TP10 (-)	VR404	Same as above

DC VOLTAGE BALANCE ADJUSTMENT

Instrument: DC Voltmeter

- Notes:** 1. Set function selector switch to AUX position.
2. Set volume control to minimum position.
3. Press in speakers 1 push button to ON (button in) position.

Step	Connect Output Meter To	Adjust	Adjust For
1	DC voltmeter to Lch terminal of Speaker System 1	VR401	0V \pm 50mV on DC voltmeter
2	DC voltmeter to Rch terminal of Speaker System 1	VR402	Same as above

ALIGNMENT PROCEDURES

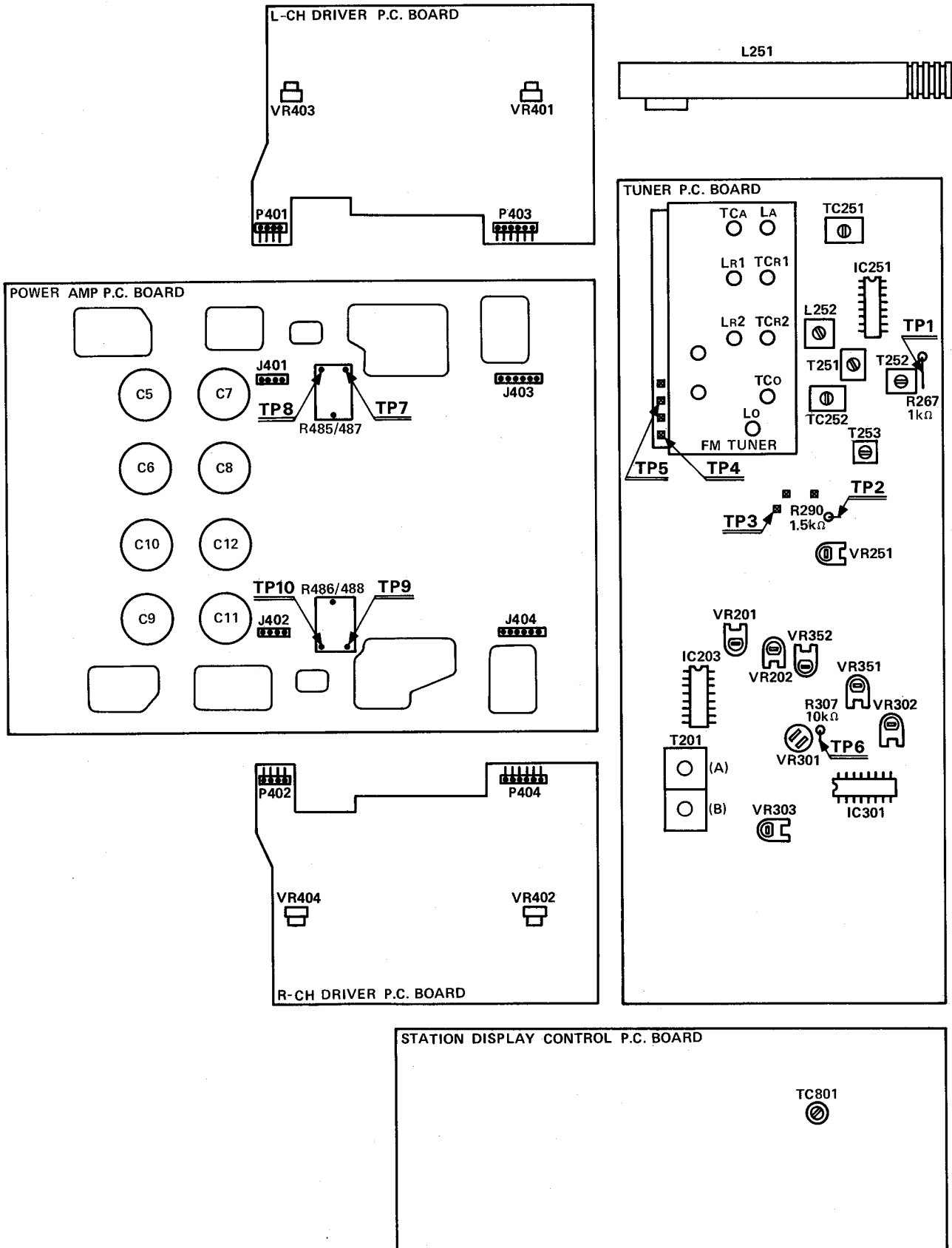
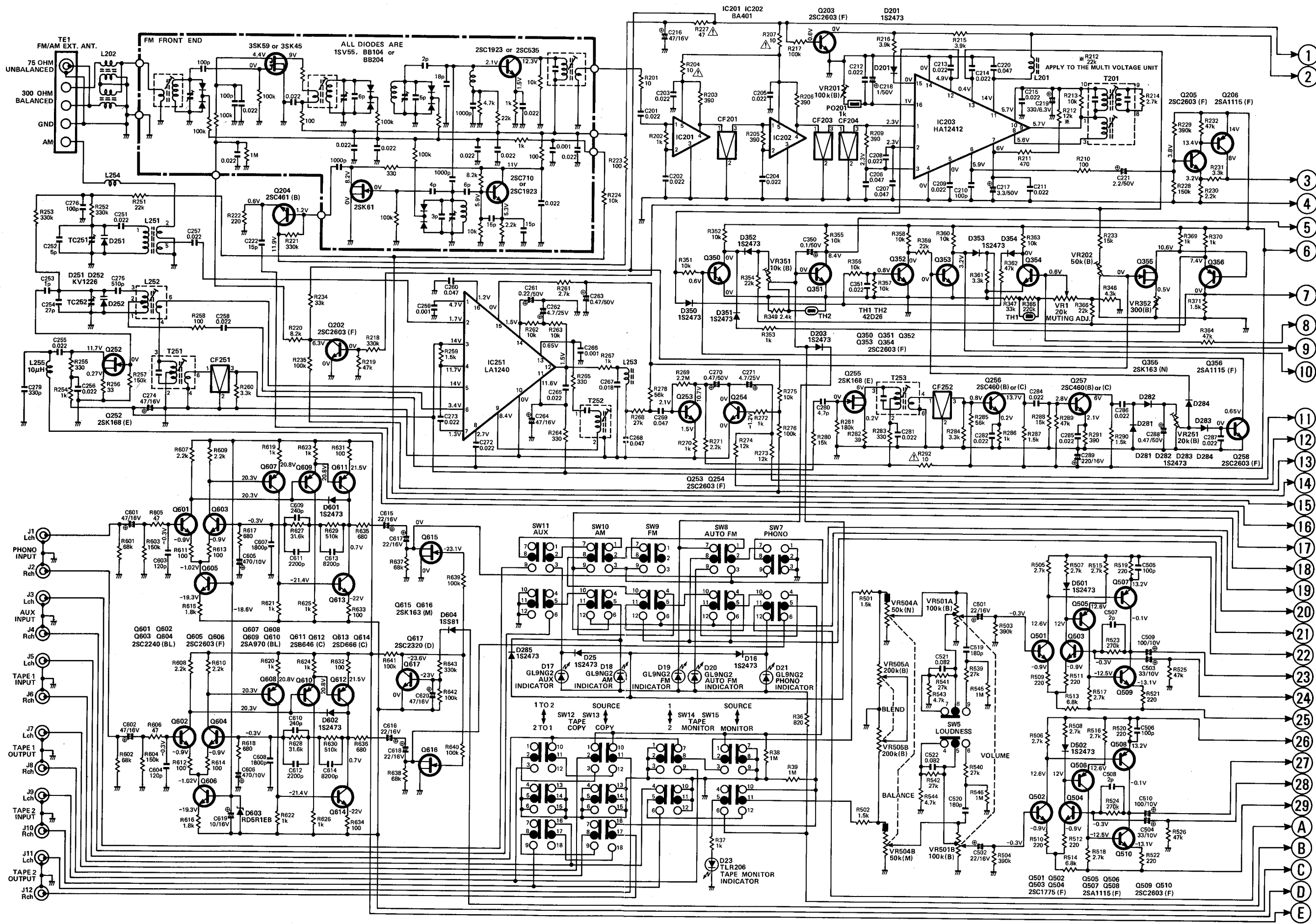
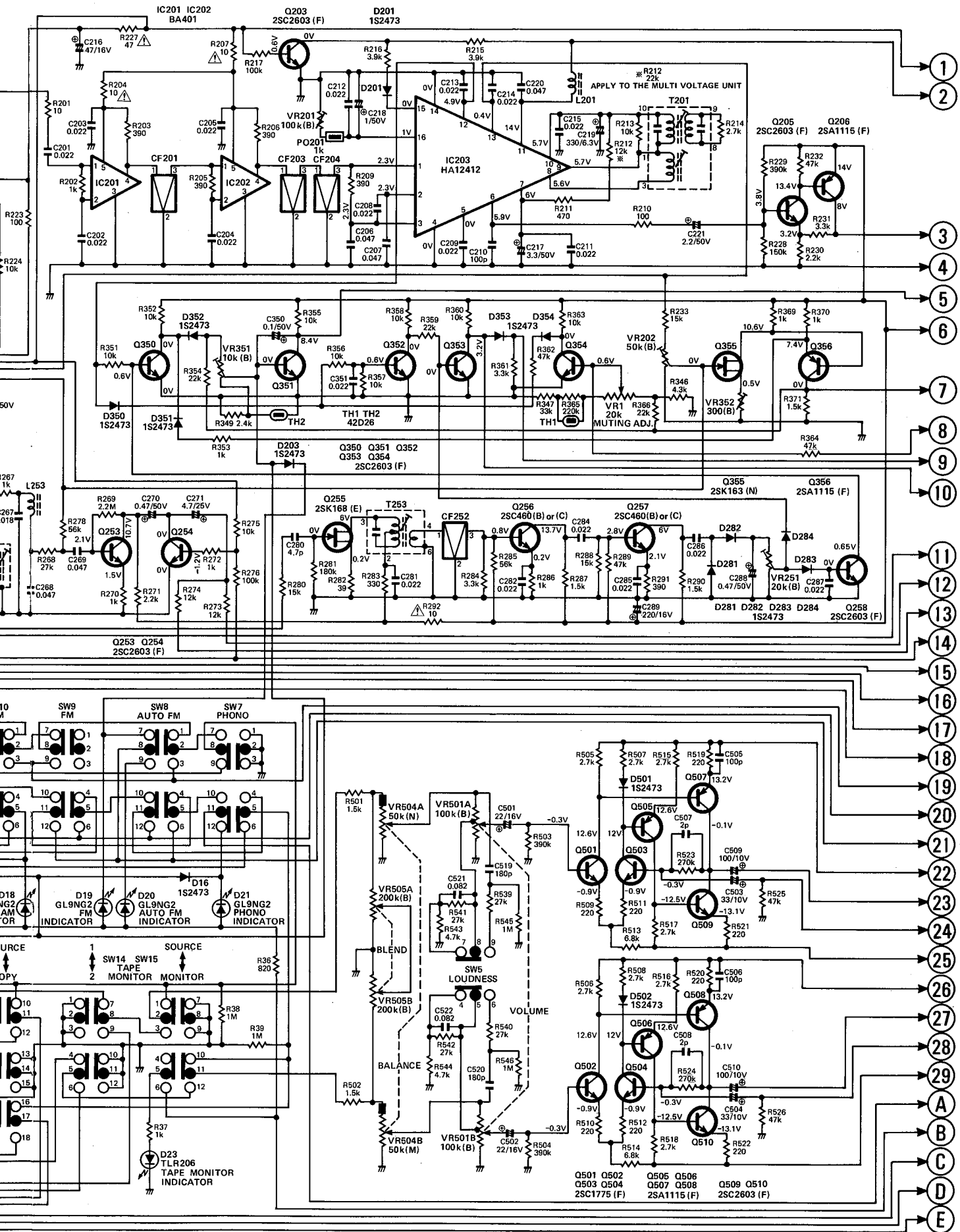

Fig. 1—Alignment Points Location

SCHEMATIC DIAGRAM





SCHEMATIC DIAGRAM

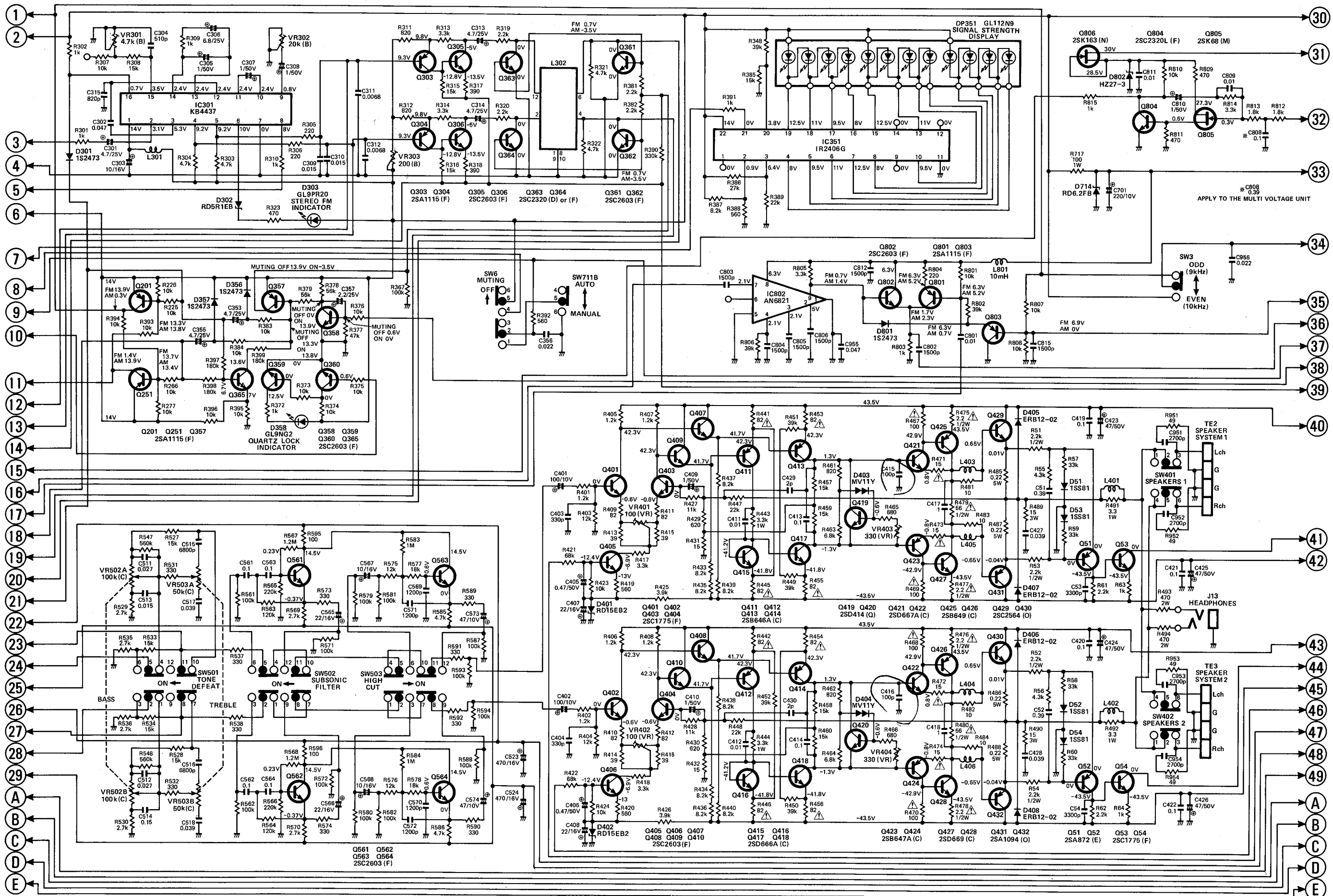

SCHEMATIC DIAGRAM

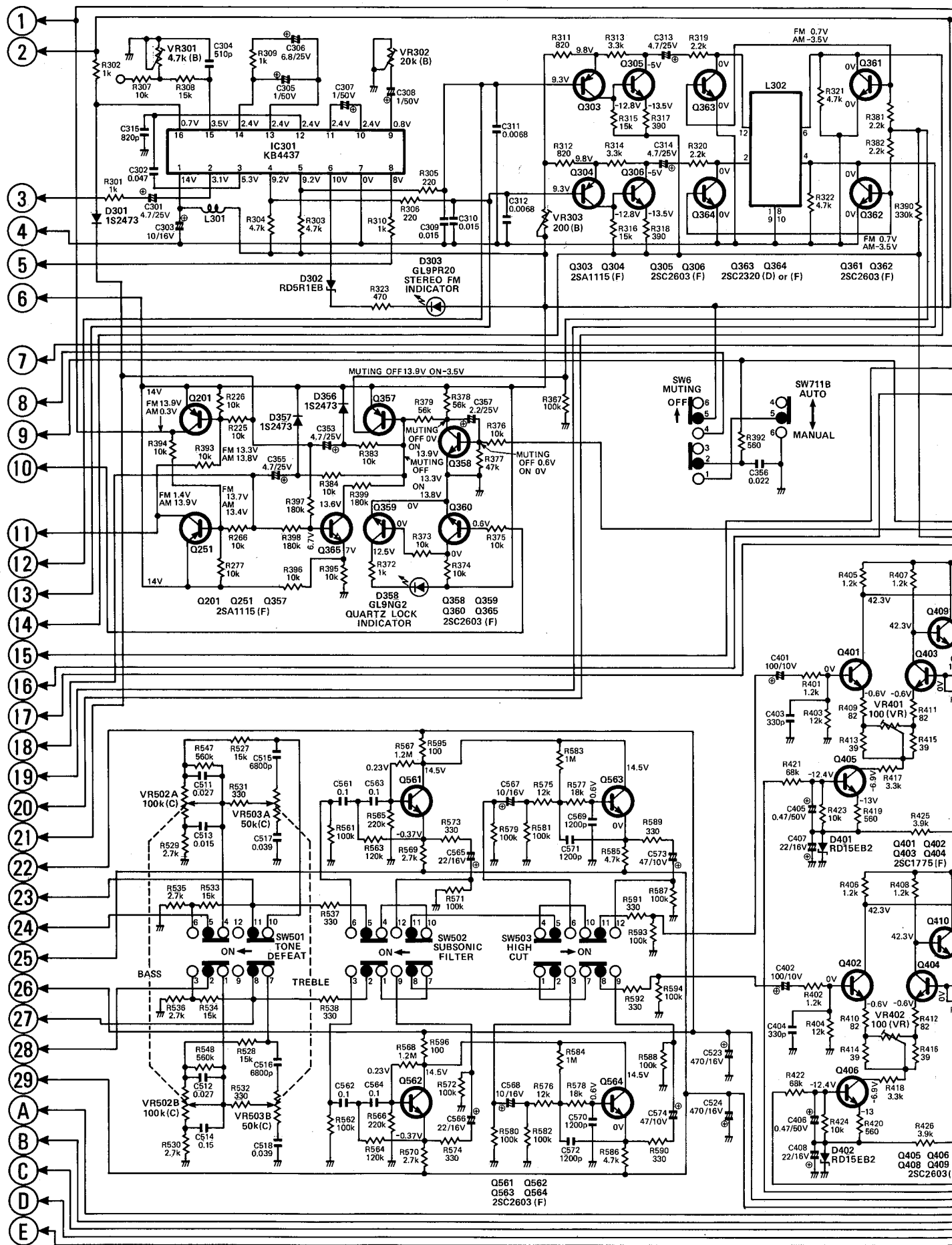

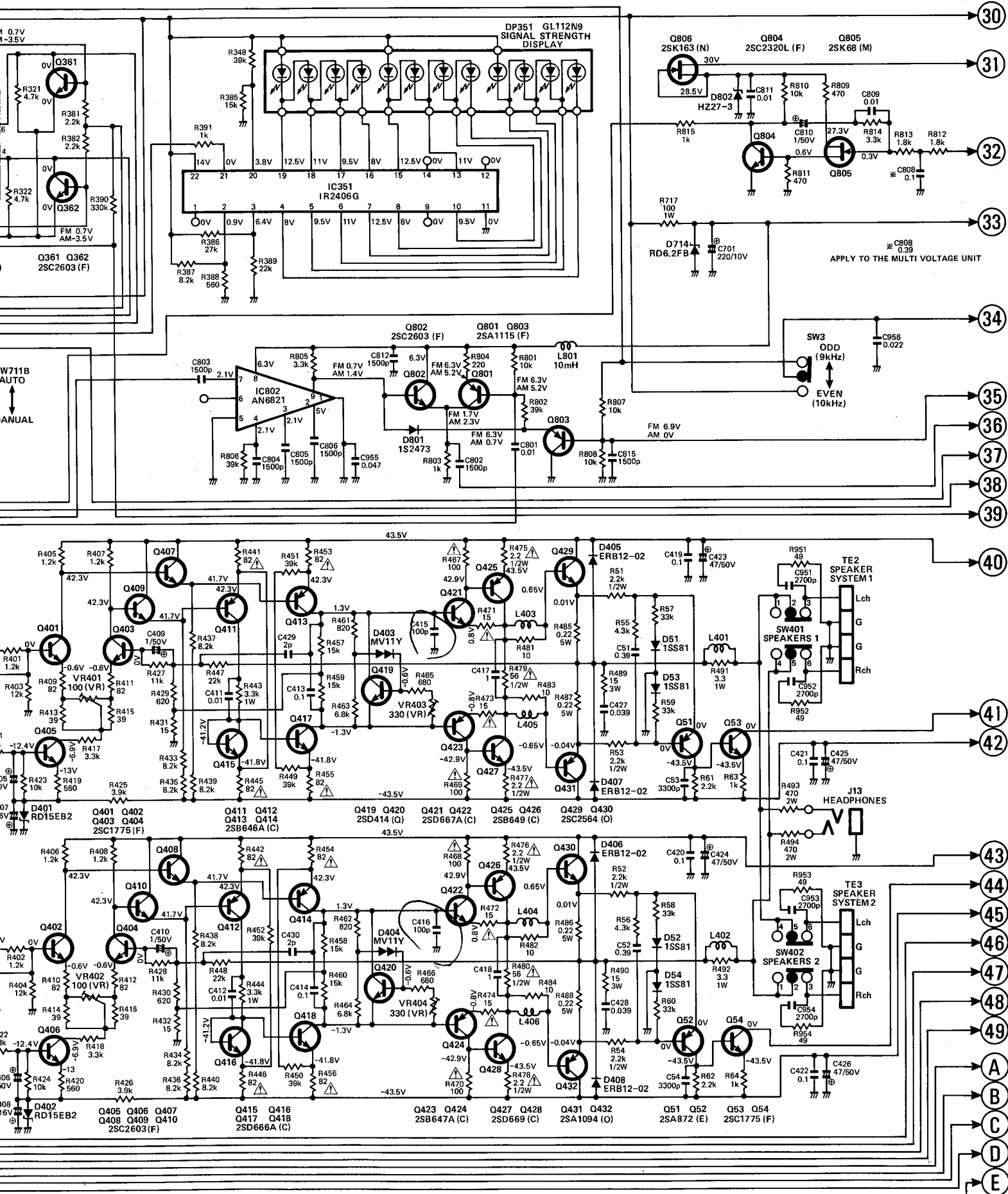

SCHEMATIC DIAGRAM

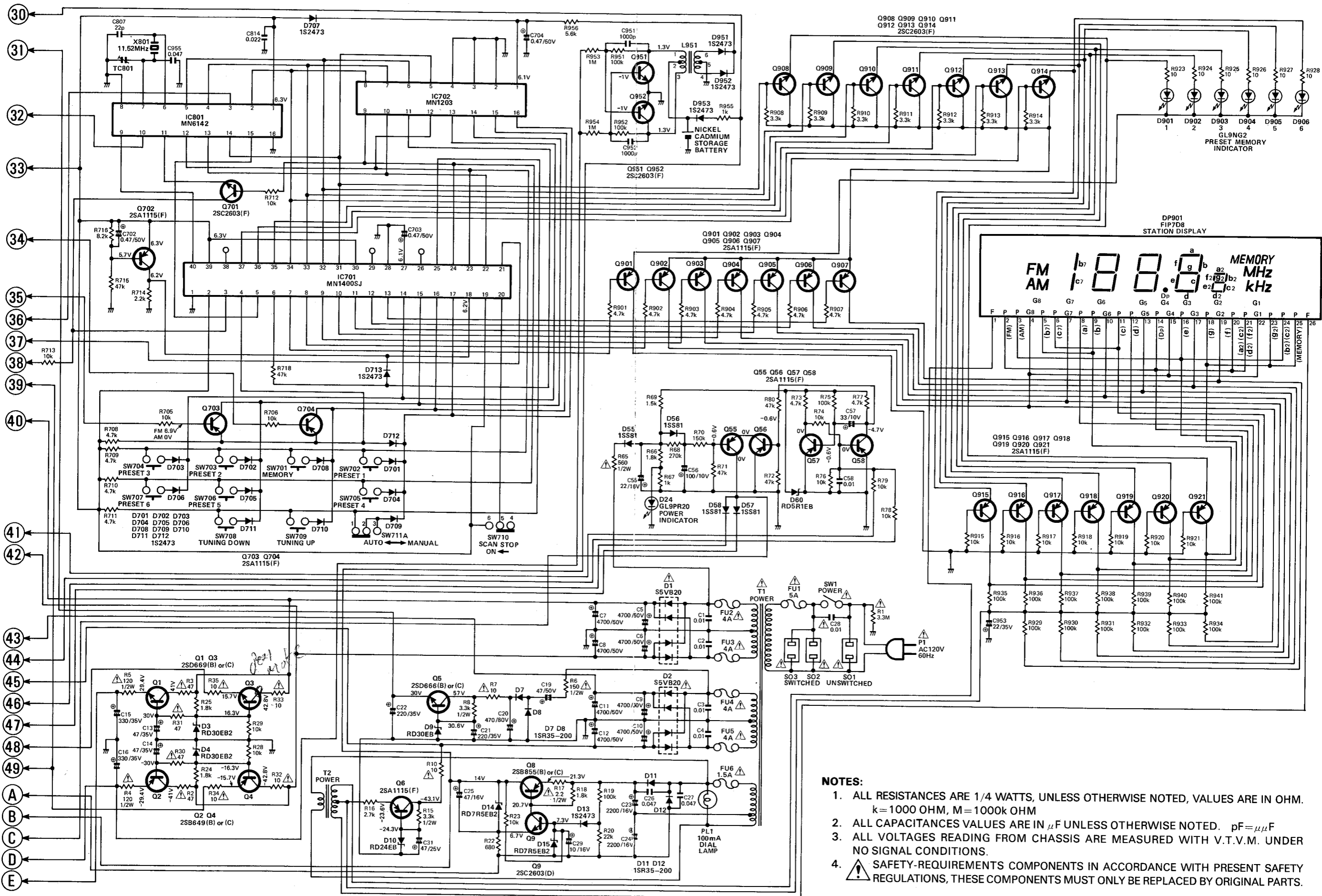

- NOTES:**
1. ALL RESISTANCES ARE 1/4 WATTS, UNLESS OTHERWISE NOTED, VALUES ARE IN OHM. k=1000 OHM, M=1000k OHM
 2. ALL CAPACITANCE VALUES ARE IN μ F UNLESS OTHERWISE NOTED. pF= μ μ F
 3. ALL VOLTAGES READING FROM CHASSIS ARE MEASURED WITH V.T.V.M. UNDER NO SIGNAL CONDITIONS.
 4. SAFETY-REQUIREMENTS COMPONENTS IN ACCORDANCE WITH PRESENT SAFETY REGULATIONS, THESE COMPONENTS MUST ONLY BE REPLACED BY ORIGINAL PARTS.

SCHEMATIC DIAGRAM

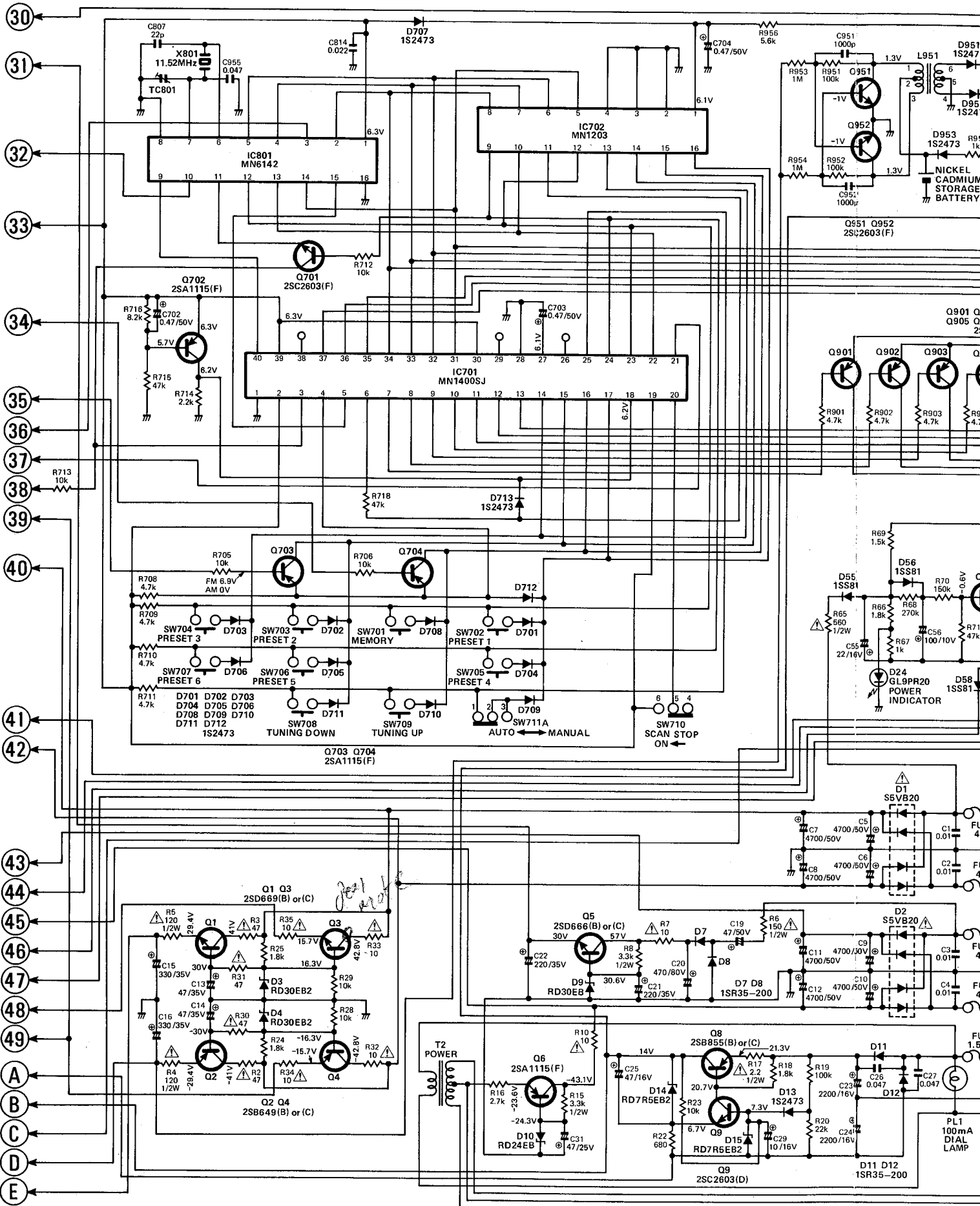

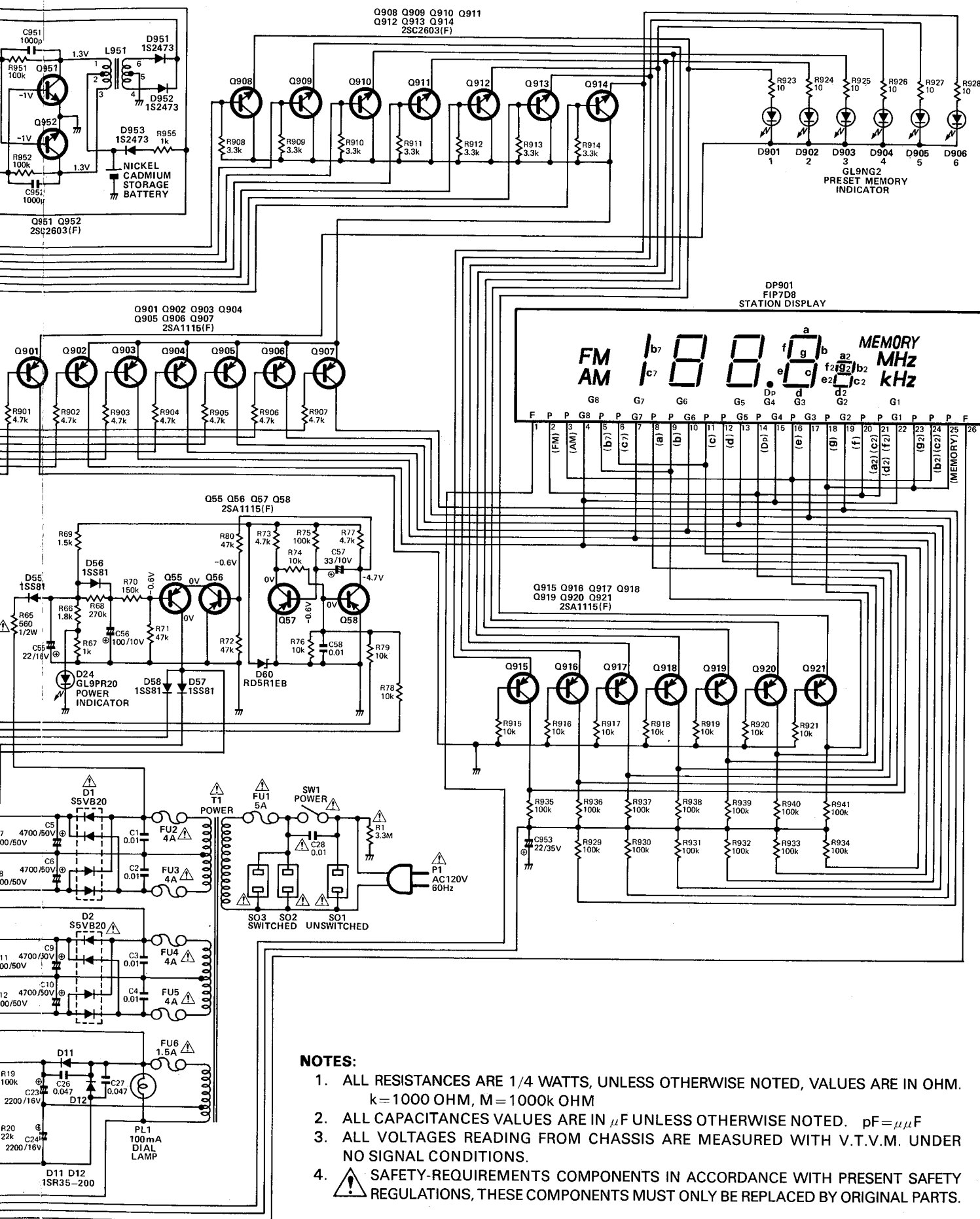

SCHEMATIC DIAGRAM

THE FOLLOWING SCHEMATIC DIAGRAM IS APPLIED TO MULTI VOLTAGE UNIT.

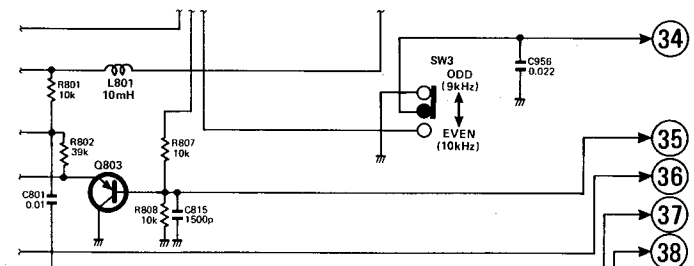
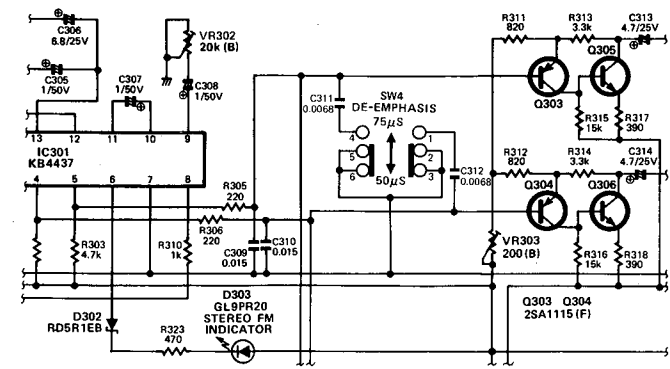
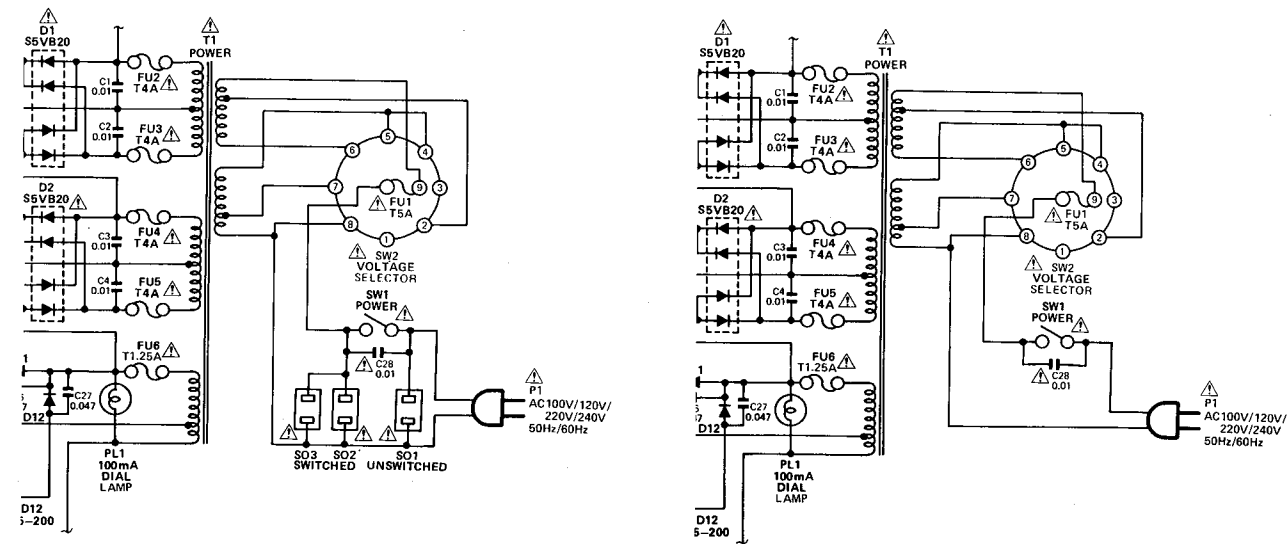

TIME/SEQUENCE CHART

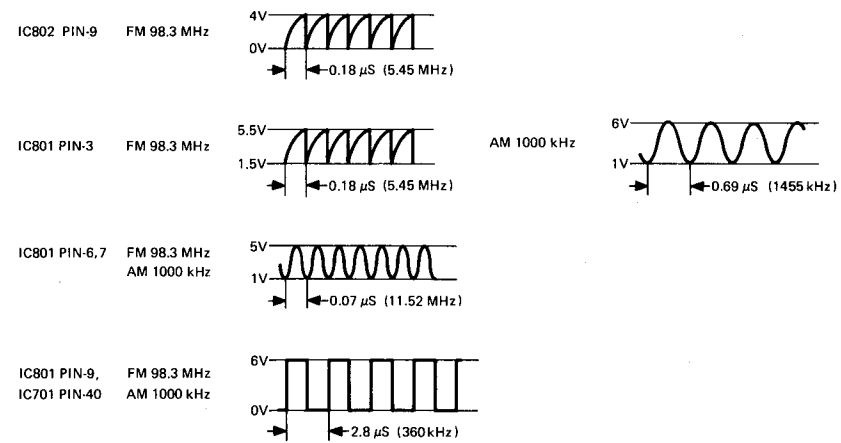

AM 1000 kHz SIGNAL RECEIVED AT MEMORY 2

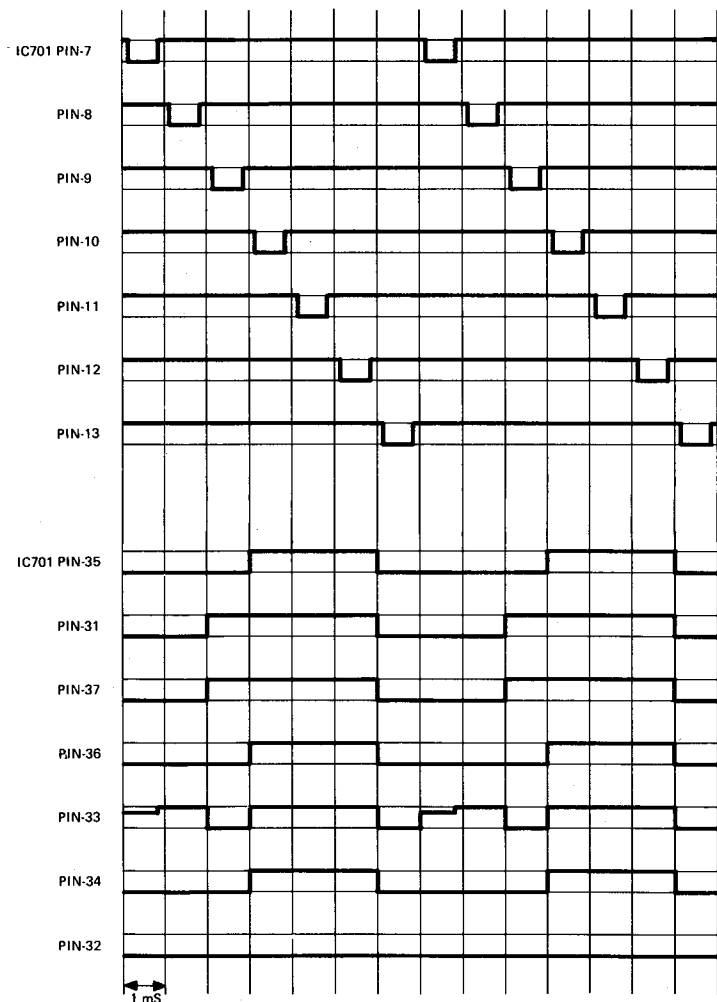

FM 98.3 MHz SIGNAL RECEIVED AT MEMORY 1

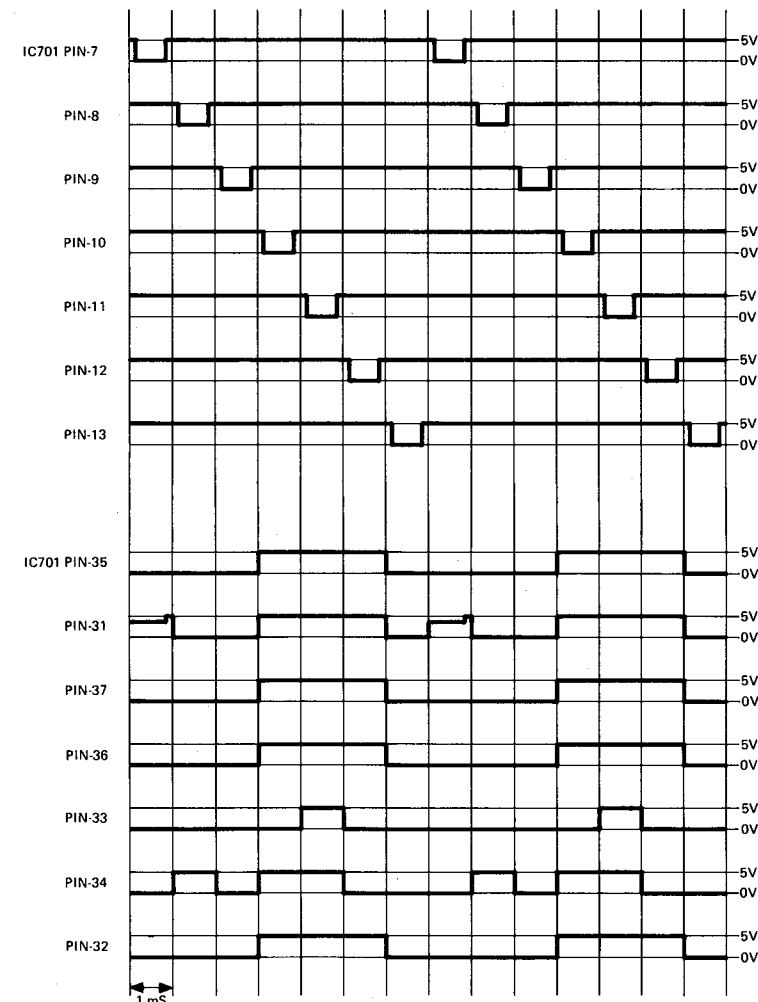

NOTE: The output signal from terminal number 7 in IC701 is applied to the oscillator trigger input.

SCHEMATIC DIAGRAM

THE FOLLOWING SCHEMATIC DIAGRAM IS APPLIED TO MULTI VOLTAGE UNIT.

TIME/

FOR EUROPE AND OCEANIA ONLY

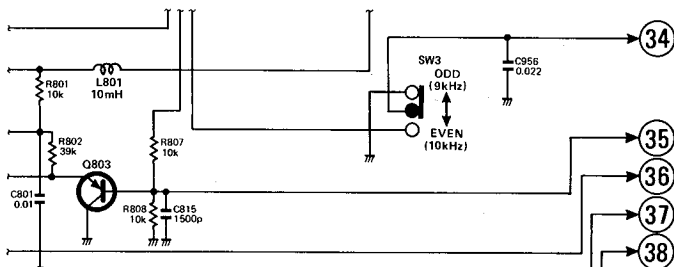
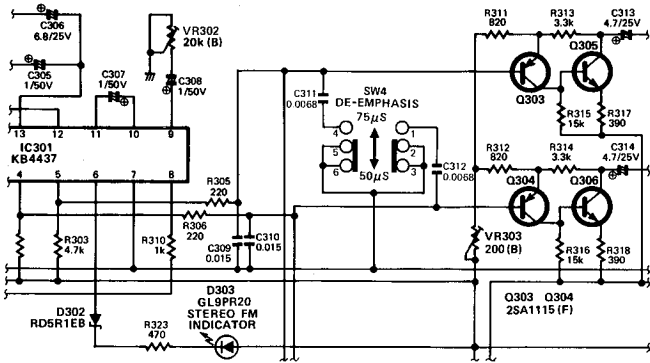
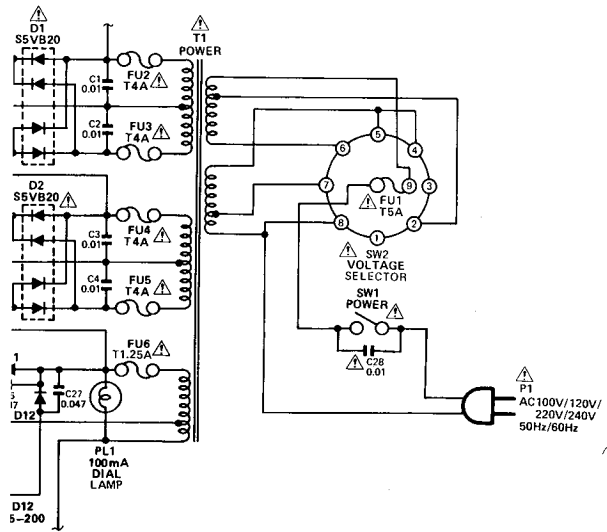
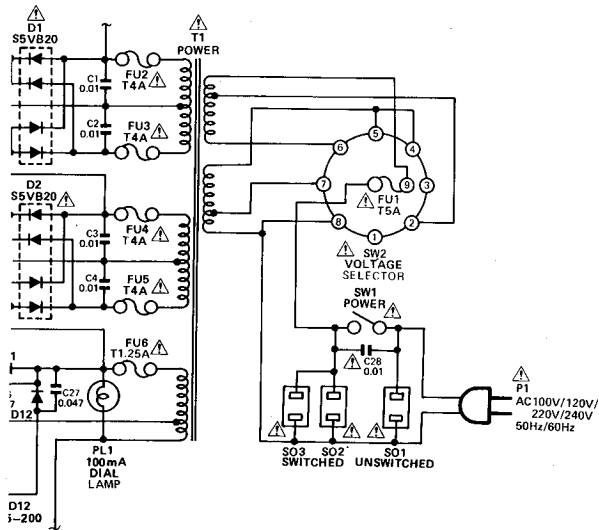

AM 1000

IC701 PIN-7

PIN-8

PIN-9

PIN-10

PIN-11

PIN-12

PIN-13

IC701 PIN-35

PIN-31

PIN-37

PIN-36

PIN-33

PIN-34

PIN-32

1 mS

TIME/SEQUENCE CHART

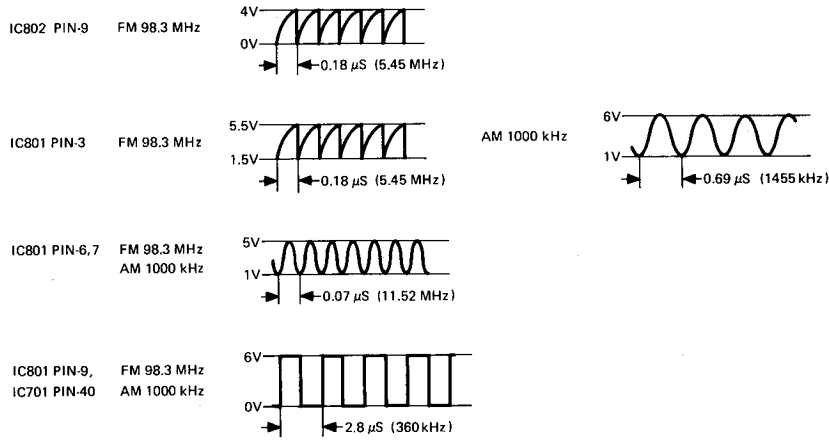

AM 1000 kHz SIGNAL RECEIVED AT MEMORY 2

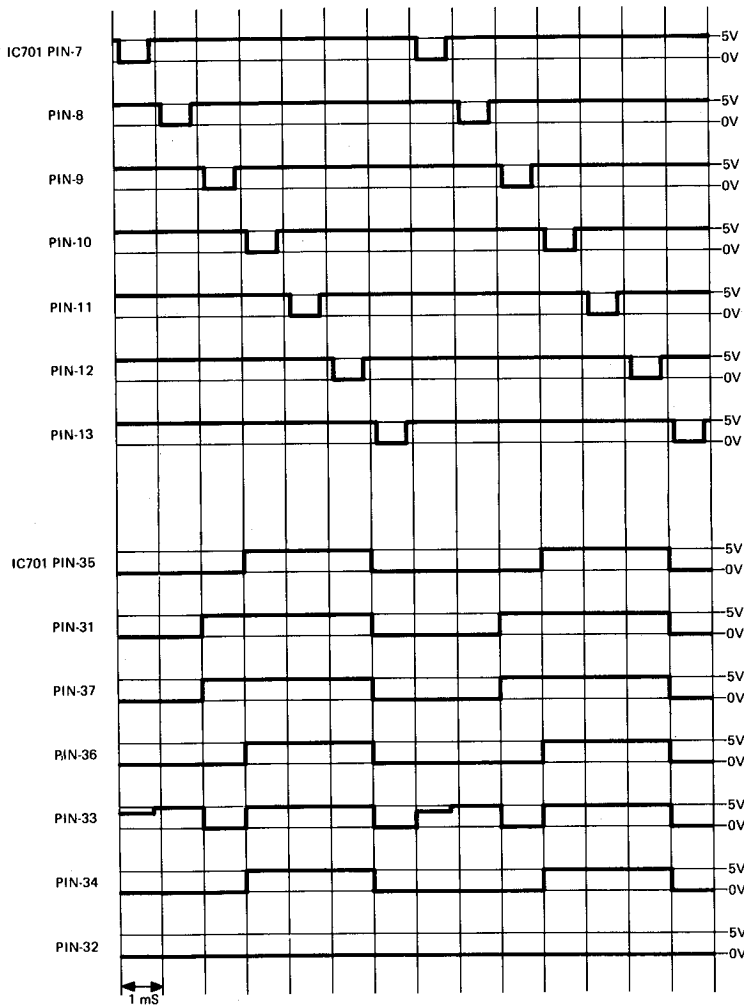

FM 98.3 MHz SIGNAL RECEIVED AT MEMORY 1

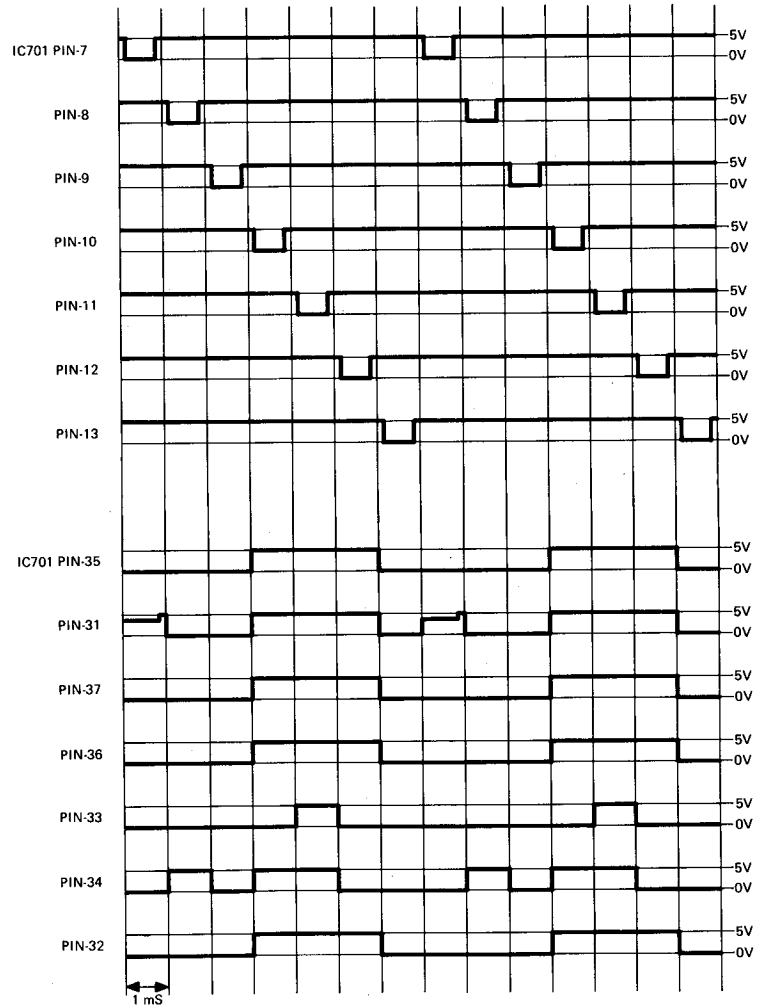

NOTE: The output signal from terminal number 7 in IC701 is applied to the oscillator trigger input.

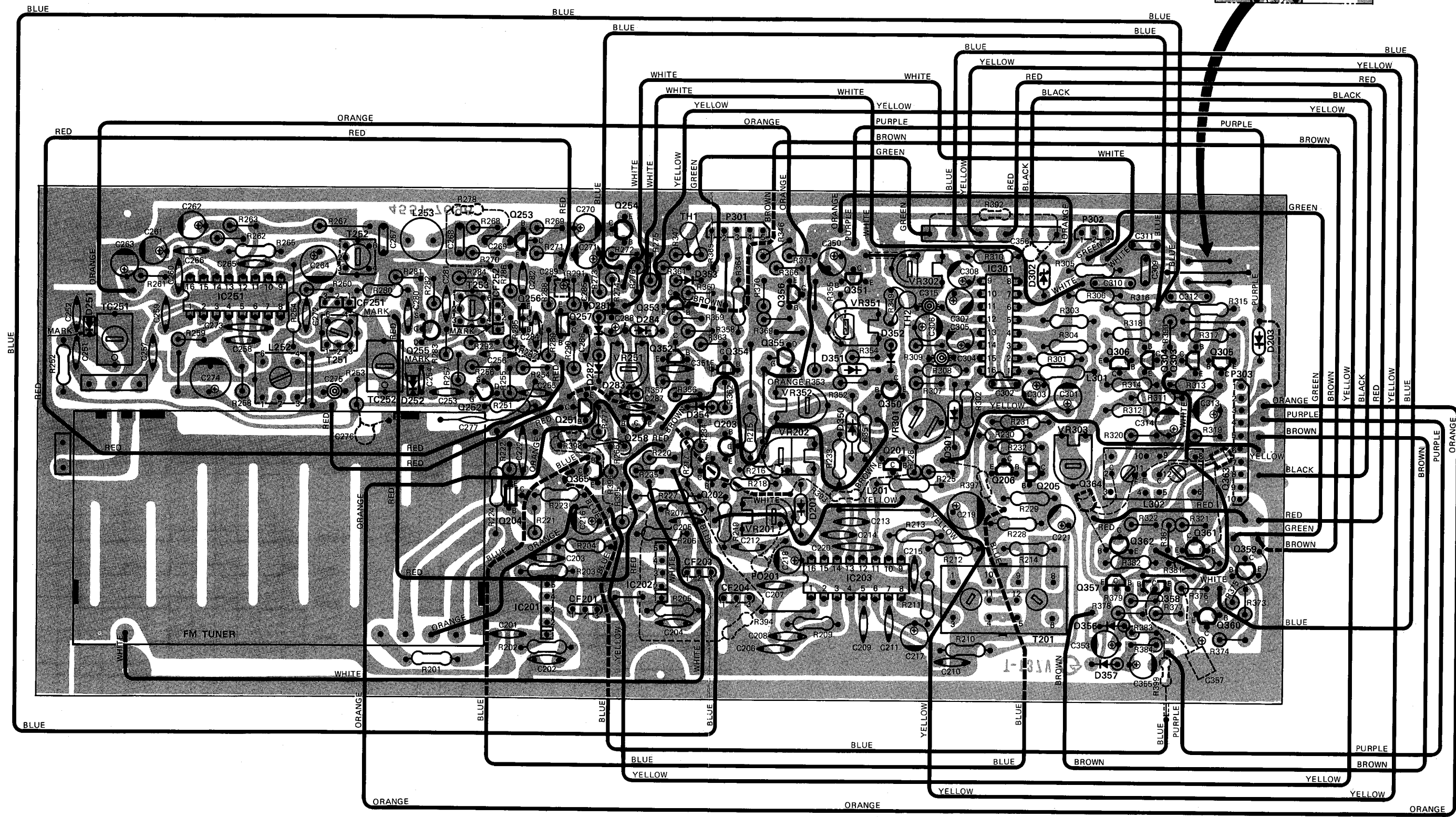
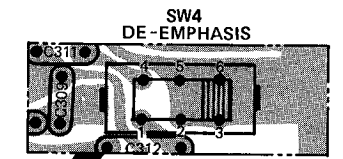

TUNER P.C.BOARD

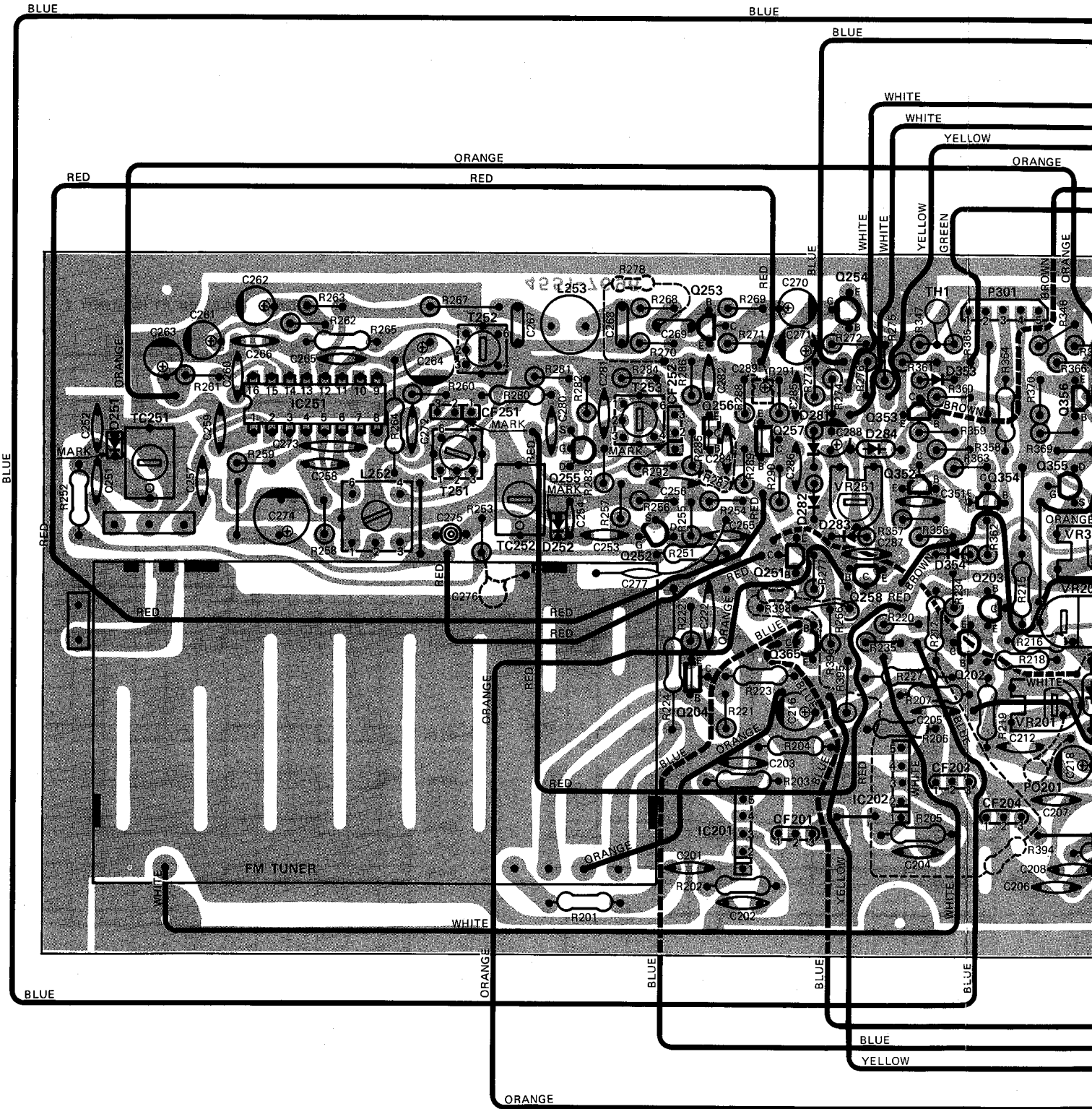

APPLY TO THE MULTI VOLTAGE UNIT

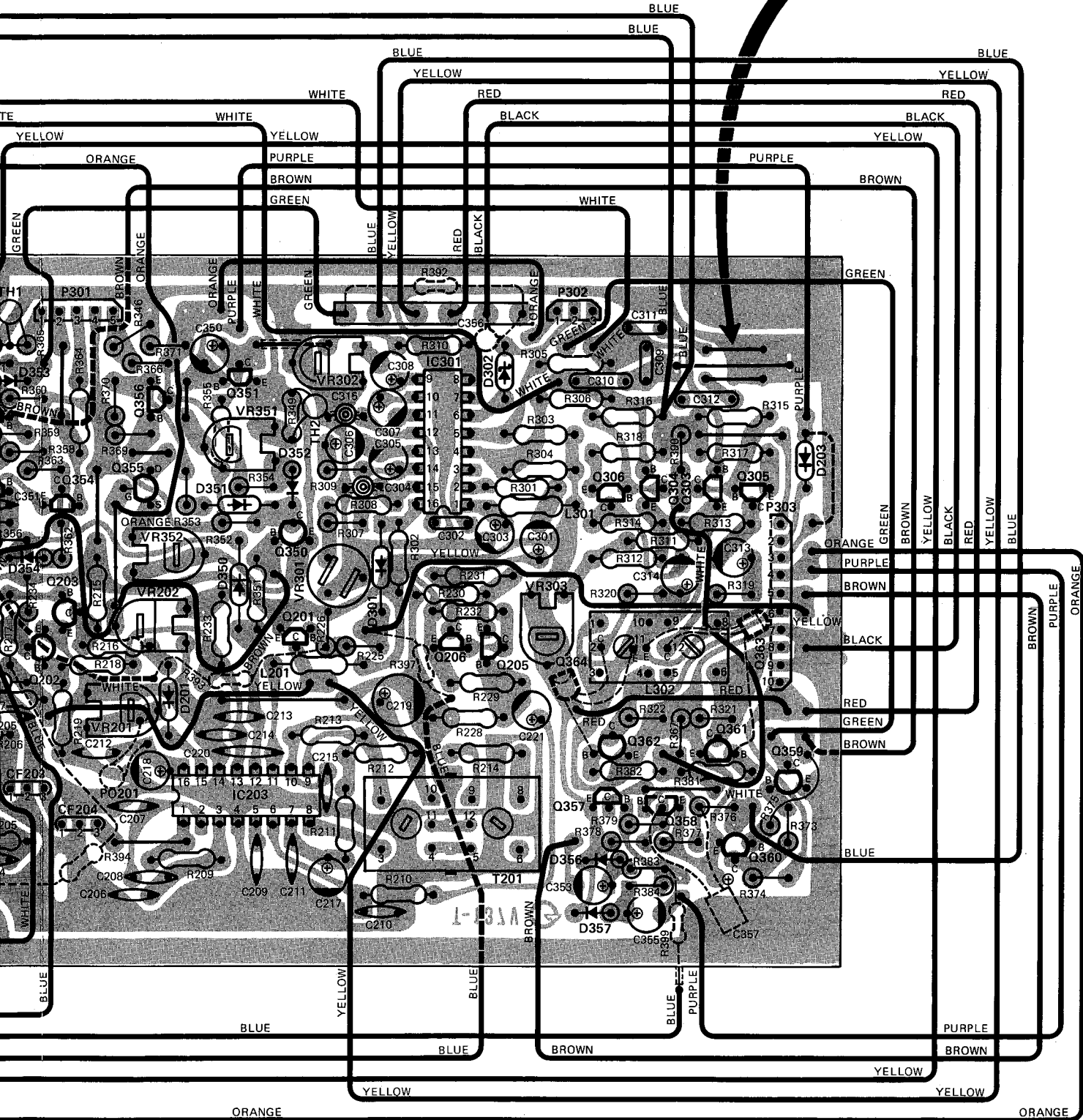
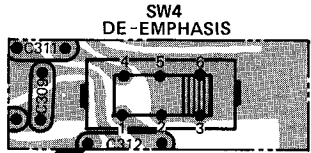

TUNER P.C. BOARD

Ref. No.	Part No.	Description
RESISTORS		
R204, 207, 292	5102-1004713	10 ohm \pm 2% 1/4W Fuse
R227	5102-4704713	47 ohm \pm 2% 1/4W Fuse
VR201	5101-10471913	Variable Resistor, 100 k ohm
VR202	5101-50371913	Variable Resistor, 50 k ohm
VR251	5101-2037187	Variable Resistor, 20 k ohm
VR301	5101-4727173	Variable Resistor, 4.7 k ohm
VR302	5101-20371913	Variable Resistor, 20 k ohm
VR303	5101-2017187	Variable Resistor, 200 ohm
VR351	5101-10371913	Variable Resistor, 10 k ohm
VR352	5101-30171913	Variable Resistor, 300 ohm
CAPACITORS		
TC251, 252	5371-49	Trimmer Capacitor
INTEGRATED CIRCUITS		
IC201, 202	5652-BA401	BA401 FM IF Amp.
IC203	5652-HA12412	HA12412 FM IF Amp./FM Det.
IC251	5652-LA1240	LA1240 AM Converter/AM IF Amp.
IC301	5652-KB4437	KB4437 FM Multiplex
TRANSISTORS		
Q201, 251	5611-1115(F)	2SA1115(F) FM Voltage Supply, AM Voltage Supply
Q202, 203, 253, 254, 258,351, 354, 365	5613-2603(F)	2SC2603(F) FM AGC, FM/AM Switching, AM AF Amp., AM Muting, Switching, Mono/Stereo Switching, Synthesizer/Quartz Lock Level Sensor, Muting
Q204	5613-461(B)	2SC461(B) FM Osc. Buffer
Q205	5613-2603(F)	2SC2603(F) } FM Demodulation Signal Amp.
Q206	5611-1115(F)	2SA1115(F) }
Q252	5616-2SK168(E)	F.E.T., 2SK168(E) AM Osc. Buffer
Q255	5616-2SK168(E)	F.E.T., 2SK168(E) } Auto Scan Stop Control Amp.
Q256, 257	5613-460(B)	2SC460(B) or (C) }
Q303, 304	5611-1115(F)	2SA1115(F) } MPX Output Amp.
Q305, 306	5613-2603(F)	2SC2603(F) }
Q350, 352, 353	5613-2603(F)	2SC2603(F) Synthesizer/Quartz Lock Switching
Q355	5616-2SK163(N)	F.E.T., 2SK163(N) } Signal Strength Display Level Amp.
Q356	5611-1115(F)	2SA1115(F) }
Q357	5611-1115(F)	2SA1115(F) } Muting
Q358	5613-2603(F)	2SC2603(F) }
Q359, 360	5613-2603(F)	2SC2603(F) Quartz Lock Indicator Driver
Q361, 362	5613-2603(F)	2SC2603(F) }
Q363, 364	5613-2320(D)	2SC2320(D) or (F) } FM Muting
DIODES		
D201, 203, 281, 282, 283, 284, 285, 301, 350, 351, 352, 353, 354, 356, 357	5631-1S2473	1S2473
D251/252	5633-KV1226	KV1226
D302	5635-RD5R1EB	Zener, RD5.1EB
COILS		
L201, 301	5995-100325	RF Choke
L252	5923-71220	AM Osc.
L253	5995-563250	Filter

TUNER P.C. BOARD

Ref. No.	Part No.	Description
TRANSFORMERS		
T201	5574-7043	Quadrature Det.
T251, 253	5552-7027	AM IF, Filter
T252	5932-7023	AM IF
MISCELLANEOUS		
CF201	6114-7119	FM Tuner Assembly
CF203, 204	5671-7120A	Ceramic Filter, FM IF
CF251	5671-7119A	Ceramic Filter, FM IF
CF252	5671-7128A	Ceramic Filter, AM IF
L302	5671-7129A	Ceramic Filter, Filter
TH1, 2	5214-8	LC Components, Low Pass Filter
PO201	5191-42D26	Thermistor, 42D26
	5192-102723	PTC Thermistor, 1 k ohm

SIGNAL STRENGTH DISPLAY P.C. BOARD

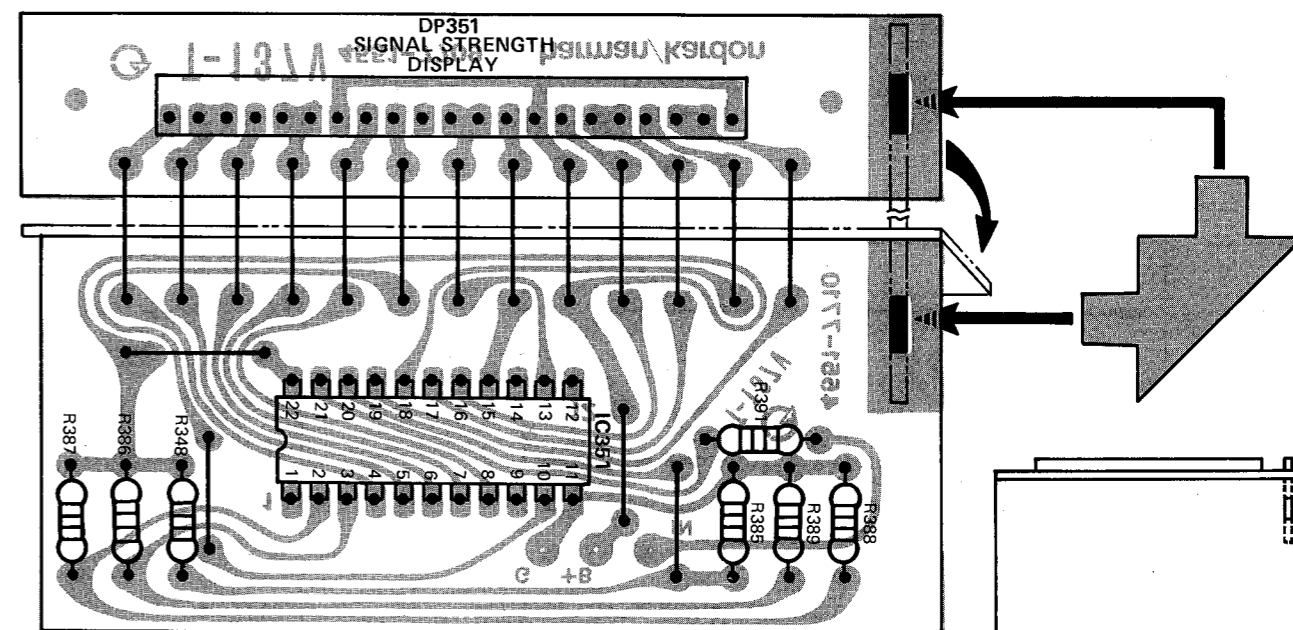

Ref. No.	Part No.	Description
IC351	5652-IR2406G	Integrated Circuit, IR2406G Signal Strength Display Driver
DP351	5623-GL112N9	LED Display Assembly, GL112N9 Signal Strength Display

TUNER P.C. BOARD

Ref. No.	Part No.	Description
RESISTORS		
R204, 207, 292	5102-1004713	10 ohm \pm 2% 1/4W Fuse
R227	5102-4704713	47 ohm \pm 2% 1/4W Fuse
VR201	5101-10471913	Variable Resistor, 100 k ohm
VR202	5101-50371913	Variable Resistor, 50 k ohm
VR251	5101-2037187	Variable Resistor, 20 k ohm
VR301	5101-4727173	Variable Resistor, 4.7 k ohm
VR302	5101-20371913	Variable Resistor, 20 k ohm
VR303	5101-2017187	Variable Resistor, 200 ohm
VR351	5101-10371913	Variable Resistor, 10 k ohm
VR352	5101-30171913	Variable Resistor, 300 ohm
CAPACITORS		
TC251, 252	5371-49	Trimmer Capacitor
INTEGRATED CIRCUITS		
IC201, 202	5652-BA401	BA401 FM IF Amp.
IC203	5652-HA12412	HA12412 FM IF Amp./FM Det.
IC251	5652-LA1240	LA1240 AM Converter/AM IF Amp.
IC301	5652-KB4437	KB4437 FM Multiplex
TRANSISTORS		
Q201, 251	5611-1115(F)	2SA1115(F) FM Voltage Supply, AM Voltage Supply
Q202, 203, 253, 254, 258, 351, 354, 365	5613-2603(F)	2SC2603(F) FM AGC, FM/AM Switching, AM AF Amp., AM Muting, Switching, Mono/Stereo Switching, Synthesizer/Quartz Lock Level Sensor, Muting
Q204	5613-461(B)	2SC461(B) FM Osc. Buffer
Q205	5613-2603(F)	2SC2603(F) } FM Demodulation Signal Amp.
Q206	5611-1115(F)	2SA1115(F) }
Q252	5616-2SK168(E)	F.E.T., 2SK168(E) AM Osc. Buffer
Q255	5616-2SK168(E)	F.E.T., 2SK168(E) } Auto Scan Stop Control Amp.
Q256, 257	5613-460(B)	2SC460(B) or (C) }
Q303, 304	5611-1115(F)	2SA1115(F) } MPX Output Amp.
Q305, 306	5613-2603(F)	2SC2603(F) }
Q350, 352, 353	5613-2603(F)	2SC2603(F) Synthesizer/Quartz Lock Switching
Q355	5616-2SK163(N)	F.E.T., 2SK163(N) } Signal Strength Display Level Amp.
Q356	5611-1115(F)	2SA1115(F) }
Q357	5611-1115(F)	2SA1115(F) } Muting
Q358	5613-2603(F)	2SC2603(F) }
Q359, 360	5613-2603(F)	2SC2603(F) Quartz Lock Indicator Driver
Q361, 362	5613-2603(F)	2SC2603(F) } FM Muting
Q363, 364	5613-2320(D)	2SC2320(D) or (F) }
DIODES		
D201, 203, 281, 282, 283, 284, 285, 301, 350, 351, 352, 353, 354, 356, 357	5631-1S2473	1S2473
D251/252	5633-KV1226	KV1226
D302	5635-RD5R1EB	Zener, RD5.1EB
COILS		
L201, 301	5995-100325	RF Choke
L252	5923-71220	AM Osc.
L253	5995-563250	Filter

TUNER P.C. BOARD

Ref. No.	Part No.	Description
TRANSFORMERS		
T201	5574-7043	Quadrature Det.
T251, 253	5552-7027	AM IF, Filter
T252	5932-7023	AM IF
MISCELLANEOUS		
	6114-7119	FM Tuner Assembly
CF201	5671-7120A	Ceramic Filter, FM IF
CF203, 204	5671-7119A	Ceramic Filter, FM IF
CF251	5671-7128A	Ceramic Filter, AM IF
CF252	5671-7129A	Ceramic Filter, Filter
L302	5214-8	LC Components, Low Pass Filter
TH1, 2	5191-42D26	Thermistor, 42D26
PO201	5192-102723	PTC Thermistor, 1 k ohm

SIGNAL STRENGTH DISPLAY P.C. BOARD

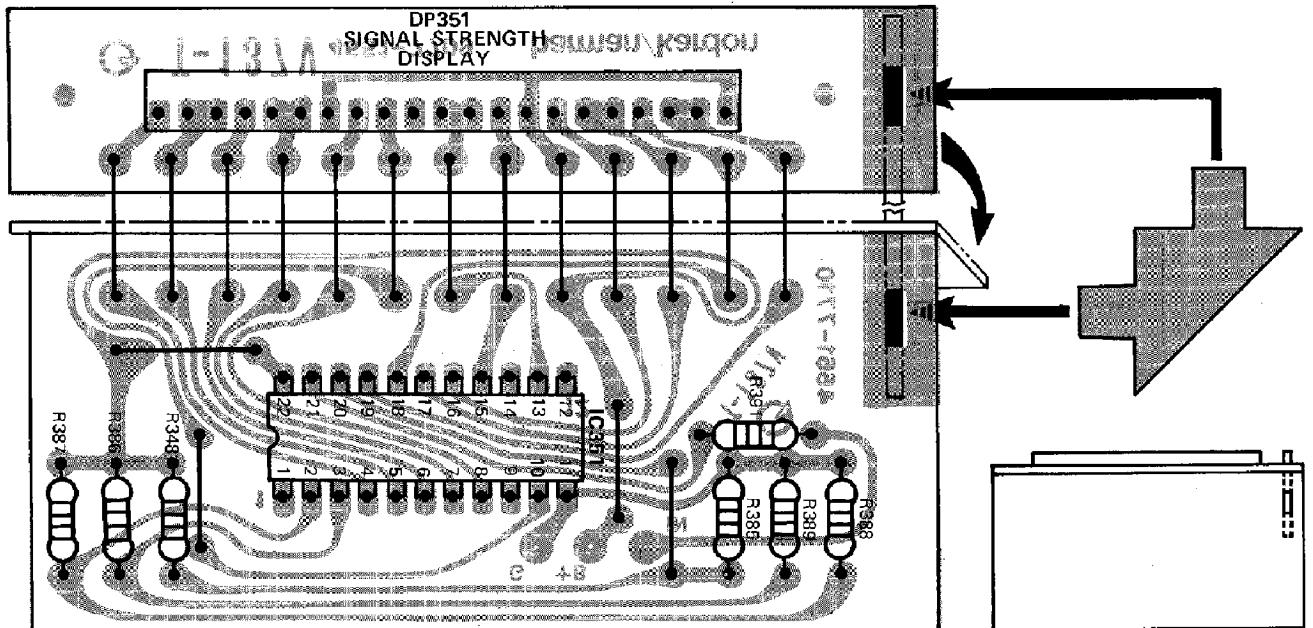

Ref. No.	Part No.	Description
IC351	5652-IR2406G	Integrated Circuit, IR2406G Signal Strength Display Driver
DP351	5623-GL112N9	LED Display Assembly, GL112N9 Signal Strength Display

Circuit Board # CTS \$100
 D551-685 021A

SIDE A

SIDE B

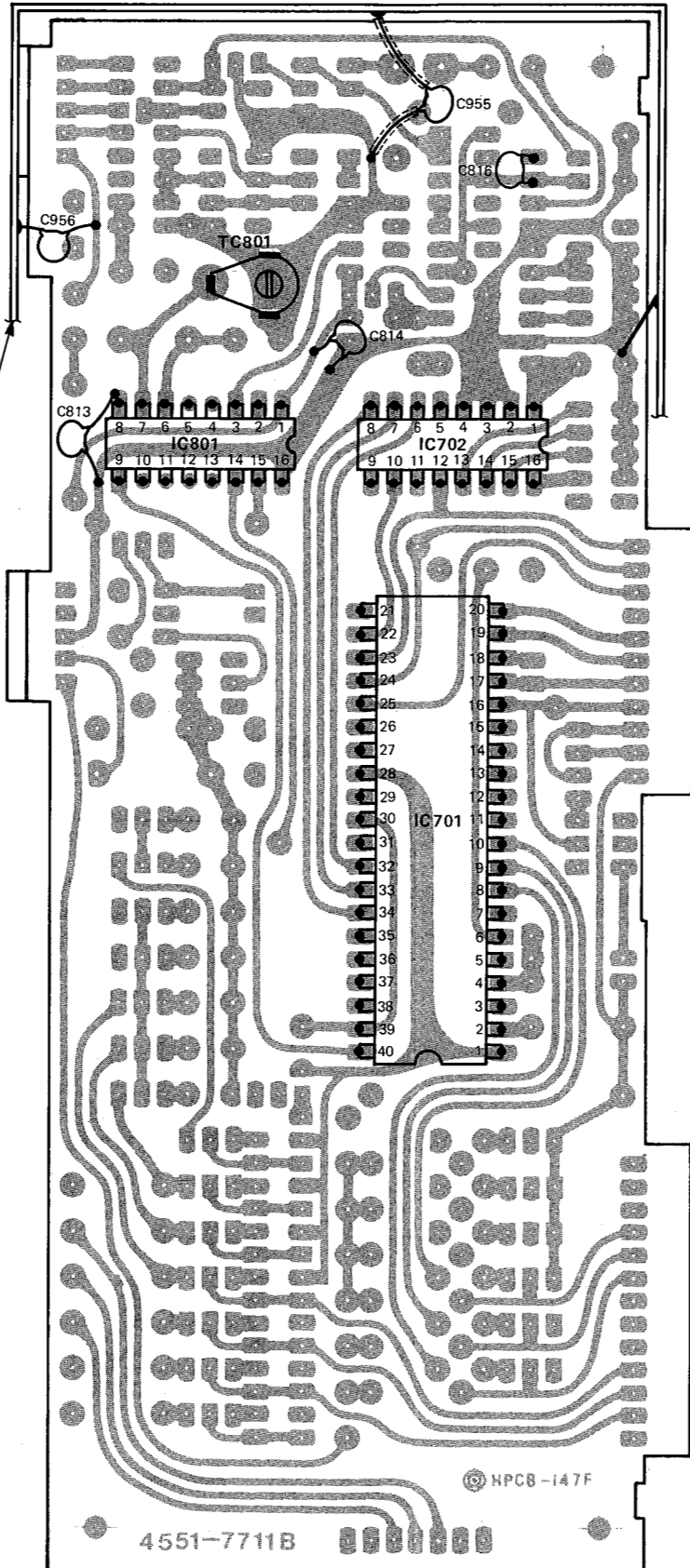
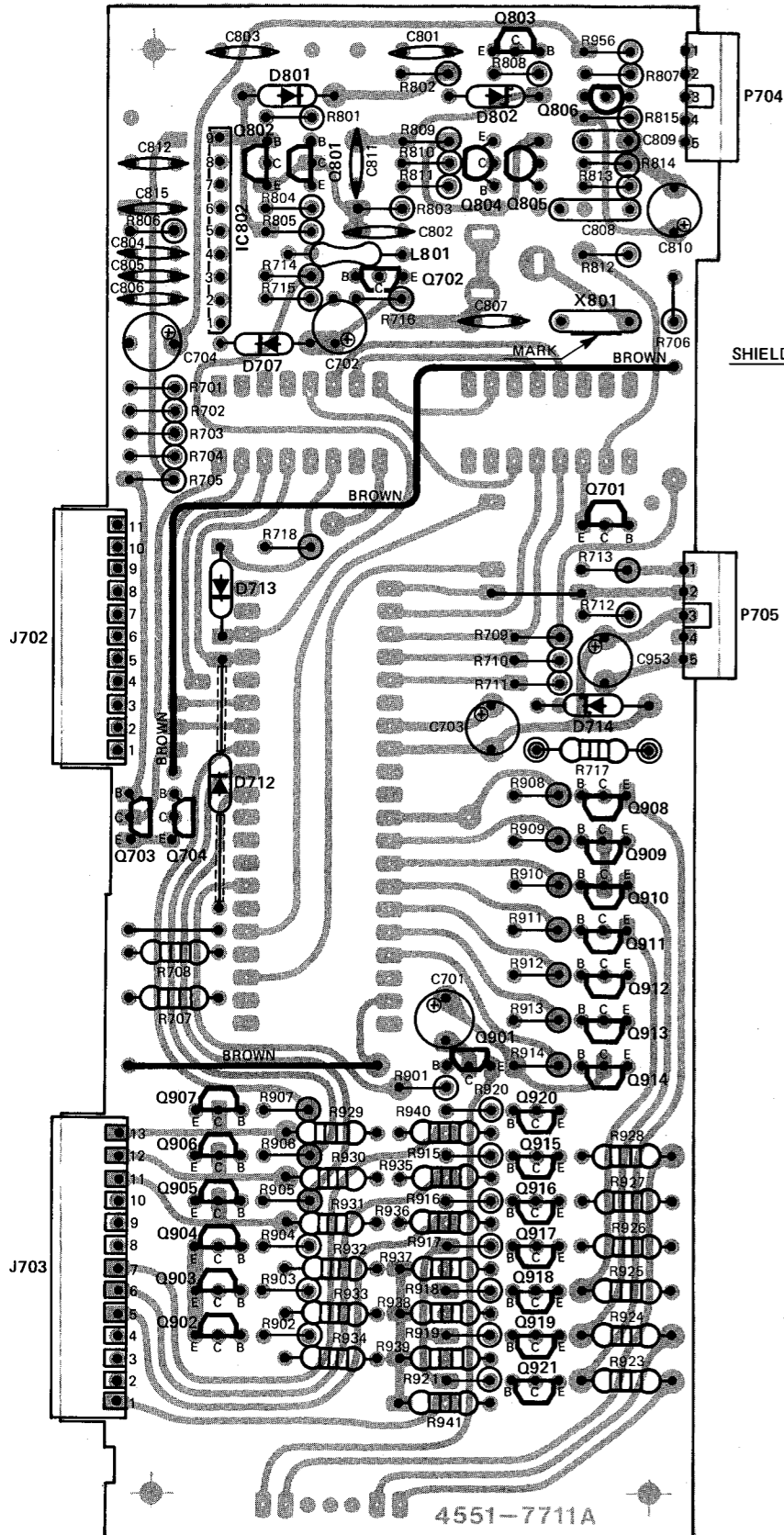

Ref. No.	Part No.	Description
CAPACITORS		
TC801	5371-59	Trimmer Capacitor
INTEGRATED CIRCUITS		
IC701	5654-MN1400SJ	MN1400SJ Synthesizer Controller
IC702	5654-MN1203	MN1203 Memory
IC801	5654-MN6142	MN6142 PLL
IC802	5654-AN6821	AN6821 Pre-Scaler
TRANSISTORS		
Q701, 802	5613-2603(F)	2SC2603(F) Switching, Pre-Scaler Buffer
Q702, 703, 704, 801, 803	5611-1115(F)	2SA1115(F) Switching, AM Osc. Amp., Switching
Q804	5613-2320L(F)	2SC2320L(F) } Low Pass Filter
Q805	5616-2SK68(M)	F.E.T., 2SK68(M) }
Q806	5616-2SK163(N)	F.E.T., 2SK163(N) Current Regulator
Q901, 902, 903, 904, 905, 906, 907, 915, 916, 917, 918, 919, 920, 921	5611-1115(F)	2SA1115(F) } Station Display/Preset Memory Indicator Driver
Q908, 909, 910, 911, 912, 913, 914	5613-2603(F)	2SC2603(F)
DIODES		
D707, 712, 713, 801	5631-1S2473	1S2473
D714	5635-RD6R2FB	Zener, RD6.2FB
D802	5635-HZ27-3	Zener, HZ27-3
MISCELLANEOUS		
X801	5691-01152019	Crystal Osc., 11.52MHz
L801	5995-100325	Coil, Choke

STATION DISPLAY CONTROL P.C. BOARD

SIDE A

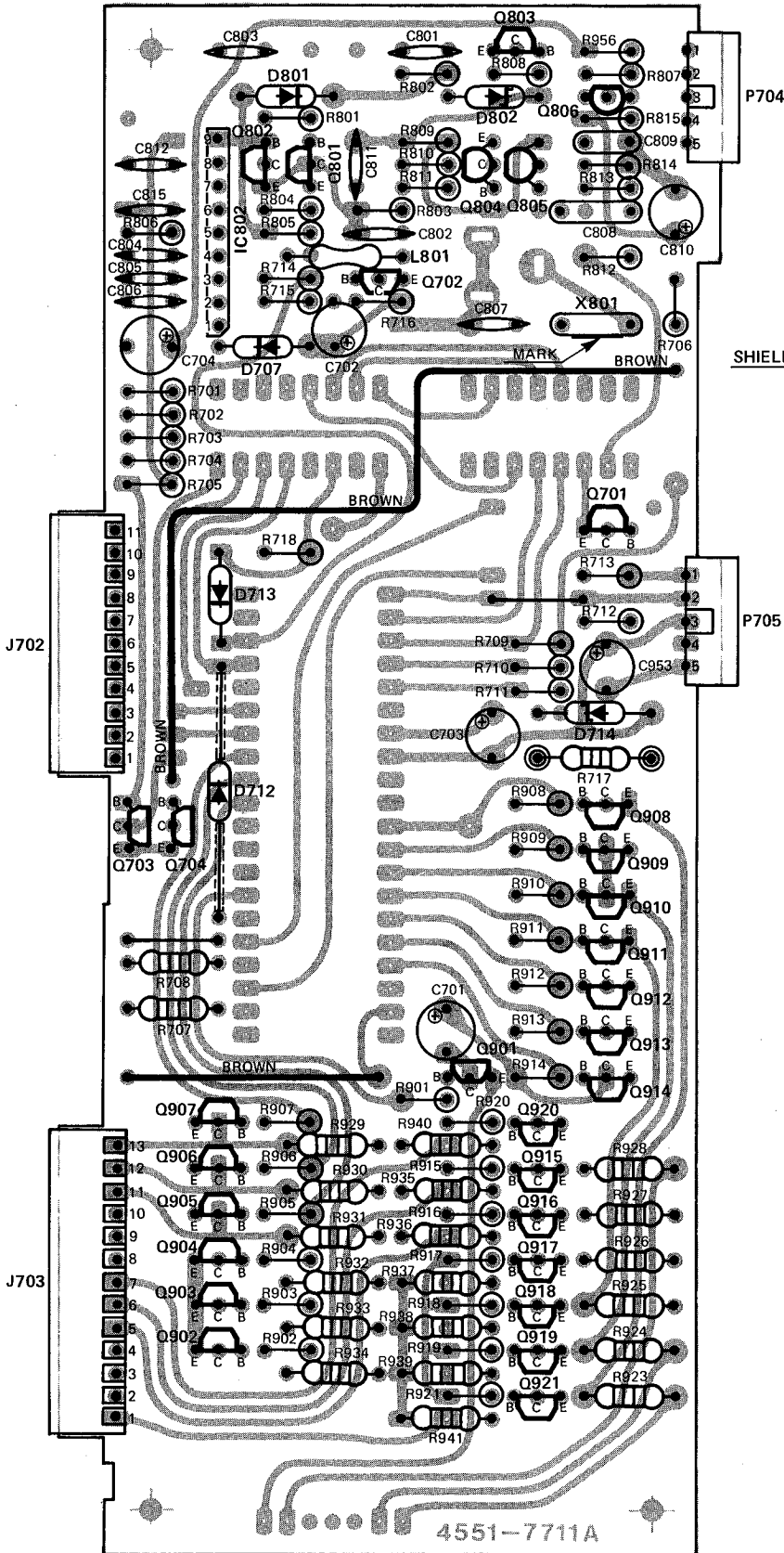

SIDE B

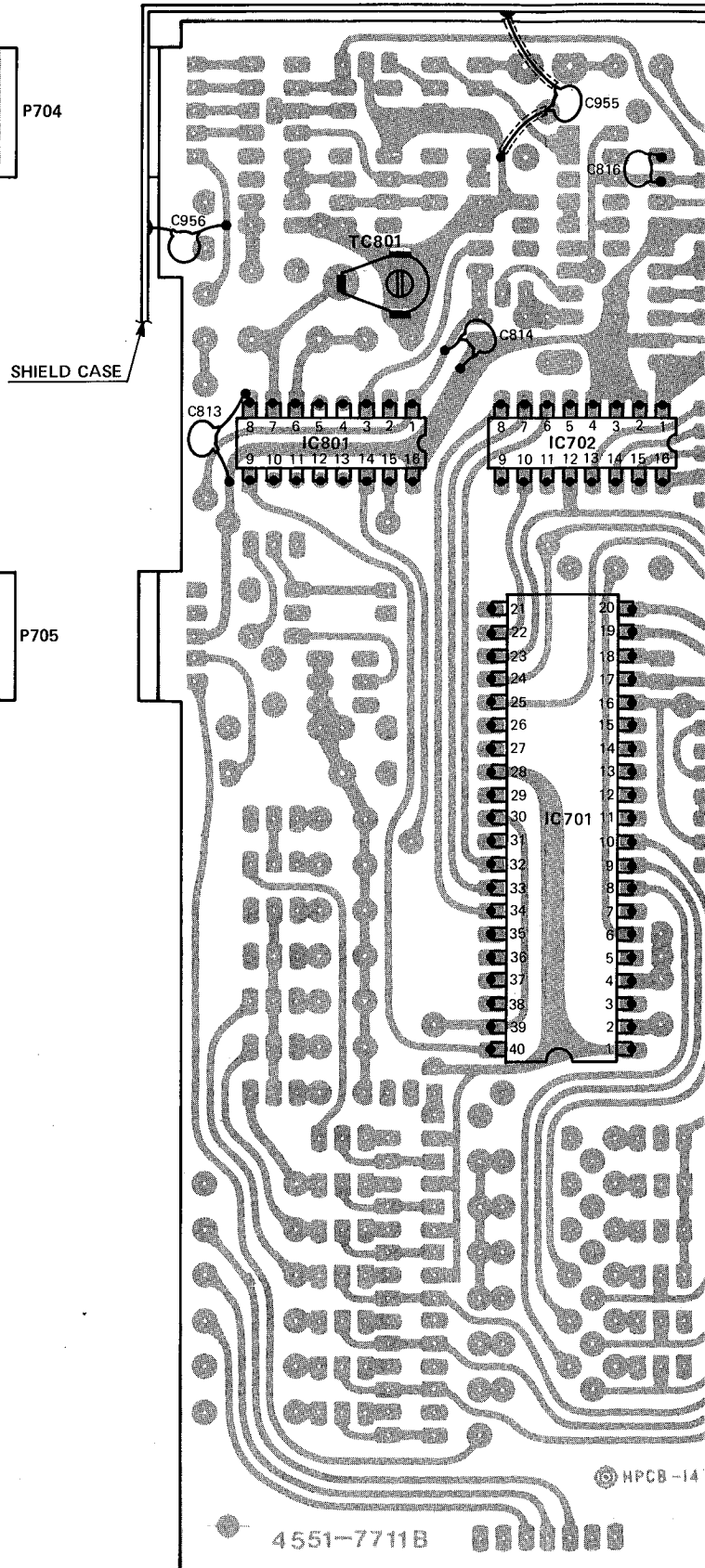

Circuit Board # CTS \$100
 D551-685 021A

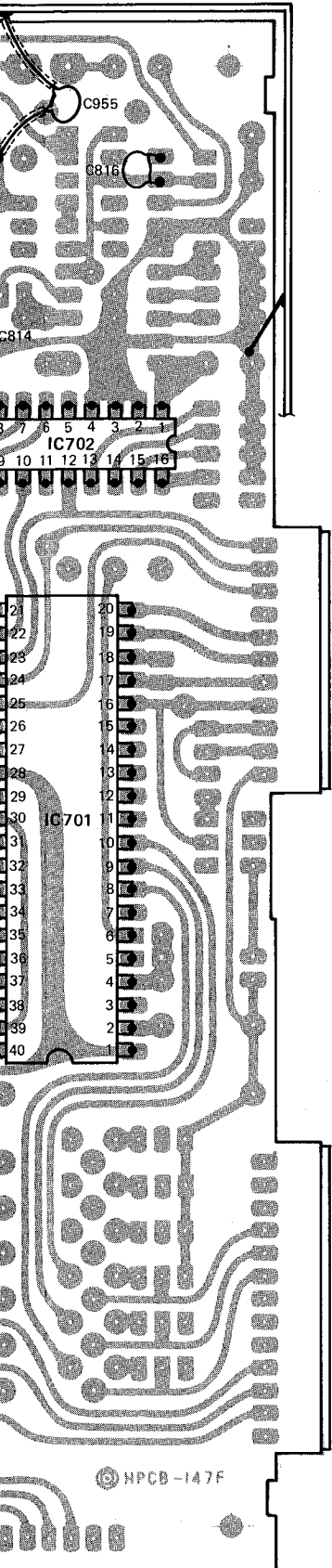

Ref. No.	Part No.	Description
CAPACITORS		
TC801	5371-59	Trimmer Capacitor
INTEGRATED CIRCUITS		
IC701	5654-MN1400SJ	MN1400SJ Synthesizer Controller
IC702	5654-MN1203	MN1203 Memory
IC801	5654-MN6142	MN6142 PLL
IC802	5654-AN6821	AN6821 Pre-Scaler
TRANSISTORS		
Q701, 802	5613-2603(F)	2SC2603(F) Switching, Pre-Scaler Buffer
Q702, 703, 704, 801, 803	5611-1115(F)	2SA1115(F) Switching, AM Osc. Amp., Switching
Q804	5613-2320L(F)	2SC2320L(F) } Low Pass Filter
Q805	5616-2SK68(M)	F.E.T., 2SK68(M) }
Q806	5616-2SK163(N)	F.E.T., 2SK163(N) Current Regulator
Q901, 902, 903, 904, 905, 906, 907, 915, 916, 917, 918, 919, 920, 921	5611-1115(F)	2SA1115(F) } Station Display/Preset Memory Indicator Driver
Q908, 909, 910, 911, 912, 913, 914	5613-2603(F)	2SC2603(F) }
DIODES		
D707, 712, 713, 801	5631-1S2473	1S2473
D714	5635-RD6R2FB	Zener, RD6.2FB
D802	5635- HZ27-3	Zener, HZ27-3
MISCELLANEOUS		
X801	5691-01152019	Crystal Osc., 11.52MHz
L801	5995-100325	Coil, Choke

PHONO EQUALIZER P.C. BOARD

DSS1-LK 680A

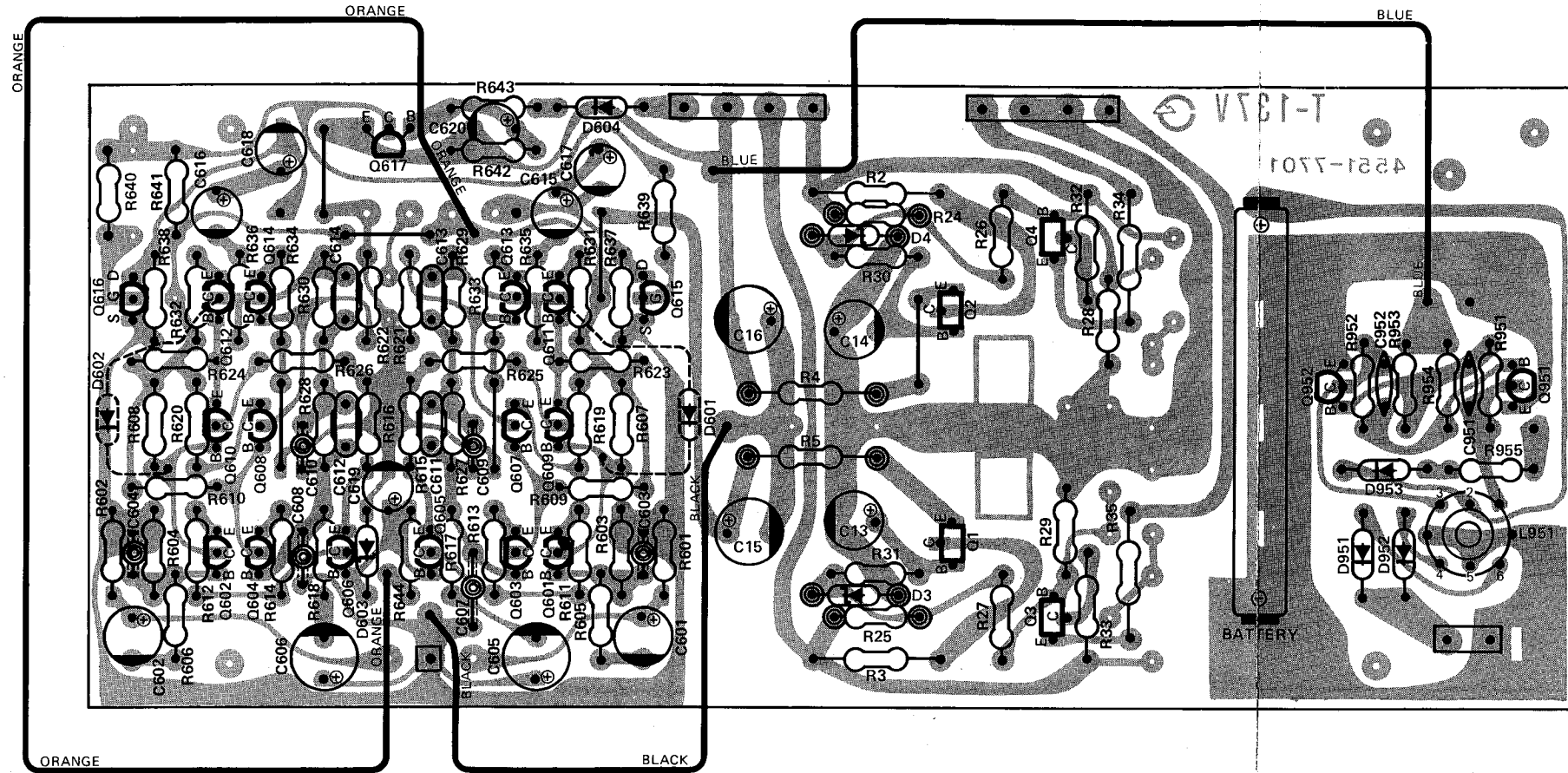

Ref. No.	Part No.	Description
RESISTORS, FUSE		
R2, 3, 30, 31	5102-4704713	47 ohm ±2% 1/4W
R4, 5	5102-1215710	120 ohm ±5% 1/2W
R32, 33, 34, 35	5102-1004713	10 ohm ±2% 1/4W
TRANSISTORS		
Q1, 3	5614-669(B)	2SD669(B)or(C) Voltage Regulator
Q2, 4	5612-649(B)	2SB649(B)or(C) Voltage Regulator
Q601, 602, 603, 604	5613-2240(BL)	2SC2240(BL)
Q605, 606	5613-2603(F)	2SC2603(F)
Q607, 608, 609, 610	5611-970(BL)	2SA970(BL)
Q611, 612	5612-646(C)	2SB646(C)
Q613, 614	5614-666(C)	2SD666(C)
Q615, 616	5616-2SK163(M)	F.E.T., 2SK163(M)
Q617	5613-2320(D)	2SC2320(D)
Q951, 952	5613-2603(F)	2SC2603(F) Memory IC Back Up Osc.
DIODES		
D3, 4	5635-RD30EB2	Zener, RD30EB2
D601, 602, 951, 952, 953	5631-1S2473	1S2473
D603	5635-RD5R1EB	Zener, RD5.1EB
D604	5636-1SS81	1SS81
MISCELLANEOUS		
	4196-NR-AA	Nickel Cadmium Storage Battery
L951	5933-70215	Coil, Back Up Osc.

PRESET MEMORY SWITCH P.C. BOARD

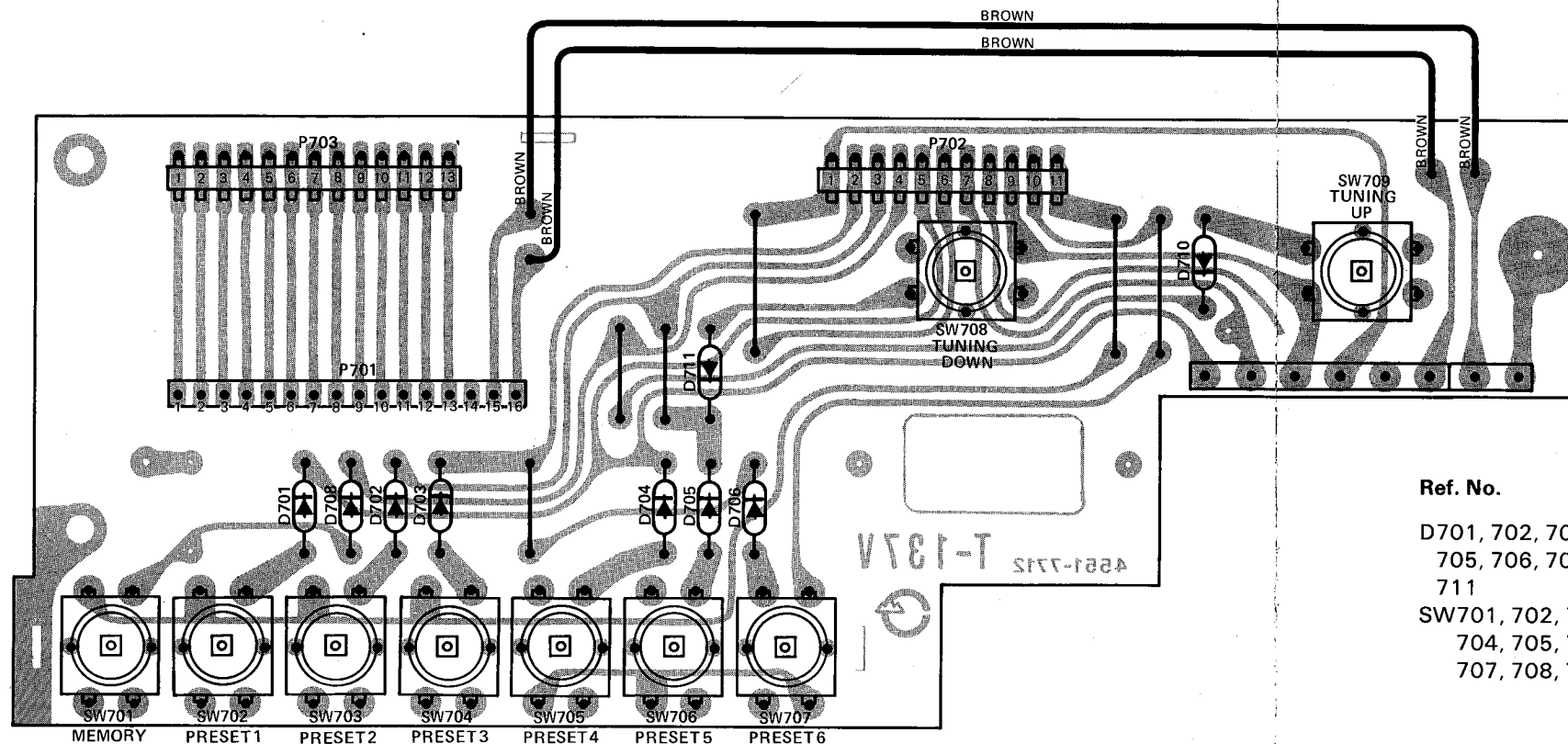

Ref. No.	Part No.	Description
D701, 702, 703, 704, 705, 706, 708, 710, 711	5631-1S2473	Diode, 1S2473
SW701, 702, 703, 704, 705, 706, 707, 708, 709	4431-01010170	Push Switch, FM/AM Preset Memory, Tuning Down, Tuning Up

PHONO EQUALIZER P.C. BOARD

D551-HK 680A

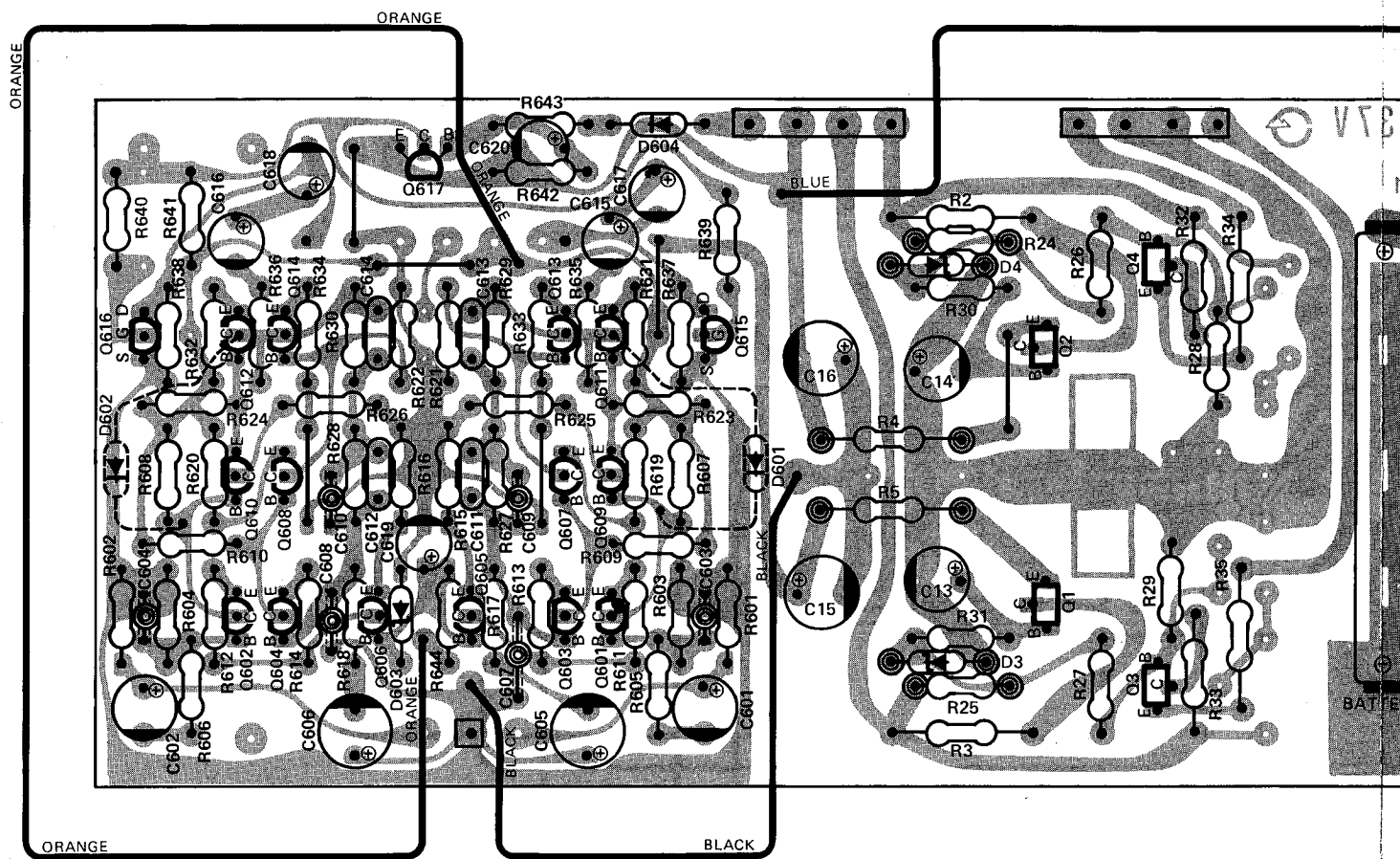

PRESET MEMORY SWITCH P.C. BOARD

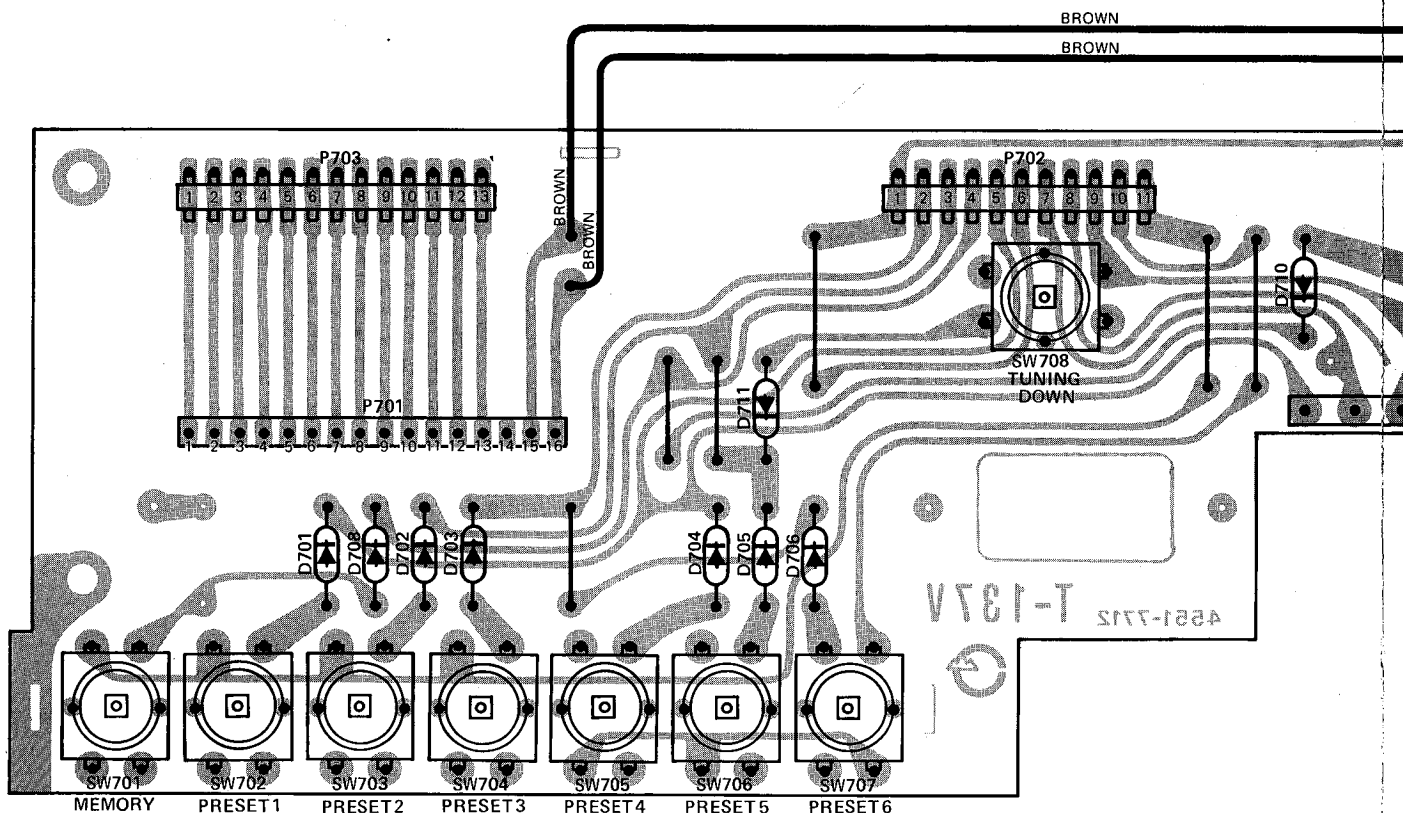

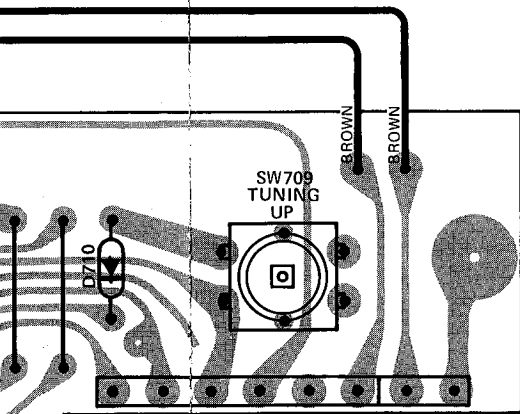
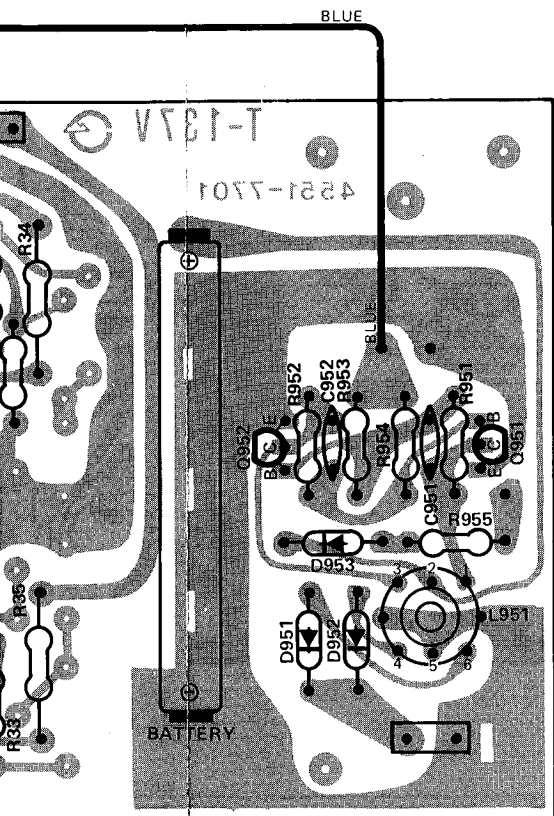

Ref. No.	Part No.	Description
RESISTORS, FUSE		
R2, 3, 30, 31	5102-4704713	47 ohm $\pm 2\%$ 1/4W
R4, 5	5102-1215710	120 ohm $\pm 5\%$ 1/2W
R32, 33, 34, 35	5102-1004713	10 ohm $\pm 2\%$ 1/4W
TRANSISTORS		
Q1, 3	5614-669(B)	2SD669(B)or(C) Voltage Regulator
Q2, 4	5612-649(B)	2SB649(B)or(C) Voltage Regulator
Q601, 602, 603, 604	5613-2240(BL)	2SC2240(BL)
Q605, 606	5613-2603(F)	2SC2603(F)
Q607, 608, 609, 610	5611-970(BL)	2SA970(BL)
Q611, 612	5612-646(C)	2SB646(C)
Q613, 614	5614-666(C)	2SD666(C)
Q615, 616	5616-2SK163(M)	F.E.T., 2SK163(M)
Q617	5613-2320(D)	2SC2320(D)
Q951, 952	5613-2603(F)	2SC2603(F) Memory IC Back Up Osc.
DIODES		
D3, 4	5635-RD30EB2	Zener, RD30EB2
D601, 602, 951, 952, 953	5631-1S2473	1S2473
D603	5635-RD5R1EB	Zener, RD5.1EB
D604	5636-1SS81	1SS81
MISCELLANEOUS		
	4196-NR-AA	Nickel Cadmium Storage Battery
L951	5933-70215	Coil, Back Up Osc.

Ref. No.	Part No.	Description
D701, 702, 703, 704, 705, 706, 708, 710, 711	5631-1S2473	Diode, 1S2473
SW701, 702, 703, 704, 705, 706, 707, 708, 709	4431-01010170	Push Switch, FM/AM Preset Memory, Tuning Down, Tuning Up

TONE CONTROL P.C. BOARD

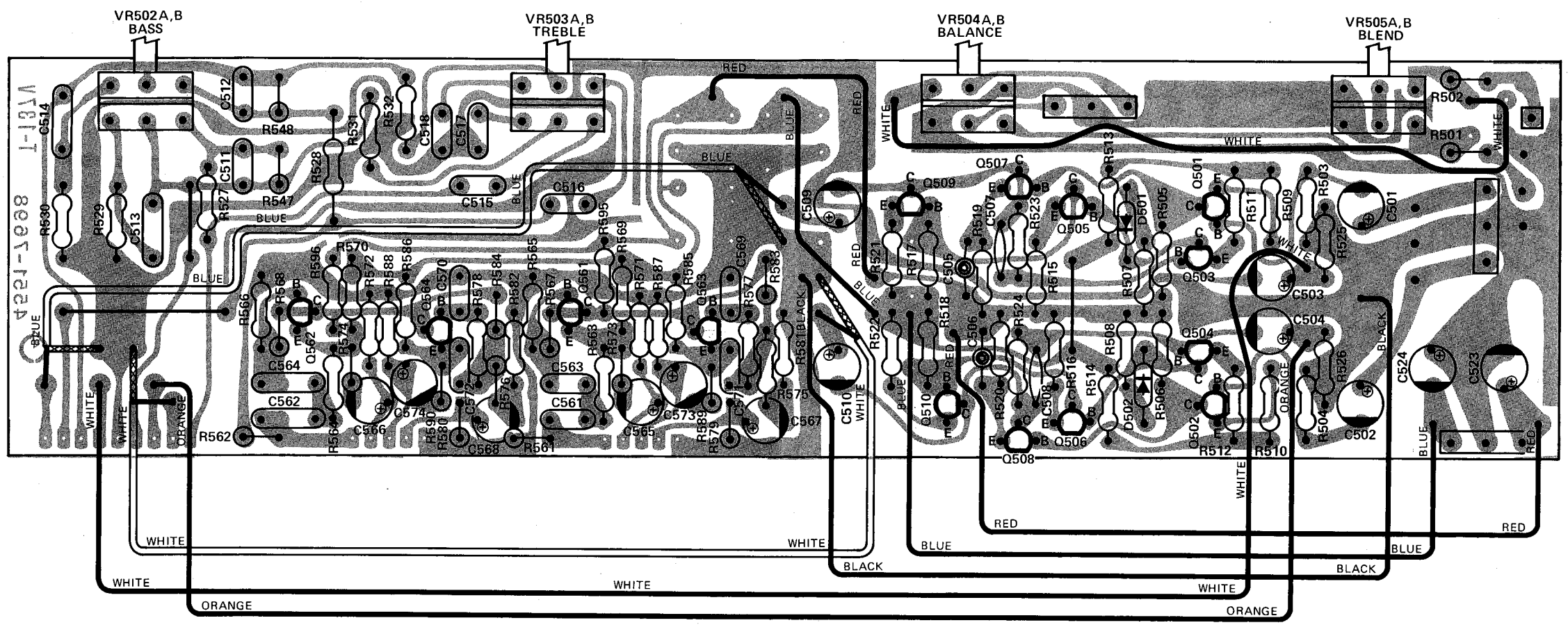

VOLUME CONTROL P.C. BOARD

FILTER SWITCH P.C. BOARD

LOUDNESS/MUTING SWITCH P.C. BOARD

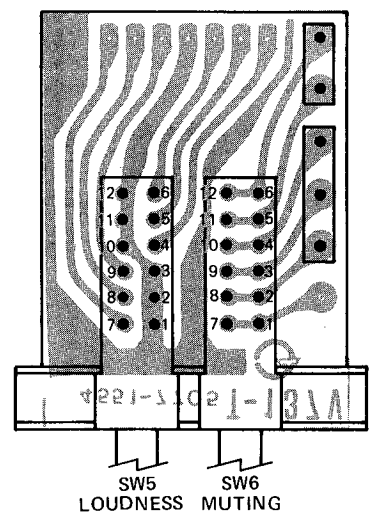
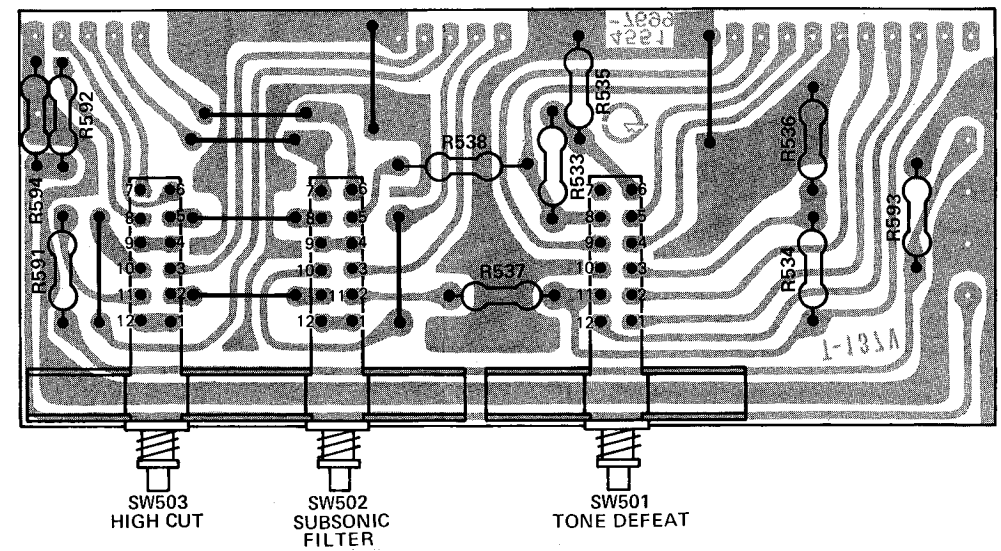
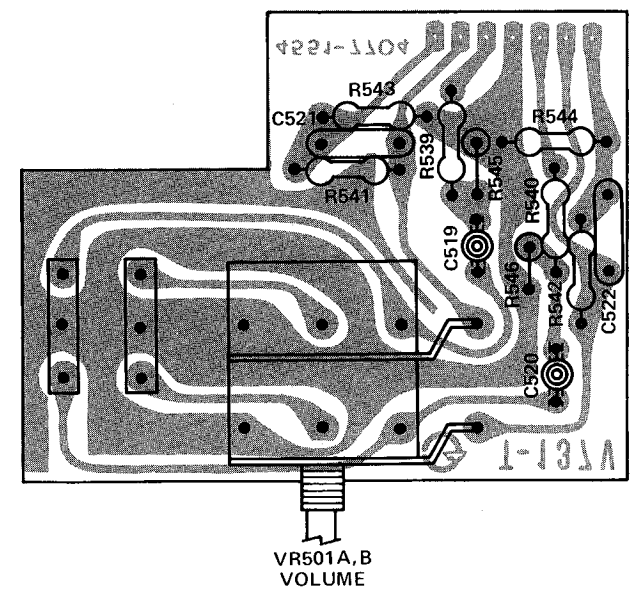

Ref. No.	Part No.	Description
VR501	5116-1047343	Variable Resistor, 100 k ohm Volume Control

Ref. No.	Part No.	Description
SW501	4431-01047994	Push Switch, Tone Defeat
SW502, 503	4431-02087259	Push Switch, Subsonic Filter, High Cut

Ref. No.	Part No.	Description
SW5, 6	4431-02087160	Push Switch, Loudness, Muting

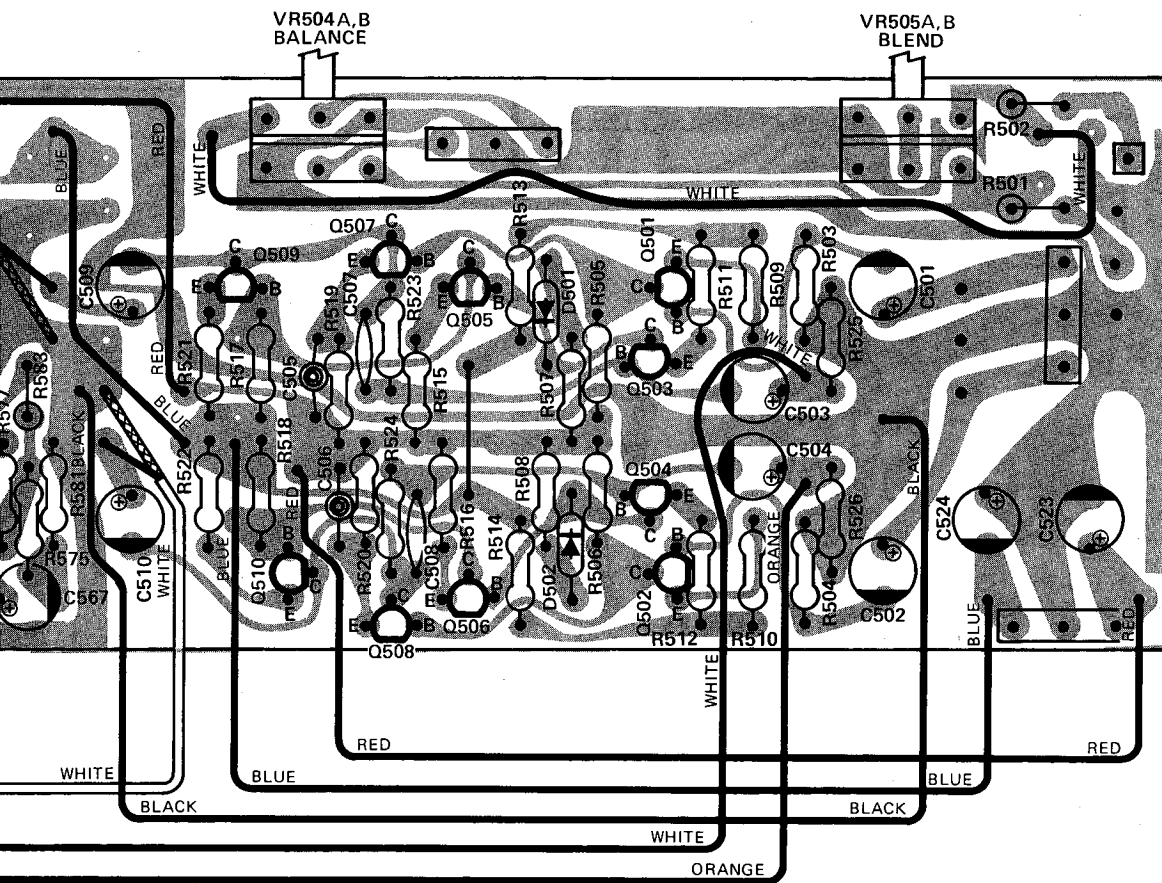

LOUDNESS/MUTING SWITCH P.C. BOARD

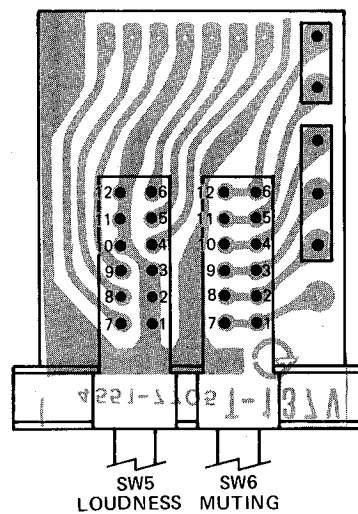
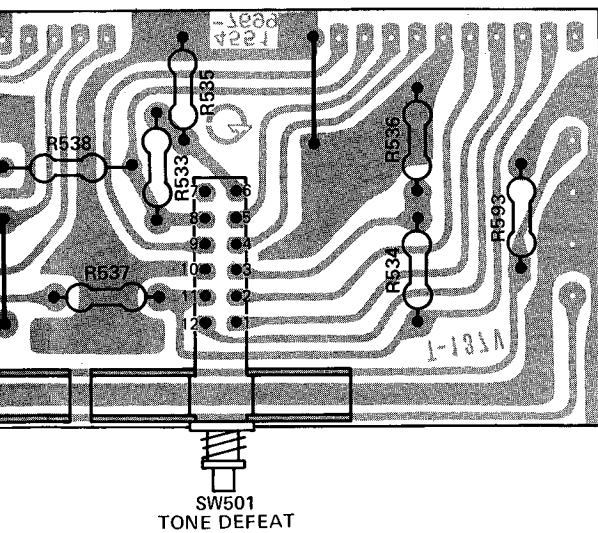

Description

- 994 Push Switch, Tone Defeat
- 259 Push Switch, Subsonic Filter, High Cut

Ref. No.

Part No.

Description

- SW5, 6 4431-02087160 Push Switch, Loudness, Muting

TONE CONTROL P.C. BOARD

Ref. No.	Part No.	Description
RESISTORS		
VR502	5113-1048177	Variable Resistor, 100 k ohm Bass Control
VR503	5113-5038277	Variable Resistor, 50 k ohm Treble Control
VR504	5113-50376100	Variable Resistor, 50 k ohm Balance Control
VR505	5113-20475122	Variable Resistor, 200 k ohm Blend Control
TRANSISTORS		
Q501, 502, 503, 504	5613-1775(F)	2SC1775(F) } Flat/Tone Control Amp.
Q505, 506, 507, 508	5611-1115(F)	
Q509, 510	5613-2603(F)	2SC2603(F) } Subsonic Filter, High-Cut Filter
Q561, 562, 563, 564	5613-2603(F)	
DIODES		
D501, 502	5631-1S2473	1S2473

FUNCTION SWITCH P.C. BOARD

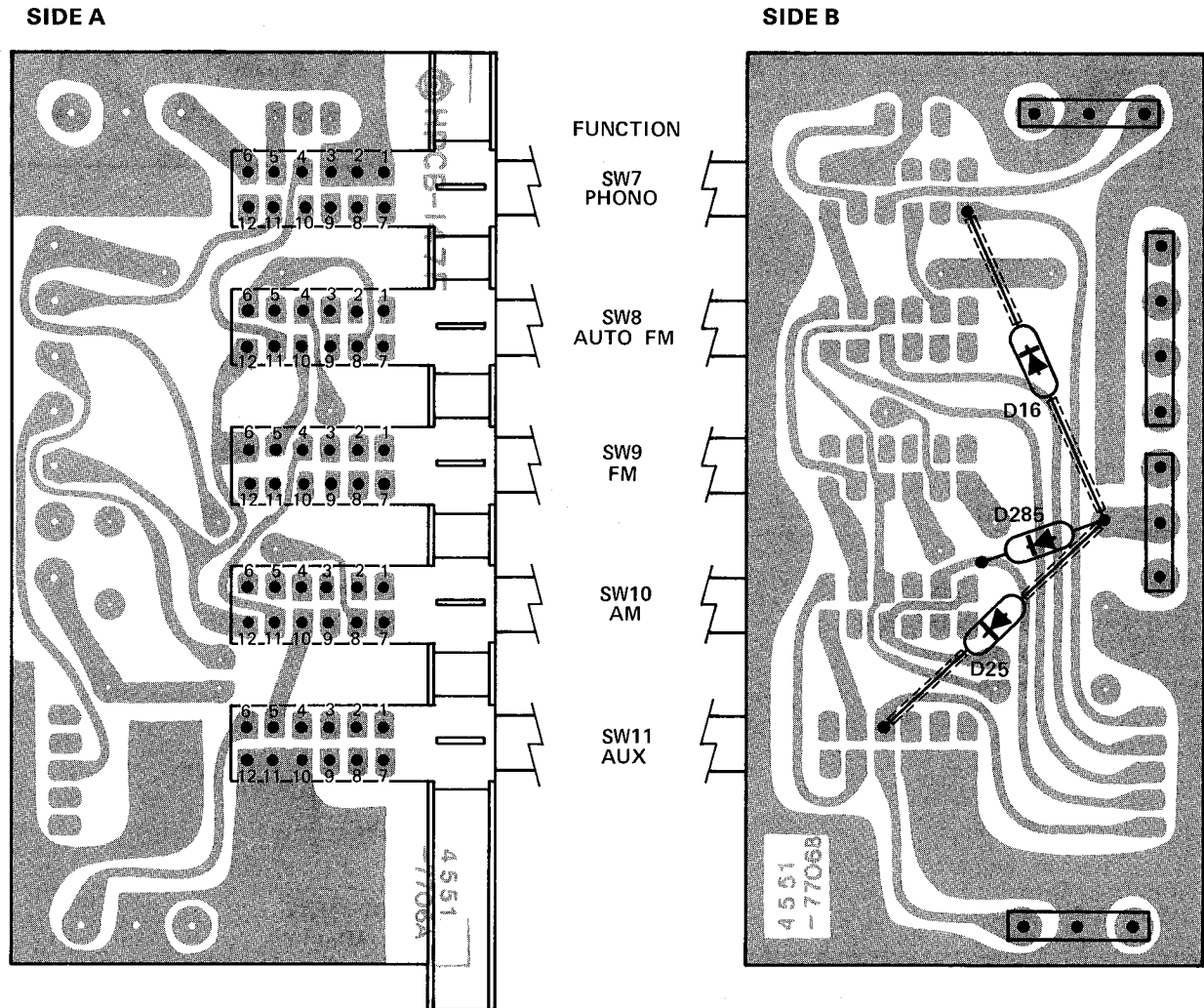

Ref. No.	Part No.	Description
D16, 25	5631-1S2473	Diode, 1S2473
SW7, 8, 9, 10, 11	4431-05207149	Push Switch, Function Selector

L-CH. DRIVER P.C. BOARD

4551-7695

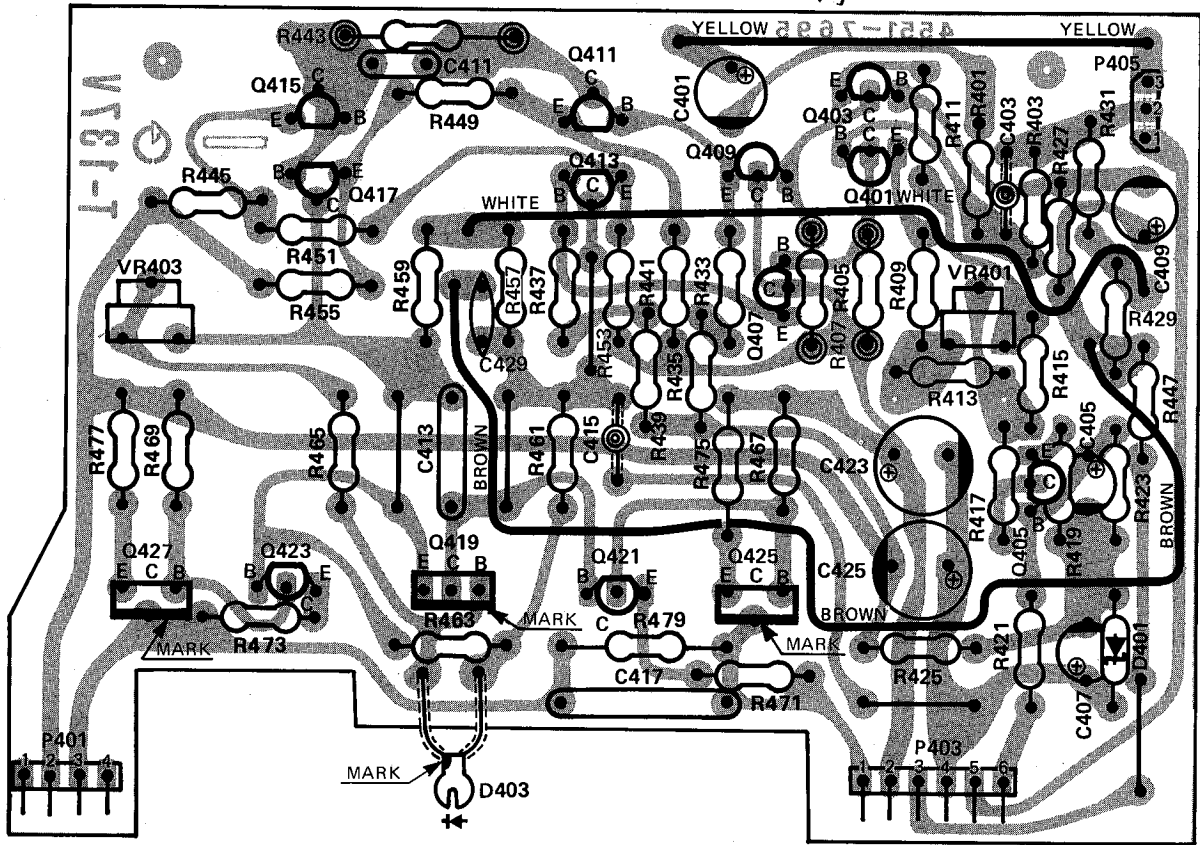

Ref. No.	Part No.	Description
RESISTORS		
R441, 445, 453, 455	5102-8204713	82 ohm $\pm 2\%$ 1/4W Fuse
R467, 469	5102-1014713	100 ohm $\pm 2\%$ 1/4W Fuse
R471, 473	5102-1504713	15 ohm $\pm 2\%$ 1/4W Fuse
R475, 477	5102-2R25710	2.2 ohm $\pm 5\%$ 1/2W Fuse
R479	5102-5605710	56 ohm $\pm 5\%$ 1/2W Fuse
VR401	5101-1017375	Variable Resistor, 100 ohm
VR403	5101-3317575	Variable Resistor, 330 ohm
TRANSISTORS		
Q401, 403	5613-1775(F)	2SC1775(F)
Q405, 407, 409	5613-2603(F)	2SC2603(F)
Q411, 413	5612-646A(C)	2SB646A(C)
Q415, 417	5614-666A(C)	2SD666A(C)
Q419	5614-414(Q)	2SD414(Q)
Q421	5614-667A(C)	2SD667A(C)
Q423	5612-647A(C)	2SB647A(C)
Q425	5612-649(C)	2SB649(C)
Q427	5614-669(C)	2SD669(C)
DIODES		
D401	5635-RD15EB2	Zener, RD15EB2
D403	5641-MV11Y	Varistor, MV11Y

C415
416

5353-10151HS
100pF

R-CH. DRIVER P.C. BOARD

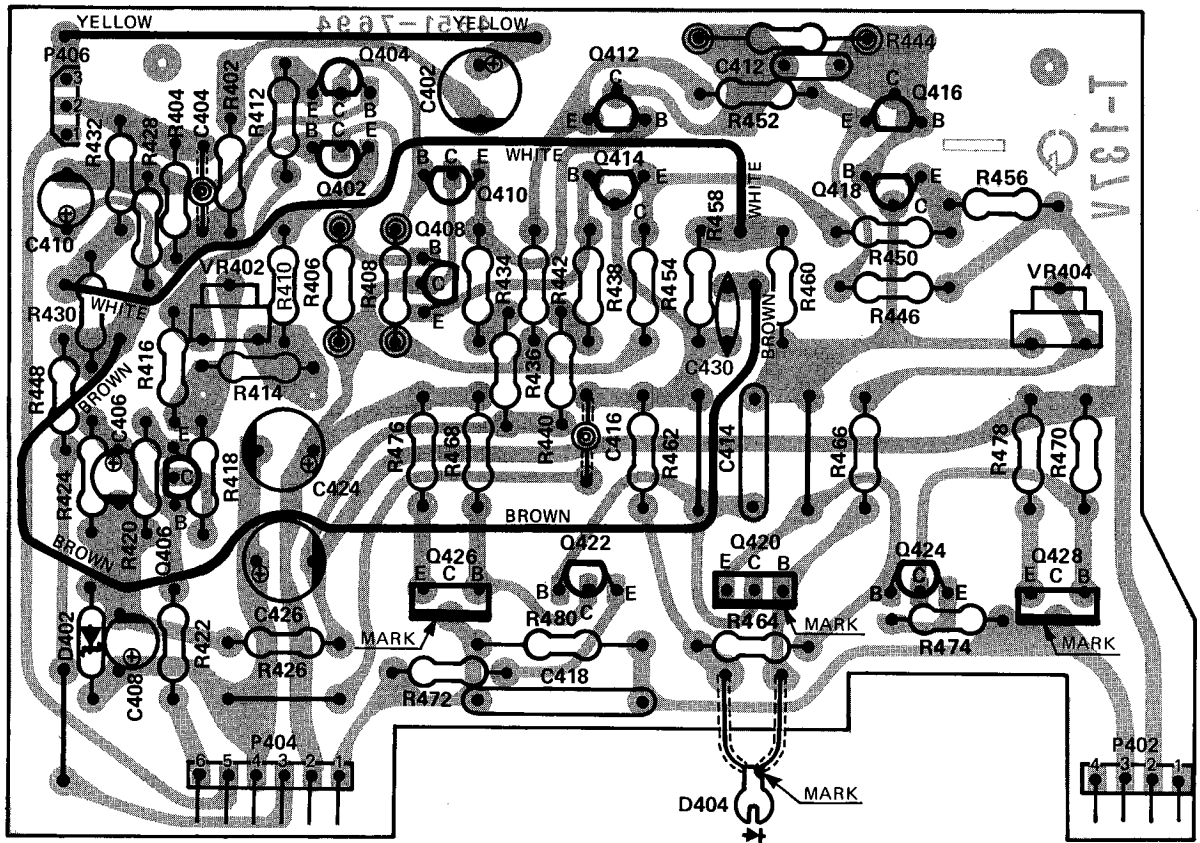

Ref. No.	Part No.	Description
RESISTORS		
R442, 446, 454, 456	5102-8204713	82 ohm \pm 2% 1/4W Fuse
R468, 470	5102-1014713	100 ohm \pm 2% 1/4W Fuse
R472, 474	5102-1504713	15 ohm \pm 2% 1/4W Fuse
R476, 478	5102-2R25710	2.2 ohm \pm 5% 1/2W Fuse
R480	5102-5605710	56 ohm \pm 5% 1/2W Fuse
VR402	5101-1017375	Variable Resistor, 100 ohm
VR404	5101-3317575	Variable Resistor, 330 ohm
TRANSISTORS		
Q402, 404	5613-1775(F)	2SC1775(F)
Q406, 408, 410	5613-2603(F)	2SC2603(F)
Q412, 414	5612-646A(C)	2SB646A(C)
Q416, 418	5614-666A(C)	2SD666A(C)
Q420	5614-414(Q)	2SD414(Q)
Q422	5614-667A(C)	2SD667A(C)
Q424	5612-647A(C)	2SB647A(C)
Q426	5612-649(C)	2SB649(C)
Q428	5614-669(C)	2SD669(C)
DIODES		
D402	5635-RD15EB2	Zener, RD15EB2
D404	5641-MV11Y	Varistor, MV11Y

} Power Amp.

SPEAKERS SWITCH P.C. BOARD

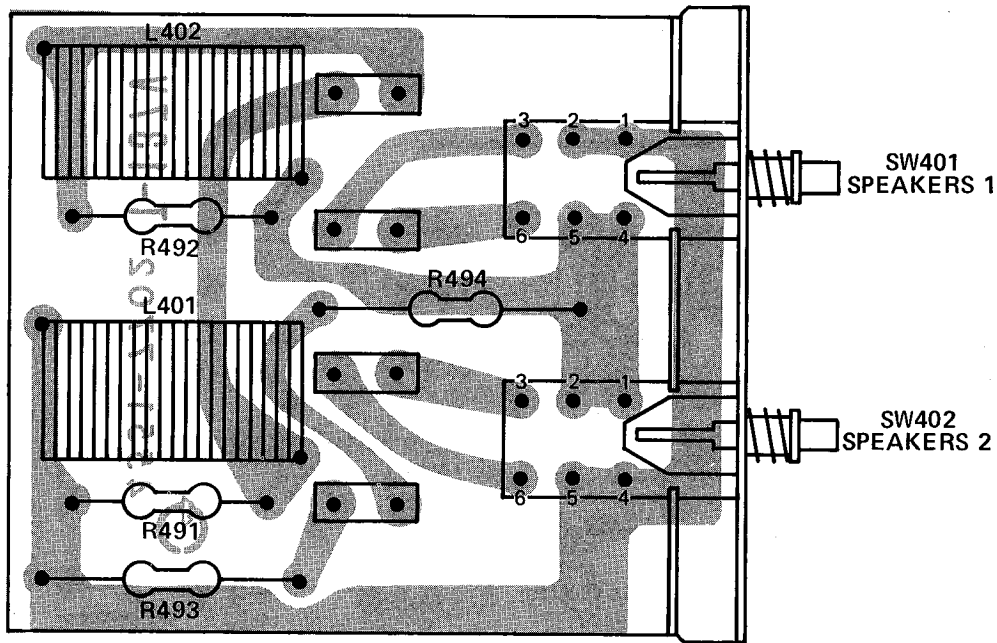

Ref. No.	Part No.	Description
L401, 402	5991-7135	Coil, RF Choke
SW401, 402	4431-02047451	Push Switch, Speakers 1, Speakers 2

POWER AMP. P.C. BOARD

Ref. No.	Part No.	Description
RESISTORS		
R6	5102-1515710	150 ohm \pm 2% 1/2W Fuse
R65	5102-5615710	560 ohm \pm 2% 1/2W Fuse
R485/487, 486/488	5275-R22671	0.22 ohm \pm 10% 5W \times 2 Cement (Special Dual)
CAPACITORS, ELECTROLYTIC		
C5, 6, 7, 8, 9, 10, 11, 12	5341-478F0955	4700uF \pm 20% 50V
C20	5345-477-80	470uF +50% -10% 80V
TRANSISTORS		
Q51, 52	5611-872(E)	2SA872(E) } Overload Protector
Q53, 54	5613-1775(F)	2SC1775(F) }
Q55, 56, 57, 58	5611-1115(F)	2SA1115(F) Audio Muting, Overload Protector
Q429, 430	5613-2564(O)	2SC2564(O) } Power Amp.
Q431, 432	5611-1094(O)	2SA1094(O) }
DIODES		
D1, 2	5685-S5VB20	Bridge Silicon, S5VB20
D7, 8	5632-1SR35-20	1SR35-200
D51, 52, 53, 54, 55, 56, 57, 58	5636-1SS81	1SS81
D60	5635-RD5R1EB	Zener, RD5.1EB
D405, 406, 407, 408	5632-ERB12-02	ERB12-02
MISCELLANEOUS		
L403, 404, 405, 406	5597-45502	Ferrite Bead

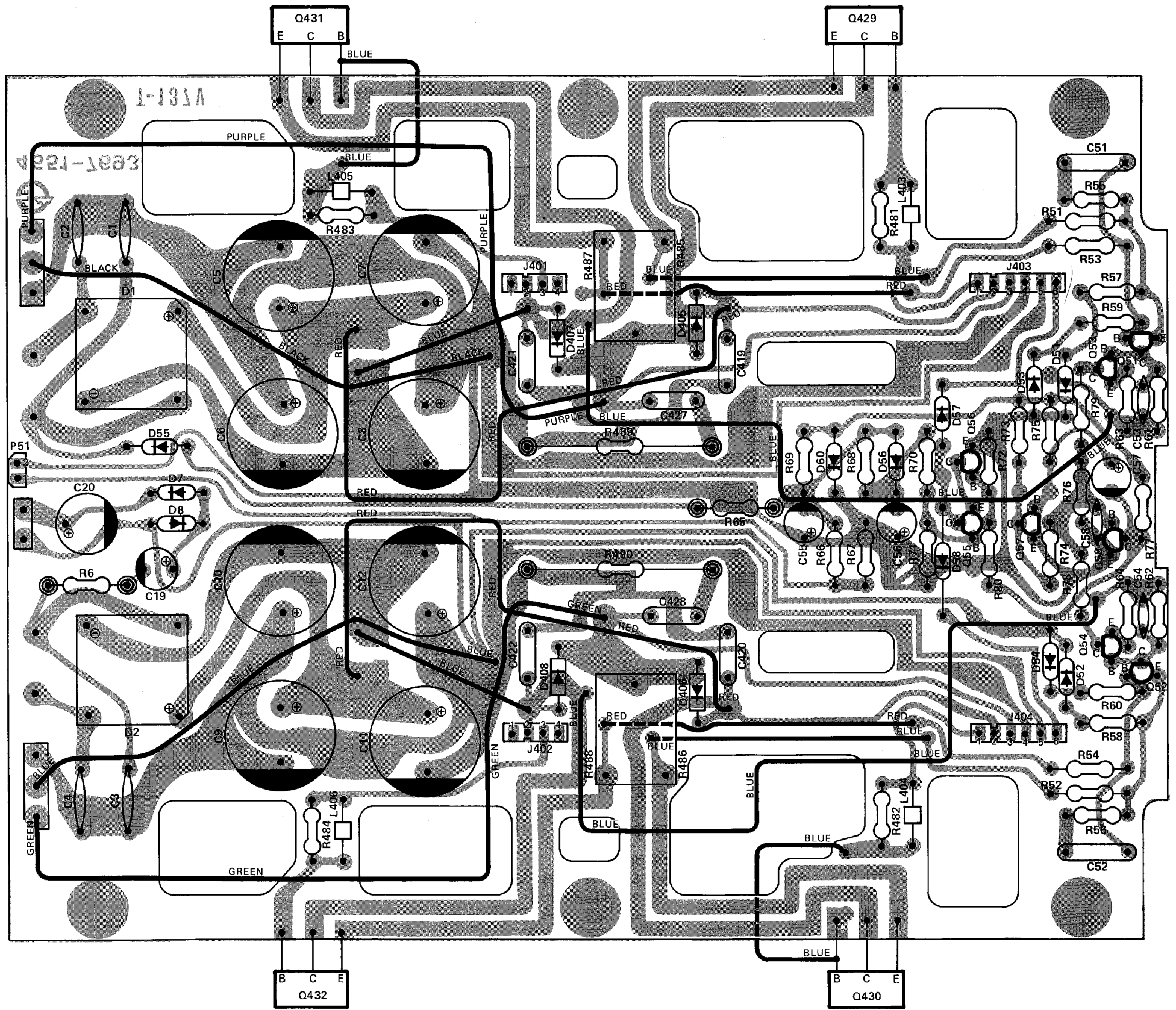

POWER AMP. P.C.BOARD

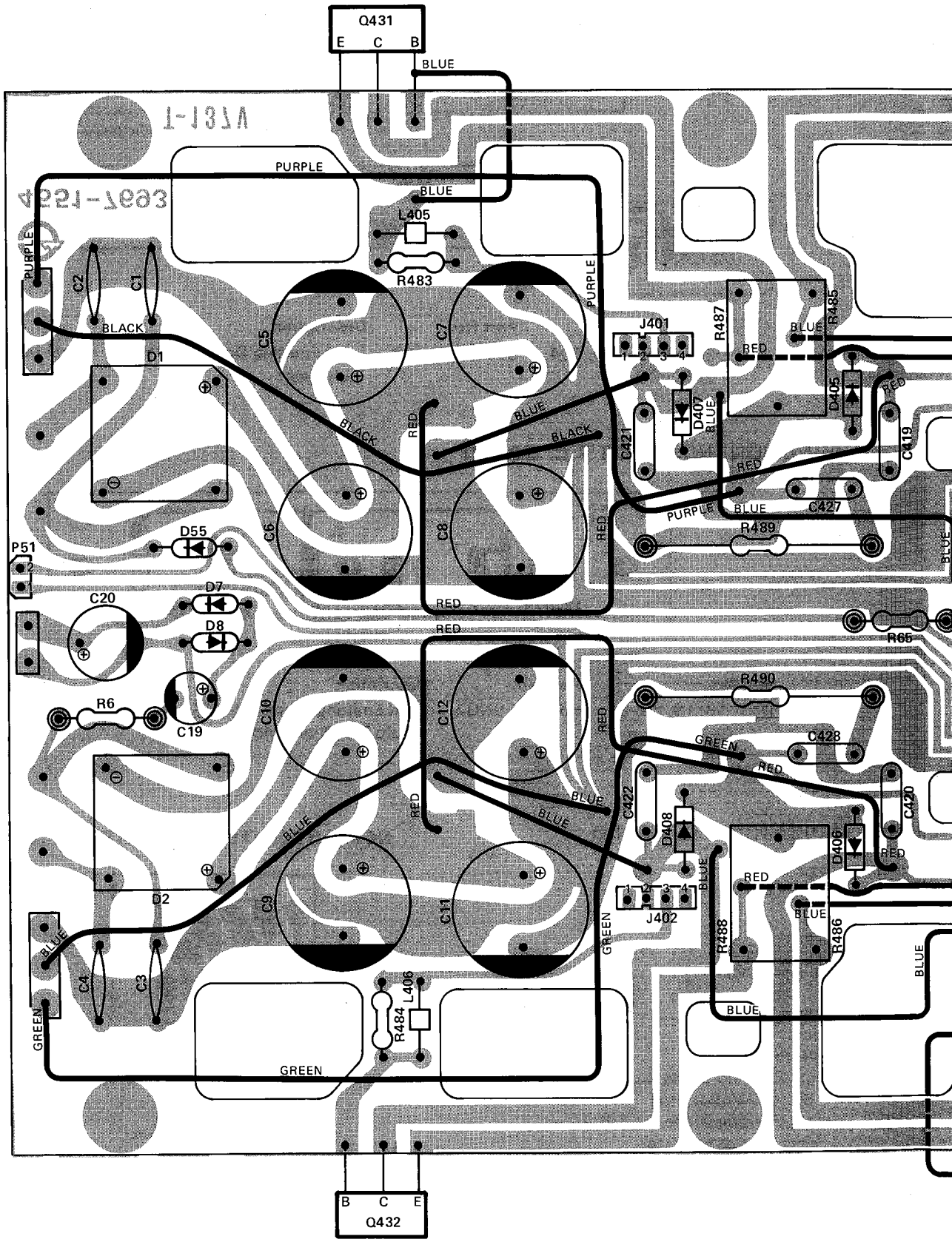

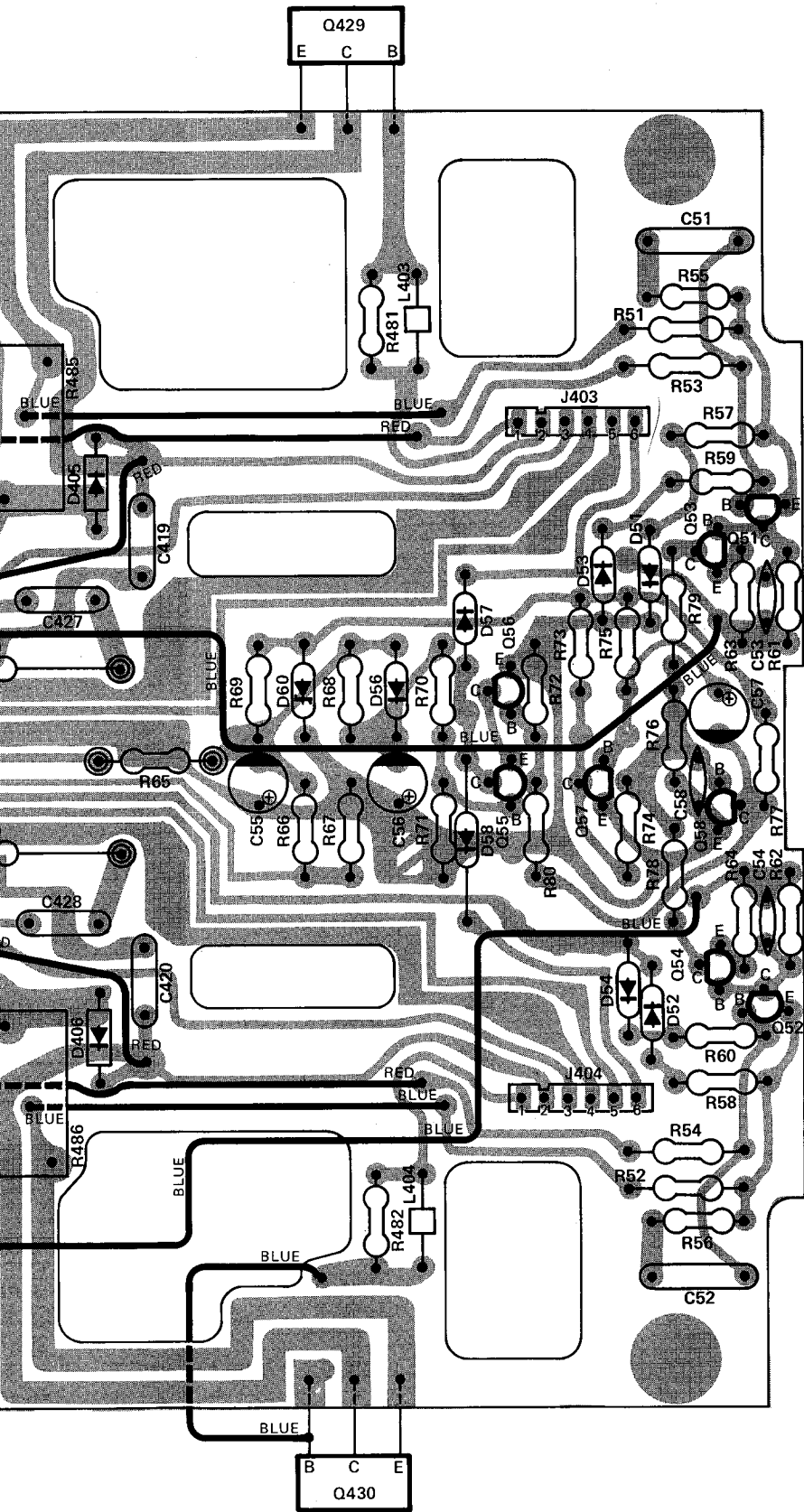

TAPE SWITCH P.C. BOARD

SIDE B

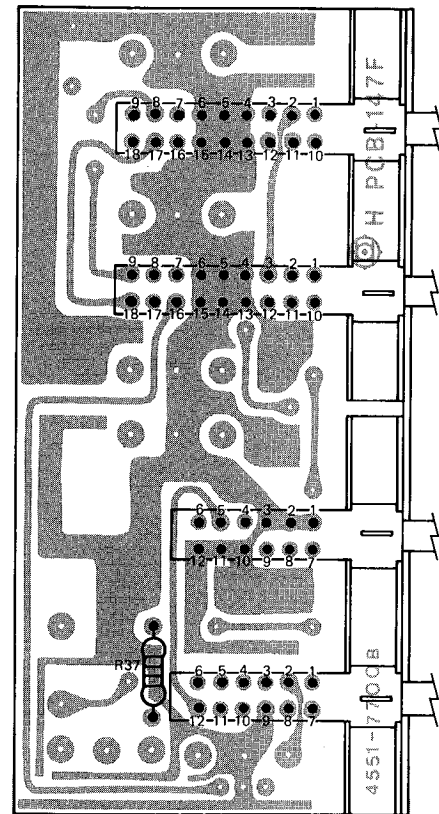

SIDE A

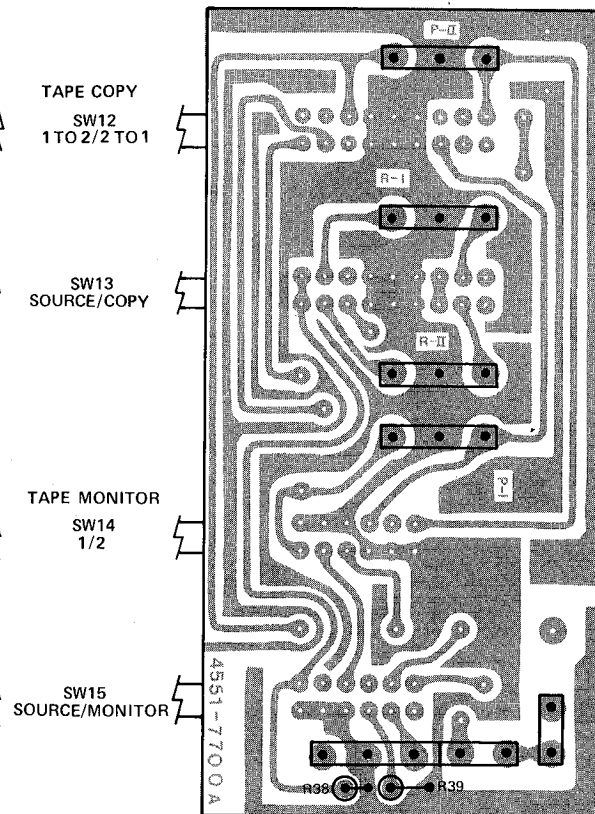

Ref. No.	Part No.	Description
SW12, 13	4431-02127359	Push Switch, Tape Copy
SW14, 15	4431-02087159	Push Switch, Tape Monitor

PRESET MEMORY INDICATOR P.C. BOARD

SIDE A

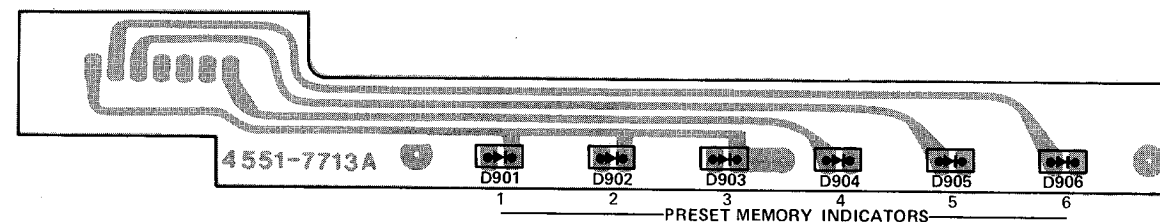

SIDE B

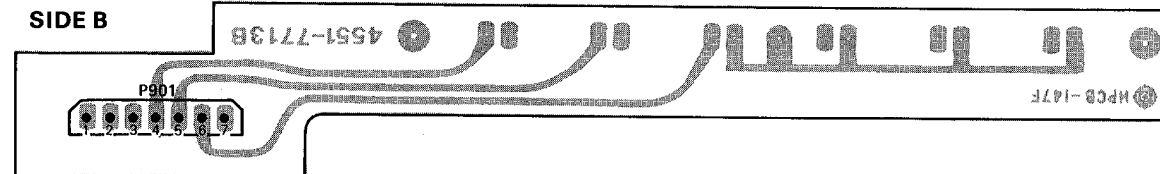

Ref. No.	Part No.	Description
D901, 902, 903, 904, 905, 906	5637-GL9NG2	Light Emitting Diode, GL9NG2 Preset Memory Indicator

FUNCTION INDICATOR P.C. BOARD

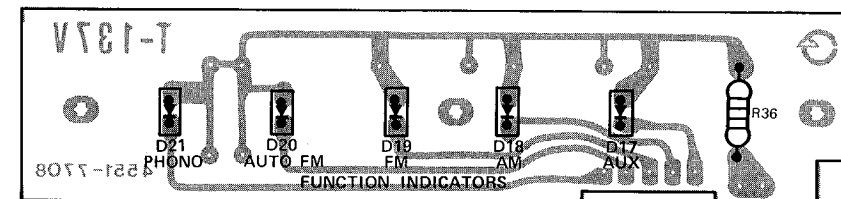

Ref. No.	Part No.	Description
D17, 18, 19, 20, 21	5637-GL9NG2	Light Emitting Diode, GL9NG2 AUX, AM, FM, Auto FM, Phono indicator

STATION DISPLAY P.C. BOARD

SIDE A

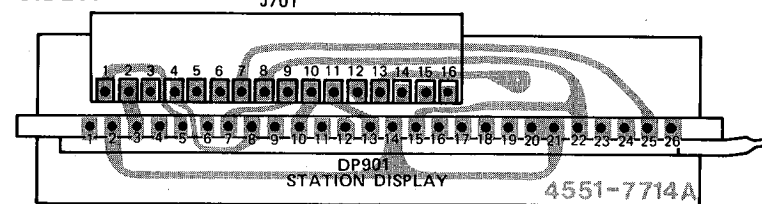

SIDE B

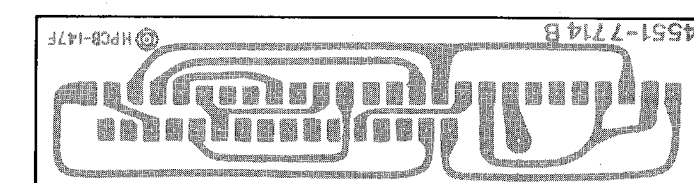

Ref. No.	Part No.	Description
DP901	5722-9	Tube Display Assembly, FIP7D8 Station Display

QUARTZ LOCK/STEREO INDICATOR P.C. BOARD

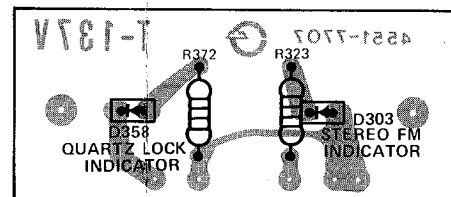

Ref. No.	Part No.	Description
D303	5637-GL9PR20	Light Emitting Diode, GL9PR20 Stereo FM Indicator
D358	5637-GL9NG2	Light Emitting Diode, GL9NG2 Quartz Lock Indicator

SCAN STOP/TUNING SWITCH P.C. BOARD

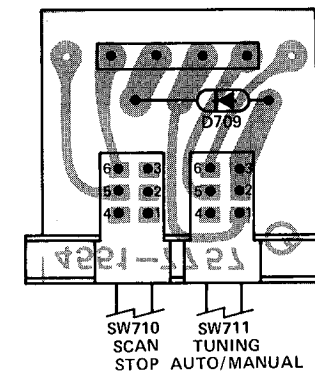

Ref. No.	Part No.	Description
D709	5631-1S2473	Diode, 1S2473
SW710, 711	4431-02047459	Push Switch, Scan Stop, Auto/Manual Tuning

TAPE SWITCH P.C. BOARD

PRESE

SIDE B

SIDE A

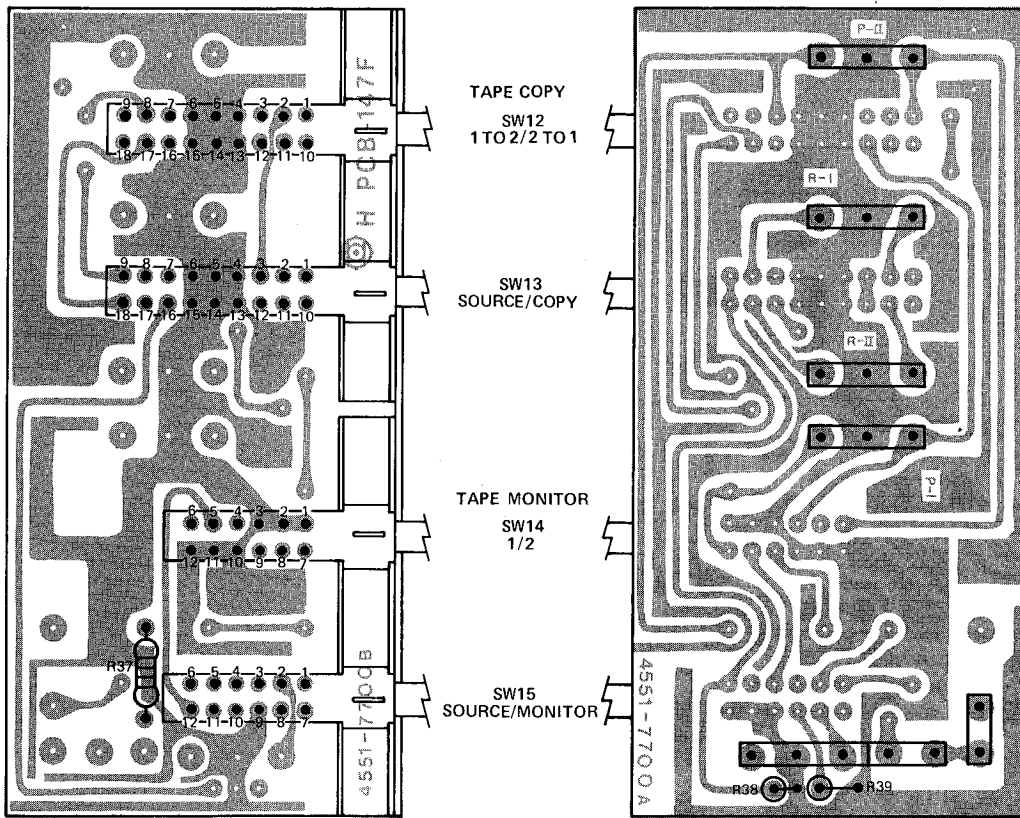

Ref. No.	Part No.	Description
SW12, 13	4431-02127359	Push Switch, Tape Copy
SW14, 15	4431-02087159	Push Switch, Tape Monitor

FUNC

STATION DISPLAY P.C. BOARD

QUARTZ LOCK/STEREO INDICATOR

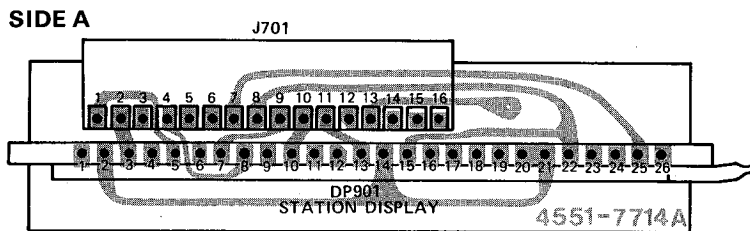

SIDE B

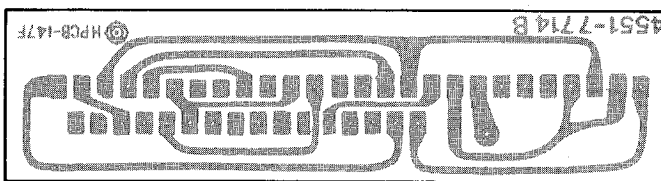

Ref. No.	Part No.	Description
DP901	5722-9	Tube Display Assembly, FIP7D8 Station Display

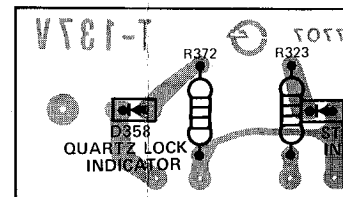

Ref. No.	Part No.	Description
D303	5637-GL9PR20	Light Emitter, Stereo Indicator
D358	5637-GL9NG2	Light Emitter, Quartz Lock Indicator

PRESET MEMORY INDICATOR P.C. BOARD

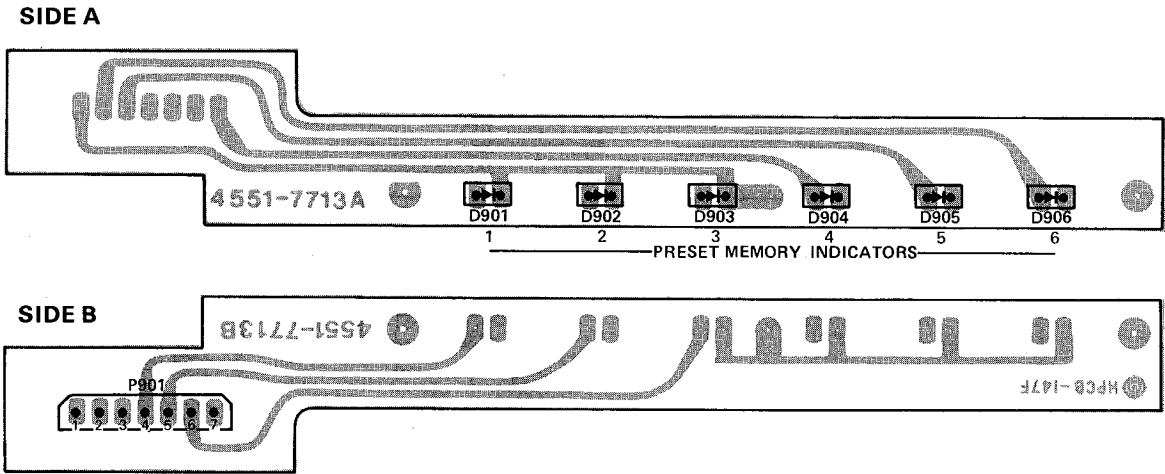

Ref. No.	Part No.	Description
D901, 902, 903, 904, 905, 906	5637-GL9NG2	Light Emitting Diode, GL9NG2 Preset Memory Indicator

FUNCTION INDICATOR P.C. BOARD

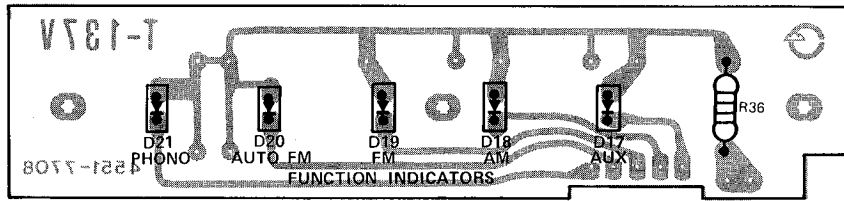

Ref. No.	Part No.	Description
D17, 18, 19, 20, 21	5637-GL9NG2	Light Emitting Diode, GL9NG2 AUX, AM, FM, Auto FM, Phono indicator

QUARTZ LOCK/STEREO INDICATOR P.C. BOARD

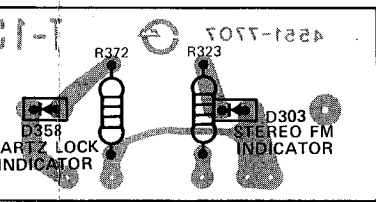

Part No.	Description
5637-GL9PR20	Light Emitting Diode, GL9PR20 Stereo FM Indicator
5637-GL9NG2	Light Emitting Diode, GL9NG2 Quartz Lock Indicator

SCAN STOP/TUNING SWITCH P.C. BOARD

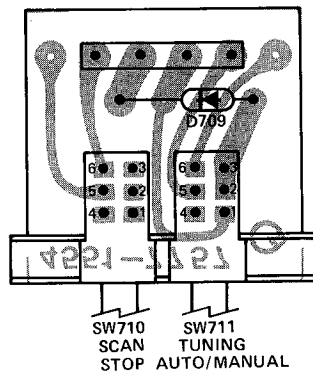

Ref. No.	Part No.	Description
D709	5631-1S2473	Diode, 1S2473
SW710, 711	4431-02047459	Push Switch, Scan Stop, Auto/Manual Tuning

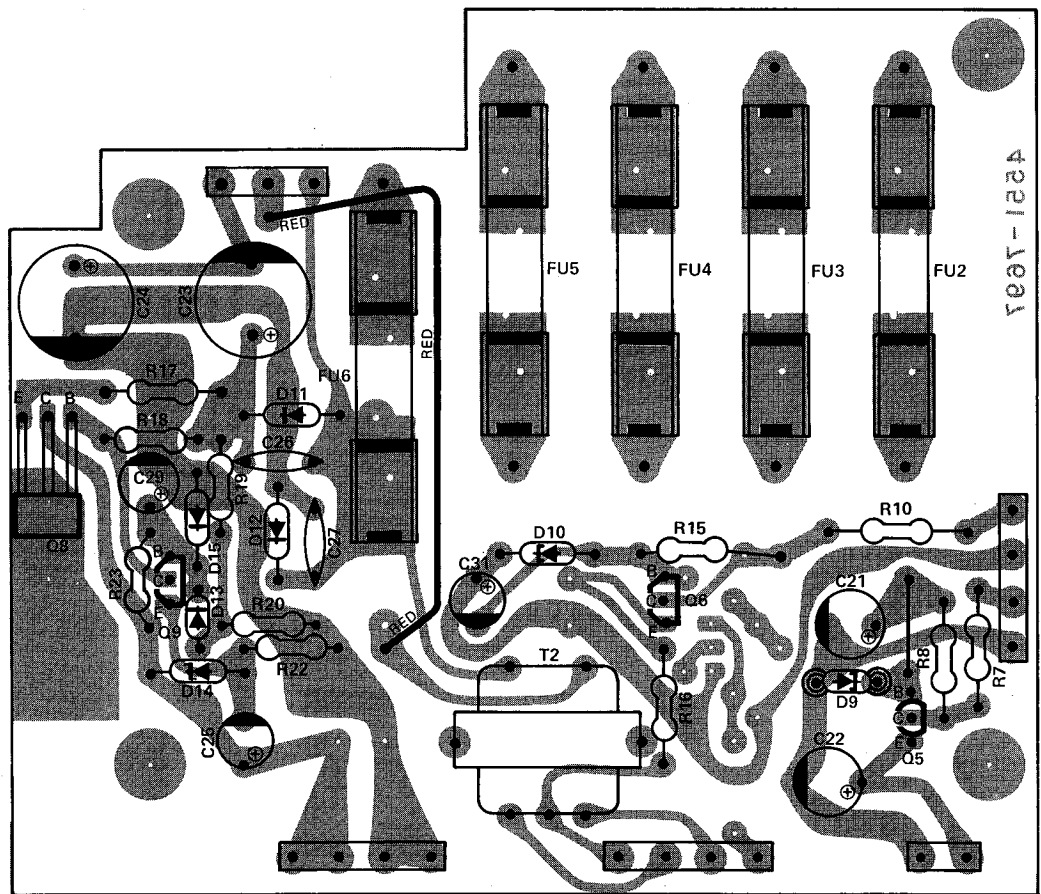

Ref. No.	Part No.	Description
RESISTORS, FUSE		
R7, 10	5102-1004713	10 ohm \pm 2% 1/4W
R17	5102-2R25710	2.2 ohm \pm 5% 1/2W
CAPACITORS, ELECTROLYTIC		
C23, 24	5345-228-16	2200uF +50% -10% 16V
TRANSISTORS		
Q5	5614-666(B)	2SD666(B)or(C) Voltage Regulator
Q6	5611-1115(F)	2SA1115(F) Voltage Regulator
Q8	5612-855(B)	2SB855(B)or(C) Voltage Regulator
Q9	5613-2603(F)	2SC2603(F) Voltage Regulator
DIODES		
D9	5635-RD30EB	Zener, RD30EB
D10	5635-RD24EB	Zener, RD24EB
D11, 12	5632-1SR35-20	1SR35-200
D13	5631-1S2473	1S2473
D14, 15	5635-RD7R5EB2	Zener, RD7.5EB2
MISCELLANEOUS		
T2	5584-701345	Transformer, Station Display Filament
FU2, 3, 4, 5	5732-402028	Fuse, 4A 125V
FU6	5732-152029	Fuse, 1.5A 125V

THE FOLLOWING WIRING DIAGRAM IS APPLIED TO MULTI VOLTAGE UNIT.

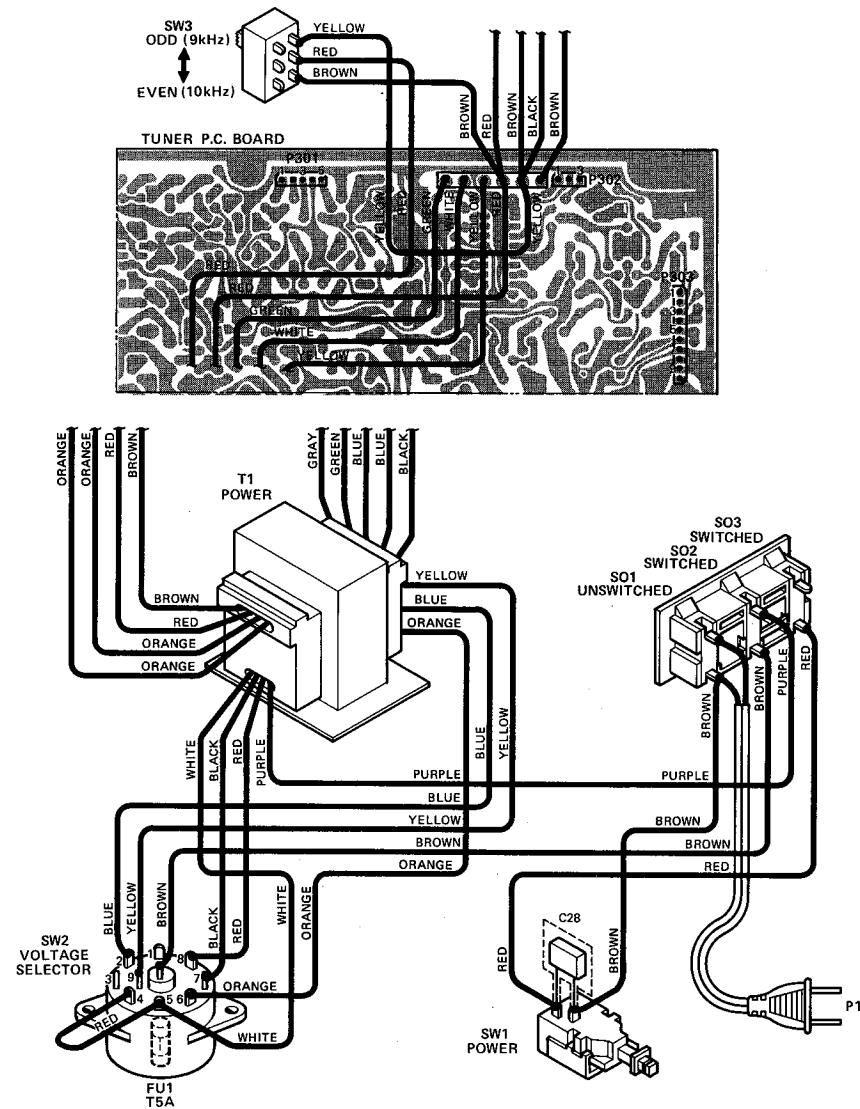

FOR EUROPE AND OCEANIA ONLY

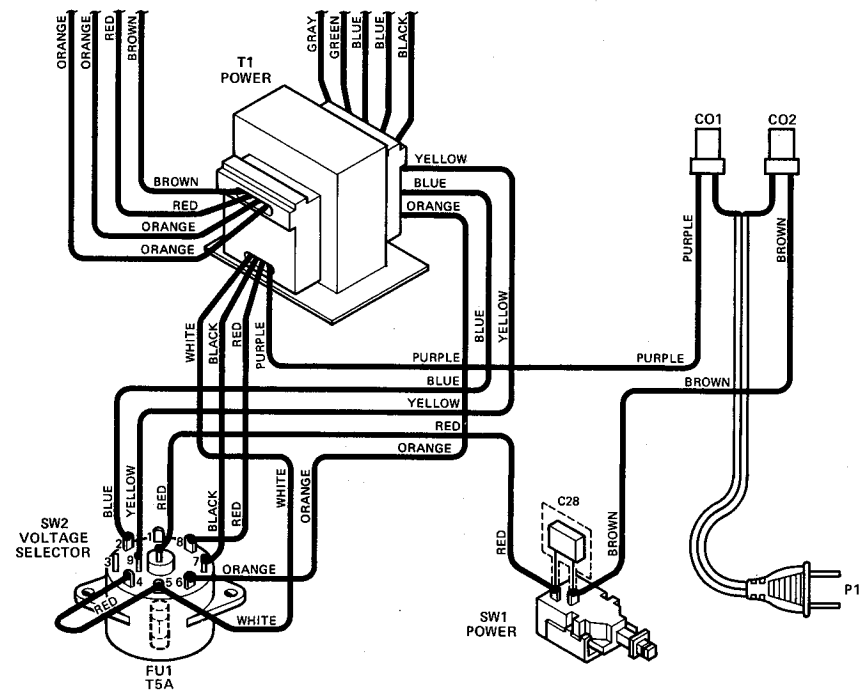

POWER SUPPLY P.C. BOARD

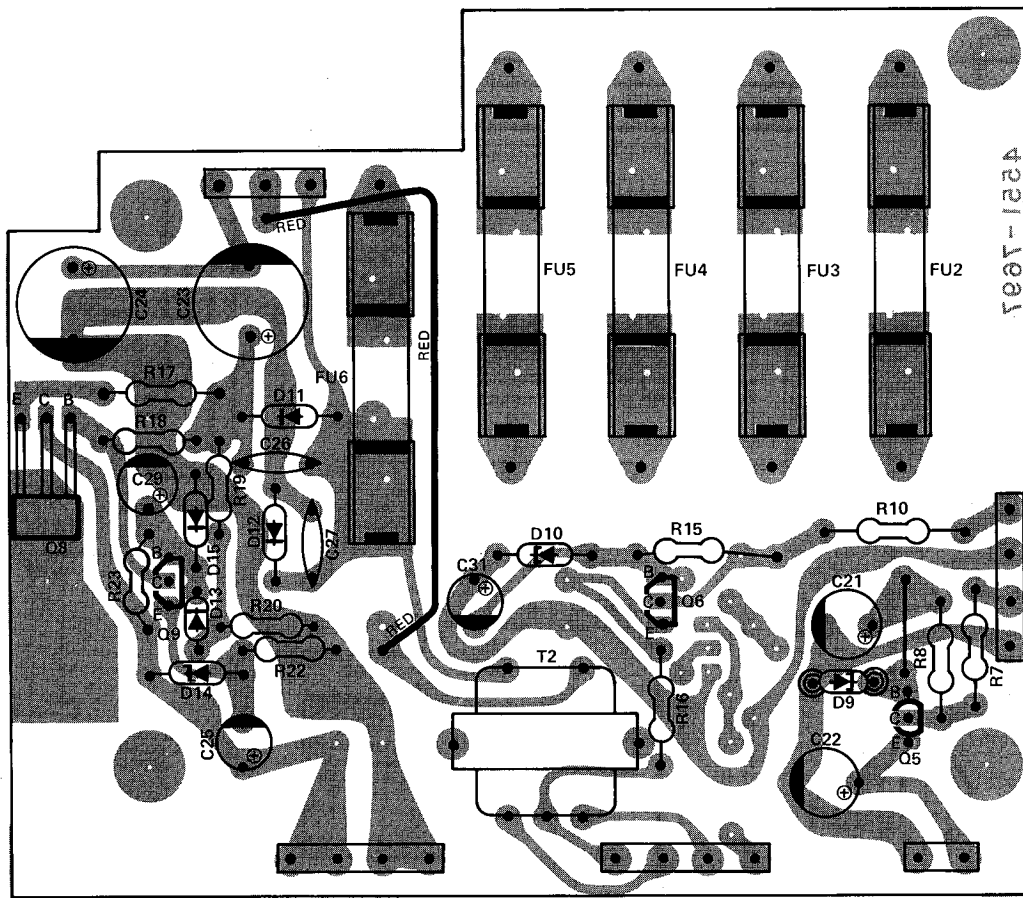

Ref. No.	Part No.	Description
RESISTORS, FUSE		
R7, 10	5102-1004713	10 ohm \pm 2% 1/4W
R17	5102-2R25710	2.2 ohm \pm 5% 1/2W
CAPACITORS, ELECTROLYTIC		
C23, 24	5345-228-16	2200uF +50% - 10% 16V
TRANSISTORS		
Q5	5614-666(B)	2SD666(B)or(C) Voltage Regulator
Q6	5611-1115(F)	2SA1115(F) Voltage Regulator
Q8	5612-855(B)	2SB855(B)or(C) Voltage Regulator
Q9	5613-2603(F)	2SC2603(F) Voltage Regulator
DIODES		
D9	5635-RD30EB	Zener, RD30EB
D10	5635-RD24EB	Zener, RD24EB
D11, 12	5632-1SR35-20	1SR35-200
D13	5631-1S2473	1S2473
D14, 15	5635-RD7R5EB2	Zener, RD7.5EB2
MISCELLANEOUS		
T2	5584-701345	Transformer, Station Display Filament
FU2, 3, 4, 5	5732-402028	Fuse, 4A 125V
FU6	5732-152029	Fuse, 1.5A 125V

WIRING DIAGRAM

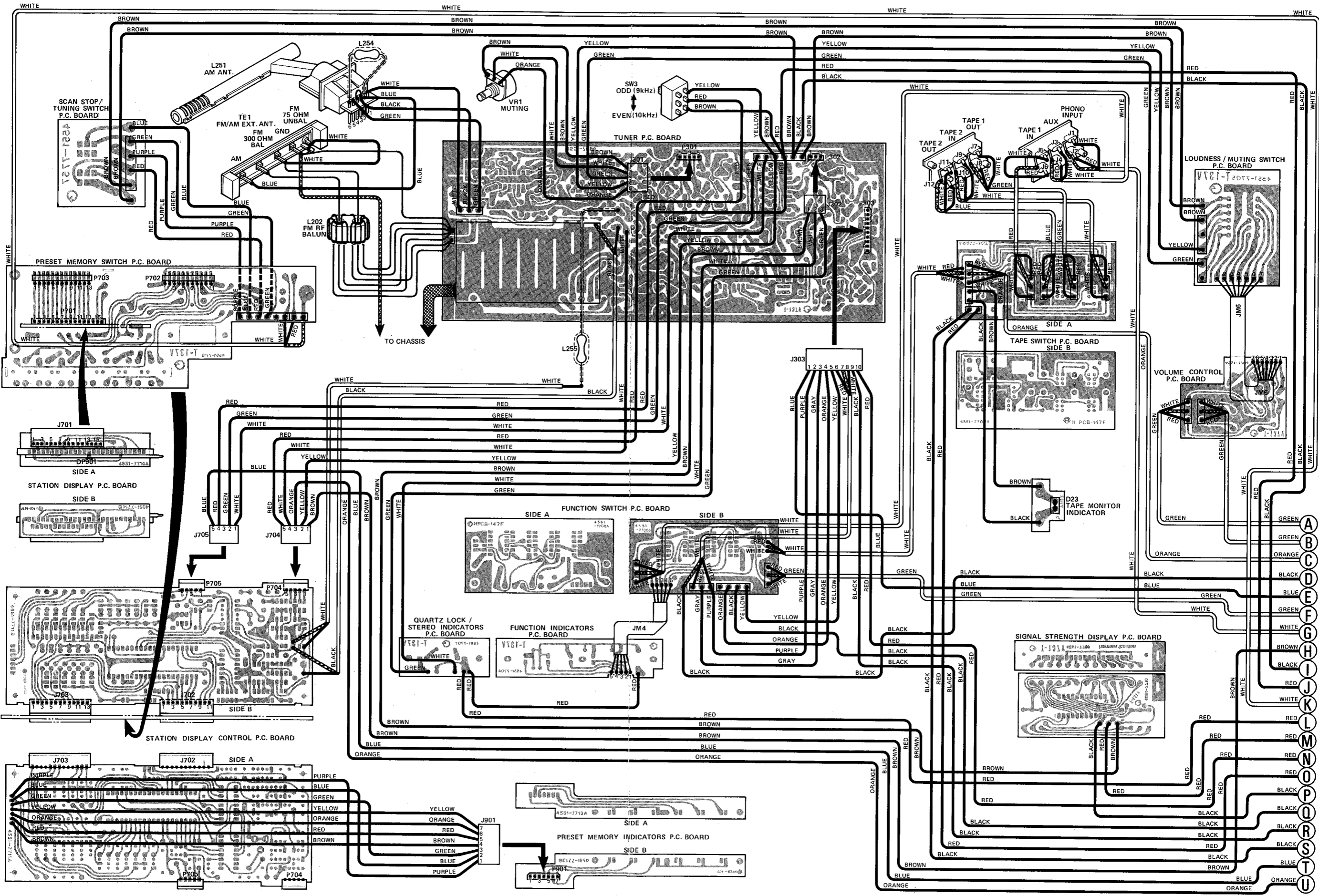

WIRING DIAGRAM

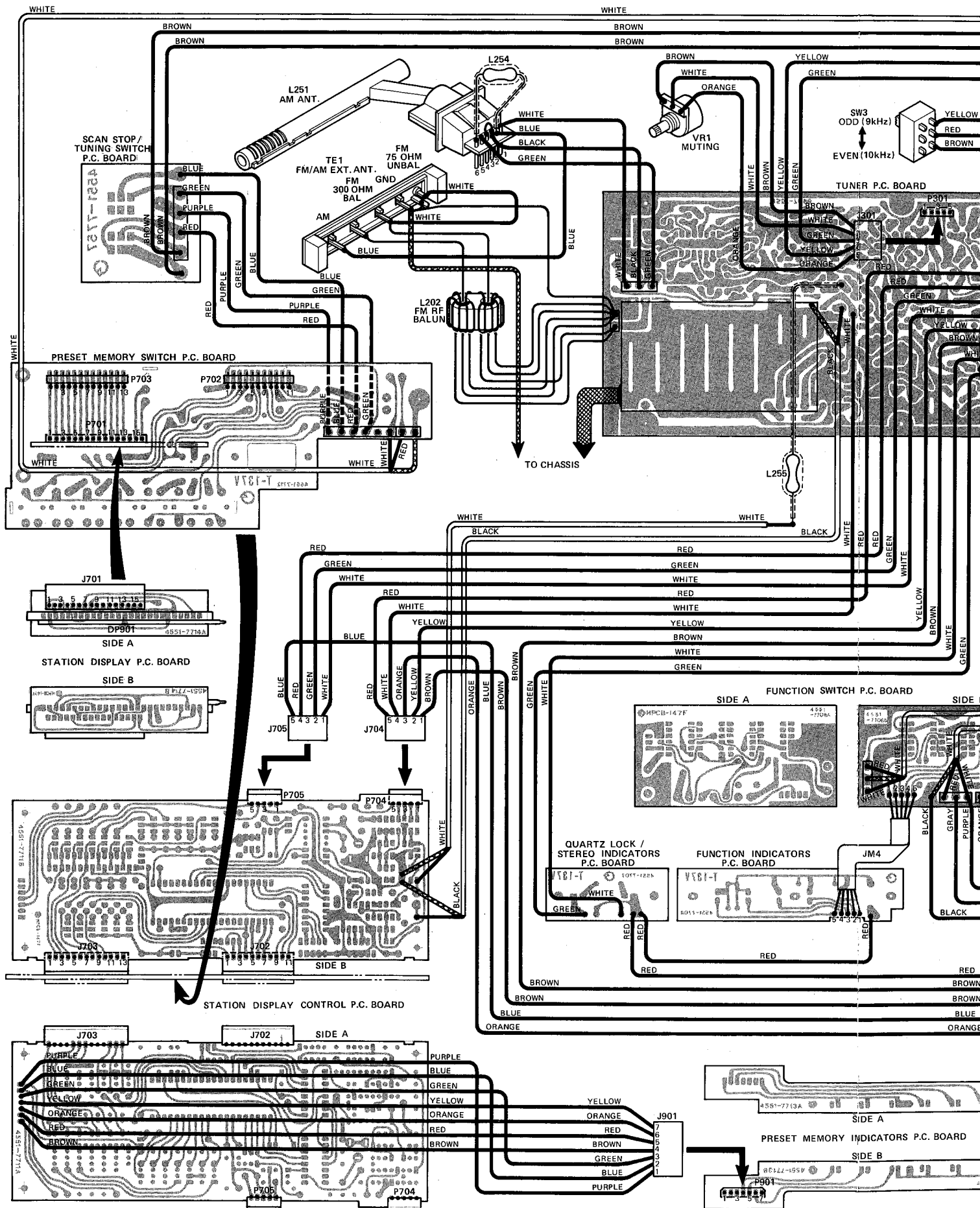

WIRING DIAGRAM

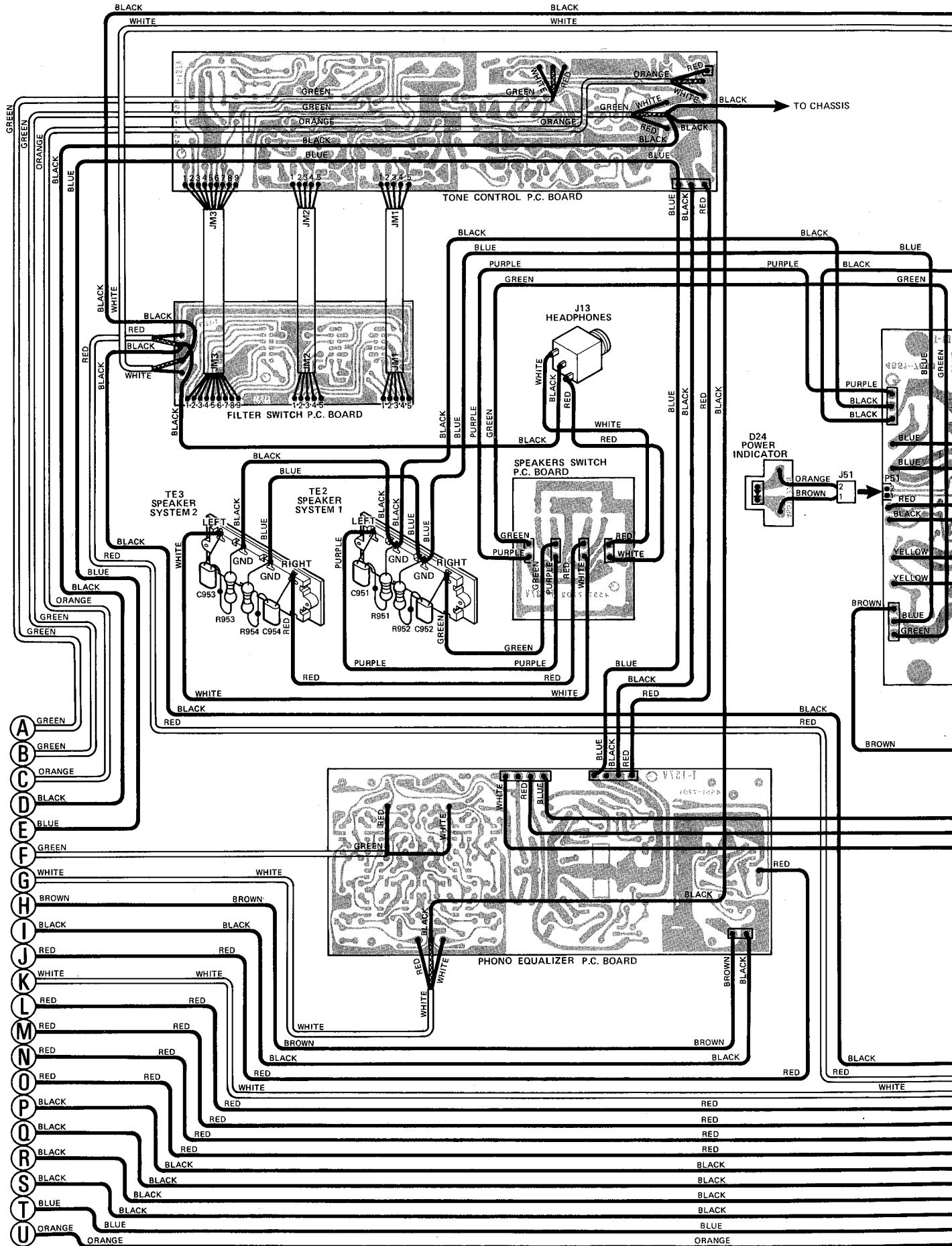

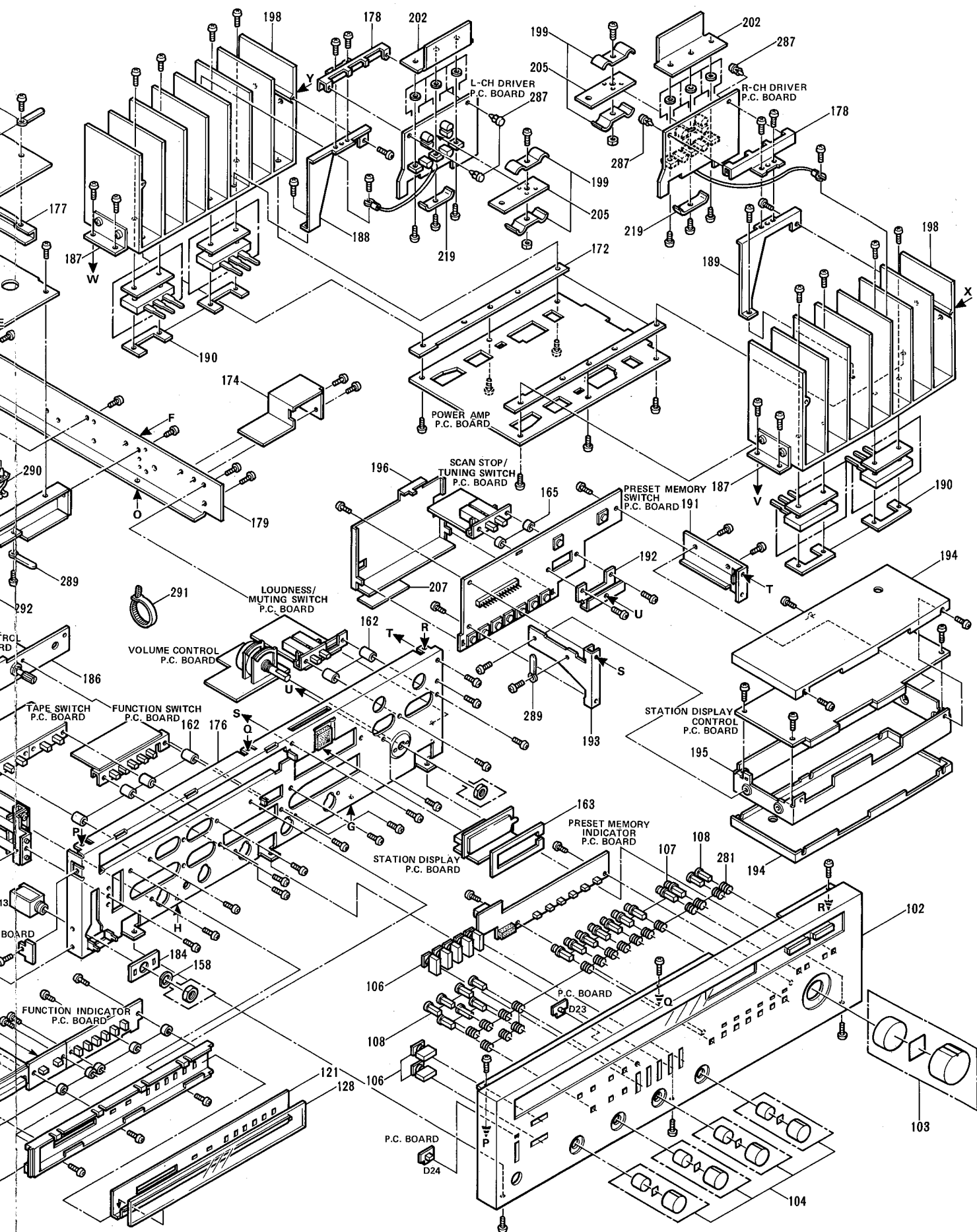

GENERAL UNIT EXPLODED VIEW

THE FOLLOWING GENERAL UNIT EXPLODED VIEW IS APPLIED TO MULTI VOLTAGE UNIT.

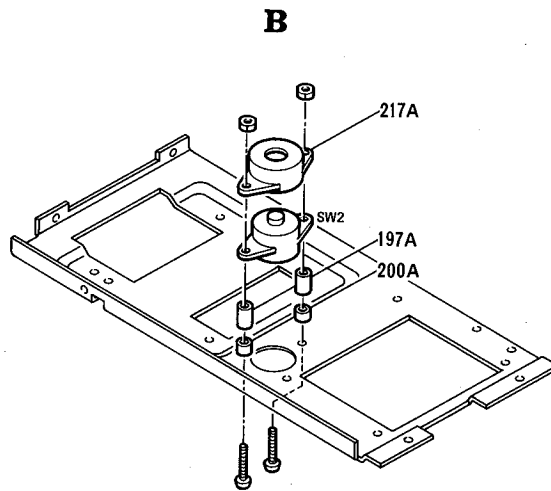
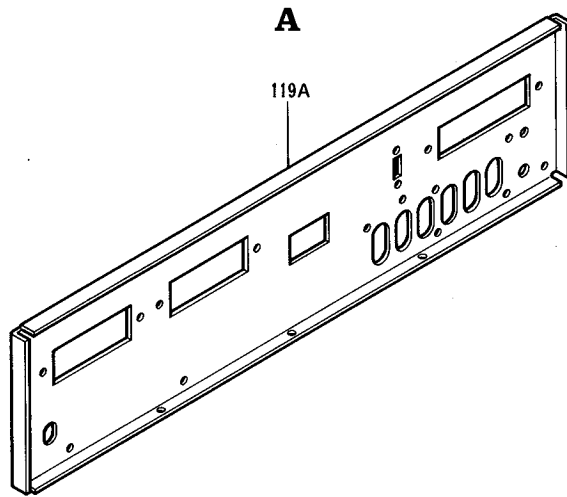

CHASSIS PARTS LIST

Ref. No.	Part No.	Description
GENERAL UNIT		
101	A423-HK680	Cabinet Bottom Assembly
102	A443-HK680	Front Panel Assembly
103	A634-HK680-A	Knob Assembly, Volume
104	A634-HK680-B	Knob Assembly, Bass, Treble, Balance, Blend
105	A662-HK680-A	Push Button Assembly, Power
106	A662-HK680-B	Push Button Assembly, Speakers 1, Speakers 2, Phono, Auto FM, FM, AM, AUX
107	A662-HK680-C	Push Button Assembly, Memory, FM/AM Preset Memory, Scan Stop, Tuning
108	A662-HK680-D	Push Button Assembly, Tape Copy, Tape Monitor, Tone Defeat, Subsonic Filter, High Cut, Loudness, Muting
115	1319-0139	Foot
116	1319-7138	Foot
117	1414-01701	Cabinet Top
119	1424-04301	Cabinet Back
121	1514-05001	Plate
128	1721-01001	Indication Plate
217	2240-7164	Holder
218	2133-7016	Protector
259	2310-7015	Special Screw
260	2410-7005	Special Washer
261	2440-7011	Special Nut
ELECTRICAL		
P1	4161-7387	AC Line Cord
S01, 2, 3	4474-151	External AC Socket, Unswitched, Switched
SW1	4431-01017358	Push Switch, Power
SW3	4421-0227131	Slide Switch, Frequency Interval Selector
T1	5584-701344	Power Transformer
FU1	5732-502028	Fuse, 5A 125V
FH1	4472-7128	Fuse Holder, FU1
TE1	4214-95	FM/AM External Antenna Terminal
TE2, 3	4214-7034	Speaker Terminal, Speaker System 1, 2
PL1	5731-1507245	Lamp, 15V 100mA Dial Illuminator
VR1	5113-2037131	Variable Resistor, 20 k ohm Muting Adj.
C28	5352-1030959	Capacitor, 0.01uF ±20% AC125V Metalized Polyester
D23	5637-TLR206	Light Emitting Diode, TLR206
D24	5637-GL9PR20	Light Emitting Diode, GL9PR20
L202	5995-703027	Coil, FM RF Balun
L251	5911-208	AM Ferrite Loopstick Antenna
L254	5995-470325	Coil, Choke
L255	5995-100325	Coil, Choke
J1, 2, 3, 4, 5, 6, 7, 8, 9, 10, 11, 12	4486-6	6-Pin Jack, Phono, AUX, Tape 1, Tape 2
J13	4451-00108	Jack, Headphones
	1397-6	Dipole Antenna

MULTI VOLTAGE VERSION PARTS LIST

AS FOR ALL OTHER PARTS EXCEPT THE FOLLOWING PARTS IN REF. NO., REFER TO REGULAR VOLTAGE UNIT (120V ONLY).

Ref. No.	Part No.	Description
PART NO. CHANGE		
119	1424-04302	Cabinet Back
119A	1424-05101	Cabinet Back (for Europe and Oceania only, (SK) (SEV))
P1	4161-71119	AC Line Cord
P1	4161-71120	AC Line Cord (for Sweden only, (SEV))
SW1	4431-01017658	Push Switch, Power
T1	5584-701355	Power Transformer
FU1	5732-502030	Fuse, T5A 250V
FU2, 3, 4, 5	5732-402030	Fuse, T4A 250V
FU6	5732-122030	Fuse, T1.25A 250V
TE1	4214-113	FM/AM External Antenna Terminal
C28	5352-1030961	Capacitor, 0.01uF \pm 20% AC250V Metalized Polyester
C28	5352-1030958	Capacitor, 0.01uF \pm 20% AC250V Metalized Polyester (for Sweden only, (SEV))
ADDITIONAL USAGE		
SW2	4467-1	Power Source Voltage Selector
SW4	4421-022110	Slide Switch, De-Emphasis
C01, 2	4443-712	Connector, AC Line Cord (for Europe and Oceania only, (SK) (SEV))