

**The Harman Kardon
Model hk 710**

AM/FM Tuner

Technical Manual

Preliminary Manual

harman/kardon

ALIGNMENT PROCEDURES

AM ALIGNMENT PROCEDURES

INSTRUMENTS: AM RF Signal Generator modulated with 400Hz at 30%.
AC VTVM

NOTE: Set AM switch to ON position.
Connect signal source to a loop placed to radiate signals into AM antenna loop stick (L251).

STEP	SIGNAL SOURCE	CONNECT	DIAL SETTING	ADJUST	ADJUST FOR
1	455kHz AM Mod.	VTVM and oscilloscope to TP(A) and ground	Quiet point on band	T251, T252, T253	Maximum and undistorted pattern on oscilloscope
2		VTVM and oscilloscope to TP(B) and ground		T254	Maximum and in-phase pattern in step 1
3	Repeat steps 1 and 2 for best sensitivity.				
4	540kHz AM Mod.	VTVM and oscilloscope to output jack	540kHz	L252	Maximum Output
5	1600kHz AM Mod.	Same as above	1600kHz	TC252	Same as above
6	Repeat steps 4 and 5 for best dial accuracy.				
7	600kHz AM Mod.	Same as above	600kHz	L251	Maximum Output
8	1400kHz AM Mod.	Same as above	1400kHz	TC251	Same as above
9	Repeat steps 7 and 8 for best sensitivity.				

FM ALIGNMENT PROCEDURE

INSTRUMENTS: FM RF Signal Generator modulated with 1000Hz at 100% (75kHz).
AC VTVM and Oscilloscope.
Distortion Meter

NOTE: Set FM switch to ON position.
Connect signal source to a FM antenna terminals.

STEP	SIGNAL SOURCE	CONNECT	DIAL SETTING	ADJUST	ADJUST FOR
1		VTVM and oscilloscope to output jack		T101	Maximum noise
2	88MHz 12dBf (2 μ V) FM Mod.	Same as above	88MHz	L104	Maximum output
3	108MHz 12dBf (2 μ V) FM Mod.	Same as above	108MHz	TC103	Same as above
4	Repeat steps 2 and 3 for best dial accuracy.				
5	90MHz 12dBf (2 μ V) FM Mod.	Same as above	90MHz	L102, L103	Same as above
6	106MHz 12dBf (2 μ V) FM Mod.	Same as above	106MHz	TC101, TC102	Same as above
7	Repeat steps 5 and 6 until no further improvement is noticed.				
8	98MHz 65dBf (970 μ V) FM Mod.		98MHz	T201(A)	Changing color of dial illumination lamp from white to green
9		Distortion meter to output jack		T201(B)	Minimum reading on distortion meter

TUNING DISPLAY LEVEL ADJUSTMENT

INSTRUMENTS: FM RF Signal Generator modulated with 1000Hz at 100% (75kHz).

NOTE: Set FM switch to ON position.
Set VR202 to center position.
Connect signal source to FM antenna terminals.

STEP	SIGNAL SOURCE	DIAL SETTING	ADJUST	ADJUST FOR
1	98MHz 21dBf (5.6 μ V)	98MHz	VR501	"1" and "2" of tuning display LEDs lights
2	98MHz OdBf			Confirm "2" of tuning display LEDs goes off
3	98MHz 21dBf (5.6 μ V)		VR201	Changing color of dial illumination lamp from white to green
4	98 MHz OdBf			Confirm changes color of dial illumination lamp from green to white

MPX ADJUSTMENT

INSTRUMENTS: FM RF Signal Generator.
Frequency Counter.

NOTE: Set FM switch to ON position.
Connect signal source to FM antenna terminals.

SIGNAL SOURCE	CONNECT	DIAL SETTING	ADJUST	ADJUST FOR
98MHz 65dBf (970 μ V) (No modulation)	Frequency Counter to TP(C) and ground	98MHz	VR301	75.95kHz \pm 40Hz

SEPARATION ADJUSTMENT

INSTRUMENTS: FM Stereo Signal Generator modulated with 1000Hz at 100% (75kHz).
(L + R = 45% L - R = 45% 19kHz = 9%)

NOTE: Set FM switch to ON position.
Connect signal source to FM antenna terminals.

STEP	SIGNAL SOURCE	CONNECT	DIAL SETTING	ADJUST	ADJUST FOR
1	Set Lch Signal ON at FM stereo signal generator.				
2	98MHz 65dBf (970 μ V)	VTVM to R ch. output jack	98MHz	VR302, VR403	Minimum Output
3	Set Rch Signal ON at FM stereo signal generator.				
4	98MHz 65dBf (970 μ V)	VTVM to L ch. output jack	98MHz	VR302, VR403	Minimum Output
5	Set Main signal ON at FM stereo signal generator.				
6	98MHz 36dBf \pm 3dB		98MHz		Confirm that FM stereo indicator lights. If FM stereo indicator does not light, adjust VR202.

OUTPUT LEVEL ADJUSTMENT

INSTRUMENTS: FM RF Signal Generator modulated with 1000Hz at 100% (75kHz).
AC VTVM

NOTE: Set FM switch to ON position.
Connect signal source to FM antenna terminals.

STEP	SIGNAL SOURCE	CONNECT	DIAL SETTING	ADJUST	ADJUST FOR
1	98MHz 65dBf (970 μ V)	VTVM to Lch. output jack	98MHz	VR401	0.775V
2		VTVM to Rch. output jack		VR402	

TEST POINTS

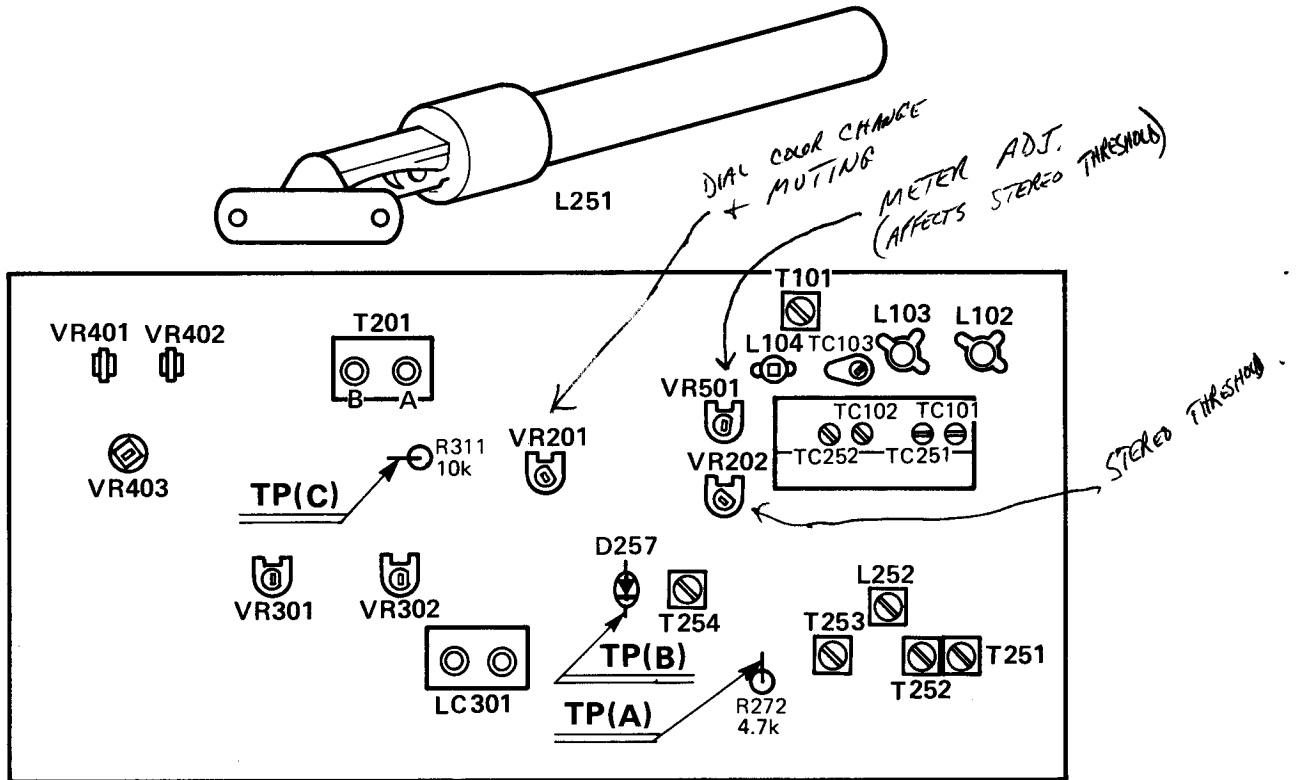

DIAL CORD STRINGING

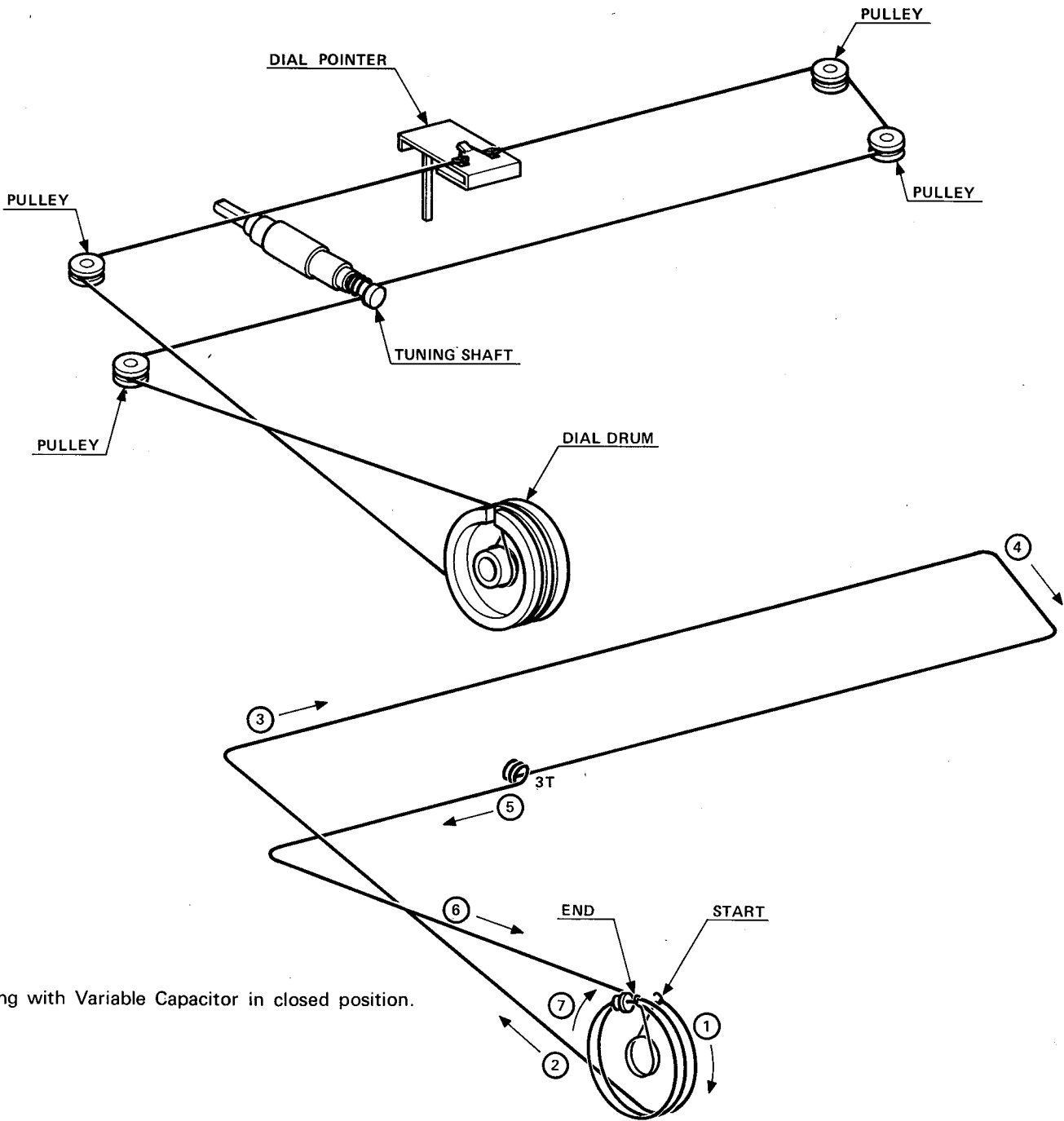

Start stringing with Variable Capacitor in closed position.

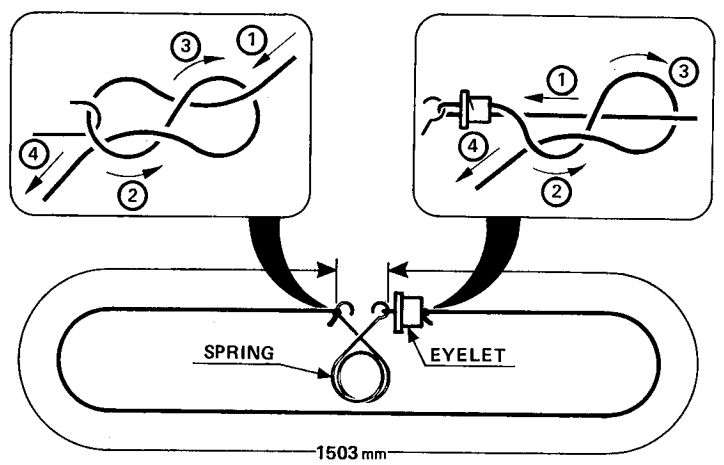
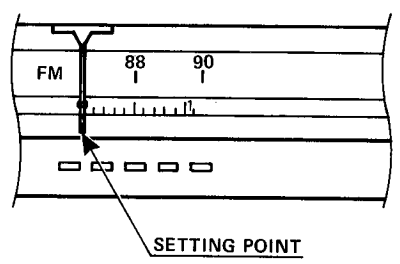

GENERAL UNIT PARTS LIST

SER. NO.	REF. NO.	PART NO.	DESCRIPTION
AA	101	A443-HK710	Front Panel Assembly
AB	102	A662-HK710-A	Push Button Assembly, Power
AC	103	A662-HK710-B	Push Button Assembly, Auto FM, AM, Hi Blend, FM Muting
AD	104	A424-HK710	Cabinet Back Assembly
AE	105	A554-HK710	Dial Back Plate Assembly
AF	106	A630-HK710	Knob Assembly, Tuning Control
112	112	1319-7330	Foot, Gold (x2)
113	113	1319-7230	Foot, Black (x2)
115	115	1414-00302	Cabinet Top
117	117	1424-00701	Cabinet Bottom
120	120	1531-01401	Clear Panel, Dial Window
122	122	1562-00602	Left Panel, Front Panel
123	123	1562-00702	Right Panel, Front Panel
125	125	1541-00502	Dial Panel
132	132	1674-01301	Dial Pointer
140	140	2211-7197	Chassis, Front
143	143	2114-71230	Spacer, Dial Window Clear Panel (x4)
146	146	2112-11754	Blind, Dial Lighting
147	147	2114-415027	Bushing, AC Line Cord (P1)
148	148	2132-239	Spacer, Dial Illuminator P.C. Board (x4)
151	151	2132-3010021	Spacer, FM Muting and Auto FM/AM/Hi Blend Switches Retaining
153	153	2240-7051	Holder, Lead Wire Settle (x3)
156	156	2240-7131	Holder, Left Dial Panel Holding
157	157	2240-7132	Holder, Right Dial Panel Holding
164	164	2222-7081	Heat Sink, Voltage Regulator Transistor (Q2)
165	165	2218-7001	Holding Bracket, Lead Wire
166	166	2218-7011	Holding Bracket, Antenna Lead Wire
167	167	2219-7359	Bracket, Power Transformer (T1) (x2)
168	168	2219-7423	Bracket, Tuning Shaft
169	169	2219-7550	Bracket, Power Switch (SW1) Mounting
170	170	2219-7567	Bracket, Main P.C. Board Retaining (Front)
171	171	2219-7568	Bracket, Main P.C. Board Retaining (Rear)
173	173	2611-7154	Dial Drum
175	175	2612-52271	Pulley, Dial Cord (x4)
176	176	2617-7014	Wheel, Tuning Shaft
182	182	2651-0000111	Spring, Dial Drum
184	184	2651-210187	Coil Spring, Push Buttons (x4)
186	186	2602-007104	Tuning Shaft
192	192	2320-15	Special Screw, Pulley (x4)
193	193	2310-7002	Special Screw, Ground Terminal
194	194	2396-300869	Special Screw, Dial Window Clear Panel (x4)
195	195	2363-501711	Bushing, Dial Window Clear Panel (x4)

SER. NO.	REF. NO.	PART NO.	DESCRIPTION
196	196	2440-7001	Special Nut, Ground Terminal
197	197	2440-7009	Special Hexagon Nut (M10)
198	198	2447-09227	Hexagon Nut (M9)
200	200	2327-300629	Screw (+) (3 x 6mm) (x17)
203	203	2327-260629	Screw (+) (2.6 x 6mm) (x8)
204	204	2327-300649	Screw (+) (3 x 6mm) (x6)
206	206	2327-301029	Screw (+) (3 x 10mm) (x2)
207	207	2327-301429	Screw (+) (3 x 14mm) (x4)
209	209	2347-301022	Self-Tapping Screw (+) (3 x 10mm) (x4)
210	210	2347-301041	Self-Tapping Screw (+) (3 x 10mm) (x4)
211	211	2347-300622	Self-Tapping Screw (+) (3 x 6mm) (x21)
213	213	2446-261Z9	Hexagon Nut (M2.6) (x2)
214	214	2446-301Z9	Hexagon Nut (M3) (x4)
216	216	2401-1072	Metal Washer (20 ϕ x 10.5 ϕ x 0.8t)
217	217	2414-302	Toothed Lock Washer (3.2 ϕ) (x3)
218	218	2401-0317	Metal Washer (3.3 ϕ x 10 ϕ x 1t) (x5)
219	219	2424-20351	Eyelet, Dial Cord

ELECTRICAL PARTS LISTMISCELLANEOUS

SER. NO.	REF. NO.	PART NO.	DESCRIPTION
777	T1	5584-702267	Power Transformer
801	SW1	4431-01017358	Push Switch, Power
805	SW2	4431-01027272	Push Switch, FM Muting
816	TE1	4214-95	FM/AM External Antenna Terminal
815	TE2	4482-7113	2-Pin Jack, Tuner Output
811	P1	4161-0487	AC Line Cord
827	J1	4163-70649	Connector with Lead Wire, FM Stereo Indicator
887	PL1,2	5731-1207144	Lamp, 12V 100mA Dial Illuminator (Green)
888	PL3,4	5731-1207244	Lamp, 12V 40mA Dial Illuminator (Orange)
506	L101	5995-703027	Coil, FM RF Balun
627	L251	5911-211	AM Ferrite Bar Antenna
835	D304	5637-GL9PG9	Light Emitting Diode, GL9PG9 FM Stereo Indicator
790	C1	5352-1030952	Capacitor, 0.01MF $\pm 20\%$ AC125V Metalized Polyester
794	R11	5135-335J50P	Resistor, 3.3 M ohm $\pm 5\%$ 1/2W Carbon
823	COL	4443-712	Connector
829	LUG1,2	4211-4	Lug Terminal
821		1397-6	"T" Type External Antenna
813		4161-7185	Plug with Cord, RCA
885		4551-7511	P.C. Board, Lamp (L ch.)
886		4551-7512	P.C. Board, Lamp (R ch.)

MAIN P.C. BOARD

SER. NO.	REF. NO.	PART NO.	DESCRIPTION
<u>RESISTORS</u> (All resistors 1/4W, <u>+5%</u> Carbon unless otherwise noted)			
784	R1,2	5102-1004713	10 ohm (<u>+2%</u> 1/4W Fuse)
786	R3	5154-102J25R	1 k ohm
535	R101,266, 277,298	5134-473J25P	47 k ohm
531	R102	5154-101J25R	100 ohm
540	R103,107, 258,264, 285,289	5134-221J25P	220 ohm
537	R104,279	5134-392J25P	3.9 k ohm
536	R105	5134-223J25P	22 k ohm
541	R106,257, 403,404	5134-681J25P	680 ohm
534	R108,255, 276,283, 284,422, 501,502	5134-104J25P	100 k ohm
539	R109,223	5134-182J25P	1.8 k ohm
538	R110,219, 252,295, 417,418, 420	5134-222J25P	2.2 k ohm
606	R201,259, 260,268, 287	5134-101J25P	100 ohm
602	R202,211, 216,218, 251,254, 288,310, 520	5134-102J25P	1 k ohm
603	R203,206, 267	5134-391J25P	390 ohm
604	R204,205, 207,209, 413,414	5134-331J25P	330 ohm
605	R208	5134-100J25P	10 ohm
598	R210,221, 227,265, 280,290, 291,292, 311,314, 315,421	5134-103J25P	10 k ohm

SER. NO.	REF. NO.	PART NO.	DESCRIPTION
599	R212,270, 272,273, 281,282, 302,303, 415,416	5134-472J25P	4.7 k ohm
597	R213	5134-123J25P	12 k ohm
592	R214	5154-153J25R	15 k ohm
594	R215	5154-362J25R	3.6 k ohm
591	R217	5154-223J25R	22 k ohm
593	R220,224, 225,316	5154-103J25R	10 k ohm
595	R222	5154-220J25R	22 ohm
596	R226,296, 297,401, 402	5154-221J25R	220 ohm
655	R253	5134-474J25P	470 k ohm
662	R256	5134-682J25P	6.8 k ohm
659	R261	5134-393J25P	39 k ohm
656	R262,271	5134-274J25P	270 k ohm
669	R263,286, 304	5134-471J25P	470 ohm
666	R269,278	5134-152J25P	1.5 k ohm
651	R274,409, 410	5154-473J25R	47 k ohm
654	R275	5134-394J25P	390 k ohm
884	R294	5134-220J25P	22 ohm
673	R299	5134-224J25P	220 k ohm
698	R301	5102-8204713	82 ohm (+2% 1/4W Fuse)
701	R305,306	5154-472J25R	4.7 k ohm
700	R307,308	5154-822J25R	8.2 k ohm
703	R309,317, 411,412	5134-333J25P	33 k ohm
704	R312	5134-153J25P	15 k ohm
708	R313	5134-751J25P	750 ohm
723	R405,406	5134-275J25P	2.7 M ohm
724	R407,408	5134-154J25P	150 k ohm
751	R419	5154-222J25R	2.2 k ohm
875	R521	5135-150J50P	15 ohm (+5% 1/2W Carbon)
877	R522	5154-332J25R	3.3 k ohm
567	VR201,302	5101-20371913	Variable Resistor, 20 k ohm
568	VR202,501	5101-503083H	Variable Resistor, 50 k ohm
685	VR301	5101-502083H	Variable Resistor, 5 k ohm
713	VR401,402	5101-503102V	Variable Resistor, 50 k ohm
714	VR403	5101-1037374	Variable Resistor, 10 k ohm

SER. NO.	REF. NO.	PART NO.	DESCRIPTION
<u>CAPACITORS</u>			
782	C2,4,5, 112,113, 114,201, 202,203, 204,205, 206,207, 208,209, 210,211, 217,254, 255,256, 257,262, 263,264, 267,273, 276,277, 280,283	5361-223ZF	0.022MF +80%-20% 50V Ceramic
780	C3,8,9	5345-477-16	470MF +50%-10% 16V Electrolytic
779	C6,7	5345-108-35	1000MF +50%-10% 35V Electrolytic
525	C101,107, 407,408	5361-100DSL	10PF \pm 0.5PF 50V Ceramic
523	C102	5361-150KSL	15PF \pm 10% 50V Ceramic
524	C103	5361-120KSL	12PF \pm 10% 50V Ceramic
526	C104	5361-050DSL	5PF \pm 0.5PF 50V Ceramic
520	C105	5361-010DCH	1PF \pm 0.5PF 50V Ceramic
522	C106	5361-152KB	1500PF \pm 10% 50V Ceramic
516	C108	5362-050096	5PF \pm 0.5PF 50V Ceramic
519	C109	5361-080DCH	8PF \pm 0.5PF 50V Ceramic
517	C110	5361-200JCH	20PF \pm 5% 50V Ceramic
518	C111,251	5361-150JCH	15PF \pm 5% 50V Ceramic
527	C115,116	5361-102KB	1000PF \pm 10% 50V Ceramic
514	C117	5345-476-16	47MF +50%-10% 16V Electrolytic
528	C118	5361-050CUJ	5PF \pm 0.25PF 50V Ceramic
576	C212,265	5361-473ZF	0.047MF +80%-20% 50V Ceramic
574	C213	5345-105-50	1MF +75%-10% 50V Electrolytic
578	C214,271, 275,279	5361-101KSL	100PF \pm 10% 50V Ceramic
573	C215,301	5345-106D0212	10MF \pm 20% 25V Electrolytic
575	C216	5343-4740658	0.47MF \pm 20% 35V Tantalum Electrolytic
636	C252	5355-331J1HS	330PF \pm 5% 50V Stylor
641	C253,268, 269	5361-472KB	4700PF \pm 10% 50V Ceramic
646	C258	5361-390JCH	39PF \pm 5% 50V Ceramic
870	C259	5343-1040658	0.1MF \pm 20% 35V Tantalum Electrolytic
633	C260	5345-475-25	4.7MF +50%-10% 25V Electrolytic
645	C261	5361-010DSL	1PF \pm 0.5PF 50V Ceramic
631	C266	5345-226-16	22MF +50%-10% 16V Electrolytic
637	C270	5354-223KLHM	0.022MF \pm 10% 50V Mylar

SER. NO.	REF. NO.	PART NO.	DESCRIPTION
642	C272	5361-222KB	2200PF $\pm 10\%$ 50V Ceramic
634	C274,281, 312	5345-474-50	0.47MF $+75\%-10\%$ 50V Electrolytic
632	C282,409, 410,411, 412	5345-106-16	10MF $+50\%-10\%$ 16V Electrolytic
690	C302,413, 415,416	5345-227-16	220MF $+50\%-10\%$ 16V Electrolytic
694	C303,304	5343-3350657	3.3MF $+20\%$ 25V Tantalum Electrolytic
697	C305	5354-473KLHM	0.047MF $+10\%$ 50V Mylar
695	C306	5355-511JLHS	510PF $\pm 5\%$ 50V Stytor
689	C307,310, 311	5345-105F0212	1MF $\pm 20\%$ 50V Electrolytic
693	C308	5343-6850655	6.8MF $\pm 20\%$ 16V Tantalum Electrolytic
696	C309	5355-821JLHS	820PF $\pm 5\%$ 50V Stytor
718	C401,402	5354-682JLHM	6800PF $\pm 5\%$ 50V Mylar
717	C403,404, 405,406	5343-1540658	0.15MF $\pm 20\%$ 35V Tantalum Electrolytic
748	C414	5345-225-50	2.2MF $+75\%-10\%$ 50V Electrolytic
504	VC101,102, 103,251, 252	5315-718	Variable Capacitor (w/Trimmers TC101,102, 251,252)
	TC101,102, 251,252	not separatory	Trimmer Capacitor (Part of VC101,102,103, 251,252)
505	TC103	5371-55	Trimmer Capacitor

SEMICONDUCTORS

562	IC201,202	5652-BA401	Integrated Circuit, BA401 FM IF Amp.
561	IC203	5652-HA11225	Integrated Circuit, HA11225 FM IF Amp./ FM Det.
681	IC301	5652-KB4437	Integrated Circuit, KB4437 FM Multiplex
773	Q1	5616-2SK163(M)	F.E.T., 2SK163(M) Constant Current
771	Q2	5613-1419(C)	Transistor, 2SC1419(C) Voltage Regulator
772	Q3	5612-647(C)	Transistor, 2SB647(C) Voltage Regulator
501	Q101	5616-2SK168(D)	F.E.T., 2SK168(D) FM RF Amp.
502	Q102	5613-535(B)	Transistor, 2SC535(B) FM Mixer
503	Q103	5613-461(B)	Transistor, 2SC461(B) FM Osc.
563	Q201,202	5613-2320(F)	Transistor, 2SC2320(F) FM In-Tune
741	Q203	5613-2320(F)	Transistor, 2SC2320(F) FM Muting
622	Q251	5613-461(B)	Transistor, 2SC461(B) AM Osc.
621	Q252	5613-461(A)	Transistor, 2SC461(A) AM Mixer
622	Q253,254	5613-461(B)	Transistor, 2SC461(B) AM IF Amp.
623	Q255	5613-2320(F)	Transistor, 2SC2320(F) AM Output Amp.
861	Q256,257	5613-461(B)	Transistor, 2SC461(B) AM In-Tune

SER. NO.	REF. NO.	PART NO.	DESCRIPTION
862	Q259,260	5613-2320(F)	Transistor, 2SC2320(F) AM In-Tune
682	Q301	5613-2320(F)	Transistor, 2SC2320(F) Stereo-Mono Switching
711	Q401,402	5613-2320L(F)	Transistor, 2SC2320L(F) Output Amp.
712	Q403,404	5611-999(F)	Transistor, 2SA999(F) Output Amp.
741	Q405,406	5613-2320(F)	Transistor, 2SC2320(F) Audio Muting
742	Q407	5611-999(F)	Transistor, 2SA999(F) Audio Muting
864	Q506,507	5614-468(C)	Transistor, 2SD468(C) Lamp Driver
776	D1,2,3	5632-1SR35-10	Diode, 1SR35-10
774	D4,5	5635-RD15EB	Zener Diode, RD15EB 14.7V \pm 0.9V
564	D201,202, 251,258, 301,302, 401,402, 403,404	5631-1S2473	Diode, 1S2473
624	D252,253, 254,256, 257	5631-1N34A	Diode, 1N34A
683	D303	5635-RD5RLEC	Zener Diode, RD5RLEC 5.4V \pm 0.3V

COILS AND TRANSFORMERS

507	L102	5995-701039	Coil, FM RF
508	L103	5995-702039	Coil, FM RF
509	L104	5995-701038	Coil, FM Osc.
511	L105	5991-7065	Coil, FM IF Trap
571	L201	5995-3R3225	Coil, RF Choke
628	L252	5923-70327	Coil, AM Osc.
510	T101	5563-0027	Transformer, FM IF
569	T201	5574-7023	Transformer, Quadrature Det.
629	T251,252	5553-0097	Transformer, AM IF
630	T253	5553-0087	Transformer, AM IF
868	T254	5553-0087	Transformer, AM In-Tune

MISCELLANEOUS

565	CF201,202, 203	5673-712Z	Ceramic Filter, FM IF
687	LC301	5214-12	LC Component, Low Pass Filter
546	FB101	5597-4	Ferrite Bead for Q103
610		4214-7008	Terminal for Lead Wire (x26)
543		4551-7510	P.C. Board
162		2216-7056	Shield Plate
163		2216-7099	Shield Cover

TUNING DISPLAY P.C. BOARD

SER. NO.	REF. NO.	PART NO.	DESCRIPTION
<u>RESISTORS</u> (All resistors 1/4W, +5% Carbon unless otherwise noted)			

845	R503,504, 510,511, 513,519	5134-103J25P	10 k ohm
851	R505	5134-471J25P	470 ohm
846	R506	5134-472J25P	4.7 k ohm
847	R507	5134-222J25P	2.2 k ohm
850	R508	5134-102J25P	1 k ohm
849	R509	5134-122J25P	1.2 k ohm
840	R512	5154-103J25R	10 k ohm
848	R514,515, 516,517, 518	5134-152J25P	1.5 k ohm

CAPACITOR

838	C501	5345-474-50	0.47MF +75%-10% 50V Electrolytic
-----	------	-------------	----------------------------------

SEMICONDUCTORS

831	Q501	5613-2320(F)	Transistor, 2SC2320(F) Tuning Display LEDs Pre-Driver
832	Q502,503, 504,505	5611-999(F)	Transistor, 2SA999(F) Tuning Display LED Driver
834	D501,502, 503,504, 505	5637-GL9PR9	Light Emitting Diode, GL9PR9 Tuning Display

MISCELLANEOUS

611		4214-7030	Terminal for Lead Wire (x4)
854		4551-7514	P.C. Board

SWITCH P.C. BOARD

SER. NO.	REF. NO.	PART NO.	DESCRIPTION
803	SW3	4431-03067248	Push Switch, FM/AM/Hi Blend
720	C417	5354-472J1HM	Capacitor, 4700PF $\pm 5\%$ 50V Mylar
612		4214-7008	Terminal for Lead Wire (x7)
819		4551-7513	P.C. Board

PARTS LIST OF MULTI VOLTAGE UNIT

AS TO ALL OTHER PARTS EXCEPT THE FOLLOWING PARTS IN REF. NO., PLEASE REFER TO THE SERVICE MANUAL OF REGULAR VOLTAGE UNIT.

SER. NO.	REF. NO.	PART NO.	DESCRIPTION
<u>PART NO. CHANGE</u>			
A4B	104	A424-HK710-A	Cabinet Back Assembly
117B	117	1424-03101	Cabinet Bottom
777B	T1	5584-703267	Power Transformer
801B	SW1	4431-01017658	Push Switch, Power
811B	P1	4161-7256	AC Line Cord
790B	C1	5352-1030958	Capacitor, 0.01MF $\pm 20\%$ AC250V Metalized Polyester
718B	C401,402	5354-472J1HM	Capacitor, 4700PF $\pm 5\%$ 50V Mylar

ADDITIONAL USAGE

215B	214	2446-301Z9	Hexagon Nut (M3) (x3)
026B	026	2132-7016	Spacer, Voltage Selector Switch (SW5) (x2)
027B	027	2132-01401	Spacer, De-Emphasis Switch P.C. Board Retaining
028B	028	2327-301229	Screw (+) (3 x 12mm) (x2)
029B	029	2327-301629	Screw (+) (3 x 16mm)
030B	030	2411-3021	Flat Washer (3.2 ϕ x 7 ϕ x 0.5t)
041B	SW4	4421-022110	Slide Switch, De-Emphasis
042B	SW5	4411-104736	Rotary Switch, Power Source Voltage Selector
044B	C421,422	5354-222J1HM	Capacitor, 2200PF $\pm 5\%$ 50V Mylar
045B		4551-7604	P.C. Board, De-Emphasis Switch

SCHEMATIC DIAGRAM NOTES

1. All resistors are 1/4 watt unless otherwise noted.
Values are in ohms. K = 1000 M = 1000K
2. All capacitance values are in MF unless otherwise noted. PF = MMF
3. Band switch (SW3) is in FM position.

VOLTAGE CHART

AC 120V, no signal, chassis ground.

FM POSITION

AM POSITION

	GATE	SOURCE	DRAIN		BASE	EMITTER	COLLECTOR		
Q1	+14.1V	+14.1V	+24.0V	Q251	+3.0V	+2.4V	+10.3V		
Q101	0V	0V	+7.2V	Q252	+1.0V	+0.4V	+11.8V		
				Q253	+1.3V	+0.6V	+11.4V		
				Q254	+1.8V	+1.1V	+7.6V		
				Q255	+1.8V	+1.2V	+7.3V		
				Q256	+5.8V	+5.1V	+12.7V		
				Q257	+5.8V	+5.1V	+12.7V		
				Q259	+0.1V	+0.2V	+0.9V		
				Q260	+0.9V	+0.2V	+0.2V		
	BASE	EMITTER	COLLECTOR	IC201	IC202	IC203	IC301		
Q2	+14.1V	+13.5V	+22.8V	FM	FM	FM	AM FM		
Q3	-14.2V	-13.7V	-26.2V	1.	+1.4V	+1.4V	+2.0V	+11.3V	+11.5V
Q102	+8.4V	+0.7V	+9.2V	2.	+1.4V	+1.4V	+2.0V	+3.1V	+3.1V
Q103	+3.6V	+3.0V	+6.1V	3.	0V	0V	+2.0V	+5.4V	+5.4V
Q201	+0.8V	+0.1V	+0.2V	4.	+7.3V	+7.2V	0V	+7.0V	+7.2V
Q202	+0.1V	+0.1V	+11.4V	5.	+7.7V	+7.6V	+0.1V	+7.0V	+7.2V
Q203	0V	0V	+13.4V	6.			+5.6V	+8.9V	+9.0V
Q301	-0.6V	0V	+9.8V	7.			+5.6V	0V	0V
Q401,402	-11.1V	-11.8V	+11.9V	8.			+5.6V	+7.4V	+9.2V
Q403,404	+11.9V	+12.5V	-0.8V	9.			+5.6V	+0.8V	+0.8V
Q405,406	0V	0V	0V	10.			+5.6V	+2.5V	+2.5V
Q407	+13.4V	+13.2V	0V	11.			+13.5V	+2.5V	+2.5V
Q501	+0.4V	0V	+13.5V	12.			+4.0V	+2.5V	+2.5V
Q502,503, 504,505	+13.5V	+13.5V	0V	13.			+0.1V	+2.5V	+2.5V
Q506	+0.7V	0V	0V	14.			0V	+2.5V	+2.5V
Q507	+0.1V	0V	+13.5V	15.			+5.0V	+5.7V	+3.5V
				16.			+3.7V	+4.0V	0V

IC BLOCK DIAGRAM

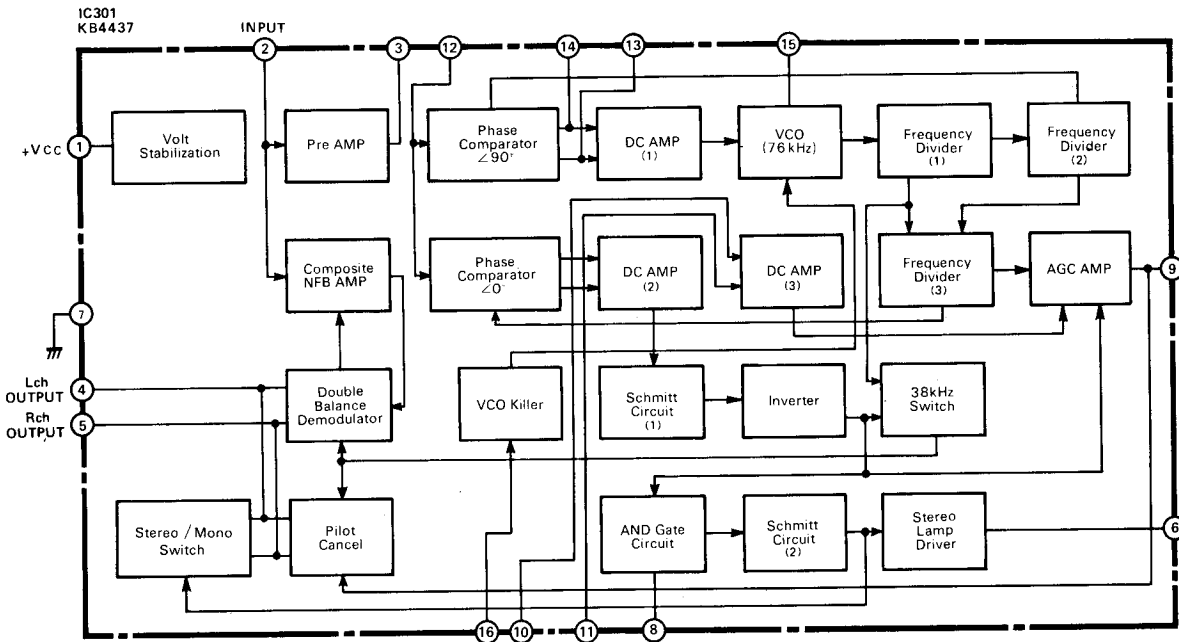
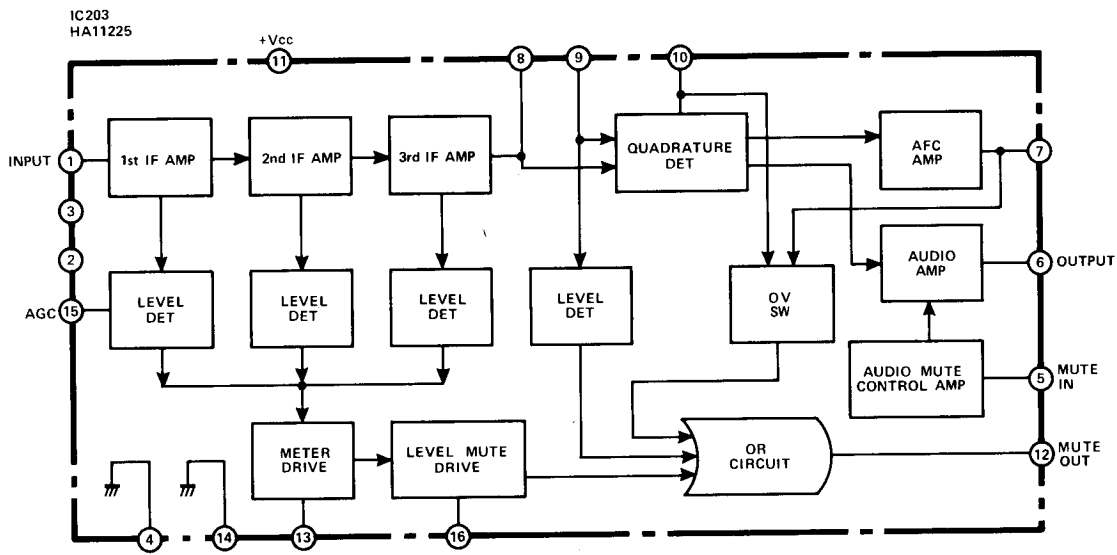
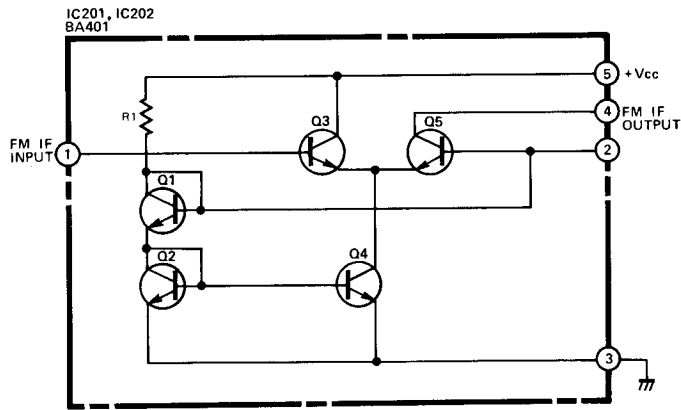

TUNING DISPLAY P.C. BOARD

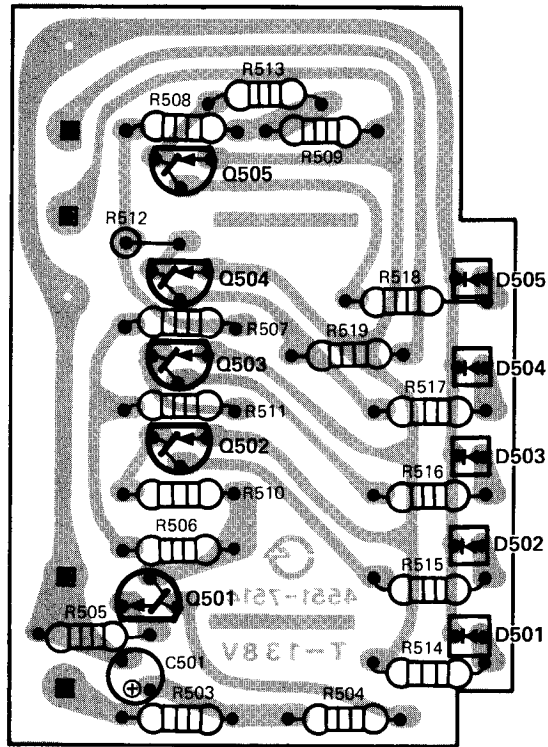

SWITCH P.C. BOARD

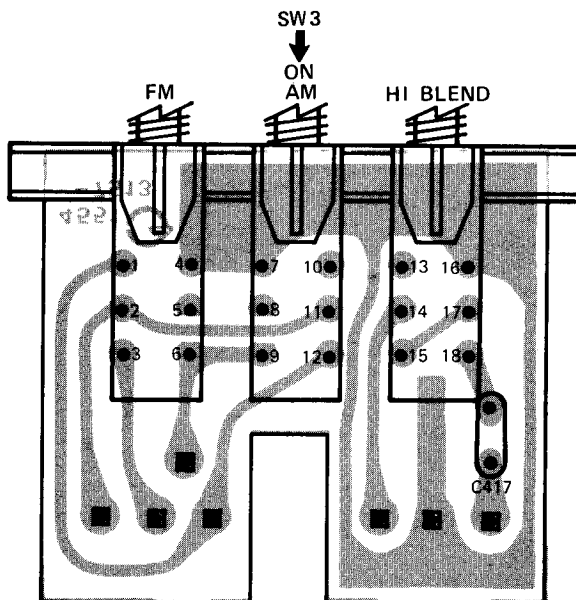

MAIN P.C. BOARD

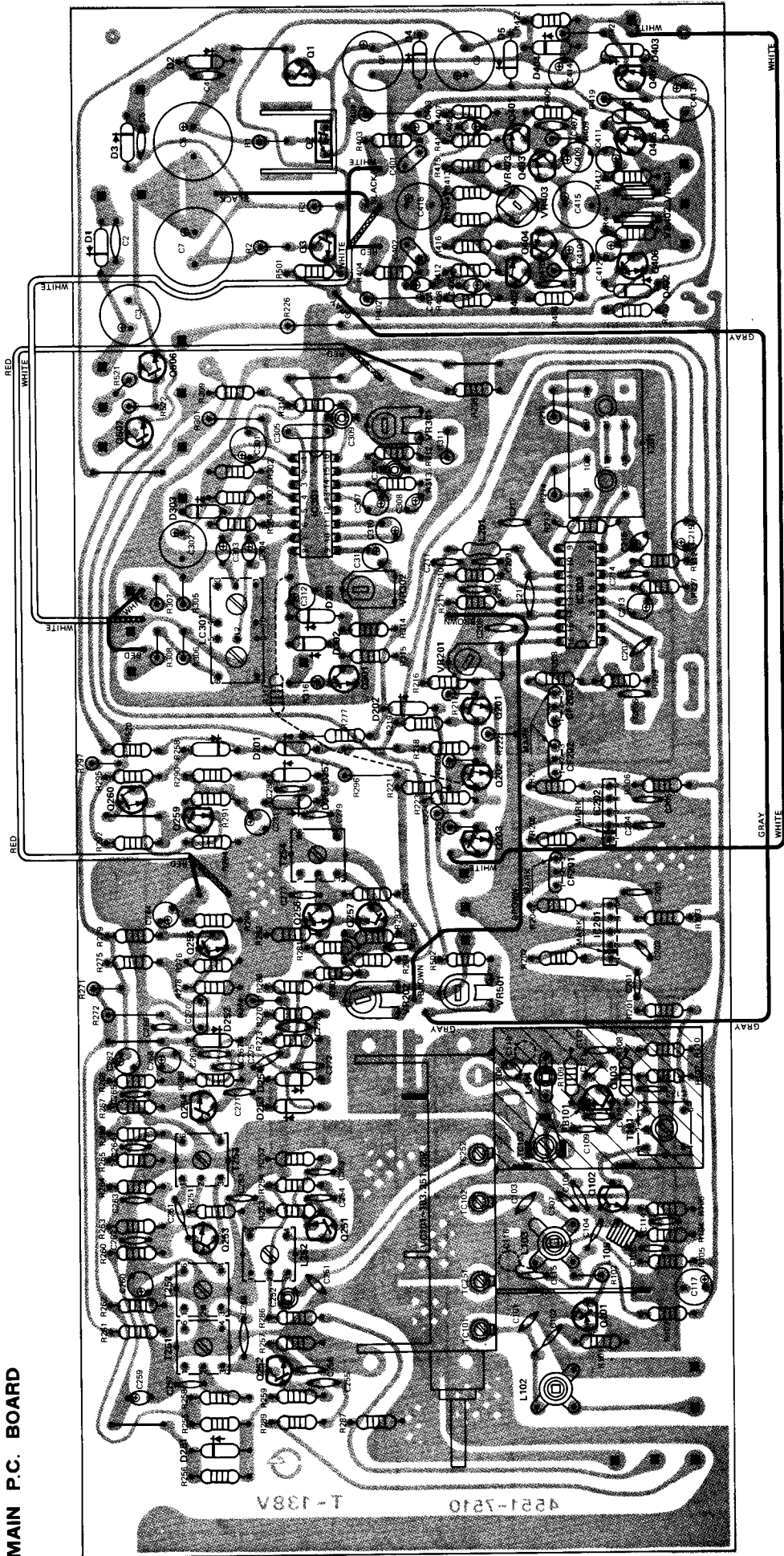

WIRING DIAGRAM — MODEL hk 710 — 120V ONLY

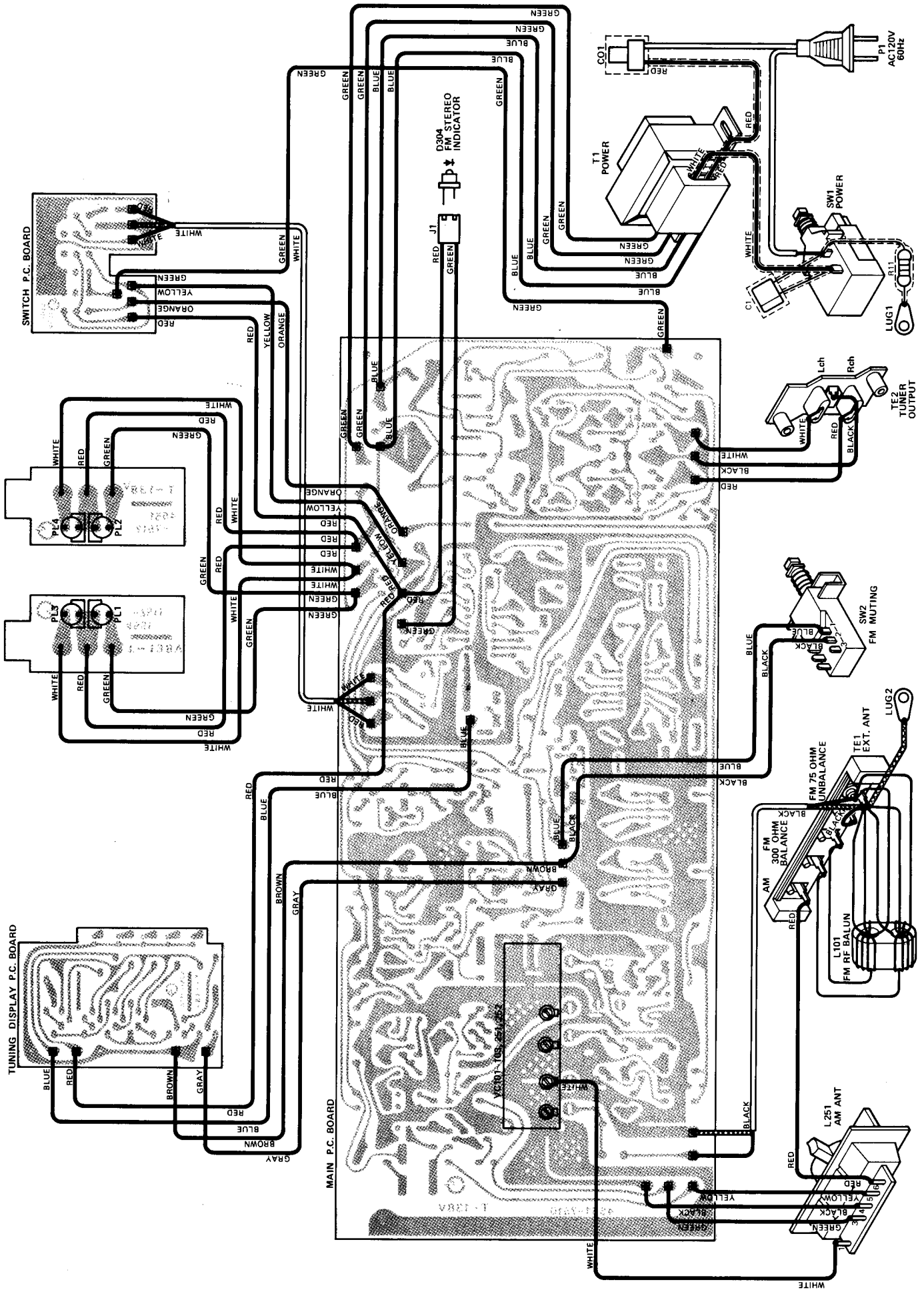

WIRING DIAGRAM — MODEL hk 710 — MULTI VOLTAGE

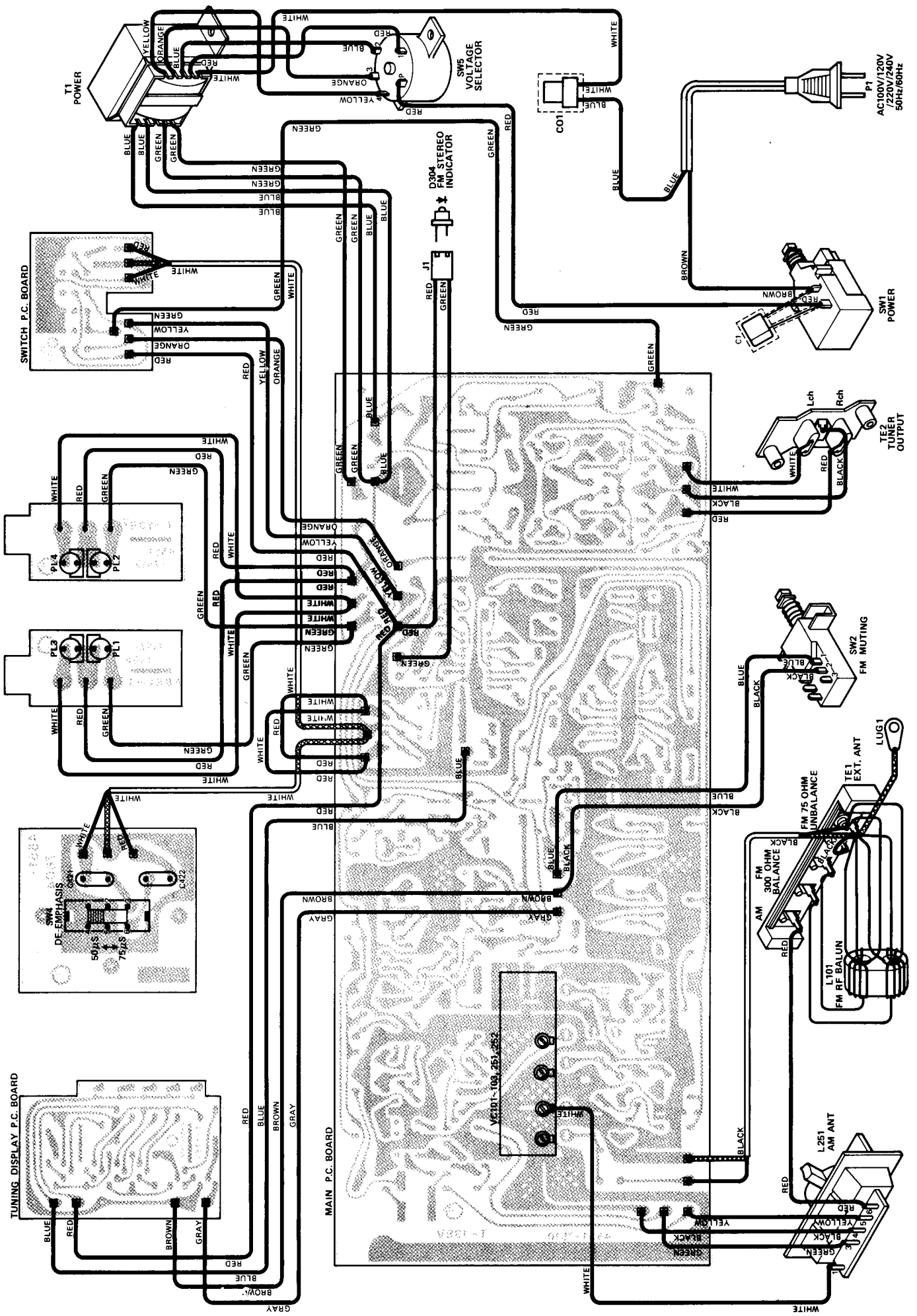

P1
AC100V/120V
/220V/240V
50Hz/60Hz

SCHEMATIC DIAGRAM — MODEL hk 710 — 120V ONLY

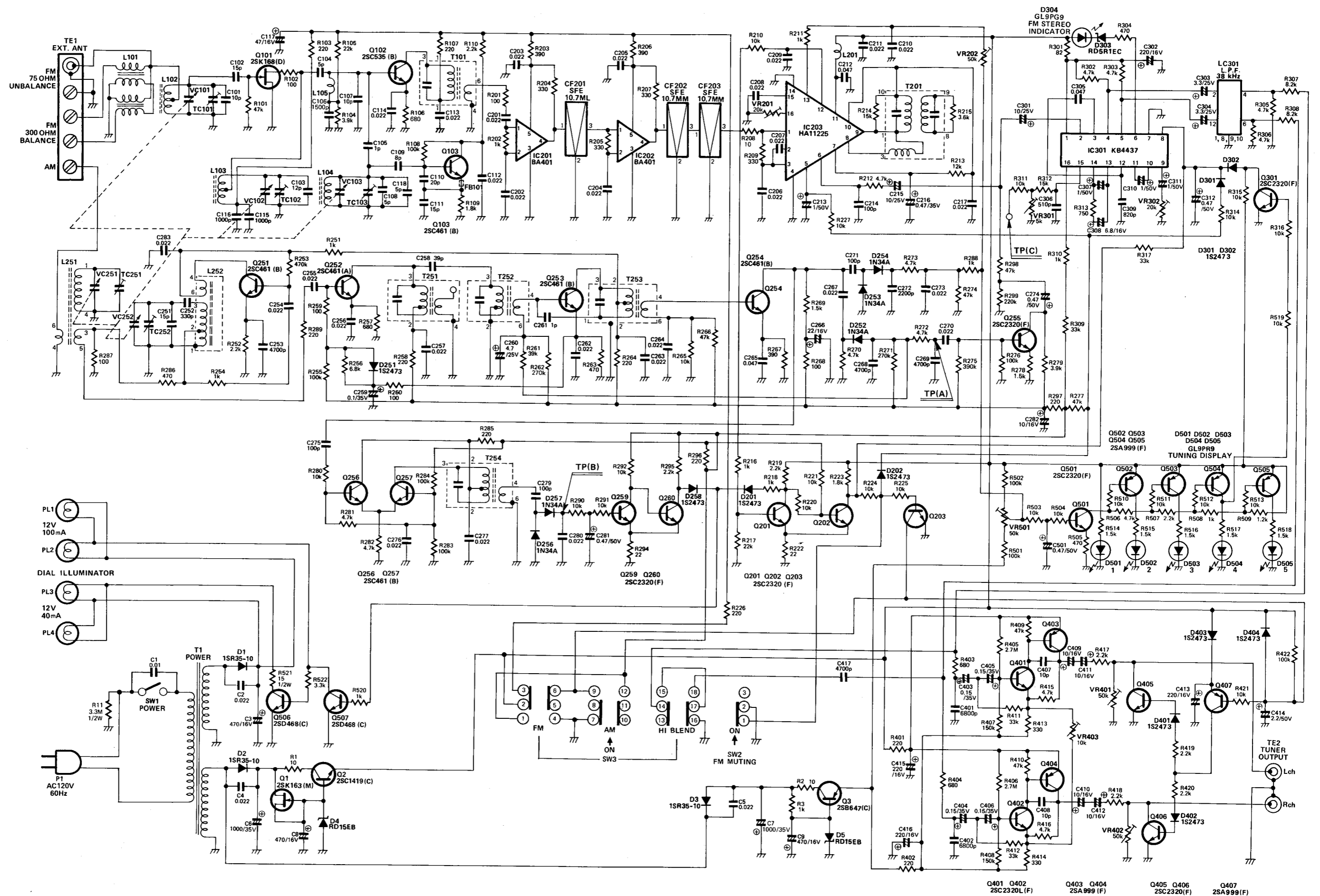

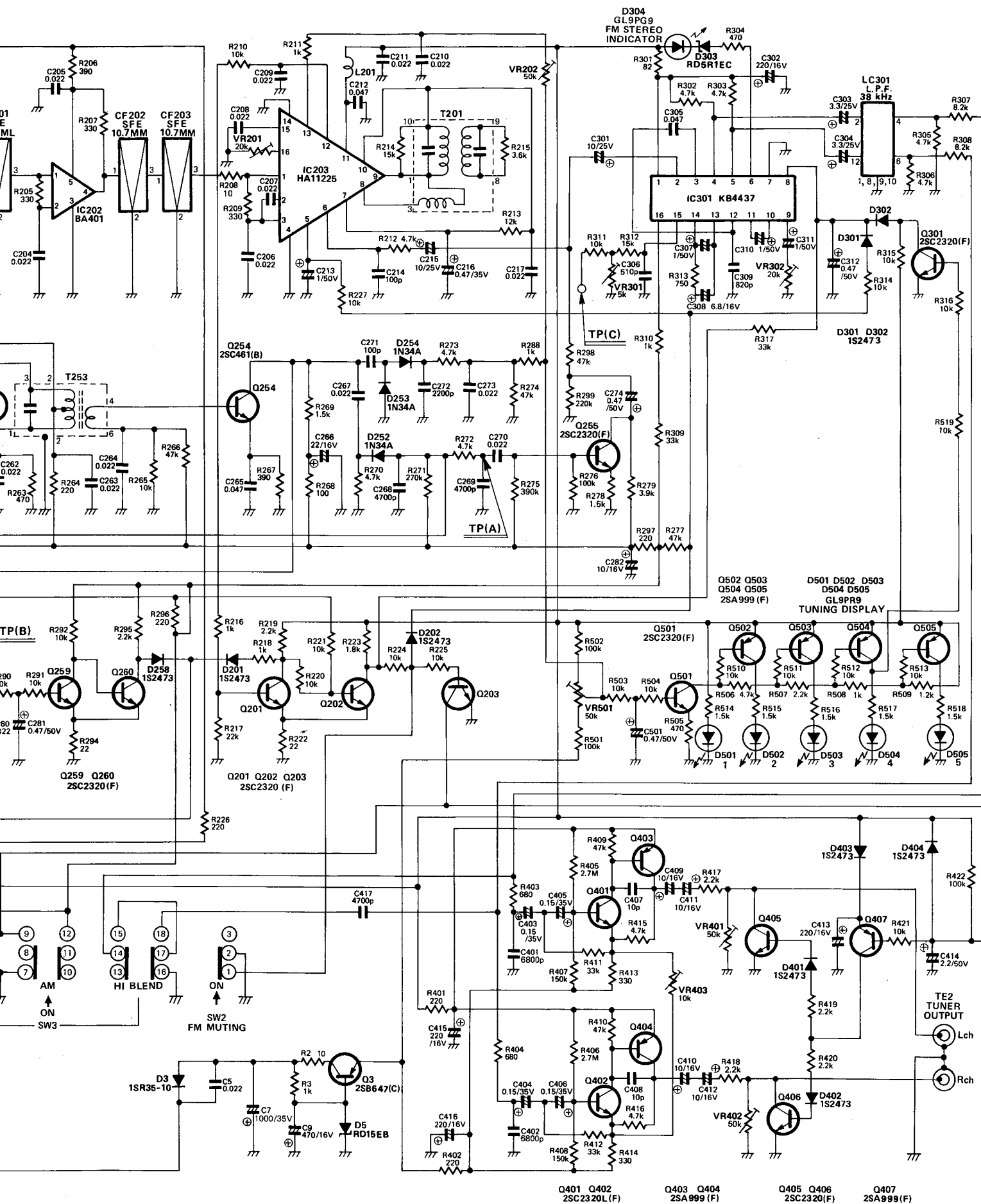

Q401 Q402 2SC2320L(F) Q403 Q404 2SA999(F) Q405 Q406 2SC2320(F) Q407 2SA999(F)

SCHEMATIC DIAGRAM — MODEL hk 710 — MULTI VOLTAGE

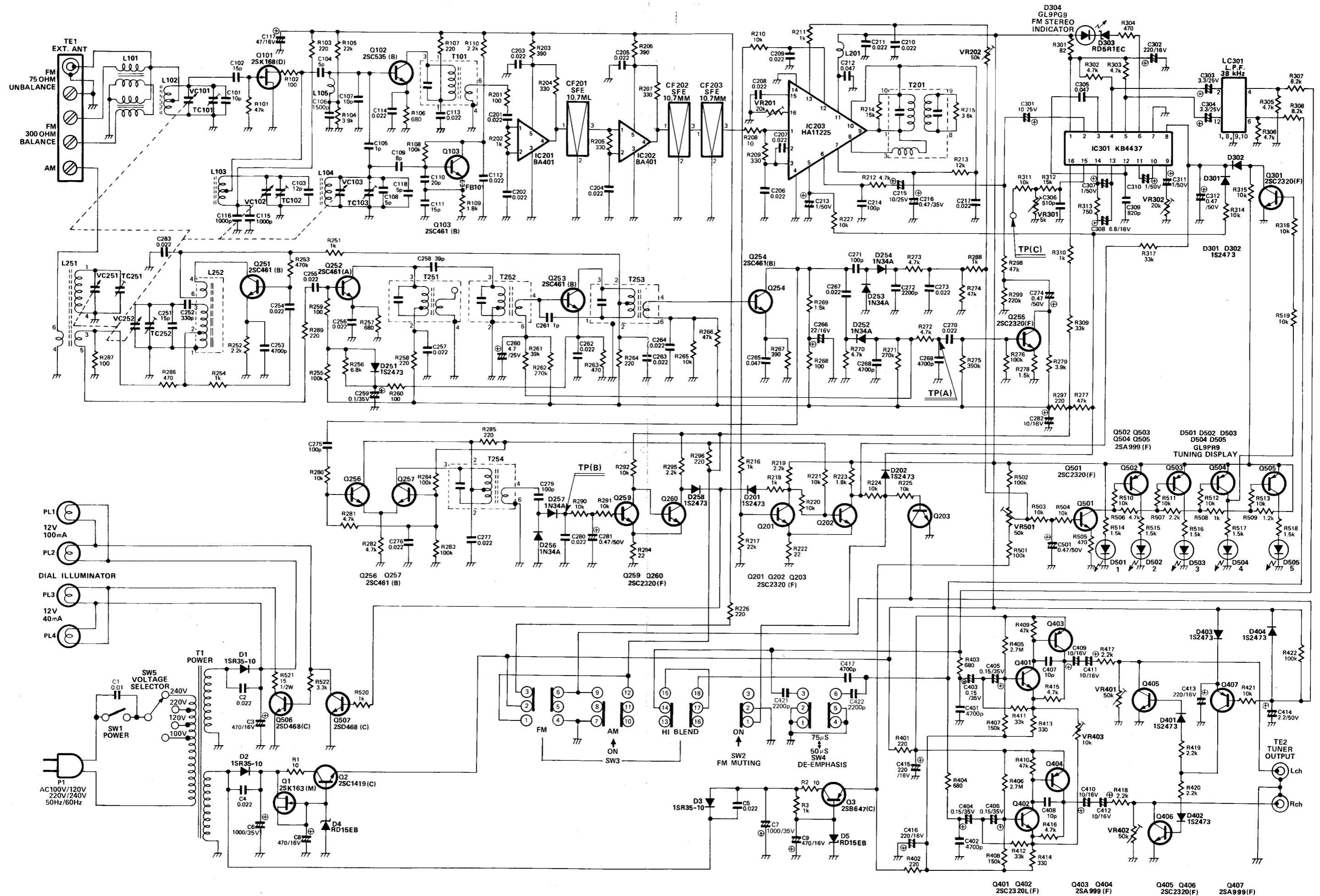

SCHEMATIC DIAGRAM — MODEL hk 710 — MULTI VOLTAGE

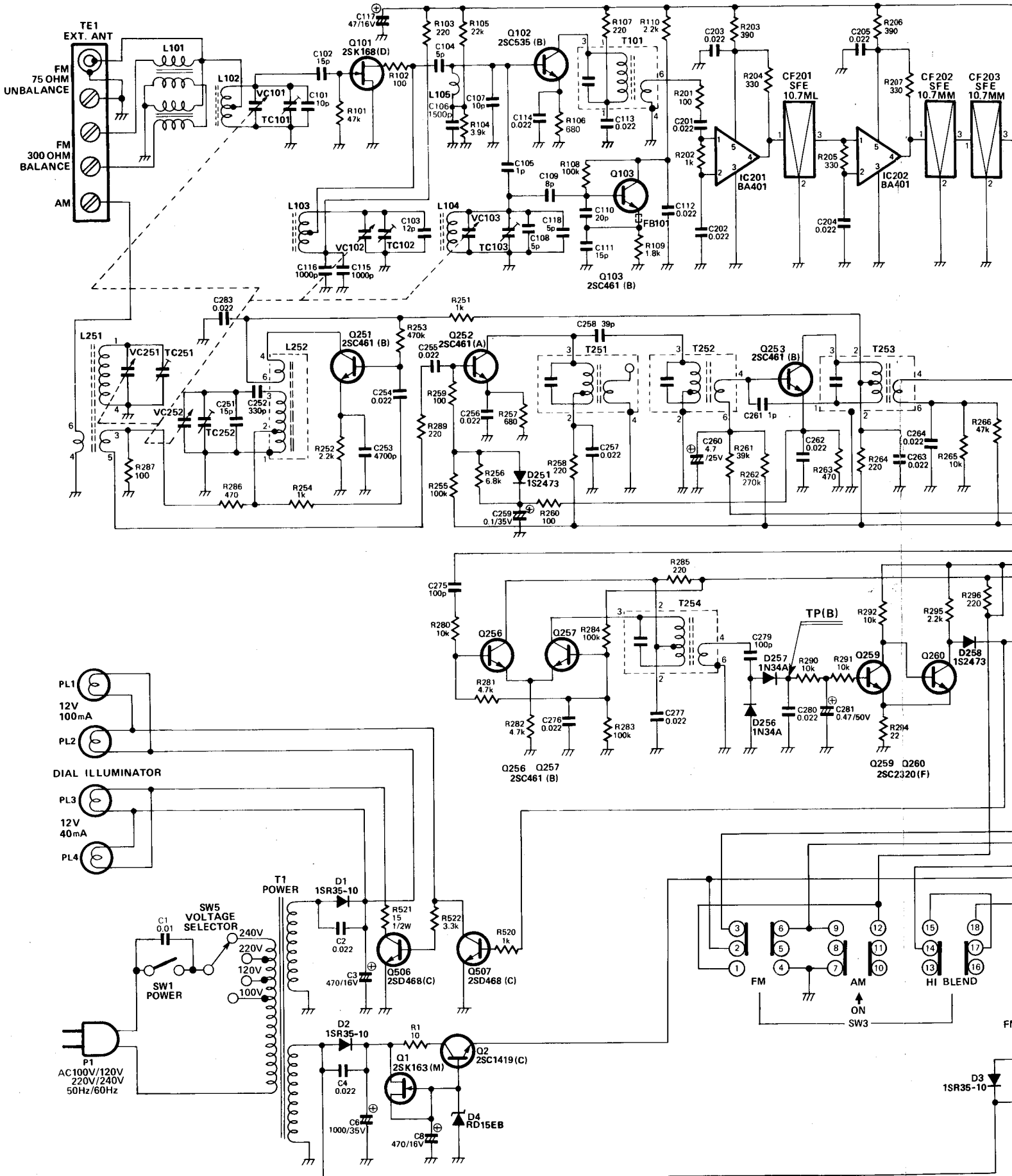

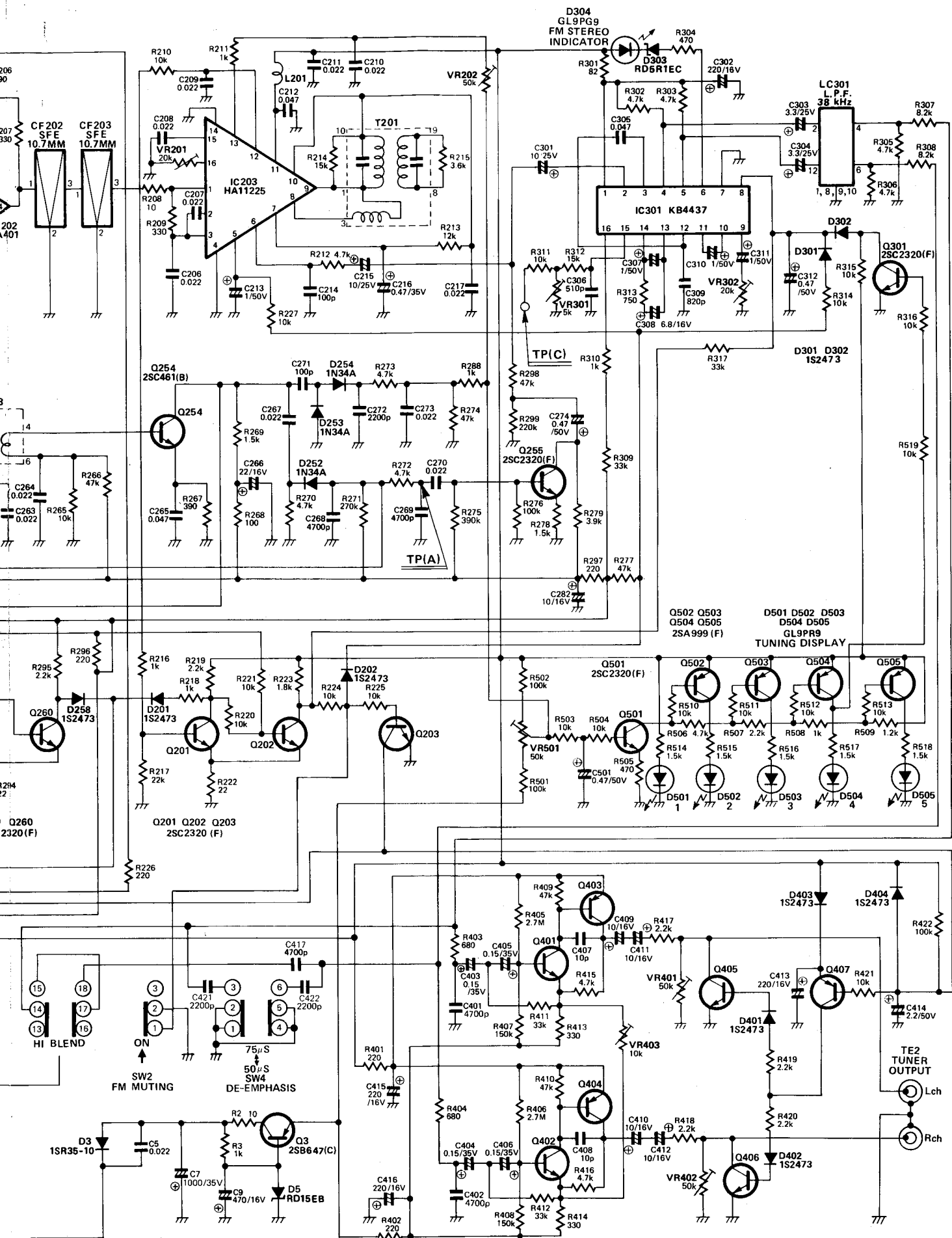

Q401 Q402 2SC2320(L) (F) Q403 Q404 2SA999 (F) Q405 Q406 2SC2320(F) Q407 2SA999(F)