

The Harman Kardon Model hk720

Semiautomatic Stereo Turntable

Technical Manual

CARTRIDGE REPLACEMENT

Be sure to use a cartridge weighing 2 to 8 grams.

Since the headshell offset angle in the hk720 is designed at 25.5 degrees, always use a Harman Kardon's headshell.

1. Release the tonearm clamp and lift the tonearm gently.
2. Loosen the thumbscrew at the end of the tonearm and gently pull the headshell.
3. Disconnect the signal wires using a pincette and then loosen the mounting screws on top of the headshell to remove.
4. Connect the signal wires of the headshell correctly to the appropriate terminals of the cartridge according to the figure right.

Color code of the signal wires:

	Left channel	Right channel
Signal	White	Red
Ground	Blue	Green

5. When all signal wires are connected properly, install cartridge to the headshell as shown in the figure right.
6. Temporarily tighten the mounting screws to hold the cartridge.
7. Insert the headshell with the cartridge fully into the end of the tonearm and tighten the thumbscrew. With a record on the turntable mat, place the stylus on the record and check to see if the tonearm is parallel with the record. If it is not, place shim(s) between the headshell and cartridge to make the tonearm parallel with the record.

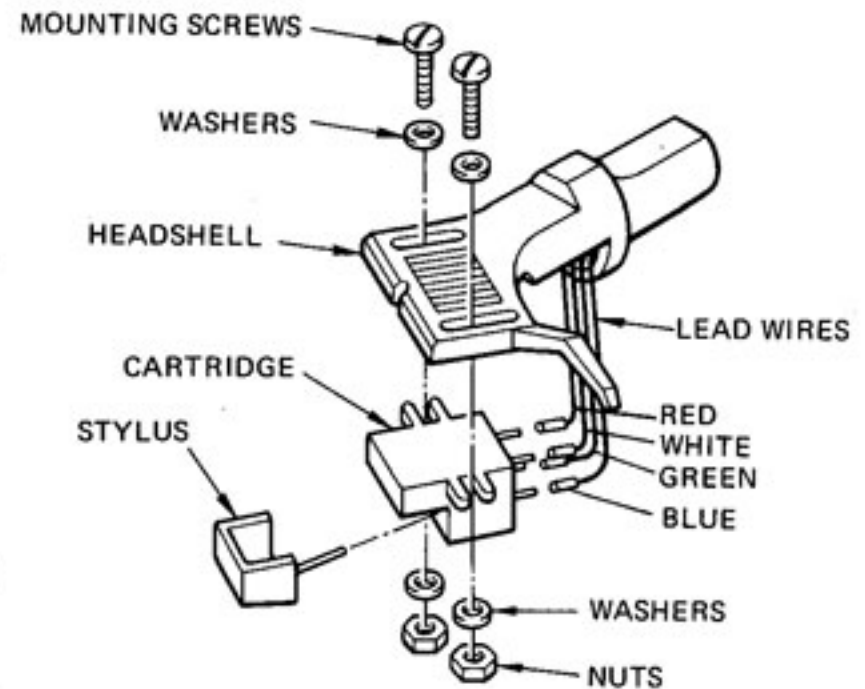

OVERHANG AND TRACKING ANGLE ADJUSTMENTS

If the cartridge is replaced with new one, it is necessary to adjust the overhang and tracking angle.

8. With the turntable mat on the platter, place the tracking angle gauge on the platter, as the hole of the gauge goes over the center spindle facing the printed side up. Fold flap of the gauge.
9. Carefully position the headshell with the cartridge assembly on the center spindle. Adjust the cartridge position so that the stylus tip is at the nearest edge of the flap and the stylus tip, center spindle and tonearm become a straight line.
10. Turn the gauge slightly left and adjust the cartridge position so that the stylus tip is over the indicated center point and cartridge edges are parallel with reference lines on the gauge.
11. Tighten the mounting screws firmly.

Note: Since this gauge is especially designed for the hk720, do not use it on other turntables.

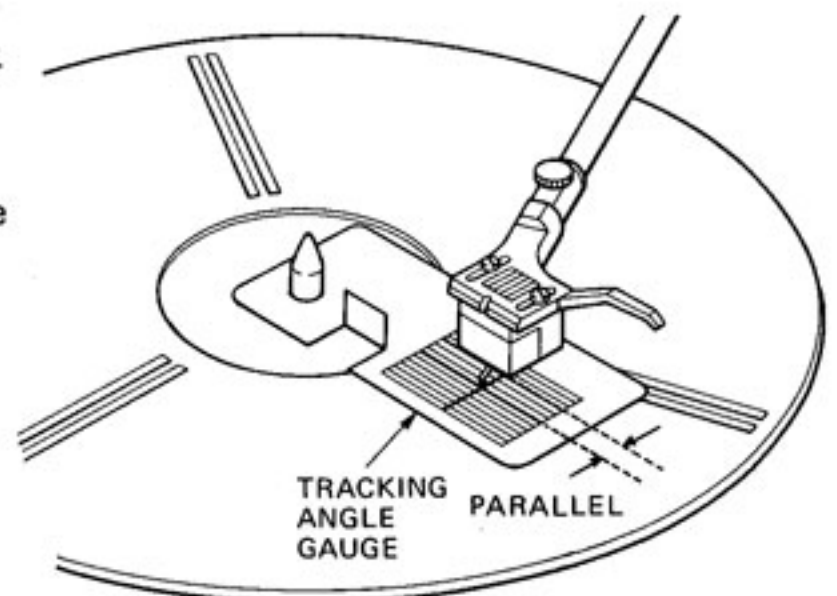
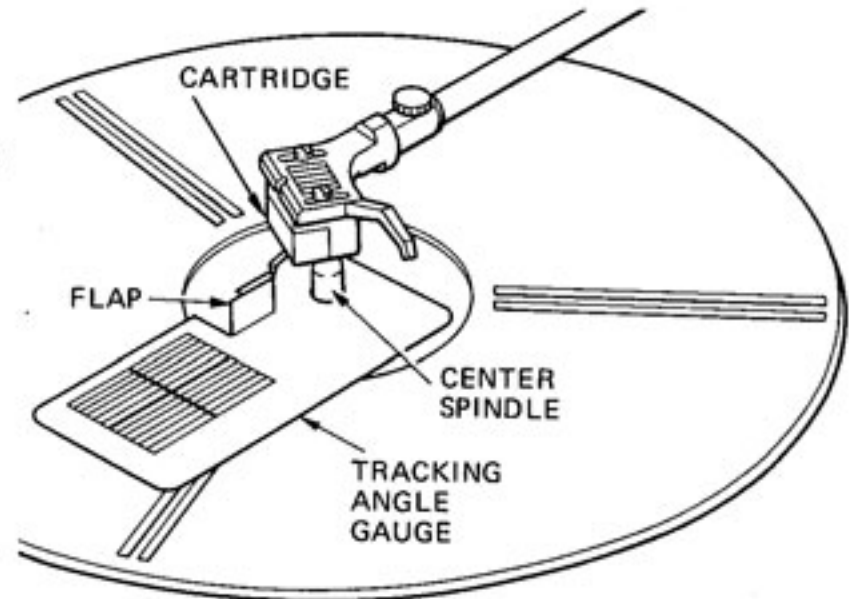

SPEED ADJUSTMENT

1. Set the speed control knob to the center position.
 2. Set the speed selector knob to the 33 rpm position.
 3. Adjust the VR102 so that the stroboscope markings correspond with the rim around the platter.
 4. Set the speed selector knob to the 45 rpm position.
 5. Adjust the VR103 so that the stroboscope markings correspond with the rim around the platter.
- However clockwise rotation of the VR102 and VR103 makes speed fast and counterclockwise of it makes speed slow.

AUTO RETURN ADJUSTMENT

Equipment Required: Test Record (NEC ES-1008) or equivalent

1. Make everything ready to operate the Record Player.
2. Set the speed selector knob to the 45 rpm position.
3. Adjust the stylus pressure to the appropriate pressure.
4. Adjust the auto return adjustment screw, so that the tone arm automatically returns in the range of Count No.11 to 18 on the 6 position (auto return position) of the 1st side of the test record.
5. Adjust the auto return adjustment screw, so that the tone arm does not return automatically in the range of Count No. 1 to 26 on the 4 position (auto return position) of the 2nd side of the test record.
6. Repeat steps 4 and 5 to complete readjustment.

Note: If the auto return motion is too fast, turn the auto return adjustment screw clockwise to adjust.
If the auto return motion is too slow, turn the auto return adjustment screw counterclockwise to adjust.

TEST RECORD 1ST SIDE
(6 POSITION P = 3 mm)

TEST RECORD 2ND SIDE
(4 POSITION P = 3 mm)

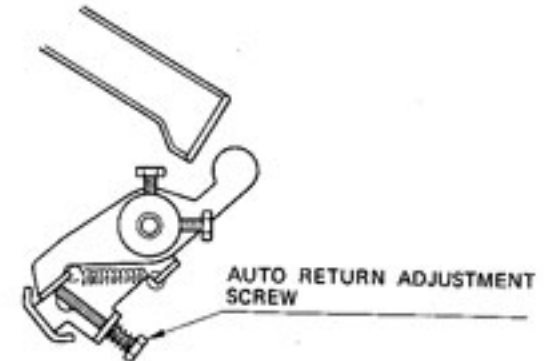
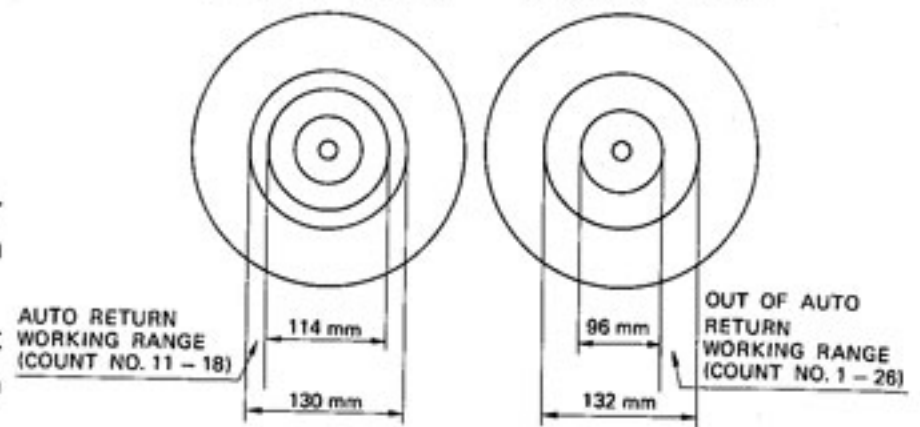

MICROSWITCH MOUNTING ADJUSTMENT

1. After being adjusted the clearance between the microswitch and the forwarding arm assembly to 0.1 to 0.5 mm with a clearance gauge, tighten the mounting screw to fix it.
2. Fix the pick-up assembly on the tone arm rest.

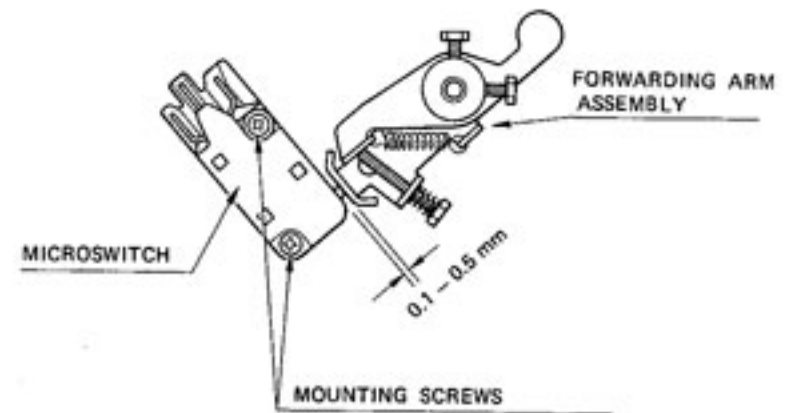

SCHEMATIC DIAGRAM

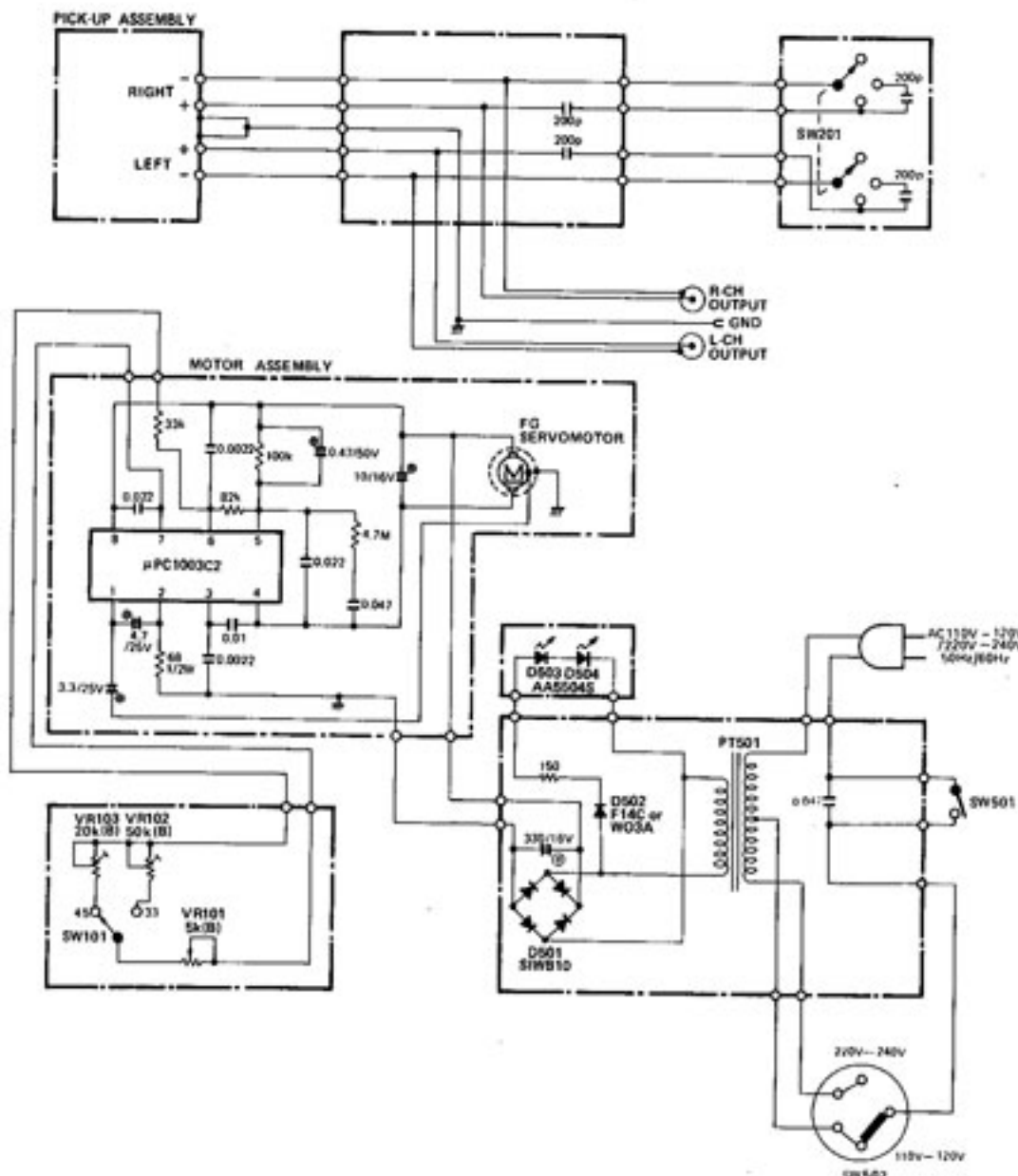

NOTES:

1. ALL RESISTANCES ARE 1/4 WATTS, UNLESS OTHERWISE NOTED, VALUES ARE IN Ω .
 $k\Omega = 1000\Omega$, $M\Omega = 1000K\Omega$
2. ALL CAPACITANCES VALUES ARE IN μF UNLESS OTHERWISE NOTED. $pF = \mu\mu F$

EXPLODED VIEW

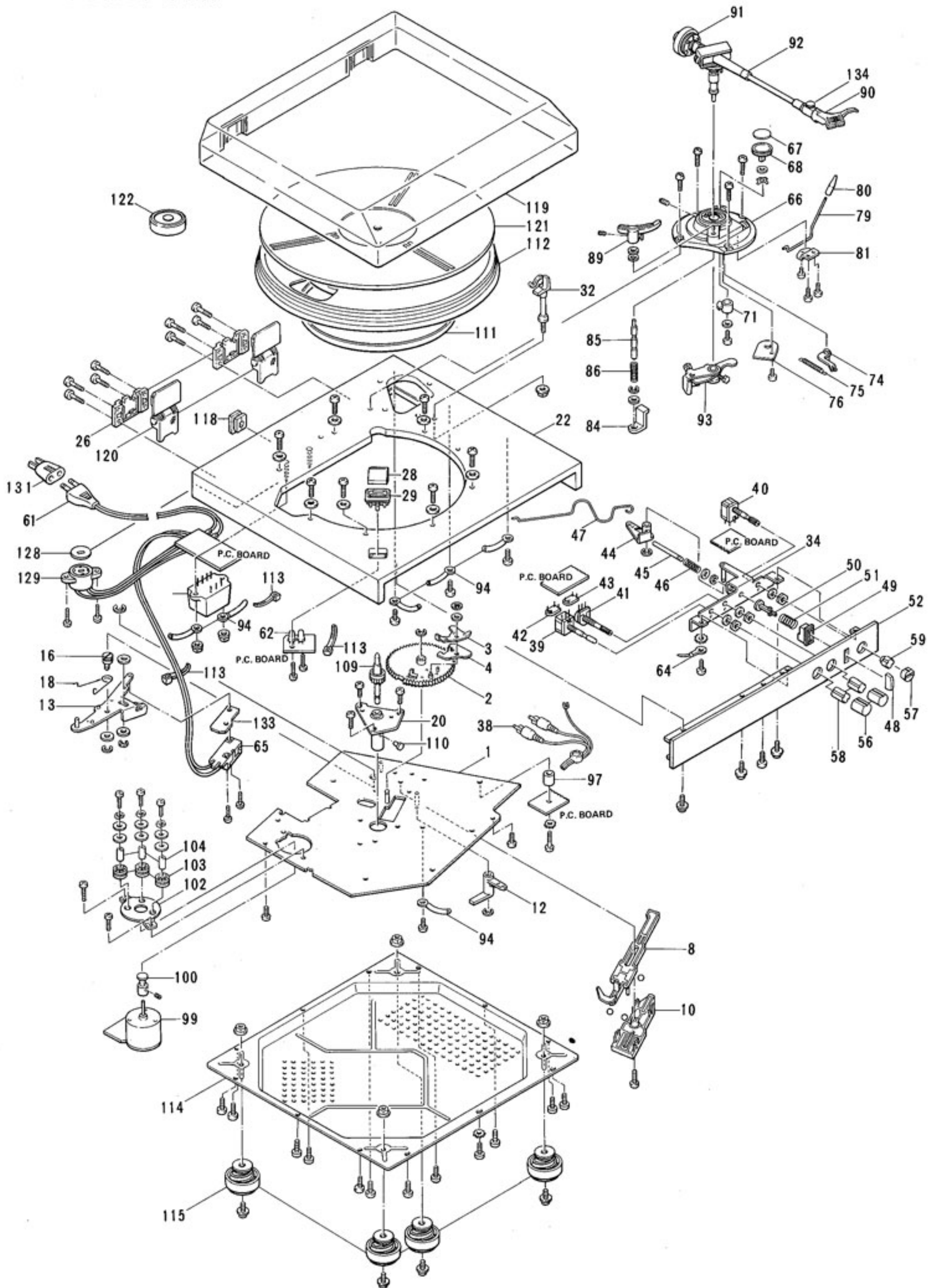

OVER-ALL PARTS LIST

Ref. No.	Part No.	Description
1	852265-2	Chassis Assembly
2	895248	Gear Assembly
3	894901	Clutch Plate
4	894902	Clutch Guide
8	870933-1	Actuating Arm
10	870932-1	Actuating Base
12	895431	Kick Lever
13	896487	Operating Plate Assembly
16	895073	Different Center Pin
18	895251	Spring
20	895092	Turntable Pillow Assembly
22	848242	Cabinet
26	895259	Lock Plate
28	896863-2	Prism
29	896864-5	Prism Holder
32	910742	Tone Arm Rest Assembly
34	872982	Switch Plate Assembly
38	870771	Phono Output Cord
39 (SW101)	910744	Rotary Switch, Speed Selector
40 (SW201)	910745	Rotary Switch, Cap. Trim
41 (VR101)	910746	Variable Resistor, 5 k ohm Speed Control
42 (VR102)	704825-11	Variable Resistor, 50 k ohm
43 (VR103)	704825-9	Variable Resistor, 20 k ohm
44	897574	Reject Lever
45	898534	Cut Shaft
46	832780-1	Elevation Spring
47	896722-4	Reject Spring
48	910724	Push Button, Cut
49	910725	Holder
50	910726	Shaft
51	910727	Spring
52	852367	Front Panel
56	910721	Knob, Speed Selector, Speed Control
57	910681	Knob, Cap. Trim
58	910722	Knob Base
59	910723	Knob Base
60 (PT501)	872292	Power Transformer
61	895617-2	AC Line Cord
62 (D503, 504)	910217	L.E.D.
64	910756	Lug Assembly
65 (SW501)	870270	Microswitch
66	851878-1	Pick-Up Base
67	896449-2	I.F.C. Mark
68	896450-1	I.F.C. Knob
71	871454	I.F.C. Boss
74	871455	I.F.C. Lever
75	896454	I.F.C. Spring
76	897596	I.F.C. Cover
79	872278	Cue Lever
80	896456	Cue Knob
81	897597	Lever Holder
84	897595	Cueing Arm
85	897622-1	Raising Spindle
86	832780	Raising Spring
89	910607	Raising Plate
90	852366S	Headshell
91	852366W	Counterweight

OVER-ALL PARTS LIST

Ref. No.	Part No.	Description
92	852366	Pick-Up Assembly (Includes: Headshell and Counter weight)
93	893583-3	Forwarding Arm Assembly
94	890755	Lug
97	E-832380-2	Spacer
99	705838	Motor Assembly
100	894021	Motor Pulley
102	893931	Motor Bracket
103	242020	Bushing
104	234971	Spacer
109	895047	Turntable Spindle Assembly
110	894271	Stopper
111	700515B	Belt
112	620021-1	Turntable
113	894408	Holder
114	852073-1	Cabinet Bottom
115	895773-7	Foot
118	871026	Bushing
119	852278-1	Dust Cover
120	898532-1	Hinge Assembly
121	873009-1	Turntable Mat
122	890876	EP Adaptor
128	911133	Plate
129 (SW502)	898256	Rotary Switch, Power Source Voltage Selector
131	894699	Adaptor, AC Plug
133	893803	Protector
134	852366A	Screw