

The Harman Kardon Model hk825 STEREO PREAMPLIFIER

Manual No. 64A

Technical Manual

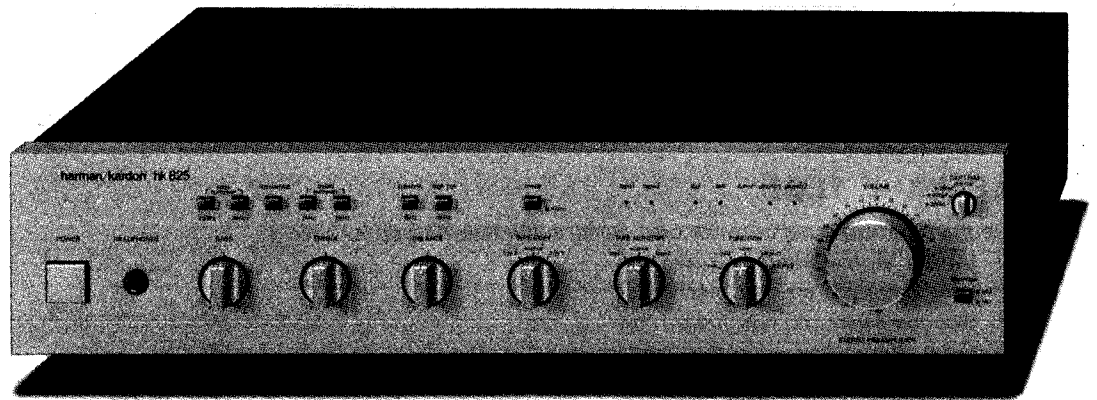

hk825

harman/kardon

240 CROSSWAYS PARK WEST, WOODBURY, N.Y. 11797
1112-H15264A9 P-08836 1250 PRINTED IN JAPAN

SPECIFICATIONS

	Nominal	Limit
Input Sensitivity/Impedance		
Phono (MM)	2.2mV/47kΩ	and 130pF
(MC)	130μV/56Ω	
Aux, Tuner, DAD, Tape	130mV/22kΩ	
Ham & Noise Ratio		
Phono (MM)	80dB	≥ 76dB
(MC)	74dB	≥ 70dB
Aux, Tuner, DAD, Tape	92dB	≥ 90dB
Signal-to Noise Ratio (IHF-A)		
Phono (MM)	84dB	≥ 80dB
(MC)	81dB	≥ 76dB
Aux, Tuner, DAD, Tape	94dB	≥ 90dB
Channel Separation		
Phono (MM)	57dB	≥ 50dB
(MC)	55dB	≥ 50dB
Aux, Tuner, DAD, Tape	59dB	≥ 50dB
Overload (20 ~ 20kHz)		
Phono (MM)	220mV	≥ 200mV
(MC)	12mV	≥ 5mV
Aux, Tuner, DAD, Tape	1.1V	≥ 0.75V

	Nominal	Limit
THD at 2V Output (1kHz)		
Phono (MM)	0.005%	≤ 0.01%
(MC)	0.008%	≤ 0.02%
Aux, Tuner, DAD, Tape	0.005%	≤ 0.01%
Frequency Response at -3dB	0.1Hz	~ 200kHz
Output Level		
Rated	1V	
Maximum	10V	
High Cut Filter at 6kHz	-3dB	± 1dB
Subsonic Filter at 15Hz	-3dB	± 1dB
Tone Control Characteristics		
Bass at 50Hz		
Boost	10dB	± 2dB
Cut	10dB	± 2dB
Treble at 10kHz		
Boost	10dB	± 2dB
Cut	10dB	± 2dB
Dimensions (W x H x D)	443 x 103 x 351	mm
Weight	5.8	kg
Power Supply	AC 120V, 60Hz	
Power Consumption	45W	

This specification is the target of servicing. But, there is a case that the specification is not applicable to the measurement condition and instrument.

Specifications and components subject to change without notice. Overall performance will be maintained or improved.

LEAKAGE TEST

Before returning the unit to the user, perform the following safety checks:

1. Inspect all lead dress to make certain that leads are not pinched or that hardware is not lodged between the chassis and other metal parts in the unit.
2. Be sure that any protective devices such as nonmetallic control knobs, insulating fishpapers, cabinet backs, adjustment and compartment covers or shields, isolation resistor-capacity networks, mechanical insulators, etc. which were removed for servicing are properly reinstalled.
3. Be sure that no shock hazard exists; check for leakage current using Simpson Model 229 Leakage Tester, standard equipment item No. 21641, RCA Model WT540A or use alternate method as follows:
 Plug the AC line cord directly into a 120-volt AC receptacle (do not use an Isolation Transformer for this test). Using two clip leads, connect a 1500 ohm, 10-watt resistor paralleled by a 0.15mf capacitor, in series with all exposed metal cabinet parts and a known earth ground, such as a water pipe or conduit. Use a VTVM or VOM with 1000 ohms per volt, or higher, sensitivity to measure the AC voltage drop across the resistor. (See Diagram.) Move the resistor connection to each exposed metal part having a return path to the chassis (antenna, metal, cabinet, screw heads, knobs and control shafts, escutcheon, etc.) and measure the AC voltage drop across the resistor. (This test should be performed with the power switch in both the On and Off positions.)
 A reading of 0,35 volt RMS or more is excessive and indicates a potential shock hazard which must be corrected before returning the unit to the owner.

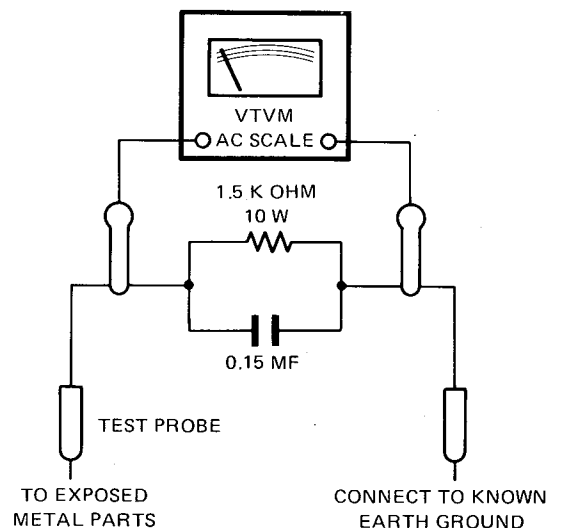
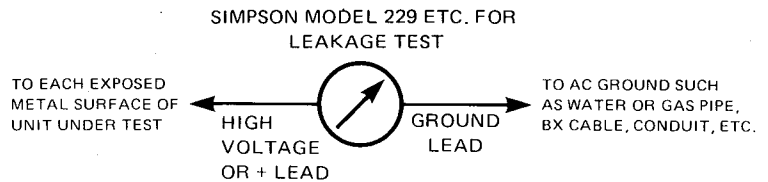

DISASSEMBLY PROCEDURES (REFER TO PAGES 4 AND 10)

1 CABINET TOP REMOVAL

Remove 6 screws (A) and remove the cabinet top.

2 FRONT PANEL ASSEMBLY (101) REMOVAL

1. Remove the cabinet top. (Refer to step 1.)
2. Remove 6 screws (B) and remove the front panel assembly with push button assemblies (104, 105).

3 POWER INDICATOR AND TAPE MONITOR & FUNCTION INDICATORS P.C. BOARDS (PCB-6 AND PCB-4) REMOVAL

1. Remove the front panel assembly. (Refer to step 2.)
2. Straighten the parts (C) of the metal fixture and remove the power indicator P.C. board (PCB-6). If necessary, unsolder the leads.
3. Disconnect J104 and J105 from P104 and P105 on the equalizer P.C. board (PCB-2).
4. Straighten the parts (D) of the metal fixture and remove the tape monitor & function indicators P.C. board (PCB-4).

4 TONE SELECTOR P.C. BOARD (PCB-3) REMOVAL

1. Remove the front panel assembly. (Refer to step 2.)
2. Remove 3 screws (E) then disconnect J106 and J107 from P106 and P107 on the equalizer P.C. board (PCB-2), and disconnect J501, J502, J503 and J504 from P501, P502, P503 and P504 on the tone amp. P.C. boards (PCB-1). Completely separate tone selector P.C. board (PCB-3) from the remaining assemblies.

5 TONE AMP. P.C. BOARD (PCB-1) REMOVAL

1. Remove the power indicator and tone selector P.C. boards (PCB-6 and PCB-3). (Refer to steps 3 and 4.)

2. Loosen 3 screws (F) fixing Bass, Treble and Balance knobs (154) and remove them.
3. Remove 21 screws (G) and remove cabinet back assembly (102) with rotary switch (SW2). If necessary, unsolder the leads.
4. Disconnect J101, J102 and J103 from P101, P102 and P103 on the equalizer P.C. board (PCB-2).
5. Remove a hexagon nut (H) mounting the headphone jack P.C. board (PCB-5).
6. Remove 9 screws (I) and 3 hexagonal nuts (J), and remove the tone amp. P.C. board (PCB-1) backward. If necessary, unsolder the leads.

6 EQUALIZER P.C. BOARD (PCB-2) REMOVAL

1. Remove the tape monitor & function indicators and tone selector P.C. boards (PCB-4 and PCB-3). (Refer to step 3 and 4.)
2. Loosen 3 screws (K) fixing Tape Copy, Tape Monitor and Function knobs (154) and remove them.
3. Loosen 6 screws (L) and remove 3 E-stop rings (M) fixing shafts (193). Slide the joints (191) forward then remove shafts (193) backward.
4. Pull off Volume and Cap. Trim knobs (103 and 155).
5. Remove 2 hexagon nuts (N) fixing the cap. trim P.C. board (PCB-8) and volume control P.C. board (PCB-7).
6. Remove the cabinet back assembly (102) with rotary switch (SW2). (Refer to step 5.)
7. Disconnect J101, J102 and J103 from P101, P102 and P103 on the equalizer P.C. board (PCB-2).
8. Remove 6 screws (O) and 2 screws (P) mounting the equalizer P.C. board (PCB-2) and remove it.

BLOCK DIAGRAM

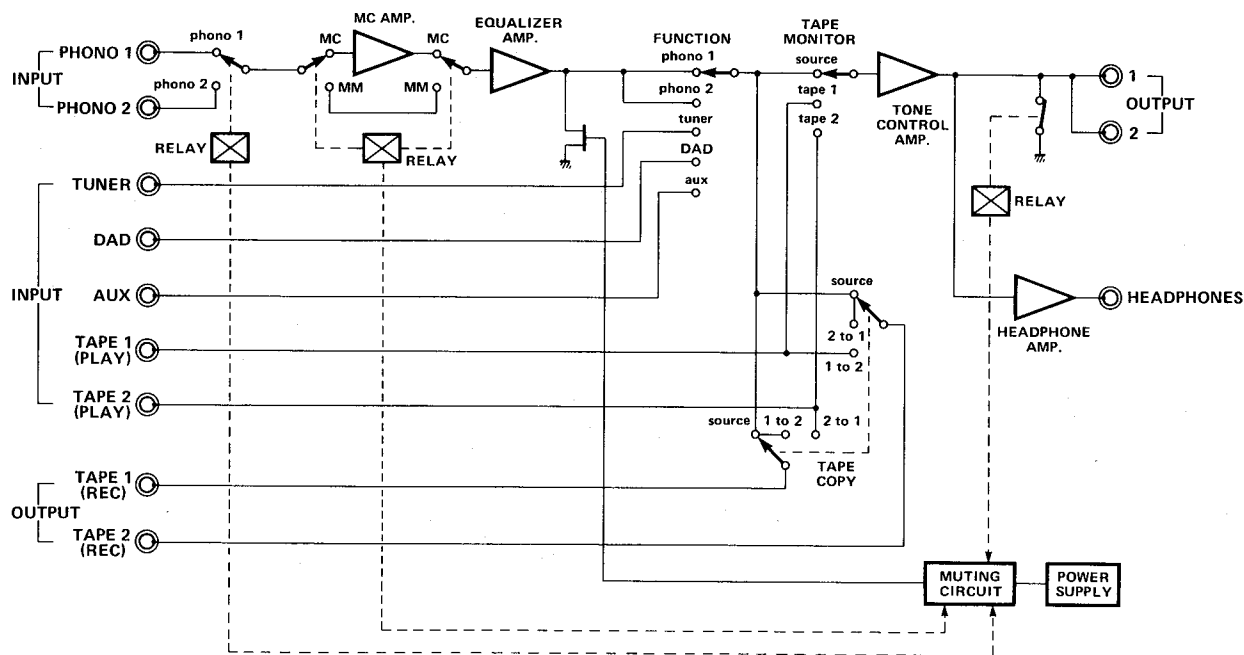

CIRCUIT DESCRIPTION

• POWER ON MUTING

After the power switch is set to on, Q31, Q11, Q12, Q14 and Q15 stay off until C14, C15 and C16 are charged up and Q28 becomes on and Q29 (Lch) and Q30 (Rch) become on. Muting operation is completed.

GENERAL UNIT EXPLODED VIEW

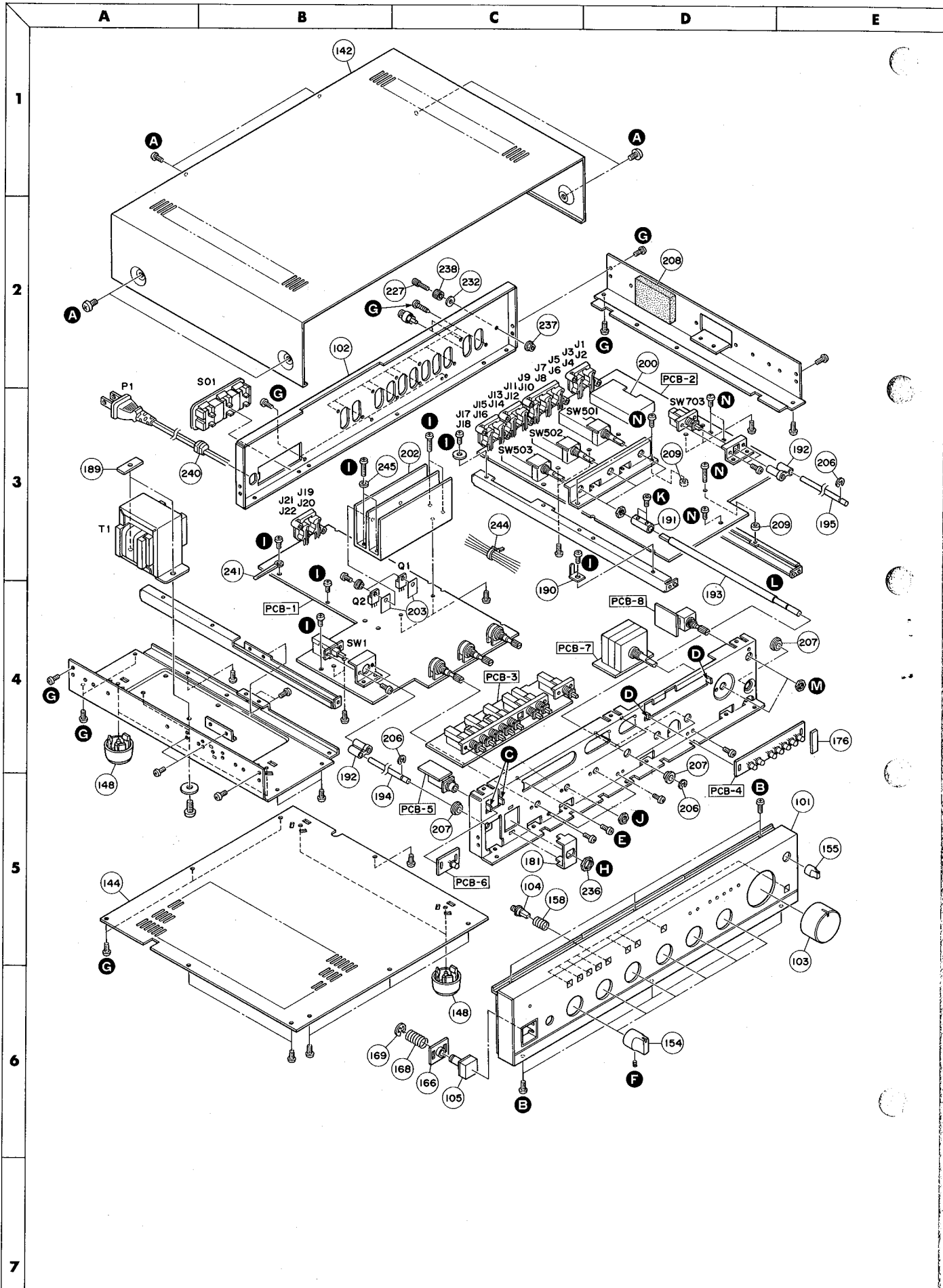

GENERAL UNIT PARTS LIST

Ref. No.	Part No.	Description
101	A443-HK825A	Front Panel Assembly
102	A424-HK825A	Cabinet Back Assembly
"	A424-HK825D	Cabinet Back Assembly (for Canada model)
103	A630-HK825A	Knob Assembly, Volume
104	A662-HK825A	Push Button Assembly, Bass Turnover, Tone Defeat, Treble Turnover, Subsonic, High Cut, Mode, Cartridge
105	A660-HK825A	Push Button Assembly, Power
142	1414-04001	Cabinet Top
144	1423-02001	Cabinet Bottom
148	1319-0139	Foot
154	1634-04401	Knob, Bass, Treble, Balance, Tape Copy, Tape Monitor, Function
155	1634-04501	Knob, Cap. Trim
158	2651-210189	Spring
166	2240-7210	Holder
168	2651-2101706	Spring
169	2461-701	E-Stop Ring
176	2111-11760	Felt
181	2219-7879	Bracket
189	2219-7093	Bracket
190	2219-7945	Bracket
191	2601-7069	Joint
192	2601-7084	Joint
193	2601-7119	Shaft
194	2601-7120	Shaft
195	2601-7121	Shaft
200	2240-7183	Holder
202	2222-7150	Heat Sink
203	2224-7071	Insulator
206	2461-401	E-Stop Ring
207	2410-100	Special Washer
208	2132-7109	Spacer
209	2132-7016	Spacer
227	2310-7015	Special Screw
232	2410-7005	Special Washer
236	2440-61	Special Nut
237	2440-7016	Special Nut
238	2440-7011	Special Nut
240	2114-415027	Bushing
241	2218-7001	Holding Bracket
244	2240-7120	Holder
245	2114-71259	Bushing
	2211-7248	Chassis, T1
	2211-7251	Chassis, Right
	2211-7247	Chassis, Front
	2219-7880	Bracket, PCB-2 Mounting
	2219-7928	Bracket, PCB-1 Mounting
	2219-7929	Bracket, SW703
	2219-7930	Bracket, SW501, 502, 503
	2219-7931	Bracket, PCB-1 Mounting
	2219-7932	Bracket, PCB-1 & 2 Mounting
	2219-7941	Bracket, SW1
	1111-J30141	Owner Guide
	1111-J30142	Owner Guide (for Canada model)
	1221-767144	Carton Box
	1222-7216	Cushion (2 Used)
	1191-1	Hexagon Headed Wrench (Accessory)

ELECTRICAL PARTS LIST

Ref. No.	Part No.	Description
CHASSIS MISCELLANEOUS		
P1	4161-71151	Power Cord
T1	5584-701430	Power Transformer
SO1	4474-156	AC Outlet, Switched, Unswitched
	4161-7185	Connection Cord (Accessory)
	4442-14	Short-pin Plug (Accessory)
PCB 1 TONE AMP. P.C. BOARD		
RESISTORS		
R1, 2, 3, 4	5102-3314713	330 Ω , \pm 2%, 1/4W, Fuse
R5, 11	5102-1804715	18 Ω , \pm 2%, 1/4W, Fuse
R16	5102-2204713	22 Ω , \pm 2%, 1/4W, Fuse
R73	5134-100J25P	10 Ω , \pm 5%, 1/4W, Carbon
R539, 540	5102-4704713	47 Ω , \pm 2%, 1/4W, Fuse
R541, 542	5102-4704715	47 Ω , \pm 2%, 1/4W, Fuse
CONTROLS		
VR502	5113-10493122	100k Ω C, Bass (w/Hexagon Nut)
VR503	5113-50394122	50k Ω C, Treble (w/Hexagon Nut)
VR504	5113-10495122	100k Ω M/N, Balance (w/Hexagon Nut)
CAPACITORS		
C1	5352-1030959	0.01 μ F, \pm 20%, AC125V, Metalized Polyester
C2, 3	5352-1041957	0.1 μ F, \pm 10%, 250V, Metalized Polyester
C4, 5	5341-478F0955	4700 μ F, \pm 20%, 50V, Electrolytic
C6, 7	5345-227E0226	220 μ F, \pm 20%, 35V, Electrolytic
C8, 9	5345-477E0226	470 μ F, \pm 20%, 35V, Electrolytic
C10, 11, 12, 13	5345-107C041	100 μ F, \pm 20%, 16V, Electrolytic
C14, 16, 38, 40, 41	5345-106C0951	10 μ F, \pm 20%, 16V, Electrolytic
C15	5345-476C0951	47 μ F, \pm 20%, 16V, Electrolytic
C32, 33	5345-226C0951	22 μ F, \pm 20%, 16V, Electrolytic
C31	5345-227F041	220 μ F, \pm 20%, 50V, Electrolytic
C34	5345-226C041	22 μ F, \pm 20%, 16V, Electrolytic
C401, 402, 403, 404	5345-107C041	100 μ F, \pm 20%, 16V, Electrolytic
C405, 406	5345-227C041	220 μ F, \pm 20%, 16V, Electrolytic
C407, 408	5345-227A041	220 μ F, \pm 20%, 6.3V, Electrolytic
C505, 506	5359-2715851	270pF, \pm 5%, 100V, Polypropylene
C507, 508	5353-120533	12pF, \pm 5%, 500V, Mica
C509, 510, 511, 512	5359-1015851	100pF, \pm 5%, 100V, Polypropylene
C513, 514	5345-106C0226	10 μ F, \pm 20%, 16V, Electrolytic
C515, 516	5353-820533	82pF, \pm 5%, 500V, Mica
C517, 518, 519, 520	5345-227B0226	220 μ F, \pm 20%, 10V, Electrolytic
C521, 522, 523, 524	5345-227D0226	220 μ F, \pm 20%, 25V, Electrolytic
C525, 526, 547, 548	5345-476C0226	47 μ F, \pm 20%, 16V, Electrolytic
C549, 550	5353-010533	1pF, \pm 5%, 500V, Mica
TRANSISTORS		
Q1	5612-596(Y)	2SB596(Y) (w/Insulator & Bushing)
Q2	5614-526(Y)	2SD526(Y) (w/Insulator & Bushing)
Q3, 4, 401, 402	5616-2SK186(C)	F.E.T., 2SK186(C)
Q5, 12, 13, 15, 27, 403, 404, 405, 406, 407, 408	5613-2603(F)	2SC2603(F)
Q6, 11, 14, 26, 31, 409, 410	5611-1115(F)	2SA1115(F)
Q7, 10, 413, 414, 519, 520	5614-667(C)	2SD667(C)
Q8, 411, 412, 521, 522	5612-647(C)	2SB647(C)
Q501, 502, 503, 504	5613-2240(BL)	2SC2240(BL)
Q505, 506, 507, 508, 509, 510	5613-2320L(F)	2SC2320L(F)
Q511, 512, 513, 514	5611-999L(F)	2SA999L(F)
Q515, 516	5612-646(C)	2SB646(C)
Q517, 518	5614-666(C)	2SD666(C)
DIODES		
D1, 2, 3, 4, 44	5632-10DF2	10DF2
D5, 6	5635-HZ20-2L	Zener, HZ20-2L
D7, 8	5635-HZ24-2L	Zener, HZ24-2L
D9, 10, 11	5635-HZ15-2L	Zener, HZ15-2L
D13, 14	5631-1S2471	1S2471
D15	5635-RD5R1JB1	Zener, RD5.1JB1
D16, 30, 43, 45	5631-1S2473	1S2473
D401, 402, 403, 404, 405, 406, 501, 502	5636-1S2473	1S2473
D503, 504	5641-MV5T	Varistor, MV5T

Ref. No.	Part No.	Description
	COILS	
L1/SW507	4331-2012726	Relay
L6	5597-45502	Ferrite Bead
	MISCELLANEOUS	
F1, 2	5732-162031	Fuse, 1.6A, 125V
SW1	4431-A01716	Push Switch, Power
P501, 503	4443-060177	Connector, 6 Pos.
P502, 504	4443-030177	Connector, 3 Pos.
J19/20/21/22	4484-36	4-Pin Jack, Output 1/2
J101	4163-031001	Connector with Lead Wire, 3 Pos.
J102	4163-050601	Connector with Lead Wire, 5 Pos.
J103	4163-060601	Connector with Lead Wire, 6 Pos.
J108	4163-040601	Connector with Lead Wire, 4 Pos.
	4472-7122	Fuse Holder (x 4)
	2132-5049	Spacer, R539, R540, D7, D8
	2132-7049	Spacer, R6, R7, R8, R12, R13, R14
PCB-2 EQUALIZER P.C. BOARD		
	RESISTORS	
R721, 722	5174-751381	750 Ω , \pm 1%, 1/4W, Metal
R723, 724	5174-102381	1k Ω , \pm 1%, 1/4W, Metal
R737, 738, 739, 740	5174-334381	330k Ω , \pm 1%, 1/4W, Metal
R741, 742	5174-103381	10k Ω , \pm 1%, 1/4W, Metal
R743, 744	5174-122381	1.2k Ω , \pm 1%, 1/4W, Metal
R755, 756	5174-Z511328	511k Ω , \pm 1%, 1/4W, Metal
R757, 758	5174-Z392228	39.2k Ω , \pm 0.5%, 1/4W, Metal
R759, 760, 761, 762	5102-4704715	47 Ω , \pm 2%, 1/4W, Fuse
	CAPACITORS	
C17, 18	5345-106C0951	10 μ F, \pm 20%, 16V, Electrolytic
C19, 20	5345-154F0952	0.15 μ F, \pm 20%, 50V, Electrolytic
C21, 22, 23, 24, 29, 30	5345-225F0952	2.2 μ F, \pm 20%, 50V, Electrolytic
C25, 26, 27, 28	5345-334F0952	0.33 μ F, \pm 20%, 50V, Electrolytic
C39	5353-680533	68pF, \pm 5%, 500V, Mica
C601, 602, 723, 724, 725, 726	5345-107C0226	100 μ F, \pm 20%, 16V, Electrolytic
C603, 604	5353-680533	68pF, \pm 5%, 500V, Mica
C605, 606, 607, 608	5345-106F0226	10 μ F, \pm 20%, 50V, Electrolytic
C705, 706	5359-3315851	330pF, \pm 5%, 100V, Polypropylene
C707, 708	5345-476C0226	47 μ F, \pm 20%, 16V, Electrolytic
C709, 710	5359-1215851	120pF, \pm 5%, 100V, Polypropylene
C711, 712	5359-1015851	100pF, \pm 5%, 100V, Polypropylene
C713, 714	5345-477B0226	470 μ F, \pm 20%, 10V, Electrolytic
C715, 716, 721, 722, 741, 742	5345-106C0226	10 μ F, \pm 20%, 16V, Electrolytic
C717, 718	5359-8225851	8200pF, \pm 5%, 100V, Polypropylene
C719, 720	5352-2235957	0.022 μ F, \pm 5%, 250V, Metalized Polyester
C727, 728	5359-2225851	2200pF, \pm 5%, 100V, Polypropylene
C729, 730, 735, 736	5359-2215851	220pF, \pm 5%, 100V, Polypropylene
C731, 732	5359-5625851	5600pF, \pm 5%, 100V, Polypropylene
C733, 734	5359-1825851	1800pF, \pm 5%, 100V, Polypropylene
C737, 738, 739, 740	5345-477D0226	470 μ F, \pm 20%, 25V, Electrolytic
	INTEGRATED CIRCUITS	
IC1, 2	5654-TC4049BP	TC4049BP
	TRANSISTORS	
Q9, 16, 17, 22, 23, 24, 25	5613-2603(F)	2SC2603(F)
Q18, 19, 20, 21, 723, 724	5614-667(C)	2SD667(C)
Q28	5611-1115(F)	2SA1115(F)
Q29, 30	5616-2SK186(C)	F.E.T., 2SK186(C)
Q601, 602, 607, 608, 721, 722	5611-1190(E)	2SA1190(E)
Q603, 604, 605, 606	5613-2855(D)	2SC2855(D)
Q701, 702, 703, 704	5613-2240(BL)	2SC2240(BL)
Q705, 706, 707, 708, 709, 710	5613-2320L(F)	2SC2320L(F)
Q711, 712, 713, 714	5611-999L(F)	2SA999L(F)
Q715, 716	5612-646(C)	2SB646(C)
Q717, 718	5614-666(C)	2SD666(C)
Q719, 720	5613-2855(E)	2SC2855(E)
Q725, 726	5612-647(C)	2SB647(C)

Ref. No.	Part No.	Description
DIODES		
D17, 18, 19, 20, 21, 22, 23, 24, 25, 26, 27, 28, 29, 33, 39, 40, 41, 42, 701, 702	5631-1S2473	1S2473
D601, 602	5635-HZ15-2L	Zener, HZ15-2L
D703, 704	5641-MV5T	Varistor, MV5T
D705, 706	5641-MV5W	Varistor, MV5W
COILS		
L2/3/SW701, L4/5/SW702	4331-40247115	Relay
L601, 602	5597-45502	Ferrite Bead
MISCELLANEOUS		
SW501	4412-045742	Rotary Slide Switch, Function (w/Hexagon Nut)
SW502, 503	4412-043732	Rotary Slide Switch, Tape Monitor, Tape Copy (w/Hexagon Nut)
SW703	4431-A027610	Push Switch, Cartridge
P101	4443-030177	Connector, 3 Pos.
P102, 105	4443-050177	Connector, 5 Pos.
P103	4443-060177	Connector, 6 Pos.
P104, 106, 107, 108	4443-040177	Connector, 4 Pos.
J1/2/3/4	4484-36	4-Pin Jack, Phono 1/2
J5/6/7/8/9/10	4486-9	6-Pin Jack, Tuner, DAD, Aux
J11/12/13/14, 15/16/17/18	4484-31	4-Pin Jack, Tape 1/2 (Play), Tape 1/2 (Rec.)
J104	4163-043001	Connector with Lead Wire, 4 Pos.
J105	4163-053001	Connector with Lead Wire, 5 Pos.
PCB-3 TONE SELECTOR P.C. BOARD		
RESISTORS		
R547, 548	5174-302381	3k Ω , \pm 1%, 1/4W, Metal
CAPACITORS		
C501, 502	5352-4741957	0.47 μ F, \pm 10%, 250V, Metalized Polyester
MISCELLANEOUS		
SW504/505/506/508/509	4431-0720713	Push Switch, Bass Turnover, Treble Turnover, Tone Defeat, Subsonic, High Cut
SW510	4431-A047510	Push Switch, Mode
J106, 107	4163-041001	Connector with Lead Wire, 4 Pos.
J501, 503	4163-061001	Connector with Lead Wire, 6 Pos.
J502, 504	4163-031001	Connector with Lead Wire, 3 Pos.
PCB-4 TAPE MONITOR & FUNCTION INDICATORS P.C. BOARD		
CAPACITORS		
C36, 37	5345-106C0226	10 μ F, \pm 20%, 16V, Electrolytic
DIODES		
D31, 32, 34, 35, 36, 37, 38	5637-GL5HD10	L.E.D., GL5HD10, Red, Tape 2, Tape 1, Phono 2, Phono 1, Tuner, DAD, Aux
PCB-5 HEADPHONE JACK P.C. BOARD		
J401	4451-00139	Jack, Headphones
PCB-6 POWER INDICATOR P.C. BOARD		
CAPACITORS		
C35	5345-106C0226	Capacitor, 10 μ F, \pm 20%, 16V, Electrolytic
D12	5637-GL5HD10	L.E.D., GL5HD10, Red, Power
PCB-7 VOLUME CONTROL P.C. BOARD		
VR501	5118-303731	Control, 30k Ω , Volume (w/Hexagon Nut)
PCB-8 CAP. TRIM P.C. BOARD		
CAPACITORS		
C701, 702	5359-5115851	510pF, \pm 5%, 100V, Polypropylene
C703, 704	5359-1515851	150pF, \pm 5%, 100V, Polypropylene
MISCELLANEOUS		
SW704	4411-204723	Rotary Switch, Cap. Trim (w/Hexagon Nut)

SCHEMATIC DIAGRAM

MC AMP.

EQUALIZER AMP.

MC AMP.

EQUALIZER AMP.

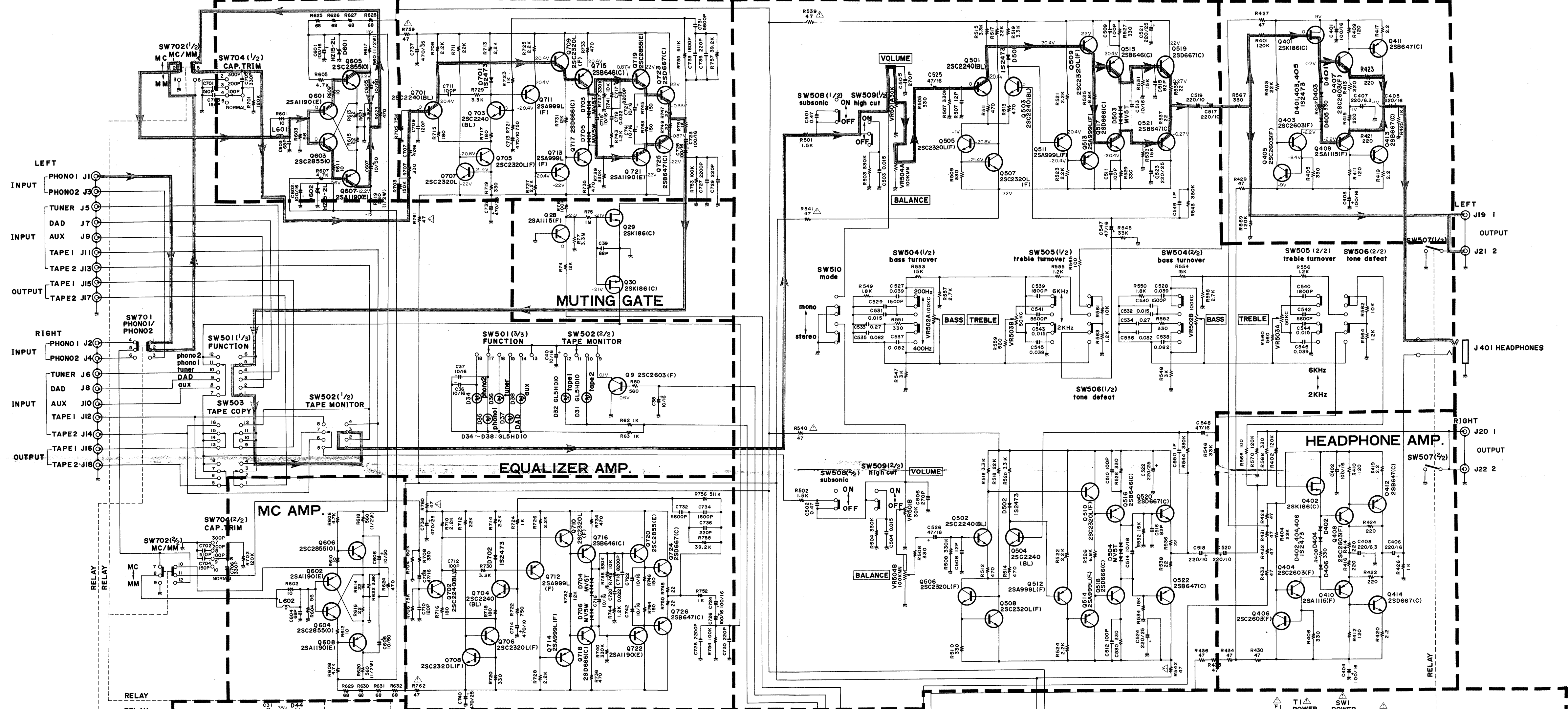

MC AMP.

EQUALIZER AMP.

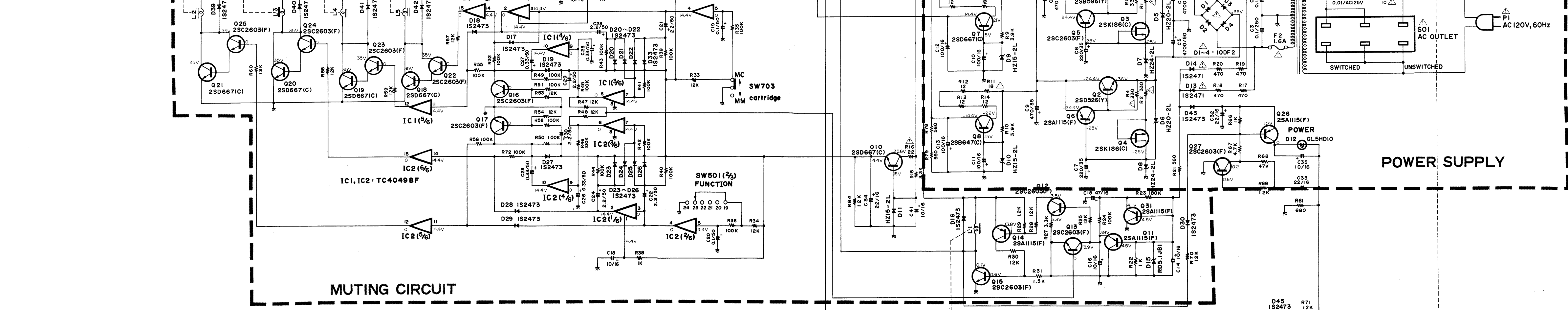

IC FUNCTIONAL BLOCK DIAGRAM

TC4049BP : IC1, 2

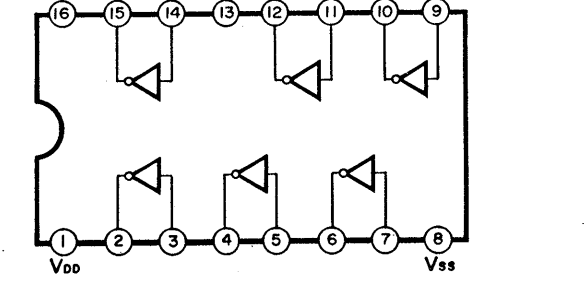

1. ALL RESISTANCE VALUES ARE IN Ω .
K Ω =1000 Ω , M Ω =1000K Ω .
2. THE WATTAGE OF RESISTORS IS 1/4W UNLESS OTHERWISE NOTED.
3. ALL CAPACITANCE VALUES ARE IN μ F UNLESS OTHERWISE NOTED. P μ =pF
AND ALL ELECTRICAL CAPACITANCE VOLTAGE VALUES ARE GIVEN WITHOUT UNIT.
THE OMITTED UNIT IS V. 47/50 \rightarrow 47pF/50V
4. V: DC VOLTAGE AT NO SIGNAL.
5. Δ SAFETY-REQUIREMENTS COMPONENTS IN ACCORDANCE WITH PRESENT SAFETY REGULATIONS. THESE COMPONENTS MUST ONLY BE REPLACED BY ORIGINAL PARTS.

A B C D
SCHEMATIC DIAGRAM

MC AMP.

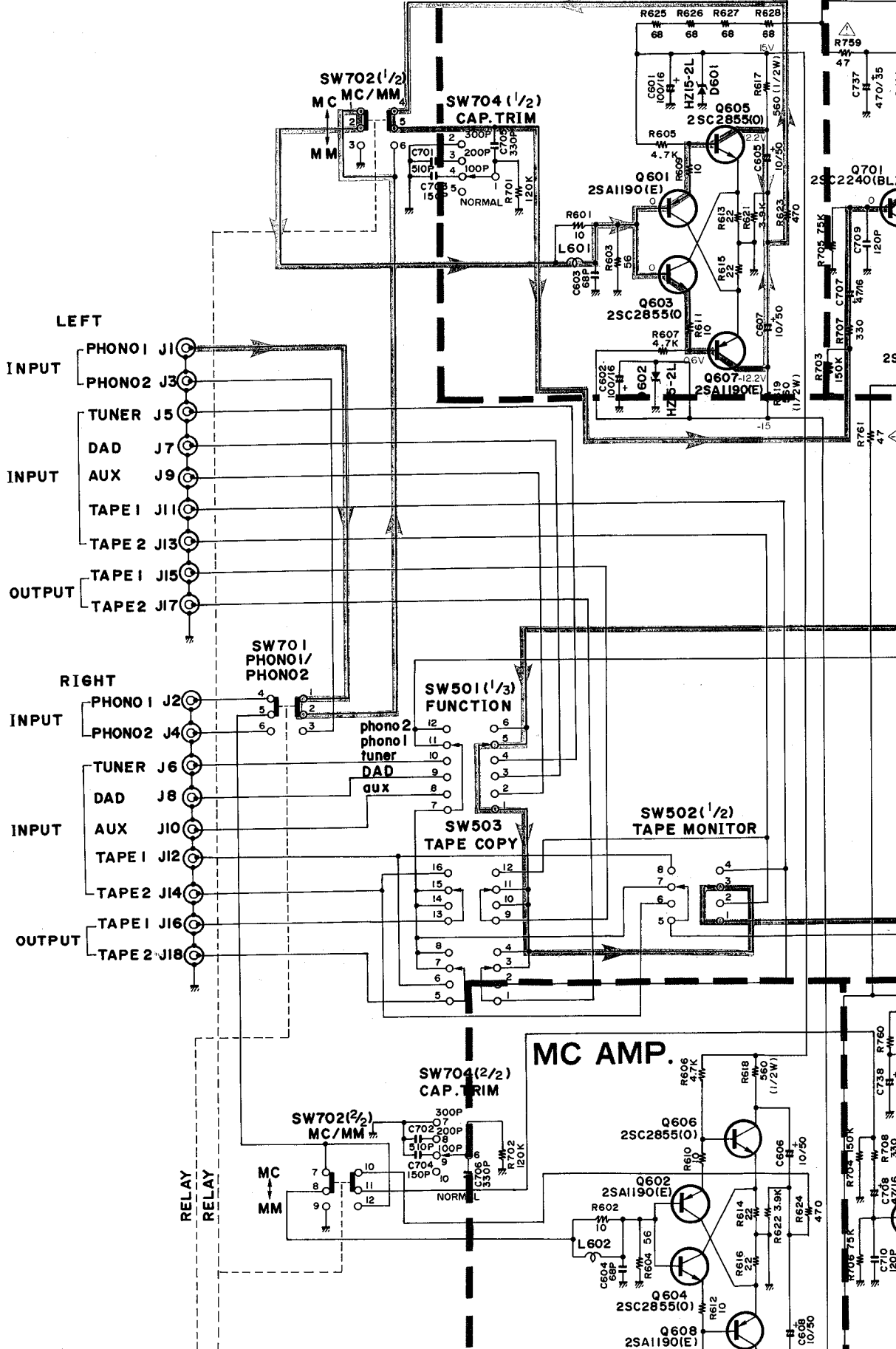

MC AMP.

EQUALIZER AMP.

TO

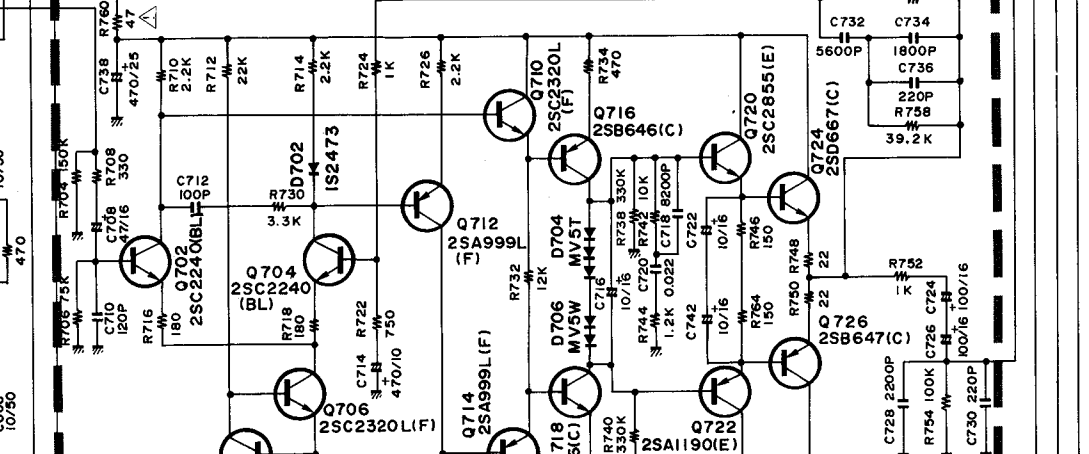
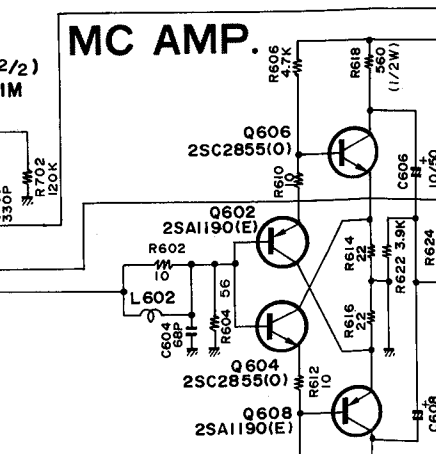
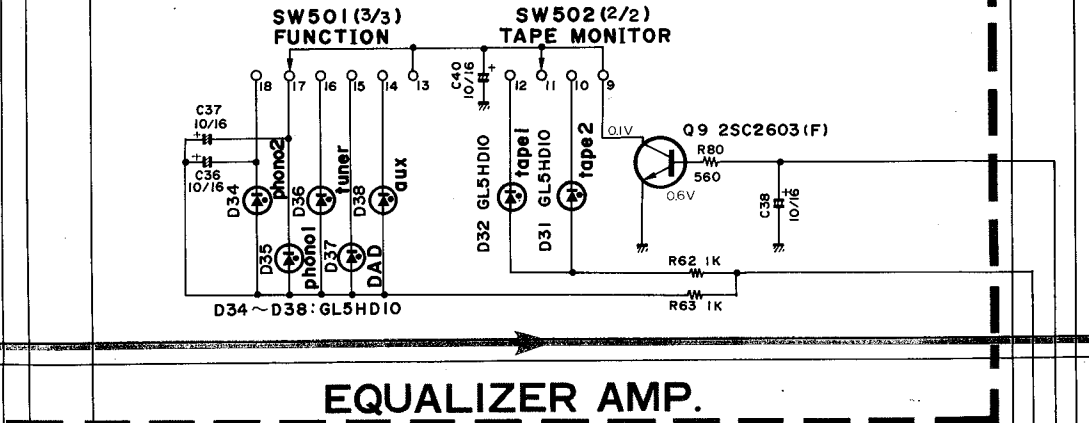
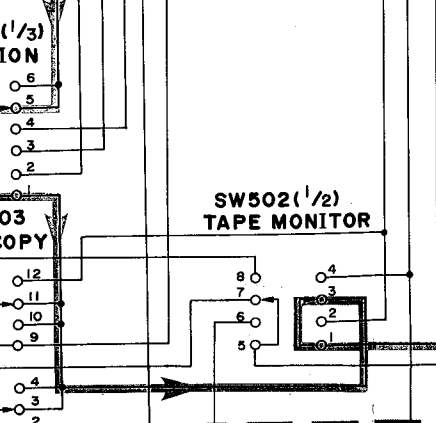
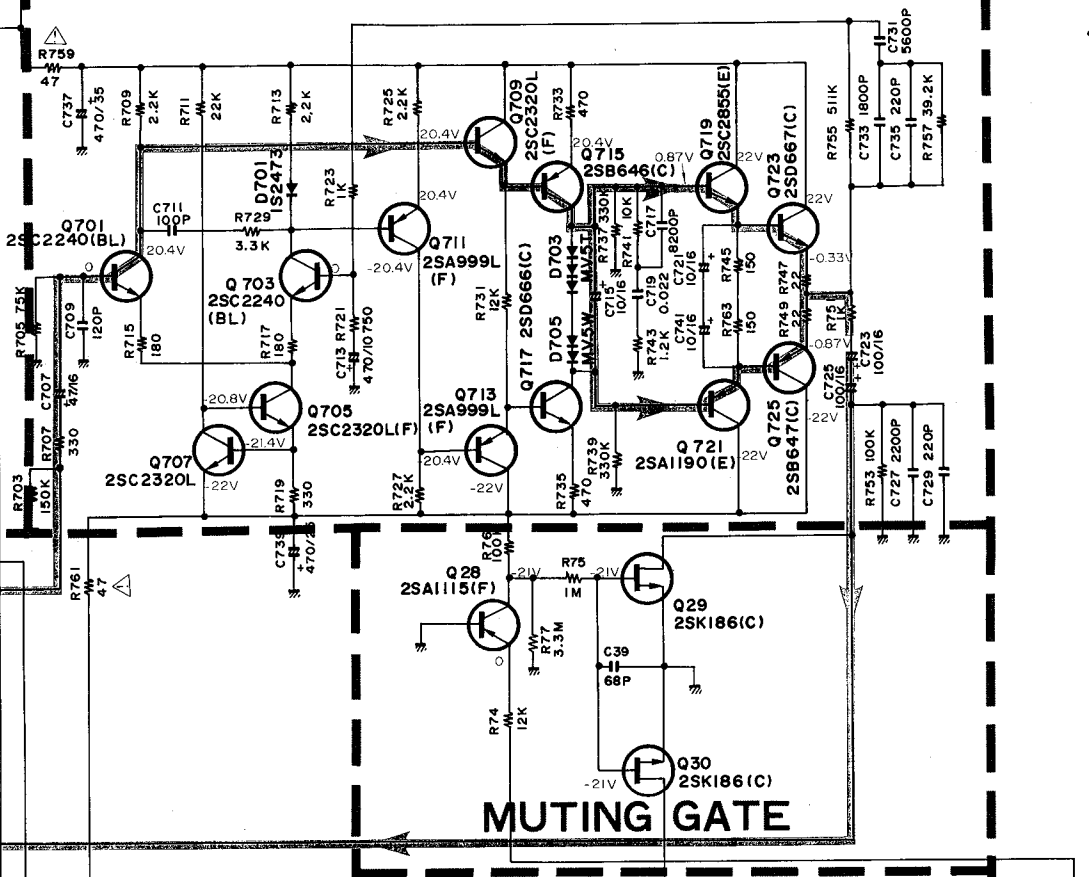
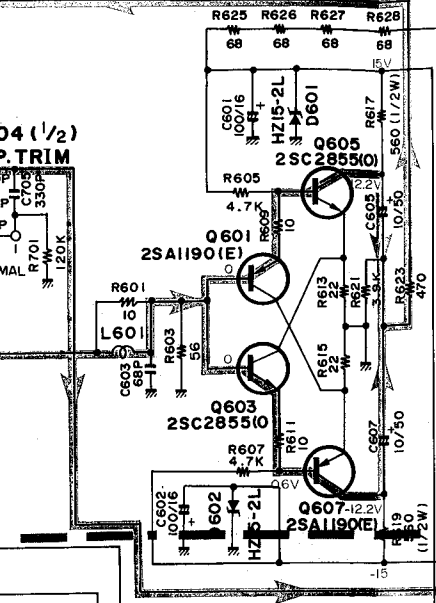

tone control circuit

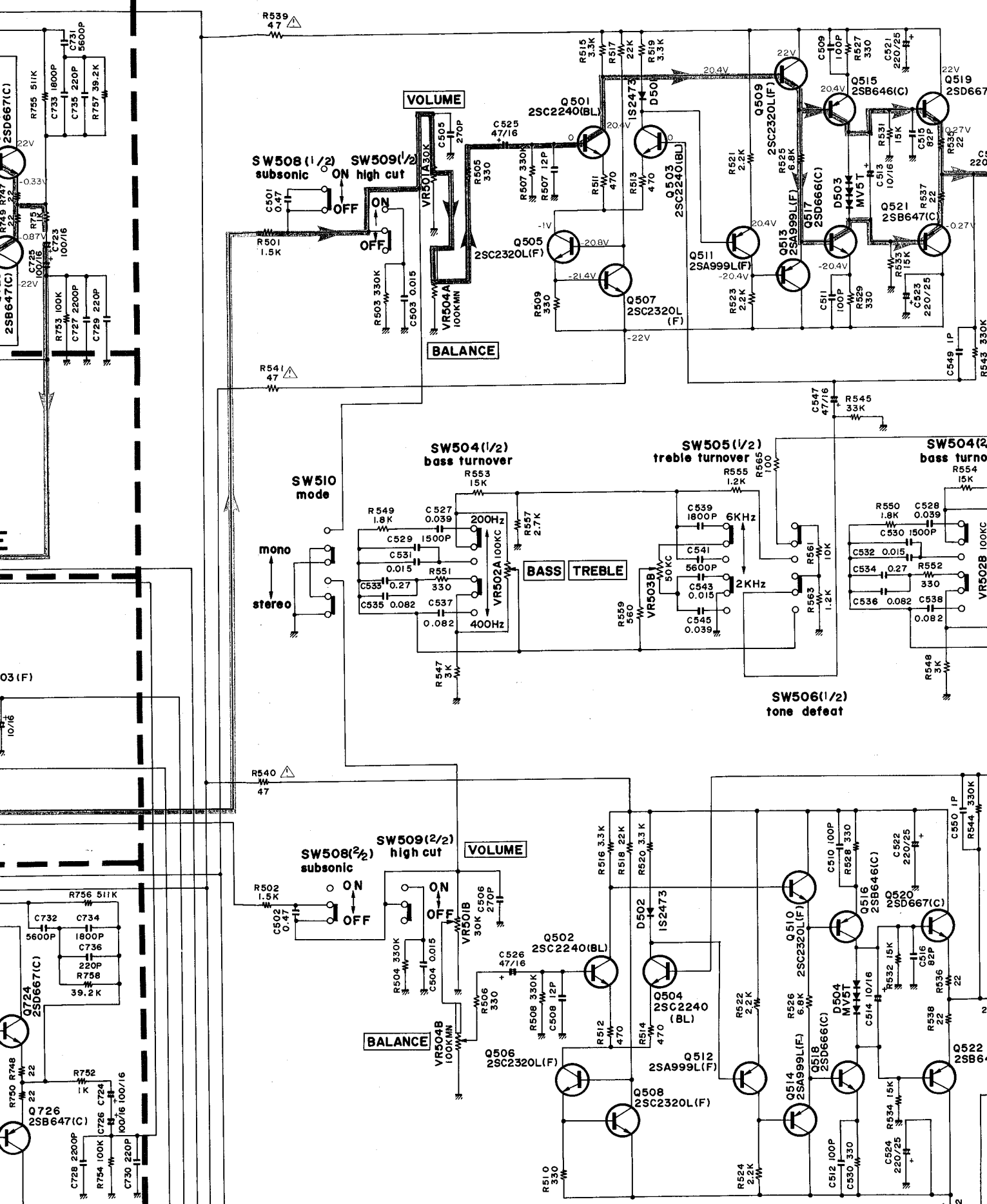

K

L

M

N

HEADPHONE AMP.

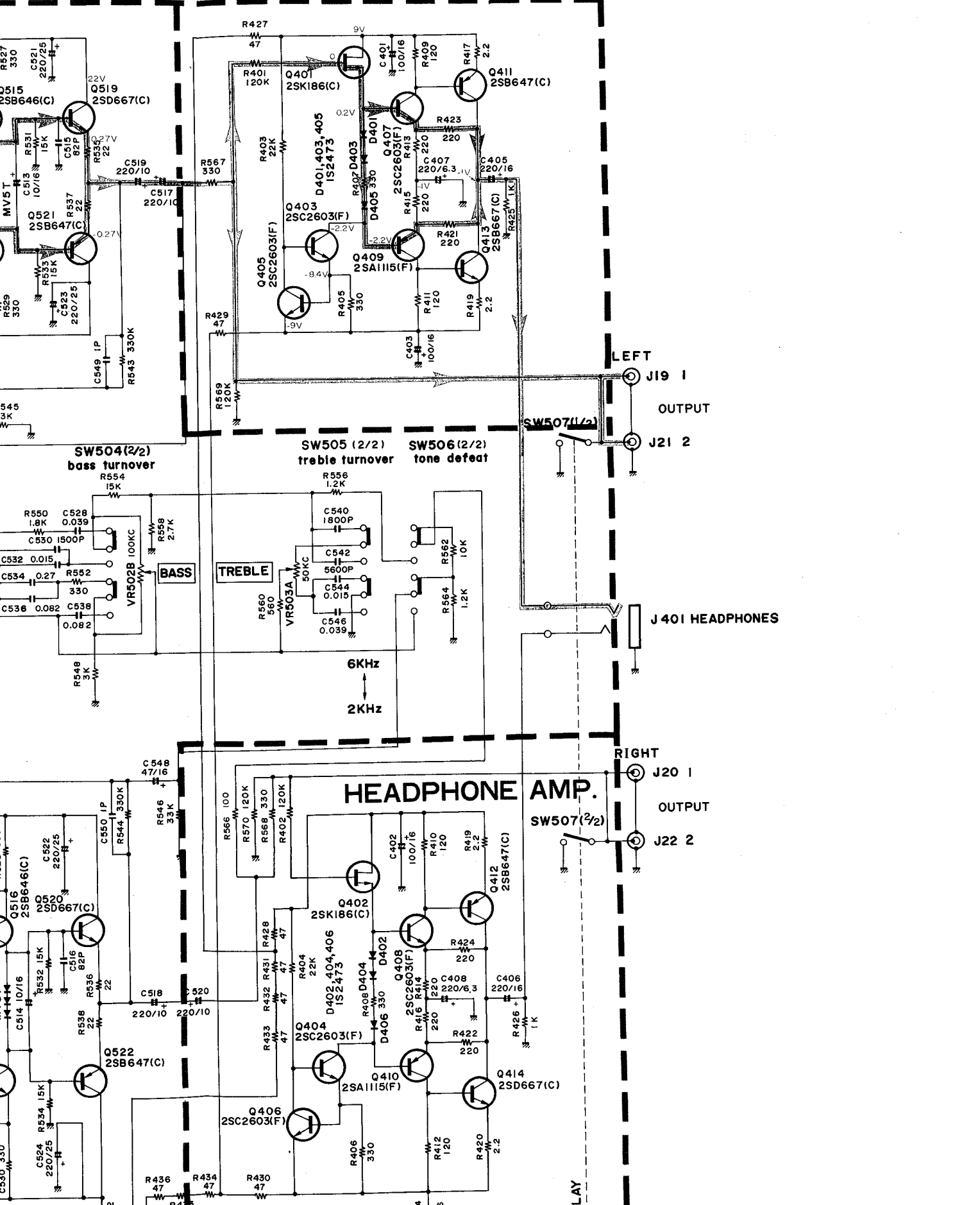

5
6
7
8
9
10

L TAPE 2 J18

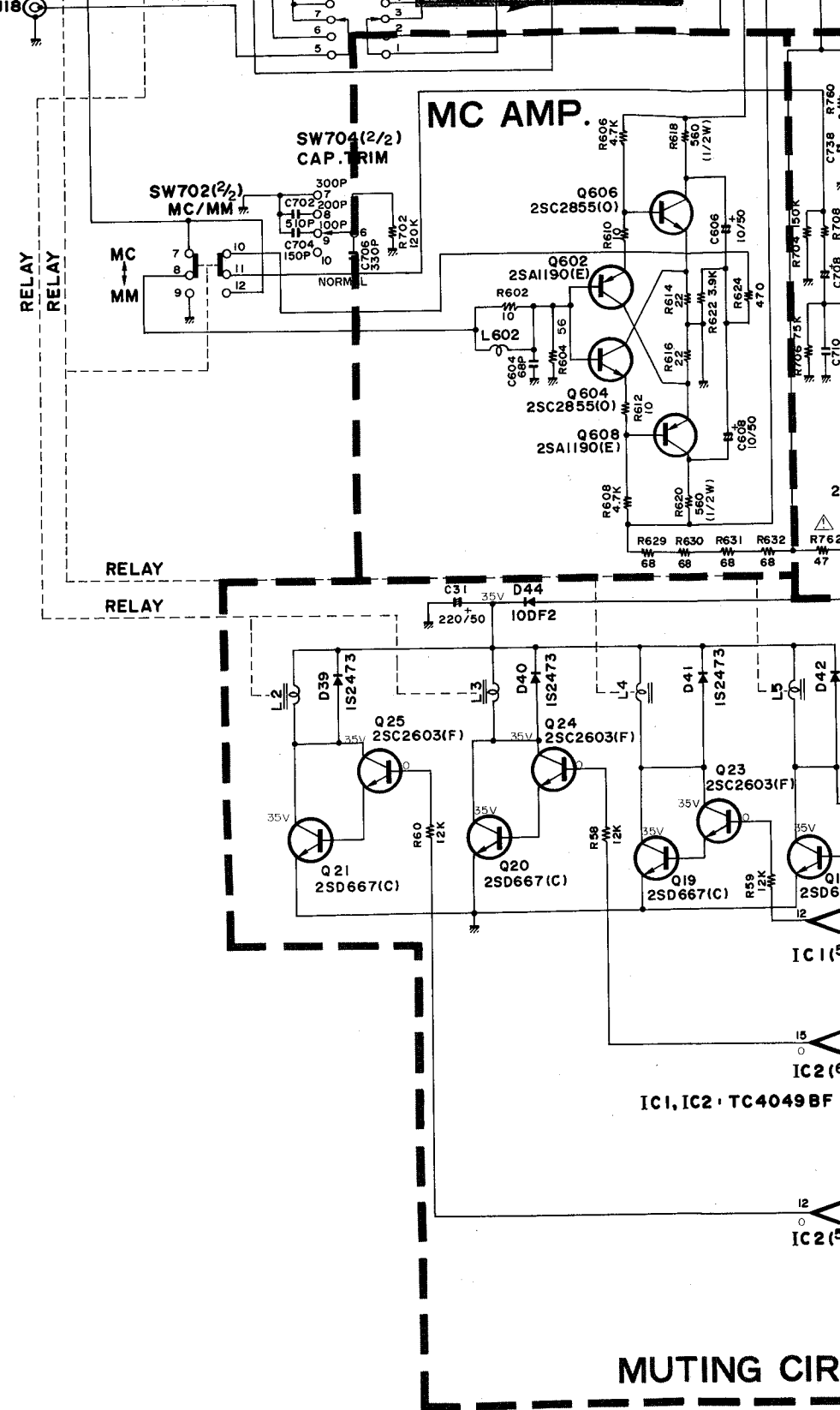

..... PHONO SIGNAL

1. ALL RESISTANCES VALUES ARE IN Ω .
K Ω =1000 Ω , M Ω =1000K Ω .
2. THE WATTAGE OF RESISTORS IS 1/4W UNLESS OTHERWISE NOTED.
3. ALL CAPACITANCES VALUES ARE IN μ F UNLESS OTHERWISE NOTED. P= μ μ F
AND ALL ELECTRICAL CAPACITANCES VOLTAGE VALUES ARE GIVEN WITHOUT UNIT.
THE OMITTED UNIT IS V. 47/50 \rightarrow 47 μ F/50V
4. V: DC VOLTAGE AT NO SIGNAL
5. SAFETY-REQUIREMENTS COMPONENTS IN ACCORDANCE WITH PRESENT SAFETY REGULATIONS. THESE COMPONENTS MUST ONLY BE REPLACED BY ORIGINAL PARTS.

IC FUNCTIONAL BLOCK

TC4049BP : IC1, 2

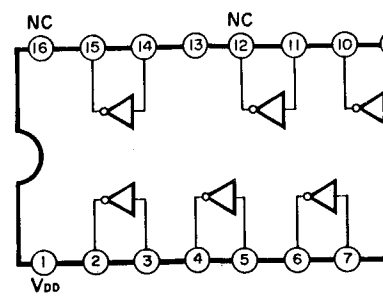

MC AMP.

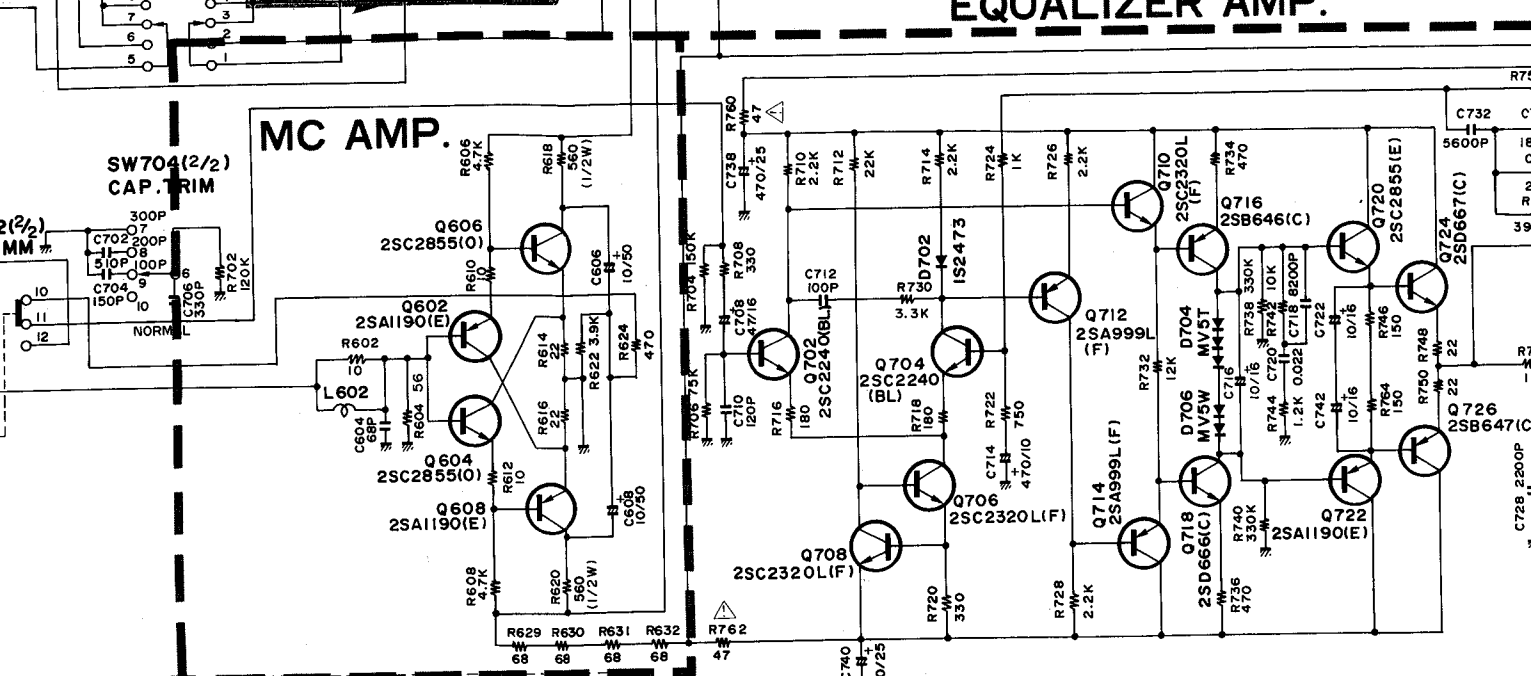

MUTING CIRCUIT

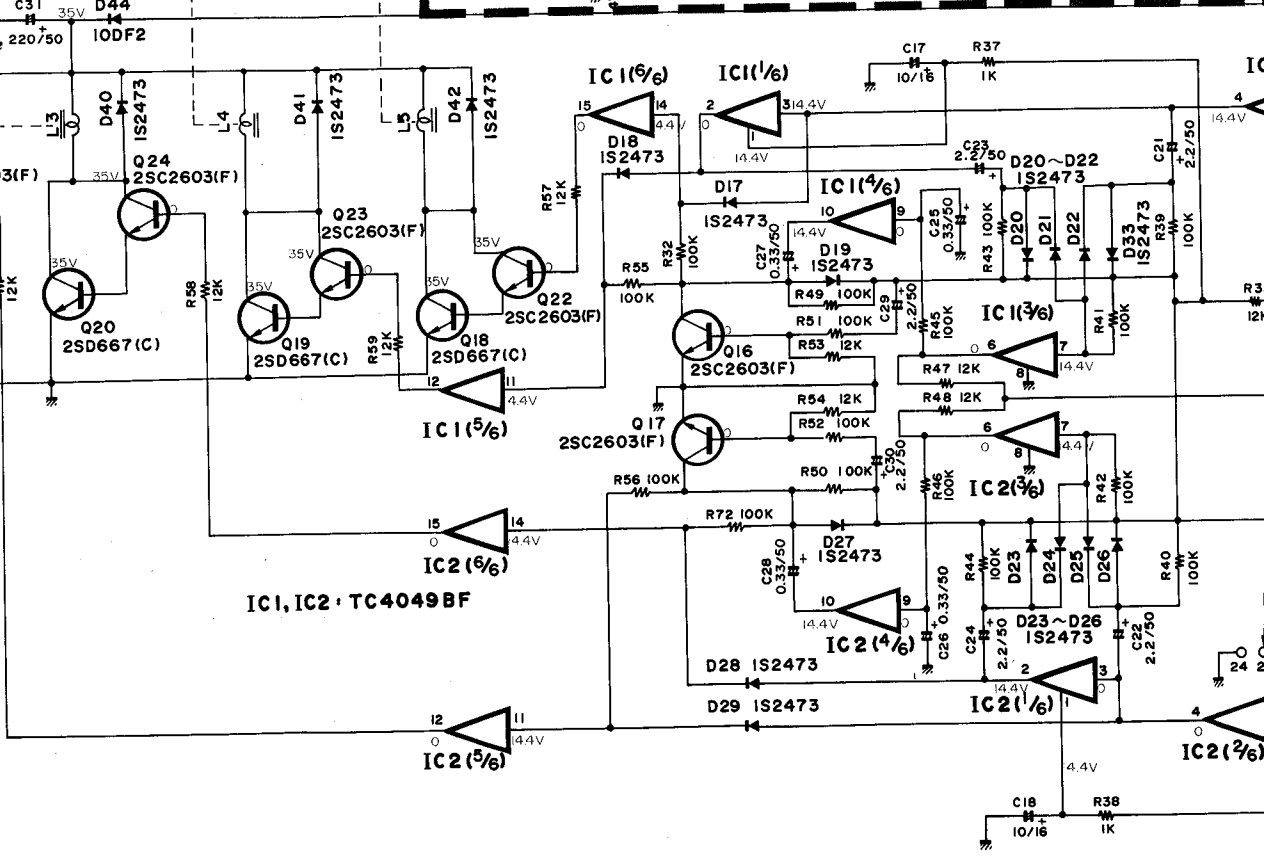

IC FUNCTIONAL BLOCK DIAGRAM

TC409BP : IC1, 2

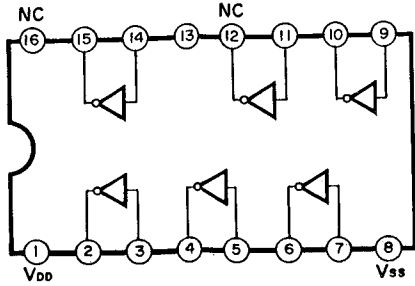

NOTE: USE NOTED. P=μF S ARE GIVEN WITHOUT UNIT.

REPLACE WITH PRESENT SAFETY PLACED BY ORIGINAL PARTS.

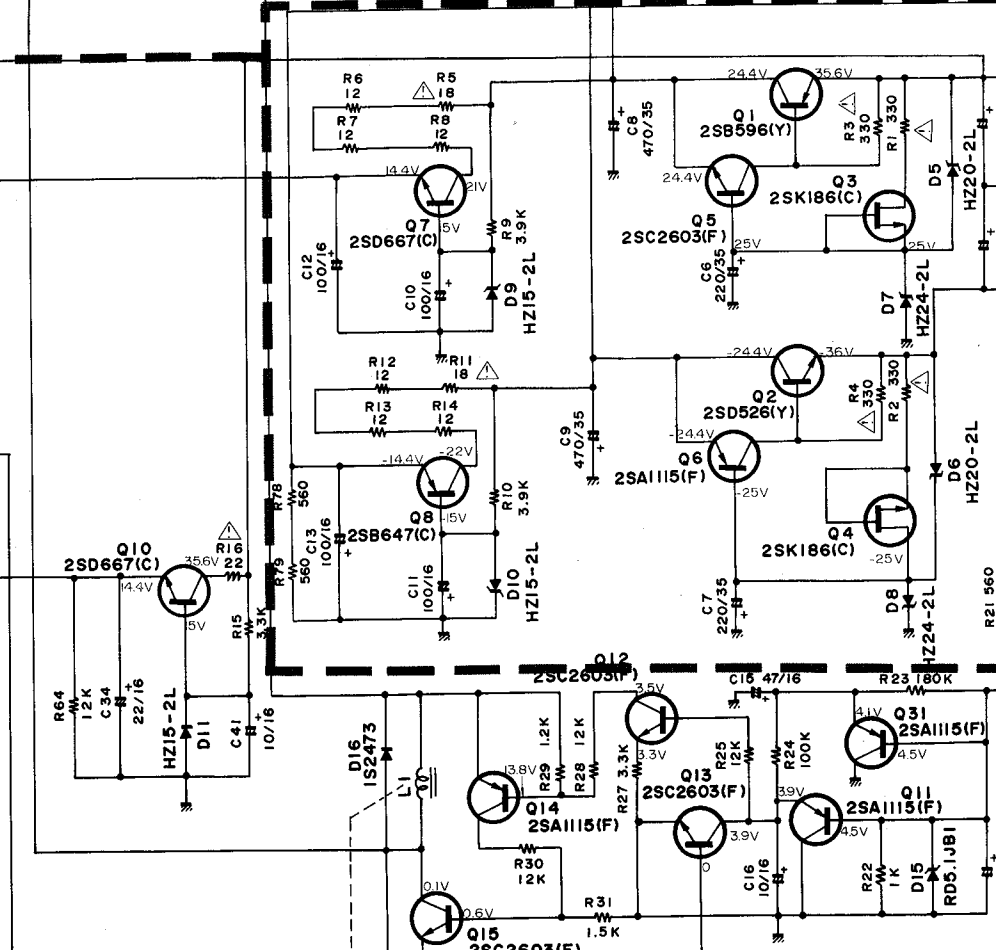
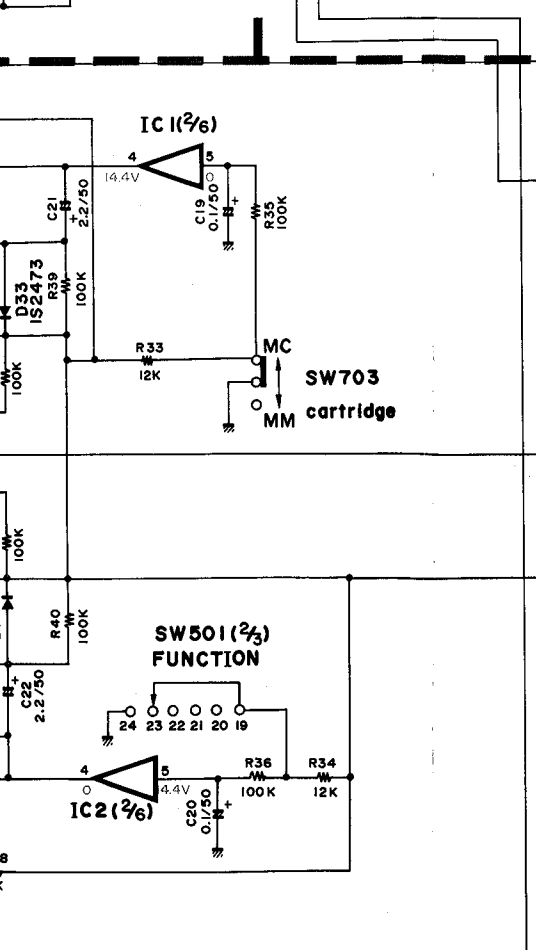
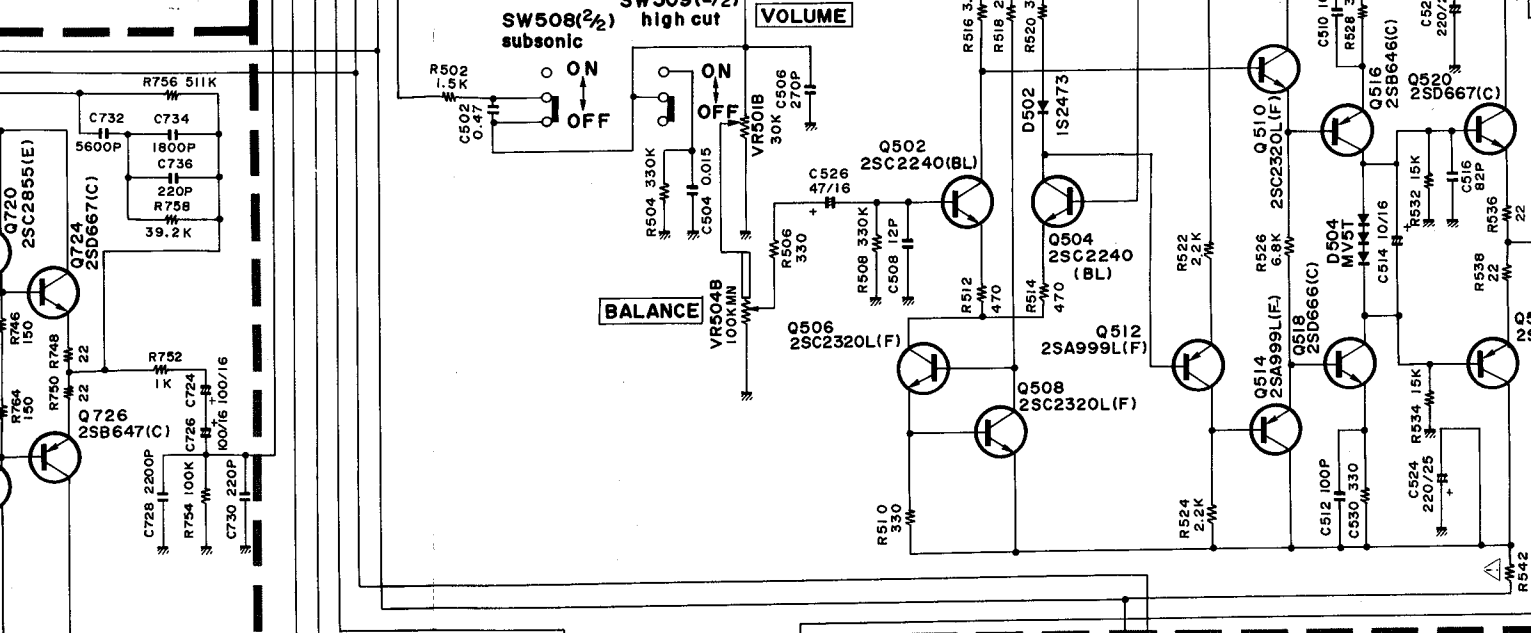

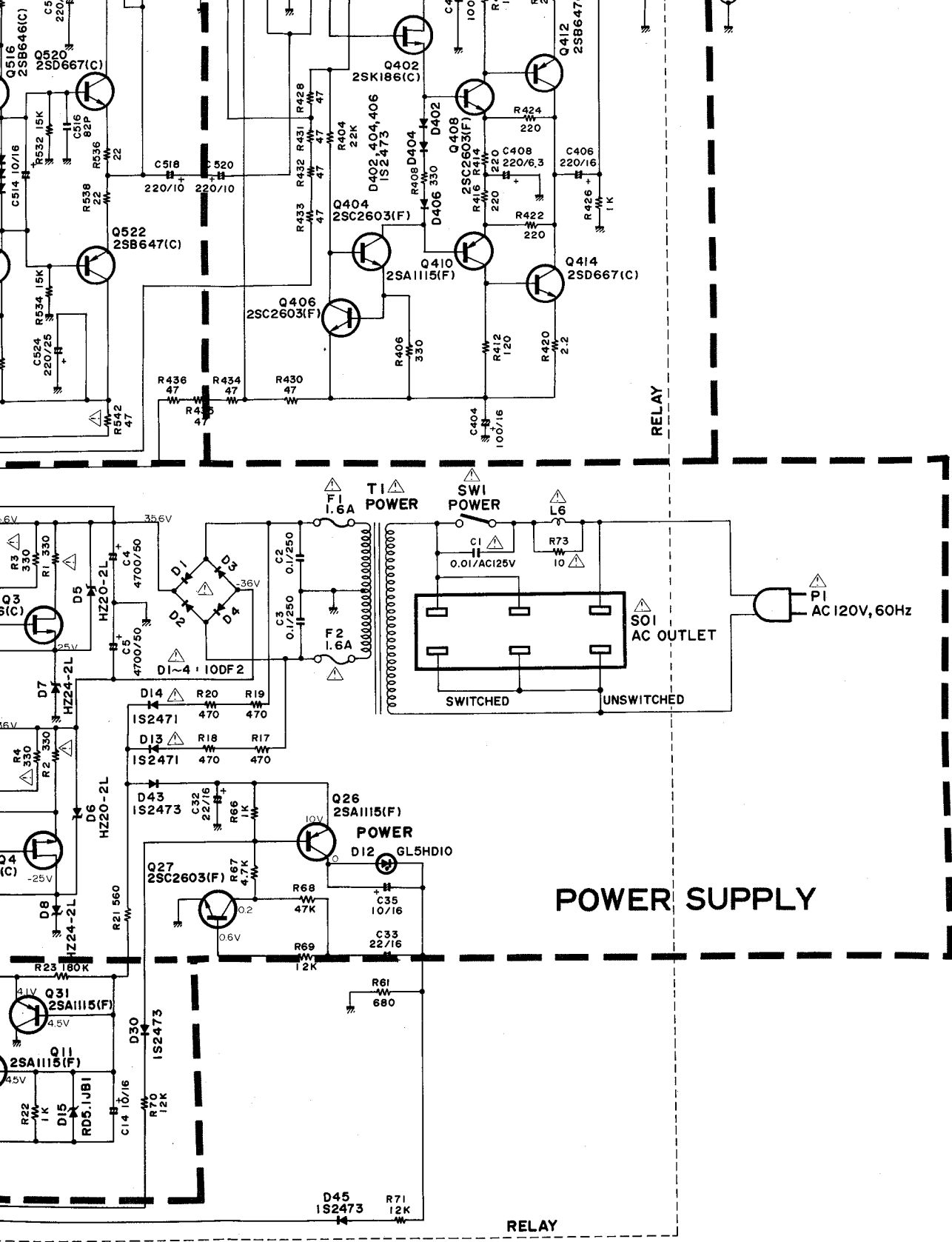

A B C D E F G H I J K L M N

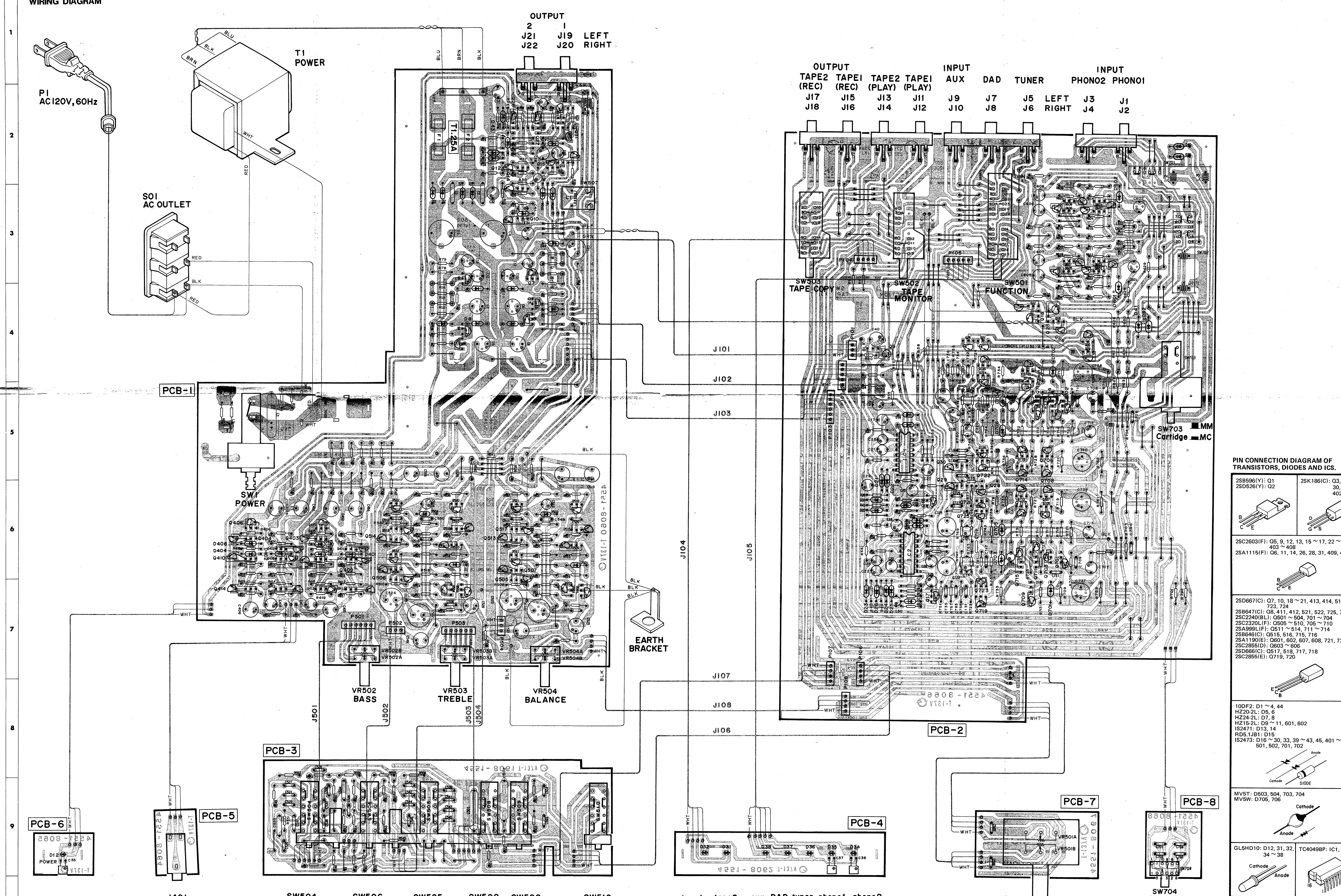

WIRING DIAGRAM

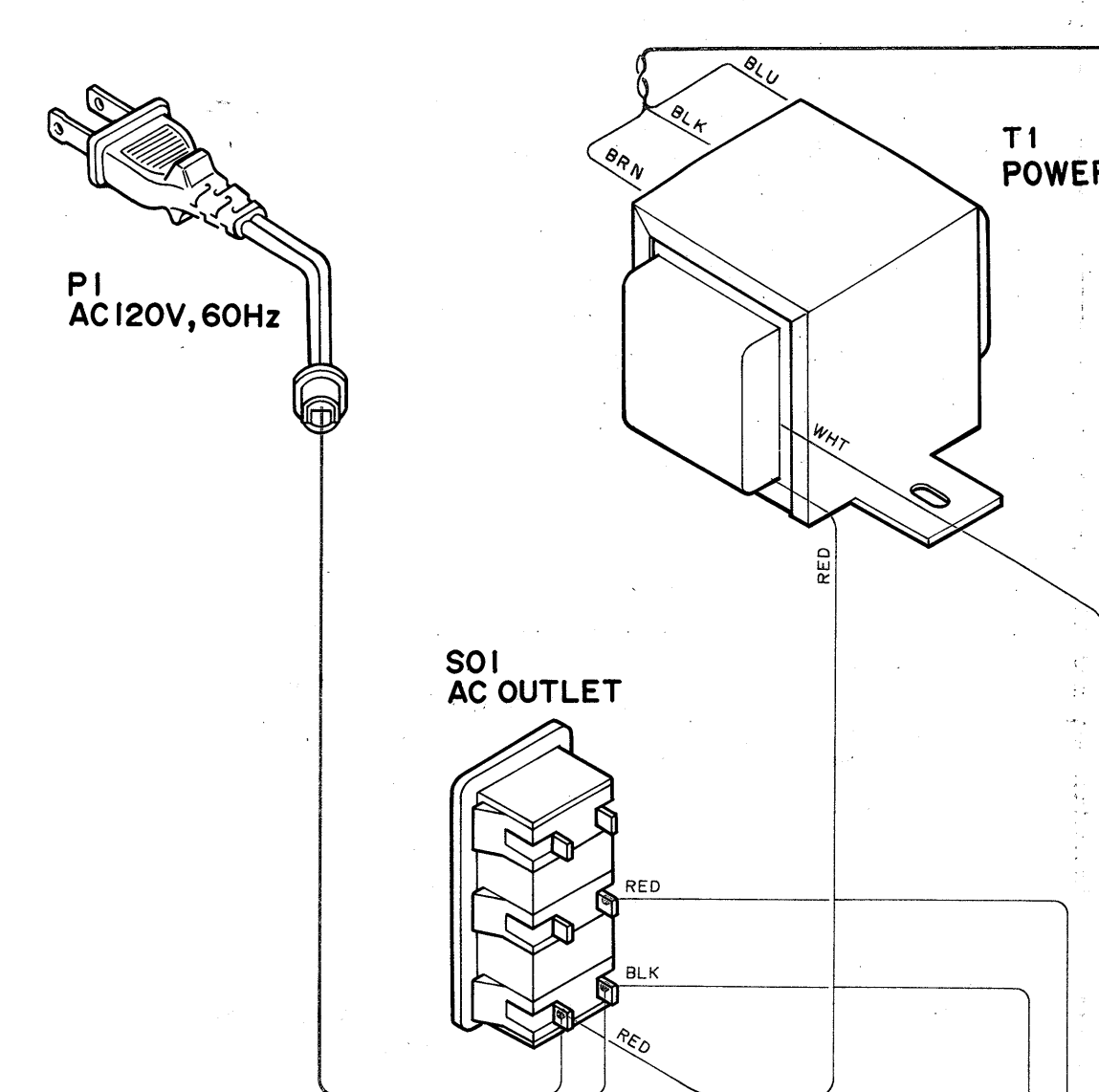

OUTPUT
2 1
J21 J19 LEFT
J22 J20 RIGHT

OUTPUT
TAPE2 TAPE1 TAPE1 TAPE1
(REC) (REC) (PLAY) (PLAY)
J17 J15 J13 J11
J18 J16 J14 J12

INPUT
AUX DAD TUNER
J9 J7 J5 LEFT
J10 J8 J6 RIGHT

INPUT
PHONO2 PHONO1
J3 J1
J4 J2

PCB-1

SW1 POWER

VR502 BASS

VR503 TREBLE

VR504 BALANCE

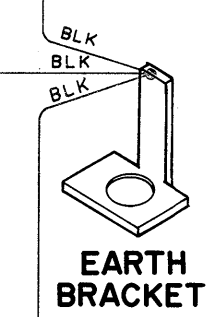

J104

J105

J107

J108

J106

PCB-2

PCB-3

PCB-4

PCB-7

PCB-8

PCB-6

PCB-5

J401 HEADPHONES

SW504
200Hz 400Hz
bass
turnover

SW506
2KHz 6KHz
tonedefeat
turnover

SW505
2KHz 6KHz
treble
turnover

SW508 SW509
15Hz 6KHz
subsonic high cut

SW510
mono
mode

tape1 tape2 aux DAD tuner phono1 phono2

VR501 VOLUME

SW704 CAP. TRIM

PIN CONNECTION DIAGRAM OF TRANSISTORS, DIODES AND ICs.

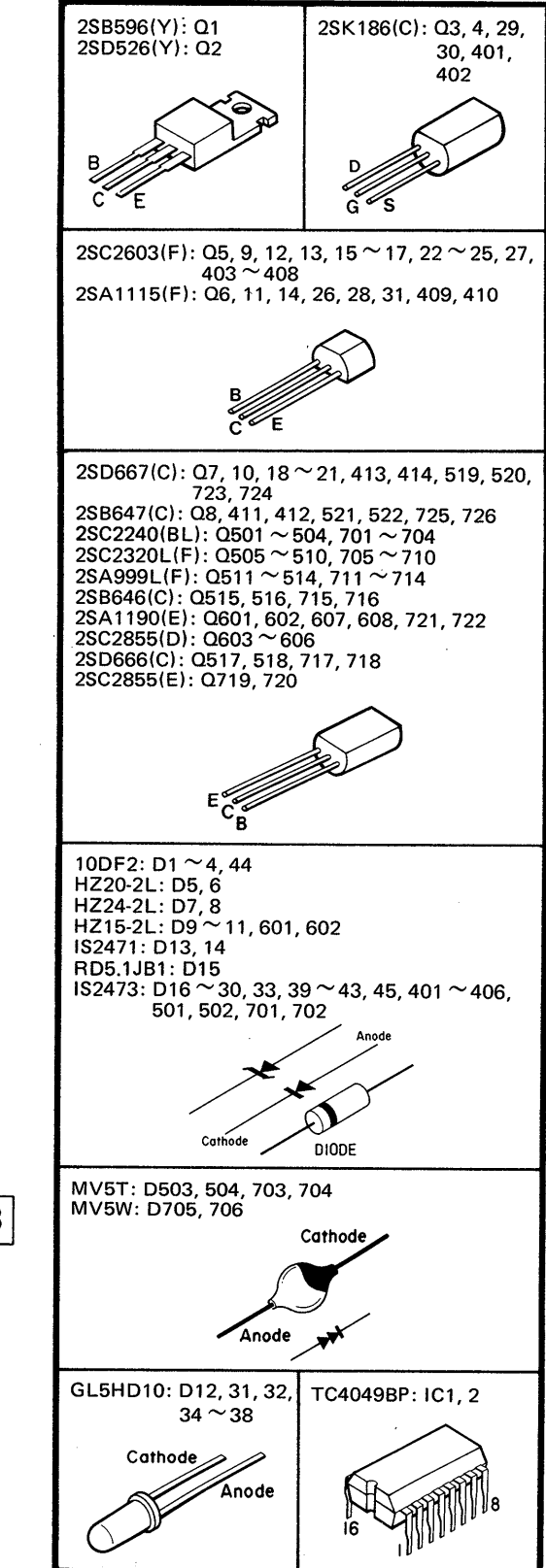

WIRE COLOR ABBREVIATIONS
RED : Red GRN : Green
WHT : White BLK : Black
BLK : Black BRN : Brown
BLU : Blue

WIRING DIAGRAM

1

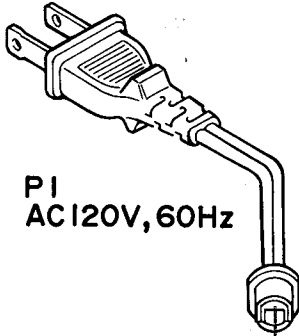

**PI
AC 120V, 60Hz**

2

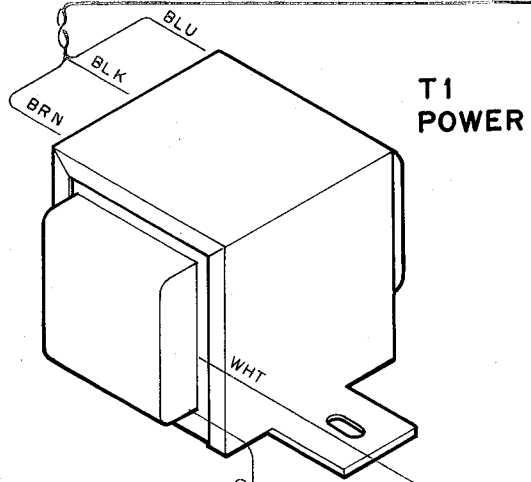

**T1
POWER**

3

**SOI
AC OUTLET**

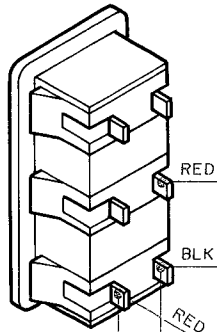

4

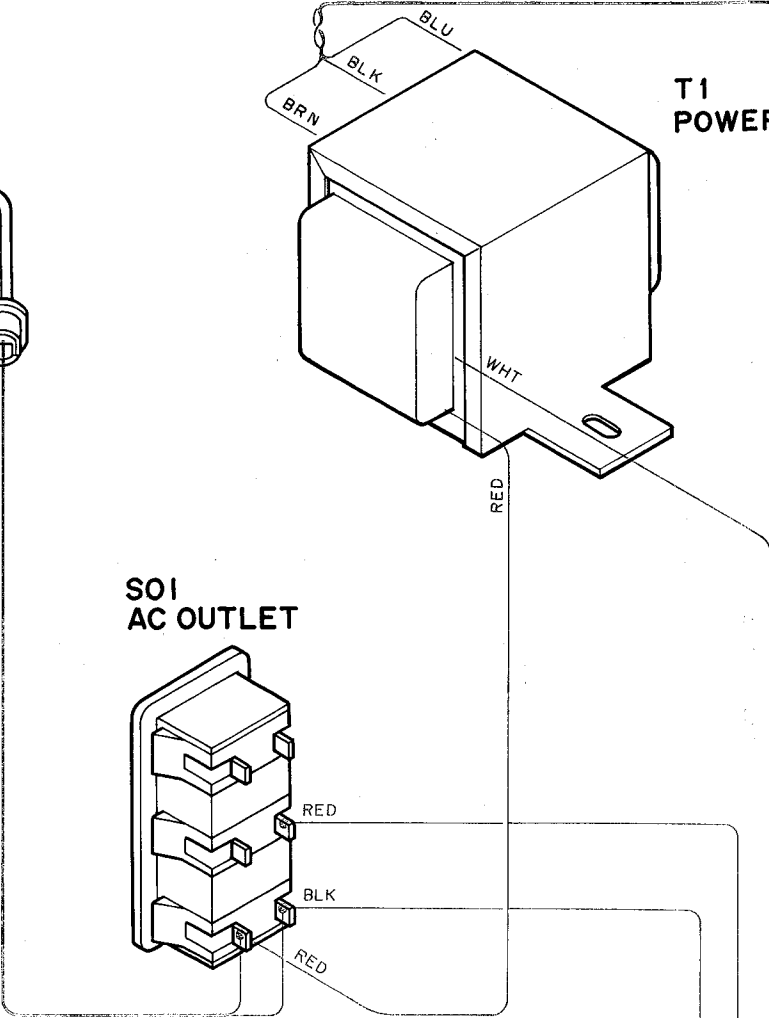

5

PCB-1

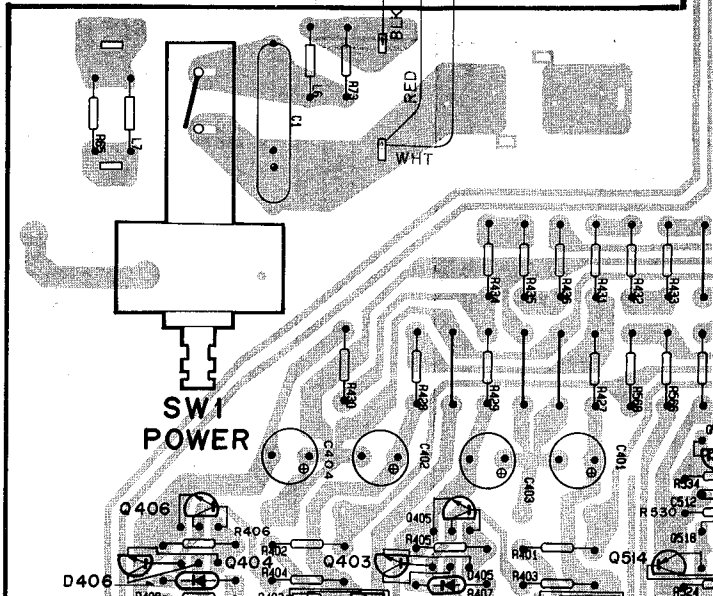

6

**SW1
POWER**

E

F

G

H

OUTPUT

2	1	
J21	J19	LEFT
J22	J20	RIGHT

BLU
BRN
BLK

T1.25A

SW 507

BLK
GRN

WHT

WHT

J101

J102

J103

BLK

42-1-8090-1
-1-0308-1224

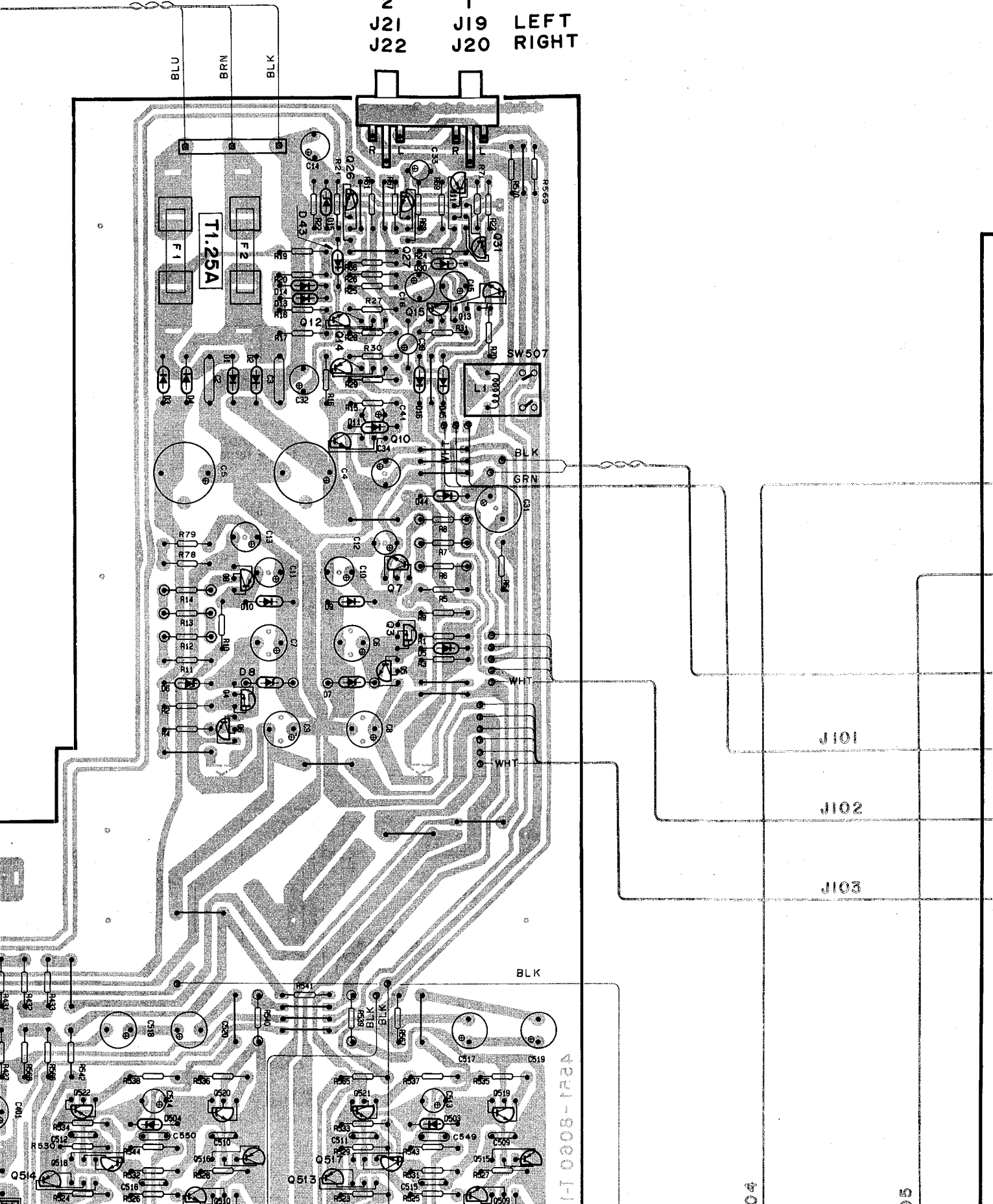

OUTPUT
TAPE2 (REC) J17
TAPE1 (REC) J15
TAPE2 (PLAY) J13
TAPE1 (PLAY) J11
 J18
 J16
 J14
 J12

INPUT
AUX J9
DAD J7
TUNER J5
 LEFT
 RIGHT
 J10
 J8
 J6

INPUT
PHONO2 J3
PHONO1 J1
 J4
 J2

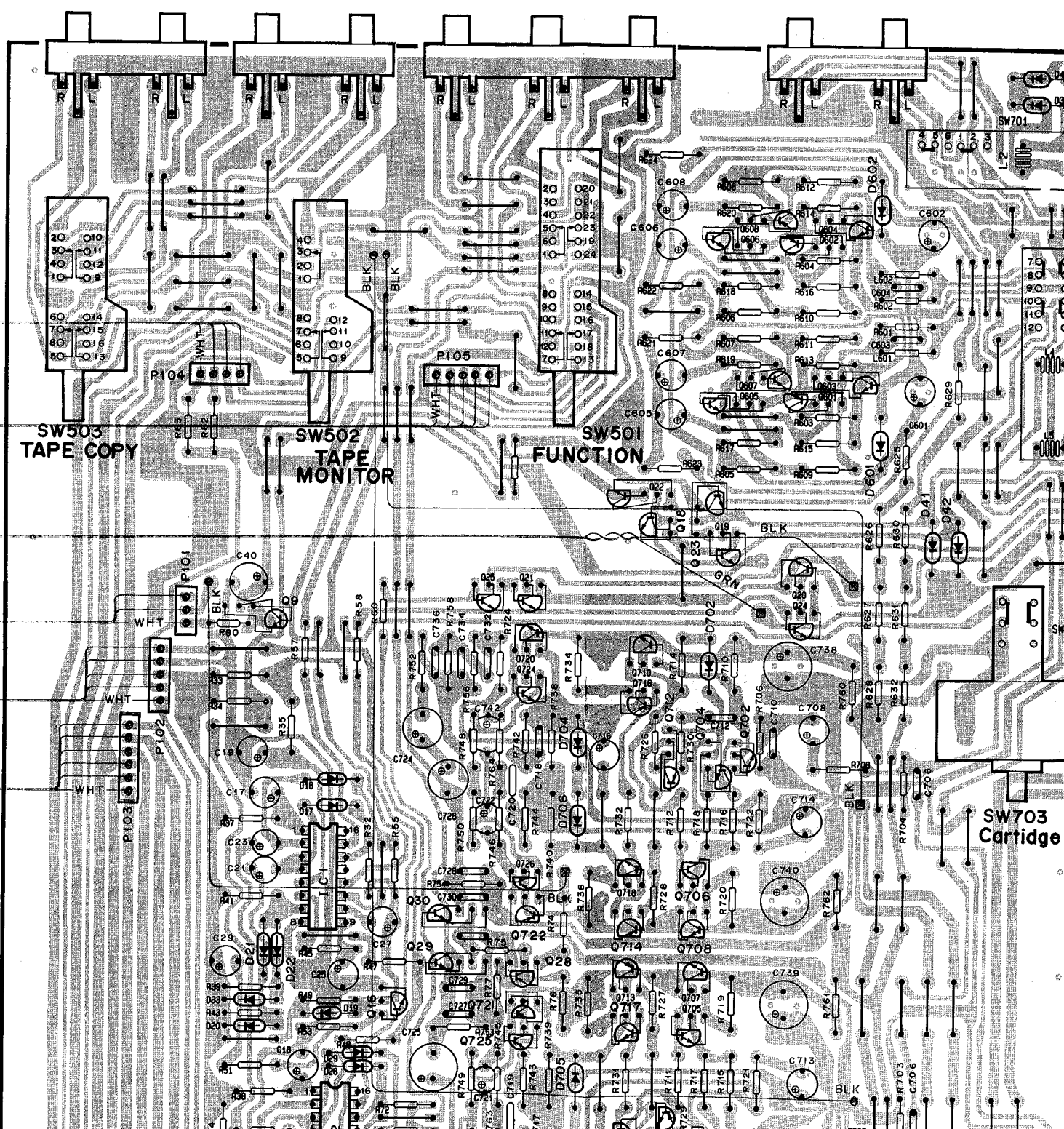

SW503
TAPE COPY

SW502
TAPE MONITOR

SW501
FUNCTION

SW703
Cartridge

INPUT
AUX DAD TUNER INPUT
PHONO2 PHONO1

J9 J7 J5 LEFT J3 J1
J10 J8 J6 RIGHT J4 J2

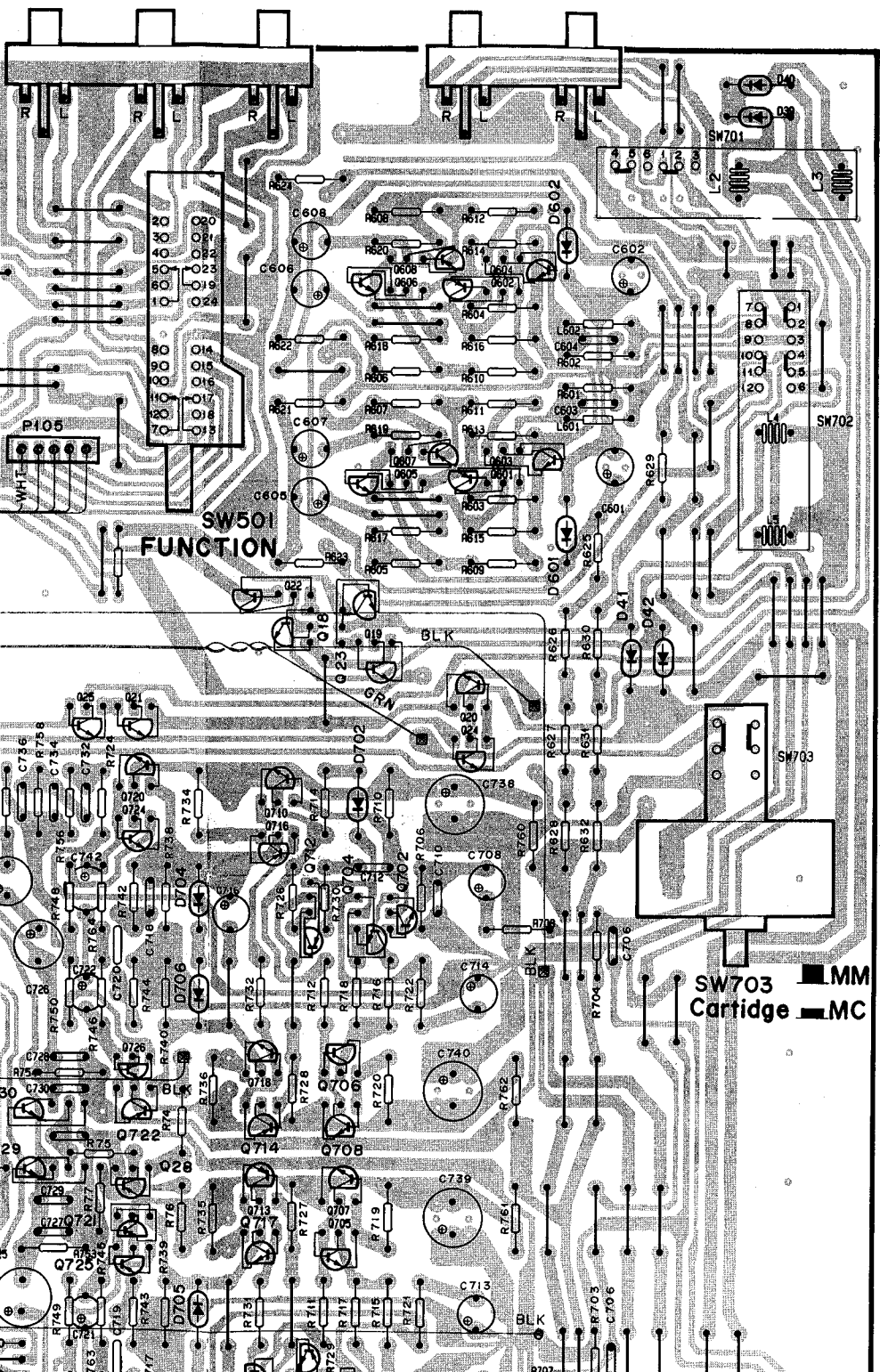

PIN CONNECTION DIAGRAM OF TRANSISTORS, DIODES AND ICs.

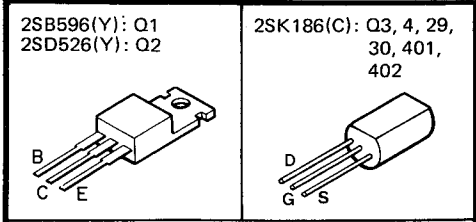

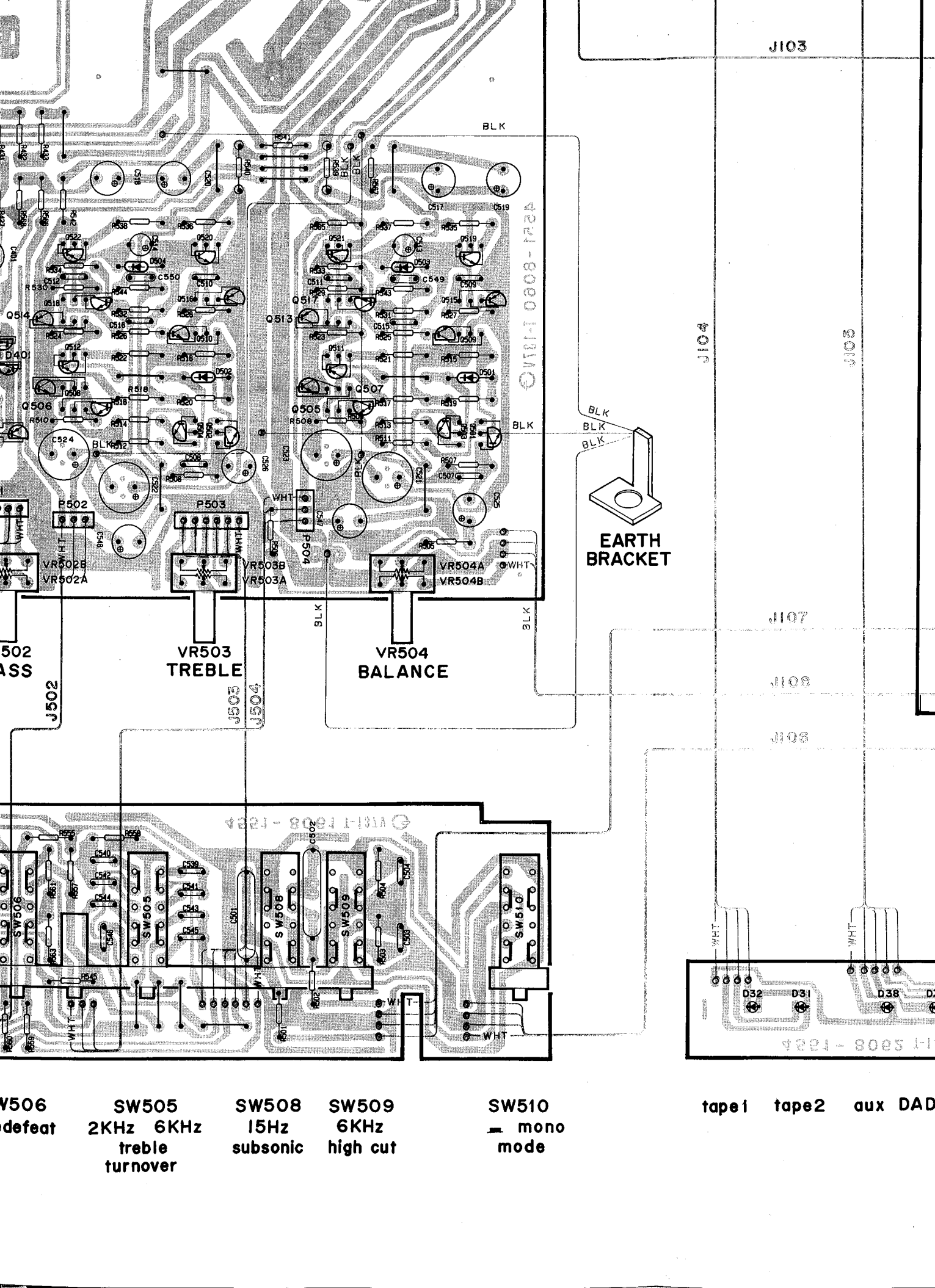

VR502
BASS

VR503
TREBLE

VR504
BALANCE

EARTH
BRACKET

SW506
defeat

SW505
2KHz 6KHz
treble
turnover

SW508
15Hz
subsonic

SW509
6KHz
high cut

SW510
mono
mode

tape1 tape2 aux DAD

J105

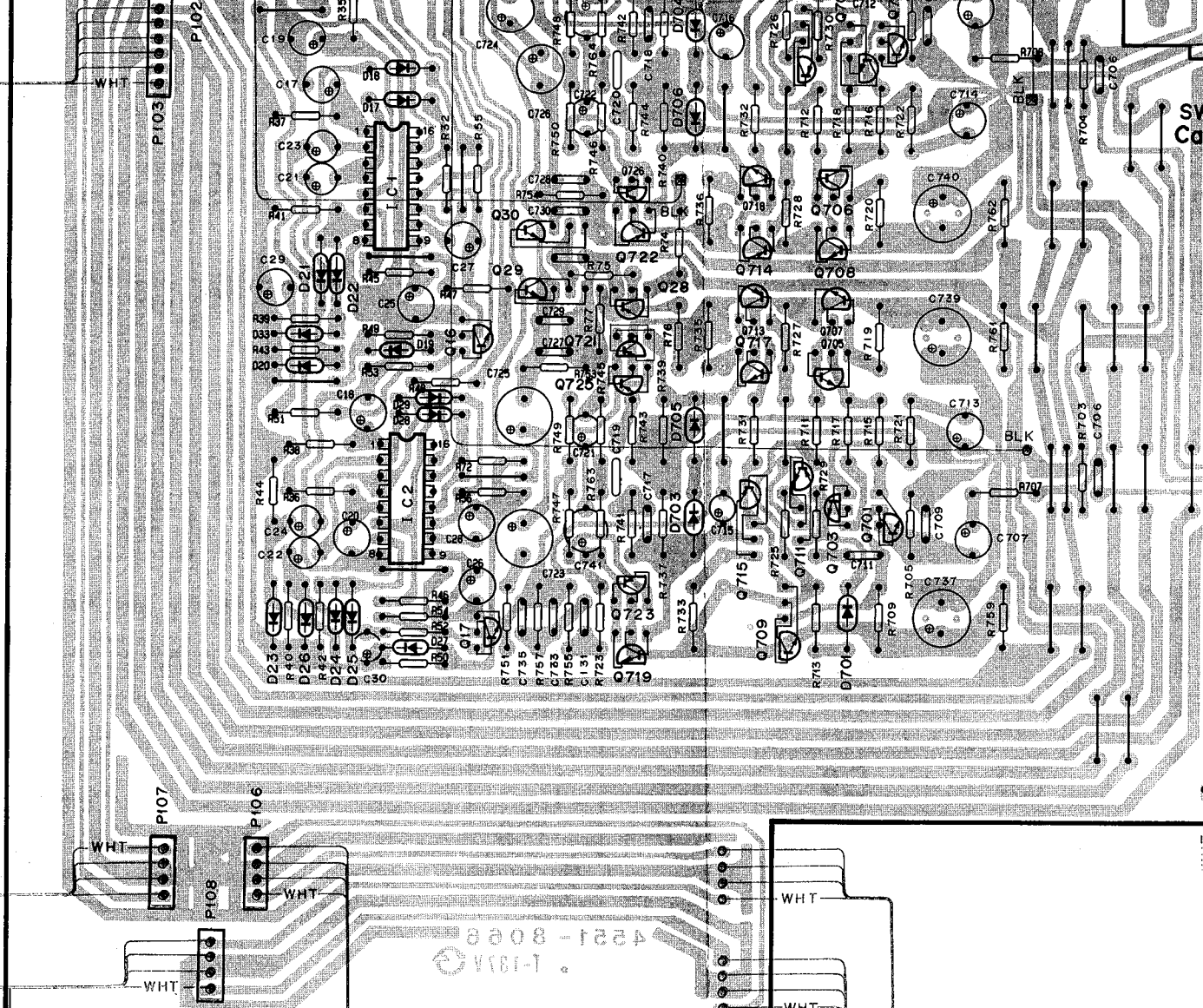

PCB-2

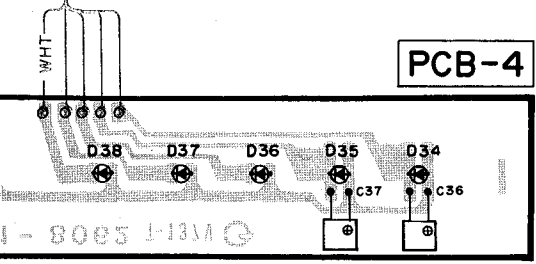

PCB-4

aux DAD tuner phono1 phono2

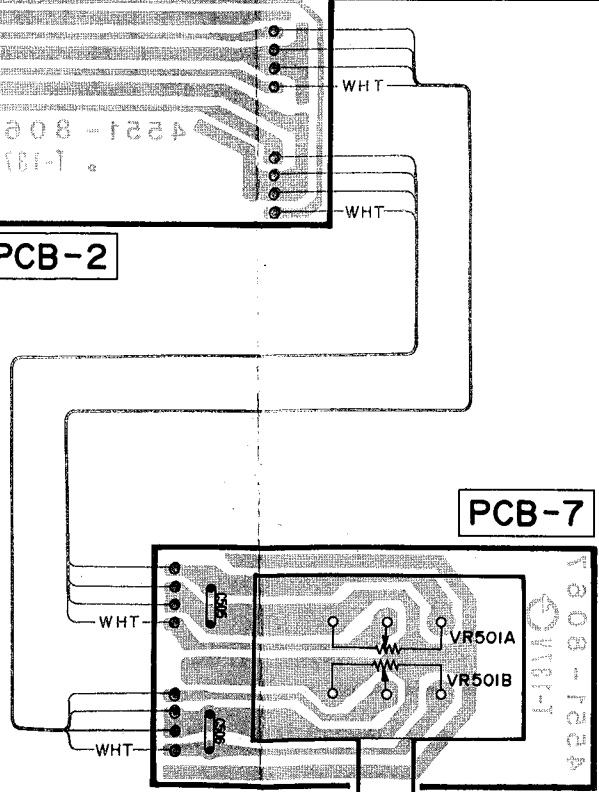

PCB-7

**VR501
VOLUME**



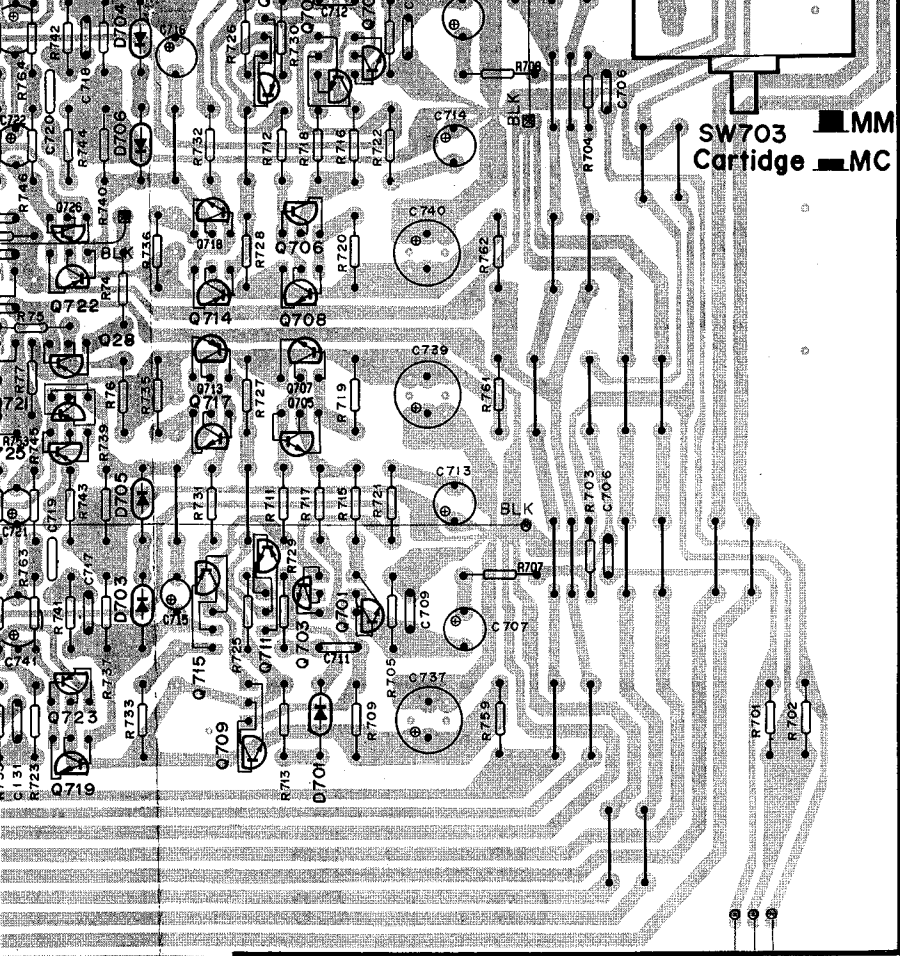

SW703 MM
Cartridge MC

PIN CONNECTION DIAGRAM OF TRANSISTORS, DIODES AND ICS.

2SB596(Y): Q1
2SD526(Y): Q2

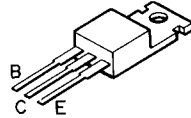

2SK186(C): Q3, 4, 29,
30, 401,
402

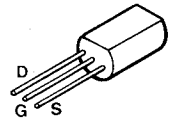

2SC2603(F): Q5, 9, 12, 13, 15 ~ 17, 22 ~ 25, 27,
403 ~ 408
2SA1115(F): Q6, 11, 14, 26, 28, 31, 409, 410

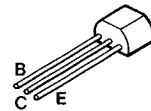

2SD667(C): Q7, 10, 18 ~ 21, 413, 414, 519, 520,
723, 724
2SB647(C): Q8, 411, 412, 521, 522, 725, 726
2SC2240(BL): Q501 ~ 504, 701 ~ 704
2SC2320L(F): Q505 ~ 510, 705 ~ 710
2SA999L(F): Q511 ~ 514, 711 ~ 714
2SB646(C): Q515, 516, 715, 716
2SA1190(E): Q601, 602, 607, 608, 721, 722
2SC2855(D): Q603 ~ 606
2SD666(C): Q517, 518, 717, 718
2SC2855(E): Q719, 720

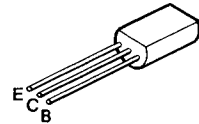

10DF2: D1 ~ 4, 44
HZ20-2L: D5, 6
HZ24-2L: D7, 8
HZ15-2L: D9 ~ 11, 601, 602
IS2471: D13, 14
RD5.1JB1: D15
IS2473: D16 ~ 30, 33, 39 ~ 43, 45, 401 ~ 406,
501, 502, 701, 702

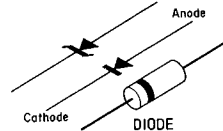

MV5T: D503, 504, 703, 704
MV5W: D705, 706

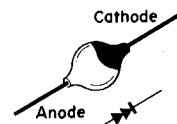

GL5HD10: D12, 31, 32,
34 ~ 38

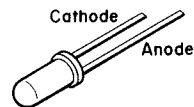

TC4049BP: IC1, 2

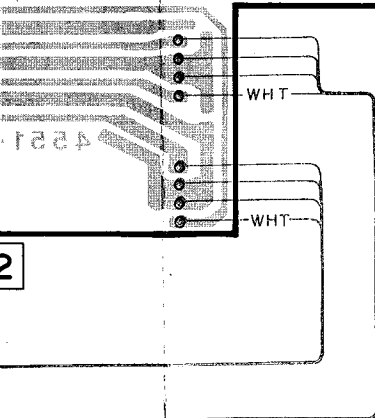
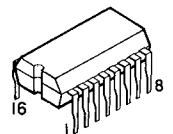

PCB-7

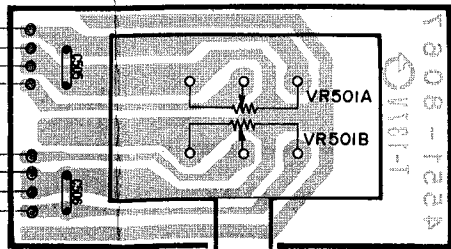

VR501
VOLUME

PCB-8

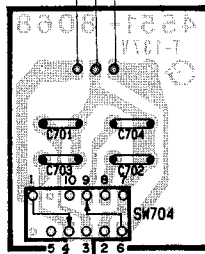

SW704
CAP. TRIM

WIRE COLOR ABBREVIATIONS

RED : Red GRN : Green
WHT : White BRN : Brown
BLK : Black
BLU : Blue