harman/kardon
Service Manual

HK 980/230

2 x 80W STEREO AMPLIFIER



CONTENTS

TECHNICAL SPECIFICATIONS	2	BLOCK DIAGRAM	8
REAR PANEL CONNECTIONS	3	SEMICONDUCTOR PINOUTS	9
FRONT PANEL CONTROLS	4	PCB DRAWINGS	24
REMOTE CONTROL INFORMATION	5	SCHEMATIC DIAGRAMS	32
AMP BIAS ADJUSTMENT	6	EXPLODED VIEW AND PARTS	38
WIRING DIAGRAM	7	ELECTRICAL PARTS LIST	40

Released EU2008

harman/kardon, Inc.
250 Crossways Park Dr.
Woodbury, New York, 11797

Rev 0, 11/2008

Specifications

		NOMINAL
Continuous Average Power Per Channel (FTC) 20 Hz – 20 kHz, both channels driven	8 Ohms:	80 Watts@<0.09%THD
	4 Ohms:	120 Watts@<0.3%THD
Dynamic Power (IHF, 1KHz Tone Burst)	8 Ohms:	115 Watts
	4 Ohms:	200 Watts
	2 Ohms:	295 Watts
	1 Ohms:	380 Watts
High instantaneous current capability (HCC)		±80 Amps
Power Bandwidth @ Half-Rated output, 8		<10 Hz - 150 kHz
Frequency response @ 1W (+0/-3dB)		5 Hz - 150 kHz
Damping factor (20Hz-20k Hz)		>125
Signal-to-noise Ratio (Reference rated power output, A-WTD)	Tuner/CD	95 dB
	Phono (MM):	75 dB
Input sensitivity/Impedance	Tuner/CD	270mV/43k Ohms
	Phono (MM):	4.0mV/47k Ohms
Overload:	Tuner/CD	6V
	Phono (MM):	90 mV
Tone control range, Bass @ 100 Hz/Treble @ 10 kHz		±10 dB/±10 dB
Power supply:		AC 230V, 50 Hz
Power consumption:		410 W
Dimensions (Width x Height x Depth):		440 x 117 x 358 mm
Weight:		10.35 kg

Harman/kardon

250 Crossways Park Drive, Woodbury, New York 11797
www.harmankardon.com
Harman Consumer Group International:
2, Route de Tours, 72500 Château-du-Loir, France
© 2005 Harman Kardon, Incorporated
Part 5100-971500-000

Connections

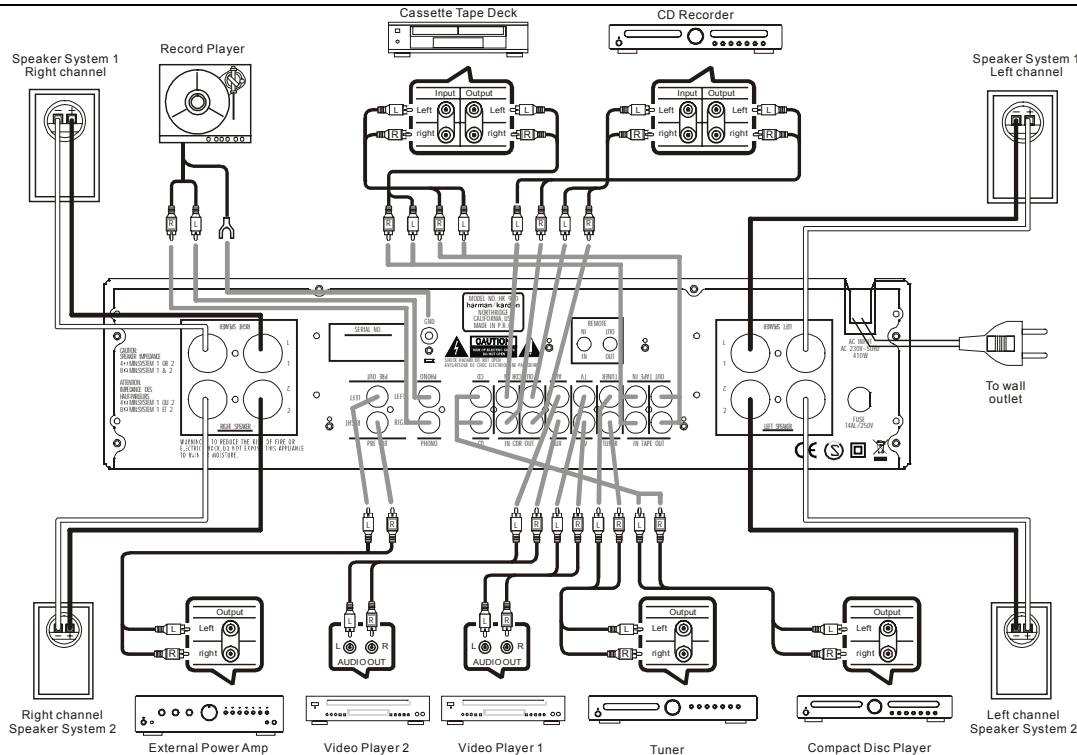

Connecting Other Components

1. Make sure your amplifier and other components are turned off.
2. Connect each component's Output/Play jacks to the corresponding Input jacks on the back of your amplifier and, if available, the component's Input/Record jacks to the Output jacks of the HK 980. Use the white, black or gray plugs to connect Left channel jacks; use the red plugs for Right channel jacks.
3. A record player with MM cartridge must be connected to the Phono Input jacks and a separate ground wire to the ground terminal screw above.

Wired Remote Control

To control your amplifier with an external infrared remote sensor, connect the wire from the remote sensor to the REMOTE IN jack on the back panel. Or, if another stereo component has a built-in infrared remote sensor and a Remote Output jack, it may be possible to connect this jack to the REMOTE IN jack of your amplifier. All Harman Kardon products with »Remote In« and »Remote Out« jacks are compatible with one another, except for the Citation 22, 24 and 25. Other manufacturers' remote sensors and components may not be compatible, but it will not hurt to experiment. A second wire may be used to connect your amplifier's REMOTE OUT jack to

the Remote Input of another stereo component. Continue this process to include additional components (if compatible).

Connecting Speakers

1. For best performance, use high quality speaker cables. However, ordinary copper wire can be used if the gauge meets the following requirements:

Wire Length	Min. Diameter
Up to 2.5 meter	1 mm
Up to 4 meter	1.25 mm
Up to 6 meter	1.6 mm
Above 6 meter	2-2.5 mm

2. Avoid rolling excess wire with or near signal interconnects.

External Power Amplifiers

For applications where higher power is desired, connect the Pre-Out Jacks to the Main In Jacks of an external power amplifier. The level of the output can be adjusted between -3 and +3 dB with an internal button. To adjust the level, gently insert a small screwdriver into the button and turn clockwise to increase or counter-clockwise to decrease the output level.

IMPORTANT: When connecting two pairs of speakers, determine the impedance of each pair by looking on the back of the speakers, in your owner's manual, or by contacting your dealer or manufacturer.

You can listen to two pairs of speakers at the same time ONLY if the impedance of EACH speaker is NOT LESS THAN 8 Ohms.

WARNING: Do not play sets of speakers simultaneously except as recommended above. Amplifier may overheat.

AC Power

Plug the cord into a 230 VAC wall socket. Power indicator will light up to indicate power ON. To completely disconnect the power input, the main plug must be disconnected from the mains.

Controls and Functions

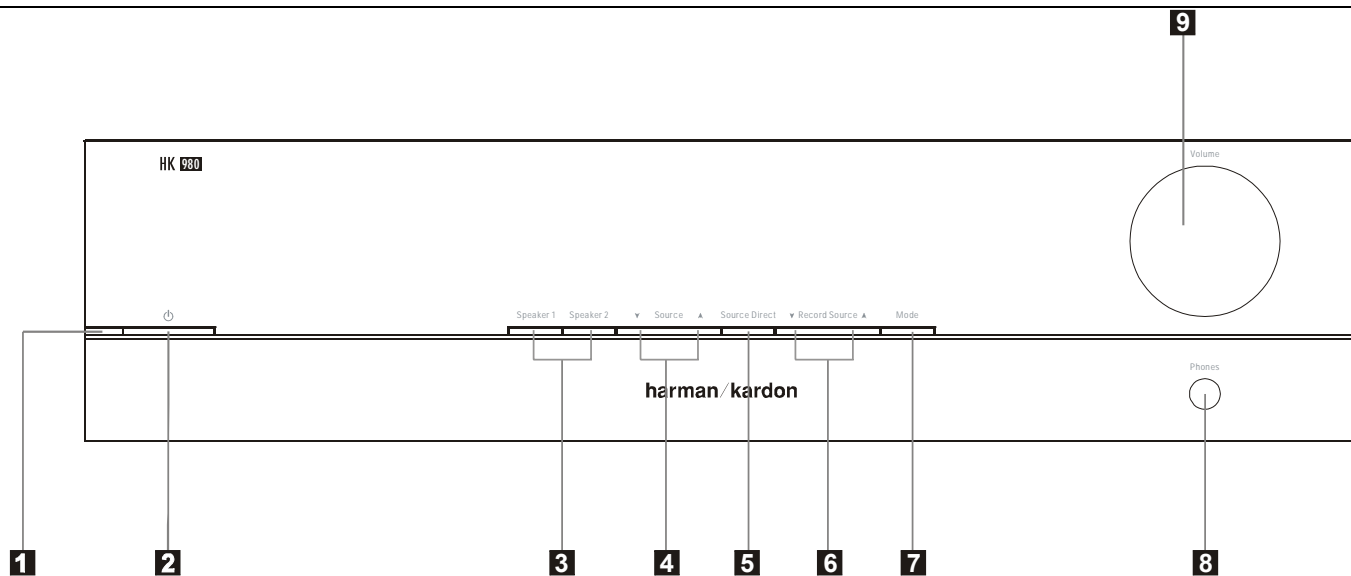

1. Power Indicator: This LED will illuminate in amber when the unit is in the Standby mode to signal that the unit is ready to be turned on. When the unit is in operation, the indicator will turn white.

2. System Power Control: Press this button to turn on the HK 980; press it again to turn the unit off (to Standby). Note that the **Power Indicator** next to the switch will turn blue when the unit is on.

3. Speaker 1 /2 Selectors: Press to select speaker pair 1 or 2, or both, or neither (headphone output only).

4. Input Source Selector: Select desired input source for listening by pressing the "Input source" button repeatedly (on the left will select downwards, right upwards) until the display for the desired source is illuminated.

5. Source Direct: Press to bypass tone control circuitry.

6. Record Source Selector: Select desired source for recording to device connected to the rear panel Tape and CDR Out sockets by pressing the "Record Source" button repeatedly until the display for the desired source is illuminated.

7. Mode Button: Press this button to make changes to the bass, treble and balance settings.

8. Headphone Jack: Plug in headphones if desired. With both "Speaker 1" and "2" selectors in the Off position, output is supplied only to headphones.

9. Volume Control: Turn to raise or lower output volume.

Remote Control

Independent Remote Control

The system remote of the HK 980 can control the amplifier and compatible Tuners, CD Players and CD Recorders. The remote In jack of units without an integrated IR receiver must be connected to the amplifier's remote control output jack so that the system remote control can operate them. The Function Table below will show all functions of the HK 980 and external devices that can be controlled by the HK 980 remote.

Important Notes:

- To remote control a tuner, CD Recorder or CD Player, the appropriate input ("TUNER", "CDR" or "CD") must have been selected with the source buttons of the remote control (selecting on the front panel is not sufficient).
- Note that DVD players or tape decks cannot be controlled by the remote.
- To control a compatible CD Recorder "CDR" must be selected as input and the drive to be controlled (CDP or CDR) must be selected appropriately with the "CDP SELECT" or "CDR SELECT" buttons.

Operating Conditions

The control unit operates effectively within a distance of 7 meters and an angle of 30° from the amplifier. Using the control near fluorescent lights may shorten this range, as will any dust or dirt that accumulates on the front of the remote control or the remote sensor area of the amplifier. Also avoid blocking the line of sight between amplifier and remote.

The control unit is powered by two AA batteries, included with your amplifier. When you replace weak batteries, replace both at the same time. When the remote is to be unused for an extended period, remove the batteries to prevent damage from corrosion.

Remote button functions

Button	HK 980	CD Player	Tuner
ON	Power On	-	-
OFF	Power Off	-	-
Tuner	Select Tuner	-	-
Phono	Select Phono	-	-
TV	Select TV	-	-
Tape	Select Tape	-	-
Aux	Select Aux	-	-
CD	Select CD	-	-
Volume+	Volume Up	-	-
CDR	Select CDR	-	-
10+	-	Current Track +10	-
Mode	Select Mode	-	-
Folder+	-	Next Folder	-
10-	-	Current Track -10	-
Volume-	Volume Down	-	-
Folder-	-	Previous Folder	-
Previous	-	Skip Previous	-
Play/Pause	-	Play/ Pause	-
Next	-	Skip Next	-
Search	-	Fast Reverse	-
Stop	-	Stop	-
Search	-	Fast Forward	-
Open/Close	-	Open/ Close	-
Scroll +	-	-	Tuning Up
Repeat	-	Repeat Play	-
Random	-	Random Play	-
Scroll -	-	-	Tuning Down
0 ~ 9 (Numeric Keys)	-	Track Select	Preset Select
Auto	-	-	Auto Tune
FM Mode	-	-	FM Mode Select
RDS	-	-	RDS Mode Select
Mute	Mute Sound	-	-
Band	-	-	Band Select
Select	-	-	Tune Mode Select

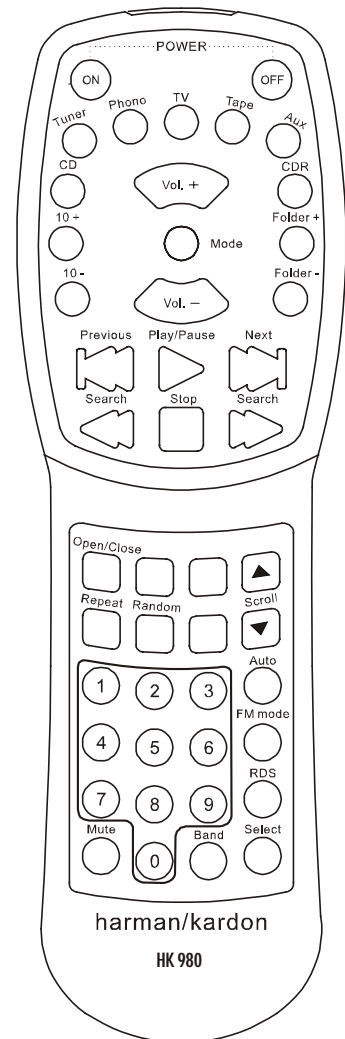

AMP Adjustment

Idling Adjustment

Precaution for handling measuring instrument

The ground side of the measuring instrument to be connected to the speaker terminal of this unit must be kept in floating condition because this unit is equipped with the floating balanced power amplifier.

Condition

- * Start adjustment 20 minutes or more after the power is turned on.
- * Non loaded condition.

Idling Adjustment

Adjust VR1 so that the DC voltage of TP1 becomes +10mV to +11mV.

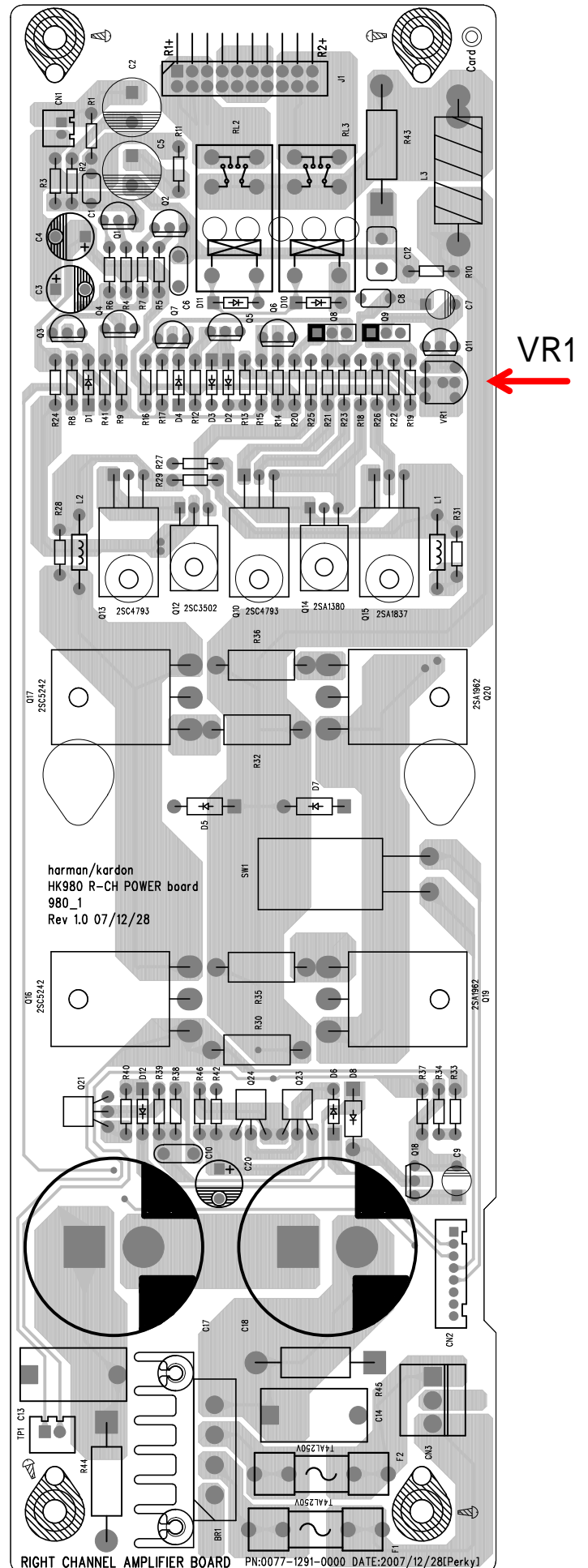

TP1 →

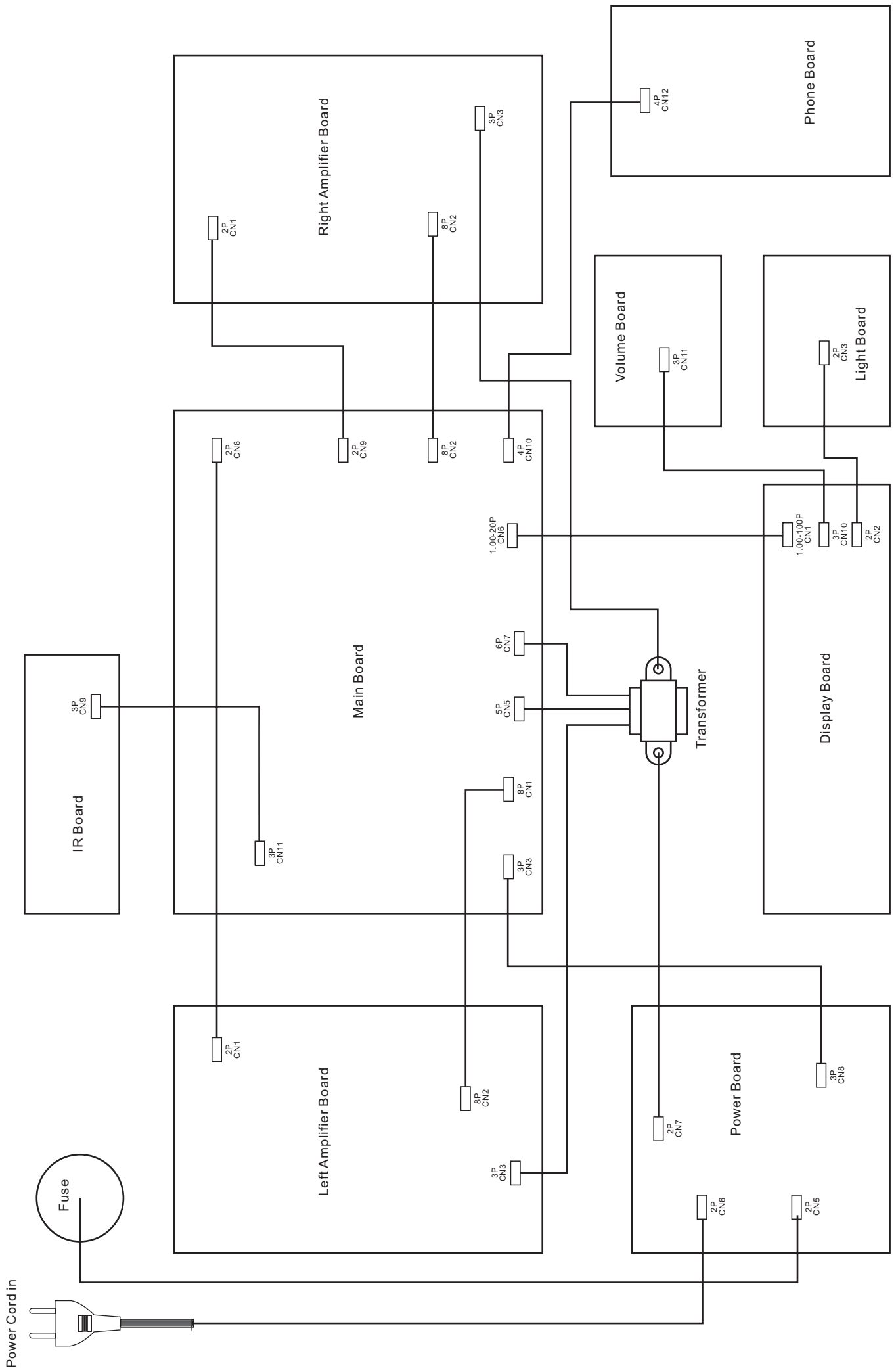

HK980x

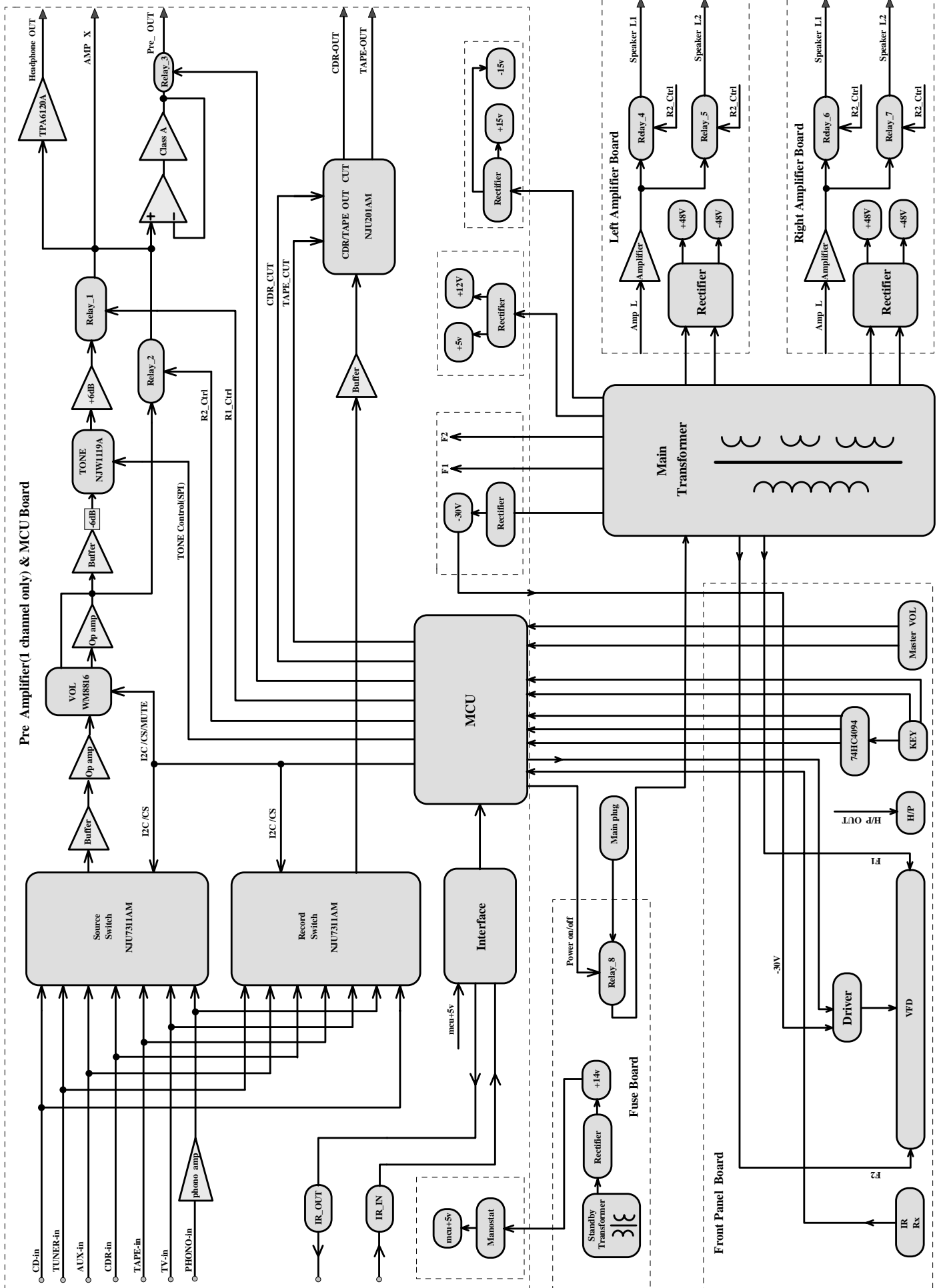

IC1

TC4094

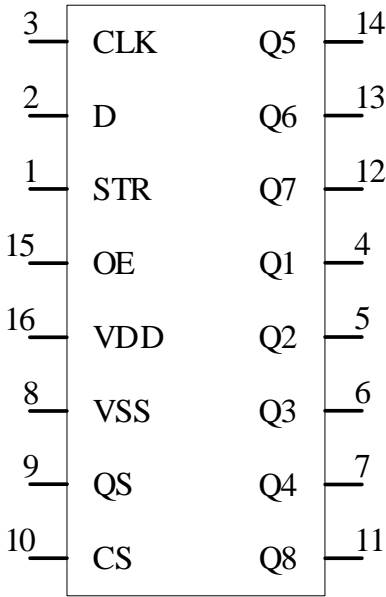

IC3
NJU731AM

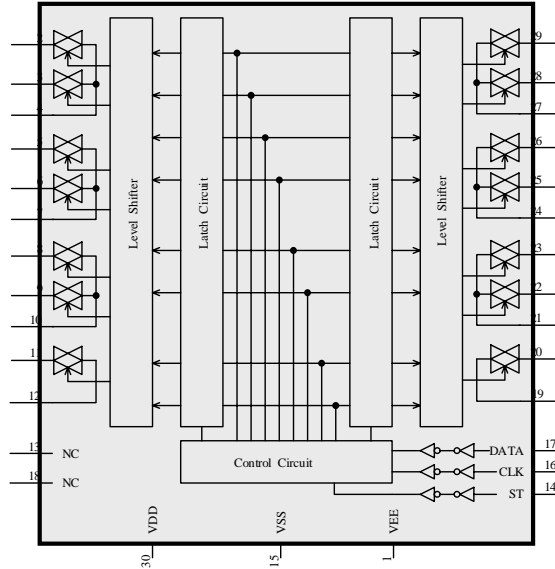

IC7
NJW119AV

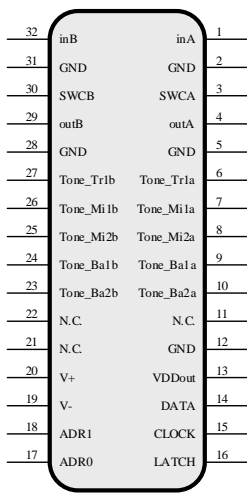

IC1
SM5964C40(PLCC4)

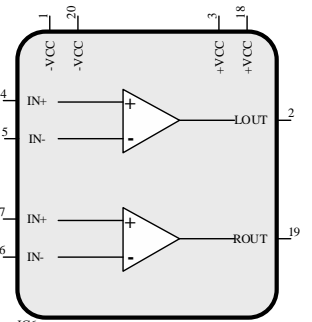
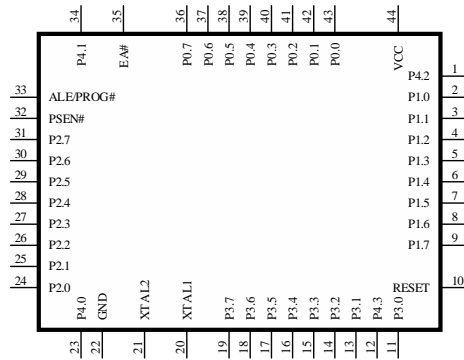

IC6
TPA6120A2DWP

IC8

NJW1159M

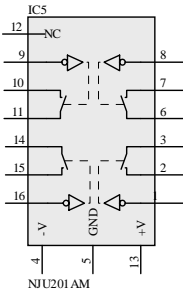
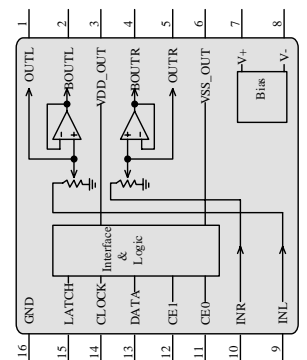

IC12A

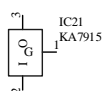
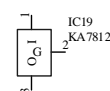
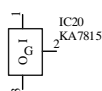
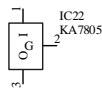
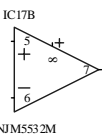
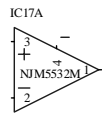
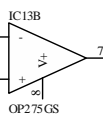
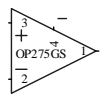



NJW1159

2-CHANNEL ELECTRONIC VOLUME

■ GENERAL DESCRIPTION

NJW1159 is a two channel electronic volume IC. It is included output buffer amplifier and also resistor output terminal for using external amplifier to customize for your application. These functions are controlled by three-wired serial data. And the chip selector is available for using four chips on same serial bus line. It's available for two-channel stereo and or multi-channel audio volume.

■ PACKAGE OUTLINE

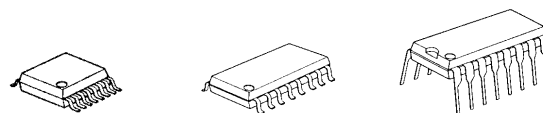

NJW1159V

NJW1159M

NJW1159D

■ FEATURES

- Operating Voltage ±4.5 to ±7.5V
- Three-Wired Serial Data Control
- Chip Selector available for using four chips on same serial bus line.
- Volume 0 to -95dB/1dBstep, MUTE
- Bi-CMOS Technology
- Package Outline SSOP16, DMP16, DIP16

■ BLOCK DIAGRAM

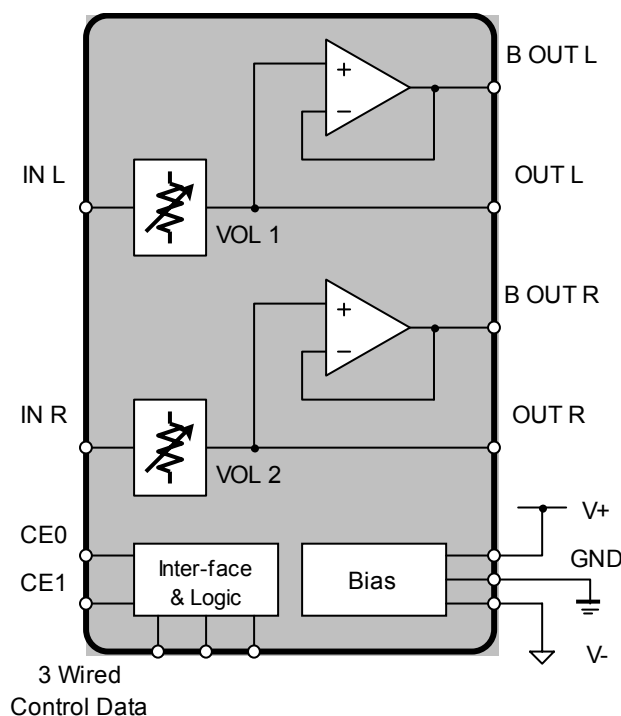



Dual Bipolar/JFET, Audio Operational Amplifier

OP275*

FEATURES

Excellent Sonic Characteristics
Low Noise: 6 nV/ $\sqrt{\text{Hz}}$
Low Distortion: 0.0006%
High Slew Rate: 22 V/ μs
Wide Bandwidth: 9 MHz
Low Supply Current: 5 mA
Low Offset Voltage: 1 mV
Low Offset Current: 2 nA
Unity Gain Stable
SOIC-8 Package

APPLICATIONS

High Performance Audio
 Active Filters
 Fast Amplifiers
 Integrators

GENERAL DESCRIPTION

The OP275 is the first amplifier to feature the Butler Amplifier front-end. This new front-end design combines both bipolar and JFET transistors to attain amplifiers with the accuracy and low noise performance of bipolar transistors, and the speed and sound quality of JFETs. Total Harmonic Distortion plus Noise equals that of previous audio amplifiers, but at much lower supply currents.

A very low 1/f corner of below 6 Hz maintains a flat noise density response. Whether noise is measured at either 30 Hz or 1 kHz, it is only 6 nV/ $\sqrt{\text{Hz}}$. The JFET portion of the input stage gives the OP275 its high slew rates to keep distortion low, even when large output swings are required, and the 22 V/ μs slew rate of the OP275 is the fastest of any standard audio amplifier. Best of all, this low noise and high speed are accomplished using less than 5 mA of supply current, lower than any standard audio amplifier.

*Protected by U.S. Patent No. 5,101,126.

PIN CONNECTIONS

8-Lead Narrow-Body SO
(S Suffix)

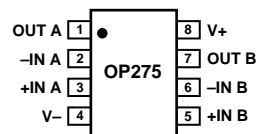

8-Lead Epoxy DIP
(P Suffix)

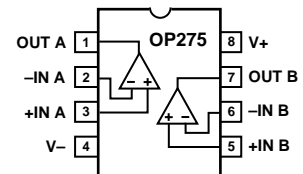

Improved dc performance is also provided with bias and offset currents greatly reduced over purely bipolar designs. Input offset voltage is guaranteed at 1 mV and is typically less than 200 μV . This allows the OP275 to be used in many dc coupled or summing applications without the need for special selections or the added noise of additional offset adjustment circuitry.

The output is capable of driving 600 Ω loads to 10 V rms while maintaining low distortion. THD + Noise at 3 V rms is a low 0.0006%.

The OP275 is specified over the extended industrial (-40°C to $+85^{\circ}\text{C}$) temperature range. OP275s are available in both plastic DIP and SOIC-8 packages. SOIC-8 packages are available in 2500 piece reels. Many audio amplifiers are not offered in SOIC-8 surface mount packages for a variety of reasons; however, the OP275 was designed so that it would offer full performance in surface mount packaging.

REV. A

Information furnished by Analog Devices is believed to be accurate and reliable. However, no responsibility is assumed by Analog Devices for its use, nor for any infringements of patents or other rights of third parties which may result from its use. No license is granted by implication or otherwise under any patent or patent rights of Analog Devices.

© Analog Devices, Inc., 1995

One Technology Way, P.O. Box 9106, Norwood, MA 02062-9106, U.S.A.
 Tel: 617/329-4700 Fax: 617/326-8703



NJW1119A

3-Band Tone Control IC

■ GENERAL DESCRIPTION

The NJW1119A is a Tone Control IC including 3-Band stereo EQ circuit.

It performs superior audio characteristics such as low distortion and low output noise. All of internal status are controlled by three-wired serial bus. Selectable 4-Chip address is available for using four chips on same serial bus line.

It is suitable for any audio applications.

■ PACKAGE OUTLINE



NJW1119AV

■ APPLICATIONS

- AV amplifier/receiver
- Car Audio
- Mini/Micro components

■ FEATURES

- Operating Voltage ± 4.5 to $\pm 7.5V$
 - 3-Wired Serial Control
 - Low Total Harmonic Distortion
 - Low Output Noise
 - Tone Control
 - Bi-CMOS Technology
 - Package Outline
 - Mute Function
- Chip Address Select Function
 0.0002% typ. @Tone=OFF
 -120dB typ. @Tone=OFF
 0 to $\pm 12dB/1dB$ Step (100Hz/1kHz/10kHz)
- SSOP32

■ BLOCK DIAGRAM

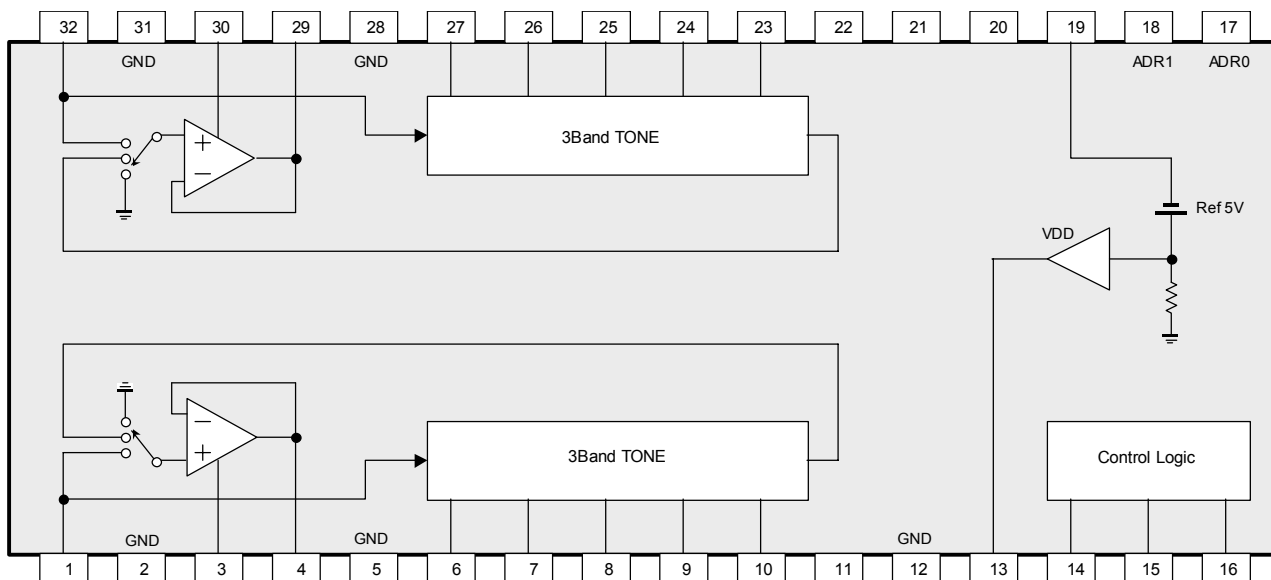

Futaba

蛍光表示管製品規格 VACUUM FLUORESCENT DISPLAY SPECIFICATION

C

双葉電子工業株式会社

電子部品事業部 電子管技術グループ
ENGINEERING GROUP, ELECTRON TUBE
ELECTRONIC COMPONENTS DIVISION
FUTABA CORPORATION

形名 Type No. 12-BD-011NK

用途 : Application AMP
外形寸法 : Outer Dimension 118.2 (L) × 18.5 (W) × 6.5 (T)mm
Cadmium Free Phosphor, Lead Free Solder
発光色 : Color of Illumination Green (G. x=0.24,y=0.41)

絶対最大定格: Absolute Maximum Rating

項目 : Item	Symbol	Terminals	Rating	Unit
フィラメント電圧 : Filament Voltage *1	Ef	F1-F2	4.0	Vac
ロジック電源電圧 : Logic Supply Voltage *3	VDD	VDD	-0.3 ~ 6.0	Vdc
ドライバ電源電圧 : Driver Supply Voltage *4	VH	VH	-0.3 ~ 36	Vdc
ロジック信号入力電圧 : Logic Input Voltage	VIN	SI,CLK,LAT,BK	-0.3 ~ VDD+0.3	Vdc
保存温度 : Storage Temperature	Tstg	—	-55 ~ +80	°C

絶対最大定格: 瞬時たりとも超えてはならない規格であり、これを超えた場合恒久的な機能障害を発生する可能性があります。
Absolute Maximum Condition : The value shall not be exceeded in any conditions. Permanent damage to VFD may be expected.

推奨動作条件: Recommended Operating Condition

項目 : Item	Symbol	Min.	Typ.	Max.	Unit
フィラメント電圧 : Filament Voltage *1	Ef	2.97	3.3	3.63	Vac
ドライバ電源電圧 : Driver Supply Voltage *4	VH	27	30	33	Vdc
ロジック電源電圧 : Logic Supply Voltage *3	VDD	4.5	5.0	5.5	Vdc
Hレベル入力電圧 : H-Level Input Voltage	VIH	VDD × 0.8	—	VDD	Vdc
Lレベル入力電圧 : L-Level Input Voltage	VIL	0	—	VDD × 0.2	Vdc
カットオフバイアス : Cut-off Bias *2	Ek	4.3	—	6.5	Vdc
動作温度 : Operating Temperature	Topr	-20	—	+70	°C

内部クロック動作特性: Characteristics of Internal Clock Circuit

項目 : Item	Symbol	条件: Condition	Typ.	Unit
自己発信周波数 : Internal Clock Frequency	f _{OSC}	V _{DD} =5.0V	1.6	MHz
表示フレーム周波数 : Display Frame Frequency	f _{FR}	R _{OSC} =24kΩ	520	Hz

Recommended Operating Condition: Quality and reliability can be assured in this condition.
(Typ. condition is the most optimized value on the life time.)

*1 AC50、60Hzまたは30kHz以上の実効値。50Hz,60Hz or > 30kHz r.m.s.

*2 フィラメントトランスのセンタータップに印加する。Ek is applied to the center tap of the filament transformer.

*3 電源シーケンス Power Supply Sequence

VHを印加中はVDDを4.5~5.5Vの間でご使用下さい。

VDD should be 4.5 to 5.5V when applying VH.

電源投入時はVDDとVHを同時、またはVDDを投入した後にVHを投入下さい。

VH and VDD should be on at the same, or VH should be on after VDD is on.

電源遮断時はVDDとVHを同時、またはVHを遮断した後にVDDを遮断下さい。

VH and VDD should be off at the same, or VDD should be off after VH is off.

*4 VHを印加中は推奨動作条件でご使用下さい。Recommended Operating Condition should be used when applying VH.

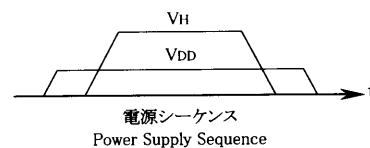

本製品は半導体製品ですので静電気のお取り扱いには十分ご注意ください。

The VFD is built with C-MOS lcs. Precautions should be taken to minimize the possibility of static charges.

本規格と異なる使い方をされる場合、品質、信頼性を確保出来ない場合がありますので事前にご相談下さい。

Since deviation from this specification may generate quality or reliability concerns, please consult to FUTABA prior to use.

この仕様書の内容はお断りなく変更することがありますのでご了承下さい。

This specification is subject to change without notice.



SINGLE-PHASE BRIDGE RECTIFIER

DF005 THRU DF10
DB101 THRU DB107

VOLTAGE RANGE

50 to 1000 Volts

CURRENT

1.0 Ampere

FEATURES

- Glass passivated chip junction
- High forward surge current capability
- Ideal for printed circuit board
- High temperature soldering guaranteed:
260°C/10 seconds at terminals

MECHANICAL DATA

- Case: Transfer molded plastic
- Epoxy: UL94V-0 rate flame retardant
- Terminals solderable per MIL-STD-202E method 208C
- Polarity: Molded on body
- Mounting position: Any
- Weight: 0.04 ounce, 1.0 gram

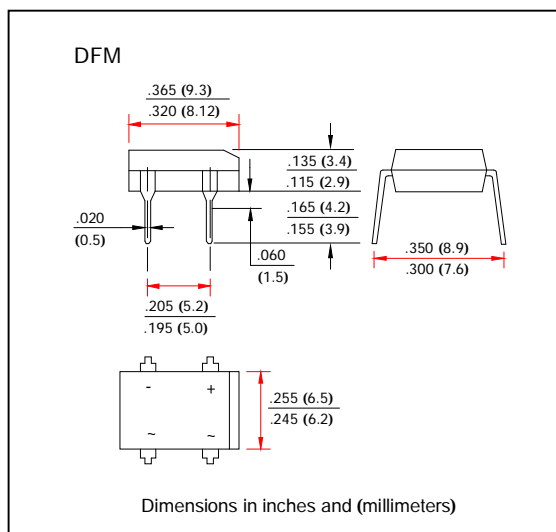

MAXIMUM RATINGS AND ELECTRICAL CHARACTERISTICS

- Ratings at 25°C ambient temperature unless otherwise specified
- Single Phase, half wave, 60Hz, resistive or inductive load
- For capacitive load derate current by 20%

	SYMBOLS	DF005 DB101	DF01 DB102	DF02 DB103	DF04 DB104	DF06 DB105	DF08 DB106	DF10 DB107	UNIT	
Maximum Reverse Peak Repetitive Voltage	V_{RRM}	50	100	200	400	600	800	1000	Volts	
Maximum RMS Voltage	V_{RMS}	35	70	140	280	420	560	700	Volts	
Maximum DC Blocking Voltage	V_{DC}	50	100	200	400	600	800	1000	Volts	
Maximum Average Forward Rectified Output Current, 0.06" (1.5mm) lead length at $T_A=40^\circ\text{C}$ (Note 2)	$I_{(AV)}$	1.0							Amps	
Peak Forward Surge Current 8.3ms single half sine wave superimposed on rated load (JEDEC Method)	I_{FSM}	50							Amps	
Rating for Fusing ($t < 8.3\text{ms}$)	I^2t	10							A^2s	
Maximum Instantaneous Forward Voltage drop Per Bridge element 1.0A	V_F	1.1							Volts	
Maximum Reverse Current at rated DC blocking voltage per element	$T_A=25^\circ\text{C}$	I_R							5	μAmps
	$T_A=125^\circ\text{C}$								0.5	mAmps
Typical Junction Capacitance (Note 1)	C_J	25							pF	
Typical Thermal Resistance (Note 2)	$R_{\theta JA}$	40							$^\circ\text{C}/\text{W}$	
Operating and Storage Temperature Range	T_J, T_{STG}	-55 to +150							$^\circ\text{C}$	

- Notes:**
1. Measured at 1.0MHz and applied reverse voltage of 4.0 Volts.
 2. Unit mounted on P.C.B. with 0.51"×0.51" (13×13mm) copper pads.



LITE-ON ELECTRONICS, INC.

Property of Lite-On Only

OUTLINE DIMENSIONS

LTV-817 :

TYPE I (INK MARK)

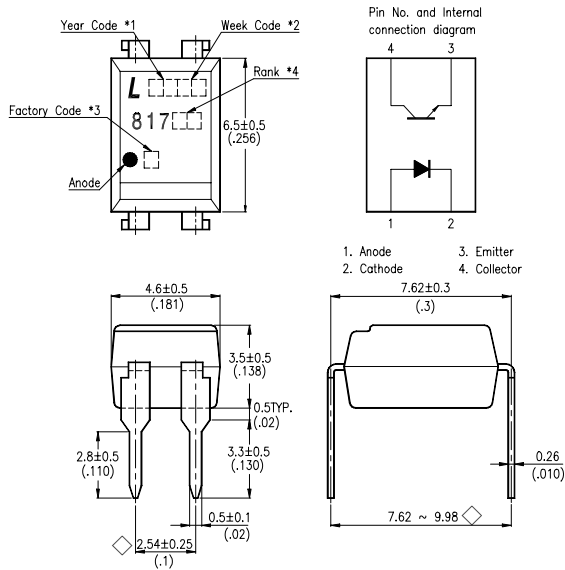

TYPE II (LASER MARK)

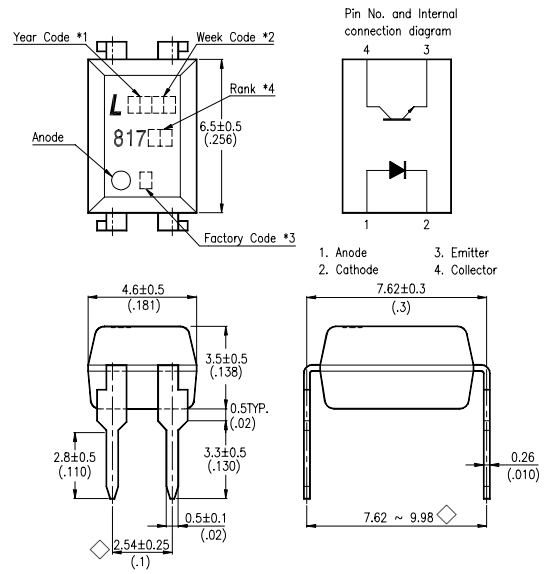

LTV-827 :

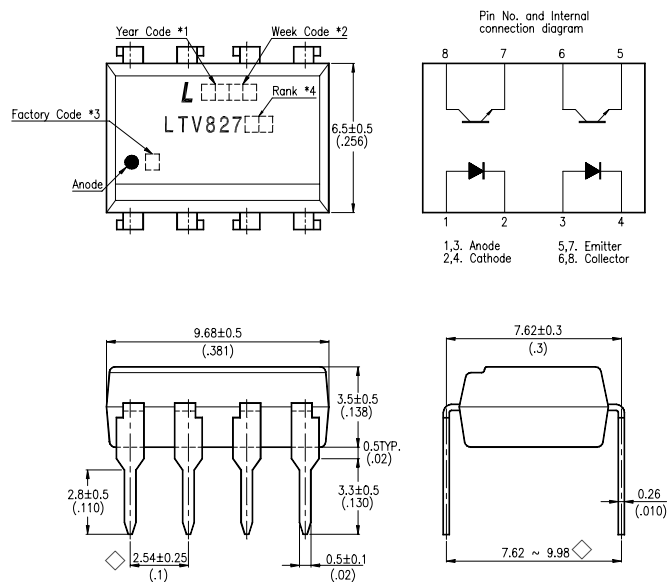

- *1. Year date code.
- *2. 2-digit work week.
- *3. Factory identification mark shall be marked (Z : Taiwan, Y : Thailand, X : China).
- *4. Rank shall be or shall not be marked.

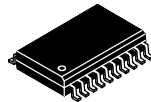

HIGH FIDELITY HEADPHONE AMPLIFIER

FEATURES

- 80 mW into 600 Ω From a ± 12 -V Supply at 0.00014% THD + N
- Current-Feedback Architecture
- Greater than 120 dB of Dynamic Range
- SNR of 120 dB
- Output Voltage Noise of 5 μ Vrms at Gain = 2 V/V
- Power Supply Range: ± 5 V to ± 15 V
- 1300 V/ μ s Slew Rate
- Differential Inputs
- Independent Power Supplies for Low Crosstalk
- Short Circuit and Thermal Protection

APPLICATIONS

- Professional Audio Equipment
- Mixing Boards
- Headphone Distribution Amplifiers
- Headphone Drivers
- Microphone Preamplifiers

DESCRIPTION

The TPA6120A2 is a high fidelity audio amplifier built on a current-feedback architecture. This high bandwidth, extremely low noise device is ideal for high performance equipment. The better than 120 dB of dynamic range exceeds the capabilities of the human ear, ensuring that nothing audible is lost due to the amplifier. The solid design and performance of the TPA6120A2 ensures that music, not the amplifier, is heard.

Three key features make current-feedback amplifiers outstanding for audio. The first feature is the high slew rate that prevents odd order distortion anomalies. The second feature is current-on-demand at the output that enables the amplifier to respond quickly and linearly when necessary without risk of output distortion. When large amounts of output power are suddenly needed, the amplifier can respond extremely quickly without raising the noise floor of the system and degrading the signal-to-noise ratio. The third feature is the gain-independent frequency response that allows the full bandwidth of the amplifier to be used over a wide range of gain settings. The excess loop gain does not deteriorate at a rate of 20 dB/decade.

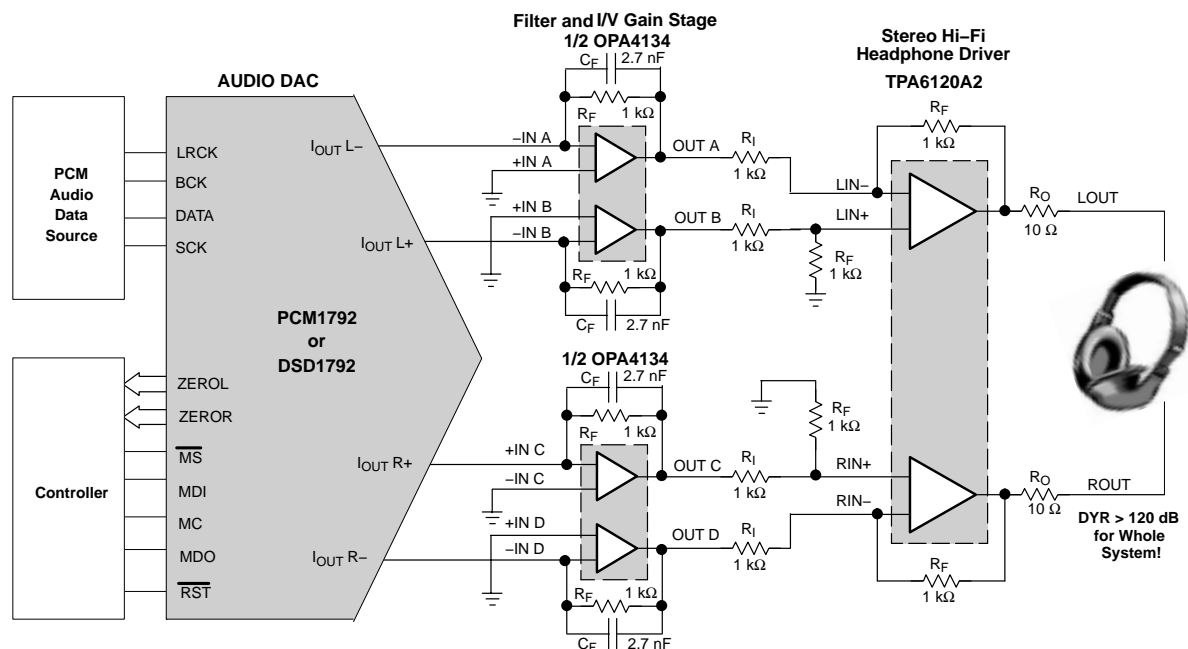

Please be aware that an important notice concerning availability, standard warranty, and use in critical applications of Texas Instruments semiconductor products and disclaimers thereto appears at the end of this data sheet.

PowerPAD is a trademark of Texas Instruments.

TOSHIBA CMOS DIGITAL INTEGRATED CIRCUIT SILICON MONOLITHIC

TC4094BP, TC4094BF, TC4094BFN

TC4094B 8 - STAGE SHIFT - AND - STORE BUSREGISTER

TC4094B is a SHIFT and STORE REGISTER that consists of an 8-bit shift register and an 8-bit latch. The read data in the shift register can be taken in the latch through the asynchronous STROBE input; therefore, the data transfer mode can hold output. And, since the parallel outputs is of 3-state construction, it can be directly connected to the 8-bit busline.

This register can be applied to Serial - to - parallel conversion, data receivers, etc.

(Note) The JEDEC SOP (FN) is not available in Japan.

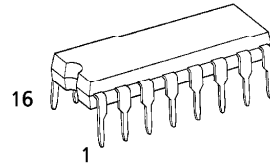

P (DIP16-P-300-2.54A)
Weight : 1.00g (Typ.)

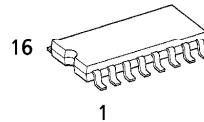

F (SOP16-P-300-1.27)
Weight : 0.18g (Typ.)

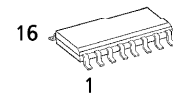

FN (SOL16-P-150-1.27)
Weight : 0.13g (Typ.)

MAXIMUM RATINGS

CHARACTERISTIC	SYMBOL	RATING	UNIT
DC Supply Voltage	V_{DD}	$V_{SS} - 0.5 \sim V_{SS} + 20$	V
Input Voltage	V_{IN}	$V_{SS} - 0.5 \sim V_{DD} + 0.5$	V
Output Voltage	V_{OUT}	$V_{SS} - 0.5 \sim V_{DD} + 0.5$	V
DC Input Current	I_{IN}	± 10	mA
Power Dissipation	P_D	300 (DIP) / 180 (SOIC)	mW
Operating Temperature Range	T_{opr}	$-40 \sim 85$	$^{\circ}C$
Storage Temperature Range	T_{stg}	$-65 \sim 150$	$^{\circ}C$

PIN ASSIGNMENT

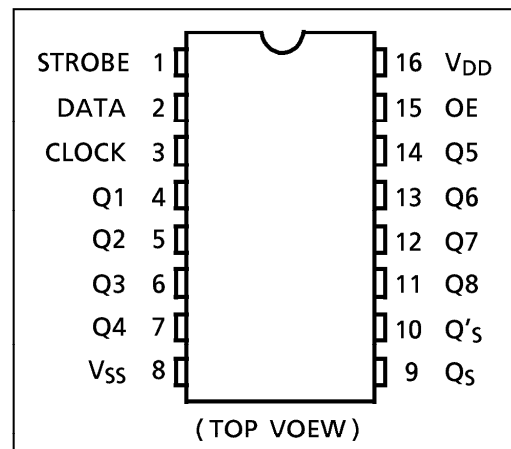

BLOCK DIAGRAM

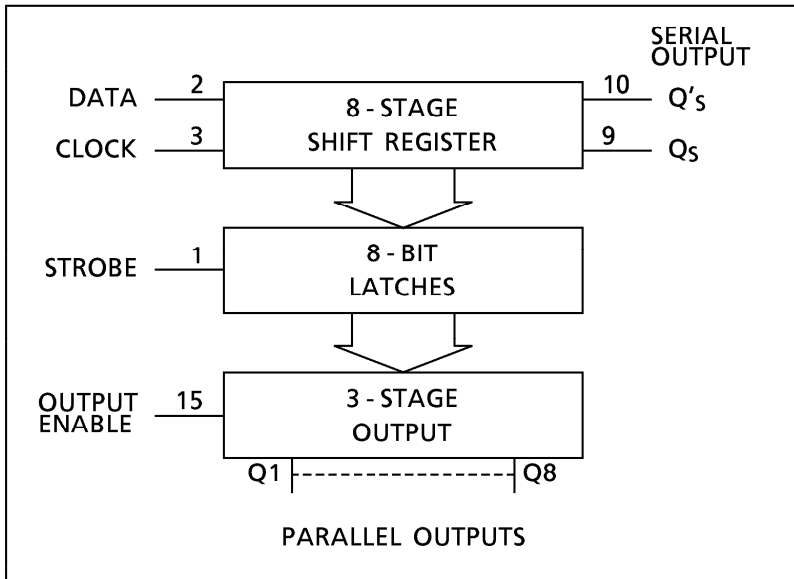

TRUTH TABLE

CL	OE	ST	D	PO		SO	
				Q1	Qn	Qs	Q's
\uparrow	H	H	L	L	$Q_n - 1$	Q7	NC
\uparrow	H	H	H	H	$Q_n - 1$	Q7	NC
\uparrow	H	L	X	NC	NC	Q7	NC
\uparrow	L	X	X	HZ	HZ	Q7	NC
\downarrow	H	X	X	NC	NC	NC	Qs
\downarrow	L	X	X	HZ	HZ	NC	Qs

CL = Clock
OE = Output Enable
ST = Strobe
D = Data
PO = Parallel Outputs
SO = Serial Output
X = Don't Care
NC = No Change
HZ = High Impedance

961001EBA2

● TOSHIBA is continually working to improve the quality and the reliability of its products. Nevertheless, semiconductor devices in general can malfunction or fail due to their inherent electrical sensitivity and vulnerability to physical stress. It is the responsibility of the buyer, when utilizing TOSHIBA products, to observe standards of safety, and to avoid situations in which a malfunction or failure of a TOSHIBA product could cause loss of human life, bodily injury or damage to property. In developing your designs, please ensure that TOSHIBA products are used within specified operating ranges as set forth in the most recent products specifications. Also, please keep in mind the precautions and conditions set forth in the TOSHIBA Semiconductor Reliability Handbook.



NJM5532

HIGH PERFORMANCE LOW-NOISE DUAL OPERATIONAL AMPLIFIER

GENERAL DESCRIPTION

The NJM5532 is a high performance dual low noise operational amplifier. Compared to the standard dual operational amplifiers, such as the NJM1458, it shows better noise performance, improved output drive capability, and considerably higher small-signal and power bandwidths.

This makes the device especially suitable for application in high quality and professional audio equipment, instrumentation, control circuits, and telephone channel amplifiers. The op amp is internally compensated for gains equal to one. If very low noise is of prime importance, version be used which has guaranteed NJM5532DD it is recommended that the noise specifications.

PACKAGE OUTLINE

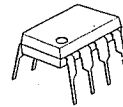

NJM5532D



NJM5532M

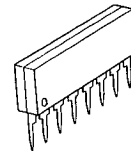

NJM5532L

FEATURES

- Operating Voltage ($\pm 3V \sim \pm 20V$)
- Small Signal Bandwidth (10MHz typ.)
- Output Drive Capability ($600\Omega, 10V_{rms}$ typ.)
- Input Noise Voltage ($5nV/\sqrt{Hz}$ typ.)
- Power Bandwidth (140kHz typ.)
- Slew Rate ($8V/\mu s$ typ.)
- Package Outline DIP8, DMP8, SIP8
- Bipolar Technology

PIN CONFIGURATION

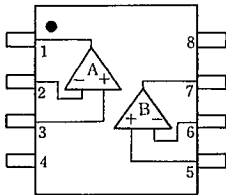

NJM5532D
NJM5532M

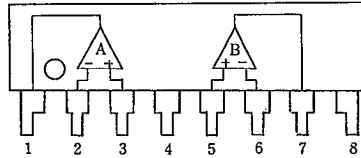

NJM5532L

PIN FUNCTION

1. A OUTPUT
2. A-INPUT
3. A+INPUT
4. V-
5. B+INPUT
6. B-INPUT
7. B OUTPUT
8. V+

EQUIVALENT CIRCUIT

(1/2 Shown)

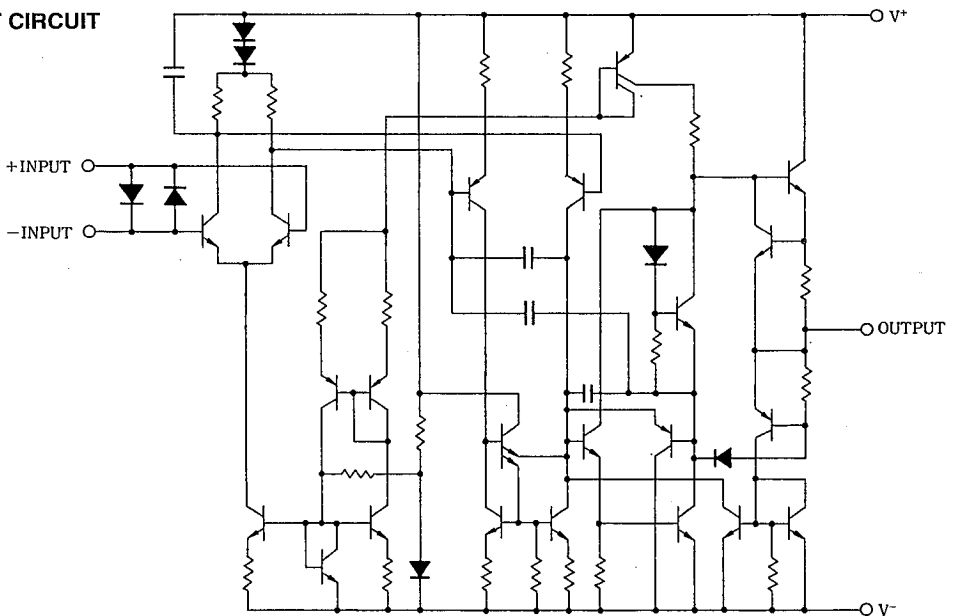

ANALOG FUNCTION SWITCH

■ GENERAL DESCRIPTION

The NJU7311A is a hexad 2-channel and dual 1-channel analog function switch, especially suitable for input selector of audio equipments.

The high break down voltage analog switch controlled by 14-bit serial data based on logic operating voltage (5V) can ON and OFF of $\pm 15V$ signal.

The analog switch is realized superior linearity of on-resistance in all voltage range, low distortion and wide dynamic range.

Furthermore, the both of single and dual power supply application provides easy designing.

■ PACKAGE OUTLINE

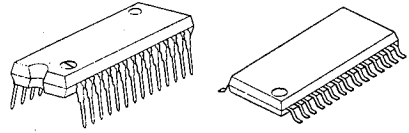

NJU7311AL

NJU7311AM

6

■ FEATURES

- Analog switch: hexad 2 channel and dual 1 channel.
- High Break Down Voltage ----- $\pm 15V$.
- Low Distortion ----- THD: 0.002% (typ).
- Superior Linearity of ON Resistance.
- Serial Data Control.
- Package Outline SDIP 28 / DMP 30
- C-MOS Technology

■ PIN CONFIGURATION

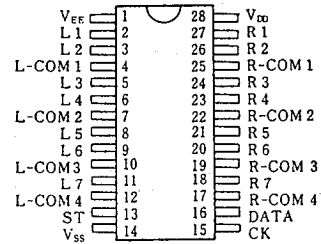

■ BLOCK DIAGRAM

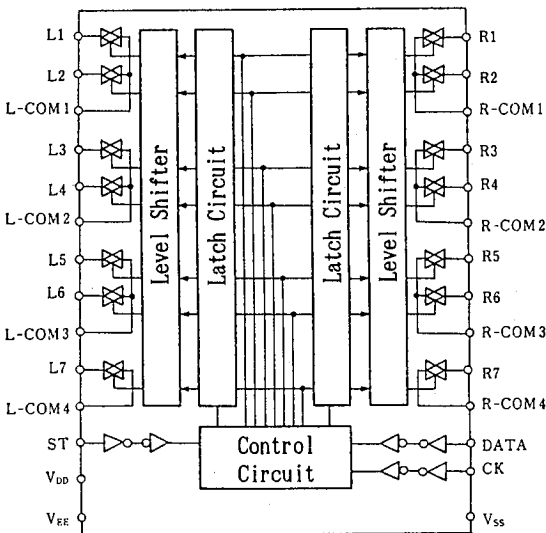

NJU7311AL

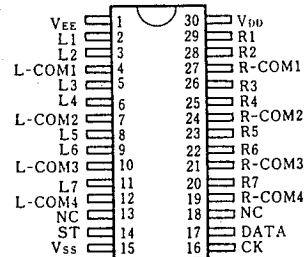

NJU7311AM

C-MOS QUAD SPST ANALOG SWITCH

■ **GENERAL DESCRIPTION**

The NJU201A is a quad break-before-make SPST analog switch protected up to 44V operating voltage.

All switches are controlled by TTL or C-MOS compatible input.

The low on-state resistance is about half compare with the NJU7301.

The NJU201A is functionally and pin-to-pin compatible with SILICONIX DG201A.

■ **PACKAGE OUTLINE**

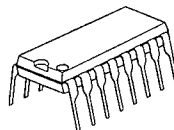

NJU201AD

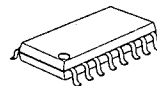

NJU201AM

■ **FEATURES**

- High Break Down Voltage -- 44V
- Low On-state Resistance
- Package Outline -- DIP/DMP 16
- C-MOS Technology

■ **PIN CONFIGURATION**

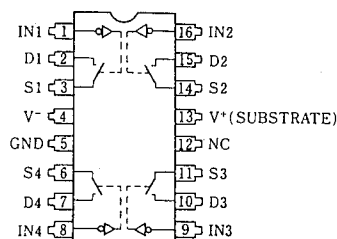

6

■ **TRUTH TABLE**

Logic (In)	Switch
0	ON
1	OFF

■ **EQUIVALENT CIRCUIT**

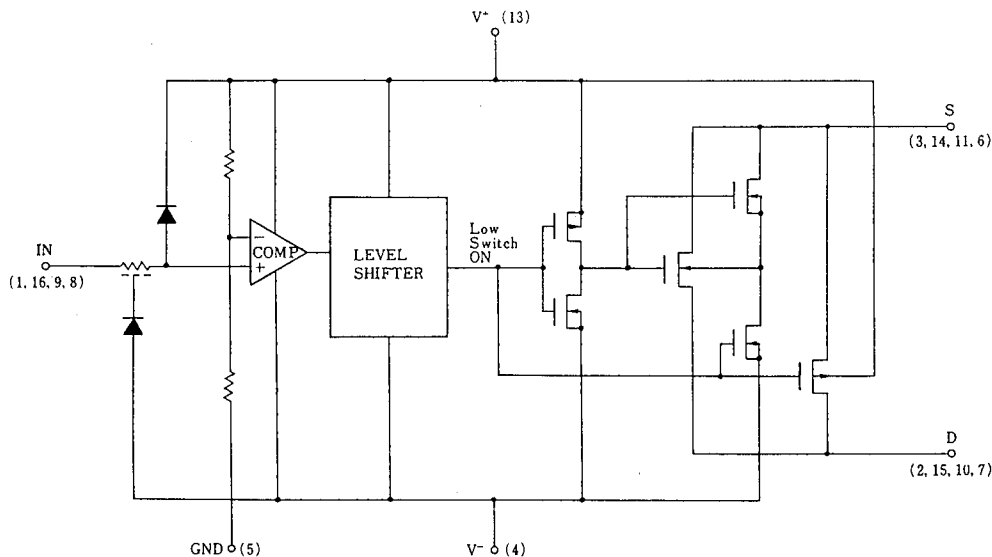

* Logic input threshold voltage V_{TH} is about $V^+ \times 0.128(V)$.
 When the designing, enough margin is required.



NJM2068

LOW-NOISE DUAL OPERATIONAL AMPLIFIER

■ GENERAL DESCRIPTION

The NJM2068 is a high performance, low noise dual operational amplifier. This amplifier features popular pin-out, superior noise performance, and superior total harmonic distortion. This amplifier also features guaranteed noise performance with substantially higher gain-bandwidth product and slew rate which far exceeds that of the 4558 type amplifier. The specially designed low noise input transistors allow the NJM2068 to be used in very low noise signal processing applications such as audio preamplifiers and servo error amplifier.

■ FEATURES

- Operating Voltage (±4V ~ ±18V)
- Low Total Harmonic Distortion (0.001% typ.)
- Low Noise Voltage (FLAT+JISA, 0.56 μV typ.)
- High Slew Rate (6V/μs typ.)
- Unity Gain Bandwidth (27MHz @f=10kHz)
- Package Outline DIP8, DMP8, SIP8, SSOP8
- Bipolar Technology

■ PACKAGE OUTLINE

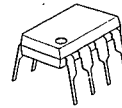

NJM2068D



NJM2068M



NJM2068V

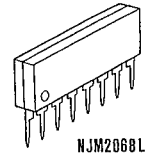

NJM2068L

■ PIN CONFIGURATION

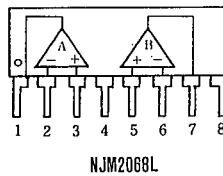
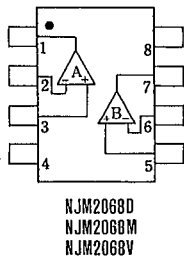

PIN FUNCTION

1. A OUTPUT
2. A-INPUT
3. A+INPUT
4. V-
5. B+INPUT
6. B-INPUT
7. B OUTPUT
8. V+

■ EQUIVALENT CIRCUIT (1/2 Shown)

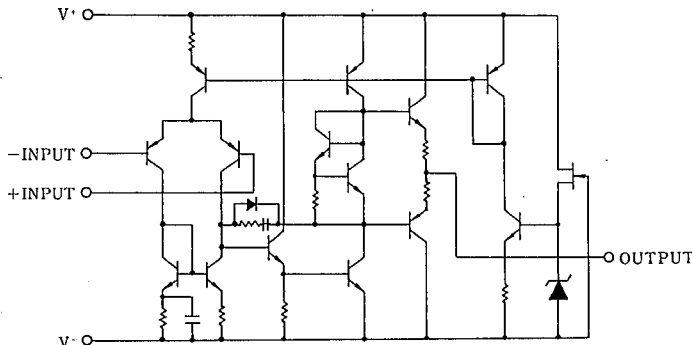

2SA1162,2SC3326,2SC3361

2SA950 , 2SC2120

2SA1035TR, 2SC2406TR

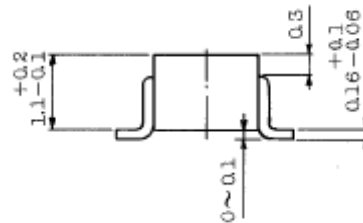
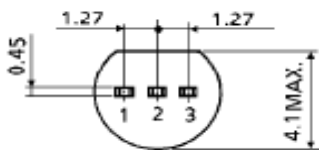
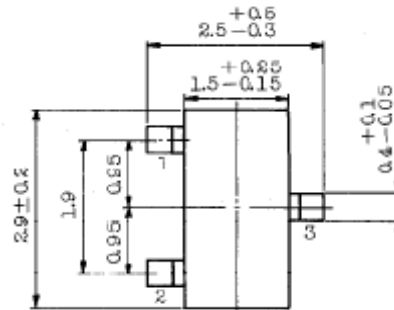
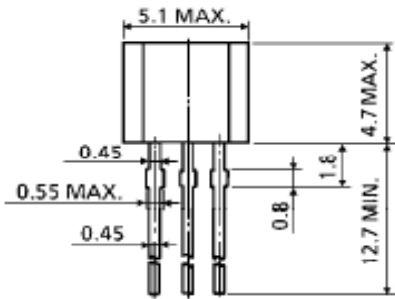

- 1. EMITTER
- 2. COLLECTOR
- 3. BASE

- 1. BASE
- 2. EMITTER
- 3. COLLECTOR

2SC2458,2SA1048

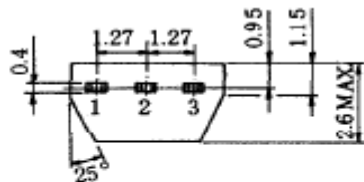
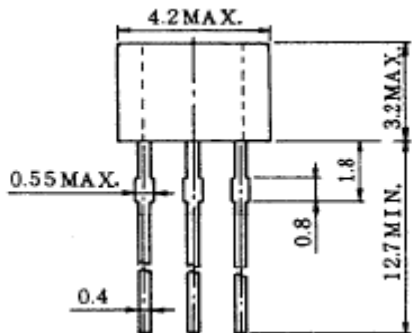

- 1. EMITTER
- 2. COLLECTOR
- 3. BASE

2SC5242
2SA1962

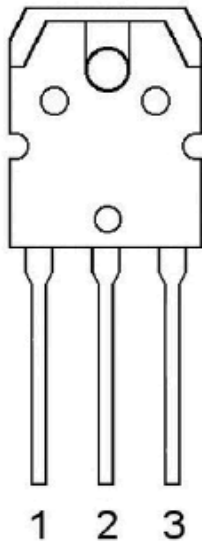

- 1. BASE
- 2. COLLECTOR
- 3. EMITTER

2SC4793
2SA1837

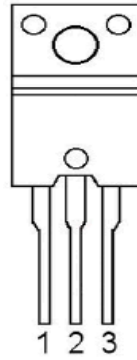

- 1. BASE
- 2. COLLECTOR
- 3. EMITTER

2SC3502
2SA1380

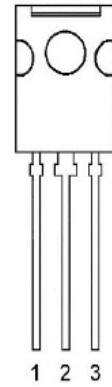

- 1. EMITTER
- 2. COLLECTOR
- 3. BASE

BF422

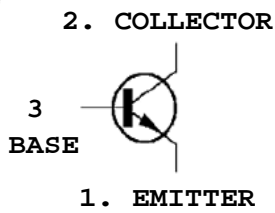

BF423

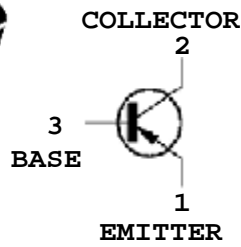

MPSA06

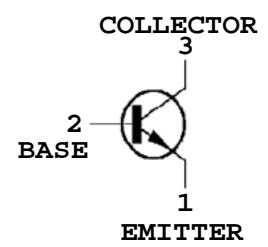

RS803

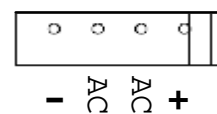
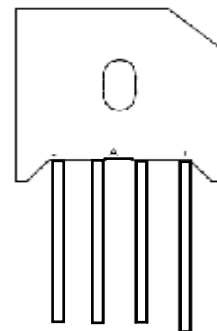

MPSA56



- 1. EMITTER
- 2. BASE
- 3. COLLECTOR

2SC1740S



- 1. EMITTER
- 2. COLLECTOR
- 3. BASE

2SC2240



- 1. BASE
- 2. COLLECTOR
- 3. EMITTER

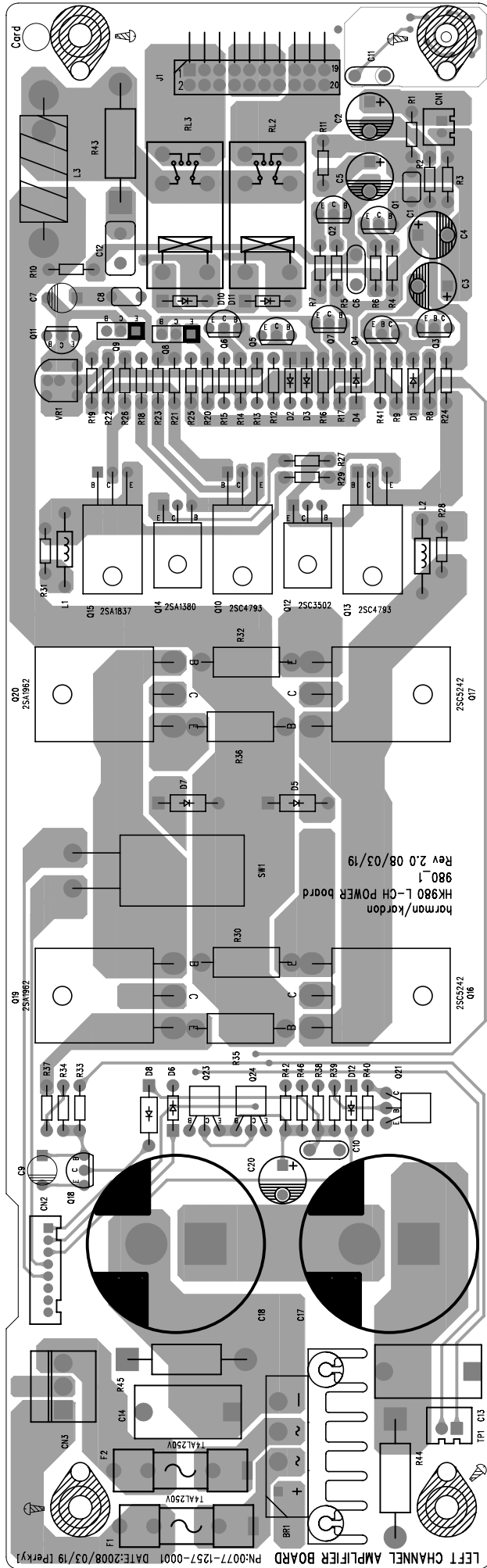

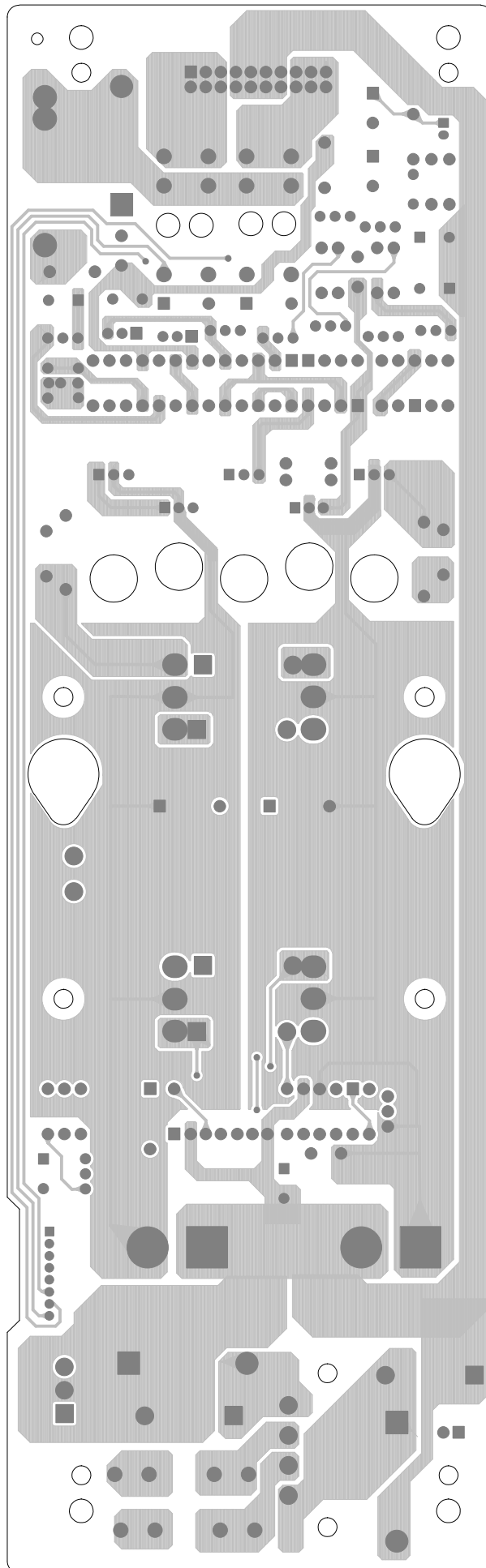

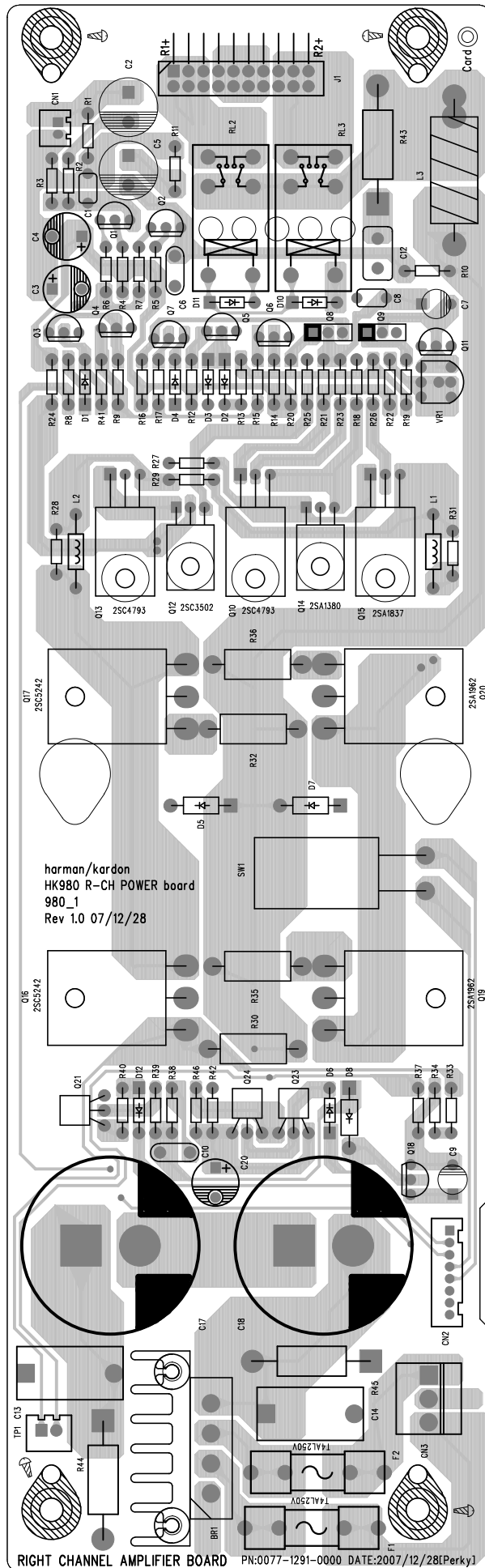

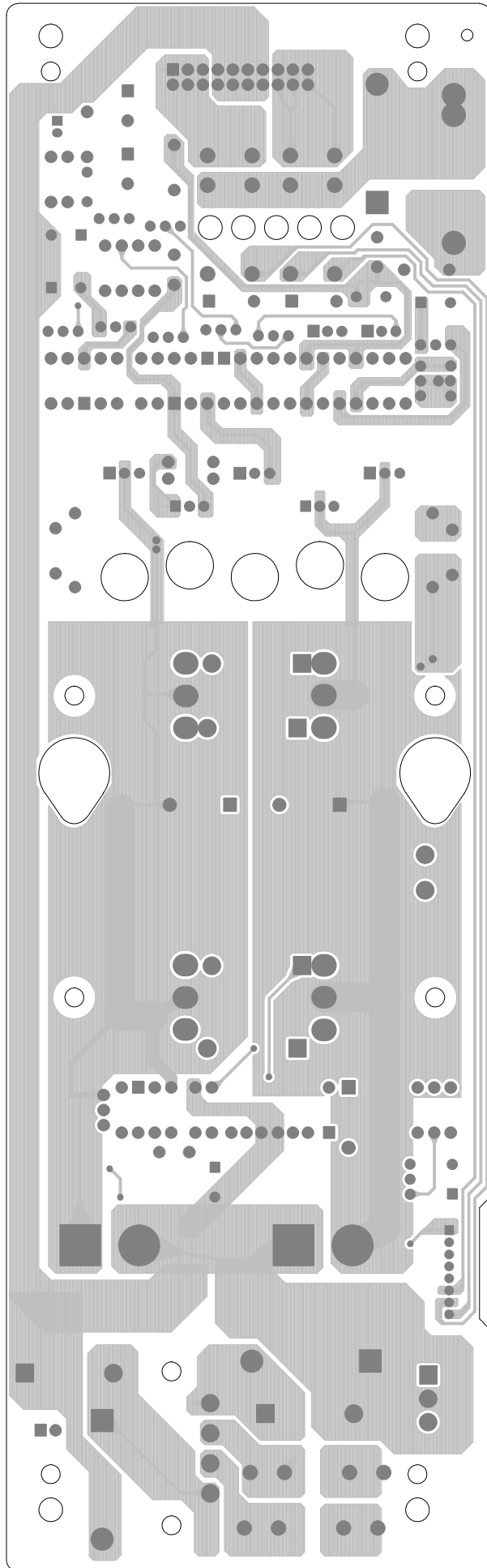

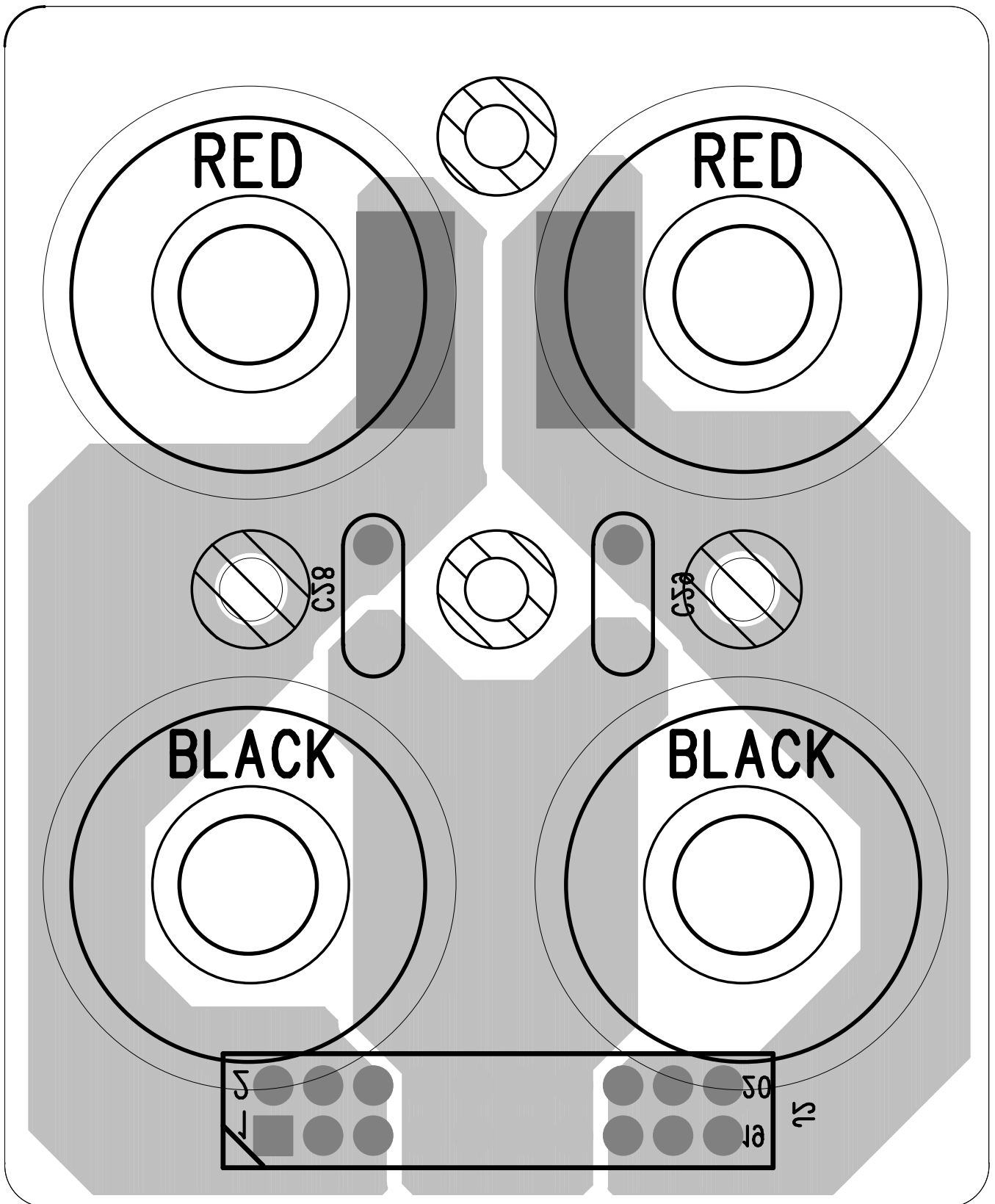

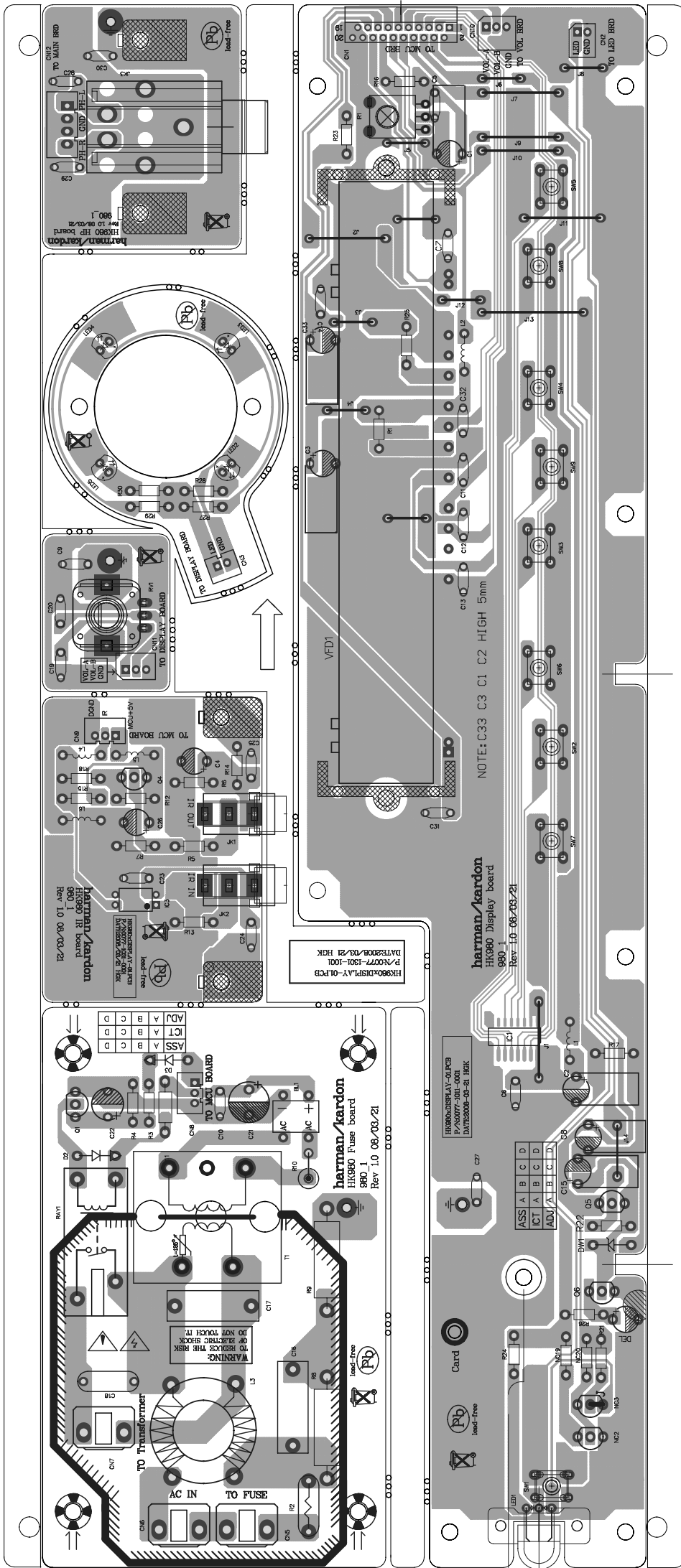

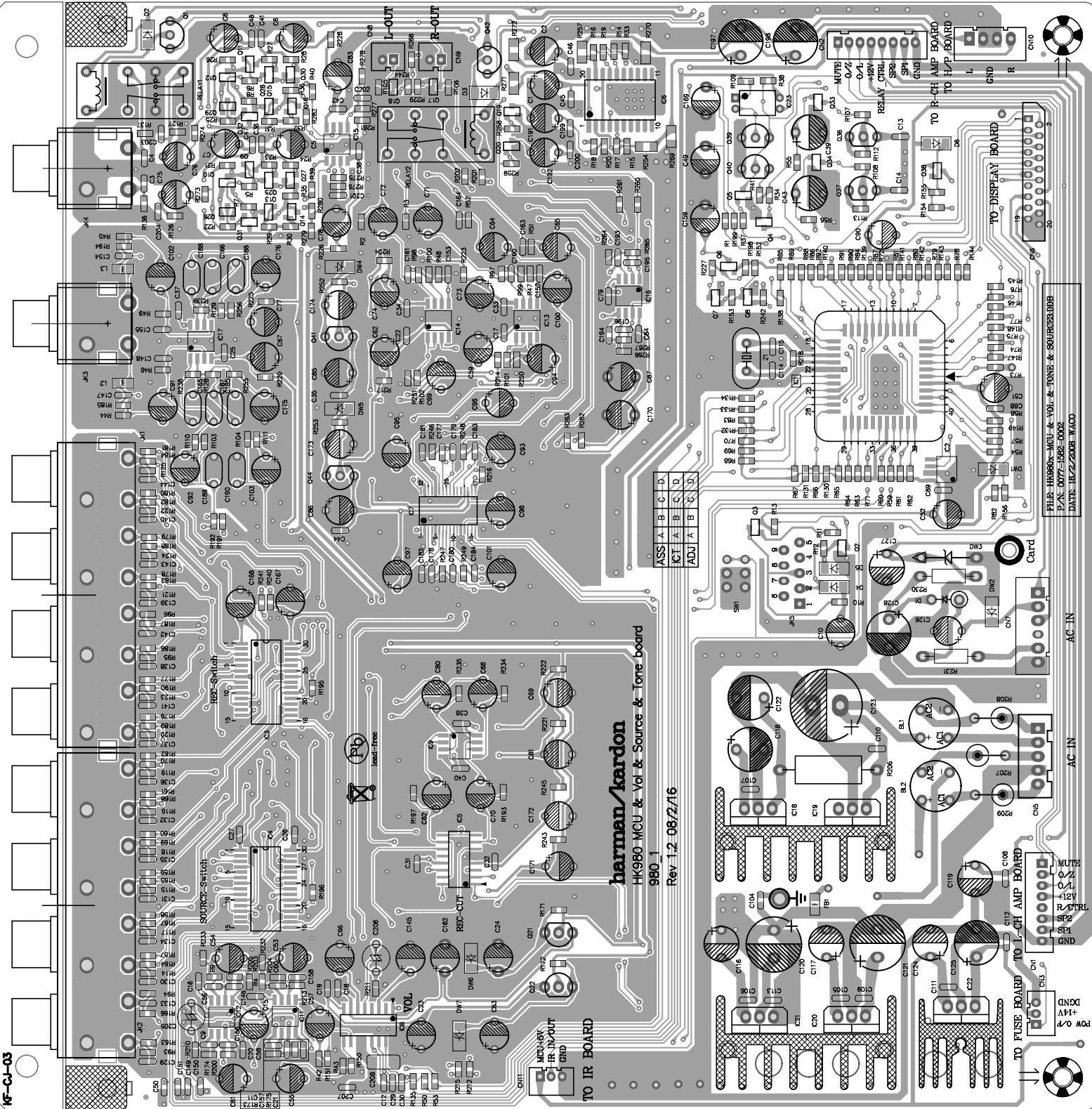

ASS	A	B	C	D
CT	A	B	C	D
ADD	A	B	C	D

FILE: HK980-MCU & VOL & TONE & SOURCE.DDD
 P/N: 0077-1582-0002
 DATE: 10/22/2008 WACO

NF-CJ-03

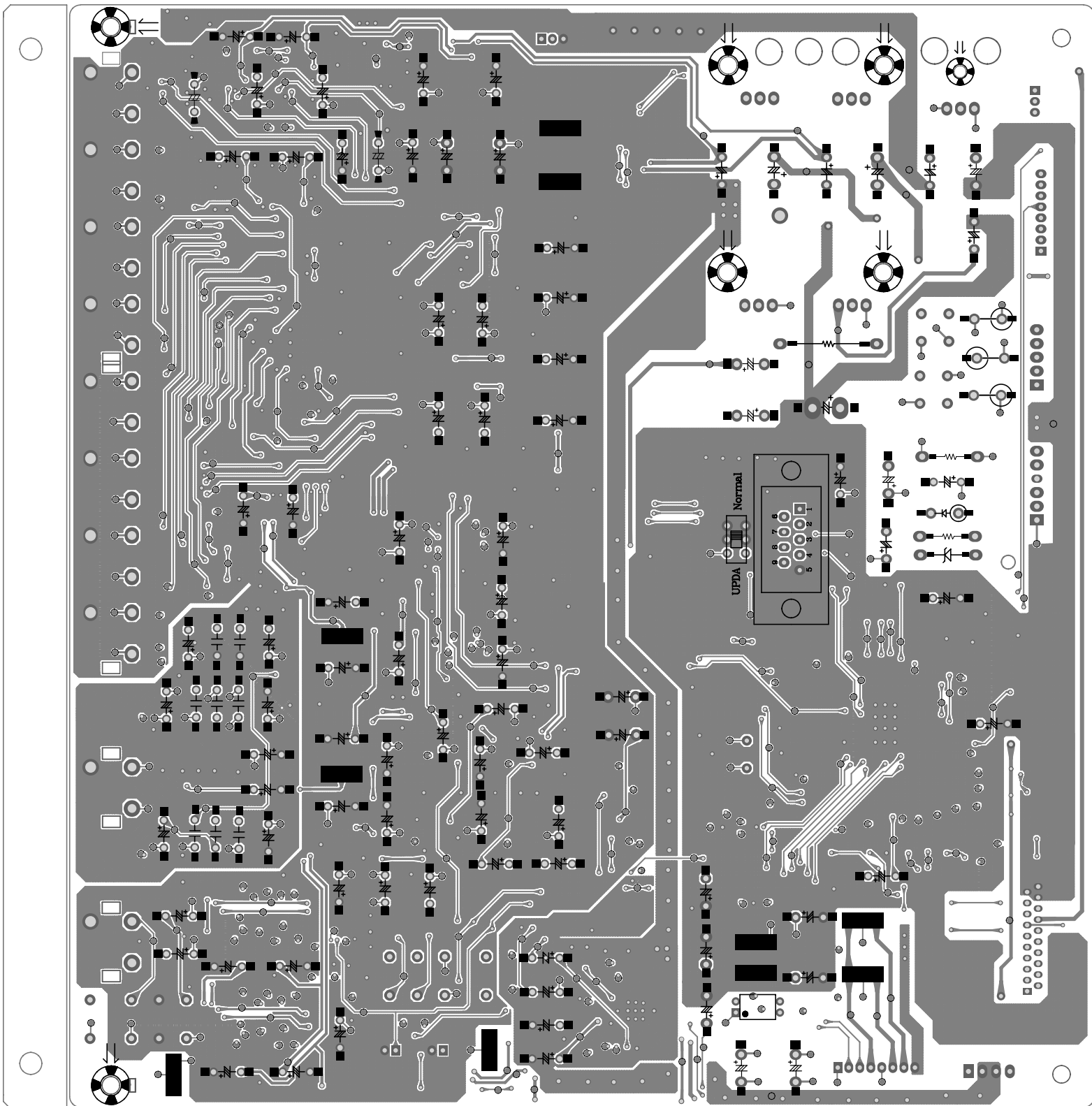

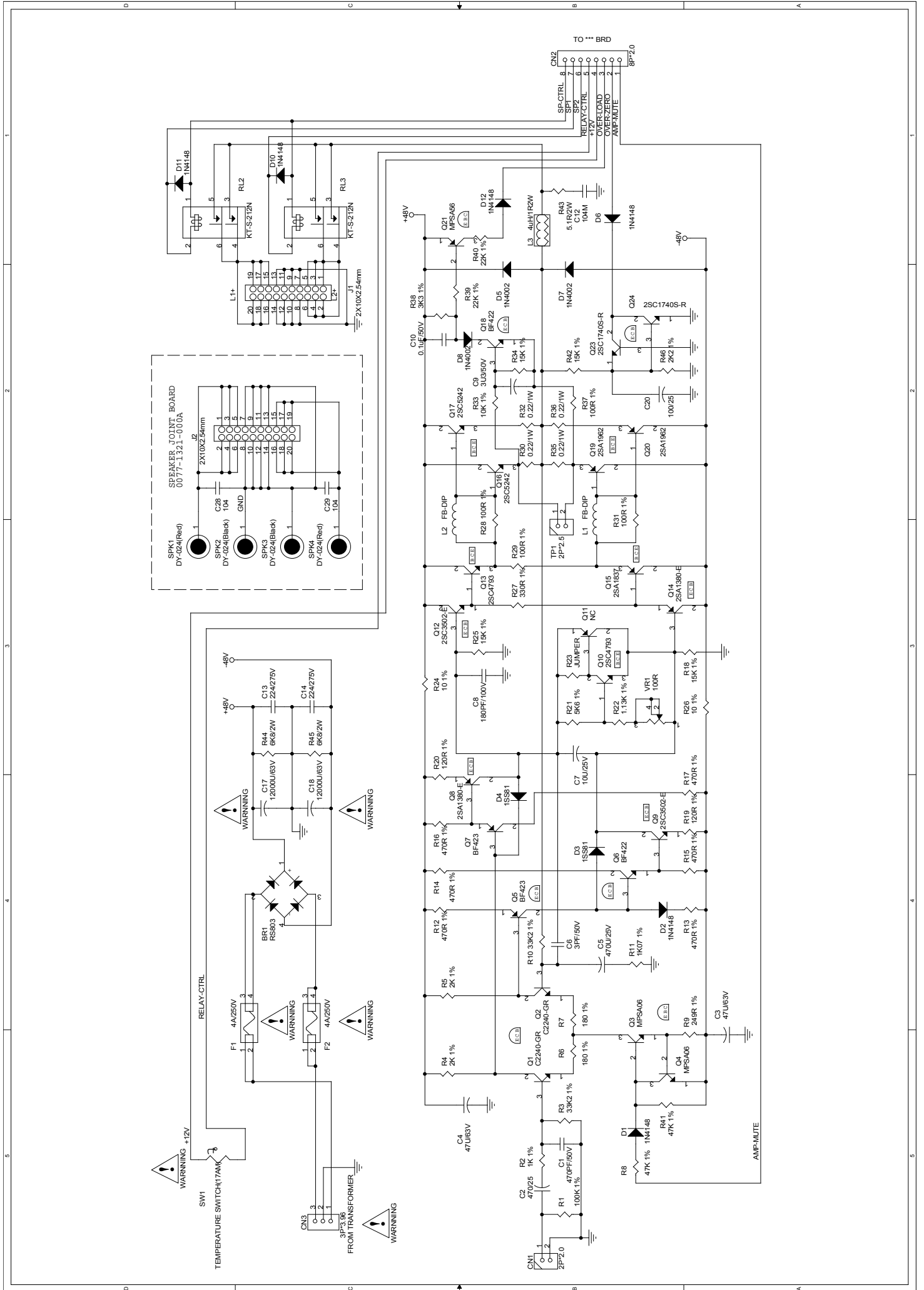

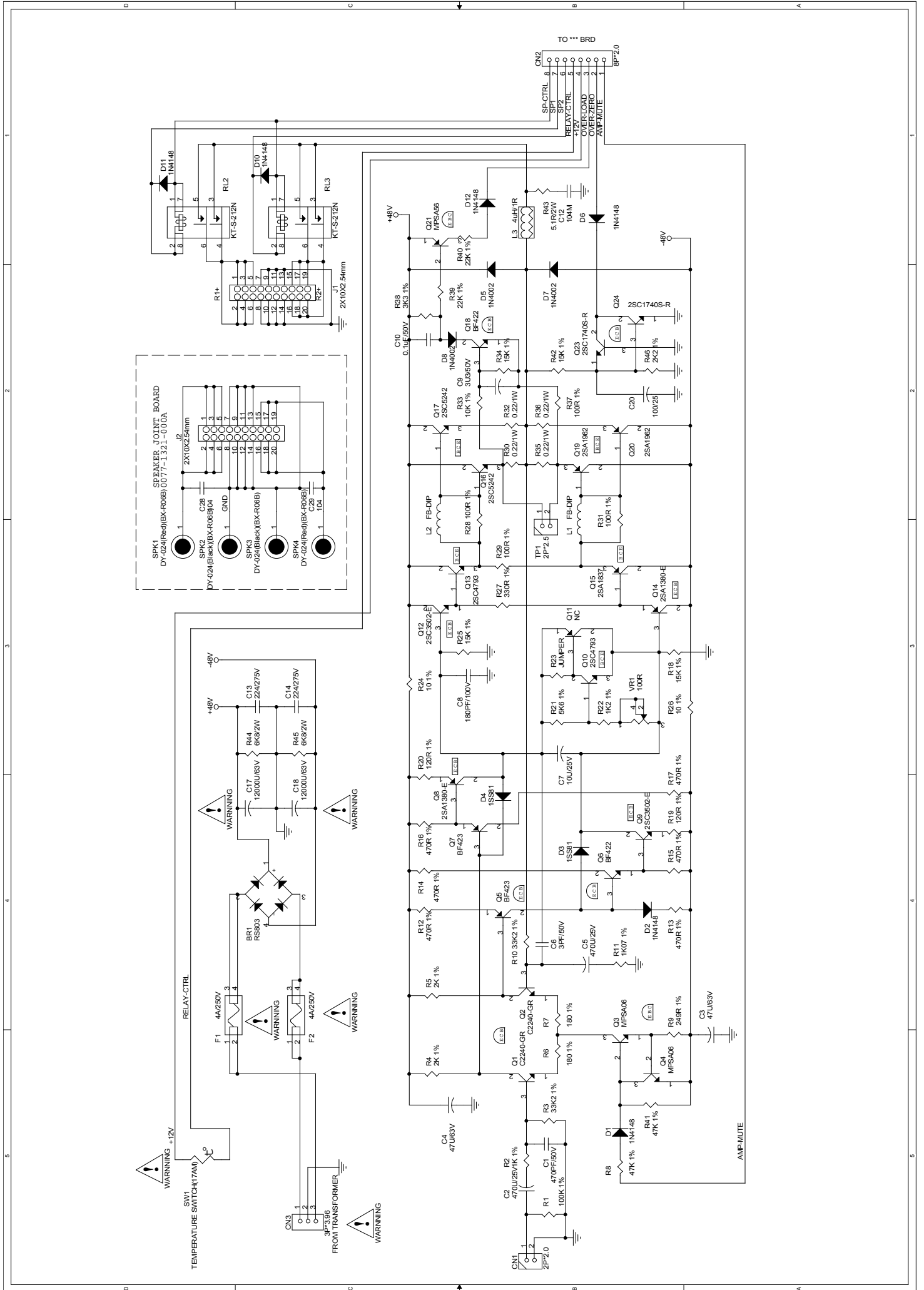

KL-YL-03

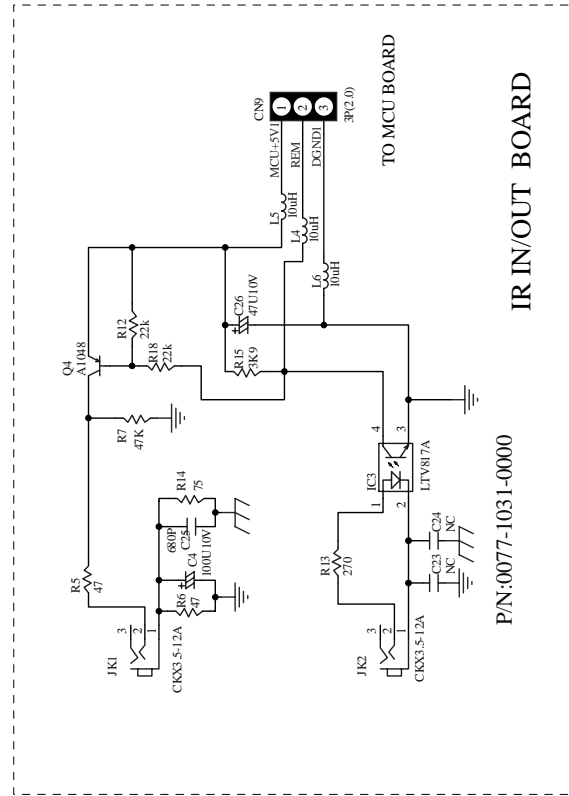
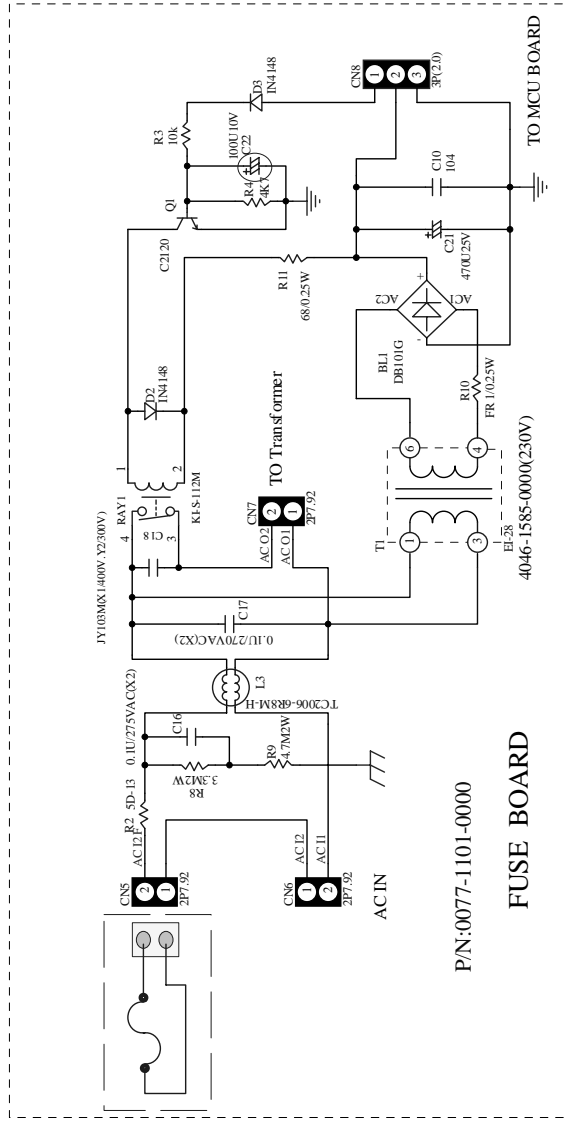
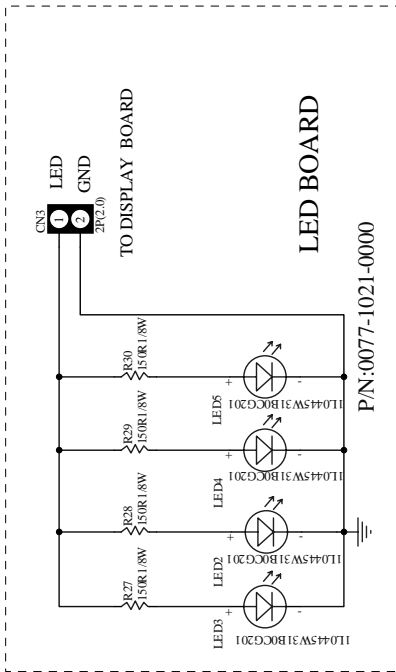
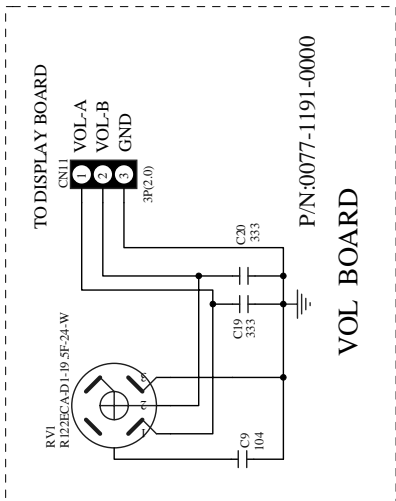
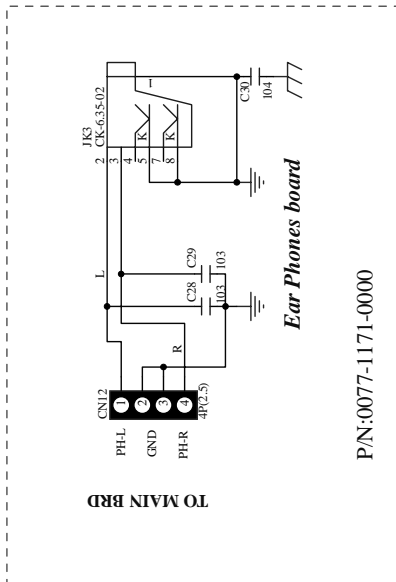

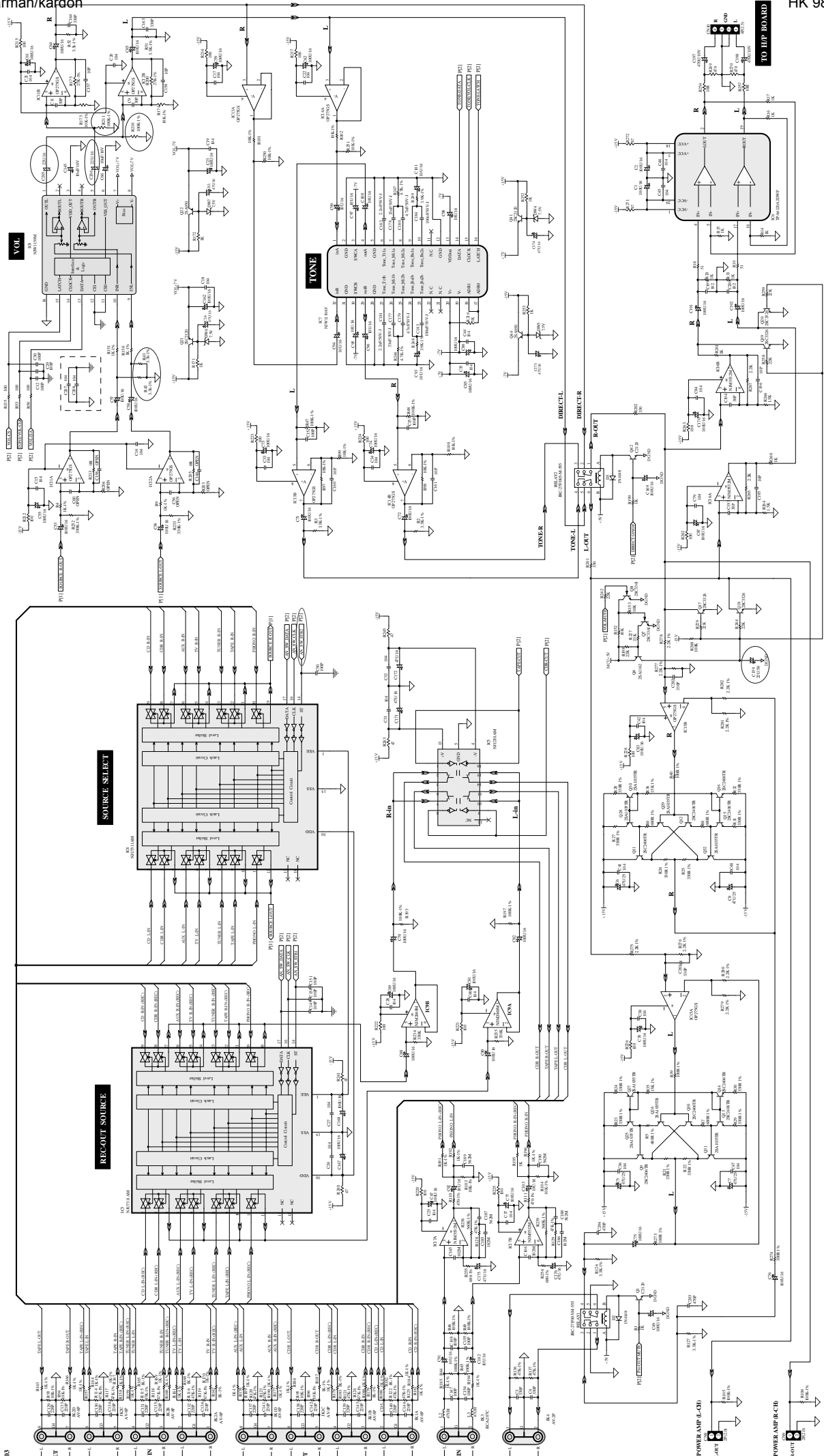

MFSL-45

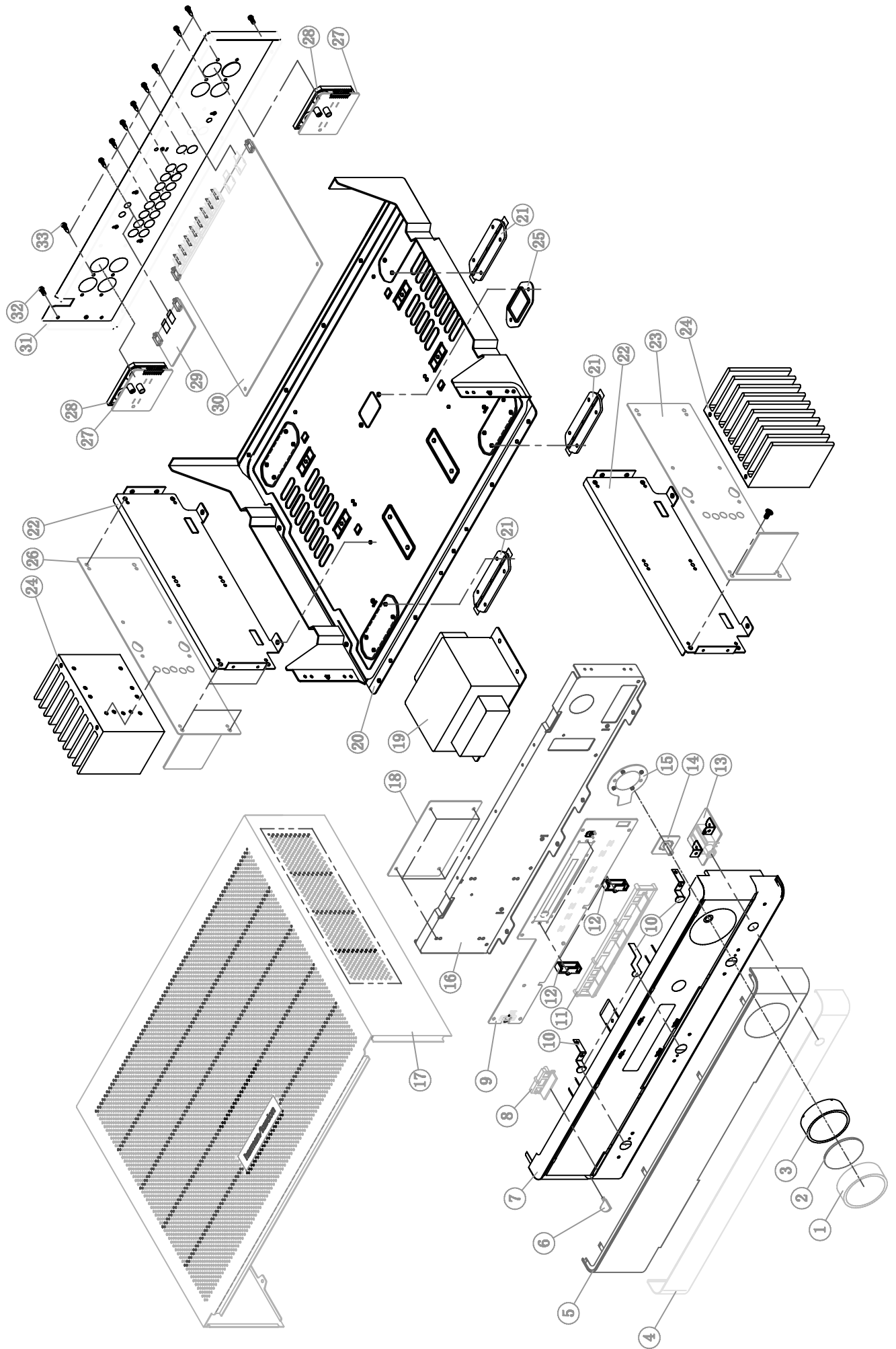

980 Explode List

NO	PART.NO	DESCRIPTION	QTY
1	7648 1010 0000	VOLUME KNOB COVER	1
2	7448 1020 0000	VOLUME KNOB LENS	1
3	7548 1010 0000	VOLUME PASTEM	1
4	6048 1010 0000	AL PANEL	1
5	7448 101C 0000	DISPLAY LENS	1
6	7448 103A 0000	STANDY LENS	1
7	7048 101D 0000	PASTEM PANEL	1
8	7348 101A 0000	POWER KNOB	1
9	0077 1011 0001	DISPLAY PCB	1
10	5548 103A 0000	EARTHING CUPREM	3
11	7348 102B 0000	FUNCTION KNOB	1
12	7548 103B 0000	DISPLAY BRACKET	2
13	0077 1171 0001	PHONES PCB	1
14	0077 1191 0001	VOL PCB	1
15	0077 1021 0001	LED PCB	1
16	5348 101C 0000	SUBPANEL	1
17	6148 101B 0000	TOP COVER	1
18	0077 1101 0001	FUSE PCB	1
19	4070 1965 0001	TRANSFORMER	1
20	6248 101C 0000	BOTTOM COVER	1
21	7948 1010 0000	FOOT	4
22	5348 102B 0000	PCB BRACKET	2
23	0077 1291 0000	RIGHT AMP PCB	1
24	5148 1010 0000	HEATSIINK	2
25	7948 102B 0000	RS232 COVER	1
26	0077 1257 0001	LEFT AMP PCB	1
27	0077 1321 0000	SPEAKER CONNECT PCB	2
28	7548 1050 0000	SPEAKER BRACKET	2
29	0077 1031 0001	IR IN/OUT PCB	1
30	0077 1582 0002	MCU & VOL & SOURCE & TONE PCB	1
31	6348 101B 0000	BACK COVER	1
32	5011 3008 0010	SCREW BTB ϕ 3.0x8	20
33	5013 3010 0010	SCREW PA ϕ 3.0x10	10

HK980x PARTS LIST

LEFT CHANNEL POWER AMPLIFIER

PN:0077-1257-0002

Used	Part number	Part Type	Designator Description
1	1360 7080 3000	RS803	BR1
1	3100 4020 0200	2P*2.0	CN1
1	3100 4080 0200	8P*2.0	CN2
1	3100 0702 0050	3P*3.96	CN3
1	2342 0610 5040	470PF/50V	C1
1	2341 4104 3000	470UF/25V	C5
1	2341 4104 3000	470uF/25V	C2
2	2340 0710 3020	47UF/63V	C3,C4
1	2115 6309 1100	3PF/50V	C6
1	2310 4101 1000	10UF/25V	C7
1	2217 2182 0200	180PF/100V	C8
1	2339 6101 1000	3.3UF/50V	C9
1	2318 6101 1000	0.1uF/50V	C10
1	2217 3104 2000	104M(0.1uF/100v)	C12
2	2210 3224 0600	224/275V	C14,C13
2	2304 0711 0153	12000U/63V	C17,C18
1	2311 4102 1000	100/25	C20
6	1311 0041 4802	1N4148	D1,D2,D6,D10,D11,D12
2	1310 8000 0812	1SS81	D4,D3
3	1360 7400 2000	1N4002	D5,D7,D8
2	1610 5141 1200	4A/250V	F2,F1
1	3109 1010 4983	2X10X2.54mm Double pins 90 degree	J1
2	1867 1138 0000	FB-DIP	L1,L2
1	1844 0812 0301	4uH/1R2W	L3
2	1132 2400 0182	C2240-GR	Q2,Q1
2	1180 0060 0622	MPSA06	Q3,Q4
2	1180 4230 0622	BF423	Q7,Q5
2	1180 4220 0622	BF422	Q6,Q18
2	1111 3800 0430	2SA1380-E	Q8,Q14
2	1133 5020 0420	2SC3502-E	Q12,Q9
2	1134 7930 0000	2SC4793	Q10,Q13
1	1111 8370 0130	2SA1837	Q15
2	1135 2420 0150	2SC5242	Q17,Q16
2	1111 9620 0130	2SA1962	Q20,Q19

1	1180 0056 0620	MPSA56	Q21
2	1131 7400 0140	2SC1740S-R	Q24,Q23
2	4712 1002 1204	KT-S-212N	RL3,RL2
1	2402 1411 0111	100K 1% 1/6W	R1
1	2402 1411 0211	1K 1% 1/6W	R2
2	2402 1413 3211	33K2 1% 1/6W	R10,R3
2	2402 1412 0211	2K 1% 1/6W	R4,R5
2	2402 1411 8111	180 1% 1/6W	R6,R7
2	2402 1414 7311	47K 1% 1/6W	R8,R41
1	2402 1412 4911	249R 1% 1/6W	R9
1	2402 1411 0711	1K07 1% 1/6W	R11
6	2402 1414 7111	470R 1% 1/6W	R12,R13,R14,R15,R16,R17
4	2402 1411 5311	15K 1% 1/6W	R18,R25,R34,R42
2	2402 1411 2111	120R 1% 1/6W	R19,R20
1	2402 1415 6211	5K6 1% 1/6W	R21
1	2402 1411 3311	1.13K 1% 1/6W	R22
2	2402 1411 0011	10 1% 1/6W	R24,R26
1	2402 1413 3111	330R 1% 1/6W	R27
4	2402 1411 0411	100R 1% 1/6W	R28,R29,R31,R37
4	2396 1412 2211	0.22/1W	R30,R32,R35,R36
1	2397 1412 2211	10K 1% 1/6W	R33
1	2398 1412 2211	3K3 1% 1/6W	R38
2	2399 1412 2211	22K 1% 1/6W	R40,R39
1	2400 1412 2211	5.1R/2W	R43
2	2401 1412 2211	6K8/2W	R45,R44
1	2402 1412 2211	2K2 1% 1/6W	R46
1	4301 7001 0000	TEMPERATURE SWITCH(17AM)	SW1
1	3100 5020 0200	2P*2.5	TP1
1	2415 1251 0103	100Ω(SEMI-FIXED)	VR1
		RESISTOR 100 OHM ±30% PA0603-VA1-B101	

HK980x PARTS LIST

RIGHT CHANNEL POWER AMPLIFIER

PN:0077-1291-0002

Used	Part number	Part Type	Designator Description
====	=====	=====	=====
1	1360 7080 3000	RS803	BR1
1	3100 4020 0200	2P*2.0	CN1

1	3100 4080 0200	8P*2.0	CN2
1	3100 0702 0050	3P*3.96	CN3
1	2342 0610 5040	470PF/50V	C1
1	2341 4104 3000	470uF/25V	C2
2	2341 4104 3000	47UF/63V	C3,C4
1	2340 0710 3020	470UF/25V	C5
1	2115 6309 1100	3PF/50V	C6
1	2310 4101 1000	10UF/25V	C7
1	2217 2182 0200	180PF/100V	C8
1	2339 6101 1000	3.3UF/50V	C9
1	2318 6101 1000	0.1uF/50V	C10
1	2217 3104 2000	104M	C12
2	2210 3224 0600	224/275V	C14,C13
2	2304 0711 0153	12000U/63V	C17,C18
1	2311 4102 1000	100/25	C20
6	1311 0041 4802	1N4148	D1,D2,D6,D10,D11,D12
2	1310 8000 0812	1SS81	D4,D3
3	1360 7400 2000	1N4002	D5,D7,D8
2	1610 5141 1200	4A/250V	F2,F1
1	3109 1010 4983	2X10X2.54mm Double pins 90 degree	J1
2	1867 1138 0000	FB-DIP	L1,L2
1	1844 0812 0301	4uH/1R2W	L3
2	1132 2400 0182	C2240-GR	Q2,Q1
2	1180 0060 0622	MPSA06	Q3,Q4
2	1180 4230 0622	BF423	Q7,Q5
2	1180 4220 0622	BF422	Q6,Q18
2	1111 3800 0430	2SA1380-E	Q8,Q14
2	1133 5020 0420	2SC3502-E	Q12,Q9
2	1134 7930 0000	2SC4793	Q10,Q13
1	1111 8370 0130	2SA1837	Q15
2	1135 2420 0150	2SC5242	Q17,Q16
2	1111 9620 0130	2SA1962	Q20,Q19
1	1180 0056 0620	MPSA56	Q21
2	1131 7400 0140	2SC1740S-R	Q24,Q23
2	4712 1002 1204	KT-S-212N	RL3,RL2
1	2402 1411 0111	100K 1% 1/6W	R1
1	2402 1411 0211	1K 1% 1/6W	R2
2	2402 1412 0211	2K 1% 1/6W	R4,R5
2	2402 1413 3211	33K2 1% 1/6W	R10,R3

2	2402 1411 8111	180 1% 1/6W	R6,R7
2	2402 1414 7311	47K 1% 1/6W	R8,R41
1	2402 1412 4911	249R 1% 1/6W	R9
1	2402 1411 0711	1K07 1% 1/6W	R11
6	2402 1414 7111	470R 1% 1/6W	R12,R13,R14,R15,R16,R17
4	2402 1411 5311	15K 1% 1/6W	R18,R25,R34,R42
2	2402 1411 2111	120R 1% 1/6W	R19,R20
1	2402 1415 6211	5K6 1% 1/6W	R21
1	2402 1411 3311	1.13K 1% 1/6W	R22
2	2402 1411 0011	10 1% 1/6W	R24,R26
1	2402 1413 3111	330R 1% 1/6W	R27
4	2402 1411 0411	100R 1% 1/6W	R28,R29,R31,R37
4	2396 1412 2211	0.22/1W	R30,R32,R35,R36
1	2397 1412 2211	10K 1% 1/6W	R33
1	2398 1412 2211	3K3 1% 1/6W	R38
2	2399 1412 2211	22K 1% 1/6W	R40,R39
1	2400 1412 2211	5.1R/2W	R43
2	2401 1412 2211	6K8/2W	R45,R44
1	2402 1412 2211	2K2 1% 1/6W	R46
1	4301 7001 0000	TEMPERATURE SWITCH(17AM)	SW1
1	3100 5020 0200	2P*2.5	TP1
1	2415 1251 0103	100Ω(SEMI-FIXED)	VR1
		RESISTOR 100 OHM ±30% PA0603-VA1-B101	

HK980x PARTS LIST

DISPLAY-PCB P/N:0077-1011-0001

Used	Part number	Part Type	Designator Description
4	2311 0210 1015	100uF/10V	C1 C2 C3 C8
7	2115 6104 0123	0.1uF/50V---0603	C5 C6 C7 C14 C27 C31 C32
2	2115 6151 0123	150P/50V---0603	C11 C12
1	2103 5101 0130	100PF/50V---0603	C13
1	2340 0310 1015	47uF/16V	C15
1	2310 0610 1015	10uF/50V	C33
1	3104 0120 7002	D100-DRA-20----1.0mm SOCKET	CN1
1	3602 4041 5032	2P PLUG TO PLUG 1533#28X1C 2.0 L=150M	CN2
1	3303 0504 0115	3P PLUG TO HOUSING2468#26X3C 2.0 L=110	CN10
1	3833 2001 2620	20P FLEXBILE CABLE TYPE B 1.0 L=260MM	
1	1304 0008 0300	KSM-803LM	IR1
1	1049 4094 1200	TC4094FN	IC1

2	1841 0012 0000	10uH	L1 L2
1	1402 1203 0015	CS-030C09-OW-C (LED)	LED1
1	1132 1200 0162	2SC2120	Q5
1	1132 4580 0172	2SC2458	Q6
1	2401 0221 0211	1K--1/8W	R22
2	2401 0221 0011	10R1/8W	R23 R25
1	2401 0222 2311	22K--1/8W	R26
1	2402 1412 4311	24K--1/6W	R1
1	2402 1414 7311	47R--1/6W	R16
1	2402 1416 8311	68R--1/6W	R21
1	2402 1413 3111	330R--1/6W	R24
9	4502 4007 8100	TSHC-78A-5.0(WHITE)	SW1 SW2 SW3 SW4 SW5 SW6 SW7 SW8 SW9
1	1521 2001 0101	12-BD-01 INK	VFD1

HK980x PARTS LIST

FUSE-PCB P/N:0077-1101-0001

Used	Part number	Part Type	Designator Description
====	=====	=====	=====
1	1361 3011 0100	DB101G	BL1
1	2115 6104 0123	104	C10
2	2210 3104 0600	0.1U/270VAC(X2)	C17 C16
1	2217 2103 2000	JY103M(X1/400V.Y2/300V)	C18
1	2341 0410 1015	470U25V	C21
1	2311 0210 1015	100U10V	C22
3	3100 0702 1015	2P7.92	CN5 CN6 CN7
1	3303 0504 0225	3P PLUG TO HOUSING2468#26X3C 2.0 L=220	CN8
1	3503 3060 4171	3P PLUG 1672#18X2C UL VH3.96 L=410MM	
2	1311 1414 8000	1N4148	D2 D3
1	1132 1200 0162	C2120	Q1
1	1609 2005 1300	5D-13	R2
1	1609 2005 1300	10k	R3
1	2401 0224 7211	4K7	R4
1	2401 0623 3711	3.3M2W	R8
1	2401 0624 7711	4.7M2W	R9
1	2406 0321 0915	FR 1/0.25W	R10
1	2401 0326 8011	68/0.25W	R11
1	4712 1001 1205	KI-S-112M	RAY1
1	1828 0210 3200	TC2006-6R8M-H	L3
1	4070 1285 0000	EI-28	T1
1	1610 1300 0000	FH1-B-MW	
2	1600 1000 0100	FUSE HOLDER	
1	1601 0514 1120	FUSE T4AL 250V	

1	1608 9000 0100	"SHINAGAWA" FUSE COVER (845220B-23)
1	7755 1000 0000	SB5R-5
1	3701 1042 0014	VDE16A 2X1.0mm 6.5FT
1	4070 1285 0000	E1-28 Transformer
1	4070 1965 0001	EI-96 Transformer

HK980x PARTS LIST

IR-PCB P/N:0077-1031-0001

Used	Part number	Part Type	Designator Description
=====	=====	=====	=====
1	2311 0210 1015	100uF/10V	C4
2	2317 0610 1010	0.1uF/50V	C23 C24
1	2115 6681 0123	680PF/50V	C25
1	2340 0210 0015	47uF/10V	C26
1	3303 0504 0115	3P PLUG TO HOUSING2468#26X3C 2.0 L=110	CN9
1	1022 8170 7012	LTV817A	IC3
2	2801 1335 1203	CKX3.5-12A	JK1 JK2
3	1841 0012 0000	10uH	L4 L5 L6
1	1111 0480 0172	2SA1048	Q4
2	2402 1414 7311	47R 1/8W	R5 R6
1	2401 0222 2311	47K 1/8W	R7
2	2401 0222 2311	22K 1/8W	R12 R18
1	2401 0222 7111	270R 1/8W	R13
1	2401 0227 5011	75R 1/8W	R14
1	2401 0223 9211	3.9K 1/8W	R15

HK980x PARTS LIST

LED-PCB P/N:0077-1021-0001

Used	Part number	Part Type	Designator Description
=====	=====	=====	=====
1	3100 4020 0200	2P2.0mm---SOCKET	CN3
4	1402 0705 0006	1L0445W31B0CG201 (Φ5mm LED)	LED2 LED3 LED4 LED5
4	2401 0221 5111	150R 1/8W	R27 R28 R29 R30

HK980x PARTS LIST

MCU-PCB P/N: 0077-1582-0003

Used	Part number	Part Type	Designator Description
=====	=====	=====	=====
2	1361 3000 0061	2W06M	BL1 BL2 C1 C2 C23 C49 C51 C52 C53 C54 C55 C57 C58

42	2311 0310 2015	100uF/16V	C59 C61 C62 C64 C65 C67 C68 C69 C70 C71 C72 C73 C74 C75 C76 C77 C78 C80 C81 C82 C83 C85 C86 C87 C162 C167 C168 C169 C170 C191 C192 C3 C4 C163 C164 C201 C202 C5 C6 C7 C8 C9 C11 C193 C194 C10 C12 C29 C30 C50 C147 C148 C149 C150 C151 C152 C153 C154 C155 C13 C14 C15 C16 C17 C18 C19 C20 C21 C22 C25 C26 C27 C28 C31 C32 C33 C34 C35 C36 C37 C38 C40 C41 C42 C44 C45 C46 C47 C48 C79 C84 C88 C89 C104 C105 C106 C107 C108 C109 C110 C111 C112 C113 C207
6	2103 5331 0130	330PF/50V---0603	C24 C63 C171 C172 C173 C174 C175 C176 C39 C43 C90 C91 C66 C145 C92 C93 C94 C95 C96 C97 C98 C99 C100 C101 C102 C103 C114 C115 C116 C117 C118 C197 C198 C119 C120 C121 C123 C124 C126 C127 C128 C125 C122 C129 C130 C131 C132 C133 C134 C135 C136 C137 C138 C139 C140 C141 C142 C143 C144 C156 C157 C160 C161 C195 C196 C159 C165 C166 C177 C178 C179 C180 C181 C182 C183 C184 C185 C186 C187 C188 C189 C190 C199 C200 C203 C204 C205 C206
4	2340 0410 1015	47uF/25V	
4	2103 5300 0130	30PF/50V---0603	
1	2319 0610 1015	1uF/50V	
13	2103 5101 0130	100PF/50V---0603	
45	2103 5104 0130	0.1uF/50V---0603	
8	2340 0310 1015	47uF/16V	
2	2320 0210 1010	22uF/10V	
16	2310 0310 1015	10uF/16V	
2	2103 5160 0130	16PF/50V---0603	
2	2321 0410 1015	220uF/25V	
3	2341 0210 3025	470uF/10V	
1	2321 0310 1015	220uF/16V	
2	2312 4105 4000	1000uF/25V	
1	2322 4105 5000	2200uF/25V	
1	2321 0210 1015	220uF/10V	
1	2310 0610 1015	10uF/50V	
1	2340 0510 1015	47uF/35V	
1	2312 0610 1015	100uF/50V	
2	2341 0410 1015	470uF/25V	
16	2103 5221 0130	220PF/50V---0603	
6	2103 5100 0130	10PF/50V---0603	
1	2320 0610 1015	22uF/50V	
2	2217 3102 0103	1000PF/50V Mylar CaP	
2	2115 5332 0130	0.033uF/50V±5%---0603	
2	2115 5472 0130	4700PF/50V±5%---0603	
2	2115 5222 0130	2200PF/50V±5%---0603	
2	2103 5104 0130	0.1uF/50V±5%---0603	
2	2217 3182 0103	1800PF/50V Mylar CaP	
4	2217 3562 0103	5600PF/50V Mylar CaP	
2	2103 5102 0130	1000PF/50V---0603	
2	2103 5471 0130	470P---0603	
2	2320 0310 1016	22uF/16V	

1	2115 7104 0150	0.1uF/50V----1206	C208
2	3100 4080 0200	8P2.0mm----SOCKET	CN1 CN2
2	3100 4030 0200	3P2.0mm----SOCKET	CN3 CN11
1	3100 5050 0200	5P2.5mm----SOCKET	CN5
1	3104 0120 9900	1.0D-20P----1.0mm SOCKET	CN6
1	3100 5060 0200	6P2.5mm----SOCKET	CN7
2	3100 4020 0200	2P2.0mm----SOCKET	CN8 CN9
1	3100 5040 0200	4P2.5mm----SOCKET	CN10
1	1360 1400 1005	1N4001	D1
5	1310 4414 8000	IN4148---SMD	D2 D3 D4 D5 D6
1	1311 3000 0051	HZK5B	DW1
1	1300 6202 0100	6C2---SMD	DW2
1	1303 0000 0200	1N4751A	DW3
4	1300 7500 0001	7.5V---SMD	DW4 DW5 DW6 DW7
1	1852 0120 9100	FB---0805	FB1
1	1005 9640 8132	SM5964C40J(PLCC44)	IC1
1	1002 4010 6620	AT24C02AN-10SI-2.7	IC2
2	1007 3110 3160	NJU7311AM	IC3 IC4
1	1000 2010 3160	NJU201AM	IC5
1	1061 2020 6181	TPA6120A2DWP	IC6
1	1001 1190 3160	NJW1119AV	IC7
1	1001 1590 3130	NJW1159M	IC8
1	1031 2068 1300	NJM2068M	IC9
5	1000 2750 0413	OP275GS	IC11 IC12 IC13 IC14 IC15
2	1005 5320 3113	NJM5532M	IC16 IC17
2	1019 7805 0800	KA7805	IC18 IC22
1	1019 7812 0800	KA7812	IC19
1	1019 7815 0800	KA7815	IC20
1	1019 7815 0800	KA7915	IC21
1	1022 8170 7012	LTV817A	IC23
2	2910 8643 0086	AV-8P	JK1 JK2
1	2910 0013 7206	RCA-207C	JK3
1	2910 2013 0026	AV-2P	JK4
1	2813 0462 2209	6222-09-M-S0-U-01	JK5
2	1844 7012 0100	47UH	L2 L3
2	1132 1200 0162	2SC2120	Q1 Q42
7	1133 3610 6100	2SC3361	Q2 Q4 Q5 Q7 Q8 Q33 Q34
1	1111 1620 0170	2SA1162GR	Q3
2	1111 1620 7100	2SA1162	Q6 Q38
8	1132 4060 5000	2SC2406TR	Q9 Q10 Q11 Q12 Q13 Q14 Q15 Q16
4	1133 3260 1000	2SC3326	Q17 Q18 Q19 Q20
2	1132 1200 0162	2SC2120	Q21 Q41
2	1110 9500 0162	2SA950	Q22 Q44

8	1111 0350 1101	2SA1035TR	Q25 Q26 Q27 Q28 Q29 Q30 Q31 Q32
2	1311 2003 3032	FJN3303R	Q39 Q40
2	1310 8008 5502	SS8550D	Q36 Q37
2	2401 1220 0003	0R---0603	R205 R213
2	2401 1221 5203	1.5K---0603	R264 R266
1	2401 1221 8203	1.8K---0603	R13
			R4 R9 R150 R151 R157 R158 R159 R160 R161
			R162 R163 R164 R165 R166 R167 R168 R169 R170
37	2402 1211 0203	1K±1%---0603	R176 R177 R178 R179 R180 R181 R182 R183 R184
			R185 R186 R187 R188 R189 R190 R191 R192 R194
			R196
17	2401 1221 0203	1K---0603	R1 R14 R15 R16 R17 R20 R33 R156 R171 R172
			R195 R199 R216 R252 R253 R260 R261
8	2402 1212 2203	2.2K±1%---0603	R275 R276 R277 R278 R279 R280 R281 R282
4	2401 1222 2203	2.2K---0603	R60 R61 R256 R267
1	2401 1222 4203	2.4K---0603	R149
8	2402 1213 3203	3.3K±1%---0603	R2 R3 R42 R43 R51 R52 R126 R127
2	2402 1213 9203	3.9K±1%---0603	R248 R249
2	2402 1214 7203	4.7K±1%---0603	R246 R247
2	2401 1224 7203	4.7K---0603	R10 R218
16	2402 1211 0303	10K±1%---0603	R93 R94 R95 R96 R97 R98 R99 R100 R101 R102
			R103 R104 R173 R174 R250 R251
			R11 R12 R152 R153 R91 R92 R89 R90 R34 R38
42	2401 1221 0303	10K---0603	R41 R54 R55 R56 R57 R58 R59 R62 R64 R65 R66
			R67 R68 R69 R70 R71 R72 R74 R75 R76 R77 R78
			R79 R80 R81 R82 R83 R84 R85 R86 R87 R88
2	2401 8210 0400	10R---0805	R254 R257
1	2401 0621 0013	10R/2W	R206
2	2402 1211 5303	15K±1%---0603	R35 R36
11	2401 1222 2303	22K---0603	R37 R63 R154 R155 R198 R227 R229 R242
			R244 R258 R259
2	2402 1212 7303	27K±1%---0603	R175 R200
16	2401 1223 3003	33R---0603	R130 R131 R132 R133 R134 R138 R139 R140
			R141 R142 R143 R144 R145 R146 R147 R148
			R240 R241
4	2401 1224 7103	47R---0603	R243 R245
2	2401 8247 0400	47R---0805	R271 R272
16	2402 1214 7303	47K±1%---0603	R114 R115 R116 R117 R118 R119 R120 R121
			R122 R123 R124 R125 R128 R129 R136 R137
2	2401 1224 7003	47K---0603	R112 R113
2	2401 1225 1003	51R---0603	R18 R19
			R50 R53 R135 R212 R214 R215 R217 R220 R221
17	2401 1221 0103	100R---0603	R222 R223 R224 R225 R226 R228 R262 R263

12	2402 1211 0103	100K±1%---0603	R44 R45 R46 R47 R48 R49 R105 R106 R193 R197 R210 R221
1	2401 1221 0103	100K---0603	R268
4	2402 1211 0103	100R±1%---0603	R39 R40 R273 R274
2	2401 1223 3103	330R---0603	R201 R202
2	2402 1213 3403	330K±1%---0603	R232 R233
2	2401 1223 3103	330K---0603	R234 R235
12	2402 1213 3103	330R±1%---0603	R21 R22 R23 R24 R25 R26 R27 R28 R29 R30 R31 R32
2	2402 1214 7103	470±1%---0603	R110 R111
3	2401 1224 7103	470R---0603	R107 R108 R109
2	2401 8247 1400	470R---0805	R269 R270
2	2402 1215 6403	560K±1%---0603	R238 R239
2	2402 1216 8103	680±1%---0603	R255 R256
1	2406 0321 0915	RF 1R/0.25W	R231
3	2410 0522 2812	RF 0.22R/1W	R207 R208 R209
1	2401 0326 8111	680R/0.25W	R230
4	2402 1216 8103	680R±1%---0603	R5 R6 R7 R8
2	4712 0000 2700	JRC-27F/005-M-555	RELAY1 RELAY2
1	4302 2002 0001	SSYB-22D01-G2-0A	SW1
2	3308 0504 0132	8P PLUG TO PLUG 2468#26X8C 2.0 L=130MM	
1	3602 4041 5032	2P PLUG TO PLUG 1533#28X1C 2.0 L=150MM	
1	3602 4043 5032	2P PLUG TO PLUG 1533#28X1C 2.0 L=350MM	
1	2705 1200 0110	12MHz	Z1

HK980x PARTS LIST

PHONES-PCB P/N:0077-1171-0001

Used	Part number	Part Type	Designator Description
2	2115 6103 0123	0.01uF/50V	C28 C29
1	2115 5104 0130	0.1uF/50V	C30
1	3504 3050 2225	4P PLUG TO HOUSING1007#20X4C 2.5 L=220	CN12
1	2802 1463 5020	CK-6.35-02	JK3

HK980x PARTS LIST

SPEAKER JOINT BOARD PN:0077-1321-0000

Bill Of Materials March 15,2008 9:05:58

Used	Part number	Part Type	Designator Description
2	2210 3104 0600	0.1uF	C29,C28

1	3109 1010 4983	2X10X2.54mm PIN	J2
2	2920 0290 6003	DY-024(Red)	SPK1,SPK4
2	2920 0300 6003	DY-024(Black)	SPK3,SPK2