

harman/kardon

HKSUB 12

Powered Subwoofer

SERVICE MANUAL



harman/kardon, Inc.
250 Crossways Park Dr.
Woodbury, New York 11797

Rev1 9/2004

CONTENTS

BASIC SPECIFICATIONS 1

DETAILED SPECIFICATIONS 2

CONTROLS & CONNECTIONS 3

CONNECTION GUIDE..... 5

CONFIGURING RECEIVER/PROCESSOR..... 8

OPERATION..... 9

BASIC TROUBLESHOOTING GUIDE..... 10

HKSUB 12 EXPLODED VIEW. 11

HKSUB 12 AMPLIFIER EXPLODED VIEW. 12

HKSUB 12 BLOCK DIAGRAM 13

HKSUB 12 TEST PROCEDURE. 14

HKSUB 12 PCB DRAWINGS. 15

HKSUB 12 ELECTRICAL PARTS LIST 17

HKSUB 12 MECHANICAL/PACKING PARTS LIST 20

HKSUB 12 IC – TRANSISTOR PINOUTS 21

HKSUB 12 SCHEMATIC DIAGRAMS 22

HKSUB 12 PACKAGE..... 25

SPECIFICATIONS

Amplifier Power (RMS)	150 Watts
Driver	12" Polymer-coated-cone woofer
Inputs	Stereo Line Level, dedicated Subwoofer (LFE) and Speaker Level with gold-plated 5-way binding posts
Outputs	Speaker Level with gold-plated 5-way binding posts
Low-Pass	Frequency Continuously variable from 50Hz – 150Hz
Frequency Response	25Hz – low-pass crossover setting
Dimensions	(H x W x D) 20-1/2" x 16" x 13-3/4" (520mm x 401mm x 350mm)
Weight	40 lb/18kg

Occasional refinements may be made to existing products without notice but will always meet or exceed original specifications unless otherwise stated.

HK SUB12		150W Powered Amplifier			
LINE VOLTAGE	Yes/No	Hi/Lo Line	Unit	Notes	
US 120vac/60Hz	Yes	108-132	Vrms	Normal Operation	
Parameter	Specification	Unit	QA Test Limits	Conditions	Notes
Amp Section					
Type (Class AB, D, other)	D	D	n/a		
Load Impedance (speaker)	4	Ohms	n/a	Nominal	
Rated Output Power	150	Watts	150	1 input driven	
THD@ Rated Power	0.08	%	1	22k filter	
THD @ 1 Watt	0.15	%	0.5	22k filter	
DC Offset	5	mV-DC	30	@ Speaker Outputs	
Damping factor	>100	DF	30		Measured at speaker terminals, Output power 140 Watts THD 0.1 %
Input Sensitivity					
Input Frequency	50	Hz	NA	Nominal Freq.	1 input driven
Line Input (L&R)	220	mVrms	±2dB	To Rated Power	1 input driven
LFE (Sub) Input	220	mVrms	±2dB	To Rated Power	LFE input driven only
Speaker/Hi Level Input	2.2	Vrms	±2dB	To Rated Power	(-20 dB below Line In)...1 input driven
Signal to Noise					
SNR-A-Weighted	100	dBA	85	rel. to rated power	A-Weighting filter
SNR-unweighted	90	dBr	80	rel. to rated power	22k filter
SNR @ 1W-unweighted	65	dBr	60	rel. to 1W Output	22k filter
Residual Noise Floor	1.2	mVrms	3.0	Volume @max, using RMS reading DMM/VOM (or A/P)	
Residual Noise Floor	0.8	mVrms(max)	2.0	Volume @max, w/ A/P Swept Bandpass Measurement (Line freq.+ harmonics)	
Input Impedance					
Line input L&R , LFE (Sub)	10	K ohms	n/a	Nominal	
Speaker/Hi Level Input	4.7	K ohms	n/a	Nominal	
Filters					
Left & Right Low Pass fixed	130 Hz	--	±2dB	@ -3dB ref. 100Hz	
LFE Low Pass fixed	220 Hz	--	±2dB	@ -3dB ref. 100Hz	
Subsonic filter (HPF)	22 Hz	--	±2dB	@ -3dB ref. 100Hz	
Limiter					
	YES	--	n/a		
Features					
LFE(Sub) Input	YES		functional		BW Limited to 220 Hz
Volume pot Taper (lin/log)	log	--	functional		
ATO	YES		functional		
Signal Sensing (ATO)					
ATO test Frequency	50	Hz	n/a		
ATO Line Level	4.0	mV	2.0 - 8.0	driven	
ATO Speaker level input	40	mV	20 - 80	driven	
ATO Turn-on time	5	ms	functional	Amp connected and AC on, then input signal applied	
Auto Mute/ Turn-OFF Time	15	minutes	10 - 25	T before muting, after signal is removed	
Power on Delay time					
	3	sec.	functional	AC Power Applied	
Transients/Pops					
ATO Transient	5	mV-peak	10	@ Speaker Outputs	
Turn-on Transient	50	mV-peak	100	@ Speaker Outputs	AC Line cycled from OFF to ON
Turn-off Transient	50	mV-peak	100	@ Speaker Outputs	AC Line cycled from ON to OFF
Efficiency					
Stand-by Input Power	10	Watts	12	@ nom. line voltage	Maximum allowable input power under nominal Input voltage and frequency, HOT or COLD operation.
Power Cons.@rated power	230	Watts	250	@ nom. line voltage	150 Watts @ 4 Ohms nominal line voltage
Protection					
Short Circuit Protection	YES	--	functional	Direct short at output	
Thermal Protection	65 deg. C	--	functional	@1/8 max unclipped Power	Temperature rise should not exceed 35K rise
DC Offset Protection	YES	--	functional	DC present at Speaker Out leads	Relay or crowbar (for driver/fire protection)
Line Fuse Rating					
US Version	3.15	Amps		Type-T or Slo Blo	External fuse with UL/SEMKO rated holder

AMPLIFIER PANEL CONTROLS AND CONNECTIONS

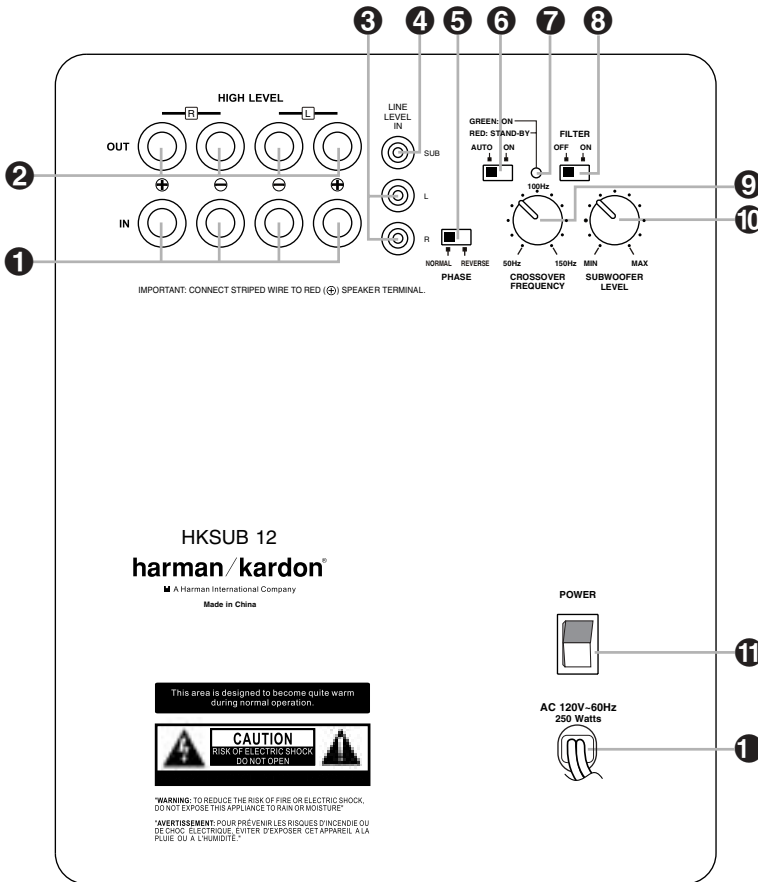

- 1 Speaker-Level Inputs
- 2 Speaker-Level Outputs
- 3 Line-Level Full-Range Inputs
- 4 Line-Level Subwoofer (SUB) Input
- 5 Phase Switch
- 6 Music-Sense On/Off Switch
- 7 LED Indicator
- 8 High-Cut (Low-Pass) Filter Switch
- 9 Crossover Frequency Control
- 10 Subwoofer Level Control
- 11 Master Power Switch
- 1 AC Power Cord

1 Speaker-Level Inputs: If your receiver or amplifier does not have a line-level subwoofer output, connect these binding post terminals to the main left and right speaker terminals of your receiver or amplifier. Remember to maintain polarity by connecting the (+) terminal on the receiver/amplifier to the (+) terminal on the HKSUB 12 subwoofer, and the (-) terminal on the receiver/ amplifier to the (-) terminal on the HKSUB 12 subwoofer.

2 Speaker-Level Outputs: If you are using the **Speaker-Level Inputs 1** on the HKSUB 12, connect these binding post terminals to your front left and right speakers,

remembering to maintain polarity by connecting the (+) terminal on the HKSUB 12 subwoofer to the (+) terminal on the speaker, and the (-) terminal on the HKSUB 12 subwoofer to the (-) terminal on the speaker. If you are not using the **Speaker-Level Inputs 1**, connect your front left and right speakers directly to your receiver or amplifier. See pages 9 through 12 for further information on speaker connections.

3 Line-Level Full-Range Inputs: Connect the full-range, unfiltered line-level subwoofer output or preamp output(s) of your receiver or amplifier to these inputs. If your receiver does not have a separate subwoofer output, use a

Y-adapter (not supplied) to bridge the receiver's preamp output to the main amp input for that channel, and connect the long end of the adapter to the corresponding line-level input on the HKSUB 12. If your receiver has only a single subwoofer output, you may connect it to either the left or right line-level input on the HKSUB 12, and no Y-adapter is needed.

4 Line-Level Subwoofer (SUB) Input: Connect the filtered subwoofer output of a receiver to this input. This input bypasses the HKSUB 12's internal crossover circuitry,

AMPLIFIER PANEL CONTROLS AND CONNECTIONS

and should only be used with a filtered signal. If your receiver does not have a filtered subwoofer output, you should use the **Line-Level Full-Range Inputs 3** instead.

5 Phase Switch: This switch determines whether the HKSUB 12 subwoofer's piston-like action moves in and out in phase with the main speakers. If the speakers are out of phase, the sound waves produced by the subwoofer will be cancelled out, reducing bass response. This phenomenon depends in part on the relative placement of the speakers in the room. In most cases, the **Phase Switch 5** should be left in the **NORMAL** position. However, it does no harm to experiment with the **Phase Switch 5**, and you may leave it in the position that maximizes bass response.

6 Music-Sense On/Off Switch: When this switch is placed in the **AUTO** position, and when the **Master Power Switch 11** is turned on, the HKSUB 12 will automatically turn on or place itself in the Standby mode, depending on whether it is receiving an audio signal. When this switch is placed in the **ON** position, the HKSUB 12 will remain on, whether or not it is receiving an audio signal.

7 LED Indicator: This LED indicates whether the HKSUB 12 is in the **ON** or **STANDBY** state when used with the **Music-Sense On/Off Switch 6** in the **AUTO** position. The LED is lit green to indicate that the HKSUB 12 is receiving an audio signal and is turned on, and the LED is lit red to indicate that no signal is being received and the HKSUB 12 is in Standby mode.

When the **Music-Sense On/Off Switch 6** is in the **ON** position, the LED will be lit green, whether or not an audio signal is present.

When the **Master Power Switch 11** is turned off, the LED goes dark, no matter

which position the **Music-Sense On/Off Switch 6** is in.

8 High-Cut (Low-Pass) Filter Switch: Placing this switch in the **ON** position activates circuitry that filters out all audio input signals above the setting of the **Crossover Frequency Control 9**. This allows the HKSUB 12 to focus its power on reproducing the low-frequency portion of the signal, avoiding inefficiency and distortion. Engage this filter when using the **Speaker-Level Inputs 1**, or when using the **Line-Level Full-Range Inputs 3**, unless your receiver or processor processes its line-level output using a low-pass filter. The filter has no effect when the **SUB Input 4** is used.

9 Crossover Frequency Control: Adjust this control to set the highest frequency the HKSUB 12 will reproduce. You should begin by setting it slightly above the lowest frequency that your main speakers are capable of reproducing. You may safely adjust the crossover frequency later as you listen to different program materials. This control will have no effect if you are using the **Line-Level Subwoofer (SUB) Input 4**, or if you have set the **High-Cut (Low-Pass) Filter Switch 8** to the **OFF** position. See page 14 for more information on adjusting the crossover setting.

10 Subwoofer-Level Control: Volume may be adjusted using the **Subwoofer-Level Control**. Turn the control clockwise to increase the HKSUB 12's volume, or counterclockwise to decrease it.

11 Master Power Switch: Press this rocker switch at the "•" mark to power-on the HKSUB 12 subwoofer. The HKSUB 12 will then be either in the Standby mode or completely on, depending on the position of the **Music-Sense On/Off Switch 6**.

1 AC Power Cord: Plug this cord into an active, unswitched electrical outlet for proper operation of the HKSUB 12. The cord should not be plugged into the accessory outlets found on some audio components.

SPEAKER CONNECTION GUIDE

Analog Receiver/Processor – Speaker-Level Connections

Use this installation method for analog receivers or processors that do not have digital processing or bass-management programming, and where the receiver/processor does not have a subwoofer output, or a volume-controlled preamp (line-) level output:

Connect your receiver or amplifier's front left and right speaker terminals to the left and right **Speaker-Level Input 1** terminals on the HKSUB 12 subwoofer that are marked "High Level In." Connect the left and right **Speaker-Level Output 2** terminals on the HKSUB 12 subwoofer that are marked "High Level Out" to the corresponding terminals on the back of your front left and right speakers.

Connect your receiver or amplifier's center, surround, and surround back speaker terminals to the corresponding terminals on the back of your center and surround speakers.

When all connections have been made, plug the **AC Power Cord 1** on the subwoofer into an AC outlet.

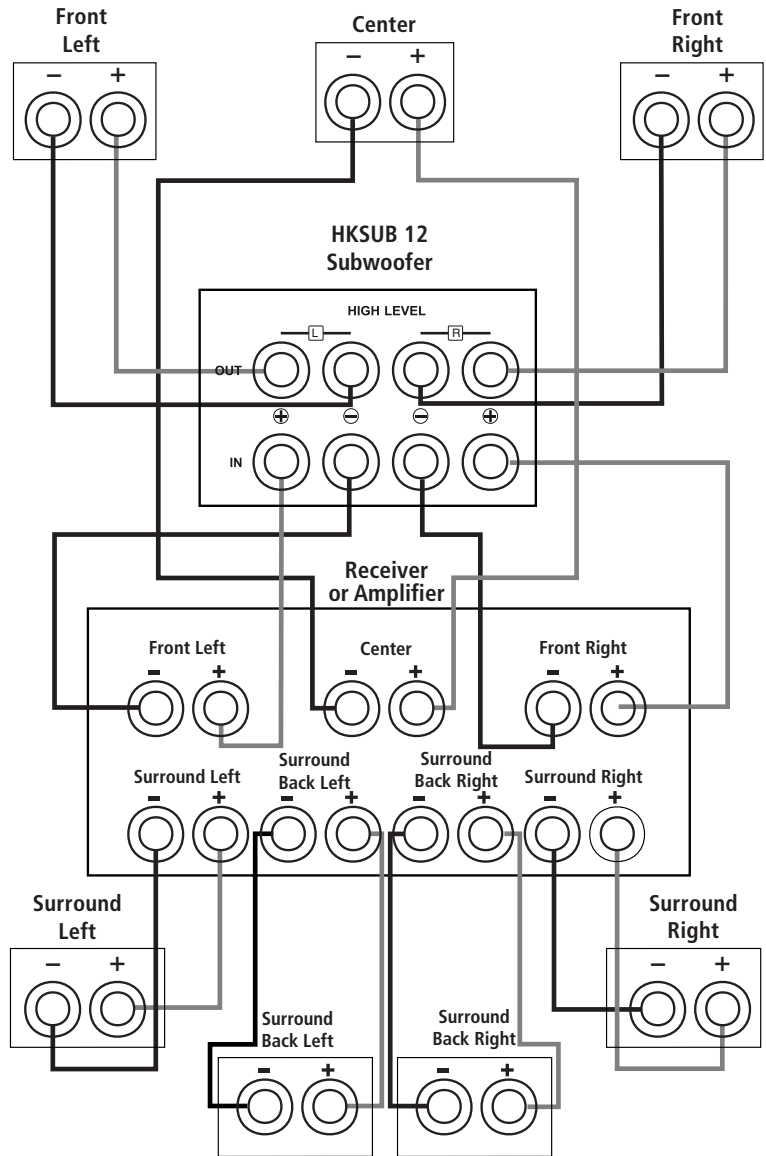

SPEAKER CONNECTION GUIDE

Analog Receiver/Processor – Line-Level Connections

Use this installation method for analog receivers or processors that do not have digital processing or bass-management programming, and where the receiver/processor is equipped with an unfiltered subwoofer output, or a volume-controlled preamp (line-) level output:

Use the supplied RCA-type patch cord to connect the line-level subwoofer output on your receiver or amplifier to *either* the left or right **Line-Level Full-Range Input** ③ on the HKSUB 12 subwoofer. Use both the left and right inputs on the subwoofer if your receiver or processor has both left and right line-level outputs. (You will need to purchase a second 15-foot interconnect cable.)

If your receiver is equipped with line-level outputs but does not have a separate subwoofer output, use a Y-adaptor (not supplied) to bridge the receiver's preamp output to the main amp input for that channel, and connect the long end of the adaptor to the corresponding line-level input on the HKSUB 12.

IMPORTANT: Do not use the **SUB Input** ④ on the subwoofer with analog receivers or processors that have a full-range subwoofer output, such as models that have Dolby Pro Logic® surround processing, but not Dolby Digital processing. However, if your analog receiver or processor has a filtered subwoofer output, such as some THX®-certified models, you may connect it to the **SUB Input** ④. Consult your receiver's or processor's owner's manual for more information.

Make sure that you have configured your surround sound processor for "Subwoofer On!"

When all connections have been made, plug the **AC Power Cord** ① on the subwoofer into an AC outlet.

Connect each speaker to the corresponding speaker terminals on your receiver or amplifier.

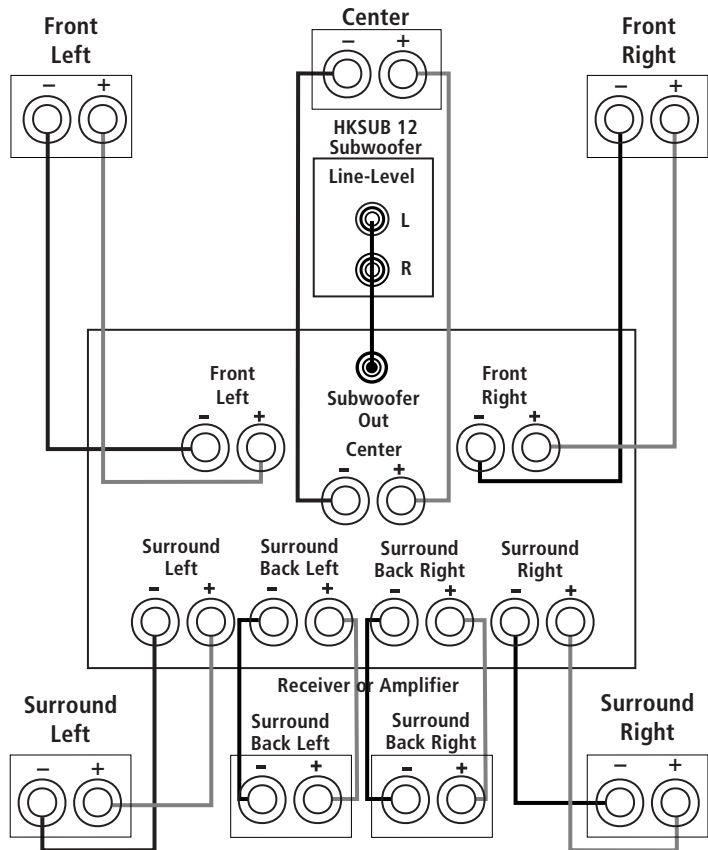

SPEAKER CONNECTION GUIDE

Connection to Digital Receiver/Processor

Use this installation method for analog receivers or processors that have Dolby Digital, DTS or other digital surround decoders and bass-management programming, or analog receivers or processors that have a filtered subwoofer output:

Use the line-level input jack marked **SUB 4** for the Low-Frequency Effects channel. Connect this jack to the subwoofer output or LFE output on your receiver or amplifier. Connect each speaker to the corresponding speaker terminals on your receiver or amplifier.

Make sure you've configured your surround sound processor for "Subwoofer On."

When all connections have been made, plug the **AC Power Cord 1** on the subwoofer into an AC outlet.

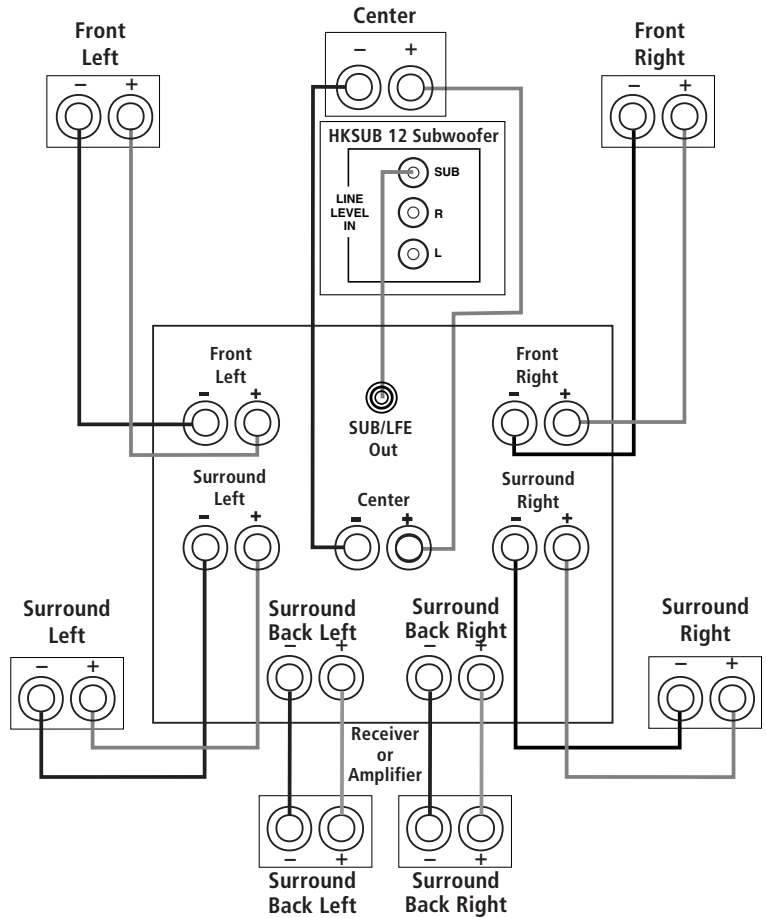

CONFIGURING YOUR RECEIVER OR PROCESSOR

Configuring Your Receiver or Processor

Modern surround sound receivers and processors are sophisticated machines that enable you to tailor the receiver's performance to match your loudspeakers by programming the bass-management function of the receiver. Bass management ensures that the lowest and most powerful frequency signals will be sent only to those loudspeakers capable of reproducing them without distortion. This is a simple matter of selecting the correct speaker "size" on the receiver to match the frequency range of your speakers.

In the case of the HKSUB 12 subwoofer, it is important to make sure that the Subwoofer channel is enabled by setting it to **ON**, **SUB**, **LFE** or **L/R + LFE**, depending upon the capabilities of your receiver. If you have full-range speakers for your front left and right channels, you may wish to configure your receiver to send only the LFE signal to the HKSUB 12. For maximum bass performance, you may prefer to send both the L/R and LFE low-frequency signals to the HKSUB 12. Consult the owner's manual for your receiver or processor for additional information.

OPERATION

Power

Press the **Master Power Switch 11** (marked **Power**) at the "•" (On) marking. The HKSUB 12 subwoofer will automatically turn on or go into Standby mode, depending on whether or not a signal is being sent to it by your receiver or surround processor, and provided that the **Music-Sense On/Off Switch 6** is moved to the left so that it is in the **AUTO** position.

When your receiver or amplifier is off, or is not sending program material to the subwoofer, the subwoofer will be in Standby mode and the **LED Indicator 7** on the amp panel will turn red. When the subwoofer senses an audio signal, it will automatically turn on and the **LED Indicator 7** will turn green. If the subwoofer does not sense a signal after approximately fifteen minutes, it will automatically go into Standby mode.

When the **Music-Sense On/Off Switch 6** is switched to the **ON** position, the subwoofer will remain on, whether or not program material is playing.

When you are away from home for an extended period of time, switch the **Master Power Switch 11** to the **OFF** position to prevent accidental activation of the HKSUB 12.

Volume

Volume may be adjusted using the **Subwoofer Level Control 10**, as shown. Turn the control knob clockwise to increase the volume of the subwoofer, and counterclockwise to decrease the subwoofer's volume.



The **Subwoofer Level Control 10** adjusts the volume of the subwoofer relative to the rest of the system. Proper level adjustment depends on several variables such as room size, subwoofer placement, type of main speakers and listener position. Adjust the subwoofer level so that the volume of the bass information is pleasing to you.

Additional Bass Adjustments

In addition to the volume adjustments described above, the HKSUB 12 subwoofer includes a **Crossover Frequency Control 9**, a **Filter Switch 8** and a **Phase Switch 5** that can be used to adjust the bass response to suit your listening environment or taste.

The **Crossover Frequency Control 9** determines the highest frequency at which the subwoofer reproduces sounds when the **Speaker-Level Inputs 1** or **Line-Level Full-Range Inputs 3** are used. Consult the owner's manual for your main speakers to determine the lowest frequency they are capable of reproducing, and set this control slightly above that frequency. For example, if the specified frequency response for your main speakers is 80Hz – 20kHz, then set the **Crossover Frequency Control 9** slightly to the left of the **100Hz** marking on the HKSUB 12's amplifier panel.

The **Crossover Frequency Control 9** has no effect when the **SUB Input 4** is in use, or when the **High-Cut (Low-Pass) Filter Switch 8** is in the **OFF** position.

The **High-Cut (Low-Pass) Filter Switch 8** limits the frequencies of the audio signal inputted to the subwoofer to the low

frequencies that the subwoofer reproduces best. This allows the subwoofer to perform more efficiently and with superior bass reproduction, minimizing distortion that might occur if the subwoofer attempted to reproduce higher frequencies. This switch should be left in the **ON** position, **except**:

1. When the **SUB Input 4** is being used, in which case it has no effect, or
2. When the **Speaker-Level Inputs 1** or the **Line-Level Full-Range Inputs 3** are being used with a crossover or filter aboard the receiver or processor.

In these two circumstances, place the switch in the **OFF** position.

If your receiver or processor allows you to select the crossover frequency for the main speakers, choose the setting just above the lowest frequency the main speakers are capable of reproducing. This will send the low-frequency portion of the signal to your HKSUB 12, which is best able to reproduce these frequencies with greatest efficiency and minimal distortion. In this case, you may use the **SUB Input 4** connection, or if that is not compatible with your receiver or processor, place the **High-Cut (Low-Pass) Filter Switch 8** in the **OFF** position in order to avoid filtering the signal twice, which may lead to signal loss and distortion.

In most situations, the **Phase Switch 5** should be left in the **NORMAL** position. If you suspect that the subwoofer is playing out of phase with the other speakers, which would tend to diminish bass response, try placing this switch in the **REVERSE** position. There is no harm in experimenting, and you may return the switch to the **NORMAL** position at any time. If you rearrange your room and reposition the speakers, it would be a good idea to check whether they are in phase by flipping this switch.

TROUBLESHOOTING

SYMPTOM

If you used the Speaker-Level Inputs ❶ and there is no sound from any of the speakers:

SOLUTION

- Check that receiver/amplifier is on and a source is playing.
- Check that the HKSUB 12 is plugged into an active electrical outlet and is switched on using the **Master Power Switch ❶**.
- Check all wires and connections between receiver/amplifier and speakers. Make sure all wires are connected. Make sure none of the speaker wires are frayed, cut, punctured or touching other wires or terminals, which may cause a short.
- Review proper operation of your receiver/amplifier.

If there is low (or no) bass output:

- Make sure that all speakers have been correctly connected in phase, with the (+) terminal on the speaker connected to the (+) terminal on the receiver/amplifier, and the (–) terminal on the speaker to the (–) terminal on the receiver/amplifier.
- Check that the HKSUB 12 is plugged into an active electrical outlet and is switched on using the **Master Power Switch ❶**.
- Slowly turn the **Subwoofer Level Control ❿** clockwise until you begin to hear the desired amount of bass.
- If you are using either the **Line-Level Full-Range Inputs ❸** or the **Line-Level Subwoofer (SUB) Input ❹**, make sure you have properly configured your receiver or processor to enable its subwoofer output.
- If you are using the **Line-Level Full-Range Inputs ❸**, try adjusting the crossover setting using the **Crossover Frequency Control ❾**.
- If you are using either the **Speaker-Level Inputs ❶** or the **Line-Level Full-Range Inputs ❸** with a full-range output from your receiver or processor, switch the **High-Cut (Low-Pass) Filter Switch ❸** to the **ON** position.
- Switch the **Phase Switch ❺** from the **NORMAL** to the **REVERSE** position, or vice versa.
- Review proper operation of your receiver or processor and amplifier.

	Part Number	Description	Qty
1	sz5999	logo	1
2	x1205000	Grille	1
3	338-RUB-00123	Grille cups	6
4	352-FM05034D482	Foot/Front Baffle Screws	4
5	XC125009	Front baffle	1
6	30PF14FM-DW04	Woofer w/gasket DCR = 3.3 ohms	1
7	352-CM04020D202	Woofer Screws	8
8	WI5334-1	rubber feet	4
9	WI5321-B	plastic feet	4
10	Not for Sale	Cabinet w/ port tube	1
11	Not for Sale	Amplifier	1
12	352-AM0402D210	Amplifier screws	10

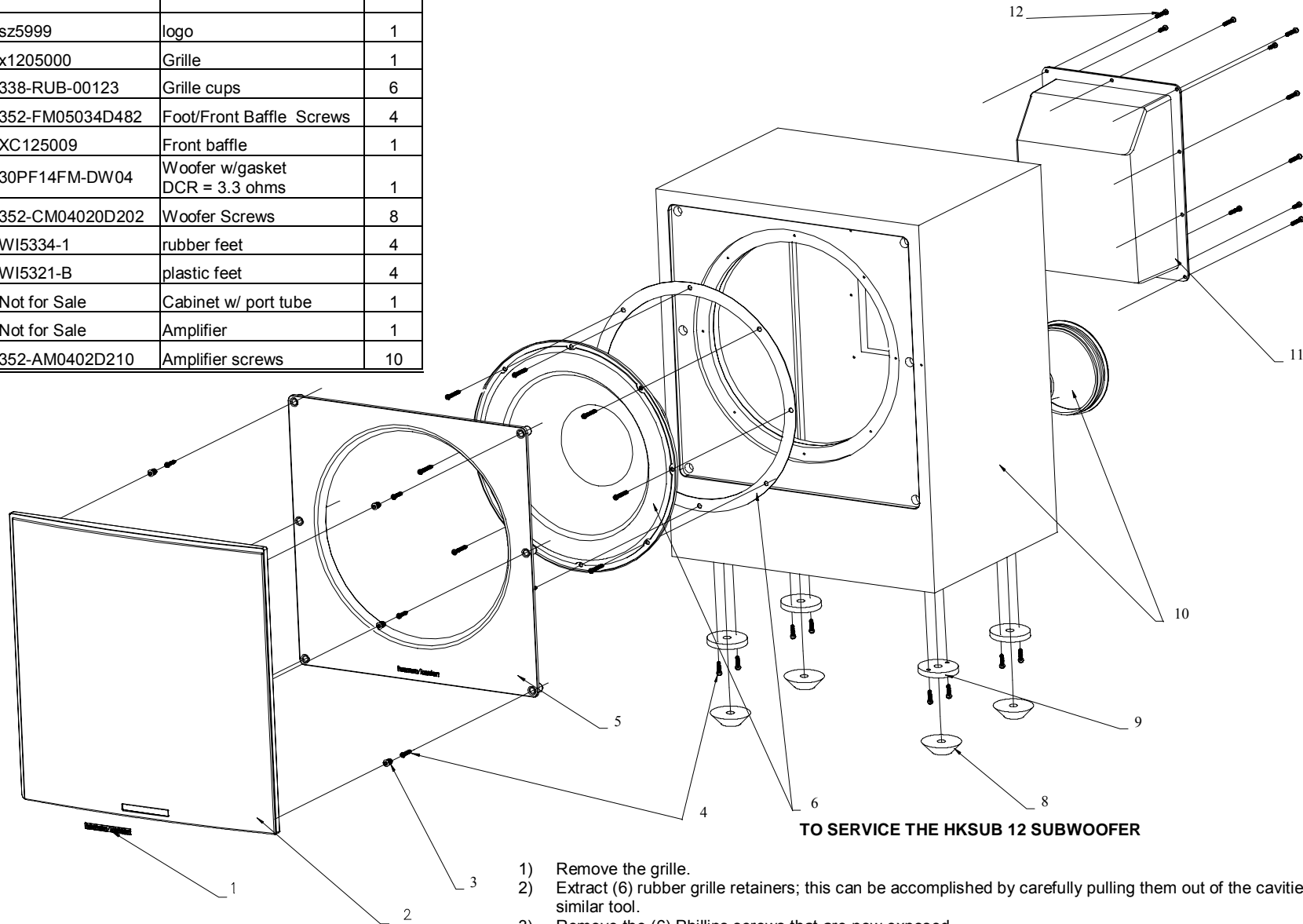

TO SERVICE THE HKSUB 12 SUBWOOFER

- 1) Remove the grille.
- 2) Extract (6) rubber grille retainers; this can be accomplished by carefully pulling them out of the cavities with long-nosed pliers or similar tool.
- 3) Remove the (6) Phillips screws that are now exposed.
- 4) Remove the front baffle.
- 5) Remove the (8) screws that secure the woofer (the screws may have a small adhesive pad atop each screw – they will have to be moved or removed); remove the woofer and unplug the wires from the terminals.
- 6) To service the amplifier, remove the (10) Phillips screws at the rear of the enclosure, and pull the amplifier out of the back.

HKSUB12 AMPLIFIER EXPLODED VIEW

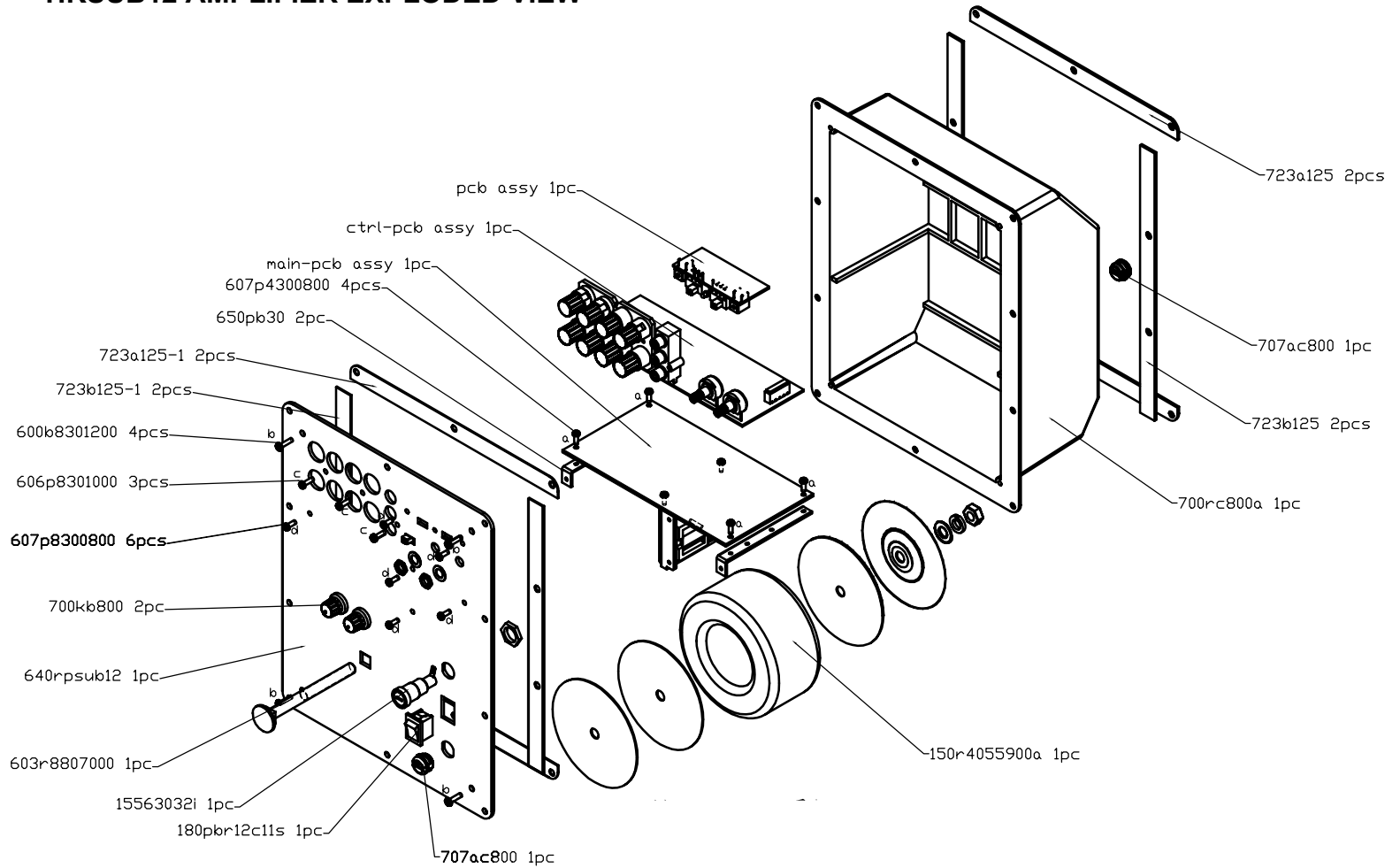

HKSUB 12 BLOCK DIAGRAM

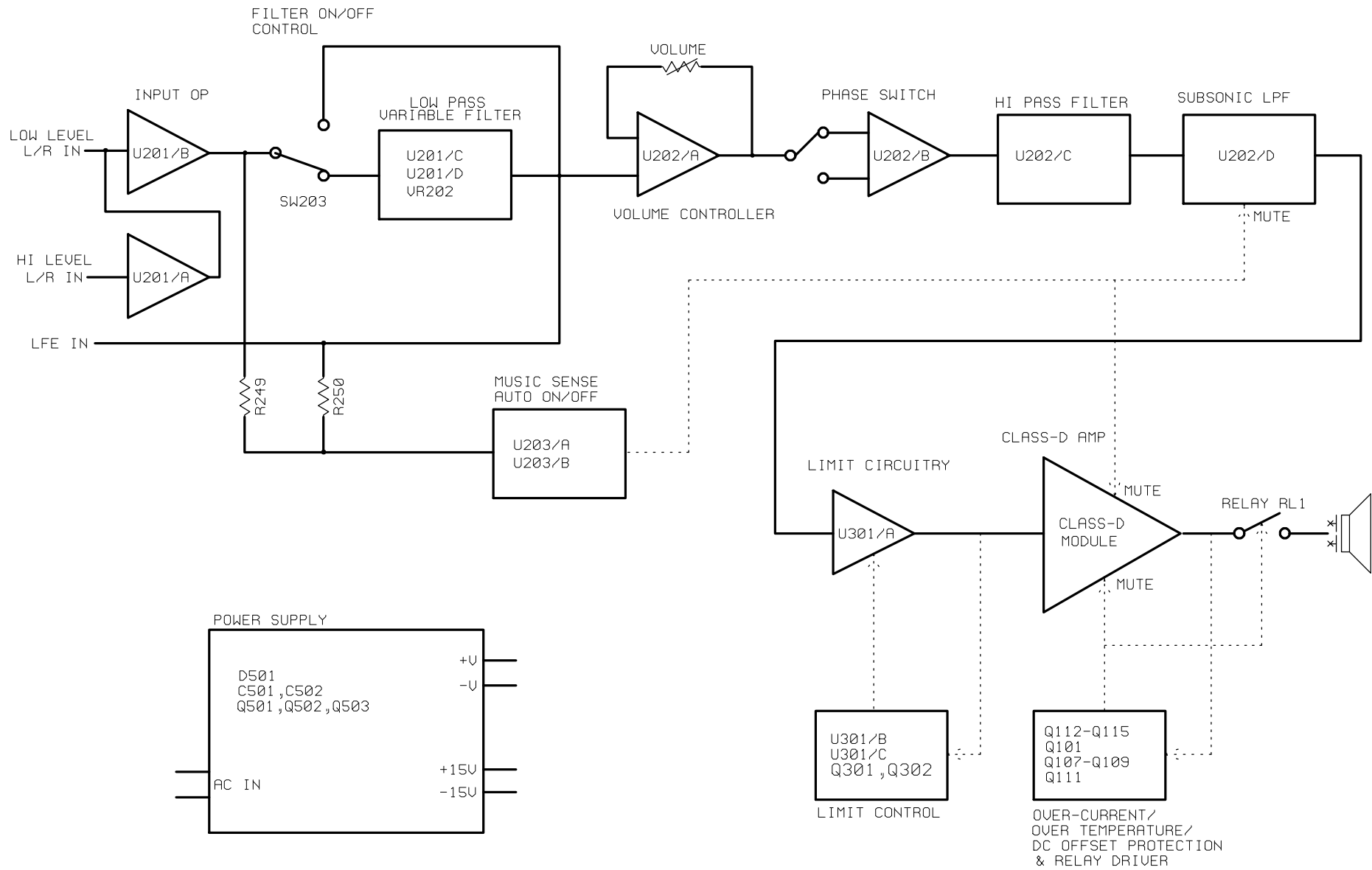

HK SUB12 BLOCK DIAGRAM

Test Set Up and Procedure

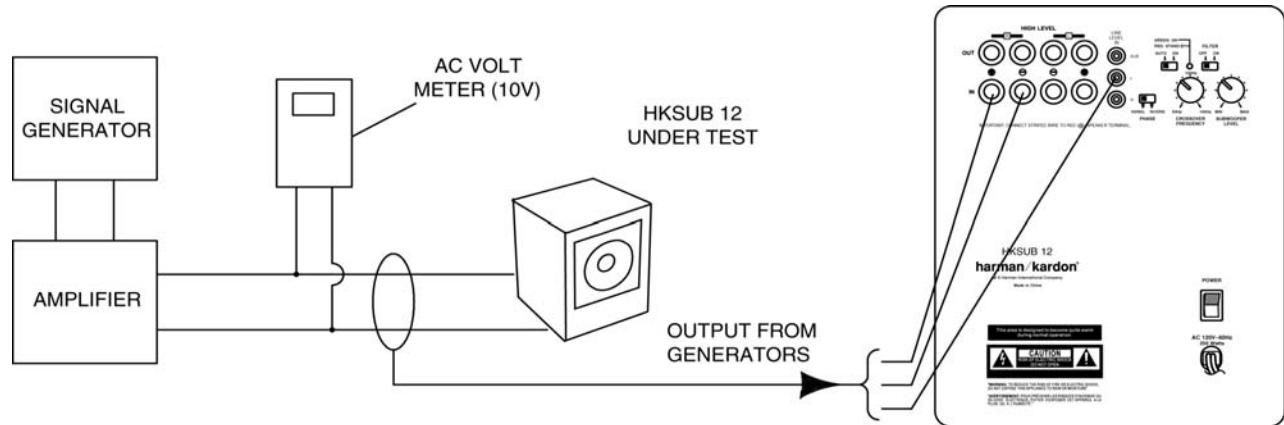

Equipment needed:

- Function/signal generator/sweep generator
- Integrated Amplifier
- Multimeter
- Speaker cables

Initial Control Settings:

- Power Switch OFF; Filter OFF
- Crossover Frequency 150Hz (Full CW)
- Level MIN (Full CCW)
- Phase, Standby switches do not matter

General Unit Function (UUT = Unit Under Test)

- 1) From the signal generator, connect one line level (RCA) cable to the Subwoofer Line Level Input jacks L/R on the UUT. Use a Y-cable from a mono source if necessary to connect to both inputs. Do not connect to the single, purple SUB input.
- 2) Turn on generator; adjust to **90mV, 50 Hz**.
- 3) Plug in UUT; turn the power switch ON. LED should switch from Red to Green. Turn LEVEL control full clockwise (MAX)
- 4) LED should Green; immediate and vigorous bass response should be heard and felt from port tube opening.
- 5) Turn off generator, turn LEVEL control full counterclockwise (MIN), and disconnect RCA cable.
- 6) Connect one pair of speaker cables to Speaker Level input terminal (IN) on UUT. Cables should be connected to an integrated amplifier fed by the signal generator.
- 7) Turn on generator and adjust so that speaker level input at the amplifier is **1.5V, 50 Hz**. Turn LEVEL control full clockwise.
- 8) Green LED should light; immediate and vigorous bass response should be heard and felt from the port tube opening.

Sweep Function

- 1) Follow steps 6-8 above, using a sweep generator as a signal source.
- 2) Sweep generator from 20Hz to 300Hz. Listen to the cabinet and drivers for any rattles, clicks, buzzes or any other noises. If any unusual noises are heard, remove woofers and test.

Driver Function

- 1) Remove woofer from cabinet (instructions on exploded view drawing); detach + and - wire clips.
- 2) Check DC resistance of woofer; it should be **3.3 ohms $\pm 10\%$**
- 3) Connect a pair of speaker cables to driver terminals. Cables should be connected to an integrated amplifier fed by a signal generator. Turn on generator and adjust so that speaker level output is **5.0V**.
- 4) Sweep generator from 20Hz to 1kHz. Listen to driver for any rubbing, buzzing, or other unusual noises.

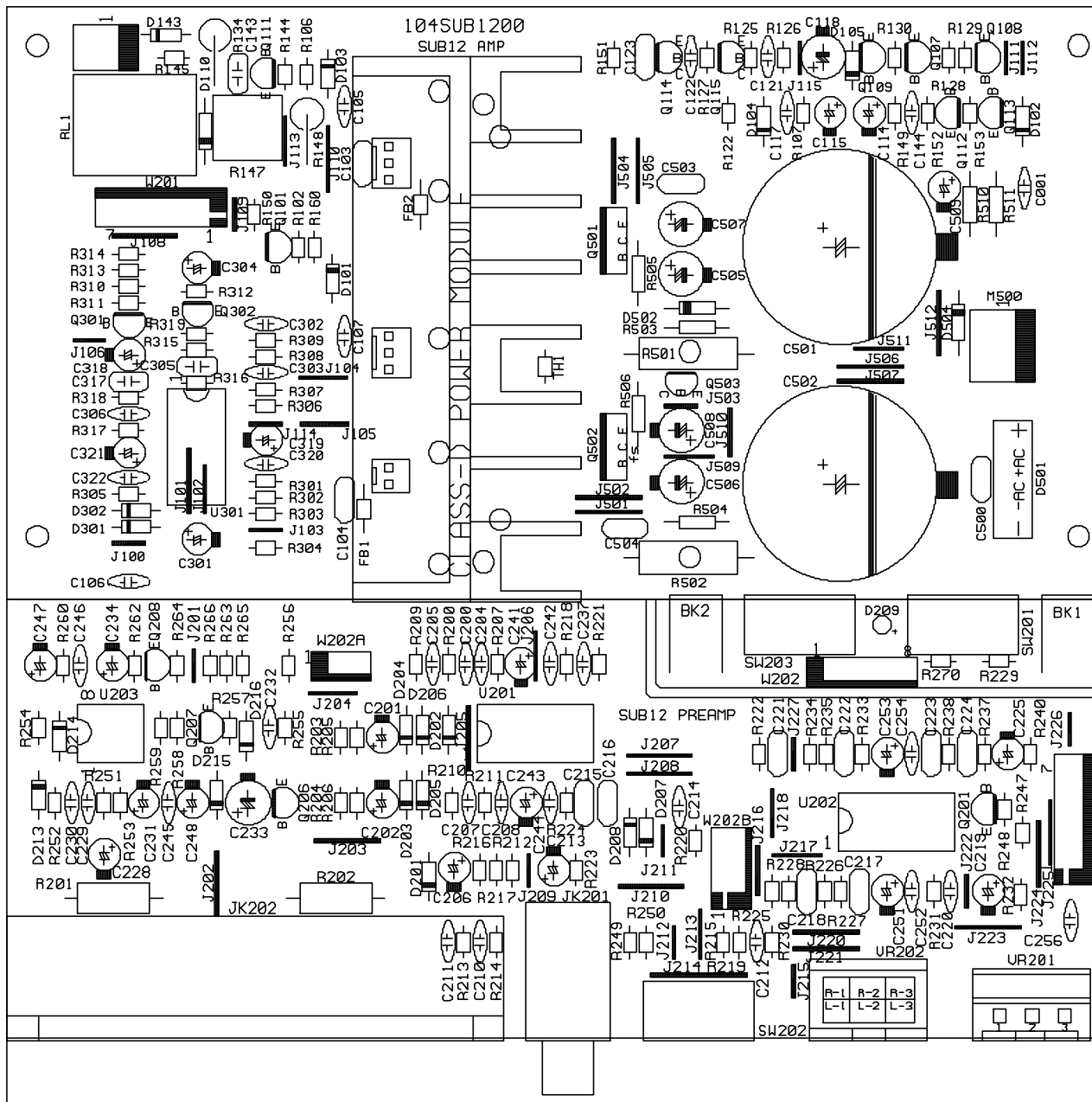

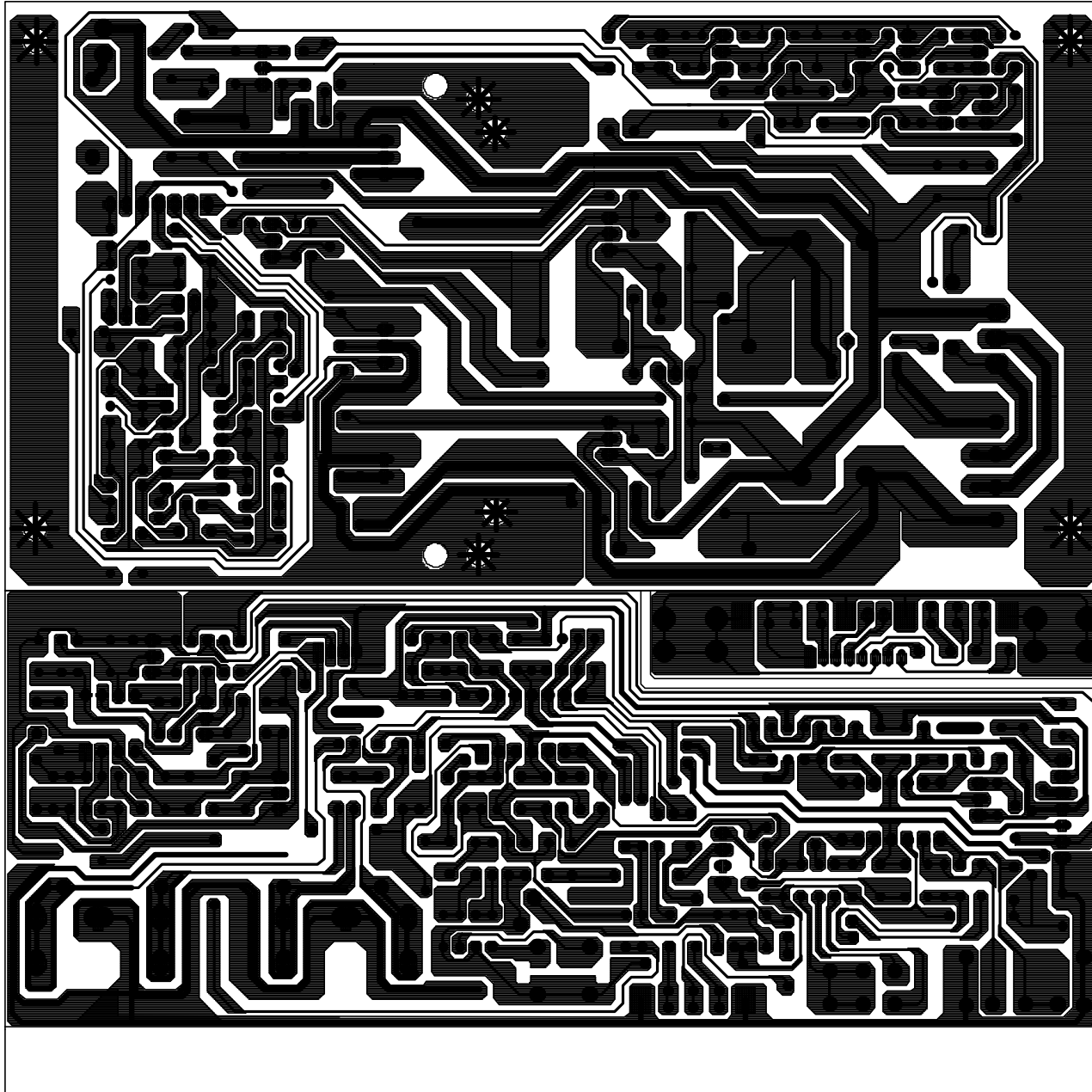

HKSUB 12 Electrical Parts List			
PART NO.	DESCRIPTION	REFERENCE DESIGNATOR	QTY
<i>Resistors</i>			
110-12472j52	Resistor 4.7K 1/2W ±5% CF	R201,202	2
110-14103j26	Resistor 10K 1/4W ±5% CF	R503,504,510	3
110-14222j26	Resistor 2.2K 1/4W ±5% CF	R511	1
110-14432j26	Resistor 4.3K 1/4W ±5% CF	R506	1
110-14472j26	Resistor 4.7K 1/4W ±5% CF	R505	1
110-16102j26	Resistor 1K 1/6W ±5% CF	R153,213,214,215,254	5
110-16103j26	Resistor 10K 1/6W ±5% CF	R128,130,149,150,209,212,216,217,218,220,221,222,225,228,229,230,232,234,235,240,248,260,270,305,306,308,311,314,319	29
110-16104j26	Resistor 100K 1/6W ±5% CF	R122,126,231,263,266,307	6
110-16105j26	Resistor 1M 1/6W ±5% CF	R259	1
110-16122j26	Resistor 1.2K 1/6W ±5% CF	R265	1
110-16124j26	Resistor 120K 1/6W ±5% CF	R233	1
110-16151j26	Resistor 150Ω 1/6W ±5% CF	R253	1
110-16153j26	Resistor 15K 1/6W ±5% CF	R107	1
110-16154j26	Resistor 150K 1/6W ±5% CF	R252	1
110-16182j26	Resistor 1.8K 1/6W ±5% CF	R145	1
110-16183j26	Resistor 18K 1/6W ±5% CF	R262	1
110-16203j26	Resistor 20K 1/6W ±5% CF	R237,238,309	3
110-16205j26	Resistor 2M 1/6W ± CF	R257	3
110-16221j26	Resistor 220Ω 1/6W ±5% CF	R144	1
110-16222j26	Resistor 2.2K 1/6W ±5% CF	R102	1
110-16223j26	Resistor 22K 1/6W ±5% CF	R247,255,256,316	4
110-16303j26	Resistor 30K 1/6W ±5% CF	R223,224	2
110-16333j26	Resistor 33K 1/6W ±5% CF	R310	1
110-16393j26	Resistor 39K 1/6W ±5% CF	R151	1
110-16472j26	Resistor 4.7K 1/6W ±5% CF	R200,207,258	3
110-16473j26	Resistor 47K 1/6W ±5% CF	R106,129,219,249,250,251,264	7
110-16474j26	Resistor 470K 1/6W ±5% CF	R127,312	2
110-16512j26	Resistor 5.1K 1/6W ±5% CF	R210,211	2
110-16562j26	Resistor 5.6K 1/6W ±5% CF	R152	1
110-16621j26	Resistor 620Ω 1/6W ±5% CF	R160	1
110-16682j26	Resistor 6.8K 1/6W ±5% CF	R226,227	2
110-16751j26	Resistor 750Ω 1/6W ±5% CF	R315	1
110-16755j26	Resistor 7.5M 1/6W ±5% CF	R313	1
110-16913j26	Resistor 91K 1/6W ±5% CF	R203,204,205,206	4
116-161002f26	P.T.C. 10K 1/6W ±1% MF	R301,303	2
116-161102f26	P.T.C. 11.0K 1/6W ±1% MF	R302	1
116-162200f26	P.T.C. 220Ω 1/6W ±1% MF	R317	1
116-162202f26	P.T.C. 22.0K 1/6W ±1% MF	R318	1
110-20332jk3	Resistor 3.3K 2W ±5%	R134	1
113-50s68j00	Cement Res. 0.068Ω 5W ±5%	R147	1
115h203b201	Variable Res. 20KB/2	VR202	1
115h503a102	Variable Res. 50KA	VR201	1
116-201001jk3x	Metal Res. 1.00K 2W ±5%	R148	1
116-304700jk2x	Metal Res. 470Ω 3W ±5%	R501,502	2
1091ttc802j0	Resistor TTC-802(JS) NTC	TH1	1
<i>Capacitors</i>			
129-a154j633	Metallze Cap. 0.15U 63V ±5% MSC	C221,222	2
129-a224j633	Metallze Cap. 0.22uF 63V ±5% MSC	C218	1

PART NO.	DESCRIPTION	REFERENCE DESIGNATOR	QTY
1302b101k503	Disc Cap. 100P 50V ±10%	C302,303,306	3
130-2b221k503	Disc Cap. 220P 50V ±10%	C200,204,205,207,208,210,211,212,214,220,230,237	12
130-2b470k503	Disc Cap. 47P 50V ±10%	C229	1
130-2f104z503	Disc Cap. 0.1U 50V +80/-20%	C107,117,122,144,232,242,245,246,252,254,256,320,322	13
132-103j503	Mylar Cap. 0.01U 50V ±5%	C305,317	2
132-103ja03	Mylar Cap. 0.01uf 100V ±5%	C103,104	2
132-104ja03	Mylar Cap. 0.1UF 100V ±5%	C123,503,504	3
132-183j503	Mylar Cap. 0.018uF 50V ±5%	C223	1
132-223ja03	Mylar Cap. 0.022uF 100V ±5%	C215	1
132-273ja03	Mylar Cap. 0.027UF 100V ±5%	C143	1
132-473j503	Mylar Cap. 0.047U 50V ±5%	C224	1
132-563j503	Mylar Cap. 0.056U 50V ±5%	C216	1
132-823j503	Mylar Cap. 0.082U 50V ±5%	C217	1
135-3105m50	Electrolytic Cap. 1U 50V ±20%	C228	1
135-3106m50	Electrolytic Cap. 10uF 50V ±20%	C201,202,206,213,219,231,241,243,251,253,319,321	12
135-3107m10	Electrolytic Cap. 100U 10V ±20%	C114,115	2
135-3107m16	Electrolytic Cap. 100uF 16V ±20%	C234	1
135-3107m35	Electrolytic Cap. 100U 35V ±20%	C507,508	2
135-3225m50	Electrolytic Cap. 2.2U 50V ±20%	C509	1
135-3226m16	Electrolytic Cap. 22U 16V ±20%	C304	1
135-3226m50	Electrolytic Cap. 22U 50V ±20%	C225,505,506	3
135-3227m16	Electrolytic Cap. 220U 16V ±20%	C118,233	2
135-3476m16	Electrolytic Cap. 47U 16V ±20%	C318	1
132-103kb00	Mylar Cap. 0.01uF 200V ±10%	C500	1
1385478m63	Electrolytic Cap.4700u 63v 20%	C501,502	2
<i>Semiconductors</i>			
192027c1815gr	Transistor 2SC1815GR	Q108,109,113,201,206,207,208,301,302	9
192027c2235y	Transistor 2SC2235Y	Q111	1
192028a1015gr	Transistor 2SA1015GR	Q101,107,112	3
1921672n5551	Transistor 2N5551	Q114,115	2
1921682n5401	Transistor 2N5401 AI-PNP 350V	Q503	1
197131n4148	Diode 1N4148	D102-105,143,201-208,214,215,216,301,302	18
199-15000335	Zener Diode 3.3V 1/2W	D213	1
199-15000625	Zener Diode 6.2V 1/2W	D101	1
199-15001605	Zener Diode 16V 1/2W	D502	1
19006m4558d	I.C. OPA 4558D	U203	1
19016tl074cn	I.C TL074CN ST	U201,202,301	3
192161tip31c	Transistor TIP31C SGS	Q501	1
192162tip32c	Transistor TIP32C SGS	Q502	1
19510204hgw	LED 204HGW 3□	D209	1
19700kbu606g	Diode 6A 800V KBU606G	D501	1
197101n4004	Diode 1n4004	D110,504	2
<i>Miscellaneous</i>			
1201000003	Inductor 10W AI YT-C3104-005	FB1,2	2
171urwh124d	Relay RWH-SH-124D (1600 ohm)	RL1	1
1740rca326p	JACK RCA-326	JK201	1
17420810360g	SPK JK BP 8PIN	JK202	1
180tms7210v	SWITCH SLIDE 6PIN MS7210V	SW201,202,203	3
150r4055900a	TRANSFER POWER 120V/60Hz	T501	1
152u602015	AC Line Cord SVT FT-2		1
154k31505t0	Fuse 3.15A 250V 30mm UL/CSA	F501	1
15563032i	Fuse Holder HTB-32I 30mm UL/CSA	for F501	1
180pbr12c11s	PUSH SW BR12C11S	SW501	1

PART NO.	DESCRIPTION	REFERENCE DESIGNATOR	QTY
16250129001	CABLE ASS'Y 120mm AWG28 WHT	W201	1
1751b08v01	8 PIN PITCH=2.0mm	W202	1
1751d02v01	2PIN PITCH=3.96mm	M100	1
1751d03v01	3PIN PITCH=3.96mm IST-VH	M500	1
16210082007	SW TO FUSE HOLDER WIRE RED AWG18 80mm#1015 □8mm		
176wjce1	CLOSE END TERMINAL CE-1		
193201815t2	CERAMIC ISOLATOR FOR Q10,1		2
600b8401200	SCREW TO R/C ψ4*12		4
602p4300800	SCREW PCB TO BRKT-4 M3*8		4
602p8300800	SCREW R/P TO BRKT-2,TO 650pf8-bk- 2 M3*8		4
603r8807000	SCREW TO XFORMER M8*70		
606p8301000	SCREW SPK-2,RCA-1 ψ3*10		3
607c8301208	SCREW H/S TO ID150-1 ψ3*12		
607p4300800	SCREW PCB TO H/S-2 ψ3*8		2
607p8300800	SCREW R/P TO H/S-2 ψ3*8		2
650sub240	PCB STAND L TYPE t=1.6mm S.P.C.C		2
653hsq1c1004	HEAT SINK		
700kb800	KNOB 46077-W P.V.C.		2
700rc800a	REAR CABINET 268*213*102 A.B.S UL		
707ac800	BUSHING 4K-4 NO-BB		2
723a125	GASKET 213*15*2.0mm		2
723a125-1	GASKET213*15*1.0t		2
723b125	GASKET 238*15*2.0mm		2
723b125-1	GASKET238*15*1.0t		2
723d125	TO PRE PCB-1 GASKET 170*5*1t		
723i125	TO LINK WIRE-1 GASKET150*15*1t UL		
723j125	TO SPK WIRE GASKET 225*15*1t UL		
860a125	TO SPEAKER		
Power Amp Module PW150D (1010DS150-1)			
<i>Resistors</i>			
118-12061001j	R2,11,29,30	RES, 1.00K 1206 5%	4
118-12061002j	R7,9,25	RES, 10.0K 1206 5%	3
118-120610r0j	R22,23	RES, 10.0 ohms 1206 5%	2
118-12061201j	R31-46	RES, 1.20K 1206 5%	16
118-12062002j	R26	RES, 20.0K 1206 5%	1
118-12062201j	R6,13,16	RES, 2.20K 1206 5%	3
118-12062701j	R10	RES, 2.70K 1206 5%	1
118-12063000j	R24	RES, 300.0 ohms 1206 5%	1
118-12063301j	R14,15,27,28	RES, 3.30K 1206 5%	4
118-12063902j	R3	RES, 39.0K 1206 5%	1
118-12064700j	R8	RES, 470 ohms 1206 5%	1
118-12064701j	R1,5,12	RES, 4.70K 1206 5%	3
118-12064702j	R17	RES, 47.0K 1206 5%	1
118-12064704j	R4	RES, 4.70M 1206 5%	1
118-120647r0j	R20,21	RES, 47.0 ohms 1206 5%	2
<i>Capacitors</i>			
141-c0101k50	C4	CAP,CA 100pF 50V 10% 1206 NPO	1
141-c0220k50	C5	CAP,CA 22pF 50V 10% 1206 SMT NPO	1
141-c0561k50	C6	CAP,CA 560pF 50V 10% 1206 NPO	1
141-c6104m50	C2,3,7,8,9,10,11,15	CAP,CA 0.1uF 50V 20% 1206 Z5U	8
141-c7223k50	C13	CAP,CA 0.022uF 50V 10% 1206 X7R	1
141-d7104ka0	C1	CAP,NP 0.1uF 100V 10% 1210 X7	1

PART NO.	DESCRIPTION	REFERENCE DESIGNATOR	QTY
128e106ma01	C16,17	CAP,E NP 10uF 100V 20%	2
141-d7104kb0		CAP,NP 0.1uF 200V 10% 1210 X7	1
Semiconductors			
19016tl072dts	IC1	SMD I.C. TL072CDT SGS Dual Op-Amp	1
19209124126qs	Q1,4,5	TRANS, NPN 50V 0.15A 2SC2412K	3
19209139066rs	Q2,8	TRANS, NPN 120V 0.05A 2SC3906K	2
19209210376qs	Q7,9	TRANS, PNP 50V 0.15A 2SA1037K	2
19209215146rs	Q3,6	TRANS, PNP 120V 0.05A 2SA1514K	2
19703rls4148s	D1,2,3,4,5,6	Diode RLS4148	6
199-15000563s	Z1,2	ZENER 5.6V 5% PHILIPS BZX84-C5 V6	2
199-15001203s	Z5,6	ZENER 12V 5% PHILIPS BZX84-C12	2
199-15001503s	Z3,4	ZENER 15V 5% PHILIPS BZX84-C15	2
192232irf9640	Q10	FET IRF9640 IR P-CH TO220	1
192233irf640	Q11	FET IRF640 IR N-CH TO-220	1
Miscellaneous			
1759f40hr2		Wafer 40PIN PITCH=2.54mm HR2*40	
12214121m4191	L1	Ferrite core LS-A6206-ST EFD-30	1
12214350j4180	L2	Inductor 35uH	1
06-t3085020	PCB TO H/S-2,PCB TO PCB/H-4	SCREW 3*8	6
06-t31207	TO HSQCL1004/ID150-1	SCREW M3*12	1

HKSUB 12 Mechanical/Packing Parts List

Part Number	Description	Qty
Not for Sale	Amplifier	1
30PF14FM-DW04	Woofer w/gasket DCR = 3.3 ohms	1
sz5999	logo	1
x1205000	Grille	1
338-RUB-00123	Grille cups	6
XC125009	Front baffle	1
352-CM04020D202	Woofer Screws	8
352-FM05034D482	Foot/Front Baffle Screws	4
352-AM0402D210	Amplifier screws	10
WI5321-B	plastic feet	4
WI5334-1	rubber feet	4
wb6390	Outer carton	1
ai5271	Owner's manual	1
405-000-00227	warranty card	1
wp5375	Packing foam	2
sal5044	cable	1

Integrated Circuit Diagrams

4558 / TLO72 DUAL OP AMP,
U203, IC1

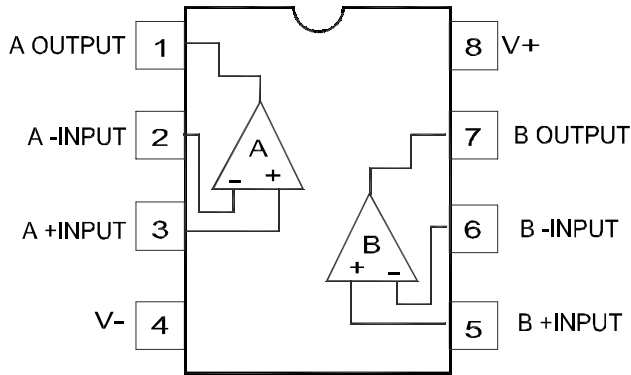

OPAMP, QUAD 14P DIL TL074
U201, 202, 301

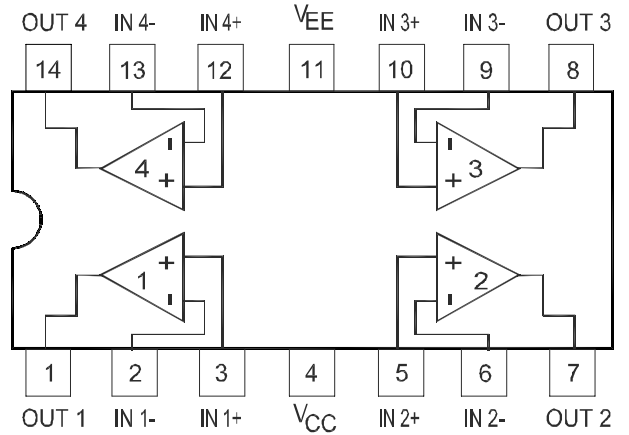

TIP31C NPN,
TIP32C PNP,
Q501,502

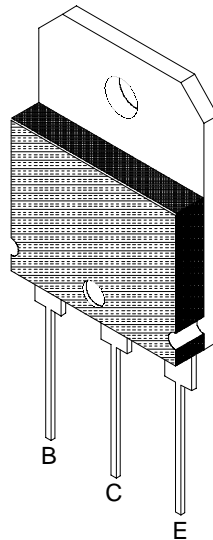

MOSFET, TO220
IRF640, 9640
Q11, 10

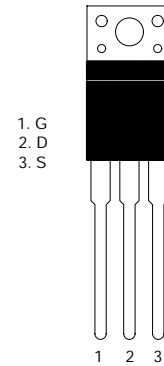

TRANS, PNP, 2N5401
TO-92,
Q503

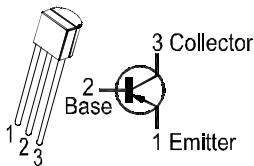

TRANS, NPN, 2N5551
Q114,115

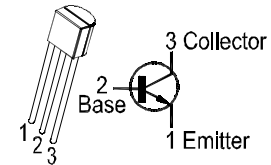

TRANS, PNP,
2SA1015GR

Q101,107,112

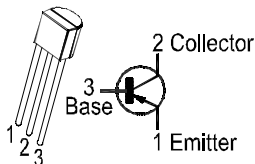

TRANS, NPN, 2SC1815GR
2SC2235,
Q108,109,111,113,201,206-208,301,302

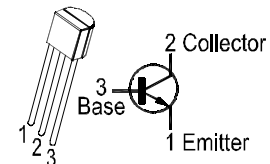

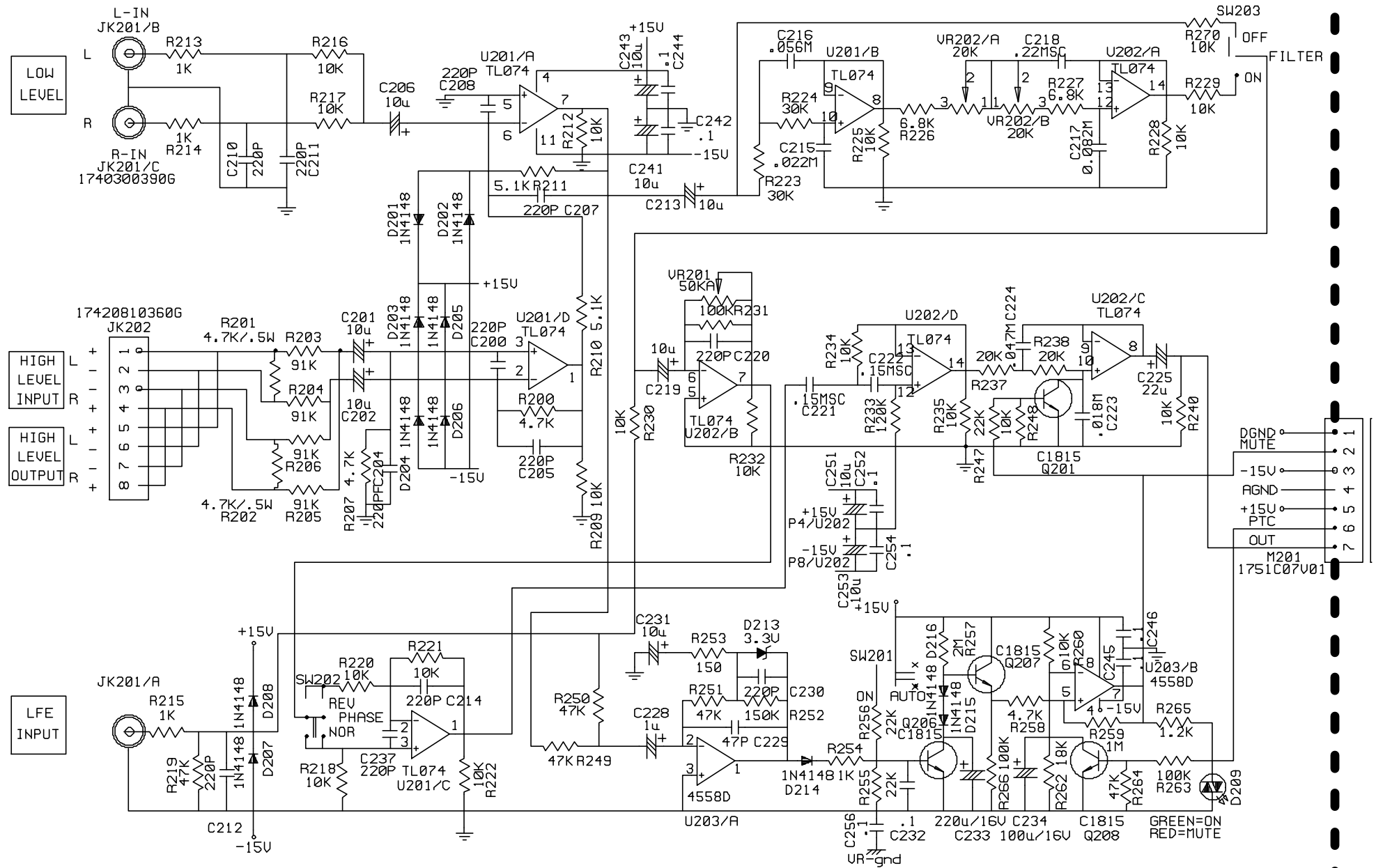

HKSUB12 JACK PANEL PCB

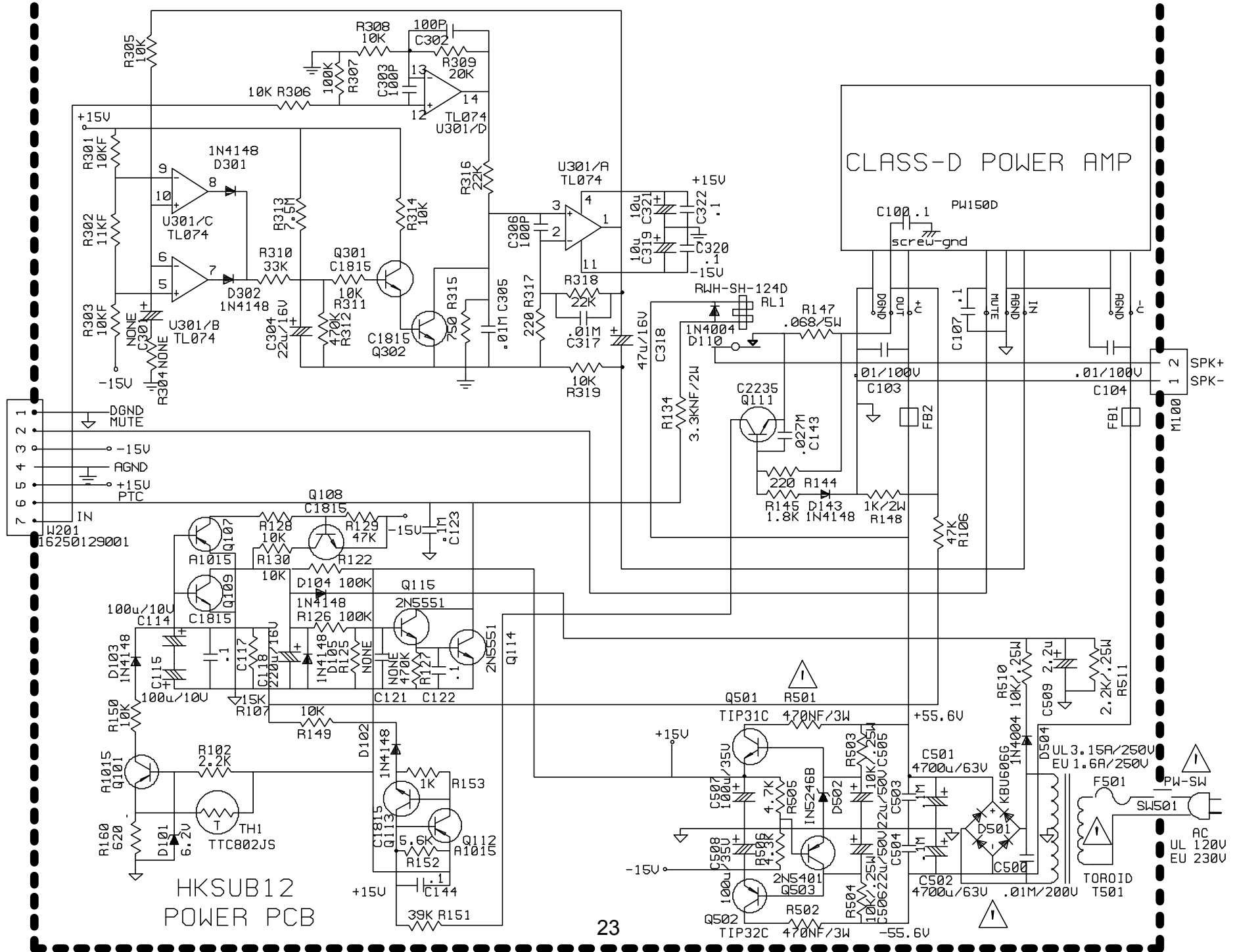

HKSUB12
POWER PCB

CLASS-D POWER AMP

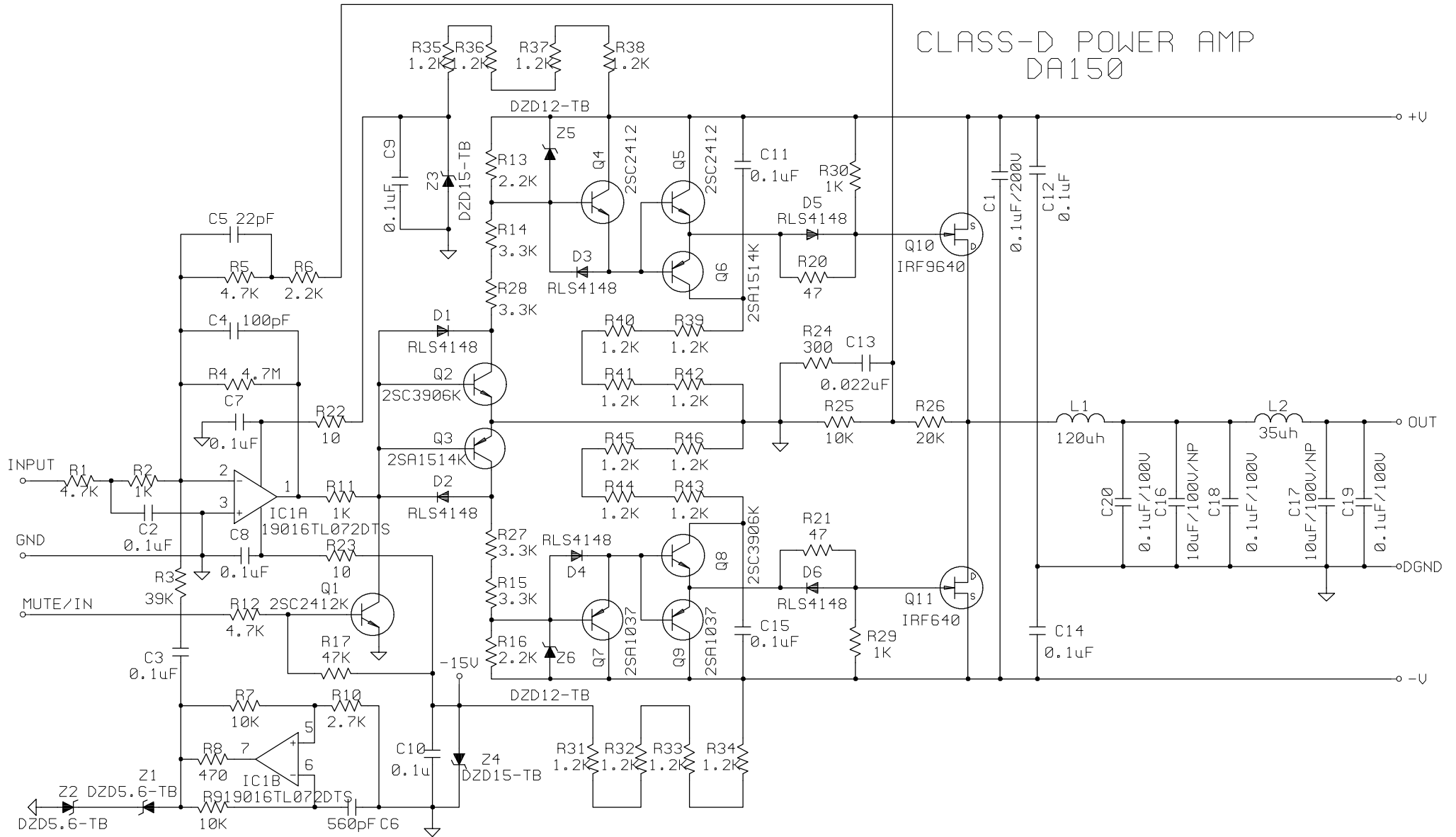

Packaging

