

harman/kardon

SUB-TS14

(HKTS 14 SUBWOOFER)

SERVICE MANUAL



harman/kardon, Inc.
250 Crossways Park Dr.
Woodbury, New York 11797

Rev1 10/2005

CONTENTS

BASIC SPECIFICATIONS	1
DETAILED SPECIFICATIONS	2
CONTROLS & CONNECTIONS	4
SPEAKER CONNECTIONS	6
OPERATION	9
BASIC TROUBLESHOOTING GUIDE	10
TEST PROCEDURE	11
UNIT EXPLODED VIEW	12
AMPLIFIER EXPLODED VIEW	13
BLOCK DIAGRAM	14
PCB DRAWINGS	15
ELECTRICAL PARTS LIST	19
SEMICONDUCTOR PINOUTS	24
SCHEMATIC DIAGRAMS	25
PACKAGING	28

SPECIFICATIONS

Amplifier Power (RMS)	200 Watts
Driver	12" woofer, Bass Reflex Enclosure
Inputs	Stereo Line Level, dedicated Subwoofer (LFE) and Speaker Level with gold-plated binding posts
Outputs	Speaker Level with gold-plated binding posts
Frequency Response	25Hz – 120Hz (Filter switch ON) 25Hz – 450Hz (Filter switch OFF)
Dimensions (H x W x D)	20-1/2" x 14-1/2" x 14-1/2" 521mm x 368mm x 368mm
Weight	48 lb/22kg

Occasional refinements may be made to existing products without notice but will always meet or exceed original specifications unless otherwise stated.

HKTS 14 Sub 200W Powered Sub/ Plate Amp

LINE VOLTAGE	Yes/No	Hi/Lo Line	Nom.	Unit	Notes
US 120vac/60Hz	Yes	108-132	120	Vrms	Normal Operation
Parameter	Nonimal Specification	Unit	QA Test Limits	Conditions	Notes
Amp Section					
Type (Class AB, D, other)	D	n/a	n/a		Bridge type amplifier, None of the speaker terminals must be connected to system GND at any
Load Impedance (speaker)	3.5	Ohms	n/a	Nominal	
Rated Output Power	200	Watts	150	50 - 250 Hz, 1 input driven, limiter off	
THD @ Rated Power	0.08	%	0.1	22k filter	
THD @ 1 Watt	0.15	%	0.5	22k filter	
DC Offset	5	mV-DC	20	@ Speaker Outputs	
Damping factor	16	n/a	10	Measured at amplifier board	Measured at the speaker at speaker output terminals on the amp board.
Input Sensitivity					
Input Frequency	50	Hz	n/a	Nominal Freq.	
Line (L&R) Input	220	mVrms	154 - 308	To Rated Power	Single input driven
SUB (LFE) Input	125	mVrms	87 - 175	To Rated Power	SUB (LFE) input driven only
Speaker/Hi Level Input	3.4	Vrms	2.4 - 4.8	To Rated Power	(20 dB below Line In), Single input
Hi Level Max. Input Voltage					
	32	Vrms	30	Nominal Freq., Min. Volume	
Signal to Noise Ratio					
SNR-A-Weighted	85	dB	82	relative to rated power	A-Weighting filter
SNR-unweighted	62	dB	59	relative to rated power	22k filter
SNR rel. 1W-unweighted	64	dB	59	relative to 1W Output	22k filter
Residual Noise Floor	1.2	mVrms	3.0	Volume @max, using RMS reading DMM/VOM (or A/P)	
Residual Noise Floor	0.8	mVrms	2.0	Volume @max, w/ A/P Swept Bandpass Measurement (Line freq. + harmonics)	
Input Impedance					
Line Input (L, R,LFE)	10K	ohms	n/a	Nominal	
Speaker/Hi Level Input	4.7K	ohms	n/a	Nominal	
Filters					
L&R Fixed Low-Pass Filter	160	Hz	140 - 180	@ -6dB ref. 100Hz	3rd order fixec
SUB (LFE) Low pass Filter	270	Hz	240 - 300	@ -3dB ref. 100Hz	2nd order fixec
Subsonic filter (HPF) 3rd Order	25	Hz	22 - 28	@ -3dB ref. 30Hz	3rd order fixec
Limiter					
THD at Max. Output Power	2.0	%	5.0		
Features					
Auto - On -Off Selection Switch	YES		functional		Refer to ATO section
Phase Switch	0-180	deg	functional		
Filter On/Off Switch	YES		functional		
Volume Pot Taper (Lin/Log)	LOG		functional		A Taper
Speaker Out	YES		functional		Binding post connector L&R
2-Color LED power indicator	YES		functional		Blue: On, Amber: Stand-by
Power Switch	YES		functional		
Fuse Holder	YES		functional		
Input Configuration					
Line In (L,R)	YES		functional		Dual RCA jack
SUB (LFE)	YES		functional		RCA jack
Speaker/Hi Level In	YES		functional		Binding post connector L&R
Signal Sensing (ATO)					
Auto-Turn-On (yes/no)	YES		functional	Auto - on selection switch in Auto	
ATO Input test frequency	50	Hz	n/a	"	
ATO Level Line & SUB Input	4.0	mV	2.0 - 6.0	"	
ATO Level Speaker in	35	mV	20 - 50	"	
ATO Turn-on time	0.9	sec.	functional	Amp connected and AC on, then input signal applied	
ATO Turn-OFF Time	12	minutes	5 - 17	Time before muting, after signal is removed	

Power on Delay time	3	sec.	functional	AC Power Applied	
Transients/Pops					
ATO Transient	5	mV-peak	10	@ Speaker Outputs	
Turn-on Transient	500	mV-peak	700	@ Speaker Outputs	AC Line cycled from OFF to ON
Turn-off Transient	500	mV-peak	700	@ Speaker Outputs	AC Line cycled from ON to OFF
Efficiency					
Stand-by Input Power	8	Watts	12	@ nom. line voltage	Maximum allowable input power under nominal input voltage and frequency, in stand-by mode (HOT)
Power Consumption @ rated power	240	Watts	250	@ nom. line voltage	200 Watts @ 3.5 ohms and nominal line voltage
Protection					
Short Circuit Protection	YES		functional	Direct short at output	Amplifier should resume operation after short circuit condition is
Thermal Protection	YES		functional		Any user accessible metal parts should always remain at 65 degree C or less for domestic version or 55 degree C or less for EU version.
DC Offset Protection	YES		functional	DC present at Speaker Out leads	Relay or crowbar (for driver/fire
Primary Fuse Rating					
USA-Domestic	3.15	Amps	n/a	Type-T or Slo Blo (no DENTORI m	User-replacable fuse with UL/SEMCO rated holder.

SUB-TS 14 SUBWOOFER AMPLIFIER PANEL CONTROLS AND CONNECTIONS

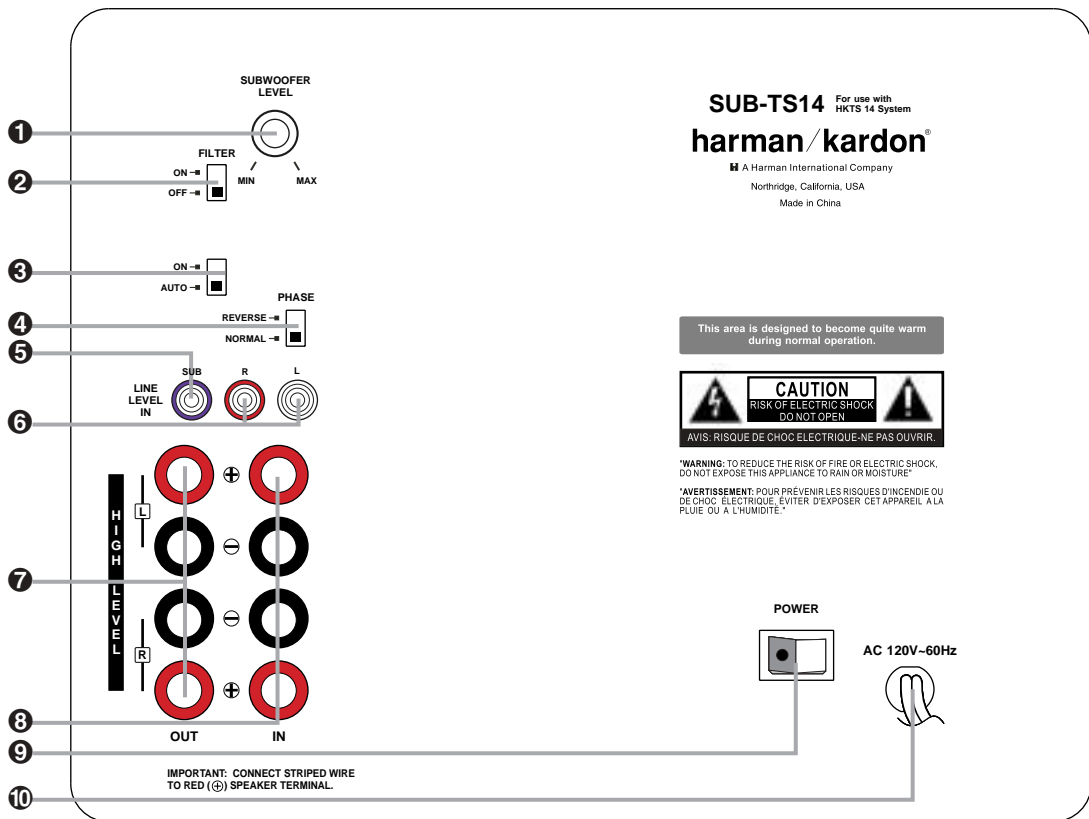

- ❶ Subwoofer-Level Control
- ❷ High-Cut (Low-Pass) Filter Switch
- ❸ Music-Sense On/Off Switch
- ❹ Phase Switch

- ❺ Line-Level Subwoofer (SUB) Input
- ❻ Line-Level Full-Range Inputs
- ❼ Speaker-Level Outputs
- ❽ Speaker-Level Inputs

- ❾ Master Power Switch
- ❿ AC Power Cord

❶ Subwoofer-Level Control: Volume may be adjusted using the **Subwoofer-Level Control**. Turn the control clockwise to increase the SUB-TS14's volume, or counterclockwise to decrease it.

❷ High-Cut (Low-Pass) Filter Switch: Placing this switch in the **ON** position activates circuitry that cuts out all audio input signals above 120Hz. This allows the SUB-TS14 to focus its power on reproducing the low-frequency portion of the signal, avoiding

inefficiency and distortion. Engage this filter when using the **Speaker-Level Inputs** **❽**, or when using the **Line-Level Full-Range Inputs** **❻**, unless your receiver or processor processes its line-level output using a low-pass filter. The filter has no effect when the **SUB Input** **❺** is used.

❸ Music-Sense On/Off Switch: When placed in the **AUTO** position, and when the **Master Power Switch** **❾** is turned on, the SUB-TS14 will automatically turn itself on or

place itself in the Standby mode, depending on whether it is receiving an audio signal. When this switch is placed in the **ON** position, the SUB-TS14 will remain on, whether or not it is receiving an audio signal.

An LED located on top of the SUB-TS14 indicates whether the SUB-TS14 is in the ON or STANDBY state when used with the **Music-Sense On/Off Switch** **❸** in the **AUTO** position. The LED is lit blue to indicate that the SUB-TS14 is receiving an

SUB-TS14 SUBWOOFER AMPLIFIER PANEL CONTROLS AND CONNECTIONS

audio signal and is turned on, and the LED is lit amber to indicate that no signal is being received and the SUB-TS14 is in Standby mode.

When the **Music-Sense On/Off Switch ③** is in the **ON** position, the LED will be lit blue, whether or not an audio signal is present.

When the **Master Power Switch ⑨** is turned off, the LED goes dark, no matter which position the **Music-Sense On/Off Switch ③** is in.

④ Phase Switch: This switch determines whether the SUB-TS14 subwoofer's piston-like action moves in and out in phase with the main speakers. If the speakers were to play out of phase, the sound waves produced by the subwoofer would be cancelled out, reducing bass response. This phenomenon depends in part on the relative placement of the speakers in the room. In most cases, the **Phase Switch ④** should be left in the **NORMAL** position. However, it does no harm to experiment with the **Phase Switch ④**, and you may leave it in the position that maximizes bass response.

⑤ Line-Level Subwoofer (SUB) Input: Connect the subwoofer output of a receiver with digital surround sound decoding, such as Dolby® Digital or DTS®, to this input. This input bypasses the SUB-TS14's internal crossover circuitry, and should only be used

with a filtered signal. If your receiver does not have digital decoding, you should use the **Line-Level Full-Range Inputs ⑥** instead.

⑥ Line-Level Full-Range Inputs: Connect the line-level subwoofer output or preamp output(s) of your receiver or amplifier to these inputs. If your receiver does not have a separate subwoofer output, use a Y-adaptor (not supplied) to bridge the receiver's preamp output to the main amp input for that channel, and connect the long end of the adaptor to the corresponding line-level input on the SUB-TS14. If your receiver has only a single subwoofer output, you may connect it to either the left or right line-level input on the SUB-TS14, and no Y-adaptor is needed.

⑦ Speaker-Level Outputs: If you are using the **Speaker-Level Inputs ⑧** on the SUB-TS14, you should connect these binding post terminals to your front left and right speakers, remembering to maintain polarity by connecting the (+) terminal on the SUB-TS14 subwoofer to the (+) terminal on the speaker, and the (-) terminal on the SUB-TS14 subwoofer to the (-) terminal on the speaker. If you are not using the **Speaker-Level Inputs ⑧**, then connect your front left and right speakers directly to your receiver or amplifier. See pages 9 through 12 for further information on speaker connections.

⑧ Speaker-Level Inputs: Connect these binding-post terminals to the main left and right speaker terminals of your receiver or amplifier, if your receiver or amplifier does not have a line-level subwoofer output. Remember to maintain polarity by connecting the (+) terminal on the receiver/amplifier to the (+) terminal on the SUB-TS14 subwoofer, and the (-) terminal on the receiver/amplifier to the (-) terminal on the SUB-TS14 subwoofer.

⑨ Master Power Switch: Place this switch in the "•" position to power-on the SUB-TS14 subwoofer. The SUB-TS14 will then be either in the Standby mode or completely on, depending on the position of the **Music-Sense On/Off Switch ③**.

⑩ AC Power Cord: Make sure to plug this cord into an active, unswitched electrical outlet for proper operation of the SUB-TS14. The cord should not be plugged into the accessory outlets found on some audio components.

SPEAKER CONNECTIONS

Dolby® Digital or DTS® (or Other Digital Surround Mode) Connection
USE THIS INSTALLATION METHOD FOR DOLBY DIGITAL, DTS OR OTHER DIGITAL SURROUND PROCESSORS:

Use the line-level input jack marked **SUB** for the Low-Frequency Effects channel. Connect this jack to the subwoofer output or LFE output on your receiver or amplifier. Connect each speaker to the corresponding speaker terminals on your receiver or amplifier.

Make sure you've configured your surround sound processor for "Subwoofer On." The front left, front right, center and surround speakers should all be set to "Small."

When all connections have been made, plug the AC power cord on the subwoofer into an AC outlet.

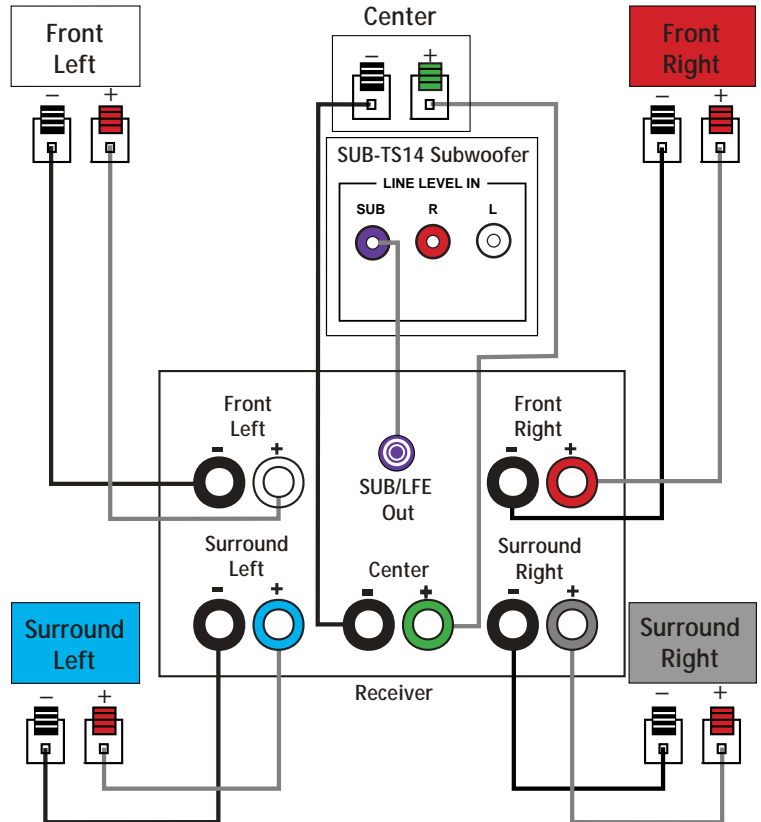

Dolby Pro Logic* (Non-Digital) – Line Level

USE THIS INSTALLATION METHOD FOR DOLBY PRO LOGIC APPLICATIONS (NOT DOLBY DIGITAL, DTS OR OTHER DIGITAL PROCESSING), WHERE THE RECEIVER/PROCESSOR IS EQUIPPED WITH A SUBWOOFER OUTPUT, OR A VOLUME-CONTROLLED PREAMP (LINE-) LEVEL OUTPUT:

Use the supplied RCA-type interconnect cable to connect the line-level subwoofer output on your receiver or amplifier to either the left or right **Line-Level Full-Range Input 6** on the SUB-TS14 subwoofer. Use both the left and right inputs on the subwoofer if your receiver or processor has both left and right line-level outputs. In that case, you will need to supply a second interconnect cable.

If your receiver is equipped with line-level outputs but does not have a separate subwoofer output, use a Y-adaptor (not supplied) to bridge the receiver's preamp output to the main amp input for that channel, and connect the long end of the adaptor to the corresponding line-level input on the SUB-TS14.

IMPORTANT: Do not use the **SUB Input 5** on the subwoofer with Dolby Pro Logic processors.

If your receiver/processor has a built-in low-pass-crossover filter for the subwoofer output, you may use the **SUB Input 5** to bypass the subwoofer's internal crossover.

Connect each speaker to the corresponding speaker terminals on your receiver or amplifier.

Make sure that you have configured your surround sound processor for "Subwoofer On." The front left, front right, center and surround speakers should all be set to "Small."

When all connections have been made, plug the AC power cord on the subwoofer into an AC outlet.

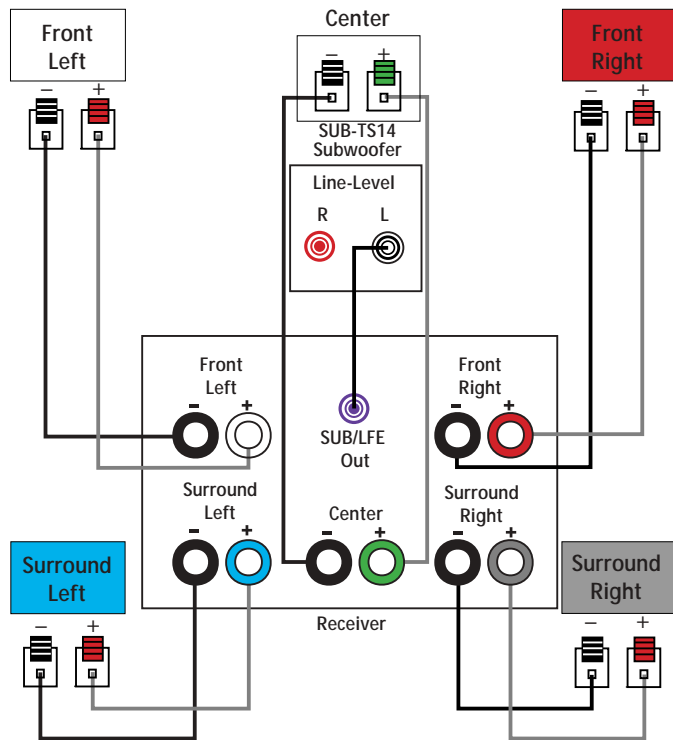

SPEAKER CONNECTIONS

Dolby Pro Logic (Non-Digital) – Speaker Level

USE THIS INSTALLATION METHOD FOR DOLBY PRO LOGIC APPLICATIONS (NOT DOLBY DIGITAL, DTS OR OTHER DIGITAL PROCESSING), WHERE THE RECEIVER/PROCESSOR DOES NOT HAVE A SUBWOOFER OUTPUT, OR A VOLUME-CONTROLLED PREAMP (LINE-) LEVEL OUTPUT:

Connect your receiver or amplifier's front left and right speaker terminals to the left and right **Speaker-Level Input 8** terminals on the SUB-TS14 subwoofer that are marked "High Level In." Connect the left and right **Speaker-Level Output 7** terminals on the SUB-TS14 subwoofer that are marked "High Level Out" to the corresponding terminals on the back of your front left and right speakers.

Connect your receiver or amplifier's center, and surround left and right speaker terminals to the corresponding terminals on the back of your center, and surround left and right speakers.

When all connections have been made, plug the AC power cord on the subwoofer into an AC outlet.

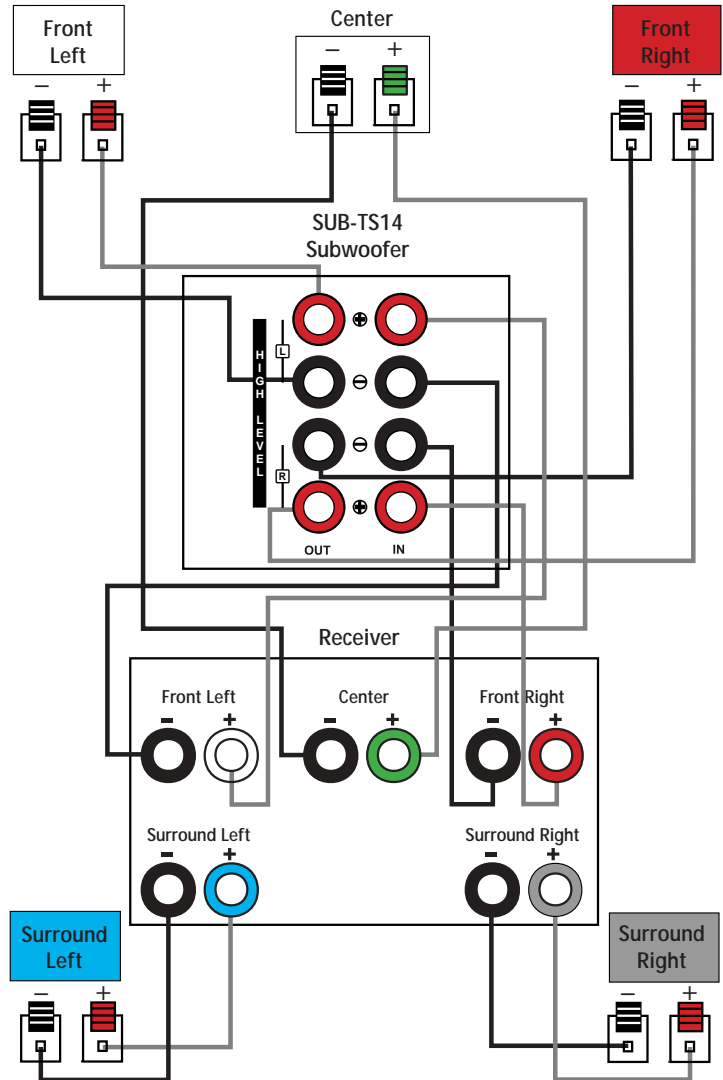

Move the **Master Power Switch 9** (marked **Power**) to the "•" (On) position. The SUB-TS14 subwoofer will automatically turn itself on or go into Standby mode, depending on whether or not a signal is being sent to it by your receiver or surround processor, and provided that the **Music-Sense On/Off Switch 3** is moved down so that it is in the **AUTO** position.

When your receiver or amplifier is off, or is not sending program material to the subwoofer, the subwoofer will be in Standby mode and the LED Indicator on the top of the subwoofer will turn amber. When the subwoofer senses an audio signal, it will automatically turn itself on and the LED Indicator will turn blue. If the subwoofer does not sense a signal after approximately twenty minutes, it will automatically go into Standby mode.

When the **Music-Sense On/Off Switch 3** is switched to the **ON** position, the subwoofer will remain on, whether or not program material is playing, and the LED Indicator will remain lit blue.

If you'll be away from home for an extended period of time, or if the subwoofer will not be used, switch the **Master Power Switch 9** to the **OFF** position.

Volume

Volume can be adjusted using the **Subwoofer-Level Control 1**, as shown. Turn the control knob clockwise to increase the volume of the subwoofer, and counterclockwise to decrease the subwoofer's volume.

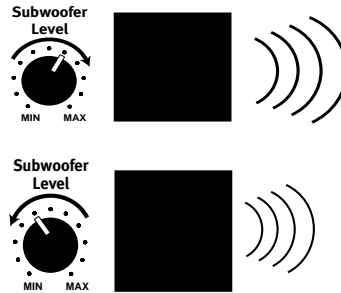

Additional Bass Adjustments

In addition to the volume adjustments described above, the SUB-TS14 subwoofer includes a **Phase Switch 4** and a **Filter Switch 2** that can be used to adjust the bass response to suit your listening environment or taste.

In most situations, the **Phase Switch 4** should be left in the **NORMAL** position. If you suspect that the subwoofer is playing out of phase with the other speakers, which would tend to diminish bass response, try placing this switch in the **REVERSE** position. There is no harm in experimenting, and you may return the switch to the **NORMAL** position at any time. If you rearrange your room and reposition the speakers, it would be a good idea to check whether they are in phase by flipping this switch.

The **High-Cut (Low-Pass) Filter Switch 2** limits the frequencies of the audio signal inputted to the subwoofer to the low frequencies that the subwoofer reproduces best. This allows the subwoofer to perform more efficiently, and with superior bass reproduction, minimizing distortion that might occur if the subwoofer attempted to reproduce higher frequencies. This switch should be left in the **ON** position, **except**:

1. When the **SUB Input 5** is being used, in which case it has no effect, or
2. When the **Speaker-Level Inputs 8** or the **Line-Level Full-Range Inputs 6** are being used with a crossover or filter aboard the receiver or processor.

In these two circumstances, place the switch in the **OFF** position.

TROUBLESHOOTING

SYMPTOM	SOLUTION
If there is no sound from any of the speakers:	<ul style="list-style-type: none"> • Check that receiver/amplifier is on and a source is playing. • Check that the powered subwoofer is plugged in and its Master Power Switch 9 is switched on to the "•" position. • Check all wires and connections between receiver/amplifier and speakers. Make sure all wires are connected. Make sure none of the speaker wires are frayed, cut, punctured or touching other wires. • Review proper operation of your receiver/amplifier.
If there is no sound coming from one speaker:	<ul style="list-style-type: none"> • Check the "Balance" control on your receiver/amplifier. • Check all wires and connections between receiver/amplifier and speakers. Make sure all wires are connected. Make sure none of the speaker wires are frayed, cut or punctured, and that no wires are touching each other. • In Dolby Digital or DTS mode, make sure that the receiver/processor is configured so that the speaker in question is enabled. • Turn off all electronics and switch the speaker in question with one of the other speakers that is working correctly. Turn everything back on, and determine whether the problem is in the same place: i.e., the speaker that was working previously now has no sound and the speaker that was not working now sounds fine; or whether it has moved: i.e., the speaker that was not working still has no sound and the speaker that was working is still fine. If the problem is in the same place, the source of the problem is most likely with your receiver or amplifier, and you should consult the owner's manual for that product for further information. If the problem has followed the speaker, consult your dealer for further assistance or, if that is not possible, visit our Web site at www.harmankardon.com for further information.
If there is no sound from the center speaker:	<ul style="list-style-type: none"> • Check all wires and connections between receiver/amplifier and speaker. Make sure all wires are connected. Make sure none of the speaker wires are frayed, cut, punctured or touching other wires. • If your receiver/processor is set in Dolby Pro Logic mode, make sure the center speaker is not in phantom mode. • If your receiver/processor is set in Dolby Digital or DTS mode, make sure the receiver/processor is configured so that the center speaker is enabled.
If the system plays at low volumes but shuts off as volume is increased:	<ul style="list-style-type: none"> • Check all wires and connections between receiver/amplifier and speakers. Make sure all wires are connected. Make sure none of the speaker wires are frayed, cut, punctured or touching other wires. • If more than one pair of main speakers is being used, check the minimum impedance requirements of your receiver/amplifier.
If there is low (or no) bass output:	<ul style="list-style-type: none"> • Make sure the SUB 5 or Line-Level Inputs 6 of the SUB-TS14 subwoofer and SUB or LFE output of your receiver or amplifier are properly connected by the RCA-type interconnect cable. • If you are using the SUB-TS14's Speaker-Level Inputs 8, check your speaker cables to make sure they are all connected; that none of the wires are frayed, cut, punctured or touching other wires; and that you have maintained the correct polarity by connecting positive terminals to positive terminals, and negative terminals to negative terminals. • Make sure the subwoofer is plugged into an active electrical outlet and its Master Power Switch 9 is switched on to the "•" position. • Check the speaker setup (bass management) settings in your A/V receiver or processor to make certain that the front, center and surround speakers are configured for "Small," and that the subwoofer is set for "Yes" or "On."
If there is no sound from the surround speakers:	<ul style="list-style-type: none"> • Check all wires and connections between receiver/amplifier and speakers. Make sure all wires are connected. Make sure none of the speaker wires are frayed, cut, punctured or touching other wires. • Review proper operation of your receiver/processor and its surround sound features. • Make sure the movie or TV show you are watching is recorded in a surround sound mode. If it is not, check to see whether your receiver/processor has other surround modes you may use. • In Dolby Digital or DTS mode, make sure your receiver/processor is configured so that the surround speakers are enabled. • Review the operation of your DVD player and the jacket of your DVD to make sure that the DVD features the desired Dolby Digital or DTS mode, and that you have properly selected that mode using both the DVD player's menu and the DVD disc's menu.

Test Set Up and Procedure

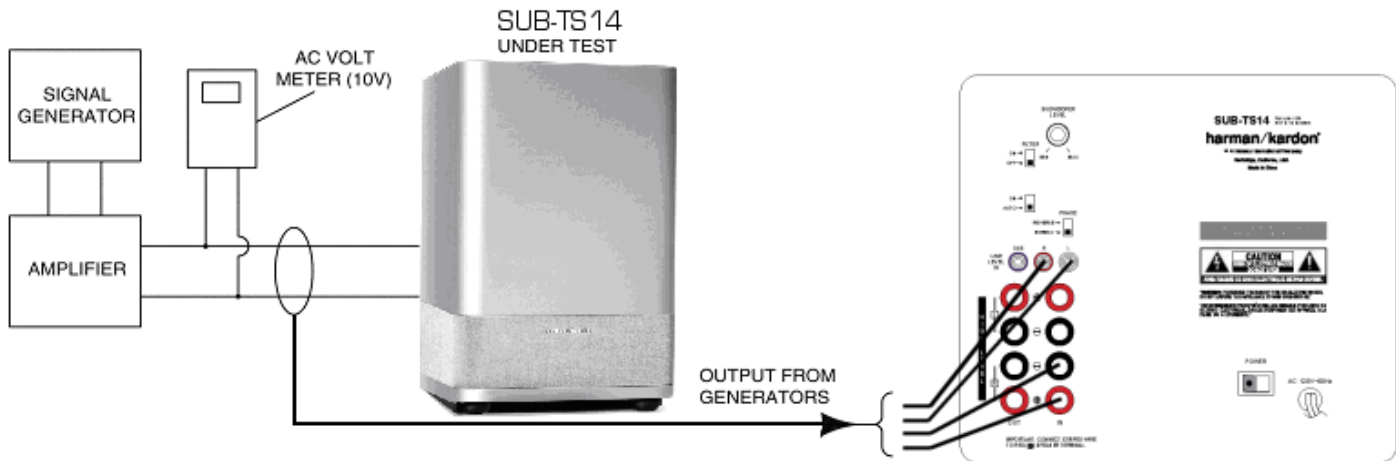

Equipment needed:

- Function/signal generator/sweep generator
- Integrated Amplifier
- Multimeter
- Speaker cables

Initial Control Settings:

- Power Switch OFF; Filter OFF
- Level MIN (Full CCW)
- Phase, Auto/On switches do not matter

General Unit Function (UUT = Unit Under Test)

- 1) From the signal generator, connect one line level (RCA) cable to the Subwoofer Line Level Input jacks L/R on the UUT. Use a Y-cable from a mono source if necessary to connect to both inputs. Do not connect to the single, purple SUB input.
- 2) Turn on generator; adjust to **60mV, 50 Hz**.
- 3) Plug in UUT; turn the power switch ON. Turn LEVEL control full clockwise (MAX)
- 4) LED should turn from Amber to Blue (on top of UUT); immediate and vigorous bass response should be heard and felt from port tube opening.
- 5) Turn off generator, turn LEVEL control full counterclockwise (MIN), and disconnect RCA cable.
- 6) Connect one pair of speaker cables to Speaker Level input terminal (IN) on UUT. Cables should be connected to an integrated amplifier fed by the signal generator.
- 7) Turn on generator and adjust so that speaker level input at the amplifier is **1.2V, 50 Hz**. Turn LEVEL control full clockwise.
- 8) LED should turn from Amber to Blue; immediate and vigorous bass response should be heard and felt from the port tube opening.

Sweep Function

- 1) Follow steps 6-8 above, using a sweep generator as a signal source.
- 2) Sweep generator from 20Hz to 300Hz. Listen to the cabinet and drivers for any rattles, clicks, buzzes or any other noises. If any unusual noises are heard, remove woofers and test.

Driver Function

- 1) Remove woofer from cabinet; detach + and - wire clips.
- 2) Check DC resistance of woofer; it should be **2.8 ohms ±10%**
- 3) Connect a pair of speaker cables to driver terminals. Cables should be connected to an integrated amplifier fed by a signal generator. Turn on generator and adjust so that speaker level output is **5.0V**.
- 4) Sweep generator from 20Hz to 1kHz. Listen to driver for any rubbing, buzzing, or other unusual noises.

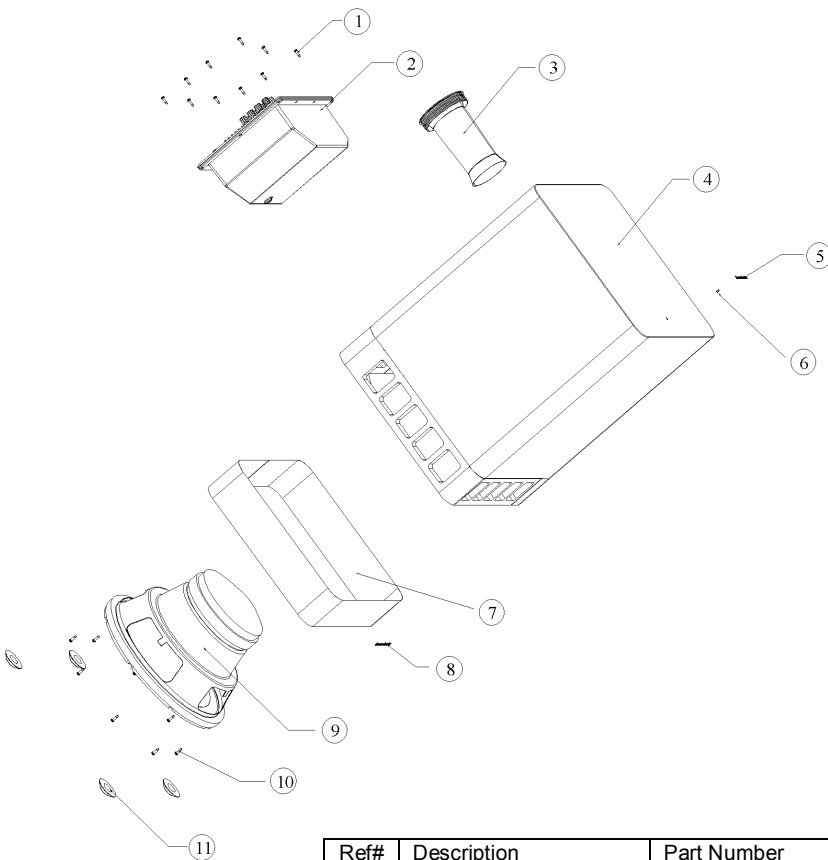

Ref#	Description	Part Number	Qty
1	Amplifier screw	352-AM04020D210	10
2	SUB-TS14 Amplifier	Not for Sale	1
3	Port Tube	Not for Sale	1
4	SUB-TS14 Cabinet	Not for Sale	1
5	Logo	316-AG-00557	1
6	LED	Not for Sale	1
7	Grille	Not for Sale	1
8	Logo	316-AL-00553	1
9	12" woofer	30PF14FM-DW05	1
10	Woofer screw	352-FM04020D605	8
11	Foot Pad	320-EVA-00057	4

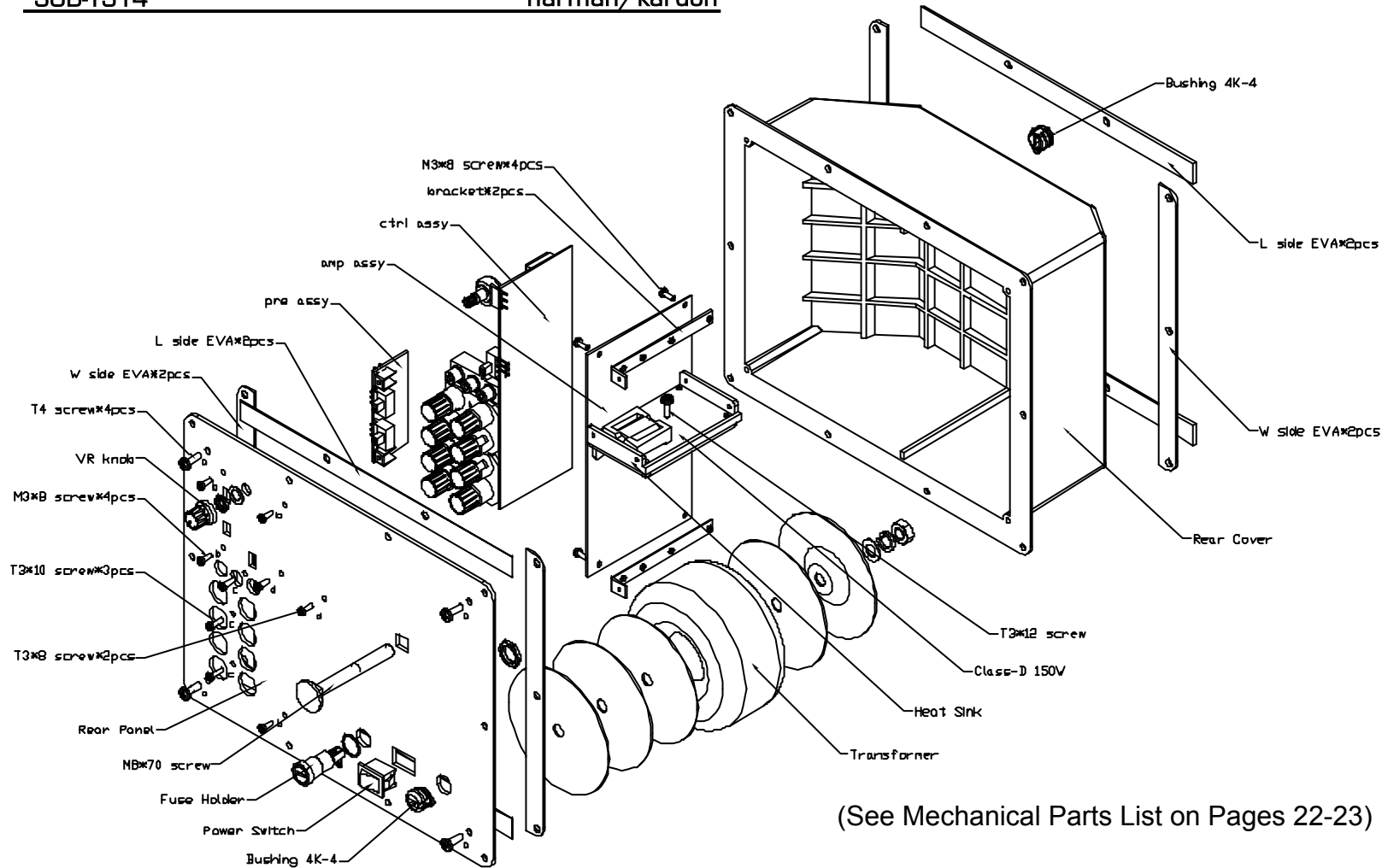

(See Mechanical Parts List on Pages 22-23)

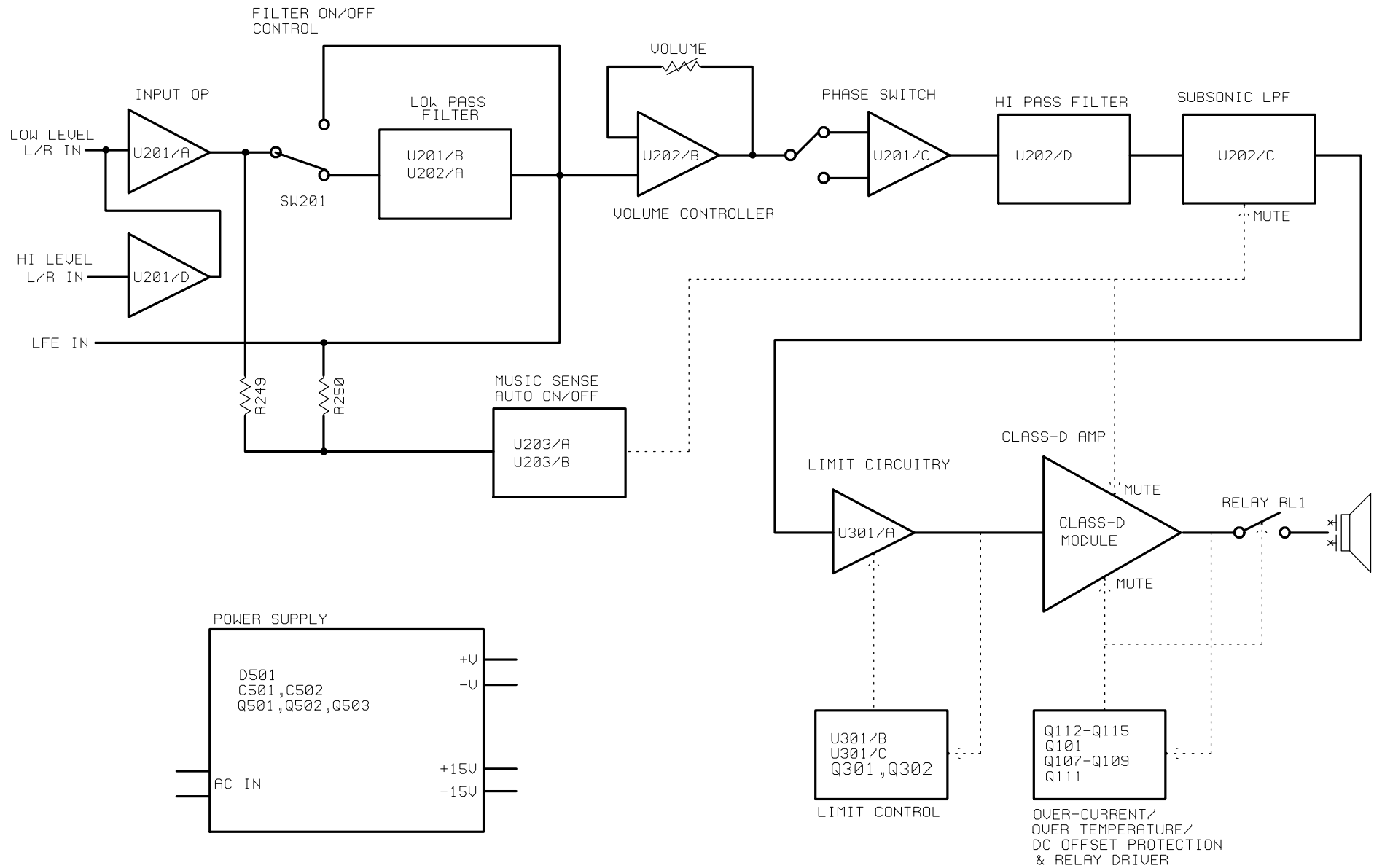

HKTS14 BLOCK DIAGRAM

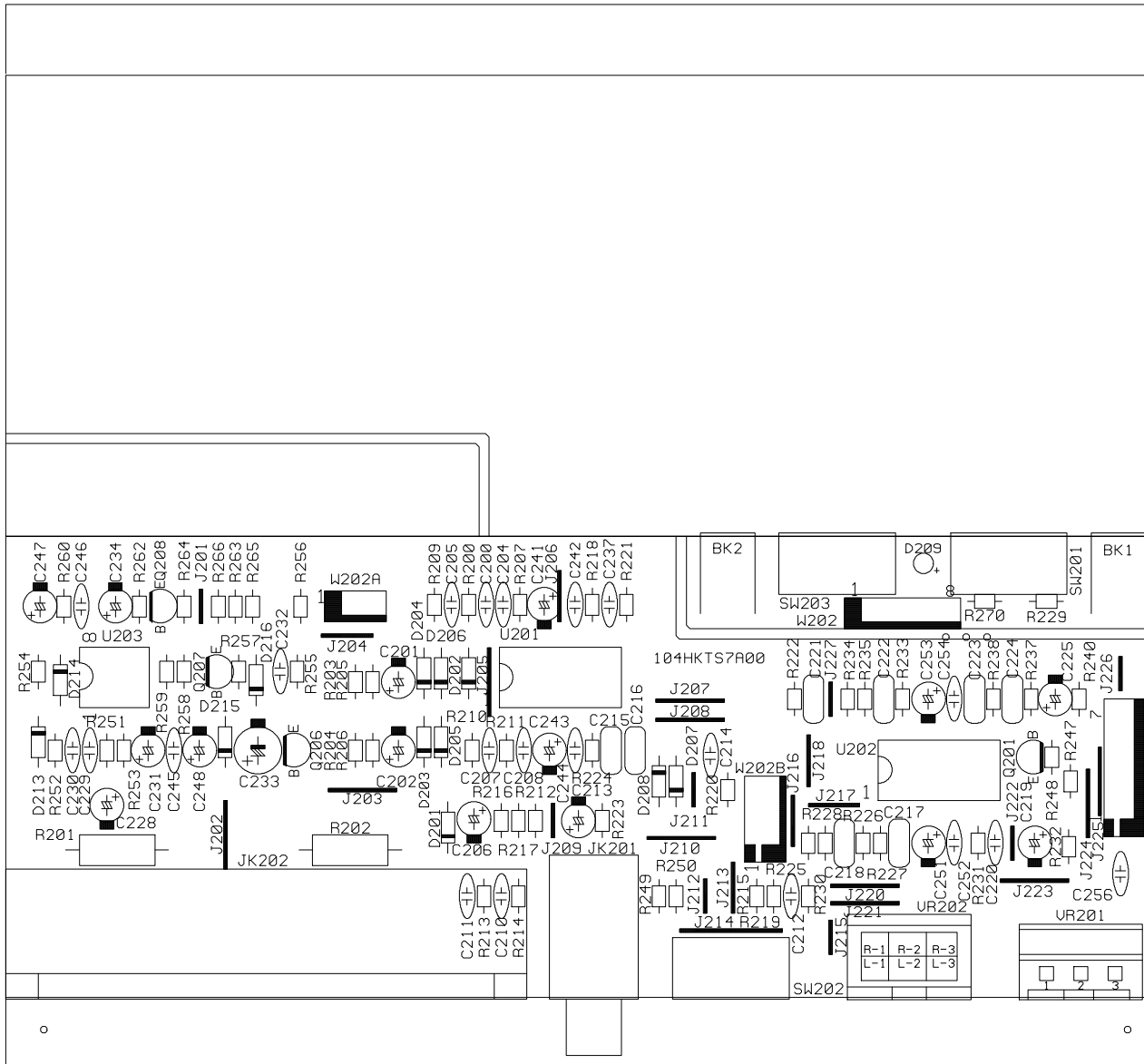

DRAW.	APUD.	FILENAME : HKTS7PRE.PCB	REVISION:
		MODEL NO. 104-HKTS7A00	1
		MATERIAL : FR-1 (94V0)	2
		LAYER SILK SCREEN	3
DSGN.			

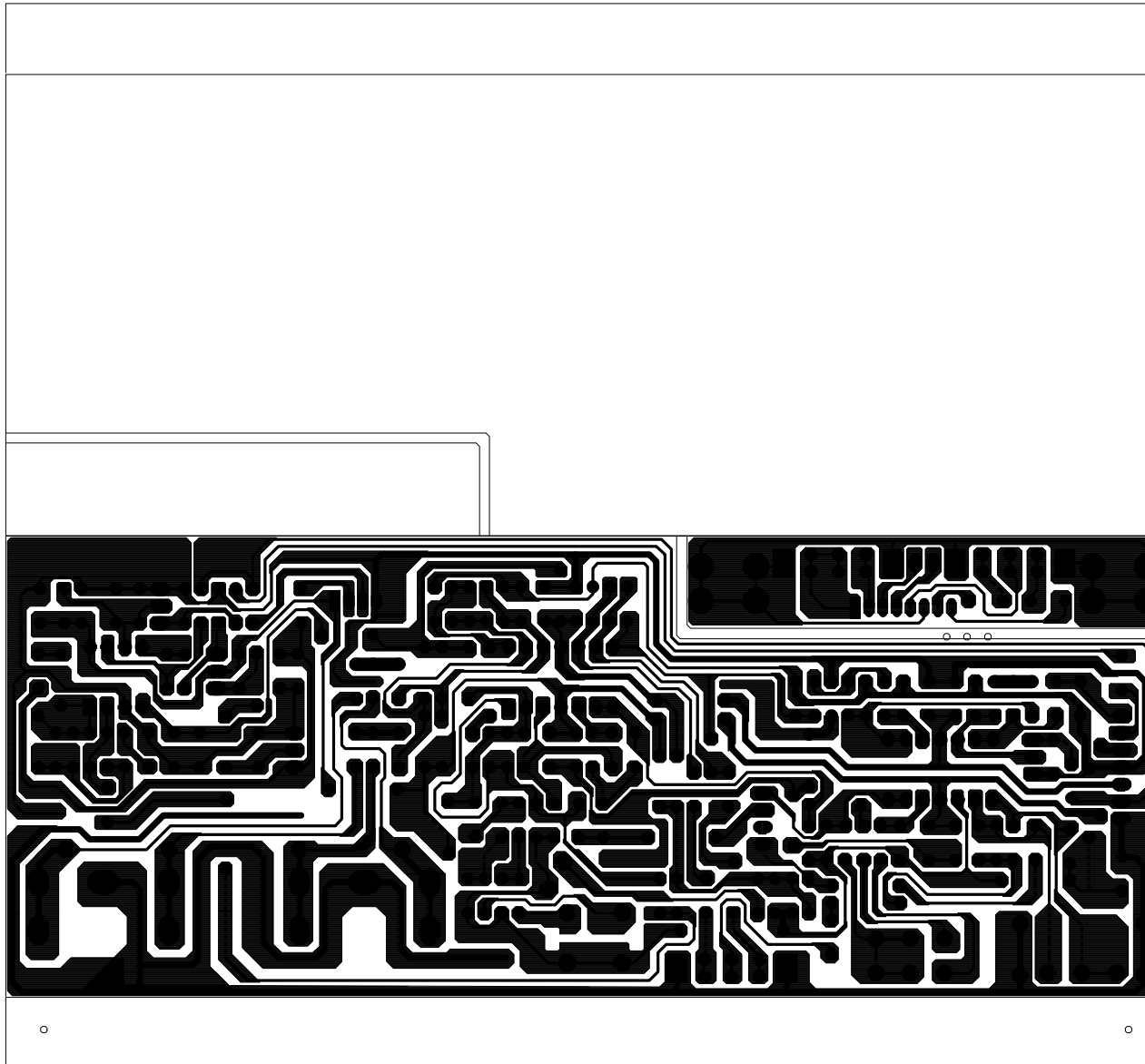

DRAW.	DSGN.	APUD.	FILENAME : HKTS7PRE.PCB	REVISION:
			MODEL NO. 104-HKTS7A00	1
			MATERIAL : FR-1 (94V0)	2
			LAYER SOLDER PATTERN	3

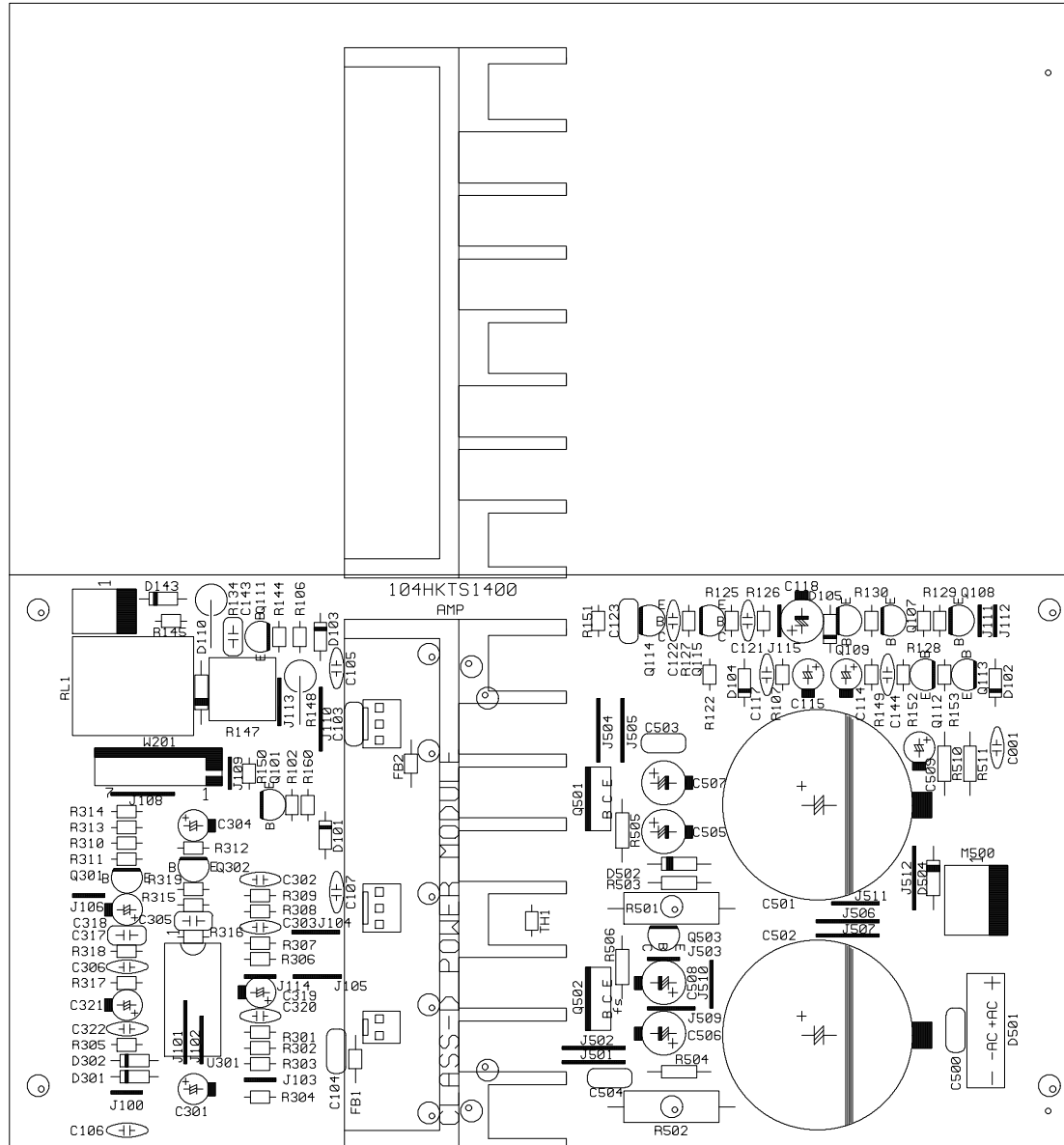

		FILENAME : HKTS14.PCB	REVISION:
DRAW.		MODEL NO. 104-HKTS1400	1
DSGN.		MATERIAL : FR-1(94V0)	2
APUD.		LAYER SILK SCREEN	3

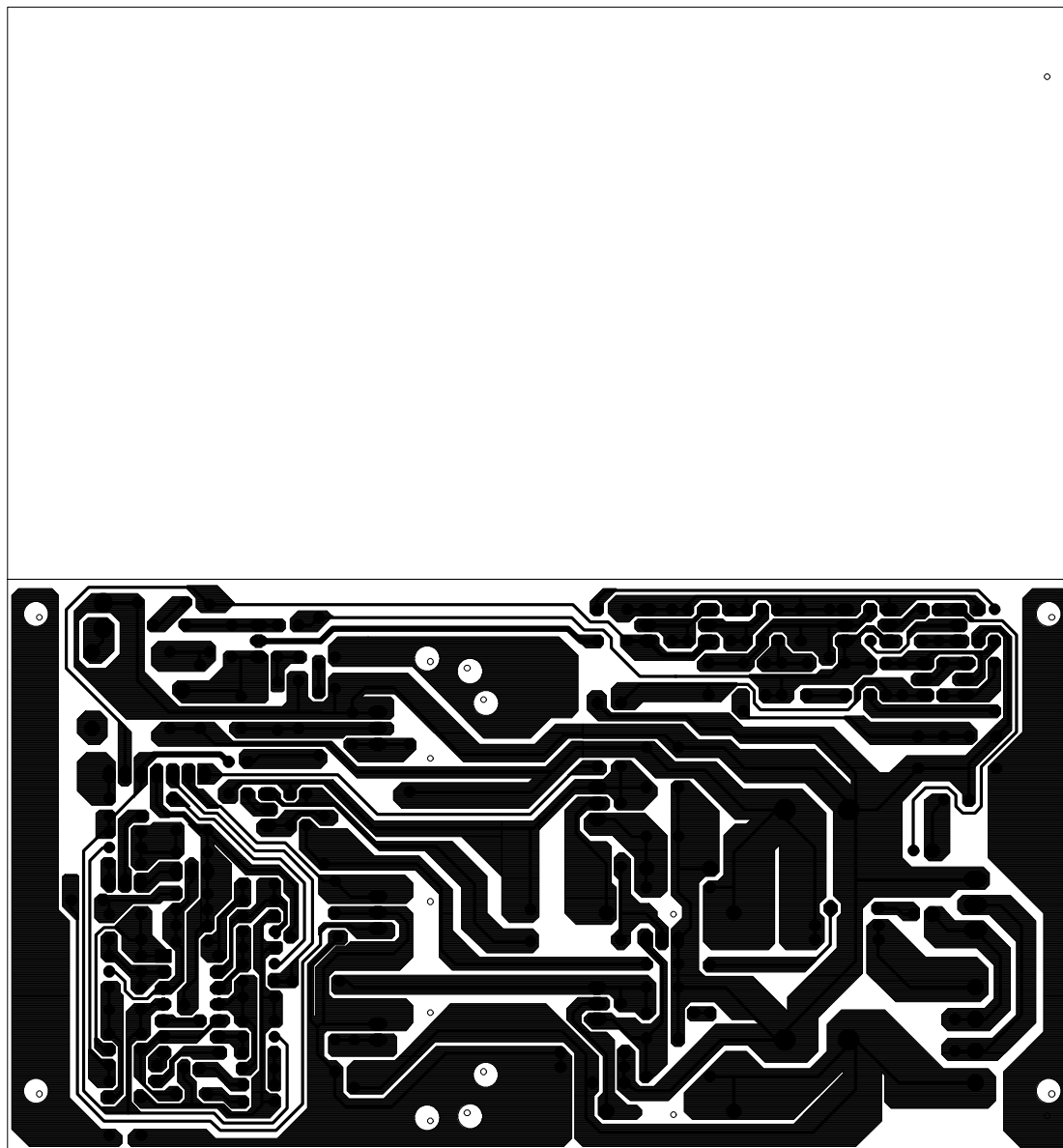

				FILENAME : HKTS14.PCB	REVISION:
	DRAW.			MODEL NO. 104-HKTS1400	1
		DSGN.		MATERIAL : FR-1(94V0)	2
			APUD.	LAYER SOLDER PATTERN	3

SUB-TS14 120V Electrical parts list			
Part number	Description	Qty	Reference Designator
PREAMP PCB			
<i>Resistors</i>			
110-12472j52	Resistor 4.7K 1/2W ±5% CF 52mm	2	R201,202
110-16102j26	Resistor 1K 1/6W ±5% CF 26mm	4	R213,214,215,254
110-16103j26	Resistor 10K 1/6W ±5% CF 26mm	18	R209,212,216,217,218,220,221,222,225,228,229,230,232,235,240,248,260,270
110-16104j26	Resistor 100K 1/6W ±5% CF 26mm	3	R231,263,266
110-16105j26	Resistor 1M 1/6W ±5% CF 26mm	1	R259
110-16122j26	Resistor 1.2K 1/6W ±5% CF 26mm	1	R265
110-16134j26	Resistor 130K 1/6W ±5% CF 26mm	1	R233
110-16151j26	Resistor 150Ω 1/6W ±5% CF 26mm	1	R253
110-16154j26	Resistor 150K 1/6W ±5% CF 26mm	1	R252
110-16183j26	Resistor 18K 1/6W ±5% CF 26mm	1	R262
110-16203j26	Resistor 20K 1/6W ±5% CF 26mm	2	R237,238
110-16205j26	Resistor 2M 1/6W ±5% CF 26mm	1	R257
110-16223j26	Resistor 22K 1/6W ±5% CF 26mm	3	R247,255,256
110-16303j26	Resistor 30K 1/6W ±5% CF 26mm	2	R223,224
110-16472j26	Resistor 4.7K 1/6W ±5% CF 26mm	3	R200,207,258
110-16473j26	Resistor 47K 1/6W ±5% CF 26mm	5	R219,249,250,251,264
110-16512j26	Resistor 5.1K 1/6W ±5% CF 26mm	2	R210,211
110-16622j26	Resistor 6.2K 1/6W ± 5% CF 26mm	1	R234
110-16913j26	Resistor 91K 1/6W ± 5% CF 26mm	4	R203,204,205,206
115-h503a102	variable Resistor RV16AE-20B2-15K-A54-104(A50K)	1	VR201
<i>Capacitors</i>			
129-a154j633	metallize capacitor 0.15U 63V ±5% MSC	2	C221,222
129-a224j633	metallize capacitor 0.22uF 63V ±5% MSC	1	C218
130-2b221k503	disc capacitor 220P 50V ±10%	12	C200,204,205,207,208,210,211,212,214,220,230,237
130-2b470k503	disc capacitor 47P 50V ±10%	1	C229
130-2f104z503	disc capacitor 0.1U 50V +80/-20%	8	C232,242,244,245,246,252,254,256
132-183j503	mylar capacitor 0.018uF 50V ±5%	1	C223
132-223ja03	mylar capacitor 0.022uF 100V ±5%	1	C215
132-473j503	mylar capacitor 0.047U 50V ±5%	1	C224
132-563j503	mylar capacitor 0.056U 50V ±5%	1	C216
132-823j503	mylar capacitor 0.082U 50V ±5%	1	C217
135-3105m50	electrolytic 1U 50V ±20%	1	C228
135-3106m50	electrolytic 10uF 50V ±20%	10	C201,202,206,213,219,231,241,243,251,253
135-3107m16	electrolytic 100uF 16V ±20%	1	C234
135-3226m50	electrolytic 22U 50V ±20%	1	C225
135-3227m16	electrolytic 220U 16V ±20%	1	C233
<i>Semiconductors</i>			
192-027c1815gr	IC 2SC1815GR NPN	3	Q201,206, 207,208
197-131n4148	diode 1N4148 26mm	11	D201,202,203,204,205,206,207,208,214,215,216
199-15000335	zener diode 3.3V 1/2W 52mm	1	D213
190-06m4558d	I.C. OPA 4558D DUAL OP-AMP	1	U203
190-16tl074cn	I.C TL074CN ST QUAD OP-AMP	2	U201,202

Part number	Description	Qty	Reference Designator
PREAMP PCB			
<i>Miscellaneous</i>			
162-50332003	2 PIN 330mm RED	1	D209
174-0rca313v	RCA JACK RCA-313G V/R/W	1	JK201
174-20810360g	JACK SPK JK BP 8PIN	1	JK202
175-1b08v01	wire connector 8 PIN PITCH=2.0mm	1	W202
175-1c07v01	wire connector 7 PIN PITCH=2.5mm	1	M201
180-tms7210v	SWITCH SLIDE 6PIN MS7210V	3	SW201,202,203
MAIN PCB			
<i>Resistors</i>			
110-14103j26	Resistor 10K 1/4W ±5% CF 26mm	3	R503,504,510
110-14222j26	Resistor 2.2K 1/4W ±5% CF 26mm	1	R511
110-14432j26	Resistor 4.3K 1/4W ±5% CF 26mm	1	R506
110-14472j26	Resistor 4.7K 1/4W ±5% CF 26mm	1	R505
110-16102j26	Resistor 1K 1/6W ±5% CF 26mm	1	R153
110-16103j26	Resistor 10K 1/6W ±5% CF 26mm	10	R128,130,149,150,305,306,308,311,314,319
110-16104j26	Resistor 100K 1/6W ±5% CF 26mm	3	R122,126,307
110-16153j26	Resistor 15K 1/6W ±5% CF 26mm	1	R107
110-16182j26	Resistor 1.8K 1/6W ±5% CF 26mm	1	R145
110-16203j26	Resistor 20K 1/6W ±5% CF 26mm	1	R309
110-16221j26	Resistor 220Ω1/6W ±5% CF 26mm	1	R144
110-16222j26	Resistor 2.2K 1/6W ±5% CF 26mm	1	R102
110-16223j26	Resistor 22K 1/6W ±5% CF 26mm	1	R316
110-16333j26	Resistor 33K 1/6W ±5% CF 26mm	1	R310
110-16393j26	Resistor 39K 1/6W ±5% CF 26mm	1	R151
110-16434j26	Resistor 430K 1/6W ±5% CF 26mm	1	R312
110-16473j26	Resistor 47K 1/6W ±5% CF 26mm	2	R106,129
110-16474j26	Resistor 470K 1/6W ±5% CF 26mm	1	R127
110-16562j26	Resistor 5.6K 1/6W ±5% CF 26mm	1	R152
110-16621j26	Resistor 620Ω1/6W ± 5% CF 26mm	1	R160
110-16751j26	Resistor 750Ω1/6W ± 5% CF 26mm	1	R315
110-16755j26	Resistor 7.5M 1/6W ± 5% CF 26mm	1	R313
116-161002f26	metal film Resistor 10K 1/6w ± 1% MF 26mm	2	R301,303
116-161202f26	metal film Resistor 12.0K 1/6w ± 1% MF 26mm	1	R302
116-162200f26	metal film Resistor 220Ω1/6w ± 1% MF 26mm	1	R317
116-162202f26	metal film Resistor 22.0K 1/6w ± 1% MF 26mm	1	R318
110-20332jk3	Resistor 3.3K 2W ±5% 7.5m	1	R134
113-50s68j00	cement Resistor 0.068Ω5w ± 5%	1	R147
116-201001jk3x	metal film Resistor 1.00K 2w ± 5% MF 7.5mm	1	R148
116-304700jk2x	metal film Resistor 470Ω3w ± 5% MF 10mm	2	R501,502
<i>Capacitors</i>			
130-2f104z503	disc capacitor 0.1U 50V ±10%	6	R107,117,122,144,320,322
130-sl101k503	disc capacitor 100P 50V SL ± 10%	3	C302,303,306
132-103j503	mylar capacitor 0.01U 50V ±5%	2	C305,317
132-103ja03	mylar capacitor 0.01uF 100V ±5%	2	C103,104
132-104ja03	mylar capacitor 0.01uF 100V ±5%	3	C123,503,504
132-273ja03	mylar capacitor 0.027uF 100V ±5%	1	C143

Part number	Description	Qty	Reference Designator
MAIN PCB			
135-3106m50	electrolytic 10uF 50V ±20%	2	C319,321
135-3107m10	electrolytic 100U 10V ±20%	2	C114,115
135-3107m35	electrolytic 100U 35V ±20%	2	C507,508
135-3225m50	electrolytic 2.2U 50V ±20%	1	C509
135-3226m16	electrolytic 22U 16V ±20%	1	C304
135-3226m50	electrolytic 22U 50V ±20%	2	C505,506
135-3227m16	electrolytic 220U 16V ±20%	1	C118
135-3476m16	electrolytic 47U 16V ±20%	1	C318
132-103kb00	mylar capacitor 0.01uF 400V +/- 10%	1	C500
138-5478m80	large aluminum 4700uF 80V ± 20% 85 □	2	C501,502
<i>Semiconductors</i>			
192-027c1815gr	transistor 2SC1815GR	5	Q108,109,113,301,302
192-027c2235y	transistor 2SC2235Y	1	Q111
192-028a1015gr	transistor 2SA1015GR	3	Q101,107,112
192-1672n5551	transistor 2SN5551	2	Q114,115
192-1682n5401	transistor 2SN5401 AI-PNP 350V 500mA TO-92	1	Q503
197-013n4148	diode 100mA 75V SIGNAL 1N4148	7	Q102,103,104,105,143,301,302
199-15000625	zener diode 6.2V 1/2W 52mm	1	D101
199-15001605	zener diode 16V 1/2W 52mm	1	D502
190-16t1074cn	IC TL074CN ST	1	U301
192-161tip31c	transistor TIP31C SGS	1	Q501
192-162tip32c	transistor TIP32C SGS	1	Q502
197-00kbu606g	diode 6A 800V KBU606G	1	D501
197-101n4004	diode 1n4004	2	D110,504
<i>Miscellaneous</i>			
109-1ttc802j0	thermister TTC-802(JS) NTC	1	TH1
120-1000003	inductor 10W AI YT-C3104-005 1CRHW 35478LTB	2	FB1,2
162-50129001	wire cable ass'y 120mm AWG28 WHT	1	W201
171-urwh124d	relay RWH-SH-124D (1600 ohm)	1	RL1
175-1d02v01	wire connector 2PIN PITH=3.96mm	1	M100
175-1d03v01	wire connector 3PIN PITH=3.96mm	1	M500
Power Amp Class D Module part# 012-7500-00022 RECOMMENDED: REPLACE ENTIRE MODULE			
<i>Resistors</i>			
118-12061001j	SMD Resistor 1.00K 1206 5%	4	R2,11,29,30
118-12061002j	SMD Resistor 10.0K 1206 5%	3	R7,9,25
118-120610r0j	SMD Resistor 10.0Ω 1206 5%	2	R22,23
118-12061201j	SMD Resistor 1.20K 1206 5%	16	R31,32,33,34,35,36,37,38,39,40,41,42,43,44,45,46
118-12062002j	SMD Resistor 20.0K 1206 5%	1	R26
118-12062201j	SMD Resistor 2.20K 1206 5%	3	R6,13,16
118-12062701j	SMD Resistor 2.70K 1206 5%	1	R10
118-12063000j	SMD Resistor 300.0Ω 1206 5%	1	R24
118-12063301j	SMD Resistor 3.30K 1206 5%	4	R14,15,27,28
118-12063902j	SMD Resistor 39.0K 1206 5%	1	R3
118-12064700j	SMD Resistor 470Ω 1206 5%	1	R8

Part number	Description	Qty	Reference Designator
Power Amp Class D Module part# 012-7500-00022 RECOMMENDED: REPLACE ENTIRE MODULE			
118-12064701j	SMD Resistor 4.70K 1206 5%	3	R1,5,12
118-12064702j	SMD Resistor 47.0K 1206 5%	1	R17
118-12064704j	SMD Resistor 4.70M 1206 5%	1	R4
118-120647r0j	SMD Resistor 47.0Ω 1206 5%	2	R20,21
<i>Capacitors</i>			
141-c0101k50	SMD Capacitor 100pF 50V 10% 1206 NPO	1	C4
141-c0220k50	SMD Capacitor 22pF 50V 10% 1206 SMT NPO	1	C5
141-c0561k50	SMD Capacitor 560pF 50V 10% 1206 NPO	1	C6
141-c5104m50	SMD Capacitor 1206 Y5V 0.1uF 50V ± 20%	8	C2,3,7,8,9,10,11,15
141-c7223k50	SMD Capacitor 0.022uF 50V 10% 1206 X7R	1	C13
141-d7104ka0	SMD Capacitor 0.1uF 100V 10% 1210 X7R	5	C12,14,18,19,20
141-d7104kb5	SMD Capacitor 0.1uF 250V 10% 1210 X7R	1	C1
<i>Semiconductors</i>			
192-232irf9640	transistor FET IRF9640 IR P-CH TO-220	1	Q10
192-233irf640	transistor FET IRF640 IR N-CH TO-220	1	Q11
190-16t072dts	SMD I.C. TL072CDT SGS THOMSON	1	IC1
192-09124126qs	SMD transistor 2SC2412K-T146Q/R	3	Q1,4,5
192-09139066rs	SMD transistor 2SC3906K-T146R ROHM	2	Q2,8
192-09210376qs	SMD transistor 2SA1037K-T146Q/R ROHM	2	Q7,9
192-09215146rs	SMD transistor 2SC1514K-T146R ROHM	2	Q3,6
197-03rls4148s	SMD diode RLS4148-TE11 ROHM	6	D1,2,3,4,5,6
199-15000563s	SMD zener diode 5.6V 5% PHILIPS BZX84-C5V6	2	Z1,2
199-15001203s	SMD zener diode 12V 5% PHILIPS BZX84-C12	2	Z5,6
199-15001503s	SMD zener diode 15V 5% PHILIPS BZX84-C15	1	Z3,4
<i>Miscellaneous</i>			
122-14121m4191	Ferrite core LS-A6206-ST EFD-30	1	L1
122-14350j4180	choke coll 35uH Ferrite Core 25	1	L2
128-e106ma01	non-polar 10uF 100V 20%	2	C16,17
175-9f40hr2	wire connector 40PIN PITCH=2.54mm HR2*40	0.2	
MISCELLANEOUS/MECHANICAL			
150-r4055903	power transformer TT0900304490	1	T501
152-u602015	line cord SVT FT-2 6FT	1	
154-k31505t0	fuse3.15A 250V 30mm UL/CSA	1	F501
155-63032i	fuse holder HTB-32I 3mm UL/CSA	1	F501
162-10082007	wire RED 18AWG 80mm 8mm#1015	1	
162-5050d003	wire ul11015 500mm	1	M100
162-10152001	wire ul1617 AWG22 150mm RED	1	
163-11009	wire tie 100mm	2	
176-Wwjcel	wire Connector & Base CE-1	1	
180-pbr12c11s	Power switch PUSH BR12C11S	1	SW501
193-201815t2	insulator	2	for Q10,Q11,
302-AL-00373-0	Alum. Back panel		
306-ABS-00004	REAR CABINET 268*213*102 A.B.S UL		
311-ABS-00028	Knob 46077-W P.V.C.		

Part number	Description	Qty	Reference Designator
MISCELLANEOUS/MECHANICAL			
317-000-00037	Ground terminal M3 t=0.3		
333-EVA-00096	EVA (gasket) 213*15*2.0mm		
333-EVA-00097	EVA (gasket)213*15*1.0t		
333-EVA-00121	8PIN BB EVA (gasket)		
333-EVA-00132	EVA (gasket) 238*15*2.0mm		
333-EVA-00133	EVA (gasket)238*15*1.0t		
333-EVA-00188	EVA (gasket) 170x5x1t		
333-EVA-00219	EVA (gasket)150*15*1t UL		
333-EVA-00220	EVA (gasket)225*15*1t UL		
333-EVA-00866	Flame less EVA (gasket) 48*18*1.5T		
350-EM04012D02	4□*12 screw		
351-AM03008A07	SCREW M3*8		
351-AM03008A07	SCREW M3*8 BLK		
352-AM03008D04	□3*8 B type screw		
352-AM03008D04	□3*8 B type screw		
352-AM03010D06	□3*10 P type screw		
352-HM03012D08	□3*12 B type Screw		
353-0870122	SCREW M8*70 BLK		

Integrated Circuit Diagrams

TLO72, 4558 Dual Op Amp
U1, 203

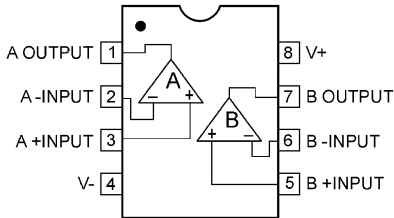

OPAMP, QUAD 14P DIL TL074
U201, 202, 301

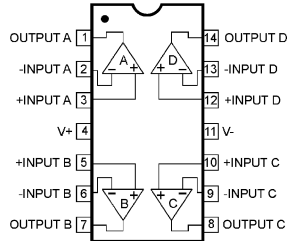

2N5401
Q503

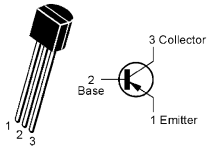

2SC2412K
2SC3906K
2SA1037K
2SA1514K

Q1-Q5, Q6-Q9

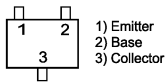

MOSFET
IRF640,
9640
Q10,11

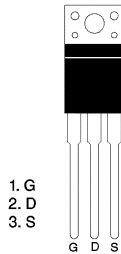

TIP 31C, 32C
Q501,502

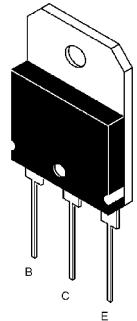

2SA1015
Q101,107,112

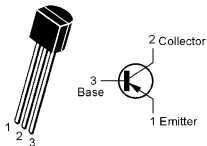

2N5551
Q114,115

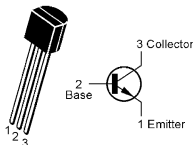

2SC2235Y
Q111

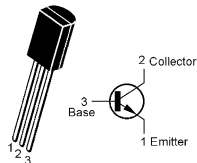

2SC1815
Q108,109,113,201,
206,207,208,301,302

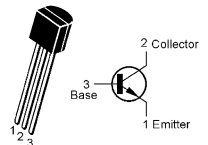

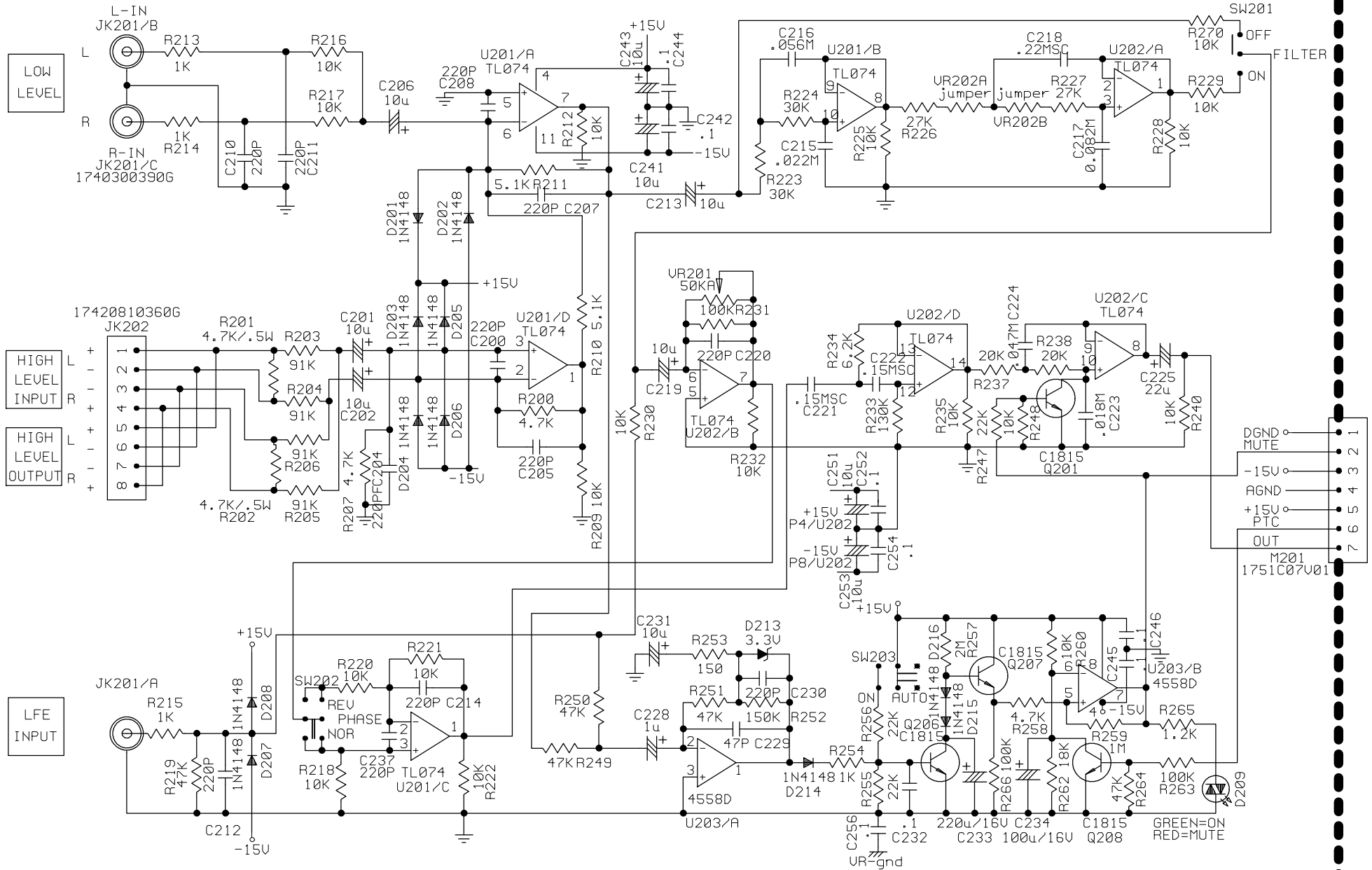

HKTS 14
JACK PANEL PCB

DRAW.	DSGN.	APVD.
-------	-------	-------

FILENAME : HKTS14.SCH	REVISION :
MODEL NO. 010-0N15-00404	1
DWN BY : C.S.WANG	2
DATE : 2003-10-14	3

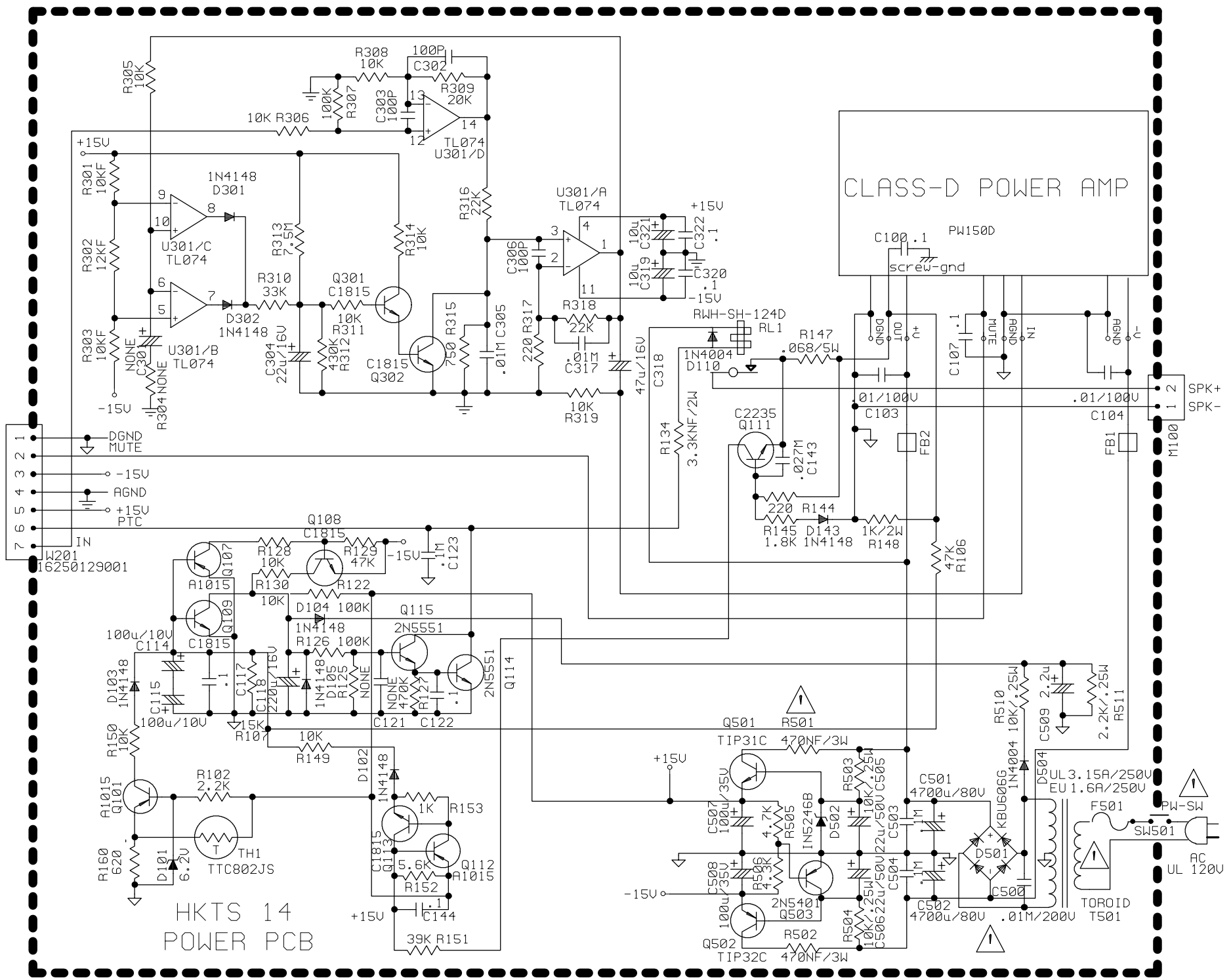

HKTS 14
POWER PCB

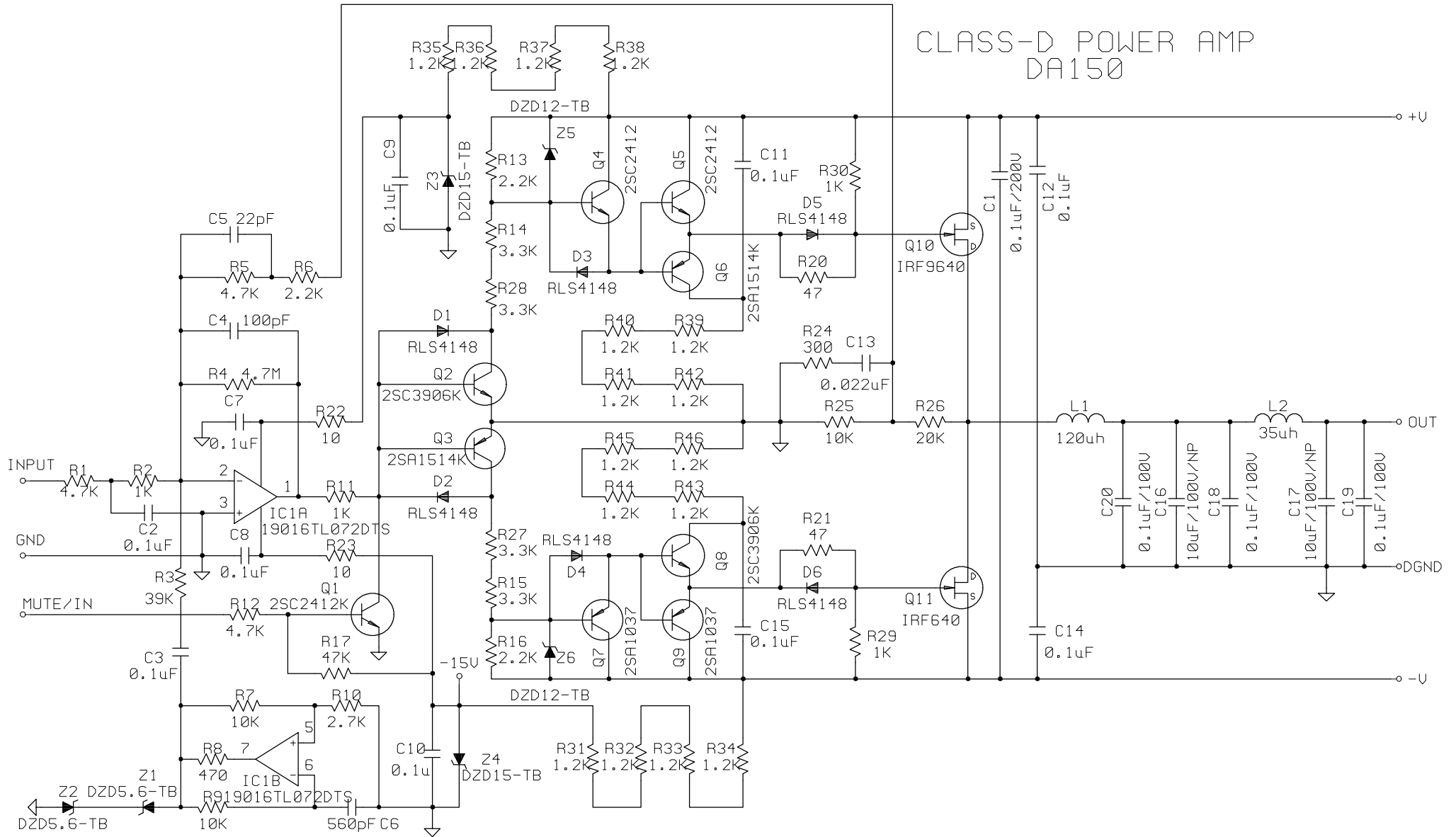

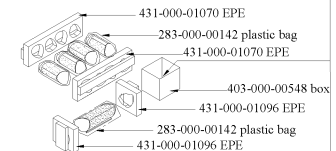

- 326-ABS-00108 Mounting bracket
- 326-FE-00109 Metal plate
- 317-PS-00172 Terminal cover
- 370-000-00257 green cable
- 370-000-00261 white cable
- 370-000-00256 red cable
- 370-000-00264 grey cable
- 370-000-00265 blue cable
- 370-000-00092 purple RCA cable
- 371-000-00360 screw package

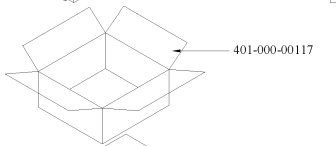

- (in a bag in inner box)
- 398-PAP-00319 color code
 - 405-000-00333 warranty card
 - 406-000-00981 owners manual

