

HS 200 Home Cinema System

SERVICE MANUAL

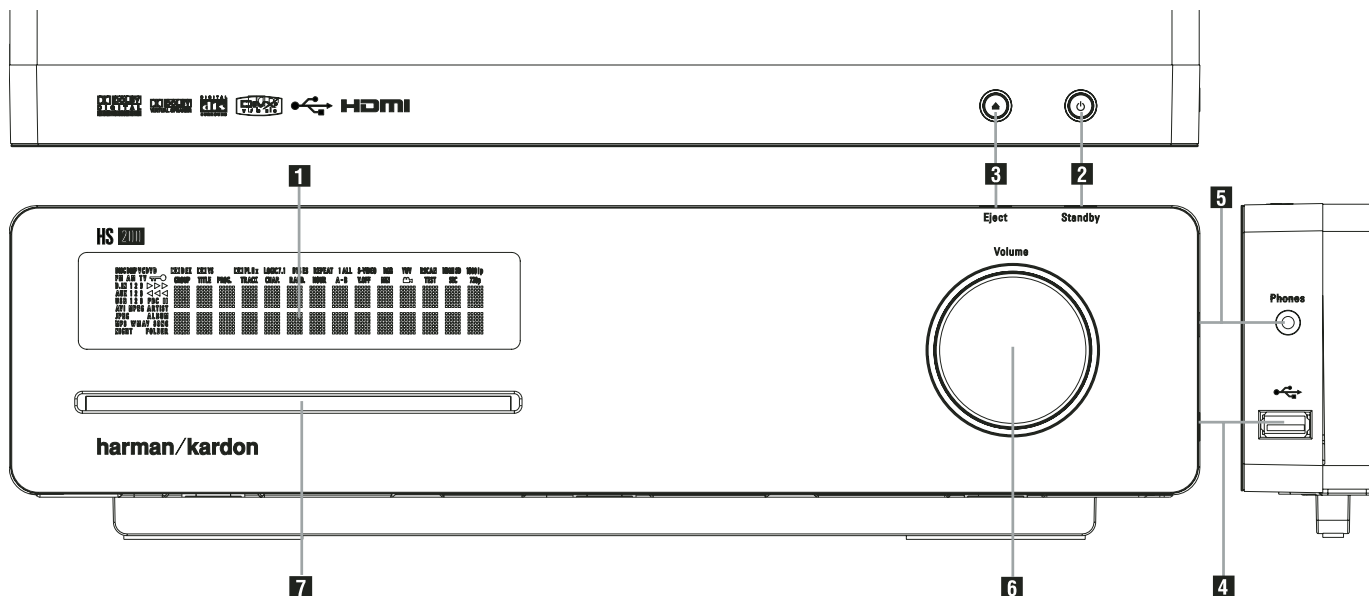

Front Panel Controls



- 1** Main Information Display
- 2** Power On/Off (Standby)
- 3** Eject

- 4** USB On-The-Go Input
- 5** Headphone Jack
- 6** Volume Control

- 7** Slot Loader

1 Main Information Display: This display delivers messages and status indications to help you operate the HS 200 Controller.

2 Power On/Off (Standby): Press the button once to turn the HS 200 Controller on, press it again to put the unit in the Standby mode. Note that when the HS 200 Controller is switched on, the Power Indicator around the button turns blue.

3 Eject: Press this button to release a disc from the loader.

4 USB On-The-Go Input: This input may be used to temporarily connect a USB thumb device or portable hard disk for direct playback of audio, image or video files or a USB hub. The USB inputs are designed to power a single USB device at a time. If additional hard disks are connected through a hub it is necessary that additional external power supplies are used to power the hub and hard disks.

5 Headphone Jack: This jack may be used to listen to the system's output through a pair of headphones. Be certain that the headphones have a standard 3.5 mm stereo phone plug. Note that the main room speakers will automatically be turned off when the headphone jack is in use.

6 Volume Control: Turn this knob clockwise to increase the volume, counterclockwise to decrease the volume. If the system is muted, adjusting volume control will automatically release the unit from the silenced condition.

7 Slot loader: Gently insert a CD or DVD into this slot, with the printed side of the disc facing up. Note there is no drawer. Press the **Eject Button 3** to release the disc.

Front Panel Display

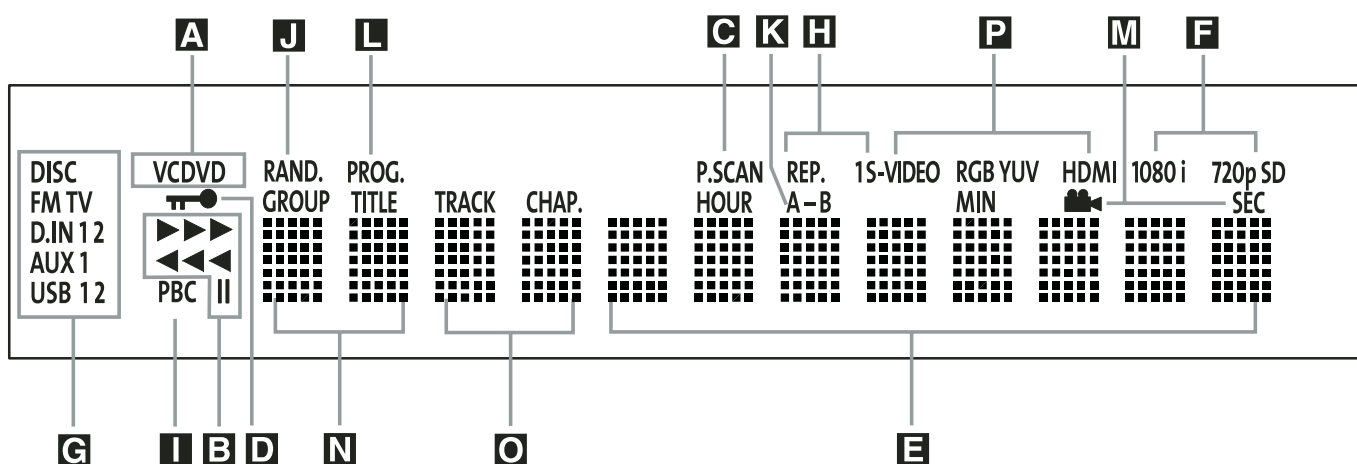

- A** Disc Type Indicators
- B** Playback-Mode Indicators
- C** Progressive Scan Indicator
- D** Parental Lock Indicator
- E** Time Indicators
- F** Video Format Indicators

- G** Source Indicators
- H** Repeat Indicators
- I** VCD Playback Control Indicator
- J** Random Indicator
- K** A-B Repeat Indicator
- L** Program Indicator

- M** Angle Indicator
- N** Title Indicators
- O** Chapter/Track Number Indicators
- P** Video Output Indicators

A Disc Type Indicators: The CD or DVD indicator will illuminate to show the type of disc currently being played.

B Playback-Mode Indicators: These indicators light to show the current playback mode:

- ▶ Lights when a disc is playing in the normal mode
- ▶▶ Lights when the disc is in the Fast Search Forward mode. The on-screen banner display indicates the selected speed (2x, 8x, 16x, 100x).
- || Lights when the disc is paused.
- ◀◀ Lights when the disc is in the Fast Search Reverse mode. The on-screen banner display indicates the selected speed (2x, 8x, 16x, 100x).

C Progressive Scan Indicator: This indicator lights when the unit sends out a progressive scan signal.

D Parental Lock Indicator: This indicator lights when the parental-lock system is engaged in order to prevent anyone from changing the rating level without a code.

E Time Indicators: These positions in the indicator will show the running time of a DVD in play. When a CD is playing, these indicators will show the current track time, time remaining in the current track, or the total remaining time on the disc.

NOTE: The Indicators **NOE** will also display text messages about the DVD's status, including **Reading** when a disc is loading, **STANDBY** when the unit is turned off, and **Disc Error** when a disc not compatible with the DVD is put into the play position.

F Video Format Indicators: These indicators will represent the video format currently playing.

G Source Indicators: These indicators will light to show which source is currently selected.

H Repeat Indicators: These indicators light when any of the Repeat functions are in use.

I VCD Playback Control Indicator: This indicator lights when the playback control function is turned on with VCDs.

J Random Indicator: This indicator lights when the unit is in the Random Play mode.

K A-B Repeat Indicator: This indicator lights when a specific passage for repeat playback has been selected.

L Program Indicator: This indicator lights when the programming functions are in use.

M Angle Indicator: This indicator blinks when alternative viewing angles are available on the DVD currently playing.

N Title Indicators: These two positions in the display will show the current title number when a DVD disc is playing.

O Chapter/Track Number Indicators: When a DVD disc is playing, these two positions in the display will show the current chapter. When a CD disc is playing they will show the current track number.

P Video Output Indicators: These indicators will represent the active video output.

Rear Panel Connections

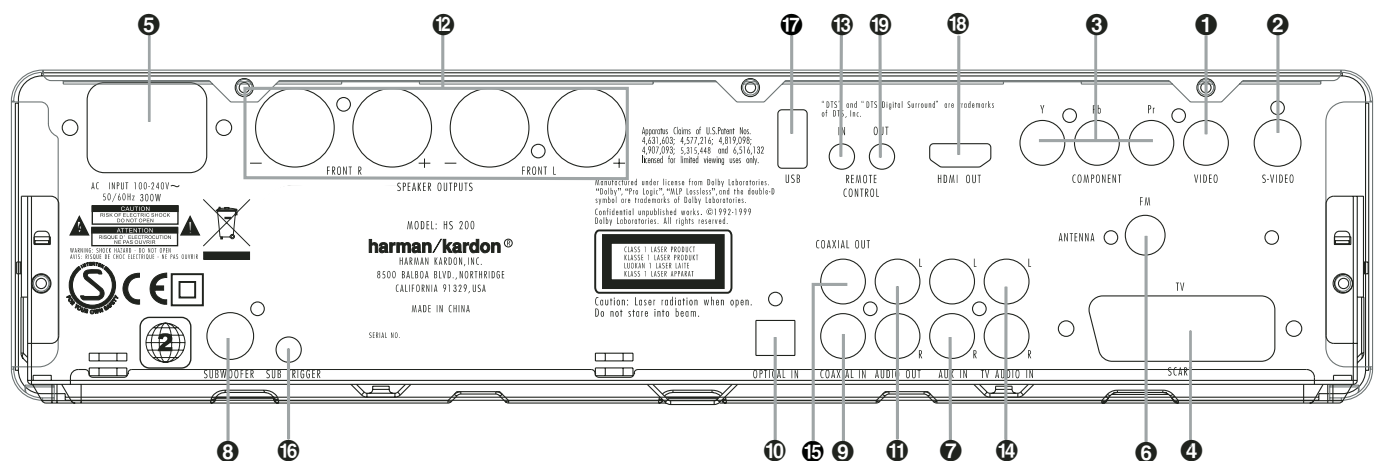

- 1 Composite Video Output
- 2 S-Video Output
- 3 Component Video Outputs
- 4 Scart TV Output
- 5 AC Power Cord
- 6 FM Antenna
- 7 Audio In
- 8 Subwoofer Output
- 9 Coaxial Digital Input
- 10 Optical Digital Input
- 11 Analog Audio Outputs
- 12 Front Speaker Outputs
- 13 Remote IR Input
- 14 TV Audio In
- 15 Coaxial Digital Output
- 16 Subwoofer Trigger Output
- 17 USB On-The-Go Input
- 18 HDMI Output
- 19 Remote IR Output

1 Composite Video Output: Connect this jack to the video input on a television or video projector.

2 S-Video Output: Connect this jack to the S-Video input on a television or video projector.

3 Component Video Outputs: These outputs carry the component video signals for connection to display monitors with component video inputs. For standard analog TV's or projectors with inputs marked Y/Pr/Pb or Y/Cr/Cb, connect these outputs to the corresponding inputs. If you have a high-definition television or projector that is compatible with high scan rate progressive video, connect these jacks to the "HD Component" inputs. Note that if you are using a progressive scan display device, then "Progressive" must be selected in the Video Set-up Menu in order to take advantage of the progressive scan circuitry. See page 20 for more information on progressive scan video.

IMPORTANT: These jacks should NOT be connected to standard composite video inputs.

4 SCART OUT (TV): If your TV has a SCART socket, you can connect a SCART cable to your TV and to your DVD Player for improved video quality. The SCART cable carries both audio and video. You can select Composite Video or RGB video for that SCART connector's video output signal.

5 AC Power Cord: Connect this plug to an AC outlet. If the outlet is controlled by a switch, make certain that it is in the ON position.

6 FM Antenna: Connect to the supplied FM antenna.

7 Audio In: Connect to a line-level analog audio source: TV, tape player, Minidisc, PC, etc.

8 Subwoofer Output: Connect to the SUB/LFE input on the subwoofer.

9 Coaxial Digital Input: Connect the coax digital output from a DVD player, HDTV receiver, LD player, MD player, satellite receiver or CD player to this jack. The signal may be either a Dolby Digital signal, DTS signal or a standard PCM digital source. Do not connect the RF digital output of an LD player to these jacks.

10 Optical Digital Input: Connect the optical digital output from a DVD player, HDTV receiver, LD player, MD player, satellite receiver or CD player to this jack. The signal may be either a Dolby Digital signal, DTS signal or a standard PCM digital source.

11 Analog Audio Outputs: Connect these jacks to the analog audio input on a TV set or external audio system for analog audio playback or to the RECORD/INPUT jacks of an audio recorder for recording.

12 Front Speaker Outputs: Connect these outputs to the matching + or – terminals on your left and right speakers. In conformance with the new CEA color code specification, the White terminal is the positive, or "+" terminal that should be connected to the red (+) terminal on Front Left speaker with the older color coding, while the Red terminal is the positive, or "+" terminal that should be connected to the red (+) terminal on Front Right speaker. Connect the black (–) terminals on the HS to the black (–) terminals on the speakers. See page 14 for more information on speaker polarity.

13 Remote IR Input: If the HS 200's front-panel IR sensor is blocked due to cabinet doors or other obstructions, an external IR sensor may be used. Connect the output of the sensor to this jack.

Rear Panel Connections

14 TV Audio Input: If your screen is connected to the HS by an HDMI, Component, S-Video or Composite cable, connect the analog output of your TV to this input. If you have your TV connected to the HS with a Scart cable, an audio connection to the TV Input is not necessary.

Note: You'll find more details about all Audio/Video connections under Setup and Connections on the following pages.

15 Coaxial Digital Output: Connect this jack to the matching digital input connector on a digital recorder such as a CD-R or MiniDisc recorder.

16 Subwoofer Trigger Output: Connect this trigger output to the trigger input of the Harman Kardon subwoofer, so that the subwoofer will switch on and off at the same time as the rest of the system.

17 USB On-The-Go Input: This input may be used to temporarily connect a USB thumb device or portable hard disk for direct playback of audio, image or video files, a digital photo camera or a USB hub.

18 HDMI Output: Connect this output to the HDMI input of high-definition LCD, Plasma or video projector for the best possible picture quality.

19 Remote IR Output: This connection permits the IR sensor in the receiver to serve other remote controlled devices. Connect this jack to the "IR IN" jack on Harman Kardon or other compatible equipment.

Remote Control

- 1 Power On/Source Selection Button
- 2 Power Off Button
- 3 Subtitle Button
- 4 Title Button
- 5 Angle Button
- 6 Audio Button
- 7 Enter Button
- 8 Eject Button
- 9 Set-Up/OSD Button
- 10 Arrows Button
- 11 Mute Button
- 12 Menu Button
- 13 Pause Button
- 14 Status Button
- 15 Skip/Step (Previous) Button
- 16 Skip/Step (Next) Button
- 17 Play Button
- 18 Search/Slow Reverse Button
- 19 STOP Button
- 20 Search/Slow Forward Button
- 21 Macro Buttons
- 22 Pic +/Pic - Button
- 23 Zoom Button
- 24 Playlist Button
- 25 Random Button
- 26 A-B Repeat Button
- 27 Volume up/down Button
- 28 Light Button
- 29 Numeric Keys Button
- 30 Repeat Button
- 31 Clear Button
- 32 Video output Button
- 33 Video format Button
- 34 Learn Button
- 35 Screen Power Buttons
- 36 Info Button
- 37 Teletext Buttons
- 38 Picture in Picture Button
- 39 Screen Format Button
- 40 IR Transmitter Window
- 41 Program Indicator

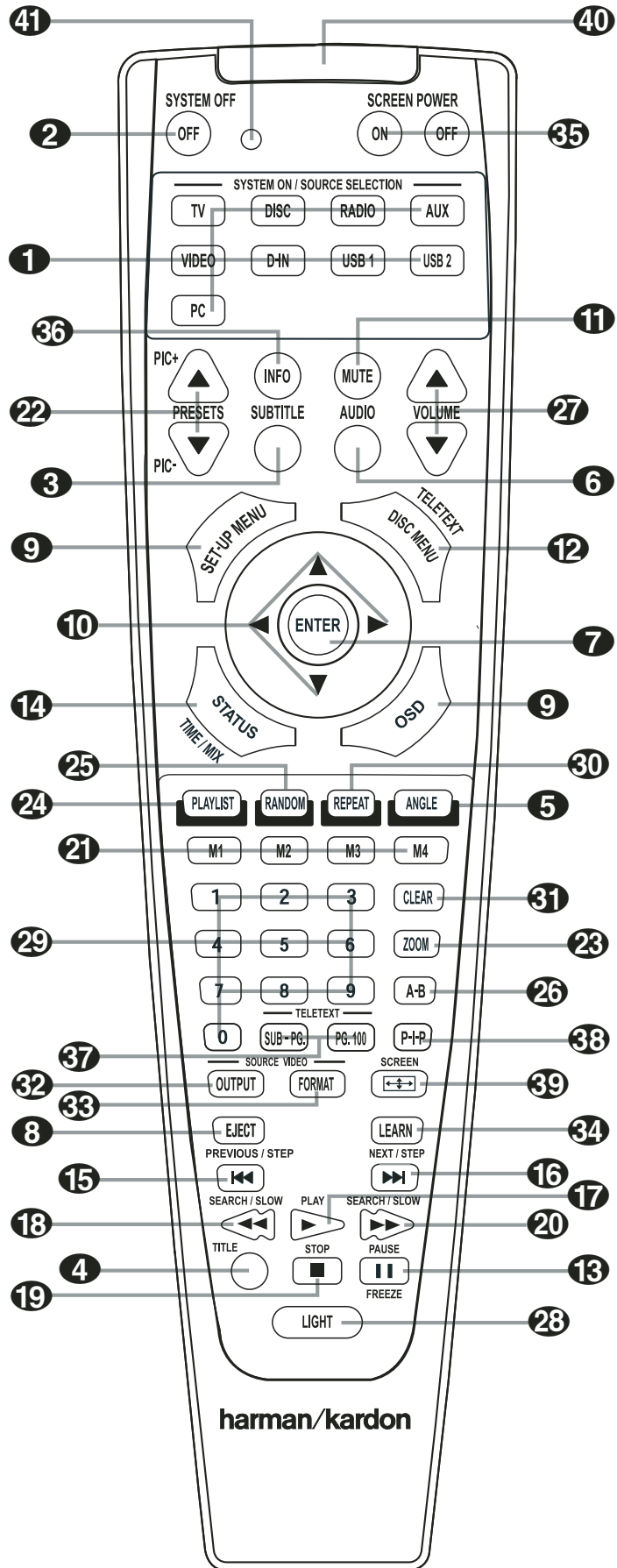

Remote Control

❶ Power On/Source Selector Buttons:

Pressing one of these buttons will perform three actions at the same time. First, if the HS System is not turned on, this will power up the unit. Next, it will select the source shown on the button as the input to the HS System. Finally, it will change the remote control so that it controls the device selected.

❷ **Power Off Button:** Turns off the HS system to standby mode.

❸ **Subtitle Button:** When a DVD is playing, press to select a subtitle language or to turn subtitles off.

❹ **Title Button:** When a disc is playing, press to make the player go back to the first section of the disc.

❺ **Angle Button:** Press to access various camera angles on a DVD (If the DVD contains multiple camera angles) or to rotate JPEG images.

❻ **Audio Button:** Press to access various audio languages on a DVD (If the DVD contains multiple audio streams).

❼ **Enter Button:** Press this button to activate a setting or option.

❽ **Eject Button:** Press to release the disc from the loader.

❾ **Set-up/OSD:** Press to access the On Screen Display Menu.

❿ **Arrow buttons (◀/▶/▲/▼) Buttons:** Use to move the cursor in the OSD.

⓫ **Mute Button:** Mutes the sound.

⓬ **Menu Button:** Displays the actual DVD Disc Menu on the TV screen in play mode. When playing discs with JPEG images, pressing this button will access the thumbnails.

⓭ **Pause Button:** Freezes a picture (with DVD/VCD) and pauses the playback signal (CD) when a disc is playing. Press again for normal playback.

⓮ **Status Button:** Press while a disc is playing to view banner display. Use the ARROW buttons to move through the different features in the Banner Display. When a symbol is highlighted, press ENTER on the remote to select it.

⓯ **Skip/Step (Previous) Button:** Press to go to beginning of current track. Press again quickly to go to beginning of previous track. After pressing the PAUSE button, each press of this button will move the image in reverse frame by frame.

⓰ **Skip/Step (Next) Button:** Press to go to beginning of next track. After pressing the PAUSE button, each press of this button will move the image forwards frame by frame.

⓱ **Play Button:** Begins to play disc (closes disc tray first, if it is open).

⓲ **Search/Slow (Rev.) Button:** Allows you to search in reverse through a disc while it is in play mode. Each time you press this button, the search speed changes as indicated by a number of arrows on the right top of your screen. After pressing the PAUSE button, each press of this button will change the slow down speed indicated by a number of arrows in the right top of the screen.

⓳ **Stop Button:** Stops playing a disc. When a disc is playing, if you press STOP and PLAY, the disc will resume play, i.e. it will start from the same point on the disc where the unit was stopped. If you press STOP twice and the PLAY button, the disc will start play from the beginning.

⓴ **Search/Slow (Fwd.) Button:** Allows you to search forward through a disc while it is in play mode. Each time you press this button, the search speed changes as indicated by a number of arrows on the right top of your screen. After pressing the PAUSE button, each press of this button will change the slow down speed as indicated by a number of arrows in the right top of the screen.

⓵ **Macro Buttons:** Press these buttons to store or recall a "Macro", which is a pre-programmed sequence of commands stored in the remote. (See page 26 for more information on storing and recalling macros.)

⓶ **Pic +/Pic - Button:** Pressing these buttons in JPEG mode will move to the previous or next image.

⓷ **Zoom Button:** When a DVD or VCD is playing, press this button to zoom the picture so that it is enlarged. There are 4 steps to the zoom function, each progressively larger. Press through each of the zoom stages to return to a normal picture. The Zoom function is not available when watching High Definition material.

⓸ **Playlist Button:** Press this button to change the playback order of the disc.

⓹ **Random Button:** Press for RANDOM playback in random order.

⓺ **A-B Button:** Press to select section A-B and to play repeatedly.

⓻ **Volume Up/Down:** Increase/decrease the master volume level.

⓼ **LIGHT Button:** Press to illuminate remote controller.

⓽ **Numeric Keys Button:** Select numbers by pressing these buttons.

⓿ **Repeat Button:** Press to go to the Repeat menu. You can repeat a chapter, track or the entire disc.

⓾ **Clear Button:** Press to remove the Banner menu from the screen.

⓿ **Video output Button:** Press to toggle between the S-Video, Component Video Outputs and SCART RGB video output of the HS System player. Note that the Composite and SCART Composite Video Outputs on the player are always active, which could help you make your initial setup.

⓿ **Video format Button:** Press this button to change the resolution of the Component Video Output between standard definition and progressive definition (PAL interlaced and PAL progressive; NTSC interlaced and NTSC progressive).

⓿ **Learn Button:** Press this button to begin the process of "learning" the codes from another product's remote into the HS System's remote. (See page 26 for more information on using the remote's learning function.)

⓿ to ⓿ These buttons do not have a direct function with the HS 200, but can be programmed to control some of the functions of your TV using the Learning function of the remote control.

⓿ **IR Transmitter Window:** Point this window towards the HS when pressing buttons on the remote to make certain that infrared commands are properly received.

⓿ **Program Indicator:** This three-color indicator is used to guide you through the process of learning commands from a remote into the HS's remote code memory. (See page 26 for more information on programming the remote.)

Troubleshooting

If you experience any of the following difficulties while using the system, use this troubleshooting guide to help you remedy the problem. Should any problem persist, consult your authorized Harman Kardon dealer.

No power.

- Is the power cord firmly plugged into the power outlet?
- One of the safety mechanisms may be operating. In this event, unplug the player from the power outlet briefly and then plug it in again.

No picture.

- Check that the system is connected correctly and securely.
- The video cable may be damaged. Replace it with a new one.
- Make sure the system is connected to a video input on the TV (see page 14).
- Make sure the TV is turned on.
- Make sure the correct video input on the TV is selected for viewing with this system.

Noise (interference) appears in the picture.

- Clean the disc.
- If video from this system has to go through your VCR to get to your TV, the copy-protection applied to some DVD programs could affect picture quality. If you still experience problems after checking your connections, please try connecting your DVD system directly to your TV's S-Video input, if your TV is equipped with this input (see page 14).

The aspect ratio of the screen is wrong (picture vertically expanded) when you play a wide picture even though you set "TV DISPLAY" in the SETUP menu to "16:9".

- If you connect the system with the SCART cable, connect directly to the TV. Otherwise the autoswitch function of the aspect ratio for the TV may not work.
- If the TV is not connected with a SCART cable to the HS, or if the autoswitch function does not work you should turn the TV to "16:9" (if possible with your TV).
- Depending on the TV, you may not be able to change the aspect ratio. In that case (TV not adjustable to 16:9) do not select "16:9" in the TV Display. Then, no change of the aspect ratio is needed.

There is no sound or volume is very low.

- Check that the speakers and components are connected correctly and securely.
- Make sure that you have selected the correct source on the system.
- Press **MUTE** on the remote control, if the words MUTE ON are blinking on the front panel display.
- The protective circuitry has been activated because of a short circuit. Turn off the system, eliminate the short circuit problem and turn on the power again.
- The audio interconnect is damaged. Replace it with a new one.
- The system is in pause mode or in slow-motion play mode, or fast forward or fast reverse. Press ► to return to normal play mode.
- Check the speaker settings (see page 19).

The left and right channels are unbalanced or reversed.

- Check that the speakers and components are connected correctly and securely.

Severe hum or noise is heard.

- Check that the speakers and components are connected securely.
- Check that the connecting cords are away from a transformer or motor and at least 3 meters away from fluorescent light.
- Move your TV away from the audio components.
- The plugs and jacks are dirty. Wipe them with a cloth slightly moistened with alcohol.
- Clean the disc.

The volume goes down automatically and can not be increased.

- The internal temperature is too high. Wait approximately one minute for the amplifier to reach normal working temperature.

Radio stations cannot be tuned in.

- Check that the antenna is connected correctly. Adjust the antenna and connect an external antenna if necessary.
- The signal strength of the stations is too weak for automatic tuning. Use manual tuning.
- No stations have been preset.
- The tuner mode is not selected, select the Radio mode.

The remote does not function.

- Remove any obstacles between the remote control and the system.
- Move the remote control closer to the system.
- Point the remote control at the remote sensor on the front panel.
- Replace all the batteries in the remote control with new ones if they are weak.
- Check that the batteries are loaded correctly.

The disc does not play.

- There is no disc inside. ("NO DISC" appears on the front panel display and the TV screen.) Insert a disc.
- Insert the disc correctly with the playback side facing down on the disc tray.
- Clean the disc.
- The system cannot play CD-ROM's, etc. (see page 3).
- DVD with wrong region code (see page 13).

The system starts playing the DVD automatically.

- The DVD features the auto playback function.

Playback stops automatically.

- Some discs include an auto pause signal. When playing such a disc, the system stops playback at the signal.

Troubleshooting

Track Skip or direct select with numeric buttons, Search, Slow-motion play, repeat play or Program play, etc., cannot be done.

- Depending on the DVD or VCD, some of the above operations may not be available (Playback control).

Messages do not appear on the TV screen in the language you want.

- Select the language for Display and Preferred Subtitle in the SETUP menu (see page 18). For all messages from the DVD (DVD menu, subtitles) in the proper language the disc must have the language you selected, if not, another language will be selected.

The audio language cannot be changed when you play a DVD.

- Multilingual sound is not recorded on the DVD.
- Changing the language for the sound by the Audio button on the remote or the Audio line in the Player Menu is prohibited on the DVD. In that case the audio language must be selected by the main menu on the DVD.

The subtitle language cannot be changed when you play a DVD.

- Multilingual subtitles are not recorded on the DVD.
- Changing the language for the subtitles by the Subtitle button on the remote or the Subtitle line in the Player Menu is prohibited on the DVD. In that case the subtitle language must be selected by the main menu on the DVD.

The subtitles cannot be turned off when you play a DVD.

- Depending on the DVD, you may not be able to turn the subtitles off.

The angles cannot be changed when you play a DVD.

- Multi-angles are not recorded on most DVDs.
- Change the angles when the angle mark appears on the TV screen.
- Changing the angles is prohibited on some DVDs.

The system does not operate properly.

- Static electricity, etc., may affect the system's operation. Disconnect the AC power cord, then connect it again.

Please also refer to the Troubleshooting guide contained in your loudspeaker Owners Manual.

Glossary

Bit rate

Value indicating the amount of video data compressed in a DVD per second. The unit is Mbps (megabit per second). 1 Mbps indicates that the data per second is 1,000,000 bits. The higher the bit rate, the larger the amount of data. However, this does not always mean higher quality pictures.

Chapter

Sections of a picture or a music piece on a DVD that are smaller than titles. Many titles are composed of several chapters, but many others are not. Each chapter is assigned a chapter number enabling you to locate the chapter you want.

Dolby Digital ("5.1", "AC-3")

This sound format for movie theaters is more advanced than Dolby Pro Logic Surround. In this format, the rear speakers output stereo sound with an expanded frequency range and a subwoofer channel for deep bass is independently provided. This format is also called "5.1" because the subwoofer channel is counted as 0.1 channel (since it functions only when a deep bass effect is needed). All six channels in this format are recorded separately for superior channel separation. Furthermore, since all the signals are processed digitally, less signal degradation occurs. The name "AC-3" comes from the fact that it is the third audio coding method to be developed by the Dolby Laboratories Licensing Corporation.

Manufactured under license from Dolby Laboratories. "Dolby", "AC-3", "Pro Logic" and the Double-D symbol are trademarks of Dolby Laboratories. Confidential Unpublished Works. © 1992, 1997 Dolby Laboratories, Inc. All rights reserved.

Dolby Pro Logic II Surround

This is a method of decoding stereo or surround recordings that produces five channels from two-channel sound. Compared with the former Dolby Surround system, Dolby Pro Logic II Surround reproduces left-to-right panning more naturally and localizes sounds more precisely. To take full advantage of Dolby Pro Logic II Surround, you should have a pair of rear speakers and a center speaker. The rear speakers output stereo sound.

DTS

Digital audio compression technology developed by Digital Theater Systems, Inc. This technology conforms to 5.1-channel surround. The rear channels are stereo and there is a discrete subwoofer channel in this format. DTS provides 5.1 discrete channels of high quality digital audio. Good channel separation is realized, because all channels are recorded discretely and processed digitally.

Manufactured under license from Digital Theater Systems, Inc. US Pat. No. 5,451,942 and other worldwide patents issued and pending. "DTS" and "DTS Digital Surround" are trademarks of Digital Theater Systems, Inc. © 1996 Digital Theater Systems, Inc. All rights reserved.

MPEG AUDIO

International standard coding system to compress audio digital signals authorized by ISO/IEC. MPEG 1 conforms to up to 2-channel stereo, used on some DVD's as alternate (other language) track.

DVD

A disc that contains up to 8 hours of moving pictures even though its diameter is the same as a CD. The data capacity of a single-layer and single-sided DVD, at 4.7 GB (Giga Byte), is 7 times that of a CD. Furthermore, the data capacity of a dual-layer and single-sided DVD is 8.5 GB, a single-layer and double-sided DVD 9.4 GB, and a dual-layer and double-sided DVD 17 GB. The picture data uses the MPEG 2 format, one of the worldwide standards of digital compression technology. The picture data is compressed to about 1/40 of its original size. The DVD also uses the variable rate coding technology that changes the data to be allocated according to the status of the picture. The audio data is recorded in Dolby Digital, DTS and/or PCM, allowing you to enjoy more natural audio presence. Furthermore, various advanced functions such as multi-angle, multilingual, and subtitles may be provided with the DVD.

Multi-angle function

Various angles or viewpoints of the video camera for a scene are recorded on some DVDs.

Multilingual function

Several languages for the sound or subtitles in a picture are recorded on some DVDs.

Parental Control

A function of some (particular US) DVD's to limit playback of the disc by the age of the users. The limitation varies from disc to disc. When it is activated, playback is completely prohibited, violent scenes are skipped or replaced with other scenes and so on.

Title

The longest sections of a picture or a music piece on a DVD; a movie, etc., for a picture piece on video software; or an album, etc., for a music piece on an audio software. Each title is assigned a title number enabling you to locate the title you want.

Track

Sections of a music piece on a CD. Each track is assigned a track number enabling you to locate the track you want.

PCM

Pulse code modulation, an uncompressed data formation.

NTSC

National TV Systems Committee: a video standard used in USA.

PAL

Phase Alternation Line: a video standard used in many European countries.

HS 200 Controller Specifications

DVD player

Pickup:	Semiconductor laser, wavelength 650nm
Signal system:	NTSC / PAL
Video signal horizontal resolution:	More than 480 lines (DVD)
Video signal-to-noise ratio:	More than 60 dB (DVD)
Audio frequency response: (Stereo)	DVD (PCM): 20 Hz ~ 22 kHz (+/- 1.0 dB) CD (PCM): 20 Hz ~ 20 kHz (+/- 1.0 dB)
Audio signal-to-noise ratio:	More than 80 dB (PCM)
Total harmonic distortion:	Less than 0.01% (PCM)
Dynamic range:	DVD (PCM): More than 85 dB (EIAJ, 2 kHz) CD: More than 85 dB (EIAJ)

FM Tuner

System:	PLL quartz-locked digital synthesizer system
Tuning range:	87.50 ~ 108.00 MHz
Antenna terminals:	75 Ohms, unbalanced
Intermediate frequency:	10.7 MHz

Video Outputs HDMI

Component Video Output:	Y: 1 Vp-p/75 Ohms, sync negative polarity Cr: 0.7 Vp-p/75 Ohms Cb: 0.7 Vp-p/75 Ohms
CVBS Video:	1 Vp-p 75 Ohms
S-video:	Y: 1 Vp-p 75 Ohms C: PAL 0.3 Vp-p 75 Ohms / NTSC 0.286 Vp-p 75 Ohms

Audio line Outputs

Audio L/R:	2 Vrms, 1 kilohms
------------	-------------------

General

Power requirements:	AC 230 V, 50 Hz
Max power consumption:	300 W
Idle power consumption:	Less than 2 W
Dimensions (WxHxD):	350mm x 84mm x 250mm
Weight:	3.8 kg

* Designs and specifications are subject to change without notice.

Depth measurement includes knobs, buttons and terminal connections. Height measurement includes feet and chassis.

All features and specifications are subject to change without notice.

Harman Kardon is a registered trademark of Harman International Industries, Incorporated.

Dolby, Pro Logic and the double-D symbol are trademarks of Dolby Laboratories, registered in the United States and/or other countries. All rights reserved.

DTS is a trademark of Digital Theater Systems, Inc.

Windows Media® Audio (WMA) is a proprietary file format developed by Microsoft.

DivX is a registered trademark of DivX, Inc.

HDMI, the HDMI logo and High-Definition Multimedia Interface are trademarks or registered trademarks of HDMI Licensing LLC.

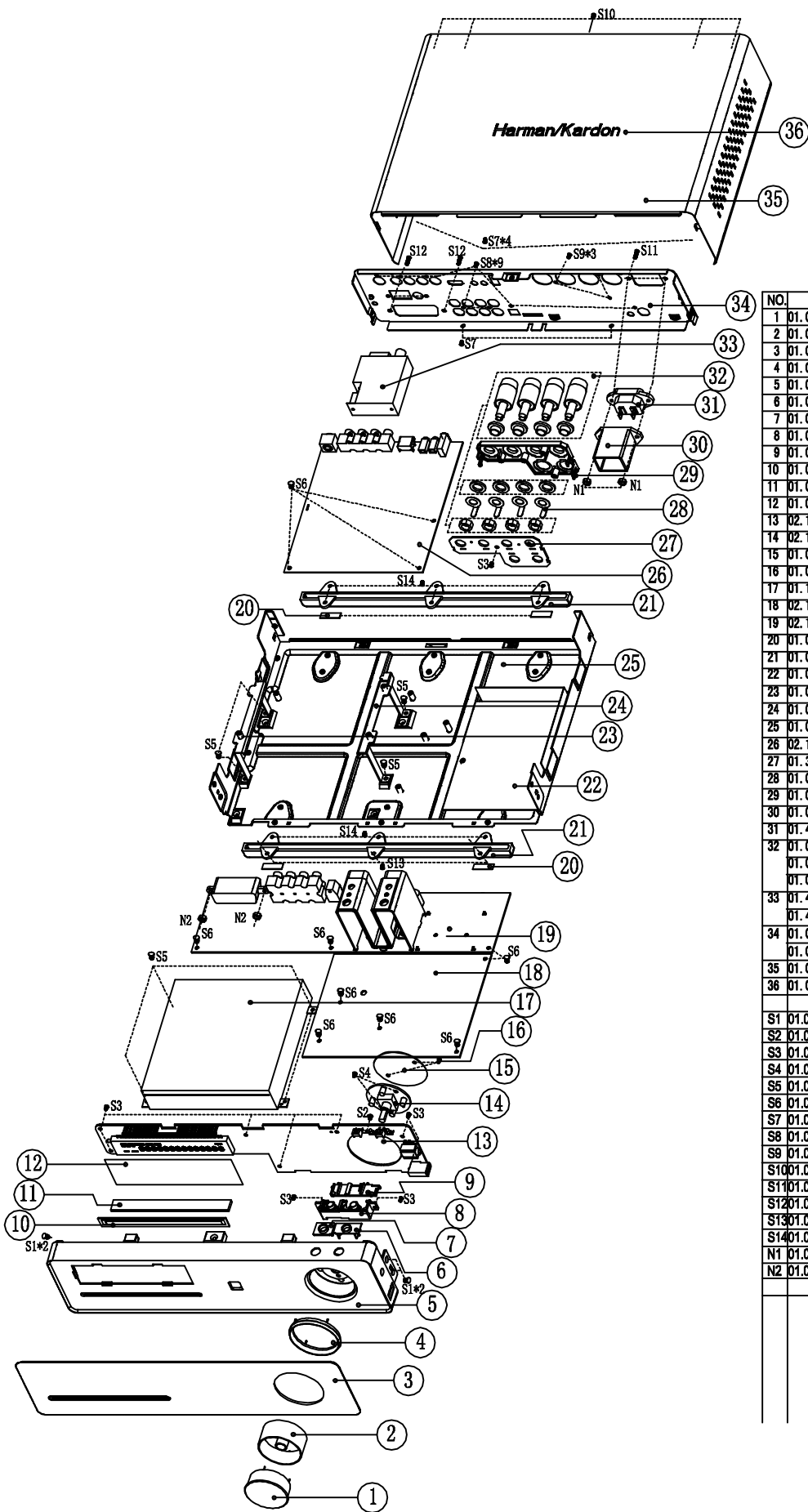

NO.	P/N	DESCRIPTION	QTY.
1	01.00.SJ.HS100.E010	HS100—Volume Button	1
2	01.00.SJ.HS100.E008	HS100—volume button lampshade	1
3	01.00.SJ.HS200.E009	HS200—Large Lens	1
4	01.00.SJ.HS100.E006	HS100—Volume Button Collar	1
5	01.00.SJ.HS200.E001	HS200—front panel	1
6	01.00.SJ.HS200.E005	HS200—Power Indicator lampshade	1
7	01.00.SJ.HS200.E003	HS200—Open button collar	1
8	01.00.SJ.HS200.E002	HS200—2 in 1 Button	1
9	01.00.SJ.HS200.E004	HS200—Button Cover Board	1
10	01.00.DP.JY.E135	Dustproof forLoder LTD-1510	1
11	01.00.DP.HM.E383	High Soft sponge 124*12*2MM	1
12	01.00.SJ.QT.E019	VFD filter 124.5*33.5*0.5mm	1
13	02.15.HAV06K3517C01	Front Panel Board ass'y HAV06K-3517C01	1
14	02.15.HAV06K3518C01	Front Panel Board ass'y HAV06K-3518C01	1
15	01.00.DP.JY.E249	Insulated PVC HS200-H02	1
16	01.00.DP.JY.E104	plastic rivet MBL3-2.5	2
17	01.15.JX.EDL05FH40P	Loader DL-05FH-40P	1
18	02.19.HAV06P3521C01	SMP/S Board ass'y HAV06P-3521C01	1
19	02.14.HAV06T3522C02	AV Board ass'y HAV06T-3522C02 (EU)	1
20	01.00.DP.XJ.E192	Silica gel gasket 5U.6*4.2*1.5mm	4
21	01.00.SJ.HS200.E009	HS200—Large Lens	1
22	01.00.DP.JY.E247	Insulated PVC HS200-H01	1
23	01.00.WJ.TJ.HS200.E005	HS200—PCB plastic frame (Left)	1
24	01.00.WJ.TJ.HS200.E006	HS200—PCB plastic frame (Right)	1
25	01.00.WJ.TJ.HS200.E001	HS200—chassis	1
26	02.11.HAV06M3627C02	Main Board ass'y HAV06M-3627C02 (EU)	1
27	01.37.PCB.2.E3520C1	Speaker Board ass'y 3520C-V1.0	1
28	01.00.WJ.TJ.HS200.E007	HS200—Connected Piece	4
29	01.00.SJ.HS200.E008	HS200—plastic scaleboard	1
30	01.00.SJ.HS200.E007	HS200—Power Jack Jacket	1
31	01.40.CON.DCZ.E178	AC power Jack WS-044-0	1
32	01.00.WJ.QT.E049	Speaker Connective Stick-Red	1
	01.00.WJ.QT.E048	Speaker Connective Stick-Black	2
	01.00.WJ.QT.E050	Speaker Connective Stick-White	1
33	01.49.E11	FM tunner moduleTFCE1E806A(EU)	1
	01.49.E07	FM/AM tunner module TFGF1E804A(US)	1
34	01.00.WJ.TJ.HS200.E003	HS200—rear panel (EU)	1
	01.00.WJ.TJ.HS200.E004	HS200—rear panel (US)	1
35	01.00.WJ.TJ.HS200.E002	HS200—top cover	1
36	01.00.SB.E036	Metal logo 100mm "Harman/Kardon"	1
S1	01.00.WJ.JG.E328	Screw 3*6KBTT0	4
S2	01.00.WJ.JG.E655	Screw 1.7*4CAHNI D=3.2	1
S3	01.00.WJ.JG.E166	Screw 3*8PAHC	10
S4	01.00.WJ.JG.E085	Screw 3*6KBTTNI	2
S5	01.00.WJ.JG.E091	Screw 3*6PWBTTTC	8
S6	01.00.WJ.JG.E451	Screw 3*6PWBTTTC	11
S7	01.00.WJ.JG.E252	Screw 3*4RBTTNI	6
S8	01.00.WJ.JG.E321	Screw 3*8PAHO	9
S9	01.00.WJ.JG.E675	Screw 3*10PAHO	3
S10	01.00.WJ.JG.E403	Screw 3*6PWBTT0	5
S11	01.00.WJ.JG.E865	Screw 3*12PMHO	2
S12	01.00.WJ.JG.E502	Screw 3*10PMHO (FOR EU)	2
S13	01.00.WJ.JG.E235	Screw 3*8PWBTTNI	3
S14	01.00.WJ.JG.E543	Screw 3*6PWBTTNI	9
N1	01.00.WJ.JG.E119	NUT M3	2
N2	01.00.WJ.JG.E119	NUT M3(FOR EU)	2

HS200 Component List

Item	P/N	Description	Specification	Qty	Location.No.	Note
1	0100WJTJHS200E001	metals part	HS200-chassis	1	HS200-PT01	
2	0100WJTJHS200E002	metals part	HS200-top cover	1	HS200-PT02	Appointed Color
3	0100WJTJHS200E003	metals part	HS200-rear panel	1	HS200-PT03	EU Vision
4	0100WJTJHS200E004	metals part	HS200-rear panel	1	HS200-PT03	US Vision
5	0100WJTJHS200E005	metals part	HS200-PCB plastic frame(Left)	1	HS200-PT04	
6	0100WJTJHS200E006	metals part	HS200-PCB plastic frame(Right)	1	HS200-PT05	
7	0100WJTJHS200E007	metals part	HS200-Connected Piece for Speaker Jack	4	HS200-PT06	
8	01.00.WJ.TJ.E889	Heatsink	50*62*65MM	1	HS200-PT07	For AV Board
9	01.00.WJ.TJ.E890	Heatsink	39*54.5*61mm	1	HS200-PT08	For AV Board
10	01.00.WJ.TJ.E891	Heatsink	122*45*51mm	1	HS200-PT09	For SMPS Board
11	01.00.WJ.TJ.E892	Heatsink	35*30*49mm	1	HS200-PT10	For SMPS Board
12	01.00.WJ.TJ.E893	Heatsink	16*12*51MM (The Hole's depth is 18MM)	4	For S503/S504/S505/S506 on SMPS Board	
13	01.00.WJ.TJ.E268	Heatsink	28*28*10mm	1	For U4 of Main Board	
14	01.13.L.H.E034	Magnetism annulus	F5BRFS11.7*6*19.75-3-P.W	2	For Amplifier Output Cord	
15	0100SJHS200E001	plastic part	HS200-front panel	1	HS200-RE01	
16	0100SJHS200E002	plastic part	HS200-2 in 1 Button	1	HS200-RE02	
17	0100SJHS200E003	plastic part	HS200-Open button collar	1	HS200-RE03	
18	0100SJHS100E006	plastic part	HS100 Volume Button Collar	1	HS100-RE06	
19	0100SJHS200E004	plastic part	HS200-Button Cover Board	1	HS200-RE04	ABS, Black
20	0100SJHS200E005	plastic part	HS200-Power Indicator lampshade	1	HS200-RE05	transparent
21	0100SJHS200E006	plastic part	HS200-pedestal underlay	2	HS200-RE06	transparent
22	0100SJHS200E007	plastic part	HS200-Power Jack Jacket	1	HS200-RE07	
23	0100SJHS200E008	plastic part	HS200-plastic scaleboard	1	HS200-RE08	

HS200 Component List

Item	P/N	Description	Specification	Qty	Location.No.	Note
24	0100SJHS200E009	plastic part	HS200-Large Lens	1	HS200-RE10	3mm Black Lens (Include "HS200" and 47mm "harman/kardon" Logo)
25	0100SJHS100E010	plastic part	HS100 Volume Button	1	HS100-RE10	
26	0100SJHS100E008	plastic part	HS100 volume button lampshade	1	HS100-RE08	
27	0100SJ1000AE016	plastic part	1000A-IR receiver support 5.5mm	1		
28	01.00.SJ.QT.E019	VFD filter	124.5*33.5*0.5mm	1		
29	01.40.CON.DCZ.E178	AC power Jack	WS-044-0	1		
30	01.00.SB.E036	Metal logo	100mm "Harman/Kardon" Thin Logo	1		
31	01.00.DP.JY.E135	Dustproof for Disc tray door of Loder	LTD-1510	1		Black
32	01.00.DP.XJ.E192	Silica gel gasket	50.6*4.2*1.5mm (with #500 glue be single sides glued)	4	For pedestal underlay HS100-H01	
33	01.00.DP.HM.E359	sponge	20*10*7MM (with #9448 glue be double sides glued)	2	For VFD(2)	
34	01.00.FZ.QT.153	Astigmatism PVC	Φ45.5*Φ9.5mm	1	Between volume button and Front Panel Board	
35	01.00.FZ.QT.E253	Mask PVC	φ38.5 (Underside Glued)	1	Inside the volume button	Black PVC
36	01.00.DP.HM.E364	sponge	10*10*7MM (with double sides glued)	1	For IR receiver	
37	01.00.DP.HM.E160	sponge	20*10*4.5mm (with Single side glued)	1	Between AV Board and Heatsink	Black
38	01.00.DP.HM.E363	High Soft sponge	124*12*2MM (with Single side glued)	1	paste in front of Disc tray door in the front panel	Black
39	01.00.DD.PM.E183	electric sponge	12*10*18mm	1	pasted under U403 of AV Board	
40	01.00.DD.PM.E271	electric sponge	20*20*10MM	1	Between front panel PCB and plastic part	
41	01.00.FZ.QT.E122	Plastic fastener	12CM	3		
42	01.00.DP.QT.E113	Sil-pad	sil-pad 400-3022	1	For Q509 on SMPS Board	

HS200 Component List

Item	P/N	Description	Specification	Qty	Location.No.	Note
43	01.00.DP.JY.E112	Diathermanous Selenium Rubber	16*11*1mm	3	For AV Board	
44	01.00.DP.JY.E247	Insulated PVC	HS200-H01	1	For SMPS Board	
45	01.00.DP.JY.E249	Insulated PVC	HS200-H02	1	Be buckled above volume button board	
46	01.00.DP.JY.E541	Insulated PVC	22.5*10*0.3mm (with Single side glued)	2	For hamulus of front panel	
47	01.00.DP.HM.E369	sponge	15*15*24mm (with Single side glued)	1	For frequency modulation module and AV Board	
48	01.00.DP.HM.E370	sponge	15*15*7mm (with Single side glued)	1	For frequency modulation module and Main Board	
49	01.00.DP.HM.E115	sponge	10*10*1.5mm	1	For hamulus of front panel	
50	01.00.DP.XJ.E560	Diathermanous Silica gel gasket	20*15*4MM	2	Between AV Board and chassis under U403	
51	01.00.WJ.JG.E265	Screw	3*8PWBTTTC	2	For AV Board and Heatsink (2)	
52	01.00.WJ.JG.E328	Screw	3*6KBTTO	5	For front Panel and Left/Right sides of chassis (4), Between two Heatsinks on SMPS Board(1)	
53	01.00.WJ.JG.E543	Screw	3*6PWBTTNI	9	For pedestal underlay and chissis (9)	
54	01.00.WJ.JG.E235	Screw	3*8PWBTTNI	3	For front panel and pedestal underlay and chissis(3)	
55	01.00.WJ.JG.E655	Screw	1.7*4CAHNI D=3.2 Free-Lead	1	For Button cover Board and button Board	

HS200 Component List

Item	P/N	Description	Specification	Qty	Location.No.	Note
56	01.00.WJ.JG.E166	Screw	3*8PAHC	10	For front panel and front panel board(9) For plastic scaleboard and Speaker Connected Board (1)	
57	01.00.WJ.JG.E085	Screw	3*6KBTTNI	2	For front panel and volume button board	
58	01.00.WJ.JG.E091	Screw	3*6PWBTTTC W=7	8	For Loader and chassis(4), For PCB Brackets and chassis (4)	
59	01.00.WJ.JG.E451	Screw	3*6PWMHC W=7	11	For SMPS Board and chassis (5), For AV Board and chassis (3), For Main Board and PCB brackets (3)	
60	01.00.WJ.JG.E252	Screw	3*4RBTTNI	6	For rear panel and the bottom side of chassis (2), For top cover and bottom side of chassis (4)	
61	01.00.WJ.JG.E417	Screw	3*8PBTTTC	9	For ICs and Heatsinks on SMPS Board (7), For Two sorts of Heatsinks on AV Board (2)	
62	01.00.WJ.JG.E321	Screw	3*8PAHO	9	For output jacks (7), For frequency modulation module (2)	
63	01.00.WJ.JG.E675	Screw	3*10PAHO	3	For plastic scaleboard and rear panel (3)	
64	01.00.WJ.JG.E403	Screw	3*6PWBTTTO	5	For top cover and chassis, top cover and rear panel (5)	
65	01.00.WJ.JG.E865	Screw	3*12PMHO	2	For AC power socket (2)	

HS200 Component List

Item	P/N	Description	Specification	Qty	Location.No.	Note
66	01.00.WJ.JG.E502	Screw	3*10 PMHO	2	For SCART Jack (2)	EU Vision
67	01.00.WJ.JG.E087	Screw	3*6PBTTTC	2	For U503/D502 on SMPS Board	
68	01.00.WJ.JG.E119	Nut	M3	2	For SCART Jack (2)	EU Vision
69	01.00.WJ.JG.E119	Nut	M3	2	For power jack2)	
70	01.00.FZ.TG.E025	Screw Jacket	Φ3*4mm	7	For uncovered Screw drilled through the chassis	
71	01.00.WJ.JG.E426	Flat Pad	M3*0.5 W=8	4	For Heatsink and AV Board (2), For Two sorts of Heatsinks on AV Board (2)	
72	01.00.SJ.QT.E104	plastic rivet	MBL3-2.5	2	For Insulated gasket and volume button Board	
73	01.00.WJ.JG.E424	Spring Pad	M3	4	For Heatsink and AV Board (2), For Two sorts of Heatsinks on AV Board (2)	
74	01.00.WJ.QT.E049	Speaker Connective Stick	HS200 Connective Stick-Red	1		
75	01.00.WJ.QT.E048	Speaker Connective Stick	HS200 Connective Stick-Black	2		
76	01.00.WJ.QT.E050	Speaker Connective Stick	HS200 Connective Stick-White	1		
77	01.00.BZ.F.P.E613	Polyfoam	HS200-Left	1		
78	01.00.BZ.F.P.E614	Polyfoam	HS200-Right	1		
79	01.00.BZ.X.B.E511	Accessories box	HS200 340*170*45mm	1	For accessories	White
80	01.00.BZ.X.W.E712	Carton box	HS200 EU Vision	1	For unit and accessory box packing	EU Vision
81	01.00.BZ.X.W.E896	Carton box	HS200 US Vision	1	For unit and accessory box packing	US Vision
82	01.00.BZ.X.W.E713	Big colored carton box	HS200 EU Vision	1	According to client, for external box and loudspeaker	EU Vision
83	01.00.BZ.X.W.E899	Big colored carton box	HS200 US Vision	1	According to client, for external box and loudspeaker	US Vision

HS200 Component List

Item	P/N	Description	Specification	Qty	Location.No.	Note
84	01.00.YS.FY3.E1176	Safety and Warning instruction manual	HS200 EU Vision	1		EU Vision
85	01.00.YS.FY3.E1177	Safety and Warning card	HS200 US Vision	1		US Vision
86	01.00.YS.FY3.E1178	Guarantee card	HS200 US Vision	1		US Vision
87	01.00.YS.SM1.E786	Owner manual	HS200 EU Vision	1		EU Vision
88	01.00.YS.SM1.E947	Owner manual	HS200 US Vision	1		US Vision
89	01.00.YS.TZ.T.E068	Laser label	Laser precaution mark	1		
90	01.00.YS.TZ.T.E057	Laser label	Laser precaution guide	1		
91	01.00.RC.EHS200	Remote control	HS200-RC	1		
92	01.14.DX.B.E0007G	Alkaline battery	GP7#	3		
93	01.00.BZ.D.S.E109	Plastic bag for unit	47*50cm	1	For unit Packing	
94	01.00.BZ.D.Z.E020	Plastic bag	25*35cm	1	For Owner manual Packing	
95	01.00.BZ.D.Z.E034	Plastic bag	9*27.5CM	1	For Remote Control Packing	
96	01.00.BZ.D.Z.E008	Plastic bag	6*9cm	1	For battery Packing	
97	01.00.BZ.D.H.E002	ROHS bag	11*28cm	1	For power cord packing	
98	0147CNTLJX5E163	HDMI Cord	CJS8T001Z	1		
99	01.47.CNT.ACX.E052	Power Cord	WS-002E+WS-019 HO5VV-F 0.75*2C BK 2M	1		EU Vision
100	01.47.CNT.ACX.E053	Power Cord	WS-002E+WS-004A SJT18AWG*2C BK 2M	1		US Vision
101	0147CNTLJX5E058	Connect cable	scart 1.5m	1		EU Vision
102	01.47.CNT.CTX.E016	Antenna	FM-TV-22 (Lead content less than 300PPM)	1		EU Vision
103	01.47.CNT.CTX.E038	Antenna	FM-TV-75-A	1		US Vision
104	01.47.CNT.CTX.E042	Antenna	AM-300-AWM	1		US Vision
105	0115JXEDL05FHH40P	Loader	DL-05FH-H40P	1		
106	01.49.E11	FM frequency modulation module	TFCF1E806A	1	IEC Head for FM Connector (NON-Screw Thread)	EU Vision
107	01.49.E07	FM/AM frequency modulation module	TFCF1E804A	1	F Head for FM Connector (Screw Thread)	US Vision

HS200 Component List

Item	P/N	Description	Specification	Qty	Location.No.	Note
108	0147CNTLJX7E603	Connect cable	VH-3Y Connector-2Y-120mm(Be same side)	1	CN501 on SMPS Board to Power Jack with solder one end	
109	0147CNTLJX7E615	Connect cable	VH-3Y Connector-2Y-2Y-100mm(Be same side)	1	CN506 on SMPS Board to CN403(L) on AV(L) Board	
110	0147CNTLJX7E649	Connect cable	VH-4Y Connector-4Y-60mm(Be same side with color is White, Black, Red and Black)	1	CN405 on AV Board to JP1.JP2 JP3.JP4 on Speaker Connected Board with solder one end	
111	01.48.BPX.1.E147	Flat cable	1.0*14P*100mmA	1	CN3(A) on Main Board to CN601(A) on Front Panel Board	
112	01.48.BPX.1.E148	Flat cable	1.0*8P*100mmA	1	CN4(B) on Main Board to CN603(B) on Front Panel Board	
113	01.48.BPX.1.E149	Flat cable	1.25*12P*80mmA(T=0.1mm)	1	CN5(C) on Main Board to CN504(C) on SMPS Board	
114	01.48.BPX.1.E150	Flat cable	1.0*16P*80mmA	1	CN9(D) on Main Board to CN301(D) on AV Board	
115	01.48.BPX.1.E151	Flat cable	1.0*24P*80mmA	1	CN8(E) on Main Board to CN302(E) on AV Board	
116	01.48.BPX.1.E152	Flat cable	1.0*5P*80mmA	1	CN6(G) on Main Board to CN304(G) on AV Board	
117	01.48.BPX.1.E153	Flat cable	1.25*14P*70mmA(T=0.1mm)	1	CN503(H) on SMPS Board to CN602(H) on Front Panel Board	
118	01.48.BPX.1.E154	Flat cable	1.0*6P*40mmA	1	CN604(J)on Front Panel Board to CN605(J) on Volume Button Board	

HS200 Component List

Item	P/N	Description	Specification	Qty	Location.No.	Note
119	01.48.BPX.1.E155	Flat cable	1.25*9P*60mmA(T=0.1mm)	1	CN505(K) on SMPS Board to CN402(K) on AV Board	
120	01.48.BPX.1.E156	Flat cable	1.0*12P*220mmA	1	For Loader and CN1 on Main Board	
121	01.48.BPX.1.E028	Flat cable	0.5*24P*200mmA	1	For Loader and CN2 on Main Board	
122	01.48.BPX.1.E157	Flat cable	1.25*11P*50mmA	1	For frequency modulation module and CN10 on Main Board	
123	0211HAV06M3627C02	Main Board (semi-manufactured goods)	HAV06M-3627C02 (EU Vision+Hitachi Loader)	1	4-layers	
124	0214HAV06I3522C02	AV Board (semi-manufactured goods)	HAV06I-3522C02 (EU Vision)	1	2-layers	
125	0219HAV06P3521C01	SMPS Board (semi-manufactured goods)	HAV06P-3521C01	1	2-layers	
126	0215HAV06K3517C01	Front Panel Board (semi-manufactured goods)	HAV06K-3517C01	1	2-layers	
127	0215HAV06K3518C01	Front Panel Board (semi-manufactured goods)	HAV06K-3518C01	1	2-layers	
128	0137PCB2E3520C1	Speaker Connected Board	3520C-V1.0	1	2-layers	
HS200 Component List for Main Board(3627C)						
Item	P/N	Description	Specification	Qty	Location.No.	Note
1	01.57.R.2.E000J	Resistor, chip	0603-0Ω ±5%	8	R4 R9 R45 R49 R50 R58 R181 FB53	
2	01.57.R.2.E100J	Resistor, chip	0603-10Ω±5%	3	R132 R156 R158	
3	01.57.R.2.E200J	Resistor, chip	0603-20Ω±5%	4	R42 R43 R61 R62	
4	01.57.R.2.E220J	Resistor, chip	0603-22Ω±5%	10	R29 R30 (R31) R32 (R33) R34 (R35) R36 (R37) R38	

HS200 Component List for Main Board(3627C)

Item	P/N	Description	Specification	Qty	Location.No.	Note
5	01.57.R.2.E330J	Resistor, chip	0603-33Ω±5%	14	R2 R47 R124 R125 R126 R127 R142 R145 R146 R147 R149 R151 R153 R155	
6	01.57.R.2.E680F	Resistor, chip	0603-68Ω ±1%	1	R99	
7	01.57.R.2.E750F	Resistor, chip	0603-75Ω±1%	17	R97 R98 R100 R101 R102 R103 R104 R105 R106 R107 R108 R109 R110 R111 R114 R116 R117	
8	01.57.R.2.E101J	Resistor, chip	0603-100Ω±5%	8	R6 (R41) (R71) (R120) (R121) R130 (R133) R139	
9	01.57.R.2.E151J	Resistor, chip	0603-150Ω±5%	1	R150	
10	01.57.R.2.E201J	Resistor, chip	0603-200Ω±5%	1	R8	
11	01.57.R.2.E221J	Resistor, chip	0603-220Ω±5%	5	R19 R136 R137 R138 R140	
12	01.57.R.2.E271J	Resistor, chip	0603-270Ω±5%	1	R173	
13	01.57.R.2.E391J	Resistor, chip	0603-390Ω±5%	1	R167	
14	01.57.R.2.E4751F	Resistor, chip	0603-475Ω 1%	1	R141	
15	01.57.R.2.E821J	Resistor, chip	0603-820Ω±5%	1	R183	
16	01.57.R.2.E102J	Resistor, chip	0603-1KΩ±5%	2	R26 R77	
17	01.57.R.2.E122J	Resistor, chip	0603-1.2KΩ±5%	2	R80 R83	
18	01.57.R.2.E152J	Resistor, chip	0603-1.5KΩ±5%	2	R79 R86	
19	01.57.R.2.E182J	Resistor, chip	0603-1.8KΩ±5%	2	R160 R161	
20	01.57.R.2.E202J	Resistor, chip	0603-2KΩ±5%	9	R13 R14 R15 R16 R18 R87 R92 R112 R115	
21	01.57.R.2.E302J	Resistor, chip	0603-3KΩ±5%	3	R65 (R188) (R189)	
22	01.57.R.2.E392J	Resistor, chip	0603-3.9KΩ±5%	3	R44 R46 R52	
23	01.57.R.2.E472J	Resistor, chip	0603-4.7KΩ±5%	19	R5 R27 R55 R57 R63 R96 R118 R131 R135 R162 R163 R168 R170 R178 R185 R186 R190 R191 R192	

HS200 Component List for Main Board(3627C)

Item	P/N	Description	Specification	Qty	Location.No.	Note
24	01.57.R.2.E512J	Resistor, chip	0603-5.1KΩ±5%	1	R89	
25	01.57.R.2.E682J	Resistor, chip	0603-6.8KΩ±5%	1	R91	
26	01.57.R.2.E103J	Resistor, chip	0603-10KΩ±5%	16	R24 R28 R56 R75 R76 R78 R82 R122 R123 R128 R129 R143 R144 R171 R172 R182	
27	01.57.R.2.E123F	Resistor, chip	0603-12KΩ±1%	2	R48 (R72)	
28	01.57.R.2.E153J	Resistor, chip	0603-15KΩ±5%	2	R17 R113	
29	01.57.R.2.E223J	Resistor, chip	0603-22KΩ±5%	2	R84 R85	
30	01.57.R.2.E273J	Resistor, chip	0603-27KΩ±5%	1	R90	
31	01.57.R.2.E333J	Resistor, chip	0603-33KΩ±5%	1	R53	
32	01.57.R.2.E393J	Resistor, chip	0603-39KΩ±5%	1	R51	
33	01.57.R.2.E473J	Resistor, chip	0603-47KΩ±5%	5	R22 R54 R93 R95 R165	
34	01.57.R.2.E105J	Resistor, chip	0603-1MΩ±5%	1	R73	
35	01.57.R.3.E2R0F	Resistor, chip	0805-2Ω±1%	2	R59 R60	
36	01.57.R.4.E020J	Resistor, chip	1206-2Ω±5%	1	R3	
37	01.57.R.8.EP1004	Resistor, thick film chip network	10Ω*4 ±5%	1	RN4	
38	01.57.R.8.EP3304	Resistor, thick film chip network	33Ω*4 ±5%	6	RN6 RN7 RN8 RN9 RN10 RN11	
39	01.57.R.8.EP4724	Resistor, thick film chip network	4.7KΩ*4 ±5%	1	RN3	
40	01.57.R.8.EP1034	Resistor, thick film chip network	10KΩ*4 ±5%	1	RN1	
41	01.57.R.Y.E270	Voltage Dependent Resistor, TDK	AVR-M1608C270MTABB,SMD	2	ESD1 ESD2	
42	01.57.R.R.E050	Thermmal Dependent Resistor, JinKe	JK-MSMD050 SMD	1	PTC1	
43	0154CS2E3P3N50V	Capacitor, multilayer ceramic, chip	0603-3.3P NPO±0.25%/50V	1	C192	
44	0154CS2E6P8N50V	Capacitor, multilayer ceramic, chip	0603-6.8P NPO±0.25PF/50V	4	(C64) (C65) (C146) (C147)	
45	0154CS2E200N50V	Capacitor, multilayer ceramic, chip	0603-20P NPO±5%/50V	4	C139 C140 C141 C142	

HS200 Component List for Main Board(3627C)

Item	P/N	Description	Specification	Qty	Location.No.	Note
46	0154CS2E330N50V	Capacitor, multilayer ceramic, chip	0603-33P NPO±5%/50V	2	(C161) (C164)	
47	0154CS2E101N50V	Capacitor, multilayer ceramic, chip	0603-100P NPO±5%/50V	2	C97 C112	
48	0154CS2E181N50V	Capacitor, multilayer ceramic, chip	0603-180P NPO±5%/50V	2	C103 C116	
49	0154CS2E221N50V	Capacitor, multilayer ceramic, chip	0603-220P NPO±5%/50V	3	C84 C87 C115	
50	0154CS2E271N50V	Capacitor, multilayer ceramic, chip	0603-270P NPO±5%/50V	1	C162	
51	0154CS2E391N50V	Capacitor, multilayer ceramic, chip	0603-390P NPO±5%/50V	1	C129	
52	0154CS2E471X50V	Capacitor, multilayer ceramic, chip	0603-470P X7R±10%/50V	3	C82 C86 C90	
53	0154CS2E561N50V	Capacitor, multilayer ceramic, chip	0603-560P NPO±5%/50V	1	C163	
54	0154CS2E681X50V	Capacitor, multilayer ceramic, chip	0603-680P X7R±10%/50V	4	C105 C106 C108 C111	
55	0154CS2E102X50V	Capacitor, multilayer ceramic, chip	0603-102 X7R±10%/50V	6	C91 C94 C96 C99 C118 C119	
56	0154CS2E152X50V	Capacitor, multilayer ceramic, chip	0603-152 X7R±10%/50V	1	(C19)	
57	0154CS2E272X50V	Capacitor, multilayer ceramic, chip	0603-272 X7R±10%/50V	1	(C20)	
58	0154CS2E332X50V	Capacitor, multilayer ceramic, chip	0603-332 X7R±10%/50V	3	C113 C114 C120	
59	0154CS2E472X50V	Capacitor, multilayer ceramic, chip	0603-472 X7R±10%/50V	1	C88	
60	0154CS2E103Y50V	Capacitor, multilayer ceramic, chip	0603-103 Y5V-20+80%/50V	1	C8	
61	0154CS2E153Y50V	Capacitor, multilayer ceramic, chip	0603-153 Y5V-20+80%/50V	1	C101	
62	0154CS2E183X50V	Capacitor, multilayer ceramic, chip	0603-183 X7R±10%/50V	2	C168 (C169)	

HS200 Component List for Main Board(3627C)						
Item	P/N	Description	Specification	Qty	Location.No.	Note
63	0154CS2E223X50V	Capacitor, multilayer ceramic, chip	0603-223 X7R±10%/50V	4	C16 C117 C127 C136	
64	0154CS2E683X50V	Capacitor, multilayer ceramic, chip	0603-683 X7R±10%/50V	2	C121 (C107)	
65	0154CS2E104Y50V	Capacitor, multilayer ceramic, chip	0603-104 Y5V-20+80%/50V	136	C3 C4 C6 C7 C9 C10 (C11) C12 C13 (C14) (C15) (C17) C18 (C21) (C22) C23 (C24) C25 (C26) (C27) (C28) (C29) (C30) C31 C32 (C33) (C34) (C35) (C36) (C37) (C38) (C39) C40 C41 C42 (C43) (C44) (C45) (C46) (C47) (C48) (C49) (C50) (C51) (C52) (C53) (C54) (C55) (C56) (C57) (C58) (C59) (C60) (C61) C62 (C63) C66 (C67) (C68) (C69) (C70) (C71) (C72) (C73) (C74) (C75) (C76) (C77) C78	

HS200 Component List for Main Board(3627C)						
Item	P/N	Description	Specification	Qty	Location.No.	Note
65	0154CS2E104Y50V	Capacitor, multilayer ceramic, chip	0603-104 Y5V-20+80%/50V	136	(C79) (C80) C81 C83 C85 C89 C92 (C93) (C95) C102 C104 C109 (C110) C122 C123 C124 (C125) C126 (C128) C130 C131 C132 (C133) (C134) (C135) C137 C138 C143 C144 C145 C148 C149 (C150) C151 (C152) (C153) (C154) (C155) (C156) (C157) (C158) (C159) (C160) C165 C166 C167 (C170) (C171) (C172) (C173) (C174) (C175) (C176) (C177) C178	
65	0154CS2E104Y50V	Capacitor, multilayer ceramic, chip	0603-104 Y5V-20+80%/50V	136	C179 (C180) (C181) C182 C183 C184 C185 C186 (C187) C188 C189 C190	
66	0154CS2E105Y16V	Capacitor, multilayer ceramic, chip	0603-105 Y5V-20+80%/16V	8	(C0) C100 (C194) (C195) (C196) (C197) (C198) (C199)	
67	0134CLDE2U216VC	Capacitor, AL.electrolytic	CD110-2.2UF/16V 5*11	1	EC37	
68	0134CLDE10U10VC	Capacitor, AL.electrolytic	CD110-10UF/10V 5*11	4	EC41 EC42 EC46 EC47	
69	0134CLDE10U16VC	Capacitor, AL.electrolytic	CD110-10UF/16V 5*11	3	EC4 EC25 EC51	
70	0134CLDE22U16VC	Capacitor, AL.electrolytic	CD110-22UF/16V 5*11	3	EC43 EC44 EC45	
71	0134CLDE33U10VC	Capacitor, AL.electrolytic	CD110-33UF/10V 5*11	1	EC27	
72	0134CLDE47U10VC	Capacitor, AL.electrolytic	CD110-47UF/10V 5*11	11	EC3 EC5 EC6 EC7 EC8 EC9 EC10 EC11 EC16 EC17 EC50	
73	0134CLDE47U16VC	Capacitor, AL.electrolytic	CD110-47UF/16V 5*11	6	EC18 EC19 EC22 EC23 EC52 EC54	
74	0134CLDE47U25VC1	Capacitor, AL.electrolytic	CD110-47UF/25V 5*11	1	EC39	

HS200 Component List for Main Board(3627C)

Item	P/N	Description	Specification	Qty	Location.No.	Note
75	0134CLDE100U10VD	Capacitor, AL.electrolytic	CD110-100UF/10V 5*12	9	EC2 EC13 EC14 EC15 EC26 EC35 EC36 EC49 EC56	
76	0134CLDE100U16VC	Capacitor, AL.electrolytic	CD110-100UF/16V 5*11	9	EC1 EC12 EC20 EC21 EC24 EC33 EC40 EC48 EC53	
77	0134CLDE100U25VD	Capacitor, AL.electrolytic	CD110-100UF/25V 6.3*12	1	EC38	
78	0134CLDE220U10VD	Capacitor, AL.electrolytic	CD110-220UF/10V 5*12	5	EC28 EC29 EC31 EC32 EC55	
79	0134CLDE220U16VD	Capacitor, AL.electrolytic	CD110-220UF/16V 6.3*12	1	EC34	
80	0134CLDEV1500U6V3S	Capacitor, AL.electrolytic	CD110-1500UF/6.3V 8*17	1	EC30	
81	01.13.L.Z.E5A50	Bead, chip	0603-50Ω	25	FB16 FB18 FB20 FB22 FB23 FB24 FB25 FB26 FB27 FB28 FB29 FB30 FB31 FB32 FB33 FB35 FB36 FB37 FB38 FB39 FB40 FB47 (FB48) FB49 FB52	
82	01.13.L.Z.E5B50	Bead, chip	0805-50Ω	11	FB1 FB5 FB7 FB9 FB11 (FB13) FB42 FB43 FB44 FB45 FB46	
83	01.13.L.Z.E102YN	Bead, chip, QiLiXin	PBY160808T-102Y-N	1	R174	Important Component For EMI.
84	01.13.L.Z.ED50A	Bead, leaded fixed	50Ω□3.5*6.0*0.8□	8	FB3 FB4 FB6 FB8 FB12 FB14 FB17 FB34	
85	01.13.L.L.S.E018	Inductor, multilayer ceramic, chip	1206-10UH	2	L1 L2	
86	01.13.L.R.E068	Pulse transformer, TOKO	EJ219	2	B1 B2	ALPS
87	01.13.L.L.S.E242	Inductor, multilayer ceramic, chip, TDK	ACM2012-900-2P	4	L3 L4 L5 L6	
88	01.41.D.PD.E5393	Diode	IN5393, In Line Package	3	D1 D2 D3	
89	01.41.D.PS.ELL4148	Diode	LL4148, DO213AA	4	D4 D5 D6 D11	
90	01.42.Q.S.E1132	Transistor	2SB1132,SOT89	2	Q1 Q6	Amplificatory Multiple is "R"

HS200 Component List for Main Board(3627C)

Item	P/N	Description	Specification	Qty	Location.No.	Note
91	01.42.Q.S.E3018	Mosfet	2SK3018T106,UMT3	1	Q9	
92	01.42.Q.S.EC8550	Transistor	KTC8550,SOT23	2	Q3 Q10	
93	01.42.Q.S.E8050	Transistor	KTC8050,SOT23	3	Q4 Q7 Q8	
94	01.00.JZ.E2700C	Crystal Oscillator,	27.00MHZ/3.3V	1	Y1	
95	01.00.JZ.E06000A	Quartz Crystal Unit	6.000MHZ-49S-6.8P	1	Y2	
96	01.00.JZ.E4332A	Quartz Crystal Unit	4.332MHZ-49S-33P	1	Y3	
97	01.44.IC.D.EL7805	IC, ST, Voltage Regulator	L7805, TO-220	1	U32	
98	01.44.IC.D.EL7809	IC, ST, Voltage Regulator	L7809, TO-220	1	U19	
99	01.44.IC.D.E78L05	IC, FairChild, Voltage Regulator	78L05, TO-92	1	U20	
100	01.44.IC.D.EBA033	IC, ROHM, Dropout Voltage Regulator	BA33BCO,TO-220	1	U22	
101	01.44.IC.S.E1117H	IC, AAC, LDO	AZ1117H-5.0, SOT-223	1	U29	
102	0144ICSEA11171V8	IC, AAC, LDO	AZ1117H-1.8, SOT-223	1	U23	
103	0144ICSEA11173V3	IC, AAC, LDO	AZ1117H-3.3, SOT-223	1	U30	
104	01.44.IC.S.EC5FP	IC, Rohm, LDO	BA00HC5FP, T0252-5	1	U1	
105	01.44.IC.S.E3278	IC, Amlogic, A/V Processor	AML3278G, PQFP256LD	1	U4	
106	0144ICSE29LV160CBT	IC, KH , FLASH	KH29LV160CBTC-70G(Can replaced by S29AL016M90TFI02) , TSOP48	1	U9	firmware burn-in (EU Version)
107	0144ICSE16400BL	IC, ISSI , SDRAM	IS42S16400B-6TL, TSOP54	2	U7 U8	
108	01.44.IC.S.E9572XL	IC, Xilinx, CPLD	XC9572XL-10VQG44C, VQFP44	1	U5	firmware burn-in on line
109	01.44.IC.S.E24C64	IC, Atmel, EEPROM	AT24C64-2.7, SO8	1	U3	
110	01.44.IC.S.E3501	IC, Amlogic, DVD/CD RF Processor	AML3501, TSSOP48	1	U12	
111	01.44.IC.S.E5888	IC, Rohm, Actuator driver	BA5888FP, HSOP-28	1	U11	
112	01.44.IC.S.E6287	IC, Rohm, Motor Driver	BA6287, SOP8	1	U6	
113	01.44.IC.S.E4410	IC, ADI, Integrated Vidio Filter	ADA4410-6ACPZ,CP-32-3	1	U15	
114	01.44.IC.S.E9030	IC, Silicon Image,HDMI Panellink Transmitter	Sii9030CTU,TQFP80	1	U21	
115	01.44.IC.S.E2561	IC, JRC, Vidio Amplifier	NJM2561F1, MTP6	1	U14	
116	01.44.IC.S.ELM358M	IC, ST, Dual Operational Amplifier	LM358M, SO8	1	U13	
117	01.44.IC.D.EPC817	IC, Sharp, Photoelectric Coupler	PC817, DIP4	1	U27	

HS200 Component List for Main Board(3627C)

Item	P/N	Description	Specification	Qty	Location.No.	Note
118	01.44.IC.S.E242L	IC, TDI, USB Controller	TDOTG242LPF, LQFP-64	1	U17	
119	01.44.IC.S.E1924	IC, Rohm, RDS/RBDS Decoder	BU1924F, SOP16	1	U18	
120	01.46.IC.E7414	IC, TI, Schmitt Trigger	74HCT14D, SO14	1	U2	
121	01.44.IC.S.E672T	IC, NEC, MOS FIELD EFFECT TRANSISTOR	UPA672T, SC-70	1	U31	
122	01.44.IC.S.E0514	IC, Semtech, Low Capalitance TVS Diode Array	RClamp0514M,MSOP-10L	4	U16 U24 U25 U26	
123	01.40.CON.DCZ.E316	HDMI Jack	1747981-1, SMD	1	J4	51UO19S-331N A
124	0140CONDDZEDSW-30	S-Vidio Connector	DSW-30	1	J1	
125	01.40.CON.DCZ.E467	Jack	AV4-8.4-14/EP, In-line Package	1	J2	
126	01.40.CON.DCZ.E217	USB Jack	USB-A-05 (ROHS, Mother Set)	1	J7	
127	01.40.CON.DCZ.E203	IR in/out jack	CKX-3.5-22	2	J5 J6	
128	01.40.CON.DPH.E028	Connector	PH-6A	1	CN12	Antiflaming
129	0140CONS10FPC1E015	FPC Connector, SMD	FPC-1.0-12P with upward touch	1	CN1	
130	0140CONS13FPC2E003	FPC Connector	1.25-12P Vertical Type and Dual Conact	1	CN5	Black
131	0140CONS10FPC2E001	FPC Connector	1.0-5P Vertical Type and Dual Conact	1	CN6	Black & Antiflaming
132	0140CONS10FPC2E002	FPC Connector	1.0-8P Vertical Type and Dual Conact	1	CN4	Black & Antiflaming
133	0140CONS10FPC2E030	FPC Connector	1.0-14P Vertical Type and Dual Conact	1	CN3	Black
134	0140CONS10FPC2E024	FPC Connector	1.0-16P Vertical Type and Dual Conact	1	CN9	Black
135	0140CONS10FPC2E003	FPC Connector	1.0-24P Vertical Type and Dual Conact	1	CN8	Black & Antiflaming
136	01.40.CON.DCZ.E062	FPC connector	1.25-11P Vertical Type	1	CN10	
137	01.40.CON.S05.E007	FPC connector, SMD	FPC-0.5-24P with upward touch	1	CN2	

HS200 Component List for AV Board(3522C)

Item	P/N	Description	Specification	Qty	Location.No.	Note
1	01.57.R.2.E000J	Resistor, chip	0603-0Ω ±5%	3	R356 R401 R404	
2	01.57.R.2.E100J	Resistor, chip	0603-10Ω±5%	1	R353	
3	01.57.R.2.E561J	Resistor, chip	0603-560Ω±5%	1	R379	
4	01.57.R.2.E750J	Resistor, chip	0603-75Ω±5%	1	R378	

5	01.57.R.2.E111J	Resistor, chip	0603-110Ω±5%	1	R343	
HS200 Component List for AV Board(3522C)						
Item	P/N	Description	Specification	Qty	Location.No.	Note
6	01.57.R.2.E151J	Resistor, chip	0603-150Ω±5%	3	R342 R385 R416	
7	01.57.R.2.E221J	Resistor, chip	0603-220Ω±5%	1	R341	
8	01.57.R.2.E271J	Resistor, chip	0603-270Ω±5%	1	R402	
9	01.57.R.2.E301J	Resistor, chip	0603-300Ω±5%	1	R405	
10	01.57.R.2.E331J	Resistor, chip	0603-330Ω±5%	3	R321 R328 R344	
11	01.57.R.2.E681J	Resistor, chip	0603-680Ω±5%	2	R320 R327	
12	01.57.R.2.E102J	Resistor, chip	0603-1KΩ±5%	1	R410	
13	01.57.R.2.E152J	Resistor, chip	0603-1.5KΩ±5%	3	R408 R409 R413	
14	01.57.R.2.E1781F	Resistor, chip	0603-1.78KΩ±1%	2	R319 R329	Important Component For Audio Frequency
15	01.57.R.2.E222J	Resistor, chip	0603-2.2KΩ±5%	10	R304 R312 R364 R366 R368 R370 R372 R374 R376 R380	
16	01.57.R.2.E332J	Resistor, chip	0603-3.3KΩ±5%	6	R310 R313 R315 R316 R317 R403	
17	01.57.R.2.E472J	Resistor, chip	0603-4.7KΩ±5%	3	R300 R305 R352	
18	01.57.R.2.E4752F	Resistor, chip	0603-4.75KΩ 1%	4	R323 R324 R336 R337	Important Component For Audio Frequency
19	01.57.R.2.E512J	Resistor, chip	0603-5.1KΩ±5%	2	R354 R355	
20	01.57.R.2.E752F	Resistor, chip	0603-7.5KΩ 1%	2	R326 R332	
21	01.57.R.2.E103J	Resistor, chip	0603-10KΩ±5%	36	R301 R302 R303 R307 R309 R311 R322 R325 R330 R331 R333 R339 R340 R345 R346 R347 R350 R351 R359 R360 R361 R362 R363 R365 R367 R369 R371 R373 R375 R377 R382 R406 R407 R411 R412 R433	

HS200 Component List for AV Board(3522C)

Item	P/N	Description	Specification	Qty	Location.No.	Note
22	01.57.R.2.E473J	Resistor, chip	0603-47KΩ±5%	4	R334 R335 R381 R415	
23	01.57.R.2.E104J	Resistor, chip	0603-100KΩ±5%	1	R349	
24	01.57.R.3.E102J	Resistor, chip	0805-1KΩ±5%	2	R418 R414	
25	01.57.R.3.E103J	Resistor, chip	0805-10KΩ±5%	3	R417 R419 R420	
26	01.57.R.4.E6R2J	Resistor, chip	1206-6.2Ω±5%	4	(R427) R428 R429 (R430)	
27	01.57.R.4.E100J	Resistor, chip	1206-10Ω±5%	4	R421 R422 R423 R424	
28	01.57.R.4.E301J	Resistor, chip	1206-300Ω±5%	2	R314 R384	
29	01.57.R.4.E102J	Resistor, chip	1206-1KΩ±5%	1	R308	
30	01.57.R.4.E202J	Resistor, chip	1206-2KΩ±5%	2	R383 R306	
31	01.57.R.8.EP0004	Resistor, thick film chip network	0Ω*4 ±5%	2	RN402 RN401	
32	01.57.R.Y.E270	Voltage Dependent Resistor, TDK	AVR-M1608C270MTABB	6	ESD300 ESD301 ESD302 ESD303 ESD304 ESD305	
33	0154CS2E200N50V	Capacitor, multilayer ceramic, chip	0603-20P NPO±5%/50V	2	C300 C303	
34	0154CS2E270N50V	Capacitor, multilayer ceramic, chip	0603-27P NPO±5%/50V	1	C406	
35	0154CS2E470N50V	Capacitor, multilayer ceramic, chip	0603-47P NPO±5%/50V	2	C325 C326	
36	0154CS3E101N50V	Capacitor, multilayer ceramic, chip	0805-100P NPO±5%/50V	2	C306 C314	Important Component For Audio Frequency
37	0154CS2E101N50V	Capacitor, multilayer ceramic, chip	0603-100P NPO±5%/50V	3	C317 C318 C405	
38	0154CS2E221N50V	Capacitor, multilayer ceramic, chip	0603-220P NPO±5%/50V	1	C421	
39	0154CS3E681N50V	Capacitor, multilayer ceramic, chip	0805-680P NPO±5%/50V	2	C307 C311	Important Component For Audio Frequency
40	0154CS2E102X50V	Capacitor, multilayer ceramic, chip	0603-102 X7R±10%/50V	1	C404	

HS200 Component List for AV Board(3522C)

Item	P/N	Description	Specification	Qty	Location.No.	Note
41	0154CS2E122X50V	Capacitor, multilayer ceramic, chip	0603-122 X7R±10%/50V	1	C422	
42	0154CS3E102N50V	Capacitor, multilayer ceramic, chip	0805-102 NPO±5%/50V	6	C305 C310 (C461) (C462) (C463) (C464)	Important Component For Audio Frequency
43	0154CS2E153Y50V	Capacitor, multilayer ceramic, chip	0603-153 Y5V-20+80%/50V	1	C400	
44	0154CS2E104Y50V	Capacitor, multilayer ceramic, chip	0603-104 Y5V-20+80%/50V	18	C301 C302 C304 C308 C309 C312 C313 C315 C316 C319 C320 C322 C324 C327 C328 C412 C418 C419	
45	0154CS2E104X50V	Capacitor, multilayer ceramic, chip	0603-104 X7R±10%/50V	5	C423 C424 C425 C426 C427	
46	0154CS3E104X50V	Capacitor, multilayer ceramic, chip	0805-104 X7R±10%/50V	10	(C434) (C435) (C447) (C448) C449 C450 C451 (C452) (C453) C465	
47	0154CS3E104Y50V	Capacitor, multilayer ceramic, chip	0805-104 Y5V+80-20%/50V	12	C401 (C402) (C403) (C407) C408 (C410) (C411) (C413) (C414) (C415) (C416) (C417)	
48	0154CS4E681N50V	Capacitor, multilayer ceramic, chip	1206-680P NPO±5%/50V	4	C441 C442 C443 C444	
49	0134CLDE10U16VC	Capacitor, AL.electrolytic	CD110-10UF/16V 5*11	10	EC300 EC301 EC304 EC305 EC306 EC308 EC315 EC316 EC318 EC320	
50	0134CLDE10U25VC1	Capacitor, AL.electrolytic	CD288H-10UF/25V 5*11	1	EC402	
51	0134CLDE47U16VC	Capacitor, AL.electrolytic	CD110-47UF/16V 5*11	4	EC302 EC303 EC307 EC310	
52	0134CLDE47U25VC1	Capacitor, AL.electrolytic	CD110-47UF/25V 5*11	4	EC313 EC314 EC400 EC401	
53	0134CLDE100U16VC	Capacitor, AL.electrolytic	CD110-100UF/16V 5*11	5	EC323 EC403 EC404 EC312 EC322	

HS200 Component List for AV Board(3522C)

Item	P/N	Description	Specification	Qty	Location.No.	Note
54	0134CLDE220U16VD	Capacitor, AL.electrolytic	CD110-220UF/16V 6.3*12	2	EC309 EC311	
55	0134CLDE1000U50VH	Capacitor, AL.electrolytic	CD288H-1000UF/50V 13*25	1	EC405	CAPXON , GF102M050I25 0A
56	01.33.CT.EB22U10V	Solid Electrolyte Tantalum Chip Capacitor	B-22UF-10V	2	C409 C420	
57	01.33.CT.EC1U50V	Solid Electrolyte Tantalum Chip Capacitor	T491C105K050AT	2	(C433) (C435)	
58	01.00.CD.JZ.E474	Box-type metallized polyester film capacitor	474J 100V	2	C459 C458	
59	01.13.L.Z.E5A50	Bead, chip	0603-50Ω	8	FB300 FB301 FB302 FB303 FB304 FB305 FB306 FB307	
60	01.13.L.Z.E5B50	Bead, chip	0805-50Ω	6	FB403 FB404 FB406 FB408 FB409 FB410	
61	01.13.L.Z.E5B300	Bead, chip	0805-300Ω	2	FB411 FB412	
62	01.13.L.Z.ED50A	Bead, leaded fixed	50Ω□3.5*6.0*0.8□	3	FB401 FB405 FB407	
63	01.13.L.L.D.E127	Magnetic shielding Inductor	983BN-1003-15UH	4	L400 L401 L402 L403	Can Replaced by TH11315-150
64	01.41.D.PS.ELL4148	Diode	LL4148, DO213AA	12	D300 D301 D302 D303 D304 D305 D306 D307 D308 D400 D401 D402	
65	01.42.Q.S.E8050	Transistor	KTC8050, SOT23	3	Q300 Q302 Q402	
66	01.42.Q.S.EC8550	Transistor	KTC8550, SOT23	4	Q301 Q303 Q311 Q401	
67	01.42.Q.S.E343	Transistor	DTC343TK, SMT3	8	Q304 Q305 Q306 Q307 Q308 309 Q310 Q400	
68	0144ICSEA11173V3	IC, AAC, LDO	AZ1117H-3.3, SOT-223	1	U406	
69	01.44.IC.S.E833	IC, NS, Operational Amplifier	LM833M, SOP8	1	U301	
70	01.44.IC.S.E8776	IC, Wolfson, Stereo audio CODEC	WM8776SEFT, TQFP48	1	U302	
71	0144ICSESTA308A	IC, ST, Digital Audio Processor	STA308A, TQFP64	1	U402	
72	01.44.IC.S.E2068	IC, JRC, Pre-amp	NJM2068M, SO8	1	U405	
73	01.44.IC.S.ESTA508	IC, ST, Power Half Bridge	STA508, PowerSO36	1	U403	

HS200 Component List for AV Board(3522C)

Item	P/N	Description	Specification	Qty	Location.No.	Note
74	0144ICSE74HC158	IC, TI or TOSHIBA, Quad 2-input Multiplexer	74HC158, SOP16	1	U303	
75	0144ICSEAAT3522IGY	IC, Analogic Tech, Reset monitor	AAT3522IGY-3.08-200-T1, SOT-23	1	U401	
76	01.46.IC.E74H04	IC, TI, Hex Inverter	74HCU04, TSSOP14	1	U304	
77	0140CONS13FPC2E004	FPC Connector	1.25-9P Vertical Type and Dual Conact	1	CN402	Black
78	0140CONS10FPC2E001	FPC Connector	1.0-5P Vertical Type and Dual Conact	1	CN304	Black & Antiflaming
79	0140CONS10FPC2E024	FPC Connector	1.0-16P Vertical Type and Dual Conact	1	CN301	Black
80	0140CONS10FPC2E003	FPC Connector	1.0-24P Vertical Type and Dual Conact	1	CN302	Black & Antiflaming
81	01.40.CON.DCZ.E244	Connector	Vertical VH Connector with four holes and four pins	1	CN405	White & Antiflaming
82	01.40.CON.DCZ.E129	Connector	Vertical VH Connector with three holes and two pins	1	CN403	White & Antiflaming
83	01.43.E004	Jack, Sharp, Fiber optic iuput jack with shutter	GP1FA513RZ, In-line Package	1	J304	
84	01.40.CON.DCZ.E203	Jack, SUB Tirgger	CKX-3.5-22	1	J401	
85	01.40.CON.DCZ.E172	Jack, SUB Woofer	AV1-8.4-6G	1	J402	Purple & Antiflaming
86	01.40.CON.DCZ.E468	Jack, Audio Input/Output	AV8-8.4-13/PB	1	J302	Appointed color
87	01.40.CON.DCZ.E181	Jack, SCART	CS-101	1	J301	Fully Shield
88	01.57.R.R.E010	Resettable Fuse,	JK-MSMD010, SMD	1	PTC400	

HS200 Component List for SMPS Board(3521C)

Item	P/N	Description	Specification	Qty	Location.No.	Note
1	01.57.R.3.E100J	Resistor, chip	0805-10Ω±5%	4	R509 R519 R578 R589 R591	
2	01.57.R.3.E220J	Resistor, chip	0805-22Ω±5%	2	R568 R509	
3	01.57.R.3.E470J	Resistor, chip	0805-47Ω±5%	1	R569	
4	01.57.R.3.E101J	Resistor, chip	0805-100Ω±5%	1	R517	
5	01.57.R.3.E471J	Resistor, chip	0805-470Ω±5%	4	R525 R536 R553 R580	

HS200 Component List for SMPS Board(3521C)

Item	P/N	Description	Specification	Qty	Location.No.	Note
6	01.57.R.3.E102J	Resistor, chip	0805-1K Ω ±5%	9	R535 R538 R542 R544 R546 R551 R554 R555 R598	
7	01.57.R.3.E202J	Resistor, chip	0805-2K Ω ±5%	2	R541 R537	
8	01.57.R.3.E302F	Resistor, chip	0805-3K Ω ±1%	2	R531 R543	
9	01.57.R.3.E362F	Resistor, chip	0805-3.6K Ω ±1%	2	R533 R534	
10	01.57.R.3.E472J	Resistor, chip	0805-4.7K Ω ±5%	6	R540 R547 R552 R556 R560 R576	
11	01.57.R.3.E103J	Resistor, chip	0805-10K Ω ±5%	9	R508 R524 R549 R571 R577 R579 R587 R532 R590	
12	01.57.R.3.E133F	Resistor, chip	0805-13K±1%	1	R511	
13	01.57.R.3.E153J	Resistor, chip	0805-15K Ω ±5%	1	R503	
14	01.57.R.3.E203J	Resistor, chip	0805-20K Ω ±5%	4	R504 R592 R593 R594	
15	01.57.R.3.E273J	Resistor, chip	0805-27K Ω ±5%	1	R567	
16	01.57.R.3.E393F	Resistor, chip	0805-39K Ω ±1%	1	R545	
17	01.57.R.3.E154J	Resistor, chip	0805-150K Ω ±5%	1	R566	
18	01.57.R.3.E364J	Resistor, chip	0805-360K Ω ±5%	1	R505	
19	01.57.R.4.ER47J	Resistor, chip	1206-0.47 Ω ±5%	4	R506 R507 R510 R512	
20	01.57.R.4.E101J	Resistor, chip	1206-100 Ω ±5%	1	R522	
21	01.57.R.4.E201J	Resistor, chip	1206-200 Ω ±5%	1	R526	
22	01.57.R.4.E331F	Resistor, chip	1206-330 Ω 1%	6	R581 R582 R583 R584 R585 R586	
23	01.57.R.4.E103J	Resistor, chip	1206-10K Ω ±5%	3	R513 R596 R597	
24	01.57.R.4.E154J	Resistor, chip	1206-150K Ω ±5%	3	R529 R520 R514	
25	01.57.R.4.E564J	Resistor, chip	1206-560K Ω ±5%	2	R501 R502	
26	01.57.R.4.E624F	Resistor, chip	1206-620K Ω ±1%	1	R518	
27	01.57.R.4.E684F	Resistor, chip	1206-680K Ω ±1%	2	R515 R516	
28	01.57.R.4.E305J	Resistor, chip	1206-3M Ω ±5%	4	R562 R563 R564 R565	
29	01.57.R.4.E335J	Resistor, chip	1206-3.3M Ω ±5%	2	R573 R574	
30	01.57.R.C.ED102	FIXED CARBON FILM	RT1/4W-1K Ω	1	R570	
31	01.57.R.C.EF101	FIXED CARBON FILM	RT1W-100 Ω	1	R548	
32	01.57.R.C.EF683	FIXED CARBON FILM	RT1W-68K Ω 5%	1	R530	
33	01.57.R.C.EF104	FIXED CARBON FILM	RT1W-100K Ω	1	R521	
34	01.57.R.C.EHR3	FIXED CARBON FILM	RT3W-0.3 Ω	1	R572	

HS200 Component List for SMPS Board(3521C)

Item	P/N	Description	Specification	Qty	Location.No.	Note
35	01.57.R.C.EH471	FIXED CARBON FILM	RT3W-470Ω	1	R595	
36	01.57.R.Y.E10K	Voltage Dependent Resistor	10K.471	1	RZ503	
37	01.57.R.R.E5D11	Thermmal Dependent Resistor	NTC-5D-11	1	RZ501	
38	01.57.R.C.E60F116	High-Resistance Cermet Resistor	RCR60-1W-11MΩ	1	R558	
39	01.57.R.R.EJK16300	Resettable Fuse, JinKe	JK16 300	1	RZ502	
40	0154CS3E470N50V	Capacitor, multilayer ceramic, chip	0805-47P NPO±5%/50V	1	C510	
41	0154CS3E331N50V	Capacitor, multilayer ceramic, chip	0805-330P NPO±5%/50V	1	C533	
42	0154CS3E102X50V	Capacitor, multilayer ceramic, chip	0805-102 X7R ±10%/50V	2	C519 C536	
43	0154CS3E103X50V	Capacitor, multilayer ceramic, chip	0805-103 X7R±10%/50V	1	C534	
44	0154CS3E473X50V	Capacitor, multilayer ceramic, chip	0805-473 X7R±10%/50V	2	C503 C532	
45	0154CS3E104Y50V	Capacitor, multilayer ceramic, chip	0805-104 Y5V+80-20%/50V	20	C517 C518 C521 C522 C523 C524 C526 C527 C528 C529 C530 C537 C538 C539 C542 C543 C544 C545 C547 C548	
46	0154CS3E224Y50V	Capacitor, multilayer ceramic, chip	0805-224 Y5V-20+80%/50V	2	C504 C516	
47	0154CS3E474Y50V	Capacitor, multilayer ceramic, chip	0805-474 Y5V+80-20%/50V	1	C535	
48	0135CCE12061U50V	Capacitor, multilayer ceramic, chip	C3216Y5V1H105ZT	1	C511	
49	0154CS6E151N1KV	Capacitor, multilayer ceramic, chip	1808-150P NPO±5%/1KV	1	C546	
50	0100CDDSE473/50V	Radial Monolithic Capacitor	473/50V X7R±10% (lead pitch: 5.08mm)	1	C507	
51	0100CDDSE10450V	Radial Monolithic Capacitor	104/50V X7R±10% (lead pitch:5.08mm)	1	C531	
52	0100CDJZE472630VA	Metallized capacitor	472/630V (lead pitch: 10mm)	1	C509	
53	0100CDJZE103630VA	Metallized capacitor	103/630V (lead pitch: 10mm)	2	C505 C515	
54	0100CDJZE105400V	Metallized capacitor	105/400V (lead pitch: 15mm)	1	C502	

HS200 Component List for SMPS Board(3521C)

Item	P/N	Description	Specification	Qty	Location.No.	Note
55	0100CDGYE4711KV	High-voltage metallized polyester film	471/1KV	1	C520	
56	0100CDGYE224275V	High-voltage metallized polyester film	224/275V X2 (lead pitch: 15mm)	2	CX502 CX503	
57	0100CDGYE334275V	High-voltage metallized polyester film	334/275V X2 (lead pitch: 15mm)	1	CX501	
58	0100CDGYE102400V250V	High-voltage metallized polyester film	102/400V(X1) 250V(Y1) (lead pitch: 10mm)	4	CY503 CY504 CY501 CY502	
59	0100CDGYE471400V250V	High-voltage metallized polyester film	471/400V (X1) 250V (Y1) (lead pitch: 10mm)	1	CY505	
60	0134CLDEH47U50VD	CAPACITOR,AL.ELECTROLYTIC	CD288H-47UF/50V 6.3*12	4	EC501 EC503 EC504 EC505	
61	0134CLDEH470U16VD	CAPACITOR,AL.ELECTROLYTIC	CD288H-470UF/16V 8*12	2	EC513 EC514	
62	0134CLDE470U25V	CAPACITOR,AL.ELECTROLYTIC	470uF/25V 8*20 ±20% 105□ Low ESR	8	EC524 EC511 EC525 EC516 EC526 EC521 EC515 EC512	
63	0134CLDE1000U50VH	CAPACITOR,AL.ELECTROLYTIC	CD288H-1000UF/50V 13*25	3	EC517 EC519 EC527	
64	0134CLDE1500U50V	CAPACITOR,AL.ELECTROLYTIC	GF152M050J410A	1	EC518	
65	0134CLDE2882200U16VH	CAPACITOR,AL.ELECTROLYTIC	CD288H-2200UF/16V 13*25	2	EC507 EC508	
66	0134CLDE288220U10VH	CAPACITOR,AL.ELECTROLYTIC	GF222M010G200A	3	EC522 EC506 EC520	
67	0134CLDE180U450V	CAPACITOR,AL.ELECTROLYTIC	HP181M450N510A	1	EC502	
68	0134CLDE28868U50	CAPACITOR,AL.ELECTROLYTIC	KM680M050E110A	1	EC528	
69	01.13.L.L.D.E071	Color Code Inductor	4.7UH	1	FB501	0.25W
70	01.13.L.L.D.E192	Common Mode Inductor	LCL-303A DIP	2	LF502 LF501	
71	01.13.L.L.D.E077	Pulse transformer	L0620-050	2	L507 L502	
72	01.13.L.L.D.E141	Filter inductor	L-200A DIP	1	L508	
73	01.13.L.L.D.E018	Common Mode Choke	LCL-471	1	LF503	
74	01.13.L.R.E122	Transformer	BCK-ER2869	1	T502	

HS200 Component List for SMPS Board(3521C)

Item	P/N	Description	Specification	Qty	Location.No.	Note
75	01.13.L.R.E123	Switching Power Transformer	BCK-ER4203	1	T503	
76	01.13.L.Z.ED100	Inductor , leaded fixed	100Ω , F10 RHW3.5*9*0.8-T	2	L509 L510	
77	01.13.L.L.D.E194	step-up inductor	L-PQ3230-01 DIP	1	T501	
78	01.13.L.L.D.E051	Inductor , leaded fixed	LH0608-22UH	3	L504 L505 L506	
79	01.41.D.PS.ELL4148	Diode	LL4148, DO213AA	3	D501 D519 D520	0.5W
80	01.41.D.PS.ESK53C	Diode	SK53C, SMD	1	D517	
81	01.41.D.PD.EFR104	Diode	FR104, In Line Package	4	D506 D505 D503 D512	
82	0141DPDEHER208G	Diode	HER208G, In Line Package	2	D508 D504	
83	01.41.D.PD.EDQ06	Diode	21DQ06, In Line Package	1	D513	
84	01.41.D.PD.E21DQ10	Diode	21DQ10, In Line Package	2	D514 D509	
85	0141DPDEMRF20200C	Diode	MBRF20200CT, In Line Package	2	D516 D515	
86	01.41.D.PD.E9R860	Diode	ISL9R860PF2, In Line Package	1	D502	
87	01.41.D.PD.E2010DN	Diode	FYPF2010DN, In Line Package	1	D510	
88	01.41.D.PD.EGBU806	Diode bridge	GBU806, In Line Package	1	BD501	
89	01.41.D.WS.E18V	Zener Diode	18V, DO213AA	4	Z501 Z502 Z505 Z506	
90	0141DWSEDDZ9707	Zener Diode	DDZ9707-F(20V), SMD	2	Z503 Z504	
91	01.42.Q.S.E8050	Transistor	KTC8050, SOT23	1	Q510	
92	01.42.Q.S.EC8550	Transistor	KTC8550, SOT23	1	Q511	
93	01.42.Q.S.ET3904	Transistor	MMBT3904, SOT23	2	Q504 Q507	
94	01.42.Q.S.E2N3906	Transistor	2N3906, SOT23	1	Q505	
95	01.42.Q.S.E1037	Transistor, Rohm	2SA1037AKR, SMT3	1	Q513	
96	01.42.Q.S.E5866	Transistor, Rohm	2SC5866, TSMT3	1	Q514	
97	01.44.IC.S.E4835	Mosfet	AF4835, SOP8	2	Q503 Q508	
98	01.44.IC.S.E2302	Mosfet	AF2302, SOT23	1	Q506	
99	01.44.IC.D.E11N90	Mosfet	FQA11N90, TO-3P	1	Q509	
100	0144MOSDEFQPF13N50	Mosfet	FQPF13N50C, TO-220F	1	Q501	
101	0144ICSEA11173V3	IC, AAC, LDO	AZ1117H-3.3, SOT-223	1	U510	
102	0144ICDE5L0380R	IC, Fairchild, Power Switch	KA5L0380RYDTU, TO-220F-4L	1	U503	
103	01.44.IC.D.E278R05	IC, Fairchild or ShiBao, Voltage Regulator	KA278R05CTU, TO-220F-4L	1	U511	
104	01.44.IC.D.E78R05	IC, Fairchild, Voltage Regulator	KA78R05TSTU, TO-220F-4L	1	U508	
105	01.44.IC.D.E78R12	IC, Fairchild, Voltage Regulator	KA78R12, TO-220F-4L	1	U514	

HS200 Component List for SMPS Board(3521C)

Item	P/N	Description	Specification	Qty	Location.No.	Note
106	01.44.IC.D.E7913	IC, Fairchild, Voltage Regulator	KA7912,TO-220	1	U513	
107	01.44.IC.D.EPC817	IC, Sharp, Photoelectric Coupler	PC817, DIP4	4	U505 U504 U502 U515	
108	01.44.IC.D.EKA431	IC, AAC, Shunt Regulator	KA431LZTA 0.5%, TO-92	2	U507 U509	
109	0144ICSEFAN7528MX	IC, Fairchild/ShiBao, PFC Controller	FAN7528MX, SOP8	1	U501	
110	0144ICSEFAN7602MX	IC, Fairchild/ShiBao, PWM Controller	FAN7602MX, SOP8	1	U506	
111	01.40.CON.DCZ.E129	Connector	Vertical VH Connector with three holes and two pins	2	CN501 CN506	White & Antiflaming
112	0138FUSEDE32S315	Fuse	32S 3.15A 250V , In Line Package	1	F501	
113	0140CONS13FPC2E005	FPC Connector	1.25-14P Vertical Type and Dual Conact	1	CN503	Black
114	0140CONS13FPC2E003	FPC Connector	1.25-12P Vertical Type and Dual Conact	1	CN504	Black
115	0140CONS13FPC2E004	FPC Connector	1.25-9P Vertical Type and Dual Conact	1	CN505	Black
116	01.00.WJ.QT.E041	3pins grounding piece	M4	3	G501 G503 G502	
117	01.00.DP.QT.E113	Sil-pad	sil-pad 400-3022	1	Match for Q509 on SMPS Board	

HS200 Component List for Front panel board(3517C)

Item	P/N	Description	Specification	Qty	Location.No.	Note
1	01.57.R.3.E000J	Resistor, chip	0805-0Ω ±5%	6	(R645) (R646) (R657) (R659) F1 F7	
2	01.57.R.3.E101J	Resistor, chip	0805-100Ω±5%	4	(R606) (R607) (R638) (R641)	
3	01.57.R.3.E201J	Resistor, chip	0805-200Ω±5%	2	(R614) (R647)	
4	01.57.R.3.E471J	Resistor, chip	0805-470Ω±5%	1	(R605)	
5	01.57.R.3.E511J	Resistor, chip	0805-510Ω±5%	2	(R615) (R648)	
6	01.57.R.3.E202J	Resistor, chip	0805-2KΩ±5%	1	(R608)	
7	01.57.R.3.E222J	Resistor, chip	0805-2.2KΩ±5%	1	(R644)	
8	01.57.R.3.E472J	Resistor, chip	0805-4.7KΩ±5%	9	(R609) (R610) (R601) (R603) (R604) (R611) (R612) (R613) (R655)	

HS200 Component List for Front panel board(3517C)

Item	P/N	Description	Specification	Qty	Location.No.	Note
9	01.57.R.3.E103J	Resistor, chip	0805-10KΩ±5%	4	(R637) (R640) (R642) (R643)	
10	01.57.R.3.E153J	Resistor, chip	0805-15KΩ±5%	1	(R602)	
11	01.57.R.3.E203J	Resistor, chip	0805-20KΩ±5%	1	(R636)	
12	01.57.R.3.E104J	Resistor, chip	0805-100KΩ±5%	1	(R639)	
13	01.57.R.4.E153J	Resistor, chip	1206-15KΩ±5%	3	(R652) (R653) (R654)	
14	01.57.R.Y.E270	Voltage Dependent Resistor, TDK	AVR-M1608C270MTABB	3	(ESD601) ESD602 ESD603	
15	0154CS3E220N50V	Capacitor, multilayer ceramic, chip	0805-22P NPO±5%/50V	2	(C604) (C605)	
16	0154CS3E300N50V	Capacitor, multilayer ceramic, chip	0805-30P NPO±5%/50V	1	(C620)	
17	0154CS3E560N50V	Capacitor, multilayer ceramic, chip	0805-56P NPO±5%/50V	2	(C611) (C612)	
18	0154CS3E123X50V	Capacitor, multilayer ceramic, chip	0805-123 X7R±10%/50V	1	(C625)	
19	0154CS3E473X50V	Capacitor, multilayer ceramic, chip	0805-473 X7R±10%/50V	2	(C618) (C626)	
20	0154CS3E104Y50V	Capacitor, multilayer ceramic, chip	0805-104 Y5V+80-20%/50V	10	(C634) (C606) (C607) (C608) (C627) (C628) (C629) (C630) (C633) (C635)	
21	0154CS3E105Y16V	Capacitor, multilayer ceramic, chip	0805-105 Y5V-20+80%/16V	1	(C624)	
22	0154CS3E225Y16V	Capacitor, multilayer ceramic, chip	0805-225 Y5V-20+80%/16V	2	(C603) (C619)	
23	0134CLDE10U16VB	Capacitor, AL.electrolytic	CD11X-10UF/16V 4*7	2	EC616 EC617	
24	0134CLDE47U16VB	Capacitor, AL.electrolytic	CD11X-47UF/16V 5*7	3	EC603 EC601 EC620	
25	0134CLDE47U50VCD	Capacitor, AL.electrolytic	CD110-47UF/50V 6.3*12	11	EC605 EC606 EC607 EC608 EC609 EC610 EC611 EC612 EC613 EC614 EC615	
26	0134CLDEX100U16VB	Capacitor, AL.electrolytic	CD11X-100UF/16V 6.3*7	1	EC602	
27	0134CLDE220U6V3B	Capacitor, AL.electrolytic	CD11X-220UF/6.3V 6*7	1	EC621	

HS200 Component List for Front panel board(3517C)

Item	P/N	Description	Specification	Qty	Location.No.	Note
28	01.13.L.Z.ESB50	Bead, chip	0805-50Ω	5	(FB601) (FB602) (FB603) (FB604) (FB605)	
29	01.00.JZ.E04000	Quartz Crystal Unit	4.000MHZ-49S-22P	1	Y601	
30	01.41.D.PS.ELL4148	Diode	LL4148, DO213AA	13	(D606) (D607) (D608) (D609) (D610) (D611) (D612) (D613) (D614) (D602) (D603) (D601) (D605)	
31	01.41.D.FD.E503	LED, color is blue & amber	HFT503CPB0	2	LED601 LED602	Hight Light
32	01.42.Q.S.EC8550	Transistor	KTC8550, SOT23	1	(Q603)	
33	01.42.Q.S.E8050	Transistor	KTC8050, SOT23	1	(Q602)	
34	01.41.D.WS.E6V2	Zener Diode	6.2V, DO213AA	1	DZ601	0.4W
35	01.44.IC.S.E9022	IC, NS, Vacuum Fluorescent Display Filament Driver	LM9022, SO8	1	(U605)	
36	01.44.IC.S.E75710	IC, SANYO, VFD Driver	LC75710N, QFP64E	1	(U604)	
37	01.46.IC.E78P156G	IC, ELAN, MCU	EM78P156ELM-G, SOIC18	1	U601	firmware burn-
38	01.44.IC.D.E38B17	IC, IR receiver	HL38B17, In Line Package	1	IR601	
39	01.44.IC.S.E0514	IC, Semtech, Low Capalitance TVS Diode Array	RClamp0514M, MSOP-10L	1	(U602)	
40	0140CONS10FPC2E030	FPC Connector	1.0-14P, Vertical Type and Dual Conact	1	CN601	Black
41	0140CONS13FPC2E005	FPC Connector	1.25-14P, Vertical Type and Dual Conact	1	CN602	Black
42	0140CONS10FPC2E002	FPC Connector	1.0-8P, Vertical Type and Dual Conact	1	CN603	Black & Antiflaming
43	0140CONS10FPC2E004	FPC Connector	1.0-6P, Vertical Type and Dual Conact	1	CN604	Black & Antiflaming
44	0139SWQCEKFCFA065	Touch switch	KFC-A06-5 (Vertical Type, Be Forbidden) Same as 6*6*5(Vertical Type 300g)	2	K602 K601	
45	01.40.CON.DCZ.E219	Earphone Connector	CKX-3.5-12	1	J602	
46	01.40.CON.DCZ.E217	USB Connector	USB-A-05 (ROHS, Mother Set)	1	J601	
47	01.16.E1303F	VFD	VFD22-1303F	1	VFD601	

HS200 Component List for Front panel board(3518C)

Item	P/N	Description	Specification	Qty	Location.No.	Note
1	01.57.R.3.E472J	Resistor, chip	0805-4.7K Ω \pm 5%	3	(R617) (R618) (R616)	
2	01.57.R.3.E181J	Resistor, chip	0805-180 Ω \pm 5%	4	(R622) (R623) (R624) (R625)	
3	0154CS3E821N50V	Capacitor, multilayer ceramic, chip	0805-820P NPO \pm 5%/50V	2	(C601) (C602)	
4	0154CS3E104Y50V	Capacitor, multilayer ceramic, chip	0805-104 Y5V+80-20%/50V	1	(C614)	
5	01.42.Q.S.E2N3904	Transistor	2N3904, SOT23	1	(Q601)	
6	01.42.Q.S.EC8550	Transistor	KTC8550, SOT23	2	(Q604) (Q605)	
7	0141DFDEHZFBA65018	LED	HZFBA65018CP Φ 5 DIP	4	LED603 LED604 LED605 LED606	High light blue and astigmatism
8	0140CONS10FPC2E036	FPC Connector	1.0-6P Horizontal Type and Dual Conact	1	CN605	Positive Pointer
9	01.36.VR.E20K	Volume encoder ,pulse	ED1612-24-24-HC-F20(2)	1	W601	

AML3278G;A/V Processor (PQFP256LD)

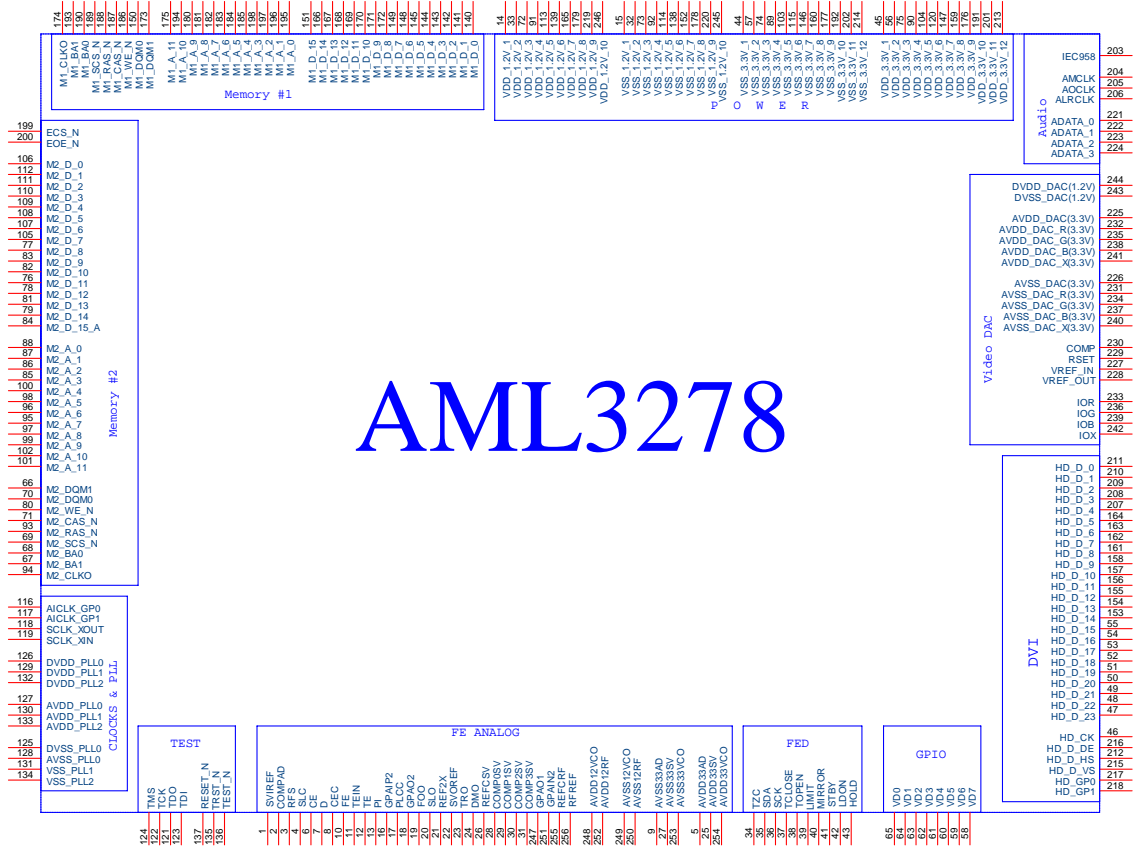

KH29LV160CBTC-70G;FLASH (TSOP48)

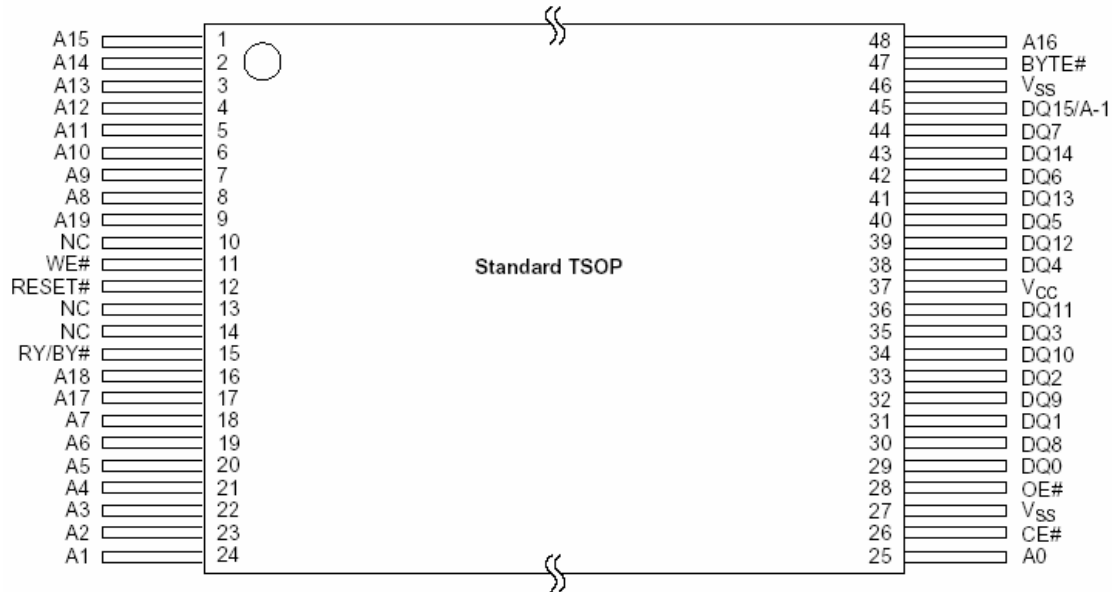

IS42S16400B-6TL;SDRAM
(TSSOP-54)

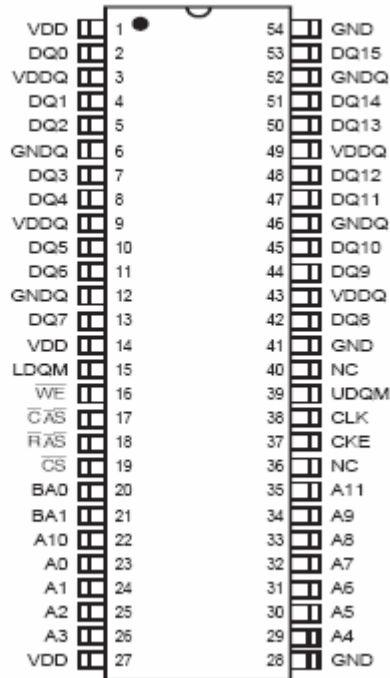

AML3501;DVD/CD RF
Processor (TSSOP48)

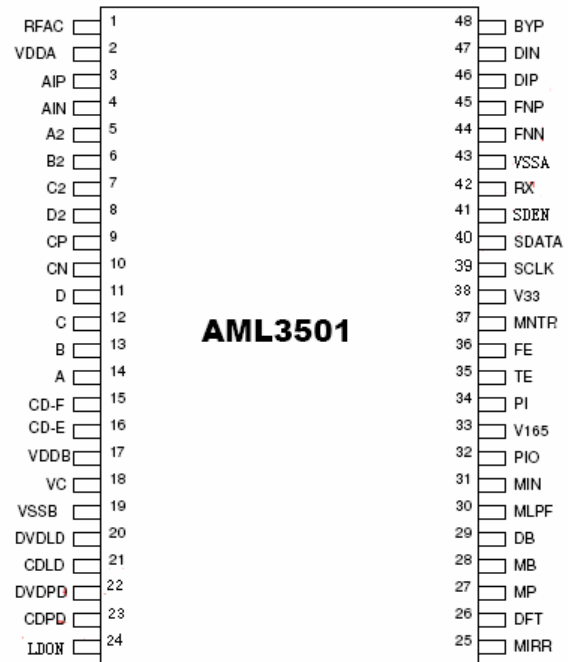

BA5888FP; Actuator driver
(HSOP-28)

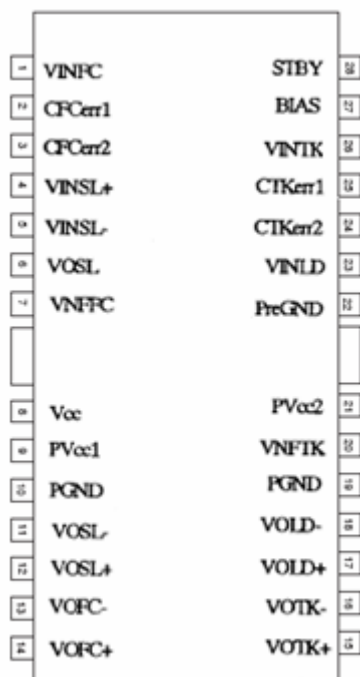

BU1924F; RDS/RBDS
Decoder (SOP16)

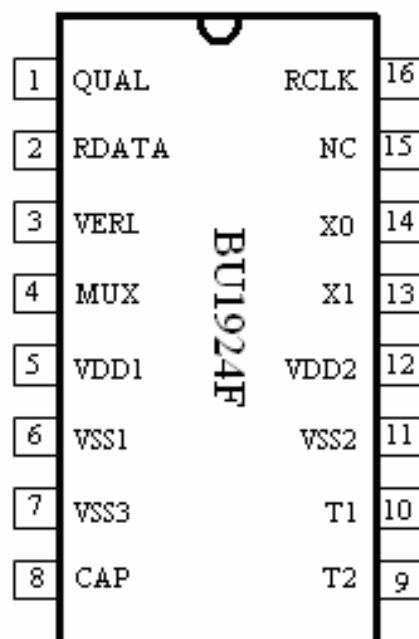

XC9572XL-10VQG44C; CPLD (VQFP44)

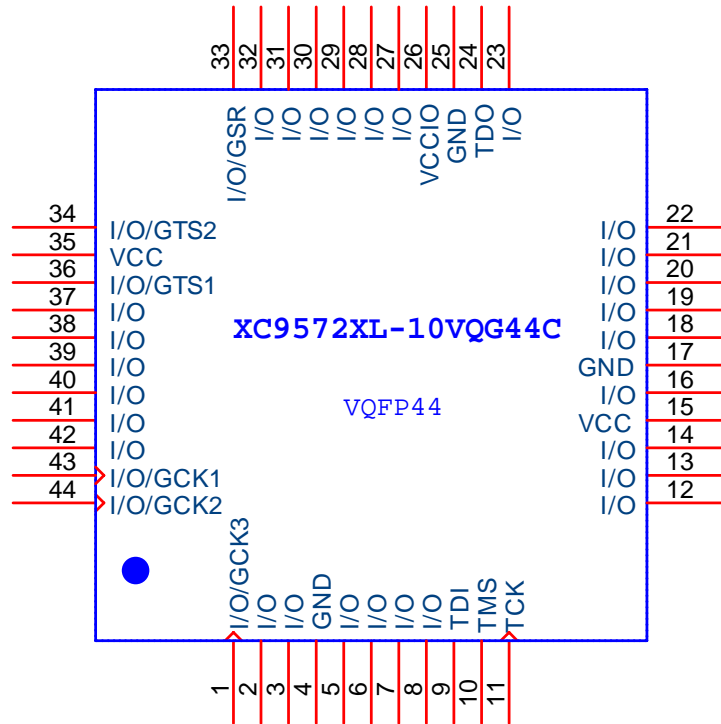

TDOTG242LPF; USB Controller (LQFP-64)

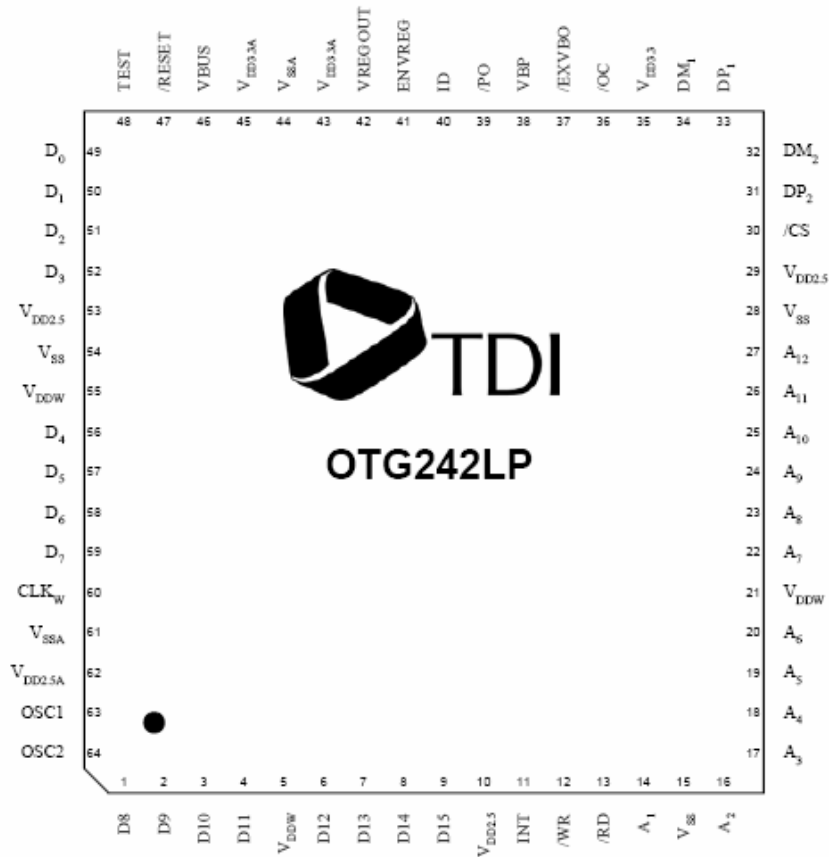

SiI9030CTU; HDMI Panellink Transmitter (TQFP80)

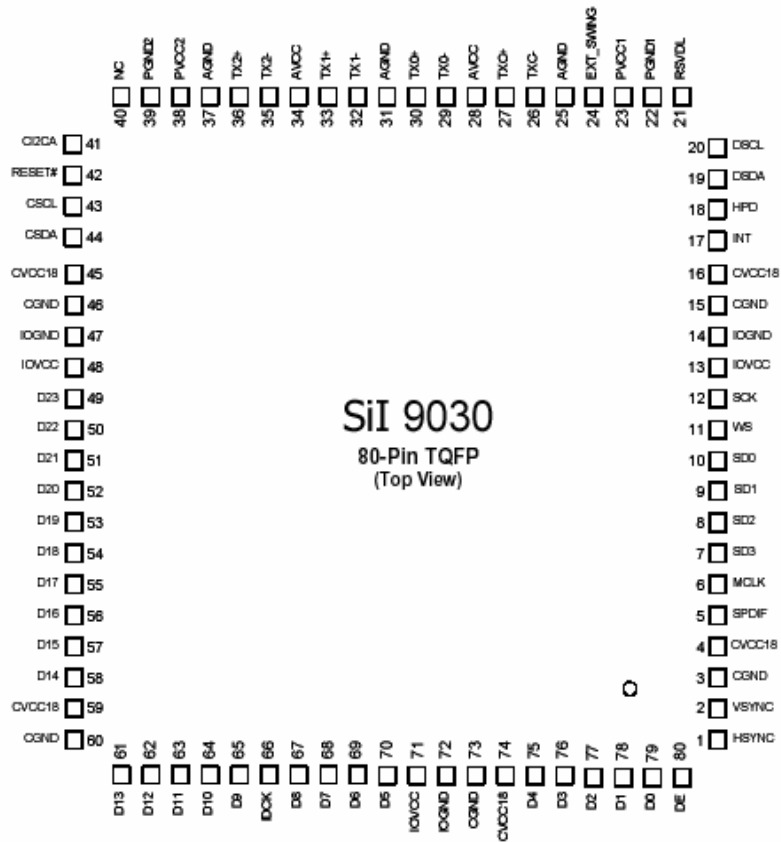

ADA4410-6ACPZ; Integrated Video Filter (CP-32-3)

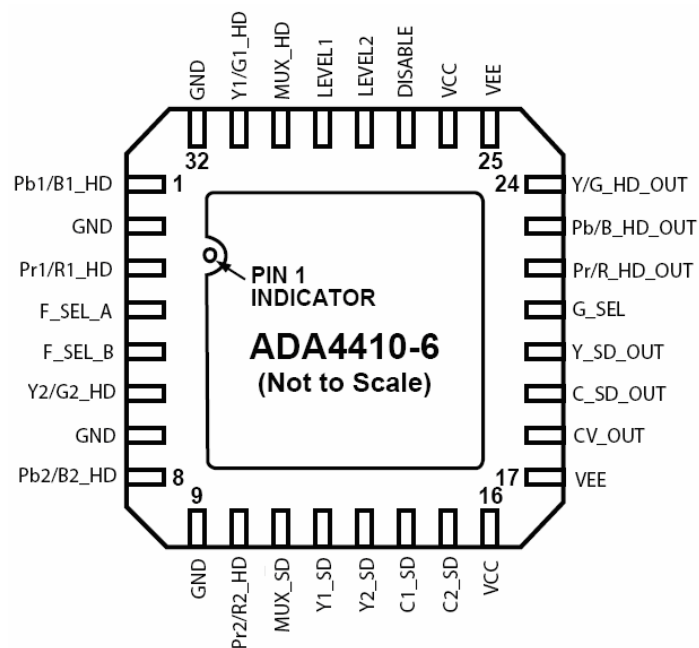

LM358M; Dual Operational Amplifier (SOP8)

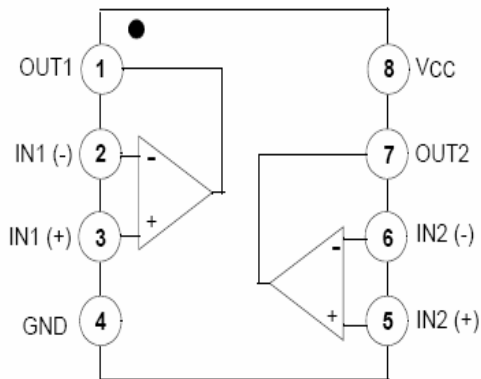

AT24C64-2.7; EEPROM (SO8)

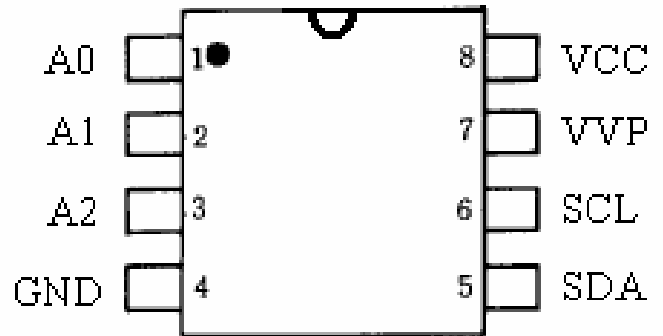

74HCT14D; Schmitt Trigger (SO14)

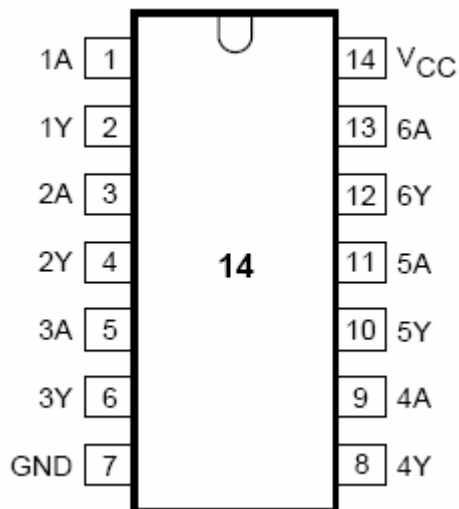

BA6287; Motor Driver (SOP8)

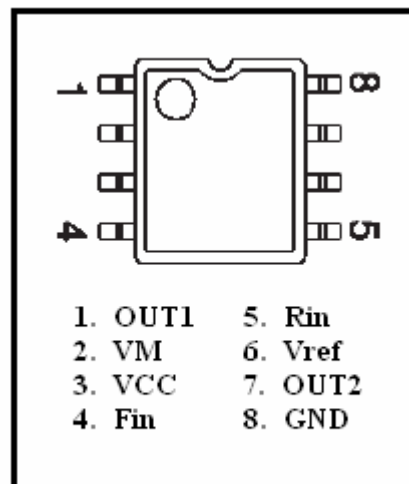

AZ1117-1.8V /3.3V/5V; LDO (SOT-223)

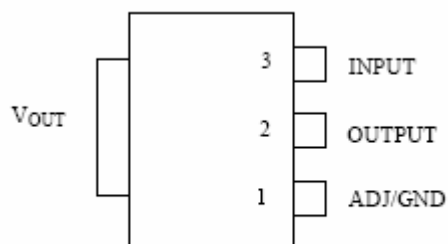

NJM2561F1; Video Amplifier (MTP6)

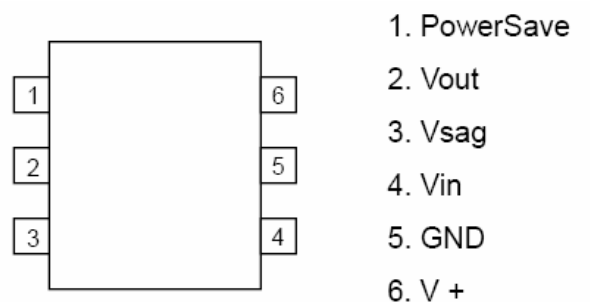

BA00HC5FP;LDO (T0252-5)

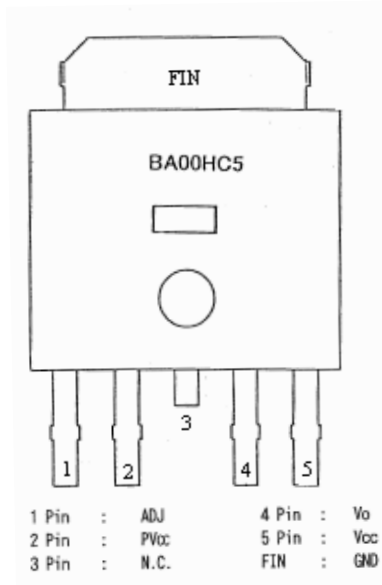

PC817; Photoelectric Coupler (DIP4)

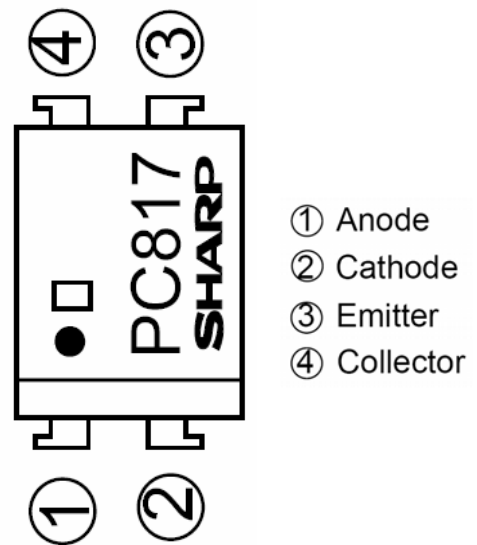

RClamp0514M; Low Capalintance TVS Diode Array(MSOP-10L)

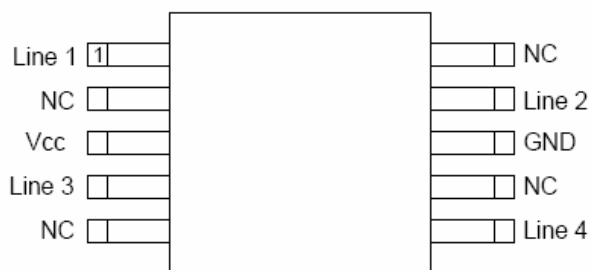

UPA672T; MOS FIELD EFFECT TRANSISTOR (SC-70)

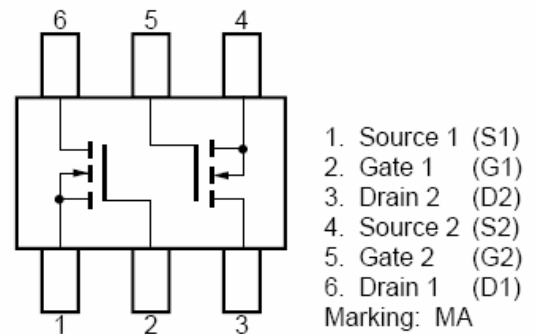

L7805/L7809; Voltage Regulator (TO-220)

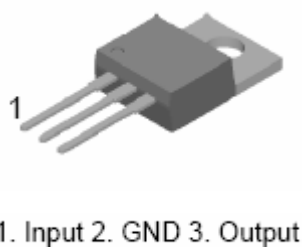

BA33BCO; Dropout Voltage Regulator (TO-220)

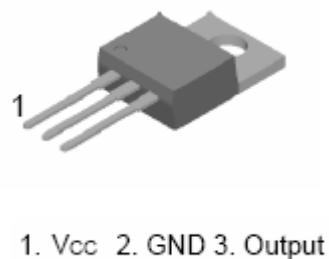

STA308A ; Digital Audio Processor (TQFP64)

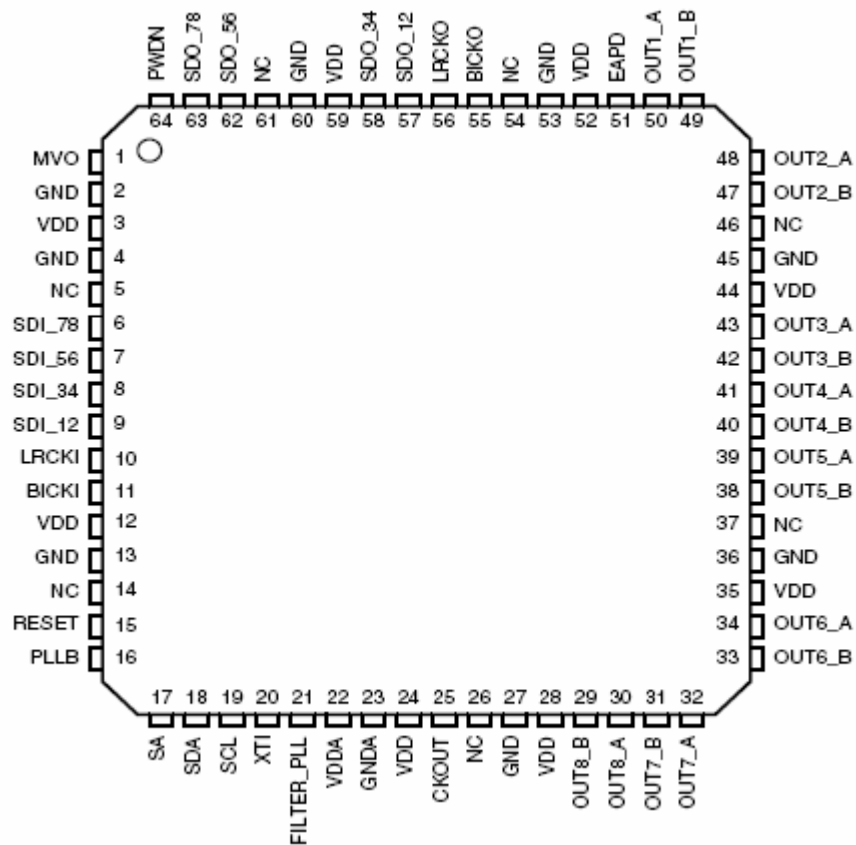

STA508; Power Half Bridge (PowerSO36)

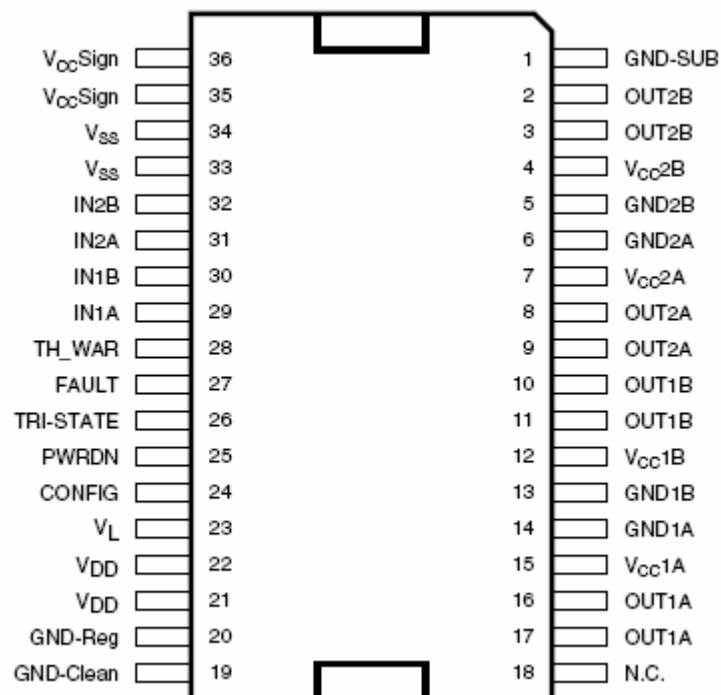

74HC158Quad;2-input
Multiplexer (SOP16)

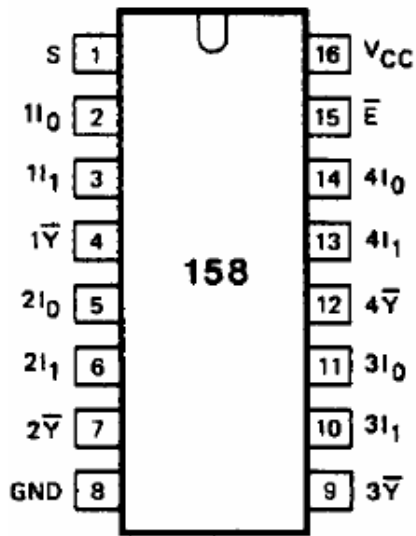

74HCU04; Hex Inverter
(TSSOP14)

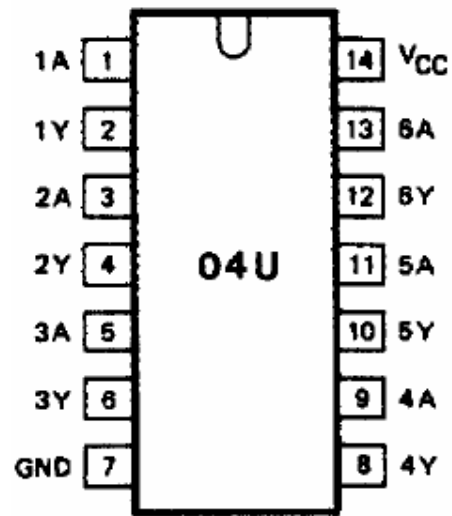

NJM2068M;
Pre-amp (SO8)

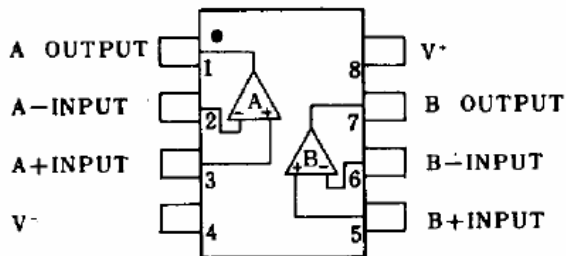

AAT3522IGY-3.08-200-T1;
Reset monitor (SOT-23)



KA5L0380RYDTU;
Power Switch (TO-220F-4L)



1. GND 2. Drain 3. V_{CC} 4. FB

KA278R05CTU;
Voltage Regulator (TO-220F-4L)



1.Vin 2. Vo 3. GND 4. Vdis

KA78R05TSTU; Voltage Regulator (TO-220F-4L)



1. Vin 2. Vo 3. GND 4. Vdis

KA78R12; Voltage Regulator (TO-220F-4L)



1. Vin 2. Vo 3. GND 4. Vdis

KA7912; Voltage Regulator (TO-220)

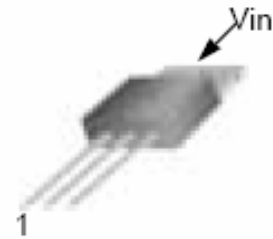

1. GND 2. Input 3. Output

KA431LZTA 0.5% ; Shunt Regulator (TO -92)



1. Ref 2. Anode 3. Cathode

FAN7528MX;PFC Controller (SOP8)

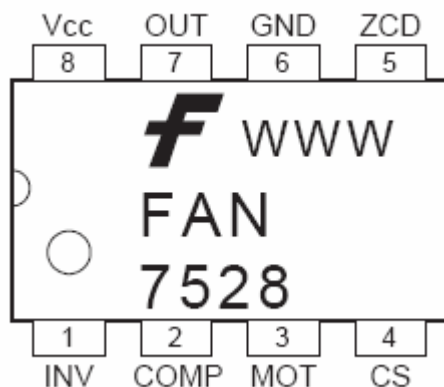

FAN7602MX; PWM Controller (SOP8)

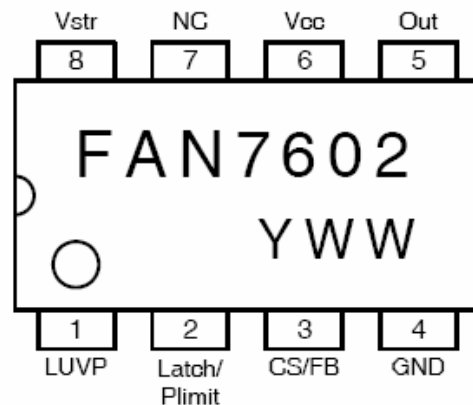

LM9022; Vacuum Fluorescent
Display Filament Driver (SOP8)

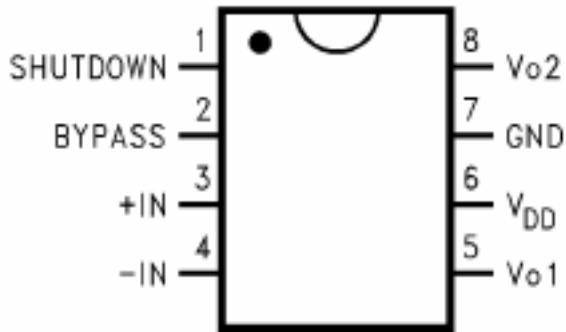

EM78P156ELM-G; MCU
(SOIC18)

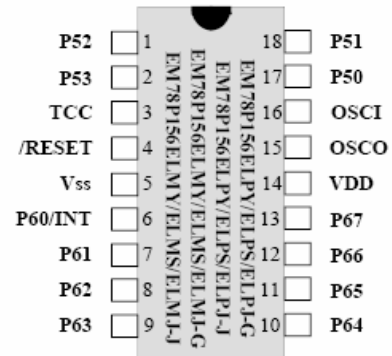

LC75710NE; VFD Driver (QFP64E)

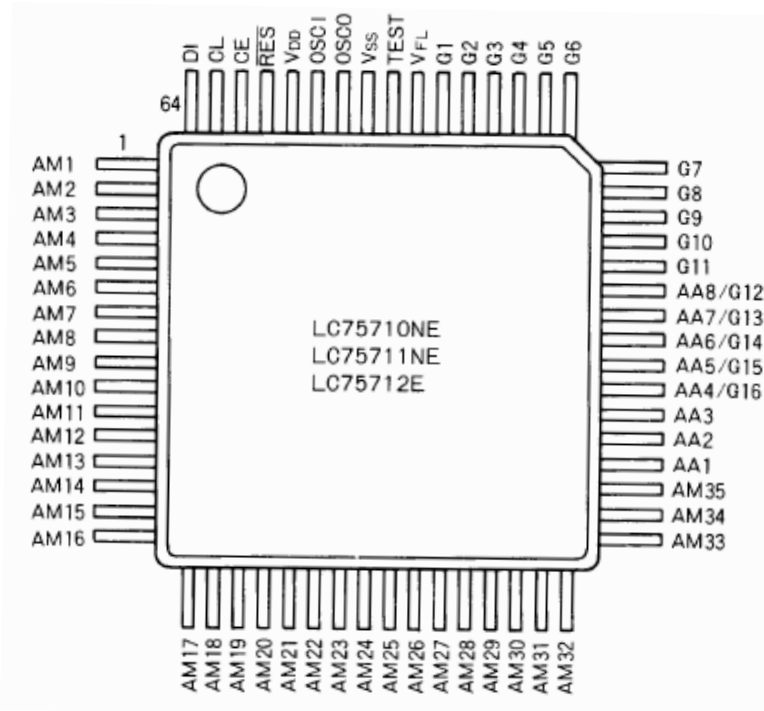

2SB1132; Medium Power
Transistor (SOT89)

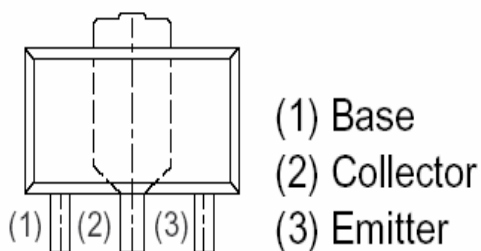

2SK3018T106; Small Switching
(UMT3)

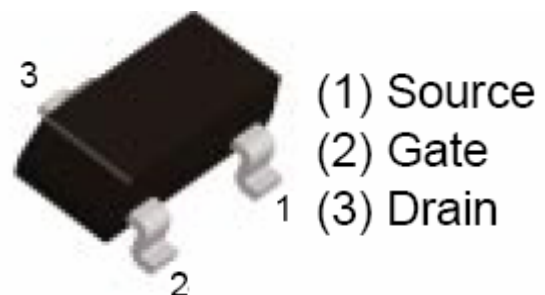

KTC8550; PNP Transistor
(SOT23)



KTC8050; NPN Transistor
(SOT23)



DTC343TK; NPN Transistor
(SMT3)

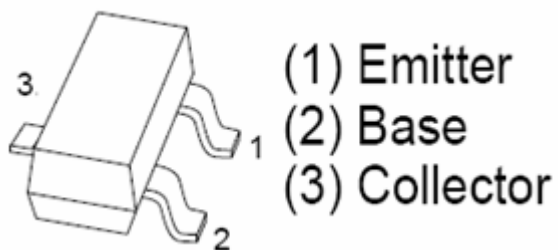

MMBT3904; NPN Switching
Transistor (SOT23)



2N3906; PNP Transistor
(SOT23)



2SA1037AKR; General Purpose
Transistor (SMT3)

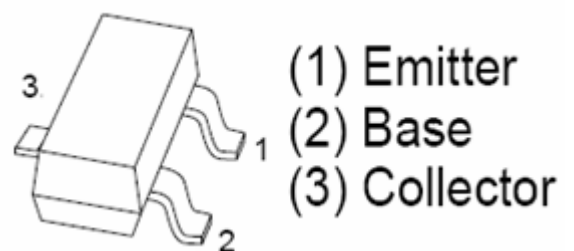

2SC5866; Medium Power Transistor (TSMT3)

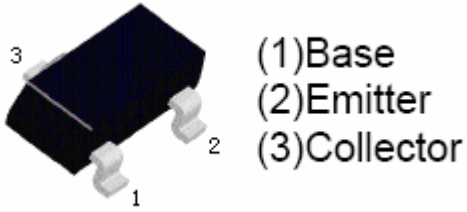

AF2302; N-Channel Mosfet (SOT23)

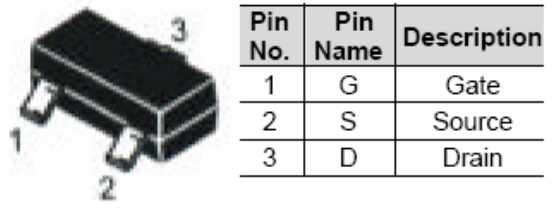

FQA11N90; N-Channel Mosfet (TO-3P)

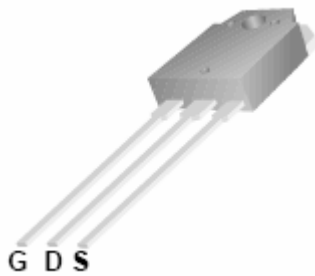

FQPF13N50C; N-Channel Mosfet (TO-220F)

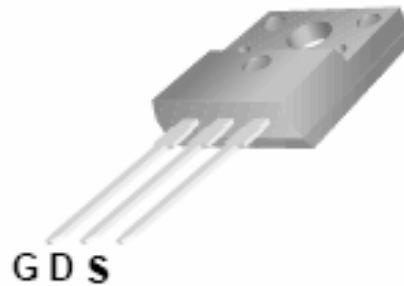

AF4835; P-Channel Mosfet (SOP8)

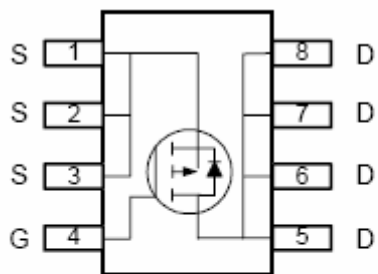

Pin Name	Description
S	Source
G	Gate
D	Drain

HS200 BLOCK DIAGRAM

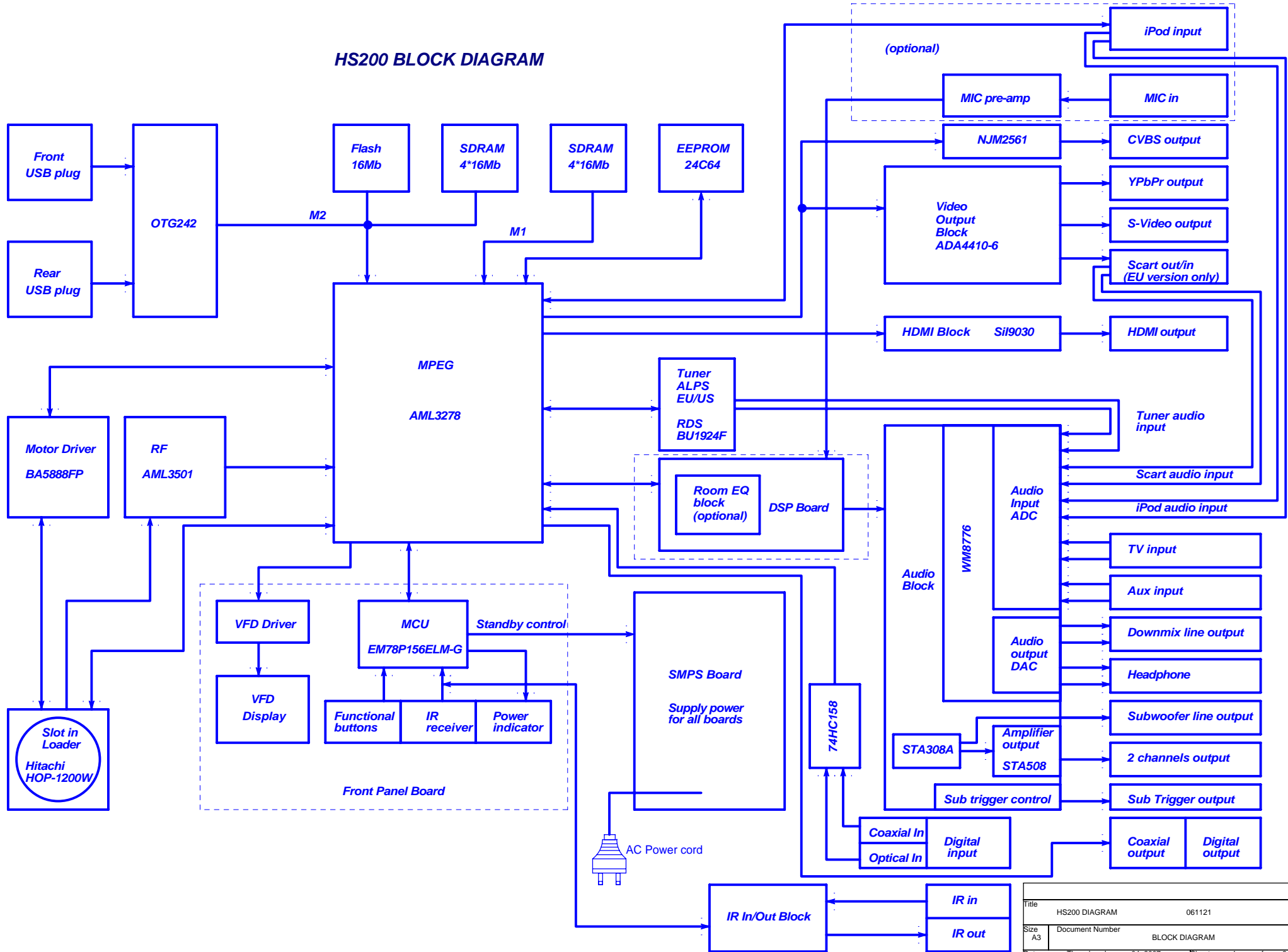

Title		HS200 DIAGRAM		061121	
Size	A3	Document Number	BLOCK DIAGRAM		Rev
Date:	Thursday, January 04, 2007		Sheet	1	of 21
					1.0

HS200 WIRING DIAGRAM

HS200 CNT REF NO. ASSIGNMENT

3627C: from 1
 3523C: from 200
 3522C AV: from 300

3522C AMP: from 400
 3521C: from 500
 3517C/3518C: from 600

TUNER MODULE ALPS

11 pins

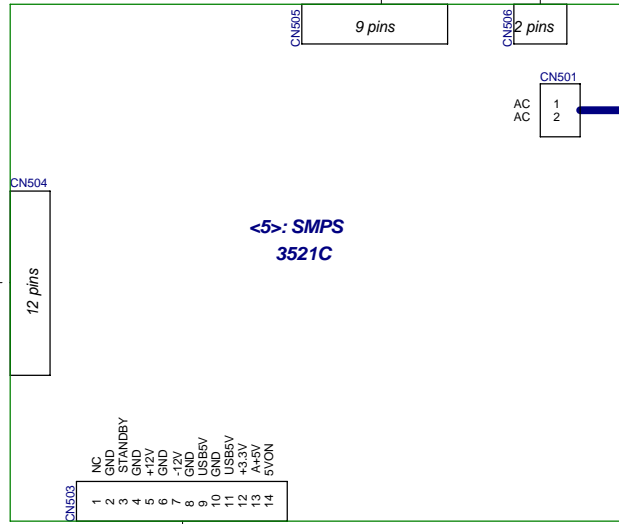
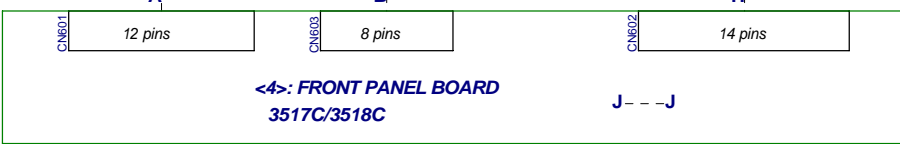
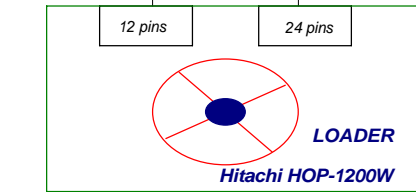
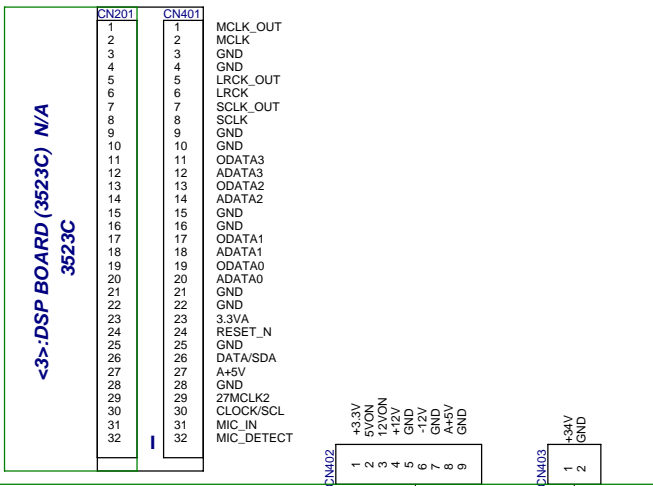
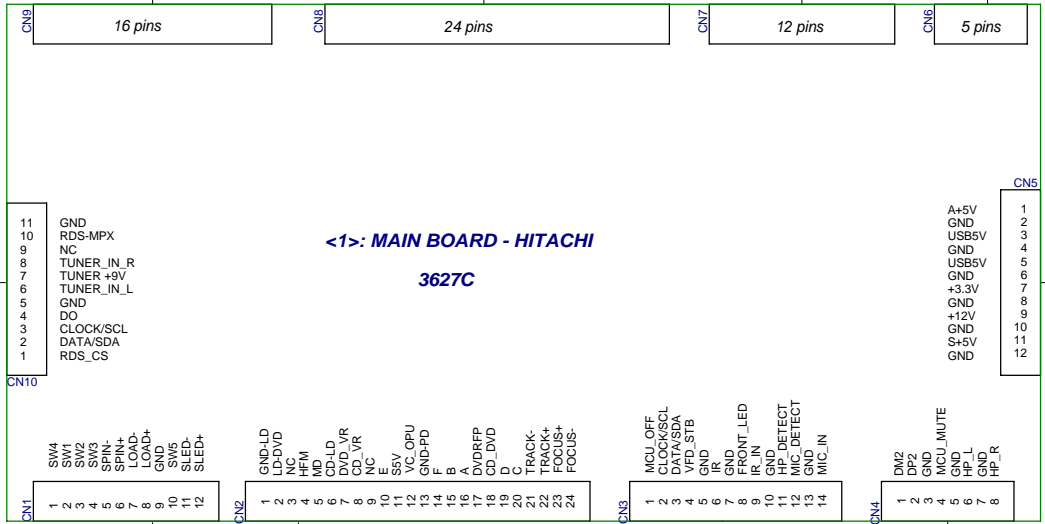
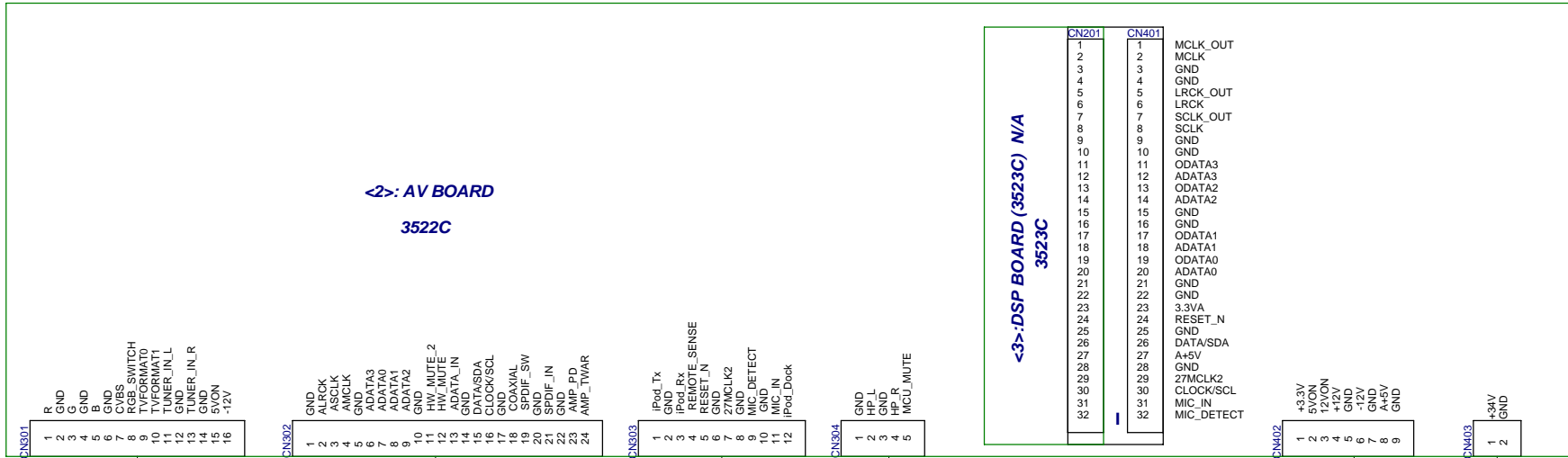

~100-240V
AC Power cord



Title		HS200 DIAGRAM		061121	
Size	Document Number	WIRING DIAGRAM			Rev
A3					1.0
Date:	Thursday, January 04, 2007	Sheet	2	of	21

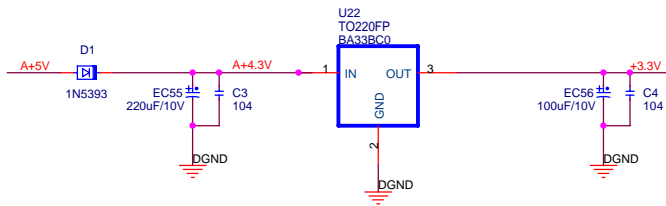
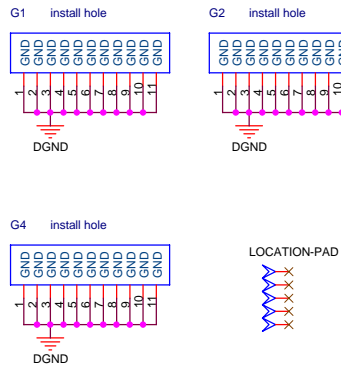
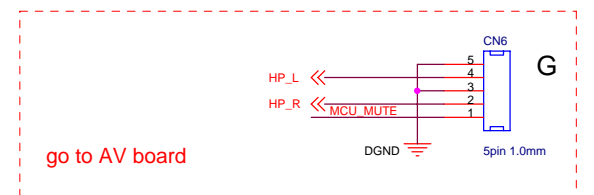
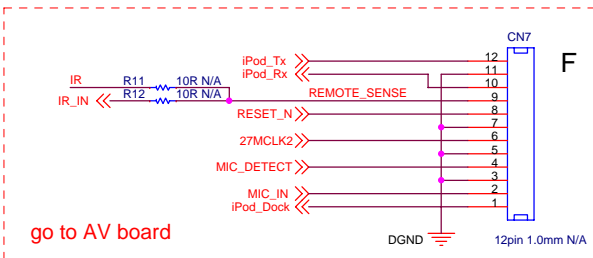
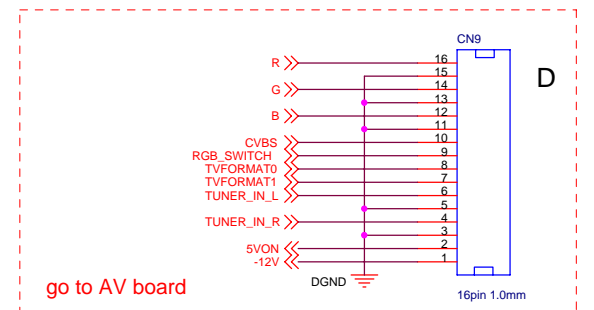
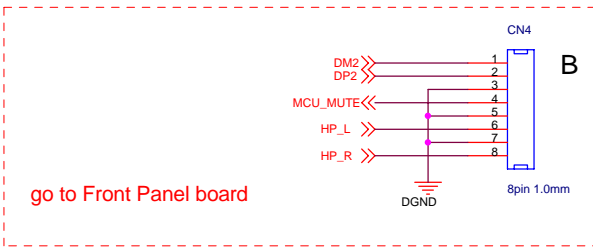
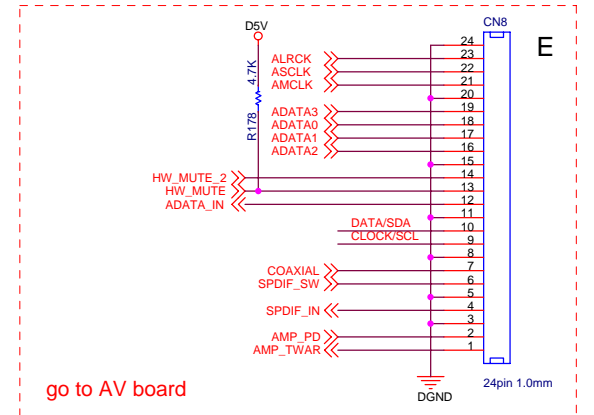
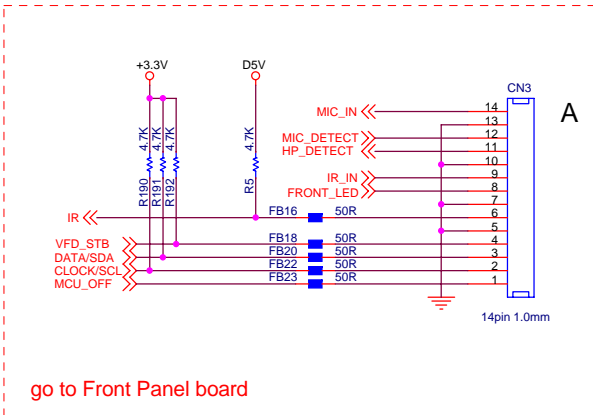
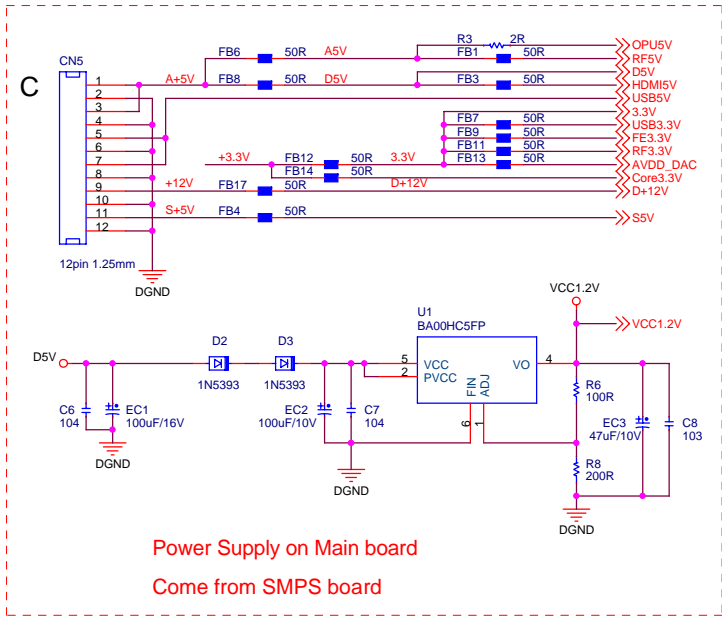

Title			Power and connector			061114		
Size	Document Number					Rev		
A3	3627C					1.2		
Date:	Thursday, January 04, 2007	Sheet	6	of	21			

U4 AML3278

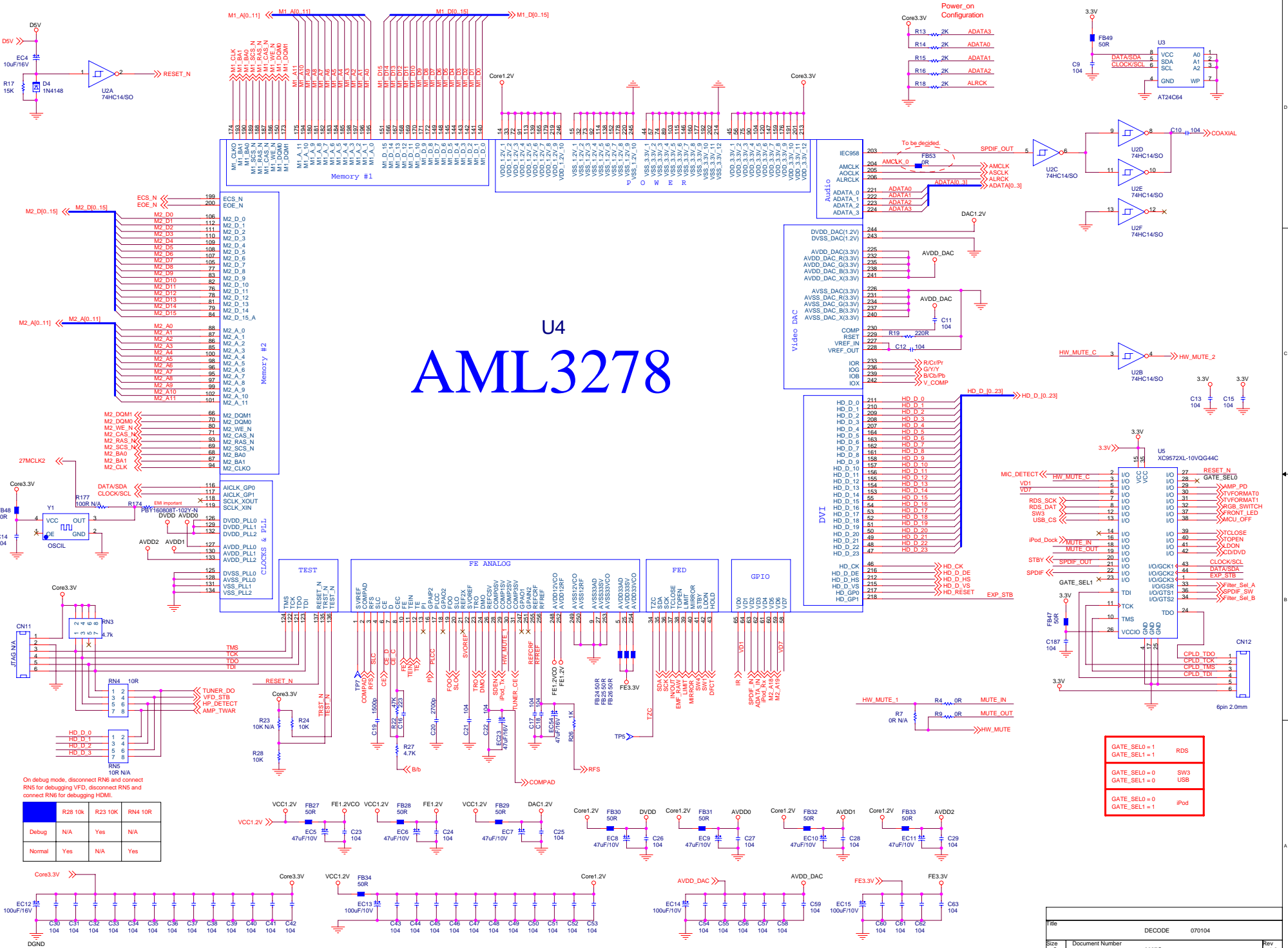

On debug mode, disconnect RNB and connect RNS for debugging VFD, disconnect RNS and connect RNB for debugging HDMI.

	R28 10k	R23 10k	RN4 10R
Debug	N/A	Yes	N/A
Normal	Yes	N/A	Yes

GATE_SEL0 = 1	RDS
GATE_SEL1 = 1	
GATE_SEL0 = 0	SW3
GATE_SEL1 = 0	USB
GATE_SEL0 = 0	IPod
GATE_SEL1 = 0	

File	DECODE 070104	
Size	Document Number	3627C
C		Rev 1.2
Date	Thursday, January 04, 2007	Sheet 7 of 21

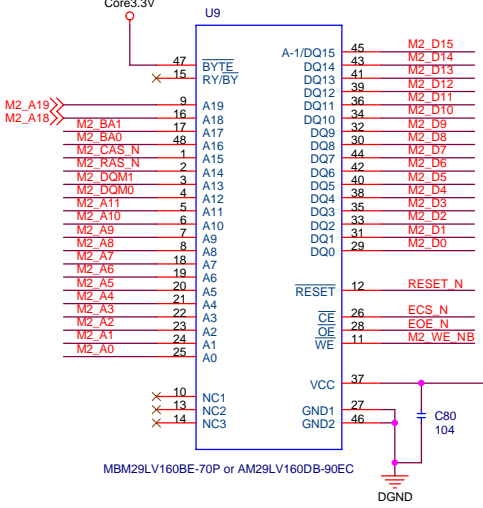
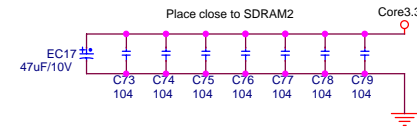
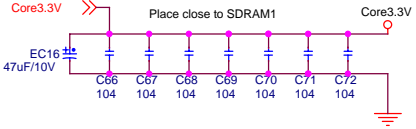
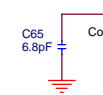
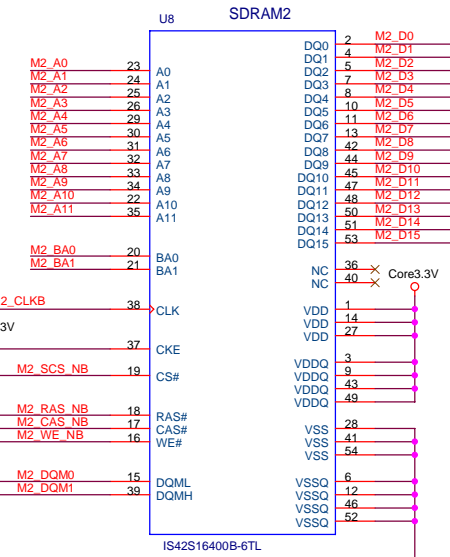
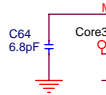
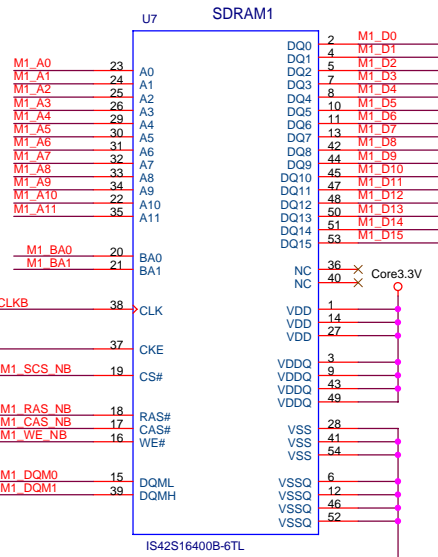
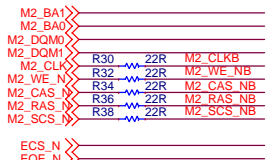
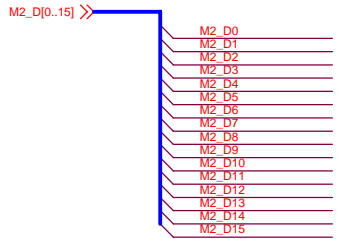
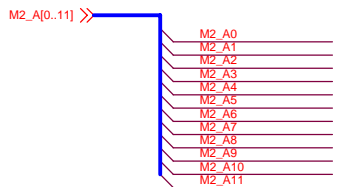
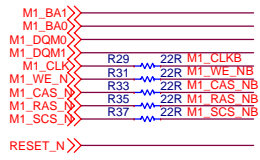
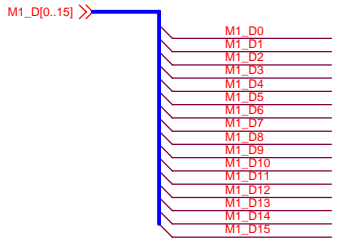
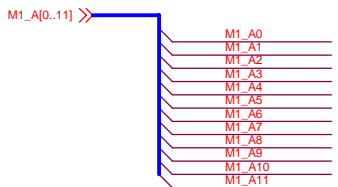

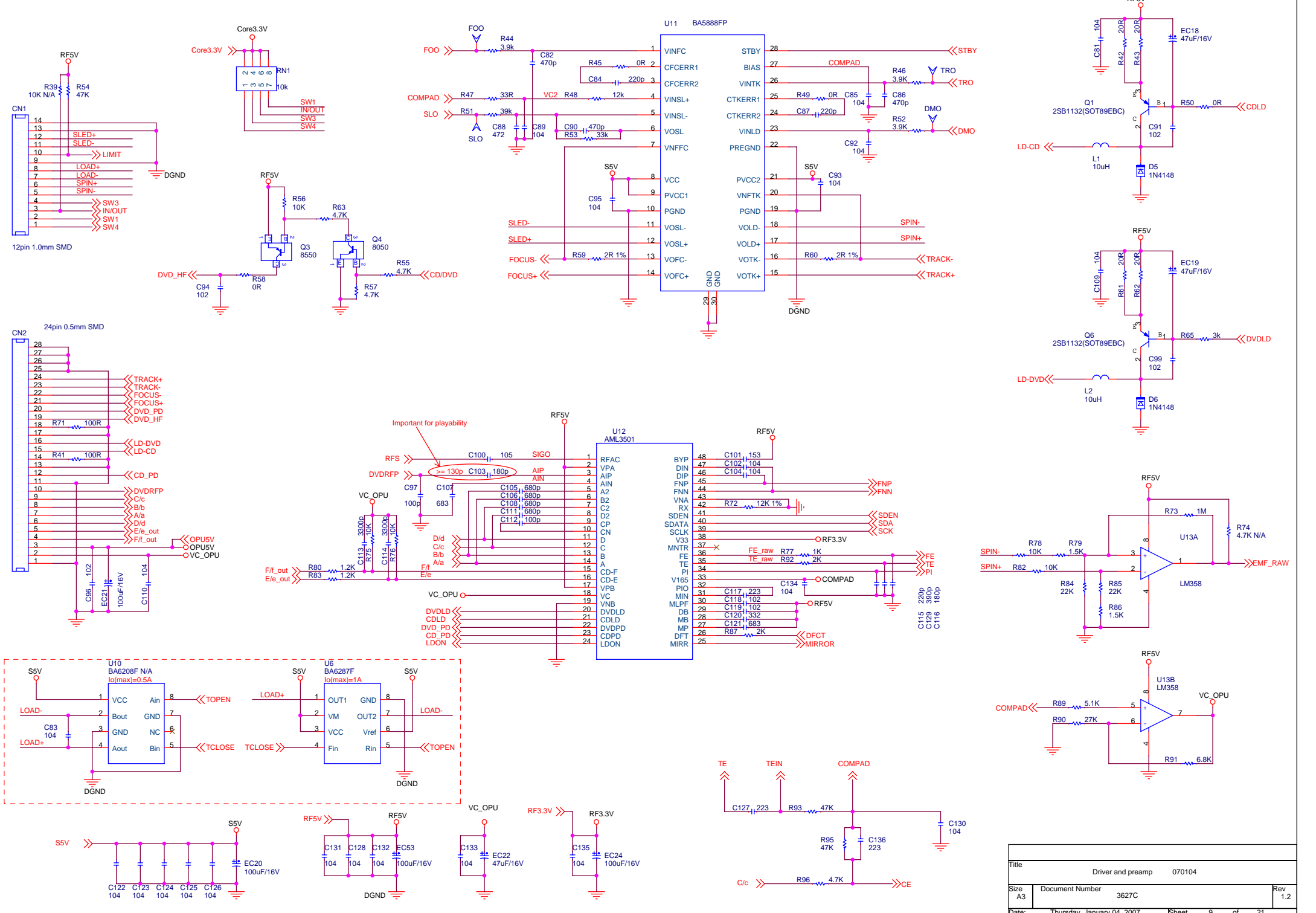

Title			Driver and preamp 070104		
Size	Document Number				Rev
A3	3627C				1.2
Date:	Thursday, January 04, 2007	Sheet	9	of	21

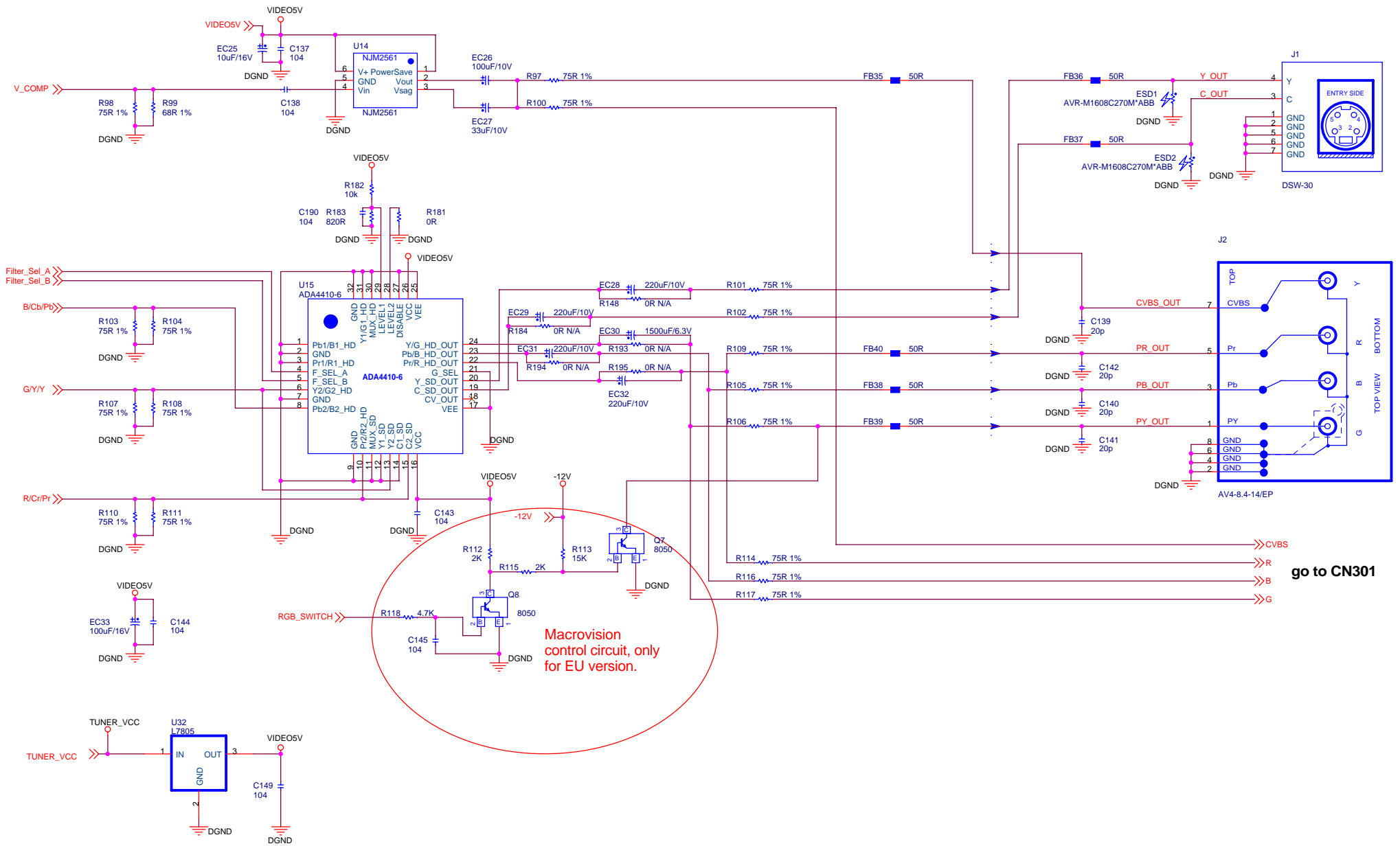

go to CN301

Title			
VIDEO OUTPUT 070104			
Size	Document Number	Rev	
A3	3627C	1.2	
Date:	Thursday, January 04, 2007	Sheet	10 of 21

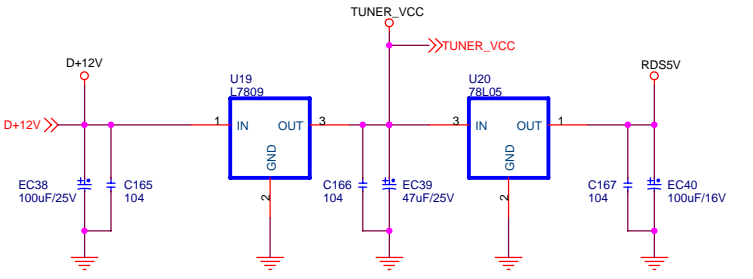
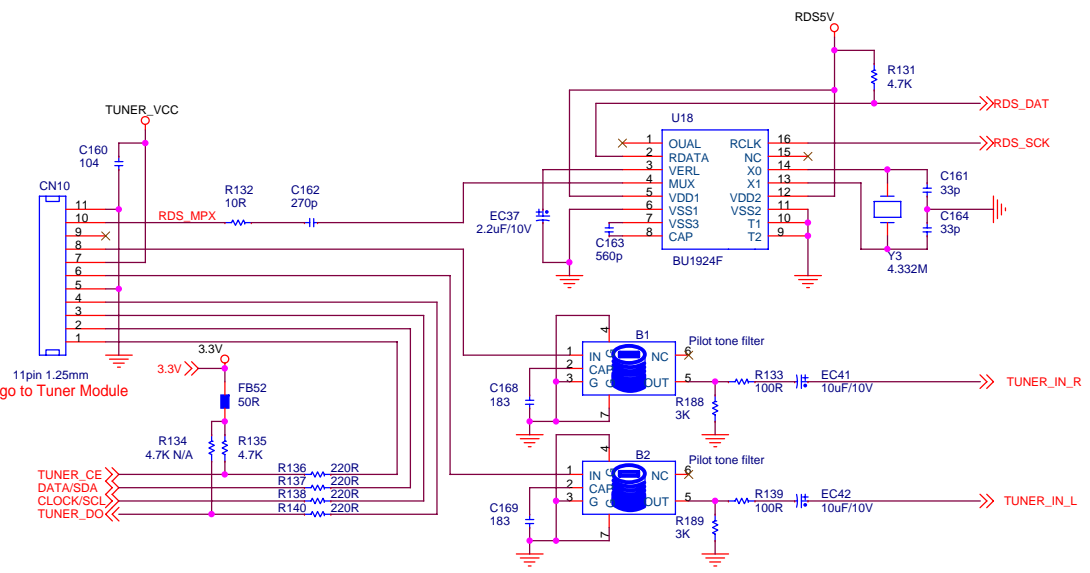
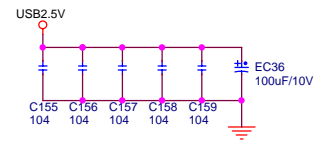
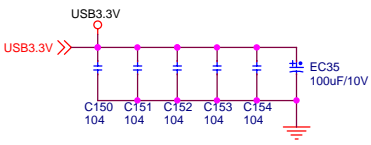
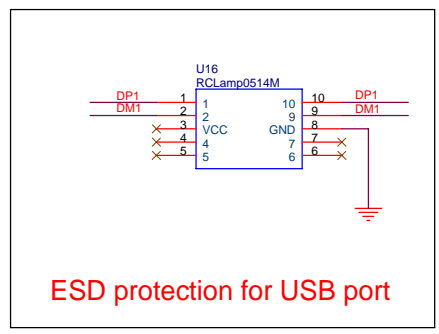
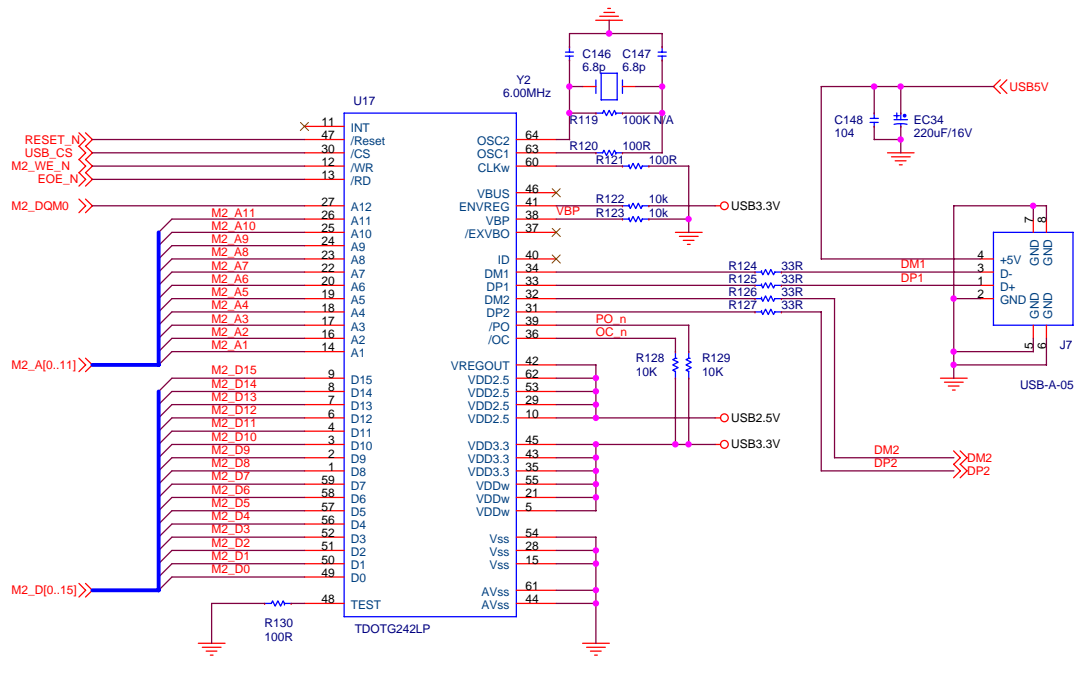

Title			USB and Tuner 070104		
Size	Document Number				Rev
A3	3627C				1.2
Date:	Thursday, January 04, 2007	Sheet	11	of	21

HD_D_DE >>
HD_D_[0..23] >> HD_D_[0..23]

NOTE:
AML3278:
R[0..7]=HD_D_[16..23];
G[0..7]=HD_D_[8..15];
B[0..7]=HD_D_[0..7];
SiL9030:
R[0..7]=D[16..23];
G[0..7]=D[8..15];
B[0..7]=D[0..7].

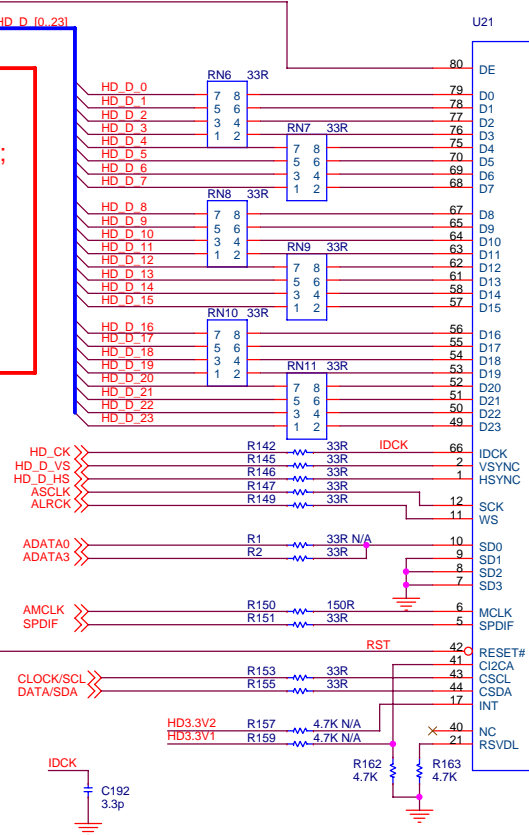
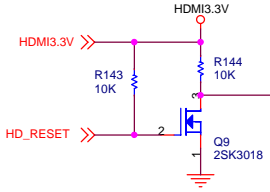

<112MHz RC = N/A
>112MHz RC = install, ESD/EMI components N/A for they may cause signal integrity problems on the high speed TMDS lines. TMDS lines should be connected directly from Si9030 to connector.

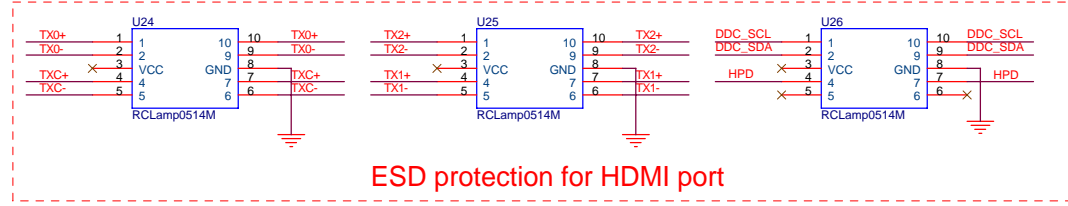

ESD protection for HDMI port

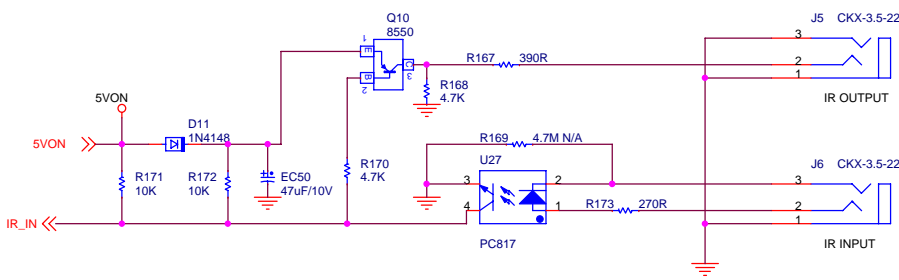
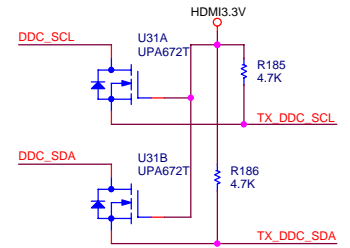
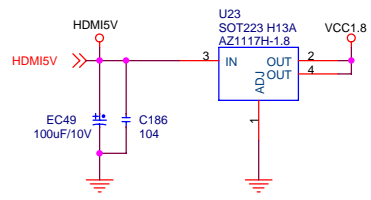
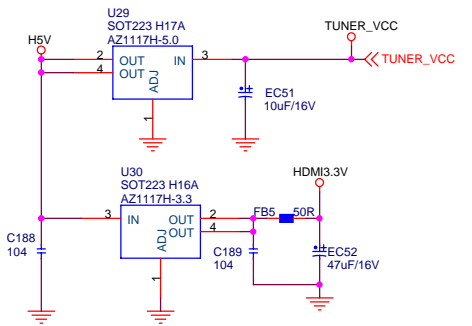
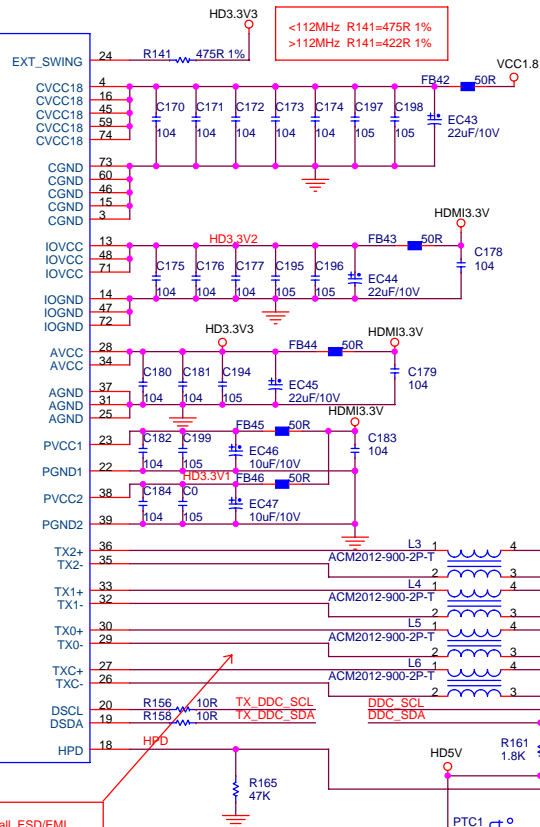

Title			HDMI and IR In/Out 070104		
Size	Document Number			Rev	
A3	3627C			1.2	
Date:	Thursday, January 04, 2007	Sheet	12	of	21

Mute logic circuit for main L&R analog output

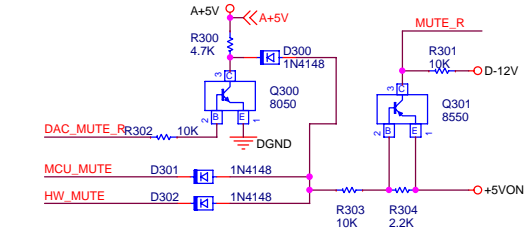

Mute logic circuit for headphone and subwoofer

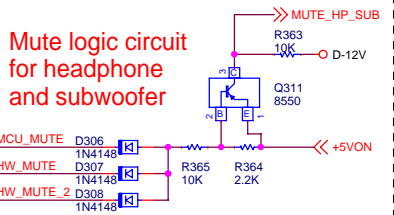
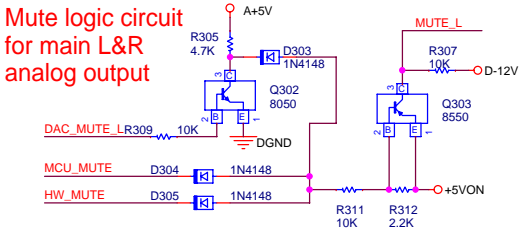

RGB SWITCH	TV FORMAT0	TV FORMAT1	TV FUNCTION	PIN8(V)	PIN16(V)
X	0	1	SCART inactive (Standby)	0V	X
X	0	0	SCART Active Auto Switch to 4:3 Aspect Ratio	12V	X
X	1	0	SCART Active Auto Switch to 16:9 Aspect Ratio	6V	X
X	X	X	RGB	1-3V	X
0	X	X	CVBS	0-0.4V	X

Scart video output and audio input, only for EU version, don't install in US version.

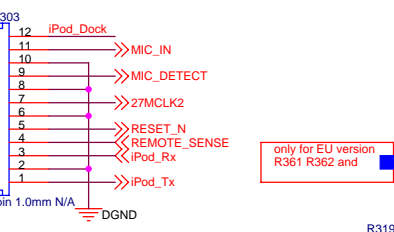
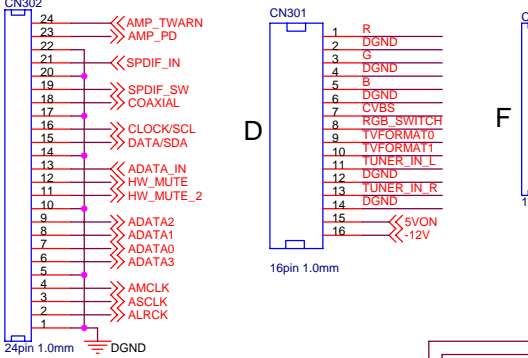
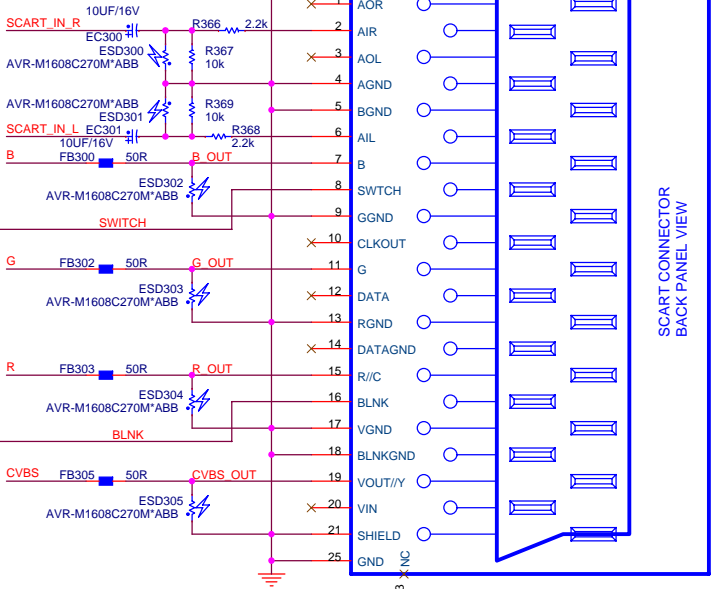
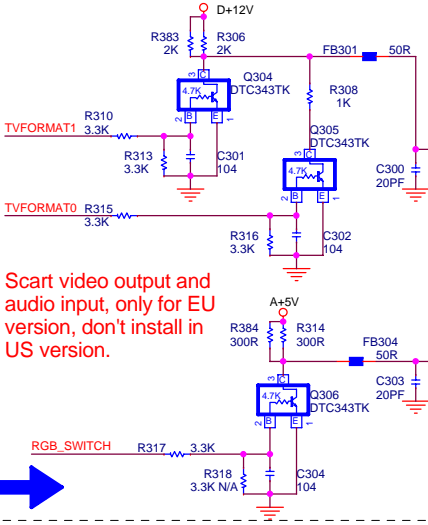

Analog audio output & input

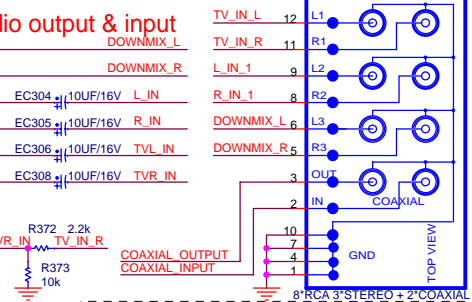
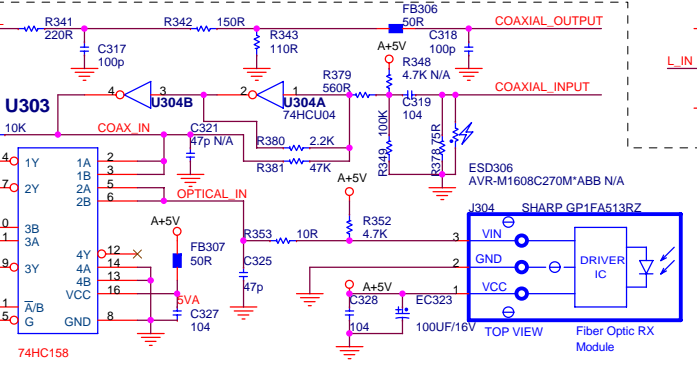
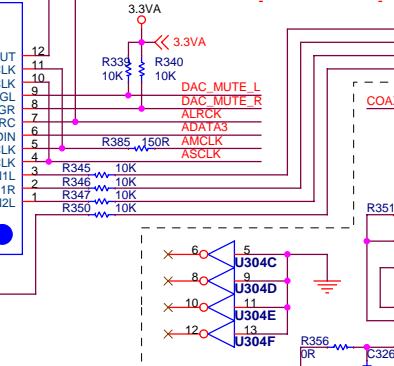
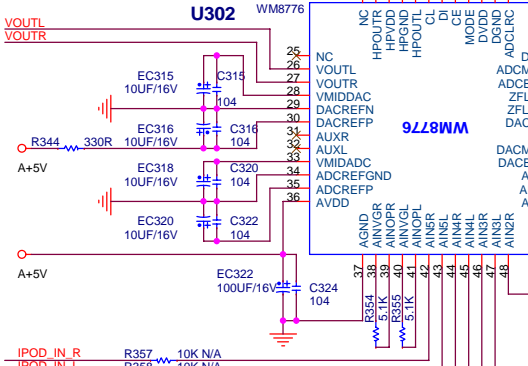
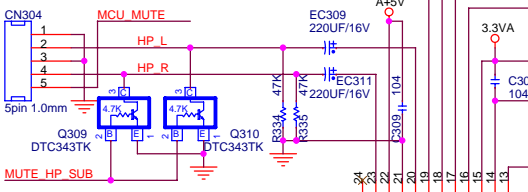
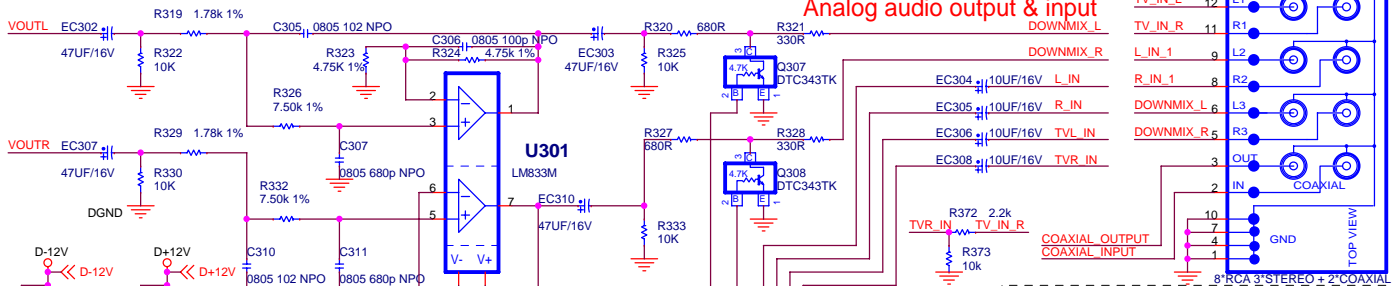

- IPOD_IN_R R357 10K N/A
 - IPOD_IN_L R358 10K N/A
 - TUNER_IN_R R359 10K
 - TUNER_IN_L R360 10K
 - SCART_IN_R R361 10K
 - SCART_IN_L R362 10K
 - SPDIF_IN
 - SPDIF_SW
- only for EU version R361 R362 and

Title		HS200 AV BOARD		061121	
Size	A3	Document Number	3522C	Rev	1.2
Date:	Thursday, January 04, 2007	Sheet	13	of	21

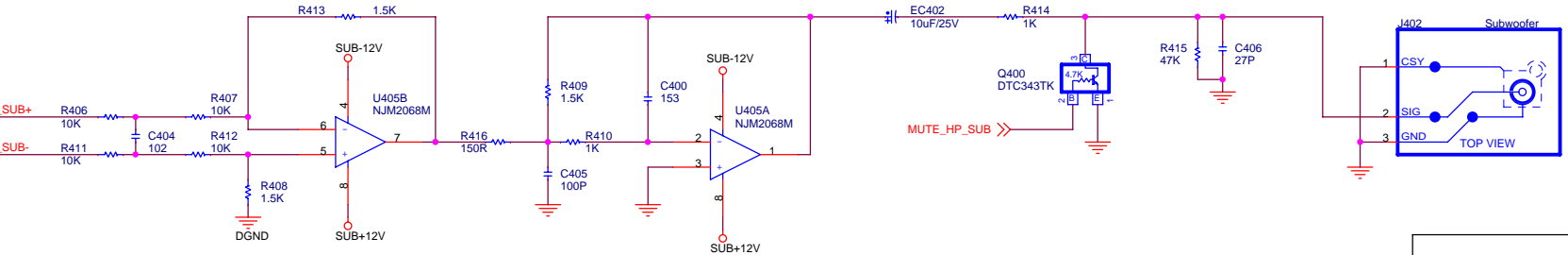
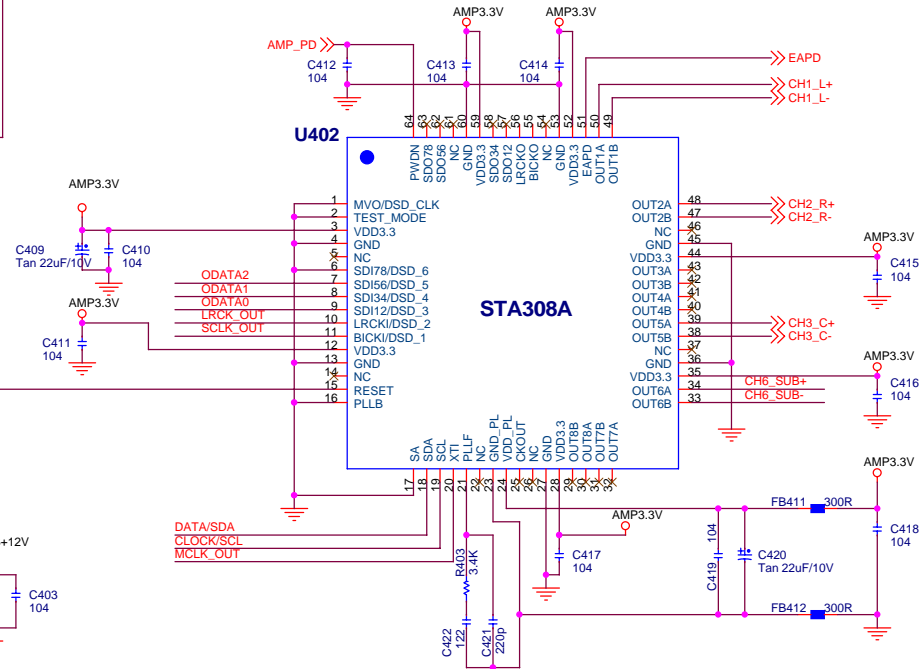
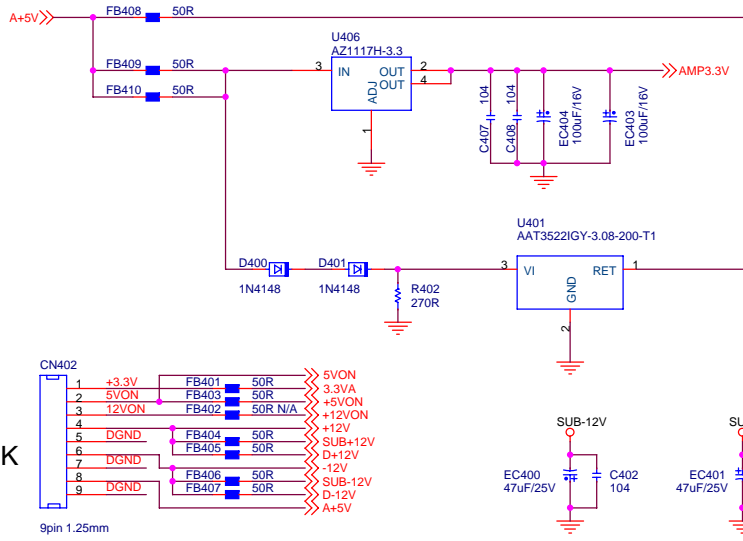
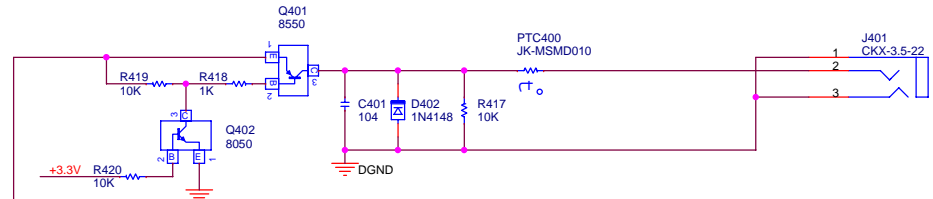
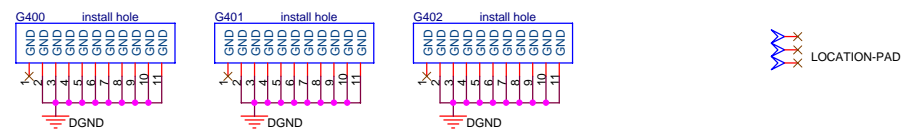
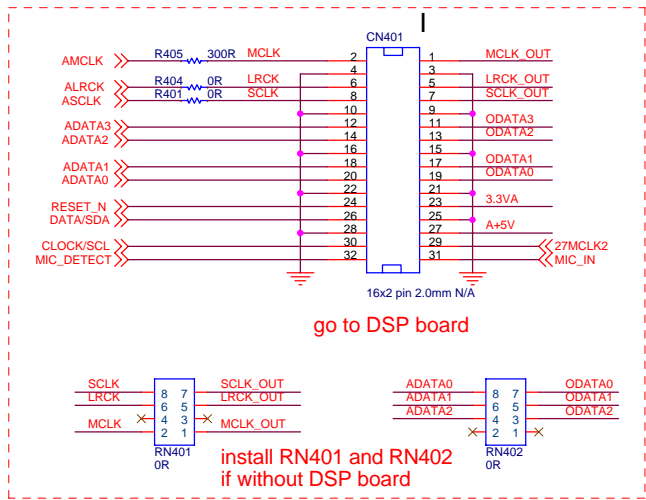

Title			HS200 AV board 060621		
Size	Document Number				Rev
A3	3522C				1.2
Date:	Thursday, January 04, 2007	Sheet	14	of	21

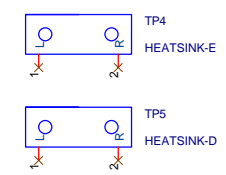
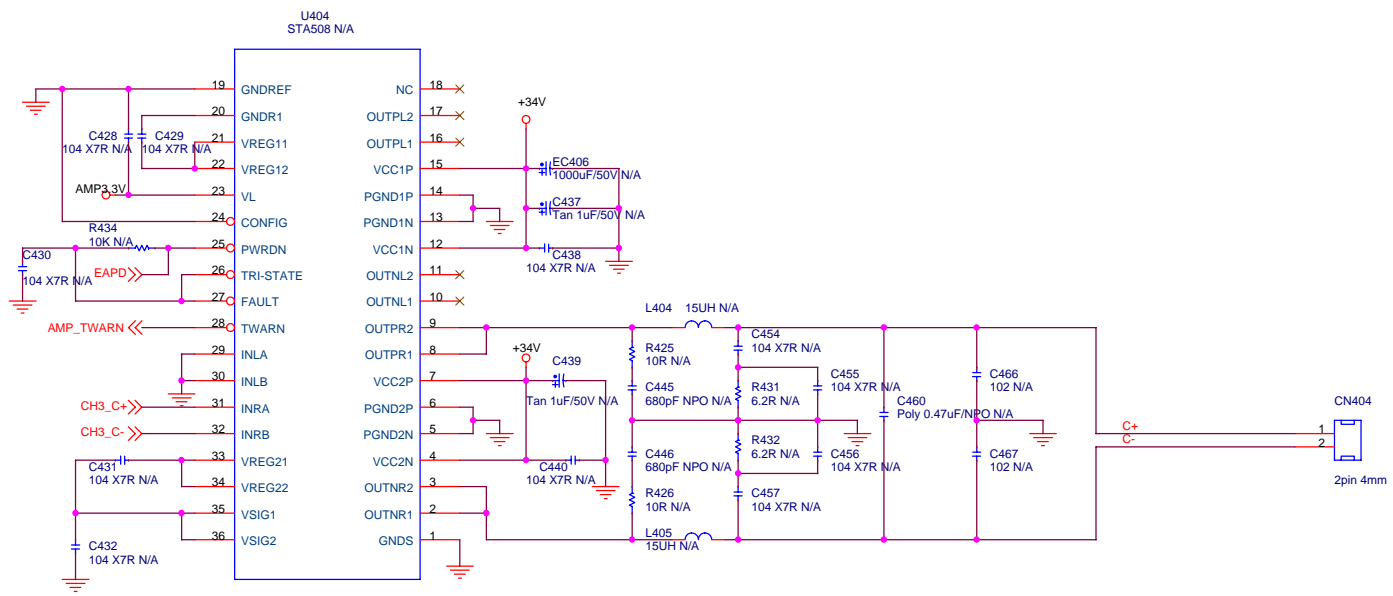
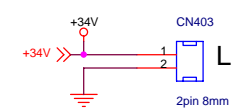
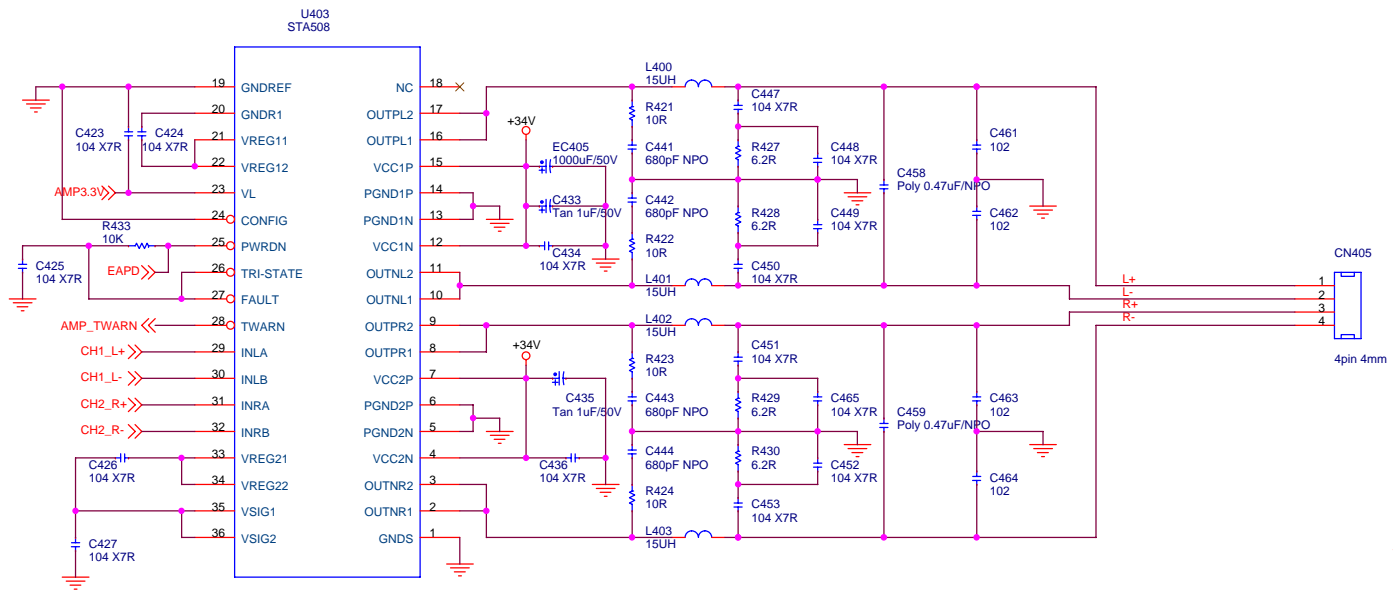

Title		HS200 AV board 060906	
Size	Document Number	3522C	Rev
A3			1.2
Date:	Thursday, January 04, 2007	Sheet	15 of 21

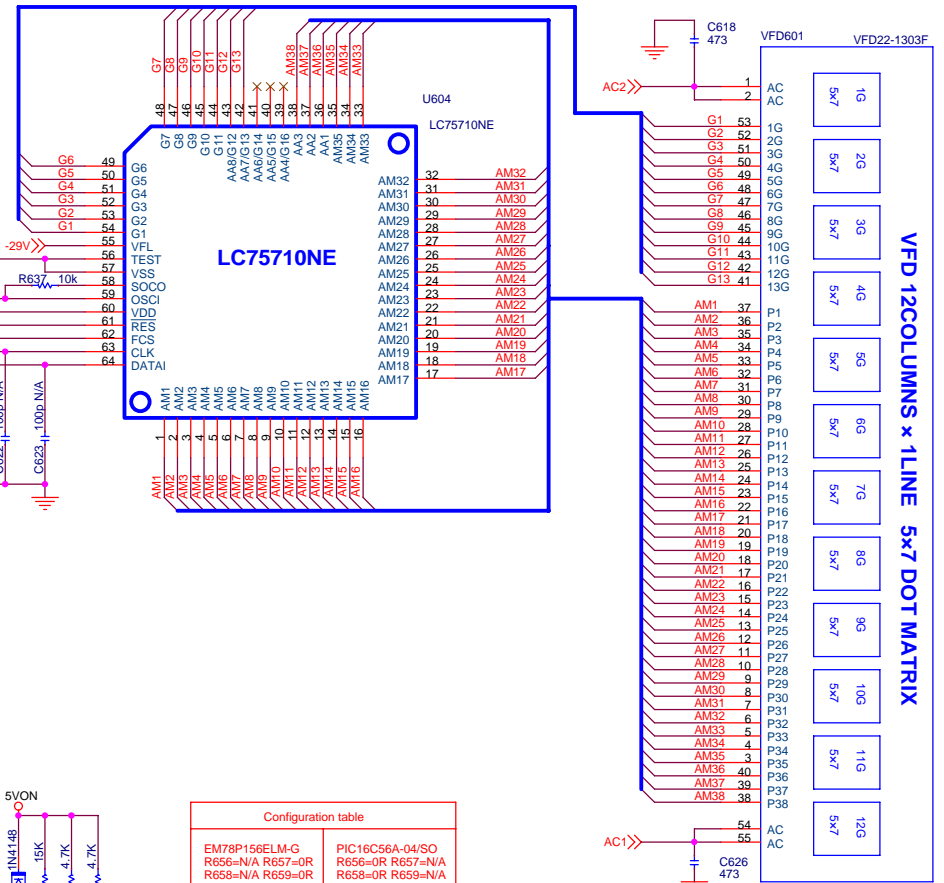
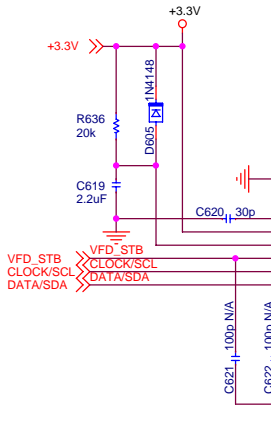
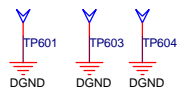
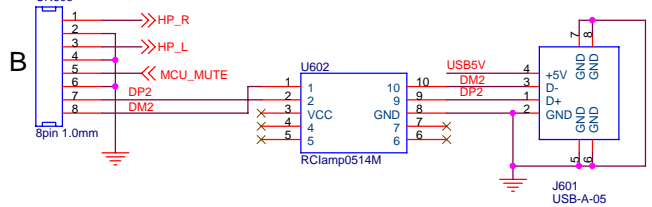
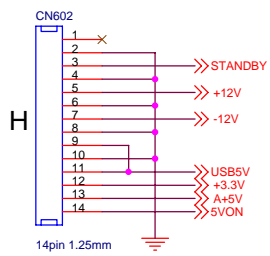
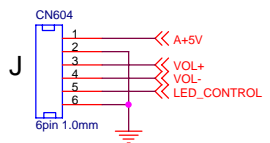
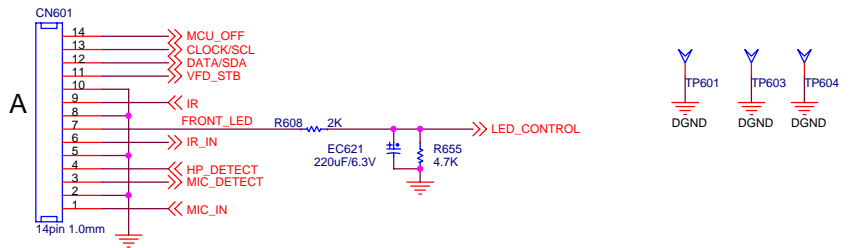

Configuration table	
EM78P156ELM-G	PIC16C56A-04/SO
R656=N/A R657=0R	R656=0R R657=N/A
R658=N/A R659=0R	R658=0R R659=N/A

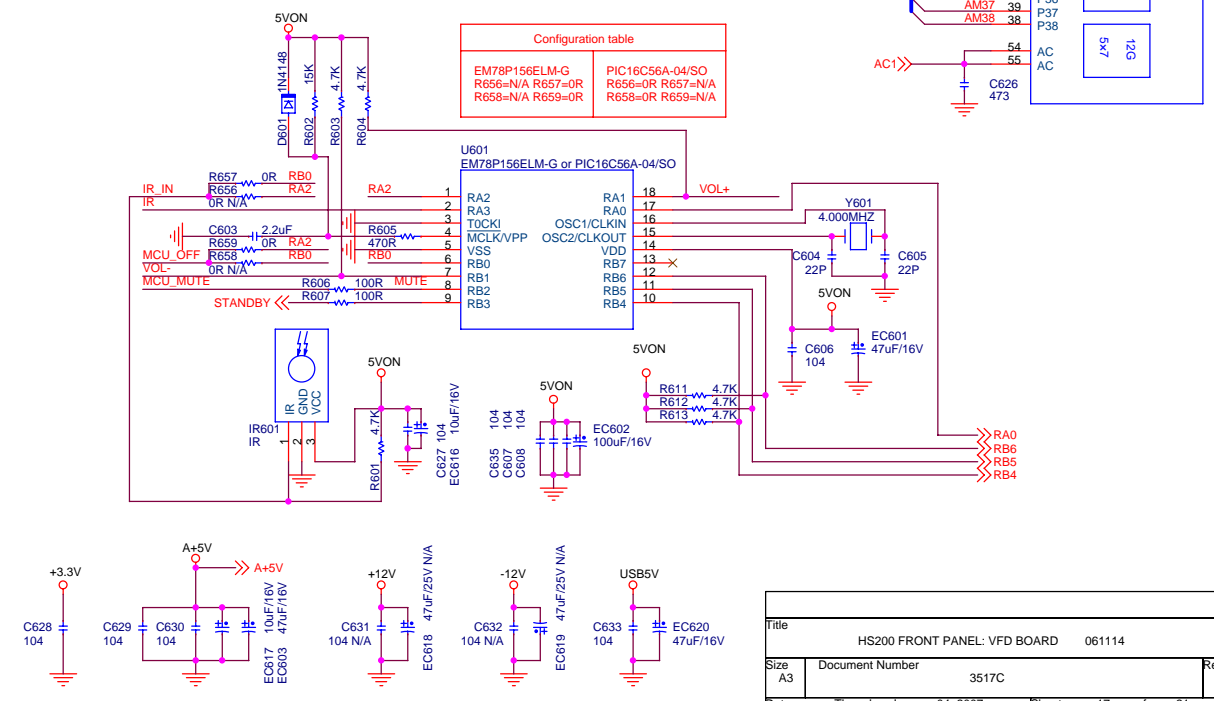
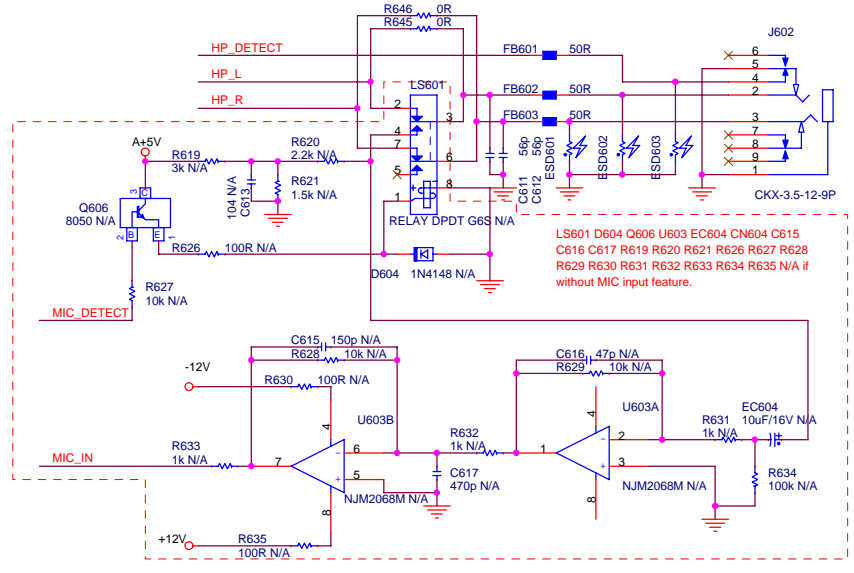

Title			HS200 FRONT PANEL: VFD BOARD	061114
Size	Document Number			Rev
A3	3517C			1.5
Date:	Thursday, January 04, 2007	Sheet	17	of 21

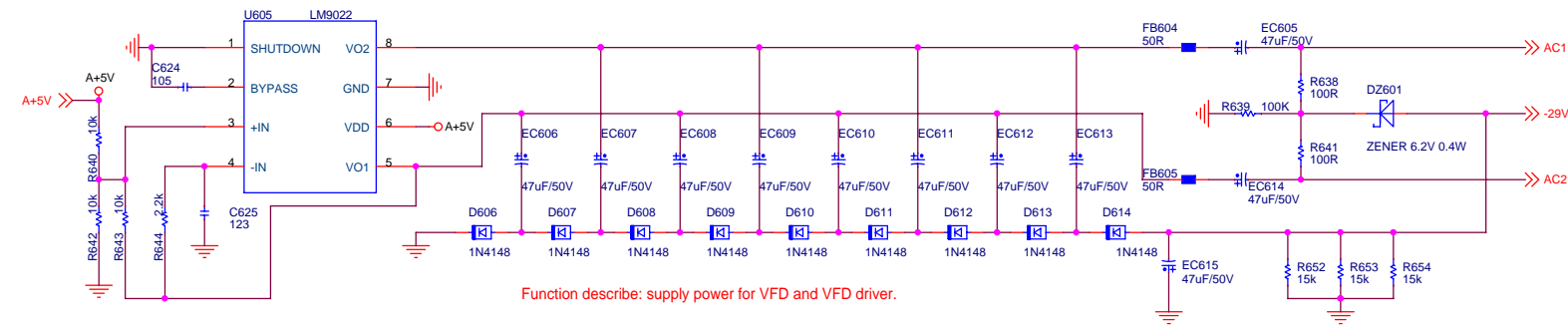
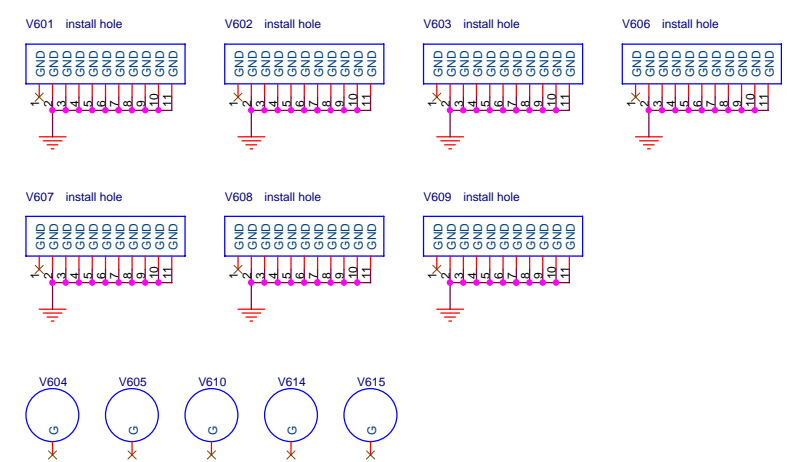
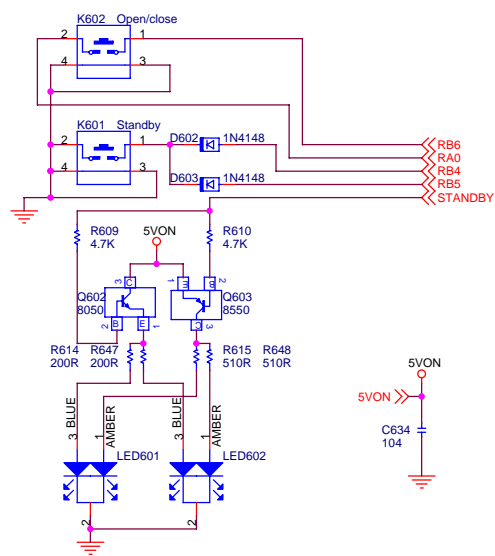

Function describe: supply power for VFD and VFD driver.

Title		
HS200 FRONT PANEL: VFD BOARD 060628		
Size	Document Number	Rev
A3	3517C	1.5
Date:	Thursday, January 04, 2007	Sheet 18 of 21

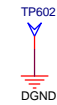
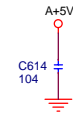
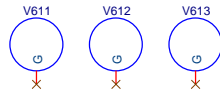
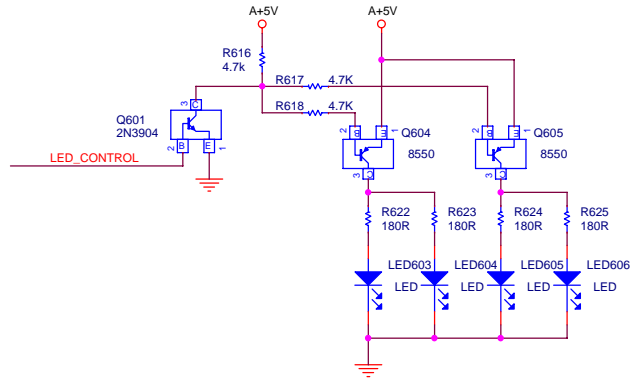
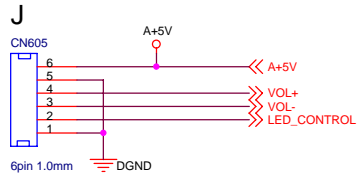
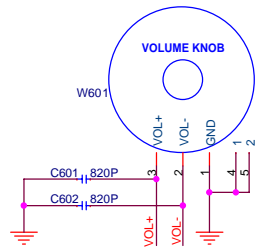

Title		
HS200 FRONT PANEL: Volume board		060714
Size	Document Number	Rev
A3	3518C	1.5
Date:	Thursday, January 04, 2007	Sheet 19 of 21

Main Transformer EER42
 Lp:650uH
 N_P: 46T 10*0.21mm*23T*2
 N_15v: 4T 0.4mm*4T
 N_34V_1: 10T 10*0.21mm*10T
 N_34V_2: 10T 10*0.21mm*10T

T501:
 L-PQ3230-01
 LP:400uH
 N1: 52T 20*0.21mm*52T
 N2: 6T 0.4mm*4T

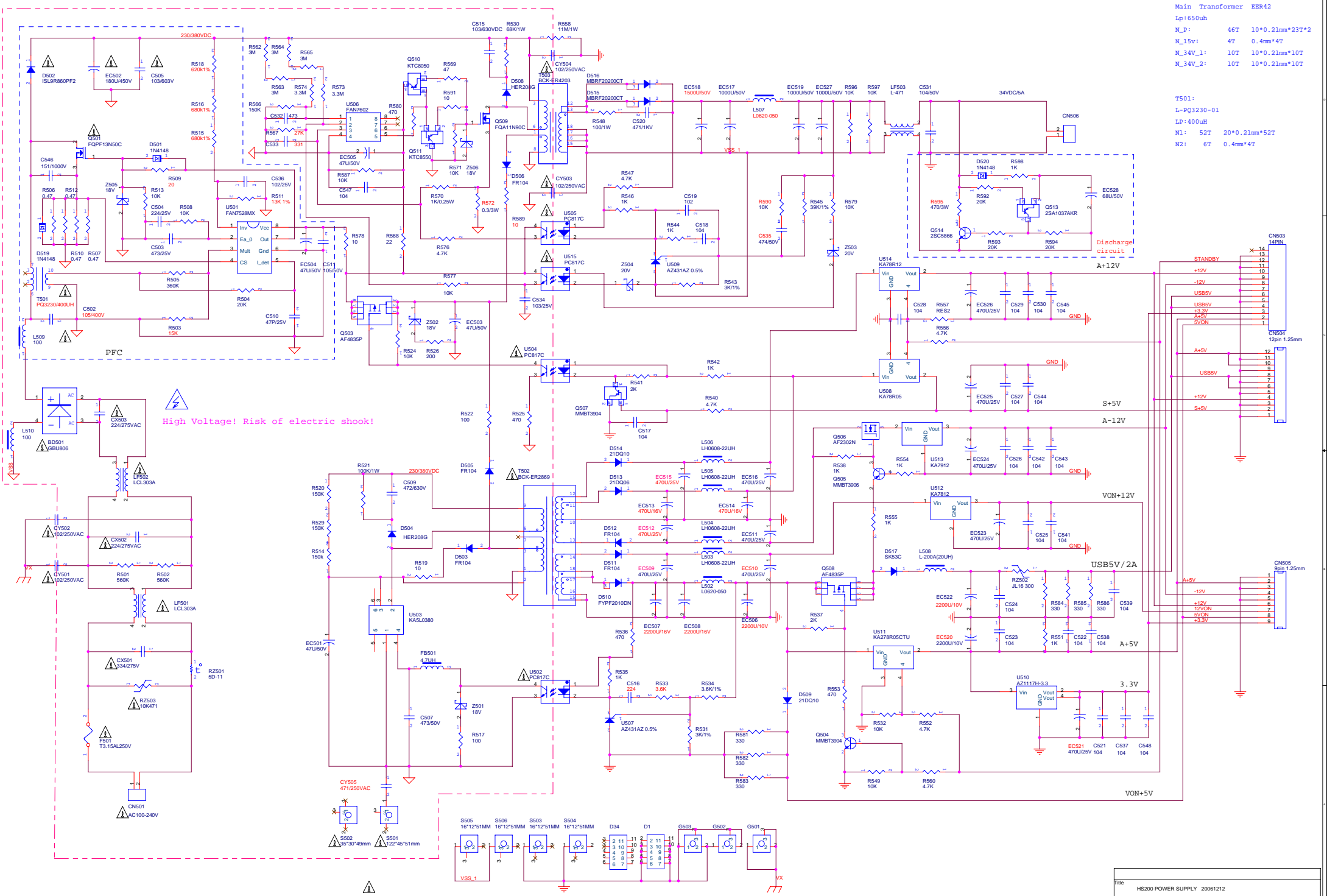

NO.	REVISION DATE	REV	REVISION HISTORY		
1	Aug 12, 2006	1.4	1. The controlling on -12V was changed to by USB5V from by S-T, because the driving capability of S-T wasn't enough, this made leds abnormal 2. Change R533 from 1K to 3.6K 3. Change C516 from 104 to 224/25V	4. Change R567 from 56K to 27K 5. Add R590 10K and C535 474/50V 6. Change FB501 to color coded inductance 4.7UH 7. Add R532 10K between GND and U511, preventing unexpected actions on USB5V	8. Add C536 102/25V 9. Change the value of T501 to 400UH
2	Sep 22, 2006	1.5	1. Add a discharge circuit of +34V power 2. Connect USB5V to CN504.6 to replace +3.3V, connect A+5V to CN504.10 to replace USB5V, because of the change of power supply 3.3V on main board	3. Delete D518, and change U510 from BA033BCO to AV1117-3.3	
3	Nov 11, 2006	2.0	1. Change CY501, CY502 from 471/400V to 102/400V 2. Change CX501, CY502 from 334/250V to 224/400V 3. Change LF501 from LCL-203A to LCL-303A, change LF502 from 20mH to LCL-303A and change L502, L507 from 47uH to L0620-050	5. Change CY505 from 222/250V to 471/250V 4. Change C502 from 474/630VDC to 105/450VDC 6. ADD beads L509, L510 0.085K 7. Delete R588, change R572 from to 0.5/3W	
4	Dec 12, 2006	2.1	1. Add R518 620K-1%, change R515 R516 from 1M-1% to 680K-1% 2. Add R573 3.3M-5%, change R564 R565 from 4.7M-5% to 3M-5%	3. Add R574 3.3M-5%, change R562 R563 from 4.7M-5% to 3M-5% 4. Reverse net lable of CN504 on PCB	

Title			HS200 SMPS REV HISTORY 061227		
Size	Document Number	Rev			
A3	3521C	2.1			
Date:	Thursday, January 04, 2007	Sheet	21	of	21

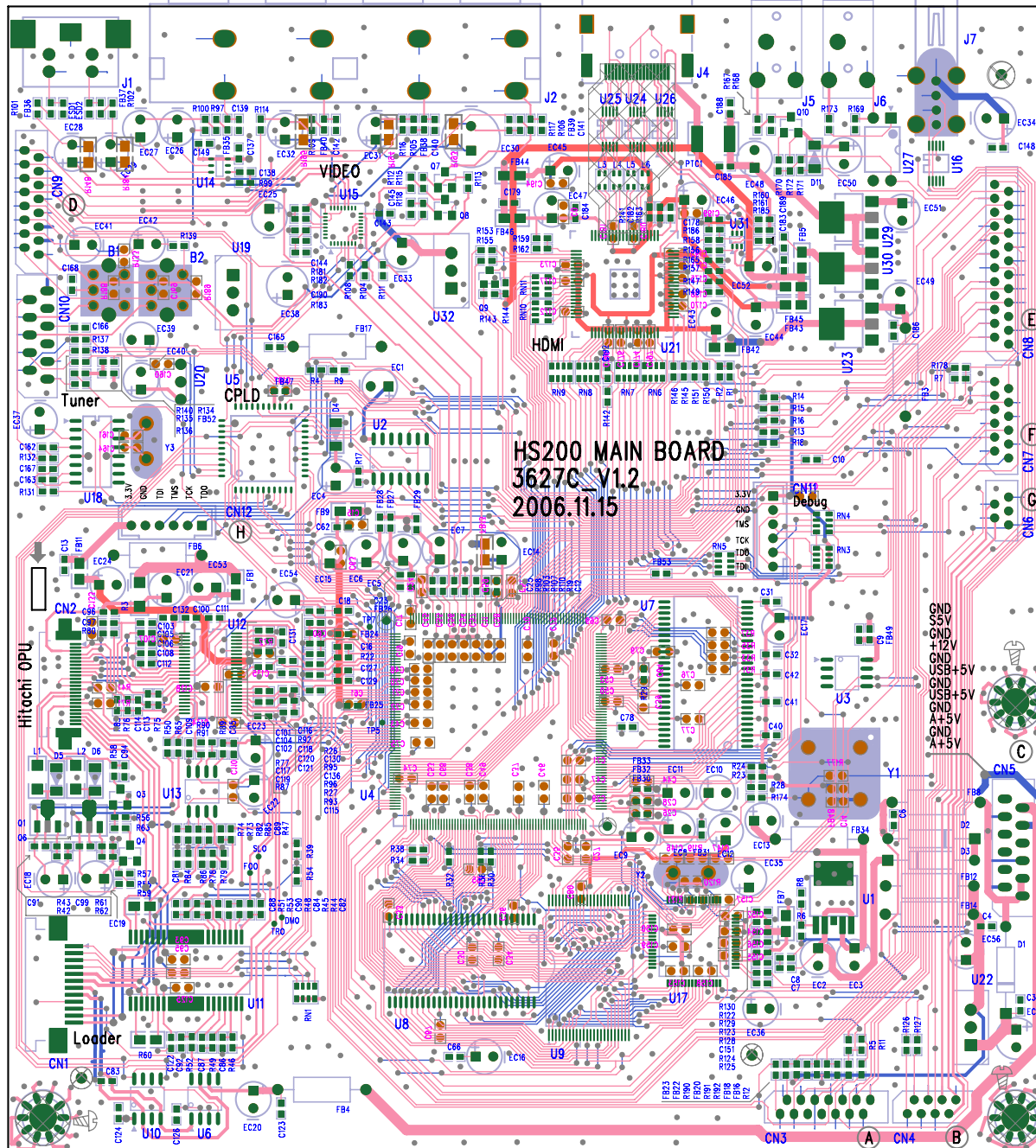

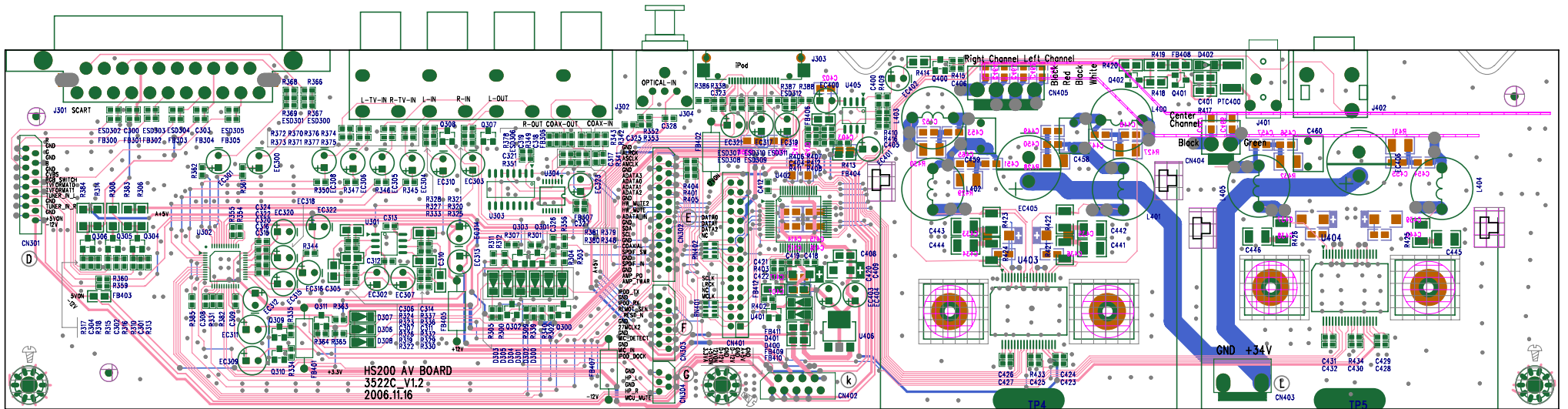

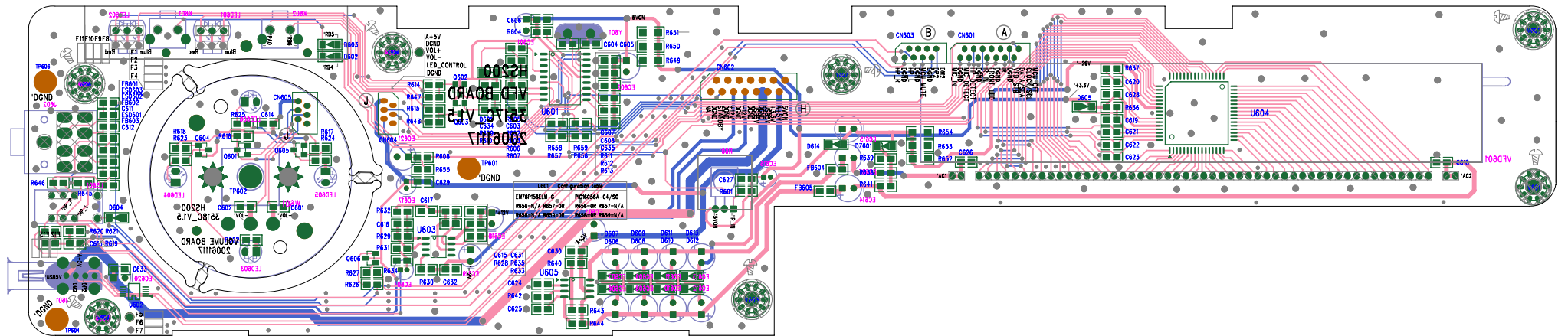

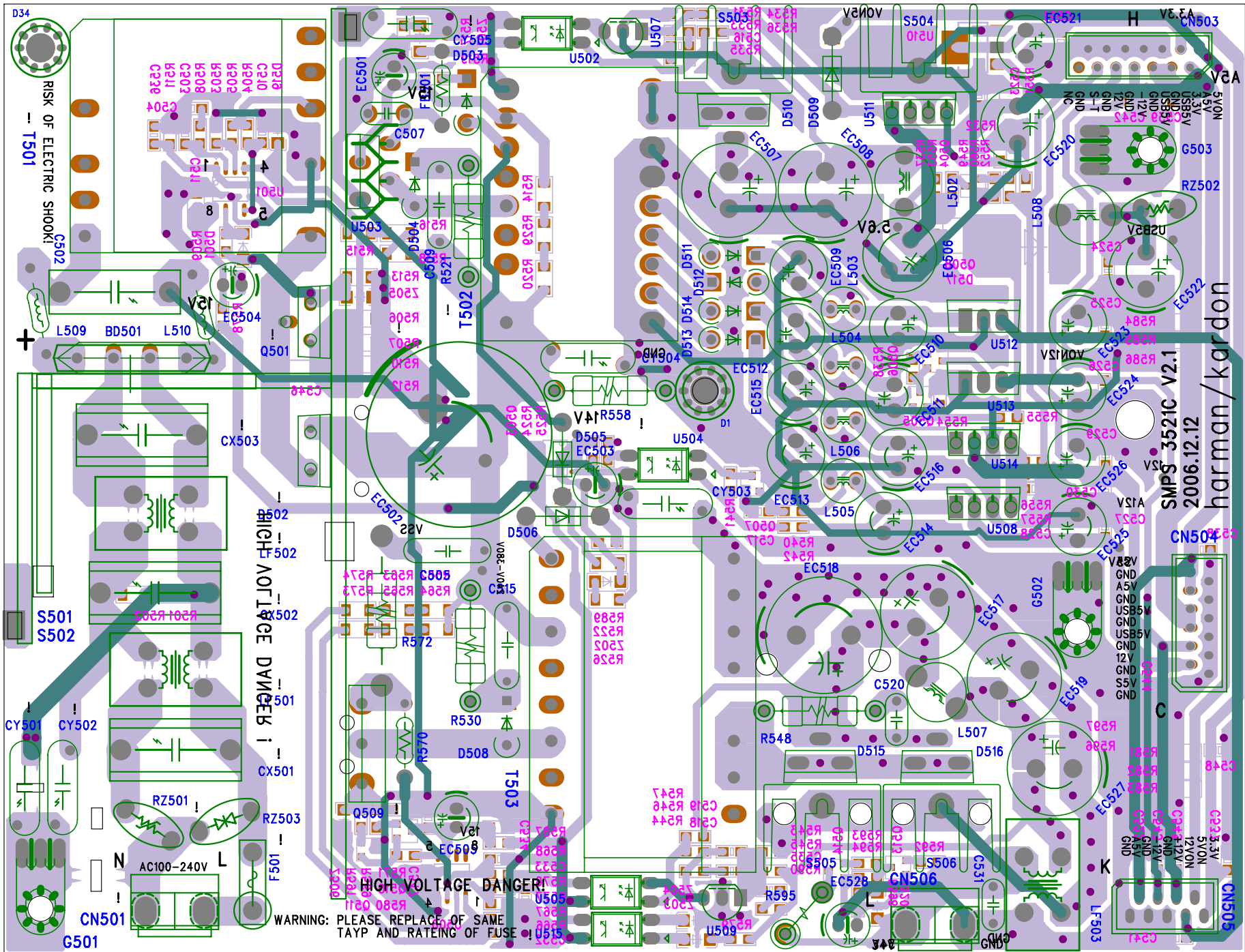

harman/kardon®

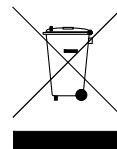

H A Harman International® Company
250 Crossways Park Drive, Woodbury, New York 11797
516.422.HKHK (4545) Fax: 516.682.3523 (USA only)
www.harmankardon.com
Harman Consumer Group, Inc.:
2, route de Tours, 72500 Château-du-Loir, France
© 2006 Harman Kardon, Incorporated
Part No.: 01.00.YS.SM1.E786