

---

**harman/kardon**
**Service Manual**

---

# Digital Lounge HS 250/230

## Integrated Home Theater System controller



## CONTENTS

TECHNICAL SPECIFICATIONS	2	EXPLODED VIEW AND PARTS	10
TROUBLESHOOTING GUIDE	3	ELECTRICAL PARTS LIST	11
FRONT PANEL CONTROLS	5	SEMICONDUCTOR PINOUTS	22
FRONT PANEL DISPLAY	6	PCB DRAWINGS	36
REAR PANEL CONNECTIONS	7	BLOCK DIAGRAM	41
PACKAGE LIST AND PARTS	9	WIRING DIAGRAM	42
		SCHEMATIC DIAGRAMS	43

## Digital Lounge Controller Specifications

<b>DVD player</b>	Pickup:	Semiconductor laser, wavelength 650nm
	Signal system:	NTSC / PAL
	Video signal horizontal resolution:	More than 480 lines (DVD)
	Video signal-to-noise ratio:	More than 60 dB (DVD)
	Audio frequency response: (Stereo)	DVD (PCM): 20 Hz ~ 22 kHz (+/- 1.0 dB) CD (PCM): 20 Hz ~ 20 kHz (+/- 1.0 dB)
	Audio signal-to-noise ratio:	More than 80 dB (PCM)
	Total harmonic distortion::	Less than 0.01% (PCM)
	Dynamic range:	DVD (PCM): More than 85 dB (EIAJ, 2 kHz) CD: More than 85 dB (EIAJ)
<b>Amplifier output</b>	Power (per channel):	65 W (6ohms)
	Signal-to-noise ratio:	> 85 dB
	Total Harmonic distortion:	< 0.2%
<b>FM Tuner</b>	System:	PLL quartz-locked digital synthesizer system
	Tuning range:	87.50 ~ 108.00 MHz
	Antenna terminals:	75 ohms, unbalanced
	Intermediate frequency:	10.7 MHz
<b>Video Outputs:</b>	HDMI™ Output: Video:	576p, 720p, 1080i HDMI Version 1.0-compliant HDCP Version 1.1-compliant
<b>Audio line Outputs</b>	Audio L/R:	2 Vrms, 1 kilohms
<b>General</b>	Power requirements:	AC 230 V, 50 Hz
	Max power consumption:	180 W
	Idle power consumption:	Less than 2 W
	Dimensions (WxHxD):	350mm x 84mm x 250mm
	Weight:	3,8 kg

\* Designs and specifications are subject to change without notice.

Depth measurement includes knobs, buttons and terminal connections. Height measurement includes feet and chassis.

All features and specifications are subject to change without notice.

Harman Kardon The Bridge,  is a registered trademark of Harman International Industries, Incorporated.

Dolby, Pro Logic and the double-D symbol are trademarks of Dolby Laboratories, registered in the United States and/or other countries.

All rights reserved.

DTS is a trademark of Digital Theater Systems, Inc.

Windows Media® Audio (WMA) is a proprietary file format developed by Microsoft.

DivX is a registered trademark of DivX, Inc.

HDMI, the HDMI logo and High-Definition Multimedia Interface are trademarks or registered trademarks of HDMI Licensing LLC.

## Troubleshooting

### For the Controller

If you experience any of the following difficulties while using the system, use this troubleshooting guide to help you remedy the problem.

Should any problem persist, consult your authorized Harman Kardon dealer.

#### No power.

- Is the power cord firmly plugged into the power outlet?
- One of the safety mechanisms may be operating. In this event, unplug the player from the power outlet briefly and then plug it in again.

#### No picture.

- Check that the system is connected correctly and securely.
- The video cable may be damaged. Replace it with a new one.
- Make sure the system is connected to a video input on the TV (see page 12).
- Make sure the TV is turned on.
- Make sure the correct video input on the TV is selected for viewing with this system.

#### Noise (interference) appears in the picture.

- Clean the disc.
- If video from this system has to go through your VCR to get to your TV, the copy-protection applied to some DVD programs could affect picture quality. If you still experience problems after checking your connections, please try connecting your DVD system directly to your TV's S-Video input.

#### The aspect ratio of the screen is wrong (picture vertically expanded) when you play a wide picture by the player or an external source connected to the screen even though you set "TV DISPLAY" in the SETUP menu to "Auto".

- If you connect the system or the external source with the SCART cable, connect directly to the TV. Otherwise the autoswitch function of the aspect ratio for the TV may not work.
- If the TV is not connected with a SCART cable to the DL (as recommended) or the external source, or if the autoswitch function does not work you should turn the TV to "Fill All".

#### There is no sound or volume is very low

- Check that the speakers and components are connected correctly and securely.
- Make sure that you have selected the correct source on the system.
- Press **MUTE** on the remote control, if the words MUTE ON are blinking on the front panel display.
- The protective circuitry has been activated because of a short circuit. Turn off the system, eliminate the short circuit problem and turn on the power again.
- The audio interconnect is damaged. Replace it with a new one.
- The system is in pause mode or in slow-motion play mode, or fast forward or fast reverse. Press ► to return to normal play mode.
- Check the speaker settings (see page 31).

#### The left and right channels are unbalanced or reversed.

- Check that the speakers and components are connected correctly and securely.

#### Severe hum or noise is heard.

- Check that the speakers and components are connected securely.
- Check that the connecting cords are away from a transformer or motor and at least 3 meters away from fluorescent light.
- Move your TV away from the audio components.
- The plugs and jacks are dirty. Wipe them with a cloth slightly moistened with alcohol.
- Clean the disc.
- Disconnect antenna cables from external sources (also PC) connected to the screen or system. If hum disappears use an antenna transformer between antenna and source.
- If PC is connected to the system disconnect the Audio and Video cables. If hum disappears use an audio transformer between PC audio out and system input. If hum persists unplug PC from your system and ask your local dealer for a proper solution (ground loop interrupt).

#### The volume goes down automatically and cannot be increased.

- The internal temperature is too high. Wait approximately one minute for the amplifier to reach normal working temperature.

#### Radio stations cannot be tuned in.

- Check that the antenna is connected correctly. Adjust the antenna and connect an external antenna if necessary.
- The signal strength of the stations is too weak for automatic tuning. Use manual tuning.
- No stations have been preset.
- The tuner mode is not selected, select the Radio mode.

#### The remote does not function.

- Remove any obstacles between the remote control and the system.
- Move the remote control closer to the system.
- Point the remote control at the remote sensor on the front panel.
- Replace all the batteries in the remote control with new ones if they are weak.
- Check that the batteries are loaded correctly.

#### The disc does not play.

- There is no disc inside. ("NO DISC" appears on the front panel display and the TV screen.) Insert a disc.
- Insert the disc correctly with the playback side facing down.
- Clean the disc.
- The system cannot play CD-ROM's, etc. (see page 3).
- DVD with wrong region code (see page 18).

#### Playback stops automatically.

- Some discs include an auto pause signal. When playing such a disc, the system stops playback at the signal.

## Troubleshooting

### Track Skip or direct select with numeric buttons, Search, Slow-motion play, repeat play or Program play, etc., cannot be done.

- Depending on the DVD or VCD, some of the above operations may not be available (Playback control).

### Messages do not appear on the TV screen in the language you want.

- Select the language for Display and Preferred Subtitle in the SETUP menu (see page 22). For all messages from the DVD (DVD menu, subtitles) in the proper language, the disc must have the language you selected, if not, another language will be selected.

### The audio language cannot be changed when you play a DVD.

- Multilingual sound is not recorded on the DVD.
- Changing the language for the sound by the Audio button on the remote or the Audio line in the Player Menu is prohibited on the DVD. In that case the audio language must be selected by the main menu on the DVD.

### The subtitle language cannot be changed when you play a DVD.

- Multilingual subtitles are not recorded on the DVD.
- Changing the language for the subtitles by the Subtitle button on the remote or the Subtitle line in the Player Menu is prohibited on the DVD. In that case the subtitle language must be selected by the main menu on the DVD.

### The subtitles cannot be turned off when you play a DVD.

- Depending on the DVD, you may not be able to turn the subtitles off.

### The angles cannot be changed when you play a DVD.



- Multi-angles are not recorded on most DVDs.
- Change the angles when the angle mark appears on the TV screen.
- Changing the angles is prohibited on some DVDs.

### The system does not operate properly.

- Static electricity, etc., may affect the system's operation. Disconnect the AC power cord, then connect it again.

**Please also refer to the Troubleshooting guide contained in your loudspeaker Owners Manual**

## For the TV

Defect	Possible cause	Possible remedy
No picture although the mains plug is inserted and the unit is switched on.	<ul style="list-style-type: none"> <li>Mains switch in position "0" (OFF).</li> <li>Mains plug of unit is not inserted into the plug receptacle.</li> <li>The HDMI cable is not properly inserted.</li> <li>Defective mains cable.</li> </ul>	<ul style="list-style-type: none"> <li>Shift mains switch to position "I".</li> <li>Insert the mains cable plug into the plug receptacle.</li> <li>Insert the HDMI cable firmly.</li> <li>Call the service hotline.</li> </ul>
Screen dark.	<ul style="list-style-type: none"> <li>Contrast setting too low.</li> <li>No input signal, wrong input selected.</li> </ul>	<ul style="list-style-type: none"> <li>Set the brightness and/or contrast correctly (see Picture Calibration).</li> <li>Check the connection cable; assign correct input to source.</li> </ul>
Weak or excessive colours.	<ul style="list-style-type: none"> <li>Colour not correctly set.</li> <li>Connection cable not correctly connected.</li> </ul>	<ul style="list-style-type: none"> <li>Set the colour correctly (see Picture Calibration).</li> <li>Connect the cable correctly.</li> </ul>
The picture is too large or too small.	<ul style="list-style-type: none"> <li>Picture format set wrongly.</li> </ul>	<ul style="list-style-type: none"> <li>Repeatedly press the <b>Screen Format Button</b>  until the picture is displayed as full screen.</li> </ul>
The displayed picture is too dark.	<ul style="list-style-type: none"> <li>The picture quality is not set correctly.</li> </ul>	<ul style="list-style-type: none"> <li>Correct the picture brightness and contrast (see Picture Calibration)</li> </ul>
The picture is displayed, but there is no sound.	<ul style="list-style-type: none"> <li>The sound is switched to mute.</li> <li>The Coaxial Digital Audio cable is not properly inserted.</li> <li>Volume is set to minimum.</li> </ul>	<ul style="list-style-type: none"> <li>Press the <b>Mute Button</b>  on the remote control.</li> <li>Insert the Coaxial Digital Audio cable firmly.</li> <li>Increase the volume.</li> </ul>
Horizontal stripes with TV or video signals.	<ul style="list-style-type: none"> <li>Signal source is placed in front of the display.</li> </ul>	<ul style="list-style-type: none"> <li>Always place the signal sources on the side of or behind the display.</li> </ul>

## Front Panel Controls

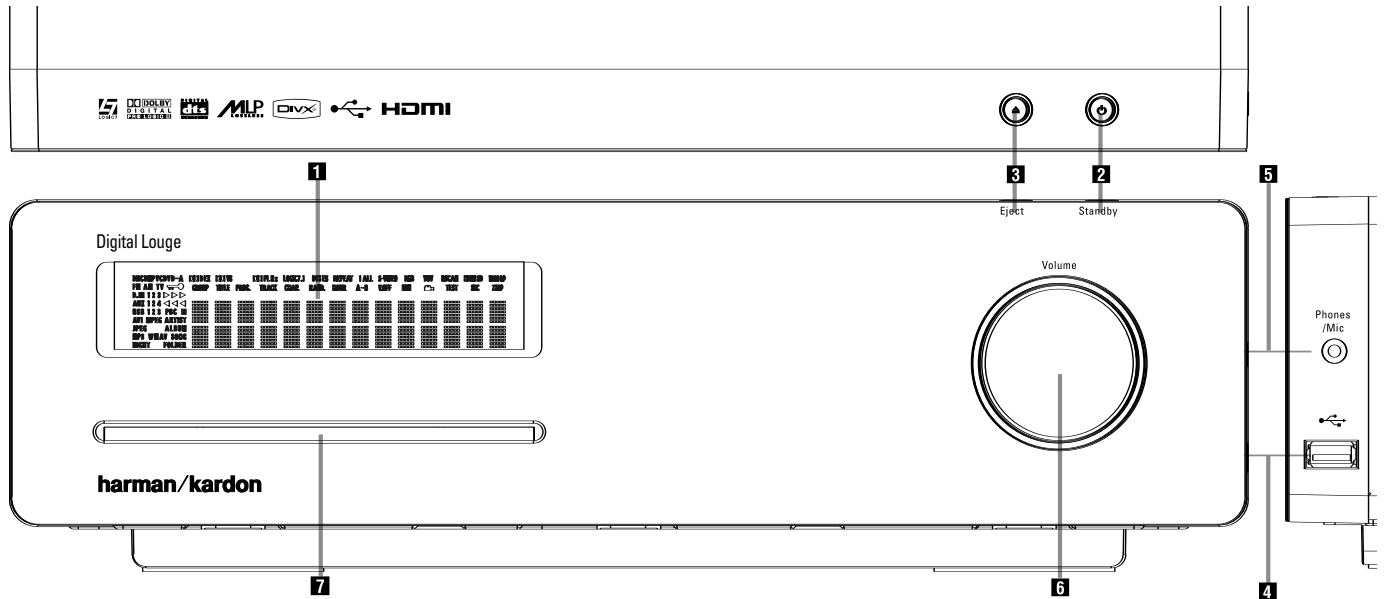

- 1** Main Information Display
- 2** Power On/Off (Standby)
- 3** Open/Close

- 4** USB On-The-Go Input
- 5** Headphone Jack
- 6** Volume Control

- 7** Slot Loader

**1 Main Information Display:** This display delivers messages and status indications to help you operate the Digital Lounge Controller.

**2 Power On/Off (Standby):** Press the button once to turn the Digital Lounge Controller on, press it again to put the unit in the Standby mode.

Note that when the Digital Lounge Controller is switched on, the Power Indicator around the button turns white

**3 Eject:** Press this button to release a disc from the loader.

**4 USB On-The-Go Input:** This input may be used to temporarily connect a USB thumb device or portable hard disk for direct playback of audio, image or video files or a USB hub. The USB inputs are designed to power a single USB device at a time. If additional hard disks are connected through a hub it is necessary that additional external power supplies are used to power the hub and hard disks.

**5 Headphone Jack:** This jack may be used to listen to the system's output through a pair of headphones. Be certain that the headphones have a standard 3.5 mm stereo phone plug. Note that the main room speakers will automatically be turned off when the headphone jack is in use.

**6 Volume Control:** Turn this knob clockwise to increase the volume, counterclockwise to decrease the volume. If the system is muted, adjusting volume control will automatically release the unit from the silenced condition.

**7 Slot loader:** Gently insert a CD or DVD into this slot, with the printed side of the disc facing up. Note there is no drawer. Press the **Eject Button 3** to release the disc

# Front Panel Display

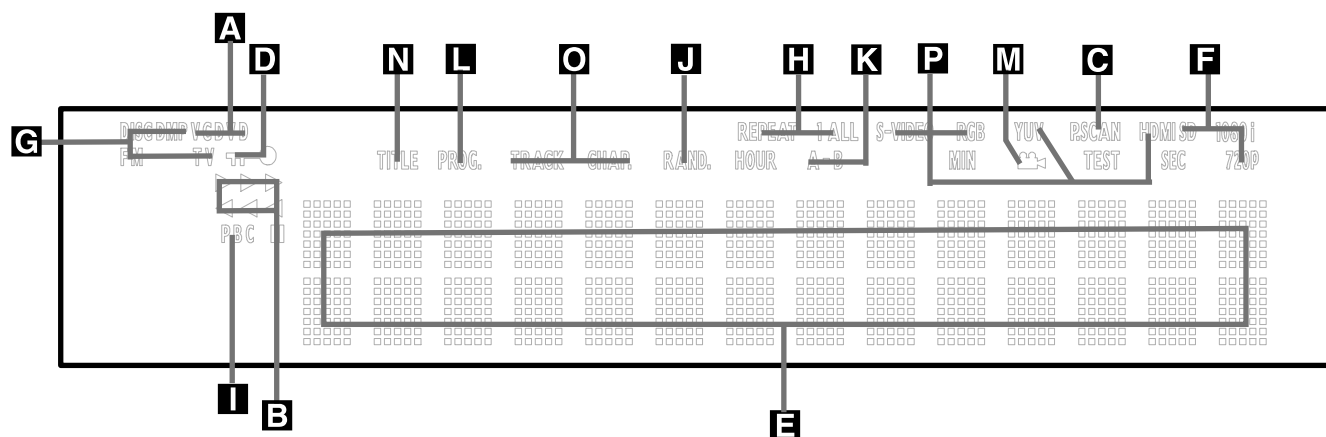

- A** Disc Type Indicators
- B** Playback-Mode Indicators
- C** Progressive Scan Indicator
- D** Parental Lock Indicator
- E** Time Indicators
- F** Video Format Indicators
- G** Source Indicators
- H** Repeat Indicators
- I** VCD Playback Control Indicator
- J** Random Indicator
- K** A-B Repeat Indicator
- L** Program Indicator
- M** Angle Indicator
- N** Title Indicators
- O** Chapter/Track Number Indicators
- P** Video Output Indicators

**A Disc Type Indicators:** The CD or DVD indicator will illuminate to show the type of disc currently being played.

**B Playback-Mode Indicators:** These indicators light to show the current playback mode:

- ▶ Lights when a disc is playing in the normal mode
- ▶▶ Lights when the disc is in the Fast Search Forward mode. The on-screen banner display indicates the selected speed (2x, 8x, 16x, 100x).
- || Lights when the disc is paused.
- ◀◀ Lights when the disc is in the Fast Search Reverse mode. The on-screen banner display indicates the selected speed (2x, 8x, 16x, 100x).

**C Progressive Scan Indicator:** This indicator lights when the unit sends out a progressive scan signal.

**D Parental Lock Indicator:** This indicator lights when the parental-lock system is engaged in order to prevent anyone from changing the rating level without a code.

**E Time Indicators:** These positions in the indicator will show the running time of a DVD in play. When a CD is playing, these indicators will show the current track time, time remaining in the current track, or the total remaining time on the disc. When an iPod is playing, the display will show the elapsed and remaining time on the top line. The bottom line will scroll information about the song, title, album and artist.

**NOTE:** The Indicators **N O E** will also display text messages about the DVD's status, including **Reading** when a disc is loading, **STANDBY** when the unit is turned off, and **Disc Error** when a disc not compatible with the DVD is put into the play position.

**F Video Format Indicators:** These indicators will represent the video format currently playing.

**G Source Indicators:** These indicators will light to show which source is currently selected.

**H Repeat Indicators:** These indicators light when any of the Repeat functions are in use.

**I VCD Playback Control Indicator:** This indicator lights when the playback control function is turned on with VCDs.

**J Random Indicator:** This indicator lights when the unit is in the Random Play mode.

**K A-B Repeat Indicator:** This indicator lights when a specific passage for repeat playback has been selected.

**L Program Indicator:** This indicator lights when the programming functions are in use.

**M Angle Indicator:** This indicator blinks when alternative viewing angles are available on the DVD currently playing.

**N Title Indicators:** These two positions in the display will show the current title number when a DVD disc is playing.

**O Chapter/Track Number Indicators:** When a DVD disc is playing, these two positions in the display will show the current chapter. When a CD disc is playing they will show the current track number.

**P Video Output Indicators:** These indicators will represent the active video output .

# Rear Panel Connections

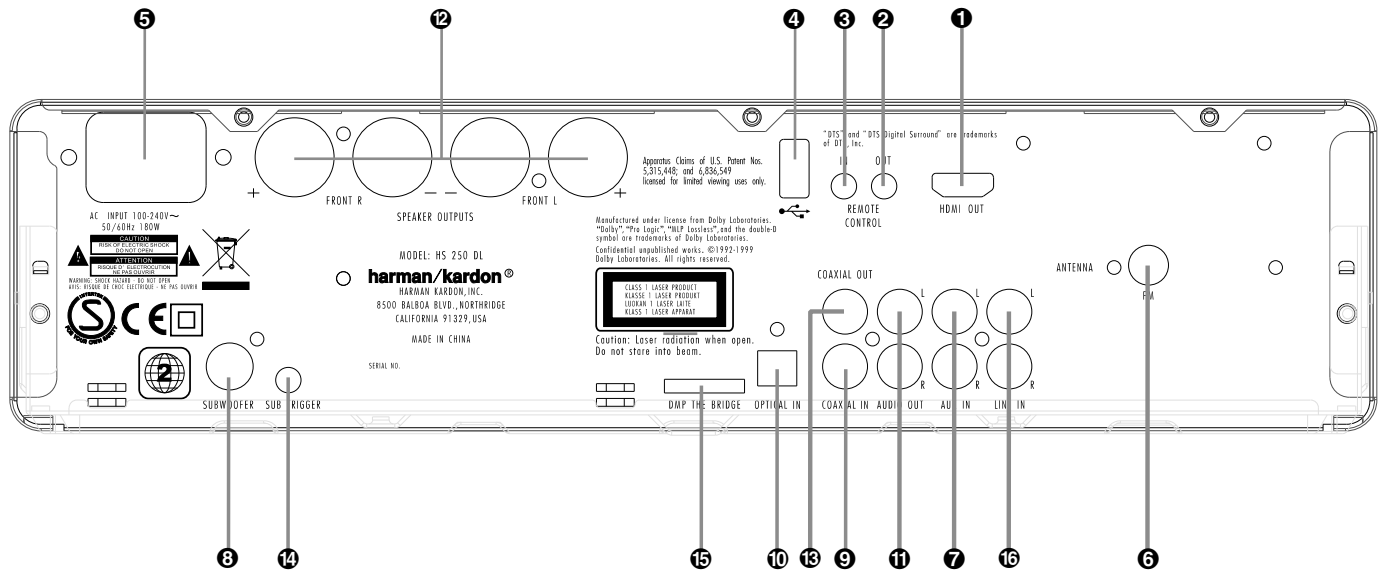

- 1 HDMI Output
- 2 Remote IR Output
- 3 Remote IR Input
- 4 USB On-The-Go Input
- 5 AC Power Cord
- 6 FM Antenna

- 7 Audio In
- 8 Subwoofer Output
- 9 Coaxial Digital Input
- 10 Optical Digital Input
- 11 Analog Audio Outputs
- 12 Speaker Outputs

- 13 Coaxial Digital Output
- 14 Subwoofer Trigger Output
- 15 DMP The Bridge Input
- 16 Analog Audio Inputs

**1 HDMI Output:** Connect this output to the HDMI input **1** of the screen, using the supplied HDMI - SP-DIF - Remote In/Out cable.

**2 Remote IR Output:** This connection permits the IR sensor in the receiver to serve other remote controlled devices. Connect this jack to the "IR IN" jack on Harman Kardon or other compatible equipment. Note this connection is only necessary for optional, additional products connected to the player. It is not necessary for proper control of the Digital Lounge system.

**3 Remote IR Input:** Connect this input to the Remote IR Output **2** of the TV, using the special HDMI - SP-DIF - Remote In/Out cable. This will allow you to control all components in your system by pointing the remote control to the TV only.

**4 USB On-The-Go Input:** This input may be used to temporarily connect a USB thumb device or portable hard disk for direct playback of audio, image or video files, a digital photo camera or a USB hub.

**5 AC Power Cord:** Connect this plug to an AC outlet. If the outlet is controlled by a switch, make certain that it is in the ON position.

**6 FM Antenna:** Connect to the supplied FM antenna.

**7 Audio In:** Connect to a line-level analog audio source: TV, tape player, Minidisc, PC, etc.

**8 Subwoofer Output:** Connect to the SUB/LFE input on the subwoofer.

**9 Coaxial Digital Input:** Connect the coaxial digital output from a DVD player, HDTV receiver, LD player, MD player, satellite receiver or CD player to this jack. The signal may be either a Dolby Digital signal, DTS signal or a standard PCM digital source.

**10 Optical Digital Input:** Connect the optical digital output from a DVD player, HDTV receiver, LD player, MD player, satellite receiver or CD player to this jack. The signal may be either a Dolby Digital signal, DTS signal or a standard PCM digital source.

**11 Analog Audio Outputs:** Connect these jacks to the RECORD/INPUT jacks of an optional audio recorder for recording.

**12 Speaker Outputs:** Connect these outputs to the matching + or – terminals on your left and right speakers. In conformance with the new CEA color code specification, the White terminal is the positive, or "+" terminal that should be connected to the red (+) terminal on Left speaker with the older color coding, while the Red terminal is the positive, or "+" terminal that should be connected to the red (+) terminal on Right speaker. Connect the black (–) terminals on the Digital Lounge system to the black (–) terminals on the speakers. See page 19 for more information on speaker polarity.

**Note:** You'll find more details about all Audio/Video connections under Setup and Connections on the following pages.

**13 Coaxial Digital Output:** Connect this jack to the matching digital input connector on a digital recorder such as a CD-R or MiniDisc recorder.

## Rear Panel Connections

**14 Subwoofer Trigger Output:** Connect this trigger output to the trigger input of the Harman Kardon subwoofer, so that the subwoofer will switch on and off at the same time as the rest of the system.

**15 <sup>The Bridge</sup> Digital Media Player (DMP) Connector:** With the Digital Lounge turned off, connect one end of the optional Harman Kardon <sup>The Bridge</sup> to this proprietary connector, and the other to your compatible Apple iPod. When the Digital Media Player source is selected, you may view your iPod's control and navigation messages on your video display and in the **Upper** and **Lower Display Lines** **E**. You may navigate the iPod and select tracks for playback using the **▲/▼/◀/▶ Buttons** **10** and the **Enter Button** **7**.

**16 Analog Audio Inputs:** Connect these jacks to the analog audio output on a TV set or external audio system for analog audio playback.





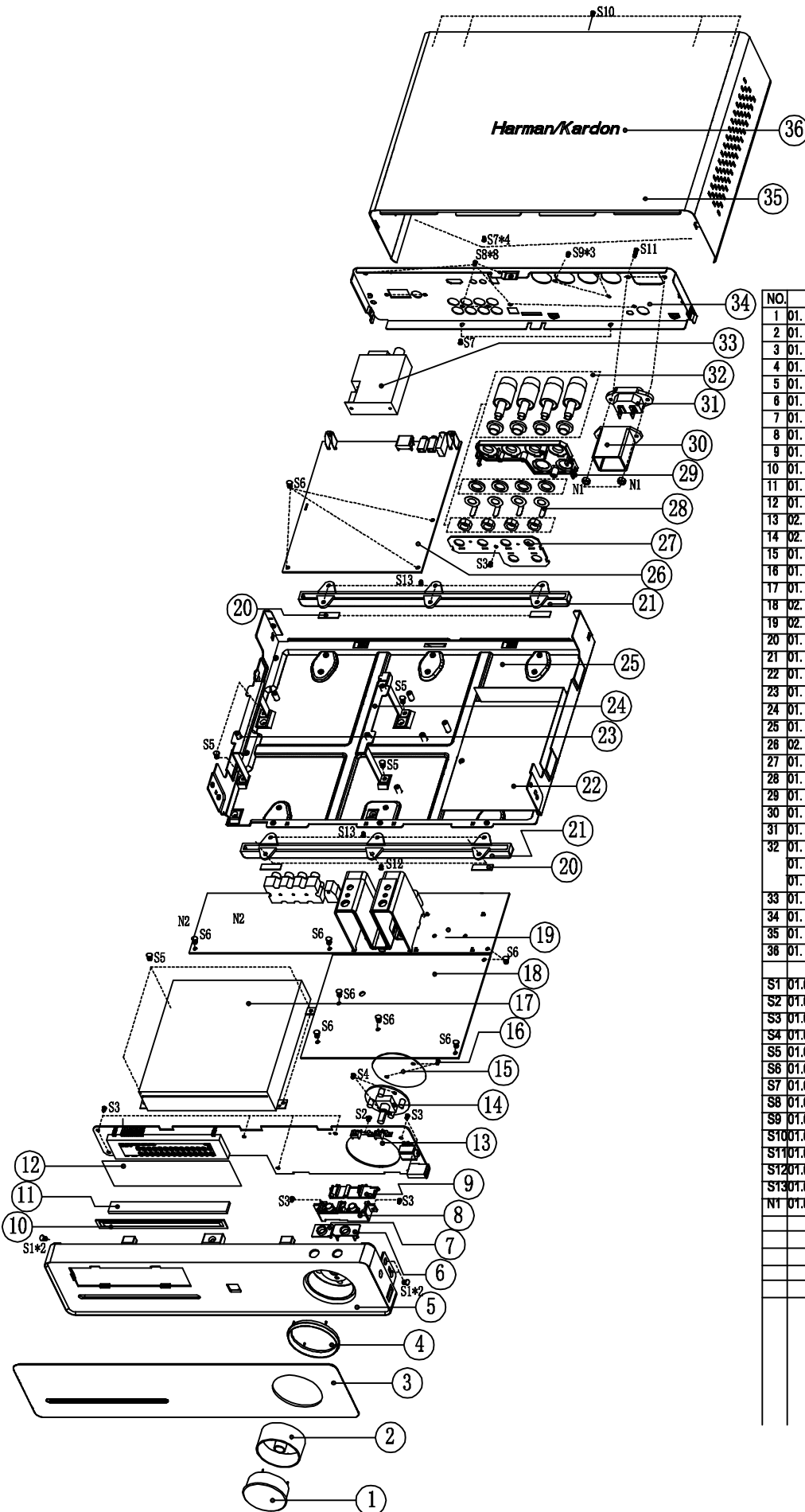

NO.	P/N	DESCRIPTION	QTY.
1	01.00.SJ.HS100.E010	HS100-Volume Button	1
2	01.00.SJ.HS100.E008	HS100-volume button lampshade	1
3	01.00.SJ.HS250.E003	HS250DL-Large Lens	1
4	01.00.SJ.HS100.E006	HS100-Volume Button Collar	1
5	01.00.SJ.HS200.E001	HS200-front panel	1
6	01.00.SJ.HS200.E005	HS200-Power Indicator lampshade	1
7	01.00.SJ.HS200.E003	HS200-Open button collar	1
8	01.00.SJ.HS200.E002	HS200-2 in 1 Button	1
9	01.00.SJ.HS200.E004	HS200-Button Cover Board	1
10	01.00.DP.JY.E135	Dustproof forLoder LTD-1510	1
11	01.00.DP.HM.E383	High Soft sponge 124*12*2MM	1
12	01.00.SJ.QT.E019	VFD filter 124.5*33.5*0.5mm	1
13	02.15.HAV07K3519C02	Front Panel Board ass'y HAV07K-3519C02	1
14	02.15.HAV06K3518C01	Front Panel Board ass'y HAV06K-3518C01	1
15	01.00.DP.JY.E249	Insulated PVC HS200-H02	1
16	01.00.SJ.QT.E104	plastic rivet MBL3-2.5	2
17	01.15.JK.EDL05FHH40P	Loader DL-05FH-R40P	1
18	02.19.HAV06P3521C02	SMPs Board ass'y HAV06P-3521C02	1
19	02.14.HAV0715229C02	AV Board ass'y HAV071-5229C02 (EU)	1
20	01.00.DP.XJ.E192	Sillica gel gasket 50.6*4.2*1.5mm	4
21	01.00.SJ.HS200.E009	HS200-Large Lens	1
22	01.00.DP.JY.E247	Insulated PVC HS200-H01	1
23	01.00.WJ.TJ.HS200.E005	HS200-PCB plastic frame(Left)	1
24	01.00.WJ.TJ.HS200.E006	HS200-PCB plastic frame(Right)	1
25	01.00.WJ.TJ.HS200.E001	HS200-chassis	1
26	02.11.HAV07M5228C02	Main Board ass'y HAV07M-5228C02 (EU)	1
27	01.37.PCB.2.E3520C1	Speaker Board ass'y 3520C-V1.0	1
28	01.00.WJ.TJ.HS200.E007	HS200-Connected Piece	4
29	01.00.SJ.HS200.E008	HS200-plastic scaleboard	1
30	01.00.SJ.HS200.E007	HS200-Power Jack Jacket	1
31	01.40.GON.DCZ.E178	AC power Jack WS-044-0	1
32	01.00.WJ.QT.E049	Speaker Connective Stick-Red	1
	01.00.WJ.QT.E048	Speaker Connective Stick-Black	2
	01.00.WJ.QT.E050	Speaker Connective Stick-White	1
33	01.49.E11	FM tuner moduleFCF1E806A (EU)	1
34	01.00.WJ.TJ.HS250.E002	HS250DL-rear panel (EU)	1
35	01.00.WJ.TJ.HS200.E002	HS200-top cover	1
36	01.00.SB.E036	Metal logo 100mm "Harman/Kardon"	1
S1	01.00.WJ.JG.E328	Screw 3*6KBTT0	4
S2	01.00.WJ.JG.E655	Screw 1.7*4CAHNI D=3.2	1
S3	01.00.WJ.JG.E166	Screw 3*6PAHC	10
S4	01.00.WJ.JG.E085	Screw 3*6BTTNI	2
S5	01.00.WJ.JG.E091	Screw 3*6PWBTTC	8
S6	01.00.WJ.JG.E451	Screw 3*6PWHMC	11
S7	01.00.WJ.JG.E252	Screw 3*4RBTNI	6
S8	01.00.WJ.JG.E321	Screw 3*6PAHO	8
S9	01.00.WJ.JG.E675	Screw 3*10PAHO	3
S10	01.00.WJ.JG.E403	Screw 3*6PWBTTO	5
S11	01.00.WJ.JG.E865	Screw 3*12PMHO	2
S12	01.00.WJ.JG.E235	Screw 3*6PWBTNI	3
S13	01.00.WJ.JG.E543	Screw 3*6PWBTNI	9
N1	01.00.WJ.JG.E119	NUT M3	2

HS250 Digital Lounge Component List			
Location.No.	Description	Specification	P/N
HS200-PT01	metals part	HS200-chassis	01.00.WJ.TJ.HS200.
HS200-PT02	metals part	HS200-top cover	01.00.WJ.TJ.HS200.
HS250-PT02	metals part	HS250 DL-rear panel	01.00.WJ.TJ.HS250.
HS200-PT04	metals part	HS200-PCB plastic frame(Left)	01.00.WJ.TJ.HS200.
HS200-PT05	metals part	HS200-PCB plastic frame(Right)	01.00.WJ.TJ.HS200.
HS200-PT06	metals part	HS200-Connected Piece for Speaker Jack	01.00.WJ.TJ.HS200.
HS650DL-PT02	metals part	HS650DL-U-shaped holder	01.00.WJ.TJ.HS650.
HS200-PT07	Heatsink	50*62*65MM	01.00.WJ.TJ.E889
HS200-PT08	Heatsink	39*54.5*61mm	01.00.WJ.TJ.E890
HS200-PT09	Heatsink	122*45*51mm	01.00.WJ.TJ.E891
HS200-PT10	Heatsink	35*30*49mm	01.00.WJ.TJ.E892
For S503/S504/S505/S506 on SMPS Board	Heatsink	16*12*51MM (The Hole's depth is 18MM)	01.00.WJ.TJ.E893
For U4 of Main Board	Heatsink	28*28*10mm	01.00.WJ.TJ.E268
For U512 on SMPS Board (HS250-PT01)	Heatsink	12*7.5*51MM (The Hole's depth is 18MM)	01.00.WJ.TJ.E982
For Amplifier Output Cord	Magnetism annulus	F5BRFS11.7*6*19.75-3-P.W	01.13.L.H.E034
HS200-RE01	plastic part	HS200-front pannel	01.00.SJ.HS200.E00
HS200-RE02	plastic part	HS200-2 in 1 Button	01.00.SJ.HS200.E00
HS200-RE03	plastic part	HS200-Open button collar	01.00.SJ.HS200.E00
HS100-RE06	plastic part	HS100 Volume Button Collar	01.00.SJ.HS100.E00
HS200-RE04	plastic part	HS200-Button Cover Board	01.00.SJ.HS200.E00
HS200-RE05	plastic part	HS200-Power Indicator lampshade	01.00.SJ.HS200.E00
HS200-RE06	plastic part	HS200-pedestal underlay	01.00.SJ.HS200.E00
HS200-RE07	plastic part	HS200-Power Jack Jacket	01.00.SJ.HS200.E00
HS200-RE08	plastic part	HS200-plastic scaleboard	01.00.SJ.HS200.E00
	plastic part	HS250 DL-Large Lens	01.00.SJ.HS250.E00
HS100-RE10	plastic part	HS100 Volume Button	01.00.SJ.HS100.E01
HS100-RE08	plastic part	HS100 volume button lampshade	01.00.SJ.HS100.E00
	plastic part	1000A-IR receiver support 5.5mm	01.00.SJ.1000A.E01
	VFD filter	124.5*33.5*0.5mm	01.00.SJ.QT.E019
	AC power Jack	WS-044-0	01.40.CON.DCZ.E178
	Metal logo	100mm "Harman/Kardon" Thin Logo	01.00.SB.E036
	Dustproof for Disc tray door of Loder	LTD-1510	01.00.DP.JY.E135
For pedestal underlay HS100-H01	Silica gel gasket	50.6*4.2*1.5mm (with #500 glue be single sides glued )	01.00.DP.XJ.E192
For VFD (2)	sponge	20*10*5MM (with #9448 glue be double sides glued )	01.00.DP.HM.E117
Between volume button and Front Panel Board	Astigmatism PVC	Φ45.5*Φ9.5mm	01.00.FZ.QT.153
Inside the volume button	Mask PVC	φ38.5 (Underside Glued)	01.00.FZ.QT.E253
For IR receiver	sponge	10*10*7MM (with double sides glued)	01.00.DP.HM.E364
Between AV Board and Heatsink	sponge	20*10*4.5mm (with Single side glued)	01.00.DP.HM.E160
paste in front of Disc tray door in the front panel	High Soft sponge	124*10*2MM (with Single side glued)	01.00.DP.HM.E378
pasted beside U403 of AV Board	electric sponge	12*10*18mm	01.00.DD.PM.E183
Between front panel PCB and plastic part	electric sponge	20*20*10MM	01.00.DD.PM.E271
	Plastic fastener	12CM	01.00.FZ.QT.E122
For Q509 on SMPS Board	Sil-pad	sil-pad 400-3022	01.00.DP.QT.E113
For AV Board	Diathermanous Selenium Rubber	16*11*1mm	01.00.DP.JY.E112
For SMPS Board	Insulated PVC	HS200-H01	01.00.DP.JY.E247
Be buckled above volume button board	Insulated PVC	HS200-H02	01.00.DP.JY.E249
For hamulus of front panel	Insulated PVC	22.5*10*0.3mm (with Single side glued)	01.00.DP.JY.E541
For frequency modulation module and AV Board	sponge	15*15*24mm (with Single side glued)	01.00.DP.HM.E369
For frequency modulation module and Main Board	sponge	15*15*7mm(with Single side glued)	01.00.DP.HM.E370
Between AV Board and chassis under U403	Diathermanous Silica gel gasket	20*15*4MM	01.00.DP.XJ.E560
For AV Board and Heatsink (2)	Screw	3*8PWBTTTC	01.00.WJ.JG.E265
For front Panel and Left/Right sides of chassis (4), Between two Heatsinks on SMPS Board(1)	Screw	3*6KBTTTO	01.00.WJ.JG.E328
For pedestal underlay and chissis (9)	Screw	3*6PWBTTNI	01.00.WJ.JG.E543
For front panel and pedestal underlay and chissis(3)	Screw	3*8PWBTTNI	01.00.WJ.JG.E235
For Button cover Board and button Board	Screw	1.7*4CAHNI D=3.2 Free-Lead	01.00.WJ.JG.E655
For front panel and front panel board(9) For plastic scaleboard and Speaker Connected Board (1)	Screw	3*8PAHC	01.00.WJ.JG.E166
For front panel and volume button board	Screw	3*6KBTTNI	01.00.WJ.JG.E085
For Loader and chassis(4), For PCB Brackets and chassis (4)	Screw	3*6PWBTTTC W=7	01.00.WJ.JG.E091
For SMPS Board and chassis (5), For AV Board and chassis (3), For Main Board and PCB brackets (3)	Screw	3*6PWMHC W=7	01.00.WJ.JG.E451

HS250 Digital Lounge Component List			
Location.No.	Description	Specification	P/N
For rear panel and the bottom side of chassis (2), For top cover and bottom side of chassis (4)	Screw	3*4RBTTNI	01.00.WJ.JG.E252
For ICs and Heatsinks on SMPS Board (5) For Two sorts of Heatsinks on AV Board (2), and U512 on SMPS Board	Screw	3*8PBTTTC	01.00.WJ.JG.E417
For output jacks (4), For frequency modulation module (2), U-shaped holder(2)	Screw	3*8PAHO	01.00.WJ.JG.E321
For plastic scaleboard and rear panel (3)	Screw	3*10PAHO	01.00.WJ.JG.E675
For top cover and chassis, top cover and rear panel (5)	Screw	3*6PWBTTTO	01.00.WJ.JG.E403
For AC power socket (2)	Screw	3*12PMHO	01.00.WJ.JG.E865
For U503/D502 on SMPS Board *2, For IC(BD501,Q501) on SMPS Board *2	Screw	3*6PBTTTC	01.00.WJ.JG.E087
For power jack(2)	Nut	M3	01.00.WJ.JG.E119
For uncovered Screw drilled through the chassis	Screw Jacket	Φ3*4mm	01.00.FZ.TG.E025
For Heatsink and AV Board (2), For Two sorts of Heatsinks on AV Board (2)	Flat Pad	M3*0.5 W=8	01.00.WJ.JG.E426
For Insulated gasket and volume button Board	plastic rivet	MBL3-2.5	01.00.SJ.QT.E104
For Heatsink and AV Board (2), For Two sorts of Heatsinks on AV Board (2)	Spring Pad	M3	01.00.WJ.JG.E424
	Speaker Connective Stick	HS200 Connective Stick-Red	01.00.WJ.QT.E049
	Speaker Connective Stick	HS200 Connective Stick-Black	01.00.WJ.QT.E048
	Speaker Connective Stick	HS200 Connective Stick-White	01.00.WJ.QT.E050
	HDMI Cord	1770261-1(2M)	01.47.CNT.LJX.5.E2
	Power Cord	WS-002E+WS-019 HO5VV-F 0.75*2C BK 2M	01.47.CNT.ACX.E052
	Antenna	FM-TV-22 (Lead content less than 300PPM)	01.47.CNT.CTX.E016
	Loader	DL-05MH-H40P	01.15.JX.EDL05MH
IEC Head for FM Connector (NON-Screw Thread)	FM frequency modulation module	TFCF1E806A	01.49.E11
CN501 on SMPS Board to Power Jack with solder one end	Connect cable	VH-3Y Connector-2Y-120mm(Be same side)	01.47.CNT.LJX.7.E6
CN506 on SMPS Board to CN403(L) on AV(L) Board	Connect cable	VH-3Y Connector-2Y-2Y-60mm(Be same side)	01.47.CNT.LJX.7.E7
CN405 on AV Board to JP1.JP2.JP3.JP4 on Speaker Connected Board with solder one end	Connect cable	VH-4Y Connector-4Y-60mm(Be same side with color is White, Black, Red and Black)	01.47.CNT.LJX.7.E6
CN3(A) on Main Board to CN601(A) on Front Panel Board	Flat cable	1.0*14P*100mmA	01.48.BPX.1.E147
CN4(B) on Main Board to CN603(B) on Front Panel Board	Flat cable	1.0*8P*100mmA	01.48.BPX.1.E148
CN5(C) on Main Board to CN504(C) on SMPS Board	Flat cable	1.25*12P*80mmA(T=0.1mm)	01.48.BPX.1.E149
CN9(D) on Main Board to CN301(D) on AV Board	Flat cable	1.0*16P*80mmA	01.48.BPX.1.E150
CN8(E) on Main Board to CN302(E) on AV Board	Flat cable	1.0*24P*80mmA	01.48.BPX.1.E151
CN6(G) on Main Board to CN304(G) on AV Board	Flat cable	1.0*5P*80mmA	01.48.BPX.1.E152
CN503(H) on SMPS Board to CN602(H) on Front Panel Board	Flat cable	1.25*14P*70mmA(T=0.1mm)	01.48.BPX.1.E153
CN604(J)on Front Panel Board to CN605(J) on Volume Button Board	Flat cable	1.0*6P*40mmA	01.48.BPX.1.E154
CN505(K) on SMPS Board to CN402(K) on AV Board	Flat cable	1.25*9P*60mmA(T=0.1mm)	01.48.BPX.1.E155
For Loader and CN1 on Main Board	Flat cable	1.0*12P*220mmA	01.48.BPX.1.E156
For Loader and CN2 on Main Board	Flat cable	0.5*24P*200mmA	01.48.BPX.1.E028
For frequency modulation module and CN10 on Main Board	Flat cable	1.25*11P*50mmA	01.48.BPX.1.E157
4-layers	Main Board (semi-manufactured goods)	HAV07M-5228C02 (EU Vision+Hitachi Loader)	02.11.HAV07M5228C0
2-layers	AV Board (semi-manufactured goods)	HAV07I-5229C02(EU Vision)	02.14.HAV07I5229C0
2-layers	AV Board (semi-manufactured goods)	HAV06P-3521C02	02.19.HAV06P3521C0
2-layers	AV Board (semi-manufactured goods)	HAV07K-3519C02	02.15.HAV07K3519C0
2-layers	AV Board (semi-manufactured goods)	HAV06K-3518C01	02.15.HAV06K3518C0
2-layers	Speaker Connected Board	3523C	01.37.PCB.2.E3523C

HS250 DL Component List for Main Board (5228C02)			
Location.No.	Description	Specification	P/N
R4 R9 R45 R49 R50 FB53	Resistor, chip	0603-0Ω ±5%	01.57.R.2.E000J
R132 R156 R158	Resistor, chip	0603-10Ω±5%	01.57.R.2.E100J
R42 R43 R61 R62	Resistor, chip	0603-20Ω±5%	01.57.R.2.E200J
R29 R30 (R31) R32 (R33) R34 (R35) R36 (R37) R38	Resistor, chip	0603-22Ω±5%	01.57.R.2.E220J
R2 R47 R124 R125 R126 R127 R142 R145 R146 R147 R149 R151 R153 R155	Resistor, chip	0603-33Ω±5%	01.57.R.2.E330J
R6 (R41) (R71) (R120) (R121) R130 (R133) R139	Resistor, chip	0603-100Ω±5%	01.57.R.2.E101J
R150	Resistor, chip	0603-150Ω±5%	01.57.R.2.E151J
R8	Resistor, chip	0603-200Ω±5%	01.57.R.2.E201J
R19 R136 R137 R138 R140	Resistor, chip	0603-220Ω±5%	01.57.R.2.E221J
R173	Resistor, chip	0603-270Ω±5%	01.57.R.2.E271J
R167	Resistor, chip	0603-390Ω±5%	01.57.R.2.E391J
R141	Resistor, chip	0603-475Ω±1%	01.57.R.2.E4750F
R26 R77 R58	Resistor, chip	0603-1KΩ±5%	01.57.R.2.E102J
R80 R83	Resistor, chip	0603-1.2KΩ±5%	01.57.R.2.E122J
R79 R86	Resistor, chip	0603-1.5KΩ±5%	01.57.R.2.E152J
R160 R161	Resistor, chip	0603-1.8KΩ±5%	01.57.R.2.E182J
R13 R14 R15 R16 R18 R87 R92	Resistor, chip	0603-2KΩ±5%	01.57.R.2.E202J
R65 (R188) (R189)	Resistor, chip	0603-3KΩ±5%	01.57.R.2.E302J
R44 R46 R52	Resistor, chip	0603-3.9KΩ±5%	01.57.R.2.E392J
R5 R27 R55 R57 R63 R96 R131 R135 R162 R163 R168 R170 R178 R185 R186 R190 R191 R192	Resistor, chip	0603-4.7KΩ±5%	01.57.R.2.E472J
R89	Resistor, chip	0603-5.1KΩ±5%	01.57.R.2.E512J
R91	Resistor, chip	0603-6.8KΩ±5%	01.57.R.2.E682J
R24 R28 R56 R75 R76 R78 R82 R122 R123 R128 R129 R143 R144 R171 R172	Resistor, chip	0603-10KΩ±5%	01.57.R.2.E103J
R48 (R72)	Resistor, chip	0603-12KΩ±1%	01.57.R.2.E123F
R17	Resistor, chip	0603-15KΩ±5%	01.57.R.2.E153J
R84 R85	Resistor, chip	0603-22KΩ±5%	01.57.R.2.E223J
R90	Resistor, chip	0603-27KΩ±5%	01.57.R.2.E273J
R53	Resistor, chip	0603-33KΩ±5%	01.57.R.2.E333J
R51	Resistor, chip	0603-39KΩ±5%	01.57.R.2.E393J
R22 R54 R93 R95 R165	Resistor, chip	0603-47KΩ±5%	01.57.R.2.E473J
R73	Resistor, chip	0603-1MΩ±5%	01.57.R.2.E105J
R59 R60	Resistor, chip	0805-2Ω±1%	01.57.R.3.E2R0F
R3	Resistor, chip	1206-2Ω±5%	01.57.R.4.E020J
RN4	Resistor, thick film chip network	0603-10Ω*4 ±5%	01.57.R.8.EP1004
RN6 RN7 RN8 RN9 RN10 RN11	Resistor, thick film chip network	0603-33Ω*4 ±5%	01.57.R.8.EP3304
RN3	Resistor, thick film chip network	0603-4.7KΩ*4 ±5%	01.57.R.8.EP4724
RN1	Resistor, thick film chip network	0603-10KΩ*4 ±5%	01.57.R.8.EP1034
PTC1	Thermal Dependent Resistor, JinKe	JK-MSMD050 SMD	01.57.R.R.E050
C192	Capacitor, multilayer ceramic, chip	0603-3.3P NPO±0.25%/50V	01.54.CS.2.E3P3N50
(C64) (C65) (C146) (C147)	Capacitor, multilayer ceramic, chip	0603-6.8P NPO±0.25PF/50V	01.54.CS.2.E6P8N50
(C161) (C164)	Capacitor, multilayer ceramic, chip	0603-33P NPO±5%/50V	01.54.CS.2.E330N50
C97 C112	Capacitor, multilayer ceramic, chip	0603-100P NPO±5%/50V	01.54.CS.2.E101N50
C103 C116	Capacitor, multilayer ceramic, chip	0603-180P NPO±5%/50V	01.54.CS.2.E181N50
C84 C87 C115	Capacitor, multilayer ceramic, chip	0603-220P NPO±5%/50V	01.54.CS.2.E221N50
C162	Capacitor, multilayer ceramic, chip	0603-270P NPO±5%/50V	01.54.CS.2.E271N50
C129	Capacitor, multilayer ceramic, chip	0603-390P NPO±5%/50V	01.54.CS.2.E391N50
C82 C86 C90	Capacitor, multilayer ceramic, chip	0603-470P X7R±10%/50V	01.54.CS.2.E471X50
C163	Capacitor, multilayer ceramic, chip	0603-560P NPO±5%/50V	01.54.CS.2.E561N50
C105 C106 C108 C111	Capacitor, multilayer ceramic, chip	0603-680P X7R±10%/50V	01.54.CS.2.E681X50
C91 C94 C96 C99 C118 C119	Capacitor, multilayer ceramic, chip	0603-102 X7R±10%/50V	01.54.CS.2.E102X50
(C19)	Capacitor, multilayer ceramic, chip	0603-152 X7R±10%/50V	01.54.CS.2.E152X50
(C20)	Capacitor, multilayer ceramic, chip	0603-272 X7R±10%/50V	01.54.CS.2.E272X50
C113 C114 C120	Capacitor, multilayer ceramic, chip	0603-332 X7R±10%/50V	01.54.CS.2.E332X50

HS250 DL Component List for Main Board (5228C02)			
Location.No.	Description	Specification	P/N
C88	Capacitor, multilayer ceramic, chip	0603-472 X7R±10%/50V	01.54.CS.2.E472X50
C8	Capacitor, multilayer ceramic, chip	0603-103 Y5V-20+80%/50V	01.54.CS.2.E103Y50
C101	Capacitor, multilayer ceramic, chip	0603-153 Y5V-20+80%/50V	01.54.CS.2.E153Y50
C168 (C169)	Capacitor, multilayer ceramic, chip	0603-183 X7R±10%/50V	01.54.CS.2.E183X50
C16 C117 C127 C136	Capacitor, multilayer ceramic, chip	0603-223 X7R±10%/50V	01.54.CS.2.E223X50
C121 (C107)	Capacitor, multilayer ceramic, chip	0603-683 X7R±10%/50V	01.54.CS.2.E683X50
(C1) C3 C4 C6 C7 C9 C10 (C11) C12 C13 (C14) (C15) (C17) C18 (C21) (C22) C23 (C24) C25 (C26) (C27) (C28) (C29) (C30) C31 C32 (C33) (C34) (C35) (C36) (C37) (C38) (C39) C40 C41 C42 (C43) (C44) (C45) (C46) (C47) (C48) (C49) (C50) (C51) (C52) (C53) (C54) (C55) (C56) (C57) (C58) (C59) (C60) (C61) C62 (C63) C66 (C67) (C68) (C69) (C70) (C71) (C72) (C73) (C74) (C75) (C76) (C77) C78 (C79) (C80) C81 C83 C85 C89 C92 (C93) (C95) C102 C104 C109 (C110) C122 C123 C124 (C125) C126 (C128) C130 C131 C132 (C133) (C134) (C135) C148 (C150) C151 (C152) (C153) (C154) (C155) (C156) (C157) (C158) (C159) (C160) C165 C166 C167 (C170) (C171) (C172) (C173) (C174) (C175) (C176) (C177) C178 C179 (C180) (C181) C182 C183 C184 C185 C186 (C187) C188 C189	Capacitor, multilayer ceramic, chip	0603-104 Y5V-20+80%/50V	01.54.CS.2.E104Y50
(C0) C100 (C194) (C195) (C196) (C197) (C198) (C199)	Capacitor, multilayer ceramic, chip	0603-105 Y5V-20+80%/16V	01.54.CS.2.E105Y16
EC37	Capacitor, AL_electrolytic	CD110-2.2UF/16V 5*11	01.34.CL.D.E2U216V
EC41 EC42 EC46 EC47	Capacitor, AL_electrolytic	CD110-10UF/10V 5*11	01.34.CL.D.E10U10V
EC4 EC51	Capacitor, AL_electrolytic	CD110-10UF/16V 5*11	01.34.CL.D.E10U16V
EC43 EC44 EC45	Capacitor, AL_electrolytic	CD110-22UF/16V 5*11	01.34.CL.D.E22U16V
EC3 EC5 EC6 EC7 EC8 EC9 EC10 EC11 EC16 EC17 EC50	Capacitor, AL_electrolytic	CD110-47UF/10V 5*11	01.34.CL.D.E47U10V
EC18 EC19 EC22 EC23 EC52 EC54	Capacitor, AL_electrolytic	CD110-47UF/16V 5*11	01.34.CL.D.E47U16V
EC39	Capacitor, AL_electrolytic	CD110-47UF/25V 5*11	01.34.CL.D.E47U25V
EC2 EC13 EC14 EC15 EC35 EC36 EC49 EC56	Capacitor, AL_electrolytic	CD110-100UF/10V 5*12	01.34.CL.D.E100U10
EC1 EC12 EC20 EC21 EC24 EC40 EC48 EC53	Capacitor, AL_electrolytic	CD110-100UF/16V 5*11	01.34.CL.D.E100U16
EC38	Capacitor, AL_electrolytic	CD110-100UF/25V 6.3*12	01.34.CL.D.E100U25
EC55	Capacitor, AL_electrolytic	CD110-220UF/10V 5*12	01.34.CL.D.E220U10
EC34	Capacitor, AL_electrolytic	CD110-220UF/16V 6.3*12	01.34.CL.D.E220U16
FB16 FB18 FB20 FB22 FB23 FB24 FB25 FB26 FB27 FB28 FB29 FB30 FB31 FB32 FB33 FB47 (FB48) FB49 FB52	Bead, chip	0603-50Ω	01.13.L.Z.ESA50
FB1 FB5 FB7 FB9 FB11 (FB13) FB42 FB43 FB44 FB45 FB46	Bead, chip	0805-50Ω	01.13.L.Z.ESB50
R174	Bead, chip, QiLiXin	PBY160808T-102Y-N	01.13.L.Z.E102YN
FB3 FB4 FB6 FB8 FB12 FB14 FB17 FB34	Bead, leaded fixed	50Ω □3.5*6.0*0.8□	01.13.L.Z.ED50A
L1 L2	Inductor, multilayer ceramic, chip	1206-10UH	01.13.L.L.S.E018
B1 B2	Pulse transformer, TOKO	EJ219	01.13.L.R.E068
L3 L4 L5 L6	Inductor, multilayer ceramic, chip, TDK	ACM2012-900-2P	01.13.L.L.S.E242
D1 D2 D3	Diode	IN5393 DIP	01.41.D.PD.E5393
D4 D5 D6 D11	Diode	LL4148 SMD	01.41.D.PS.ELL4148
Q1 Q6	Transistor	2SB1132 SMD	01.42.Q.S.E1132
Q9	Mosfet	2SK3018T106 SMD	01.42.Q.S.E3018
Q3 Q10	Transistor	KTC8550 SMD	01.42.Q.S.EC8550
Q4	Transistor	KTC8050 SMD	01.42.Q.S.E8050
Y1	Crystal Oscillator,	27.00MHZ □□□□(□□)	01.00.JZ.E2700C
Y2	Crystal Oscillator,	6.000MHZ-49S-6.8P (□□)	01.00.JZ.E06000A
Y3	Crystal Oscillator,	4.332MHZ-49S-33P	01.00.JZ.E4332A

<b>HS250 DL Component List for Main Board (5228C02)</b>			
<b>Location.No.</b>	<b>Description</b>	<b>Specification</b>	<b>P/N</b>
U19	IC, ST, Voltage Regulator	L7809, TO-220	01.44.IC.D.EL7809
U20	IC, FairChild, Voltage Regulator	78L05, TO-92	01.44.IC.D.E78L05
U22	IC, ROHM, Dropout Voltage Regulator	BA33BC0T, TO-220	01.44.IC.D.EBA33B
U29	IC, AAC, LDO	AZ1117H-5.0, SOT-223	01.44.IC.S.E1117H
U23	IC, AAC, LDO	AZ1117H-1.8, SOT-223	01.44.IC.S.EA11171
U30	IC, AAC, LDO	AZ1117H-3.3, SOT-223	01.44.IC.S.EA11173
U1	IC, Rohm, LDO	BA00HC5FP, T0252-5	01.44.IC.S.EC5FP
U4	IC, Amllogic, A/V Processor	AML3390DTS-G, PQFP256LD	01.44.IC.S.EAML339
U9	IC, KH, FLASH	KH29LV160CBTC-70G (Can replaced by S29AL016M90TFI02), TSOP48	01.44.IC.S.E29LV16
U7 U8	IC, ISSI, SDRAM	IS42S16400B-6TL (Can repalced by K4S641632K-UC60), TSOP54	01.44.IC.S.E16400B
U5	IC, Xilinx, CPLD	XC9572XL-10VQG44C SMD	01.44.IC.S.E9572XL
U3	IC, Atmel, EEPROM	AT24C64-2.7, SO8	01.44.IC.S.E24C64
U12	IC, Amllogic, DVD/CD RF Processor	AML3501, TSSOP48	01.44.IC.S.E3501
U11	IC, Rohm, Actuator driver	BA5888FP, HSOP-28	01.44.IC.S.E5888
U6	IC, Rohm, Motor Driver	BA6287, SOP8	01.44.IC.S.E6287
U21	IC, Silicon Image, HDMI PanelLink Transmitter	SI19030CTU, TQFP80	01.44.IC.S.E9030
U13	IC, ST, Dual Operational Amplifier	LM358M, SO8	01.44.IC.S.ELM358M
U27	IC, Sharp, Photoelectric Coupler	PC817, DIP4	01.44.IC.D.EPC817
U17	IC, TDI, USB Controller	TDOTG242LPF, LQFP-64	01.44.IC.S.E242L
U18	IC, Rohm, RDS/RBDS Decoder	BU1924F, SOP16	01.44.IC.S.E1924
U2	IC, TI, Schmitt Trigger	74HCT14D, SO14	01.46.IC.E7414
U31	IC, NEC, MOS FIELD EFFECT TRANSISTOR	UPA672T, SC-70	01.44.IC.S.E672T
U28	IC, FairChild, Multiplexer/Demultiplexer Bus Switch	FSTU3257MTC, TSSOP16	01.44.IC.S.EFSTU32
U16 U24 U25 U26	IC, Semtech, Low Capalitance TVS Diode Array	RClamp0514M, MSOP-10L	01.44.IC.S.E0514
J4	HDMI Jack	1747981-1 SMD	01.40.CON.DCZ.E316
J7	USB Jack	USB-A-05 (ROHS, Mother Set)	01.40.CON.DCZ.E217
J5 J6	IR in/out jack	CKX-3.5-22	01.40.CON.DCZ.E203
CN12	Connector	PH-6A	01.40.CON.DPH.E028
CN1	FPC Connector, SMD	FPC-1.0-12P Vertical Type and Dual Conact	01.40.CON.S10.FPC1
CN5	FPC Connector	1.25-12P Vertical Type and Dual Conact	01.40.CON.S13.FPC2
CN6	FPC Connector	1.0-5P Vertical Type and Dual Conact	01.40.CON.S10.FPC2
CN4	FPC Connector	1.0-8P Vertical Type and Dual Conact	01.40.CON.S10.FPC2
CN3	FPC Connector	1.0-14P Vertical Type and Dual Conact	01.40.CON.S10.FPC2
CN9	FPC Connector	1.0-16P Vertical Type and Dual Conact	01.40.CON.S10.FPC2
CN8	FPC Connector	1.0-24P Vertical Type and Dual Conact	01.40.CON.S10.FPC2
CN10	FPC Connector	1.25-11P Vertical Type and Dual Conact	01.40.CON.DCZ.E062
CN2	FPC connector, SMD	FPC-0.5-24P Vertical Type and Dual Conact	01.40.CON.S05.E007

<b>HS250 DL Component List for AV Board (5229C02)</b>			
<b>Location.No.</b>	<b>Description</b>	<b>Specification</b>	<b>P/N</b>
R353	Resistor, chip	0603-10Ω±5%	01.57.R.2.E100J
R379	Resistor, chip	0603-560Ω±5%	01.57.R.2.E561J
R378	Resistor, chip	0603-75Ω±5%	01.57.R.2.E750J
R343	Resistor, chip	0603-110Ω±5%	01.57.R.2.E111J
R342 R385 R416	Resistor, chip	0603-150Ω±5%	01.57.R.2.E151J
R341	Resistor, chip	0603-220Ω±5%	01.57.R.2.E221J
R402	Resistor, chip	0603-270Ω±5%	01.57.R.2.E271J
R405	Resistor, chip	0603-300Ω±5%	01.57.R.2.E301J
R321 R328 R344	Resistor, chip	0603-330Ω±5%	01.57.R.2.E331J
R320 R327	Resistor, chip	0603-680Ω±5%	01.57.R.2.E681J
R410	Resistor, chip	0603-1KΩ±5%	01.57.R.2.E102J
R408 R409 R413	Resistor, chip	0603-1.5KΩ±5%	01.57.R.2.E152J
R319 R329	Resistor, chip	0603-1.78KΩ±1%	01.57.R.2.E1781F
R304 R312 R364 R370 R372 R374 R376 R380 R348 R391 R397 R396	Resistor, chip	0603-2.2KΩ±5%	01.57.R.2.E222J



HS250 DL Component List for AV Board (5229C02)			
Location.No.	Description	Specification	P/N
R399 R400	Resistor, chip	0603-3K $\Omega$ ±5%	01.57.R.2.E302J
R403	Resistor, chip	0603-3.3K $\Omega$ ±5%	01.57.R.2.E332J
R300 R305 R352 R389 R398	Resistor, chip	0603-4.7K $\Omega$ ±5%	01.57.R.2.E472J
R323 R324 R336 R337	Resistor, chip	0603-4.75K $\Omega$ ±1%	01.57.R.2.E4751F
R354 R355	Resistor, chip	0603-5.1K $\Omega$ ±5%	01.57.R.2.E512J
R326 R332	Resistor, chip	0603-7.5K $\Omega$ ±1%	01.57.R.2.E752F
R301 R302 R303 R307 R309 R311 R322 R325 R330 R331 R333 R339 R340 R345 R346 R347 R350 R351 R359 R360 R363 R365 R371 R373 R375 R377 R382 R387 R390 R392 R318 R406 R407 R411 R412 R433	Resistor, chip	0603-10K $\Omega$ ±5%	01.57.R.2.E103J
R334 R335 R381 R415 R388 R395	Resistor, chip	0603-47K $\Omega$ ±5%	01.57.R.2.E473J
R349 R356 R393	Resistor, chip	0603-100K $\Omega$ ±5%	01.57.R.2.E104J
R338	Resistor, chip	0603-549K $\Omega$ ±1%	01.57.R.2.E5493F
R418 R414	Resistor, chip	0805-1K $\Omega$ ±5%	01.57.R.3.E102J
R357 R358 R417 R419 R420	Resistor, chip	0805-10K $\Omega$ ±5%	01.57.R.3.E103J
(R427) (R428) (R429) (R430)	Resistor, chip	1206-6.2 $\Omega$ ±5%	01.57.R.4.E6R2J
R421 R422 R423 R424	Resistor, chip	1206-10 $\Omega$ ±5%	01.57.R.4.E100J
ESD307 ESD308 ESD309 ESD310 ESD311	Voltage Dependent Resistor, TDK	AVR-M1608C270MTABB SMD	01.57.R.Y.E270
C329 C330	Capacitor, multilayer ceramic, chip	0603-22P NPO±5%/50V	01.54.CS.2.E220N50
C406	Capacitor, multilayer ceramic, chip	0603-27P NPO±5%/50V	01.54.CS.2.E270N50
C325 C326	Capacitor, multilayer ceramic, chip	0603-47P NPO±5%/50V	01.54.CS.2.E470N50
C306 C314	Capacitor, multilayer ceramic, chip	0805-100P NPO±5%/50V	01.54.CS.3.E101N50
C317 C318 C405	Capacitor, multilayer ceramic, chip	0603-100P NPO±5%/50V	01.54.CS.2.E101N50
C421	Capacitor, multilayer ceramic, chip	0603-220P NPO±5%/50V	01.54.CS.2.E221N50
C332 C331	Capacitor, multilayer ceramic, chip	0603-470P NPO±5%/50V	01.54.CS.2.E471N50
C307 C311	Capacitor, multilayer ceramic, chip	0805-680P NPO±5%/50V	01.54.CS.3.E681N50
C404	Capacitor, multilayer ceramic, chip	0603-102 X7R±10%/50V	01.54.CS.2.E102X50
C422	Capacitor, multilayer ceramic, chip	0603-122 X7R±10%/50V	01.54.CS.2.E122X50
C305 C310 (C461) (C462) (C463) (C464)	Capacitor, multilayer ceramic, chip	0805-102 NPO±5%/50V	01.54.CS.3.E102N50
C400	Capacitor, multilayer ceramic, chip	0603-153 Y5V-20+80%/50V	01.54.CS.2.E153Y50
C308 C309 C312 C313 C315 C316 C319 C320 C322 C323 C324 C327 C328 C333 C412 C418 C419	Capacitor, multilayer ceramic, chip	0603-104 Y5V-20+80%/50V	01.54.CS.2.E104Y50
C423 C424 C425 C426 C427	Capacitor, multilayer ceramic, chip	0603-104 X7R±10%/50V	01.54.CS.2.E104X50
C336	Capacitor, multilayer ceramic, chip	0603-223 X7R±10%/50V	01.54.CS.2.E223X50
(C434) (C436) (C447) (C448) (C449) (C450) (C451) (C452) (C453) (C465)	Capacitor, multilayer ceramic, chip	0805-104 X7R±10%/50V	01.54.CS.3.E104X50
C401 (C402) (C403) (C407) C408 (C410) (C411) (C413) (C414) (C415) (C416) (C417)	Capacitor, multilayer ceramic, chip	0805-104 Y5V+80-20%/50V	01.54.CS.3.E104Y50
C441 C442 C443 C444	Capacitor, multilayer ceramic, chip	1206-680P NPO±5%/50V	01.54.CS.4.E681N50
EC304 EC305 EC306 EC308 EC315 EC316 EC318 EC320 EC327 EC328	Capacitor, AL.electrolytic	CD110-10UF/16V 5*11	01.34.CL.D.E10U16V
EC402	Capacitor, AL.electrolytic	CD288H-10UF/25V 5*11	01.34.CL.D.E10U25V
EC302 EC303 EC307 EC310	Capacitor, AL.electrolytic	CD110-47UF/16V 5*11	01.34.CL.D.E47U16V
EC313 EC314 EC324 EC400 EC401	Capacitor, AL.electrolytic	CD110-47UF/25V 5*11	01.34.CL.D.E47U25V
EC312 EC322 EC323 EC403 EC404	Capacitor, AL.electrolytic	CD110-100UF/16V 5*11	01.34.CL.D.E100U16
EC321	Capacitor, AL.electrolytic	CD110-100UF/25V 6.3*12	01.34.CL.D.E100U25
EC309 EC311 EC325	Capacitor, AL.electrolytic	CD110-220UF/16V 6.3*12	01.34.CL.D.E220U16
EC317 EC319 EC326	Capacitor, AL.electrolytic	CD110-1UF/50V 5*11	01.34.CL.D.E1U50VC
EC405	Capacitor, AL.electrolytic	GF102M050I250A	01.34.CL.D.E1000U5
C409 C420	Solid Electrolyte Tantalum Chip Capacitor	B-22UF-10V	01.33.CT.EB22U10V



HS250 DL Component List for AV Board (5229C02)			
Location.No.	Description	Specification	P/N
(C433) (C435)	Capacitor, multilayer ceramic, chip	1206-105 X7R±10%/50V	01.54.CS.4.E105X50
C459 C458	Box-type metallized polyester film capacitor	474J/100V DIP	01.00.CD.DL.E47410
FB306 FB307	Bead, chip	0603-50Ω	01.13.L.Z.ESA50
FB403 FB404 FB406 FB408 FB409 FB410 FB413	Bead, chip	0805-50Ω	01.13.L.Z.ESB50
FB411 FB412	Bead, chip	0805-300Ω	01.13.L.Z.ESB300
FB401 FB402 FB405 FB407	Bead, leaded fixed	50Ω □ 3.5*6.0*0.8 □	01.13.L.Z.ED50A
L400 L401 L402 L403	Magnetic shielding Inductor	983BN-1003-15UH	01.13.L.L.D.E127
D300 D301 D302 D303 D304 D305 D306 D307 D400 D401 D402	Diode	LL4148, DO213AA	01.41.D.PS.ELL4148
Q300 Q302 Q402	Transistor	KTC8050, SOT23	01.42.Q.S.E8050
Q301 Q303 Q311 Q401	Transistor	KTC8550, SOT23	01.42.Q.S.EC8550
Q307 Q308 Q309 Q310 Q400	Transistor	DTC343TK, SMT3	01.42.Q.S.E343
Q312	Transistor	DTC114EUA, UMT3	01.42.Q.S.E114
U406	IC, AAC, LDO	AZ1117H-3.3, SOT-223	01.44.IC.S.EA11173
U301	IC, NS, Operational Amplifier	LM833M, SOP8	01.44.IC.S.E833
U302	IC, Wolfson, Stereo audio CODEC	WM8776SEFT, TQFP48	01.44.IC.S.E8776
U402	IC, ST, Digital Audio Processor	STA308A, TQFP64	01.44.IC.S.ETA308
U306 U305 U405	IC, JRC, Pre-amp	NJM2068M, SO8	01.44.IC.S.E2068
U403	IC, ST, Power Half Bridge	STA508, PowerSO36	01.44.IC.S.ETA508
U303	IC, TI or TOSHIBA, Quad 2-input Multiplexer	74HC158, SOP16	01.44.IC.S.E74HC15
U401	IC, Analogic Tech, Reset monitor	AAT3522, SOT-23	01.44.IC.S.E3522
U304	IC, TI, Hex Inverter	74HCU04, TSSOP14	01.46.IC.E74H04
CN402	FPC Connector	1.25-9P Vertical Type and Dual Conact	01.40.CON.S13.FPC2
CN304	FPC Connector	1.0-5P Vertical Type and Dual Conact	01.40.CON.S10.FPC2
CN301	FPC Connector	1.0-16P Vertical Type and Dual Conact	01.40.CON.S10.FPC2
CN302	FPC Connector	1.0-24P Vertical Type and Dual Conact	01.40.CON.S10.FPC2
CN405	Connector	Vertical VH Connector with four holes and four pins	01.40.CON.DCZ.E244
CN403	Connector	Vertical VH Connector with three holes and two pins	01.40.CON.DCZ.E129
J304	Jack, Sharp, Fiber optic iuput jack with shutter	GP1FA513RZ, In-line Package	01.43.E004
J401	Jack, YuanChang, SUB Tirgger Jack	CKX-3.5-22	01.40.CON.DCZ.E203
J402	Jack, YuanChang, SUB Woofer Jack	AV1-8.4-6G	01.40.CON.DCZ.E172
J302	Jack, YuanChang, Audio Input/Output Jack	AV8-8.4-13/PB	01.40.CON.DCZ.E468
J303	Connector, JAE, iPod Connector	DA1R018H91E SMD	01.40.CON.DCZ.E243
PTC400	Resettable Fuse, JinKe	JK-MSMD010 SMD	01.57.R.R.E010
R519 R578 R589 R591	Resistor, chip	0805-10Ω±5%	01.57.R.3.E100J
R568 R509	Resistor, chip	0805-22Ω±5%	01.57.R.3.E220J
R569	Resistor, chip	0805-47Ω±5%	01.57.R.3.E470J
R517	Resistor, chip	0805-100Ω±5%	01.57.R.3.E101J
R525 R536 R553 R580	Resistor, chip	0805-470Ω±5%	01.57.R.3.E471J
R535 R538 R542 R544 R546 R551 R554 R555 R598	Resistor, chip	0805-1KΩ±5%	01.57.R.3.E102J
R541 R537	Resistor, chip	0805-2KΩ±5%	01.57.R.3.E202J
R531 R543	Resistor, chip	0805-3KΩ±1%	01.57.R.3.E302F
R533 R534	Resistor, chip	0805-3.6KΩ±1%	01.57.R.3.E362F
R540 R547 R552 R556 R560 R576	Resistor, chip	0805-4.7KΩ±5%	01.57.R.3.E472J
R508 R524 R549 R571 R577 R579 R587 R532 R590	Resistor, chip	0805-10KΩ±5%	01.57.R.3.E103J
R511	Resistor, chip	0805-13KΩ±1%	01.57.R.3.E133F
R503	Resistor, chip	0805-15KΩ±5%	01.57.R.3.E153J
R504 R592 R593 R594	Resistor, chip	0805-20KΩ±5%	01.57.R.3.E203J
R567	Resistor, chip	0805-27KΩ±5%	01.57.R.3.E273J
R545	Resistor, chip	0805-39KΩ±1%	01.57.R.3.E393F
R566	Resistor, chip	0805-150KΩ±5%	01.57.R.3.E154J
R505	Resistor, chip	0805-360KΩ±5%	01.57.R.3.E364J
R506 R507 R510 R512	Resistor, chip	1206-0.47Ω±5%	01.57.R.4.ER47J
R522	Resistor, chip	1206-100Ω±5%	01.57.R.4.E101J
R526	Resistor, chip	1206-200Ω±5%	01.57.R.4.E201J
R581 R582 R583 R584 R585 R586	Resistor, chip	1206-330Ω±1%	01.57.R.4.E331F

HS250 DL Component List for SMPS Board (3521C02)			
Location.No.	Description	Specification	P/N
R513 R596 R597	Resistor, chip	1206-10KΩ±5%	01.57.R.4.E103J
R529 R520 R514	Resistor, chip	1206-150KΩ±5%	01.57.R.4.E154J
R501 R502	Resistor, chip	1206-560KΩ±5%	01.57.R.4.E564J
R518	Resistor, chip	1206-620KΩ±1%	01.57.R.4.E624F
R515 R516	Resistor, chip	1206-680KΩ±1%	01.57.R.4.E684F
R562 R563 R564 R565	Resistor, chip	1206-3MΩ±5%	01.57.R.4.E305J
R573 R574	Resistor, chip	1206-3.3MΩ±5%	01.57.R.4.E335J
R570	FIXED CARBON FILM	RT1/4W-1KΩ	01.57.R.C.ED102
R548	FIXED CARBON FILM	RT1W-100Ω	01.57.R.C.EF101
R530	FIXED CARBON FILM	RT1W-68KΩ±5%	01.57.R.C.EF683
R521	FIXED CARBON FILM	RT1W-100KΩ	01.57.R.C.EF104
R572	FIXED CARBON FILM	RT3W-0.3Ω	01.57.R.C.EHR3
R595	FIXED CARBON FILM	RT3W-470Ω	01.57.R.C.EH471
RZ503	Voltage Dependent Resistor	10K.471	01.57.R.Y.E10K
RZ501	Thermmal Dependent Resistor	NTC-5D-11	01.57.R.R.E5D11
2 in 1 at R558	High-Resistance Cermet Resistor ,KOA	RCR60-1W-11MΩ	01.57.R.C.E60F116
RZ502	Resettable Fuse, JinKe	JK16 300	01.57.R.R.EJK16300
C510	Capacitor, multilayer ceramic, chip	0805-47P NPO±5%/50V	01.54.CS.3.E470N50
C533	Capacitor, multilayer ceramic, chip	0805-330P NPO±5%/50V	01.54.CS.3.E331N50
C519 C536	Capacitor, multilayer ceramic, chip	0805-102 X7R ±10%/50V	01.54.CS.3.E102X50
C534	Capacitor, multilayer ceramic, chip	0805-103 X7R±10%/50V	01.54.CS.3.E103X50
C503 C532	Capacitor, multilayer ceramic, chip	0805-473 X7R±10%/50V	01.54.CS.3.E473X50
C517 C518 C521 C522 C523 C524 C525 C526 C527 C528 C529 C530 C537 C538 C539 C541 C542 C543 C544 C545 C547 C548	Capacitor, multilayer ceramic, chip	0805-104 Y5V+80-20%/50V	01.54.CS.3.E104Y50
C504 C516	Capacitor, multilayer ceramic, chip	0805-224 Y5V-20+80%/50V	01.54.CS.3.E224Y50
C535	Capacitor, multilayer ceramic, chip	0805-474 Y5V+80-20%/50V	01.54.CS.3.E474Y50
C511	Capacitor, multilayer ceramic, chip	C3216Y5V1H105ZT	01.35.CC.E12061U50
C546	Capacitor, multilayer ceramic, chip	1808-150P NPO±5%/1KV	01.54.CS.6.E151N1K
C507	Radial Monolithic Capacitor	473/50V X7R±10% (lead pitch: 5.08mm)	01.00.CD.DS.E473/5
C531	Radial Monolithic Capacitor	104/50V X7R±10% (lead pitch: 5.08mm)	01.00.CD.DS.E10450
C509	Metallized capacitor	472/630V (lead pitch: 10mm)	01.00.CD.JZ.E47263
C505 C515	Metallized capacitor	103/630V (lead pitch: 10mm)	01.00.CD.JZ.E10363
C502	Metallized capacitor	105/400V(lead pitch: 15mm)	01.00.CD.JZ.E10540
C520	High-voltage metallized polyester film	471/1KV	01.00.CD.GY.E4711K
CX502 CX503	High-voltage metallized polyester film	224/275V X2 (lead pitch: 15mm)	01.00.CD.GY.E22427
CX501	High-voltage metallized polyester film	334/275V X2 (lead pitch: 15mm)	01.00.CD.GY.E33427
CY503 CY504 CY501 CY502	High-voltage metallized polyester film	102/400V(X1) 250V(Y1) (lead pitch: 10mm)	01.00.CD.GY.E10240
CY505	High-voltage metallized polyester film	471/400V (X1) 250V (Y1) (lead pitch: 10mm)	01.00.CD.GY.E47140
EC501 EC503 EC504 EC505	CAPACITOR,AL.ELE CTROLYTIC	GF470M050E110A	01.34.CL.D.EH47U50
EC513 EC514	CAPACITOR,AL.ELE CTROLYTIC	GF471M016F115A	01.34.CL.D.EH470U1
EC511 EC512 EC515 EC516 EC526 EC521 EC524 EC525 EC509 EC510 EC523	CAPACITOR,AL.ELE CTROLYTIC	470UF/25V 8*20 ±20% 105 Low ESR	01.34.CL.D.E470U25
EC517 EC519 EC527	CAPACITOR,AL.ELE CTROLYTIC	GF102M050I250A	01.34.CL.D.E1000U5

<b>HS250 DL Component List for SMPS Board (3521C02)</b>			
<b>Location.No.</b>	<b>Description</b>	<b>Specification</b>	<b>P/N</b>
EC518	CAPACITOR,AL.ELE CTROLYTIC	GF152M050J410A	01.34.CL.D.E1500U5
EC507 EC508	CAPACITOR,AL.ELE CTROLYTIC	CD288H-2200UF/16V 13*25	01.34.CL.D.E288220
EC522 EC506 EC520	CAPACITOR,AL.ELE CTROLYTIC	GF222M010G200A	01.34.CL.D.E288220
EC502	CAPACITOR,AL.ELE CTROLYTIC	HP181M450N510A	01.34.CL.D.E180U45
EC528	CAPACITOR,AL.ELE CTROLYTIC	KM680M050E110A	01.34.CL.D.E28868U
FB501	Color Code Inductor	4.7UH	01.13.L.L.D.E071
LF502 LF501	Common Mode Inductor	LCL-303A, DIP	01.13.L.L.D.E192
L507 L502	Pulse transformer	L0620-050, DIP	01.13.L.L.D.E077
L508	Filter inductor	L-200A, DIP	01.13.L.L.D.E141
LF503	Common Mode Choke	LCL-471	01.13.L.L.D.E018
T502	Transformer	BCK-ER2869	01.13.L.R.E122
T503	Switching Power Transformer	BCK-ER4203	01.13.L.R.E123
T501	step-up inductor	L-PQ3230-01, DIP	01.13.L.L.D.E194
L503 L504 L505 L506	Inductor , leaded fixed	LH0608-22UH	01.13.L.L.D.E051
L509 L510	Inductor , leaded fixed	100Q,F10 RHW3.5*9*0.8-T	01.13.L.Z.ED100
D501 D519 D520	Diode	LL4148, DO213AA	01.41.D.PS.ELL4148
D517	Diode	SK53C, SMD	01.41.D.PS.ESK53C
D506 D505 D503 D511 D512	Diode	FR104, In Line Package	01.41.D.PD.EFR104
D508 D504	Diode	HER208G, In Line Package	01.41.D.PD.EHER208G
D513	Diode	21DQ06, In Line Package	01.41.D.PD.EDQ06
D514 D509	Diode	21DQ10, In Line Package	01.41.D.PD.E21DQ10
D516 D515	Diode	MBRF20200CT , In Line Package	01.41.D.PD.EMBRF20
D502	Diode	ISL9R860PF2 , In Line Package	01.41.D.PD.E9R860
D510	Diode	FYPF2010DN , In Line Package	01.41.D.PD.E2010DN
BD501	Diode bridge	GBU806, In Line Package	01.41.D.PD.EGBU806
Z501 Z502 Z505 Z506	Zener Diode	18V, DO213AA	01.41.D.WS.E18V
Z503 Z504	Zener Diode	DDZ9707-F(20V), SMD	01.41.D.WS.EDDZ970
Q510	Transistor	KTC8050, SOT23	01.42.Q.S.E8050
Q511	Transistor	KTC8550, SOT23	01.42.Q.S.EC8550
Q504 Q507	Transistor	2N3904, SOT23	01.42.Q.S.E2N3904
Q505	Transistor	2N3906, SOT23	01.42.Q.S.E2N3906
Q513	Transistor	2SA1037AKR, SMT3	01.42.Q.S.E1037
Q514	Transistor	2SC5866, TSMT3	01.42.Q.S.E5866
Q503 Q508	Mosfet	AF4835, SOP8	01.44.IC.S.E4835
Q506	Mosfet	AF2302, SOT23	01.44.IC.S.E2302
Q509	Mosfet	FQA11N90, TO-3P	01.44.IC.D.E11N90
Q501	Mosfet	FQPF13N50C, TO-220F	01.44.MOS.D.EFQPF1
U510	IC, AAC, LDO	AZ1117H-3.3, SOT-223	01.44.IC.S.EA11173
U503	IC, Fairchild, Power Switch	KA5L0380RYDTU, TO-220F-4L	01.44.IC.D.E5L0380
U511	IC, Fairchild or ShiBao, Voltage Regulator	KA278R05CTU, TO-220F-4L	01.44.IC.D.E278R05
U508	IC, Fairchild, Voltage Regulator	KA78R05CTU, TO-220F-4L	01.44.IC.D.E78R05C
U514	IC, Fairchild, Voltage Regulator	KA78R12, TO-220F-4L	01.44.IC.D.E78R12
U512	IC, Fairchild, Voltage Regulator	KA7812, TO-220	01.44.IC.D.EKA7812
U513	IC, Fairchild, Voltage Regulator	KA7912, TO-220	01.44.IC.D.EKA7912
U505 U504 U502 U515	IC, Sharp, Photoelectric Coupler	PC817, DIP4	01.44.IC.D.EPC817
U507 U509	IC, AAC, Shunt Regulator	KA431LZTA 0.5%, TO-92	01.44.IC.D.EKA431
U501	IC, Fairchild/ShiBao, PFC Controller	FAN7528MX , SOP8	01.44.IC.S.EFAN752
U506	IC, Fairchild/ShiBao, PWM Controller	FAN7602MX , SOP8	01.44.IC.S.EFAN760
CN501 CN506	Connector	Vertical VH Connector with three holes and two pins	01.40.CON.DCZ.E129
F501	Fuse	32S 3.15A 250V, In Line Package	01.38.FUSE.D.E32S3
CN503	FPC Connector	1.25-14P Vertical Type and Dual Conact	01.40.CON.S13.FPC2
CN504	FPC Connector	1.25-12P Vertical Type and Dual Conact	01.40.CON.S13.FPC2
CN505	FPC Connector	1.25-9P Vertical Type and Dual Conact	01.40.CON.S13.FPC2
G501 G503 G502	3pins grounding piece	M4	01.00.WJ.QT.E041
Match for Q509 on SMPS Board	Sil-pad	sil-pad 400-3022	01.00.DP.QT.E113

HS250 DL Component List for Front panel board (3519C02)			
Location.No.	Description	Specification	P/N
(R645) (R646) (R668)	Resistor, chip	0805-0Ω ±5%	01.57.R.3.E000J
(R606) (R607) (R638) (R641) (R656) (R657) (R659)	Resistor, chip	0805-100Ω±5%	01.57.R.3.E101J
(R614) (R647)	Resistor, chip	0805-200Ω±5%	01.57.R.3.E201J
(R605)	Resistor, chip	0805-470Ω±5%	01.57.R.3.E471J
(R615) (R648)	Resistor, chip	0805-510Ω±5%	01.57.R.3.E511J
(R608) (R652)	Resistor, chip	0805-2KΩ±1%	01.57.R.3.E202F
(R644)	Resistor, chip	0805-2.2KΩ±5%	01.57.R.3.E222J
(R601) (R603) (R604) (R609) (R610) (R611) (R612) (R613) (R655)	Resistor, chip	0805-4.7KΩ±5%	01.57.R.3.E472J
(R637)	Resistor, chip	0805-6.2KΩ±1%	01.57.R.3.E622F
(R640) (R642) (R643)	Resistor, chip	0805-10KΩ±5%	01.57.R.3.E103J
(R602)	Resistor, chip	0805-15KΩ±5%	01.57.R.3.E153J
(R636)	Resistor, chip	0805-20KΩ±5%	01.57.R.3.E203J
(R666)	Resistor, chip	0805-62KΩ±5%	01.57.R.3.E623J
□R654 □ R661 □	Resistor, chip	1206-3.3Ω±5%	01.57.R.4.E3R3J
□R653 □	Resistor, chip	1206-200Ω±5%	01.57.R.4.E201J
(R639) (R660)	Resistor, chip	1206-10KΩ±5%	01.57.R.4.E103J
(ESD601) (ESD602) (ESD603)	Voltage Dependent Resistor, TDK	AVR-M1608C270MTABB SMD	01.57.R.Y.E270
(C604) (C605)	Capacitor, multilayer ceramic, chip	0805-22P NPO±5%/50V	01.54.CS.3.E220N50
(C620)	Capacitor, multilayer ceramic, chip	0805-39P NPO±5%/50V	01.54.CS.3.E390N50
(C610)	Capacitor, multilayer ceramic, chip	0805-47P NPO±5%/50V	01.54.CS.3.E470N50
(C611) (C612)	Capacitor, multilayer ceramic, chip	0805-56P NPO±5%/50V	01.54.CS.3.E560N50
(C625)	Capacitor, multilayer ceramic, chip	0805-123 X7R±10%/50V	01.54.CS.3.E123X50
(C618) (C626)	Capacitor, multilayer ceramic, chip	0805-473 X7R±10%/50V	01.54.CS.3.E473X50
(C606) (C607) (C608) (C627) (C628) (C629) (C630) (C633) (C634) (C635)	Capacitor, multilayer ceramic, chip	0805-104 Y5V+80-20%/50V	01.54.CS.3.E104Y50
(C636)	Capacitor, multilayer ceramic, chip	0805-104 X7R±10%/100V	01.54.CS.3.E104X10
(C624)	Capacitor, multilayer ceramic, chip	0805-105 Y5V-20+80%/16V	01.54.CS.3.E105Y16
(C603) (C619)	Capacitor, multilayer ceramic, chip	0805-225 Y5V-20+80%/16V	01.54.CS.3.E225Y16
(C637)	Solid Electrolyte Tantalum Chip Capacitor	T491B476K010AT	01.33.CT.EB47U10V
EC616 EC617	Capacitor, AL.electrolytic	CD11X-10UF/16V 4*7	01.34.CL.D.E10U16V
EC603	Capacitor, AL.electrolytic	CD110-33UF/10V 5*11	01.34.CL.D.E33U10V
EC601 EC620	Capacitor, AL.electrolytic	CD11X-47UF/16V 5*7	01.34.CL.D.E47U16V
EC607 EC608	Capacitor, AL.electrolytic	CD110-47UF/50V 6.3*12	01.34.CL.D.E47U50V
EC602	Capacitor, AL.electrolytic	CD11X-100UF/16V 6.3*7	01.34.CL.D.EX100U1
EC605	Capacitor, AL.electrolytic	CD110-100UF/25V 6.3*12	01.34.CL.D.E100U25
EC621	Capacitor, AL.electrolytic	CD11X-220UF/6.3V 6*7	01.34.CL.D.E220U6V
EC606	Capacitor, AL.electrolytic	GF101M063G125A	01.34.CL.D.E100U63
L601	Magnetic shielding Inductor	TH11009-331(330UH) DIP	01.13.L.L.D.E208
(FB601) (FB602) (FB603)	Bead, chip	0805-50Ω	01.13.L.Z.ESB50
Y601	Quartz Crystal Unit	4.000MHZ-49S-22P	01.00.JZ.E04000
(D601) (D602) (D603) (D605)	Diode	LL4148, DO213AA	01.41.D.PS.ELL4148
(D606)	Schottky Rectifier	5819 1A, SS14	01.41.D.PS.E5819
LED601 LED602	LED, color is blue & amber	HFT503CPB0, DIP	01.41.D.FD.E503
(Q603)	Transistor	KTC8550, SOT23	01.42.Q.S.EC8550
(Q602)	Transistor	KTC8050, SOT23	01.42.Q.S.E8050
(DZ601)	Zener Diode	6.2V, DO213AA	01.41.D.WS.E6V2
(U605)	IC, NS, Vacuum Fluorescent Display Filament Driver	LM9022M, SO8	01.44.IC.S.E9022
(U604)	IC, ONSEMI, DC/DC Converter	MC34063ADG, SO8	01.44.IC.S.EMC3406
U601	IC, ELAN, MCU	EM78P156ELM-G, SOIC18	01.46.IC.E78P156G
IR601	IC, IR receiver	HL38B17, In Line Package	01.44.IC.D.E38B17
(U602)	IC, Semtech, Low Capalitance TVS Diode Array	RClamp0514M, MSOP-10L	01.44.IC.S.E0514

<b>HS250 DL Component List for Front panel board (3519C02)</b>			
<b>Location.No.</b>	<b>Description</b>	<b>Specification</b>	<b>P/N</b>
CN601	FPC Connector	1.0-14P, Vertical Type and Dual Contact	01.40.CON.S10.FPC2
CN602	FPC Connector	1.25-14, Vertical Type and Dual Contact	01.40.CON.S13.FPC2
CN603	FPC Connector	1.0-8P, Vertical Type and Dual Contact	01.40.CON.S10.FPC2
CN604	FPC Connector	1.0-6P, Vertical Type and Dual Contact	01.40.CON.S10.FPC2
K602 K601	Touch switch	KFC-A06-05, Vertical Type	01.39.SW.QC.EDKFC
J602	Earphone Jack	CKX-3.5-12	01.40.CON.DCZ.E219
J601	USB Jack	USB-A-05 (ROHS, Mother Set)	01.40.CON.DCZ.E217
VFD601	VFD	VFD33-1701I	01.16.E1701I

<b>HS250 DL Component List for Front panel board (3518C01)</b>			
<b>Location.No.</b>	<b>Description</b>	<b>Specification</b>	<b>P/N</b>
(R617) (R618) (R616)	Resistor, chip	0805-4.7K $\Omega$ ±5%	01.57.R.3.E472J
(R622) (R623) (R624) (R625)	Resistor, chip	0805-180 $\Omega$ ±5%	01.57.R.3.E181J
(C601) (C602)	Capacitor, multilayer ceramic, chip	0805-820P NPO±5%/50V	01.54.CS.3.E821N50V
(C614)	Capacitor, multilayer ceramic, chip	0805-104 Y5V+80-20%/50V	01.54.CS.3.E104Y50V
(Q601)	Transistor	2N3904, SOT23	01.42.Q.S.E2N3904
(Q604) (Q605)	Transistor	KTC8550, SOT23	01.42.Q.S.EC8550
LED603 LED604 LED605 LED606	LED	HZFBFA65018CP $\Phi$ 5, DIP	01.41.D.FD.EHZFBFA6
CN605	FPC Connector	1.0-6P Horizontal Type and Dual Conact	01.40.CON.S10.FPC2
W601	Volume encoder ,pulse	ED1612-24-24-HC-F20(2)	01.36.VR.E20K



IS42S16400B-6TL;SDRAM  
(TSSOP-54)

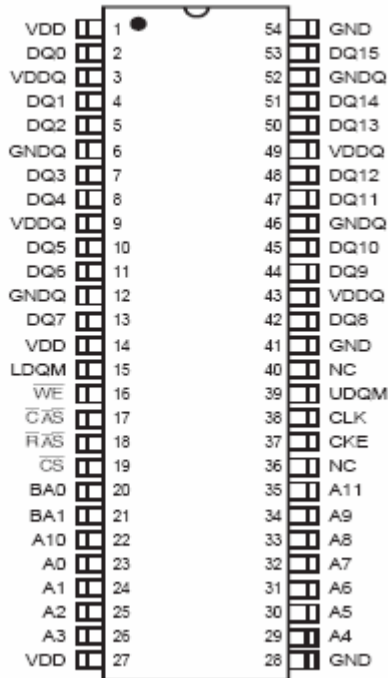

AML3501;DVD/CD RF  
Processor (TSSOP48)

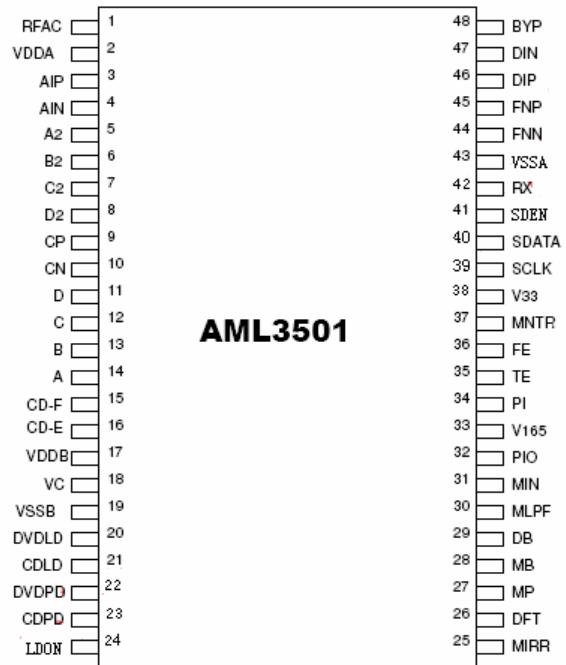

BA5888FP; Actuator driver  
(HSOP-28)

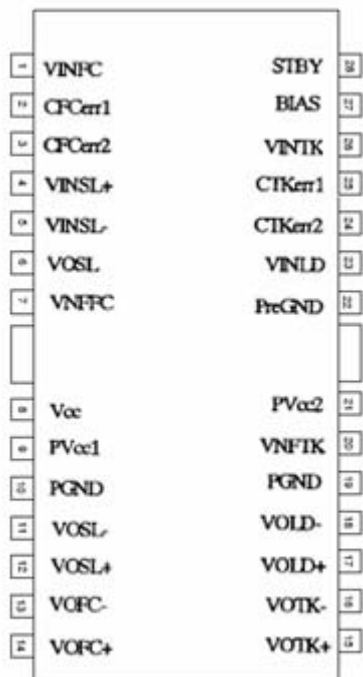

BU1924F; RDS/RBDS  
Decoder (SOP16)

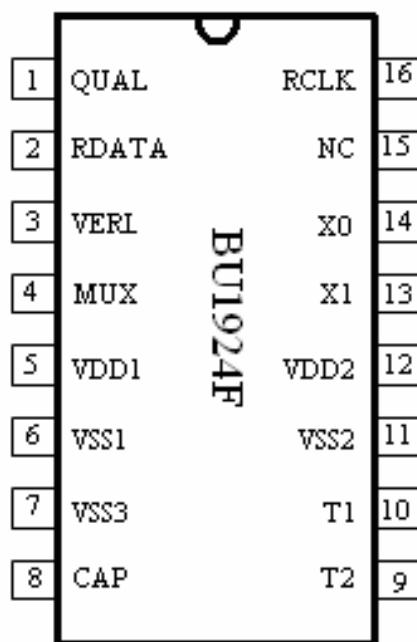



### XC9572XL-10VQG44C; CPLD (VQFP44)

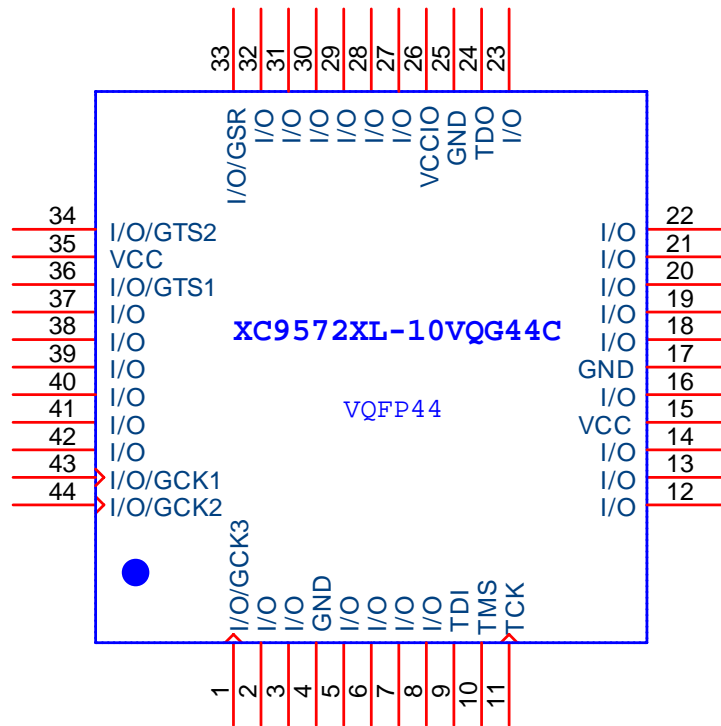

### TDOTG242LPF; USB Controller (LQFP-64)

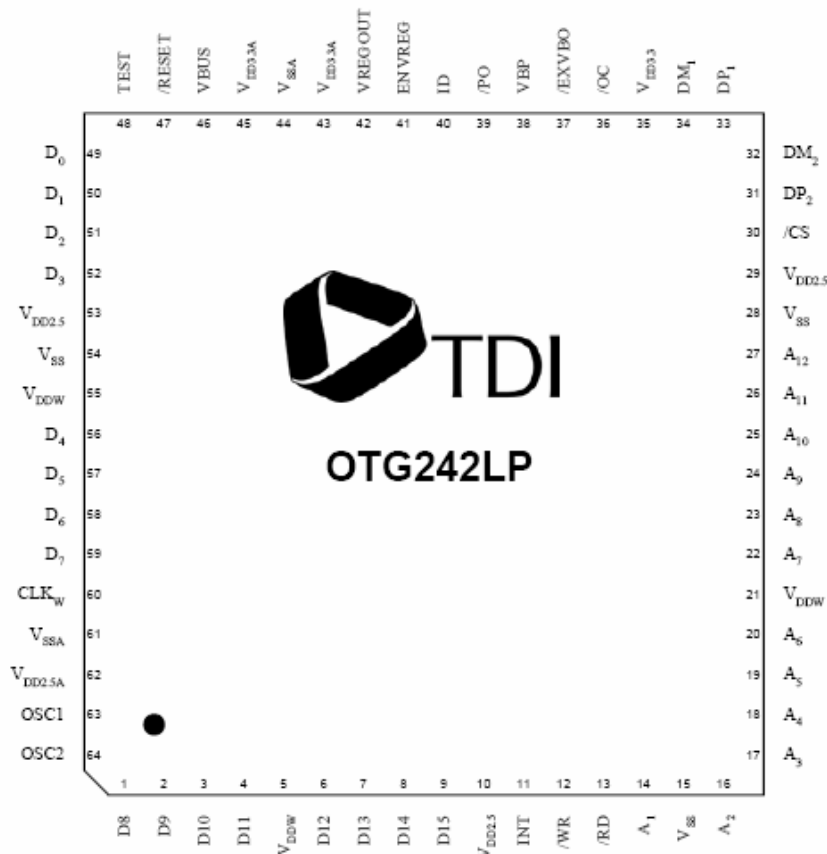



### SiI9030CTU; HDMI Panellink Transmitter (TQFP80)

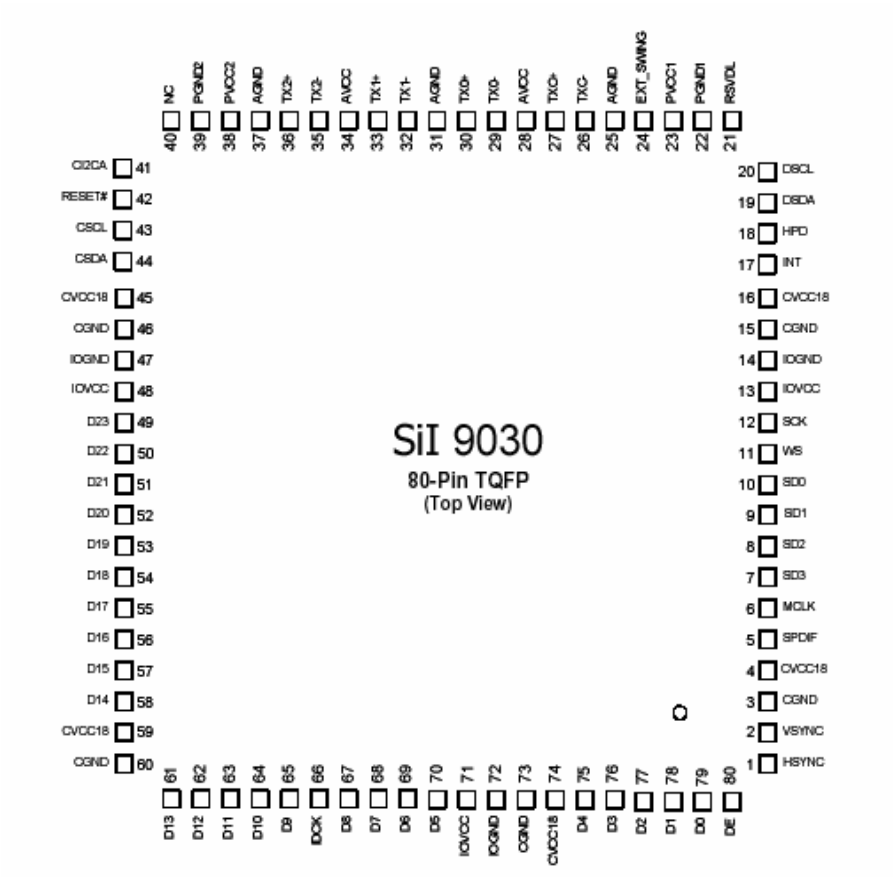

### ADA4410-6ACPZ; Integrated Vidio Filter (CP-32-3)

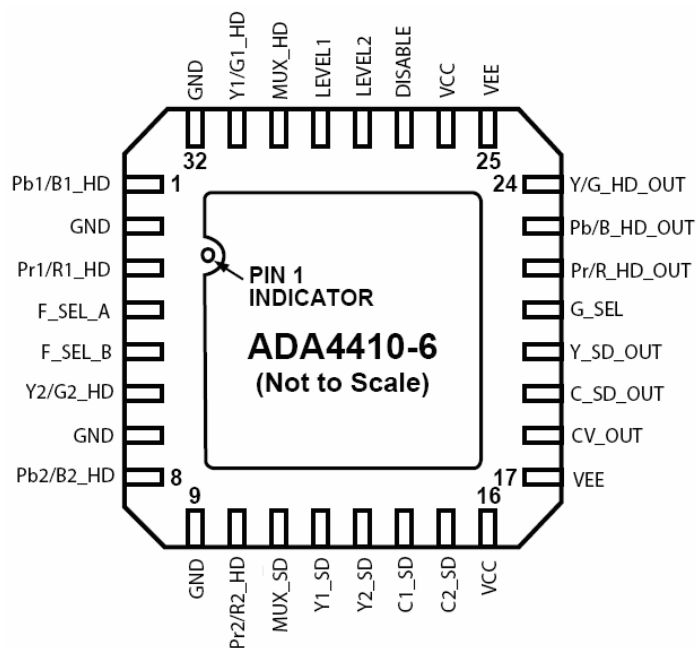

LM358M; Dual Operational Amplifier (SOP8)

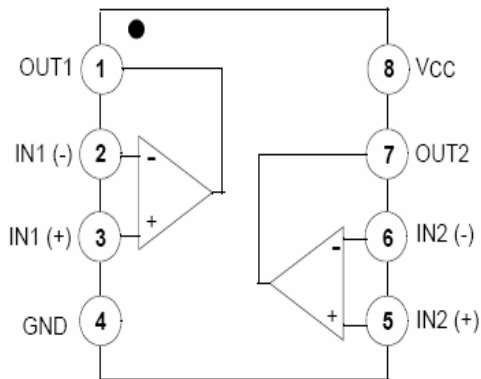

AT24C64-2.7; EEPROM (SO8)

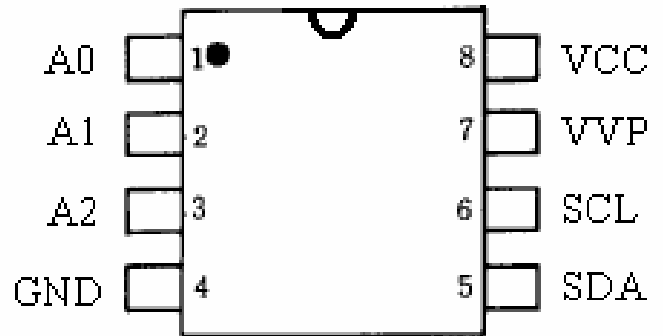

74HCT14D; Schmitt Trigger (SO14)

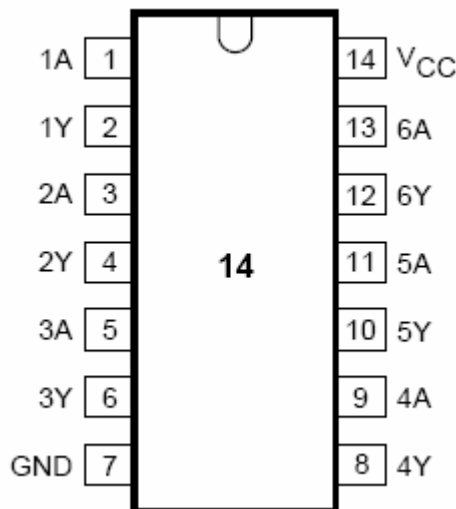

BA6287; Motor Driver (SOP8)

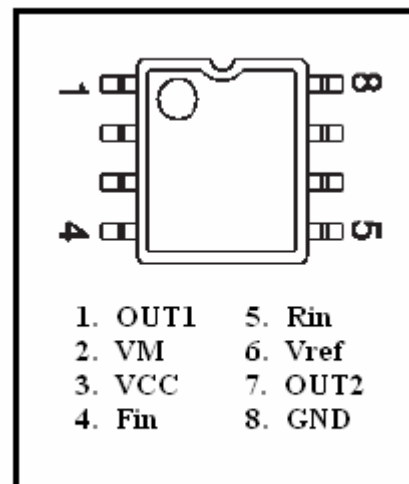

AZ1117-1.8V /3.3V/5V; LDO (SOT-223)

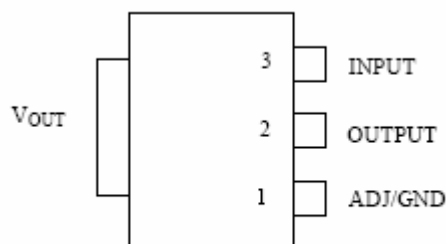

NJM2561F1; Video Amplifier (MTP6)

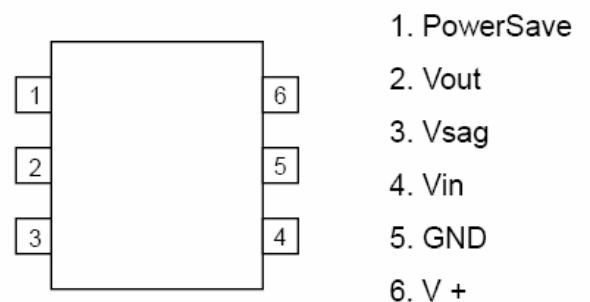

BA00HC5FP;LDO (T0252-5)

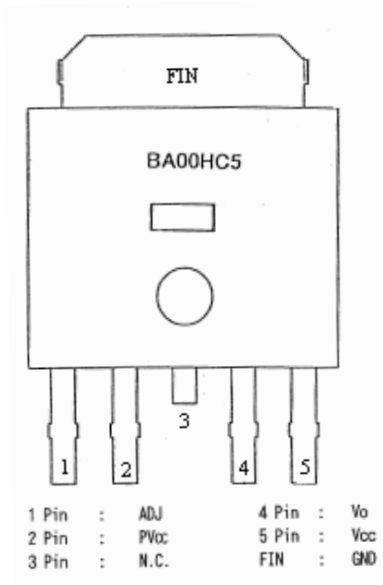

PC817; Photoelectric Coupler (DIP4)

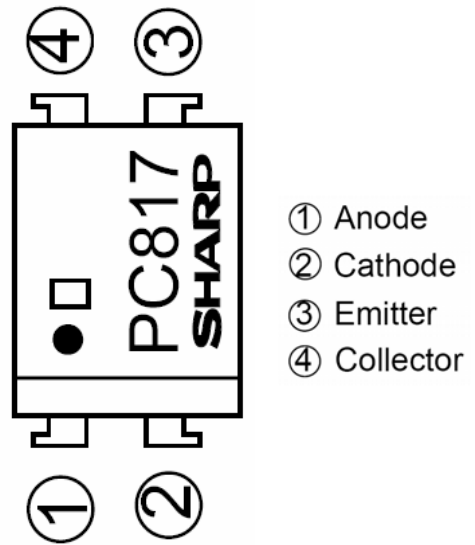

RClamp0514M; Low Capalitance TVS Diode Array(MSOP-10L)

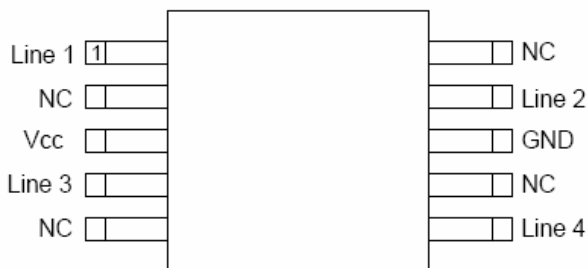

UPA672T; MOS FIELD EFFECT TRANSISTOR (SC-70)

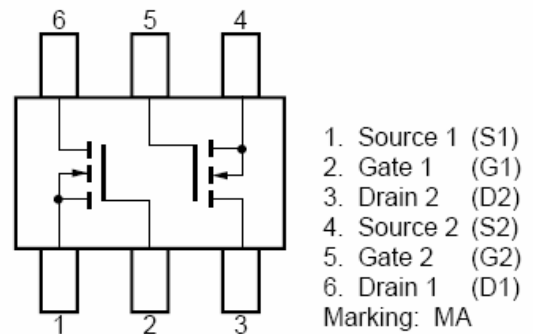

L7805/L7809; Voltage Regulator (TO-220)

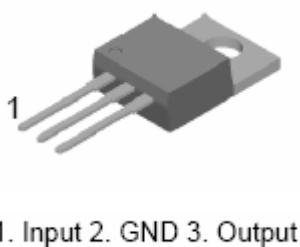

BA33BCO; Dropout Voltage Regulator (TO-220)

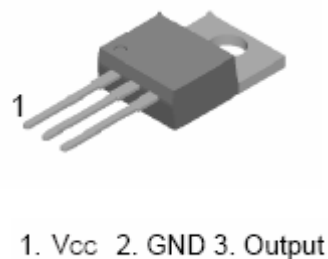



### STA308A ; Digital Audio Processor (TQFP64)

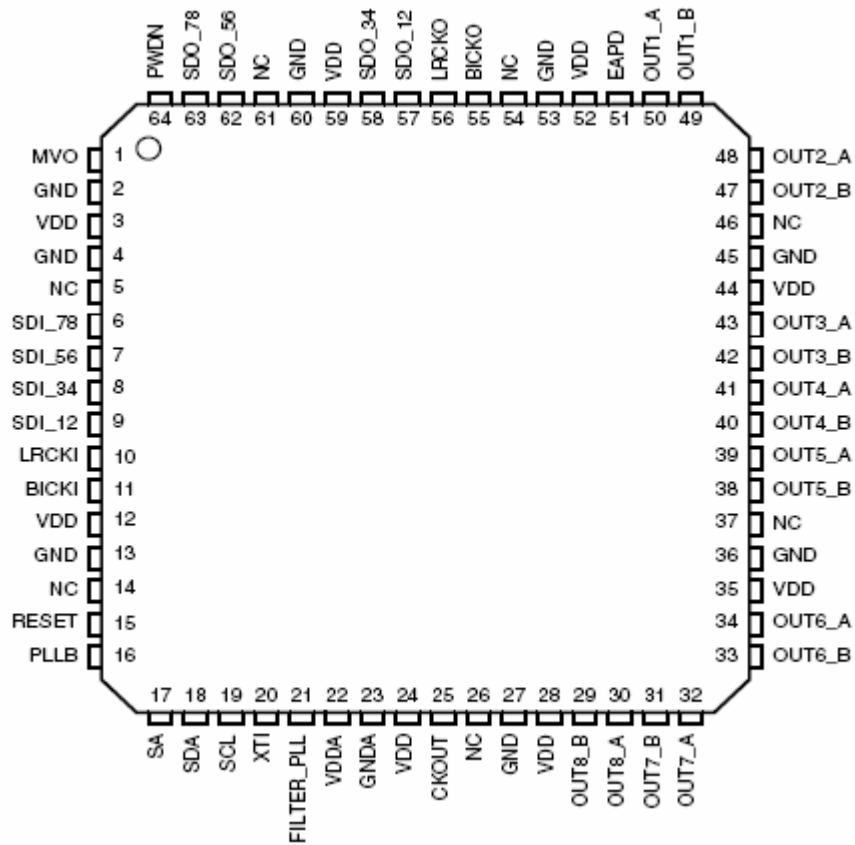

### STA508; Power Half Bridge (PowerSO36)

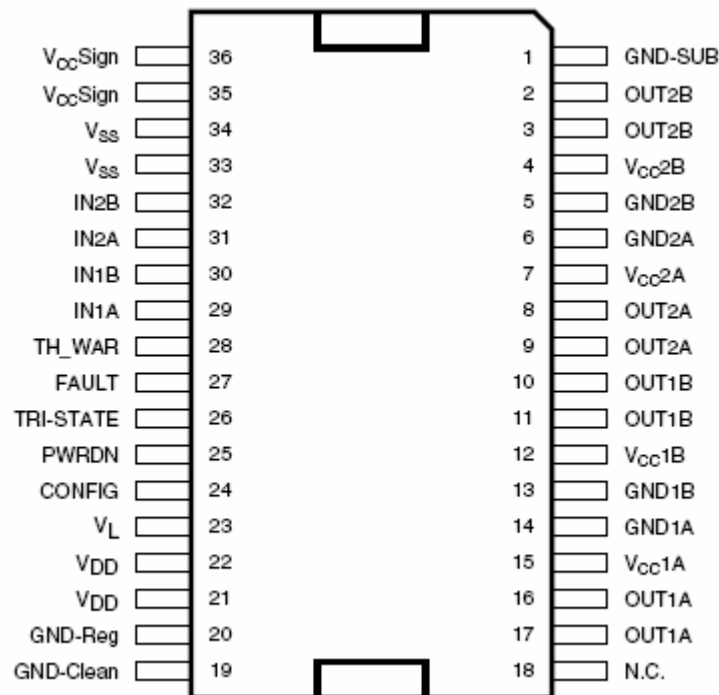

74HC158Quad;2-input  
Multiplexer (SOP16)

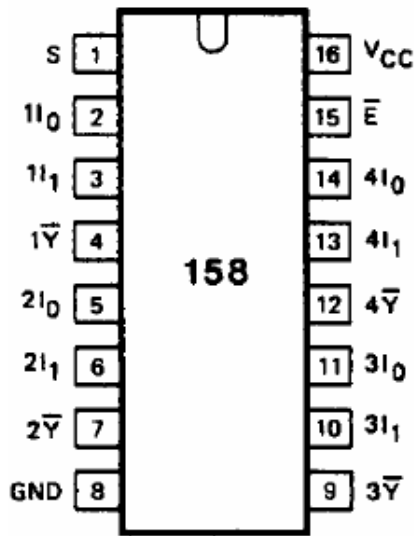

74HCU04; Hex Inverter  
(TSSOP14)

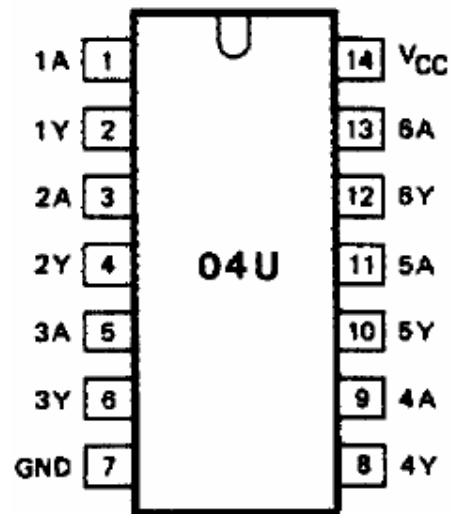

NJM2068M;  
Pre-amp (SO8)

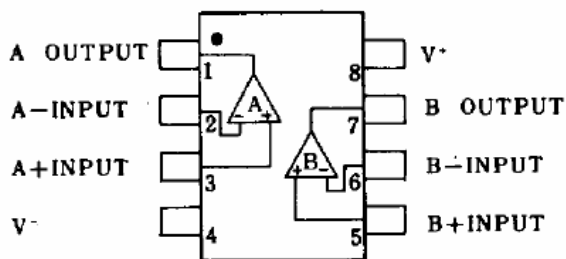

AAT3522IGY-3.08-200-T1;  
Reset monitor (SOT-23)



KA5L0380RYDTU;  
Power Switch (TO-220F-4L)



1. GND 2. Drain 3. V<sub>CC</sub> 4. FB

KA278R05CTU;  
Voltage Regulator (TO-220F-4L)



1.Vin 2. Vo 3. GND 4. Vdis

KA78R05TSTU; Voltage Regulator (TO-220F-4L)



1. Vin 2. Vo 3. GND 4. Vdis

KA78R12; Voltage Regulator (TO-220F-4L)



1. Vin 2. Vo 3. GND 4. Vdis

KA7912; Voltage Regulator (TO-220)

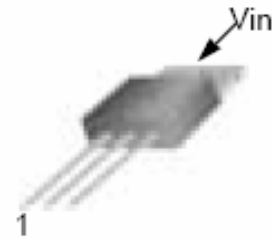

1. GND 2. Input 3. Output

KA431LZTA 0.5% ; Shunt Regulator (TO -92)



1. Ref 2. Anode 3. Cathode

FAN7528MX;PFC Controller (SOP8)

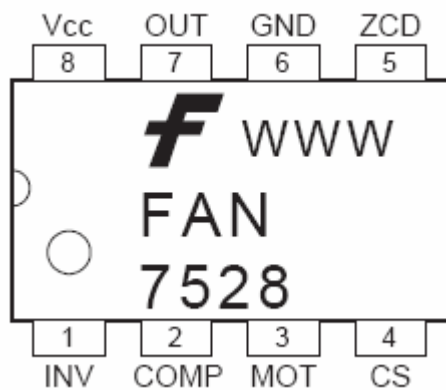

FAN7602MX; PWM Controller (SOP8)

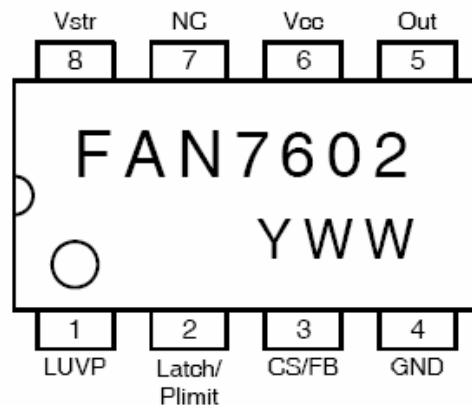

KA7812; Voltage Regulator  
(TO-220)

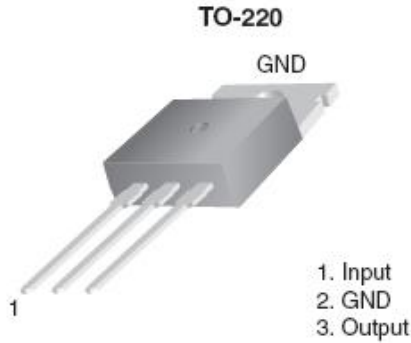

DTC114EUA; Built-in Resistor  
Transistor (UMT3)

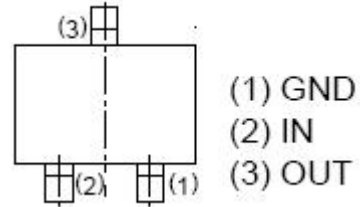

LM9022; Vacuum Fluorescent  
Display Filament Driver (SOP8)

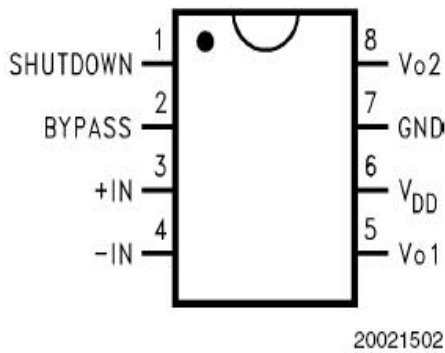

EM78P156ELM-G; MCU  
(SOIC18)

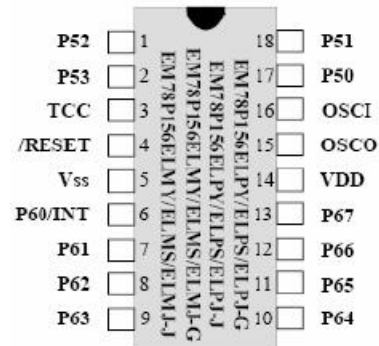

2SB1132; Medium Power  
Transistor (SOT89)

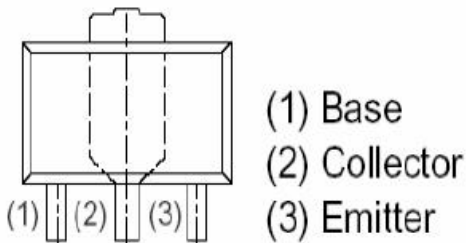

2SK3018T106; Small Switching  
(UMT3)





KTC8550; PNP Transistor  
(SOT23)



KTC8050; NPN Transistor  
(SOT23)



DTC343TK; NPN Transistor  
(SMT3)

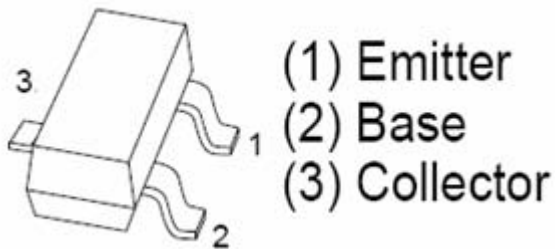

MMBT3904; NPN Switching Transistor (SOT23)



2N3906; PNP Transistor  
(SOT23)



2SA1037AKR; General Purpose Transistor (SMT3)

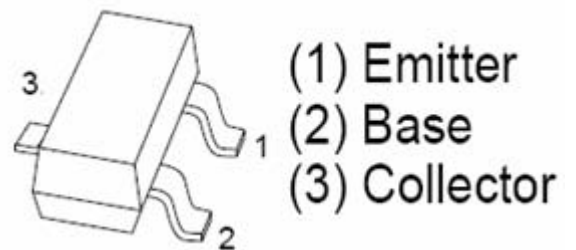

2SC5866; Medium Power Transistor (TSMT3)

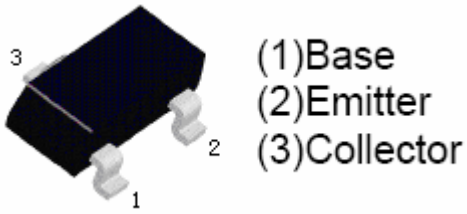

AF2302; N-Channel Mosfet (SOT23)

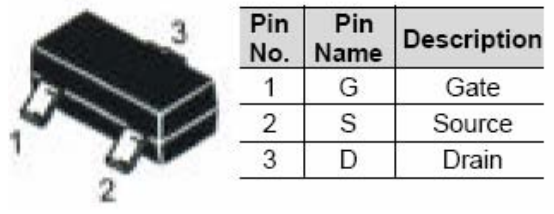

FQA11N90; N-Channel Mosfet (TO-3P)

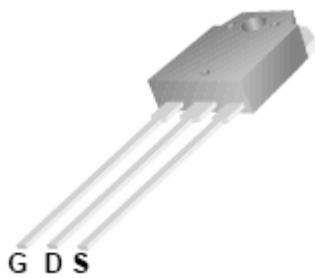

FQPF13N50C; N-Channel Mosfet (TO-220F)

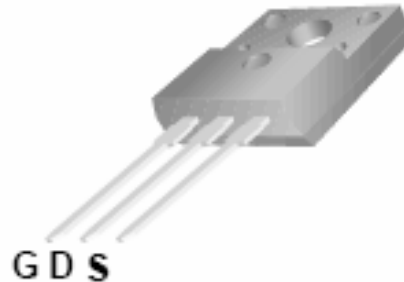

AF4835; P-Channel Mosfet (SOP8)

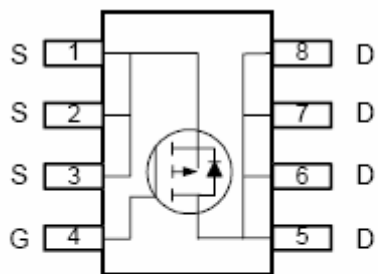

Pin Name	Description
S	Source
G	Gate
D	Drain

FSTU3257MTC; Bus

Switch (TSSOP16)

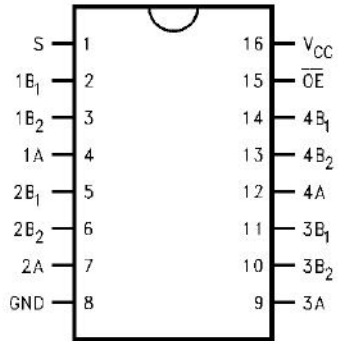

MC34063ADG; DC/DC

Regulator (SO8)

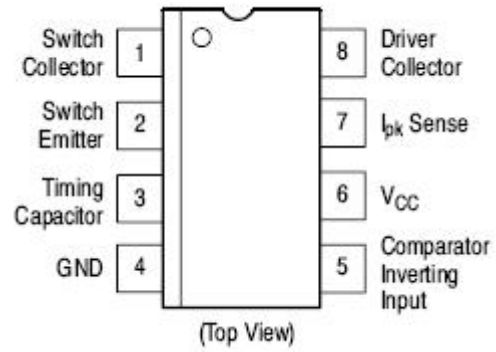

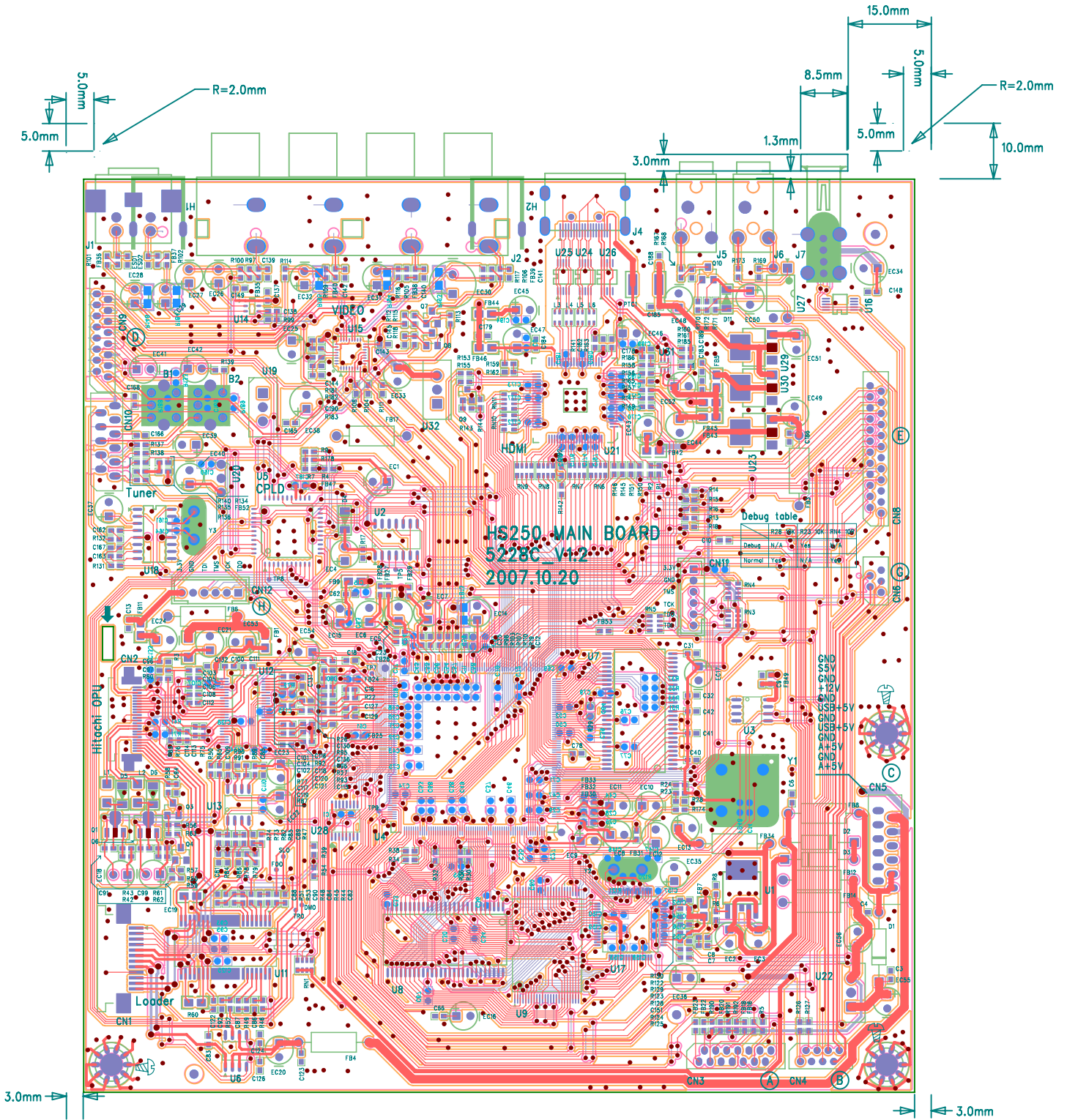

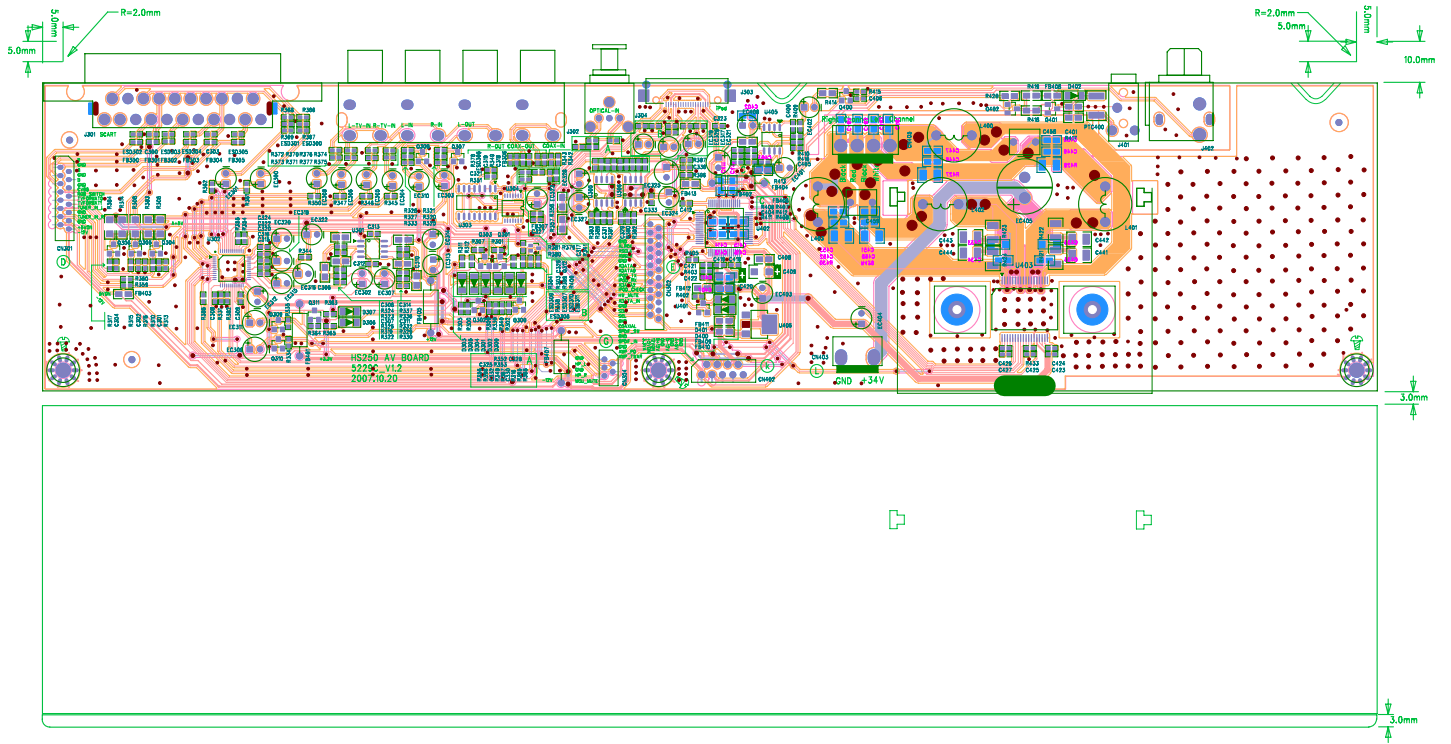



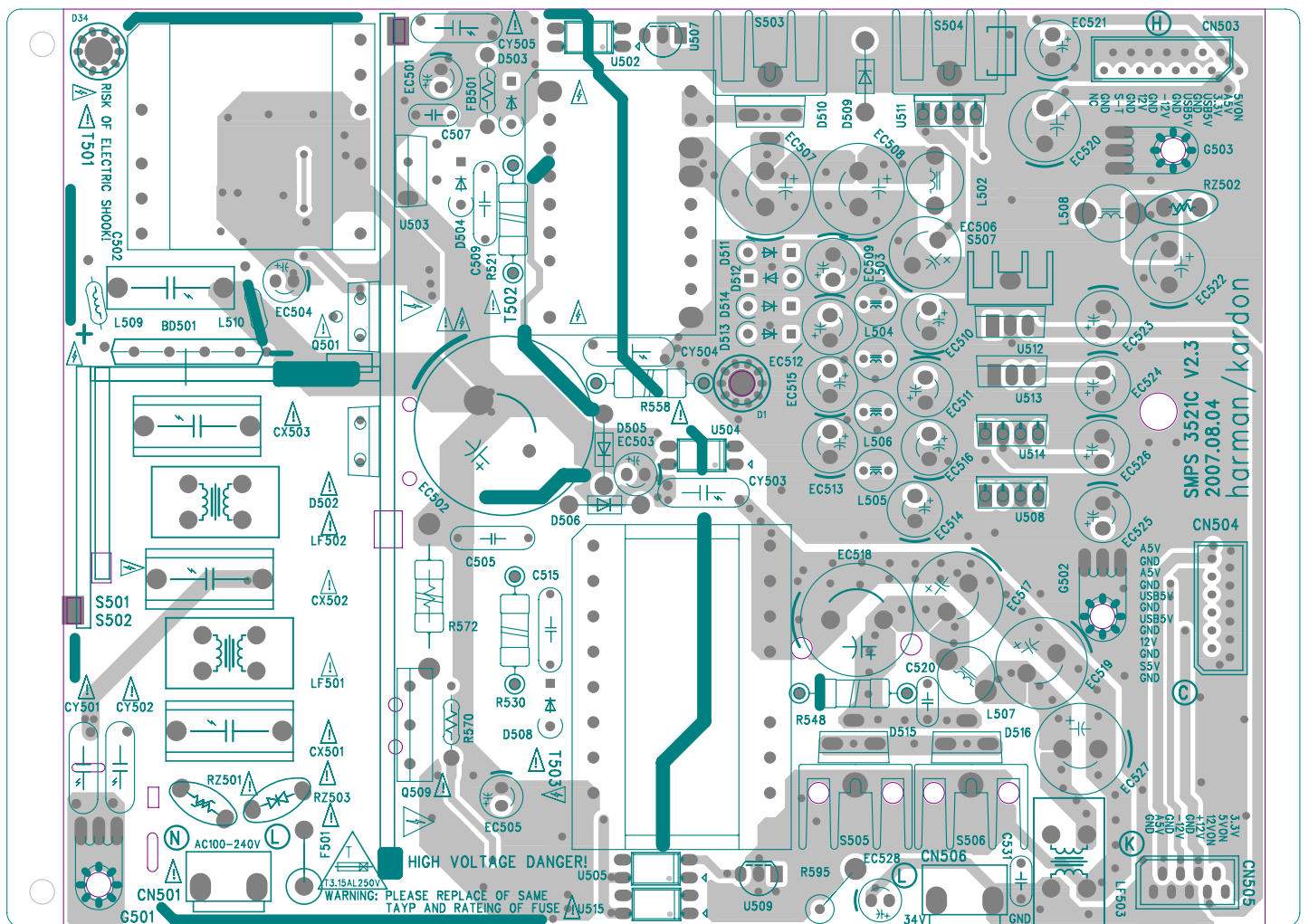



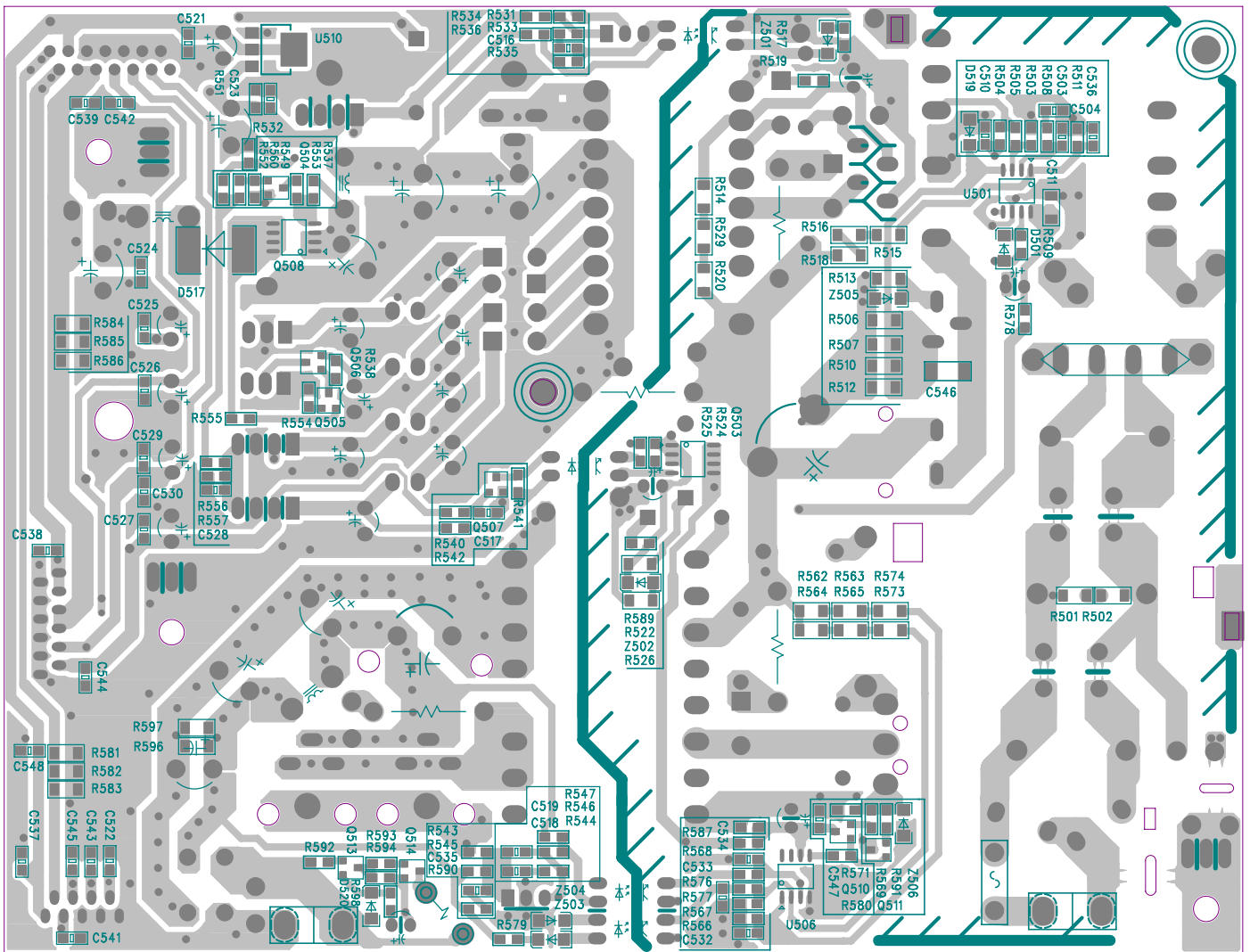



### HS250 BLOCK DIAGRAM

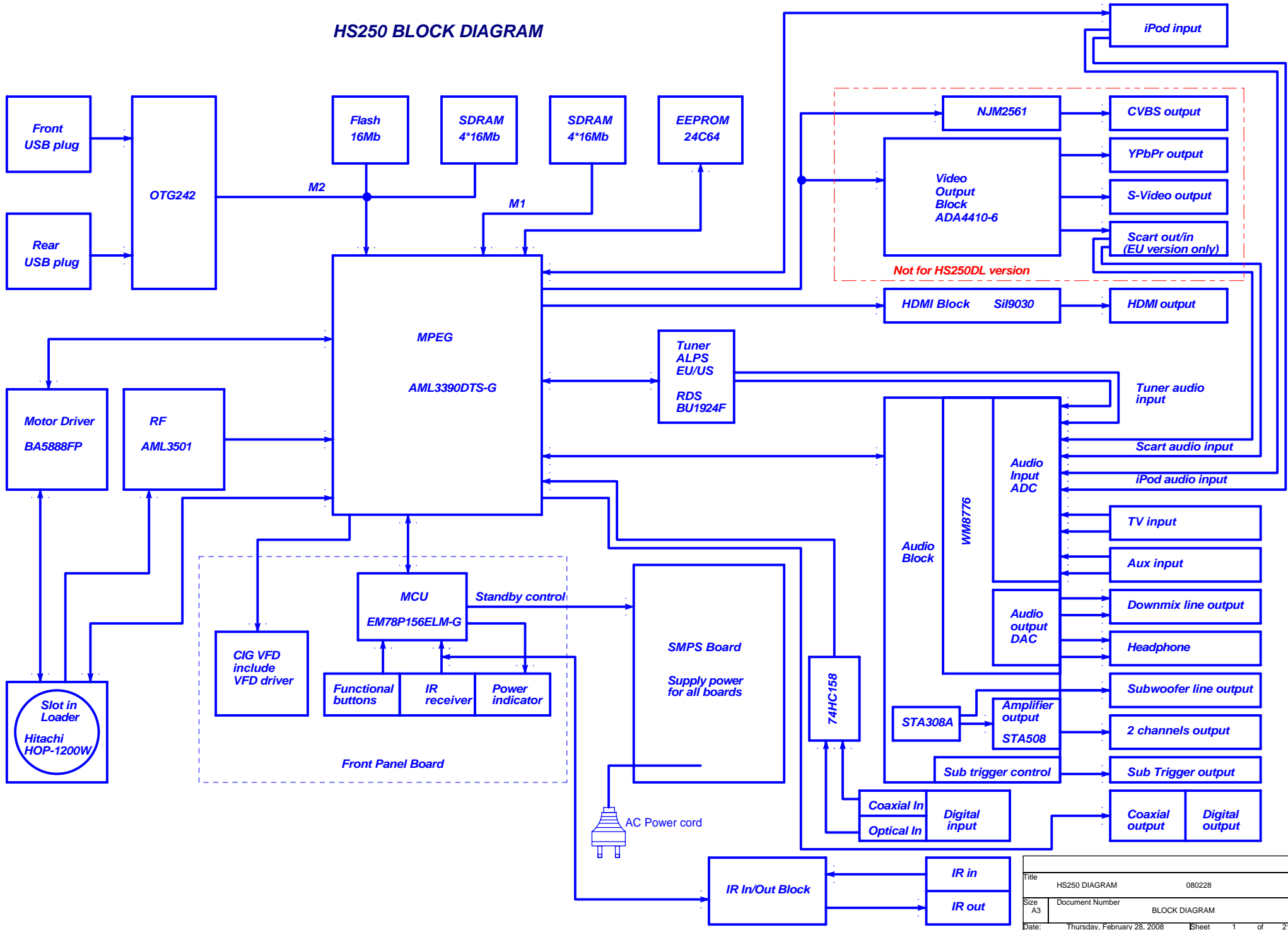

Title		HS250 DIAGRAM		080228	
Size	A3	Document Number	BLOCK DIAGRAM		Rev
Date:	Thursday, February 28, 2008		Sheet	1	of 21
					1.2

# HS250 WIRING DIAGRAM

**HS250 CNT REF NO. ASSIGNMENT**

3522C AMP: from 400  
3521C: from 500  
3519C/3518C: from 600

3627C: from 1  
3522C AV: from 300

**TUNER MODULE ALPS**

11 pins

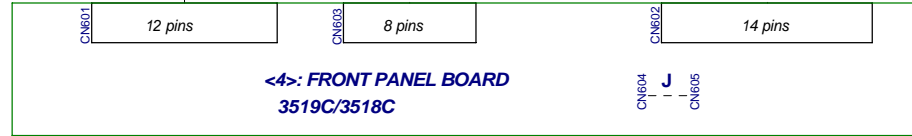
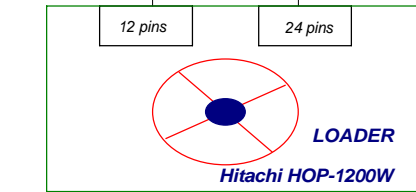
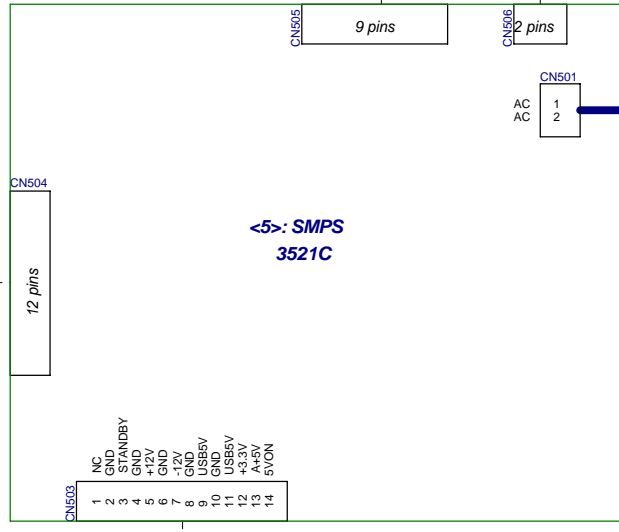
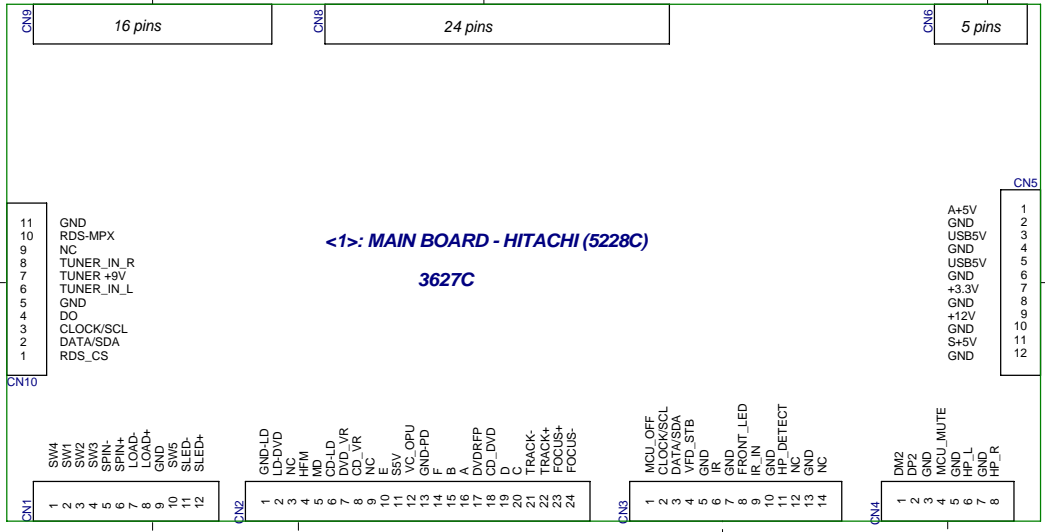
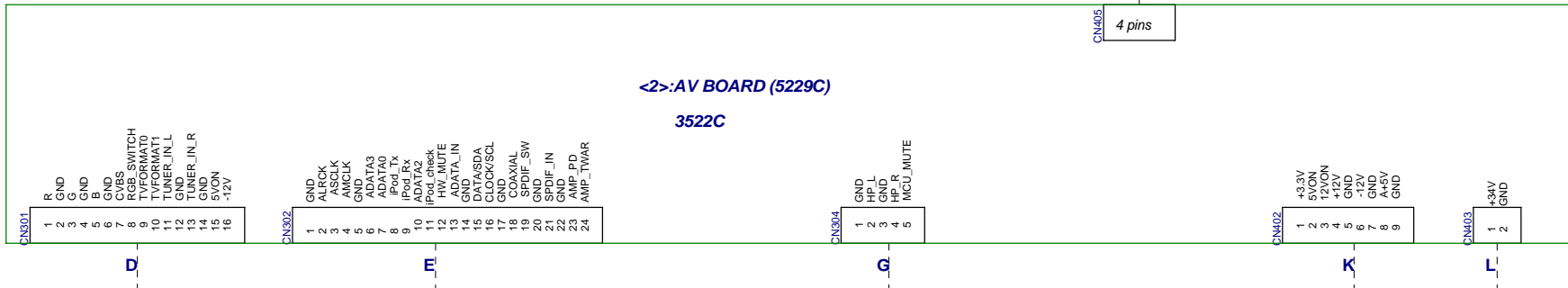

~100-240V  
AC Power cord



Title		HS250 DIAGRAM		070913	
Size	A3	Document Number	WIRING DIAGRAM		Rev
Date:	Thursday, February 28, 2008	Sheet	2	of	21

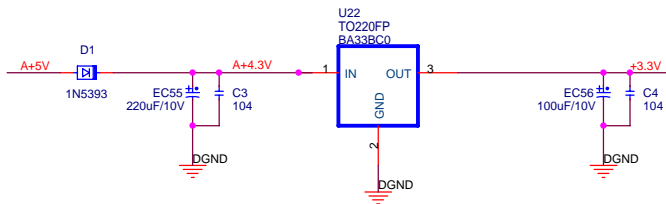
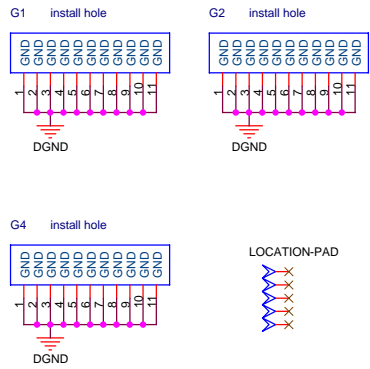
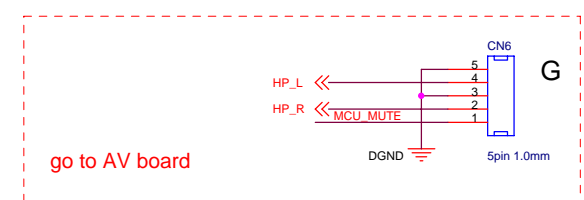
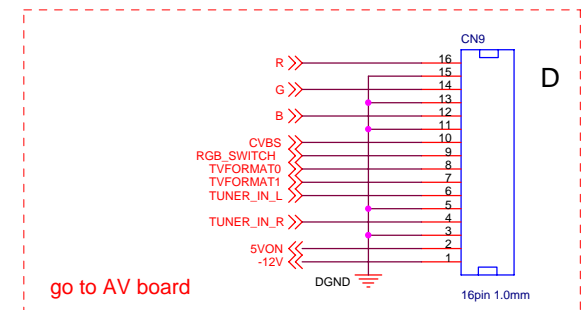
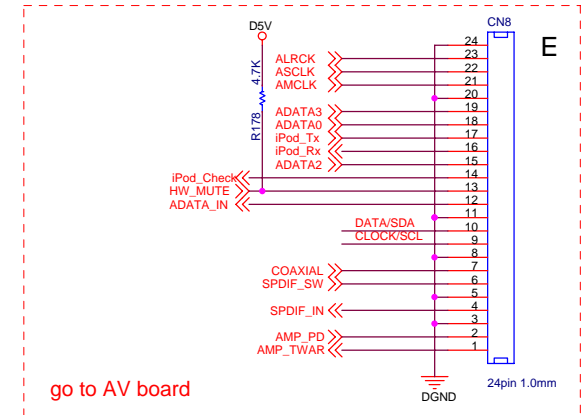
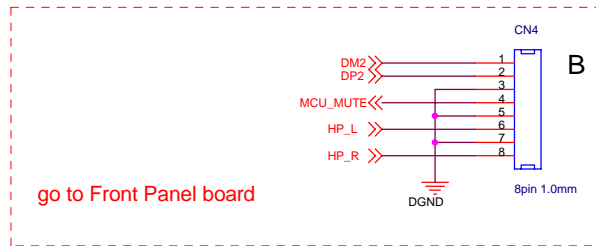
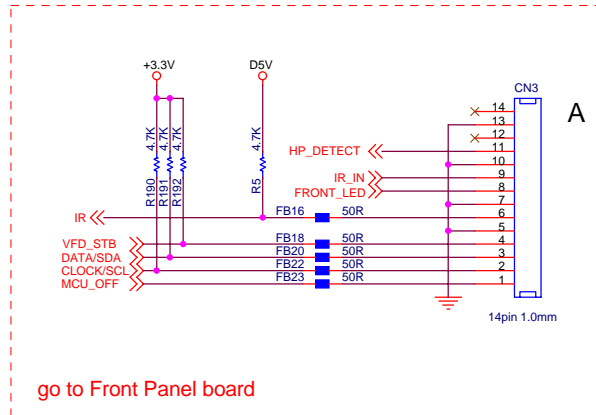
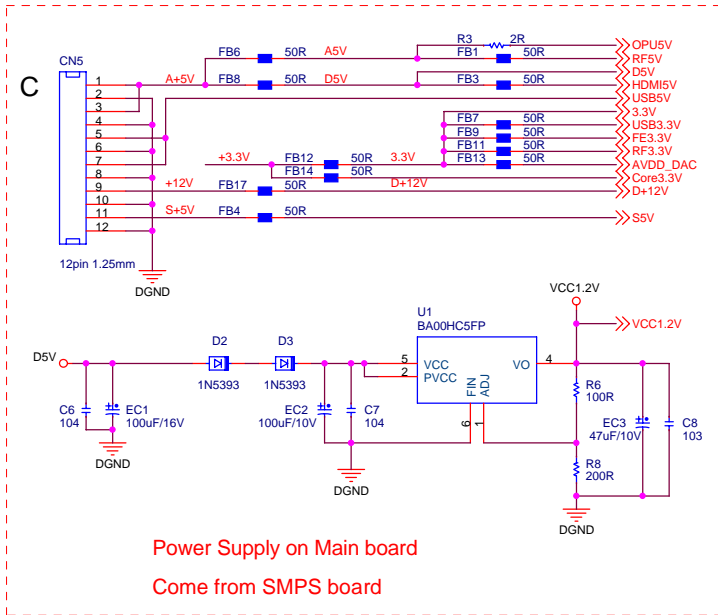

Title		Power and connector		070913	
Size	Document Number			Rev	
A3	5228C			1.2	
Date:	Thursday, February 28, 2008	Sheet	6	of 21	

harman/kardon

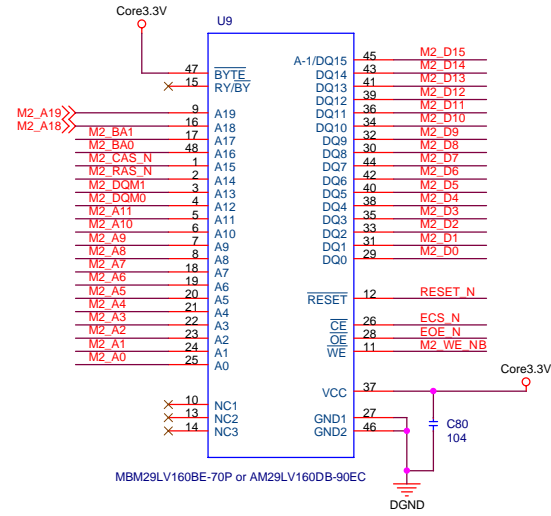
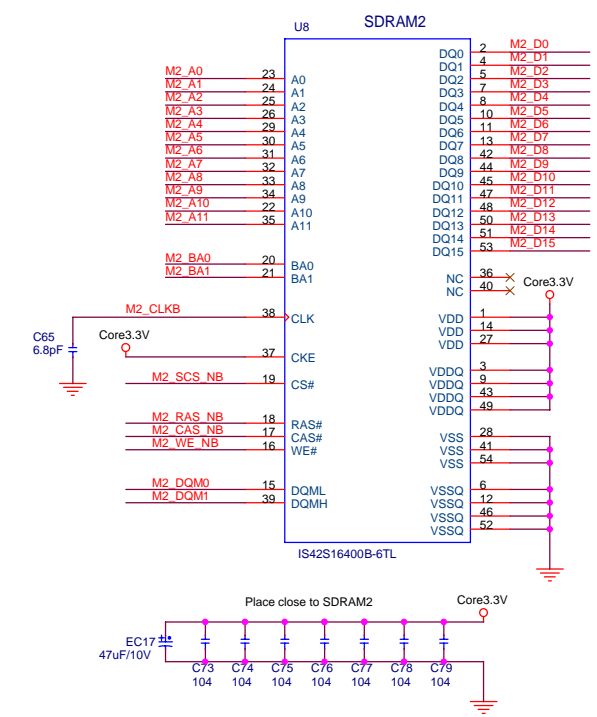
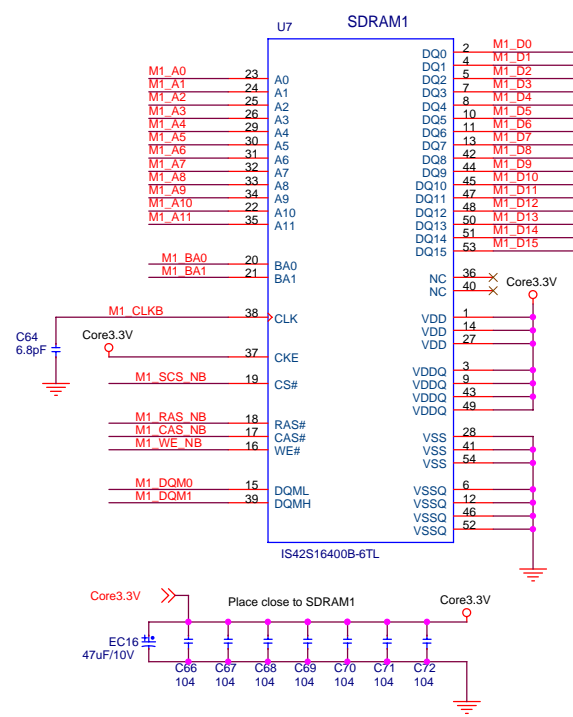
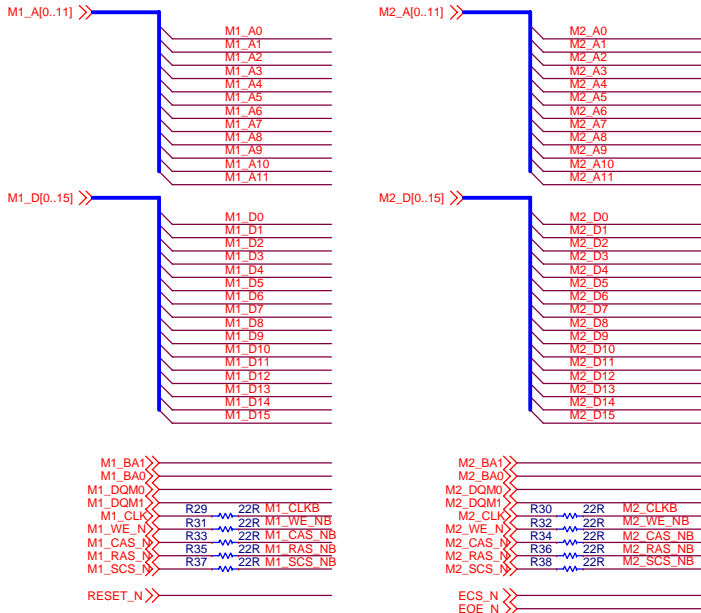

Title			SDRAM and FLASH 070104		
Size	Document Number			Rev	
A3	5228C			1.2	
Date:	Thursday, February 28, 2008	Sheet	8	of	21

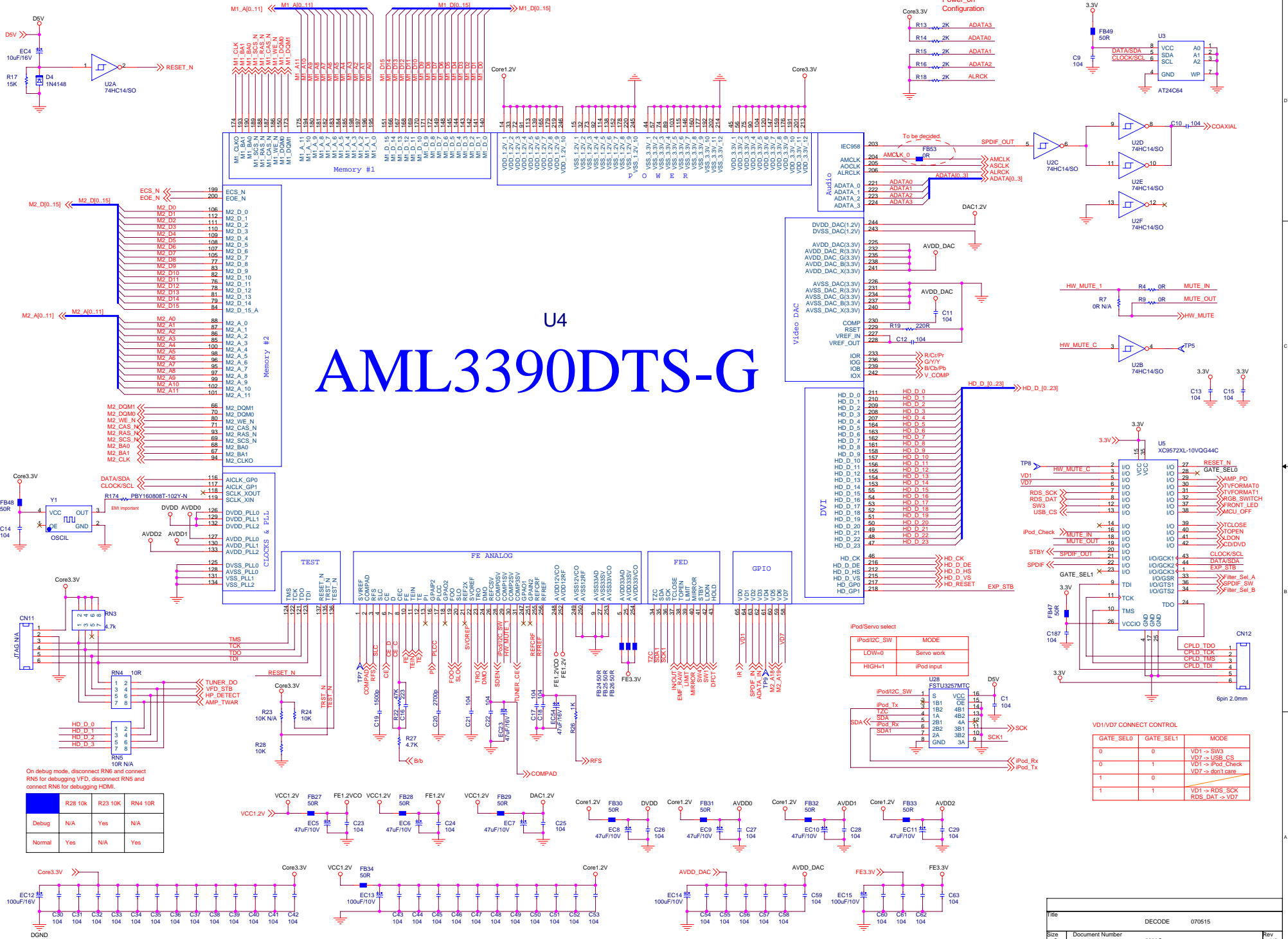

GATE_SEL0	GATE_SEL1	MODE
0	0	VD1 -> SW3
0	1	VD7 -> USB_CS
1	0	VD1 -> iPod_Check
1	1	VD7 -> don't care

File	DECODE 070515	
Size	Document Number	5228C
Date	Thursday, February 28, 2008	Sheet 7 of 21
		Rev 1.2

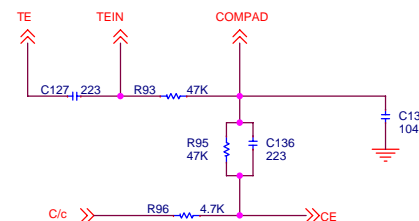
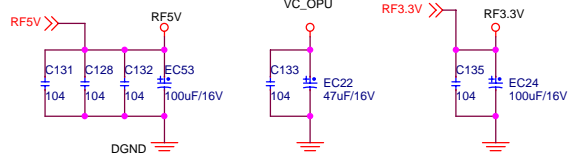
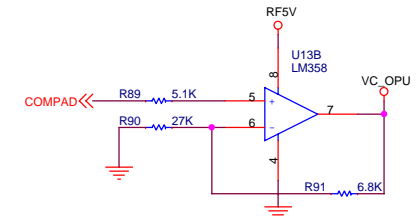
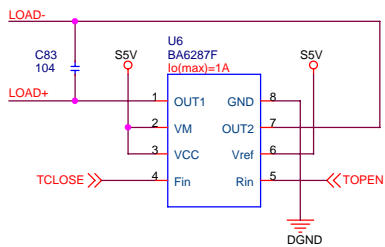
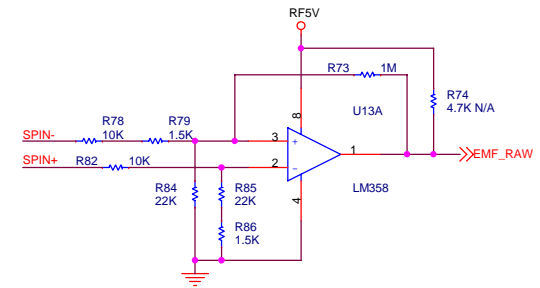
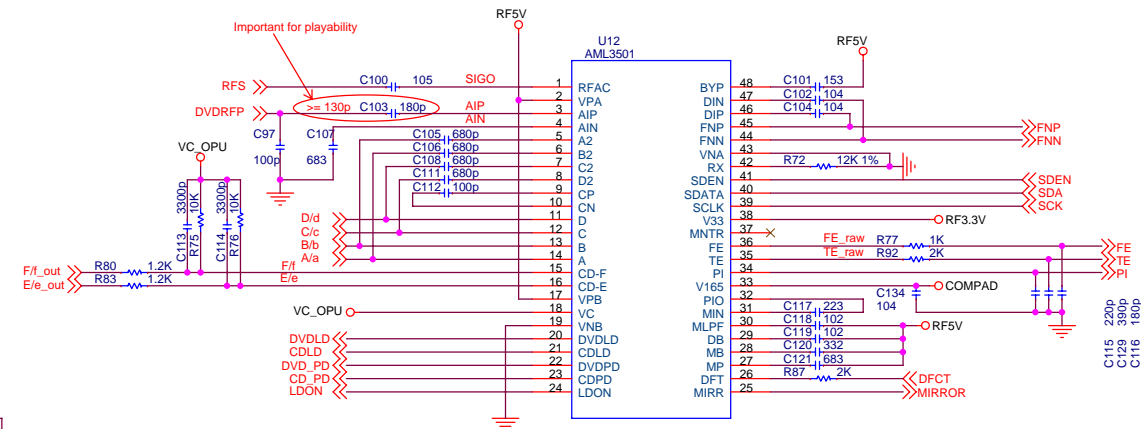
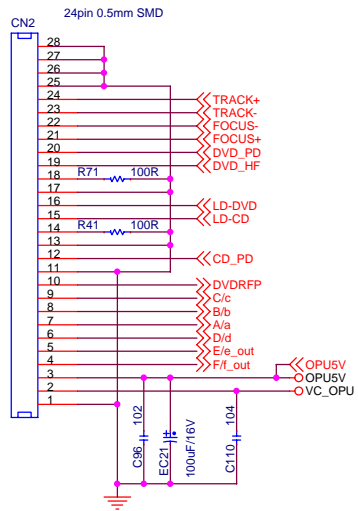
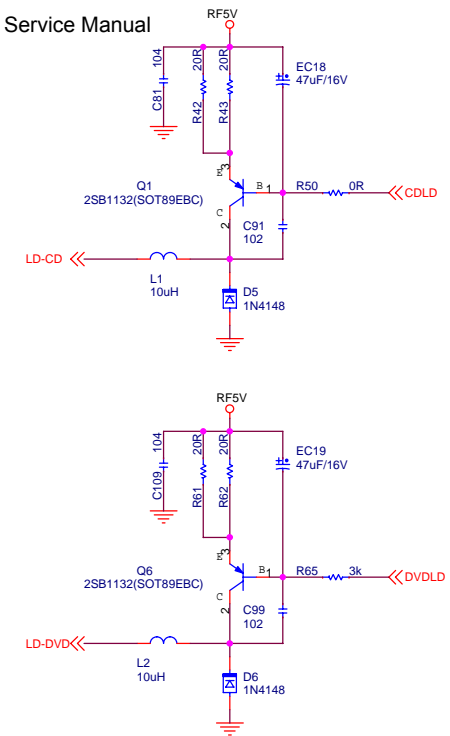
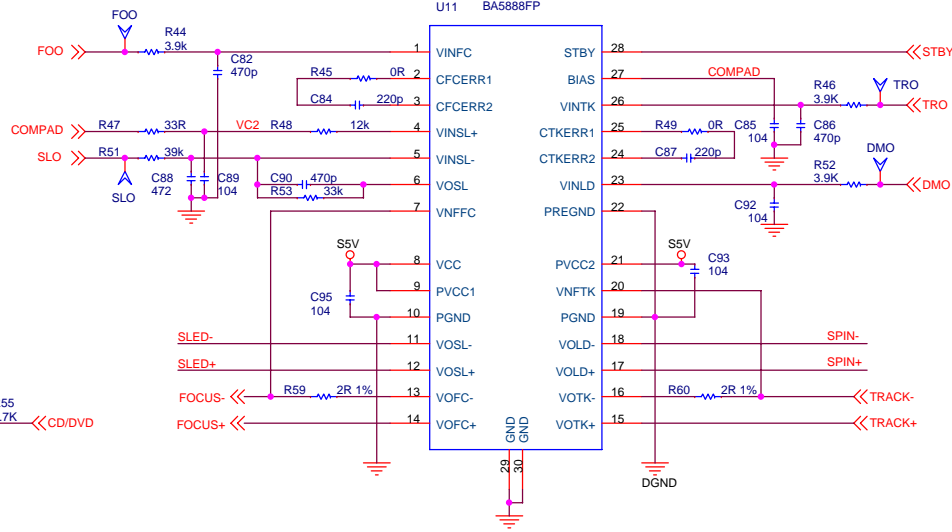
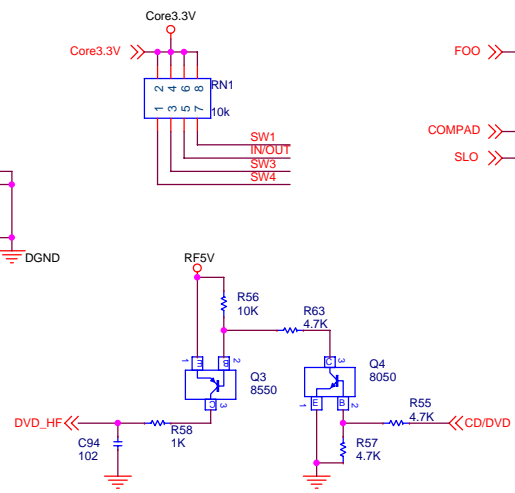
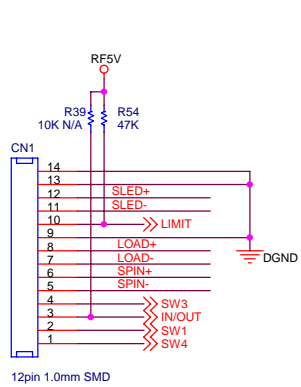

Title			
Driver and preamp 071203			
Size	Document Number		Rev
A3	5228C		1.2
Date:	Thursday, February 28, 2008	Sheet	9 of 21

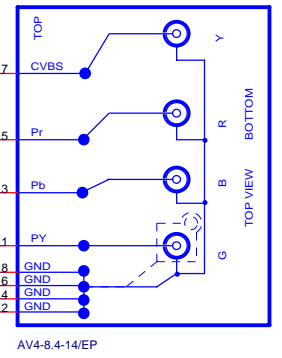
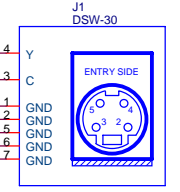
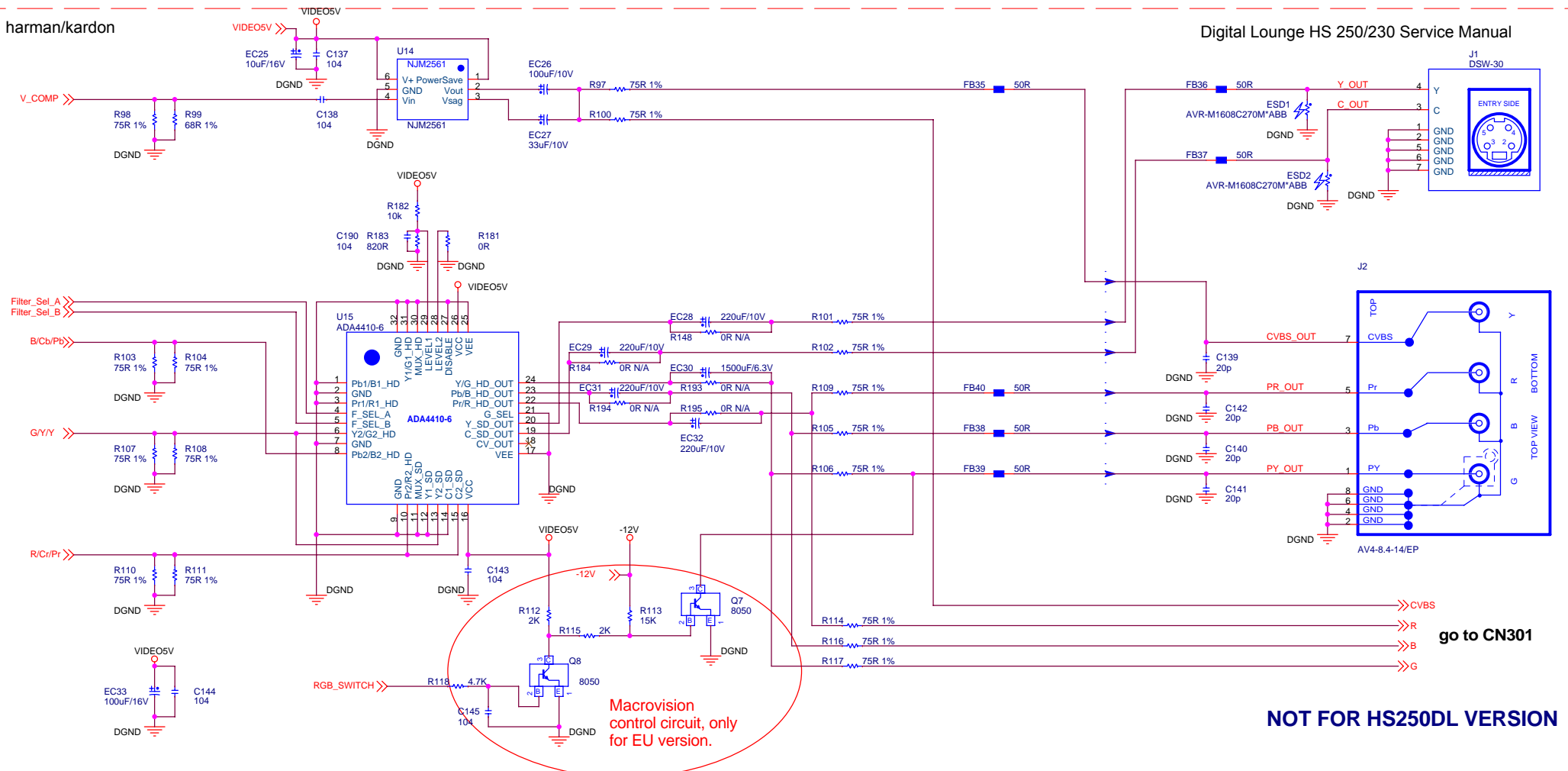

go to CN301

**NOT FOR HS250DL VERSION**

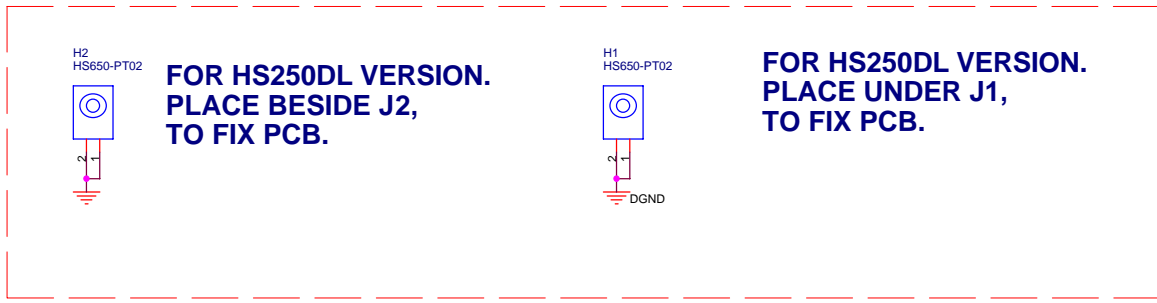
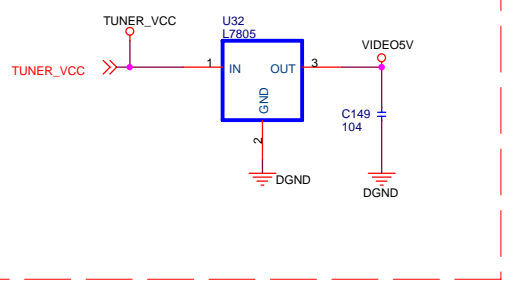

**FOR HS250DL VERSION.  
PLACE UNDER J1,  
TO FIX PCB.**

Title			
VIDEO OUTPUT 071007			
Size	Document Number	Rev	
A3	5228C	1.2	
Date:	Thursday, February 28, 2008	Sheet	10 of 21

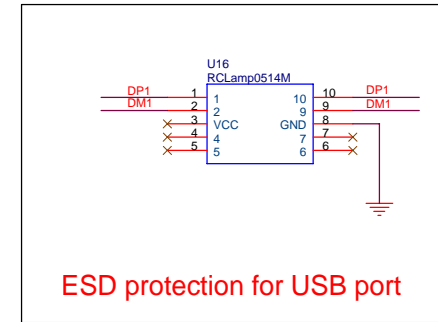
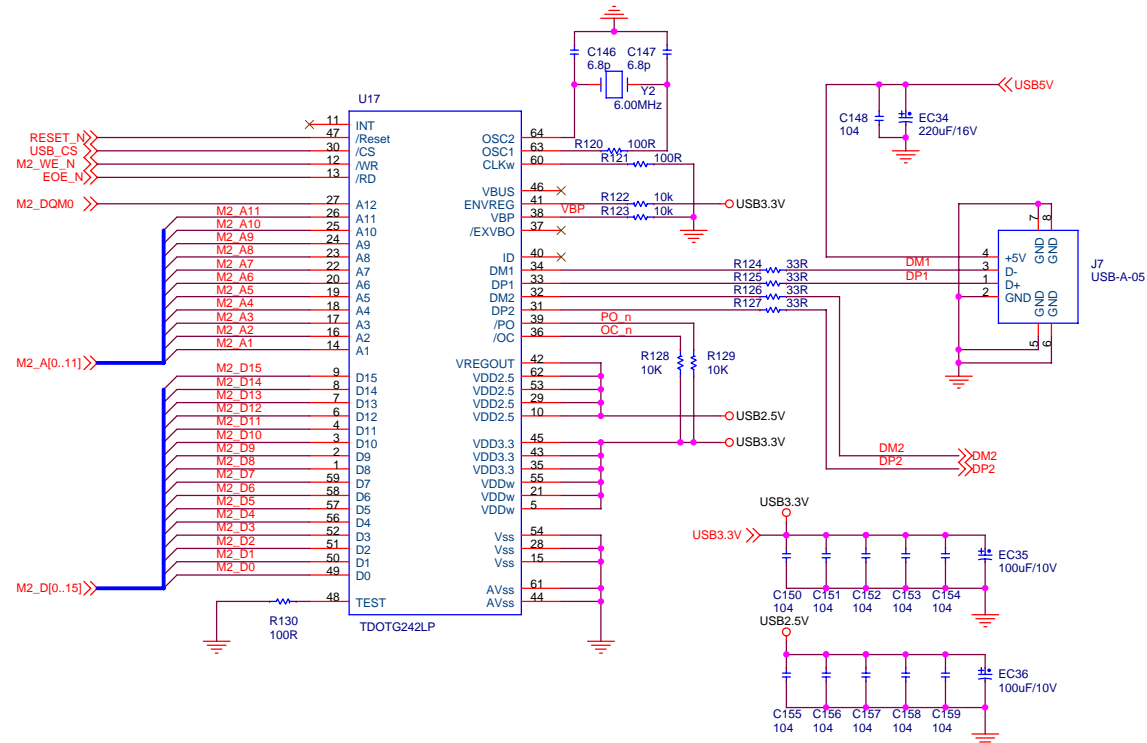

ESD protection for USB port

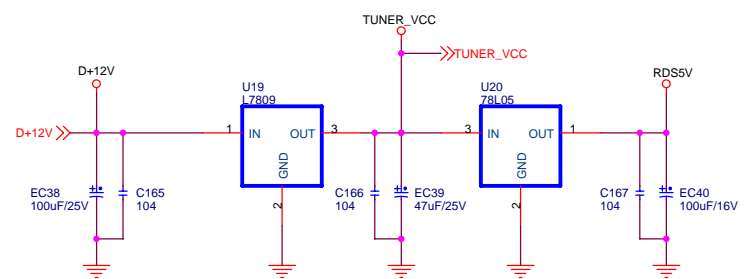
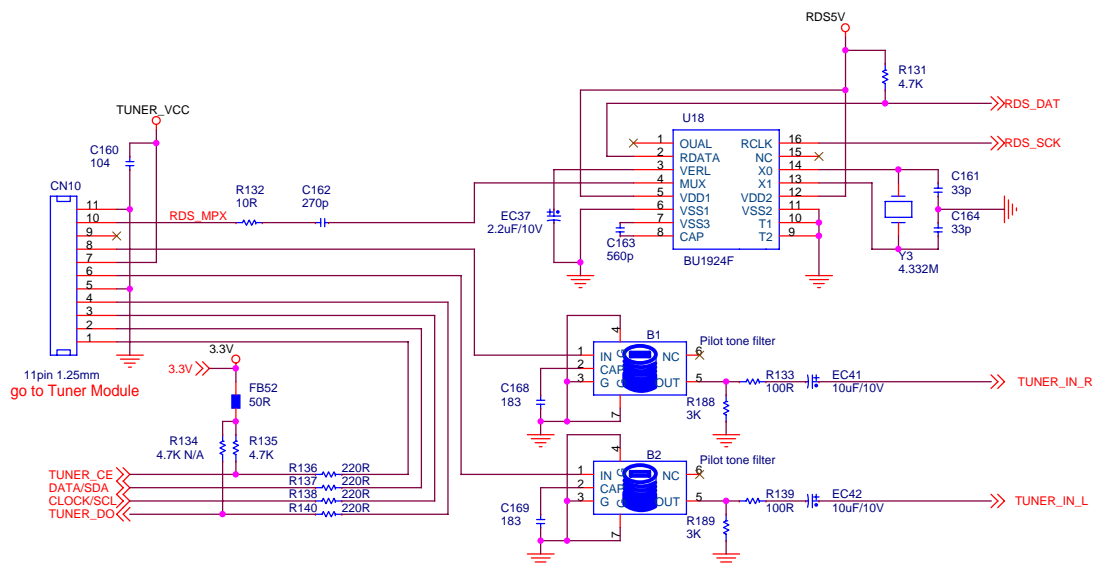

Title			USB and Tuner 071007		
Size	Document Number			Rev	
A3	5228C			1.2	
Date:	Thursday, February 28, 2008	Sheet	11	of	21



**NOTE:**  
 AML3278:  
 R[0..7]=HD\_D\_[16..23];  
 G[0..7]=HD\_D\_[8..15];  
 B[0..7]=HD\_D\_[0..7];  
 SiL9030:  
 R[0..7]=D[16..23];  
 G[0..7]=D[8..15];  
 B[0..7]=D[0..7].

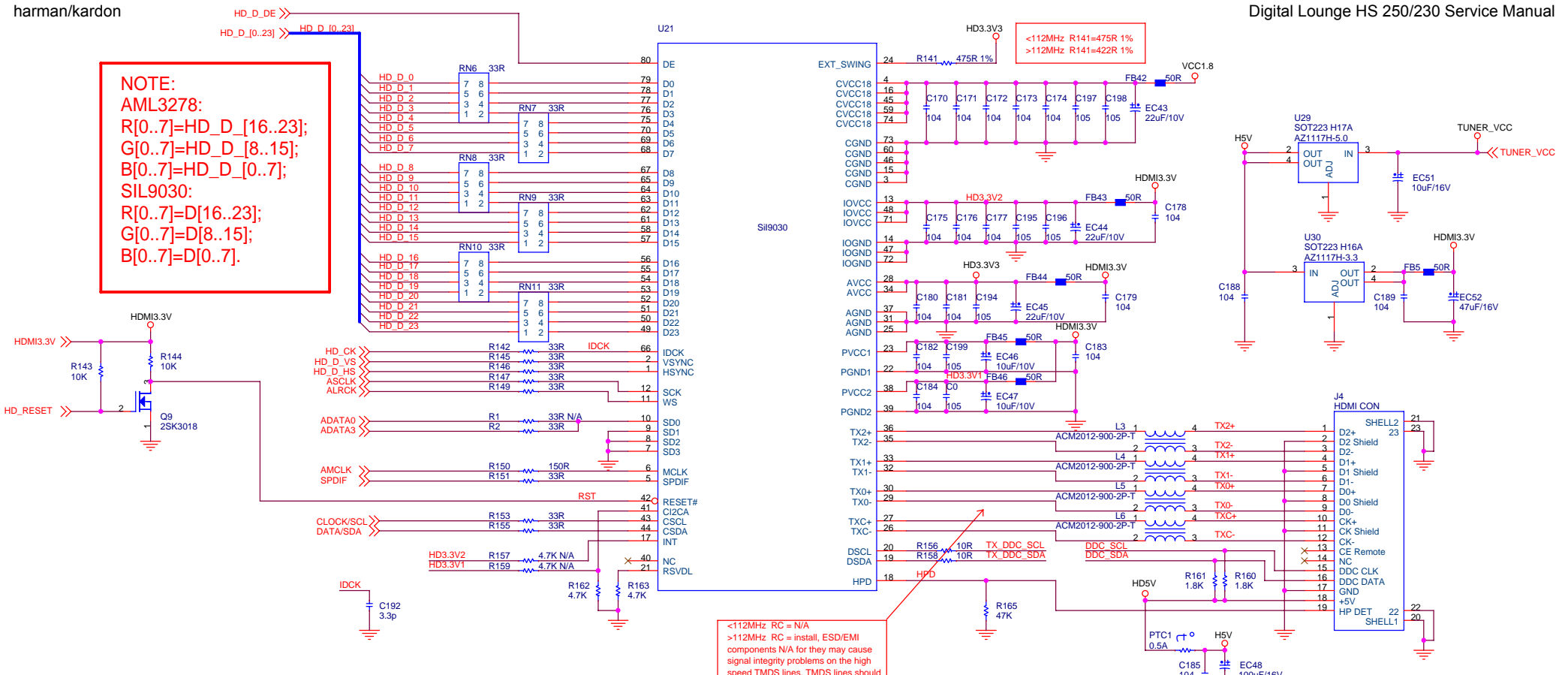

<112MHz RC = N/A  
 >112MHz RC = install, ESD/EMI components N/A for they may cause signal integrity problems on the high speed TMDS lines, TMDS lines should be connected directly from Si9030 to connector.

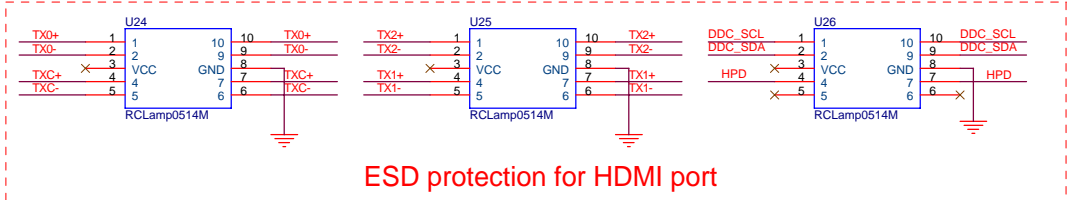

ESD protection for HDMI port

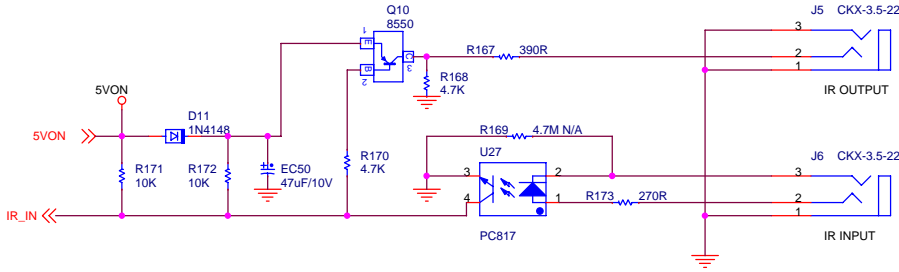

Title			HDMI and IR In/Out 070104		
Size	Document Number			Rev	
A3	5228C			1.2	
Date:	Thursday, February 28, 2008	Sheet	12	of	21



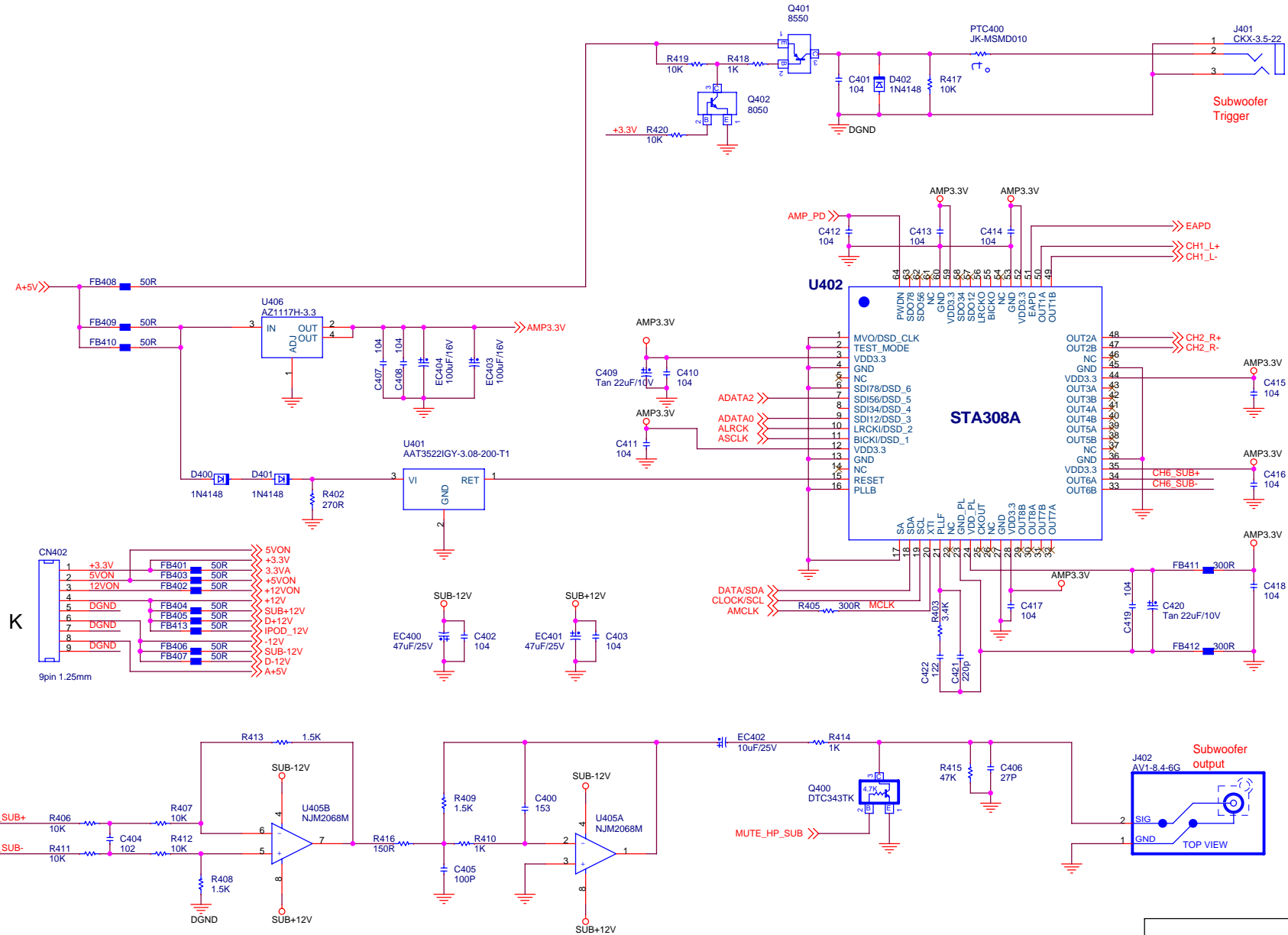
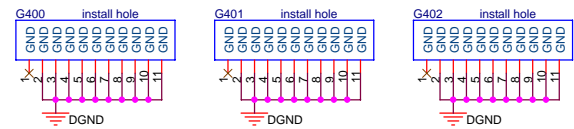

Title		HS250 AV board 070913	
Size A3	Document Number	5229C	Rev 1.2
Date:	Saturday, March 01, 2008	Sheet	14 of 20

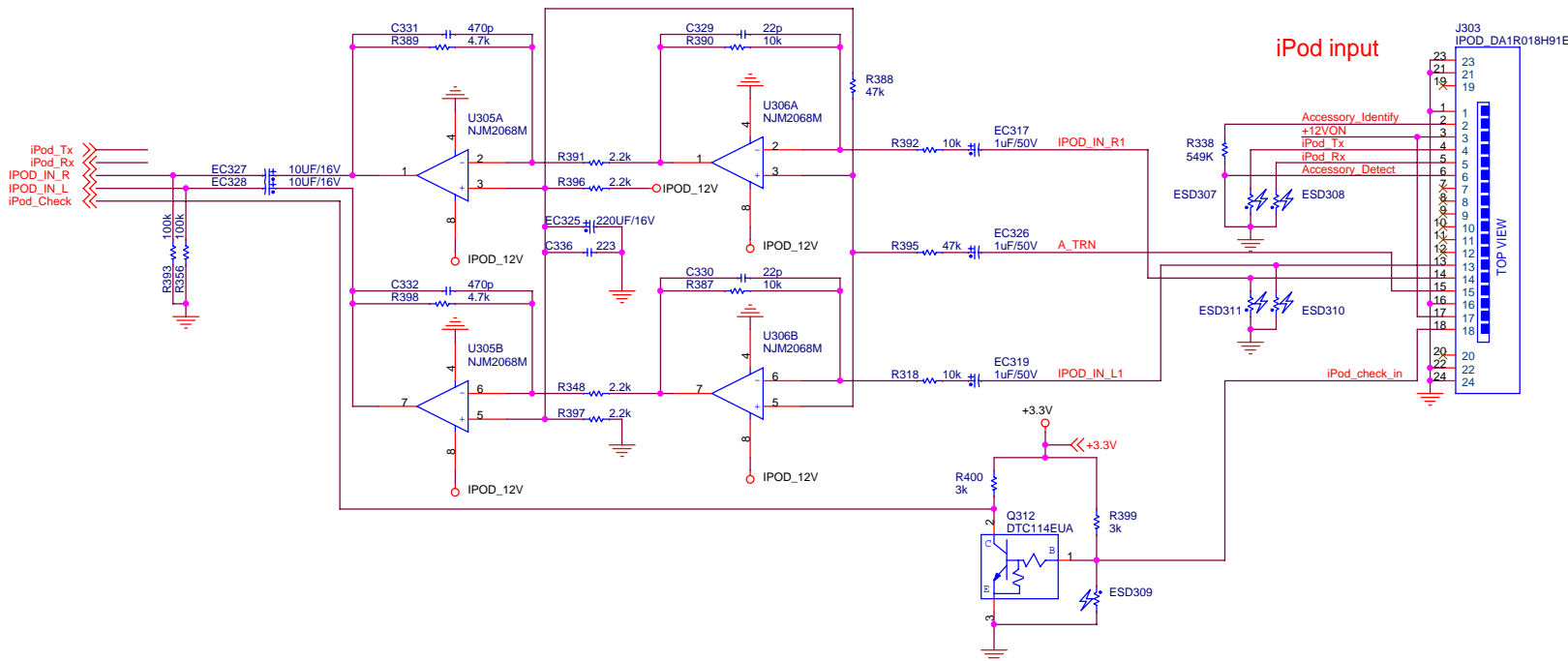
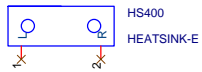
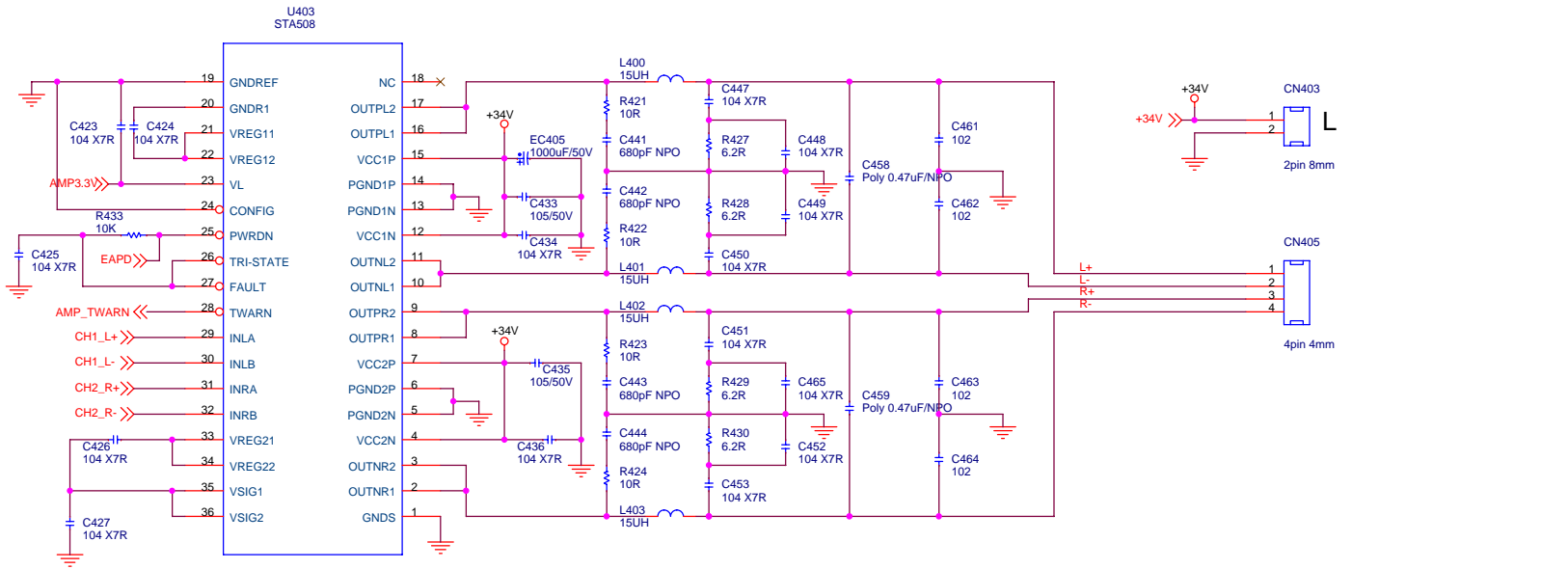

Title		HS250 AV board 070828	
Size A3	Document Number	5229C	Rev 1.2
Date:	Saturday, March 01, 2008	Sheet 15	of 20

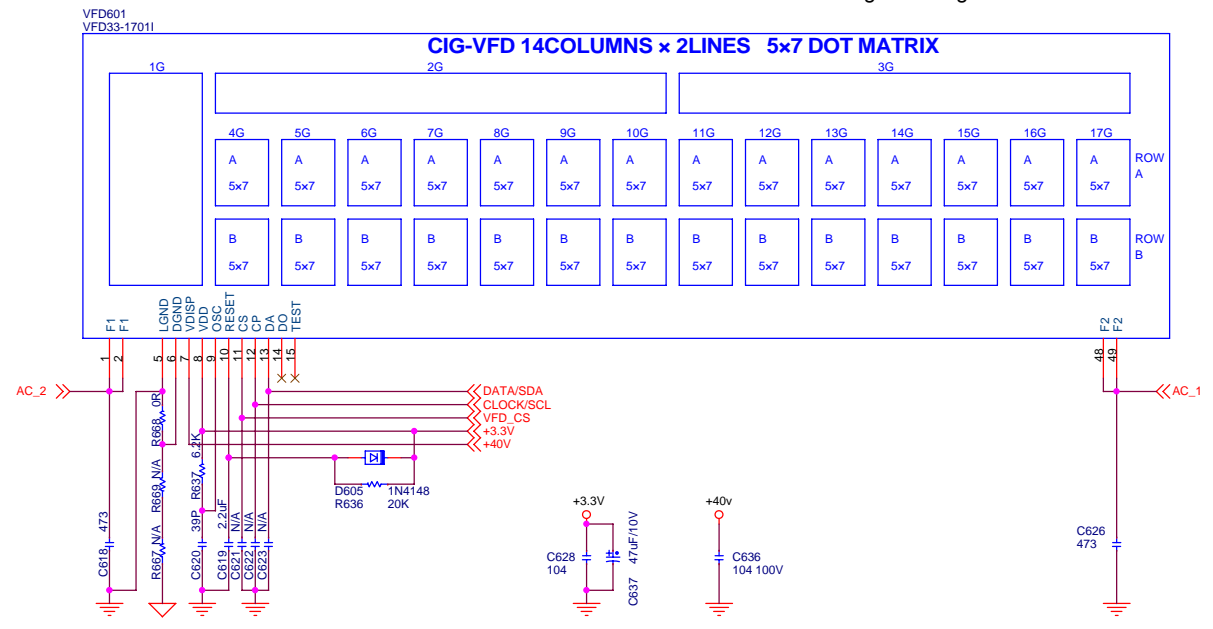
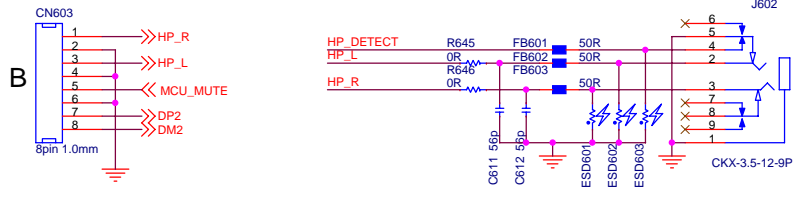
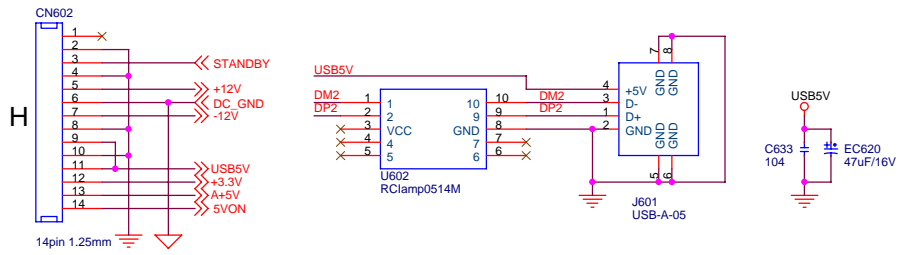
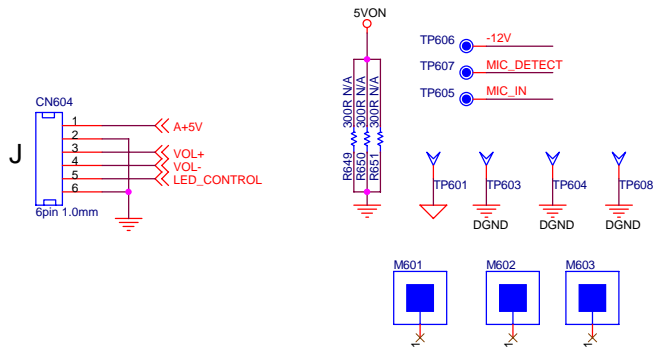
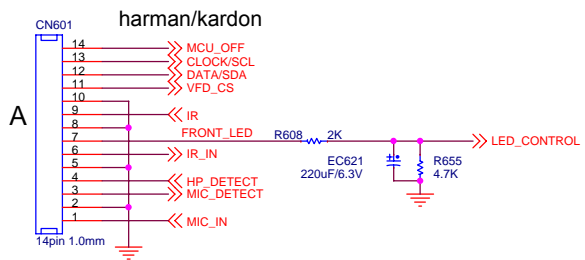

Layout note:  
 1. R668, R669 place colsed to Pin5, Pin6.  
 2. R667 place closed to DC/DC.

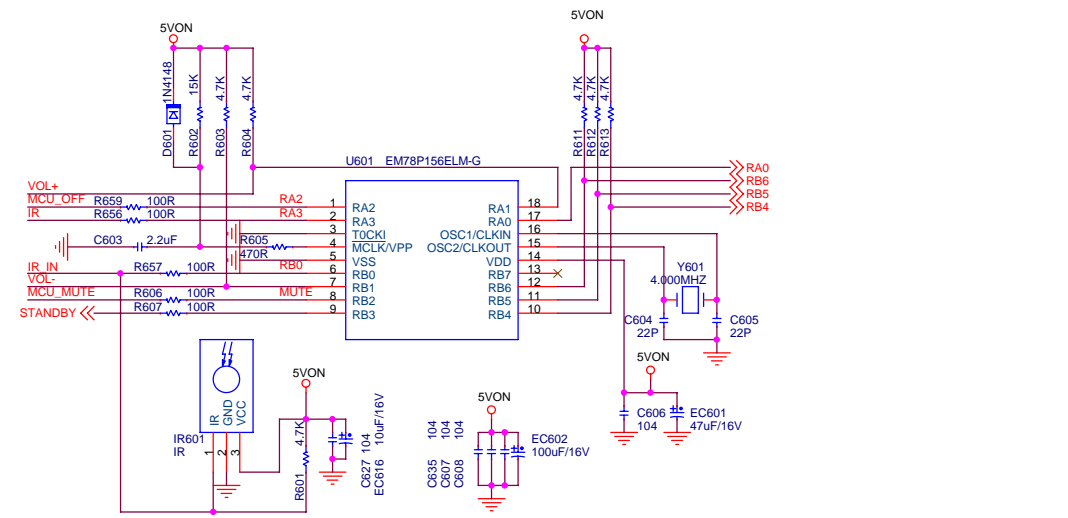

Title		
HS250 FRONT PANEL: 2line VFD BOARD 070821		
Size	Document Number	Rev
A3	3519C	1.3
Date:	Monday, December 03, 2007	Sheet 17 of 21

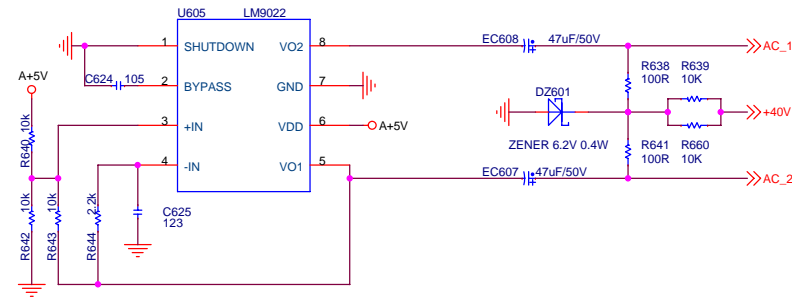
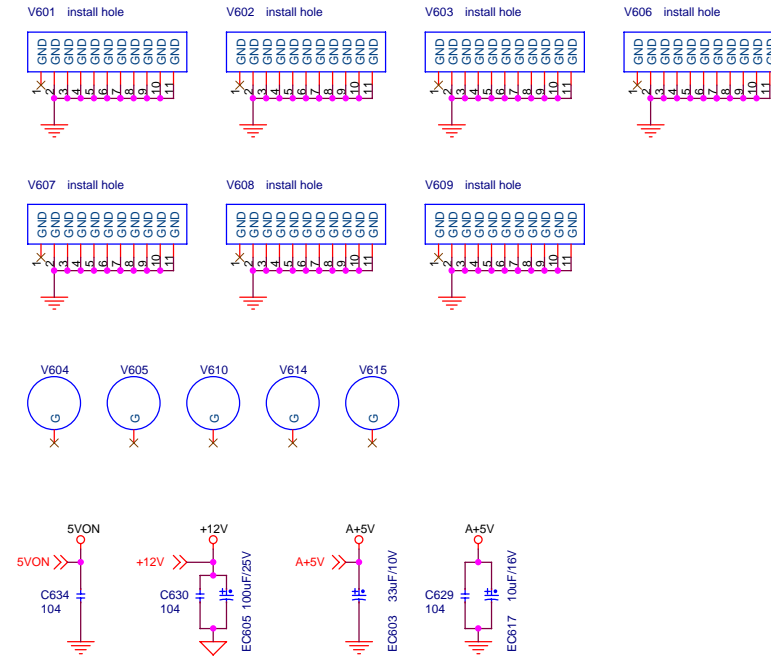
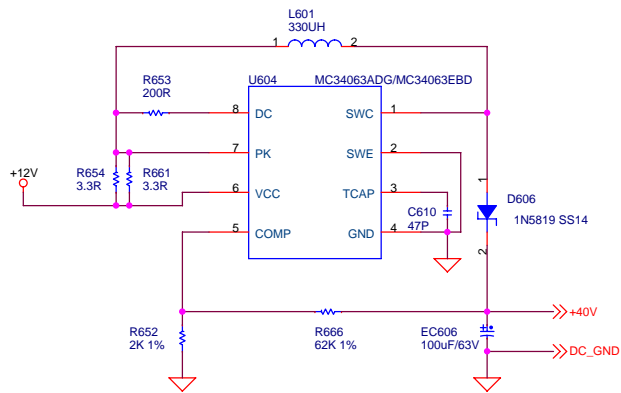
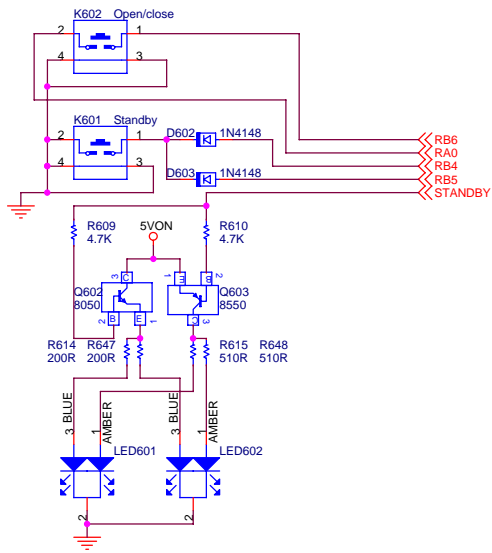

Title		
HS250 FRONT PANEL: 2line VFD BOARD 070809		
Size	Document Number	Rev
A3	3519C	1.3
Date:	Monday, December 03, 2007	Sheet 18 of 21

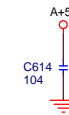
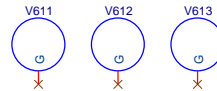
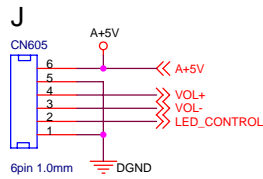
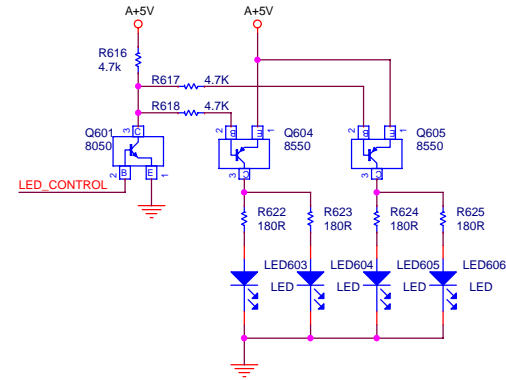
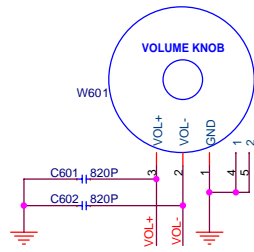

Title		
HS250 FRONT PANEL: Volume board 070324		
Size	Document Number	Rev
A3	3518C	1.1
Date:	Monday, December 03, 2007	Sheet 19 of 21

Main Transformer EER42  
 Lp:650uH  
 N\_p: 46T 10\*0.21mm\*23T\*2  
 N\_15v: 4T 0.4mm\*4T  
 N\_34V\_1: 10T 10\*0.21mm\*10T  
 N\_34V\_2: 10T 10\*0.21mm\*10T

T501:  
 L-PQ3230-01  
 LP:400uH  
 N1: 52T 20\*0.21mm\*52T  
 N2: 6T 0.4mm\*4T

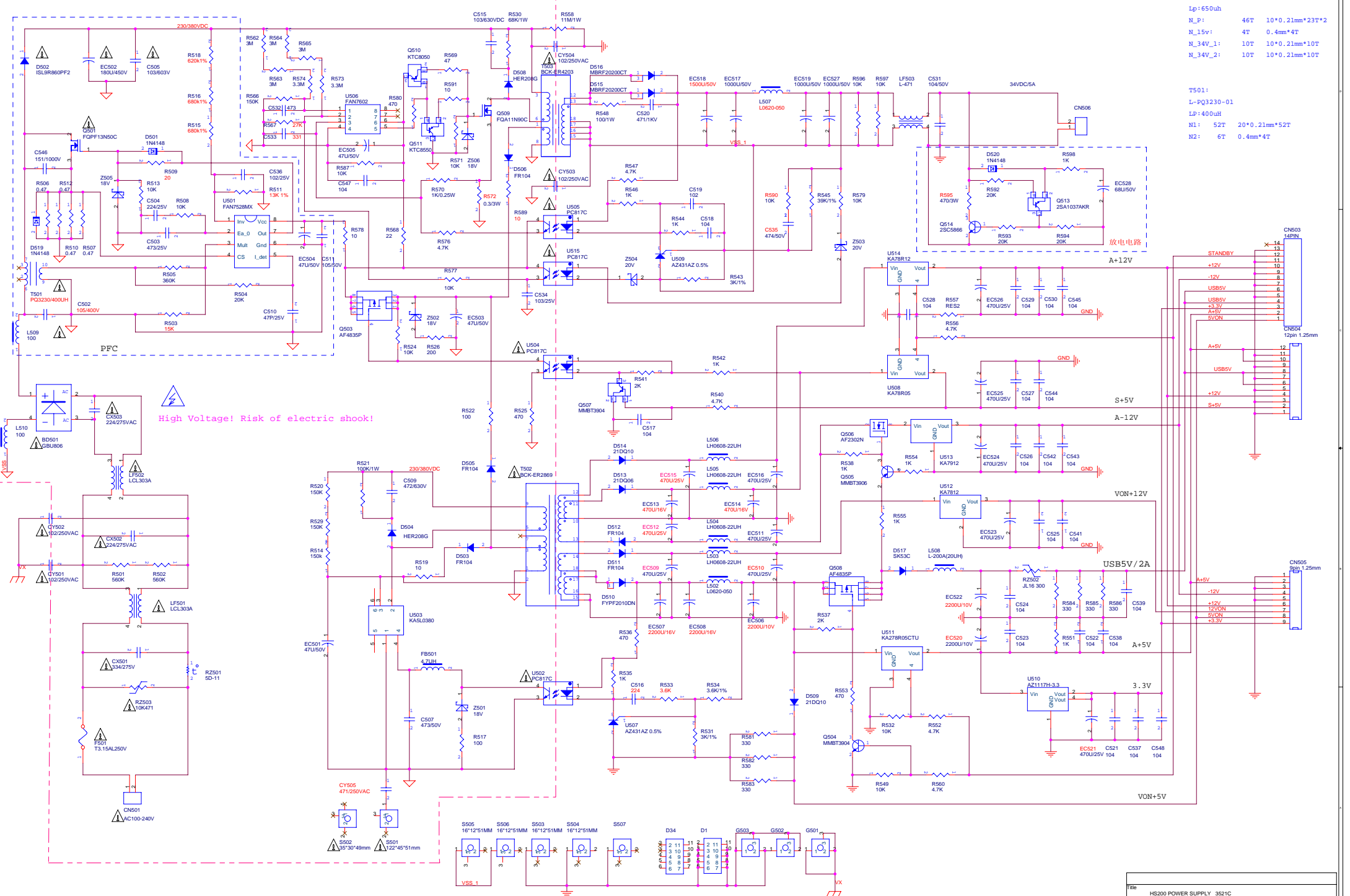

File	HS200 POWER SUPPLY 3521C	
Size	Document Number	Rev
A2	xyz	V2.3
Date:	Wednesday, August 22, 2007	Sheet 1 of 1