harman/kardon
Service Manual

HS 350/230

< G*) \$#& \$

Digital Lounge HS 650/230

Integrated Home Theater System controllers



CONTENTS

HS 350 TECHNICAL SPECIFICATIONS	2	HS 350 PACKAGE LIST AND PARTS	15
HS 350 TROUBLESHOOTING GUIDE	3	HS 650 PACKAGE LIST AND PARTS	16
HS 350 FRONT PANEL CONTROLS	5	EXPLODED VIEW AND PARTS	17
HS 350 FRONT PANEL DISPLAY	6	ELECTRICAL PARTS LIST	18
HS 350 REAR PANEL CONNECTIONS	7	SEMICONDUCTOR PINOUTS	33
HS 650 TECHNICAL SPECIFICATIONS	9	PCB DRAWINGS	47
HS 650 TROUBLESHOOTING GUIDE	10	BLOCK DIAGRAM	59
HS 650 FRONT PANEL CONTROLS	12	WIRING DIAGRAM	60
HS 650 FRONT PANEL DISPLAY	13	REVISION HISTORY	61
HS 650 REAR PANEL CONNECTIONS	14	SCHEMATIC DIAGRAMS	62-89

HS 350 Controller Specifications

DVD player

Pickup:	Semiconductor laser, wavelength 650nm
Signal system:	NTSC / PAL
Video signal horizontal resolution:	More than 480 lines (DVD)
Video signal-to-noise ratio:	More than 60 dB (DVD)
Audio frequency response: (Stereo)	DVD (PCM): 20Hz ~ 22kHz (+/- 1.0dB) CD (PCM): 20Hz ~ 20kHz (+/- 1.0dB)
Audio signal-to-noise ratio:	More than 80 dB (PCM)
Total harmonic distortion:	Less than 0.01% (PCM)
Dynamic range:	DVD (PCM): More than 85 dB (EIAJ, 2kHz) CD: More than 85 dB (EIAJ)

FM Tuner

System:	PLL quartz-locked digital synthesizer system
Tuning range:	87.50 ~ 108.00 MHz
Antenna terminals:	75 Ohms, unbalanced
Intermediate frequency:	10.7 MHz

Video Outputs HDMI:

Component Video Output:	Y: 1 Vp-p/75 Ohms, sync negative polarity Cr: 0.7 Vp-p/75 Ohms Cb: 0.7 Vp-p/75 Ohms
CVBS Video:	1 Vp-p 75 Ohms
S-video:	Y: 1 Vp-p 75 Ohms C: PAL 0.3 Vp-p 75 Ohms / NTSC 0.286 Vp-p 75 Ohms

Audio line Outputs

Audio L/R:	2 Vrms, 1 kilohms
------------	-------------------

General

Power requirements:	AC 100-240 V, 50/60 Hz
Max power consumption:	230W
Idle power consumption:	Less than 2 W
Dimensions (WxHxD):	357mm x 105mm x 293mm
Weight:	7.5 kg

* Designs and specifications are subject to change without notice.

Depth measurement includes knobs, buttons and terminal connections. Height measurement includes feet and chassis.

All features and specifications are subject to change without notice.

Harman Kardon, The Bridge  and Logic 7 are registered trademarks of Harman International Industries, Incorporated.

Dolby, Pro Logic and the double-D symbol are trademarks of Dolby Laboratories, registered in the United States and/or other countries. All rights reserved.

DTS is a trademark of Digital Theater Systems, Inc.

Windows Media® Audio (WMA) is a proprietary file format developed by Microsoft.

DivX is a registered trademark of DivX, Inc.

HDMI, the HDMI logo and High-Definition Multimedia Interface are trademarks or registered trademarks of HDMI Licensing LLC.

Apple and iPod are registered trademarks of Apple Computer, Inc.

HS 350

Troubleshooting

If you experience any of the following difficulties while using the system, use this troubleshooting guide to help you remedy the problem. Should any problem persist, consult your authorized Harman Kardon dealer.

No power.

- Is the power cord firmly plugged into the power outlet?
- One of the safety mechanisms may be operating. In this event, unplug the player from the power outlet briefly and then plug it in again.

No picture.

- Check that the system is connected correctly and securely.
- The video cable may be damaged. Replace it with a new one.
- Make sure the system is connected to a video input on the TV (see page 14).
- Make sure the TV is turned on.
- Make sure the correct video input on the TV is selected for viewing with this system.

Noise (interference) appears in the picture.

- Clean the disc.
- If video from this system has to go through your VCR to get to your TV, the copy-protection applied to some DVD programs could affect picture quality. If you still experience problems after checking your connections, please try connecting your DVD system directly to your TV's S-Video input, if your TV is equipped with this input (see page 14).

The aspect ratio of the screen is wrong (picture vertically expanded) when you play a wide picture even though you set "TV DISPLAY" in the SETUP menu to "16:9".

- If you connect the system with the SCART cable, connect directly to the TV. Otherwise the autoswitch function of the aspect ratio for the TV may not work.
- If the TV is not connected with a SCART cable to the HS, or if the autoswitch function does not work you should turn the TV to "16:9" (if possible with your TV).
- Depending on the TV, you may not be able to change the aspect ratio. In that case (TV not adjustable to 16:9) do not select "16:9" in the TV Display. Then, no change of the aspect ratio is needed.

There is no sound or volume is very low.

- Check that the speakers and components are connected correctly and securely.
- Make sure that you have selected the correct source on the system.
- Press **MUTE** on the remote control, if the words MUTE ON are blinking on the front panel display.
- The protective circuitry has been activated because of a short circuit. Turn off the system, eliminate the short circuit problem and turn on the power again.
- The audio interconnect is damaged. Replace it with a new one.
- The system is in pause mode or in slow-motion play mode, or fast forward or fast reverse. Press ► to return to normal play mode.
- Check the speaker settings (see page 20).

The left and right channels are unbalanced or reversed.

- Check that the speakers and components are connected correctly and securely.

Severe hum or noise is heard.

- Check that the speakers and components are connected securely.
- Check that the connecting cords are away from a transformer or motor and at least 3 meters away from fluorescent light.
- Move your TV away from the audio components.
- The plugs and jacks are dirty. Wipe them with a cloth slightly moistened with alcohol.
- Clean the disc.

The surround effect is difficult to hear when you are playing a Dolby Digital sound track.

- Check to see if the Dolby Digital mode is turned on properly, otherwise unload and load the disc again.
- Check the speaker connections.
- Depending on the DVD disc, the output signal may at times be mono or stereo even if the soundtrack is recorded in Dolby Digital format.

The sound comes from the center speaker only.

- Depending on the disc, sound may sometimes come from the center speaker only. This also applies to mono recordings (from disc or any analog source), when Pro Logic mode is selected. This is normal.

No sound is heard from the center speaker.

- Adjust center speaker volume (see pages 20).

No sound or only very low volume from the rear speakers.

- Adjust the rear speaker volume (see page 20).

The volume goes down automatically and can not be increased.

- The internal temperature is too high. Wait approximately one minute for the amplifier to reach normal working temperature.

Radio stations cannot be tuned in.

- Check that the antenna is connected correctly. Adjust the antenna and connect an external antenna if necessary.
- The signal strength of the stations is too weak for automatic tuning. Use manual tuning.
- No stations have been preset.
- The tuner mode is not selected, select the Radio mode.

The remote does not function.

- Remove any obstacles between the remote control and the system.
- Move the remote control closer to the system.
- Point the remote control at the remote sensor on the front panel.
- Replace all the batteries in the remote control with new ones if they are weak.
- Check that the batteries are loaded correctly.

The disc does not play.

- There is no disc inside. ("NO DISC" appears on the front panel display and the TV screen.) Insert a disc.
- Insert the disc correctly with the playback side facing down on the disc tray.
- Clean the disc.
- The system cannot play CD-ROM's, etc. (see page 3).
- DVD with wrong region code (see page 13).

The system starts playing the DVD automatically.

- The DVD features the auto playback function.

Playback stops automatically.

- Some discs include an auto pause signal. When playing such a disc, the system stops playback at the signal.

Troubleshooting

Track Skip or direct select with numeric buttons, Search, Slow-motion play, repeat play or Program play, etc., cannot be done.

- Depending on the DVD or VCD, some of the above operations may not be available (Playback control).

Messages do not appear on the TV screen in the language you want.

- Select the language for Display and Preferred Subtitle in the SETUP menu (see page 18). For all messages from the DVD (DVD menu, subtitles) in the proper language the disc must have the language you selected, if not, another language will be selected.

The audio language cannot be changed when you play a DVD.

- Multilingual sound is not recorded on the DVD.
- Changing the language for the sound by the Audio button on the remote or the Audio line in the Player Menu is prohibited on the DVD. In that case the audio language must be selected by the main menu on the DVD.

The subtitle language cannot be changed when you play a DVD.

- Multilingual subtitles are not recorded on the DVD.
- Changing the language for the subtitles by the Subtitle button on the remote or the Subtitle line in the Player Menu is prohibited on the DVD. In that case the subtitle language must be selected by the main menu on the DVD.

The subtitles cannot be turned off when you play a DVD.

- Depending on the DVD, you may not be able to turn the subtitles off.

The angles cannot be changed when you play a DVD.

- Multi-angles are not recorded on most DVDs.
- Change the angles when the angle mark appears on the TV screen.
- Changing the angles is prohibited on some DVDs.

The system does not operate properly.

- Static electricity, etc., may affect the system's operation.
Disconnect the AC power cord, then connect it again.

Please also refer to the Troubleshooting guide contained in your loudspeaker Owners Manual.

HS 350

Front Panel Controls

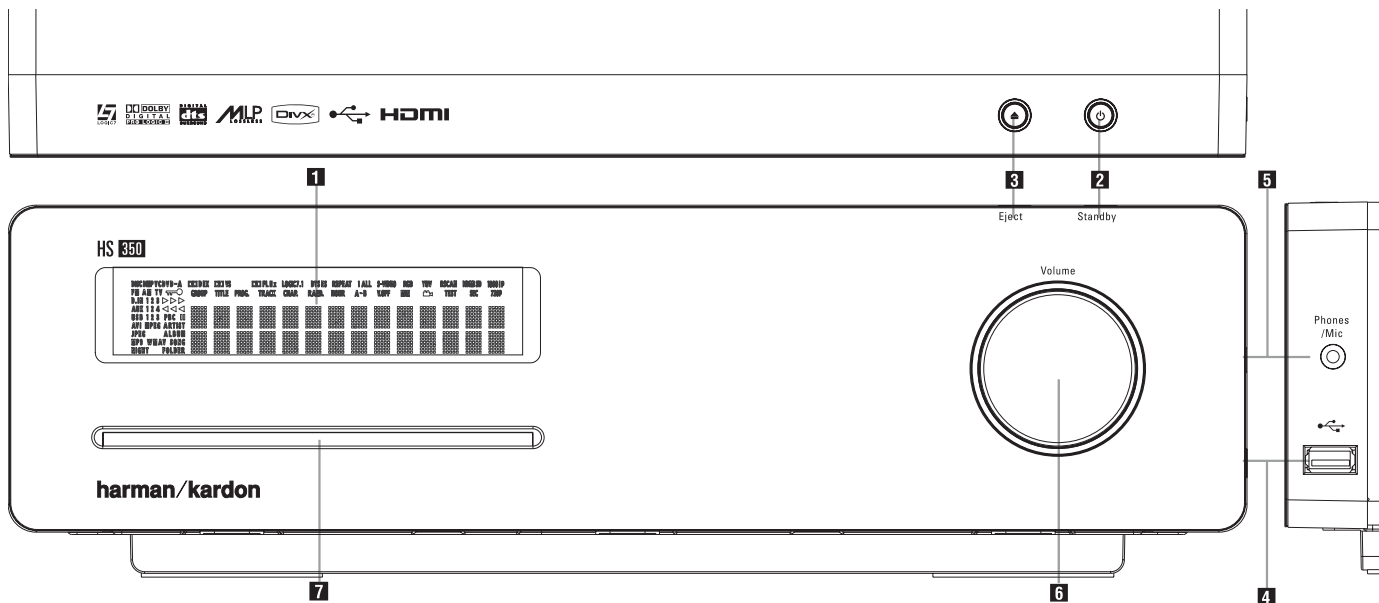

- 1** Main Information Display
- 2** Power On/Off (Standby)
- 3** Open/Close

- 4** USB On-The-Go Input
- 5** Headphone Jack
- 6** Volume Control

- 7** Slot Loader

1 Main Information Display: This display delivers messages and status indications to help you operate the HS 350 Controller.

2 Power On/Off (Standby): Press the button once to turn the HS 350 Controller on, press it again to put the unit in the Standby mode. Note that when the HS 350 Controller is switched on, the Power Indicator around the button turns white.

3 Eject: Press this button to release a disc from the loader.

4 USB On-The-Go Input: This input may be used to temporarily connect a USB thumb device or portable hard disk for direct playback of audio, image or video files or a USB hub. The USB inputs are designed to power a single USB device at a time. If additional hard disks are connected through a hub it is necessary that additional external power supplies are used to power the hub and hard disks.

5 Headphone Jack: This jack may be used to listen to the system's output through a pair of headphones. Be certain that the headphones have a standard 3.5 mm stereo phone plug. Note that the main room speakers will automatically be turned off when the headphone jack is in use.

When configuring your system using EzSet/EQ, the calibration microphone should be plugged into this jack **5**.

6 Volume Control: Turn this knob clockwise to increase the volume, counterclockwise to decrease the volume. If the system is muted, adjusting volume control will automatically release the unit from the silenced condition.

7 Slot loader: Gently insert a CD or DVD into this slot, with the printed side of the disc facing up. Note there is no drawer. Press the **Eject Button 3** to release the disc

HS 350

Front Panel Display

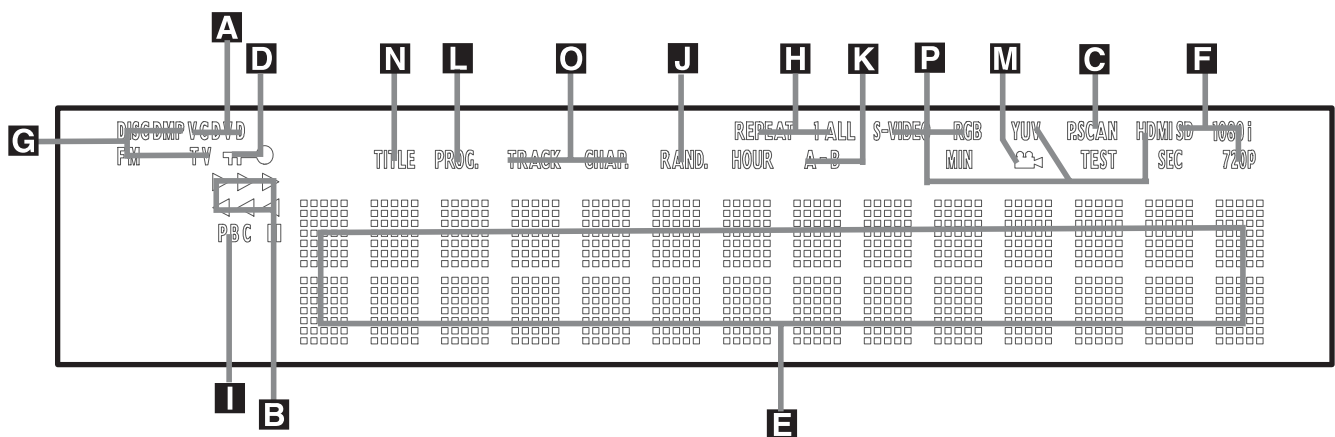

- A** Disc Type Indicators
- B** Playback-Mode Indicators
- C** Progressive Scan Indicator
- D** Parental Lock Indicator
- E** Time Indicators
- F** Video Format Indicators

- G** Source Indicators
- H** Repeat Indicators
- I** VCD Playback Control Indicator
- J** Random Indicator
- K** A-B Repeat Indicator
- L** Program Indicator

- M** Angle Indicator
- N** Title Indicators
- O** Chapter/Track Number Indicators
- P** Video Output Indicators

A Disc Type Indicators: The CD or DVD indicator will illuminate to show the type of disc currently being played.

B Playback-Mode Indicators: These indicators light to show the current playback mode:

▶ Lights when a disc is playing in the normal mode

▶▶ Lights when the disc is in the Fast Search Forward mode. The on-screen banner display indicates the selected speed (2x, 8x, 16x, 100x).

|| Lights when the disc is paused.

◀◀ Lights when the disc is in the Fast Search Reverse mode. The on-screen banner display indicates the selected speed (2x, 8x, 16x, 100x).

C Progressive Scan Indicator: This indicator lights when the unit sends out a progressive scan signal.

D Parental Lock Indicator: This indicator lights when the parental-lock system is engaged in order to prevent anyone from changing the rating level without a code.

E Time Indicators: These positions in the indicator will show the running time of a DVD in play. When a CD is playing, these indicators will show the current track time, time remaining in the current track, or the total remaining time on the disc. When an iPod is playing, the display will show the elapsed and remaining time on the top line. The bottom line will scroll information about the song, title, album and artist.

NOTE: The Indicators **NOE** will also display text messages about the DVD's status, including **Reading** when a disc is loading, **STANDBY** when the unit is turned off, and **Disc Error** when a disc not compatible with the DVD is put into the play position.

F Video Format Indicators: These indicators will represent the video format currently playing.

G Source Indicators: These indicators will light to show which source is currently selected.

H Repeat Indicators: These indicators light when any of the Repeat functions are in use.

I VCD Playback Control Indicator: This indicator lights when the playback control function is turned on with VCDs.

J Random Indicator: This indicator lights when the unit is in the Random Play mode.

K A-B Repeat Indicator: This indicator lights when a specific passage for repeat playback has been selected.

L Program Indicator: This indicator lights when the programming functions are in use.

M Angle Indicator: This indicator blinks when alternative viewing angles are available on the DVD currently playing.

N Title Indicators: These two positions in the display will show the current title number when a DVD disc is playing.

O Chapter/Track Number Indicators: When a DVD disc is playing, these two positions in the display will show the current chapter. When a CD disc is playing they will show the current track number.

P Video Output Indicators: These indicators will represent the active video output.

HS 350

Rear Panel Connections

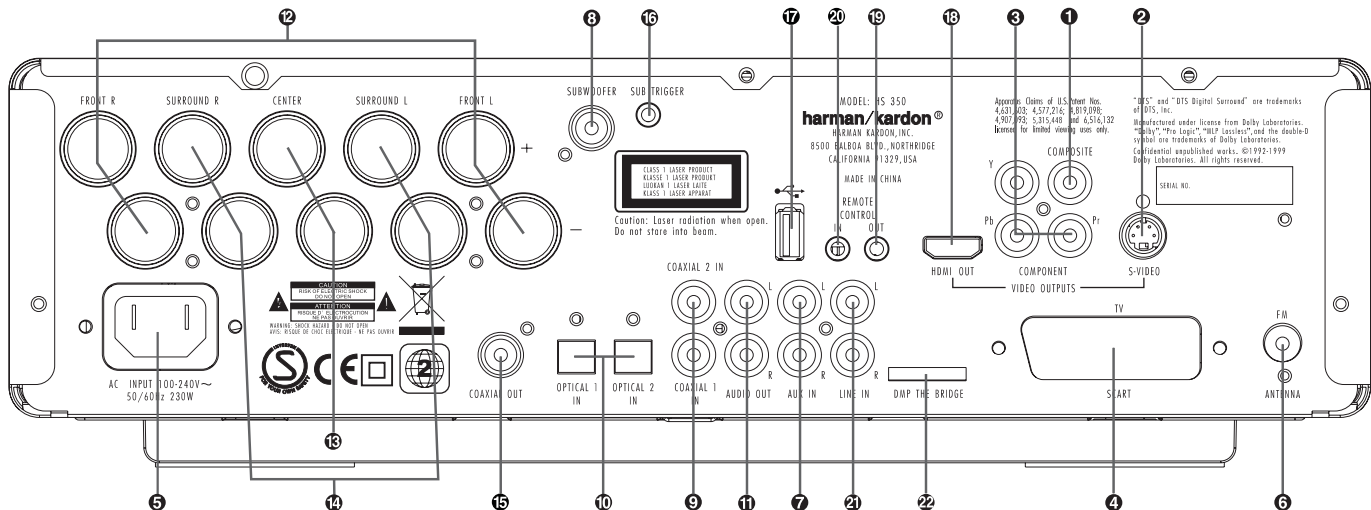

- 1 Composite Video Output
- 2 S-Video Output
- 3 Component Video Outputs
- 4 Scart TV Output
- 5 AC Power Cord
- 6 FM Antenna
- 7 Audio In
- 8 Subwoofer Output
- 9 Coaxial Digital Input
- 10 Optical Digital Input
- 11 Analog Audio Outputs
- 12 Front Speaker Outputs
- 13 Center Speaker Outputs
- 14 Surround Speaker Outputs
- 15 Coaxial Digital Output
- 16 Subwoofer Trigger Output
- 17 USB On-The-Go Input
- 18 HDMI Output
- 19 Remote IR Output
- 20 Remote IR Input
- 21 TV Audio In
- 22 ^{the Bridge} DMP Connector

1 Composite Video Output: Connect this jack to the video input on a television or video projector.

2 S-Video Output: Connect this jack to the S-Video input on a television or video projector.

3 Component Video Outputs: These outputs carry the component video signals for connection to display monitors with component video inputs. For standard analog TV's or projectors with inputs marked Y/Pr/Pb or Y/Cr/Cb, connect these outputs to the corresponding inputs. If you have a high-definition television or projector that is compatible with high scan rate progressive video, connect these jacks to the "HD Component" inputs. Note that if you are using a progressive scan display device, then "Progressive" must be selected in the Video Set-up Menu in order to take advantage of the progressive scan circuitry. See page 22 for more information on progressive scan video.

IMPORTANT: These jacks should NOT be connected to standard composite video inputs.

4 SCART OUT (TV): If your TV has a SCART socket, you can connect a SCART cable to your TV and to your DVD Player for improved video quality. The SCART cable carries both audio and video. You can select Composite Video or RGB video for that SCART connector's video output signal.

5 AC Power Cord: Connect this plug to an AC outlet. If the outlet is controlled by a switch, make certain that it is in the ON position.

6 FM Antenna: Connect to the supplied FM antenna.

7 Audio In: Connect to a line-level analog audio source: TV, tape player, Minidisc, PC, etc.

8 Subwoofer Output: Connect to the SUB/LFE input on the subwoofer.

9 Coaxial Digital Input: Connect the coax digital output from a DVD player, HDTV receiver, LD player, MD player, satellite receiver or CD player to this jack. The signal may be either a Dolby Digital signal, DTS signal or a standard PCM digital source. Do not connect the RF digital output of an LD player to these jacks.

10 Optical Digital Input: Connect the optical digital output from a DVD player, HDTV receiver, LD player, MD player, satellite receiver or CD player to this jack. The signal may be either a Dolby Digital signal, DTS signal or a standard PCM digital source.

11 Analog Audio Outputs: Connect these jacks to the analog audio input on a TV set or external audio system for analog audio playback or to the RECORD/INPUT jacks of an audio recorder for recording.

12 Front Speaker Outputs: Connect these outputs to the matching + or – terminals on your left and right speakers. In conformance with the new CEA color code specification, the White terminal is the positive, or "+" terminal that should be connected to the red (+) terminal on Front Left speaker with the older color coding, while the Red terminal is the positive, or "+" terminal that should be connected to the red (+) terminal on Front Right speaker. Connect the black (–) terminals on the HS to the black (–) terminals on the speakers. See page 14 for more information on speaker polarity.

13 Center Speaker Outputs: Connect these outputs to the matching + and – terminals on your center channel speaker. In conformance with the new CEA color code specification, the Green Terminal is the positive, or "+" terminal that should be connected to the red (+) terminal on speakers with the older color coding. Connect the black (–) terminal on the HS to the black negative (–) terminal on your speaker. (See page 14 for more information on speaker polarity.)

HS 350

Rear Panel Connections

14 Surround Speaker Outputs: Connect these outputs to the matching + and – terminals on your surround channel speakers. In conformance with the new CEA color code specification, the Blue terminal is the positive, or "+", terminal that should be connected to the red (+) terminal on the Surround Left speaker with older color coding, while the Gray terminal should be connected to the red (+) terminal on the Surround Right speaker with the older color coding. Connect the black (–) terminal on the HS to the matching black negative (–) terminals for each surround speaker. (See page 14 for more information on speaker polarity.)

Note: You'll find more details about all Audio/Video connections under Setup and Connections on the following pages.

15 Coaxial Digital Output: Connect this jack to the matching digital input connector on a digital recorder such as a CD-R or MiniDisc recorder.

16 Subwoofer Trigger Output: Connect this trigger output to the trigger input of the Harman Kardon subwoofer, so that the subwoofer will switch on and off at the same time as the rest of the system.

17 USB On-The-Go Input: This input may be used to temporarily connect a USB thumb device or portable hard disk for direct playback of audio, image or video files, a digital photo camera or a USB hub.

18 HDMI Output: Connect this output to the HDMI input of high-definition LCD, Plasma or video projector for the best possible picture quality.

19 Remote IR Output: This connection permits the IR sensor in the receiver to serve other remote controlled devices. Connect this jack to the "IR IN" jack on Harman Kardon or other compatible equipment.

20 Remote IR Input: If the HS 350's front-panel IR sensor is blocked due to cabinet doors or other obstructions, an external IR sensor may be used. Connect the output of the sensor to this jack.

21 TV Audio Input: If your screen is connected to the HS by an HDMI, Component, S-Video or Composite cable, connect the analog output of your TV to this input. If you have your TV connected to the HS with a Scart cable, an audio connection to the TV Input is not necessary.

22 The Bridge Digital Media Player (DMP) Connector: With the HS 350 turned off, connect one end of the optional Harman Kardon The Bridge to this proprietary connector, and the other to your compatible Apple iPod. When the Digital Media Player source is selected, you may view your iPod's control and navigation messages on your video display (if one is connected to one of the **Video Monitor Outputs 1 2 3 4 18**), and in the **Upper and Lower Display Lines E**. You may navigate the iPod and select tracks for playback using the **▲/▼/◀▶ Buttons 10** and the **Enter Button 7**.

DIGITAL LOUNGE 6XX

Digital Lounge Controller Specifications

DVD player	Pickup:	Semiconductor laser, wavelength 650nm
	Signal system:	NTSC / PAL
	Video signal horizontal resolution:	More than 480 lines (DVD)
	Video signal-to-noise ratio:	More than 60 dB (DVD)
	Audio frequency response: (Stereo)	DVD (PCM): 20 Hz ~ 22 kHz (+/- 1.0 dB) CD (PCM): 20 Hz ~ 20 kHz (+/- 1.0 dB)
	Audio signal-to-noise ratio:	More than 80 dB (PCM)
	Total harmonic distortion::	Less than 0.01% (PCM)
	Dynamic range:	DVD (PCM): More than 85 dB (EIAJ, 2 kHz) CD: More than 85 dB (EIAJ)
Amplifier output	Power (per channel):	65 W (6ohms)
	Signal-to-noise ratio:	> 85 dB
	Total Harmonic distortion:	< 0.2%
FM Tuner	System:	PLL quartz-locked digital synthesizer system
	Tuning range:	87.50 ~ 108.00 MHz
	Antenna terminals:	75 ohms, unbalanced
	Intermediate frequency:	10.7 MHz
Video Outputs:	HDMI™ Output: Video:	576p, 720p, 1080i HDMI Version 1.0-compliant HDCP Version 1.1-compliant
	Component Video Output:	Y: 1 Vp-p/75 ohms, sync negative polarity Cr: 0.7 Vp-p/75 ohms Cb: 0.7 Vp-p/75 ohms
	CVBS Video:	1 Vp-p 75 ohms
	S-video:	Y: 1 Vp-p 75 ohms C: PAL 0.3 Vp-p 75 ohms / NTSC 0.286 Vp-p 75 ohms
	Audio line Outputs	Audio L/R:
General	Power requirements:	AC 230 V, 50 Hz
	Max power consumption:	500 W
	Idle power consumption:	Less than 2 W
	Dimensions (WxHxD):	440 mm x 68 mm x 380 mm
	Weight:	8.5 kg

* Designs and specifications are subject to change without notice.

Depth measurement includes knobs, buttons and terminal connections. Height measurement includes feet and chassis.

All features and specifications are subject to change without notice.

Harman Kardon The Bridge, [™]Bridge and Logic 7 are registered trademarks of Harman International Industries, Incorporated.

Dolby, Pro Logic and the double-D symbol are trademarks of Dolby Laboratories, registered in the United States and/or other countries.

|||||EzSet+ is a trademark of Harman International Industries, Inc.

All rights reserved.

DTS is a trademark of Digital Theater Systems, Inc.

Windows Media® Audio (WMA) is a proprietary file format developed by Microsoft.

DivX is a registered trademark of DivX, Inc.

HDMI, the HDMI logo and High-Definition Multimedia Interface are trademarks or registered trademarks of HDMI Licensing LLC.

Troubleshooting

For the Controller

If you experience any of the following difficulties while using the system, use this troubleshooting guide to help you remedy the problem.

Should any problem persist, consult your authorized Harman Kardon dealer.

No power.

- Is the power cord firmly plugged into the power outlet?
- One of the safety mechanisms may be operating. In this event, unplug the player from the power outlet briefly and then plug it in again.

No picture.

- Check that the system is connected correctly and securely.
- The video cable may be damaged. Replace it with a new one.
- Make sure the system is connected to a video input on the TV (see page 14).
- Make sure the TV is turned on.
- Make sure the correct video input on the TV is selected for viewing with this system.

Noise (interference) appears in the picture.

- Clean the disc.
- If video from this system has to go through your VCR to get to your TV, the copy-protection applied to some DVD programs could affect picture quality. If you still experience problems after checking your connections, please try connecting your DVD system directly to your TV's S-Video input, if your TV is equipped with this input (see page 14).

The aspect ratio of the screen is wrong (picture vertically expanded) when you play a wide picture by the player or an external source connected to the screen even though you set "TV DISPLAY" in the SETUP menu to "Auto".

- If you connect the system or the external source with the SCART cable, connect directly to the TV. Otherwise the autoswitch function of the aspect ratio for the TV may not work.
- If the TV is not connected with a SCART cable to the HS (as recommended) or the external source, or if the autoswitch function does not work you should turn the TV to "Fill All".

There is no sound or volume is very low

- Check that the speakers and components are connected correctly and securely.
- Make sure that you have selected the correct source on the system.
- Press **MUTE** on the remote control, if the words MUTE ON are blinking on the front panel display.
- The protective circuitry has been activated because of a short circuit. Turn off the system, eliminate the short circuit problem and turn on the power again.
- The audio interconnect is damaged. Replace it with a new one.
- The system is in pause mode or in slow-motion play mode, or fast forward or fast reverse. Press ► to return to normal play mode.
- Check the speaker settings (see page 19).

The left and right channels are unbalanced or reversed.

- Check that the speakers and components are connected correctly and securely.

Severe hum or noise is heard.

- Check that the speakers and components are connected securely.
- Check that the connecting cords are away from a transformer or motor and at least 3 meters away from fluorescent light.
- Move your TV away from the audio components.
- The plugs and jacks are dirty. Wipe them with a cloth slightly moistened with alcohol.
- Clean the disc.
- Disconnect antenna cables from external sources (also PC) connected to the screen or system. If hum disappears use an antenna transformer between antenna and source.
- If PC is connected to the system disconnect the Audio and Video cables. If hum disappears use an audio transformer between PC audio out and system input. If hum persists unplug PC from your system and ask your local dealer for a proper solution (ground loop interrupt).

The surround effect is difficult to hear when you are playing a Dolby Digital sound track.

- Check to see if the Dolby Digital mode is turned on properly, otherwise unload and load the disc again.
- Check the speaker connections.
- Depending on the DVD disc, the output signal may at times be mono or stereo even if the soundtrack is recorded in Dolby Digital format.

The sound comes from the center speaker only.

- Depending on the disc, sound may sometimes come from the center speaker only. This also applies to mono recordings (from disc or any analog source), when Pro Logic mode is selected. This is normal.

No sound is heard from the center speaker.

- Adjust center speaker volume (see pages 19).

No sound or only very low volume from the rear speakers.

- Adjust the rear speaker volume (see page 19).

The volume goes down automatically and cannot be increased.

- The internal temperature is too high. Wait approximately one minute for the amplifier to reach normal working temperature.

Radio stations cannot be tuned in.

- Check that the antenna is connected correctly. Adjust the antenna and connect an external antenna if necessary.
- The signal strength of the stations is too weak for automatic tuning. Use manual tuning.
- No stations have been preset.
- The tuner mode is not selected, select the Radio mode.

The remote does not function.

- Remove any obstacles between the remote control and the system.
- Move the remote control closer to the system.
- Point the remote control at the remote sensor on the front panel.
- Replace all the batteries in the remote control with new ones if they are weak.
- Check that the batteries are loaded correctly.

The disc does not play.

- There is no disc inside. ("NO DISC" appears on the front panel display and the TV screen.) Insert a disc.
- Insert the disc correctly with the playback side facing down.
- Clean the disc.
- The system cannot play CD-ROM's, etc. (see page 3).
- DVD with wrong region code (see page 13).

Playback stops automatically.

- Some discs include an auto pause signal. When playing such a disc, the system stops playback at the signal.

Troubleshooting

Track Skip or direct select with numeric buttons, Search, Slow-motion play, repeat play or Program play, etc., cannot be done.

- Depending on the DVD or VCD, some of the above operations may not be available (Playback control).

Messages do not appear on the TV screen in the language you want.

- Select the language for Display and Preferred Subtitle in the SETUP menu (see page 18). For all messages from the DVD (DVD menu, subtitles) in the proper language, the disc must have the language you selected, if not, another language will be selected.

The audio language cannot be changed when you play a DVD.

- Multilingual sound is not recorded on the DVD.
- Changing the language for the sound by the Audio button on the remote or the Audio line in the Player Menu is prohibited on the DVD. In that case the audio language must be selected by the main menu on the DVD.

The subtitle language cannot be changed when you play a DVD.

- Multilingual subtitles are not recorded on the DVD.
- Changing the language for the subtitles by the Subtitle button on the remote or the Subtitle line in the Player Menu is prohibited on the DVD. In that case the subtitle language must be selected by the main menu on the DVD.

The subtitles cannot be turned off when you play a DVD.

- Depending on the DVD, you may not be able to turn the subtitles off.

The angles cannot be changed when you play a DVD.



- Multi-angles are not recorded on most DVDs.
- Change the angles when the angle mark appears on the TV screen.
- Changing the angles is prohibited on some DVDs.

The system does not operate properly.

- Static electricity, etc., may affect the system's operation. Disconnect the AC power cord, then connect it again.

Please also refer to the Troubleshooting guide contained in your loudspeaker Owners Manual

For the TV

Defect	Possible cause	Possible remedy
No picture although the mains plug is inserted and the unit is switched on.	<ul style="list-style-type: none"> • Mains switch in position "0" (OFF). • Mains plug of unit is not inserted into the plug receptacle. • The HDMI cable is not properly inserted. • Defective mains cable. 	<ul style="list-style-type: none"> • Shift mains switch to position "1". • Insert the mains cable plug into the plug receptacle. • Insert the HDMI cable firmly. • Call the service hotline.
Screen dark.	<ul style="list-style-type: none"> • Contrast setting too low. • No input signal, wrong input selected. 	<ul style="list-style-type: none"> • Set the brightness and/or contrast correctly (see Picture Calibration). • Check the connection cable; assign correct input to source.
Weak or excessive colours.	<ul style="list-style-type: none"> • Colour not correctly set. • Connection cable not correctly connected. 	<ul style="list-style-type: none"> • Set the colour correctly (see Picture Calibration). • Connect the cable correctly.
The picture is too large or too small.	<ul style="list-style-type: none"> • Picture format set wrongly. 	<ul style="list-style-type: none"> • Repeatedly press the Screen Format Button  until the picture is displayed as full screen.
The displayed picture is too dark.	<ul style="list-style-type: none"> • The picture quality is not set correctly. 	<ul style="list-style-type: none"> • Correct the picture brightness and contrast (see Picture Calibration)
The picture is displayed, but there is no sound.	<ul style="list-style-type: none"> • The sound is switched to mute. • The Coaxial Digital Audio cable is not properly inserted. • Volume is set to minimum. 	<ul style="list-style-type: none"> • Press the Mute Button  on the remote control. • Insert the Coaxial Digital Audio cable firmly. • Increase the volume.
Horizontal stripes with TV or video signals.	<ul style="list-style-type: none"> • Signal source is placed in front of the display. 	<ul style="list-style-type: none"> • Always place the signal sources on the side of or behind the display.

DIGITAL LOUNGE 6XX

Front Panel Controls

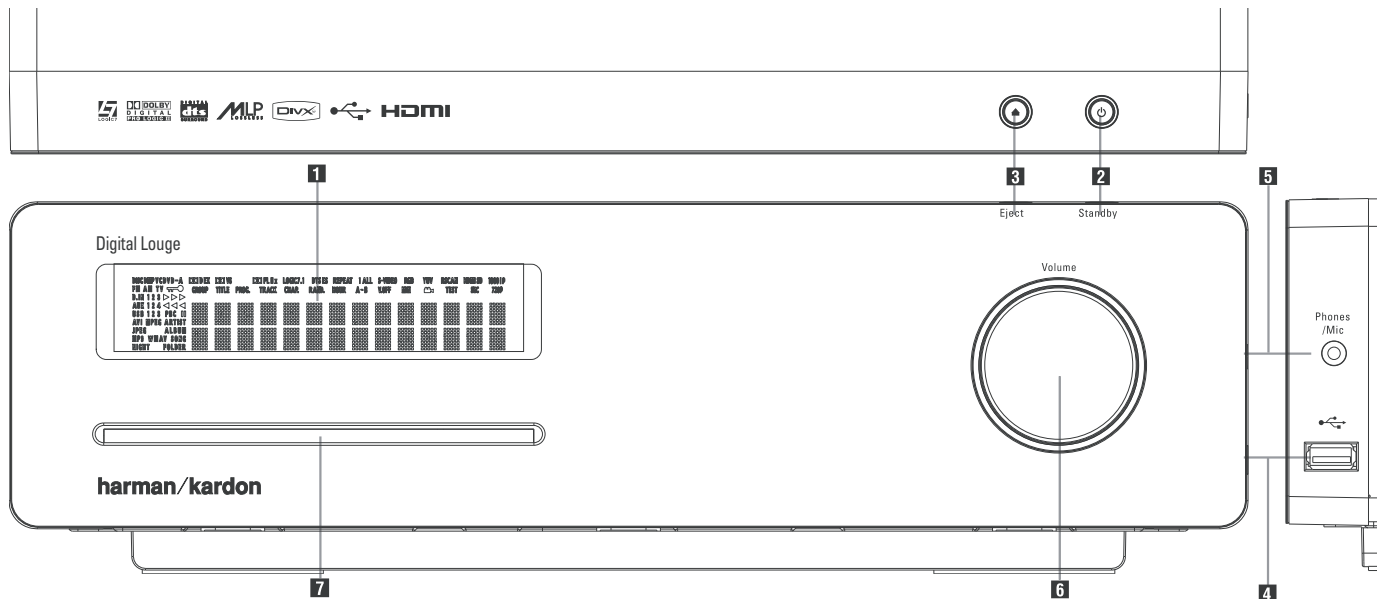

- 1** Main Information Display
- 2** Power On/Off (Standby)
- 3** Open/Close
- 4** USB On-The-Go Input
- 5** Headphone Jack
- 6** Volume Control
- 7** Slot Loader

1 Main Information Display: This display delivers messages and status indications to help you operate the Digital Lounge Controller.

2 Power On/Off (Standby): Press the button once to turn the Digital Lounge Controller on, press it again to put the unit in the Standby mode.

Note that when the Digital Lounge Controller is switched on, the Power Indicator around the button turns blue.

3 Eject: Press this button to release a disc from the loader.

4 USB On-The-Go Input: This input may be used to temporarily connect a USB thumb device or portable hard disk for direct playback of audio, image or video files or a USB hub. The USB inputs are designed to power a single USB device at a time. If additional hard disks are connected through a hub it is necessary that additional external power supplies are used to power the hub and hard disks.

5 Headphone Jack: This jack may be used to listen to the system's output through a pair of headphones. Be certain that the headphones have a standard 3.5 mm stereo phone plug. Note that the main room speakers will automatically be turned off when the headphone jack is in use.

When configuring your system using EzSet/EQ, the calibration microphone should be plugged into this jack **5**.

6 Volume Control: Turn this knob clockwise to increase the volume, counterclockwise to decrease the volume. If the system is muted, adjusting volume control will automatically release the unit from the silenced condition.

7 Slot loader: Gently insert a CD or DVD into this slot, with the printed side of the disc facing up. Note there is no drawer. Press the **Eject Button 3** to release the disc

DIGITAL LOUNGE 6XX

Front Panel Display

ENGLISH

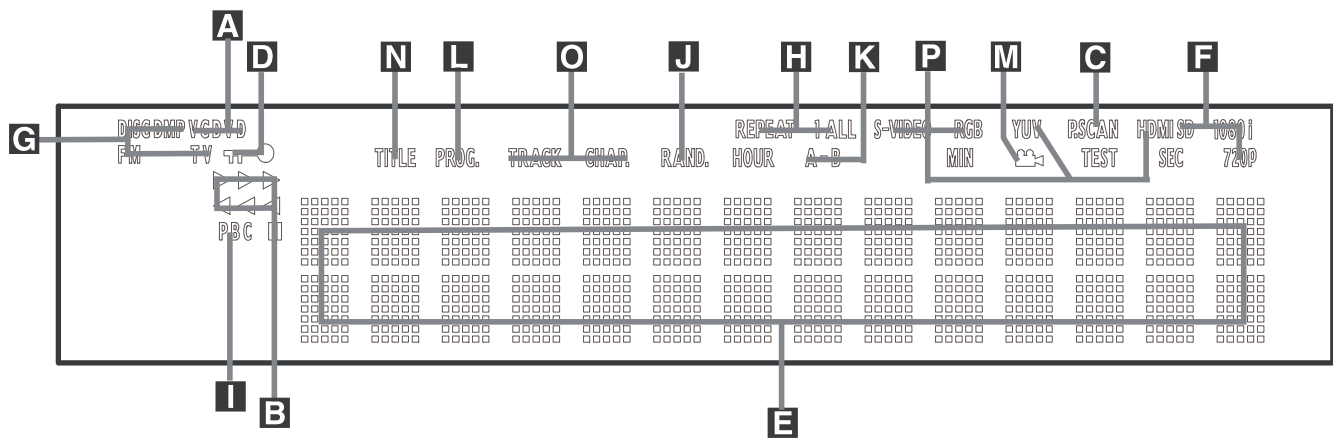

- A** Disc Type Indicators
- B** Playback-Mode Indicators
- C** Progressive Scan Indicator
- D** Parental Lock Indicator
- E** Time Indicators
- F** Video Format Indicators
- G** Source Indicators
- H** Repeat Indicators
- I** VCD Playback Control Indicator
- J** Random Indicator
- K** A-B Repeat Indicator
- L** Program Indicator
- M** Angle Indicator
- N** Title Indicators
- O** Chapter/Track Number Indicators
- P** Video Output Indicators

A Disc Type Indicators: The CD or DVD indicator will illuminate to show the type of disc currently being played.

B Playback-Mode Indicators: These indicators light to show the current playback mode:

- ▶ Lights when a disc is playing in the normal mode
- ▶▶ Lights when the disc is in the Fast Search Forward mode. The on-screen banner display indicates the selected speed (2x, 8x, 16x, 100x).
- || Lights when the disc is paused.
- ◀◀ Lights when the disc is in the Fast Search Reverse mode. The on-screen banner display indicates the selected speed (2x, 8x, 16x, 100x).

C Progressive Scan Indicator: This indicator lights when the unit sends out a progressive scan signal.

D Parental Lock Indicator: This indicator lights when the parental-lock system is engaged in order to prevent anyone from changing the rating level without a code.

E Time Indicators: These positions in the indicator will show the running time of a DVD in play. When a CD is playing, these indicators will show the current track time, time remaining in the current track, or the total remaining time on the disc. When an iPod is playing, the display will show the elapsed and remaining time on the top line. The bottom line will scroll information about the song, title, album and artist.

NOTE: The Indicators **N O E** will also display text messages about the DVD's status, including **Reading** when a disc is loading, **STANDBY** when the unit is turned off, and **Disc Error** when a disc not compatible with the DVD is put into the play position.

F Video Format Indicators: These indicators will represent the video format currently playing.

G Source Indicators: These indicators will light to show which source is currently selected.

H Repeat Indicators: These indicators light when any of the Repeat functions are in use.

I VCD Playback Control Indicator: This indicator lights when the playback control function is turned on with VCDs.

J Random Indicator: This indicator lights when the unit is in the Random Play mode.

K A-B Repeat Indicator: This indicator lights when a specific passage for repeat playback has been selected.

L Program Indicator: This indicator lights when the programming functions are in use.

M Angle Indicator: This indicator blinks when alternative viewing angles are available on the DVD currently playing.

N Title Indicators: These two positions in the display will show the current title number when a DVD disc is playing.

O Chapter/Track Number Indicators: When a DVD disc is playing, these two positions in the display will show the current chapter. When a CD disc is playing they will show the current track number.

P Video Output Indicators: These indicators will represent the active video output.

DIGITAL LOUNGE 6XX

Rear Panel Connections

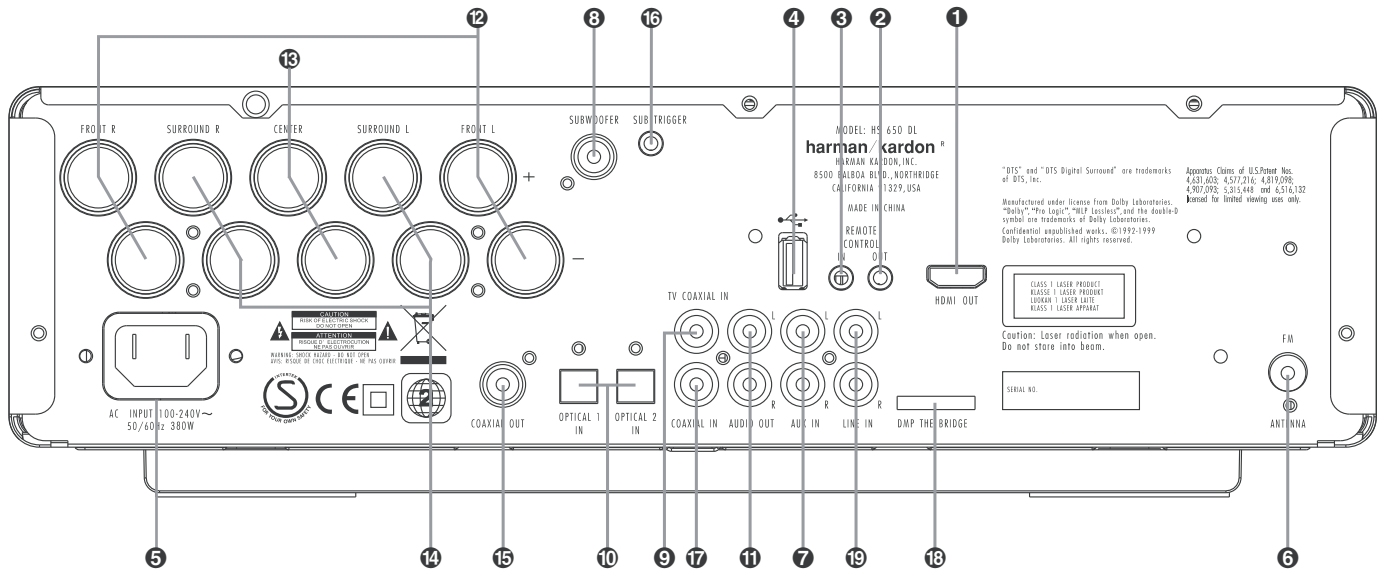

- 1 HDMI Output
- 2 Remote IR Output
- 3 Remote IR Input
- 4 USB On-The-Go Input
- 5 AC Power Cord
- 6 FM Antenna
- 7 Audio In
- 8 Subwoofer Output
- 9 Coaxial Digital TV Input
- 10 Optical Digital Input
- 11 Analog Audio Outputs
- 12 Front Speaker Outputs
- 13 Center Speaker Outputs
- 14 Surround Speaker Outputs
- 15 Coaxial Digital Output
- 16 Subwoofer Trigger Output
- 17 Coaxial Digital Input
- 18 DMP The Bridge Input
- 19 Analog Audio Inputs

1 HDMI Output: Connect this output to the HDMI input **1** of the screen, using the supplied HDMI - SP-DIF - Remote In/Out cable.

2 Remote IR Output: This connection permits the IR sensor in the receiver to serve other remote controlled devices. Connect this jack to the "IR IN" jack on Harman Kardon or other compatible equipment. Note this connection is only necessary for optional, additional products connected to the player. It is not necessary for proper control of the Digital Lounge system.

3 Remote IR Input: Connect this input to the Remote IR Output **1** of the TV, using the special HDMI - SP-DIF - Remote In/Out cable. This will allow you to control all components in your system by pointing the remote control to the TV only.

4 USB On-The-Go Input: This input may be used to temporarily connect a USB thumb device or portable hard disk for direct playback of audio, image or video files, a digital photo camera or a USB hub.

5 AC Power Cord: Connect this plug to an AC outlet. If the outlet is controlled by a switch, make certain that it is in the ON position.

6 FM Antenna: Connect to the supplied FM antenna.

7 Audio In: Connect to a line-level analog audio source: TV, tape player, Minidisc, PC, etc.

8 Subwoofer Output: Connect to the SUB/LFE input on the subwoofer.

9 Coaxial Digital TV Input: Connect the Coax Digital TV Output **15** of the screen to this jack, using the supplied HDMI - SP-DIF - Remote In/Out cable.

10 Optical Digital Input: Connect the optical digital output from a DVD player, HDTV receiver, LD player, MD player, satellite receiver or CD player to this jack. The signal may be either a Dolby Digital signal, DTS signal or a standard PCM digital source.

11 Analog Audio Outputs: Connect these jacks to the RECORD/INPUT jacks of an optional audio recorder for recording.

12 Front Speaker Outputs: Connect these outputs to the matching + or – terminals on your left and right speakers. In conformance with the new CEA color code specification, the White terminal is the positive, or "+" terminal that should be connected to the red (+) terminal on Front Left speaker with the older color coding, while the Red terminal is the positive, or "+" terminal that should be connected to the red (+) terminal on Front Right speaker. Connect the black (–) terminals on the Digital Lounge system to the black (–) terminals on the speakers. See page 15 for more information on speaker polarity.

13 Center Speaker Outputs: Connect these outputs to the matching + and – terminals on your center channel speaker. In conformance with the new CEA color code specification, the Green Terminal is the positive, or "+" terminal that should be connected to the red (+) terminal on speakers with the older color coding. Connect the black (–) terminal on the Digital Lounge system to the black negative (–) terminal on your speaker. (See page 15 for more information on speaker polarity.)

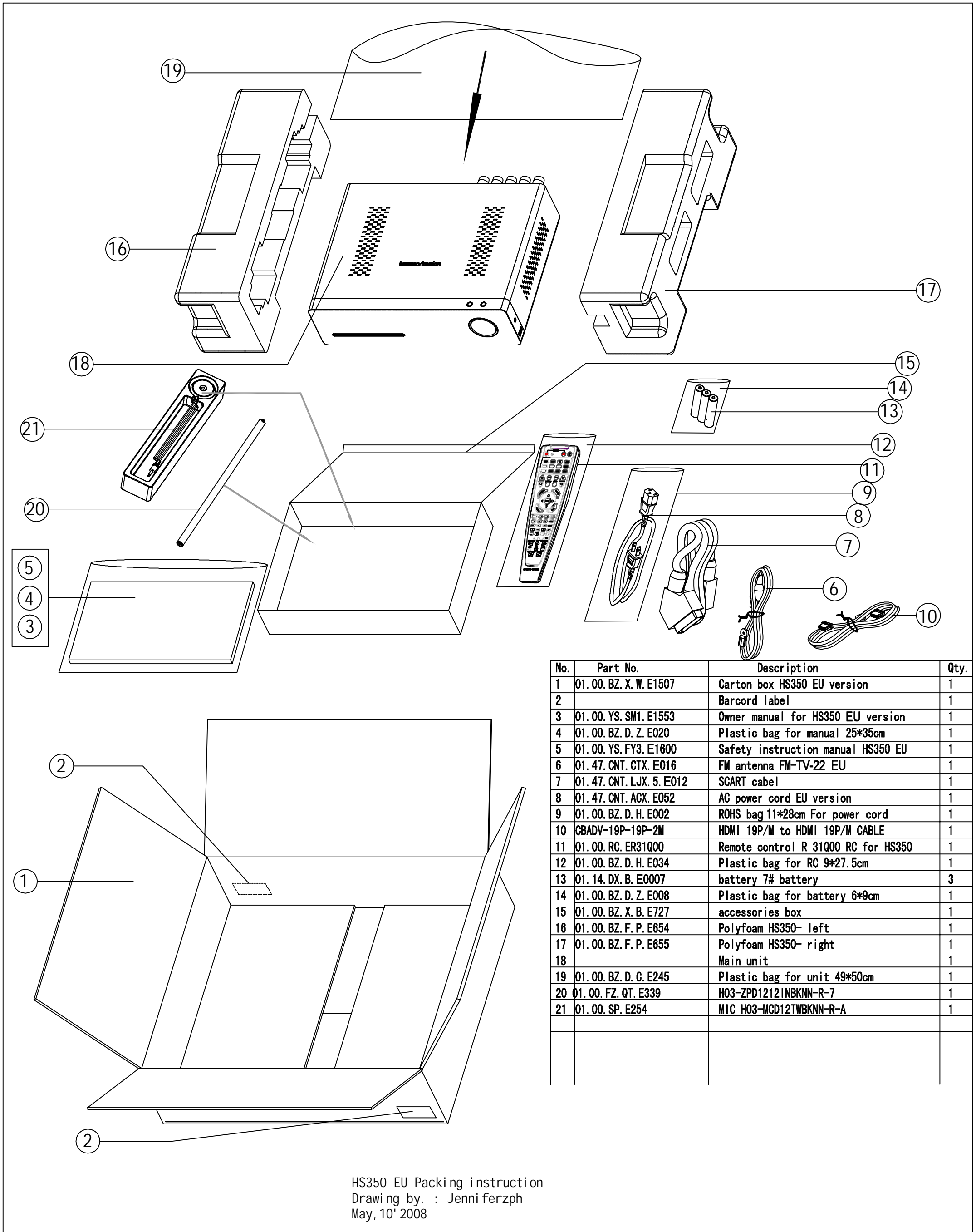

No.	Part No.	Description	Qty.
1	01.00.BZ.X.W.E1507	Carton box HS350 EU version	1
2		Barcod label	1
3	01.00.YS.SM1.E1553	Owner manual for HS350 EU version	1
4	01.00.BZ.D.Z.E020	Plastic bag for manual 25*35cm	1
5	01.00.YS.FY3.E1600	Safety instruction manual HS350 EU	1
6	01.47.CNT.CTX.E016	FM antenna FM-TV-22 EU	1
7	01.47.CNT.LJX.5.E012	SCART cabel	1
8	01.47.CNT.ACX.E052	AC power cord EU version	1
9	01.00.BZ.D.H.E002	ROHS bag 11*28cm For power cord	1
10	CBADV-19P-19P-2M	HDMI 19P/M to HDMI 19P/M CABLE	1
11	01.00.RC.ER31Q00	Remote control R 31Q00 RC for HS350	1
12	01.00.BZ.D.H.E034	Plastic bag for RC 9*27.5cm	1
13	01.14.DX.B.E0007	battery 7# battery	3
14	01.00.BZ.D.Z.E008	Plastic bag for battery 6*9cm	1
15	01.00.BZ.X.B.E727	accessories box	1
16	01.00.BZ.F.P.E654	Polyfoam HS350- left	1
17	01.00.BZ.F.P.E655	Polyfoam HS350- right	1
18		Main unit	1
19	01.00.BZ.D.C.E245	Plastic bag for unit 49*50cm	1
20	01.00.FZ.QT.E339	H03-ZPD12121NBKNN-R-7	1
21	01.00.SP.E254	MIC H03-MCD12TWBKNN-R-A	1

HS350 EU Packing instruction
 Drawing by. : Jenni ferzph
 May, 10' 2008

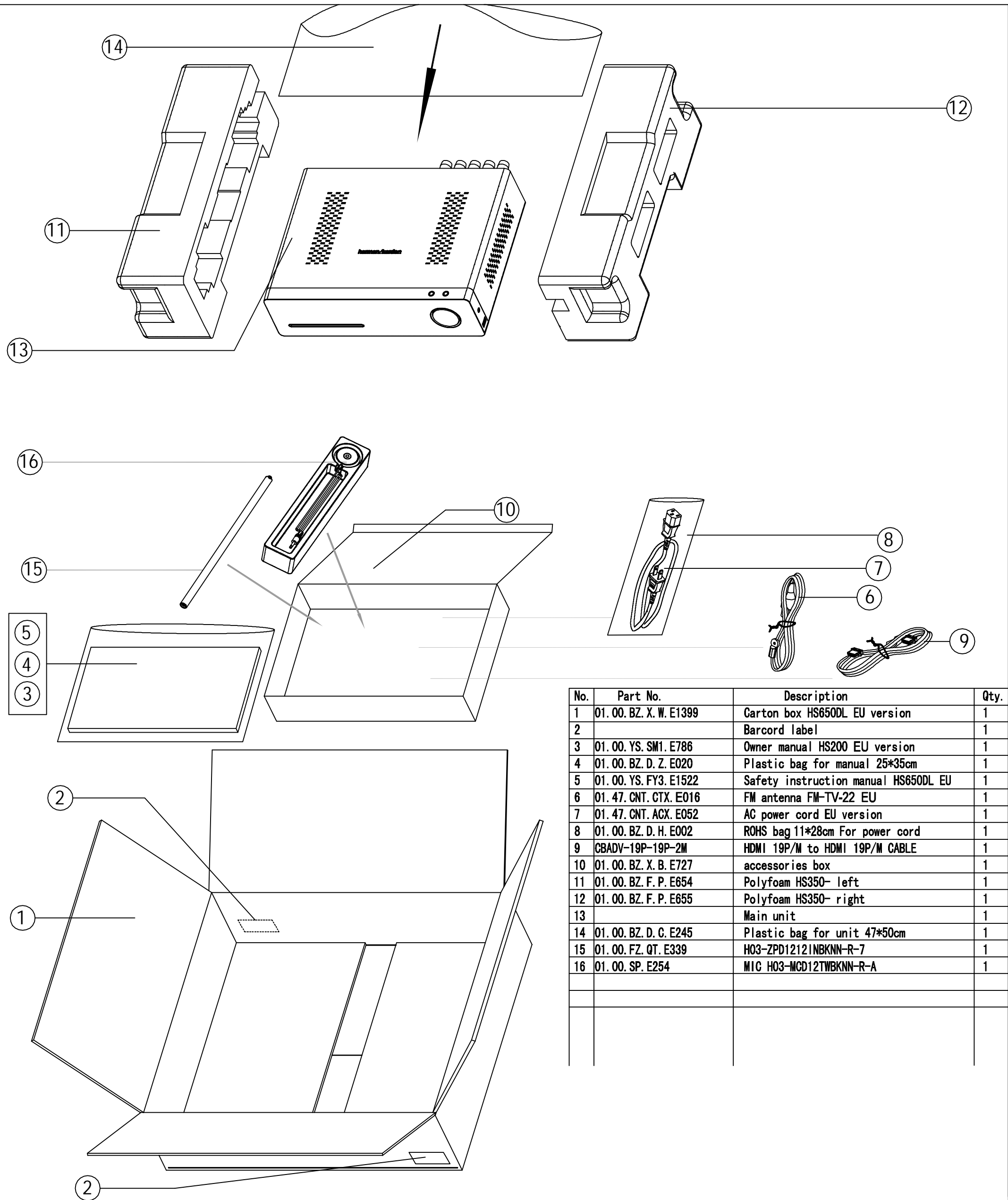

No.	Part No.	Description	Qty.
1	01.00.BZ.X.W.E1399	Carton box HS650DL EU version	1
2		Barcode label	1
3	01.00.YS.SM1.E786	Owner manual HS200 EU version	1
4	01.00.BZ.D.Z.E020	Plastic bag for manual 25*35cm	1
5	01.00.YS.FY3.E1522	Safety instruction manual HS650DL EU	1
6	01.47.CNT.CTX.E016	FM antenna FM-TV-22 EU	1
7	01.47.CNT.ACX.E052	AC power cord EU version	1
8	01.00.BZ.D.H.E002	ROHS bag 11*28cm For power cord	1
9	CBADV-19P-19P-2M	HDMI 19P/M to HDMI 19P/M CABLE	1
10	01.00.BZ.X.B.E727	accessories box	1
11	01.00.BZ.F.P.E654	Polyfoam HS350- left	1
12	01.00.BZ.F.P.E655	Polyfoam HS350- right	1
13		Main unit	1
14	01.00.BZ.D.C.E245	Plastic bag for unit 47*50cm	1
15	01.00.FZ.QT.E339	H03-ZPD12121NBKNN-R-7	1
16	01.00.SP.E254	MIC H03-MCD12TWBKNN-R-A	1

HS650DL EU Packing instruction
 Drawing by. : Jenni ferzph
 May, 10' 2008

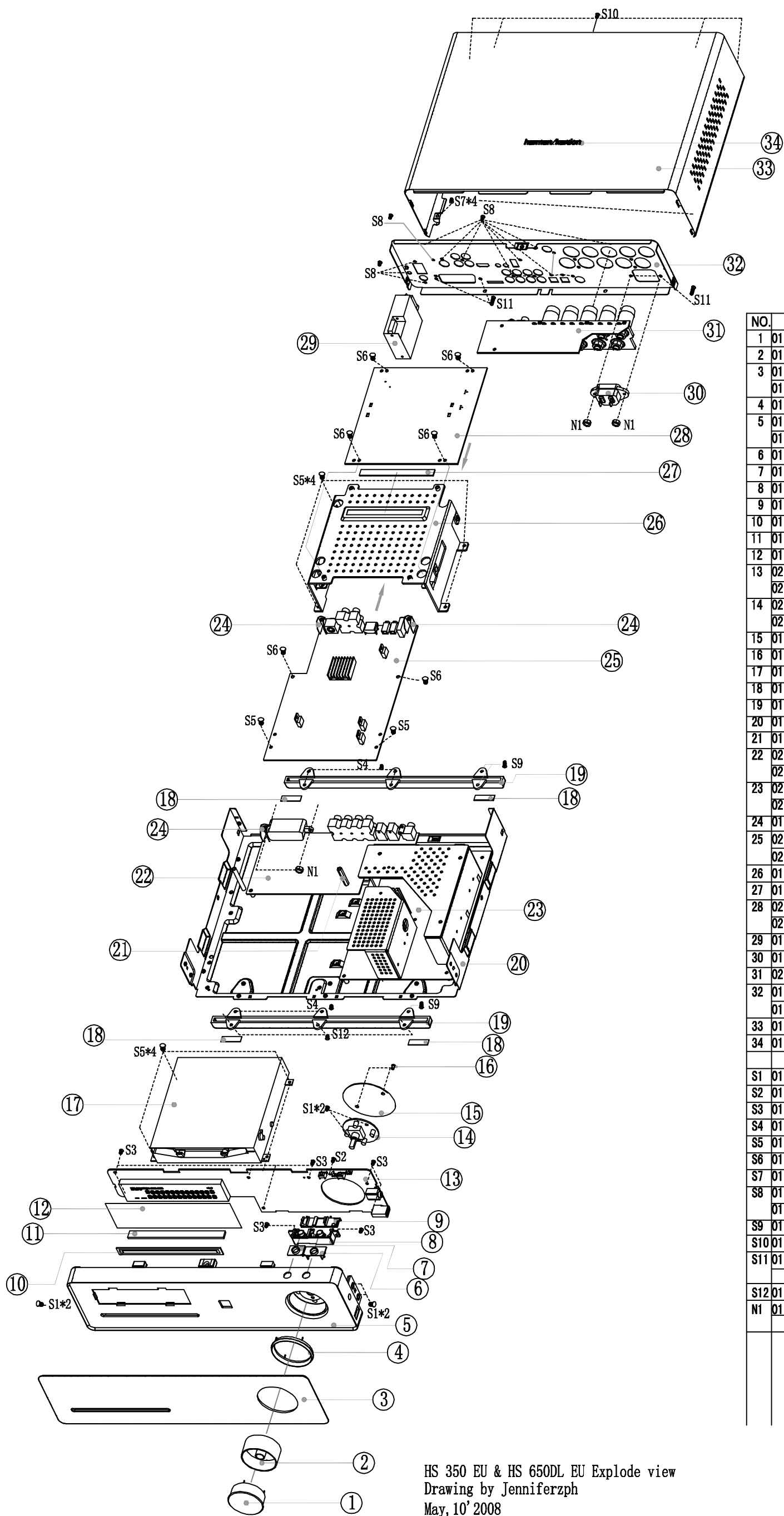

NO.	P/N	DESCRIPTION	QTY.
1	01.00.SJ.HS100.E010	HS100—Volume Button	1
2	01.00.SJ.HS100.E008	HS100—volume button lampshade	1
3	01.00.SJ.HS350.E002	HS350—Large Lens	1
	01.00.SJ.HS650.E001	HS650DL—Large Lens	1
4	01.00.SJ.HS100.E006	HS100—Volume Button Collar	1
5	01.00.SJ.HS350.E001	HS350—front panel	1
	01.00.SJ.HS650.E003	HS650DL—front panel	1
6	01.00.SJ.HS200.E005	HS200—Power Indicator lampshade	1
7	01.00.SJ.HS200.E003	HS200—Open button collar	1
8	01.00.SJ.HS200.E002	HS200—2 in 1 Button	1
9	01.00.SJ.HS200.E004	HS200—Button Cover Board	1
10	01.00.DP.JY.E135	Dustproof for Loder LTD-1510	1
11	01.00.DP.HM.E363	High Soft sponge 124*12*2MM	1
12	01.00.SJ.QT.E019	VFD filter 124.5*33.5*0.5mm	1
13	02.15.HAV07K5115C02	Front Panel Board ass'y for HS350	1
	02.15.HAV07K5115C01	Front Panel Board ass'y for HS650DL	1
14	02.15.HAV07K5115C02	Front Panel Board ass'y for HS350	1
	02.15.HAV07K5115C01	Front Panel Board ass'y for HS650DL	1
15	01.00.DP.JY.E249	Insulated PVC HS200-H02	1
16	01.00.SJ.QT.E104	plastic rivet MBL3-2.5	2
17	01.15.JX.EDL05FHH40P	Loader DL-05FH-H40P	1
18	01.00.DP.XJ.E192	Silica gel gasket 50.6*4.2*1.5mm	4
19	01.00.SJ.HS200.E006	HS200—pedestal underlay	2
20	01.00.WJ.TJ.HS350.E001	HS350—chassis	1
21	01.00.WJ.JG.E946	hexagon Nut M3*30	1
22	02.14.HAV07I5113C02	AV BOARD ASS'Y FOR HS350	1
	02.14.HAV07I5113C01	AV BOARD ASS'Y FOR HS650DL	1
23	02.19.HAV07P5117C02	SMPS Board ass'y FOR HS350	1
	02.19.HAV07P5117C01	SMPS Board ass'y FOR HS650DL	1
24	01.00.WJ.TJ.HS650.E002	U type connect piece FOR HS650DL	3
25	02.11.HAV07M5112C02	Main Board ass'y FOR HS350 (EU)	1
	02.11.HAV07M5112C01	Main Board ass'y FOR HS650DL (EU)	1
26	01.00.WJ.TJ.HS350.E003	HS350— pcb bracket	1
27	01.00.DP.JY.E583	Diathermanous Selenium Rubber100*8*1mm	1
28	02.17.HAV07A5329C02	Main Board ass'y FOR HS350	1
	02.11.HAV07A5329C01	Main Board ass'y FOR HS650DL	1
29	01.40.CON.DCZ.E178	AC power Jack WS-044-0	1
30	01.49.E11	FM tuner moduleTFCF1E806A (EU)	1
31	02.14.HAV07I5118C01	Speaker Board ass'y	1
32	01.00.WJ.TJ.HS350.E009	Rear panel FOR HS350 (EU)	1
	01.00.WJ.TJ.HS650.E001	Rear panel FOR HS650DL (EU)	1
33	01.00.WJ.TJ.HS350.E002	HS350—top cover	1
34	01.00.SB.E036	Metal logo 100mm "Harman/Kardon"	1
S1	01.00.WJ.JG.E085	Screw 3*6KBTNI	6
S2	01.00.WJ.JG.E655	Screw 1.7*4CAHNI D=3.2	1
S3	01.00.WJ.JG.E166	Screw 3*8PAHC	9
S4	01.00.WJ.JG.E543	Screw 3*6PWBTTNI	6
S5	01.00.WJ.JG.E091	Screw 3*6PWBTTTC	10
S6	01.00.WJ.JG.E451	Screw 3*6PMMHC	13
S7	01.00.WJ.JG.E252	Screw 3*4RBTTNI	6
S8	01.00.WJ.JG.E321	Screw 3*8PAHO for HS350	14
	01.00.WJ.JG.E321	Screw 3*8PAHO for HS650DL	15
S9	01.00.WJ.JG.E795	Screw 3*6PMMHNI	3
S10	01.00.WJ.JG.E403	Screw 3*6PWBTTTO	5
S11	01.00.WJ.JG.E502	Screw 3*10PMHO for HS350	4
		Screw 3*10PMHO for HS650DL	2
S12	01.00.WJ.JG.E235	Screw 3*8PWBTTNI	3
N1	01.00.WJ.JG.E119	NUT M3 for HS350	4
		NUT M3 for HS650DL	2

HS 350 EU & HS 650DL EU Explode view
 Drawing by Jenniferzph
 May, 10' 2008

HS650DL Component List			
Location.No.	Description	Specification	P/N
HS350-PT01	Metals Part	HS350-chassis	01.00.WJ.TJ.HS350.E001
HS350-PT02	Metals Part	HS350-top cover	01.00.WJ.TJ.HS350.E002
HS650DL-PT01	Metals Part	HS650DL-rear panel	01.00.WJ.TJ.HS650.E001
HS650DL-PT02	Metals Part	HS650DL-U type connect piece	01.00.WJ.TJ.HS650.E002
HS350-PT04	Metals Part	HS350-PCB bracket	01.00.WJ.TJ.HS350.E003
For S702 on SMPS board	Heatsink	HS350-PT05 100*55*55	01.00.WJ.TJ.HS350.E004
For S703 on SMPS board	Heatsink	HS350-PT06 67*53*22	01.00.WJ.TJ.HS350.E005
For S704 on SMPS board	Heatsink	HS350-PT07 143*53*22	01.00.WJ.TJ.HS350.E006
For S704 and S703 on SMPS board	Heatsink	HS350-PT08 143*134*2	01.00.WJ.TJ.HS350.E007
For S701 on SMPS board	Heatsink	HS350-PT09 35*11*48 (Hole height is 18mm)	01.00.WJ.TJ.HS350.E008
HS350-PT10 Between AV board and Mainboard	Hexagonal Nut	M3*30	01.00.WJ.JG.E946
For U4 on Mainboard	Heatsink	28*28*10mm	01.00.WJ.TJ.E268
HS350-RE01	plastic part	HS650-front pannel	01.00.SJ.HS650.E003
HS200-RE02	plastic part	HS200-2 in 1 Button	01.00.SJ.HS200.E002
HS200-RE03	plastic part	HS200-Open button collar	01.00.SJ.HS200.E003
HS100-RE06	plastic part	HS100-Volume Button Collar	01.00.SJ.HS100.E006
HS200-RE04	plastic part	HS200-Button Cover Board	01.00.SJ.HS200.E004
HS200-RE05	plastic part	HS200-Power Indicator lampshade	01.00.SJ.HS200.E005
HS200-RE06	plastic part	HS200-pedestal underlay	01.00.SJ.HS200.E006
HS350-RE02	plastic part	HS650DL-Large Lens	01.00.SJ.HS650.E001
HS100-RE10	plastic part	HS100-Volume Button	01.00.SJ.HS100.E010
HS100-RE08	plastic part	HS100-Volume Button Lampshade	01.00.SJ.HS100.E008
	plastic part	1000A-IR receiver support 5.5mm	01.00.SJ.1000A.E016
Add on Power cord	Magnetism annulus	M248	01.13.L.H.E020
	VFD filter	124.5*33.5*0.5mm	01.00.SJ.QT.E019
	AC power Jack	WS-044-0	01.40.CON.DCZ.E178
	Metal logo	100mm "Harman/Kardon" Thin Logo	01.00.SB.E036
Black color	Dustproof for Disc tray door of Loder	LTD-1510	01.00.DP.JY.E135
For pedestal underlay HS100-H01	Silica gel gasket	50.6*4.2*1.5mm (with #500 glue be single sides glued)	01.00.DP.XJ.E192
For VFD (2)	sponge	20*10*5MM (with #9448 glue be double sides glued)	01.00.DP.HM.E117
Between volume button and Front Panel Board	Astigmatism PVC	Φ45.5*Φ9.5mm	01.00.FZ.QT.153
Inside the volume button	Mask PVC	φ38.5(Underside Glued)Black color, PVC	01.00.FZ.QT.E253
For IR receiver	sponge	10*10*7MM (with double sides glued)	01.00.DP.HM.E364
paste in front of Disc tray door in the front panel	High Soft sponge	124*10*2MM (with Single side glued,Black color)	01.00.DP.HM.E378
Between Front Panel Board and Plastic Part	electric sponge	20*20*10MM	01.00.DD.PM.E271
	Plastic fastener	12CM	01.00.FZ.QT.E122
For Q509 on SMPS board	Sil-pad	sil-pad 400-3022	01.00.DP.QT.E113
For Amplifier board	Diathermanous Selenium Rubber	100*8*1mm	01.00.DP.JY.E583
Be buckled above volume button board	Insulated PVC	HS200-H02	01.00.DP.JY.E249
For hamulus of front panel	Insulated PVC	22.5*10*0.3mm(with Single side glued)	01.00.DP.JY.E541
	Insulated PVC	HS350-H01	01.00.DP.JY.E134
Between Tuner and chassis	sponge	20*10*8MM(with double sides glued)	01.00.DP.HM.E263
For Front Panel and Left/Right sides of chassis (4),For Front Panel and Volume Board(2)	Screw	3*6KBTNI	01.00.WJ.JG.E085
For chassis and pedestal underlay(6)	Screw	3*6PWBTTNI	01.00.WJ.JG.E543
For chassis and pedestal underlay(3)	Screw	3*6PWMHNI	01.00.WJ.JG.E795
For Front panel board and chassis and pedestal underlay(3)	Screw	3*8PWBTTNI	01.00.WJ.JG.E235
For Front panel and Front panel board/key(9)	Screw	3*8PAHC	01.00.WJ.JG.E166
For Loader and chassis(4),For PCB Bracket and chassis(4),For Mainboar and Bracket(2)	Screw	3*6PWBTTTC W=7	01.00.WJ.JG.E091
For SMPS board and chassis(6),For AV board and chassis(1),For Mainboard(2),For Amplifier board and Bracket(4)	Screw	3*6PWMHC W=7	01.00.WJ.JG.E451

HS650DL Component List			
Location.No.	Description	Specification	P/N
For Rear panel and chassis(2),For Top cover and the bottom side of chassis(4)	Screw	3*4RBTTNI	01.00.WJ.JG.E252
For output jacks(10),For frequency modulation module(2),For U type connect piece and rear panel(3)	Screw	3*8PAHO	01.00.WJ.JG.E321
For top cover and chassis, top cover and rear panel(5)	Screw	3*6PWBTTTO	01.00.WJ.JG.E403
For AC power socket (2)	Screw	3*10 PMHO	01.00.WJ.JG.E502
For IC and Heatsinks on SMPS board (10)	Screw	3*6PBTTTC	01.00.WJ.JG.E087
Among Heatsinks on SMPS board 3	Screw	3*6PWTTC W=7	01.00.WJ.JG.E093
For Button cover Board and button Board	Screw	1.7*4CAHNI D=3.2 Free-Lead	01.00.WJ.JG.E655
BD701 fixed with Heatsink on SMPS board(1)	Screw	3*8PBTTTC	01.00.WJ.JG.E417
For power jack(2)	Nut	M3	01.00.WJ.JG.E119
For uncovered Screw drilled through the chassis	Screw Jacket	Φ3*4mm	01.00.FZ.TG.E025
For Insulated gasket and volume button Board	Plastic Rivet	MBL3-2.5	01.00.SJ.QT.E104
	HDMI Cord	1770261-1(2M)	01.47.CNT.LJX.5.E241
	Microphone	H03-MCD12TWBKNN-R-A	01.00.SP.E254
WS-002E+WS-019 HO5VV-F 0.75x2C BK 2M	Power Cord	WS-002E+WS-019 HO5VV-F 0.75x2C BK 2M	01.47.CNT.ACX.E052
	Antenna	FM-TV-22 (Lead content less than 300PPM)	01.47.CNT.CTX.E016
	Loader	DL-05MH-H40P	01.15.JX.EDL05MH
IEC Head for FM Connector (NON-Screw Thread)	FM frequency modulation module	TFCF1E806A	01.49.E11
CN701 on SMPS to Power Jack with solder one end	Connect cable	VH-3Y Connector-2Y-240mm(Be same side)	01.47.CNT.LJX.7.E776
CN706 on SMPS to CN403 on Amplifier board	Connect cable	VH-4Y Connector-4Y-4Y-150mm(Be same side)	01.47.CNT.LJX.7.E726
CN405 on Amplifier board to CN902 on Speaker board	Connect cable	VH-10Y Connector-10Y-10Y-100mm(Be different side)	01.47.CNT.LJX.7.E777
Connect ground beside headphone jack to SMPS	Connect cable	70mm single-core cable (with solder one end and ground piece φ4 connect another end)	01.47.CNT.LJX.7.E795
CN601(A) on Front panel board to CN5(A) on Mainboard	Flat cable	1.0*22P*80mmA	01.48.BPX.1.E170
CN6(C) on Mainboard to CN704(C) on SMPS board	Flat cable	1.25*16P*80mmA(T=0.1mm)	01.48.BPX.1.E171
CN9(D) on Mainboard to CN301(D) on AV board,CN8(E) on Mainboard to CN302(E) on AV board	Flat cable	1.0*20P*70mmA	01.48.BPX.1.E172
CN7(F) on Mainboard to CN303(F) on AV board	Flat cable	1.25*18P*70mmA(T=0.1mm)	01.48.BPX.1.E173
CN702(G) on SMPS board to CN602(G) on Front panel board	Flat cable	1.25*14P*110mmA(T=0.1mm)	01.48.BPX.1.E174
CN703(I) on SMPS board to CN402(I) on Amplifier board	Flat cable	1.25*6P*110mmA(T=0.1mm)	01.48.BPX.1.E176
CN404 on Amplifier to CN901 on Speaker board	Flat cable	1.0*8P*50mmA	01.48.BPX.1.E177
CN4(B) on Mainboard to CN401 on Amplifier board	Flat cable	1.0*16P*80mmA	01.48.BPX.1.E150
CN604(J) on Front panel board to CN605(J) on Volume board	Flat cable	1.0*6P*40mmA	01.48.BPX.1.E154
Loader to CN2 on Mainboard	Flat cable	1.0*12P*220mmA	01.48.BPX.1.E156
Loader to CN1 on Mainboard	Flat cable	0.5*24P*200mmA	01.48.BPX.1.E028
Tuner to CN304 on AV board	Flat cable	1.25*11P*70mmA	01.48.BPX.1.E085
4-layers	Main Board (semi-manufactured goods)	HAV07M-5112C01(EU Version+Hitachi Loader)	02.11.HAV07M5112C01
2-layers	AV Board (semi-manufactured goods)	HAV07I-5113C01(EU Version)	02.14.HAV07I5113C01
2-layers	Speaker Board (semi-manufactured goods)	HAV07I-5118C01	02.14.HAV07I5118C01
2-layers	Front panel Board (semi-manufactured goods)	HAV07K-5115C01	02.15.HAV07K5115C01
2-layers	Front panel Board (semi-manufactured goods)	HAV07K-5116C01	02.15.HAV07K5116C01
4-layers	Amplifier Board (semi-manufactured goods)	HAV07A-5329C01	02.17.HAV07A5329C01
2-layers	SMPS Board (semi-manufactured goods)	HAV07P-5117C01	02.19.HAV07P5117C01

HS650DL Component List for Main Board (5112C01)			
Location.No.	Description	Specification	P/N
R4 R9 R45 R49 R50 R174 R202 R205 R207 R215 (R219) R223 R224 R225 R227 R228 R229 R230 R231 R233 R238 R239 FB17 FB19	Resistor, chip	0603-0Ω ±5%	01.57.R.2.E000J
R156 R158	Resistor, chip	0603-10Ω±5%	01.57.R.2.E100J
R42 R43 R61 R62	Resistor, chip	0603-20Ω±5%	01.57.R.2.E200J
R29 R30 (R31) R32 (R33) R34 (R35) R36 (R37) R38	Resistor, chip	0603-22Ω±5%	01.57.R.2.E220J
R2 R47 R124 R125 R126 R127 R142 R145 R146 R147 R149 R150 R151 R153 R155 R201 (R211)	Resistor, chip	0603-33Ω±5%	01.57.R.2.E330J
R6 (R41) (R71) (R120) (R121) R130 R177 R221	Resistor, chip	0603-100Ω±5%	01.57.R.2.E101J
R206	Resistor, chip	0603-150Ω±5%	01.57.R.2.E151J
R8 R235	Resistor, chip	0603-200Ω±5%	01.57.R.2.E201J
R19	Resistor, chip	0603-220Ω±5%	01.57.R.2.E221J
R173	Resistor, chip	0603-270Ω±5%	01.57.R.2.E271J
R167	Resistor, chip	0603-390Ω±5%	01.57.R.2.E391J
R141	Resistor, chip	0603-475Ω±1%	01.57.R.2.E4750F
R26 R77 R58	Resistor, chip	0603-1KΩ±5%	01.57.R.2.E102J
R80 R83	Resistor, chip	0603-1.2KΩ±5%	01.57.R.2.E122J
R79 R86	Resistor, chip	0603-1.5KΩ±5%	01.57.R.2.E152J
R69 R160 R161	Resistor, chip	0603-1.8KΩ±5%	01.57.R.2.E182J
R13 R14 R15 R16 R18 R87 R92	Resistor, chip	0603-2KΩ±5%	01.57.R.2.E202J
R204	Resistor, chip	0603-2.2KΩ±5%	01.57.R.2.E222J
R65	Resistor, chip	0603-3KΩ±5%	01.57.R.2.E302J
(R11) R88 R209 R210 (R232)	Resistor, chip	0603-3.3KΩ±5%	01.57.R.2.E332J
R44 R46 R52	Resistor, chip	0603-3.9KΩ±5%	01.57.R.2.E392J
R5 R10 R21 R27 R55 R57 R63 R67 R96 R162 R163 R168 R170 R178 R185 R186 R190 R191 R192	Resistor, chip	0603-4.7KΩ±5%	01.57.R.2.E472J
R89	Resistor, chip	0603-5.1KΩ±5%	01.57.R.2.E512J
R91	Resistor, chip	0603-6.8KΩ±5%	01.57.R.2.E682J
R12 R20 R24 R25 R28 R56 R64 R66 R68 R75 R76 R78 R81 R82 R122 R123 R128 R129 R143 R144 R171 R172	Resistor, chip	0603-10KΩ±5%	01.57.R.2.E103J
R48 (R72)	Resistor, chip	0603-12KΩ±1%	01.57.R.2.E123F
R17	Resistor, chip	0603-15KΩ±5%	01.57.R.2.E153J
R84 R85	Resistor, chip	0603-22KΩ±5%	01.57.R.2.E223J
R40	Resistor, chip	0603-24KΩ±5%	01.57.R.2.E243J
R90	Resistor, chip	0603-27KΩ±5%	01.57.R.2.E273J
R53	Resistor, chip	0603-33KΩ±5%	01.57.R.2.E333J
R51	Resistor, chip	0603-39KΩ±5%	01.57.R.2.E393J
R22 R54 R93 R95 R165	Resistor, chip	0603-47KΩ±5%	01.57.R.2.E473J
R73	Resistor, chip	0603-1MΩ±5%	01.57.R.2.E105J
R59 R60	Resistor, chip	0805-2Ω±1%	01.57.R.3.E2R0F
R3	Resistor, chip	1206-2Ω±5%	01.57.R.4.E020J
RN4	Resistor, thick film chip network	0603-10Ω*4 ±5%	01.57.R.8.EP1004
RN6 RN7 RN8 RN9 RN10 RN11	Resistor, thick film chip network	0603-33Ω*4 ±5%	01.57.R.8.EP3304
RN3	Resistor, thick film chip network	0603-4.7KΩ*4 ±5%	01.57.R.8.EP4724
RN1	Resistor, thick film chip network	0603-10KΩ*4 ±5%	01.57.R.8.EP1034
PTC1	Thermmal Dependent Resistor, JinKe	JK-MSMD050 SMD	01.57.R.R.E050
C192	Capacitor, multilayer ceramic, chip	0603-3.3P NPO±0.25%/50V	01.54.CS.2.E3P3N50V
(C65) (C64) (C147) (C146)	Capacitor, multilayer ceramic, chip	0603-6.8P NPO±0.25PF/50V	01.54.CS.2.E6P8N50V
C97 C112	Capacitor, multilayer ceramic, chip	0603-100P NPO±5%/50V	01.54.CS.2.E101N50V
C103 C116	Capacitor, multilayer ceramic, chip	0603-180P NPO±5%/50V	01.54.CS.2.E181N50V
C84 C87 C115	Capacitor, multilayer ceramic, chip	0603-220P NPO±5%/50V	01.54.CS.2.E221N50V
C129	Capacitor, multilayer ceramic, chip	0603-390P NPO±5%/50V	01.54.CS.2.E391N50V
C82 C86 C90	Capacitor, multilayer ceramic, chip	0603-470P X7R±10%/50V	01.54.CS.2.E471X50V
C105 C106 C108 C111	Capacitor, multilayer ceramic, chip	0603-680P X7R±10%/50V	01.54.CS.2.E681X50V

HS650DL Component List for Main Board (5112C01)			
Location.No.	Description	Specification	P/N
C91 C94 C96 C99 C118 C119	Capacitor, multilayer ceramic, chip	0603-102 X7R±10%/50V	01.54.CS.2.E102X50V
(C19)	Capacitor, multilayer ceramic, chip	0603-152 X7R±10%/50V	01.54.CS.2.E152X50V
(C20)	Capacitor, multilayer ceramic, chip	0603-272 X7R±10%/50V	01.54.CS.2.E272X50V
C113 C114 C120	Capacitor, multilayer ceramic, chip	0603-332 X7R±10%/50V	01.54.CS.2.E332X50V
C191	Capacitor, multilayer ceramic, chip	0603-392 X7R±10%/50V	01.54.CS.2.E392X50V
C88	Capacitor, multilayer ceramic, chip	0603-472 X7R±10%/50V	01.54.CS.2.E472X50V
C6 C8	Capacitor, multilayer ceramic, chip	0603-103 Y5V-20+80%/50V	01.54.CS.2.E103Y50V
C101	Capacitor, multilayer ceramic, chip	0603-153 Y5V-20+80%/50V	01.54.CS.2.E153Y50V
C16 C117 C127 C136	Capacitor, multilayer ceramic, chip	0603-223 X7R±10%/50V	01.54.CS.2.E223X50V
(C107) C121	Capacitor, multilayer ceramic, chip	0603-683 X7R±10%/50V	01.54.CS.2.E683X50V
C1 C2 C3 C4 C5 C7 C9 C10 (C11) C12 C13 (C14) (C15) (C17) C18 (C21) (C22) C23 (C24) C25 (C26) (C27) (C28) (C29) (C30) C31 (C32) (C33) (C34) (C35) (C36) (C37) (C38) (C39) C40 C41 C42 (C43) (C44) (C45) (C46) (C47) (C48) (C49) (C50) (C51) (C52) (C53) (C54) (C55) (C56) (C57) (C58) (C59) (C60) (C61) C62 (C63) C66 (C67) (C68) (C69) (C70) (C71) (C72) (C73) (C74) (C75) (C76) (C77) C78 (C79) (C80) C81 C83 C85 C89 C92 (C93) (C95) C98 C102 C104 C109 (C110) C122 C123 C124 (C125) C126 (C128) C130 C131 C132 (C133) (C134) (C135) C148 (C149) (C150) C151 (C152) (C153) (C154) (C155) (C156) (C157) (C158) (C159) C163 (C164) C165	Capacitor, multilayer ceramic, chip	0603-104 Y5V-20+80%/50V	01.54.CS.2.E104Y50V
C100 (C194) (C195) (C196) (C197) (C198) (C199) C204 (C206) (C0)	Capacitor, multilayer ceramic, chip	0603-105 Y5V-20+80%/16V	01.54.CS.2.E105Y16V
C166 C168 C169 (C170) (C171) (C172) (C173) (C174) (C175) (C176) (C177) C178 C179 (C180) (C181) C182 C183 C184 C185 C186 (C187) C188 C189 (C202) C203 (C207) (C208) (C209) (C210) (C211) (C212) (C213) (C214) C215 (C216) (C217) (C218) (C219) (C220) C221 (C222) (C223) (C224) C225 C226 (C227) C228 C229 (C230) (C231) (C232) (C233) (C234) (C235) (C236) (C237) (C238) (C239) (C240) (C241) (C242) (C243) (C244) (C245) (C246) (C247) (C248)	Capacitor, multilayer ceramic, chip	0603-104 Y5V-20+80%/50V	01.54.CS.2.E104Y50V
C193	Capacitor, multilayer ceramic, chip	ECJMF1A226Z	01.35.CC.E120622U10V
CE4 CE46 CE47	Capacitor, AL.electrolytic	CD288H-10UF/10V 5*11	01.34.CL.D.E10U10VC1
CE43 CE44 CE45	Capacitor, AL.electrolytic	CD288H-22UF/16V 5*11	01.34.CL.D.E22U16VC1
CE1 CE3 CE5 CE6 CE7 CE8 CE9 CE10 CE11 CE16 CE17 CE18 CE19 CE22 CE23 CE50 CE52 CE54 CE201 CE202	Capacitor, AL.electrolytic	KM470M010C110AP	01.34.CL.D.E47U10VC1
CE2 CE12 CE13 CE14 CE15 CE20 CE21 CE24 CE35 CE36 CE48 CE49 CE53 CE56 CE203 CE204	Capacitor, AL.electrolytic	CD288H-100UF/10V 5*11	01.34.CL.D.EH100U10VC
CE34 CE55 CE205	Capacitor, AL.electrolytic	CD288H-220UF/10V 6*11	01.34.CL.D.E288220U10VC
CE62 CE66	Capacitor, AL.electrolytic	CD288H-470UF/10V 8*11.5	01.34.CL.D.E470U10VD1
CE63	Capacitor, AL.electrolytic	CD288H-470UF/25V 10*12	01.34.CL.D.EH470U25VD
CE51 CE61 CE65	Capacitor, AL.electrolytic	CD288H-1000UF/10V 10*12	01.34.CL.D.E1000U10VD
FB16 FB18 FB20 FB22 FB23 FB24 FB25 FB26 FB27 FB28 FB29 FB30 FB31 FB32 FB33 FB47 (FB48) FB49 FB200	Bead, chip,	0603-50Ω	01.13.L.Z.ESA50

HS650DL Component List for Main Board (5112C01)			
Location.No.	Description	Specification	P/N
FB1 FB5 FB7 FB9 FB11 (FB13) FB42 FB43 FB44 FB45 FB46	Bead, chip,	0805-50Ω	01.13.L.Z.ESB50
FB10 FB15 FB53	Bead, chip, QiLiXin	PBY160808T-102Y-N	01.13.L.Z.E102YN
L3 L4 L5 L6	Inductor, multilayer ceramic, chip, TDK	ACM2012-900-2P SMD	01.13.L.L.S.E242
L7	Inductor, SMD, DADON	SPI1048QR-150(15uH/3A)	01.13.L.L.S.E320
D1 D2	Diode	IN5393, DO-15	01.41.D.PD.E5393
D3	Diode	B340LA, SMA	01.41.D.PS.EB340LA
D4 D5 D6 D7 D8	Diode	LL4148, DO213AA	01.41.D.PS.ELL4148
Q1 Q6	Transistor	2SB1132, SOT89	01.42.Q.S.E1132
MQ1	Mosfet	2SK3018T106, UMT3	01.42.Q.S.E3018
Q2 Q3 Q10	Transistor	KTC8550, SOT23	01.42.Q.S.EC8550
Q4	Transistor	KTC8050, SOT23	01.42.Q.S.E8050
Y1	Crystal Oscillator,	27.00MHZ	01.00.JZ.E2700C
Y2	Quartz Crystal Unit	6.000MHZ-49S-6.8P	01.00.JZ.E06000A
U22	IC, ROHM, Dropout Voltage Regulator	BA33BC0T, TO-220	01.44.IC.D.EBA33B
U23	IC, AAC, LDO	AZ1117H-1.8, SOT-223	01.44.IC.S.EA11171V8
U29	IC, AAC, LDO	AZ1117H-3.3, SOT-223	01.44.IC.S.EA11173V3
U1 U204	IC, Rohm, LDO	BA00HC5FP, T0252-5	01.44.IC.S.EC5FP
U201	IC, TI, DSP	D708E001BRFP266, S-PQFP-G144	01.46.IC.ED708E001BRFP266
U9 burn-in decoder firmware U202(burn-in DSP code)	IC, KH, FLASH	KH29LV160CBTC-70G (Can replaced by S29AL016M90TFI02), TSOP48	01.44.IC.S.E29LV160CBTC
U7 U8	IC, ISSI, SDRAM	IS42S16400B-6TTL(Can replaced by K4S641632K-UC60), TSOP54	01.44.IC.S.E16400BL
U203	IC, ISSI, SDRAM	IS42S16400B-7TTL, TSOP54	01.46.IC.E16400B7TL
U5	IC, Xilinx, CPLD	XC9572XL-10VQG44C, VQFP44	01.44.IC.S.E9572XL
U3	IC, Atmel, EEPROM	AT24C64-2.7, SO8	01.44.IC.S.E24C64
U4	IC, Amlogic, A/V Processor	AML3390DTS-G, PQFP256	01.44.IC.S.EAML3390DTS
U10 U14 U28	IC, FairChild, Low Dropout Voltage Regulator	KA78R05CTU, TO-220F-4L	01.44.IC.D.E78R05CTU
U12	IC, Amlogic, DVD/CD RF Processor	AML3501, TSSOP48	01.44.IC.S.E3501
U11	IC, Rohm, Actuator driver	BA5888FP, HSOP-28	01.44.IC.S.E5888
U6	IC, Rohm, Motor Driver	BA6287, SOP8	01.44.IC.S.E6287
U21	IC, Silicon Image, HDMI PanelLink Transmitter	SiI9030CTU, TQFP80	01.44.IC.S.E9030
U13	IC, ST, Dual Operational Amplifier	LM358M, SO8	01.44.IC.S.ELM358M
U27	IC, Sharp, Photoelectric Coupler	PC817, DIP4	01.44.IC.D.EPC817
U17	IC, TDI, USB Controller	TDOTG242LPF, LQFP-64	01.44.IC.S.E242L
U2	IC, TI, Schmitt Trigger	74HCT14D, SO14	01.46.IC.E7414
U19	IC, NEC, MOS FIELD EFFECT TRANSISTOR	UPA672T, SC-70	01.44.IC.S.E672T
U18	IC, FairChild, Multiplexer/Demultiplexer Bus Switch	FSTU3257MTC, TSSOP16	01.44.IC.S.EFSTU3257MTC
U16 U24 U25 U26	IC, Semtech, Low Capacitance TVS Diode Array	RClamp0514M, MSOP-10L	01.44.IC.S.E0514
U20	IC, MPS, Step-Down Converter	MP1411DH, MSOP-10	01.44.IC.S.EMP1411DH
U206	IC, TI, 9-BIT BUS-INTERFACE FLIP-FLOP	SN74LVC823APWR, TSSOP24	01.44.IC.S.ESN74LVC823APW
JP3	HDMI Jack	1747981-1 SMD	01.40.CON.DCZ.E316
JP6	USB Jack	USB-A-05 (ROHS, Mother Set)	01.40.CON.DCZ.E217
JP4 JP5	IR in/out jack	CKX-3.5-22	01.40.CON.DCZ.E203

HS650DL Component List for Main Board (5112C01)			
Location.No.	Description	Specification	P/N
CN11 CN10	Connector	PH-6A	01.40.CON.DPH.E028
CN2	FPC Connector, SMD	FPC-1.0-12P, horizontal type and up contact	01.40.CON.S10.FPC1.E015
CN5	FPC Connector	1.0-22P, Horizontal type and dual contact	01.40.CON.S10.FPC2.E006
CN6	FPC Connector	1.25-16P, Horizontal type and single contact	01.40.CON.S13.FPC2.E013
CN7	FPC Connector	1.25-18P, Vertical Type and single contact	01.40.CON.S13.FPC2.E015
CN8 CN9	FPC Connector	1.0-20P, Vertical Type and dual contact	01.40.CON.S10.FPC2.E031
HS650DL Component List for AV Board (5113C01)			
Location.No.	Description	Specification	P/N
R385 R393	Resistor, chip	0603-0 Ω \pm 5%	01.57.R.2.E000J
R390	Resistor, chip	0603-10 Ω \pm 5%	01.57.R.2.E100J
R340 R378	Resistor, chip	0603-75 Ω \pm 5%	01.57.R.2.E750J
R391 R397	Resistor, chip	0603-100 Ω \pm 5%	01.57.R.2.E101J
R343	Resistor, chip	0603-110 Ω \pm 5%	01.57.R.2.E111J
R342	Resistor, chip	0603-150 Ω \pm 5%	01.57.R.2.E151J
R341 R394 R395 R396 R398	Resistor, chip	0603-220 Ω \pm 5%	01.57.R.2.E221J
R321 R328	Resistor, chip	0603-330 Ω \pm 5%	01.57.R.2.E331J
R379 3R003	Resistor, chip	0603-560 Ω \pm 5%	01.57.R.2.E561J
R320 R327	Resistor, chip	0603-680 Ω \pm 5%	01.57.R.2.E681J
R319 R329	Resistor, chip	0603-1.78K Ω \pm 1%	01.57.R.2.E1781F
R304 R307 R318 R370 R372 R380 3R004	Resistor, chip	0603-2.2K Ω \pm 5%	01.57.R.2.E222J
R311 R312 R392 R399	Resistor, chip	0603-3K Ω \pm 5%	01.57.R.2.E302J
R364	Resistor, chip	0603-3.3K Ω \pm 5%	01.57.R.2.E332J
R300 R348 R352 R353 R389 R386 R387	Resistor, chip	0603-4.7K Ω \pm 5%	01.57.R.2.E472J
R323 R324 R336 R337	Resistor, chip	0603-4.75K Ω \pm 1%	01.57.R.2.E4751F
R326 R332	Resistor, chip	0603-7.5K Ω \pm 1%	01.57.R.2.E752F
R301 R302 R303 R322 R325 R330 R333 R334 R335 R339 R356 R363 R365 R366 R368 R374 R376	Resistor, chip	0603-10K Ω \pm 5%	01.57.R.2.E103J
R351	Resistor, chip	0603-12K Ω \pm 1%	01.57.R.2.E123F
R354 R355	Resistor, chip	0603-18K Ω \pm 5%	01.57.R.2.E183J
R309 R331 R344 R345 R346 R347 R350 R357 R358 R359 R360 R381 R388 3R005	Resistor, chip	0603-47K Ω \pm 5%	01.57.R.2.E473J
R305 R349 R371 R373 R375 R377 3R002 3R006 3R001	Resistor, chip	0603-100K Ω \pm 5%	01.57.R.2.E104J
R338	Resistor, chip	0603-549K Ω \pm 1%	01.57.R.2.E5493F
R382	Resistor, chip	0805-5.1 Ω \pm 5%	01.57.R.3.E5R1J
ESD306 ESD307 ESD308 ESD309 ESD310 ESD311 ESD312	Voltage Dependent Resistor, TDK	AVR-M1608C270MTABB SMD	01.57.R.Y.E270
C339 C340	Capacitor, multilayer ceramic, chip	0603-22P NPO \pm 5%/50V	01.54.CS.2.E220N50V
C330 C333	Capacitor, multilayer ceramic, chip	0603-33P NPO \pm 5%/50V	01.54.CS.2.E330N50V
C326	Capacitor, multilayer ceramic, chip	0603-47P NPO \pm 5%/50V	01.54.CS.2.E470N50V
C306 C314	Capacitor, multilayer ceramic, chip	0805-100P NPO \pm 5%/50V	01.54.CS.3.E101N50V
C317 C318	Capacitor, multilayer ceramic, chip	0603-100P NPO \pm 5%/50V	01.54.CS.2.E101N50V
C331	Capacitor, multilayer ceramic, chip	0603-270P NPO \pm 5%/50V	01.54.CS.2.E271N50V
C341 C342	Capacitor, multilayer ceramic, chip	0603-470P NPO \pm 5%/50V	01.54.CS.2.E471N50V
C332	Capacitor, multilayer ceramic, chip	0603-560P NPO \pm 5%/50V	01.54.CS.2.E561N50V
C307 C311	Capacitor, multilayer ceramic, chip	0805-680P NPO \pm 5%/50V	01.54.CS.3.E681N50V
C305 C310	Capacitor, multilayer ceramic, chip	0805-102 NPO \pm 5%/50V	01.54.CS.3.E102N50V
C319 C325 C356 C357	Capacitor, multilayer ceramic, chip	0603-103 Y5V-20+80%/50V	01.54.CS.2.E103Y50V
C334 C335	Capacitor, multilayer ceramic, chip	0603-183 X7R \pm 10%/50V	01.54.CS.2.E183X50V
C359	Capacitor, multilayer ceramic, chip	0603-223 X7R \pm 10%/50V	01.54.CS.2.E223X50V

HS650DL Component List for AV Board (5113C01)			
Location.No.	Description	Specification	P/N
C312 C313 C315 C316 C320 C321 C322 C323 C328 C329 C336 C337 C338 C343 C344 C345 C346 C347 C348 C349 C350 C353 C354 C358 C324	Capacitor, multilayer ceramic, chip	0603-104 Y5V-20+80%/50V	01.54.CS.2.E104Y50V
C327	Capacitor, multilayer ceramic, chip	0805-105 Y5V-20+80%/16V	01.54.CS.3.E105Y16V
CE317 CE319 CE330	Capacitor, AL.electrolytic	CD110-1UF/50V 5*11	01.34.CL.D.E1U50VC
CE315 CE324	Capacitor, AL.electrolytic	CD110-2.2UF/25V 5*11	01.34.CL.D.E2U225VC
CE316 CE318 CE320 CE325 CE326	Capacitor, AL.electrolytic	CD110-10UF/10V 5*11	01.34.CL.D.E10U10VC
CE304 CE305 CE306 CE308 CE340 CE341 CE342	Capacitor, AL.electrolytic	CD110-10UF/16V 5*11	01.34.CL.D.E10U16VC
CE302 CE303 CE307 CE310	Capacitor, AL.electrolytic	CD110-47UF/16V 5*11	01.34.CL.D.E47U16VC
CE313 CE314 CE331	Capacitor, AL.electrolytic	CD110-47UF/25V 5*11	01.34.CL.D.E47U25VC1
CE329 CE322	Capacitor, AL.electrolytic	CD110-100UF/10V 5*12	01.34.CL.D.E100U10VD
CE321 CE328	Capacitor, AL.electrolytic	CD110-100UF/16V 5*11	01.34.CL.D.E100U16VC
CE327 CE333 CE338	Capacitor, AL.electrolytic	CD110-100UF/25V 6.3*12	01.34.CL.D.E100U25VD
CE336	Capacitor, AL.electrolytic	CD110-220UF/10V 5*12	01.34.CL.D.E220U10VD
CE309 CE311 CE345	Capacitor, AL.electrolytic	CD110-220UF/16V 6.3*12	01.34.CL.D.E220U16VD
CE312 CE332 CE334 CE339	Capacitor, AL.electrolytic	CD110-220UF/25V 8*12	01.34.CL.D.E220U25VD
CE343	Capacitor, AL.electrolytic	CD110-470UF/10V 6.3*12	01.34.CL.D.E470U10VD
CE337	Capacitor, AL.electrolytic	CD110-470UF/25V 8*14	01.34.CL.D.E470U25VE
FB306 FB307	Bead, chip	0603-50Ω	01.13.L.Z.ESA50
FB311 FB312	Bead, chip	0805-50Ω	01.13.L.Z.ESB50
FB308 FB310 FB313	Bead, leaded fixed	50Ω 3.5*6.0*0.8	01.13.L.Z.ED50A
ZZ300 ZZ301	Pulse transformer, TOKO	EJ219	01.13.L.R.E068
D300 D301 D302 D303 D304 D305 D306 D307	Diode	LL4148, DO213AA	01.41.D.PS.ELL4148
Q303	Transistor	KTC8050, SOT23	01.42.Q.S.E8050
Q304 Q305	Transistor	KTC8550, SOT23	01.42.Q.S.EC8550
Q310	Transistor	DTC114EUA, UMT3	01.42.Q.S.E114
Q306 Q307 Q308 Q309	Transistor	DTC343TK, SMT3	01.42.Q.S.E343
U301	IC, AKM, Stereo audio CODEC	AK4683EQ, LQFP-64	01.46.IC.EAK4683EQ
U302 U304 U313	IC, NJRC, Pre-amp	NJM2068M, SO8	01.44.IC.S.E2068
U303	IC, Onsemi, Hex Inverter	74HCU04, TSSOP14	01.46.IC.E74H04
U305	IC, PRINCETON, RDS Demodulator IC	PT2579-SN(L), SOP16	01.44.IC.S.EPT2579
U306	IC, FairChild, Low Dropout Voltage Regulator	KA78R05CTU, TO-220F-4L	01.44.IC.D.E78R05CTU
U307	IC, ST, Negative voltage regulators	79L12 (Can replaced by KA79L12AZ,Fairchild), TO-92	01.44.IC.D.E79L12
U308 U310	IC, Fairchild, Positive Voltage Regulator	KA7812, TO-220	01.44.IC.D.EKA7812
U311	IC, Fairchild, Positive Voltage Regulator	KA7809, TO-220	01.44.IC.D.E7809
U312	IC, NS, Positive Voltage Regulator	78L05, SOT-89	01.44.IC.S.EL78L05
Y300	Quartz Crystal Unit	4.332MHz-49S-33P	01.00.JZ.E4332A
JP304 JP305	Jack, Richcon, Fiber Optic Receiving Module	VSR5G	01.43.E010
CN304	FPC Connector	1.25-11P, Vertical Type and Single Contact	01.40.CON.S13.FPC2.E014
CN303	FPC Connector	1.25-18P, Vertical Type and Single Contact	01.40.CON.S13.FPC2.E015
CN301 CN302	FPC Connector	1.0-20P, Vertical Type and Dual Contact	01.40.CON.S10.FPC2.E031

HS650DL Component List for AV Board (5113C01)			
Location.No.	Description	Specification	P/N
JP306	Jack, YuanChang, Audio Input/Output Jack	AV1-8.4-6G	01.40.CON.DCZ.E123
JP303	Jack, YuanChang, Audio Input/Output Jack	AV8-8.4-13/PB-31-1	01.40.CON.DCZ.E650
JP302	Connector, JAE, iPod Connector	DA1R018H91E SMD	01.40.CON.DCZ.E243
HS650DL Component List for SMPS Board (5117C01)			
Location.No.	Description	Specification	P/N
R739 R717	Resistor, chip	0805-2.2Ω±5%	01.57.R.3.E2R2J
R709 R755	Resistor, chip	0805-10Ω±5%	01.57.R.3.E100J
R838	Resistor, chip	0805-15Ω±5%	01.57.R.3.E150J
R720 R723 R738 R769 R776	Resistor, chip	0805-22Ω±5%	01.57.R.3.E220J
R811 R710	Resistor, chip	0805-47Ω±5%	01.57.R.3.E470J
R731	Resistor, chip	0805-100Ω±5%	01.57.R.3.E101J
R837	Resistor, chip	0805-270Ω±5%	01.57.R.3.E271J
R787 R781	Resistor, chip	0805-330Ω±5%	01.57.R.3.E331J
R826	Resistor, chip	0805-470Ω±5%	01.57.R.3.E471J
R724 R736 R742 R752 R763 R806 R808 R810 R823 R825 R827 R782 R820 R824	Resistor, chip	0805-1KΩ±5%	01.57.R.3.E102J
R754	Resistor, chip	0805-1.2KΩ±5%	01.57.R.3.E122J
R822 R747 R761 R783	Resistor, chip	0805-2KΩ±5%	01.57.R.3.E202J
R732	Resistor, chip	0805-2.2KΩ±5%	01.57.R.3.E222J
R771 R793 R829	Resistor, chip	0805-3KΩ±1%	01.57.R.3.E302F
R821	Resistor, chip	0805-3.6KΩ±1%	01.57.R.3.E362F
R784 R828 R830 R835 R836	Resistor, chip	0805-4.7KΩ±5%	01.57.R.3.E472J
R760	Resistor, chip	0805-4.99KΩ±1%	01.57.R.3.E4991F
R713 R819 R722 R748 R749 R751 R756 R788 R790 R814 R833 R750 R768	Resistor, chip	0805-10KΩ±5%	01.57.R.3.E103J
R746	Resistor, chip	0805-13KΩ±1%	01.57.R.3.E133F
R757 R780	Resistor, chip	0805-15KΩ±1%	01.57.R.3.E153F
R791	Resistor, chip	0805-20KΩ±5%	01.57.R.3.E203J
R818	Resistor, chip	0805-27KΩ±5%	01.57.R.3.E273J
R764	Resistor, chip	0805-30KΩ±1%	01.57.R.3.E303F
R719 R743	Resistor, chip	0805-36KΩ±5%	01.57.R.3.E363J
R762 R789	Resistor, chip	0805-47KΩ±5%	01.57.R.3.E473J
R718	Resistor, chip	0805-60.4KΩ±1%	01.57.R.3.E6042F
R729 R770 R774	Resistor, chip	0805-68KΩ±5%	01.57.R.3.E683J
R733	Resistor, chip	0805-100KΩ±5%	01.57.R.3.E104J
R779	Resistor, chip	0805-150KΩ±5%	01.57.R.3.E154J
R817	Resistor, chip	0805-180KΩ±5%	01.57.R.3.E184J
R735	Resistor, chip	0805-412KΩ±1%	01.57.R.3.E4123F
R816 R815	Resistor, chip	1206-0.47Ω±5%	01.57.R.4.ER47J
R792	Resistor, chip	1206-10Ω±5%	01.57.R.4.E100J
R807	Resistor, chip	1206-15Ω±5%	01.57.R.4.E150J
R812 R813	Resistor, chip	1206-39Ω±5%	01.57.R.4.E390J
R707 R708 R714 R715 R727 R728 R734 R740 R741	Resistor, chip	1206-100Ω±5%	01.57.R.4.E101J
R786	Resistor, chip	1206-200Ω±5%	01.57.R.4.E201J
R803 R804 R805 R831 R832 R834	Resistor, chip	1206-330Ω±1%	01.57.R.4.E331F
R711	Resistor, chip	1206-470Ω±5%	01.57.R.4.E471J
R785	Resistor, chip	1206-3KΩ±1%	01.57.R.4.E302F
R745	Resistor, chip	1206-100KΩ±5%	01.57.R.4.E104J
R706 R744 R758 R766 R772	Resistor, chip	1206-150KΩ±1%	01.57.R.4.E154F
R703 R704 R705 R759 R767 R773	Resistor, chip	1206-200KΩ±1%	01.57.R.4.E204F
R801	Resistor, chip	1206-1MΩ±5%	01.57.R.4.E105J
R794 R795 R797 R798 R799 R800	Resistor, chip	1206-2MΩ±5%	01.57.R.4.E205J
R802	Resistor, chip	1206-3MΩ±5%	01.57.R.4.E305J
R796	FIXED CARBON FILM	RT1W-68KΩ±5%	01.57.R.C.EF683
R716 R721 R725 R730	FIXED CARBON FILM	RT2W-0.1Ω	01.57.R.C.EGR1
R777 R778 R737	FIXED CARBON FILM	RT3W-0.22Ω±5%	01.57.R.C.EHR22
R726 R712	shunt resistor	5W-1.6KΩ ±5% DIP	01.57.R.S.EE162
RZ704	Voltage Dependent Resistor	10K.471	01.57.R.Y.E10K
RZ702 RZ701	Thermmal Dependent Resistor	8R210 DIP	01.57.R.R.E8R210
RZ703	Resettable Fuse, JinKe	JK16 300	01.57.R.R.EJK16300
R809	High-Resistance Cermet Resistor, KOA	RI82-0.5W-1MΩ	01.57.R.C.40E105
R701 R702	High-Resistance Cermet Resistor, KOA	RCR60-1W-11MΩ	01.57.R.C.E60F116

HS650DL Component List for SMPS Board (5117C01)			
Location.No.	Description	Specification	P/N
C708	Capacitor, multilayer ceramic, chip	0805-150P NPO±5%/50V	01.54.CS.3.E151N50V
C724 C745	Capacitor, multilayer ceramic, chip	0805-330P NPO±5%/50V	01.54.CS.3.E331N50V
C718	Capacitor, multilayer ceramic, chip	0805-470P NPO±5%/50V	01.54.CS.3.E471N50V
C721 C720	Capacitor, multilayer ceramic, chip	0805-102 X7R ±10%/50V	01.54.CS.3.E102X50V
C709	Capacitor, multilayer ceramic, chip	0805-152 X7R±10%/50V	01.54.CS.3.E152X50V
C732	Capacitor, multilayer ceramic, chip	0805-332 X7R±10%/50V	01.54.CS.3.E332X50V
C727 C719	Capacitor, multilayer ceramic, chip	0805-103 X7R±10%/50V	01.54.CS.3.E103X50V
C726	Capacitor, multilayer ceramic, chip	0805-153 X7R±10%/50V	01.54.CS.3.E153X50V
C744	Capacitor, multilayer ceramic, chip	0805-473 X7R±10%/50V	01.54.CS.3.E473X50V
C706 C728 C729 C730 C731 C735 C736 C737 C740 C746 C751 C752 C753 C754 C755 C757 C758 C759 C760 C761 C762 C764 C765 C766	Capacitor, multilayer ceramic, chip	0805-104 X7R±10%/50V	01.54.CS.3.E104X50V
C714 C715 C716 C733 C725 C707	Capacitor, multilayer ceramic, chip	0805-474 Y5V+80-20%/50V	01.54.CS.3.E474Y50V
C717 C722 C723 C770	Capacitor, multilayer ceramic, chip	0805-105 X7R±10%/25V	01.54.CS.3.E105X25V
C769 C775	Capacitor, multilayer ceramic, chip	0805-475 X7R±20%/25V	01.54.CS.3.E475X25V
C773	Capacitor, multilayer ceramic, chip	1808-100P NPO±5%/3KV	01.54.CS.6.E101N3KV
C702 C703 C712 C713	High-voltage metallized polyester film	471/1KV	01.00.CD.GY.E4711KV
C742	Capacitor, multilayer ceramic, chip	1206-102 X7R±10%/200V	01.54.CS.4.E102X200V
C774	Capacitor, multilayer ceramic, chip	1206-106 X7R±10%/16V	01.54.CS.4.E106X16V
C704 C705	Radial Monolithic Capacitor	104/50V X7R±10% (lead pitch: 5.08mm)	01.00.CD.DS.E10450V
C711	Metallized capacitor	474/630V (lead pitch: 15mm)	01.00.CD.JZ.E474630VA
C701	Metallized capacitor	104/630V	01.00.CD.JZ.E104630V
C767	Metallized capacitor	103/630V (lead pitch: 10mm)	01.00.CD.JZ.E103630VA
C738	Metallized capacitor	472/630V (lead pitch: 10mm)	01.00.CD.JZ.E472630VA
C734	Metallized capacitor	105/450V (lead pitch: 15mm)	01.00.CD.JZ.E105450V
C710	Capacitor, multilayer ceramic	103/1KV (lead pitch: 7.5mm)	01.00.CD.CP.E1031KV
CX703 CX701	High-voltage metallized polyester film	224/275V X2 (lead pitch: 15mm)	01.00.CD.GY.E224275V
CX702	High-voltage metallized polyester film	334/275V X2 (lead pitch: 15mm)	01.00.CD.GY.E334275V
CY701 CY705	High-voltage metallized polyester film	102/400V(X1) 250V(Y1) (lead pitch: 10mm)	01.00.CD.GY.E102400V250V
CY702 CY703	High-voltage metallized polyester film	471/400V (X1) 250V (Y1) (lead pitch: 10mm)	01.00.CD.GY.E471400V250V
CE712	Capacitor, AL.electrolytic	GF4R7M050C110A	01.34.CL.D.E4U750VC1
CE707 CE711 CE722 CE703	Capacitor, AL.electrolytic	GF470M050E110A	01.34.CL.D.EH47U50VD
CE713	Capacitor, AL.electrolytic	GF221M025F115A	01.34.CL.D.EGF221M025F115A
CE717 CE718 CE725 CE726 CE714 CE715	Capacitor, AL.electrolytic	GF471M025F200A	01.34.CL.D.E288470U25VE
CE719 CE723 CE727	Capacitor, AL.electrolytic	1000UF/16V 10*20 ±20% 105	01.34.CL.D.E1000U16V
CE704 CE705 CE706 CE708 CE709 CE710 CE728 CE729	Capacitor, AL.electrolytic	GF102M063I350A	01.34.CL.D.E1000U63VJ
CE701	Capacitor, AL.electrolytic	HP680V450M360A	01.34.CL.D.E68U450VH
CE720 CE721	Capacitor, AL.electrolytic	GF222M016I250A	01.34.CL.D.E288220U16VH

HS650DL Component List for SMPS Board (5117C01)			
Location.No.	Description	Specification	P/N
CE702	Capacitor, AL.electrolytic	HS331V450P420A	01.34.CL.D.E330U450VK1
D703 D706 D710 D712 D705 D709	Bead, hollow	HF57 BB3.5*3*1.3	01.13.L.Z.EHF57
FB701 FB703 FB704 FB705	Bead, leaded fixed	100Ω(3.5*6.0*0.8)	01.13.L.Z.ED100A
LF704 LF705	Common Mode Choke	LCL-ET2812-01 DIP	01.13.L.L.D.E209
LF703	Common Mode Choke	L-200B DIP	01.13.L.L.D.E210
L702	Inductor , leaded fixed	L-EE1901(45UH)±10% DIP	01.13.L.L.D.E211
L703	Inductor , leaded fixed	L-ER4203(750UH)±10% DIP	01.13.L.L.D.E212
L705 L706 L708	Inductor , leaded fixed	LH0608-22UH	01.13.L.L.D.E051
L701 L704 L707	Pulse transformer	L0620-050 DIP	01.13.L.L.D.E077
T702	Transformer	BCK-PQ3230-04 DIP	01.13.L.R.E142
T701	Transformer	BCK-ER4401 DIP	01.13.L.R.E143
D714 D715	Diode	1N4001, DO-41	01.41.D.PD.EIN4001
D719 D720 D722 D735	Diode	UF1004, DO-41	01.41.D.PD.EUF1004
D724	Diode	FR104, DO-41	01.41.D.PD.EFR104
D713 D716 D717 D718	Diode	LL4148 SMD	01.41.D.PS.ELL4148
D704 D707 D711	Diode	BAS16, SOT23	01.41.D.PS.EBAS16
D723 D732	Diode	B540C, SMC	01.41.D.PS.EB540C
D733	Diode	1N4007, DO-41	01.41.D.PD.EIN4007
D708 D734	Diode	1U08, DO-41	01.41.D.PD.E1U08
D721	Diode	FR107, DO-41	01.41.D.PD.EFR107
D705 D709	Diode	HER208G, DO-15	01.41.D.PD.EHER208G
D725	Diode	SBR20100CTF, TO-220	01.41.D.PD.ESBR20100
D703 D706 D710 D712	Diode	SBR20A300CTFP, TO-220	01.41.D.PD.ESBR20A300CTFP
Z706	Zener diode	15V 0.5W	01.41.D.WS.E15V
Z701 Z702 Z703 Z704 Z705 Z707 Z710	Zener diode	18V 0.5W	01.41.D.WS.E18V
Z708	Zener diode	20V 0.5W	01.41.D.WS.E20V
Z709	Zener diode	27V 0.5W	01.41.D.WS.E27V
BD701	Diode	D10XB60, 3S	01.41.D.PD.ED10XB60
D702	Diode	ISL9R1560PF2, TO-220	01.41.D.PD.E1560
Q701	Transistor	KTC8050, SOT23	01.42.Q.S.E8050
Q704 Q705 Q707	Transistor	KTC8550, SOT23	01.42.Q.S.EC8550
Q708 Q715 Q716 Q717 Q723 Q724	Transistor	2N3904, SOT23	01.42.Q.S.E2N3904
Q711 Q713 Q714 Q719	Transistor	2N3906, SOT23	01.42.Q.S.E2N3906
Q712 Q721 Q725	Mosfet	AF4835, SOP-8	01.44.IC.S.E4835
Q718	Mosfet	DMN3033LSN, SOT23	01.44.MOS.S.EDMN3033LSN
Q706 Q702	Mosfet	FDPF18N50, TO-220	01.44.MOS.D.EFDPF18N50
Q703	Mosfet	FDPF20N50, TO-220	01.44.MOS.D.EFDPF20N50
Q720	Mosfet	FQPF7N80C, TO-220	01.44.MOS.D.E7N80C
U705	IC, Fairchild, Dual Operational Amplifier	LM358M, SOP-8	01.44.IC.S.ELM358M
U702	IC, Fairchild, Half-Bridge Gate-Drive IC	FAN73832, SOP-8	01.44.IC.S.EFAN73832
U701	IC, Fairchild, Power Factor Correction and PWM Controller	ML4800CS, SOIC16	01.44.IC.S.E4800
U709	IC, Fairchild, FAN7602MX	FAN7602MX, SOP-8	01.44.IC.S.EFAN7602MX
U704 U707 U711	IC, EVERLIGHT, Photocouple	EL817 DIP	01.44.IC.D.EL817
U703 U706 U712	IC, AAC, Shunt Regulator	AZ431AZ-A, TO-92	01.44.IC.D.EAZ431
CN701	Connector	Vertical VH Connector with three holes and two pins	01.40.CON.DCZ.E129
CN706	Connector	Vertical VH Connector with four holes and four pins	01.40.CON.DCZ.E244
CN702	FPC Connector	1.25-14P, Vertical Type and Single Contact	01.40.CON.S13.FPC2.E016
CN704	FPC Connector	1.25-16P, Vertical Type and Single Contact	01.40.CON.S13.FPC2.E018
CN703	FPC Connector	1.25-6P, Vertical Type and Single Contact	01.40.CON.S13.FPC2.E017
F701	Fuse	F3.15A/250V(φ3.6*10, In Line Package)	01.38.FUSE.D.E3F15A250V
F702	Fuse	T6.3AL/250V(φ3.6*10, In Line Package)	01.38.FUSE.D.E6A3250V
G701 G702 G703 G704	3pins grounding piece	M4	01.00.WJ.QT.E041

HS650DL Component List for Front panel board (5115C01)			
Location.No.	Description	Specification	P/N
(R619)	Resistor, chip	0805-10Ω±5%	01.57.R.3.E100J
(R606) (R607) (R630) (R635) (R638) (R641) (R656) (R657) (R659)	Resistor, chip	0805-100Ω±5%	01.57.R.3.E101J
(R614) (R647)	Resistor, chip	0805-200Ω±5%	01.57.R.3.E201J
(R605)	Resistor, chip	0805-470Ω±5%	01.57.R.3.E471J
(R615) (R648)	Resistor, chip	0805-510Ω±5%	01.57.R.3.E511J
(R631) (R632) (R633) (R626)	Resistor, chip	0805-1KΩ±5%	01.57.R.3.E102J
(R608) (R652)	Resistor, chip	0805-2KΩ±1%	01.57.R.3.E202F
(R620) (R644)	Resistor, chip	0805-2.2KΩ±5%	01.57.R.3.E222J
(R627)	Resistor, chip	0805-3.3KΩ±5%	01.57.R.3.E332J
(R601) (R603) (R604) (R609) (R610) (R611) (R612) (R613) (R655) (R658)	Resistor, chip	0805-4.7KΩ±5%	01.57.R.3.E472J
(R637)	Resistor, chip	0805-6.2KΩ±1%	01.57.R.3.E622F
(R628) (R629) (R640) (R642) (R643) (R662) R645	Resistor, chip	0805-10KΩ±5%	01.57.R.3.E103J
(R602)	Resistor, chip	0805-15KΩ±5%	01.57.R.3.E153J
(R636)	Resistor, chip	0805-20KΩ±5%	01.57.R.3.E203J
(R661)	Resistor, chip	0805-62KΩ±1%	01.57.R.3.E623F
(R634)	Resistor, chip	0805-100KΩ±1%	01.57.R.3.E104F
(R654) (R663)	Resistor, chip	1206-3.3Ω±5%	01.57.R.4.E3R3J
(R653)	Resistor, chip	1206-200Ω±5%	01.57.R.4.E201J
(R649) (R650) (R651)	Resistor, chip	1206-300Ω±5%	01.57.R.4.E301J
(R639) (R660)	Resistor, chip	1206-10KΩ±5%	01.57.R.4.E103J
R646	Resistor, chip	1210-0Ω±5%	01.57.R.5.E000J
(ESD601) (ESD602) (ESD603)	Voltage Dependent Resistor, TDK	AVR-M1608C270MTABB SMD	01.57.R.Y.E270
(C604) (C605)	Capacitor, multilayer ceramic, chip	0805-22P NPO±5%/50V	01.54.CS.3.E220N50V
(C620)	Capacitor, multilayer ceramic, chip	0805-39P NPO±5%/50V	01.54.CS.3.E390N50V
(C610) (C616)	Capacitor, multilayer ceramic, chip	0805-47P NPO±5%/50V	01.54.CS.3.E470N50V
(C611) (C612)	Capacitor, multilayer ceramic, chip	0805-56P NPO±5%/50V	01.54.CS.3.E560N50V
(C615)	Capacitor, multilayer ceramic, chip	0805-150P NPO±5%/50V	01.54.CS.3.E151N50V
(C617)	Capacitor, multilayer ceramic, chip	0805-470P NPO±5%/50V	01.54.CS.3.E471N50V
(C625)	Capacitor, multilayer ceramic, chip	0805-123 X7R±10%/50V	01.54.CS.3.E123X50V
(C618) (C626)	Capacitor, multilayer ceramic, chip	0805-473 X7R±10%/50V	01.54.CS.3.E473X50V
(C606) (C607) (C608) (C609) (C613) (C627) (C628) (C629) (C630) (C631) (C632) (C633) (C634) (C635) (C638) (C639) (C640) (C641) (C642) (C643)	Capacitor, multilayer ceramic, chip	0805-104 Y5V+80-20%/50V	01.54.CS.3.E104Y50V
(C636)	Capacitor, multilayer ceramic, chip	0805-104 X7R±10%/100V	01.54.CS.3.E104X100V
(C624)	Capacitor, multilayer ceramic, chip	0805-105 Y5V-20+80%/16V	01.54.CS.3.E105Y16V
(C603) (C619)	Capacitor, multilayer ceramic, chip	0805-225 Y5V-20+80%/16V	01.54.CS.3.E225Y16V
C637 C644	Capacitor, multilayer ceramic, chip	1206-105 X7R±10%/50V	01.54.CS.4.E105X50V
(CA601)	Capacitor, Tantalum, Chip	C-22UF-10V	01.33.CT.EC22U10V
CE622	Capacitor, AL.electrolytic	CDV-10UF/6.3V 4*5	01.34.CL.D.E10U6V3A
CE604 CE616	Capacitor, AL.electrolytic	CD11X-10UF/16V 4*7	01.34.CL.D.E10U16VB
CE603	Capacitor, AL.electrolytic	CD110-33UF/10V 5*11	01.34.CL.D.E33U10VC
CE611	Capacitor, AL.electrolytic	CD110-47UF/10V 5*11	01.34.CL.D.E47U10VC
CE620 CE601	Capacitor, AL.electrolytic	CD11X-47UF/16V 5*7	01.34.CL.D.E47U16VB
CE612 CE613 CE618 CE619	Capacitor, AL.electrolytic	CD110-47UF/25V 5*11	01.34.CL.D.E47U25VC1
CE608 CE607	Capacitor, AL.electrolytic	CD110-47UF/50V 6.3*12	01.34.CL.D.E47U50VCD
CE610 CE617 CE614	Capacitor, AL.electrolytic	CD110-100UF/10V 5*12	01.34.CL.D.E100U10VD

HS650DL Component List for Front panel board (5115C01)			
Location.No.	Description	Specification	P/N
CE602	Capacitor, AL.electrolytic	CD11X-100UF/16V 6.3*7	01.34.CL.D.EX100U16VB
CE605	Capacitor, AL.electrolytic	CD110-100UF/25V 6.3*12	01.34.CL.D.E100U25VD
CE606	Capacitor, AL.electrolytic	GF101M063G125A	01.34.CL.D.E100U63VD
CE621	Capacitor, AL.electrolytic	CD110-220UF/10V 5*12	01.34.CL.D.E220U10VD
CE609	Capacitor, AL.electrolytic	CD11X-220UF/10V 6.3*7	01.34.CL.D.E220U10VB
L601	Magnetic shielding Inductor	TH11009-331(330UH) DIP	01.13.L.L.D.E208
(FB601)	Inductor, multilayer ceramic, chip	0805-10UH SMD	01.13.L.L.S.E007
(FB602) (FB603)	Bead, chip	0805-50Ω	01.13.L.Z.E5B50
Y601	Quartz Crystal Unit	4.000MHZ-49S-22P	01.00.JZ.E04000
(D601) (D602) (D603) (D605) D604	Diode	LL4148, DO213AA	01.41.D.PS.ELL4148
(D606)	Schottky Rectifier	5819 1A, SS14	01.41.D.PS.E5819
LED601 LED602	LED, color is orange & blue	HFT503CPB0	01.41.D.FD.E503
(Q603)	Transistor	KTC8550, SOT23	01.42.Q.S.EC8550
(Q602)	Transistor	KTC8050, SOT23	01.42.Q.S.E8050
MQ601	Transistor	BSS123 SMD	01.42.Q.S.E123
(DZ601)	Zener diode	6.2V, 0.4W	01.41.D.WS.E6V2
U604	IC, FairChild, Low Dropout Voltage Regulator	KA78R05CTU, TO-220F-4L	01.44.IC.D.E78R05CTU
(U611)	IC, ST, Negative voltage regulators	79L12 (Can replaced by KA79L12AZ,Fairchild), TO-92	01.44.IC.D.E79L12
(U610)	IC, Fairchild, Positive Voltage Regulator	KA78L12AMTF, SOT-89	01.44.IC.S.EKA78L12AMTF
(U608)	IC, AAC, LDO	AZ1117H-3.3, SOT-223	01.44.IC.S.EA11173V3
(U607)	IC, NS, Vacuum Fluorescent Display Filament Driver	LM9022M, SO8	01.44.IC.S.E9022
(U609)	IC, ONSEMI, Step-Up/Down/ Inverting Switching Regulators	MC34063ADG (Can be replaced by MC34063EBD, ST),SO8	01.44.IC.S.EMC34063ADG
(U601)	IC, ELAN, MCU	EM78P156ELM-G, SOIC18	01.46.IC.E78P156G
(U603)	IC, NJRC, Pre-amp	NJM2068M, SO8	01.44.IC.S.E2068
IR601	IC, IR receiver	HL38B17, In Line Package	01.44.IC.D.E38B17
(U602)	IC, Semtech, Low Capalitance TVS Diode Array	RClamp0514M, MSOP-10L	01.44.IC.S.E0514
K603	Relay, HONGFA	HFD3/5 DIP	01.00.ZJ.BHQ.E007
CN601	FPC Connector	1.0-22P, Vertical Type and Dual Contact	01.40.CON.S10.FPC2.E026
CN602	FPC Connector	1.25-14P, Vertical Type and Single Contact	01.40.CON.S13.FPC2.E016
CN604	FPC Connector	1.0-6P, Vertical Type and Dual Contact	01.40.CON.S10.FPC2.E004
K602 K601	Touch switch	KFC-A06-05, Vertical Type	01.39.SW.QC.EDKFC
JP602	Earphone Jack	CKX-3.5-12	01.40.CON.DCZ.E219
JP601	USB Jack	USB-A-05 (ROHS, Mother Set)	01.40.CON.DCZ.E217
VFD601	VFD	VFD33-1701I	01.16.E1701I
	5115C	Front panel board	01.37.PCB.2.E5115C
(R617) (R618) (R616)	Resistor, chip	0805-4.7KΩ±5%	01.57.R.3.E472J
(R622) (R623) (R624) (R625)	Resistor, chip	0805-180Ω±5%	01.57.R.3.E181J
(C601) (C602)	Capacitor, multilayer ceramic, chip	0805-820P NPO±5%/50V	01.54.CS.3.E821N50V
(C614)	Capacitor, multilayer ceramic, chip	0805-104 Y5V+80-20%/50V	01.54.CS.3.E104Y50V
(Q601)	Transistor	KTC8050, SOT23	01.42.Q.S.E8050
(Q604) (Q605)	Transistor	KTC8550, SOT23	01.42.Q.S.EC8550
LED603 LED604 LED605 LED606	LED	HZFBA65018CP Φ5, DIP	01.41.D.FD.EHZFBA65018
CN605	FPC Connector	1.0-6P Horizontal Type and Dual Contact	01.40.CON.S10.FPC2.E036
W601	Volume encoder, pulse	ED1612-24-24-HC-F20(2)	01.36.VR.E20K

HS650DL Component List for Amplifier board (5329C01)			
Location.No.	Description	Specification	P/N
R584 R1009 R1010 R1011	Resistor, chip	0603-10Ω±5%	01.57.R.2.E100J
R597	Resistor, chip	0603-100Ω±5%	01.57.R.2.E101J
R420 R451 R487 R519 R553	Resistor, chip	0603-300Ω±5%	01.57.R.2.E301J
R585 R404	Resistor, chip	0603-1KΩ±5%	01.57.R.2.E102J
R573 R599	Resistor, chip	0603-1.2KΩ±5%	01.57.R.2.E122J
R591 R595	Resistor, chip	0603-9.1KΩ ±1%	01.57.R.2.E912F
R426 R434 R439 R459 R466 R473 R493 R501 R507 R526 R532 R540 R558 R566 R571 R590 R594	Resistor, chip	0603-4.7KΩ±1%	01.57.R.2.E472F
R427 R435 R460 R467 R494 R502 R527 R533 R559 R567	Resistor, chip	0603-6.2KΩ±1%	01.57.R.2.E622F
R401 R583 R586 R589 R412 R416	Resistor, chip	0603-10KΩ±5%	01.57.R.2.E103J
R402 R405 R407 R409 R410 R413 R414 R1003	Resistor, chip	0603-20KΩ±5%	01.57.R.2.E203J
R436 R468 R503 R534 R568	Resistor, chip	0603-22KΩ±5%	01.57.R.2.E223J
R403 R406 R408 R411 R415 R592 R598	Resistor, chip	0603-47KΩ±5%	01.57.R.2.E473J
R419 R424 R454 R458 R486 R491 R522 R525 R552 R557	Resistor, chip	0805-1Ω±5%	01.57.R.3.E1R0J
R465 R506 R538	Resistor, chip	0805-10Ω±5%	01.57.R.3.E100J
R418 R442 R448 R472 R485 R509 R516 R539 R551 R574 R588 R596	Resistor, chip	0805-30Ω±5%	01.57.R.3.E300J
R445 R479 R513 R546 R577	Resistor, chip	0805-47Ω±5%	01.57.R.3.E470J
R1018 R1022 R1026	Resistor, chip	0805-604Ω±1%	01.57.R.3.E6040F
R444 R478 R512 R545 R576 R1030	Resistor, chip	0805-1KΩ±1%	01.57.R.3.E102F
R446 R480 R514 R547 R578 R1004 R1007	Resistor, chip	0805-1KΩ±5%	01.57.R.3.E102J
R449 R482 R517 R549 R582	Resistor, chip	0805-3.3KΩ±1%	01.57.R.3.E332F
R1019 R1023	Resistor, chip	0805-3.32KΩ±1%	01.57.R.3.E3321F
R443 R476 R510 R543 R580	Resistor, chip	0805-4.7KΩ±1%	01.57.R.3.E472F
R422 R428 R453 R456 R489 R495 R521 R523 R555 R560	Resistor, chip	0805-5.1KΩ±1%	01.57.R.3.E512F
R1027	Resistor, chip	0805-5.11KΩ±1%	01.57.R.3.E5111F
R440 R474 R508 R541 R572	Resistor, chip	0805-5.6KΩ±1%	01.57.R.3.E562F
R447 R481 R515 R548 R579	Resistor, chip	0805-7.87KΩ±1%	01.57.R.3.E7871F
R432 R464 R499 R531 R564	Resistor, chip	0805-10KΩ±1%	01.57.R.3.E103F
R431 R463 R498 R530 R563	Resistor, chip	0805-10KΩ±5%	01.57.R.3.E103J
R1006	Resistor, chip	0805-20KΩ±5%	01.57.R.3.E203J
R421 R452 R488 R520 R554	Resistor, chip	0805-30KΩ±5%	01.57.R.3.E303J
R1028	Resistor, chip	0805-38.3KΩ±1%	01.57.R.3.E3832F
R429 R461 R496 R528 R561	Resistor, chip	0805-46.4KΩ±1%	01.57.R.3.E4642F
R1024 R1020	Resistor, chip	0805-47KΩ±1%	01.57.R.3.E473F
R1012 R1013 R1014 R1015 R1016	Resistor, chip	0805-75KΩ±1%	01.57.R.3.E753F
R433 R438 R470 R471 R500 R505 R536 R537 R565 R570 R1005 R1008	Resistor, chip	0805-100KΩ±5%	01.57.R.3.E104J
R1017 R1021 R1025	Resistor, chip	1206-0.15Ω±1%	01.57.R.4.ER15F
R441 R475 R511 R542 R575	Resistor, chip	1206-1Ω±5%	01.57.R.4.E010J
R417 R450 R483 R518 R550	Resistor, chip	1206-100KΩ±5%	01.57.R.4.E104J
R430 R462 R497 R529 R562	Resistor, chip	1210-1KΩ±1%	01.57.R.5.E102F
R437 R469 R504 R535 R569	Resistor, chip	1210-5.49KΩ±1%	01.57.R.5.E5491F
R425 R455 R492 R544 R581	FIXED CARBON FILM	RT2W-10Ω±5% DIP	01.57.R.C.EG100
R600 R601 R602 R603 R604	Resettable Fuse	JK60-050 DIP	01.57.R.R.E050A
R593	Thermal Dependent Resistor, JinKe	JK-MSMD010 SMD	01.57.R.R.E010
RN401 RN402	Resistor, thick film chip network	0603-10KΩ*4 ±5%	01.57.R.8.EP1034
C421 C443 C467 C493 C517	Capacitor, multilayer ceramic, chip	0603-47P NPO±5%/50V	01.54.CS.2.E470N50V
C416 C420 C436 C442 C459 C466 C483 C492 C507 C516 C529 C533	Capacitor, multilayer ceramic, chip	0603-470P NPO±5%/50V	01.54.CS.2.E471N50V
C410 C411 C432 C433 C456 C460 C481 C484 C505 C508	Capacitor, multilayer ceramic, chip	0603-102 X7R±10%/50V	01.54.CS.2.E102X50V
C401 C404 C408 C430 C445 C453 C454 C458 C474 C478 C479 C491 C501 C503 C506 C519 C527 C532 C537 C540	Capacitor, multilayer ceramic, chip	0603-104 Y5V-20+80%/50V	01.54.CS.2.E104Y50V
C429 C451 C476 C502 C526	Capacitor, multilayer ceramic, chip	0805-47P NPO±5%/50V	01.54.CS.3.E470N50V
C412 C434 C461 C485 C509	Capacitor, multilayer ceramic, chip	0805-150P NPO±5%/200V	01.54.CS.3.E151N200V
C541	Capacitor, multilayer ceramic, chip	0805-102 NPO±5%/50V	01.54.CS.3.E102N50V
C547 C551 C554	Capacitor, multilayer ceramic, chip	0805-392 X7R±10%/50V	01.54.CS.3.E392X50V
C409 C423 C431 C446 C455 C470 C480 C496 C504 C520 C528 C534	Capacitor, multilayer ceramic, chip	0805-224 Y5V-20+80%/50V	01.54.CS.3.E224Y50V

HS650DL Component List for Amplifier board (5329C01)			
Location.No.	Description	Specification	P/N
C546 C550	Capacitor, multilayer ceramic, chip	0805-225 Y5V-20+80%/25V	01.54.CS.3.E225YA25V
C415 C427 C440 C449 C465 C473 C490 C500 C514 C525	Capacitor, multilayer ceramic, chip	1206-104 X7R±10%/100V	01.54.CS.4.E104X100V
C414 C422 C439 C444 C468 C489 C494 C513 C518 C464	Capacitor, multilayer ceramic, chip	1206-104 X7R±10%/250V	01.54.CS.4.E104X250V
C403	Capacitor, multilayer ceramic, chip	1206-225 Y5V+80-20%/50V	01.54.CS.4.E225Y50V
C413 C424 C435 C447 C457 C471 C488 C497 C512 C521	Capacitor, multilayer ceramic, chip	1206-225 X7R±10%/25V	01.54.CS.4.E225X25V
C402 C407 C548 C549 C552 C553	Capacitor, multilayer ceramic, chip	1206-106 Y5V+80-20%/25V	01.54.CS.4.E106Y25V
C544 C545	Capacitor, multilayer ceramic, chip	1206-106 Y5V+80-20%/50V	01.54.CS.4.E106Y50V
C425 C448 C472 C498 C522 C426 C450 C475 C499 C524 C417 C418 C437 C438 C462 C463 C486 C487 C510 C511	Capacitor, multilayer ceramic, chip	1206-106 X7R±10%/16V	01.54.CS.4.E106X16V
C428 C452 C477 CC482 C515	Capacitor, polyester film	334J/100V DIP	01.00.CD.DL.E334100V
C419 C441 C469 C495 C523	Capacitor, polyester film	474J/100V DIP	01.00.CD.DL.E474100V
C560 C561 C562 C563 C564	High-voltage metallized polyester film	471/1KV	01.00.CD.GY.E4711KV
CE401 CE406 CE414 CE421 CE426 CE427	Capacitor, AL.electrolytic	47UF/35V(Bipolar)	01.34.CL.D.E47U35VW
CE450 CE451 CE452	Capacitor, AL.electrolytic	220UF/25V 8*12 ±20% 105 LOW ESR	01.34.CL.D.E220U25VD1
CE453	Capacitor, AL.electrolytic	1000UF/10V 8*16 ±20% 105	01.34.CL.D.E1000U10V
CE402 CE403 CE404 CE405 CE407 CE408 CE409 CE410 CE411 CE412 CE413 CE415 CE416 CE417 CE418 CE419 CE420 CE422 CE423 CE424 CE425 CE428 CE431 CE432	Capacitor, AL.electrolytic	KM470M016C110AP	01.34.CL.D.E47U16V
CE433 CE434	Capacitor, AL.electrolytic	KM470M025C110AP	01.34.CL.D.EH47U25VD
CE435	Capacitor, AL.electrolytic	KM101M050F115AP	01.34.CL.D.E288100U50VD
CE429 CE430 CE436 CE437 CE438 CE439 CE440 CE441 CE442 CE443 CE444 CE445	Capacitor, AL.electrolytic	GF471M063J210A (Can be replaced by UPW1J471MHD3 nichicon)	01.34.CL.D.E470U63VG
L404 L406 L408 L410 L412	Inductor,DIP,Panasonic	ETQA17B220(22uH) DIP	01.13.L.L.D.E217
L401 L405 L407 L409 L411 L413	Bead, chip	0603-750Ω PB	01.13.L.Z.ESA750P
L402 L403 L414 L415 L416 L417	Inductor,SMD, TDK	SLF7032T-680MR59-2PF(68UH) SMD	01.13.L.L.S.E354
D405 D406 D407 D408 D412 D413 D414 D415 D419 D420 D421 D422 D426 D427 D428 D429 D433 D434 D435 D436 D437 D442 D443 D446 D447 D448 D449	Diode	LL4148, DO213AA	01.41.D.PS.ELL4148
D401 D404 D410 D411 D417 D418 D423 D425 D431 D432	Diode	1N4448HWS, SOD-323	01.41.D.PS.E1N4448HWS
D402 D444 D445 D450	Diode	B1100, SMA	01.41.D.PS.EB1100
D403 D409 D416 D424 D430	Zener diode	5.1V(Can be replaced by ZMM5V1 DIODES), SOD-80	01.41.D.WS.E5V1
D438 D441	Diode	1N4001 DIP	01.41.D.PD.EIN4001
Q403	Transistor	BSS123, SOT23	01.42.Q.S.E123
Q404	Transistor	DTC343TK, SMT3	01.42.Q.S.E343
Q402	Transistor	KTC8550, SOT23	01.42.Q.S.EC8550
Q415	Transistor	2SA1037AKR, SOT23	01.42.Q.S.E1037
Q416 Q401	Transistor	2SC5866, SOT23	01.42.Q.S.E5866
Q405 Q406 Q407 Q408 Q409 Q410 Q411 Q412 Q413 Q414	Mosfet, IR	IRF6645TRPbF, DirectFET-SJ	01.42.Q.S.EIRF6645TRPBF
U401	IC, Microchip, MCU	PIC16F690-I/SS, SSOP20	01.44.IC.S.EPIC16F690
U403 U405 U408 U411 U414	IC, ADI, Pre-amp	ADTL082ARZ, SOIC8	01.44.IC.S.EADTL082ARZ
U404 U406 U409 U412 U415	IC, IR, PROTECTED DIGITAL AUDIO DRIVER	IRS20955STRPbF, SOIC16	01.46.IC.EIRS20955STRPBF
U407 U410 U413	IC, Wolfson, 24-bits,High performance 192KHz stereo DAC	WM8740SEDS, SSOP28	01.44.IC.S.E8740
U416	IC, AAC, LDO	AZ1117H-3.3, SOT-223	01.44.IC.S.EA11173V3
U417	IC, NJRC, Pre-amp	NJM2068M, SO8	01.44.IC.S.E2068

HS650DL Component List for Amplifier board (5329C01)			
Location.No.	Description	Specification	P/N
U420	IC, FairChild, Low Dropout Voltage Regulator	KA78R05CTU, TO-220F-4L	01.44.IC.D.E78R05CTU
U421 U422 U423	IC, ONSEMI, 1.5 A, Step-Up/Down/Inverting Switching Regulators	NCP3063BPG, DIP8	01.44.IC.D.ENCP3063BPG
CN403	Connector	Horizontal VH Connector with four holes and four pins	01.40.CON.DCZ.E298
CN401	FPC Connector	1.0-16P, Vertical Type and Dual Contact	01.40.CON.S10.FPC2.E024
CN404	FPC Connector	1.0-8P, Vertical Type and Dual Contact	01.40.CON.S10.FPC2.E002
CN402	FPC Connector	1.25-6P, Vertical Type and Single Contact	01.40.CON.S13.FPC2.E017
J401	Connector	TJC3-6A	01.40.CON.DTJ.E012
CN405	Connector	Horizontal VH Connector with ten holes and ten pins	01.40.CON.DCZ.E560
HS650DL Component List for Speaker board (5118C01)			
Location.No.	Description	Specification	P/N
(R903) (R908) (R913) (R918) (R923)	Resistor, chip	0805-10K Ω \pm 5%	01.57.R.3.E103J
(R902) (R907) (R912) (R917) (R922)	Resistor, chip	0805-30K Ω \pm 5%	01.57.R.3.E303J
(R901) (R904) (R906) (R909) (R911) (R914) (R916) (R919) (R921) (R924)	Resistor, chip	0805-47K Ω \pm 5%	01.57.R.3.E473J
(R905) (R910) (R915) (R920) (R925)	Resistor, chip	0805-100K Ω \pm 5%	01.57.R.3.E104J
(C900)	Capacitor, multilayer ceramic, chip	0805-27P NPO \pm 5%/50V	01.54.CS.3.E270N50V
(C901)	Capacitor, multilayer ceramic, chip	0805-104 Y5V+80-20%/50V	01.54.CS.3.E104Y50V
C902 C903 C904 C905 C906	Capacitor, polyester film	474J/100V DIP	01.00.CD.DL.E474100V
connect the JP903 output pin with ground on speaker board (for EMI)	High-voltage metallized polyester film	221/1KV	01.00.CD.GY.E2211KV
connect the JP903 GND pin with ground on speaker board (for EMI)	3pins grounding piece	M4	01.00.WJ.QT.E041
(D901) (D903) (D905) (D907) (D909)	Diode	LL4148, DO213AA	01.41.D.PS.ELL4148
(D902) (D904) (D906) (D908) (D910)	Zener diode	15V	01.41.D.WS.E15V
(Q901) (Q905) (Q909) (Q913) (Q917)	Transistor	KTC8550 SMD	01.42.Q.S.EC8550
(Q902) (Q906) (Q910) (Q914) (Q918)	Transistor	KTC8050 SMD	01.42.Q.S.E8050
(Q903) (Q904) (Q907) (Q908) (Q911) (Q912) (Q915) (Q916) (Q919) (Q920)	Transistor, Rohm	DTC114TUA, UMT3	01.42.Q.S.EDTC114TUA
(MQ901) (MQ902) (MQ903) (MQ904) (MQ905)	Mosfet, IR	IRF7341, SO-8	01.44.MOS.S.EIRF7341
JP901	Earphone Jack	CKX-3.5-22	01.40.CON.DCZ.E203
JP902	Jack, YuanChang, SUB Woofer Jack	AV1-8.4-6G	01.40.CON.DCZ.E172
CN901	FPC Connector	1.0-8P, Horizontal type and dual contact	01.40.CON.S10.FPC2.E037
JP903	Connector	WP10-24-1, DIP	01.40.CON.DCZ.E561
CN902	Connector	Horizontal VH Connector with ten holes and ten pins	01.40.CON.DCZ.E560

AML3390DTS-G;A/V Processor (PQFP256LD)

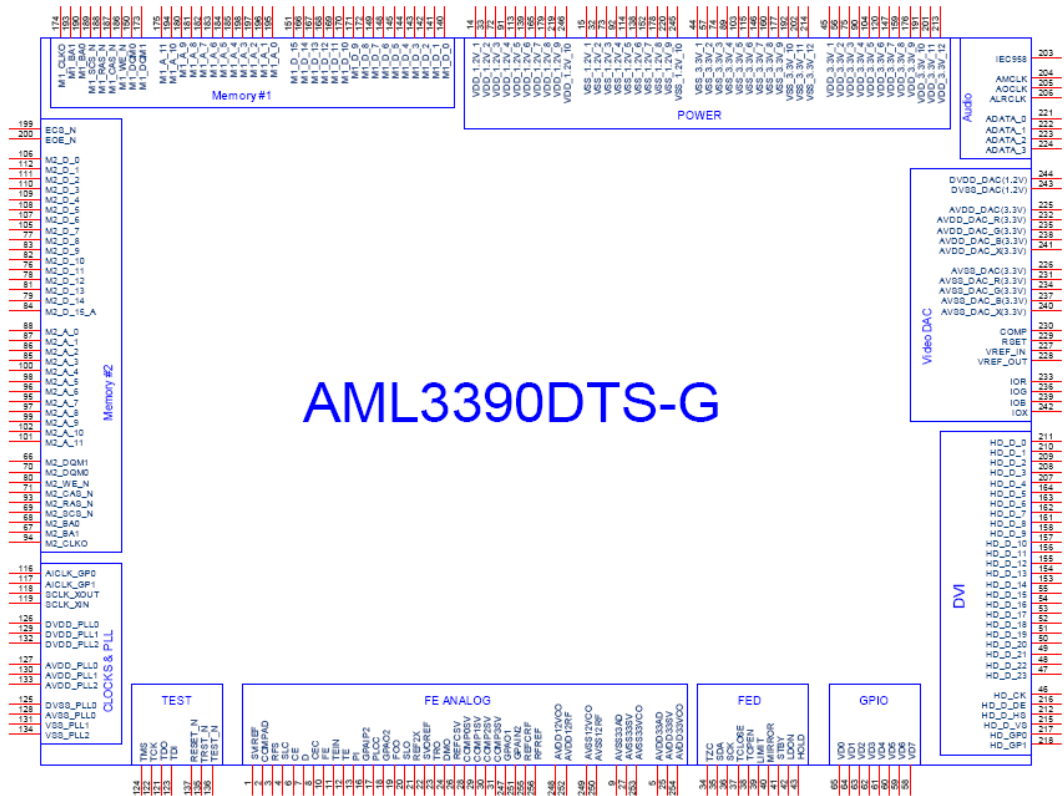

KH29LV160CBTC-70G;FLASH (TSOP48)

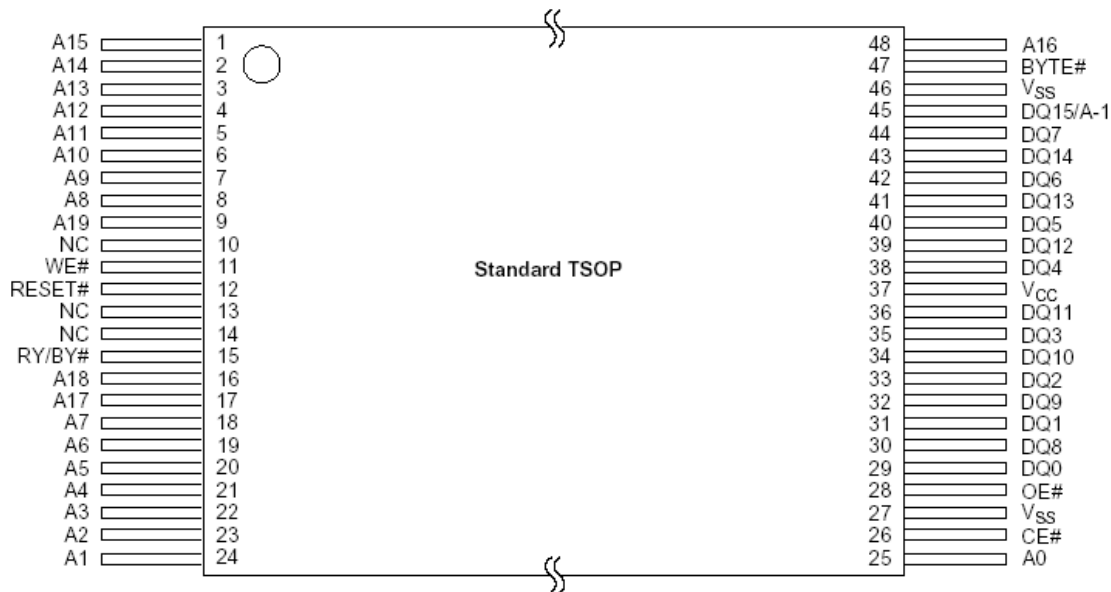

D708E001BRFP266;DSP(S-PQFP-G144)

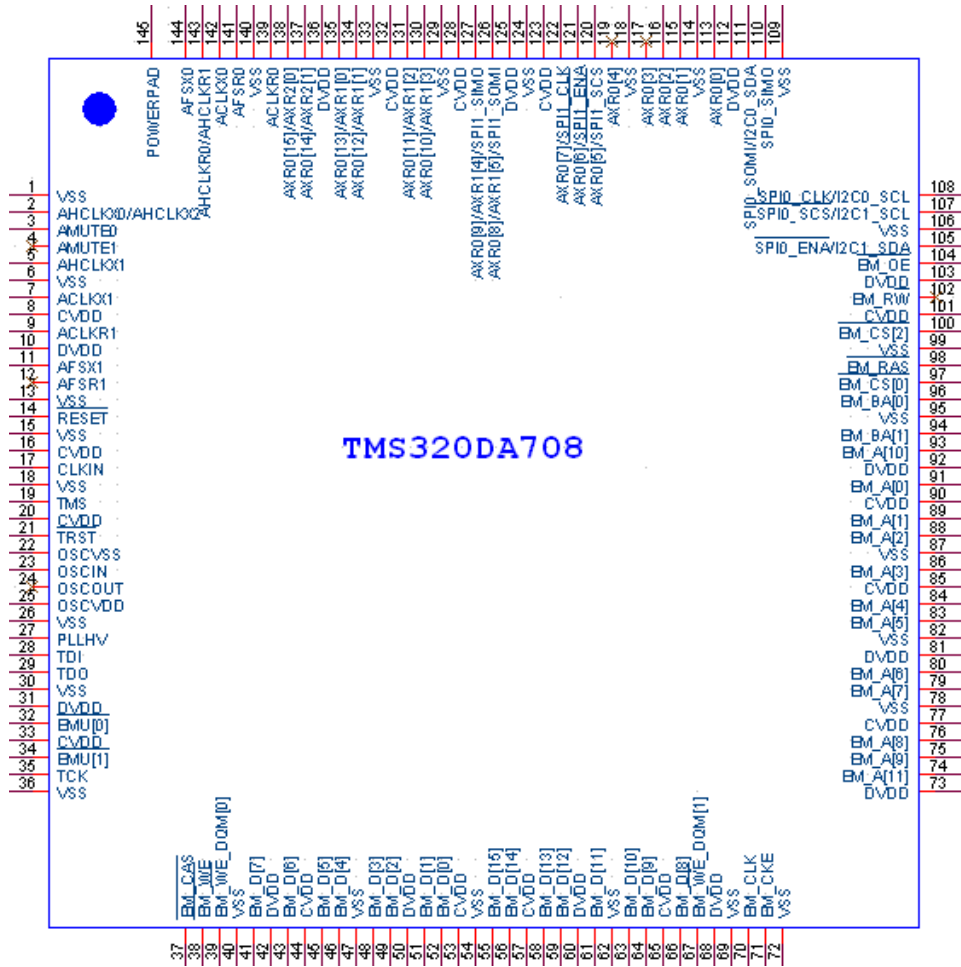

IS42S16400B-6TL;SDRAM(TSSOP-54)

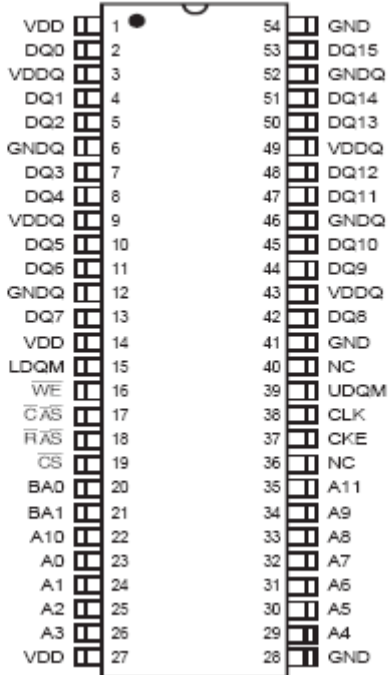

BH7868FS; 6ch 75ohm driver(SSOP-A32)

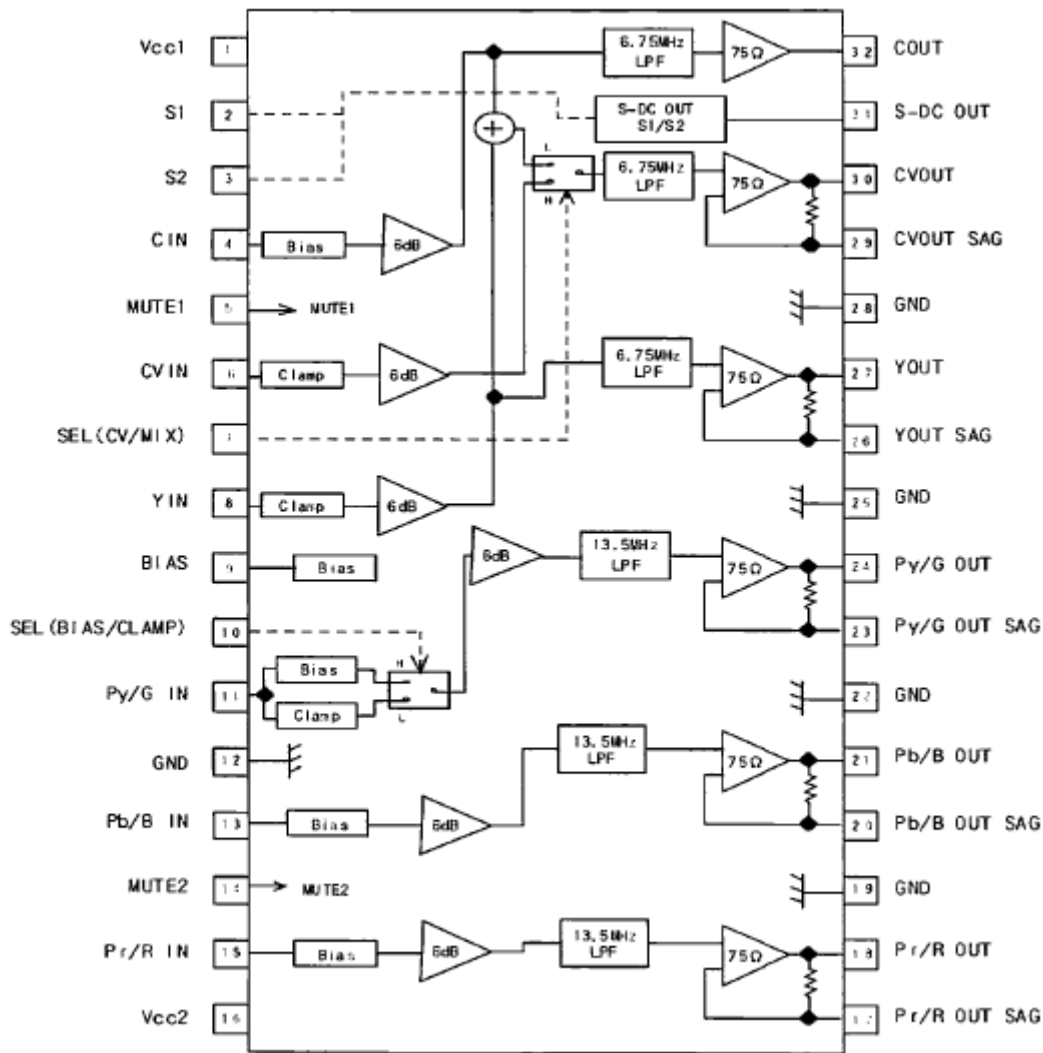

FSTU3257MTC; Multiplexer/Demultiplexer Bus Switch (TSSOP16)

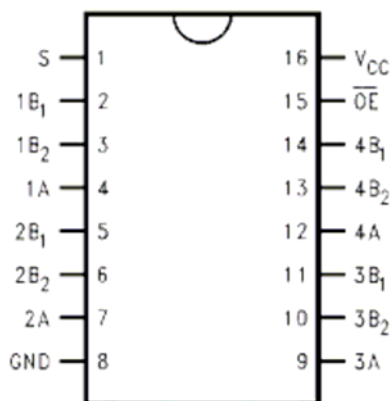

Truth Table

S	OE	Function
X	H	Disconnect
L	L	A = B ₁
H	L	A = B ₂

AML3501;DVD/CD RF
Processor (TSSOP48)

BA5888FP; Actuator driver
(HSOP-28)

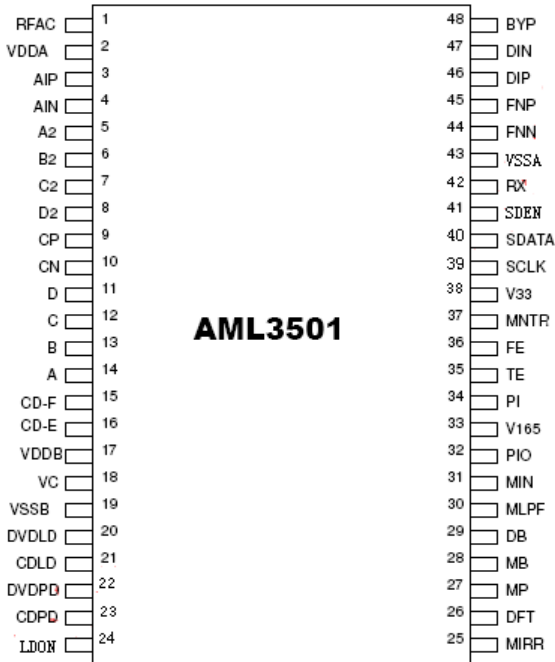

XC9572XL-10VQG44C; CPLD (VQFP44)

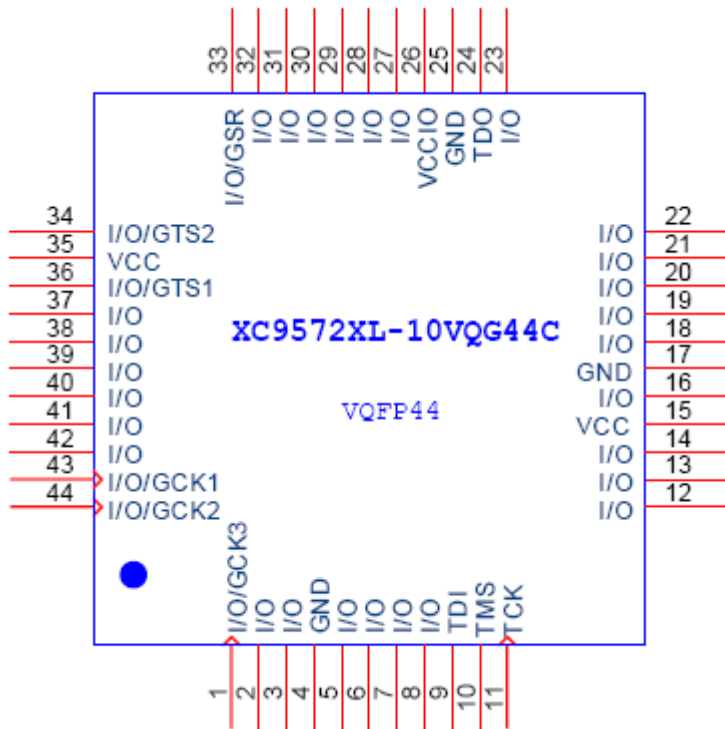

TDOTG242LPF; USB Controller (LQFP-64)

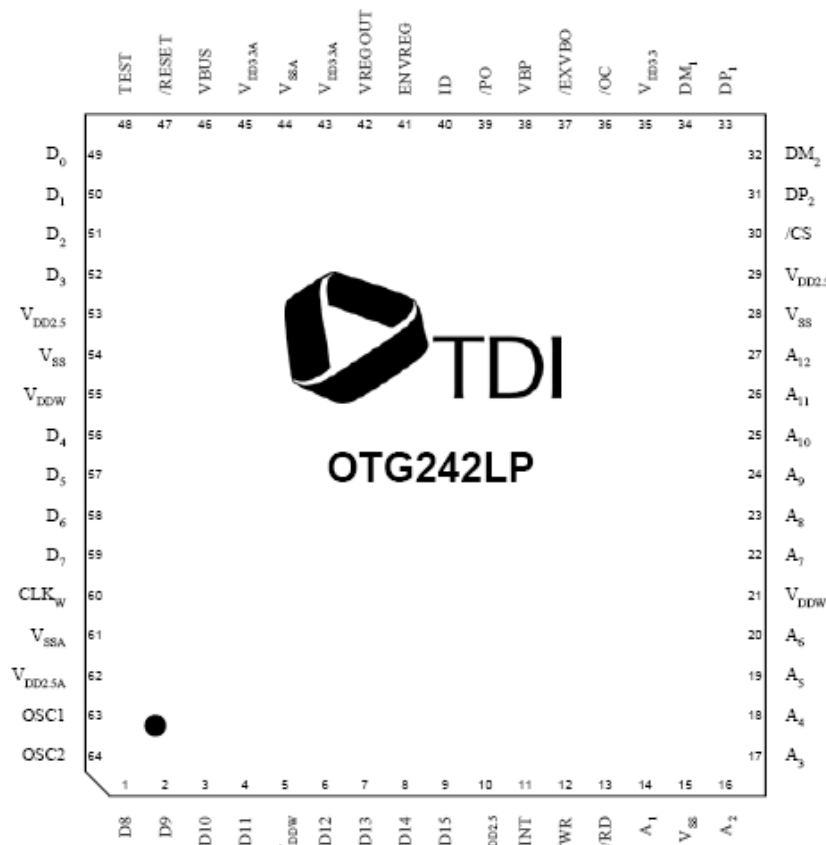

SiI9030CTU; HDMI PanelLink Transmitter (TQFP80)

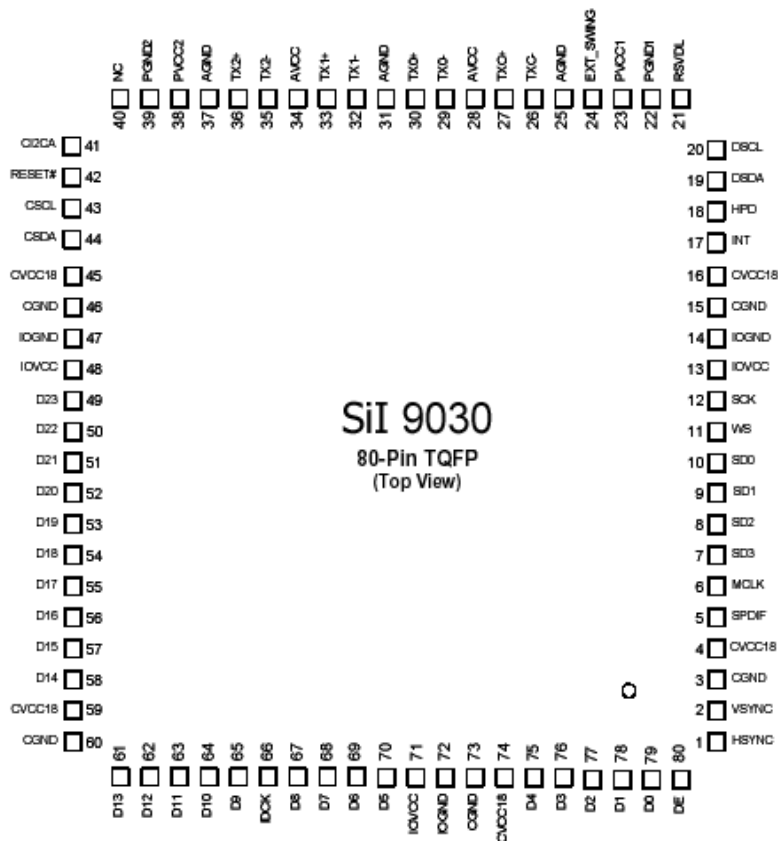

SN74LVC823APWR; 9-BIT BUS-INTERFACE FLIP-FLOP (TSSOP24)

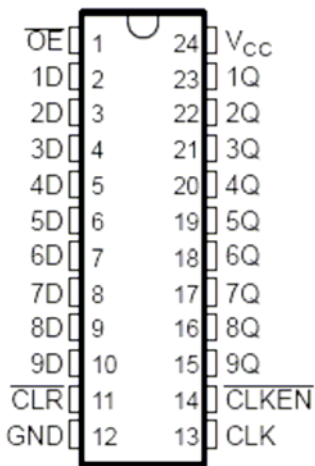

**FUNCTION TABLE
(EACH FLIP-FLOP)**

INPUTS					OUTPUT Q
OE	CLR	CLKEN	CLK	D	
L	L	X	X	X	L
L	H	L	↑	H	H
L	H	L	↑	L	L
L	H	H	X	X	Q ₀
H	X	X	X	X	Z

LM358M; Dual Operational Amplifier (SOP8)

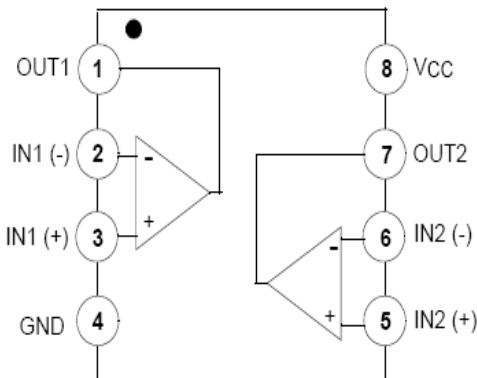

AT24C64-2.7; EEPROM (SO8)

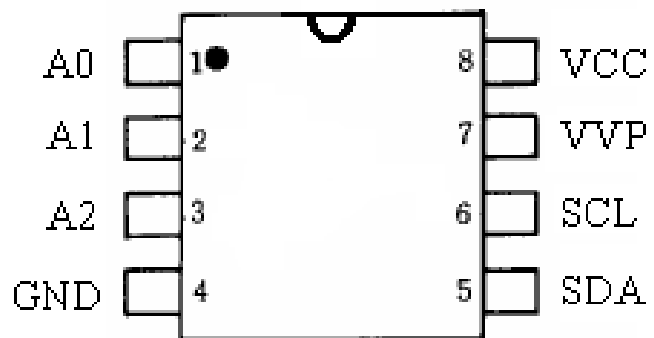

74HCT14D; Schmitt Trigger(SO14)

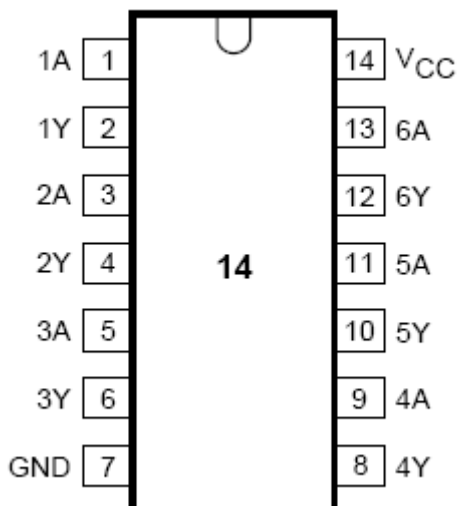

BA6287; Motor Driver(SOP8)

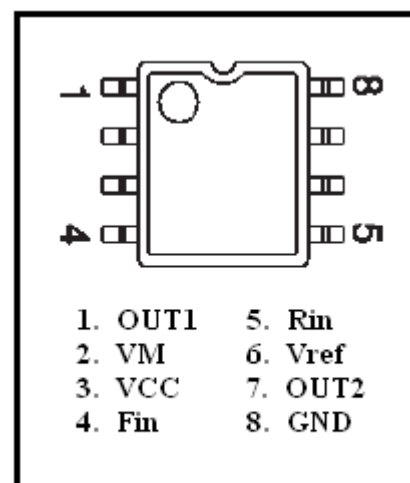

RClamp0514M; Low Capalitance TVS Diode Array(MSOP-10L)

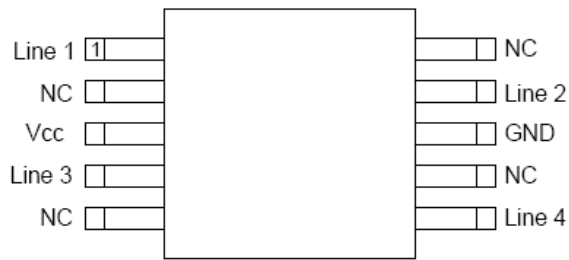

UPA672T; MOS FIELD EFFECT TRANSISTOR (SC-70)

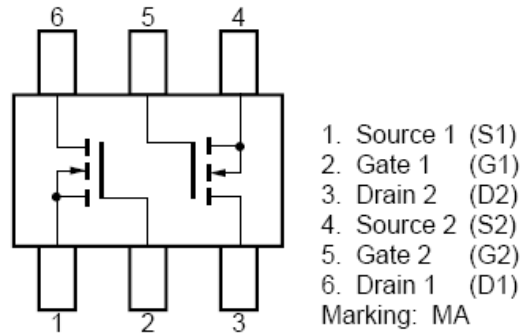

AK4683EQ; Stereo audio CODEC (LQFP-64)

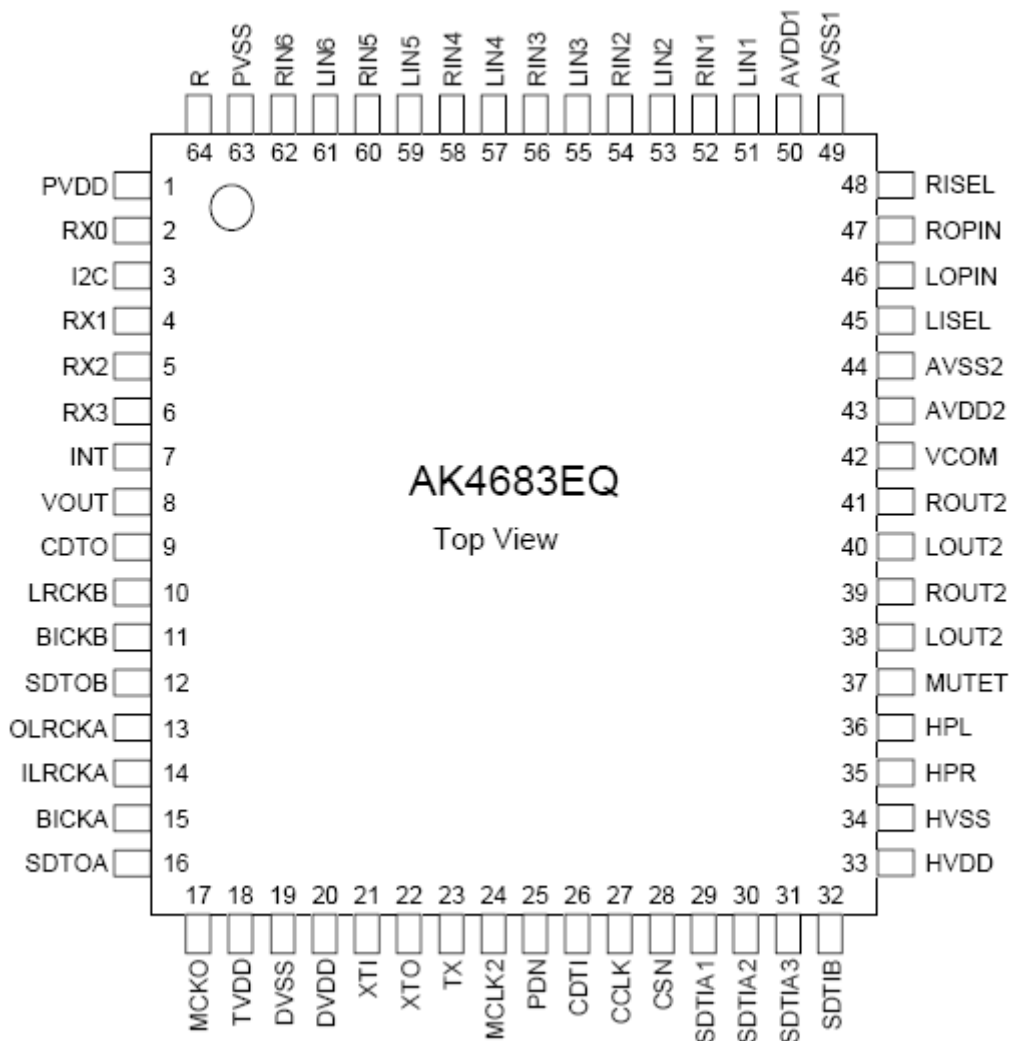

PT2579-SN(L); RDS Demodulator IC
(SOP16)

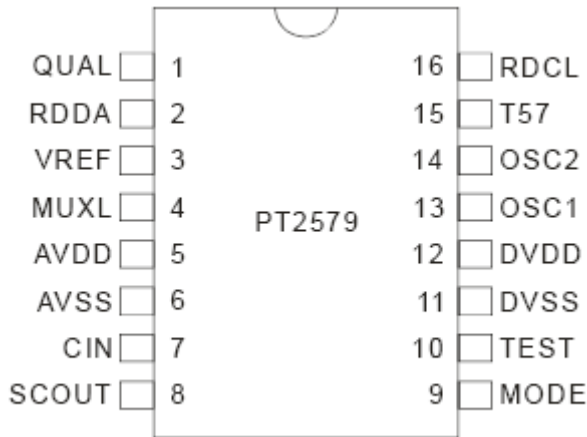

NJM2068M; Pre-amp
(SO8)

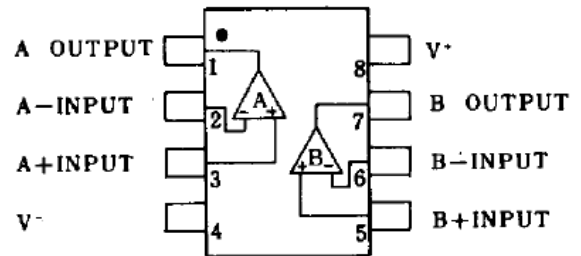

EM78P156ELM-G; MCU (SOIC18)

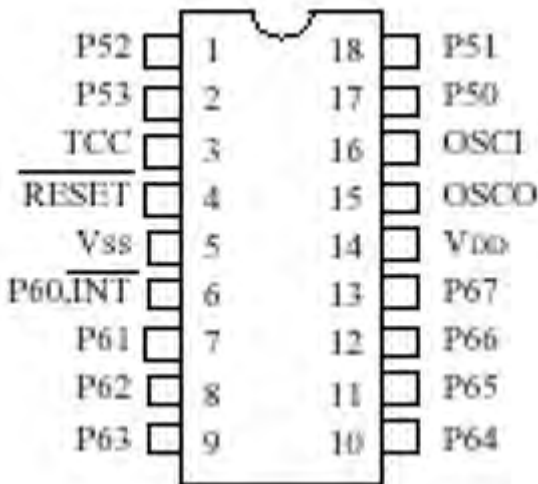

74HCU04; Hex Inverter(TSSOP14)

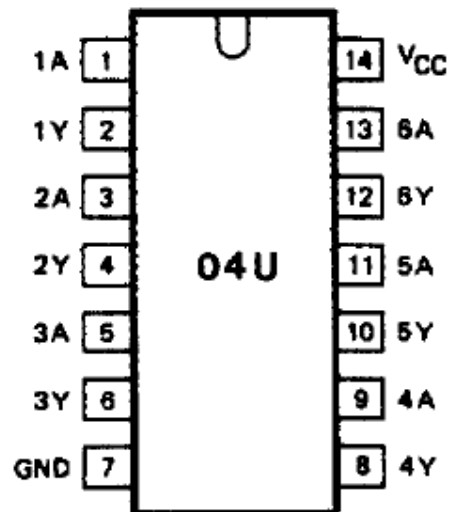

LM9022M; Vacuum Fluorescent Display Filament Driver (SOP8)

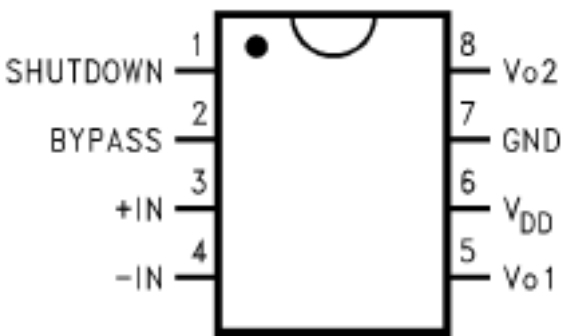

PC817; Photoelectric Coupler (DIP4)

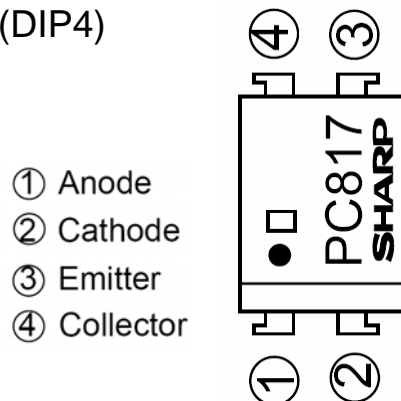

PIC16F690-I/SS; MCU (SSOP20)

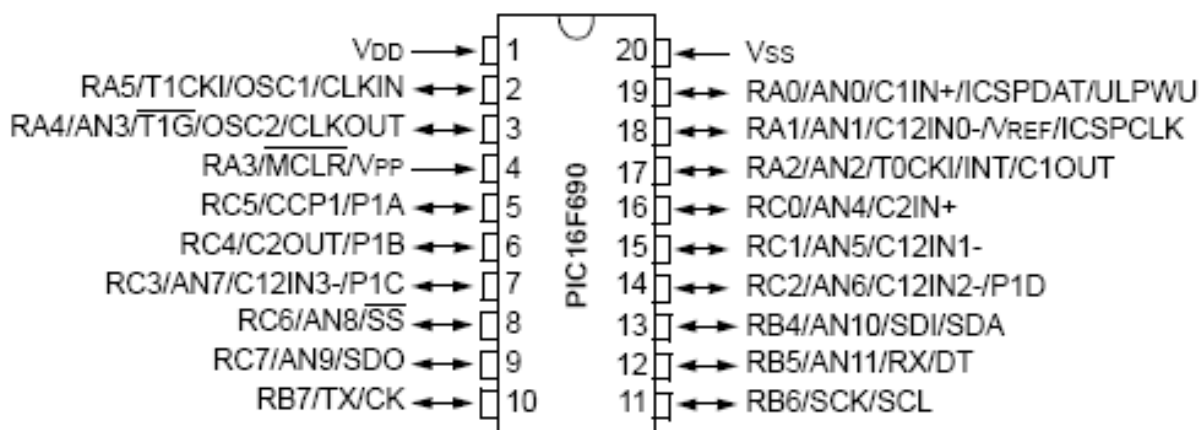

WM8740SEDS; DAC (SSOP28)

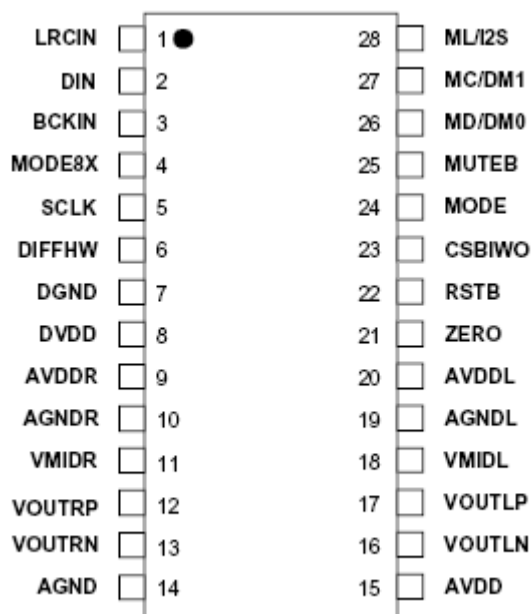

ADTL082ARZ; Pre-amp(SO8)

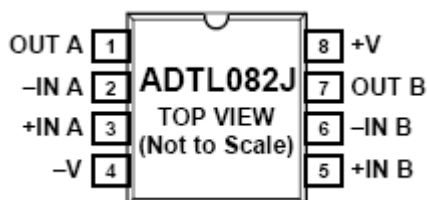

IRS20955STRPbF; PROTECTED DIGITAL AUDIO DRIVER (SOIC16)

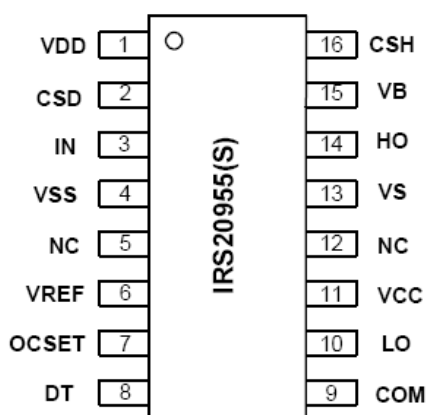

IRF6645TRPbF; DirectFET (SJ)

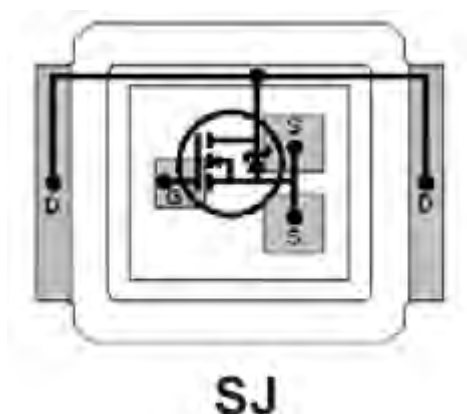

ML4800CS; Power Factor Correction and PWM Controller(SOIC16)

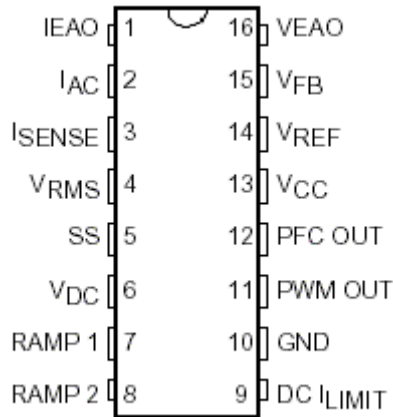

EL817; Photocoupler (DIP4)

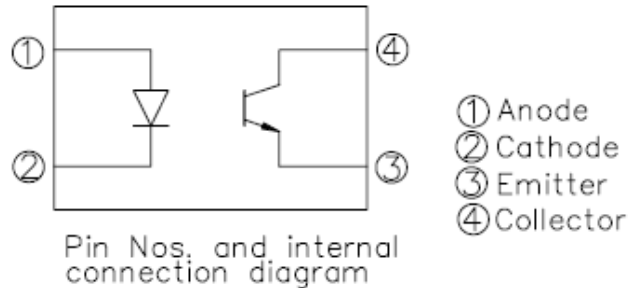

IRF7341; Mosfet (SO-8)

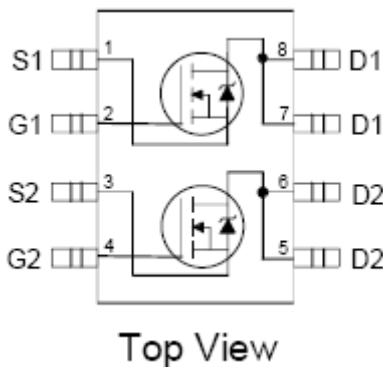

MP1411DH; Step-Down Converter (MSOP-10)

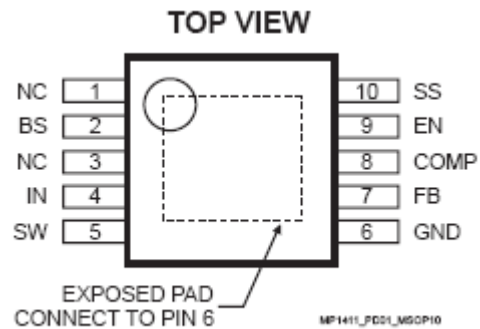

MC34063ADG; Step-Up/Down/ Inverting Switching Regulators (SO-8)

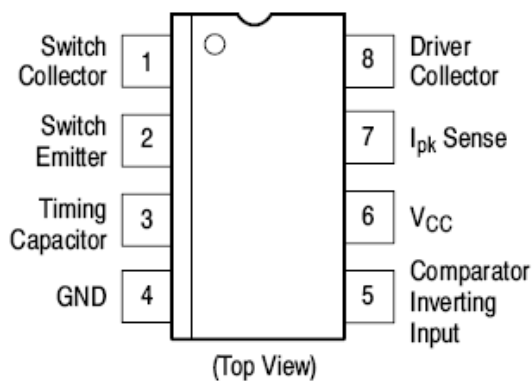

NCP3063BPG; Step-Up/Down/ Inverting Switching Regulators (DIP8)

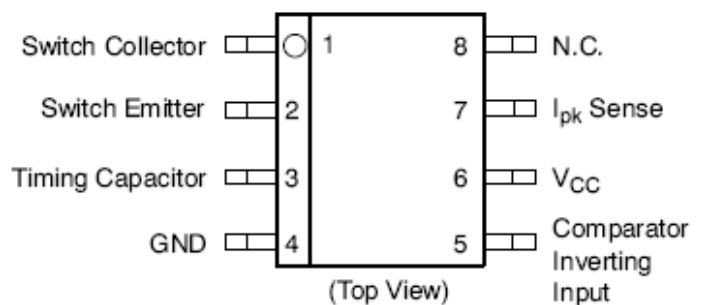

AZ1117-1.8V /3.3V; LDO
(SOT-223)

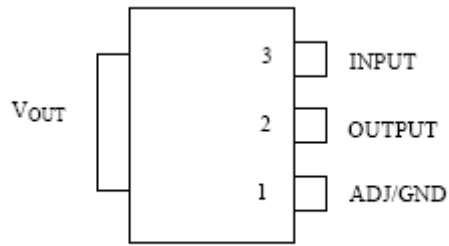

BA33BCO; Dropout Voltage
Regulator (TO-220)

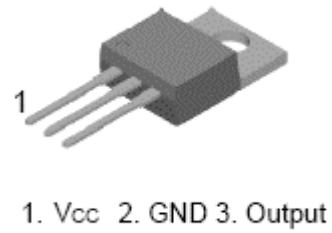

KA7809/7812; Voltage Regulator
(TO-220)

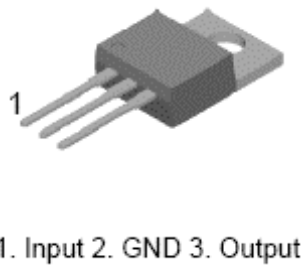

78L05/78L12; Voltage Regulator
(SOT-89)

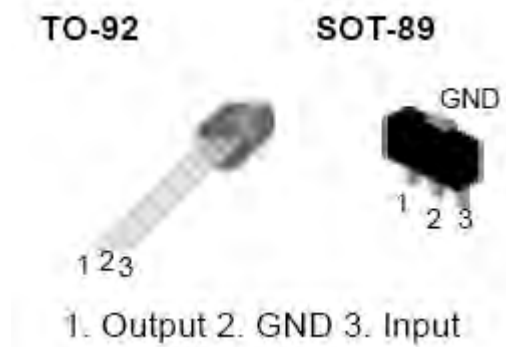

79L12; Negative voltage regulators
(TO-92)

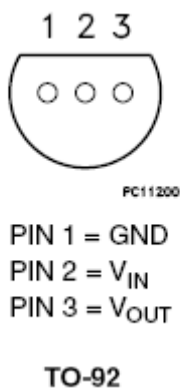

KA78R05CTU; Voltage Regulator
(TO-220F-4L)



BA00HC5FP;LDO (T0252-5)

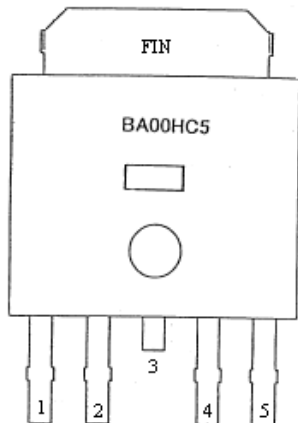

1 Pin : ADJ 4 Pin : Vo
 2 Pin : PVoc 5 Pin : Vcc
 3 Pin : N.C. FIN : GND

AZ431AZ-A; Shunt Regulator (TO -92)



1. Ref 2. Anode 3. Cathode

FAN73832; Half-Bridge Gate-Drive IC (SOP8)

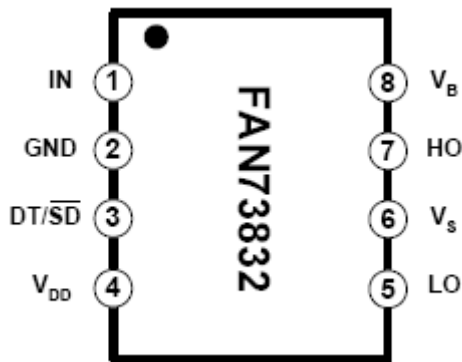

FAN7602MX; PWM Controller (SOP8)

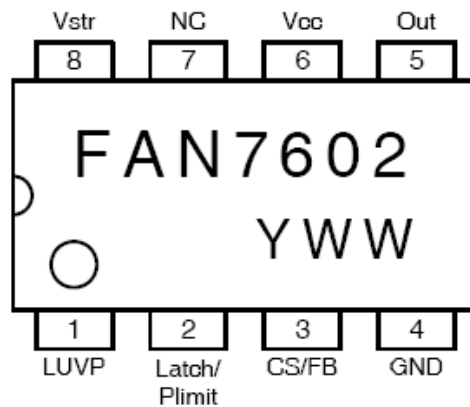

2SB1132; Medium Power Transistor (SOT89)

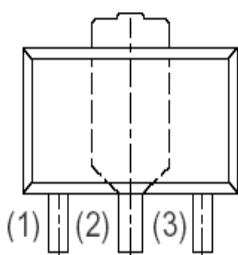

(1) Base
 (2) Collector
 (3) Emitter

2SK3018T106; Small Switching (UMT3)

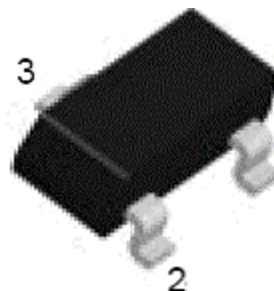

(1) Source
 (2) Gate
 (3) Drain

KTC8550; PNP Transistor(SOT23)



KTC8050; NPN Transistor(SOT23)



2N3906; PNP Transistor(SOT23)



2N3904; NPN Transistor (SOT23)



DTC114EUA; 100mA / 50V
Digital transistors (SOT23)

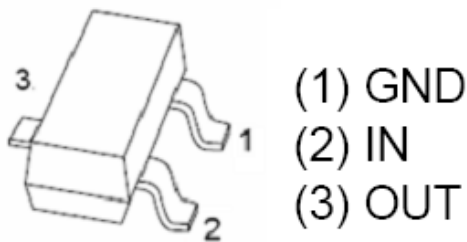

DTC343TK; NPN Transistor
(SMT3)

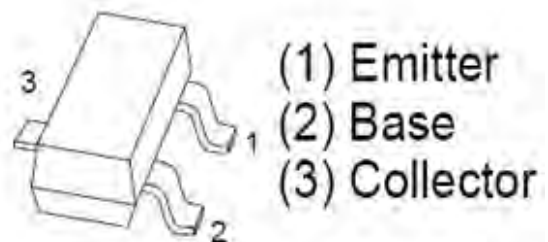

BSS123; N-Channel FET
(SOT23)

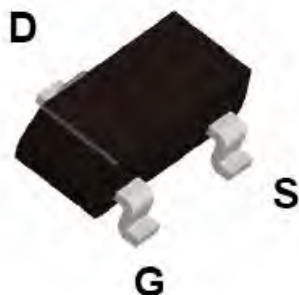

2SA1037AKR; General Purpose
Transistor (SMT3)

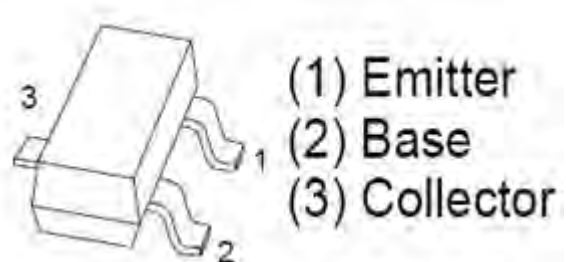

2SC5866; Medium Power Transistor
(TSMT3)

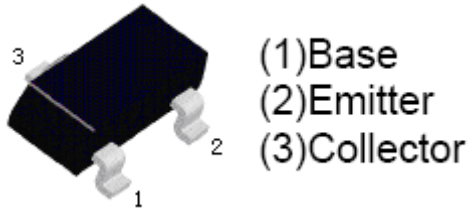

AF4835; P-Channel Mosfet(SO8)

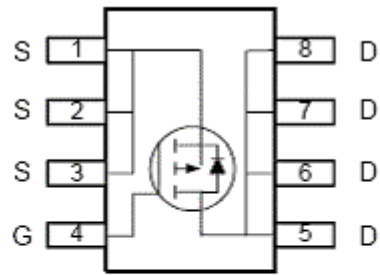

Pin Name	Description
S	Source
G	Gate
D	Drain

FQPF13N50C; N-Channel
Mosfet (TO-220F)

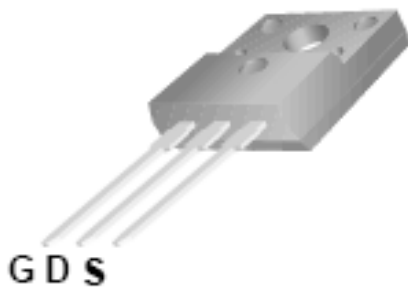

DMN3033LSN; N-Channel
Mosfet (SOT-23)

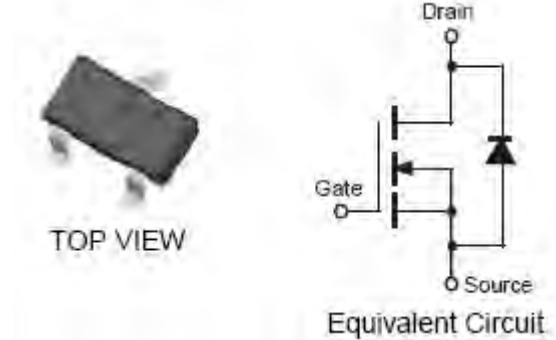

FDPF18N50; 500V N-Channel
MOSFET(TO-220)

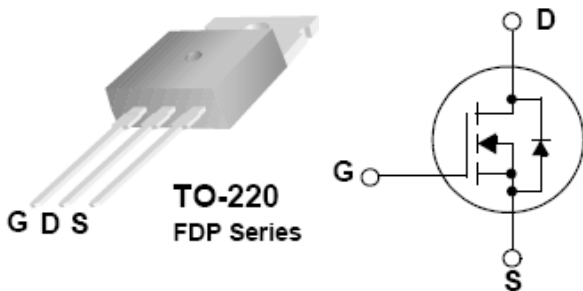

FQPF7N80C ;800V N-Channel
MOSFET(TO-220)

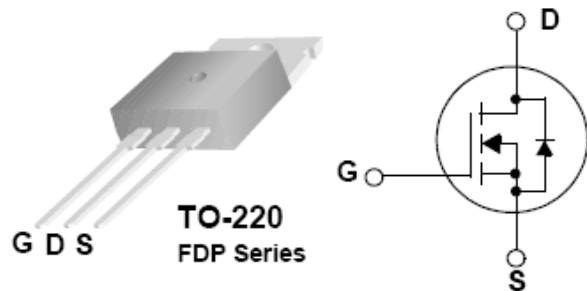

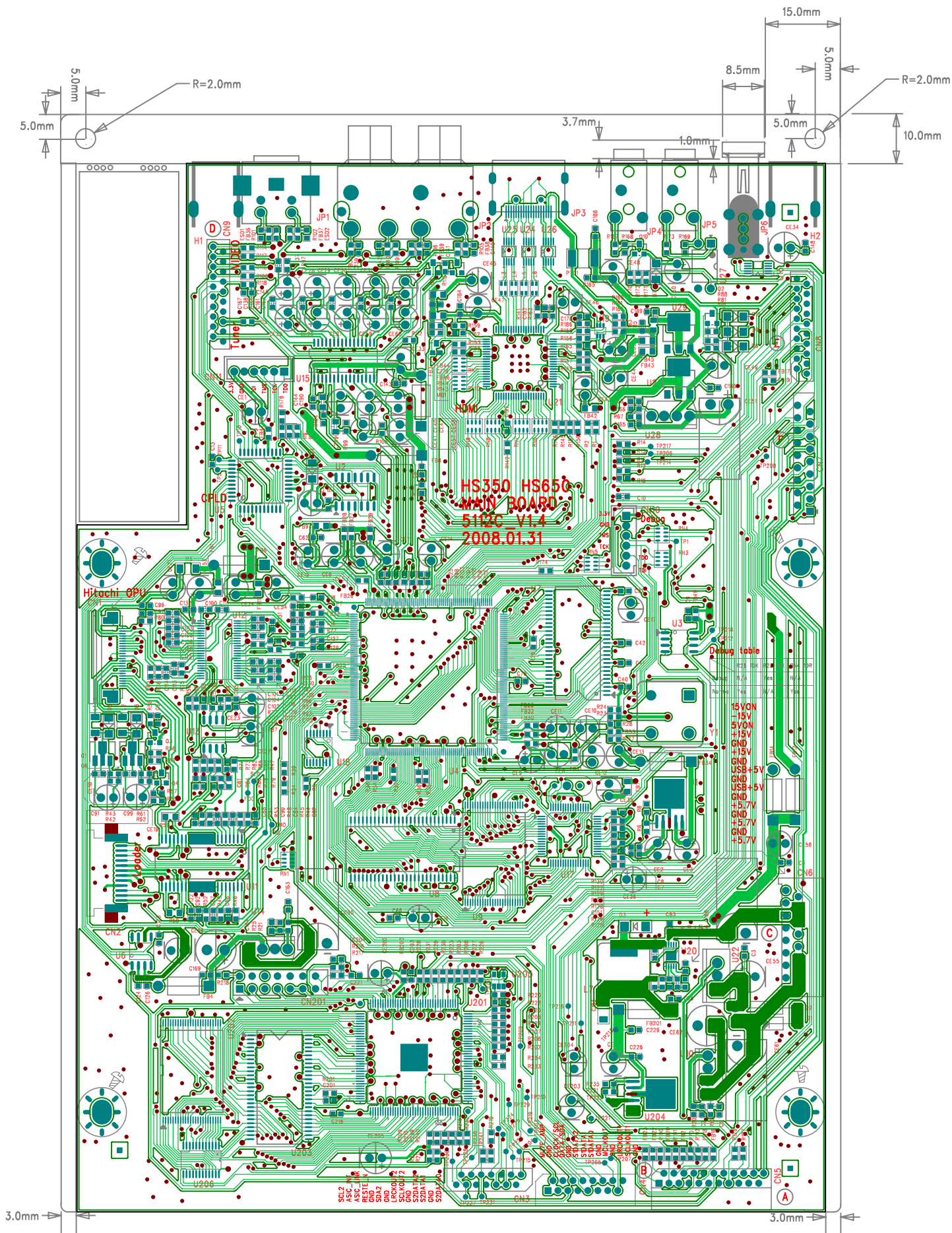

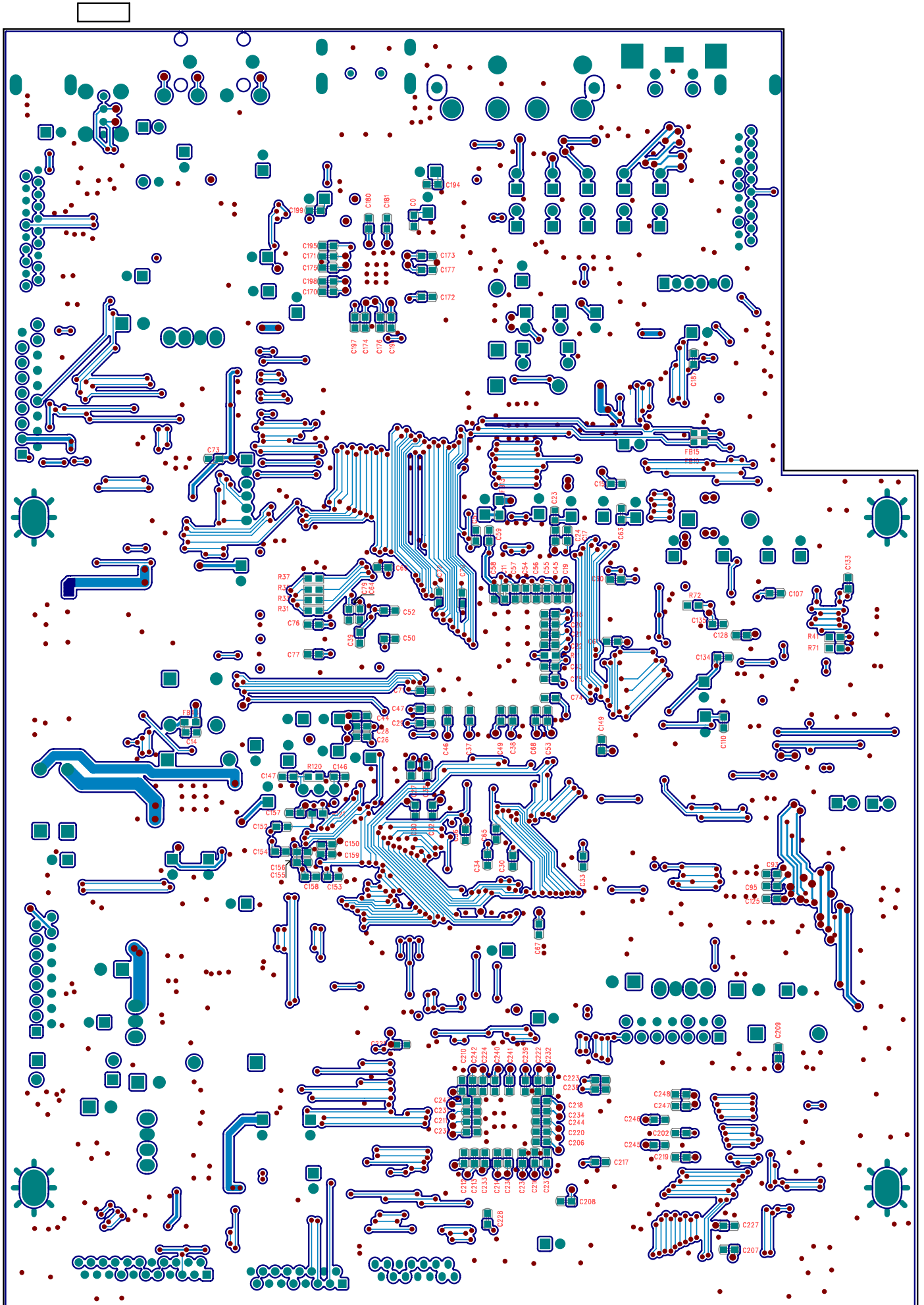

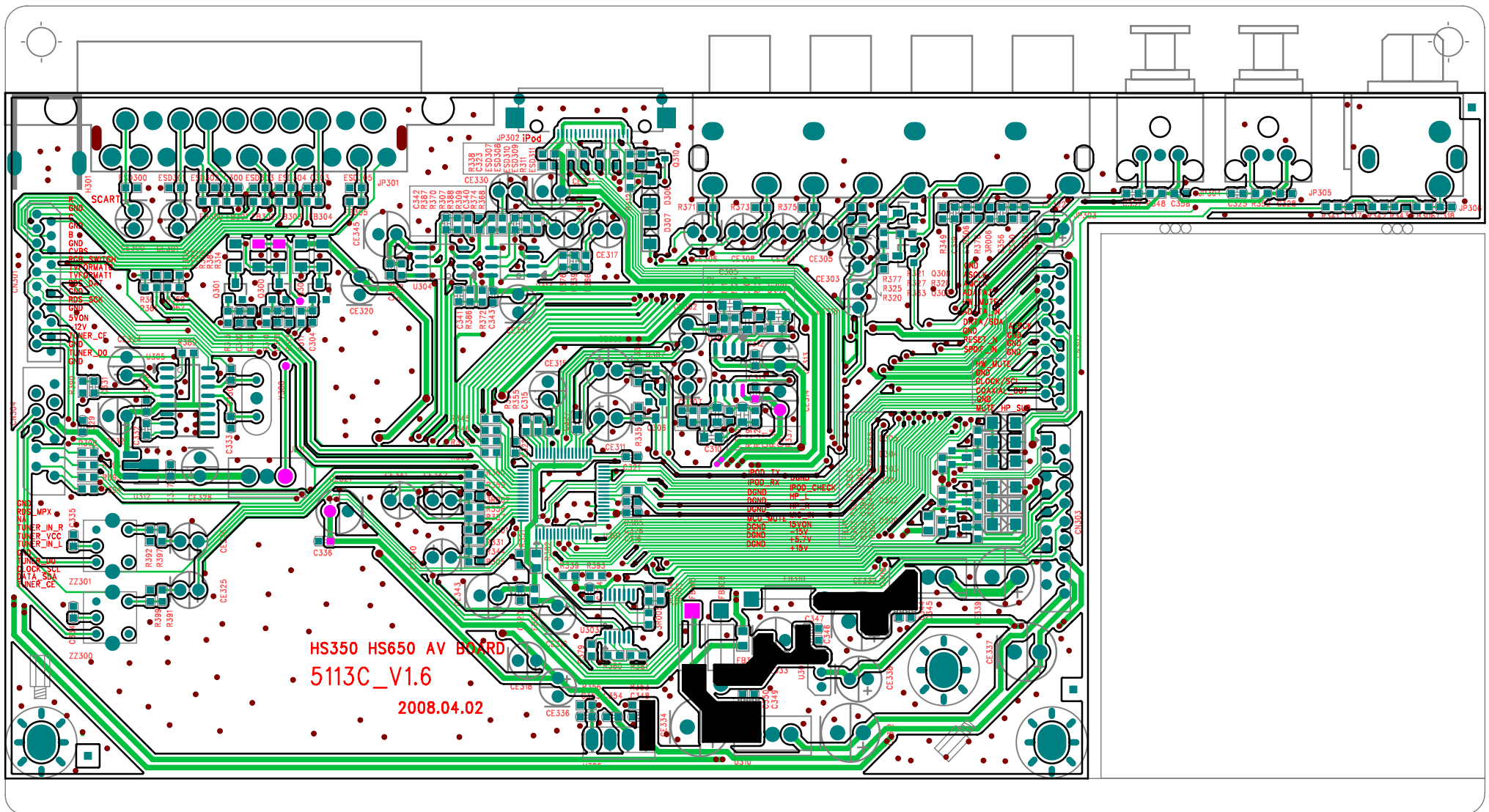

HS350 HS650 AV BOARD
5113C_V1.6
2008.04.02

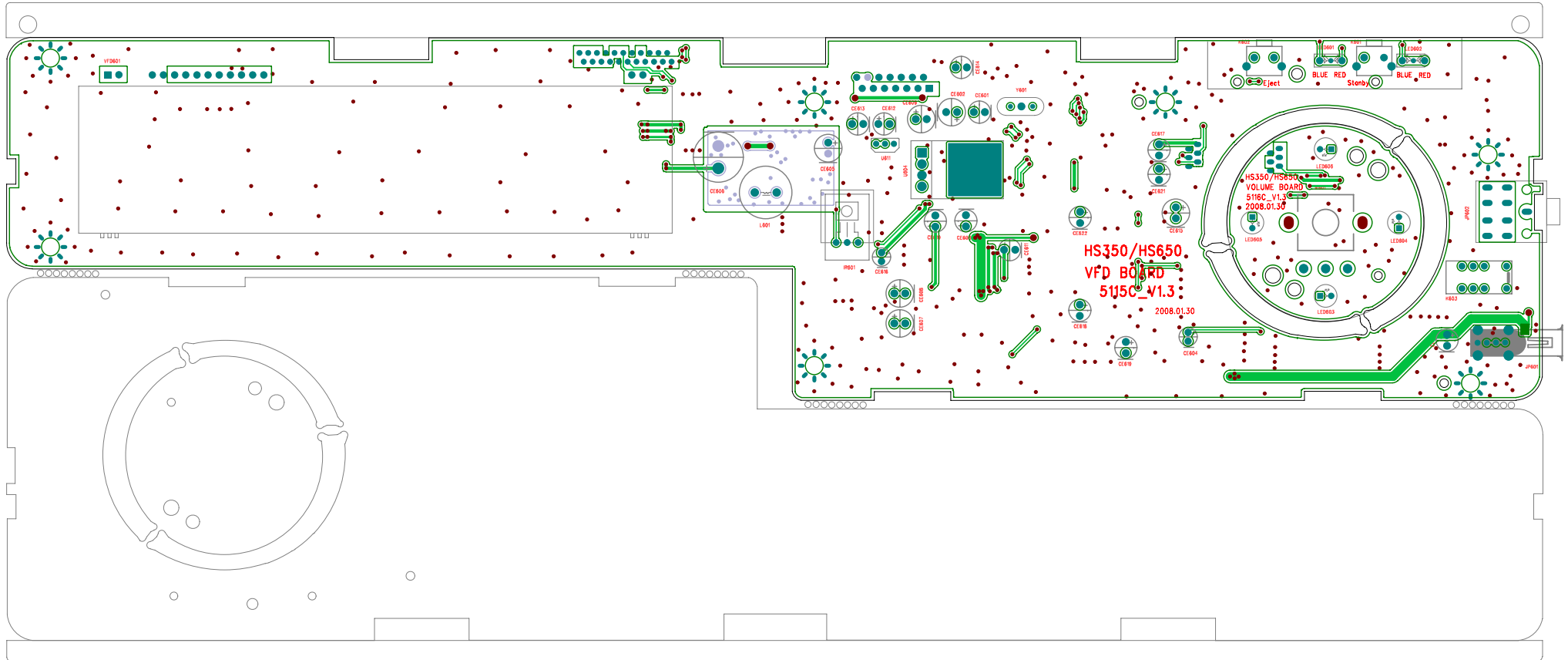

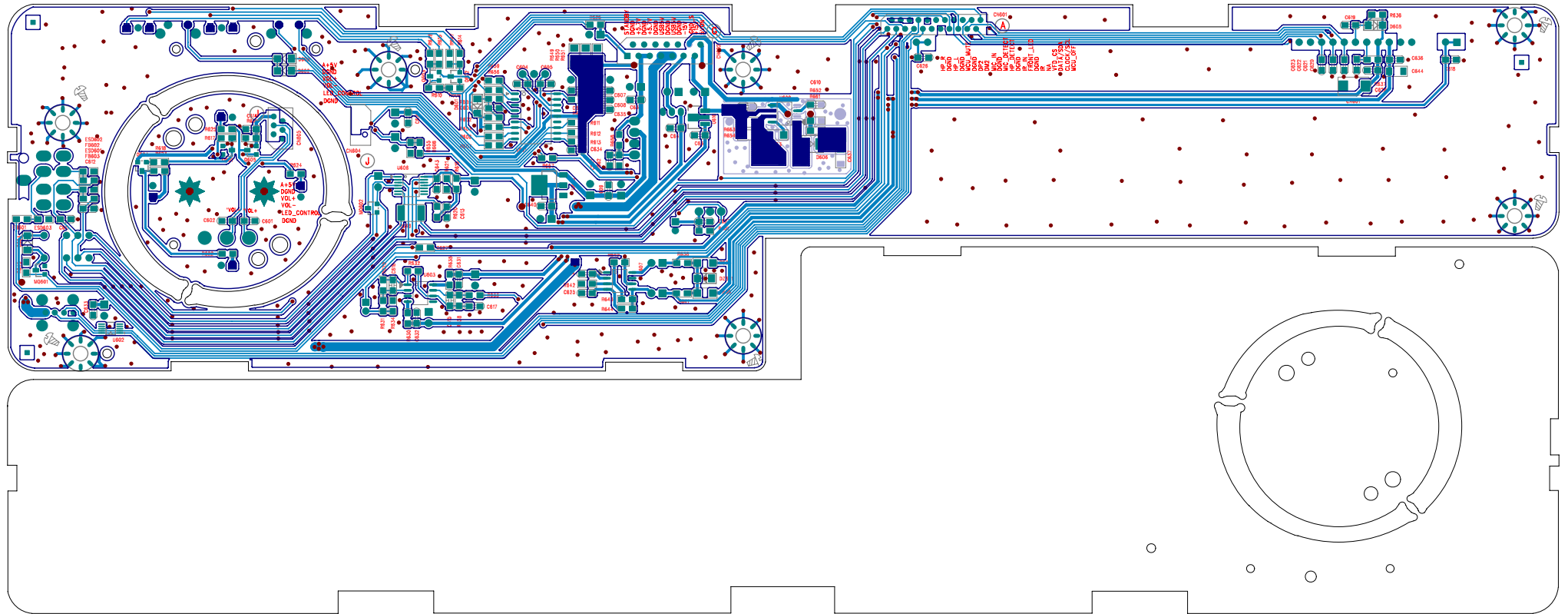

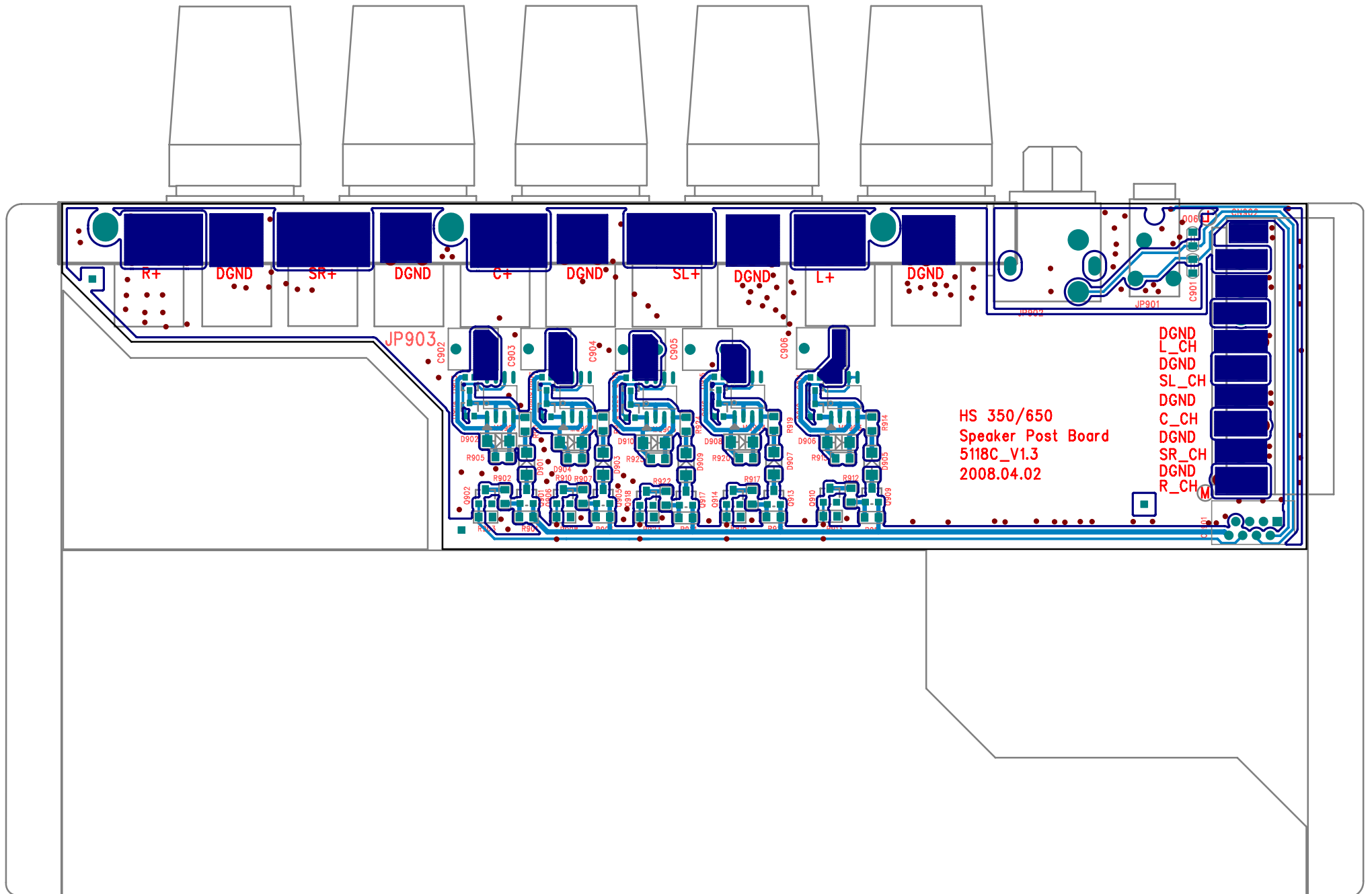

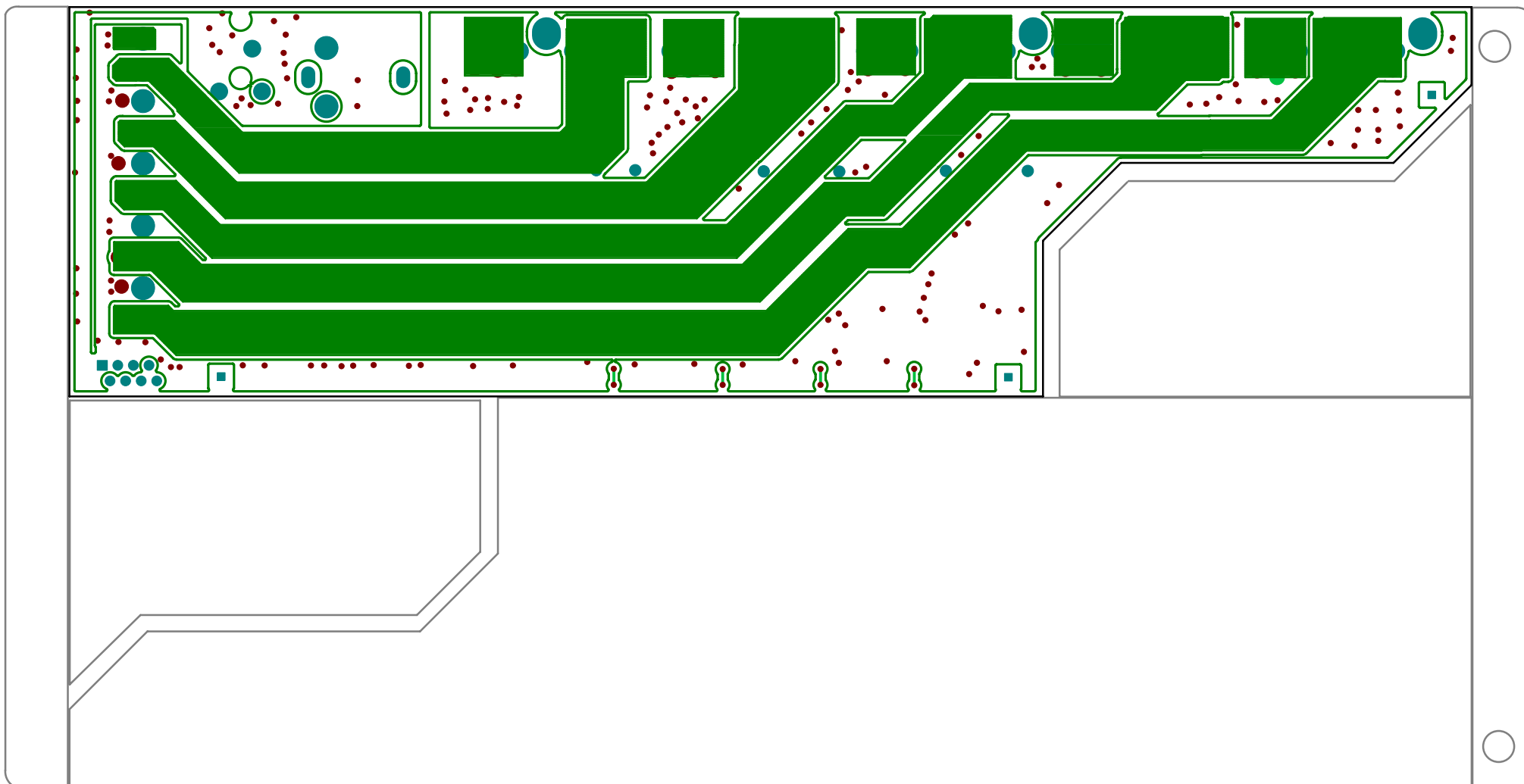

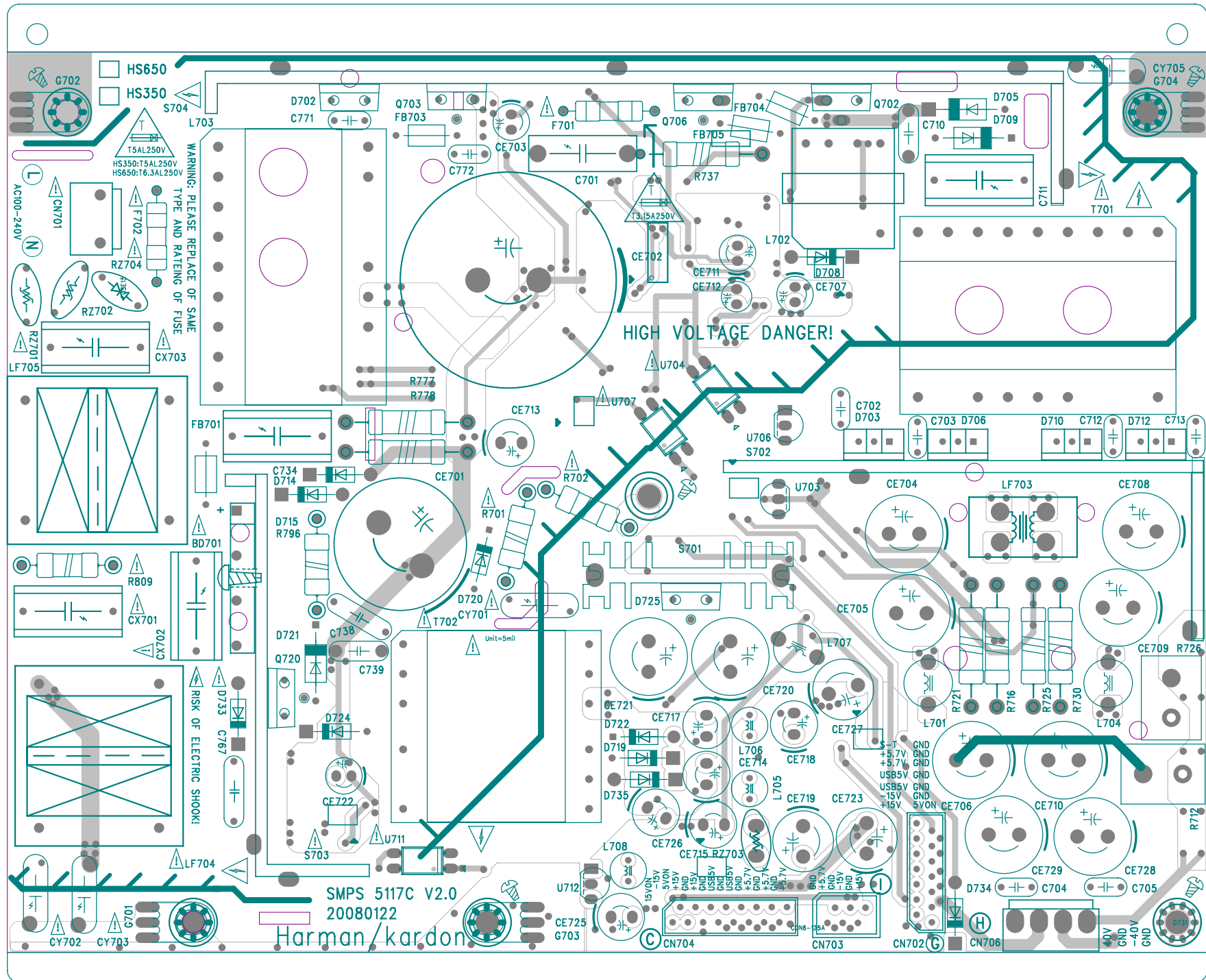

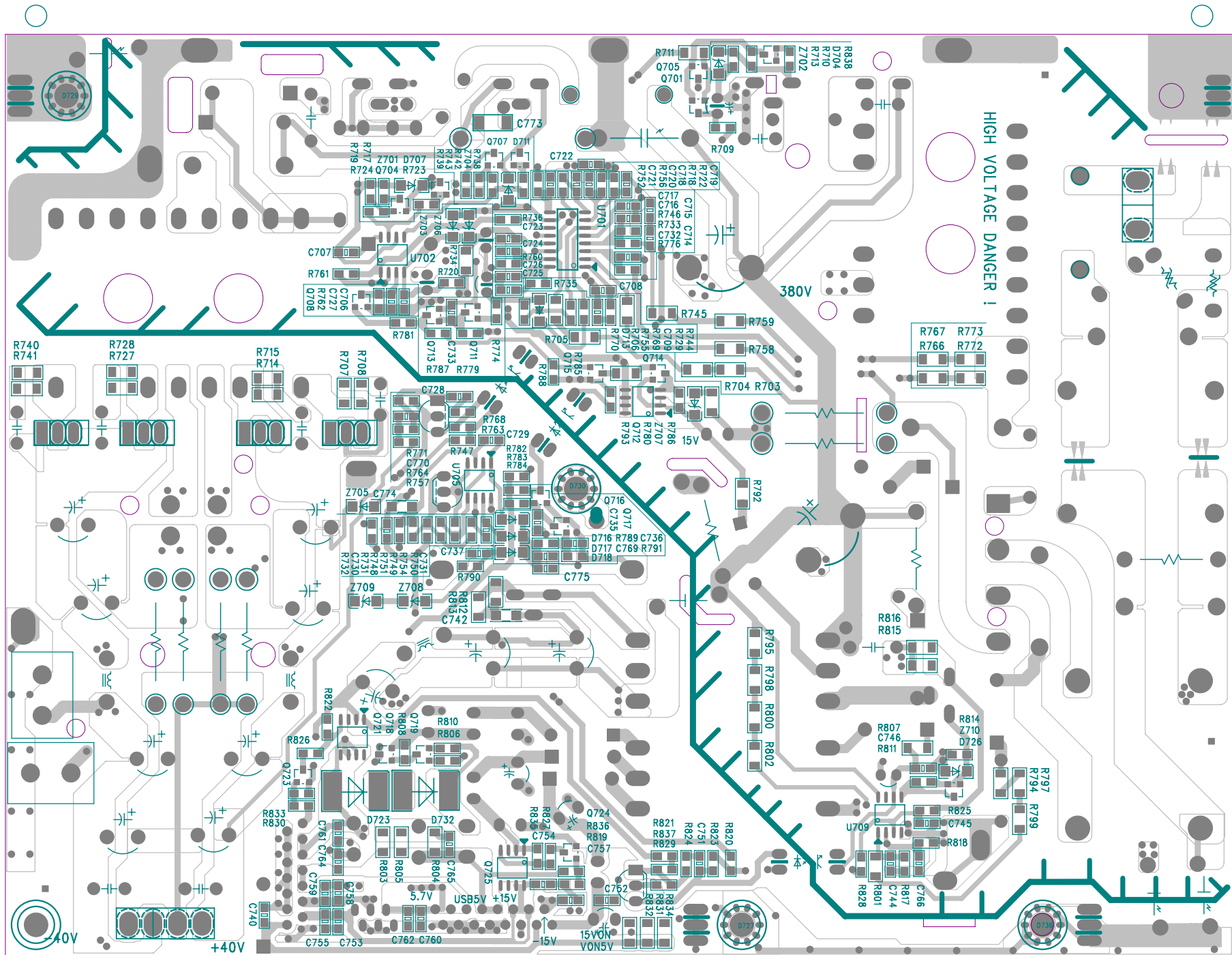

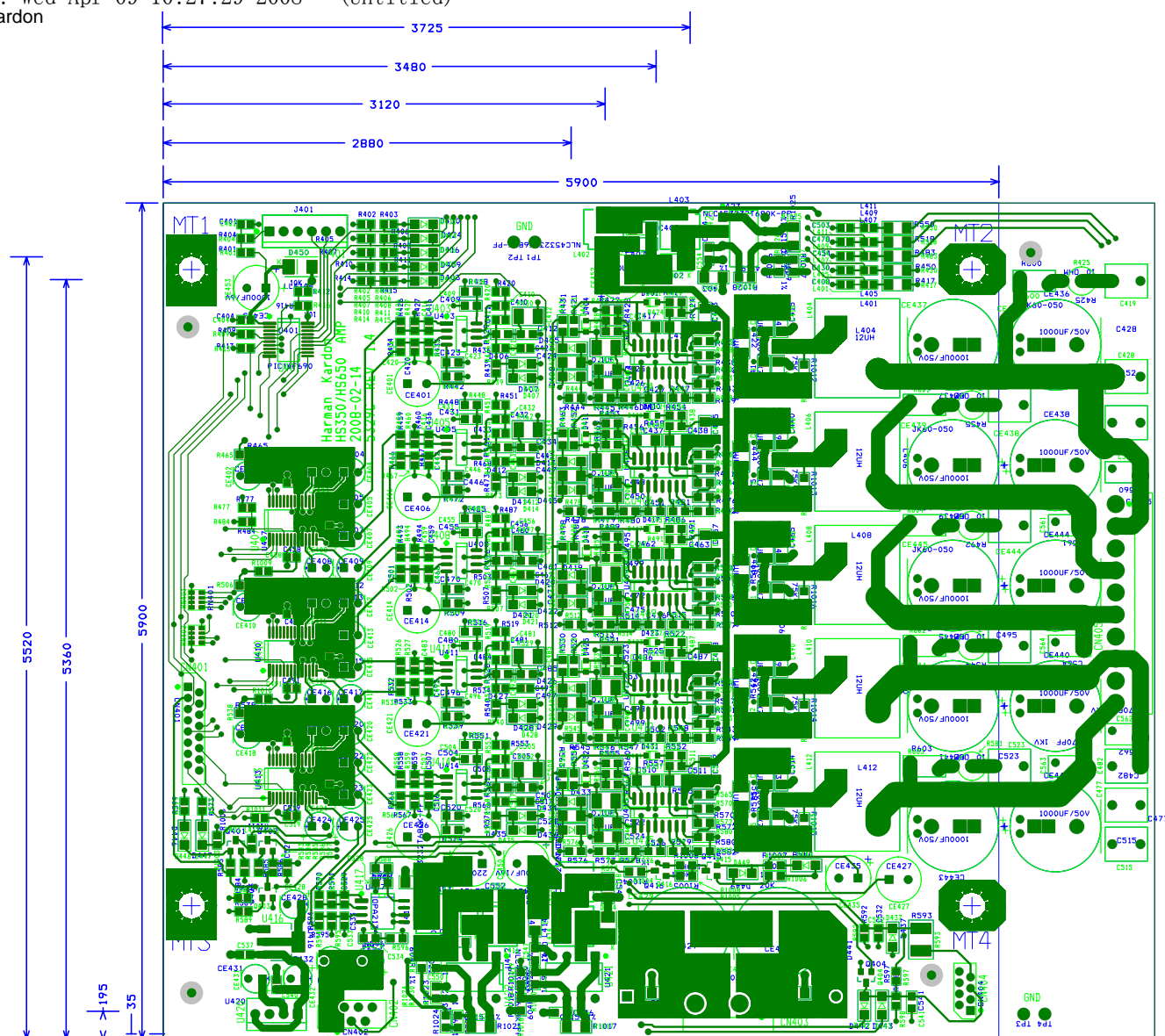

TOP LAYER
 ASEM TOP
 MSKTOP
 PASTETOP
 SILKTOP

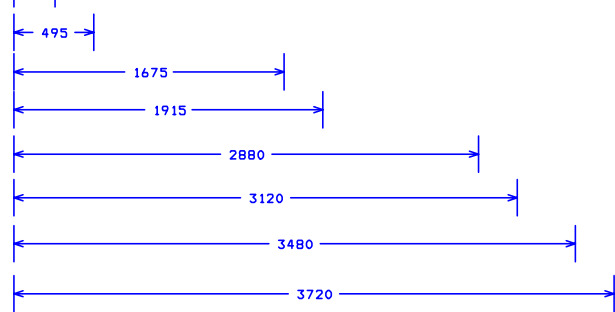

Harman Kardon		
5329C Audio Amp Board Layout		
	Changes Per	Schematic # 013-02-200-5329C
7-31-07		

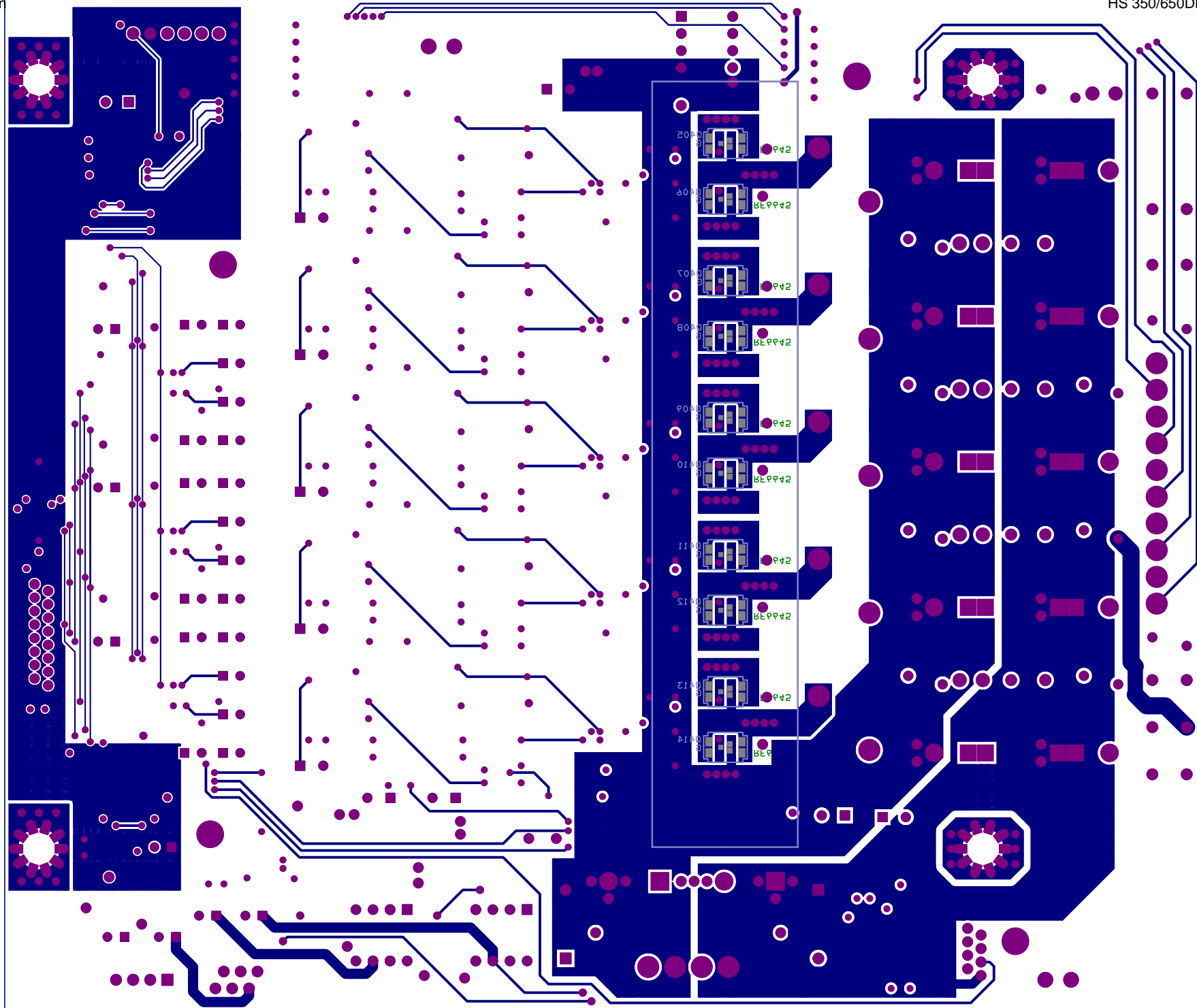

BOT LAYER
ASEMBOT

MSKBOT

PASTEBOT

SILKBOT

HS350 HS650DL HTiB System Schematic

KEY COMPONENTS LIST

DECODER	AML3390DTS-G	FLASH MEMORY	16M Bits, Bottom boot
IO EXPANDER	XC9572XL-10VQG44C	SDRAM MEMORY	64M Bits -6ns * 2 pcs
SERVO RF	AML3501	DSP FLASH	16M Bits, Bottom boot
AUDIO CODEC	AK4683EQ	DSP SDRAM	64M Bits -7ns
AUDIO DSP	TMS320DA708	MOTOR DRIVER	BA6287F
HDMI TRANSMITTER	SiI9030CTU	AMPLIFIER	HARMAN COOL SOLUTION
VIDEO DRIVER	BU7868FS (NOT FOR HS650DL)	RDS DECODER	PT2579-SN(L)
USB CONTROLLER	TDOTG242LP	CIG VFD	VFD33-1701I
TUNER MODULE	US: TFCF1E807A EU: TFCF1E806B	LOADER	DL-05MH-H40P

INDEX OF SCHEMATIC PAGE

PAGE	DESCRIPTION	PAGE	DESCRIPTION	PAGE	DESCRIPTION	PAGE	DESCRIPTION
1	INDEX & KEY COMPONENTS LIST	10	Motor driver and RF-AMP	19	Amplifier Audio DAC	28	HS650 SMPS
2	BLOCK DIAGRAM	11	Video output	20	Audio Sound Processor	29	SMPS Rev history
3	WIRING DIAGRAM	12	USB and IR In/Out	21	L and SL AMP	30	Speaker output
4	Rev history 1	13	HDMI	22	R and SR AMP		
5	Rev history 2	14	DSP DA708	23	C AMP		
6	Rev history 3	15	SCART and MUTE Logic	24	VFD and MCU		
7	Power and connector	16	Audio Codec	25	VFD Power supply and button		
8	Decoder	17	Tuner and iPod input	26	Volume Encoder		
9	Memory	18	Power supply and MCU	27	HS350 SMPS		

***The schematic revision will follow the mainboard revision.**

Title			
Index and key components list		070725	
Size	Document Number	Index	Rev
A3			1.2
Date:		Wednesday, March 19, 2008	Sheet 1 of 32

HS350 HS650DL BLOCK DIAGRAM

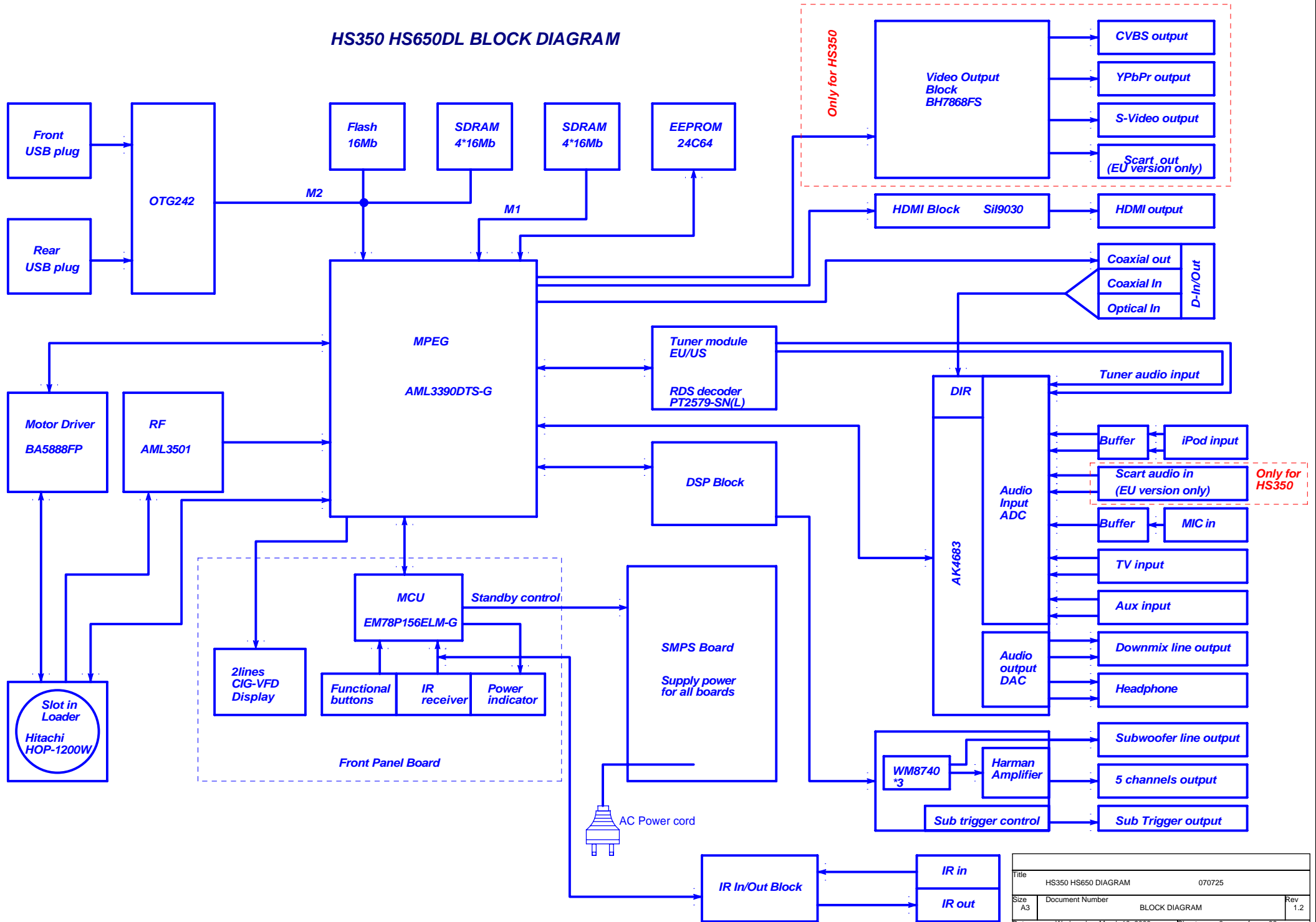

Title		HS350 HS650 DL DIAGRAM		070725	
Size	A3	Document Number	BLOCK DIAGRAM		Rev
Date:	Wednesday, March 19, 2008		Sheet	2	of 32

HS350 HS650DL WIRING DIAGRAM

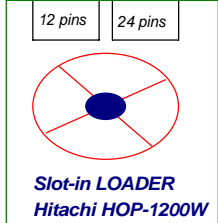
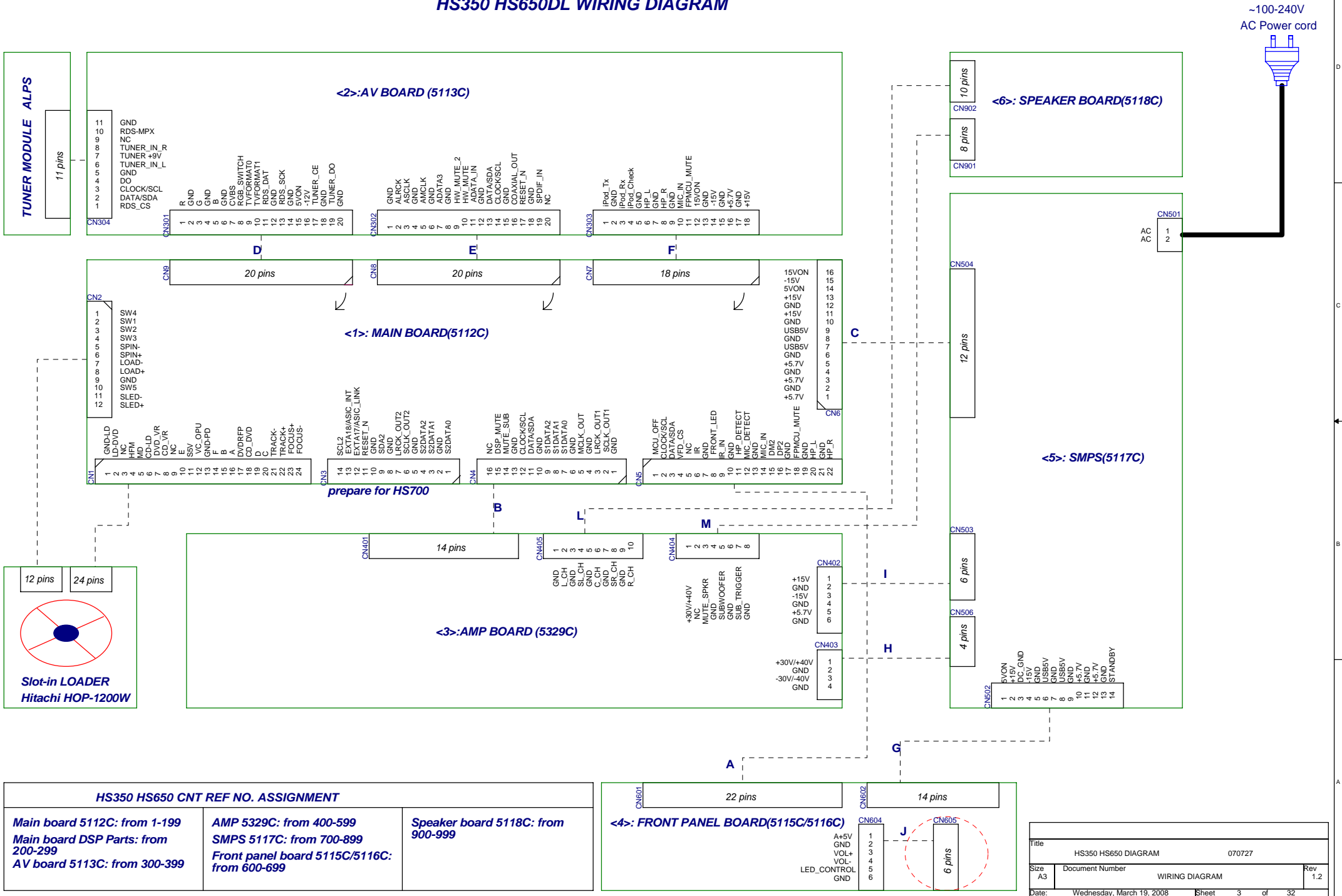

HS350 HS650 CNT REF NO. ASSIGNMENT		
Main board 5112C: from 1-199	AMP 5329C: from 400-599	Speaker board 5118C: from 900-999
Main board DSP Parts: from 200-299	SMPS 5117C: from 700-899	
AV board 5113C: from 300-399	Front panel board 5115C/5116C: from 600-699	

Title		HS350 HS650 DIAGRAM		070727	
Size	A3	Document Number	WIRING DIAGRAM		Rev
Date:	Wednesday, March 19, 2008	Sheet	3	of	32

NO.	REVISION DATE	REV	REVISION HISTORY		
1	Mar 20, 2007	1.0	1. initial version.		
2	May 5, 2007	1.1	1. change U204 from TPS78601DCQR to BA00HC5FP. 2. add pull-up R11 for TUNER_CE. 3. change I2C2 -> I2C1 on CN4, ASIC_TEST -> SCL2 and EXTA16/ASIC -> SDA2 on CN3.	4. add MUTE_AMP circuit for amplifier board. 5. change ADC from PORTB to PORTA of AK3683. 6. pin2 of U18 change to float in order to improve the playability.	7. update DSP page, add SN74LVC823APW, change the Flash to top boot type.
3	June 5, 2007	1.2	1. change R240 R241 to N/A, install R655 CE621. 2. improve iPod noise issue, related components: Q310, 3R007, 3R008, 3R009, 3R010, 3R012, 3R013, FB314, C308, C309, C339, C340, C341, C342, C359, C360, CE345, D308, R307, R309, R311, R312, R318, R340, R348, R366, R368, R370, R372, R374, R376, R386, R387, R388. 3. change R393 in order to fix analog input no sound issue. 4. change DSP Flash from top boot type to bottom boot type. 5. change MUTE_DSP to DSP_MUTE on mainboard, change front panel MCU_MUTE to FPMCU_MUTE. 6. add FB10/FB15 on I2C which go to CPLD, add FB17(0 ohm)/FB19(0 ohm) on I2C which go to CN8, they are for avoiding misoperation.	7. change R385->0R, R205->0R, R206->150R, R207->0R, in order to fix amp output noise. 8. CN402/CN703/CN704/CN702/CN602 -> 180 degree + pin X-turn. 9. the power supply for AV board was changed to come from mainboard, that can cancel one flat cable which close to the high-voltage heatsink on SMPS board, CN7/CN303(12pin-1.0mm -> 18pin-1.25mm), CN6(12pin-1.25mm -> 16pin-1.25mm). 10. change MUTE LOGIC CIRCUIT on mainboard, change CN4(14pin-1.0mm -> 16pin-1.0mm). 11. add mute circuit on speaker board, change CN901(5pin-1.0mm -> 8pin-1.0mm).	12. amplifier board: change subwoofer mute circuit, add discharge circuit for fixing the noise cause by plug out AC cord, change CN404(5pin-1.0mm -> 8pin-1.0mm), CN401(14pin-1.0mm -> 16pin-1.0mm). 13. add R626/CE614 to fix random DC supply when power on, change R619 from 1.5k to 10R and R621 to N/A. 14. change MUTE_HP_SUB to MUTE_HP on AV board. 15. add mute circuit on speaker board.
4	Jan 31, 2008	1.4	1. change R58 from 0R to 1K to improve EMI issue from pick up. 2. R99 68R -> 75R, CE33 10uF->330uF, CE37 -> C249, to improve CVBS light noise and gain. 3. Exchange the pin order of CN3 4. Add C367, C644 to decrease the ripple voltage of +40V.	5. Add Relay K603 to replace FSA2257 to improve Heaphone THD, but FSA2257 still left, need to improve. 6. Change the coaxial 2 from C, D gate to E, F gate, add C324 to improve the crosstalk issue between coaxial 1 and coaxial 2.	7. Change CE322 ->100UF, add CE343 470UF, to improve the headphone THD.

Title			
HS350 HS650 REVISION HISTORY 080131			
Size	Document Number	Rev	
A3	1	1.3	
Date: Wednesday, March 19, 2008		Sheet 4 of 32	

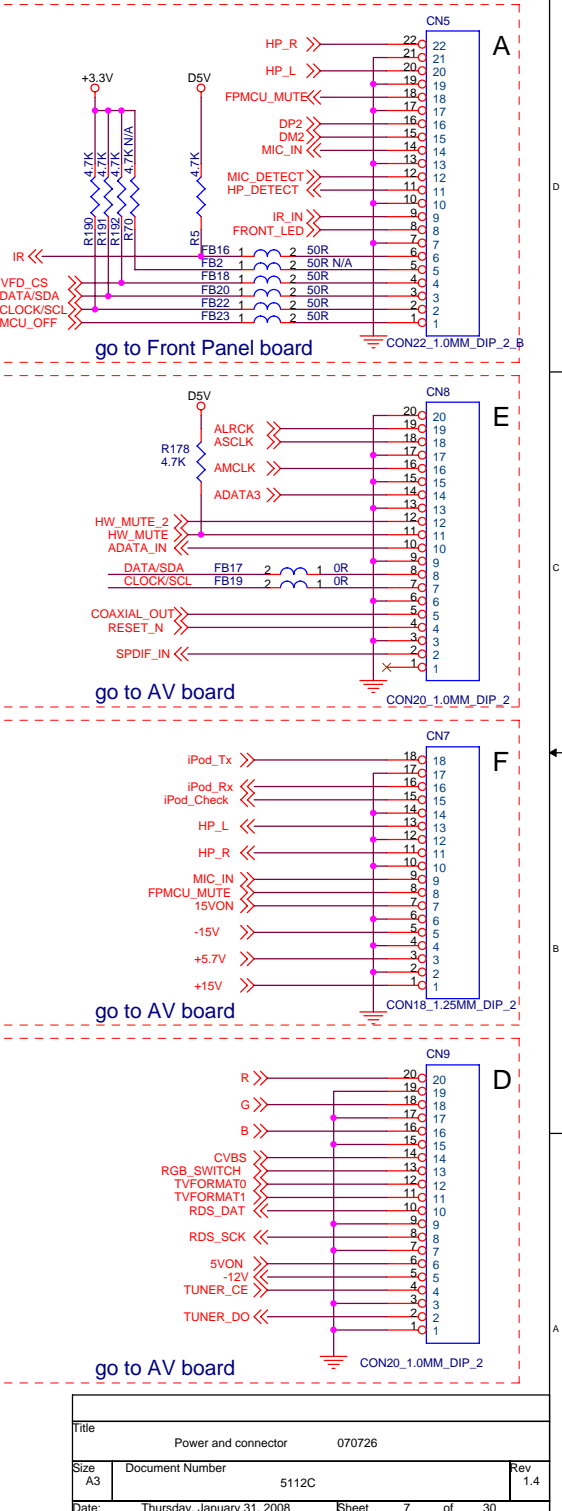
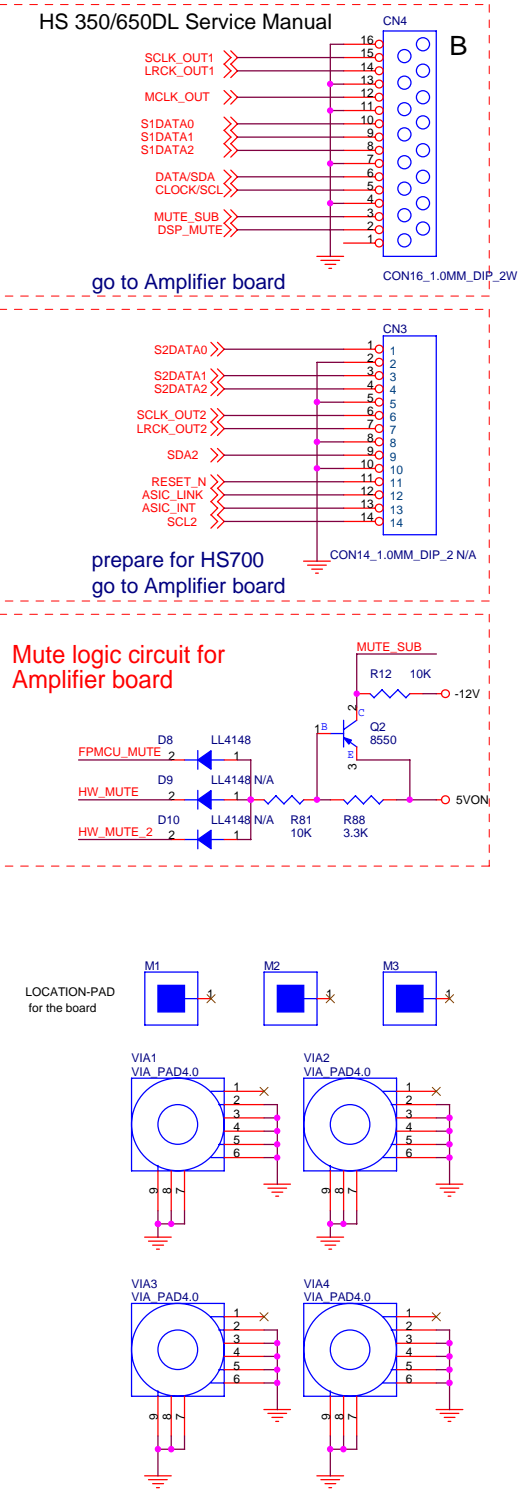
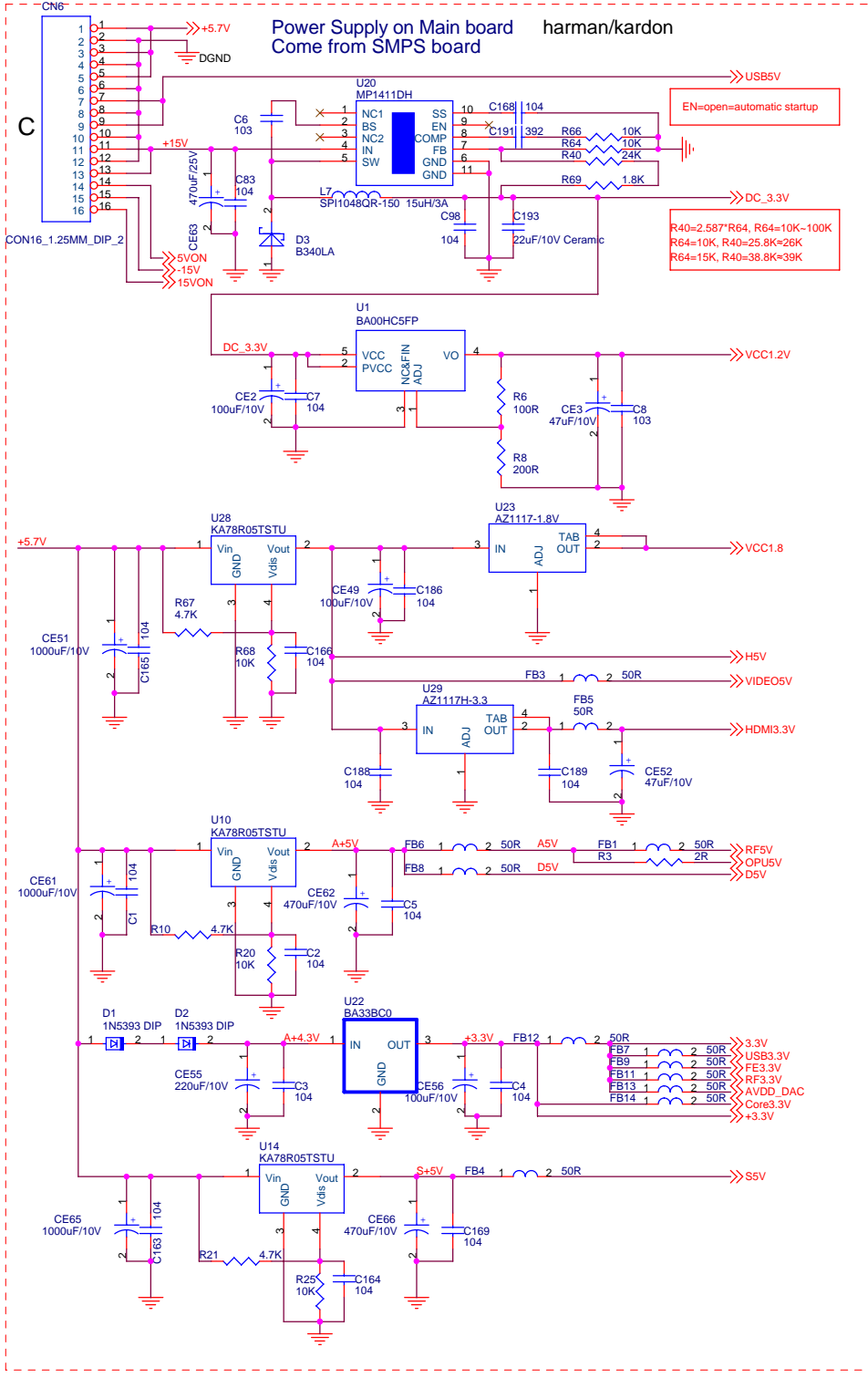

Title		Power and connector		070726	
Size	A3	Document Number	5112C		Rev
Date:	Thursday, January 31, 2008	Sheet	7	of	30

AML3390DTS-G

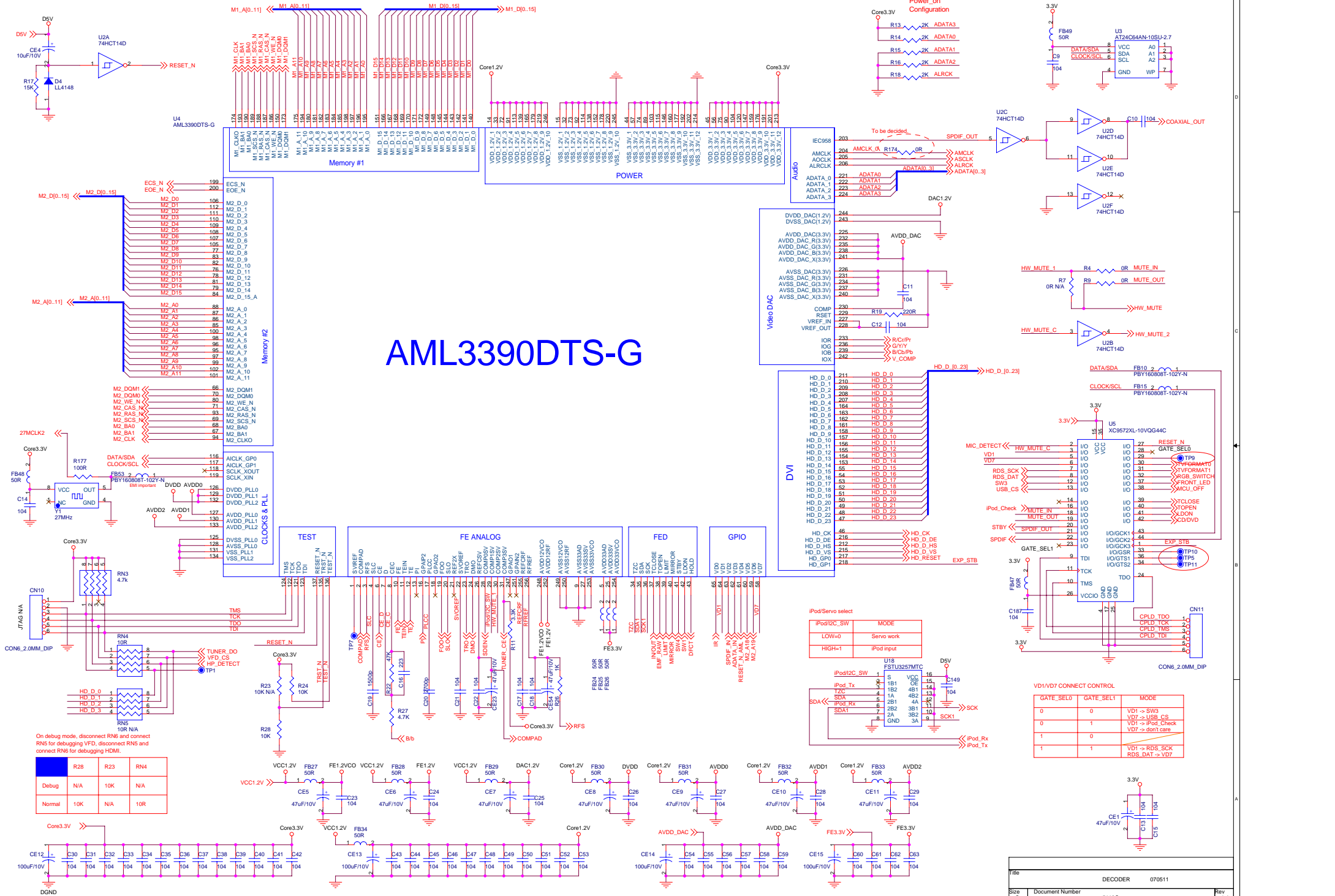

On debug mode, disconnect R28 and connect RNS for debugging VFD. Disconnect RNS and connect RNS for debugging HDMI.

	R28	R23	RN4
Debug	N/A	10K	N/A
Normal	10K	N/A	10R

VD1/VD7 CONNECT CONTROL

GATE_SEL0	GATE_SEL1	MODE
0	0	VD1 -> SW3 VD7 -> USB_CS
0	1	VD1 -> iPod_Check VD7 -> don't care
1	0	VD1 -> RDS_SCK
1	1	VD1 -> RDS_SCK RDS_DAT -> VD7

File	DECODER 070511	
Size	Document Number	5112C
Date	Thursday, January 31, 2008	Sheet 8 of 30

harman/kardon

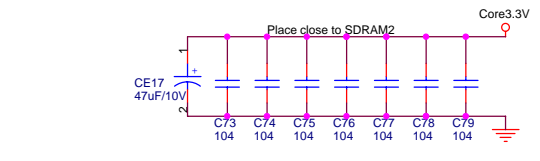
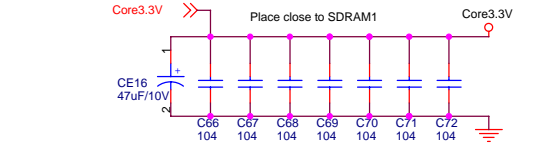
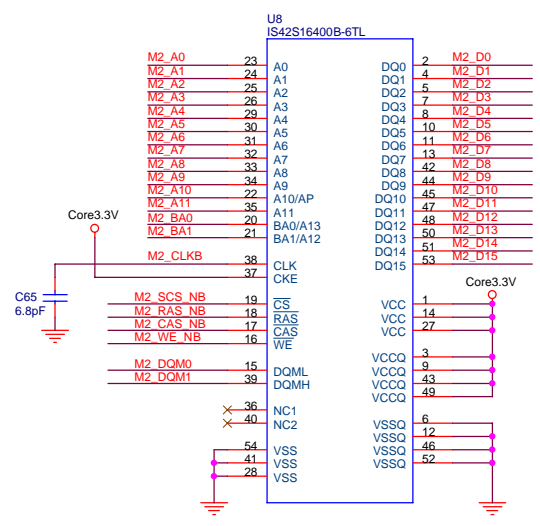
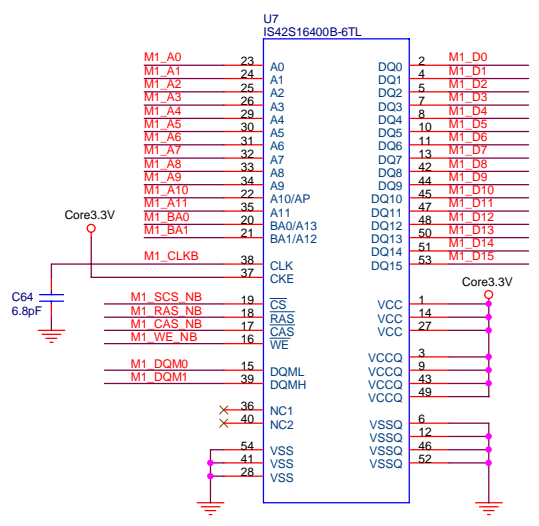
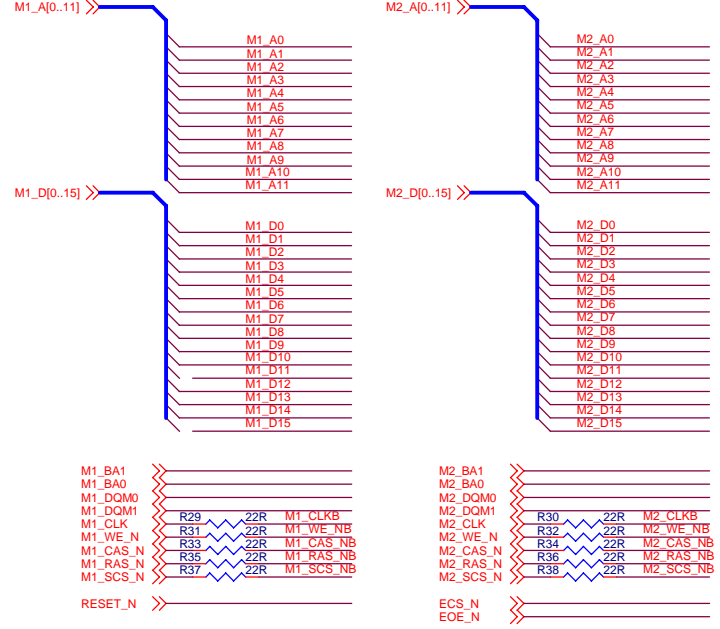

SDRAM1

- 64M bits SDRAM equivalent:
1. IS42S16400B-6TL
 2. K4S641632K-UC60
 3. HY57V641620ETP-6
 4. IS42S16400D-6TL **pending

U9 KH29LV160CBTC-70G

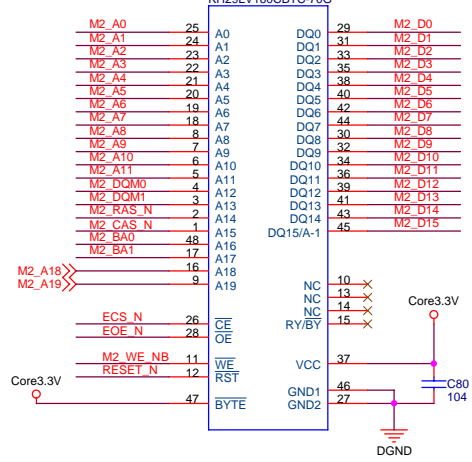

- 16M bits FLASH equivalent:
1. KH29LV160CBTC-70G
 2. S29AL016M90TFI02
 3. S29AL016D70TFI020
 4. AM29LV160DB-90EC
 5. MBM29LV160BE-70P

Title			Memory: SDRAM and FLASH 070616		
Size	Document Number			Rev	
A3	5112C			1.4	
Date:	Thursday, January 31, 2008	Sheet	9	of	30

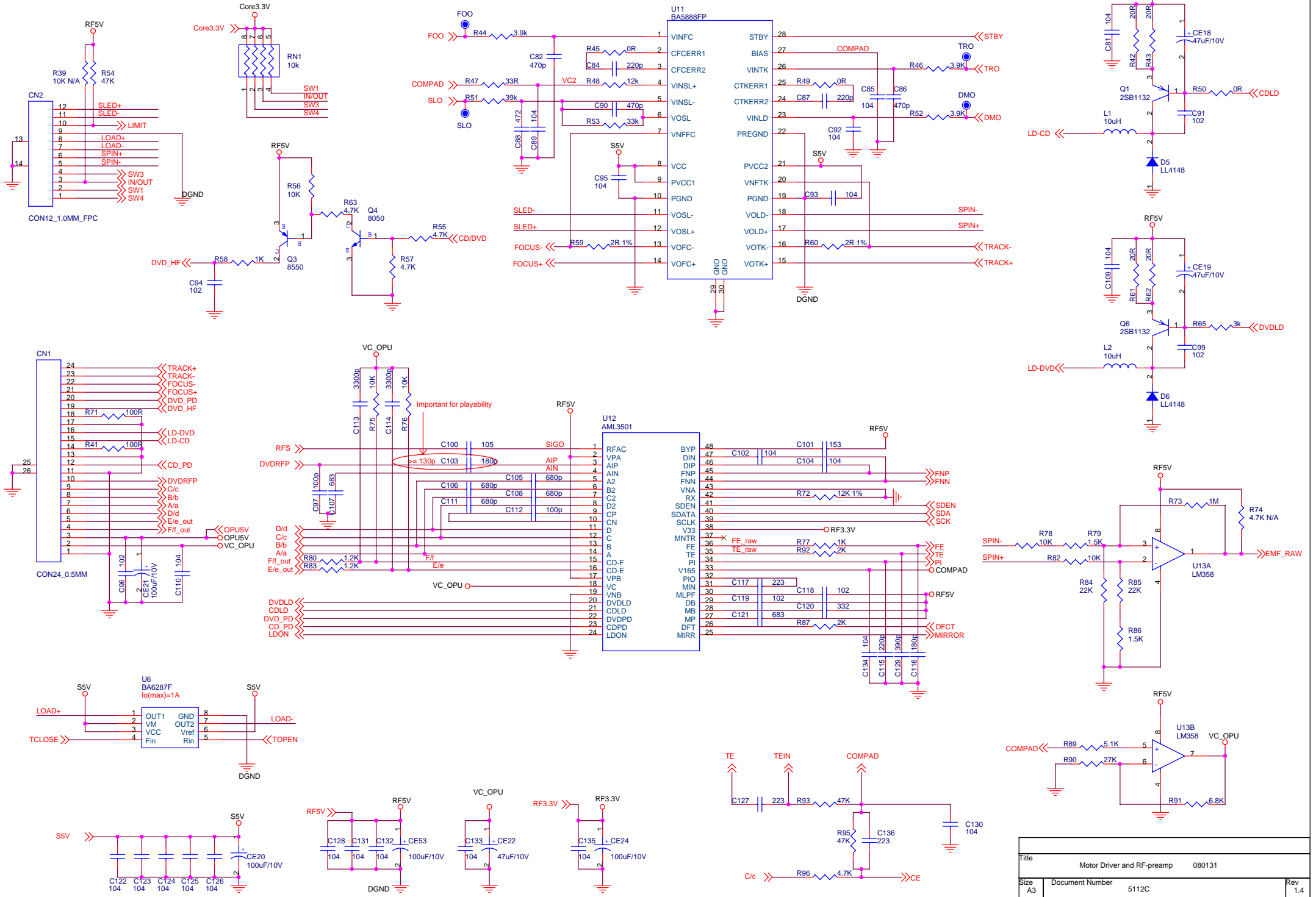

Title			Motor Driver and RF-preamp 080131		
Size	A3	Document Number	5112C	Rev	1.4
Date:	Thursday, January 31, 2008	Sheet	10	of	30

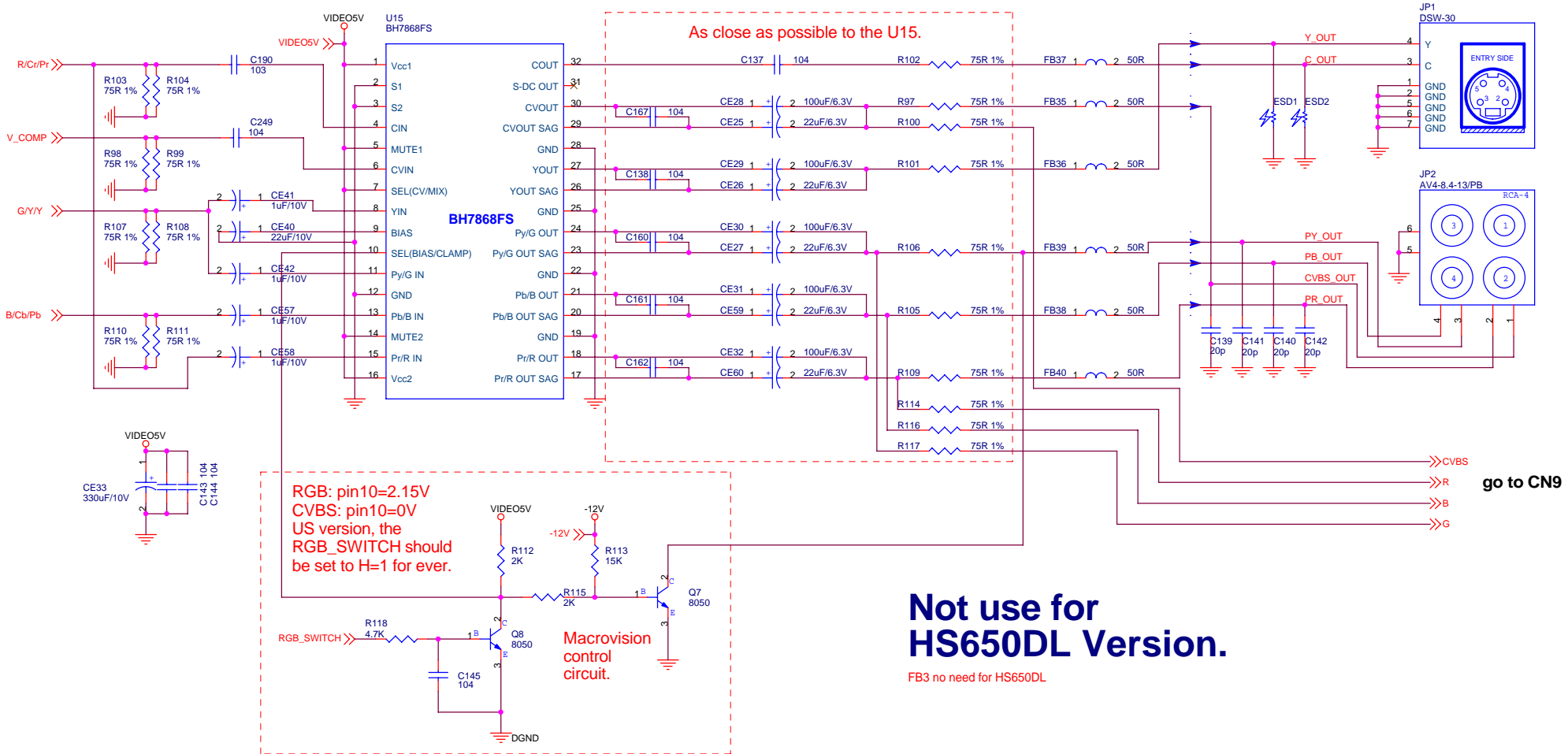

Not use for HS650DL Version.

FB3 no need for HS650DL

go to CN9

Only for HS650DL Version, close to JP1 connector.

Title			
VIDEO OUTPUT 080131			
Size	Document Number	Rev	
A3	5112C	1.4	
Date:	Thursday, January 31, 2008	Sheet	11 of 30

Only for HS650DL Version, close to JP6 connector.

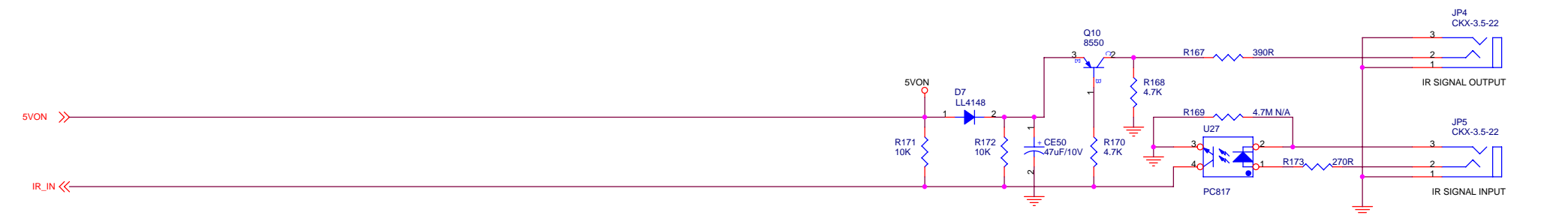
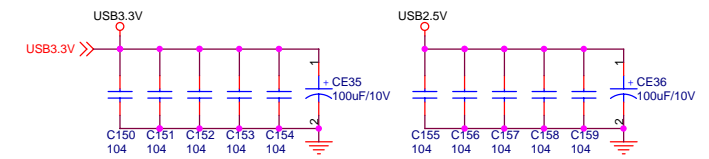
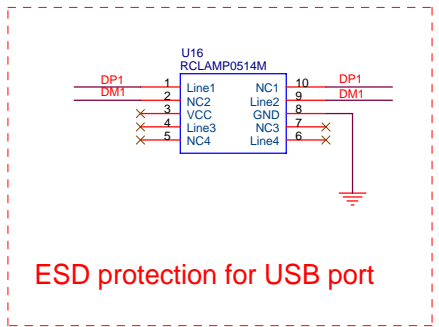
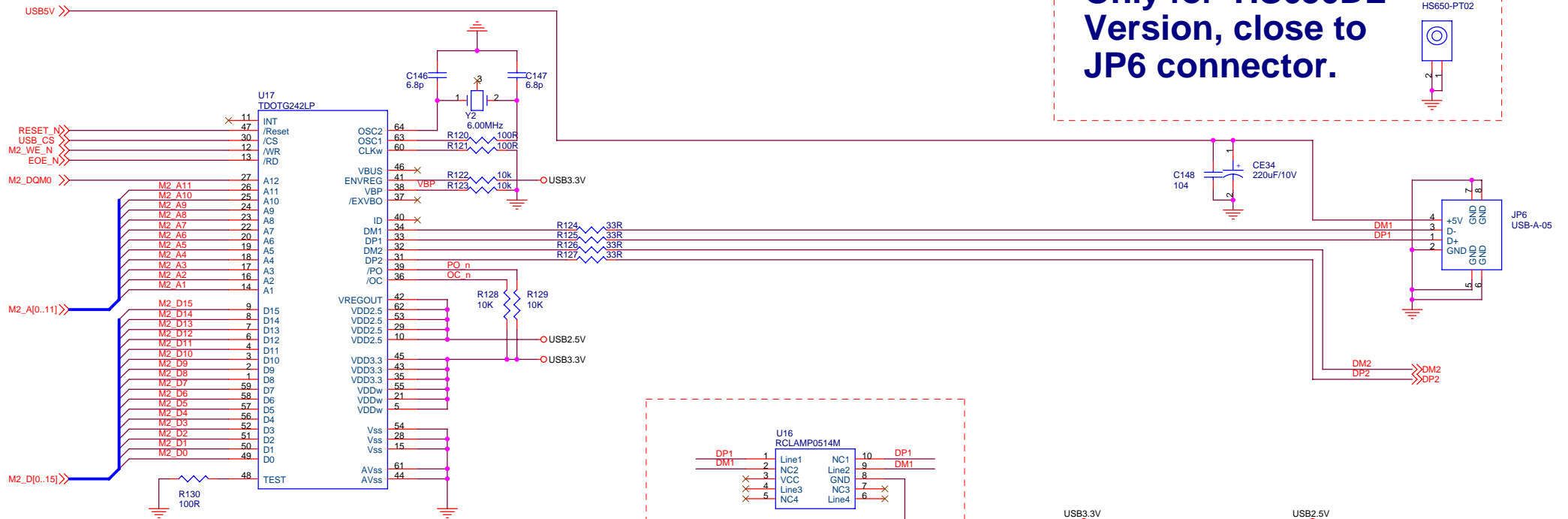
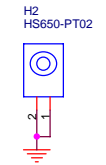

Title			USB and IR In/Out 070725		
Size	Document Number			Rev	
A3	5112C			1.4	
Date:	Thursday, January 31, 2008	Sheet	12	of	30

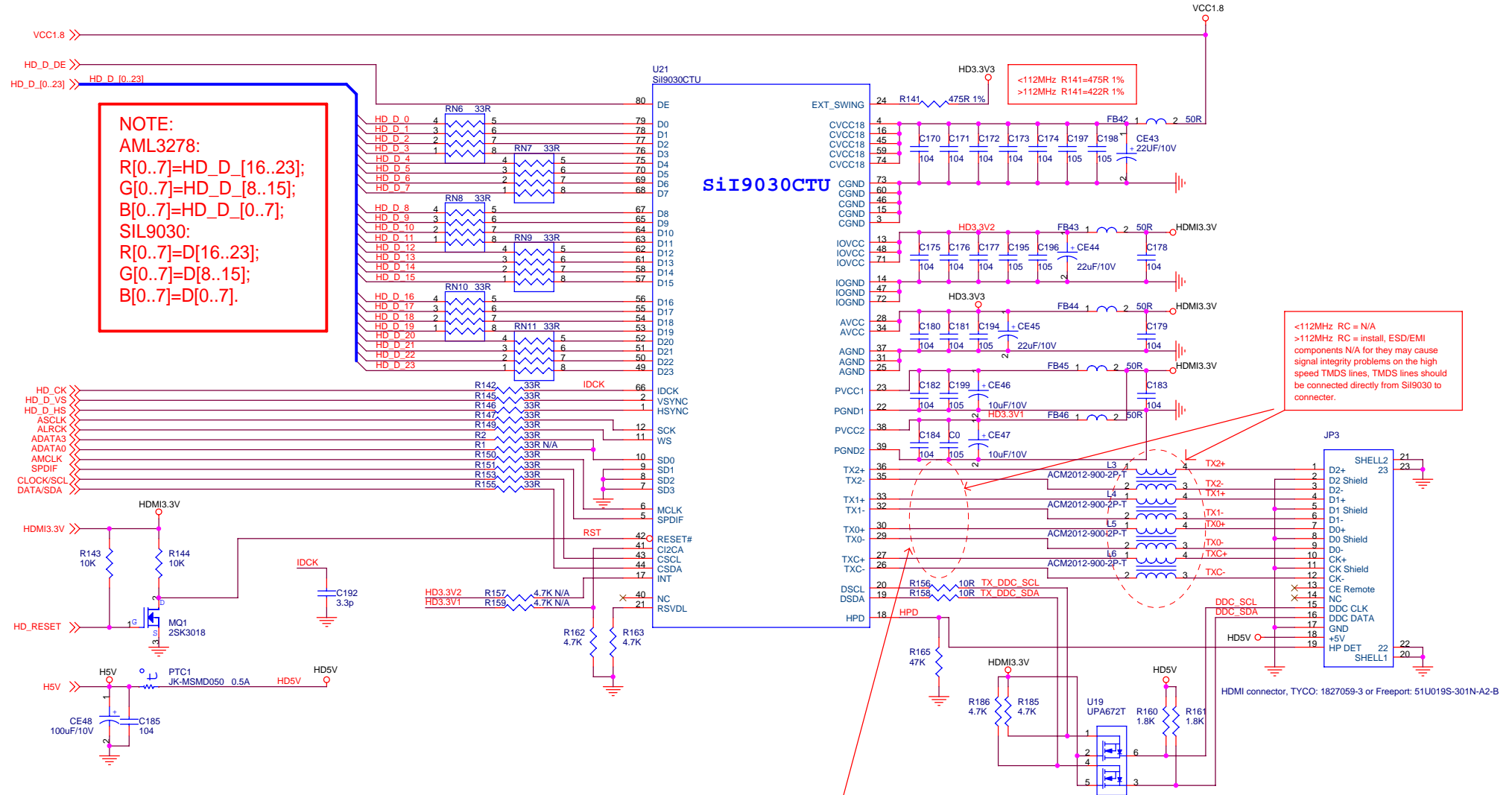

NOTE:
AML3278:
 R[0..7]=HD_D_[16..23];
 G[0..7]=HD_D_[8..15];
 B[0..7]=HD_D_[0..7];
SiI9030:
 R[0..7]=D[16..23];
 G[0..7]=D[8..15];
 B[0..7]=D[0..7].

<112MHz R141=475R 1%
 >112MHz R141=422R 1%

<112MHz RC = N/A
 >112MHz RC = install, ESD/EMI components N/A for they may cause signal integrity problems on the high speed TMDS lines, TMDS lines should be connected directly from SiI9030 to connector.

Title			HDMI 070725		
Size	Document Number	5112C		Rev	1.4
Date:	Thursday, January 31, 2008	Sheet	13	of	30

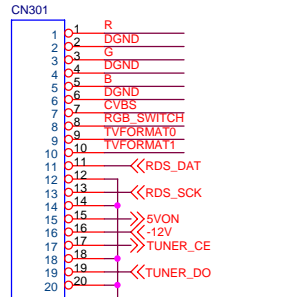

D CON20_1.0MM_DIP_2

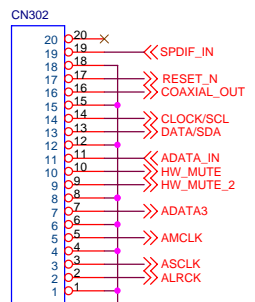

E CON20_1.0MM_DIP_2

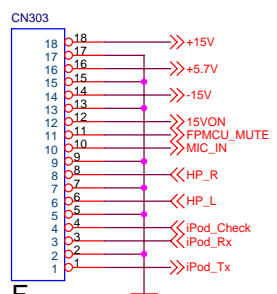

F CON18_1.25MM_DIP_2

H301 HS650-PT02

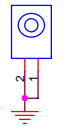

Only for HS650DL Version.

Not use for HS650DL Version.

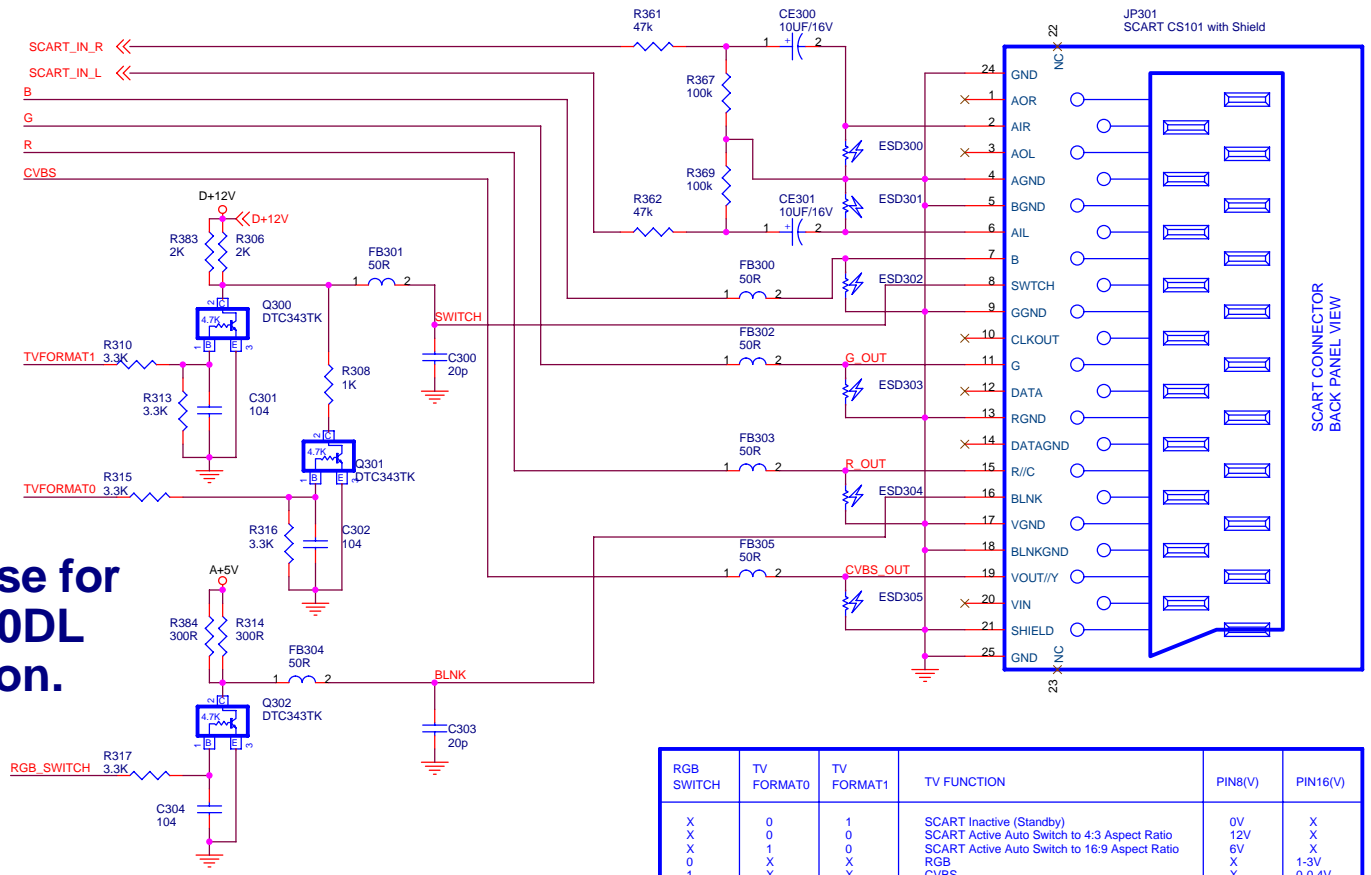

RGB SWITCH	TV FORMAT0	TV FORMAT1	TV FUNCTION	PIN8(V)	PIN16(V)
X	0	1	SCART Inactive (Standby)	0V	X
X	0	0	SCART Active Auto Switch to 4:3 Aspect Ratio	12V	X
X	1	0	SCART Active Auto Switch to 16:9 Aspect Ratio	6V	X
0	X	X	RGB	X	1-3V
1	X	X	CVBS	X	0-0.4V

Scart video output and audio input, only for EU version.

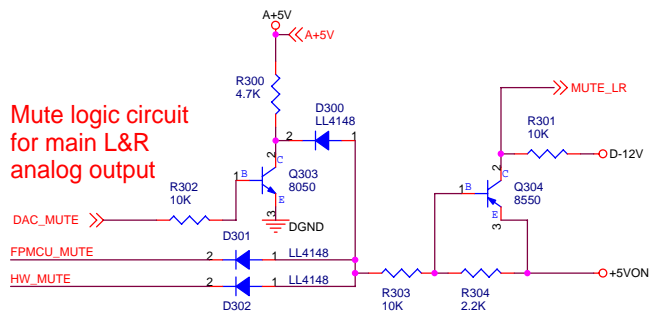

Mute logic circuit for main L&R analog output

Mute logic circuit for headphone and subwoofer

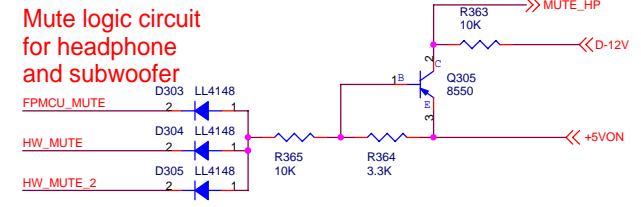

Title		SCART and MUTE Logic		070725	
Size	Document Number	5113C		Rev 1.6	
A3	Date: Wednesday, April 02, 2008				Sheet 15 of 30

harman/kardon

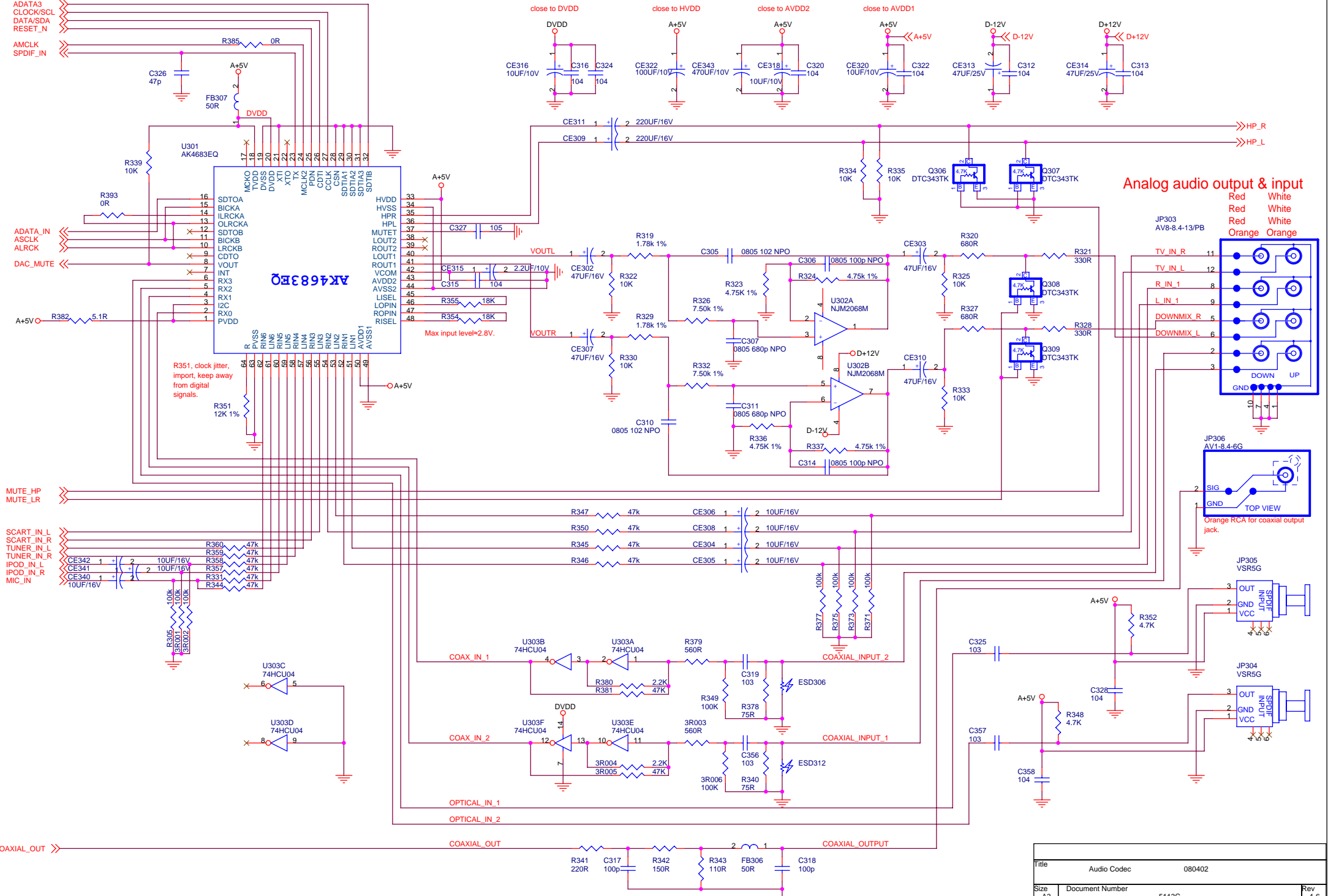

Analog audio output & input

- Red White
- Red White
- Red White
- Orange Orange

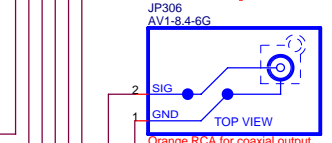
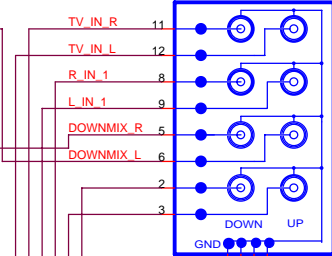

Title		Audio Codec 080402	
Size	A3	Document Number	5113C
Date:	Wednesday, April 02, 2008	Sheet	16 of 30
		Rev	1.6

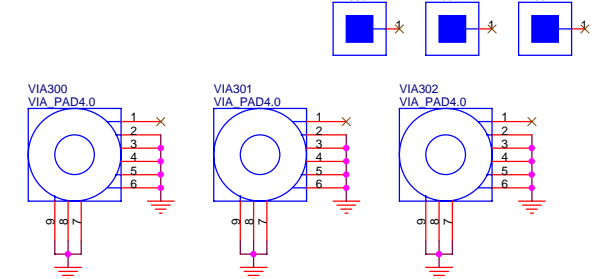
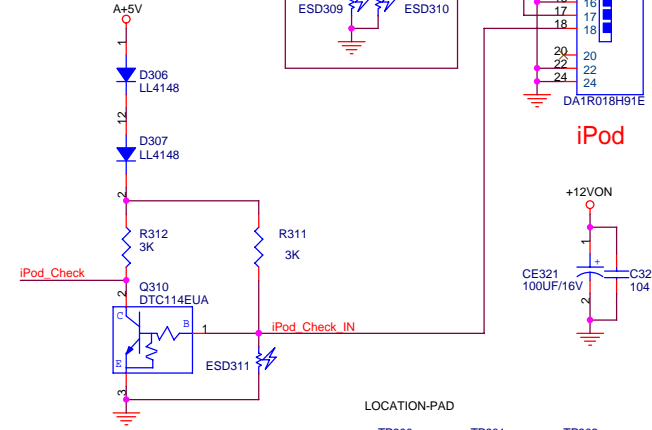
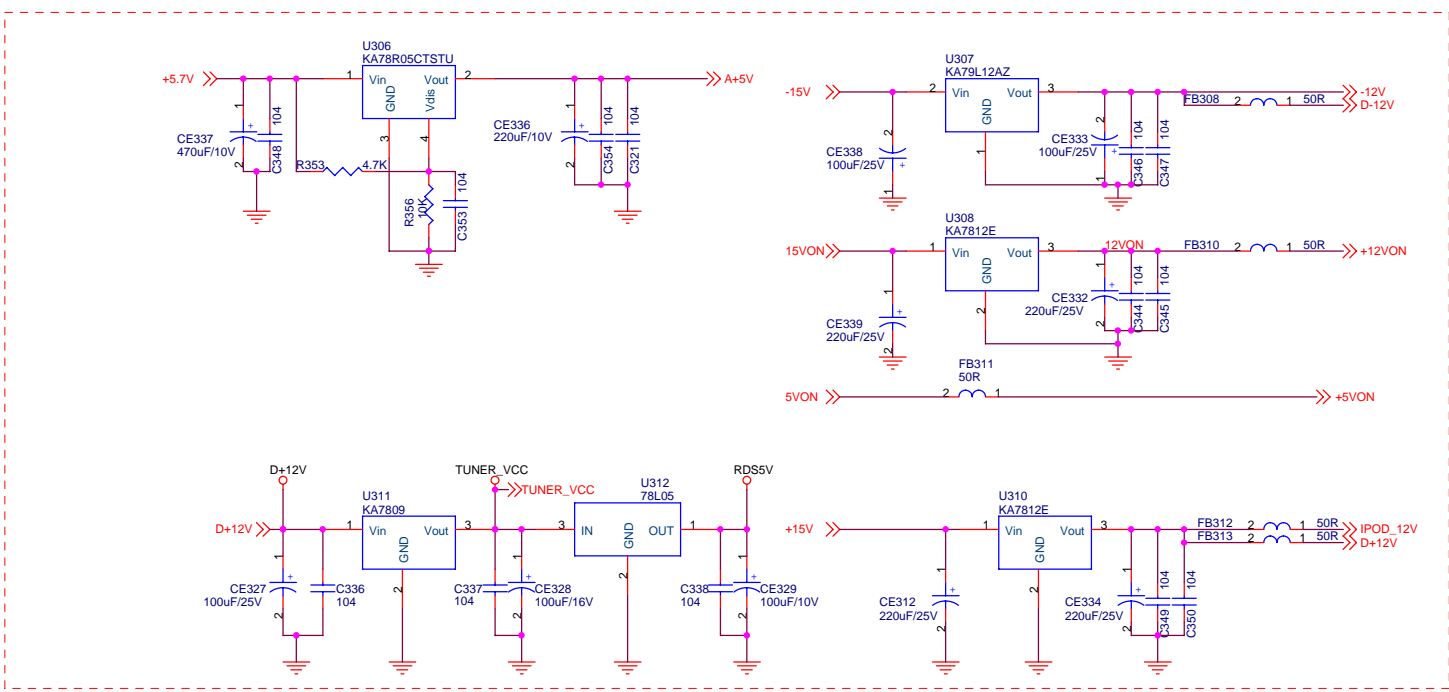
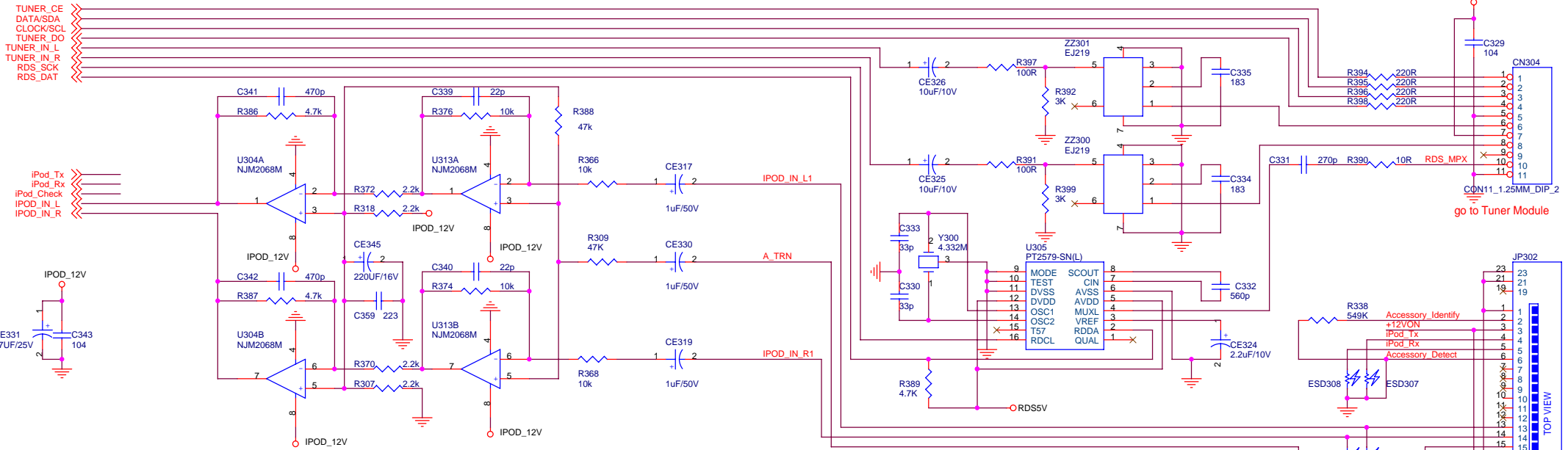

Title			Tuner and iPod Input	080402
Size	Document Number	5113C		Rev
A3			17	1.6
Date:	Wednesday, April 02, 2008	Sheet	17	of 30

harman/kardon

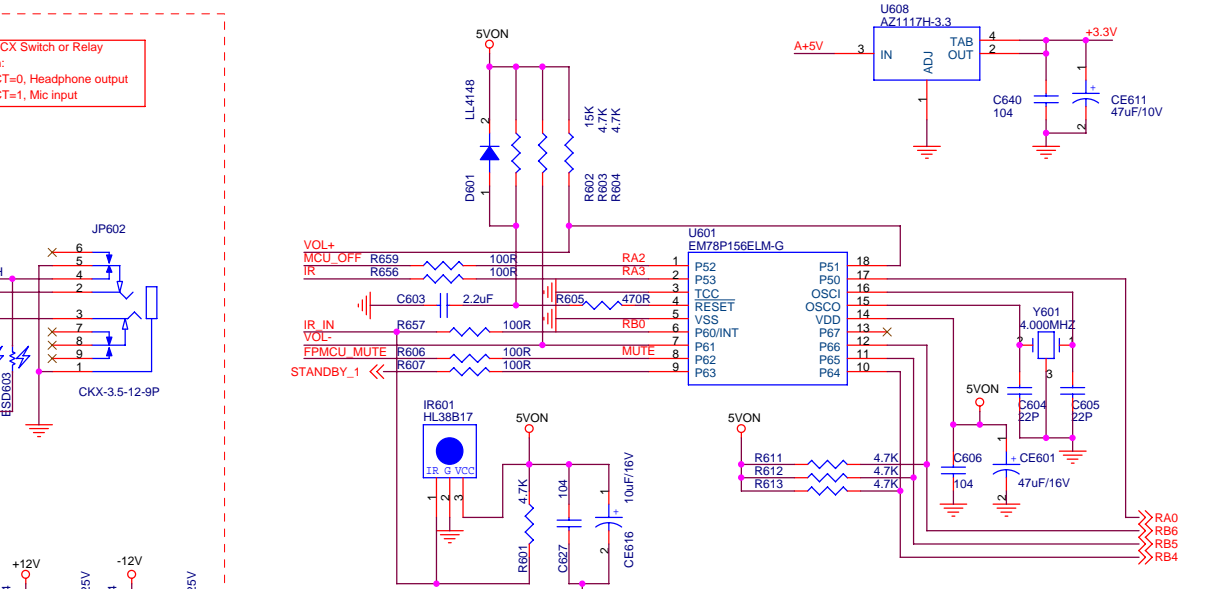
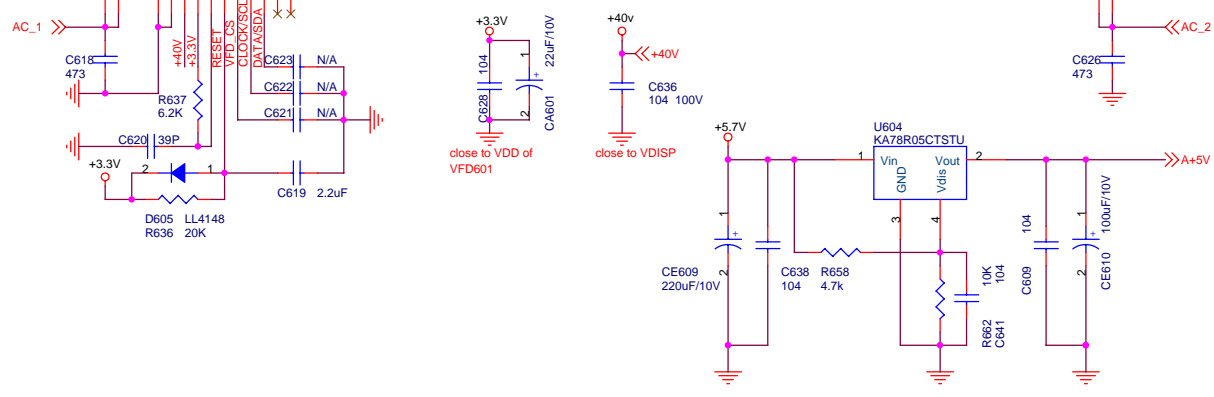
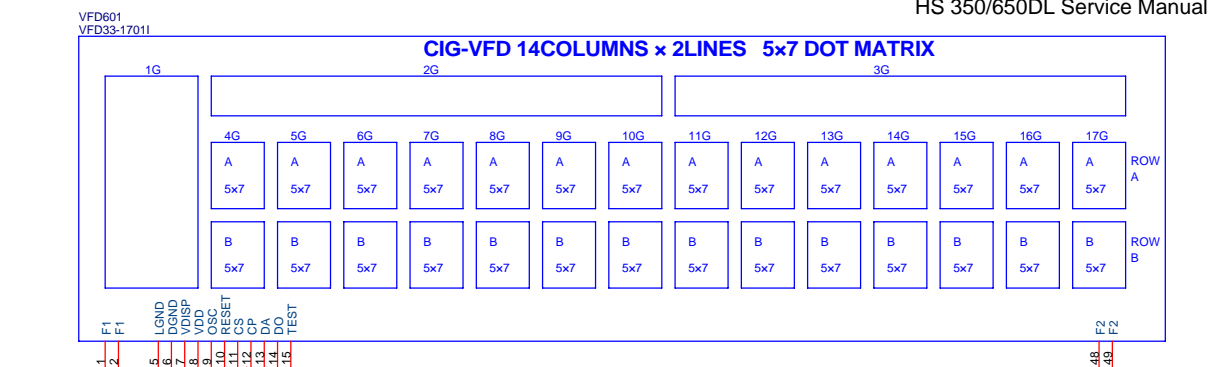
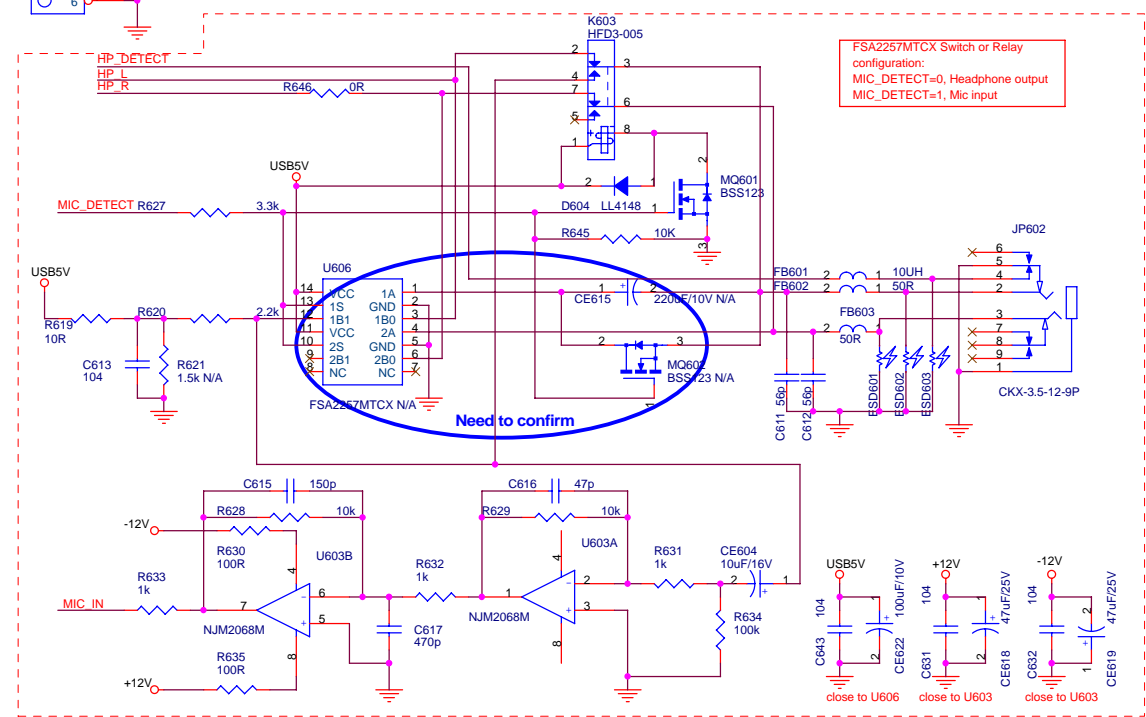
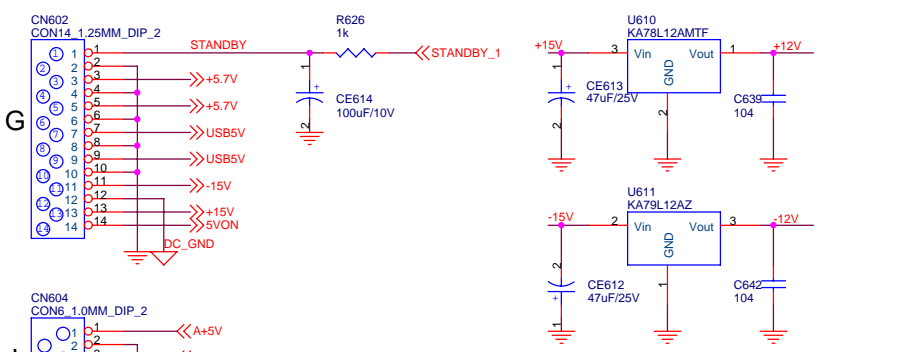
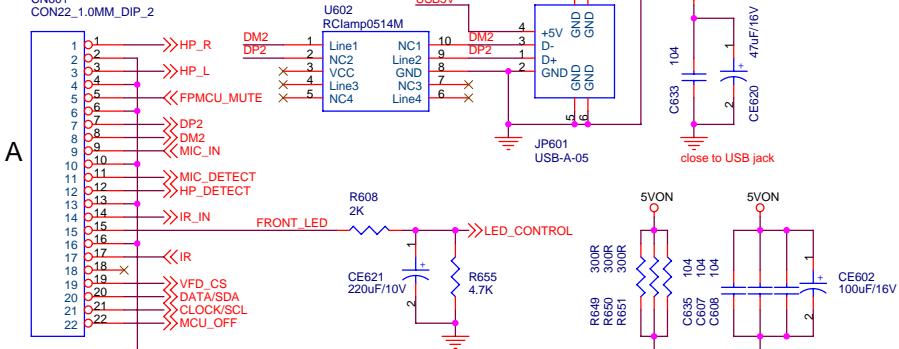

Title		VFD and MCU 080130	
Size	A3	Document Number	5115C
Date:	Thursday, January 31, 2008	Sheet	24 of 30

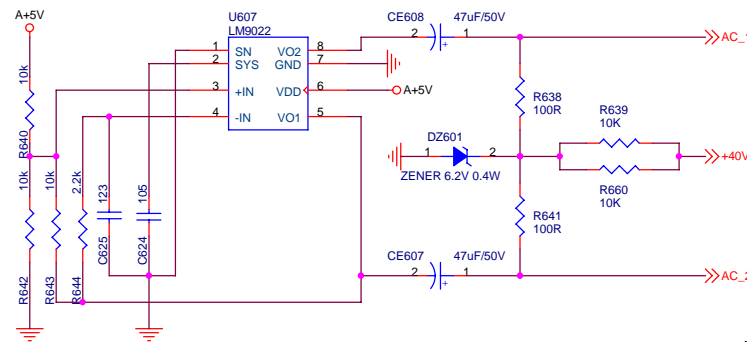
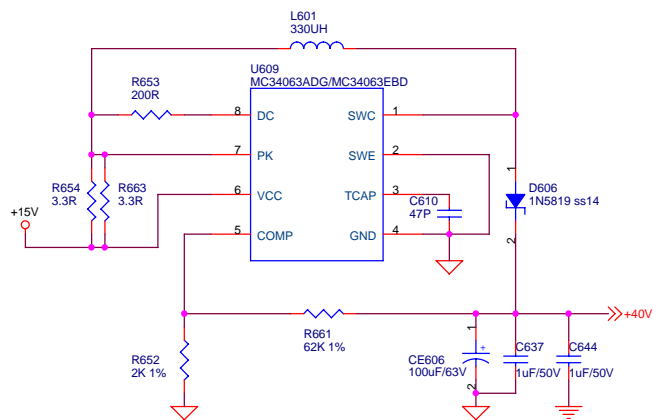
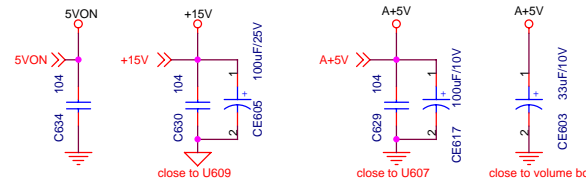
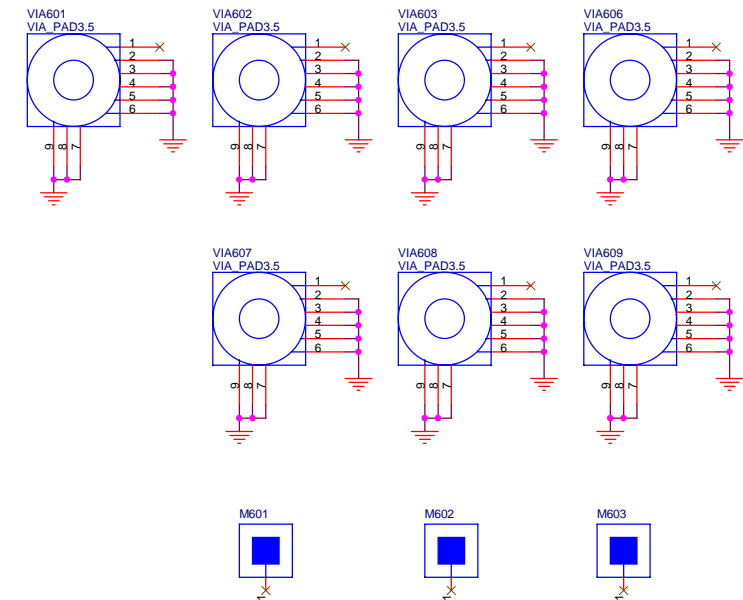
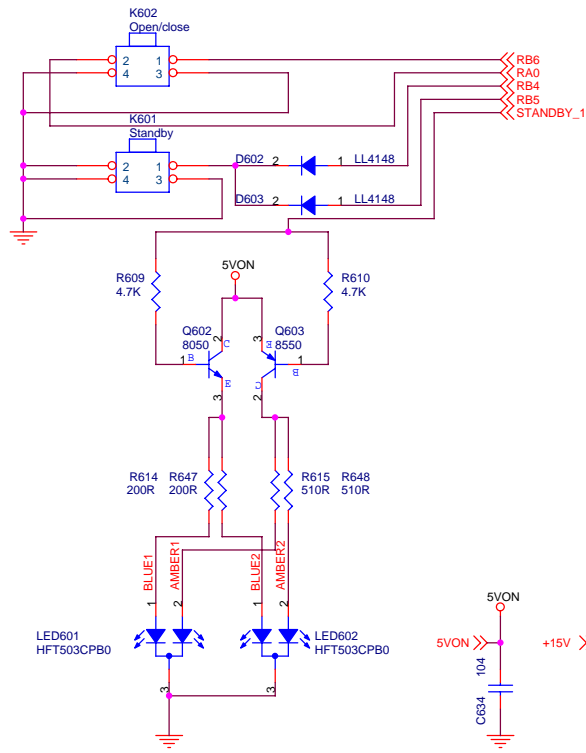

Title		Power and Button	080130
Size	Document Number	5115C	Rev 1.3
Date:	Thursday, January 31, 2008	Sheet	25 of 30

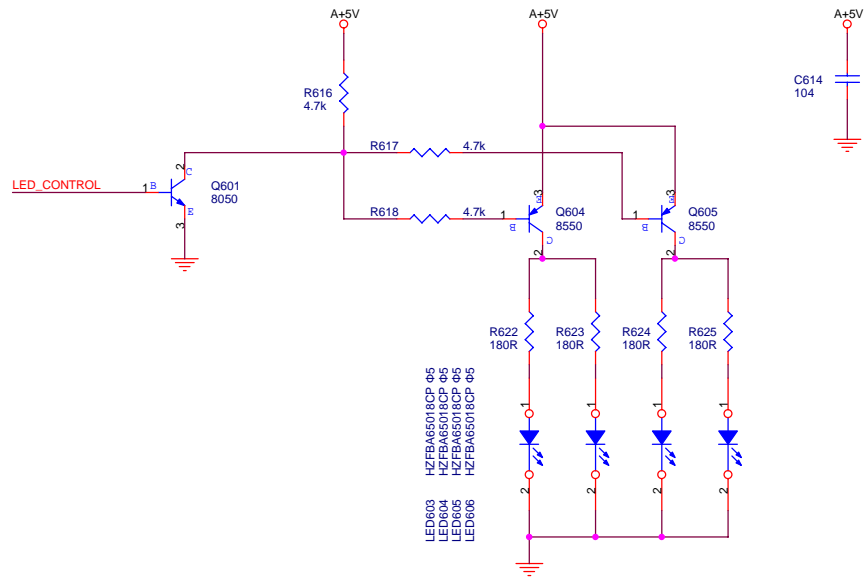
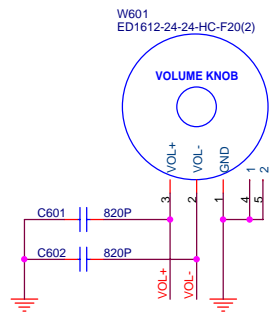
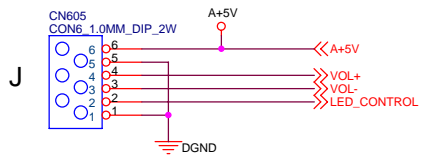

Title		
Volume Encoder 070322		
Size	Document Number	Rev
A3	5116C	1.3
Date:	Thursday, January 31, 2008	Sheet 26 of 30

harman/kardon

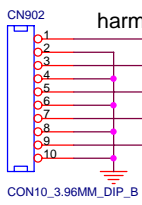

R+
SR+
C+
SL+
L+

Mute circuit for amplifier right channel

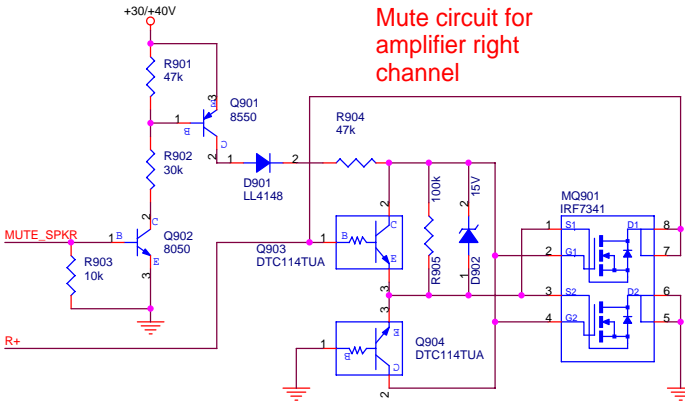

Mute circuit for amplifier right surround channel

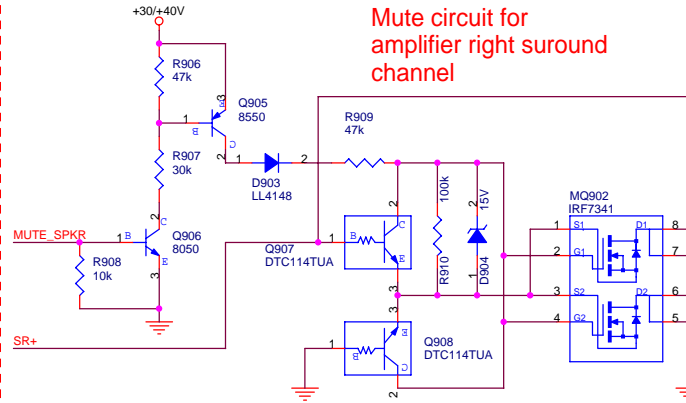

Mute circuit for amplifier left channel

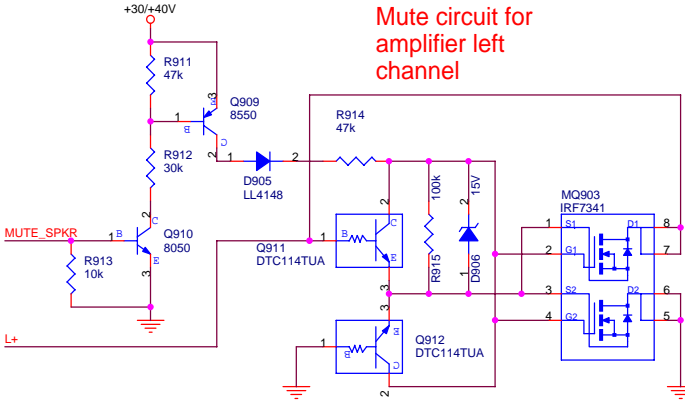

Mute circuit for amplifier left surround channel

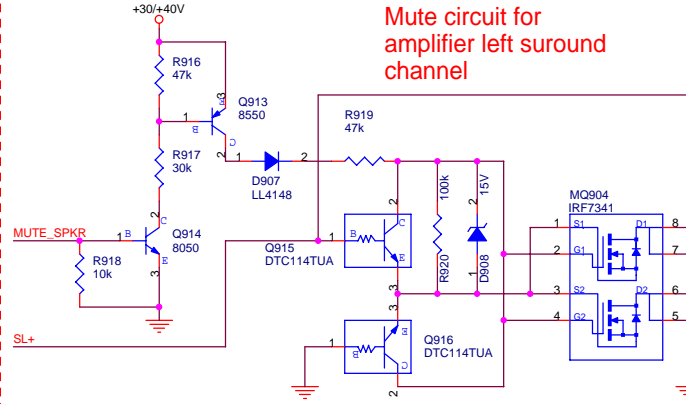

Mute circuit for amplifier center channel

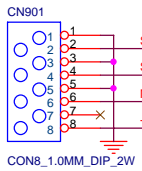
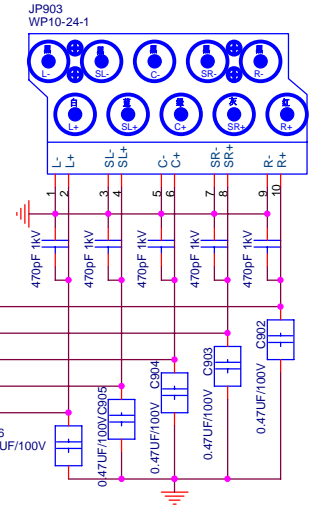
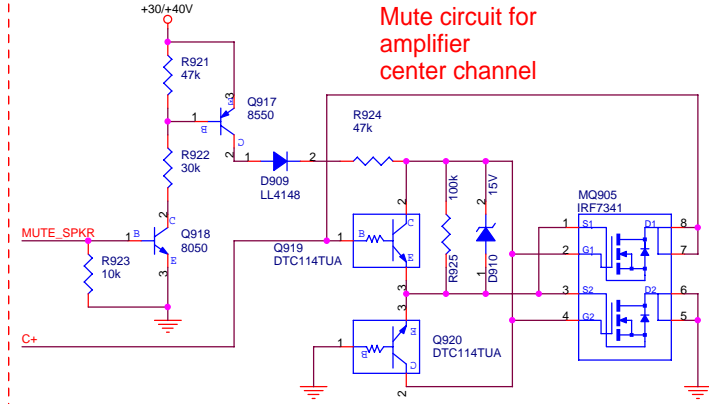

SUB_TRIGGER
SUBWOOFER
MUTE_SPKR
+30/+40V

LOCATION-PAD

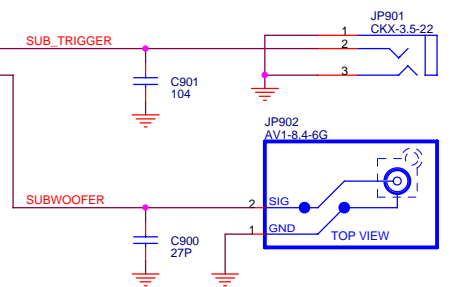
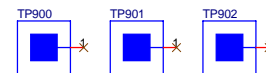

Title			HS350 HS650 Speaker Board 080131		
Size A3	Document Number	5118C		Rev	1.3
Date:	Thursday, May 08, 2008	Sheet	30	of	30

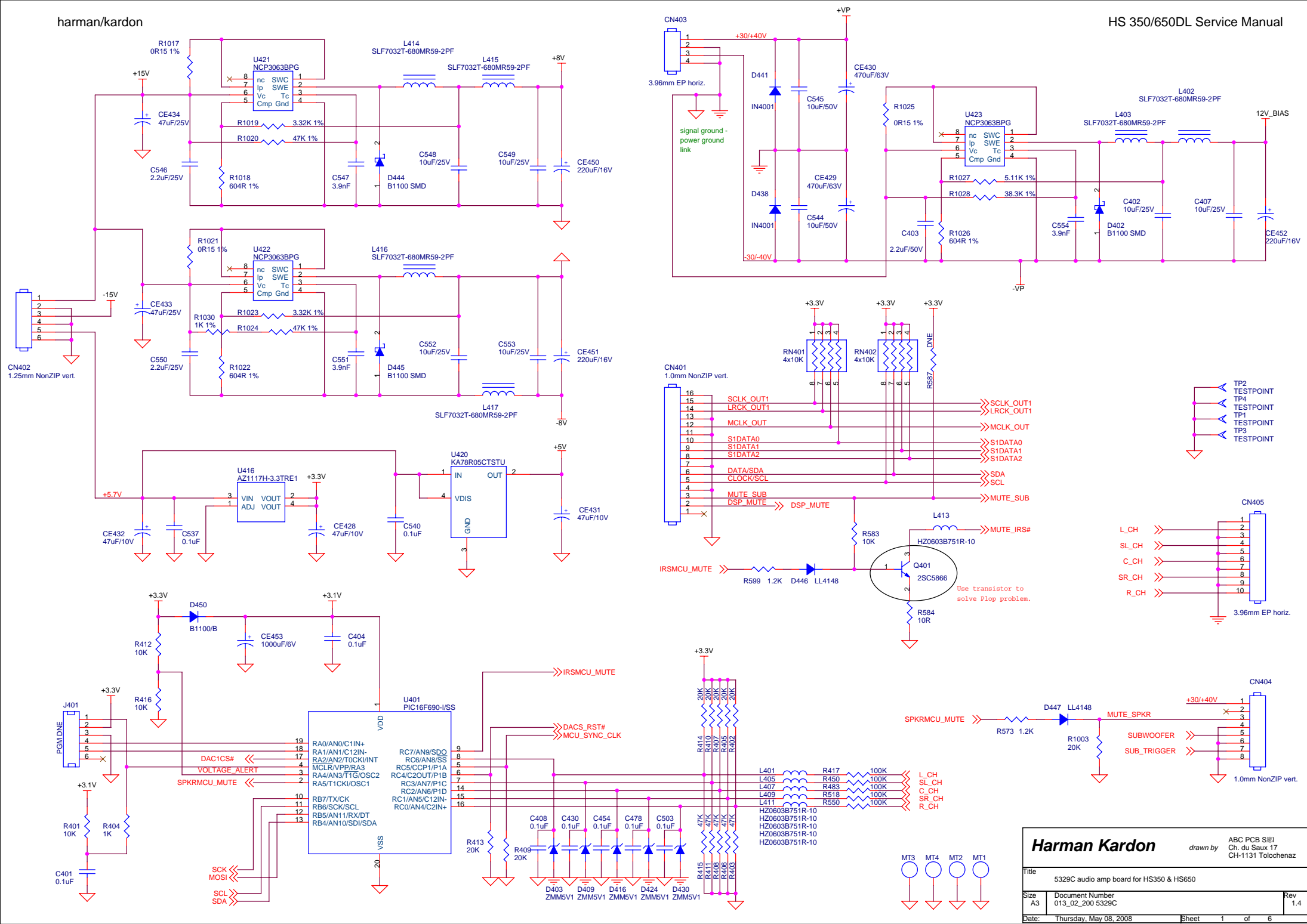

Harman Kardon		drawn by	ABC PCB SIII Ch. du Saux 17 CH-1131 Tolochenaz
Title	5329C audio amp board for HS350 & HS650		
Size	Document Number	Rev	
A3	013_02_200 5329C	1.4	
Date:	Thursday, May 08, 2008	Sheet	1 of 6

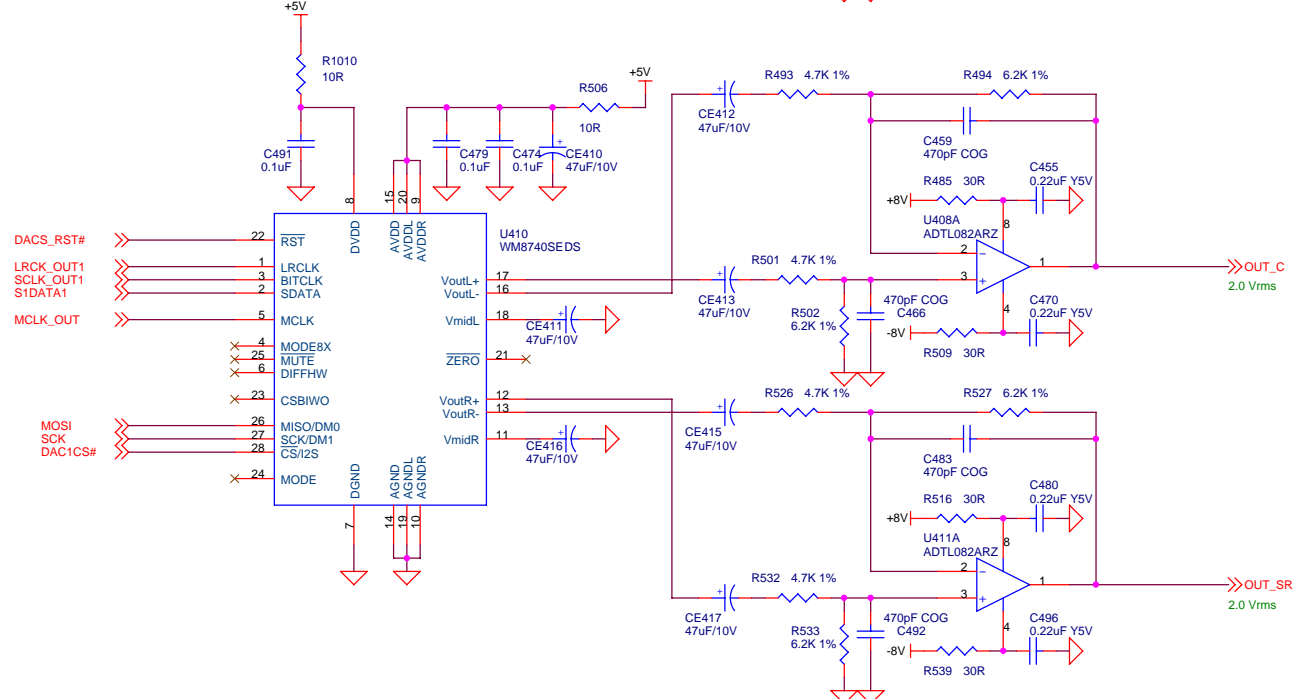
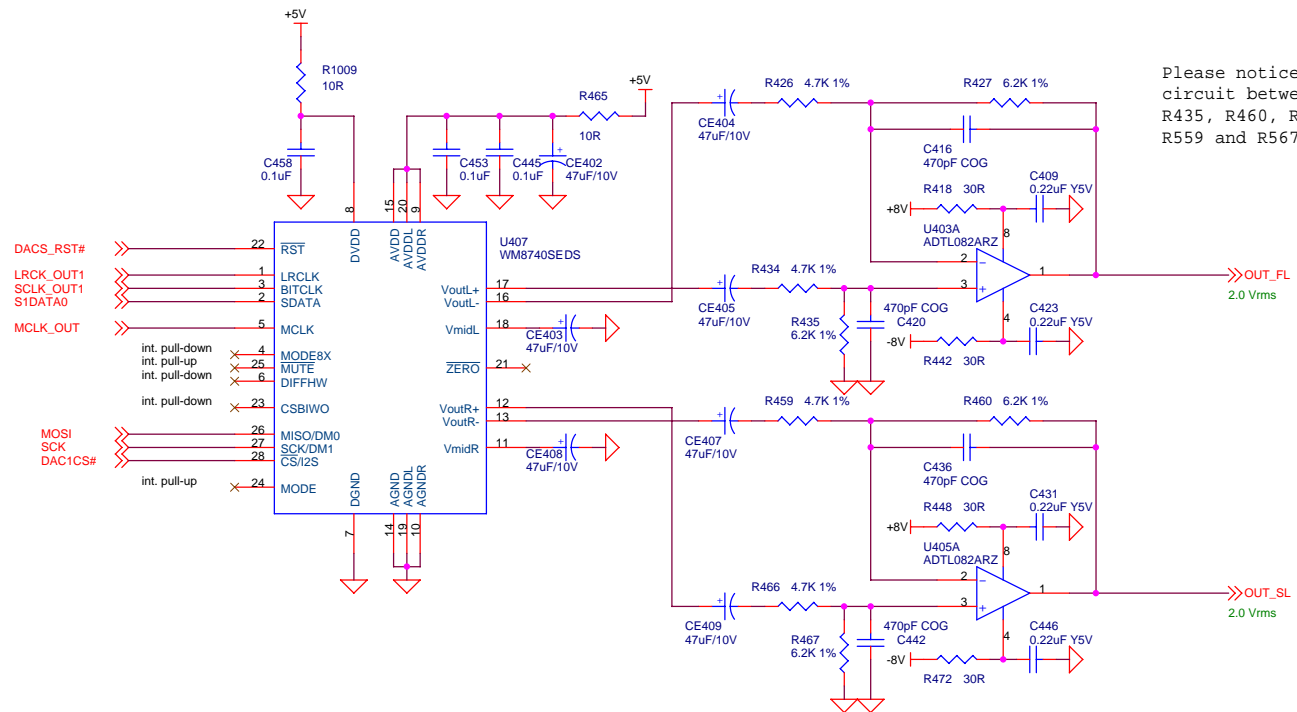

Harman Kardon		drawn by	ABC PCB SIII Ch. du Saux 17 CH-1131 Tolochenaz
Title 5329C audio amp board for HS350 & HS650			
Size A3	Document Number 013_02_200 5329C	Rev 1.4	
Date: Thursday, May 08, 2008	Sheet 2	of 6	

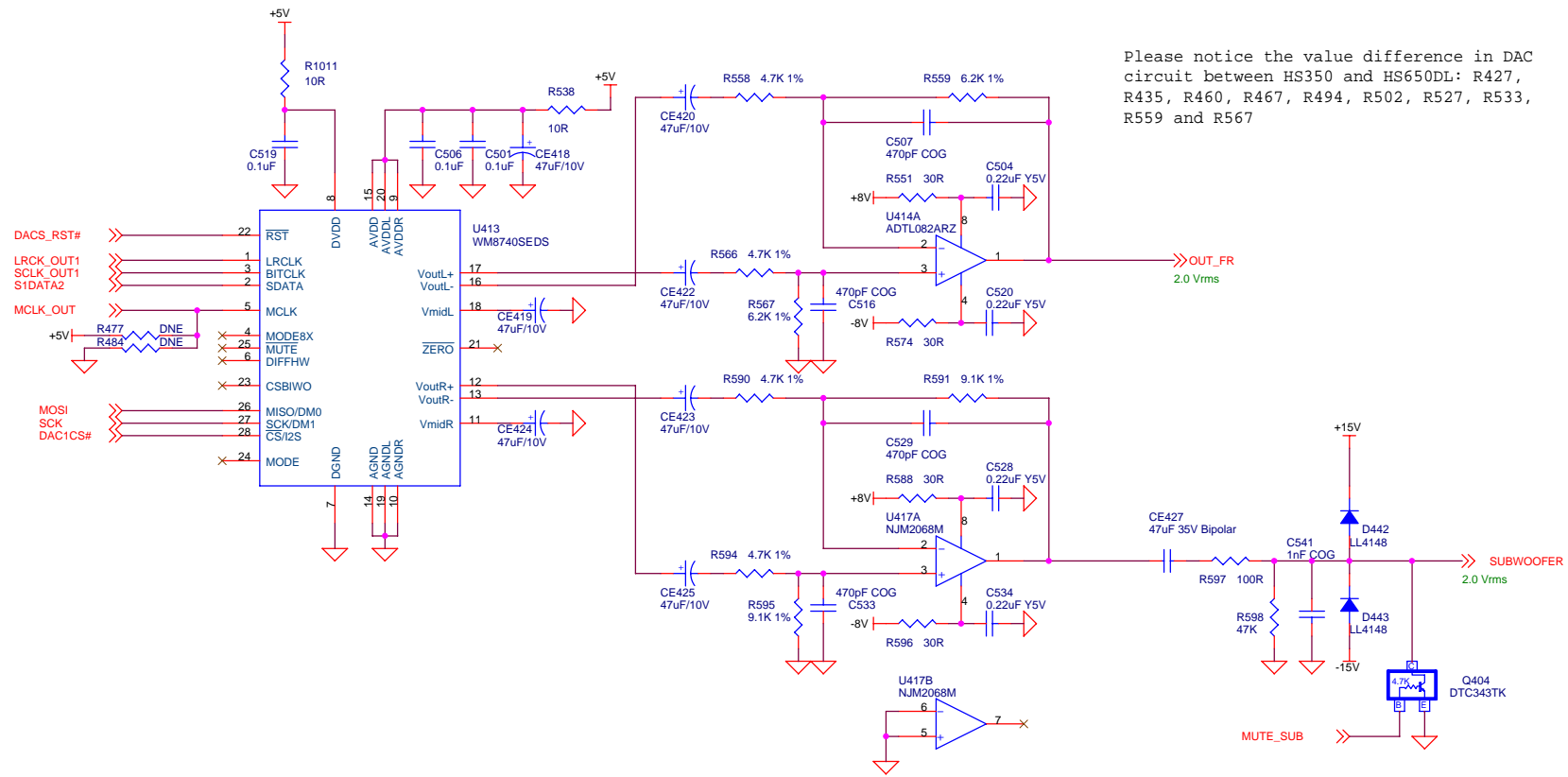

Please notice the value difference in DAC circuit between HS350 and HS650DL: R427, R435, R460, R467, R494, R502, R527, R533, R559 and R567

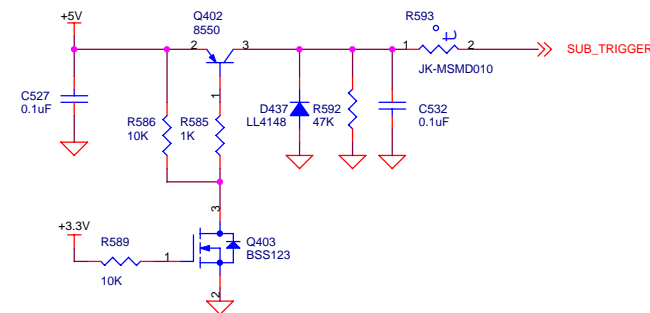

Harman Kardon		drawn by ABC PCB SIII Ch. du Saux 17 CH-1131 Tolochenaz
		Title 5329C audio amp board for HS350 & HS650
Size A3	Document Number 013_02_200 5329C	Rev 1.4
Date: Thursday, May 08, 2008	Sheet 3 of 6	

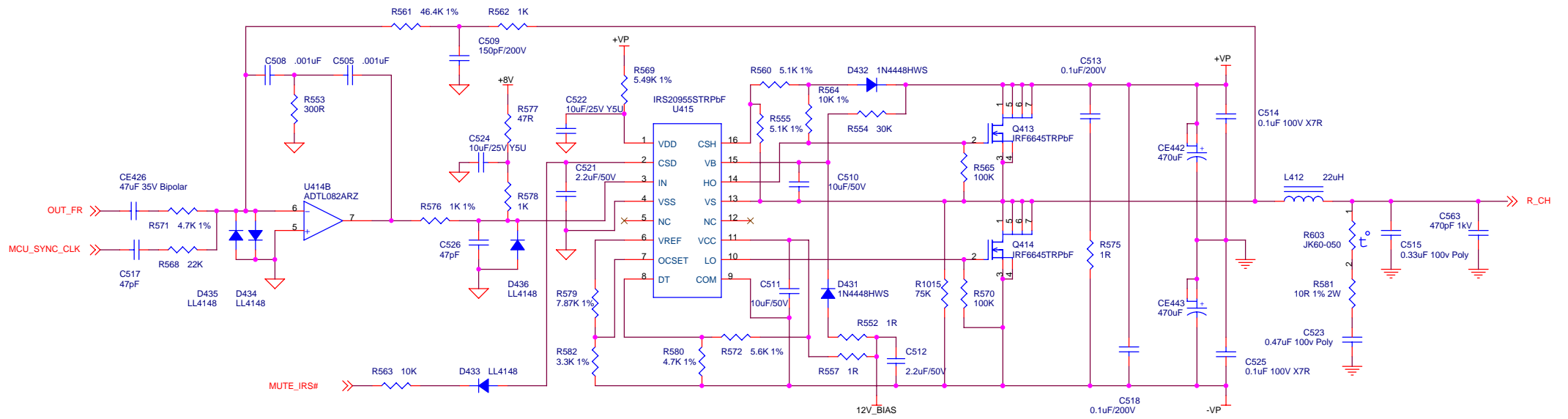
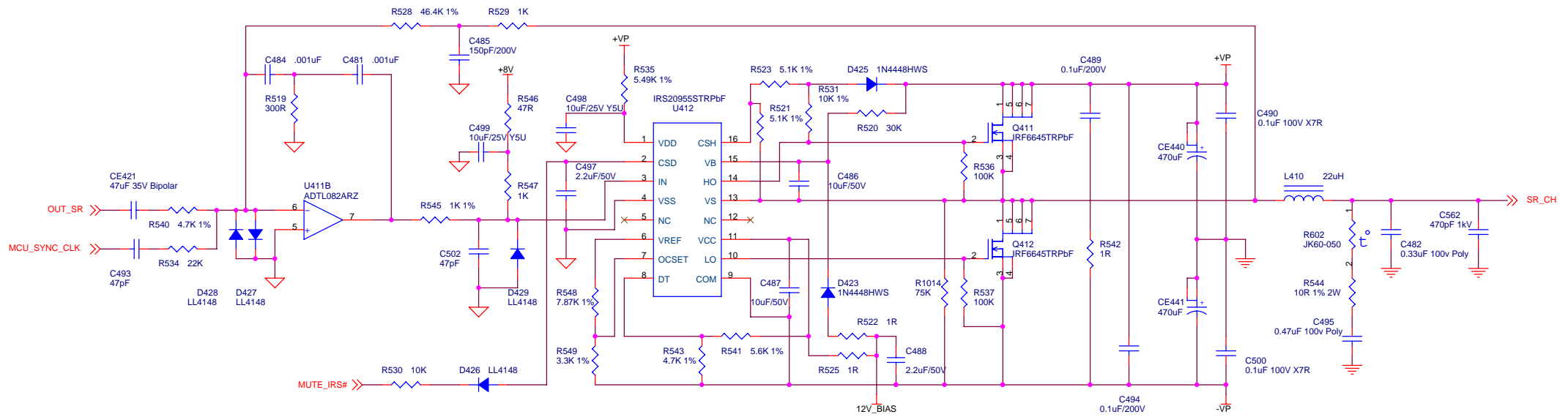

Harman Kardon		drawn by	ABC PCB SIII Ch. du Saux 17 CH-1131 Tolochenaz
Title: 5329C audio amp board for HS350 & HS650			
Size: A3	Document Number: 013_02_200 5329C	Rev: 1.4	
Date: Thursday, May 08, 2008	Sheet: 5	of 6	

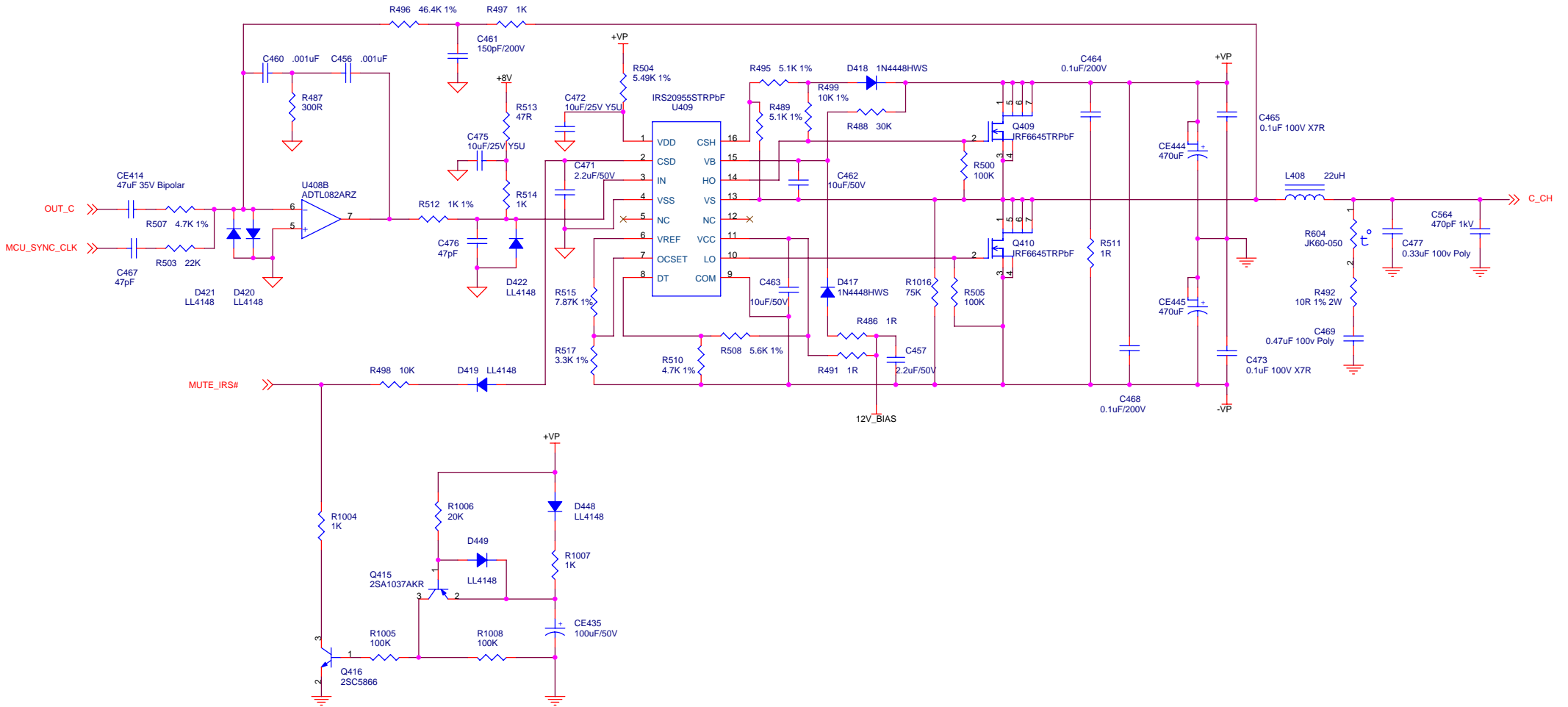

Harman Kardon		drawn by	ABC PCB SIII Ch. du Saux 17 CH-1131 Tolochenaz
Title: 5329C audio amp board for HS350 & HS650			
Size: A3	Document Number: 013_02_200 5329C	Rev: 1.4	
Date: Thursday, May 08, 2008	Sheet: 6	of 6	

