

harman/kardon
by HARMAN



MAS 101/102/111 **AMP**

Music system

Service Manual

CONTENTS

1. Specification	1
2. Packing	3
3. Front panel information	4
4. Rear panel information	5
5. Remote control information	6
6. Wiring diagrams	8
7. IC spec	9
8. Printed circuit boards	41
9. Schematic diagram	48
10. Exploded view	52
11. Electrical parts list	54

System

Power output	65 watts per channel, 20Hz – 20kHz, THD <0.07%, into 6 ohms, both channels driven
Bandwidth	20Hz – 35kHz, –3dB
System frequency response	20Hz – 20kHz, ±0.5dB
Signal-to-noise ratio, A-weighted	90dB (Analog inputs), 96dB (Digital inputs)
Channel separation	≥65dB
Crosstalk between sources	≥70dB
Line-level input sensitivity at 1kHz	250mV RMS, ±1dB
Phono MM input sensitivity at 1kHz	7.5mV

Loudspeakers

Low-frequency transducers	Two 130mm honeycomb composite drivers, ported
High-frequency transducers	Two 25mm MMD® domes, shielded
Nominal impedance	8 ohms
Sensitivity (2.83V/1m)	85dB
Frequency response	60Hz – 25kHz (–3dB)
Crossover frequency	2200Hz

FM Tuner Section

Frequency range	87 – 108.0MHz
Usable sensitivity	IHF 1.3µV/13.2dBf
Frequency response	10Hz to 15.3kHz
Signal-to-noise ratio	mono/stereo 68/65dB
Distortion	mono/stereo 0.15/0.3%
Stereo separation	35dB @ 1kHz, 100% deviation @ 65dBf
Selectivity	±300kHz; 65dBf
Image rejection	80dB
IF rejection	90dB
Tuner output level	1kHz, ±50kHz, Dev 500mV
Number of presets	30
RDS capability	PS (program service), RT (dynamic radio text)

CD Section

Disc compatibility	CD, CD-R, CD-RW, MP3, WMA
THD+N (20Hz – 20kHz)	<0.025%
Frequency response	20Hz to 20kHz, 0dB \pm 0.5
Channel separation	\geq 65dB
Signal-to-noise ratio	"A" WTG >96dB; 22kHz filter > 94dB

General

Power requirement	AC 230V/50Hz (MAS 101/MAS 111); AC 120V/60Hz (MAS 102)
Power consumption	<1W full standby (clock not activated); <2W standby (clock activated); 150W maximum (both channels driven)
Operating temperature	0°C to 40°C
Dimensions (H x W x D)	Controller: 90mm x 240mm x 240mm (3-9/16" x 9-7/16" x 9-7/16") Amplifier: 90mm x 240mm x 240mm (3-9/16" x 9-7/16" x 9-7/16") Loudspeakers (each, with grille): 272mm x 181mm x 196mm (10-23/32" x 7-1/8" x 7-3/4")
Weight	System 13.9kg (30,5lb) Controller 2.0kg (4,4lb) Amplifier 2.8kg (6,3lb) Loudspeakers (each): 4.4kg (9,8lb)



1. Instruction manual ass'y - Accessories

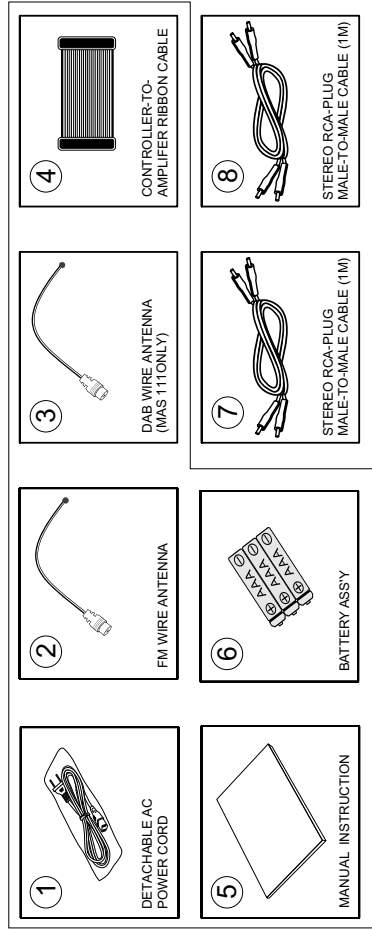

NO	DESCRIPTION	PARTS NO.	Qty
1	DETACHABLE AC POWER CORD	3701 1011 0839	1
2	FM WIRE ANTENNA	3813 0015 0330	1
3	DAB WIRE ANTENNA (MAS 111 ONLY)	3810 0030 0011	1
4	CONTROLLER-TO-AMPLIFIER RIBBON CABLE	3320 0805 0352	1
5	MANUAL INSTRUCTION	8524 5053 3100	1
6	BATTERY ASS'Y	3006 2002 0000	3
7	STEREO RCA-PLUG MALE-TO-MALE CABLE (1M)	3820 0002 1106	1
8	STEREO RCA-PLUG MALE-TO-MALE CABLE (1M)	3820 0002 1106	1

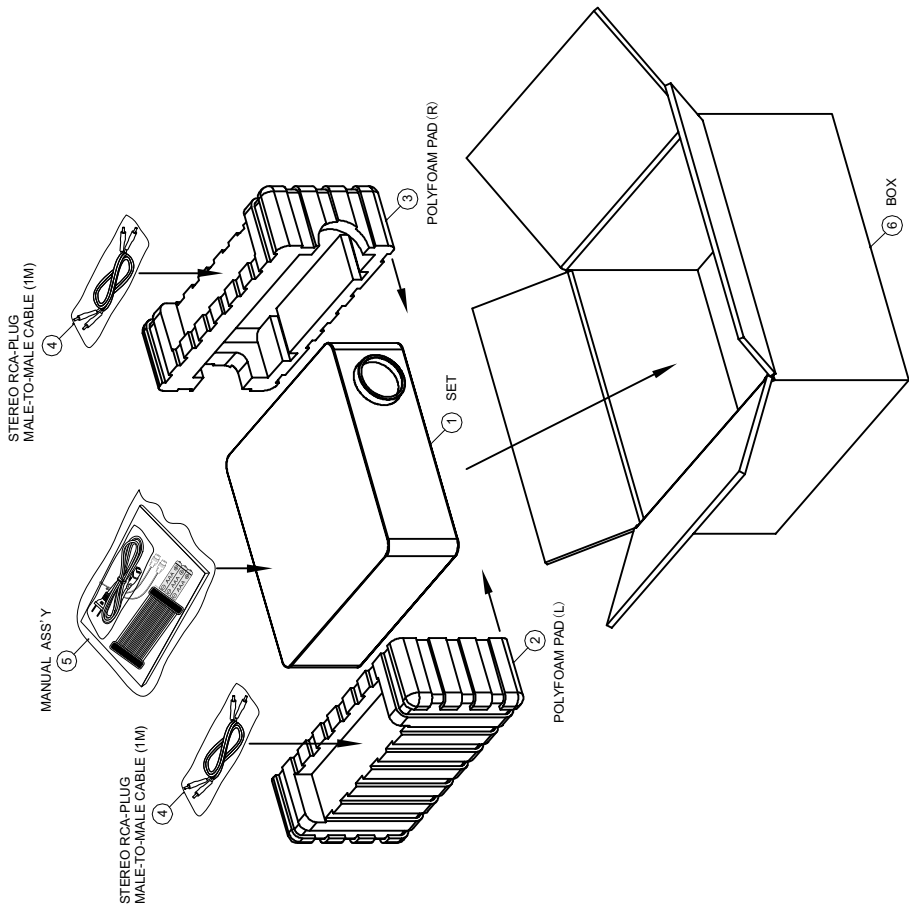

NO	DESCRIPTION	PARTS NO.	Qty
1	SET		1
2	POLYFOAM PAD (L)	8250 5013 0000	1
3	POLYFOAM PAD (R)	8250 5023 0000	1
4	STEREO RCA-PLUG MALE-TO-MALE CABLE (1M)	3320 0805 0352	2
5	MANUAL ASS'Y		1
6	BOX	8150 5011 0000	1

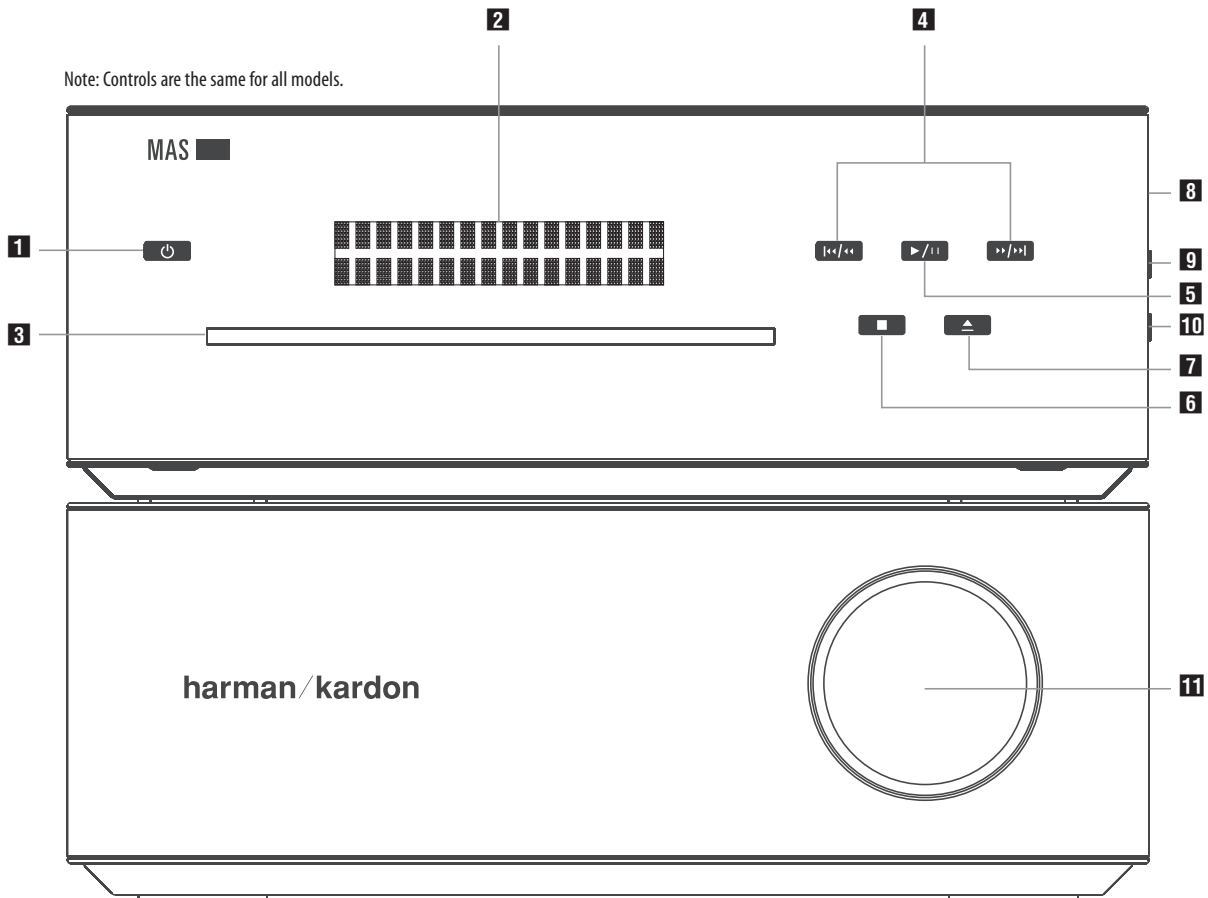

The MAS systems use touch-sensitive controls. To use a control, tap gently on its lit icon.

NOTE: Controls are the same for all models.

- 1 Power:** Turns the MAS system on or places it in Standby mode. To completely power off the unit, unplug the power supply.
- 2 Message Display:** The time and messages are displayed in this two-line text display.
- 3 CD Slot:** Load compatible discs here.
- 4 Skip/Scan Forward/Reverse:** These buttons function differently, depending on the current source:
 - **iPod, CD or USB:** Press and release to skip to the next track. Press the Reverse button twice to skip to the previous track. Press and hold a button to scan forward or reverse within a track.
 - **Radio:** Press and release a button to select the next higher or lower programmed preset station. Press and hold a button to scan to the next available higher or lower station. When you release the button, the tuner continues to scan until it finds a station of acceptably strong signal quality, and then it stops. To stop the scan before a station is found, press the button while the tuner is scanning.
- 5 Play/Pause:** Each tap toggles between the Play and Pause functions.
- 6 Stop:** Fully stops playback.
- 7 Eject:** When a CD is loaded, tap here to eject it.

- 8 USB Port A:** Connect a compatible USB device here to enjoy playback of audio MP3 or WMA files. Although most USB flash and hard-disk drives in the FAT32 file format, as well as many MP3 players, are compatible with the MAS system, due to the wide variety of manufacturers, playback cannot be guaranteed. Do not connect an iPod or iPhone to this port. Do not connect a personal computer or any peripherals to this port.
- 9 Line-In Jack (Line Input):** Connect a stereo 3.5mm male-to-male cable (not included) to the headphone or line-level output on a portable player or other device.
- 10 Headphone Jack:** Outputs a stereo signal for private listening through most headphones that are equipped with a stereo 3.5mm plug.
- 11 Volume Control:** Increases or decreases the volume.

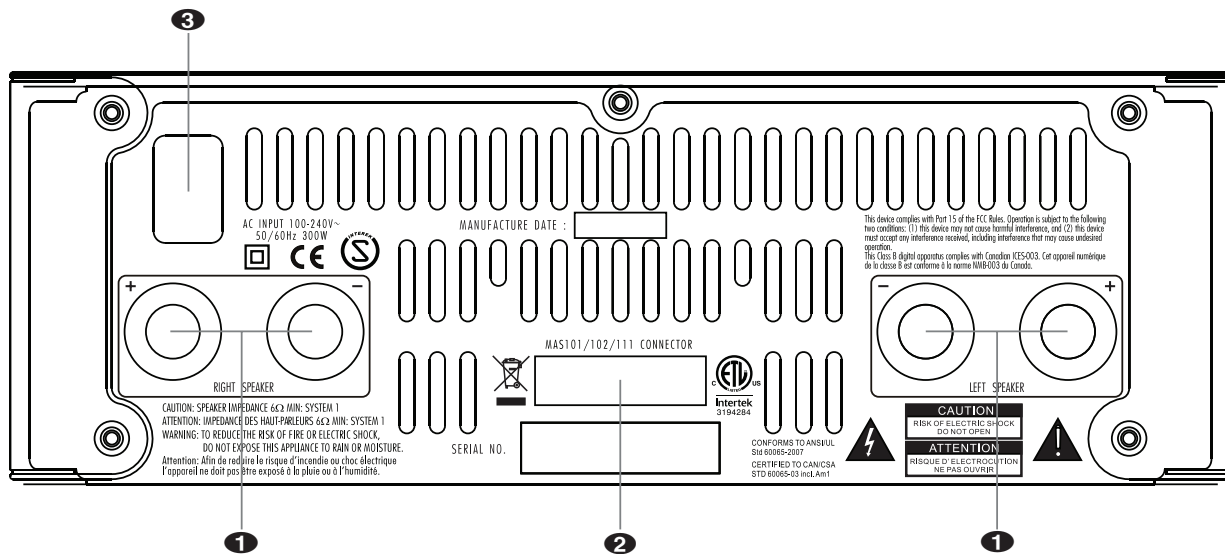

- 1 Right and Left Speaker Output Terminals:** Use two-conductor speaker wire to connect each set of terminals to the correct speaker. Remember to observe the correct polarity (positive and negative connections).
- 2 Input From Controller:** Connect the included ribbon cable to this connector and to the corresponding connector on the MAS controller. This cable passes audio signals from the controller to the amplifier, and it transfers DC power from the amplifier to the controller. If this cable is ever damaged, do not use it, and contact Harman Kardon for a replacement.
- 3 AC Power Input:** After you have made all other connections, plug the AC power cord into this receptacle and into an unswitched wall outlet.

NOTE: MAS 101/111 systems require 230V, 50/60Hz AC current. MAS 102 systems require 120V, 60HZ AC current.

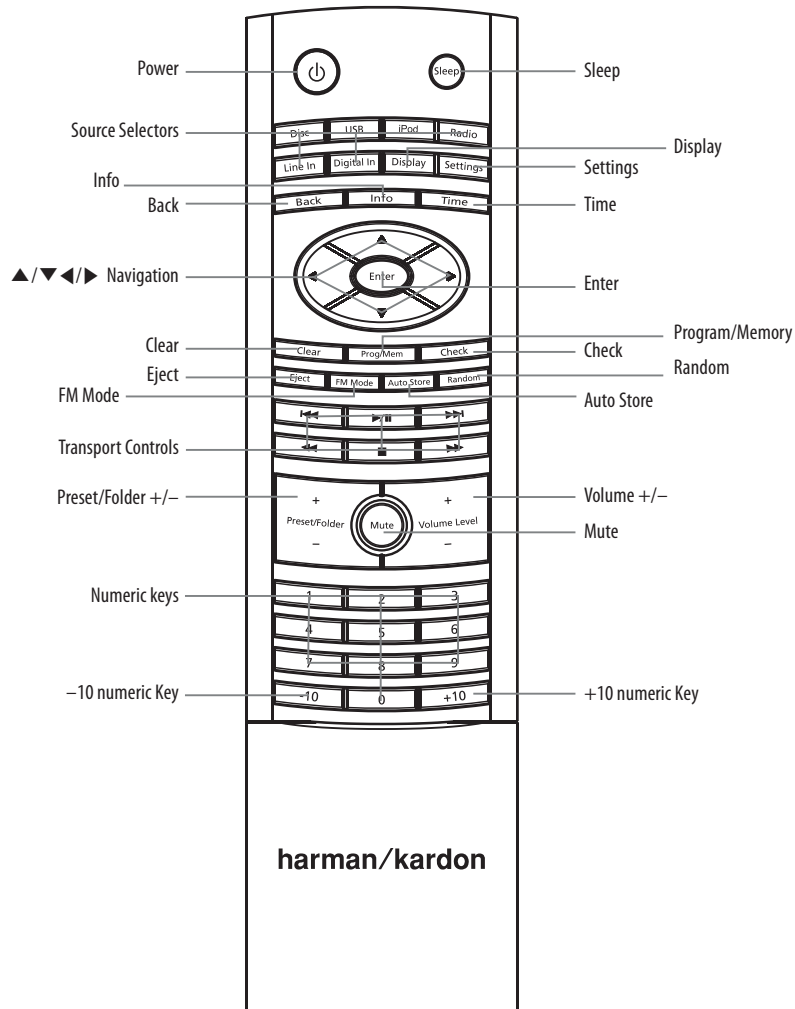

Power: Turns the MAS system on or off. To completely power off the unit, unplug the power supply.

Sleep: Each press increases the time until turn-off, from 10 to 90 minutes, in increments of 10 minutes. The next press after the 90 minutes setting turns off the Sleep function.

Source Selectors: Selects a source input. Each press of the Line In or Digital In button toggles among the available analog (Line Input on right-side panel; TV, AUX or Phono Input on rear panel) or digital audio inputs (Coaxial 1 or 2, Optical 1 or 2), respectively. Press the iPod button to select an iPod docked in The Bridge III.

Display: Adjusts the brightness of the message display. Each time the button is pressed and held for one second, the message display brightness will cycle between full, half and off. When the display is off while the system is turned on, the LEDs inside the Volume knob and behind the front-panel function buttons will remain lit to remind you that the system is still on.

Settings: Accesses menus for Speaker Setup (tone controls), Time Setup (clock), Alarm Setup, System Version and System Reset. See the Operation section for more information.

Back: Returns to previous menu level.

Info: Displays the status of the current source:

- **Radio:** When FM band is in use, each press of the button toggles between the PS (Program Service) and RT (Radio Text) RDS information, if available. When a DAB radio station is playing (MAS 111 only), press this button to access the menu system for the DAB tuner. See pages 13 and 14 for more information.

- **Audio CD:** Displays CD Text information, if available. Each press of the button displays the following items: Song, Artist, Album.

- **USB or Data CD:** Scrolls all ID3 tag information for current source, if available. Each press of the button displays the individual items Song, Artist, Album, File type and Folder, and then goes back to scrolling. If ID3 tags are not available, the file name will appear.

Time: Displays elapsed track time for the current Audio CD (no effect on data CDs or other sources). Each additional press changes the display as follows: remaining track time, elapsed disc time, remaining disc time then back to elapsed track time.

▲/▼◀▶ Navigation buttons: Use the ◀ and ▶ buttons to scroll forward and reverse through the Settings Menus, or through lists of content, and press the Enter button to make selections. Press the Back button to return to the previous menu or content level.

Enter: Selects a menu item, or saves setting changes and returns to the previous menu level.

Clear: Clears the current preset station or a playlist entry.

- **Radio:** To delete the current preset station, press the Clear button while it is playing.
- **Playlist:** While programming a playlist, press the Clear button to delete the track just entered. After the playlist has been saved by pressing the Stop button, press the Clear button to delete the entire playlist. To delete a single track, stop play, press the Check button repeatedly until the desired track appears and press the Clear button. Press the Play or Stop button to exit the Check mode.

Program/Memory: Used to program playlists and radio presets.

- **Radio:** If the current station has not been programmed into a preset, press Program/Memory and press the Enter button to store the station at the current preset number, or use the numeric keys to enter a different preset number. The new preset will overwrite the existing one.
- **USB or CD (Audio or Data):** Press the Program button to begin Program Mode. Add tracks to the playlist by using the Skip/Scan Transport Controls or the numeric keys to select the track, then press the Program button to enter the selection. Add up to 30 files. Press Play to play the playlist, or Stop to save the playlist without playing it. During playback, the order of the track in the playlist will appear on the left, with the disc's track number to the right. See page 14 and 15.

Check: After a playlist has been programmed and play has been stopped, each press of the Check button displays the tracks in the playlist.

Eject: When a CD is loaded, press this button to eject it.

FM Mode: Used with FM radio, each press toggles between Stereo and Monaural playback.

Auto Store: Scans through all frequencies, searching for stations with acceptably strong signal quality, and stores them as presets.

Random: Each press turns Random playback mode (shuffle) on or off. This mode plays the tracks of the current disc or drive in random order.

Transport Controls

Track Skip Up/Down (iPod, CD or USB): Press and release the Next/Previous skip buttons to skip to the next track, or the beginning of the current track. Press the Previous Skip button twice to skip to the previous track.

Scan Forward/Reverse: These buttons function differently, depending on which source has been selected:

- **iPod, CD or USB:** Press and hold a button to scan forward or reverse within a track.
- **Radio:** Press and release a button to tune to the next higher or lower frequency by one increment/decrement. Press and hold a button to scan quickly through the frequencies for next available station. Press the same button again to stop scanning.

Play/Pause: Each tap toggles between the Play and Pause functions.

Stop: Fully stops playback.

Preset/Folder +/-: Selects a preset station or folder on a USB or data CD.

- **Radio:** Each press changes to the next or previous preset station, if any have been programmed.
- **USB or Data CD:** Press once to open the current folder. Each additional press changes to the next or previous folder. After 3 seconds, the first track in the new folder will begin playing.

Mute: Press to temporarily silence the speakers. Press again to restore audio. Muting is also canceled if the MAS system is turned off.

NOTE: Pressing the Mute button also mutes the Analog Audio Outputs. See page 6.

Volume +/-: Increases or decreases the volume. Press and hold to change the volume more quickly.

Numeric keys: Used to enter track numbers, radio stations or preset numbers, or while adjusting the clock and alarm times.

-10 and +10 numeric Key: Used with a USB device or CD to quickly advance through a large number of tracks. Each press of these keys changes to the next or previous track in increments of 10.

WIRING DIAGRAM

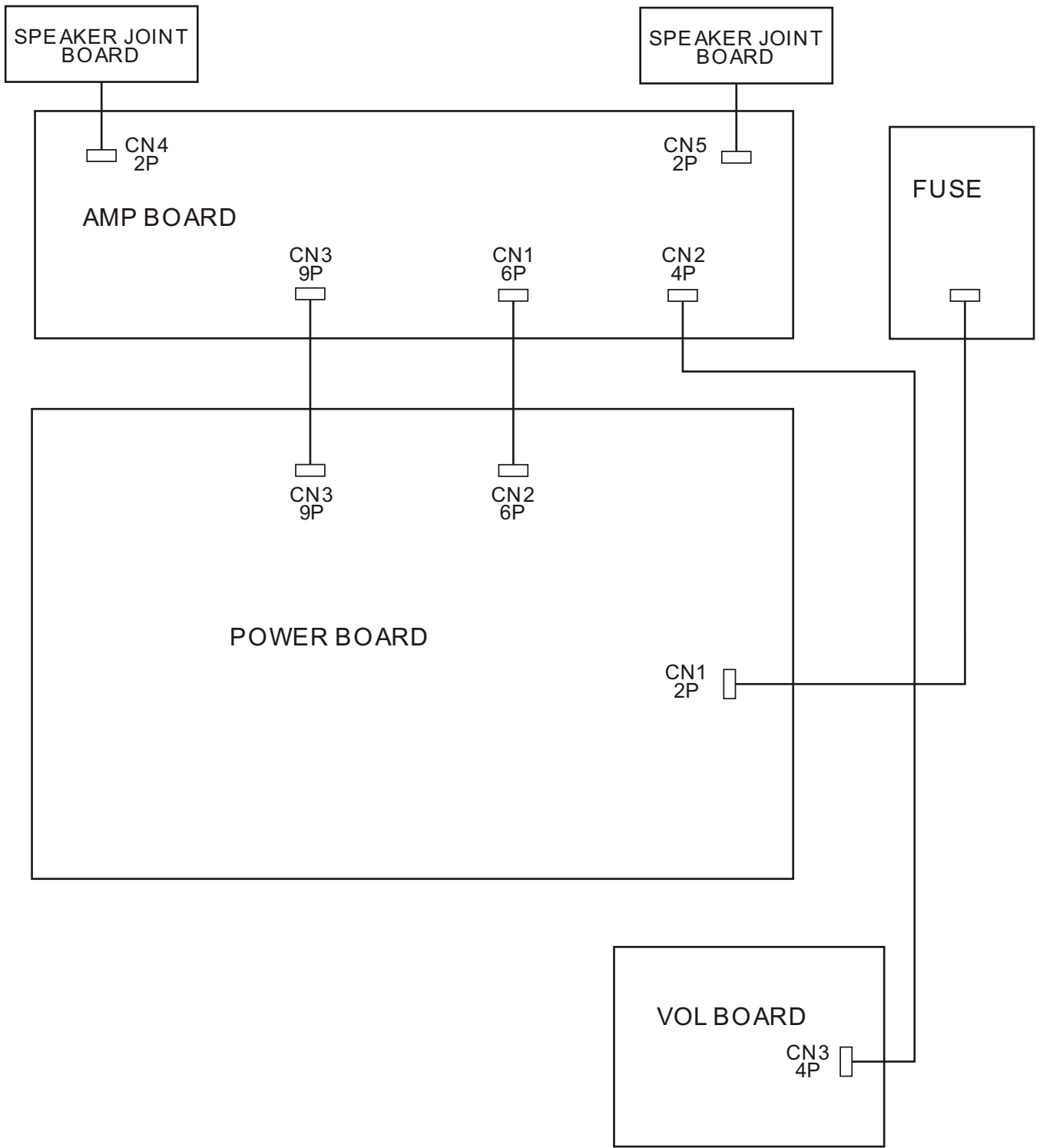

Features

- Low On-Resistance
 - 14mΩ @ V_{GS} = -10V
 - 25mΩ @ V_{GS} = -4.5V
- Low Gate Threshold Voltage
- Low Input Capacitance
- Fast Switching Speed
- Low Input/Output Leakage
- **Lead Free By Design/RoHS Compliant (Note 2)**
- **"Green" Device (Note 4)**
- **Qualified to AEC-Q101 Standards for High Reliability**

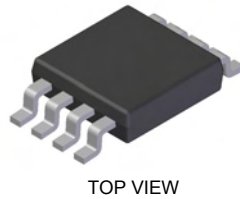

SOP-8L

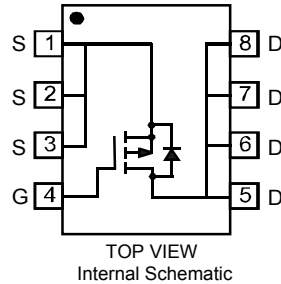

Mechanical Data

- Case: SOP-8L
- Case Material: Molded Plastic, "Green" Molding Compound. UL Flammability Classification Rating 94V-0
- Moisture Sensitivity: Level 1 per J-STD-020D
- Terminals Connections: See Diagram
- Terminals: Finish - Matte Tin annealed over Copper lead frame. Solderable per MIL-STD-202, Method 208
- Marking Information: See Page 3
- Ordering Information: See Page 3
- Weight: 0.072g (approximate)

Maximum Ratings @T_A = 25°C unless otherwise specified

Characteristic	Symbol	Value	Units
Drain-Source Voltage	V _{DSS}	-30	V
Gate-Source Voltage	V _{GSS}	±20	V
Drain Current (Note 1)	I _D	-12 -6	A
		Steady State T _A = 25°C T _A = 70°C	
Pulsed Drain Current (Note 3)	I _{DM}	-40	A

Thermal Characteristics

Characteristic	Symbol	Value	Unit
Total Power Dissipation (Note 1)	P _D	2.5	W
Thermal Resistance, Junction to Ambient	R _{θJA}	50	°C/W
Operating and Storage Temperature Range	T _J , T _{STG}	-55 to +150	°C

Electrical Characteristics @T_A = 25°C unless otherwise specified

Characteristic	Symbol	Min	Typ	Max	Unit	Test Condition
OFF CHARACTERISTICS (Note 5)						
Drain-Source Breakdown Voltage	BV _{DSS}	-30	—	—	V	V _{GS} = 0V, I _D = -250μA
Zero Gate Voltage Drain Current	I _{DSS}	—	—	-1	μA	V _{DS} = -30V, V _{GS} = 0V
Gate-Source Leakage	I _{GSS}	—	—	±100	nA	V _{GS} = ±20V, V _{DS} = 0V
ON CHARACTERISTICS (Note 5)						
Gate Threshold Voltage	V _{GS(th)}	-1	—	-2	V	V _{DS} = V _{GS} , I _D = -250μA
Static Drain-Source On-Resistance	R _{DS(ON)}	—	11.6 18.6	14 25	mΩ	V _{GS} = -10V, I _D = -8A V _{GS} = -4.5V, I _D = -5A
Forward Transconductance	g _{fs}	—	12	—	S	V _{DS} = -10V, I _D = -12A
Diode Forward Voltage (Note 5)	V _{SD}	-0.5	—	-1.1	V	V _{GS} = 0V, I _S = -2A
DYNAMIC CHARACTERISTICS						
Input Capacitance	C _{iss}	—	1655	—	pF	V _{DS} = -20V, V _{GS} = 0V f = 1.0MHz
Output Capacitance	C _{oss}	—	286	—	pF	
Reverse Transfer Capacitance	C _{rss}	—	240	—	pF	

- Notes:
1. Device mounted on 2 oz. Copper pads on FR-4 PCB with R_{θJA} = 50°C/W.
 2. No purposefully added lead.
 3. Pulse width ≤ 10μS, Duty Cycle ≤ 1%.
 4. Diodes Inc.'s "Green" policy can be found on our website at http://www.diodes.com/products/lead_free/index.php.
 5. Short duration pulse test used to minimize self-heating effect.

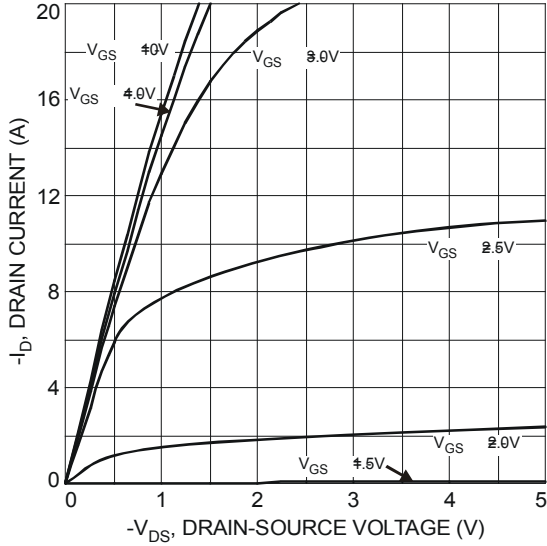

Fig. 1 Typical Output Characteristic

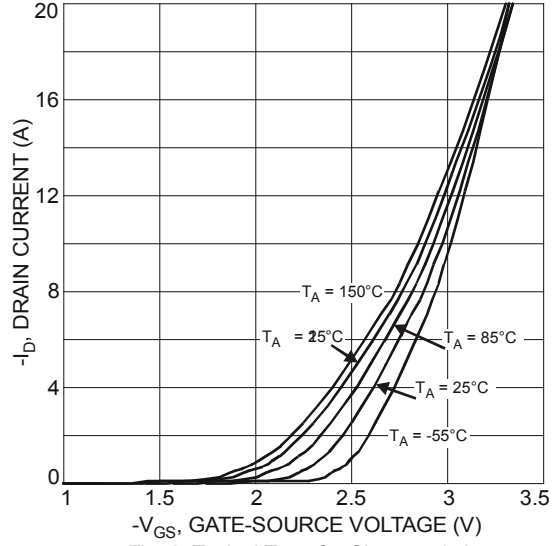

Fig. 2 Typical Transfer Characteristic

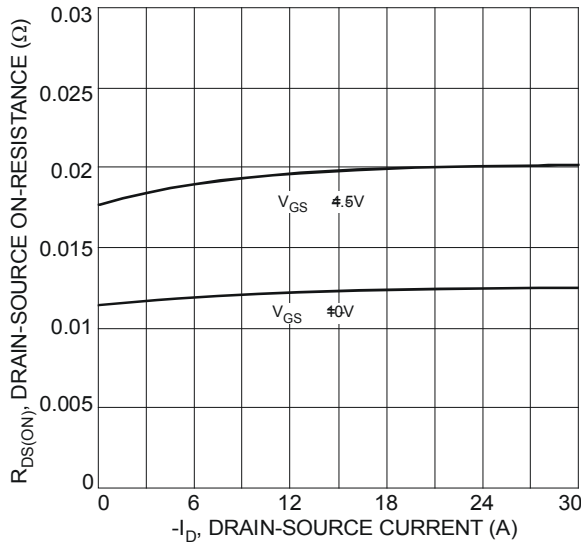

Fig. 3 Typical On-Resistance vs. Drain Current and Gate Voltage

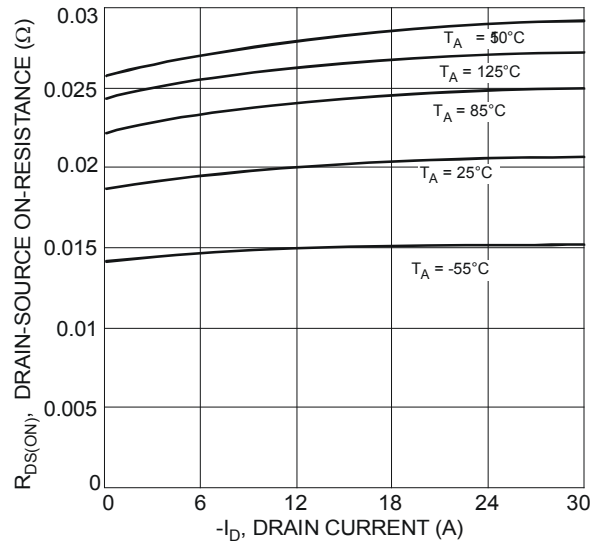

Fig. 4 Typical On-Resistance vs. Drain Current and Temperature

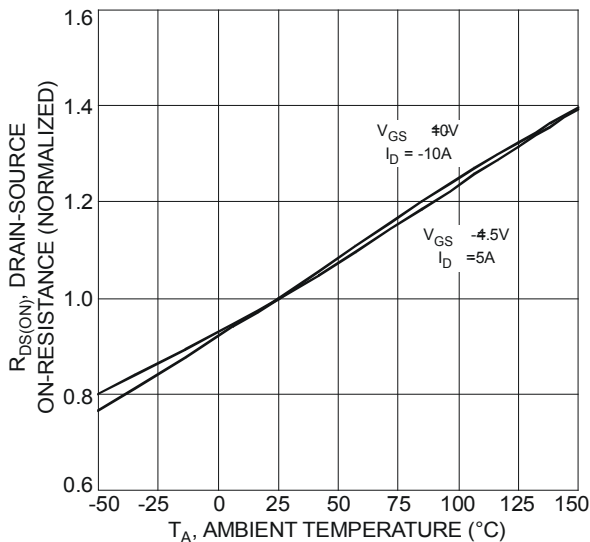

Fig. 5 Normalized On-Resistance vs. Ambient Temperature

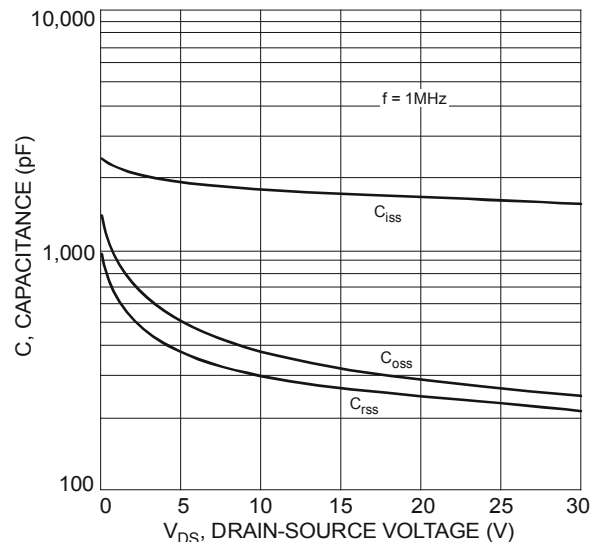

Fig. 6 Typical Total Capacitance

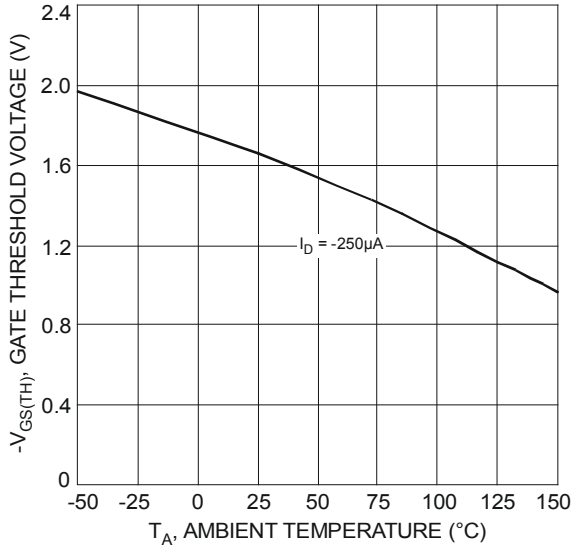

Fig. 7 Gate Threshold Variation vs. Ambient Temperature

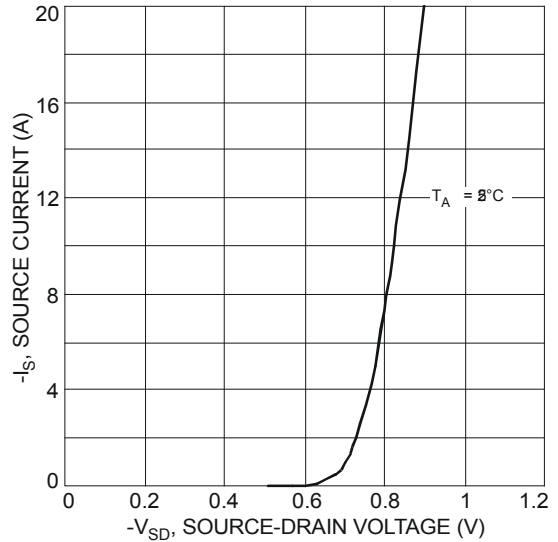

Fig. 8 Diode Forward Voltage vs. Current

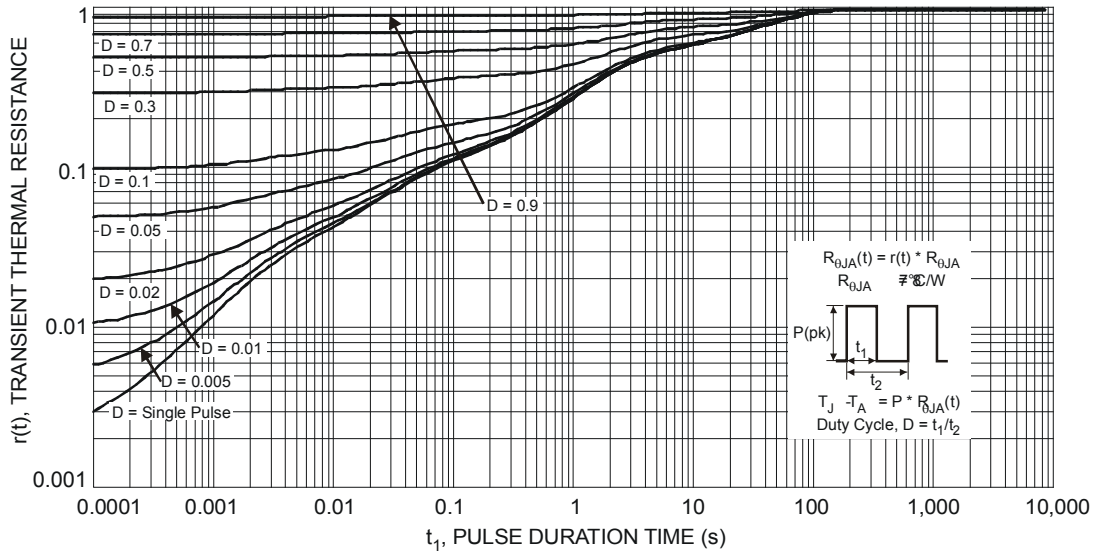

Fig. 9 Transient Thermal Response

Ordering Information (Note 6)

Part Number	Case	Packaging
DMP3020LSS-13	SOP-8L	2500/Tape & Reel

Notes: 6. For packaging details, go to our website at <http://www.diodes.com/datasheets/ap02007.pdf>.

Marking Information

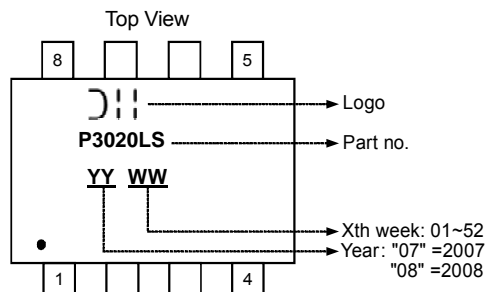

Package Outline Dimensions

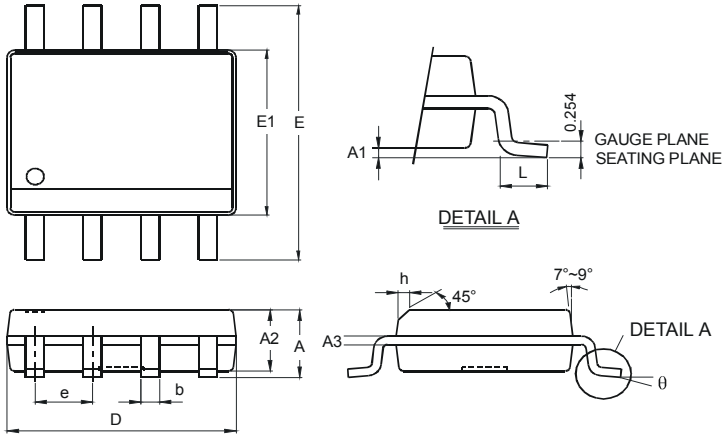

SOP-8L		
Dim	Min	Max
A	—	1.75
A1	0.08	0.25
A2	1.30	1.50
A3	0.20 Typ.	
b	0.3	0.5
D	4.80	5.30
E	5.79	6.20
E1	3.70	4.10
e	1.27 Typ.	
h	—	0.35
L	0.38	1.27
θ	0°	8°
All Dimensions in mm		

Suggested Pad Layout

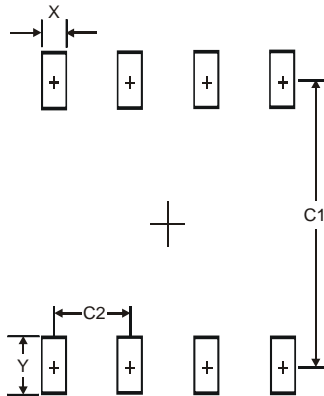

Dimensions	Value (in mm)
X	0.60
Y	1.55
C1	5.4
C2	1.27

IMPORTANT NOTICE

Diodes Incorporated and its subsidiaries reserve the right to make modifications, enhancements, improvements, corrections or other changes without further notice to any product herein. Diodes Incorporated does not assume any liability arising out of the application or use of any product described herein; neither does it convey any license under its patent rights, nor the rights of others. The user of products in such applications shall assume all risks of such use and will agree to hold Diodes Incorporated and all the companies whose products are represented on our website, harmless against all damages.

LIFE SUPPORT

Diodes Incorporated products are not authorized for use as critical components in life support devices or systems without the expressed written approval of the President of Diodes Incorporated.

FAN7602

Green Current Mode PWM Controller

Features

- Green Current Mode PWM Control
- Fixed 65kHz Operation with Frequency Modulation
- Internal High-Voltage Start-up Switch
- Burst Mode Operation
- Line Voltage Feed Forward to Limit Maximum Power
- Line Under-Voltage Protection
- Latch Protection & Internal Soft-Start (10ms) Function
- Overload Protection
- Over Voltage Protection
- Low Operation Current: Typ. 1mA
- 8-pin DIP

Applications

- Adapter
- LCD Monitor Power
- Auxiliary Power Supply

Related Application Notes

- **AN6014** - Green Current Mode PWM Controller FAN7602

Description

The FAN7602 is a green current mode PWM controller. It is specially designed for off-line adapter application, DVDP, VCR, LCD monitor application, and auxiliary power supplies.

The internal high-voltage start-up switch and the burst mode operation reduce the power loss in standby mode. Because of the internal start-up switch and the burst mode, it is possible to supply 0.5W load limiting the input power under 1W when the input line voltage is 265Vac. On no-load condition, the input power is under 0.3W.

The maximum power can be limited constantly, regardless of the line voltage change using the power limit function.

The switching frequency is internally fixed to be 65kHz and the frequency modulation technique reduces EMI.

The FAN7602 includes various protections for the system reliability and the internal soft start prevents the output voltage over-shoot at start-up.

Ordering Information

Part Number	Operating Temp. Range	Pb-Free	Package	Packing Method	Marking Code
FAN7602N	-25°C to +125°C	Yes	8-DIP	Rail	FAN7602

Typical Application Diagram

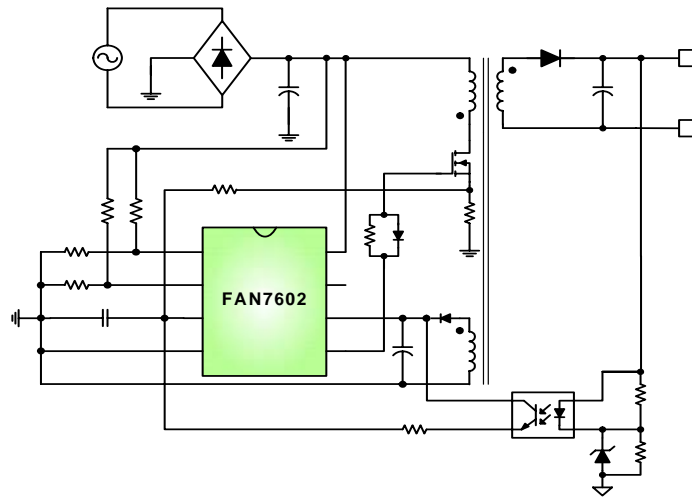

Figure 1. Typical Flyback Application

Internal Block Diagram

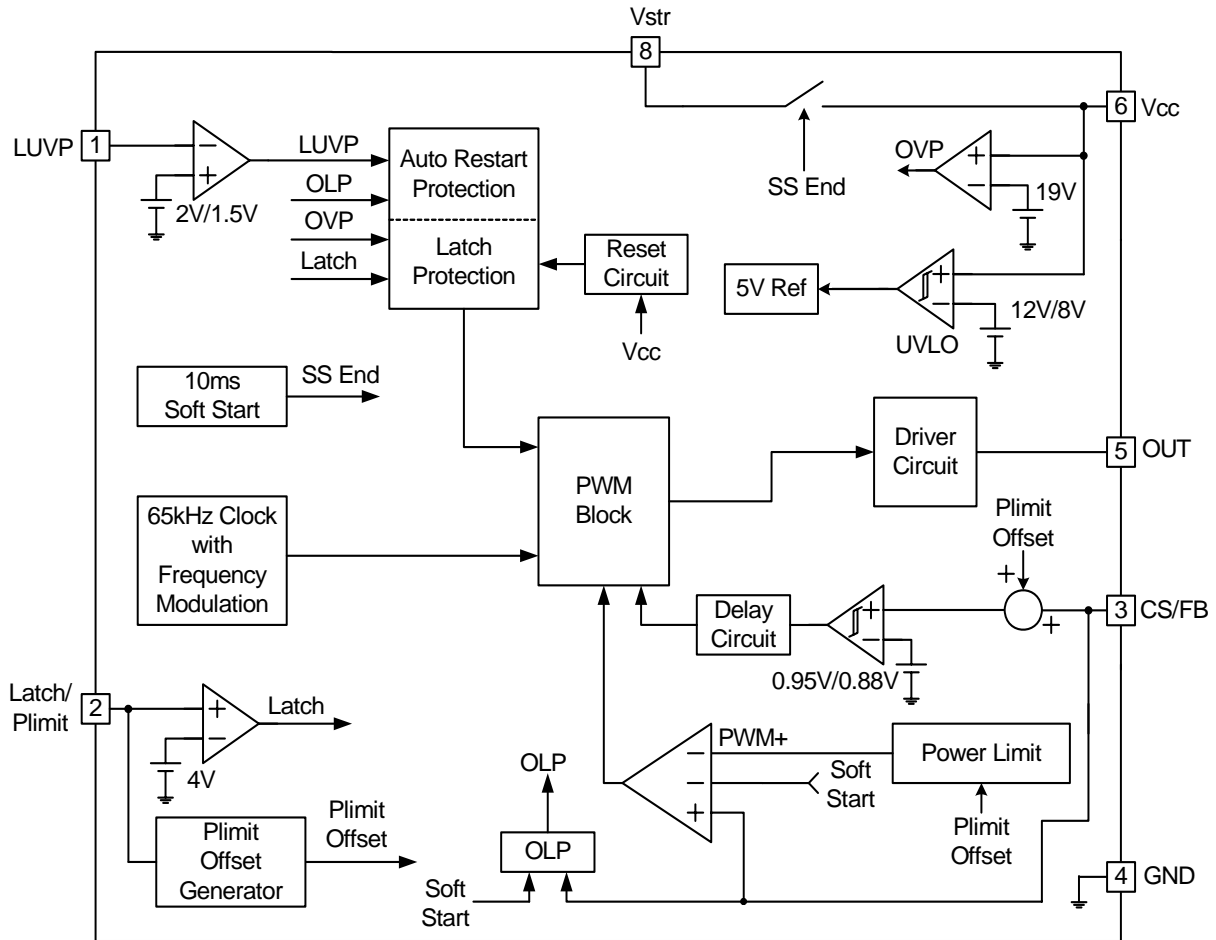

Figure 2. Functional Block Diagram of FAN7602

Pin Assignments

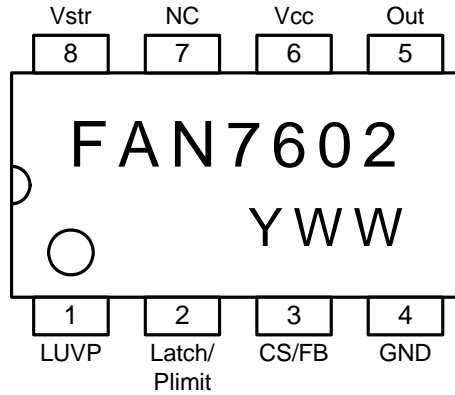

Figure 3. Pin Configuration (Top View)

Pin Definitions

Pin Number	Pin Name	Pin Function Description
1	LUVP	Line Under Voltage Protection Pin. This pin is used to protect the set when the input voltage is lower than the rated input voltage range.
2	Latch/Plimit	Latch Protection and Power Limit Pin. When the pin voltage exceeds 4V, the latch protection works and the latch protection is reset when the Vcc voltage is lower than 5V. For the power limit function, the OCP level decreases as the pin voltage increases.
3	CS/FB	Current Sense and Feedback Pin. This pin is used to sense the MOSFET current for the current mode PWM and OCP. The output voltage feedback information and the current sense information are added using external RC filter.
4	GND	Ground Pin. This pin is used for the ground potential of all the pins. For proper operation, the signal ground and the power ground should be separated.
5	OUT	Gate Drive Output Pin. This pin is an output pin to drive an external MOSFET. The peak sourcing current is 450mA and the peak sinking current is 600mA. For proper operation, the stray inductance in the gate driving path must be minimized.
6	Vcc	Supply Voltage Pin. IC operating current and MOSFET driving current are supplied using this pin.
7	NC	No Connection.
8	Vstr	Start-up Pin. This pin is used to supply IC operating current during IC start-up. After start-up, the internal JFET is turned off to reduce power loss.



FSFR-Series — Fairchild Power Switch (FPS™) for Half-Bridge Resonant Converters

Features

- Variable Frequency Control with 50% Duty Cycle for Half-Bridge Resonant Converter Topology
- High Efficiency through Zero Voltage Switching (ZVS)
- Internal SuperFET™s with Fast-Recovery Type Body Diode ($t_{rr}=120\text{ns}$) for FSFR2100 and UniFETs with Fast-Recovery Type Body Diode ($t_{rr}<160\text{ns}$) for FSFR2100U/2000/1900/1800/1700.
- Fixed Dead Time (350ns) Optimized for MOSFETs
- Up to 300kHz Operating Frequency
- Pulse Skipping for Frequency Limit (Programmable) at Light-Load Condition
- Remote On/Off Control Using Control Pin
- Protection Functions: Over-Voltage Protection (OVP), Over-Load Protection (OLP), Over-Current Protection (OCP), Abnormal Over-Current Protection (AOCP), Internal Thermal Shutdown (TSD)

Applications

- PDP and LCD TVs
- Desktop PCs and Servers
- Adapters
- Telecom Power Supplies
- Audio Power Supplies

Description

The FSFR-series are a highly integrated power switches designed for high-efficiency half-bridge resonant converters. Offering everything necessary to build a reliable and robust resonant converter, the FSFR-series simplifies designs and improves productivity, while improving performance. The FSFR-series combines power MOSFETs with fast-recovery type body diodes, a high-side gate-drive circuit, an accurate current controlled oscillator, frequency limit circuit, soft-start, and built-in protection functions. The high-side gate-drive circuit has a common-mode noise cancellation capability, which guarantees stable operation with excellent noise immunity. The fast-recovery body diode of the MOSFETs improves reliability against abnormal operation conditions, while minimizing the effect of the reverse recovery. Using the zero-voltage-switching (ZVS) technique dramatically reduces the switching losses and efficiency is significantly improved. The ZVS also reduces the switching noise noticeably, which allows a small-sized Electromagnetic Interference (EMI) filter.

The FSFR-series can be applied to various resonant converter topologies such as series resonant, parallel resonant, and LLC resonant converters.

Related Resources

[AN4151 — Half-bridge LLC Resonant Converter Design using FSFR-series Fairchild Power Switch \(FPS™\)](#)

Ordering Information

Part Number	Package	Eco Status	Operating Junction Temperature	$R_{DS(ON_MAX)}$	Maximum Output Power without Heatsink ($V_{IN}=350\sim 400\text{V}$) ^(1,2)	Maximum Output Power with Heatsink ($V_{IN}=350\sim 400\text{V}$) ^(1,2)
FSFR2100	9-SIP	RoHS	-40 to +130°C	0.38Ω	200W	450W
FSFR2100U				0.51Ω	180W	400W
FSFR2000				0.67Ω	160W	350W
FSFR1900				0.85Ω	140W	300W
FSFR1800				0.95Ω	120W	260W
FSFR1700				1.25Ω	100W	200W

Notes:

- The junction temperature can limit the maximum output power.
- Maximum practical continuous power in an open-frame design at 50°C ambient.

For Fairchild's definition of Eco Status, please visit: http://www.fairchildsemi.com/company/green/rohs_green.html.

Application Circuit Diagram

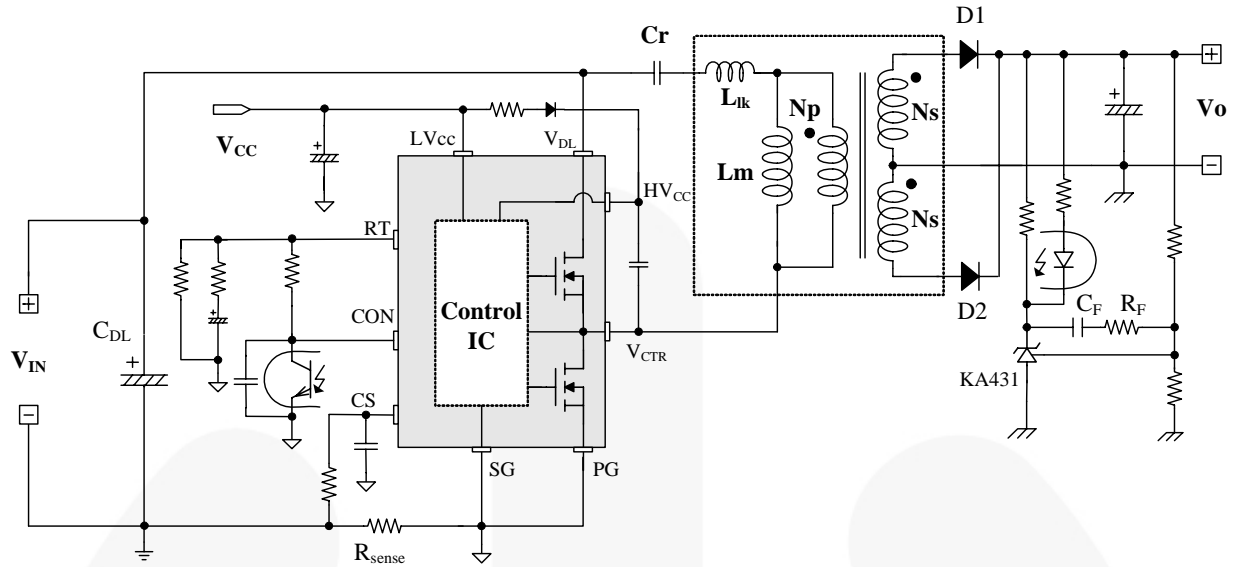

Figure 1. Typical Application Circuit (LLC Resonant Half-Bridge Converter)

Block Diagram

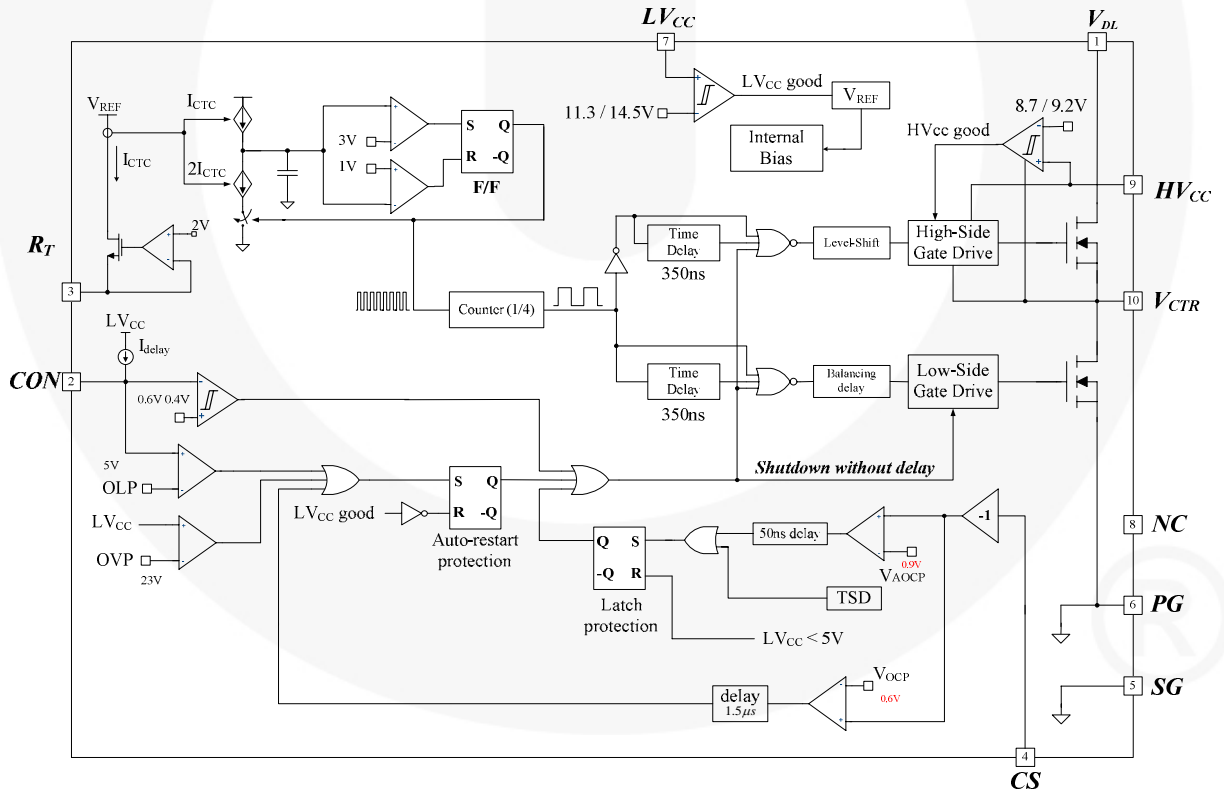

Figure 2. Internal Block Diagram

Pin Configuration

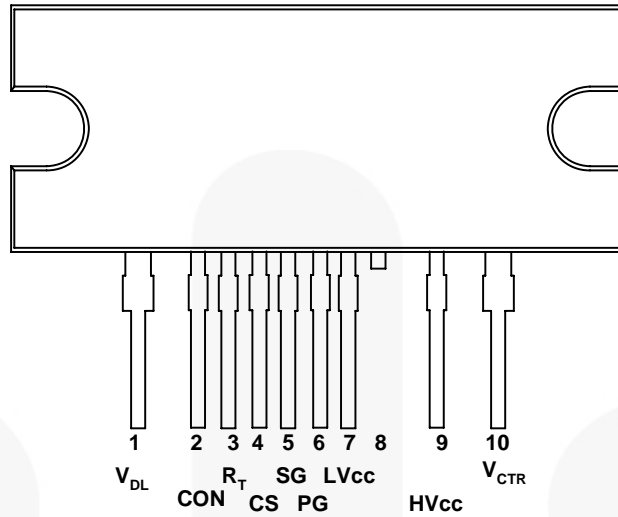

Figure 3. Package Diagram

Pin Definitions

Pin #	Name	Description
1	V _{DL}	This is the drain of the high-side MOSFET, typically connected to the input DC link voltage.
2	CON	This pin is for enable/disable and protection. When the voltage of this pin is above 0.6V, the IC operation is enabled. When the voltage of this pin drops below 0.4V, gate drive signals for both MOSFETs are disabled. When the voltage of this pin increases above 5V, protection is triggered.
3	R _T	This pin programs the switching frequency. Typically, an opto-coupler is connected to control the switching frequency for the output voltage regulation.
4	CS	This pin senses the current flowing through the low-side MOSFET. Typically, negative voltage is applied on this pin.
5	SG	This pin is the control ground.
6	PG	This pin is the power ground. This pin is connected to the source of the low-side MOSFET.
7	LV _{CC}	This pin is the supply voltage of the control IC.
8	NC	No connection.
9	HV _{CC}	This is the supply voltage of the high-side gate-drive circuit IC.
10	V _{CTR}	This is the drain of the low-side MOSFET. Typically, a transformer is connected to this pin.

Features

- Integrated analog input Class D audio amplifier driver in a small 16 pin package
- Floating inputs enable easy half bridge implementation
- Programmable bidirectional over-current protection with self-reset function
- Programmable preset deadtime for improved THD performances
- Start and stop click noise reduction
- High noise immunity
- ± 100 V ratings deliver up to 500 W in output power
- Operates up to 800 kHz
- RoHS compliant

Product Summary

V_{OFFSET} (max)		± 100 V
Gate driver	lo+	1.0 A
	lo -	1.2 A
Selectable Deadtime		25/40/65/105 ns
OC protection delay (max)		500 ns
DC offset		<20 mV
PWM frequency		~800 kHz
Error amplifier open loop gain		>60 dB
THD+N* (1kHz, 50W, 4 Ω)		0.01 %
Residual Noise* (AES-17 Filter)		200 μ Vrms

* measured with recommended circuit

Typical Applications

- Home theater systems
- Mini component stereo systems
- Powered speaker systems
- General purpose audio power amplifiers

Package Options

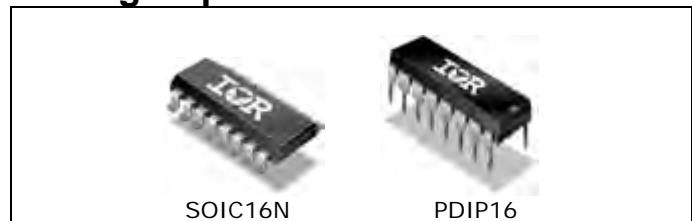

Typical Connection Diagram

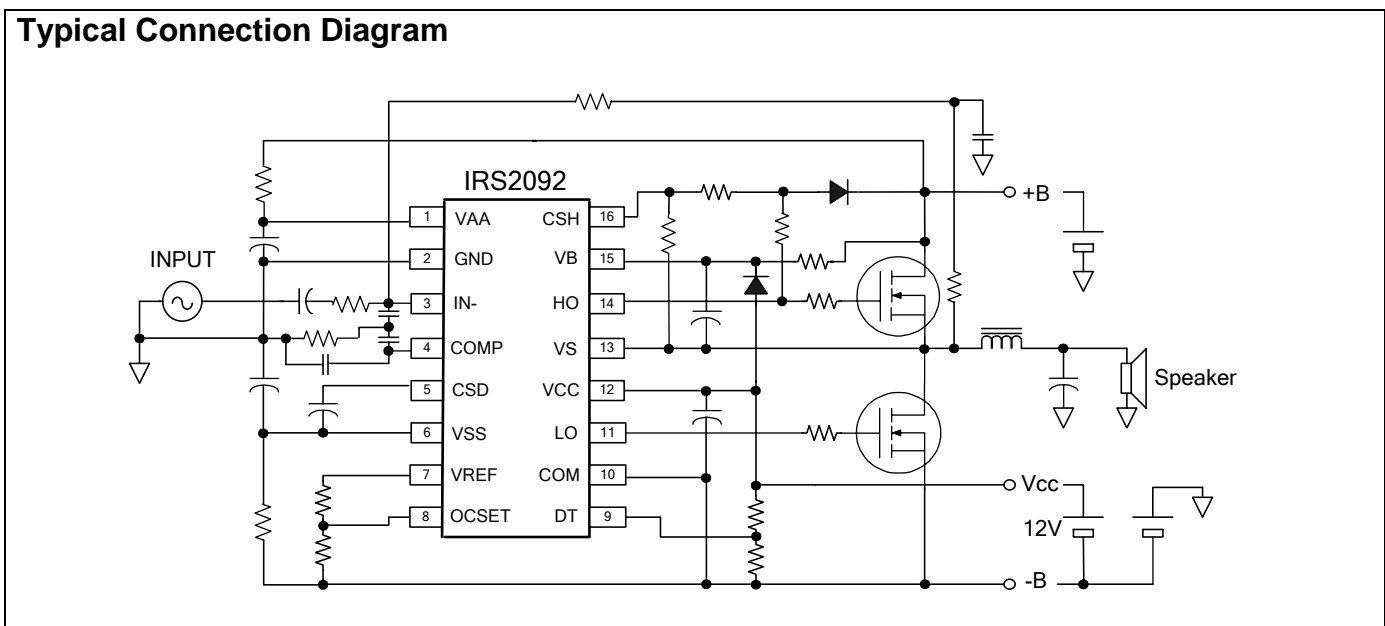

PRODUCT SPECIFICATION

COSMO ELECTRONICS CO., LTD.	Photocoupler : K1010	SHEET 1 OF 5
---------------------------------------	--------------------------------	--------------

High Reliability Photocoupler

● Features

1. Current transfer ratio
(CTR : MIN. 60% at $I_F=5\text{mA}$ $V_{ce}=5\text{V}$)
2. High isolation voltage between input and output (Viso : 5000Vrms).
3. Compact dual-in-line package.

● Applications

1. Registers, copiers, automatic vending machines.
2. System appliances, measuring instruments.
3. Computer terminals, programmable controllers.
4. Communications, telephone, etc.
5. Electric home appliances, such as oil fan heaters, Microwave oven, Washer, Refrigerator, Air conditioner, etc.
6. Medical instruments, physical and chemical equipment.
7. Signal transmission between circuits of different potentials and impedances.
8. Facsimile equipment, Audio, Video.
9. Switching power supply, Laser beam printer.

PRODUCT SPECIFICATION

COSMO ELECTRONICS CO., LTD.	Photocoupler : K1010	SHEET 2 OF 5
---------------------------------------	--------------------------------	--------------

1. OUTSIDE DIMENSION : UNIT (mm)

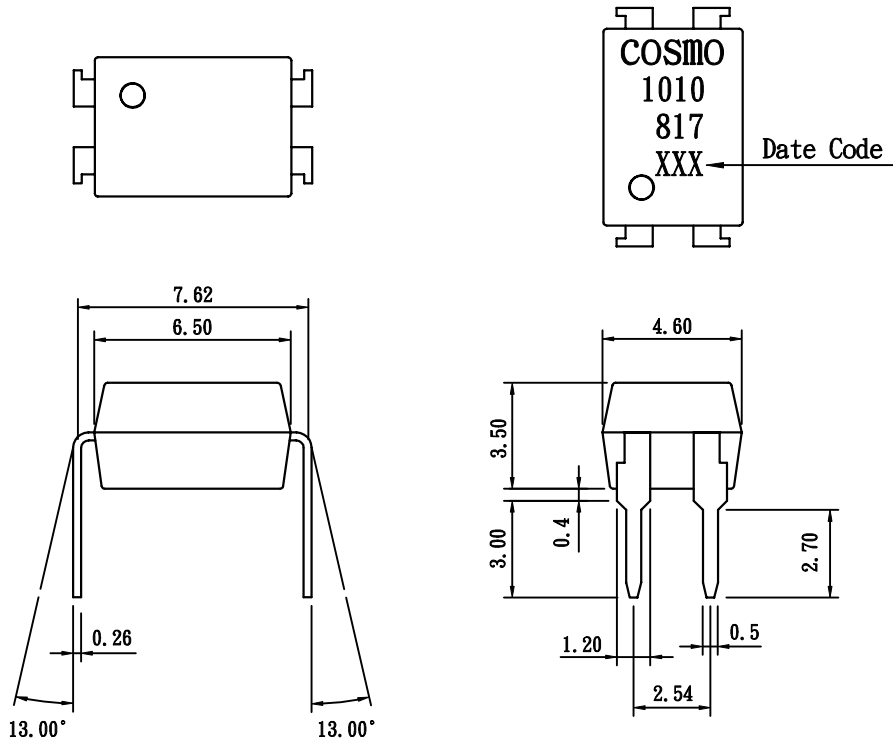

TOLERANCE : $\pm 0.2\text{mm}$

2. SCHEMATIC : TOP VIEW

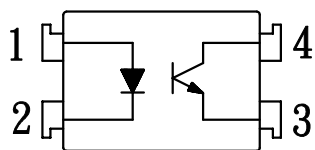

1. Anode
2. Cathode
3. Emitter
4. Collector

Power Factor Controller

SG6961

FEATURES

- Boundary Mode PFC Controller
- Low Input Current THD
- Controlled On-Time PWM
- Zero-Current Detection
- Cycle-by-Cycle Current Limiting
- Leading-Edge Blanking Instead of RC Filtering
- Low Start-up Current (10µA Typical)
- Low Operating Current (4.5mA Typical)
- Feedback Open-Loop Protection
- Programmable Maximum On-Time (MOT)
- Output Over-Voltage Clamping Protection
- Clamped Gate Output Voltage 16.5V

DESCRIPTION

The SG6961 is an 8-pin boundary mode PFC controller IC intended for controlling PFC pre-regulators. The SG6961 provides a controlled on-time to regulate the output DC voltage and achieve natural power factor correction. The maximum on-time of the external switch is programmable to ensure safe operation during AC brownouts. An innovative multi-vector error amplifier is built in to provide rapid transient response and precise output voltage clamping. A built-in circuit disables the controller if the output feedback loop is opened. The start-up current is lower than 20µA and the operating current is under 4.5mA. The supply voltage can be up to 20V, maximizing application flexibility.

APPLICATIONS

- Electric Lamp Ballasts
- AC-DC Switching Mode Power Converter
- Open-Frame Power Supplies and Power Adapters
- Flyback Power Converters with ZCS/ZVS

TYPICAL APPLICATION

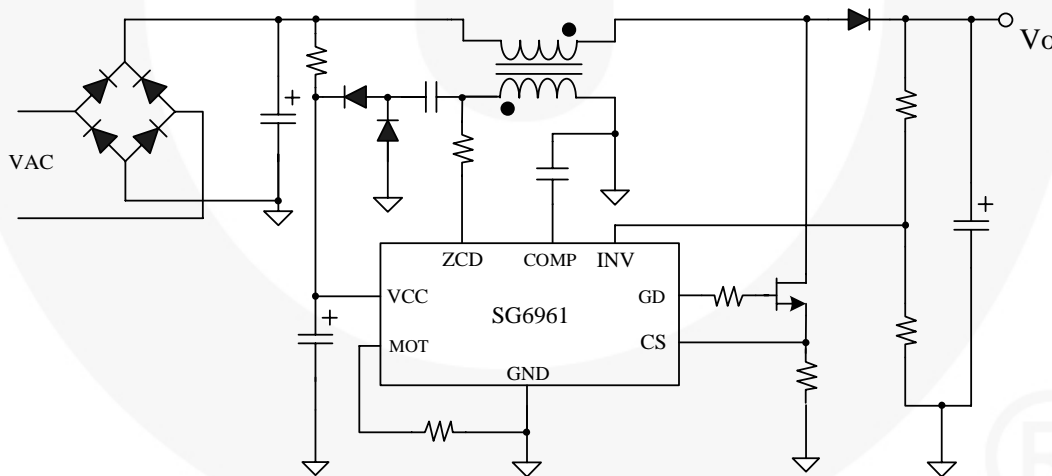

MARKING DIAGRAMS

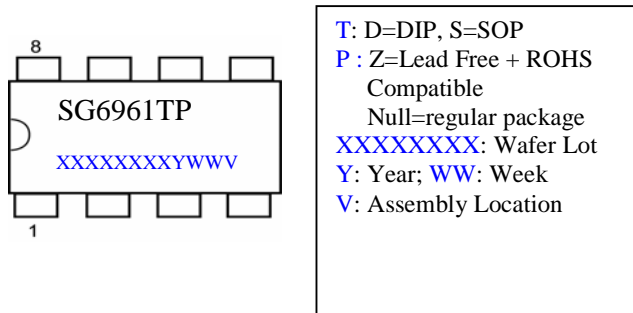

PIN CONFIGURATION

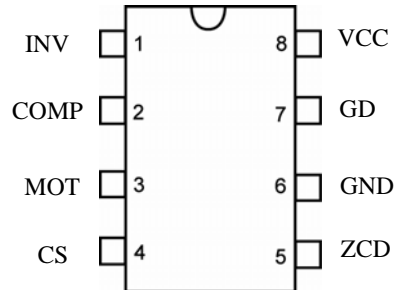

ORDERING INFORMATION

Part Number	Pb-Free	Package
SG6961SZ		8-Pin SOP
SG6961DZ		8-Pin DIP

PIN DESCRIPTIONS

Pin No.	Symbol	Description
1	INV	Inverting input of the error amplifier. INV is connected to the converter output via a resistive divider. This pin is also used for over-voltage clamping and open-loop feedback protection.
2	COMP	The output of the error amplifier. To create a precise clamping protection, a compensation network between this pin and GND is suggested.
3	MOT	A resistor from MOT to GND is used to determine the maximum on-time of the external power MOSFET. The maximum output power of the converter is a function of the maximum on-time.
4	CS	Input to the over-current protection comparator. When the sensed voltage across the sense resistor reaches the internal threshold (0.82V), the switch is turned off to activate cycle-by-cycle current limiting.
5	ZCD	Zero Current Detection. This pin is connected to an auxiliary winding via a resistor to detect the zero crossing of the switch current. When the zero crossing is detected, a new switching cycle is started. If it is connected to GND, the device is disabled.
6	GND	The power ground and signal ground. Placing a 0.1µF decoupling capacitor between the VCC and GND pins is recommended.
7	GD	Totem-pole driver output to drive the external power MOSFET. The clamped gate output voltage is 16.5V.
8	VCC	Driver and control circuit supply voltage.

**ADJUSTABLE PRECISION SHUNT REGULATORS****AZ431-A****Description**

The AZ431-A series ICs are three-terminal adjustable shunt regulators with guaranteed thermal stability over a full operation range. These ICs feature sharp turn-on characteristics, low temperature coefficient and low output impedance, which make them ideal substitutes for Zener diodes in applications such as switching power supply, charger and other adjustable regulators.

The AZ431-A series ICs are of 40V voltage type. Its output voltage can be set to any value between $V_{REF}(2.5V)$ and 36V.

The AZ431-A precision reference is offered in two band-gap tolerance: 0.4% and 0.8%.

Features

- Programmable Precise Output Voltage from 2.5V to 36V
- Very Accurate Reference Voltage: 0.15% Typical
- High Stability under Capacitive Load
- Low Temperature Deviation: 4.5mV Typical
- Low Equivalent Full-range Temperature Coefficient with 20PPM/°C Typical
- Low Dynamic Output Resistance: 0.2Ω Typical
- Sink Current Capacity from 1mA to 100 mA
- Low Output Noise
- Wide Operating Range of -40 to 125°C

Applications

- Charger
- Voltage Adapter
- Switching Power Supply
- Graphic Card
- Precision Voltage Reference

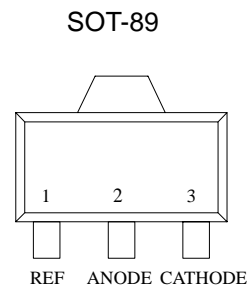
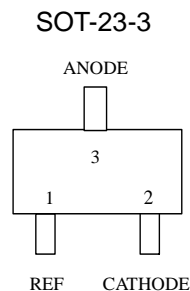
Pin Configuration**Parametric Table**

	AZ431A-A	AZ431B-A
I_{KA} (Max) (mA)	100	100
I_{KA} (Min) (mA)	0.4	0.4
V_{OUT} / V_{REF} Initial Tol. (%)	0.4	0.8
V_{OUT} (Max) (V)	36	36
V_{OUT} (Min) (V)	2.5	2.5
Z_{KA} (Typ) (Ω)	0.15	0.15
Temp Coeff. (Typ) (PPM/°C)	20	20
Operating Temperature (Min) (°C)	-40	-40
Operating Temperature (Max) (°C)	+125	+125

Benefits

- Easier to Stabilize
- Ultra Low Temperature Coefficient
- Higher V_{REF} Accuracy
- Wider Operating Temperature Range
- Very Competitive Price

Additional Available Materials

- Samples
- Datasheet
- Reliability Report
- ESD Report

TL071, TL071A, TL071B, TL072 TL072A, TL072B, TL074, TL074A, TL074B LOW-NOISE JFET-INPUT OPERATIONAL AMPLIFIERS

SLOS080D – SEPTEMBER 1978 – REVISED AUGUST 1996

- Low Power Consumption
- Wide Common-Mode and Differential Voltage Ranges
- Low Input Bias and Offset Currents
- Output Short-Circuit Protection
- Low Total Harmonic Distortion
0.003% Typ
- Low Noise
 $V_n = 18 \text{ nV}/\sqrt{\text{Hz}}$ Typ at $f = 1 \text{ kHz}$
- High Input Impedance . . . JFET Input Stage
- Internal Frequency Compensation
- Latch-Up-Free Operation
- High Slew Rate . . . 13 V/ μs Typ
- Common-Mode Input Voltage Range
Includes V_{CC+}

description

The JFET-input operational amplifiers in the TL07_ series are designed as low-noise versions of the TL08_ series amplifiers with low input bias and offset currents and fast slew rate. The low harmonic distortion and low noise make the TL07_ series ideally suited for high-fidelity and audio preamplifier applications. Each amplifier features JFET inputs (for high input impedance) coupled with bipolar output stages integrated on a single monolithic chip.

The C-suffix devices are characterized for operation from 0°C to 70°C. The I-suffix devices are characterized for operation from –40°C to 85°C. The M-suffix devices are characterized for operation over the full military temperature range of –55°C to 125°C.

AVAILABLE OPTIONS

T _A	V _{IO} max AT 25°C	PACKAGE							
		SMALL OUTLINE (D)†	CHIP CARRIER (FK)	CERAMIC DIP (J)	CERAMIC DIP (JG)	PLASTIC DIP (N)	PLASTIC DIP (P)	TSSOP PACKAGE (PW)	FLAT PACKAGE (W)
0°C to 70°C	10 mV 6 mV 3 mV	TL071CD TL071ACD TL071BCD	—	—	—	—	TL071CP TL071ACP TL071BCP	TL071CPWLE — —	—
	10 mV 6 mV 3 mV	TL072CD TL072ACD TL072BCD	—	—	—	—	TL072CP TL072ACP TL072BCP	TL072CPWLE — —	—
	10 mV 6 mV 3 mV	TL074CD TL074ACD TL074BCD	—	—	—	TL074CN TL074ACN TL074BCN	—	TL074CPWLE — —	—
–40°C to 85°C	6 mV	TL071ID TL072ID TL074ID	—	—	—	— — TL074IN	TL071IP TL072IP —	—	—
–55°C to 125°C	6 mV 6 mV 9 mV	—	TL071MFK TL072MFK TL074MFK	— — TL074MJ	TL071MJG TL072MJG —	— — TL074MN	— TL072MP —	—	— — TL074MW

† The D package is available taped and reeled. Add the suffix R to the device type (e.g., TL071CDR). The PW package is only available left-ended taped and reeled (e.g., TL072CPWLE).



Please be aware that an important notice concerning availability, standard warranty, and use in critical applications of Texas Instruments semiconductor products and disclaimers thereto appears at the end of this data sheet.

PRODUCTION DATA information is current as of publication date. Products conform to specifications per the terms of Texas Instruments standard warranty. Production processing does not necessarily include testing of all parameters.



POST OFFICE BOX 655303 • DALLAS, TEXAS 75265

Copyright © 1996, Texas Instruments Incorporated

TOSHIBA TRANSISTOR SILICON PNP EPITAXIAL TYPE (PCT PROCESS)

2SA1048

AUDIO FREQUENCY AMPLIFIER APPLICATIONS

Unit in mm

- Small Package
- High Voltage : $V_{CEO} = -50V$ (Min.)
- High h_{FE} : $h_{FE} = 70 \sim 400$
- Excellent h_{FE} Linearity
: $h_{FE}(I_C = -0.1mA) / h_{FE}(I_C = -2mA) = 0.95$ (Typ.)
- Low Noise : $NF = 1dB$ (Typ.), $10dB$ (Max.)
- Complementary to 2SC2458

MAXIMUM RATINGS ($T_a = 25^\circ C$)

CHARACTERISTIC	SYMBOL	RATING	UNIT
Collector-Base Voltage	V_{CBO}	-50	V
Collector-Emitter Voltage	V_{CEO}	-50	V
Emitter-Base Voltage	V_{EBO}	-5	V
Collector Current	I_C	-150	mA
Base Current	I_B	-50	mA
Collector Power Dissipation	P_C	200	mW
Junction Temperature	T_j	125	$^\circ C$
Storage Temperature Range	T_{stg}	-55~125	$^\circ C$

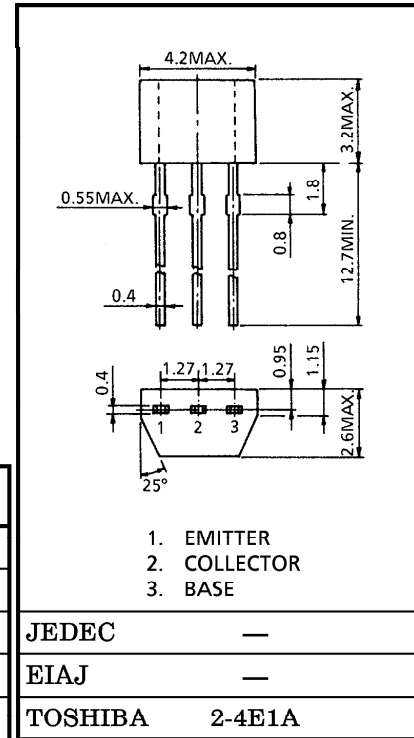

JEDEC	—
EIAJ	—
TOSHIBA	2-4E1A

Weight : 0.13g

ELECTRICAL CHARACTERISTICS ($T_a = 25^\circ C$)

CHARACTERISTIC	SYMBOL	TEST CONDITION	MIN.	TYP.	MAX.	UNIT
Collector Cut-off Current	I_{CBO}	$V_{CB} = -50V, I_E = 0$	—	—	-0.1	μA
Emitter Cut-off Current	I_{EBO}	$V_{EB} = -5V, I_C = 0$	—	—	-0.1	μA
DC Current Gain	h_{FE} (Note)	$V_{CE} = -6V, I_C = -2mA$	70	—	400	
Collector-Emitter Saturation Voltage	$V_{CE(sat)}$	$I_C = -100mA, I_B = -10mA$	—	-0.1	-0.3	V
Transition Frequency	f_T	$V_{CE} = -10V, I_C = -1mA$	80	—	—	MHz
Collector Output Capacitance	C_{ob}	$V_{CB} = -10V, I_E = 0, f = 1MHz$	—	4	7	pF
Noise Figure	NF	$V_{CE} = -6V, I_C = -0.1mA$ $f = 1kHz, R_G = 10k\Omega$	—	1.0	10	dB

Note : h_{FE} Classification 0 : 70~140, Y : 120~240, GR : 200~400

961001EAA2

- TOSHIBA is continually working to improve the quality and the reliability of its products. Nevertheless, semiconductor devices in general can malfunction or fail due to their inherent electrical sensitivity and vulnerability to physical stress. It is the responsibility of the buyer, when utilizing TOSHIBA products, to observe standards of safety, and to avoid situations in which a malfunction or failure of a TOSHIBA product could cause loss of human life, bodily injury or damage to property. In developing your designs, please ensure that TOSHIBA products are used within specified operating ranges as set forth in the most recent products specifications. Also, please keep in mind the precautions and conditions set forth in the TOSHIBA Semiconductor Reliability Handbook.
- The information contained herein is presented only as a guide for the applications of our products. No responsibility is assumed by TOSHIBA CORPORATION for any infringements of intellectual property or other rights of the third parties which may result from its use. No license is granted by implication or otherwise under any intellectual property or other rights of TOSHIBA CORPORATION or others.
- The information contained herein is subject to change without notice.

TOSHIBA TRANSISTOR SILICON NPN EPITAXIAL TYPE (PCT PROCESS)

2SC2235

AUDIO POWER AMPLIFIER APPLICATIONS.
DRIVER STAGE AMPLIFIER APPLICATIONS.

Unit in mm

- Complementary to 2SA965.

MAXIMUM RATINGS (Ta = 25°C)

CHARACTERISTIC	SYMBOL	RATING	UNIT
Collector-Base Voltage	V _{CB0}	120	V
Collector-Emitter Voltage	V _{CEO}	120	V
Emitter-Base Voltage	V _{EBO}	5	V
Collector Current	I _C	800	mA
Emitter Current	I _E	-800	mA
Collector Power Dissipation	P _C	900	mW
Junction Temperature	T _j	150	°C
Storage Temperature Range	T _{stg}	-55~150	°C

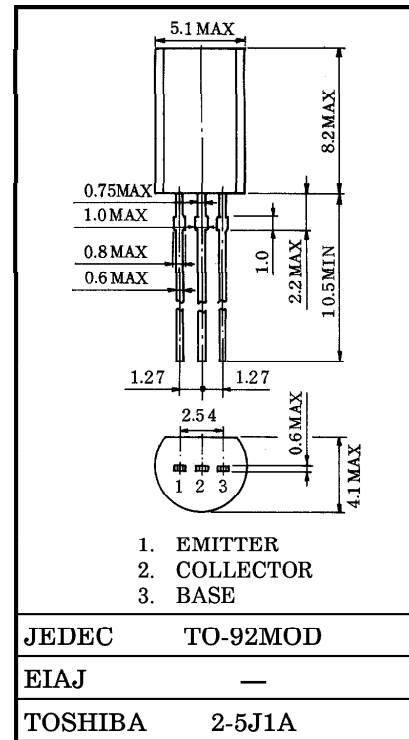

Weight : 0.36g

ELECTRICAL CHARACTERISTICS (Ta = 25°C)

CHARACTERISTIC	SYMBOL	TEST CONDITION	MIN.	TYP.	MAX.	UNIT
Collector Cut-off Current	I _{CB0}	V _{CB} = 120V, I _E = 0	—	—	100	nA
Emitter Cut-off Current	I _{EBO}	V _{EB} = 5V, I _C = 0	—	—	100	nA
Collector-Emitter Breakdown Voltage	V _{(BR)CEO}	I _C = 10mA, I _B = 0	120	—	—	V
Emitter-Base Breakdown Voltage	V _{(BR)EBO}	I _E = 1mA, I _C = 0	5	—	—	V
DC Current Gain	h _{FE} (Note)	V _{CE} = 5V, I _C = 100mA	80	—	240	
Collector-Emitter Saturation Voltage	V _{CE(sat)}	I _C = 500mA, I _B = 50mA	—	—	1.0	V
Base-Emitter Voltage	V _{BE}	V _{CE} = 5V, I _C = 500mA	—	—	1.0	V
Transition Frequency	f _T	V _{CE} = 5V, I _C = 100mA	—	120	—	MHz
Collector Output Capacitance	C _{ob}	V _{CB} = 10V, I _E = 0, f = 1MHz	—	—	30	pF

Note : h_{FE} Classification O : 80~160, Y : 120~240

961001EAA2

● TOSHIBA is continually working to improve the quality and the reliability of its products. Nevertheless, semiconductor devices in general can malfunction or fail due to their inherent electrical sensitivity and vulnerability to physical stress. It is the responsibility of the buyer, when utilizing TOSHIBA products, to observe standards of safety, and to avoid situations in which a malfunction or failure of a TOSHIBA product could cause loss of human life, bodily injury or damage to property. In developing your designs, please ensure that TOSHIBA products are used within specified operating ranges as set forth in the most recent products specifications. Also, please keep in mind the precautions and conditions set forth in the TOSHIBA Semiconductor Reliability Handbook.

● The information contained herein is presented only as a guide for the applications of our products. No responsibility is assumed by TOSHIBA CORPORATION for any infringements of intellectual property or other rights of the third parties which may result from its use. No license is granted by implication or otherwise under any intellectual property or other rights of TOSHIBA CORPORATION or others.

● The information contained herein is subject to change without notice.

TOSHIBA TRANSISTOR SILICON NPN EPITAXIAL TYPE (PCT PROCESS)

2SC2458

AUDIO AMPLIFIER APPLICATIONS.

Unit in mm

- High Current Capability : $I_C = 150\text{mA}$ (Max.)
- High DC Current Gain : $h_{FE} = 70 \sim 700$
- Excellent h_{FE} Linearity
: $h_{FE}(I_C = 0.1\text{mA}) / h_{FE}(I_C = 2\text{mA}) = 0.95$ (Typ.)
- Low Noise : $NF(2) = 1\text{dB}$ (Typ.), 10dB (Max.)
- Complementary to 2SA1048.
- Small Package.

MAXIMUM RATINGS ($T_a = 25^\circ\text{C}$)

CHARACTERISTIC	SYMBOL	RATING	UNIT
Collector-Base Voltage	V_{CBO}	50	V
Collector-Emitter Voltage	V_{CEO}	50	V
Emitter-Base Voltage	V_{EBO}	5	V
Collector Current	I_C	150	mA
Base Current	I_B	50	mA
Collector Power Dissipation	P_C	200	mW
Junction Temperature	T_j	125	$^\circ\text{C}$
Storage Temperature Range	T_{stg}	-55~125	$^\circ\text{C}$

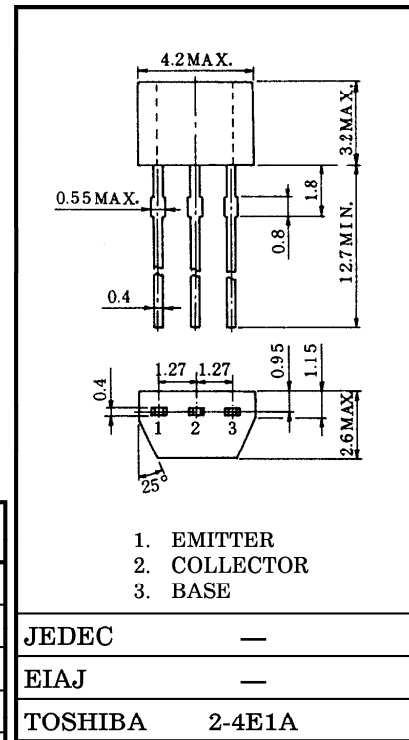

Weight : 0.13g

ELECTRICAL CHARACTERISTICS ($T_a = 25^\circ\text{C}$)

CHARACTERISTIC	SYMBOL	TEST CONDITION	MIN.	TYP.	MAX.	UNIT
Collector Cut-off Current	I_{CBO}	$V_{CB} = 50\text{V}, I_E = 0$	—	—	0.1	μA
Emitter Cut-off Current	I_{EBO}	$V_{EB} = 5\text{V}, I_C = 0$	—	—	0.1	μA
DC Current Gain	h_{FE} (Note)	$V_{CE} = 6\text{V}, I_C = 2\text{mA}$	70	—	700	
Collector-Emitter Saturation Voltage	$V_{CE(sat)}$	$I_C = 100\text{mA}, I_B = 10\text{mA}$	—	0.1	0.25	V
Transition Frequency	f_T	$V_{CE} = 10\text{V}, I_C = 1\text{mA}$	80	—	—	MHz
Collector Output Capacitance	C_{ob}	$V_{CB} = 10\text{V}, I_E = 0, f = 1\text{MHz}$	—	2.0	3.5	pF
Noise Figure	NF	$V_{CE} = 6\text{V}, I_C = 0.1\text{mA}, f = 1\text{kHz}, R_g = 10\text{k}\Omega$	—	1.0	10	dB

Note : h_{FE} Classification O : 70~140, Y : 120~240, GR : 200~400, BL : 350~700

961001EAA2

● TOSHIBA is continually working to improve the quality and the reliability of its products. Nevertheless, semiconductor devices in general can malfunction or fail due to their inherent electrical sensitivity and vulnerability to physical stress. It is the responsibility of the buyer, when utilizing TOSHIBA products, to observe standards of safety, and to avoid situations in which a malfunction or failure of a TOSHIBA product could cause loss of human life, bodily injury or damage to property. In developing your designs, please ensure that TOSHIBA products are used within specified operating ranges as set forth in the most recent products specifications. Also, please keep in mind the precautions and conditions set forth in the TOSHIBA Semiconductor Reliability Handbook.

FDP20N50 / FDPF20N50

500V N-Channel MOSFET

Features

- 20A, 500V, $R_{DS(on)} = 0.23\Omega @V_{GS} = 10V$
- Low gate charge (typical 45.6 nC)
- Low C_{iss} (typical 27 pF)
- Fast switching
- 100% avalanche tested
- Improved dv/dt capability

Description

These N- Channel enhancement mode power field effect transistors are produced using Fairchild's proprietary, planar stripe, DMOS technology.

This advanced technology has been especially tailored to minimize on-state resistance, provide superior switching performance, and withstand high energy pulse in the avalanche and commutation mode. These devices are well suited for high efficient switched mode power supplies and active power factor correction.

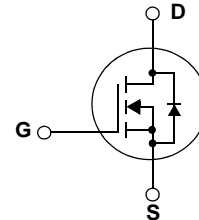
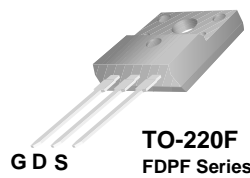
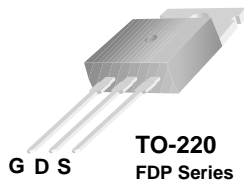

Absolute Maximum Ratings

Symbol	Parameter	FDP20N50	FDPF20N50	Unit
V_{DSS}	Drain-Source Voltage	500		V
I_D	Drain Current - Continuous ($T_C = 25^\circ C$) - Continuous ($T_C = 100^\circ C$)	20 12.9	20 * 12.9 *	A A
I_{DM}	Drain Current - Pulsed (Note 1)	80	80 *	A
V_{GSS}	Gate-Source voltage	± 30		V
E_{AS}	Single Pulsed Avalanche Energy (Note 2)	1110		mJ
I_{AR}	Avalanche Current (Note 1)	20		A
E_{AR}	Repetitive Avalanche Energy (Note 1)	25		mJ
dv/dt	Peak Diode Recovery dv/dt (Note 3)	4.5		V/ns
P_D	Power Dissipation ($T_C = 25^\circ C$) - Derate above $25^\circ C$	250 2.0	62 0.5	W W/ $^\circ C$
T_J, T_{STG}	Operating and Storage Temperature Range	-55 to +150		$^\circ C$
T_L	Maximum Lead Temperature for Soldering Purpose, 1/8" from Case for 5 Seconds	300		$^\circ C$

* Drain current limited by maximum junction temperature

Thermal Characteristics

Symbol	Parameter	FDP20N50	FDPF20N50	Unit
$R_{\theta JC}$	Thermal Resistance, Junction-to-Case	0.5	2.0	$^\circ C/W$
$R_{\theta CS}$	Thermal Resistance, Case-to-Sink Typ.	0.5	--	$^\circ C/W$
$R_{\theta JA}$	Thermal Resistance, Junction-to-Ambient	62.5	62.5	$^\circ C/W$

FQP7N80C/FQPF7N80C

800V N-Channel MOSFET

General Description

These N-Channel enhancement mode power field effect transistors are produced using Fairchild's proprietary, planar stripe, DMOS technology. This advanced technology has been especially tailored to minimize on-state resistance, provide superior switching performance, and withstand high energy pulse in the avalanche and commutation mode. These devices are well suited for high efficiency switch mode power supplies.

Features

- 6.6A, 800V, $R_{DS(on)} = 1.9\Omega$ @ $V_{GS} = 10V$
- Low gate charge (typical 27 nC)
- Low C_{rss} (typical 10 pF)
- Fast switching
- 100% avalanche tested
- Improved dv/dt capability

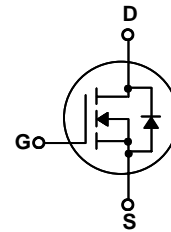
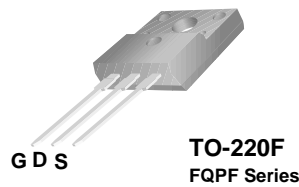
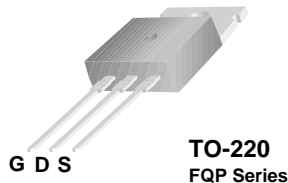

Absolute Maximum Ratings $T_C = 25^\circ\text{C}$ unless otherwise noted

Symbol	Parameter	FQP7N80C	FQPF7N80C	Units
V_{DSS}	Drain-Source Voltage	800		V
I_D	Drain Current - Continuous ($T_C = 25^\circ\text{C}$) - Continuous ($T_C = 100^\circ\text{C}$)	6.6	6.6 *	A
		4.2	4.2 *	A
I_{DM}	Drain Current - Pulsed (Note 1)	26.4	26.4 *	A
V_{GSS}	Gate-Source Voltage	± 30		V
E_{AS}	Single Pulsed Avalanche Energy (Note 2)	580		mJ
I_{AR}	Avalanche Current (Note 1)	6.6		A
E_{AR}	Repetitive Avalanche Energy (Note 1)	16.7		mJ
dv/dt	Peak Diode Recovery dv/dt (Note 3)	4.5		V/ns
P_D	Power Dissipation ($T_C = 25^\circ\text{C}$) - Derate above 25°C	167	56	W
		1.33	0.44	W/ $^\circ\text{C}$
T_J, T_{STG}	Operating and Storage Temperature Range	-55 to +150		$^\circ\text{C}$
T_L	Maximum lead temperature for soldering purposes, 1/8" from case for 5 seconds	300		$^\circ\text{C}$

* Drain current limited by maximum junction temperature.

Thermal Characteristics

Symbol	Parameter	FQP7N80C	FQPF7N80C	Units
$R_{\theta JC}$	Thermal Resistance, Junction-to-Case	0.75	2.25	$^\circ\text{C}/\text{W}$
$R_{\theta JS}$	Thermal Resistance, Case-to-Sink Typ.	0.5	--	$^\circ\text{C}/\text{W}$
$R_{\theta JA}$	Thermal Resistance, Junction-to-Ambient	62.5	62.5	$^\circ\text{C}/\text{W}$

IRFI4212H-117P

Features

- Integrated half-bridge package
- Reduces the part count by half
- Facilitates better PCB layout
- Key parameters optimized for Class-D audio amplifier applications
- Low $R_{DS(ON)}$ for improved efficiency
- Low Q_g and Q_{sw} for better THD and improved efficiency
- Low Q_{rr} for better THD and lower EMI
- Can delivery up to 150W per channel into 4Ω load in half-bridge configuration amplifier
- Lead-free package

Key Parameters ⑤		
V_{DS}	100	V
$R_{DS(ON)}$ typ. @ 10V	58	mΩ
Q_g typ.	12	nC
Q_{sw} typ.	6.9	nC
$R_{G(int)}$ typ.	3.4	Ω
T_J max	150	°C

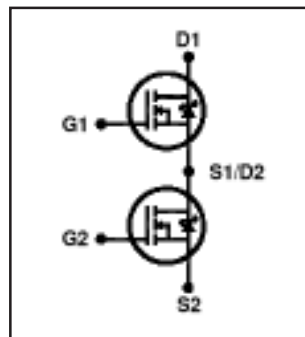

G1, G2	D1, D2	S1, S2
Gate	Drain	Source

Description

This Digital Audio MosFET Half-Bridge is specifically designed for Class D audio amplifier applications. It consists of two power MosFET switches connected in half-bridge configuration. The latest process is used to achieve low on-resistance per silicon area. Furthermore, Gate charge, body-diode reverse recovery, and internal Gate resistance are optimized to improve key Class D audio amplifier performance factors such as efficiency, THD and EMI. These combine to make this Half-Bridge a highly efficient, robust and reliable device for Class D audio amplifier applications.

Absolute Maximum Ratings ⑤

	Parameter	Max.	Units
V_{DS}	Drain-to-Source Voltage	100	V
V_{GS}	Gate-to-Source Voltage	±20	
I_D @ $T_C = 25^\circ\text{C}$	Continuous Drain Current, V_{GS} @ 10V	11	A
I_D @ $T_C = 100^\circ\text{C}$	Continuous Drain Current, V_{GS} @ 10V	6.8	
I_{DM}	Pulsed Drain Current ①	44	
P_D @ $T_C = 25^\circ\text{C}$	Power Dissipation ④	18	W
P_D @ $T_C = 100^\circ\text{C}$	Power Dissipation ④	7.0	
	Linear Derating Factor	0.14	W/°C
E_{AS}	Single Pulse Avalanche Energy②	41	mJ
T_J	Operating Junction and	-55 to + 150	°C
T_{STG}	Storage Temperature Range		
	Soldering Temperature, for 10 seconds (1.6mm from case)		
	Mounting torque, 6-32 or M3 screw	10lb·in (1.1N·m)	

Thermal Resistance ⑤

	Parameter	Typ.	Max.	Units
$R_{\theta JC}$	Junction-to-Case ④	—	7.1	°C/W
$R_{\theta JA}$	Junction-to-Ambient (free air)	—	65	

ISL9R1560PF2

15A, 600V Stealth™ Diode

General Description

The ISL9R1560PF2 is a Stealth™ diode optimized for low loss performance in high frequency hard switched applications. The Stealth™ family exhibits low reverse recovery current ($I_{RM(REC)}$) and exceptionally soft recovery under typical operating conditions.

This device is intended for use as a free wheeling or boost diode in power supplies and other power switching applications. The low $I_{RM(REC)}$ and short t_a phase reduce loss in switching transistors. The soft recovery minimizes ringing, expanding the range of conditions under which the diode may be operated without the use of additional snubber circuitry. Consider using the Stealth™ diode with an SMPS IGBT to provide the most efficient and highest power density design at lower cost.

Formerly developmental type TA49410.

Features

- Soft Recovery $t_b / t_a > 1.2$
- Fast Recovery $t_{rr} < 30ns$
- Operating Temperature 150°C
- Reverse Voltage 600V
- Internally Isolated 1kV
- Avalanche Energy Rated

Applications

- Switch Mode Power Supplies
- Hard Switched PFC Boost Diode
- UPS Free Wheeling Diode
- Motor Drive FWD
- SMPS FWD
- Snubber Diode

Package

Symbol

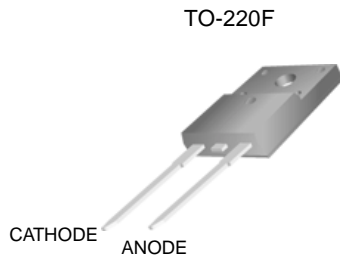

Device Maximum Ratings $T_C = 25^\circ\text{C}$ unless otherwise noted

Symbol	Parameter	Ratings	Units
V_{RRM}	Repetitive Peak Reverse Voltage	600	V
V_{RWM}	Working Peak Reverse Voltage	600	V
V_R	DC Blocking Voltage	600	V
$I_{F(AV)}$	Average Rectified Forward Current ($T_C = 25^\circ\text{C}$)	15	A
I_{FRM}	Repetitive Peak Surge Current (20kHz Square Wave)	30	A
I_{FSM}	Nonrepetitive Peak Surge Current (Halfwave 1 Phase 60Hz)	200	A
P_D	Power Dissipation	30	W
E_{AVL}	Avalanche Energy (1A, 40mH)	20	mJ
T_J, T_{STG}	Operating and Storage Temperature Range	-55 to 150	°C
T_L	Maximum Temperature for Soldering Leads at 0.063in (1.6mm) from Case for 10s	300	°C

CAUTION: Stresses above those listed in "Device Maximum Ratings" may cause permanent damage to the device. This is a stress only rating and operation of the device at these or any other conditions above those indicated in the operational sections of this specification is not implied.

MMBT5401

PNP General Purpose Amplifier

- This device is designed as a general purpose amplifier and switch for applications requiring high voltage.

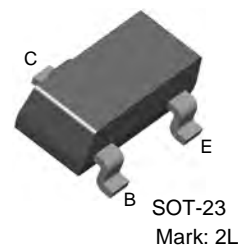

PNP Epitaxial Silicon Transistor

Absolute Maximum Ratings* $T_a=25^\circ\text{C}$ unless otherwise noted

Symbol	Parameter	Value	Units
V_{CEO}	Collector-Emitter Voltage	-150	V
V_{CBO}	Collector-Base Voltage	-160	V
V_{EBO}	Emitter-Base Voltage	-5.0	V
I_C	Collector Current - Continuous	-600	mA
T_J, T_{STG}	Operating and Storage Junction Temperature Range	-55 ~ 150	$^\circ\text{C}$

* These ratings are limiting values above which the serviceability of any semiconductor device may be impaired.

Notes:

- These ratings are based on a maximum junction temperature of 150 degrees C.
- These are steady state limits. The factory should be consulted on applications involving pulsed or low duty cycle operations.

Electrical Characteristics $T_a=25^\circ\text{C}$ unless otherwise noted

Symbol	Parameter	Test Condition	Min.	Max.	Units
Off Characteristics					
BV_{CEO}	Collector-Emitter Breakdown Voltage *	$I_C = -1.0\text{mA}, I_B = 0$	-150		V
BV_{CBO}	Collector-Base Breakdown Voltage	$I_C = -100\mu\text{A}, I_E = 0$	-160		V
BV_{EBO}	Emitter-Base Breakdown Voltage	$I_E = -10\mu\text{A}, I_C = 0$	-5.0		V
I_{CBO}	Collector Cutoff Current	$V_{CB} = -120\text{V}, I_E = 0$ $V_{CB} = -120\text{V}, I_E = 0, T_a = 100^\circ\text{C}$		-50	nA μA
I_{EBO}	Emitter Cutoff Current	$V_{EB} = -3.0\text{V}, I_C = 0$		-50	nA
On Characteristics *					
h_{FE}	DC Current Gain	$I_C = -1.0\text{mA}, V_{CE} = -5.0\text{V}$ $I_C = -10\text{mA}, V_{CE} = -5.0\text{V}$ $I_C = -50\text{mA}, V_{CE} = -5.0\text{V}$	50 60 50	240	
$V_{CE}(\text{sat})$	Collector-Emitter Saturation Voltage	$I_C = -10\text{mA}, I_B = -1.0\text{mA}$ $I_C = -50\text{mA}, I_B = -5.0\text{mA}$		-0.2 -0.5	V V
$V_{BE}(\text{sat})$	Base-Emitter Saturation Voltage	$I_C = -10\text{mA}, I_B = -1.0\text{mA}$ $I_C = -50\text{mA}, I_B = -5.0\text{mA}$		-1.0 -1.0	V V
Small Signal Characteristics					
f_T	Current Gain Bandwidth Product	$I_C = -10\text{mA}, V_{CE} = -10\text{V}$, $f = 100\text{MHz}$	100	300	MHz
C_{ob}	Output Capacitance	$V_{CB} = -10\text{V}, I_E = 0, f = 1\text{MHz}$		6.0	pF
N_F	Noise Figure	$I_C = -250\mu\text{A}, V_{CE} = -5.0\text{V}, R_S = 1.0\text{K}\Omega$ $f = 10\text{Hz to } 15.7\text{KHz}$		8.0	dB

* Pulse Test: Pulse Width $\leq 300\mu\text{s}$, Duty Cycle $\leq 2.0\%$

2N5551 / MMBT5551

NPN General Purpose Amplifier

Features

- This device is designed for general purpose high voltage amplifiers and gas discharge display drivers.
- Suffix “-C” means Center Collector in 2N5551 (1. Emitter 2. Collector 3. Base)
- Suffix “-Y” means h_{FE} 180~240 in 2N5551 (Test condition : $I_C = 10\text{mA}$, $V_{CE} = 5.0\text{V}$)

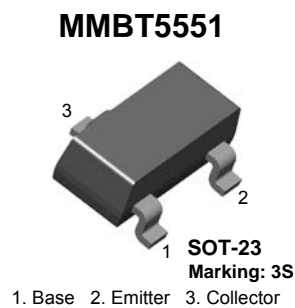
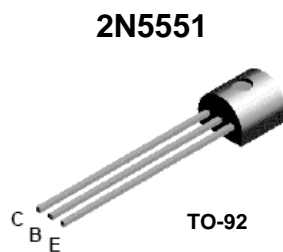

Absolute Maximum Ratings * $T_A = 25^\circ\text{C}$ unless otherwise noted

Symbol	Parameter	Value	Units
V_{CEO}	Collector-Emitter Voltage	160	V
V_{CBO}	Collector-Base Voltage	180	V
V_{EBO}	Emitter-Base Voltage	6.0	V
I_C	Collector current - Continuous	600	mA
T_J, T_{stg}	Junction and Storage Temperature	-55 to +150	$^\circ\text{C}$

* These ratings are limiting values above which the serviceability of any semiconductor device may be impaired.

NOTES:

1. These ratings are based on a maximum junction temperature of 150 degrees C.
2. These are steady state limits. The factory should be consulted on applications involving pulsed or low duty cycle operations.

Thermal Characteristics $T_A=25^\circ\text{C}$ unless otherwise noted

Symbol	Parameter	Max		Units
		2N5551	*MMBT5551	
P_D	Total Device Dissipation	625	350	mW
	Derate above 25°C	5.0	2.8	$\text{mW}/^\circ\text{C}$
$R_{\theta JC}$	Thermal Resistance, Junction to Case	83.3		$^\circ\text{C}/\text{W}$
$R_{\theta JA}$	Thermal Resistance, Junction to Ambient	200	357	$^\circ\text{C}/\text{W}$

* Device mounted on FR-4 PCB 1.6" \times 1.6" \times 0.06."

MUR1610CT, MUR1615CT, MUR1620CT, MUR1640CT, MUR1660CT

SWITCHMODE™ Power Rectifiers

... designed for use in switching power supplies, inverters and as free wheeling diodes, these state-of-the-art devices have the following features:

- Ultrafast 35 and 60 Nanosecond Recovery Times
- 175°C Operating Junction Temperature
- Popular TO-220 Package
- Epoxy Meets UL94, V_O @ 1/8"
- High Temperature Glass Passivated Junction
- High Voltage Capability to 600 Volts
- Low Leakage Specified @ 150°C Case Temperature
- Current Derating @ Both Case and Ambient Temperatures

Mechanical Characteristics:

- Case: Epoxy, Molded
- Weight: 1.9 grams (approximately)
- Finish: All External Surfaces Corrosion Resistant and Terminal Leads are Readily Solderable
- Lead Temperature for Soldering Purposes: 260°C Max. for 10 Seconds
- Shipped 50 units per plastic tube
- Marking: U1610, U1615, U1620, U1640, U1660

MAXIMUM RATINGS

Please See the Table on the Following Page



<http://onsemi.com>

**ULTRAFAST
RECTIFIERS
8.0 AMPERES
100-600 VOLTS**

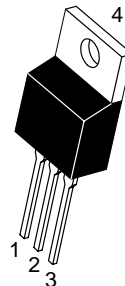
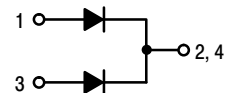

**TO-220AB
CASE 221A
PLASTIC**

MARKING DIAGRAM

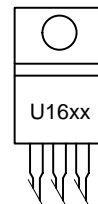

U16xx = Device Code
xx = 10, 15, 20, 40 or 60

ORDERING INFORMATION

Device	Package	Shipping
MUR1610CT	TO-220	50 Units/Rail
MUR1615CT	TO-220	50 Units/Rail
MUR1620CT	TO-220	50 Units/Rail
MUR1640CT	TO-220	50 Units/Rail
MUR1660CT	TO-220	50 Units/Rail

MUR1620CTR, MURB1620CTR

Preferred Device

SWITCHMODE™ Power Rectifier

These state-of-the-art devices are designed for use in negative switching power supplies, inverters and as free wheeling diodes. Also, used in conjunction with common cathode dual Ultrafast Rectifiers, makes a single phase full-wave bridge.

Features

- Common Anode Dual Rectifier (8.0 A per Leg or 16 A per Package)
- Ultrafast 35 Nanosecond Reverse Recovery Times
- Exhibits Soft Recovery Characteristics
- High Temperature Glass Passivated Junction
- Low Leakage Specified @ 150°C Case Temperature
- Current Derating @ Both Case and Ambient Temperatures
- Epoxy Meets UL 94 V-0 @ 0.125 in
- Complement to MUR1620CT and MURB1620CT Common Cathode Device
- Pb-Free Packages are Available

Mechanical Characteristics:

- Case: Epoxy, Molded
- Weight: MUR1620CTR: 1.9 Grams (Approximately)
MURB1620CTR: 1.7 Grams (Approximately)
- Finish: All External Surfaces Corrosion Resistant and Terminal Leads are Readily Solderable
- Lead Temperature for Soldering Purposes:
260°C Max. for 10 Seconds

MAXIMUM RATINGS (Per Leg)

Rating	Symbol	Value	Unit
Peak Repetitive Reverse Voltage Working Peak Reverse Voltage DC Blocking Voltage	V_{RRM} V_{RWM} V_R	200	V
Average Rectified Forward Voltage (Rated V_R , $T_C = 160^\circ\text{C}$) Per Leg Per Total Device	$I_{F(AV)}$	8.0 16	A
Peak Repetitive Surge Current (Rated V_R , Square Wave, 20 kHz, $T_C = 140^\circ\text{C}$) Per Diode	I_{FM}	16	A
Non-Repetitive Peak Surge Current (Surge Applied at Rated Load Conditions Halfwave, Single Phase, 60 Hz)	I_{FSM}	100	A
Operating Junction and Storage Temperature Range	T_J, T_{stg}	-65 to +175	°C

Stresses exceeding Maximum Ratings may damage the device. Maximum Ratings are stress ratings only. Functional operation above the Recommended Operating Conditions is not implied. Extended exposure to stresses above the Recommended Operating Conditions may affect device reliability.



ON Semiconductor®

<http://onsemi.com>

ULTRAFAST RECTIFIER 16 AMPERES, 200 VOLTS

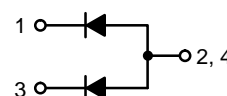

MARKING DIAGRAMS

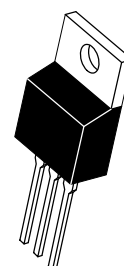

TO-220AB
CASE 221A
STYLE 7

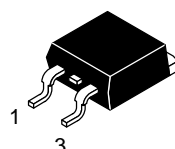

D²PAK
CASE 418B
STYLE 5



U1620R = Device Code
KAK = Diode Polarity
A = Assembly Location
Y = Year
WW = Work Week
G = Pb-Free Package

ORDERING INFORMATION

See detailed ordering and shipping information in the package dimensions section on page 4 of this data sheet.

Preferred devices are recommended choices for future use and best overall value.

S8050LT1 TRANSISTOR (NPN)

FEATURES

Power dissipation

P_{CM} : 0.3 W ($T_{amb}=25^{\circ}C$)

Collector current

I_{CM} : 0.5 A

Collector-base voltage

$V_{(BR)CBO}$: 40 V

Operating and storage junction temperature range

T_J, T_{stg} : $-55^{\circ}C$ to $+150^{\circ}C$

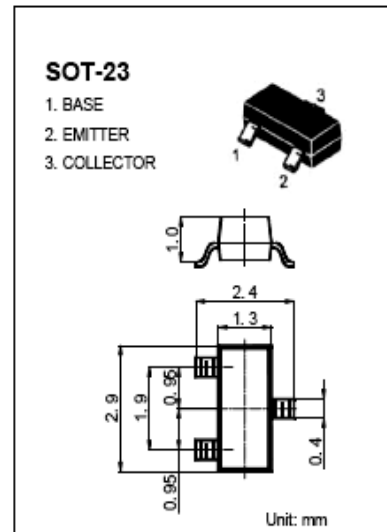

ELECTRICAL CHARACTERISTICS ($T_{amb}=25^{\circ}C$ unless otherwise specified)

Parameter	Symbol	Test conditions	MIN	TYP	MAX	UNIT
Collector-base breakdown voltage	$V_{(BR)CBO}$	$I_C=100\mu A, I_E=0$	40			V
Collector-emitter breakdown voltage	$V_{(BR)CEO}$	$I_C=1mA, I_B=0$	25			V
Emitter-base breakdown voltage	$V_{(BR)EBO}$	$I_E=100\mu A, I_C=0$	5			V
Collector cut-off current	I_{CBO}	$V_{CB}=40V, I_E=0$			0.1	μA
Collector cut-off current	I_{CEO}	$V_{CB}=20V, I_E=0$			0.1	μA
Emitter cut-off current	I_{EBO}	$V_{EB}=5V, I_C=0$			0.1	μA
DC current gain	$h_{FE(1)}$	$V_{CE}=1V, I_C=50mA$	120		350	
	$h_{FE(2)}$	$V_{CE}=1V, I_C=500mA$	50			
Collector-emitter saturation voltage	$V_{CE(sat)}$	$I_C=500mA, I_B=50mA$			0.6	V
Base-emitter saturation voltage	$V_{BE(sat)}$	$I_C=500mA, I_B=50mA$			1.2	V
Transition frequency	f_T	$V_{CE}=6V, I_C=20mA$ $f=30MHz$	150			MHz

CLASSIFICATION OF $h_{FE(1)}$

Rank	L	H
Range	120-200	200-350

S8550LT1 TRANSISTOR (PNP)

FEATURES

Power dissipation

$$P_{CM}: 0.3 \text{ W (Tamb=25°C)}$$

Collector current

$$I_{CM}: -0.5 \text{ A}$$

Collector-base voltage

$$V_{(BR)CBO}: -40 \text{ V}$$

Operating and storage junction temperature range

$$T_J, T_{stg}: -55°C \text{ to } +150°C$$

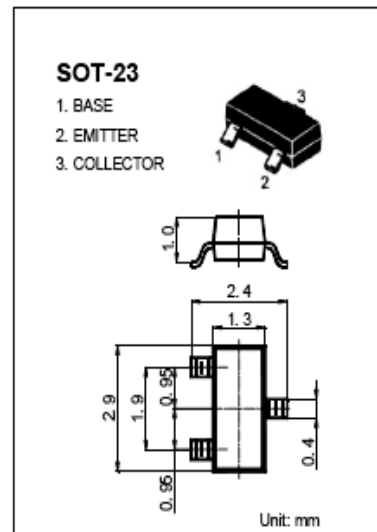

ELECTRICAL CHARACTERISTICS (Tamb=25°C unless otherwise specified)

Parameter	Symbol	Test conditions	MIN	MAX	UNIT
Collector-base breakdown voltage	$V_{(BR)CBO}$	$I_C = -100\mu A, I_E = 0$	-40		V
Collector-emitter breakdown voltage	$V_{(BR)CEO}$	$I_C = -1mA, I_B = 0$	-25		V
Emitter-base breakdown voltage	$V_{(BR)EBO}$	$I_E = -100\mu A, I_C = 0$	-5		V
Collector cut-off current	I_{CBO}	$V_{CB} = -40V, I_E = 0$		-0.1	μA
Collector cut-off current	I_{CEO}	$V_{CE} = -20V, I_B = 0$		-0.1	μA
Emitter cut-off current	I_{EBO}	$V_{EB} = -3V, I_C = 0$		-0.1	μA
DC current gain	$h_{FE(1)}$	$V_{CE} = -1V, I_C = -50mA$	120	350	
	$h_{FE(2)}$	$V_{CE} = -1V, I_C = -500mA$	50		
Collector-emitter saturation voltage	$V_{CE(sat)}$	$I_C = -500mA, I_B = -50mA$		-0.6	V
Base-emitter saturation voltage	$V_{BE(sat)}$	$I_C = -500mA, I_B = -50mA$		-1.2	V
Transition frequency	f_T	$V_{CE} = -6V, I_C = -20mA$ $f = 30MHz$	150		MHz

CLASSIFICATION OF $h_{FE(1)}$

Rank	L	H
Range	120-200	200-350

TIP31 Series(TIP31/31A/31B/31C)

Medium Power Linear Switching Applications

- Complementary to TIP32/32A/32B/32C

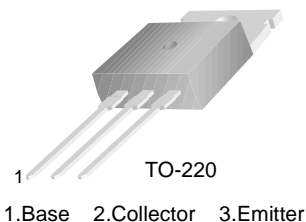

NPN Epitaxial Silicon Transistor

Absolute Maximum Ratings $T_C=25^\circ\text{C}$ unless otherwise noted

Symbol	Parameter	Value	Units
V_{CBO}	Collector-Base Voltage : TIP31	40	V
	: TIP31A	60	V
	: TIP31B	80	V
	: TIP31C	100	V
V_{CEO}	Collector-Emitter Voltage : TIP31	40	V
	: TIP31A	60	V
	: TIP31B	80	V
	: TIP31C	100	V
V_{EBO}	Emitter-Base Voltage	5	V
I_C	Collector Current (DC)	3	A
I_{CP}	Collector Current (Pulse)	5	A
I_B	Base Current	1	A
P_C	Collector Dissipation ($T_C=25^\circ\text{C}$)	40	W
P_C	Collector Dissipation ($T_a=25^\circ\text{C}$)	2	W
T_J	Junction Temperature	150	$^\circ\text{C}$
T_{STG}	Storage Temperature	- 65 ~ 150	$^\circ\text{C}$

Electrical Characteristics $T_C=25^\circ\text{C}$ unless otherwise noted

Symbol	Parameter	Test Condition	Min.	Max.	Units
$V_{CEO(sus)}$	* Collector-Emitter Sustaining Voltage : TIP31	$I_C = 30\text{mA}, I_B = 0$	40		V
	: TIP31A				V
	: TIP31B				V
	: TIP31C				V
I_{CEO}	Collector Cut-off Current : TIP31/31A	$V_{CE} = 30\text{V}, I_B = 0$		0.3	mA
	: TIP31B/31C	$V_{CE} = 60\text{V}, I_B = 0$		0.3	mA
I_{CES}	Collector Cut-off Current : TIP31	$V_{CE} = 40\text{V}, V_{EB} = 0$		200	μA
	: TIP31A	$V_{CE} = 60\text{V}, V_{EB} = 0$		200	μA
	: TIP31B	$V_{CE} = 80\text{V}, V_{EB} = 0$		200	μA
	: TIP31C	$V_{CE} = 100\text{V}, V_{EB} = 0$		200	μA
I_{EBO}	Emitter Cut-off Current	$V_{EB} = 5\text{V}, I_C = 0$		1	mA
h_{FE}	* DC Current Gain	$V_{CE} = 4\text{V}, I_C = 1\text{A}$	25		
		$V_{CE} = 4\text{V}, I_C = 3\text{A}$	10	50	
$V_{CE(sat)}$	* Collector-Emitter Saturation Voltage	$I_C = 3\text{A}, I_B = 375\text{mA}$		1.2	V
$V_{BE(sat)}$	* Base-Emitter Saturation Voltage	$V_{CE} = 4\text{V}, I_C = 3\text{A}$		1.8	V
f_T	Current Gain Bandwidth Product	$V_{CE} = 10\text{V}, I_C = 500\text{mA}$	3.0		MHz

* Pulse Test: $PW \leq 300\mu\text{s}$, Duty Cycles $\leq 2\%$

TIP32 Series(TIP32/32A/32B/32C)

Medium Power Linear Switching Applications

- Complement to TIP31/31A/31B/31C

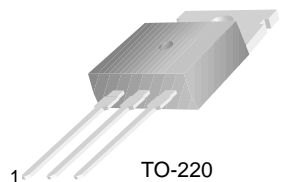

1.Base 2.Collector 3.Emitter

PNP Epitaxial Silicon Transistor

Absolute Maximum Ratings $T_C=25^\circ\text{C}$ unless otherwise noted

Symbol	Parameter	Value	Units
V_{CBO}	Collector-Base Voltage : TIP32 : TIP32A : TIP32B : TIP32C	- 40	V
		- 60	V
		- 80	V
		- 100	V
V_{CEO}	Collector-Emitter Voltage : TIP32 : TIP32A : TIP32B : TIP32C	- 40	V
		- 60	V
		- 80	V
		-100	V
V_{EBO}	Emitter-Base Voltage	- 5	V
I_C	Collector Current (DC)	- 3	A
I_{CP}	Collector Current (Pulse)	- 5	A
I_B	Base Current	- 3	A
P_C	Collector Dissipation ($T_C=25^\circ\text{C}$)	40	W
P_C	Collector Dissipation ($T_a=25^\circ\text{C}$)	2	W
T_J	Junction Temperature	150	$^\circ\text{C}$
T_{STG}	Storage Temperature	- 65 ~ 150	$^\circ\text{C}$

Electrical Characteristics $T_C=25^\circ\text{C}$ unless otherwise noted

Symbol	Parameter	Test Condition	Min.	Max.	Units
$V_{CEO(sus)}$	* Collector-Emitter Sustaining Voltage : TIP32 : TIP32A : TIP32B : TIP32C	$I_C = - 30\text{mA}, I_B = 0$	-40		V
			-60		V
			-80		V
			-100		V
I_{CEO}	Collector Cut-off Current : TIP32/32A : TIP32B/32C	$V_{CE} = - 30\text{V}, I_B = 0$		- 0.3	mA
		$V_{CE} = - 60\text{V}, I_B = 0$		- 0.3	mA
I_{CES}	Collector Cut-off Current : TIP32 : TIP32A : TIP32B : TIP32C	$V_{CE} = - 40\text{V}, V_{EB} = 0$		- 200	μA
		$V_{CE} = - 60\text{V}, V_{EB} = 0$		- 200	μA
		$V_{CE} = - 80\text{V}, V_{EB} = 0$		- 200	μA
		$V_{CE} = - 100\text{V}, V_{CE} = 0$		- 200	μA
I_{EBO}	Emitter Cut-off Current	$V_{EB} = - 5\text{V}, I_C = 0$		- 1	mA
h_{FE}	* DC Current Gain	$V_{CE} = - 4\text{V}, I_C = - 1\text{A}$	25		
		$V_{CE} = - 4\text{V}, I_C = - 3\text{A}$	10	50	
$V_{CE(sat)}$	* Collector-Emitter Saturation Voltage	$I_C = - 3\text{A}, I_B = - 375\text{mA}$		- 1.2	V
$V_{BE(sat)}$	* Base-Emitter Saturation Voltage	$V_{CE} = - 4\text{V}, I_C = - 3\text{A}$		- 1.8	V
f_T	Current Gain Bandwidth Product	$V_{CE} = - 10\text{V}, I_C = - 500\text{mA}$	3.0		MHz

* Pulse Test: $PW \leq 300\mu\text{s}$, Duty Cycle $\leq 2\%$

AMP PCB 1/2

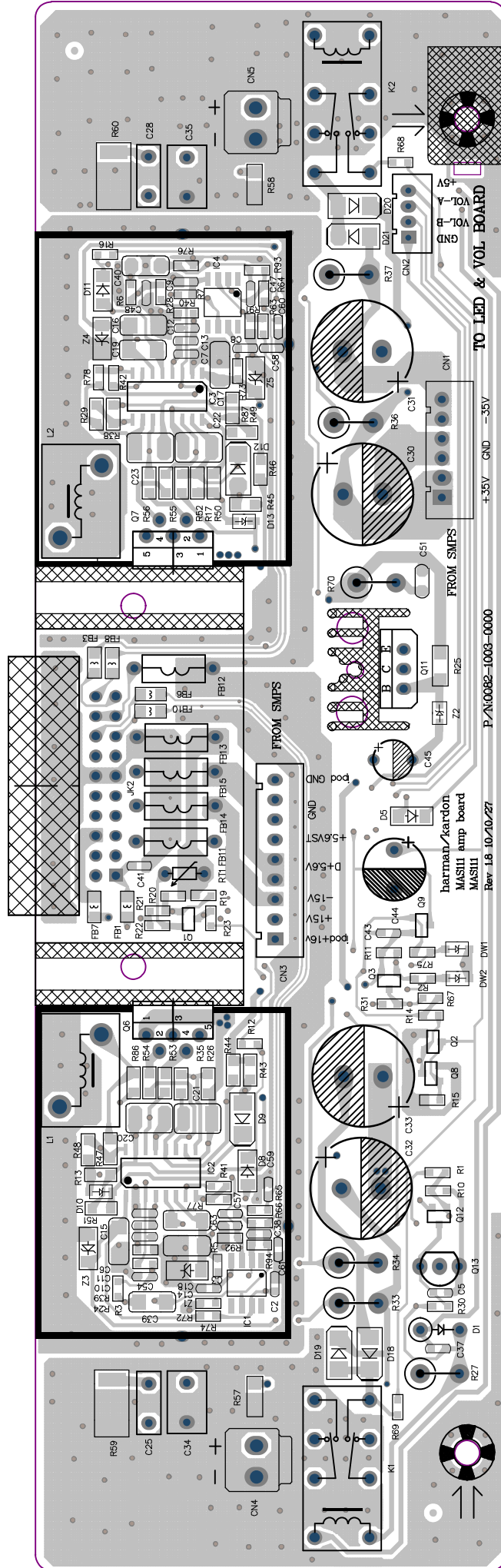

AMP PCB 2/2

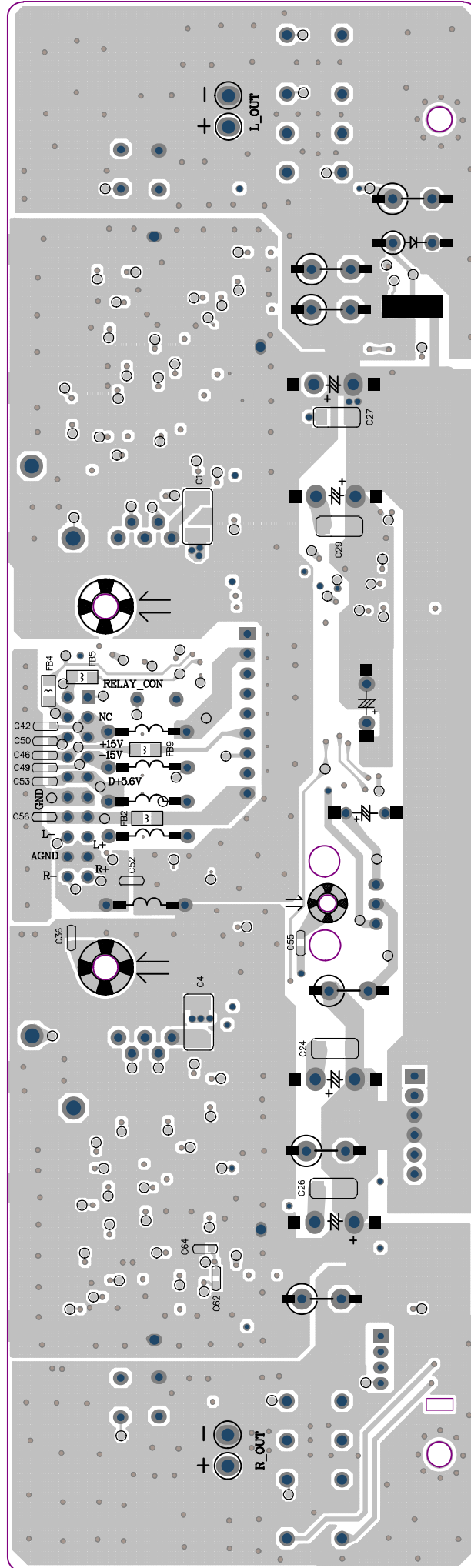

POWER PCB 1/2

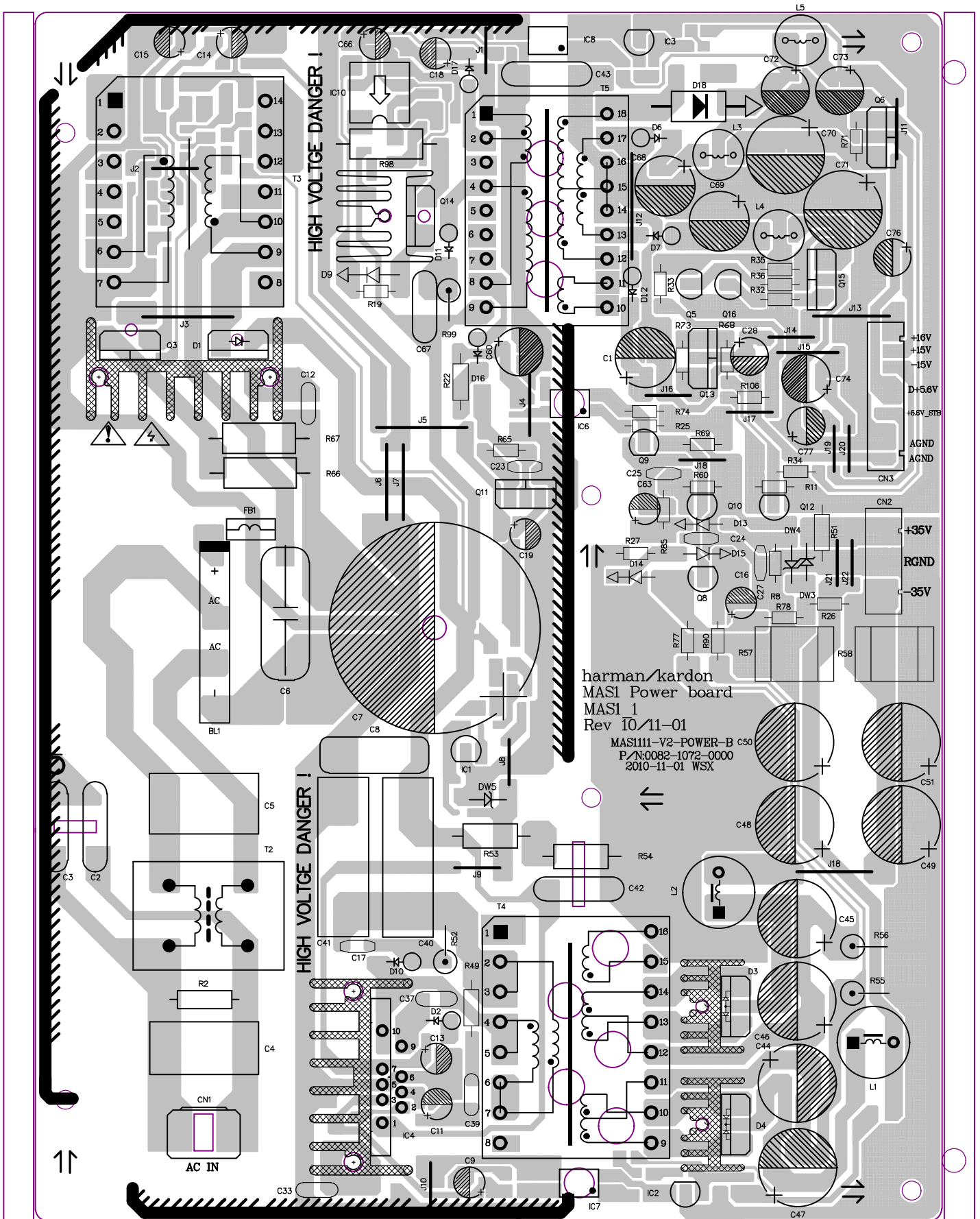

POWER PCB 2/2

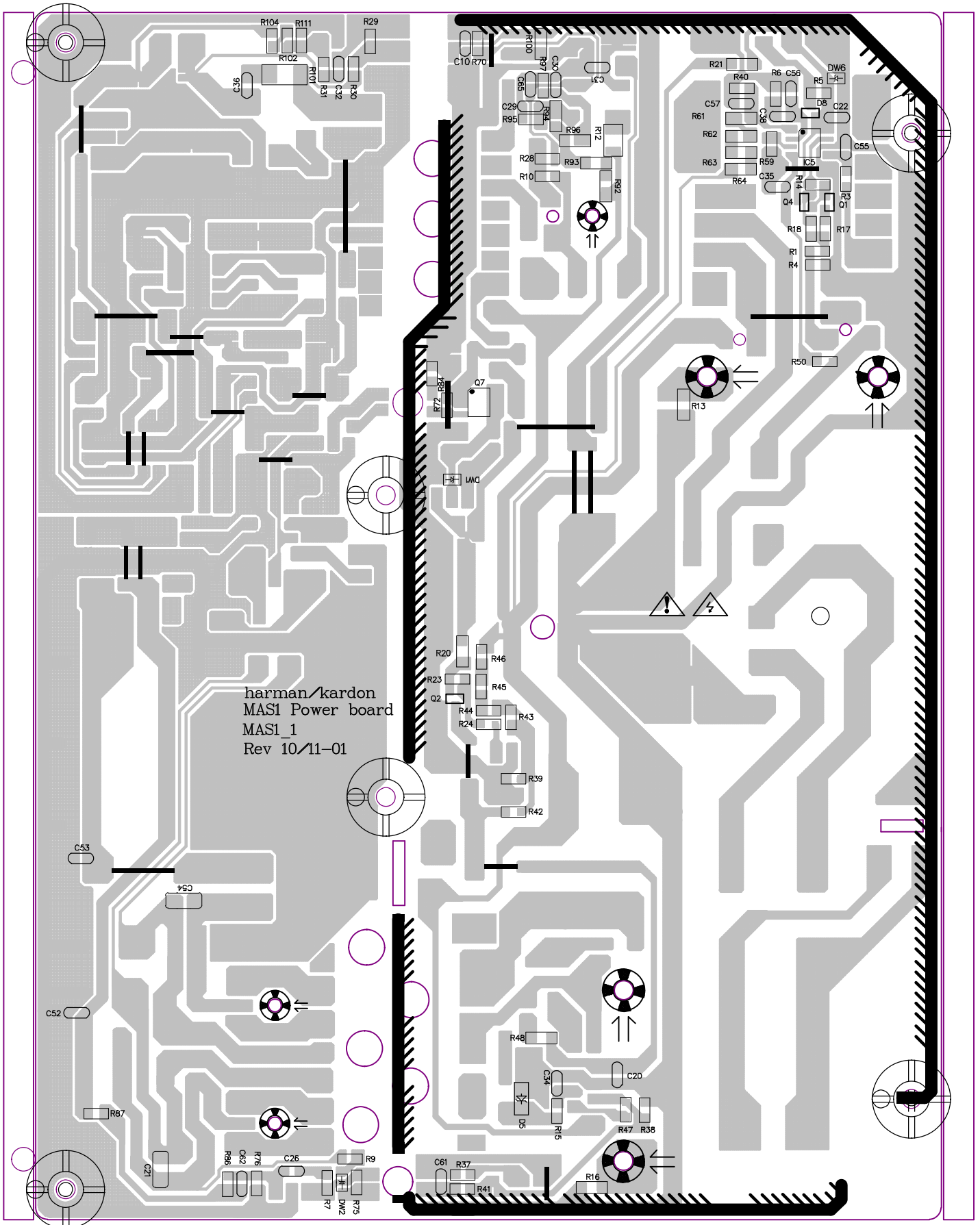

LED & VOL PCB / FUSE PCB

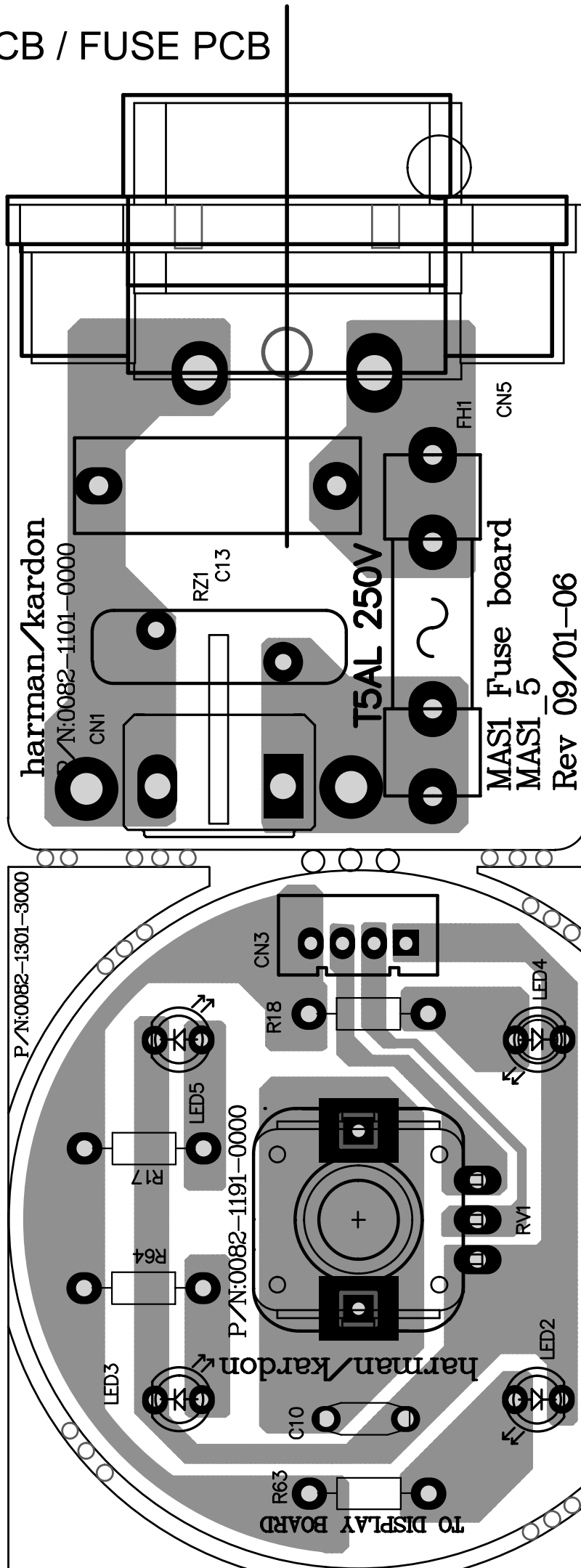

SPEAKER JOINT
PCB (1/2)

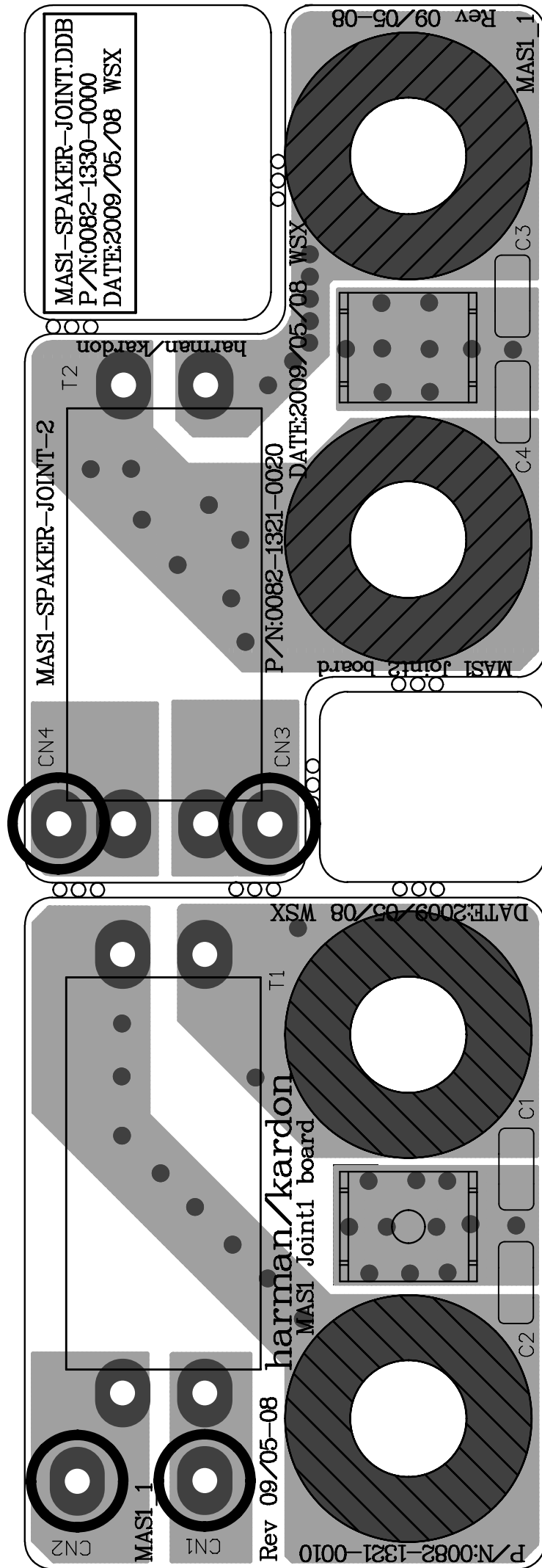

SPEAKER JOINT
PCB(2/2)

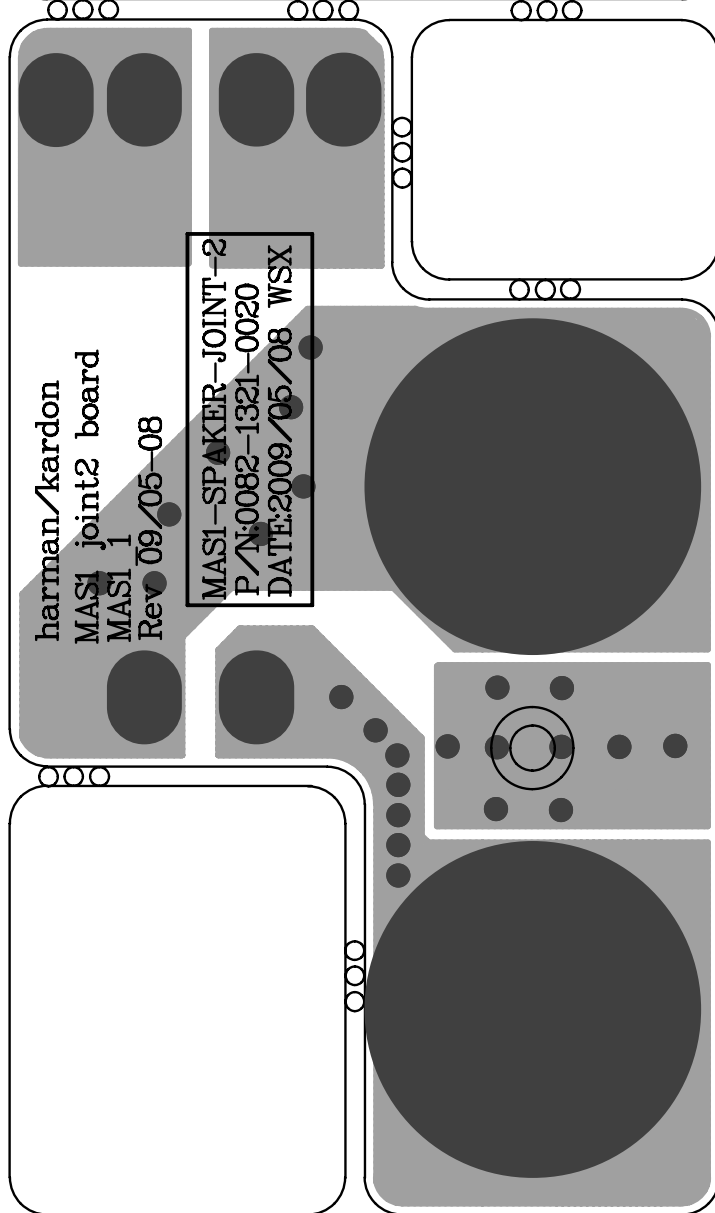
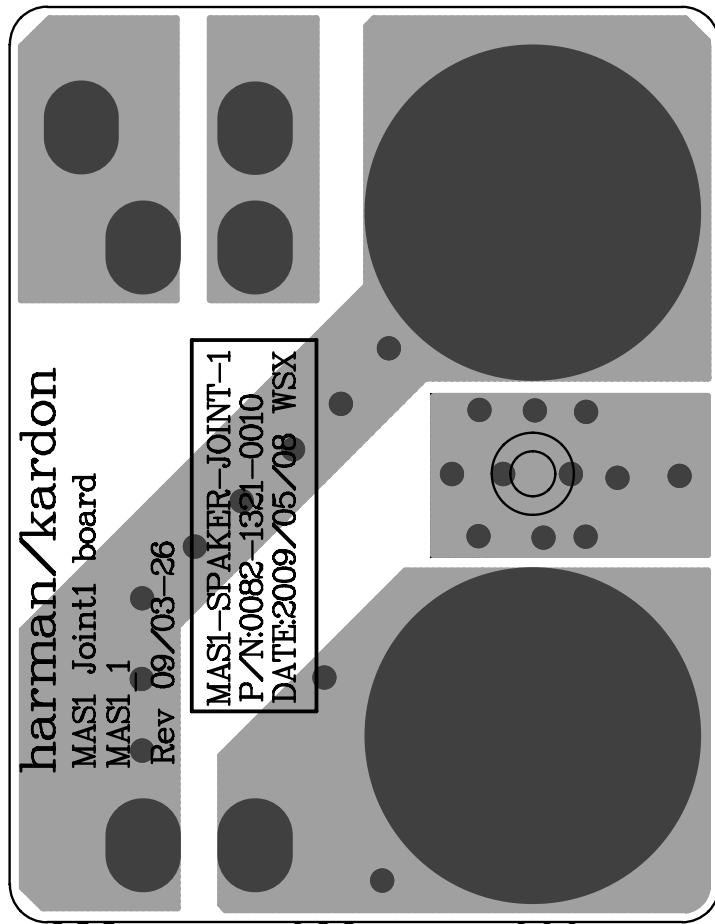

AMP SCH

KF-YL-03

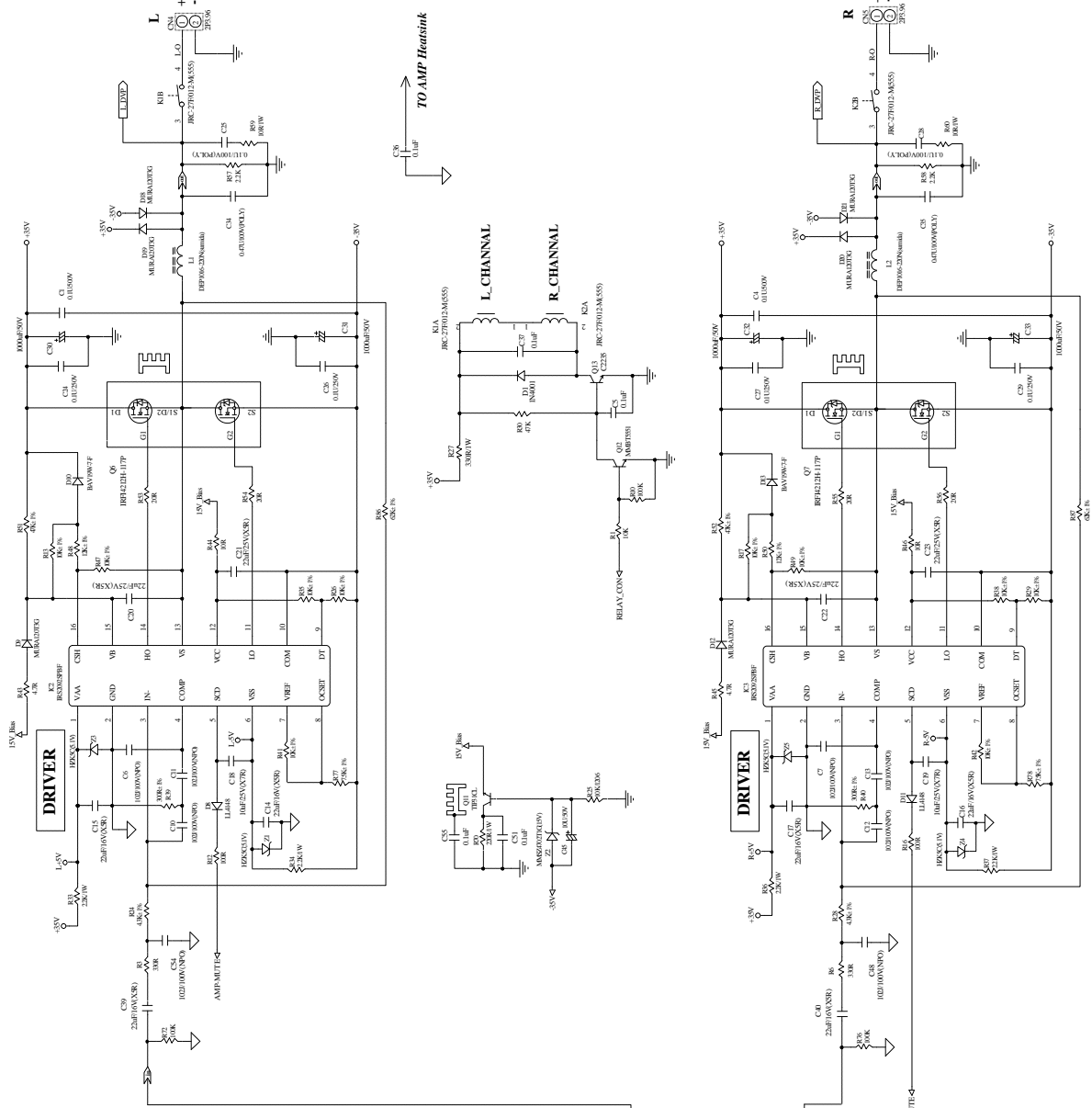

TO AMP HeatSink

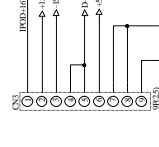
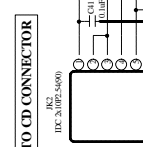
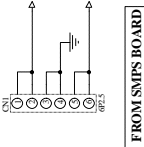
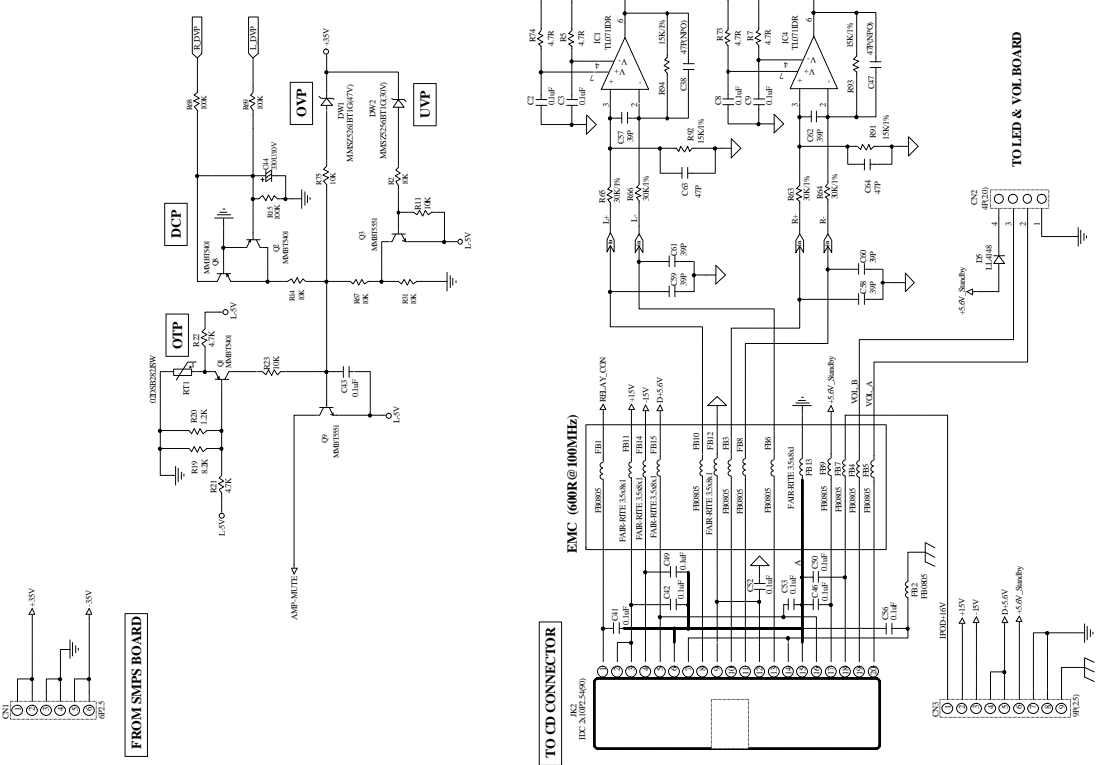
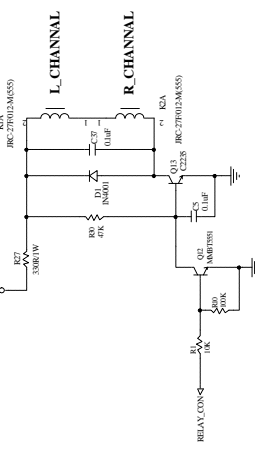

AMP-SMPS

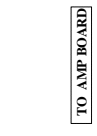
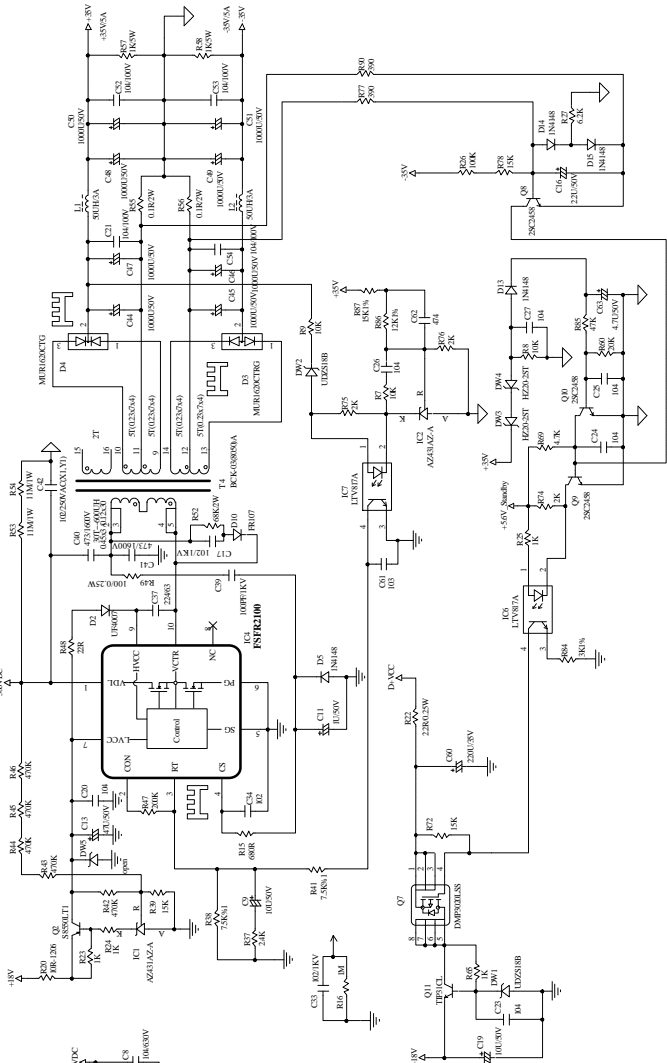

PFC

TERMINAL BIRTH

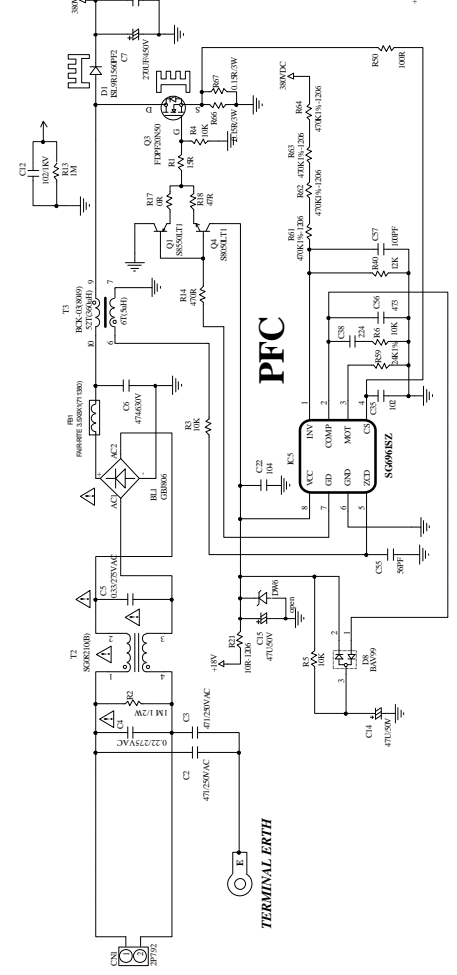

CD-SMPS

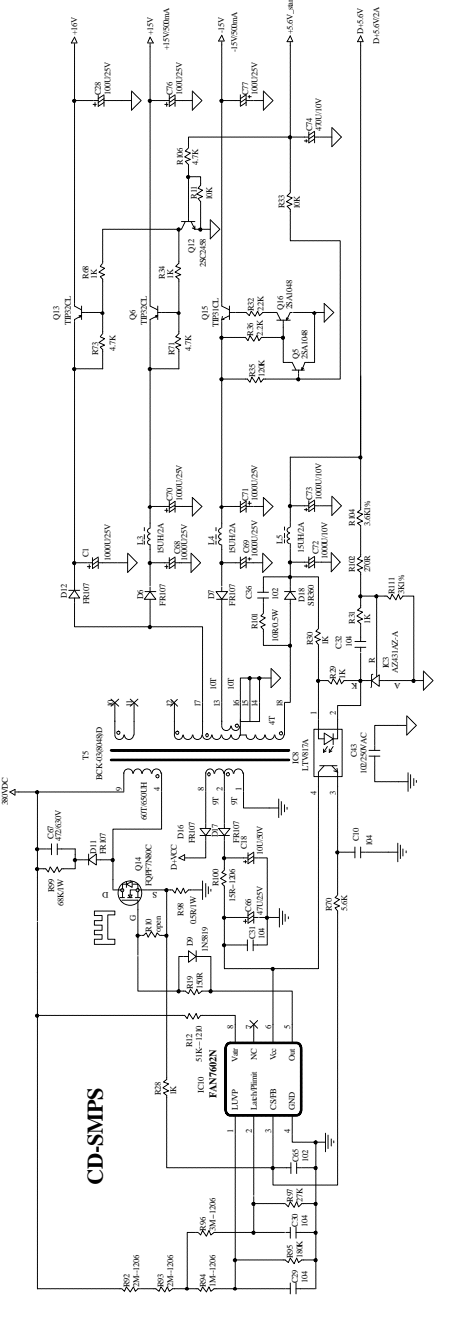

LED & VOL SCH / FUSE SCH

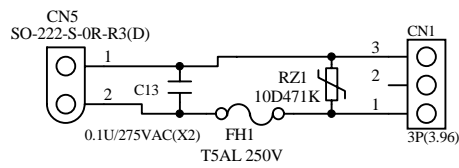
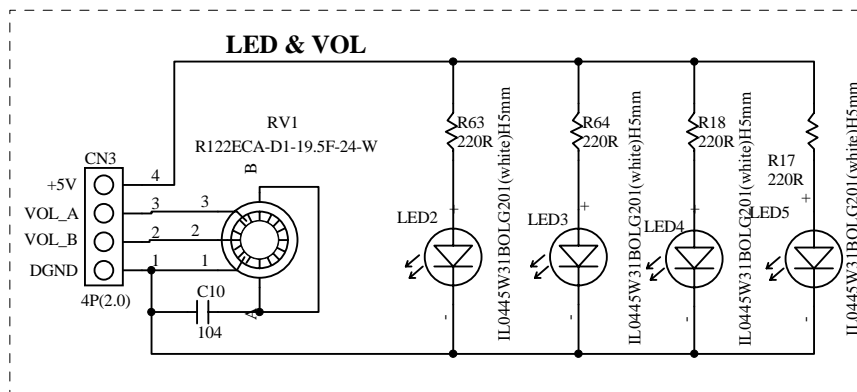

SPEAKER JIONT SCH

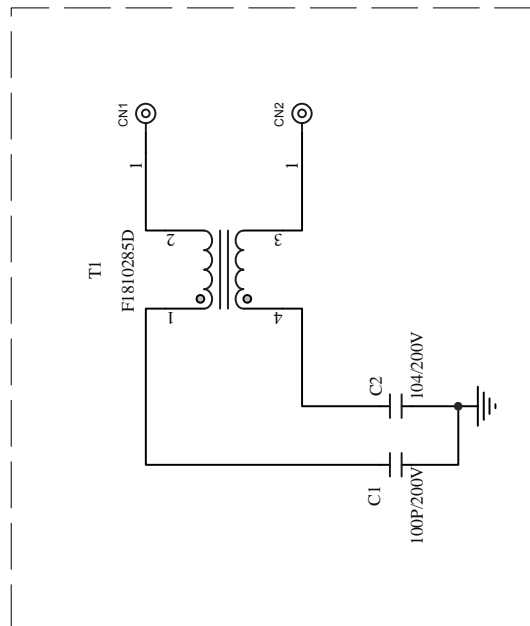
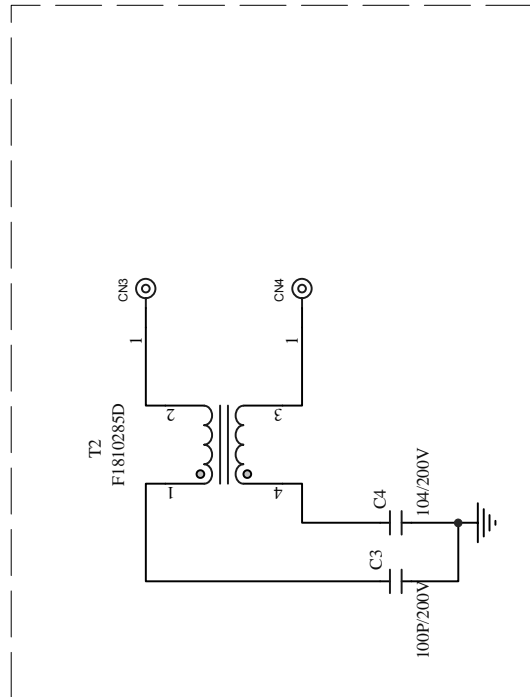

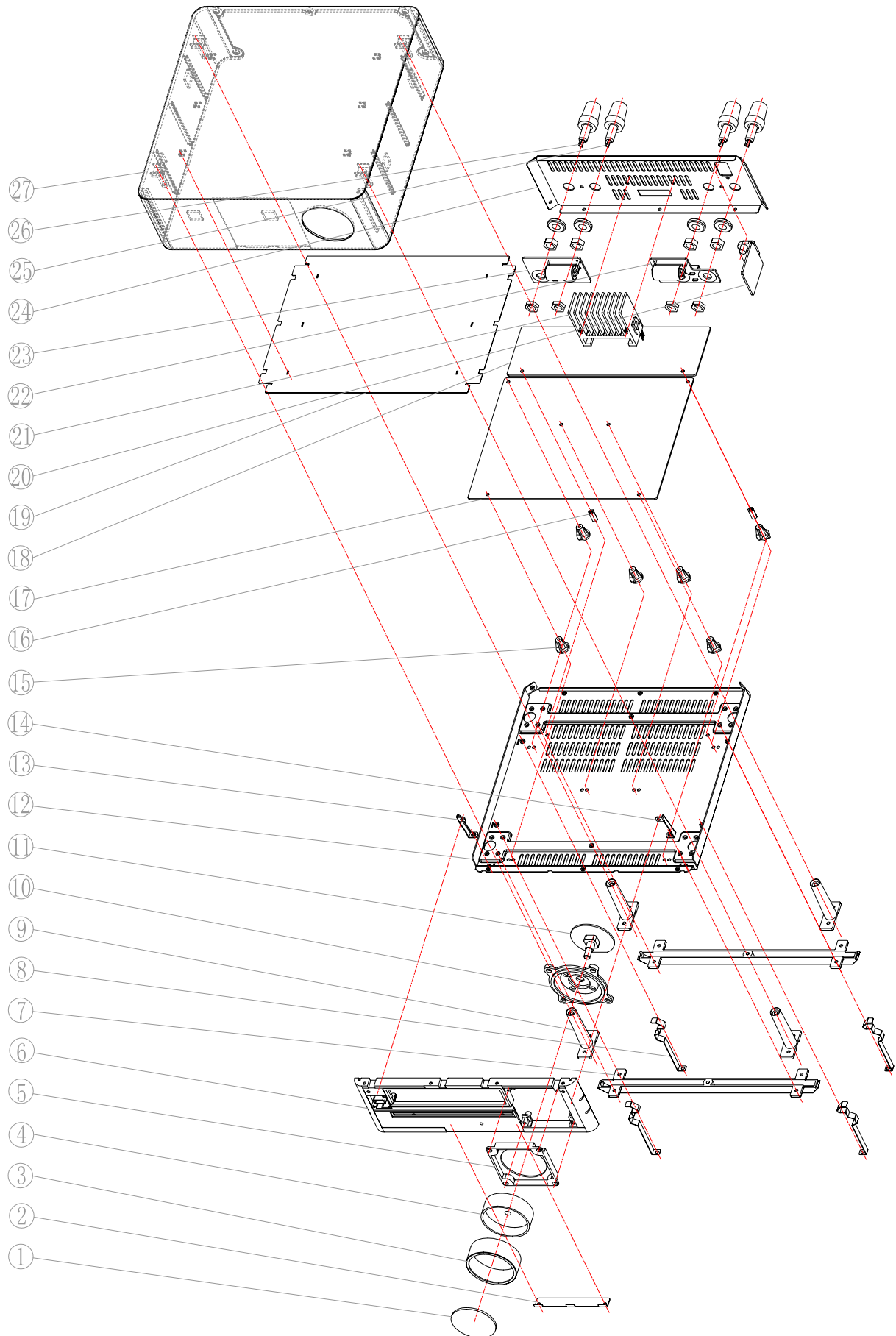

MAS AMP Explode List

NO	PART.NO	DESCRIPTION	QTY
1	7448 1020 0000	VOLUME KNOB LENS	1
2	6950 102A 0000	LOCK SHEET	1
3	7548 101C 0000	VOLUME PASTEM	1
4	7648 1010 0000	VOLUME KNOB COVER	1
5	7550 1020 0000	VOLUME KNOB BRACKET	1
6	7550 501A 0000	SUB PANEL	1
7	7950 5020 0000	FOOT	2
8	5550 102D 0000	GROUNDING COPPER SHEET	4
9	7550 502A 0000	PLASTIC POST	4
10	7549 102B 0000	LAMPSHADE	1
11	0082 1191 0000	LED PCB	1
12	6250 1010 0011	BUTTOM COVER	1
13	5350 5020 0000	SUB PANEL RIGHT BRACKET	1
14	5350 503A 0000	SUB PANEL LEFT BRACKET	1
15	7900 0040 0000	PCB PLASTIC POST	6
16	5350 1010 0000	M3x12 COPPER POST	2
17	0082 1072 0000	POWER PCB	1
18	0082 1003 0000	AMP PCB	1
19	5650 101A 0000	POWER PCB SHIELDING SHEET	1
20	0082 1101 0000	FUSE PCB	1
21	5150 1010 0000	HEATSINK	1
22	0082 1321 0020	SPEAKER JOINT PCB-1	1
23	0082 1321 0010	SPEAKER JOINT PCB-1	1
24	6350 101C 0011	BACK COVER	1
25	2920 0290 6003	SPEAKER Terminal	2
26	2920 0300 6003	SPEAKER Terminal	2
27	7950 1010 0000	TOP COVER	1

Qty	Part Type	Ref. Designator	Part Number
	AMP.Bom P/N: 0082-1003-0000		
2	IRS2092SPBF (IRF) Protected Digital Audio amplifier	IC2 IC3	1002 0920 3038
2	TL071IDR (TI) Low Noise OP Amp	IC1 IC4	1002 0920 3038
1	2SC2235 - TRANSISTOR	Q13	1132 2350 0162
2	IRFI4212H-117P (IRF) Digital Audio Mosfet	Q6 Q7	1194 2120 1630
3	MMBT5401 - TRANSISTOR	Q1 Q2 Q8	1185 4015 1011
3	MMBT5551 - TRANSISTOR	Q3 Q9 Q12	1185 5515 1011
1	TIP31CL - TRANSISTOR	Q11	1110 0310 6000
2	BAV19W-7-F - DIODE	D10 D13	1321 0005 0100
3	LL4148 - DIODE	D5 D8 D11	1301 4148 0100
1	1N4001 - DIODE , RECT	D1	1360 1400 1005
1	MMSZ4702T1G(15V) - DIODE ZENER	Z2	1301 5002 0100
1	MMSZ5256BT1G(30V) - DIODE ZENER	DW2	1303 0002 0100
1	MMSZ5261BT1G(47V) - DIODE ZENER	DW1	1304 7002 0100
6	MURA120T3G - DIODE ULTRA FAST	D9 D12 D18 D19 D20 D21	1301 2035 0100
4	HZK5C(5.1V) - DIODE ZENER	Z1 Z3 Z4 Z5	1300 5100 0000
2	DEP1016-220N(sumida)	L1 L2	1842 2010 0001
1	02DSB282JSW	RT1	1609 0002 8225
5	FAIR-RITE 3.5x8x1	FB11 FB12 FB13 FB14 FB15	1893 8780 0001
10	FB0805	FB1 FB2 FB3 FB4 FB5 FB6 FB7 FB8 FB9	1852 0120 9100
		FB10	
2	JRC-27F/012-M(555)	K1 K2	4712 2027 0006
2	2P3.96	CN4 CN5	3101 6030 0200
1	4P(2.0)	CN2	3100 4040 0200
1	6P2.5	CN1	3100 4060 0250
1	9P(2.5)	CN3	3100 5090 0200
1	IDC 2x10P2.54(90)	JK2	3109 0520 4632
2	300R±1% - RES, CHIP	R39 R40	2401 1213 0103
2	4.3K±1% - RES, CHIP	R24 R28	2401 1214 3203
2	7.5K±1% - RES, CHIP	R77 R78	2401 1217 5203
2	10K±1% - RES, CHIP	R41 R42	2401 1211 0303
4	15K/1% - RES, CHIP	R91 R92 R93 R94	2401 1211 5303
4	30K/1% - RES, CHIP	R63 R64 R65 R66	2401 1213 0303
4	4.7R - RES, CHIP	R5 R7 R73 R74	2401 1224 7003
2	100R - RES, CHIP	R12 R16	2401 1221 0103
2	330R - RES, CHIP	R3 R6	2401 1223 3103
1	1.2K - RES, CHIP	R20	2401 1221 2203
2	4.7K - RES, CHIP	R21 R22	2401 1224 7203
1	8.2K - RES, CHIP	R19	2401 1228 2203
8	10K - RES, CHIP	R1 R2 R11 R14 R23 R31 R67 R75	2401 1221 0303
1	47K - RES, CHIP	R30	2401 1224 7303
6	100K - RES, CHIP	R10 R15 R68 R69 R72 R76	2401 1221 0403
8	10K±1% - RES, CHIP	R13 R17 R26 R29 R35 R38 R47 R49	2401 0811 0304
2	12K±1% - RES, CHIP	R48 R50	2401 0811 2204
2	47K±1% - RES, CHIP	R51 R52	2401 7147 3400
2	62K±1% - RES, CHIP	R86 R87	2401 0816 2304
2	4.7R - RES, CHIP	R43 R45	2401 8247 9400
2	10R - RES, CHIP	R44 R46	2401 8210 0400
4	20R - RES, CHIP	R53 R54 R55 R56	2401 8220 0400
2	2.2K - RES, CHIP	R57 R58 R36 R37	2401 0922 2305
1	10K/1206 - RES, CHIP	R25	2401 0921 0306
2	10R/1W - RES, CARBON	R59 R60	2401 0521 0020

1	220R/1W - RES, CARBON	R70	2413 0322 2112
1	330R/1W - RES, CARBON	R27	2413 0523 3112
4	2.2K/1W - RES, CARBON	R33 R34	2413 0522 2212
6	39P	C57 C58 C59 C60 C61 C62	2103 5390 0130
2	47P(NPO)	C38 C47	2103 5470 0130
2	47P	C63 C64	2103 5470 0130
17	0.1uF	C2 C3 C5 C8 C9 C36 C37 C41 C42 C43 C46	2115 6104 0130
		C49 C50 C52 C53 C55 C56	
8	102J/100V(NPO) - CAP , CHIP	C6 C7 C10 C11 C12 C13 C48 C54	2103 5102 0235
1	0.1uF - CAP , CHIP	C51	2115 6104 0145
4	0.1U/250V - CAP ,	C24 C26 C27 C29	2103 5102 0235
2	10uF/25V(X7R) - CAP , CHIP	C18 C19	2115 6104 1755
6	22uF/16V(X5R) - CAP , CHIP	C14 C15 C16 C17 C39 C40	2103 5226 1355
4	22uF/25V(X5R) - CAP , CHIP	C20 C21 C22 C23	2103 5226 0925
2	0.1U/500V - CAP , CHIP	C1 C4	2115 6104 0395
2	0.1U/100V(POLY)	C25 C28	2207 2104 0200
2	0.47U/100V(POLY)	C34 C35	2207 2474 0200
1	330U/10V - CAP , ELECT	C44	2331 0210 1000
1	10U/50V - CAP , ELECT	C45	2310 0610 1015
4	1000uF/50V - CAP , ELECT	C30 C31 C32 C33	2312 0610 5050
	Power.Bom P/N: 0082-1072-0000		
Qty	Part Type	Ref. Designator	Part Number
3	AZ431AZ-A	IC1 IC2 IC3	1709 0004 3100
1	FAN7602N (FAIRCHILD) PWM CONTROLLER	IC10	1007 6020 1901
1	FSFR2100 (FAIRCHILD)HALF-BRIDGE RESONANT CONVERTERS	IC4	1002 1002 1006
3	K1010 (COSMO) PHOTOCOULER	IC6 IC7 IC8	1000 8172 1901
1	SG6961SZ (SYSTEM GENERAL) POWER FACTOR CONTROLLER	IC5	1006 9610 1913
2	2SA1048 - TRANSISTOR	Q5 Q16	1111 0480 0002
4	2SC2458 - TRANSISTOR	Q8 Q9 Q10 Q12	1132 4580 5002
1	DMP3020LSS (DIODES) ENHANCEMENT MODE FILELD EFFECT TRANSISTOR	Q7	1153 0200 1900
1	FDPF20N50 (FAIRCHILD) MOSFET	Q3	1172 0500 1000
1	FQPF7N80C (FAIRCHILD) MOSFET	Q14	1170 7800 1030
1	S8050LT1 - TRANSISTOR	Q4	1108 0502 1828
2	S8550LT1 - TRANSISTOR	Q1 Q2	1108 5502 1828
2	TIP31CL - TRANSISTOR	Q11 Q15	1110 0310 6000
2	TIP32CL - TRANSISTOR	Q6 Q13	1110 0320 6000
3	1N4148 - DIODE	D13 D14 D15	1310 1414 8000
1	1N4148 - DIODE	D5	1310 4414 8000
1	1N5819 - DIODE	D9	1320 1005 8192
1	BAV99 - DIODE	D8	1310 5009 9000
7	FR107 - DIODE RECT	D6 D7 D10 D11 D12 D16 D17	1360 7000 1075
2	HZ20-2ST - DIODE ZENER	DW3 DW4	1300 0205 0102
1	ISL9R1560PF2 - DIODE	D1	1191 5600 1000
1	MUR1620CTG - DIODE RECT	D4	1311 6200 0000
1	MUR1620CTRG - DIODE RECT	D3	1311 6200 0020
1	SR360 - DIODE RECT	D18	1360 7000 3602
2	UDZS18B - DIODE ZENER	DW1 DW2	1300 0185 0100
1	UF4007 - DIODE RECT	D2	1360 0004 0075
1	GBJ806 - DIODE RECT	BL1	1360 0000 8060
1	FAIR-RITE 3.5X8X1(711380)	FB1	1893 8780 0001

3	15UH/2A	L3 L4 L5	1702 0155 0000
2	50UH/3A	L1 L2	1703 0500 0000
1	BCK-03(8048)D	T5	1709 8048 0000
1	BCK-03(8049)	T3	1709 8049 0000
1	BCK-03(8050)A	T4	1709 8050 0000
1	SG08210(B)	T2	1891 0700 0001
1	2P7.92	CN1	3101 6030 0200
1	6P2.5	CN2	3100 4060 0250
1	9P(2.5)	CN3	3100 5090 0200
1	150Ω1/8W ±5% - RES, CARBON	R19	2401 0221 5111
2	390Ω1/8W ±5% - RES, CARBON	R77 R90	2401 0223 9111
4	1KΩ1/8W ±5% - RES, CARBON	R25 R34	2401 0221 0211
1	2KΩ1/8W ±5% - RES, CARBON	R74	2401 0222 0211
2	2.2KΩ1/8W ±5% - RES, CARBON	R32 R36	2401 0222 2211
4	4.7KΩ1/8W ±5% - RES, CARBON	R69 R71 R73 R106	2401 0224 7211
1	6.2KΩ1/8W ±5% - RES, CARBON	R27	2401 0226 2211
3	10KΩ1/8W ±5% - RES, CARBON	R8 R11 R33	2401 0221 0311
1	15KΩ1/8W ±5% - RES, CARBON	R78	2401 0221 5311
1	20KΩ1/8W ±5% - RES, CARBON	R60	2401 0222 0311
1	47KΩ1/8W ±5% - RES, CARBON	R85	2401 0224 7311
1	100KΩ1/8W ±5% - RES, CARBON	R26	2401 0221 0411
1	120KΩ1/8W ±5% - RES, CARBON	R35	2401 0221 2411
1	2.2R/0.25W - RES, CARBON	R22	2401 0322 2911
1	100/0.25W - RES, CARBON	R49	2413 0321 0111
1	120(0.25W) - RES, CARBON	R51	2401 0321 2111
1	10R/0.5W - RES, CARBON	R101	2401 0421 0011
1	1M 1/2W - RES, CARBON	R2	2413 0421 0511
1	0.5R/1W - RES, CARBON	R98	2413 0525 0911
1	68K/1W - RES, CARBON	R99	2413 0526 8312
2	11M/1W - RES, CARBON	R53 R54	2413 0521 1611
2	0.1R/2W - RES, CARBON	R55 R56	2413 0621 0812
1	68K/2W - RES, CARBON	R52	2413 0626 8312
2	0.15R/3W - RES, CARBON	R66 R67	2413 0721 5823
2	1K/5W - RES, CARBON	R57 R58	2413 1021 0210
2	3K1% - RES, CHIP	R84 R111	2401 0813 0204
1	3.6K1% - RES, CHIP	R104	2401 0813 6204
2	7.5K%1 - RES, CHIP	R38 R41	2401 0817 5204
1	12K1% - RES, CHIP	R86	2401 0811 2204
1	15K1% - RES, CHIP	R87	2401 0811 5304
1	24K1% - RES, CHIP	R59	2402 0812 4304
1	0R - RES, CHIP	R17	2401 0820 0004
1	15R - RES, CHIP	R1	2401 0821 5004
1	47R - RES, CHIP	R18	2401 0824 7004
1	100R - RES, CHIP	R50	2401 0821 0104
1	270R - RES, CHIP	R102	2401 0822 7104
1	470R - RES, CHIP	R14	2401 0824 7104
1	680R - RES, CHIP	R15	2401 0826 8104
6	1K - RES, CHIP	R23 R24 R28 R29 R65 R68	2401 0821 0204
2	2K - RES, CHIP	R75 R76	2401 0822 0204
1	2.4K - RES, CHIP	R37	2401 0822 4204
1	5.6K - RES, CHIP	R70	2401 0825 6204
6	10K - RES, CHIP	R3 R4 R5 R6 R7 R9	2401 0821 0304
1	12K - RES, CHIP	R40	2401 0821 2304

2	15K - RES, CHIP	R39 R72	2401 0821 5304
1	27K - RES, CHIP	R97	2401 0822 7304
1	180K - RES, CHIP	R95	2401 0821 8404
1	200K - RES, CHIP	R47	2401 0822 0404
5	470K - RES, CHIP	R42 R43 R44 R45 R46	2401 0824 7404
4	470K1%-1206 - RES, CHIP	R61 R62 R63 R64	2401 0914 7405
2	10R-1206 - RES, CHIP	R20 R21	2401 0921 0005
1	15R--1206 - RES, CHIP	R100	2401 0921 5905
1	22R - RES, CHIP	R48	2401 0922 2005
1	1M--1206 - RES, CHIP	R94	2401 0921 0505
2	1M - RES, CHIP	R13 R16	2401 0921 0505
2	2M--1206 - RES, CHIP	R92 R93	2401 0922 0505
1	3M--1206 - RES, CHIP	R96	2401 0923 0505
1	51K---1210 - RES, CHIP	R12	2401 1725 1318
1	56PF - CAP , CHIP	C55	2115 6560 0145
1	100PF - CAP , CHIP	C57	2115 6101 0145
4	102(1000PF) - CAP , CHIP	C34 C35 C36 C65	2115 6102 0145
1	103(0.01UF) - CAP , CHIP	C61	2115 6103 0145
1	473(0.047UF) - CAP , CHIP	C56	2115 6473 0145
8	104(0.1UF) - CAP , CHIP	C10 C20 C22 C26 C29 C30 C31 C32	2115 6104 0145
1	224(0.22UF) - CAP , CHIP	C38	2115 6224 0145
1	474(0.47UF) - CAP , CHIP	C62	2115 6474 0145
2	104/100V(0.1UF/100V) - CAP , CHIP	C52 C53	2115 6104 0245
2	104/100V(0.1UF/100V) - CAP , CHIP	C21 C54	2115 6104 0255
1	0.22/275VAC	C4	2210 3224 0604
1	0.33/275VAC	C5	2210 3334 0604
1	100PF/1KV	C39	2115 6101 0413
2	102/1KV(1000PF/1KV)	C12 C33	2118 6102 0413
1	102/1KV(1000PF/1KV)	C17	2118 6102 0413
4	104(0.1UF/50V)	C23 C24 C25 C27	2115 6104 0113
2	471/250VAC(470PF/250VAC)	C2 C3	2115 7471 1015
1	102/250VAC(1000PF/25VAC)	C43	2115 7102 1015
1	102/250VAC(X1, Y1)	C42	2115 7102 1015
1	472/630V(4700PF/630V)	C67	2207 2472 0700
1	104/630V(0.1UF/630V)	C8	2207 2106 0700
1	474/630V(0.47UF/630V)	C6	2207 2474 0700
2	473/1600V(0.047UF/1600V)	C40 C41	2207 2473 1500
1	1U/50V - CAP , ELECT	C11	2319 0610 1015
1	2.2U/50V - CAP , ELECT	C16	2329 0610 1015
1	4.7U/50V - CAP , ELECT	C63	2349 0610 1015
3	10U/50V - CAP , ELECT	C9 C18 C19	2310 0610 1015
3	47U/50V - CAP , ELECT	C13 C14 C15	2340 0610 2015
1	224/63(0.22UF/63V) - CAP , ELECT	C37	2207 2223 0843
1	470U/10V - CAP , ELECT	C74	2341 0210 3025
2	1000U/10V - CAP , ELECT	C72 C73	2312 2101 4000
1	47U/25V - CAP , ELECT	C66	2340 0410 1015
3	100U/25V - CAP , ELECT	C28 C76 C77	2311 0410 2015
3	1000U/25V - CAP , ELECT	C1 C68 C69	2312 4105 4000
2	1000U/25V - CAP , ELECT	C70 C71	2312 4105 4000
1	220U/35V - CAP , ELECT	C60	2321 0510 3025
8	1000U/50V - CAP , ELECT	C44 C45 C46 C47 C48 C49 C50 C51	2312 0610 5050
1	270UF/450V - CAP , ELECT	C7	2371 1711 0075

LED.Bom P/N: 0082-1191-0000			
Qty	Part Type	Ref. Designator	Part Number
4	IL0445W31BOLG201(white)H5mm	LED2 LED3 LED4 LED5	1402 0705 0006
1	R122ECA-D1-19.5F-24-W	RV1	4401 2211 9524
1	4P(2.0) JEDEC	CN3	3100 4040 0200
4	220R±5%	R17 R18 R63 R64	2401 0222 2111
1	0.1uF/50V±5%	C10	2115 6104 0113
FUSE.Bom P/N: 0082-1101-0000			
Qty	Part Type	Ref. Designator	Part Number
1	T5AL 250V	FH1	1601 0515 0120
1	SO-222-S-0R-R3(D)	CN5	2810 0302 2203
1	3P(3.96) JEDEC	CN1	3100 0702 0050
1	0.1U/275VAC(X2)	C13	2210 3104 0604
1	10D471K	RZ1	2416 2000 0008
SPEAKER JOINT-LEFT PCB P/N: 0082-1321-0010			
Qty	Part Type	Ref. Designator	Part Number
1	F1810285	T1	1875 1802 8500
1	1000PF/200V±10% 1206	C2	2103 5102 0150
1	0.1UF/200V±10% 1206	C1	2103 5104 0150
SPEAKER JOINT-RIGHT PCB P/N: 0082-1321-0020			
Qty	Part Type	Ref. Designator	Part Number
1	F1810285	T2	1875 1802 8500
1	1000PF/200V±10% 1206	C3	2103 5102 0150
1	0.1UF/200V±10% 1206	C4	2103 5104 0150