

harman/kardon
by HARMAN



MAS 101/102/111 **CD**

Music system

Service Manual

CONTENTS

1. Specification	1
2. Packing	3
3. Front panel information	4
4. Rear panel information	5
5. Remote control information	6
6. Block diagram	8
7. Wiring diagrams	9
8. IC spec	10
9. Printed circuit boards	87
10. Schematic diagram	97
11. Exploded view	108
12. Electrical parts list	110

System

Power output	65 watts per channel, 20Hz – 20kHz, THD <0.07%, into 6 ohms, both channels driven
Bandwidth	20Hz – 35kHz, –3dB
System frequency response	20Hz – 20kHz, ±0.5dB
Signal-to-noise ratio, A-weighted	90dB (Analog inputs), 96dB (Digital inputs)
Channel separation	≥65dB
Crosstalk between sources	≥70dB
Line-level input sensitivity at 1kHz	250mV RMS, ±1dB
Phono MM input sensitivity at 1kHz	7.5mV

Loudspeakers

Low-frequency transducers	Two 130mm honeycomb composite drivers, ported
High-frequency transducers	Two 25mm MMD® domes, shielded
Nominal impedance	8 ohms
Sensitivity (2.83V/1m)	85dB
Frequency response	60Hz – 25kHz (–3dB)
Crossover frequency	2200Hz

FM Tuner Section

Frequency range	87 – 108.0MHz
Usable sensitivity	IHF 1.3µV/13.2dBf
Frequency response	10Hz to 15.3kHz
Signal-to-noise ratio	mono/stereo 68/65dB
Distortion	mono/stereo 0.15/0.3%
Stereo separation	35dB @ 1kHz, 100% deviation @ 65dBf
Selectivity	±300kHz; 65dBf
Image rejection	80dB
IF rejection	90dB
Tuner output level	1kHz, ±50kHz, Dev 500mV
Number of presets	30
RDS capability	PS (program service), RT (dynamic radio text)

CD Section

Disc compatibility	CD, CD-R, CD-RW, MP3, WMA
THD+N (20Hz – 20kHz)	<0.025%
Frequency response	20Hz to 20kHz, 0dB \pm 0.5
Channel separation	\geq 65dB
Signal-to-noise ratio	"A"WTG >96dB; 22kHz filter > 94dB

General

Power requirement	AC 230V/50Hz (MAS 101/MAS 111); AC 120V/60Hz (MAS 102)
Power consumption	<1W full standby (clock not activated); <2W standby (clock activated); 150W maximum (both channels driven)
Operating temperature	0°C to 40°C
Dimensions (H x W x D)	Controller: 90mm x 240mm x 240mm (3-9/16" x 9-7/16" x 9-7/16") Amplifier: 90mm x 240mm x 240mm (3-9/16" x 9-7/16" x 9-7/16") Loudspeakers (each, with grille): 272mm x 181mm x 196mm (10-23/32" x 7-1/8" x 7-3/4")
Weight	System 13.9kg (30,5lb) Controller 2.0kg (4,4lb) Amplifier 2.8kg (6,3lb) Loudspeakers (each): 4.4kg (9,8lb)



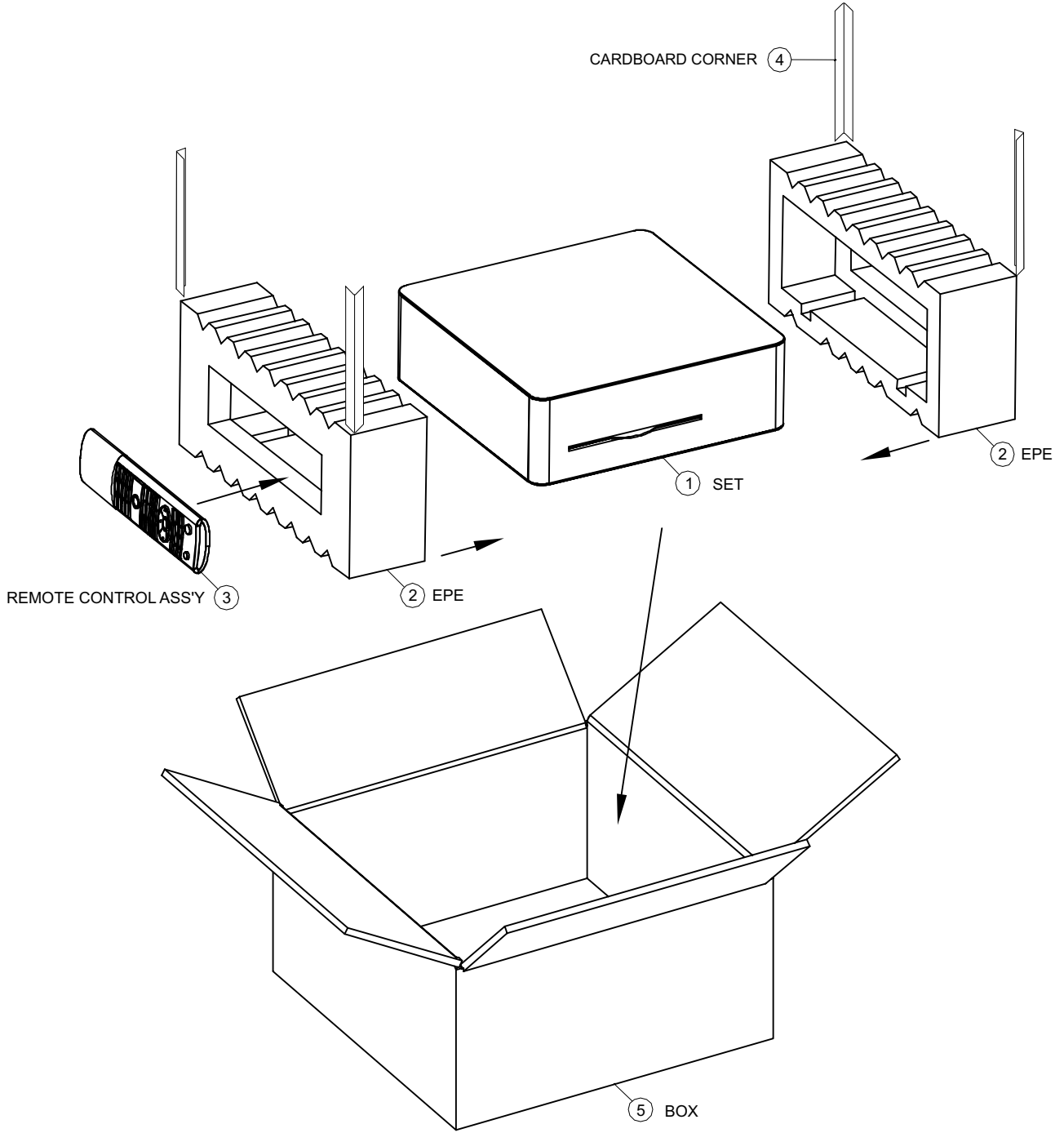

NO	DESCRIPTION	PARTS NO.	Q.ty
1	SET		1
2	EPE	8250 503B 0000	2
3	REMOTE CONTROL ASSY	3320 0805 0352	1
4	CARDBOARD CORNER	8150 5030 0000	4
5	BOX	8150 5011 0000	1

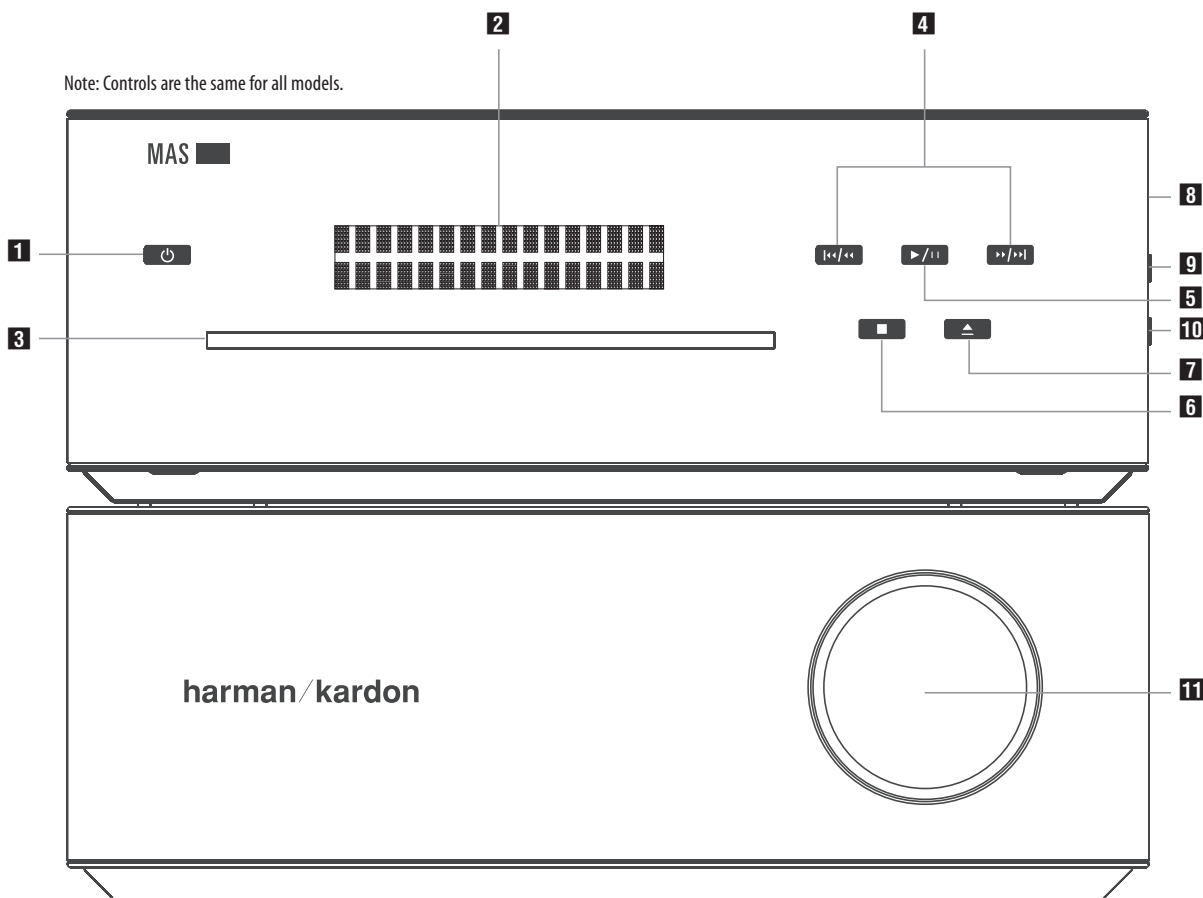

The MAS systems use touch-sensitive controls. To use a control, tap gently on its lit icon.

NOTE: Controls are the same for all models.

- 1 Power:** Turns the MAS system on or places it in Standby mode. To completely power off the unit, unplug the power supply.
- 2 Message Display:** The time and messages are displayed in this two-line text display.
- 3 CD Slot:** Load compatible discs here.
- 4 Skip/Scan Forward/Reverse:** These buttons function differently, depending on the current source:
 - **iPod, CD or USB:** Press and release to skip to the next track. Press the Reverse button twice to skip to the previous track. Press and hold a button to scan forward or reverse within a track.
 - **Radio:** Press and release a button to select the next higher or lower programmed preset station. Press and hold a button to scan to the next available higher or lower station. When you release the button, the tuner continues to scan until it finds a station of acceptably strong signal quality, and then it stops. To stop the scan before a station is found, press the button while the tuner is scanning.
- 5 Play/Pause:** Each tap toggles between the Play and Pause functions.
- 6 Stop:** Fully stops playback.
- 7 Eject:** When a CD is loaded, tap here to eject it.

- 8 USB Port A:** Connect a compatible USB device here to enjoy playback of audio MP3 or WMA files. Although most USB flash and hard-disk drives in the FAT32 file format, as well as many MP3 players, are compatible with the MAS system, due to the wide variety of manufacturers, playback cannot be guaranteed. Do not connect an iPod or iPhone to this port. Do not connect a personal computer or any peripherals to this port.
- 9 Line-In Jack (Line Input):** Connect a stereo 3.5mm male-to-male cable (not included) to the headphone or line-level output on a portable player or other device.
- 10 Headphone Jack:** Outputs a stereo signal for private listening through most headphones that are equipped with a stereo 3.5mm plug.
- 11 Volume Control:** Increases or decreases the volume.

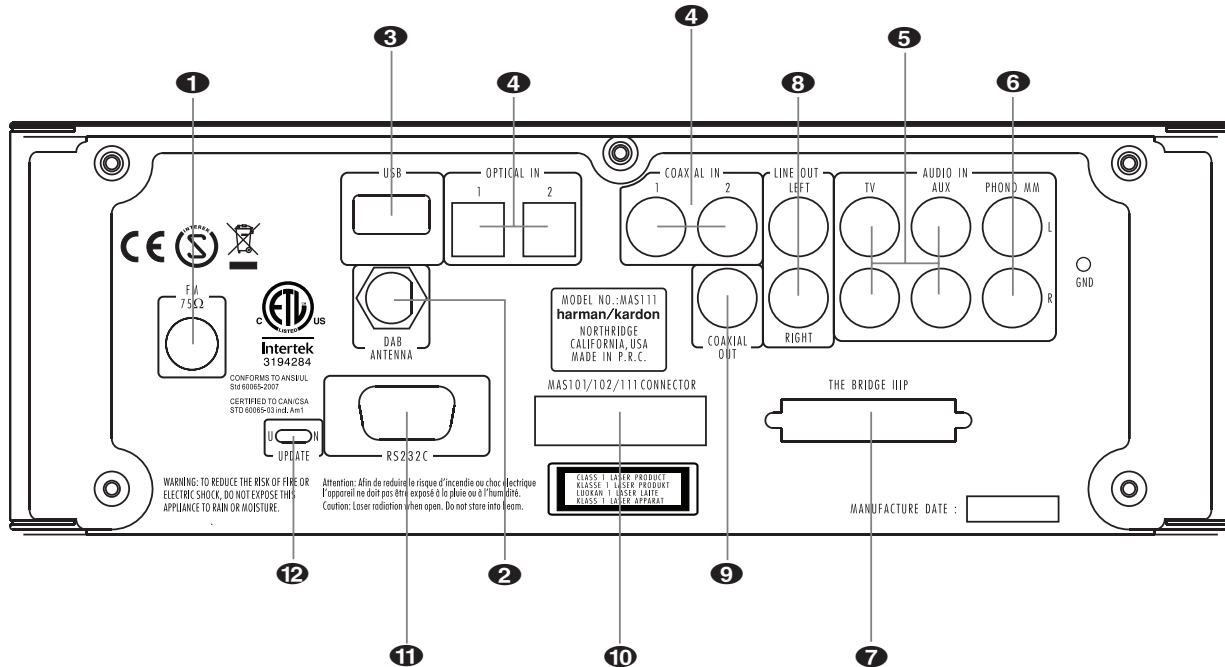

1 FM Antenna Terminal: Connect the included FM antenna wire here.

2 DAB Antenna Terminal (MAS 111 Only): Connect the included DAB antenna wire lead here to enjoy programming from digital DAB, DAB+ or T-DMB-Audio radio stations available in your area.

3 USB Port B: Connect a compatible USB device here to enjoy playback of audio MP3 or WMA files. Although most USB flash and hard-disk drives in the FAT32 file format, as well as many MP3 players, are compatible with the MAS system, due to the wide variety of manufacturers, playback cannot be guaranteed. Do not connect an iPod or iPhone to this port. Do not connect a personal computer or any peripherals to this port.

4 Optical 1/2 and Coaxial 1/2 Digital Audio Inputs: Connect a source device's optical or coaxial digital audio output to the corresponding input. Only the uncompressed PCM format is supported.

5 TV and AUX Analog Audio Inputs: Connect the analog audio outputs of a television or any source device to enjoy playback through the high-performance MAS system.

6 Phono Input: Connect the outputs of a moving-magnet (MM) type turntable to this input. Do not connect any other type of turntable to this input, and do not connect the outputs of an MM-type turntable to any other analog audio inputs on the MAS system without using a phono preamp, available separately from many electronics stores.

7 The Bridge IIIP Input: To enjoy playback of audio materials stored on a compatible iPod (see page 4), connect The Bridge IIIP. Make sure the insert for The Bridge IIIP is installed, and install the appropriate dock adapter for your iPod within the insert, as shown in Figure 1 on page 10.

8 Analog Audio Outputs: Connect these outputs to the analog audio inputs of an audio recorder. When a source connected to the MAS system is playing, the signal will be available at these outputs for recording. **IMPORTANT:** The Analog Audio Outputs will mute when the Mute button on the remote is pressed. See page 9.

9 Coaxial Digital Audio Output: Connect this output to the coaxial digital audio input of a digital audio recorder. When the following sources are playing, the signal will be available at this output for recording: CD, USB Ports A/B, Coaxial 1/2, Optical 1/2. The following sources are not available at this output: FM/DAB, TV, Aux, Phono, The Bridge IIIP.

NOTES:

- **The MAS system can convert analog sources to the digital domain, or digital sources to the analog domain for recording.**

- **It is the user's responsibility to comply with all laws pertaining to the copying of audio materials.**

10 Output to Amplifier: Connect the included ribbon cable to this connector and to the corresponding connector on the MAS amplifier. This cable passes audio signals from the controller to the amplifier, and it transfers DC power from the amplifier to the controller. If this cable is ever damaged, do not use it, and contact Harman Kardon for a replacement.

11 RS-232 Serial Port: This port is used only for system upgrades. Do not connect it to any devices unless instructed to do so at the time a system upgrade is released.

12 Update Switch: This switch is used only for system upgrades. Leave it in the "N" position for normal operation unless instructed to switch it to the "U" position to install a system update.

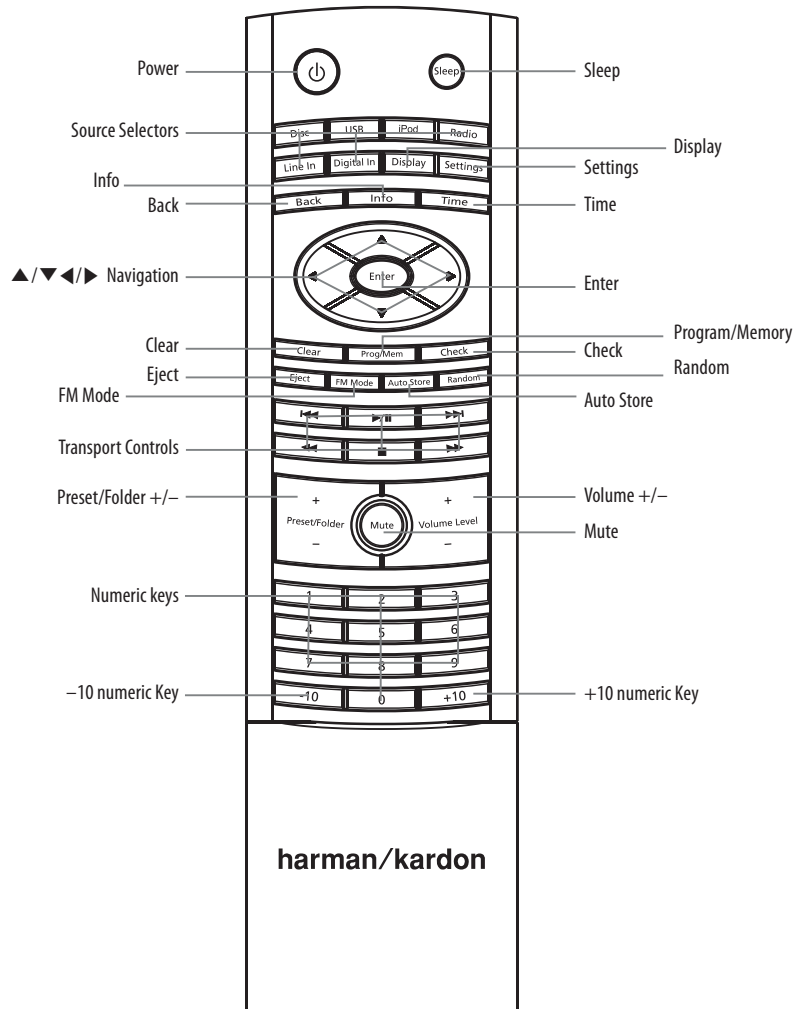

Power: Turns the MAS system on or off. To completely power off the unit, unplug the power supply.

Sleep: Each press increases the time until turn-off, from 10 to 90 minutes, in increments of 10 minutes. The next press after the 90 minutes setting turns off the Sleep function.

Source Selectors: Selects a source input. Each press of the Line In or Digital In button toggles among the available analog (Line Input on right-side panel; TV, AUX or Phono Input on rear panel) or digital audio inputs (Coaxial 1 or 2, Optical 1 or 2), respectively. Press the iPod button to select an iPod docked in The Bridge III.

Display: Adjusts the brightness of the message display. Each time the button is pressed and held for one second, the message display brightness will cycle between full, half and off. When the display is off while the system is turned on, the LEDs inside the Volume knob and behind the front-panel function buttons will remain lit to remind you that the system is still on.

Settings: Accesses menus for Speaker Setup (tone controls), Time Setup (clock), Alarm Setup, System Version and System Reset. See the Operation section for more information.

Back: Returns to previous menu level.

Info: Displays the status of the current source:

- **Radio:** When FM band is in use, each press of the button toggles between the PS (Program Service) and RT (Radio Text) RDS information, if available. When a DAB radio station is playing (MAS 111 only), press this button to access the menu system for the DAB tuner. See pages 13 and 14 for more information.

- **Audio CD:** Displays CD Text information, if available. Each press of the button displays the following items: Song, Artist, Album.

- **USB or Data CD:** Scrolls all ID3 tag information for current source, if available. Each press of the button displays the individual items Song, Artist, Album, File type and Folder, and then goes back to scrolling. If ID3 tags are not available, the file name will appear.

Time: Displays elapsed track time for the current Audio CD (no effect on data CDs or other sources). Each additional press changes the display as follows: remaining track time, elapsed disc time, remaining disc time then back to elapsed track time.

▲/▼◀▶ Navigation buttons: Use the ◀ and ▶ buttons to scroll forward and reverse through the Settings Menus, or through lists of content, and press the Enter button to make selections. Press the Back button to return to the previous menu or content level.

Enter: Selects a menu item, or saves setting changes and returns to the previous menu level.

Clear: Clears the current preset station or a playlist entry.

- **Radio:** To delete the current preset station, press the Clear button while it is playing.
- **Playlist:** While programming a playlist, press the Clear button to delete the track just entered. After the playlist has been saved by pressing the Stop button, press the Clear button to delete the entire playlist. To delete a single track, stop play, press the Check button repeatedly until the desired track appears and press the Clear button. Press the Play or Stop button to exit the Check mode.

Program/Memory: Used to program playlists and radio presets.

- **Radio:** If the current station has not been programmed into a preset, press Program/Memory and press the Enter button to store the station at the current preset number, or use the numeric keys to enter a different preset number. The new preset will overwrite the existing one.
- **USB or CD (Audio or Data):** Press the Program button to begin Program Mode. Add tracks to the playlist by using the Skip/Scan Transport Controls or the numeric keys to select the track, then press the Program button to enter the selection. Add up to 30 files. Press Play to play the playlist, or Stop to save the playlist without playing it. During playback, the order of the track in the playlist will appear on the left, with the disc's track number to the right. See page 14 and 15.

Check: After a playlist has been programmed and play has been stopped, each press of the Check button displays the tracks in the playlist.

Eject: When a CD is loaded, press this button to eject it.

FM Mode: Used with FM radio, each press toggles between Stereo and Monaural playback.

Auto Store: Scans through all frequencies, searching for stations with acceptably strong signal quality, and stores them as presets.

Random: Each press turns Random playback mode (shuffle) on or off. This mode plays the tracks of the current disc or drive in random order.

Transport Controls

Track Skip Up/Down (iPod, CD or USB): Press and release the Next/Previous skip buttons to skip to the next track, or the beginning of the current track. Press the Previous Skip button twice to skip to the previous track.

Scan Forward/Reverse: These buttons function differently, depending on which source has been selected:

- **iPod, CD or USB:** Press and hold a button to scan forward or reverse within a track.
- **Radio:** Press and release a button to tune to the next higher or lower frequency by one increment/decrement. Press and hold a button to scan quickly through the frequencies for next available station. Press the same button again to stop scanning.

Play/Pause: Each tap toggles between the Play and Pause functions.

Stop: Fully stops playback.

Preset/Folder +/-: Selects a preset station or folder on a USB or data CD.

- **Radio:** Each press changes to the next or previous preset station, if any have been programmed.
- **USB or Data CD:** Press once to open the current folder. Each additional press changes to the next or previous folder. After 3 seconds, the first track in the new folder will begin playing.

Mute: Press to temporarily silence the speakers. Press again to restore audio. Muting is also canceled if the MAS system is turned off.

NOTE: Pressing the Mute button also mutes the Analog Audio Outputs. See page 6.

Volume +/-: Increases or decreases the volume. Press and hold to change the volume more quickly.

Numeric keys: Used to enter track numbers, radio stations or preset numbers, or while adjusting the clock and alarm times.

-10 and +10 numeric Key: Used with a USB device or CD to quickly advance through a large number of tracks. Each press of these keys changes to the next or previous track in increments of 10.

MAS111 Head Unit Block Diagram

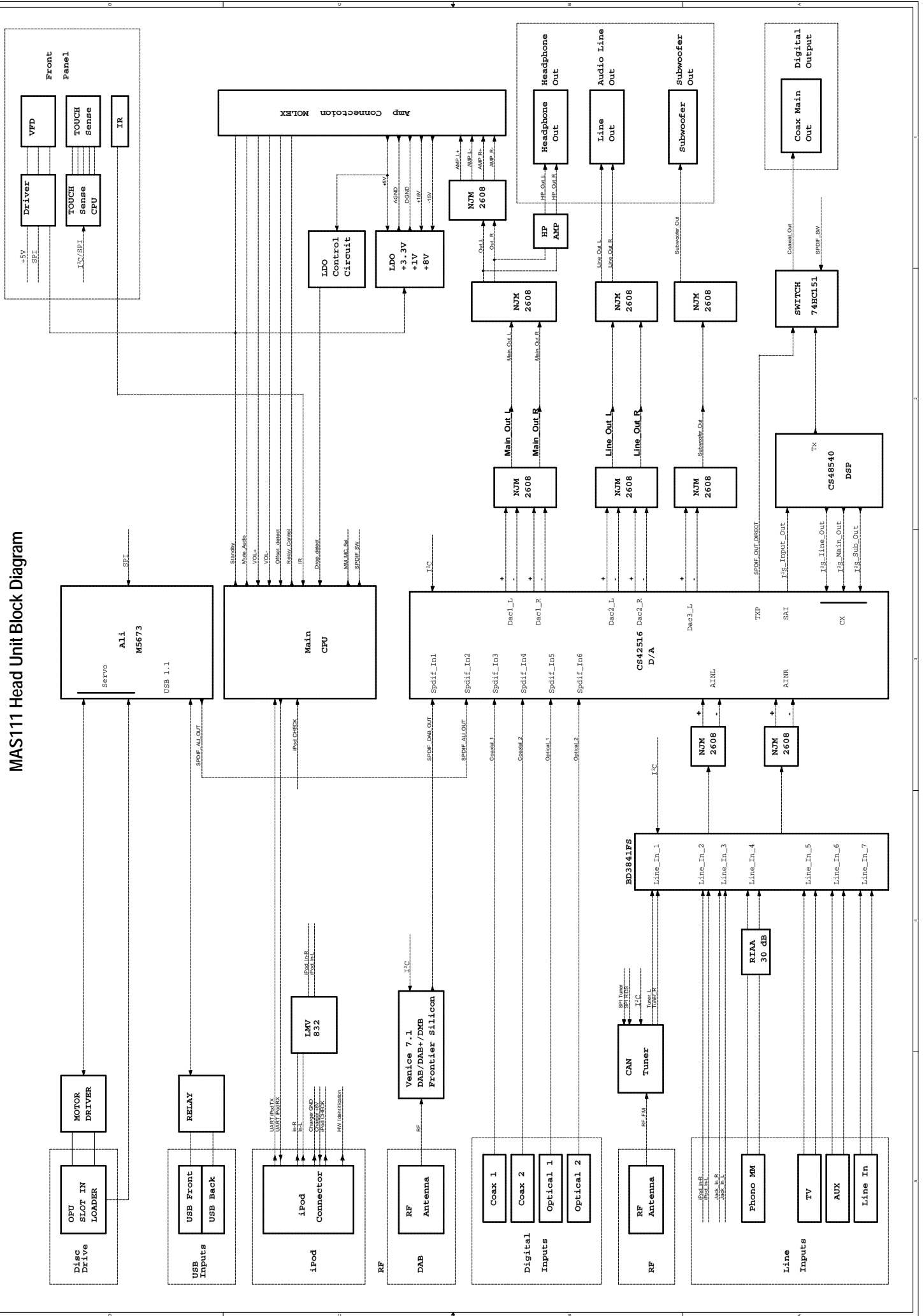

WIRING DIAGRAM

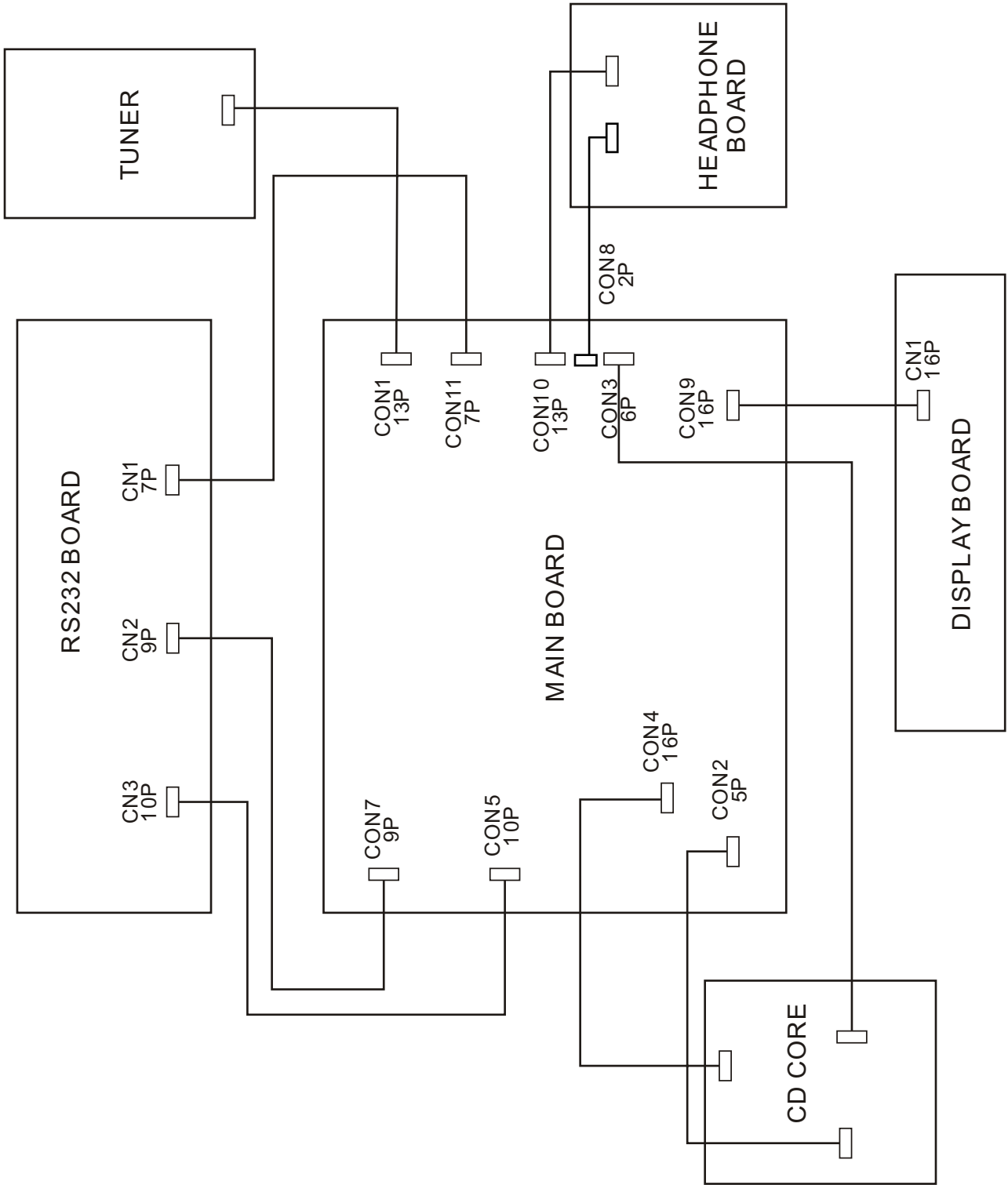

Hex inverter

74HCU04

FEATURES

- Output capability: standard
- I_{CC} category: SSI

GENERAL DESCRIPTION

The 74HCU04 is a high-speed Si-gate CMOS device and is pin compatible with low power Schottky TTL (LSTTL). It is specified in compliance with JEDEC standard no. 7A.

The 74HCU04 is a general purpose hex inverter. Each of the six inverters is a single stage

QUICK REFERENCE DATA

GND = 0 V; $T_{amb} = 25\text{ }^{\circ}\text{C}$; $t_r = t_f = 6\text{ ns}$

SYMBOL	PARAMETER	CONDITIONS	TYP.	UNIT
t_{PHL}/t_{PLH}	propagation delay nA to nY	$C_L = 15\text{ pF}$; $V_{CC} = 5\text{ V}$	5	ns
C_I	input capacitance		3.5	pF
C_{PD}	power dissipation capacitance per inverter	note 1	10	pF

Note

1. C_{PD} is used to determine the dynamic power dissipation (P_D in μW):

$$P_D = C_{PD} \times V_{CC}^2 \times f_i + \sum (C_L \times V_{CC}^2 \times f_o) \text{ where:}$$

f_i = input frequency in MHz

f_o = output frequency in MHz

C_L = output load capacitance in pF

V_{CC} = supply voltage in V

$\sum (C_L \times V_{CC}^2 \times f_o)$ = sum of outputs

ORDERING INFORMATION

See *"74HC/HCT/HCU/HCMOS Logic Package Information"*.

FUNCTION TABLE

INPUT	OUTPUT
nA	nY
L	H
H	L

Note

1. H = HIGH voltage level
L = LOW voltage level

Hex inverter

74HCU04

PIN DESCRIPTION

PIN NO.	SYMBOL	NAME AND FUNCTION
1, 3, 5, 9, 11, 13	1A to 6A	data inputs
2, 4, 6, 8, 10, 12	1Y to 6Y	data outputs
7	GND	ground (0 V)
14	V _{CC}	positive supply voltage

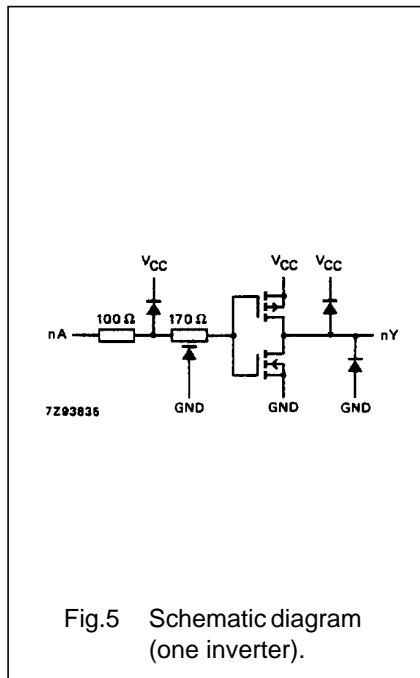
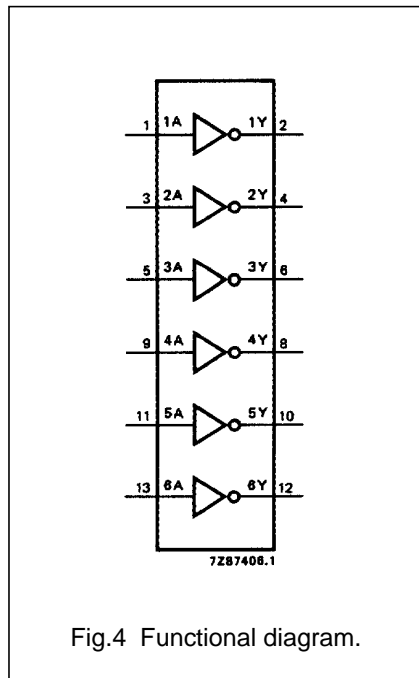
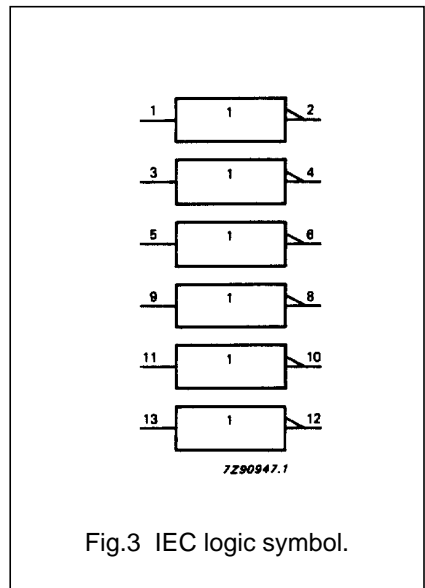
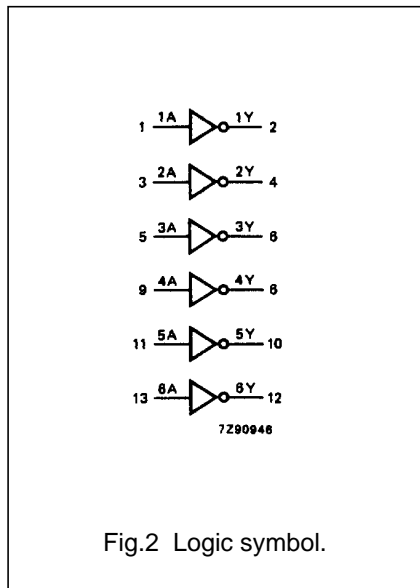
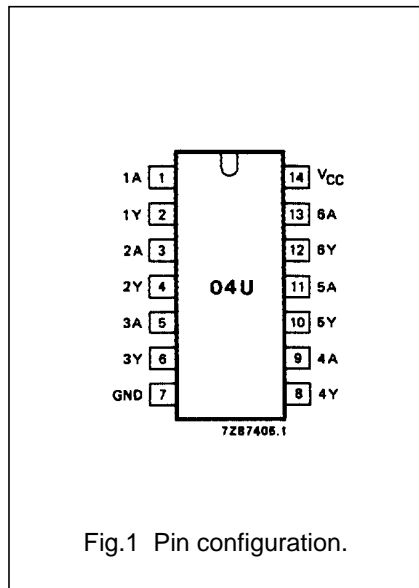

5-channel BTL Driver for DVD player

AM5888S

The AM5888S is a five-channel BTL driver IC for driving the motors and actuators such as used in DVD player and consists of two independent precision voltage regulators with adjustable range from 1.5V to 4 V. It supports a variety of applications. Also, Pb free package is selectable (Please refer to Marking Identification).

● Applications

BTL driver for CD, CD-ROM and DVD.

● Features

- 1) Two channels are voltage-type BTL drivers for actuators of tracking and focus. Two channels are voltage-type BTL driver for sled and spindle motors. It is also built-in one channel bi-direction DC motor driver for tray.
- 2) Wide dynamic range [9.0V (*typ.*) when $V_{cc1}=V_{cc2}=12V$, at $R_L=20\Omega$ load].
- 3) Separating power of V_{cc1} and V_{cc2} is to improve power efficiency by a low supply voltage for tracking, focus, and spindle.
- 4) Level shift circuit built-in.
- 5) Thermal shut down circuit built-in.
- 6) Mute mode built-in.
- 7) **Dual actuator drivers:**
A general purpose input OP provides differential input for signal addition. The output structure is two power OPAMPS in bridge configuration.
- 8) **Sled motor driver:**
A general purpose input OP provides differential input for signal addition. The output structure is one power OPAMP in bridge configuration.
- 9) **Spindle driver:**
Single input linear BTL driver. The output structure are two power OPAMPS in bridge configuration.
- 10) **Tray in-out driver:**
The DC motor driver supports forward/reverse control for tray motor.
- 11) **2 Built-in regulator controllers**
Adjustable range 1.5V ~ 4V

● **Absolute maximum ratings (Ta=25°C)**

Parameter	Symbol	Limits	Unit
Supply voltage	Vcc1 Vcc2	13.5	V
Power dissipation	P _d	*1.7	W
Operate Temp range	T _{opr}	-35 ~ +85	°C
Storage Temp range	T _{stg}	** -55 ~ +150	°C

*When mounted on a 70mm×70mm×1.6mm glass epoxy board.

*Reduced by 13.6mW for each increase in T_a of 1°C over 25°C.

**Should not exceed P_d or ASO and T_j=150°C values

● **Guaranteed operating conditions (Ta=25°C)**

Parameter	Symbol	Limits	Unit
Power supply voltage	Vcc1	4.3 ~ 13.2	V
	Vcc2	4.3 ~ Vcc1	V

● **Block diagram**

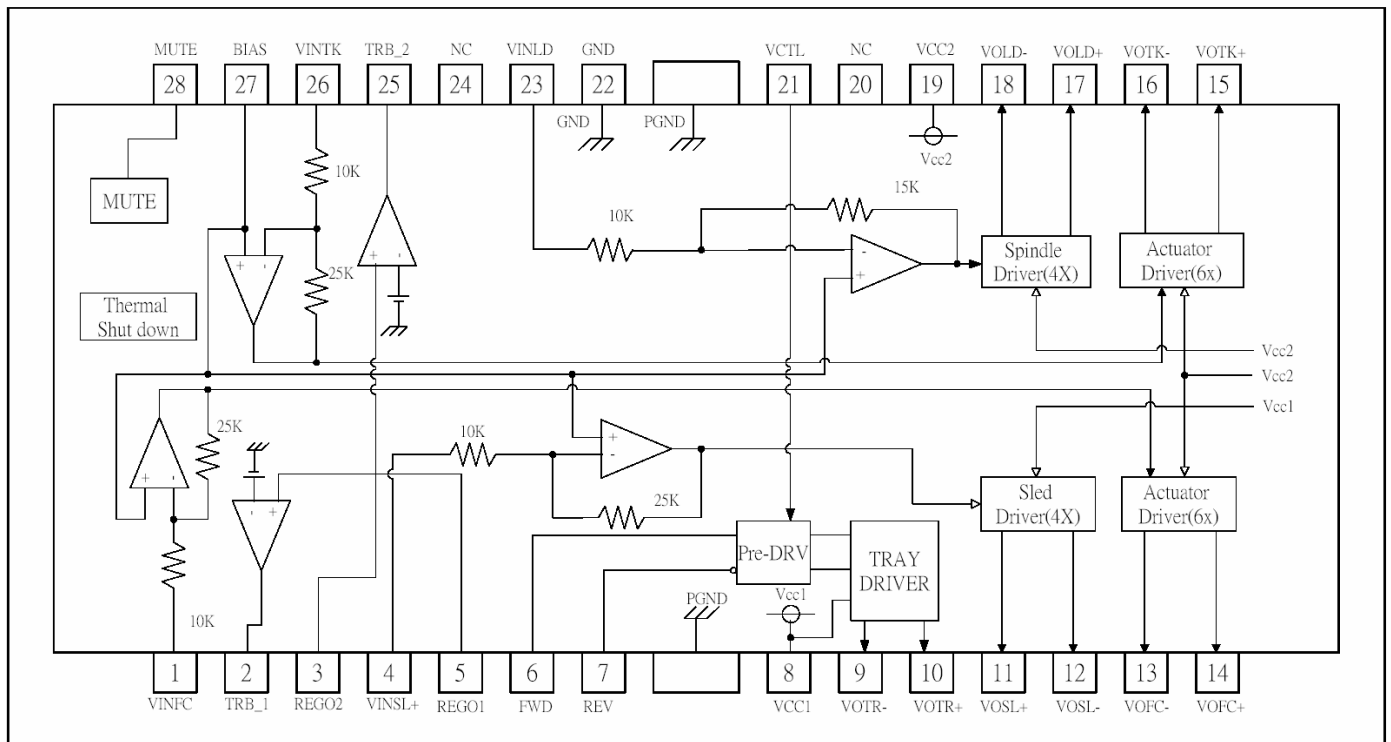

● Pin description

PIN No	Pin Name	Function
1	VINFC	Input for focus driver
2	TRB_1	Connect to external transistor base
3	REGO2	Regulator voltage output, connect to external transistor collector
4	VINSL+	Input for the sled driver
5	REGO1	Regulator voltage output, connect to external transistor collector
6	FWD	Tray driver forward input
7	REV	Tray driver reverse input
8	Vcc1	Vcc for pre-drive block and power block of sled and tray
9	VOTR-	Tray driver output (-)
10	VOTR+	Tray driver output (+)
11	VOSL+	Sled driver output (+)
12	VOSL-	Sled driver output (-)
13	VOFC-	Focus driver output (-)
14	VOFC+	Focus driver output (+)
15	VOTK+	Tracking driver output (+)
16	VOTK-	Tracking driver output (-)
17	VOLD+	Spindle driver output (+)
18	VOLD-	Spindle driver output (-)
19	Vcc2	Vcc for power block of spindle, tracking and focus
20	NC	No Connection
21	VCTL	Speed control input of tray driver
22	GND	Ground
23	VINLD	Input for spindle driver
24	NC	No Connection
25	TRB_2	Connect to external transistor base
26	VINTK	Input for tracking driver
27	BIAS	Input for reference voltage
28	MUTE	Input for mute control

Notes) Symbol of + and – (output of drivers) means polarity to input pin.

(For example, if voltage of pin1 is high, pin14 is high.)

Features

- Low-voltage and Standard-voltage Operation
 - 1.8 ($V_{CC} = 1.8V$ to 5.5V)
- Internally Organized 256 x 8 (2K)
- Two-wire Serial Interface
- Schmitt Trigger, Filtered Inputs for Noise Suppression
- Bidirectional Data Transfer Protocol
- 1 MHz (5V), 400 kHz (1.8V, 2.5V, 2.7V) Compatibility
- Write Protect Pin for Hardware Data Protection
- 8-byte Page (2K) Write Modes
- Partial Page Writes Allowed
- Self-timed Write Cycle (5 ms max)
- High-reliability
 - Endurance: 1 Million Write Cycles
 - Data Retention: 100 Years
- 8-lead PDIP, 8-lead JEDEC SOIC, 8-lead Ultra Thin Mini-MAP (MLP 2x3), 5-lead SOT23, 8-lead TSSOP and 8-ball dBGAA2 Packages
- Lead-free/Halogen-free
- Available in Automotive
- Die Sales: Wafer Form, Tape and Reel and Bumped Wafers

Description

The AT24C02B provides 2048 bits of serial electrically erasable and programmable read-only memory (EEPROM) organized as 256 words of 8 bits each. The device is optimized for use in many industrial and commercial applications where low-power and low-voltage operation are essential. The AT24C02B is available in space-saving 8-lead PDIP, 8-lead JEDEC SOIC, 8-lead Ultra Thin Mini-MAP (MLP 2x3), 5-lead SOT23, 8-lead TSSOP, and 8-ball dBGAA2 packages and is accessed via a Two-wire serial interface. In addition, the AT24C02B is available in 1.8V (1.8V to 5.5V) version.

Table 0-1. Pin Configuration

Pin Name	Function
A0 - A2	Address Inputs
SDA	Serial Data
SCL	Serial Clock Input
WP	Write Protect
GND	Ground
VCC	Power Supply

8-lead Ultra-Thin Mini-MAP (MLP 2x3)

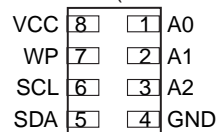

Bottom View

8-ball dBGAA2

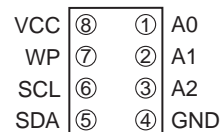

Bottom View

8-lead TSSOP

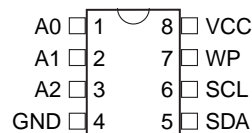

8-lead SOIC

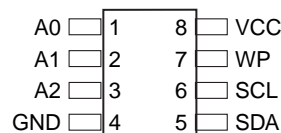

Note: For use of 5-lead SOT23, the software A2, A1, and A0 bits in the device address word must be set to zero to properly communicate.

5-lead SOT23

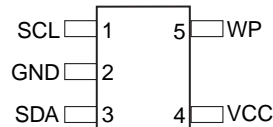

8-lead PDIP

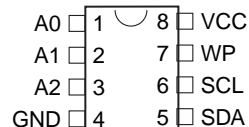

Two-wire Serial EEPROM

2K (256 x 8)

AT24C02B

5126H-SEEPR-8/07



Structure : Silicon Monolithic Integrated Circuit

Product : 9ch Function Switch

Type : **BD3841FS**

- Feature :
- (1) For 2nd room entertainment.
 - (2) For 2nd source recording.

Absolute Maximum Ratings (Ta=25°C)

Parameter	Symbol	Limits	Unit
Power Supply Voltage	Vcc	15	V
Power Dissipation	Pd	SSOP 950※	mW
Operating Temperature	Topr	-20~+75	°C
Storage Temperature	Tastg	-55~+125	°C

※ Over Ta = 25°C, derating at the rate of 9.5mW/°C. When installed on the standard board (size : 70 x70 x 1.6mm).

Operating Voltage Range

Parameter	Symbol	Limit	Unit
Power Supply Voltage (both power sources)	VCC-GND	5~7.3	V
	VEE-GND	-5~-7.3	
Power Supply Voltage (single power source)	VCC- VEE	10~14.6	V

(It must function normally at Ta = 25°C)

Application example

Note that ROHM cannot provide adequate confirmation of patents.

The product described in this specification is designed to be used with ordinary electronic equipment or devices (such as audio-visual equipment, office-automation equipment, communications devices, electrical appliances, and electronic toys). Should you intend to use this product with equipment or devices which require an extremely high level of reliability and the malfunction of which would directly endanger human life (such as medical instruments, transportation equipment, aerospace machinery, nuclear-reactor controllers, fuel controllers and other safety devices), please be sure to consult with our sales representative in advance.

Electrical characteristics

Ta=25°C, VCC=7V, VEE=7V, f=1kHz, Vin=1Vrms, RL=10kΩ, Rg=600Ω, unless otherwise noted.

	Symbol	Parameter	Limit			Unit	Conditions
			Min.	Typ.	Max.		
	IQ	Circuit current	—	3	10	mA	No signal
Output	Gv1	Output voltage gain 1ch	-2	0	2	dB	Measure : Pin20
	Gv2	Output voltage gain 2ch	-2	0	2	dB	Measure : Pin19
	THD1	Total harmonic distortion ratio 1ch	—	0.004	0.05	%	Measure : Pin20 BW=400~30kHz
	THD2	Total harmonic distortion ratio 2ch	—	0.004	0.05	%	Measure : Pin19 BW=400~30kHz
	Vomax1	Maximum output voltage 1ch	3.4	4.2	—	Vrms	Measure : Pin20 THD=1%
	Vomax2	Maximum output voltage 2ch	3.4	4.2	—	Vrms	Measure : Pin19 THD=1%
	Vno1	Output noise voltage 1ch	—	1	5	μVrms	Measure : Pin 20 Rg=0Ω, BW=IHF-A
	Vno2	Output noise voltage 2ch	—	1	5	μVrms	Measure : Pin 19 Rg=0Ω, BW=IHF-A
	CTC12	Cross-talk between channels 1ch→2ch	—	-95	-80	dB	Measure : Pin19(OUT2), Rg=0Ω, BW=IHF-A Reference: Pin20(OUT1)=1Vrms
	CTC21	Cross-talk between channels 2ch→1ch	—	-95	-80	dB	Measure : Pin20(OUT1), Rg=0Ω, BW=IHF-A Reference: Pin19(OUT2)=1Vrms
	CTS1	Cross-talk between selectors 1ch	—	-95	-80	dB	Measure : Pin20 Rg=0Ω, BW=IHF-A
	CTS2	Cross-talk between selectors 2ch	—	-95	-80	dB	Measure : Pin19 Rg=0Ω, BW=IHF-A
REC output	GVR1	R voltage gain 1ch	-2	0	2	dB	RL=47kΩ, Measure : Pin 22, 24, 26
	GVR2	R voltage gain 2ch	-2	0	2	dB	RL=47kΩ, Measure : Pin 21, 23, 25
	THDR1	R Total harmonic distortion ratio 1ch	—	0.01	0.09	%	RL=47kΩ, Measure : Pin 22, 24, 26 BW=400~30kHz
	THDR2	R Total harmonic distortion ratio 2ch	—	0.01	0.09	%	RL=47kΩ, Measure : Pin 21, 23, 25 BW=400~30kHz
	VnoR1	R output noise voltage 1ch	—	1	5	μVms	Measure : Pin 22, 24,26 Rg=0Ω, BW=IHF-A
	VnoR2	R output noise voltage 2ch	—	1	5	μVms	Measure : Pin 21, 23,25 Rg=0Ω, BW=IHF-A
	RoutR1	R output impedance 1ch	—	50	100	Ω	Measure : Pin 22, 24, 26
	RoutR2	R output impedance 2ch	—	50	100	Ω	Measure : Pin 21, 23, 25

Outline dimension • Marking dimension

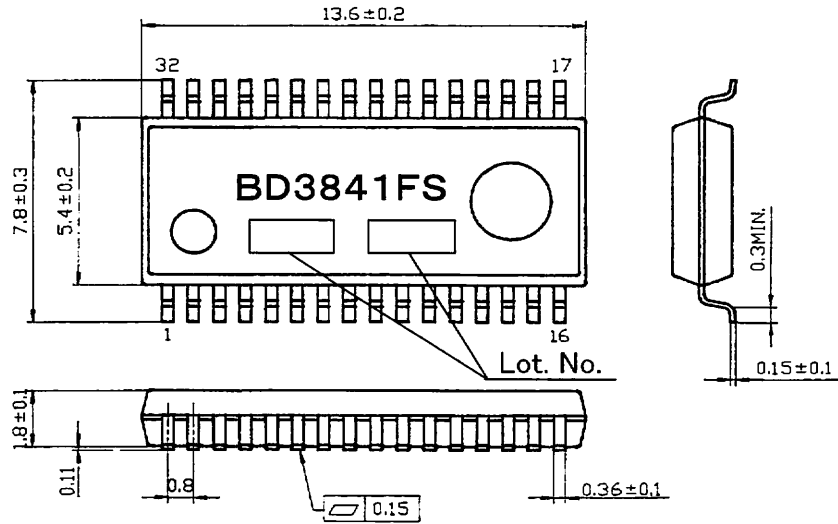

SSOP – A32 (Unit: mm)

Block diagram

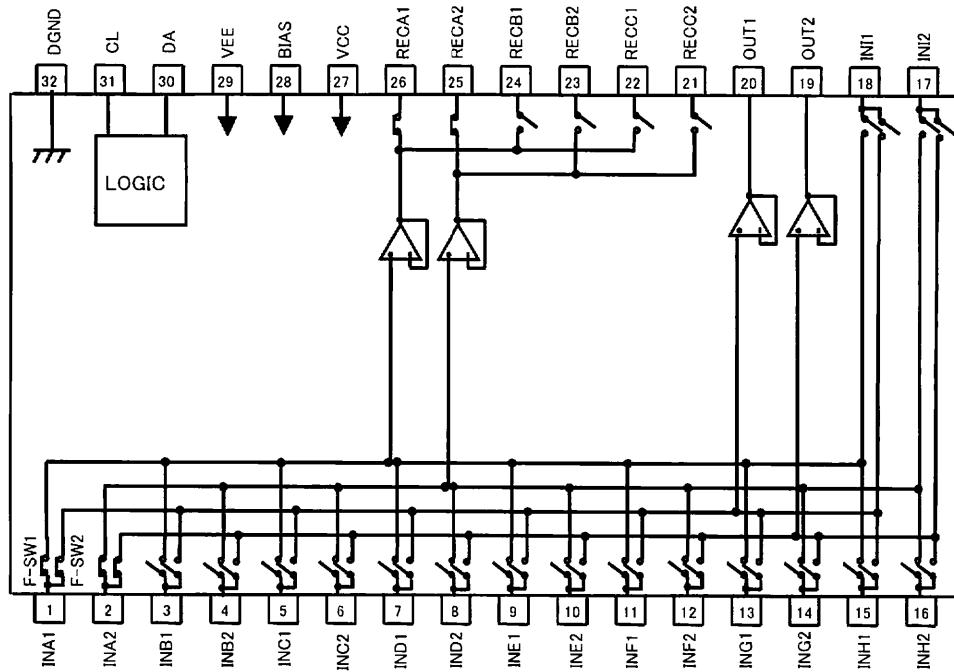

* F-SW1: INPUT FUNCTION1
 F-SW2: INPUT FUNCTION2

110 dB, 192 kHz 6-Ch Codec with S/PDIF Receiver

Features

- ◆ Six 24-bit D/A, two 24-bit A/D Converters
- ◆ 110 dB DAC / 114 dB ADC Dynamic Range
- ◆ -100 dB THD+N
- ◆ System Sampling Rates up to 192 kHz
- ◆ S/PDIF Receiver Compatible with EIAJ CP1201 and IEC-60958
- ◆ Recovered S/PDIF Clock or System Clock Selection
- ◆ 8:2 S/PDIF Input MUX
- ◆ ADC High-Pass Filter for DC Offset Calibration
- ◆ Expandable ADC Channels and One-Line Mode Support
- ◆ Digital Output Volume Control with Soft Ramp
- ◆ Digital +/-15 dB Input Gain Adjust for ADC
- ◆ Differential Analog Architecture
- ◆ Supports Logic Levels between 1.8 V and 5 V

General Description

The CS42516 codec provides two analog-to-digital and six digital-to-analog delta-sigma converters, as well as an integrated S/PDIF receiver.

The CS42516 integrated S/PDIF receiver supports up to eight inputs, clock recovery circuitry and format auto-detection. The internal stereo ADC is capable of independent channel gain control for single-ended or differential analog inputs. All six channels of DAC provide digital volume control and differential analog outputs. The general-purpose outputs may be driven high or low, or mapped to a variety of DAC mute controls or ADC overflow indicators.

The CS42516 is ideal for audio systems requiring wide dynamic range, negligible distortion and low noise, such as A/V receivers, DVD receivers, digital speaker and automotive audio systems.

The CS42516 is available in a 64-pin LQFP package in both Commercial (-10° to 70° C) and Automotive (-40° to 85° C) grades. The CDB42518 Customer Demonstration board is also available for device evaluation. Refer to ["Ordering Information" on page 89](#).

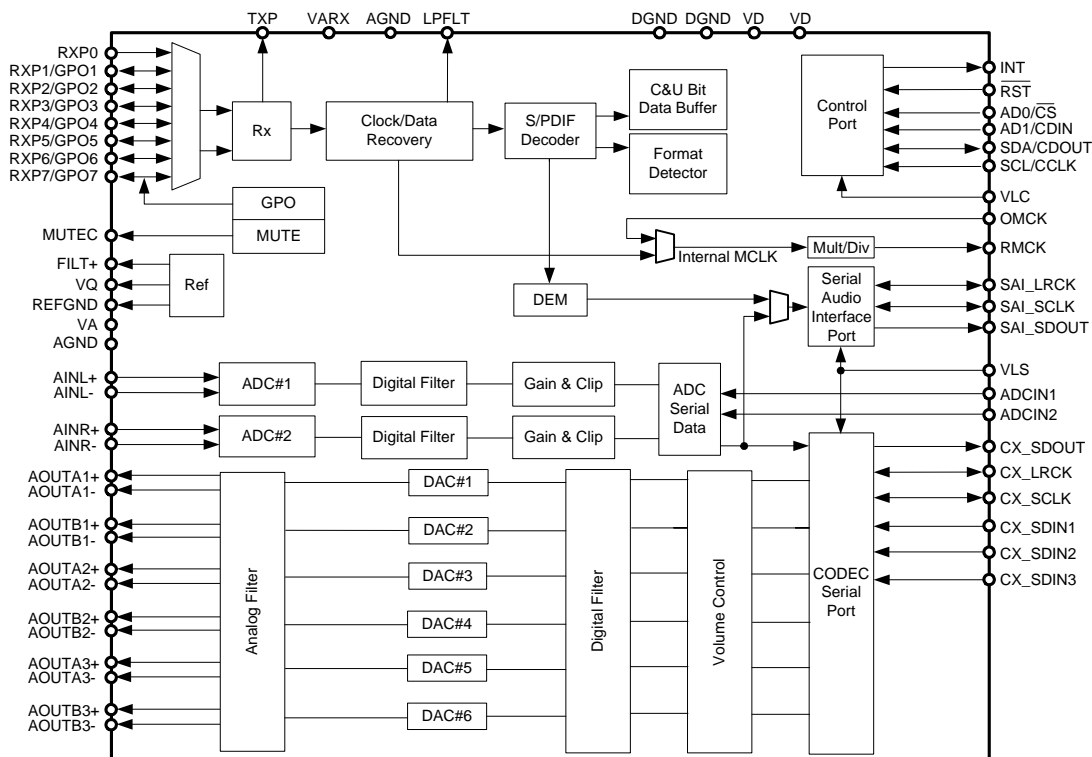

2. PIN DESCRIPTIONS

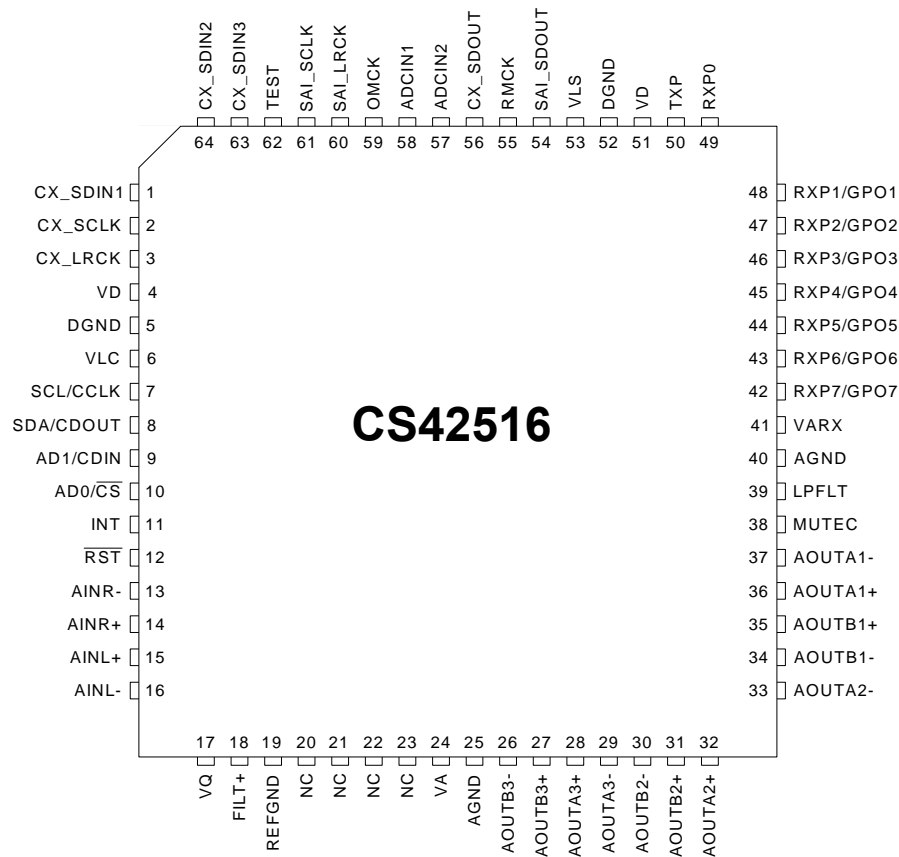

Pin Name	#	Pin Description
CX_SDIN1	1	
CX_SDIN2	64	Codec Serial Audio Data Input (Input) - Input for two's complement serial audio data.
CX_SDIN3	63	
CX_SCLK	2	CODEC Serial Clock (Input/Output) - Serial clock for the CODEC serial audio interface.
CX_LRCK	3	CODEC Left Right Clock (Input/Output) - Determines which channel, Left or Right, is currently active on the CODEC serial audio data line.
VD	4 51	Digital Power (Input) - Positive power supply for the digital section.
DGND	5 52	Digital Ground (Input) - Ground reference. Should be connected to digital ground.
VLC	6	Control Port Power (Input) - Determines the required signal level for the control port.
SCL/CCLK	7	Serial Control Port Clock (Input) - Serial clock for the serial control port. Requires an external pull-up resistor to the logic interface voltage in I ² C mode as shown in the Typical Connection Diagram.
SDA/CDOUT	8	Serial Control Data (Input/Output) - SDA is a data I/O line in I ² C mode and requires an external pull-up resistor to the logic interface voltage, as shown in the Typical Connection Diagram. CDOUT is the output data line for the control port interface in SPI mode.
AD1/CDIN	9	Address Bit 1 (I²C)/Serial Control Data (SPI) (Input) - AD1 is a chip address pin in I ² C mode; CDIN is the input data line for the control port interface in SPI mode.
AD0/ $\overline{\text{CS}}$	10	Address Bit 0 (I²C)/Control Port Chip Select (SPI) (Input) - AD0 is a chip address pin in I ² C mode; $\overline{\text{CS}}$ is the chip select signal in SPI mode.

INT	11	Interrupt (Output) - The CS42516 will generate an interrupt condition as per the Interrupt Mask register. See " Interrupts " on page 40 for more details.
$\overline{\text{RST}}$	12	Reset (Input) - The device enters a low power mode and all internal registers are reset to their default settings when low.
AINR- AINR+	13 14	Differential Right Channel Analog Input (Input) - Signals are presented differentially to the delta-sigma modulators via the AINR+/- pins.
AINL+ AINL-	15 16	Differential Left Channel Analog Input (Input) - Signals are presented differentially to the delta-sigma modulators via the AINL+/- pins.
VQ	17	Quiescent Voltage (Output) - Filter connection for internal quiescent reference voltage.
FILT+	18	Positive Voltage Reference (Output) - Positive reference voltage for the internal sampling circuits.
REFGND	19	Reference Ground (Input) - Ground reference for the internal sampling circuits.
	20	
NC	21 22 23	No Connect Pins - Do not make any connection to these pins.
AOUTA1 +,- AOUTB1 +,- AOUTA2 +,- AOUTB2 +,- AOUTA3 +,- AOUTB3 +,-	36,37 35,34 32,33 31,30 28,29 27,26	Differential Analog Output (Output) - The full-scale differential analog output level is specified in the Analog Characteristics specification table.
VA VARX	24 41	Analog Power (Input) - Positive power supply for the analog section.
AGND	25 40	Analog Ground (Input) - Ground reference. Should be connected to analog ground.
MUTE $\overline{\text{C}}$	38	Mute Control (Output) - The Mute Control pin outputs high impedance following an initial power-on condition or whenever the PDN bit is set to a '1', forcing the codec into power-down mode. The signal will remain in a high impedance state as long as the part is in power-down mode. The Mute Control pin goes to the selected "active" state during reset, muting, or if the master clock to left/right clock frequency ratio is incorrect. This pin is intended to be used as a control for external mute circuits to prevent the clicks and pops that can occur in any single supply system. The use of external mute circuits are not mandatory but may be desired for designs requiring the absolute minimum in extraneous clicks and pops.
LPFLT	39	PLL Loop Filter (Output) - An RC network should be connected between this pin and ground.
RXP7/GPO7 RXP6/GPO6 RXP5/GPO5 RXP4/GPO4 RXP3/GPO3 RXP2/GPO2 RXP1/GPO1	42 43 44 45 46 47 48	S/PDIF Receiver Input/ General Purpose Output (Input/Output) - Receiver inputs for S/PDIF encoded data. The CS42516 has an internal 8:2 multiplexer to select the active receiver port, according to the Receiver Mode Control 2 register. These pins can also be configured as general purpose output pins, ADC Overflow indicators or Mute Control outputs according to the RXP/General Purpose Pin Control registers.
RXP0	49	S/PDIF Receiver Input (Input) - Dedicated receiver input for S/PDIF encoded data.
TXP	50	S/PDIF Transmitter Output (Output) - S/PDIF encoded data output, mapped directly from one of the receiver inputs as indicated by the Receiver Mode Control 2 register.
VLS	53	Serial Port Interface Power (Input) - Determines the required signal level for the serial port interfaces.
SAI_SDO $\overline{\text{U}}$ T	54	Serial Audio Interface Serial Data Output (Output) - Output for two's complement serial audio PCM data from the S/PDIF incoming stream. This pin can also be configured to transmit the output of the internal and external ADCs.
RMCK	55	Recovered Master Clock (Output) - Recovered master clock output from the External Clock Reference (OMCK, pin 59) or the PLL which is locked to the incoming S/PDIF stream or CX_LRCK.
CX_SDO $\overline{\text{U}}$ T	56	CODEC Serial Data Output (Output) - Output for two's complement serial audio data from the internal and external ADCs.

ADCIN1	58	External ADC Serial Input (Input) - The CS42516 provides for up to two external stereo analog to digital converter inputs to provide a maximum of six channels on one serial data output line when the CS42516 is placed in One-Line Mode.
ADCIN2	57	
OMCK	59	External Reference Clock (Input) - External clock reference that must be within the ranges specified in the register " OMCK Frequency (OMCK Freqx) " on page 53.
TEST	62	Test Pin (Input) - This pin must be connected to DGND.
SAI_LRCK	60	Serial Audio Interface Left/Right Clock (Input/Output) - Determines which channel, Left or Right, is currently active on the serial audio data line.
SAI_SCLK	61	Serial Audio Interface Serial Clock (Input/Output) - Serial clock for the Serial Audio Interface.

3. TYPICAL CONNECTION DIAGRAM

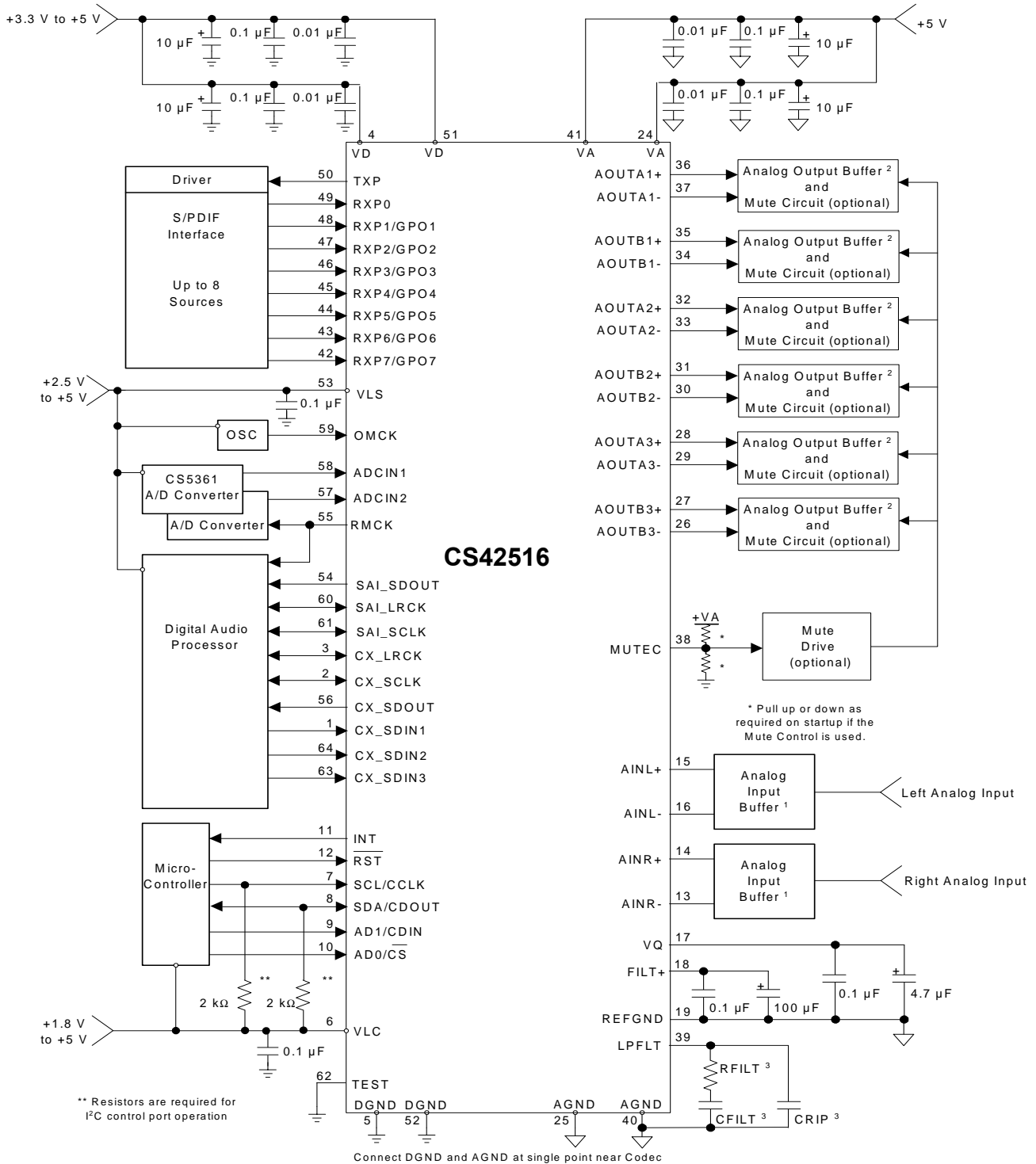

Figure 5. Typical Connection Diagram

FEATURES

- ❑ Cost-effective, High-performance 32-bit DSP
 - 300,000,000 MAC/S (multiply accumulates per second)
 - Dual MAC cycles per clock
 - 72-bit accumulators are the most accurate in the industry
 - 24k x 32 SRAM, 2k blocks - assignable to data or program
 - Internal ROM contains a variety of configurable sound enhancement feature sets
 - 8-channel internal DMA
 - Internal watch-dog DSP lock-up prevention
- ❑ DSP Tool Set w/ Private Keys for Protecting Customer IP
- ❑ Configurable Serial Audio Inputs/Outputs
 - Configurable for all input/output types
 - Maximum 32-bit @ 192 kHz
 - Supports 32-bit audio sample I/O between DSP chips
 - TDM input modes (multiple channels on same line)
 - 192 kHz SPDIF transmitter
 - Multi-channel DSD direct stream digital SACD input
- ❑ Supports Two Different Input Fs Sample Rates
 - Output can be master or slave
 - Dual processing path capability
 - Input supports dual domain slave clocking
 - Hardware assist time sampling for sample rate conversion
- ❑ Integrated Clock Manager/PLL
 - Can operate from external crystal, external oscillator
- ❑ Input Fs Auto Detection
- ❑ Host & Boot via Serial Interface
- ❑ Configurable GPIOs and External Interrupt Input
- ❑ 1.8V Core and a 3.3V I/O that is tolerant to 5V input
- ❑ Low-power Mode
 - “Energy-Star Ready” via low-power mode, 268 μ W in standby

Differentiating from the legacy Cirrus multi-standard, multi-channel decoders, this new CS485xx family is still based on the same high-performance 32-bit fixed point Digital Signal Processor core but instead is equipped with much less memory, tailoring it for more cost-effective applications associated with multi-channel and virtual-channel sound enhancements. Target applications are:

- Digital Televisions
- Multimedia Peripherals
- iPod® Docking Stations
- Automotive Head Units
- Automotive Outboard Amplifiers
- HD-DVD & Blu-ray Disc DVD Receivers
- PC Speakers

There are also a wide variety of licensable DSP codes available today as seen by the following examples:



Cirrus also has developed, or is developing their own royalty-free versions of popular features sets like Cirrus Bass Manager, Cirrus Dynamic Volume Leveler, Cirrus Original Multichannel Surround, Cirrus Virtual Speaker & Cirrus 3D-Audio.

The CS485xx family is programmed using the Cirrus proprietary DSP Composer™ GUI development tool. Processing chains may be designed using a drag-and-drop interface to place/utilize functional macro audio DSP primitives. The end result is a software image that is downloaded to the DSP via serial host or serial boot modes.

Ordering Information:

See [page 20](#) for ordering information

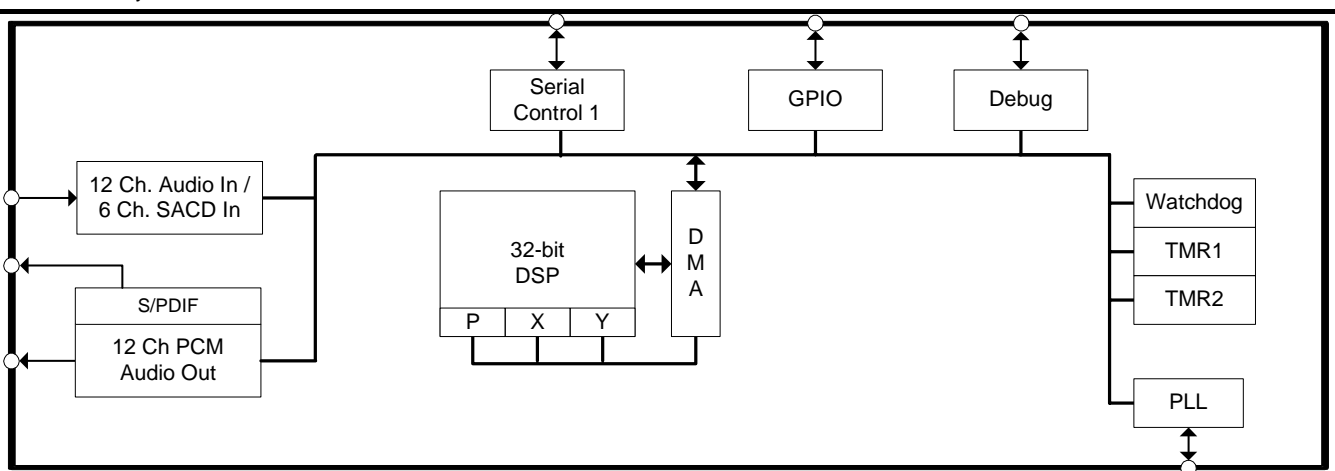

8.2 CS48540, 48-pin LQFP Pinout Diagram

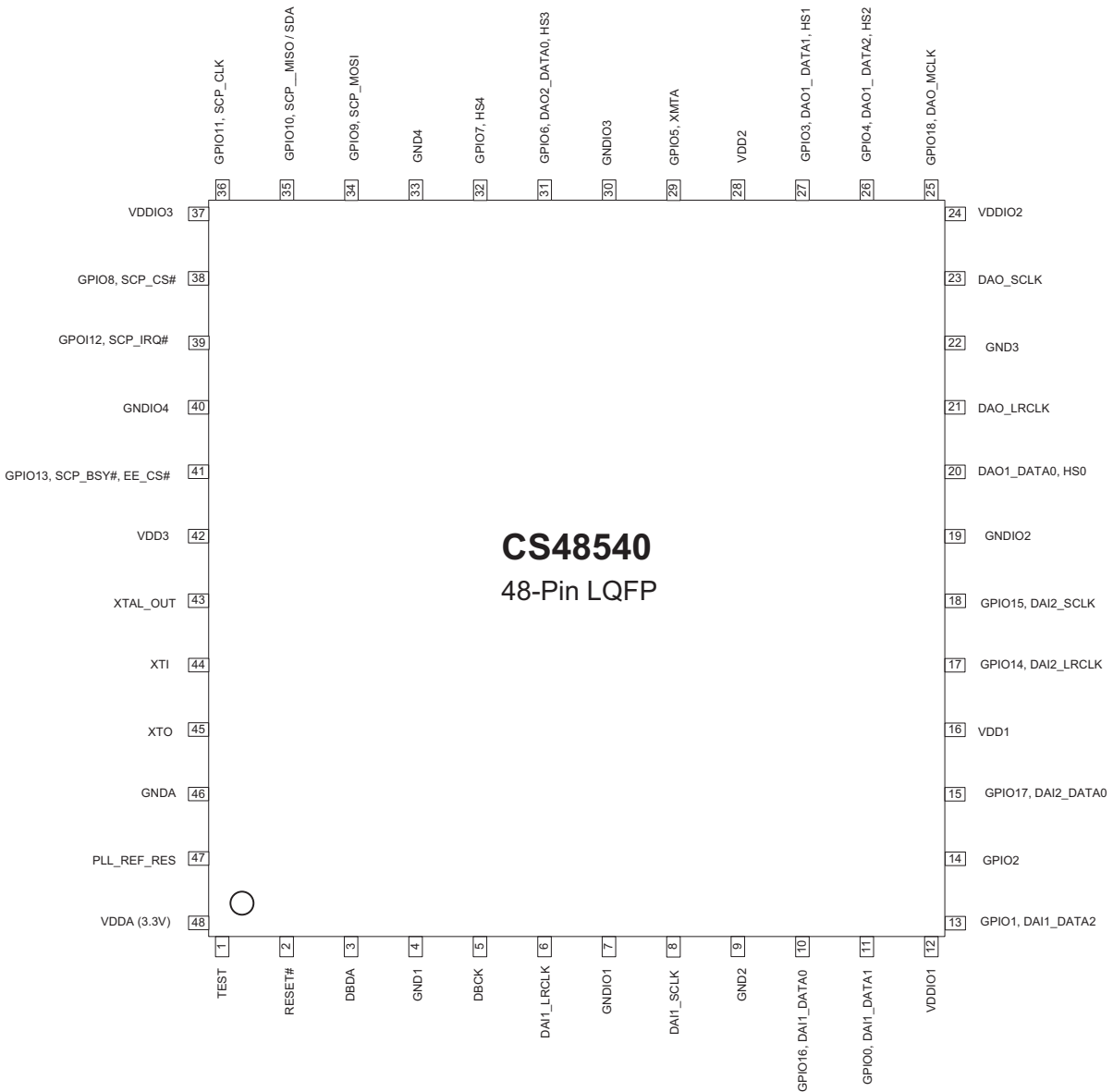

Figure 12. CS48540, 48-Pin LQFP Pinout

FAN1112

1A 1.2V Low Dropout Linear Regulator

Features

- Low dropout voltage
- Load regulation: 0.05% typical
- Trimmed current limit
- On-chip thermal limiting
- Standard SOT-223 and TO-252 packages
- Three-terminal fixed 1.2V

Applications

- Post regulator for switching supplies
- Supply for low-voltage processors

Description

The FAN1112 is a 1.2V low dropout three-terminal regulator with 1A output current capability. The device has been optimized for low voltage where transient response and minimum input voltage are critical.

Current limit is trimmed to ensure specified output current and controlled short-circuit current. On-chip thermal limiting provides protection against any combination of overload and ambient temperatures that would create excessive junction temperatures.

Unlike PNP type regulators where up to 10% of the output current is wasted as quiescent current, the quiescent current of the FAN1112 flows into the load, increasing efficiency.

The FAN1112 regulator is available in the industry-standard SOT-223 and TO-252 (DPAK) power packages.

Typical Application

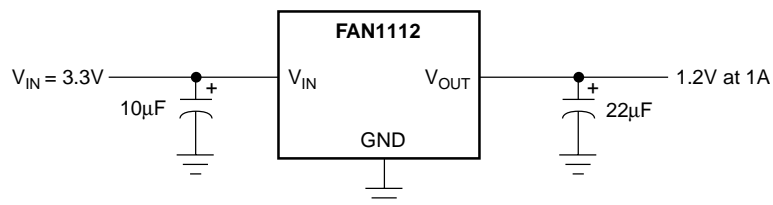

Pin Assignments

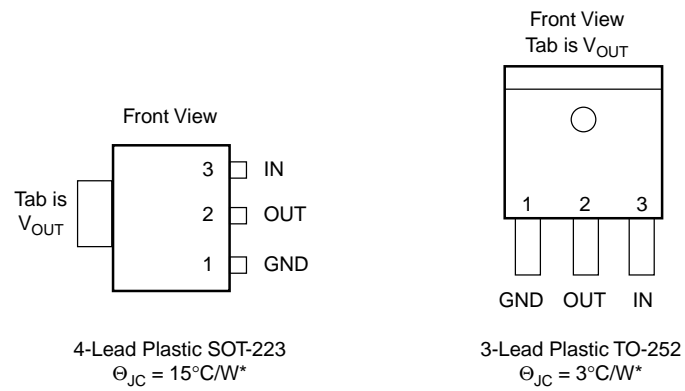

*With package soldered to 0.5 square inch copper area over backside ground plane or internal power plane., Θ_{JA} can vary from 30°C/W to more than 50°C/W . Other mounting techniques may provide better thermal resistance than 30°C/W .

Absolute Maximum Ratings

Parameter	Min.	Max.	Unit
V_{IN}		18	V
$(V_{IN} - V_{OUT}) * I_{OUT}$		See Figure 1	
Operating Junction Temperature Range	0	125	$^{\circ}\text{C}$
Storage Temperature Range	-65	150	$^{\circ}\text{C}$
Lead Temperature (Soldering, 10 sec.)		300	$^{\circ}\text{C}$

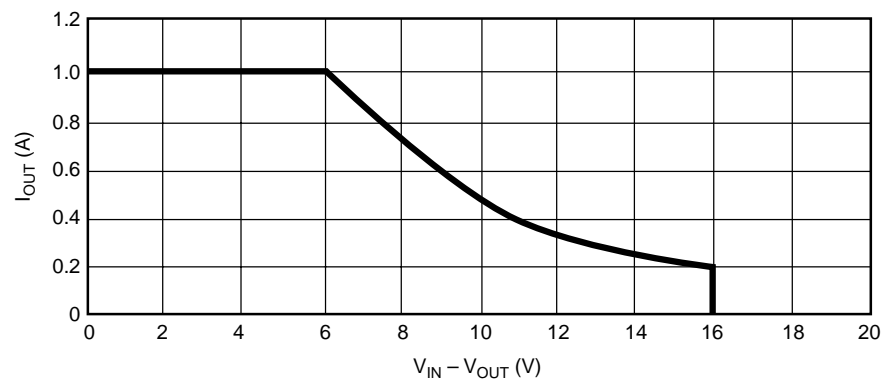

Figure 1. Absolute Maximum Safe Operating Area

HEF4094B

8-stage shift-and-store register

Rev. 08 — 2 April 2010

Product data sheet

1. General description

The HEF4094B is an 8-stage serial shift register. It has a storage latch associated with each stage for strobing data from the serial input to parallel buffered 3-state outputs QP0 to QP7. The parallel outputs may be connected directly to common bus lines. Data is shifted on positive-going clock transitions. The data in each shift register stage is transferred to the storage register when the strobe (STR) input is HIGH. Data in the storage register appears at the outputs whenever the output enable (OE) signal is HIGH.

Two serial outputs (QS1 and QS2) are available for cascading a number of HEF4094B devices. Serial data is available at QS1 on positive-going clock edges to allow high-speed operation in cascaded systems with a fast clock rise time. The same serial data is available at QS2 on the next negative going clock edge. This is used for cascading HEF4094B devices when the clock has a slow rise time.

It operates over a recommended V_{DD} power supply range of 3 V to 15 V referenced to V_{SS} (usually ground). Unused inputs must be connected to V_{DD} , V_{SS} , or another input. It is also suitable for use over the industrial ($-40\text{ }^{\circ}\text{C}$ to $+85\text{ }^{\circ}\text{C}$) and automotive ($-40\text{ }^{\circ}\text{C}$ to $+125\text{ }^{\circ}\text{C}$) temperature ranges.

2. Features and benefits

- Fully static operation
- 5 V, 10 V, and 15 V parametric ratings
- Standardized symmetrical output characteristics
- Operates across the automotive temperature range $-40\text{ }^{\circ}\text{C}$ to $+125\text{ }^{\circ}\text{C}$
- Complies with JEDEC standard JESD 13-B

3. Ordering information

Table 1. Ordering information

All types operate from $-40\text{ }^{\circ}\text{C}$ to $+125\text{ }^{\circ}\text{C}$.

Type number	Package		Version
	Name	Description	
HEF4094BP	DIP16	plastic dual in-line package; 16 leads (300 mil)	SOT38-4
HEF4094BT	SO16	plastic small outline package; 16 leads; body width 3.9 mm	SOT109-1
HEF4094BTS	SSOP16	plastic shrink small outline package; 16 leads; body width 5.3 mm	SOT338-1

4. Functional diagram

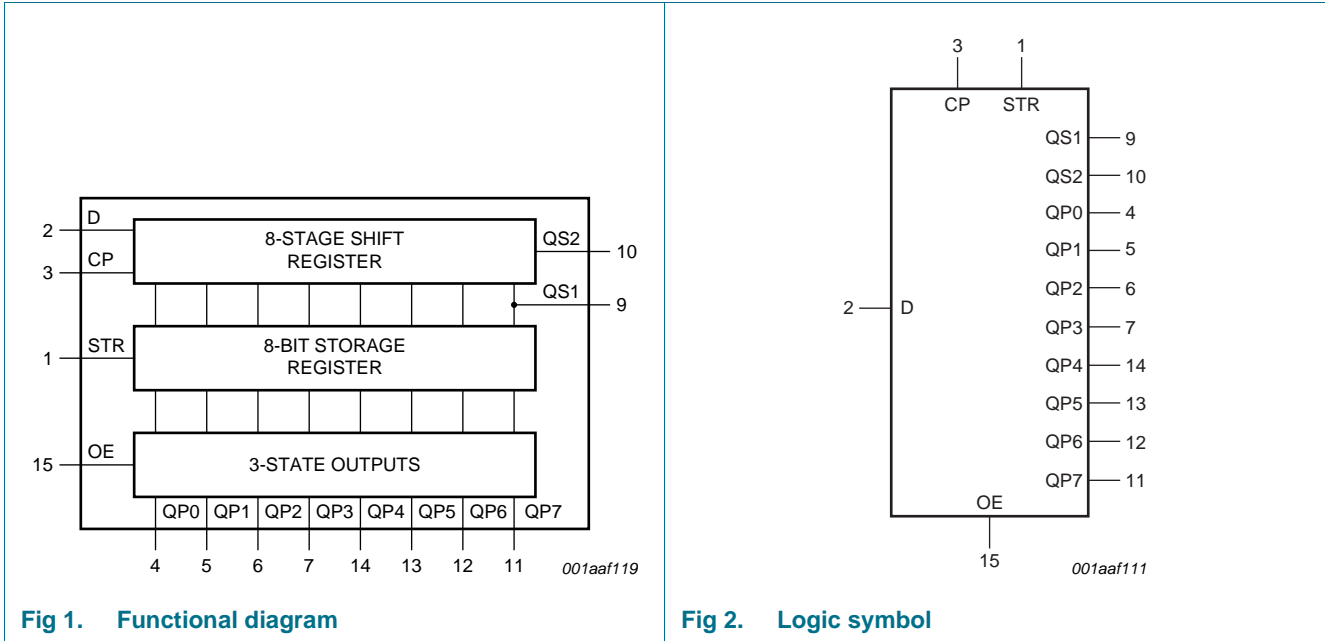

Fig 1. Functional diagram

Fig 2. Logic symbol

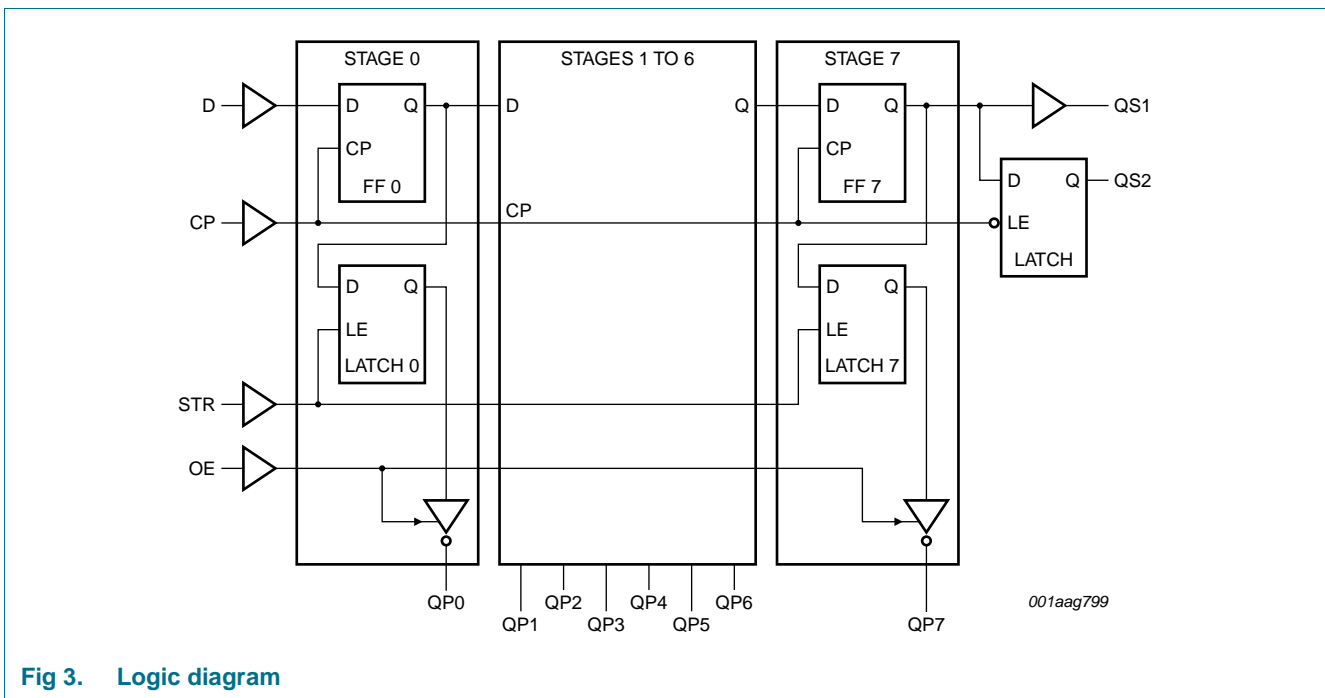
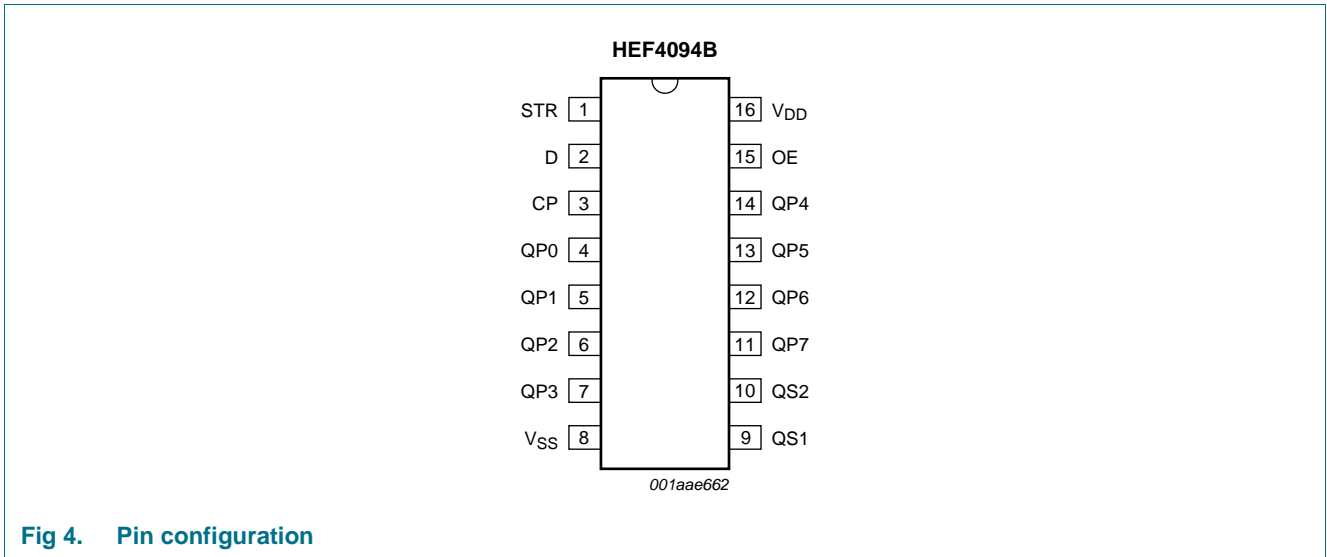

Fig 3. Logic diagram

5. Pinning information

5.1 Pinning



5.2 Pin description

Table 2. Pin description

Symbol	Pin	Description
STR	1	strobe input
D	2	data input
CP	3	clock input
QP0 to QP7	4, 5, 6, 7, 14, 13, 12, 11	parallel output
V _{SS}	8	ground supply voltage
QS1	9	serial output
QS2	10	serial output
OE	15	output enable input
V _{DD}	16	supply voltage

6. Functional description

Table 3. Function table^[1]

Inputs				Parallel outputs		Serial outputs	
CP	OE	STR	D	QP0	QPn	QS1	QS2
↑	L	X	X	Z	Z	Q6S	NC
↓	L	X	X	Z	Z	NC	Q7S
↑	H	L	X	NC	NC	Q6S	NC
↑	H	H	L	L	QPn - 1	Q6S	NC
↑	H	H	H	H	QPn - 1	Q6S	NC
↓	H	H	H	NC	NC	NC	Q7S

- [1] At the positive clock edge, the information in the 7th register stage is transferred to the 8th register stage and the QSn outputs.
 H = HIGH voltage level; L = LOW voltage level; X = don't care;
 ↑ = positive-going transition; ↓ = negative-going transition;
 Z = HIGH-impedance OFF-state; NC = no change;
 Q6S = the data in register stage 6 before the LOW to HIGH clock transition;
 Q7S = the data in register stage 7 before the HIGH to LOW clock transition.

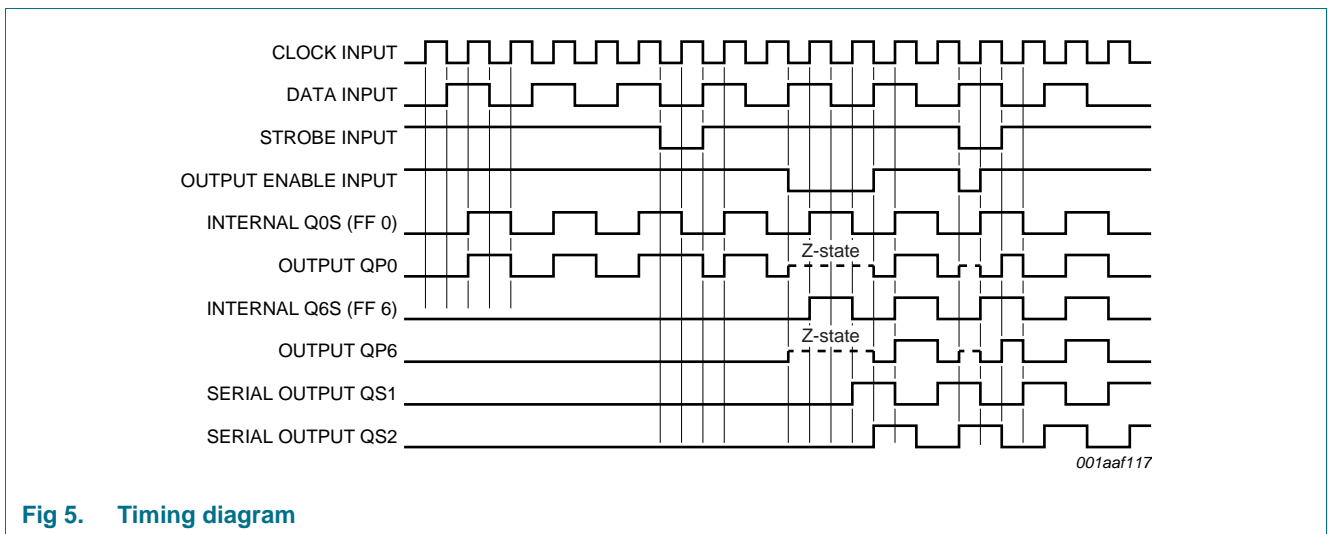

Fig 5. Timing diagram

Features

- Operating voltage: 2.0V~5.5V
- Maximum input serial clock: 500kHz at $V_{DD}=2V$, 2MHz at $V_{DD}=5V$
- Operating current: less than 1 μ A at 2V, less than 1.2 μ A at 5V
- TTL compatible
 - V_{IH} : 2.0V~ $V_{DD}+0.3V$ at $V_{DD}=5V$
 - V_{IL} : -0.3V~+0.8V at $V_{DD}=5V$
- Two data transmission modes: single-byte, or burst mode
- Serial I/O transmission
- All registers store BCD format
- HT1380: 8-pin DIP package
HT1381: 8-pin SOP package

Applications

- Microcomputer serial clock
- Clock and Calendar

General Description

The HT1380/HT1381 is a serial timekeeper IC which provides seconds, minutes, hours, day, date, month and year information. The number of days in each month and leap years are automatically adjusted. The HT1380/HT1381 is designed for low power consumption and can operate in two modes: one is the 12-hour mode with an AM/PM indicator, the other is the 24-hour mode.

The HT1380/HT1381 has several registers to store the corresponding information with 8-bit data format. A 32768Hz crystal is required to provide the correct timing. In order to minimize the pin number, the HT1380/HT1381 use a serial I/O transmission method to interface with a microprocessor. Only three wires are required: (1) \overline{REST} , (2) SCLK and (3) I/O. Data can be delivered 1 byte at a time or in a burst of up to 8 bytes.

Block Diagram

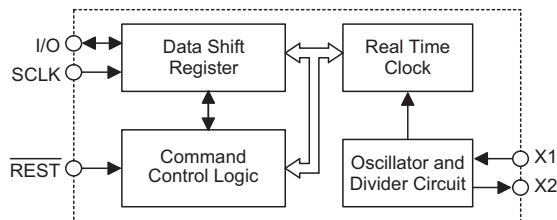

Pin Assignment

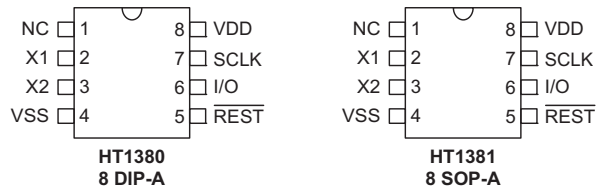

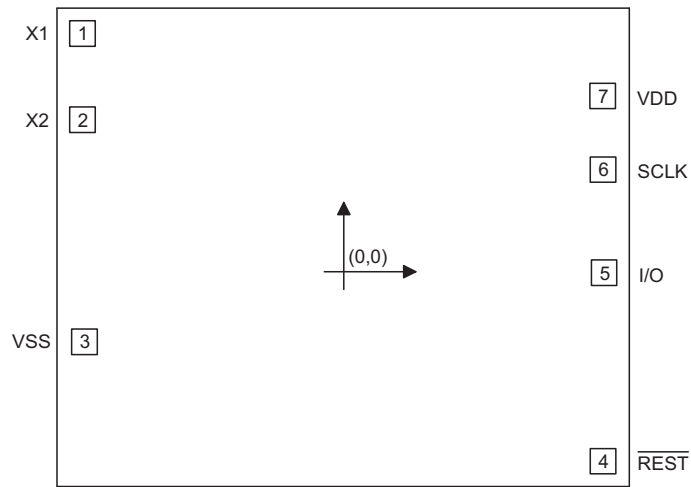
Pad Assignment

Chip size: 2010 × 1920 (μm)²

* The IC substrate should be connected to VSS in the PCB layout artwork.

Pad Coordinates

Unit: μm

Pad No.	X	Y
1	-851.40	775.00
2	-851.40	494.60
3	-844.40	-203.90
4	845.90	-618.30
5	848.40	-4.30
6	845.90	332.60
7	844.40	572.60

Pad Description

Pad No.	Pad Name	I/O	Internal Connection	Description
1	X1	I	CMOS	32768Hz crystal input pad
2	X2	O	CMOS	Oscillator output pad
3	VSS	—	CMOS	Negative power supply, ground
4	$\overline{\text{REST}}$	I	CMOS	Reset pin with serial transmission
5	I/O	I/O	CMOS	Data input/output pin with serial transmission
6	SCLK	I	CMOS	Serial clock pulse pin with serial transmission
7	VDD	—	CMOS	Positive power supply

LM1117/LM317A/LM317 3-Terminal Adjustable Regulator

General Description

The LM1117 series of adjustable 3-terminal positive voltage regulators is capable of supplying in excess of 1.5A over a 1.2V to 37V output range. They are exceptionally easy to use and require only two external resistors to set the output voltage. Further, both line and load regulation are better than standard fixed regulators. Also, the LM1117 is packaged in standard transistor packages which are easily mounted and handled.

In addition to higher performance than fixed regulators, the LM1117 series offers full overload protection available only in IC's. Included on the chip are current limit, thermal overload protection and safe area protection. All overload protection circuitry remains fully functional even if the adjustment terminal is disconnected.

Normally, no capacitors are needed unless the device is situated more than 6 inches from the input filter capacitors in which case an input bypass is needed. An optional output capacitor can be added to improve transient response. The adjustment terminal can be bypassed to achieve very high ripple rejection ratios which are difficult to achieve with standard 3-terminal regulators.

Besides replacing fixed regulators, the LM1117 is useful in a wide variety of other applications. Since the regulator is "floating" and sees only the input-to-output differential volt-

age, supplies of several hundred volts can be regulated as long as the maximum input to output differential is not exceeded, i.e., avoid short-circuiting the output.

Also, it makes an especially simple adjustable switching regulator, a programmable output regulator, or by connecting a fixed resistor between the adjustment pin and output, the LM1117 can be used as a precision current regulator. Supplies with electronic shutdown can be achieved by clamping the adjustment terminal to ground which programs the output to 1.2V where most loads draw little current.

For applications requiring greater output current, see LM150 series (3A) and LM138 series (5A) data sheets. For the negative complement, see LM137 series data sheet.

Features

- Guaranteed 1% output voltage tolerance (LM317A)
- Guaranteed max. 0.01%/V line regulation (LM317A)
- Guaranteed max. 0.3% load regulation (LM1117)
- Guaranteed 1.5A output current
- Adjustable output down to 1.2V
- Current limit constant with temperature
- P+ Product Enhancement tested
- 80 dB ripple rejection
- Output is short-circuit protected

Typical Applications

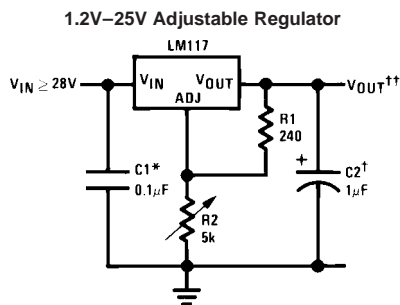

Full output current not available at high input-output voltages

*Needed if device is more than 6 inches from filter capacitors.

†Optional — improves transient response. Output capacitors in the range of 1 μF to 1000 μF of aluminum or tantalum electrolytic are commonly used to provide improved output impedance and rejection of transients.

$$\dagger\dagger V_{OUT} = 1.25V \left(1 + \frac{R2}{R1} \right) + I_{ADJ}(R2)$$

LM1117 Series Packages

Part Number Suffix	Package	Design Load Current
K	TO-3	1.5A
H	TO-39	0.5A
T	TO-220	1.5A
E	LCC	0.5A
S	TO-263	1.5A
EMP	SOT-223	1A
MDT	TO-252	0.5A

SOT-223 vs D-Pak (TO-252) Packages

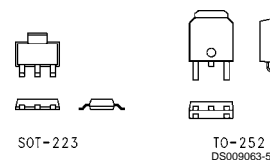

Scale 1:1

LM9022

Vacuum Fluorescent Display Filament Driver

General Description

The LM9022 is a bridged power amplifier capable of delivering typically 2W of continuous average power into a 10 Ω filament load when powered by a 5V power supply.

To conserve power in portable applications, the LM9022's micropower shutdown mode ($I_Q = 0.6\mu\text{A}$, typ) is activated when V_{DD} is applied to the SHUTDOWN pin.

Additional LM9022 features include thermal shutdown protection, unity-gain stability, and external gain set.

Key Specifications

- I_{DD} during shutdown
- Thermal Shutdown Protection

 0.6 μA (typ)

Features

- No transformers required
- SO or DIP packaging

Applications

- VCR/DVD Displays
- RADIO/TUNER Displays

Typical Application $T_A = 25^\circ\text{C}$, $V_{DD} = 5\text{V}$, unless otherwise specified.

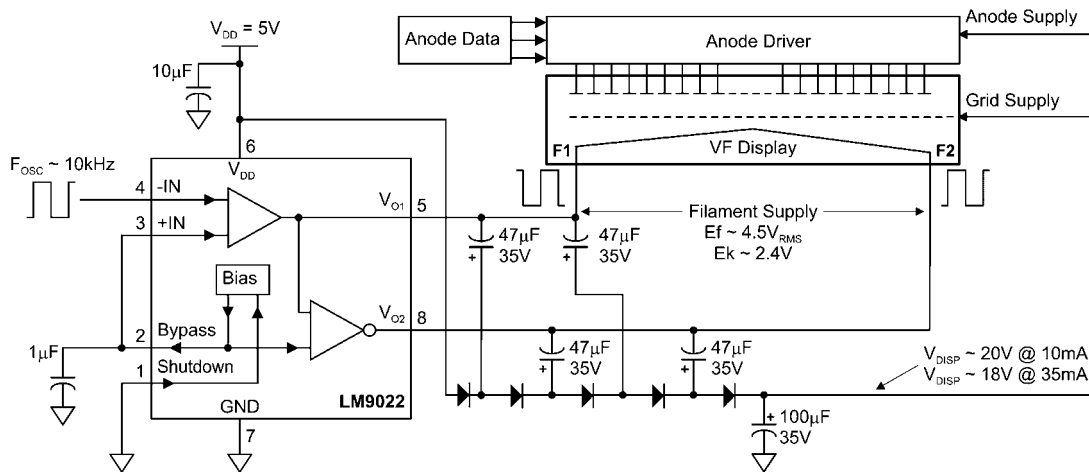

20021501

FIGURE 1. Typical Application Circuit

Connection Diagram

MSOP, Small Outline, and DIP Package

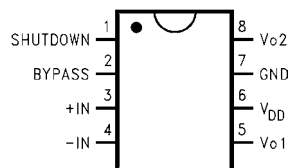

20021502

Top View

Order Number LM9022M or LM9022N
See NS Package Number M08A or N08E

LMV831 Single/ LMV832 Dual/ LMV834 Quad 3.3 MHz Low Power CMOS, EMI Hardened Operational Amplifiers

General Description

National's LMV831, LMV832, and LMV834 are CMOS input, low power op amp IC's, providing a low input bias current, a wide temperature range of -40°C to 125°C and exceptional performance making them robust general purpose parts. Additionally, the LMV831/LMV832/LMV834 are EMI hardened to minimize any interference so they are ideal for EMI sensitive applications.

The unity gain stable LMV831/LMV832/LMV834 feature 3.3 MHz of bandwidth while consuming only 0.24 mA of current per channel. These parts also maintain stability for capacitive loads as large as 200 pF. The LMV831/LMV832/LMV834 provide superior performance and economy in terms of power and space usage.

This family of parts has a maximum input offset voltage of 1 mV, a rail-to-rail output stage and an input common-mode voltage range that includes ground. Over an operating range from 2.7V to 5.5V the LMV831/LMV832/LMV834 provide a PSRR of 93 dB, and a CMRR of 91 dB. The LMV831 is offered in the space saving 5-Pin SC70 package, the LMV832 in the 8-Pin MSOP and the LMV834 is offered in the 14-Pin TSSOP package.

Features

Unless otherwise noted, typical values at $T_A = 25^{\circ}\text{C}$, $V_+ = 3.3\text{V}$

■ Supply voltage	2.7V to 5.5V
■ Supply current (per channel)	240 μA
■ Input offset voltage	1 mV max
■ Input bias current	0.1 pA
■ GBW	3.3 MHz
■ EMIRR at 1.8 GHz	120 dB
■ Input noise voltage at 1 kHz	12 nV/ $\sqrt{\text{Hz}}$
■ Slew rate	2 V/ μs
■ Output voltage swing	Rail-to-Rail
■ Output current drive	30 mA
■ Operating ambient temperature range	-40°C to 125°C

Applications

- Photodiode preamp
- Piezoelectric sensors
- Portable/battery-powered electronic equipment
- Filters/buffers
- PDAs/phone accessories

Typical Application

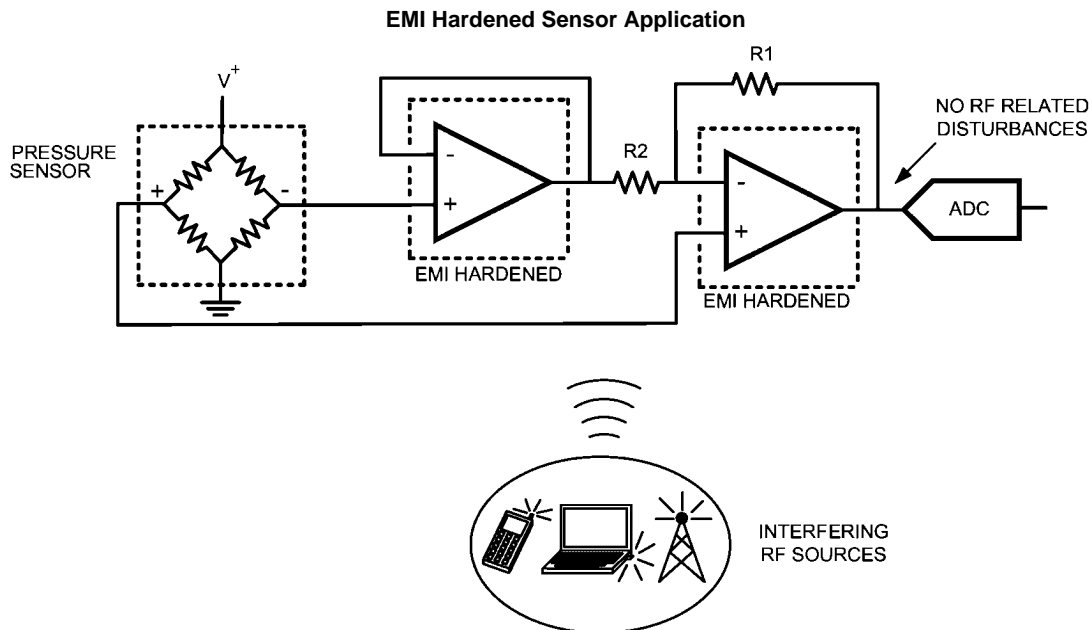

30024101

Absolute Maximum Ratings (Note 1)

If Military/Aerospace specified devices are required, please contact the National Semiconductor Sales Office/ Distributors for availability and specifications.

ESD Tolerance (Note 2)	
Human Body Model	2 kV
Charge-Device Model	1 kV
Machine Model	200V
V_{IN} Differential	\pm Supply Voltage
Supply Voltage ($V_S = V^+ - V^-$)	6V
Voltage at Input/Output Pins	$V^+ + 0.4V$, $V^- - 0.4V$

Storage Temperature Range	-65°C to 150°C
Junction Temperature (Note 3)	150°C
Soldering Information	
Infrared or Convection (20 sec)	260°C

Operating Ratings (Note 1)

Temperature Range (Note 3)	-40°C to 125°C
Supply Voltage ($V_S = V^+ - V^-$)	2.7V to 5.5V
Package Thermal Resistance (θ_{JA} (Note 3))	
5-Pin SC-70	302°C/W
8-Pin MSOP	217°C/W
14-Pin TSSOP	135°C/W

3.3V Electrical Characteristics (Note 4)

Unless otherwise specified, all limits are guaranteed for at $T_A = 25^\circ\text{C}$, $V^+ = 3.3\text{V}$, $V^- = 0\text{V}$, $V_{CM} = V^+/2$, and $R_L = 10\text{ k}\Omega$ to $V^+/2$.

Boldface limits apply at the temperature extremes.

Symbol	Parameter	Conditions	Min (Note 6)	Typ (Note 5)	Max (Note 6)	Units
V_{OS}	Input Offset Voltage (Note 9)			± 0.25	± 1.00 ± 1.23	mV
TCV_{OS}	Input Offset Voltage Temperature Drift (Notes 9, 10)			± 0.5	± 1.5	$\mu\text{V}/^\circ\text{C}$
		LMV831, LMV832				
		LMV834		± 0.5	± 1.7	
I_B	Input Bias Current (Note 10)			0.1	10 500	pA
I_{OS}	Input Offset Current			1		pA
CMRR	Common-Mode Rejection Ratio (Note 9)	$0.2\text{V} \leq V_{CM} \leq V^+ - 1.2\text{V}$	76 75	91		dB
PSRR	Power Supply Rejection Ratio (Note 9)	$2.7\text{V} \leq V^+ \leq 5.5\text{V}$, $V_{OUT} = 1\text{V}$	76 75	93		dB
EMIRR	EMI Rejection Ratio, IN+ and IN- (Note 8)	$V_{RF_PEAK} = 100\text{ mV}_P$ (-20 dB _P), $f = 400\text{ MHz}$		80		dB
		$V_{RF_PEAK} = 100\text{ mV}_P$ (-20 dB _P), $f = 900\text{ MHz}$		90		
		$V_{RF_PEAK} = 100\text{ mV}_P$ (-20 dB _P), $f = 1800\text{ MHz}$		110		
		$V_{RF_PEAK} = 100\text{ mV}_P$ (-20 dB _P), $f = 2400\text{ MHz}$		120		
CMVR	Input Common-Mode Voltage Range	$CMRR \geq 65\text{ dB}$	-0.1		2.1	V
A_{VOL}	Large Signal Voltage Gain (Note 11)	$R_L = 2\text{ k}\Omega$, $V_{OUT} = 0.15\text{V to } 1.65\text{V}$, $V_{OUT} = 3.15\text{V to } 1.65\text{V}$	LMV831, LMV832 LMV834	102 102	121	dB
		$R_L = 10\text{ k}\Omega$, $V_{OUT} = 0.1\text{V to } 1.65\text{V}$, $V_{OUT} = 3.2\text{V to } 1.65\text{V}$	LMV831, LMV832 LMV834	104 104	126	
				104 103	123	

Symbol	Parameter	Conditions	Min (Note 6)	Typ (Note 5)	Max (Note 6)	Units		
V_{OUT}	Output Voltage Swing High	$R_L = 2\text{ k}\Omega$ to $V^+/2$	LMV831, LMV832		29	36 43	mV from either rail	
			LMV834		31	38 44		
		$R_L = 10\text{ k}\Omega$ to $V^+/2$	LMV831, LMV832		6	8 9		
			LMV834		7	9 10		
	Output Voltage Swing Low	$R = 2\text{ k}\Omega$ to $V^+/2$			25	34 43		
		$R_L = 10\text{ k}\Omega$ to $V^+/2$			5	8 10		
I_{OUT}	Output Short Circuit Current	Sourcing, $V_{OUT} = V_{CM}$, $V_{IN} = 100\text{ mV}$	LMV831, LMV832	27 22	28		mA	
			LMV834	24 19	28			
		Sinking, $V_{OUT} = V_{CM}$, $V_{IN} = -100\text{ mV}$			27 21	32		
I_S	Supply Current		LMV831		0.24	0.27 0.30	mA	
			LMV832		0.46	0.51 0.58		
			LMV834		0.90	1.00 1.16		
SR	Slew Rate (Note 7)	$A_V = +1$, $V_{OUT} = 1\text{ V}_{PP}$, 10% to 90%		2		V/ μ s		
GBW	Gain Bandwidth Product			3.3		MHz		
Φ_m	Phase Margin			65		deg		
e_n	Input Referred Voltage Noise Density	$f = 1\text{ kHz}$		12		$nV/\sqrt{\text{Hz}}$		
		$f = 10\text{ kHz}$		10				
i_n	Input Referred Current Noise Density	$f = 1\text{ kHz}$		0.005		$pA/\sqrt{\text{Hz}}$		
R_{OUT}	Closed Loop Output Impedance	$f = 2\text{ MHz}$		500		Ω		
C_{IN}	Common-mode Input Capacitance			15		pF		
	Differential-mode Input Capacitance			20				
THD+N	Total Harmonic Distortion + Noise	$f = 1\text{ kHz}$, $A_V = 1$, $BW \geq 500\text{ kHz}$		0.02		%		

5V Electrical Characteristics (Note 4)

Unless otherwise specified, all limits are guaranteed for at $T_A = 25^\circ\text{C}$, $V^+ = 5\text{V}$, $V^- = 0\text{V}$, $V_{CM} = V^+/2$, and $R_L = 10\text{ k}\Omega$ to $V^+/2$.

Boldface limits apply at the temperature extremes.

Symbol	Parameter	Conditions	Min (Note 6)	Typ (Note 5)	Max (Note 6)	Units
V_{OS}	Input Offset Voltage (Note 9)			± 0.25	± 1.00 ± 1.23	mV
TCV_{OS}	Input Offset Voltage Temperature Drift (Notes 9, 10)	LMV831, LMV832		± 0.5	± 1.5	$\mu\text{V}/^\circ\text{C}$
		LMV834		± 0.5	± 1.7	
I_B	Input Bias Current (Note 10)			0.1	10 500	pA
I_{OS}	Input Offset Current			1		pA
CMRR	Common-Mode Rejection Ratio (Note 9)	$0\text{V} \leq V_{CM} \leq V^+ - 1.2\text{V}$	77 77	93		dB

Symbol	Parameter	Conditions	Min (Note 6)	Typ (Note 5)	Max (Note 6)	Units	
PSRR	Power Supply Rejection Ratio (Note 9)	$2.7V \leq V_+ \leq 5.5V$, $V_{OUT} = 1V$	76 75	93		dB	
EMIRR	EMI Rejection Ratio, IN+ and IN- (Note 8)	$V_{RF_PEAK} = 100 \text{ mV}_P (-20 \text{ dB}_P)$, $f = 400 \text{ MHz}$		80		dB	
		$V_{RF_PEAK} = 100 \text{ mV}_P (-20 \text{ dB}_P)$, $f = 900 \text{ MHz}$		90			
		$V_{RF_PEAK} = 100 \text{ mV}_P (-20 \text{ dB}_P)$, $f = 1800 \text{ MHz}$		110			
		$V_{RF_PEAK} = 100 \text{ mV}_P (-20 \text{ dB}_P)$, $f = 2400 \text{ MHz}$		120			
CMVR	Input Common-Mode Voltage Range	$CMRR \geq 65 \text{ dB}$	-0.1		3.8	V	
A_{VOL}	Large Signal Voltage Gain (Note 11)	$R_L = 2 \text{ k}\Omega$, $V_{OUT} = 0.15V \text{ to } 2.5V$, $V_{OUT} = 4.85V \text{ to } 2.5V$	LMV831, LMV832	107 106	127	dB	
			LMV834	104 104	127		
		$R_L = 10 \text{ k}\Omega$, $V_{OUT} = 0.1V \text{ to } 2.5V$, $V_{OUT} = 4.9V \text{ to } 2.5V$	LMV831, LMV832	107 107	130		
			LMV834	105 104	127		
V_{OUT}	Output Voltage Swing High	$R_L = 2 \text{ k}\Omega \text{ to } V+/2$	LMV831, LMV832		32	42 49	mV from either rail
			LMV834		35	45 52	
		$R_L = 10 \text{ k}\Omega \text{ to } V+/2$	LMV831, LMV832		6	9 10	
			LMV834		7	10 11	
	Output Voltage Swing Low	$R_L = 2 \text{ k}\Omega \text{ to } V+/2$			27	43 52	
		$R_L = 10 \text{ k}\Omega \text{ to } V+/2$			6	10 12	
I_{OUT}	Output Short Circuit Current	Sourcing $V_{OUT} = V_{CM}$ $V_{IN} = 100 \text{ mV}$	LMV831, LMV832	59 49	66	mA	
			LMV834	57 45	63		
		Sinking $V_{OUT} = V_{CM}$ $V_{IN} = -100 \text{ mV}$	LMV831, LMV832	50 41	64		
			LMV834	53 41	63		
I_S	Supply Current	LMV831		0.25	0.27 0.31	mA	
		LMV832		0.47	0.52 0.60		
		LMV834		0.92	1.02 1.18		
SR	Slew Rate (Note 7)	$A_V = +1$, $V_{OUT} = 2V_{PP}$, 10% to 90%		2		V/ μ s	
GBW	Gain Bandwidth Product			3.3		MHz	
Φ_m	Phase Margin			65		deg	
e_n	Input Referred Voltage Noise	$f = 1 \text{ kHz}$		12		nV/ $\sqrt{\text{Hz}}$	
		$f = 10 \text{ kHz}$		10			

Symbol	Parameter	Conditions	Min (Note 6)	Typ (Note 5)	Max (Note 6)	Units
i_n	Input Referred Current Noise	$f = 1 \text{ kHz}$		0.005		$\text{pA}/\sqrt{\text{Hz}}$
R_{OUT}	Closed Loop Output Impedance	$f = 2 \text{ MHz}$		500		Ω
C_{IN}	Common-mode Input Capacitance			14		pF
	Differential-mode Input Capacitance			20		
THD+N	Total Harmonic Distortion + Noise	$f = 1 \text{ kHz}, A_V = 1, BW \geq 500 \text{ kHz}$		0.02		%

Note 1: Absolute Maximum Ratings indicate limits beyond which damage to the device may occur. Operating Ratings indicate conditions for which the device is intended to be functional, but specific performance is not guaranteed. For guaranteed specifications and the test conditions, see the Electrical Characteristics Tables.

Note 2: Human Body Model, applicable std. MIL-STD-883, Method 3015.7. Machine Model, applicable std. JESD22-A115-A (ESD MM std. of JEDEC) Field-Induced Charge-Device Model, applicable std. JESD22-C101-C (ESD FICDM std. of JEDEC).

Note 3: The maximum power dissipation is a function of $T_{J(MAX)}$, θ_{JA} , and T_A . The maximum allowable power dissipation at any ambient temperature is $P_D = (T_{J(MAX)} - T_A) / \theta_{JA}$. All numbers apply for packages soldered directly onto a PC board.

Note 4: Electrical Table values apply only for factory testing conditions at the temperature indicated. Factory testing conditions result in very limited self-heating of the device such that $T_J = T_A$. No guarantee of parametric performance is indicated in the electrical tables under conditions of internal self-heating where $T_J > T_A$.

Note 5: Typical values represent the most likely parametric norm as determined at the time of characterization. Actual typical values may vary over time and will also depend on the application and configuration. The typical values are not tested and are not guaranteed on shipped production material.

Note 6: Limits are 100% production tested at 25°C. Limits over the operating temperature range are guaranteed through correlations using statistical quality control (SQC) method.

Note 7: Number specified is the slower of positive and negative slew rates.

Note 8: The EMI Rejection Ratio is defined as $EMIRR = 20\log(V_{RF_PEAK}/\Delta V_{OS})$.

Note 9: The typical value is calculated by applying absolute value transform to the distribution, then taking the statistical average of the resulting distribution.

Note 10: This parameter is guaranteed by design and/or characterization and is not tested in production.

Note 11: The specified limits represent the lower of the measured values for each output range condition.

Connection Diagrams

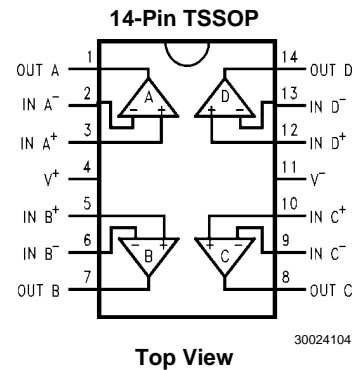
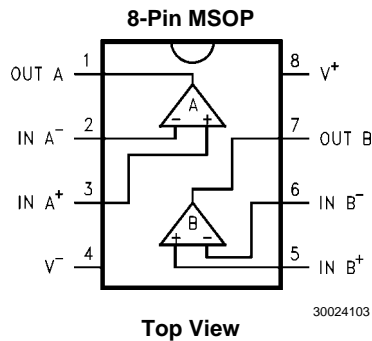
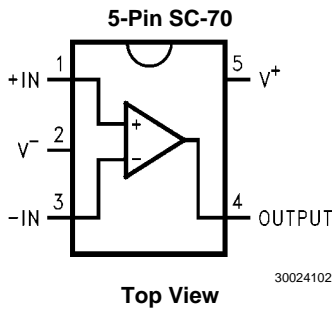

Ordering Information

Package	Part Number	Package Marking	Transport Media	NSC Drawing
5-Pin SC-70	LMV831MG	AFA	1k Units Tape and Reel	MAA05A
	LMV831MGE		250 Units Tape and Reel	
	LMV831MGX		3k Units Tape and Reel	
8-Pin MSOP	LMV832MM	AU5A	1k Units Tape and Reel	MUA08A
	LMV832MME		250 Units Tape and Reel	
	LMV832MMX		3.5k Units Tape and Reel	
14-Pin TSSOP	LMV834MT	LMV834MT	94 Units/Rail	MTC14
	LMV834MTX		2.5k Units Tape and Reel	

1. Features

Ali's M5673 provides cost-effective solutions for playback audio from disc, SD/MMC/MS flash card and USB mass storage device. It built-in audio 24-bit Digital Signal Processor. With state-of-the-art technology and cost-effective integration in mind, M5673 is developed to provide many leading features in a system-on-chip solution, including CD RF PreAmp, CD Servo controller, EDC/ECC error detection and correction, full-speed USB1.1 host controller, SD/MMC/MS memory card interface, high-performance caching micro-controller with user-configurable I/Os, high-performance mixed-mode audio macros, etc.

CD Servo

- Integrated RF Amp, Servo control, CD-DSP and CD-ROM decoder.
- Support CD/CD-R/CD-RW physical format disc.
- Support CDDA, CD-ROM(mode 1, mode2 form 1)logical format playback.
- Support up to 4X speed optical pickup unit.
- Embedded SRAM for ECC buffer, no need extra external DRAM.

USB1.1 Controller

- on-chip USB transceiver compliant with USB Specification revision 1.1 Full-Speed(FS)
- Support full-speed USB1.1 host mode for USB disc.
- Built-in Configurable Four USB Endpoint FIFOs.
 - Endpoint 0: 64-byte FIFO support for Control transfer.
 - Endpoint A: 64-byte double-buffered bulk-In transfer.
 - Endpoint B: 64-byte double-buffered bulk-Out transfer.
 - Endpoint C: 8-byte interrupt transfer.
- Support USB wakeup/suspend.
- support DMA operation for bulk transfer.

Data Storage Controller

- Support flash cards including Secure-Digital (SD) and Multi-Media Card (MMC), Memory Stick (MS), MS-Pro, etc.
- Support DMA operation.

High performance Micro-controller

- High-performance 8-bit 56MHz micro-controller with 8051 compatible instruction set.
- Built-in 8KBytes 2-way i-cache SRAM.
- Support up to 256 KBytes external Serial-Flash.
- Maximum 32K-bytes internal program SRAM for system FW upgrade when audio DSP is disabled.

Audio DSP

- High-performance 24-bit digital Signal Processor.
- Support MPEG1 Layer 1/Layer 2/Layer 3 decode.
- Support MPEG2/2.5 Layer 3 decode.
- Support WMA full class decode.
- Support ADPCM 4 bit mode encode/decode.

Integrated Audio Codec

- Built-in high-performance stereo A/D and D/A converters.
- Support Line In/FM in inputs.
- Microphone input with boost.
- Built-in Bass filter and PGA gain controller.

Integrated Linear Regulator

- Built-in 3.3V to 1.8V regulator for M5673 core power .
- Programmable 1.8V power ranges: 1.6V~1.9V.

General feature

- Programmable GPIOs for Buttons and LED control.
- Build-in 3 ADC for key detection or other application.

www.ali.com.tw

specifications subject to change without notice

M5673 Data Sheet V1.0

Preliminary Confidential Proprietary

3. Block Diagram

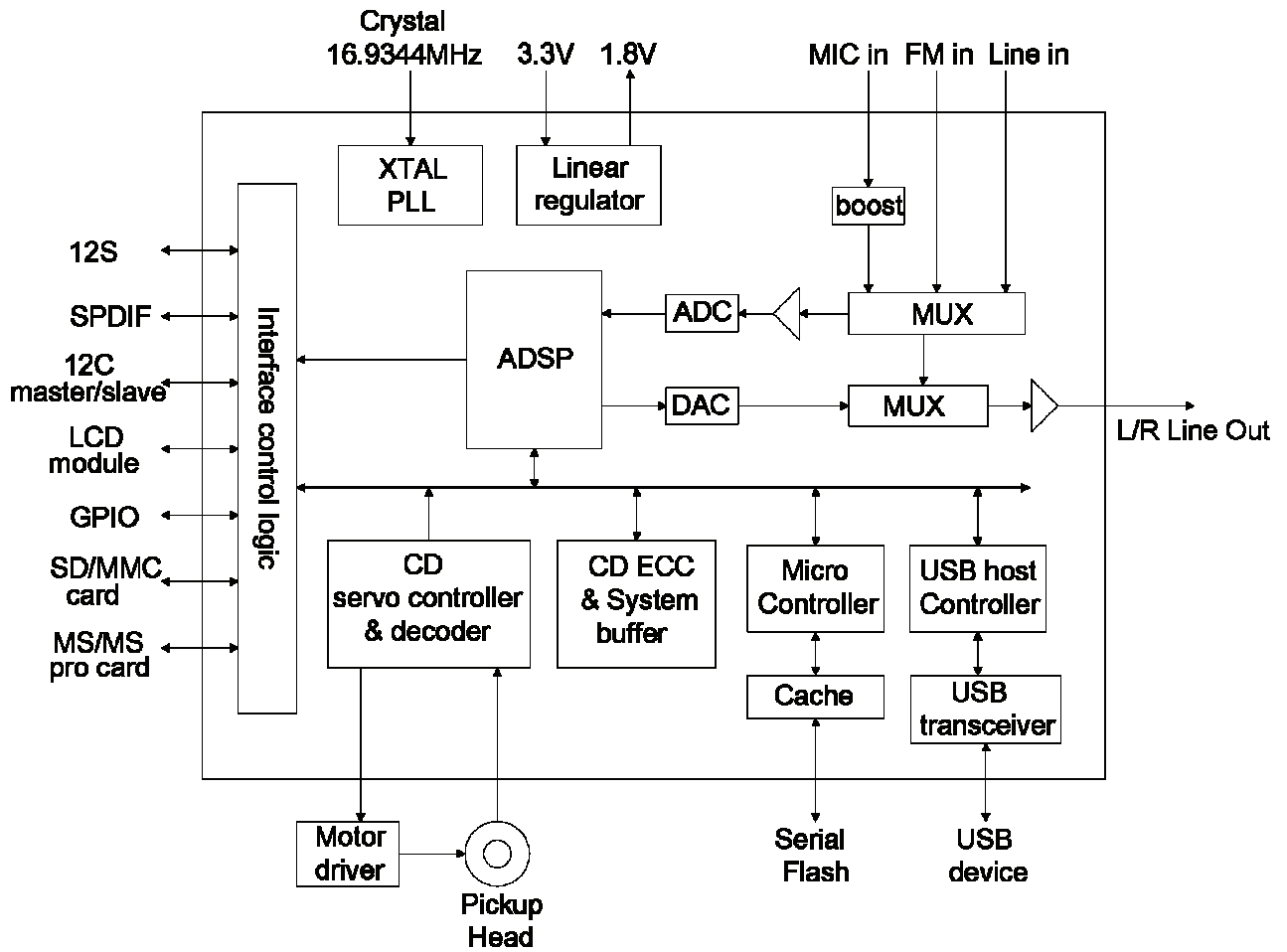

4. Pin Configuration

Table 4-4. Pins Listed in Numeric Order

Pin	Signal	Pin	Signal	Pin	Signal	Pin	Signal
1	LDO	33	LINEOUTL	65	GPIOD1/ 12CM-DAT	97	GPIOH5/LCDRS
2	TP1	34	BICAPR	66	GPIOD2/ 12S-SCLK	98	GPIOH6/LCDCSJ
3	TP2	35	BOCAPR	67	GPIOD3/ 12S-REFCLK	99	PRSTB
4	MC	36	LINEOUTR	68	GPIOD4/ 12S-D0	100	GPIOH7/LCDRDJ
5	MB	37	AVSS33-AUD	69	GPIOD5/ 12S-D1	101	GPIO10/LCDWRJ
6	MD	38	AVSS33-AUD	70	GPIOD6/ 12S-WCLK	102	GPIOI1/PWMO/ LCD-ALE
7	MA	39	FMINR	71	GPIOD7/SPDIF	103	GPIOI2/IRC
8	AVDD33-2	40	LINEINR	72	GPIOE0	104	GPIOI3/PWM1
9	HAVC	41	MICIN	73	GPIOE1	105	GPIOI4/PWM2
10	V12	42	FMINL	74	GPIOE2	106	GPIOI5
11	AVSS33-2	43	LINEINL	75	GPIOE3	107	GPIOI6
12	TELP	44	MICBIAS	76	GPIOE4/SDD0	108	GPIOI7/ 12CS-CLK
13	MPXOUT1	45	V08L	77	GPIOE5/SDD1	109	GPIOJ0/ 12CS-DAT
14	MPXOUT2	46	V15L	78	GPIOE6/SDD2	110	GPIOJ1
15	MPXOUT3	47	V08R	79	GPIOE7/SDD3	111	GPIOJ2
16	COSP	48	V15R	80	GPIOF0/SDCMD	112	GND-PAD
17	COSN	49	VREF	81	GPIOF1/SD-CLK	113	VDD-PAD
18	AVDD33-3	50	SFGP	82	GPIOF2	114	GND-CORE
19	VTB	51	SFGN	83	GPIOF3	115	VDD-CORE
20	VTP	52	DM	84	GND-PAD	116	AVDD-D33
21	AVSS33-3	53	DP	85	VDD-PAD	117	BTN-ADIN1
22	AVSS33-LDO	54	VDD-CORE	86	GPIOG2	118	BTN-ADIN2
23	AVDD33-LDO	55	GND-CORE	87	GPIOG3	119	BTN-ADIN3
24	AVDD18-LDO	56	GND-PAD	88	GPIOG4	120	VREF16
25	AVDD33-CKG	57	VDD-PAD	89	GPIOG5/LCDDDB0	121	FMO
26	XTAL1	58	GPIOB6/SFDO	90	GPIOG6/LCDDDB1	122	AVD33-1
27	XTALO	59	GPIOB7/SFDI	91	GPIOG7/LCDDDB2	123	DMO
28	AVSS33-CKG	60	GPIOC0/SFCSB	92	GPIOH0/LCDDDB3	124	AVSS33-1
29	AVDD18-1	61	GPIOC1/SFCSK	93	GPIOH1/LCDDDB4	125	GPWM
30	AVSS18-1	62	GPIOC2/URTX	94	GPIOH2/LCDDDB5	126	FOO
31	BICAPL	63	GPIOC3/URRX	95	GPIOH3/LCDDDB6	127	TRO
32	BOCAPL	64	GPIOD0/ 12CM-CLK	96	GPIOH4/LCDDDB7	128	MDI

5. Pin Description

Table 5-2. Pin Description

Pin(s) No.	Signal	Attribute	Description
1	LDO	O/A	Laser Driver Output of APC
2	TP1	I/A	3 Beam Satellite PD Positive Input
3	TP2	I/A	3 Beam Satellite PD Negative Input
4	MC	I/A	Input of main Beam Signal (C)
5	MB	I/A	Input of main Beam Signal (B)
6	MD	I/A	Input of main Beam Signal (D)
7	MA	I/A	Input of main Beam Signal (A)
8	AVDD33-2	P	Servo Analog Power
9	HAVC	O/A	Voltage Reference (programmable)
10	V12	O/A	Voltage Reference (1.2V)
11	AVSS33-2	G	Servo Analog Ground
12	TELP	O/A	Low Pass Filter Capacitor Connecting for TEZC Detection
13	MPXOUT1	O/A	Multiplexer output 1 for Analog Signal Monitoring
14	MPXOUT2	O/A	Multiplexer output 2 for Analog Signal Monitoring
15	MPXOUT3	O/A	Multiplexer output 3 for Analog Signal Monitoring
16	COSP	O/A	External Capacitor Connection of offset Cancellation Loop for VGA in EQRF Block (Positive)
17	COSN	O/A	External Capacitor Connection of offset Cancellation Loop for VGA in EQRF Block (Negative)
18	AVDD33-3	P	PRML ADC Power
19	VTB	B/O	PRML ADC Voltage Control, connect to Capacitor
20	VTP	B/O	PRML ADC Voltage Control, connect to Capacitor
21	AVSS33-3	G	PRML ADC Ground
22	AVSS33-LDO	G	LDO Ground
23	AVDD33-LDO	P	LDO 3.3V input
24	AVDD18-LDO	O/A	LDO 1.8V output
25	AVDD33-CKG	P	Clock Generator Power
26	XTAL1	I/A	External XTAL (I), 16.9344MHz
27	XTALO	O/A	External XTAL (O), 16.9344MHz
28	AVSS33-CKG	G	Clock Generator Ground
29	AVDD18-1	P	Analog Power for PLL
30	AVSS18-1	G	Analog Ground for PLL
31	BICAPL	I/A	Left channel Bass capacitor in
32	BOCAPL	O/A	Left channel Bass capacitor out
33	LINEOUTL	O/A	Left Channel Audio out
34	BICAPR	I/A	Right channel Bass capacitor in
35	BOCAPR	O/A	Right channel Bass capacitor out
36	LINEOUTR	O/A	Right channel Audio out
37	AVSS33-AUD	G	VSS of ADC/DAC
38	AVDD33-AUD	P	VDD of ADC/DAC
39	FMINR	I/A	Right channel ADC FM in
40	LINEINR	I/A	Right channel ADC line in
41	MICIN	I/A	ADC MIC in
42	FMINL	I/A	Left channel ADC FM in
43	LINEINL	I/A	Left channel ADC line in
44	MICBIAS	I/A	MIC DC bias
45	V08L	O/A	Left channel VCM reference
46	V15L	O/A	Left channel voltage reference
47	V08R	O/A	Right channel VCM reference
48	V15R	O/A	Right channel voltage reference
49	VREF	O/A	Internal resistor string provide Vref
50	SFGP	I/A	DISC stop pos input/GPIO
51	SFGN	I/A	DISC stop neg input/GPIO
52	DM		USB D-
53	DP		USB D+
54	VDD-CORE	P	Digital Core power
55	GND-CORE	G	Digital Core Ground
56	GND-PAD	G	Digital PAD Ground

Pin(s) No.	Signal	Attribute	Description
57	VDD-PAD	P	Digital PAD power
58	GPIOB6/SFDO	B / D	GPIOB6/Seriel flash data input
59	GPIOB7/SFDI	B / D	GPIOB7/Seriel flash data output
60	GPIOC0/SFCSB	B / D	GPIOC0/Seriel flash csj
61	GPIOC1/SFSCK	B / D	GPIOC1/Seriel flash clk
62	GPIOC2/URTX	B / D	GPIOC2/RS-232 TX
63	GPIOC3/URRX	B / D	GPIOC3/RS-232 RX
64	GPIOD0/12CM-CLK	B / D	GPIOD0/12C clk output (M5673 is master)
65	GPIOD1/12CM-DAT	B / D	GPIOD1/12C data (M5673 is master)
66	GPIOD2/12S-SCLK	B / D	GPIOD2/12S bit clk output
67	GPIOD3/12S-REFCLK	B / D	GPIOD3/12S system(reference) clk output
68	GPIOD4/12S-D0	B / D	GPIOD4/12S data output
69	GPIOD5/12S-D1	B / D	GPIOD5/12S data input
70	GPIOD6/12S-WCLK	B / D	GPIOD6/12S word clk(LRCK) output
71	GPIOD7/SPDIF	B / D	GPIOD7/SPDIF output
72	GPIOE0	B / D	GPIOE0
73	GPIOE1	B / D	GPIOE1
74	GPIOE2	B / D	GPIOE2
75	GPIOE3	B / D	GPIOE3
76	GPIOE4/SDD0	B / D	GPIOE4/SD Card data0
77	GPIOE5/SDD1	B / D	GPIOE5/SD Card data1
78	GPIOE6/SDD2	B / D	GPIOE6/SD Card data2
79	GPIOE7/SDD3	B / D	GPIOE7/SD Card data3
80	GPIOF0/SDCMD	B / D	GPIOE0/SD Card command
81	GPIOF1/SD-CLK	B / D	GPIOE1/SD Card clk
82	GPIOF2	B / D	GPIOF2
83	GPIOF3	B / D	GPIOF3
84	GND-PAD	G	Digital PAD Ground
85	VDD-PAD	P	Digital PAD power
86	GPIOG2	B / D	GPIOG2
87	GPIOG3	B / D	GPIOG3
88	GPIOG4	B / D	GPIOG4
89	GPIOG5/LCDDDB0	B / D	GPIOG5/LCD data0
90	GPIOG6/LCDDDB1	B / D	GPIOG6/LCD data1
91	GPIOG7/LCDDDB2	B / D	GPIOG7/LCD data2
92	GPIOH0/LCDDDB3	B / D	GPIOH0/LCD data3
93	GPIOH1/LCDDDB4	B / D	GPIOH1/LCD data4
94	GPIOH2/LCDDDB5	B / D	GPIOH2/LCD data5
95	GPIOH3/LCDDDB6	B / D	GPIOH3/LCD data6
96	GPIOH4/LCDDDB7	B / D	GPIOH4/LCD data7
97	GPIOH5/LCDRS	B / D	GPIOH5/LCD status/command
98	GPIOH6/LCDCSJ	B / D	GPIOH6/LCD CSJ
99	PRSTB	B / D	Chip reset, low active
100	GPIOH7/LCDRDJ	B / D	GPIOH7/LCD read control signal
101	GPIO10/LCDWRJ	B / D	GPIO10/LCD write control signal
102	GPIO11/PWMO/LCD-ALE	B / D	GPIO11/PWMO output /LCD ALE signal when address /data share bus
103	GPIO12/IRC	B / D	GPIO12/remote controller received
104	GPIO13/PWM1	B / D	GPIO13/PWM1 output
105	GPIO14/PWM2	B / D	GPIO14/PWM2 output
106	GPIO15	B / D	GPIO15
107	GPIO16	B / D	GPIO16
108	GPIO17/12CS-CLK	B / D	GPIO17/12C clk when M5673 is slave
109	GPIOJ0/12CS-DAT	B / D	GPIOJ0/12C data when M5673 slave
110	GPIOJ1	B / D	GPIOJ1
111	GPIOJ2	B / D	GPIOJ2
112	GND-PAD	G	Digital PAD Ground
113	VDD-PAD	P	Digital PAD power
114	GND-CORE	G	Digital Core ground
115	VDD-CORE	P	Digital Core power
116	AVDD-D33	P	3.3V for digital circuit in a analog.

Pin(s) No.	Signal	Attribute	Description
117	BTN-ADIN1	I/A	Bottom check input, connect to servo ADC
118	BTN-ADIN2	I/A	Bottom check input, connect to servo ADC
119	BTN-ADIN3	I/A	Bottom check input, connect to servo ADC
120	VREF16	O/A	SERVO DAC common mode voltage
121	FMO	O/A	Focus servo output, 3 level PWM output
122	AVD33-1	P	Servo Analog Power
123	DMO	O/A	Disk motor control output. 3 level PWM output
124	AVSS33-1	G	Servo Analog Ground
125	GPWM	O/A	General purpose 3 level PWM output
126	FOO	O/A	Focus servo output. 3 level PWM output
127	TRO	O/A	Tracking servo output. 3 level PWM output
128	MDI	I/A	Laser Power Monitor Input For APC

The definitions of the signal attributes:

D: Digital

I: Input

O: Output

B: Bi-direction

P: Power

G: Ground

A: Analog Pad

6. DC Characteristics

Absolute Maximum Rating

Power Supply(Vcc).....-0.3V to 3.6V

Input Voltage.....-0.3V to VCC+0.3V

Output Voltage-0.3V to VCC+0.3V

Storage Temperature-55°C to 150°C

Comments

Stresses above those listed under “Absolute Maximum Ratings” may cause permanent damage to this device. These are stress ratings only. Functional operation of this device at these or any other conditions above those indicated in the operational sections of this specification is not implied, and exposure to absolute maximum rating conditions for extended periods may affect device reliability.

Table 6-1. DC Electrical Characteristics(Operation Condition Vcc=3.0V~3.6V, Tj=0°C~70°C)

PARAMETER	CONDITION	MIN	TYP	MAX	UNIT
Input low voltage	CMOS	-	-	0.3*Vcc	V
Input High Voltage	CMOS	0.7*Vcc	-	-	V
Schmitt trigger negative going threshold voltage	CMOS	-	1.20	-	V
Schmitt trigger positive going threshold voltage	CMOS	-	2.10	-	V
Output low voltage	I _{OL} =4mA	-	-	0.4	V
Output high voltage	I _{OH} =4mA	2.4	-	-	V
Input Pull-up resistance	V _{IL} =0V or V _{IH} =V _{CC}	-	75	-	KΩ
Input Leakage current	No pull-up	-1	-	1	uA
		-1	-	1	mA
Input capacity		-	10	-	pF
Audio Codec Characteristics					
VddA (Codec)		3.0	3.3	3.6	V
Full Scale Input Voltage	Gain=0 and Boost=0			1	Vp-p
Signal-to-noise Ratio of all Line Inputs	Note 1	86			
Signal-to-noise Ratio of Microphone	Note 1	45			dB
Total Harmonic Distortion of all Line Inputs/Microphone	Note 2	0.03			%
Total Harmonic Distortion of Microphone		0.55			
Line inputs/Microphone PGA gain		-20		14.8	dB
Microphone Boost Gain		0		20	dB
Headphone Full Scale output Voltage	VddHP=1.8V		0.74		V _{rms}
Headphone PGA gain		-57		6	dB
Total Harmonic Distortion of DAC to Headphone	Note 4	0.018			dB
Dynamic Range of DAC	Note 5	85			dB
In band ripple (0~20kHz)			-1		dB
Inter-channel isolation		90			dB

Note 1: -60dB @ 1kHz input is applied to LINEIN/FMIV. The SNR result is obtained at the output of ADC with A-weighting filter (20Hz~20kHz).

Note 2: 0dB @ 1kHz input is applied to LINEIN/FMIV. The SNR result is obtained at the output of ADC with A-weighting filter (20Hz~20kHz).

Note 4: 0dB @ 1kHz sigma-delta bit-stream is applied to DAC. The THD result is obtained at the output of Line out with A-weighting filter (20Hz~20kHz).

Note 5: -60dB @ 1kHz sigma-delta bit-stream is applied to DAC. The SNR result is obtained at the output of Line out with A-weighting filter (20Hz~20kHz).

7. Package Information

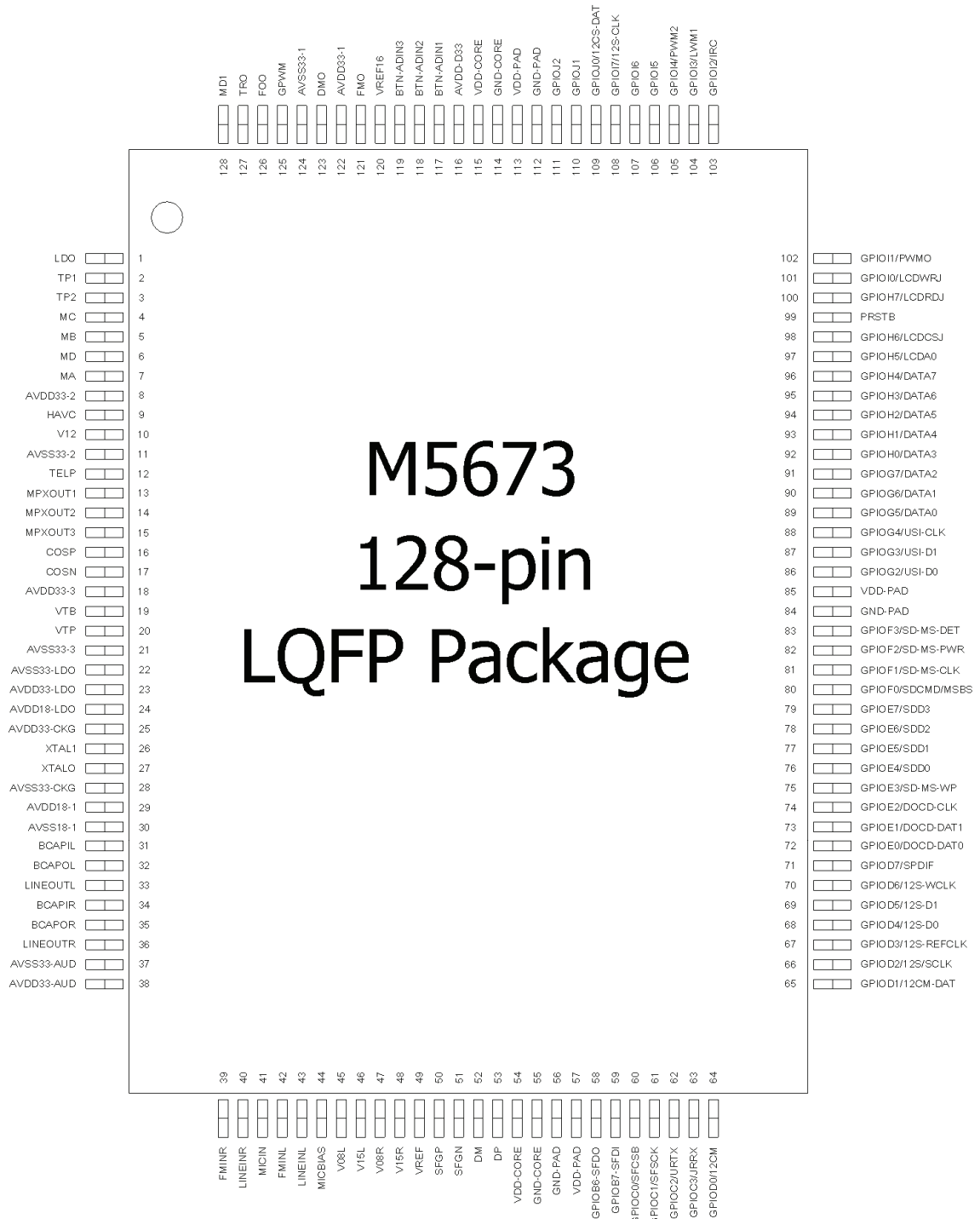

1. Introduction

MosArt's Touch Sensor Solution is divided into 2 series:

MA81/83/85P0x MCU series: It is a general purpose MCU with powerful functions (Ex. touch sensor, serial interfaceetc.).

The MA81P0x has 6 models and it has SPI, ADC, LCD driver ...etc.

The MA83P0x has 9 models and it has SPI, UART, I2C ... etc.

The MA85P0x has 3 models and it has SPI, UART, I2C ... etc.

The difference between MA81P0x, MA83P0x and MA85P0x refer to 1.1 The Features of MA81/83/85P0x Series.

MA81xxx series: This series had been built in the touch sensor and application firmware (a communication interface with a simple protocol).

The MA81xxx series can be used as a slave and can be controlled by a master through a communication interface.

The touch sensor can be used as human-machine-interface like key pads, scrolling bar ...etc

	MA83P05	MA83P06	MA83P07	MA83P08	MA83P09	MA83P10	MA83P11	MA83P12	MA83P13
Core CPU	65C02 CMOS 8-bit core CPU compatible								
Instruction set	166 bytes								
Instruction execution time	1μs @ 2MHz (2 clocks / instruction)								
OTP ROM capacity	8K bytes								
RAM capacity	256 bytes								
Low-speed oscillation circuit	32.768KHz (X'tal)	N/A	32.768KHz (X'tal)	N/A	N/A	N/A	N/A	N/A	N/A
High-speed oscillation circuit	2 kind of clock source which can be selected by software: 1. On-chip RC oscillator (4.5MHz ~ 310KHz) 2. RC oscillation circuit (Max. 16MHz) (there is no RC oscillation circuit in MA83P08)								
I/O ports	12 bits (Max.) P13, P17 P20	10 bits (Max.) P13, P17 P20	20 bits (Max.) P13, P17 P20 ~ P22 P30 ~ P34 P40 ~ P47 P50 ~ P51	2 bits (Max.) P30, P31	7 bits (Max.) P13 P20 P30, P31, P34 P50 ~ P51	7 bits (Max.) P13 P20 P30, P31, P34 P50 ~ P51	4 bits (Max.) P20 P30, P31, P34	8 bits (Max.) P13, P17 P20 P30, P31, P34 P50 ~ P51	14 bits (Max.) P13, P17 P20 P30, P31, P34 P40 ~ P47
Input mode: with or w/o pull-up									
Output mode: N-channel open drain or Complementary									
Wake-up pins	P17, P20	P17, P20	P17, P20~P22	N/A	P20	P20	P20	P17, P20	P17, P20
Watchdog timer	Built-in								
Clock timer	8-bit								
Programmable timer	8 bits x1 and 16 bits x1 (can be cascaded to form a 24-bit timer)								
Serial peripheral interface	SPI master / slave mode, I2C slave mode, UART			I2C slave mode				SPI master / slave mode, I2C slave mode, UART	
Pulse width modulation	8-bit * 1			N/A	8-bit * 1	8-bit * 1	N/A	8-bit * 1	8-bit * 1
Power on / down reset	Built-in								
Touch sensor channel	Built-in								
LCD driver	12 channels	N/A	N/A	2 channels	7 channels	7 channels	6 channels	6 channels	8 channels
Analog to digital converter (12 bits ADC)	N/A	N/A	N/A	N/A	N/A	N/A	N/A	N/A	N/A
External interrupt (It is divided by group)	4 pins Group 1: K20, K21 Group 2: K10 Group 3: K00	4 pins Group 1: K20, K21 Group 2: K10 Group 3: K00	8 pins Group 1: K20 ~ K23 Group 2: K10 Group 3: K00 ~ K02	2 pins Group 1: K20, K21	3 pins Group 1: K20, K21 Group 2: ~ Group 3: K00	3 pins Group 1: K20, K21 Group 2: ~ Group 3: K00	3 pins Group 1: K20, K21 Group 2: ~ Group 3: K00	4 pins Group 1: K20, K21 Group 2: K10 Group 3: K00	4 pins Group 1: K20, K21 Group 2: K10 Group 3: K00
Internal interrupt	Programmable timer 0 interrupt Programmable timer 1 interrupt SPI interrupt (There is no SPI interrupt in MA83P08) PWM interrupt (There is no PWM interrupt in MA83P08, MA83P11) Clock timer interrupt UART interrupt (There is no UART interrupt in MA83P08) Touch sensor interrupt I2C interrupt								
Current consumption	Chip current consumption (@ 3.3V) During SLEEP mode : (OSC1 off, OSC3 off, power on/down reset on): 10uA During IDLE mode : (OSC1 off, RC-OSC3 @ 1MHz): 100uA During operation : (OSC1 on, OSC3 off, LCD off): 50uA (OSC1 off, RC-OSC3 @ 2MHz, LCD off): 850uA (OSC1 off, X'tal-OSC3 @ 2MHz, LCD off): 1200uA								
Power supply voltage	2.2V ~ 3.6V								
Operating temperature range	-40°C ~ 85°C								
Package	QFN32	SSOP28L	QFN40	SOP8	QFN20	SSOP20	SSOP16	SSOP20	SSOP28

2. Selection Table

2.1 MA81/83/85P0x Series Selection Table

Order-Number	Package	Memory		Clock Sources			IO (max)	Timer			SPI	I2C	UART/PWM	Touch Sensor	LCD	12bit ADC		SVD	Wake-up	Interrupt	
		OTP ROM	SRAM	High-speed	Low-speed	CT		PT	WD	Int. ch						Ext. ch	Int.			Ext.	
				Int.	Ext.			8bit	16bit						Int. ch	Ext. ch					
MA81P01	LQFP100	8KB	512B	V	V	V	60	V	1	1	V	1	-	1	32x4	1	5	V	5	8	9
MA81P02	LQFP64	8KB	512B	V	V	V	36	V	1	1	V	1	-	1	16x4	1	3	V	3	8	5
MA81P03	LQFP48	8KB	512B	V	V	V	26	V	1	1	V	1	-	1	-	-	4	V	5	8	8
MA81P05	QFN32	4KB	256B	V	V	V	12	V	1	1	V	1	-	1	-	-	-	V	2	7	4
MA81P06	SSOP28L	4KB	256B	V	V	V	10	V	1	1	V	1	-	1	-	-	-	V	2	7	4
MA81P07	QFN40	4KB	256B	V	V	V	20	V	1	1	V	1	-	1	-	-	-	V	4	7	8
MA83P05	QFN32	8KB	256B	V	V	V	12	V	1	1	V	1	V	1	-	-	-	-	2	8	4
MA83P06	SSOP28L	8KB	256B	V	V	V	10	V	1	1	V	1	V	1	-	-	-	-	2	8	4
MA83P07	QFN40	8KB	256B	V	V	V	20	V	1	1	V	1	V	1	-	-	-	-	4	8	8
MA83P08	SOP8	8KB	256B	V	-	V	2	V	1	1	V	-	V	-	-	-	-	-	-	5	2
MA83P09	QFN20	8KB	256B	V	V	V	7	V	1	1	V	1	V	V	-	-	-	-	1	8	3
MA83P10	SSOP20	8KB	256B	V	V	V	7	V	1	1	V	1	V	V	-	-	-	-	1	8	3
MA83P11	SSOP16	8KB	256B	V	V	V	4	V	1	1	V	1	V	V	-	-	-	-	1	7	3
MA83P12	SSOP20	8KB	256B	V	V	V	8	V	1	1	V	1	V	V	-	-	-	-	2	8	4
MA83P13	SSOP28L	8KB	256B	V	V	V	14	V	1	1	V	1	V	V	-	-	-	-	2	8	4
MA85P01	LQFP64	8KB	256B	V	V	V	16	V	1	1	V	1	V	V	-	-	-	V	2	12	10
MA85P02	LQFP48	8KB	256B	V	V	V	16	V	1	1	V	1	V	V	-	-	-	V	2	12	10
MA85P03	QFN40	8KB	256B	V	V	V	8	V	1	1	V	1	V	V	-	-	-	V	2	12	2

3.1.8 MA83P06 (SSOP 28L-209 MIL)

3.1.8.1 MA83P06 Pin Assignment

Pin Name	Pin No	In/Out	Pin Description
S5	1	I	Touch sensor pad 5
S4	2	I	Touch sensor pad 4
S3	3	I	Touch sensor pad 3
S2	4	I	Touch sensor pad 2
S1	5	I	Touch sensor pad 1
S0	6	I	Touch sensor pad 0
P17/K10	7	I/O	I/O port (with pull-up resistor and wake-up/system-reset function), and input port (K10)
VDD	8	P	Power (+) supply pin
OSC3	9	I	External resistor connecting pin for RC-ring oscillator type
VSS	10	P	Power (-) supply pin
P13	11	I/O	I/O port (with pull-up resistor) When PWM is used, P13 can be used as PWM output pin (PWM)
XRESET	12	I	Initial reset input pin, low active (with pull-up resistor)
P20/K00	13	I/O	I/O port (with pull-up resistor and wake-up/system-reset function) and input port (K00) When UART is used, P20 can be used as UART Rx pin
P34	14	I/O	I/O port (with pull-up resistor) When SPI is used, P34 can be used as SPI data serial input "SDI" When UART is used, P34 can be used as UART Tx pin
P31/K21	15	I/O	I/O port (with pull-up resistor) and input port (K21) When SPI is used, P31 can be used as SPI data serial output "SDO". When I2C is used, P31 can be used as I2C data "SDA".
P30/K20	16	I/O	I/O port (with pull-up resistor) and input port (K20) When SPI is used, P30 can be used as serial clock "SCK". When I2C is used, P30 can be used as I2C clock "SCL"
P40	17	I/O	I/O ports (with pull-up resistor)
P41	18	I/O	I/O ports (with pull-up resistor)
P42	19	I/O	I/O ports (with pull-up resistor)
P43	20	I/O	I/O ports (with pull-up resistor)
S11	21	I	Touch sensor pad 11
TSAREF	22	I	Reference pin for touch sensor
VPP	23	P	Power (+) supply pin for OTP ROM: in programming mode: operates at 6.5V; In normal mode: be connected to VDD
S10	24	I	Touch sensor pad 10
S9	25	I	Touch sensor pad 9
S8	26	I	Touch sensor pad 8
S7	27	I	Touch sensor pad 7
S6	28	I	Touch sensor pad 6

3.1.8.2 MA83P06 Application Circuit

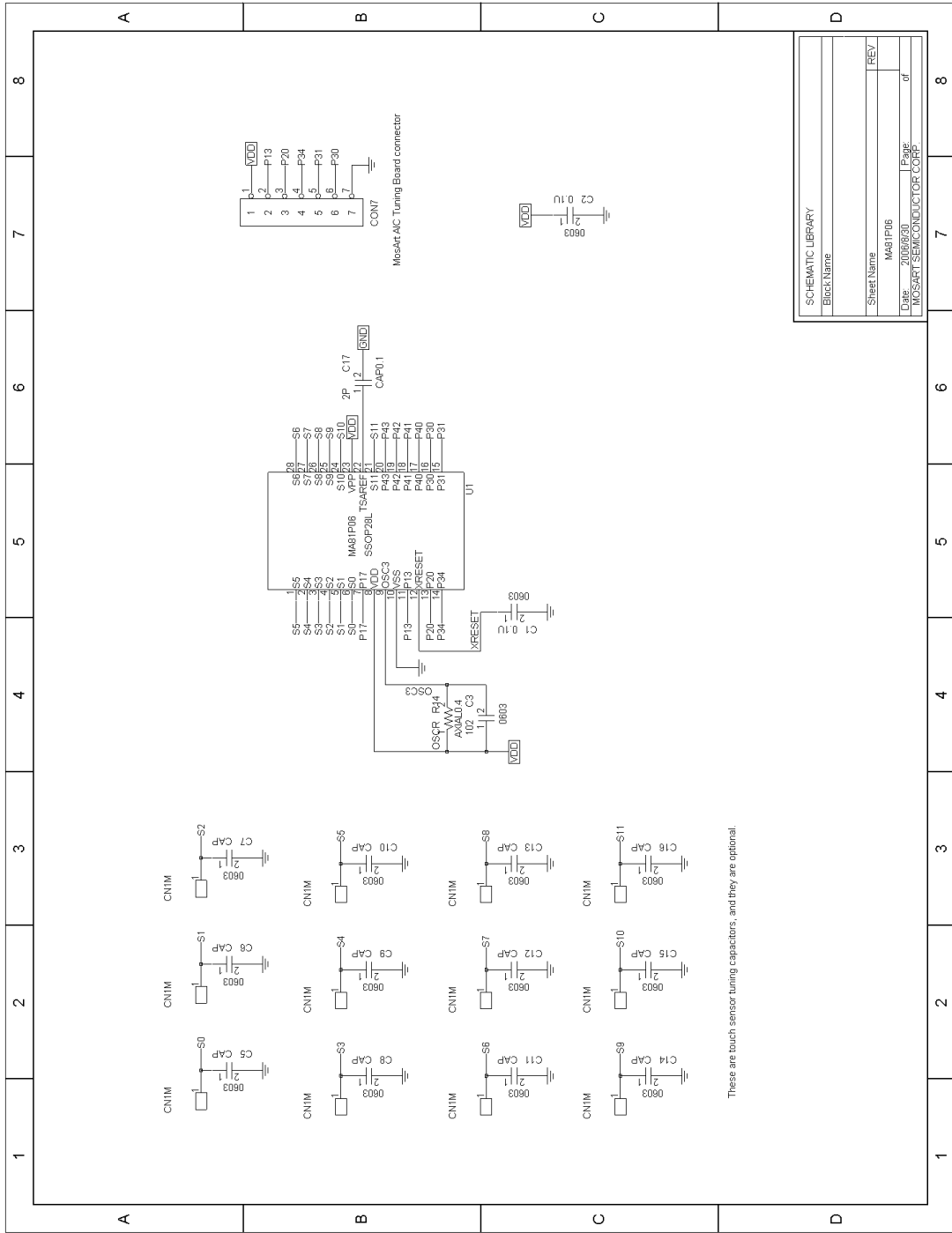



The Future of Analog IC Technology™

PRELIMINARY SPECIFICATIONS SUBJECT TO CHANGE – INTERNAL USE ONLY

MP1423

3A, 23V, 385KHz
Step-Down Converter

DESCRIPTION

The MP1423 is a step-down regulator with a built in internal Power MOSFET. It achieves 3A continuous output current over a wide input supply range with excellent load and line regulation.

Current mode operation provides fast transient response and eases loop stabilization.

Fault condition protection includes cycle-by-cycle current limiting and thermal shutdown. Adjustable soft-start reduces the stress on the input source at turn-on. In shutdown mode the regulator draws 20µA of supply current.

The MP1423 requires a minimum number of readily available external components to complete a 3A step-down DC to DC converter solution.

EVALUATION BOARD REFERENCE

Board Number	Dimensions
TBD	TBD

FEATURES

- 3A Output Current
- Programmable Soft-Start
- 100mΩ Internal Power MOSFET Switch
- Stable with Low ESR Output Ceramic Capacitors
- Up to 95% Efficiency
- 20µA Shutdown Mode
- Fixed 385KHz frequency
- Thermal Shutdown
- Cycle-by-Cycle Over Current Protection
- Wide 6V to 23V Operating Input Range
- Output is Adjustable From 1.22V to 21V
- Under Voltage Lockout

APPLICATIONS

- Distributed Power Systems
- Battery Chargers
- Pre-Regulator for Linear Regulators

"MPS" and "The Future of Analog IC Technology" are Trademarks of Monolithic Power Systems, Inc.

TYPICAL APPLICATION

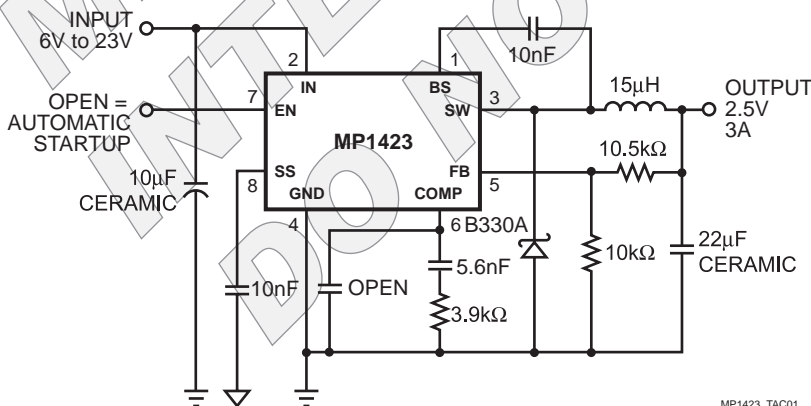

MP1423_TAC01

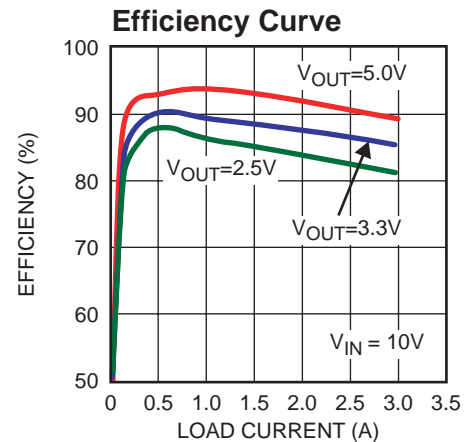

MP1423_EC01

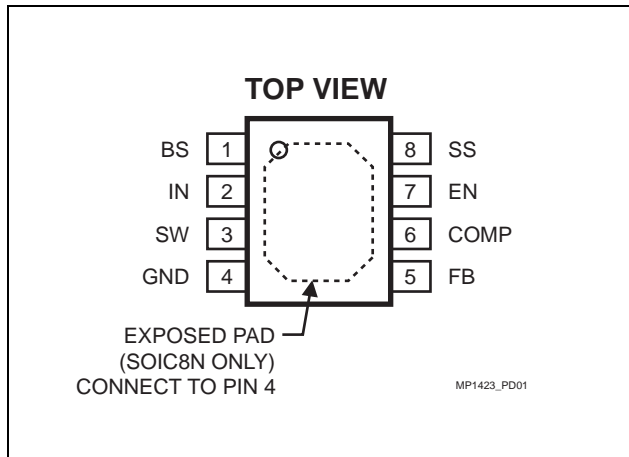
PACKAGE REFERENCE

Part Number*	Package	Temp
MP1423DN	SOIC8N	-40°C to +85°C
MP1423DP	PDIP8	-40°C to +85°C

* For Tape & Reel, add suffix -Z (eg. MP1423DN-Z)
 For Lead Free, add suffix -LF (eg. MP1423DN-LF-Z)

ABSOLUTE MAXIMUM RATINGS ⁽¹⁾

Supply Voltage V_{IN}	-0.3V to +28V
Switch Voltage V_{SW}	-1V to $V_{IN} + 0.3V$
Bootstrap Voltage V_{BS}	$V_{SW} - 0.3V$ to $V_{SW} + 6V$
All Other Pins.....	-0.3V to 6V
Junction Temperature.....	150°C
Lead Temperature.....	260°C
Storage Temperature.....	-65°C to 150°C

Recommended Operating Conditions ⁽²⁾

Input Voltage V_{IN}	6V to 23V
Ambient Operating Temp.....	-40°C to +85°C

Thermal Resistance ⁽³⁾

	θ_{JA}	θ_{JC}	
SOIC8N.....	50	10	°C/W
PDIP8.....	95	55	°C/W

Notes:

- 1) Exceeding these ratings may damage the device.
- 2) The device is not guaranteed to function outside of its operating conditions.
- 3) Measured on approximately 1" square of 1 oz copper.

ELECTRICAL CHARACTERISTICS

$V_{IN} = 12V$, $T_A = +25^\circ C$, unless otherwise noted.

Parameters	Symbol	Condition	Min	Typ	Max	Units
Shutdown Supply Current		$V_{EN} = 0V$		20	30	μA
Supply current		$V_{EN} = 2.8V$, $V_{FB} = 1.4V$		1.0	1.2	mA
Feedback Voltage	V_{FB}	$6V \leq V_{IN} \leq 23V$	1.194	1.222	1.250	V
Error Amplifier Voltage Gain	A_{VEA}			400		V/V
Error Amplifier Transconductance	G_{EA}	$\Delta I_{COMP} = \pm 10\mu A$	500	800	1120	$\mu A/V$
High Side Switch On Resistance	$R_{DS(ON)1}$			0.1		Ω
Low Side Switch On Resistance	$R_{DS(ON)2}$			10		Ω
High Side Switch Leakage Current		$V_{EN} = 0V$, $V_{SW} = 0V$		0	10	μA
Current Limit			4.0	4.9	6.0	A
Current Sense to COMP Transconductance	G_{CS}			3.8		A/V
Oscillation Frequency	f_s		335	385	435	KHz
Short Circuit Oscillation Frequency	D_{MAX}	$V_{FB} = 0V$	25	40	55	KHz
Maximum Duty Cycle		$V_{FB} = 1.0V$		90		%
Minimum Duty Cycle		$V_{FB} = 1.5V$			0	%
EN Threshold Voltage			0.9	1.2	1.5	V
Enable Pull Up Current		$V_{EN} = 0V$	1.1	1.8	2.5	μA
Under Voltage Lockout Threshold		V_{IN} Rising	2.37	2.54	2.71	V
Under Voltage Lockout Threshold Hysteresis				210		mV
Soft Start Period		$C_{SS} = 0.1\mu F$		10		ms
Thermal Shutdown				160		°C

TYPICAL PERFORMANCE CHARACTERISTICS

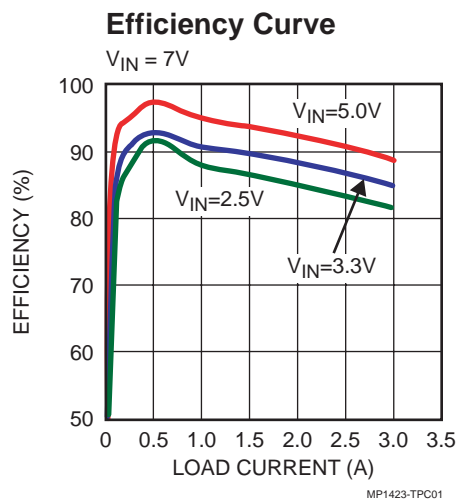

Soft-Start

C_{SS} Open, $V_{IN} = 10V$, $V_{OUT} = 3.3V$,
 1.5A Resistive Load

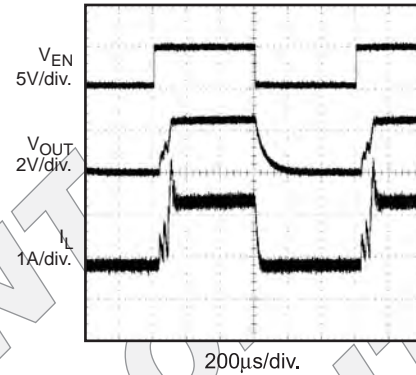

Soft-Start

$C_{SS} = 0.01\mu F$, $V_{IN} = 10V$, $V_{OUT} = 3.3V$,
 1.5A Resistive Load

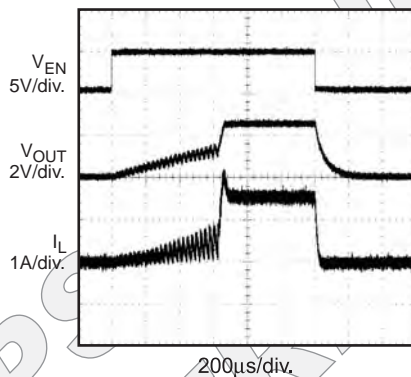

Soft-Start

$C_{SS} = 0.1\mu F$, $V_{IN} = 10V$, $V_{OUT} = 3.3V$,
 1.5A Resistive Load

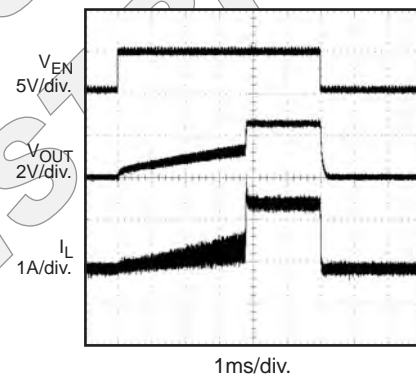

PIN FUNCTIONS

Pin #	Name	Description
1	BS	High-Side Gate Drive Bootstrap Input. BS supplies the drive for the high-side N-Channel MOSFET switch. Connect a 4.7nF or greater capacitor from SW to BS to power the high side switch.
2	IN	Power Input. IN supplies the power to the IC, as well as the step-down converter switches. Drive IN with a 6V to 23V power source. Bypass IN to GND with a suitably large capacitor to eliminate noise on the input to the IC. See <i>Input Capacitor</i>
3	SW	Power Switching Output. SW is the switching node that supplies power to the output. Connect the output LC filter from SW to the output load. Note that a capacitor is required from SW to BS to power the high-side switch.
4	GND	Ground. (Note: For the SOIC8N package, connect the exposed pad on backside to Pin 4).
5	FB	Feedback Input. FB senses the output voltage to regulate said voltage. Drive FB with a resistive voltage divider from the output voltage. The feedback threshold is 1.222V. See <i>Setting the Output Voltage</i>

PIN FUNCTIONS *(continued)*

Pin #	Name	Description
6	COMP	Compensation Node. COMP is used to compensate the regulation control loop. Connect a series RC network from COMP to GND to compensate the regulation control loop. In some cases, an additional capacitor from COMP to GND is required. See <i>Compensation</i>
7	EN	Enable Input. EN is a digital input that turns the regulator on or off. Drive EN high to turn on the regulator, low to turn it off. For automatic startup, leave EN unconnected.
8	SS	Soft Start Control Input. SS controls the soft start period. Connect a capacitor from SS to GND to set the soft-start period. A 0.1 μ F capacitor sets the soft-start period to 10ms. To disable the soft-start feature, leave SS unconnected.

OPERATION

The MP1423 is a current-mode step-down regulator. It regulates input voltages from 6V to 23V down to an output voltage as low as 1.222V, and is able to supply up to 3A of load current.

The MP1423 uses current-mode control to regulate the output voltage. The output voltage is measured at FB through a resistive voltage divider and amplified through the internal error amplifier. The output current of the transconductance error amplifier is presented at COMP where a network compensates the regulation control system.

The voltage at COMP is compared to the switch current measured internally to control the output voltage.

The converter uses an internal N-Channel MOSFET switch to step-down the input voltage to the regulated output voltage. Since the MOSFET requires a gate voltage greater than the input voltage, a boost capacitor connected between SW and BS drives the gate. The capacitor is internally charged while SW is low.

An internal 10 Ω switch from SW to GND is used to insure that SW is pulled to GND when SW is low to fully charge the BS capacitor.

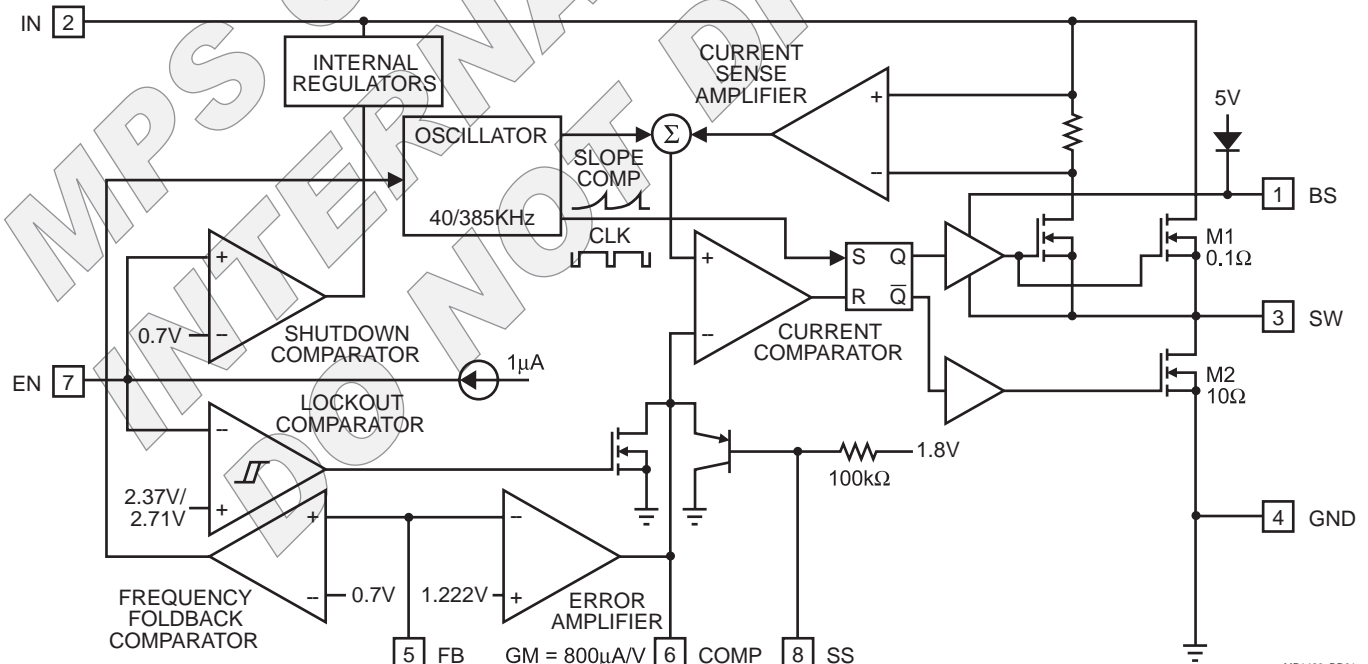
Figure 1—Functional Block Diagram

MP1423_BD01

LOW-NOISE DUAL OPERATIONAL AMPLIFIER

■ GENERAL DESCRIPTION

The NJM2068 is a high performance, low noise dual operational amplifier. This amplifier features popular pin-out, superior noise performance, and superior total harmonic distortion. This amplifier also features guaranteed noise performance with substantially higher gain-bandwidth product and slew rate which far exceeds that of the 4558 type amplifier. The specially designed low noise input transistors allow the NJM2068 to be used in very low noise signal processing applications such as audio preamplifiers and servo error amplifier.

■ FEATURES

- Operating Voltage (±4V ~ ±18V)
- Low Total Harmonic Distortion (0.001% typ.)
- Low Noise Voltage (FLAT+JISA, 0.56 μV typ.)
- High Slew Rate (6V/μs typ.)
- Unity Gain Bandwidth (27MHz @f=10kHz)
- Package Outline DIP8, DMP8, SIP8, SSOP8
- Bipolar Technology

■ PACKAGE OUTLINE

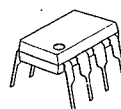

NJM2068D



NJM2068M



NJM2068V

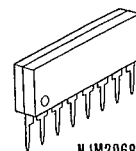

NJM2068L

■ PIN CONFIGURATION

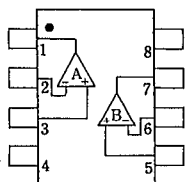

NJM2068D
NJM2068M
NJM2068V

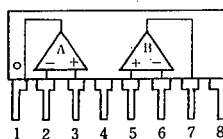

NJM2068L

PIN FUNCTION

1. A OUTPUT
2. A- INPUT
3. A+ INPUT
4. V-
5. B+ INPUT
6. B- INPUT
7. B OUTPUT
8. V+

■ EQUIVALENT CIRCUIT (1/2 Shown)

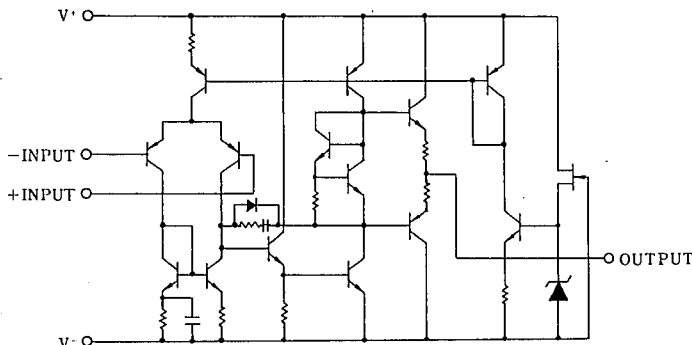

DUAL OPERATIONAL AMPLIFIER

■ GENERAL DESCRIPTION

NJM4580 is the dual operational amplifier, specially designed for improving the tone control, which is most suitable for the audio application.

Featuring noiseless, higher gain bandwidth, high output current and low distortion ratio, and it is most suitable not only for acoustic electronic parts of audio pre-amp and active filter, but also for the industrial measurement tools. It is also suitable for the head phone amp at higher output current, and further more, it can be applied for the handy type set operational amplifier of general purpose in application of low voltage single supply type which is properly biased of the low voltage source.

■ FEATURES

- Operating Voltage ($\pm 2V \sim \pm 18V$)
- Low Input Noise Voltage ($0.8\mu V_{rms}$ typ.)
- Wide Gain Bandwidth Product ($15MHz$ typ.)
- Low Distortion (0.0005% typ.)
- Slew Rate ($5V/\mu s$ typ.)
- Package Outline DIP8, SIP8, EMP8, SSOP8, DMP8
- Bipolar Technology

■ PACKAGE OUTLINE

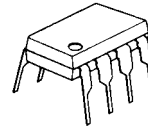

NJM4580D

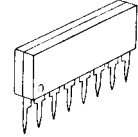

NJM4580L



NJM4580E



NJM4580V

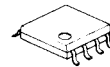

NJM4580M

■ PIN CONFIGURATION

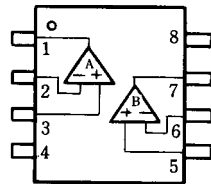

NJM4580D, NJM4580E
NJM4580M, NJM4580V

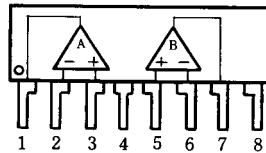

NJM4580L

PIN FUNCTION

- 1. A OUTPUT
- 2. A -INPUT
- 3. A +INPUT
- 4. V⁻
- 5. B +INPUT
- 6. B -INPUT
- 7. B OUTPUT
- 8. V⁺

■ EQUIVALENT CIRCUIT (1/2 Shown)

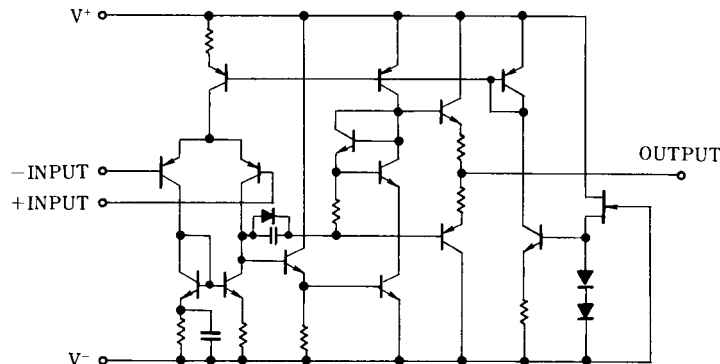



Product List

SM59128C25, 25MHz 128KB internal flash MCU
SM59128C40, 40MHz 128KB internal flash MCU

Description

The SM59128 series product is an 8-bit single chip microcontroller embedded with 128KB on-chip flash with In-System Programming (ISP) capability and 1024 bytes RAM. It is a derivative of the 8052 microcontroller family. In addition, SM59128 has IIC interface which is compatible with standard VESA DDC/CI and built in 4-channel SPWM. User can access on-chip expanded RAM by its 'bank mapping direct addressing mode' scheme. With its hardware features and powerful instruction sets, it's straight forward to make it a versatile and cost effective controller for those applications which demand up to 32 I/O pins for PDIP package or up to 36 I/O pins for PLCC or QFP package, or applications which need up to 64K bytes flash memory for program and/or for data. To program the on-chip flash memory, commercial writers are available by parallel programming method. On the other hand, the on-chip flash memory can be programmed through either parallel or serial interface with its ISP feature.

Ordering Information

yymm
SM59128ihhkL

yy: year, ww: month
v: version identifier { , A, B,... }
i: process identifier { L=3.0V~3.6V,C=4.5V~ 5.5V }
hh: working clock in MHz { 25, 40 }
k: package type postfix { as below table }
L: PB Free identifier
{No text is Non-PB Free , " P" is PB Free }

Table with 4 columns: Postfix, Package, Pin / Pad Configuration, Dimension. Rows include P (40L PDIP), J (44L PLCC), and Q (44L QFP).

Features

- Working Voltage: 4.5V to 5.5 V
General 8052 family compatible
12 clocks per machine cycle
128K bytes on-chip flash with In-System Programming (ISP) capability
IIC (Two wire serial bus) interface compliant with VESA DDC 2B/2Bi/2B+ standard
On-chip 1024 bytes RAM
Three 16-bit Timers/Counters
One Watch Dog Timer
Four 8-bit I/O ports for PDIP package
Four 8-bit I/O ports + one 4-bit I/O ports for PLCC or QFP package
Full duplex serial channel
Bit operation instruction
Temperature range of Industrial level
8-bit Unsigned Division
8-bit Unsigned Multiply
BCD arithmetic
Direct Addressing
Indirect Addressing
Nested Interrupt
Two priority level interrupt
A serial I/O port
Power-Saving mode: Idle mode and Power-down mode
Code protection function
Low EMI (inhibit ALE)
Reset with address \$0000 blank initiate ISP service program
Configurable ISP service program space with N*512 bytes (N=0 to 8) size
4-channel SPWM function

Taiwan
6F, No.10-2 Li- Hsin 1st Road ,
Science-based Industrial Park,
Hsinchu, Taiwan 30078

TEL: 886-3-567-1820
886-3-567-1880
FAX: 886-3-567-1891
886-3-567-1894

Specifications subject to change without notice contact your sales representatives for the most recent information.



Pin Configuration

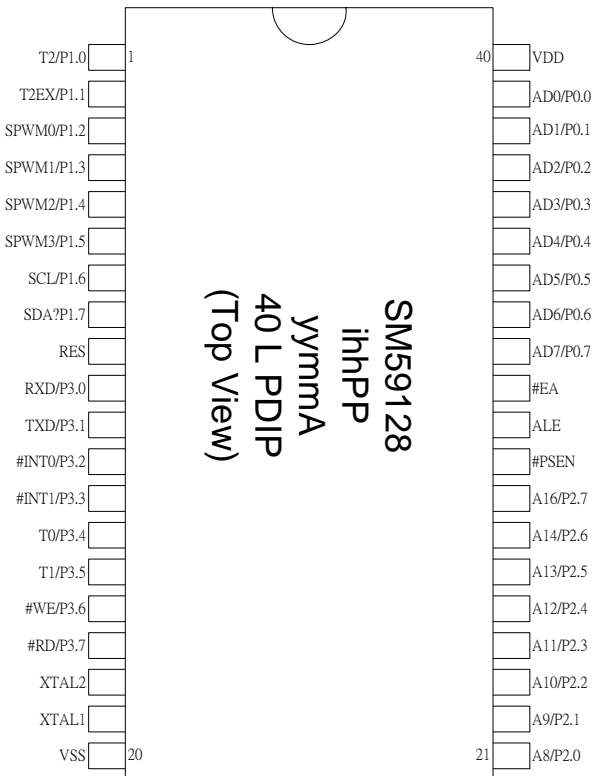
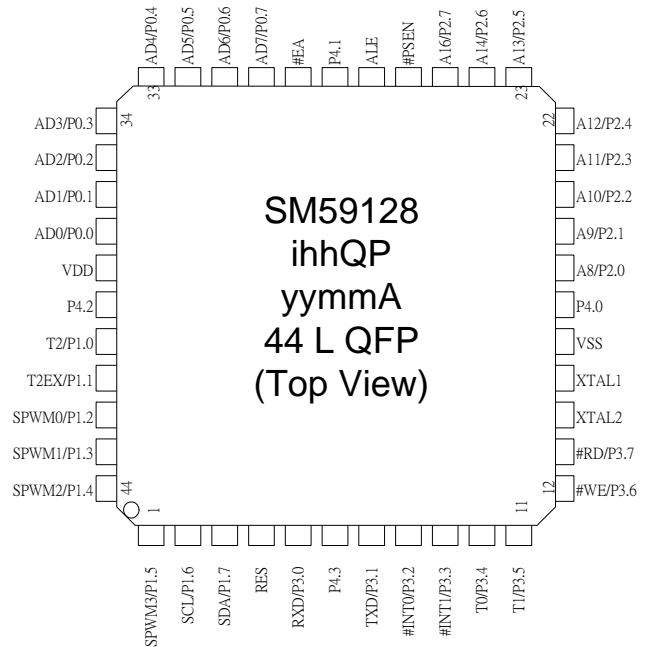
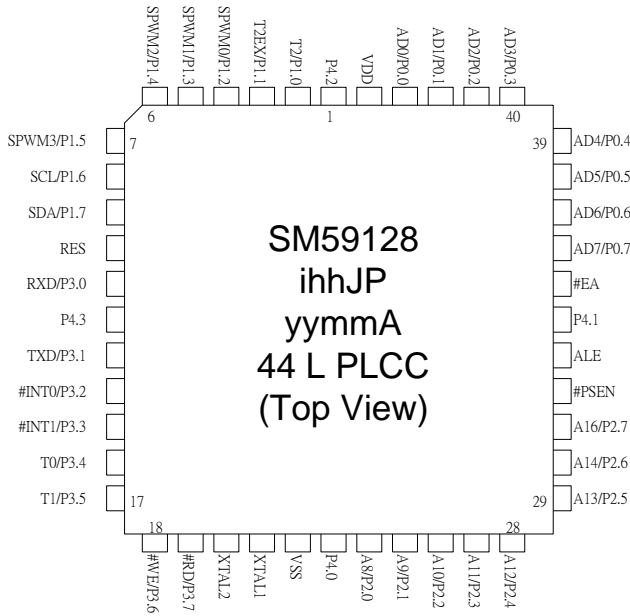

Specifications subject to change without notice contact your sales representatives for the most recent information.



Block Diagram

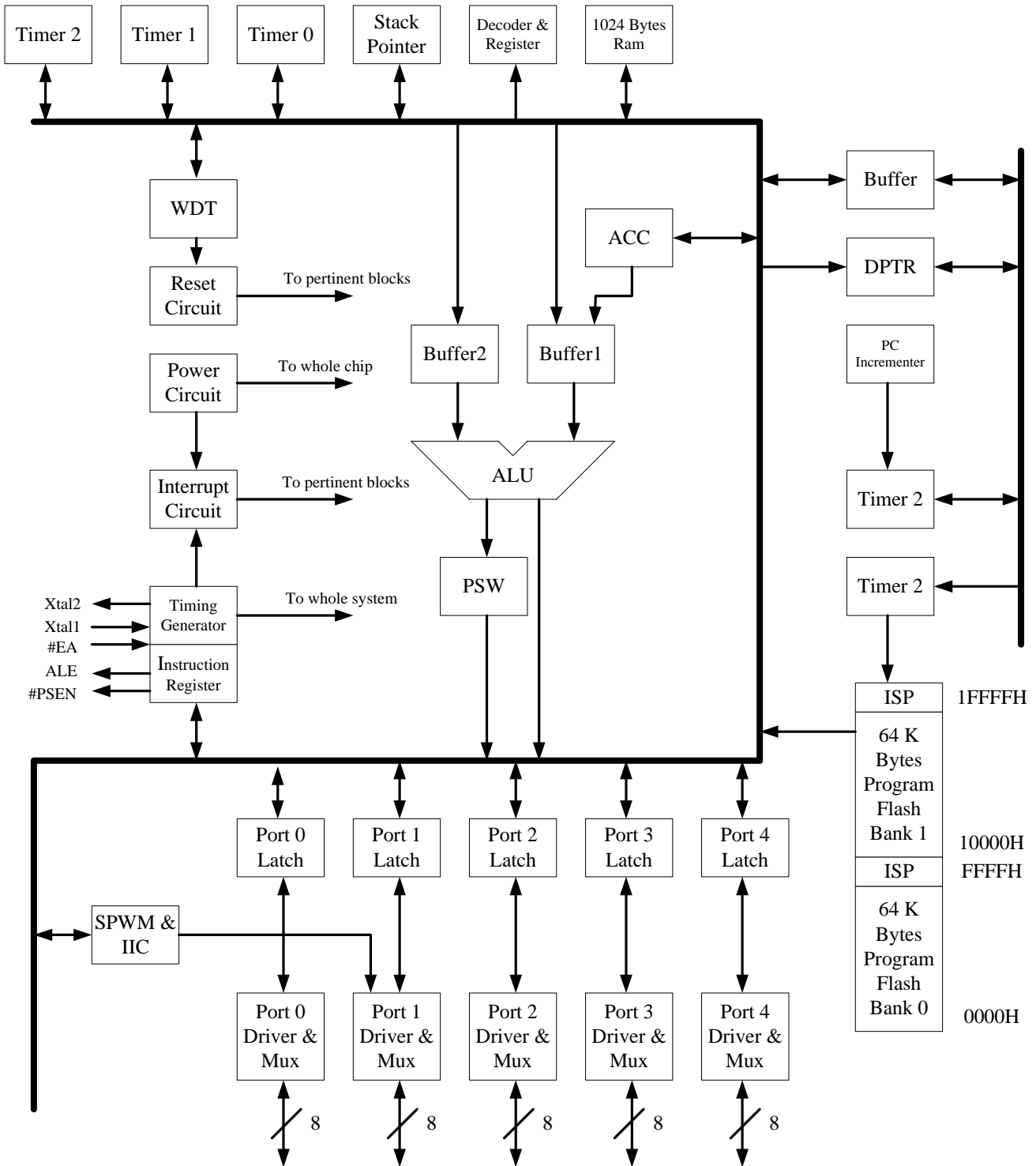

Specifications subject to change without notice contact your sales representatives for the most recent information.



Pin Description

40L PDIP Pin#	44L QFP Pin#	44L PLCC Pin#	Symbol	Active	I/O	Names
1	40	2	P1.0/T2		i/o	bit 0 of port 1 & timer 2 clock out
2	41	3	P1.1/T2EX		i/o	bit 1 of port 1 & timer 2 control
3	42	4	P1.2		i/o	bit 2 of port 1
4	43	5	P1.3/SPWM0		i/o	bit 3 of port 1 & SPWM channel 0
5	44	6	P1.4/SPWM1		i/o	bit 4 of port 1 & SPWM channel 1
6	1	7	P1.5/SPWM2		i/o	bit 5 of port 1 & SPWM channel 2
7	2	8	P1.6/SCL		i/o	bit 6 of port 1 & IIC Bus Clock
8	3	9	P1.7/SDA		i/o	bit 7 of port 1 & IIC Bus Data
9	4	10	RES	H	i	Reset
10	5	11	P3.0/RXD		i/o	bit 0 of port 3 & Receiver data
11	7	13	P3.1/TXD		i/o	bit 1 of port 3 & Transmit data
12	8	14	P3.2/#INT0	L/-	i/o	bit 2 of port 3 & low true interrupt 0
13	9	15	P3.3/#INT1	L/-	i/o	bit 3 of port 3 & low true interrupt 1
14	10	16	P3.4/T0		i/o	bit 4 of port 3 & Timer 0
15	11	17	P3.5/T1		i/o	bit 5 of port 3 & Timer 1
16	12	18	P3.6/#WR		i/o	bit 6 of port 3 & ext. memory write
17	13	19	P3.7/#RD		i/o	bit 7 of port 3 & ext. memory Read
18	14	20	XTAL2		o	Crystal out
19	15	21	XTAL1		i	Crystal in
20	16	22	VSS			Sink Voltage, Ground
21	18	24	P2.0/A8		i/o	bit 0 of port 2 & bit 8 of ext. memory address
22	19	25	P2.1/A9		i/o	bit 1 of port 2 & bit 9 of ext. memory address
23	20	26	P2.2/A10		i/o	bit 2 of port 2 & bit 10 of ext. memory address
24	21	27	P2.3/A11		i/o	bit 3 of port 2 & bit 11 of ext. memory address
25	22	28	P2.4/A12		i/o	bit 4 of port 2 & bit 12 of ext. memory address
26	23	29	P2.5/A13		i/o	bit 5 of port 2 & bit 13 of ext. memory address
27	24	30	P2.6/A14		i/o	bit 6 of port 2 & bit 14 of ext. memory address
28	25	31	P2.7/A15		i/o	bit 7 of port 2 & bit 15 of ext. memory address
29	26	32	#PSEN		o	program storage enable
30	27	33	ALE		o	address latch enable
31	29	35	#EA	L	I	external access
32	30	36	P0.7/AD7		i/o	bit 7 of port 0 & data/address bit 7 of ext. memory
33	31	37	P0.6/AD6		i/o	bit 6 of port 0 & data/address bit 6 of ext. memory
34	32	38	P0.5/AD5		i/o	bit 5 of port 0 & data/address bit 5 of ext. memory
35	33	39	P0.4/AD4		i/o	bit 4 of port 0 & data/address bit 4 of ext. memory
36	34	40	P0.3/AD3		i/o	bit 3 of port 0 & data/address bit 3 of ext. memory
37	35	41	P0.2/AD2		i/o	bit 2 of port 0 & data/address bit 2 of ext. memory
38	36	42	P0.1/AD1		i/o	bit 1 of port 0 & data/address bit 1 of ext. memory
39	37	43	P0.0/AD0		i/o	bit 0 of port 0 & data/address bit 0 of ext. memory
40	38	44	VDD			Drive Voltage, +5 Vcc
	17	23	P4.0		i/o	bit 0 of Port 4
	28	34	P4.1		i/o	bit 1 of Port 4
	39	1	P4.2		i/o	bit 2 of Port 4
	6	12	P4.3		i/o	bit 3 of port 4

Specifications subject to change without notice contact your sales representatives for the most recent information.

2 Mbit SPI Serial Flash

SST25VF020



Data Sheet

FEATURES:

- **Single 2.7-3.6V Read and Write Operations**
- **Serial Interface Architecture**
 - SPI Compatible: Mode 0 and Mode 3
- **20 MHz Max Clock Frequency**
- **Superior Reliability**
 - Endurance: 100,000 Cycles (typical)
 - Greater than 100 years Data Retention
- **Low Power Consumption:**
 - Active Read Current: 7 mA (typical)
 - Standby Current: 8 μ A (typical)
- **Flexible Erase Capability**
 - Uniform 4 KByte sectors
 - Uniform 32 KByte overlay blocks
- **Fast Erase and Byte-Program:**
 - Chip-Erase Time: 70 ms (typical)
 - Sector- or Block-Erase Time: 18 ms (typical)
 - Byte-Program Time: 14 μ s (typical)
- **Auto Address Increment (AAI) Programming**
 - Decrease total chip programming time over Byte-Program operations
- **End-of-Write Detection**
 - Software Status
- **Hold Pin (HOLD#)**
 - Suspends a serial sequence to the memory without deselecting the device
- **Write Protection (WP#)**
 - Enables/Disables the Lock-Down function of the status register
- **Software Write Protection**
 - Write protection through Block-Protection bits in status register
- **Temperature Range**
 - Commercial: 0°C to +70°C
 - Industrial: -40°C to +85°C
 - Extended: -20°C to +85°C
- **Packages Available**
 - 8-lead SOIC 150 mil body width
 - 8-contact WSON (5mm x 6mm)
- **All non-Pb (lead-free) devices are RoHS compliant**

PRODUCT DESCRIPTION

The SST serial flash family features a four-wire, SPI-compatible interface that allows for a low pin-count package occupying less board space and ultimately lowering total system costs. SST25VF020 SPI serial flash memories are manufactured with SST's proprietary, high performance CMOS SuperFlash Technology. The split-gate cell design and thick-oxide tunneling injector attain better reliability and manufacturability compared with alternate approaches.

The SST25VF020 device significantly improves performance, while lowering power consumption. The total energy consumed is a function of the applied voltage, cur-

rent, and time of application. Since for any given voltage range, the SuperFlash technology uses less current to program and has a shorter erase time, the total energy consumed during any Erase or Program operation is less than alternative flash memory technologies. The SST25VF020 device operates with a single 2.7-3.6V power supply.

The SST25VF020 device is offered in an 8-lead SOIC 150 mil body width (SA) package, and in an 8-contact WSON package. See Figure 2 for the pin assignments.

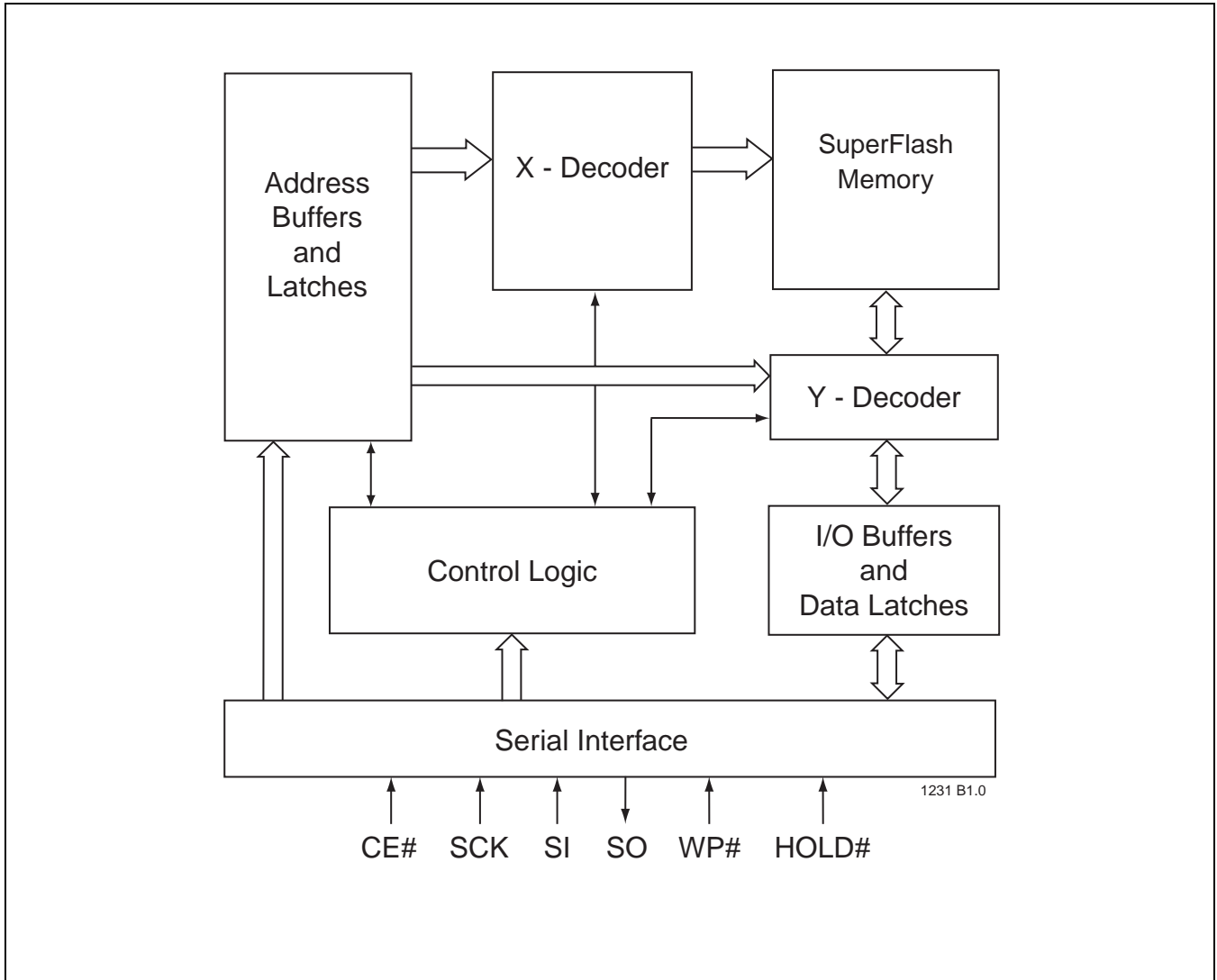

FIGURE 1: Functional Block Diagram

PIN DESCRIPTION

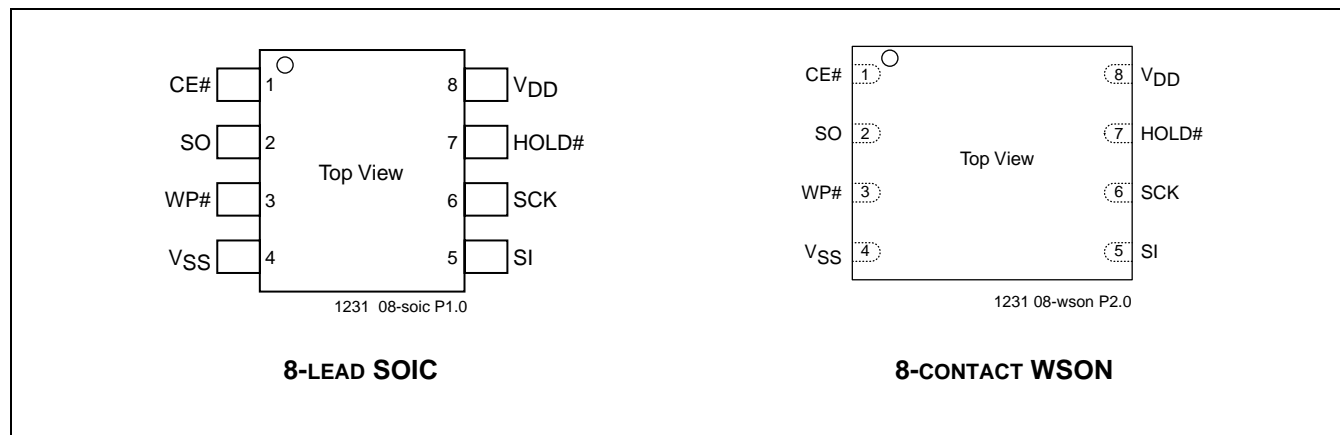

FIGURE 2: Pin Assignments

TABLE 1: Pin Description

Symbol	Pin Name	Functions
SCK	Serial Clock	To provide the timing of the serial interface. Commands, addresses, or input data are latched on the rising edge of the clock input, while output data is shifted out on the falling edge of the clock input.
SI	Serial Data Input	To transfer commands, addresses, or data serially into the device. Inputs are latched on the rising edge of the serial clock.
SO	Serial Data Output	To transfer data serially out of the device. Data is shifted out on the falling edge of the serial clock.
CE#	Chip Enable	The device is enabled by a high to low transition on CE#. CE# must remain low for the duration of any command sequence.
WP#	Write Protect	The Write Protect (WP#) pin is used to enable/disable BPL bit in the status register.
HOLD#	Hold	To temporarily stop serial communication with SPI flash memory without resetting the device.
V _{DD}	Power Supply	To provide power supply (2.7-3.6V).
V _{SS}	Ground	

T1.0 1231

TOSHIBA TRANSISTOR SILICON PNP EPITAXIAL TYPE (PCT PROCESS)

2SA950

AUDIO POWER AMPLIFIER APPLICATIONS

Unit in mm

- High h_{FE} : $h_{FE} = 100 \sim 320$
- 1W Output Applications
- Complementary to 2SC2120

MAXIMUM RATINGS ($T_a = 25^\circ\text{C}$)

CHARACTERISTIC	SYMBOL	RATING	UNIT
Collector-Base Voltage	V_{CB0}	-35	V
Collector-Emitter Voltage	V_{CEO}	-30	V
Emitter-Base Voltage	V_{EBO}	-5	V
Collector Current	I_C	-800	mA
Base Current	I_B	-160	mA
Collector Power Dissipation	P_C	600	mW
Junction Temperature	T_j	150	$^\circ\text{C}$
Storage Temperature Range	T_{stg}	-55 ~ 150	$^\circ\text{C}$

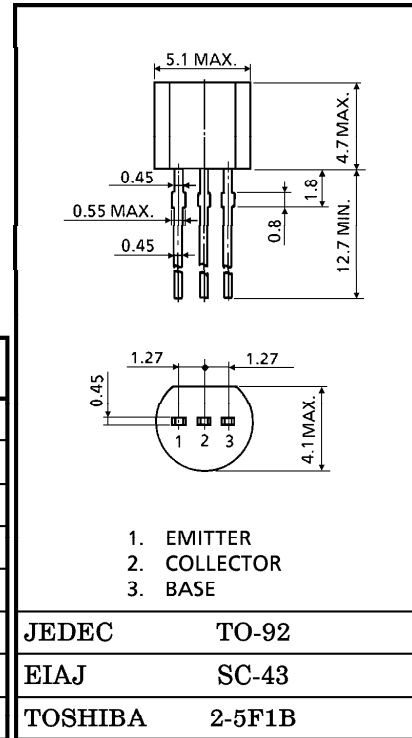

Weight : 0.21g

ELECTRICAL CHARACTERISTICS ($T_a = 25^\circ\text{C}$)

CHARACTERISTIC	SYMBOL	TEST CONDITION	MIN.	TYP.	MAX.	UNIT
Collector Cut-off Current	I_{CBO}	$V_{CB} = -35\text{V}, I_E = 0$	—	—	-0.1	μA
Emitter Cut-off Current	I_{EBO}	$V_{EB} = -5\text{V}, I_C = 0$	—	—	-0.1	μA
Collector-Emitter Breakdown Voltage	$V_{(BR)CEO}$	$I_C = -10\text{mA}, I_B = 0$	-30	—	—	V
DC Current Gain	$h_{FE(1)}$ (Note)	$V_{CE} = -1\text{V}, I_C = -100\text{mA}$	100	—	320	
	$h_{FE(2)}$	$V_{CE} = -1\text{V}, I_C = -700\text{mA}$	35	—	—	
Collector-Emitter Saturation Voltage	$V_{CE(sat)}$	$I_C = -500\text{mA}, I_B = -20\text{mA}$	—	—	-0.7	V
Base-Emitter Voltage	V_{BE}	$V_{CE} = -1\text{V}, I_C = -10\text{mA}$	-0.5	—	-0.8	V
Transition Frequency	f_T	$V_{CE} = -5\text{V}, I_C = -10\text{mA}$	—	120	—	MHz
Collector Output Capacitance	C_{ob}	$V_{CB} = -10\text{V}, I_E = 0,$ $f = 1\text{MHz}$	—	19	—	pF

Note : $h_{FE(1)}$ Classification O : 100~200、Y : 160~320

961001EAA2

- TOSHIBA is continually working to improve the quality and the reliability of its products. Nevertheless, semiconductor devices in general can malfunction or fail due to their inherent electrical sensitivity and vulnerability to physical stress. It is the responsibility of the buyer, when utilizing TOSHIBA products, to observe standards of safety, and to avoid situations in which a malfunction or failure of a TOSHIBA product could cause loss of human life, bodily injury or damage to property. In developing your designs, please ensure that TOSHIBA products are used within specified operating ranges as set forth in the most recent products specifications. Also, please keep in mind the precautions and conditions set forth in the TOSHIBA Semiconductor Reliability Handbook.
- The information contained herein is presented only as a guide for the applications of our products. No responsibility is assumed by TOSHIBA CORPORATION for any infringements of intellectual property or other rights of the third parties which may result from its use. No license is granted by implication or otherwise under any intellectual property or other rights of TOSHIBA CORPORATION or others.
- The information contained herein is subject to change without notice.

TOSHIBA Transistor Silicon PNP Epitaxial Type (PCT process)

2SA1162

Audio Frequency General Purpose Amplifier Applications

- High voltage and high current: $V_{CEO} = -50\text{ V}$, $I_C = -150\text{ mA}$ (max)
- Excellent h_{FE} linearity: $h_{FE}(I_C = -0.1\text{ mA})/h_{FE}(I_C = -2\text{ mA}) = 0.95$ (typ.)
- High h_{FE} : $h_{FE} = 70\sim 400$
- Low noise: $NF = 1\text{ dB}$ (typ.), 10 dB (max)
- Complementary to 2SC2712
- Small package

Absolute Maximum Ratings ($T_a = 25^\circ\text{C}$)

Characteristics	Symbol	Rating	Unit
Collector-base voltage	V_{CBO}	-50	V
Collector-emitter voltage	V_{CEO}	-50	V
Emitter-base voltage	V_{EBO}	-5	V
Collector current	I_C	-150	mA
Base current	I_B	-30	mA
Collector power dissipation	P_C	150	mW
Junction temperature	T_j	125	$^\circ\text{C}$
Storage temperature range	T_{stg}	-55~125	$^\circ\text{C}$

Note: Using continuously under heavy loads (e.g. the application of high temperature/current/voltage and the significant change in temperature, etc.) may cause this product to decrease in the reliability significantly even if the operating conditions (i.e. operating temperature/current/voltage, etc.) are within the absolute maximum ratings.

Please design the appropriate reliability upon reviewing the Toshiba Semiconductor Reliability Handbook ("Handling Precautions"/"Derating Concept and Methods") and individual reliability data (i.e. reliability test report and estimated failure rate, etc).

Electrical Characteristics ($T_a = 25^\circ\text{C}$)

Characteristics	Symbol	Test Condition	Min	Typ.	Max	Unit
Collector cut-off current	I_{CBO}	$V_{CB} = -50\text{ V}$, $I_E = 0$	—	—	-0.1	μA
Emitter cut-off current	I_{EBO}	$V_{EB} = -5\text{ V}$, $I_C = 0$	—	—	-0.1	μA
DC current gain	h_{FE} (Note)	$V_{CE} = -6\text{ V}$, $I_C = -2\text{ mA}$	70	—	400	
Collector-emitter saturation voltage	$V_{CE(sat)}$	$I_C = -100\text{ mA}$, $I_B = -10\text{ mA}$	—	-0.1	-0.3	V
Transition frequency	f_T	$V_{CE} = -10\text{ V}$, $I_C = -1\text{ mA}$	80	—	—	MHz
Collector output capacitance	C_{ob}	$V_{CB} = -10\text{ V}$, $I_E = 0$, $f = 1\text{ MHz}$	—	4	7	pF
Noise figure	NF	$V_{CE} = -6\text{ V}$, $I_C = -0.1\text{ mA}$, $f = 1\text{ kHz}$, $R_g = 10\text{ k}\Omega$,	—	1.0	10	dB

Note: h_{FE} classification O (O): 70~140, Y (Y): 120~240, GR (G): 200~400, () marking symbol

Marking

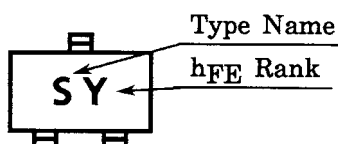

Unit: mm

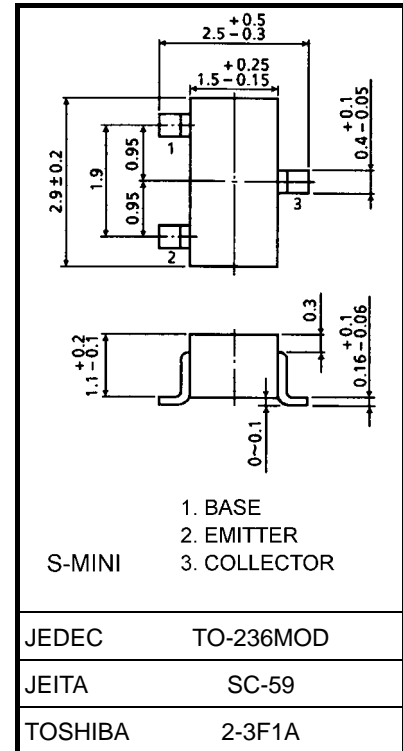

Weight: 0.012 g (typ.)



2SA1331/2SC3361

High-Speed Switching Applications

Features

- Fast switching speed.
- High breakdown voltage.
- Small-sized package permitting the 2SA1331/2SC3361-applied sets to be made small and slim.

Switching Time Test Circuit

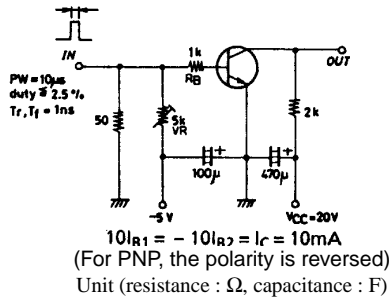

() : 2SA1331

Specifications

Absolute Maximum Ratings at Ta = 25°C

Parameter	Symbol	Conditions	Ratings	Unit
Collector-to-Base Voltage	V_{CBO}		(-)60	V
Collector-to-Emitter Voltage	V_{CEO}		(-)50	V
Emitter-to-Base Voltage	V_{EBO}		(-)5	V
Collector Current	I_C		(-)150	mA
Collector Current (Pulse)	I_{CP}		(-)400	mA
Base Current	I_B		(-)40	mA
Collector Dissipation	P_C		150	mW
Junction Temperature	T_J		125	°C
Storage Temperature	T_{stg}		-55 to +125	°C

Electrical Characteristics at Ta = 25°C

Parameter	Symbol	Conditions	Ratings		Unit
			min	typ	
Collector Cutoff Current	I_{CBO}	$V_{CB} = (-)40V, I_E = 0$		(-)0.1	μA
Emitter Cutoff Current	I_{EBO}	$V_{EB} = (-)4V, I_C = 0$		(-)0.1	μA
DC Current Gain	h_{FE}	$V_{CE} = (-)6V, I_C = (-)1mA$	90*	400*	
Gain-Bandwidth Product	f_T	$V_{CE} = (-)6V, I_C = (-)1mA$		100	MHz
Common Base Output Capacitance	C_{ob}	$V_{CB} = (-)6V, f = 1MHz$		(3.5) 2.7	pF
Collector-to-Emitter Saturation Voltage	$V_{CE(sat)}$	$I_C = (-)10mA, I_B = (-)1mA$	(-)0.1	(-)0.4	V
Base-to-Emitter Saturation Voltage	$V_{BE(sat)}$	$I_C = (-)10mA, I_B = (-)1mA$	(-)0.75	(-)1.1	V
Collector-to-Base Breakdown Voltage	$V_{(BR)CBO}$	$I_C = (-)10μA, I_E = 0$	(-)60		V
Collector-to-Emitter Breakdown Voltage	$V_{(BR)CEO}$	$I_C = (-)1mA, R_{BE} = ∞$	(-)50		V
Emitter-to-Base Breakdown Voltage	$V_{(BR)EBO}$	$I_E = (-)10μA, I_C = 0$	(-)5		V
Delay Time	t_d	See specified Test Circuit		40	ns
Rise Time	t_r	See specified Test Circuit		(120) 80	ns
Storage Time	t_{stg}	See specified Test Circuit		(190) 230	ns
Fall Time	t_f	See specified Test Circuit		(200) 160	ns

* : The 2SA1331/2SC3361 are classified by 1mA h_{FE} as follows :

90	4	180	135	5	270	200	6	400
----	---	-----	-----	---	-----	-----	---	-----

Package Dimensions

unit:mm

2018A

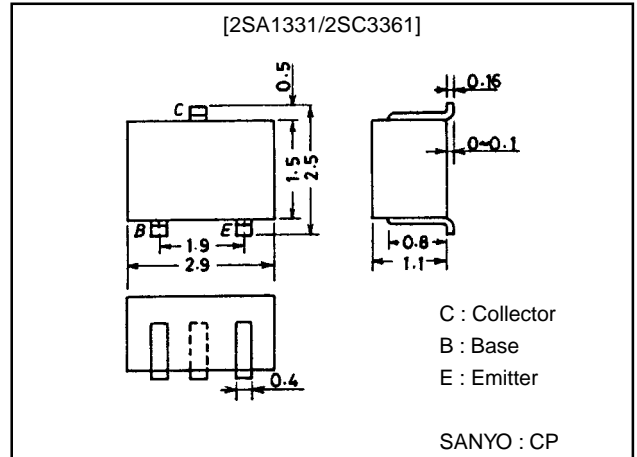

Marking 2SA1331 : O, 2SC3361 : S

h_{FE} rank : 4, 5, 6

SANYO Electric Co.,Ltd. Semiconductor Business Headquarters

TOKYO OFFICE Tokyo Bldg., 1-10, 1 Chome, Ueno, Taito-ku, TOKYO, 110-8534 JAPAN

TOSHIBA TRANSISTOR SILOCON NPN EPITAXIAL TYPE (PCT PROCESS)

2SC2120

AUDIO POWER AMPLIFIER APPLICATIONS

Unit in mm

- High h_{FE} : $h_{FE(1)} = 100 \sim 320$
- 1 Watts Amplifier Applications.
- Complementary to 2SA950

MAXIMUM RATINGS ($T_a = 25^\circ\text{C}$)

CHARACTERISTIC	SYMBOL	RATING	UNIT
Collector-Base Voltage	V_{CBO}	35	V
Collector-Emitter Voltage	V_{CEO}	30	V
Emitter-Base Voltage	V_{EBO}	5	V
Collector Current	I_C	800	mA
Base Current	I_B	160	mA
Collector Power Dissipation	P_C	600	mW
Junction Temperature	T_j	150	$^\circ\text{C}$
Storage Temperature Range	T_{stg}	-55~150	$^\circ\text{C}$

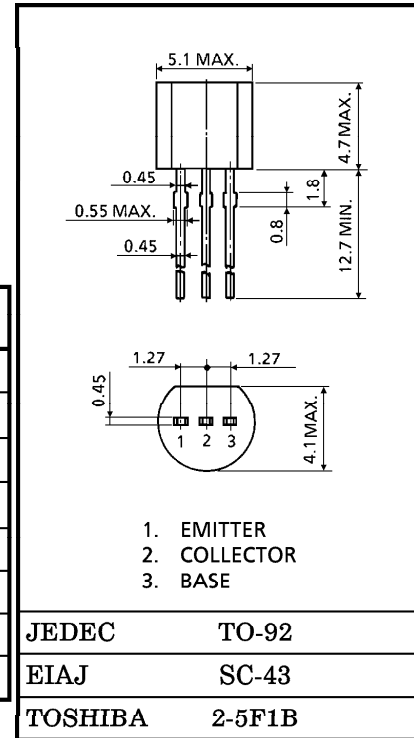

Weight : 0.21g

ELECTRICAL CHARACTERISTICS ($T_a = 25^\circ\text{C}$)

CHARACTERISTIC	SYMBOL	TEST CONDITION	MIN.	TYP.	MAX.	UNIT
Collector Cut-off Current	I_{CBO}	$V_{CB} = 35\text{V}, I_E = 0$	—	—	0.1	μA
Emitter Cut-off Current	I_{EBO}	$V_{EB} = 5\text{V}, I_C = 0$	—	—	0.1	μA
Collector-Emitter Breakdown Voltage	$V_{(BR)CEO}$	$I_C = 10\text{mA}, I_B = 0$	30	—	—	V
DC Current Gain	$h_{FE(1)}$ (Note)	$V_{CE} = 1\text{V}, I_C = 100\text{mA}$	100	—	320	
	$h_{FE(2)}$	$V_{CE} = 1\text{V}, I_C = 700\text{mA}$	35	—	—	
Collector-Emitter Breakdown Voltage	$V_{CE(sat)}$	$I_C = 500\text{mA}, I_B = 20\text{mA}$	—	—	0.5	V
Base-Emitter Voltage	V_{BE}	$V_{CE} = 1\text{V}, I_C = 10\text{mA}$	0.5	—	0.8	V
Transition Frequency	f_T	$V_{CE} = 5\text{V}, I_C = 10\text{mA}$	—	120	—	MHz
Collector Output Capacitance	C_{ob}	$V_{CB} = 10\text{V}, I_E = 0,$ $f = 1\text{MHz}$	—	13	—	pF

Note : $h_{FE(1)}$ Classification O : 100~200, Y : 160~3200

961001EAA2

- TOSHIBA is continually working to improve the quality and the reliability of its products. Nevertheless, semiconductor devices in general can malfunction or fail due to their inherent electrical sensitivity and vulnerability to physical stress. It is the responsibility of the buyer, when utilizing TOSHIBA products, to observe standards of safety, and to avoid situations in which a malfunction or failure of a TOSHIBA product could cause loss of human life, bodily injury or damage to property. In developing your designs, please ensure that TOSHIBA products are used within specified operating ranges as set forth in the most recent products specifications. Also, please keep in mind the precautions and conditions set forth in the TOSHIBA Semiconductor Reliability Handbook.
- The information contained herein is presented only as a guide for the applications of our products. No responsibility is assumed by TOSHIBA CORPORATION for any infringements of intellectual property or other rights of the third parties which may result from its use. No license is granted by implication or otherwise under any intellectual property or other rights of TOSHIBA CORPORATION or others.
- The information contained herein is subject to change without notice.

TOSHIBA TRANSISTOR SILICON NPN EPITAXIAL TYPE (PCT PROCESS)

2SC2712

AUDIO FREQUENCY GENERAL PURPOSE AMPLIFIER APPLICATIONS.

Unit in mm

- High Voltage and High Current
: $V_{CE0} = 50V, I_C = 150mA$ (Max.)
- Excellent h_{FE} Linearity
: $h_{FE}(I_C = 0.1mA) / h_{FE}(I_C = 2mA) = 0.95$ (Typ.)
- High h_{FE} : $h_{FE} = 70 \sim 700$
- Low Noise : $NF = 1dB$ (Typ.), $10dB$ (Max.)
- Complementary to 2SA1162
- Small Package

MAXIMUM RATINGS ($T_a = 25^\circ C$)

CHARACTERISTIC	SYMBOL	RATING	UNIT
Collector-Base Voltage	V_{CBO}	60	V
Collector-Emitter Voltage	V_{CEO}	50	V
Emitter-Base Voltage	V_{EBO}	5	V
Collector Current	I_C	150	mA
Base Current	I_B	30	mA
Collector Power Dissipation	P_C	150	mW
Junction Temperature	T_j	125	$^\circ C$
Storage Temperature Range	T_{stg}	-55~125	$^\circ C$

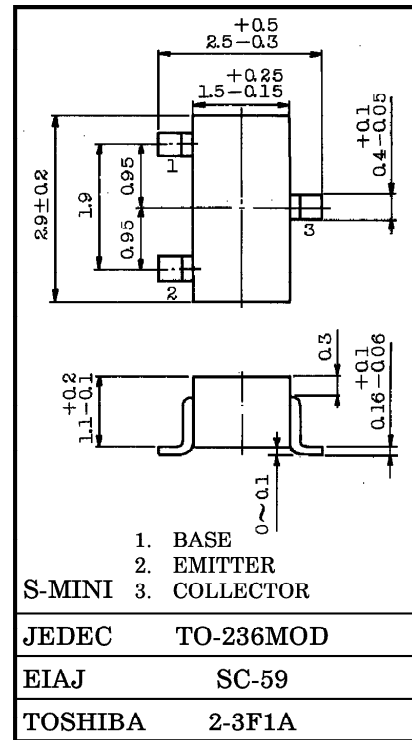

Weight : 0.012g

ELECTRICAL CHARACTERISTICS ($T_a = 25^\circ C$)

CHARACTERISTIC	SYMBOL	TEST CONDITION	MIN.	TYP.	MAX.	UNIT
Collector Cut-off Current	I_{CBO}	$V_{CB} = 60V, I_E = 0$	—	—	0.1	μA
Emitter Cut-off Current	I_{EBO}	$V_{EB} = 5V, I_C = 0$	—	—	0.1	μA
DC Current Gain	$h_{FE}(\text{Note})$	$V_{CE} = 6V, I_C = 2mA$	70	—	700	
Collector-Emitter Saturation Voltage	$V_{CE(sat)}$	$I_C = 100mA, I_B = 10mA$	—	0.1	0.25	V
Transition Frequency	f_T	$V_{CE} = 10V, I_C = 1mA$	80	—	—	MHz
Collector Output Capacitance	C_{ob}	$V_{CB} = 10V, I_E = 0, f = 1MHz$	—	2.0	3.5	pF
Noise Figure	NF	$V_{CE} = 6V, I_C = 0.1mA, f = 1kHz, R_g = 10k\Omega$	—	1.0	10	dB

Note : h_{FE} Classification

O (O) : 70~140, Y (Y) : 120~240, GR (G) : 200~400,

BL (L) : 350~700

() Marking Symbol

MARKING

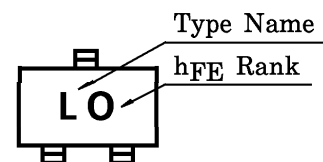

961001EAA2

● TOSHIBA is continually working to improve the quality and the reliability of its products. Nevertheless, semiconductor devices in general can malfunction or fail due to their inherent electrical sensitivity and vulnerability to physical stress. It is the responsibility of the buyer, when utilizing TOSHIBA products, to observe standards of safety, and to avoid situations in which a malfunction or failure of a TOSHIBA product could cause loss of human life, bodily injury or damage to property. In developing your designs, please ensure that TOSHIBA products are used within specified operating ranges as set forth in the most recent products specifications. Also, please keep in mind the precautions and conditions set forth in the TOSHIBA Semiconductor Reliability Handbook.

TOSHIBA TRANSISTOR SILICON NPN EPITAXIAL TYPE (PCT PROCESS)

2SC3326

FOR MUTING AND SWITCHING APPLICATIONS

Unit in mm

- High Emitter-Base Voltage : $V_{EBO} = 25V$ (Min.)
- High Reverse h_{FE} : Reverse $h_{FE} = 150$ (Typ.)
($V_{CE} = -2V, I_C = -4mA$)
- Low On Resistance : $R_{ON} = 1\Omega$ (Typ.) ($I_B = 5mA$)
- High DC Current Gain : $h_{FE} = 200 \sim 1200$
- Small Package

MAXIMUM RATINGS ($T_a = 25^\circ C$)

CHARACTERISTIC	SYMBOL	RATING	UNIT
Collector-Base Voltage	V_{CBO}	50	V
Collector-Emitter Voltage	V_{CEO}	20	V
Emitter-Base Voltage	V_{EBO}	25	V
Collector Current	I_C	300	mA
Base Current	I_B	60	mA
Collector Power Dissipation	P_C	150	mW
Junction Temperature	T_j	125	$^\circ C$
Storage Temperature Range	T_{stg}	$-55 \sim 125$	$^\circ C$

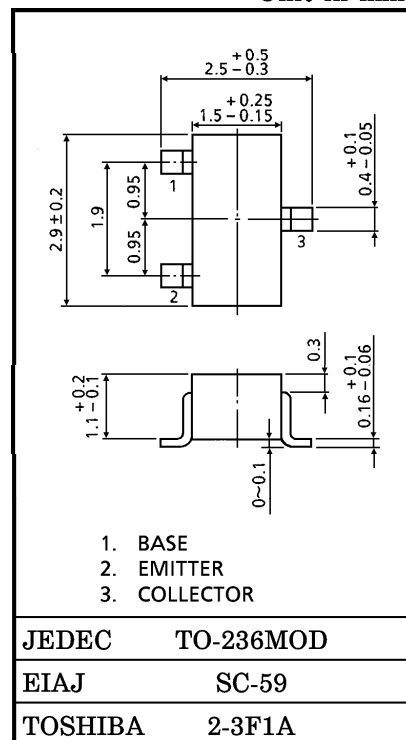

Weight : 0.012g

MARKING

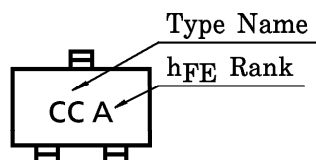

961001EAA1

- TOSHIBA is continually working to improve the quality and the reliability of its products. Nevertheless, semiconductor devices in general can malfunction or fail due to their inherent electrical sensitivity and vulnerability to physical stress. It is the responsibility of the buyer, when utilizing TOSHIBA products, to observe standards of safety, and to avoid situations in which a malfunction or failure of a TOSHIBA product could cause loss of human life, bodily injury or damage to property. In developing your designs, please ensure that TOSHIBA products are used within specified operating ranges as set forth in the most recent products specifications. Also, please keep in mind the precautions and conditions set forth in the TOSHIBA Semiconductor Reliability Handbook.
- The information contained herein is presented only as a guide for the applications of our products. No responsibility is assumed by TOSHIBA CORPORATION for any infringements of intellectual property or other rights of the third parties which may result from its use. No license is granted by implication or otherwise under any intellectual property or other rights of TOSHIBA CORPORATION or others.
- The information contained herein is subject to change without notice.

FEATURES

- Three Terminal Adjustable or Fixed Voltages*
1.5V, 1.8V, 2.5V, 2.85V, 3.3V and 5.0V
- Output Current of 800mA
- Operates Down to 1V Dropout
- Line Regulation: 0.2% Max.
- Load Regulation: 0.4% Max.
- SOT-223 and TO-252 package available

APPLICATIONS

- High Efficiency Linear Regulators
- Post Regulators for Switching Supplies
- 5V to 3.3V Linear Regulator
- Battery Chargers
- Active SCSI Terminators
- Power Management for Notebook
- Battery Powered Instrumentation

GENERAL DESCRIPTION

The AMS1117 series of adjustable and fixed voltage regulators are designed to provide 800mA output current and to operate down to 1V input-to-output differential. The dropout voltage of the device is guaranteed maximum 1.3V at maximum output current, decreasing at lower load currents.

On-chip trimming adjusts the reference voltage to 1%. Current limit is also trimmed, minimizing the stress under overload conditions on both the regulator and power source circuitry.

The AMS1117 devices are pin compatible with other three-terminal SCSI regulators and are offered in the low profile surface mount SOT-223 package and in the TO-252 (DPAK) plastic package.

ORDERING INFORMATION:

PACKAGE TYPE		OPERATING JUNCTION TEMPERATURE RANGE
TO-252	SOT-223	
AMS1117CD	AMS1117	0 to 125° C
AMS1117CD-1.5	AMS1117-1.5	0 to 125° C
AMS1117CD-1.8	AMS1117-1.8	0 to 125° C
AMS1117CD-2.5	AMS1117-2.5	0 to 125° C
AMS1117CD-2.85	AMS1117-2.85	0 to 125° C
AMS1117CD-3.3	AMS1117-3.3	0 to 125° C
AMS1117CD-5.0	AMS1117-5.0	0 to 125° C

*For additional available fixed voltages contact factory.

PIN CONNECTIONS

FIXED VERSION

- 1- Ground
- 2- V_{OUT}
- 3- V_{IN}

ADJUSTABLE VERSION

- 1- Adjust
- 2- V_{OUT}
- 3- V_{IN}

SOT-223 Top View

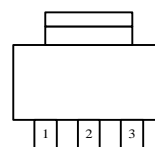

TO-252 FRONT VIEW

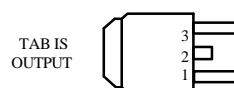

ABSOLUTE MAXIMUM RATINGS (Note 1)

Power Dissipation	Internally limited
Input Voltage	15V
Operating Junction Temperature	
Control Section	0°C to 125°C
Power Transistor	0°C to 150°C
Storage temperature	- 65°C to +150°C

Soldering information

Lead Temperature (10 sec)	300°C
Thermal Resistance	
TO-252 package	$\phi_{JA} = 80^\circ\text{C/W}$
SOT-223 package	$\phi_{JA} = 90^\circ\text{C/W}^*$
* With package soldering to copper area over backside ground plane or internal power plane ϕ_{JA} can vary from 46°C/W to >90°C/W depending on mounting technique and the size of the copper area.	

ELECTRICAL CHARACTERISTICS

Electrical Characteristics at $I_{OUT} = 0$ mA, and $T_J = +25^\circ\text{C}$ unless otherwise specified.

Parameter	Device	Conditions	Electrical Characteristics			Units
			Min	Typ	Max	
Reference Voltage (Note 2)	AMS1117	$I_{OUT} = 10$ mA $10\text{mA} \leq I_{OUT} \leq 800\text{mA}$, $1.5\text{V} \leq (V_{IN} - V_{OUT}) \leq 12\text{V}$	1.238	1.250	1.262	V
			1.225	1.250	1.270	V
Output Voltage (Note 2)	AMS1117-1.5	$0 \leq I_{OUT} \leq 800\text{mA}$, $3.0\text{V} \leq V_{IN} \leq 12\text{V}$	1.485	1.500	1.515	V
			1.476	1.500	1.524	V
	AMS1117-1.8	$0 \leq I_{OUT} \leq 800\text{mA}$, $3.3\text{V} \leq V_{IN} \leq 12\text{V}$	1.782	1.800	1.818	V
			1.773	1.800	1.827	V
	AMS1117-2.5	$0 \leq I_{OUT} \leq 800\text{mA}$, $4.0\text{V} \leq V_{IN} \leq 12\text{V}$	2.475	2.500	2.525	V
			2.460	2.500	2.560	V
	AMS1117-2.85	$0 \leq I_{OUT} \leq 800\text{mA}$, $4.35\text{V} \leq V_{IN} \leq 12\text{V}$	2.82	2.850	2.88	V
			2.79	2.850	2.91	V
	AMS1117-3.3	$0 \leq I_{OUT} \leq 800\text{mA}$, $4.75\text{V} \leq V_{IN} \leq 12\text{V}$	3.267	3.300	3.333	V
			3.235	3.300	3.365	V
	AMS1117-5.0	$0 \leq I_{OUT} \leq 800\text{mA}$, $6.5\text{V} \leq V_{IN} \leq 12\text{V}$	4.950	5.000	5.050	V
			4.900	5.000	5.100	V
Line Regulation	AMS1117	$I_{LOAD} = 10$ mA, $1.5\text{V} \leq (V_{IN} - V_{OUT}) \leq 12\text{V}$		0.015	0.2	%
				0.035	0.2	%
	AMS1117-1.5	$3.0\text{V} \leq V_{IN} \leq 12\text{V}$		0.3	5	mV
				0.6	6	mV
	AMS1117-1.8	$3.3\text{V} \leq V_{IN} \leq 12\text{V}$		0.3	5	mV
				0.6	6	mV
	AMS1117-2.5	$4.0\text{V} \leq V_{IN} \leq 12\text{V}$		0.3	6	mV
				0.6	6	mV
	AMS1117-2.85	$4.35\text{V} \leq V_{IN} \leq 12\text{V}$		0.3	6	mV
				0.6	6	mV
	AMS1117-3.3	$4.75\text{V} \leq V_{IN} \leq 12\text{V}$		0.5	10	mV
				1.0	10	mV
	AMS1117-5.0	$6.5\text{V} \leq V_{IN} \leq 12\text{V}$		0.5	10	mV
				1.0	10	mV
Load Regulation (Notes 2, 3)	AMS1117	$(V_{IN} - V_{OUT}) = 3\text{V}$, $10\text{mA} \leq I_{OUT} \leq 800\text{mA}$		0.1	0.3	%
				0.2	0.4	%
	AMS1117-1.5	$V_{IN} = 5\text{V}$, $0 \leq I_{OUT} \leq 800\text{mA}$		3	10	mV
				6	20	mV
	AMS1117-1.8	$V_{IN} = 5\text{V}$, $0 \leq I_{OUT} \leq 800\text{mA}$		3	10	mV
				6	20	mV
	AMS1117-2.5	$V_{IN} = 5\text{V}$, $0 \leq I_{OUT} \leq 800\text{mA}$		3	12	mV
				6	20	mV

ELECTRICAL CHARACTERISTICS

Electrical Characteristics at $I_{OUT} = 0$ mA, and $T_J = +25^\circ\text{C}$ unless otherwise specified.

Parameter	Device	Conditions	Min	Typ	Max	Units
Load Regulation (Notes 2, 3)	AMS1117-2.85	$V_{IN} = 5V, 0 \leq I_{OUT} \leq 800\text{mA}$		3 6	12 20	mV mV
	AMS1117-3.3	$V_{IN} = 5V, 0 \leq I_{OUT} \leq 800\text{mA}$		3 7	15 25	mV mV
	AMS1117-5.0	$V_{IN} = 8V, 0 \leq I_{OUT} \leq 800\text{mA}$		5 10	20 35	mV mV
Dropout Voltage ($V_{IN} - V_{OUT}$)	AMS1117-1.5/-1.8/-2.5/-2.85/-3.3/-5.0	$\Delta V_{OUT}, \Delta V_{REF} = 1\%, I_{OUT} = 800\text{mA}$ (Note 4)		1.1	1.3	V
Current Limit	AMS1117-1.5/-1.8/-2.5/-2.85/-3.3/-5.0	$(V_{IN} - V_{OUT}) = 5V$	900	1,100	1,500	mA
Minimum Load Current	AMS1117	$(V_{IN} - V_{OUT}) = 12V$ (Note 5)		5	10	mA
Quiescent Current	AMS1117-1.5/-1.8/-2.5/-2.85/-3.3/-5.0	$V_{IN} \leq 12V$		5	10	mA
Ripple Rejection	AMS1117	$f = 120\text{Hz}, C_{OUT} = 22\mu\text{F}$ Tantalum, $I_{OUT} = 800\text{mA}$, $(V_{IN} - V_{OUT}) = 3V, C_{ADJ} = 10\mu\text{F}$	60	75		dB
	AMS1117-1.5/-1.8/-2.5/-2.85	$f = 120\text{Hz}, C_{OUT} = 22\mu\text{F}$ Tantalum, $I_{OUT} = 800\text{mA}$, $V_{IN} = 6V$	60	72		dB
	AMS1117-3.3	$f = 120\text{Hz}, C_{OUT} = 22\mu\text{F}$ Tantalum, $I_{OUT} = 800\text{mA}$ $V_{IN} = 6.3V$	60	72		dB
	AMS1117-5.0	$f = 120\text{Hz}, C_{OUT} = 22\mu\text{F}$ Tantalum, $I_{OUT} = 800\text{mA}$ $V_{IN} = 8V$	60	68		dB
Thermal Regulation	AMS1117	$T_A = 25^\circ\text{C}, 30\text{ms}$ pulse		0.008	0.04	%W
Adjust Pin Current	AMS1117	$10\text{mA} \leq I_{OUT} \leq 800\text{mA}, 1.5V \leq (V_{IN} - V_{OUT}) \leq 12V$		55	120	μA μA
Adjust Pin Current Change	AMS1117	$10\text{mA} \leq I_{OUT} \leq 800\text{mA}, 1.5V \leq (V_{IN} - V_{OUT}) \leq 12V$		0.2	5	μA
Temperature Stability				0.5		%
Long Term Stability		$T_A = 125^\circ\text{C}, 1000\text{Hrs}$		0.3	1	%
RMS Output Noise (% of V_{OUT})		$T_A = 25^\circ\text{C}, 10\text{Hz} \leq f \leq 10\text{kHz}$		0.003		%
Thermal Resistance Junction-to-Case					15	$^\circ\text{C}/\text{W}$

Parameters identified with **boldface type** apply over the full operating temperature range.

Note 1: Absolute Maximum Ratings indicate limits beyond which damage to the device may occur. For guaranteed specifications and test conditions, see the Electrical Characteristics. The guaranteed specifications apply only for the test conditions listed.

Note 2: Line and Load regulation are guaranteed up to the maximum power dissipation of 1.2 W. Power dissipation is determined by the input/output differential and the output current. Guaranteed maximum power dissipation will not be available over the full input/output range.

Note 3: See thermal regulation specifications for changes in output voltage due to heating effects. Line and load regulation are measured at a constant junction temperature by low duty cycle pulse testing. Load regulation is measured at the output lead $\sim 1/8''$ from the package.

Note 4: Dropout voltage is specified over the full output current range of the device.

Note 5: Minimum load current is defined as the minimum output current required to maintain regulation. When $1.5V \leq (V_{IN} - V_{OUT}) \leq 12V$ the device is guaranteed to regulate if the output current is greater than 10mA.

APPLICATION HINTS

The AMS1117 series of adjustable and fixed regulators are easy to use and are protected against short circuit and thermal overloads. Thermal protection circuitry will shut-down the regulator should the junction temperature exceed 165°C at the sense point.

Pin compatible with older three terminal adjustable regulators, these devices offer the advantage of a lower dropout voltage, more precise reference tolerance and improved reference stability with temperature.

Stability

The circuit design used in the AMS1117 series requires the use of an output capacitor as part of the device frequency compensation. The addition of 22µF solid tantalum on the output will ensure stability for all operating conditions.

When the adjustment terminal is bypassed with a capacitor to improve the ripple rejection, the requirement for an output capacitor increases. The value of 22µF tantalum covers all cases of bypassing the adjustment terminal. Without bypassing the adjustment terminal smaller capacitors can be used with equally good results.

To ensure good transient response with heavy load current changes capacitor values on the order of 100µF are used in the output of many regulators. To further improve stability and transient response of these devices larger values of output capacitor can be used.

Protection Diodes

Unlike older regulators, the AMS1117 family does not need any protection diodes between the adjustment pin and the output and from the output to the input to prevent over-stressing the die. Internal resistors are limiting the internal current paths on the AMS1117 adjustment pin, therefore even with capacitors on the adjustment pin no protection diode is needed to ensure device safety under short-circuit conditions.

Diodes between the input and output are not usually needed. Microsecond surge currents of 50A to 100A can be handled by the internal diode between the input and output pins of the device. In normal operations it is difficult to get those values of surge currents even with the use of large output capacitances. If high value output capacitors are used, such as 1000µF to 5000µF and the input pin is instantaneously shorted to ground, damage can occur. A diode from output to input is recommended, when a crowbar circuit at the input of the AMS1117 is used (Figure 1).

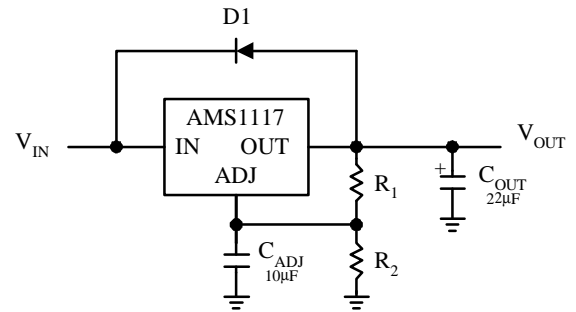

Figure 1.

Output Voltage

The AMS1117 series develops a 1.25V reference voltage between the output and the adjust terminal. Placing a resistor between these two terminals causes a constant current to flow through R1 and down through R2 to set the overall output voltage. This current is normally the specified minimum load current of 10mA. Because I_{ADJ} is very small and constant it represents a small error and it can usually be ignored.

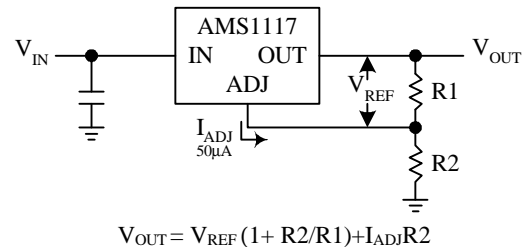

Figure 2. Basic Adjustable Regulator

Load Regulation

True remote load sensing it is not possible to provide, because the AMS1117 is a three terminal device. The resistance of the wire connecting the regulator to the load will limit the load regulation. The data sheet specification for load regulation is measured at the bottom of the package. Negative side sensing is a true Kelvin connection, with the bottom of the output divider returned to the negative side of the load.

The best load regulation is obtained when the top of the resistor divider R1 is connected directly to the case not to the load. If R1 were connected to the load, the effective resistance between the regulator and the load would be:

$$R_P \times \left(\frac{R2+R1}{R1} \right), \quad R_P = \text{Parasitic Line Resistance}$$

APPLICATION HINTS

Connected as shown, R_p is not multiplied by the divider ratio

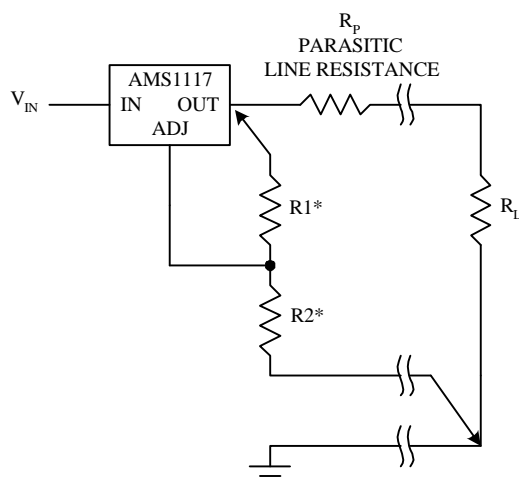

*CONNECT R1 TO CASE
CONNECT R2 TO LOAD

Figure 3. Connections for Best Load Regulation

In the case of fixed voltage devices the top of R1 is connected Kelvin internally, and the ground pin can be used for negative side sensing.

Thermal Considerations

The AMS1117 series have internal power and thermal limiting circuitry designed to protect the device under overload conditions. However maximum junction temperature ratings of 125°C should not be exceeded under continuous normal load conditions. Careful consideration must be given to all sources of thermal resistance from junction to ambient. For the surface mount package SOT-223 additional heat sources mounted near the device must be considered. The heat dissipation capability of the PC board and its copper traces is used as a heat sink for the device. The thermal resistance from the junction to the tab for the AMS1117 is 15°C/W. Thermal resistance from tab to ambient can be as low as 30°C/W.

Table 1.

COPPER AREA		BOARD AREA	THERMAL RESISTANCE (JUNCTION-TO-AMBIENT)
TOP SIDE*	BACK SIDE		
2500 Sq. mm	2500 Sq. mm	2500 Sq. mm	45°C/W
1000 Sq. mm	2500 Sq. mm	2500 Sq. mm	45°C/W
225 Sq. mm	2500 Sq. mm	2500 Sq. mm	53°C/W
100 Sq. mm	2500 Sq. mm	2500 Sq. mm	59°C/W
1000 Sq. mm	1000 Sq. mm	1000 Sq. mm	52°C/W
1000 Sq. mm	0	1000 Sq. mm	55°C/W

* Tab of device attached to topside copper.

The total thermal resistance from junction to ambient can be as low as 45°C/W. This requires a reasonable sized PC board with at least on layer of copper to spread the heat across the board and couple it into the surrounding air.

Experiments have shown that the heat spreading copper layer does not need to be electrically connected to the tab of the device. The PC material can be very effective at transmitting heat between the pad area, attached to the pad of the device, and a ground plane layer either inside or on the opposite side of the board. Although the actual thermal resistance of the PC material is high, the Length/Area ratio of the thermal resistance between layers is small. The data in Table 1, was taken using 1/16" FR-4 board with 1 oz. copper foil, and it can be used as a rough guideline for estimating thermal resistance.

For each application the thermal resistance will be affected by thermal interactions with other components on the board. To determine the actual value some experimentation will be necessary.

The power dissipation of the AMS1117 is equal to:

$$P_D = (V_{IN} - V_{OUT})(I_{OUT})$$

Maximum junction temperature will be equal to:

$$T_J = T_{A(MAX)} + P_D(\text{Thermal Resistance (junction-to-ambient)})$$

Maximum junction temperature must not exceed 125°C.

Ripple Rejection

The ripple rejection values are measured with the adjustment pin bypassed. The impedance of the adjust pin capacitor at the ripple frequency should be less than the value of R1 (normally 100Ω to 200Ω) for a proper bypassing and ripple rejection approaching the values shown. The size of the required adjust pin capacitor is a function of the input ripple frequency. If R1=100Ω at 120Hz the adjust pin capacitor should be >13μF. At 10kHz only 0.16μF is needed.

The ripple rejection will be a function of output voltage, in circuits without an adjust pin bypass capacitor. The output ripple will increase directly as a ratio of the output voltage to the reference voltage (V_{OUT} / V_{REF}).

TYPICAL PERFORMANCE CHARACTERISTICS

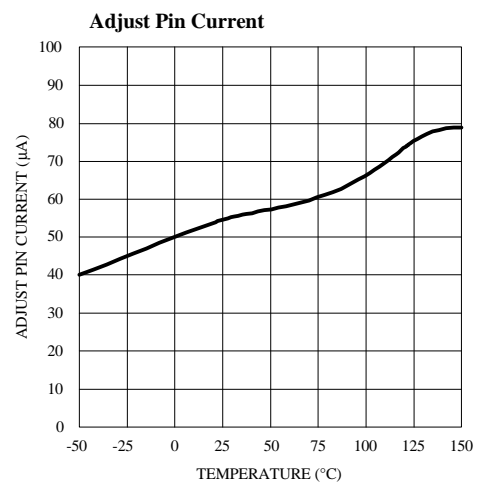
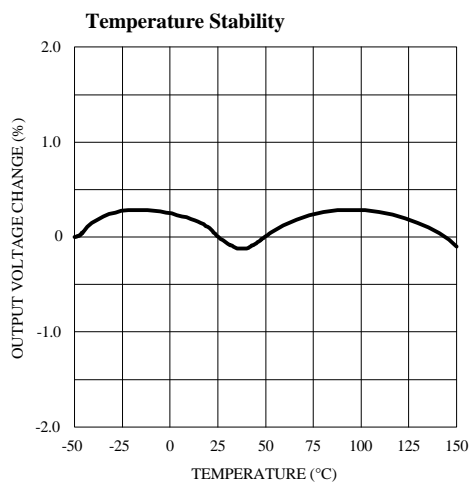
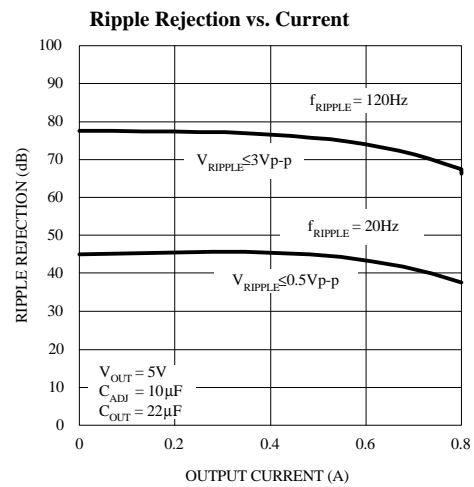
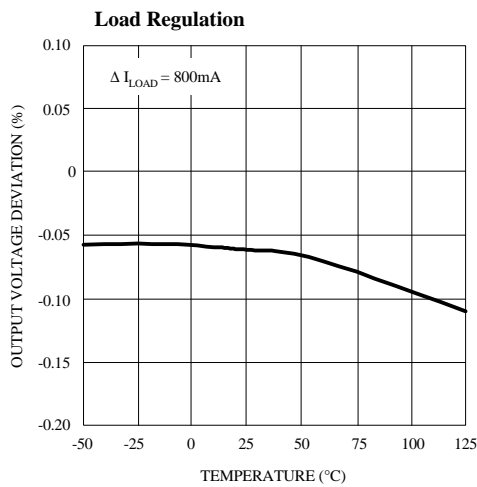
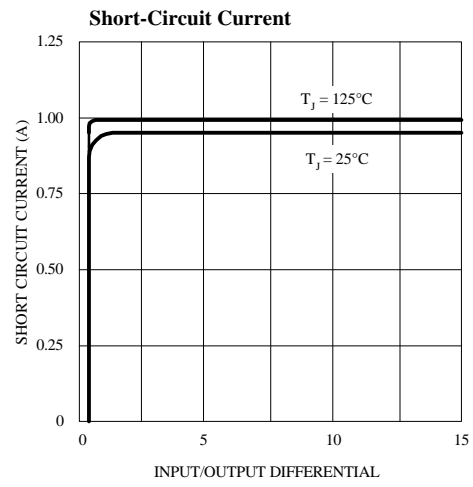
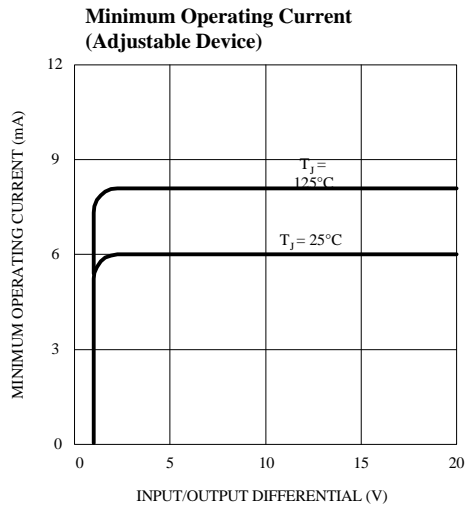

PACKAGE DIMENSIONS inches (millimeters) unless otherwise noted.

TO-252 PLASTIC PACKAGE (D)

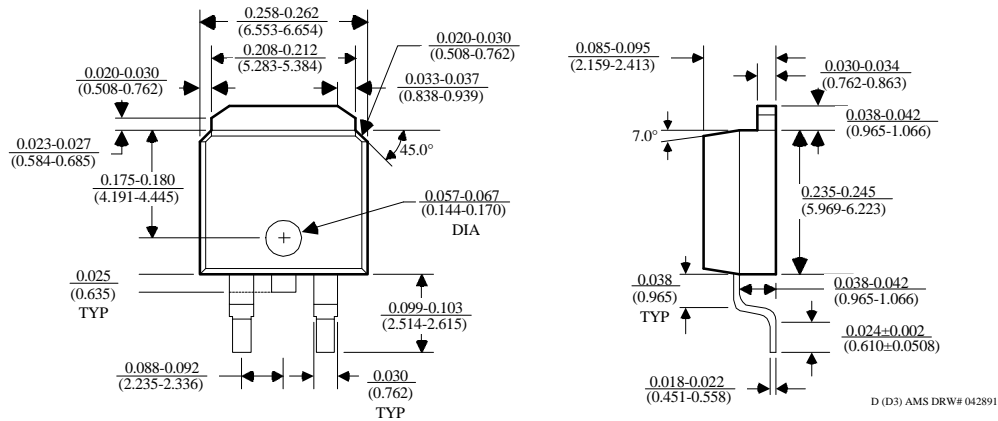

3 LEAD SOT-223 PLASTIC PACKAGE

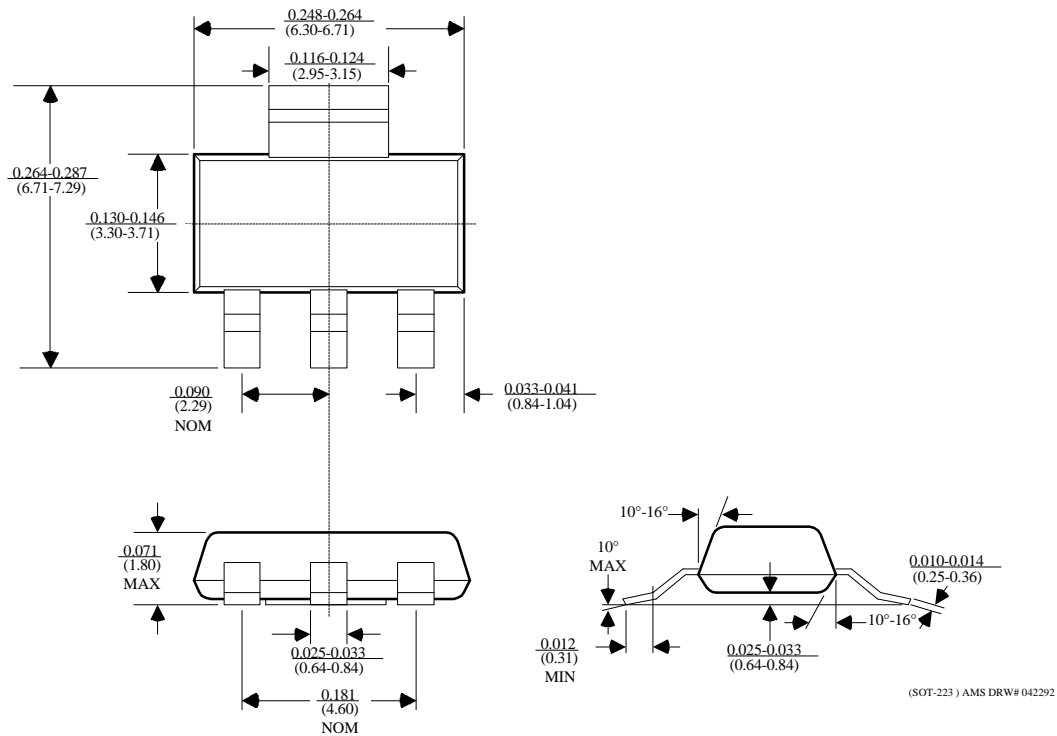

Features

- Low On-Resistance
 - 14mΩ @ $V_{GS} = -10V$
 - 25mΩ @ $V_{GS} = -4.5V$
- Low Gate Threshold Voltage
- Low Input Capacitance
- Fast Switching Speed
- Low Input/Output Leakage
- **Lead Free By Design/RoHS Compliant (Note 2)**
- **"Green" Device (Note 4)**
- **Qualified to AEC-Q101 Standards for High Reliability**

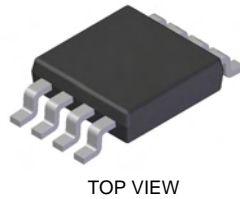

SOP-8L

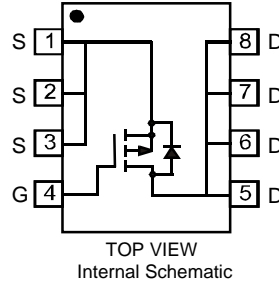

Mechanical Data

- Case: SOP-8L
- Case Material: Molded Plastic, "Green" Molding Compound. UL Flammability Classification Rating 94V-0
- Moisture Sensitivity: Level 1 per J-STD-020D
- Terminals Connections: See Diagram
- Terminals: Finish - Matte Tin annealed over Copper lead frame. Solderable per MIL-STD-202, Method 208
- Marking Information: See Page 3
- Ordering Information: See Page 3
- Weight: 0.072g (approximate)

Maximum Ratings @ $T_A = 25^\circ C$ unless otherwise specified

Characteristic	Symbol	Value	Units	
Drain-Source Voltage	V_{DSS}	-30	V	
Gate-Source Voltage	V_{GSS}	± 20	V	
Drain Current (Note 1)	Steady State	$T_A = 25^\circ C$	-12	A
		$T_A = 70^\circ C$	-6	A
Pulsed Drain Current (Note 3)	I_{DM}	-40	A	

Thermal Characteristics

Characteristic	Symbol	Value	Unit
Total Power Dissipation (Note 1)	P_D	2.5	W
Thermal Resistance, Junction to Ambient	$R_{\theta JA}$	50	$^\circ C/W$
Operating and Storage Temperature Range	T_J, T_{STG}	-55 to +150	$^\circ C$

Electrical Characteristics @ $T_A = 25^\circ C$ unless otherwise specified

Characteristic	Symbol	Min	Typ	Max	Unit	Test Condition
OFF CHARACTERISTICS (Note 5)						
Drain-Source Breakdown Voltage	BV_{DSS}	-30	—	—	V	$V_{GS} = 0V, I_D = -250\mu A$
Zero Gate Voltage Drain Current	I_{DSS}	—	—	-1	μA	$V_{DS} = -30V, V_{GS} = 0V$
Gate-Source Leakage	I_{GSS}	—	—	± 100	nA	$V_{GS} = \pm 20V, V_{DS} = 0V$
ON CHARACTERISTICS (Note 5)						
Gate Threshold Voltage	$V_{GS(th)}$	-1	—	-2	V	$V_{DS} = V_{GS}, I_D = -250\mu A$
Static Drain-Source On-Resistance	$R_{DS(ON)}$	—	11.6	14	mΩ	$V_{GS} = -10V, I_D = -8A$
		—	18.6	25		$V_{GS} = -4.5V, I_D = -5A$
Forward Transconductance	g_{fs}	—	12	—	S	$V_{DS} = -10V, I_D = -12A$
Diode Forward Voltage (Note 5)	V_{SD}	-0.5	—	-1.1	V	$V_{GS} = 0V, I_S = -2A$
DYNAMIC CHARACTERISTICS						
Input Capacitance	C_{iss}	—	1655	—	pF	$V_{DS} = -20V, V_{GS} = 0V$ $f = 1.0MHz$
Output Capacitance	C_{oss}	—	286	—	pF	
Reverse Transfer Capacitance	C_{rss}	—	240	—	pF	

- Notes:
1. Device mounted on 2 oz. Copper pads on FR-4 PCB with $R_{\theta JA} = 50^\circ C/W$.
 2. No purposefully added lead.
 3. Pulse width $\leq 10\mu s$, Duty Cycle $\leq 1\%$.
 4. Diodes Inc.'s "Green" policy can be found on our website at http://www.diodes.com/products/lead_free/index.php.
 5. Short duration pulse test used to minimize self-heating effect.

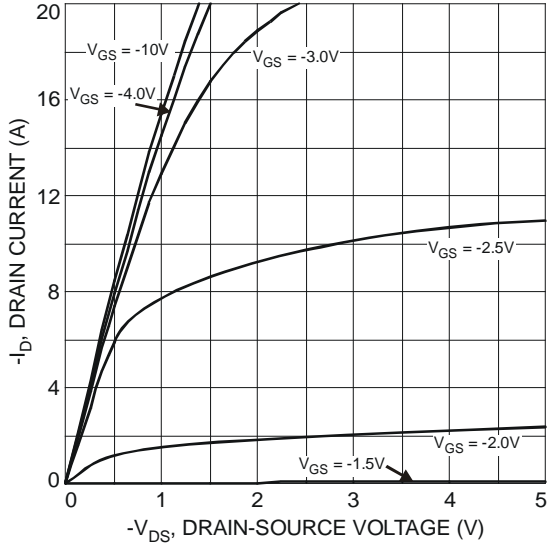

Fig. 1 Typical Output Characteristic

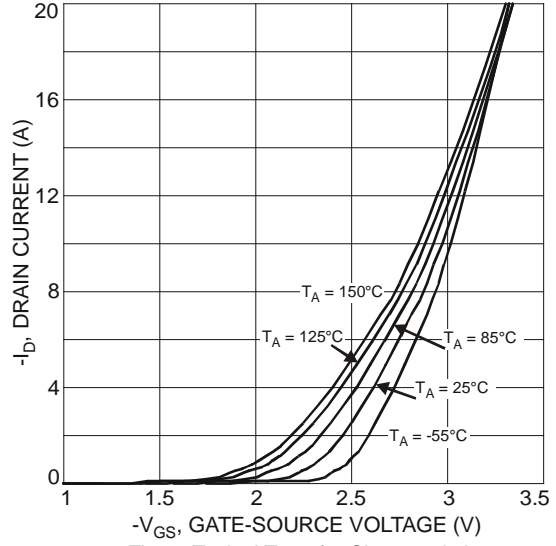

Fig. 2 Typical Transfer Characteristic

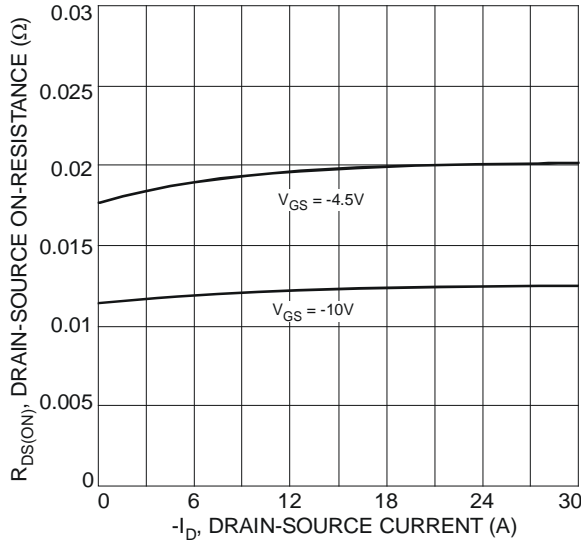

Fig. 3 Typical On-Resistance vs. Drain Current and Gate Voltage

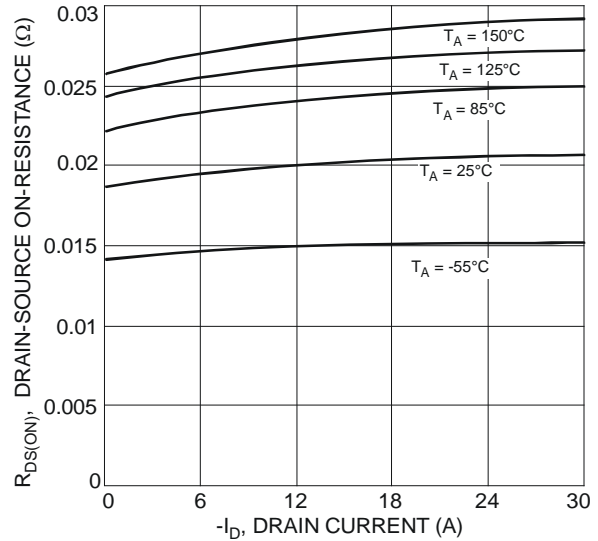

Fig. 4 Typical On-Resistance vs. Drain Current and Temperature

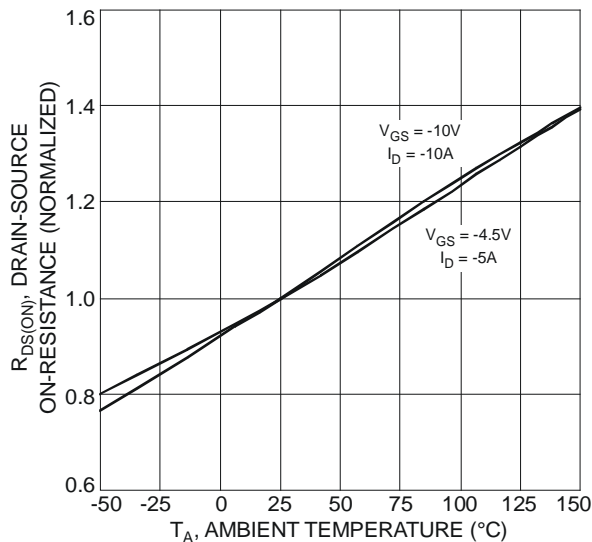

Fig. 5 Normalized On-Resistance vs. Ambient Temperature

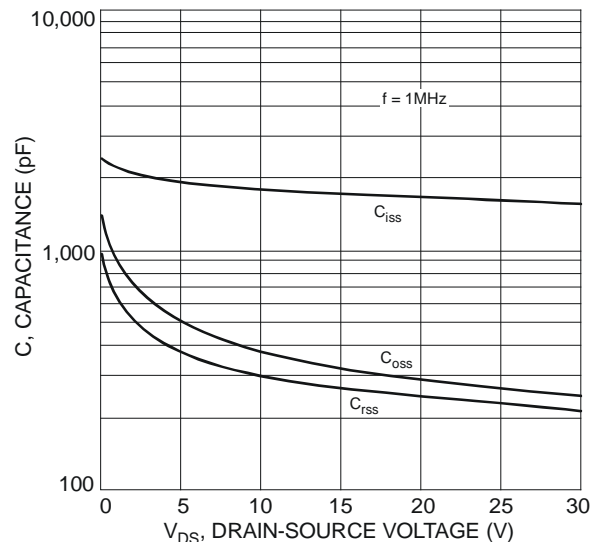

Fig. 6 Typical Total Capacitance

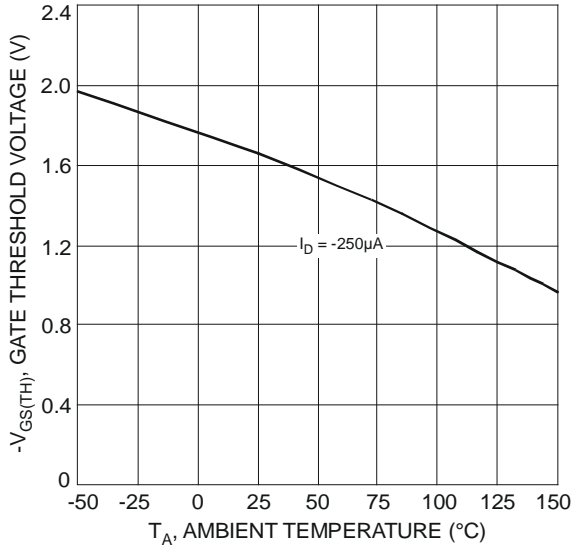

Fig. 7 Gate Threshold Variation vs. Ambient Temperature

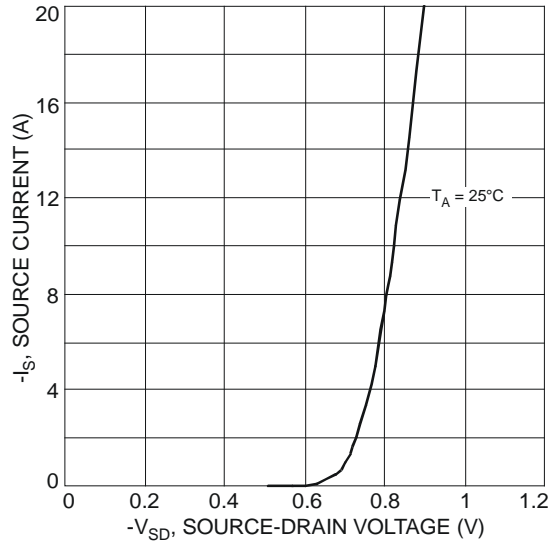

Fig. 8 Diode Forward Voltage vs. Current

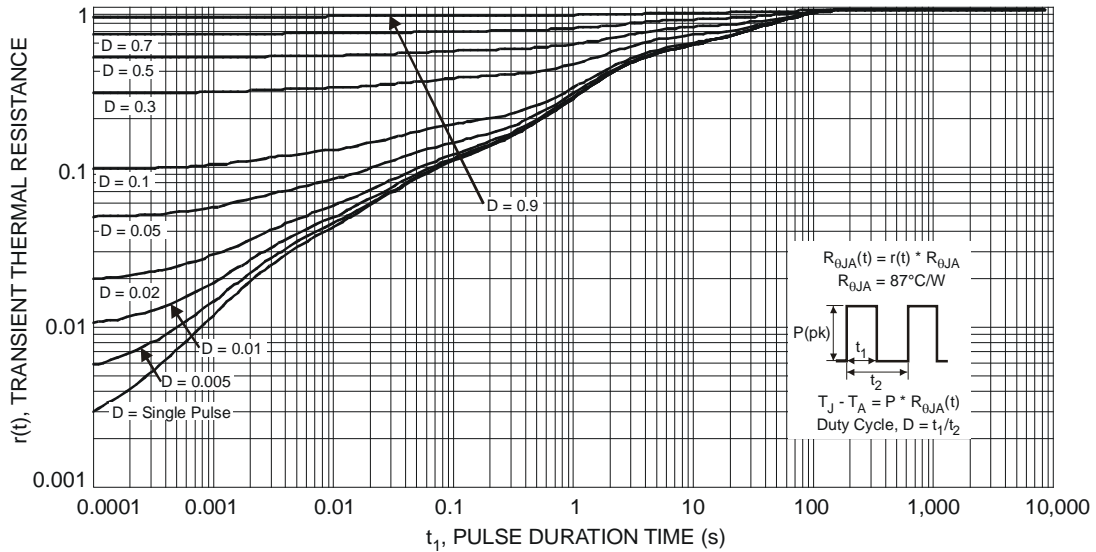

Fig. 9 Transient Thermal Response

Ordering Information (Note 6)

Part Number	Case	Packaging
DMP3020LSS-13	SOP-8L	2500/Tape & Reel

Notes: 6. For packaging details, go to our website at <http://www.diodes.com/datasheets/ap02007.pdf>.

Marking Information

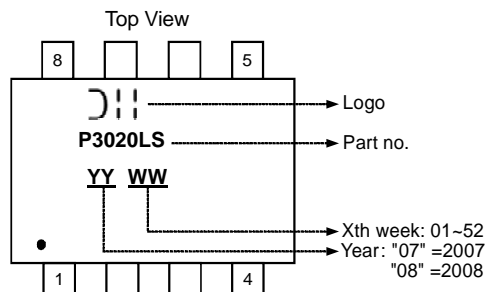

Package Outline Dimensions

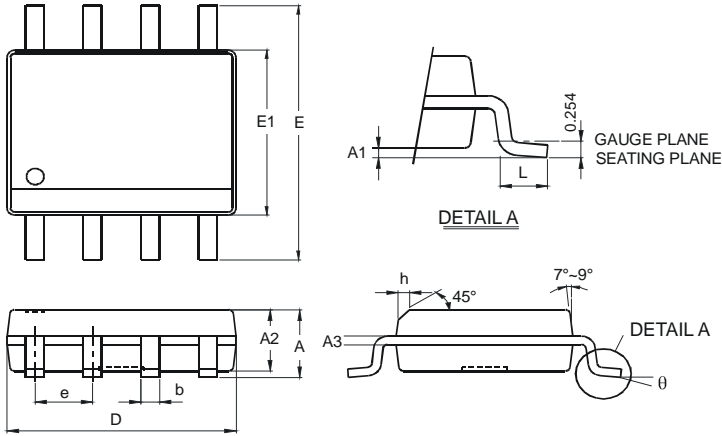

SOP-8L		
Dim	Min	Max
A	—	1.75
A1	0.08	0.25
A2	1.30	1.50
A3	0.20 Typ.	
b	0.3	0.5
D	4.80	5.30
E	5.79	6.20
E1	3.70	4.10
e	1.27 Typ.	
h	—	0.35
L	0.38	1.27
θ	0°	8°
All Dimensions in mm		

Suggested Pad Layout

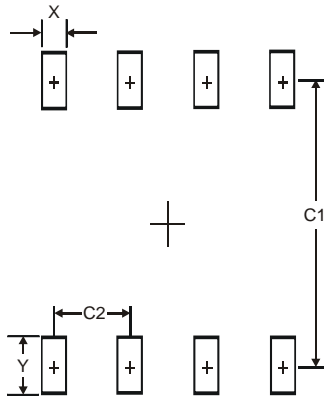

Dimensions	Value (in mm)
X	0.60
Y	1.55
C1	5.4
C2	1.27

IMPORTANT NOTICE

Diodes Incorporated and its subsidiaries reserve the right to make modifications, enhancements, improvements, corrections or other changes without further notice to any product herein. Diodes Incorporated does not assume any liability arising out of the application or use of any product described herein; neither does it convey any license under its patent rights, nor the rights of others. The user of products in such applications shall assume all risks of such use and will agree to hold Diodes Incorporated and all the companies whose products are represented on our website, harmless against all damages.

LIFE SUPPORT

Diodes Incorporated products are not authorized for use as critical components in life support devices or systems without the expressed written approval of the President of Diodes Incorporated.



SOT-23 Plastic-Encapsulate Transistors

S8050LT1 TRANSISTOR (NPN)

FEATURES

Power dissipation

P_{CM} : 0.3 W ($T_{amb}=25^{\circ}C$)

Collector current

I_{CM} : 0.5 A

Collector-base voltage

$V_{(BR)CBO}$: 40 V

Operating and storage junction temperature range

T_J, T_{stg} : $-55^{\circ}C$ to $+150^{\circ}C$

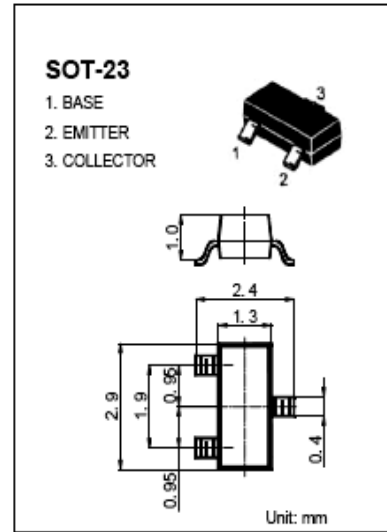

ELECTRICAL CHARACTERISTICS ($T_{amb}=25^{\circ}C$ unless otherwise specified)

Parameter	Symbol	Test conditions	MIN	TYP	MAX	UNIT
Collector-base breakdown voltage	$V_{(BR)CBO}$	$I_C=100\mu A, I_E=0$	40			V
Collector-emitter breakdown voltage	$V_{(BR)CEO}$	$I_C=1mA, I_B=0$	25			V
Emitter-base breakdown voltage	$V_{(BR)EBO}$	$I_E=100\mu A, I_C=0$	5			V
Collector cut-off current	I_{CBO}	$V_{CB}=40V, I_E=0$			0.1	μA
Collector cut-off current	I_{CEO}	$V_{CB}=20V, I_E=0$			0.1	μA
Emitter cut-off current	I_{EBO}	$V_{EB}=5V, I_C=0$			0.1	μA
DC current gain	$h_{FE(1)}$	$V_{CE}=1V, I_C=50mA$	120		350	
	$h_{FE(2)}$	$V_{CE}=1V, I_C=500mA$	50			
Collector-emitter saturation voltage	$V_{CE(sat)}$	$I_C=500mA, I_B=50mA$			0.6	V
Base-emitter saturation voltage	$V_{BE(sat)}$	$I_C=500mA, I_B=50mA$			1.2	V
Transition frequency	f_T	$V_{CE}=6V, I_C=20mA$ $f=30MHz$	150			MHz

CLASSIFICATION OF $h_{FE(1)}$

Rank	L	H
Range	120-200	200-350

S8550LT1 TRANSISTOR (PNP)

FEATURES

Power dissipation

$$P_{CM}: 0.3 \text{ W (Tamb=25}^\circ\text{C)}$$

Collector current

$$I_{CM}: -0.5 \text{ A}$$

Collector-base voltage

$$V_{(BR)CBO}: -40 \text{ V}$$

Operating and storage junction temperature range

$$T_J, T_{stg}: -55^\circ\text{C to } +150^\circ\text{C}$$

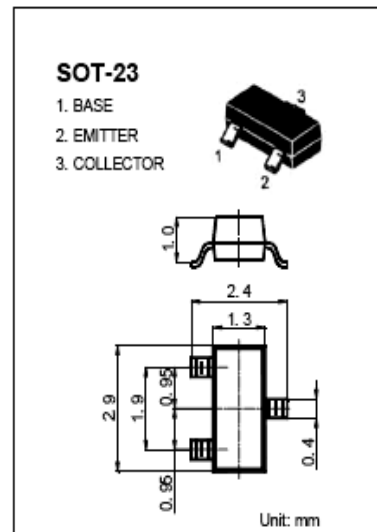

ELECTRICAL CHARACTERISTICS (Tamb=25°C unless otherwise specified)

Parameter	Symbol	Test conditions	MIN	MAX	UNIT
Collector-base breakdown voltage	$V_{(BR)CBO}$	$I_C = -100\mu\text{A}, I_E = 0$	-40		V
Collector-emitter breakdown voltage	$V_{(BR)CEO}$	$I_C = -1\text{mA}, I_B = 0$	-25		V
Emitter-base breakdown voltage	$V_{(BR)EBO}$	$I_E = -100\mu\text{A}, I_C = 0$	-5		V
Collector cut-off current	I_{CBO}	$V_{CB} = -40\text{V}, I_E = 0$		-0.1	μA
Collector cut-off current	I_{CEO}	$V_{CE} = -20\text{V}, I_B = 0$		-0.1	μA
Emitter cut-off current	I_{EBO}	$V_{EB} = -3\text{V}, I_C = 0$		-0.1	μA
DC current gain	$h_{FE(1)}$	$V_{CE} = -1\text{V}, I_C = -50\text{mA}$	120	350	
	$h_{FE(2)}$	$V_{CE} = -1\text{V}, I_C = -500\text{mA}$	50		
Collector-emitter saturation voltage	$V_{CE(sat)}$	$I_C = -500 \text{mA}, I_B = -50\text{mA}$		-0.6	V
Base-emitter saturation voltage	$V_{BE(sat)}$	$I_C = -500 \text{mA}, I_B = -50\text{mA}$		-1.2	V
Transition frequency	f_T	$V_{CE} = -6\text{V}, I_C = -20\text{mA}$ $f = 30\text{MHz}$	150		MHz

CLASSIFICATION OF $h_{FE(1)}$

Rank	L	H
Range	120-200	200-350

SS8550

2W Output Amplifier of Portable Radios in Class B Push-pull Operation.

- Complimentary to SS8050
- Collector Current: $I_C=1.5A$
- Collector Power Dissipation: $P_C=2W$ ($T_C=25^\circ C$)



TO-92
1. Emitter 2. Base 3. Collector

PNP Epitaxial Silicon Transistor

Absolute Maximum Ratings $T_a=25^\circ C$ unless otherwise noted

Symbol	Parameter	Ratings	Units
V_{CBO}	Collector-Base Voltage	-40	V
V_{CEO}	Collector-Emitter Voltage	-25	V
V_{EBO}	Emitter-Base Voltage	-6	V
I_C	Collector Current	-1.5	A
P_C	Collector Power Dissipation	1	W
T_J	Junction Temperature	150	$^\circ C$
T_{STG}	Storage Temperature	-65 ~ 150	$^\circ C$

Electrical Characteristics $T_a=25^\circ C$ unless otherwise noted

Symbol	Parameter	Test Condition	Min.	Typ.	Max.	Units
BV_{CBO}	Collector-Base Breakdown Voltage	$I_C = -100\mu A, I_E = 0$	-40			V
BV_{CEO}	Collector-Emitter Breakdown Voltage	$I_C = -2mA, I_B = 0$	-25			V
BV_{EBO}	Emitter-Base Breakdown Voltage	$I_E = -100\mu A, I_C = 0$	-6			V
I_{CBO}	Collector Cut-off Current	$V_{CB} = -35V, I_E = 0$			-100	nA
I_{EBO}	Emitter Cut-off Current	$V_{EB} = -6V, I_C = 0$			-100	nA
h_{FE1}	DC Current Gain	$V_{CE} = -1V, I_C = -5mA$	45	170		
h_{FE2}		$V_{CE} = -1V, I_C = -100mA$	85	160	300	
h_{FE3}		$V_{CE} = -1V, I_C = -800mA$	40	80		
$V_{CE(sat)}$	Collector-Emitter Saturation Voltage	$I_C = -800mA, I_B = -80mA$		-0.28	-0.5	V
$V_{BE(sat)}$	Base-Emitter Saturation Voltage	$I_C = -800mA, I_B = -80mA$		-0.98	-1.2	V
$V_{BE(on)}$	Base-Emitter on Voltage	$V_{CE} = -1V, I_C = -10mA$		-0.66	-1.0	V
C_{ob}	Output Capacitance	$V_{CB} = -10V, I_E = 0$ $f = 1MHz$		15		pF
f_T	Current Gain Bandwidth Product	$V_{CE} = -10V, I_C = -50mA$	100	200		MHz

h_{FE} Classification

Classification	B	C	D
h_{FE2}	85 ~ 160	120 ~ 200	160 ~ 300

CD MAIN PCB 1/2

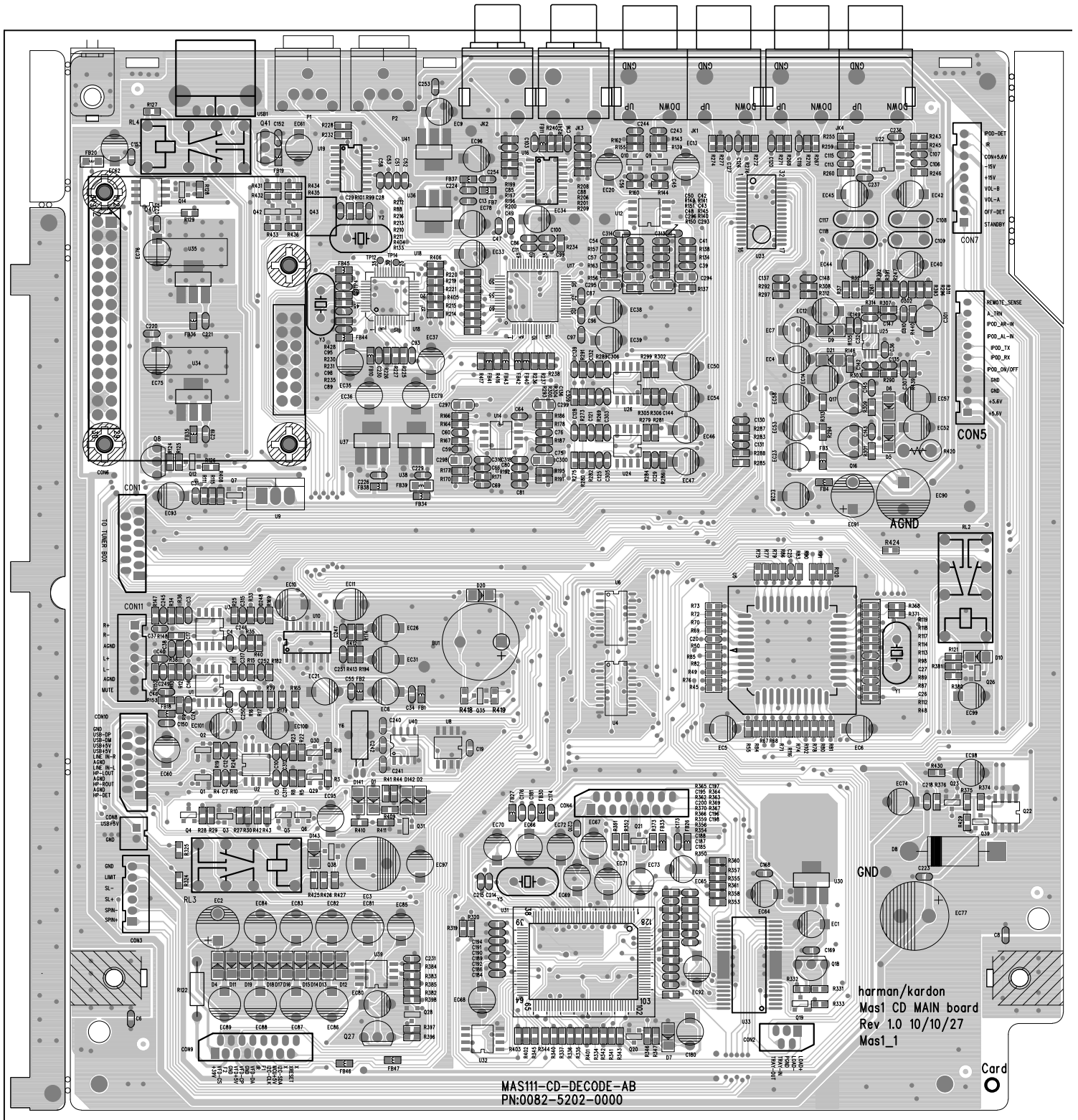

harman/kardon
Mas1 CD MAIN board
Rev 1.0 10/10/27
Mas1_1

MAS111-CD-DECODE-AB
PN:0082-5202-0000

Card

CD MAIN PCB 2/2

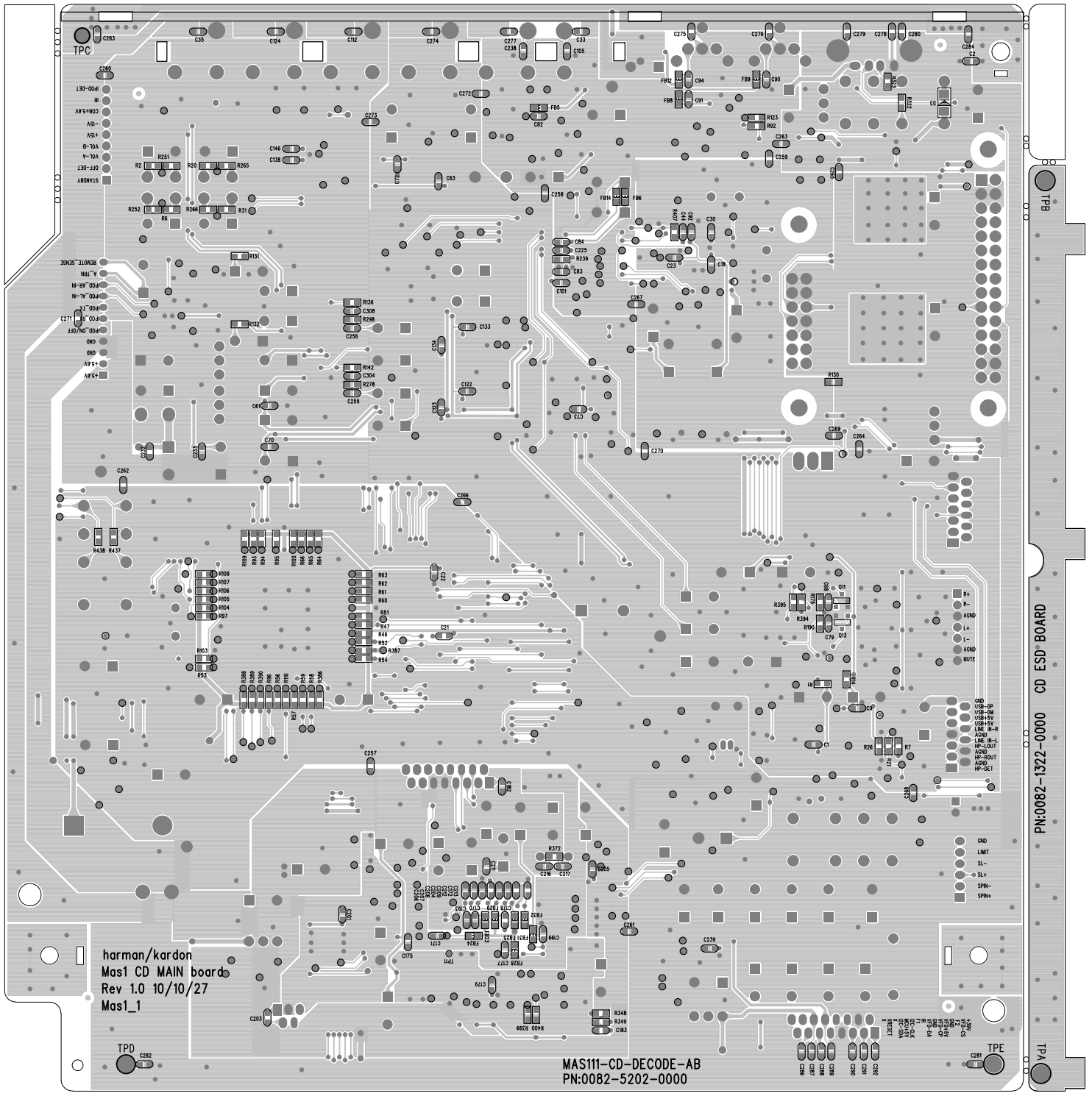

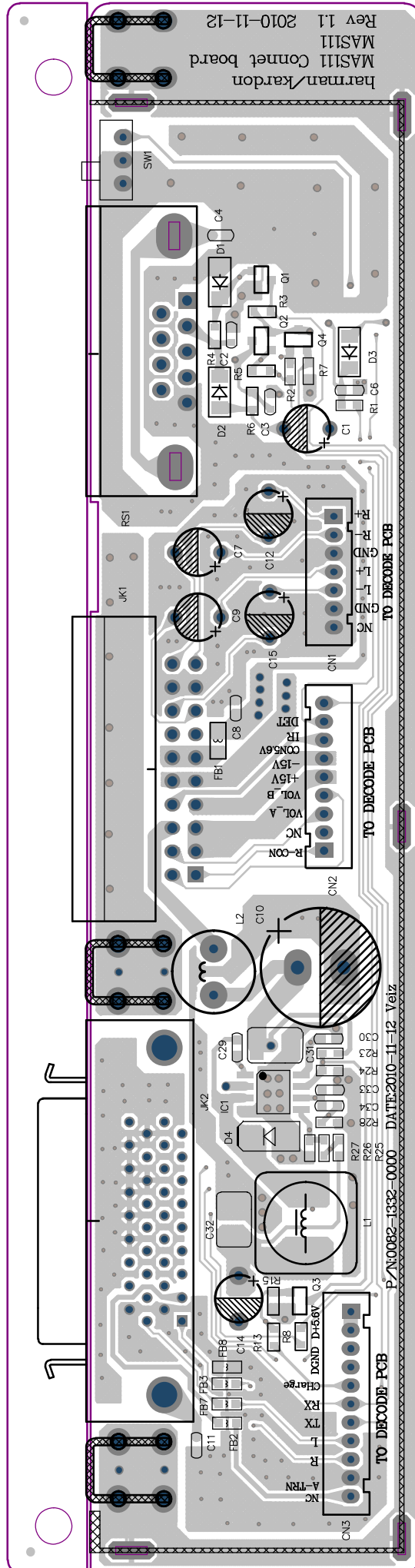

RS232 PCB 2/2

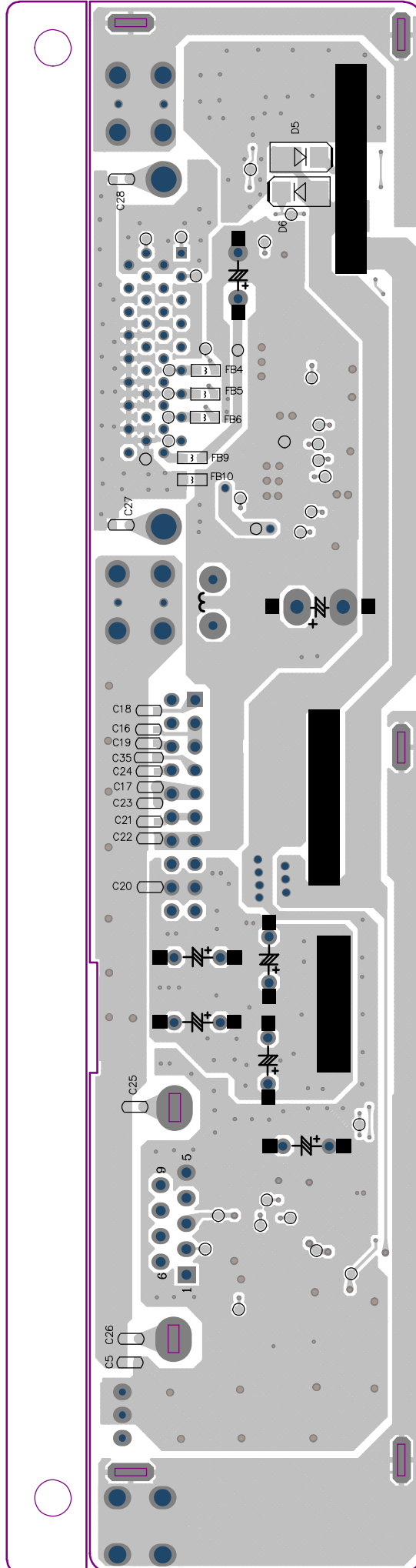

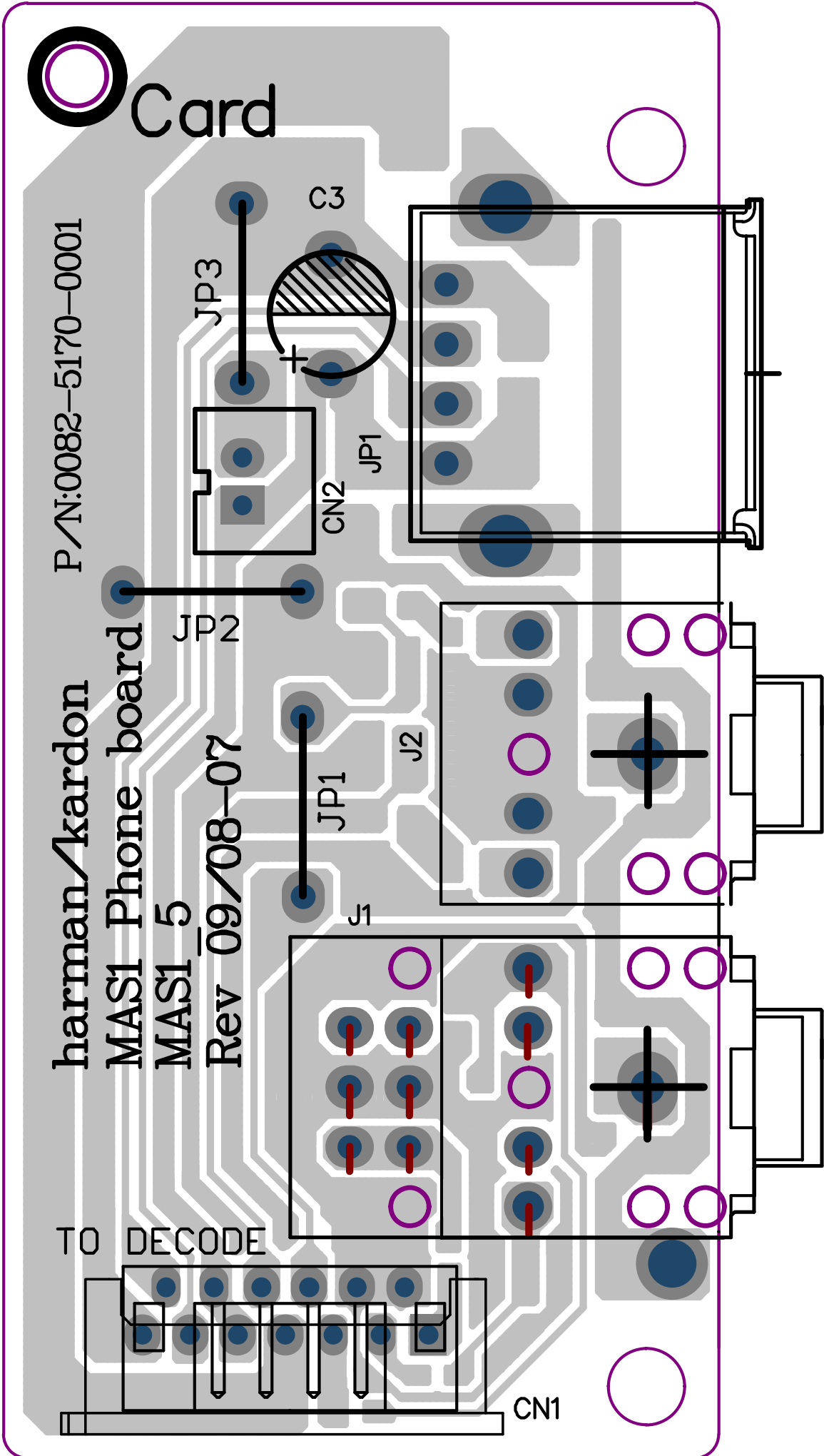

Card

P/N:0082-5170-0001

harman/kardon

MAS1 Phone board

MAS1 5

Rev 09/08-07

PHONE PCB 2/2

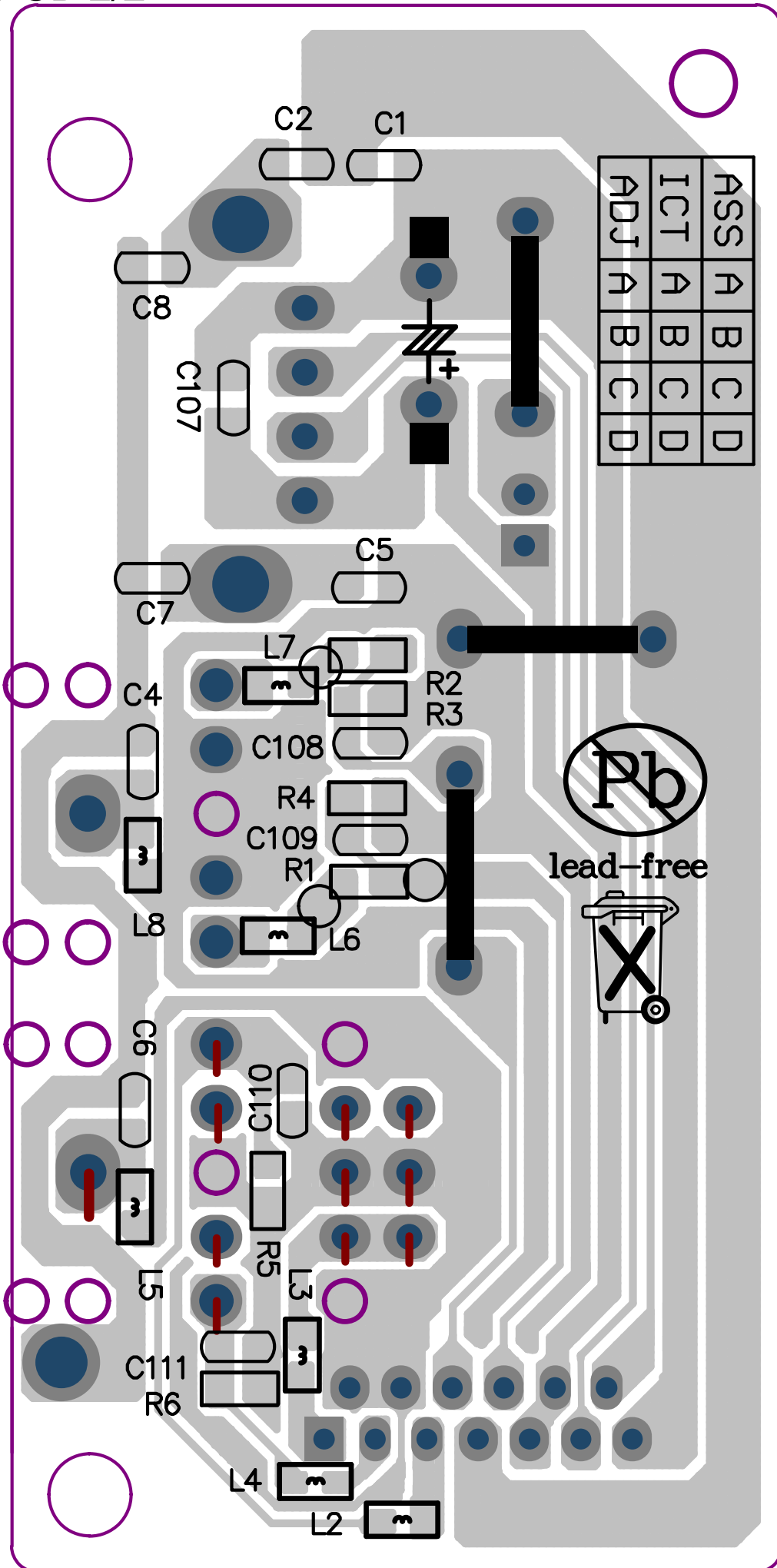

DISPLAY PCB(1/2)

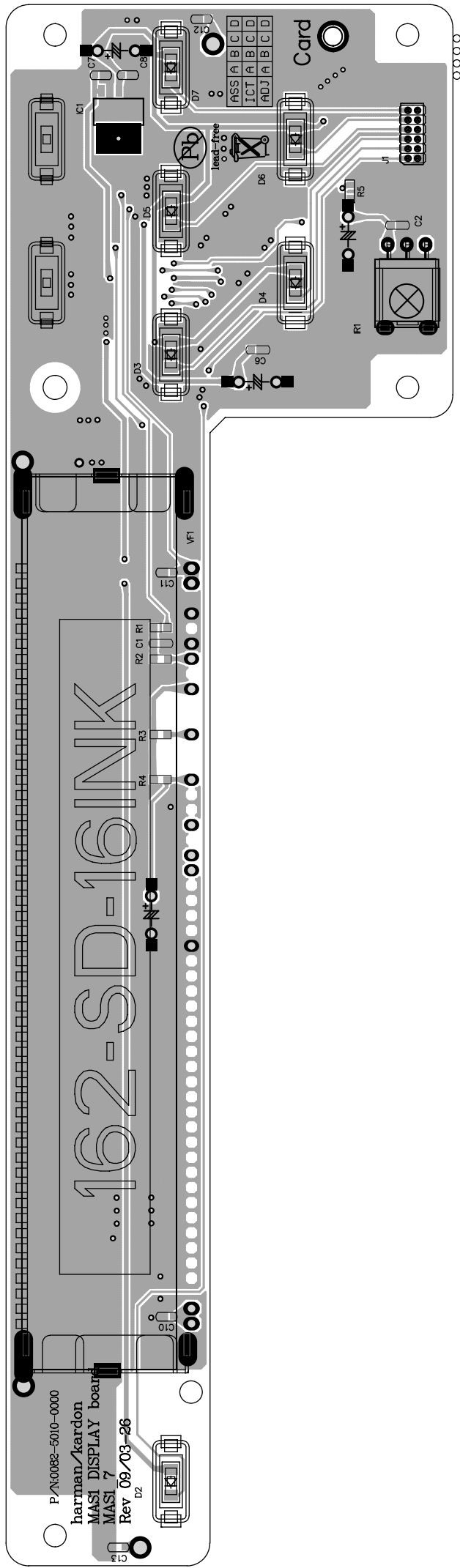

DISPLAY PCB(2/2)

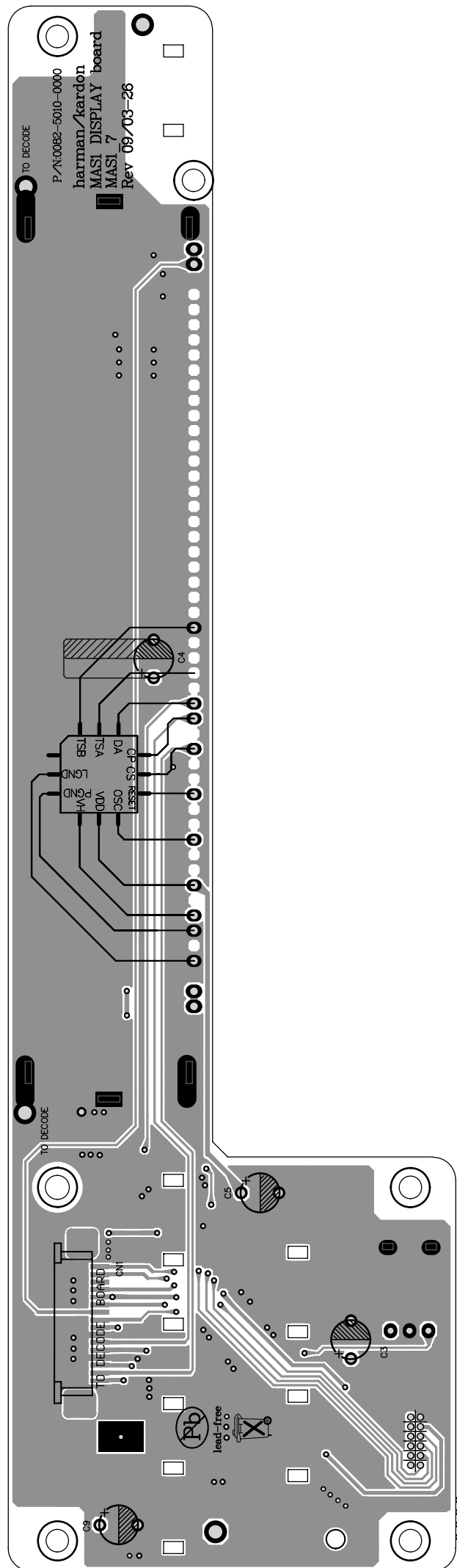

TOUCH PCB(1/2)

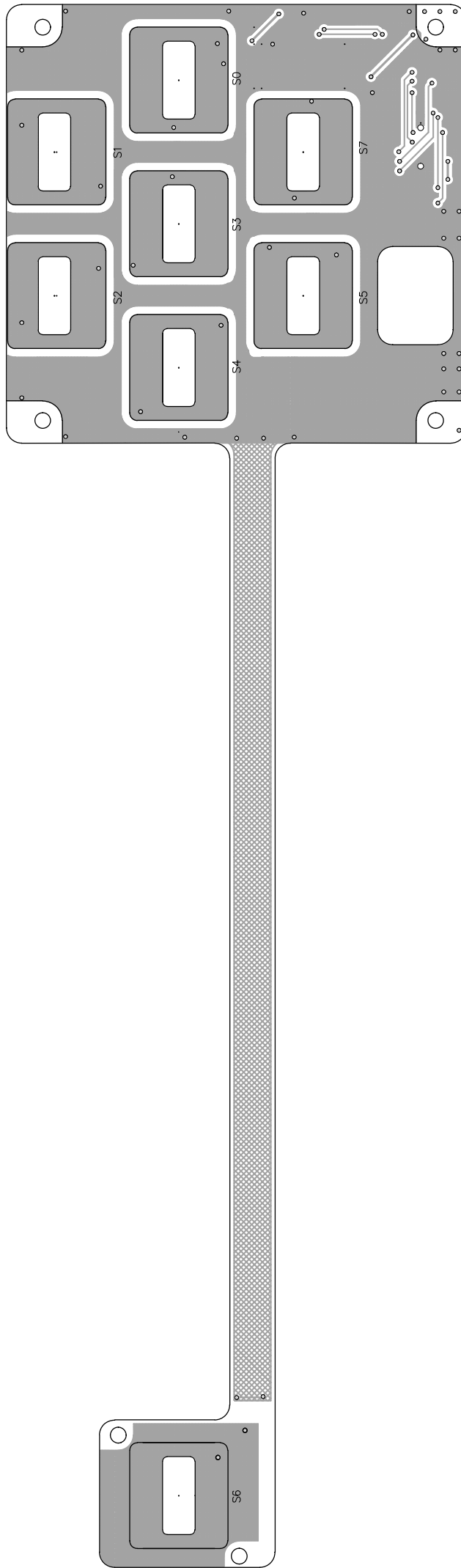

TOUCH PCB(2/2)

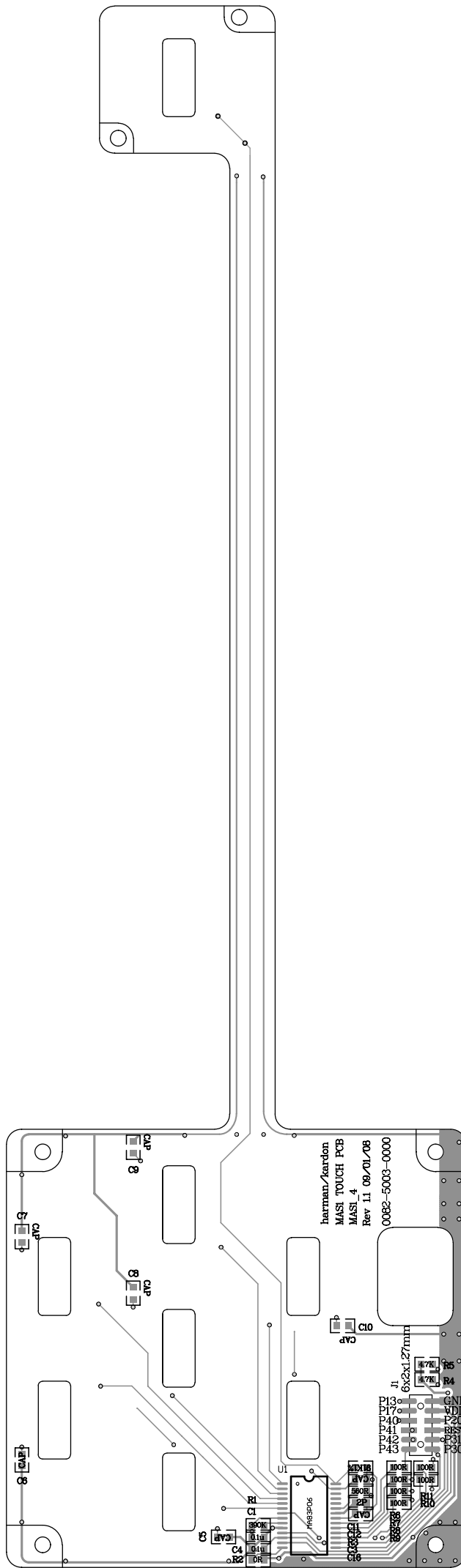

CD MAIN SCH 1/7

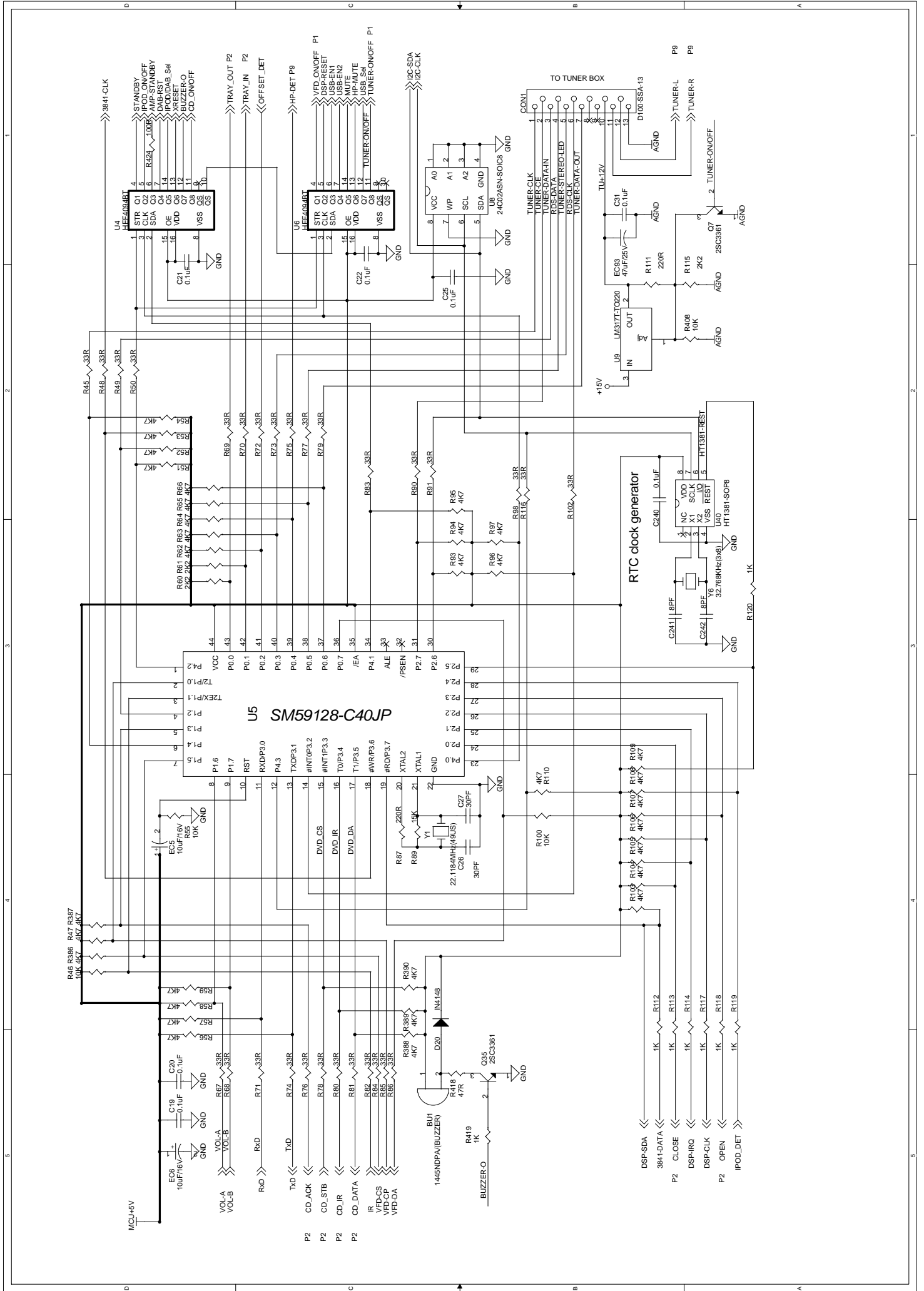

CD MAIN SCH 2/7

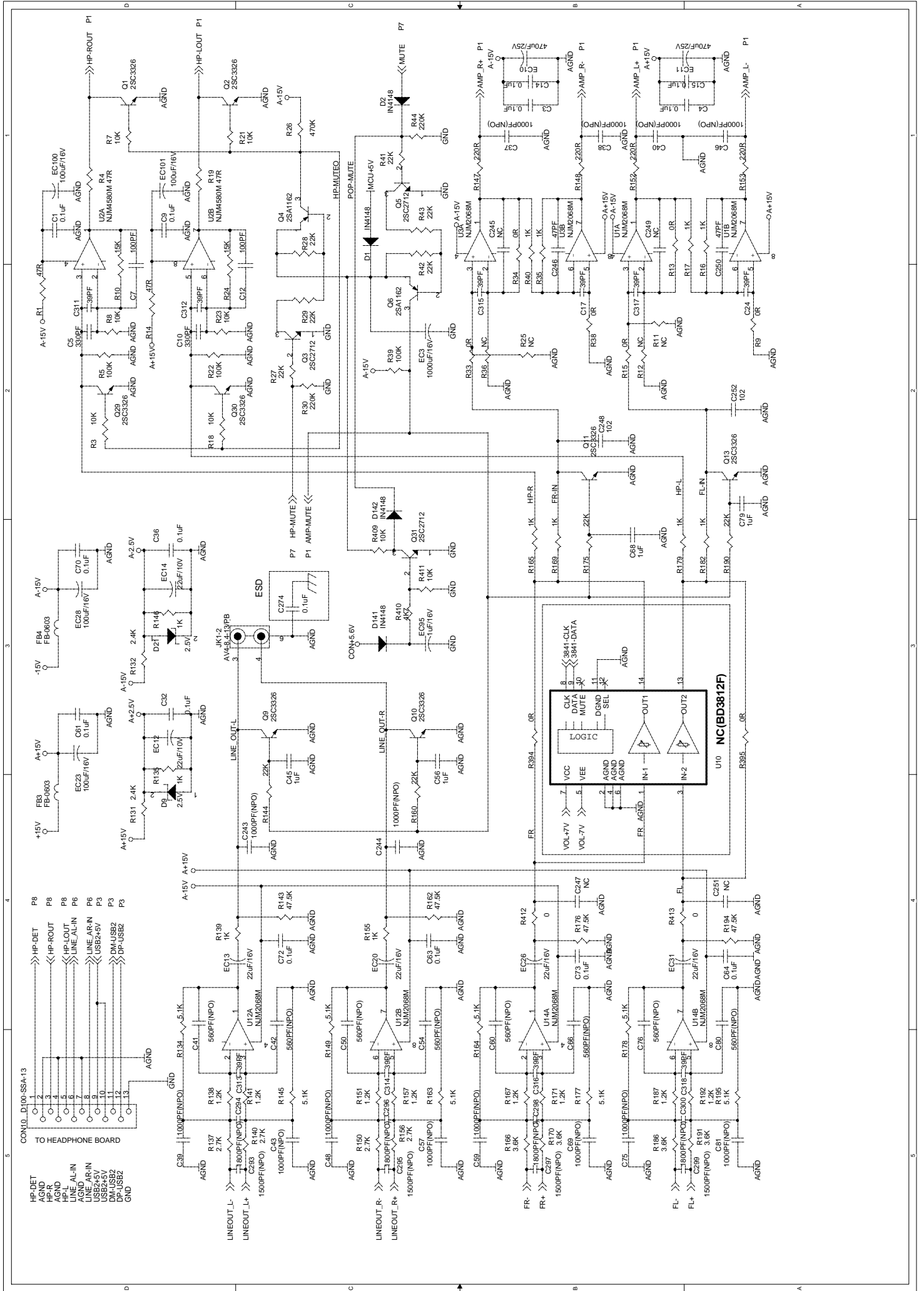

CD MAIN SCH 3/7

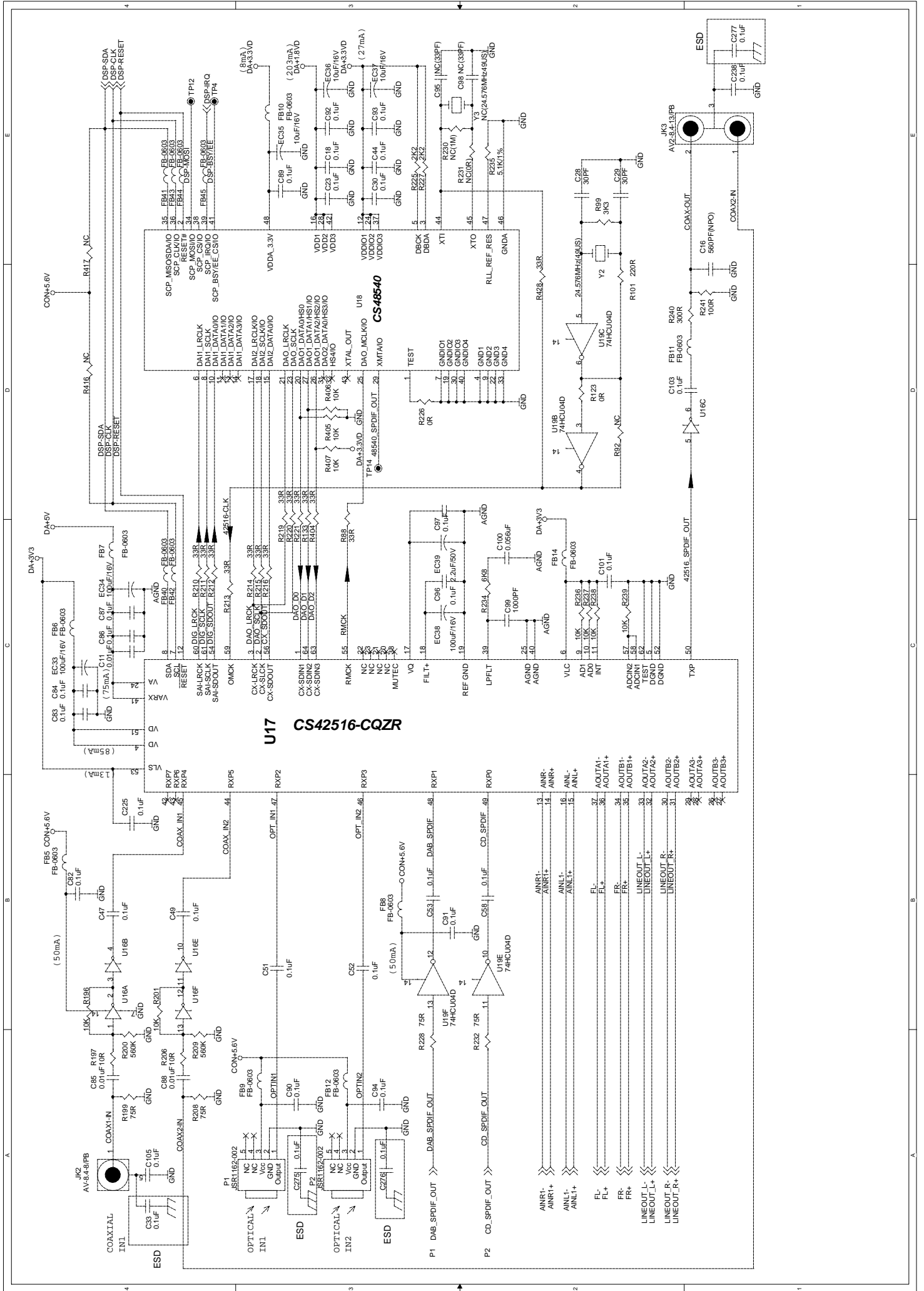

CD MAIN SCH 4/7

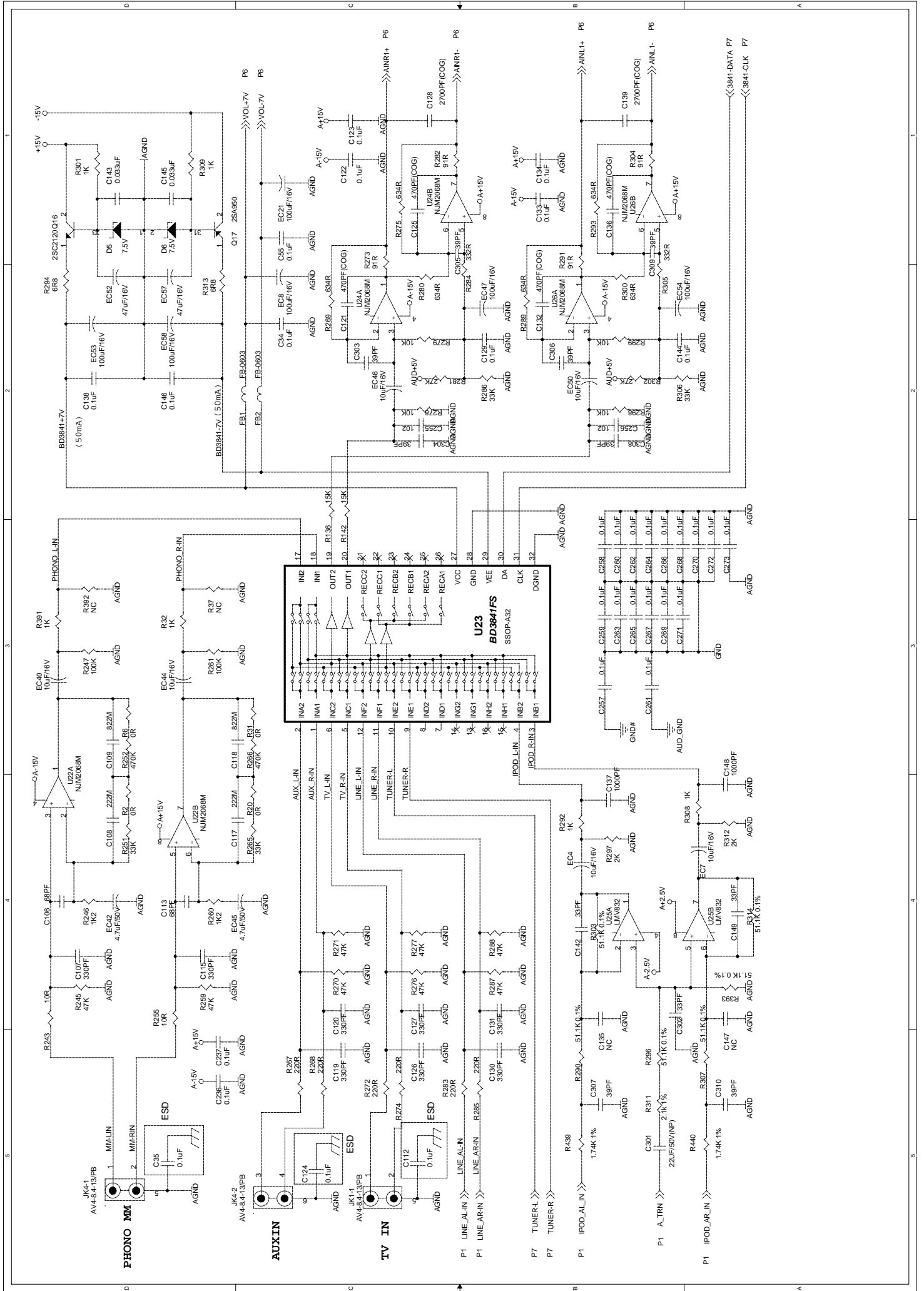

CD MAIN SCH 5/7

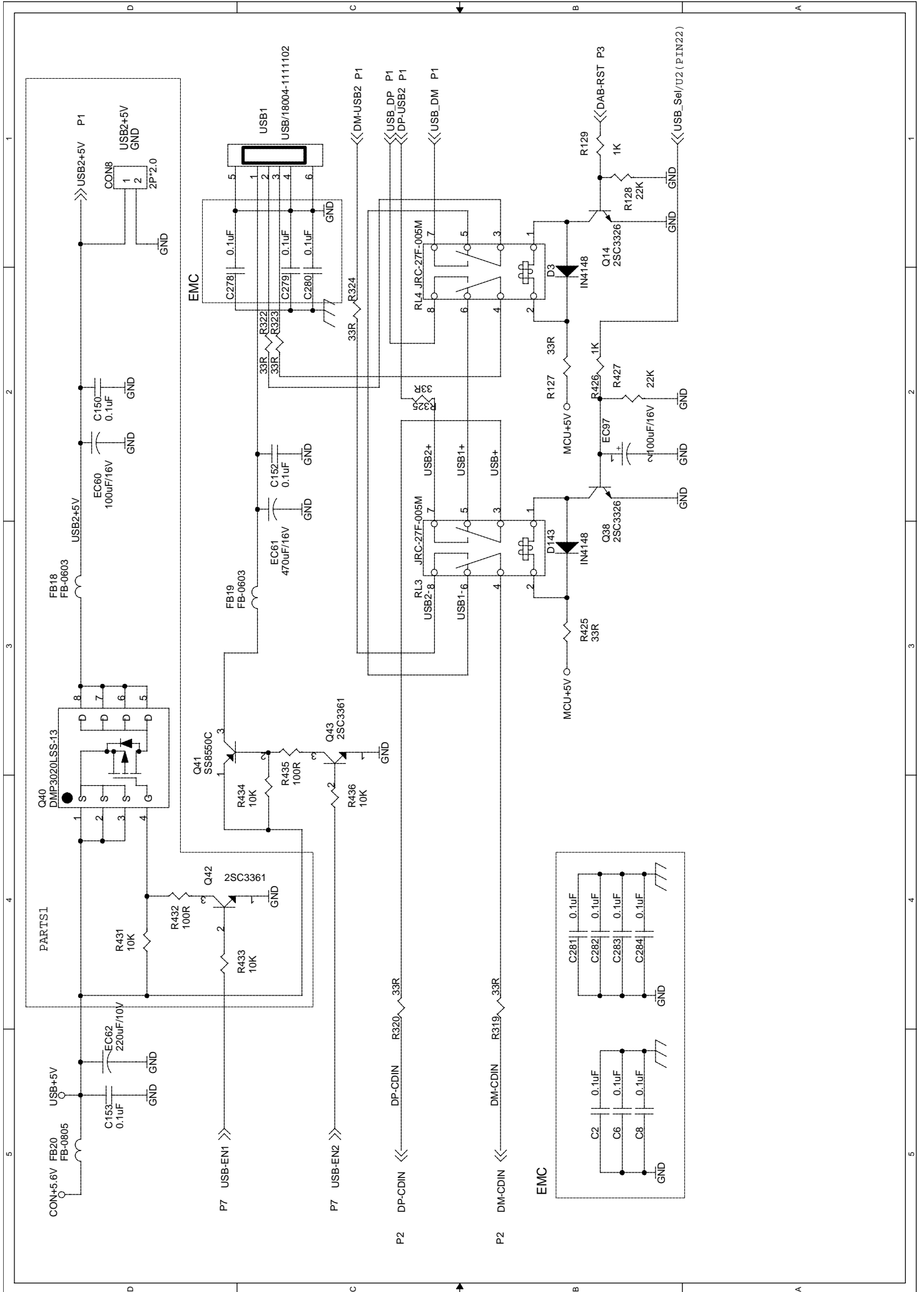

CD MAIN SCH 6/7

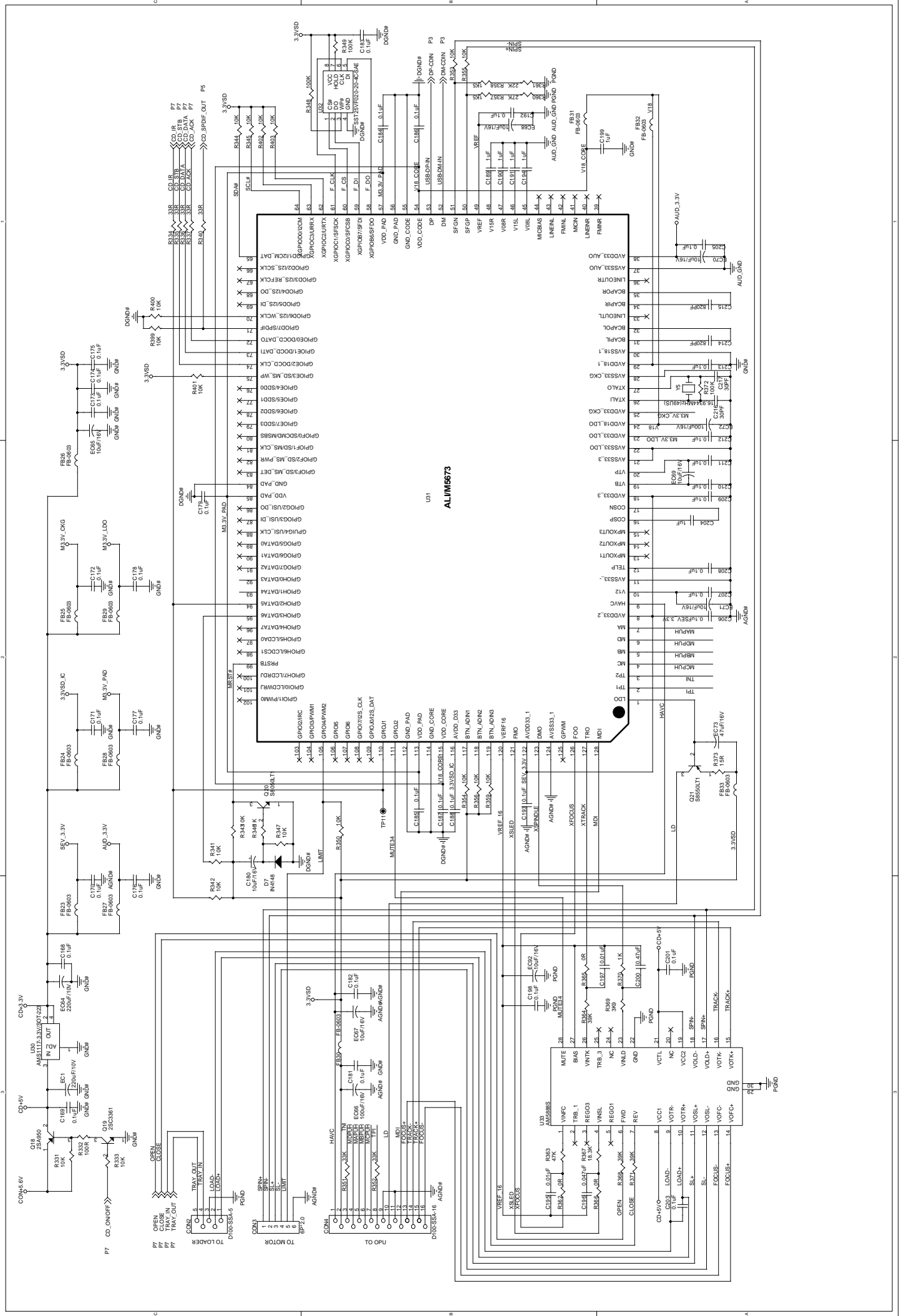

CD MAIN SCH 7/7

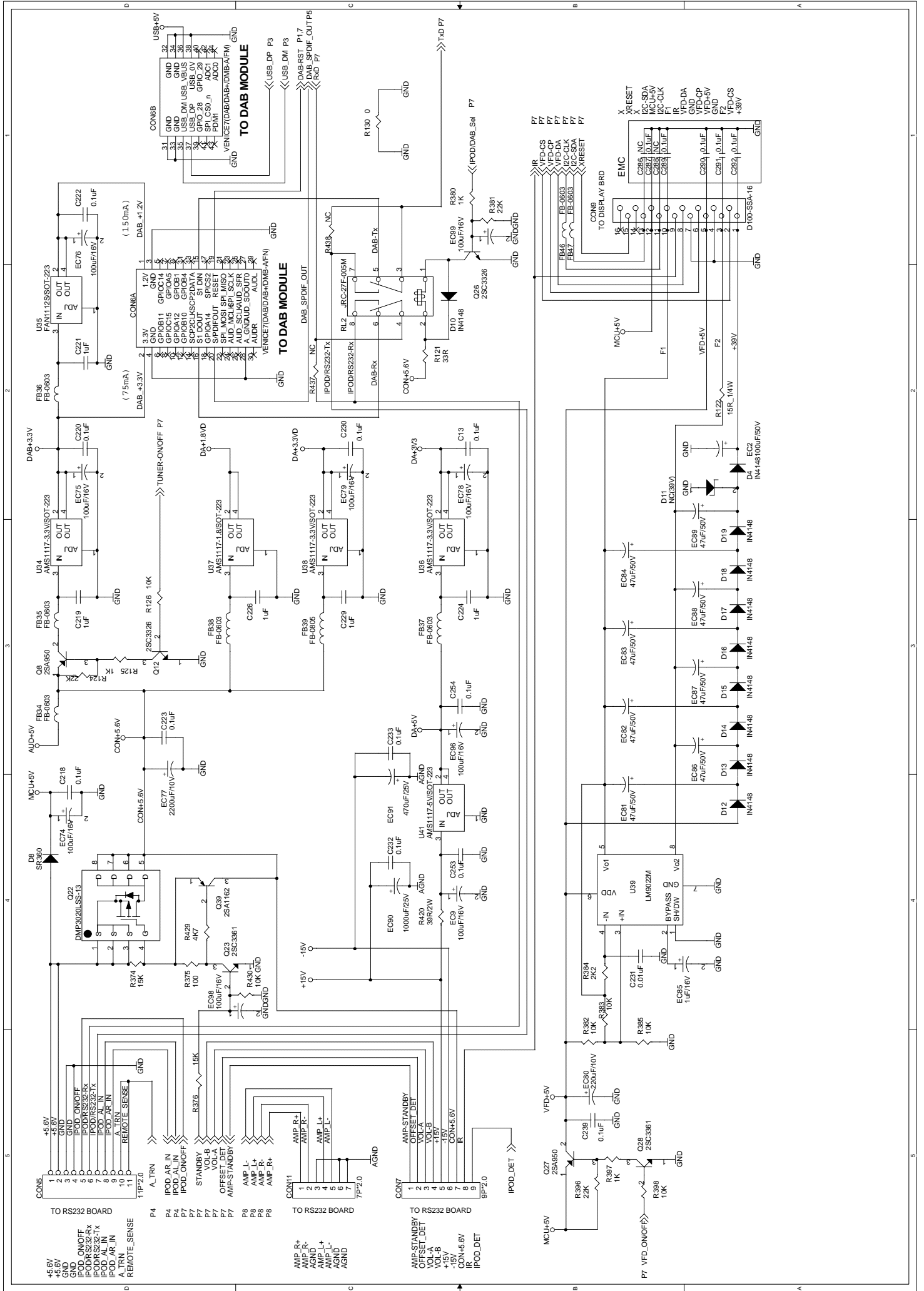

RS232 SCH

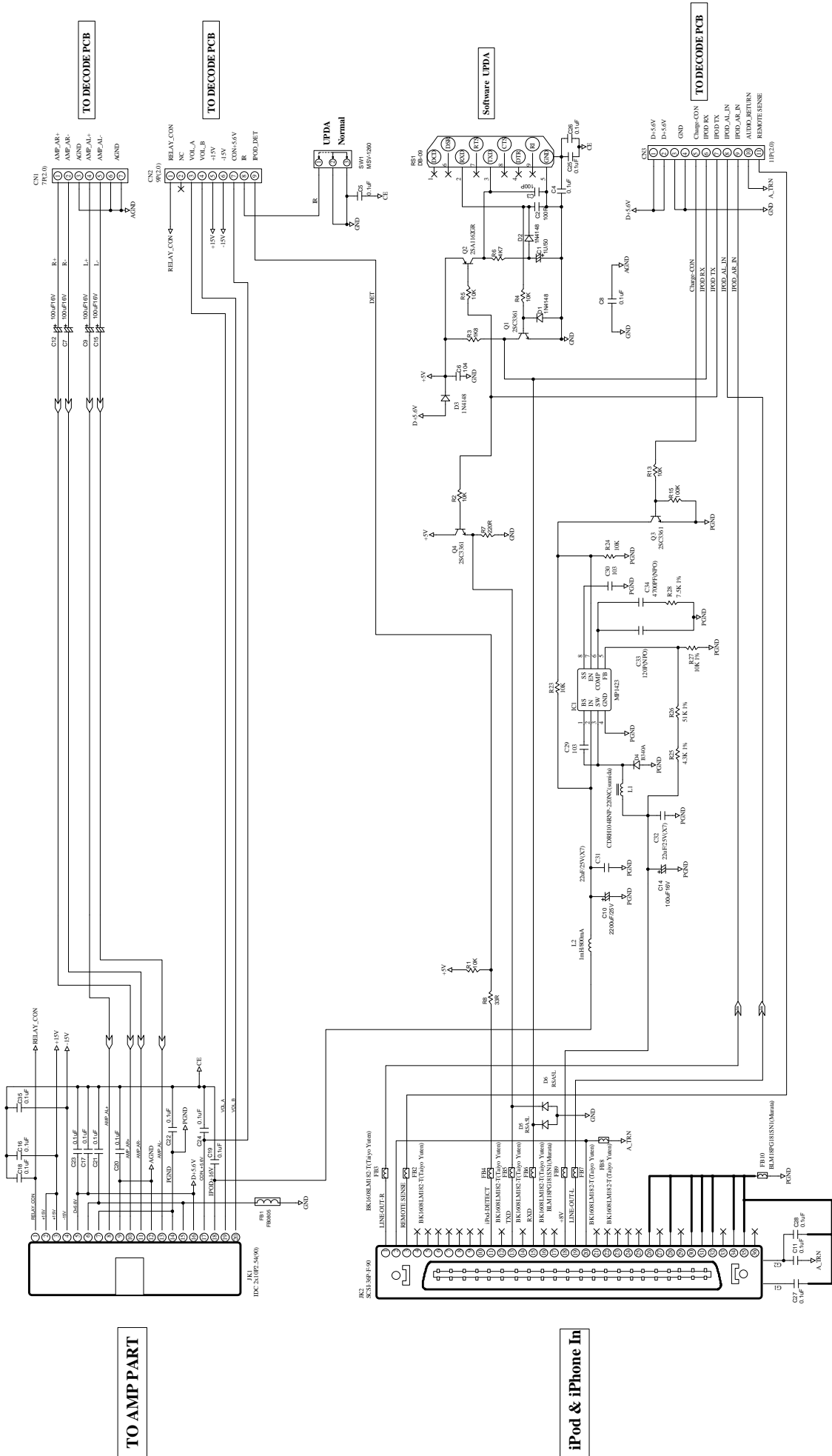

PHONE SCH

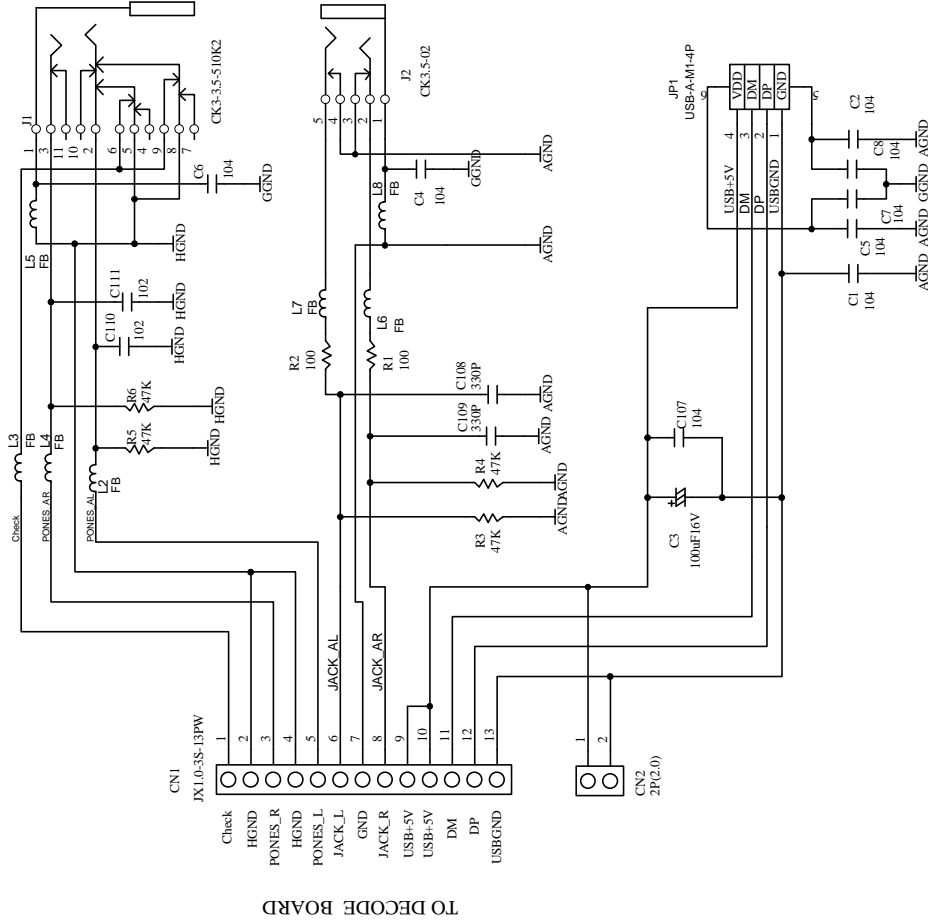

DISPLAY SCH

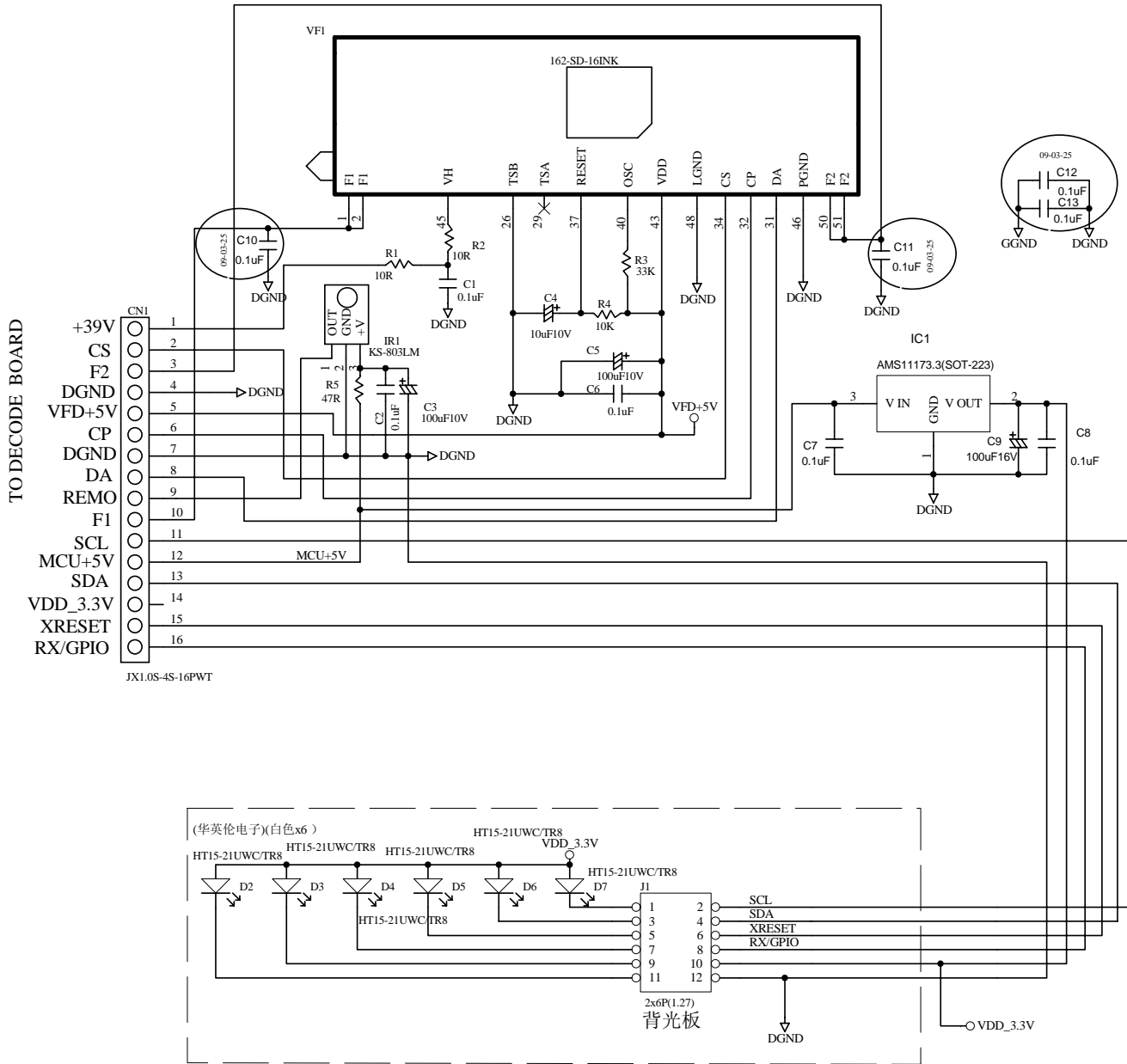

TOUCH SCH

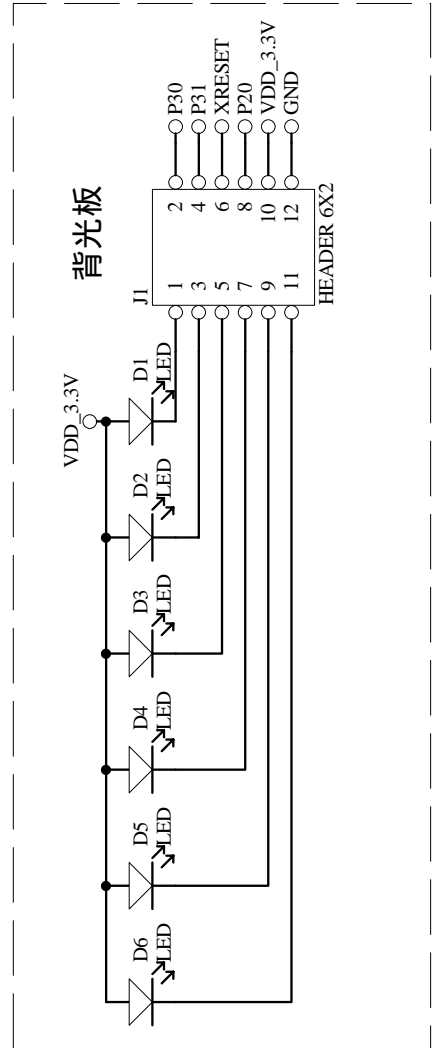
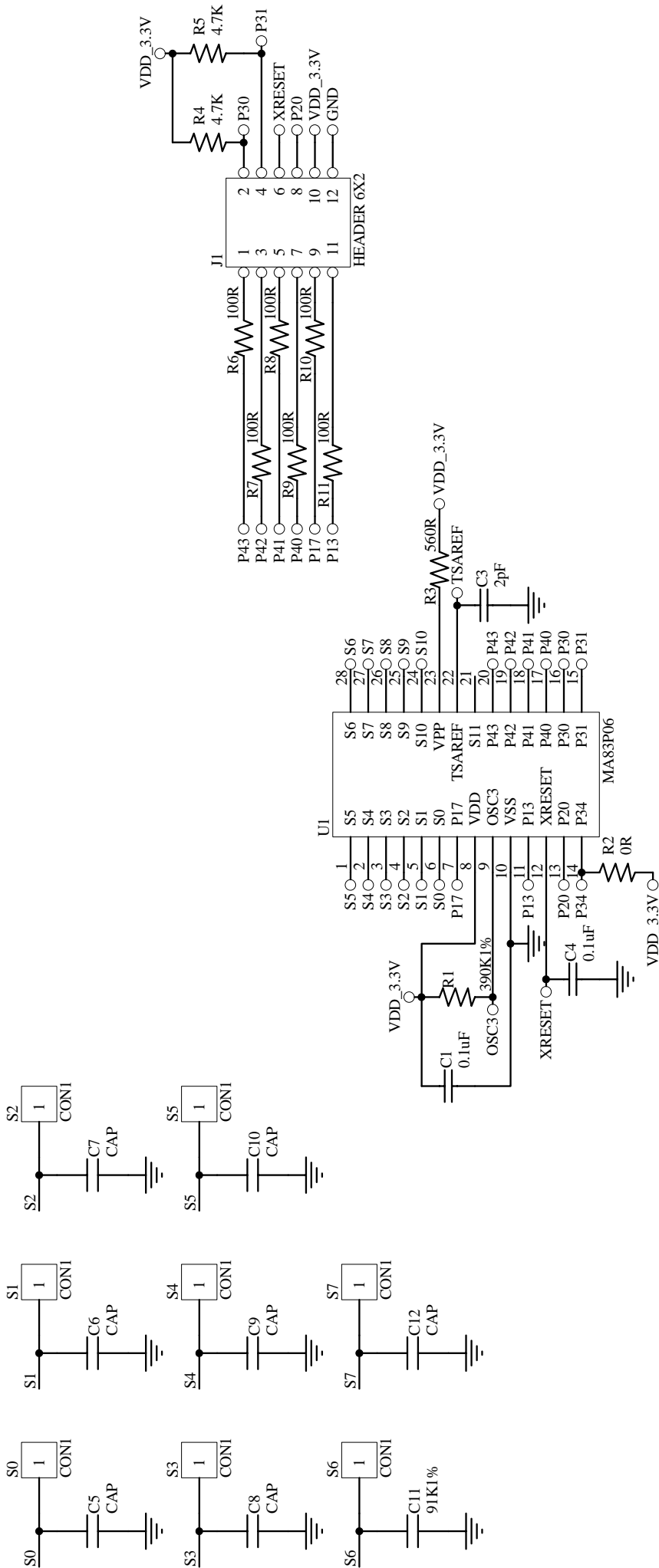

Sensor	Led	Function
S0		无键按下
S1		▶▶
S2		
S3		KK
S4		▶/
S5		□
S6		U
S7		△

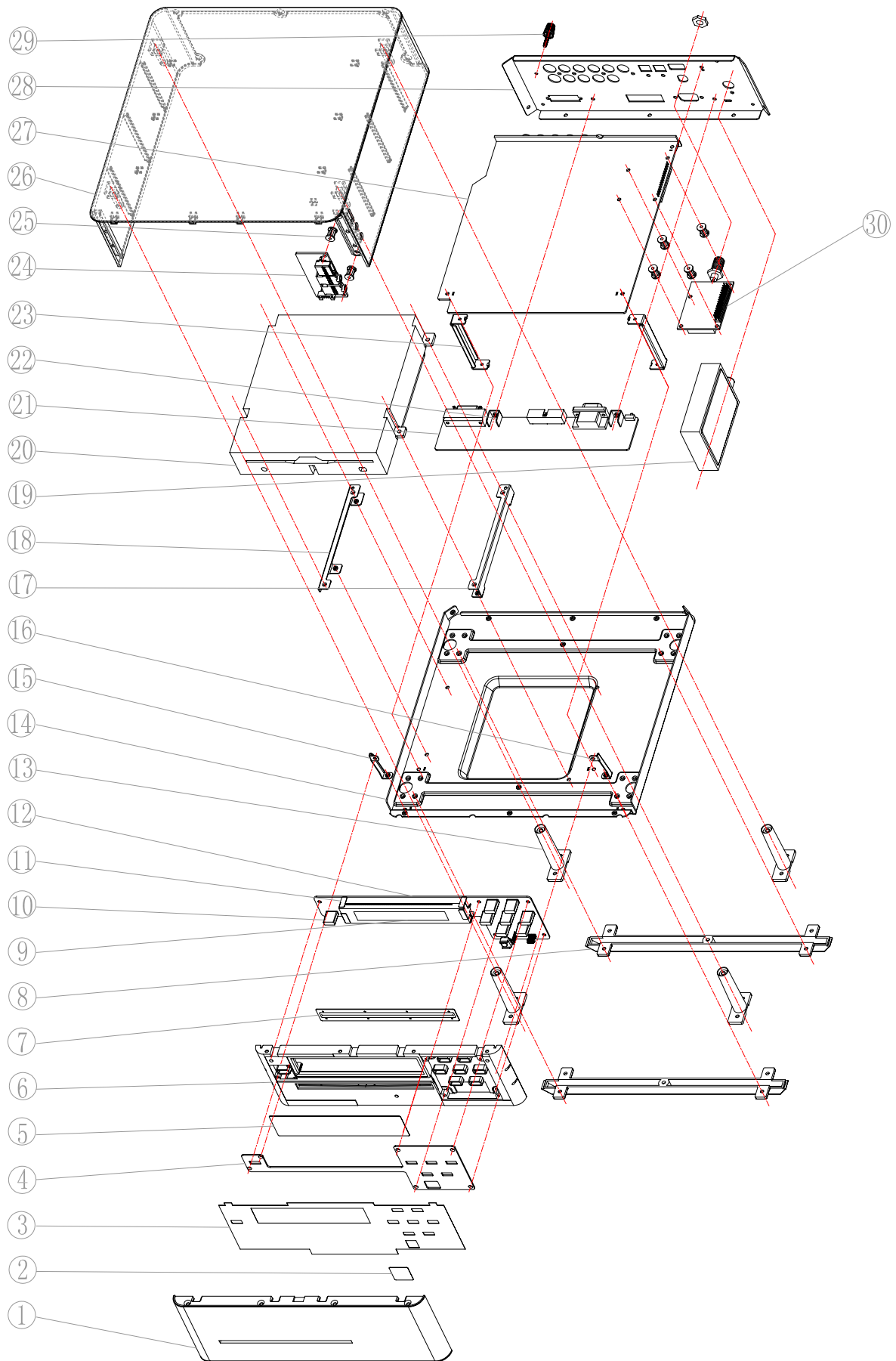

MAS CD Explode List

NO	PART.NO	DESCRIPTION	QTY
1	7450 5010 0000	DISPLAY LENS	1
2	7750 5040 0000	BLUE PVC SHEET	1
3	7750 501D 0000	FRONT PANEL PVC SHEET	1
4	0082 5003 0000	TOUCH PCB	1
5	7450 503A 0000	FILTER LENS	1
6	7550 501A 0000	SUB PANEL	1
7	7950 503C 0000	DUSTPROOF CLOTH	1
8	7950 5020 0000	FOOT	2
9	1521 6216 0101	162-SD-16INK	1
10	7450 502A 0000	LIGHTGUIDE	6
11	5337 5010 0000	DISPLAY BRACKET	2
12	0082 5010 0000	DISPLAY PCB	1
13	7550 502A 0000	PLASTIC POST	4
14	6250 501B 0011	BUTTOM COVER	1
15	5350 5010 0000	SUB PANEL LEFT BRACKET	1
16	5350 5020 0000	SUB PANEL RIGHT BRACKET	1
17	5350 503A 0000	LOADER LEFT BRACKET	1
18	5350 504A 0000	LOADER RIGHT BRACKET	1
*19	0082 3270 0000	TUNER PCB(MAS101 MAS102 MAS111)	1
*19	0082 3271 0000	TUNER PCB(SAS101)	1
20	7500 0070 0000	DLM1D07 BRACKET	1
21	0082 1332 0000	RS232 PCB	1
22	5331 1080 0060	U FORM PCB BRACKET (A)	2
23	5349 105A 0000	DECODER BRACKET	2
24	0082 5170 0001	PHONE PC	1
25	8730 1000 0000	KDDT-382	4
26	7950 5010 0000	TOP COVER	1
27	0082 5202 0000	CD MAIN PCB	1
*28	6350 5030 001 1	BACK COVER(MAS111)	1
*28	6350 5040 001 1	BACK COVER(MAS101 MAS102 SAS101)	1
29	5017 3012 0000	GROUNDING SCREW S-056B M3x12	1
*30	9520 2500 0001	DAB MODULE(MAS111)	1

Qty	Part Type	Ref. Designator	Part Number
	CD Decoder .Bom P/N: 0082-5202-0000		
1	SST25VF020-20-4C-SAE (SST) 2MBIT SPI SERIAL FLASH	U32	1025 0200 7387
2	74HCU04D (PHILIPS) HEX INVERTER	U19,U16	1049 1004 1200
2	HEF4094BT (PHILIPS) 8 STAGE SHIFT AND STORE REGISTER	U4,U6	1004 0940 4912
1	AMS1117-1.8 (AMS) LOW DROPOUT VOLTAGE REGULATOR	U37	1011 7180 0156
4	AMS1117-3.3V (AMS) LOW DROPOUT VOLTAGE REGULATOR	U30,U34,U36,U38	1011 7330 0128
1	AMS1117-5V (AMS) LOW DROPOUT VOLTAGE REGULATOR	U41	1011 7500 0129
1	AM5888S (AMTEK) MOTOR DRIVER	U33	1005 8880 9753
1	BD3841FS (ROHM) 9CH FUNCTION SWITCH	U23	1003 8410 5122
1	CS42516-CQZR (CIRRUS LOGIC) 6CH CODEC WITH S/PDIF RECEIVER	U17	1042 5160 0934
1	CS48540 (CIRRUS LOGIC) DSP	U18	1048 5400 0934
1	M5673 (ALI) CD CONTROLLER	U31	1005 6732 2034
7	NJM2068M (JRC) DUAL OP AMP	U1,U3,U12,U14,U22,U24, U26	1002 0680 3113
1	NJM4580M (JRC) DUAL OP AMP	U2	1004 5800 3113
1	SM59128-C40JP (SYNCMOS) FLASH MCU	U5	1059 1280 9125
1	24C02ASN-SOIC8 (ATMEL) SERIAL EEPROM	U8	1002 4020 0601
1	LM317T-TO220 (NATIONAL) ADJUSTABLE REGULATOR	U9	1043 0317 0861
1	LMV832 (NATIONAL) EMI HARDENED OPERATIONAL AMPLIFIER	U25	1000 8320 4313
1	LM9022M (NATIONAL) VFD FILAMENT DRIVER	U39	1009 0220 4313
1	FAN1112S (FAIRCHILD) LOW DROPOUT REGULATOR	U35	1000 0050 5133
1	HT1381-SOP8 (HOLTEK) SERIAL TIMEKEEPER CHIP	U40	1001 3810 8113
4	2SA950 - TRANSISTOR	Q8,Q17,Q18,Q27	1110 9500 0162
3	2SA1162 - TRANSISTOR	Q4,Q6,Q39	1111 1620 7100
1	2SC2120 - TRANSISTOR	Q16	1130 1200 0162
3	2SC2712 - TRANSISTOR	Q3,Q5,Q31	1132 7120 7100
12	2SC3326 - TRANSISTOR	Q1,Q2,Q9,Q10,Q11,Q12,Q13,Q14,Q26,Q29,	1133 3260 1000
		Q30,Q38	
7	2SC3361 - TRANSISTOR	Q7,Q19,Q23,Q28,Q35,Q42,Q43	1133 3610 6100
1	S8050LT1 - TRANSISTOR	Q20	1108 0502 1828
1	S8550LT1 - TRANSISTOR	Q21	1108 5502 1828
1	SS8550C - TRANSISTOR	Q41	1108 5500 1988
2	DMP3020LSS-13 - TRANSISTOR	Q40,Q22	1153 0200 1900
1	SR360 - DIODE , RECT	D8	1360 7000 3602
2	2.5V - DIODE ZENER	D9,D21	1300 2500 0001
2	7.5V - DIODE ZENER	D6,D5	1300 7500 0001
18	IN4148 - DIODE	D1,D2,D3,D4,D7,D10,D12,D13,D14,D15,D16,	1320 1004 1480
		D17,D18,D19,D20,D141,D142,D143	
1	16.9344MHz(49US) - CRYSTAL	Y5	2705 1693 4010
1	22.1184MHz(49US) - CRYSTAL	Y1	2705 2211 8429
1	24.576MHz(49US) - CRYSTAL	Y2	2705 2457 6020
1	32.768KHz(3x8) - CRYSTAL	Y6	2705 3276 8029
39	FB-0603 FERRITE , CHIP BEAD	FB1,FB2,FB3,FB4,FB5,FB6,FB7,FB8,FB9,FB10,	1871 6081 8201
		FB11,FB12,FB14,FB18,FB19,FB23,FB24,FB25,	
		FB26,FB27,FB28,FB29,FB30,FB31,FB32,FB33,	
		FB34,FB35,FB36,FB37,FB38,FB40,FB41,FB42,	
		FB43,FB44,FB45,FB46,FB47	
2	FB-0805 FERRITE , CHIP BEAD	FB20,FB39	1852 0120 9100

1	1445NDPA/(BUZZER)	BU1	7982 5010 0101
1	VENICE7(DAB/DAB+A/FM) DAB MODULE	CON6	9500-0000-0004
3	JRC-27F-005M- RELAY	RL2,RL3,RL4	4712 0000 2700
1	D100-SSA-5 - CONNECTOR	CON2	3104 0105 0050
2	D100-SSA-13 - CONNECTOR	CON1,CON10	3104 0113 0050
2	D100-SSA-16 - CONNECTOR	CON4,CON9	3104 0116 0050
1	2P*2.0 - CONNECTOR	CON8	3100 4020 0200
1	6P*2.0 - CONNECTOR	CON3	3100 4060 0200
1	7P*2.0 - CONNECTOR	CON11	3100 4070 0200
1	9P*2.0 - CONNECTOR	CON7	3100 4090 0250
1	10P*2.0 - CONNECTOR	CON5	3100 4100 0200
1	AV-8.4-8/PB - JACK	JK2	2910 1032 3383
1	AV2-8.4-13/PB - JACK	JK3	2910 2051 0310
2	AV4-8.4-13/PB - JACK	JK1,JK4	2910 4002 0310
2	JSR1162-002 - MODULE , OPTICAL(RX)	P2,P1	1341 1621 0100
1	USB/18004-1111102 - USB JACK	USB1	2800 1018 0040
1	15R_1/4W - RES, CARBON	R122	2401 0321 5011
6	51.1K 0.1% - RES, CHIP	R290,R296,R303,R307,R314,R393	2402 1265 1103
2	1.74K 1% - RES, CHIP	R439,R440	2401 1211 7203
1	2.1k 1% - RES, CHIP	R311	2401 1212 1203
1	5.1K/1% - RES, CHIP	R235	2401 1215 1203
17	0R - RES, CHIP	R2,R6,R9,R13,R15,R20,R31,R33,R34,R38,R123, R226,R362,R365,R366,R394,R395R130,R412,R413	2401 1220 0003
2	6R8 - RES, CHIP	R294,R313	2401 1226 8903
4	10R - RES, CHIP	R197,R206,R243,R255	2401 1221 0003
1	15R - RES, CHIP	R373	2401 1221 5003
57	33R - RES, CHIP	R45,R48,R49,R50,R67,R68,R69,R70,R71,R72, R73,R74,R75,R76,R77,R78,R79,R80,R81,R82, R83,R84,R85,R86,R88,R90,R91,R98,R102,R116, R121,R127,R133,R210,R211,R212,R213,R214, R215,R216,R219,R220,R221,R319,R320,R322, R323,R324,R325,R334,R335,R336,R337,R340, R404,R425,R428	2401 1223 3003
5	47R - RES, CHIP	R1,R4,R14,R19,R418	2401 1224 7003
4	75R - RES, CHIP	R199,R208,R228,R232	2401 1275 0203
4	91R - RES, CHIP	R273,R282,R291,R304	2401 1291 0203
6	100R - RES, CHIP	R241,R332,R375,R424,R432,R435	2401 1221 0103
13	220R - RES, CHIP	R87,R101,R111,R147,R148,R152,R153,R267, R268,R272,R274,R283,R285	2401 1222 2103
1	300R - RES, CHIP	R240	2401 1223 0103
2	332R - RES, CHIP	R284,R305	2403 1233 2003
6	634R - RES, CHIP	R269,R275,R280,R289,R293,R300	2403 1263 4003
33	1K - RES, CHIP	R16,R17,R32,R35,R40,R112,R113,R114,R117, R118,R119,R120,R125,R129,R135,R139,R146, R155,R165,R169,R179,R182,R292,R301,R308, R309,R346,R370,R380,R391,R397,R419,R426	2401 1221 0203
10	1.2K - RES, CHIP	R138,R141,R151,R157,R167,R171,R187,R192 R246,R260	2401 1221 2203
2	1.5K - RES, CHIP	R357,R358	2401 1221 5203
2	2K - RES, CHIP	R297,R312	2401 1222 0203
6	2.2K - RES, CHIP	R60,R61,R115,R225,R227,R384	2401 1222 2203
2	2.4K - RES, CHIP	R131,R132	2401 1222 2403
4	2.7K - RES, CHIP	R137,R140,R150,R156	2401 1222 7203

1	3.3K - RES, CHIP	R99	2401 1223 3203
4	3.6K - RES, CHIP	R166,R170,R186,R191	2401 1223 6203
1	3.9K - RES, CHIP	R369	2401 1223 9203
34	4.7K - RES, CHIP	R47,R51,R52,R53,R54,R56,R57,R58,R59,R62, R63,R64,R65,R66,R93,R94,R95,R96,R97,R103, R104,R105,R106,R107,R108,R109,R110,R386, R387,R388,R389,R390,R410,R429	2401 1224 7203
8	5.1K - RES, CHIP	R134,R145,R149,R163,R164,R177,R178,R195	2401 1225 1203
1	6.8K - RES, CHIP	R234	2401 1226 8203
54	10K - RES, CHIP	R3,R7,R8,R18,R21,R23,R46,R55,R100,R126, R196,R201,R236,R237,R238,R239,R278,R279, R298,R299,R331,R333,R341,R342,R343,R344, R345,R347,R350,R353,R354,R355,R356,R359, R382,R383,R385,R398,R399,R400,R401,R402, R403,R405,R406,R407,R408,R409,R411,R430, R431,R433,R434,R436	2401 1221 0303
7	15K - RES, CHIP	R10,R24,R89,R136,R142,R374,R376	2401 1221 5303
1	18.3K - RES, CHIP	R367	2403 1218 3203
16	22K - RES, CHIP	R27,R28,R29,R41,R42,R43,R124,R128,R144, R160,R175,R190,R361,R381,R396,R427	2401 1222 2303
3	27K - RES, CHIP	R281,R302,R360	2401 1222 7303
6	33K - RES, CHIP	R251,R265,R286,R306,R351,R352	2401 1223 3303
3	39K - RES, CHIP	R364,R368,R371	2401 1223 9303
9	47K - RES, CHIP	R245,R259,R270,R271,R276,R277,R287,R288,R363	2401 1224 7303
4	47.5K - RES, CHIP	R143,R162,R176,R194	2403 1247 5203
8	100K - RES, CHIP	R5,R22,R39,R247,R261,R348,R349,R372	2401 1221 0403
2	220K - RES, CHIP	R30,R44	2401 1222 2403
3	470K - RES, CHIP	R26,R252,R266	2401 1224 7103
2	560K - RES, CHIP	R209,R200	2401 1225 6103
1	39R/2W - RES, CARBON	R420	2413 0623 9012
2	8PF - CAP , CHIP	C241,C242	2115 5809 0135
6	30PF - CAP , CHIP	C26,C27,C28,C29,C216,C217	2115 5809 0135
3	33PF - CAP , CHIP	C142,C149,C302	2103 5330 0130
18	39PF - CAP , CHIP	C17,C24,C303,C304,C305,C306,C307,C308, C309,C310,C311,C312,C313,C314,C315,C316, C317,C318	2103 5390 0130
2	47PF - CAP , CHIP	C246,C250	2103 5470 0130
2	68PF - CAP , CHIP	C106,C113	2103 5680 0130
2	100PF - CAP , CHIP	C12,C7	2103 5101 0130
10	330PF - CAP , CHIP	C5,C10,C107,C115,C119,C120,C126,C127, C130,C131	2103 5331 0130
9	560PF(NPO) - CAP , CHIP	C16,C41,C42,C50,C54,C60,C66,C76,C80	2103 5561 0130
2	820PF - CAP , CHIP	C214,C215	2103 5821 0130
21	1000PF(NPO) - CAP , CHIP	C37,C38,C39,C40,C43,C46,C48,C57,C59,C69, C75,C81,C99,C137,C148,C243,C244,C248,C252, C255,C256	2103 5102 0130
4	1500PF(NPO) - CAP , CHIP	C293,C295,C297,C299	2103 5152 0145
4	1800PF(NPO) - CAP , CHIP	C294,C296,C298,C300	2103 5182 0145
6	0.01uF - CAP , CHIP	C11,C85,C88,C195,C197,C231	2115 6103 0130
2	0.033uF - CAP , CHIP	C143,C145	2115 6333 0130
1	0.047uF - CAP , CHIP	C196	2115 6473 0130
1	0.056uF - CAP , CHIP	C100	2115 6563 0130
149	0.1uF - CAP , CHIP	C1,C2,C3,C4,C6,C8,C9,C13,C14,C15,C18,C19,	2115 6104 0145

		C20,C21,C22,C23,C25,C30,C31,C32,C33,C34,	
		C35,C36,C44,C47,C49,C51,C52,C53,C55,C58,	
		C61,C63,C64,C70,C72,C73,C82,C83,C84,C86,	
		C87,C89,C90,C91,C92,C93,C94,C96,C97,C101,	
		C103,C105,C112,C122,C123,C124,C129,C133,	
		C134,C138,C144,C146,C150,C152,C153,C168,	
		C169,C170,C171,C172,C173,C174,C175,C176,	
		C177,C178,C179,C181,C182,C183,C184,C185,	
		C186,C187,C188,C192,C193,C198,C201,C203,	
		C205,C206,C207,C208,C209,C210,C211,C212,	
		C213,C218,C220,C222,C223,C225,C230,C232,	
		C233,C236,C237,C238,C239,C240,C253,C254,	
		C257,C258,C259,C260,C261,C262,C263,C264,	
		C265,C266,C267,C268,C269,C270,C271,C272,	
		C273,C274,C275,C276,C277,C278,C279,C280,	
		C281,C282,C283,C284,C287,C289,C290,C291,C292	
1	0.47uF - CAP , CHIP	C200	2115 6474 0130
15	1uF - CAP , CHIP	C45,C56,C68,C79,C189,C190,C191,C194,	2115 6105 0130
		C199,C204,C219,C221,C224,C226,C229	
2	222M - CAP , MYLAR	C108,C117	2203 3222 0103
2	822M - CAP , MYLAR	C109,C118	2203 3822 0103
4	470PF(COG) - CAP , CHIP	C121,C125,C132,C136	2103 5471 0130
2	2700PF(COG) - CAP , CHIP	C139,C128	2115 6272 0130
2	22uF/10V - CAP , ELECT	EC12,EC14	2320 0210 1010
4	220uF/10V - CAP , ELECT	EC1,EC62,EC64,EC80	2321 0210 2015
1	2200uF/10V - CAP , ELECT	EC77	2322 2101 1000
2	1uF/16V - CAP , ELECT	EC95,EC85	2319 0310 1015
19	10uF/16V - CAP , ELECT	EC4,EC5,EC6,EC7,EC35,EC36,EC37,EC40,	2310 0310 1015
		EC44,EC46,EC50,EC65,EC67,EC68,EC69,	
		EC70,EC71,EC92,C180	
4	22uF/16V - CAP , ELECT	EC13,EC20,EC26,EC31	2320 0310 1015
3	47uF/16V - CAP , ELECT	EC52,EC57,EC73	2340 0310 1015
1	470uF/16V - CAP , ELECT	EC61	2341 0310 4025
26	100uF/16V - CAP , ELECT	EC8,EC9,EC21,EC23,EC28,EC33,EC34,EC38,	2311 0310 2015
		EC47,EC53,EC54,EC58,EC60,EC66,EC72,EC74,	
		EC75,EC76,EC78,EC79,EC96,EC97,EC98,EC99,	
		EC100,EC101	
1	1000uF/16V - CAP , ELECT	EC3	2312 3104 4000
1	47uF/25V - CAP , ELECT	EC93	2340 0410 1015
3	470uF/25V - CAP , ELECT	EC10,EC11,EC91	2341 0410 4025
1	1000uF/25V - CAP , ELECT	EC90	2312 4105 4000
1	2.2uF/50V - CAP , ELECT	EC39	2329 0610 1015
2	4.7uF/50V - CAP , ELECT	EC42,EC45	2349 0610 1015
8	47uF/50V - CAP , ELECT	EC81,EC82,EC83,EC84,EC86,EC87,EC88,EC89	2340 0610 2015
1	100uF/50V - CAP , ELECT	EC2	2311 0610 3025
1	22UF/50V(NP) - CAP , ELECT	C301	2320 0610 1013

Connet.Bom P/N: 0082-1332-0000			
Qty	Part Type	Ref. Designator	Part Number
1	MP1423 (MPS) STEP DOWN CONVERTER	IC1	1001 4232 2971
1	2SA1162GR - TRANSISTOR	Q2	1111 1620 7100
3	2SC3361 - TRANSISTOR	Q1 Q3 Q4	1133 3610 6100
3	1N4148 - DIODE	D1 D2 D3	1310 4414 8000
1	B340A - DIODE	D4	1180 3400 1901
2	RSA5L - DIODE	D5 D6	1350 0050 0100
7	BK1608LM182-T(Taiyo Yuten)FERRITE , CHIP BEAD	FB2 FB3 FB4 FB5 FB6 FB7 FB8	1871 6081 8201
2	BLM18PG181SN1(Murata)FERRITE , CHIP BEAD	FB9 FB10	1871 1818 1001
1	CDRH104RNP-220NC(sumida) COIL SMD POWER	L1	1871 0422 0001
1	FB0805 FERRITE , CHIP BEAD	FB1	1852 0120 9100
1	DB-09 - JACK	RS1	2806 0590 0000
1	MSV-1260 - SWITCH	SW1	4330 3002 1311
1	SCSI-36P-F-90 - JACK	JK2	3109-0536-4632
1	IDC 2x10P2.54(90) - CONNECTOR	JK1	3109 0520 4632
1	1mH/800mA - COIL SMD POWER	L2	1808 0010 0001
1	7P(2.0) - CONNECTOR	CN1	3100 4070 0200
1	9P(2.0) - CONNECTOR	CN2	3100 4090 0250
1	10P(2.0) - CONNECTOR	CN3	1808 0010 0001
1	4.3K 1% - RES, CHIP	R25	2401 1214 3203
1	7.5K 1% - RES, CHIP	R28	2401 1217 5203
1	10K 1% - RES, CHIP	R27	2401 1211 0303
1	51K 1% - RES, CHIP	R26	2401 1215 1303
1	33R - RES, CHIP	R8	2401 1223 3003
1	220R - RES, CHIP	R7	2401 1222 2103
1	1.8K - RES, CHIP	R3	2401 1221 8203
1	4K7 - RES, CHIP	R6	2401 1224 7203
7	10K - RES, CHIP	R1 R2 R4 R5 R13 R23 R24	2401 1221 0303
1	100K - RES, CHIP	R15	2401 1221 0403
2	100P - CAP , CHIP	C2 C3	2103 5101 0130
1	120P(NPO) - CAP , CHIP	C33	2103 5121 0130
1	4700PF(NPO) - CAP , CHIP	C34	2103 5472 0130
2	103(0.01UF) - CAP , CHIP	C29 C30	2115 6103 0130
19	0.1uF - CAP , CHIP	C4 C5 C6 C8 C11 C16 C17 C18 C19 C20 C21	2115 6104 0130
		C22 C23 C24 C25 C26 C27 C28 C35	
2	22uF/25V(X7) - CAP , CHIP	C31 C32	2103 5226 0925
5	100uF16V - CAP , ELECT	C7 C9 C12 C14 C15	2311 0310 2015
1	2200uF/25V - CAP , ELECT	C10	2322 4105 5000
1	1uF/50 - CAP , ELECT	C1	2319 0610 1015
	PHONE.Bom P/N: 0082-5170-0001		
Qty	Part Type	Ref. Designator	Part Number
7	FB FERRITE , CHIP BEAD	L2 L3 L4 L5 L6 L7 L8	1852 0120 9200
1	CK3-3.5-510K2 - HEADPHONE JACK	J1	2821 2350 7000
1	CK3.5-02	J2	2801 1335 0203
1	JX1.0-3S-13PW - CONNECTOR	CN1	3104 0113 1050
1	USB-A-MI-4P - USB JACK	JP1	2800 1018 0040
1	2P(2.0) - CONNECTOR	CN2	3100 4020 0200
2	100 - RES, CHIP	R1 R2	2401 1221 0103
4	47K - RES, CHIP	R3 R4 R5 R6	2401 1224 7303
2	330P - CAP , CHIP	C108 C109	2103 5331 0130

2	102(1000pF) - CAP , CHIP	C110 C111	2103 5102 0130
8	104(0.1uF) - CAP , CHIP	C1 C2 C4 C5 C6 C7 C8 C107	2115 6104 0130
1	100uF16V - CAP , ELECT	C3	2311 0310 2015
	Display bom P/N: 0082-5010-0000		
Qty	Part Type	Ref. Designator	Part Number
1	AMS1117-3.3V (AMS) LOW DROPOUT VOLTAGE REGULATOR	IC1	1011 7330 0128
1	KS-803LM (REMOTE SENSOR)	IR1	1304 0008 0301
6	HT15-21UWC/TR8 (LED) WHITE	D2 D3 D4 D5 D6 D7	1403 0712 0603
1	162-SD-16INK - VFD	VF1	1521 6216 0101
1	JX1.0S-4S-16PWT - CONNECTOR	CN1	3109 0116 3103
1	2x6P(1.27) - CONNECTOR	J1	3112 0200 5022
2	10R±5% 0603 - RES, CHIP	R1 R2	2401 1221 0003
1	47R±5% 0603 - RES, CHIP	R5	2401 1224 7003
1	10K±5% 0603 - RES, CHIP	R4	2401 1221 0303
1	33K±5% 0603 - RES, CHIP	R3	2401 1223 3303
9	0.1uF/50V±10% 0603 - CAP , CHIP	C1 C2 C6 C7 C8 C10 C11 C12 C13	2115 6104 0130
1	10uF10V±20% - CAP , ELECT	C4	2310 0210 1015
2	100uF10V±20% - CAP , ELECT	C3 C5	2311 0210 1015
1	100uF16V±20% - CAP , ELECT	C9	2311 0310 2015
	TOUCH-PCB P/N: 0082-5003-0000		
Qty	Part Type	Ref. Designator	Part Number
1	MA83P06(SSOP-28) (MOSART) TOUCH SENSOR	U1	1008 3062 2514
1	HEADER 6X2 - CONNECTOR	J1	3113 0200 6002
1	0R±5% 0603 - RES, CHIP	R2	2401 1220 0003
6	100R±5% 0603 - RES, CHIP	R6 R7 R8 R9 R10 R11	2401 1221 0103
1	560R±5% 0603 - RES, CHIP	R3	2401 1225 6103
2	4.7K±5% 0603 - RES, CHIP	R4 R5	2401 1224 7203
1	91K±1% 0603 - RES, CHIP	C11	2403 1219 1303
1	390K±1% 0603 - RES, CHIP	R1	2401 0913 9405
1	2pF/50V±10% 0603 - CAP , CHIP	C3	2115 5209 0135
2	0.1uF/50V±10% 0603 - CAP , CHIP	C1 C4	2115 6104 0130

LM9022

Vacuum Fluorescent Display Filament Driver

General Description

The LM9022 is a bridged power amplifier capable of delivering typically 2W of continuous average power into a 10Ω filament load when powered by a 5V power supply.

To conserve power in portable applications, the LM9022's micropower shutdown mode ($I_{OQ} = 0.6\mu\text{A}$, typ) is activated when V_{DD} is applied to the SHUTDOWN pin.

Additional LM9022 features include thermal shutdown protection, unity-gain stability, and external gain set.

Key Specifications

- I_{DD} during shutdown
- Thermal Shutdown Protection

0.6μA (typ)

Features

- No transformers required
- SO or DIP packaging

Applications

- VCR/DVD Displays
- RADIO/TUNER Displays

Typical Application $T_A = 25^\circ\text{C}$, $V_{DD} = 5\text{V}$, unless otherwise specified.

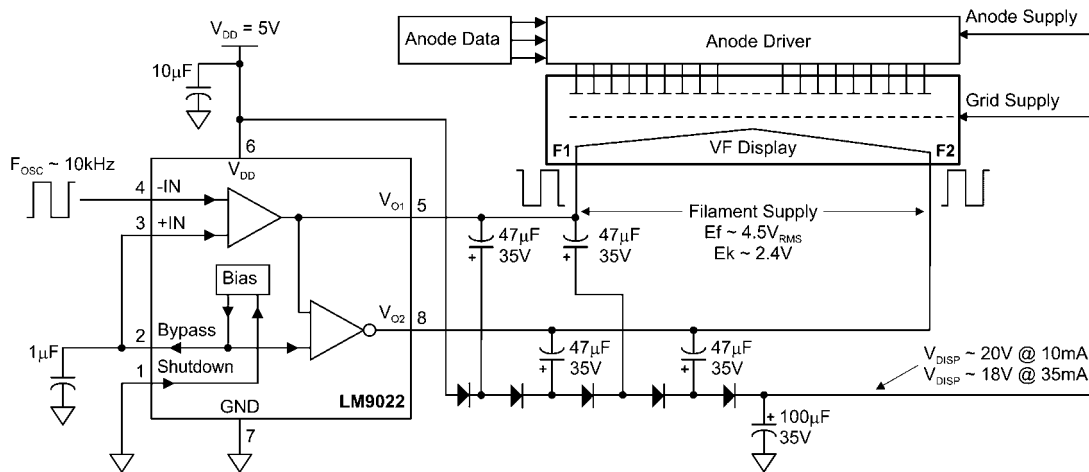

20021501

FIGURE 1. Typical Application Circuit

Connection Diagram

MSOP, Small Outline, and DIP Package

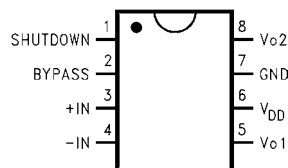

20021502

Top View

Order Number LM9022M or LM9022N
See NS Package Number M08A or N08E