

The Harman Kardon Model PM640 Vxi

Manual 121A

ULTRAWIDEBAND INTEGRATED AMPLIFIER

Technical Manual

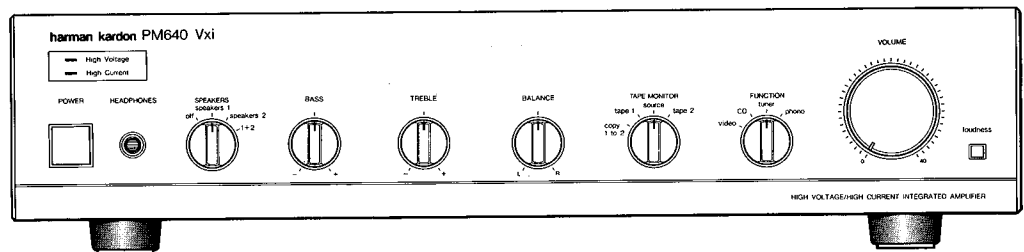

PM640 Vxi

The following marks found in the parts list of this manual identify the models as follows.

- UA : North America area model
- BK : North America area model Black version
- G : General model
- GB : General model Black version
- N : Japan model

harman/kardon

240 Crossways Park West, Woodbury, N. Y. 11797
1112-3152121A5 P-088710 1500 Printed in Japan

SPECIFICATIONS

	Nominal	Limit
RMS Output Power		
8Ω, 1kHz THD 0.1%	50W	≥ 45W
4Ω, 1kHz THD 0.3%	55.7W	≥ 45W
High Instantaneous Current Capability (HCC)	29.6	≥ 25A
Half Power Bandwidth	10Hz ~ 100kHz	
Frequency Response at -3dB	0.56Hz ~ 167kHz	
Input Sensitivity		
Tuner	135mV ± 25mV	
Phono	2.2mV ± 0.2mV	
Signal to Noise Ratio		
Tuner	83.7dB	≥ 75dB
Phono	80.0dB	≥ 73dB
Channel Separation at 10kHz		
Tuner	67dB	≥ 50dB
Phono	58dB	≥ 45dB
IM Distortion Ratio	0.022%	≥ 0.1%
Damping Factor at 1kHz	58	≥ 50
Tone Control Characteristics		
Bass Turnover Frequency (200Hz/400Hz)		
Bass at 50Hz/100Hz		
Boost	10dB	± 2dB
Cut	10dB	± 2dB
Treble Turnover Frequency (2kHz/6kHz)		
Treble at 10kHz/30kHz		
Boost	10dB	± 2dB
Cut	10dB	± 2dB

	Nominal	Limit
Loudness Control (with Volume Control at -40dB)		
at 10kHz	3dB	± 1dB
at 50Hz	10dB	± 2dB
DC Output Voltage		
L channel	0mV	± 60mV
R channel	0mV	± 60mV
RIAA Equalization at Tape Out (20Hz/20kHz) (No load)	0.12dB + 1.0dB	0.12dB - 0.2dB
Phono Over Load (No load)		
Phono	104mV	≥ 95mV
Dimensions (W x H x D)	17-1/2" x 4-1/16" x 13-7/8"	(443 x 103 x 351mm)
Weight	12 lbs.	2oz. (5.5kg)
Power Supplies		
North America area model	AC 120V, 60Hz	
General model	AC 220/240V, 50/60Hz	
Japan model	AC 100V, 50/60Hz	
Power Consumption		
North America area model	215W	(277VA)
General model	151W	
Japan model	110W	

This specification is the target of servicing. But, there is a case that the specification is not applicable to the measurement condition and instrument.

Specifications and components subject to change without notice. Overall performance will be maintained or improved.

PM640 Vxi

LEAKAGE TEST (FOR SERVICE ENGINEERS IN THE U.S.A.)

Before returning the unit to the user, perform the following safety checks:

1. Inspect all lead dress to make certain that leads are not pinched or that hardware is not lodged between the chassis and other metal parts in the unit.
2. Be sure that any protective devices such as nonmetallic control knobs, insulating fishpapers, cabinet backs, adjustment and compartment covers or shields, isolation resistor-capacity networks, mechanical insulators, etc. which were removed for servicing are properly reinstalled.
3. Be sure that no shock hazard exists; check for leakage current using Simpson Model 229 Leakage Tester, standard equipment item No. 21641, RCA Model WT540A or use alternate method as follows: Plug the power cord directly into a 120-volt AC receptacle (do not use an Isolation Transformer for this test). Using two clip leads, connect a 1500 Ohm, 10-watt resistor paralleled by a 0.15 μF capacitor, in series with all exposed metal cabinet parts and a known earth ground, such as a water pipe or conduit. Use a VTVM or VOM with 1000 Ohms per volt, or higher sensitivity to measure the AC voltage drop across the resistor. (See Diagram.) Move the resistor connection to each exposed metal part having a return path to the chassis (antenna, metal, cabinet, screw heads, knobs and control shafts, escutcheon, etc.) and measure the AC voltage drop across the resistor. (This test should be performed with the power switch in both the On and Off positions.) A reading of 0.35 volt RMS or more is excessive and indicates a potential shock hazard which must be corrected before returning the unit to the owner.

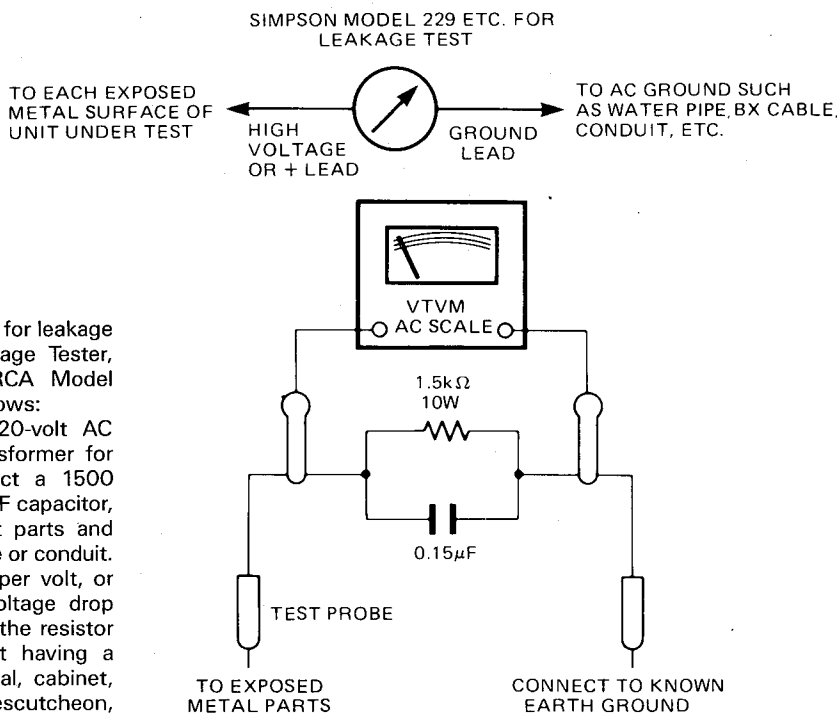

DISASSEMBLY PROCEDURES (REFER TO PAGES 5 AND 13)

1 CABINET TOP REMOVAL

Remove 6 screws (A) and then remove the Cabinet Top (131).

2 FRONT PANEL ASS'Y (AA) REMOVAL

1. Remove the Cabinet Top (131), referring to the previous step 1.
2. Pull out 6 Rotary Knobs (152 and 153) and Volume Rotary Knob (150).
3. Remove 5 screws (B) and then Front Panel Ass'y (AA).

3 MAIN P. C. BOARD (PCB-1) REMOVAL

1. Remove the Front Panel Ass'y (AA), referring to the previous step 2.
2. Open the lid of connector (CN601) on the Main P. C. Board (PCB-1).
3. Remove 7 hexagon nuts (C) and then remove the Speaker Switch, VR and Function P. C. Board (PCB-5, PCB-7 and

PCB-10).

4. Remove 4 screws (D) and then remove the Main P. C. Board (PCB-1).
If necessary, unsolder the lead wires.

4 EQUALIZER P.C. BOARD (PCB-11) REMOVAL

1. Remove the Main P. C. Board (PCB-1), referring to the previous step 3.
2. Pull out the Shaft (213).
3. Remove 2 screws (E) and then remove the Power Switch P. C. Board (PCB-9).
4. Remove 2 screws (F) and then remove the 4/8 Switch P. C. Board (PCB-6).
5. Remove 13 screws (G) and then remove the Cabinet Back Ass'y (AB), and the Speaker Terminal, Equalizer P. C. Board (PCB-2 and PCB-11).
If necessary, unsolder the lead wires.

POWER CORD REPLACEMENT (FOR SERVICE ENGINEERS OTHER THAN NOTRH AMERICA)

In order to prevent fire or shock hazard when replacing the power cord, follow the procedure below to replace the parts with the standard supply parts.

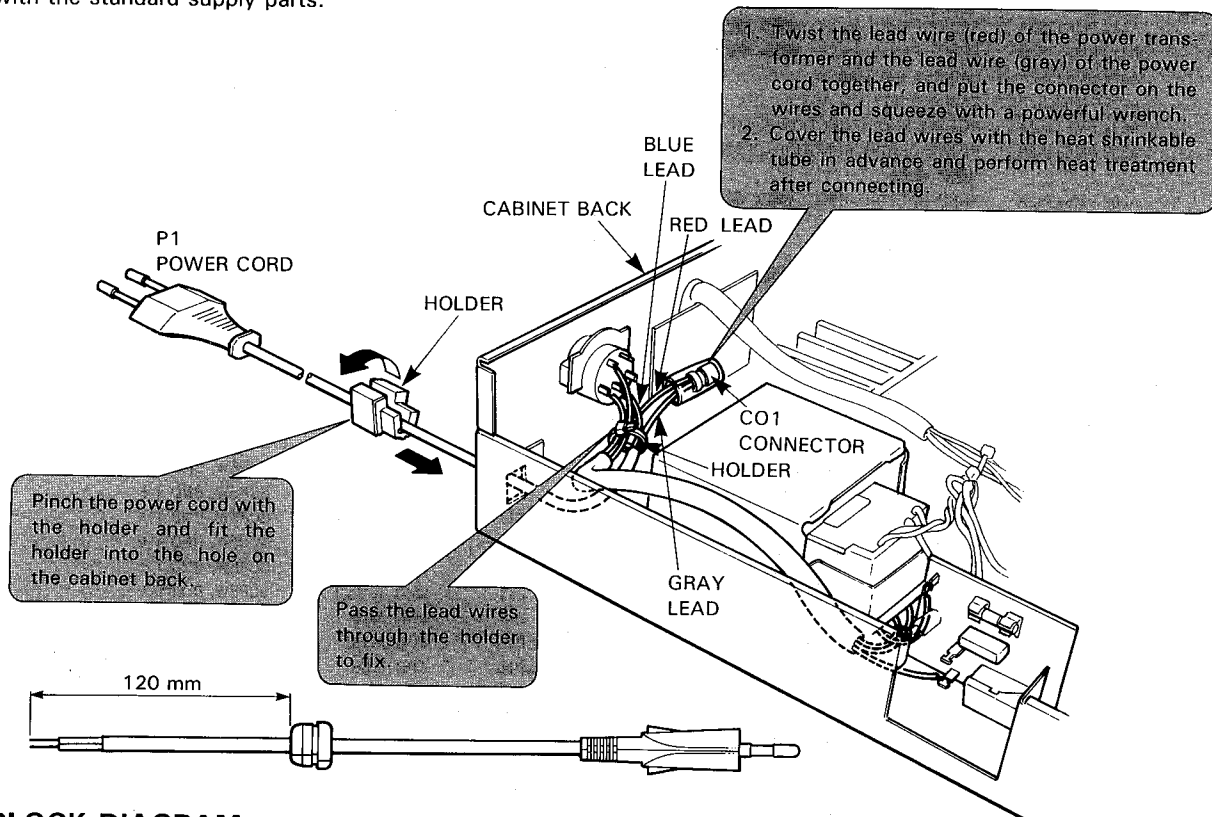

BLOCK DIAGRAM

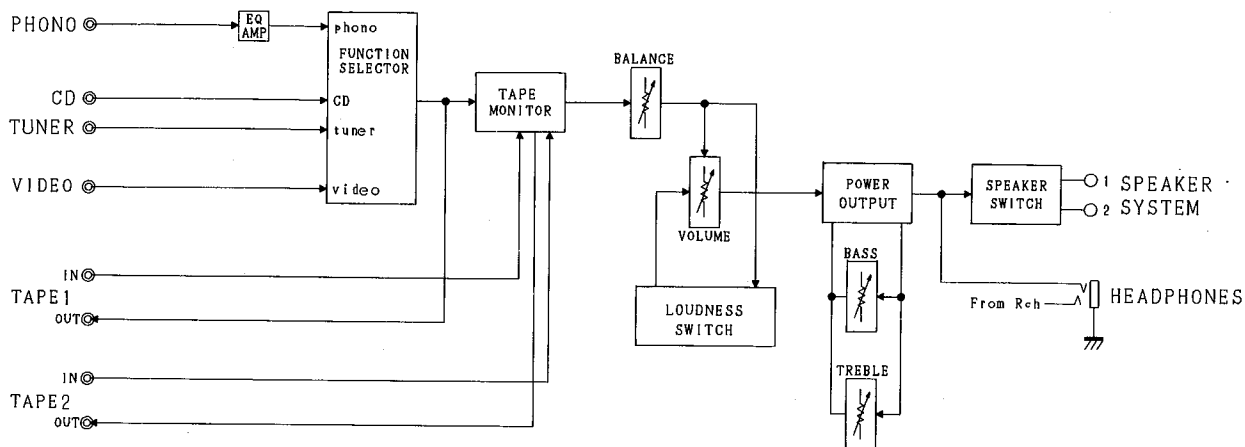

ALIGNMENT PROCEDURES (REFER TO PAGES 6, 7 AND 12)

- Conditions:
- Set the Volume control to minimum.
 - Set the Speaker selector to "1 + 2" position.
 - Set the Speaker Operating Mode switch to "8Ω" position.
 - Make the adjustment at a room temperature of 77°F (25°C).
 - After the Power switch is pushed on, wait for 30 minutes before measuring to be sure of the most stable operation.

IDLING CURRENT ADJUSTMENT

Step	Connection Equipments	Adjustment	For
1	Connect the Digital Volt Meter to TP1 and TP2.	VR401 (L ch)	40mV ± 2mV
2	Connect the Digital Volt Meter to TP3 and TP4.	VR402 (R ch)	40mV ± 2mV

PARTS LIST

Ref. No.	Part No.	Description	Ref. No.	Part No.	Description
AA	A443-PM635S2A	FRONT PANEL ASS'Y UA G	186	2240-7209	HOLDER, POWER
AAA	A443-PM635S2B	FRONT PANEL ASS'Y BK GB N	187	2240-7315	HOLDER, LED
AB	A424-PM635S2A	CABINET BACK ASS'Y	188	2240-7316	HOLDER, PANEL
AC	A424-PM635S2B	CABINET BOTTOM ASS'Y	189	2240-7050	HOLDER, WIRING
AD	A632-PM635S2A	ROTARY KNOB FUNCTION SWITCH ASS'Y UA G	191	2240-364	HOLDER, AC CORD
ADA	A632-PM635S2B	ROTARY KNOB FUNCTION SWITCH ASS'Y BK GB N	197	2112-11755	SPONGE, SIDE
AE	A662-PM635S2A	PUSH BUTTON ASS'Y UA G	198	2112-11762	SPONGE, PANEL
AEA	A662-PM635S2B	PUSH BUTTON ASS'Y BK GB N	199	2112-11784	SPONGE, CASSIS
023B	2132-7116	SPACER G GB	206	2401-0376	WASHER, METAL
024B	2327-R0130124	SCREW, BND+ G GB	211	2310-7017	SCREW, SPE
025B	2440-7017	NUT, SPE G GB	213	2672-7018	LEVER, POWER SHAFT
063B	2347-R0130084	SCREW, BND+ G GB	214	2601-7077	SHAFT
113	1117-78	SERIAL LABEL	220	2651-210189	SPRING, PUSH BUTTON
116	1756-05910	LABEL, FUSE CAUTION	224	2360-7015	BOSS, SPE
118	1756-CSA	LABEL UA	230	2327-R0130064	SCREW, BND+
131	1414-04901	CABINET TOP	231	2327-R0130102	SCREW, BND+
133	1424-23201	CABINET BOTTOM	234	2347-R0126084	SCREW, BND T+
134	1424-23001	CABINET BACK UA BK	235	2347-R0130062	SCREW, BND T+
134B	1424-23003	CABINET BACK G GB	236	2347-R0130062	SCREW, BND T+
134D	1424-23002	CABINET BACK N	237	2347-R0130084	SCREW, BND T+
136	1443-11301	FRONT PANEL UA G	239	2347-R0130102	SCREW, BND T+
136A	1443-11302	FRONT PANEL BK GB N	241	2347-R0140064	SCREW, BND T+
138	1513-09501	PANEL, PLATE	242	2347-R0140082	SCREW, BND T+
139	1531-11301	PANEL, WINDOW	245	2557-301029	SCREW, B SPW+
141	1562-02801	FRAME, RIGHT UA G	248	2440-7016	NUT, SPE
141A	1562-02802	FRAME, RIGHT BK GB N	ΔPI	4161-71151	CORD W/PLUG UA BK
142	1562-02701	FRAME, LEFT UA G	ΔPIB	4161-7256	CORD W/PLUG G GB
142A	1562-02702	FRAME, LEFT BK GB N	ΔPID	4161-71133	CORD W/PLUG N
146	1660-00401	PUSH BUTTON, POWER UA G	ΔTI	5584-S08	XFORMER, POWER UA BK
146A	1660-00403	PUSH BUTTON, POWER BK GB N	ΔTIB	5584-S09	XFORMER, POWER G GB
147	1662-05701VN	PUSH BUTTON UA G	ΔTID	5584-S10	XFORMER, POWER N
147A	1662-05702	PUSH BUTTON BK GB N	ΔSOI	4474-227	SOCKET, AC OUTLET
150	1630-02601	ROTARY KNOB, VOLUME UA G	LUG1	4211-4	LUG G GB
150A	1630-02603	ROTARY KNOB, VOLUME BK GB N	LUG2	4211-4	LUG
152	1630-16502	ROTARY KNOB, FUNCTION SWITCH UA G	ΔSW101	4411-102729	SWITCH, ROTARY G GB
152A	1630-16501	ROTARY KNOB, FUNCTION SWITCH BK GB N	Q425	5613-945(K)or(P)	XISTOR, NPN R
153	1630-16502	ROTARY KNOB UA G	Q426	5613-945(K)or(P)	XISTOR, NPN R
153A	1630-16501	ROTARY KNOB BK GB N	Q427	5614-667A(C)	XISTOR, NPN A
157	1319-0139	LEG	Q428	5614-667A(C)	XISTOR, NPN A
161	2211-7295	CHASSIS	Q429	5612-647A(C)	XISTOR, PNP A
163	2219-8179	METAL FITTING, MAIN HEAT SINK	Q430	5612-647A(C)	XISTOR, PNP A
173	2219-8182	METAL FITTING, MAIN HEAT SINK	Q431	5613-3181(O)or(R)	XISTOR, NPN R
174	2219-7879	METAL FITTING, H/P JACK	Q432	5613-3181(O)or(R)	XISTOR, NPN R
177	2222-7227	HEAT SINK, MAIN UA BK N	Q433	5611-1264(O)or(R)	XISTOR, PNP R
177B	2222-7232	HEAT SINK, MAIN G GB	Q434	5611-1264(O)or(R)	XISTOR, PNP R
178	2222-7106	HEAT SINK, DRIVER	D401	5641-MV12YM	VARISTOR
179	2222-7231	HEAT SINK, DRIVER	D402	5641-MV12YM	VARISTOR
182	2240-7320	HOLDER, POWER SWITCH			
183	2240-7141	HOLDER, LOUDNESS UA G			
183A	2240-7202	HOLDER BK GB N			

GENERAL UNIT
EXPLODED VIEW

1
2
3
4
5
6
7

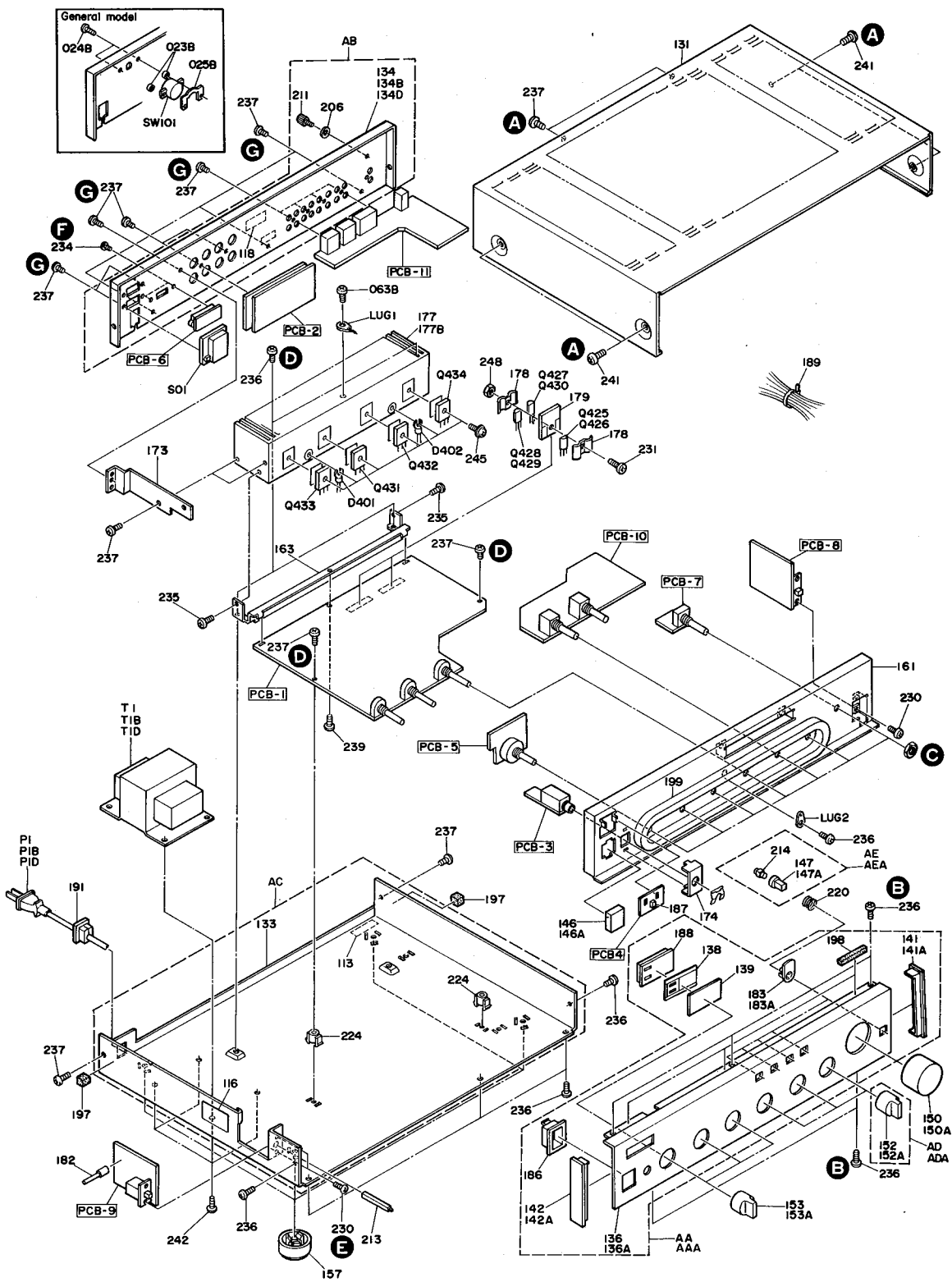

P. C. BOARDS

PCB-10 Function P. C. Board

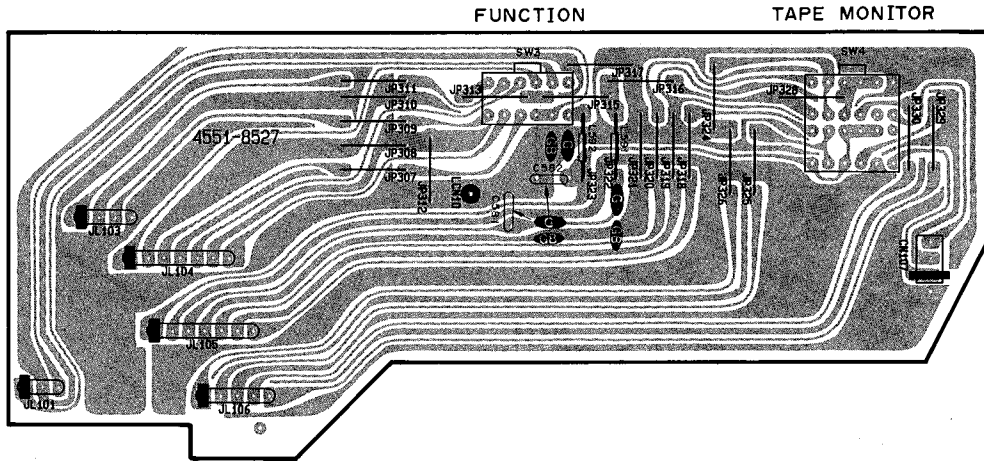

PCB-11 Equalizer P. C. Board

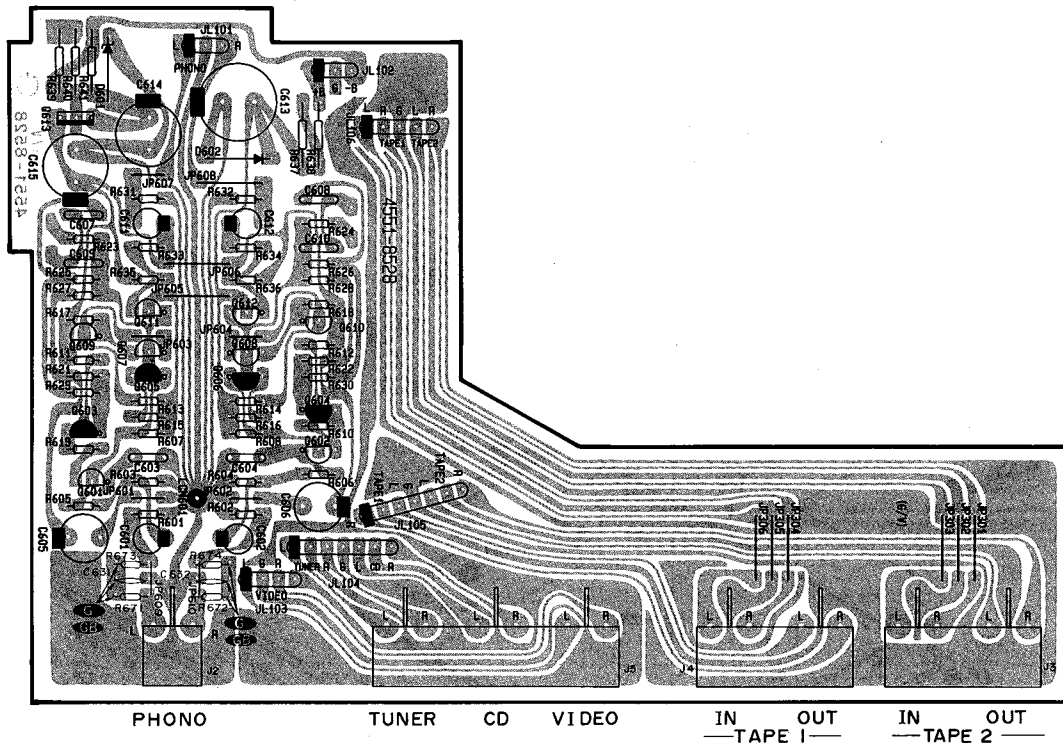

P. C. BOARDS

PCB-1 Main P. C. Board

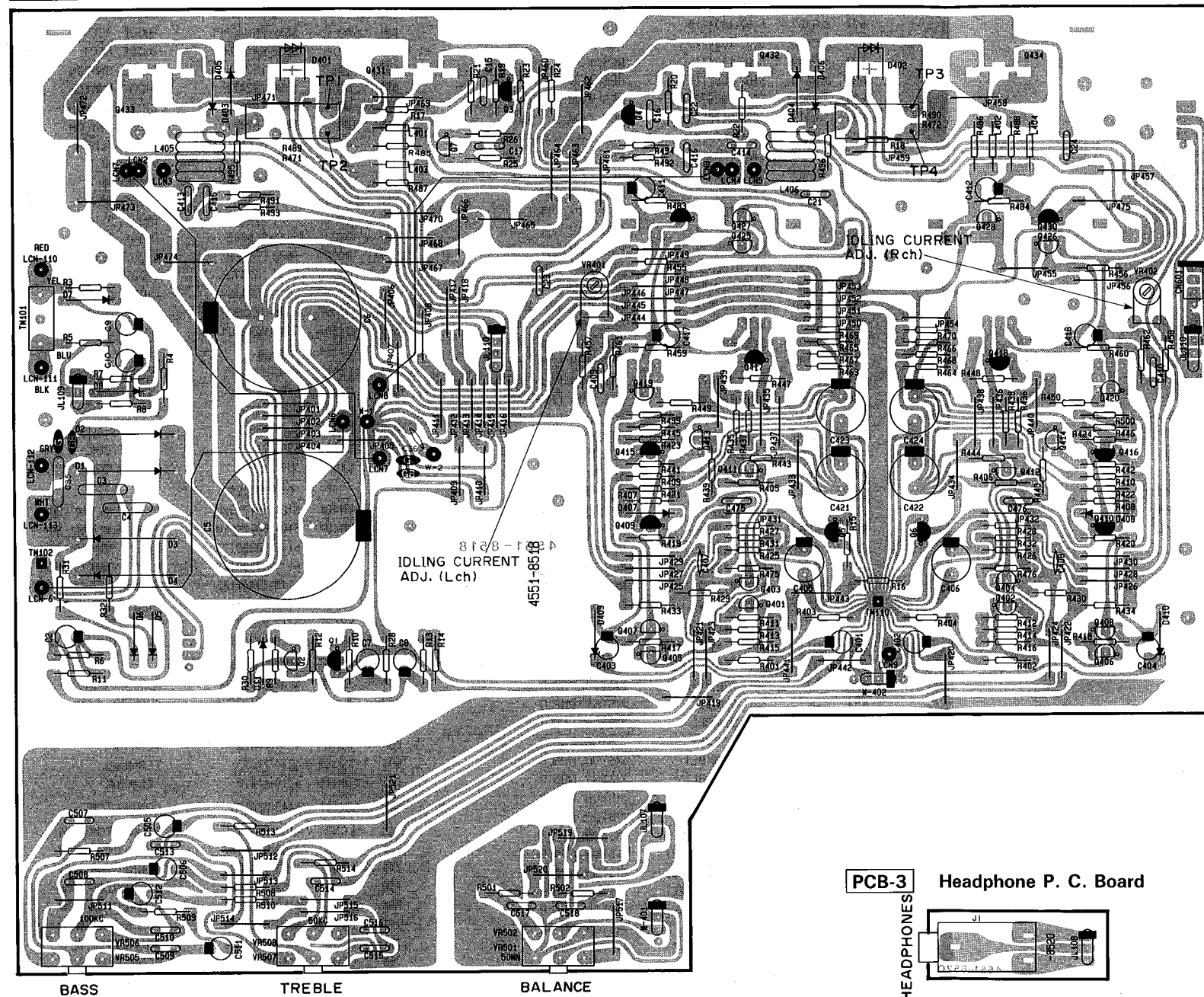

PCB-5 Speaker Switch P. C Board

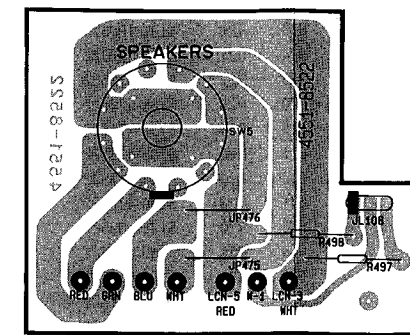

PCB-9 Power Switch P. C. Board

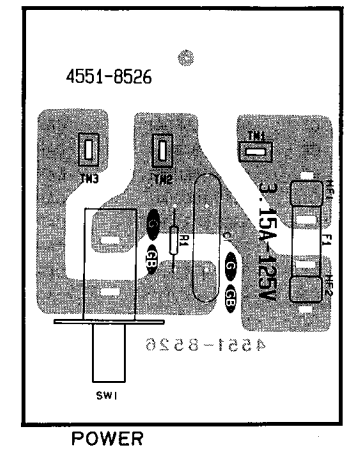

PCB-6 Switch P. C. Board

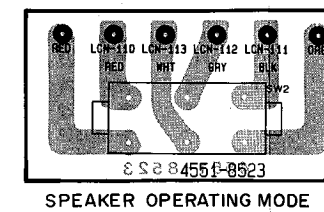

PCB-7 VR P. C. Board

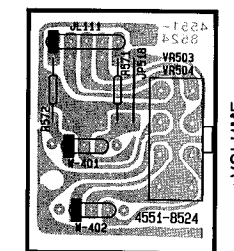

PCB-3 Headphone P. C. Board

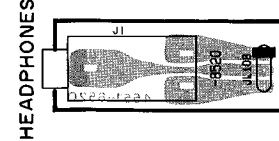

PCB-2 Speaker Terminal P. C. Board

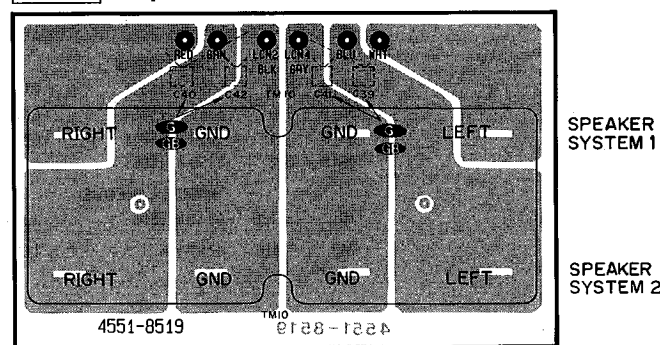

PCB-4 LED P. C. Board

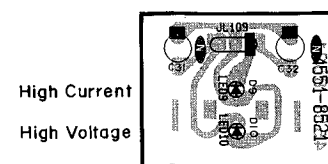

PCB-8 Loudness P. C. Board

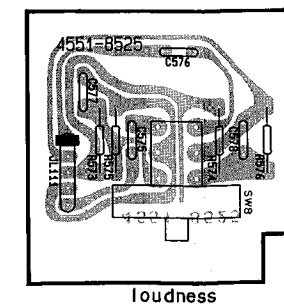

P. C. BOARDS

PCB-1 Main P. C. Board

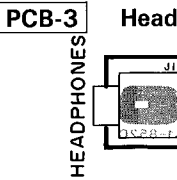
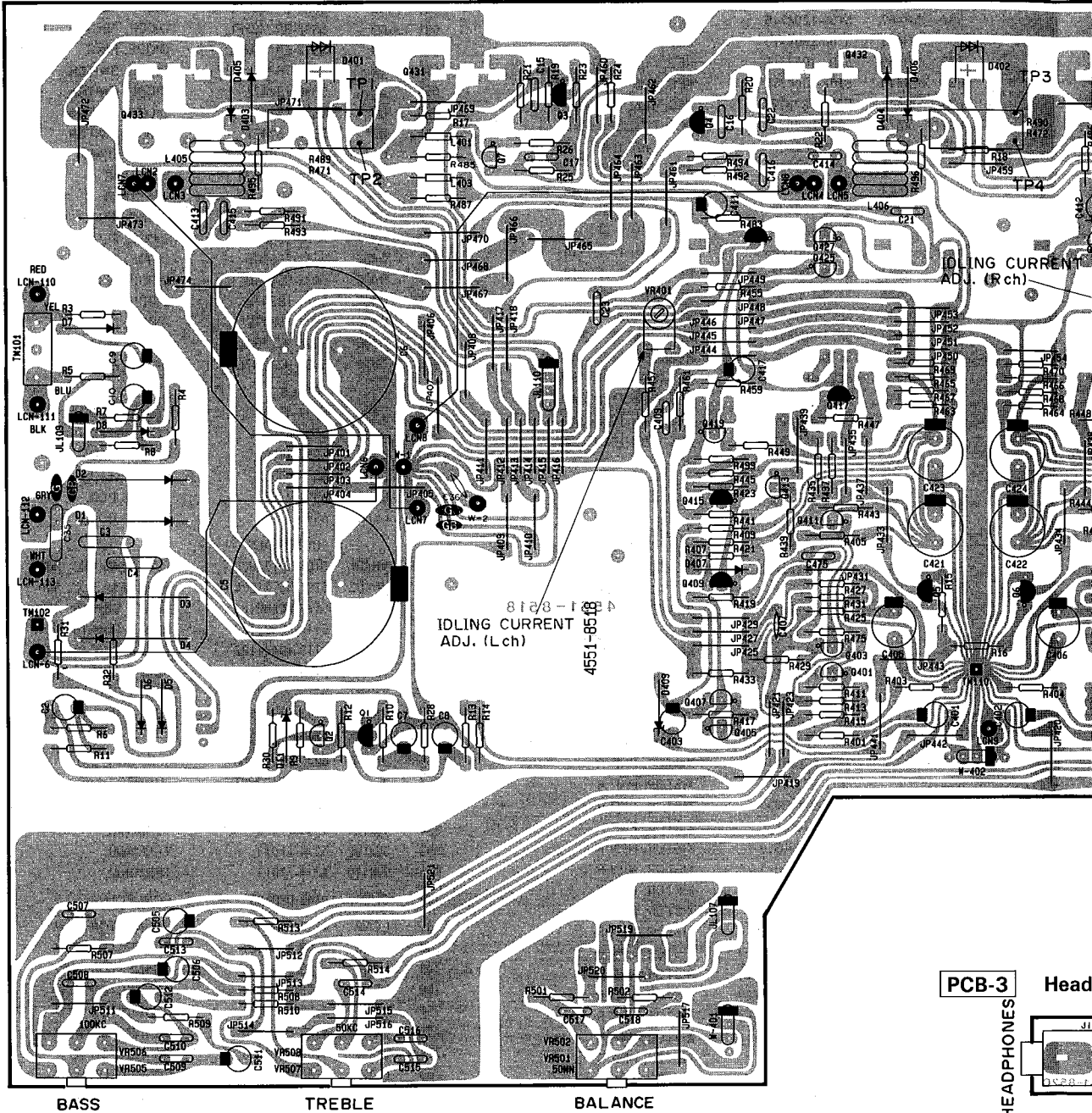

PCB-2 Speaker Terminal P. C. Board

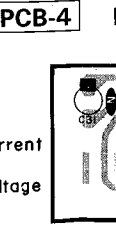
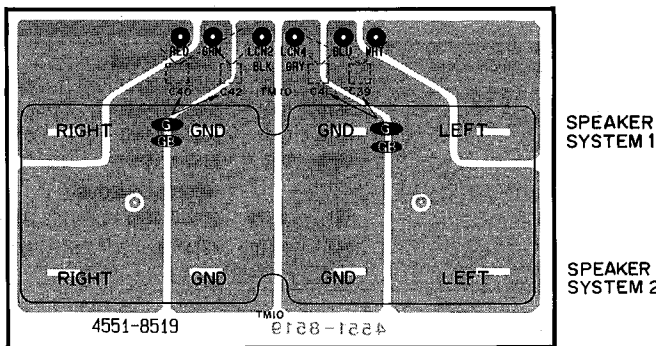

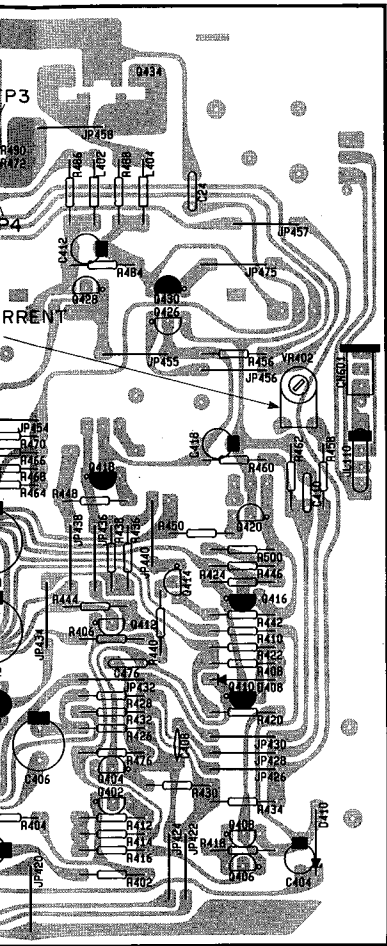

PCB-5 Speaker Switch P. C. Board

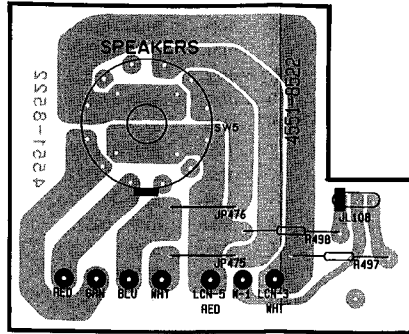

PCB-9 Power Switch P. C. Board

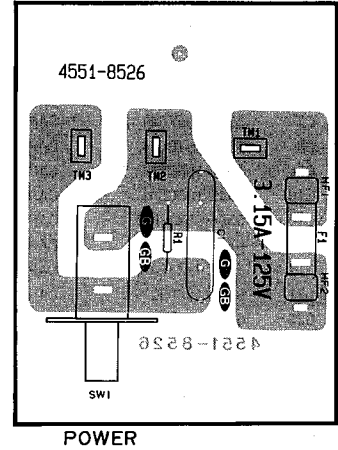

PCB-6 Switch P. C. Board

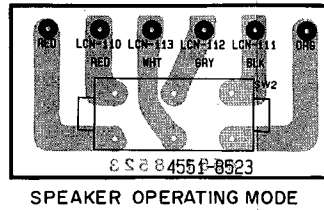

PCB-7 VR P. C. Board

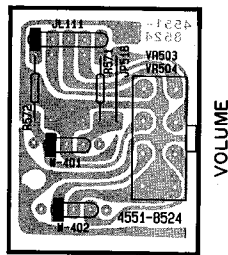

Headphone P. C. Board

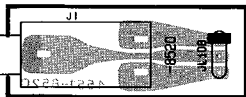

PCB-4 LED P. C. Board

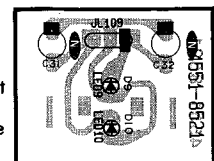

PCB-8 Loudness P. C. Board

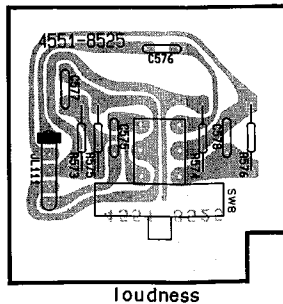

ELECTRICAL PARTS LIST

Ser. No.	Ref. No.	Part No.	Description	Ser. No.	Ref. No.	Part No.	Description
PCB-1 MAIN P.C. BOARD							
CAPACITORS							
662	C2	5345-106F041	CAP, MINI ELE 10μ/50V	672	R15	5135-223522	RES, CBN 1/2P 22K
689	C3	5362-103048	CAP, CER .01μ	672	R16	5135-223522	RES, CBN 1/2P 22K
689	C4	5362-103048	CAP, CER .01μ	674	R17	5135-332522	RES, CBN 1/2P 3.3K
687	C5	5341-828F0355	CAP, ELE 8200μ/50V	674	R18	5135-332522	RES, CBN 1/2P 3.3K
687	C6	5341-828F0355	CAP, ELE 8200μ/50V	673	R19	5135-102522	RES, CBN 1/2P 1K
660	C7	5345-105F041	CAP, MINI ELE 1μ/50V	673	R20	5135-102522	RES, CBN 1/2P 1K
661	C8	5345-107B041	CAP, MINI ELE 100μ/10V	674	R21	5135-332522	RES, CBN 1/2P 3.3K
659	C9	5345-106C041	CAP, MINI ELE 10μ/16V	674	R22	5135-332522	RES, CBN 1/2P 3.3K
659	C10	5345-106C041	CAP, MINI ELE 10μ/16V	670	R23	5135-472522	RES, CBN 1/2P 4.7K
663	C15	5354-683J1HM	CAP, MYL .068μ	670	R24	5135-472522	RES, CBN 1/2P 4.7K
663	C16	5354-683J1HM	CAP, MYL .068μ	671	R25	5135-473522	RES, CBN 1/2P 47K
664	C17	5354-473J1HM	CAP, MYL .047μ	672	R26	5135-223522	RES, CBN 1/2P 22K
665	C21	5354-104593	CAP, MYL .1μ	671	R28	5135-473522	RES, CBN 1/2P 47K
665	C22	5354-104593	CAP, MYL .1μ	668	R30	5135-103522	RES, CBN 1/2P 10K
665	C23	5354-104593	CAP, MYL .1μ	666	R31	5135-682522	RES, CBN 1/2P 6.8K
665	C24	5354-104593	CAP, MYL .1μ	666	R32	5135-682522	RES, CBN 1/2P 6.8K
057B	C35	5352-1041957	CAP, MTL .1μ G GB	603	R401	5135-102522	RES, CBN 1/2P 1K
060B	C36	5361-103ZF	CAP, CER .01μ G GB	603	R402	5135-102522	RES, CBN 1/2P 1K
581	C401	5345-476B0951	CAP, MINI ELE 47μ/10V	604	R403	5135-683522	RES, CBN 1/2P 68K
581	C402	5345-476B0951	CAP, MINI ELE 47μ/10V	604	R404	5135-683522	RES, CBN 1/2P 68K
583	C403	5345-106C041	CAP, MINI ELE 10μ/16V	605	R405	5135-122522	RES, CBN 1/2P 1.2K
583	C404	5345-106C041	CAP, MINI ELE 10μ/16V	605	R406	5135-122522	RES, CBN 1/2P 1.2K
582	C405	5345-227A0951	CAP, MINI ELE 220μ/6.3V	605	R407	5135-122522	RES, CBN 1/2P 1.2K
582	C406	5345-227A0951	CAP, MINI ELE 220μ/6.3V	605	R408	5135-122522	RES, CBN 1/2P 1.2K
592	C407	5353-020934	CAP, MCA 2p	606	R409	5135-682522	RES, CBN 1/2P 6.8K
592	C408	5353-020934	CAP, MCA 2p	606	R410	5135-682522	RES, CBN 1/2P 6.8K
590	C409	5359-1015851	CAP, PPP 100p	607	R411	5135-680522	RES, CBN 1/2P 68
590	C410	5359-1015851	CAP, PPP 100p	607	R412	5135-680522	RES, CBN 1/2P 68
583	C411	5345-106C041	CAP, MINI ELE 10μ/16V	607	R413	5135-680522	RES, CBN 1/2P 68
583	C412	5345-106C041	CAP, MINI ELE 10μ/16V	607	R414	5135-680522	RES, CBN 1/2P 68
595	C413	5354-683J1HM	CAP, MYL .068μ	623	R415	5135-222522	RES, CBN 1/2P 2.2K
595	C414	5354-683J1HM	CAP, MYL .068μ	623	R416	5135-222522	RES, CBN 1/2P 2.2K
595	C415	5354-683J1HM	CAP, MYL .068μ	609	R417	5135-561522	RES, CBN 1/2P 560
595	C416	5354-683J1HM	CAP, MYL .068μ	609	R418	5135-561522	RES, CBN 1/2P 560
583	C417	5345-106C041	CAP, MINI ELE 10μ/16V	604	R419	5135-683522	RES, CBN 1/2P 68K
583	C418	5345-106C041	CAP, MINI ELE 10μ/16V	604	R420	5135-683522	RES, CBN 1/2P 68K
584	C421	5345-337F041	CAP, MINI ELE 330μ/50V	638	△R421	5102-3314715	RES, FUSE 330
584	C422	5345-337F041	CAP, MINI ELE 330μ/50V	638	△R422	5102-3314715	RES, FUSE 330
584	C423	5345-337F041	CAP, MINI ELE 330μ/50V	638	△R423	5102-3314715	RES, FUSE 330
584	C424	5345-337F041	CAP, MINI ELE 330μ/50V	638	△R424	5102-3314715	RES, FUSE 330
590	C475	5359-1015851	CAP, PPP 100p	610	R425	5135-473522	RES, CBN 1/2P 47K
590	C476	5359-1015851	CAP, PPP 100p	610	R426	5135-473522	RES, CBN 1/2P 47K
585	C505	5345-225F0951	CAP, MINI ELE 2.2μ/50V	610	R427	5135-473522	RES, CBN 1/2P 47K
585	C506	5345-225F0951	CAP, MINI ELE 2.2μ/50V	610	R428	5135-473522	RES, CBN 1/2P 47K
596	C507	5354-563J1HM	CAP, MYL .056μ	611	R429	5135-224522	RES, CBN 1/2P 220K
596	C508	5354-563J1HM	CAP, MYL .056μ	611	R430	5135-224522	RES, CBN 1/2P 220K
599	C509	5354-224593	CAP, MYL .22μ	618	R431	5135-910522	RES, CBN 1/2P 91
599	C510	5354-224593	CAP, MYL .22μ	618	R432	5135-910522	RES, CBN 1/2P 91
586	C511	5345-106C0951	CAP, MINI ELE 10μ/16V	612	R433	5135-272522	RES, CBN 1/2P 2.7K
586	C512	5345-106C0951	CAP, MINI ELE 10μ/16V	612	R434	5135-272522	RES, CBN 1/2P 2.7K
597	C513	5354-822J1HM	CAP, MYL 8200p	613	R435	5135-223522	RES, CBN 1/2P 22K
597	C514	5354-822J1HM	CAP, MYL 8200p	613	R436	5135-223522	RES, CBN 1/2P 22K
598	C515	5354-393J1HM	CAP, MYL .039μ	613	R437	5135-223522	RES, CBN 1/2P 22K
598	C516	5354-393J1HM	CAP, MYL .039μ	613	R438	5135-223522	RES, CBN 1/2P 22K
591	C517	5359-3915851	CAP, PPP 390p	624	R439	5135-153522	RES, CBN 1/2P 15K
591	C518	5359-3915851	CAP, PPP 390p	624	R440	5135-153522	RES, CBN 1/2P 15K
RESISTORS							
680	△R3	5102-2204715	RES, FUSE 22	614	R441	5135-123522	RES, CBN 1/2P 12K
680	△R4	5102-2204715	RES, FUSE 22	614	R442	5135-123522	RES, CBN 1/2P 12K
679	△R5	5102-5R64715	RES, FUSE 5.6	633	R443	5174-222381	RES, MTL 1/4 2.2K
668	R6	5135-103522	RES, CBN 1/2P 10K	633	R444	5174-222381	RES, MTL 1/4 2.2K
677	R7	5135-220522	RES, CBN 1/2P 22	633	R445	5174-222381	RES, MTL 1/4 2.2K
677	R8	5135-220522	RES, CBN 1/2P 22	633	R446	5174-222381	RES, MTL 1/4 2.2K
670	R9	5135-472522	RES, CBN 1/2P 4.7K	636	△R447	5102-4704715	RES, FUSE 47
670	R10	5135-472522	RES, CBN 1/2P 4.7K	636	△R448	5102-4704715	RES, FUSE 47
667	R11	5135-822522	RES, CBN 1/2P 8.2K	636	△R449	5102-4704715	RES, FUSE 47
669	R12	5135-104522	RES, CBN 1/2P 100K	636	△R450	5102-4704715	RES, FUSE 47
675	R13	5135-683522	RES, CBN 1/2P 68K	615	R455	5135-821522	RES, CBN 1/2P 820
676	R14	5135-333522	RES, CBN 1/2P 33K	615	R456	5135-821522	RES, CBN 1/2P 820
				615	R457	5135-821522	RES, CBN 1/2P 820
				615	R458	5135-821522	RES, CBN 1/2P 820
				625	R459	5135-183522	RES, CBN 1/2P 18K
				625	R460	5135-183522	RES, CBN 1/2P 18K
				625	R461	5135-183522	RES, CBN 1/2P 18K

Ser. No.	Ref. No.	Part No.	Description
625	R462	5135-183522	RES, CBN 1/2P 18K
617	R463	5135-100522	RES, CBN 1/2P 10
617	R464	5135-100522	RES, CBN 1/2P 10
617	R465	5135-100522	RES, CBN 1/2P 10
617	R466	5135-100522	RES, CBN 1/2P 10
637	△R467	5102-1004715	RES, FUSE 10
637	△R468	5102-1004715	RES, FUSE 10
637	△R469	5102-1004715	RES, FUSE 10
637	△R470	5102-1004715	RES, FUSE 10
639	R471	5273-R27672	RES, CEM 3P .27
639	R472	5273-R27672	RES, CEM 3P .27
605	R475	5135-122522	RES, CBN 1/2P 1.2K
605	R476	5135-122522	RES, CBN 1/2P 1.2K
616	R483	5135-820522	RES, CBN 1/2P 82
616	R484	5135-820522	RES, CBN 1/2P 82
617	R485	5135-100522	RES, CBN 1/2P 10
617	R486	5135-100522	RES, CBN 1/2P 10
617	R487	5135-100522	RES, CBN 1/2P 10
617	R488	5135-100522	RES, CBN 1/2P 10
639	R489	5273-R27672	RES, CEM 3P .27
639	R490	5273-R27672	RES, CEM 3P .27
627	R491	5135-4R7522	RES, CBN 1/2P 4.7
627	R492	5135-4R7522	RES, CBN 1/2P 4.7
627	R493	5135-4R7522	RES, CBN 1/2P 4.7
627	R494	5135-4R7522	RES, CBN 1/2P 4.7
626	R495	5135-220522	RES, CBN 1/2P 22
626	R496	5135-220522	RES, CBN 1/2P 22
607	R499	5135-680522	RES, CBN 1/2P 68
607	R500	5135-680522	RES, CBN 1/2P 68
619	R501	5135-152522	RES, CBN 1/2P 1.5K
619	R502	5135-152522	RES, CBN 1/2P 1.5K
620	R507	5135-822522	RES, CBN 1/2P 8.2K
620	R508	5135-822522	RES, CBN 1/2P 8.2K
621	R509	5135-182522	RES, CBN 1/2P 1.8K
621	R510	5135-182522	RES, CBN 1/2P 1.8K
622	R513	5135-271522	RES, CBN 1/2P 270
622	R514	5135-271522	RES, CBN 1/2P 270
TRANSISTORS			
652	Q1	5611-1115(F)or(E)	XISTOR, PNP R
651	Q2	5613-2603(F)or(E)	XISTOR, NPN R
653	Q3	5611-970(BL)	XISTOR, PNP R
653	Q4	5611-970(BL)	XISTOR, PNP R
653	Q5	5611-970(BL)	XISTOR, PNP R
653	Q6	5611-970(BL)	XISTOR, PNP R
654	Q7	5613-2240(BL)	XISTOR, NPN R
561	Q401	5613-2240(BL)	XISTOR, NPN R
561	Q402	5613-2240(BL)	XISTOR, NPN R
561	Q403	5613-2240(BL)	XISTOR, NPN R
561	Q404	5613-2240(BL)	XISTOR, NPN R
562	Q405	5613-2603(F)or(E)	XISTOR, NPN R
562	Q406	5613-2603(F)or(E)	XISTOR, NPN R
562	Q407	5613-2603(F)or(E)	XISTOR, NPN R
562	Q408	5613-2603(F)or(E)	XISTOR, NPN R
563	Q409	5611-970(BL)	XISTOR, PNP R
563	Q410	5611-970(BL)	XISTOR, PNP R
573	Q411	5613-2240(BL)	XISTOR, NPN R
573	Q412	5613-2240(BL)	XISTOR, NPN R
573	Q413	5613-2240(BL)	XISTOR, NPN R
573	Q414	5613-2240(BL)	XISTOR, NPN R
563	Q415	5611-970(BL)	XISTOR, PNP R
563	Q416	5611-970(BL)	XISTOR, PNP R
564	Q417	5612-646A(C)	XISTOR, PNP A
564	Q418	5612-646A(C)	XISTOR, PNP A
565	Q419	5614-666A(C)	XISTOR, NPN A
565	Q420	5614-666A(C)	XISTOR, NPN A
566	Q425	5613-945(K)or(P)	XISTOR, NPN R
566	Q426	5613-945(K)or(P)	XISTOR, NPN R
567	Q427	5614-667A(C)	XISTOR, NPN A
567	Q428	5614-667A(C)	XISTOR, NPN A
568	Q429	5612-647A(C)	XISTOR, PNP A
568	Q430	5612-647A(C)	XISTOR, PNP A
569	Q431	5613-3181(O)or(R)	XISTOR, NPN R
569	Q432	5613-3181(O)or(R)	XISTOR, NPN R

Ser. No.	Ref. No.	Part No.	Description
571	Q433	5611-1264(O)or(R)	XISTOR, PNP R
571	Q434	5611-1264(O)or(R)	XISTOR, PNP R
DIODES			
681	△D1	5632-ERC402FL	DIODE, RECT
681	△D2	5632-ERC402FL	DIODE, RECT
681	△D3	5632-ERC402FL	DIODE, RECT
681	△D4	5632-ERC402FL	DIODE, RECT
656	D5	5636-1S2471	DIODE, SWITCH
656	D6	5636-1S2471	DIODE, SWITCH
656	D7	5636-1S2471	DIODE, SWITCH
656	D8	5636-1S2471	DIODE, SWITCH
657	D11	5635-HZ6B-1L	DIODE, ZENER
579	D401	5641-MV12YM	VARIATOR
579	D402	5641-MV12YM	VARIATOR
577	D403	5632-S5566B	DIODE, RECT
577	D404	5632-S5566B	DIODE, RECT
577	D405	5632-S5566B	DIODE, RECT
577	D406	5632-S5566B	DIODE, RECT
575	D407	5631-1S2473	DIODE, DET
575	D408	5631-1S2473	DIODE, DET
576	D409	5635-HZ12B2L	DIODE, ZENER
576	D410	5635-HZ12B2L	DIODE, ZENER
COILS			
643	L401	5597-45502	CORE, BEADS
643	L402	5597-45502	CORE, BEADS
643	L403	5597-45502	CORE, BEADS
643	L404	5597-45502	CORE, BEADS
644	L405	5991-7165	SPRING COIL
644	L406	5991-7165	SPRING COIL
CONTROLS			
641	VR401	5101-50171920	RES, SEMI FIX 500
641	VR402	5101-50171920	RES, SEMI FIX 500
720	VR501	5113-50399122	RES, V CBN 16 50K
720	VR502	5113-50399122	RES, V CBN 16 50K
714	VR505	5113-10441122	RES, V CBN 16 100K
714	VR506	5113-10441122	RES, V CBN 16 100K
717	VR507	5113-50342122	RES, V CBN 16 50K
717	VR508	5113-50342122	RES, V CBN 16 50K
MISCELLANEOUS			
764	JL107	4242-R0203600	JUMPER LEAD
763	JL109	4242-R0103201	JUMPER LEAD
762	JL110	4242-R0104181	JUMPER LEAD
694	TM101	4214-11023	TERMINAL
693	TM102	4214-11013	TERMINAL
646	TM110	4214-11013	TERMINAL
699	CN601	4443-030185	CONNECTOR
747	LCN2	4163-0140026	CONNECTOR W/W
748	LCN3	4163-0140027	CONNECTOR W/W
749	LCN4	4163-0140024	CONNECTOR W/W
750	LCN5	4163-0140025	CONNECTOR W/W
751	LCN6	4163-0116024	CONNECTOR W/W
751	LCN7	4163-0116024	CONNECTOR W/W
751	LCN8	4163-0116024	CONNECTOR W/W
753	LCN9	4163-0116020	CONNECTOR W/W
755	LCN110	4163-0125025	CONNECTOR W/W
756	LCN111	4163-0125024	CONNECTOR W/W
757	LCN112	4163-0125026	CONNECTOR W/W
758	LCN113	4163-0125027	CONNECTOR W/W
PCB-2 SPEAKER TERMINAL P.C BOARD			
CAPACITORS			
061B	C39	5359-4715851	CAP, PPP 470p 
061B	C40	5359-4715851	CAP, PPP 470p 
061B	C41	5359-4715851	CAP, PPP 470p 
061B	C42	5359-4715851	CAP, PPP 470p 
MISCELLANEOUS			
761	JL120	4242-043805	JUMPER LEAD
743	TM10	4214-156	TERMINAL

PCB-3 HEADPHONE P.C. BOARD

RESISTORS				
634	R497	5171-471571	RES, MTL 1	470
634	R498	5171-471571	RES, MTL 1	470
MISCELLANEOUS				
736	J1	4451-00159	JACK, 1P	

PCB-4 LED P.C. BOARD

CAPACITORS				
051D	C31	5345-106C0356	CAP, MINI ELE	10μ/16V N
051D	C32	5345-106C0356	CAP, MINI ELE	10μ/16V N
DIODES				
741	D9	5637-SLP965B5	LED	
741	D10	5637-SLP965B5	LED	

PCB-5 SPEAKER SWITCH P.C. BOARD

729	SW5	4411-00301104	SWITCH, ROTARY	
765	JL108	4242-R0103101	JUMPER LEAD	

PCB-6 SWITCH P.C. BOARD

734	SW2	4421-0227143	SWITCH, SLIDE	
-----	-----	--------------	---------------	--

PCB-7 VR P.C. BOARD

RESISTORS				
631	R571	5135-273522	RES, CBN 1/2P	27K
631	R572	5135-273522	RES, CBN 1/2P	27K
CONTROLS				
711	VR503	5113-10419122	RES, V CBN 16	100K
711	VR504	5113-10419122	RES, V CBN 16	100K

PCB-8 LOUDNESS P.C. BOARD

CAPACITORS				
589	C575	5359-1815851	CAP, PPP	180p
589	C576	5359-1815851	CAP, PPP	180p
594	C577	5354-823J1HM	CAP, MYL	.082μ
594	C578	5354-823J1HM	CAP, MYL	.082μ
RESISTORS				
629	R573	5135-472522	RES, CBN 1/2P	4.7K
629	R574	5135-273522	RES, CBN 1/2P	27K
630	R575	5135-273522	RES, CBN 1/2P	27K
630	R576	5232-823J16P	RES, CBN 1/2P	82K
MISCELLANEOUS				
733	SW8	4431-A027610	SWITCH, PUSH	
766	JL111	4242-R0105800	JUMPER LEAD	

PCB-9 POWER SWITCH P.C. BOARD

CAPACITORS				
688	ΔC1	5361-1030419	CAP, CER	.01μ UA BK
688B	ΔC1	5352-1030958	CAP, MTL	.01μ G GB
688D	ΔC1	5352-1030961	CAP, MTL	.01μ N
RESISTORS				
054B	ΔR1	5135-335522	RES, CBN 1/2P	3.3M G GB
MISCELLANEOUS				
732	ΔSW1	4431-A01716	SWITCH, PUSH	
684	ΔHF1	4472-0131	HOLDER, FUSE	
684	ΔHF2	4472-0131	HOLDER, FUSE	
696	TM1	4214-122	TERMINAL	
696	TM2	4214-122	TERMINAL	
696	TM3	4214-122	TERMINAL	

PCB-10 FUNCTION P.C. BOARD

CAPACITORS				
059B	C581	5359-1015851	CAP, PPP	100p G GB
059B	C582	5359-1015851	CAP, PPP	100p G GB
COILS				
058B	L591	5597-45502	CORE, BEADS	G GB
058B	L592	5597-45502	CORE, BEADS	G GB
723	SW3	4411-00203104	SWITCH, ROTARY	
726	SW4	4411-00204204	SWITCH, ROTARY	
700	CN107	4443-030185	CONNECTOR	
754	LCN10	4163-0108020	CONNECTOR W/W	
768	JL101	4242-R0103181	JUMPER LEAD	
767	JL102	4242-R0203101	JUMPER LEAD	
769	JL103	4242-R0104301	JUMPER LEAD	
772	JL104	4242-R0107301	JUMPER LEAD	
771	JL105	4242-R0107251	JUMPER LEAD	
770	JL106	4242-R0105181	JUMPER LEAD	

PCB-11 EQUALIZER P.C. BOARD

CAPACITORS				
513	C601	5345-336C0951	CAP, MINI ELE	33μ/16V
513	C602	5345-336C0951	CAP, MINI ELE	33μ/16V
520	C603	5359-1215851	CAP, PPP	120p
520	C604	5359-1215851	CAP, PPP	120p
514	C605	5345-107B0951	CAP, MINI ELE	100μ/10V
514	C606	5345-107B0951	CAP, MINI ELE	100μ/10V
521	C607	5359-5625851	CAP, PPP	5600p
521	C608	5359-5625851	CAP, PPP	5600p
522	C609	5359-2025851	CAP, PPP	2000p
522	C610	5359-2025851	CAP, PPP	2000p
515	C611	5345-106C0951	CAP, MINI ELE	10μ/16V
515	C612	5345-106C0951	CAP, MINI ELE	10μ/16V
517	C613	5345-337F041	CAP, MINI ELE	330μ/50V
516	C614	5345-227D041	CAP, MINI ELE	220μ/25V
516	C615	5345-227D041	CAP, MINI ELE	220μ/25V
056B	C631	5353-820534	CAP, MCA	82p G GB
056B	C632	5353-820534	CAP, MCA	82p G GB

RESISTORS				
526	R601	5232-823J16P	RES, CBN 1/6P	82K
526	R602	5232-124J16P	RES, CBN 1/6P	120K
527	R603	5232-124J16P	RES, CBN 1/6P	120K
527	R604	5232-221J16P	RES, CBN 1/6P	220
528	R605	5232-221J16P	RES, CBN 1/6P	220
528	R606	5232-392J16P	RES, CBN 1/6P	3.9K
529	R607	5232-392J16P	RES, CBN 1/6P	3.9K
529	R608	5232-681J16P	RES, CBN 1/6P	680
530	R609	5232-681J16P	RES, CBN 1/6P	680
530	R610	5232-122J16P	RES, CBN 1/6P	1.2K
531	R611	5232-122J16P	RES, CBN 1/6P	1.2K
531	R612	5232-223J16P	RES, CBN 1/6P	22K
532	R613	5232-223J16P	RES, CBN 1/6P	22K
532	R614	5232-221J16P	RES, CBN 1/6P	220
528	R615	5232-221J16P	RES, CBN 1/6P	220
528	R616	5232-101J16P	RES, CBN 1/6P	100
533	R617	5232-101J16P	RES, CBN 1/6P	100
533	R618	5232-101J16P	RES, CBN 1/6P	100
534	R621	5232-751J16P	RES, CBN 1/6P	750
534	R622	5232-751J16P	RES, CBN 1/6P	750
535	R623	5232-393J16P	RES, CBN 1/6P	39K
535	R624	5232-393J16P	RES, CBN 1/6P	39K
536	R625	5232-684J16P	RES, CBN 1/6P	680K
536	R626	5232-684J16P	RES, CBN 1/6P	680K
537	R627	5232-334J16P	RES, CBN 1/6P	330K
537	R628	5232-334J16P	RES, CBN 1/6P	330K
538	R629	5232-102J16P	RES, CBN 1/6P	1K
538	R630	5232-102J16P	RES, CBN 1/6P	1K
539	R631	5232-104J16P	RES, CBN 1/6P	100K
539	R632	5232-104J16P	RES, CBN 1/6P	100K

Ser. No.	Ref. No.	Part No.	Description
528	R633	5232-221J16P	RES, CBN 1/6P 220
528	R634	5232-221J16P	RES, CBN 1/6P 220
540	R635	5232-222J16P	RES, CBN 1/6P 2.2K
540	R636	5232-222J16P	RES, CBN 1/6P 2.2K
546	R637	5176-S010J47I	RES, MTL 1/2 470
550	△R638	5102-2214715	RES, FUSE 220
551	△R639	5102-1814715	RES, FUSE 180
545	R640	5176-S010J33I	RES, MTL 1/2 330
544	R641	5135-123522	RES, CBN 1/2P 12K
055B	R671	5232-102J16P	RES, CBN 1/6P 1K G GB
055B	R672	5232-102J16P	RES, CBN 1/6P 1K G GB
055B	R673	5232-102J16P	RES, CBN 1/6P 1K G GB
055B	R674	5232-102J16P	RES, CBN 1/6P 1K G GB

TRANSISTORS

501	Q601	5613-2320L(F)	XISTOR, NPN R
501	Q602	5613-2320L(F)	XISTOR, NPN R
503	Q603	5611-999L(F)	XISTOR, PNP R
503	Q604	5611-999L(F)	XISTOR, PNP R
504	Q605	5611-1115(F)or(E)	XISTOR, PNP R
504	Q606	5611-1115(F)or(E)	XISTOR, PNP R
502	Q607	5613-2603(F)or(E)	XISTOR, NPN R
502	Q608	5613-2603(F)or(E)	XISTOR, NPN R
502	Q609	5613-2603(F)or(E)	XISTOR, NPN R
502	Q610	5613-2603(F)or(E)	XISTOR, NPN R
502	Q611	5613-2603(F)or(E)	XISTOR, NPN R
502	Q612	5613-2603(F)or(E)	XISTOR, NPN R
505	Q613	5611-1359(Y)or(O)	XISTOR, PNP R

DIODES

509	D601	5635-HZ15-2L	DIODE, ZENER
510	D602	5632-S5566B	DIODE, RECT

MISCELLANEOUS

737	J2	4482-0133	PIN JACK, 2P UA BK G GB
737D	J2	4482-7136	PIN JACK, 2P N
738	J3	4484-46	PIN JACK, 4P UA BK G GB
738D	J3	4484-50	PIN JACK, 4P N
738	J4	4484-46	PIN JACK, 4P UA BK G GB
738D	J4	4484-50	PIN JACK, 4P N
739	J5	4486-15	PIN JACK, 6P UA BK G GB
739D	J5	4486-18	PIN JACK, 6P N
752	LCN601	4163-0130020	CONNECTOR W/W

CHASSIS MISCELLANEOUS

683	△T1	5584-S08	XFORMER, POWER UA BK
683B	△T1	5584-S09	XFORMER, POWER G GB
683D	△T1	5584-S10	XFORMER, POWER N
685	△F1	5732-312031	FUSE UA BK
685B	△F1	5732-162052	FUSE G GB
685D	△F1	5732-402036	FUSE N
744	△S01	4474-227	SOCKET, AC OUTLET
745	△P1	4161-71151	CORD W/PLUG UA BK
745B	△P1	4161-7256	CORD W/PLUG G GB
745D	△P1	4161-71133	CORD W/PLUG N
062C	LUG1	4211-4	LUG G GB
062C	LUG2	4211-4	LUG G GB

PACKAGE PARTS LIST

021B	1756-06303	LABEL G GB
021D	1756-03113	LABEL N
022B	1756-03108	LABEL G GB
023D	1241-PB	POLYETHYLENE BAG N
027B	1119-026	ATTACH SHEET G GB
106	1111-J90915	OWNER GUIDE
107	1111-J30267	OWNER GUIDE UA BK
107B	1111-J30268	OWNER GUIDE G GB
107D	1111-J2038	OWNER GUIDE N
108	1113-717004	OWNER CARD UA BK G GB
108D	1113-OC	OWNER CARD N
109	1119-047	ATTACH SHEET UA BK G GB

Ser. No.	Ref. No.	Part No.	Description
109D		1119-GC	ATTACH SHEET N
110		1119-0137	ATTACH SHEET
121		1241-C12732	POLYETHYLENE BAG
122		1241-C1491	POLYETHYLENE BAG
124		1221-857144	CARTON BOX
125		1222-7216	CUSHION
127		1223-11729	SOFT SHEET

ABBREVIATIONS IN PARTS LIST

CAPACITORS

CAP, MINI ELE	: Electrolytic
CAP, CER	: Ceramic
CAP, PPP	: Polypropylene
CAP, MYL	: Mylar
CAP, MCA	: Mica
CAP, MINI BP	: Bipolar
CAP, ELE BP	: Electrolytic Bipolar
CAP, STY	: Polystyrene Film
CAP, SPE	: Special
CAP, TAN	: Tantalum

470μ	: 470μF
6800p	: 6800pF
.047μ	: 0.047μF

RESISTORS

RES, CBN 1/6P	: Carbon 1/6W
RES, FUSE	: Fuse
RES, CEM 5P	: Cement 5W
RES, MTL 1P	: Metal 1W
	2.2K : 2.2kΩ
	220 : 220Ω

TRANSISTORS

XISTOR	: Transistor
FET	: Field Effect Transistor

CONTROLS

RES, V CBN	: Variable Carbon Resistor
RES, SEMI FIX	: Semi-fixed Resistor

NOTE



SAFETY RELATED COMPONENT. USE ONLY EXACT REPLACEMENT PART AS SPECIFIED.

SCHEMATIC DIAGRAM

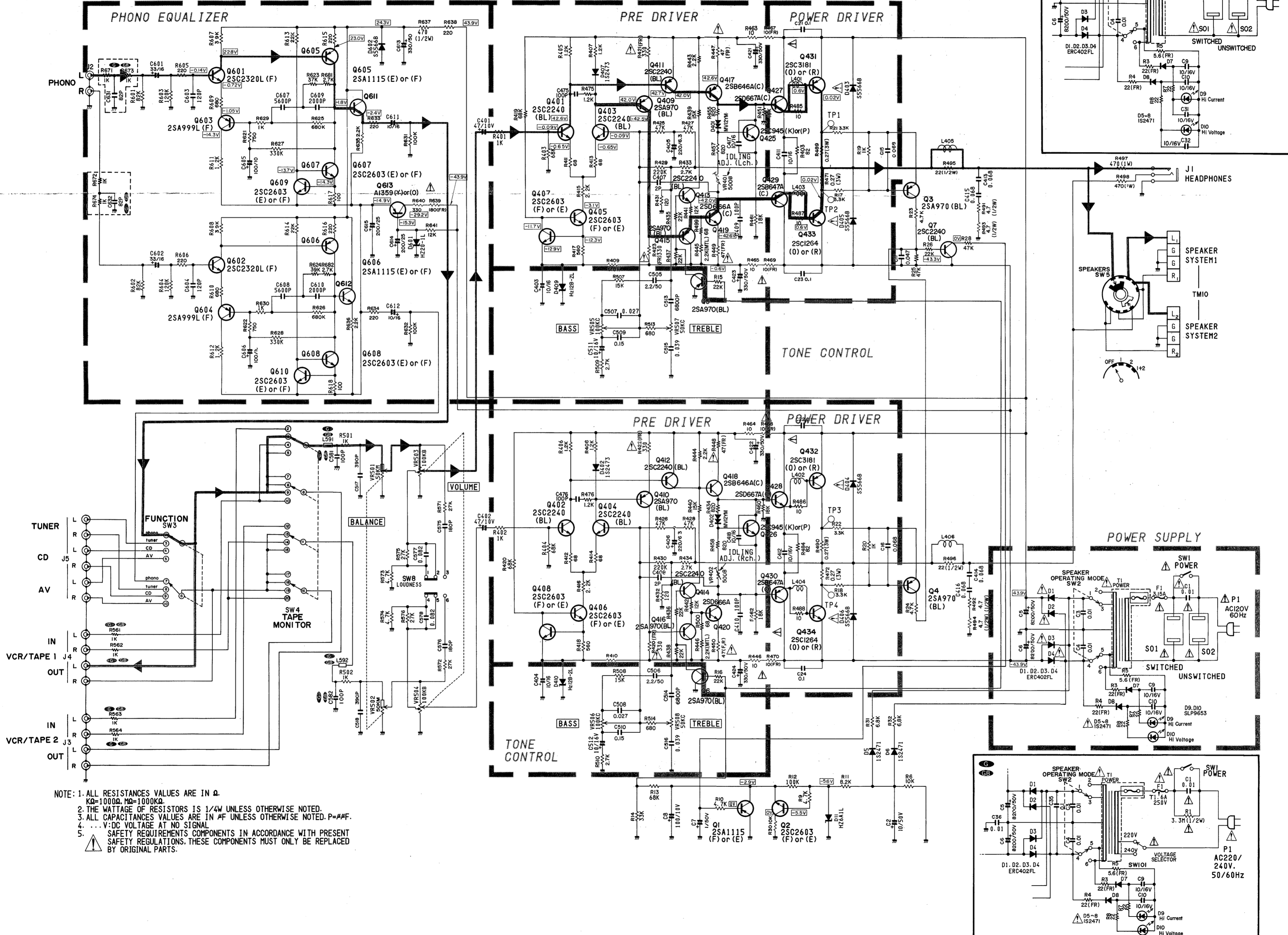

NOTE: 1. ALL RESISTANCES VALUES ARE IN Ω .
 K Ω =1000 Ω , M Ω =1000K Ω .
 2. THE WATTAGE OF RESISTORS IS 1/4W UNLESS OTHERWISE NOTED.
 3. ALL CAPACITANCES VALUES ARE IN μ F UNLESS OTHERWISE NOTED. P=# μ F.
 4. ... V:DC VOLTAGE AT NO SIGNAL
 5. SAFETY REQUIREMENTS COMPONENTS IN ACCORDANCE WITH PRESENT SAFETY REGULATIONS. THESE COMPONENTS MUST ONLY BE REPLACED BY ORIGINAL PARTS.

SCHEMATIC DIAGRAM

PHONO EQUALIZER

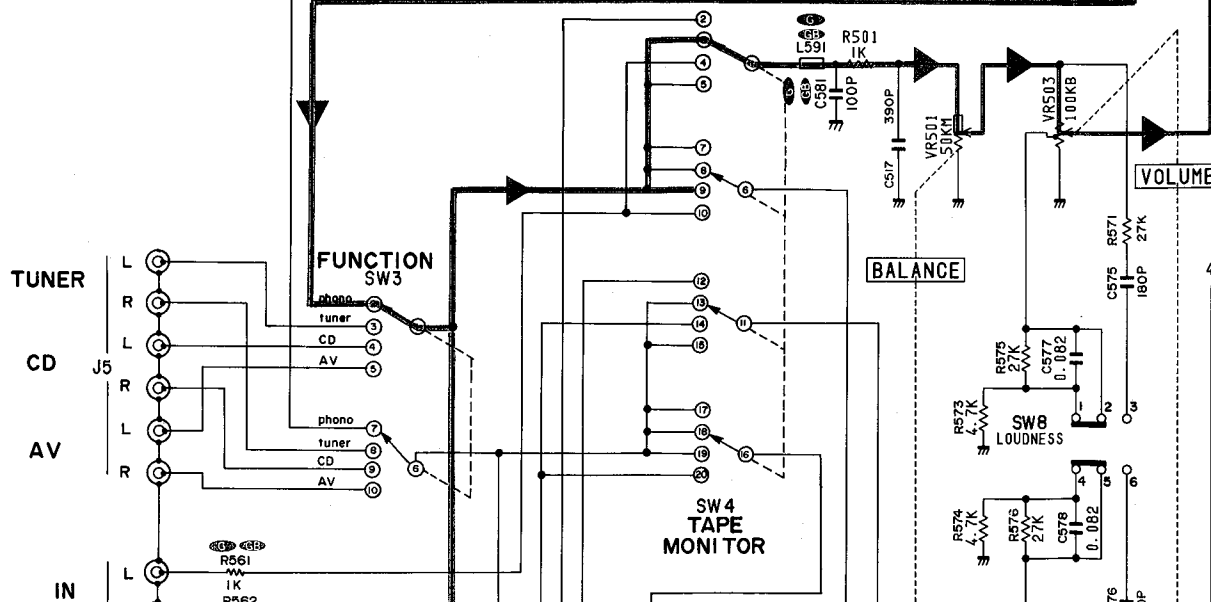
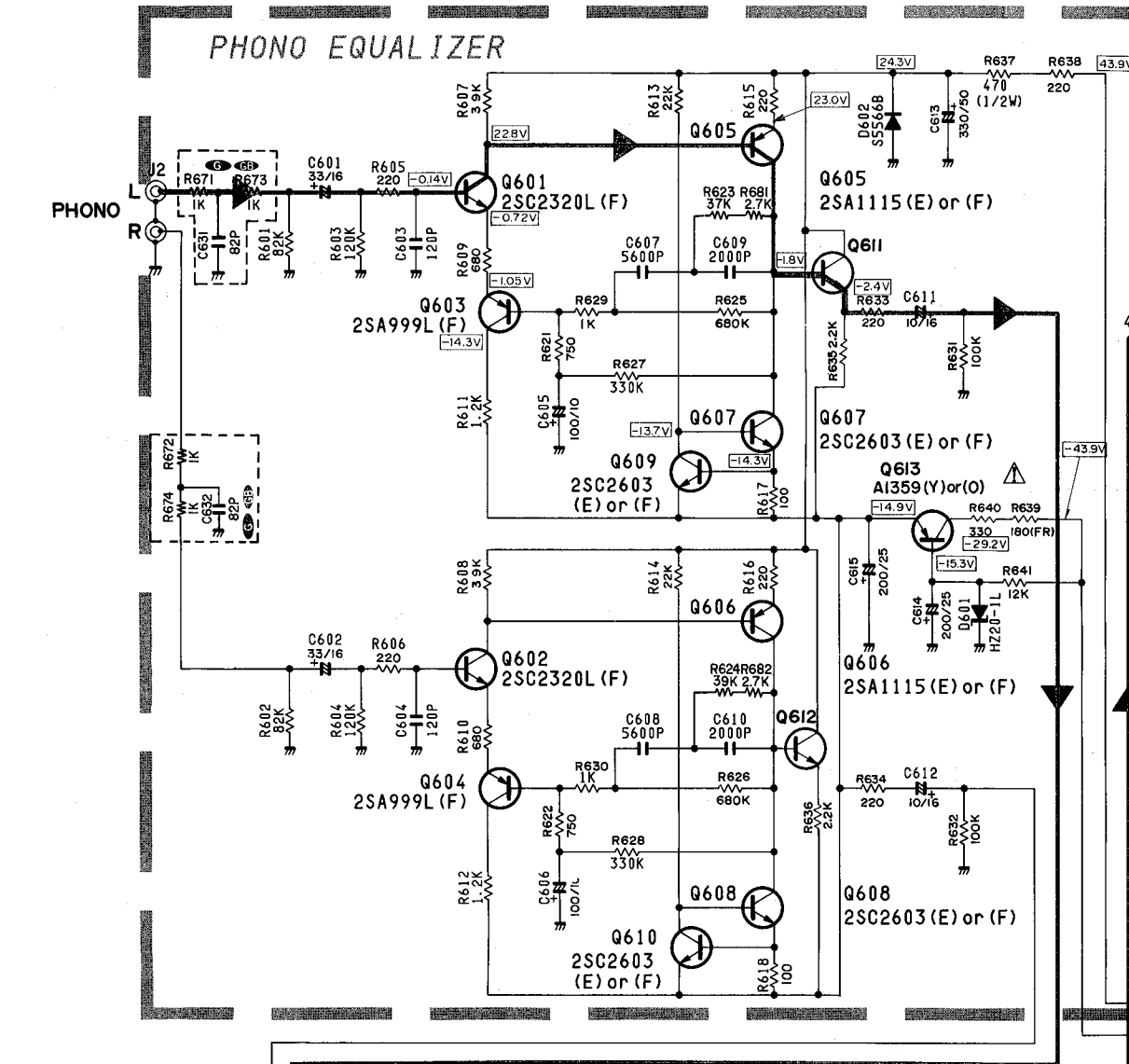

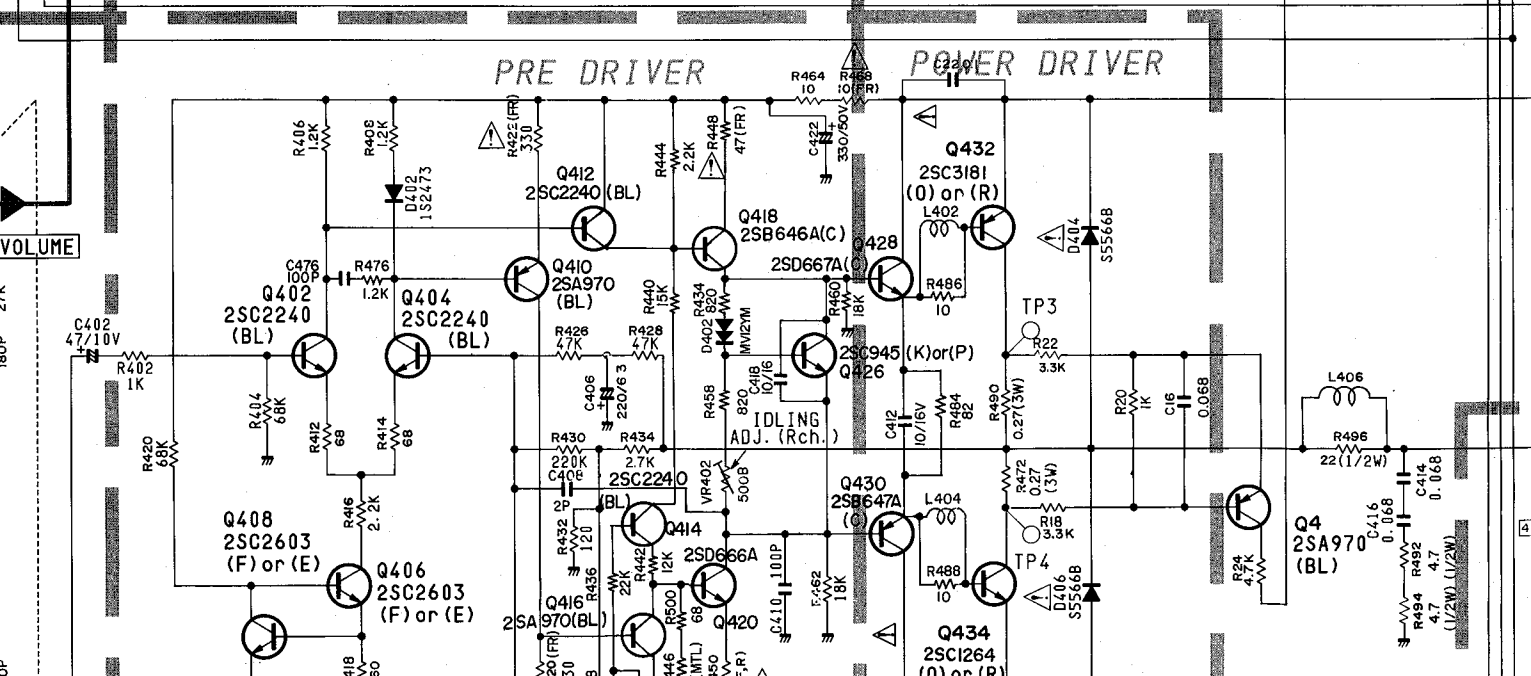
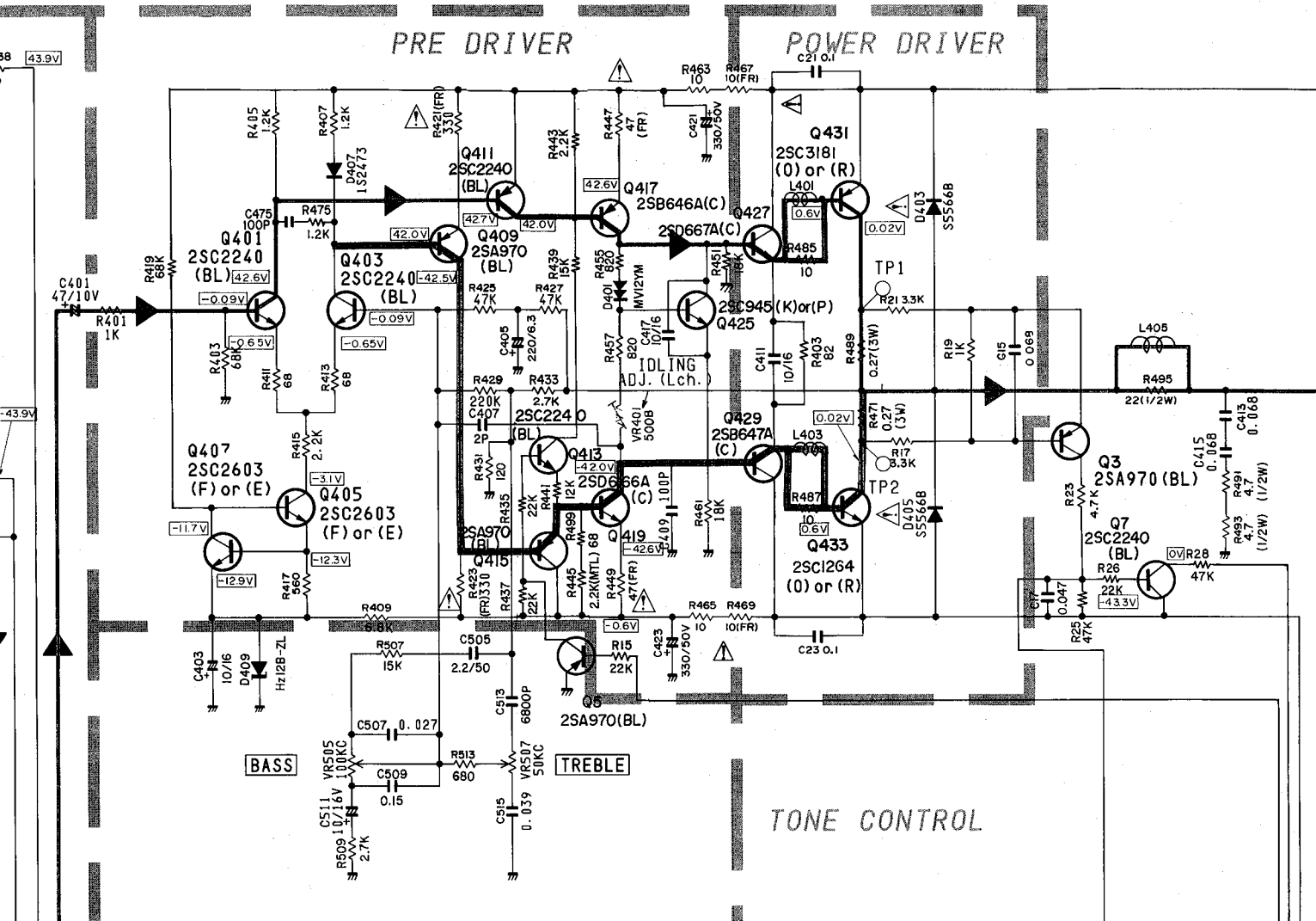

J

K

L

M

N

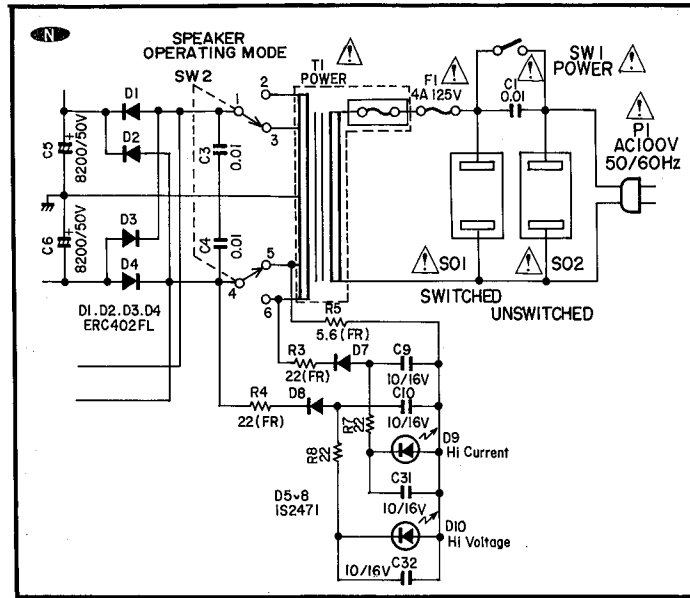

VER

OL

VER

55566B

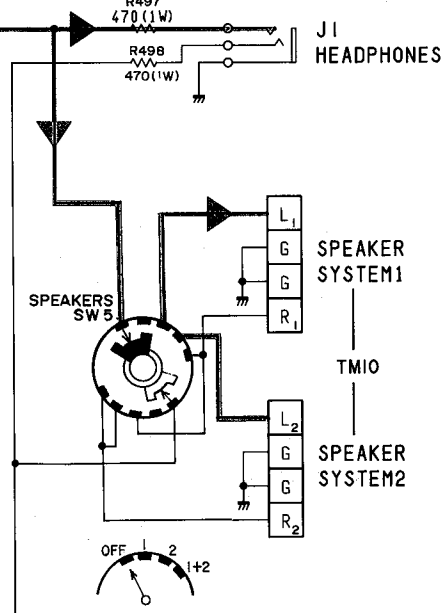
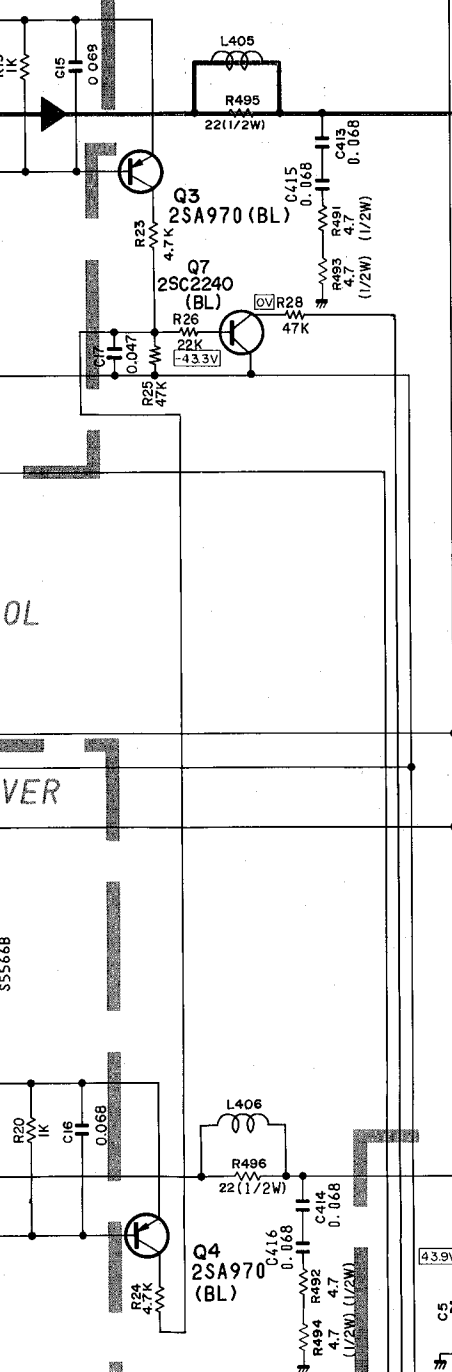

POWER SUPPLY

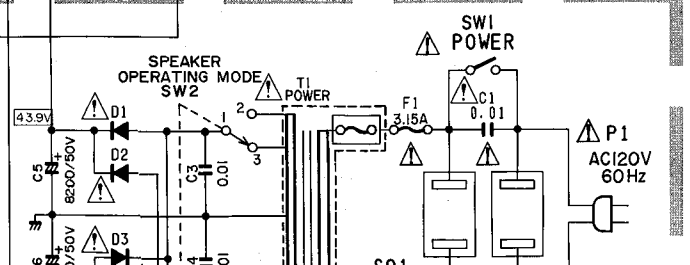

4

5

6

7

8

9

10

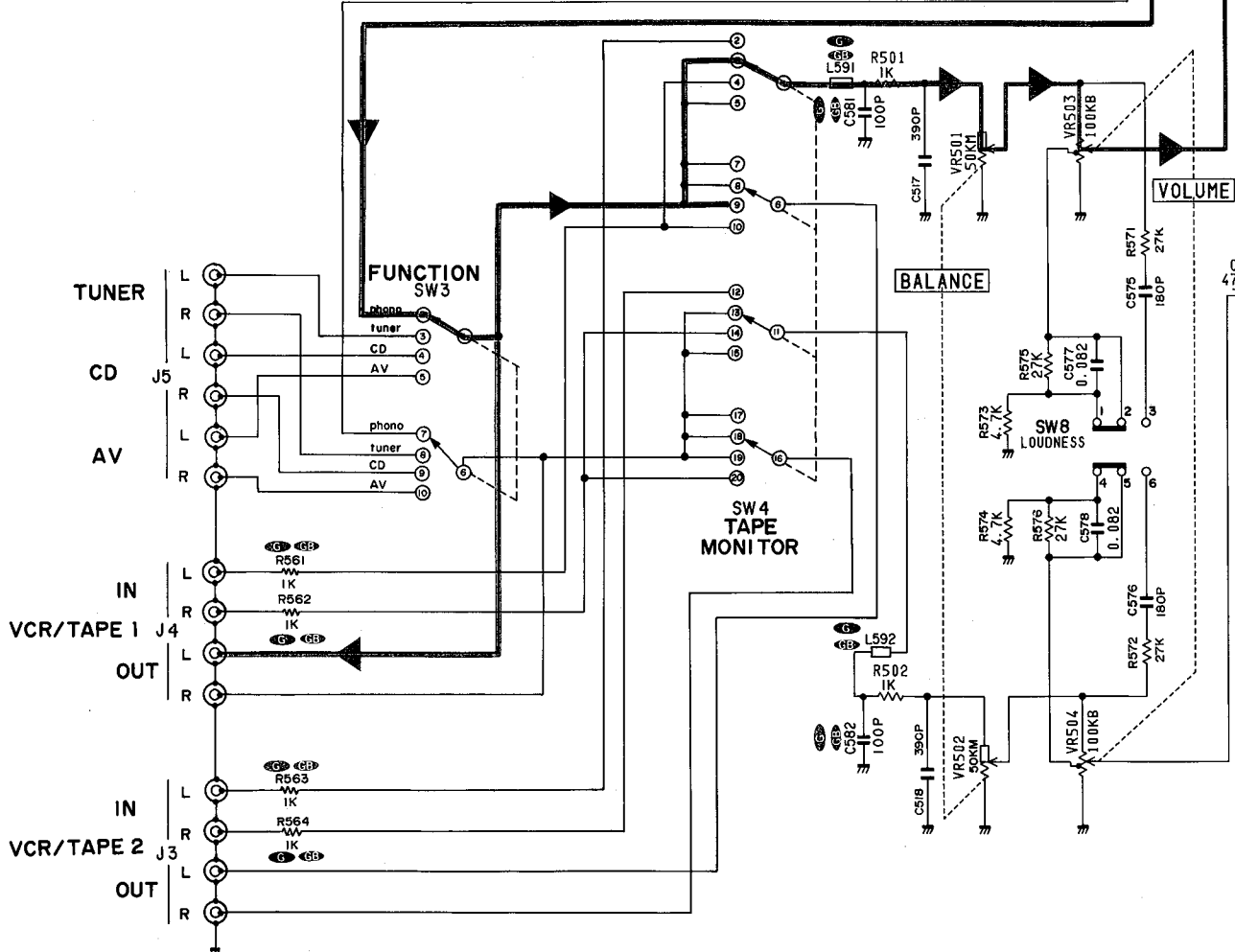
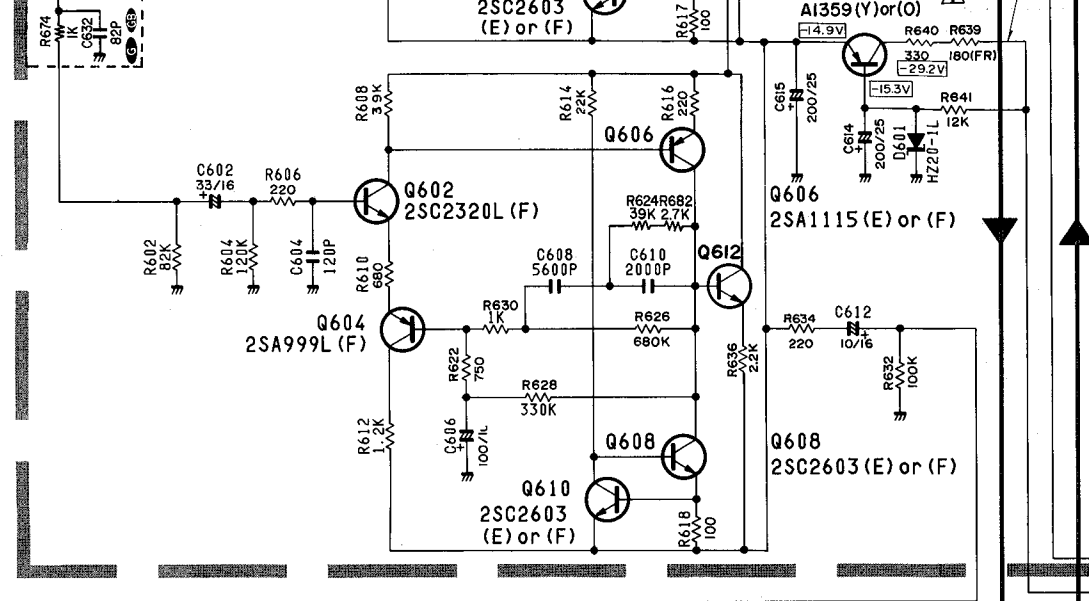

NOTE: 1. ALL RESISTANCES VALUES ARE IN Ω .
 $K\Omega=1000\Omega$, $M\Omega=1000K\Omega$.
 2. THE WATTAGE OF RESISTORS IS 1/4W UNLESS OTHERWISE NOTED.
 3. ALL CAPACITANCES VALUES ARE IN μF UNLESS OTHERWISE NOTED. P=# μF .
 4. ... V:DC VOLTAGE AT NO SIGNAL
 5. SAFETY REQUIREMENTS COMPONENTS IN ACCORDANCE WITH PRESENT SAFETY REGULATIONS. THESE COMPONENTS MUST ONLY BE REPLACED BY ORIGINAL PARTS.

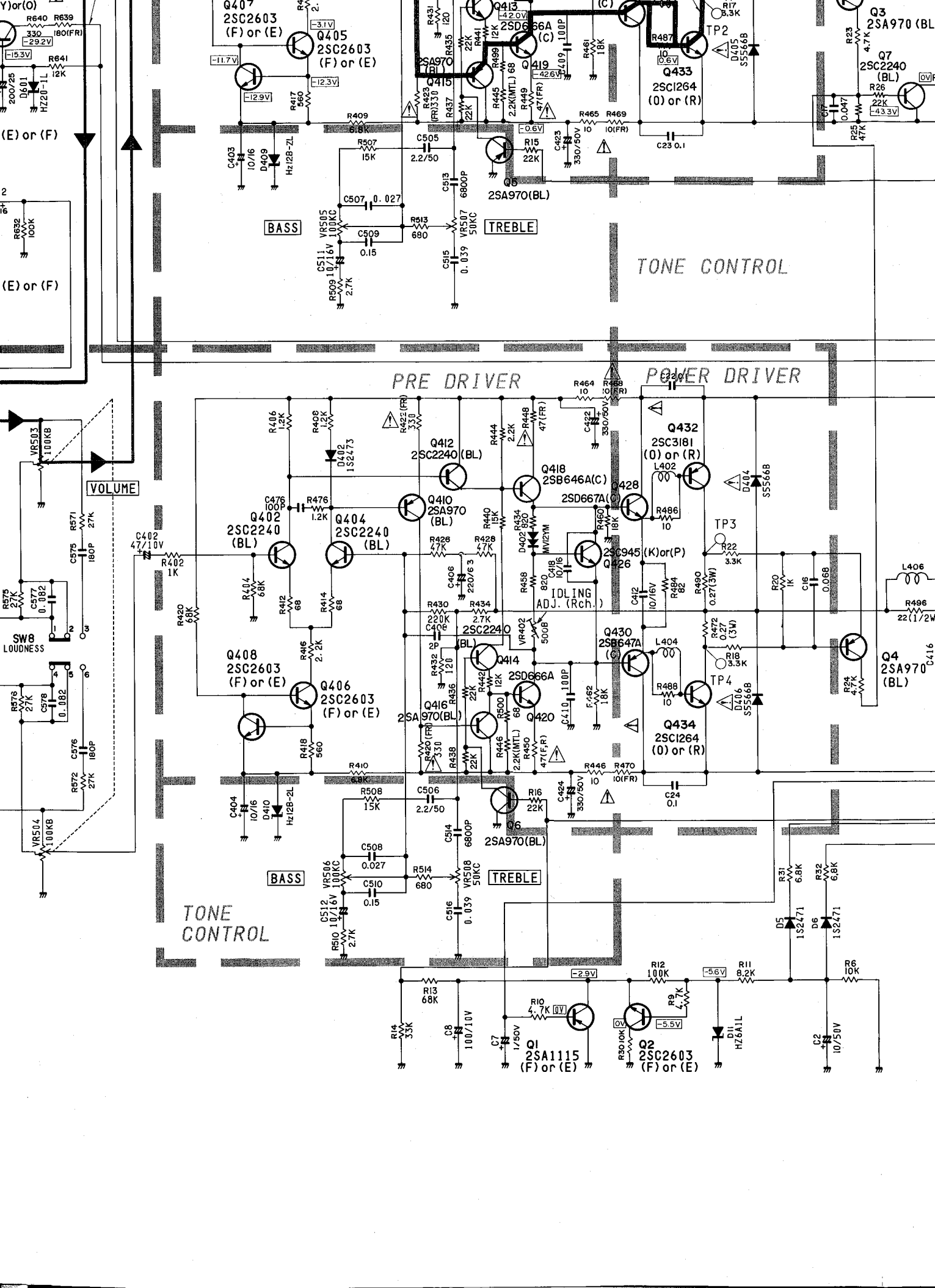

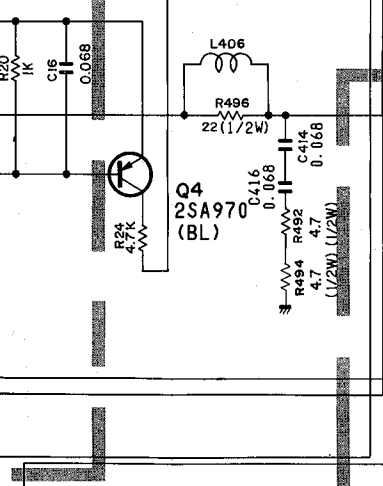
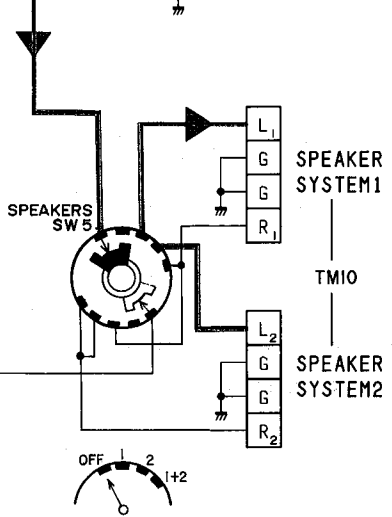
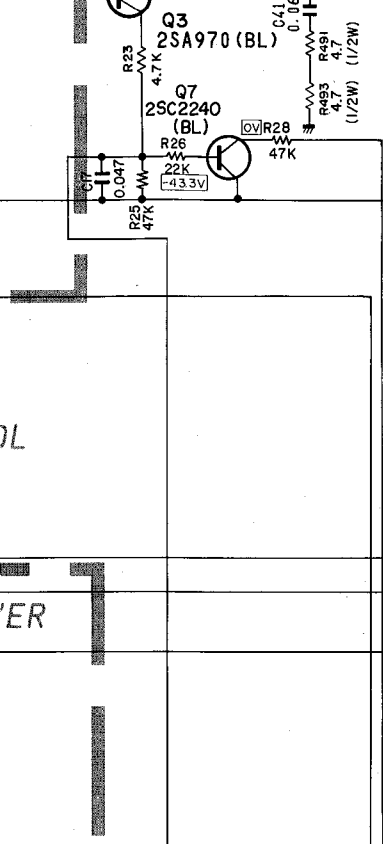

POWER SUPPLY

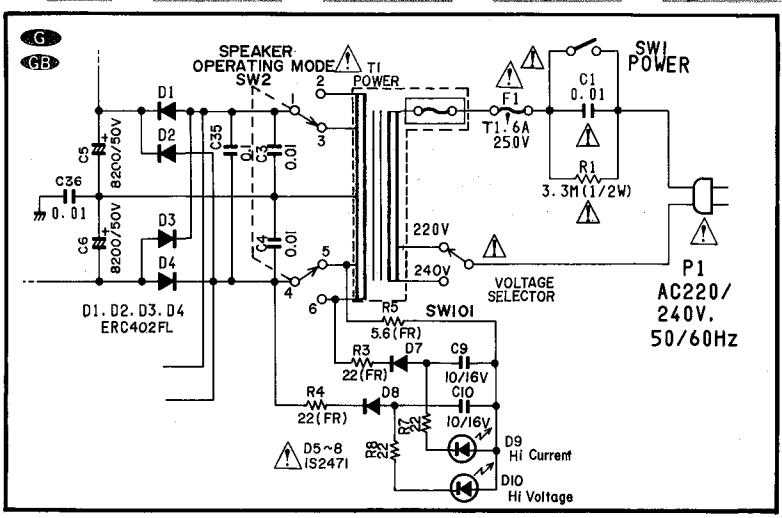
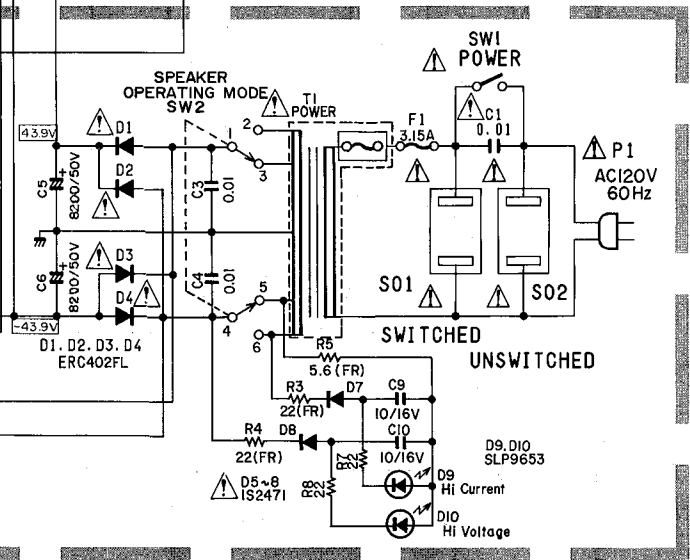

WIRING DIAGRAM

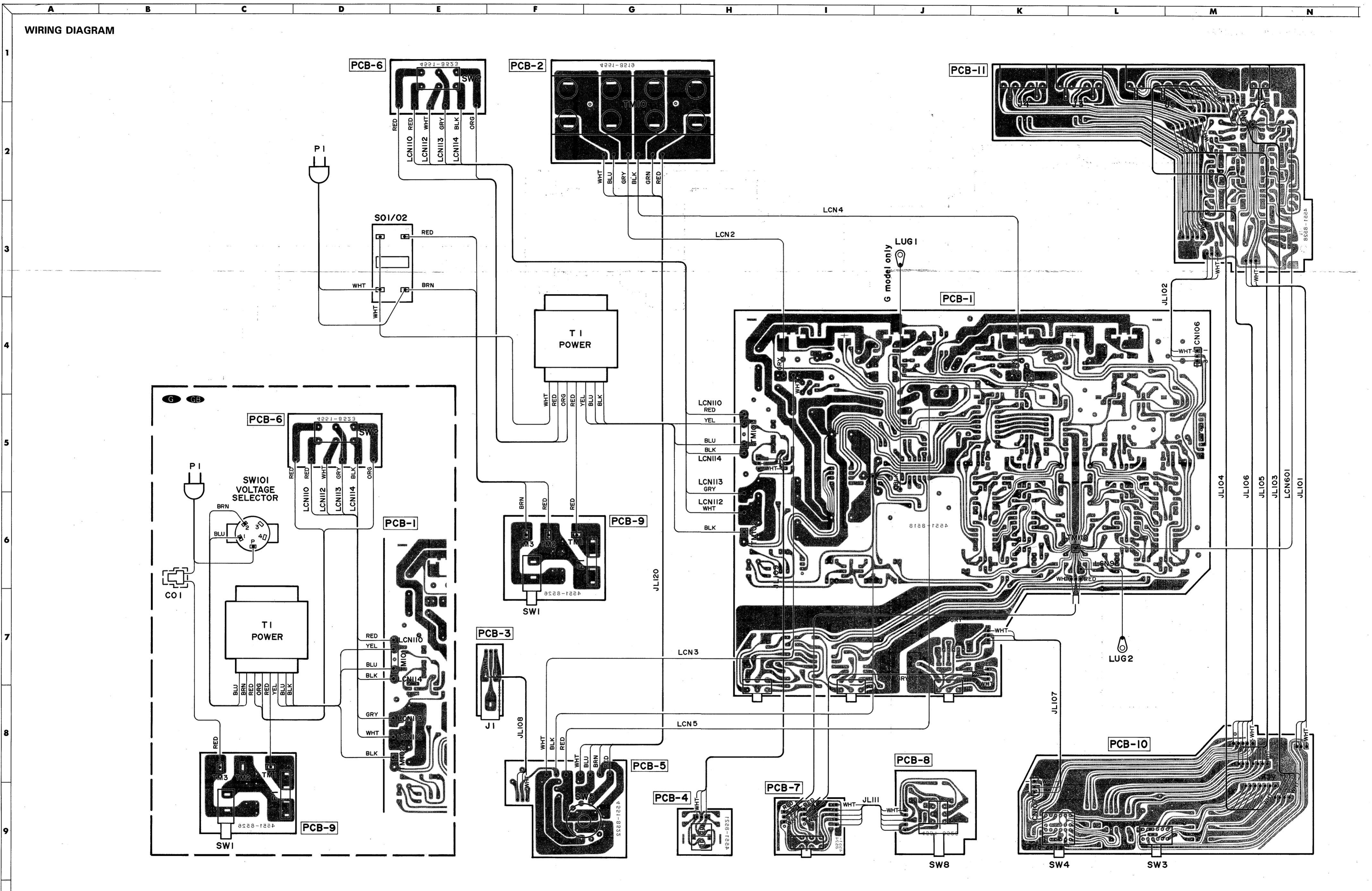

WIRE COLOR ABBREVIATIONS

RED	: Red	YEL	: Yellow
ORG	: Orange	PUR	: Purple
BLU	: Blue	PIK	: Pink
WHT	: White	GRY	: Gray
GRN	: Green	BRN	: Brown
BLK	: Black		

WIRING DIAGRAM

PCB-6

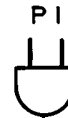
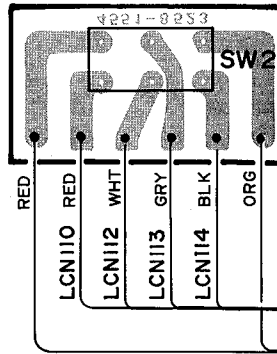

S01/02

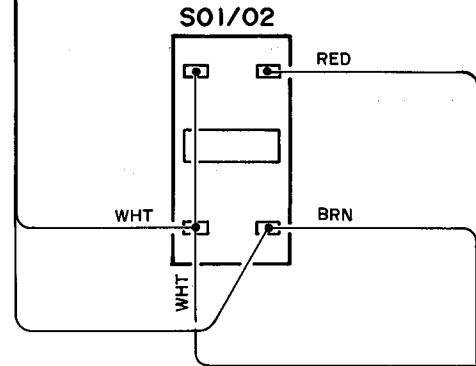

G GB

PCB-6

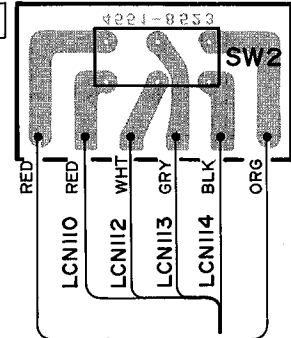

SW101
VOLTAGE
SELECTOR

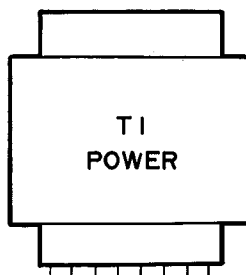
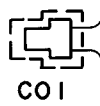
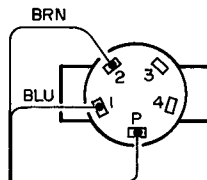

PCB-1

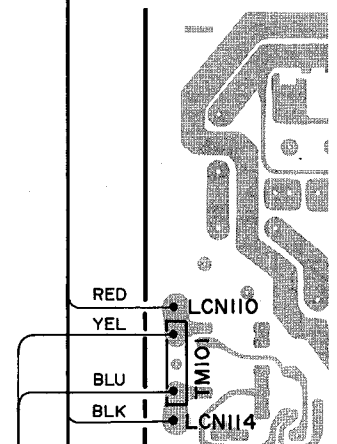

1

2

3

4

5

6

7

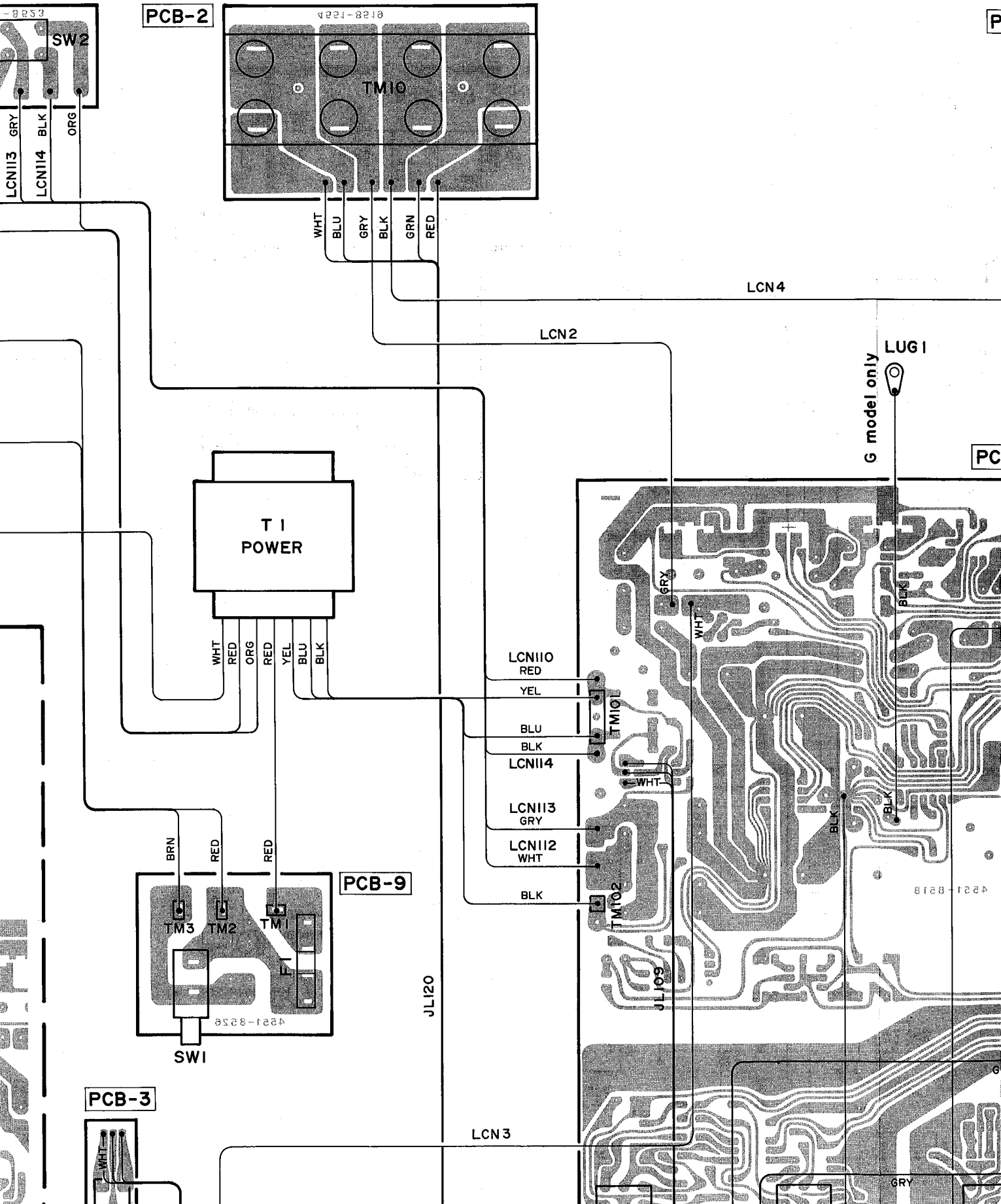

J

K

L

M

N

PCB-II

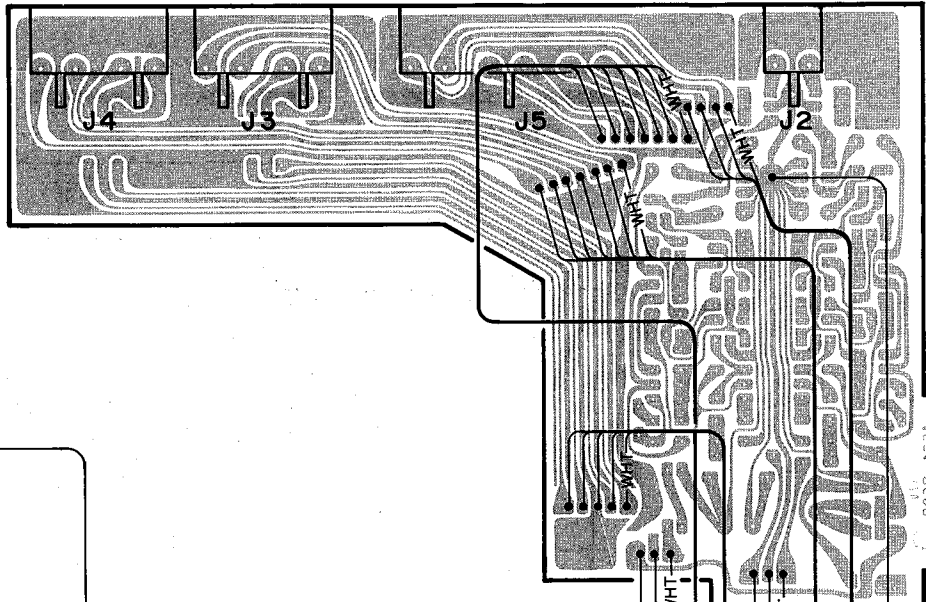

6528-102A

4

G model only LUG1

PCB-I

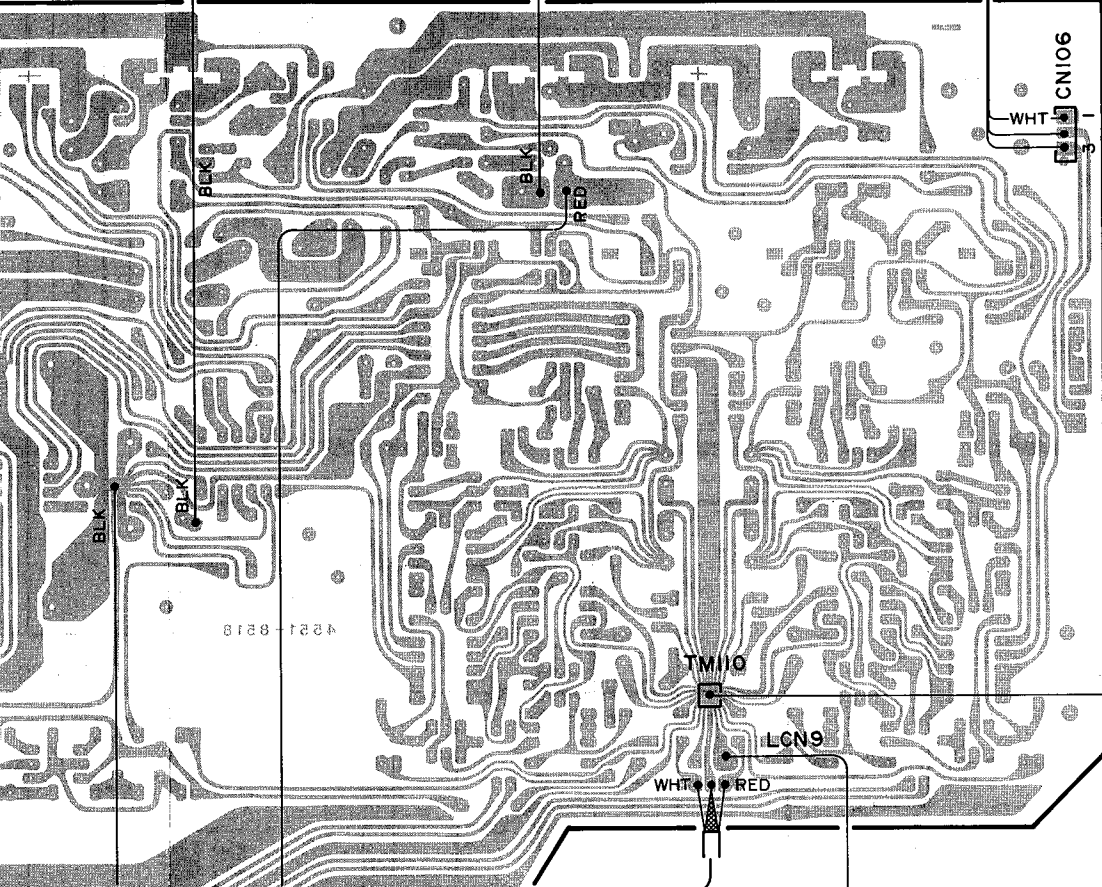

JL102

WHT CN106

JL104

JL106

JL105

JL103

LCN601

JL101

WHT RED

TM10

LCN9

GRY

WHT

RED

GRY

WHT

LUG2

4

5

6

7

8

9

10

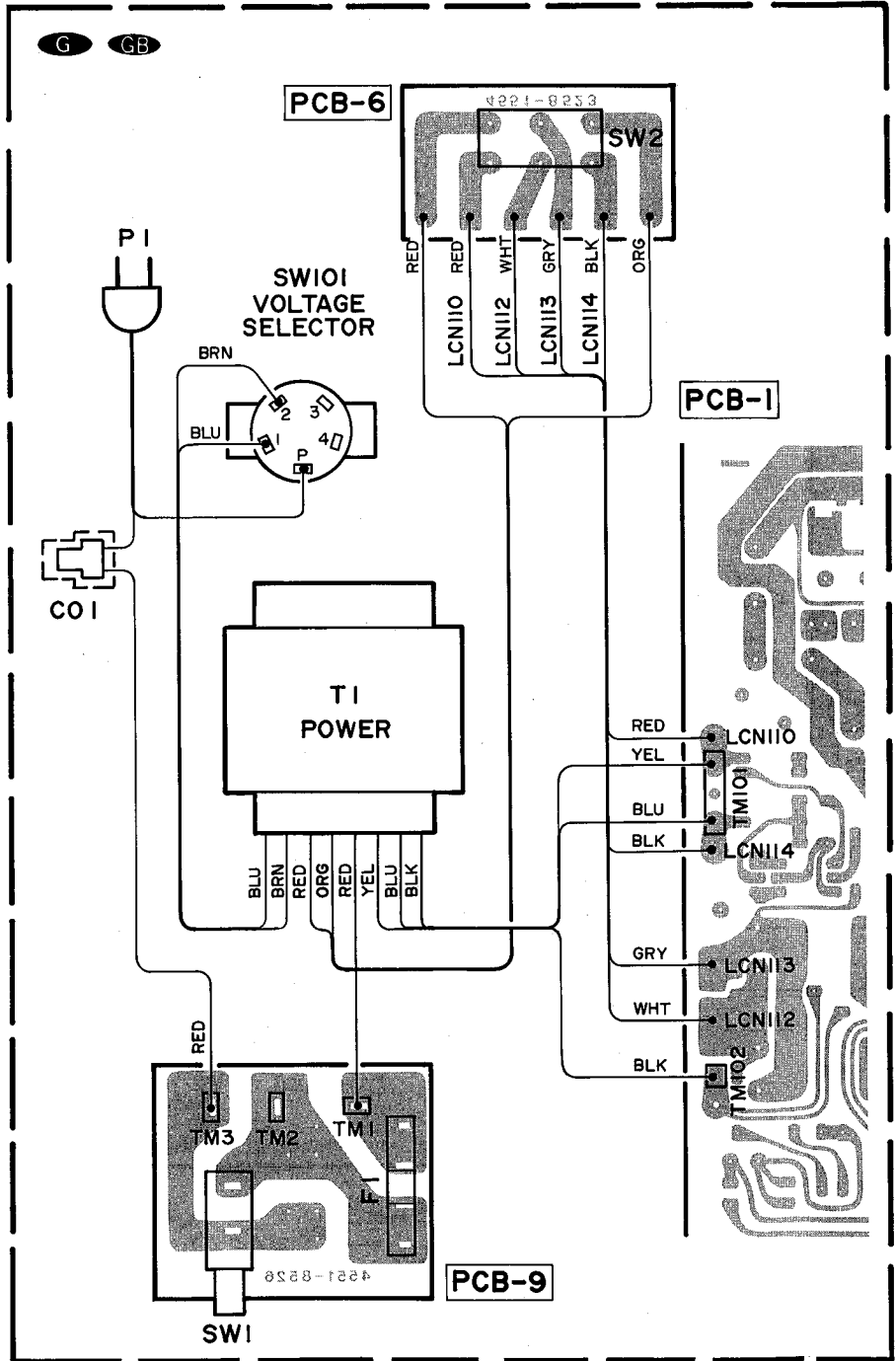
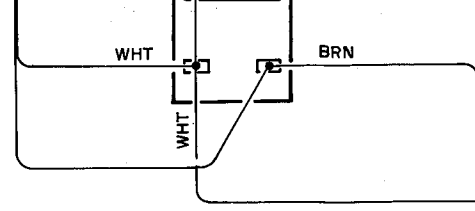

WIRE COLOR ABBREVIATIONS

- | | | | |
|-----|----------|-----|----------|
| RED | : Red | YEL | : Yellow |
| ORG | : Orange | PUP | : Purple |
| BLU | : Blue | PIK | : Pink |
| WHT | : White | GRY | : Gray |
| GRN | : Green | BRN | : Brown |
| BLK | : Black | | |

BRN

T 1
POWER

WHT
RED
ORG
RED
YEL
BLU
BLK

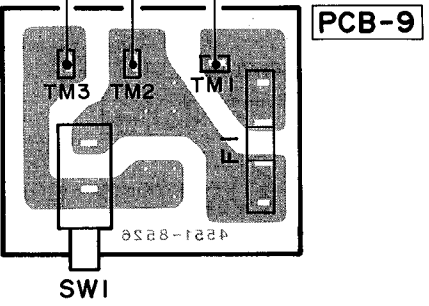

PCB-3

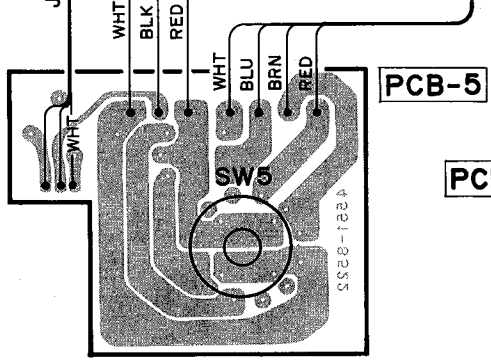

JL120

LCN110
RED
YEL

BLU
BLK
LCN114

LCN113
GRY

LCN112
WHT

BLK

LCN3

LCN5

PCB-4

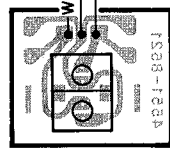

PCB-7

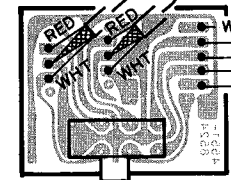

PCB-8

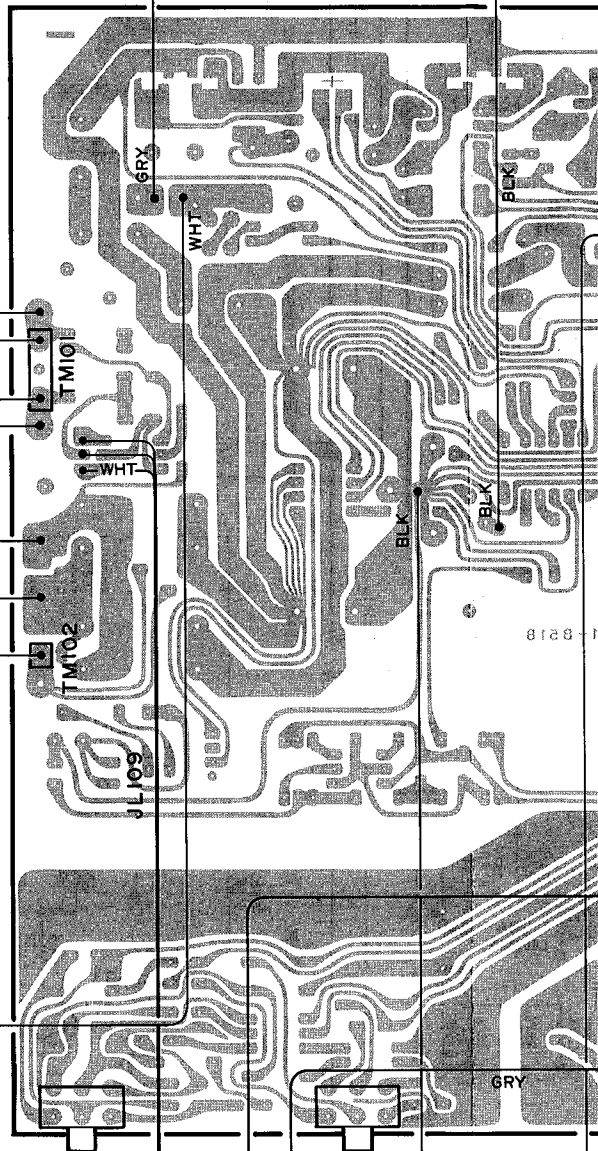
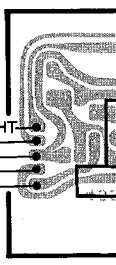

G mode

G mode

PCB-1

JL102

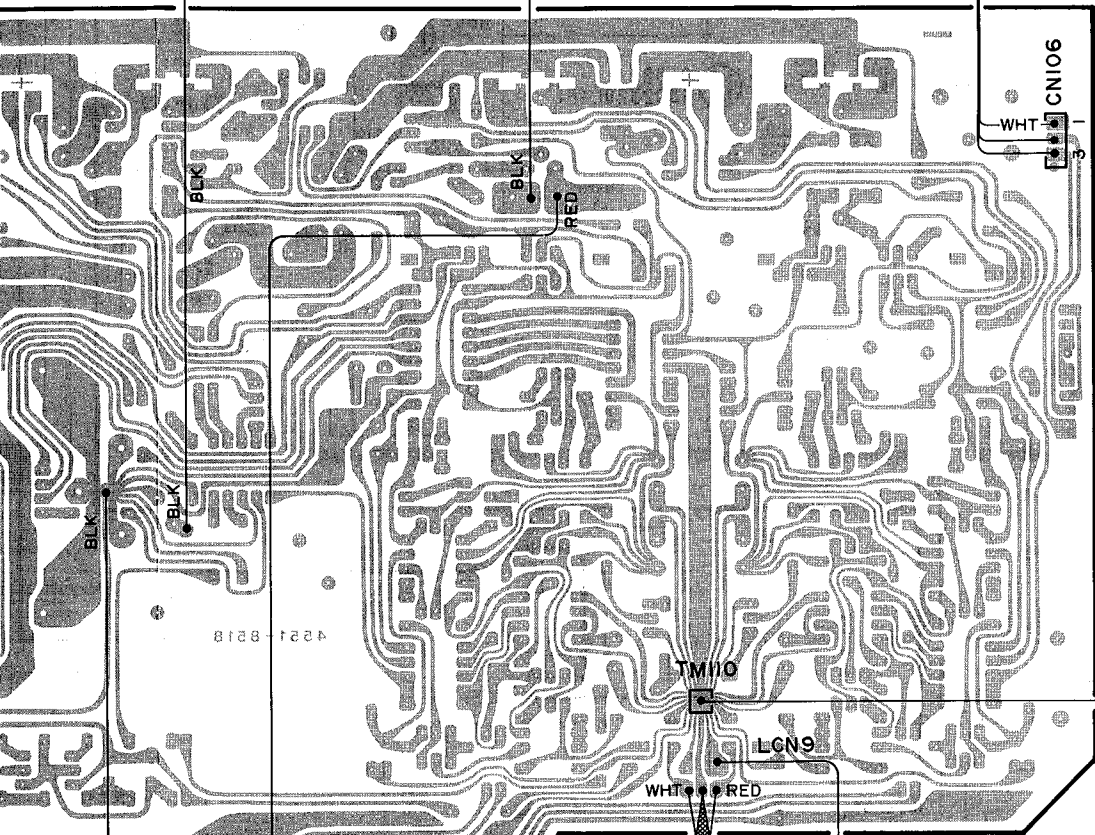

JL104

JL106

JL105

JL103

LCN601

JL101

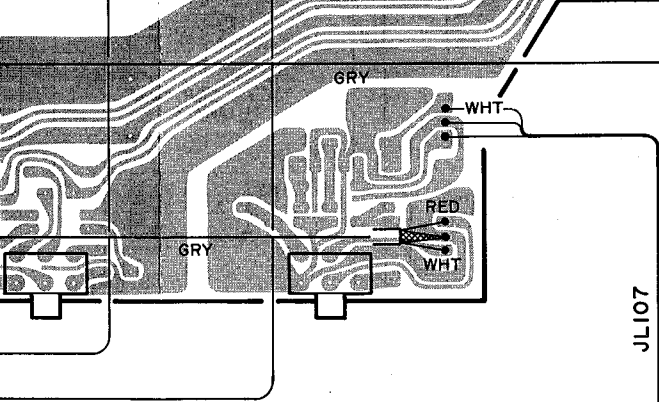

JL107

PCB-10

PCB-8

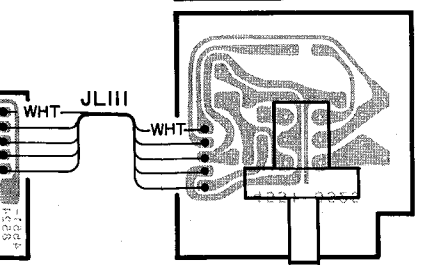

SW8

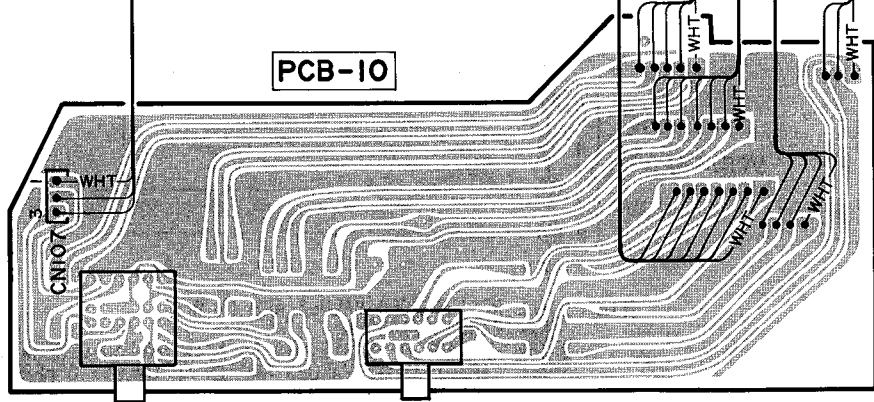

SW4

SW3