

The Harman Kardon Model PM650 Vxi

Manual 138A

HIGH VOLTAGE/HIGH CURRENT INTEGRATED AMPLIFIER

Technical Manual

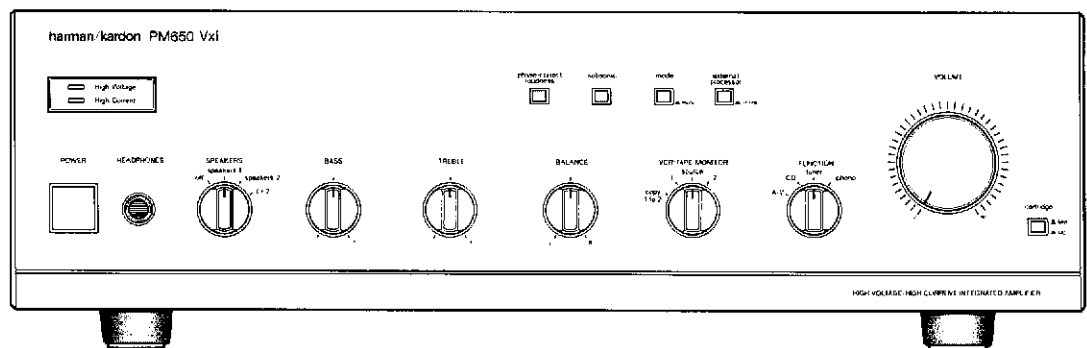

The following marks found in the parts list of this manual identify the models as follows.

- JA : North America area model
- BK : North America area model Black version
- G : General model
- GB : General model Black version

harman/kardon

240 Crossways Park West, Woodbury, N.Y. 11797
1112-3152138A1 P-088809 1500 Printed in Japan

SPECIFICATIONS

	Nominal	Limit
RMS Output Power		
8Ω, 1kHz THD 0.1%	74W	≧ 70W
4Ω, 1kHz THD 0.3%	75W	≧ 70W
High Instantaneous Current Capability (HCC)	45A	≧ 40A
Half Power Bandwidth	10Hz ~ 60kHz	
Frequency Response at -3dB	1Hz ~ 150kHz	
Input Sensitivity		
CD	135mV ± 25mV	
Phono (MM)	2.2mV ± 0.2mV *	
Phono (MC)	120μV ± 20μV *	
Signal to Noise Ratio		
CD	77dB	≧ 74dB
Phono (MM)	77dB	≧ 73dB
Phono (MC)	74dB	≧ 70dB
Channel Separation at 10kHz		
CD	50dB	≧ 45dB
Phono (MM)	54dB	≧ 45dB
Phono (MC)	51dB	≧ 43dB
IM Distortion Ratio	0.085%	≧ 0.1%
Damping Factor at 1kHz	71dB	≧ 50dB
Tone Control Characteristics		
Bass at 50Hz		
Boost	10dB	± 2dB
Cut	10dB	± 2dB
Treble at 10kHz		
Boost	10dB	± 2dB
Cut	10dB	± 2dB

	Nominal	Limit
Filters		
Subsonic	15Hz,	-3dB ± 1.5dB/Octave
Phase Correct Loudness at 50Hz		10dB ± 2dB
DC Output Voltage		
L channel		0mV ± 60mV
R channel		0mV ± 60mV
RIAA Equalization at Tape Out (20Hz/20kHz) (No load)		
		0.33dB ± 0.5dB / -0.02dB ± 0.5dB
Phono Over Load (No load THD 0.1%)		
Phono (MM)		145mV ≧ 100mV
Phono (MC)		8.9mV ≧ 5mV
Dimensions (W x H x D)	17-1/2" x 5-5/16" x 15-11/16"	(443 x 134 x 398mm)
Weight	19.2lbs.	(8.7kg)
Power Supplies		
North America area model	AC 120V,	60Hz
General model	AC 220/240V,	50/60Hz
Power Consumption		
North America area model	280W (340VA)	
General model	210W	

* Input Sensitivity for General model are 2.3mV ± 0.3mV (MM) and 145μV ± 20μV (MC).

These specifications are service target specs.

Specifications and components subject to change without notice. Overall performance will be maintained or improved.

LEAKAGE TEST (FOR SERVICE ENGINEERS IN THE U.S.A.)

Before returning the unit to the user, perform the following safety checks:

1. Inspect all lead dress to make certain that leads are not pinched or that hardware is not lodged between the chassis and other metal parts in the unit.
2. Be sure that any protective devices such as nonmetallic control knobs, insulating fishpapers, cabinet backs, adjustment and compartment covers or shields, isolation resistor-capacity networks, mechanical insulators, etc. which were removed for servicing are properly reinstalled.
3. Be sure that no shock hazard exists; check for leakage current using Simpson Model 229 Leakage Tester, standard equipment item No. 21641, RCA Model WT540A or use alternate method as follows: Plug the power cord directly into a 120-volt AC receptacle (do not use an Isolation Transformer for this test). Using two clip leads, connect a 1500 Ohm, 10-watt resistor paralleled by a 0.15 μF capacitor, in series with all exposed metal cabinet parts and a known earth ground, such as a water pipe or conduit. Use a VTVM or VOM with 1000 Ohms per volt, or higher sensitivity to measure the AC voltage drop across the resistor. (See Diagram.) Move the resistor connection to each exposed metal part having a return path to the chassis (antenna, metal, cabinet, screw heads, knobs and control shafts, escutcheon, etc.) and measure the AC voltage drop across the resistor. (This test should be performed with the power switch in both the On and Off positions.) A reading of 0.35 volt RMS or more is excessive and indicates a potential shock hazard which must be corrected before returning the unit to the owner.

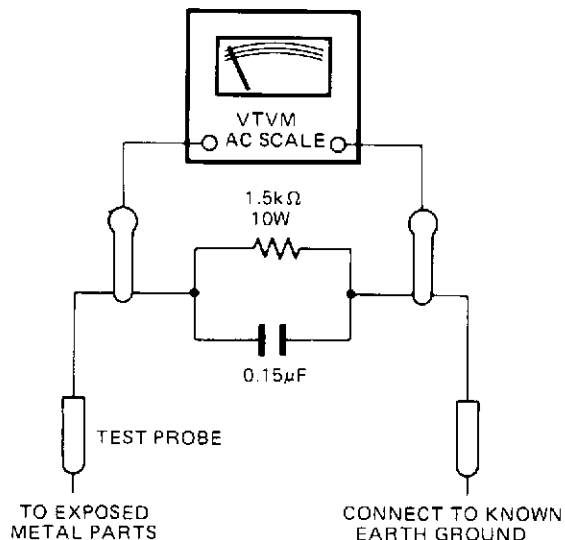
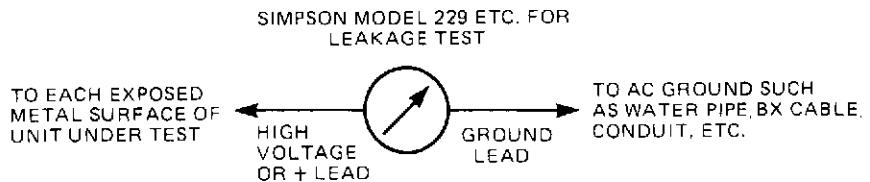

DISASSEMBLY PROCEDURES (REFER TO PAGE 5 AND 18)**1 CABINET TOP (131) REMOVAL**

Remove 6 screws (A) and then remove the Cabinet Top (131).

2 FRONT PANEL ASS'Y (AA) REMOVAL

1. Remove the Cabinet Top (131), referring to the previous step 1.
2. Remove 5 screws (B) and then remove the Front Panel Ass'y (AA).

3 MAIN P.C. BOARD (PCB-1) REMOVAL

Remove 7 screws (C) and then remove the Main P.C. Board (PCB-1) with the Heat Sink (177). At this time unsolder the lead wires connected to the Main P.C. Board (PCB-1).

4 POWER SWITCH P.C. BOARD (PCB-8) REMOVAL

1. Remove the Front Panel Ass'y (AA), referring to the previous step 2.
2. Pull out the Push Button (146) and Lever (213).
3. Remove 2 screws (D), then remove the Power Switch P.C. Board (PCB-8). If necessary unsolder the lead wires.

5 TONE CONTROL P.C. BOARD (PCB-9) REMOVAL

1. Remove the Front Panel Ass'y (AA), referring to the previous step 2.
2. Pull out the 3 Rotary knobs (152) and then remove 3 hexagon nuts (E), then remove the Tone Control P.C. Board (PCB-9). If necessary unsolder the lead wires.

POWER CORD REPLACEMENT (FOR SERVICE ENGINEERS OTHER THAN NOTRH AMERICA)

In order to prevent fire or shock hazard when replacing the power cord, follow the procedure below to replace the parts with the standard supply parts.

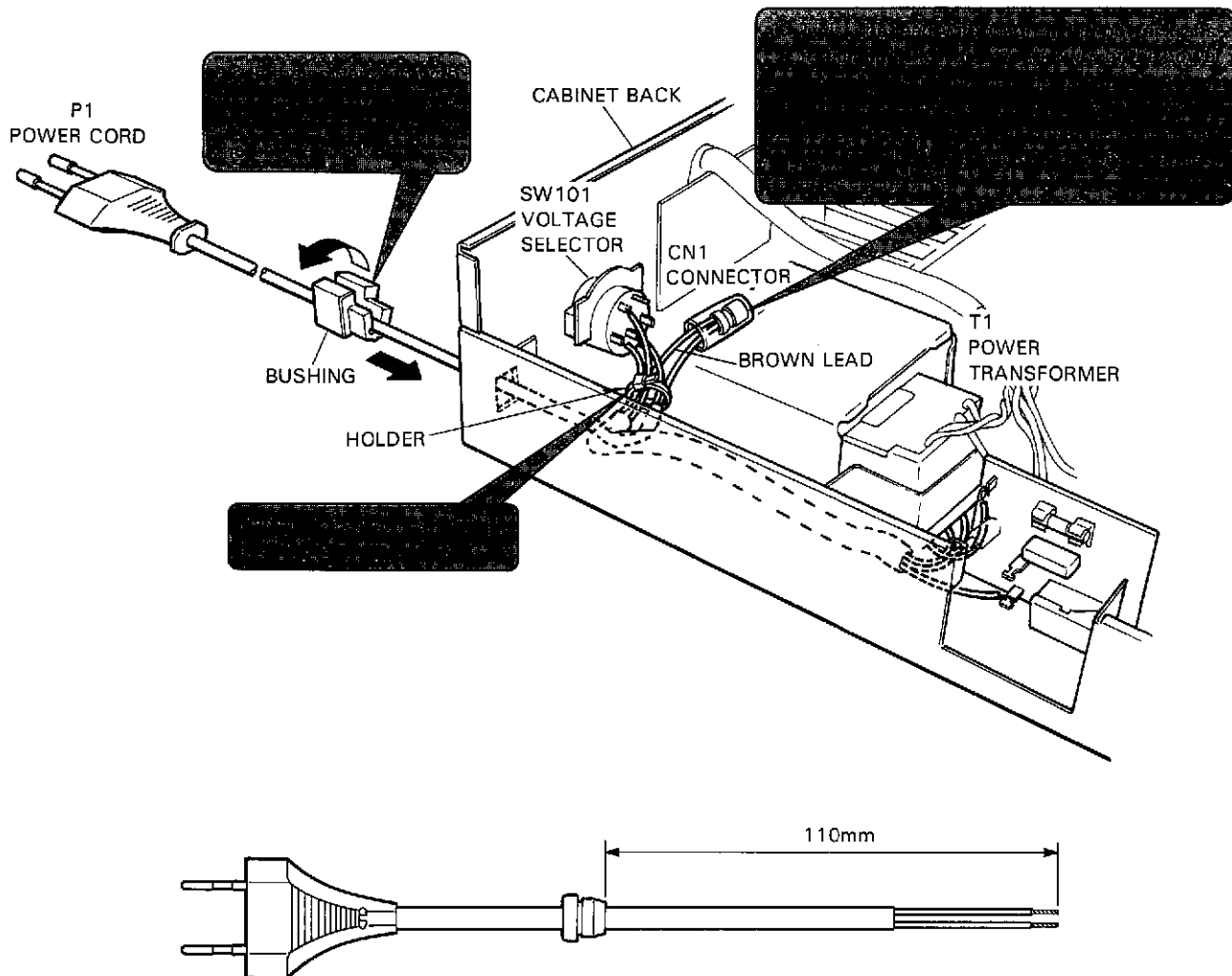

ALIGNMENT PROCEDURES (REFER TO PAGES 7, 8, 9 AND 17)

- Conditions:
 - Set the Function selector to the "CD" position.
 - Set the Volume control to minimum.
 - Set the Speaker selector to the "off" position.
 - Make the adjustment at a room temperature of 77°F (25°C).

DC BALANCE ADJUSTMENT

- Set the Speaker Operating Mode switch to the "8Ω" position.

Connect the Digital Volt Meter to TP1 and TP2.	VR401	0 ± 10mV
Connect the Digital Volt Meter to TP3 and TP2.	VR402	0 ± 10mV

IDLING CURRENT ADJUSTMENT

Connect the Digital Volt Meter to TP4 and TP5.	VR403	30mV
Connect the Digital Volt Meter to TP6 and TP7.	VR404	30mV

DC BALANCE ADJUSTMENT

- Set the Speaker Operating Mode switch to the "4Ω" position.

Connect the Digital Volt Meter to TP1 and TP2.	VR401	0 ± 10mV
Connect the Digital Volt Meter to TP3 and TP2.	VR402	0 ± 10mV

- After the above adjustment, leave the unit with its power on for longer than 15 minutes and then repeat the same adjustment.

BLOCK DIAGRAM

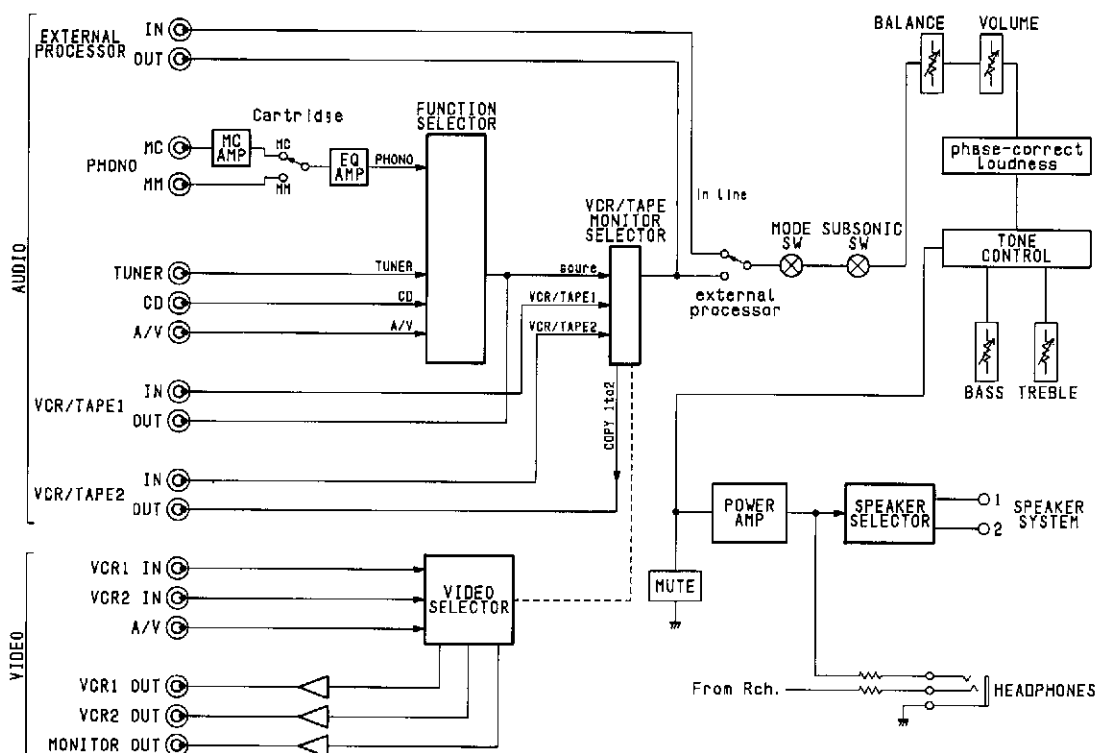

PARTS LIST

Ref. No.	Part No.	Description	Ref. No.	Part No.	Description
AA	A443-PM650S2A	PANEL ASS'Y UA G	225	2327-R0130064	SCREW, BND+ (3X6mm)
AAA	A443-PM650S2B	PANEL ASS'Y BK	226	2132-7120	SPACER AV
AAC	A443-PM650S2C	PANEL ASS'Y GB	228	2327-R0130082	SCREW, BND+ (3X8mm)
AB	A424-PM650S2A	CABI BACK ASS'Y UA BK	229	2327-R0130082	SCREW, BND+ (3X8mm)
ABB	A424-PM650S2D	CABI BACK ASS'Y G	230	2327-R0130122	SCREW, BND+ (3X12mm)
ABC	A424-PM650S2G	CABI BACK ASS'Y GB	232	2347-R0130082	SCREW, BND T+ (3X8mm)
AC	A424-PM650S2B	CABI BOTTOM ASS'Y UA BK	235	2347-R0130062	SCREW, BND T+ (3X6mm)
ACB	A424-PM650S2E	CABI BOTTOM ASS'Y G	236	2347-R0130062	SCREW, BND T+ (3X6mm)
ACC	A424-PM650S2H	CABI BOTTOM ASS'Y GB	237	2347-R0130084	SCREW, BND T+ (3X8mm)
AD	A424-PM650S2C	CABI BOTTOM COVER ASS'Y UA BK	238	2347-R0130124	SCREW, BND T+ (3X12mm)
ADB	A424-PM650S2F	CABI BOTTOM COVER ASS'Y G	241	2347-R0140064	SCREW, BND T+ (4X6mm)
ADC	A424-PM650S2J	CABI BOTTOM COVER ASS'Y GB	245	2557-301029	SCREW, B SPW+ (3X10mm)
AE	A662-PM650S2A	PUSH BUTTON ASS'Y UA G	247	2592-400826	SCREW, FPT+ (4X8mm)
AEA	A662-PM650S2B	PUSH BUTTON ASS'Y BK	249	2440-7016	NUT, SPE VIDEO
AEC	A662-PM650S2C	PUSH BUTTON ASS'Y GB	746	4442-14	PIN PLUG
023B	2132-7116	SPACER G GB	△PI	4161-71151	CORD W/PLUG
024B	2327-R0130124	SCREW, BND+ (3X12mm) G GB	△PIB	4161-7256	CORD W/PLUG G GB
025B	2440-7017	NUT, SPE G GB	△TI	5584-S1408	XFORMER POWER
131B	1414-13901	CABINET TOP G GB	△T1B	5584-S1409	XFORMER POWER G GB
131	1414-11601	CABINET TOP	S01	4474-157	SOCKET
133	1424-25001	CABI BACK BOTTOM	LUG1	4211-4	LUG
134	1424-26301	CABI BACK REAR	SW2	4421-0227230	SWITCH, SLIDE
134B	1424-26302	CABI BACK REAR G GB	△SW101	4411-102729	SWITCH, ROTARY G GB
135	1424-26101	CABI BACK	Q437	5611-1306(Y)	XISTOR, PNP R
136	1443-12601	PANEL FRONT	Q438	5611-1306(Y)	XISTOR, PNP R
136A	1443-12602	PANEL FRONT BK GB	Q439	5613-3298(Y)	XISTOR, NPN R
138	1513-09501	PLATE PANEL	Q440	5613-3298(Y)	XISTOR, NPN R
139	1531-11301	WINDOW PANEL	Q441	5613-3907(O)	XISTOR, NPN R
141	1562-01602	FRAME R-SIDE	Q442	5613-3907(O)	XISTOR, NPN R
141A	1562-01603	FRAME R-SIDE BK GB	Q443	5611-1516(O)	XISTOR, PNP R
142	1562-01702	FRAME L-SIDE	Q444	5611-1516(O)	XISTOR, PNP R
142A	1562-01703	FRAME L-SIDE BK GB	Q519	5614-1266(Q)or(P)	XISTOR, NPN A
146	1660-00401	PUSH BUTTON POWER	Q520	5612-941(Q)or(P)	XISTOR, PNP A
146A	1660-00403	PUSH BUTTON POWER BK GB	Q613	5612-941(P)or(Q)	XISTOR, PNP A
147	1662-05701VN	PUSH BUTTON	Q614	5614-1266(P)or(Q)	XISTOR, NPN A
147A	1662-05702	PUSH BUTTON BK GB	Q807	5614-1266(Q)or(P)	XISTOR, NPN A
150	1630-02601	ROTARY KNOB VOLUME	△DI	5685-D5SB20	SILICON BRIDGE
150A	1630-02603	ROTARY KNOB VOLUME BK GB			
152	1632-16502	ROTARY KNOB			
152A	1632-17101	ROTARY KNOB BK GB			
157	1319-0139	LEG BOTTOM			
161	2211-7303	CHASSIS FRONT			
163	2219-8212	METAL FITTING			
165	2219-8210	METAL FITTING L			
166	2219-8211	METAL FITTING R			
167	2219-8237	METAL FITTING EQ			
168	2219-8238	METAL FITTING POWER			
170	2219-7879	METAL FITTING H/P			
173	2218-7011	BRACKET, FIX WIRING			
176	2222-7229	HEAT SINK VIDEO			
177	2222-7249	HEAT SINK MAIN			
177B	2222-7250	HEAT SINK MAIN G GB			
178	2222-7256	HEAT SINK MAIN			
179	2222-7243	HEAT SINK			
180	2222-7240	HEAT SINK EQ			
182	2240-7320	HOLDER POWER			
183	2240-7141	HOLDER			
183A	2240-7202	HOLDER BK GB			
185	2240-7239	HOLDER WIRING			
186	2240-7209	HOLDER POWER			
187	2240-7315	HOLDER LED			
188	2240-7316	HOLDER PANEL			
191	2240-364	HOLDER AC			
194	2360-7015	BOSS, SPE MAIN			
198	2112-11762	SPONGE PANEL			
205	4214-168	TERMINAL (GND)			
210	2402-0374	WASHER, PLASTIC MAIN			
213	2672-7018	LEVER			
214	2601-7077	SHAFT			
216	2601-7178	SHAFT MC/MM			
220	2651-210189	SPRING			
221	2224-7120	INSULATOR VIDEO			
222	2459-3005511	RIVET, PLASTIC AV			
224	2323-300829	SCREW, CSK+ (3X8mm)			

P. C. BOARDS

PCB-1 Main P. C. Board

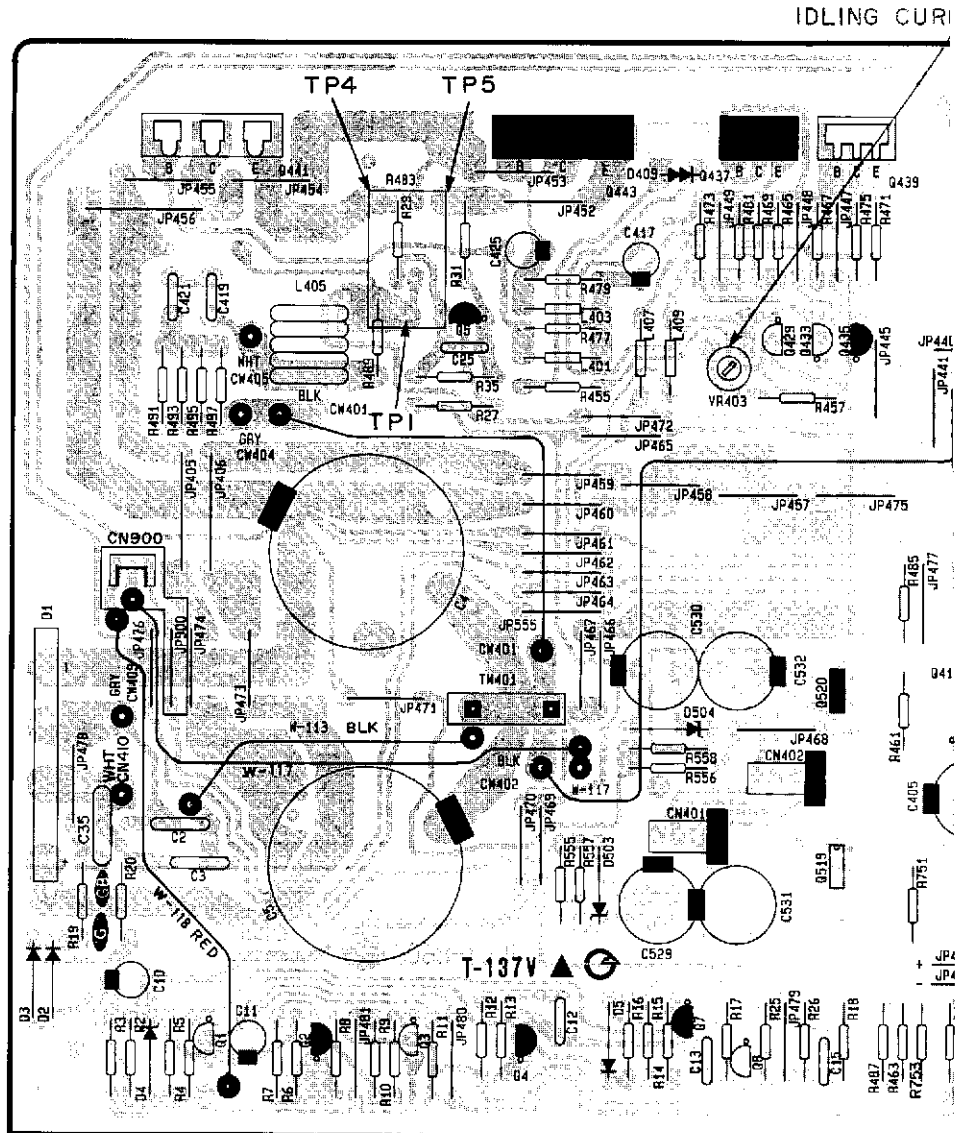

PCB-3 Headphone P. C. Board



HEADPHONES

PCB-4 LED P. C. Board

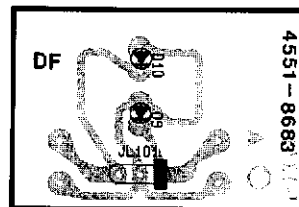

1
2
3
4
5
6
7

E F G H I J

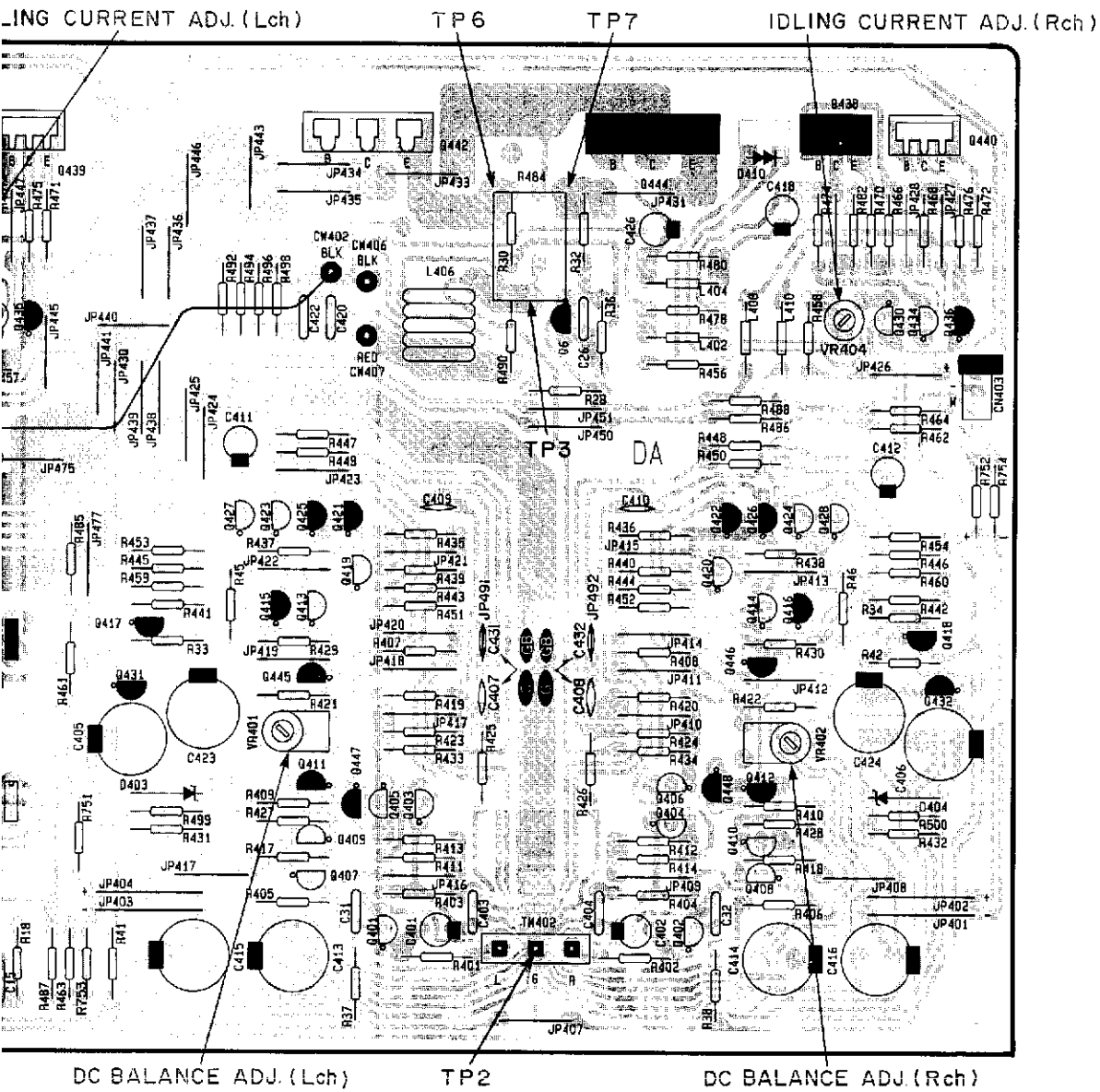

PCB-5 Speaker Switch P. C. Board

PCB-12 Main Volume P. C. Board

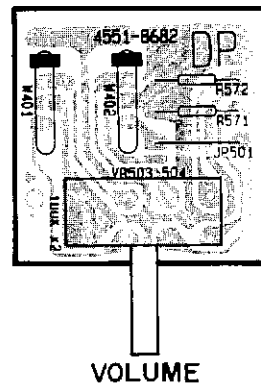
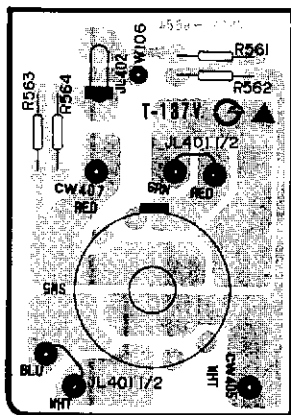

VOLUME

P. C. BOARDS

PCB-6 Equalizer P. C. Board

A B C D E

1

2

3

4

5

6

7

L A/V CD TUNER PHONO MC MM

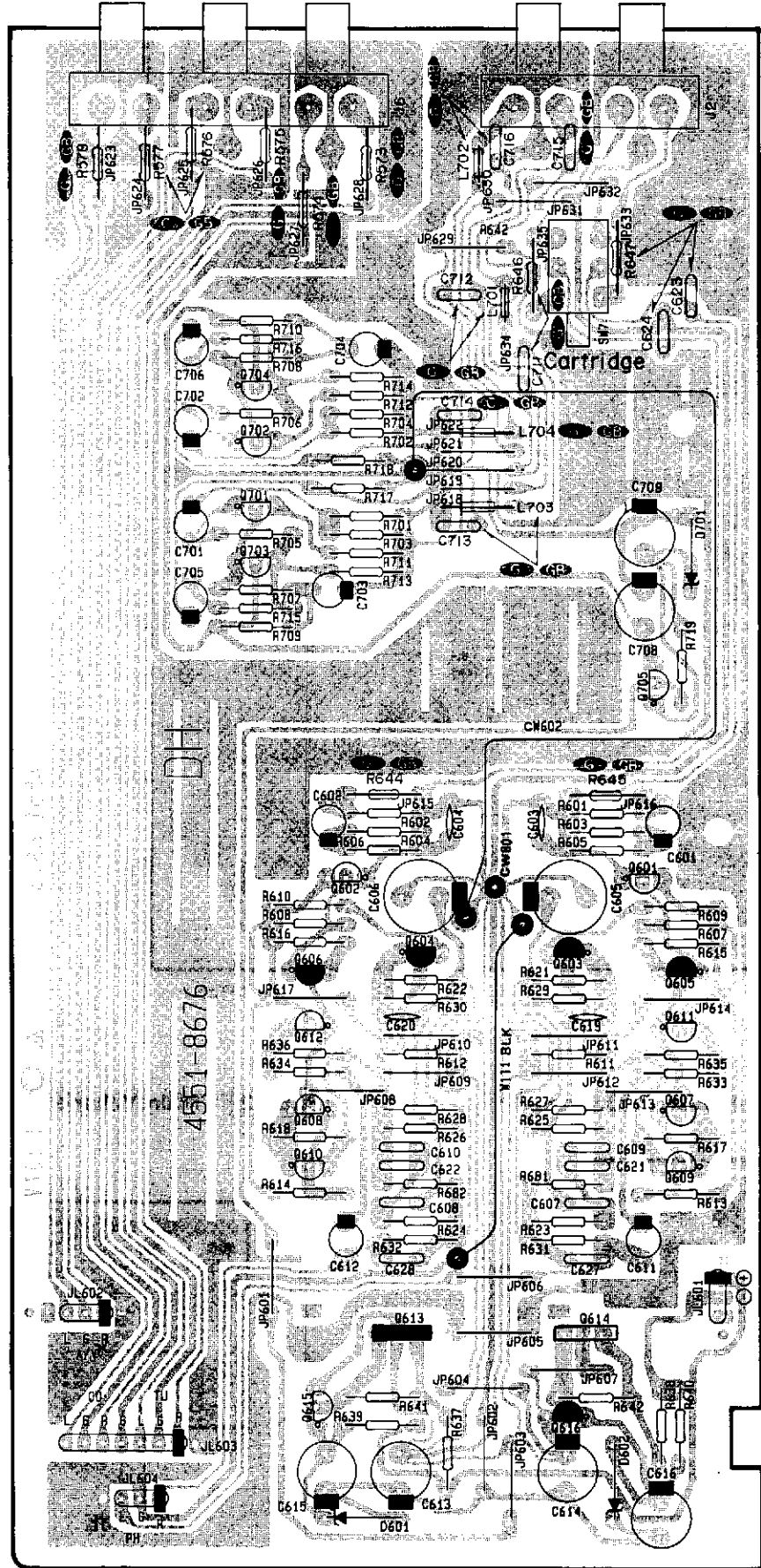

PCB-7 A/V P. C. Board

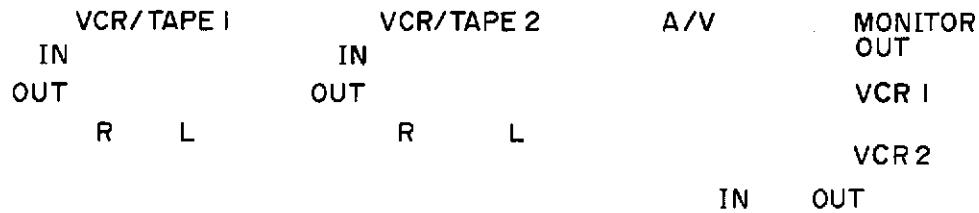
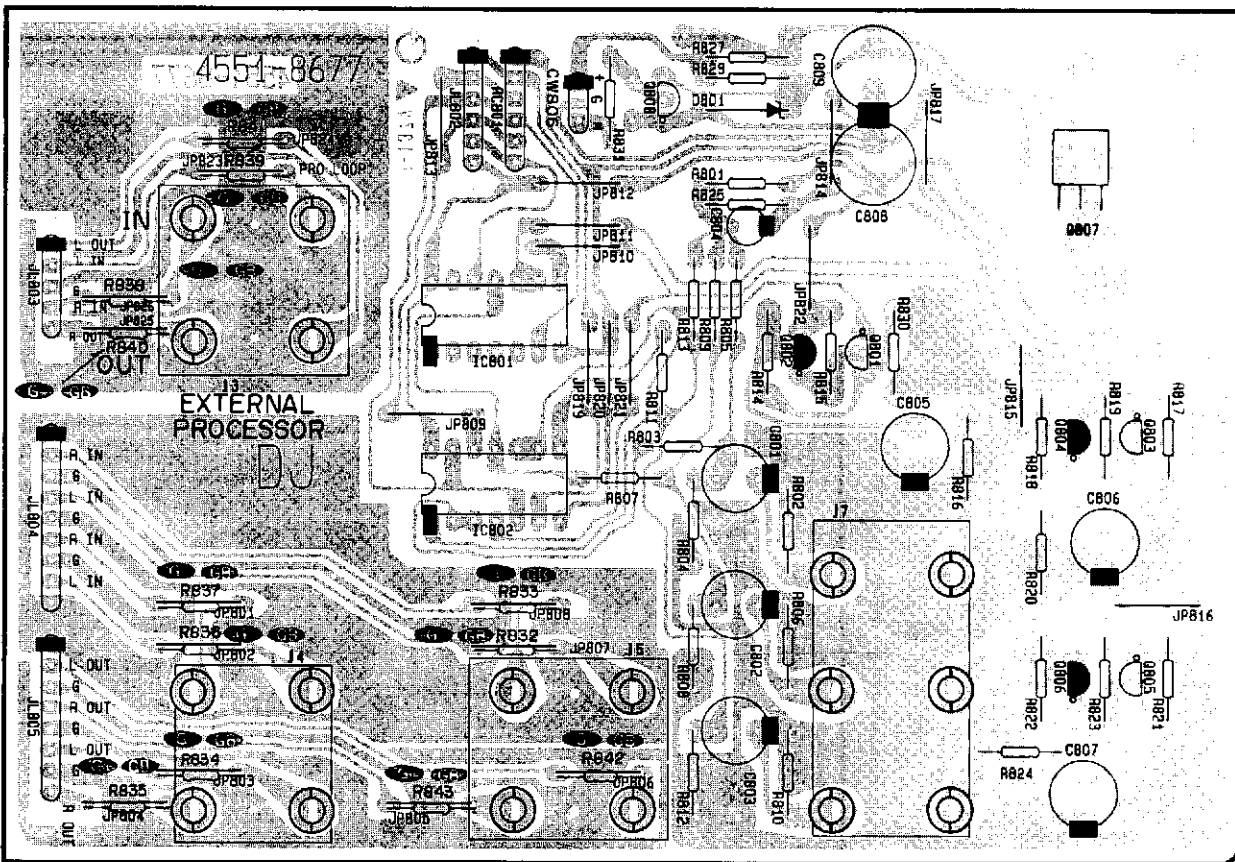

PCB-11 Function P. C. Board

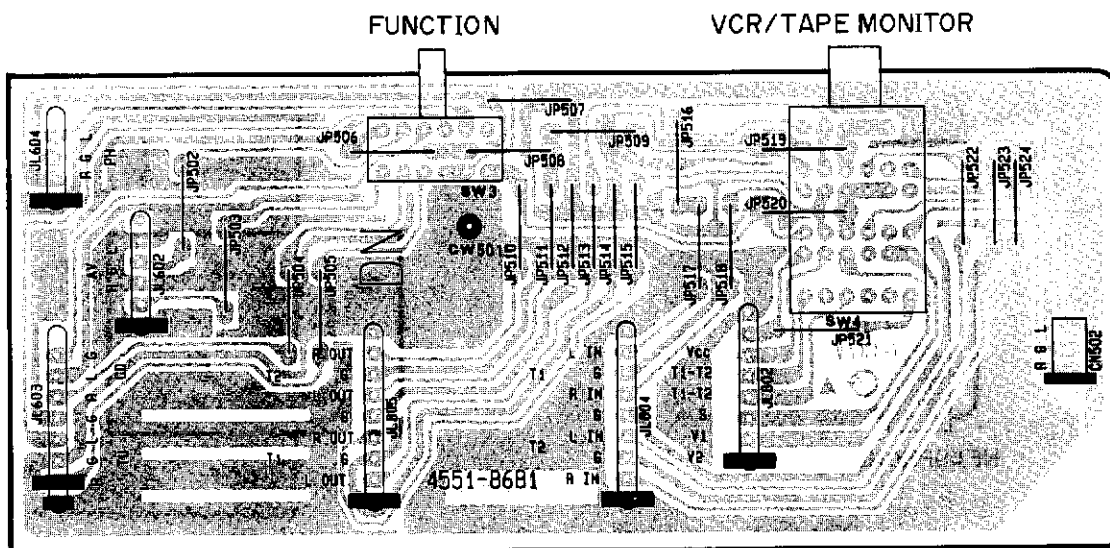

A

B

C

D

E

P. C. BOARDS

1

PCB-2 Speaker P. C. Board

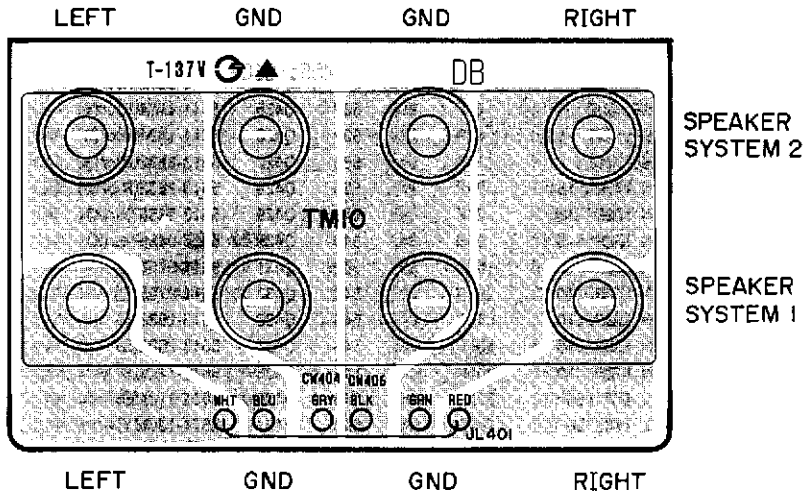

2

3

4

PCB-8 Power Switch P. C. Board

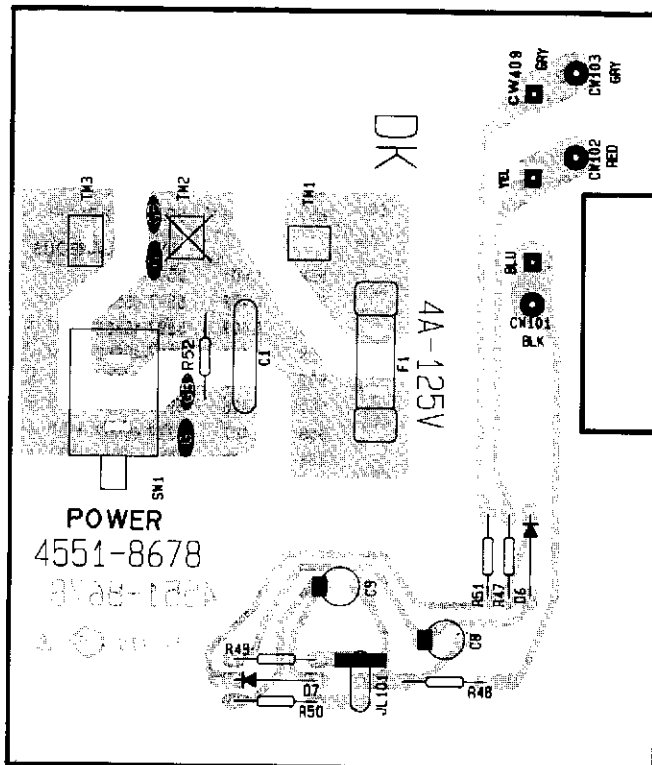

5

6

7

F

G

H

I

J

PCB-9 Tone Control P. C. Board

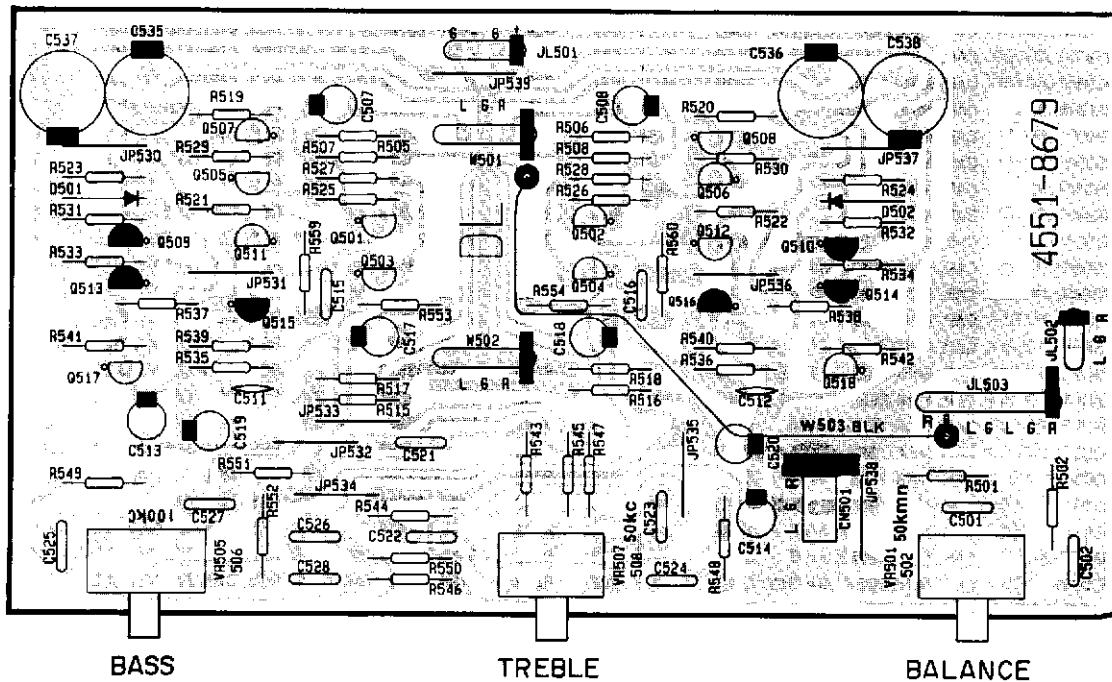

PCB-10 Basscon P. C. Board

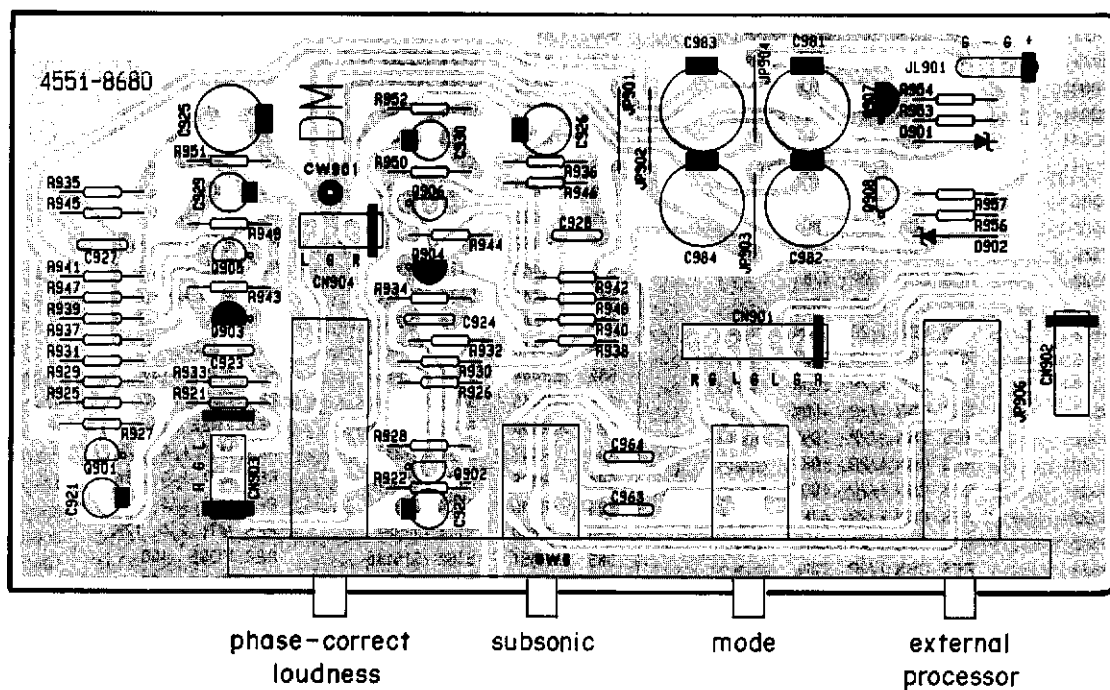

ELECTRICAL PARTS LIST

Ser. No.	Ref. No.	Part No.	Description	Ser. No.	Ref. No.	Part No.	Description
CAPACITORS				650	R25	5135-152522	RES, CBN 1/2P 1.5K
689	C2	5352-1041957	CAP, MTL .1 μ	645	R26	5135-473522	RES, CBN 1/2P 47K
689	C3	5352-1041957	CAP, MTL .1 μ	648	R27	5135-472522	RES, CBN 1/2P 4.7K
687	Δ C4	5341-S10GM139	CAP, ELE 13000 μ /63V	648	R28	5135-472522	RES, CBN 1/2P 4.7K
687	Δ C5	5341-S10GM139	CAP, ELE 13000 μ /63V	648	R29	5135-472522	RES, CBN 1/2P 4.7K
631	C10	5345-475F0951	CAP, MINI ELE 4.7 μ /50V	648	R30	5135-472522	RES, CBN 1/2P 4.7K
632	C11	5345-336C0951	CAP, MINI ELE 33 μ /16V	648	R31	5135-472522	RES, CBN 1/2P 4.7K
633	C12	5354-334593	CAP, MYL .33 μ	648	R32	5135-472522	RES, CBN 1/2P 4.7K
633	C13	5354-334593	CAP, MYL .33 μ	646	R33	5135-223522	RES, CBN 1/2P 22K
636	C15	5354-223M1HM	CAP, MYL .022 μ	646	R34	5135-223522	RES, CBN 1/2P 22K
635	C25	5354-683593	CAP, MYL .068 μ	637	R35	5135-751522	RES, CBN 1/2P 750
635	C26	5354-683593	CAP, MYL .068 μ	637	R36	5135-751522	RES, CBN 1/2P 750
634	C31	5354-224593	CAP, MYL .22 μ	639	R37	5135-105522	RES, CBN 1/2P 1M
634	C32	5354-224593	CAP, MYL .22 μ	639	R38	5135-105522	RES, CBN 1/2P 1M
057B	C35	5352-1041957	CAP, MTL .1 μ G GB	646	R41	5135-223522	RES, CBN 1/2P 22K
561	C401	5345-107B0951	CAP, MINI ELE 100 μ /10V	646	R42	5135-223522	RES, CBN 1/2P 22K
561	C402	5345-107B0951	CAP, MINI ELE 100 μ /10V	646	R45	5135-223522	RES, CBN 1/2P 22K
566	C403	5359-1215851	CAP, PPP 120P	646	R46	5135-223522	RES, CBN 1/2P 22K
566	C404	5359-1215851	CAP, PPP 120P	598	R401	5135-102522	RES, CBN 1/2P 1K
563	C405	5345-227A0951	CAP, MINI ELE 220 μ /6.3V	598	R402	5135-102522	RES, CBN 1/2P 1K
563	C406	5345-227A0951	CAP, MINI ELE 220 μ /6.3V	599	R403	5135-223522	RES, CBN 1/2P 22K
570	C407	5353-050933	CAP, MCA 5P	599	R404	5135-223522	RES, CBN 1/2P 22K
066B	C407	5353-050933	CAP, MCA 5P G GB	600	R405	5135-333522	RES, CBN 1/2P 33K
570	C408	5353-050933	CAP, MCA 5P	600	R406	5135-333522	RES, CBN 1/2P 33K
066B	C408	5353-050933	CAP, MCA 5P G GB	589	R407	5174-122381	RES, MTL 1/4 1.2K
571	C409	5353-680533	CAP, MCA 68P	589	R408	5174-122381	RES, MTL 1/4 1.2K
571	C410	5353-680533	CAP, MCA 68P	589	R409	5174-122381	RES, MTL 1/4 1.2K
562	C411	5345-106C0951	CAP, MINI ELE 10 μ /16V	589	R410	5174-122381	RES, MTL 1/4 1.2K
562	C412	5345-106C0951	CAP, MINI ELE 10 μ /16V	602	R411	5135-221522	RES, CBN 1/2P 220
564	Δ C413	5345-337G0962	CAP, MINI ELE 330 μ /63V	602	R412	5135-221522	RES, CBN 1/2P 220
564	Δ C414	5345-337G0962	CAP, MINI ELE 330 μ /63V	604	R413	5135-221522	RES, CBN 1/2P 220
564	Δ C415	5345-337G0962	CAP, MINI ELE 330 μ /63V	604	R414	5135-221522	RES, CBN 1/2P 220
564	Δ C416	5345-337G0962	CAP, MINI ELE 330 μ /63V	604	R417	5135-331522	RES, CBN 1/2P 330
562	C417	5345-106C0951	CAP, MINI ELE 10 μ /16V	604	R418	5135-331522	RES, CBN 1/2P 330
562	C418	5345-106C0951	CAP, MINI ELE 10 μ /16V	605	R419	5135-333522	RES, CBN 1/2P 33K
568	C419	5354-104593	CAP, MYL .1 μ	605	R420	5135-333522	RES, CBN 1/2P 33K
568	C420	5354-104593	CAP, MYL .1 μ	606	R421	5135-182522	RES, CBN 1/2P 1.8K
568	C421	5354-104593	CAP, MYL .1 μ	606	R422	5135-182522	RES, CBN 1/2P 1.8K
568	C422	5354-104593	CAP, MYL .1 μ	592	R423	5174-621381	RES, MTL 1/4 620
563	C423	5345-227A0951	CAP, MINI ELE 220 μ /6.3V	592	R424	5174-621381	RES, MTL 1/4 620
563	C424	5345-227A0951	CAP, MINI ELE 220 μ /6.3V	591	R425	5174-220381	RES, MTL 1/4 22
562	C425	5345-106C0951	CAP, MINI ELE 10 μ /16V	591	R426	5174-220381	RES, MTL 1/4 22
562	C426	5345-106C0951	CAP, MINI ELE 10 μ /16V	587	Δ R427	5102-1224713	RES, FUSE 1.2K
066B	C431	5353-050933	CAP, MCA 5P G GB	587	Δ R428	5102-1224713	RES, FUSE 1.2K
066B	C432	5353-050933	CAP, MCA 5P G GB	587	Δ R429	5102-1224713	RES, FUSE 1.2K
659	C529	5345-337D041	CAP, MINI ELE 330 μ /25V	587	Δ R430	5102-1224713	RES, FUSE 1.2K
659	C530	5345-337D041	CAP, MINI ELE 330 μ /25V	603	R431	5135-562522	RES, CBN 1/2P 5.6K
659	C531	5345-337D041	CAP, MINI ELE 330 μ /25V	603	R432	5135-562522	RES, CBN 1/2P 5.6K
659	C532	5345-337D041	CAP, MINI ELE 330 μ /25V	593	R433	5174-243381	RES, MTL 1/4 24K
RESISTORS				593	R434	5174-243381	RES, MTL 1/4 24K
641	R2	5135-103522	RES, CBN 1/2P 10K	613	R435	5135-153522	RES, CBN 1/2P 15K
648	R3	5135-472522	RES, CBN 1/2P 4.7K	613	R436	5135-153522	RES, CBN 1/2P 15K
645	R4	5135-473522	RES, CBN 1/2P 47K	608	R437	5135-123522	RES, CBN 1/2P 12K
644	R5	5135-334522	RES, CBN 1/2P 330K	608	R438	5135-123522	RES, CBN 1/2P 12K
642	R6	5135-684522	RES, CBN 1/2P 680K	595	R439	5174-222381	RES, MTL 1/4 2.2K
647	R7	5135-184522	RES, CBN 1/2P 180K	595	R440	5174-222381	RES, MTL 1/4 2.2K
643	R8	5135-225522	RES, CBN 1/2P 2.2M	595	R441	5174-222381	RES, MTL 1/4 2.2K
640	R9	5135-104522	RES, CBN 1/2P 100K	595	R442	5174-222381	RES, MTL 1/4 2.2K
640	R10	5135-104522	RES, CBN 1/2P 100K	585	Δ R443	5102-1515116	RES, FUSE 150
641	R11	5135-103522	RES, CBN 1/2P 10K	585	Δ R444	5102-1515116	RES, FUSE 150
640	R12	5135-104522	RES, CBN 1/2P 100K	585	Δ R445	5102-1515116	RES, FUSE 150
645	R13	5135-473522	RES, CBN 1/2P 47K	585	Δ R446	5102-1515116	RES, FUSE 150
646	R14	5135-223522	RES, CBN 1/2P 22K	594	R447	5174-123381	RES, MTL 1/4 12K
646	R15	5135-223522	RES, CBN 1/2P 22K	594	R448	5174-123381	RES, MTL 1/4 12K
645	R16	5135-473522	RES, CBN 1/2P 47K	594	R449	5174-123381	RES, MTL 1/4 12K
641	R17	5135-103522	RES, CBN 1/2P 10K	594	R450	5174-123381	RES, MTL 1/4 12K
646	R18	5135-223522	RES, CBN 1/2P 22K	585	Δ R451	5102-1515116	RES, FUSE 150
649	R19	5135-682522	RES, CBN 1/2P 6.8K	585	Δ R452	5102-1515116	RES, FUSE 150
649	R20	5135-682522	RES, CBN 1/2P 6.8K	585	Δ R453	5102-1515116	RES, FUSE 150
				585	Δ R454	5102-1515116	RES, FUSE 150
				609	R455	5135-561522	RES, CBN 1/2P 560
				609	R456	5135-561522	RES, CBN 1/2P 560
				610	R457	5135-221522	RES, CBN 1/2P 220

Ser. No.	Ref. No.	Part No.	Description	Ser. No.	Ref. No.	Part No.	Description
610	R458	5135-221522	RES, CBN 1/2P 220	534	Q413	5613-2320L(F)	XISTOR, NPN R
597	R459	5135-131522	RES, CBN 1/2P 130	534	Q414	5613-2320L(F)	XISTOR, NPN R
597	R460	5135-131522	RES, CBN 1/2P 130	532	Q415	5611-999L(F)	XISTOR, PNP R
584	△R461	5102-3R35116	RES, FUSE 3.3	532	Q416	5611-999L(F)	XISTOR, PNP R
584	△R462	5102-3R35116	RES, FUSE 3.3	533	Q417	5611-970(BL)	XISTOR, PNP R
584	△R463	5102-3R35116	RES, FUSE 3.3	533	Q418	5611-970(BL)	XISTOR, PNP R
584	△R464	5102-3R35116	RES, FUSE 3.3	536	Q419	5613-2632(R)or(S)	XISTOR, NPN R
586	△R465	5102-1015116	RES, FUSE 100	536	Q420	5613-2632(R)or(S)	XISTOR, NPN R
586	△R466	5102-1015116	RES, FUSE 100	537	Q421	5611-1124(R)or(S)	XISTOR, PNP R
586	△R467	5102-1015116	RES, FUSE 100	537	Q422	5611-1124(R)or(S)	XISTOR, PNP R
586	△R468	5102-1015116	RES, FUSE 100	536	Q423	5613-2632(R)or(S)	XISTOR, NPN R
588	△R469	5102-2R25116	RES, FUSE 2.2	536	Q424	5613-2632(R)or(S)	XISTOR, NPN R
588	△R470	5102-2R25116	RES, FUSE 2.2	537	Q425	5611-1124(R)or(S)	XISTOR, PNP R
588	△R471	5102-2R25116	RES, FUSE 2.2	537	Q426	5611-1124(R)or(S)	XISTOR, PNP R
588	△R472	5102-2R25116	RES, FUSE 2.2	536	Q427	5613-2632(R)or(S)	XISTOR, NPN R
611	R473	5135-150522	RES, CBN 1/2P 15	536	Q428	5613-2632(R)or(S)	XISTOR, NPN R
611	R474	5135-150522	RES, CBN 1/2P 15	540	Q429	5613-945(P)or(K)	XISTOR, NPN R
611	R475	5135-150522	RES, CBN 1/2P 15	540	Q430	5613-945(P)or(K)	XISTOR, NPN R
611	R476	5135-150522	RES, CBN 1/2P 15	542	Q431	5611-970(BL)	XISTOR, PNP R
612	R477	5135-100522	RES, CBN 1/2P 10	542	Q432	5611-970(BL)	XISTOR, PNP R
612	R478	5135-100522	RES, CBN 1/2P 10	546	Q433	5613-2632(S)	XISTOR, NPN R
612	R479	5135-100522	RES, CBN 1/2P 10	546	Q434	5613-2632(S)	XISTOR, NPN R
612	R480	5135-100522	RES, CBN 1/2P 10	545	Q435	5611-1124(S)	XISTOR, PNP R
590	R481	5174-560381	RES, MTL 1/4 56	545	Q436	5611-1124(S)	XISTOR, PNP R
590	R482	5174-560381	RES, MTL 1/4 56	544	Q437	5611-1306(Y)	XISTOR, PNP R
575	R483	5275-R27671	RES, CEM 5P .27	544	Q438	5611-1306(Y)	XISTOR, PNP R
575	R484	5275-R27671	RES, CEM 5P .27	541	Q439	5613-3298(Y)	XISTOR, NPN R
614	R485	5135-3R3522	RES, CBN 1/2P 3.3	541	Q440	5613-3298(Y)	XISTOR, NPN R
614	R486	5135-3R3522	RES, CBN 1/2P 3.3	547	Q441	5613-3907(O)	XISTOR, NPN R
614	R487	5135-3R3522	RES, CBN 1/2P 3.3	547	Q442	5613-3907(O)	XISTOR, NPN R
614	R488	5135-3R3522	RES, CBN 1/2P 3.3	549	Q443	5611-1516(O)	XISTOR, PNP R
617	R489	5135-220522	RES, CBN 1/2P 22	549	Q444	5611-1516(O)	XISTOR, PNP R
617	R490	5135-220522	RES, CBN 1/2P 22	538	Q445	5611-872(E)	XISTOR, PNP R
615	R491	5135-390522	RES, CBN 1/2P 39	538	Q446	5611-872(E)	XISTOR, PNP R
615	R492	5135-390522	RES, CBN 1/2P 39	538	Q447	5611-872(E)	XISTOR, PNP R
615	R493	5135-390522	RES, CBN 1/2P 39	538	Q448	5611-872(E)	XISTOR, PNP R
615	R494	5135-390522	RES, CBN 1/2P 39	655	Q519	5614-1266(Q)or(P)	XISTOR, NPN A
615	R495	5135-390522	RES, CBN 1/2P 39	656	Q520	5612-941(Q)or(P)	XISTOR, PNP A
615	R496	5135-390522	RES, CBN 1/2P 39				
615	R497	5135-390522	RES, CBN 1/2P 39				
615	R498	5135-390522	RES, CBN 1/2P 39				
616	R499	5135-273522	RES, CBN 1/2P 27K				
616	R500	5135-273522	RES, CBN 1/2P 27K				
660	△R555	5102-1005116	RES, FUSE 10				
660	△R556	5102-1005116	RES, FUSE 10				
661	R557	5135-562522	RES, CBN 1/2P 5.6K				
661	R558	5135-562522	RES, CBN 1/2P 5.6K				
614	R751	5135-3R3522	RES, CBN 1/2P 3.3				
614	R752	5135-3R3522	RES, CBN 1/2P 3.3				
614	R753	5135-3R3522	RES, CBN 1/2P 3.3				
614	R754	5135-3R3522	RES, CBN 1/2P 3.3				
TRANSISTORS							
621	Q1	5613-2603(E)or(F)	XISTOR, NPN R	558	L401	5597-45502	CORE, BEADS
622	Q2	5611-1115(E)or(F)	XISTOR, PNP R	558	L402	5597-45502	CORE, BEADS
621	Q3	5613-2603(E)or(F)	XISTOR, NPN R	558	L403	5597-45502	CORE, BEADS
622	Q4	5611-1115(E)or(F)	XISTOR, PNP R	558	L404	5597-45502	CORE, BEADS
624	Q5	5611-970(BL)	XISTOR, PNP R	557	L405	5991-7165	SPRING COIL
624	Q6	5611-970(BL)	XISTOR, PNP R	557	L406	5991-7165	SPRING COIL
622	Q7	5611-1115(E)or(F)	XISTOR, PNP R	558	L407	5597-45502	CORE, BEADS
623	Q8	5613-2240(BL)	XISTOR, NPN R	558	L408	5597-45502	CORE, BEADS
625	Q401	5616-2SK364(V)or(BL)	FET, N-CH	558	L409	5597-45502	CORE, BEADS
625	Q402	5616-2SK364(V)or(BL)	FET, N-CH	558	L410	5597-45502	CORE, BEADS
531	Q403	5613-1775(F)	XISTOR, NPN R	693	CN401	4443-040185	CONNECTOR
531	Q404	5613-1775(F)	XISTOR, NPN R	693	CN402	4443-040185	CONNECTOR
531	Q405	5613-1775(F)	XISTOR, NPN R	694	CN403	4443-030185	CONNECTOR
531	Q406	5613-1775(F)	XISTOR, NPN R	695	CN900	4443-0301140	CONNECTOR
535	Q407	5613-2320L(F)	XISTOR, NPN R	747	CW401	4163-0107024	CONNECTOR W/W
535	Q408	5613-2320L(F)	XISTOR, NPN R	748	CW402	4163-0115024	CONNECTOR W/W
535	Q409	5613-2320L(F)	XISTOR, NPN R	749	CW404	4163-0140026	CONNECTOR W/W
535	Q410	5613-2320L(F)	XISTOR, NPN R	750	CW405	4163-0140027	CONNECTOR W/W
538	Q411	5611-872(E)	XISTOR, PNP R	751	CW406	4163-0140024	CONNECTOR W/W
538	Q412	5611-872(E)	XISTOR, PNP R	752	CW407	4163-0140025	CONNECTOR W/W
				757	CW409	4163-0130022	CONNECTOR W/W
DIODES							
				681	D1	5685-D55B20	SILICON, BRIDGE
				628	D2	5636-1S2471	DIODE, SWITCH
				628	D3	5636-1S2471	DIODE, SWITCH
				627	D4	5635-HZ6A-2L	DIODE, ZENER
				629	D5	5631-1S2473	DIODE, DET
				553	D403	5635-HZ6A2L	DIODE, ZENER
				553	D404	5635-HZ6A2L	DIODE, ZENER
				551	D409	5641-MV12YM	VARIATOR
				551	D410	5641-MV12YM	VARIATOR
				657	D503	5635-HZ22-2L	DIODE, ZENER
				657	D504	5635-HZ22-2L	DIODE, ZENER
MISCELLANEOUS							
				558	L401	5597-45502	CORE, BEADS
				558	L402	5597-45502	CORE, BEADS
				558	L403	5597-45502	CORE, BEADS
				558	L404	5597-45502	CORE, BEADS
				557	L405	5991-7165	SPRING COIL
				557	L406	5991-7165	SPRING COIL
				558	L407	5597-45502	CORE, BEADS
				558	L408	5597-45502	CORE, BEADS
				558	L409	5597-45502	CORE, BEADS
				558	L410	5597-45502	CORE, BEADS
				693	CN401	4443-040185	CONNECTOR
				693	CN402	4443-040185	CONNECTOR
				694	CN403	4443-030185	CONNECTOR
				695	CN900	4443-0301140	CONNECTOR
				747	CW401	4163-0107024	CONNECTOR W/W
				748	CW402	4163-0115024	CONNECTOR W/W
				749	CW404	4163-0140026	CONNECTOR W/W
				750	CW405	4163-0140027	CONNECTOR W/W
				751	CW406	4163-0140024	CONNECTOR W/W
				752	CW407	4163-0140025	CONNECTOR W/W
				757	CW409	4163-0130022	CONNECTOR W/W

Ser. No.	Ref. No.	Part No.	Description
756	CW410	4163-0130023	CONNECTOR W/W
691	TM401	4214-11023	TERMINAL
692	TM402	4214-11031	TERMINAL
581	VR401	5101-50271920	RES, SEMI FIX 5K
581	VR402	5101-50271920	RES, SEMI FIX 5K
582	VR403	5101-50101934	RES, SEMI FIX 500
582	VR404	5101-50101934	RES, SEMI FIX 500

MISCELLANEOUS

763	JL401	4242-043805	JUMPER LEAD
743	TM10	4214-156	TERMINAL

MISCELLANEOUS

736	J1	4451-00159	JACK, IP
797	JL402	4242-R0103161	JUMPER LEAD

DIODES

741	D9	5637-SLP965B5	LED
741	D10	5637-SLP965B5	LED

RESISTORS

619	R561	5134-221522	RES, CBN 1/2P
619	R562	5134-221522	RES, CBN 1/2P
619	R563	5134-221522	RES, CBN 1/2P
619	R564	5134-221522	RES, CBN 1/2P

MISCELLANEOUS

729	SW5	4411-00301104	SWITCH, ROTARY
-----	-----	---------------	----------------

CAPACITORS

419	C601	5345-475D0951	CAP, MINI ELE 4.7μ/25V
419	C602	5345-475D0951	CAP, MINI ELE 4.7μ/25V
423	C603	5359-1215851	CAP, PPP 120P
423	C604	5359-1215851	CAP, PPP 120P
420	C605	5345-227A0951	CAP, MINI ELE 220μ/6.3V
420	C606	5345-227A0951	CAP, MINI ELE 220μ/6.3V
424	C607	5359-5625851	CAP, PPP 5600P
424	C608	5359-5625851	CAP, PPP 5600P
423	C609	5359-1215851	CAP, PPP 120P
423	C610	5359-1215851	CAP, PPP 120P
421	C611	5345-106C0951	CAP, MINI ELE 10μ/16V
421	C612	5345-106C0951	CAP, MINI ELE 10μ/16V
456	C613	5345-227D041	CAP, MINI ELE 220μ/25V
456	C614	5345-227D041	CAP, MINI ELE 220μ/25V
456	C615	5345-227D041	CAP, MINI ELE 220μ/25V
456	C616	5345-227D041	CAP, MINI ELE 220μ/25V
427	C619	5353-040933	CAP, MCA 4P
427	C620	5353-040933	CAP, MCA 4P
422	C621	5359-S010J182	CAP, PPP 1800P
422	C622	5359-S010J182	CAP, PPP 1800P
056B	C623	5353-820534	CAP, MCA 82P G GB
056B	C624	5353-820534	CAP, MCA 82P G GB
425	C627	5359-1825851	CAP, PPP 1800P
425	C628	5359-1825851	CAP, PPP 1800P
867	C701	5345-107B0951	CAP, MINI ELE 100μ/10V
867	C702	5345-107B0951	CAP, MINI ELE 100μ/10V
867	C703	5345-107B0951	CAP, MINI ELE 100μ/10V
867	C704	5345-107B0951	CAP, MINI ELE 100μ/10V
866	C705	5345-106C0951	CAP, MINI ELE 10μ/16V
866	C706	5345-106C0951	CAP, MINI ELE 10μ/16V

Ser. No.	Ref. No.	Part No.	Description
868	C708	5345-107D041	CAP, MINI ELE 100μ/25V
868	C709	5345-107D041	CAP, MINI ELE 100μ/25V
064B	C711	5359-S010J103	CAP, PPP .01μ G GB
064B	C712	5359-S010J103	CAP, PPP .01μ G GB
064B	C713	5359-S010J103	CAP, PPP .01μ G GB
064B	C714	5359-S010J103	CAP, PPP .01μ G GB
061B	C715	5359-1215851	CAP, PPP 120P G GB
061B	C716	5359-1215851	CAP, PPP 120P G GB

RESISTORS

055B	R573	5135-102522	RES, CBN 1/2P 1K G GB
055B	R574	5135-102522	RES, CBN 1/2P 1K G GB
055B	R575	5135-102522	RES, CBN 1/2P 1K G GB
055B	R576	5135-102522	RES, CBN 1/2P 1K G GB
055B	R577	5135-102522	RES, CBN 1/2P 1K G GB
055B	R578	5135-102522	RES, CBN 1/2P 1K G GB
429	R601	5135-823522	RES, CBN 1/2P 82K
429	R602	5135-823522	RES, CBN 1/2P 82K
430	R603	5135-124522	RES, CBN 1/2P 120K
430	R604	5135-124522	RES, CBN 1/2P 120K
431	R605	5135-221522	RES, CBN 1/2P 220
431	R606	5135-221522	RES, CBN 1/2P 220
432	R607	5135-122522	RES, CBN 1/2P 1.2K
432	R608	5135-122522	RES, CBN 1/2P 1.2K
433	R609	5135-220522	RES, CBN 1/2P 22
433	R610	5135-220522	RES, CBN 1/2P 22
432	R611	5135-122522	RES, CBN 1/2P 1.2K
432	R612	5135-122522	RES, CBN 1/2P 1.2K
434	R613	5135-223522	RES, CBN 1/2P 22K
434	R614	5135-223522	RES, CBN 1/2P 22K
435	R615	5135-820522	RES, CBN 1/2P 82
435	R616	5135-820522	RES, CBN 1/2P 82
436	R617	5135-121522	RES, CBN 1/2P 120
436	R618	5135-121522	RES, CBN 1/2P 120
428	R621	5135-821522	RES, CBN 1/2P 820
428	R622	5135-821522	RES, CBN 1/2P 820
438	R623	5135-393522	RES, CBN 1/2P 39K
438	R624	5135-393522	RES, CBN 1/2P 39K
439	R625	5135-564522	RES, CBN 1/2P 560K
439	R626	5135-564522	RES, CBN 1/2P 560K
440	R627	5135-334522	RES, CBN 1/2P 330K
440	R628	5135-334522	RES, CBN 1/2P 330K
441	R629	5135-102522	RES, CBN 1/2P 1K
441	R630	5135-102522	RES, CBN 1/2P 1K
443	R631	5135-104522	RES, CBN 1/2P 100K
443	R632	5135-104522	RES, CBN 1/2P 100K
441	R633	5135-102522	RES, CBN 1/2P 1K
441	R634	5135-102522	RES, CBN 1/2P 1K
442	R635	5135-222522	RES, CBN 1/2P 2.2K
442	R636	5135-222522	RES, CBN 1/2P 2.2K
452	△R637	5102-4705116	RES, FUSE 47
452	△R638	5102-4705116	RES, FUSE 47
454	R639	5135-103522	RES, CBN 1/2P 10K
454	R640	5135-103522	RES, CBN 1/2P 10K
453	R641	5135-331522	RES, CBN 1/2P 330
453	R642	5135-331522	RES, CBN 1/2P 330
055B	R644	5135-102522	RES, CBN 1/2P 1K G GB
055B	R645	5135-102522	RES, CBN 1/2P 1K G GB
055B	R646	5135-102522	RES, CBN 1/2P 1K G GB
055B	R647	5135-102522	RES, CBN 1/2P 1K G GB
442	R681	5135-222522	RES, CBN 1/2P 2.2K
442	R682	5135-222522	RES, CBN 1/2P 2.2K
871	R701	5135-1R0522	RES, CBN 1/2P 1
871B	R701	5135-100522	RES, CBN 1/2P 10 G GB
871	R702	5135-1R0522	RES, CBN 1/2P 1
871B	R702	5135-100522	RES, CBN 1/2P 10 G GB
874	R703	5135-560522	RES, CBN 1/2P 56
874B	R703	5135-470522	RES, CBN 1/2P 47 G GB
874	R704	5135-560522	RES, CBN 1/2P 56
874B	R704	5135-470522	RES, CBN 1/2P 47 G GB
877	R705	5135-562522	RES, CBN 1/2P 5.6K
877	R706	5135-562522	RES, CBN 1/2P 5.6K
876	R707	5174-681381	RES, MTL 1/4 680

Ser. No.	Ref. No.	Part No.	Description	Ser. No.	Ref. No.	Part No.	Description
876	R708	5174-681381	RES, MTL 1/4 680	848	R806	5135-750522	RES, CBN 1/2P 75
875	R709	5135-272522	RES, CBN 1/2P 2.7K	849	R807	5135-331522	RES, CBN 1/2P 330
875	R710	5135-272522	RES, CBN 1/2P 2.7K	850	R808	5135-393522	RES, CBN 1/2P 39K
873	R711	5135-220522	RES, CBN 1/2P 22	850	R809	5135-393522	RES, CBN 1/2P 39K
873	R712	5135-220522	RES, CBN 1/2P 22	848	R810	5135-750522	RES, CBN 1/2P 75
872	R713	5135-121522	RES, CBN 1/2P 120	849	R811	5135-331522	RES, CBN 1/2P 330
872	R714	5135-121522	RES, CBN 1/2P 120	850	R812	5135-393522	RES, CBN 1/2P 39K
872	R715	5135-121522	RES, CBN 1/2P 120	850	R813	5135-393522	RES, CBN 1/2P 39K
872	R716	5135-121522	RES, CBN 1/2P 120	851	R814	5135-221522	RES, CBN 1/2P 220
870	R717	5135-822522	RES, CBN 1/2P 8.2K	852	R815	5135-271522	RES, CBN 1/2P 270
870	R718	5135-822522	RES, CBN 1/2P 8.2K	848	R816	5135-750522	RES, CBN 1/2P 75
879	R719	5135-152522	RES, CBN 1/2P 1.5K	851	R817	5135-221522	RES, CBN 1/2P 220
TRANSISTORS				851	R818	5135-221522	RES, CBN 1/2P 220
411	Q601	5613-2320L(F)	XISTOR, NPN R	852	R819	5135-271522	RES, CBN 1/2P 270
411	Q602	5613-2320L(F)	XISTOR, NPN R	848	R820	5135-750522	RES, CBN 1/2P 75
414	Q603	5611-999L(F)	XISTOR, PNP R	851	R821	5135-221522	RES, CBN 1/2P 220
414	Q604	5611-999L(F)	XISTOR, PNP R	851	R822	5135-221522	RES, CBN 1/2P 220
414	Q605	5611-999L(F)	XISTOR, PNP R	852	R823	5135-271522	RES, CBN 1/2P 270
414	Q606	5611-999L(F)	XISTOR, PNP R	848	R824	5135-750522	RES, CBN 1/2P 75
411	Q607	5613-2320L(F)	XISTOR, NPN R	853	R825	5135-272522	RES, CBN 1/2P 2.7K
411	Q608	5613-2320L(F)	XISTOR, NPN R	858	△R827	5102-3305116	RES, FUSE 33
411	Q609	5613-2320L(F)	XISTOR, NPN R	855	R829	5135-153522	RES, CBN 1/2P 15K
411	Q610	5613-2320L(F)	XISTOR, NPN R	851	R830	5135-221522	RES, CBN 1/2P 220
411	Q611	5613-2320L(F)	XISTOR, NPN R	854	R831	5135-105522	RES, CBN 1/2P 1M
411	Q612	5613-2320L(F)	XISTOR, NPN R	058B	R832	5135-102522	RES, CBN 1/2P 1K
448	Q613	5612-941(P)or(Q)	XISTOR, PNP A	058B	R833	5135-102522	RES, CBN 1/2P 1K
447	Q614	5614-1266(P)or(Q)	XISTOR, NPN A	058B	R834	5135-102522	RES, CBN 1/2P 1K
449	Q615	5613-2603(E)or(F)	XISTOR, NPN R	058B	R835	5135-102522	RES, CBN 1/2P 1K
450	Q616	5611-1115(E)or(F)	XISTOR, PNP R	058B	R836	5135-102522	RES, CBN 1/2P 1K
862	Q701	5613-2855(E)	XISTOR, NPN R	058B	R837	5135-102522	RES, CBN 1/2P 1K
862	Q702	5613-2855(E)	XISTOR, NPN R	058B	R838	5135-102522	RES, CBN 1/2P 1K
862	Q703	5613-2855(E)	XISTOR, NPN R	058B	R839	5135-102522	RES, CBN 1/2P 1K
862	Q704	5613-2855(E)	XISTOR, NPN R	058B	R840	5135-102522	RES, CBN 1/2P 1K
863	Q705	5613-2320L(F)	XISTOR, NPN R	058B	R841	5135-102522	RES, CBN 1/2P 1K
DIODES				058B	R842	5135-102522	RES, CBN 1/2P 1K
451	D601	5635-HZ18-2L	DIODE, ZENER	058B	R843	5135-102522	RES, CBN 1/2P 1K
451	D602	5635-HZ18-2L	DIODE, ZENER	INTEGRATED CIRCUITS			
864	D701	5635-15B2L	DIODE, ZENER	831	IC801	5654-TC4066BP	IC, DIGITAL
MISCELLANEOUS				831	IC802	5654-TC4066BP	IC, DIGITAL
737	J2	4484-46	PIN JACK, 4P	TRANSISTORS			
739	J6	4486-15	PIN JACK, 6P	833	Q801	5613-2603(F)or(E)	XISTOR, NPN R
065B	L701	5597-45502	CORE, BEADS	835	Q802	5611-1115(F)or(E)	XISTOR, PNP R
065B	L702	5597-45502	CORE, BEADS	833	Q803	5613-2603(F)or(E)	XISTOR, NPN R
065B	L703	5597-45502	CORE, BEADS	835	Q804	5611-1115(F)or(E)	XISTOR, PNP R
065B	L704	5597-45502	CORE, BEADS	833	Q805	5613-2603(F)or(E)	XISTOR, NPN R
753	CW601	4163-0130020	CONNECTOR W/W	835	Q806	5611-1115(F)or(E)	XISTOR, PNP R
761	CW602	4163-0118024	CONNECTOR W/W	834	Q807	5614-1266(Q)or(P)	XISTOR, NPN A
768	JL601	4242-R0403201	JUMPER LEAD	836	Q808	5616-2SK364(V)or(BL)	FET, N-CH
769	JL602	4242-R0304181	JUMPER LEAD	DIODES			
770	JL603	4242-R0307181	JUMPER LEAD	837	D801	5635-HZ12B2L	DIODE, ZENER
791	JL604	4242-R0303181	JUMPER LEAD	MISCELLANEOUS			
733	SW7	4431-S0302102	SWITCH, PUSH	738	J3	4489-01001004	PIN JACK, MLT
CAPACITORS				738	J4	4489-01001004	PIN JACK, MLT
842	C801	5345-107B041	CAP, MINI ELE 100μ/10V	738	J5	4489-01001004	PIN JACK, MLT
842	C802	5345-107B041	CAP, MINI ELE 100μ/10V	740	J7	4489-00901006	PIN JACK, MLT
842	C803	5345-107B041	CAP, MINI ELE 100μ/10V	798	CW806	4163-S0203551	CONNECTOR W/W
843	C804	5345-106C041	CAP, MINI ELE 10μ/16V	765	JL802	4242-R0306451	JUMPER LEAD
840	C805	5345-337B041	CAP, MINI ELE 330μ/10V	766	JL803	4242-R0405401	JUMPER LEAD
840	C806	5345-337B041	CAP, MINI ELE 330μ/10V	767	JL804	4242-R0307401	JUMPER LEAD
840	C807	5345-337B041	CAP, MINI ELE 330μ/10V	767	JL805	4242-R0307401	JUMPER LEAD
841	C808	5345-227C041	CAP, MINI ELE 220μ/16V	845	RC801	5212-473J0501	R COMPOSITE
841	C809	5345-227C041	CAP, MINI ELE 220μ/16V	CAPACITORS			
RESISTORS				667	△C1	5352-S010M103	CAP, MTL .01μ
847	R8D1	5135-122522	RES, CBN 1/2P 1.2K	668	C8	5345-106C041	CAP, MINI ELE 10μ/16V
848	R8D2	5135-750522	RES, CBN 1/2P 75	668	C9	5345-106C041	CAP, MINI ELE 10μ/16V
849	R8D3	5135-331522	RES, CBN 1/2P 330	RESISTORS			
850	R8D4	5135-393522	RES, CBN 1/2P 39K	664	△R47	5102-2205116	RES, FUSE 22
850	R8D5	5135-393522	RES, CBN 1/2P 39K	666	△R48	5102-5R65116	RES, FUSE 5.6

Ser. No.	Ref. No.	Part No.	Description
665	R49	5135-221522	RES, CBN 1/2P 220
665	R50	5135-221522	RES, CBN 1/2P 220
664	△R51	5102-2205116	RES, FUSE 22
054B	R52	5135-335522	RES, CBN 1/2P 3.3M G GB
DIODES			
663	D6	5636-1S2471	DIODE, SWITCH
663	D7	5636-1S2471	DIODE, SWITCH
MISCELLANEOUS			
758	CW101	4163-0140020	CONNECTOR W/W
759	CW102	4163-0140021	CONNECTOR W/W
760	CW103	4163-0140022	CONNECTOR W/W
684	HF1	4472-0131	HOLDER, FUSE
684	HF2	4472-0131	HOLDER, FUSE
796	JL101	4242-R0103101	JUMPER LEAD
732	△SW1	4431-A01716	SWITCH, PUSH
675	TM1	4214-122	TERMINAL
675	TM2	4214-122	TERMINAL JA BK
675	TM3	4214-122	TERMINAL

Ser. No.	Ref. No.	Part No.	Description
507	R529	5135-331522	RES, CBN 1/2P 330
507	R530	5135-331522	RES, CBN 1/2P 330
508	R531	5135-222522	RES, CBN 1/2P 2.2K
508	R532	5135-222522	RES, CBN 1/2P 2.2K
508	R533	5135-222522	RES, CBN 1/2P 2.2K
508	R534	5135-222522	RES, CBN 1/2P 2.2K
509	R535	5135-274522	RES, CBN 1/2P 270K
509	R536	5135-274522	RES, CBN 1/2P 270K
510	R537	5135-153522	RES, CBN 1/2P 15K
510	R538	5135-153522	RES, CBN 1/2P 15K
507	R539	5135-331522	RES, CBN 1/2P 330
507	R540	5135-331522	RES, CBN 1/2P 330
507	R541	5135-331522	RES, CBN 1/2P 330
507	R542	5135-331522	RES, CBN 1/2P 330
519	R543	5135-122522	RES, CBN 1/2P 1.2K
519	R544	5135-122522	RES, CBN 1/2P 1.2K
507	R545	5135-331522	RES, CBN 1/2P 330
507	R546	5135-331522	RES, CBN 1/2P 330
511	R547	5135-121522	RES, CBN 1/2P 120
511	R548	5135-121522	RES, CBN 1/2P 120
510	R549	5135-153522	RES, CBN 1/2P 15K
510	R550	5135-153522	RES, CBN 1/2P 15K
512	R551	5135-272522	RES, CBN 1/2P 2.7K
512	R552	5135-272522	RES, CBN 1/2P 2.7K
504	R553	5135-473522	RES, CBN 1/2P 47K
504	R554	5135-473522	RES, CBN 1/2P 47K
501	R559	5135-102522	RES, CBN 1/2P 1K
501	R560	5135-102522	RES, CBN 1/2P 1K

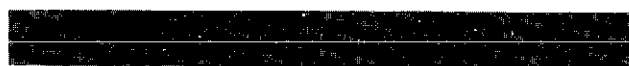

Ser. No.	Ref. No.	Part No.	Description
CAPACITORS			
484	C501	5359-6815851	CAP, PPP 680P
484B	C501	5359-2715851	CAP, PPP 270P G GB
484	C502	5359-6815851	CAP, PPP 680P
484B	C502	5359-2715851	CAP, PPP 270P G GB
480	C507	5345-475D0951	CAP, MINI ELE 4.7μ/25V
480	C508	5345-475D0951	CAP, MINI ELE 4.7μ/25V
487	C511	5353-010933	CAP, MCA 1P
487	C512	5353-010933	CAP, MCA 1P
481	C513	5345-226B0951	CAP, MINI ELE 22μ/10V
481	C514	5345-226B0951	CAP, MINI ELE 22μ/10V
488	C515	5359-3315851	CAP, PPP 330P
488	C516	5359-3315851	CAP, PPP 330P
478	C517	5345-107B0951	CAP, MINI ELE 100μ/10V
478	C518	5345-107B0951	CAP, MINI ELE 100μ/10V
482	C519	5345-476C0951	CAP, MINI ELE 47μ/16V
482	C520	5345-476C0951	CAP, MINI ELE 47μ/16V
497	C521	5354-682JIHM	CAP, MYL 6800P
497	C522	5354-682JIHM	CAP, MYL 6800P
498	C523	5354-393JIHM	CAP, MYL .039μ
498	C524	5354-393JIHM	CAP, MYL .039μ
499	C525	5354-273JIHM	CAP, MYL .027μ
499	C526	5354-273JIHM	CAP, MYL .027μ
491	C527	5354-154593	CAP, MYL .15μ
491	C528	5354-154593	CAP, MYL .15μ
479	C535	5345-227D041	CAP, MINI ELE 220μ/25V
479	C536	5345-227D041	CAP, MINI ELE 220μ/25V
479	C537	5345-227D041	CAP, MINI ELE 220μ/25V
479	C538	5345-227D041	CAP, MINI ELE 220μ/25V

Ser. No.	Ref. No.	Part No.	Description
TRANSISTORS			
471	Q501	5613-2320L(F)	XISTOR, NPN R
471	Q502	5613-2320L(F)	XISTOR, NPN R
471	Q503	5613-2320L(F)	XISTOR, NPN R
471	Q504	5613-2320L(F)	XISTOR, NPN R
471	Q505	5613-2320L(F)	XISTOR, NPN R
471	Q506	5613-2320L(F)	XISTOR, NPN R
471	Q507	5613-2320L(F)	XISTOR, NPN R
471	Q508	5613-2320L(F)	XISTOR, NPN R
473	Q509	5611-999L(F)	XISTOR, PNP R
473	Q510	5611-999L(F)	XISTOR, PNP R
476	Q511	5613-2320L(F)	XISTOR, NPN R
476	Q512	5613-2320L(F)	XISTOR, NPN R
473	Q513	5611-999L(F)	XISTOR, PNP R
473	Q514	5611-999L(F)	XISTOR, PNP R
475	Q515	5612-646A(C)	XISTOR, PNP A
475	Q516	5612-646A(C)	XISTOR, PNP A
474	Q517	5614-666A(C)	XISTOR, NPN A
474	Q518	5614-666A(C)	XISTOR, NPN A

Ser. No.	Ref. No.	Part No.	Description
RESISTORS			
501	R501	5135-102522	RES, CBN 1/2P 1K
501	R502	5135-102522	RES, CBN 1/2P 1K
503	R505	5135-224522	RES, CBN 1/2P 220K
503	R506	5135-224522	RES, CBN 1/2P 220K
502	R507	5135-394522	RES, CBN 1/2P 390K
502	R508	5135-394522	RES, CBN 1/2P 390K
514	R515	5135-183522	RES, CBN 1/2P 18K
514	R516	5135-183522	RES, CBN 1/2P 18K
507	R517	5135-331522	RES, CBN 1/2P 330
507	R518	5135-331522	RES, CBN 1/2P 330
504	R519	5135-473522	RES, CBN 1/2P 47K
504	R520	5135-473522	RES, CBN 1/2P 47K
505	R521	5135-332522	RES, CBN 1/2P 3.3K
505	R522	5135-332522	RES, CBN 1/2P 3.3K
505	R523	5135-332522	RES, CBN 1/2P 3.3K
505	R524	5135-332522	RES, CBN 1/2P 3.3K
506	R525	5135-471522	RES, CBN 1/2P 470
506	R526	5135-471522	RES, CBN 1/2P 470
506	R527	5135-471522	RES, CBN 1/2P 470
506	R528	5135-471522	RES, CBN 1/2P 470

Ser. No.	Ref. No.	Part No.	Description
DIODES			
477	D501	5631-1S2473	DIODE, DET
477	D502	5631-1S2473	DIODE, DET
MISCELLANEOUS			
703	CN501	4443-030185	CONNECTOR
793	JL501	4242-R0404141	JUMPER LEAD
794	JL502	4242-R0203500	JUMPER LEAD
795	JL503	4242-R0407181	JUMPER LEAD
720	VR501	5113-50399122	RES, V CBN 16 50K
720	VR502	5113-50399122	RES, V CBN 16 50K
714	VR505	5113-10441122	RES, V CBN 16 100K
714	VR506	5113-10441122	RES, V CBN 16 100K
717	VR507	5113-50342122	RES, V CBN 16 50K
717	VR508	5113-50342122	RES, V CBN 16 50K



Ser. No.	Ref. No.	Part No.	Description
CAPACITORS			
806	C921	5345-104F0951	CAP, MINI ELE .1μ/50V
806	C922	5345-104F0951	CAP, MINI ELE .1μ/50V
810	C923	5354-154593	CAP, MYL .15μ
810	C924	5354-154593	CAP, MYL .15μ
808	C925	5345-107D041	CAP, MINI ELE 100μ/25V
808	C926	5345-107D041	CAP, MINI ELE 100μ/25V

Ser. No.	Ref. No.	Part No.	Description
811	C927	5354-334593	CAP, MYL .33μ
811	C928	5354-334593	CAP, MYL .33μ
807	C929	5345-224F0951	CAP, MINI ELE .22μ/50V
807	C930	5345-224F0951	CAP, MINI ELE .22μ/50V
812	C963	5354-474593	CAP, MYL .47μ
812	C964	5354-474593	CAP, MYL .47μ
809	C981	5345-227D041	CAP, MINI ELE 220μ/25V
809	C982	5345-227D041	CAP, MINI ELE 220μ/25V
809	C983	5345-227D041	CAP, MINI ELE 220μ/25V
809	C984	5345-227D041	CAP, MINI ELE 220μ/25V

RESISTORS

814	R921	5135-471522	RES, CBN 1/2P 470
814	R922	5135-471522	RES, CBN 1/2P 470
815	R925	5135-684522	RES, CBN 1/2P 680K
815	R926	5135-684522	RES, CBN 1/2P 680K
816	R927	5135-224522	RES, CBN 1/2P 220K
816	R928	5135-224522	RES, CBN 1/2P 220K
817	R929	5135-332522	RES, CBN 1/2P 3.3K
817	R930	5135-332522	RES, CBN 1/2P 3.3K
817	R931	5135-332522	RES, CBN 1/2P 3.3K
817	R932	5135-332522	RES, CBN 1/2P 3.3K
818	R933	5135-183522	RES, CBN 1/2P 18K
818	R934	5135-183522	RES, CBN 1/2P 18K
819	R935	5135-472522	RES, CBN 1/2P 4.7K
819	R936	5135-472522	RES, CBN 1/2P 4.7K
820	R937	5135-562522	RES, CBN 1/2P 5.6K
820	R938	5135-562522	RES, CBN 1/2P 5.6K
817	R939	5135-332522	RES, CBN 1/2P 3.3K
817	R940	5135-332522	RES, CBN 1/2P 3.3K
817	R941	5135-332522	RES, CBN 1/2P 3.3K
817	R942	5135-332522	RES, CBN 1/2P 3.3K
818	R943	5135-183522	RES, CBN 1/2P 18K
818	R944	5135-183522	RES, CBN 1/2P 18K
821	R945	5135-331522	RES, CBN 1/2P 330
821	R946	5135-331522	RES, CBN 1/2P 330
823	R947	5135-221522	RES, CBN 1/2P 220
823	R948	5135-221522	RES, CBN 1/2P 220
821	R949	5135-331522	RES, CBN 1/2P 330
821	R950	5135-331522	RES, CBN 1/2P 330
822	R951	5135-104522	RES, CBN 1/2P 100K
822	R952	5135-104522	RES, CBN 1/2P 100K
824	R953	5135-153522	RES, CBN 1/2P 15K
830	△R954	5102-8215116	RES, FUSE 820
824	R956	5135-153522	RES, CBN 1/2P 15K
830	△R957	5102-8215116	RES, FUSE 820

TRANSISTORS

801	Q901	5613-2603(F)or(E)	XISTOR, NPN R
801	Q902	5613-2603(F)or(E)	XISTOR, NPN R
802	Q903	5611-1115(F)or(E)	XISTOR, PNP R
802	Q904	5611-1115(F)or(E)	XISTOR, PNP R
801	Q905	5613-2603(F)or(E)	XISTOR, NPN R
801	Q906	5613-2603(F)or(E)	XISTOR, NPN R
804	Q907	5612-647(C)	XISTOR, PNP A
803	Q908	5614-667(C)	XISTOR, NPN A

DIODES

805	D901	5635-HZ12B2L	DIODE, ZENER
805	D902	5635-HZ12B2L	DIODE, ZENER

MISCELLANEOUS

699	CN901	4443-070185	CONNECTOR
700	CN902	4443-050185	CONNECTOR
701	CN903	4443-030185	CONNECTOR
701	CN904	4443-030185	CONNECTOR
755	CW901	4163-0118020	CONNECTOR W/W
792	JL901	4242-R0404301	JUMPER LEAD
731	SW6	4431-04127170	SWITCH, PUSH

MISCELLANEOUS

702	CN502	4443-030185	CONNECTOR
754	CW501	4163-0115020	CONNECTOR W/W

Ser. No.	Ref. No.	Part No.	Description
723	SW3	4411-00203104	SWITCH, ROTARY
726	SW4	4411-00205304	SWITCH, ROTARY

RESISTORS

523	R571	5135-472522	RES, CBN 1/2P 4.7K
523	R572	5135-472522	RES, CBN 1/2P 4.7K

MISCELLANEOUS

711	VR503	5113-10419122	RES, V CBN 16 100K
711	VR504	5113-10419122	RES, V CBN 16 100K

MISCELLANEOUS

685	△FI	5732-402031	FUSE
685B	△FI	5732-202030	FUSE (G) (GB)
745	△PI	4161-71151	CORD W/PLUG
745B	△PI	4161-7256	CORD W/PLUG (G) (GB)
683	△TI	5584-S1408	XFORMER, POWER
683B	△TI	5584-S1409	XFORMER, POWER (G) (GB)
744	△SO1	4474-157	SOCKET (LA) (BK)
734	△SW2	4421-0227230	SWITCH, SLIDE
051B	△SW101	4411-102729	SWITCH, ROTARY (G) (GB)
705	LUG1	4211-4	LUG

021B	1756-06303	LABEL (G) (GB)
022B	1756-03108	LABEL (I) (G) (GB)
027B	1119-026	ATTACH SHEET FTZ (G) (GB)
105	1111-J30303	OWNER GUIDE OG
105B	1111-J30304	OWNER GUIDE OG (G) (GB)
106	1113-717004	OWNER CARD (LA) (BK)
107	1119-047	ATTACH SHEET WARANTY (LA) (BK)
108	1119-0137	ATTACH SHEET (LA) (BK)
109	1119-01201	ATTACH SHEET UL (LA)
121	1241-C12732	POLYETHYLENE BAG OG
122	1241-C1491	POLYETHYLENE BAG SET
124	1221-797167	CARTON BOX
125	1222-7331	CUSHION L
126	1222-7332	CUSHION R
127	1223-11729	SOFT SHEET

ABBREVIATIONS IN PARTS LIST

CAPACITORS

CAP, MINI ELE	: Electrolytic
CAP, CER	: Ceramic
CAP, PPP	: Polypropylene
CAP, MYL	: Mylar
CAP, MCA	: Mica
CAP, MINI BP	: Bipolar
CAP, ELE BP	: Electrolytic Bipolar
CAP, STY	: Polystyrene Film
CAP, SPE	: Special
CAP, TAN	: Tantalum
470μ	: 470μF
6800p	: 6800pF
.047μ	: 0.047μF

RESISTORS

RES, CBN 1/6P	: Carbon 1/6W
RES, FUSE	: Fuse
RES, CEM 5P	: Cement 5W
RES, MTL 1P	: Metal 1W
2.2K	: 2.2kΩ
220	: 220Ω

TRANSISTORS

XISTOR	: Transistor
FET	: Field Effect Transistor

CONTROLS

RES, V CBN	: Variable Carbon Resistor
RES, SEMI FIX	: Semi-fixed Resistor

NOTE

SAFETY RELATED COMPONENT. USE ONLY EXACT REPLACEMENT PART AS SPECIFIED.

SCHMATIC DIAGRAM

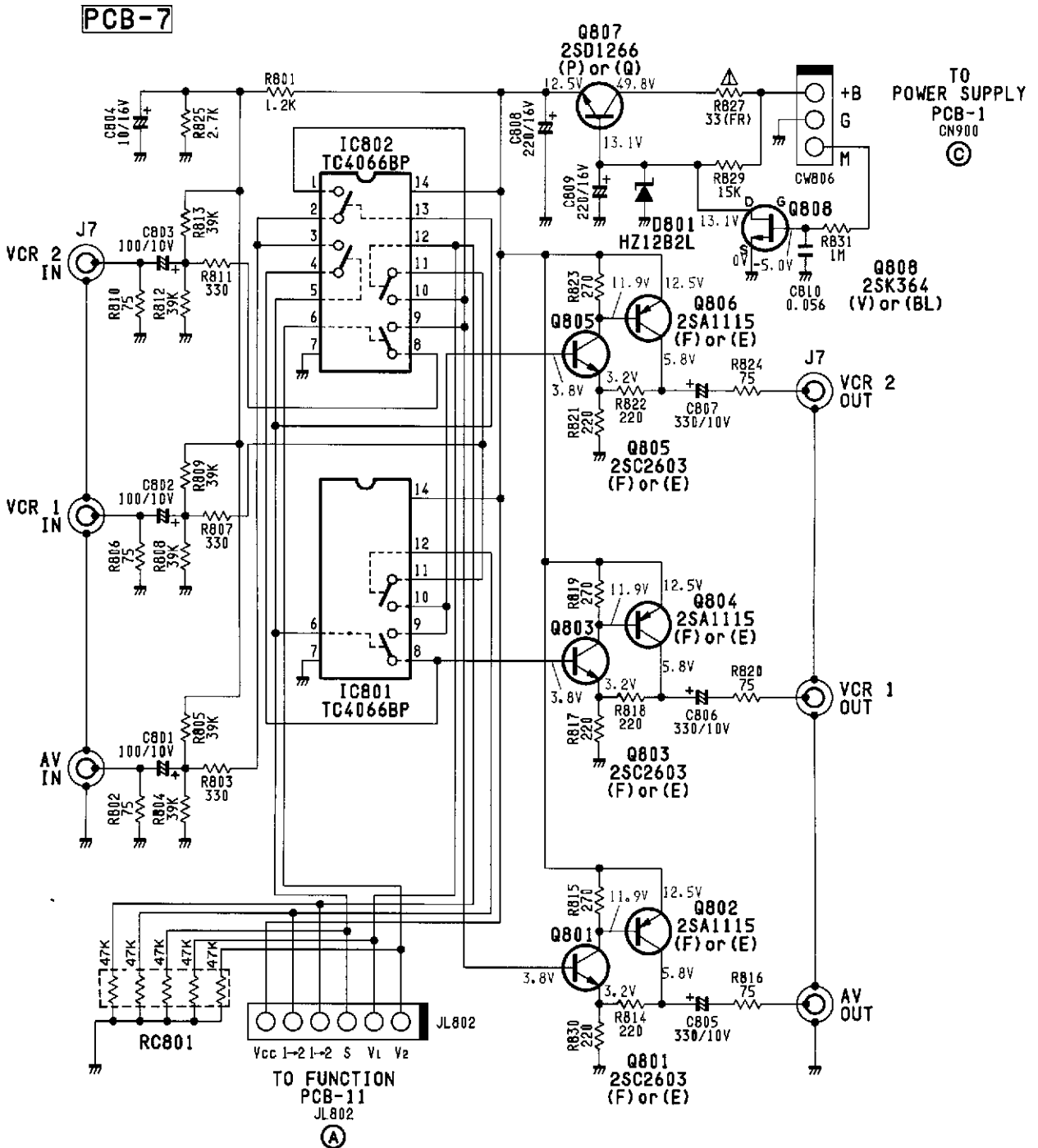

NOTE:

1. ALL RESISTANCES VALUES ARE IN Ω .
K Ω =1000 Ω , M Ω =1000K Ω .
2. THE WATTAGE OF RESISTORS IS 1/2W UNLESS OTHERWISE NOTED.
3. ALL CAPACITANCES VALUES ARE IN μ F UNLESS OTHERWISE NOTED. P= μ F.
4. ...V:DC VOLTAGE AT NO SIGNAL UNLESS OTHERWISE NOTED.
5. SAFETY REQUIREMENTS COMPONENTS IN ACCORDANCE WITH PRESENT SAFETY REGULATIONS.THESE COMPONENTS MUST ONLY BE REPLACED BY ORIGINAL PARTS.



SCHEMATIC DIAGRAM

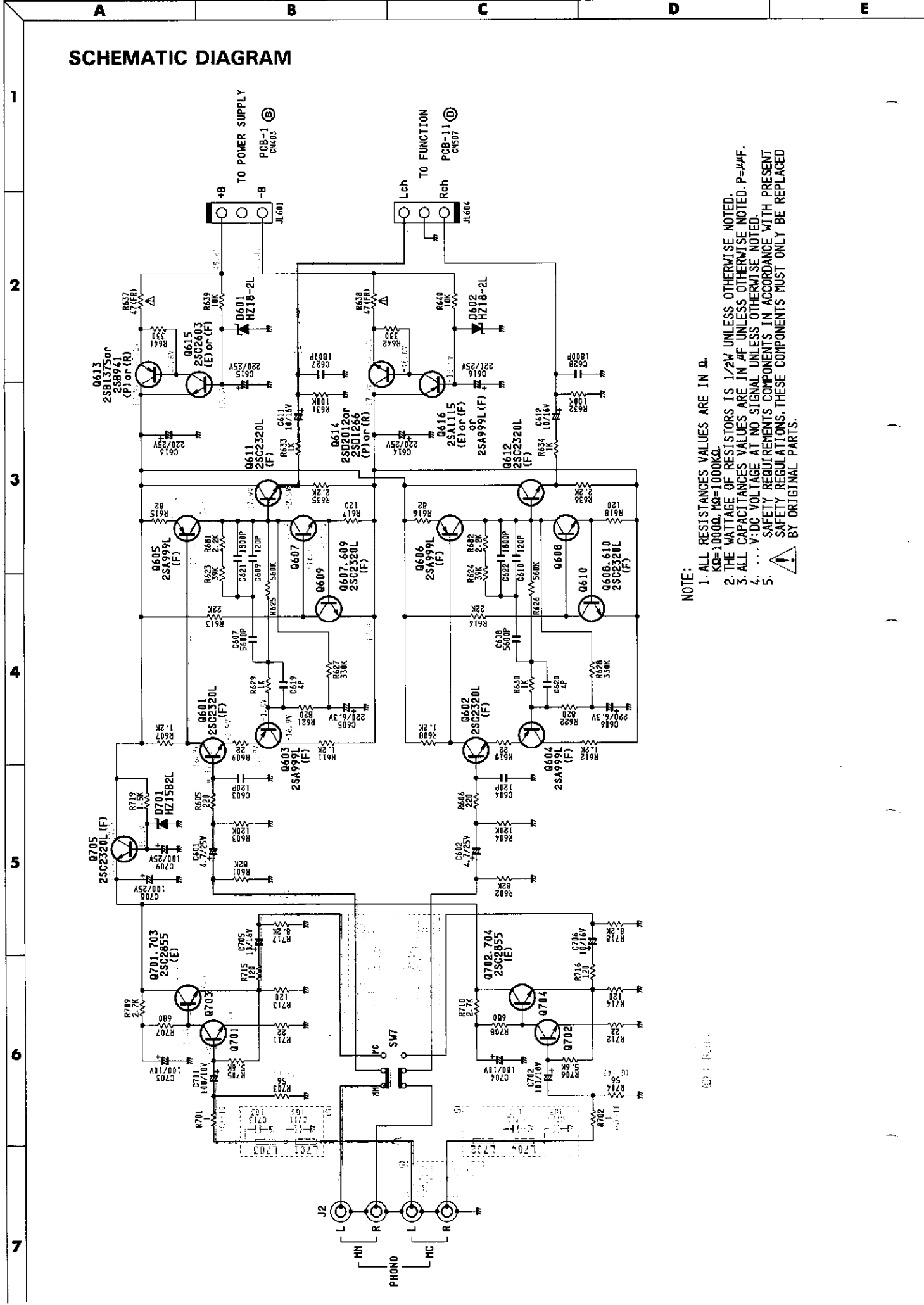

NOTE:

1. ALL RESISTANCE VALUES ARE IN Ω .
K Ω =1000 Ω , M Ω =1000K Ω .
2. THE WATTAGE OF RESISTORS IS 1/2W UNLESS OTHERWISE NOTED.
3. ALL CAPACITANCE VALUES ARE IN pF UNLESS OTHERWISE NOTED. P=µF.
4. ... V:DC VOLTAGE AT NO SIGNAL UNLESS OTHERWISE NOTED.
5. SAFETY REQUIREMENTS COMPONENTS IN ACCORDANCE WITH PRESENT SAFETY REGULATIONS. THESE COMPONENTS MUST ONLY BE REPLACED BY ORIGINAL PARTS.

SCHEMATIC DIAGRAM

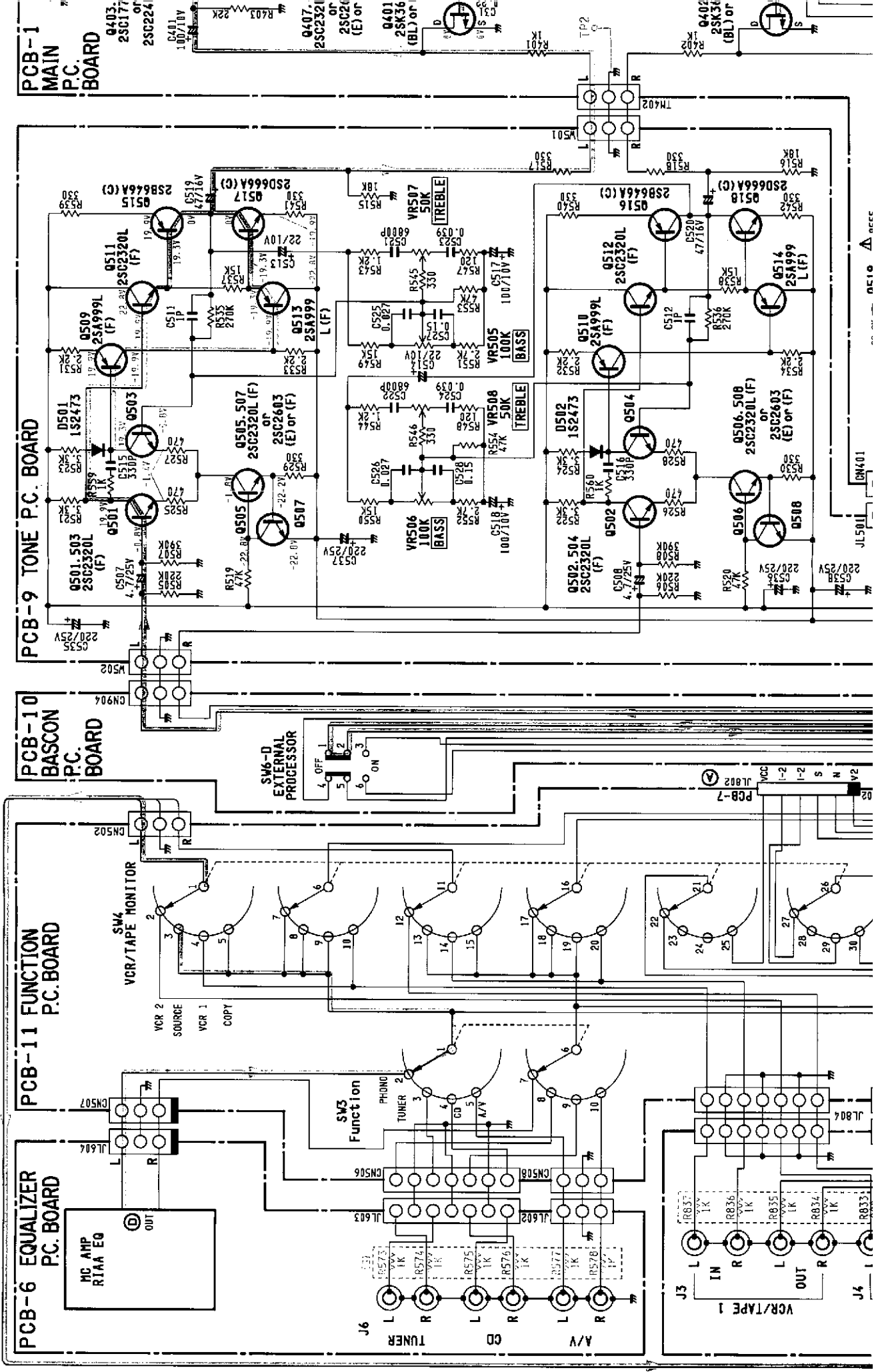

A B C D E F G

1 2 3 4 5

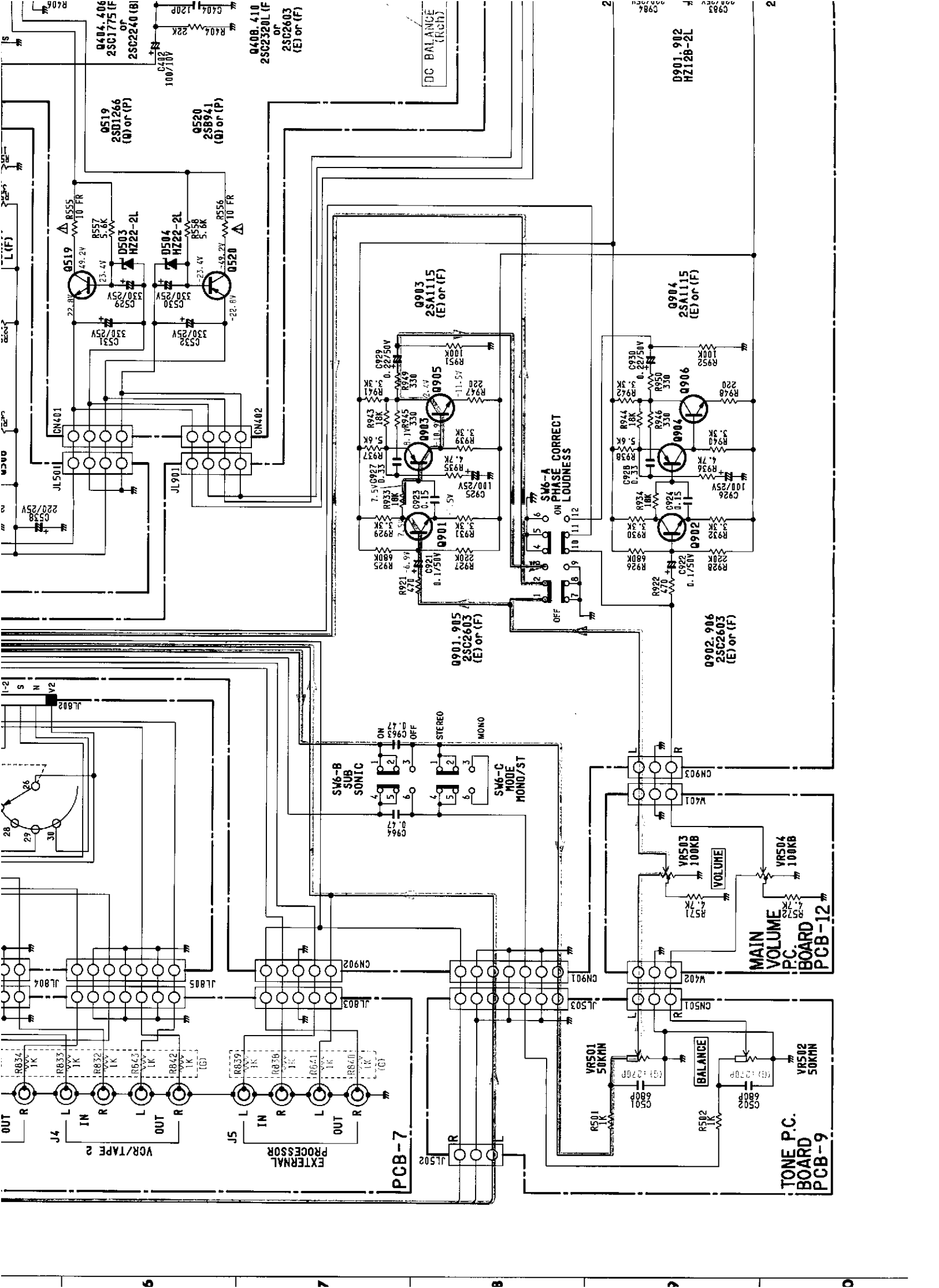

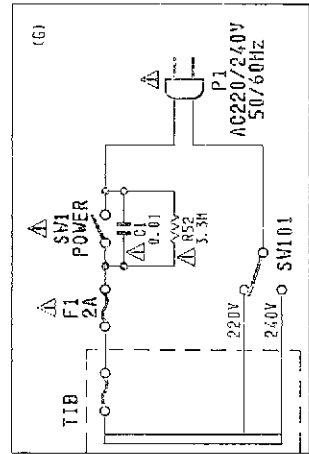
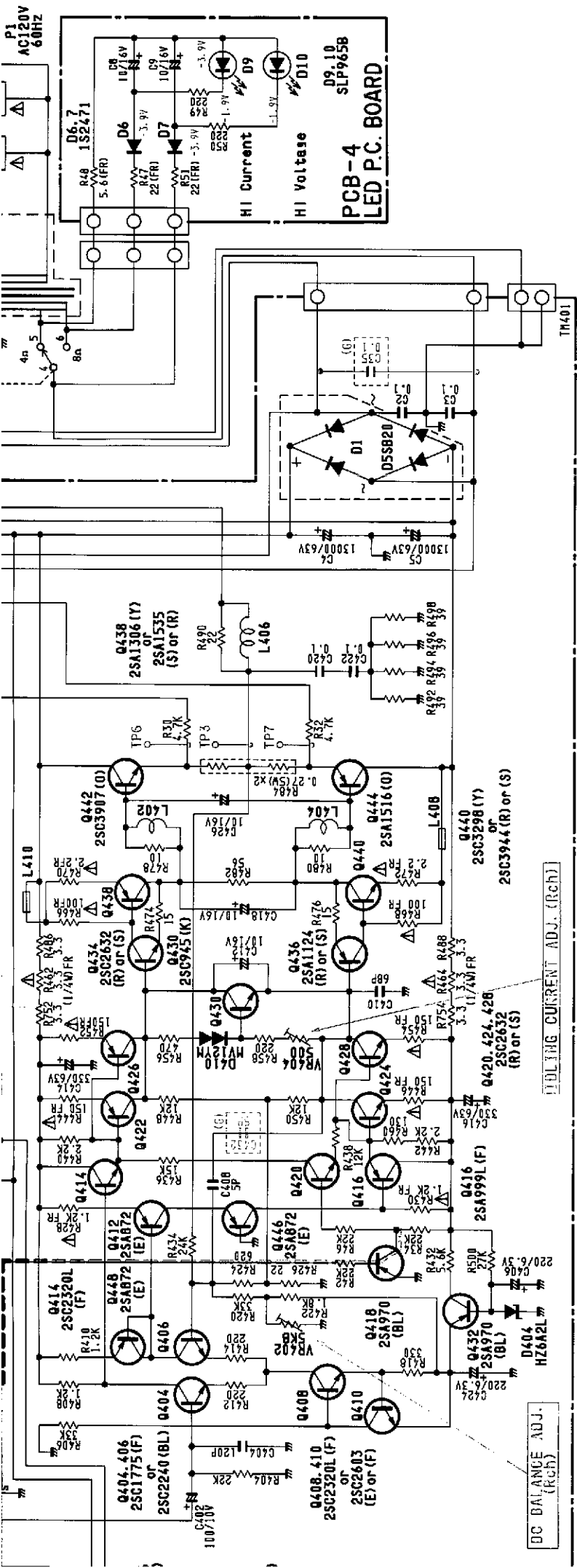

NOTE:

1. ALL RESISTANCE VALUES ARE IN Ω .
K Ω =1000 Ω , M Ω =1000K Ω .
2. THE WATTAGE OF RESISTORS IS 1/2W UNLESS OTHERWISE NOTED.
3. ALL CAPACITANCE VALUES ARE IN μ F UNLESS OTHERWISE NOTED.
4. ... V:DC VOLTAGE AT NO SIGNAL UNLESS OTHERWISE NOTED.
5. SAFETY REQUIREMENTS COMPONENTS IN ACCORDANCE WITH PRESENT SAFETY REGULATIONS, THESE COMPONENTS MUST ONLY BE REPLACED BY ORIGINAL PARTS.

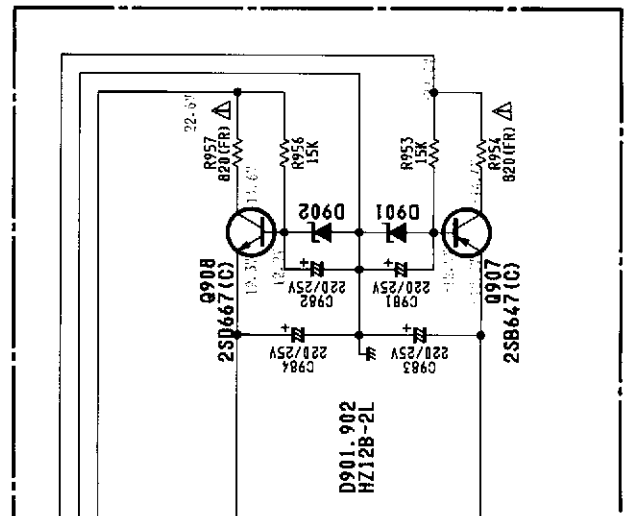

A B C D E F G

WIRING DIAGRAM

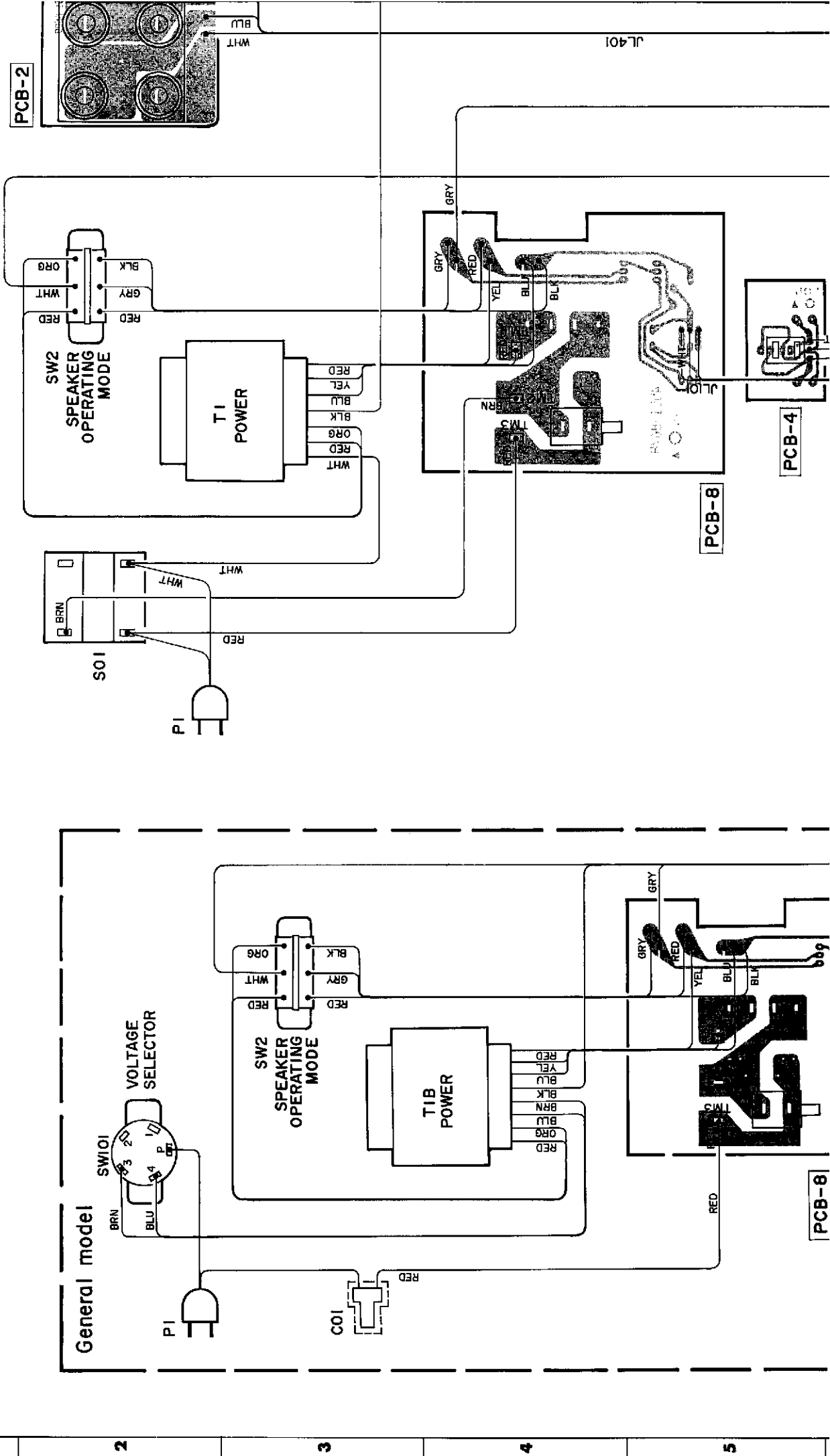

1 2 3 4 5

JL401

PCB-2

PCB-8

PCB-4

PCB-8

SO1

PI

T1 POWER

T1B POWER

General model

SW2 SPEAKER OPERATING MODE

VOLTAGE SELECTOR

SW101

CO1



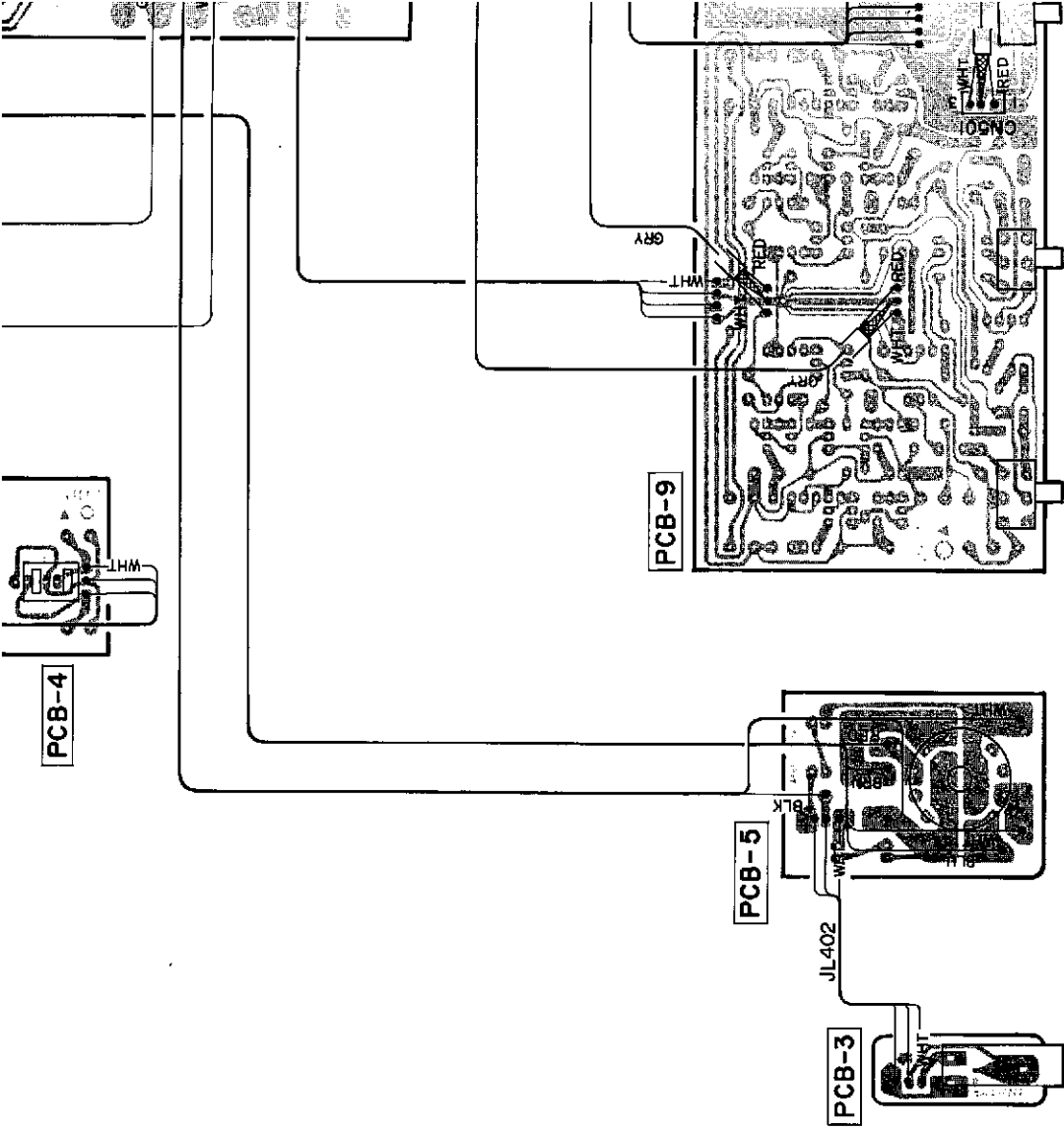
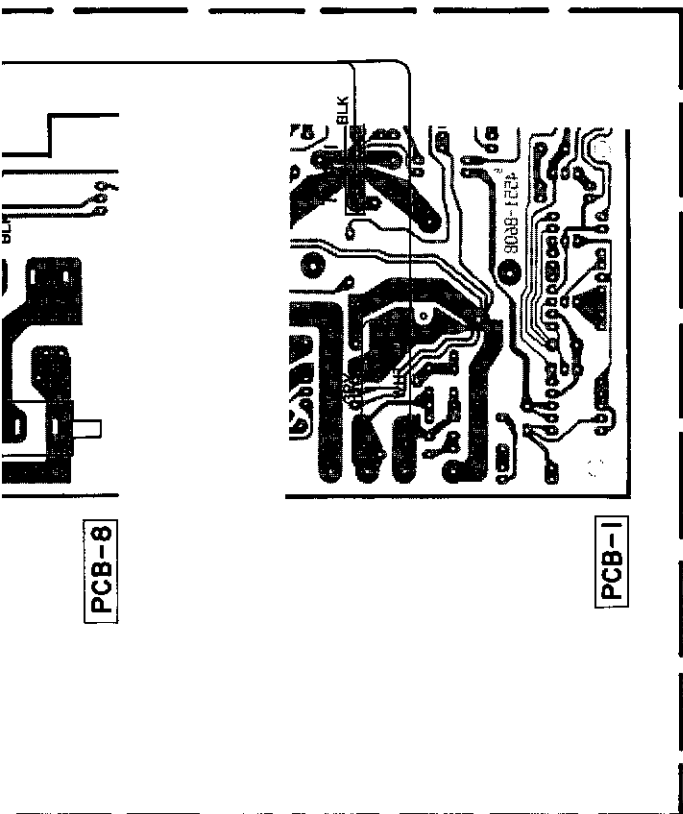

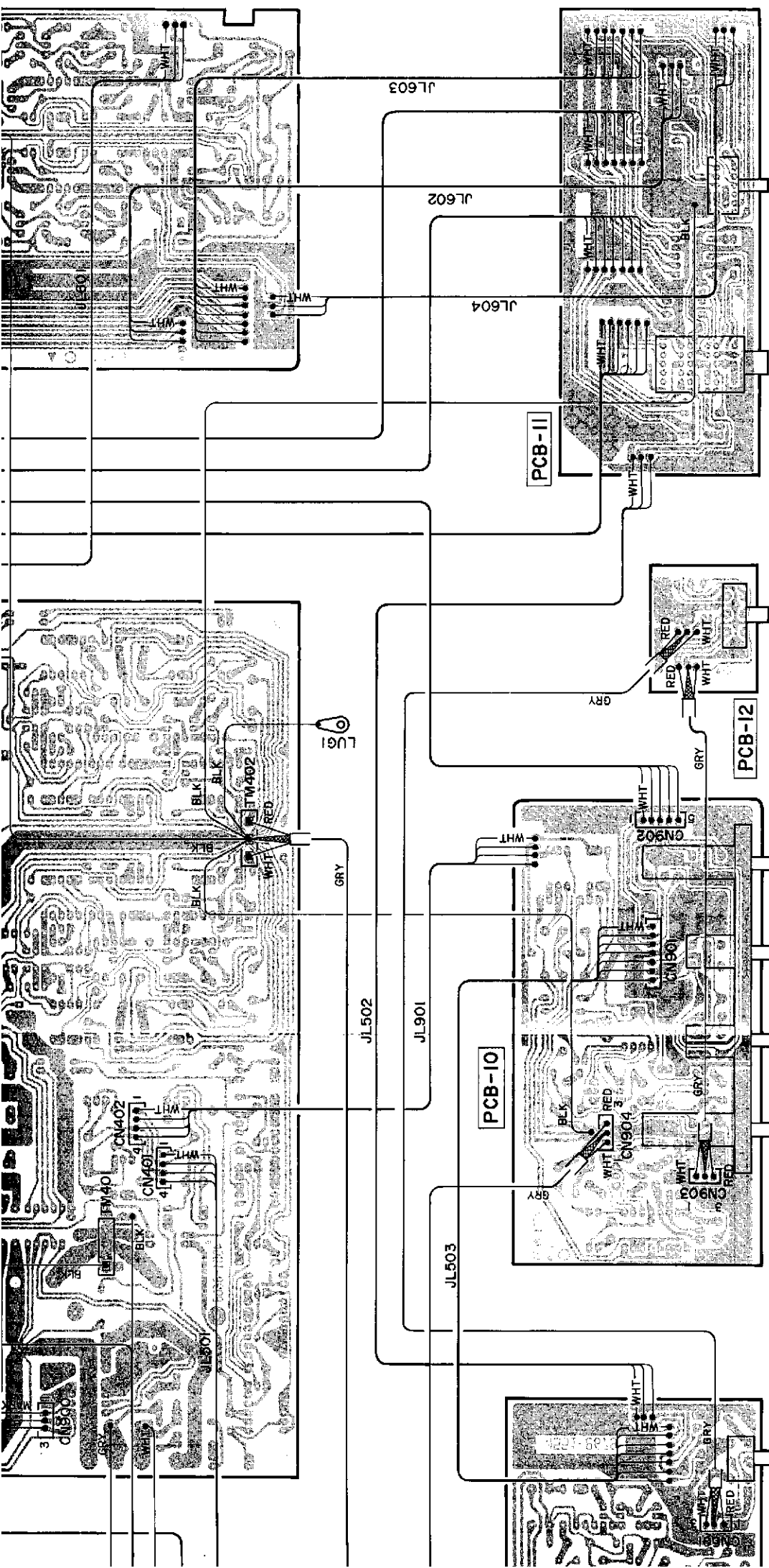

WIRE COLOR ABBREVIATIONS

- Red : RED
- ORG : Orange
- BLU : Blue
- WHT : White
- GRN : Green
- BLK : Black
- YEL : Yellow
- PUR : Purple
- PIK : Pink
- GRY : Gray
- BRN : Brown