

The Harman Kardon Model PT2500

Manual A

A/V SURROUND TUNER CONTROLLER

Technical Manual

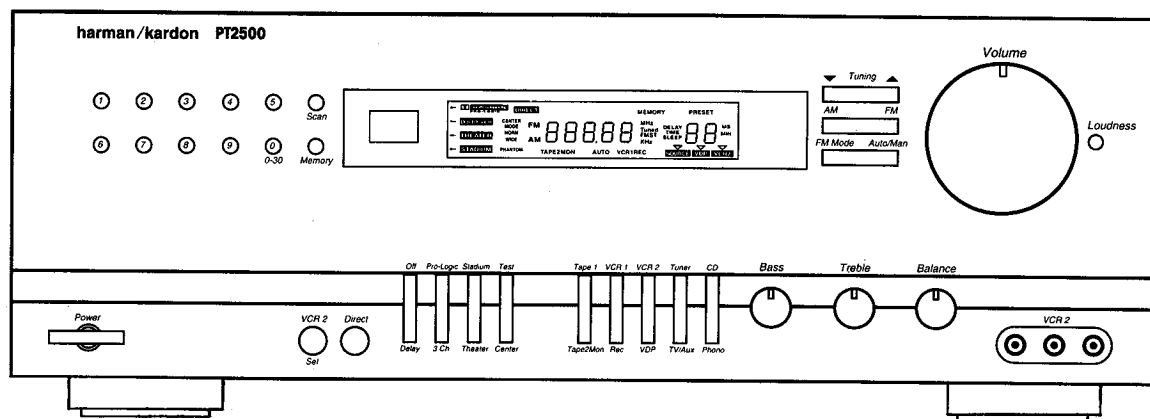

■ CONTENTS ■

SPECIFICATIONS	1	PRINTED CIRCUIT BOARDS	25
LEAKAGE TEST	3	ELECTRICAL PARTS LIST	28
BLOCK DIAGRAM	4	IC FUNCTIONAL BLOCK DIAGRAM	32
CONTROLS AND FUNCTIONS	5	WIRING DIAGRAM	38
DISASSEMBLY PROCEDURES	6	SCHEMATIC DIAGRAM (I).....	39
CIRCUIT DESCRIPTION	8	SCHEMATIC DIAGRAM (II)	40
ALIGNMENT PROCEDURES	17	SCHEMATIC DIAGRAM (III)	41
TROUBLESHOOTING	20	REAR PANEL CONNECTIONS	42
GENERAL UNIT PARTS LIST	23	PACKAGE	43
GENERAL UNIT EXPLODED VIEW	24		

harman/kardon

Parts and Service Office
80 Crossways Park West, Woodbury, N.Y. 11797
1112-PT2500 G9711 1200 Printed in Korea

SPECIFICATIONS

FRONT AMP SECTION

	Normal	Limit
RMS Pre-output		
Both Channels Driven at 20 Hz - 20 kHz	1 ± 0.2 V	1 ± 0.3 V
THD (20 Hz - 20 kHz) at 1 V output		
20 Hz	≤ 0.09%	≤ 0.2%
1 kHz	≤ 0.09%	≤ 0.2%
20 kHz	≤ 0.09%	≤ 0.2%
Input Sensitivity at 65 W, 8 ohms		
PHONO (MM)	2.5 ± 0.2 mV	2.5 ± 0.3 mV
CD, AUX, VCR	150 ± 30 mV	150 ± 40 mV
S/N Ratio Input Shorted at Volume Max. (WTD IHF-A) at 1 V output		
PHONO	≥ 70 dB	≥ 65 dB
CD, AUX	≥ 91 dB	≥ 88 dB
TV, VCR1,2	≥ 91 dB	≥ 88 dB
Phono Overload at 1 kHz, THD: 0.5%		
Phono Input → Tape Monitor Output	≥ 140 mV	≥ 120 mV
Phono Equalization (RIAA 30 Hz - 15 kHz)		
Tape Monitor Output	RIAA ± 1.0 dB	RIAA ± 2.0 dB
Tone Control		
Bass: 100 Hz	± 10 ± 1.0 dB	± 10 ± 2.0 dB
Treble: 10 kHz	± 10 ± 1.0 dB	± 10 ± 2.0 dB
Loudness Contour at -40 dB		
100 Hz	+6 ± 2.0 dB	+6 ± 3.0 dB
10 kHz	+3 ± 2.0 dB	+3 ± 3.0 dB
Frequency Response		
CD/AUX		
20 Hz, 20 kHz	± 1.0 dB	± 2.0 dB
Channel Crosstalk Input Shorted at 1 V output		
1 kHz	≥ 50 dB	≥ 45 dB
10 kHz	≥ 45 dB	≥ 37 dB

CENTER AMP SECTION

	Normal	Limit
RMS Pre-output		
Only Center Channel Driven	1 ± 0.2 V	1 ± 0.3 V
S/N Ratio		
Input Shorted, IHF-A WTD	≥ 75 dB	≥ 68 dB
Frequency Response at -3 dB		
Normal	130 Hz - 20 kHz	180 Hz - 15 kHz
Wide	50 Hz - 20 kHz	60 Hz - 15 kHz

REAR AMP SECTION

	Normal	Limit
RMS Pre-output		
Both Rear Channels Driven	1 ± 0.2 V	1 ± 0.3 V
S/N Ratio (Input Shorted, IHF-A WTD)		
Dolby	≥ 65 dB	≥ 57 dB
Stadium	≥ 65 dB	≥ 57 dB
Theater	≥ 65 dB	≥ 57 dB
Frequency Response at -3 dB		
8 ohms, Dolby Pro-Logic	100 Hz - 6 kHz	120 Hz - 5 kHz

VIDEO AMP SECTION

	Normal	Limit
Input Sensitivity/Impedance		
VCR1, VCR2, VDP	1 V _{p-p} /75 Ω	± 0.5 dB
Output Level/Impedance		
VCR1, REC out, TV Monitor out	1 V _{p-p} /75 Ω ± 0.3	± 1.0 dB
Frequency Response at -3 dB	DC-10 MHz	5 - 6 MHz
Crosstalk at 1.0 MHz	≥ 50 dB	≥ 43 dB

FM SECTION

	Normal	Limit
Tuning Cover Range		
75 kHz DEV.	87.5 - 108.0 MHz	
Usable Sensitivity (75 ohms Input)		
30 dB S/N	≤ 11.2 dbf	≤ 17.2 dbf
Image Rejection (at 106 MHz)	≥ 60 dB	≥ 55 dB
IF Rejection (at 90 MHz)	≥ 110 dB	≥ 100 dB
Full Limiting (at -3 dB)	≤ 12.2 dbf	≤ 15.2 dbf
50 dB Quieting Sensitivity (at 98.1 MHz, 100% MOD.)		
IHF Band Pass Filter		
Mono	≤ 19.2 dbf	≤ 23.2 dbf
Stereo	≤ 40.2 dbf	≤ 43.2 dbf
Distortion (1 kHz, 100% MOD. at 98.1 MHz)		
IHF Band Pass Filter		
Mono	≤ 0.2%	≤ 0.5%
Stereo	≤ 0.4%	≤ 0.8%
S/N Ratio (1 mV Input, 100% MOD. at 98.1 MHz)		
IHF Band Pass Filter		
Mono	≥ 70 dB	≥ 63 dB
Stereo	≥ 65 dB	≥ 57 dB
Frequency Response (at +1 dB, -3 dB)	20 Hz - 15 kHz	50 Hz - 15 kHz
AM Rejection Ratio (100 uV - 20 mV Input)	≥ 60 dB	≥ 50 dB
Search Level (at 98.1 MHz)	31.2 ± 3 dbf	31.2 ± 6 dbf
Automatic Stereo Threshold (at 98.1 MHz)	31.2 ± 3 dbf	31.2 ± 6 dbf
Muting Threshold (at 98.1 MHz)	31.2 ± 3 dbf	31.2 ± 6 dbf
Overload at 98.1 MHz (100% MOD. 100 mV RF Input)	≤ 0.2%	≤ 0.5%
Spurious Response (at 98.1 MHz)		
Antenna Input 3 uV	≥ 70 dB	≥ 60 dB
Capture Ratio at 40/60 dbf	≤ 2 dB	≤ 3 dB
Alternative Channel Selectivity (at 98.1 MHz ± 400 kHz)	≥ 65 dB	≥ 55 dB
Stereo Separation (at 98.1 MHz, 100% MOD., 1 mV Input)		
IHF Band Pass Filter		
100 Hz	≥ 40 dB	≥ 33 dB
1 kHz	≥ 45 dB	≥ 38 dB
10 kHz	≥ 35 dB	≥ 28 dB
Output Voltage (at 100% MOD., 1 kHz Input)		
Mono	500 ± 100 mV	500 ± 150 mV
Stereo	450 ± 100 mV	450 ± 150 mV

AM SECTION

	Normal	Limit
Tuning Cover Range		
10 kHz Step	520 - 1710 kHz	
Usable Sensitivity (400 Hz, 30% MOD., S/N 20 dB)		
	≤ 500 uV/m	≤ 800 uV/m
Image Rejection (at 1400 kHz)	≥ 35 dB	≥ 30 dB
IF Rejection (at 600 kHz)	≥ 60 dB	≥ 50 dB
AGC Figure of Merit (From 100 mV/m at 1000 kHz)	≥ 50 dB	≥ 43 dB
Distortion (400 Hz, 30% MOD. 5 mV/m Input)	≤ 0.8%	≤ 1.5%
IF Bandwidth (6 dB Down, 350 uV/m)	5 - 8 kHz	4 - 9 kHz
Audio Response (5 mV/m Input 1 kHz 0 dB, 1000 kHz) at -6 dB	80 Hz - 2.3 kHz	100 Hz - 2 kHz
Selectivity (at 350 uV/m)		
± 10 kHz	≥ 25 dB	≥ 20 dB
S/N Ratio (1000 kHz, With Antenna Input 5 mV/m)	≥ 45 dB	≥ 38 dB
RF Overload (400 Hz 80% MOD, 100 mV/m Input)	≤ 5%	≤ 10%
Search Level (at 1000 kHz)	800 uV ± 4 dB	800 uV ± 6 dB
Output Voltage (400 Hz 30% MOD., 5 mV/m Input)	165 ± 30 mV	165 ± 50 mV
Whistle	≤ 7%	≤ 12%

GENERAL

Power Consumption;	23 W
Power Supplies;	AC 120 V, 60 Hz
Dimensions (W×H×D);	
inches	17 ^{3/8} × 6 ^{1/8} × 16 ^{1/2}
mm	440 × 155 × 420
Weight (lbs/kgs)	19.5 / 8.8

These specifications are service target specs.
 Specifications and components are subject to change without notice.
 Overall performance will be maintained or improved.

ELECTROSTATICALLY SENSITIVE (ES) DEVICES

Some semiconductor (solid state) devices can be damaged easily by static electricity. Such components commonly are called Electrostatically Sensitive (ES) Devices. Examples of typical ES devices are integrated circuits and some fieldeffect transistors and semiconductor "chip" components. The following techniques should be used to help reduce the incidence of component damage caused by static electricity.

1. Immediately before handling any semiconductor component or semiconductor-equipped assembly, drain off any electrostatic charge on your body by touching a known earth ground. Alternatively, obtain and wear a commercially available discharging wrist strap device, which should be removed for potential shock reasons prior to applying power to the unit under test.
2. After removing an electrical assembly equipped with ES devices, place the assembly on a conductive surface such as aluminum foil, to prevent electrostatic charge buildup or exposure of the assembly.
3. Use only a grounded-tip soldering iron to solder or unsolder ES devices.
4. Use only an anti-static solder removal device. Some solder removal devices not classified as "anti-static" can generate electrical charges sufficient to damage ES devices.
5. Do not use freon-propelled chemicals. These can generate electrical charge sufficient to damage ES devices.
6. Do not remove a replacement ES device from its protective package until immediately before you are ready to install it. (Most replacement ES devices are packaged with leads electrically shorted together by conductive foam, aluminum foil or comparable conductive material).
7. Immediately before removing the protective material from the leads of a replacement ES device, touch the protective material to the chassis or circuit assembly into which the device will be installed.

CAUTION: Be sure no power is applied to the chassis or circuit, and observe all other safety precautions.

8. Minimize bodily motions when handling unpacked replacement ES devices. (Otherwise harmless motion such as the brushing together of your clothes fabric or the lifting of your foot from a carpeted floor can generate static electricity sufficient to damage an ES device.)

LEAKAGE TEST

Before returning the unit to the user, perform the following safety checks:

1. Inspect all lead dress to make certain that leads are not pinched or that hardware is not lodged between the chassis and other metallic parts in the unit.
2. Be sure that any protective devices such as nonmetallic control knobs, insulating fishpapers, cabinet backs, adjustment and compartment covers or shields, isolation resistor-capacity networks, mechanical insulators, etc. Which were removed for servicing are properly reinstalled.
3. Be sure that no shock hazard exists; check for leakage current using Simpson Model 229 Leakage Tester, standard equipment item No. 21641, RCA Model WT540A or use alternate method as follows: Plug the power cord directly into a 120-volt AC receptacle (do not use an Isolation Transformer for this test).

Using two clip leads, connect a 1500 Ohm, 10-watt resistor paralleled by a 0.15 μ F capacitor, in series with all exposed metal cabinet parts and a known earth ground, such as a water pipe or conduit. Use a VTVM or VOM with 1000 Ohms per volt, or higher sensitivity to measure the AC voltage drop across the resistor. (See Diagram.) Move the resistor connection to each exposed metal part having a return path to the chassis (antenna, metal cabinet, screw heads, knobs and control shafts, escutcheon, etc.) and measure the AC voltage drop across the resistor. (This test should be performed with the power switch in both the On and Off positions.)

A reading of 0.35 volt RMS or more is excessive and indicates a potential shock hazard which must be corrected before returning the unit to the owner.

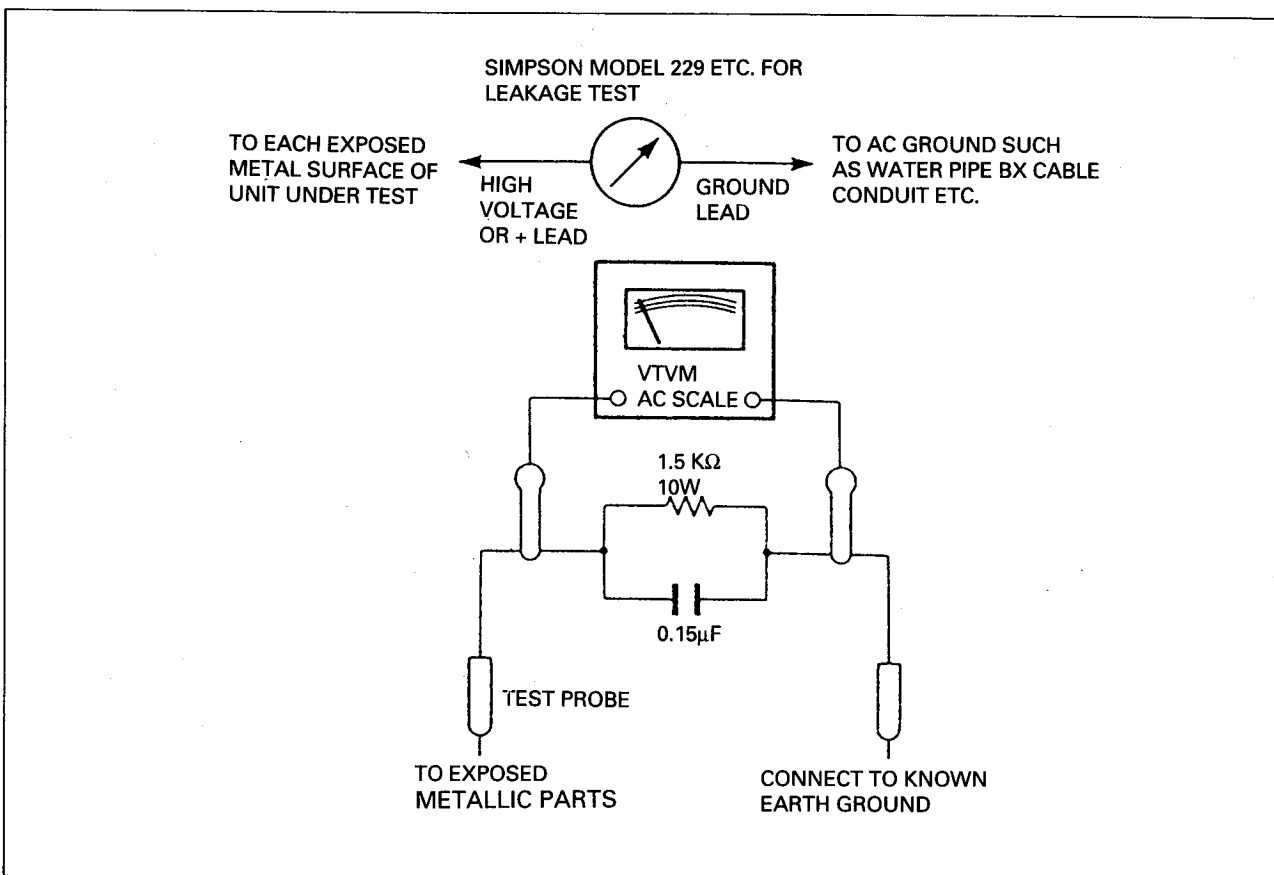

BLOCK DIAGRAM

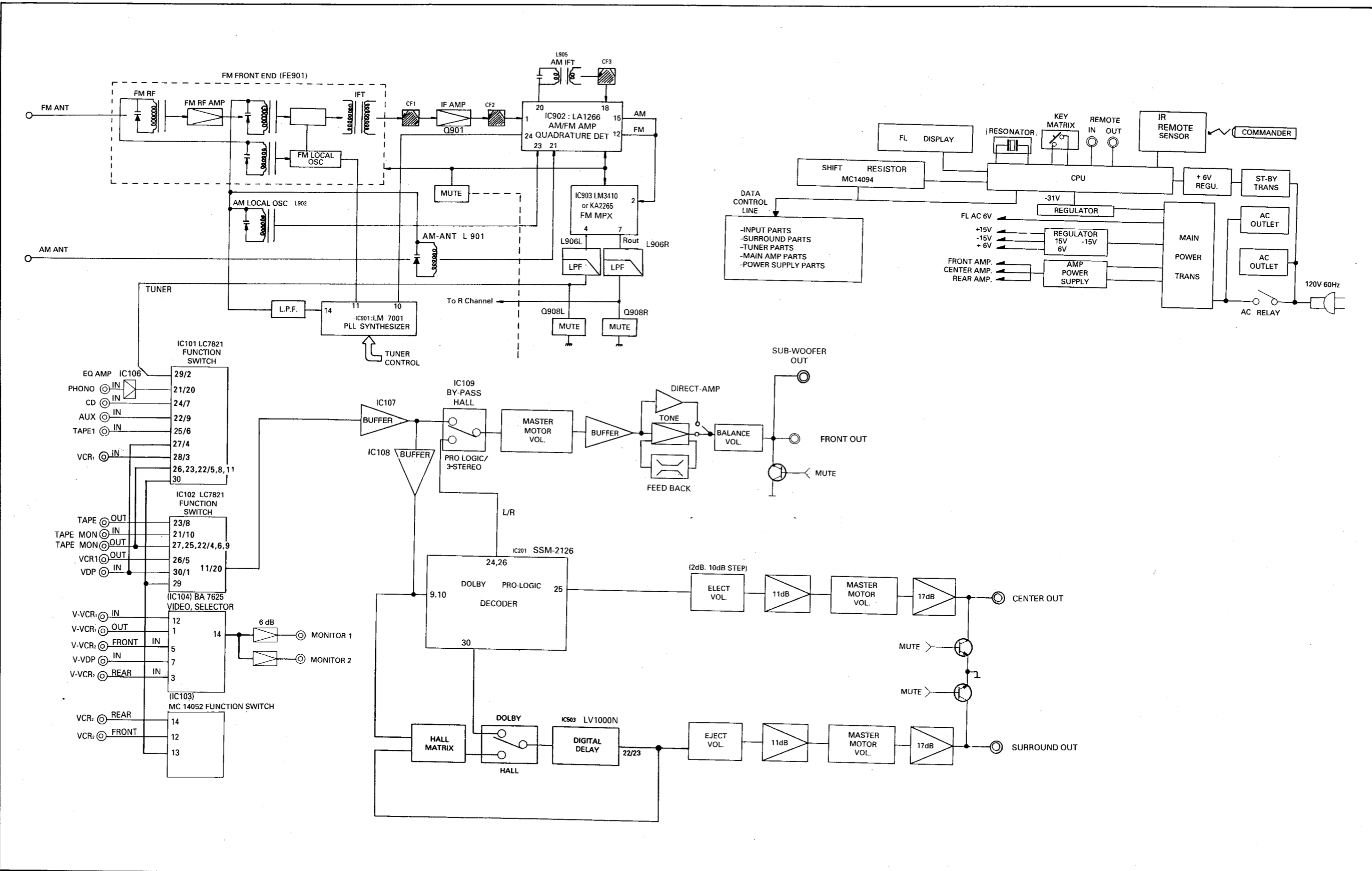

BLOCK DIAGRAM

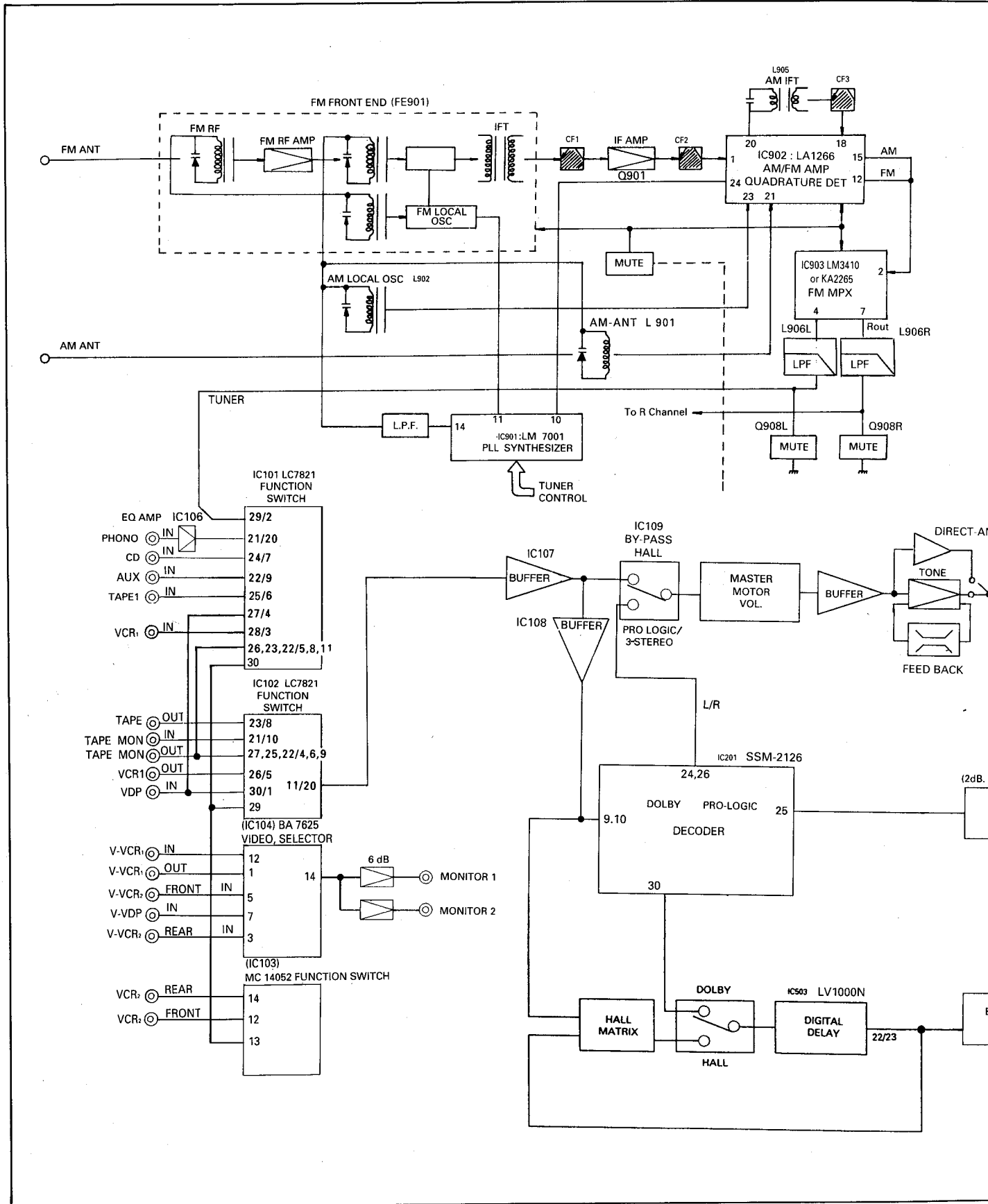

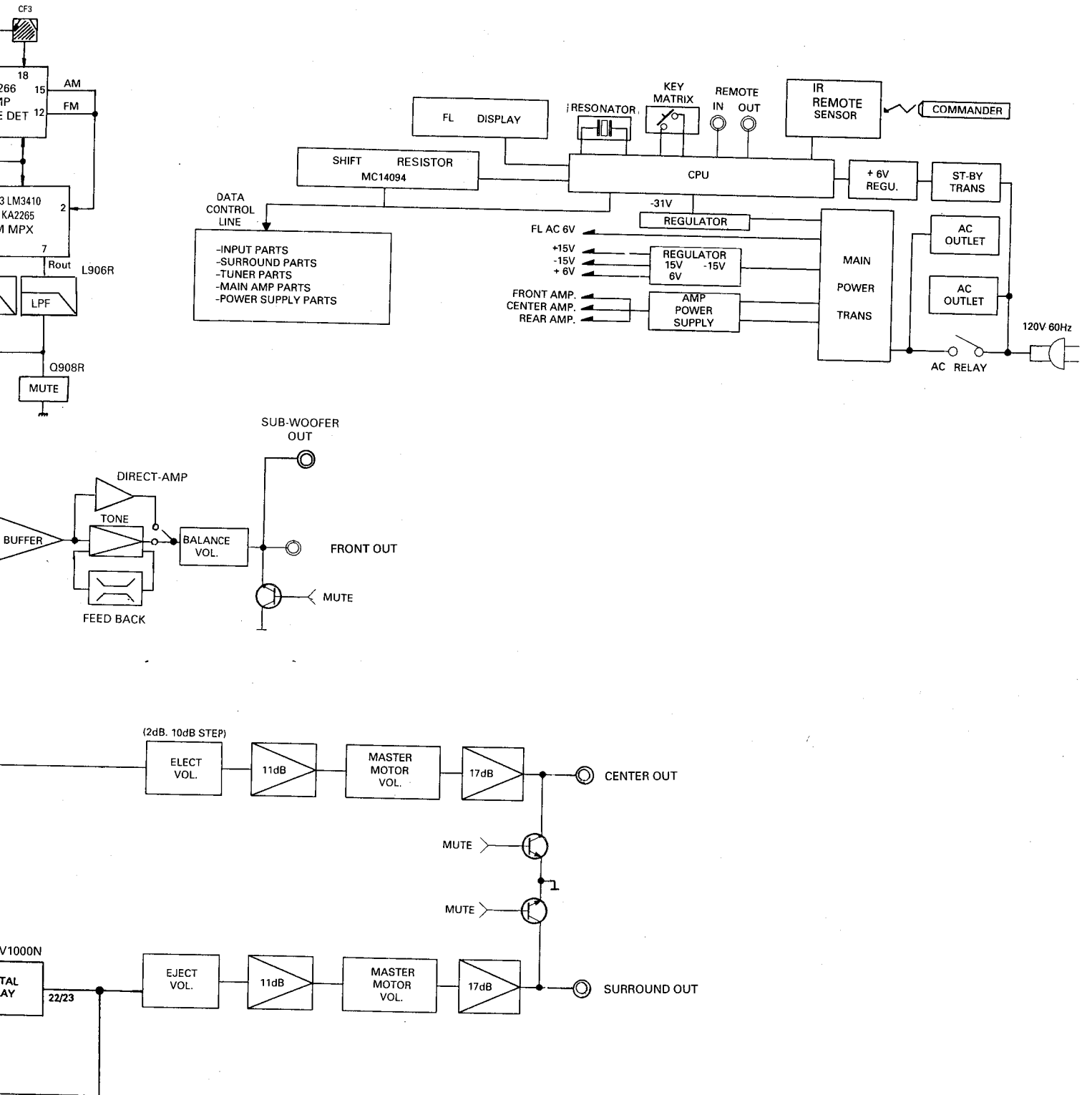

CONTROLS AND FUNCTIONS

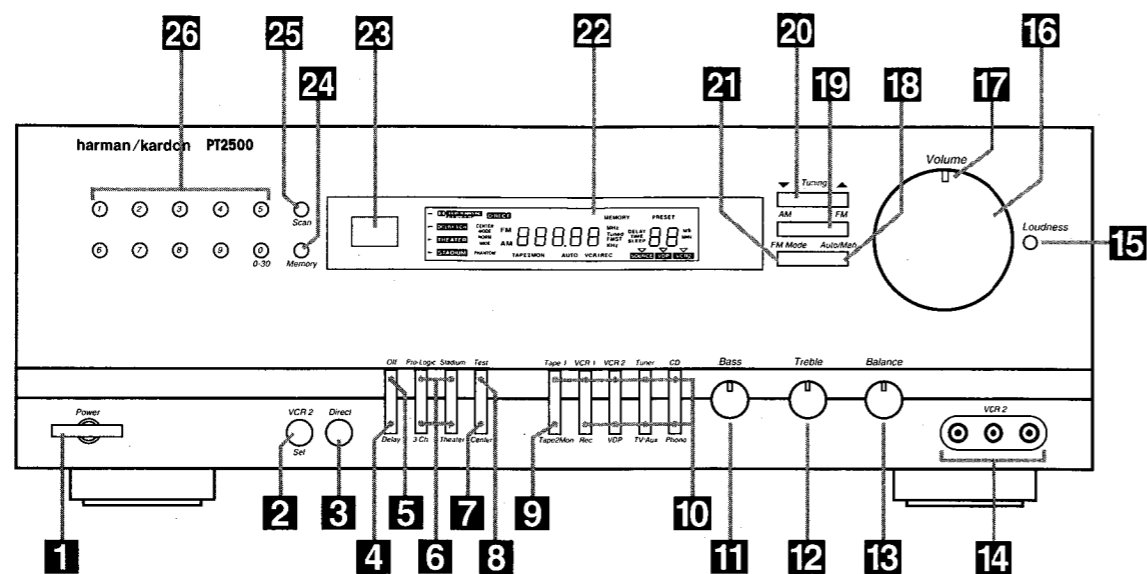

1 Power Switch: Press this button to turn the PT2500 on or off. In order to use the power button on the remote this power switch must be pressed once and left in the "standby" mode. Note that a green indicator around the switch will illuminate when the unit is on, and an orange "standby" indicator will illuminate when the unit has been turned off using the remote control.

2 VCR2 Selector: Press this button to select the front panel VCR2 inputs rather than the rear panel inputs.

3 Direct Input Selector: Press this button to select direct input to the preamp circuits, bypassing all tone controls and surround processing. When this feature is activated, the **DIRECT** indicator illuminates within the information display.

4 Delay Time Adjust: Press this button to adjust the delay time between the front and rear channels.

5 Surround Off: Press this button to select conventional two channel stereo reproduction and to cancel surround processing.

6 Surround Mode Selectors: Press one of these buttons to select a surround processing mode.

7 Center Channel Mode Selector: Press this button to change the center channel mode.

8 Test Mode Selector: Press this button to place the unit in the Test mode for adjustment of system output levels.

9 Tape 2 Monitor: Press this button to monitor the output of the tape deck connected to the Tape 2 Inputs. For normal operation this control should be in the off position.

10 Input Selectors: Press one of these buttons to select an input source.

11 Bass Control: Turn this control to adjust the low frequency output of the left/right channels by as much as ± 10 dB. Set this control to a suitable position for your taste and room acoustics.

12 Treble Control: Turn this control to adjust the high frequency output of the left/right channels by as much as ± 10 dB. Set this control to a suitable position for your taste and room acoustics.

13 Balance Control: Turn this control to change the relative volume for the front left/right channels.

NOTE: For normal operation of the surround modes this control should be at the midpoint, or "12 O'clock" position.

14 VCR2 Inputs: This alternate set of VCR2 Inputs may be used for the connection of a camcorder or video game. Select this input by pressing the **VCR2** button **2** on the front panel.

15 Loudness Button: Press this button when listening at low levels to activate special circuits that compensate for the response of the human ear at lower volumes. In the off position the unit will provide flat frequency response.

16 Volume Control: Rotate this control to raise or lower the volume. Note that this is a motorized control, and when the volume is changed using the remote control **14** it will move in response to remote commands.

17 Mute/Volume Indicator: In normal operation this green LED provides a relative indication of the unit's volume level. When the PT2500 is in the MUTE mode, this indicator flashes to remind you that output to the speakers has momentarily been silenced.

18 Auto/Man Selector: Press this button to select AUTO or MANUAL tuning. In the AUTO mode the tuner will stop only at stations with a strong signal. In the MANUAL mode the tuner will step in 50 kHz increments for FM and 10 kHz increments for AM.

19 AM/FM Selector: Press this button to select AM or FM stations.

20 Up/Down Tuning Button: Press the left side ∇ of the button to tune lower frequency stations and the right side \blacktriangle of the button to tune higher frequency stations. When a station with a strong frequency is tuned, the **TUNED** indicator will illuminate in the Information Display **22**.

21 FM Mode: Press this button to select the stereo or mono mode for FM tuning. In the STEREO mode an **F M S T** indicator will illuminate in the information display, and stereo reception will be provided when stations are transmitting stereo signals. In the MONO mode the left and right signals from stereo broadcasts will be mixed together and reproduced through all channels. Select the MONO mode for better reception of weak signals.

22 Information Display: The indicators in this display illuminate to provide visual display of the unit's operation.

23 Remote Sensor: This sensor receives the signals from the remote control to operate the unit. Do not block this area.

24 Tuner Memory Button: Press this button to store an AM or FM frequency in the unit's memory. The **MEMORY** indicator will flash in the display to remind you to choose a numeric location using **Numeric Buttons** on the front panel or remote **(26 4)**. Press this button a second time to complete the memorization process. Storing a station in a memory location that has already been used will overwrite the existing data.

NOTE: The preset memories are protected from power loss for two weeks. If the unit is unplugged for more than two weeks all stored frequencies will be erased.

25 Preset Scan Button: Press this button to scan the stations entered in the unit's memory. When the desired station is reached, press the button again to stop the scan.

26 Numeric Buttons: Use these buttons to enter or recall stations from the tuner memory.

CONTROLS AND FUNCTIONS

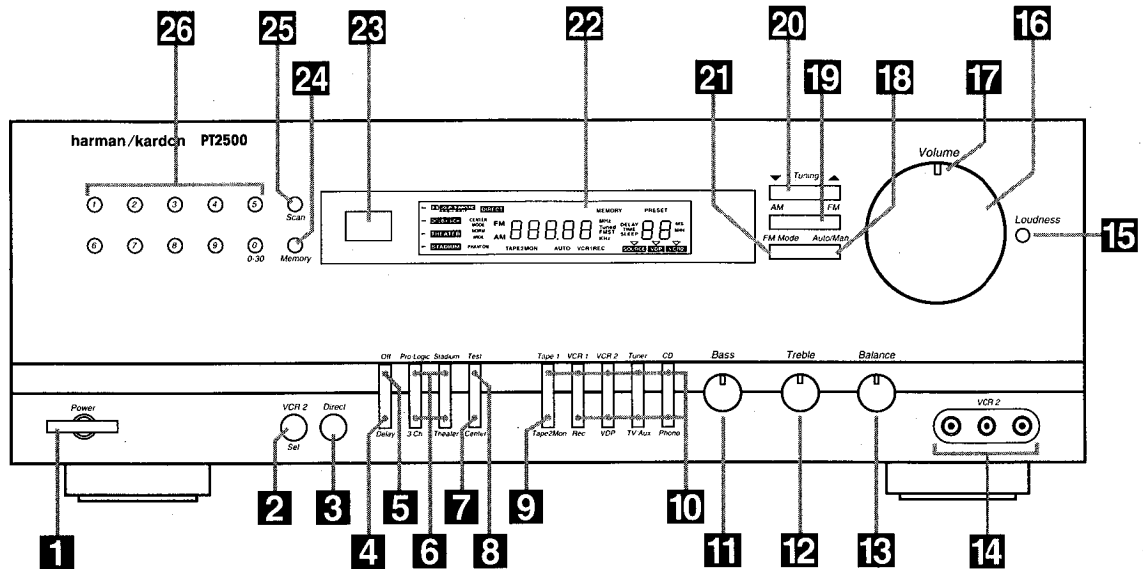

1 Power Switch: Press this button to turn the PT2500 on or off. In order to use the power button on the remote this power switch must be pressed once and left in the "standby" mode. Note that a green indicator around the switch will illuminate when the unit is on, and an orange "standby" indicator will illuminate when the unit has been turned off using the remote control.

2 VCR2 Selector: Press this button to select the front panel VCR2 inputs rather than the rear panel inputs.

3 Direct Input Selector: Press this button to select direct input to the preamp circuits, bypassing all tone controls and surround processing. When this feature is activated, the **DIRECT** indicator illuminates within the information display.

4 Delay Time Adjust: Press this button to adjust the delay time between the front and rear channels.

5 Surround Off: Press this button to select conventional two channel stereo reproduction and to cancel surround processing.

6 Surround Mode Selectors: Press one of these buttons to select a surround processing mode.

7 Center Channel Mode Selector: Press this button to change the center channel mode.

8 Test Mode Selector: Press this button to place the unit in the Test mode for adjustment of system output levels.

9 Tape 2 Monitor: Press this button to monitor the output of the tape deck connected to the Tape 2 Inputs. For normal operation this control should be in the off position.

10 Input Selectors: Press one of these buttons to select an input source.

11 Bass Control: Turn this control to adjust the low frequency output of the left/right channels by as much as ± 10 dB. Set this control to a suitable position for your taste and room acoustics.

12 Treble Control: Turn this control to adjust the high frequency output of the left/right channels by as much as ± 10 dB. Set this control to a suitable position for your taste and room acoustics.

13 Balance Control: Turn this control to change the relative volume for the front left/right channels.

NOTE: For normal operation of the surround modes this control should be at the midpoint, or "12 O'clock" position.

14 VCR2 Inputs: This alternate set of VCR2 Inputs may be used for the connection of a camcorder or video game. Select this input by pressing the **VCR2** button **2** on the front panel.

15 Loudness Button: Press this button when listening at low levels to activate special circuits that compensate for the response of the human ear at lower volumes. In the off position the unit will provide flat frequency response.

16 Volume Control: Rotate this control to raise or lower the volume. Note that this is a motorized control, and when the volume is changed using the remote control **14** it will move in response to remote commands.

17 Mute/Volume Indicator: In normal operation this green LED provides a relative indication of the unit's volume level. When the PT2500 is in the MUTE mode, this indicator flashes to remind you that output to the speakers has momentarily been silenced.

18 Auto/Man Selector: Press this button to select AUTO or MANUAL tuning. In the AUTO mode the tuner will stop only at stations with a strong signal. In the MANUAL mode the tuner will step in 50 kHz increments for FM and 10kHz increments for AM.

19 AM/FM Selector: Press this button to select AM or FM stations.

20 Up/Down Tuning Button: Press the left side \blacktriangledown of the button to tune lower frequency stations and the right side \blacktriangle of the button to tune higher frequency stations. When a station with a strong frequency is tuned, the **TUNE D** indicator will illuminate in the Information Display **22**.

21 FM Mode: Press this button to select the stereo or mono mode for FM tuning. In the STEREO mode an **F M S, T** indicator will illuminate in the information display, and stereo reception will be provided when stations are transmitting stereo signals. In the MONO mode the left and right signals from stereo broadcasts will be mixed together and reproduced through all channels. Select the MONO mode for better reception of weak signals.

22 Information Display: The indicators in this display illuminate to provide visual display of the unit's operation.

23 Remote Sensor: This sensor receives the signals from the remote control to operate the unit. Do not block this area.

24 Tuner Memory Button: Press this button to store an AM or FM frequency in the unit's memory. The **MEMORY** indicator will flash in the display to remind you to choose a numeric location using **Numeric Buttons** on the front panel or remote (**26 4**). Press this button a second time to complete the memorization process. Storing a station in a memory location that has already been used will overwrite the existing data.

NOTE: The preset memories are protected from power loss for two weeks. If the unit is unplugged for more than two weeks all stored frequencies will be erased.

25 Preset Scan Button: Press this button to scan the stations entered in the unit's memory. When the desired station is reached, press the button again to stop the scan.

26 Numeric Buttons: Use these buttons to enter or recall stations from the tuner memory.

DISASSEMBLY PROCEDURES

REFER TO PAGES (23-24).

1 COVER TOP REMOVAL

Remove 6 screws **S2** and 2 screws **S1** and then remove the Cover Top **50**.

2 COVER BOTTOM REMOVAL

Remove 9 screws **S1** and then remove the Cover Bottom **31**.

3 FRONT PANEL ASSEMBLY REMOVAL

1. Remove the Cover Top **50**, referring to the previous step **1**.
2. Remove the card cable from wafer (CP802 and CN502) on the Dolby P.C.Board (PCB5).
3. Remove the card cable from wafer (CP803) on the Tuner P.C.Board (PCB9).
4. Disconnect (CP401) from the Dolby P.C.Board (PCB5).
5. Disconnect (CP402) from the Main P.C.Board (PCB1).
6. Disconnect (CP801) from the Power Supply P.C.Board (PCB1).
7. Remove lug wire from the right Frame **29**.
8. Remove 4 screws **S5**, 4 screws **S1** and then remove the Front Panel Assembly **AA**.

4 VOLUME P.C.BOARD (PCB3) REMOVAL

1. Remove the Cover Top **50**, referring to the previous step **1**.
2. Remove the Front Panel Assembly **AA**, referring to the previous step **3**.
3. Pull out the Volume Knob **6** with Volume LED P.C.Board (PCB6).
4. Remove the Hex Nut from the volume-motor **23**.
5. Remove 2 screws **S1** and then remove the Volume P.C.Board (PCB3).

5 TONE P.C.BOARD (PCB4) REMOVAL

1. Remove the Cover Top **50**, referring to the previous step **1**.
2. Remove the Front Panel Assembly **AA**, referring to the previous step **3**.
3. Pull out the Bass/Treble/Balance knobs **8**.
4. Remove the Hex Nuts from the variable resistors **19**, **20**.
5. Remove 4 screws **S1** on the Tone P.C.Board (PCB4) and then remove it.

6 FRONT P.C.BOARD (PCB8) REMOVAL

1. Remove the Cover Top **50**, referring to the previous step **1**.
2. Remove the Front Panel Assembly **AA**, referring to the previous step **3**.
3. Remove 11 screws **S1** on the Front P.C.Board (PCB8) and then remove by pressing the hooks around it outward.

7 DOLBY P.C.BOARD (PCB5) REMOVAL

1. Remove the Cover Top **50**, referring to the previous step **1**.
2. Remove the card cable from wafer (CP802, CN501, CN502) on the Dolby P.C.Board (PCB5).
3. Disconnect (CP401) from the Dolby P.C.Board (PCB5).
4. Disconnect (CP501) from the Tuner P.C.Board (PCB9).
5. Remove lug wire from the left Frame **35**.
6. Unjoin 2 Fasteners **33** and then remove the Dolby P. C. Board (PCB5).

8 TUNER P.C.BOARD (PCB9) REMOVAL

1. Remove the Cover Top **50**, referring to the previous step **1**.
2. Remove the card cable from wafer (CP803) on the Tuner P.C.Board (PCB9)
3. Disconnect (CP102 and CP501) from the Tuner P.C.Board (PCB9).
4. Remove 4 screws **S1** from the Chassis Back **46**.
5. Remove 2 screws **S5** on the Tuner P.C.Board (PCB9) and then remove it.

9 REGULATOR P.C.BOARD (PCB2) REMOVAL

1. Remove the Cover Top **50**, referring to the previous step **1**.
2. Disconnect (CP103) from the Main P.C.Board (PCB1).
3. Remove screw **S1** from the left Frame **35** and then remove the Regulator P.C.Board (PCB2).

10 POWER SUPPLY P.C.BOARD (PCB7) REMOVAL

1. Remove the Cover Top **50**, referring to the previous step **1**.
2. Disconnect (CP801,CP703,CP101,CP702 and CP701) from the Power Supply P.C.Board (PCB7).
3. Unsolder all leads (P1 and P2) from the AC Power Cord **48**.
4. Remove 2 screws **S1**, from the Chassis Back **46**.
5. Remove 2 screws **S5** on the Power Supply P.C.Board (PCB7) and then remove it.

11 MAIN P.C.BOARD (PCB1) REMOVAL

1. Remove the Cover Top **50**, referring to the previous step **1**.
2. Remove the Tuner P.C.Board (PCB9), referring to the previous step **8**.
3. Disconnect (CP103 and CP401) from the Main P.C.Board (PCB1).
4. Disconnect (CP101) from the Power Supply P.C.Board (PCB7).
5. Remove the card cable from wafer (CP501) on the Main P.C.Board (PCB1).
6. Remove 8 screws **S1** and 2 screws **S3** from the Chassis Back **46**.
7. Remove 8 screws **S5** on the Main P.C.Board (PCB1) and then remove it.

CIRCUIT DESCRIPTION

CPU (IC801) : CXP82220-107Q (8 bit SINGLE-CHIP MICROCOMPUTER)

1. Pin Connection Diagram & Block Diagram

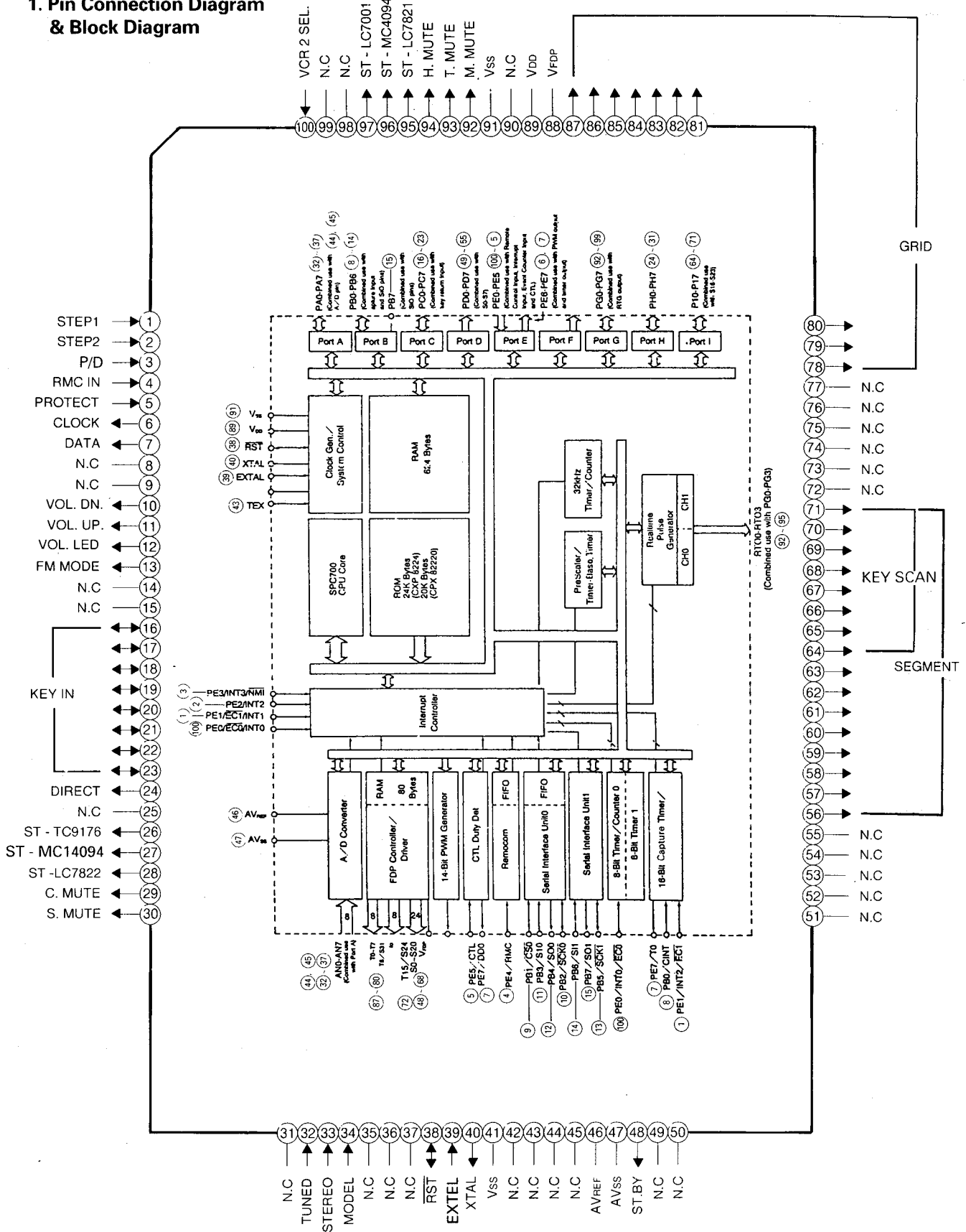

2. Pin Functions

Pin No.	Symbol	Description										
1 / 2	STEP 1 / STEP 2	Input to select frequency band and step according to region. <table border="1" data-bbox="613 323 1390 432"> <thead> <tr> <th>REGION</th> <th>FREQUENCY</th> <th>STEP</th> <th>STEP 1</th> <th>STEP 2</th> </tr> </thead> <tbody> <tr> <td>AMERICA</td> <td>FM: 87.5 - 107.9 MHz AM: 520 - 1710 kHz</td> <td>200 kHz 10 kHz</td> <td>H</td> <td>H</td> </tr> </tbody> </table>	REGION	FREQUENCY	STEP	STEP 1	STEP 2	AMERICA	FM: 87.5 - 107.9 MHz AM: 520 - 1710 kHz	200 kHz 10 kHz	H	H
REGION	FREQUENCY	STEP	STEP 1	STEP 2								
AMERICA	FM: 87.5 - 107.9 MHz AM: 520 - 1710 kHz	200 kHz 10 kHz	H	H								
3	P / D	Input to detect power down. (At "L", it is active.)										
4	RMC IN	Input for remote control signal. (At "L", it is active.)										
5	PROTECT	Signal input for protection. (At "L", it is active.)										
6 / 7	CK / DA	Clock/Data output for LC7821, LC7822, GD4094, TC9176 and LM7001.										
8 / 9	N.C.	Not used !										
10	VOL. DOWN	Output to drive volume motor for decreasing volume level. (At "H", it is active.)										
11	VOL. UP	Output to drive volume motor for increasing volume level. (At "H", it is active.)										
12	VOL. LED	Output to drive volume LED.										
13	FM MODE	Output to select FM MONO or STEREO. At "H", FM MONO is selected and at "L", FM STEREO is selected.										
14 / 15	N.C.	Not used !										
16 - 23	KEY IN	Data input for key scan.										
24	DIRECT	Output to allow sound signal to by-pass tone control circuitry. (At "H", it is active.)										
25	N.C.	Not used !										
26	ST-TC9176	Chip enable output for TC9176.										
27	ST-MC14094	Chip enable output for MC14094.										
28	ST-LC7822	Chip enable output for LC7822.										
29	C. MUTE	Output for center mute. Output, "H" under the following conditions. <ol style="list-style-type: none"> 1. When power is turned on or off. 2. When center mode is turned on or off. 3. When center mode is selected. 4. When test tone mode is on or off or when the channel is changed in the test tone mode. 5. When the protection terminal's level is "L". 6. When "-∞" mute signal is received from the commander. 										
30	S. MUTE	Output for surround mute. Output, "H" under the following conditions. <ol style="list-style-type: none"> 1. When power is turned on or off. 2. When surround mode is selected. 3. When test tone mode is on or off or when channel is changed in the test tone mode. 4. When adjusting delay time. 5. When the protection terminal's level is "L". 6. When "-∞" mute signal is received from the commander. 										
31	N.C.	Not used !										
32	TUNED	Input to detect station during tuning. If "L" is inputted during tuning, tuning stops at that frequency.										
33	STEREO	Input to light "STEREO" indicator. (At "L", it is active.)										

Pin No.	Symbol	Description
34	MODEL	Input to select. (At "H", it is active)
35 - 37	N.C.	Not used ! (Connected to V_{DD})
38	RST	Input to reset CPU.
39	EXTAL	Input for crystal oscillator.
40	XTAL	Output for crystal oscillator.
41	V_{SS}	Ground.
42	N.C.	Not used !
43 - 45	N.C.	Not used ! (Connected to V_{DD})
46	AV_{ref}	Reference voltage. (Connected to 5 V, not V_{DD} .)
47	AV_{SS}	Ground.
48	ST.BY	When power is on, control data output is "H". When power is off, control data output is "L" and last memory function is activated.
49 - 55	N.C.	Not used !
56 - 63	SEGMENT	Segment signal output for FIP.
64 - 71	SEGMENT / KEY SCAN	Segment signal output for FIP and Data output for key scan.
72 - 77	N.C.	Not used !
78 - 87	GRID	Grid signal output for FIP.
88	V_{FDP}	Power supply for FIP controller.
89	V_{DD}	+5 V power supply.
90	N.C.	Not used !
91	V_{SS}	Ground.
92	M. MUTE	Output for main mute. Output is "H" under the following conditions. 1. When power is turned on or off. 2. When function is changed. 3. When the protection terminal's level is "L". 4. When "-∞" mute signal is received from the commander.
93	T. MUTE	Output for tuner mute. Output, "H" under the following conditions. 1. When power is turned on or off. 2. When tuner band or FM mode is changed. 3. When Tuning Up or Down button is pressed. 4. When recalling the station stored in memory. 5. When the protection terminal's level is "L". 6. When "-∞" mute signal is received from the commander.
94	H. MUTE	Output for headphone mute. Output, "H" under the following conditions. 1. When power is turned on or off. 2. When selecting the input function. 3. When the protection terminal's level is "L". 4. When "-∞" mute signal is received from the commander.
95	ST-LC7821	Chip enable output for LC7821.
96	ST-MC4094	Chip enable output for MC4094.
97	ST-LC7001	Chip enable output for LC7001.
98 / 99	N.C.	Not used !
100	VCR 2 SEL.	Input to select VCR 2 rear or front. At "H", VCR 2 rear is selected and at "L", VCR 2 front is selected.

3. Key Matrix

Pin No.	64	65	66	67	68	69	70	71
16	3 CHANNEL	TAPE2 MON.			TV/AUX		TUNER ▶	TUNER ◀
17	DIRECT	CENTER		SURR. MODE			AUTO/MANU.	MODE
18	THEATER	VCR1/REC			VDP	VCR2	FM	AM
19								
20							CD	TUNER
21	P.SCAN	5	9		MEMO.	VCR1		
22	1	4	2	3		TAPE1	TEST TONE	OFF
23	6	0	7	8	PWR		STADIUM	PRO-LOGIC

4. Digital Tuning System Description

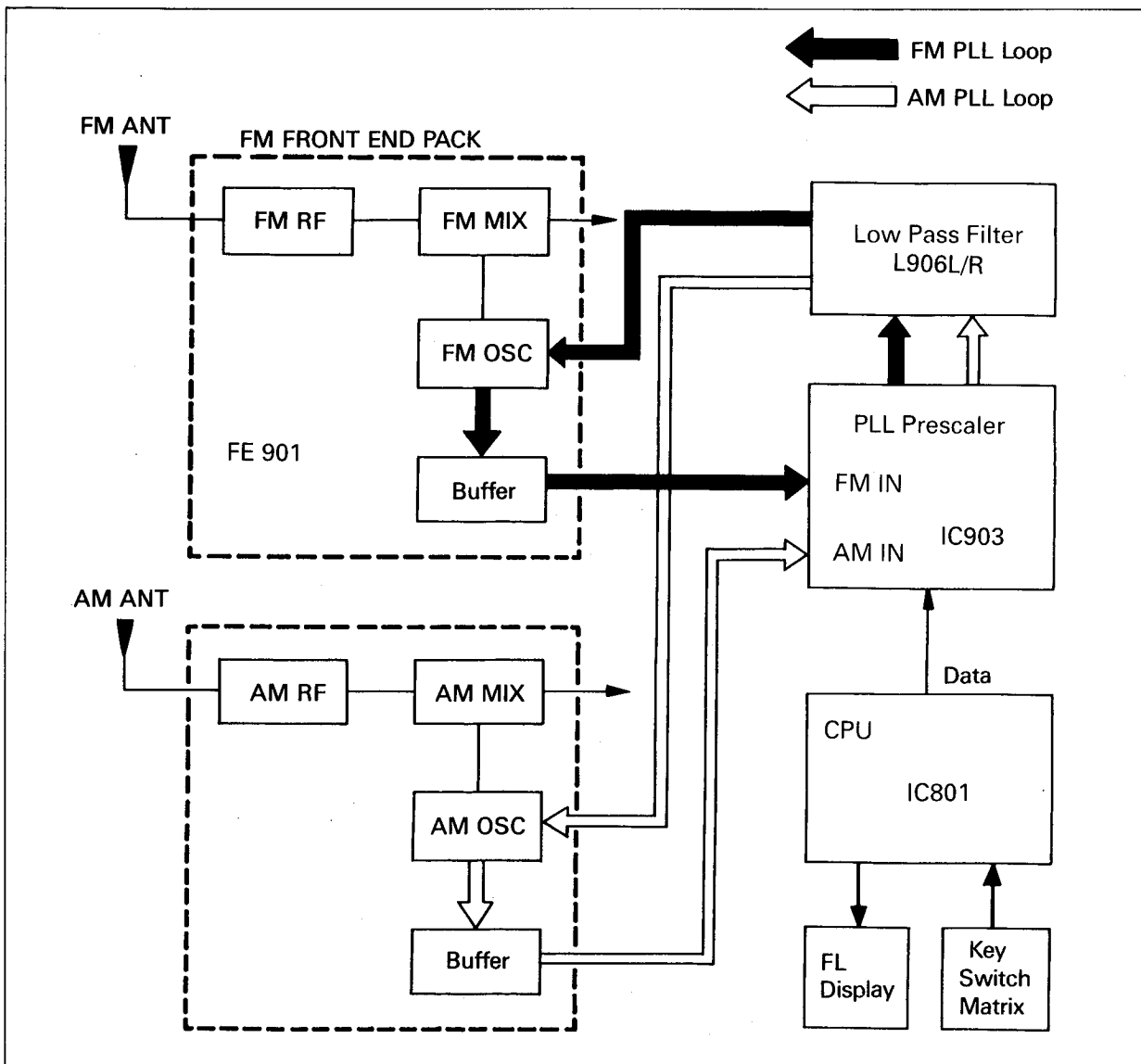

• Vco vs. FM Band Frequency Curve

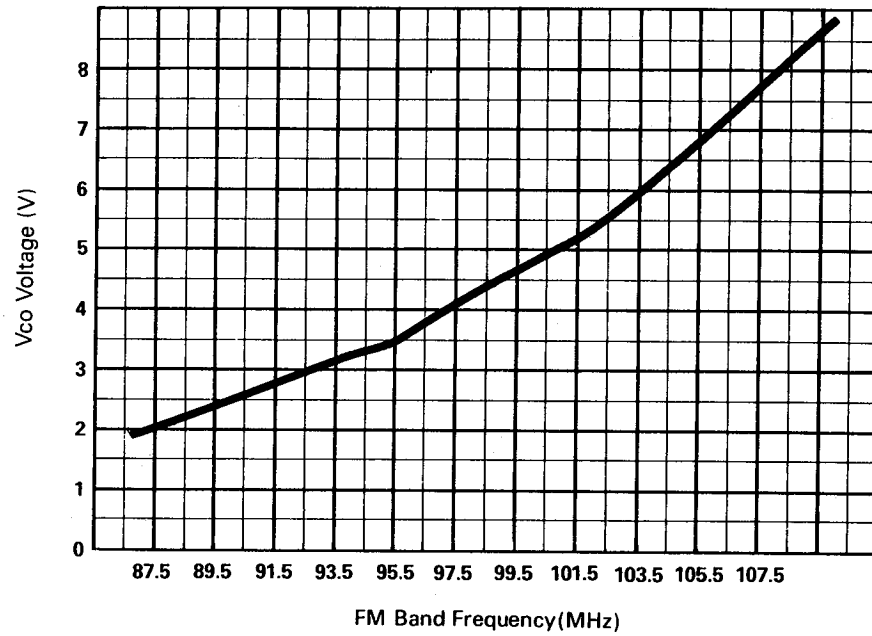

• Vco vs. AM Band Frequency Curve

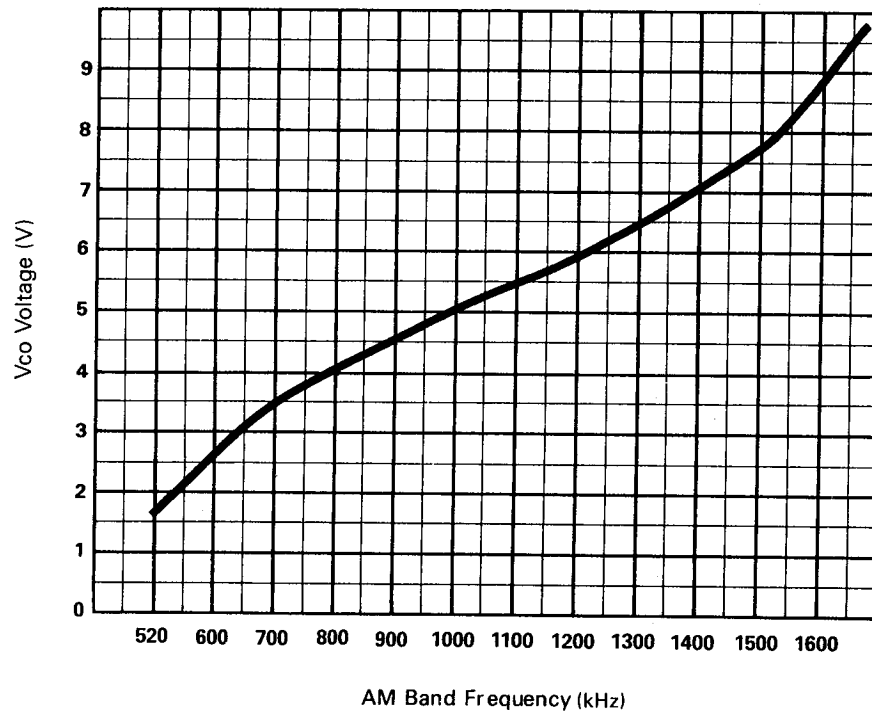

5. DOLBY SURROUND CIRCUITS

Fig. 1 is a block diagram of the Dolby surround circuit.

The microprocessor transfers the data to the Dolby Pro – Logic decoder and Time Delay Device to operate the circuits in each mode.

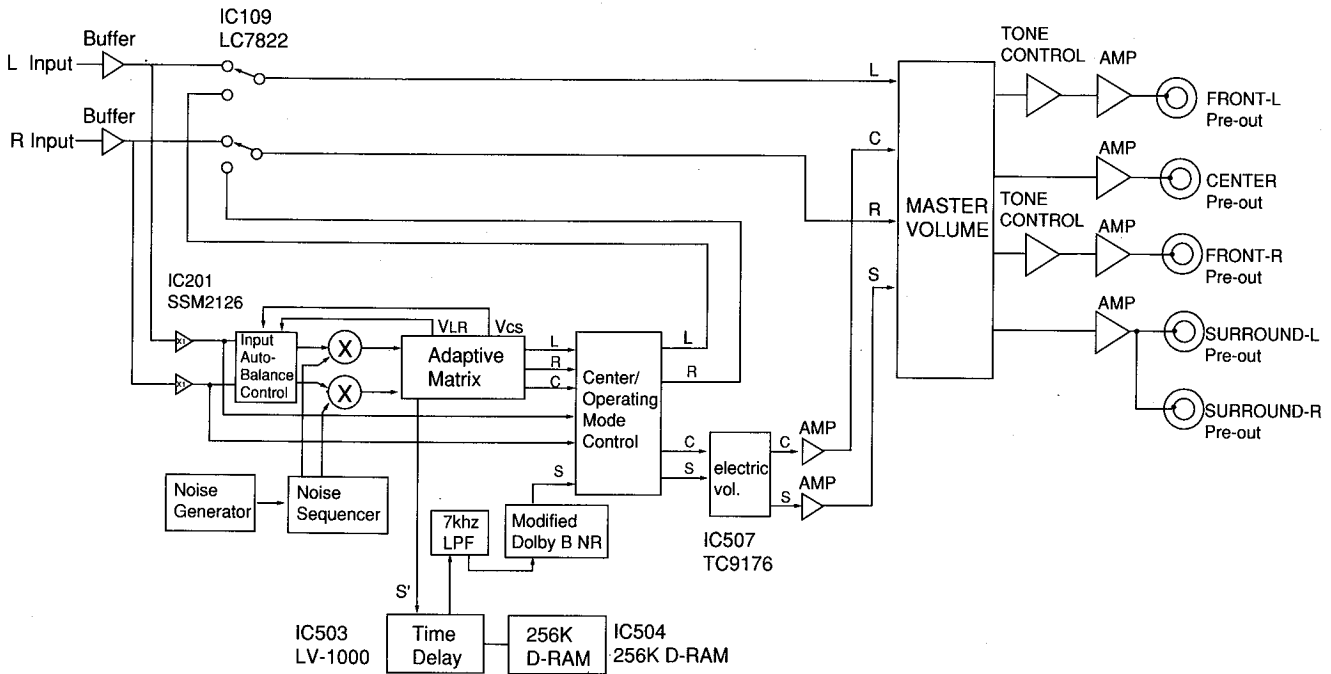

<Block diagram of the Dolby surround circuit>
Fig. 1

1) OFF

Set to this mode to listen to ordinary stereo sound.
The rear L/R and center outputs will be muted.

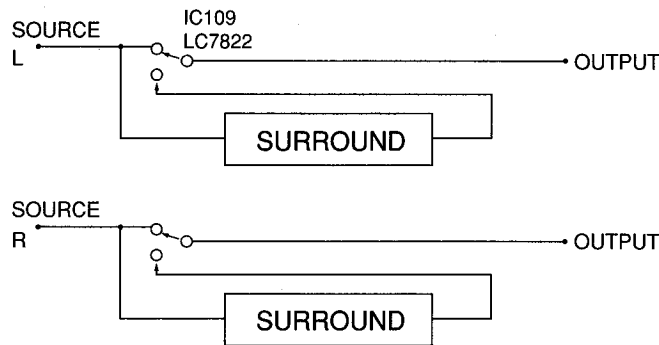
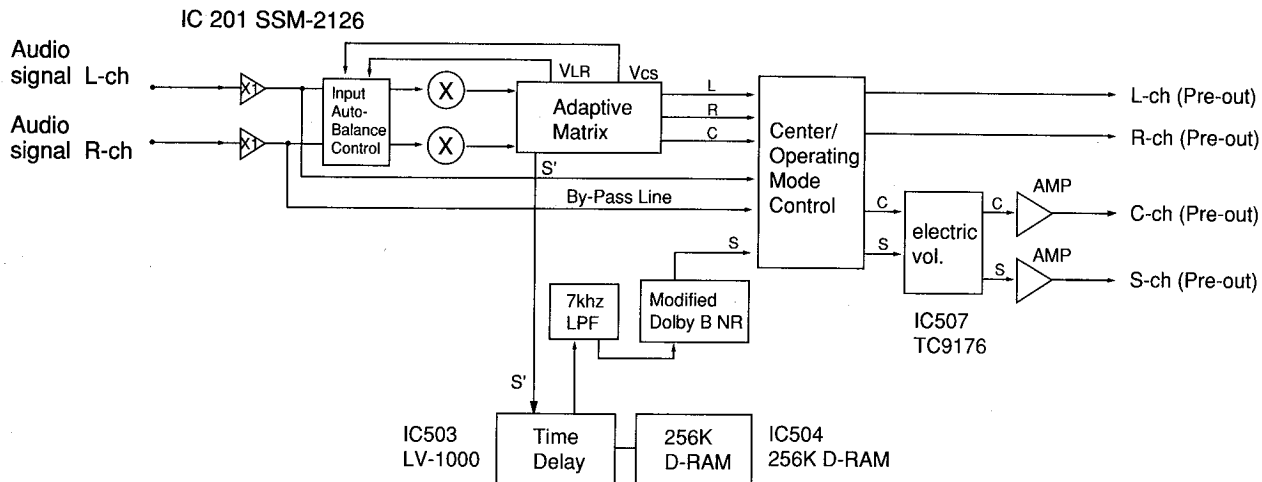

Fig. 2

2) DOLBY PRO – LOGIC CIRCUIT

Dolby Pro – Logic is a sound effect system for movies developed by the Dolby Laboratories Licensing Corp. IC201 (SSM2126) is a Dolby Pro – Logic decoder IC. When an audio signal recorded using the Dolby Pro – Logic system is sent to this IC, the left, right, center and surround components are separated. The surround signal component is delayed by the delay IC503 (LV-1000), IC504 (256K D-RAM). Fig. 3 Shows the configuration of the dolby decoder.



<Flow of signals within the system in the Dolby Pro – Logic mode>
Fig. 3

With Dolby pro logic, three center modes depend on the use of a center speaker as follows.

NORMAL	: Bass frequencies are sent only to the Left and Right Front channels. Select this mode when the Center Speaker is smaller than the Left and Right speakers.
WIDE	: Bass frequencies are sent to the Left, Center and Right speakers. Select this mode when the Center speaker is approximately the same size as the Left and Right speakers.
PHANTOM	: Center channel information is sent to the Left and Right speakers. Select this mode when you do not have a center channel speaker.

3) 3-STEREO CIRCUIT

In 3 – stereo mode, surround sound is sent to front Light channel and front Right channel and no surround sound is sent to surround channel.

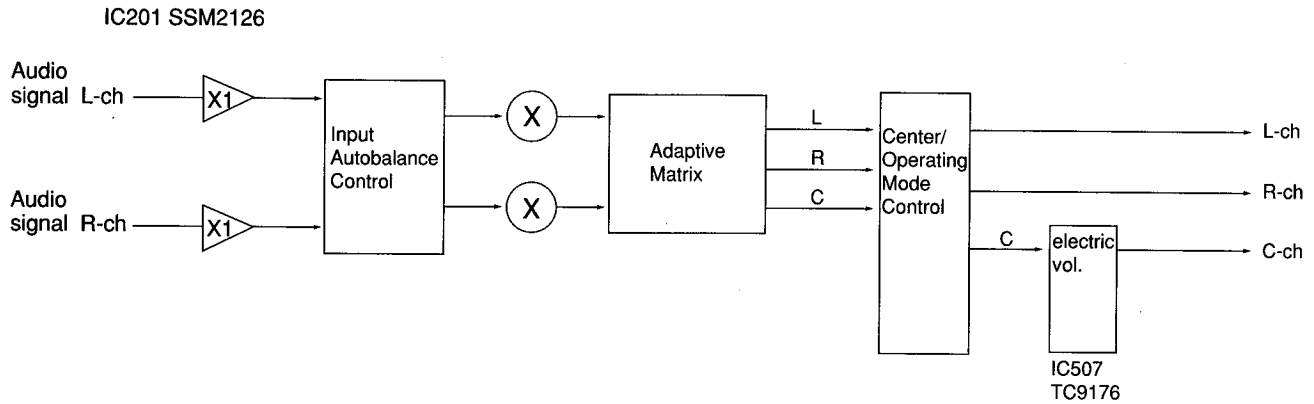

<Flow of signal within the system in the 3 – stereo mode>
Fig. 4

4) TEST TONE GENERATOR

The test tone generator generates a test tone (noise) to check the balance of sound output from each speaker in the Dolby pro logic mode. (This circuit is produced under license of the Dolby Laboratories Licensing Corp.) The noise generator signals shown the table below applies to the DM -1 / 2 / 3 / 4 pins of IC 201. The test tone is sent to the loud – speakers at 2 second intervals in the following sequence : Left, Center, Right, Rear (both rear channels).

Pin Name	DM-1 (Pin 23)	DM-2 (Pin 24)	DM-3 (Pin 25)	DM-4 (Pin 26)
L – CH.	L	H	L	L
C – CH.	L	H	L	H
R – CH.	L	H	H	L
S – CH.	L	H	H	H

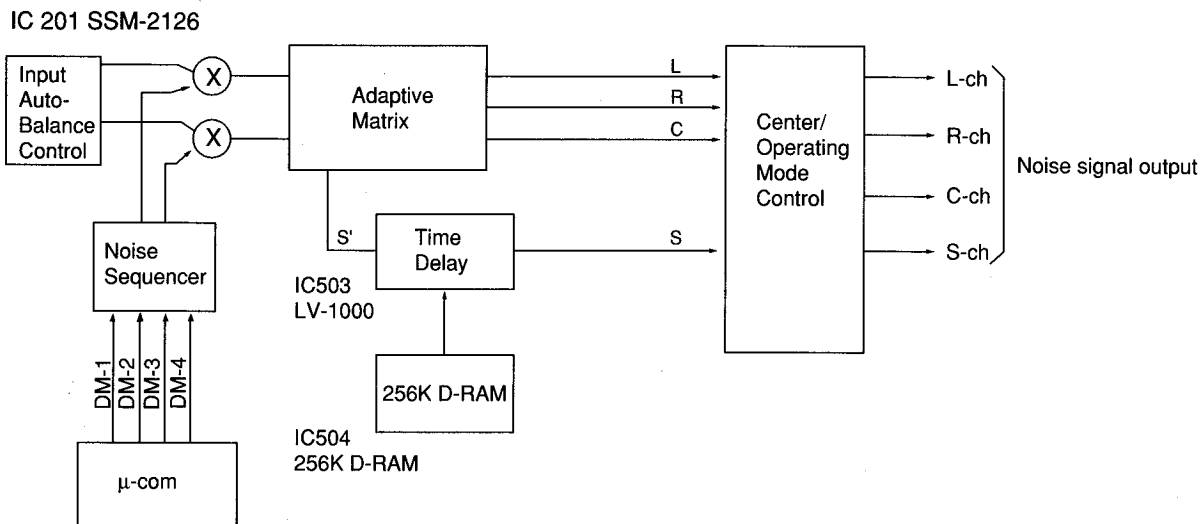

<Flow of noise signals within the system>
Fig. 5

6. OTHER SURROUND CIRCUITS

This model has Theater and Stadium surround circuits, except Dolby surround circuits. Theater / Stadium modes work best for recorded concerts and other music programs. In these modes, the front speakers provide a normal stereo effect while the rear speakers provide a reverberated sound. This reverberation helps simulate the sound you might hear at a live concert.

1) THEATER SURROUND CIRCUIT

Fig. 6 flow of signal of the theater surround circuit. In this mode, the center output will be muted.

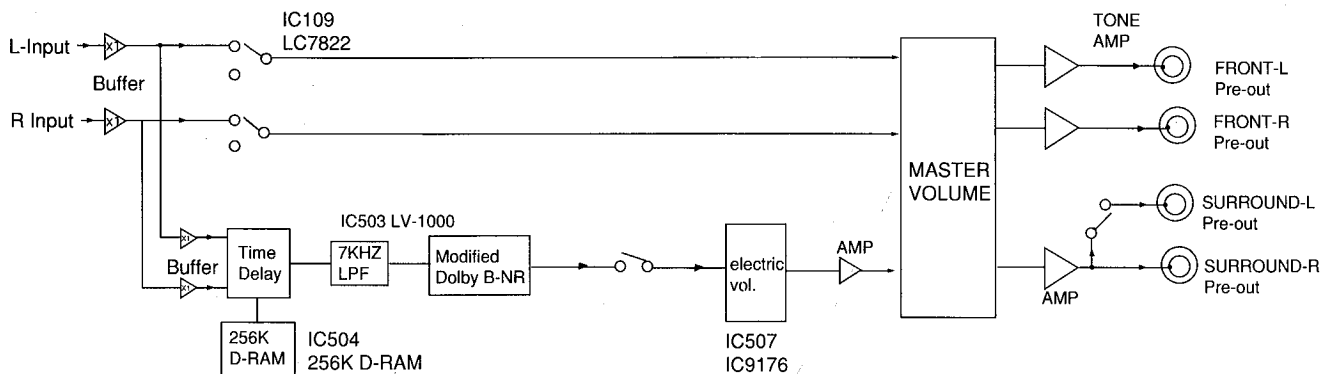

<Flow of signal of the theater surround circuit>
Fig. 6

2) STADIUM SURROUND CIRCUIT

Fig. 7 is flow of signal of the stadium surround circuit. In this mode, the center output will be muted.

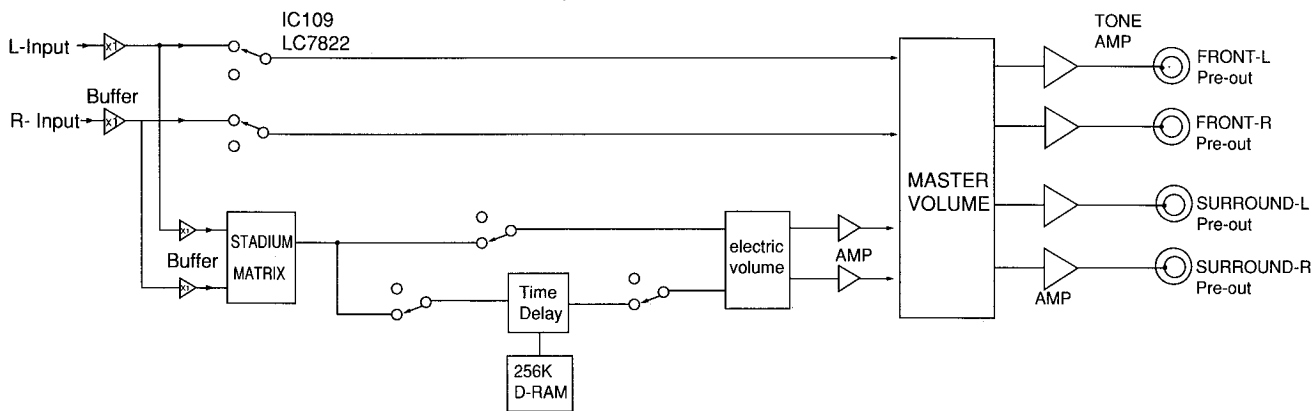

<Flow of signal of the theater surround circuit>
Fig. 7

ALIGNMENT PROCEDURES

1. Equipment Required

- AM Standard Signal Generator (AM SSG)
- Oscilloscope
- AC Voltmeter
- FM Standard Signal Generator (FM SSG)
- Stereo Modulator
- Audio Generator
- Distortion Meter
- DC Voltmeter
- Frequency Counter

Note : Disconnect external FM antenna prior to alignment.

2. Alignment and Test Points (PCB9)

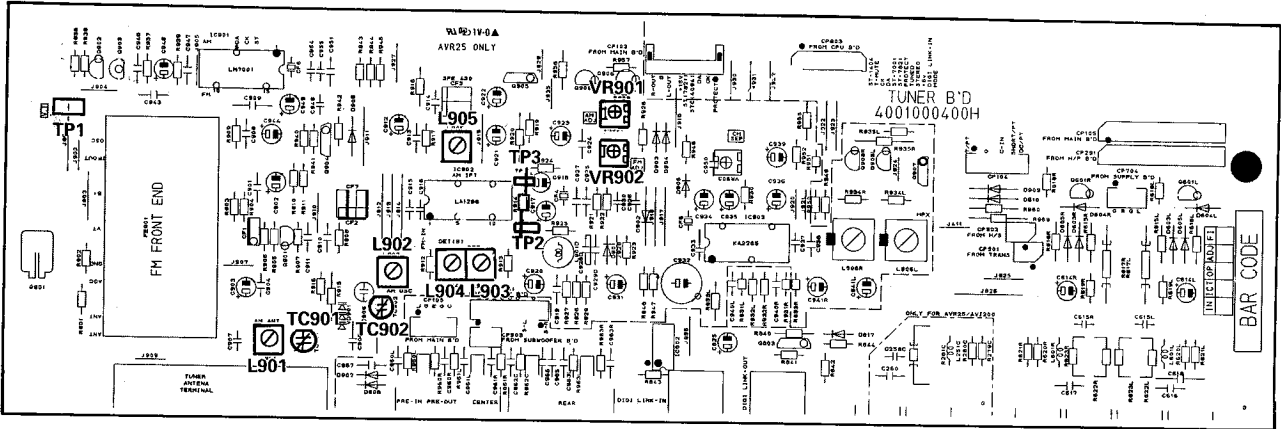

3. AM IF and RF Alignment

Preparation

1. Output of Signal Generator should not be higher than necessary to obtain an optimum output reading.
2. Signal Generator Modulation: 30%.
3. Switch: Press to AM.

Step	Signal Generator Frequency	Receiver Frequency on the Display	Equipment Connection	Adjustment Point	Adjust for
1	999 kHz (400 Hz, Mod.)	522 kHz	DC Voltmeter TP1	L902	1.2 V reading
		1611 kHz	DC Voltmeter TP1	TC902	8.5 V reading
2	594 kHz (400 Hz, Mod.)	594 kHz	AC Voltmeter to TAPE OUT jack.	L901 (ANT Coil)	Maximum reading
3	1404 kHz (400 Hz, Mod.)	1404 kHz	AC Voltmeter to TAPE OUT jack.	TC901 (ANT Trimmer)	Maximum reading
4	450 kHz (400 Hz, Mod.)	Place at a non-interference spot around 600 kHz.	AC Voltmeter to TAPE OUT jack.	L905 (IFT)	Maximum reading
5	999 kHz (400 Hz, Mod.)	999 kHz	Same as Step 1.	VR901	FL display 'TUNED' Indication on receiver with AM SSG Output level of 800 μ V/m

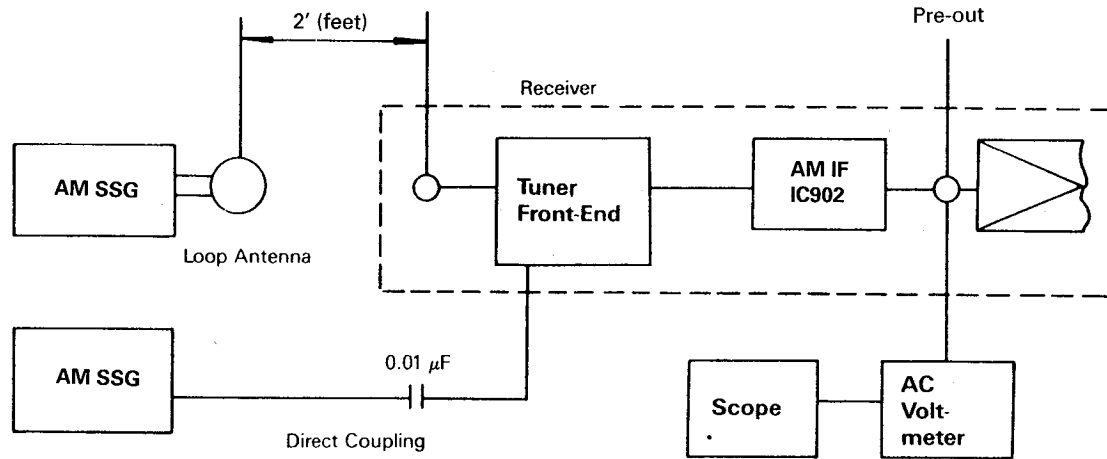

AM Alignment Connection

4. FM IF Alignment

Preparation

1. Signal Generator output should be no higher than necessary to obtain an optimum output reading.
2. Switch Press to FM.
3. Signal generator deviation : 40 kHz.

Step	Signal Generator Frequency	Receiver Frequency Display	Equipment Connection	Adjustment Point	Adjust for
1	98.0 MHz (1 kHz, Mod.)	98.0 MHz	Distortion meter to TAPE OUT jack	L904	Minimum distortion (0.2%) 1kHz mono.
3	98.0 MHz (1 kHz, Mod.)	98.0 MHz	Same as Step 1	VR902	FL display 'TUNED' Indication on receiver with FM SSG output level of 10 μV/m
3	98.0 MHz (1 kHz, Mod.)	98.0 MHz	DC Volt meter across R914 which are TP2 and TP3.	L903	Zero reading on DC volt meter.

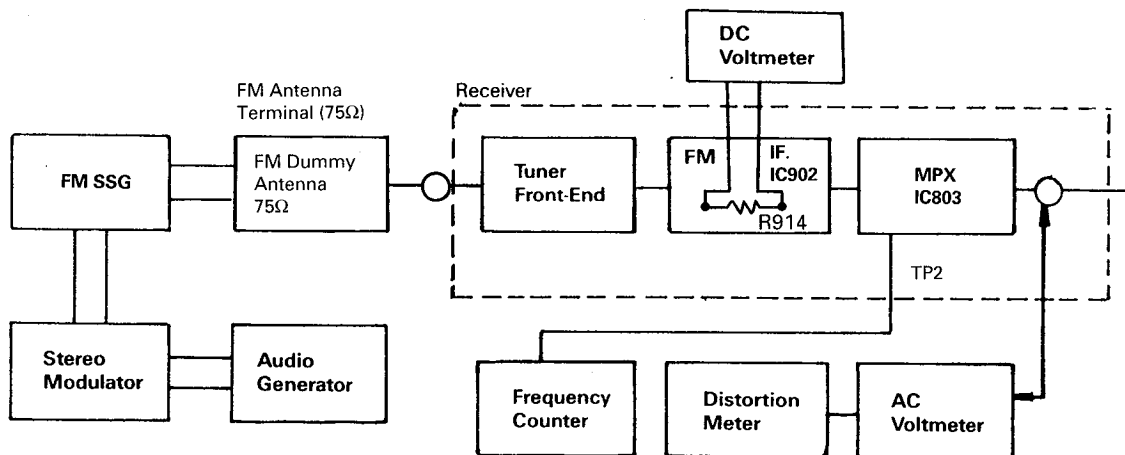

FM RF/IF and MPX Alignment Connction

5. MPX Alignment

Preparation

1. Switch : Press to FM.
2. Tuner for 98 MHz on band.
3. Signal Generator output level : 1000 μ V.
- 4 Deviation : 40 kHz, at 100% modulation of composite signal.
5. Connect Signal Generator to FM antenna terminal through FM dummy antenna (75 Ω).

Step	19 kHz Modulation Level	Signal Generator Frequency Setting	Equipment Connection	Adjustment Point	Adjust for
1	8% Mod.	Composite to channel 1kHz R	AC voltmeter to TAPE OUT jack of R channel	–	Confirm audio output as about 450mV and reference as "0dB".
2	8% Mod.	Composite to channel 1 kHz L	AC voltmeter to TAPE OUT jack of R channel	VR803	AC voltmeter reading should be at least 40 dB below.
3	8% Mod.	Composite to channel 1 kHz R	AC voltmeter to TAPE OUT jack of L channel	VR803	Same as Step 2.
If you could not obtain –40dB readings in Steps 2 and 3 (compared with Step 1), readjust VR803 until you obtain –40dB readings for both Steps 2 and 3. Nominal is –45 dB.					

TROUBLESHOOTING

Symptom	Cause and Remedy
Receiver inoperative (FIP indicator does not light)	<ul style="list-style-type: none"> A) Faulty AC power cord. Replace. B) Defective the power switch. Replace. C) Broken wire in the power transformer. Replace the power transformer. D) Blown power Replace the fuse.
Fuse blows when power is turned on.	<ul style="list-style-type: none"> A) Defective power transformer. Replace. B) Short in the primary or secondary of the transformer circuitry. Repair the trace.
PHONO input inoperative	<ul style="list-style-type: none"> A) Poor contact in phono input jack. Repair or replace the jack. B) Defective phono switch or IC106. Replace.
LOUDNESS has no effect	<ul style="list-style-type: none"> A) Defective loudness switch. Replace. B) Defective resistors R301 L/R and capacitors C301 L/R. Replace the defective component(s).
FM inoperative	<ul style="list-style-type: none"> A) Defective front-end. (FE-901) Replace. B) Defective FM switch. Replace the switch C) Defective transistor Q901, Q904, Q905 and IC'S IC901, IC902, IC903 Replace the defective transistor(s) or IC(s). D) Defective coil L903 or L904. Replace the coil(s). E) Defective lead-in. Repair or replace the lead-in. F) Ceramic filter CF901, CF902 defective. Replace the defective ceramic filter(s). G) Defective controller circuit component. Replace.
Poor multiplex separation	<ul style="list-style-type: none"> A) Improper adjustment. Readjust VR803. (Refer to MPX Alignment.) B) IC903 defective. Replace. C) Variable resistor VR803 defective. Replace the variable resistor.
STEREO indicator does not light	<ul style="list-style-type: none"> A) Defective indicator in FIP (Fluorescent Indicator Panel). Replace. B) Improper adjustment of VR903 of tuner board. (PCB9). Make readjustment. C) Defective IC903. Replace the defective component.

Symptom	Cause and Remedy
FM volume not sufficient	<p>A) If volume from both L and R channels is not loud enough :</p> <p>Front end Section defective. Faulty IC902, Coil L903 Defective C907 of tuner Board (PCB9). If sound of one channel is not loud enough: Defective L906 L/R.</p>
FM Mono has no effect	<p>A) Defective FM MODE switch. Replace.</p>
AM inoperative	<p>A) Damaged IC902 of tuner board. Replace.</p> <p>B) Defective L901, L902, L905 or CF3 of tuner board (PCB9). Replace the defective component(s).</p> <p>C) Resistor R915, R926 defective. Replace the defective resistor(s).</p> <p>D) Capacitor C906, C922, C926 defective. Replace the defective capacitor(s).</p> <p>E) Defective AM switch Replace.</p> <p>F) Defective varicap diode VD901, VD902. Replace varicap diode(s).</p> <p>G) Damaged AM loop antenna. Repair or replace.</p> <p>H) Defective controller circuit component. Replace.</p>
Bass control has no effect	<p>A) Variable resistor BASS defective. Replace.</p> <p>B) Defective R416L/R, R417L/R, R418L/R, C414L/R, C415L/R Replace the defective component(s).</p>
Treble control has no effect	<p>A) Variable resistor TREBLE defective. B) Defective C417L/R, C418L/R, R419L/R, R420L/R Replace the defective components(s).</p>
Auto tune inoperative (UP/DOWN)	<p>A) Poor contact in Up/Down key. Repair replace.</p> <p>B) Defective IC801 Replace.</p> <p>C) Defective FIP Display. Replace.</p> <p>D) Defective tuner circuit component. Replace.</p> <p>E) In case of FM only, improper adjustment of FM front-end. Readjust.</p>
Manual tune inoperative (UP/DOWN) (AM or FM)	<p>A) Poor contact in Up/Down key. Replace.</p> <p>B) Defective IC801. Replace.</p>

Symptom	Cause and Remedy
Memory setting (keys 1-10) inoperative	A) Poor contact in memory keys 1-10. Replace. B) Poor contact in memory set key. Replace. C) Defective IC801. Replace the defective component.
FIP inoperative	A) FIP defective. Replace. B) Defective IC801. Replace. C) Defective X-TAL 801. Replace.
Noise Volume control	A) Defective IC301. Replace. B) Defective capacitor C304 or C305 Replace the defective capacitor(s).
Remote Control Unit inoperative	A) Weak Battery. Replace. B) Defective. Replace. C) Defective IC801 or Sensor 801 (CPU Board) or IC01. Replace.

GENERAL UNIT PARTS LIST

REF. NO.	DESCRIPTION	MFR. PART NO.	Q'TY
CABINET AND CHASSIS			
1	PANEL, FRONT	048602019331	1
2	BODY, FRONT	8521008910	1
3	SHIELD FENCE	6163115010	1
4	WINDOW, FL	8553020110	1
5	FILTER, FL	048535042611	1
6	KNOB, VOLUME	048643006711	1
7	INDICATOR, VOLUME	8555049210	1
8	KNOB, ROTARY	048545124311	3
9	BUTTON, POWER	048543061011	1
10	LIGHT SHIELD	8535042810	1
11	INDICATOR, POWER	8555048710	1
12	BUTTON, SPEAKER	048545124111	1
13	BOTTOM, SOURCE	048543060911	1
14	SPONGE RUBBER	6715020730	1
15	BUTTON, SEESAW	048543060811	1
16	SHIELD FENCE	6163114510	1
17	BUTTON, TUNING	048543059711	1
18	BUTTON, LOUD	048545124211	1
19	VOLUME, RK16K128000114C RMD41	3208049510	2
20	VOLUME, RK16K118000114H RMM44	3208052010	1
21	JACK RCA, 3P	4438109710	1
22	SWITCH, SPUL-12X1H091-SUE33	4628059610	1
23	VOLUME MOTOR, RK16314MC1R253B RM094	3228019410	1
24	SWITCH, SPEA-122SC011-SU504	4628054410	1
25	SWITCH, SKHV10910D01-KB581	4658003710	38
26	REMOTE SENSOR, TFMT5380 (38 kHz)	2408005001	1
27	FL DISPLAY, FIP12LM8	2328130301	1
28	BUTTON, PRE-SET	048543059611	1
29	FRAME RIGHT	6122632210	1
30	FOOT	046033102511	4
31	COVER BOTTOM	6122420520	1
32	CHASSIS, FRONT	6122214610	1
33	FASTENER, KGLS-4S	6528300110	2
34	STOPPER PCB	6515013810	1
35	FRAME LEFT	6122632110	1
36	HEATSINK, REGULATOR TR.(15X45)	7505206220	1
37	HEATSINK, REGULATOR TR.(15X30)	7505202410	1
38	JACK RCA, 2P	4438108510	1
39	JACK RCA, 6P	4438108710	2
40	JACK RCA, 3P, JE0300390N	4438108830	4
41	JACK RCA, 2P	4438114210	1
42	PHONE JACK, YKB21-5130	4438112710	1
43	JACK, HSJ0912-01-052	4438006510	2
44	JACK RCA, 4P	4438108610	2
45	TERMINAL ANTENNA	4408108320	1
46	CHASSIS, BACK	046102048521	1
47	TERMINAL, S4011062KN	4408103720	1
△ 48	AC CORD, EHD-0008-266P	4308001410	1
49	STOPPER, AC CORD, SR-4N-4	6518000710	1
50	COVER, TOP	046122022621	1
△ 51	POWER TRANSFORMER, 120V, 60Hz	2828101307	1
52	SPONGE RUBBER	6715026720	1
53	HEATSINK, REGULATOR TR.(15X30)	7505206210	1
54	LOCKING TIE, WPM13248	6528002810	1
△ 55	AC OUTLET, CCT1306-0212	4448102910	1
HARDWARE KIT			
S1	SCREW, #B BTT 3 X 8B	8179130083	69
S2	SCREW, WSAM 4 X 8B	8159440083	10
S3	SCREW, GND #B BT 3X10B	8198001910	2
S4	SCREW, #2 FTC 3X8B	8129230083	4
S5	SCREW, #B WPTT 3X6Y	8179230061	10
MISCELLANEOUS			
	CABLE, UL2896-1.25-12-350-C	4118612355	1
	CABLE, YS=1.25-19-300-C	4118619305	1
	CABLE, YS=1.25-15-180-C	4118615189	1
	CABLE, YS=1.25-18-140-C	4118618149	1
PCB1	P.C.BOARD MAIN	4001000300	1
PCB2	P.C.BOARD REGULATOR	4001000450	1
PCB3	P.C.BOARD VOLUME	4001000440	1
PCB4	P.C.BOARD TONE	4001000430	1
PCB5	P.C.BOARD DOLBY	4001000510	1
PCB6	P.C.BOARD VOLUME LED	4001000530	1
PCB7	P.C.BOARD POWER SUPPLY	4001000410	1
PCB8	P.C.BOARD FRONT	4001000500	1
PCB9	P.C.BOARD TUNER	4001000400	1

PRODUCT SAFETY NOTICE

Each precaution in this manual should be followed during servicing. Components identified with the IEC symbol Δ in the parts list are of special significance to safety. When replacing a component identified with Δ , use only the replacement parts designated, or parts with the same ratings of resistance, wattage or voltage that are designated in the parts list in this manual. Leakage-current or resistance measurements must be made to determine that exposed parts are acceptably insulated from the supply circuit before returning the product to the customer.

GENERAL UNIT EXPLODED VIEW

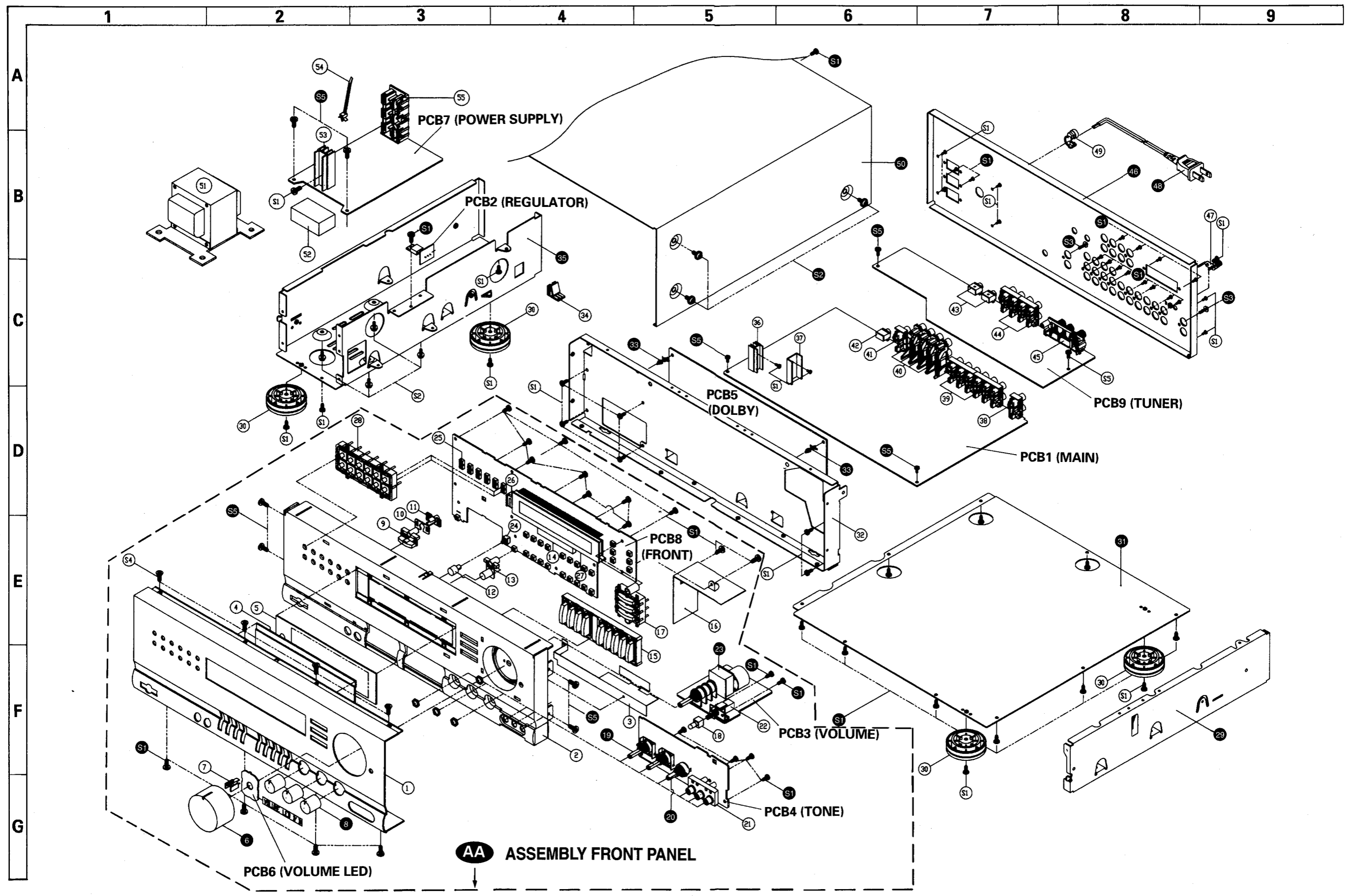

GENERAL UNIT EXPLODED VIEW

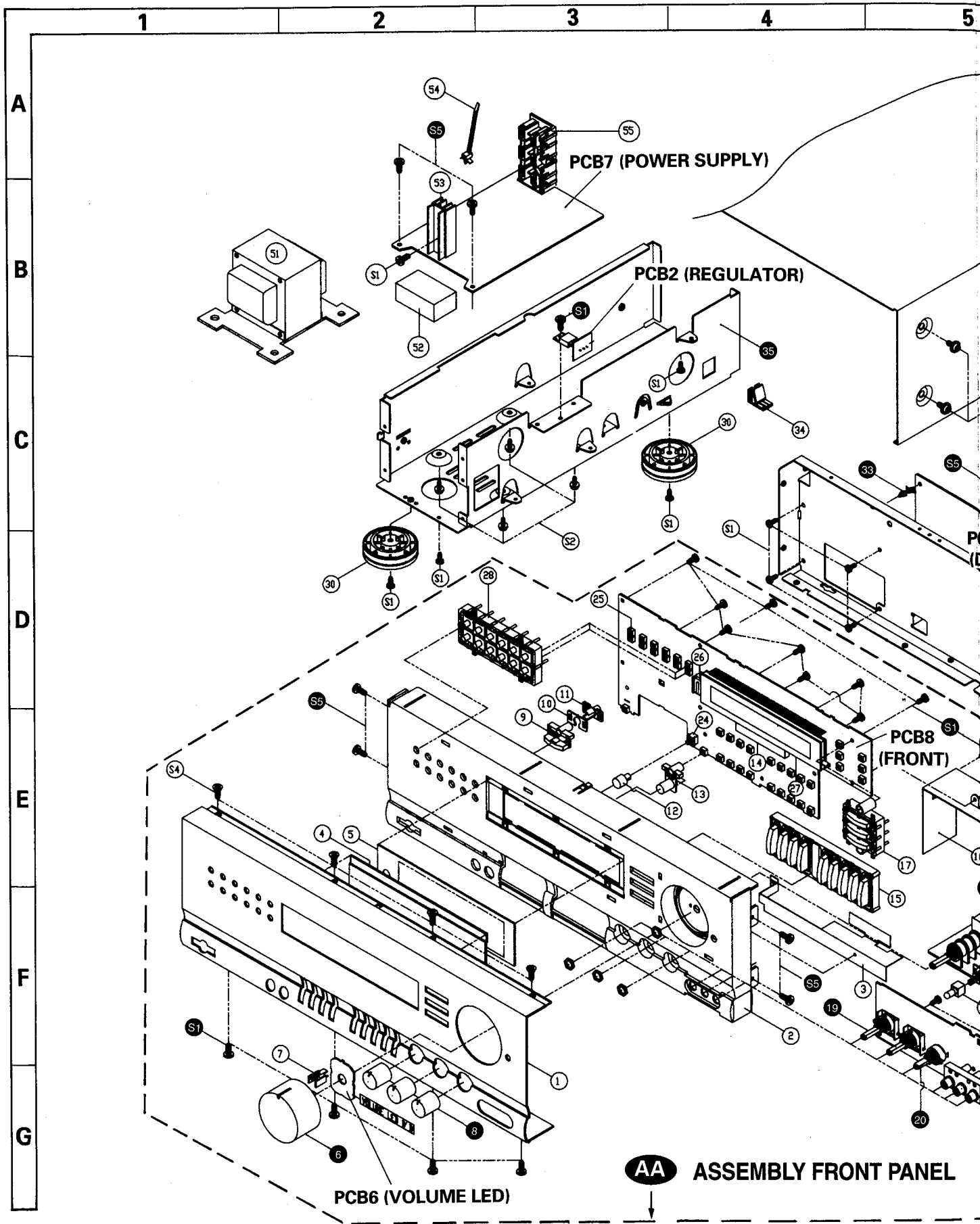

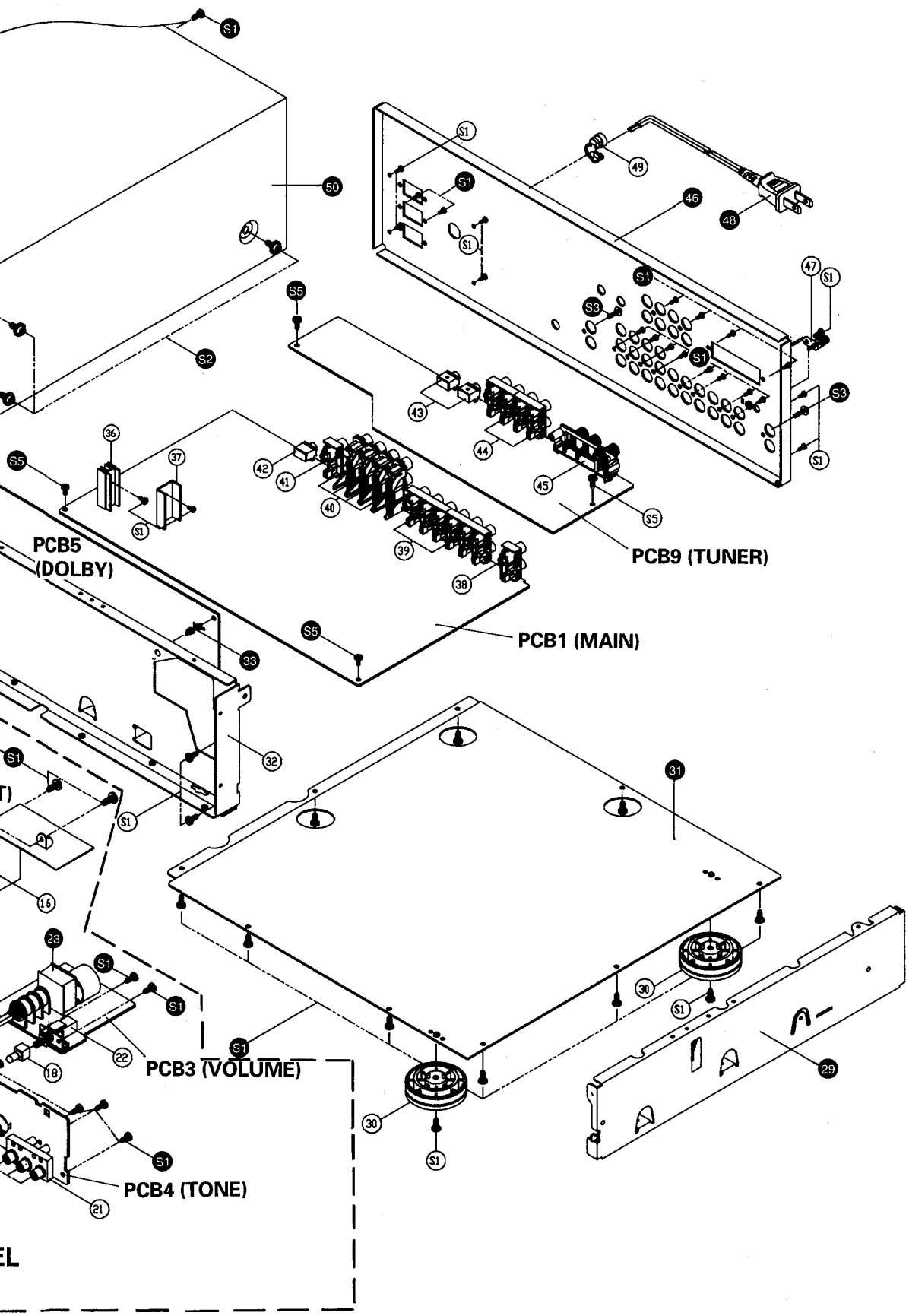
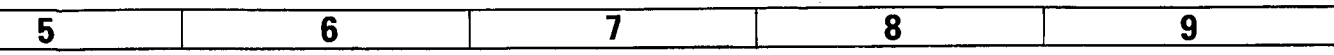

PRINTED CIRCUIT BOARDS

PC-1 MAIN

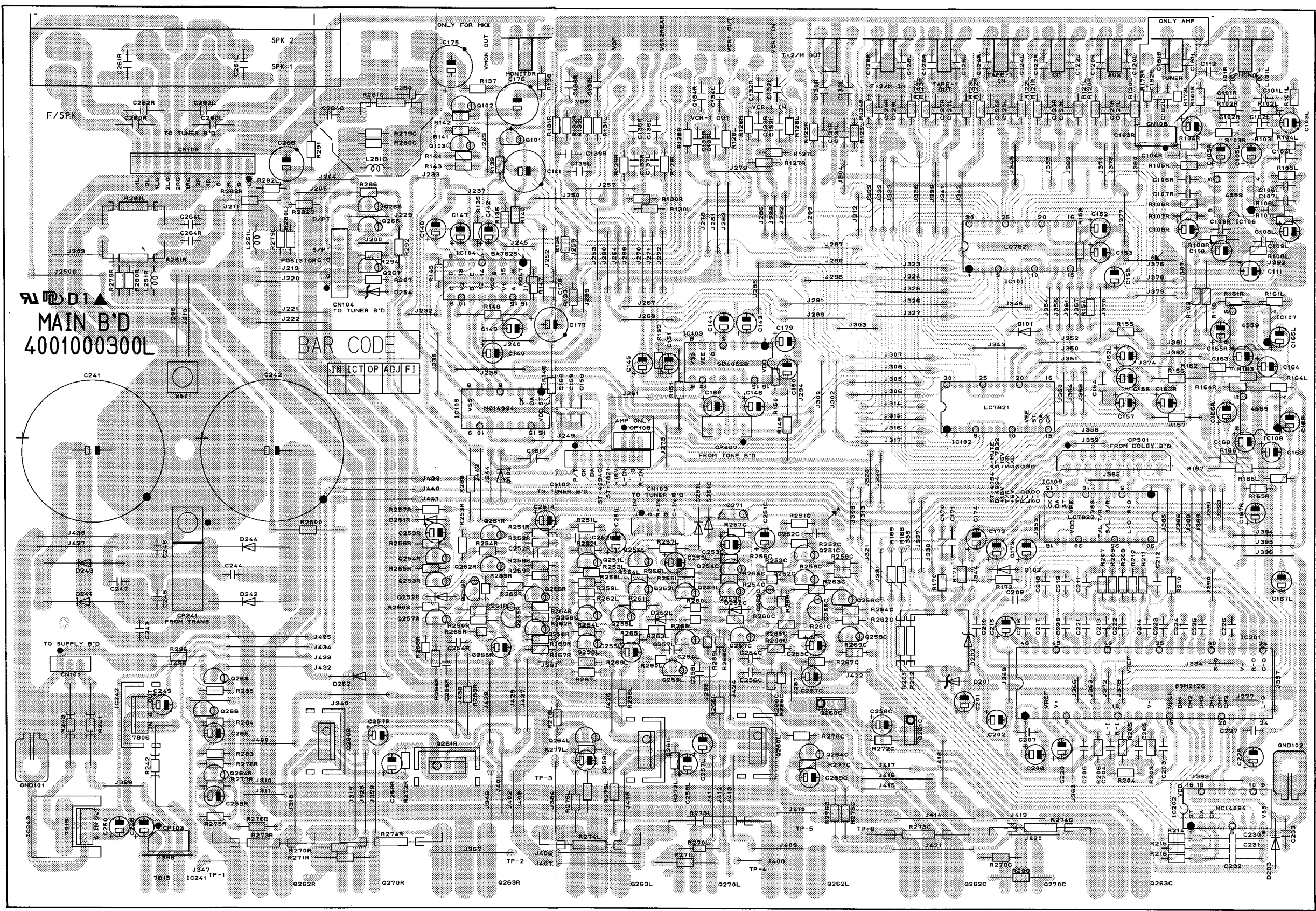

PRINTED CIRCUIT BOARDS

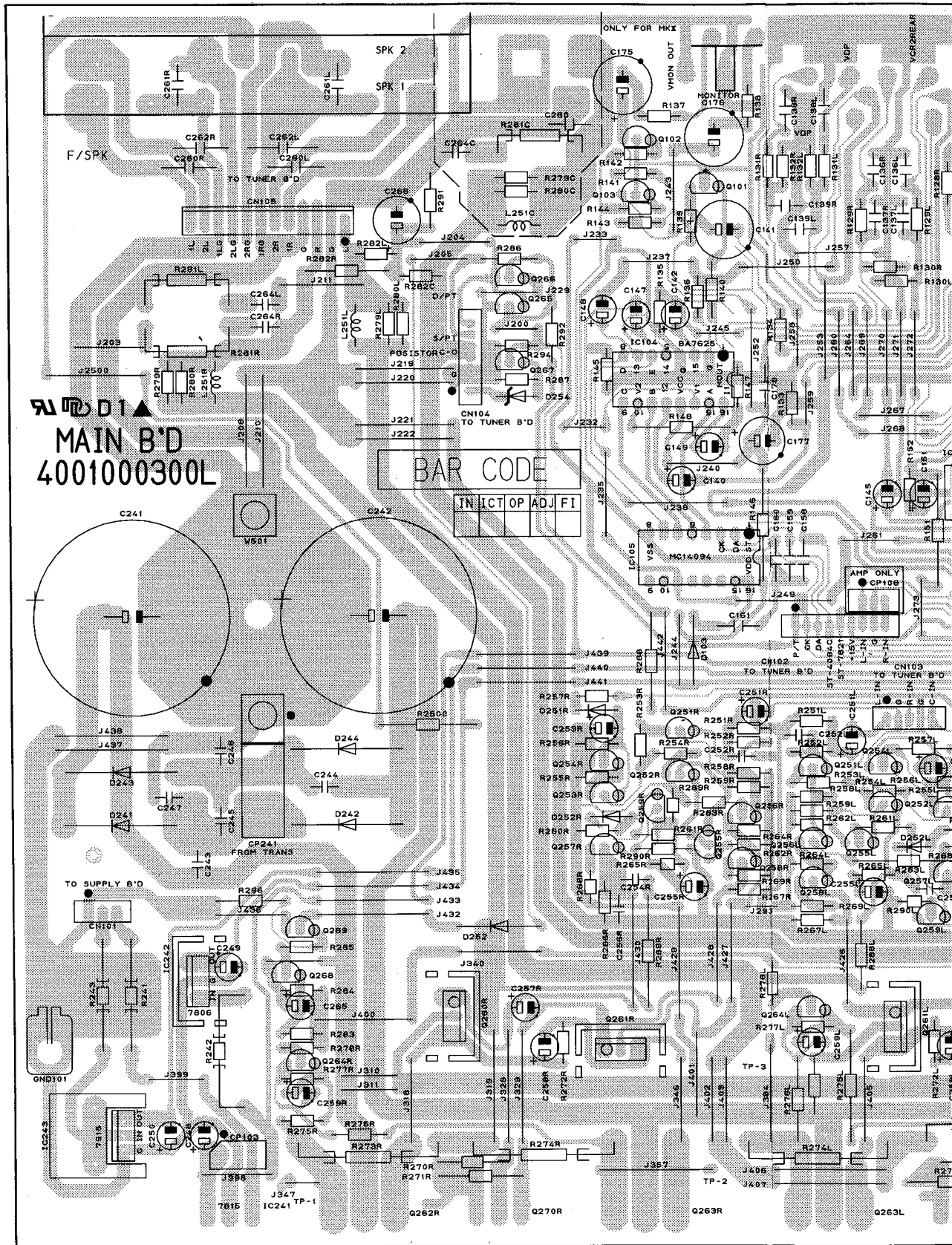

PC-1 MAIN

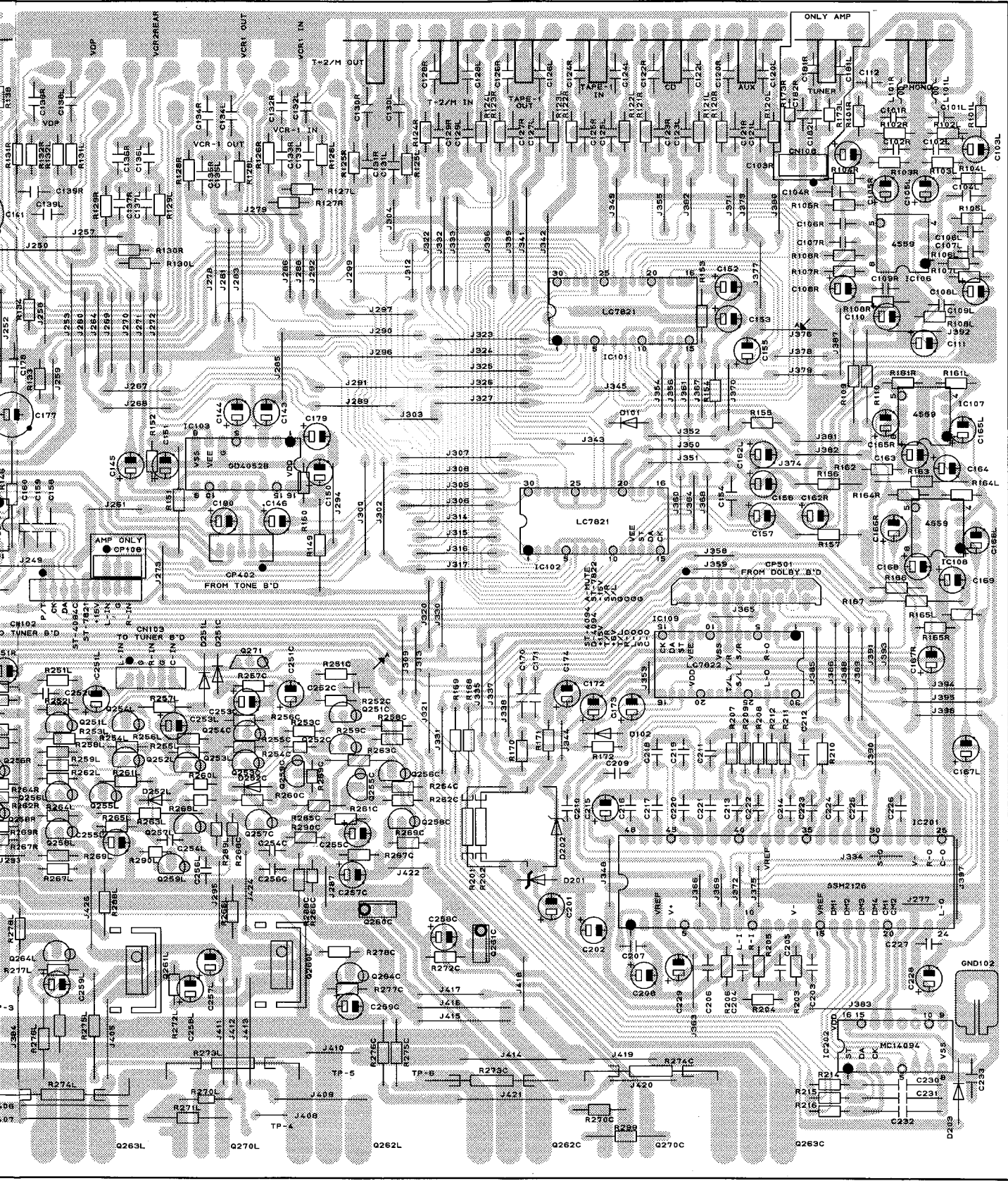

PCB8 (FRONT)

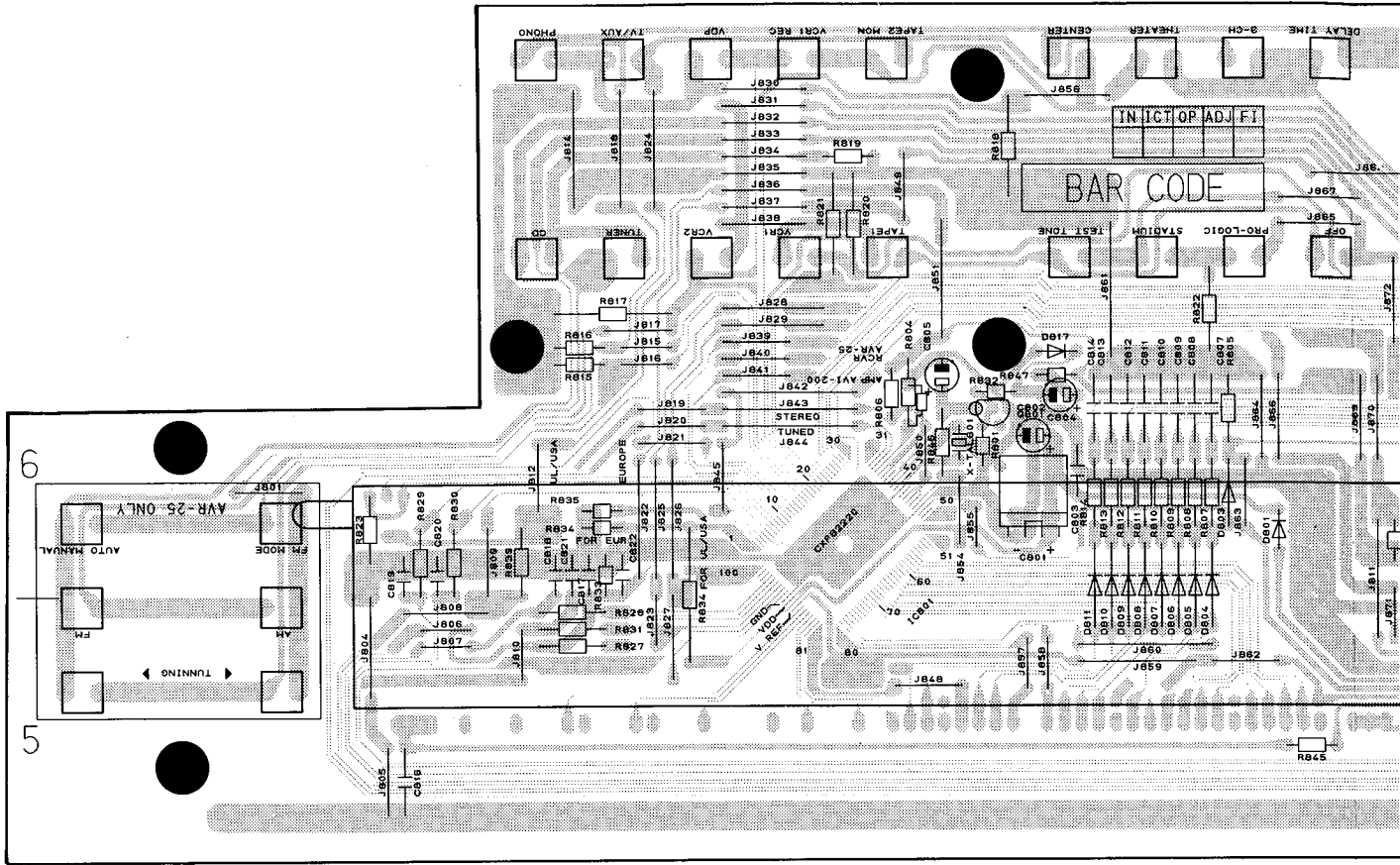

PCB9 (TUNER)

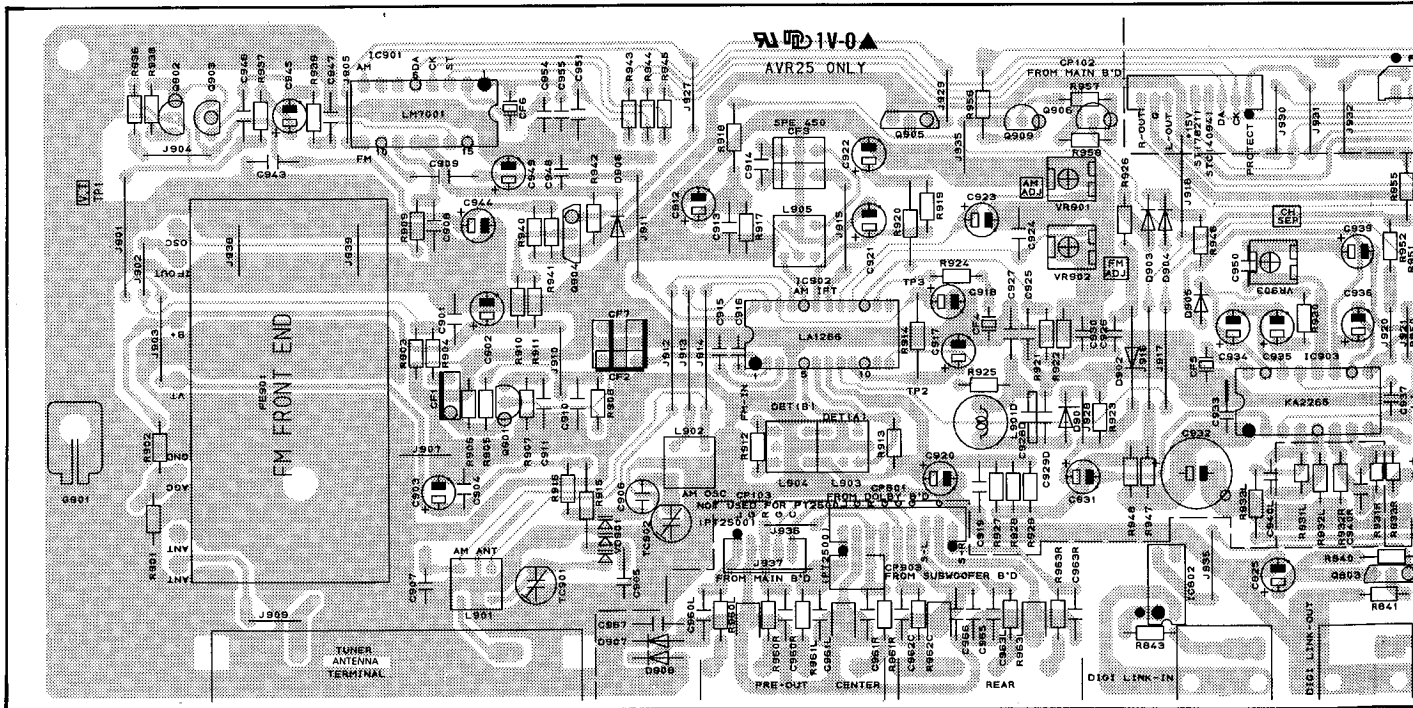

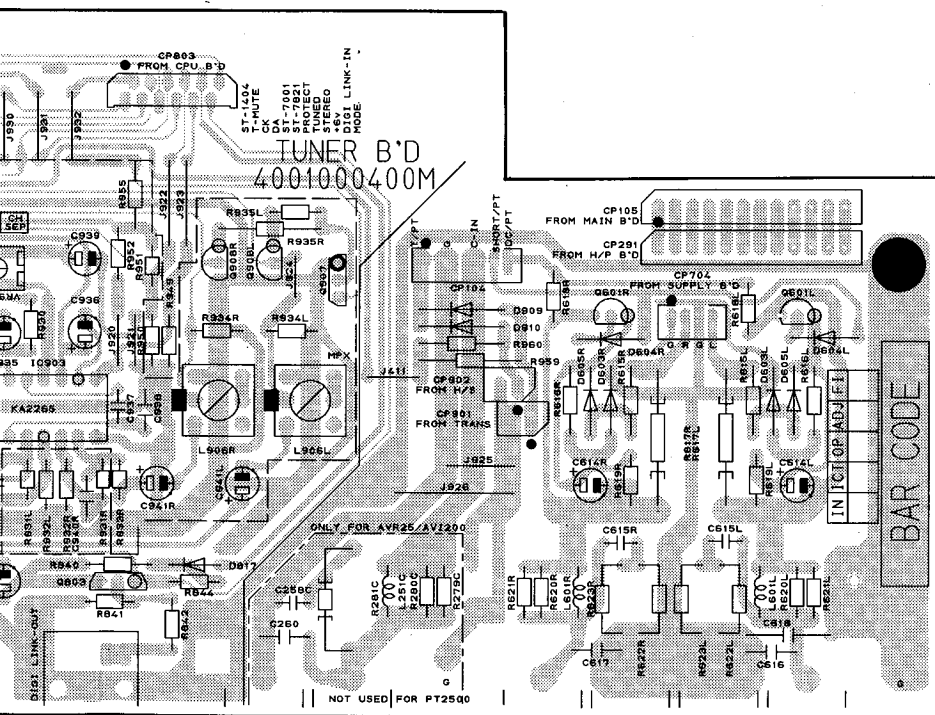
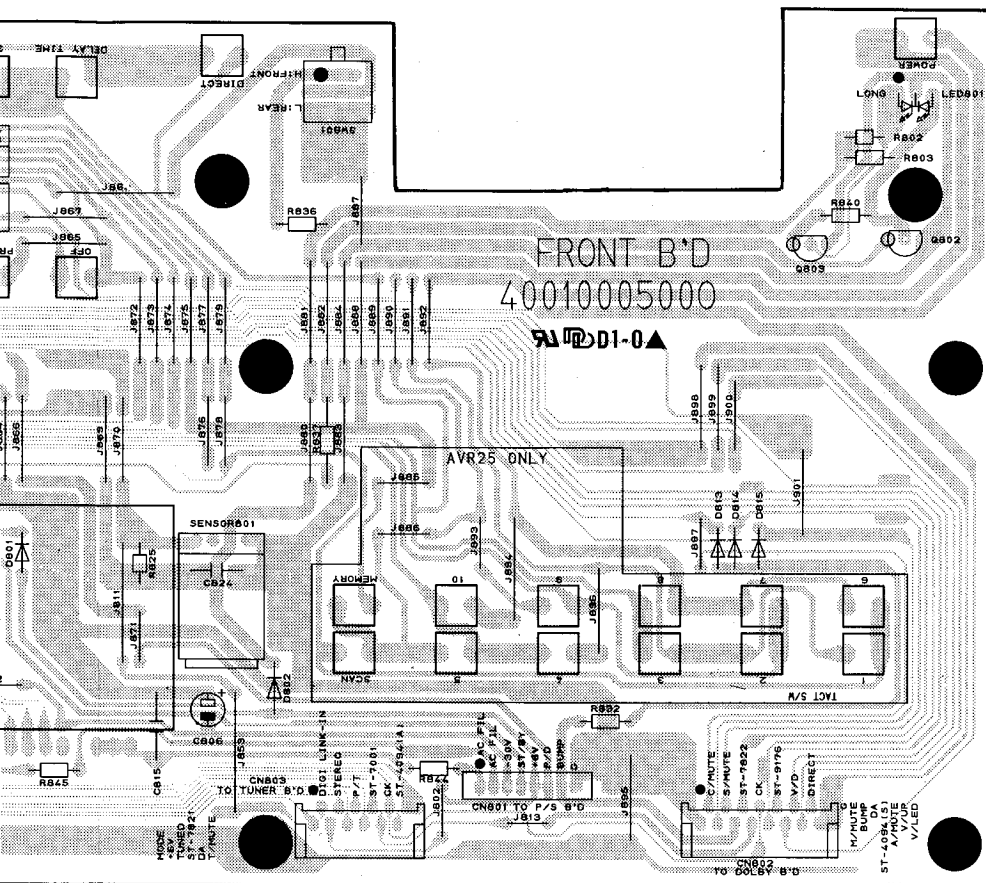

PCB5 (DOLBY)

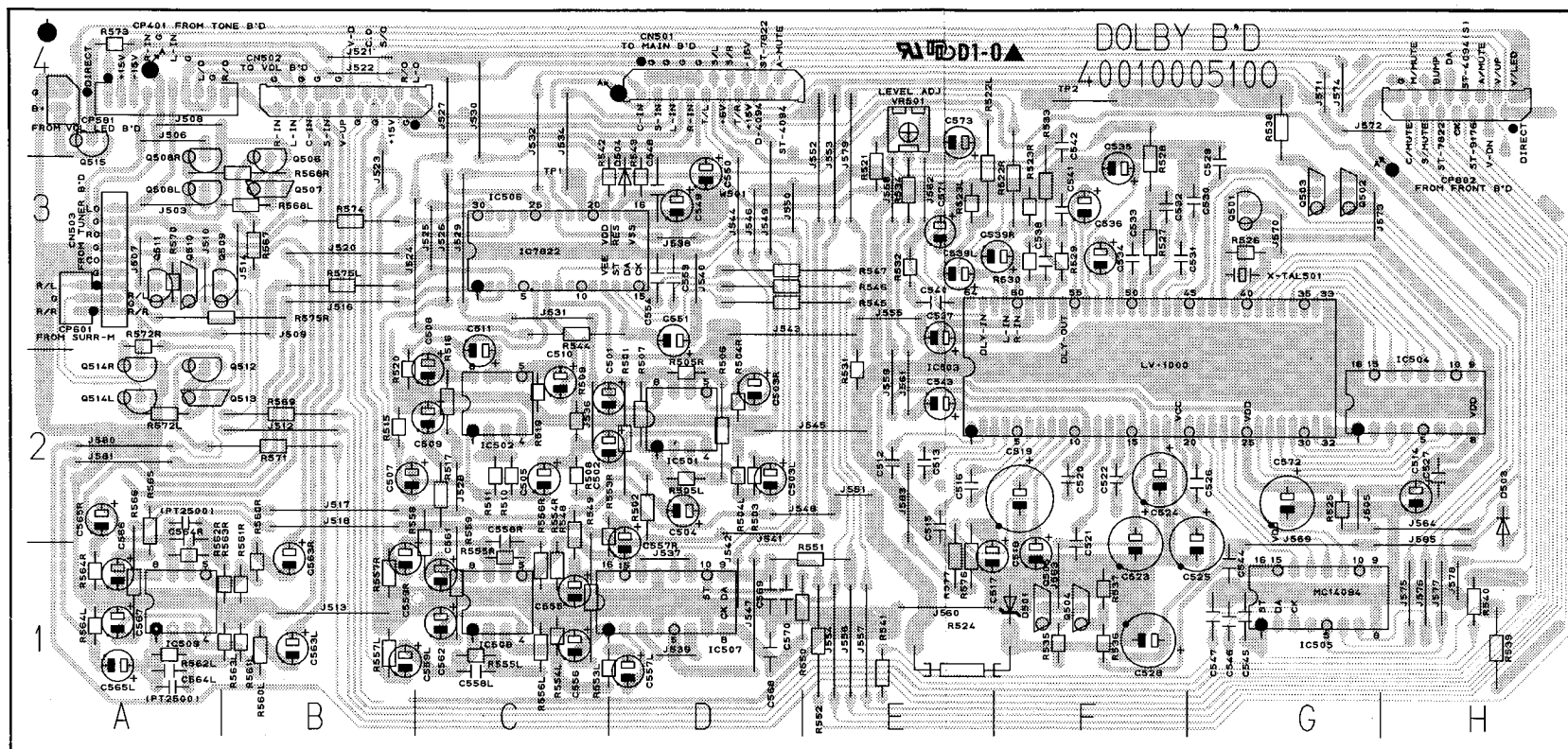

PCB3 (VOLUME)

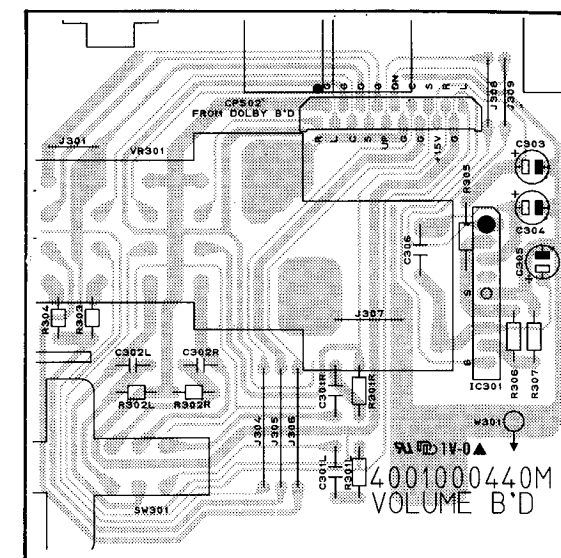

PCB6 (VOLUME LED)

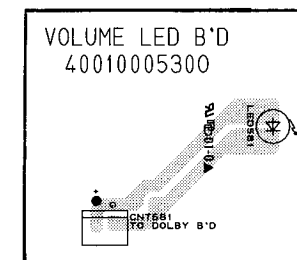

PCB2 (REGULATOR)

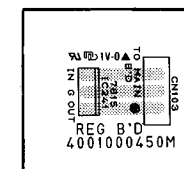

PCB7 (POWER SUPPLY)

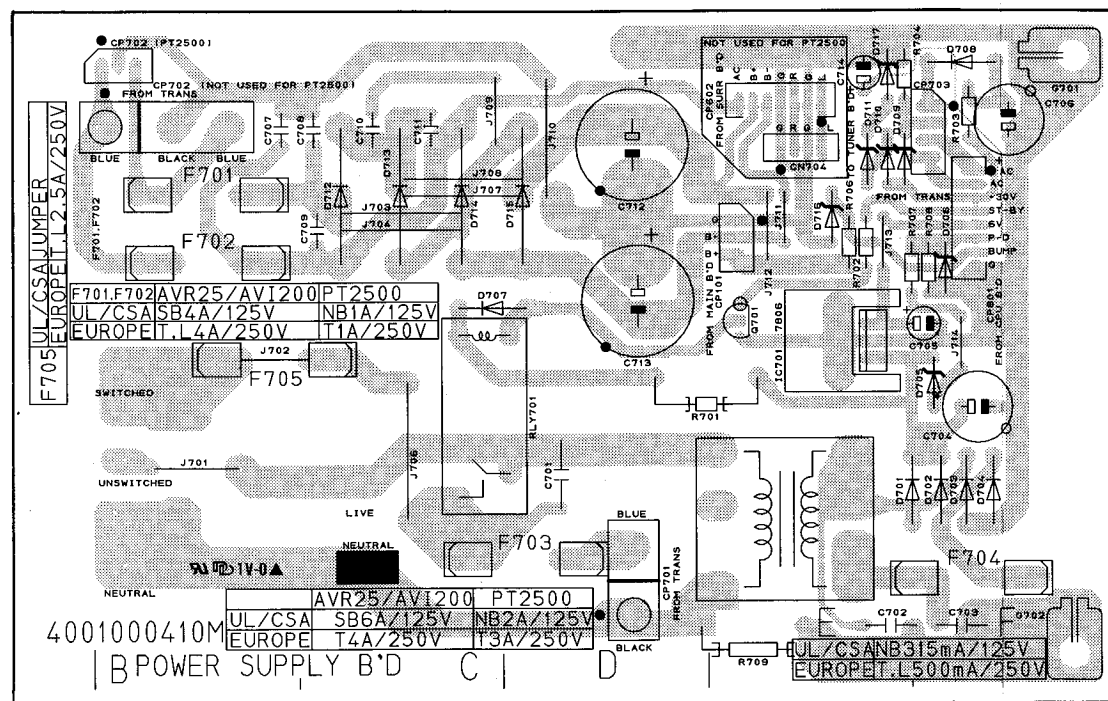

PCB4 (TONE)

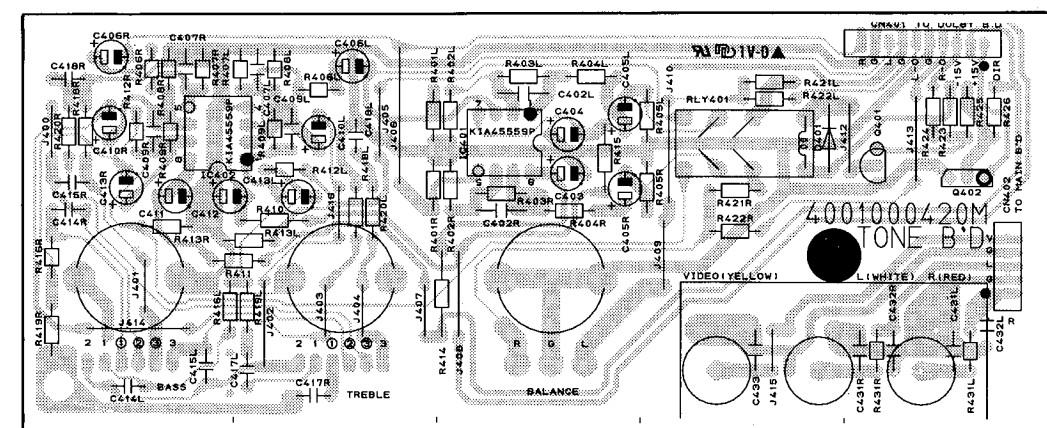

PCB5 (DOLBY)

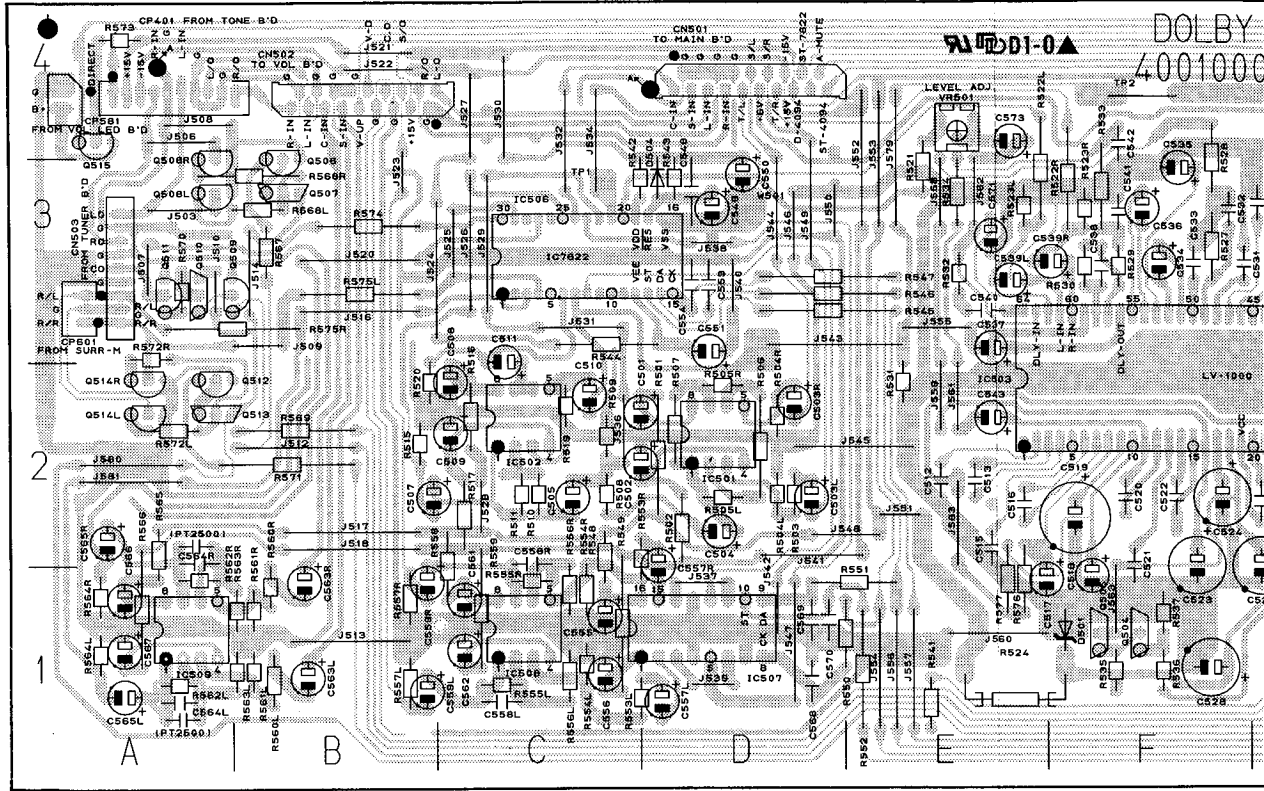

PCB7 (POWER SUPPLY)

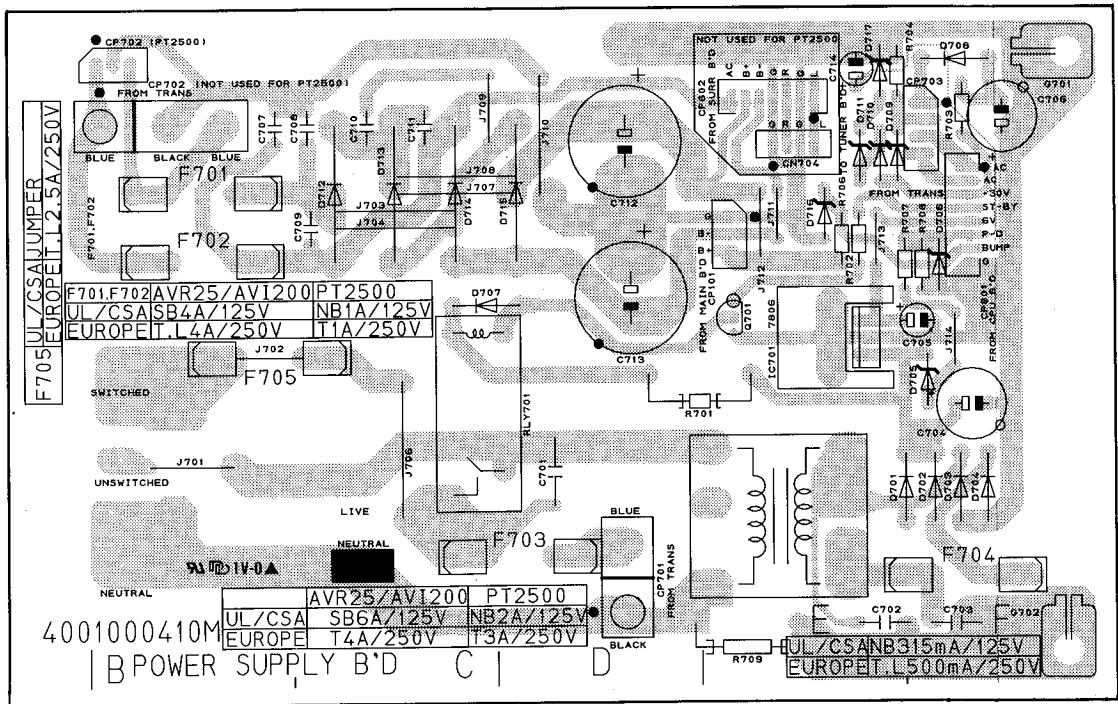

ELECTRICAL PARTS LIST

REF. NO.	DESCRIPTION	MFR. PART NO.	Q'TY	REF. NO.	DESCRIPTION	MFR. PART NO.	Q'TY
PCB1	ASSEMBLY P.C. BOARD MAIN	054002011728			RESISTORS		
	CAPACITORS			R101L/R	METAL FILM	1 kohm 1/5 W J	3029102970 2
C102L/R	CERAMIC TUBULAR	100 pF 50 V J	3519101935 2	R102L/R	CARBON FILM	91 kohm 1/5 W J	3069913970 2
C103L/R	ELECTROLYTIC SG	4.7 uF 50 V M	3479347971 2	R103L/R	CARBON FILM	91 kohm 1/5 W J	3069913970 2
C105L/R	ELECTROLYTIC SG	33 uF 25 V M	3479333041 2	R104L/R	METAL FILM	750 ohm 1/5 W J	3029751970 2
C106L/R	MYLAR	0.0018 uF 100 V J	3679182120 2	R105L/R	CARBON FILM	43 kohm 1/5 W J	3069433970 2
C107L/R	MYLAR	0.0056 uF 100 V J	3679562120 2	R106L/R	CARBON FILM	560 kohm 1/5 W J	3069564970 2
C108L/R	ELECTROLYTIC SG	1 uF 50 V M	3479310971 2	R107L/R	METAL FILM	560 ohm 1/5 W J	3029561970 2
C109L/R	MYLAR	0.0018 uF 100 V J	3679182120 2	R108L/R	CARBON FILM	100 kohm 1/5 W J	3069104970 2
C110/C111	ELECTROLYTIC SG	47 uF 25 V M	3479347041 2	R109/R110	METAL FILM	220 ohm 1/5 W J	3029221970 2
C112	CERAMIC DISC	0.01 uF 50 V Z	3579103530 1	R120L/R	METAL FILM	470 ohm 1/5 W J	3029471970 2
C140	ELECTROLYTIC SG	33 uF 25 V M	3479333041 1	R121L/R	METAL FILM	470 ohm 1/5 W J	3029471970 2
C141	ELECTROLYTIC SG	470 uF 10 V M	3479347121 1	R122L/R	METAL FILM	470 ohm 1/5 W J	3029471970 2
C142	ELECTROLYTIC SG	33 uF 25 V M	3479333041 1	R123L/R	METAL FILM	470 ohm 1/5 W J	3029471970 2
C143-C146	ELECTROLYTIC SG	10 uF 50 V M	3479310071 4	R124L/R	METAL FILM	1 kohm 1/5 W J	3029102970 2
C147/C148	ELECTROLYTIC SG	33 uF 25 V M	3479333041 2	R125L/R	METAL FILM	470 ohm 1/5 W J	3029471970 2
C149	ELECTROLYTIC SG	2.2 uF 50 V M	3479322971 1	R126L/R	METAL FILM	470 ohm 1/5 W J	3029471970 2
C150-C153	ELECTROLYTIC SG	47 uF 25 V M	3479347041 4	R127L/R	CARBON FILM	100 kohm 1/5 W J	3069104970 2
C154	CERAMIC DISC	0.01 uF 50 V Z	3579103530 1	R128L/R	METAL FILM	470 ohm 1/5 W J	3029471970 2
C155	ELECTROLYTIC SG	1 uF 50 V M	3479310971 1	R129L/R	METAL FILM	470 ohm 1/5 W J	3029471970 2
C156/C157	ELECTROLYTIC SG	47 uF 25 V M	3479347041 2	R130L/R	CARBON FILM	100 kohm 1/5 W J	3069104970 2
C158	CERAMIC TUBULAR	1000 pF 50 V J	3519102935 1	R131L/R	METAL FILM	470 ohm 1/5 W J	3029471970 2
C159/C160	CERAMIC TUBULAR	100 pF 50 V J	3519101935 2	R132L/R	CARBON FILM	100 kohm 1/5 W J	3069104970 2
C161	CERAMIC TUBULAR	0.1 uF 50 V Z	3519104935 1	R133-R138	METAL FILM	75 ohm 1/5 W J	3029750970 5
C162L/R	ELECTROLYTIC SG	4.7 uF 50 V M	3479347971 2	R139-R144	METAL FILM	100 ohm 1/5 W J	3029101970 6
C163/C164	ELECTROLYTIC SG	47 uF 25 V M	3479347041 2	R145	METAL FILM	75 ohm 1/5 W J	3029750970 1
C165L/R	ELECTROLYTIC SG	4.7 uF 50 V M	3479347971 2	R146	METAL FILM	10 ohm 1/5 W J	3029100970 1
C166L/R	ELECTROLYTIC SG	10 uF 50 V M	3479310071 2	R147/R148	METAL FILM	100 ohm 1/5 W J	3029101970 2
C167L/R	ELECTROLYTIC SG	10 uF 50 V M	3479310071 2	R149-R152	METAL FILM	3.3 kohm 1/5 W J	3029332970 4
C168/C169	ELECTROLYTIC SG	47 uF 25 V M	3479347041 2	R153/R154	METAL FILM	220 ohm 1/5 W J	3029221970 2
C170/C171	CERAMIC TUBULAR	100 pF 50 V J	3519101935 2	R155	CARBON FILM	100 kohm 1/5 W J	3069104970 1
C172	ELECTROLYTIC SG	47 uF 25 V M	3479347041 1	R156/R157	METAL FILM	220 ohm 1/5 W J	3029221970 2
C173	ELECTROLYTIC SG	1 uF 50 V M	3479310971 1	R161L/R	CARBON FILM	100 kohm 1/5 W J	3069104970 2
C174	ELECTROLYTIC SG	47 uF 25 V M	3479347041 1	R162/R163	METAL FILM	220 ohm 1/5 W J	3029221970 2
C175-C177	ELECTROLYTIC SG	470 uF 10 V M	3479347121 3	R164L/R	CARBON FILM	100 kohm 1/5 W J	3069104970 2
C178	CERAMIC TUBULAR	0.1 uF 50 V Z	3519104935 1	R165L/R	CARBON FILM	100 kohm 1/5 W J	3069104970 2
C179/C180	ELECTROLYTIC SG	10 uF 50 V M	3479310071 2	R166/R167	METAL FILM	220 ohm 1/5 W J	3029221970 2
C201/C202	ELECTROLYTIC SG	220 uF 10 V M	3479322121 2	R168/R169	METAL FILM	100 ohm 1/5 W J	3029101970 2
C203-C205	MYLAR	0.01 uF 100 V J	3679103120 3	R170/R171	METAL FILM	220 ohm 1/5 W J	3029221970 2
C206/C207	MYLAR	0.22 uF 63 V J	3633224187 2	R172	CARBON FILM	100 kohm 1/5 W J	3069104970 1
C208	ELECTROLYTIC SG	4.7 uF 50 V M	3479347971 1	R201/R202	METAL FILM	150 ohm 1 W J	3029151470 2
C209-C212	MYLAR	0.1 uF 63 V J	3633104187 4	R203-R205	CARBON FILM	22 kohm 1/5 W J	3069223970 3
C213/C214	POLY	680 pF 50 V J	3619681110 2	R206	CARBON FILM	10 Mohm 1/5 W J	3069106970 1
C215	ELECTROLYTIC SG	4.7 uF 50 V M	3479347971 1	R207	CARBON FILM	47 kohm 1/5 W J	3069473970 1
C216/C217	MYLAR	0.22 uF 63 V J	3633224187 2	R208	CARBON FILM	15 kohm 1/5 W J	3069153970 1
C218-C221	MYLAR	0.33 uF 63 V J	3633334187 4	R209/R210	CARBON FILM	7.5 kohm 1/5 W J	3069752970 2
C222-C225	MYLAR	0.022 uF 100 V J	3679223120 4	R211	CARBON FILM	47 kohm 1/5 W J	3069473970 1
C226/C227	MYLAR	0.1 uF 63 V J	3633104187 2	R212	CARBON FILM	15 kohm 1/5 W J	3069153970 1
C228	ELECTROLYTIC SG	100 uF 10 V M	3479310121 1	R214-R216	METAL FILM	1 kohm 1/5 W J	3029102970 3
C229	ELECTROLYTIC AH	10 uF 50 V M	3479210064 1	R241	METAL FILM	4.7 ohm 2 W J	3029479572 1
C230-C232	CERAMIC TUBULAR	100 pF 50 V J	3519101935 3	R242/R243	METAL FILM	10 ohm 2 W J	3029100570 2
C233	CERAMIC DISC	0.01 uF 50 V Z	3579103530 1	R2500	METAL FILM	220 ohm 1/5 W J	3029221970 1
C248-C250	ELECTROLYTIC SG	1 uF 50 V M	3479310971 3				
	CONNECTORS				MISCELLANEOUS		
CN101	LEAD ASS'Y, 3P, 200 mm		436103203331 1	36	HEATSINK, REGULATOR TR.(15X45)		7505206220 1
CN102	LEAD ASS'Y, 9P 100 mm		436209103332 1	37	HEATSINK, REGULATOR TR.(15X30)		7505202410 1
CP402	PLUG, S-G1L-05P-S2T2		4428516410 1	38	JACK RCA, 2P		4438108510 1
CP501	PLUG, FPC-8370-19P		4428526310 1	39	JACK RCA, 6P		4438108710 2
CP103	PLUG, ST-5267-03P		4428505710 1	40	JACK RCA, 3P, JE0300390N		4438108830 4
				41	JACK RCA, 2P		4438114210 1
				42	PHONE JACK, YKB21-5130		4438112710 1
					TERMINAL GROUND		4235007310 2
					WIRE HI-WP #24BK FF140		152624101444 1
	DIODES						
D101-D103	1N4148M, SWITCHING		2058322101 3				
D201/D202	ZENER, DZ 6.8BSC		2258599121 2				
D203	1N4148M, SWITCHING		2058322101 1				
	INTEGRATED CIRCUITS						
IC101/IC102	LC7821, AUDIO SIGNAL SWITCHING		2168017132 2	PCB2	ASSEMBLY P.C. BOARD REGULATOR	054002011739	
IC103	GD4052B, AUDIO SIGNAL SWITCHING		2138001114 1	△ IC241	IC, KA7815, REGULATOR		2168602109 1
IC104	BA7625, VIDEO SWITCHING		2168027106 1	CN103	CNT, LEAD ASS'Y, 3P, 140mm		436103143331 1
IC105	MC14094BCP, SHIFT REGISTER		2138009115 1				
IC106	KIA4559P/KIA75559P, OP AMP		2168206104 1	PCB3	ASSEMBLY P.C. BOARD VOLUME	054002011748	
IC107/IC108	NE5532N, OP AMP		2168299100 2		CAPACITORS		
IC109	LC7822, AUDIO SIGNAL SWITCHING		2168017139 1	C301L/R	CERAMIC TUBULAR	470 pF 50 V J	3519471935 2
IC201	SSM-2126A, DOLBY DECODER		2168000122 1	C302L/R	MYLAR	0.33 uF 63 V J	3679334297 2
IC202	MC14094BCP, SHIFT REGISTER		2138009115 1	C303	ELECTROLYTIC SG	47 uF 25 V M	3479347041 1
△ IC242	KA7806, REGULATOR		2168602106 1	C304/C305	ELECTROLYTIC SG	100 uF 10 V M	3479310121 2
△ IC243	KA7915, REGULATOR		2168602114 1	C306	CERAMIC DISC	0.047 uF 50 V Z	3579473530 1
	TRANSISTORS				CONNECTOR		
Q101-Q103	BKTA1266Y/KTA1015Y, PNP		2208206105 3	CP502	PLUG, IL-FPC-A-18P		4428526305 1
					INTEGRATED CIRCUITS		
				IC301	TA7291S, BRIDGE DRIVER		2168007204 1

REF. NO.	DESCRIPTION	MFR. PART NO.	Q'TY	REF. NO.	DESCRIPTION	MFR. PART NO.	Q'TY
RESISTORS							
R301/LR	CARBON FILM	51 kohm 1/5 W J	3069513970	2	C507	ELECTROLYTIC SG	3.3 uF 50 V M
R302/LR	METAL FILM	3.3 kohm 1/5 W J	3029332970	2	C508/C509	ELECTROLYTIC SG	47 uF 25 V M
R303/R304	METAL FILM	3.3 kohm 1/5 W J	3029332970	2	C510	ELECTROLYTIC SG	2.2 uF 50 V M
R305	METAL FILM	33 ohm 1/5 W J	3029330970	1	C511	ELECTROLYTIC SG	3.3 uF 50 V M
R306	CARBON FILM	15 kohm 1/5 W J	3069153970	1	C512	MYLAR	0.15 uF 63 V J
R307	CARBON FILM	4.7 kohm 1/5 W J	3069472970	1	C513	CERAMIC DISC	150 pF 50 V J
MISCELLANEOUS							
W301	WIRE LUG #24BK140		152624101458	1	C514	ELECTROLYTIC SG	220 uF 10 V M
22	SWITCH, SPUL-12X1H091-SUE33		4628059610	1	C515	MYLAR	0.022 uF 100 V J
23	VOLUME MOTOR, RK16314MC1R253B RM094		3228019410	1	C516	POLY	680 pF 50 V J
PCB4 ASSEMBLY P.C BOARD TONE 054002011746							
CAPACITORS							
C402/LR	CERAMIC TUBULAR	22 pF 50 V J	3519220935	2	C522	CERAMIC DISC	150 pF 50 V J
C403/C404	ELECTROLYTIC SG	47 uF 25 V M	3479347041	2	C523-C525	ELECTROLYTIC SG	220 uF 16 V M
C405/LR	ELECTROLYTIC SG	10 uF 50 V M	3479310071	2	C526/C527	CERAMIC TUBULAR	0.1 uF 50 V Z
C406/LR	ELECTROLYTIC SG	10 uF 50 V M	3479310071	2	C528	ELECTROLYTIC SG	220 uF 16 V M
C407/LR	CERAMIC DISC	39 pF 50 V J	3579390130	2	C529	MYLAR	0.22 uF 63 V K
C408	NOT USED!				C530	MYLAR	0.068 uF 100 V J
C409/LR	CERAMIC TUBULAR	39 pF 50 V J	3519390935	2	C531	MYLAR	0.0039 uF 100 V J
C410/LR	ELECTROLYTIC SG	10 uF 50 V M	3479310071	2	C532	MYLAR	0.0047 uF 100 V J
C411/C412	ELECTROLYTIC SG	47 uF 25 V M	3479347041	2	C533	MYLAR	0.033 uF 100 V J
C413/LR	ELECTROLYTIC SG	10 uF 50 V M	3479310071	2	C534	ELECTROLYTIC SG	10 uF 50 V M
C414/LR	MYLAR	0.015 uF 100 V J	3679153120	2	C535	ELECTROLYTIC SG	1 uF 50 V M
C415/LR	MYLAR	0.082 uF 100 V J	3679823120	2	C536/C537	ELECTROLYTIC SG	10 uF 50 V M
C417/LR	MYLAR	0.0018 uF 100 V J	3679182120	2	C538	CERAMIC TUBULAR	560 pF 50 V J
C418/LR	MYLAR	0.015 uF 100 V J	3679153120	2	C539/LR	ELECTROLYTIC SG	10 uF 50 V M
CONNECTORS							
CN401	LEAD ASS'Y, 10P, 220 mm		436210223332	1	C540	CERAMIC TUBULAR	680 pF 50 V J
CN402	LEAD ASS'Y, 5P, 350 mm		436205353332	1	C541	MYLAR	0.0082 uF 100 V J
DIODE							
D401	1N4148M, SWITCHING		2058322101	1	C542	MYLAR	0.0047 uF 100 V J
INTEGRATED CIRCUITS							
IC401/IC402	NE5532N, OP AMP		2168299100	2	C543	ELECTROLYTIC SG	0.47 uF 50 V M
TRANSISTORS							
Q401	BKTA1266Y/KTA1015Y, PNP		2208206105	1	C544	CERAMIC TUBULAR	0.1 uF 50 V Z
Q402	DTC114YS		2208622106	1	C545-C547	CERAMIC TUBULAR	100 pF 50 V J
RESISTORS							
R401/LR	CARBON FILM	100 kohm 1/5 W J	3069104970	2	C548	CERAMIC TUBULAR	0.01 uF 50 V Z
R402/LR	METAL FILM	820 ohm 1/5 W J	3029821970	2	C549	ELECTROLYTIC SG	1 uF 50 V M
R403/LR	CARBON FILM	5.1 kohm 1/5 W J	3069512970	2	C550/C551	ELECTROLYTIC SG	47 uF 25 V M
R404/LR	METAL FILM	560 ohm 1/5 W J	3029561970	2	C553/C554	CERAMIC TUBULAR	100 pF 50 V J
R405/LR	CARBON FILM	100 kohm 1/5 W J	3069104970	2	C555/C556	ELECTROLYTIC SG	47 uF 25 V M
R406/LR	METAL FILM	1 kohm 1/5 W J	3029102970	2	C557/LR	ELECTROLYTIC SG	1 uF 50 V M
R407/LR	CARBON FILM	100 kohm 1/5 W J	3069104970	2	C558/LR	CERAMIC TUBULAR	470 uF 50 V Z
R408/LR	CARBON FILM	82 kohm 1/5 W J	3069823970	2	C559/LR	ELECTROLYTIC SG	3.3 uF 50 V M
R409/LR	CARBON FILM	1 Mohm 1/5 W J	3069105970	2	C561/C562	ELECTROLYTIC SG	47 uF 25 V M
R410/R411	METAL FILM	220 ohm 1/5 W J	3029221970	2	C563/LR	ELECTROLYTIC SG	1 uF 50 V M
R412/LR	METAL FILM	560 ohm 1/5 W J	3029561970	2	C564/LR	MYLAR	0.001 uF 100 V J
R413/LR	CARBON FILM	100 kohm 1/5 W J	3069104970	2	C565/LR	ELECTROLYTIC SG	3.3 uF 50 V M
R414/R415	METAL FILM	220 ohm 1/5 W J	3029221970	2	C566/C567	ELECTROLYTIC SG	47 uF 25 V M
R416/LR	CARBON FILM	22 kohm 1/5 W J	3069223970	2	C568-C570	CERAMIC TUBULAR	100 pF 50 V J
R417/LR	METAL FILM	3.3 kohm 1/5 W J	3029332970	2	C571	ELECTROLYTIC SG	10 uF 50 V M
R418/LR	METAL FILM	3.6 kohm 1/5 W J	3029362970	2	C572	ELECTROLYTIC SG	220 uF 16 V M
R419/LR	CARBON FILM	6.2 kohm 1/5 W J	3069622970	2	C573	ELECTROLYTIC SG	10 uF 50 V M
R420/LR	METAL FILM	1 kohm 1/5 W J	3029102970	2	CONNECTORS		
R421/LR	METAL FILM	1.2 kohm 1/5 W J	3029122970	2	CN501	PLUG, FPC-8370-19P	4428526310
R422/LR	METAL FILM	220 ohm 1/5 W J	3029221970	2	CN502	PLUG, IL-FPC-A-18P	4428526305
R423	CARBON FILM	12 kohm 1/5 W J	3069123970	1	CN503	LEAD ASS'Y, 9P, 350 mm	436209353332
R424	METAL FILM	100 ohm 1/5 W J	3029101970	1	CP401	PLUG, S-G1L-10P-S2T2	4428516910
R425/R426	METAL FILM	3.6 kohm 1/5 W J	3029362970	2	CP581	PLUG, ST-5267-02P	4428508210
R431/LR	METAL FILM	470 ohm 1/5 W J	3029471970	2	CP802	PLUG, FPC-8370-15P	4428526270
MISCELLANEOUS							
RLY401	RELAY, G5V-2-H1		5528040001	1	DIODES		
19	VOLUME, RK16K128000114C RMD41		3208049510	2	D501	ZENER, UZ 12.0BSC	2258599116
20	VOLUME, RK16K118000114H RMM44		3208052010	1	D502-D504	1N4148M, SWITCHING	2058322101
21	JACK RCA, 3P		4438109710	1	INTEGRATED CIRCUITS		
PCB5 ASSEMBLY P.C BOARD DOLBY 054002011733							
CAPACITORS							
C501/C502	ELECTROLYTIC SG	47 uF 25 V M	3479347041	2	IC501/IC502	NE5532N, OP AMP	2168299100
C503/LR	ELECTROLYTIC SG	4.7 uF 50 V M	3479347971	2	IC503	LV-1000NA, TIME DELAY DEVICE	2168017142
C504	ELECTROLYTIC SG	3.3 uF 50 V M	3479333971	1	IC504	uPD61256, DRAM	2138430001
C505	ELECTROLYTIC SG	10 uF 50 V M	3479310071	1	IC505	MC14094BCP, SHIFT REGISTER	2138009115
TRANSISTORS							
Q501	BKTA1266Y/KTA1015Y, PNP		2208206105	1	IC506	LC7822, AUDIO SIGNAL SWITCHING	2168017139
Q502	DTC114YS		2208622106	1	IC507	TC9176P, ELECTRIC VOLUME	2138007124
Q503	KRA107M/DTA114YS, PNP		2238006103	1	IC508/IC509	NE5532N, OP AMP	2168299100
Q504/Q505	DTC114YS		2208622106	2	CONNECTORS		
Q506	KTC3198Y/KTC1815Y, NPN		2208606104	1	Q501	BKTA1266Y/KTA1015Y, PNP	2208206105
Q507	KRA107M/DTA114YS, PNP		2238006103	1	Q502	DTC114YS	2208622106
Q508/LR	KTD1302, NPN		2208606112	2	Q503	KRA107M/DTA114YS, PNP	2238006103
Q509	KTC3198Y/KTC1815Y, NPN		2208606104	1	Q504	KRA107M/DTA114YS, PNP	2238006103
Q510	KRA107M/DTA114YS, PNP		2238006103	1	Q505	KTD1302, NPN	2208606112
Q511	KTD1302, NPN		2208606112	1	Q506	KTC3198Y/KTC1815Y, NPN	2208606104

REF. NO.	DESCRIPTION	MFR. PART NO.	Q'TY	REF. NO.	DESCRIPTION	MFR. PART NO.	Q'TY
Q512	KTC3198Y/KTC1815Y, NPN	2208606104	1	C704	ELECTROLYTIC SG	1000	uF 16 V M
Q513	KRA107M/DTA114YS, PNP	2238006103	1	C705	ELECTROLYTIC SG	1	uF 50 V M
Q514/LR	KTD1302, NPN	2208606112	2	C706	ELECTROLYTIC SG	100	uF 50 V M
Q515	KTC3198Y/KTC1815Y, NPN	2208606104	1	C707-C711	MYLAR	0.047	uF 100 V J
				C712	ELECTROLYTIC SG	1000	uF 35 V M
				C713	ELECTROLYTIC SG	1000	uF 35 V M
	RESISTORS				CONNECTORS		
R501/R502	METAL FILM	100 ohm 1/5 W J	3029101970	2			
R503	CARBON FILM	10 kohm 1/5 W J	3069103970	1	CP101	PLUG, ST-5267-03P	4428505710
R504L	CARBON FILM	10 kohm 1/5 W J	3069103970	1	CP701	PLUG, AC S-2P	4428525780
R504R	CARBON FILM	22 kohm 1/5 W J	3069223970	1	CP702	PLUG, ST-5267-03P	4428505710
R505L/R	CARBON FILM	22 kohm 1/5 W J	3069223970	2	CP703	PLUG, ST-5267-04P	4428505610
R506	CARBON FILM	22 kohm 1/5 W J	3069223970	1	CP801	PLUG, G-G1L-08P-S2T2	4428516710
R507	METAL FILM	1.5 kohm 1/5 W J	3029152970	1			
R508	METAL FILM	750 ohm 1/5 W J	3029751970	1			
R509	METAL FILM	1.8 kohm 1/5 W J	3029182970	1			
R510	METAL FILM	3.9 kohm 1/5 W J	3029392970	1	△ D701-D704	1N4002, RECTIFIER	2258100135
R511	METAL FILM	4.7 kohm 1/5 W J	3029472970	1	D705/D706	ZENER, UZ 5.1BSB	2258599103
R515	METAL FILM	3.3 kohm 1/5 W J	3029332970	1	D707/D708	1N4002, RECTIFIER	2258100135
R516/R517	METAL FILM	100 ohm 1/5 W J	3029101970	2	D709	ZENER, UZ 7.5BSC	2258599130
R519	CARBON FILM	10 kohm 1/5 W J	3069103970	1	△ D710/D711	ZENER, UZ 9.1BSC	2258599107
R520	CARBON FILM	100 kohm 1/5 W J	3069104970	1	△ D712-D715	1N5402, RECTIFIER	2058100136
R521	METAL FILM	3.9 kohm 1/5 W J	3029392970	1	D716	ZENER, UZ 5.1BSB	2258599103
R522L/R	CARBON FILM	6.8 kohm 1/5 W J	3069682970	2	D717	ZENER, UZ 9.1BSC	2258599107
R523L/R	CARBON FILM	100 kohm 1/5 W J	3069104970	2			
R524	METAL FILM	56 ohm 1 W J	3029560470	1			
R525	METAL FILM	56 ohm 1/5 W J	3029560970	1	△ IC701	KA7806, REGULATOR	2168602106
R526	CARBON FILM	1 Mohm 1/5 W J	3069105970	1			
R527	CARBON FILM	47 kohm 1/5 W J	3069473970	1			
R528	METAL FILM	3.3 kohm 1/5 W J	3029332970	1	Q701	KTC3206Y, NPN	2208606118
R529	CARBON FILM	15 kohm 1/5 W J	3069153970	1			
R530	CARBON FILM	8.2 kohm 1/5 W J	3069822970	1			
R531	CARBON FILM	100 kohm 1/5 W J	3069104970	1	R701	METAL FILM	10 ohm 1 W J
R532	CARBON FILM	39 kohm 1/5 W J	3069393970	1	R702	CARBON FILM	2 kohm 1/5 W J
R533/R534	CARBON FILM	8.2 kohm 1/5 W J	3069822970	2	R703	METAL FILM	330 ohm 1/5 W J
R535	CARBON FILM	47 kohm 1/5 W J	3069473970	1	R704	CARBON FILM	15 kohm 1/5 W J
R536	CARBON FILM	5.6 kohm 1/5 W J	3069562970	1	R706	CARBON FILM	6.8 kohm 1/5 W J
R537	METAL FILM	1 kohm 1/5 W J	3029102970	1	R707	METAL FILM	1 kohm 1/5 W J
R538	CARBON FILM	10 kohm 1/5 W J	3069103970	1	R708	CARBON FILM	10 kohm 1/5 W J
R539-R541	METAL FILM	1 kohm 1/5 W J	3029102970	3	R709	ERC-12UGK335	3.3 Mohm 1/2 W J
R542	METAL FILM	220 ohm 1/5 W J	3029221970	1			
R543	CARBON FILM	100 kohm 1/5 W J	3069104970	1			
R544	METAL FILM	220 ohm 1/5 W J	3029221970	1	△ F701	GMA 1A, 125V	5508202021
R545-R547	METAL FILM	1 kohm 1/5 W J	3029102970	3	△ F702	GMA 1A, 125V	5508202021
R548/R549	METAL FILM	220 ohm 1/5 W J	3029221970	2	△ F703	GMA 2A, 125V	5508202421
R550-R552	METAL FILM	1 kohm 1/5 W J	3029102970	3	△ F704	GMA 315mA 125V	5508201421
R553L/R	METAL FILM	680 ohm 1/5 W J	3029681970	2			
R554L/R	CARBON FILM	1 Mohm 1/5 W J	3069105970	2			
R555L/R	CARBON FILM	10 kohm 1/5 W J	3069103970	2	RLY701	RELAY, HR-CR313 (TV-8)	5528042002
R556L/R	METAL FILM	2.2 kohm 1/5 W J	3029222970	2	G701	TERMINAL GROUND	4235007310
R557L/R	CARBON FILM	2 kohm 1/5 W J	3069202970	2	G702	TERMINAL GROUND	4235007310
R558/R559	METAL FILM	100 ohm 1/5 W J	3029101970	2	53	HEATSINK, REGULATOR TR.(15X30)	7505206210
R560L/R	METAL FILM	680 ohm 1/5 W J	3029681970	2	55	△ AC OUTLET, CCT1306-0212	4448102910
R561L/R	CARBON FILM	1 Mohm 1/5 W J	3069105970	2		△ ST-BY TRANS, 120V, 60Hz	2828089007
R562L/R	METAL FILM	4.7 kohm 1/5 W J	3029472970	2		PIN SOLDER	4228001410
R563L/R	METAL FILM	1.5 kohm 1/5 W J	3029152970	2		CLIP FUSE	4255001010
R564L/R	CARBON FILM	2 kohm 1/5 W J	3069202970	2			
R565/R566	METAL FILM	100 ohm 1/5 W J	3029101970	2			
R567	METAL FILM	2.2 kohm 1/5 W J	3029222970	1	PCB8 ASSEMBLY P.C.BOARD FRONT	054002011731	
R568L/R	METAL FILM	2.2 kohm 1/5 W J	3029222970	2			
R569-R571	METAL FILM	2.2 kohm 1/5 W J	3029222970	3	C801	ELECTROLYTIC	0.047 F 5.5 V
R572L/R	METAL FILM	2.2 kohm 1/5 W J	3029222970	2	C802	ELECTROLYTIC SG	47 uF 25 V M
R573	METAL FILM	820 ohm 1/5 W J	3029821970	1	C803	CERAMIC TUBULAR	0.1 uF 50 V Z
R574	METAL FILM	2.2 kohm 1/5 W J	3029202970	1	C804	ELECTROLYTIC SG	10 uF 50 V M
R575L/R	METAL FILM	2.2 kohm 1/5 W J	3029202970	2	C805	ELECTROLYTIC SG	0.1 uF 50 V M
R576/R577	CARBON FILM	220 kohm 1/5 W J	3069224970	2	C806	ELECTROLYTIC SG	33 uF 25 V M
					C807-C814	CERAMIC TUBULAR	100 pF 50 V J
					C815/C816	CERAMIC TUBULAR	0.047 uF 50 V Z
					C817-C821	CERAMIC TUBULAR	100 pF 50 V J
					C822	CERAMIC TUBULAR	0.1 uF 50 V Z
					C824	CERAMIC TUBULAR	0.1 uF 50 V Z
VR501	SEMI FIXED RESISTOR						
	SEMI, EVN-DCAA03B14	3248010353	1				
	MISCELLANEOUS						
X-TAL501	RESONATOR, CST8.00MTW-TF01	3938124009	1				
	WIRE HI-WP #24BK FF120	152624101244	1				
	WIRE LUG #24BK140	152624101458	1				
	PCB6 ASSEMBLY P.C.BOARD VOLUME LED	054002011737					
CNT581	CNT, LEAD ASS'Y, 2P, 140mm	435102143481	1				
LED581	LED, SLR40MG3	2308220324	1				
	PCB7 ASSEMBLY P.C.B POWER SUPPLY	054002011744					
	CAPACITORS						
C701	CERAMIC DISC	0.0047 uF 400 V Z	3549472108	1			
C702/C703	CERAMIC TUBULAR	0.047 uF 50 V Z	3519473935	2			
					CONNECTORS		
					CN801	LEAD ASS'Y, 8P 350 mm	436208353332
					CN802	PLUG, FPC-8370-15P	4428526690
					CN803	PLUG, IL-FPC-B-12P	4428526246
					DIODES		
					D801-D816	1N4148M, SWITCHING	2058322101
					LED801	LED, SPR54MDW3, GREEN/AMBER	2308222205
					INTEGRATED CIRCUIT		
					IC801	CXP82220-107Q, CPU	2138322182

REF. NO.	DESCRIPTION	MFR. PART NO.	Q'TY	REF. NO.	DESCRIPTION	MFR. PART NO.	Q'TY				
TRANSISTORS				TC901	TRIMMER, 20P	3838001160	1				
Q801	MPSA06Y, NPN	2208606114	1	TC902	TRIMMER, 10P	3838001150	1				
Q802	KTC3198Y/KTC1815Y, NPN	2208606104	1	FILTERS							
Q803	KRA107M/DTA114YS, PNP	2238006103	1	CF1/CF2	CERAMIC, SFE 10.7MS3GH-ATF21	3978011011	2				
RESISTORS				CF3	CERAMIC, SFZ450B	3908001150	1				
R801	CARBON FILM	10 kohm	1/5 W J	3069103970	1	CF4	CERAMIC, BFU450C4N	3908001020	1		
R802	METAL FILM	180 ohm	1/5 W J	3029181970	1	CF5	RESONATOR, CSB456F11	3938001009	1		
R803	METAL FILM	150 ohm	1/5 W J	3029151970	1	CF6	X-TAL, HC49U T 7.2MHZ CL12PF	3938223003	1		
R804	CARBON FILM	22 kohm	1/5 W J	3069223970	1	CONNECTORS					
R805	CARBON FILM	47 kohm	1/5 W J	3069473970	1	CP102	PLUG, GIL-09P-S2L2-EF	4428525590	1		
R806	CARBON FILM	10 kohm	1/5 W J	3069103970	1	CP501	PLUG, S-G1L-09P-S2T2	4428516810	1		
R807-R814	METAL FILM	1 kohm	1/5 W J	3029102970	8	CP803	PLUG, IL-FPC-A-12P	4428526245	1		
R815-R822	CARBON FILM	47 kohm	1/5 W J	3069473970	8	DIODES					
R823	CARBON FILM	220 kohm	1/5 W J	3069224970	1	D817	1N4148M, SWITCHING	2058322101	1		
R825	METAL FILM	3.3 kohm	1/5 W J	3029332970	1	D901-D905	1N4148M, SWITCHING	2058322101	5		
R827-R831	METAL FILM	100 ohm	1/5 W J	3029101970	5	D906	ZENER, UZ 5.1BSB	2258599103	1		
R832	METAL FILM	1 kohm	1/5 W J	3029102970	1	D907-D908	1N4148M, SWITCHING	2058322101	2		
R834/R835	CARBON FILM	47 kohm	1/5 W J	3069473970	2	VD901	VARACTOR, KV1236Z	2058819106	1		
R836	METAL FILM	470 ohm	1/5 W J	3029471970	1	INTEGRATED CIRCUITS					
R837	METAL FILM	1 kohm	1/5 W J	3029102970	1	IC802	LTV817, PHOTO-COUPLER	2408000136	1		
R838	METAL FILM	330 ohm	1/5 W J	3029331970	1	IC901	LM7001, PLL	2138017112	1		
R839	CARBON FILM	47 kohm	1/5 W J	3069473970	1	IC902	LA1266, AM/FM IF	2168017128	1		
R844/R845	METAL FILM	3.3 ohm	1/5 W J	3029339970	2	IC903	LA3410, MPX	2168417117	1		
RESONATOR				COILS							
X-TAL801	RESONATOR, CST10.00MTW-TF01	3938124010	1	L906/LR	FILTER, MPX, BLACK	2658001050	2				
MISCELLANEOUS				L901	AM ANT	2608201120	1				
14	SPONGE RUBBER	6715020730	1	L902	AM OSC	2638201150	1				
24	SWITCH, SPEA-122SC011-SU504	4628054410	1	L903	DET (A) FM, K5713FKG	2628000100	1				
25	SWITCH, SKHV10910D01-KB581	4658003710	38	L904	DET (B) FM, K5714X	2628000110	1				
26	REMOTE SENSOR, TFMT5380 (38 kHz)	2408005001	1	L905	AM IFT, P-7SB	2848001250	1				
27	FL DISPLAY, FIP12LM8	2328130301	1	TRANSISTORS							
PCB9 ASSEMBLY P.C. BOARD TUNER 054002011742				Q901	KTC1923Y/KTC3194Y, NPN	2208406103	1				
CAPACITORS				Q902	KTC2240BL/KTC3200, NPN	2208606108	1				
C825	ELECTROLYTIC SG	47 uF	25 V M	3479347041	1	Q903	FET, 2SK168D, N-CH.	2218211100	1		
C901	CERAMIC TUBULAR	0.01 uF	50 V Z	3519103935	1	Q904/Q905	KRA107M/DTA114YS, PNP	2238006103	2		
C902	ELECTROLYTIC SG	100 uF	16 V M	3479310131	1	Q906	BKTA1266Y/KTA1015Y, PNP	2208206105	1		
C903	ELECTROLYTIC SG	0.47 uF	50 V M	3479347871	1	Q907	KRA107M/DTA114YS, PNP	2238006103	1		
C904	CERAMIC TUBULAR	0.01 uF	50 V Z	3519103935	1	Q908/LR	KTD1302, NPN	2208606112	2		
C905	CERAMIC TUBULAR	2200 uF	16 V Z	3519222915	1	Q909	KTC3198Y/KTC1815Y, NPN	2208606104	1		
C906	POLY	470 pF	50 V J	3619471110	1	RESISTORS					
C907	CERAMIC TUBULAR	2200 uF	16 V Z	3519222915	1	R840	METAL FILM	100 ohm	1/5 W J	3029101970	1
C908	CERAMIC TUBULAR	10 pF	50 V J	3519100935	1	R841	CARBON FILM	47 kohm	1/5 W J	3069473970	1
C909	CERAMIC TUBULAR	0.01 uF	50 V Z	3519103935	1	R842	METAL FILM	47 ohm	1/5 W J	3029470970	1
C910/C911	CERAMIC TUBULAR	2200 uF	16 V Z	3519222915	2	R843	CARBON FILM	270 ohm	1/5 W J	3069271970	1
C912	ELECTROLYTIC SG	4.7 uF	50 V M	3479347971	1	R844	METAL FILM	3.9 kohm	1/5 W J	3029392970	1
C913	CERAMIC TUBULAR	2200 uF	16 V Z	3519222915	1	R901	CARBON FILM	56 kohm	1/5 W J	3069563970	1
C914	CERAMIC TUBULAR	47 pF	50 V J	3519470935	1	R902	CARBON FILM	100 kohm	1/5 W J	3069104970	1
C915/C916	CERAMIC DISC	0.047 uF	50 V Z	3579473530	2	R903	METAL FILM	560 ohm	1/5 W J	3029561970	1
C917	ELECTROLYTIC SG	2.2 uF	50 V M	3479322971	1	R904	METAL FILM	180 ohm	1/5 W J	3029181970	1
C918	ELECTROLYTIC SG	4.7 uF	50 V M	3479347971	1	R905	METAL FILM	3.3 kohm	1/5 W J	3029332970	1
C919	CERAMIC TUBULAR	0.01 uF	50 V Z	3519103935	1	R906	METAL FILM	470 ohm	1/5 W J	3029471970	1
C920	ELECTROLYTIC SG	47 uF	25 V M	3479347041	1	R907/R908	METAL FILM	330 ohm	1/5 W J	3029331970	2
C921	ELECTROLYTIC SG	2.2 uF	50 V M	3479322971	1	R909	METAL FILM	560 ohm	1/5 W J	3029561970	1
C922	ELECTROLYTIC SG	3.3 uF	50 V M	3479333971	1	R910/R911	METAL FILM	180 ohm	1/5 W J	3029181970	2
C923	ELECTROLYTIC SG	10 uF	50 V M	3479310071	1	R912	METAL FILM	3.3 kohm	1/5 W J	3029332970	1
C924	CERAMIC TUBULAR	0.047 uF	50 V Z	3519473935	1	R913	CARBON FILM	5.6 kohm	1/5 W J	3069562970	1
C925	CERAMIC TUBULAR	330 pF	50 V J	3519331935	1	R914	CARBON FILM	47 kohm	1/5 W J	3069473970	1
C926	MYLAR	0.047 uF	100 V J	3679473120	1	R915/R916	CARBON FILM	100 kohm	1/5 W J	3069104970	2
C927	CERAMIC TUBULAR	330 pF	50 V J	3519331935	1	R917	CARBON FILM	68 kohm	1/5 W J	3069683970	1
C931	ELECTROLYTIC SG	4.7 uF	50 V M	3479347971	1	R918	CARBON FILM	43 kohm	1/5 W J	3069432970	1
C932	ELECTROLYTIC SG	220 uF	16 V M	3479322131	1	R919	CARBON FILM	10 kohm	1/5 W J	3069103970	1
C933	CERAMIC TUBULAR	0.01 uF	50 V Z	3519103935	1	R920	CARBON FILM	24 kohm	1/5 W J	3069243970	1
C934/C935	ELECTROLYTIC SG	0.47 uF	50 V M	3479347871	2	R921	CARBON FILM	6.8 kohm	1/5 W J	3069682970	1
C936	ELECTROLYTIC SG	1 uF	50 V M	3479310971	1	R922	METAL FILM	82 ohm	1/5 W J	3029820970	1
C937	MYLAR	0.047 uF	100 V J	3679473120	1	R925	METAL FILM	1.8 kohm	1/5 W J	3029182970	1
C938	CERAMIC TUBULAR	680 pF	50 V J	3519681935	1	R926	CARBON FILM	100 kohm	1/5 W J	3069104970	1
C939	ELECTROLYTIC SG	10 uF	50 V M	3479310071	1	R927-R929	METAL FILM	330 ohm	1/5 W J	3029331970	3
C940/LR	POLY	390 pF	50 V J	3619391110	2	R930	METAL FILM	1 kohm	1/5 W J	3029102970	1
C941/LR	ELECTROLYTIC SG	2.2 uF	50 V M	3479322971	2	R931/LR	CARBON FILM	180 kohm	1/5 W J	3069184970	2
C943	CERAMIC TUBULAR	0.01 uF	50 V Z	3519103935	1	R932/LR	CARBON FILM	150 kohm	1/5 W J	3069154970	2
C944	ELECTROLYTIC SG	47 uF	25 V M	3479347041	1	R933/LR	METAL FILM	3.3 kohm	1/5 W J	3029332970	2
C945	ELECTROLYTIC SG	1 uF	50 V M	3479310971	1	R934/LR	METAL FILM	3.3 kohm	1/5 W J	3029332970	2
C946	CERAMIC TUBULAR	2200 uF	16 V Z	3519222915	1	R935/LR	METAL FILM	3.3 kohm	1/5 W J	3029332970	2
C947/C948	CERAMIC TUBULAR	0.01 uF	50 V Z	3519103935	2	R936	METAL FILM	1 kohm	1/5 W J	3029102970	1
C949	ELECTROLYTIC SG	47 uF	25 V M	3479347041	1	R937	METAL FILM	1.5 kohm	1/5 W J	3029152970	1
C950	CERAMIC TUBULAR	270 pF	50 V J	3519271935	1	R938	METAL FILM	82 ohm	1/5 W J	3029820970	1
C951	CERAMIC TUBULAR	100 pF	50 V J	3519101935	1	R939	METAL FILM	820 ohm	1/5 W J	3029821970	1
C954/C955	CERAMIC DISC (CH)	18 pF	50 V J	3528180210	2						
C965-C967	CERAMIC TUBULAR	0.1 uF	50 V Z	3519104935	3						

REF. NO.	DESCRIPTION	MFR. PART NO.	Q'TY
R940-R942	METAL FILM	330 ohm 1/5 W J	3029331970 3
R943-R945	METAL FILM	100 ohm 1/5 W J	3029101970 3
R946	METAL FILM	2.7 kohm 1/5 W J	3029272970 1
R947/R948	CARBON FILM	270 ohm 1/5 W J	3069271970 2
R949/R950	METAL FILM	4.7 kohm 1/5 W J	3029472970 2
R951/R952	CARBON FILM	10 kohm 1/5 W J	3069103970 2
R955	CARBON FILM	100 kohm 1/5 W J	3069104970 1
R956	METAL FILM	3.3 kohm 1/5 W J	3029332970 1
R957	CARBON FILM	47 kohm 1/5 W J	3069473970 1
R958	CARBON FILM	10 kohm 1/5 W J	3069103970 1
R960L/R	METAL FILM	1 kohm 1/5 W J	3029102970 2
R961L/R	METAL FILM	1 kohm 1/5 W J	3029102970 2
R962C	METAL FILM	1 kohm 1/5 W J	3029102970 1
R963L/R	METAL FILM	1 kohm 1/5 W J	3029102970 2

SEMI FIXED RESISTORS			
VR901	SEMI, EVN-DJAA03B54	3248050343	1
VR902	SEMI, EVN-DJAA03B54	3248050343	1
VR903	SEMI, EVM-DJAA03B25	3248020443	1

MISCELLANEOUS			
FE901	FM TUNER, FE407-A15	3928801970	1
G901	TERMINAL GROUND	4235007310	1
43	JACK, HSJ0912-01-052	4438006510	2
44	JACK RCA, 4P	4438108610	2
45	TERMINAL ANTENNA	4408108320	1

IC FUNCTIONAL BLOCK DIAGRAM

GD4052B : IC103 (Audio Signal Switching)

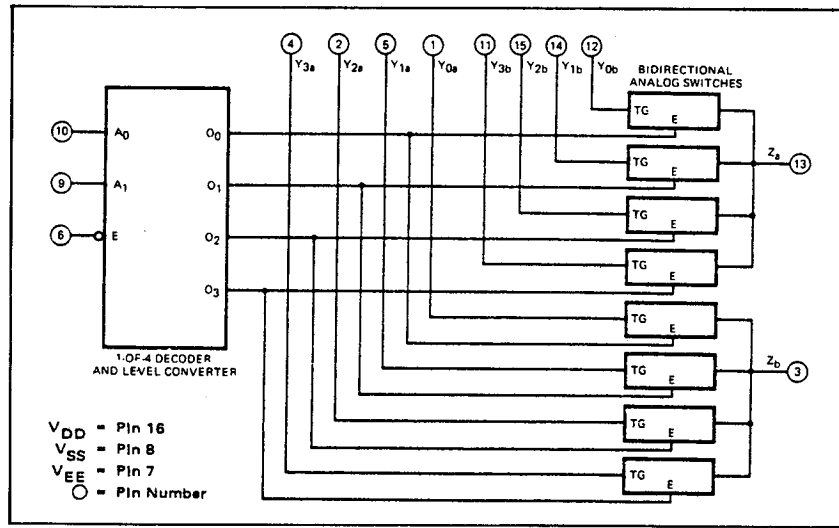

KIA4559P/KIA75559P : IC106 (OP-Amp)

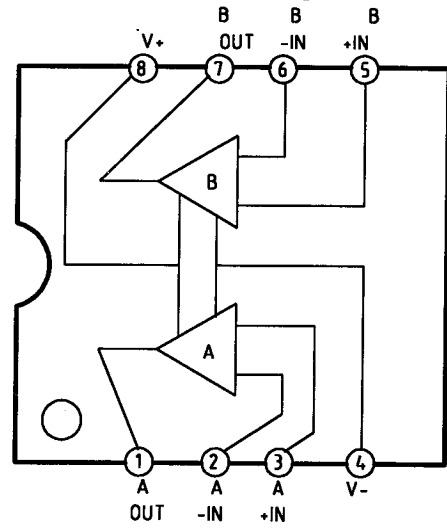

TC9176P : IC507 (Electronic Volume)

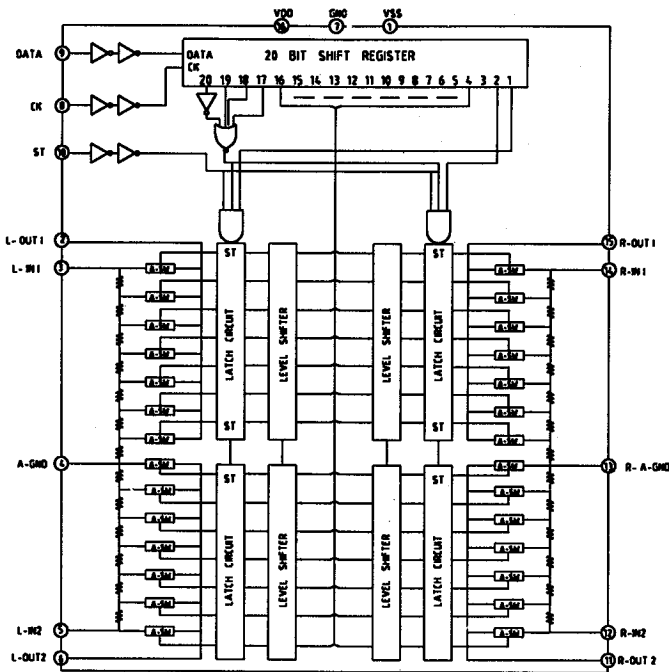

KA7915 : IC243 (Regulator)

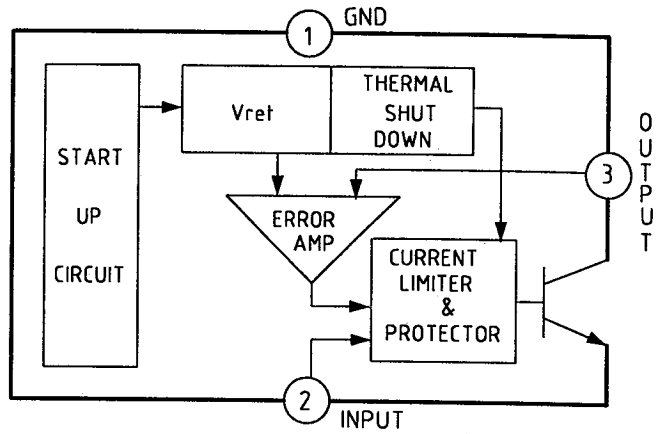

KA7806 : IC242, IC701, IC241 (Regulator)

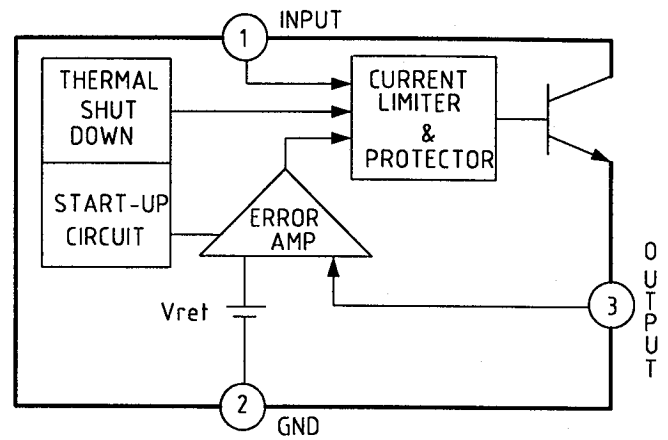

LV-1000NA : IC503 (Time Delay Device)

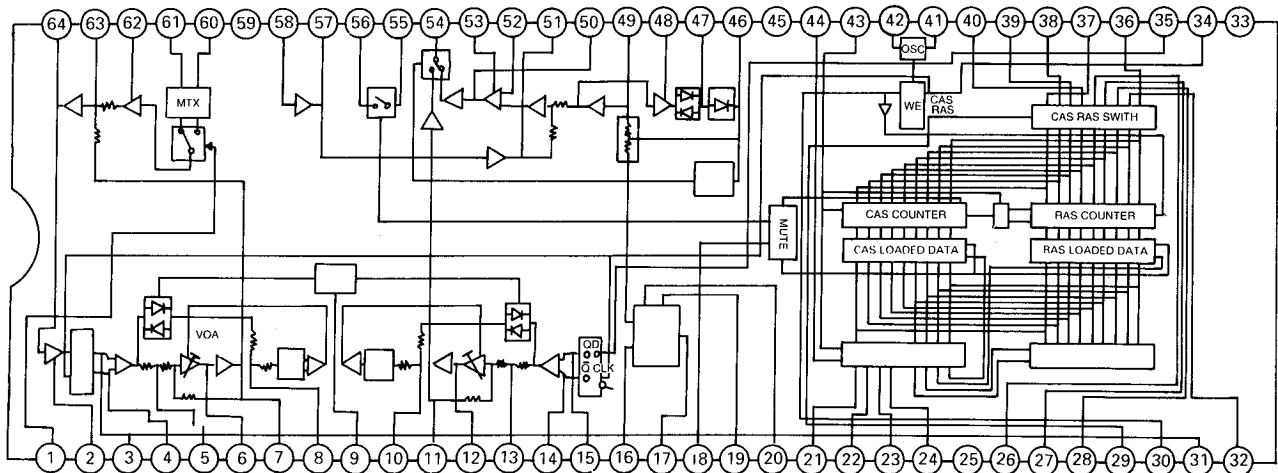

MC14094BCP : IC105, IC202, IC505 (Shift Register)

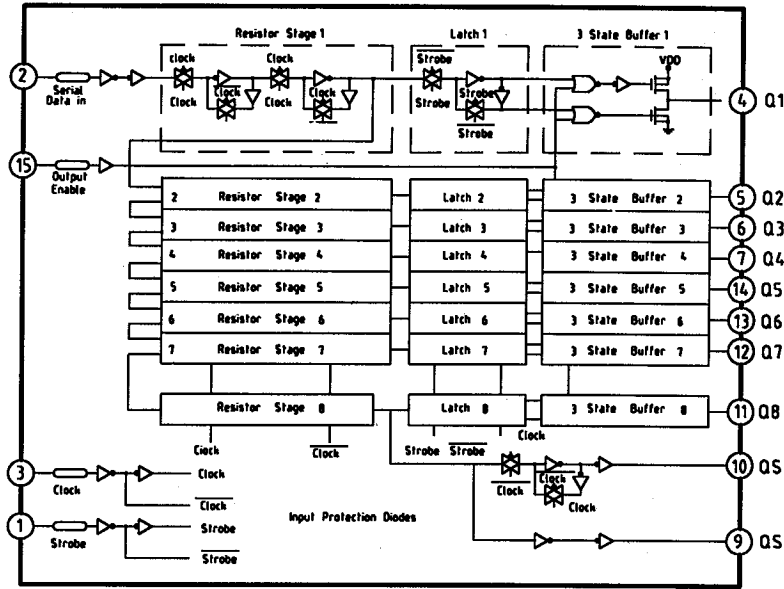

TA7291S : IC301 (Bridge Driver)

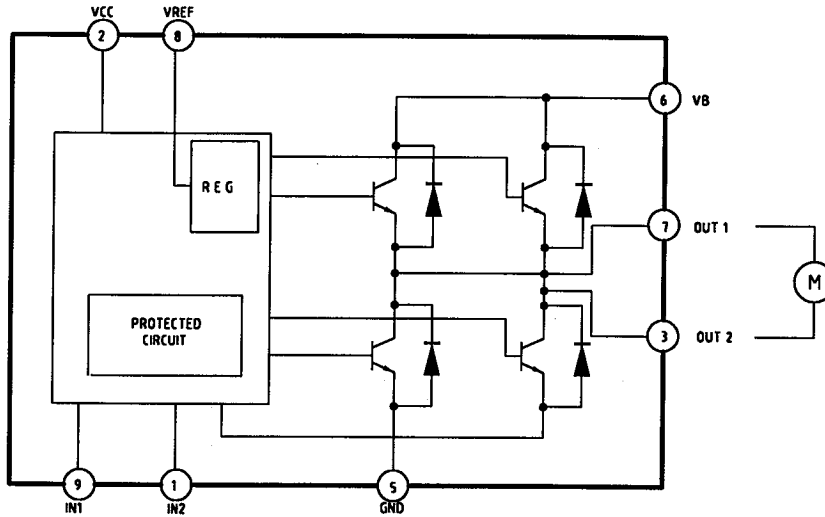

LA3410 : IC903 (MPX)

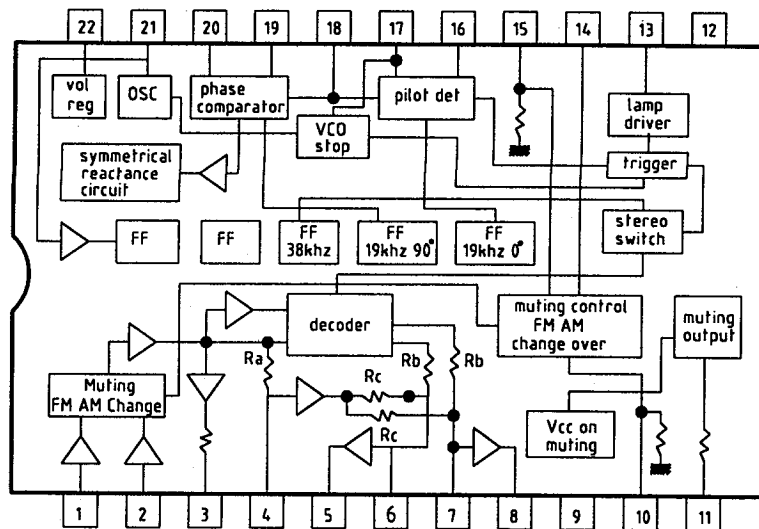

LC7822 : IC109, IC506 (Audio Signal Switching)

BA7625 : IC104 (Video Switching)

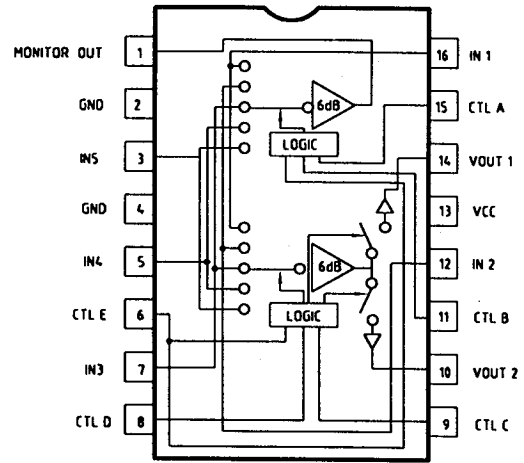
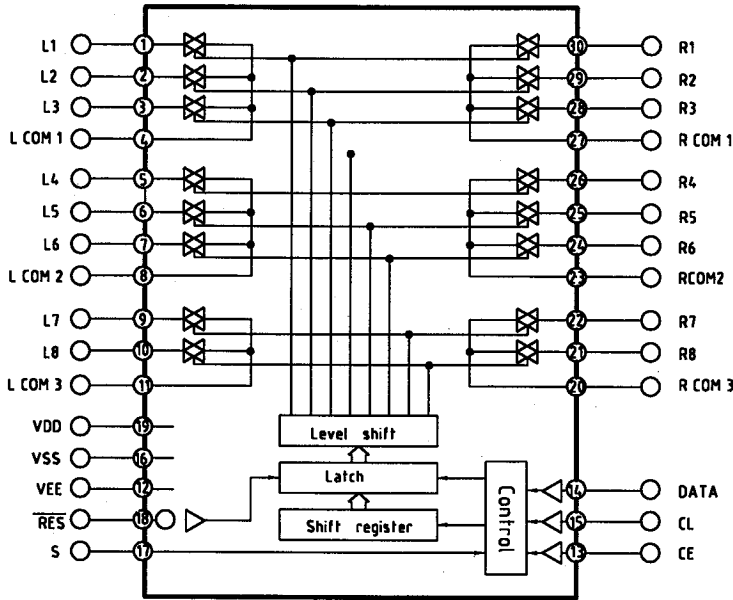

SSM-2126A : IC201 (Dolby Decoder)

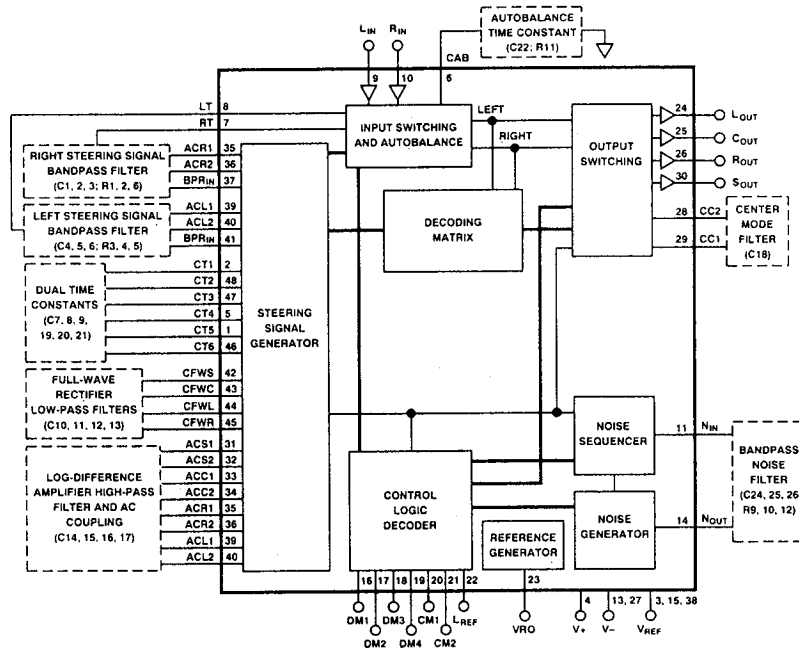

LA1266 : IC902 (AM/FM IF)

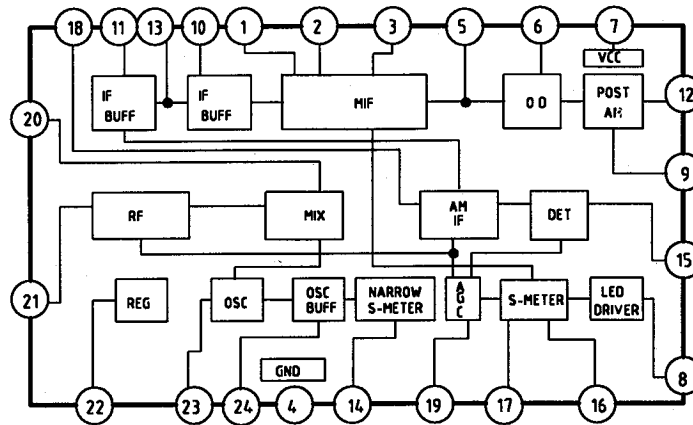

LM7001 : IC901 (PLL)

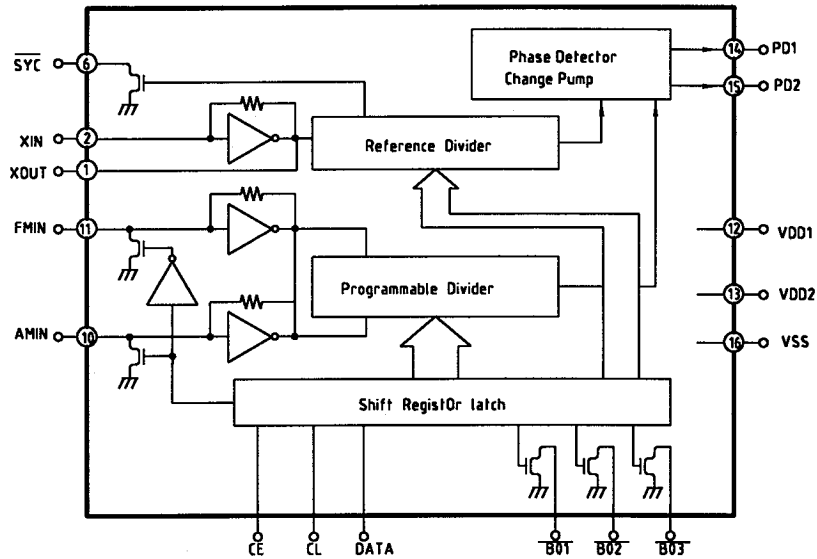

LC7821 : IC101, IC102 (Audio Signal Switching)

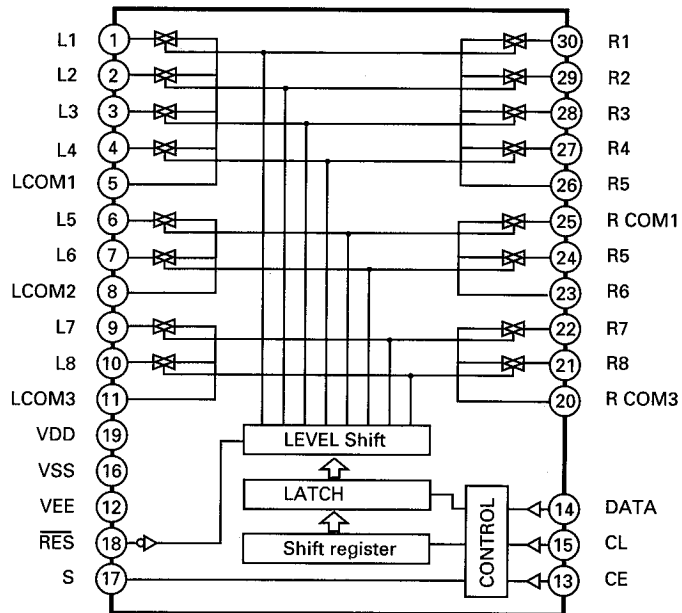

FE901 FE407-A15

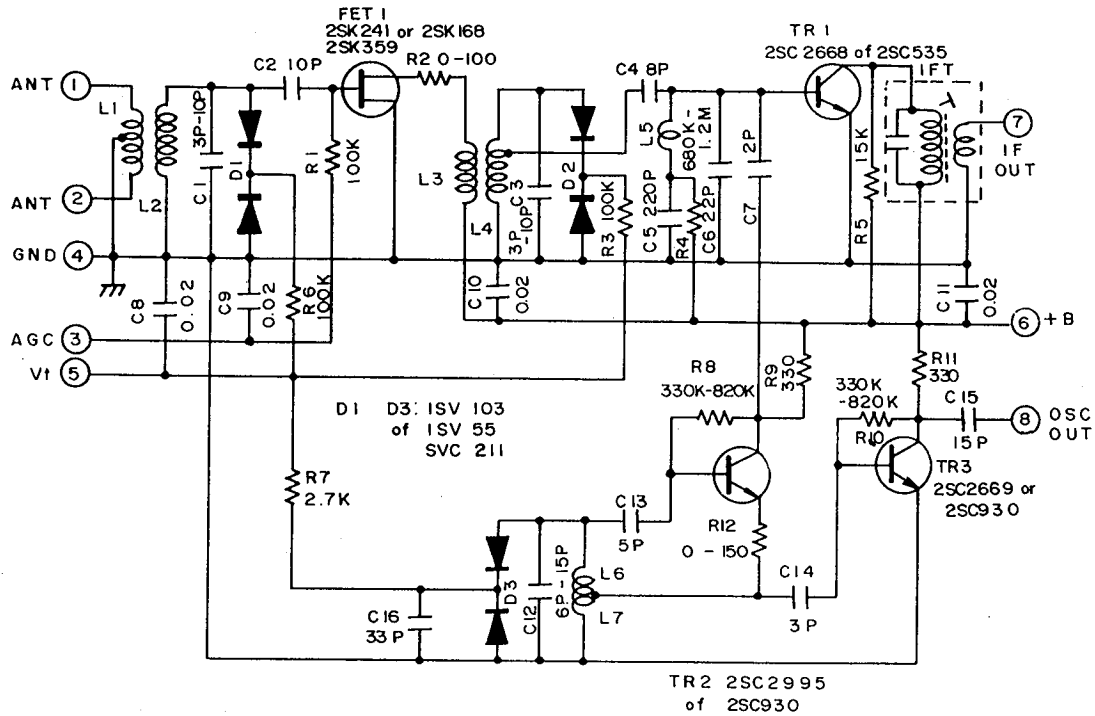

NE5532N : IC107, IC108, IC401, IC402, IC501, IC502, IC508, IC509 (OP-Amp)

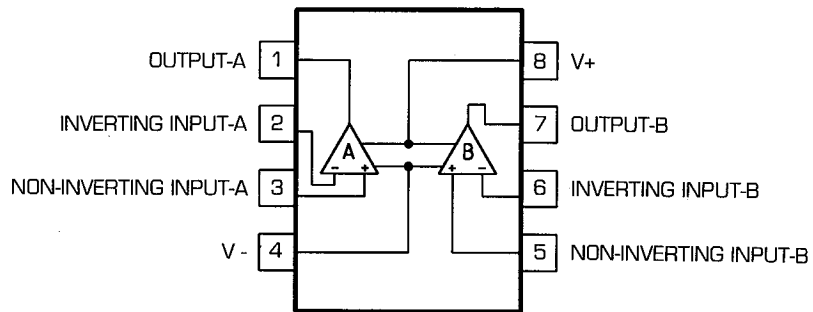

WIRING DIAGRAM

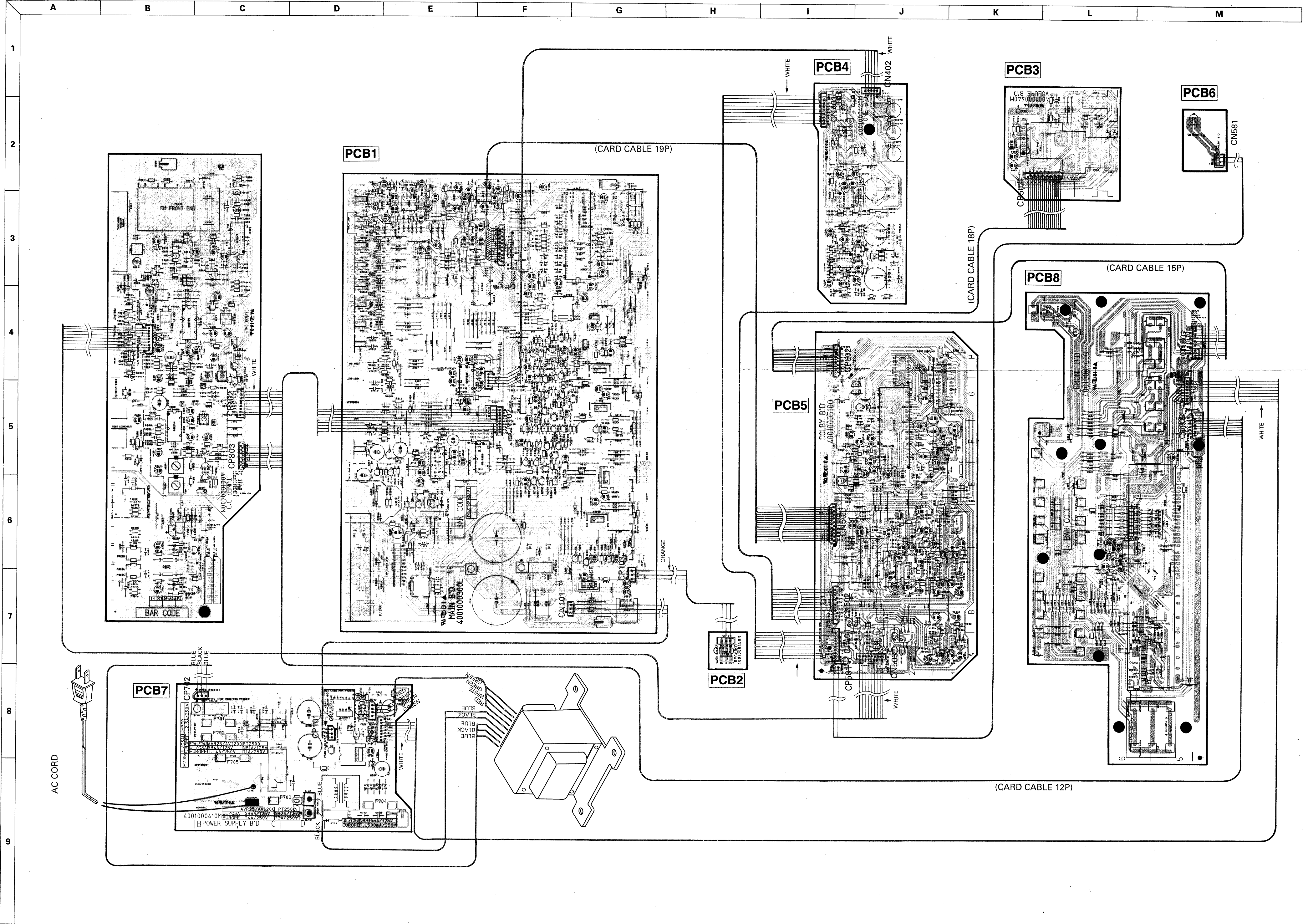

WIRING DIAGRAM

A B C D E

1

2

3

4

5

6

PCB1

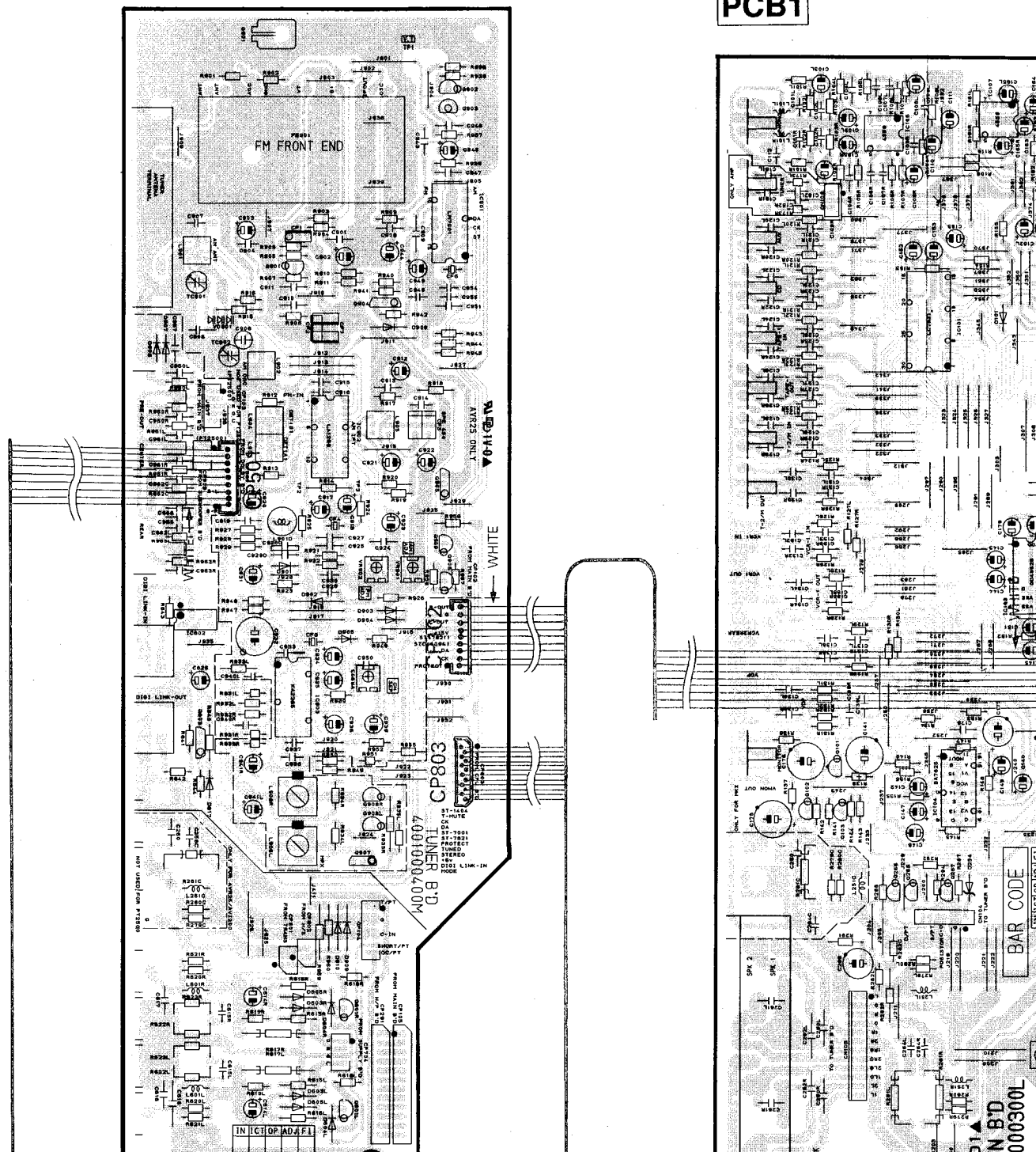

E

F

G

H

I

J

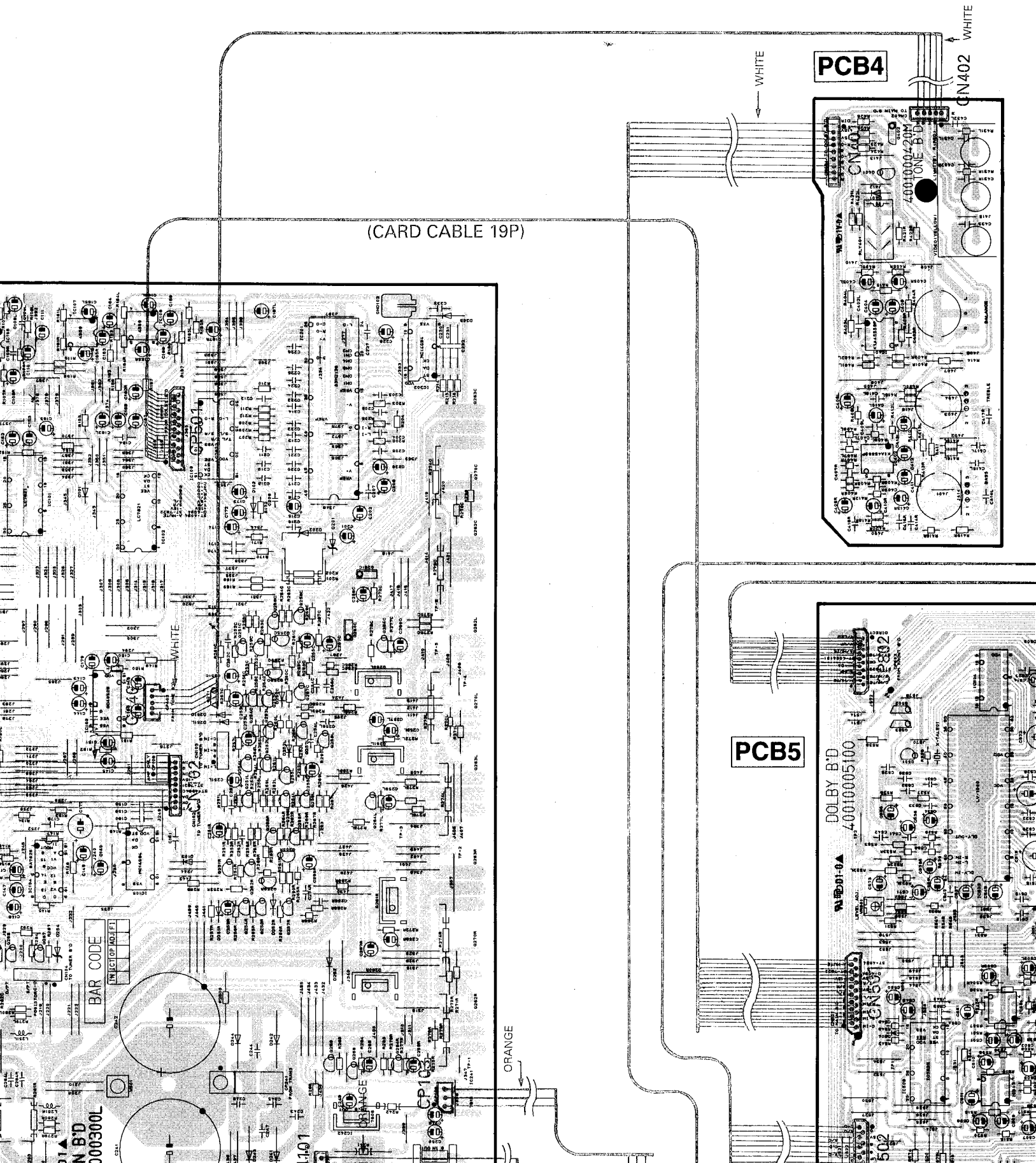

(CARD CABLE 19P)

PCB4

PCB5

DOLBY B'D
40010005100

BAR CODE
IN LOT OF ADD 71

000300L
N N B'D

1.01

ORANGE

WHITE

WHITE

CN402

4001000420M
ONE B'D

502

J

K

L

M

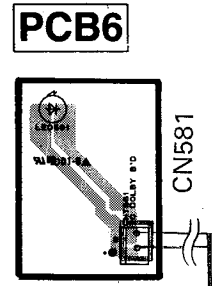
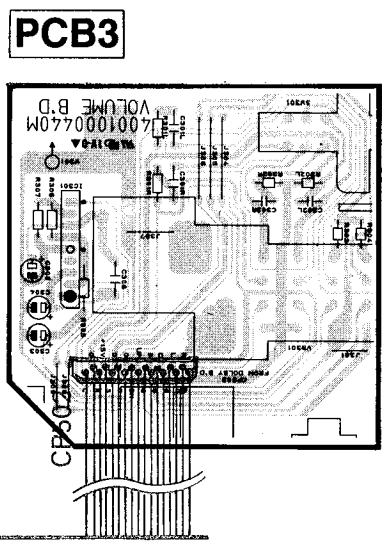
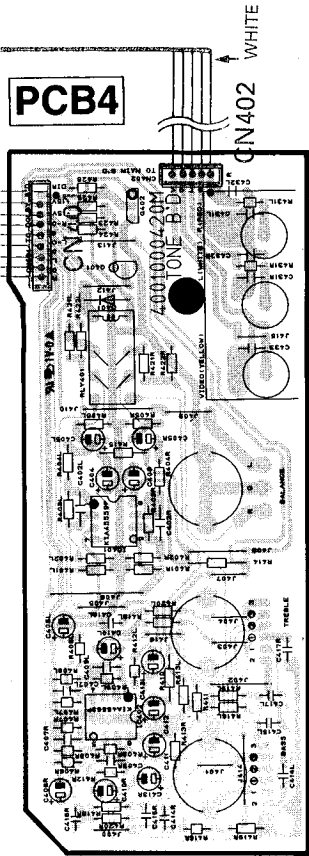

(CARD CABLE 18P)

(CARD CABLE 15P)

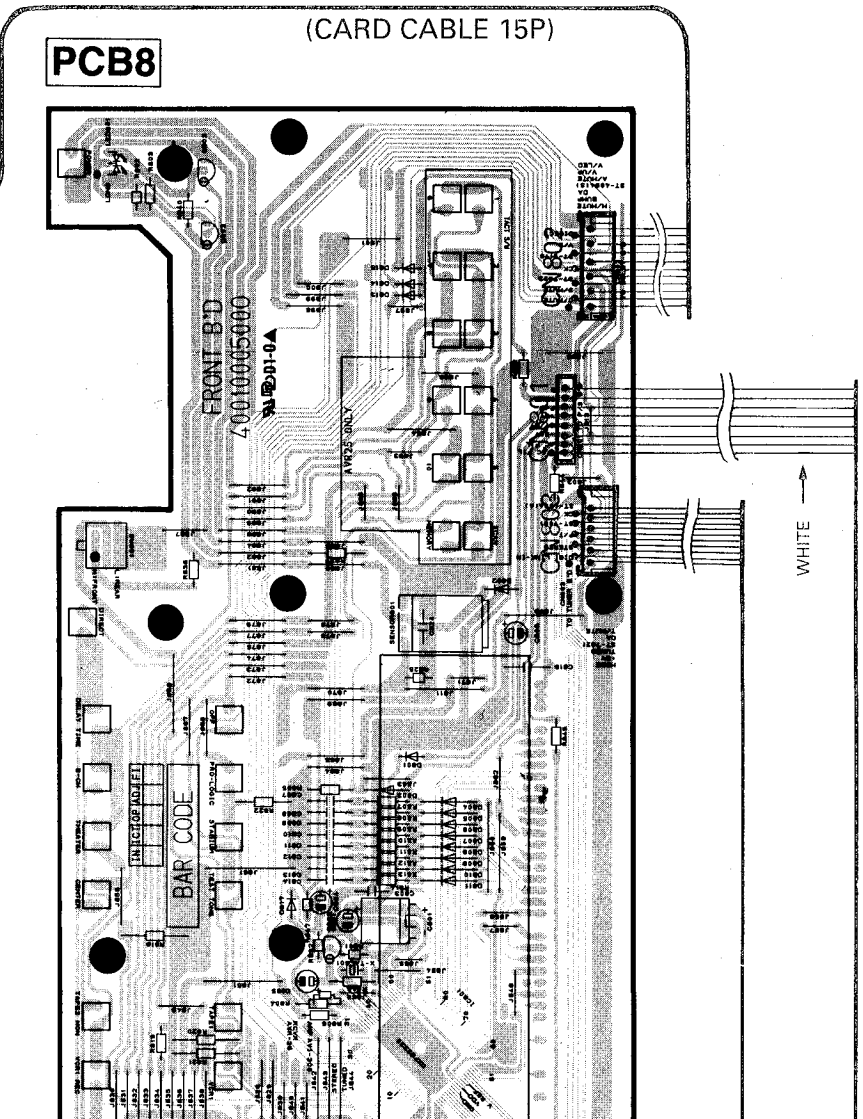
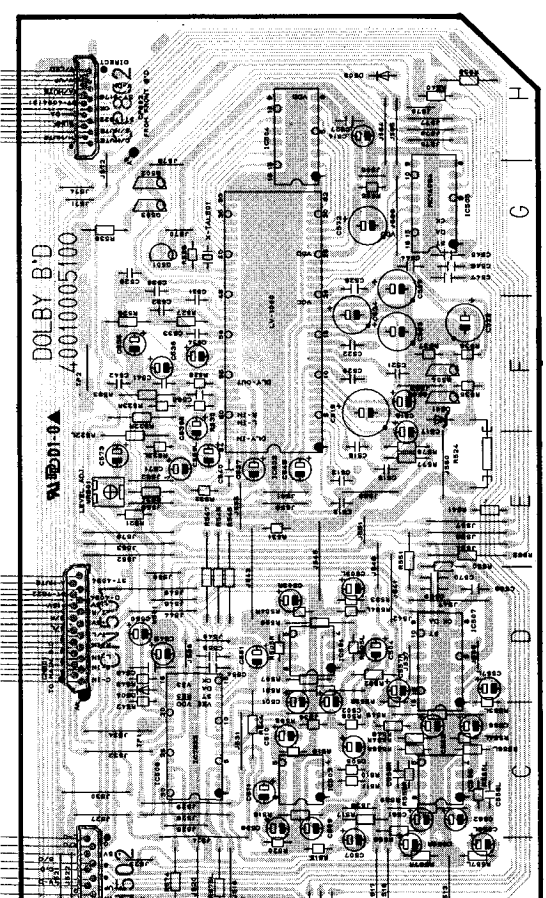

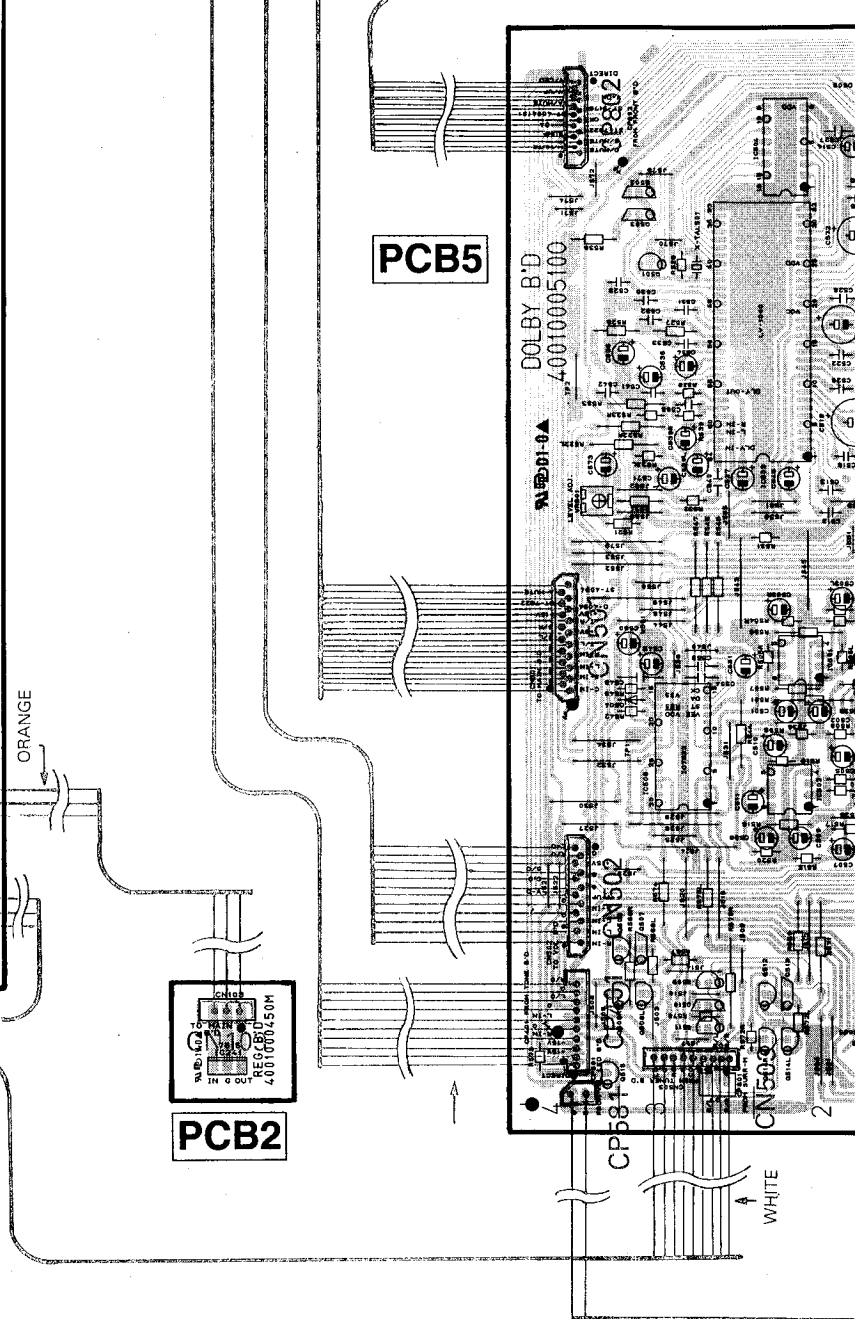
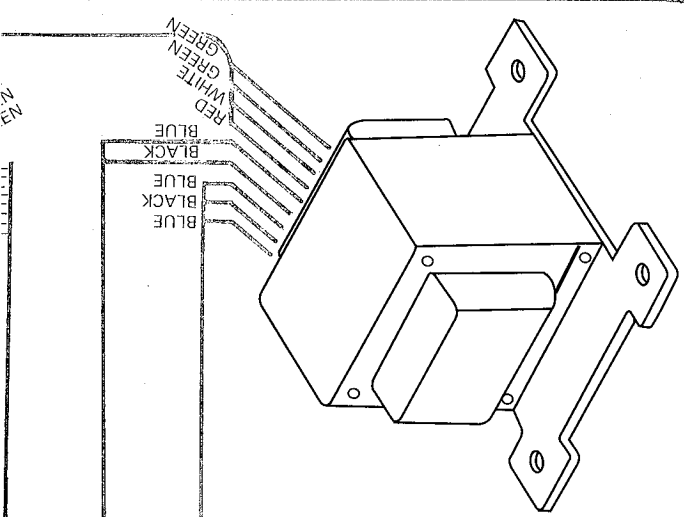
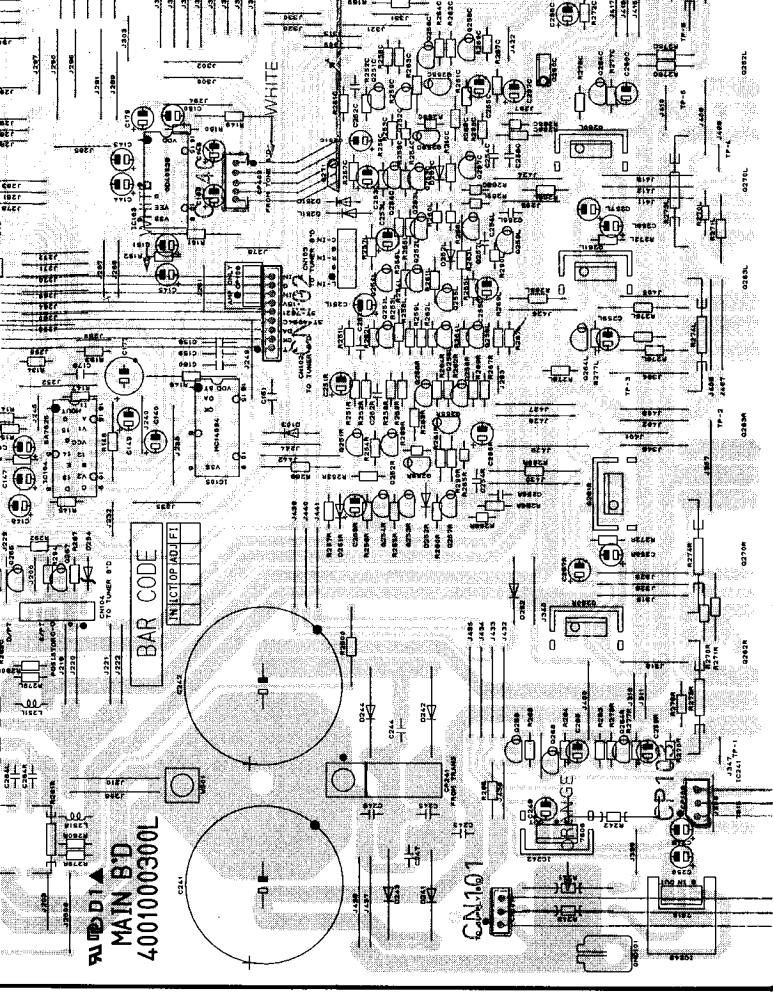

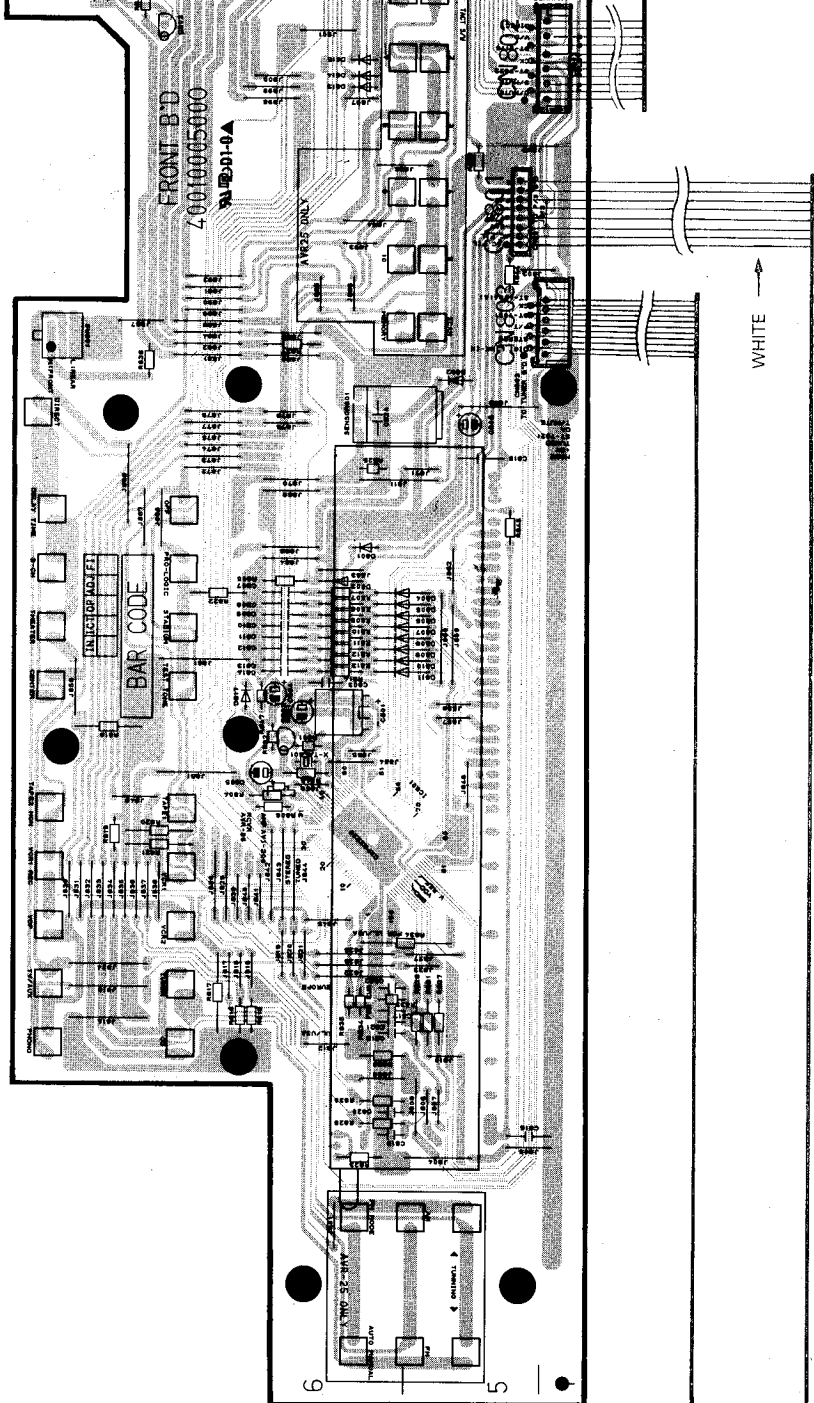
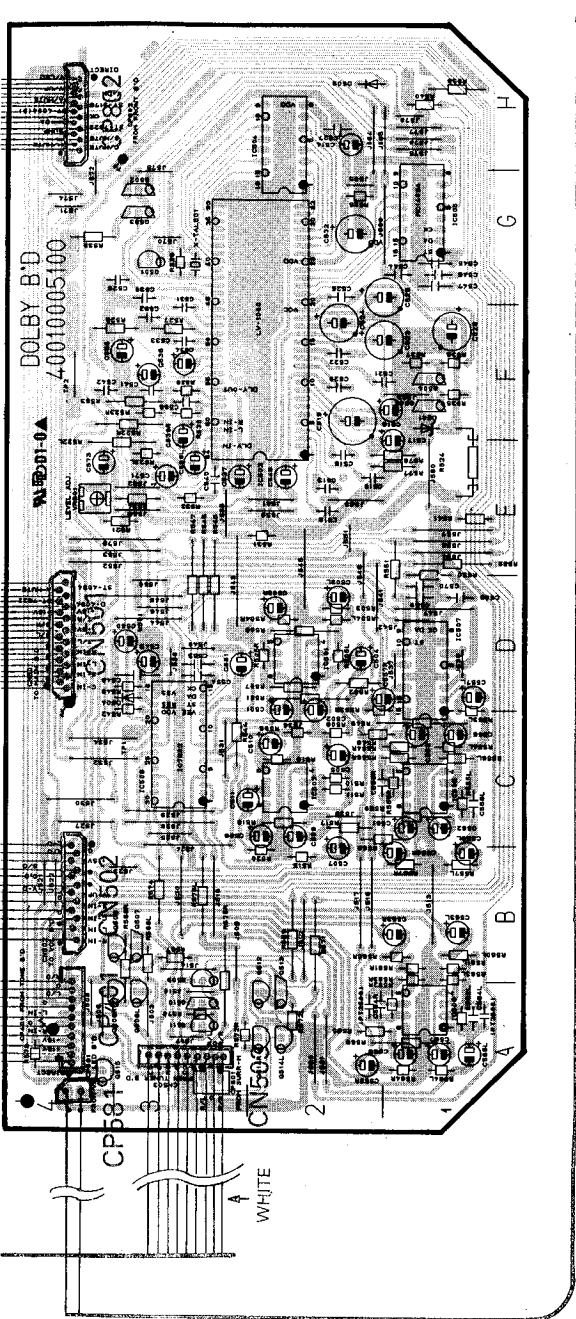

(CARD CABLE 12P)

SCHEMATIC DIAGRAM I

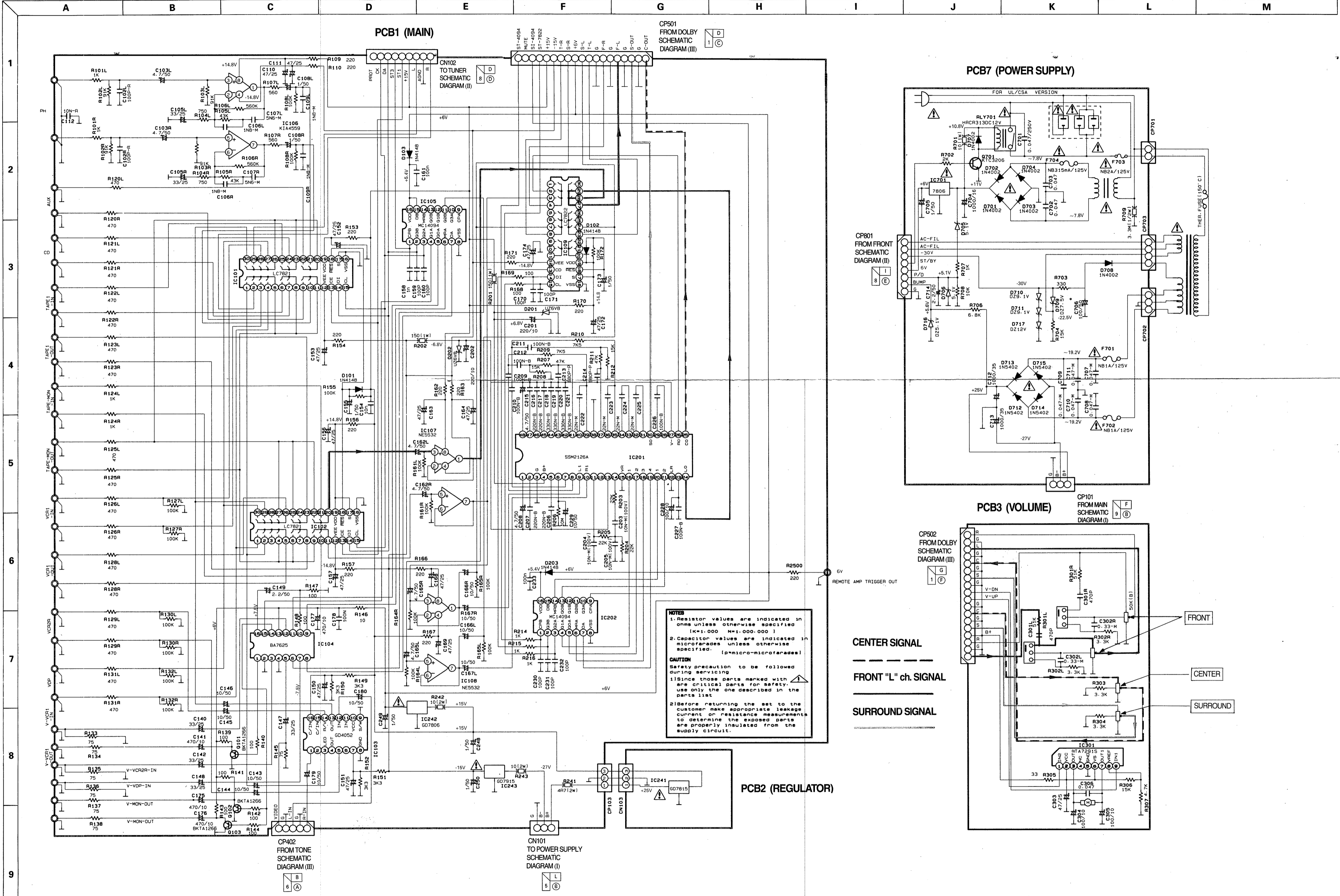

PIN CONNECTION DIAGRAM OF ICs.

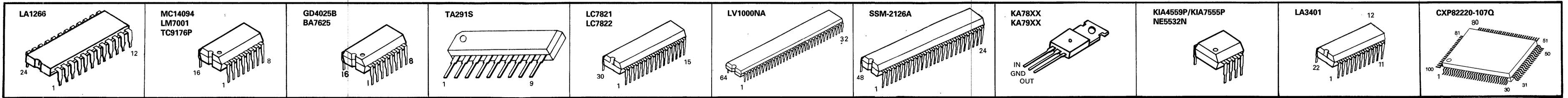

SCHEMATIC DIAGRAM I

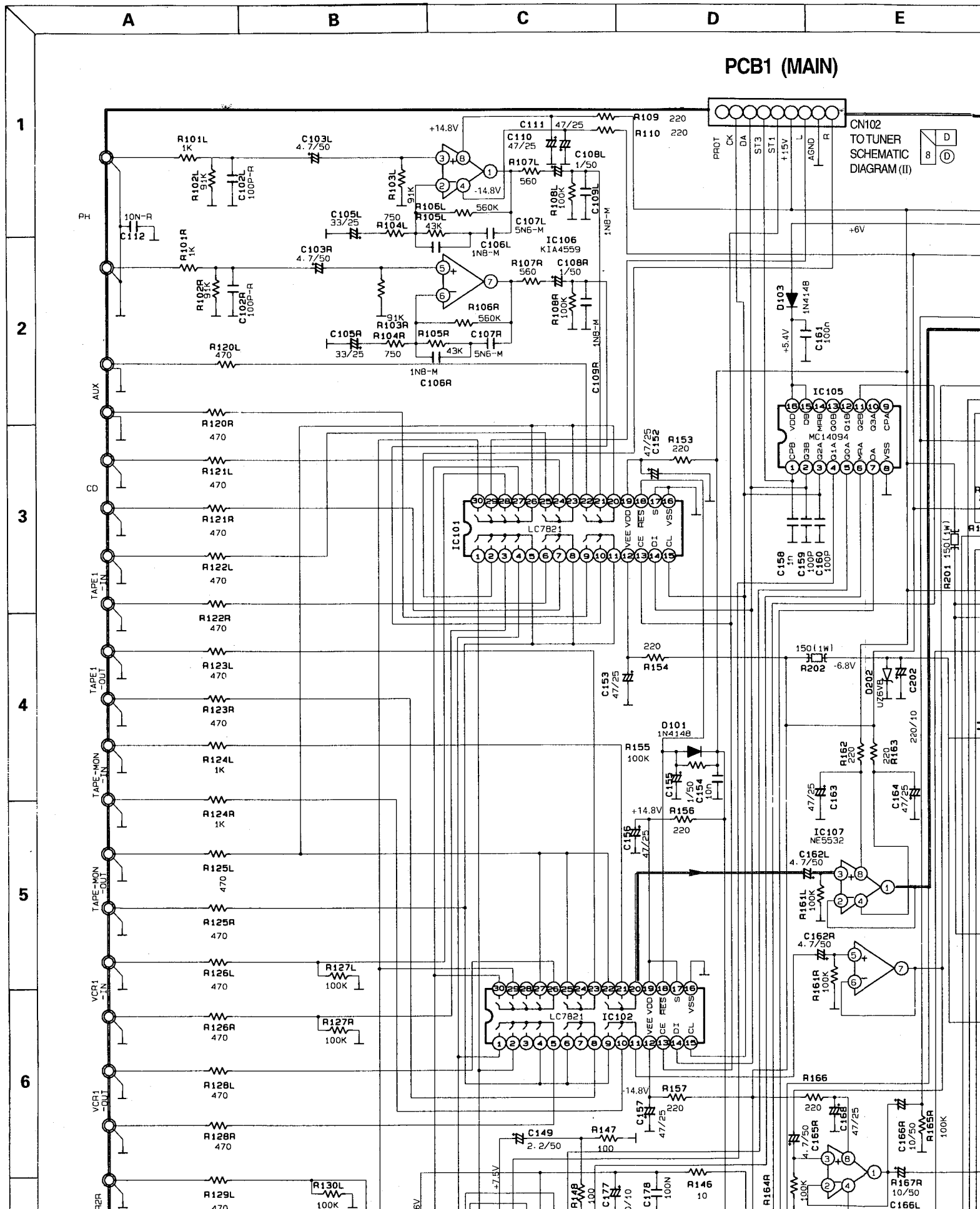

CP501
FROM DOLBY
SCHEMATIC
DIAGRAM (III)



CN102
TO TUNER
SCHEMATIC
DIAGRAM (II)



CP801
FROM FRONT
SCHEMATIC
DIAGRAM (II)



CP502
FROM DOLBY
SCHEMATIC
DIAGRAM (III)

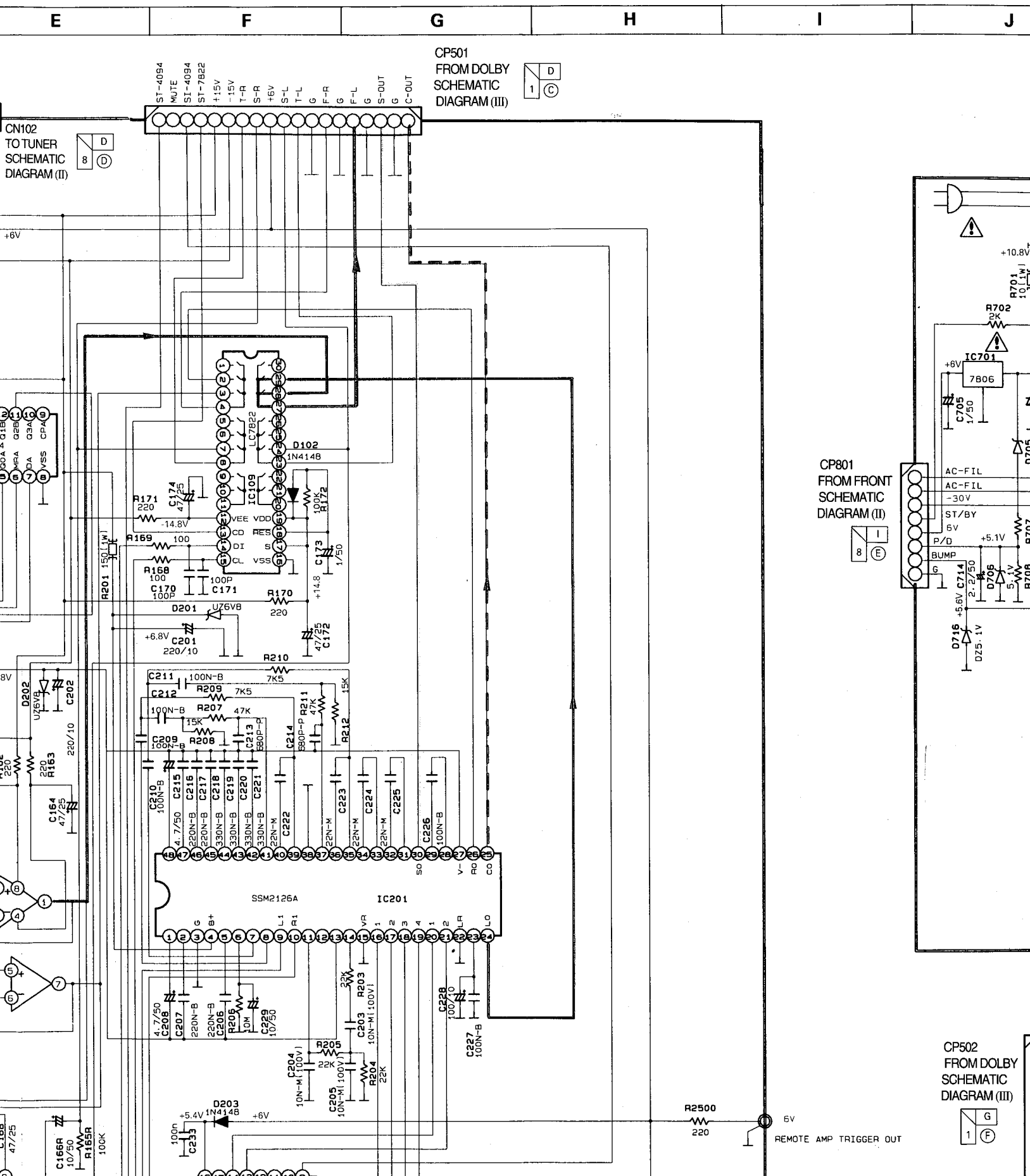

NOTES
1. Resistor values are indicated in ohms unless otherwise specified

PCB7 (POWER SUPPLY)

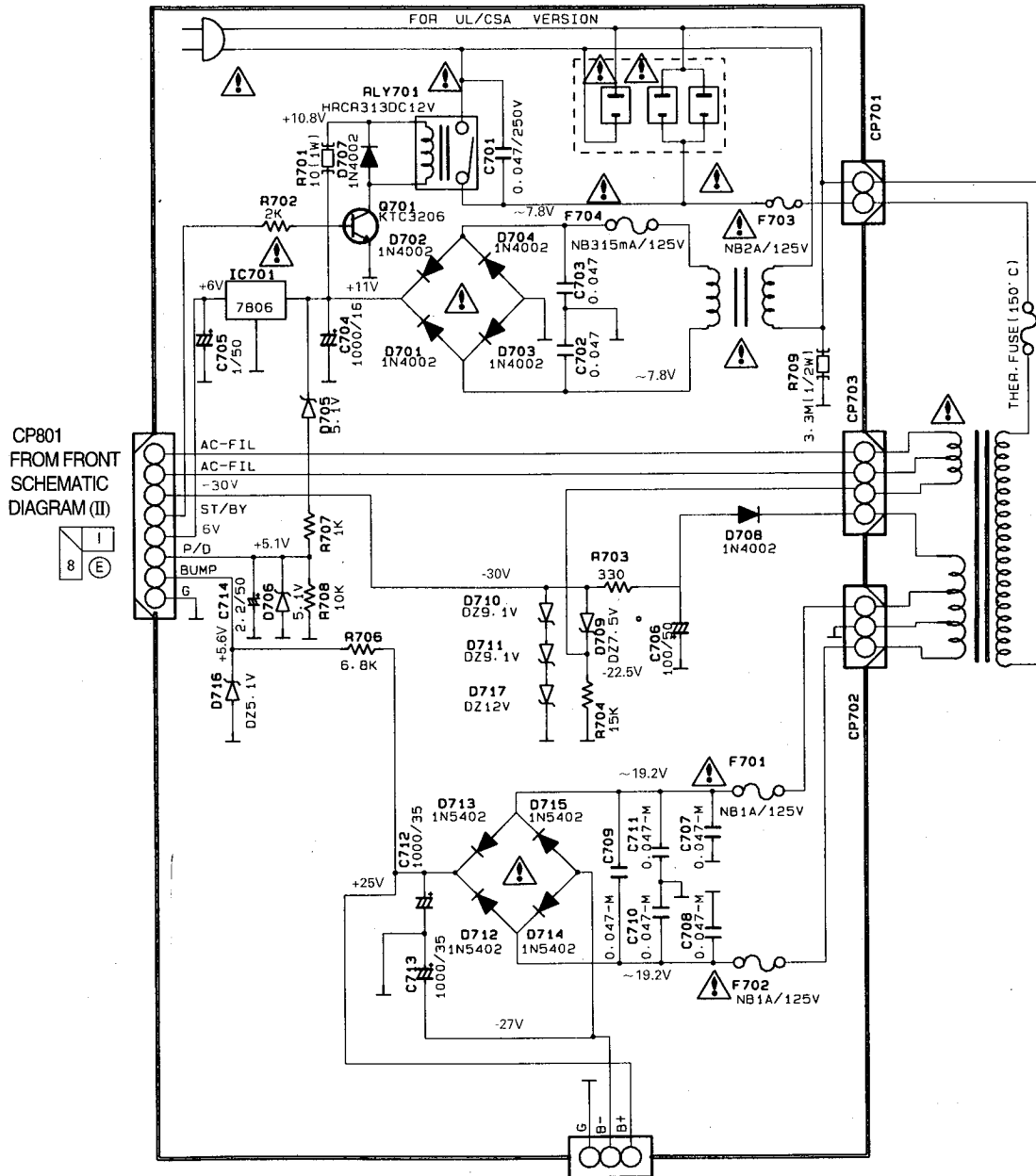

PCB3 (VOLUME)

CP101 FROM MAIN SCHEMATIC DIAGRAM (I)

9	B	F																			

CP502 FROM DOLBY SCHEMATIC DIAGRAM (III)

1	G	F																			

TE AMP TRIGGER OUT

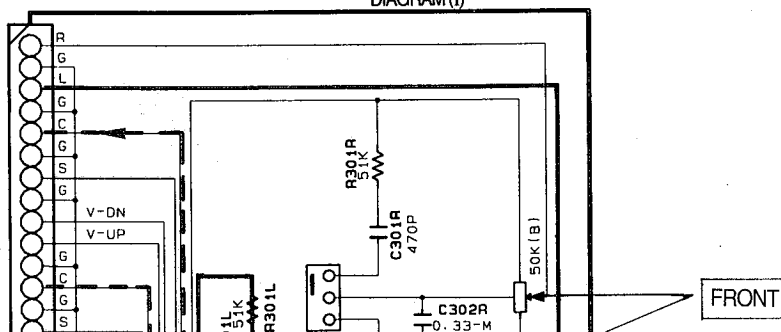

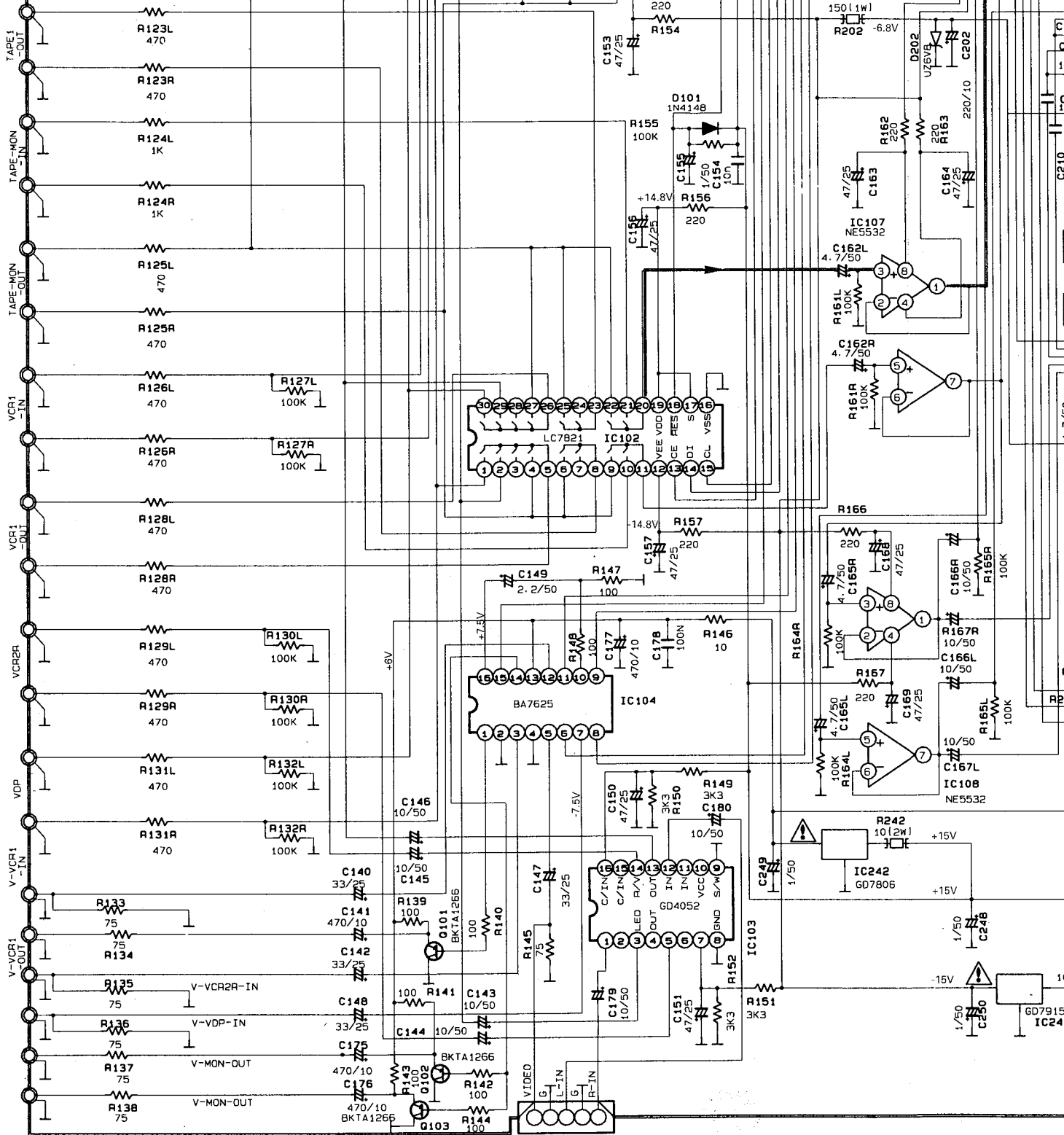

CP402
FROM TONE
SCHEMATIC
DIAGRAM (III)



PIN CONNECTION DIAGRAM OF ICS.

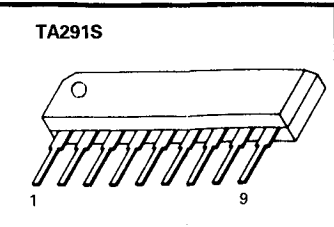
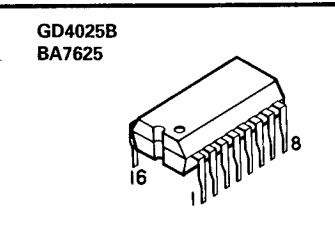
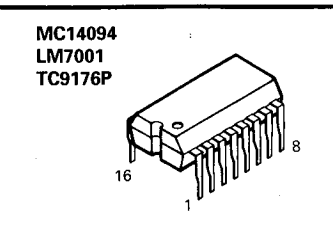
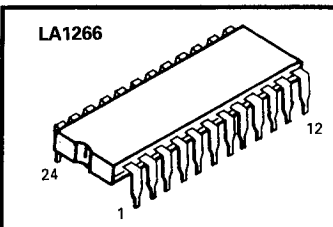

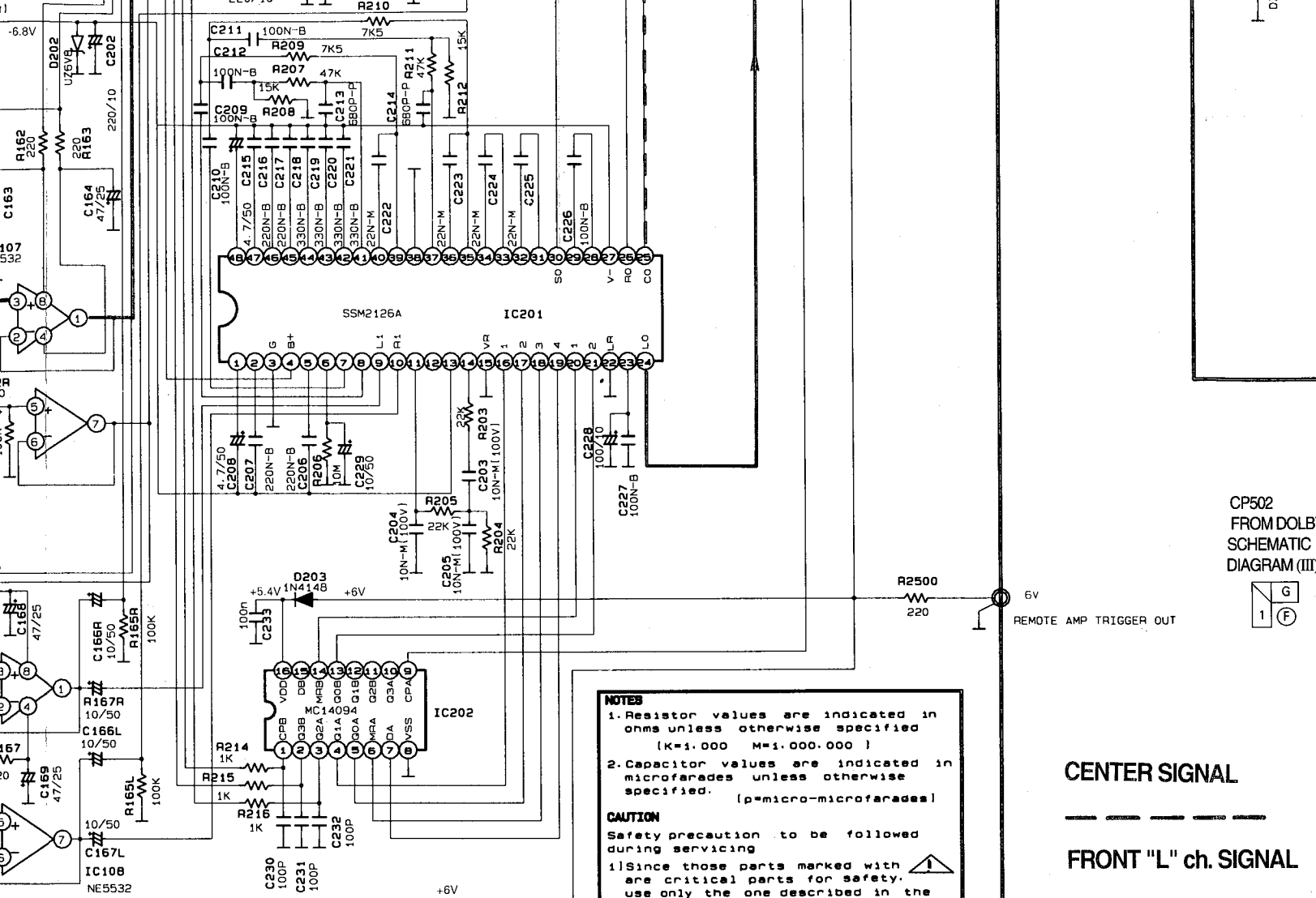

CP502
FROM DOLBY
SCHEMATIC
DIAGRAM (III)



NOTES

1. Resistor values are indicated in ohms unless otherwise specified (K=1,000 M=1,000,000)
2. Capacitor values are indicated in microfarades unless otherwise specified. (p=micro-microfarades)

CAUTION
Safety precaution to be followed during servicing

- 1) Since those parts marked with are critical parts for safety, use only the one described in the parts list
- 2) Before returning the set to the customer make appropriate leakage current or resistance measurements to determine the exposed parts are properly insulated from the supply circuit.

PCB2 (REGULATOR)

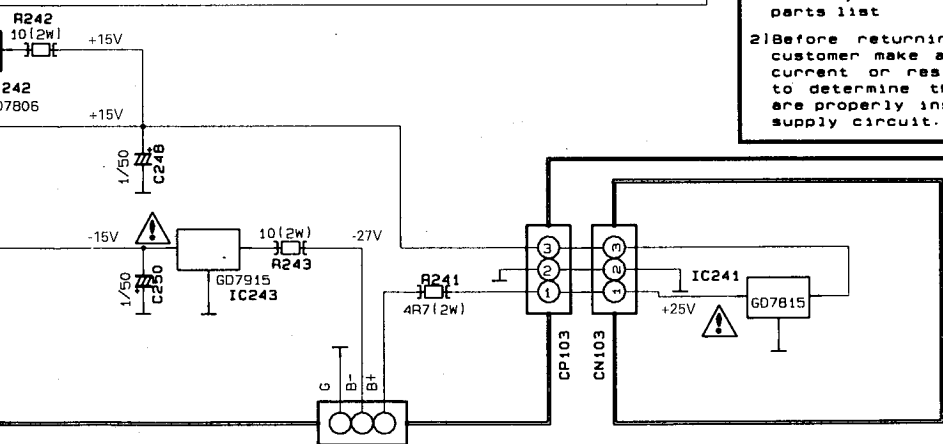

CN101
TO POWER SUPPLY
SCHEMATIC
DIAGRAM (I)

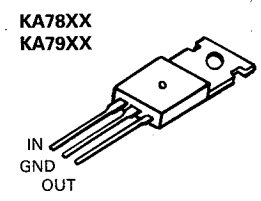
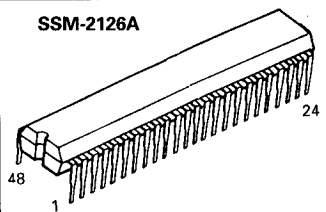
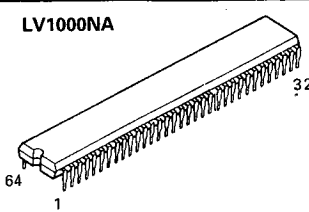
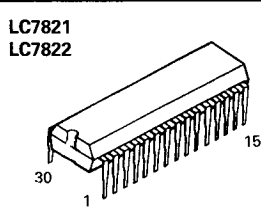
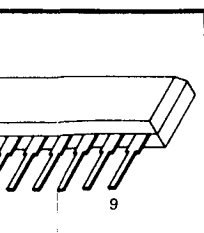

KIA
NE

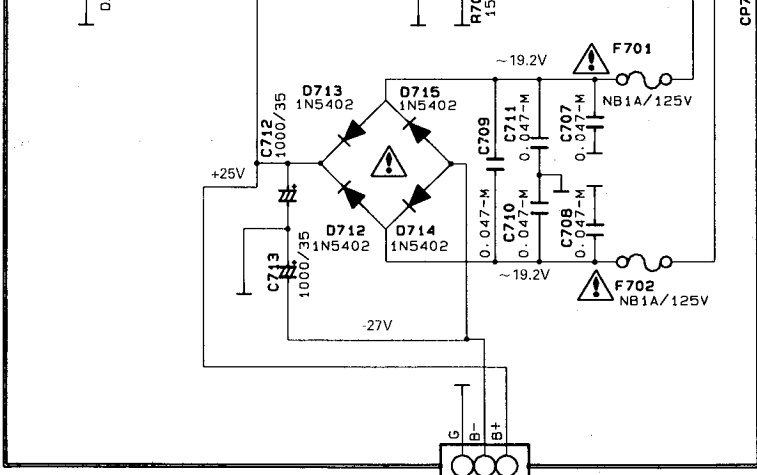

PCB3 (VOLUME)

CP101
FROM MAIN
SCHEMATIC
DIAGRAM (I)



CP502
FROM DOLBY
SCHEMATIC
DIAGRAM (III)

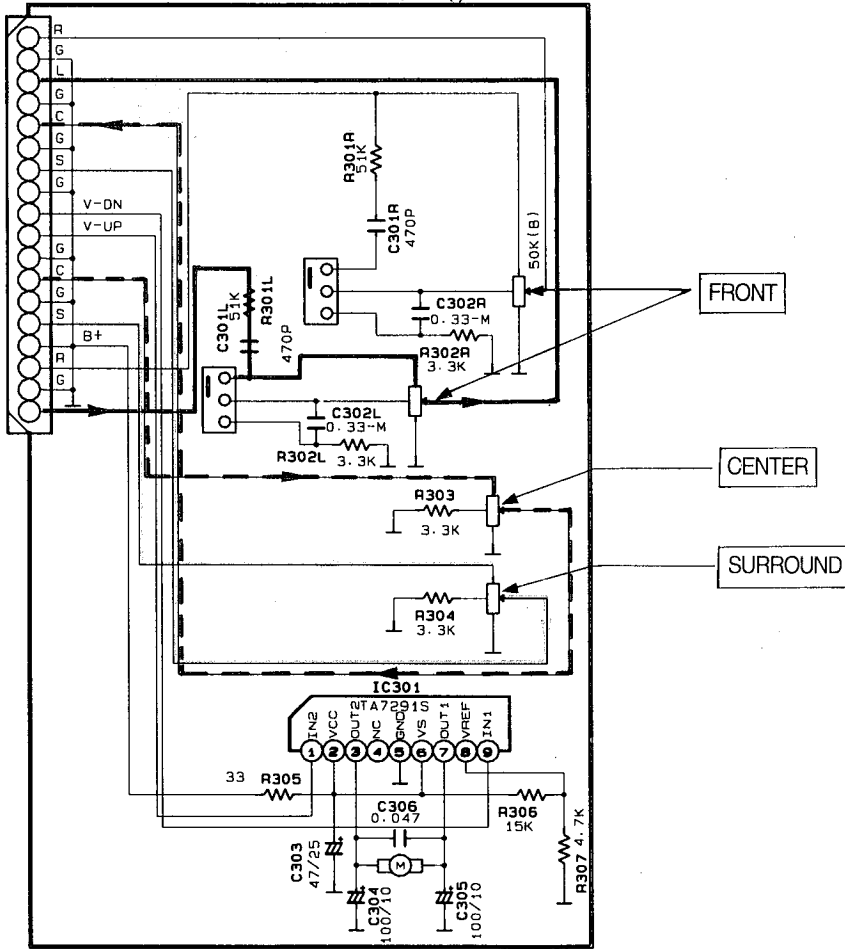

SIGNAL

L ch. SIGNAL

ND SIGNAL

	<p>KIA4559P/KIA7555P NE5532N</p>	<p>LA3401</p> <p>12</p>	<p>CXP82220-107Q</p>
--	--------------------------------------	-------------------------	----------------------

SCHEMATIC DIAGRAM II

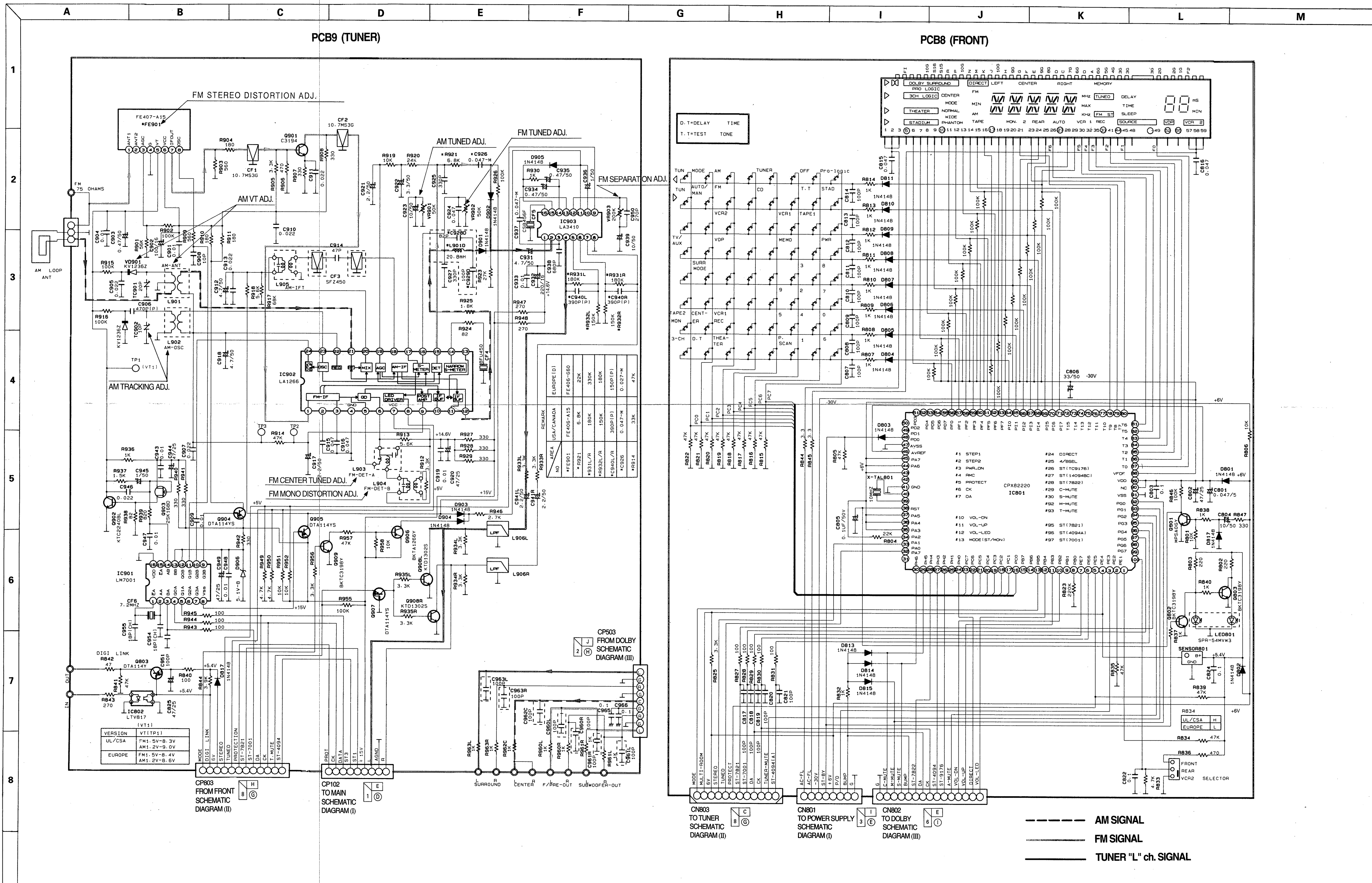

PIN CONNECTION DIAGRAM OF TRANSISTORS AND DIODES

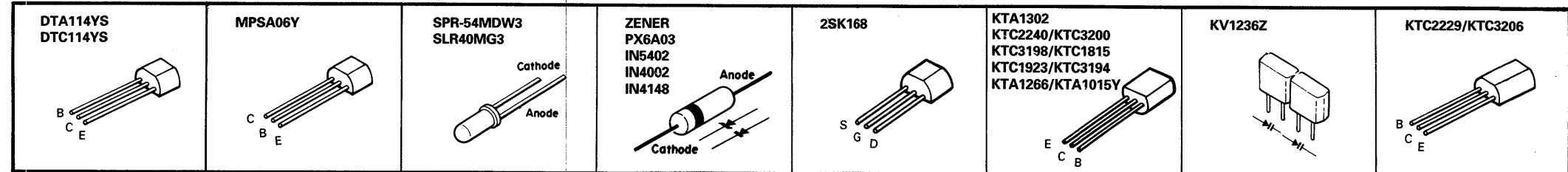

SCHEMATIC DIAGRAM II

PCB9 (TUNER)

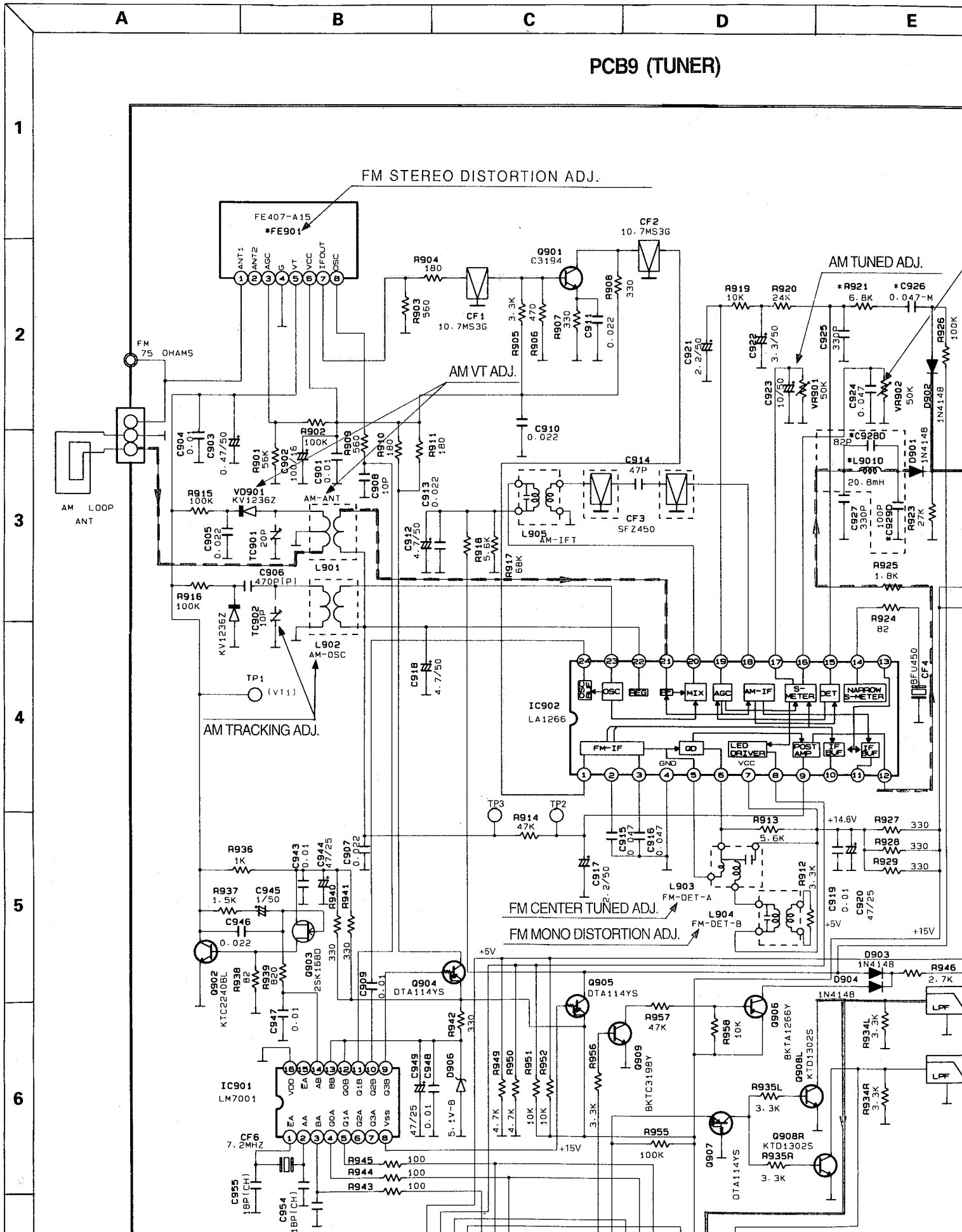

E

F

G

H

I

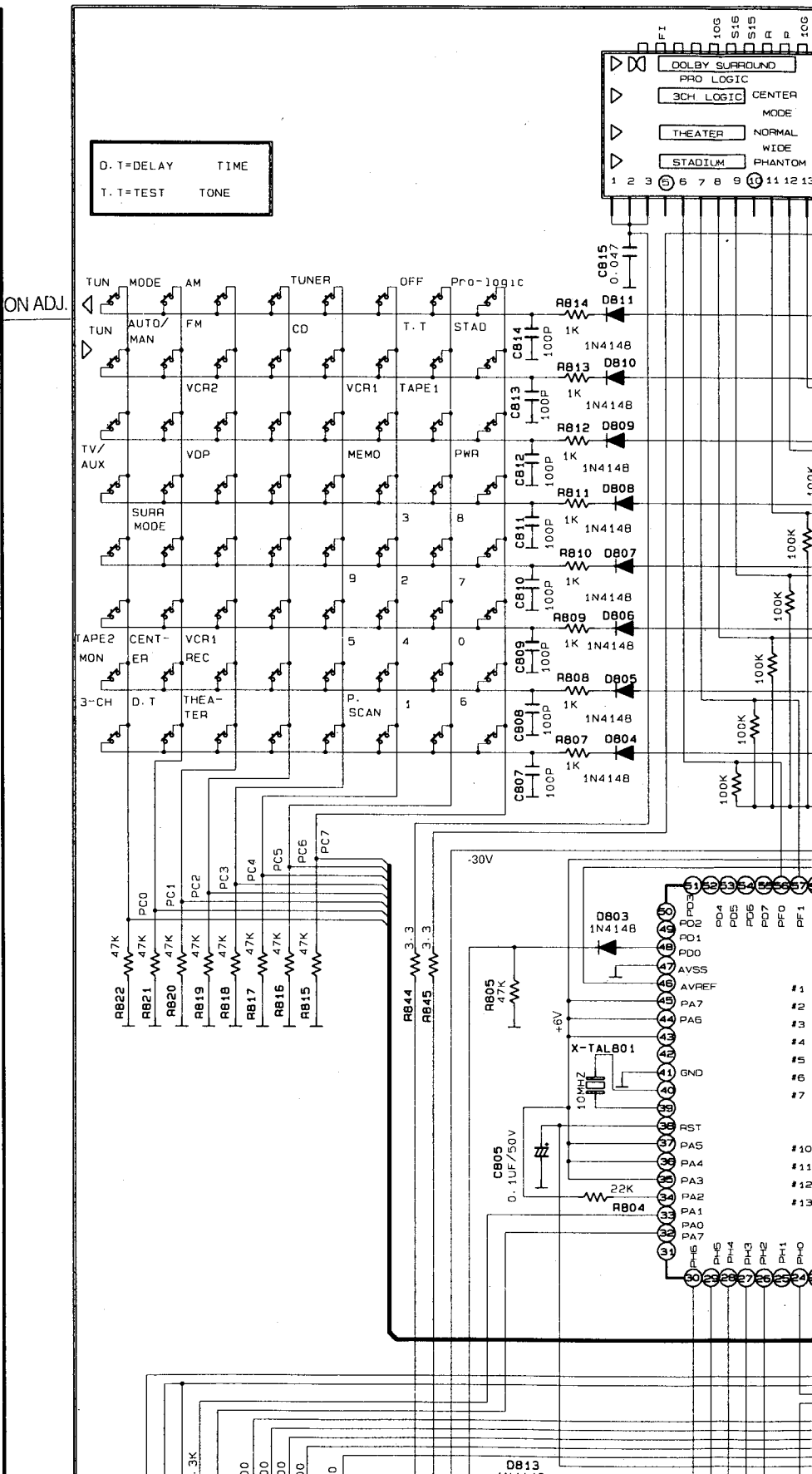
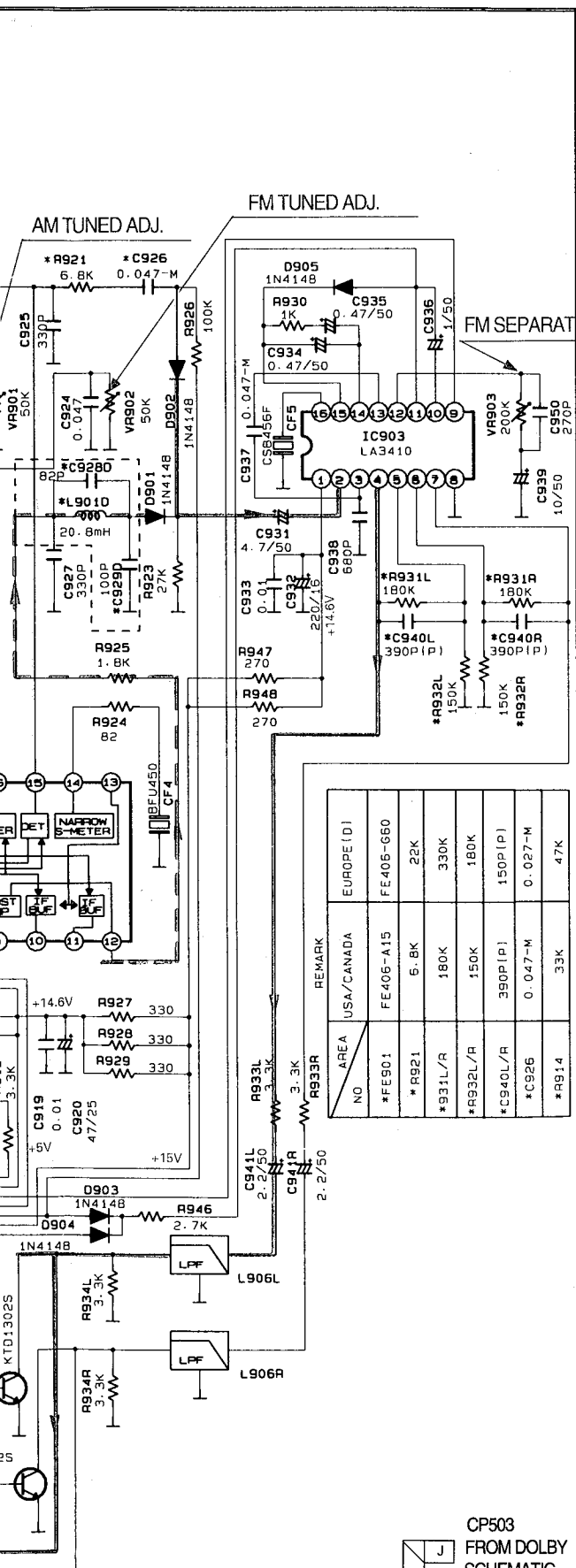

I J K L M

PCB8 (FRONT)

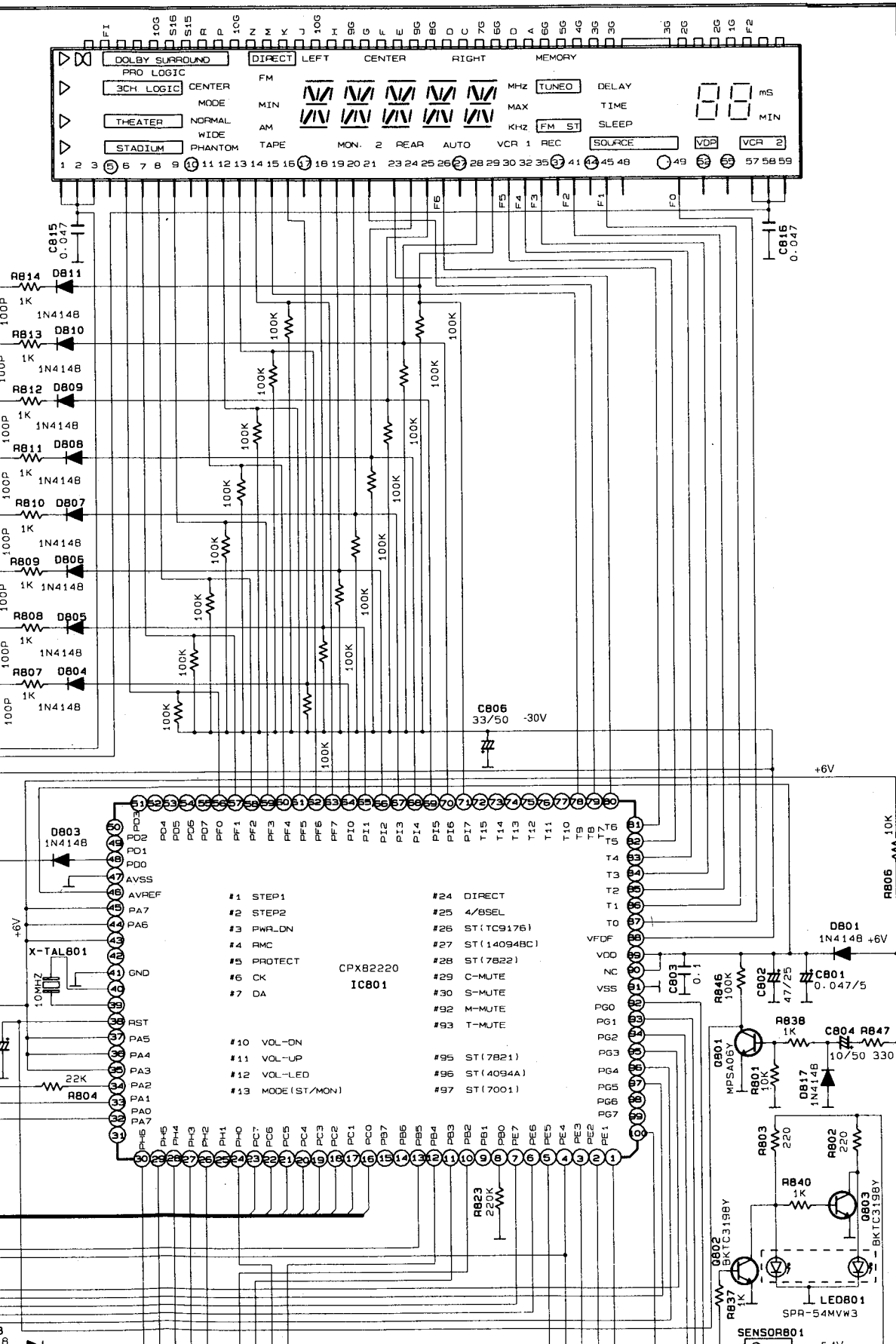

4
5
6
7
8
9

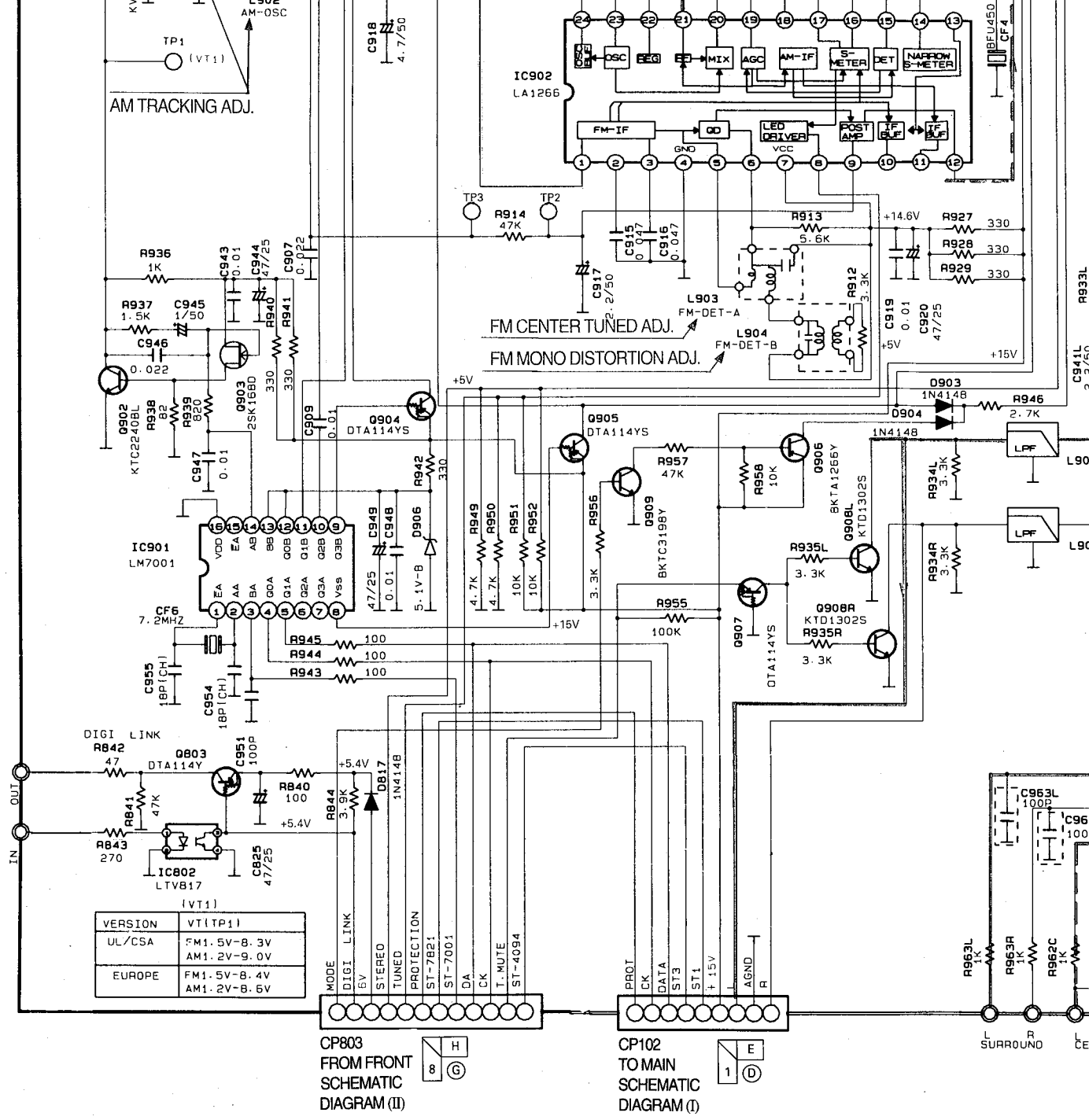

PIN CONNECTION DIAGRAM OF TRANSISTORS AND DIODES

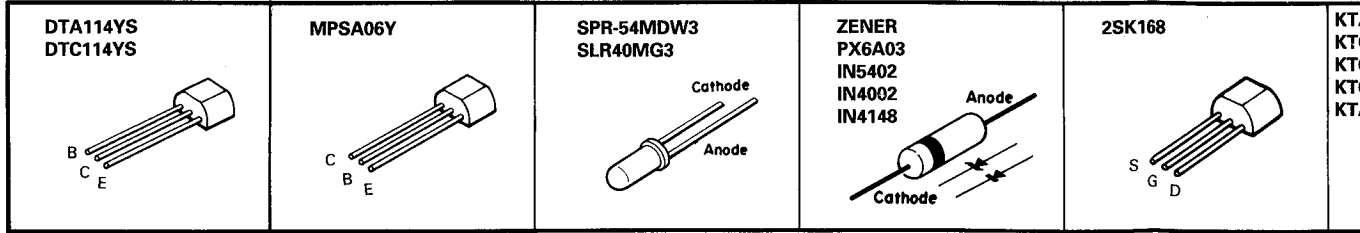

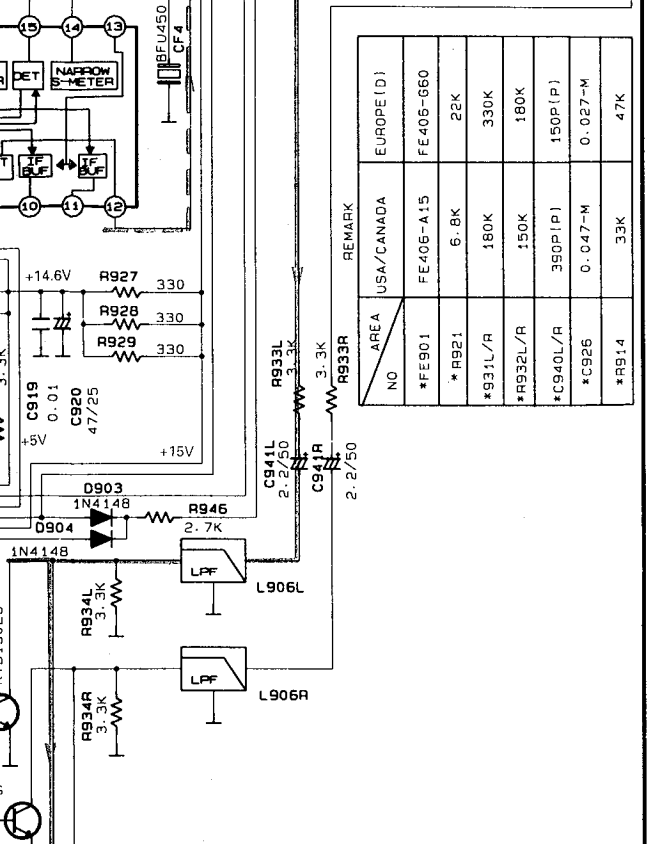

REMARK

CP503
FROM DOLBY
SCHEMATIC
DIAGRAM (III)

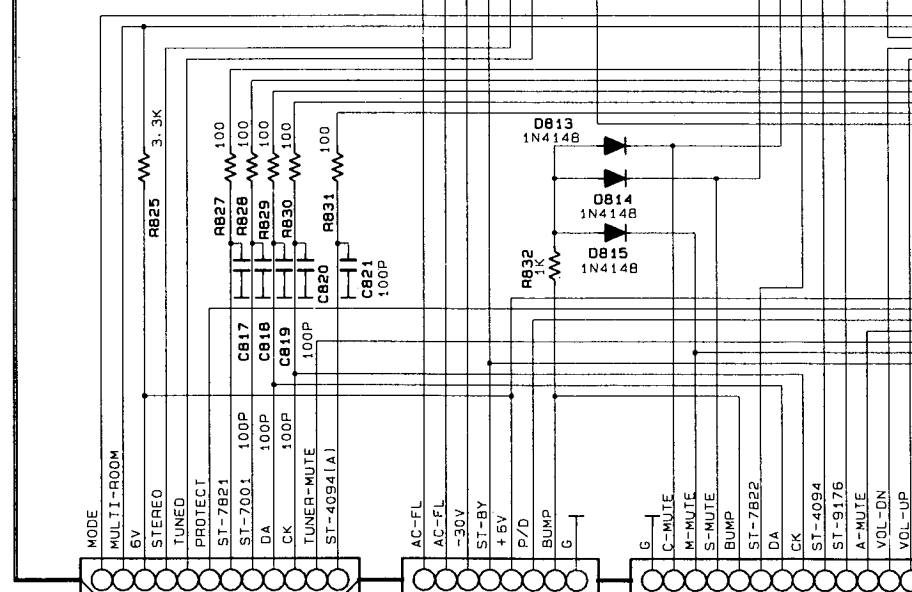
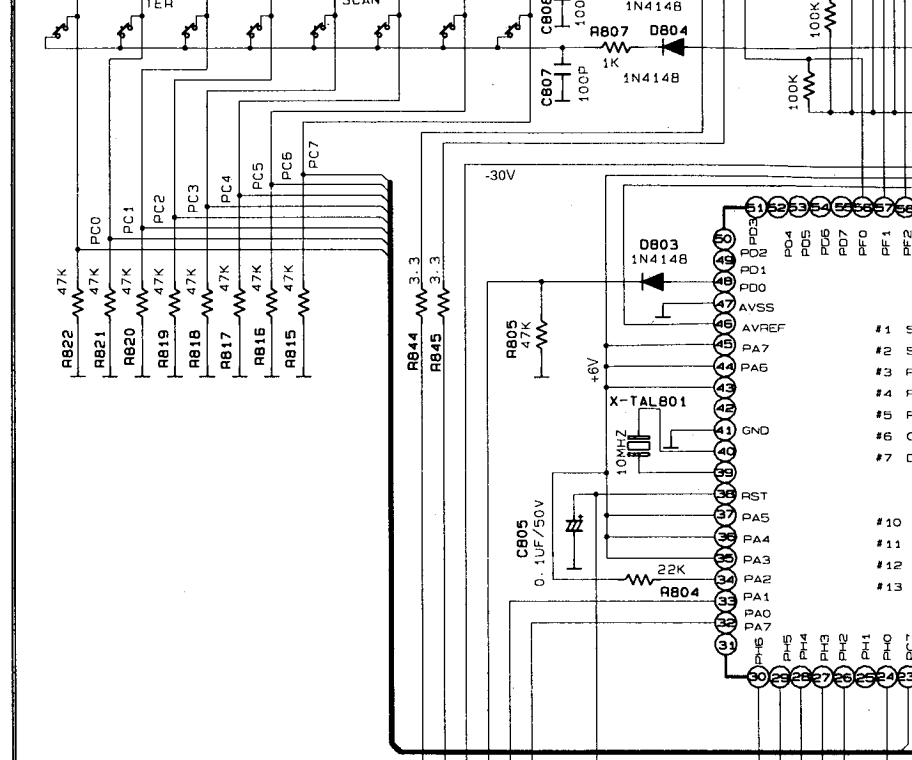
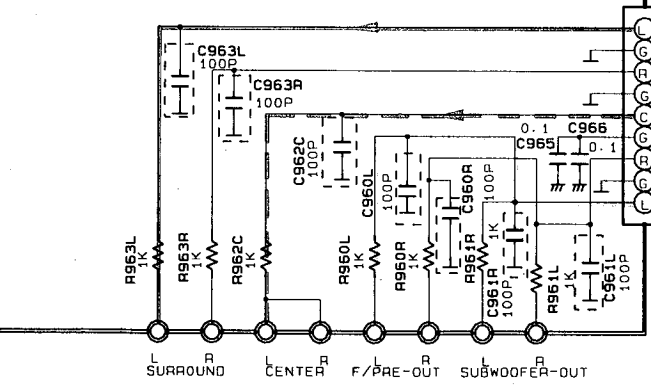

CN803
TO TUNER
SCHEMATIC
DIAGRAM (II)

CN801
TO POWER SUPPLY
SCHEMATIC
DIAGRAM (I)

CN802
TO DOLBY
SCHEMATIC
DIAGRAM (III)

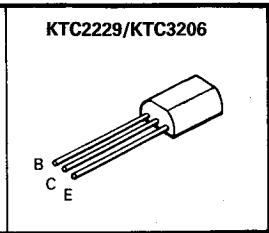
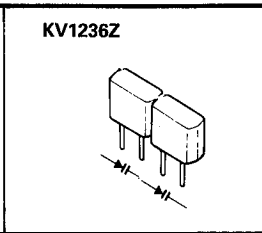
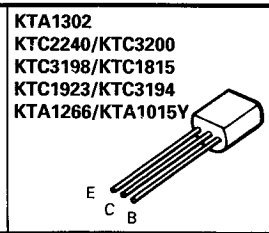
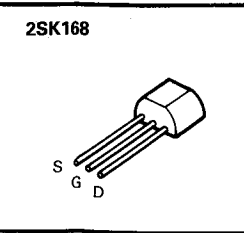

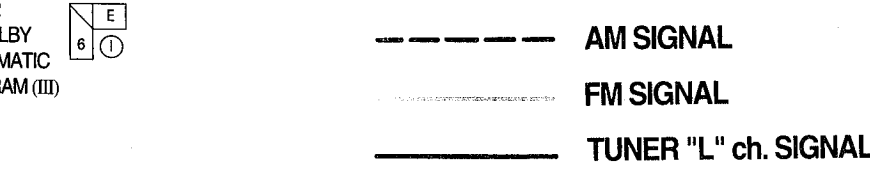
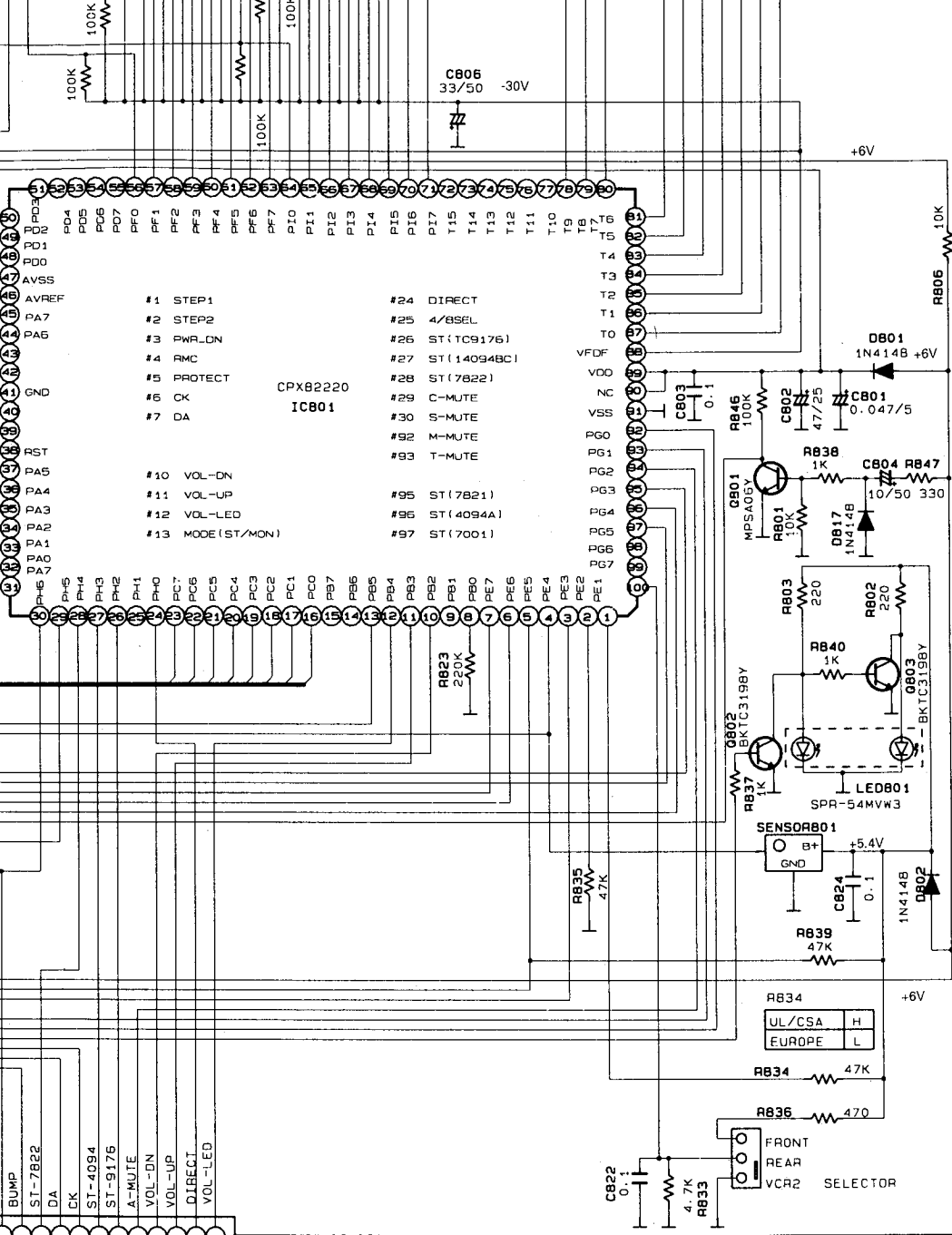

SCHEMATIC DIAGRAM III

A B C D E F G H I J K L M

1

2

3

4

5

6

7

8

9

PCB5 (DOLBY)

CN501
TO MAIN
SCHEMATIC
DIAGRAM (I)

CP401
FROM TONE
SCHEMATIC
DIAGRAM (II)

CN502
TO VOLUME
SCHEMATIC
DIAGRAM (I)

COMMANDER

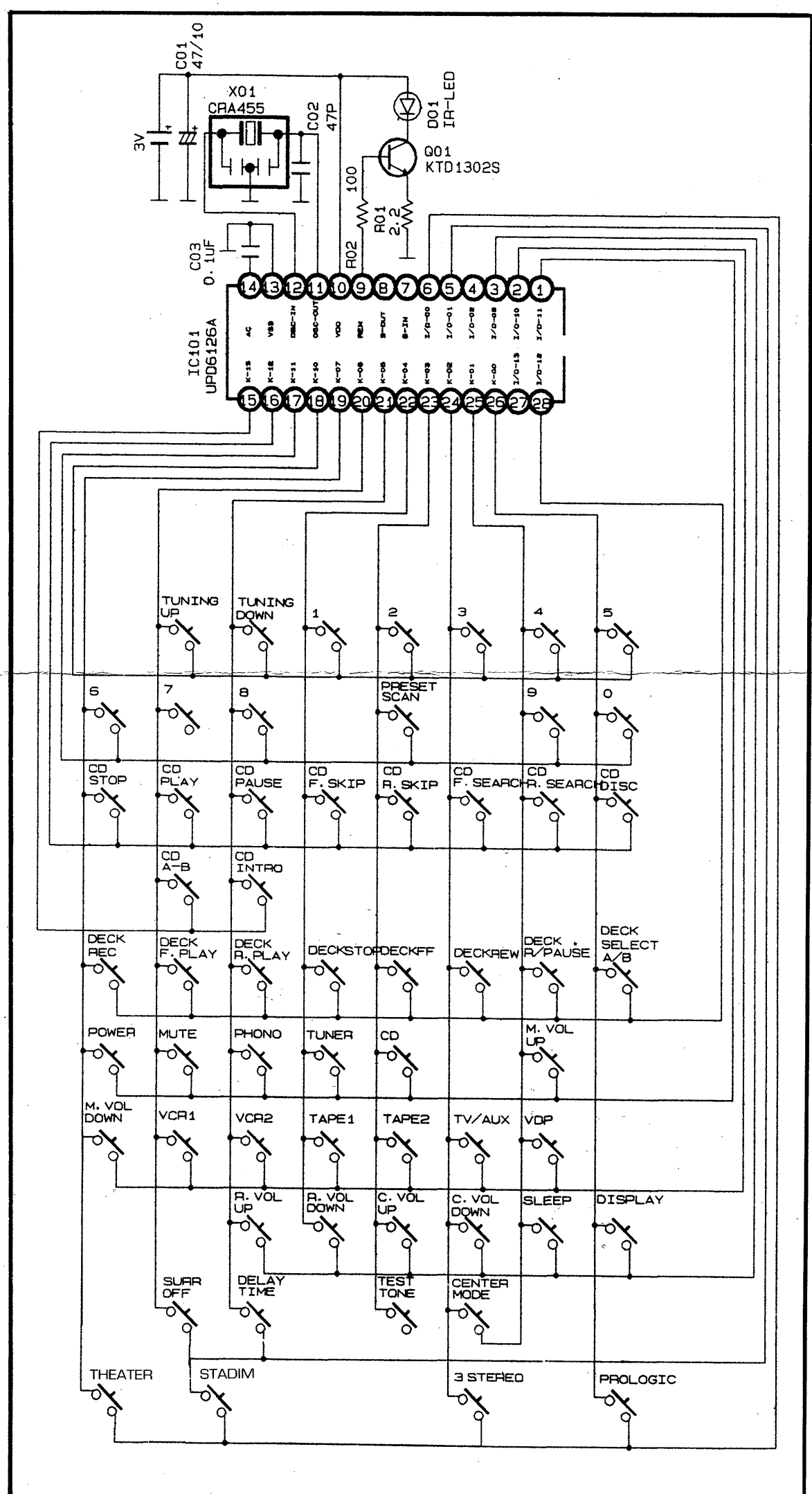
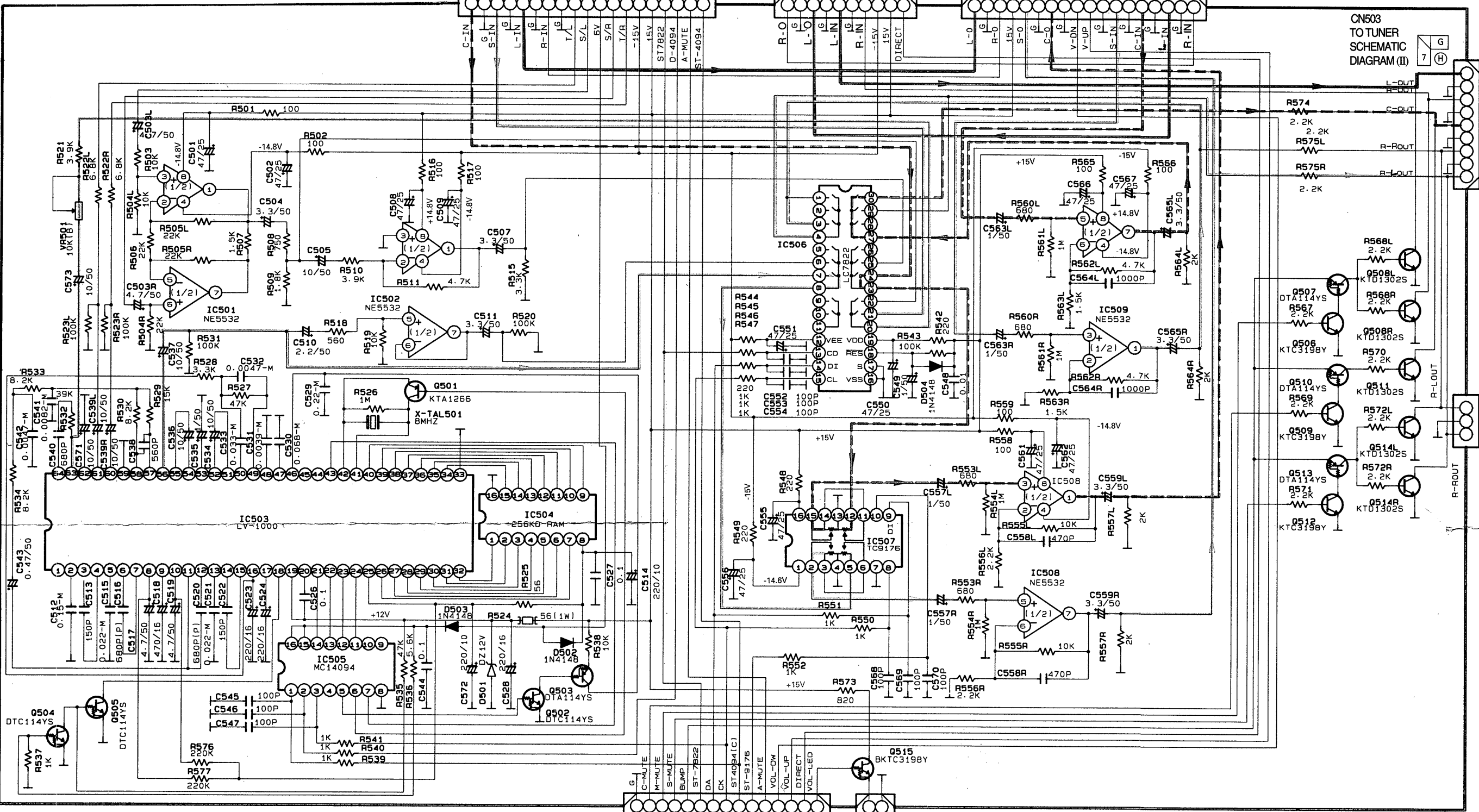

PCB4 (TONE)

CN402
TO MAIN
SCHEMATIC
DIAGRAM (I)

CP802
FROM FRONT
SCHEMATIC
DIAGRAM (II)

CP581
FROM VOLLED
SCHEMATIC
DIAGRAM (III)

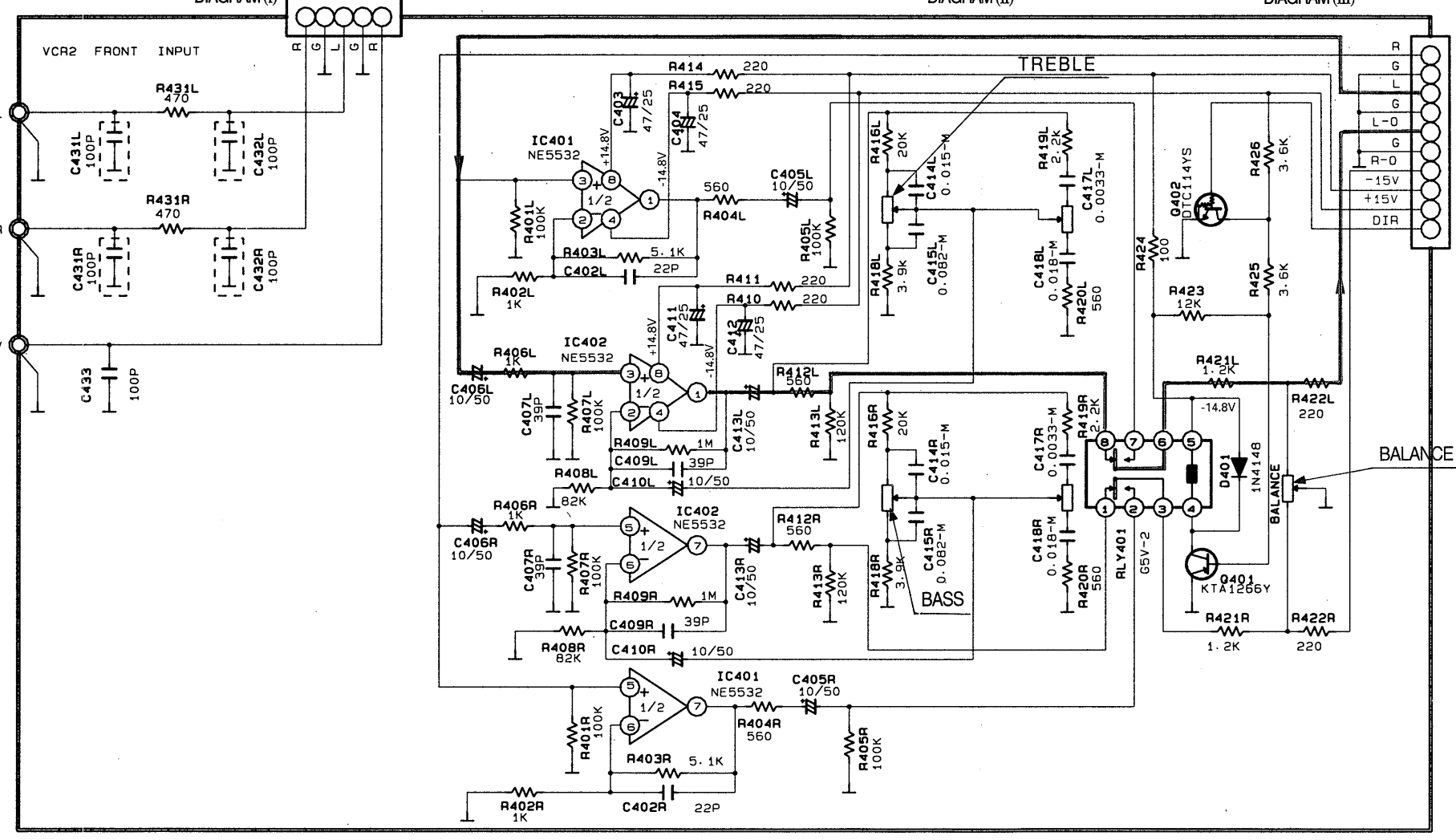

PCB6 (VOLUME LED)

CN401
TO DOLBY
SCHEMATIC
DIAGRAM (III)

CN581
TO DOLBY
SCHEMATIC
DIAGRAM (III)

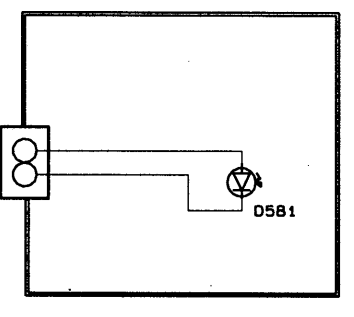

NOTES

- Resistor values are indicated in ohms unless otherwise specified (K=1,000 M=1,000,000)
- Capacitor values are indicated in microfarads unless otherwise specified. (p=micro-microfarads)

CAUTION
Safety precaution to be followed during servicing:

- Since those parts marked with are critical parts for safety, use only the one described in the parts list.
- Before returning the set to the customer make appropriate leakage current or resistance measurements to determine the exposed parts are properly insulated from the supply circuit.

— SURROUND SIGNAL
— FRONT "L" ch. SIGNAL
- - - CENTER SIGNAL

SCHEMATIC DIAGRAM III

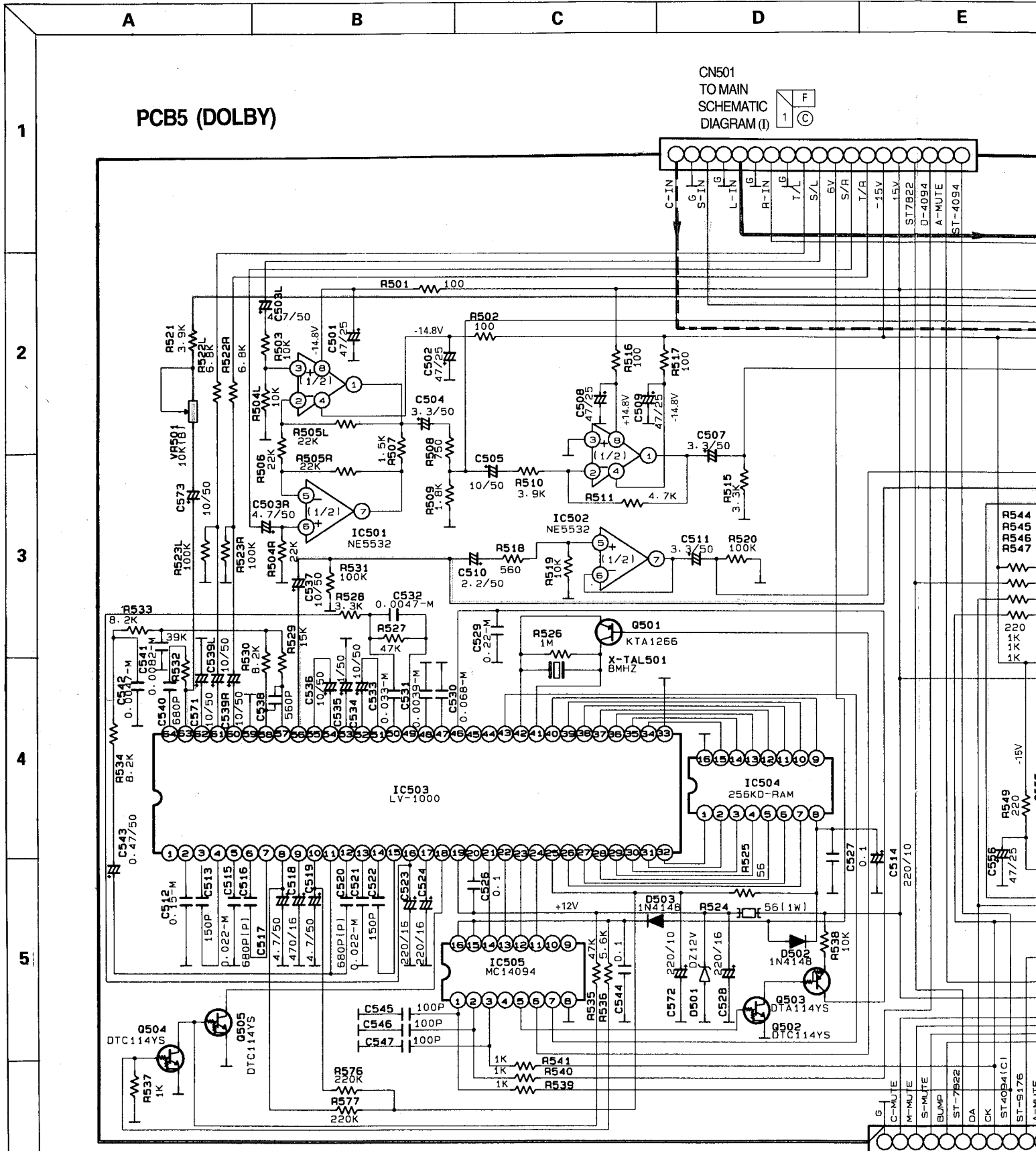

PCB5 (DOLBY)

CN501
TO MAIN
SCHEMATIC
DIAGRAM (I)

1	F
1	C

CN402
TO MAIN
SCHEMATIC
DIAGRAM (I)

9	C
9	A

PCB4 (TONE)

CP802
FROM FRONT
SCHEMATIC
DIAGRAM (II)

8	I
8	1

VCR2 FRONT INPUT

TREBLE

E

F

G

H

I

CP401
FROM TONE
SCHEMATIC
DIAGRAM (III)

CN502
TO VOLUME
SCHEMATIC
DIAGRAM (I)

CN503
TO TUNER
SCHEMATIC
DIAGRAM (II)

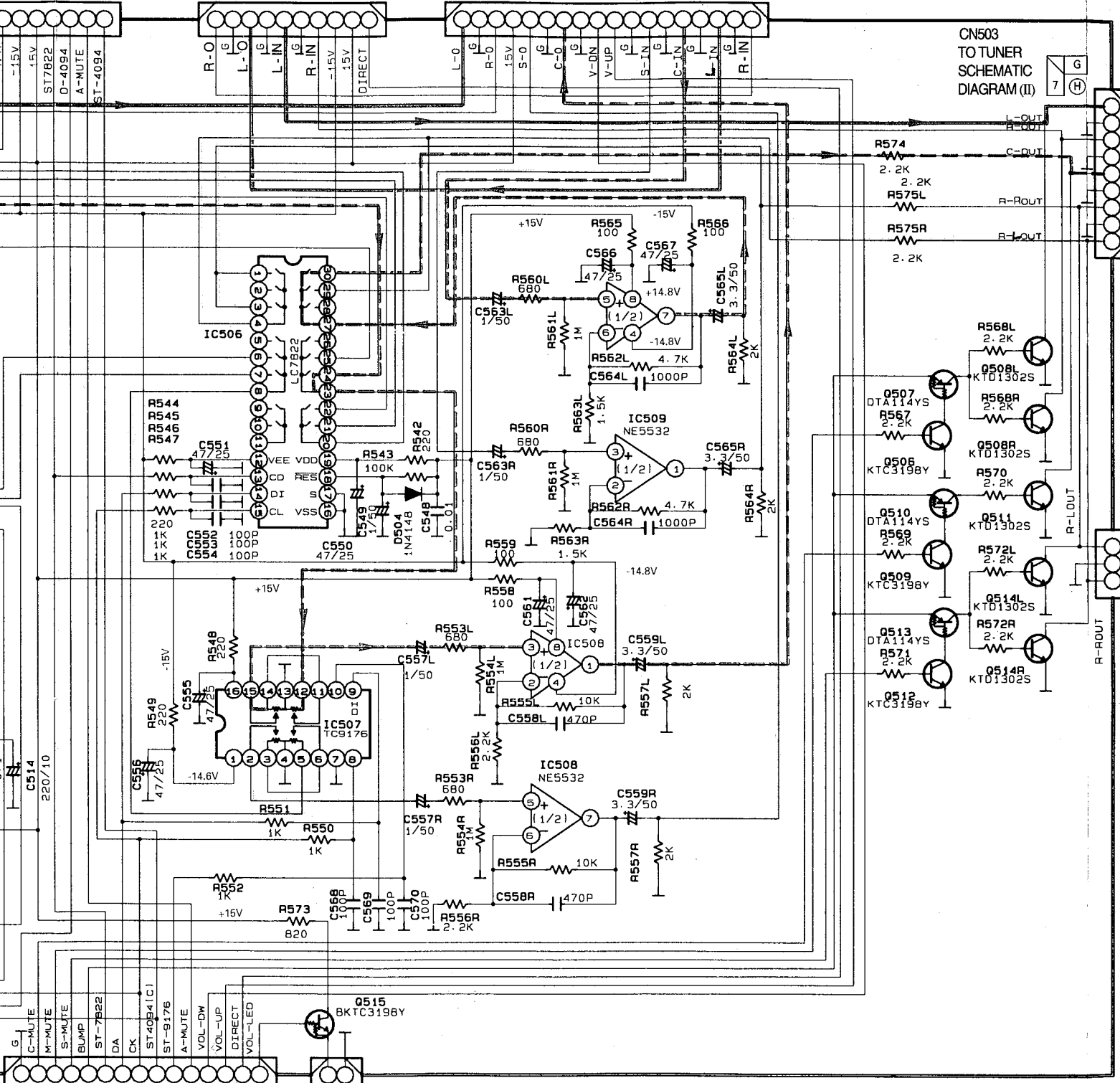

CP802
FROM FRONT
SCHEMATIC
DIAGRAM (II)

CP581
FROM VOLLED
SCHEMATIC
DIAGRAM (III)

PCB6 (VOLUME LED)

CN401
TO DOLBY

TREBLE

COMMANDER

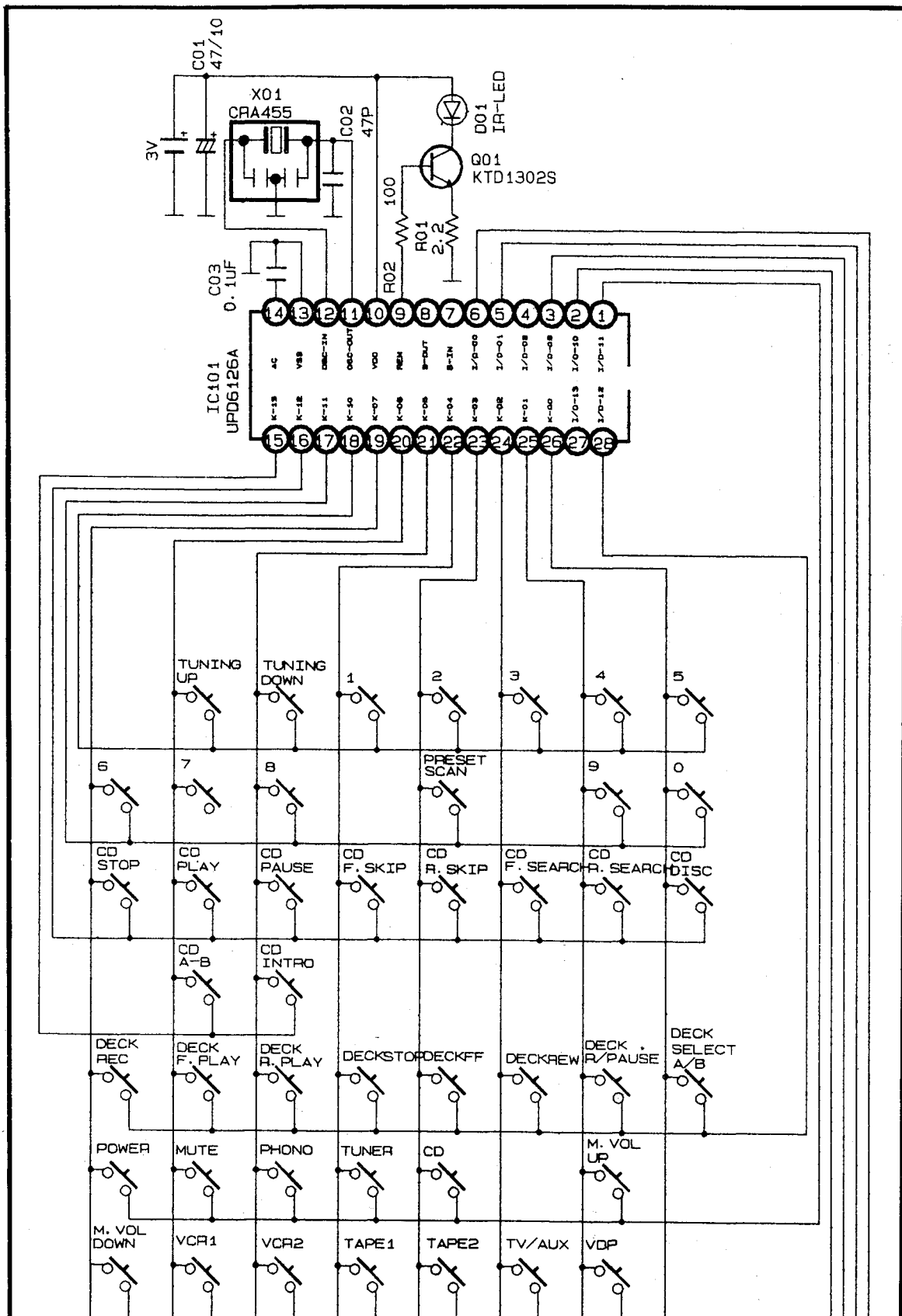
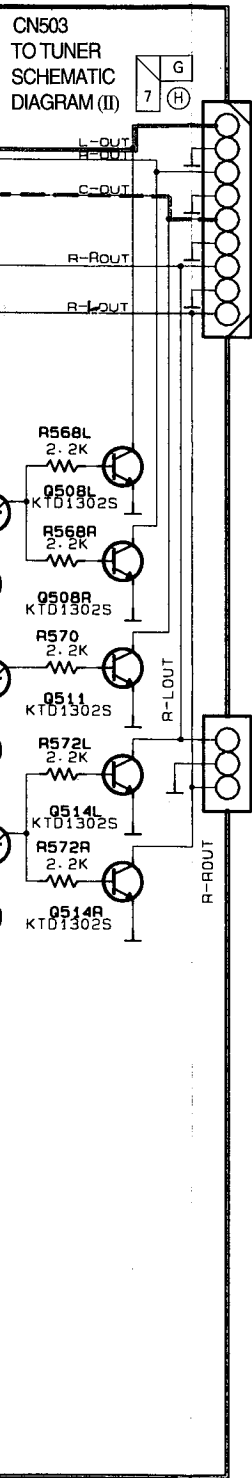

4
5
6
7
8
9

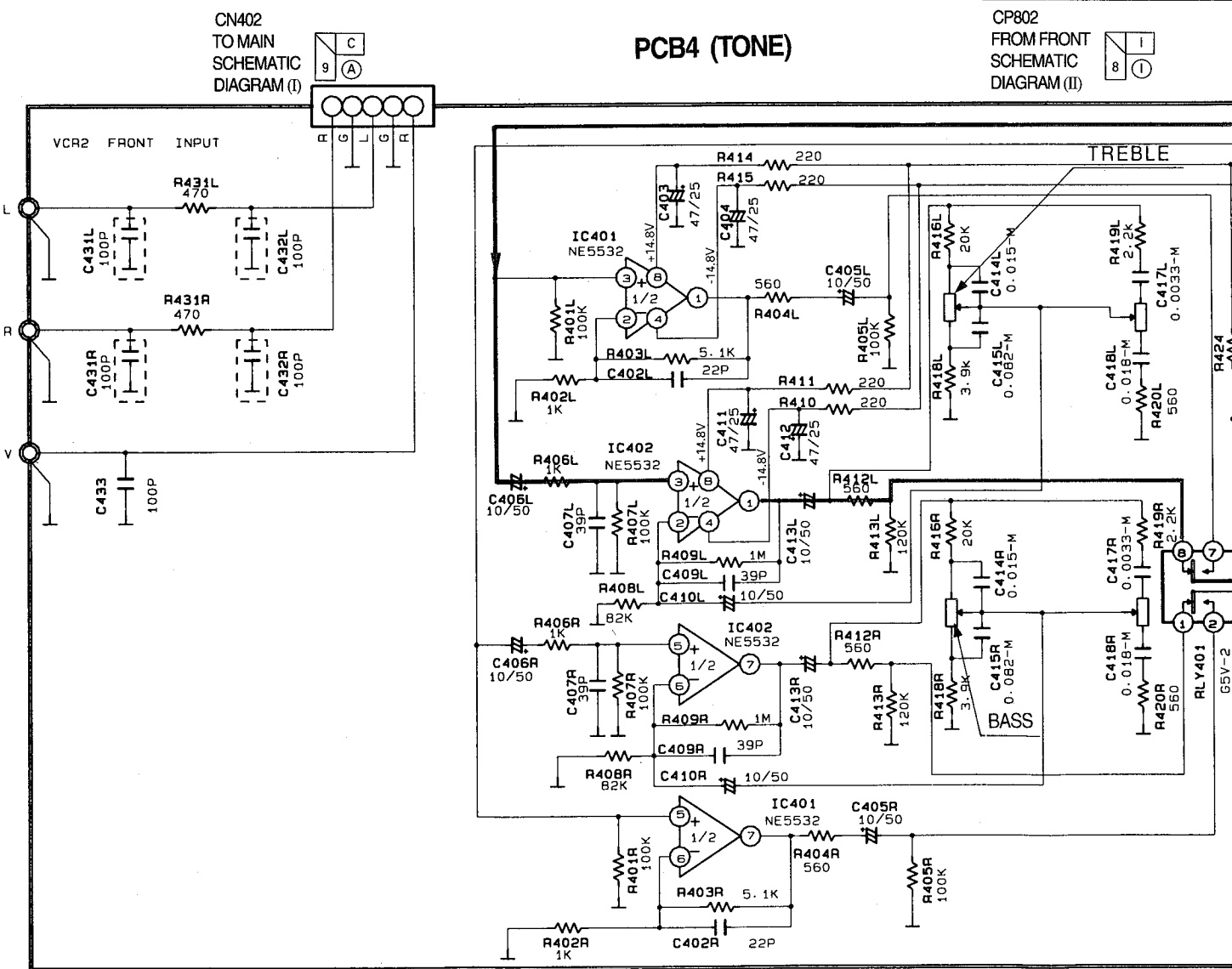
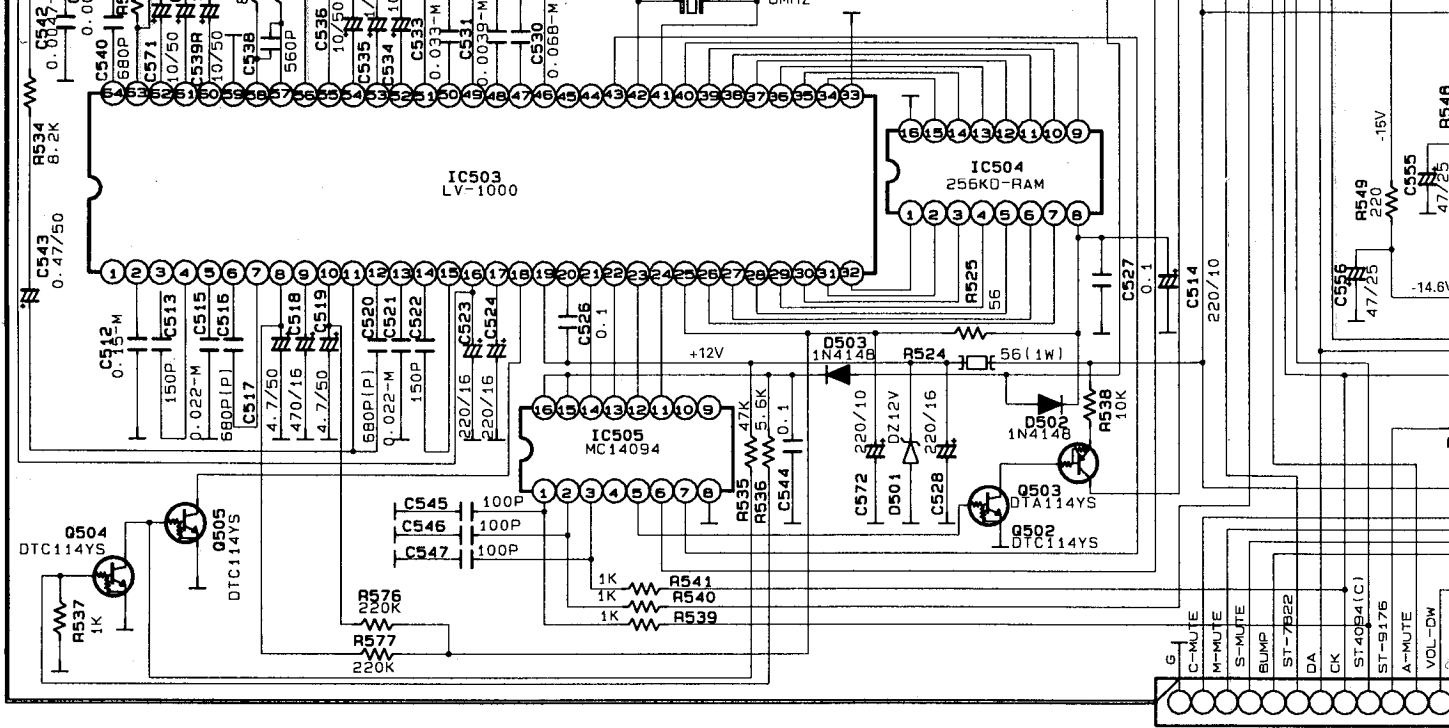

CN402
TO MAIN
SCHEMATIC
DIAGRAM (I)

PCB4 (TONE)

CP802
FROM FRONT
SCHEMATIC
DIAGRAM (II)

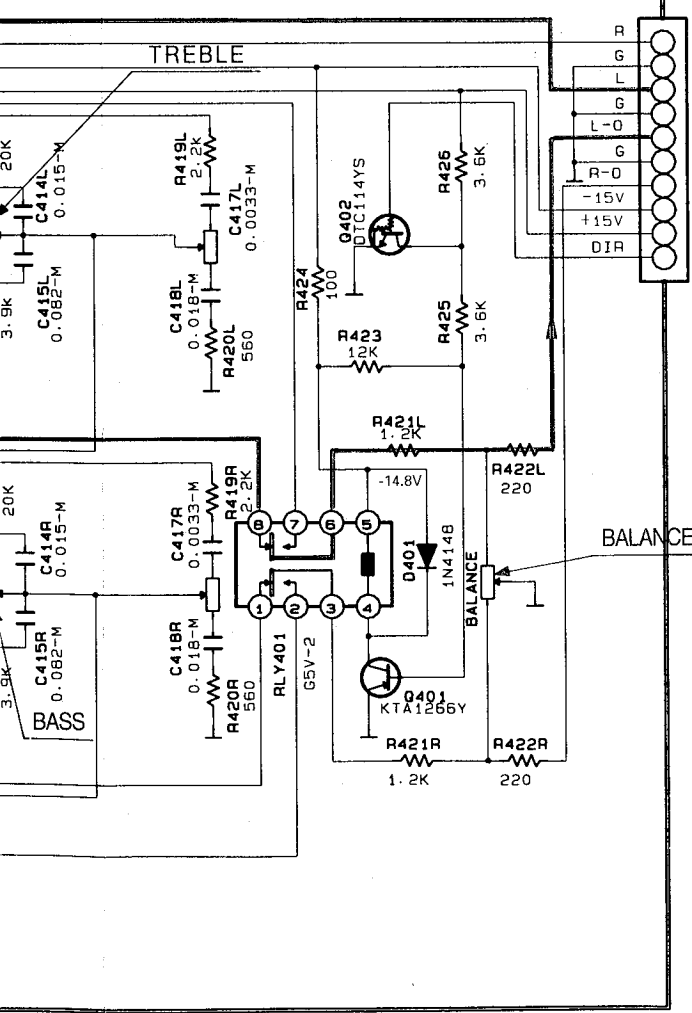
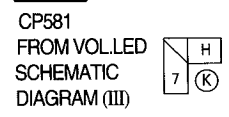
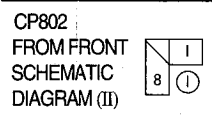
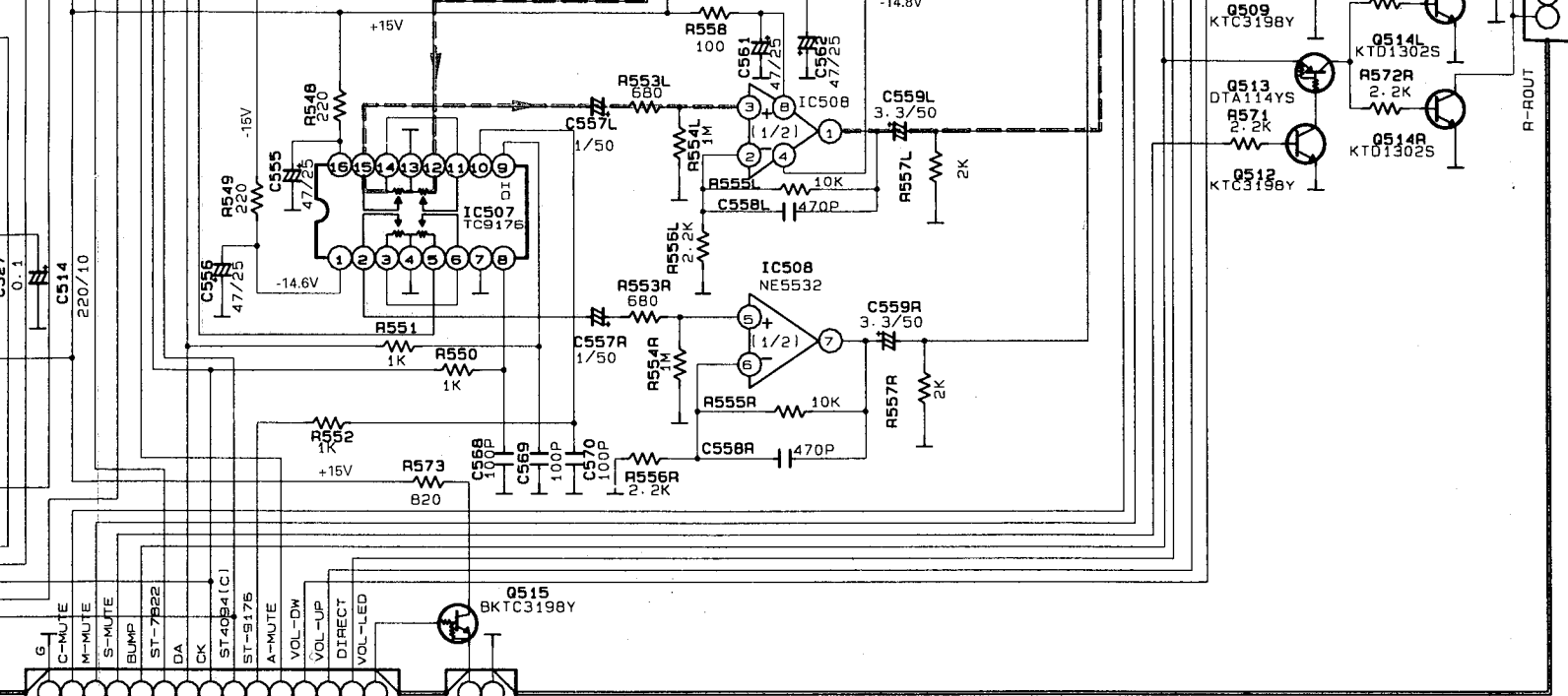

PCB6 (VOLUME LED)

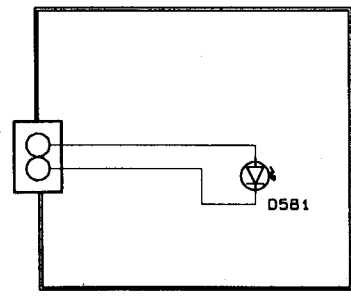
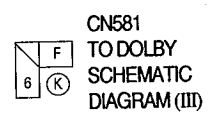
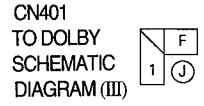

NOTES

1. Resistor values are indicated in ohms unless otherwise specified
(K=1,000 M=1,000,000)
2. Capacitor values are indicated in microfarads unless otherwise specified.
(p=micro-microfarads)

CAUTION

Safety precaution to be followed during servicing

- 1) Since those parts marked with are critical parts for safety, use only the one described in the parts list
- 2) Before returning the set to the customer make appropriate leakage current or resistance measurements to determine the exposed parts are properly insulated from the supply circuit.

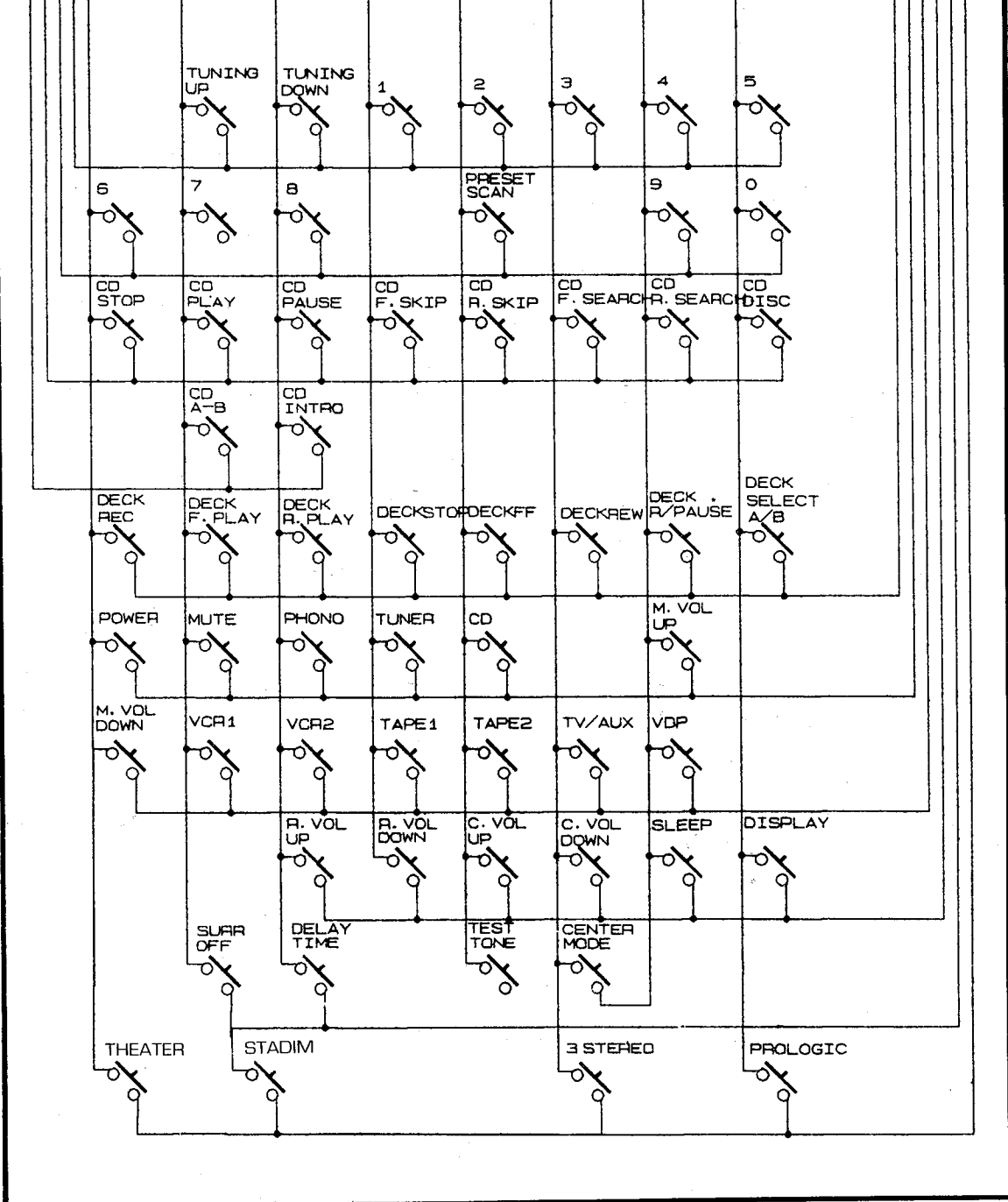

SURROUND SIGNAL



FRONT "L" ch. SIGNAL



CENTER SIGNAL

REAR PANEL CONNECTIONS

Rear Panel - Audio and System Connections

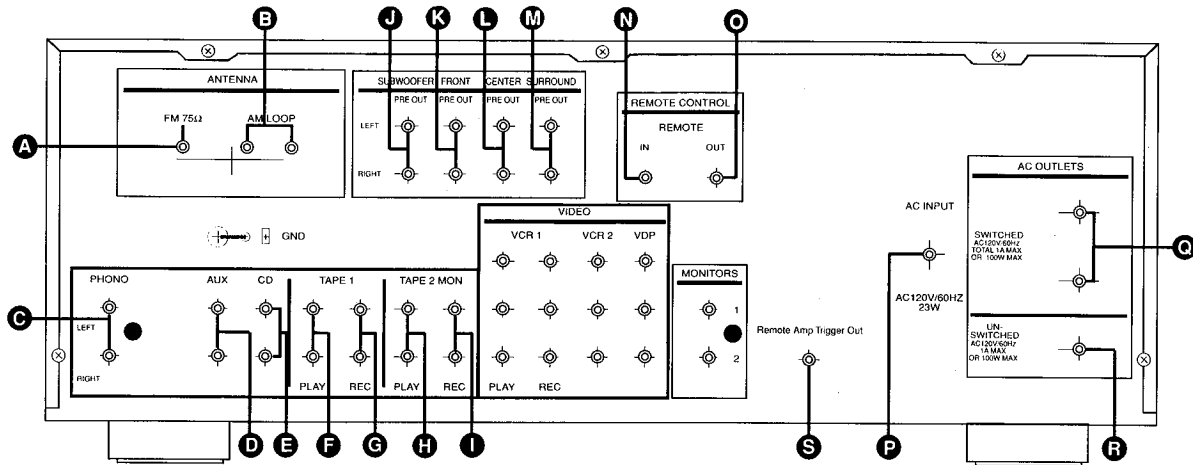

- | | | |
|--------------------------|----------------------------------|---------------------------------|
| A FM Antenna | H Tape2 Monitor In | N Remote Control-In |
| B AM Antenna | I Tape2 Monitor Out (REC) | O Remote Control-Out |
| C Phone In | J Subwoofer Pre-Out | P Power Cable |
| D Aux In | K Front Pre-Out | Q Switched AC Outlets |
| E CD In | L Center Pre-Out | R UnSwitched AC Outlets |
| F Tape1 In | M Surround Pre-Out | S Remote Amp Trigger Out |
| G Tape1 Out (REC) | | |

Rear Panel - Video Connections

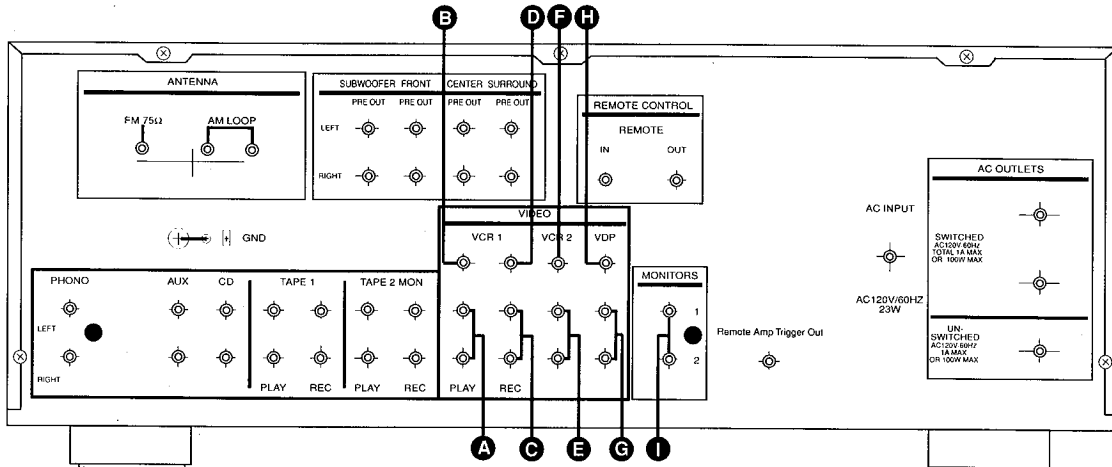

- | | |
|-------------------------------|-------------------------|
| A VCR1 Audio In (PLAY) | F VCR2 Video In |
| B VCR1 Video In | G VDP Audio In |
| C VCR1 Audio Out (REC) | H VDP Video In |
| D VCR1 Video Out | I TV Monitor Out |
| E VCR2 Audio In | |

PACKAGE

