harman/kardon
Service Manual

MAS 100

MAS 110

SAS 100

Compact Music System
Service Manual for CD section
and MAS 1 loudspeaker



CONTENTS

BASIC SPECIFICATIONS	2	PARTS LIST	10
FRONT PANEL INFORMATION	3	SEMICONDUCTOR PINOUTS	12
REAR PANEL INFORMATION	4	PCB DRAWINGS	19
REMOTE CONTROL INFORMATION	5	SCHEMATIC DIAGRAMS	31
EXPLODED VIEW	7	MAS 1 LOUDSPEAKER, EXPLODED VIEW	35
WIRING DIAGRAM	9	MAS 1 PARTS LIST	36

TECHNICAL SPECIFICATIONS

SYSTEM:

Power output: 65 watts per channel, 20Hz – 20kHz,
THD < 0.07%, into 6 ohms, both channels driven

Bandwidth: 20Hz – 35kHz, –3dB

System frequency response: 20Hz – 20kHz, ± 0.5 dB

Signal-to-noise ratio, A-weighted: 98dB

Channel separation: ≥ 65 dB

Crosstalk between sources: ≥ 70 dB

Line-level input sensitivity at 1kHz: 250mV RMS, ± 1 dB

LOUDSPEAKERS:

Low-frequency transducers: Two 130mm honeycomb
composite drivers, ported

High-frequency transducers: Two 25mm MMD
domes, shielded

Nominal impedance: 8 ohms

Sensitivity (2.83V/1m): 85dB

Frequency response: 60Hz – 25kHz (–3dB)

Crossover frequency: 2200Hz

FM TUNER SECTION:

Frequency range: 76 – 108.0MHz

Usable sensitivity: IHF 1.3 μ V/13.2dBf

Frequency Response: 10Hz to 15.3kHz

Signal-to-noise ratio: mono/stereo 70/68dB

Distortion: mono/stereo 0.15/0.3%

Stereo separation: 35dB @ 1kHz, 100% deviation @ 65dBf

Selectivity: ± 300 kHz: 65dBf

Image rejection: 80dB

IF rejection: 90dB

Tuner output level: 1kHz, ± 50 kHz, Dev 500mV

Number of presets: 30

RDS capability: PS (program service), RT (dynamic radio text)

CD SECTION:

Disc compatibility: CD, CD-R, CD-RW, MP3, WMA

THD+N (20Hz – 20kHz): <0.025%

Frequency response: 20Hz to 20kHz, 0dB ± 0.5

Channel separation: ≥ 65 dB

Signal-to-noise ratio:

- “A” WTG > 96dB
- 22kHz filter > 94dB

GENERAL:

Power requirement: AC 230V/50Hz

Power consumption: <1W full standby (clock not activated);
<2W standby (clock activated); 80W maximum
(both channels driven)

Operating temperature: 0°C to 40°C

Dimensions (H x W x D):

Controller: 90mm x 240mm x 240mm

Amplifier: 90mm x 240mm x 240mm

Loudspeakers (each, with grille): 272mm x 181mm x 196mm

Weight:

System: 8.2kg

Controller: 8kg

Amplifier: 8kg

Loudspeakers (each): 4.4kg



Features, specifications and appearance are subject to change without notice.

Harman Kardon is a trademark of Harman International Industries, Incorporated, registered in the United States and/or other countries. Designed to Entertain and The Bridge II logo are trademarks of Harman International Industries, Incorporated.

iPod is a trademark of Apple Inc., registered in the U.S. and other countries. iPhone is a trademark of Apple Inc. iPod not included. “Made for iPod” means that an electronic accessory has been designed to connect specifically to iPod and has been certified by the developer to meet Apple performance standards. Apple is not responsible for the operation of this device or its compliance with safety and regulatory standards.

Please register your product at www.harmankardon.com. You’ll need your product’s serial number. At the same time, you can choose to be notified about new products and/or special promotions.

FRONT-PANEL CONTROLS CONTROLLER AND AMPLIFIER

The MAS 100 and MAS 110 use touch-sensitive controls. To use a control, tap gently on its lit icon.

NOTE: Controls are the same for all models.

Power: Turns the MAS 100/MAS 110 on or places it in Standby mode. To completely power off the unit, unplug the power supply.

Message Display: The time and messages are displayed in this two-line text display.

CD Slot: Load compatible discs here.

Skip/Scan Forward/Reverse: These buttons function differently, depending on the current source:

iPod, CD or USB: Press and release to skip to the next track. Press the reverse button twice to skip to the previous track. Press and hold to scan forward or reverse within a track.

Radio: Press and release to select the next programmed preset station. Press and hold to scan quickly through the stations. When you release the button, the tuner continues to scan until it finds a station of acceptably strong signal quality, and then it stops. To stop the scan before a station is found, press the button again.

Play/Pause: Each tap toggles between the Play and Pause functions.

Stop: Fully stops playback.

Eject: When a CD is loaded, tap here to eject it.

USB Port A: Connect a compatible USB device here to enjoy playback of audio MP3 or WMA files. Although most USB flash and hard-disk drives in the FAT32 file format, as well as many MP3 players, are compatible with the MAS 100 and MAS 110 systems, due to the wide variety of manufacturers, playback cannot be guaranteed. Do not connect an iPod or iPhone to this port. Do not connect a personal computer or any peripherals to this port.

Line-In Jack (Line Input): Connect a 3.5mm male-to-male cable (not included) to the headphone or line-level output on a portable player or other device.

Headphone Jack: Outputs a stereo signal for private listening through most headphones that are equipped with a 3.5mm plug.

Volume Control: Increases or decreases the volume.

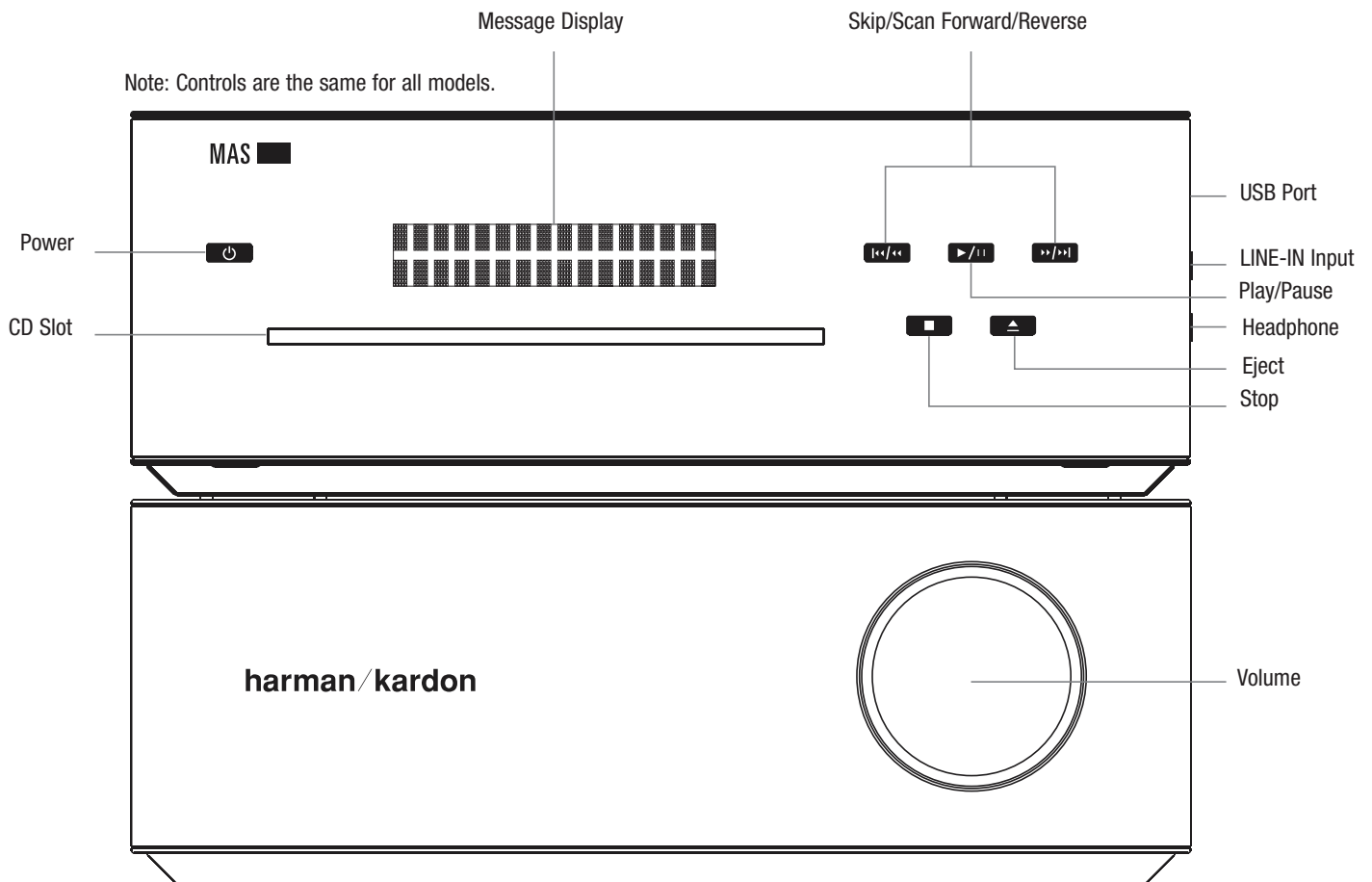

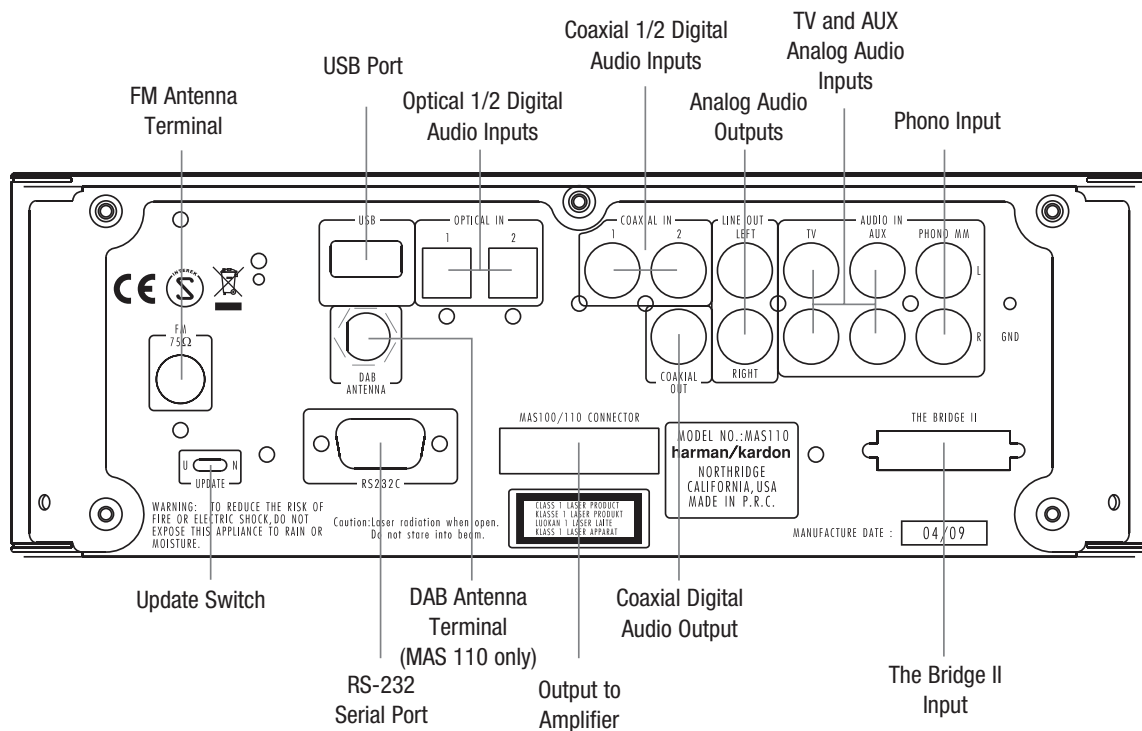

FM Antenna Terminal: Connect the included FM antenna wire here.

DAB Antenna Terminal (MAS 110 Only): Connect the included DAB antenna wire lead here to enjoy programming from digital DAB, DAB+ or T-DMB-Audio radio stations available in your area.

USB Port B: Connect a compatible USB device here to enjoy playback of audio MP3 or WMA files. Although most USB flash and hard-disk drives in the FAT32 file format, as well as many MP3 players, are compatible with the MAS 100 and MAS 110 systems, due to the wide variety of manufacturers, playback cannot be guaranteed. Do not connect an iPod or iPhone to this port. Do not connect a personal computer or any peripherals to this port.

Optical 1/2 and Coaxial 1/2 Digital Audio Inputs: Connect a source device's optical or coaxial digital audio output to the corresponding input. Only the PCM uncompressed format is supported.

TV and AUX Analog Audio Inputs: Connect the analog audio outputs of a television or any source device to enjoy playback through the high-performance MAS system.

Phono Input: Connect the outputs of a moving magnet (MM) type turntable to this input. Do not connect any other type of turntable to this input, and do not connect the outputs of an MM-type turntable to any other analog audio inputs on the MAS 100 or MAS 110 without using a phono preamp, available separately from many electronics stores.

The Bridge II Input: To enjoy playback of audio materials stored on a compatible iPod (see page 4), connect The Bridge II dock (included with the MAS 110/240 system; available separately for the MAS 100 and MAS 110/230 systems). Make sure the insert for The Bridge II is installed, and install the appropriate dock adapter for your iPod within the insert, as shown in Figure 1 on page 10.

Analog Audio Outputs: Connect these outputs to the analog audio inputs of an audio recorder. When a source connected to the MAS system is playing, the signal will be available at these outputs for recording.

Coaxial Digital Audio Output: Connect this output to the coaxial digital audio input of a digital audio recorder. When a source connected to the MAS system is playing, the signal will be available at this output for recording.

NOTES:

- The MAS system **does not** convert analog sources to the digital domain, or digital sources to the analog domain for recording.
- It is the user's responsibility to comply with all laws pertaining to the copying of audio materials.

Output to Amplifier: Connect the included ribbon cable to this connector and to the corresponding connector on the MAS amplifier. This cable passes audio signals from the controller to the amplifier, and it transfers DC power from the amplifier to the controller. If this cable is ever damaged, do not use it, and contact Harman Kardon, Inc., for a replacement.

RS-232 Serial Port: This port is used only for system upgrades. Do not connect it to any devices unless instructed to do so at the time a system upgrade is released.

Update Switch: This switch is used only for system upgrades. Leave it in the "N" position for normal operation unless instructed to switch it to the "U" position to install a system update.

REMOTE CONTROL FUNCTIONS

Power: Turns the MAS 100/MAS 110 on or off. To completely power off the unit, unplug the power supply.

Sleep: Each press increases the time until turn-off, from 10 to 90 minutes, in increments of 10 minutes. The next press after the 90 minutes setting turns off the Sleep function.

Source Selectors: Selects a source input. Each press of the Line In or Digital In Buttons toggles among the available analog (Line Input on right-side panel; TV, AUX or Phono Input on rear panel) or digital audio inputs (Coaxial 1 or 2, Optical 1 or 2), respectively. Press the Bridge Button to select an iPod docked in The Bridge II.

Display: Adjusts the brightness of the Message Display when hold pressed for more than one second in every mode or access to some special information on DAB mode if less than one second. In DAB mode, selects station-defined information when pressed for less than one second. Each press changes the brightness: Full, Half or Off. When the display is fully dimmed while the system is turned on, the LED inside the Volume Knob and the LED behind the Power Button will remain lit to remind you that the system is still on.

Settings: Accesses menus for Speaker Setup (tone controls), Time Setup (clock), Alarm Setup, System Version and System Reset. See the Operation section for more information.

- **Back:** Returns to previous menu level.
- **Info:** Displays status of current source.
- **Radio:** When FM band is in use, each press toggles between the PS (Program Service) and RT (Radio Text) RDS information, if available. When a DAB radio station is playing, press this button to access the menu system for the DAB tuner. See pages 14 and 15 for more information.
- **Audio CD:** Displays CD Text information, if available. Each press displays the following items: Song, Artist, Album.
- **USB or Data CD:** Scrolls all ID3 tag information for current source, if available. Each press displays the following individual items: Song, Artist, Album, File type, Folder, then back to scrolling. If ID3 tags are not available, the filename will appear.

Time: Displays elapsed track time for the current Audio CD (no effect on data CDs or other sources). Each additional press changes the display as follows: remaining track time, elapsed disc time, remaining disc time, then back to elapsed track time.

▲/▼◀/▶ Navigation Buttons: Use the ◀ and ▶ Buttons to scroll forward and reverse through the Settings Menus, or through lists of content, and press the Enter Button to make selections. Press the Back Button to return to the previous menu or content level.

Enter: Selects a menu item, or saves setting changes and returns to the previous menu level.

Clear: Clears the current preset station or a playlist entry.

Radio: To delete the current preset station, press the Clear Button while it is playing.

Playlist: While programming a playlist, press to delete the track just entered. After the playlist has been saved by pressing the Stop Button, press the Clear Button to delete the entire playlist. To delete a single track, stop play, press the Check Button repeatedly until the desired track appears and press the Clear Button. Press the Play Button to exit Check mode.

Program/Memory: Used to program playlists and radio presets.

- **Radio:** If the current station has not been programmed into a preset, press Program/Memory and press the Enter Button to store the station at the current preset number, or use the Numeric Keys to enter a different preset number. The new preset will overwrite the existing one.
- **USB or CD (Audio or Data):** Press the Program Button to begin Program Mode. Add tracks to the playlist by using the Skip/Scan Transport Controls or the Numeric Keys to select the track, then press the Program Button to enter the selection. Add up to 99 files. Press Play to play the playlist, or Stop to save the playlist without playing it. During playback, the order of the track in the playlist will appear on the left, with the disc's track number to the right. See page 16.

Check: After a playlist has been programmed and play has been stopped, each press of the Check Button displays the tracks in the playlist.

Eject: When a CD is loaded, press this button to eject it.

FM Mode: Used with FM radio, each press toggles between Stereo and Monaural playback.

Auto Store: Scans through all frequencies, searching for stations with acceptably strong signal quality, and stores them as presets.

Random: Each press turns Random playback mode (shuffle) on or off. This mode plays the tracks of the current disc or drive in random order.

Transport Controls

Track-Skip/Tuning Up/Down: These buttons function differently, depending on which source has been selected:

- **iPod, CD or USB:** Press and release to skip to the next track. Press the reverse button twice to skip to the previous track.
- **Radio:** Press and release the Track Skip Buttons to tune to the next higher or lower station by one frequency increment. Press and hold to scan quickly through the stations.

Scan Forward/Reverse: Press and hold to scan forward or in reverse within a track when the iPod, CD or USB sources are playing.

Play/Pause: Each tap toggles between the Play and Pause functions.

Stop: Fully stops playback.

REMOTE CONTROL FUNCTIONS

Preset/Folder +/-: Selects a preset station or folder on a USB or data CD.

Radio: Each press changes to the next or previous preset station, if any have been programmed.

USB or Data CD: Press once to open the current folder. Each additional press changes to the next or previous folder. After 3 seconds, the first track in the new folder will begin playing.

Mute: Press to temporarily silence the speakers. Press again to restore audio. Muting is canceled if the MAS 100/MAS 110 is turned off.

Volume +/-: Increases or decreases the volume. Press and hold to change the volume more quickly.

Numeric Keys: Used to enter track numbers, radio stations or preset numbers, or while adjusting the clock and alarm times.

-10 and +10 Numeric Key: Used with a USB device or CD to quickly advance through a large number of tracks. Each press of these keys changes to the next or previous track in increments of 10.

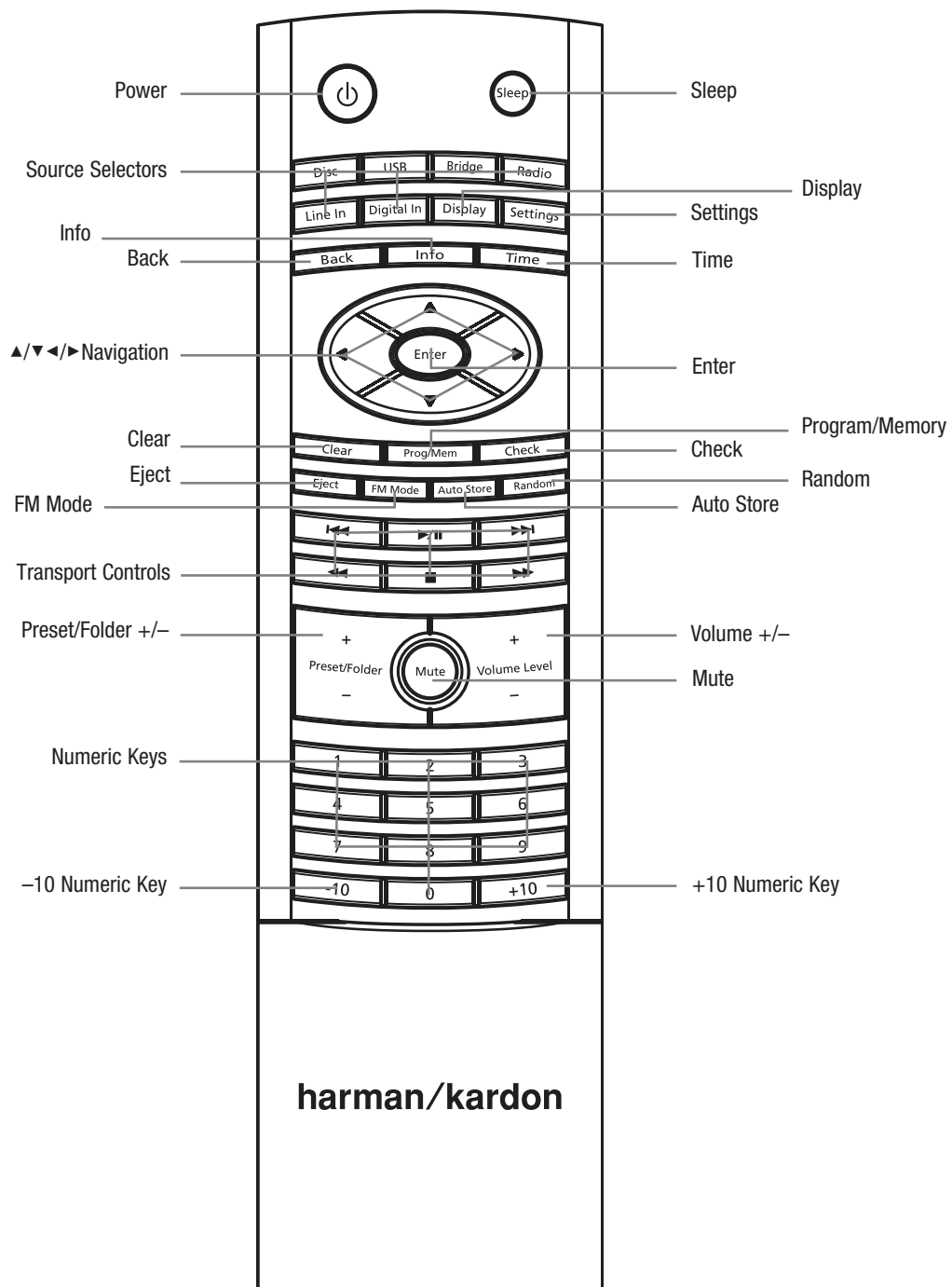

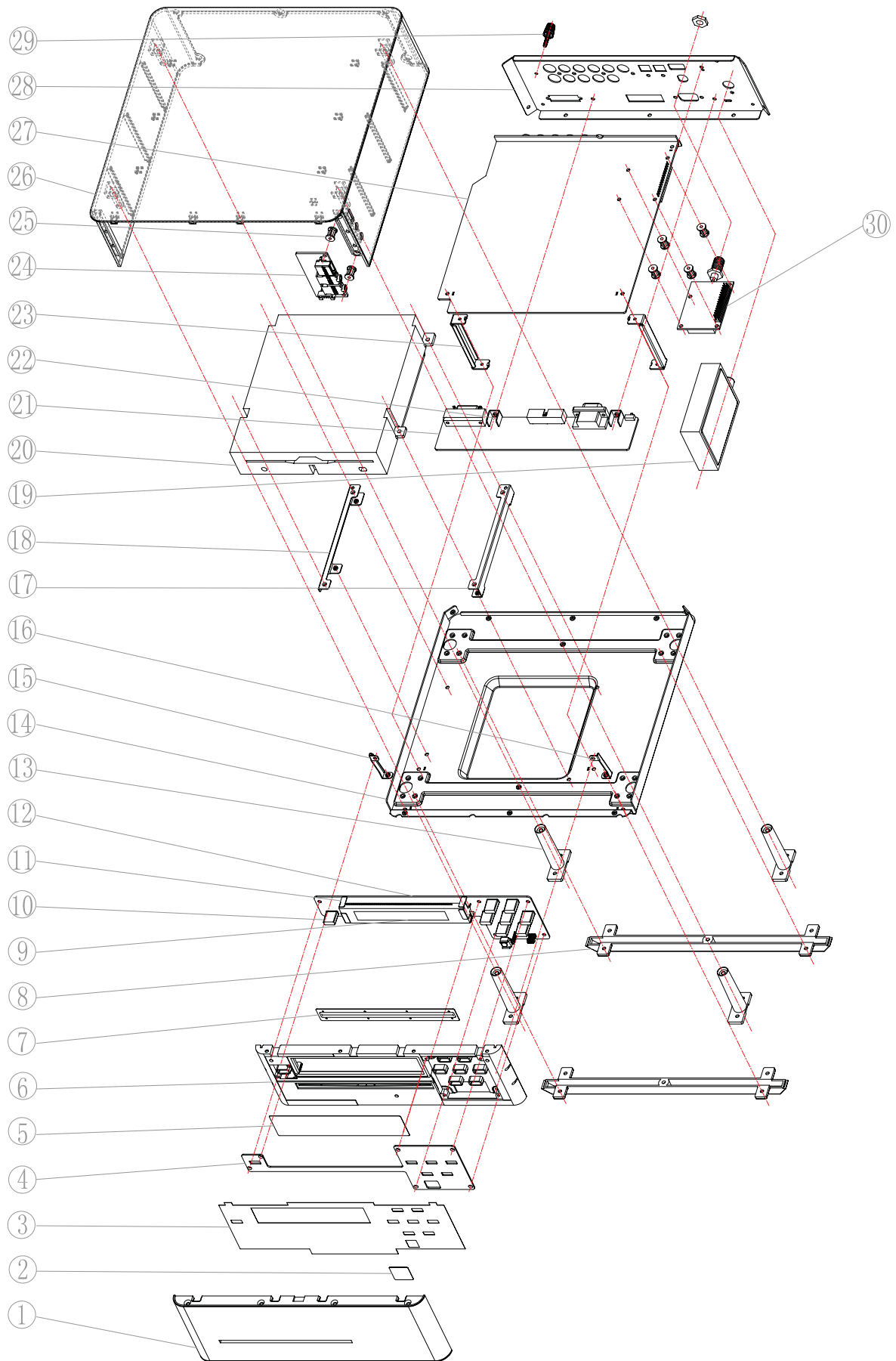

MAS CD Explode List

NO	PART.NO	DESCRIPTION	QTY
1	7450 5010 0000	DISPLAY LENS	1
2	7750 5040 0000	BLUE PVC SHEET	1
3	7750 501D 0000	FRONT PANEL PVC SHEET	1
4	0082 5003 0000	TOUCH PCB	1
5	7450 503A 0000	FILTER LENS	1
6	7550 501A 0000	SUB PANEL	1
7	7950 503C 0000	DUSTPROOF CLOTH	1
8	7950 5020 0000	FOOT	2
9	1521 6216 0101	162-SD-16INK	1
10	7450 502A 0000	LIGHTGUIDE	6
11	5337 5010 0000	DISPLAY BRACKET	2
12	0082 5010 0000	DISPLAY PCB	1
13	7550 502A 0000	PLASTIC POST	4
14	6250 501B 0011	BUTTOM COVER	1
15	5350 5010 0000	SUB PANEL LEFT BRACKET	1
16	5350 5020 0000	SUB PANEL RIGHT BRACKET	1
17	5350 503A 0000	LOADER LEFT BRACKET	1
18	5350 504A 0000	LOADER RIGHT BRACKET	1
*19	0082 3270 0000	TUNER PCB(MAS100 MAS110)	1
*19	0082 3271 0000	TUNER PCB(SAS100)	1
20	7500 0070 0000	DLM1D07 BRACKET	1
21	0082 5430 0000	RS232 PCB	1
22	5331 1080 0060	U FORM PCB BRACKET (A)	2
23	5349 105A 0000	DECODER BRACKET	2
24	0082 5070 0000	PHONE PCB	1
25	8730 1000 0000	KDDT-382	4
26	7950 5010 0000	TOP COVER	1
27	0082 5200 0005	CD MAIN PCB (MAS 100)	1
*28	6350 501C 0011	BACK COVER(MAS110)	1
*28	6350 502A 0011	BACK COVER(MAS100 SAS100)	1
29	5017 3012 0000	GROUNDING SCREW S-056B M3x12	1
*30	9520 2500 0001	DAB MODULE(MAS110)	1



REMOTE CONTROL parts number: 9843 3191 0901

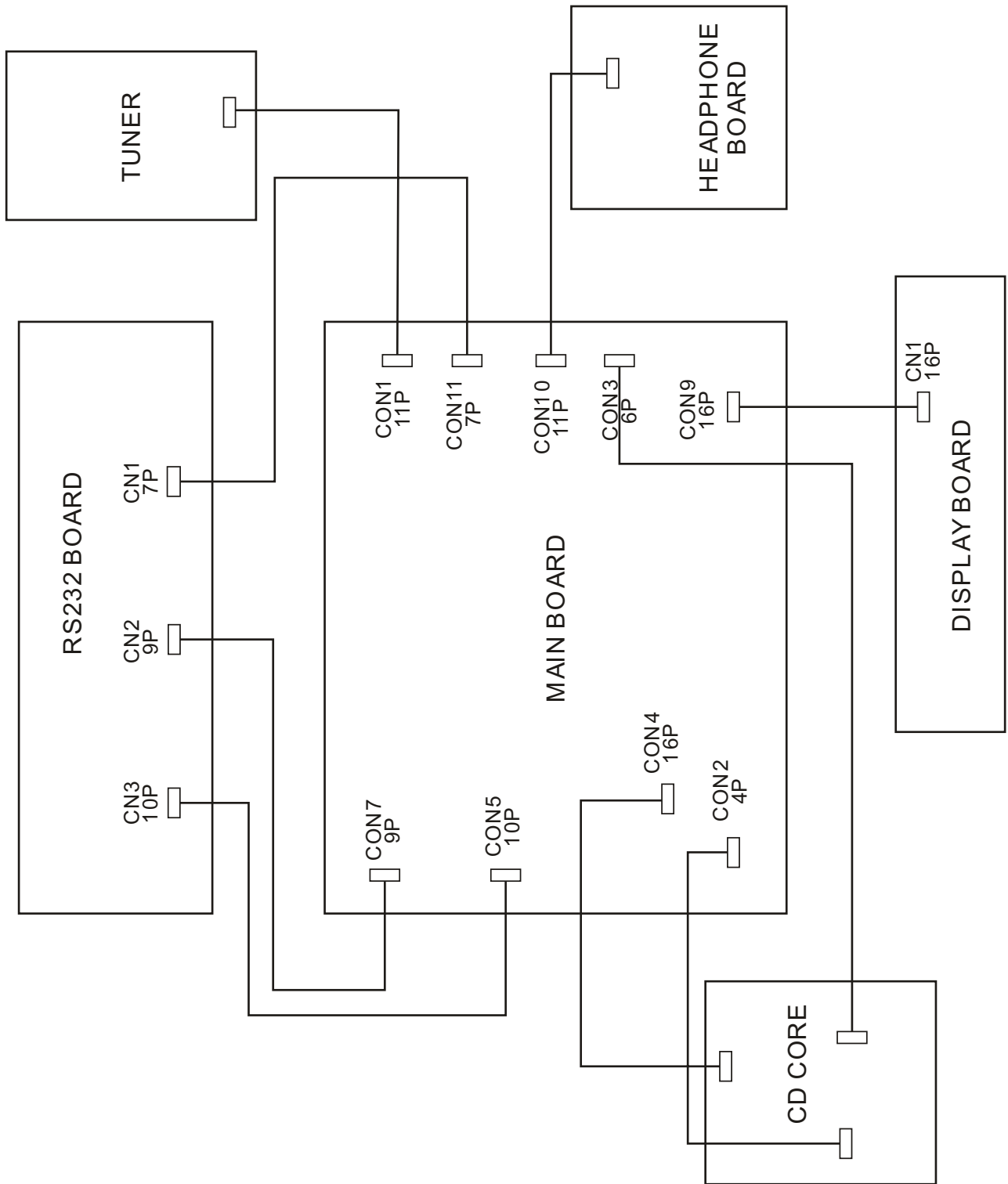

DISPLAY-PCB PN:0082-5010-0000

Used	Part Type	Designator Description	Part number
1	AMS11173.3(SOT-223)	IC1	1011 7330 0128
1	KS-803LM(90°)	IR1	1304 0008 0301
6	HT15-21UWC/TR8	D2 D3 D4 D5 D6 D7	1403 0712 0603
1	162-SD-16INK	VF1	1521 6216 0101
1	JX1.0S-4S-16PWT JACK	CN1	3109 0116 3103
1	2x6P(1.27) JACK	J1	3112 0200 5022
1	10K±5% 0603	R4	2401 1221 0303
2	10R±5% 0603	R1 R2	2401 1221 0003
1	10uF10V±20% E.CAP	C4	2310 0210 1015
1	33K±5% 0603	R3	2401 1223 3303
1	47R±5% 0603	R5	2401 1224 7003
9	0.1uF/50V±10% 0603	C1 C2 C6 C7 C8 C10 C11 C12 C13	2115 6104 0130
2	100uF10V±20% E.CAP	C3 C5	2311 0210 1015
1	100uF16V±20% E.CAP	C9	2311 0310 2015

PHONE-PCB PN:0082-5170-0000

Used	Part Type	Designator Description	Part number
1	FB L0805	L1	1852 0120 9100
7	FB L0603	L2 L3 L4 L5 L6 L7 L8	1852 0120 9200
1	CK3-3.5-510K2 JACK	J1	2821 2350 7000
1	CK3.5-02 JACK	J2	2801 1335 0203
1	USB(18004-1111102) JACK	JP1	2800 1018 0040
1	JX1.0-3S-13PW JACK	CN1	3104 0113 1050
4	47K±5% 0603	R3 R4 R5 R6	2401 1224 7303
2	100±5% 0603	R1 R2	2401 1221 0103
4	330pF/50V±10% 0603	C108 C109 C110 C111	2103 5331 0130
8	0.1uF/50V±10% 0603	C1 C2 C4 C5 C6 C7 C8 C107	2115 6104 0130
1	100uF16V±20% E.CAP	C3	2311 0310 2015

RS232-PCB PN:0082-5430-0000

Used	Part Type	Designator Description	Part number
1	2SA950 TO-92	Q4	1110 9500 0162
1	2SA1162GR SC-59	Q2	1111 1620 7100
2	2SC3361 SC-59	Q1 Q3	1133 3610 6100
1	IN4001	D3	1360 1400 1000
2	1N4148 SMD	D1 D2	1310 4414 8000
1	MMBT5551 SC-59	Q5	1185 5515 1011
1	DB-09 JACK	RS1	2806 0590 0000
1	IDC 2x10P2.54(90)	JK1	3109 0520 4632
1	SCSI-26P-F-90 JACK	JK2	3109 0526 4632
1	7P(2.0) JACK	CN1	3100 4070 0200

1	9P(2.0) JACK	CN2	3100 4090 0250
1	10P(2.0) JACK	CN3	3100 4100 0200
1	MSV-1260	SW1	4330 3002 1311
1	549K±1% 0603	R8	2402 1254 9403
4	0 ±5% 0805	R2 R10 R11 R12	2401 0820 0004
1	1K8±5% 0603	R3	2401 1221 8203
1	1K±5% 0603	R14	2401 1221 0203
1	4K7±5% 0603	R6	2401 1224 7203
5	10K±5% 0603	R4 R5 R7 R13 R17	2401 1221 0303
2	22K±5% 0603	R15 R20	2401 1222 2303
2	33K±5% 0603	R21 R22	2401 1223 3303
1	33R±5% 0603	R18	2401 1223 3003
1	47K±5% 0603	R19	2401 1224 7303
2	100pF/50V±10% 0603	C2 C3	2103 5101 0130
19	0.1uF/50V±10% 0603	C4 C5 C8 C10 C11 C13 C16 C17 C18 C19 C20 C21 C22 C23 C24 C25 C26 C27 C28	2115 6104 0130
1	100R±5% 0603	R16	2401 1221 0103
1	1uF/50V±20% E.CAP	C1	2319 0610 1015
6	100uF16V±20% E.CAP	C6 C7 C9 C12 C14 C15	2311 0310 2015

TOUCH-PCB PN:0082-5003-0000

Used	Part Type	Designator Description	Part number
1	MA83P06(SSOP-28)	U1	1008 3062 2514
1	HEADER 6X2 JACK	J1	3113 0200 6002
1	91K±1% 0603	C11	2403 1219 1303
1	390K±1% 0603	R1	2401 0913 9405
1	0R±5% 0603	R2	2401 1220 0003
6	100R±5% 0603	R6 R7 R8 R9 R10 R11	2401 1221 0103
1	560R±5% 0603	R3	2401 1225 6103
2	4.7K±5% 0603	R4 R5	2401 1224 7203
1	2pF/50V±10% 0603	C3	2115 5209 0135
2	0.1uF/50V±10% 0603	C1 C4	2115 6104 0130

Advanced Monolithic Systems

AMS1117

800mA LOW DROPOUT VOLTAGE REGULATOR

FEATURES

- Three Terminal Adjustable or Fixed Voltages*
1.5V, 1.8V, 2.5V, 2.85V, 3.3V and 5.0V
- Output Current of 800mA
- Operates Down to 1V Dropout
- Line Regulation: 0.2% Max.
- Load Regulation: 0.4% Max.
- SOT-223 and TO-252 package available

APPLICATIONS

- High Efficiency Linear Regulators
- Post Regulators for Switching Supplies
- 5V to 3.3V Linear Regulator
- Battery Chargers
- Active SCSI Terminators
- Power Management for Notebook
- Battery Powered Instrumentation

GENERAL DESCRIPTION

The AMS1117 series of adjustable and fixed voltage regulators are designed to provide 800mA output current and to operate down to 1V input-to-output differential. The dropout voltage of the device is guaranteed maximum 1.3V at maximum output current, decreasing at lower load currents.

On-chip trimming adjusts the reference voltage to 1%. Current limit is also trimmed, minimizing the stress under overload conditions on both the regulator and power source circuitry.

The AMS1117 devices are pin compatible with other three-terminal SCSI regulators and are offered in the low profile surface mount SOT-223 package and in the TO-252 (DPAK) plastic package.

ORDERING INFORMATION:

PACKAGE TYPE		OPERATING JUNCTION TEMPERATURE RANGE
TO-252	SOT-223	
AMS1117CD	AMS1117	0 to 125° C
AMS1117CD-1.5	AMS1117-1.5	0 to 125° C
AMS1117CD-1.8	AMS1117-1.8	0 to 125° C
AMS1117CD-2.5	AMS1117-2.5	0 to 125° C
AMS1117CD-2.85	AMS1117-2.85	0 to 125° C
AMS1117CD-3.3	AMS1117-3.3	0 to 125° C
AMS1117CD-5.0	AMS1117-5.0	0 to 125° C

*For additional available fixed voltages contact factory.

PIN CONNECTIONS

FIXED VERSION

- 1- Ground
- 2- V_{OUT}
- 3- V_{IN}

ADJUSTABLE VERSION

- 1- Adjust
- 2- V_{OUT}
- 3- V_{IN}

SOT-223 Top View

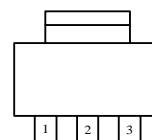

TO-252 FRONT VIEW

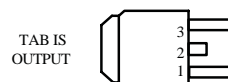

AMS1117

ABSOLUTE MAXIMUM RATINGS (Note 1)

Power Dissipation	Internally limited
Input Voltage	15V
Operating Junction Temperature	
Control Section	0°C to 125°C
Power Transistor	0°C to 150°C
Storage temperature	- 65°C to +150°C

Soldering information	
Lead Temperature (10 sec)	300°C
Thermal Resistance	
TO-252 package	$\phi_{JA} = 80^\circ\text{C/W}$
SOT-223 package	$\phi_{JA} = 90^\circ\text{C/W}^*$
* With package soldering to copper area over backside ground plane or internal power plane ϕ_{JA} can vary from 46°C/W to >90°C/W depending on mounting technique and the size of the copper area.	

ELECTRICAL CHARACTERISTICS

Electrical Characteristics at $I_{OUT} = 0$ mA, and $T_J = +25^\circ\text{C}$ unless otherwise specified.

Parameter	Device	Conditions	Min	Typ	Max	Units
Reference Voltage (Note 2)	AMS1117	$I_{OUT} = 10$ mA $10\text{mA} \leq I_{OUT} \leq 800\text{mA}$, $1.5\text{V} \leq (V_{IN} - V_{OUT}) \leq 12\text{V}$	1.238	1.250	1.262	V
			1.225	1.250	1.270	V
Output Voltage (Note 2)	AMS1117-1.5	$0 \leq I_{OUT} \leq 800\text{mA}$, $3.0\text{V} \leq V_{IN} \leq 12\text{V}$	1.485 1.476	1.500 1.500	1.515 1.524	V V
	AMS1117-1.8	$0 \leq I_{OUT} \leq 800\text{mA}$, $3.3\text{V} \leq V_{IN} \leq 12\text{V}$	1.782 1.773	1.800 1.800	1.818 1.827	V V
	AMS1117-2.5	$0 \leq I_{OUT} \leq 800\text{mA}$, $4.0\text{V} \leq V_{IN} \leq 12\text{V}$	2.475 2.460	2.500 2.500	2.525 2.560	V V
	AMS1117-2.85	$0 \leq I_{OUT} \leq 800\text{mA}$, $4.35\text{V} \leq V_{IN} \leq 12\text{V}$	2.82 2.79	2.850 2.850	2.88 2.91	V V
	AMS1117-3.3	$0 \leq I_{OUT} \leq 800\text{mA}$, $4.75\text{V} \leq V_{IN} \leq 12\text{V}$	3.267 3.235	3.300 3.300	3.333 3.365	V V
	AMS1117-5.0	$0 \leq I_{OUT} \leq 800\text{mA}$, $6.5\text{V} \leq V_{IN} \leq 12\text{V}$	4.950 4.900	5.000 5.000	5.050 5.100	V V
Line Regulation	AMS1117	$I_{LOAD} = 10$ mA, $1.5\text{V} \leq (V_{IN} - V_{OUT}) \leq 12\text{V}$		0.015	0.2	%
				0.035	0.2	%
	AMS1117-1.5	$3.0\text{V} \leq V_{IN} \leq 12\text{V}$		0.3 0.6	5 6	mV mV
	AMS1117-1.8	$3.3\text{V} \leq V_{IN} \leq 12\text{V}$		0.3 0.6	5 6	mV mV
	AMS1117-2.5	$4.0\text{V} \leq V_{IN} \leq 12\text{V}$		0.3 0.6	6 6	mV mV
	AMS1117-2.85	$4.35\text{V} \leq V_{IN} \leq 12\text{V}$		0.3 0.6	6 6	mV mV
	AMS1117-3.3	$4.75\text{V} \leq V_{IN} \leq 12\text{V}$		0.5 1.0	10 10	mV mV
	AMS1117-5.0	$6.5\text{V} \leq V_{IN} \leq 12\text{V}$		0.5 1.0	10 10	mV mV
Load Regulation (Notes 2, 3)	AMS1117	$(V_{IN} - V_{OUT}) = 3\text{V}$, $10\text{mA} \leq I_{OUT} \leq 800\text{mA}$		0.1	0.3	%
				0.2	0.4	%
	AMS1117-1.5	$V_{IN} = 5\text{V}$, $0 \leq I_{OUT} \leq 800\text{mA}$		3 6	10 20	mV mV
	AMS1117-1.8	$V_{IN} = 5\text{V}$, $0 \leq I_{OUT} \leq 800\text{mA}$		3 6	10 20	mV mV
	AMS1117-2.5	$V_{IN} = 5\text{V}$, $0 \leq I_{OUT} \leq 800\text{mA}$		3 6	12 20	mV mV

AMS1117

ELECTRICAL CHARACTERISTICS

Electrical Characteristics at $I_{OUT} = 0$ mA, and $T_J = +25^\circ\text{C}$ unless otherwise specified.

Parameter	Device	Conditions	Min	Typ	Max	Units
Load Regulation (Notes 2, 3)	AMS1117-2.85	$V_{IN} = 5\text{V}, 0 \leq I_{OUT} \leq 800\text{mA}$		3 6	12 20	mV mV
	AMS1117-3.3	$V_{IN} = 5\text{V}, 0 \leq I_{OUT} \leq 800\text{mA}$		3 7	15 25	mV mV
	AMS1117-5.0	$V_{IN} = 8\text{V}, 0 \leq I_{OUT} \leq 800\text{mA}$		5 10	20 35	mV mV
Dropout Voltage ($V_{IN} - V_{OUT}$)	AMS1117-1.5/-1.8/-2.5/-2.85/-3.3/-5.0	$\Delta V_{OUT}, \Delta V_{REF} = 1\%, I_{OUT} = 800\text{mA}$ (Note 4)		1.1	1.3	V
Current Limit	AMS1117-1.5/-1.8/-2.5/-2.85/-3.3/-5.0	$(V_{IN} - V_{OUT}) = 5\text{V}$	900	1,100	1,500	mA
Minimum Load Current	AMS1117	$(V_{IN} - V_{OUT}) = 12\text{V}$ (Note 5)		5	10	mA
Quiescent Current	AMS1117-1.5/-1.8/-2.5/-2.85/-3.3/-5.0	$V_{IN} \leq 12\text{V}$		5	10	mA
Ripple Rejection	AMS1117	$f = 120\text{Hz}, C_{OUT} = 22\mu\text{F}$ Tantalum, $I_{OUT} = 800\text{mA}$, $(V_{IN} - V_{OUT}) = 3\text{V}, C_{ADJ} = 10\mu\text{F}$	60	75		dB
	AMS1117-1.5/-1.8/-2.5/-2.85	$f = 120\text{Hz}, C_{OUT} = 22\mu\text{F}$ Tantalum, $I_{OUT} = 800\text{mA}$, $V_{IN} = 6\text{V}$	60	72		dB
	AMS1117-3.3	$f = 120\text{Hz}, C_{OUT} = 22\mu\text{F}$ Tantalum, $I_{OUT} = 800\text{mA}$ $V_{IN} = 6.3\text{V}$	60	72		dB
	AMS1117-5.0	$f = 120\text{Hz}, C_{OUT} = 22\mu\text{F}$ Tantalum, $I_{OUT} = 800\text{mA}$ $V_{IN} = 8\text{V}$	60	68		dB
Thermal Regulation	AMS1117	$T_A = 25^\circ\text{C}, 30\text{ms}$ pulse		0.008	0.04	%W
Adjust Pin Current	AMS1117	$10\text{mA} \leq I_{OUT} \leq 800\text{mA}, 1.5\text{V} \leq (V_{IN} - V_{OUT}) \leq 12\text{V}$		55	120	μA μA
Adjust Pin Current Change	AMS1117	$10\text{mA} \leq I_{OUT} \leq 800\text{mA}, 1.5\text{V} \leq (V_{IN} - V_{OUT}) \leq 12\text{V}$		0.2	5	μA
Temperature Stability				0.5		%
Long Term Stability		$T_A = 125^\circ\text{C}, 1000\text{Hrs}$		0.3	1	%
RMS Output Noise (% of V_{OUT})		$T_A = 25^\circ\text{C}, 10\text{Hz} \leq f \leq 10\text{kHz}$		0.003		%
Thermal Resistance Junction-to-Case					15	$^\circ\text{C}/\text{W}$

Parameters identified with **boldface type** apply over the full operating temperature range.

Note 1: Absolute Maximum Ratings indicate limits beyond which damage to the device may occur. For guaranteed specifications and test conditions, see the Electrical Characteristics. The guaranteed specifications apply only for the test conditions listed.

Note 2: Line and Load regulation are guaranteed up to the maximum power dissipation of 1.2 W. Power dissipation is determined by the input/output differential and the output current. Guaranteed maximum power dissipation will not be available over the full input/output range.

Note 3: See thermal regulation specifications for changes in output voltage due to heating effects. Line and load regulation are measured at a constant junction temperature by low duty cycle pulse testing. Load regulation is measured at the output lead $\sim 1/8''$ from the package.

Note 4: Dropout voltage is specified over the full output current range of the device.

Note 5: Minimum load current is defined as the minimum output current required to maintain regulation. When $1.5\text{V} \leq (V_{IN} - V_{OUT}) \leq 12\text{V}$ the device is guaranteed to regulate if the output current is greater than 10mA.

AMS1117

APPLICATION HINTS

The AMS1117 series of adjustable and fixed regulators are easy to use and are protected against short circuit and thermal overloads. Thermal protection circuitry will shut-down the regulator should the junction temperature exceed 165°C at the sense point.

Pin compatible with older three terminal adjustable regulators, these devices offer the advantage of a lower dropout voltage, more precise reference tolerance and improved reference stability with temperature.

Stability

The circuit design used in the AMS1117 series requires the use of an output capacitor as part of the device frequency compensation. The addition of 22µF solid tantalum on the output will ensure stability for all operating conditions.

When the adjustment terminal is bypassed with a capacitor to improve the ripple rejection, the requirement for an output capacitor increases. The value of 22µF tantalum covers all cases of bypassing the adjustment terminal. Without bypassing the adjustment terminal smaller capacitors can be used with equally good results.

To ensure good transient response with heavy load current changes capacitor values on the order of 100µF are used in the output of many regulators. To further improve stability and transient response of these devices larger values of output capacitor can be used.

Protection Diodes

Unlike older regulators, the AMS1117 family does not need any protection diodes between the adjustment pin and the output and from the output to the input to prevent over-stressing the die. Internal resistors are limiting the internal current paths on the AMS1117 adjustment pin, therefore even with capacitors on the adjustment pin no protection diode is needed to ensure device safety under short-circuit conditions.

Diodes between the input and output are not usually needed. Microsecond surge currents of 50A to 100A can be handled by the internal diode between the input and output pins of the device. In normal operations it is difficult to get those values of surge currents even with the use of large output capacitances. If high value output capacitors are used, such as 1000µF to 5000µF and the input pin is instantaneously shorted to ground, damage can occur. A diode from output to input is recommended, when a crowbar circuit at the input of the AMS1117 is used (Figure 1).

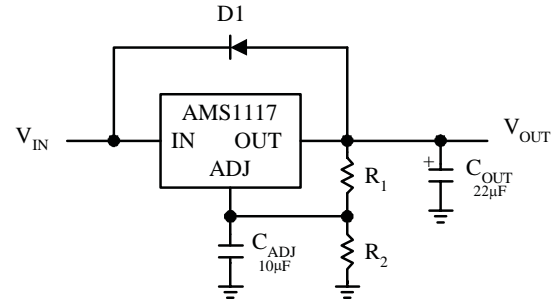
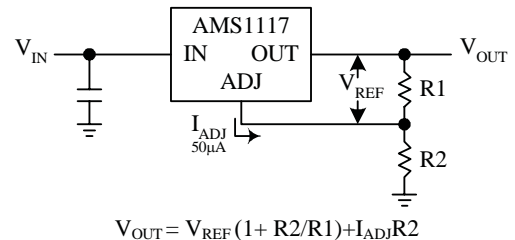

Figure 1.

Output Voltage

The AMS1117 series develops a 1.25V reference voltage between the output and the adjust terminal. Placing a resistor between these two terminals causes a constant current to flow through R1 and down through R2 to set the overall output voltage. This current is normally the specified minimum load current of 10mA. Because I_{ADJ} is very small and constant it represents a small error and it can usually be ignored.



$$V_{OUT} = V_{REF} (1 + R2/R1) + I_{ADJ}R2$$

Figure 2. Basic Adjustable Regulator

Load Regulation

True remote load sensing it is not possible to provide, because the AMS1117 is a three terminal device. The resistance of the wire connecting the regulator to the load will limit the load regulation. The data sheet specification for load regulation is measured at the bottom of the package. Negative side sensing is a true Kelvin connection, with the bottom of the output divider returned to the negative side of the load.

The best load regulation is obtained when the top of the resistor divider R1 is connected directly to the case not to the load. If R1 were connected to the load, the effective resistance between the regulator and the load would be:

$$R_p \times \frac{R2+R1}{R1}, \quad R_p = \text{Parasitic Line Resistance}$$

AMS1117

APPLICATION HINTS

Connected as shown, R_P is not multiplied by the divider ratio

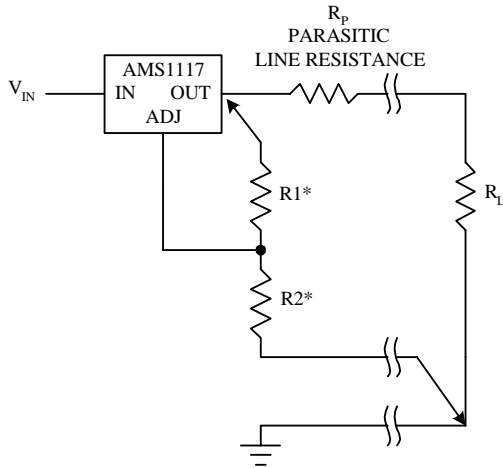

*CONNECT R1 TO CASE
CONNECT R2 TO LOAD

Figure 3. Connections for Best Load Regulation

In the case of fixed voltage devices the top of R1 is connected Kelvin internally, and the ground pin can be used for negative side sensing.

Thermal Considerations

The AMS1117 series have internal power and thermal limiting circuitry designed to protect the device under overload conditions. However maximum junction temperature ratings of 125°C should not be exceeded under continuous normal load conditions. Careful consideration must be given to all sources of thermal resistance from junction to ambient. For the surface mount package SOT-223 additional heat sources mounted near the device must be considered. The heat dissipation capability of the PC board and its copper traces is used as a heat sink for the device. The thermal resistance from the junction to the tab for the AMS1117 is 15°C/W. Thermal resistance from tab to ambient can be as low as 30°C/W.

Table 1.

COPPER AREA		BOARD AREA	THERMAL RESISTANCE (JUNCTION-TO-AMBIENT)
TOP SIDE*	BACK SIDE		
2500 Sq. mm	2500 Sq. mm	2500 Sq. mm	45°C/W
1000 Sq. mm	2500 Sq. mm	2500 Sq. mm	45°C/W
225 Sq. mm	2500 Sq. mm	2500 Sq. mm	53°C/W
100 Sq. mm	2500 Sq. mm	2500 Sq. mm	59°C/W
1000 Sq. mm	1000 Sq. mm	1000 Sq. mm	52°C/W
1000 Sq. mm	0	1000 Sq. mm	55°C/W

* Tab of device attached to topside copper.

The total thermal resistance from junction to ambient can be as low as 45°C/W. This requires a reasonable sized PC board with at least on layer of copper to spread the heat across the board and couple it into the surrounding air.

Experiments have shown that the heat spreading copper layer does not need to be electrically connected to the tab of the device. The PC material can be very effective at transmitting heat between the pad area, attached to the pad of the device, and a ground plane layer either inside or on the opposite side of the board. Although the actual thermal resistance of the PC material is high, the Length/Area ratio of the thermal resistance between layers is small. The data in Table 1, was taken using 1/16" FR-4 board with 1 oz. copper foil, and it can be used as a rough guideline for estimating thermal resistance.

For each application the thermal resistance will be affected by thermal interactions with other components on the board. To determine the actual value some experimentation will be necessary.

The power dissipation of the AMS1117 is equal to:

$$P_D = (V_{IN} - V_{OUT})(I_{OUT})$$

Maximum junction temperature will be equal to:

$$T_J = T_{A(MAX)} + P_D(\text{Thermal Resistance (junction-to-ambient)})$$

Maximum junction temperature must not exceed 125°C.

Ripple Rejection

The ripple rejection values are measured with the adjustment pin bypassed. The impedance of the adjust pin capacitor at the ripple frequency should be less than the value of R1 (normally 100Ω to 200Ω) for a proper bypassing and ripple rejection approaching the values shown. The size of the required adjust pin capacitor is a function of the input ripple frequency. If R1=100Ω at 120Hz the adjust pin capacitor should be >13μF. At 10kHz only 0.16μF is needed.

The ripple rejection will be a function of output voltage, in circuits without an adjust pin bypass capacitor. The output ripple will increase directly as a ratio of the output voltage to the reference voltage (V_{OUT} / V_{REF}).

AMS1117

TYPICAL PERFORMANCE CHARACTERISTICS

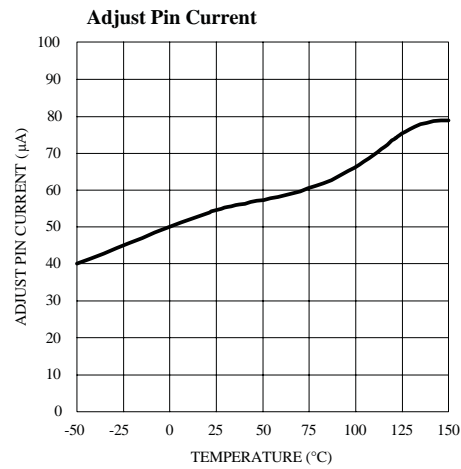
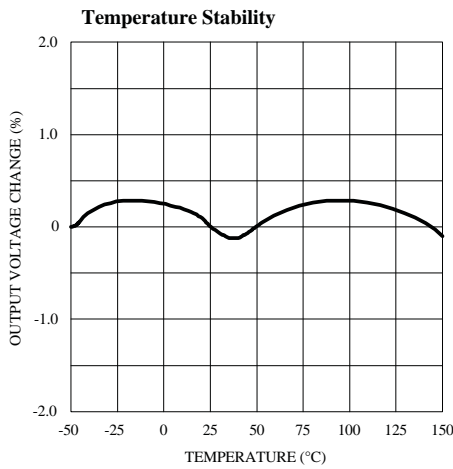
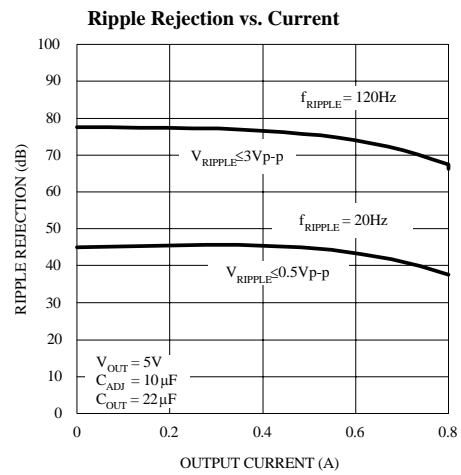
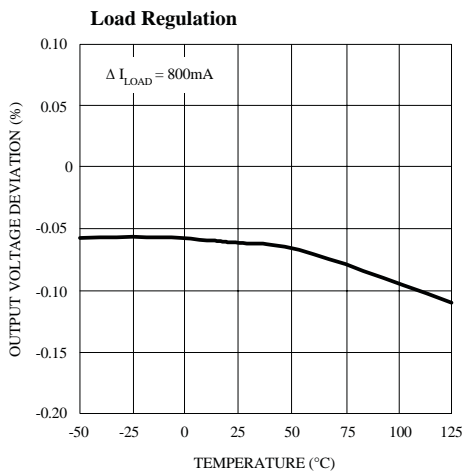
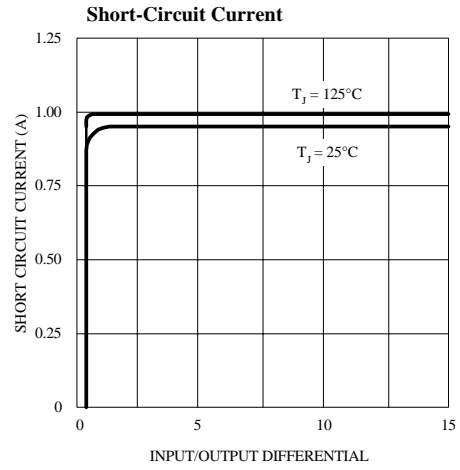
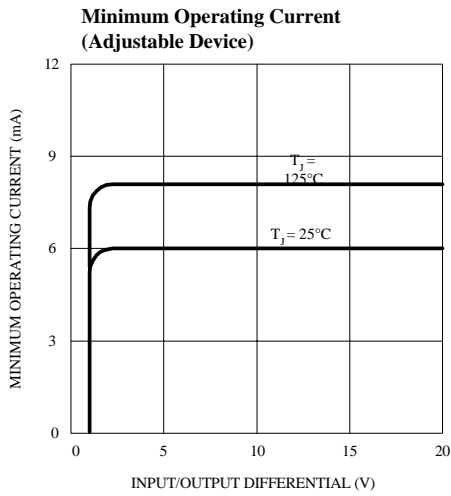

AMS1117

PACKAGE DIMENSIONS inches (millimeters) unless otherwise noted.

TO-252 PLASTIC PACKAGE (D)

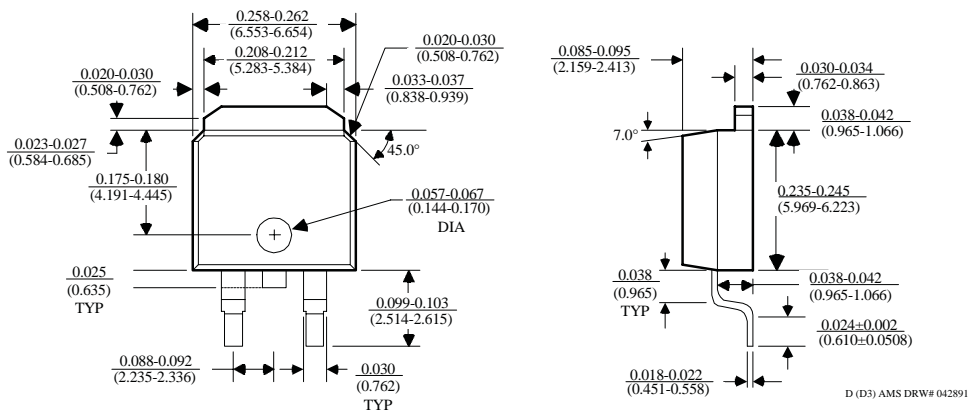

3 LEAD SOT-223 PLASTIC PACKAGE

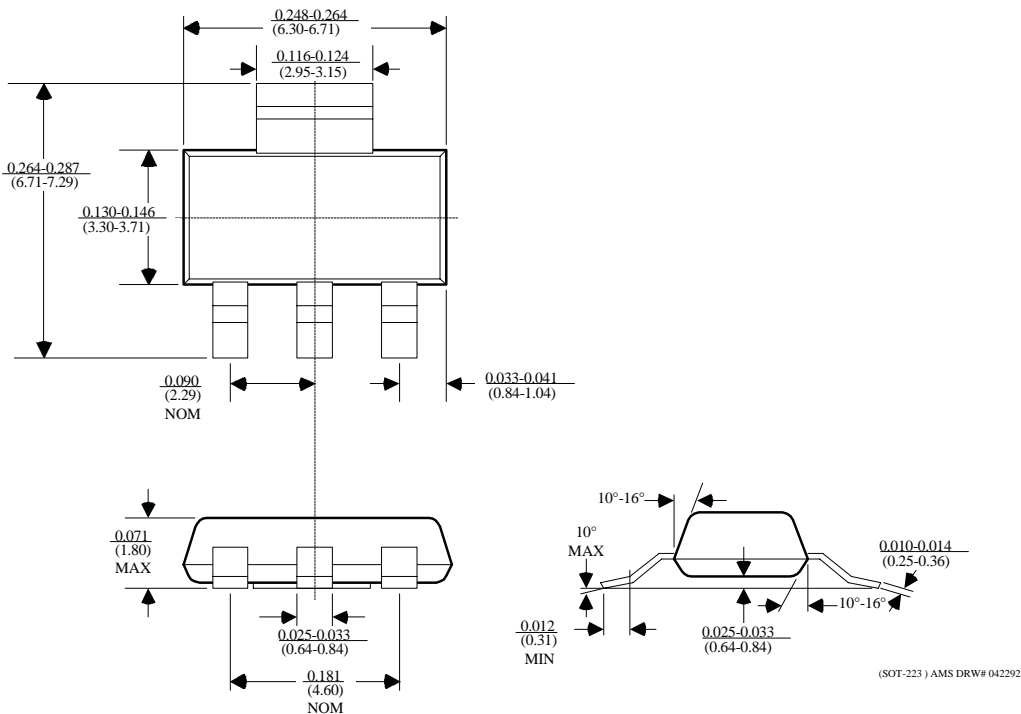

CD-MAIN PCB(1/2)

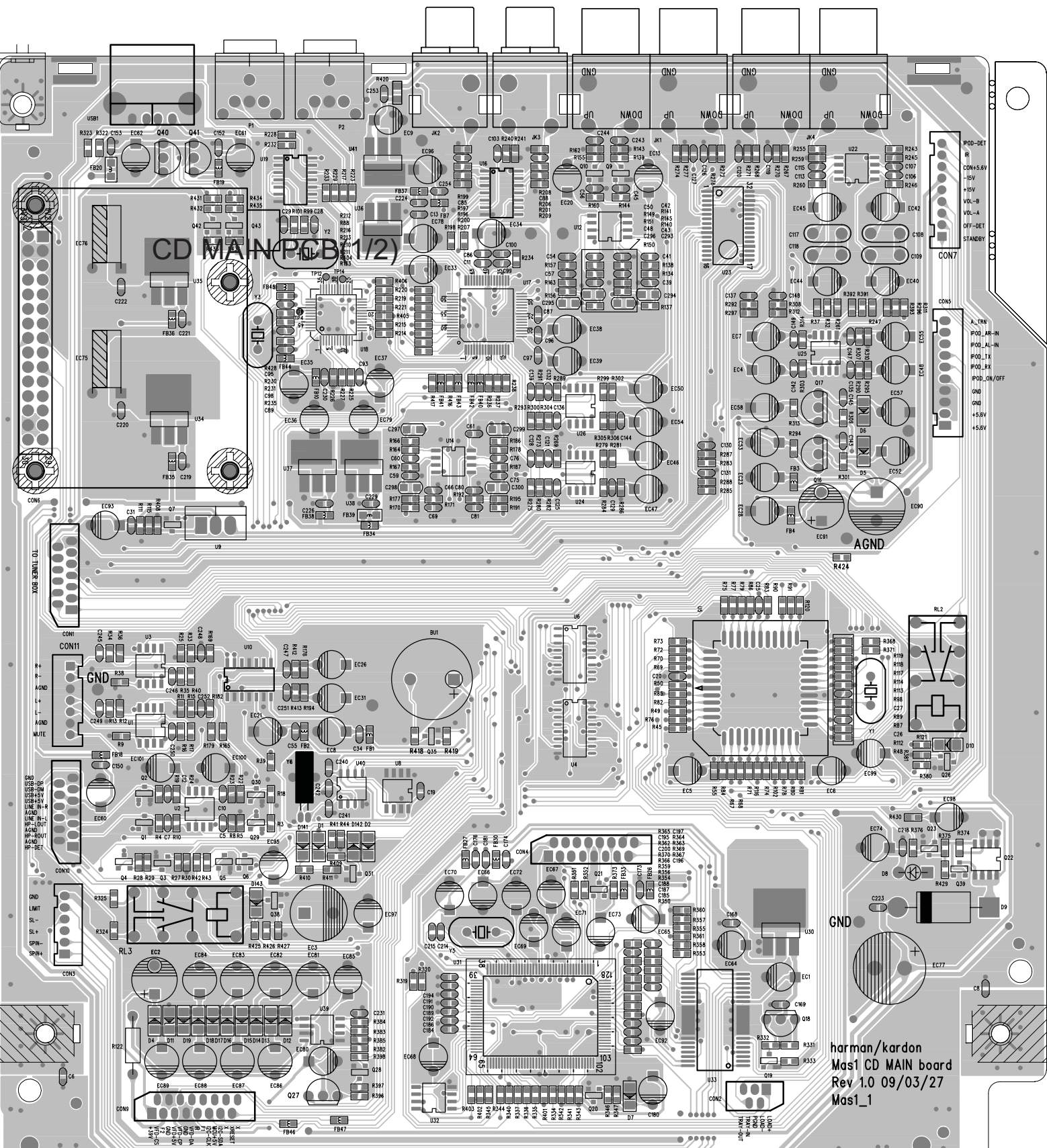

harman/kardon
 Mas1 CD MAIN board
 Rev 1.0 09/03/27
 Mas1_1

PN:0082-5200-0000

CD-MAIN PCB (2/2)

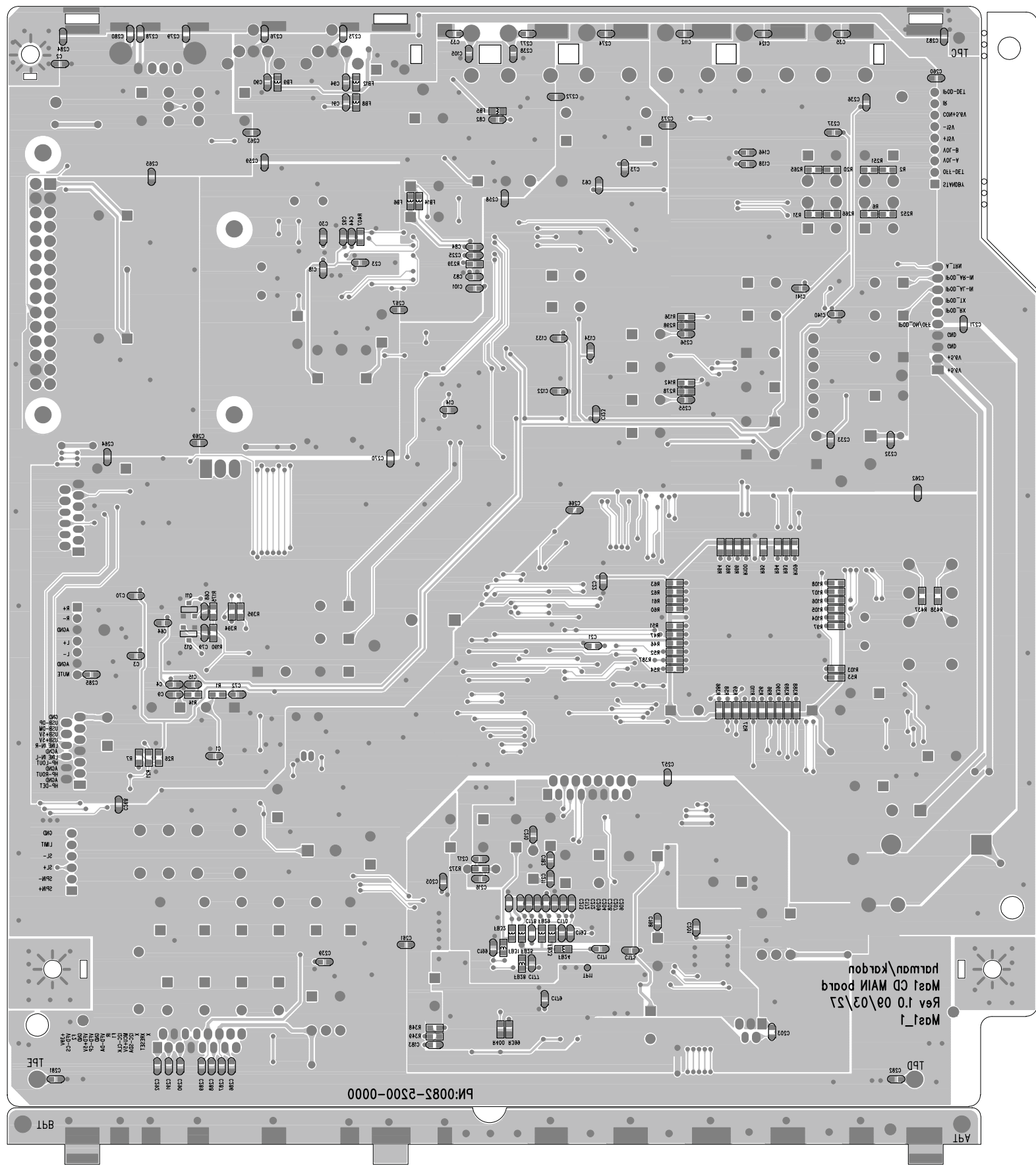

* TUNER PCB(MAS100&MAS110)

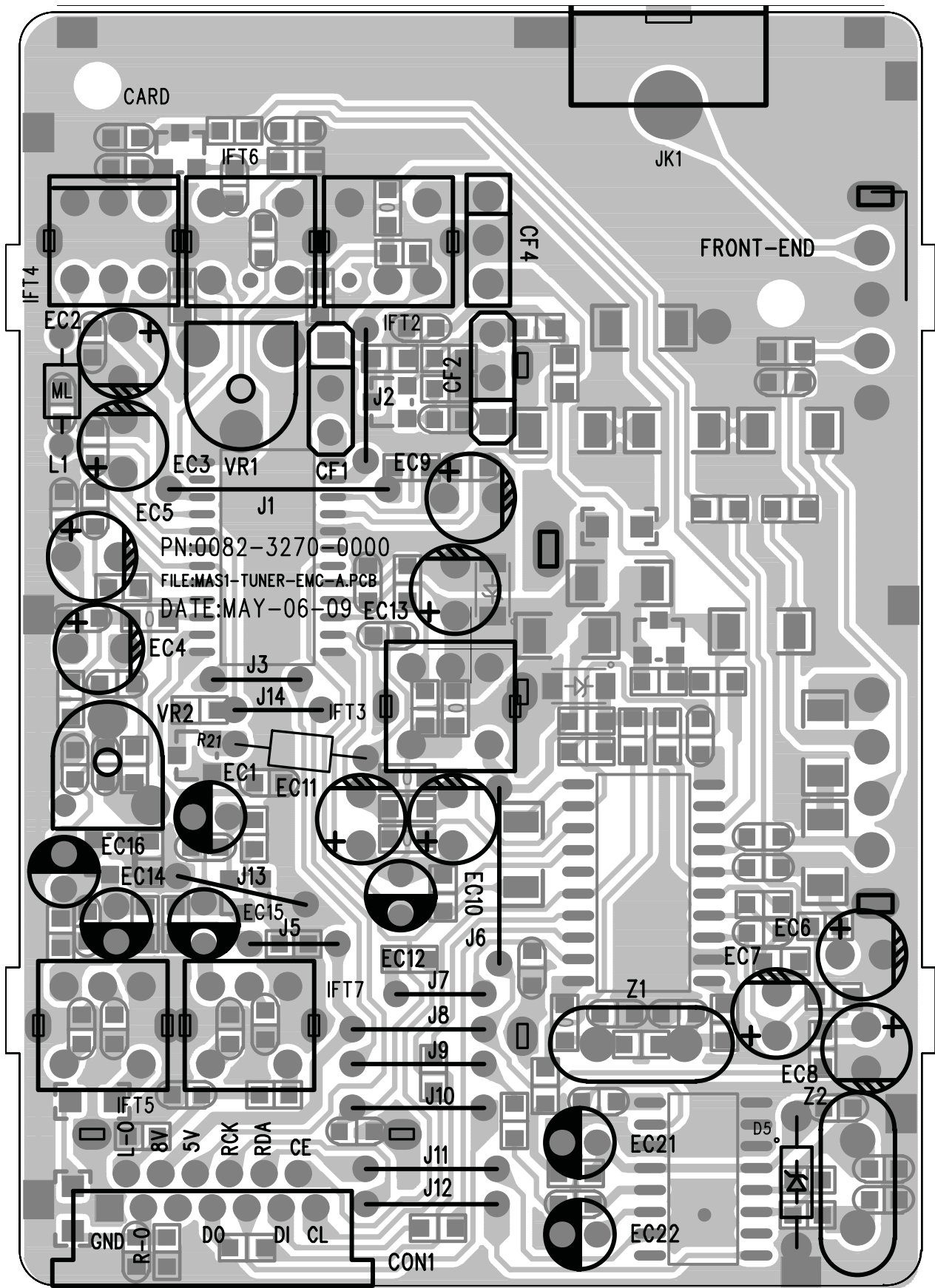

*TUNER PCB(SAS100)

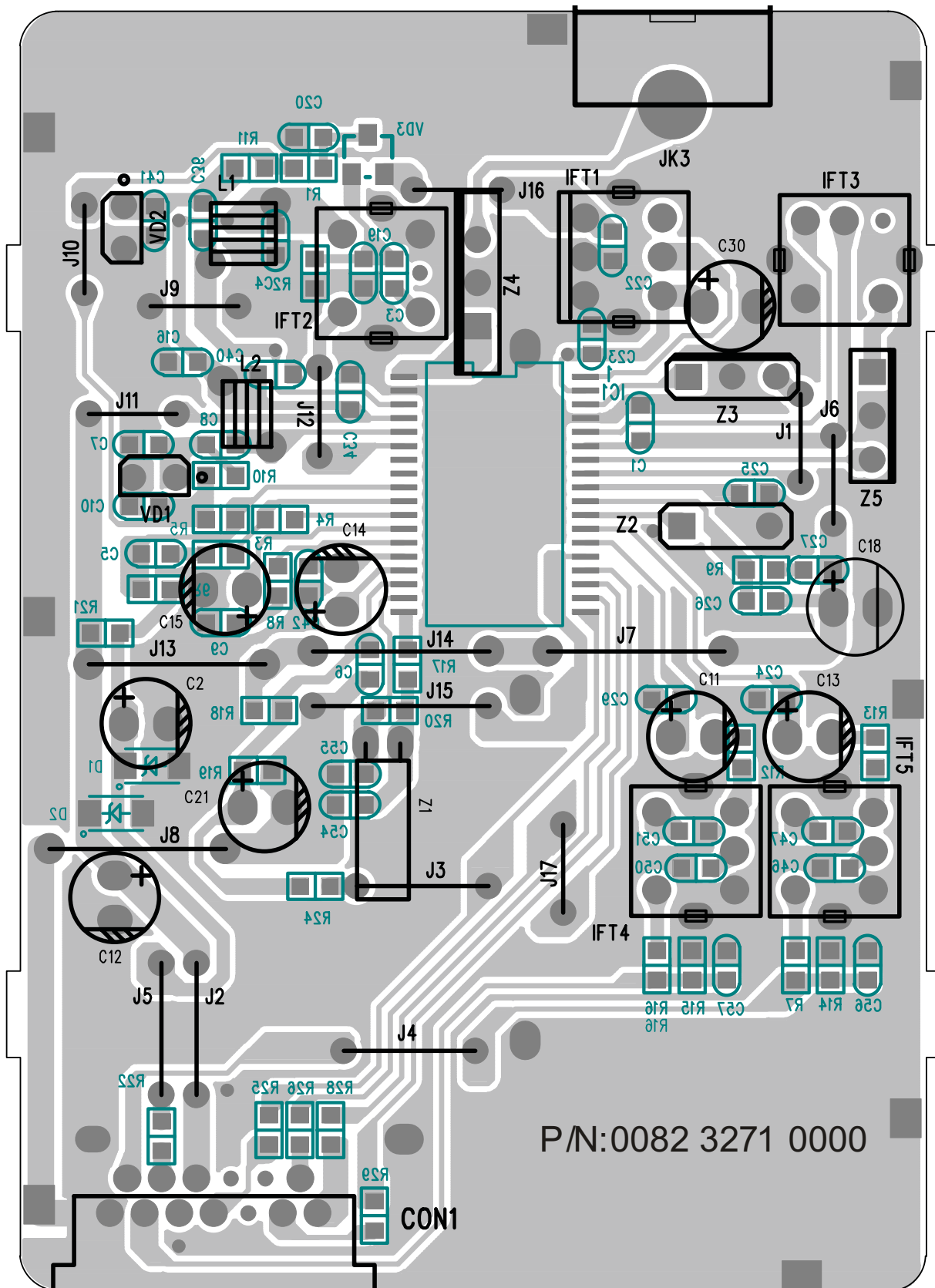

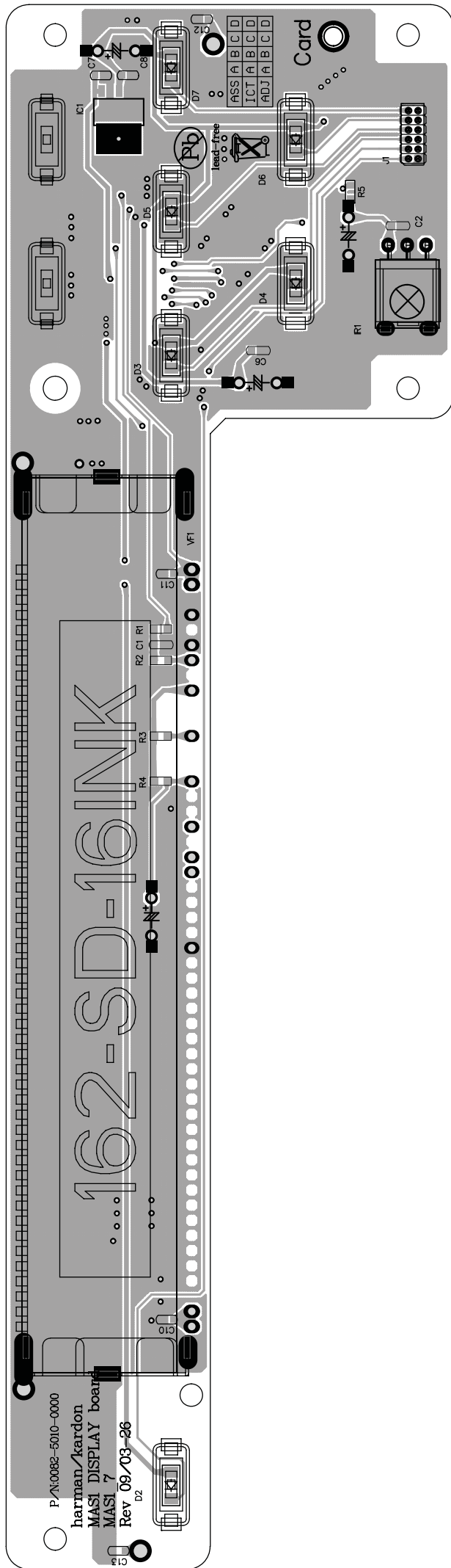

DISPLAY PCB(2/2)

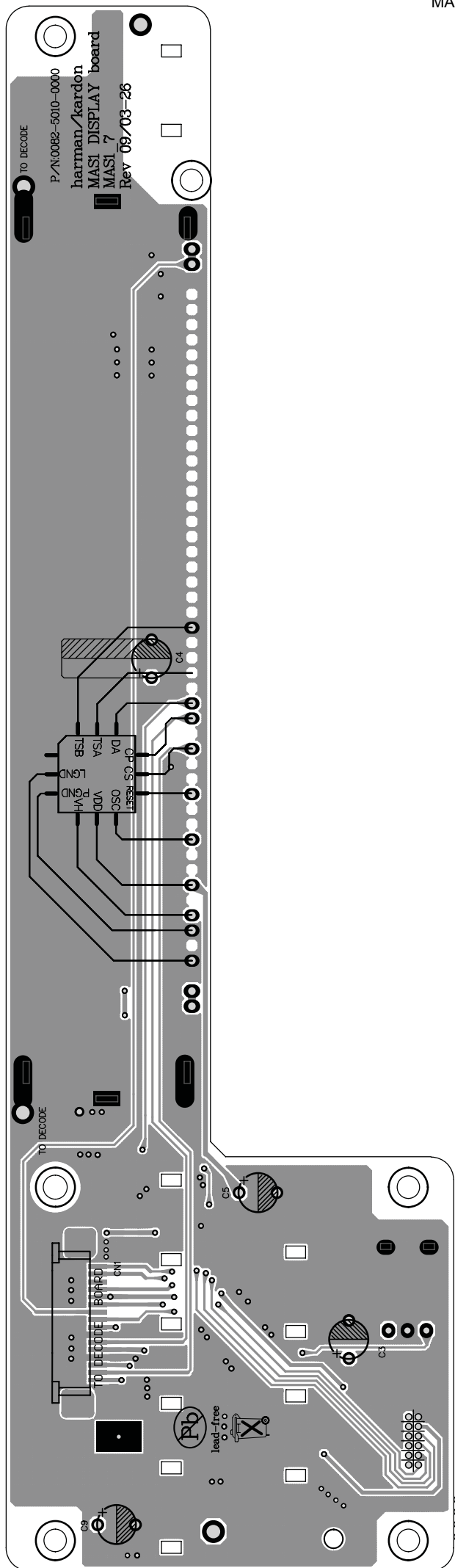

PHONE
PCB(1/2)



Card

harman/kardon

MAS1 Phone board

MAS1_5

Rev 09/03-26

P/N:0082-5170-0000

TO DECODE

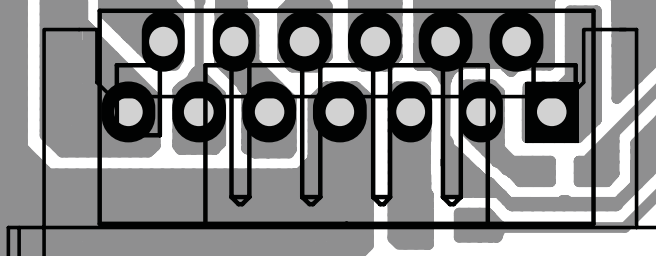

CN1



C3

JP1

JP2



JP1

J1

J2

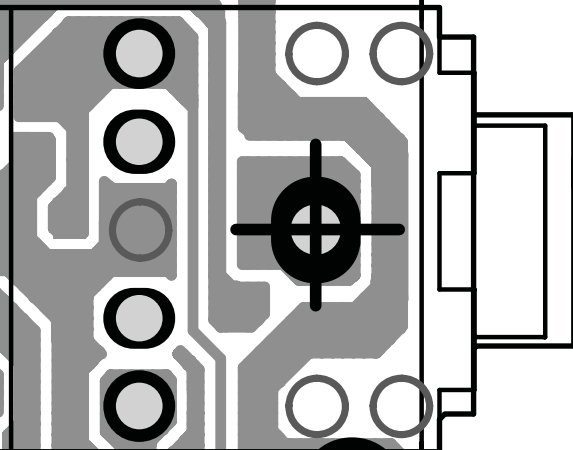
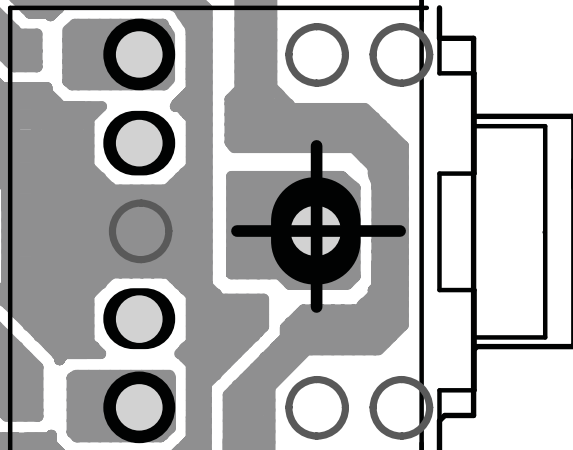
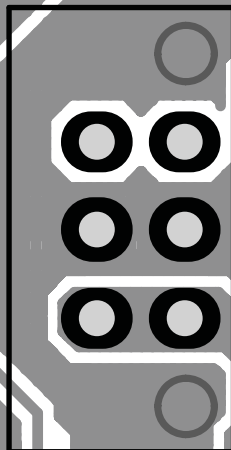

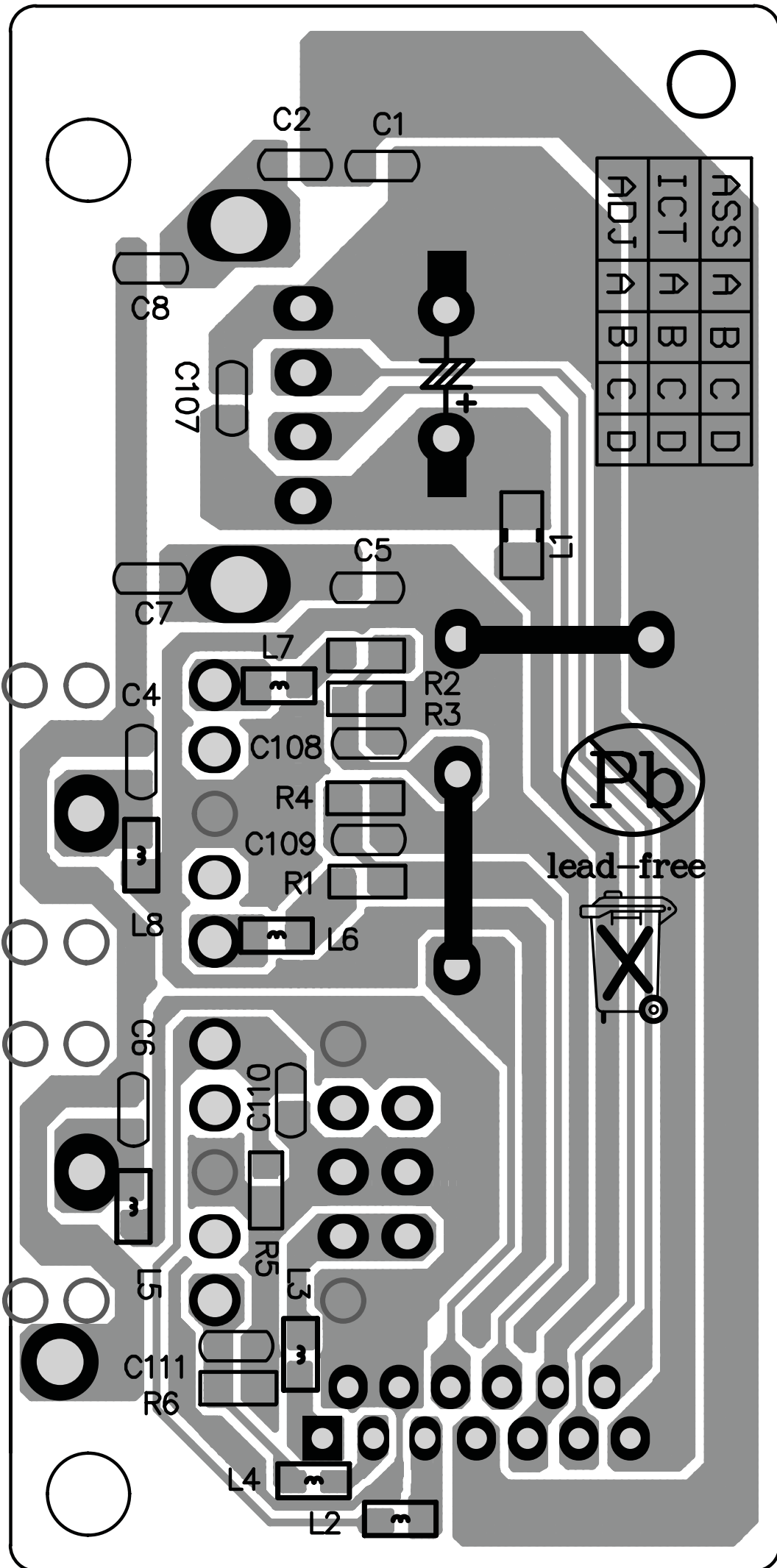

RS232 PCB(1/2)

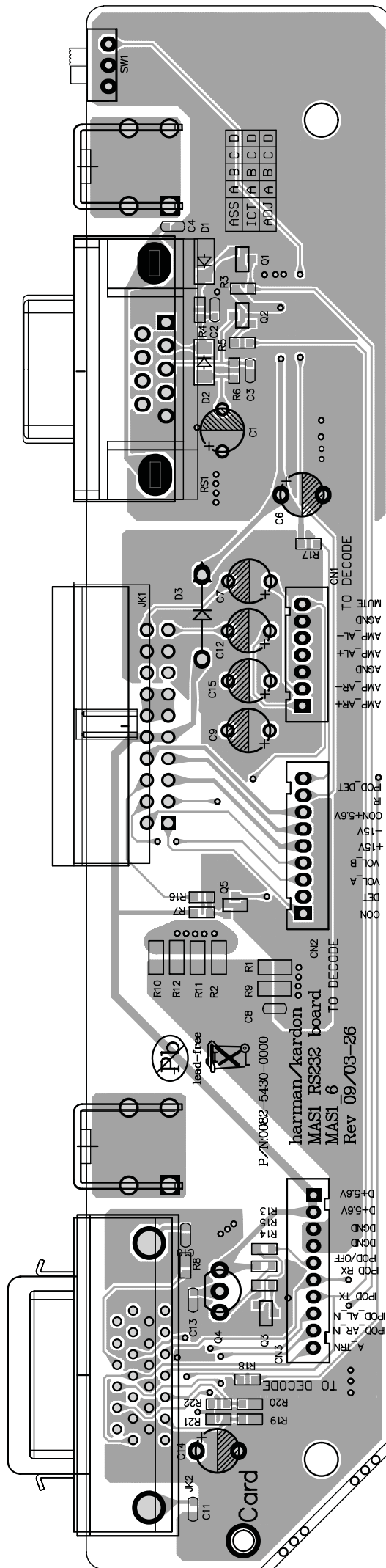

RS232 PCB(2/2)

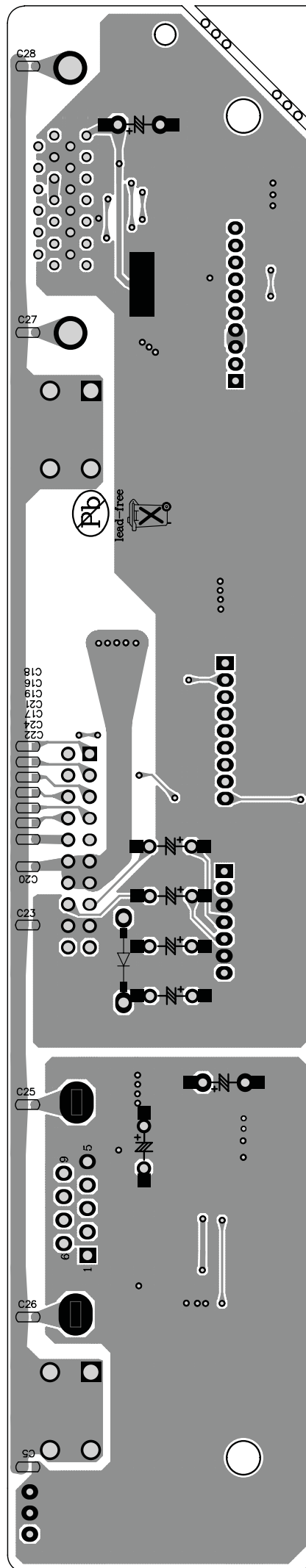

TOUCH PCB(1/2)

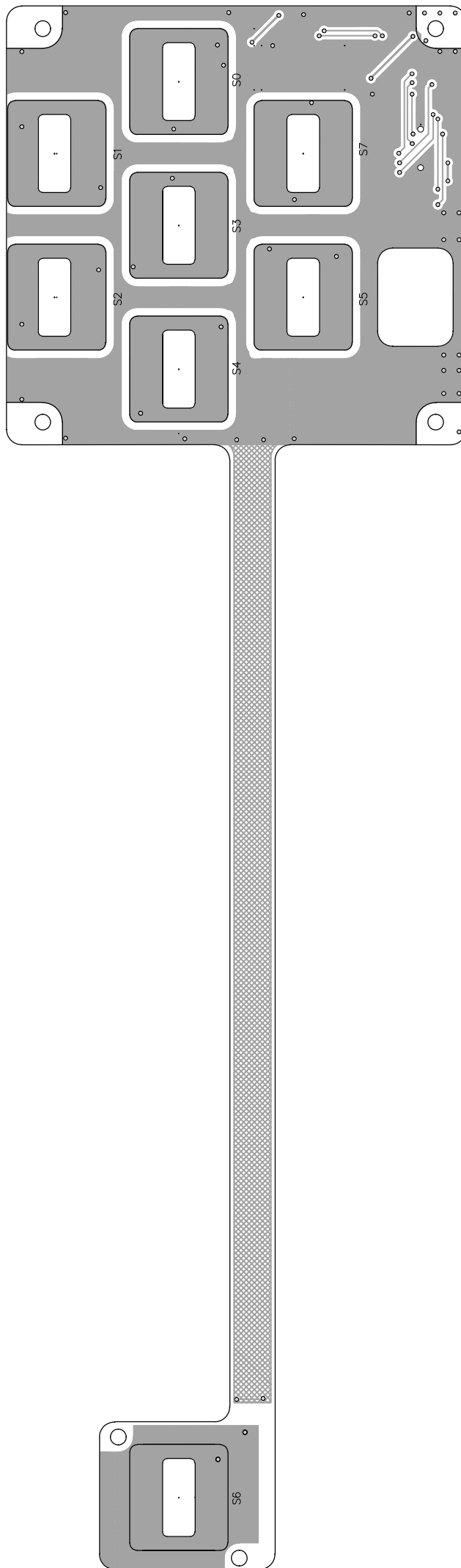

TOUCH PCB(2/2)

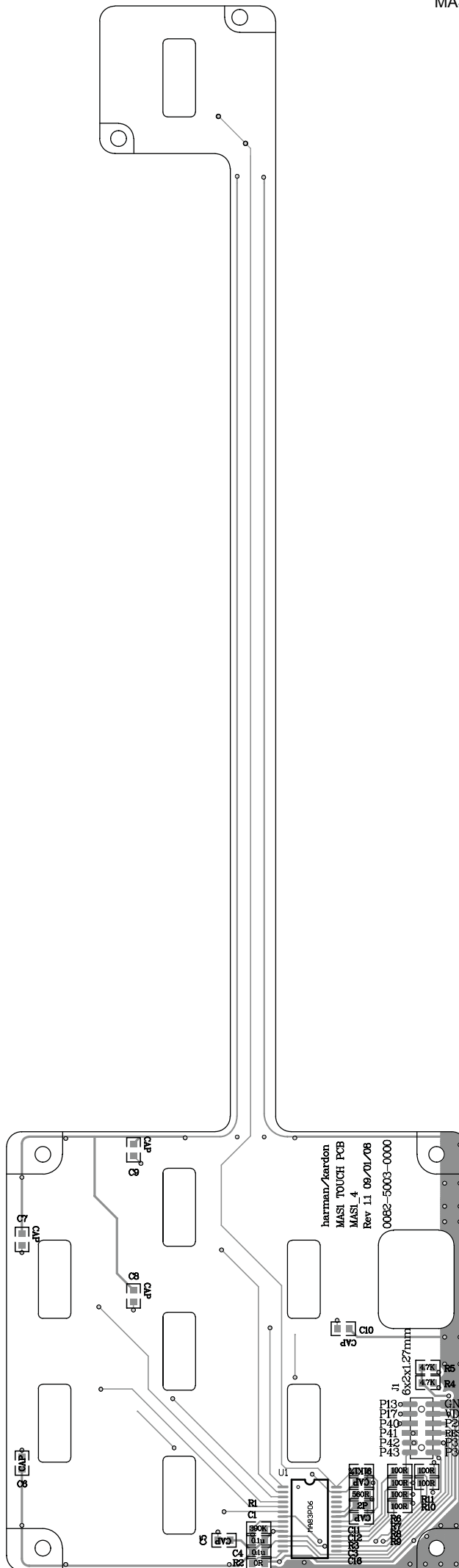

DISPLAY SCH

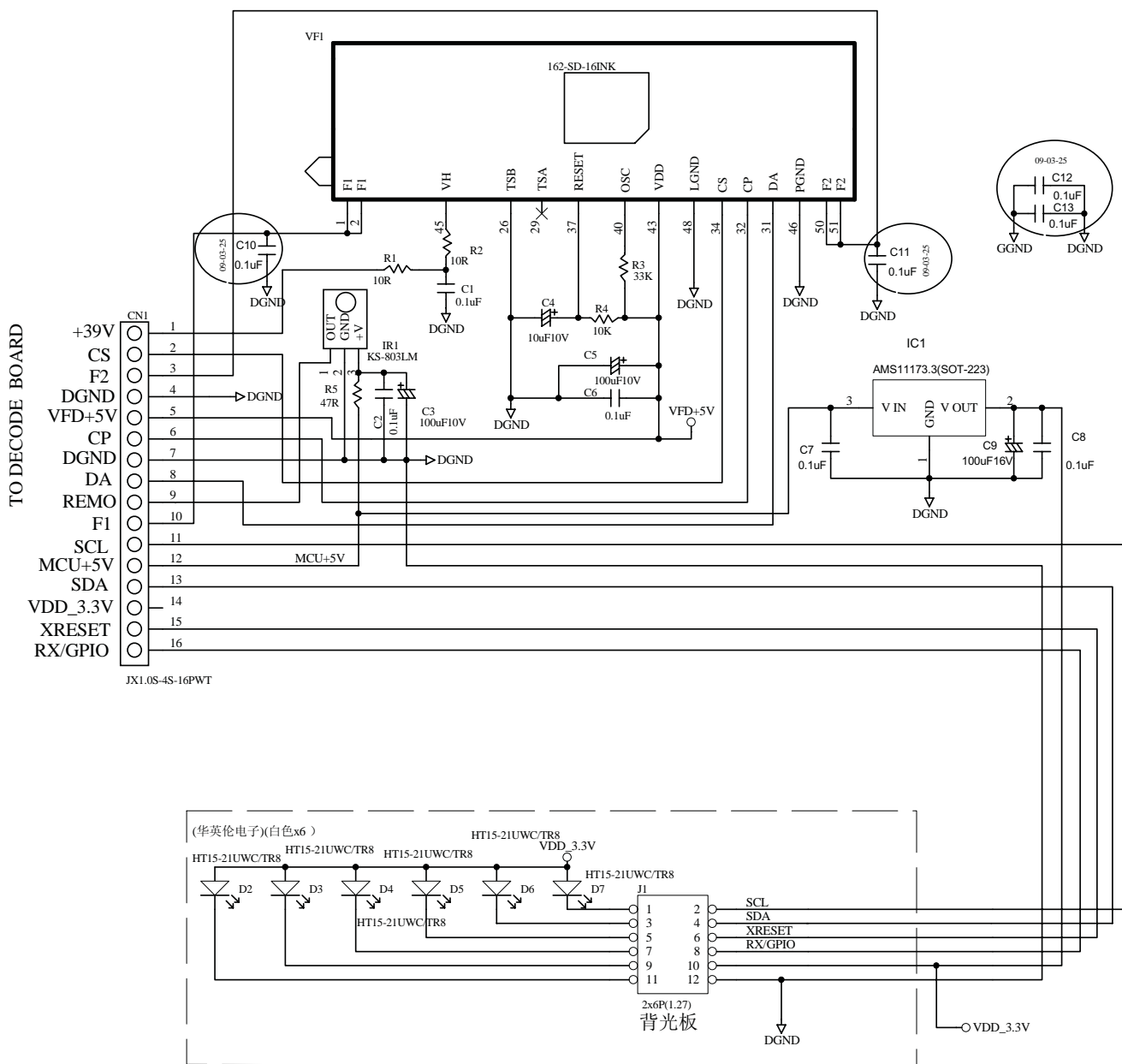

PHONE SCH

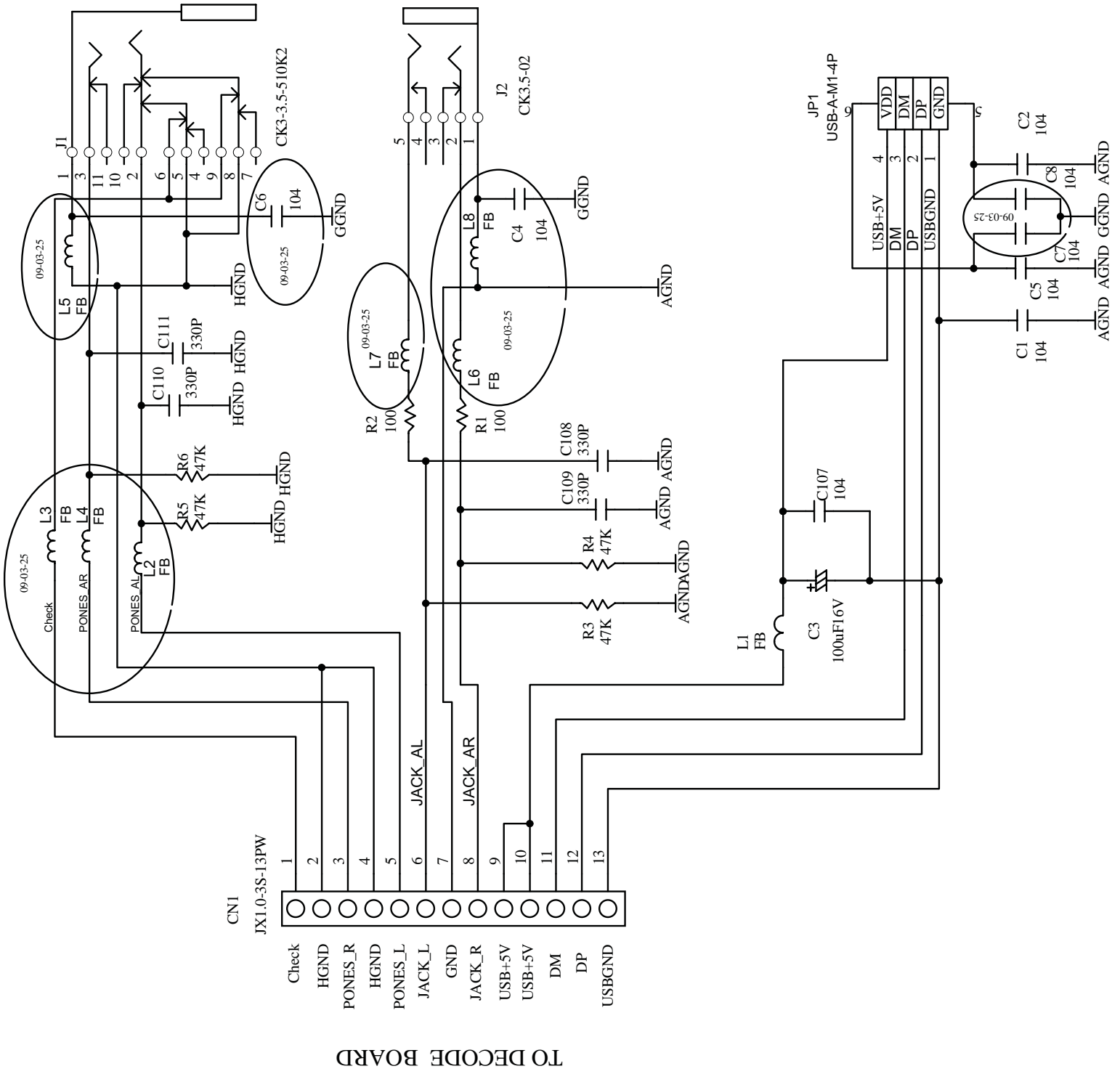

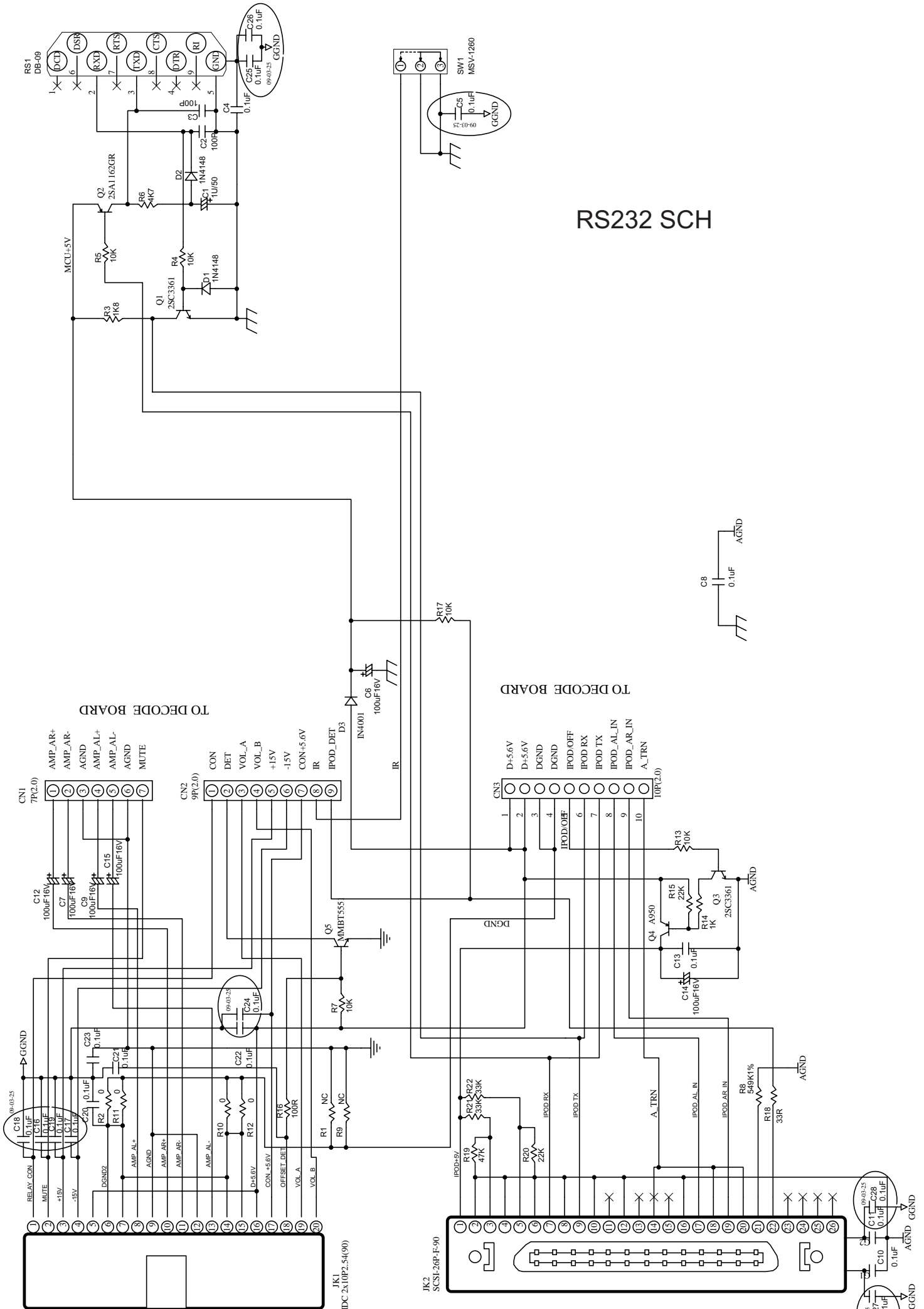

RS232 SCH

TO DECODE BOARD

TO DECODE BOARD

TOUCH SCH

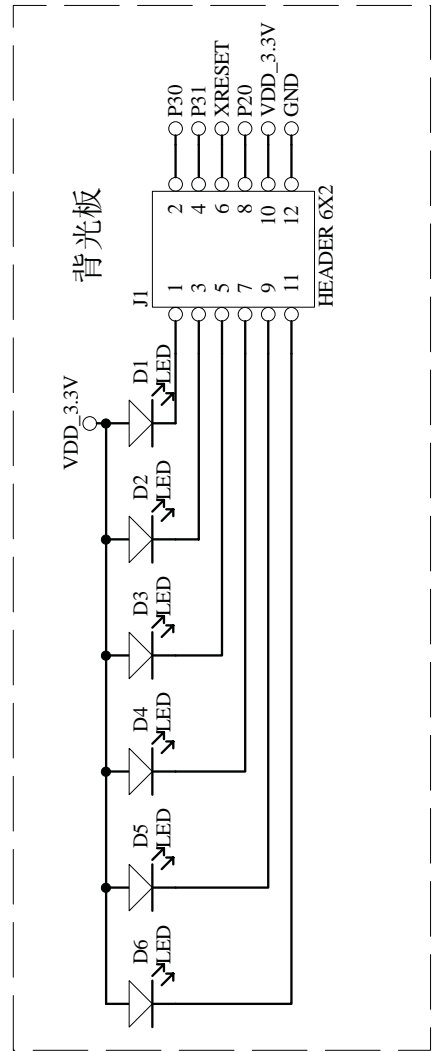
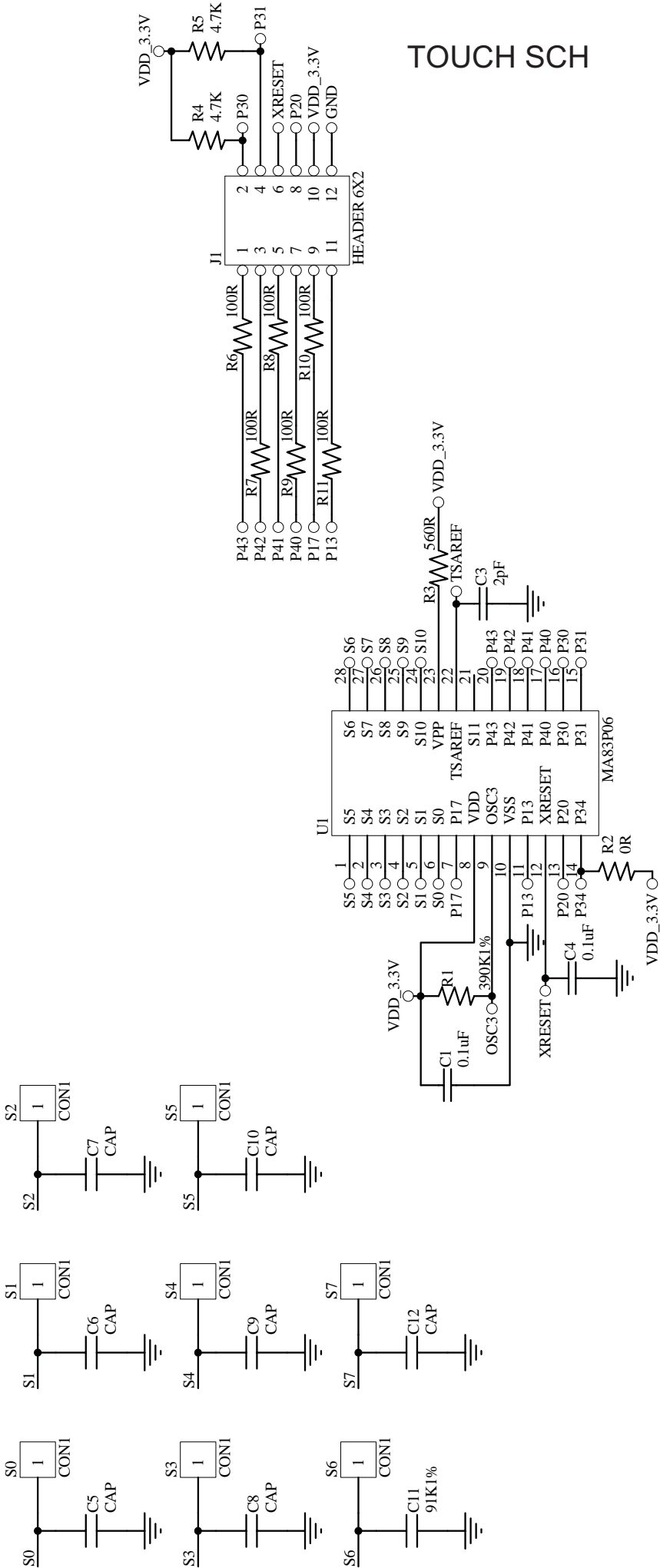

Sensor	Led	Function
S0		无键按下
S1		▶▶
S2		
S3		KK
S4		▶/
S5		□
S6		⤴
S7		

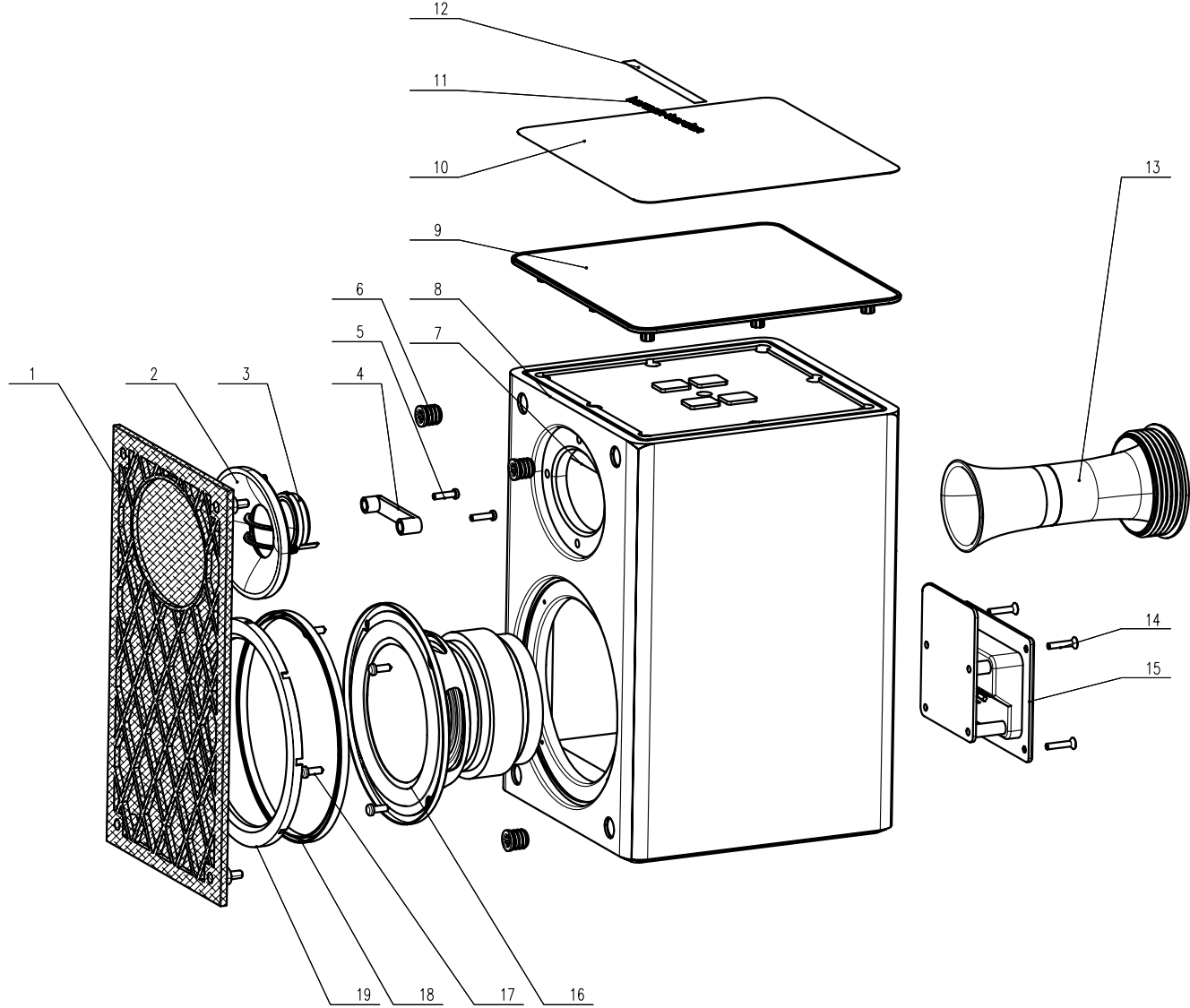

Item	GSEC part no.	name	qty	comment
1	WT0264001010	assy grill cloth	1	grill+cloth
2	MB0097001010	waveguide	1	
3	320025 10001	tweeter	1	
4	AJ0060001010	tweeter bar	1	
5	JCS69068	screw	2	
6	TT0013014010	grill cup	4	
7	QQ0768001010	damping material	1	
8	XT0268001010	cabinet	1	
9	QT0184001010	plastic cover	1	
10	QT0180005010	aluminum cover	1	
11	MP0080014010	logo	1	
12	815001002512	safe film	1	
13	DG0070018010	port tube	1	
14	SEW040162141	screw	4	
15	FP0080008010	terminal cap with nut&wt	1	
16	110130 06001	woofer	1	
17	SPW0401221A0	screw	4	
18	QT0440001010	gasket	1	
19	QT0140004010	trim ring	1	

SCALE: 1:1	UNIT: MM	MATL:	TREAT:	WEIGHT:	DATE: 2009-5-6
TITLE: HARMAN MAS1			MARK:	REVISIONS:	DATE:
CODE: 710130 06001/2					
DRAW NO:					

harman/kardon

SIZE: 199.3*180.5*275.2

All composite wood products are demonstrated compliance with section 93120.2(a), Title 17, California Code of Regulations.

MAS 1 loudspeaker for HK MAS 100 and MAS 110 systems

Description	Harman Part Number
Speaker Assembly (drawing 441037)	
Woofer	110130-06001
Woofer trim ring	441062-001
Tweeter Waveguide	441061-001
Tweeter	300-0058-004
Terminal cup with terminals	?
Port tube	364952-001
Plastic Top	441063-001
Decorative Aluminum (Brushed) Top	442006-001
Grille	442005-001
Logo	MP0080014010
Tweeter Mounting Strap	338059-001
Network	FP0080008010
#6 wood screw	?
#8 wood screw	?
#6 hi-low self threading plastic screw	JG589068
Grille Cloth	?
Grille cup	TT0013014010
Trim ring gasket	QT0440001010
Packaging & Accessories (drawing 441067)	
End Pad - top / bottom	?
Carton	?

Rubber Feet

TT0019006010