

ST-4 CIRCUIT DIAGRAM

78119

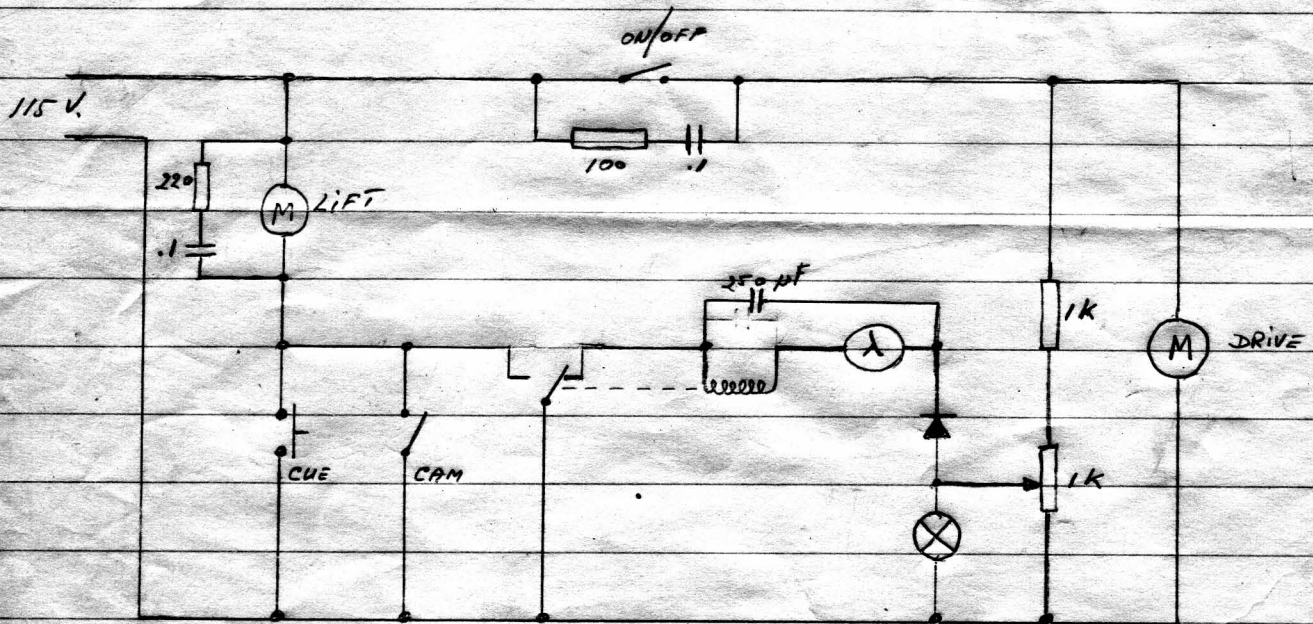

ST-4

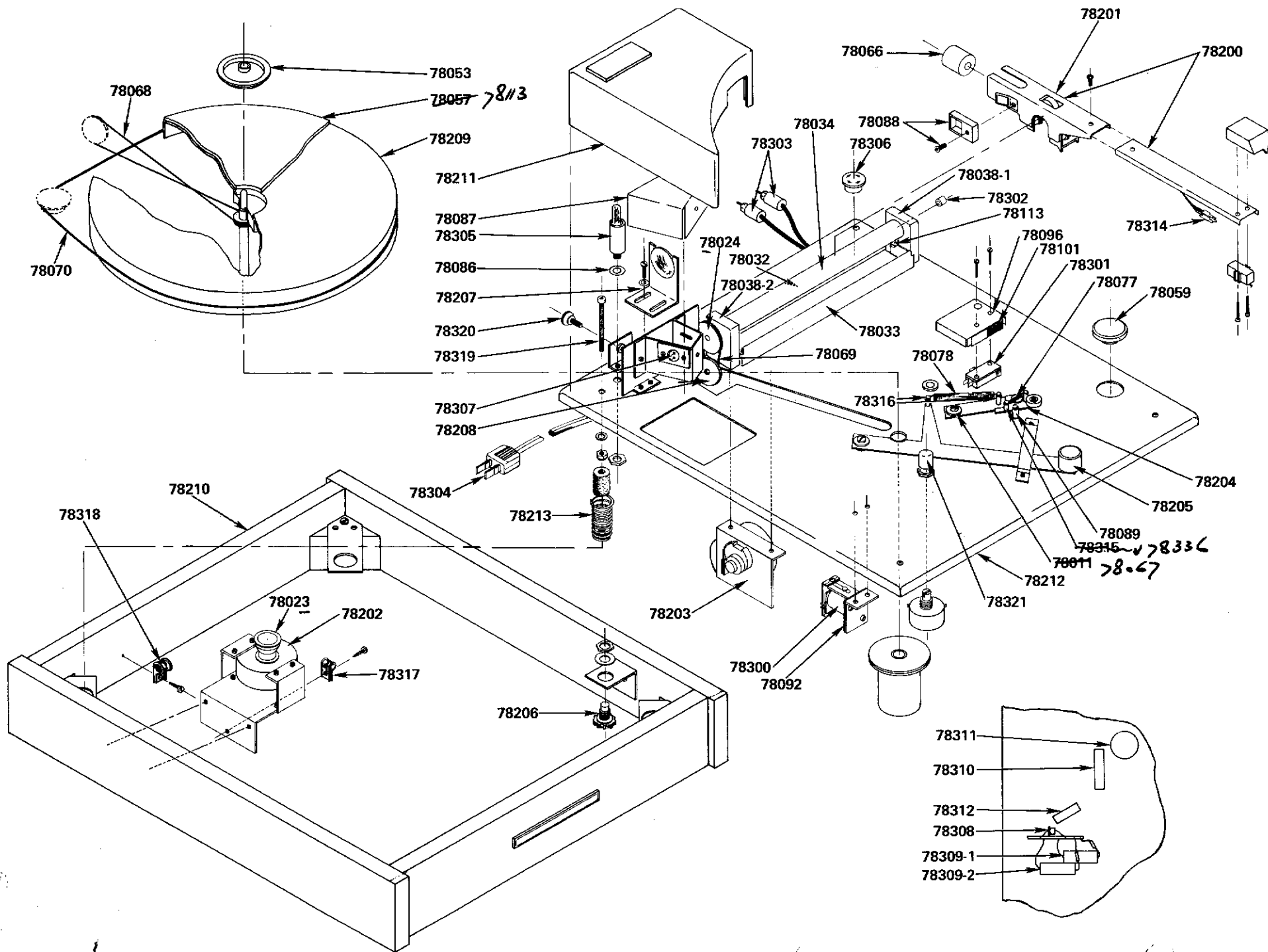

ST-4 SPARE PARTS LIST

ASSEMBLIES

		LIST	NET
78200	Tone Arm Assembly	40.00	24.00
78201	Tone Arm Assembly less Cartridge Holder	30.00	18.00
78202	Drive Motor Assembly	7.50	4.50
78203	Lift Motor Assembly	8.00	4.80
78204	Kick Foot Assembly	2.35	1.35
78205	On-Off Lever Assembly	.80	.48
78206	Cue Switch Assembly	.70	.42
78207	Lens Assembly	.50	.30
78208	Step Pulley Assembly	1.00	.60
78209	Platter Assembly	11.20	6.72
78210	Base Assembly (Base, Suspension Brackets, Nameplate)	21.00	12.60
78211	Motor Cover Assembly	.70	.42
78212	Deck Assembly (Pem nuts, Motor Cover Bracket, Bearing Assembly, Suspension Screws, Guide Bar, Photo-cell Assembly, Relay Bracket)	17.00	10.20
78213	Suspension Spring Assembly	.60	.36

PARTS

78011	Pivot Washer (Kick Lever & On-Off Lever)	.10	.05
78023	Drive Pulley Assembly (With Weight)	1.50	.90
78024	Tracking Shaft Pulley	1.00	.60
78032	Rear Lift Bar	1.85	1.50
78033	Cuing Bar	2.55	1.50
78034	Tracking Shaft	4.50	2.80
78038-1	Bearing Block-Outside	1.80	1.10
78038-2	Bearing Block-Inside	1.80	1.10
78053	45 Adapter	.90	.55
78057	Matt	1.00	.60
78059	Cue Switch Knob	1.00	.60
78066	Counterweight	1.00	.60
78068	Long Drive Belt	.60	.36
78069	Short Drive Belt	.30	.20
78070	Platter Belt	1.00	.60
78077	Kick Foot Spring	.20	.10
78078	Kick Lever Spring, Assembly (With Sleeving)	.50	.30
78086	Lamp Socket Washers	.16	.10
78087	Light Seal	.50	.30
78088	Mirror Cover & Screw	.50	.30
78089	Stop Bushing	.16	.10
78092	Relay Insulator & Screws	.30	.20
78096	Switch Cover	.50	.30
78101	Switch Stop	.16	.10
78113	Cue Bar Screw	.50	.30
78300	Relay	2.85	1.70
78301	On-Off Switch	.80	.50
78302	Tracking Shaft Bearing	.16	.10
78303	Audio Cable	3.00	1.80
78304	AC Cable	.80	.50
78305	Lamp Socket	.75	.45
78306	Audio Socket	.40	.25
78307	Photocell	2.85	1.70
78308	Rectifier	.75	.45
78309	Condenser Assembly 1fmd 600V DC	.40	.25
78310	Power Resistor	1.00	.60
78311	Potentiometer	1.60	.95
78312	Condenser (Electrolytic)	1.00	.60
78313	Solder Lug - Audio Cable	.16	.10
78314	Audio Clips - Set of 4	.16	.10
78315	Groov Pin 3/8- <i>BEARI</i>	.16	.10
78316	Groov Pin 1/2	.16	.10
78317	Cable Clamp - Small	.16	.10
78318	Cable Clamp - AC Cord	.16	.10
78319	Suspension Screw	.16	.10
78320	Motor Cover Screw	.25	.15
78321	Potentiometer Cap	.16	.10

ST-4

Service Bulletin # 1

LAMP VOLTAGE ADJUSTMENT

- Step 1 - Remove Motor cover by removing the screw on the back of the cover.
- Step 2 - Remove Platter by pulling straight up. The tracking shaft drive belt will come off the platter shaft at this time.
- Step 3 - Now remove the red plastic cap covering the potentiometer adjusting shaft. The plastic cap is removed by pulling straight up. It does not unscrew.
- Step 4 - Turn the potentiometer shaft counterclockwise all the way.
- Step 5 - Move the platter on-off lever to the on position.
- Step 6 - Place the arm on the tracking shaft with the mirror surface approximately $2\frac{1}{4}$ inches from the left bearing block.
- Step 7 - With the right hand supporting the cartridge holder, increase the voltage by turning the potentiometer shaft clockwise until the image of the lamp filament can just be seen on the photocell housing. Keep the voltage low enough so that the relay is not actuated.
- Step 8 - Now pivot the tone arm until the image crosses the front of the photocell aperture as shown in Figure 1.
- Step 9 - Hold the image in this position and slowly increase the voltage (clockwise) until the relay can be heard to click. This will be accompanied by a dimming of the light.
- Step 10 - Now increase the voltage slightly by continuing to turn the shaft clockwise 5 to 10 degrees.
- Step 11 - With the tone arm in the down position, pivot the tone arm so that the lamp filament image is just in front of the photocell aperture as shown in Figure 2. In that position, the relay should not operate. If it does, the voltage is too high, and it should be reduced.

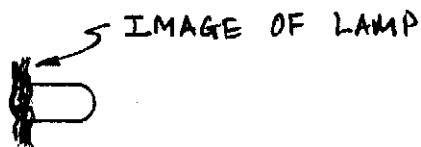

FIGURE 1



FIGURE 2

ST-4
Service Bulletin # 2
Tone Arm Adjustment

I. Tracking Angle Adjustment

- Step 1. Check tracking angle. Lower arm to record surface near outer edge of record and permit the unit to run for two or three minutes.
- Step 2. Now gently stall the turntable platter, taking care not to cause the stylus to jump grooves. With the platter still, lay a draftsman's plastic triangle on the record surface with one edge against the tracking shaft. (See Figure 1) Use the other edge to sight along the arm.
- Step 3. If the angle is open as shown in Figure 1, the axis of the tracking roller must be rotated counterclockwise as viewed from above. (See Figure 2) If the angle is closed, the roller must be rotated clockwise. To do this, loosen the two upper screws on one side of the tone arm. Either side can be used, but be sure to loosen the two screws on the same side.
- Step 4. With screws loose on one side slide the screws about 1/64 of an inch, taking care to keep some pressure up on the bottom side of the roller. Now tighten the screws, taking care not to overtighten and strip the threads.
- Step 5. Again, check the tracking angle as described in Step 2. Repeat the adjustment procedure if necessary.

II. Adjustment for side movement as arm comes down.

If the cartridge moves to the left, as the arm descends, this is an indication that the left rear nylon foot is not protruding enough. Loosen the left rear lower screw and pull the foot down slightly. (See Figure 3) 1/64" will be the maximum adjustment needed. Now re-tighten the screw, taking care not to strip the threads in the nylon. If the arm still moves to the left, more adjustment is needed.

If the cartridge moves to the right as the arm descends, the right rear foot will have to be adjusted with the same procedure as described above. Use the right rear lower screw to loosen the foot.

III. Adjustment for side movement as arm raises.

If the cartridge moves sideways when raised during play; this is an indication that the front nylon feet are out of adjustment. To check, turn the platter off and raise the arm to its "up" position. Now lay a plastic triangle or other right angle device on the platter surface with one edge against the tracking shaft and the other edge below the arm. (See Figure 1) By viewing from above, it will be easy to see any angle deviation. The arm should be straight in this position.

If the angle is open as shown in Figure 1, then the right front nylon foot will have to be adjusted down slightly. To do this, loosen the right front lower screw and pull the foot out a small amount. The movement should be no more than $1/64$ of an inch. Tighten the screw, taking care not to strip the threads and check the angle again. When the arm is straight (90° to the tracking shaft) in the up position, and if the tracking angle is correct, very little side movement should occur when the arm raises.

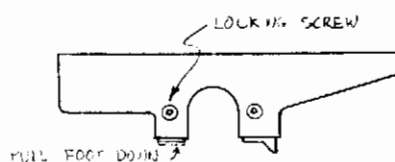
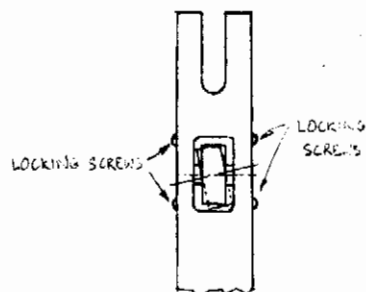
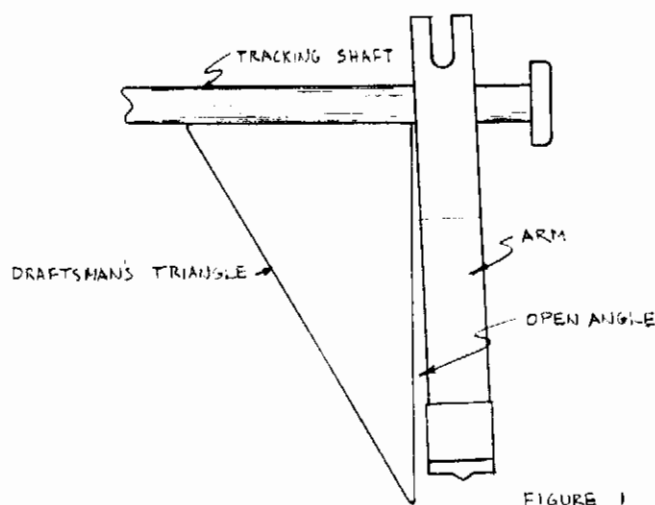

SERVICE BULLETIN #3

CUEING MECHANISM ADJUSTMENT

- STEP #1 Remove the bottom of the unit.
- STEP #2 Tip the unit up on it's right side, with the notched nylon cam facing up as shown in Figure #1.
- STEP #3 With the power off, rotate the cam clockwise by hand and observe the leaf switch contacts. With the "Vee" actuator of the switch in the notch as shown in Figure #1, the "Vee" leaf should be adjusted so that it is just touching the cam surface at point A as shown in Figure #1. There should be very little deflection of the leaf at this point, but it should be touching the cam. With small needle nose pliers, bend the leaf to the proper position.
- STEP #4 Now check the clearance between the switch contacts, with the switch open as shown in Figure #1. Clearance should be between .015 inches and .030 inches. Bend the straight leaf of the switch to obtain this clearance.
- STEP #5 Now rotate the cam clockwise by hand and observe the switch movement. It should clearly be open in both notches of the cam, and should close firmly on the high portions of the cam. As the switch closes, you should be able to visually detect a slight deflection of the leaf. Too much deflection of the switch can put an unnecessarily high load on the lift motor, thus causing the motor to stall.
- STEP #6 With the unit still in the tipped up position, plug the power cord in, taking care to avoid all open wiring inside the unit. Now, reach around to the normal top surface of the unit and depress the cueing button. This will take more force than normal since, in the tipped up position, the suspension springs are pushing hard against the deck. Observe the amount of coast of the cam after the switch drops into the notch. It should stop quite abruptly, approximately 1/8 of an inch, into the notch as shown in Figure #2. Cycle the cueing mechanism several times to make sure the switch is operating properly.

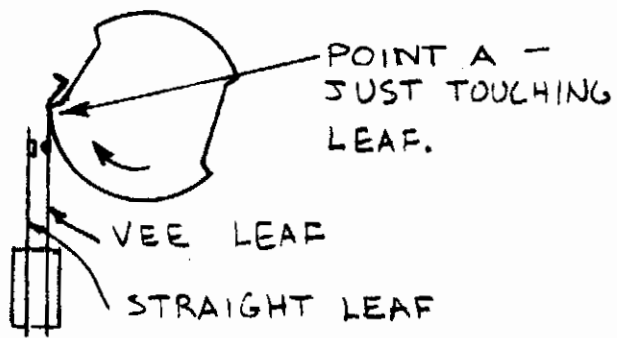

FIGURE 1

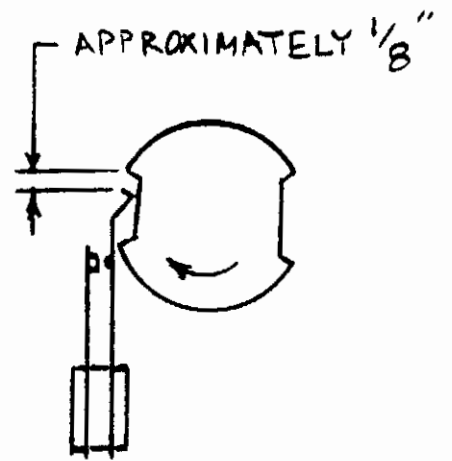
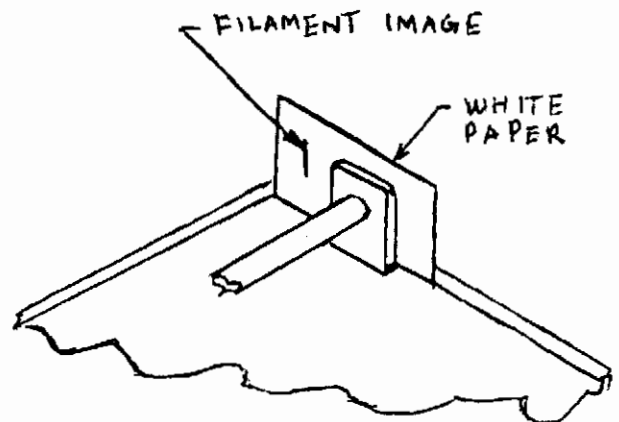
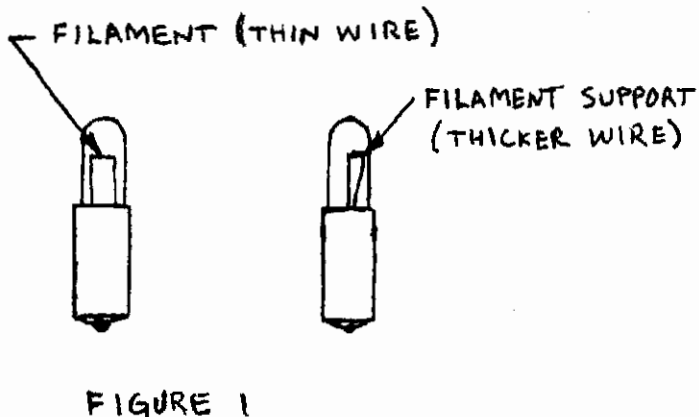

FIGURE 2

Service Bulletin #4

LAMP FOCUS ADJUSTMENT

- Step 1. Install lamp. Use only a GE #1829. The bulb filament is in the shape of an inverted "U" with filament supports on one side. (See Figure 1) When installing the bulb place the filament supports towards the rear of the unit. Note that the socket can be twisted as described in Step 3, to obtain this position.
- Step 2. With the unit on, place a piece of white paper or cardboard at the right side of the unit just behind the tracking shaft bearing block. (See Figure 2)
- Step 3. Now twist the socket, and observe the filament image projected on the white paper. Twist the socket until the two vertical legs of the "U" become a single vertical line. In most cases this will not be a perfect single line, nor will the image be perfectly vertical. Check to be sure that the filament supports are towards the rear of the unit.



Service Bulletin #5

MIRROR ADJUSTMENT

After installing a new bulb or a new tone arm assembly, if may be necessary to adjust the mirror on the tone arm assembly. In order to adjust the mirror, the lamp voltage must be pre-adjusted as explained in Service Bulletin #1.

- Step 1. Remove the mirror cover located on the left rear of the arm.
- Step 2. Remove the motor housing cover.
- Step 3. Using a record with a narrow run-off groove, (3/8") cue the tone arm down at a point within 1/4" of the end of the recorded music.
- Step 4. As the arm tracks close to the finish of the record, observe the lamp filament image on the photocell housing. (See Figure #1)

Just as the music ends, the filament image should be between 1/16" and 1/8" from the front of the photocell aperture as shown in Figure #1.

- Step 5. If the image is too far from the aperture bend the mirror closer to the tone arm as shown in Figure #2. The mirror is fastened to a soft aluminum bracket, and it bends easily.

Take care not to bend the mirror too far, as it requires very little movement to move the image.

If the image is too close to the aperture, use a small screwdriver, and bend the mirror away from the tone arm. If the automatic lift circuit does not trip before the end of the recorded music, the image is not too close to the aperture.

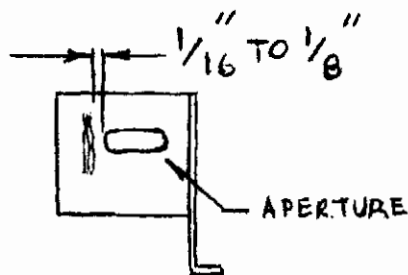

FIGURE 1

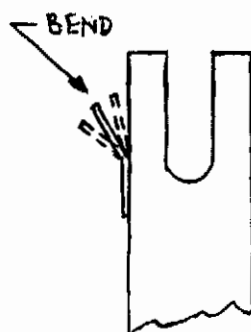

FIGURE 2

SERVICE BULLETIN #6-

DRIVE MOTOR ADJUSTMENT FOR PROPER BELT POSITION ON DRIVE PULLEY

- STEP #1 Remove the bottom of the turntable base.
- STEP #2 Note that there are 3 screws holding the drive motor bracket to the side of the wooden base. (See Figure #1)
- STEP #3 Loosen all 3 screws to a point where the bracket will move. Leave the lower center screw slightly snug so that when the bracket is moved it will stay in place.
- STEP #4 Now tip the bracket either to the right or left as required. If the bracket is tipped to the right, the belt will ride lower on the drive pulley. If the bracket is tipped to the left, the belt will ride higher on the pulley. (See Figure #1) The belt should normally ride just clear of the flanges as shown in Figure #2.
- STEP #5 When the proper belt position has been obtained, tighten the 3 bracket screws taking care not to strip the threads in the wooden base.
- STEP #6 Replace the bottom of the unit.

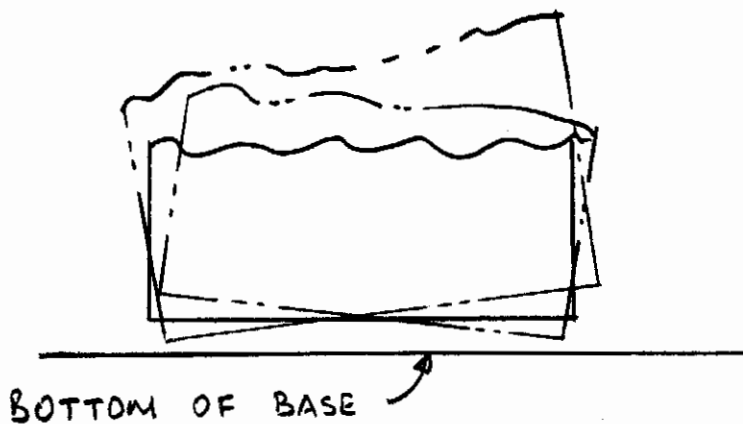

FIGURE 1

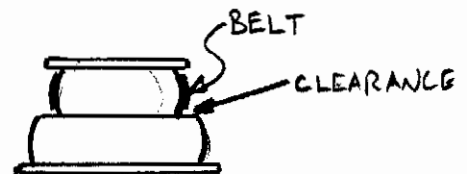
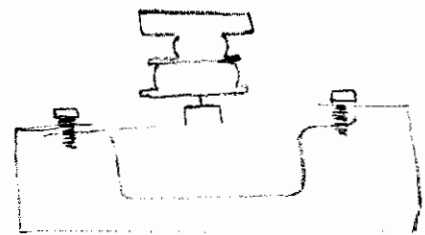

FIGURE 2

SERVICE BULLETIN #7

TRACKING SHAFT ADJUSTMENT FOR FREE RUNNING

- STEP #1 Check for free running by rolling the tracking shaft with your hand. The small belt must be removed from the tracking shaft pulley at this time.
- STEP #2 Check for end clearance between the tracking shaft and the bearing blocks. There should be a minimum of .015 of an inch.
- STEP #3 If there is insufficient clearance, remove the bottom from the wooden base.
- STEP #4 Now from underneath the deck, loosen the 4 screws holding the bearing blocks and move the bearing blocks apart. Tighten the screws and check for proper end play. Take care to be sure the bearing blocks are square with the shaft as shown in Figure #1.
- STEP #5 If end play is still insufficient, it is possible that the deck is warped. Place a small adjustable wrench on the right bearing block as shown in Figure #2 and bend outwards.
- STEP #6 Verify for free rotation of the shaft and replace the bottom of the unit.

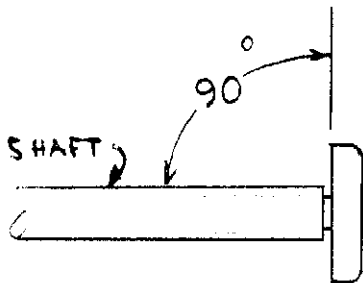

FIGURE 1
(TOP VIEW)

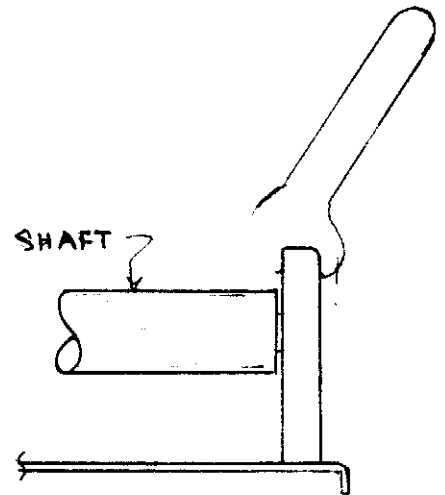

FIGURE 2
SIDE VIEW

ST-4
Service Bulletin No. 8

LIFT MOTOR CIRCUIT CHANGE TO PREVENT
COAST THRU OR JAMMING OF CUEING BAR

In Units after Serial No. 2438, a minor circuit change was instituted to prevent the possibility of a jammed cue bar. (Failure to raise or lower with the operation of the cue switch). This circuit also prevents the possibility of the lift-lower motor coasting thru and repeating the cycle. This bulletin should be used in conjunction with Service Bulletin No. 3.

- Step 1 - Remove the bottom of the unit.
- Step 2 - You will note two identical capacitors located adjacent to the terminal strip. One capacitor is connected to terminals 3 and 6, and the other is connected to terminals 1 and 8. See Figure 1. Disconnect the capacitor on 1 and 8. Remove the resistor attached to one terminal of the capacitor.
- Step 3 - Solder a 220 ohm $\frac{1}{4}$ watt resistor (\pm 10% or better), to either end of the capacitor.
- Step 4 - Now solder the resistor to terminal No. 8 and the other end of the capacitor to terminal No. 6.
- Step 5 - Now plug the unit into an AC outlet and operate the lift motor with the cue switch several times. A jam condition indicates excessive friction on the lift cam. Refer to Service Bulletin No. 3 to alleviate this condition. Please note that friction is no longer necessary to control coast thru.

ST-4

SERVICE BULLETIN #9

NOISY PLATTER MOTOR

From Serial #4788 up, a grease filled bearing cup was added to the platter drive motor as shown in Figure number 1. The cup is filled with a special lubricant.

For units under that number, if desired, the cup can be added by carefully removing the pulley and pushing the cup into place. Wipe off excess grease and push the pulley back in place. Filled cups will be supplied by RABCO.

NOTE: There must be clearance between the bottom of the pulley and the top of the cup. Allow between ".010 and ".030. A piece of paper folded several times or thin cardboard will suffice as a shim.

