

ST-6

Straight Line Tracking System

Technical Manual



WARNING

These technical instructions are for use by qualified service personnel only. To avoid electric shock, do not perform any servicing other than that contained in the operating instructions unless qualified to do so.

harman/kardon

CONTENTS

- Mechanical Concept
- Troubleshooting
- Disassembly
- Adjustments
- Parts List

Figure 1. General view of ST-6 turntable



Warning: To prevent fire or shock hazard, do not expose this turntable to rain or moisture.

I MECHANICAL CONCEPT

The concept of the ST-6 mechanism is shown in Figure 2. The tone arm is supported in a two-axis gimbal mount. The horizontal axis contains the dashpot – damped stylus elevation mechanism. In the vertical axis the tone arm is supported by a tracking roller that rolls against the tracking shaft. When the tone arm is tangential to the record groove the tracking wheel is biased in angle so that the carriage travels toward the platter center at approximately 0.17 inch per minute. This corresponds to the average velocity of the master disc. As the tone arm attempts to pivot in angle to track pitch variations, the angle of the tracking roller axis changes relative to the cylinder axis. This change in direction of the tracking roller accelerates or decelerates the motion of the carriage to track the pitch of the groove. The correction is continuous, self-adjusting, and automatic.

Figure 2. Tracking and drive schematic

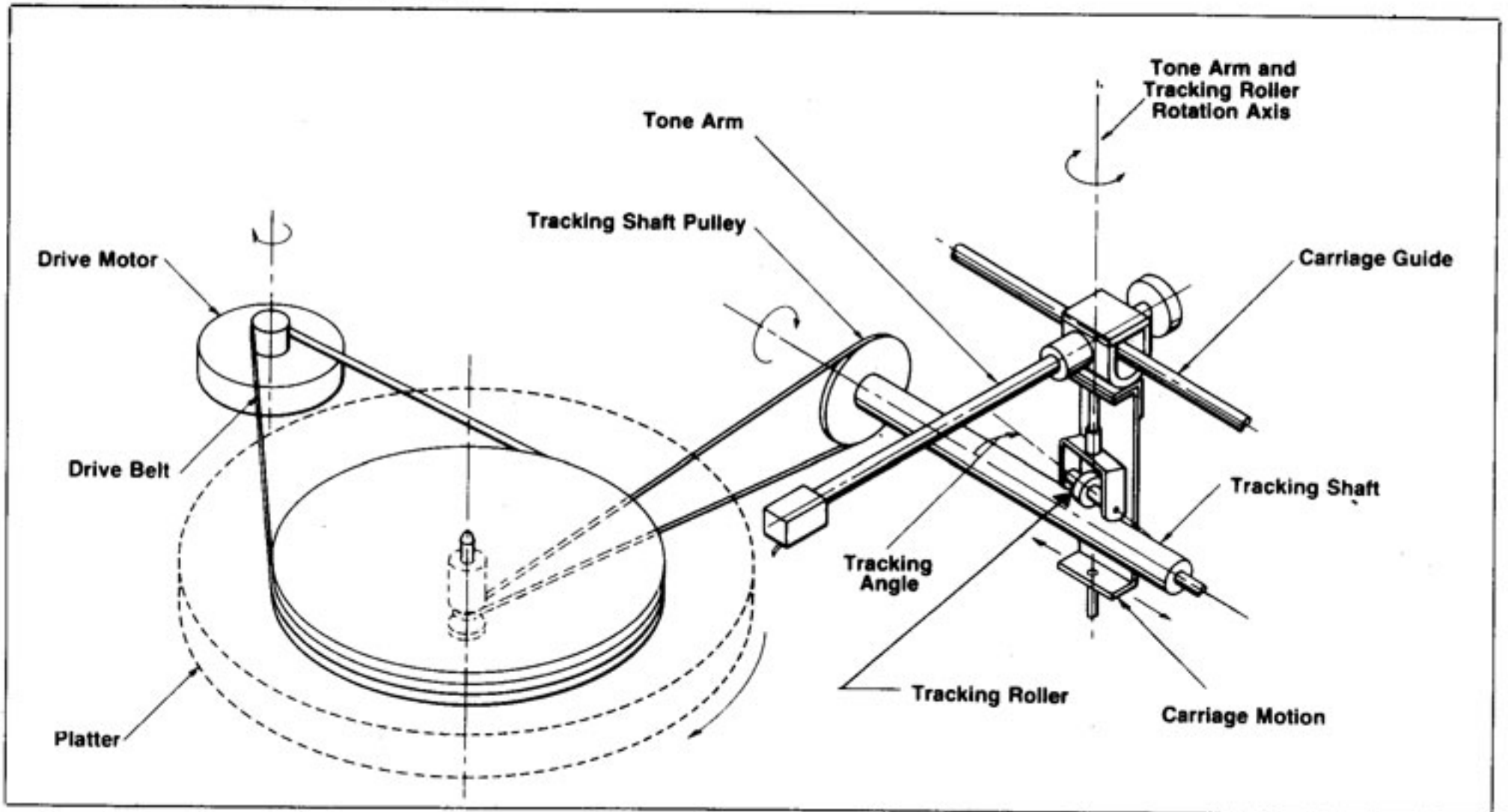

II TROUBLESHOOTING

(Refer to Figures 3, 10, and 11)

Conditions	Possible Cause & Corrective Measures
1. When the arm is cued to the "up" position, the arm does not nestle all the way up into the notch of the restrictor arm.	1. a. Stop bar screw not properly adjusted or loose. Refer to stop bar screw adjustment procedure. b. Gap between threaded lift pin and lift bracket too large. Refer to threaded lift pin adjustment. c. Incorrect position of dashpot stud. Refer to dashpot adjustment.
2. With the arm "up" the carriage assembly does not move freely enough from left to right.	2. a. Insufficient gap between threaded lift pin and lift bracket. Refer to threaded lift pin adjustment. b. Dirt build up under slide tube bushings. Clean slide rod and bushing area with alcohol. c. Stop bar set screw too tight. Refer to stop bar set screw adjustment.
3. When the arm is cued "down", the stylus does not reach the surface of the record.	3. a. Pivot pin on pivot bracket dirty or excess grease. Clean. b. Stop bar set screw adjusted too far down so that it prevents the roller assembly from allowing the tone arm to drop to the correct position. Refer to stop bar set screw adjustment.
4. When the arm is cued "down", an initial fast drop occurs before the damping action takes place.	4. a. Dashpot adjustment wrong causing a space between the tip of the dashpot plunger and the lift bracket surface. Refer to dashpot adjustment. b. Threaded lift pin adjusted for too much air gap between the lift pin and the lift bracket. Refer to threaded lift pin adjustment. c. Stop bar set screw set incorrectly. Refer to stop bar set screw adjustment.
5. When the arm is cued "down", no damping takes place at all. Arm drops hard and quickly to the record surface.	5. a. Defective dashpot. Replace dashpot. b. Dashpot set all the way up to the full height of the mounting stud. Refer to dashpot adjustment.
6. Extreme drift of tone arm as it comes down on the record.	6. a. ST6 not on a level surface. b. Uneven tip on stop bar set screw. Replace screw or use emery cloth to make tip of screw smooth. c. Uneven surface on top of roller assembly rear flat surface. Make surface smooth by using very fine emery cloth. d. Binding in pivot bracket assembly at bearing points. Lubricate nylon bearing with molykote 33 or equivalent. e. Slide tube flat surface not correctly positioned inside roller assembly. Remove top cap of roller assembly and observe that flat portion of the slide tube is vertical facing the front of the unit. To reposition, remove the 2 rear screws holding the stop bar; loosen the 2 set screws, and rotate the slide tube to the proper position. Retighten the set screws. Reassemble the stop bar.
7. As arm tracks across record, arm starts to "lead" the carriage.	7. a. Mis-adjustment of tracking screw/handle. Turn handle clockwise in very small increments until proper tracking occurs. Recheck for proper tracking. b. Mis-adjustment of carriage guide. See carriage guide alignment. c. Threaded lift pin adjusted with no air gap between the lift pin and the lift bracket. See threaded lift pin adjustment.

8. As arm tracks across record, arm starts to "lag" behind carriage.
 8. a. Mis-adjustment of tracking screw/handle. Turn handle counter-clockwise in very small increments until proper tracking occurs. Recheck for proper tracking.
 8. b. Tracking roller Spring (113) broken or one end disconnected.
9. Arm lifts and unit returns to "stop" mode before record material has been completely played.
10. Arm gets to end of record but does not switch to "stop" mode.
 9. a. Check tracking-if arm is "leading" the carriage, reset tracking as per step 7a.
 10. a. Check tracking-if arm is "lagging" the carriage; reset tracking as per step 8.
 10. b. Refer to tripping adjustment.
11. Arm gets to end of record and lifts up but the unit does not switch to "stop" mode.
 11. a. Micro-switch incorrectly positioned. Refer to micro-switch adjustment.
 11. b. Micro-switch defective; replace micro-switch.
12. Arm gets to end of record and lifts off record but does not return all the way up into the notch in the restrictor arm.
 12. a. Insufficient tension for the tone arm caused by too large a gap between the threaded lift pin and the lift bracket. Refer to threaded lift pin adjustment.
 12. b. Restrictor arm incorrectly positioned. To replace restrictor arm refer to paragraph IV-8.
 12. c. Stop bar set screw too loose. Refer to stop bar set screw adjustment.
13. Unit tracks poorly and jams tripping gears-particularly after being disassembled for service.
14. Scraping noise heard when platter is running.
 13. "O" ring installed with reversed twist. Install "O" ring so that as the spindle and bearing assembly is turned clockwise, the tracking shaft rotates clockwise as viewed from the tracking gear end.
 14. a. Pulley not properly positioned.
 14. b. Turntable belt twisted. Carefully remove the belt and reinstall properly with the shiny side of the belt out.
 14. c. Motor not properly positioned. Refer to motor alignment.
15. Excessive "Wow and Flutter."
 15. a. Turntable belt twisted, worn or with rough spots. Replace or reposition belt.
 15. b. Motor binding. Replace motor.
 15. c. Tracking shaft binding. Loosen tracking shaft pulley wheel and reposition for more end play.
 15. d. Defective "O" ring. Replace.
 15. f. Turntable bearing contaminated. Clean and relubricate.
 15. e. Nick on tracking shaft pulley. Polish with very fine emery paper.
16. Excessive "rumble."
 16. a. Motor mounts loose, tighten.
 16. b. Defective motor. Replace.
17. Arm intermittently does not return to notch in restrictor arm. Also binding of carriage left to right.
18. Loss of L or R channel.
 17. Slide tube flat area not properly positioned. Refer to step 6e.
 18. a. Defective cartridge.
 18. b. Open (broken) or shorted wires between receptacle on roller assembly and output cables. Check continuity of all 4 wire paths.

19. Hum
20. Hum pick up as hand goes near arm. Static audible as carriage is moved manually from left to right.
21. Unit does not light up.
22. Unit starts but shuts off immediately.
23. Platter wobble.
24. Cueing lever works but arm won't drop.
25. Acoustic feedback.
26. Chattering or scraping as carriage is moved with arm up.
27. Binding or squeaking as carriage is moved with arm up.
28. Unit will not cue up and shut off with certain records.
29. High frequency content of program material sounds excessively brilliant.
19. Broken circuit in ground path. Scrape through anodize on underside of cartridge holder, and check continuity between receptacle shell and chassis. (See note in owners manual on cartridge)
20. Loose knurled nut on tone arm. Tighten by hand as securely as possible.
21.
 - a. Blown fuse.
 - b. Check that AC switch is "on".
 - c. Faulty pilot light assembly; replace.
22.
 - a. Insure clutch has been positioned initially by sliding tone arm carriage to extreme left and returned right.
 - b. Trip pin positioned incorrectly. Refer to micro-switch position adjustment.
23.
 - a. Check for defective platter.
 - b. Check for defective post and hub assembly.
24.
 - a. Improperly balanced arm-no zero balance.
 - b. Extension spring (110) off.
 - c. Insufficient gram weight.
25.
 - a. Check all four feet; four are equally soft.
 - b. Check unit is level.
 - c. Check for close proximity of speaker.
26. Dirt on lift plate; clean.
27. Slide tube set screws (202) too tight. Remove stop bar, to obtain access to set screws. Loosen set screws slightly. Set screws should be firm but should not bind on slide tube.
28. Excessive or insufficient lead out groove area; leadout beyond RIAA standards.
29. Cable capacitance needs to be matched more closely to cartridge. Refer to cable capacitance matching in adjustment section. ST6 cable capacitance is approximately 110 pf. (including tone arm)

III DISASSEMBLY PROCEDURE

To service various portions of the ST6, it may be necessary to partially or fully disassembly the unit. For purposes of explanation, we will identify these as four stages of disassembly. For each adjustment, we will specify which stage or stages of disassembly are required to accomplish the repairs or adjustments.

STAGE 1 – REMOVAL OF PLATTER AND MAIN DRIVE BELT

STAGE 2 – REMOVAL OF TOP PLATE, FRONT

STAGE 3 – REMOVAL OF LEFT HAND COVER AND TOP PANEL, REAR

STAGE 4 – REMOVAL OF SIDE WALL

A WORD OF CAUTION . . . The items described are ALL dress pieces and have been finished to provide a high quality aesthetic appearance.

EXTREME CARE should be taken when removing, storing, or replacing these parts to avoid scratching or damaging their appearance.

STAGE 1 – REMOVE dress disc, spring washer and retainer ring. Remove platter and main drive belt.

STAGE 2 – Remove entire tone arm assembly from carriage, remove two screws holding top front panel in place; remove top front panel.

STAGE 3 – Remove two screws and then left hand cover; remove two panel screws and then rear top panel.

STAGE 4 – Remove six screws from the bottom and then the entire side wall as an assembly.

IV ADJUSTMENTS

Figure 3 shows the ST6 after all four stages of disassembly. The callouts represent location of adjustments that will be referred to in the following paragraphs. It is recommended that you familiarize yourself with the location of these adjustments.

For some adjustments supplementary line drawings are included with the actual procedure, to provide greater clarity.

Adjustments included are:

1. Stop Bar Set Screw
2. Dashpot
3. Threaded Lift Pin
4. Tripping
5. Carriage Guide
6. Microswitch Position
7. Motor Alignment
8. Restrictor Arm
9. Conversion of ST6 Multivoltage Units
10. Cable Capacitance Matching
11. Carriage Assembly Removal.

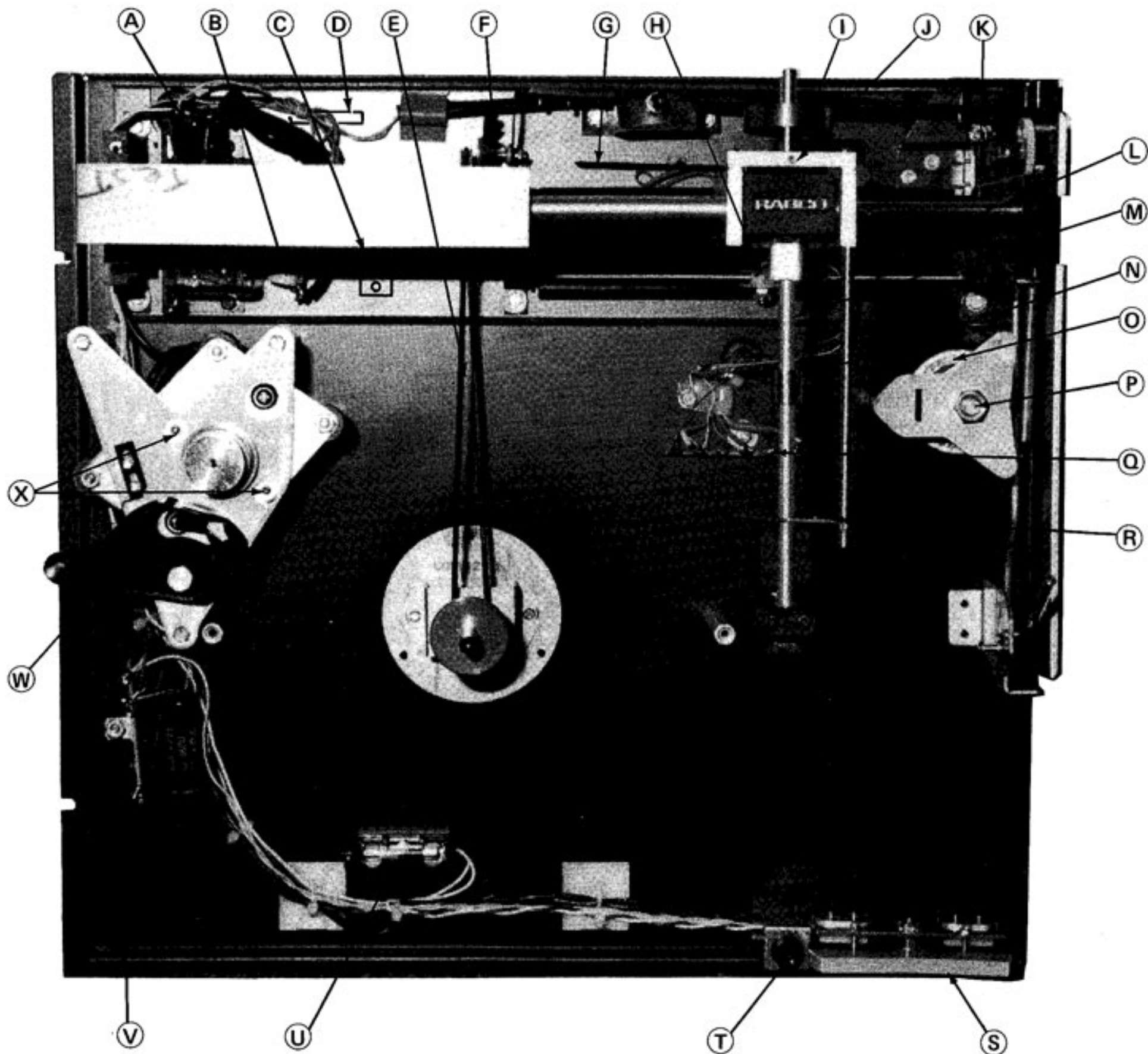

Figure 3.

Relay	A	Lift Plate	L
Terminal Board TB3	B	Tone Arm	M
Multivoltage Switch (position only)	C	Gram Weight	N
Terminal Board TB4 (position only)	D	Dashpot	O
Tracking Belt	E	Dashpot Locknut	P
Trip Clutch	F	Terminal Board TB1	Q
Trip Actuator	G	Restrictor	R
Carriage Guide	H	Power Switch	S
Counterweight	I	Pilot Light	T
Stop Bar Set Screw	J	Fuse	U
Magnet	K	Terminal Board TB2	V
		Belt Shifter	W
		Motor Alignment Screws	X

1. STOP BAR SET SCREW

A. Reason For Adjustment

To allow the arm to drop sufficiently far down so the preset weighting applies and allows the arm to track. (Refer to Figures 1 and 4.)

B. Pre-Condition for Adjustment

Arm must be installed with cartridges and shims (when required), and be properly adjusted for balancing and tracking force.

C. Required Disassembly

None

D. Method of Adjustment

With the cue lever positioned for the arm to be in the "down" position, the set screw is adjusted to permit the lower surface of the cartridge (next to the stylus) to just reach the top surface of the metal platter (not mat or record).

*WITH TONE ARM CUED DOWN ON RECORD.

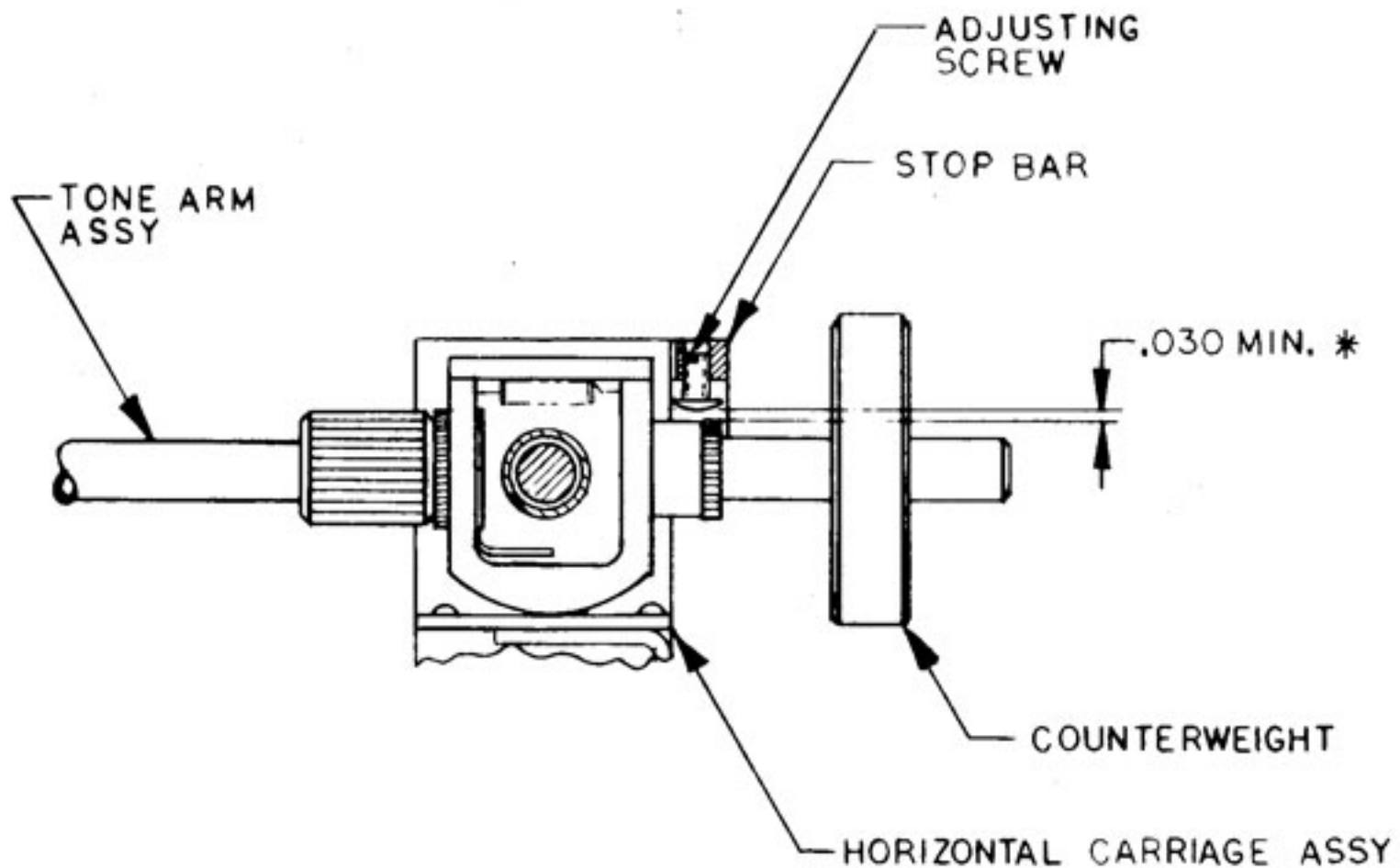

Figure 4. Tone arm cue lift adjustment

2. DASH POT

A. Reason for Adjustment

To permit the arm to lower itself slowly to the record surface when the cue lever is moved downward rapidly. (Refer to Figure 3.)

B. Pre-Condition for Adjustment

None

C. Required Disassembly

Stage 1 and 2

D. Method of Adjustment

With the arm cued to the "up" position, loosen the locking nut on the dash pot stud. Turn the entire dash pot counter-clockwise until there is a large gap between the dash pot plunger and the top surface of the lift plate. Then adjust the dash pot clockwise until the plunger is snug against the lift plate surface. (Refer to Figure 5.) Hold the body of the dash pot and secure the locking nut to hold in place.

* GAP MUST BE MAINTAINED FOR COMPLETE TRAVEL OF CARRIAGE.

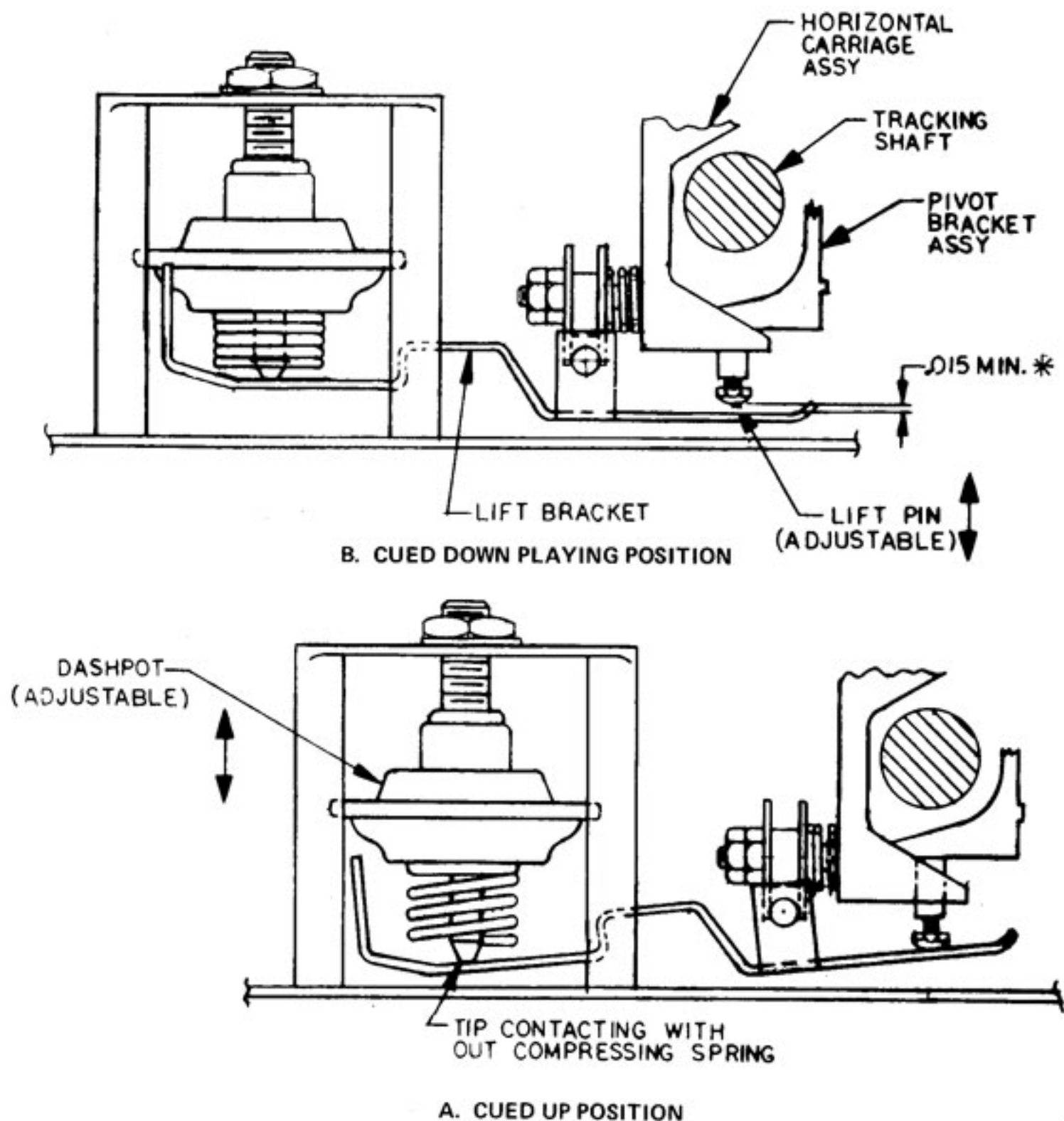

Figure 5. Tone arm lift adjustments

3. THREADED LIFT PIN ADJUSTMENT

A. Reason for Adjustment

To allow for a clearance between the lift pin and the lift plate surface, in the arm "down" position, so that tracking will occur as a function of the tracking roller and the tracking wheel touching each other properly. (Refer to Figure 6.)

B. Pre-Condition for Adjustment

The dash pot, stop bar set screw, and the carriage guide adjustments must be properly set before adjusting the lift pin.

C. Required Disassembly

Stages 1 through 4

D. Method of Adjustment

With the arm "down" on the surface of a record, adjust the threaded lift pin with a small 3/16" open end wrench to produce an air gap between the head of the lift pin and the surface of the lift plate. This gap should be approximately .020 inches.

After adjustment, the arm, when cued "up", must cradle properly into the restrictor arm notch and the carriage should move freely from left to right in the arm "up" position. A very tight left to right action would indicate insufficient gap between the lift pin and the lift plate.

The adjustment of the stop bar set screw must be rechecked after setting the lift pin adjustment.

SPECIAL NOTE:

The gap between the lift plate and the lift pin while typically .020 can vary from unit to unit. The gap can be made smaller if necessary to achieve the following:

1. Free lateral movement of carriage in the arm "up" position.
2. Arm must remain cradled in the restrictor notch as the carriage is moved left to right with the arm "up".
3. A gap is visible between the lift pin and lift plate at the extreme ends of the extreme ends of the left and right carriage position with the arm in the "down" position.

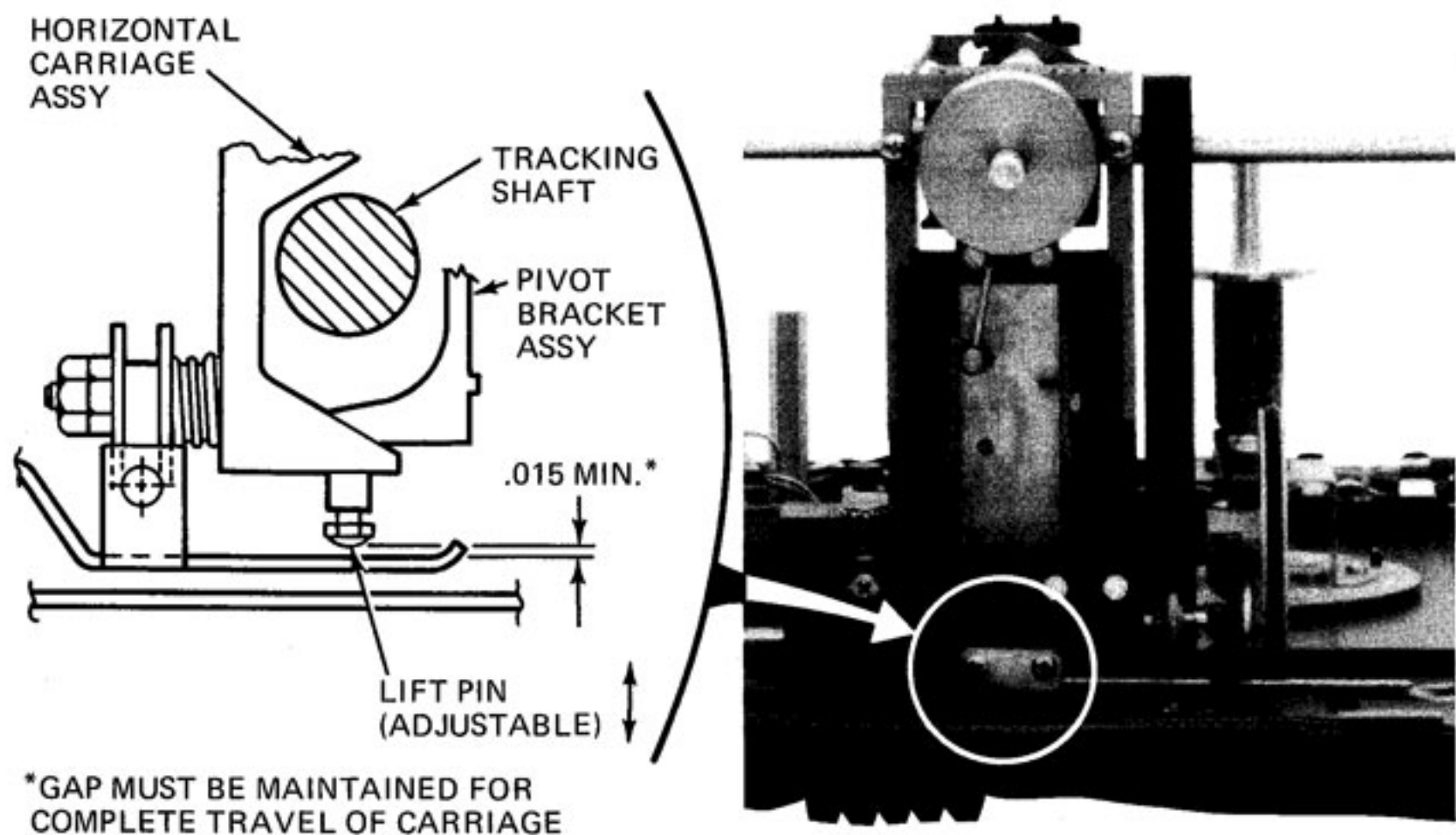

Figure 6. Threaded lift pin adjustment

4. TRIPPING ADJUSTMENTS

A. Reason for Adjustment

To ensure that trip function operates properly at the end of a record.

B. Pre-Condition for Adjustment

Tracking adjustments must be complete before attempting to adjust the tripping.

C. Required Disassembly

Stage 3

D. Method of Adjustment

1. Pivot bearing freedom adjustment:
Adjust pivot screw so that trip plate assembly swings freely by itself when mounted on a level surface. Freedom is not to be excessive. Lock jam nut.
2. Adjust stop screw against bracket for nominal $\frac{3}{64}$ gap between trip plate and trip pin when in maximum back position.
3. Adjust clutch spring loading for slipping at 2.2gm/cm. The unit should trip on a commercial record with small run out margin (approx $\frac{3}{8}$ " wide) with tracking force set at 0.75gms minimum.
4. Check tripping on a commercial record with large run out margin (approx 1" wide). Lift off should be smooth. If motion is abrupt, check for dirty stylus, improper tracking force or restriction of trip plate.
5. Readjust stop screw, if necessary, for no trip actuation on a commercial record with a large interband crossover (approx $\frac{1}{16}$ wide) by increasing gap slightly (see para 2). Recheck tripping in small run out margin.
6. Adjust magnet holder so that force to break away trip plate from contact with tripping gear is 0.4 to 0.6 grams, when measured at catch mounting screw. Insure that actuator rod is disengaged from clutch when making the measurement.

NOTE: a) A clean record and stylus in good condition must be used.

b) When checking tripping functions, the stylus should be set down in the preceding band a short distance to allow the tracking to normalize.

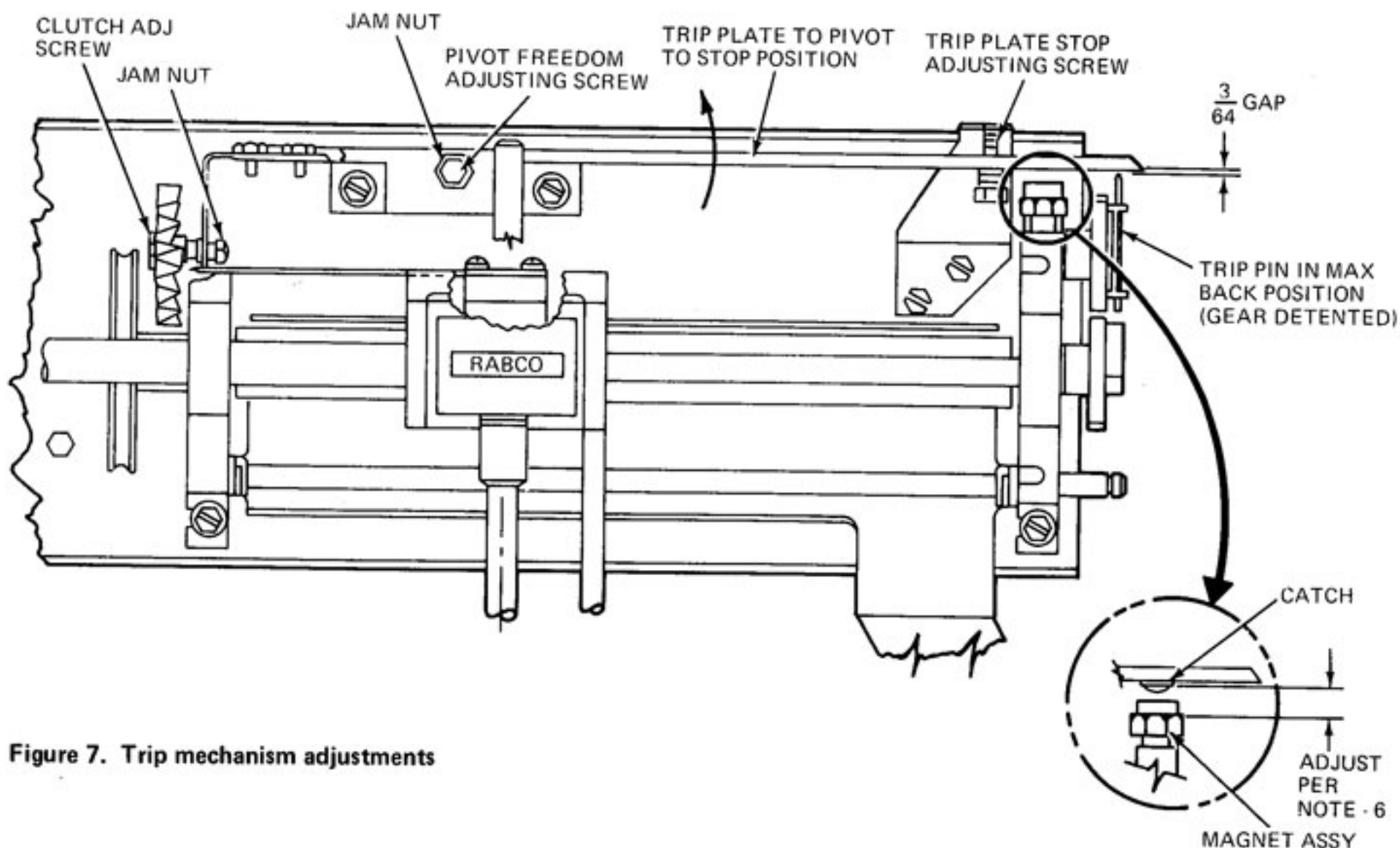

Figure 7. Trip mechanism adjustments

5. CARRIAGE GUIDE

A. Reason for Adjustment

To position the tracking roller directly above the center of the tracking shaft.

B. Pre-Condition for Adjustment

None

C. Required Disassembly

Stages 1, 2, and 3

D. Method of Adjustment

The carriage guide adjustment (Figure 8) must be made so that when the arm is "down," the tracking roller is directly above the center of the tracking shaft. Loosen the outside nut on the carriage guide, and either loosen or tighten the inside nut against the spring tension to position the tracking roller to be exactly centered above the tracking shaft.

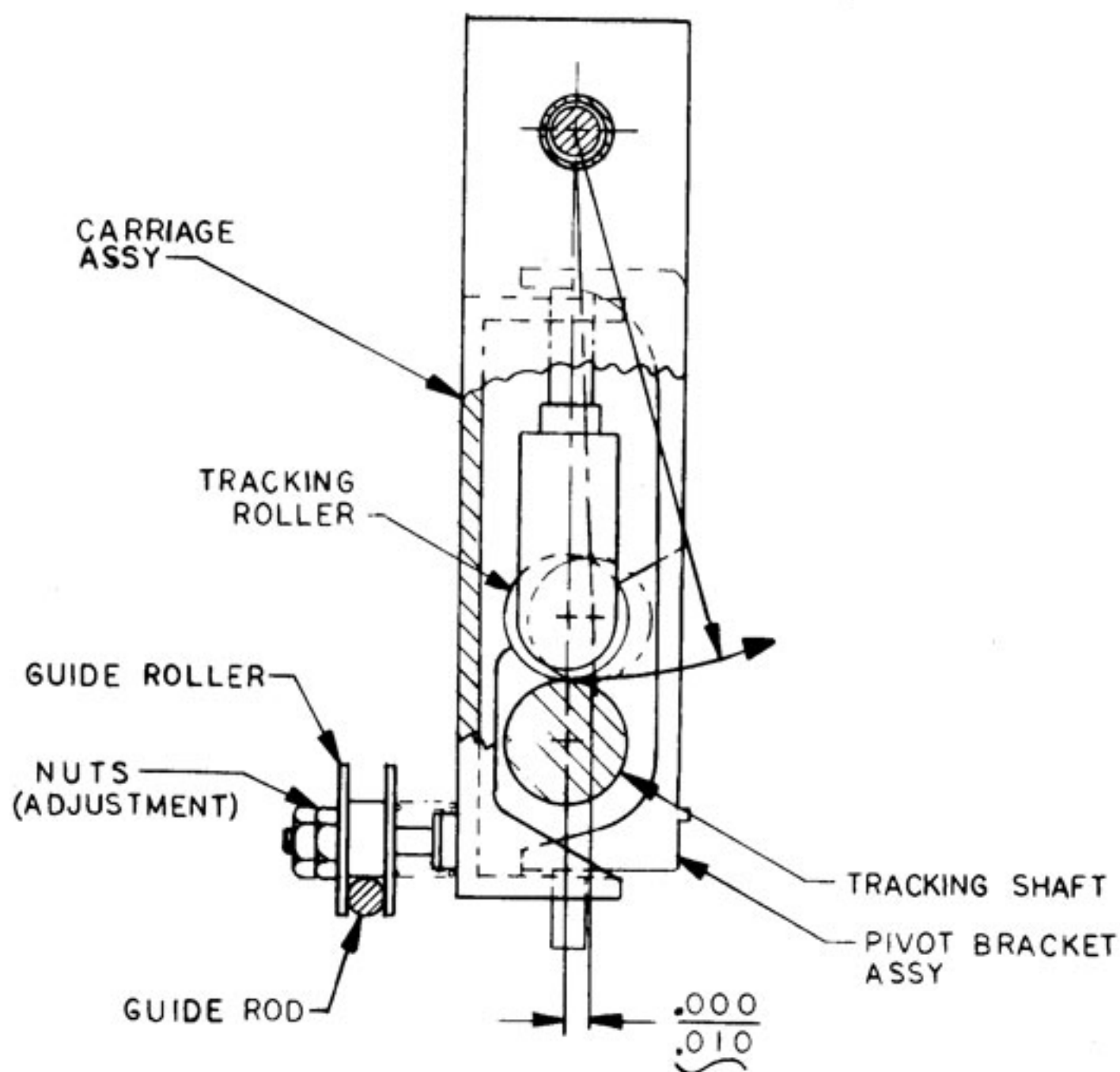

Figure 8. Carriage position adjustment

6. MICROSWITCH POSITION ADJUST

The microswitch must be positioned so that when the roller on the lever is engaged in the neutral position of the trip gear, the trip pin going through the gear must be tilted slightly from the horizontal in clockwise direction, but not beyond the tolerance shown. (Refer to Figure 9.)

A. Reason for Adjustment

To position the microswitch for proper operation of the trip gear assembly.

B. Pre-Condition

Remove retaining ring (155) and washer (207) securing-cue lever linkage (11) to trip gear staking assembly, and swing cue lever linkage down for clear access to microswitch.

C. Required Disassembly

Stages 1 through 4

D. Method of Adjustment

Position the microswitch so that the trip pin is slightly off the horizontal as shown in the figure. The switch body should be level. The switch body should be adjusted vertically so the switch clicks on each trip cycle. There should be approximately 1/16 inch clearance between the switch arm and the switch body.

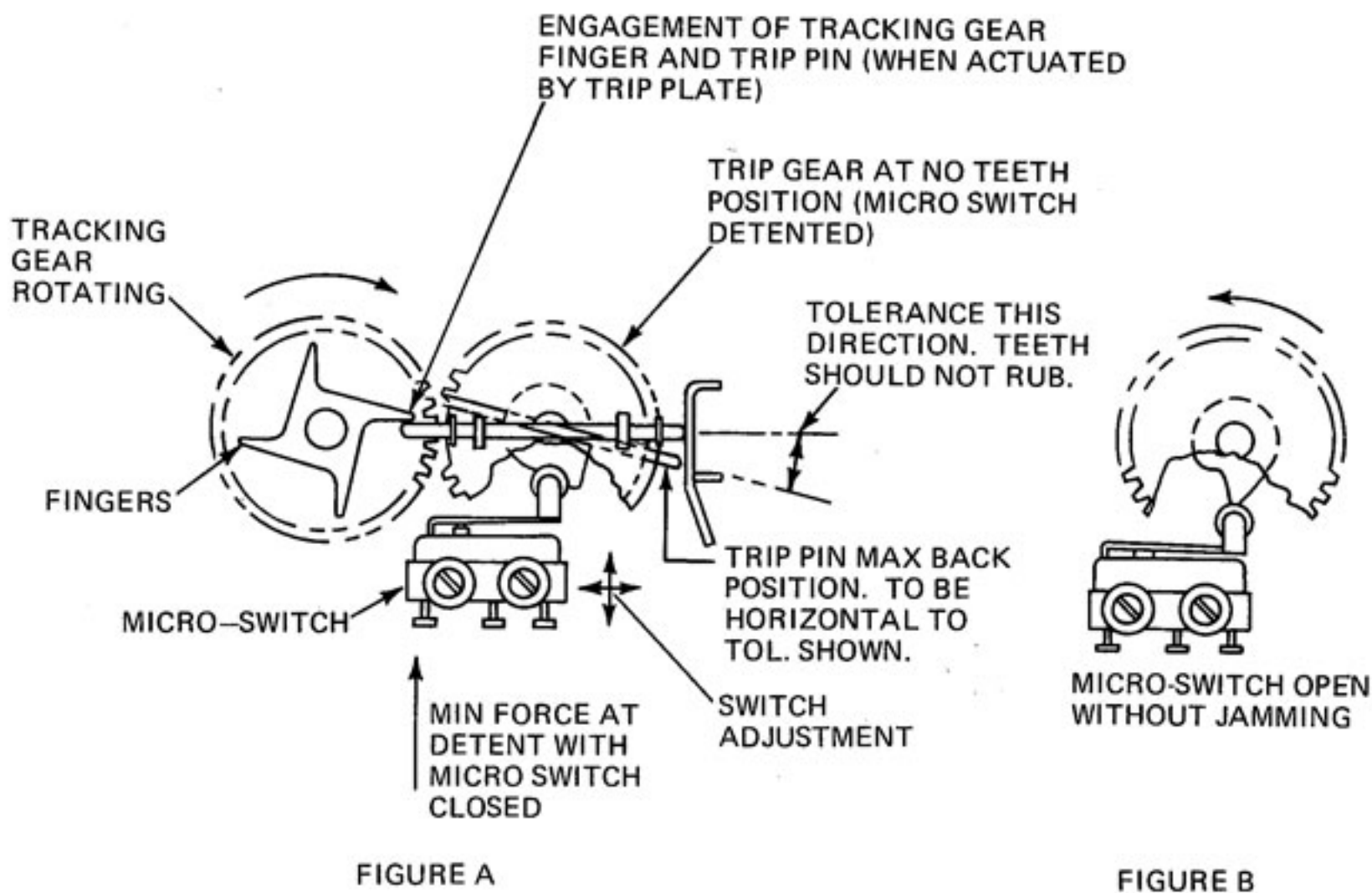

Figure 9. Microswitch adjustment

7. MOTOR ALIGNMENT

A. Reason for Adjustment

To position the motor pulley so it is perfectly parallel with the platter belt surface.

B. Pre-Condition for Adjustment

None

NOTE

A special 7 inch test platter is required to make this adjustment. Test platters are available from Harman Kardon.

C. Disassembly

Stages 1 and 2

D. Method of Adjustment

Set up unit with 7" test platter in place of regular platter. Install belt with shiny side out. Run at 33-1/3 speed and observe belt position on motor pulley. Start with both adjustment screws not touching the motor housing. Turn whichever screw is required to cause the belt to ride exactly in the center of the motor pulley. Turn the second screw to just touch the motor housing but not add any additional tension to the motor. Check belt shifting.

8. RESTRICTOR ARM REPLACEMENT

A. Reason for Adjustment

To allow the tone arm to be recaptured into the notch of the restrictor from any normal angles of record run out grooves.

B. Pre-Condition

None

C. Disassembly

None

D. Method

Loosen the restrictor nut. Position the restrictor arm so that when the tone arm, with cartridge properly shimmed (if required), is placed on the record and moved manually to the extreme left of its pivot; it clears the under side of the arm by approx 1/32".

9. CONVERSION OF ST6 MULTIVOLTAGE UNITS

A. Reason for Adjustment

To convert unit to required voltage and frequency. (Refer to Figure 3).

B. Pre-Condition for Adjustment

Line cord removed from socket.

C. Required Disassembly

Stages 1 and 2

D. Method of Adjustment

1. Locate multivoltage switch (Figure 3) and move lever to desired voltage.
2. Replace pulley with RV (smaller) domestic type.
3. Replace belt with smaller domestic type.
4. Replace the line cord, or select adapter for appropriate wall outlet.

10. CABLE CAPACITANCE MATCHING

A. Reason for Adjustment

To match ST6 cable capacitance as closely as possible to cartridge manufacturer recommendation, if desired.

B. Pre-Condition for Adjustment

Determine cable capacitance recommended by manufacturer.

C. Required Disassembly

Stages 1 and 2

D. Method of Adjustment

Locate Terminal Strip TB1 on Figure 3. The signal cable pairs are terminals 1 and 2, and 5 and 6. The existing cable capacitance for each pair is approximately 110 picofarads. Add the difference in capacitance (manufacturers recommendation less 110 pf) across each pair of terminals (1-2 and 5-6).

11. CARRIAGE ASSEMBLY REMOVAL

A. Reason for Adjustment

To facilitate repair and/or replacement of component parts of carriage assembly.

B. Pre-Conditioning

Remove counterweight and tone arm.

C. Disassembly

Stages 1 through 4

D. Method of Removal

Locate Terminal Strip TB1 on Figure 3. Unsolder five tone arm signal leads (red, green, yellow, white, black). Referring to Figure 10 and 11, locate LH cover (6) and RH cover (7). Remove machine screws (195, 196) fastening covers, and remove both covers. Loosen setscrews (202) on back of LH and RH slide support assys (22) and (49), and remove slide rod (71). Loosen two setscrews (203) on tracking shaft pulley (51) and remove from tracking shaft (72). Remove two machine screws anchoring tracking shaft support (49) to base. Carefully slide carriage assembly off tracking shaft (72).

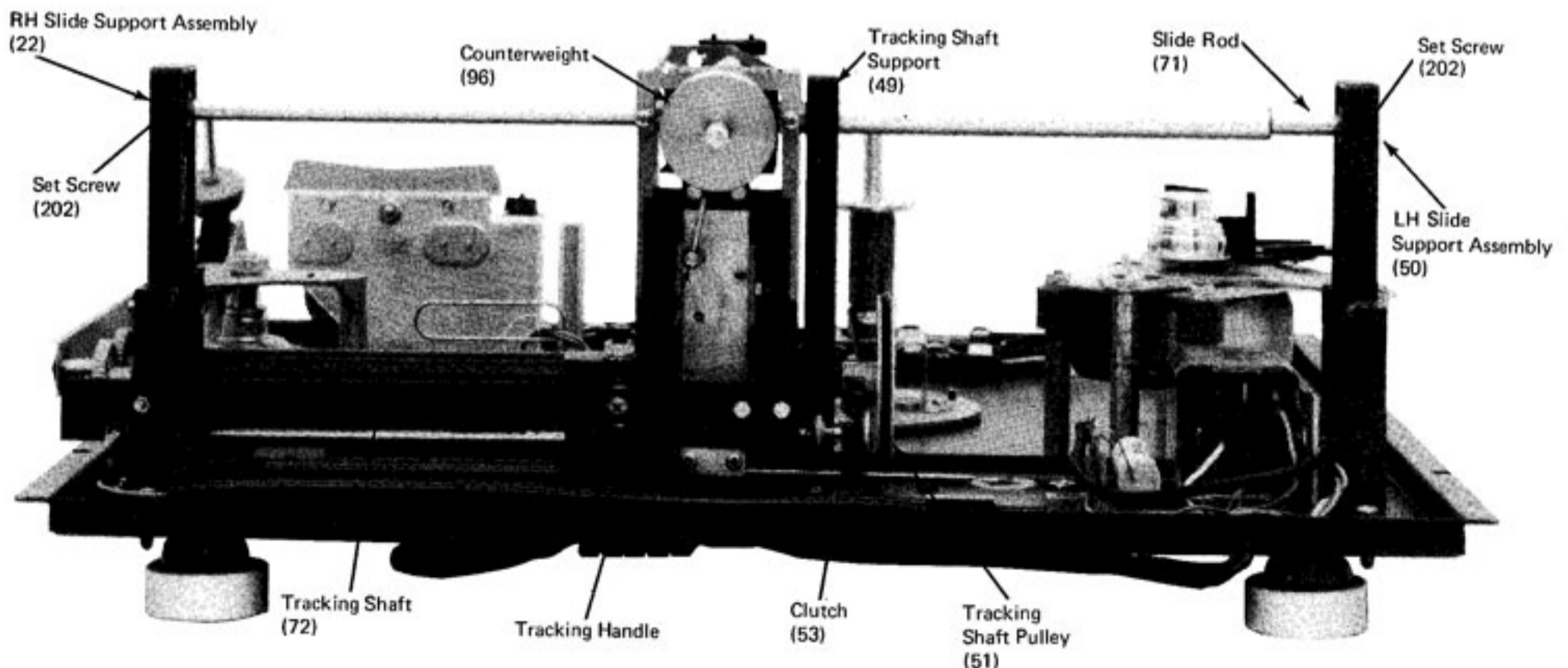

Figure 10

OVERALL PARTS LIST ST-6
(Referenced to Figure 12)

Ref. No.	Part Number	Description	Ref. No.	Part Number	Description
1	60132181	Base Plate	46	62031486	Isolator
2	60130298	Disc	47	62030230	Foot, Mounting
3	60130151	Side Wall	48	60830127	Gear, Tracking Shaft
4	60132180	Top Plate, Front	49	61630287	Support, Tracking Shaft
5	60130190	Top Plate, Rear	50	61631342	Support, L.H.
6	60130147	Cover, L.H.	51	60830145	Pulley, Tracking Shaft
7	60130148	Cover, R.H.	52	61630194	Bracket
8	60132170	Bracket On-Off Control	53	61630215	Clutch Plate
9	60130301	Locknut Plate	54	61630161	Cover, Roller
10	01930003	Cam Brkt & Shaft Assy	55	61630101	Mtg Plate, Cartridge
11	60130183	Linkage, Cue Lever	56	61631718	Clamp, Cover
12	60130193	Trip Plate	57	61630109	Sleeve, Gram Weight
13	60132440	Clutch Mounting Bracket	58	61130202	Guide, Carriage
14	60132087	Plate Mtg, Carriage Assy	59	61430743	Grommet, Eccentric
15	60130177	Lift Plate	60	61630286	Holder, Trip Actuator
16	01930007	Hub & Post Assy	61	61430746	Pad, Foam
17	01930006	Spindle & Bearing Assy	62	61630116	Shim, Hinge
18	60130294	Retainer, Bearing	63	61630134	Bracket, Tracking Roller
19	60130283	Bracket, Dampening	64	61130130	Slide Bushing
20	60133079	Plate, Motor Mtg.	65	61432276	Pad, Rubber
21	60133084	Plate, Shifter Mtg.	66	61631800	Belt Shifter
22	01933032	Slide Support Assy, R.H.	67	60431594	Insert, Lift Pin
23	60132514	Stop Bracket, Trip Mechanism	68	60430181	Shaft, Linkage, Cue Cam
24	60132517	Mounting Bracket, Relay	69	60430144	Guide Rod
25	60131571	Stop Bar, Cue Lift	70	60430211	Trip Pin
26	01930026	Horizontal Carriage Staked Assy	71	60430139	Slide Rod
27	60131592	Pivot Bracket	72	60430143	Tracking Shaft
28	01930021	Roller Base Riveting Assy	73	60430187	Rod, Release
29	60130156	Receptacle, Connector	74	60431994	Adjusting Hub, Tracking
30	60132532	Restrictor, Tone Arm	75	60431610	Button, Tracking, Adjust
31	60131603	Cover, Cartridge	76	60431995	Adjusting Stud, Tracking
32	01930018	Trip Gear Staking Assy	77	60431593	Bearing Rod
33	57530106	Cable Assy, Tone Arm	78	60433304	Lift Pin, Threaded
34	57530217	Cable Assy, Roller	79	60430200	Rod, Restrictor
35	60133522	Actuator Rod, Trip	80	60430272	Rod, Counterweight
36	62930202	Platter	81	60432178	Spacer, Bracket Adjust
37	62930167	Adaptor, 1.50 I.D. (38MM)	82	60432175	Pivot Stud
38	61131525	Tracking Roller Assy	83	60430192	Pivot
39	61130110	Roller, Tone Arm	84	60431728	Adjusting Scr, Stop Bar
40	61630239	Dust Cover	85	63230178	Lever, Cueing Cam
41	61632233	Grommet, Cue Lever	86	63231799	Rod, Shifter
42	61632081	Grommet, Speed Shifter	87	61730102	Tone Arm Tube
43	62830179	Cam, Cueing	88	61730276	Gram Weight
44	61632145	Actuator, On-Off	89	84030758	Locknut, Tone Arm
45	61632179	Spacer	90	84031027	Nut, Restrictor

01935088
4.09

OVERALL PARTS LIST ST-6 (continued)

Ref. No.	Part Number	Description	Ref. No.	Part Number	Description
91	60831780	Drive Pulley (Domestic)	*136	30532273	Capacitor .25UF 400VAC (C3)
92	60832011	Drive Pulley (Export)	137	67031885	Clamp
93	01030208	Turntable Mat	138	65611705	Ground Lug
94	60630121	Retainer, Grommet	139	61131575	Bearing
95	60631797	Spring, Detent	140	65730737	Ground Lug, Tone Arm
96	61930271	Counterweight	141	86530233	Spacer Rod
97	61730129	Slide Tube	142	67030831	Free Stop Hinge Assy
98	63231996	Adjusting Handle, Tracking	143	67030830	Lock Plate (Hinge)
99	80619422	Nut, Hex Keps 6-32	144	62431559	Tape, Double Sided
100	60332007	Wire Guide, Audio	145	84030199	Nut, Jam, Counterweight
101	61830745	Inner Covering	146	84030117	Nut, Jam, Receptacle
102	62021307	Felt Pad	147	61431884	Grommet, Phono Cable
*103	61433164	Belt, Turntable (Domestic)	148	60432397	Grommet, Pilot Light
*104	61431730	Belt, Tracking	149	61430856	Grommet, Strain Relief
105	79032220	Adjusting Screw	150	61430510	Grommet
106	61632239	Lens	151	67030808	Retaining Ring
107	61430303	'O' Ring	152	67030828	Retaining Ring
108	60630126	Spring, Band	153	67030815	Retaining Ring
109	60630279	Spring, Comp, Screw Locking	154	67032260	Retaining Ring
110	60631578	Spring, Extension	155	67030801	Retaining Ring
111	60630299	Spring, Compression	156	67030812	Retaining Ring
112	60630191	Spring, Compression	157	67030813	Retaining Ring
113	60630137	Spring, Tracking Roller	158	67030818	Retaining Ring
114	60630292	Spring, Comp, Guide	159	67032443	Retaining Ring
115	87230118	Standoff, Top Plate	160	67030815	Retaining Ring
116	67032787	Retaining Ring	161	85431586	Curved Washer
117	87232275	Standoff, Threaded	162	70930459	Screw, 4-40x3/8 M.S.
*118	25031791	Micro Switch (S1, S2, S3)	163	85432254	Curved Washer
119	01732245	Motor (M1)	164	60132868	Nut Plate
*120	24532274	Slide Switch (Export) (S4)	165	85431410	Curved Washer
*121	13032263	Relay (K1)	166	77830776	Screw M4x0.7x.80M M.S.
122	65430519	Fuseholder	167	70230712	Screw 2-56x3/4 M.S.
*123	45031348	Fuse .5A Slo-Blo (F1)	168	79432247	Screw 4-40x7/16 Type "23"
124	53031873	Phono Cable (Audio)	169	77830910	Screw 4-40x3/16 M.S.
125	53029083	Line Cord	170	60432813	Adjusting Screw, Clutch
126	53030949	Line Cord (Export)	171	79432247	Screw 4-40x7/16 Type "23"
127	65033587	Terminal Strip (TB3)	172	78931210	Screw 2-56x1/8 M.S.
128	65231715	Terminal Strip (TB1)	173	70230712	Screw 2-56x3/4 M.S.
129	47632269	Neon Lamp (DS1)	174	87930849	Screw, Drive #00x1/8 Type U
130	61931581	Dash Pot	175	71930931	Screw 6-32x3/16 M.S.
*131	36916525	Resistor 6.5kΩ (R1)	176	78732222	Screw 4-40x1/4 Type "23"
*132	36915125	Resistor 5.1kΩ (R2)	177	70818675	Screw 4-40x1-1/8 M.S.
*133	30418307	Capacitor .01UF 150VAC (C1,C5,C4)			
*134	30532486	Capacitor .047UF 1000VAC (C2)			
*135	30532534	Capacitor .33UF 400VAC (C3)			

OVERALL PARTS LIST ST-6 (continued)

Ref. No.	Part Number	Description	Ref. No.	Part Number	Description
178	78730929	Screw 4-40x3/16 Type "23"	222	80619582	Nut, Hex, Keps 8-32
179	77831589	Screw 4-40x3/8 M.S.	223	80131582	Nut, Hex, Jam 5/16-24
180	80619403	Nut, Hex, Keps 4-40	224	80130853	Nut, Hex 6-32
181	72532246	Screw #4x1/4 Type "B"	225	80130860	Nut, Hex 4-40
182	79632767	Screw 6-32x3/8 Type "23"	226	84030814	Nut, Square 4-40
183	79632768	Screw 6-32x1/2 Type "23"	227	85319818	Lockwasher, Ext Tooth #4
184	77630917	Screw 6-32x5/16 Type "23"	228	61432696	Screw Tip Cover
185	77830893	Screw 6-32x1/4 M.S.	229	60132873	Plate Retaining-Actuator
186	77832277	Screw 4-40x1/4 M.S.	230	60132701	Shield, Motor
187	79031798	Shoulder Screw	231	86532811	Washer, Spacer-Pulley
188	77832426	Screw 6-32x1/2 M.S.	232	67029865	Clamp
189	75830777	Screw 4-40x3/8 Type "F"	233	61532882	Disc, Clutch
190	76530706	Screw #8x1/4	234	67029700	Harness Mount
191	77830891	Screw 4-40x5/16 M.S.	235	80132786	Nut Hex 8-32
192	70230709	Screw 4-40x7/16 M.S.	236	62033059	Vibration Mount
193	71833143	Screw 6-32x5/16 M.S.	237	87233082	Standoff, Shifter Plate
194	77832262	Screw 8-32x7/16 M.S.	238	87233081	Standoff, Motor Plate
195	70630773	Screw 4-40x5/16 M.S.	239	60432995	Holder, Magnet
196	70630890	Screw 4-40x3/16 M.S.	240	60432997	Magnet
197	74431237	Screw 6-32x1/4 Type "F"	241	60433019	Catch, Magnet
†198	60132523	Shield, Electric-Hazard-Rear	242	77833068	Screw 2-56x3/16 P.H.M.
†199	60132226	Shield, Electric-Hazard-Front	243	80130821	Nut Hex #2-56
200	81219328	Nut, Hex, Self-locking 6-32	244	61433165	Pad, Shifter
201	72132491	Screw, Set 2-56x3/32	245	61433166	Rubber Channel, Shifter
202	72132185	Screw, Set 4-40x1/4	246	80119579	Nut Hex #8
203	72130713	Screw, Set 4-40x1/8	247	85019242	Washer, Flat #8
204	72131738	Screw, Set 6-32x5/16 Oval Pt	†248	77833890	Screw, 6-32x3/8 M.S. Blk
205	85530267	Washer, Shoulder	†249	85033891	Washer, Flat #6 Blk
206	85030847	Washer, Flat #2 Med.	†250	80633749	Nut, Hex, Keps 6-32 Blk
207	85030244	Washer Flat, Linkage	251	85033947	Washer, Flat
208	85030884	Washer, Flat #3 Med.	252	65030973	Terminal Strip (TB2, 4)
209	85030845	Washer, Flat #4	253	85033761	Washer, Flat
210	85030850	Washer, Flat #6	300	01931745	Side Wall Assy
211	85033946	Washer, Flat	301	01932445	Top Plate Assy (Front)
212	85032082	Thrust Washer	302	01930747	Top Plate Assy (Rear)
213	85030236	Washer, Flat	*303	01832550	Pilot Light Assy (DSI)
214	85019248	Washer, Flat #8	304	01930029	Slide Tube Assy
215	85130848	Lockwasher #2 Split	305	01930035	Mtg Foot Assy
216	85219238	Washer Int. Lock 5/16	306	01930036	Counterweight Assy
217	85231487	Lockwasher Int. Receptacle	307	01930023	Roller Assy
*218	61434037	Belt, Turntable (Export)	308	01931782	Roller & Base Assy
219	85130863	Lockwasher #6 Split	309	01631609	Tone Arm Assy (Only)
220	80619508	Nut, Hex, Keps 6-32	310	01932883	Clutch Screw Assy
221	81932251	Nut, Hex 4-40 (Palnut)	311	01933018	Magnet & Holder Assy

*Recommended Spares

†Not on all models

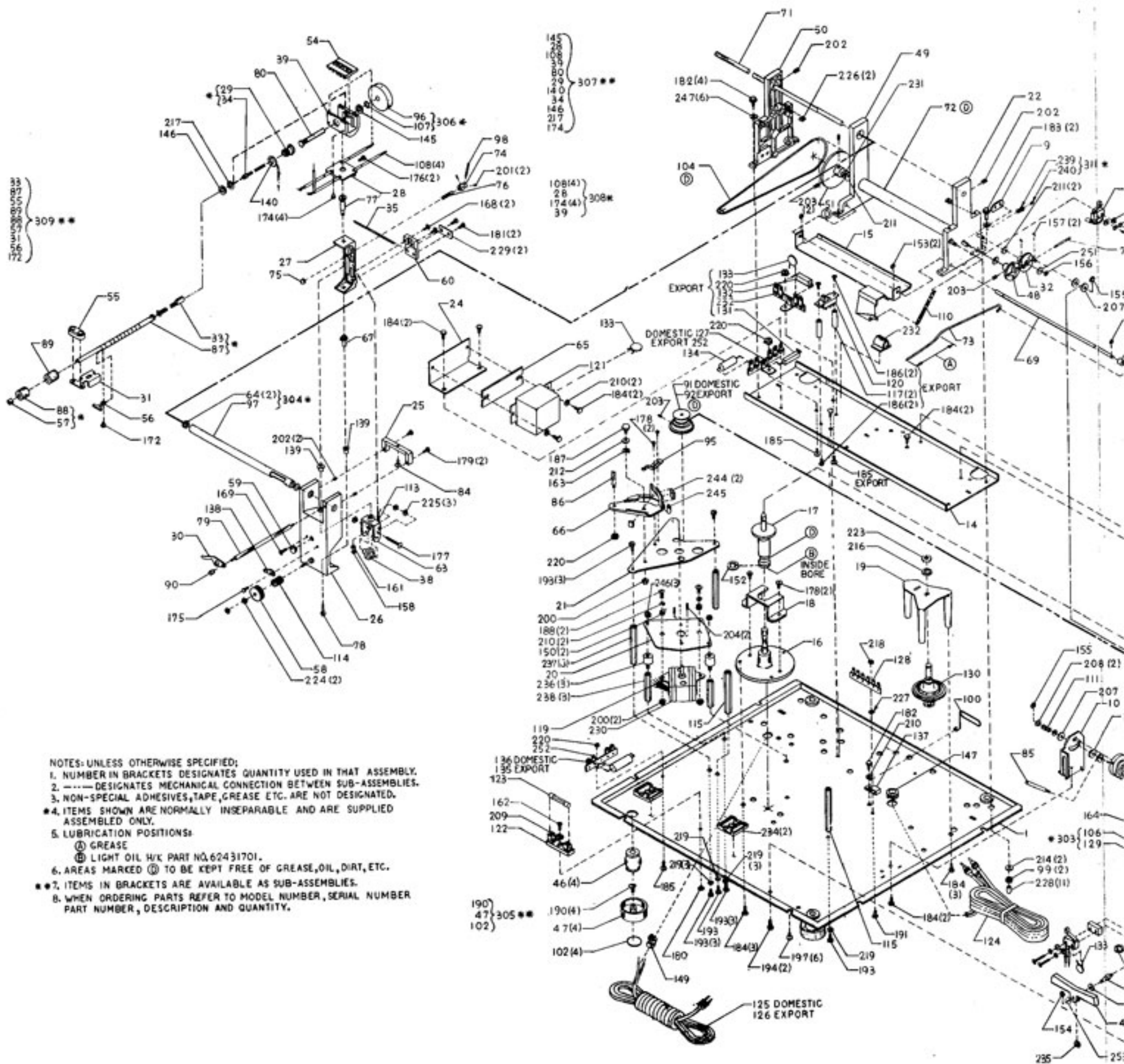

NOTES-UNLESS OTHERWISE SPECIFIED;

1. NUMBER IN BRACKETS DESIGNATES QUANTITY USED IN THAT ASSEMBLY.
2. --- DESIGNATES MECHANICAL CONNECTION BETWEEN SUB-ASSEMBLIES.
3. NON-SPECIAL ADHESIVES, TAPE, GREASE ETC. ARE NOT DESIGNATED.
- * 4. ITEMS SHOWN ARE NORMALLY INSEPARABLE AND ARE SUPPLIED ASSEMBLED ONLY.
5. LUBRICATION POSITIONS:
 - A GREASE
 - B LIGHT OIL H/K PART NO. 62431701.
6. AREAS MARKED B TO BE KEPT FREE OF GREASE, OIL, DIRT, ETC.
- * 7. ITEMS IN BRACKETS ARE AVAILABLE AS SUB-ASSEMBLIES.
8. WHEN ORDERING PARTS REFER TO MODEL NUMBER, SERIAL NUMBER, PART NUMBER, DESCRIPTION AND QUANTITY.

190 } 305 **
47 }
102 }

144 } 307 **
140 }
134 }
146 }
217 }
174 }

108(4) } 308 **
28 }
174(4) }
39 }

3 } 309 **
1 }
2 }
176 }

64(2) } 304 **
97 }

EXPORT }
220 }
220 }
220 }

DOMESTIC 127 }
EXPORT 252 }
134 }

91 DOMESTIC }
92 EXPORT }

EXPORT }
186(2) }
120 }
171(2) }
186(2) }

136 DOMESTIC }
135 EXPORT }

* 303 }
106 }
129 }

125 DOMESTIC }
126 EXPORT }

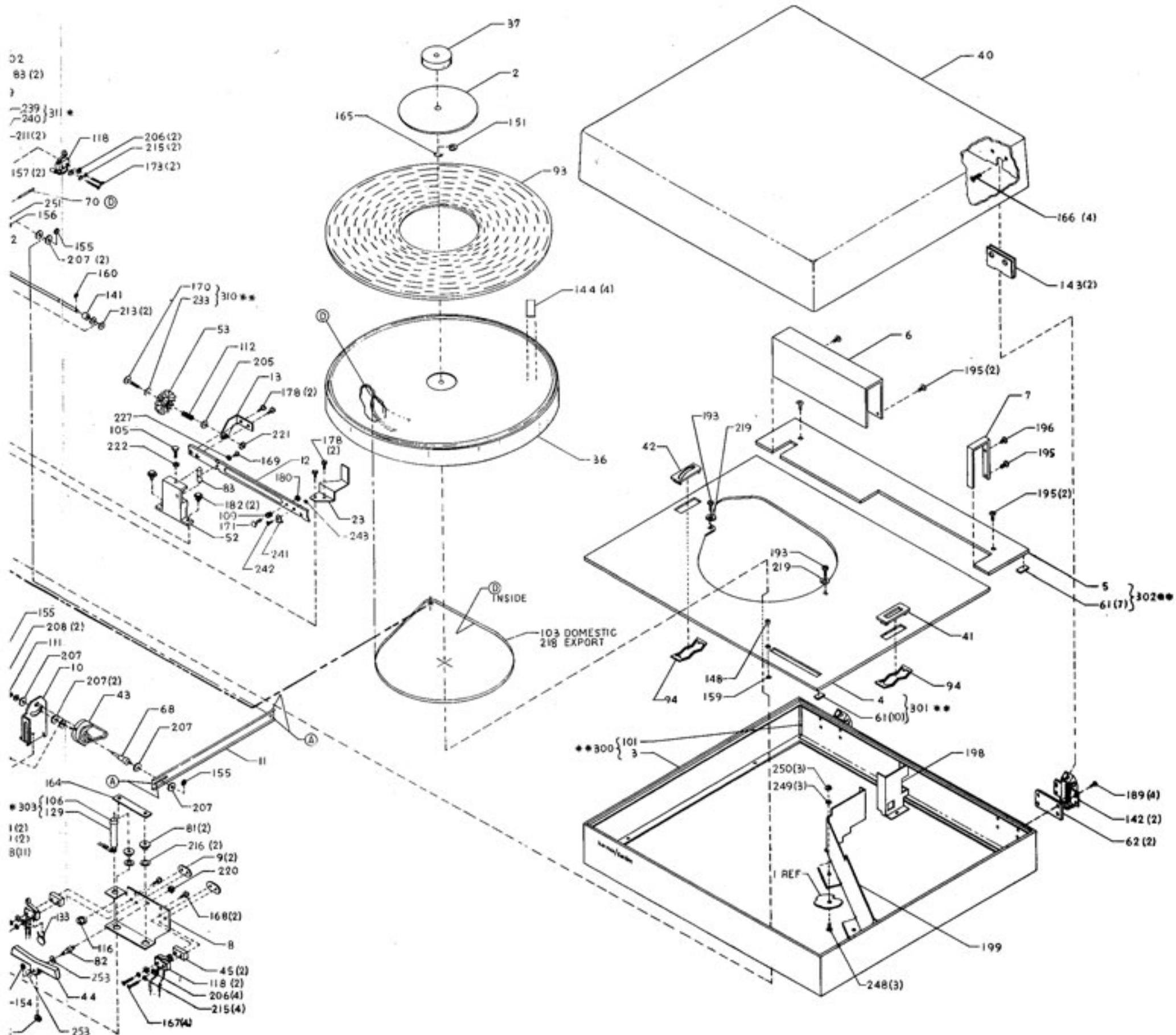
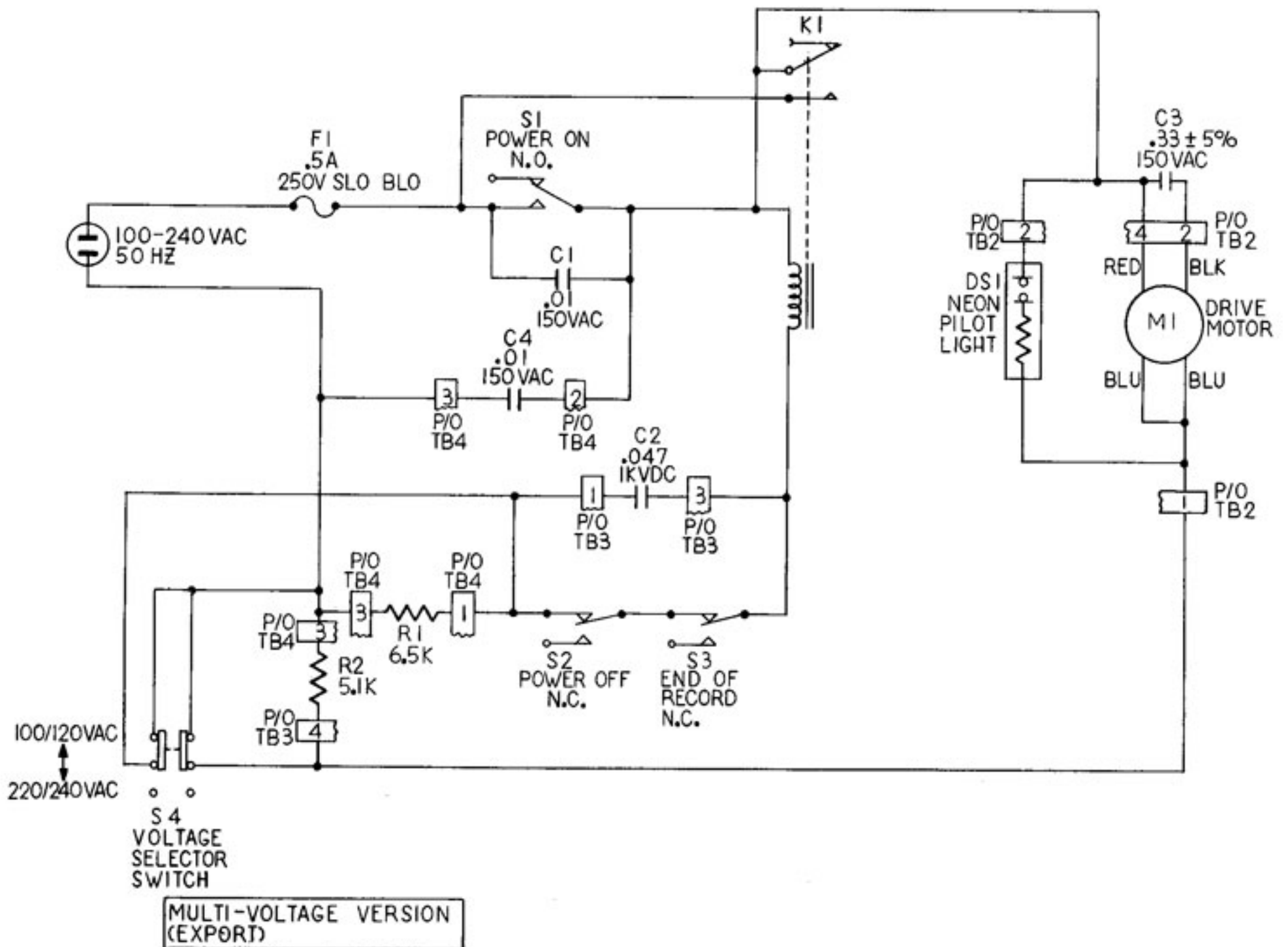
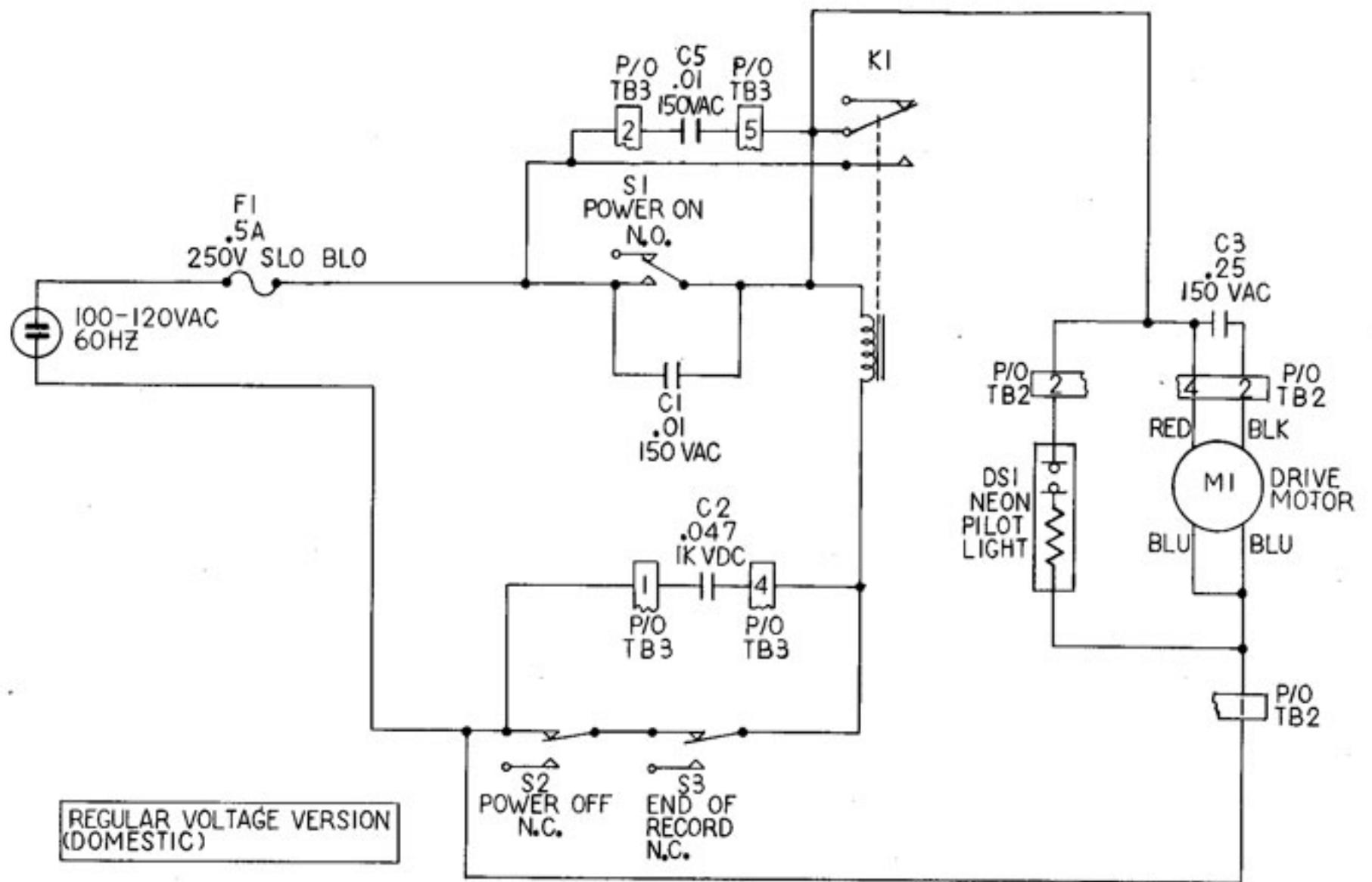
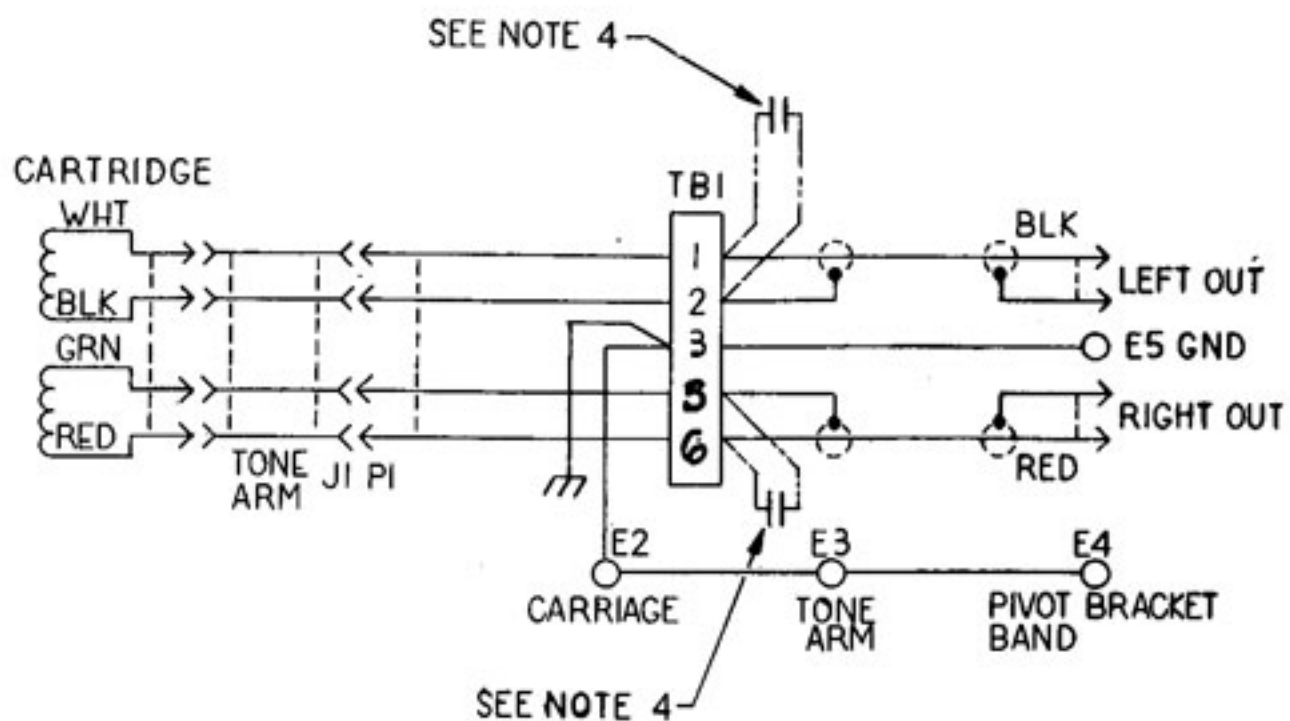

Figure 11. ST6 Exploded View





- NOTES: UNLESS OTHERWISE SPECIFIED;
1. ALL CAPACITORS VALUES IN MICROFARADS $\pm 10\%$.
 2. ALL RESISTOR VALUES IN OHMS $\pm 5\%$, 10W.
 3. S1, S2, S3 ARE MOMENTARY.
 4. CABLE MATCHING CAPACITANCE. SEE ADJUSTMENT 10.

CHASSIS COMPONENTS	
HIGHEST REF DES USED	REF DES NOT USED
C5	R2
F1	S4
M1	K1
DS1	TB4
E5	E1

Figure 12. ST6 Schematic Diagram