

# RABCO ST-7

---

## Straight Line Tracking System

# Technical Manual



### WARNING

These technical instructions are for use by qualified service personnel only. To avoid electric shock, do not perform any servicing other than that contained in the operating instructions unless qualified to do so.

**harman/kardon**

## CONTENTS

Mechanical Concept  
PC Board Assembly  
Troubleshooting  
Disassembly  
Adjustments  
Parts List

Figure 1. General view of ST-7 turntable

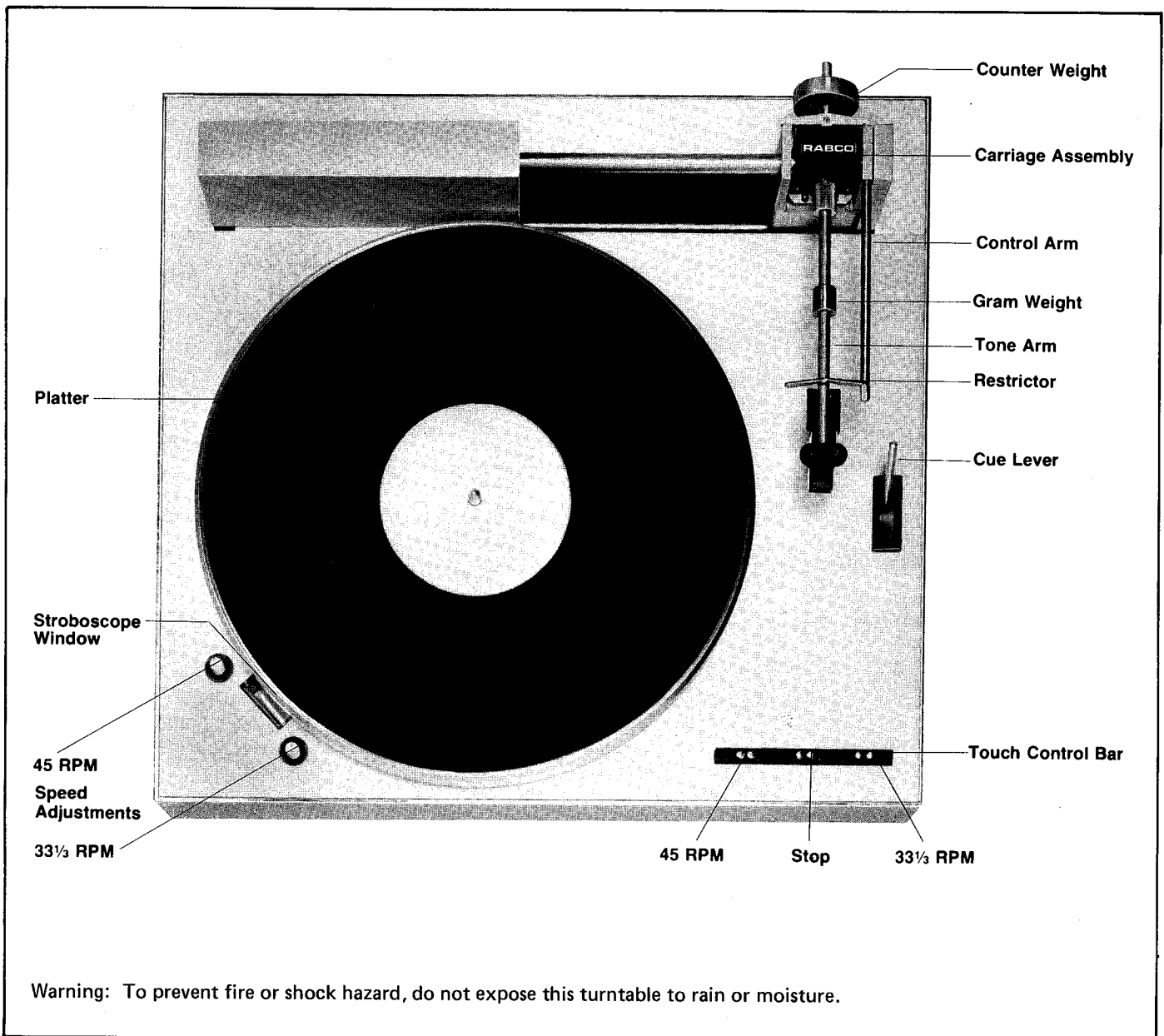

## I MECHANICAL CONCEPT

The concept of the ST-7 mechanism is shown in Figure 2. The tone arm is supported in a two-axis gimbal mount. The horizontal axis contains the dashpot – damped stylus elevation mechanism. In the vertical axis the tone arm is supported by a tracking roller that rolls against the tracking shaft. When the tone arm is tangential to the record groove the tracking wheel is biased in angle so that the carriage travels toward the platter center at approximately 0.17 inch per minute. This corresponds to the average velocity of the master disc. As the tone arm attempts to pivot in angle to track pitch variations, the angle of the tracking roller axis changes relative to the cylinder axis. This change in direction of the tracking roller accelerates or decelerates the motion of the carriage to track the pitch of the groove. The correction is continuous, self-adjusting, and automatic.

FIGURE 2. TRACKING AND DRIVE SCHEMATIC

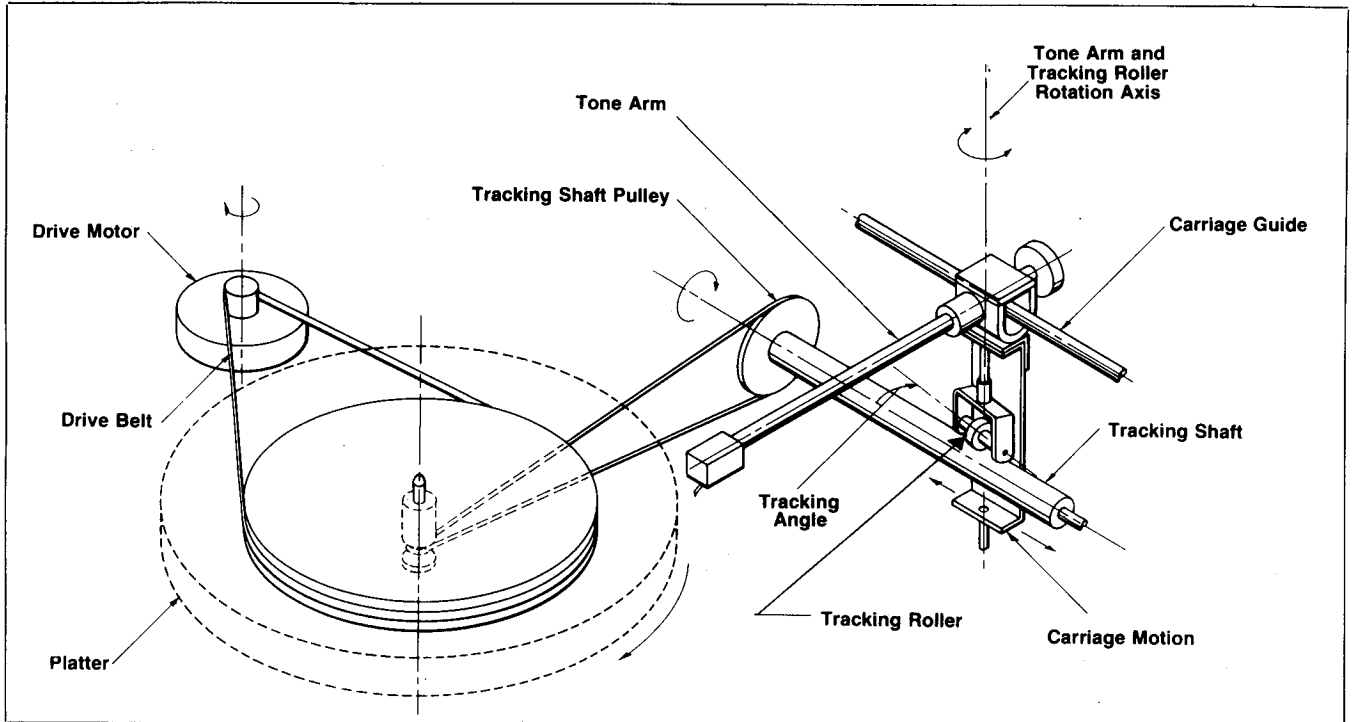

## II PRINTED CIRCUIT BOARD

The ST-7 is activated by turning on power switch S2 located under the front edge of the unit. This provides primary voltage to the power supply, enabling voltage to the motor assembly, and 9 volts to the transistor circuits. The red stop lamp will be illuminated since emitter follower Q5 is conducting in stop mode. Buffer Q6 also conducts, which disables motor drive switch Q7. In addition Q21 will conduct in stop mode, which will inhibit Q22 and, thereby, eliminate a ground return for trip solenoid L1. Also, on initial turn-on stop mode transistors, Q11 and Q12 will conduct since the emitters are at 9 volts and the bases initially at ground through C1 and C2. This causes bistable switch transistor Q2 and Q9 to conduct, ensuring that both 33-1/3 and 45 RPM circuits are in stop mode.

In addition, the red stop lamp will be illuminated. With the bases of Q2 and Q9 positive, there will be no current flow through diodes CR2 and CR3. As a result the base of stop lamp driver Q5 will be positive and it will conduct, and stop lamp DS2 will light. When Q5 conducts it will also cause buffer Q6 to conduct, driving the base of motor driver switch Q7 to ground. Since the emitter is at ground Q7 will not conduct, and no return will be provided for motor drive voltage at pin 15 of the board.

Since the 33-1/3 and 45 RPM start circuits are essentially identical, only 33-1/3 RPM will be discussed. The basic 33-1/3 start circuit is comprised of buffer Q1 and bistable switch comprised of Q2 and Q3. When the 33-1/3 touch control is shorted by finger contact, it grounds the base of Q1 causing it to conduct. This places a positive voltage on the base of bistable switch Q3 which, in turn, conducts, providing a return for the green 33-1/3 RPM lamp, DS3. In addition the current flow through diode CR2 inhibits stop lamp driver Q5, which extinguishes the red stop lamp and causes buffer Q4 to conduct. When Q4 conducts it enables IC1 which closes providing a return for the 33-1/3 RPM motor drive at pin 7 of the board.

The end of record function operates as follows:

Q19 and Q20 function as a single pole double throw switch, the action of which provides one second of activating voltage to the solenoid when the trip function is initiated.

When the unit is turned on, light from DS1 impinges on photocell VI, reducing the resistance to several thousand ohms. This places voltage on the base of Q18, which conducts, causing Q17 to conduct. When Q17 conducts, the positive voltage at the base of Q19 causes it to conduct, charging capacitor C5.

At the end of a record the photocell interrupter breaks the light path to VI, which rapidly increases in resistance.

Accordingly the supply current to the base of Q18 is reduced, and it no longer conducts. This inhibits Q17, and the bases of Q19 and Q20 are effectively grounded. With its base grounded and Q19 inhibited, Q20 conducts because of the positive charge on C5. For approximately one second, 9 volts which C5 was charged to is applied through Q20 to the base of Q22, which conducts. This provides a return circuit for the solenoid, which is activated for one second. The solenoid plunger moves the trip pin which engages the tracking shaft gear assembly. The gear assembly is connected to the cue lever linkage, and returns the cue lever to the rear position.

### III TROUBLESHOOTING

(Refer to Figures 3 and 11)

#### Conditions

1. When the arm is cued to the "up" position, the arm does not nestle all the way up into the notch of the restrictor arm
2. With the arm "up" the carriage assembly does not move freely enough from left to right.
3. When the arm is cued "down", the stylus does not reach the surface of the record.
4. When the arm is cued "down", an initial fast drop occurs before the damping action takes place.
5. When the arm is cued "down", no damping takes place at all. Arm drops hard and quickly to the record surface.
6. Extreme drift of tone arm as it comes down on the record.

#### Possible Cause & Corrective Measures

1. a. Stop bar screw not properly adjusted or loose. Refer to stop bar screw adjustment procedure.  
b. Gap between threaded lift pin and lift bracket too large. Refer to threaded lift pin adjustment.  
c. Incorrect position of dashpot stud. Refer to dashpot adjustment.
2. a. Insufficient gap between threaded lift pin and lift bracket. Refer to threaded lift pin adjustment.  
b. Dirt build up under slide tube bushings. Clean slide rod and bushing area with alcohol.  
c. Stop bar set screw too loose. Refer to stop bar set screw adjustment.
3. a. Pivot pin on pivot bracket (139) dirty or excess grease. Clean.  
b. Stop bar set screw adjusted too far down so that it prevents the roller assembly from allowing the tone arm to drop to the correct position. Refer to stop bar set screw adjustment.
4. a. Dashpot adjustment wrong causing a space between the tip of the dashpot plunger and the lift bracket surface. Refer to dashpot adjustment.  
b. Threaded lift pin adjusted for too much air gap between the lift pin and the lift bracket. Refer to threaded lift pin adjustment.  
c. Stop bar set screw set incorrectly. Refer to stop bar set screw adjustment.
5. a. Defective dashpot—Replace dashpot.  
b. Dashpot set all the way up to the full height of the mounting stud. Refer to dashpot adjustment.
6. a. ST-7 not on a level surface.  
b. Uneven tip on stop bar set screw. Replace screw or use emery cloth to make tip of screw smooth.  
c. Uneven surface on top of roller assembly rear flat surface. Make surface smooth by using very fine emery cloth.  
d. Binding in pivot bracket assembly at bearing points. Lubricate nylon bearings with molykote 33 or equivalent.  
e. Slide tube flat surface not correctly positioned inside roller assembly. Remove top cap of roller assembly and observe that flat portion of the slide tube is vertical facing the front of the unit. To reposition, remove the 2 rear screws holding the stop bar, loosen the 2 set screws, rotate the slide tube to the proper position and retighten the set screw. Reassemble the stop bar.

### III TROUBLESHOOTING (continued)

Conditions	Possible Cause & Corrective Measures
7. As arm tracks across record, arm starts to "lead" the carriage.	7. a. Mis-adjustment of tracking screw. Turn handle clockwise in very small increments until proper tracking occurs. Tighten locking nut and recheck for proper tracking. b. Mis-adjustment of carriage guide. See carriage guide alignment. c. Threaded lift pin adjusted with no air gap between the lift pin and the lift bracket. See threaded lift pin adjustment.
8. As arm tracks across record, arm starts to lag behind carriage.	8. a. Mis-adjustment of tracking screw. Turn handle counterclockwise in very small increments until proper tracking occurs. b. Tracking roller Spring (149) broken or one end disconnected.
9. Arm lifts and unit returns to "stop" mode before record material has been completely played.	9. a. Check tracking—if arm is "leading" the carriage, reset tracking as per step 7a. b. Check position of photocell receptacle—refer to tripping adjustments. c. Check for defective bulb located over Photocell. d. Check sensitivity adjustment of Photocell. e. Check for correct position of bulb over photocell housing.
10. Arm gets to end of record but does not lift off and unit does not switch to "stop" mode.	10. a. Check tracking—if arm is "lagging" the carriage; reset tracking as per step 8. b. Check for solenoid "click" when arm enters reject record grooves. If no "click" is heard, check solenoid, photocell, and tripping adjustment. If click is heard, check solenoid position adjustment and micro-switch adjustment.
11. Arm gets to end of record and lifts up but the unit does not switch to "stop" mode.	11. a. Micro-switch incorrectly positioned. Refer to micro-switch adjustment. b. Micro-switch defective—replace micro-switch.
12. Arm gets to end of record and lifts off record but does not return all the way up into the notch in the restrictor arm.	12. a. Insufficient tension for the tone arm caused by too large a gap between the threaded lift pin and the lift bracket. Refer to threaded lift pin adjustment. b. Restrictor arm incorrectly positioned. Refer to restrictor arm adjustment. c. Stop bar set screw too loose. Refer to stop bar set screw adjustment.
13. Unit tracks poorly and jams tripping gears—particularly after being disassembled for service.	13. "O" ring installed with reversed twist. Install "O" ring so that as the spindle and bearing assembly is turned clockwise, the tracking shaft rotates clockwise as viewed from the tracking gear end.
14. Scraping noise heard when platter is running.	14. a. Turntable belt twisted. Carefully remove the belt and re-install properly with the shiny side of the belt out. b. Motor not properly positioned. Refer to motor alignment.

### III TROUBLESHOOTING (continued)

Conditions	Possible Cause & Corrective Measures
15. Cannot synchronize strobe at 33 1/3 RPM or at 45 RPM.	15. a. Turntable belt riding on shoulder of motor pulley. Reposition belt to the center area. b. Strobe mask may be covering wrong portion of strobe mirror for line voltage used. For 50 hz, mask should be on outer edge of the mirror. For 60 hz, mask should be on inner edge of mirror. c. Coarse speed control incorrectly set. Refer to coarse speed adjustment. d. Defective coarse speed control. Replace. e. Green or blue lamp defective. Replace.
16. Cannot synchronize 33 1/3 RPM.	16. Blue (45 RPM) lamp defective. Replace.
17. Cannot synchronize 45 RPM.	17. Green (33 1/3 RPM) lamp defective. Replace.
18. Excessive "Wow and Flutter."	18. a. Turntable belt twisted, worn or with rough spots. Replace or reposition belt. b. Motor binding. Replace motor. c. Tracking shaft binding. Loosen tracking shaft pulley wheel and reposition for more end play. d. Defective "O" ring. Replace. e. Nick on-tracking shaft pulley. Polish with very fine emery paper.
19. Excessive "rumble."	19. a. Nylon set screws too tight against motor housing. Refer to motor alignment. b. Defective motor. Replace
20. Arm intermittently does not return to notch in restrictor arm. Also binding of carriage left to right.	20. Slide tube flat area not properly positioned. Refer to step 6e.
21. Loss of L or R channel.	21. a. Defective cartridge. b. Open (broken) or shorted wires between receptacle on roller assembly and output cables. Check continuity of all 4 wire paths.
22. Hum	22. Broken circuit in ground path. Scrape through anodize on underside of cartridge holder, and check continuity between receptacle shell and chassis.
23. Hum pick up as hand goes near arm. Static audible as carriage is moved manually from left to right.	23. Loose knurled nut on tone arm. Tighten by hand as securely as possible.
24. Unit does not light up.	24. a. Blown fuse. Check power supply components. b. Check that AC master switch is "on."
25. Unit starts but shuts off immediately.	25. a. Trip pin positioned incorrectly. Refer to micro-switch position adjustment. b. Check photo cell sensitivity adjustment.

### III TROUBLESHOOTING (continued)

Conditions	Possible Cause & Corrective Measures
26. Platter wobble.	26. a. Check for defective platter. b. Check for defective post and hub assembly.
27. Unit changes speed while playing record.	27. Check power supply regulation.
28. Cueing lever works but arm won't drop.	28. a. Improperly balanced arm—no zero balance. b. Extension spring (112) off. c. Insufficient gram weight.
29. Acoustic feedback.	29. a. Check all four feet; three are soft and one hard rubber. Hard rubber foot must be under power transformer. b. Check unit is level. c. Check for close proximity of speaker.
30. Chattering or scraping as carriage is moved with arm up.	30. a. Defective lift bracket. Replace. b. Burr on head of lift pin. Remove with fine emery cloth.
31. Binding or squeaking as carriage is moved with arm up.	31. Slide tube set screws (193) too tight. Remove stop bar, to obtain access to set screws. Loosen set screws slightly. Set screws should be firm but should not bind on slide tube.
32. Unit will not shut off with certain records.	32. Excessive or insufficient lead out groove area; leadout beyond RIAA standards.
33. High frequency content of program material sounds excessively brilliant.	33. Cable capacitance needs to be matched more closely to cartridge. Refer to cable capacitance matching in adjustment section. ST-7 cable capacitance is approximately 110 pfd. (incl. tone arm).
34. Strobe mirror scratched or broken.	34. Replace mirror by cementing new mirror directly on defective one.



#### IV DISASSEMBLY PROCEDURE

To service various portions of the ST-7, it may be necessary to partially or fully disassembly the unit. For purposes of explanation, we will identify these as four stages of disassembly. For each adjustment, we will specify which stage or stages of disassembly are required to accomplish the repairs or adjustments.

STAGE 1 – REMOVAL OF PLATTER AND MAIN DRIVE BELT

STAGE 2 – REMOVAL OF TOP PLATE, FRONT

STAGE 3 – REMOVAL OF LEFT HAND COVER AND TOP PANEL, REAR

STAGE 4 – REMOVAL OF SIDE WALL

**A WORD OF CAUTION** . . . The items described are ALL dress pieces and have been finished to provide a high quality aesthetic appearance.

**EXTREME CARE** should be taken when removing, storing, or replacing these parts to avoid scratching or damaging their appearance.

STAGE 1 – REMOVE dress disc, spring washer and retainer ring. Remove platter and main drive belt.

STAGE 2 – Remove entire tone arm assembly from carriage, remove two screws holding top front panel in place (These are two different screws, note their positions so they may be properly re-installed), remove top front panel.

STAGE 3 – Remove two screws and then left hand cover, remove two panel screws and then rear top panel.

STAGE 4 – Remove six screws from the bottom and then the entire side wall as an assembly.

## V ADJUSTMENTS

Figure 3 shows the ST-7 after all four stages of disassembly. The callouts represent location of adjustments that will be referred to in the following paragraphs. It is recommended that you familiarize yourself with the location of these adjustments.

For some adjustments supplementary line drawings are included with the actual procedure, to provide greater clarity.

Adjustments included are:

1. Stop Bar Set Screw
2. Dashpot
3. Threaded Lift Pin
4. Tracking Screw
5. Tripping
6. Carriage Guide
7. Solenoid Position
8. Microswitch Position
9. Photocell Sensitivity
10. Motor Alignment
11. Coarse Speed Adjust
12. Restrictor Arm
13. Conversion of ST-7 Multivoltage Units
14. Cable Capacitance Matching
15. Carriage Assembly Removal.

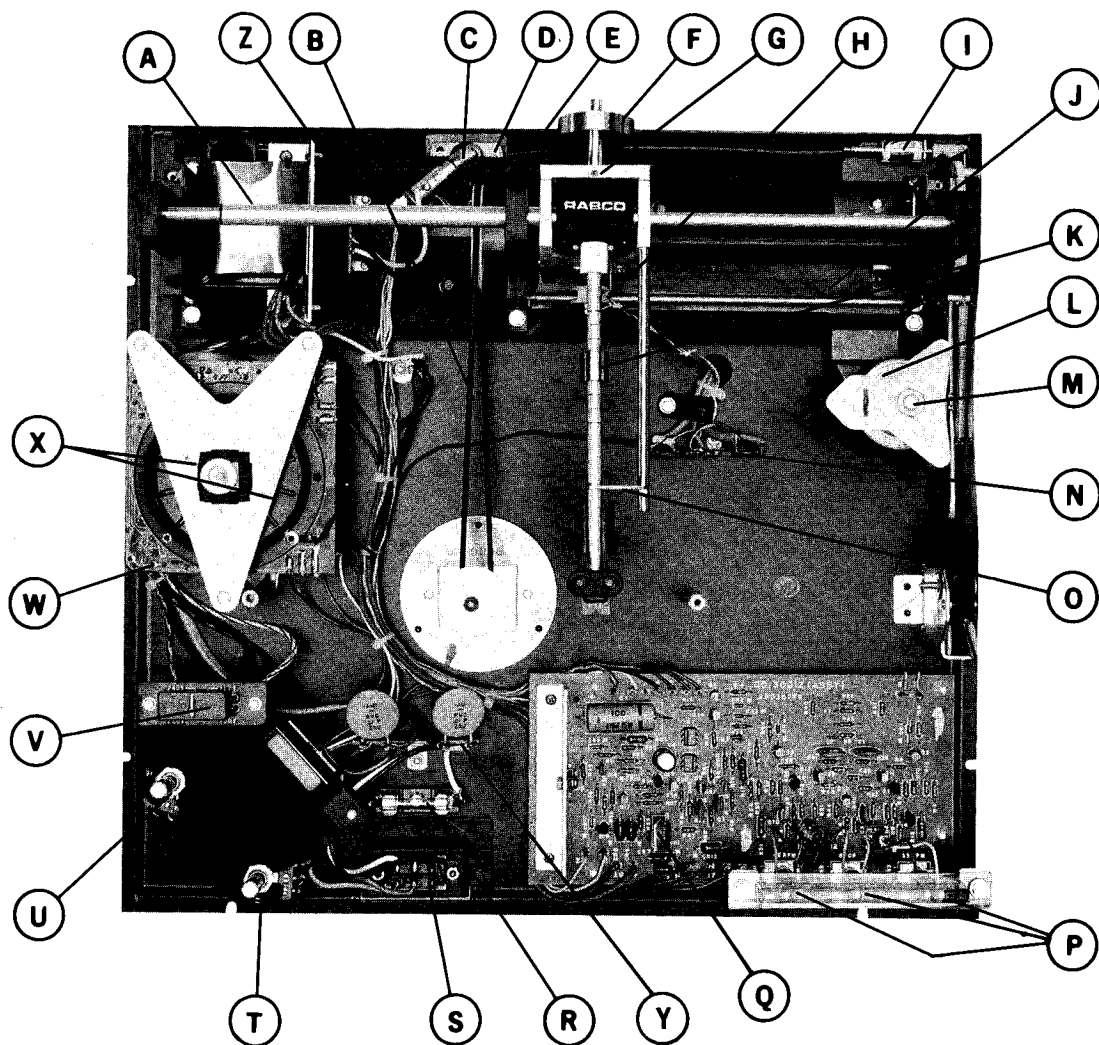

FIGURE 3. TOP VIEW WITH STAGES 1 THRU 4 OF DISASSEMBLY

FIGURE 3 LEGEND

Carriage Guide	H	Photocell Lamp	C
Coarse Speed Adjustment	W	Photocell Sensitivity Adjustment	Q
Counterweight	F	Power Switch	S
Dashpot	L	Restrictor Arm	O
Dashpot Locknut	M	Solenoid	I
Fuse	R	Stop Bar Set Screw	G
Gram Weight	K	Terminal Strip TBI	N
Lift Bracket	J	Touch Controls	P
Motor Alignment Screws	X	Tracking Belt	B
Multivoltage Plug (non-Domestic Units only)	V	Transformer	A
Photocell Assembly	D	33 1/3 RPM Speed Adjust	T
Photocell Interrupter	E	45 RPM Speed Adjust	U
		Terminal Strip TB3	Y
		Terminal Strip TB2	Z

## 1. STOP BAR SET SCREW

### A. Reason For Adjustment

To allow the arm to drop sufficiently far down so the preset weighting applies and allows the arm to track. (Refer to Figures 1 and 4.)

### B. Pre-Condition for Adjustment

Arm must be installed with cartridges and be properly adjusted for balancing and gram weight force.

### C. Required Disassembly

None

### D. Method of Adjustment

With cue levér positioned for the arm to be in the "down" position, the set screw is adjusted to permit the lower surface of the cartridge (next to the stylus) to just reach the top surface of the metal platter (not mat or record).

\*WITH TONE ARM CUED DOWN ON RECORD.

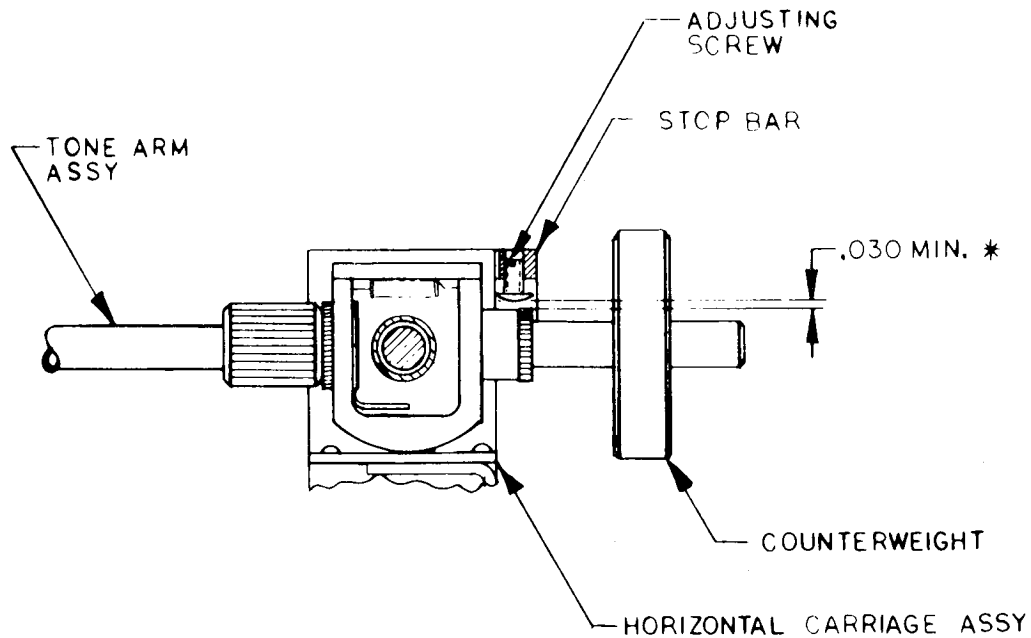

FIGURE 4. TONE ARM CUE LIFT ADJUSTMENT

## 2. DASH POT

### A. Reason for Adjustment

To permit the arm to lower itself slowly to the record surface when the cue lever is moved downward rapidly. (Refer to Figure 3.)

### B. Pre-Condition for Adjustment

None

### C. Required Disassembly

Stage 1 and 2

### D. Method of Adjustment

With the arm cued to the "up" position, loosen the locking nut on the dash pot stud. Turn the entire dash pot counter-clockwise until there is a large gap between the dash pot plunger and the top surface of the lift plate. Then adjust the dash pot clockwise until the plunger is snug against the lift plate surface. (Refer to Figure 5.) Hold the body of the dash pot and secure the locking nut to hold in place.

\* GAP MUST BE MAINTAINED FOR COMPLETE TRAVEL OF CARRIAGE

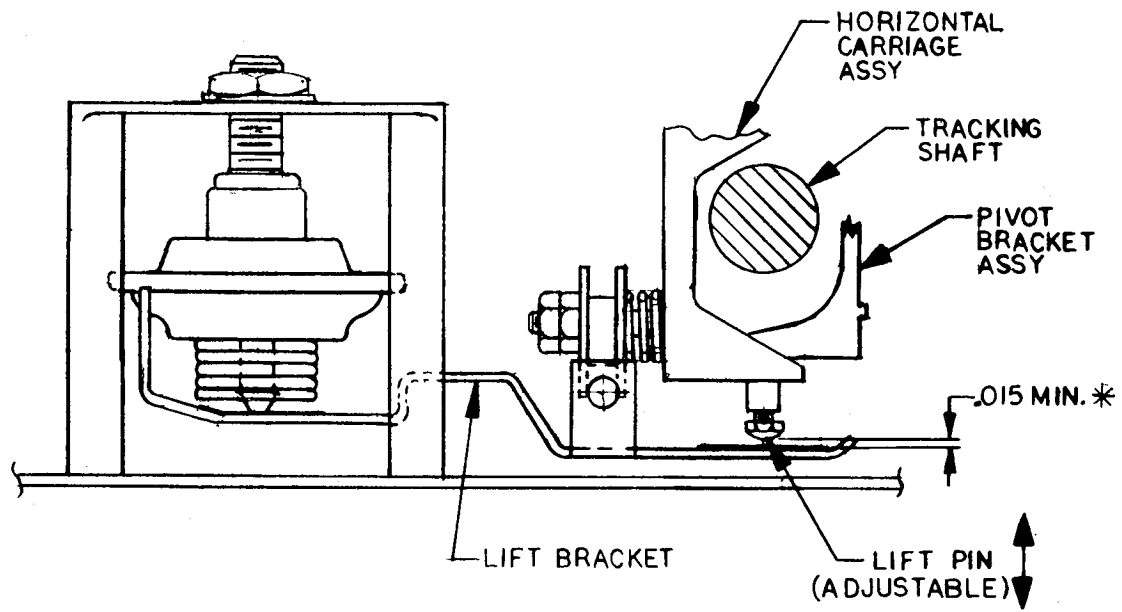

B. CUED DOWN PLAYING POSITION

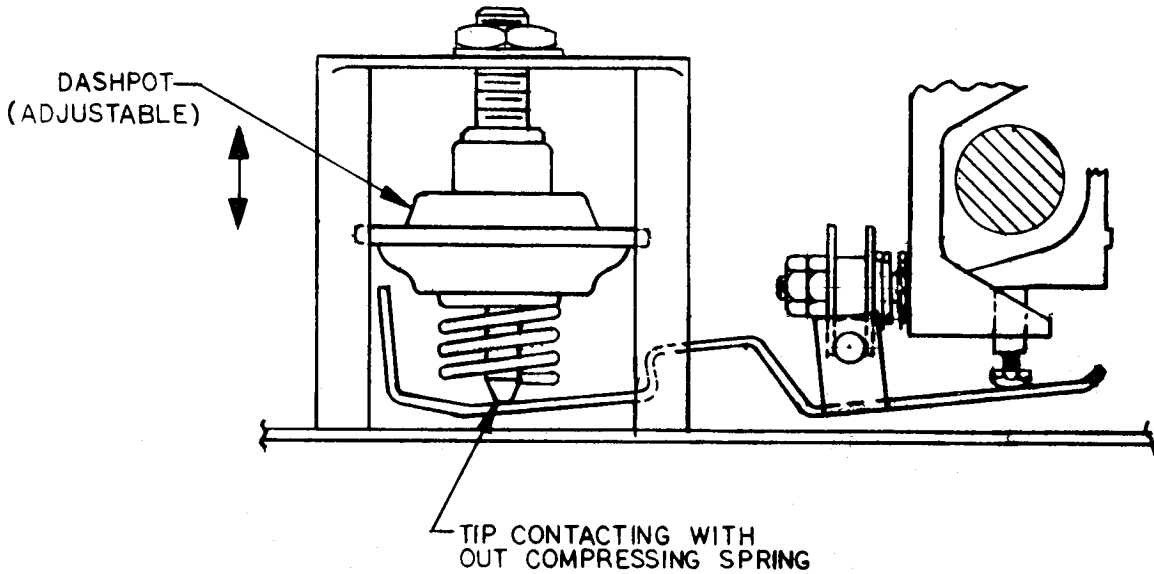

A. CUED UP POSITION

FIGURE 5. TONE ARM LIFT ADJUSTMENTS

### 3. THREADED LIFT PIN ADJUSTMENT

#### A. Reason for Adjustment

To allow for a clearance between the lift pin and the lift plate surface in the arm "down" position so that tracking will occur as a function of the tracking roller and the tracking wheel touching each other properly. (Refer to Figure 6.)

#### B. Pre-Condition for Adjustment

The dash pot, stop bar set screw, and the carriage guide adjustments must be properly set before adjusting the lift pin.

#### C. Required Disassembly

Stages 1 through 4

#### D. Method of Adjustment

With the arm "down" on the surface of a record, adjust the threaded lift pin with a small 3/16" open end wrench to produce a very slight air gap between the head of the lift pin and the surface of the lift plate. This gap should be approximately .020 inches.

After adjustment, the arm, when cued "up", must cradle properly into the restrictor arm notch and the carriage should move freely from left to right in the arm "up" position. A very tight left to right action would indicate insufficient gap between the lift pin and the lift plate.

The adjustment of the stop bar set screw must be rechecked after setting the lift pin adjustment.

#### SPECIAL NOTE:

The gap between the lift plate and the lift pin while typically .020 can vary from unit to unit. The gap can be made smaller if necessary to achieve the following:

1. Free lateral movement of carriage in the arm "up" position.
2. Arm must remain cradled in the restrictor notch as the carriage is moved left to right with the arm "up."
3. A gap is visible between the lift pin and lift plate at the extreme ends of the left and right carriage position with the arm in the "down" position.

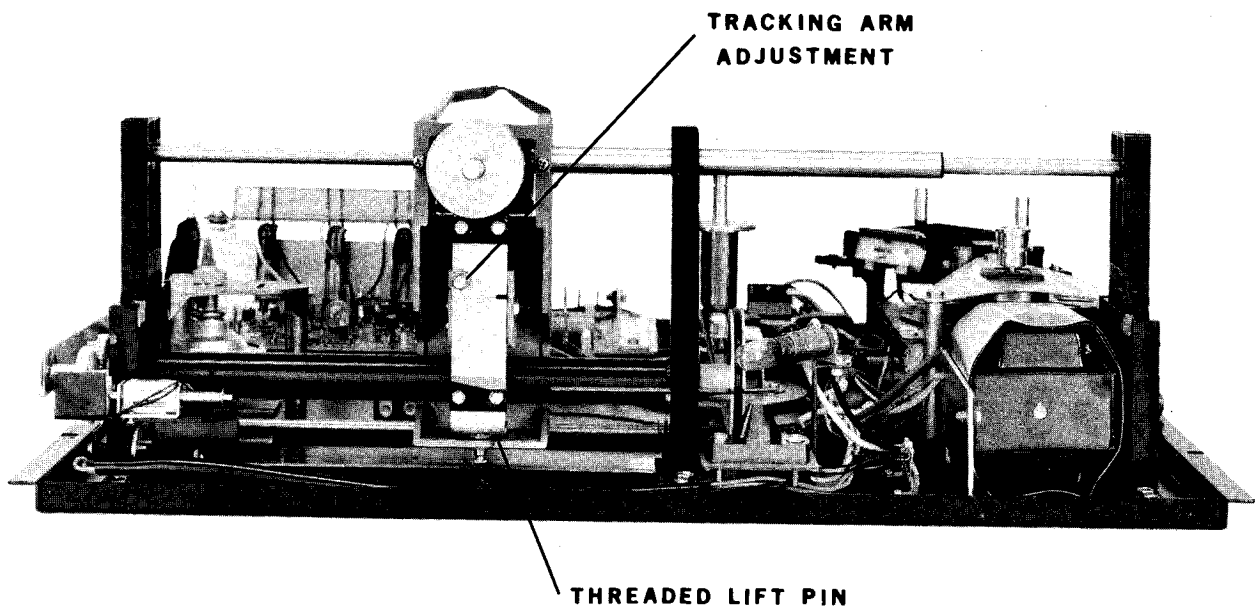

FIGURE 6. THREADED LIFT PIN AND TRACKING ADJUSTMENTS

#### 4. TRACKING SCREW ADJUSTMENT

**A. Reason for Adjustment**

To correct any leading or lagging of the tone arm with respect to the carriage assembly. (Refer to Figure 6.)

**B. Pre-Condition for Adjustment**

The following adjustments must have been completed; dashpot, threaded lift pin and stop bar setscrew; the tone arm must be balanced and properly weighted.

**C. Required Disassembly**

None

**D. Method of Adjustment**

Set the tone arm down on a commercial record turning at 33-1/3 RPM. Allow the arm to travel across approximately 1" of the record. Observe if the arm is leading or lagging the carriage by reference to the restrictor arm. If the arm is leading, the screw must be turned clockwise. If the arm is lagging, the screw must be turned counter-clockwise. After each adjustment, the arm must be observed for the 1" travel as previously described. When the arm is tracking properly, it should be checked across an entire 33-1/3 12" record to determine if any accumulated lead or lag occurs. Correct the adjustment if necessary.

#### 5. TRIPPING ADJUSTMENTS

**A. Reason for Adjustment**

To ensure that trip function operates properly at the end of a record.

**B. Pre-Condition for Adjustment**

Tracking adjustments must be complete before attempting to adjust the tripping. The lamp bracket and shield must be checked to ensure that the bulb is directly over the photocell receptacle opening. The arm when cued down must drop straight down.

**C. Required Disassembly**

Stage 3

**D. Method of Adjustment**

With the turntable in the "stop" position and the arm "up", move the carriage completely to the left. Lower the arm with the cue lever. The photo cell receptacle should be adjusted by loosening the 2 screws and positioning the receptacle until the rear edge of the photo cell interruptor is just in line with the outer circle around the opening in the photo cell receptacle (Figure 7). Tighten both screws and recheck to ensure that the location did not move during tightening.



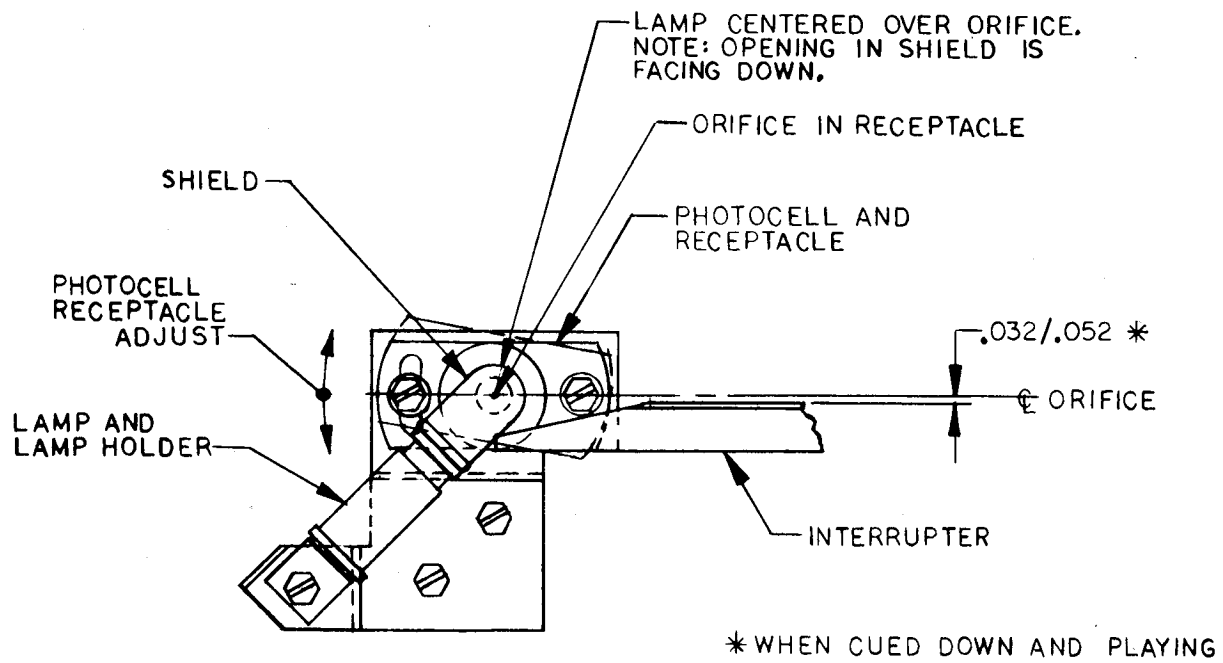

FIGURE 7. TRIPPING ADJUSTMENT

## 6. CARRIAGE GUIDE

### A. Reason for Adjustment

To position the tracking roller directly above the center of the tracking shaft.

### B. Pre-Condition for Adjustment

None

### C. Required Disassembly

Stages 1, 2, and 3

### D. Method of Adjustment

The carriage guide adjustment (Figure 8) must be made so that when the arm is "down," the tracking roller is directly above the center of the tracking shaft. Loosen the outside nut on the carriage guide, and either loosen or tighten the inside nut against the spring tension to position the tracking roller to be exactly centered above the tracking shaft.

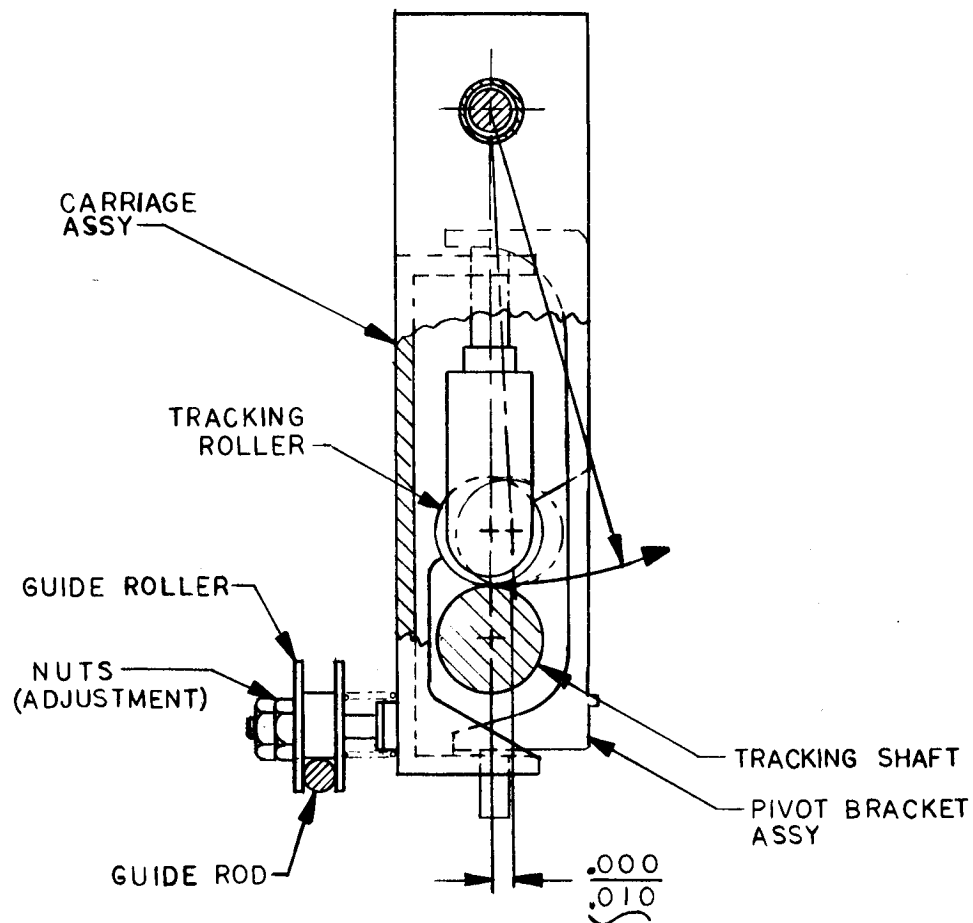

FIGURE 8. CARRIAGE POSITION ADJUSTMENT

## 7. SOLENOID POSITION ADJUST

The solenoid bracket must be positioned so that when the solenoid is activated, the trip pin is centered in the plunger V-groove as shown in Figure 9. There should be 1/16" clearance between the gear and the edge of the plunger when activated.

### A. Reason for Adjustment

To position the solenoid bracket so that when the solenoid plunger is activated, the trip pin is fully engaged with the tracking gear. (Refer to Figures 2 and 9.)

### B. Pre-Condition

None

### C. Required Disassembly

Stage 3

### D. Method of Adjustment

Loosen the two screws holding solenoid bracket. Line up rear edge of plunger as shown in Figure 9. Check that there is 1/16 inch clearance between the gear and the edge of the plunger when in activated position.

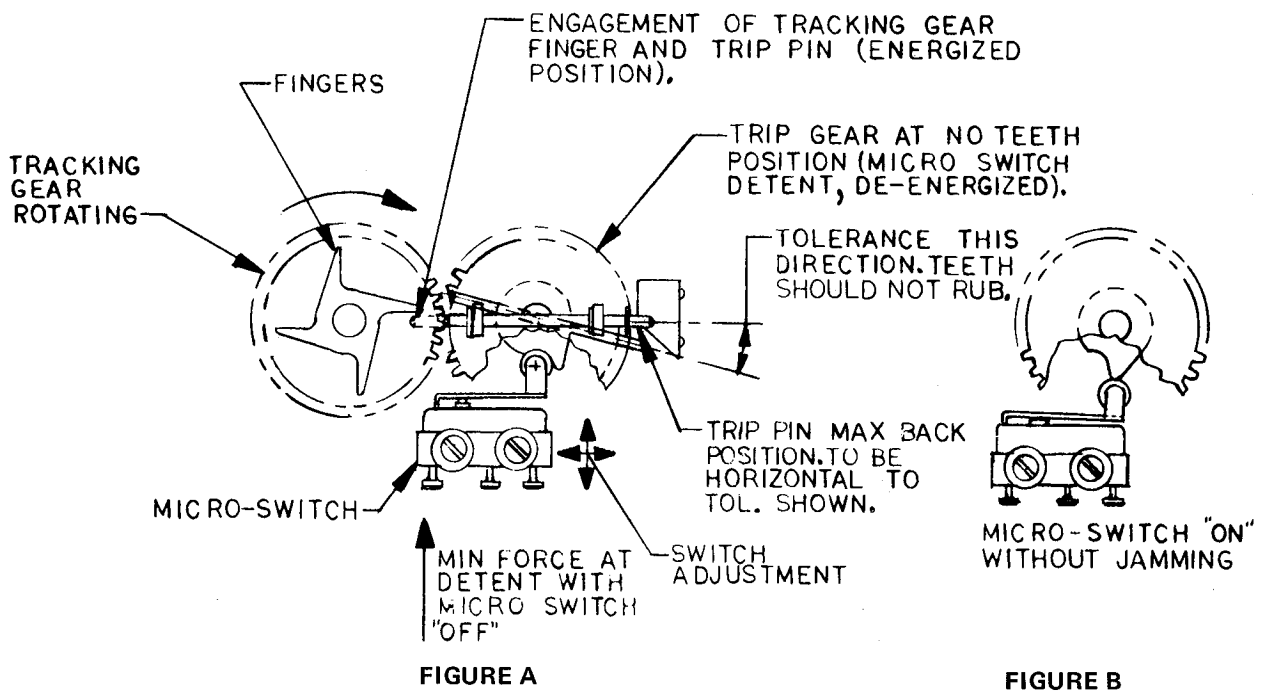
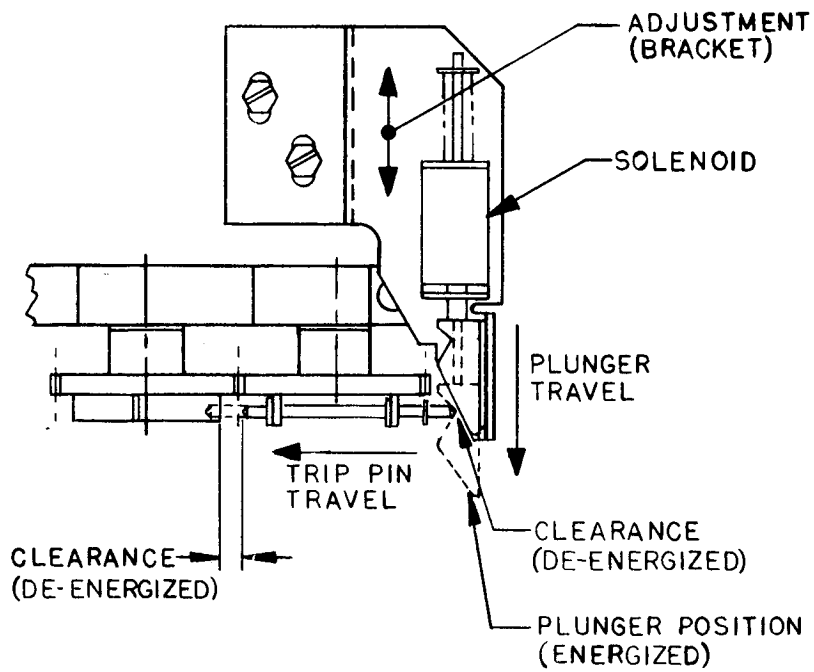

FIGURE 9. MICROSWITCH AND TRIP SOLENOID ADJUSTMENT

## 8. MICROSWITCH POSITION ADJUST

The microswitch must be positioned so that when the roller on the lever is engaged in the neutral position of the trip gear, the trip pin going through the gear must be tilted slightly from the horizontal in clockwise direction, but not beyond the tolerance shown. (Refer to Figure 9.)

### A. Reason for Adjustment

To position the microswitch for proper operation of the trip gear assembly.

### B. Pre-Condition

Remove retaining ring (50) and washer (44) securing cue lever linkage (47) to trip gear staking assembly, and swing cue lever linkage down for clear access to microswitch.

### C. Required Disassembly

Stages 1 through 4

### D. Method of Adjustment

Position the microswitch so that the trip pin is slightly off the horizontal as shown in the figure. The switch body should be level. The switch body should be adjusted vertically so the switch clicks on each trip cycle. There should be approximately  $.1/16$  inch clearance between the switch arm and the switch body.

## 9. PHOTO CELL SENSITIVITY

### A. Reason for Adjustment

To assure a proper pick-up of the tone arm when at the end of the record. (Reference Figure 3.)

### B. Pre-Condition

None

### C. Required Disassembly

Stages 1 through 4

### D. Method of Adjustment

The sensitivity control on the P. C. board should be adjusted to permit the solenoid to be activated 8 times during one normal shut off cycle.

Have the ST-7 operating at  $33 \frac{1}{3}$  RPM, the arm in the "up" position, and the carriage at the extreme right hand position. Start with the control in approximately the center of its range. Using a small piece of dark paper or cardboard, (it must not be able to transfer light) sequentially cover the small hole in the photo cell receptacle and count the number of times the solenoid will activate before shut off occurs. The sensitivity control should be turned clockwise until the solenoid can be activated 8 times prior to shut off. This adjustment is normally near the center of the range of the control.

### CAUTION:

All tests are invalid if the device used to cover the hole in the photo cell allows light to come through. The black cartridge gauge supplied with the ST-7 can be used for this purpose.

## 10. MOTOR ALIGNMENT

### A. Reason for Adjustment

To position the motor pulley so it is perfectly parallel with the platter belt surface.

**B. Pre-Condition**

Check the location of the nylon adjustment screws. If their location is not as shown in Figure 3 remove the upper motor mounting plate (61), turn it over, and remount on motor mounting bracket (64). The position of the nylon adjustment screws should now agree with the figure.

**NOTE**

A special 7 inch test platter is required to make this adjustment. Test platters are available from Harman Kardon.

**C. Disassembly**

Stages 1 and 2

**D. Method of Adjustment**

Set up unit with 7" test platter in place of regular platter. Install belt. Run at 33-1/3 speed and observe belt position on motor pulley. Start with both nylon adjustment screws not touching the motor housing. Turn whichever screw is required to cause the belt to ride exactly in the center of the motor pulley. Turn the second screw to just touch the motor housing but not add any additional tension to the motor.

## 11. SPEED ADJUSTMENT (COARSE)

The coarse speed adjustment, if required, should be adjusted so that proper strobe indication occurs with the 45 and 33-1/3 speed adjustments in the approximate mechanical center.

**A. Reason for Adjustment**

To ensure that the proper speed range can be obtained by adjustment of the 45 and 33-1/3 speed controls. (Refer to Figure 3.)

**B. Pre-Conditioning**

Be absolutely certain that this adjustment is made with the belt in the center of the motor pulley and not riding on either side of the hub.

**C. Disassembly**

Stages 1 and 2. Then replace platter on spindle and replace belt.

**D. Method of Adjustment**

Set both fine speed controls at their approximate mechanical centers. Adjust the coarse speed adjustment so the proper strobe indication occurs.

**CAUTION**

Be absolutely sure that the adjustment is made with the belt in the center of the motor pulley, not riding on either side of the hub.

## 12. RESTRICTOR ARM ADJUSTMENT

**A. Reason for Adjustment**

To allow the tone arm to be properly recaptured into the notch of the restrictor arm from any normal angles of record grooves. (Refer to Figure 3.)

**B. Pre-Conditioning**

None

**C. Disassembly**

None

**D. Method of Adjustment**

Loosen restrictor nut slightly. Position the restrictor arm so that when the tone arm is placed on the record and very carefully moved manually to the extreme left of the roller assembly movement, it just clears the underside of the restrictor arm.

**13. CONVERSION OF ST-7 MULTIVOLTAGE UNITS**

**A. Reason for Adjustment**

To convert unit to required voltage and frequency. (Refer to Figure 3).

**B. Pre-Condition for Adjustment**

Line cord removed from socket.

**C. Required Disassembly**

Stages 1 and 2

**D. Method of Adjustment**

1. Locate multivoltage plug (Figure 3) and remove from socket. Reorient by aligning arrow to desired voltage. Reinsert into socket.
2. Locate strobe mirror and select appropriate black fishpaper mask for 50 or 60Hz operation. The 60Hz mask should cover the outer portion of mirror. The 50Hz mask should cover inside portion of mirror.
3. Replace the line cord, or select adapter for appropriate wall outlet.
4. Select appropriate fuse from the following table.

	110/117 VAC	200/240 VAC
50 Hz	2/10 A-250V	1/10 A-250V
60 Hz	2/10 A-250V	1/10 A-250V

**14. CABLE CAPACITANCE MATCHING**

**A. Reason for Adjustment**

To match ST-7 cable capacitance as closely as possible to cartridge manufacturer recommendation.

**B. Pre-Condition for Adjustment**

Determine cable capacitance recommended by manufacturer.

**C. Required Disassembly**

Stages 1 and 2

**D. Method of Adjustment**

Locate Terminal Strip TB1 on Figure 3. The signal cable pairs are terminals 1 and 2, and 5 and 6. The existing cable capacitance for each pair is approx. 110 pf. Add the difference in capacitance (Manufacturers recommendation less 110 pf) across each pair of terminals (1-2 and 5-6).

**15. CARRIAGE ASSEMBLY REMOVAL**

**A. Reason for Adjustment**

To facilitate repair and/or replacement of component parts of carriage assembly.

**B. Pre-Conditioning**

Remove counterweight and tone arm.

**C. Disassembly**

Stages 1 through 4

**D. Method of Removal**

Locate Terminal Strip TB1 on Figure 3. Unsolder five tone arm signal leads (red, green yellow, white, black). Referring to Figures 10 and 11, locate LH cover (11) and RH cover (13). Remove machine screws (12) fastening covers, and remove both covers. Loosen setscrews (193) on back of LH and RH slide support assys (111) and (116), and remove slide rod (115). Loosen two setscrews (192) on tracking shaft pulley (114) and remove from tracking shaft (105). Remove two machine screws anchoring tracking shaft support (113) to base. Carefully slide carriage assembly off tracking shaft (105).

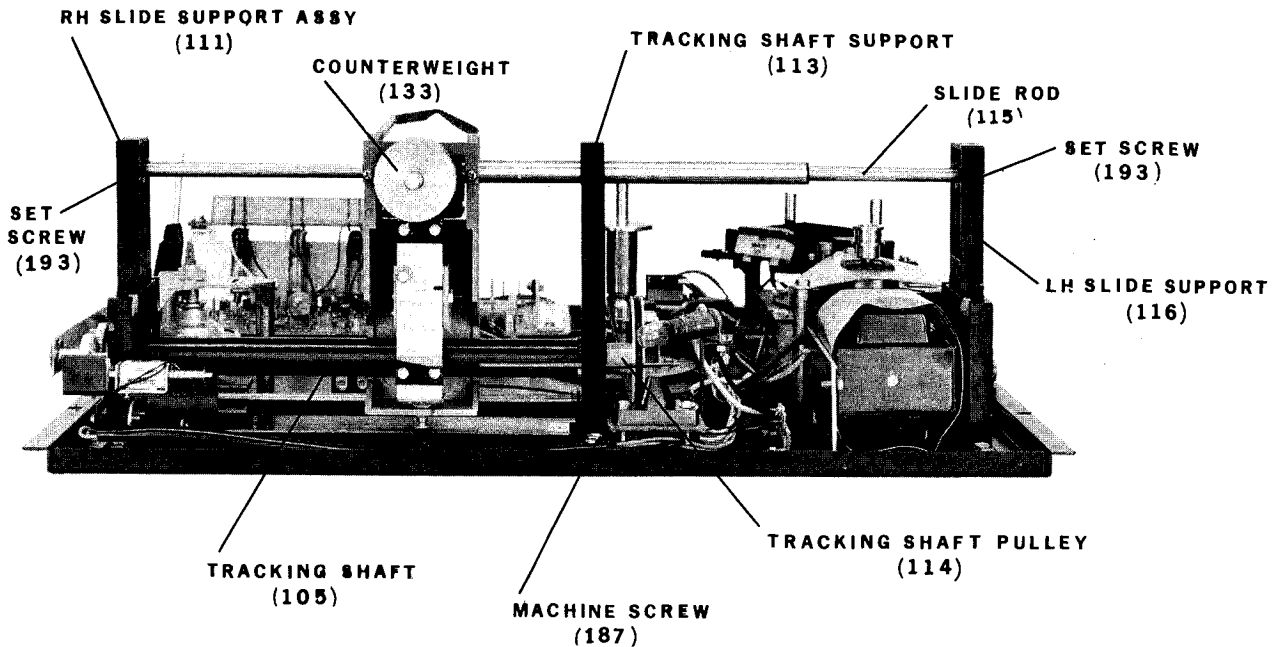

**FIGURE 10. CARRIAGE ASSEMBLY REMOVAL**

**OVERALL MECHANICAL PARTS LIST  
(Referenced to Figure 12)**

Ref. No.	Part Number	Description	Ref. No.	Part Number	Description
1	60130152	Base Plate	10	77830776	Screw, 4 X 0.7 X 8.0 mm
2	60130298	Disc	11	60130147	Cover, LH
3	67030808	Retaining Ring	12	70630773	Screw, 4-40 X 5/16
4	01030208	Turntable Mat	13	60130148	Cover, RH
5	62930202	Platter	14	70630890	Screw, 4-40 X 3/16
6	63030216	Disc, Strobe	15	60130190	Top Plate, Rear
*7	61433164	Belt, Turntable	*16	61430746	Pad, Foam
8	61630239	Dust Cover	17	60130189	Top Plate, Front
9	67030830	Lockplate	18	61630120	Grommet, Cue Lever

## OVERALL MECHANICAL PARTS LIST (continued)

Ref. No.	Part Number	Description	Ref. No.	Part Number	Description
19	60630121	Retainer, Cue Grommet	62	01730001	Motor & Pulley Assy
20	61030149	Window, Strobe	63	60130256	Plate, Motor Mtg., Lower
21	61630293	Grommet, Resistor Knob	64	60130284	Bracket, Motor Mtg.
22	67030802	Retaining Ring	65	61230736	Neon Pilot Light (DS2)
23	62930167	Adaptor, 1.50 I.D. (38 mm)	66	60130304	Bracket, Light
24	71819755	Screw, 6-32 X 5/16	67	60130285	Bracket, Speed Control
25	60130151	Side Wall	*68	63231703	Knob, Resistor
26	61830745	Inner Covering	*69	38130247	Resistor, Variable (VR1, VR2)
27	67030831	Free Stop Hinge Assy	70	80119587	Nut, Hex, Thin Elect 3/8-32
28	75830777	Screw, 4-40 X 3/8, Type F	71	85230804	L'washer, Int Tooth 3/8 Light
29	61630116	Shim, Hinge	*72	61030214	Mirror, Strobe
30	00130012	P. C. Board Assy	73	61830751	Mask, Strobe (Export)
*31	46530750	Lamp, (Blue), 45 (DS1)	74	61830742	Mask, Strobe
*32	46530748	Lamp, (Red), Stop (DS2)	75	65427580	Voltage Block
*33	46530749	Lamp, (Green), 33-1/3 (DS3)	76	10130734	Transformer (T1)
34	61630170	Housing, Control Switch	77	60130732 <sup>1</sup>	Shield, Transformer
35	60130169	Bracket, Support, Switch	78	60130731	Bracket, Transformer
36	79030114	Screw, Shoulder	79	10130155	Transformer (Export) (T1)
37	85430806	Washer, Curved	*80	25530859	Switch, Rocker (S2)
38	85030115	Flatwasher	81	61630119	Housing, Switch
39	85030302	Flatwasher	*82	45031015	Fuse 1/10, 3AG 250V (Export) (F1)
40	67030807	Retaining Ring	*83	45030817	Fuse .2A, 3AG 250V (F1)
41	65430171	Contact, Touch Control	84	65430519	Fuseholder
42	88531496	Eyelet	85	65030973	Terminal Strip, 4 Pos. (TB3)
43	01930003	Cam Bracket & Shaft Assy	86	30418307	Capacitor, .01M Z5U (C1, C2)
44	85030244	Flatwasher, Linkage	87	62031486	Isolator
45	62830179	Cam, Cueing	88	62030230	Foot, Mounting
46	60430181	Shaft, Linkage, Cue Cam	89	65231715	Terminal Strip (TB1)
47	60130183	Linkage, Cue Lever	90	53029083	Line Cord
48	60630299	Spring, Compression	91	53030949	Line Cord (Export)
49	85030884	Flatwasher #3	92	61430856	Grommet, Strain Relief
50	67030801	Retaining Ring	93	53031873	Phono Cable (Audio)
51	60130283	Bracket, Dampening	94	61431884	Grommet, Phono Cable
52	60431593	Bearing Rod	95	67031885	Clamp
53	60132225 <sup>2</sup>	Shield, Electric Hazard—Rear	96	61629713	Standoff
54	60132226 <sup>2</sup>	Shield, Electric Hazard—Front	97	65611705	Ground Lug
55	62431559	Tape, Double Sided	98	61415863	Rubber Channel
56	61931581	Dash Pot	99	87230118	Standoff, Top Plate
57	01930006	Spindle & Bearing Assy	100	63230178	Lever, Cueing Cam
58	60130294	Retainer, Bearing	101	60130289	Plate Mtg., Carriage Assy
59	01930007	Hub & Post Assy	102	60430144	Guide Rod
60	67030828	Retaining Ring	103	60430187	Rod, Release
61	60130174	Plate, Motor Mtg., Upper	104	60130177	Lift Bracket



## OVERALL MECHANICAL PARTS LIST (continued)

Ref. No.	Part Number	Description	Ref. No.	Part Number	Description
105	60430143	Tracking Shaft	148	61630134	Bracket, Tracking Roller
106	60130301	Locknut Plate	149	60630137	Spring, Tracking Roller
107	60830127	Gear, Tracking Shaft	150	61131525	Tracking Roller Assy
108	01930018	Trip Gear Staking Assy	151	61131575	Bearing
109	60430211	Trip Pin	152	01930026	Horizontal Carriage Staked Assy
110	25031791	Micro Switch (S1)	153	60630292	Spring, Comp, Guide
111	01930019	Slide Support Assy, RH	154	61132568	Guide, Carriage
112	60631578	Spring, Extension	155	60132532	Restrictor, Tone Arm
113	61630287	Support, Tracking Shaft	156	84031027	Nut, Restrictor
114	60830145	Pulley, Tracking Shaft	157	60430200	Rod, Restrictor
115	60430139	Slide Rod	158	61430743	Grommet, Eccentric
116	61631342	Support, LH	159	61730129	Slide Tube
117	61431730	Belt, Tracking	160	61130130	Slide Bushing
118	85033946	Washer, Flat	161	57530106	Cable Assy, Tone Arm
119	86530233	Spacer Rod	162	61730102	Tone Arm Tube
120	85030236	Flatwasher	163	61630101	Mtg. Plate, Cartridge
121	01830016	Solenoid Assy (L1)	164	84030758	Lock Nut, Tone Arm
122	60130131	Bracket, Trip Solenoid	165	61730276	Gram Weight
123	61830759	Shroud, Solenoid	166	61630109	Sleeve, Gram Weight
124	65031714	Terminal Strip (TB2)	167	60131603	Cover, Cartridge
125	60130128	Bracket, Lamp & Photo Cell	168	61631718	Clamp, Cover
126	61830296	Cover, Photo Cell	169	78931210	Screw, 2-56 X 1/8
*127	01930044	Photo Cell Wired Assy (V1)	170	80130853	Nut, Hex, 6-32
128	61630124	Receptacle, Photo Cell	171	77630917	Screw, 6-32 X 5/16, Type 23
129	61230846	Lamp Holder	172	77632224	Screw, 6-32 X 1/4, Type 23
*130	46530809	Lamp (DS1)	173	74431237	Screw, 6-32 X 1/4, Type F
131	61211349	Light Shield	174	76530706	Screw, #8 X 1/4, Type A
132	61630161	Cover, Roller	175	77830910	Screw, #4-40 X 3/16
133	61930271	Counterweight	176	72132223	Set Screw, 6-32 X 7/16 (Nylon)
134	84030199	Nut, Jam, Counterweight	177	78730929	Screw, 4-40 X 3/16, Type 23
135	61430303	O Ring	178	70930918	Screw, 1-72 X 1/8
136	01930021	Roller Base Riveting Assy	179	79432247	Screw, 4-40 X 7/16 Type 23
137	60630126	Spring, Band	180	85030845	Washer, Flat, #4
138	60132455	Interrupter, Photo Cell	181	67030812	Retaining Ring
139	60131592	Pivot Bracket	182	67030813	Retaining Ring
140	61130110	Roller, Tone Arm	183	85130848	Split Lockwasher, #2
141	60430272	Rod, Counterweight	184	85030847	Flatwasher, #2
142	60130156	Receptacle, Connector	185	70230712	Screw, 2-56 X 3/4
143	65130737	Ground Lug, Tone Arm	186	84030814	Square Nut, 4-40
144	57530217	Cable Assy, Roller	187	79632767	Screw, 6-32 X 3/8, Type 23
145	84030117	Nut, Jam, Receptacle	188	85030850	Flatwasher, #6
146	87930849	Drive Screw #00 X 1/8, Type U	189	85431410	Curved Washer
147	60131571	Stop Bar, Cue Lift	190	85431586	Curved Washer

## OVERALL MECHANICAL PARTS LIST (continued)

Ref. No.	Part Number	Description	Ref. No.	Part Number	Description
191	67030815	Retaining Ring	222	77831589	Screw, 4-40 X 3/8
192	72130713	Screw, Set, 4-40 X 1/8	223	60431594	Insert, Lift Pin
193	72132185	Screw, Set, 4-40 X 1/4	224	60431995	Adjusting Stud
194	80131582	Hex Nut, Jam 5/16-24	225	60431610	Button, Tracking, Adjust
195	60433304	Lift Pin, Threaded	226	60431994	Adjusting Hub
196	67030818	Retaining Ring	227	63231996	Adjusting Handle
*197	60431728	Adjusting Screw, Stop Bar	228	72132491	Set Screw 2-56 X 3/32
198	85130863	Split Lockwasher, #6	229	79632768	Screw 6-32 X 1/2, Type 23
199	79131151	Screw, # X 5/16, Type 25	230	85019248	Washer, Flat #8
200	80130860	Nut, Hex, 4-40	231	80619422	Nut, Hex, KEPS 6-32
201	85130858	Lockwasher, Split, #4	232	60332007	Wire Guide, Audio
202	77830891	Screw, 4-40 X 5/16	233	78732222	Screw, 4-40 X 1/4 Type 23
203	77830892	Screw, 2-56 X 1/4	234	61432696	Screw Tip Cover
204	80130821	Nut, Hex, 2-56	235	85019842	Washer, Flat #8
205	79130934	Screw, #6 X 1/4, Type 25	236	77833890 <sup>2</sup>	Screw, 6-32 X 3/8 Blk
206	71931152	Screw, 4-40 X 5/16	237	85033891 <sup>2</sup>	Washer, Flat #6 Blk
207	70930459	Screw, 4-40 X 3/8	238	80633749 <sup>2</sup>	Nut, Hex, Keps 6-32 Blk
208	77830893	Screw, 6032 X 1/4	239	85033947	Washer, Flat
209	74830930	Screw, 4-40 X 3/8, Type F	240	80619508	Nut, Hex, Keps 6-32
210	78730928	Screw, 6-32 X 3/8, Type 23	300	01930029	Slide Tube Assy
211	01930031	Wire & Receptacle Assy	301	01930035	Mtg Foot Assy
212	85531233	Flatwasher	302	01930046	Platter Assy
213	71930931	Screw, 6-32 X 3/16	303	01930010	Housing & Contact Assy
214	70818675	Screw, 4-40 X 1-1/8	304	01931745	Side Wall Assy
215	61829901	Shield, Fishpaper	305	01931746	Top Plate Assy (Front)
216	62021307	Felt Pad	306	01930747	Top Plate Assy (Rear)
217	85219238	Lockwasher, Int Tooth 5/16	307	01930036	Counterweight Assy
218	62030231	Isolator	308	01631609	Tone Arm Assy (Only)
219	70219352	Screw 4-40 X 5/16		CH-7W	Tone Arm Assy Kit
220	80619403	Nut, Hex, Keps 4-40	309	01931782	Roller & Base Assy
221	85231487	Lockwasher, Internal	310	01930023	Roller Assy

\* Recommended Spares

<sup>1</sup> Incorporated in transformer on some models

<sup>2</sup> Not on all models

## PC BOARD ASSEMBLY PARTS LIST

Circuit Ref. No.	H/K Part No.	Description
	00130012	PC Board Assembly
CAPACITOR, FIXED		
C1, C2	30430718	Disc, .01 UF, 500 V, I 20%
C3	30418317	Disc, 001 UF, 100 V, I 10%
C4	31530719	Lytic, 470 UF, 25 V
C5	31819180	Lytic, 100 UF, 16 V
DIODE		
*CR1-4 CR9, CR11	41629897	Zener
*CR5-8, CR12	41020618	Rectifier 2A, 100 V
*CR10	42030720	Zener, 8.2 V = 5%
INTEGRATED CIRCUIT		
*1C1, 1C2	43130725	Optical Coupler, MOT 4N27
TRANSISTOR		
*Q1, Q8	43030721	Siemens BC309C
*Q2, Q9	43027872	Siemens BC239C
*Q3, Q19	43030722	Siemens BC238C
*Q4, Q11-14 Q17, Q20	43027722	GP, PNP
*Q5, Q6, Q16 Q18-18, Q21	43025972	GP, NPN
*Q7, Q22	4303723	MOT MJE181
*Q15	43030724	MOT MJE171
RESISTOR, FIXED		
R1, R21, R45	33212251	2.2 Meg. 1/4 W I 10%
R2, R14	33211031	10 K, 1/4 W, I 10%
R22, R34		
R3, R8, R20	33211021	1 K, 1/4 W, I 10%
R23, R28, R38		
R41, R44, R55		
R58		
R4, R24	33213321	3.3 R, 1/4 W, I 10%
R5, R25	33215621	5.6 K, 1/4 W, I 10%
R6, R26, R36	33214731	47 K, 1/4 W I 10%
R39, R62		
R7, R10, R18	33212231	22 K, 1/4 W, I 10%
R27, R30		

\*Recommended Spares

## PC BOARD ASSEMBLY PARTS LIST (continued)

Circuit Ref. No.	H/K Part No.	Description
R9, R29	33211221	1.2 K, 1/4 W, I 10%
R11, R32	33213331	33 K, 1/4 W, I 10%
R12, R31, R63	33316801	68 $\Omega$ , 1/2 W, I 10%
R13, R33	33215631	56 K, 1/4 W, I 10%
R15, R35, R49	33216811	680 $\Omega$ , 1/4 W, I 10%
R16	33211521	1500 $\Omega$ , 1/4 W, I 10%
R17	33315601	56 $\Omega$ , 1/2 W, I 10%
R19, R47, R48	33211041	100 K, 1/4 W, I 10%
R42, R43	33211841	180 K, 1/4 W, I 10%
R37, R40, R54	33214721	4700 $\Omega$ , 1/4 W, I 10%
R50	33215611	560 $\Omega$ , 1/4 W, I 10%
R51	33218205	82 $\Omega$ , 1/4 W, I 5%
R52	33214715	470 $\Omega$ , 1/4 W, I 5%
R53	33216821	6800 $\Omega$ , 1/4 W, I 10%
R59	33212711	270 $\Omega$ , 1/4 W, I 10%
R61	33214711	470 $\Omega$ , 1/4 W, I 10%
R64, R65	33212261	22 Meg, 1/4 W, I 10%
RESISTOR, VARIABLE		
*VR1	21630716	25 R, I 30%, Centralab TSC1BB253C
LAMPHOLDER		
XDS1-3	61230717	AE PC16-526

\*Recommended Spares

### REPLACEMENT PARTS LIST ORDER NOTE:

To speed handling of your order be sure to include both the model and serial numbers that appear at the back of the chassis, in addition to the quantity, part number and part description of the items ordered. Orders from independent dealers, independent servicemen, and retail customers will be shipped on a cash-in-advance basis. Harman-Kardon reserves the right to substitute equivalent parts for those originally installed in this chassis. All parts should be ordered from Harman Kardon, 55 Ames Court, Plainview, L.I., N.Y. 11803, Att: Parts Department.

### NOTE TO WARRANTY STATIONS

Items marked with an asterisk (\*) are recommended spare parts stock. Printed circuit board assembly numbers are shown for reference only. Harman Kardon does not normally supply assembled printed circuit boards.

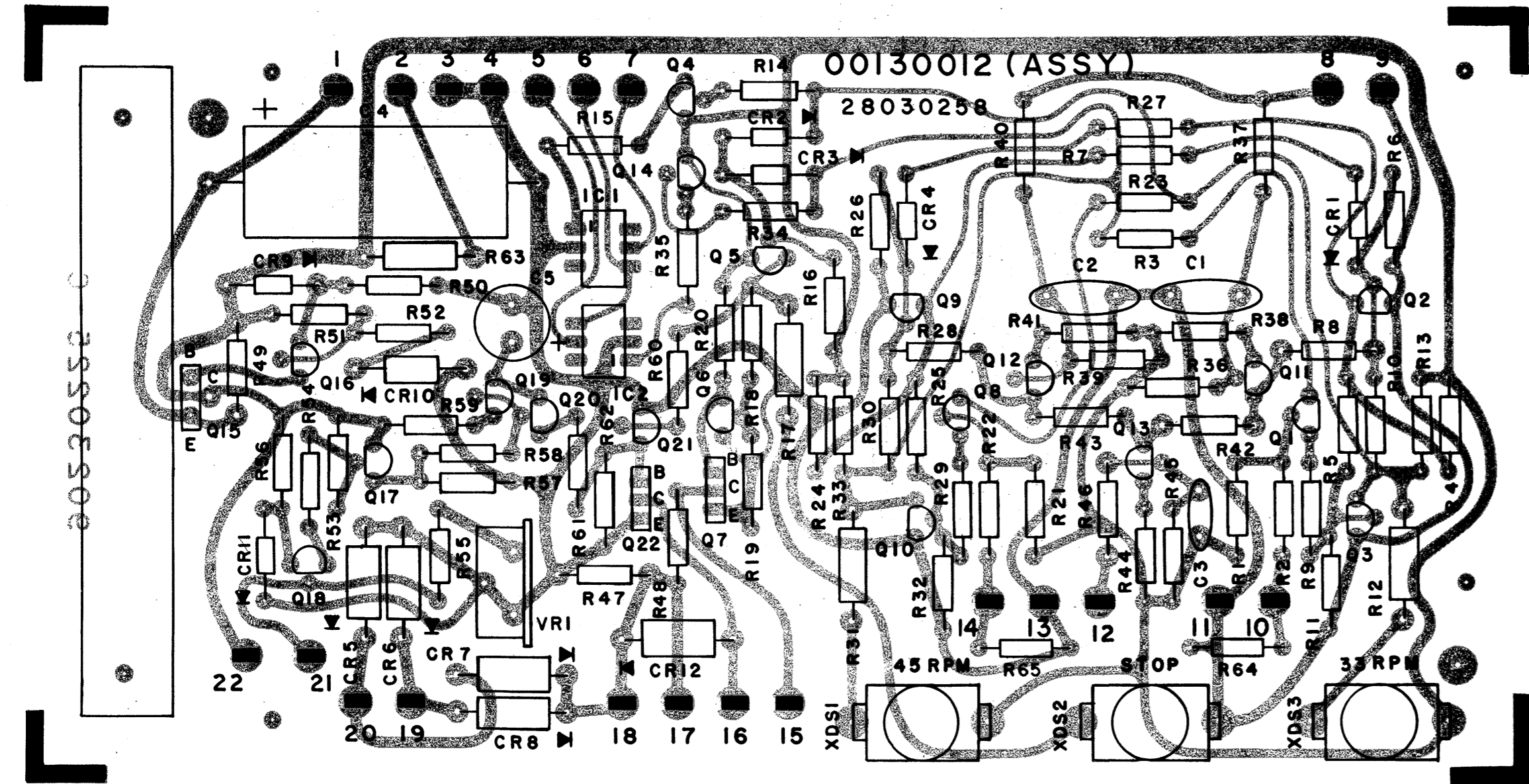

PC BOARD ASSY

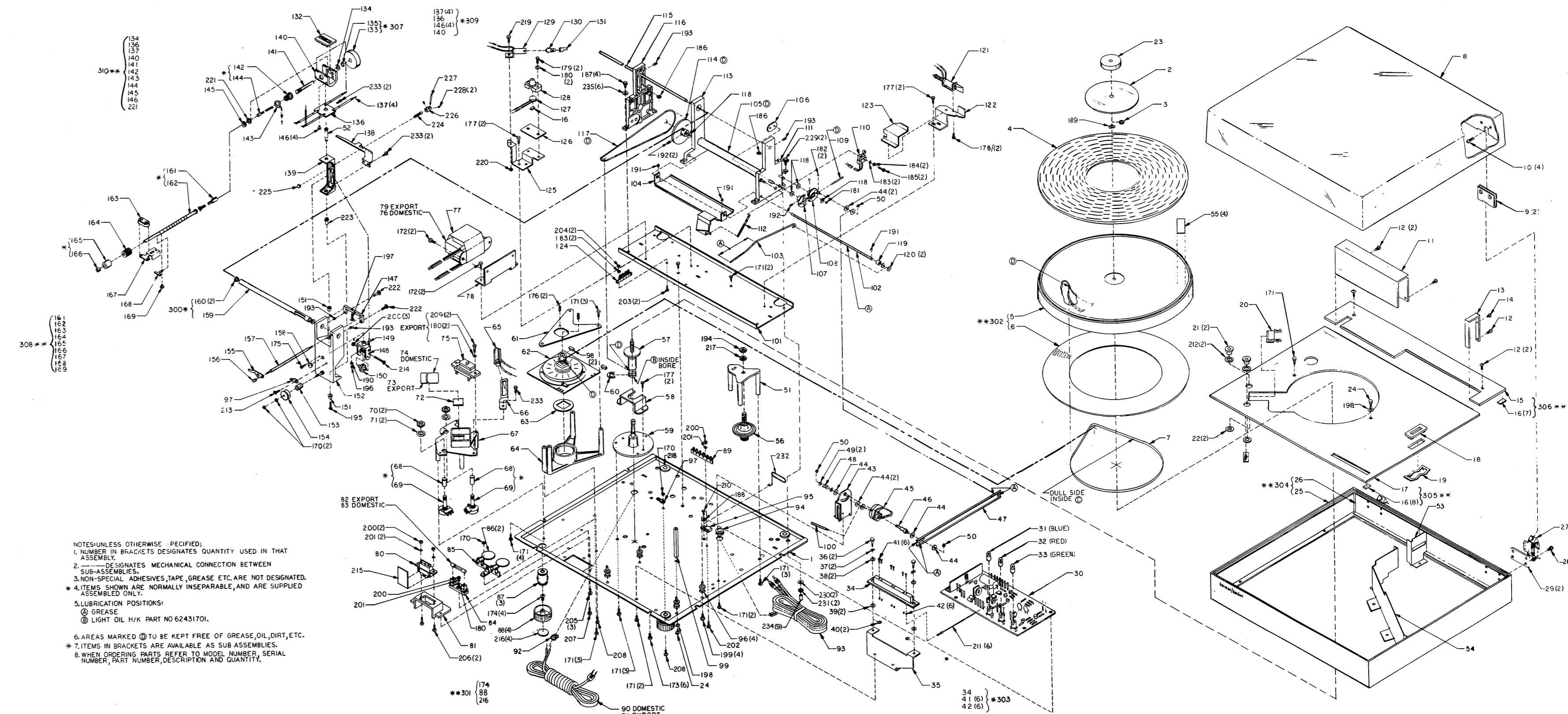

NOTES: UNLESS OTHERWISE SPECIFIED:  
 1. NUMBER IN BRACKETS DESIGNATES QUANTITY USED IN THAT ASSEMBLY.  
 2. --- DESIGNATES MECHANICAL CONNECTION BETWEEN SUB-ASSEMBLIES.  
 3. NON-SPECIAL ADHESIVES, TAPE, GREASE ETC. ARE NOT DESIGNATED.  
 4. ITEMS SHOWN ARE NORMALLY INSEPARABLE, AND ARE SUPPLIED ASSEMBLED ONLY.  
 5. LUBRICATION POSITIONS:  
 (A) GREASE  
 (B) LIGHT OIL H/K PART NO 62431701.  
 6. AREAS MARKED (C) TO BE KEPT FREE OF GREASE, OIL, DIRT, ETC.  
 7. ITEMS IN BRACKETS ARE AVAILABLE AS SUB ASSEMBLIES.  
 8. WHEN ORDERING PARTS REFER TO MODEL NUMBER, SERIAL NUMBER, PART NUMBER, DESCRIPTION AND QUANTITY.

FIGURE 11. EXPLODED VIEW OF ST-7 OVERALL ASSEMBLY

00530555

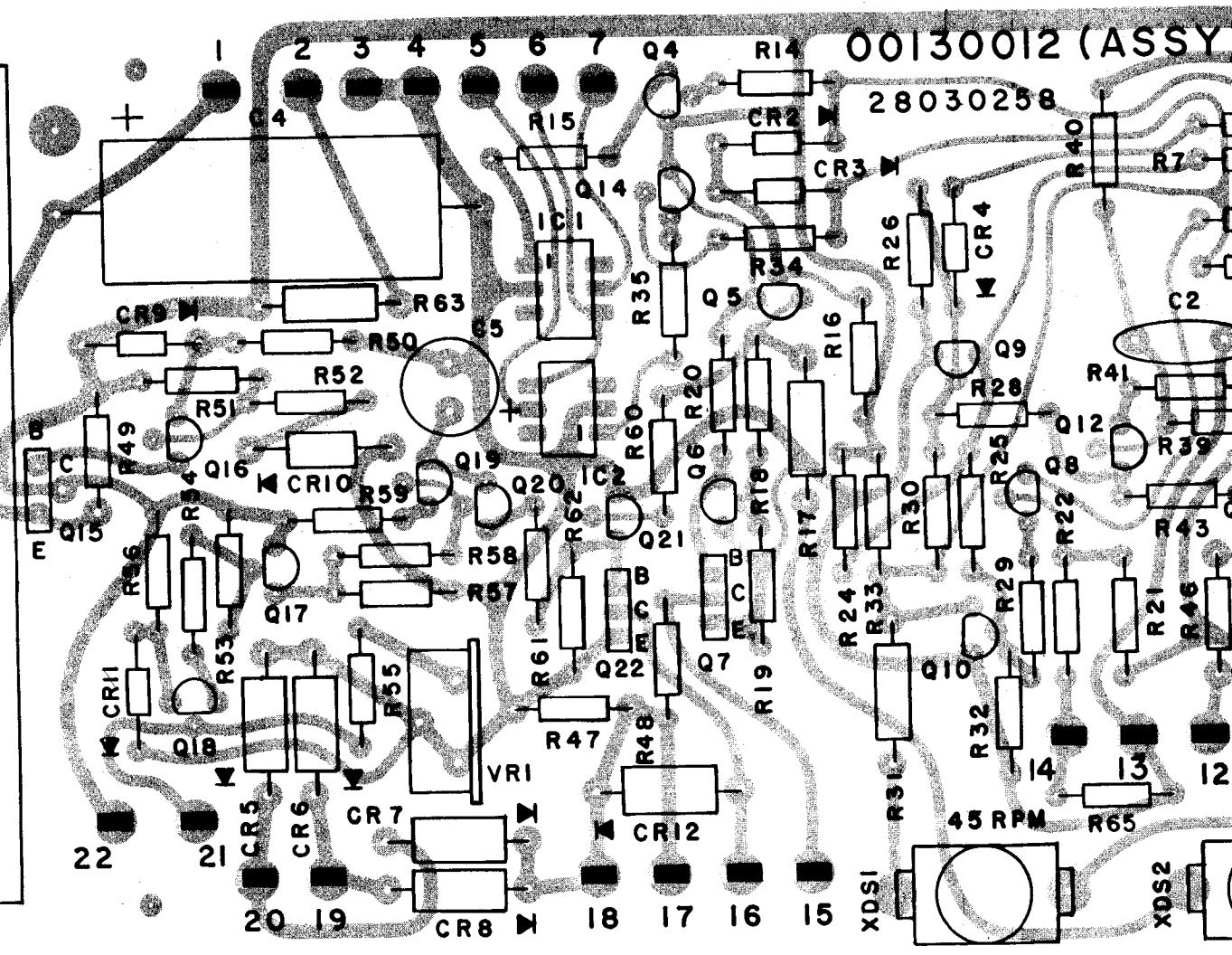

PC BOARD ASSY

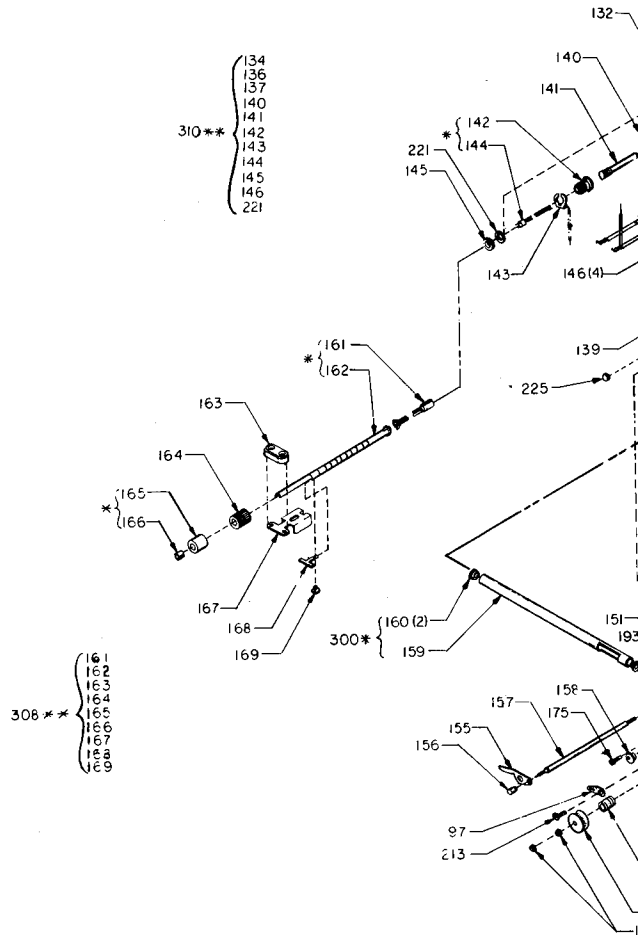
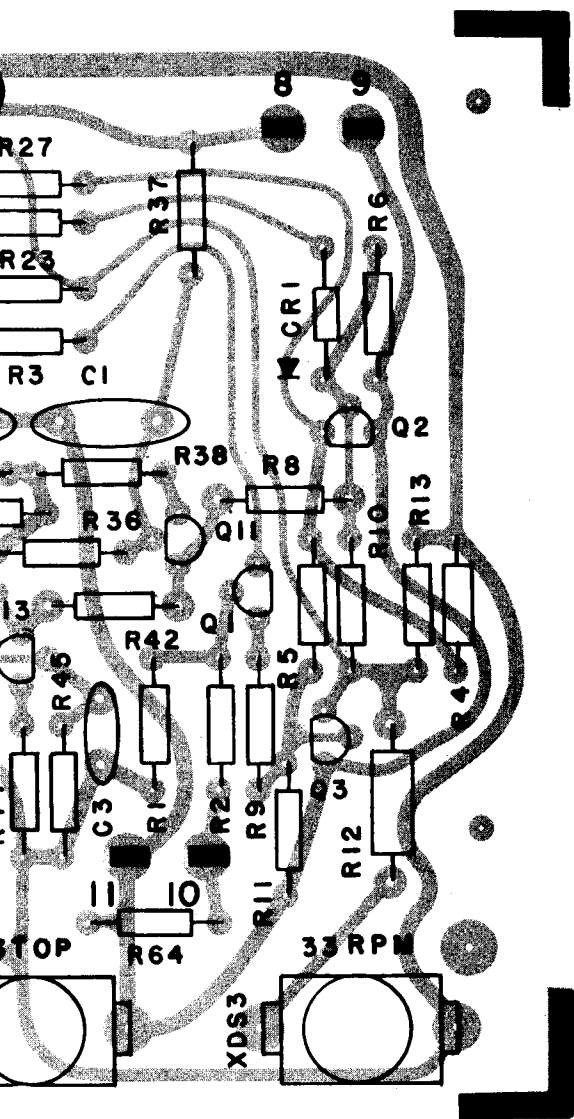

NOTES: UNLESS OTHERWISE SPECIFIED:

1. NUMBER IN BRACKETS DESIGNATES QUANTITY USED IN THAT ASSEMBLY.
2. --- DESIGNATES MECHANICAL CONNECTION BETWEEN SUB-ASSEMBLIES.
3. NON-SPECIAL ADHESIVES, TAPE, GREASE ETC. ARE NOT DESIGNATED.
- \* 4. ITEMS SHOWN ARE NORMALLY INSEPARABLE, AND ARE SUPPLIED ASSEMBLED ONLY.
5. LUBRICATION POSITIONS:
  - Ⓐ GREASE
  - Ⓑ LIGHT OIL H/K PART NO 62431701.
6. AREAS MARKED Ⓣ TO BE KEPT FREE OF GREASE, OIL, DIRT, ETC.
- \* 7. ITEMS IN BRACKETS ARE AVAILABLE AS SUB ASSEMBLIES.
8. WHEN ORDERING PARTS REFER TO MODEL NUMBER, SERIAL NUMBER, PART NUMBER, DESCRIPTION AND QUANTITY.

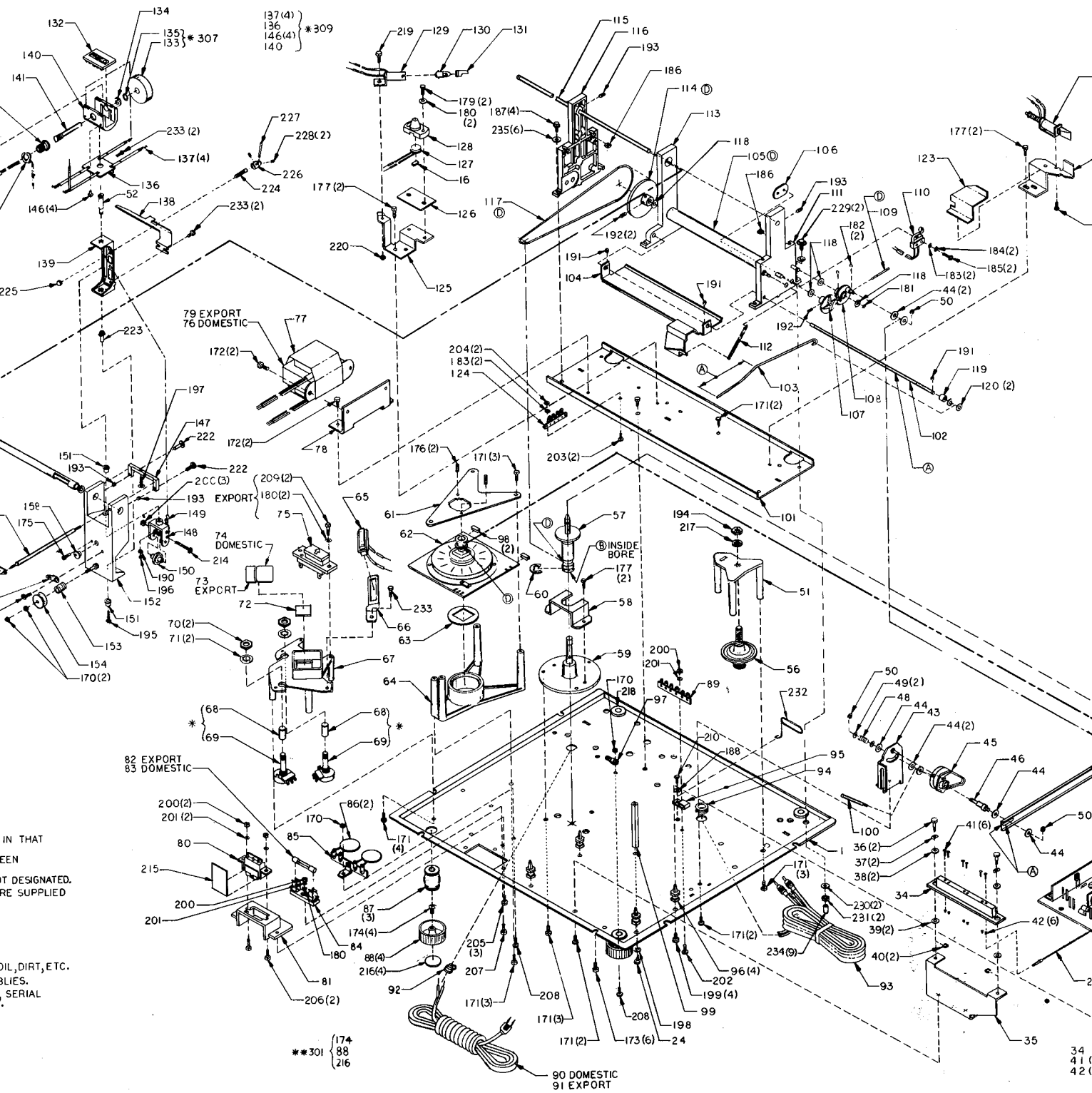

{ 137(4)  
136  
146(4) } \*309  
140

79 EXPORT  
76 DOMESTIC

74 DOMESTIC

73 EXPORT

82 EXPORT  
83 DOMESTIC

90 DOMESTIC  
91 EXPORT

\*\*301 { 174  
88  
216 }

IN THAT  
EEN  
IT DESIGNATED.  
RE SUPPLIED

OIL, DIRT, ETC.  
BLIES.  
SERIAL

34  
41  
42



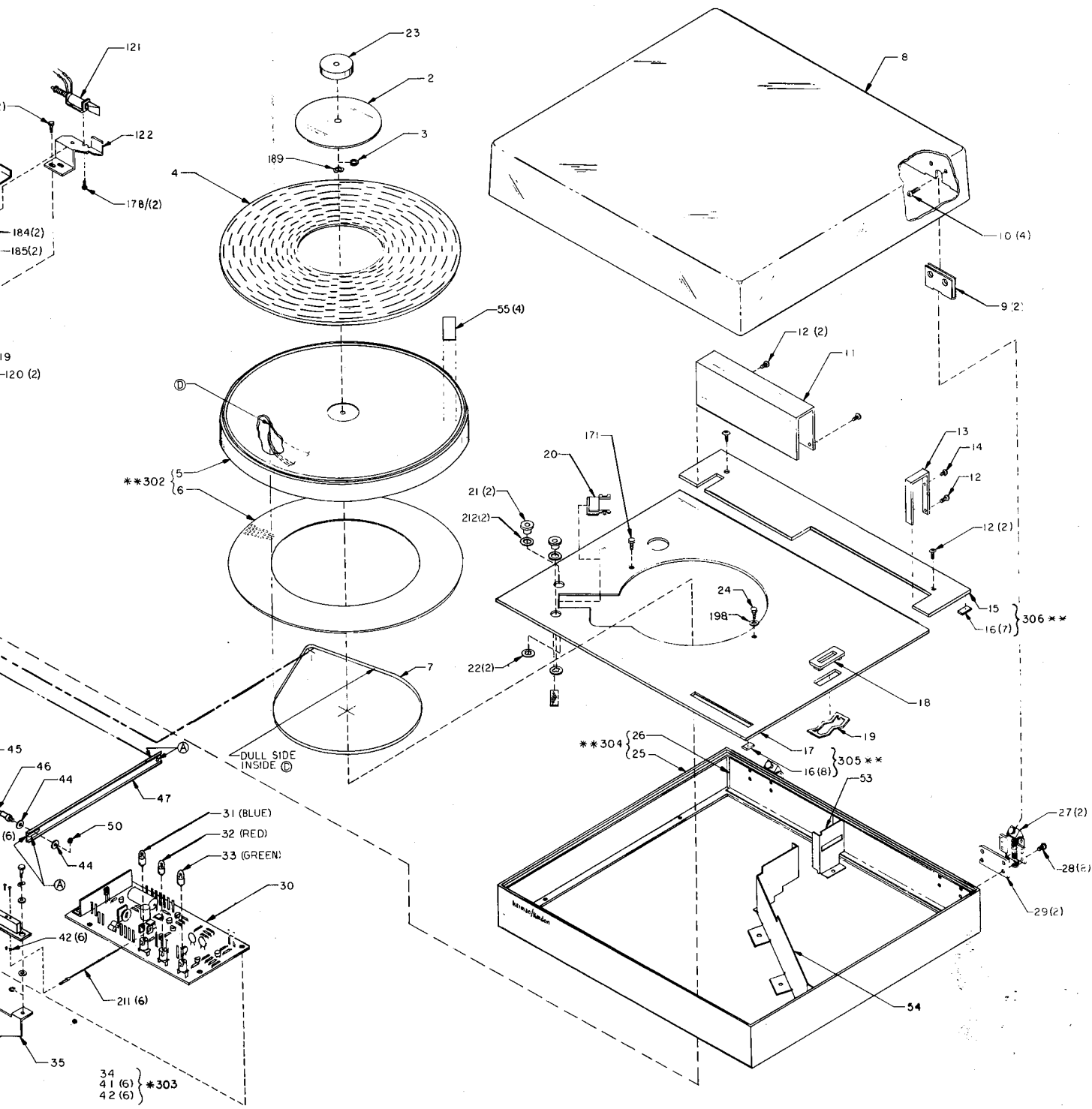
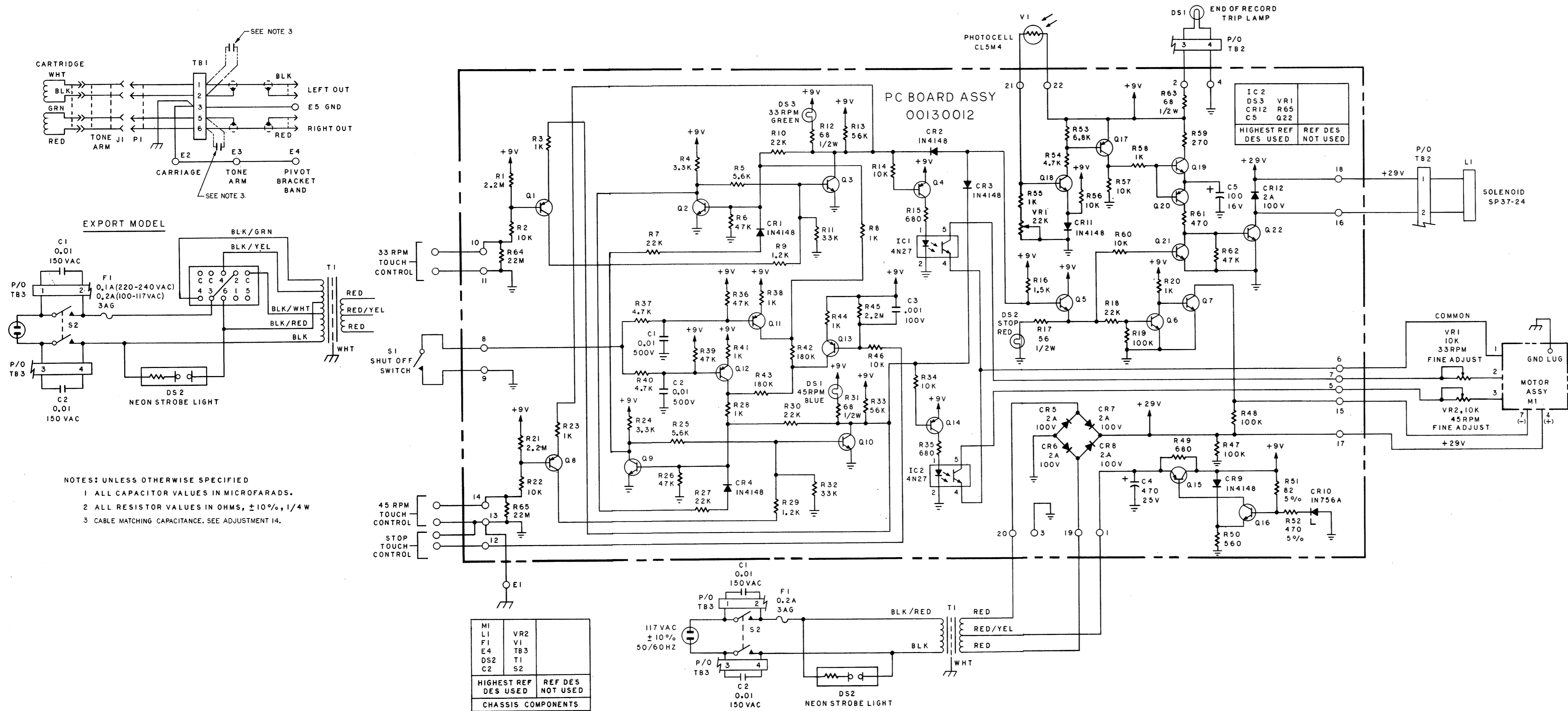

FIGURE 11. EXPLODED VIEW OF ST-7 OVERALL ASSEMBLY



ST 7 DC VOLTAGES TO GND  
LINE: 117 VAC, 60 HZ  
METER: WESTON 4444 DVM

REF DES	TURN TABLE MODE	V <sub>C</sub>	V <sub>B</sub>	V <sub>E</sub>	REF DES	TURN TABLE MODE	V <sub>C</sub>	V <sub>B</sub>	V <sub>E</sub>	REF DES	TURN TABLE MODE	PHOTO CELL* AMBIENT	V <sub>C</sub>	V <sub>B</sub>	V <sub>E</sub>
Q1	STOP	0.00	9.00	9.00	Q9	STOP	0.00	0.70	0.00	Q17	STOP	LIGHT	9.00	8.30	9.00
	33 1/3	0.80	9.00	9.00		33 1/3	0.00	0.70	0.00		33 1/3 OR 45 RPM	DARK	9.00	8.30	9.00
	45	0.00	7.50	0.16		45	5.50	0.13	0.00		33 1/3 OR 45 RPM	LIGHT	0.60	1.30	0.60
Q2	STOP	0.00	0.70	0.00	Q10	STOP	9.00	0.00	0.00	Q18	STOP	LIGHT	0.60	1.30	0.60
	33 1/3	5.50	0.13	0.00		33 1/3	9.00	0.00	0.00		33 1/3 OR 45 RPM	DARK	9.00	0.10	0.60
	45	0.00	0.70	0.00		45	0.16	0.80	0.00		33 1/3 OR 45 RPM	LIGHT	0.60	1.30	0.60
Q3	STOP	9.00	0.00	0.00	Q11	STOP	0.70	9.00	9.00	Q19	STOP	LIGHT	9.00	9.00	8.90
	33 1/3	0.16	0.80	0.00		33 1/3	0.13	9.00	9.00		STOP	DARK	9.00	0.00	0.40
	45	9.00	0.00	0.00		45	0.70	9.00	9.00		33 1/3 OR 45 RPM	LIGHT	9.00	9.00	8.80
Q4	STOP	0.00	9.00	9.00	Q12	STOP	0.70	9.00	9.00	Q20	STOP	LIGHT	0.00	9.00	8.80
	33 1/3	8.90	8.30	9.00		33 1/3	0.70	9.00	9.00		STOP	DARK	0.00	0.00	0.40
	45	0.00	9.00	9.00		45	0.13	9.00	9.00		33 1/3 OR 45 RPM	LIGHT	0.00	9.00	8.80
Q5	STOP	9.00	8.90	8.20	Q13	STOP	0.70	9.00	9.00	Q21	STOP	LIGHT	0.00	0.70	0.00
	33 1/3	9.00	0.80	0.20		33 1/3	0.40	9.00	9.00		STOP	DARK	0.00	0.70	0.00
	45	9.00	0.80	0.20		45	0.40	9.00	9.00		33 1/3 OR 45 RPM	LIGHT	0.00	0.20	0.00
Q6	STOP	0.00	0.70	0.00	Q14	STOP	0.00	9.00	9.00	Q22	STOP	LIGHT	23.0	0.00	0.00
	33 1/3	0.70	0.20	0.00		33 1/3	0.00	9.00	9.00		STOP	DARK	23.0	0.00	0.00
	45	0.70	0.20	0.00		45	8.90	8.30	9.00		33 1/3 OR 45 RPM	LIGHT	23.0	0.00	0.00
Q7	STOP	23.0	0.00	0.00	Q15	STOP	9.00	12.6	13.3	Q22	STOP	LIGHT	23.0	0.00	0.00
	33 1/3	0.00	0.70	0.00		33 1/3	9.00	12.2	12.9		STOP	DARK	23.0	0.00	0.00
	45	0.00	0.70	0.00		45	9.00	12.2	12.9		33 1/3 OR 45 RPM	LIGHT	23.0	0.00	0.00
Q8	STOP	0.00	9.00	9.00	Q16	STOP	12.6	8.90	8.30	Q22	STOP	LIGHT	23.0	0.00	0.00
	33 1/3	0.00	7.50	0.16		33 1/3	12.2	8.90	8.30		STOP	DARK	23.0	0.00	0.00
	45	0.80	9.00	9.00		45	12.2	8.90	8.30		33 1/3 OR 45 RPM	LIGHT	23.0	0.00	0.00

\* THE LIGHT CONDITION IS SIMULATED BY END OF RECORD LAMP, DS1, BEING ON AND UNOBSTRUCTED. THE DARK CONDITION IS SIMULATED BY OBSTRUCTING THE LIGHT EMITTED BY DS1 BY PLACING A SHEET OF DENSE MATERIAL OVER THE PHOTOCELL, V1, APERTURE.

FIGURE 12. ST-7 SCHEMATIC DIAGRAM

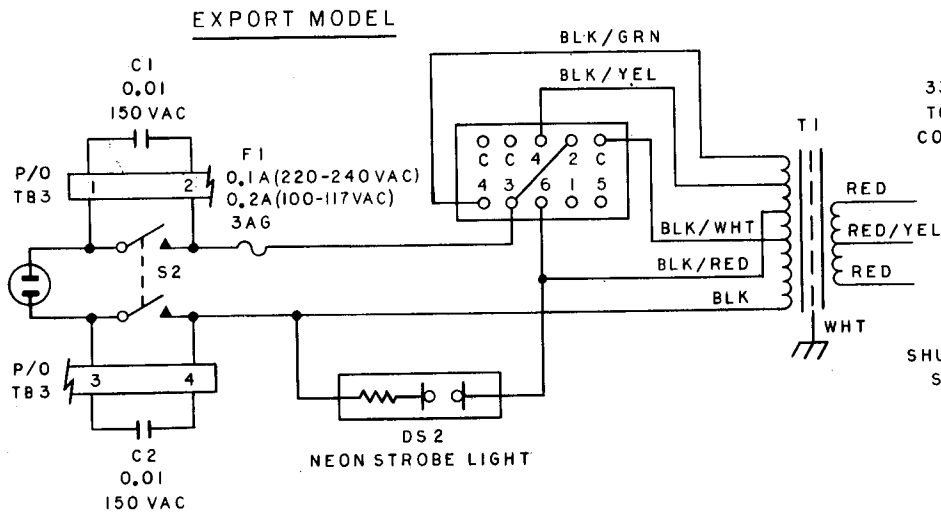
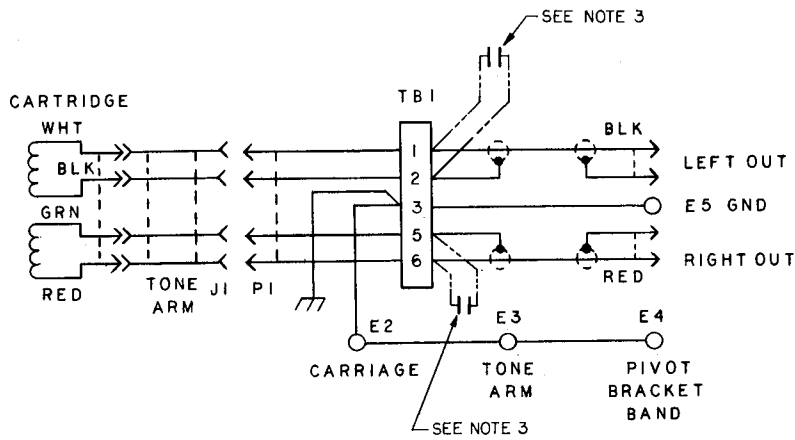

**NOTES: UNLESS OTHERWISE SPECIFIED**

- 1 ALL CAPACITOR VALUES IN MICROFARADS.
- 2 ALL RESISTOR VALUES IN OHMS,  $\pm 10\%$ , 1/4 W
- 3 CABLE MATCHING CAPACITANCE. SEE ADJUSTMENT 14.

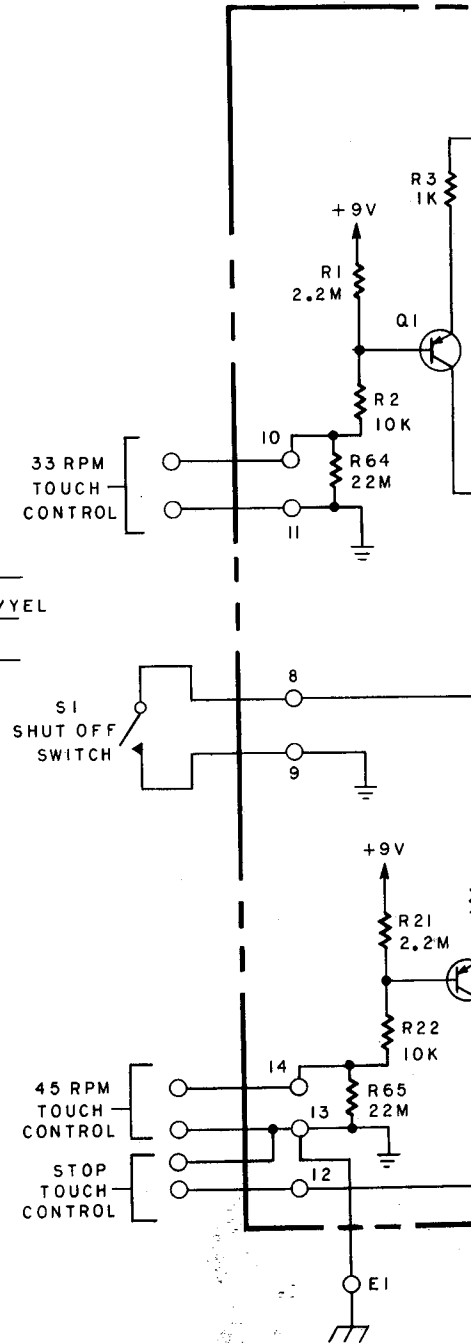

M1	VR2	
L1	V1	
F1	TB3	
E4	T1	
DS2	S2	
C2		
HIGHEST REF DES USED		RE NO
CHASSIS COMPON		

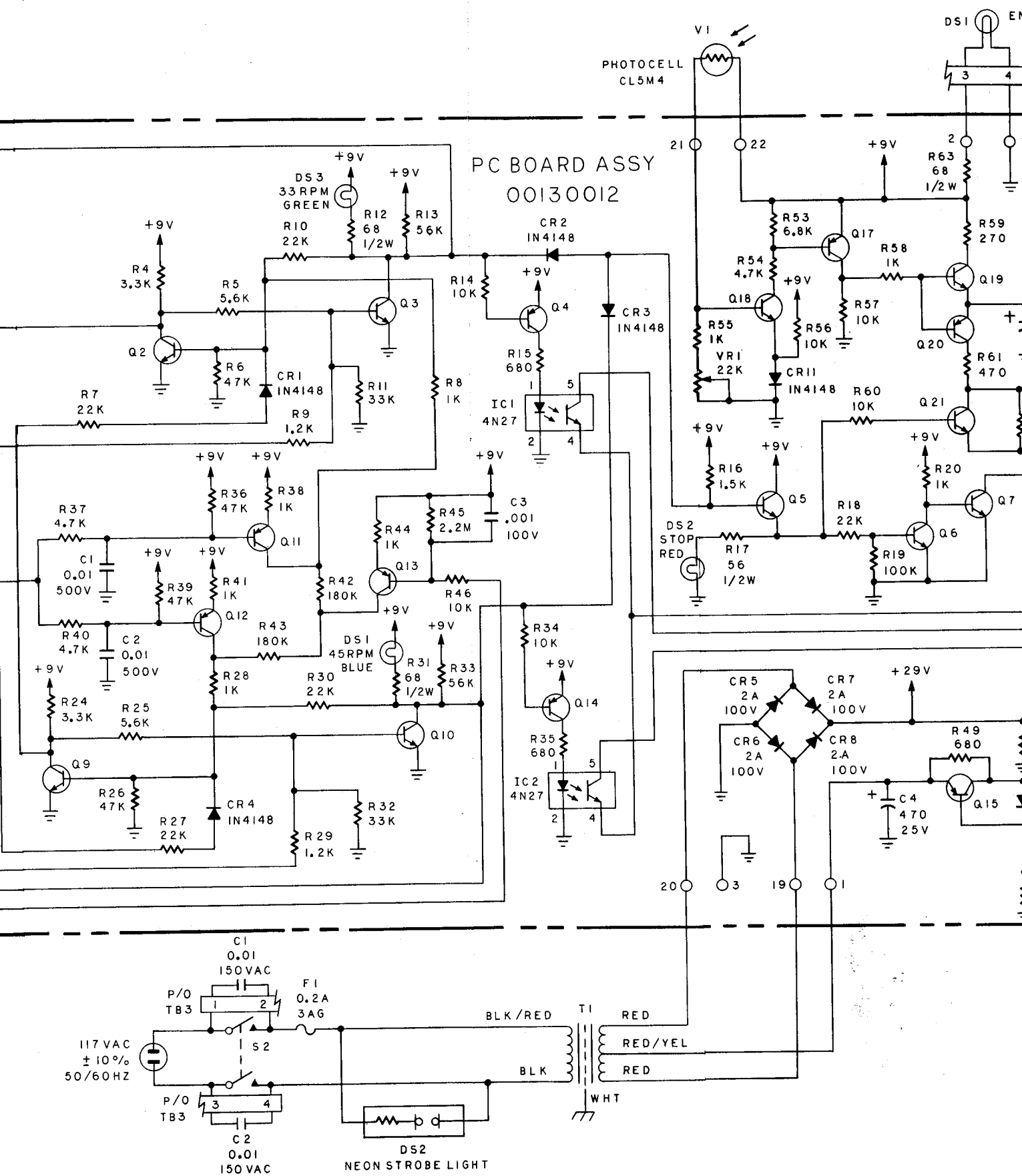

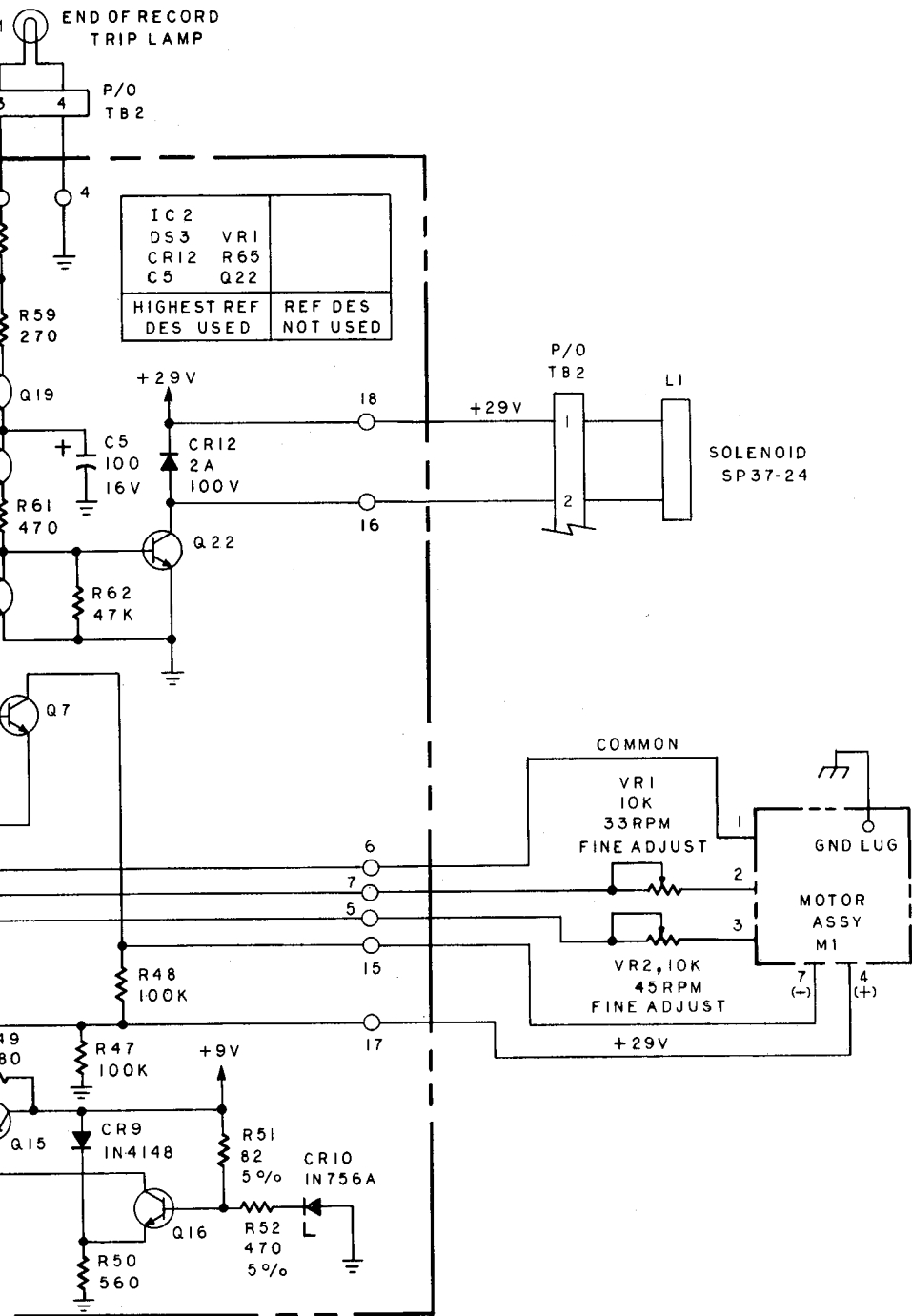

REF DES	TURN TABLE MODE	V <sub>C</sub>	V <sub>B</sub>	V <sub>E</sub>	REF DES
Q1	STOP	0.00	9.00	9.00	Q9
	33 1/3	0.80	9.00	9.00	
	45	0.00	7.50	0.16	
Q2	STOP	0.00	0.70	0.00	Q10
	33 1/3	5.50	0.13	0.00	
	45	0.00	0.70	0.00	
Q3	STOP	9.00	0.00	0.00	Q11
	33 1/3	0.16	0.80	0.00	
	45	9.00	0.00	0.00	
Q4	STOP	0.00	9.00	9.00	Q12
	33 1/3	8.90	8.30	9.00	
	45	0.00	9.00	9.00	
Q5	STOP	9.00	8.90	8.20	Q13
	33 1/3	9.00	0.80	0.20	
	45	9.00	0.80	0.20	
Q6	STOP	0.00	0.70	0.00	Q14
	33 1/3	0.70	0.20	0.00	
	45	0.70	0.20	0.00	
Q7	STOP	23.0	0.00	0.00	Q15
	33 1/3	0.00	0.70	0.00	
	45	0.00	0.70	0.00	
Q8	STOP	0.00	9.00	9.00	Q16
	33 1/3	0.00	7.50	0.16	
	45	0.80	9.00	9.00	

\* THE LIGHT CONDITION IS SIMULATED BY  
 THE DARK CONDITION IS SIMULATED BY  
 A SHEET OF DENSE MATERIAL OVER THE

ST 7 DC VOLTAGES TO GND  
 LINE: 117 VAC, 60 HZ  
 METER: WESTON 4444 DVM

V <sub>E</sub>	REF DES	TURN TABLE MODE	V <sub>C</sub>	V <sub>B</sub>	V <sub>E</sub>	REF DES	TURN TABLE MODE	PHOTO CELL* AMBIENT	V <sub>C</sub>	V <sub>B</sub>	V <sub>E</sub>
9.00	Q9	STOP	0.00	0.70	0.00	Q17	STOP	LIGHT	9.00	8.30	9.00
9.00		33 1/3	0.00	0.70	0.00		STOP	DARK	9.00	8.30	9.00
0.16		45	5.50	0.13	0.00		33 1/3 OR 45 RPM	LIGHT	9.00	8.30	9.00
0.00	Q10	STOP	9.00	0.00	0.00	Q18	STOP	LIGHT	0.60	1.30	0.60
0.00		33 1/3	9.00	0.00	0.00		STOP	DARK	9.00	0.10	0.60
0.00		45	0.16	0.80	0.00		33 1/3 OR 45 RPM	LIGHT	0.60	1.30	0.60
0.00	Q11	STOP	0.70	9.00	9.00	Q19	STOP	LIGHT	9.00	9.00	8.90
0.00		33 1/3	0.13	9.00	9.00		STOP	DARK	9.00	0.00	0.40
0.00		45	0.70	9.00	9.00		33 1/3 OR 45 RPM	LIGHT	9.00	9.00	8.80
9.00	Q12	STOP	0.70	9.00	9.00	Q20	STOP	LIGHT	0.00	9.00	8.80
9.00		33 1/3	0.70	9.00	9.00		STOP	DARK	0.00	0.00	0.40
9.00		45	0.13	9.00	9.00		33 1/3 OR 45 RPM	LIGHT	0.00	9.00	8.80
8.20	Q13	STOP	0.70	9.00	9.00	Q21	STOP	LIGHT	0.00	0.70	0.00
0.20		33 1/3	0.40	9.00	9.00		STOP	DARK	0.00	0.70	0.00
0.20		45	0.40	9.00	9.00		33 1/3 OR 45 RPM	LIGHT	0.00	0.20	0.00
0.00	Q14	STOP	0.00	9.00	9.00	Q22	STOP	LIGHT	23.0	0.00	0.00
0.00		33 1/3	0.00	9.00	9.00		STOP	DARK	23.0	0.00	0.00
0.00		45	8.90	8.30	9.00		33 1/3 OR 45 RPM	LIGHT	23.0	0.00	0.00
0.00	Q15	STOP	9.00	12.6	13.3	Q16	STOP	LIGHT	9.00	12.6	13.3
0.00		33 1/3	9.00	12.2	12.9		STOP	DARK	9.00	12.2	12.9
0.00		45	9.00	12.2	12.9		33 1/3 OR 45 RPM	LIGHT	9.00	12.2	12.9
9.00	Q16	STOP	12.6	8.90	8.30	Q17	STOP	LIGHT	12.6	8.90	8.30
0.16		33 1/3	12.2	8.90	8.30		STOP	DARK	12.2	8.90	8.30
9.00		45	12.2	8.90	8.30		33 1/3 OR 45 RPM	LIGHT	12.2	8.90	8.30

IS SIMULATED BY END OF RECORD LAMP, DSI, BEING ON AND UNOBSTRUCTED.  
 IS SIMULATED BY OBSTRUCTING THE LIGHT EMITTED BY DSI BY PLACING  
 MATERIAL OVER THE PHOTOCCELL, VI, APERTURE.

FIGURE 12. ST-7 SCHEMATIC DIAGRAM