

harman/kardon

SUB-TS1

Amplifier/Subwoofer

TECHNICAL MANUAL



Harman Consumer Group
250 Crossways Park Drive
Woodbury, N.Y. 11797
1-800 422-8026 in the USA

H A Harman International Company

Rev A 11/99

The SUB-TS1 is part of the HKTS1 system

TABLE OF CONTENTS

COVER.....	1	HKTS1 PACKING.....	10
GENERAL SPECIFICATIONS	2	SUB-TS1 EXPLODED VIEW.....	11
TABLE OF CONTENTS.....	2	SUB-TS1 PCB COMPONENT SIDE	12
HKTS1 SPECIFICATIONS.....	3	SUB-TS1 PCB SOLDER SIDE.....	13
CONTROLS AND THEIR FUNCTION.....	5	SUB-TS1 ELECTRICAL PARTS LIST.....	14
HKTS1 SPEAKER LEVEL CONNECTIONS	6	SUB-TS1 INTEGRATED CIRCUIT DIAGRAMS	16
HKTS1 LINE LEVEL CONNECTIONS	7	SUB-TS1 POWER AMP SCHEMATIC DIAGRAM.....	17
SUB-TS1 TEST SET UP AND PROCEDURE	8	SUB-TS1 PRE-AMP SCHEMATIC DIAGRAM.....	18
SIMPLE TROUBLESHOOTING.....	9		

GENERAL SPECIFICATIONS

HKTS-1 System

Frequency Response
35Hz – 20kHz (–6dB)

SUB-TS1

Amplifier . . . 75 watts RMS

Bass 8" woofer, bass-reflex enclosure

Dimensions (H x W x D)
10½ x 18½ x 10½ inches
267 x 470 x 267mm

Weight . . . 29.9 lbs/13.6 kg

Refinements may be made on occasion to existing products without notice,
but will always meet or exceed original specifications unless otherwise stated.

HKTS1 SPECIFICATIONS

LINE VOLTAGE	Yes/No	Hi/Lo Line	Unit	Notes	
US 120vac/60Hz	Yes	108-132	Vrms	Normal Operation	
EU 230vac/50-60Hz	Yes	207-264	Vrms	Normal operation, MOMS required	
Asia 100vac/50Hz	Yes	90-110	Vrms	Normal Operation	
	Spec.	Unit	Limits	Conditions	Notes
Amp Section					
Type (Class AB, D, other)	AB	AB	n/a		Sink required for Class AB
Load Impedance (speaker)	4	Ohms	n/a	Nominal	Z-curve required
Rated Output Power	80	Watts	80	1 input driven	
THD@ Rated Power	0.08	%	0.3	22k filter	
THD @ 1 Watt	0.1	%	0.5	22k filter	
DC Offset	10	mV-DC	20	@ Speaker Outputs	
Damping factor	<200	DF	n/a		
Input Sensitivity					
Input Frequency	50	Hz	50	Nominal Freq.	1 input driven
Line Input	220	mVrms	±2dB	To Rated Power	1 input driven
Speaker/Hi Level Input	4.26	Vrms	±2dB	To Rated Power	(-26dB below Line In)...1 input driven
Signal to Noise					
SNR-A-Weighted	100	dBA	90	rel. to rated power	A-Weighting filter
SNR-unweighted	80	dBr	60	rel. to rated power	22k filter
SNR @ 1W-unweighted	60	dBr	55	rel. to 1W Output	22k filter
Residual Noise Floor	1.5	mVrms	2.5	Volume @max, using RMS reading DMM/VOM (or A/P)	
Residual Noise Floor	1	mVrms(max)	2	Volume @max, w/ A/P Swept Bandpass Measurement (Line freq.+ harmonics)	
Input Impedance					
Line Input	15K	ohms	n/a	Nominal	
Speaker/Hi Level Input	4.7K	ohms	n/a	Nominal	
Filters					
Low Pass (fixed or variable)	fixed	—	—		
Low Pass filter (point or range)	135	Hz	±2dB	-3dB Point	
Slope	24	dB/Octave	n/a		
Q	1.8	Damping	n/a	2 cascaded 2nd order filters of 1.8 & 0.7 Q	
Subsonic filter (HPF)	31	Hz	±2dB	-3dB Point	
Slope	12	dB/Octave	n/a		
Q	1.4	Damping	n/a		

Signal Sensing (ATO)					
Auto-Turn-On (yes/no)	yes	—	functional		
ATO Input Frequency	50	Hz	functional		
ATO Level	2	mV	functional	2mV@50Hz into Line Input w/ 1 ch. driven	
ATO Bandwidth	5k	Hz	functional	ATO-LPF for noise immunity	DV1 measured 7mV @ 5kHz.... 2mV @ 1kHz
ATO Turn-on time	5	ms	functional	Amp connected and AC on, then input signal applied	
Auto Mute/ Turn-OFF Time	20	minutes	functional	T before muting, after signal is removed	
Power on Delay time					
	3	sec.	functional	AC Power Applied	
Transients/Pops					
ATO Transient	5	mV-peak	10	@ Speaker Outputs	
Turn-on Transient	50	mV-peak	100	@ Speaker Outputs	AC Line cycled from OFF to ON
Turn-off Transient	50	mV-peak	100	@ Speaker Outputs	AC Line cycled from ON to OFF
Efficiency					
Stand-by Input Power	10	Watts	n/a	@ nom. line voltage	
Power Cons.@rated power	160	Watts	n/a	@ nom. line voltage	
Protection					
Short Circuit Protection	Yes	—	functional	Direct short at output	
Thermal Protection	65 deg. C	—	functional	@ 1/8 max unclipped Power	DV1:Plate=50deg.C max.Tab=90deg.C max.T-on =65deg.C
DC Offset Protection	yes	—	functional	DC present at Speaker Out leads	Relay or crowbar (for driver/fire protection)
Line Fuse Rating	2	Amps	2	Type-T or Slo Blo	External fuse with UL/SEMKO rated holder

CONTROLS AND THEIR FUNCTION

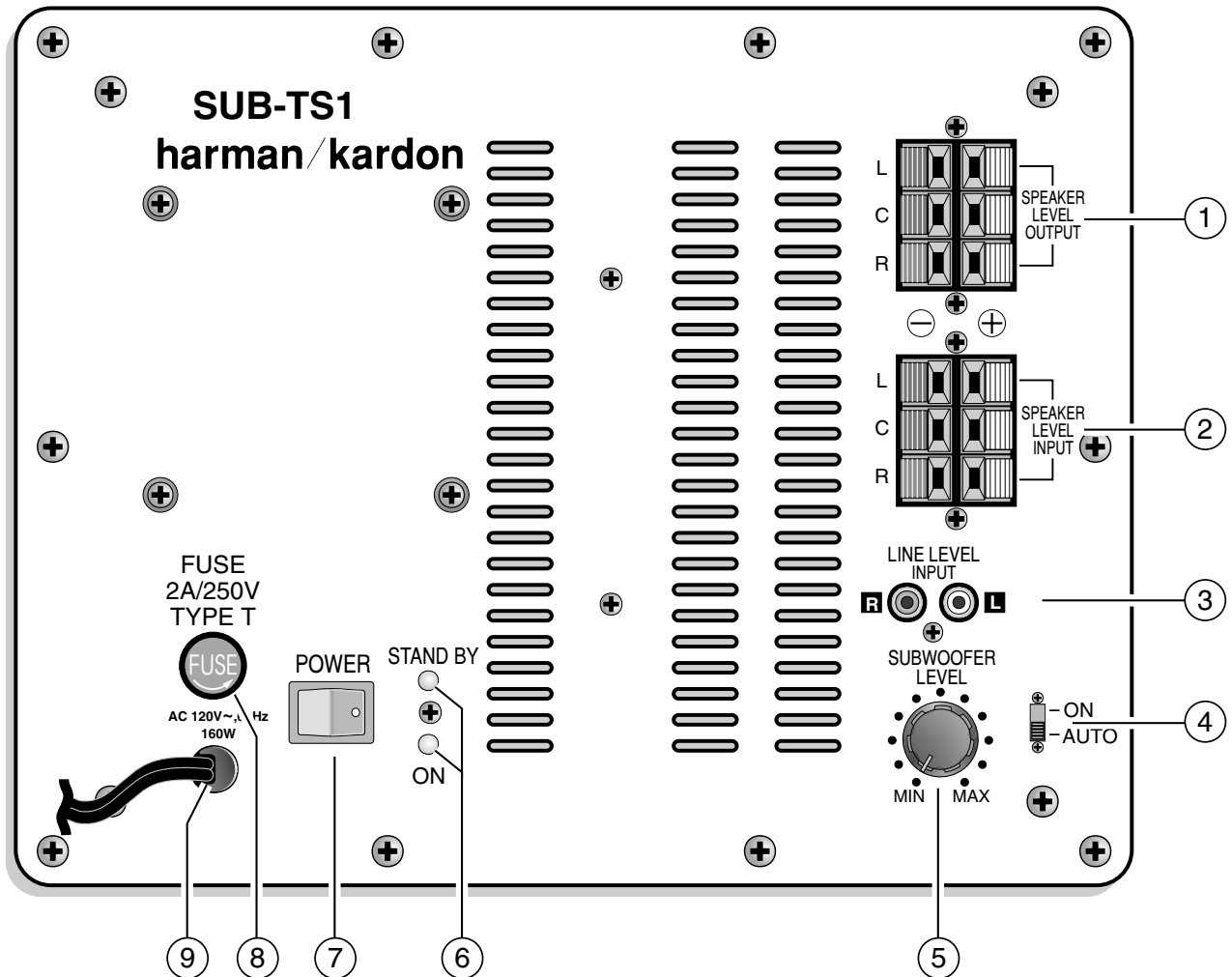

1. **Speaker Level Outputs** - Connect the Left, Center and Right speakers to these connectors.
2. **Speaker Level Inputs** - These High Level Inputs are for receivers that do not have line-level "pre-amp out" or "subwoofer out" jacks. When a pair of main or satellite speakers are attached to the OUTPUT terminals, they are driven the full range of frequencies as generated by the music source (receiver, amplifier, etc.)
3. **Line Level Input** - These left and right Line Level Inputs are normally used when the receiver/ processor has line-level "pre-amp out" or "subwoofer out" jacks.
4. **Auto/On Switch** - This switch allows you to set the Mode of the Amplifier. Turn the switch to Auto to cause it to **Auto**-matically turn on when it receives a signal and **Auto**-matically turn off after twenty minutes without a signal. If this switch is left "On", the subwoofer will always be ON when the power switch is turned On, regardless of input signal.
5. **Subwoofer Level** - This knob controls the volume level of the SUB125.
6. **LED** - Red & Green. The LEDs indicate the Mode status that the subwoofer is in. When the SUB125 is turned OFF neither LED will be lit. The Green LED will light when the SUB125 is ON and receiving a signal. The Red LED will light when the amplifier has not received a signal for twenty minutes. The subwoofer will turn on when your receiver/amplifier begins playing again.
7. **Power Switch** - This the master power switch. Use it (in Off mode) to disconnect power to the amplifier.
8. **Fuse** - Use only same type of fuses. For the U.S. 120V version use only a 2A 250V fuse. For the European 230V version use only a 1A fuse.
9. **AC Cord**

HKTS1 SPEAKER LEVEL CONNECTIONS

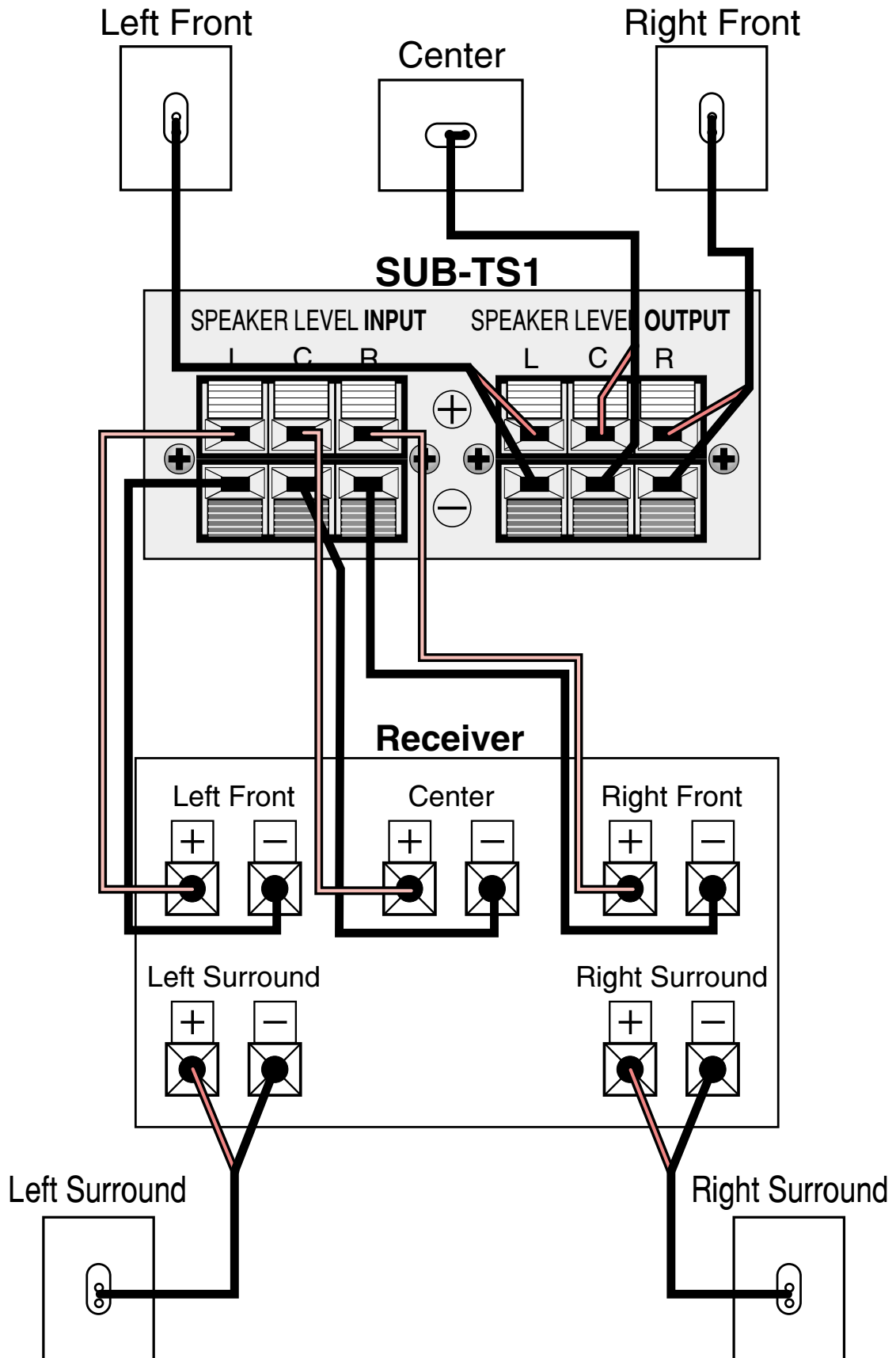

HKTS1 LINE LEVEL CONNECTIONS

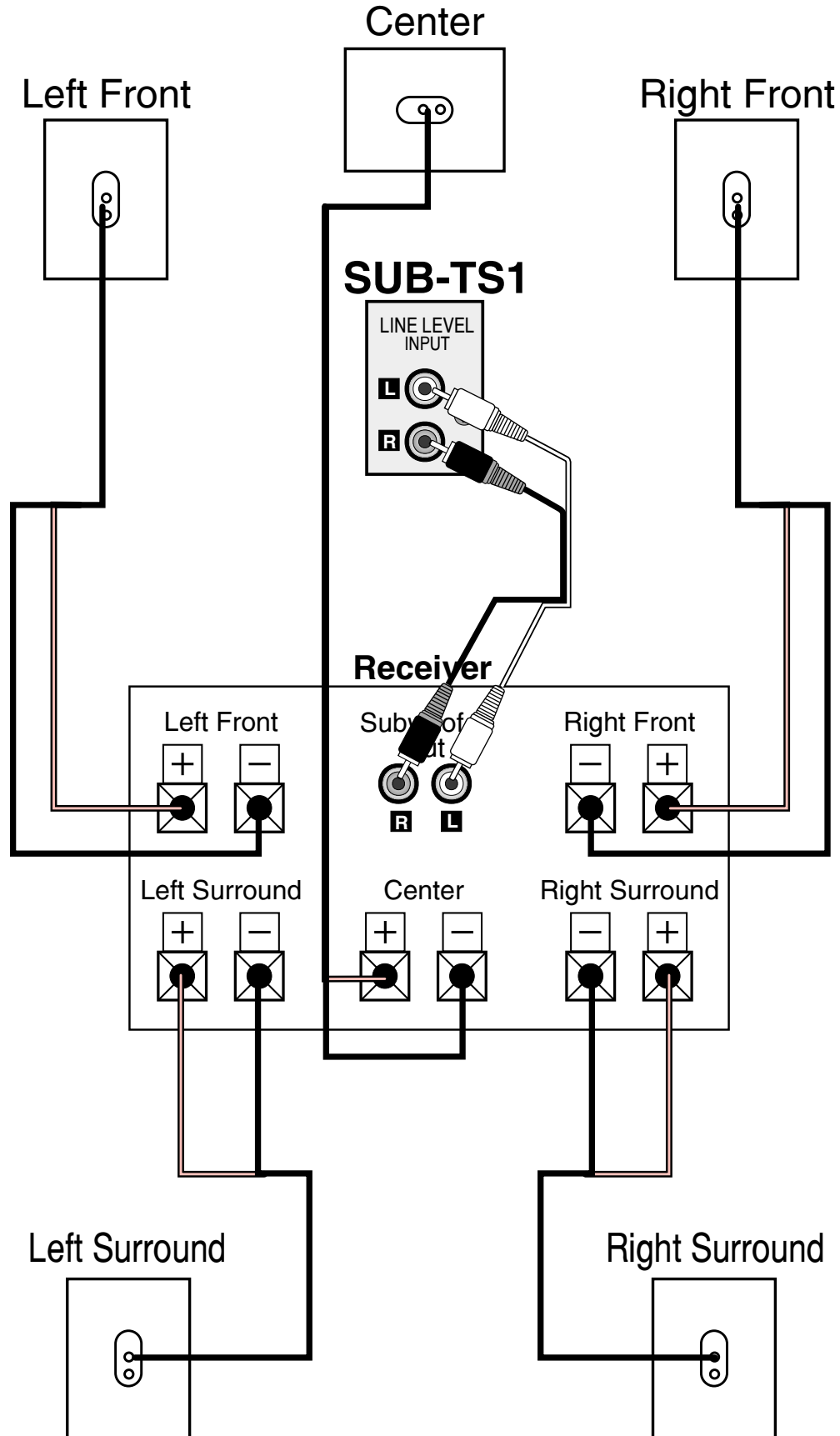

SUB-TS1 TEST SET UP AND PROCEDURE

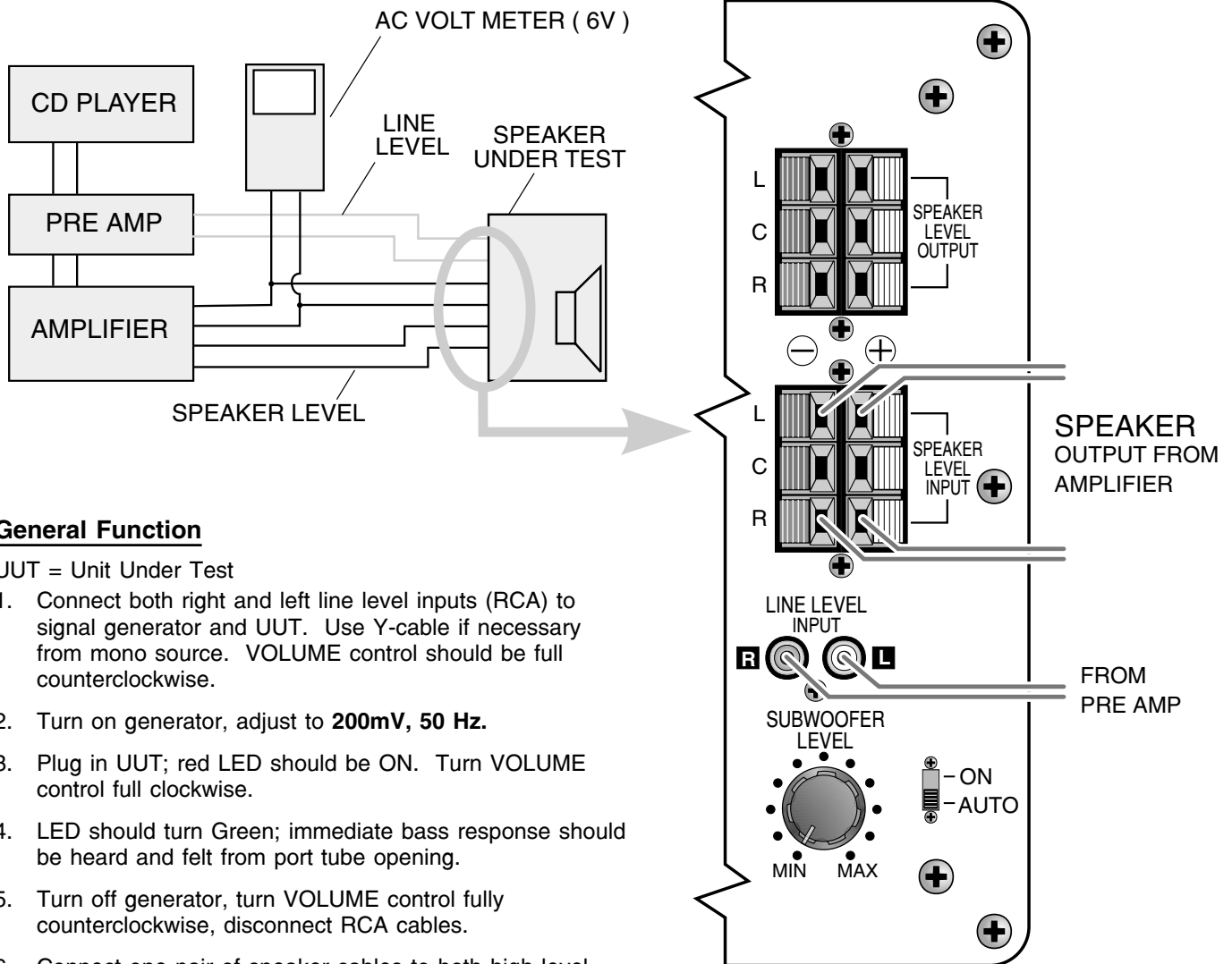

General Function

UUT = Unit Under Test

1. Connect both right and left line level inputs (RCA) to signal generator and UUT. Use Y-cable if necessary from mono source. VOLUME control should be full counterclockwise.
2. Turn on generator, adjust to **200mV, 50 Hz**.
3. Plug in UUT; red LED should be ON. Turn VOLUME control full clockwise.
4. LED should turn Green; immediate bass response should be heard and felt from port tube opening.
5. Turn off generator, turn VOLUME control fully counterclockwise, disconnect RCA cables.
6. Connect one pair of speaker cables to both high level input terminals on UUT. Cables should be connected to an integrated amplifier fed by the signal generator.
7. Turn on generator and adjust so that speaker level output is **3.0V, 50 Hz**. Turn VOLUME control full clockwise.
8. Green LED should light, immediate bass response should be heard and felt from the port tube opening.

Sweep Function

1. Follow steps 1-4 above, using a sweep generator as a signal source.
2. Sweep generator from **20Hz to 300Hz**. Listen to the cabinet and drivers for any rattles, clicks, buzzes or any other noises. If any unusual noises are heard, remove driver and test.

Driver Function

1. Remove driver from cabinet; detach + and - wire clips.
2. Check DC resistance of driver; it should be **3.3 ohms**.
3. Connect a pair of speaker cables to driver terminals. Cables should be connected to an integrated amplifier fed by a signal generator. Turn on generator and adjust so that speaker level output is **5.0V**.
4. Sweep generator from **20Hz to 1kHz**. Listen to driver for any rubbing, buzzing, or other unusual noises.

SIMPLE TROUBLESHOOTING

If there is no sound from any of the speakers, check the following:

- Receiver/amplifier is on and a source is playing.
- Powered subwoofer is plugged in and is either in the “On” or “Auto” position.
- Check all wires and connections between receiver/amplifier and speakers. Make sure all wires are connected. Make sure none of the speaker wires are frayed, cut or punctured.
- Review proper operation of your receiver/amplifier. If there is no sound coming from one speaker, check the following:
 - Check the “Balance” control on your receiver/amplifier.

If the system plays at low volumes but shuts off as volume is increased, check the following:

- Check all wires and connections between receiver/amplifier and speakers. Make sure all wires are connected. Make sure none of the speaker wires are frayed, cut or punctured.
- If more than one pair of main speakers is being used, check the minimum impedance requirements of your receiver/amplifier.

If there is low bass output, check the following:

- Make sure the connections to the left and right “Speaker Inputs” have the correct polarity (+ and –).
- Powered subwoofer is plugged in and is either in the “On” or “Auto” position.

If there is no sound from the surround speakers, check the following:

- Check all wires and connections between receiver/amplifier and speakers. Make sure all wires are connected. Make sure none of the speaker wires are frayed, cut or punctured.
- Review proper operation of your receiver/amplifier and its surround sound features.
- Receiver mode must be in Dolby Pro logic, Dolby Digital, or any other mode that creates a surround-sound effect. Even under normal operation, when viewing movies and television, surround sound is not present at all times at a high volume - only when the program has chosen to send information there.

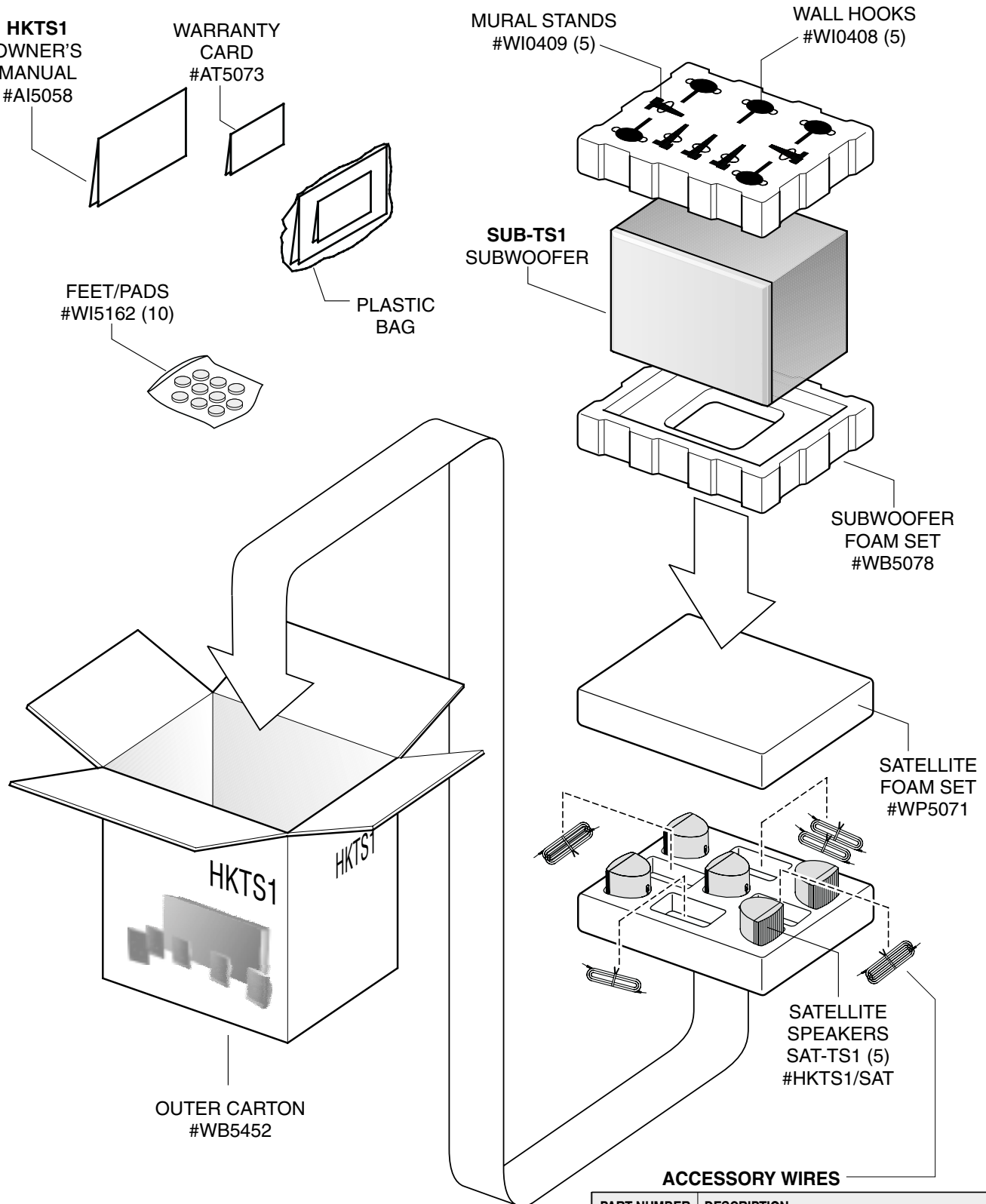

OPTIONAL SAT-TS1 SPEAKER STANDS: FSTS1

PART NUMBER	DESCRIPTION
SAL5010	Right, Left & Center cables (1 pack, 3 pairs)
SAL063-1	High level input cables (3 pack, 1 pair each)
SAL5009	Surround cables (2 pack, 1 pair each)

SUB-TS1 EXPLODED VIEW

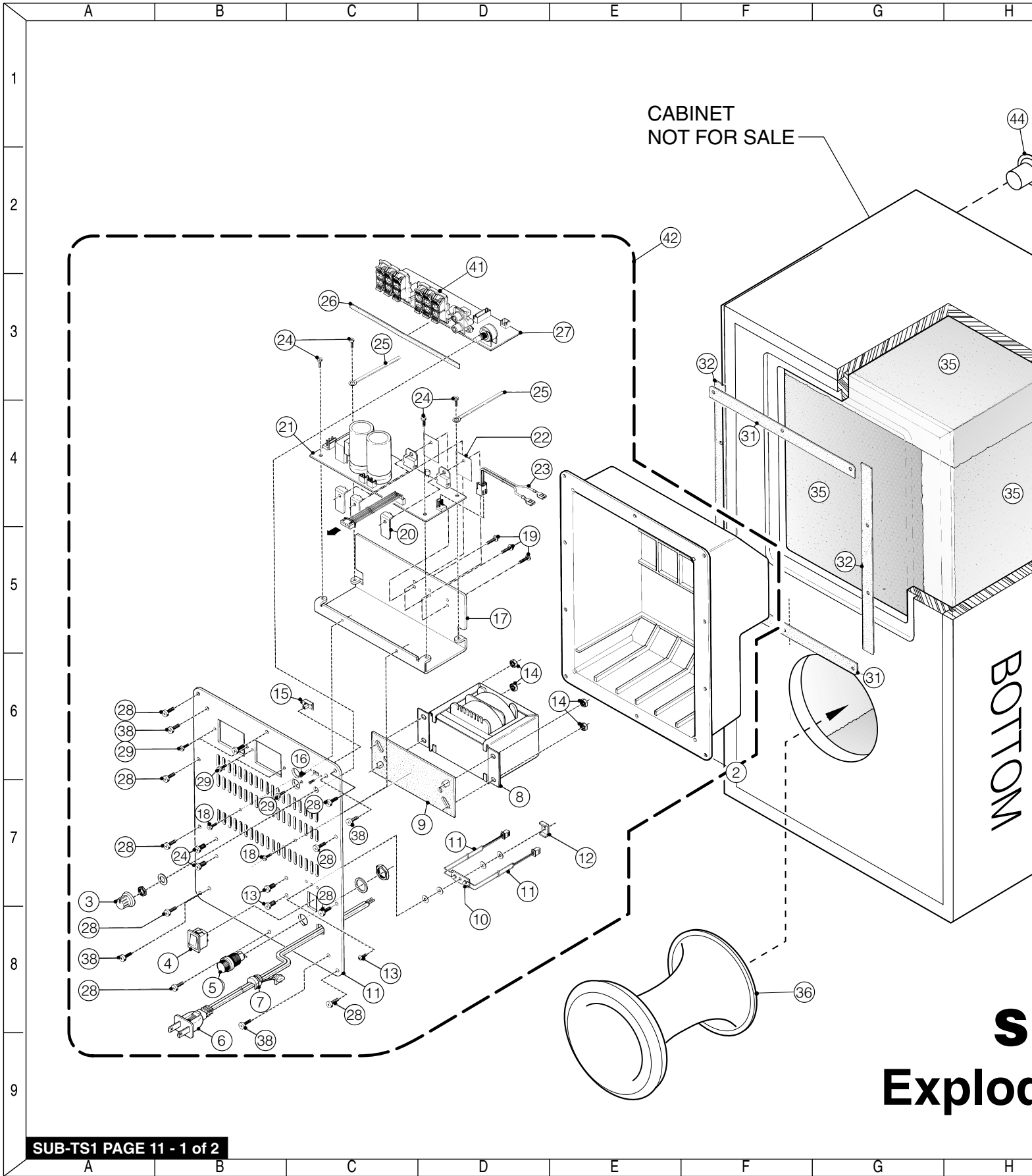

SUB-TS1 EXPLODED VIEW

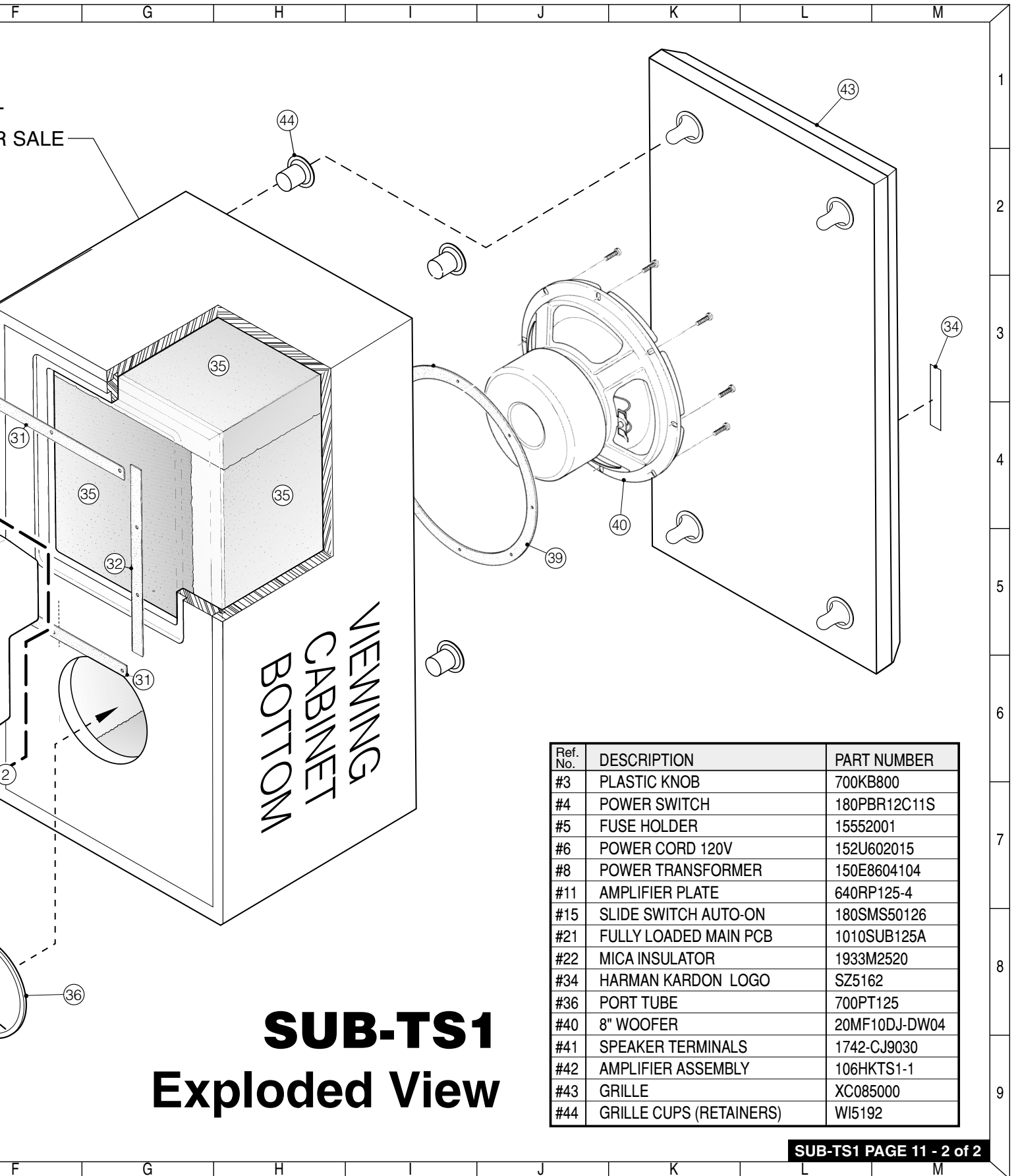

SUB-TS1
Exploded View

SUB-TS1 PCB COMPONENT SIDE

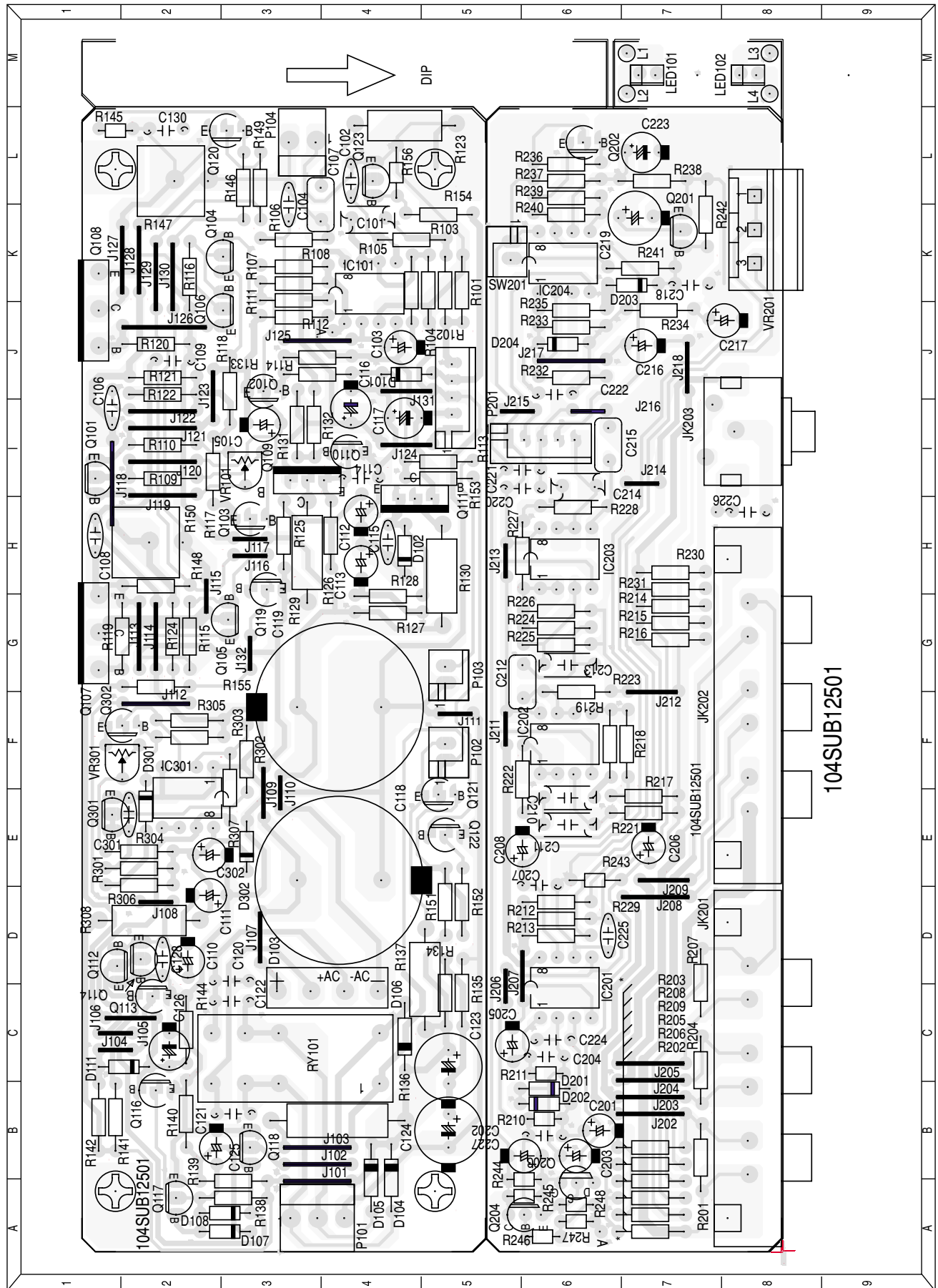

SUB-TS1 PCB SOLDER SIDE

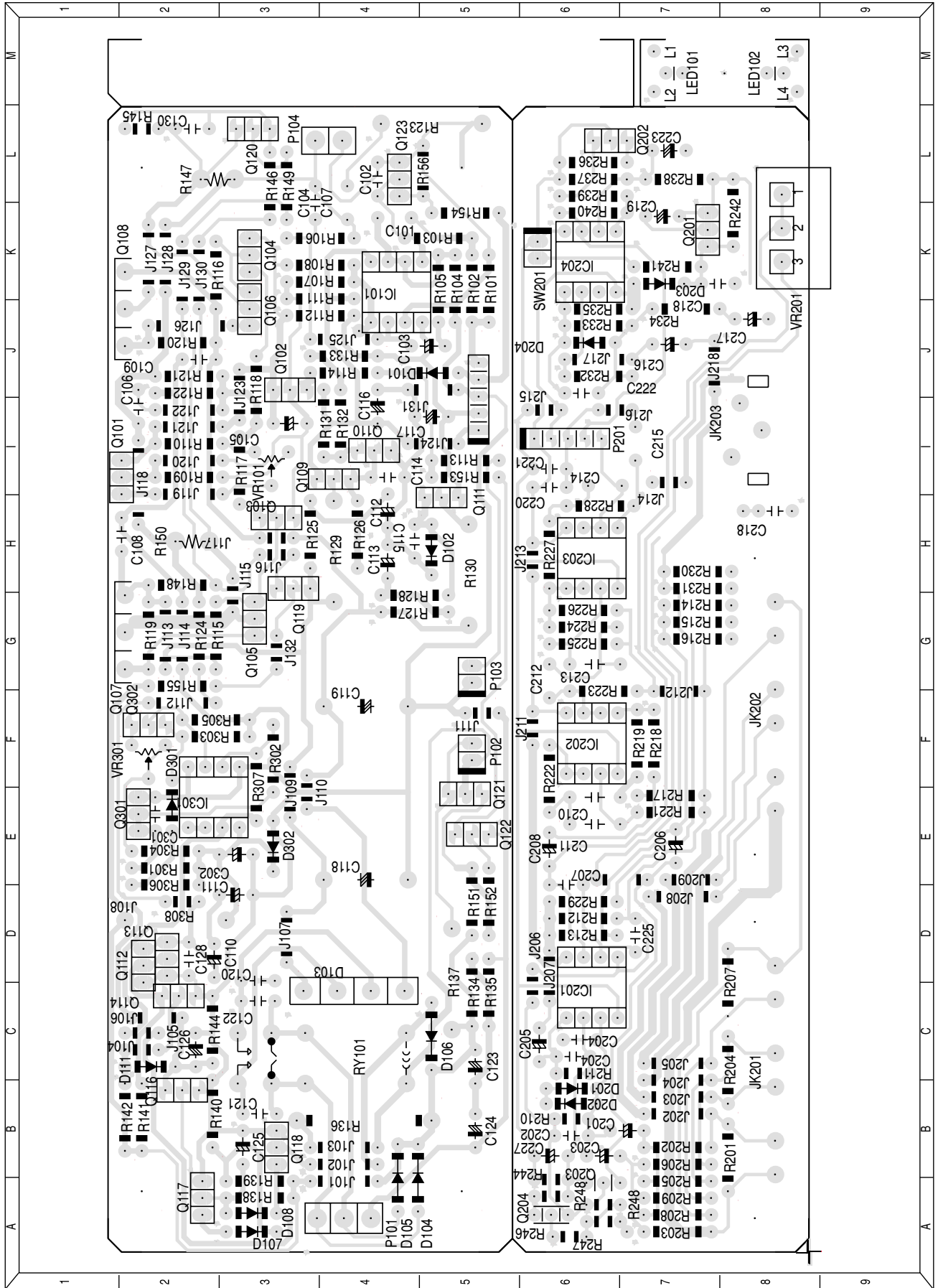

SUB-TS1 ELECTRICAL PARTS LIST

REF #	PART #	DESCRIPTION	QTY	REF #	PART #	DESCRIPTION	QTY
Capacitors				R106, 124, 134, 135, 141, 142, 144, 155, 229, 230, 231, 232, 302	11014473J52	RESISTOR 47K 1/4W +5%	13
C101	132334J504	MYLAR CAP. 0.33U/50V +5%	1	R107, 108, 125, 127, 145, 148	11014332J52	RESISTOR 3.3K 1/4W +5%	6
C102, 215	132223J504	MYLAR CAP. 0.022U 50V +5%	2	R109	116144751F26	PRECISION RESISTOR 4.75K 1/4W+1%	1
C103, 110, 111, 112, 113, 201, 203	1353226M50	ELECT. CAP. 22U/50V +20%	7	R110	116143821F26	PRECISION RESISTOR 3.82K 1/4W+1%	1
C104	1302B150K503	DISK CAP. 15PF 50V +-10% TAP	1	R111, 112	11014392J52	RESISTOR 3K9 1/4W +5%	2
C105, 216	1353105M50	ELECT. CAP. 1U/50V +20%	2	R113	11014222J52	RESISTOR 2.2K 1/4W +5%	1
C106, 202, 204, 222	1302B221K503	DISK CAP. 220P 50V +-10%	4	R114, 131, 133, 140, 213, 214, 215, 224	11014153J52	RESISTOR 15K 1/4W +5%	8
C107, 212, 213	132104J504	MYLAR CAP. 0.1U/50V +5%	3	R115, 116	11014221J52	RESISTOR 220OHM 1/4W +5%	2
C108, 109, 114, 115, 128, 130, 218, 220, 221, 301	1302F104Z503	DISC CAPACITOR 0.1U 50V +20/-20%	10	R117, 118	11014470J52	RESISTOR 470OHM 1/4W +5%	2
C116, 117, 126, 223, 302	1353107M16	ELECT. CAP. 100U/16V +-20%	5	R119, 120	11014101J26	RESISTOR 100OHM 1/4W +5%	2
C118, 119	1354688M50	ELECT. CAP. 6800U/50V +-20%	2	R121, 304	11014682J52	RESISTOR 6K8 1/4W +5%	2
C120	132333J504	MYLAR CAP. 0.033U/50V +5%	1	R122	11014331J52	RESISTOR 330OHM 1/4W +5%	1
C121, 122	132103J504	MYLAR CAP. 0.01U 50V +5%	2	R123	11012100J52	RESISTOR 100OHM 1/2W +5%	1
C123, 124	1353107M50	ELECT. CAP. 100U/50V +-20%	2	R129, 130	11010561J15	RESISTOR 560OHM 1W +5%	2
C125	1354476M25	ELECT. CAP. 47U/25V +-20%	1	R132	11014182J52	RESISTOR 1K8 1/4OHM +5%	1
C127	1302G472MD00	DISC CAPACITOR 4700P 400V +-20%	1	R136	11020102J20	RESISTOR 1K 26W +5% CF 20MM	1
C205, 206, 208, 217	1353106M50	ELECT. CAP. 10U/50V +-20%	4	R137	11012272J52	RESISTOR 1/2W +5%	1
C207	130S1101K503	DISC CAP. 100P 50V +350/-1000	1	R138, 139, 149, 151	11014333J52	RESISTOR 33K 1/4W +5%	4
C214	132473J503	MYLAR CAP. 0.047U/50V +5%	1	R147, 150	11350R22J20	CERAMIC RESISTOR 0.22OHM 5W	2
C219	1354227M16	ELECT. CAP. 220U/16V +-20%	1	R152	11014123J52	RESISTOR 12K 1/4W +5%	1
Diodes				R153, 154, 238, 241, 242,	11014223J52	RESISTOR 22K 1/4W +5%	5
D101, 108, 111, 201, 202, 203, 301	197131N4148	DIODE IN4148 52MM	7	R156	11016103J52	RESISTOR 10K 1/6W +5%	1
D102, 107	19915001503	ZENER DIODE 15V 1/2W 52MM	2	R201, 204, 207 303, 305	11014472J52	RESISTOR 4K7 1/4W +5%	5
D103	19700KB1405	BRIDGE DIODE 4A 500V KBL405	1	R202, 203, 205, 206, 208, 209	11014913J52	RESISTOR 91K 1/4W +5%	6
D104, 105, 106	197131N4004	DIODE IN4004	3	R216, 235	11014102J26	RESISTOR 1K 1/4W +5%	2
D204	1991500333	ZENER DIODE 3.3V 1/2W 52MM	1	R225	11014124J52	RESISTOR 120K 1/4W +5%	1
D302	19915000623	ZENER DIODE 6.2V 1/2W 52MM	1	R227	11014273J52	RESISTOR 27K 1/4W +5%	1
Integrated Circuits				R228	11014513J52	RESISTOR 51K 1/4W +5%	1
IC101, 201, 203, 204	19006M4558D	I.C. OPA 4558D OP-AMP	4	R233	11014154J52	RESISTOR 150K 1/4W +5%	1
IC301	190161M311N	I.C. LM311 COMPARATOR	1	R234	11014151J52	RESISTOR 150OHM 1/4W +-5%	1
Resistors				R236	11014275J52	RESISTOR 2.7M 1/4W +5%	1
R101, 102, 104, 146, 210, 211, 212, 217, 226, 237	11014103J52	RESISTOR 10K 1/4W +5%	10	R239	11014104J52	RESISTOR 100K 1/4W +5%	1
R103	11014183J52	RESISTOR 18K 1/4W +5%	1	R240	11014106J52	RESISTOR 10M 1/4W +5%	1
R105, 126, 128	11014272J52	RESISTOR 2K7 1/4W +5%	3	R301	11014562J52	RESISTOR 5K6 1/4W +5%	1
				R306	11014911J52	RESISTOR 910OHM 1/4W +5%	1
				R307	11014105J52	RESISTOR 1M 1/4W +5%	1
				R308	11010272J15	RESISTOR 2.7K 1W +5%	1
				VR301	11403302M0	TRIMER RESISTOR 3K 0.3W +-20%	1
				VR201	115V503B1	VARIABLE RESISTOR D16 50K/1 A	1

Amplifier/Subwoofer

Harman Kardon

REF #	PART #	DESCRIPTION	QTY	REF #	PART #	DESCRIPTION	QTY
Transistors				Miscellaneous			
Q101, 102, 103, 110, 112, 113, 114, 116, 117, 122, 123, 201, 202, 301	192027C1815GR	2SC1815GR	14	Q107, 108	1933M2520	MICA ISOLATOR TO-3P 25*20MM	1
Q104, 119, 121, 302	192028A1015GR	2SA1015GR	4	LED1	19510204GD	LED GREEN 3MM FOR ON	1
Q105	192028A965Y	2SA965R Y	1	LED2	19510204HD	LED RED 3MM FOR STANDBY	1
Q106, 118	192027C2235Y	2SC2235Y	2	*****	650IH125	IC HOLDER	3
Q107	192022TIP36C	TIP36C	1	FS101	FS1067	FUSE 2.0A 120V 5x20mm	1
Q108	192021TIP35C	TIP35C	1	FS101	154U20006T0	FUSE 1.0A 230V 20MM UL	1
Q109	192201D882Y	KSD882Y	1	*****	15520001	FUSE HOLDER R3-12	1
Q111	192202B772Y	KSB772Y	1	SW101	180PBR12C11S	POWER SWITCH PUSH BR12C11S	1
Q120	192027C2240GR	2SC2240GR	1	*****	180SMS50126	SLIDE SWITCH M50126	1
				*****	700KB800	PLASTICKNOB 46077-W P.V.C.	1
				*****	161506520	JUMPER WIRE 52MM TAP	53
				*****	16210088001	CABLE ASS'Y 2PIN AWG28 80MM	1
				P201	16211508001	WIRE ASS'Y 5PINA ON BOARD 150MM1	
				P102, 3	16213008002	CABLE ASS'Y 2PIN FORLED AWG26 225MM	2
				*****	16210082007	WIRE RED 18AWG 80MM BOTH END TRIPPED AND TINNED	2
				*****	16210302001	"SPEAKER WIRE 300MM, #205 0.5T"	1
				RY101	171UGS2121	RELAYMI-SH-212L	1
				JK203	1740RCB202V	OUTLET RCA JACK RCB-202V	1
				JK201,2	1742CJ9030	SPEAKER TEMINAL 6PIN C.J-9030	2
				P102/A,103/A, SW201	1751C02V1B	CONNECTOR 2PIN PITCH=2.5MM	3
				P201/A	1751C05V01	CONNECTOR 5PIN PITCH=2.5MM	1
				P104/A	1751D02V01	CONNECTOR 2PIN PITCH=3.96MM	1
				P101	1751D03V01	CONNECTOR 3PIN PITCH=3.96MM	1
					150E8604104	POWER TRANSFORMER (120V)	1
					150E8604102	POWER TRANSFORMER (230V)	1
					152U602012	POWER CORD (120V)	1
					152U602015	POWER CORD (230V)	1

SUB-TS1 INTEGRATED CIRCUIT DIAGRAMS

IC301 - LM311 COMPARATOR

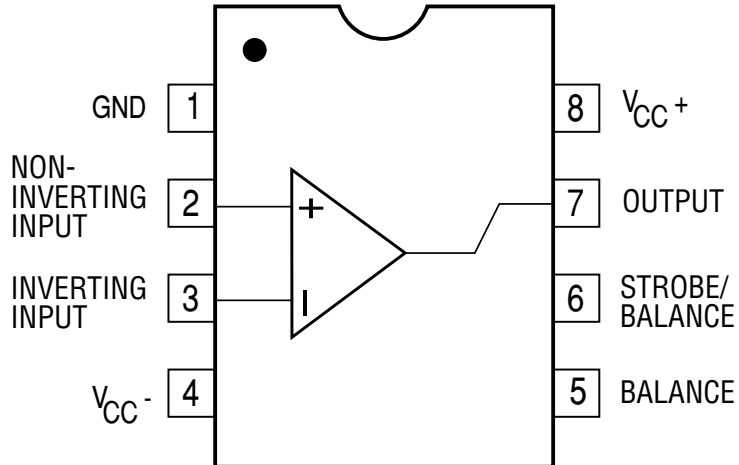

C101, 201, 203, 204 - 4558D OP-AMP

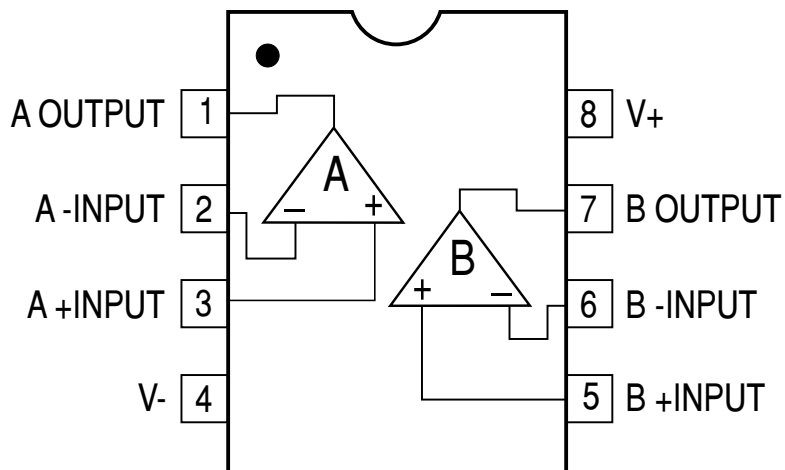

SUB-TS1 POWER AMP SCHEMATIC DIAGRAM

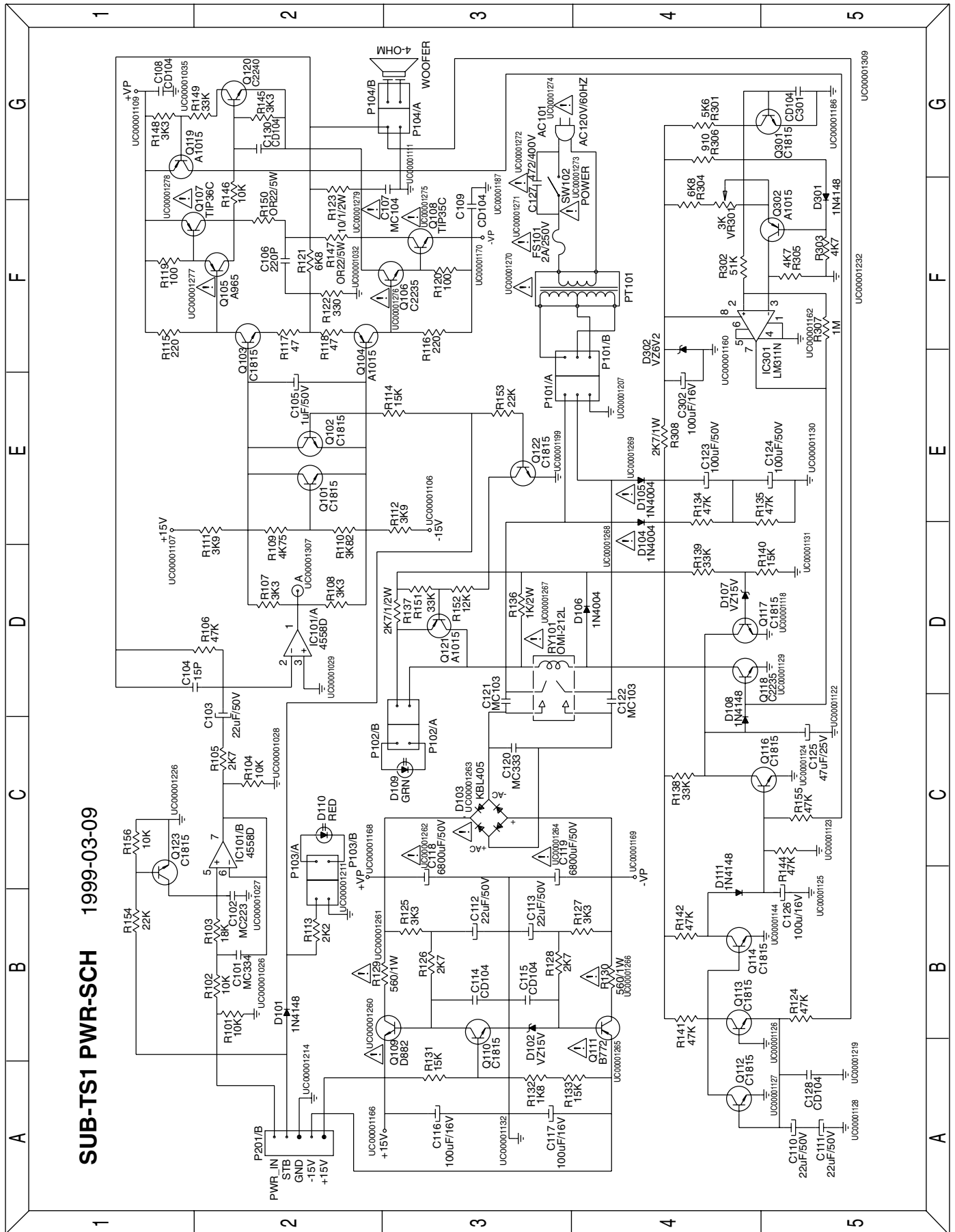

SUB-TS1 PWR-SCH 1999-03-09

SUB-TS1 PRE-AMP SCHEMATIC DIAGRAM

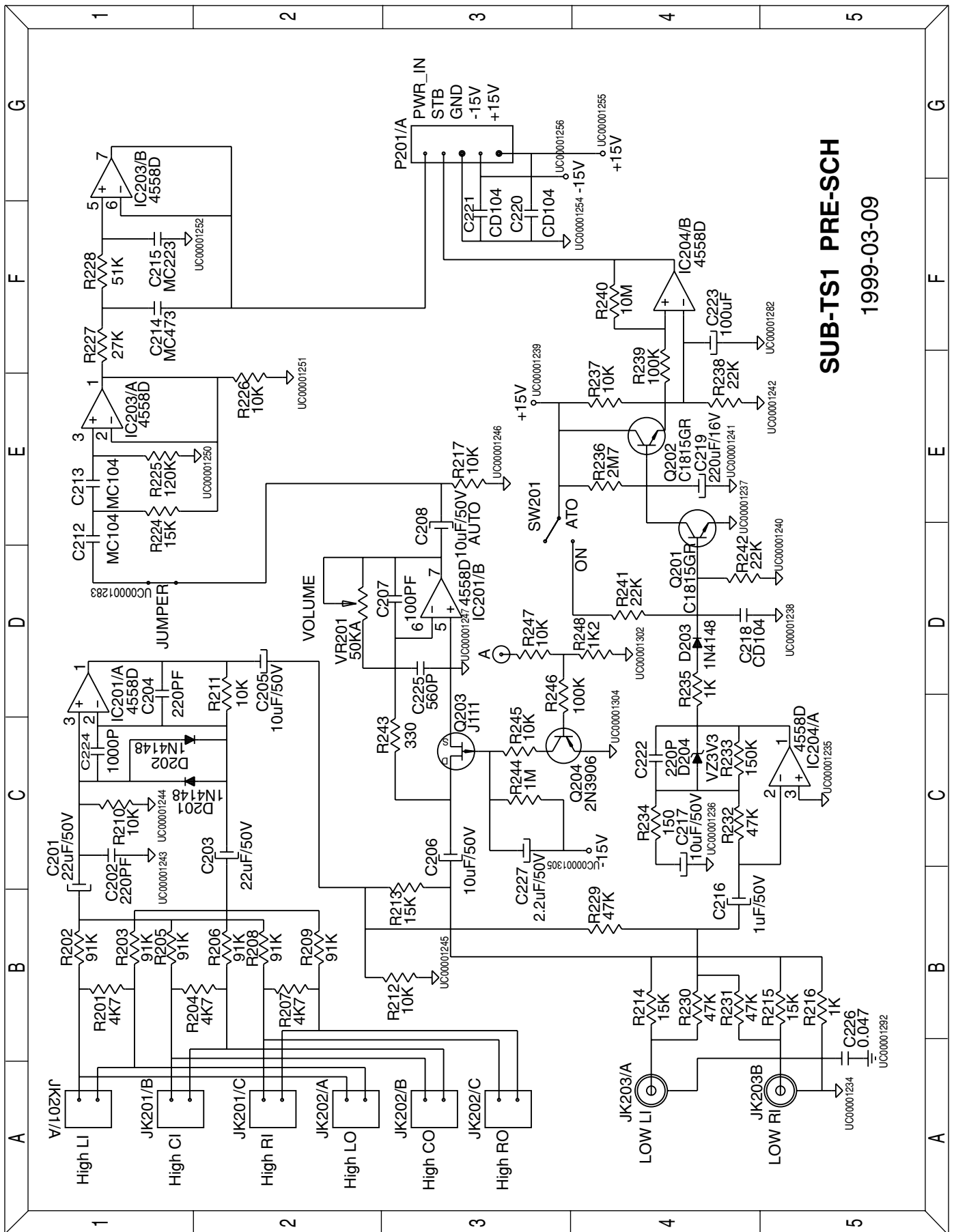

SUB-TS1 PRE-SCH
1999-03-09