

harman/kardon

Signature 1.5

Two Channel Amplifier

TECHNICAL MANUAL



Harman Consumer Group
250 Crossways Park Drive
Woodbury, N.Y. 11797
1-800 645-7484 in the USA

H A Harman International Company

Part No.: 1112-SIGNATURE1.5 Rev A 7/99

TABLE OF CONTENTS

SPECIFICATIONS.....1	Signature 1.5 PACKING EXPLODED VIEW9
Signature 1.5 FRONT PANEL CONTROLS.....2	Signature 1.5 POWER SWITCH/INDICATOR PCBs10
FEATURES2	Signature 1.5 POWER AMPLIFIER PCB Rev B.....11
REAR PANEL CONNECTIONS.....3	Signature 1.5 Electrical Parts List12
INSTALLATION.....4	Signature 1.5 (120V) TRANSFORMER WIRING Rev A.....14
OPERATION6	Signature 1.5 (120V) TRANSFORMER WIRING Rev B.....15
IDLE CURRENT ADJUSTMENT FOR SIGNATURE 1.5.....6	Signature 1.5 (230V) TRANSFORMER WIRING Rev A.....16
OUTPUT TRANSISTOR REPLACEMENT6	Signature 1.5 (230V) TRANSFORMER WIRING Rev B.....17
ON THE SIGNATURE 1.5	INTEGRATED CIRCUITS18
TROUBLE SHOOTING.....7	Signature 1.5 POWER SWITCH/INDICATOR.....19
PROTECT MODE7	SCHEMATIC (1 of 1)
Signature 1.5 MECHANICAL EXPLODED VIEW.....8	Signature 1.5 POWER AMP SCHEMATIC (1 of 2)20
Signature 1.5 MECHANICAL PARTS LIST.....9	Signature 1.5 POWER AMP SCHEMATIC (2 of 2)21

SPECIFICATIONS

Power Requirements:

120V version: 120VAC, 50/60Hz

230V version: 230VAC, 50Hz

Power Output: 2 x 200 watts @8 ohms
 20Hz - 20kHz, <0.03% THD, Both Channels Driven
 1 x 700watts @ 8 ohms
 20Hz - 20kHz, <0.03% THD, Bridged Mono Mode
 2 x 350 watts @ 4 ohms
 20Hz - 20kHz, <0.03% THD, Both Channels Driven

High-Current Capability: 130 Amps

Frequency Response: <1Hz - >170kHz \pm 3dB

Power Bandwidth: <5Hz - >160kHz

THD/IMD: <0.03% at rated output

Crosstalk >-87 dBr between any two channels at maximum output

Negative Feedback: <25dB

Input Impedance: 33K ohms

Input Sensitivity: 1 volt for rated output

Remote Trigger Voltage: 6 - 12 volts DC (tip of plug must be "positive"(+))

Remote Trigger Impedance: 20K ohms

Dimensions (H x W x D): 7 ½ x 17 ¼ x 15 ¼ inches
 191 x 438 x 387 mm

Weight: 47 lbs/21 kg

FEATURES

The Harman Kardon Signature 1.5 is a flexible, state-of-the-art audio power amplifier designed to deliver high performance for use in home theater or music reproduction applications. The following are among its many features:

- Designed and manufactured in the United States
- High-current output capability
- Two channels with bridgeable outputs
- Ultrawide bandwidth design
- Low negative feedback
- Low harmonic and intermodulation distortion
- Massive heat sinks for quiet convection cooling
- High-current power supply
- Remote turn-on/turn-off circuitry with select Signature Series and Harman Kardon products or through optional accessories.

Signature 1.5 FRONT PANEL CONTROLS

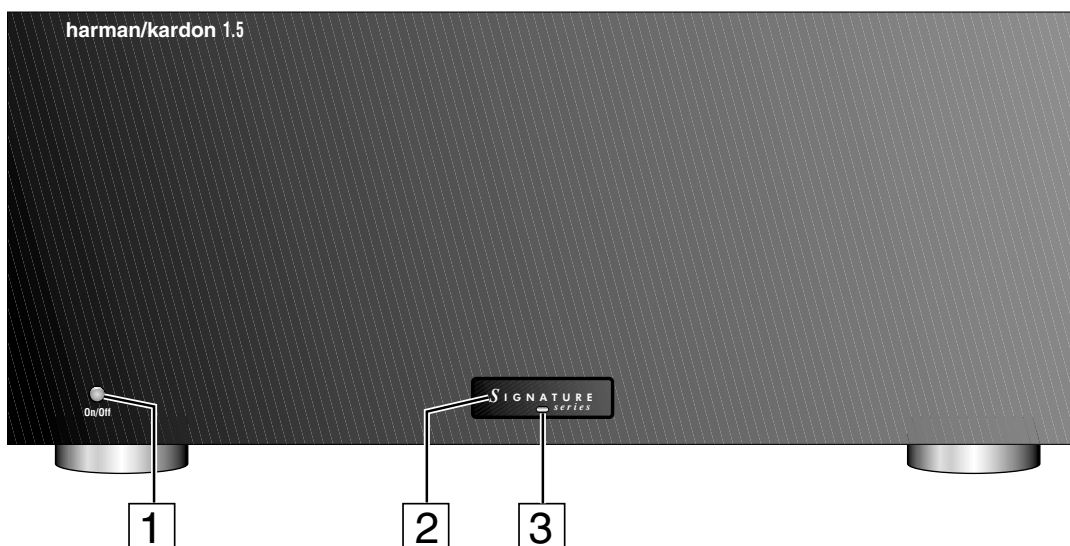

1 Power Switch: Press this switch to turn the 1.5 on for manual operation, or to place it in the Standby mode for automatic/remote turn-on when the 1.5 is connected to a device with a compatible trigger circuit.

Note: Even when the Power Switch is off, the unit is still connected to the AC power supply.

2 Power-On Indicator: When the word SIGNATURE is illuminated in blue, the 1.5 is in a normal operating condition.

3 LED Indicator: The color of this indicator varies with the status of the 1.5. It is red when the unit is off and in Manual Operation, amber in the Standby mode, and flashing green during Warm-Up. If the indicator flashes and alternates between red and amber, the 1.5 is in the Protect mode, indicating a problem in the unit or connections to the speakers.

REAR PANEL CONNECTIONS

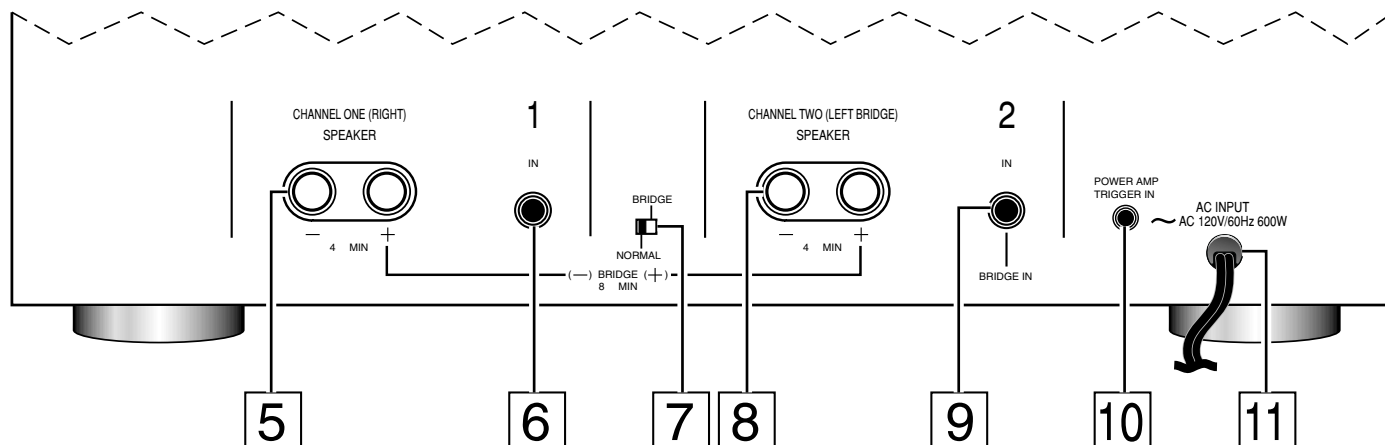

5 Channel One Output: When the amplifier is being used in the two-channel (Stereo) mode, connect the right channel speaker to the positive (+) and negative (-) terminals. When the amplifier is being used in the Bridged Mono mode connect the Positive (+) terminal ONLY to the Negative (-) terminal on your speaker.

6 Channel One Input: When the amplifier is being used in the two-channel (Stereo) mode, connect the right channel output of your preamp or processor to this input jack. When the amplifier is being used in the Bridged Mono mode, this jack is not used.

7 Bridge/ Normal Switch: When the amplifier is used for two-channel stereo operation, this switch should be in the NORMAL position. For Bridged Mono use only, place the switch in the BRIDGE position.

8 Channel Two Output: When the amplifier is being used in the two-channel (Stereo) mode, connect the left channel speaker to the positive (+) and negative (-) terminals.

When the amplifier is being used in the Bridged Mono mode connect the Positive (+) terminal ONLY to the Positive (+) terminal on your speaker.

Important Note: When the 1.5 is used in the Bridged Mono mode, do not connect a speaker with an impedance less than 8 ohms.

9 Channel Two/ Bridged Input: When the amplifier is being used in the two-channel (Stereo) mode, connect the left channel output of your preamp or processor to this input jack. When the amplifier is being used in the Bridged Mono mode, connect the output of your preamplifier or other line-level signal source to this jack.

10 Power Amp Trigger Input: Connect this jack to a matching 6- to 12-VDC trigger output on a compatible device to have the 1.5 automatically turn on from the Standby mode when voltage is applied from the triggering unit. Note that a 3.5mm mono mini-plug with a positive tip should be used for the connection.

11 AC Power Cord: Connect this plug to a non-switched AC outlet. Due to the high-current draw of the Signature 1.5, it is NOT recommended that the accessory outputs on the back of audio/video components be used to power this product.

INSTALLATION

Note: When making any connections between source components, processors or preamplifiers and the 1.5, or when making any connections to speakers, be certain that both the input device and the 1.5 are turned off. To ensure that there will be no unwanted signal transients that can damage equipment or speakers, it is always best to unplug all equipment from AC power outlets before making any connections. Modern electronic products often have a “standby” mode that may be activated even though the product may appear to be turned off.

Power Control Connections

The Signature Series 1.5 amplifier features a built-in remote turn-on system that will automatically turn on the amplifier when another device in the system is switched on. To activate this system, this amplifier must be used in conjunction with compatible Signature Series or Harman Kardon products or other approved devices.

Note: Before making any connections to remote trigger outlets, it is critical that both the 1.5 and the triggering device be turned off. For additional safety, it is best that these connections be made while both products are unplugged from AC power sources.

Remote Turn-On with the Signature Series 2.0 and Compatible Harman Kardon Products

Connect one end of the accessory cable supplied with the 2.0 to the **Power Amp Trigger In** jack **10** on the rear of the 1.5. Connect the other end to the TRIGGER OUTPUT jack on the 2.0.

Remote Turn-On Using an External AC-to-DC Converter

If the 1.5 is not used with a compatible Harman Kardon product, it is still possible to activate the unit for automatic turn-on.

To control the amplifier in this manner you will need a small UL/CSA-approved class-2 AC-to-DC power converter capable of delivering a 6- to 12-volt DC signal. The DC voltage should terminate in a standard 3.5 mm mono miniplug, with the tip of the plug “positive” (+). This type of converter may be obtained as a “Power Adapter” from many electronics retailers. Consult your dealer for further information.

Plug the AC adapter into a switched outlet that will be activated when you wish to have the amplifier turn on. This may be the switched outlet at the rear of an AV receiver or other audio equipment, an AC outlet that is part of a current sensing control unit activated by a pre-amp or surround processor or a switched AC wall outlet.

Connect the 3.5 mm miniplug from the power converter to the **Power Amp Trigger In** jack **10** on the rear of the 1.5.

Audio System Connections

As a general rule, avoid running any input signal or speaker wire connections next to or parallel with AC power cords. This may cause undesired hum or other interference that will greatly degrade signal performance.

When making input connections with RCA-type plugs on interconnect cables, make certain to gently but firmly insert the plugs into the jacks on the rear of the 1.5. Loose connections can cause intermittent sound and may damage your speakers.

Input Connections

Stereo Mode: For conventional two-channel stereo operation, connect the right channel output of your pre-amp or processor to the **Channel One Input** **6** and the left channel output to the **Channel Two Input** **9**. Make certain that the **Bridge/ Normal Switch** **7** is in the NORMAL position.

Bridged Mono Mode: To use the 1.5 as a single-channel, mono amplifier, connect the line-level output of your preamp, processor or other signal source to the **Channel Two/ Bridged Input** connector **9** on the rear panel. No connection is required to the Channel One connector in this mode. Make certain that the **Bridge/ Normal Switch** **7** is in the BRIDGE position.

Output Connections

The final step of the installation process is to connect the amplifier to your speakers using high-quality cable. A pair of binding posts is provided for each channel output. These posts will accept bare wire or banana-type plugs. To ensure that the high-quality signals produced by the 1.5 are carried to your speakers without loss of clarity or resolution, we recommend that you use high-quality speaker cable. Many brands of cable are available, and the choice of cable may be influenced by the distance between your speakers and the amplifier, the type of speakers you use, personal preferences and other factors. Your dealer or installer is a valuable resource to consult in selecting a proper cable for connections between your amplifier and speakers.

Regardless of the brand or type of cable selected, we recommend that you use a cable constructed of high-strand-count copper with a gauge of 14 or smaller. When specifying cable, remember that the smaller the number, the thicker the cable.

Cable with a gauge of 16 may be used for short runs of less than ten feet. We do not recommend the use of cables with an AWG equivalent of 18 or higher due to the power loss and degradation in performance that will occur.

Cables run inside walls should have the appropriate markings to indicate listing with UL ("CL-2/CL-3"), CSA ("FT-4") or appropriate safety agency standards that may be required in your area. Questions about running cables inside walls should be referred to your installer or a licensed electrical contractor who is familiar with the NEC and/or the applicable building or electrical codes in your area.

Two-Channel/Stereo Systems: When installing a two-channel (stereo) system, connect the positive (+) and negative (-) terminals from the right and left speakers to the matching terminals **5** **8** on the rear panel of the 1.5. Make certain that the **Bridge/Normal Switch** **7** is in the NORMAL position. When the 1.5 is used for two-channel/stereo operation, speakers with an impedance of no less than 4 ohms may be used.

Bridged Mono Applications: To use the 1.5 as a single-channel, mono amplifier, connect the (+) terminal on your speaker to the (+) terminal on the **Channel Two Output** **8** on the 1.5. Connect the negative (-) terminal on your speaker to the positive (+) terminal on the **Channel One Output** **5**.

Note: For mono applications, no connections are made to the negative (-) speaker output terminals on the 1.5. Make certain that the **Bridge/Normal Switch** **7** is in the BRIDGE position.

Important Note: When the 1.5 is used in the Bridged Mono mode, do not use speakers with an impedance of less than 8 ohms.

When making speaker connections, note that one conductor of the speaker cable may have no markings or an indication of (-) for negative polarity, and the other will have a red line, brand-name markings, a colored thread or some other positive-polarity indication (+).

The wire with the positive indication should be connected to the red terminals on both the 1.5 and your speakers. The negative wire should be connected to the black terminal on the 1.5 and the speakers.

If bare wire is used for connections, strip approximately 3/4"(20 mm) of insulation from the end of each wire and carefully twist the strands of each conductor together. Be careful not to cut the individual strands or twist them off; for optimal performance, all strands must be used.

Next, loosen the knobs of the speaker output terminals far enough so that the cap moves back on its threads past the

holes at the rear of the terminal. Making certain that you observe the correct polarity for the type of system being installed (Stereo or Bridged Mono), pass the exposed wire through the hole until the wire is visible from the bottom end. Holding the wire in place, twist the cap back so that the connection is secured. Do not overtighten or use tools, as this may damage the plastic terminal cap or break the delicate wire strands and decrease system performance.

Important Note: When making speaker wire connections, be certain that none of the strands from one lead touch any other lead. This will cause a short circuit and may damage your amplifier or speakers. Damage from short circuits caused in this manner is not covered by the product warranty.

Connections may also be made using spade lugs or standard 4 mm OD banana plugs. Before using a banana-type jack, make certain that the plastic screw caps on the 1.5 are firmly tightened by turning them clockwise until they are snug against the chassis. This will ensure that the maximum surface area of the plug is in contact with the jack. Once the wire has been attached to the banana plug following the plug manufacturer's instructions, simply insert the banana plug into the hole provided on the rear of the colored screw caps on the terminal posts. Be certain to observe proper polarity.

Finally, run the cables to the speaker locations. It is highly recommended that the length of cable connecting any pair of speakers be identical. For example, make certain that the cable length connecting left and right front or left and right rear (surround) speakers is identical, even though one speaker may be physically closer to the amplifier than the other. Do not coil any excess cable, as this may become an inductor that creates frequency response variations in your system.

Connect the wires to the speakers, again being certain to observe proper polarity. Remember to connect the negative or black wire to the matching terminal on the speaker. Similarly, the positive or red wire should be connected to the like terminal on the speaker.

Note: While most speaker manufacturers adhere to an industry standard of using black terminals for negative and red ones for positive, some manufacturers may not adhere to this configuration. To ensure properly phased connections and optimal performance, consult the identification plate on your speaker terminals, or the speaker's manual to verify polarity. If you do not know the polarity of your speaker, ask your dealer or installer for advice before proceeding, or consult the speaker's manufacturer.

OPERATION

The Signature 1.5 may be operated in either a manual or automatic mode. If the unit is being used in a stand-alone operation you should follow the instructions below for Manual Operation. When the Signature 1.5 is connected to another compatible device such as the Signature 2.0 or PT2500 tuner, follow the instructions for Automatic Operation.

Make sure the power switch is in the off position before plugging in the AC power cord. After all the connections have been made to the amplifier's input jacks and speaker terminals, connect the power cord to an AC outlet. Turn on your source component and receiver/processor first; start with a low volume level to protect your speakers.

Manual Operation

The LED indicator should be glowing red if the unit is plugged in. Press the front panel switch to turn the unit on.

The indicator will flash green briefly, and then go out; the front panel will then illuminate to blue.

To turn the unit off, press the power switch again. The LED indicator will return to red.

Automatic Operation

Before proceeding, make certain the connection between the Signature 2.0, PT2500, or other trigger source has been connected properly to the unit following the previous directions. At this point the trigger source should be off.

After all cables are connected and the Signature 1.5 is plugged in, the LED Indicator should be glowing red. Press the power switch and the indicator will turn amber indicating the unit is in the standby mode and ready to turn on when it receives a signal from the triggering device. Finally, turn on your Signature 2.0, PT2500, or other trigger source to turn the Signature 1.5 on.

The indicator will flash green briefly, and then go out; the front panel will then illuminate to blue.

At the conclusion of your listening session, there is no need to turn the Signature 1.5 off manually. When the Signature 2.0, PT2500, or other trigger source is turned off, the Signature 1.5 will return to the standby mode.

Important Note: If you will not be using your audio system for an extended period of time, such as a vacation, we recommend turning the Signature 1.5 off using the power switch.

IDLE CURRENT ADJUSTMENT FOR SIGNATURE 1.5

Locate test points **P4** and **P5**; these are 2 pin female molex connectors (2 total, 1 per channel) on the MAIN AMPLIFIER PCB near the speaker terminals.

Attach a DC voltmeter (set to a low range) to these points. This is best accomplished by making up a "test plug" using a male molex connector that fits into the one in the unit, with wires attached, for connection to the voltmeter. An alternate method is to use two "mini-grabbers" to attach to the two outer pins on each connection. Warning: Do not accidentally short the two points together with a meter probe during adjustment.

Adjustment Points: R60, R69

Adjust to 18mv across test points, one channel at a time, until both channels comply.

OUTPUT TRANSISTOR REPLACEMENT ON THE SIGNATURE 1.5

- 1) Remove the top cover.
- 2) Remove all molex connectors on the main amplifier board.
- 3) Remove the (4) outer screws holding the heatsink plate to the chassis.
- 4) Remove all outer Philips screws holding both speaker terminals and RCA connectors to the rear panel.
- 5) Angle and lift the entire amplifier assembly and heatsink up and out of the chassis.

PROTECT MODE

Input/Output Protection

Under some conditions, such as a shorted speaker wire, DC voltage on an input connection or thermal overload, the amplifier will place itself in a “protect mode” to prevent damage to the amplifier. When this happens, the LED Power Indicator will flash and alternate between red and amber.

When this occurs, **IMMEDIATELY** turn off the unit using the power switch and correct the problem. Then turn the unit back on. If the unit continues to go into protect mode, contact your dealer or installer for assistance.

TROUBLE SHOOTING

The items listed below are a brief guide to minor problems that may arise with audio equipment such as the Signature 1.5. Before taking a unit in for service, you should check to see if any of these hints solve the problem. If these solutions do not rectify the problem or if the problem recurs, contact your dealer or an authorized Harman kardon service depot for assistance.

PROBLEM	DIAGNOSIS	TROUBLESHOOTING HINTS
Amplifier will not turn on.	<ul style="list-style-type: none"> ■ Power Switch turned off. (No Power Light LED) ■ Remote trigger cable not properly connected. 	<ul style="list-style-type: none"> ■ Turn on Power Switch ■ Verify connection of trigger cable at both ends
Amplifier turns on, but no audio From One or more channels	<ul style="list-style-type: none"> ■ Inputs not connected to proper jack. ■ Speakers not connected Properly. ■ Improper settings or output levels from processor or Controller. 	<ul style="list-style-type: none"> ■ Check input connections. ■ Check speaker connections. ■ Check the settings on your preamp, processor or controller.
Audio plays, then cuts off.	<ul style="list-style-type: none"> ■ Amplifier shorted (LED flashes amber and red). 	<ul style="list-style-type: none"> ■ Check speaker connections for Short circuit.

Signature 1.5 MECHANICAL EXPLODED VIEW

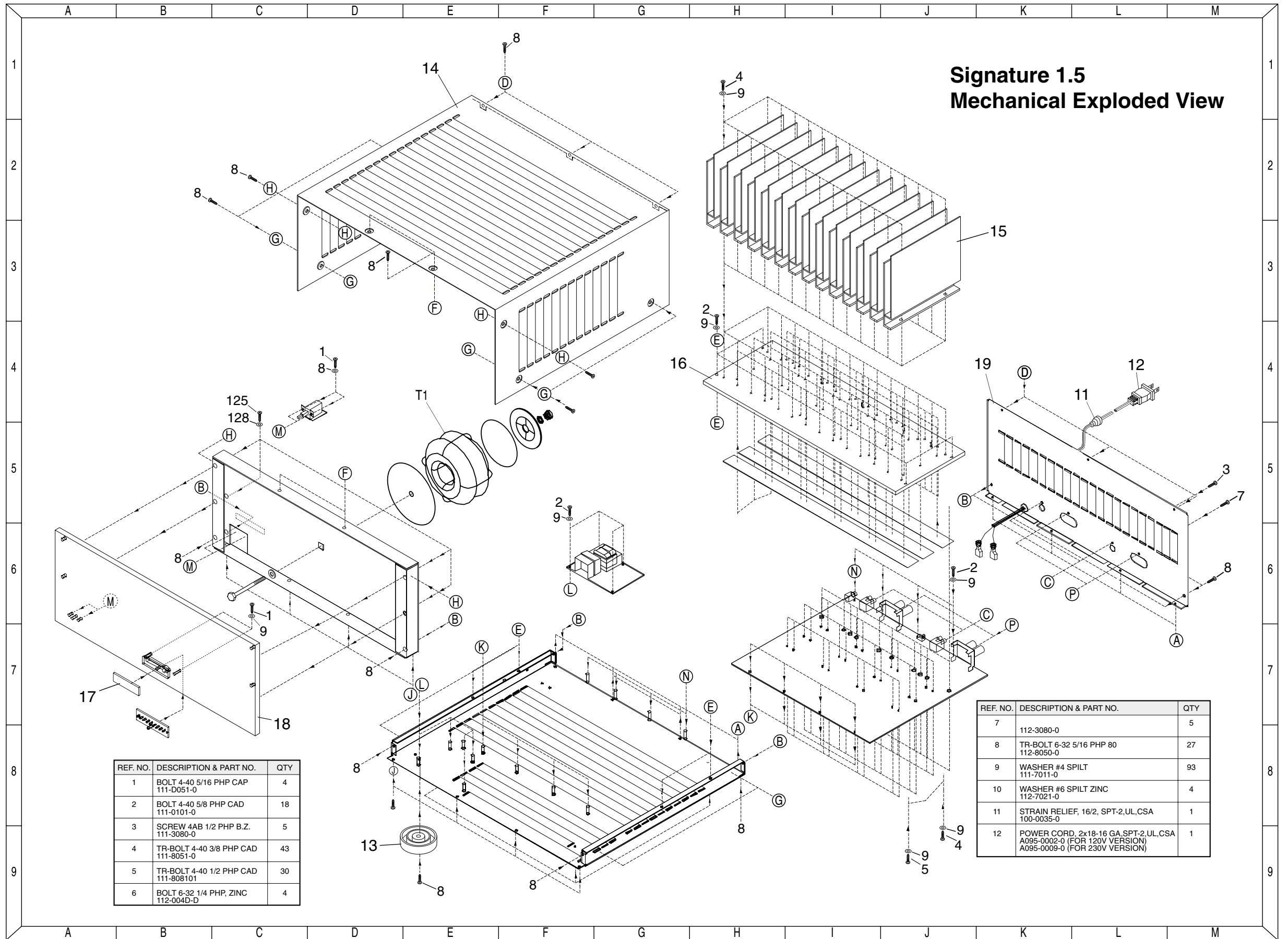

Signature 1.5
Mechanical Exploded View

REF. NO.	DESCRIPTION & PART NO.	QTY
1	BOLT 4-40 5/16 PHP CAP 111-D051-0	4
2	BOLT 4-40 5/8 PHP CAD 111-0101-0	18
3	SCREW 4AB 1/2 PHP B.Z. 111-3080-0	5
4	TR-BOLT 4-40 3/8 PHP CAD 111-8051-0	43
5	TR-BOLT 4-40 1/2 PHP CAD 111-808101	30
6	BOLT 6-32 1/4 PHP, ZINC 112-004D-D	4

REF. NO.	DESCRIPTION & PART NO.	QTY
7	112-3080-0	5
8	TR-BOLT 6-32 5/16 PHP 80 112-8050-0	27
9	WASHER #4 SPILT 111-7011-0	93
10	WASHER #6 SPILT ZINC 112-7021-0	4
11	STRAIN RELIEF, 16/2, SPT-2,UL,CSA 100-0035-0	1
12	POWER CORD, 2x18-16 GA,SPT-2,UL,CSA A095-0002-0 (FOR 120V VERSION) A095-0009-0 (FOR 230V VERSION)	1

Signature 1.5 MECHANICAL PARTS LIST

Ref. #	Part #	Description	Qty			
				112-7001-0	WASHER, #6, FLAT, CAD	4
11	100-0008-0	STRAIN RELIEF, SJT, BLK, UL, CSA	1	112-7021-0	WASHER, #6, SPLIT ZINC	4
12	A095-0015-0	CORD, 2X16GA, RND, 8FT, 13A, 250V, DOM	1	112-8050-0	TR-BOLT, 6-32, 5/16, PHP, BO	27
13	101-0002-0	FOOT BLACK ANODIZED/RUBBER GASKET	4	153-0000-0	TIE WRAP, BLACK	1
14	HA132-0014-B	SIG 1.5 TOP COVER	1	153-0100-1	SAFETY LABEL(RISK OF FIRE), FAST F	1
15	HA132-0009-A	SIG 1.5, FIN PLATE	28	120-0002-1	ALUM .080, 5052-H32, 6.00X5.15 +/-	1
16	HA132-0016-B	SIG 1.5 SINK PLATE	1	120-0012-0	STEEL, 20 GA.036 EGC 48X120	615
17	HA132-0021-A	LOGO, SIGNATURE SERIES, ACRYLIC	1	HA132-0015-B	SIG 1.5 CROSS BRACE	1
18	HA132-0030-A	SIG 1.5, FRONT PANEL	1	120-0008-0	STEEL, 16 GA.EGC. 48X120	198
19	HA132-0032-B	SIG 1.5 REAR PANEL, 120V	1	129-0003-A	PA5800 SINK PLATE BLANK 16.7000"	1
T1	A080-0025-A	POWER TRANSFORMER 120V	1	HA132-0031-B	SIG 1.5 CHASSIS	1
	A095-0009-0	POWER TRANSFORMER 230V	1	111-6036-0	NUT, PEM, S-440-1 FOR .040 MIN. THK	4
	A095-0500-0	WIRE, 14GA, BLACK, 600V	1	112-6009-0	STANDOFF, SO-6440-24	12
	A095-1002-0	WIRE 25 AWG, BLK, 7 STRAND, UL1061 1	1	120-0019-0	STEEL, 18 GA.EGC .047 48X120 FPR	480
	100-0035-0	CABLE TIE, BLACK, 4"-18 LB	8	120-0019-0	STEEL, 18 GA.EGC .047 48X120 FPR	198
	100-0126-0	HOLDER, CABLE TIE .75" SQUARE, ADHE	5	HA153-0106-0	LABEL, UPC, 120V, SIG 1.5	2
	102-0003-0	BUTTON CAP, LOUDNESS, H/K	1	HA202-0003-A	WIRE ASSY, 26GA, BLK, 9", 2PIN, UL/CSA	1
	105-0005-0	INSULATOR, 9MIL, TO-126, GRY, GREASLE	4	A093-1000-0	HSG, 2MMX2, 26GA, IDC	2
	105-0009-0	INSULATOR TAPE, 3/4"X7 MIL ADHESIVE	4	A095-1002-0	WIRE 26 AWG, BLK, 7 STRAND, UL1061 1	1
	111-0051-0	BOLT, 4-40, 5/16, PHP, CAD	4	HA202-0004-A	WIRE ASSY, 26GA, BLK, 7", 7PIN, UL/CSA	1
	111-0101-0	BOLT, 4-40, 5/8, PHP, CAD.	16	A093-2500-0	HSG, 2MMX7, 26GA, IDC	1
	111-3080-0	SCREW, 4AB, □, PHP, B.Z.	2	A095-1002-0	WIRE 26 AWG, BLK, 7 STRAND, UL1061 1	1
	111-7011-0	WASHER, #4, SPLIT	82	HA202-0005-A	WIRE ASSY, 26GA, BLK, 18.5", 5PIN, UL/	1
	111-8061-0	TR-BOLT, 4-40, 3/8, PHP, CAD	38	A093-1003-0	HSG, 2MMX5, 26GA, IDC	2
	111-8081-0	TR-BOLT, 4-40, □, PHP, CAD	24	A095-1002-0	WIRE 26 AWG, BLK, 7 STRAND, UL1061 1	1
	112-0040-0	BOLT, 6-32, 1/4, PHP, ZINC	4			
	112-3080-0	SCREW, 6AB, □, PHP, B.Z.	2			

Signature 1.5 PACKING EXPLODED VIEW

Ref.#	Part #	Description	Qty			
			50	HA150-0003-A	SIGNATURE 1.5 CARTON	1
			51	HA151-0002-A	SIGNATURE 1.5 FOAM PACK	1
			52	HA160-0001-A	HARMAN WARRANTY SHEET	1
			53	HA160-0002-A	HARMAN CUSTOMER CARD	1
			54	HA160-0005-A	SIGNATURE 1.5 OWNER'S MANUAL	1
			55	150-0089-0	BAG POLY 24X30 3 MIL WITH VENT HO	1
			56	150-0103-0	BAG, PLOY 9"X12"X2MIL CLEAR	1
			57	160-0005-0	GROUNDING SAFETY SHEET	1

Signature 1.5 POWER SWITCH/INDICATOR PCBs

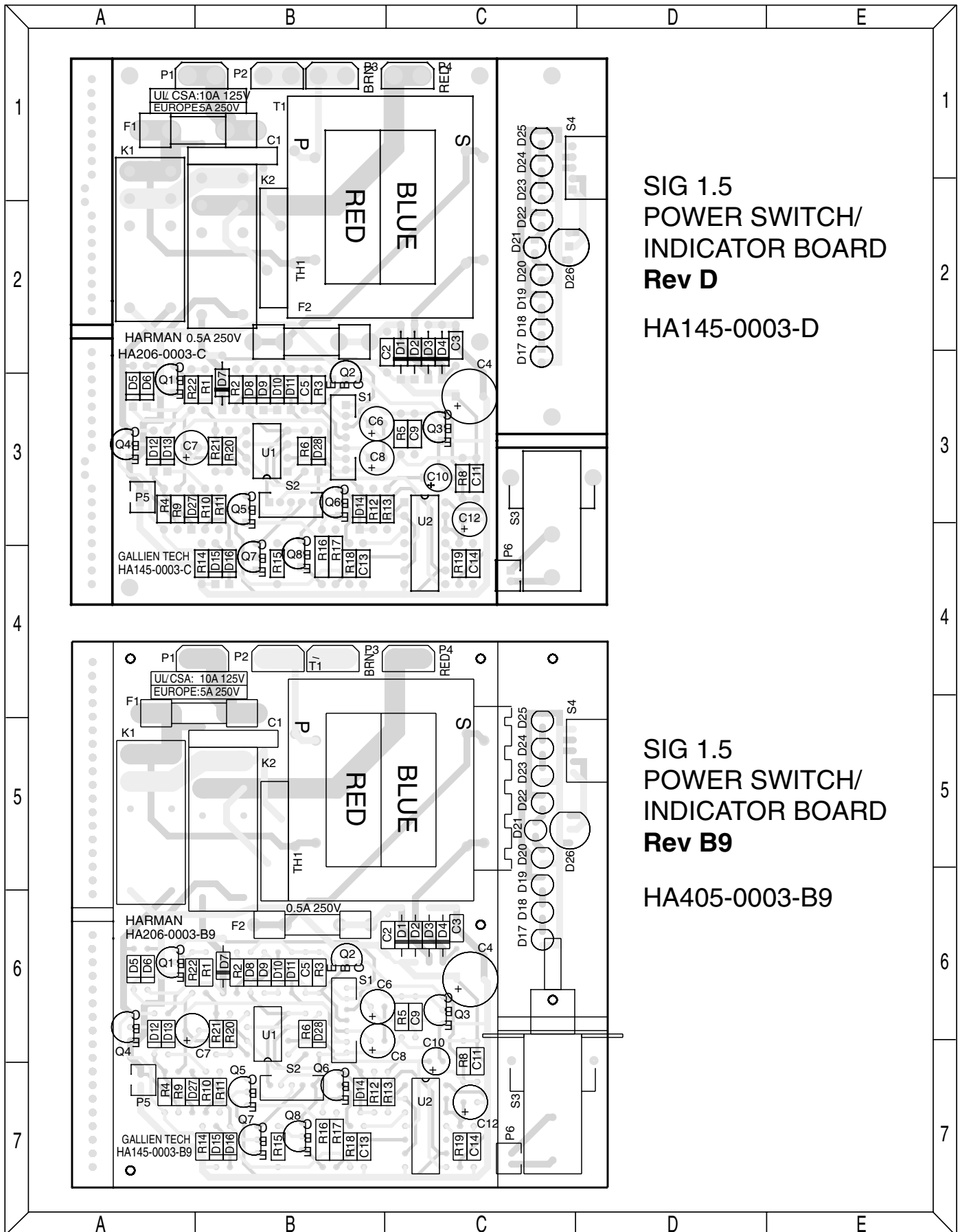

SIG 1.5
POWER SWITCH/
INDICATOR BOARD
Rev D

HA145-0003-D

SIG 1.5
POWER SWITCH/
INDICATOR BOARD
Rev B9

HA405-0003-B9

Signature 1.5 POWER AMPLIFIER PCB Rev B

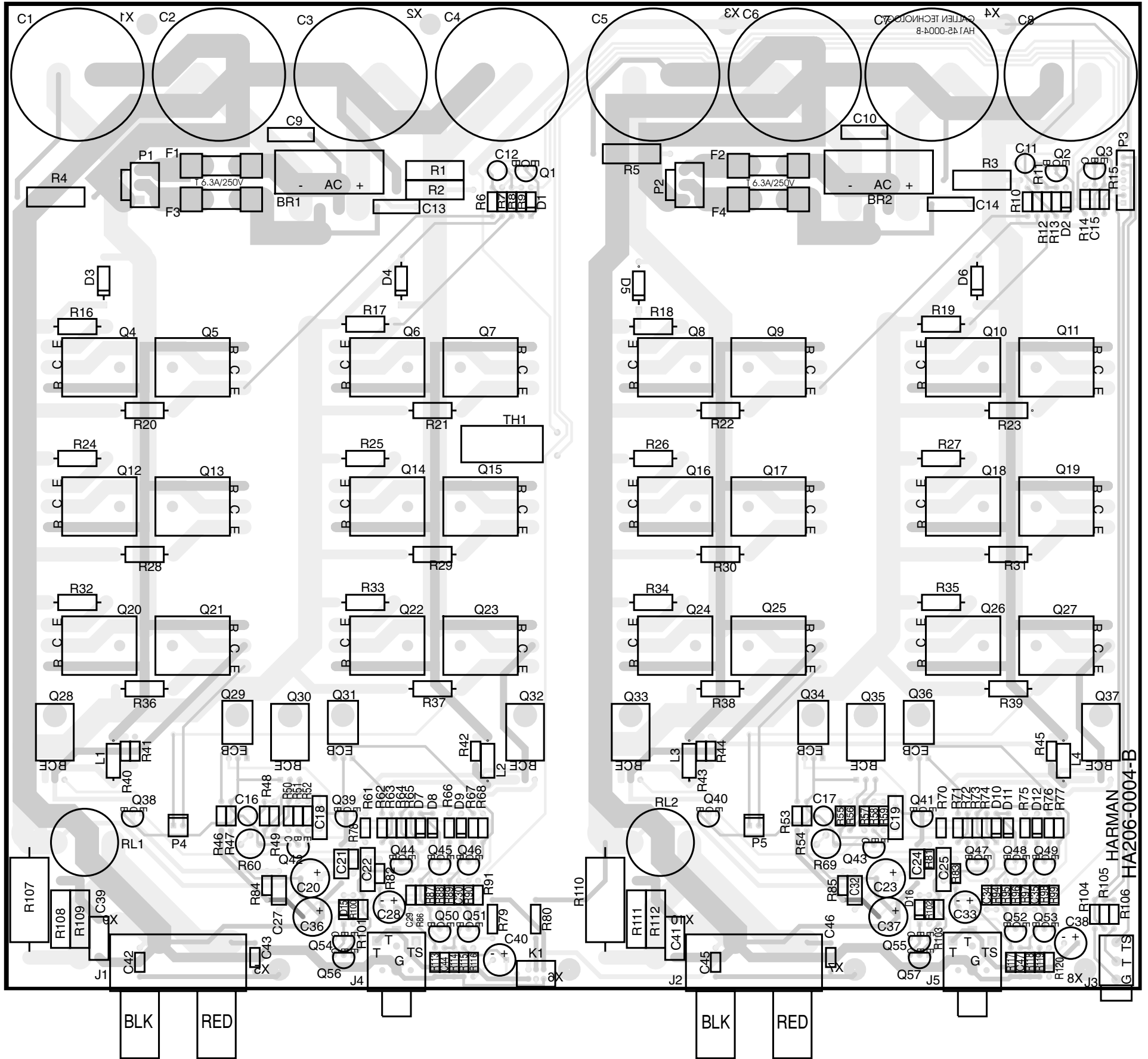

Signature 1.5 Electrical Parts List

POWER SWITCH/INDICATOR BOARD

Ref. #	Part #	Description	Qty.
Fuses			
FUSE1	A091-0007-0	5 x 20mm, 0.5A, 125V, FAST, UL, CSA	1
FUSE2	A091-0011-0	5 x 20mm, 10A, 125V, FAST, UL, CSA	1
Integrated Circuits			
U1	A001-0005-0	LM393N, DUAL COMPARATOR, 8 PIN DI	1
U2	A001-2009-0	LM556CN DUAL TIMER	1
Transistors			
Q1, 5, 6	A010-1013-0	MPSA56 PNP 80V 500MA TO-92	3
Q2, 3, 4, 7, 8	A010-0012-0	MPSA06 NPN 80V 500MA TO-92	5
Q29, 34	A010-0003-0	2SC3502-F, NPN, 200V, 100MA, TO-126	2
Q31, 36	A010-1003-0	2SA1380-F, PNP, 200V, 100MA, TO-126	2
Diodes			
D1, 2, 3, 4, 7	A020-2106-0	1N4004, RECT, 1A, 150V, DO-41	5
D5, 6, 8, 9, 10, 11, 12, 13, 14, 15, 16, 27	A020-1000-0	1N4148, RECT-FAST, 200MA, 100V, 4NS,	12
D17, 18, 19, 20, 21, 22, 23, 24, 25	A025-0030-0	LED, BLUE, T1, .190, 470NM, SMALL	9
D26	A025-0012-0	LED, RED/GRN, 5MM, 630NM/560NM, 15MCD	1
D28	A020-0004-0	1N755A, ZENER, 7.5V, 500MW, DO-35	1
Capacitor			
C1	A034-7103-0	CAP, CERAMIC DISK, .01 F, 10%, X-250V	1
C2, 3, 5, 9, 11	A030-2104-0	CAP, CERAMIC, AX, .1 F, 10%, 50V, X7R	5
C4	A031-0108-0	CAP, ELEC, RAD, 1000 F, -10%+50%, 16V	1
C6, 7, 8, 12	A031-0107-0	CAP, ELEC, RAD, 100 F, +/-20%, 16V, LOW L	4
C10	A031-0106-1	CAP, ELEC, RAD, 10 F, 20%, 25V, NP	1
C13, 14	A030-2103-0	CAP, CERAMIC, AX, .01 F, 10%, 50V, X7R	2
Resistors			
R1, 2, 5, 9, 10, 15, 18, 20, 22	A050-1003-0	RES, CARBON FILM, 10K OHM, 1/8W, 5%	9
R3, 4, 6, 19	A050-1004-0	RES, CARBON FILM, 100K OHM, 1/8W, 5%	4
R8, 13	A050-4703-0	RES, CARBON FILM, 47K OHM, 1/8W, 5%	2
R11, 12	A050-4702-0	RES, CARBON FILM, 4.7K OHM, 1/8W, 5%	2
R14	A050-0750-0	RES, CARBON FILM, 7.5 OHM, 1/8W, 5%	1
R17	A051-1502-0	RES, CARBON FILM, 1.5K OHM, 1/4W, 5%	1
R16	A051-2202-0	RES, CARBON FILM, 2.2K OHM, 1/4W, 5%	1
R21	A050-1005-0	RES, CARBON FILM, 1M OHM, 1/8W, 5%	1

Miscellaneous

	A022-3001-0	THERMISTOR, 120 OHM, 2AMP, CL-90	1
	A080-0002-A	TRANS. STANDBY, 120V 10V@.35A	1
	A080-0003-A	TRANS. STANDBY, 230V 10V@.35A	1
K1, 2	A084-0001-0	RELAY SPNO 12VDC, 20A/125VAC, TV-10	2
S3	A090-0007-0	SWITCH, 8A/128A, 250V, PP, PCB	1
P1, 3, 4	A092-0010-0	FASTON, M, PC, .25"	3
P2	A092-0024-0	FASTON, M, PC, .187"	1
S4	A093-0049-0	HDR, 2MMX5, HORIZ, MALE, LOCK	1
T1	A080-0025-A	TRANSFORMER SIG 1.5, 120VA	1
	A095-0009-0	TRANSFORMER SIG 1.5, 230V	1
P5, 6	A093-0051-0	HDR, 2MMX2, VERT, MALE, LOCK	2
S2	A093-0151-0	HDR, 2MMX5, VERT, MALE, LOCKING	1
S1	A093-2005-0	HDR, 2MMX7, VERT, SHROUDED	1
	A094-0004-0	FUSE CLIP, 5MM, P.C. MOUNT	2
	HA206-0003-C	Loaded Sig. 1.5 Power Switch Board	1

POWER AMP BOARD (120V)

Ref. #	Part #	Description	Qty.
Transistors			
Q1, 2, 39, 41, 44, 47	A010-0001-0	2SC3478, NPN, 180V, 100MA	6
Q3, 42, 43	A010-1013-0	MPSA56 PNP 80V 500MA TO-92	3
Q4, 5, 8, 9, 12, 13, 16, 17, 20, 21, 24, 25	A012-1003-0	2SA1962, PNP, 230V, 15A, 2-16C1A	12
Q6, 7, 10, 11, 14, 15, 18, 19, 22, 23, 26, 27	A012-0003-0	2SC5242, NPN, 230V, 15A, 2-16C1A	12
Q28, 33	A012-1002-0	2SA1837 PNP 200V 1.5A 2-10R1A	2
Q30, 32, 35, 37	A012-0002-0	2SC4793 NPN 200V 1.5A 2-10R1A	4
Q38, 40, 45, 46, 48, 49	A010-1002-0	2SA1376, PNP, 180V, 100MA, TO-92	6
Q50, 51, 52, 53	A010-0010-0	2SC2240, NPN, 120V, 100MA, TO-92	4
Q54, 55, 56, 57	A010-0012-0	MPSA06 NPN 80V 500MA TO-92	4
Diodes			
BR1, 2	A023-0112-0	BRIDGE, 25A, 200V, VERT, PC, MP25S-02	2
D1, 2, 7, 10, 15, 16	A020-1000-0	1N4148, RECT-FAST, 200MA, 100V, 4NS	6
D3, 4, 5, 6	A020-2106-0	1N4004, RECT, 1A, 150V, DO-41	4
D8, 9, 11, 12	A020-1022-0	BAV20, DIODE RECT, 200V	4

Capacitors

C1, 2, 3, 4, 5, 6, 7, 8	A031-4828-0	CAP, ELEC, RAD, 8200 F, 20%, 80V	8	R52, 59	A050-1502-0	RES, CARBON FILM, 1.5K OHM, 1/8W, 5%	2
C9, 10, 13, 14	A032-7104-0	CAP, PE, .1 F, 20%, 250V	4	R60, 69	A070-0520-0	POT, 500 OHM TRIM, .375 ROUND, SLOT,	2
C11, 12, 16, 17	A031-2106-0	CAP, ELEC, RAD, 10 F, -10%+50%, 50V	4	R61, 70	A050-1202-0	RES, CARBON FILM, 1.2K OHM, 1/8, 5%	2
C15	A030-2104-0	CAP, CER, AX, .1 F, 10%, 50V, X7R	1	R78, 81, 84, 85	A050-0101-0	RES, CARBON FILM, 10 OHM, 1/8W, 5%	4
C18, 19	A035-8181-0	CAP, MICA, 180 PF, 5%, 500V	2	R79, 80	A052-1583-0	RES, METAL FILM, 15.8K OHM, 1/4W, 1%	2
C20, 23, 36, 37	A031-4476-0	CAP, ELEC, RAD, 47 F, 20%, 100V	4	R82, 83, 114, 118	A060-3323-0	RES, METAL FILM, 33.2K OHM, 1/8W, 1%	4
C21, 24, 27, 32	A030-4104-0	CAP, CER AXIAL, .1 F, 10%, 100V, X7R	4	R87, 90, 95, 98	A050-1302-0	RES, CARBON FILM, 1.3K OHM, 1/8W, 5%	4
C22, 25	A035-8100-0	CAP, MICA, 10PF, 5%, 500V	2	R88, 91, 96, 99	A050-1201-0	RES, CARBON FILM, 120 OHM, 1/8W 5%	4
C28, 33, 38, 40	A031-0477-0	CAP, ELEC, RAD, 470 F, 20%, 10V	4	R101, 103	A050-1801-0	RES, CARBON FILM, 180 OHM, 1/8W, 5%	2
C29, 30, 34, 35	A030-2102-0	CAP, CER, AX, .001 F, 10%, 50V, X7R	4	R107, 110	A056-0100-0	RES, WIRE WOUND, 1.0 OHM, 5W, 10%	2
C39, 41	A032-4104-0	CAP, PE, .1 F, 10%, 100V	2	R113, 177	A060-7501-0	RES, METAL FILM, 750 OHM, 1/8W, 1%	2
C42, 43, 44, 45, 46, 47	A030-2271-0	CAP, CER AXIAL, 2700pf, 10%, 50V, NPO	6	R115, 119	A050-1004-0	RES, CARBON FILM, 100K OHM, 1/8W, 5%	2

Resistors

R1, 108, 109, 111, 112	A055-0101-0	RES, METAL OXIDE, 10 OHM, 2W, 5%	5
R2, 3, 4, 5	A055-6802-0	RES, METAL OXIDE, 6.8K, 2W, 5%	4
R6, 10, 40, 41, 42, 43, 44, 45, 86, 89, 94, 97, 104	A050-1001-0	RES, CARBON FILM, 100 OHM, 1/8W, 5%	13
R7, 9, 11, 13, 41, 100, 102	A050-4703-0	RES, CARBON FILM, 47K OHM, 1/8W, 5%	7
R8, 12, 105, 106	A050-1003-0	RES, CARBON FILM, 10K OHM, 1/8W, 5%	4
R15	A050-3302-0	RES, CARBON FILM, 3.3K OHM, 1/8W, 5%	1
R16, 17, 18, 19, 20, 21, 22, 23, 24, 25, 26, 27, 28, 29, 30, 31, 32, 33, 34, 35, 36	A054-330-0	RES, WIRE WOUND, .33 OHM, 1W, %5	21
R46, 53, 62, 71	A050-7500-0	RES, CARBON FILM, 75 OHM, 1/8W, 5%	4
R47, 51, 54, 58	A050-1503-0	RES, CARBON FILM, 15K OHM, 1/8W, 5%	4
R48, 55	A050-0331-0	RES, CARBON FILM, 33 OHM, 1/8W, 5%	2
R49, 56	A050-5602-0	RES, CARBON FILM, 5.6K OHM, 1/8W, 5%	2
R50, 57, 63, 64, 65, 66, 67, 68, 72, 73, 74, 75, 76, 77, 92, 93, 116, 120	A050-1002-0	RES, CARBON FILM, 1K OHM, 1/8W, 5%	18

Miscellaneous

F1, 2, 3, 4	A091-0013-0	FUSE, 5MM, 6.3A, 250V, SLB, SEMKO	4
F1, 2, 3, 4	A094-0004-0	FUSE CLIP, 5MM, P.C. MOUNT	8
J1, 2	A092-0012-0	BINDING POST, X2, H, PC, GOLD, GALLIEN	2
J3	A092-0022-0	JACK, PHONE, 3.5MM, H, PC	1
J4, 5	A092-0032-0	JACK, RCAX1, H, GOLD, WT, SWITCH T/S	2
K1	A090-0006-0	SWITCH, 2P2T, SLIDE, 30V, .3A, PCHOR, G	1
L1, 2, 3, 4	A081-0055-0	INDUCTOR, 2UH, 20A, AIR CORE	4
RL1, 2	A081-0057-0	INDUCTOR, 2UH, 7A, 2743002112 FERRIT	2
	A091-1003-0	THRM BRKR 100C +/-5, 0-DIFF, PC	1
	A093-0001-0	HDR, .1X2, VERT, MALE	2
P4, 5	A093-0025-0	HDR, .1X2, VERT, MALE, LOCK, GOLD	2
P1, 2	A093-0080-0	HDR, .156X3, VERT, MALE, LOCK, SQR PIN	2
P3	A093-2005-0	HDR, 2MMX7, VERT, SHROUDED	1
	100-0105-0	SPACER NYLON, .187" #4	4
	105-0007-0	INSULATOR TUBE	1
	HA206-0004-B	Loaded Sig. 1.5 Amplifier Board	1

Signature 1.5 (120V) TRANSFORMER WIRING Rev A

VERY IMPORTANT

THIS TRANSFORMER MUST BE BUILT TO UL1411 SPECIFICATIONS. 5MM CREEPAGE AND THREE LAYERS OF .7MM MYLAR INSULATION MUST BE MAINTAINED BETWEEN ALL PRIMARY AND SECONDARY WINDINGS.

ALL LEAD WIRES MUST BE GLUED TO 4MM MYLAR BASE THAT IS LARGE ENOUGH TO PROTECT THE SOLDER JOINTS. FOR PRIMARY LEADS, BOTH SIDES OF THIS TERMINATION BASE MUST BE PROTECTED WITH AN ADDITIONAL LAYER OF .18MM MYLAR. ALL PRIMARY MAG WIRE LEADS MUST BE SLEEVED WITH .4MM INSULATION TO TERMINATION BASE. OTHER CONSTRUCTION METHODS MAY BE USED OR REQUIRED TO INSURE COMPLIANCE.

NOTES:

1. APPLICATION AUDIO AMPLIFIER.
2. ALL FIVE SECONDARIES ARE IDENTICAL AND LOADED AS SHOWN ABOVE.
3. DRAWING SHOWS FULL POWER REQUIREMENTS. VA AT FULL POWER IS EQUAL TO 1362W. DESIGN FOR LESS THAN 70°C RISE AT 650W (RATED POWER), UL RESISTANCE METHOD.
4. CORE TO BE IMPREGNATED AND FLUX DENSITY MUST BE LESS THAN 12,000 GAUSS.
5. MECHANICAL NOISE INAUDIBLE AT ONE METER.
6. 110°C THERMAL BREAKER RATED FOR 10A/125V.
7. EXTERIOR WRAPPING TAPE TRANSLUCENT.
8. ALL LEAD WIRE TO MEET AWN 1015 VW-1 CSA TEW 105°C, 600V.
9. TEMP CUTOUT EQUIV TO PEPI B 110°C RESETTABLE WITH < 12°C DERATING AT 15A.

NOTES:

6.5 ABSOLUTE MAXIMUM DIAMETER. SECONDARIES ARE TERMINATED WITH MOLEX 08-52-0071 TERMINALS AND MOLEX 09-50-8033 HOUSINGS. EQUIVALENT TERMINATIONS ARE ACCEPTABLE IF APPROVED BY GALLIEN TECHNOLOGY ENG. DEPT.

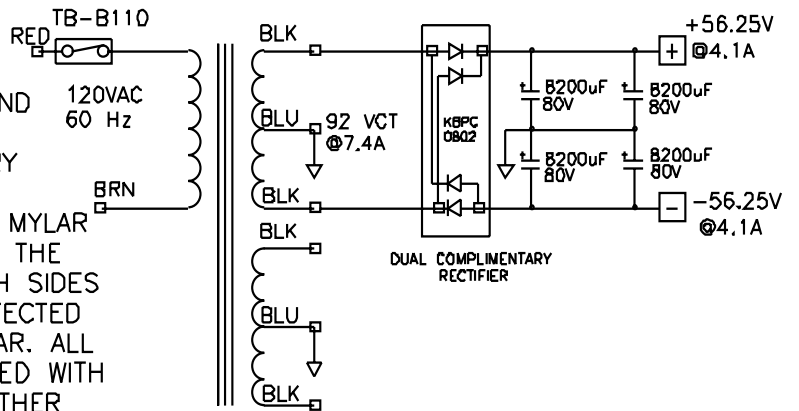

Signature 1.5 (120V) Transformer Wiring Rev A

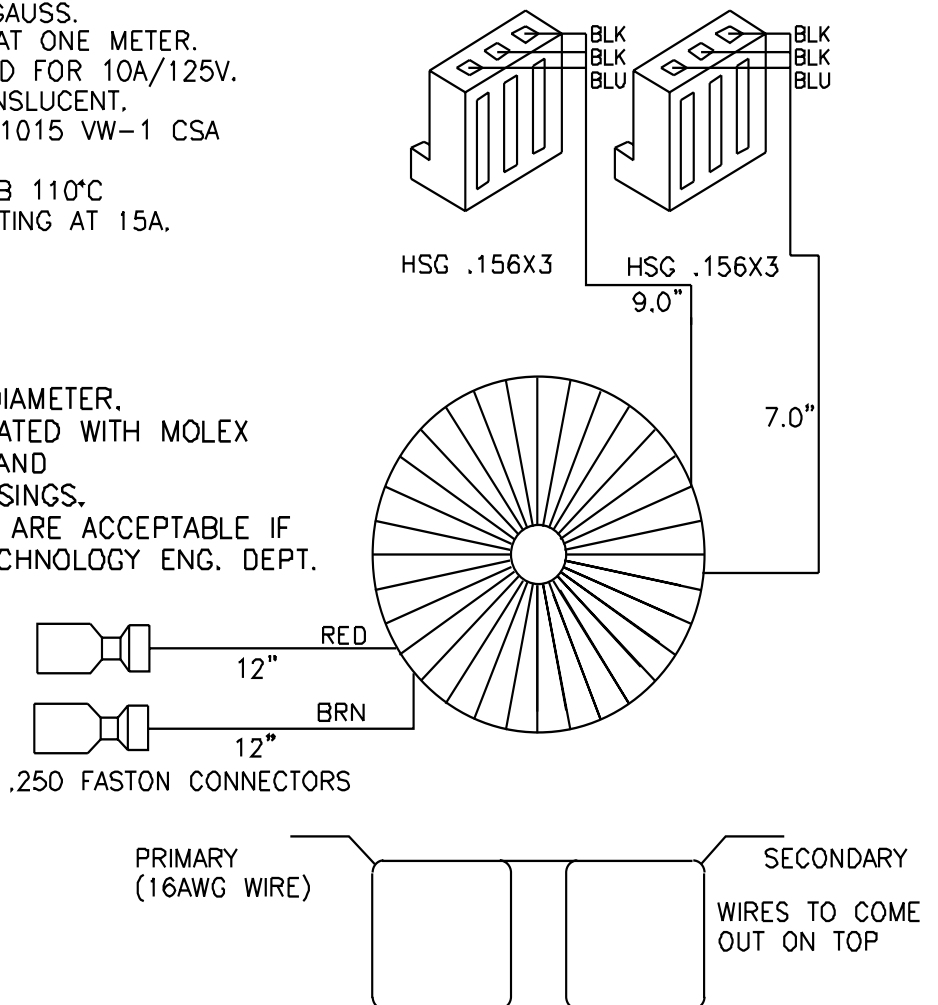

Signature 1.5 (120V) TRANSFORMER WIRING Rev B

VERY IMPORTANT

THIS TRANSFORMER MUST BE BUILT TO EN60065 SPECIFICATIONS. 5MM CREEPAGE AND THREE LAYERS OF .7MM MYLAR INSULATION MUST BE MAINTAINED BETWEEN ALL PRIMARY AND SECONDARY WINDINGS. ALL LEAD WIRES MUST BE GLUED TO 4MM MYLAR BASE THAT IS LARGE ENOUGH TO PROTECT THE SOLDER JOINTS. FOR PRIMARY LEADS, BOTH SIDES OF THIS TERMINATION BASE MUST BE PROTECTED WITH AN ADDITIONAL LAYER OF .18MM MYLAR. ALL PRIMARY MAG WIRE LEADS MUST BE SLEEVED WITH .4MM INSULATION TO TERMINATION BASE. OTHER CONSTRUCTION METHODS MAY BE USED OR REQUIRED TO INSURE COMPLIANCE.

NOTES:

1. APPLICATION AUDIO AMPIFIER.
2. ALL FIVE SECONDARIES ARE IDENTICAL AND LOADED AS SHOWN ABOVE.
3. DRAWING SHOWS FULL POWER REQUIREMENTS. VA AT FULL POWER IS EQUAL TO 1362W. DESIGN FOR LESS THAN 70°C RISE AT 650W (RATED POWER), UL RESISTANCE METHOD.
4. CORE TO BE IMPREGNATED AND FLUX DENSITY MUST BE LESS THAN 12,000 GAUSS.
5. MECHANICAL NOISE INAUDIBLE AT ONE METER.
6. 110°C THERMAL BREAKER RATED FOR 10A/125V, TEMP CUTOUT EQUIV TO PEPI B 110°C RESETTABLE WITH < 12°C DERATING AT 15A.
7. EXTERIOR WRAPPING TAPE TRANSLUCENT.
8. SECONDARY WIRE TO MEET AWN 1015 VW-1 CSA TEW 105°C, 600V.
9. PRIMARY WIRE TO MEET AWN 1672, 105°, DOUBLE INSULATION TYPE.

NOTES:
 6.5 ABSOLUTE MAXIMUM DIAMETER.
 SECONDARIES ARE TERMINATED WITH MOLEX 08-52-0071 TERMINALS AND MOLEX 09-50-8033 HOUSINGS.
 EQUIVALENT TERMINATIONS ARE ACCEPTABLE IF APPROVED BY GALLIEN TECHNOLOGY ENG. DEPT.

REVISIONS				
ZONE	REV	DESCRIPTION OF CHANGE(S)	INT	DATE

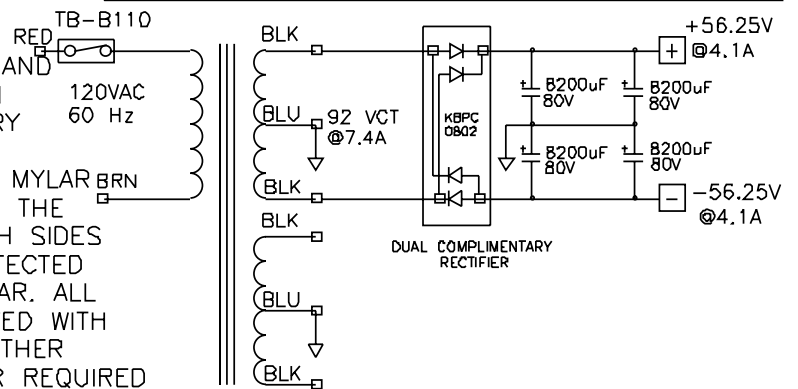

Signature 1.5 (120V) Transformer Wiring Rev B

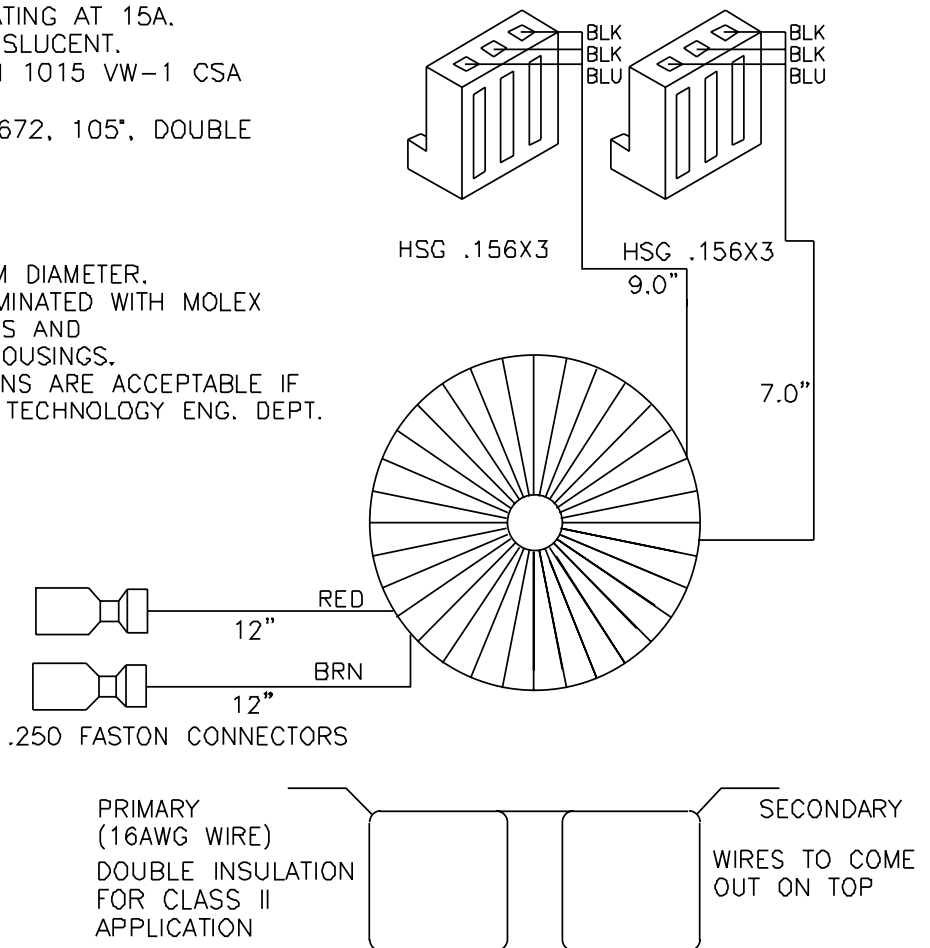

Signature 1.5 (230V) TRANSFORMER WIRING Rev A

VERY IMPORTANT

THIS TRANSFORMER MUST BE BUILT TO EN60065 SPECIFICATIONS. 5MM CREEPAGE AND THREE LAYERS OF .7MM MYLAR INSULATION MUST BE MAINTAINED BETWEEN ALL PRIMARY AND SECONDARY WINDINGS. ALL LEAD WIRES MUST BE GLUED TO 4MM MYLAR BASE THAT IS LARGE ENOUGH TO PROTECT THE SOLDER JOINTS. FOR PRIMARY LEADS, BOTH SIDES OF THIS TERMINATION BASE MUST BE PROTECTED WITH AN ADDITIONAL LAYER OF .18MM MYLAR. ALL PRIMARY MAG WIRE LEADS MUST BE SLEEVED WITH .4MM INSULATION TO TERMINATION BASE. OTHER CONSTRUCTION METHODS MAY BE USED OR REQUIRED TO INSURE COMPLIANCE.

NOTES:

1. APPLICATION AUDIO AMPLIFIER.
2. ALL FIVE SECONDARIES ARE IDENTICAL AND LOADED AS SHOWN ABOVE.
3. DRAWING SHOWS FULL POWER REQUIREMENTS. VA AT FULL POWER IS EQUAL TO 1362W. DESIGN FOR LESS THAN 70°C RISE AT 650W (RATED POWER), UL RESISTANCE METHOD.
4. CORE TO BE IMPREGNATED AND FLUX DENSITY MUST BE LESS THAN 12,000 GAUSS.
5. MECHANICAL NOISE INAUDIBLE AT ONE METER.
6. 110°C THERMAL BREAKER RATED FOR 5A/250V.
7. EXTERIOR WRAPPING TAPE TRANSLUCENT.
8. ALL LEAD WIRE TO MEET AWN 1015 VW-1 CSA TEW 105°C, 600V.
9. TEMP CUTOUT EQUIV TO PEPI B 110°C RESETTABLE WITH < 12°C DERATING AT 5A.

NOTES:

6.5 ABSOLUTE MAXIMUM DIAMETER. SECONDARIES ARE TERMINATED WITH MOLEX 08-52-0071 TERMINALS AND MOLEX 09-50-8033 HOUSINGS. EQUIVALENT TERMINATIONS ARE ACCEPTABLE IF APPROVED BY GALLIEN TECHNOLOGY ENG. DEPT.

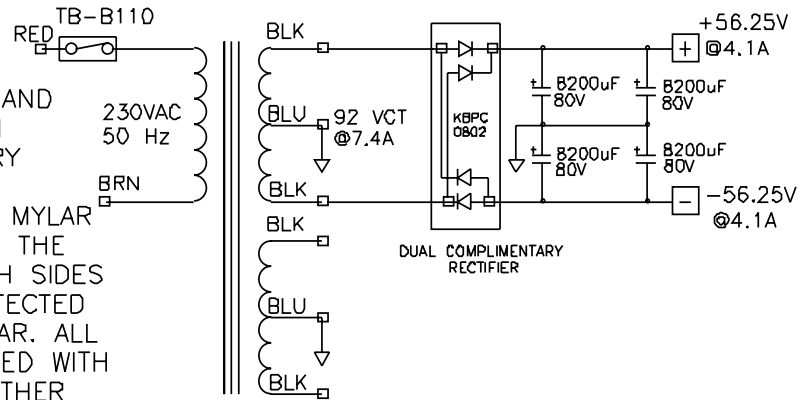

Signature 1.5 (230V) Transformer Wiring Rev A

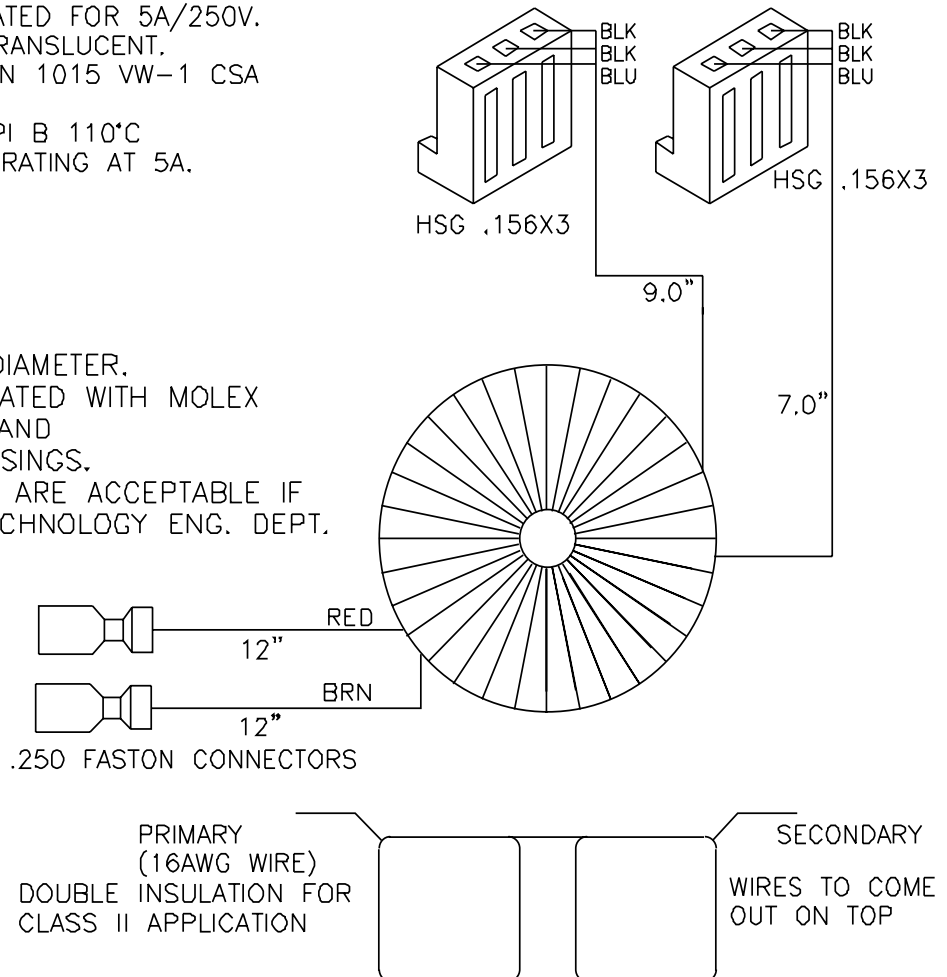

Signature 1.5 (230V) TRANSFORMER WIRING Rev B

VERY IMPORTANT

THIS TRANSFORMER MUST BE BUILT TO EN60065 SPECIFICATIONS. 5MM CREEPAGE AND THREE LAYERS OF .7MM MYLAR INSULATION MUST BE MAINTAINED BETWEEN ALL PRIMARY AND SECONDARY WINDINGS. ALL LEAD WIRES MUST BE GLUED TO 4MM MYLAR BASE THAT IS LARGE ENOUGH TO PROTECT THE SOLDER JOINTS. FOR PRIMARY LEADS, BOTH SIDES OF THIS TERMINATION BASE MUST BE PROTECTED WITH AN ADDITIONAL LAYER OF .18MM MYLAR. ALL PRIMARY MAG WIRE LEADS MUST BE SLEEVED WITH .4MM INSULATION TO TERMINATION BASE. OTHER CONSTRUCTION METHODS MAY BE USED OR REQUIRED TO INSURE COMPLIANCE.

NOTES:

1. APPLICATION AUDIO AMPIFIER.
2. ALL FIVE SECONDARIES ARE IDENTICAL AND LOADED AS SHOWN ABOVE.
3. DRAWING SHOWS FULL POWER REQUIREMENTS. VA AT FULL POWER IS EQUAL TO 1362W. DESIGN FOR LESS THAN 70°C RISE AT 650W (RATED POWER), UL RESISTANCE METHOD.
4. CORE TO BE IMPREGNATED AND FLUX DENSITY MUST BE LESS THAN 12,000 GAUSS.
5. MECHANICAL NOISE INAUDIBLE AT ONE METER.
6. 110°C THERMAL BREAKER RATED FOR 5A/250V, TEMP CUTOUT EQUIV TO PEPI B 110°C RESETTABLE WITH < 12°C DERATING AT 5A.
7. EXTERIOR WRAPPING TAPE TRANSLUCENT.
8. SECONDARY WIRE TO MEET AWN 1015 VW-1 CSA TEW 105°C, 600V.
9. PRIMARY WIRE TO MEET AWN 1672, 105°, DOUBLE INSULATION TYPF

NOTES:

6.5 ABSOLUTE MAXIMUM DIAMETER. SECONDARIES ARE TERMINATED WITH MOLEX 08-52-0071 TERMINALS AND MOLEX 09-50-8033 HOUSINGS. EQUIVALENT TERMINATIONS ARE ACCEPTABLE IF APPROVED BY GALLIEN TECHNOLOGY ENG. DEPT.

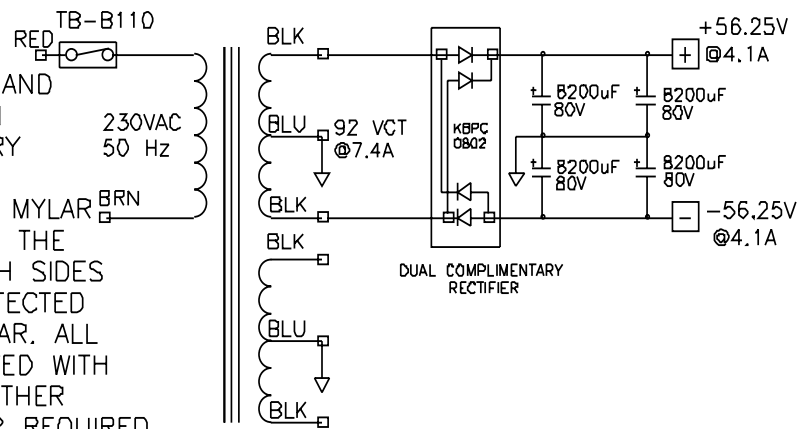

Signature 1.5 (230V) Transformer Wiring Rev B

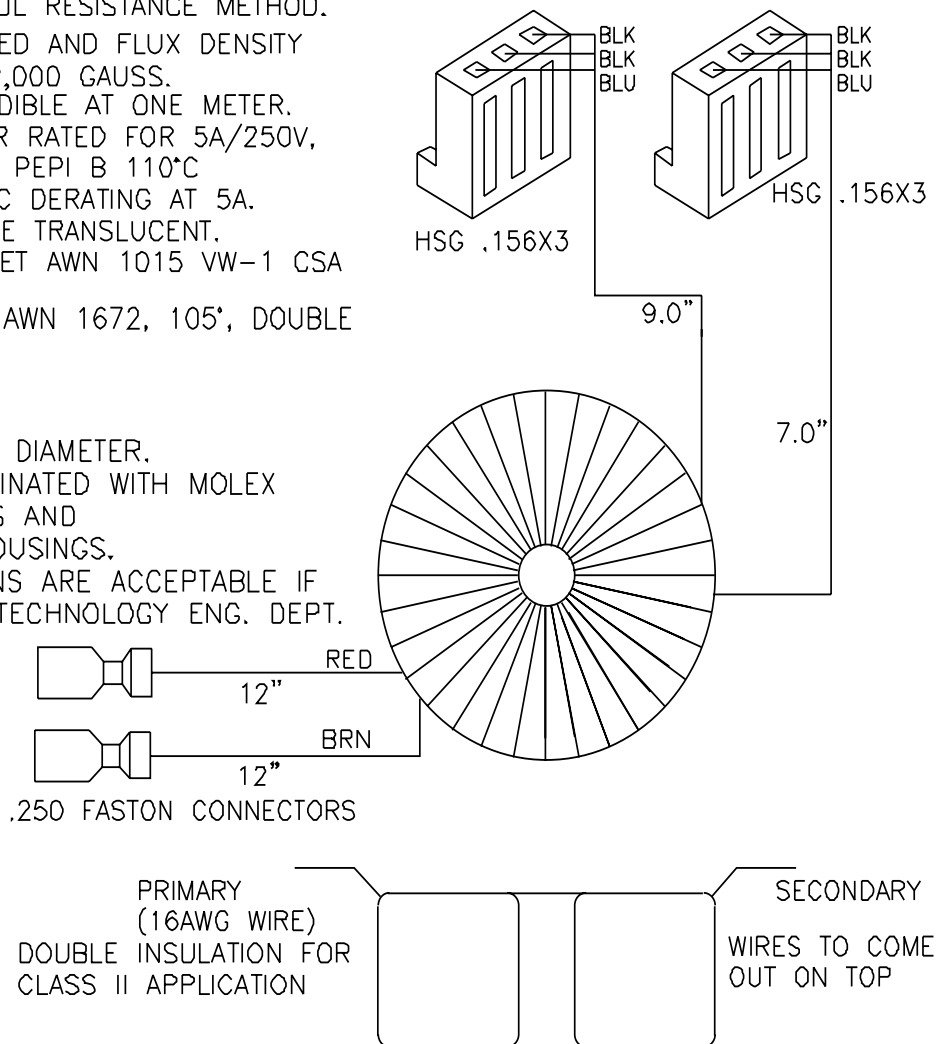

INTEGRATED CIRCUITS

U1 - LM393N DUAL COMPARATOR
A001-0005-0

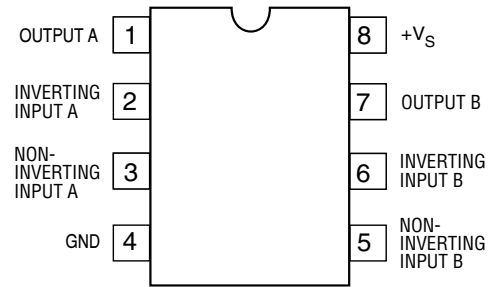

U2 - LM556CN DUAL TIMER
A001-2009-0

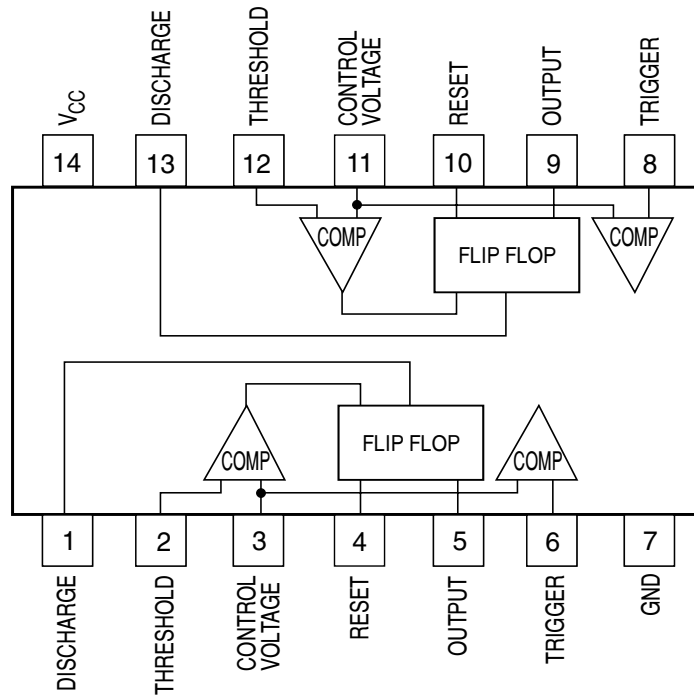

Signature 1.5 POWER AMP SCHEMATIC (1 of 2)

Signature 1.5 POWER AMPLIFIER SCHEMATIC 1 of 2

NOTES

- 1. ALL RESISTORS ARE 1/8W UNLESS OTHERWISE SPECIFIED
- 2. SET BIAS ACROSS P4-1, P4-2 TO 18 MV BY ADJUSTING R69

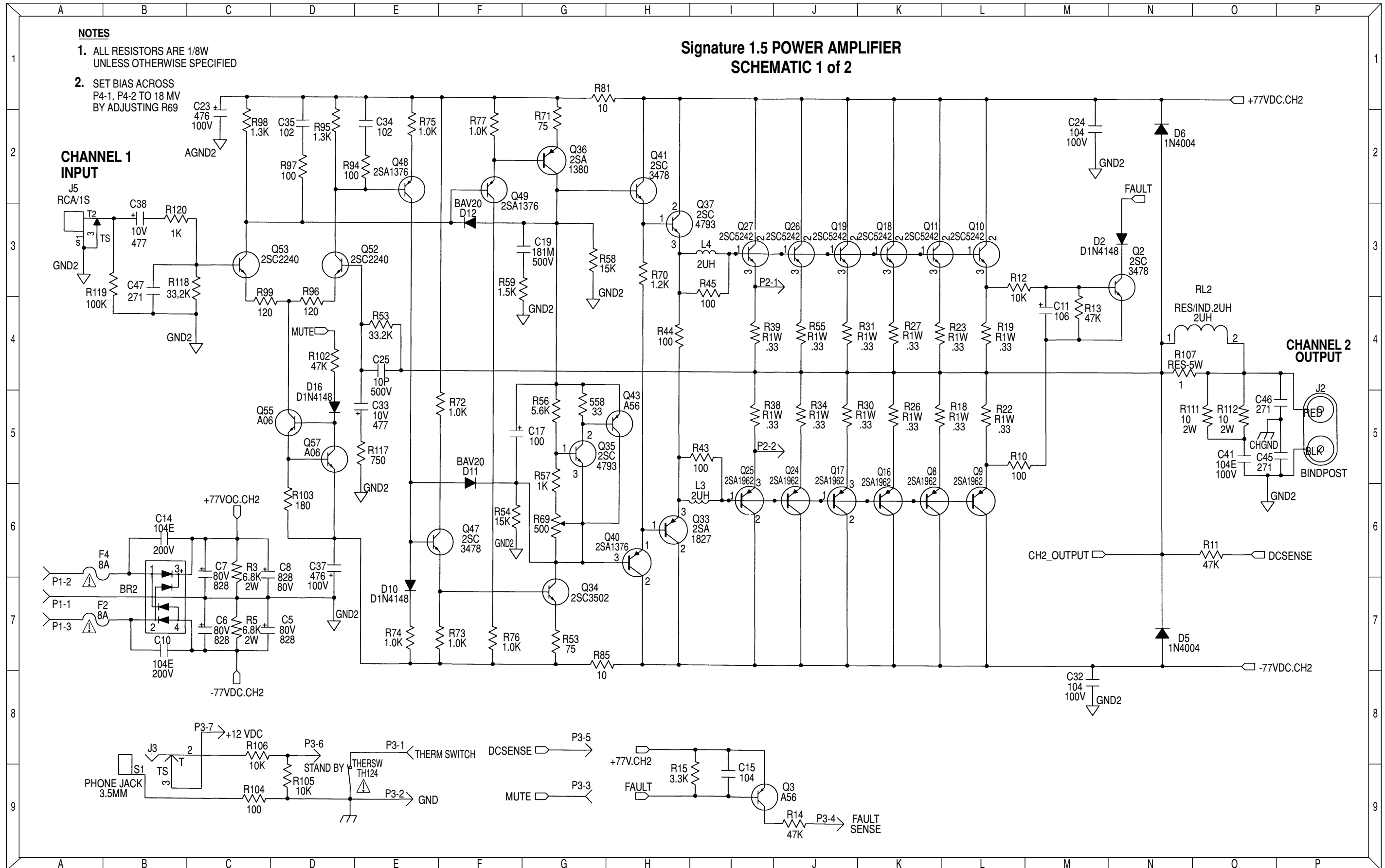

Signature 1.5 POWER AMP SCHEMATIC (2 of 2)

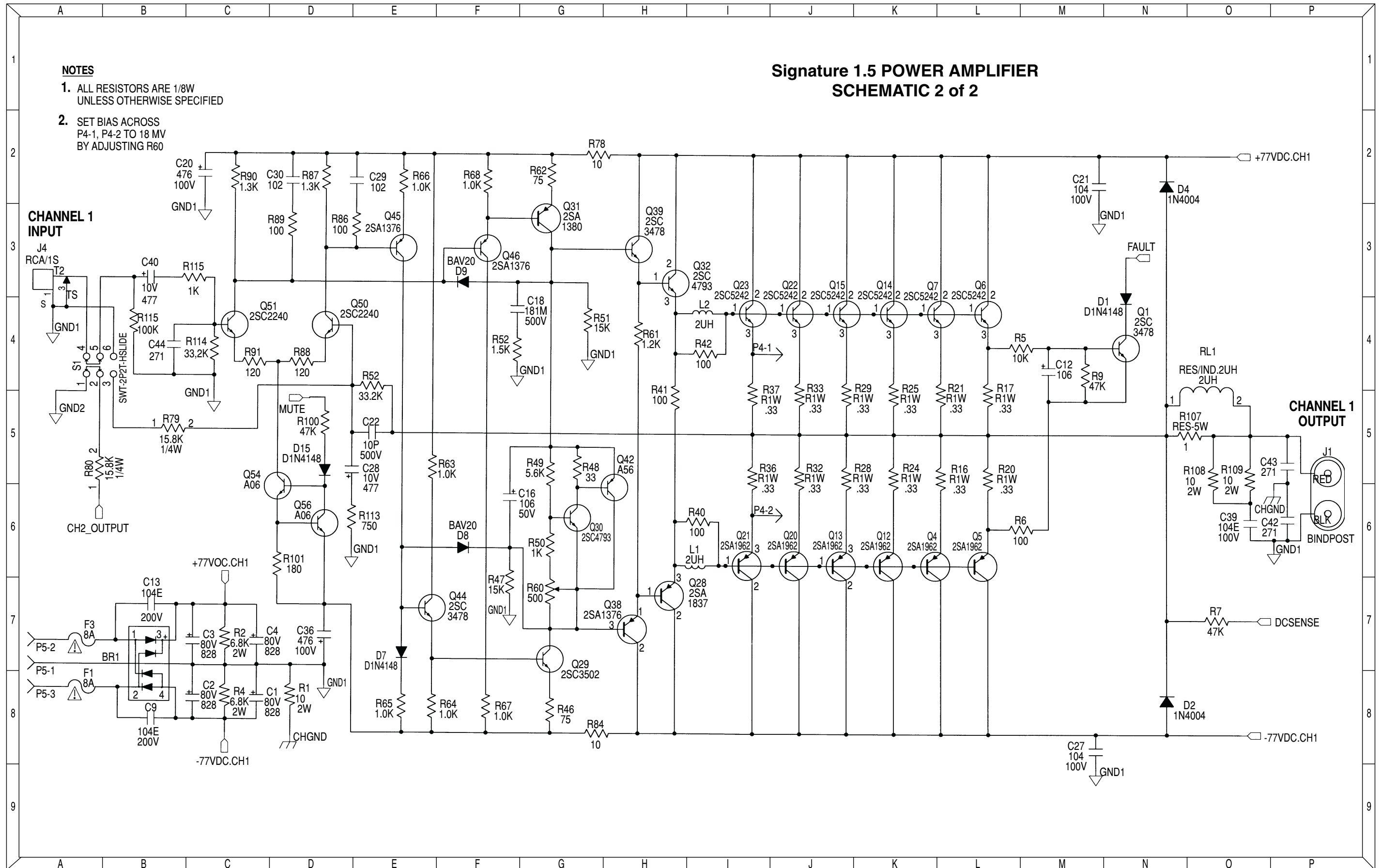

NOTES

- 1. ALL RESISTORS ARE 1/8W UNLESS OTHERWISE SPECIFIED
- 2. SET BIAS ACROSS P4-1, P4-2 TO 18 MV BY ADJUSTING R60

Signature 1.5 POWER AMPLIFIER SCHEMATIC 2 of 2