

harman/kardon

SIGNATURE 2.0 PROCESSOR/TUNER

SERVICE MANUAL



CONTENTS

ESD, LEAKAGE, SAFETY	2	BULLETIN HK9708.....	30
BASIC SPECIFICATIONS.....	5	BULLETIN HK9709.....	31
FEATURES.....	7	BULLETIN HK9904.....	32
QUICK START GUIDE.....	9	BULLETIN HK2000-07.....	33
FRONT PANEL CONTROLS.....	13	IC U305 Replacement Instructions.....	34
REAR PANEL CONNECTIONS.....	15	Signature 2.0 Upgrade Procedure.....	35
REMOTE CONTROL FUNCTIONS.....	17	VERSION CHANGES.....	36
TROUBLESHOOTING GUIDE.....	21	Auto Detect Mode ON.....	40
PROCESSOR RESET.....	21	SCHEMATICS.....	41
TROUBLESHOOTING CHART.....	23	PCB DRAWINGS.....	70
BASS/TREBLE CHARTS.....	24	ELECTRICAL PARTS LIST.....	76
MECHANICAL ASSEMBLY.....	25		

harman/kardon, Inc.
250 Crossways Park Dr.
Woodbury, New York 11797

Rev0 8/2006

ELECTROSTATICALLY SENSITIVE (ES) DEVICES

Some semiconductor (solid state) devices can be damaged easily by static electricity. Such components commonly are called Electrostatically Sensitive (ES) Devices. Examples of typical ES devices are integrated circuits and some field effect transistors and semiconductor "chip" components.

The following techniques should be used to help reduce the incidence of component damage caused by static electricity.



1. Immediately before handling any semiconductor component or semiconductor-equipped assembly, drain off any electrostatic charge on your body by touching a known earth ground. Alternatively, obtain and wear a commercially available discharging wrist strap device, which should be removed for potential shock reasons prior to applying power to the unit under test.
2. After removing an electrical assembly equipped with ES devices, place the assembly on a conductive surface such as aluminum foil, to prevent electrostatic charge build-up or exposure of the assembly.
3. Use only a grounded-tip soldering iron to solder or unsolder ES devices.
4. Use only an anti-static solder removal device. Some solder removal devices not classified as "anti-static" can generate electrical charges sufficient to damage ES devices.
5. Do not use freon-propelled chemicals. These can generate electrical change sufficient to damage ES devices.
6. Do not remove a replacement ES device from its protective package until immediately before you are ready to install it. (Most replacement ES devices are packaged with leads electrically shorted together by conductive foam, aluminum foil or comparable conductive material.)
7. Immediately before removing the protective material from the leads of a replacement ES device, touch the protective material to the chassis or circuit assembly into which the device will be installed.

CAUTION : Be sure no power is applied to the chassis or circuit, and observe all other safety precautions.

8. Minimize bodily motions when handling unpackaged replacement ES devices. (Otherwise harmless motion such as the brushing together or your clothes fabric or the lifting of your foot from a carpeted floor can generate static electricity sufficient to damage an ES devices.

PRODUCT SAFETY NOTICE

Each precaution in this manual should be followed during servicing.

Components identified with the IEC symbol  in the parts list are special significance to safety. When replacing a component identified with , use only the replacement parts designated, or parts with the same ratings or resistance, wattage, or voltage that are designated in the parts list in this manual. Leakage-current or resistance measurements must be made to determine that exposed parts are acceptably insulated from the supply circuit before returning the product to the customer.

LEAKAGE TEST(FOR SERVICE ENGINEERS IN THE U.S.A)

Before returning the unit to the user, perform the following safety checks :

1. Inspect all lead dress to make certain that leads are not pinched or that hardware is not lodged between the chassis and other metal parts in the unit.
2. Be sure that any protective devices such as nonmetallic control knobs, insulating fish-papers, cabinet backs, adjustment and compartment covers or shields, isolation resistor-capacity networks, mechanical insulators, etc. Which were removed for the servicing are properly re-installed.
3. Be sure that no shock hazard exists ; check for leakage current using Simpson Model 229 Leakage Tester, standard equipment item No. 21641, RCA Model WT540A or use alternate method as follows : Plug the power cord directly into a 120 volt AC receptacle (do not use an Isolation Transformer for this test). Using two clip leads, connect a

1500 ohms, 10watt Resistor paralleled by a 0.15uF capacitor, in series with all exposed metal cabinet parts and a known earth ground, such as a water pipe or conduit. Use a VTVM or VOM with 1000 ohms per volt, or higher sensitivity to measure the AC voltage drop across the resistor. (See diagram) Move the resistor connection to each exposed metal part having a return path to the chassis (antenna, metal, cabinet, screw heads, knobs and control shafts, escutcheon, etc.) and measure the AC voltage drop across the resistor. (This test should be performed with the 0.35 volt RMS or more is excessive and indicates a potential shock hazard which must be corrected before returning the unit to the owner.

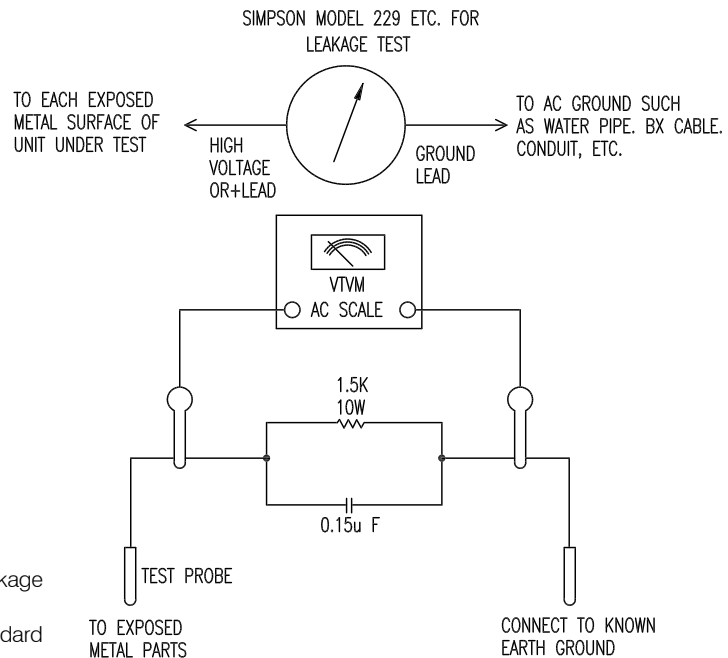

Signature 2.0

Important Safety Information

Verify Line Voltage Before Use

This Signature 2.0 has been designed for use with 120-volt AC current. Connection to a line voltage other than that for which it is intended can create a safety and fire hazard, and may damage the unit.

If you have any questions about the voltage requirements for your specific model, or about the line voltage in your area, contact your selling dealer before plugging the unit into a wall outlet.

Do Not Use Extension Cords





To avoid safety hazards, use only the power cord attached to your unit. We do not recommend that extension cords be used with this product. As with all electrical devices, do not run power cords under rugs or carpets or place heavy objects on them. Damaged power cords should be replaced immediately with cords meeting factory specifications.

Handle the AC Power Cord Gently

When disconnecting the power cord from an AC outlet, always pull the plug, never pull the cord. If you do not intend to use the unit for any considerable length of time, disconnect the plug from the AC outlet.

Do Not Open The Cabinet

There are no user-serviceable components inside this product. Opening the cabinet may present a shock hazard, and any modification to the product will void your guarantee. If water or any metal object such as a paper clip, wire or a staple accidentally falls inside the unit, disconnect it from the AC power source immediately, and consult an authorized service station.

	CAUTION RISK OF ELECTRIC SHOCK DO NOT OPEN	
<p>CAUTION: TO REDUCE THE RISK OF ELECTRIC SHOCK, DO NOT REMOVE COVER (OR BACK). NO USER-SERVICEABLE PARTS INSIDE. REFER SERVICING TO QUALIFIED SERVICE PERSONNEL.</p>		
<p> The lightning flash with arrowhead symbol, within an equilateral triangle, is intended to alert the user to the presence of uninsulated "dangerous voltage" within the product's enclosure that may be of sufficient magnitude to constitute a risk of electric shock to persons.</p>	<p> The exclamation point within an equilateral triangle is intended to alert the user to the presence of important operating and maintenance (servicing) instructions in the literature accompanying the appliance.</p>	
<p>WARNING: TO REDUCE THE RISK OF FIRE OR ELECTRIC SHOCK, DO NOT EXPOSE THIS APPLIANCE TO RAIN OR MOISTURE.</p>		
<p>CAUTION: TO PREVENT ELECTRIC SHOCK, MATCH WIDE BLADE OF PLUG TO WIDE SLOT, FULLY INSERT. ATTENTION: POUR EVITER LES CHOCs ELECTRIQUES, INTRODUIRE LA LAME LA PLUS LARGE DE LA FICHE DANS LA BORNE CORRESPONDANTE DE LA PRISE ET POUSSER JUSQU'AU FOND.</p>		

CATV or Antenna Grounding

If an outside antenna or cable system is connected to this product, be certain that it is grounded so as to provide some protection against voltage surges and static charges. Section 810 of the National Electrical Code, ANSI/NFPA No. 70-1984, provides information with respect to proper grounding of the mast and supporting structure, grounding of the lead-in wire to an antenna discharge unit, size of grounding conductors, location of antenna discharge unit, connection to grounding electrodes and requirements of the grounding electrode.

NOTE TO CATV SYSTEM INSTALLER:

This reminder is provided to call the CATV (Cable TV) system installer's attention to article 820-40 of the NEC that provides guidelines for proper grounding and, in particular, specifies that the cable ground shall be connected to the grounding system of the building, as close to the point of cable entry as possible.

Installation Location

- To assure proper operation, and to avoid the potential for safety hazards, place the unit on a firm and level surface. When placing the unit on a shelf, be certain that the shelf and any mounting hardware can support the weight of the product.
- Make certain that proper space is provided both above and below the unit for ventilation. If this product will be installed in a cabinet or other enclosed area, make certain that there is sufficient air movement within the cabinet. Under some circumstances a fan may be required.
- Do not place the unit directly on a carpeted surface.
- Avoid installation in extremely hot or cold locations, or an area that is exposed to direct sunlight or heating equipment.
- Avoid moist or humid locations.
- Do not obstruct the ventilation slots on the top of the unit, or place objects directly over them.

*Signature 2.0***Signature 2.0 Processor/Tuner Specifications****Inputs:**

Analog Audio:	Six Stereo pairs via RCA jacks
Digital Audio:	Four Coaxial S/P-DIF, Two Optical TosLink
External Adapter:	Six Direct Analog channels via RCA jacks
Composite Video:	Six RCA jacks
S-Video:	Two 4-pin mini DIN
IR Sensor Input:	3.5mm mono mini-plug

Outputs:

Main Audio:	Six Analog Outputs via RCA jacks (left, center, right, right surround, left surround, subwoofer)
Main Video:	One Composite RCA jack output paralleled with one S-Video 4-pin mini DIN
Record Audio:	Two pair (paralleled) analog via RCA jacks
Record Video:	One Composite via RCA jack paired with one S-Video via 4-pin mini DIN
IR Sensor:	Loop-through output via 3.5mm mono mini plug
Accessory Trigger:	6 – 12 volt DC via 3.5mm mono mini plug, tip positive, 150mA maximum.

Surround Modes:

Analog:	Dolby Pro Logic, Four Movie Modes, Four Music Modes, Stereo, Mono, Mono +
Digital:	Dolby Digital, Dolby Digital Late Night, Dolby Digital Pro Logic, Dolby Digital Mono, DTS 5.1, DTS 4-Channel, DTS 2-Channel, Stereo, Mono +

Preamplifier:

Frequency Response:	Front Channels (Analog Stereo): 20Hz to 50kHz, \pm 0.5dB Center and Surround Channels: 20Hz to 30kHz, \pm 1dB Subwoofer Channel: 10Hz to 100Hz, \pm 1dB
THD + N:	0.03%, 20Hz to 20kHz
S/N Ratio:	> -87dB, 20Hz to 20kHz
Crosstalk:	< 60dB
Input Impedance:	Audio: >10K Ω Video: 75 Ω
Output Impedance:	Audio: 300 Ω Video: 75 Ω
Crossovers:	Low Pass: 3 Pole (18dB/Octave) @ 100Hz High Pass: 3 Pole (18dB/Octave) @ 100Hz
Tone Controls:	Treble Cut: -0dB to -8dB in 2dB steps @ 10kHz shelving Bass Boost: +0dB to +8dB in 2 steps @ 50Hz
Video Standards:	NTSC, PAL

*Signature 2.0***Signature 2.0 Processor/Tuner Specifications (continued)****Tuner Section FM:**

Frequency Range:	87.5 to 108.0MHz in 200kHz steps
Usable Sensitivity:	<1.0 μ V/11.2dBf
Signal-To-Noise:	70dB (Stereo, A-weighted)
S/N 50dB Sensitivity:	<45dBf
THD + N:	<0.5%
Capture Ratio:	<2.5dB
AM Suppression:	>50dB
Image Rejection:	>70dB (@ 106MHz)
IF Rejection:	>85dB
Effective Selectivity:	>50dB (\pm 400kHz)
Stereo Separation:	>40dB (1kHz)
RDS Modes:	Station ID, Program Type, Radio Text Data, Program Type Search

Tuner Section AM:

Frequency Range:	520 – 1710 kHz in 10kHz steps
Signal-To-Noise Ratio:	>40dB
Usable Sensitivity:	\leq 500 μ V/M
Selectivity:	\geq 30dB (\pm 10kHz)

General:

Power Requirement:	AC 115V/60Hz
Power Consumption:	5.5W Idle, 75W Maximum
Dimensions: (Max, including knobs, jacks, buttons)	
	Width: 17 $\frac{3}{8}$ inches (441mm)
	Height: 4 $\frac{1}{8}$ inches (105mm)
	Depth: 15 $\frac{3}{8}$ inches (395mm)
Weight:	22 lbs. (10.5 kg)

All features and specifications are subject to change without notice.

*Trademarks of Dolby Laboratories.

†DTS and DTS Surround are trademarks of Digital Theater Systems.

Signature 2.0

Congratulations! With the purchase of a Harman Kardon Signature Series product you are about to begin many years of listening enjoyment. The Model 2.0 Processor/Tuner has been designed to provide all the excitement and detail of motion picture soundtracks and reproduce every subtle nuance of your favorite musical selection. On-board Dolby* Digital and DTS⁺ decoding enables the 2.0 to deliver six channels of fully discrete sound from the exciting new digital audio formats that are a part of DVD and HDTV broadcasts. A wide selection of matrix decoding modes delivers full compatibility with conventional Dolby Surround stereo and mono programs. The 2.0 is also ready to accept future surround systems through the use of six-channel direct inputs that accommodate optional outboard decoders for future surround systems.

the meaning of the on-screen and front panel display messages will enable you to take advantage of all the power the Signature 2.0 is able to deliver.

Harman Kardon has been a part of the audio world since it invented the first high-fidelity receiver over forty-five years ago. With the combination of state-of-the-art circuitry and time honored design philosophies, the Signature 2.0 is one of the most innovative products ever offered by Harman Kardon. Should you have any questions about this product, its operation or installation that are not answered in this manual please contact your retailer or custom installer. They are your best source for product information. You may also contact Harman Kardon via the World Wide Web at www.harmankardon.com

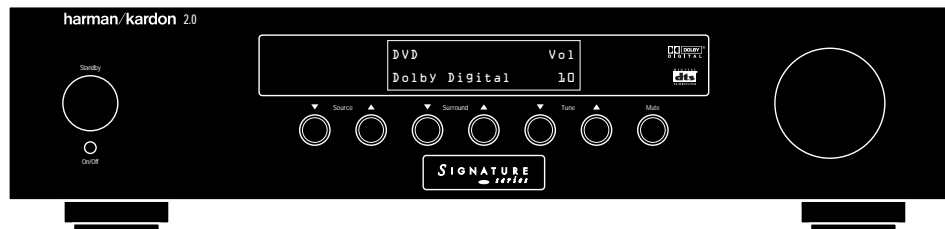

While complex digital circuits are hard at work within the 2.0, a simple F menu system and learning remote control make the unit easy to install and operate.

In addition to selecting from a variety of audio/video sources, the Signature 2.0 is equipped with the latest in tuner technology, including the RDS data system that automatically identifies FM stations transmitting special data and provides information they transmit about the station's programming. The RDS system even lets you automatically search for a station with a specific program type from the participating stations in your reception area.

To obtain maximum benefit from the Signature 2.0's many features we urge you to take a few minutes to read through this manual. That will ensure that connections to playback sources, power amplifiers and other external devices are made properly. In addition, a few minutes spent learning the functions for the various controls and

The following are among the 2.0's many features:

- On-Board Dolby Digital and DTS Decoding
- Multiple Coax and Optical Digital Inputs
- Composite and S-Video Switching
- Easy-To-Use On-Screen Menu Control System
- FM Stereo/AM Tuner With RDS Data System and 30 Presets
- Learning Remote Control Pre-Programmed With Harman Kardon and RC-5 Control Codes
- Trigger Output For Automatic Control of Signature Series Power Amplifiers
- RS-232 Control Port For Connection To External Automation Systems
- Six-Channel Direct Inputs For Use With External Audio Adapters or Decoders.

Signature 2.0

Cleaning

When the unit gets dirty, wipe it with a clean, soft dry cloth. If necessary, wipe it with a soft cloth dampened with mild soapy water, then a fresh cloth with clean water. Wipe dry immediately with a dry cloth. NEVER use benzene, aerosol cleaners, thinner, alcohol or any other volatile cleaning agent. Do not use abrasive cleaners, as they may damage the finish of metal parts. Avoid spraying insecticide near the unit.

Moving The Unit

Before moving the unit, be certain to disconnect any interconnection cords with other components, and make certain that you disconnect the unit from the AC outlet.

Important information for the user

NOTE: This equipment has been tested and found to comply with the limits for a Class B digital device, pursuant to Part 15 of the FCC Rules. The limits are designed to provide reasonable protection against harmful interference in a residential installation. This equipment generates, uses and can radiate radio frequency energy and, if not installed and used in accordance with the instructions, may cause harmful interference to radio communication. However, there is no guarantee that harmful interference will not occur in a particular installation. If this equipment does cause harmful interference to radio or television reception, which can be determined by turning the equipment off and on, the user is encouraged to try to correct the interference by one or more of the following measures:

- Reorient or relocate the receiving antenna.
- Increase the separation between the equipment and receiver.
- Connect the equipment into an outlet on a circuit different from that to which the receiver is connected.
- Consult the dealer or an experienced radio/TV technician for help.

This device complies with Part 15 of the FCC Rules. Operation is subject to the following two conditions: (1) this device may not cause harmful interference, and (2) this device must accept interference received, including interference that may cause undesired operation.

NOTE: Changes or modifications may cause this unit to fail to comply with Part 15 of the FCC Rules and may void the user's authority to operate the equipment.

Unpacking and Installation

The carton and shipping materials used to protect your new 2.0 during shipment were specially designed to cushion it from shock and vibration. We suggest that you save the carton and packing materials for use in shipping if you move or should the unit ever need repair.

To minimize the size of the carton in storage, you may wish to flatten it. This is done by carefully slitting the tape seams on the bottom and collapsing the carton down to a more two-dimensional appearance. Other cardboard inserts may be stored in the same manner. Packing materials that cannot be collapsed should be saved along with the carton in a plastic bag.

If you do not wish to save the packaging materials, please note that the carton and other sections of the shipping protection are recyclable. Please respect the environment and discard those materials at a local recycling center.

Typographic Conventions

In order to help you use this manual with diagrams of the remote control, front panel controls, rear panel connections and on-screen menus, certain conventions have been used.

Example – (bold type) indicates a specific remote control or front panel button, or rear panel connection jack

Example – (OCR type) indicates a message that is visible through the on-screen menu system or on the front panel information display

1 – (number in a square) indicates a specific front panel control

1 – (number in an oval) indicates a button or indicator on the remote

1 – (number in a circle) indicates a rear panel connection

Signature 2.0

Quick-Start Instructions

The Signature 2.0 is a powerful, yet easy-to-use product. In order to obtain the maximum benefit from its many features and options, it is strongly recommended that you take the time to carefully read the instructions in the manual. It contains a wealth of information that will help you to safely and properly install and use this product.

We realize, however, that you may be anxious to use your system, so the following steps are provided to outline the minimum instructions needed to get everything connected and “on the air.” Please follow the directions carefully in order to avoid damage to the Signature 2.0 or other components in your system.

If you choose to take advantage of these Quick-Start instructions we nevertheless urge you to read through the Owner's Manual at a later time so that your system may be adjusted for optimal performance. That small investment of your time will yield major dividends in the long term in the form of hours of greater listening pleasure.

IMPORTANT NOTE: Before connecting your new Signature 2.0, you will need to physically locate it in your system.

To ensure proper operation, and to prevent possible heat damage, it is important that the 2.0 NOT be placed on top of an amplifier such as the Signature 2.1, or other heat sources. For optimal air circulation, we strongly recommend that the 2.0 be placed on a shelf by itself, with 1½ to 2 inches of clearance between the top of the 2.0 and any shelf or equipment above it.

Equipment Required for Quick-Start Installation:

- ✓ Signature 2.0 Processor/Tuner and Supplied Accessories
- ✓ Front Left, Center and Right Speakers
- ✓ Left and Right Surround Speakers
- ✓ Five Channels of Audio Power Amplification
- ✓ Powered Subwoofer or Passive Subwoofer and External Amplifier
- ✓ Source Equipment (e.g., VCR, DVD, CD, Satellite Receiver, etc.)
- ✓ Interconnect and Speaker Cables

NOTE: If your equipment does not match the list above you should **NOT** use the Quick-Start instructions, as additional settings must be made beyond those shown on the next two pages. For complete installation instructions, see page 19.

Signature 2.0

Quick Start Connection and Setup

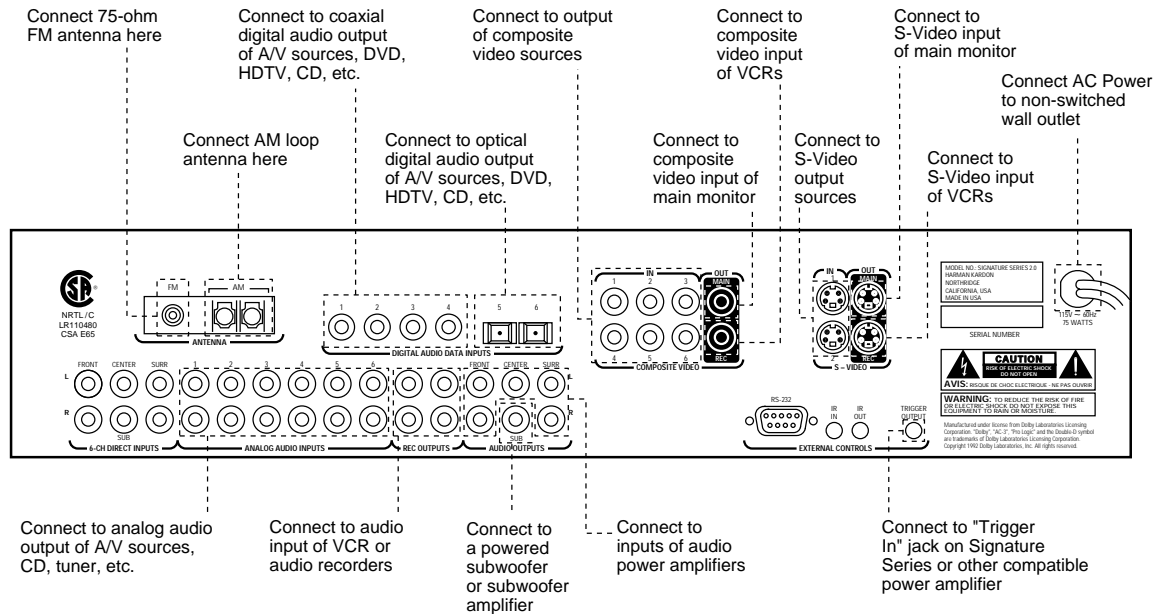

1. Before proceeding, make certain that all equipment, including the 2.0, is unplugged from AC power. This will prevent any damage due to the unintended activation of automatic turn-on circuits.

2. Use high-quality audio and video interconnect cables to connect your source equipment to the rear of the 2.0 as shown in the diagram above and the table below. It is important to note that unlike conventional audio/video equipment, the 2.0 does not have inputs that are labeled for connection to a specific type of equipment (e.g., inputs labeled "CD," "Tape" or "VCR"). Instead, the 2.0 allows you to connect the analog or digital audio and composite or S-Video outputs of your source equipment to any of the inputs. Then, using the setup procedures detailed on page 28 of this manual, you can custom configure the input sources. However, for a quick starting point, follow the input suggestions outlined in the chart shown below. They conform to the preset conditions for the 2.0.

Source Equipment	Remote Button	Video Input Connection	Audio Input Connection
Cable Box, Satellite Receiver, TV Tuner	TV	Analog 2	Composite 2
VCR	Video 1	Analog 1	Composite 1
DVD	Video 2	Digital 1	S-Video 1
HDTV, Satellite with Digital Audio, Laser Disc	Video 3	Digital 2	S-Video 2
Tuner (internal)	Tuner	(Internal Tuner)	Composite 2
CD Player	CD	Digital 3	N/A
Cassette or Tape Deck	Tape	Analog 5	N/A
Outboard Decoder	Aux	6-Ch. Direct Inputs	Composite 1

Signature 2.0

NOTE: To use the sources when they are connected as shown in the chart on the previous page, press the button name shown. The button names may not correspond exactly to the type of source used for any input profile, but you may rename the input source for the on-screen display by following the instructions shown on page 27 of this manual.

3. Connect the video “Record Inputs” of your VCR to the **Composite** or **S-Video “Rec” Outputs**.

4. Connect the audio “Record Inputs” of your VCR and/or audio tape recorder to the **“Rec” Outputs** on the rear of the 2.0. There is no problem in sending the feed to both recorders and two recordings may be made at one time from the same source.

5. Connect the **Composite** or **S-Video “Main” Outputs** to the matching Composite or S-Video input on your TV monitor or projector.

6. Connect the AM and FM antennae supplied with the 2.0 to the proper antenna connections on the rear panel.

7. If a Signature Series audio power amplifier, or other compatible amplifier, is being used, connect the power trigger cable supplied with the 2.0 to the **Trigger Output** on the 2.0 and the amplifier’s compatible Trigger Input.

8. Connect the **Audio Outputs** of the 2.0 to the inputs of your five-channel power amplifier. Be certain that channels are properly matched (e.g., connect left to left, right to right, etc.) Connect the **Sub Output** to the mono “line level” input of a powered subwoofer, or to the audio input of the amplifier channel feeding a passive subwoofer. Connect the audio amplifier to the speakers, carefully following the instructions provided with the speaker and amplifier, and ensure that polarity is matched between the speaker and amplifier when connections are made.

9. Install the batteries in the remote control, being careful to observe the (+) and (–) polarity indicators on the remote and the batteries.

10. Connect all devices, including the 2.0, to AC power and turn everything on EXCEPT for the 2.0 and any audio amplifier not connected to the 2.0’s triggered output.

11. Press the **Master Power Switch** on the 2.0 in until it latches and is flush with the front panel. A green standby LED will light, and the front panel **Information Display** will come on briefly to display the software version installed in your unit and then a **Power Off Standby** message will show briefly. The unit will then go into the Standby mode.

- To use the On-Screen Menu System, make certain that your TV or other video display device is turned on and switch to the proper video input at this point.

12. To turn the 2.0 on, press either the front panel **Standby** button, the **Main On** button on the remote, or any of the source buttons on the remote (e.g., **TV**, **Vid 1**, **Tuner**, etc.). The front panel **Information Display** will illuminate, the amber standby LED will go out and be replaced by blue illumination behind the word “Signature” on the front panel. A message will briefly appear in the on-screen display with the source, surround mode and volume.

- If you are using a Signature Series amplifier or another compatible amplifier connected to the **Trigger Output** jack, it will receive a turn-on signal as soon as the 2.0 is turned on. Note that with most amplifiers there will be a short, intentional delay between the turn-on signal and when the amplifier sends signals to the speakers. This is a normal function designed to prevent damage to your speakers.

- If you are using an amplifier not controlled by the 2.0’s **Trigger Output**, turn it on at least 10 seconds AFTER the 2.0 is turned on.

Signature 2.0

13. The factory presets for most settings are designed to accommodate the typical home-theater system. If the speakers being used are a "satellite/subwoofer" system with compact speakers at the front left/right, center and surround positions, and a subwoofer connected for low-frequency reproduction, no further adjustment is needed. However, if you have larger front, center or surround speakers that are capable of low-frequency reproduction below 100Hz, or if a subwoofer is not installed, you should change the Speaker Setup, as shown on page 24 of this manual.

14. You may change the input source by pressing the front panel **Source** buttons or any of the **Source** buttons on the remote. Volume for the 2.0 may be raised or lowered using the front panel **Volume** knob or the **Volume Up/Down** buttons on the remote. Finally, to change the surround mode, press **Surround** buttons on the front panel or the **Mono +, Music, Movies** or **Stereo** buttons on the remote.

At this point you are "on the air"! Sit back and enjoy the best in home entertainment.

Operating Hints

The following hints will help you to enjoy the sonic power and operating flexibility of the Signature Series 2.0 while you become accustomed to the way it works. Depending on the type of equipment in use in your system, it may, or may not be necessary to follow these hints:

- If you change the Speaker Setup, keep in mind that the changes apply to all modes. You may not change the Speaker Setup for one mode, and not another.
- When the front channel speakers are set to the LARGE mode, the subwoofer output will only be active when a Dolby* Digital source with Low-Frequency Effects (LFE) or DTS are in use. In order to have a full-time output from the subwoofer channel, the front speakers must be set to SMALL. (This is the factory preset configuration.)
- If the Surround Mode indication flashes in the front panel display, that is an indication that the input source is not compatible with the desired mode. The flashing mode is not the one originally selected, rather, it is the mode automatically selected by the 2.0 to match the input source. For example, when the Pro Logic* mode is selected, but a Dolby Digital source is playing, the 2.0 will automatically select Dolby Digital, but the mode will flash to remind you that while it is correct, it is not the mode originally selected.
- Note that when a DVD is in use, the digital audio output is interrupted when the player is in the pause, fast search, slow speed or reverse modes. Since the 2.0 does not receive a digital signal in these cases, it will momentarily try the Pro Logic mode as an alternate. This temporary mode change does not indicate any fault or problem with the 2.0, and the unit will return to the Dolby Digital or DTS Mode shortly after the DVD is put back into a standard play mode.
- If one input source requires a significantly higher volume level than others, or when there is a distinct increase in the noise level or distortion with one input in comparison to others, this is a sign that the input level needs to be adjusted. See pages 29–30 of this manual for instructions on adjusting the input level.
- When certain DVD players are used, it is normal to hear an occasional click or pop noise when the DVD player is put back into play after being paused, or when some DVD discs change chapters. This is a normal side effect of the way in which some DVD players and digital decoders work, and it does NOT indicate a problem with the 2.0 or with your DVD player.

Of course, this is only the tip of the iceberg. Although you have successfully completed a minimal installation we strongly recommend that you take time to read this manual thoroughly. It will show you how to use the many features, modes and controls that are a vital part of the Signature 2.0. Correct setup and installation is important to optimizing the sound quality of your new controller, and will also make it easier to operate. A few minutes spent reading the manual and making certain that your new 2.0 is set up to meet the individual characteristics of your system and listening room will enable the 2.0 to deliver all the performance it is capable of.

Signature 2.0

Front Panel Controls

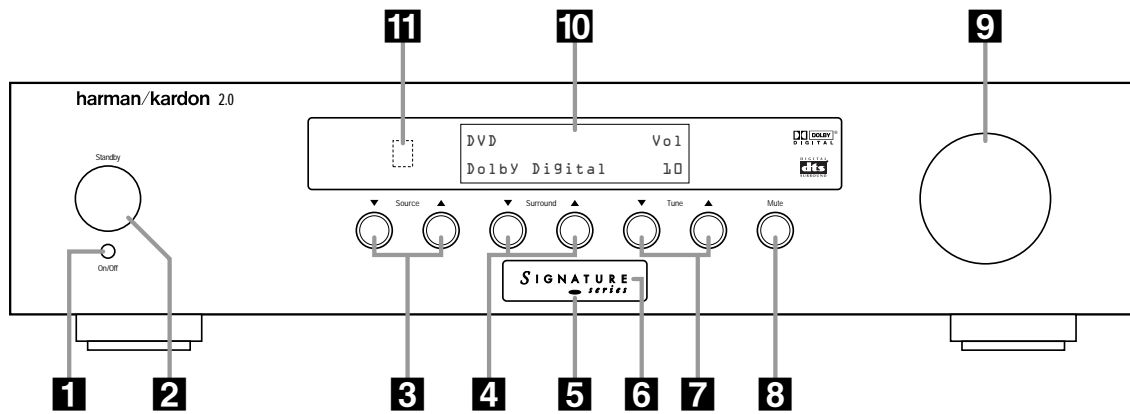

- | | | |
|------------------------------|--------------------------|--------------------------------|
| 1 Master Power Switch | 5 Standby LED | 9 Volume Control |
| 2 Standby Switch | 6 Power Indicator | 10 Information Display |
| 3 Source Selectors | 7 Tune Buttons | 11 Remote Sensor Window |
| 4 Surround Selectors | 8 Mute Button | |

1 Master Power Switch: This is the main power control for the 2.0. To turn the unit on, press this switch in until it latches and is flush with the front panel. To turn the unit off press in briefly, and the switch will unlatch and pop out. Once this switch is in the “ON” position you may leave it there and use the remote control or standby switch to turn the 2.0 on or off.

NOTE: Even when the **Master Power Switch** is in the “OFF” position, the 2.0 is still connected to the AC power source.

2 Standby Switch: Press this switch to turn the unit on from the Standby mode. Press it again to return to the Standby mode. Note that in order for this switch to operate the 2.0, the **Master Power Switch 1** must be in the “ON” position, as indicated by the amber **Standby LED 5**.

3 Source Selectors: Press these buttons to change the input source selection. Use them to scroll through the list of sources you watch and listen to.

4 Surround Selectors: Press these buttons to change the surround mode in use. Note that the list of modes available is different for digital or analog audio sources.

5 Standby LED: When this indicator lights in an amber color, the 2.0 is in the Standby mode, and it is ready to be turned on or off when either the **Standby Switch 2**, or the remote **Main On/Off 1** is pressed. When the **Standby LED** is out, but the **Power Indicator 6** is illuminated in blue, the unit is on. When both of these indicators are dark, the 2.0 is fully off, indicating that the **Master Power Switch 1** is in the “OFF” position or the 2.0 is not plugged into a live AC power source.

6 Power Indicator: This indicator is illuminated in blue when the 2.0 is in full operation. If it is not lit, and the **Standby LED 5** is amber, the unit is in the Standby mode. When neither indicator is lit, the 2.0 is off, or the unit is not connected to a live AC power source.

Signature 2.0

7 Tune Buttons: Press these buttons when the tuner is the input source to select the station being listened to from the frequencies previously entered into the preset memories.

8 Mute Button: Press this button to temporarily silence the audio output. Press the button again, or change the volume level to return to normal operation. Note that when the Mute function is activated, the feed to any recorders connected to the **Record Outputs 3** will remain uninterrupted. When Mute is engaged a reminder message will appear in the on-screen display (see figure OSD-15 on page 38) and the word **Mute** will replace the volume level in the **Information Display 10** (see figure FPD-9 on page 38).

9 Volume Control: Turn this knob to the right or left to raise or lower the volume. This is an electronic volume control, so unlike the conventional volume controls you may be used to, it does not have a start or end point to its rotation. Volume indications are provided

in both the front panel **Information Display 10** and the on-screen control system (see figure OSD-13 on page 38) to provide information about the relative volume setting.

10 Information Display: This two-line display is your window into the status and operation of the 2.0. In normal operation it displays the current input source and surround mode at the left side of the display, and the volume level on the right side. When the tuner is in use the top line of the display will show the preset number and frequency of the station being listened to. Additional messages will be displayed depending on which input or mode is in use, including RDS data from the FM tuner, and abbreviated versions of the on-screen menus used during installation, setup and configuration.

11 Remote Sensor Window: This area contains the sensor that receives commands from the Signature 2.0's infrared remote control. Make certain that it is not blocked by cabinets, smoked glass or doors or other objects that may interfere with the line of sight from the remote.

Signature 2.0

Rear Panel Connections

IMPORTANT NOTE: Never make or remove any connections to the Signature 2.0 with the Master Power Switch in the “ON” position. It is also a good practice to make certain that the power amplifiers connected to the 2.0 are also turned off when making or removing any connections. This eliminates the risk of possible damage to your speakers or other system components.

When making connections to the Signature 2.0 make certain that the plugs are firmly seated into the jacks. This prevents intermittent connections which may interfere with performance.

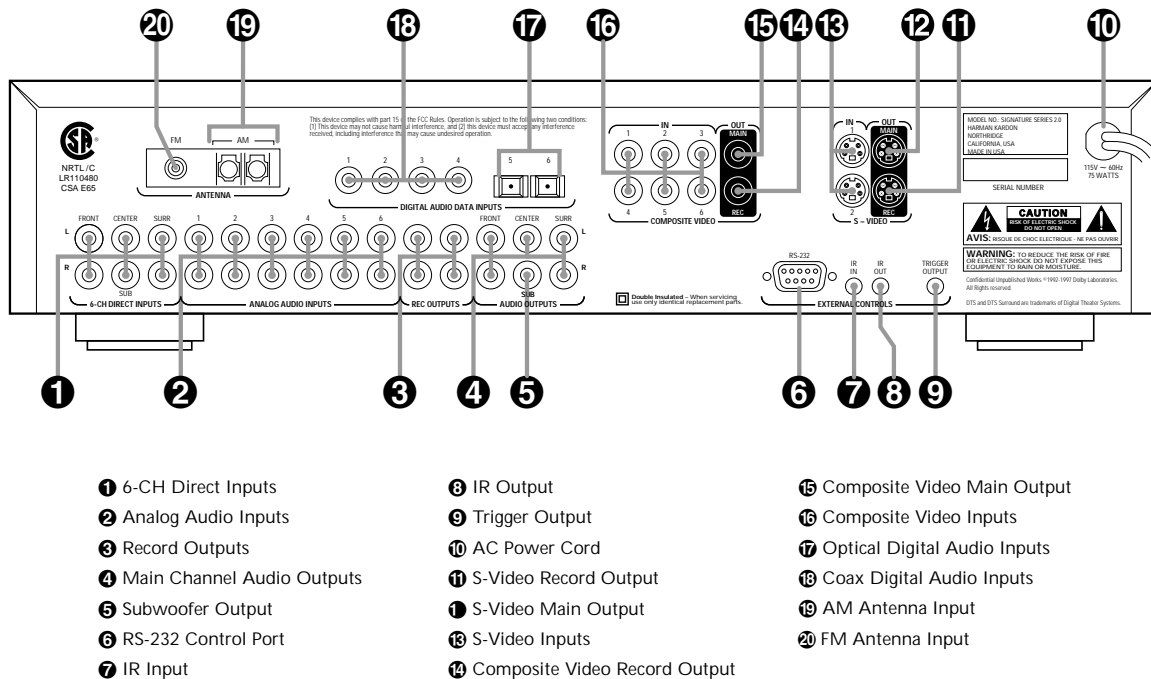

① 6-CH Direct Inputs: Use these inputs for connections to optional, external audio adapters. To select a device connected to these jacks, the audio input for a source must be changed to “6-CH Direct” using the **Source Menu** (see figure OSD-6 on page 29).

② Analog Audio Inputs: Connect the output of analog audio devices to these inputs. Note the left channel input is on top, and the right channel input is on the bottom. Once the inputs have been connected they may be assigned to any of the 2.0’s seven source positions using the **Source Menu** (see figure OSD-6 on page 29).

③ Record Outputs: Each of these two pairs of jacks carries the identical audio signal, which is the audio output selected through the **Record Outputs** menu (see figures OSD-35 and OSD-36 on pages 50 and 51). Connect these jacks to the “REC IN” input of a VCR, cassette recorder, DAT, reel-to-reel recorder, or another audio recording device.

④ Main Channel Audio Outputs: Connect these jacks to the input of the audio power amplifier. When making connections to an amplifier make certain that channels are connected to a matching input on the amp. (e.g., front left to front left, center to center, etc.).

Signature 2.0

- 5 Subwoofer Output** Connect this jack to the line level mono input of an optional powered subwoofer, or the audio input of an external amplifier used to drive a passive subwoofer. If you are using a passive subwoofer that has both left and right inputs and no indication of which to use for mono subwoofer inputs, it is advisable that a “Y” cable be used so that the signal is fed to both inputs.
- 6 RS-232 Control Port:** This jack is provided to permit operation of the Signature 2.0 by computers or home automation systems. The use of this control port requires additional optional software and it is strongly recommended that a Harman Kardon dealer be consulted before any connections are made.
- 7 IR Input:** If the 2.0’s front panel IR sensor is blocked due to cabinet doors or other obstructions, an external IR sensor may be used. Connect the output of the sensor to this jack.
- 8 IR Output:** This jack may be connected to other compatible Harman Kardon products so that they will receive infrared commands captured by the 2.0’s remote sensor.
- 9 Trigger Output:** If a compatible Signature Series or Harman Kardon audio power amplifier will be used with the 2.0, connect the amplifier connection cable supplied with the 2.0 between this jack and the “Trigger Input” of the amplifier. When connected by a properly trained dealer or installer, this output may also be used to control other devices designed to accept a 6- to 12-volt “Power On” trigger signal, such as projection television screens or automatic blinds. The MAXIMUM current draw for all circuits connected to this output is 150 milliamperes.
- 10 AC Power Cord:** Connect this plug to an unswitched, wall-mounted AC outlet.
- 11 S-Video Record Output:** Connect this jack to the S-Video “REC-IN” input of a VCR.

- 12 S-Video Main Output:** Connect this jack to the S-Video input of the TV, video monitor, projector or display that will be used to view the On-Screen Control Menus of the 2.0 along with any selected S-Video input.
- 13 S-Video Inputs:** Connect the output of S-Video sources to these input jacks. Once the inputs have been connected they may be assigned to any of the 2.0’s seven source positions using the **Source Menu** (see figure OSD-5 on page 27).
- 14 Composite Video Record Output:** Connect this jack to the composite video “REC-IN” input of a VCR.
- 15 Composite Video Main Output:** Connect this jack to the composite video input of a TV set, video monitor, projection television or other video display device that will be used to view the On-Screen Control Menus of the 2.0 along with the selected video input.
- 16 Composite Video Inputs:** Connect the output of composite video sources to these input jacks. Once the inputs have been connected they may be assigned to any of the 2.0’s source positions using the **Source Menu** (see figure OSD-5 on page 27).
- 17 Optical Digital Audio Inputs:** Connect the Optical (TosLink) digital audio output of audio sources to these jacks. Once the inputs have been connected they may be assigned to any of the 2.0’s source positions using the **Source Menu** (see figure OSD-5 on page 27).
- 18 Coax Digital Audio Inputs:** Connect the coax digital audio output of audio sources to these jacks. Once the inputs have been connected they may be assigned to any of the 2.0’s source positions using the **Source Menu** (see figure OSD-5 on page 27).
- 19 AM Antenna Input:** Connect the AM loop antenna supplied with the 2.0 to these terminals. An external AM antenna may also be connected here.
- 20 FM Antenna Input:** Connect an FM antenna to these terminals. Note that the supplied 300-ohm to 75-ohm adapter is required for connections from twin-lead dipole antennas.

Signature 2.0

Remote Control Operation

Remote Control Operation

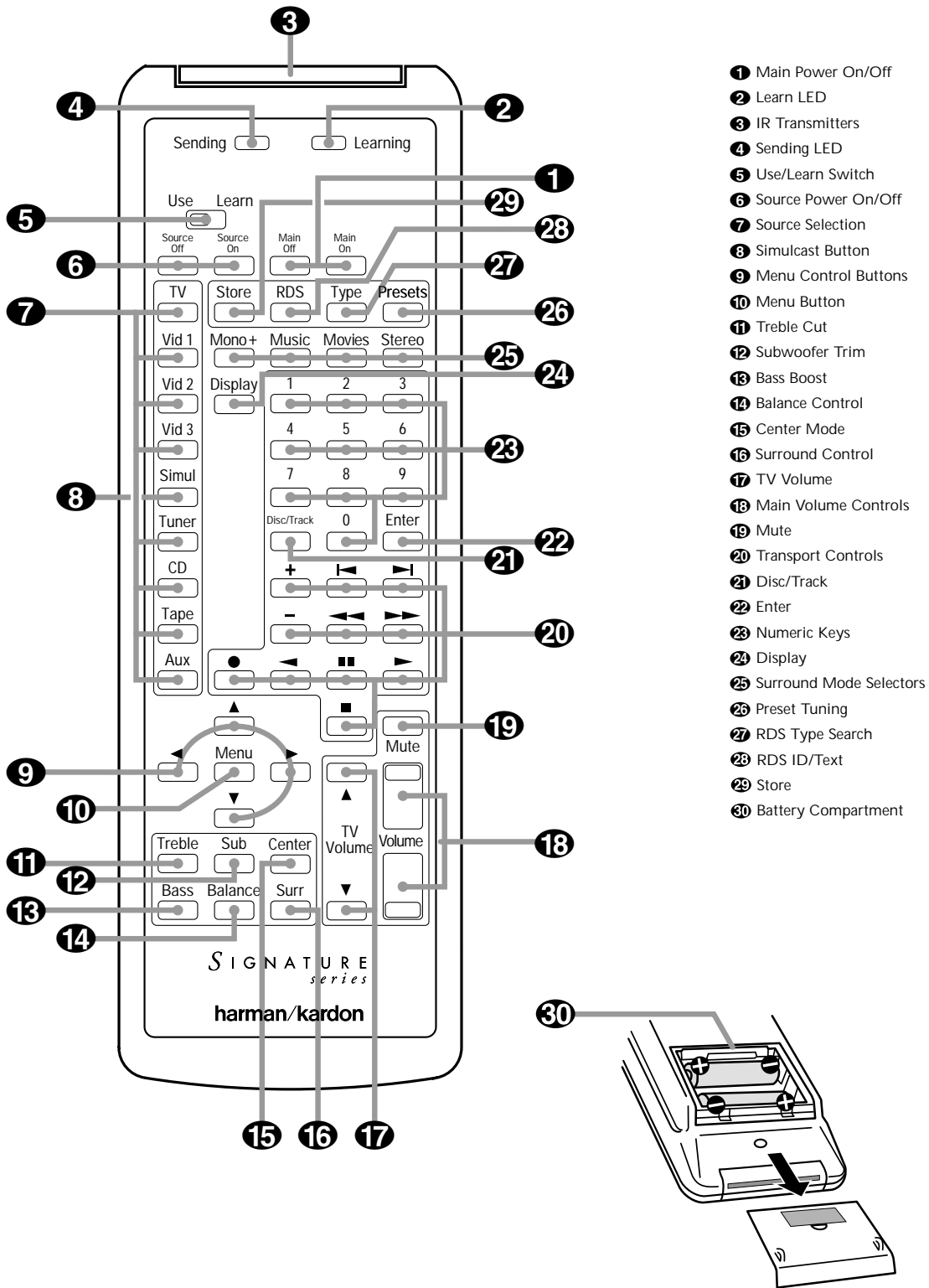

Signature 2.0

Although the basic functions of the Signature 2.0 may be operated from the front panel, most operation will be controlled through the wireless remote. The remote is a powerful tool, and it is worth taking a few minutes to familiarize yourself with the interaction of the various controls. In addition to the functions listed below, the 2.0's remote may be programmed to operate most infrared controlled products on the market. For complete information on how to program the remote, read pages 17-18.

1 Main Power On/Off: Press these buttons to turn the 2.0 on or to place it in the standby mode.

NOTE: The **Master Power Switch 1** must be in the "ON" position for these, or any other buttons on the remote to operate any function on the 2.0.

2 Learn LED: This indicator will illuminate when a button on the remote is being programmed with signals from another remote during the "learning" mode. The light will go out when the signal is received and memorized.

3 IR Transmitters: Behind this translucent panel are the infrared transmitters that send signals from the remote unit to the 2.0. When pressing buttons to issue commands, point this area towards the 2.0.

4 Sending LED: This indicator should flash any time a button is pressed to confirm that a command is being sent to the receiver of another unit. If the light is dim or does not illuminate when a button is pressed the batteries in the remote should be replaced.

5 Use/Learn Switch: This switch selects the operation mode of the remote control. Slide it to the left for normal operation. Slide it to the right when the remote is being programmed.

6 Source Power On/Off: Pressing these buttons will send a turn-on, turn-off command to the source device last accessed by pressing one of the **Source Selection** buttons **7**. Note that these commands may require programming of the remote control as explained on pages 17-18.

7 Source Selection: Pressing these buttons will select the input source for the 2.0. It will also activate the transport and numeric control buttons associated with that device, enabling control of the source with the 2.0 remote. If the 2.0 is in the Standby mode when one of these buttons is pressed, the unit will automatically turn on and switch to the selected input.

8 Simulcast Button: Using this button enables you to listen to one source while you watch the video from another. To use the Simulcast feature, first press the **Source Selection** button **7** for the desired video source, followed immediately by pressing this button. Release the **Simulcast** button, and press the desired audio source within 5 seconds.

9 Menu Control Buttons: These buttons control the location of the on-screen cursor to select items from on-screen menus, and they also act to select, move, increase or decrease items from control functions. The **▶** button is often used to move from a main menu to a sub-menu, the **◀** and **▶** buttons are used to select choices within menus, and the **▲** and **▼** buttons are used to move up and down through lists of selections.

10 Menu Button: This button is used to activate the On-Screen Menu Control System when it is not being used, or to enter selections and exit from the control system when it is active.

11 Treble Cut: Press this button to activate the Treble Cut feature. When the button is pressed a menu will appear on the screen (see figure OSD-19 on page 42), and you may reduce the high-frequency level of the output by pressing the **◀** or **▶** **Menu Control** buttons **9**. When you have completed the adjustment, press this button again to enter the setting and remove the menu from the screen.

12 Subwoofer Trim: Press this button to activate the Subwoofer Trim feature. When the button is pressed a menu will appear on the screen (see figure OSD-21 on page 42) and you may adjust the subwoofer output volume by pressing the **◀** or **▶** **Menu Control** buttons **9**. When you have completed the adjustment, press this button again to enter the setting and remove the menu from the screen.

Signature 2.0

13 Bass Boost: Press this button to activate the Bass Boost feature. When the button is pressed a menu will appear on the screen (see figure OSD-20 on page 42) and you may adjust the subwoofer output volume by pressing the ◀ or ▶ **Menu Control** buttons 9. When you have completed the adjustment, press this button again to enter the setting and remove the menu from the screen.

14 Balance Control: Press this button to activate the Balance Control feature. When the button is pressed a diagram will appear on the screen (see figure OSD-9 on page 32) that shows a small circle as the current listening position. To adjust the front/back fade and left/right balance use all four **Menu Control** buttons 9 to “move” the listening position with respect to the center of the room. Press this button again to enter the setting and remove the diagram from the screen.

15 Center Mode: Press this button to select the center mode. When the button is pressed a menu will appear on the screen (see figure OSD-22 on page 43) and you may then make a selection using the ◀ or ▶ **Menu Control** buttons 9. Press the button again to enter the setting and remove the menu from the screen.

16 Surround Control: Press this button to turn the surround channel output off or on. When the button is pressed a menu will appear on the screen (see figure OSD-23 on page 43) and you may then make a selection using the ◀ or ▶ **Menu Control** buttons 9. Turning the surround channel feed off with this control will change the setting only until the source is changed, at which point the setup configuration selected in the **Spkr Setup Menu** will take effect. Press the button again to enter the setting and remove the menu from the screen.

IMPORTANT NOTE: Adjustments made using the **Treble Cut, Subwoofer Trim, Bass Boost, Balance Control, Center Mode** and **Surround Control** buttons 11 12 13 14 15 16 are temporary. When the mode or input source is changed, or the 2.0 is turned off, the adjustment is canceled and the system preset will return. To make a permanent change to any of these settings, use the **Effects Menu**, as described starting on page 30.

17 TV Volume: These buttons may be used to control the volume of a TV, set-top converter box or other audio device not connected to the 2.0. When shipped from the factory, the buttons will control television sets with the popular RC-5 remote code system. To use these buttons to control other television sets you must program the codes into the remote as described on page 37.

18 Main Volume Control: These buttons control the unit's volume. Note that all channels are controlled simultaneously.

19 Mute: Press this button to temporarily silence the audio output of the receiver. Press it again to return to the previous volume level.

20 Transport Controls: These buttons may be programmed to control the transport functions of compatible VCR's, DVD player, CD player, cassette decks, and other source equipment by following the instructions on pages 17 and 18. As shipped from the factory, the remote will control compatible Harman Kardon CD players and cassette decks when the **CD** or **Tape Source Selection** buttons 7 have been pressed. Some of these buttons also have specific functions to operate the 2.0's tuner when it is selected.

- a) The ◀ and ▶ buttons are used for seek tuning. Each press of these buttons will cause the tuner to search for the station with the next higher or lower frequency that has a signal strong enough for acceptable reception.
- b) The ◀◀ and ▶▶ buttons may be used to manually tune stations in single frequency increments or, by pressing and holding one of these buttons, it is possible to quickly tune to a specific station.

21 Disk/Track: When a compatible Harman Kardon CD player or cassette deck is in use, this button has different functions. It may also be re-programmed to any compatible IR code function following the instructions on page 18.

- a) When **CD** is selected and the unit is a CD changer, these buttons will change to the next disc + or previous disc -.

Signature 2.0

- b) When **Tape 1** is the input source, and the tape machine is a compatible Harman Kardon dual cassette deck, these buttons will switch between the "A" and "B" wells.

22 Enter: Press this button to select a station after you have entered its frequency or preset location using the **Numeric Keys** **23**.

23 Numeric Keys: When the 2.0's tuner is in use, press these buttons to access a radio station's frequency or to enter a station to a specific preset location. See page 46 for complete information on tuning stations and programming preset memories. When other inputs are in use these keys may be programmed to use with TV, CD, and VCR functions that require numeric inputs. When shipped from the factory, the remote is programmed with the RC-5 control codes that activate many popular brands. It may also be re-programmed for use with most compatible infrared control systems by following the instructions on page 17.

24 Display: Press this button to show the details of the current input source via the On-Screen Display System. When a digital input is in use, the comprehensive display (see figure OSD-26 on page 44) will also show information when Dolby Digital sources are being decoded. Press it again to remove the display from the screen.

25 Surround Mode Selectors: Press these buttons to select a Surround mode for the current listening session. Note that the selection of available modes will change based on the use of an analog or digital input.

- a) Pressing the **Mono +** button will switch between the current surround mode and mono enhancement circuits that create an enveloping soundfield from a mono input.
- b) Pressing the **Music** button will scroll through the list of surround modes that are most appropriate to musical selections.

- c) Pressing the **Movies** button will scroll through the list of surround modes that are most appropriate for movie soundtracks.
- d) Pressing the **Stereo** button will switch between pure two-channel stereo sound and the previously selected surround mode.

IMPORTANT NOTE: Using these buttons will change the surround mode for a current listening session only. Once the input source is changed, the 2.0 will revert to the surround mode that has been entered using the **Source Menu**. To permanently change the surround mode that is assigned to an input source, use the Source Menu as described on page 28.

26 Preset Tuning: Pressing this button when the tuner is active to scroll up through the list of stations entered into the preset memory.

27 RDS Type Search: When the FM tuner is active, press this button to initiate a search for a station with a specific program type. For more information on RDS tuning, see page 48.

28 RDS: When the 2.0 is tuned to an FM station that is transmitting RDS data, press this button once to display the station's **Text** message. Press it again to view information that the station is transmitting about the station's call letters, network affiliation or other identifying information, as well as the station's program type (PTY). See page 48 for complete information on using the RDS system.

29 Store: When the tuner is in use, press this button to enter a station into the preset memory after selecting a location number between 1 and 30 using the **Numeric Keys** **23**.

30 Battery Compartment: Insert fresh AAA batteries here, being certain to observe proper polarity by matching the (+) and (-) indications on both the batteries and case. To remove the cover press down slightly on the raised ridges and gently push the cover away from you. To replace the cover, slide it back towards you until you hear the latch click.

Signature 2.0

Troubleshooting Guide

The Signature 2.0 is designed for trouble-free operation. In normal use, most users will not encounter any trouble with the unit. However, as with any sophisticated electronic device, there may be occasional problems on initial installation or during the life of the unit. The items described on this page and in the table below are a brief guide to the minor problems that you may be able to correct yourself, and to certain anomalies that result from outside conditions.

If these solutions do not rectify a problem, or if the problem persists, contact your dealer or installer. Problems may also be solved by an authorized Harman Kardon Service Center. To locate the Service Center nearest you, call (800) 422-8027 toll free in the United States. Harman Kardon may be contacted via the Internet at www.harmankardon.com

Error Messages

When the surround mode name blinks in the front panel **Information Display** (Figure FPD-12) that is your indication that there is a mismatch between the input source and the surround mode, or that there is no digital input at all.

Mode Mismatch

Certain modes are digital only, while others operate with analog signals only. The blinking light is an indication of a source/mode mismatch.

When this condition exists, the 2.0 will automatically select a properly matched surround mode and continue normal operation. To view the name of the mode selected, press the **Display** button **24**. The correct mode will be displayed next to the **Alt Mode** indication (Figure OSD-27). To stop the flashing message, press the appropriate **Surround Mode Selector** **25** **4** until the correct mode is selected.

No Data

If the mode name flashes when the mode and input are matched, this is an indication that the 2.0 is not receiving digital data from the source machine. This will typically occur when a DVD player is in pause or a fast scan

mode, as no digital data is typically output unless the disc is playing. To confirm that the lack of data is the cause of the error message, press the **Display** button **24** and check the on-screen status screen. If a **NO AC-3 Info** message appears (Figures OSD-14/OSD-18/OSD-27), this is your indication that the player is not sending a digital signal. Put the unit into Play, check the digital input connections or check to see that a digital input is selected to solve this problem.

Digital Noise With DVD Players

Certain early models of DVD players may occasionally cause a sharp “crack” or “snap” in the output channels during track or chapter changes. This is caused by a momentary discontinuity in the digital data output which is not long enough to trigger the flashing error message, but long enough to disrupt the processor. This type of random noise is caused by the DVD player, and it does not indicate a problem with the 2.0.

System Reset

In rare cases where the 2.0's operation or the displays seem abnormal, the cause may be erratic operation of the system's memory or microprocessor.

The first step to correct this problem is to turn the 2.0 off using the **Master Power Switch** **1** and unplug the unit from the AC wall outlet and wait at least three minutes. After the pause, reconnect the AC power cord and turn the unit on again. If the system still malfunctions, a system reset may clear the problem.

Note that clearing the system memory may correct the problem, but will also erase all system configuration data, input source assignments, input profile names, effects level settings and tuner preset memories. It is always a good idea to record your system configuration information in the Worksheets in Appendix B, if possible, before resetting the system. To reset the system, press the **Menu** button **10** to view the **Setup Menu**. Press the **▼ Menu Control** button **9** until **Advanced Setup** > is highlighted. Press the **► Menu Control** button **9** to go to the next screen.

Signature 2.0

At the **Advanced Settings** menu (Figure OSD-10), press the **▼ Menu Control** button **9** twice until **SYSTEM RESET >** is highlighted. Press the **▶ Menu Control** button **9** again.

This will bring up the **System Reset Menu** (Figure OSD-40). If you wish to exit at this point, press the **Menu** button **10**. To proceed with the reset, press the **▼ Menu Control** button **9** to move the highlighted area to the **Yes >** line, and then press the **▶ Menu Control** button **9**.

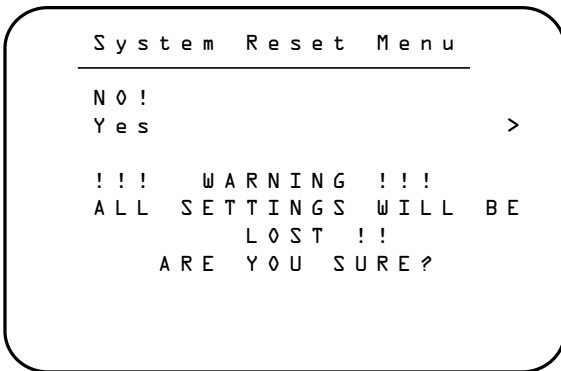

Figure OSD-40

The next screen (Figure OSD-41) instructs you to proceed by pressing and HOLDING the **Store** button **29** until the reset is complete.

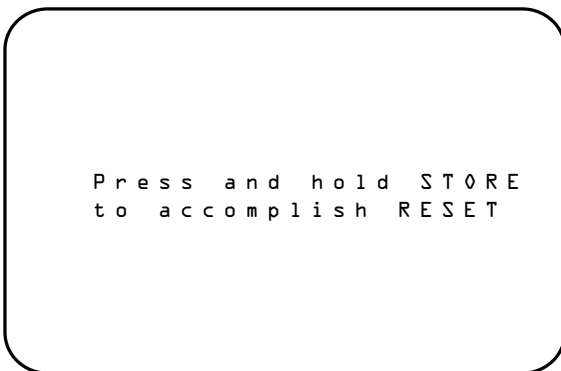

Figure OSD-41

Follow that instruction by holding the **Store** button until the **Reset Completed** message appears briefly on screen (Figure OSD-42) and the front panel **Information Display**. This is your indication that the reset has been accomplished, and you may release the **Store** button. The system will automatically return to the **Advanced Settings** menu.



Figure OSD-42

After a reset the system is returned to the original factory default settings as shown in Appendix A, and the micro-processor system is re-initialized. Press the **Menu** button **10** twice to return to normal operation, but remember that you will have to re-enter any settings previously established that differ from the factory presets.

If a reset does not solve the system problem, consult an authorized Harman Kardon service depot.

Signature 2.0

Troubleshooting Chart

Symptom	Possible Cause	Solution
Unit does not operate when standby switch or remote power is pressed.	<ul style="list-style-type: none"> No AC Power. Main Power Switch Off. 	<ul style="list-style-type: none"> Make certain AC power cord is plugged into a live outlet. Check to see if AC outlet is switch controlled. Turn on Main Power Switch.
Display lights, but no sound is heard from any channel.	<ul style="list-style-type: none"> Intermittent Connections. Mute is engaged. Amplifier is off. 	<ul style="list-style-type: none"> Make certain connections to source equipment and amplifiers are secure. Turn Volume control or press Mute button. Turn Amplifier on and/or check trigger connections.
Unit does not respond to remote commands.	<ul style="list-style-type: none"> Weak batteries in remote. Remote is in Learn position. Remote sensor is obscured. 	<ul style="list-style-type: none"> Change both remote batteries. Slide Use/Learn switch to Use. Make certain front panel sensor is visible.
Intermittent buzzing in tuner.	<ul style="list-style-type: none"> Local interference. 	<ul style="list-style-type: none"> Move unit or antenna away from computers, fluorescent lights, TVs, motors or other electrical appliances.
Status Menus visible, but setup menus do not appear.	<ul style="list-style-type: none"> Menu background set to "video" but no video is present. 	<ul style="list-style-type: none"> Switch to input with video signal present. Viewing the front panel display, use the menu system to reach Display Options, under the Advanced Settings menu. Switch the "Menu Bkgrnd" to "Blue" (see page 36).
Amplifier connected to the trigger output cycles on and off.	<ul style="list-style-type: none"> Connection problems. 	<ul style="list-style-type: none"> Make certain that the jack used is a 1/8" (3.5mm) MONO miniplug, not a stereo plug. Check to see that the plugs are firmly seated on both ends.
Audio signals distort for analog inputs.	<ul style="list-style-type: none"> Input level too high. 	<ul style="list-style-type: none"> Adjust input level to proper reference (see page 29).

Signature 2.0

Bass Boost

This chart, using data from a sample Signature 2.0 unit and automated test equipment, shows the frequencies at which low-frequency information is boosted when settings are changed with the **Bass Boost** control **(13)**, or through the use of the **Effects Menu** (Figure OSD-8).

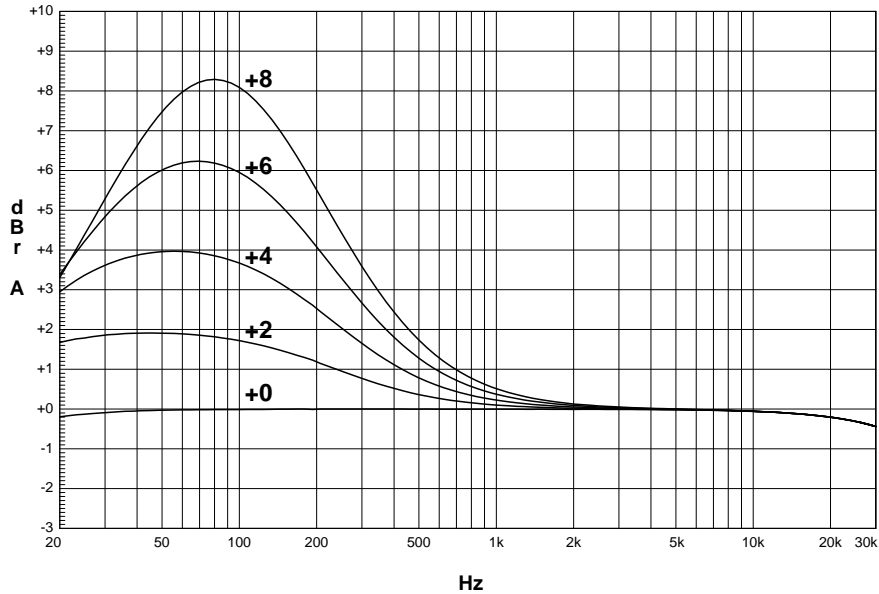

Treble Cut

This chart, using data from a sample Signature 2.0 unit and automated test equipment, shows the frequencies at which high-frequency information is rolled off when settings are changed with the **Treble Cut** control **(11)**, or through the use of the **Effects Menu** (Figure OSD-8).

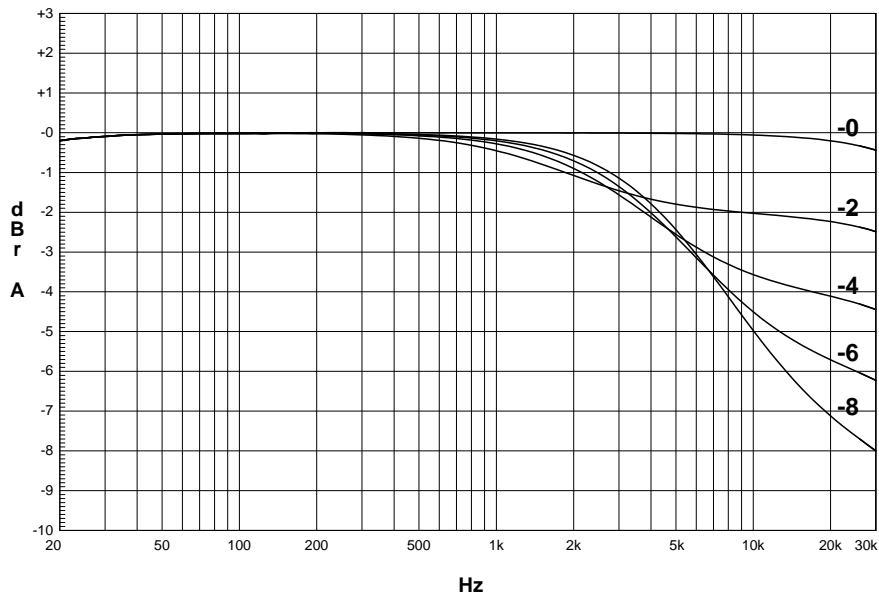

Signature 2.0

harman/kardon

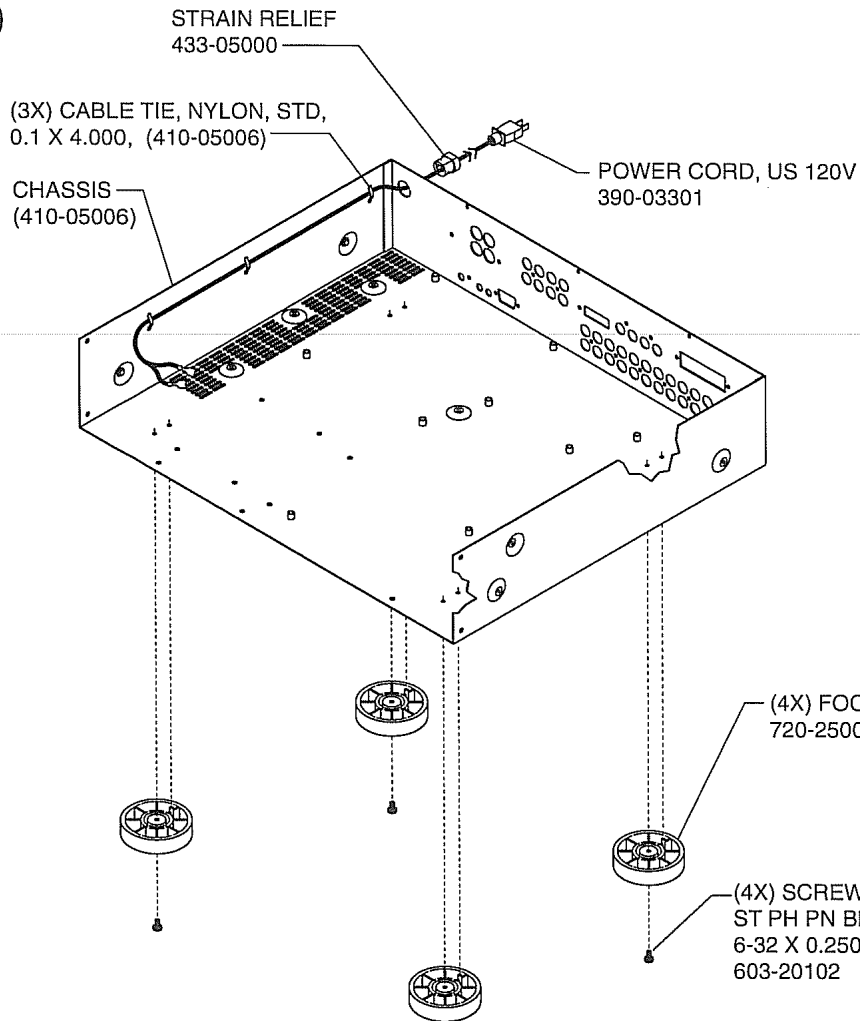

1.

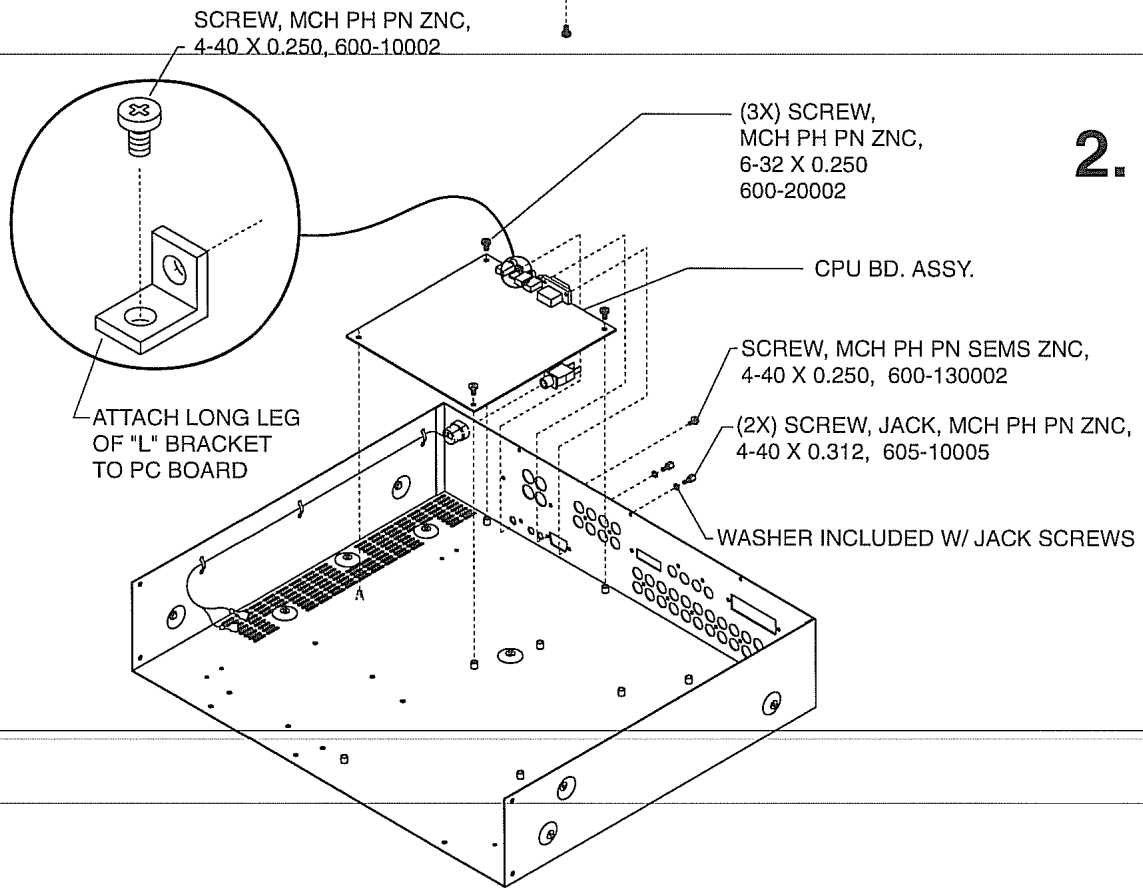

2.

Signature 2.0

harman/kardon

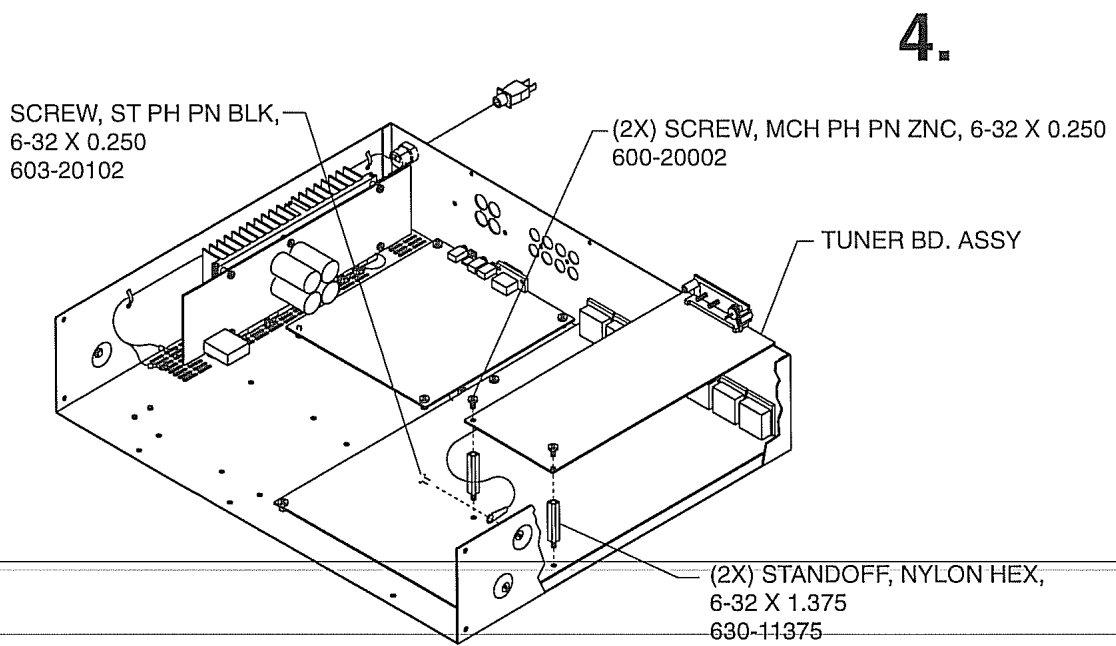
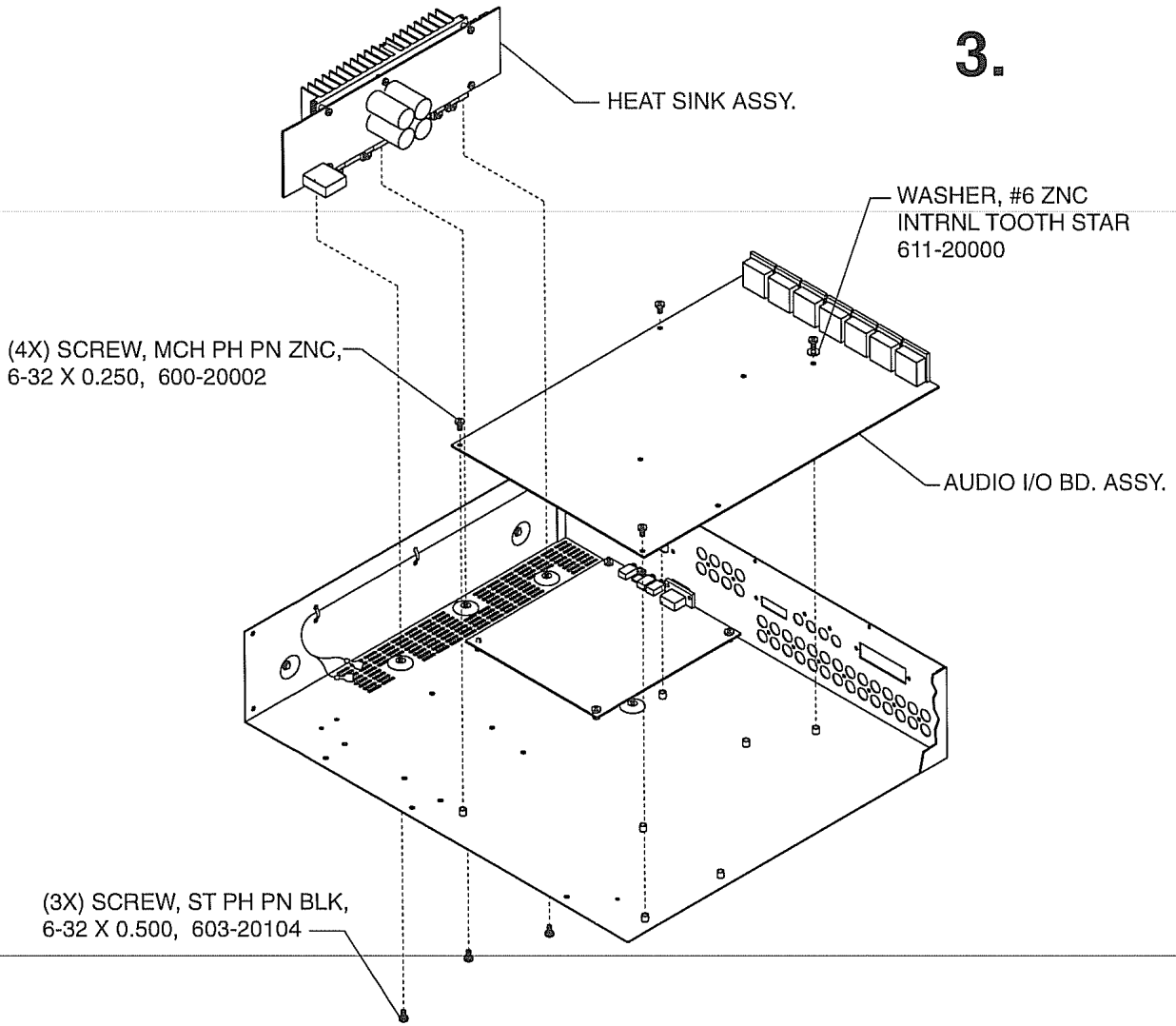

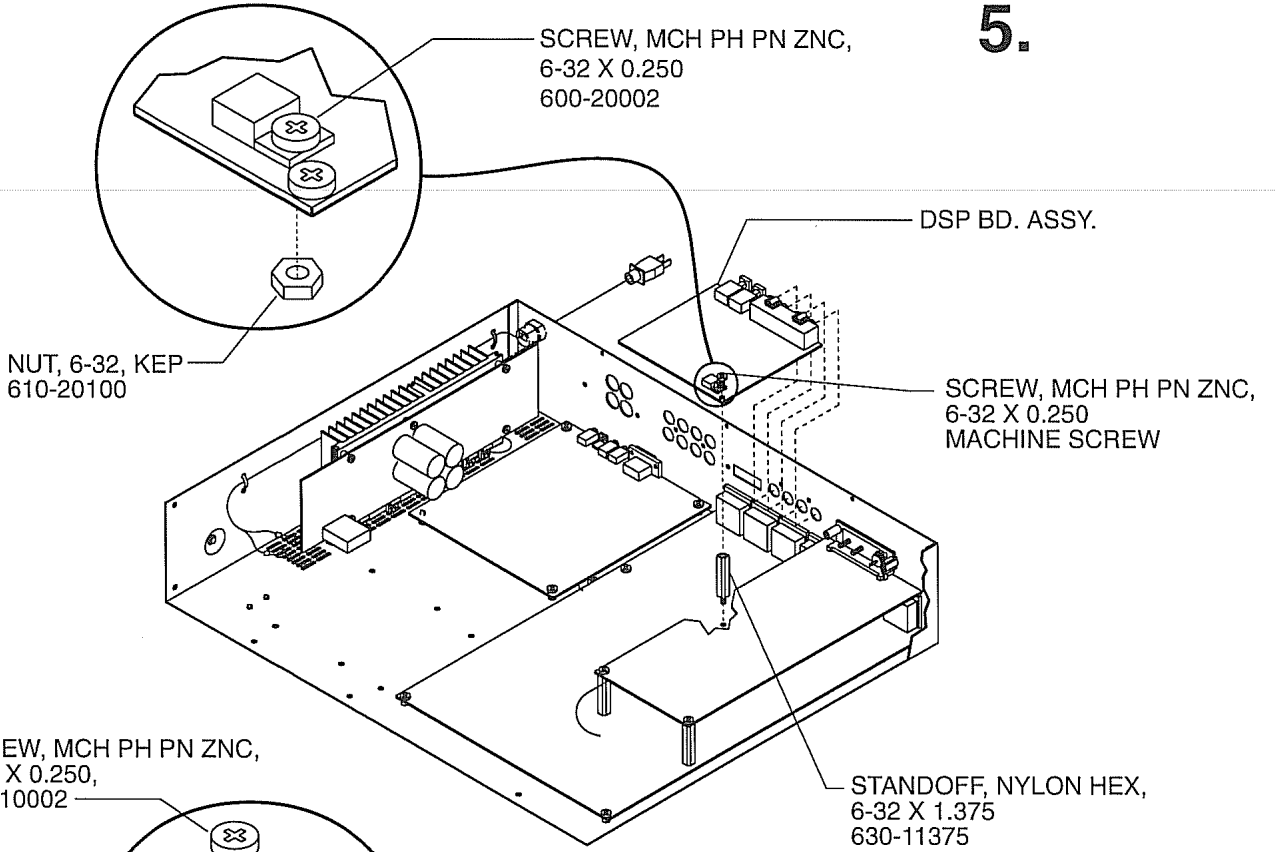

SCREW, MCH PH PN ZNC,
4-40 X 0.250,
600-10002

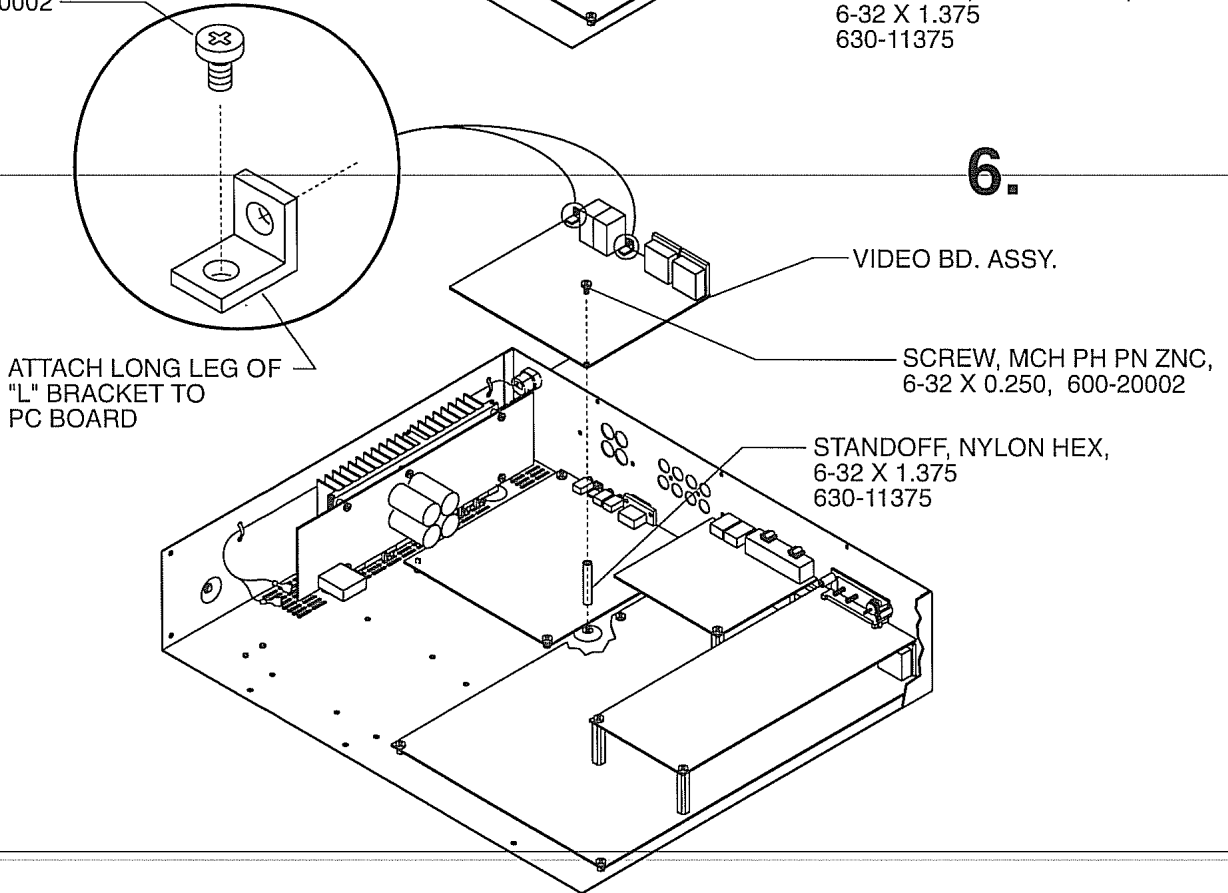

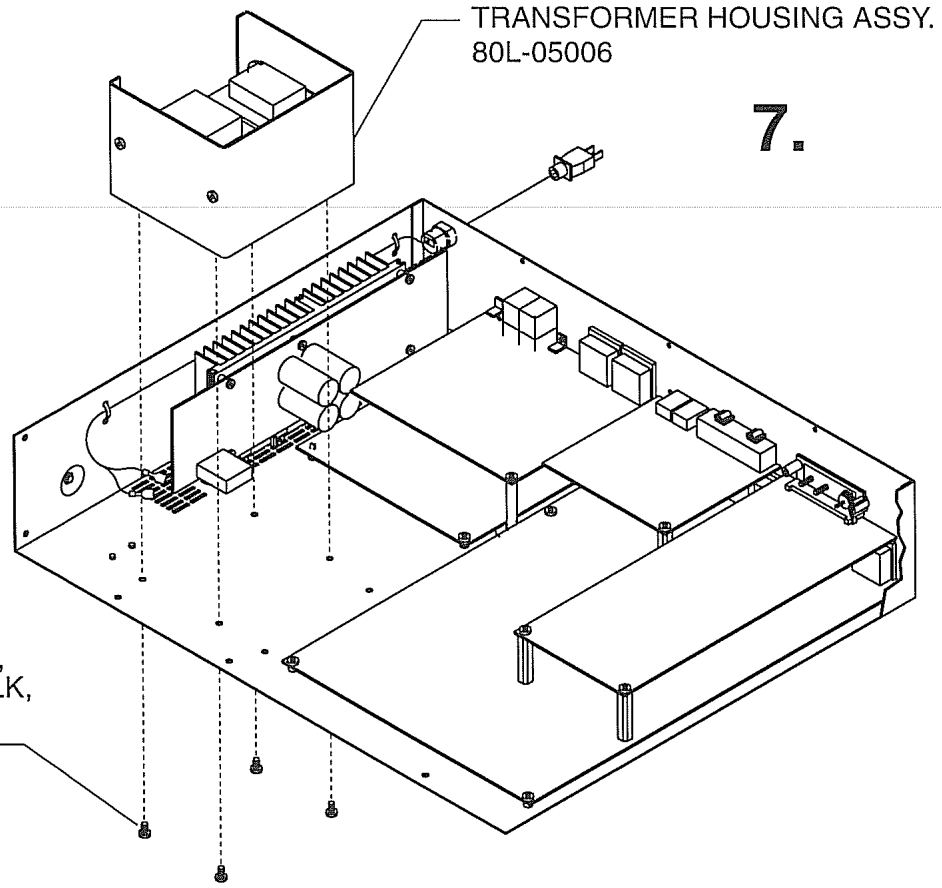

TRANSFORMER SHIELD
(416-05006)

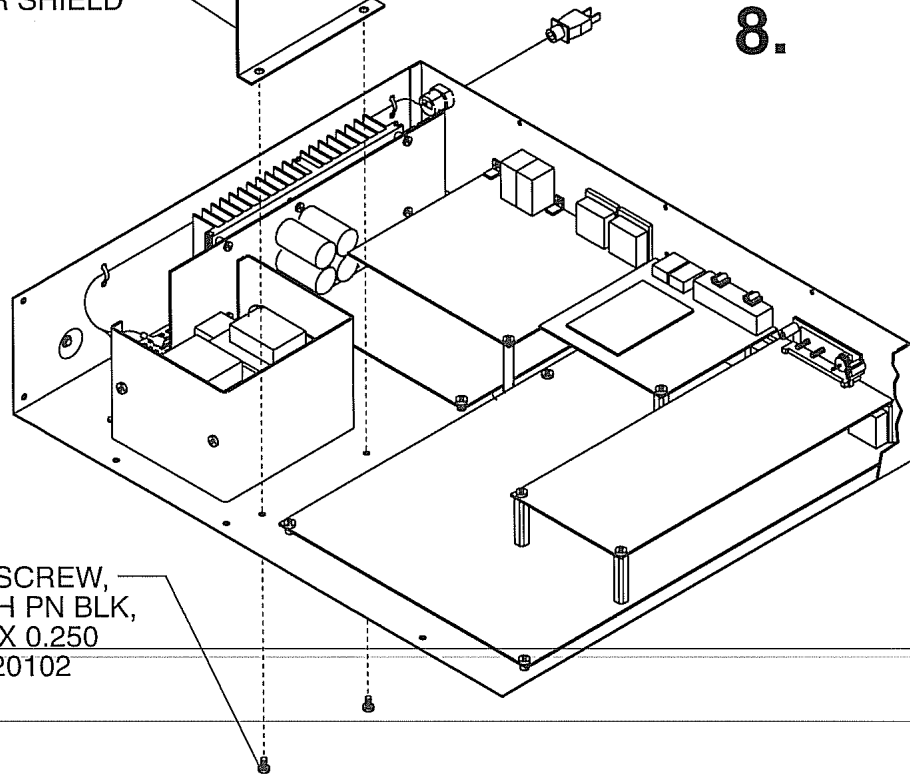

Signature 2.0

harman/kardon

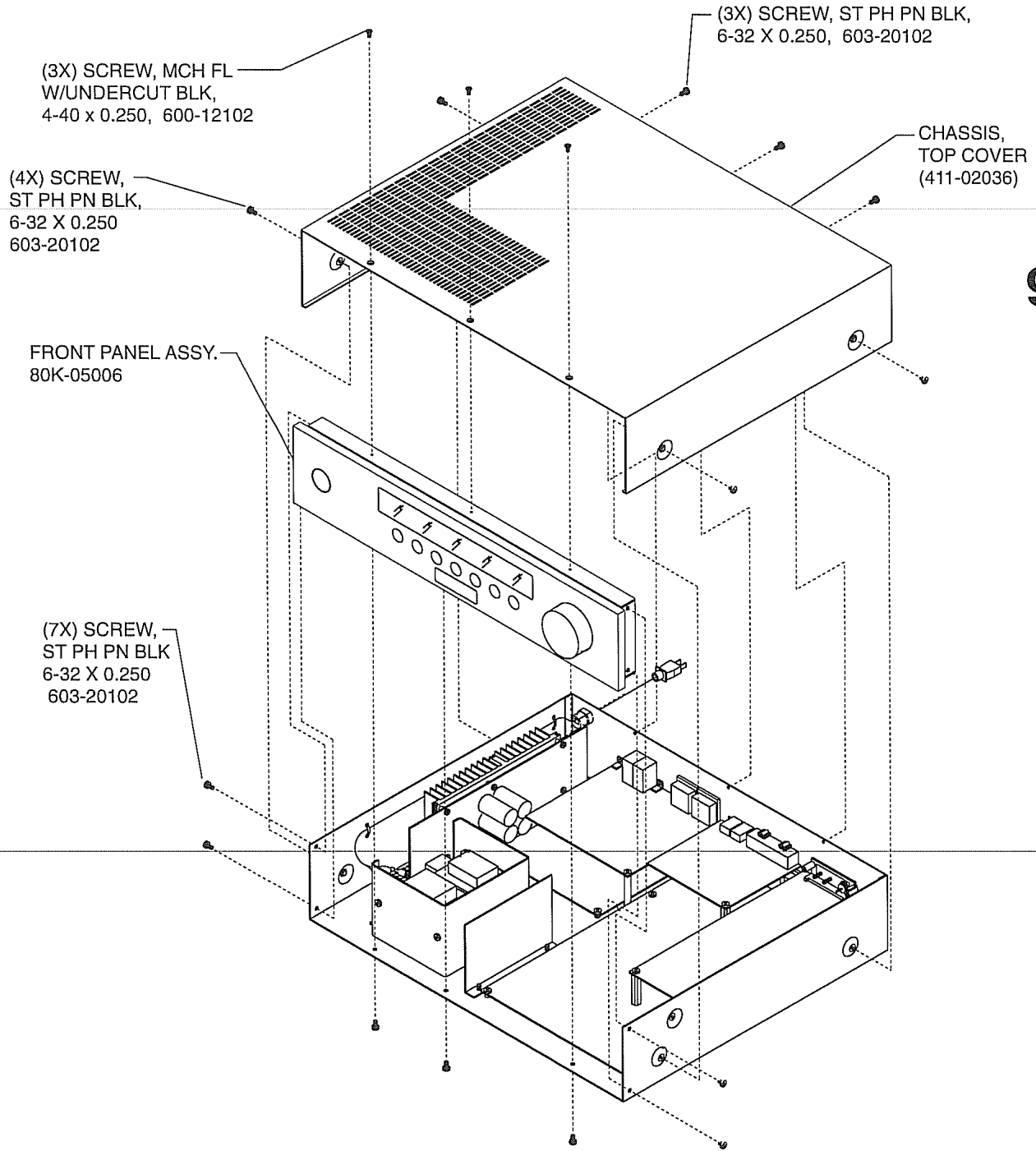

10.

HARDWARE CHART		
LOC	DESCRIPTION	QTY.
A	SCREW, SM PH PN BLK, 4-40 X 0.375 P/N 602-10103	11
B	SCREW, ST PH PN BLK, 6-32 X 0.250 P/N 603-20102	2
C	SCREW, MCH PH PN SEMS ZNC, 4-40 X 0.250 P/N 600-13002	3
D	SCREW, JACK, MCH PH PN ZNC, 4-40 X 0.312 P/N 605-10005	2

REAR VIEW

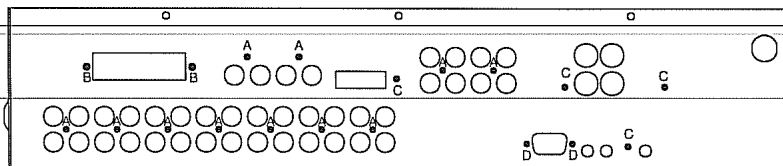

Service bulletin # H/K2000-07 July 2000

Warranty labor rate: MINOR repair

To: All harman/kardon Service Centers

Models: Signature 2.0 Processor/Tuner

Subject: Remote Control Works Intermittently

In the event you receive a Signature 2.0 with the complaint of “the remote control only works at certain angles, or when it’s very close to the unit,” perform the necessary steps listed below:

1. Make sure there are fresh batteries in the remote, and they are installed correctly.
2. Question for customer: Are you sure the area between the remote control and receiver is not blocked by some object, and the distance is no more than 15 feet, at an angle no greater than 30° from the front of the receiver ?
3. Question for customer: Are you sure strong lighting is not being directed towards the IR sensor of the unit ?

If the remote control of the Signature 2.0 Processor/Tuner still does not function correctly under proper conditions, then verify that the position of the IR sensor located behind the Signature 2.0 front panel is correct, as per steps below.

4. Remove the top cover to the unit (10 Phillips screws).
5. In the front left corner, carefully unplug the two colored female connectors on the Power Switch PCB.
6. Remove the (5) Phillips screws holding the front panel onto the chassis; there is one screw on either side, and three bottom screws.
7. Carefully disengage the front panel from the chassis; you may now remove the four plated Phillips screws deep in the recesses of the stamped metal cover plate at the rear of the front panel. A magnetic screwdriver bit is recommended.
8. Disengage rear cover from the front panel; you should now see the rectangular IR sensor at the left side of the VLF display. Align and straighten the sensor as indicated below; it should be straight and parallel in relation to the front panel; the rounded lens should be pointed straight forward.
9. Replace all screws and reassemble, following the instructions in reverse order; be sure and replace the two power switch connectors.
10. Connect all cables necessary for proper operation; power up the unit and check that the remote control is working properly.

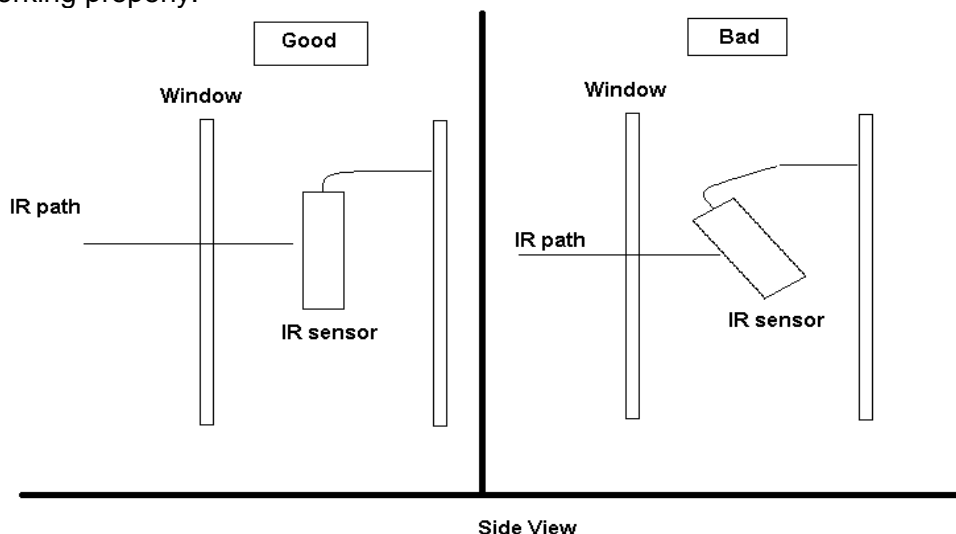

Service bulletin # H/K9709 Dec. 1997

Repair rate does not apply

To: All harman/kardon Service Centers

Models: Signature 2.0 Processor/Tuner

Subject: Turn on/ turn off "thump"

In the event you receive a Signature 2.0 that is being used with a power amplifier other than the Signature 2.1 which exhibits a "thump" when the unit is turned ON or OFF:

When a power amplifier *other than the Signature Series 2.1* is used with the Signature Series 2.0 Processor/Tuner, you may experience a mild turn-on or turn-off "thump". The Signature 2.1 power amplifier has a delay circuit that prevents this from happening.

There was a running change made by the factory that will prevent this symptom using *any* power amplifier. The change was made starting with the serial numbers listed below:

Model	Serial number 120V	Serial number 230V	Status	Action
Signature 2.0	GT0003-01001 to GT0003-02162	GT0006-01001 to GT0006-01157	Mild turn-on or turn-off "thump" when not using 2.1	Call for factory replacement of unit under warranty
Signature 2.0	GT0003-02163 and above	GT0006-01158 and above	Factory Installed Modification	NONE REQUIRED

To replace a unit under these conditions, please contact harman/kardon to obtain a unit for exchange in the latest serial number range listed above.

Service bulletin # H/K9708 Dec. 1997

This is considered a Major Repair

To: All harman/kardon Service Centers

Models: Signature 2.0 Processor/Tuner

Subject: Complaints related to version 2.0 - 2.3 Software

In the event you receive a Signature 2.0 with one or more of the symptoms listed below, upgrade the software to revision 2.4. Page 2 of this bulletin provides replacement instructions for IC U305.

Confirmation: Immediately after Power ON, the displays indicates the software revision. If the display indicates a Rev number less than 2.4 (i.e. rev. 2.0 or 2.3) then replace IC U305.

Note: Internally, IC U305 will be marked with a label reading 1.0 (A misprint – it's actually 2.0), 2.0 or 2.3.

SYMPTOMS APPLICABLE TO VERSION 2.0 ONLY:

- When a mode other than Stereo is selected, and the system is muted, adjusting the volume will not UNMUTE the system.
- "VOL" text erroneously continues to be displayed when direct tuner frequency access is used.
- Dolby Digital Mono is erroneously selectable from the front panel buttons when an analog source is selected.
- Display flashes source/volume information when items are changed in the tuner menu.
- When a preset is selected from the tuner menu, the manual RDS items are enabled/disabled incorrectly based on the band of the selected preset (i.e. AM stations shouldn't get manual RDS ID and Type).
- When switching between 2 inputs in stereo mode, one analog and the other digital, the sound is muted erroneously (however, changing modes will seem to restore the sound).
- Remote Seek Up and Seek Down buttons do not work in tuner menu for frequency selection.
- There is an erroneous level boost when switching into 6-ch direct mode.
- When switching from Stereo mode to 6-ch direct mode, the Center and Surround speakers remain muted, as though still in Stereo.
- Tuning in Long Wave in European setup is in 9kHz increments, as opposed to the correct 1kHz increments; not North America.
- When exiting the 6-Ch direct Audio input, the mode erroneously stays in 6-Ch Direct mode. (i.e. when going from 6-Ch Direct input to Analog #1 input, the mode stays in 6-Ch Direct...which is wrong. Note the difference between Audio input and mode).
- In the Speaker Setup menu, when switching selected speakers from on to off, or vice versa, those speaker outputs are not immediately muted (i.e. sound continues to come from the Center speaker, even though the user just changed the menu item to read "Center: None".)
- OSD timeout value allows a value of 00 which never times out.
- When selecting a source, the unit may not select the correct input level value.
- "Sensitive" remote button problem when cycling through the sources/modes from the menuing system. (e.g. one button press results in two value changes; hit the button once and you jump from Analog 2 to Analog 4).
- "High" indicator (signal level input) on the display from some CD players, some tracks, with subsequent distortion.

SYMPTOMS APPLICABLE TO VERSION 2.3 ONLY:

- Random characters are generated at the bottom-right of the video output.
- Center channel "Boost" function doesn't boost the Center channel sound level.
- "Sensitive" remote button problem when cycling through the Center/Surround effects. (e.g. one button press results in two value changes).

Model	Serial number 120V	Serial number 230V	Status	Action
Signature 2.0	GT0003-01001 to GT0003-02162	GT0006-01001 to GT0006-01157	Has early software version 2.0 or 2.3	Replace IC U305 with version 2.4 h/k part# A003-0020-4
Signature 2.0	GT0003-02163 and above	GT0006-01158 and above	Factory Installed version 2.4	NONE REQUIRED

SIGNATURE series 2.0 Software (IC U305) Replacement Instructions

Before replacing the software in the SIGNATURE 2.0 Processor, confirm the Software revision in the unit. To check, plug the unit in and turn it ON. The display will read "Ver ____". Make sure the version you are replacing is a higher number than what's on the display.

CAUTION: IC U305 EPROM IS AN ELECTROSTATICALLY SENSITIVE DEVICE AND CAN BE DAMAGED BY CARELESS HANDLING; YOU MUST FOLLOW PROPER STATIC CONTROL PROCEDURES TO PREVENT DAMAGE TO THE DEVICE.

1. Confirm the unit is unplugged and OFF.
2. Remove the 7 top cover screws. There are 2 on each side and 3 on the upper portion of the back panel.
3. Remove the top cover; slide it towards the back of the unit about an inch and lift it off from the back first.
4. Locate the video board directly behind the video jacks. Unplug the ribbon cable marked "CONTROL" on the circuit board under the ribbon. Unplug the green power supply cable marked "PWR"; apply only upward force to remove it.
5. Locate and remove the (4) screws and (1) nut holding the video board on. Two screws are located between the "COMPOSITE VIDEO" RCA jacks on the back panel. Two screws, with washers, are located on either lower side of the "S VIDEO" jacks on the back panel. The (1) nut is located on the inside corner of the printed circuit board next to capacitor C504.
6. Remove the video board by lifting the edge of the circuit board that has the connectors on it (CONTROL and PWR) up and out of the way of the power supply capacitors before complete removal.
7. The software IC (U305) should be visible at this point. Find it on the CPU circuit board under the video board, plugged into a 32 pin IC socket marked U305. You may need to move the 10 conductor ribbon cable aside to read the locator number; there is also a label on the IC stating the software version. (On one side of the IC there is a ribbon connector, on the other side of the IC is another device - MS6264L).
8. Apply a "L" shaped pick or jewelers flat blade screwdriver between the IC (U305) and socket at the notched end. Pry the end of the IC up enough to grab it and carefully lift straight up without further bending the pins while you complete the extraction.
9. Test fit the new IC (h/k part# A003-0020-4). The legs usually need to be bent inward. Do this by placing one side of the IC legs against the edge of a table to bend all of them at the same time. Do this on both sides just enough for the IC to fit properly into the socket.
10. Position the IC so the notch faces towards the transformers. Line up the legs into the socket and press down hard enough to seat the IC into the socket. Look at the legs on both sides of the IC and make sure there are not bent or misaligned.
11. Reinstall the video board in the same manner it was removed as in step 5, and reinstall the screws in their respective locations.
12. Plug the ribbon cable into the connector marked "CONTROL" and the green power cable into the connector marked "PWR".
13. Replace the top cover in the same manner it was removed in step 2, and reinstall the 7 screws. Tighten the rear panel screws first.
14. **You must do a reset for the new software to be enabled.** Make sure the On/Off button is in the OFF position. Plug the unit into an AC outlet. While pressing the SOURCE and MUTE buttons down at the same time, turn the On/Off button to the ON position. At this moment, the lower line of the display must read "Initialized". You may then release the buttons.

Service bulletin # H/K9904 October 1999

Warranty labor rate: MINOR repair

To: All harman/kardon Service Centers

Models: Signature 2.0

Subject: DTS Upgrade

The following instructions detail the steps needed to upgrade a Harman Kardon Signature Series 2.0 Processor/Tuner with a new DSP board and operating system EEPROM. These additions will provide significant improvements in performance, with the following major new advantages:

- Greatly improved audio decoding in all modes, using the highly regarded Crystal Semiconductor, CS4926, audio-decoding circuit.
- DTS processing, along with Dolby Digital, Dolby Pro Logic, and a wide variety of music and movie surround modes.
- Easier programming when used with computer-controlled RS-232 remote systems.
- Faster microprocessor operation for quicker response to remote commands
- Improved and updated on-screen menus with added features.

- 1) Order h/k DTS Upgrade kit, part number: SIG2.0 DTS UPGRADE.
- 2) A new Owner's manual (h/k part # HA160-0004-Arev1) should be ordered for the 2.0 that covers the operation of the DTS upgrade.
- 3) Following the detailed instructions on the following page.

Model	Serial number (120V)	Serial number (230V)	Status	Action
Signature 2.0	GT0003-01001 to GT0003-04000	GT0006-01001 to GT0006-02070	Unmodified	Replace IC305, DSP board Supplied with Upgrade kit
Signature 2.0	GT0003-04001 and above*	GT0006-02071 and above*	Changed by factory	NONE REQUIRED

* Additionally, factory modified units have a yellow label on the outer carton stating "Now with DTS".

Signature 2.0 Upgrade Procedure

WARNING: Please use caution during the removal of the DTS board and EEPROM IC305 from their protective packages, and during installation. ESD protection is required to assure the parts are not damaged.

PART I REPLACEMENT OF EEPROM IC305

1. Turn the unit off with the **Master Power Switch (on/off button on front panel)** and unplug it from the AC power source; remove any input and output cables.
2. Remove all (10) screws holding the cover on; there are two on the right and left sides, three at the rear, and three at the top near the front of the unit.
3. Remove the top cover by gently lifting it up slightly from the rear, and then pulling it back away from the unit.
4. Remove the two plated screws to the left and right of the S-Video jacks on the rear panel.
5. Remove the two black screws that are between the yellow video jacks.
6. Inside the unit, the video board is secured at the rear by a metal nut attached to a white plastic post on the corner of the board. Remove this nut.
7. Lift the video board up slightly, and pull it into the unit. Turn the board upside down and rest it carefully inside the unit. It is not necessary to unplug any additional connectors.
8. Locate the large EEPROM chip (IC305) on the CPU board that is now visible. The IC is in the center of the board and has a label with the word "Signature" and a revision number. Note there is a notch in the front edge.
9. Using an IC Chip Removal & Installation tool (Radio Shack model #276-2101 or equivalent), carefully remove the IC by gently rocking it from side to side and then pulling straight up.
10. Remove the new EEPROM from the upgrade kit and place it in the socket. *When inserting the chip, make certain that the notched end is facing forward, toward the front of the unit.* An outline of the chip with the notch in the proper position is screened on the board). The new EEPROM will be labeled "2.10a".
IMPORTANT NOTE: When inserting the new chip, take extra care to ensure all pins are seated in their respective holes, and they are not bent or damaged before the IC is seated. If needed, use a small flat-blade screwdriver to gently align the pins into the socket holes.
11. When all the pins are lined up, gently push down on the chip so that it seats firmly in the socket.
12. Replace the video board, pushing the RCA jacks back through the holes in the rear of the chassis and reseating the hole in the back corner of the board on the plastic support post; replace the nut.
13. Replace the two plated screws and the two black screws that secure the video board to the chassis.

PART II REPLACEMENT OF DSP AUDIO BOARD

14. Remove the plated screw to the right of the optical input jacks (near terminal #6) on the rear panel.
15. Remove the two black screws that are above the digital audio input jacks (#1- 4)
16. Pull the DSP board into the unit, free from the back panel. Remove the white plug at the rear of the board; then remove the ribbon connectors at either side of the DSP board by gently rocking the connector from side to side, while carefully pulling each connector upwards.
17. Remove the new DSP board from the upgrade kit. (New DSP boards are $\approx 5 \frac{1}{2}$ " in length; original DSP board is much shorter). Replace the three connectors; slide the white connector into the header socket on the rear of the new board. Replace two ribbon connectors back in their sockets on either side of the board. The side of the ribbon cable with the red line should face towards the front of the unit. Position each connector over the socket and press into position.
18. Put the new DSP board back into position through the holes in the rear panel.
19. Replace the two black screws above the RCA jacks and the single plated screw.
20. Replace the unit's cover and (10) screws.
21. Make certain the front panel **Master Power On/Off Switch** is in the "Off" position; it should extend out beyond the front panel.
22. To test: Before turning the unit On, it is important that the unit be reset. To reset, *first* hold in the two outer buttons on the front panel **Source** and **Mute**, then press the **Master Power On/Off Switch** to the "On" position; then release the **Source** and **Mute** buttons. The front-panel display should now read "Signature 2.0" and "Initialized." The unit has been reset and is ready for operation.
23. Attach a colored label to the bottom of the unit, and on the outer carton (if available), stating "**DTS upgrade**".

The following code changes were made from ver 2.0 to create 2.1 of the Signature 2.0.

1. When a mode other than Stereo is selected, and the system is muted, adjusting the volume will now cause the system to unmute correctly.
2. VOL text is no longer left hanging on the VFD when direct tuner frequency access is used.
3. Mute timing during power on/off has been adjusted to fit new output muting circuitry.
4. Dolby Digital Mono is no longer selectable from the front panel buttons when an analog source is selected.
5. VFD no longer flashes source/volume info when items changed from the tuner menu.
6. When a preset is selected from the tuner menu, the items are enabled/disabled correctly based on the band of the selected preset.
7. Speaker trim values have been changed from +10dB –10dB to +10dB –20dB to compensate for some highly efficient amp/speaker configurations.
8. OSD, and Volume chip communications sped up.
9. Switching between 2 inputs in stereo mode, one analog and the other digital now works correctly.
10. Removed long delay in power down sequence. This was necessary before the hardware change to reduce the power off thumping.
11. Enabled Seek Up and Seek Dwn buttons in tuner menu for frequency selection.
12. Updated RDS types to 2.0 spec
13. Removed level boost when switching into 6-ch direct mode
14. Corrected speaker setup problem when switching from Stereo mode to 6-ch direct.
15. US/EURO setup now enabled only from front panel button setup.

The following code changes were made from ver 2.1 to create 2.2 of the Signature 2.0.

1. Tuning in Long Wave in Euro setup is now 1kHz increments (as opposed to 9kHz increments)
2. When exiting 6-Ch direct, audio mode is now left alone, i.e., if you were in ProLogic mode when 6-ch direct input was selected, you're still in ProLogic mode when an analog or digital input is selected. In version 2.0 and 2.1, the mode was left in the 6-Ch direct.
3. In the Speaker Setup menu, when switching selected speakers from on to off, or vice versa, those speaker outputs are immediately muted.
4. OSD timeout value now has a value between 1 and 15 seconds. Previous versions would allow a value of 00 which would never timeout.
5. Bug fixed which, under certain conditions, when selecting a source, would not select the correct input level value.

The following code changes were made from ver 2.2 to create 2.3 of the Signature 2.0.

1. Fixed problem introduced in version 2.2, which caused the subwoofer to be muted when Stereo mode was selected.
2. Fixed the "twitchy" button problem when cycling through the sources/modes from the menuing system.

The following code changes were made from ver 2.3 to create 2.4 of the Signature 2.0.

1. Added changes required for Rev 3 audio board to reduce power transition “thumping”.
2. Code change to eliminate random characters at bottom-right of video output.
3. Center channel “Boost” function now works correctly.
4. Reduced remote button “twitchyness” when selecting Center/Surround effects.

The following code changes were made from ver 2.4 to create 2.4E of the Signature 2.0.

1. Fixed record bus problem. Tracking/Selectable now work correctly.
2. Auto mode switching no longer erroneously unmutes.
3. ‘<’ and ‘>’ key in tuner menu now work correctly. Both used to execute ‘>’ function.
4. Green characters changed to white in RDS Type menu.
5. Implemented Traffic program type for search.
6. Radio Text display rate upped to approx. 6 cps.
7. Input levels limited to +30 dB.
8. Tuner put into mono mode when mono DSP mode enabled.
9. Check for digital stream re-lock during auto-mode switching.
10. Added menu options to set power-up state for ‘ON’, ‘MUTE’ and ‘STANDBY’ into ADV SETTINGS menu.
11. No longer experience a program error when selecting ‘<’ key from RDS Manual menu
12. We now ‘Kick-Spanky’ during all DSP communications.
13. Mode name now restored correctly if stream restored while blink is off.
14. Unconfigured speakers always muted.
15. Rear delay now correctly set in Dolby Digital mode.
16. System vars updated automatically when new EPROM installed.
17. Preset storage selection in Tuner menu now has white characters instead of green.
18. DLBY Late Nite mode changed to Dolby Lt Nite.
19. Setting VFD status to OFF now correctly keeps the VFD off after power-up.
20. Default mode for CD and Tape now set to Stereo.
21. Removed “squeally” noise during power-up.
22. Program type name now right justified on VFD.
23. Add up and down arrow support for DVD remote.
24. Speaker delays are now reset when System Reset is performed.

The following code changes were made from ver 2.4E to create 2.5 of the Signature 2.0.

1. Support for new tuner board, including auto-detect of tuner version.
2. New tuner seek method, which speeds up searching.
3. Speed up RDS text scrolling to meet European requirements.
4. Disabled Longwave band from tuner.
5. Remote no longer ignores a tune down command after a fast seek up.
6. Mono (menu mono) now actually puts the tuner in mono mode.
7. Doing “ANY RDS” search will now stop at a “MANUAL RDS” preset.
8. Fixed stereo indicator: no longer lights when mono selected from Music Mode
9. Added RDS Traffic search.

10. Modified Traffic support to look for both “announce” and programming.
11. Added Traffic as a preset type.
12. RDS not supports TextA and TextB bit for displaying total of 128 character strings.
13. Detect new style DSP board and issue correct mode commands. Also enable DTS modes.
14. Added new Dolby Digital commands for correct mixing of matrixed streams.
15. Fixed DTS flash bug.
16. Center boost value changed from +2 to +4.
17. Subwoofer speaker setup mute bug fixed.
18. Personal1 will only search presets, not the entire band.
19. Center mode status now displayed correctly on the OSD.
20. “Center Wide” mode now blends correctly into L and R.
21. Pro Logic volume shift now added correctly when auto-selecting Pro Logic mode.
22. Correct Stereo 3 downmixing when disabling surround speakers.
23. When cycling through Center modes, boost is no longer cumulative.

24. Fixed random characters on OSD when powering up with OSD display turned off.
25. Significantly enhanced front panel button response.
26. Selected analog record input no longer bleeds through during power up.
27. Obnoxious popping removed from power up sequence.
28. When speaker setting indicates small surrounds, the surround low pass info is no longer mixed into either the fronts or subwoofer in a Pro Logic or other matrixed mode.
29. RS-232 interface and external control software enabled.
30. “Debounced” sync signal to video board to get rid of annoying flashing when a weak or no signal is present on video input.
31. When changing audio inputs from Sources menu, and a change is made from either analog to digital or vice-versa, the current mode is changed to the first available mode that is appropriate for the type of input selected.
32. Re-configure speakers for any stereo mode to remove the center speaker from the setup.

The following code changes were made from ver 2.5 to create 2.5E of the Signature 2.0.

1. When powering up main, initialize the video chip correctly to display a Blue screen rather than black.
2. Correctly set mixer latches when toggling between Stereo and any matrixed mode.

The following code changes were made from ver 2.5E to create 2.6 of the Signature 2.0.

1. Added menu entry in “Source Menu” for Video Detect. This allows the user to configure each individual source to switch to a Blue Screen when a loss of video sync pulses is detected, as in the default or “Auto” mode, or disable the detection altogether in the “Off” mode. The “Off” mode is useful when a video source is used that may exhibit video sync pulses that may be too weak for the Signature video board to deal with correctly, causing the Blue screen to appear rather than the selected video.

2. When cycling through the "Mode" line of the "Source Menu" the DSP (new Crystal model ONLY) would remain muted, thereby causing no output. This has now been fixed.
3. When a digital input stream is Auto-detected as a DTS stream, the default mode set is now full 3/2 rather than 2/0.
4. With the Tuner selected, if a numeric input sequence is left unfinished, the OSD will no be correctly updated with the current Tuner information.
5. When selecting a station via numeric input from the remote, the OSD display is now correctly updated when the Tuner becomes tuned.
6. From the "Tuner" menu, when RDS: entry is set to Manual and a Preset is then stored, the screen and system are then correctly stored and updated on the OSD. The lack of OSD update would create confusion as to whether the preset had actually been accomplished.
7. From the Tuner menu with any mode except "Stereo" selected, if the user presses the >| button on the "FREQ:" line to search for the next station, the Tuner will no longer stay muted. I believe this problem would only show up with the Crystal DSP board.

The following code changes were made from ver 2.6 to create 2.7 of the Signature 2.0.

1. Fixed problem that prohibited generation of pink noise in speaker calibration menu if a valid stream was present on a selected digital input.
2. Changed code to ensure that all unused output channels were muted when in Stereo mode.
3. Fixed screen timeout problem that caused an "unfinished" numeric input to remain on the OSD when attempting to change the tuner frequency with the Tuner selected.

The following code changes were made from ver 2.7 to create 2.8 of the Signature 2.0.

1. With a Dolby Digital 2/0/0 stream present, if the Stereo button on the remote is pressed, the 2.0 will go into Pro Logic mode. This is required by Dolby to fix their problem of some incorrectly flagged program material.
2. Trim control ranges are now limited to +10 –20 dB.
3. All channels will now track the master volume in level. This will compensate for trimmed channels and the non-linearity of the volume pots
4. Balance control now works correctly.

Steps to turn Auto Detect Mode ON for Sig. 2.0 version 2.10

This can be accomplished by viewing the **On Screen Display** or the front panel display.

- 1) Turn the unit ON. **TV PRO LOGIC** should be in the display
- 2) Press the **MENU** button on the remote control. **SET-UP MENU RECORD OUTPUTS** should be in the display.
- 3) Press the “down” arrow button on the remote; **SOURCES** should be in the display.
- 4) Press the right arrow button on the remote; **SOURCES TV** should be in the display.
- 5) Press the “down” arrow button on the remote until **AUDIO ANALOG 2** is in the display.
- 6) Press the right arrow button on the remote until **DIGITAL 1** is in the display.
- 7) Press the “down” arrow button on the remote until **AUTO MODE DETECT : OFF** is in the display.
- 8) Press *any* arrow button on the remote to display **AUTO MODE DETECT: AUTO**
- 9) Press the **MENU** button twice on the remote to return to the beginning of the menu choices.

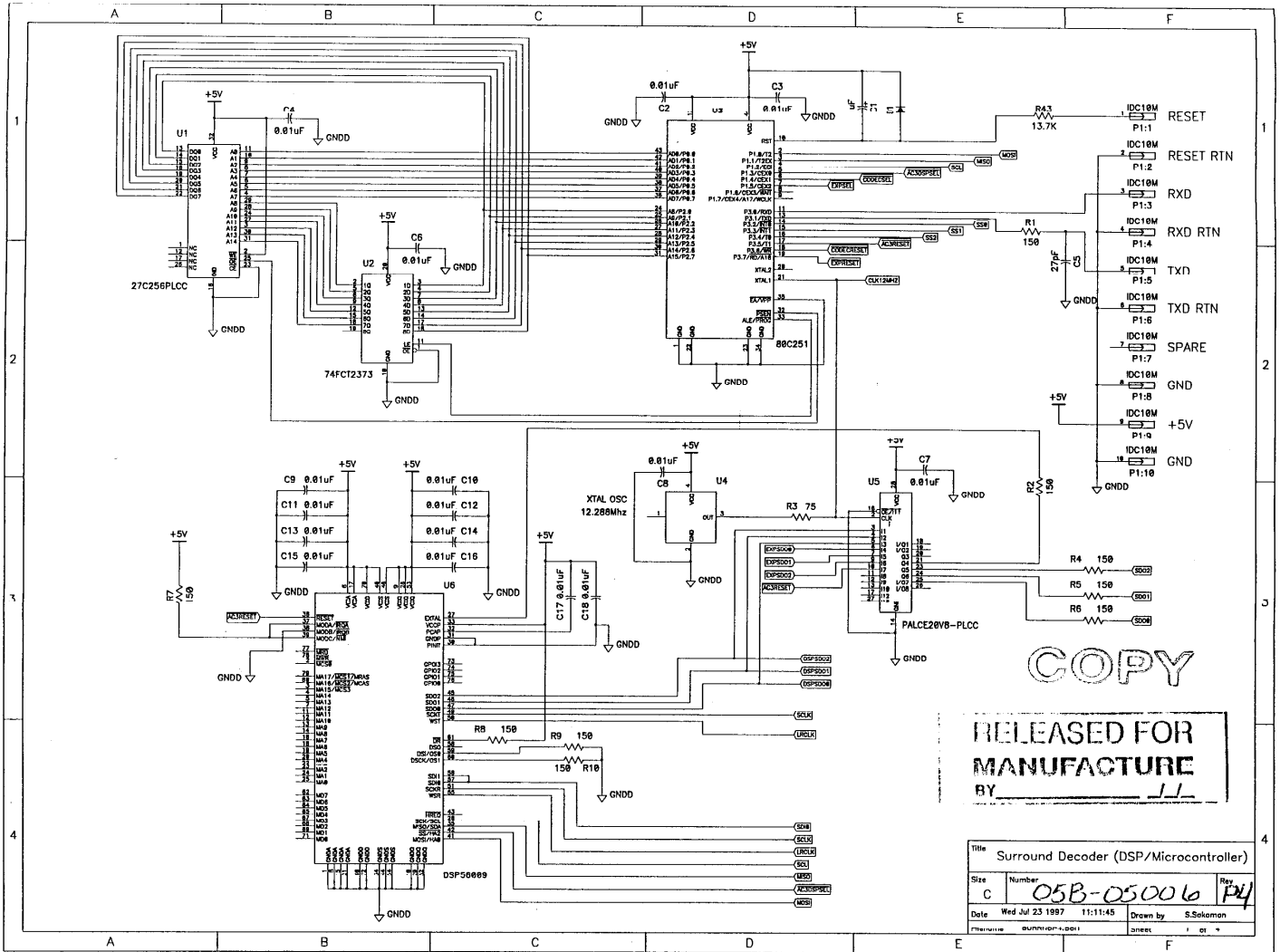

COPY
 RELEASED FOR
 MANUFACTURE
 BY

Title			Surround Decoder (DSP/Microcontroller)		
Size	Number	Rev			
C	05B-05006	P4			
Date	Wed Jul 23 1997 11:11:45	Drawn by	S.Sokolov		
Part Number			Sheet 1 of 1		

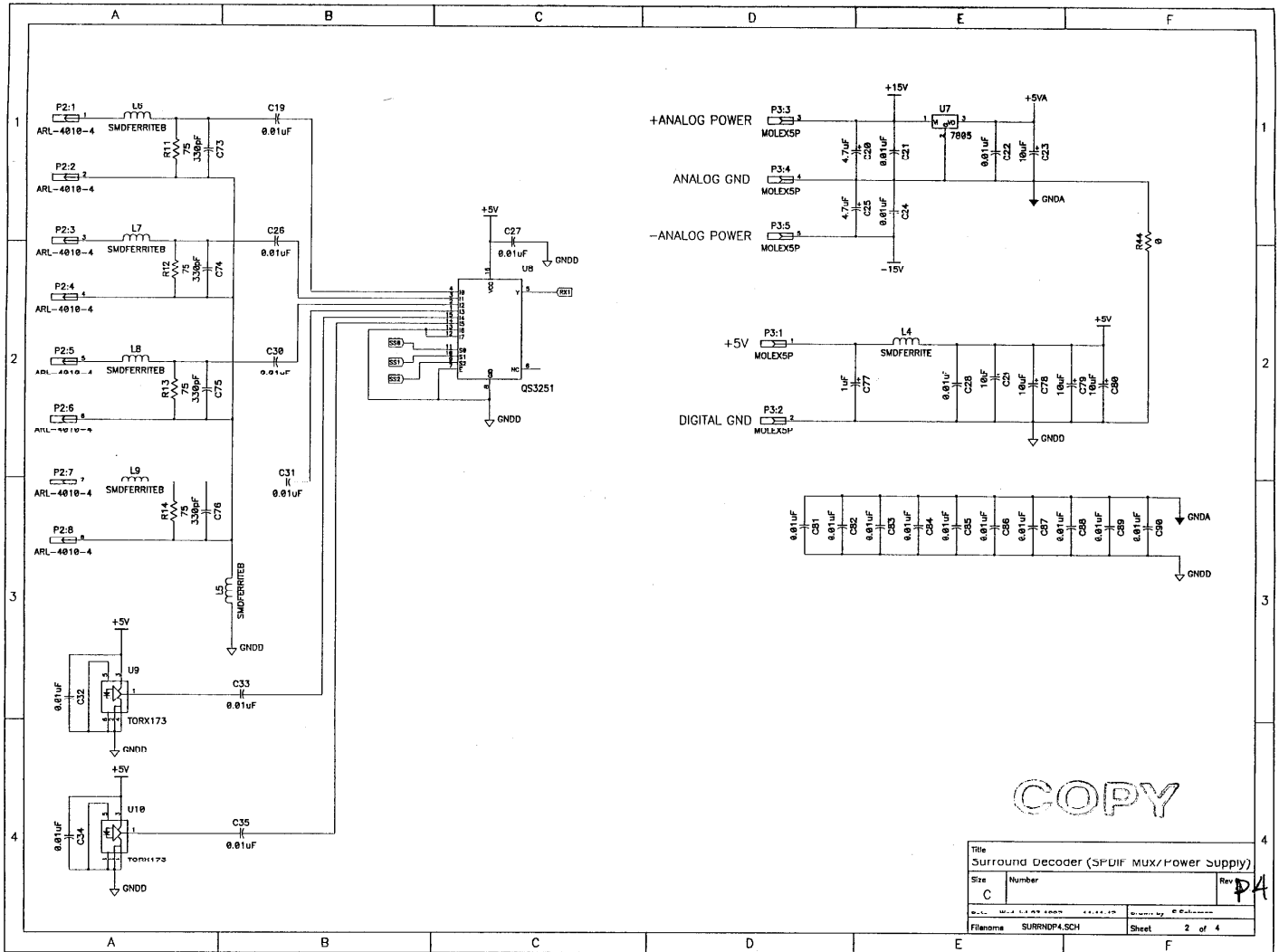

COPY

Title		
Surround Decoder (SPDIF Mux/Power Supply)		
Size	Number	Rev
C		P4
Filename		Sheet
SURRNDP4.SCH		2 of 4

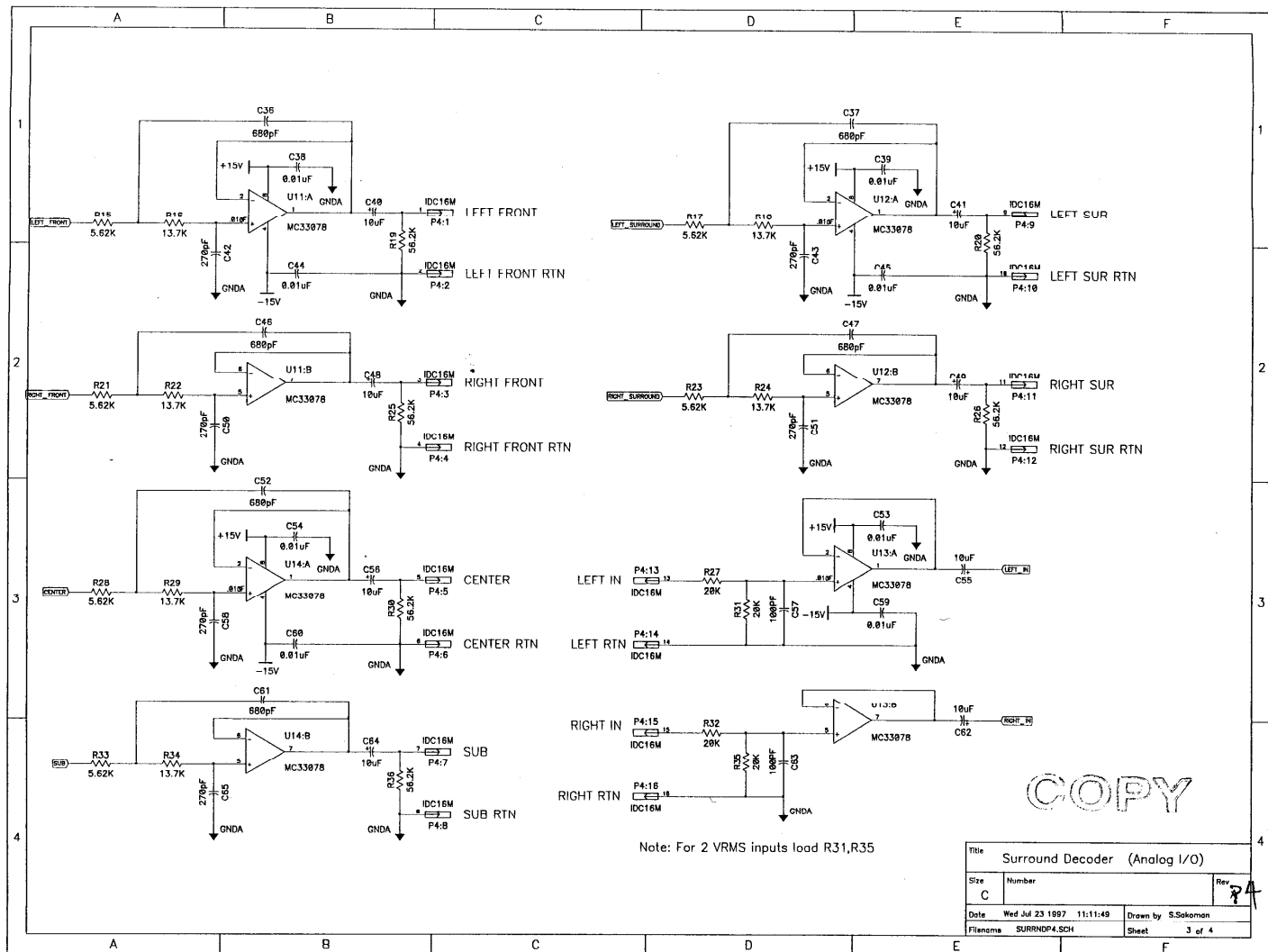

Title		Surround Decoder (Analog I/O)	
Size	Number	Rev	
C		8A	
Date	Wed Jul 23 1997 11:11:49	Drawn by	S.Sakoman
Filename	SURRNDPA.SCH	Sheet	3 of 4

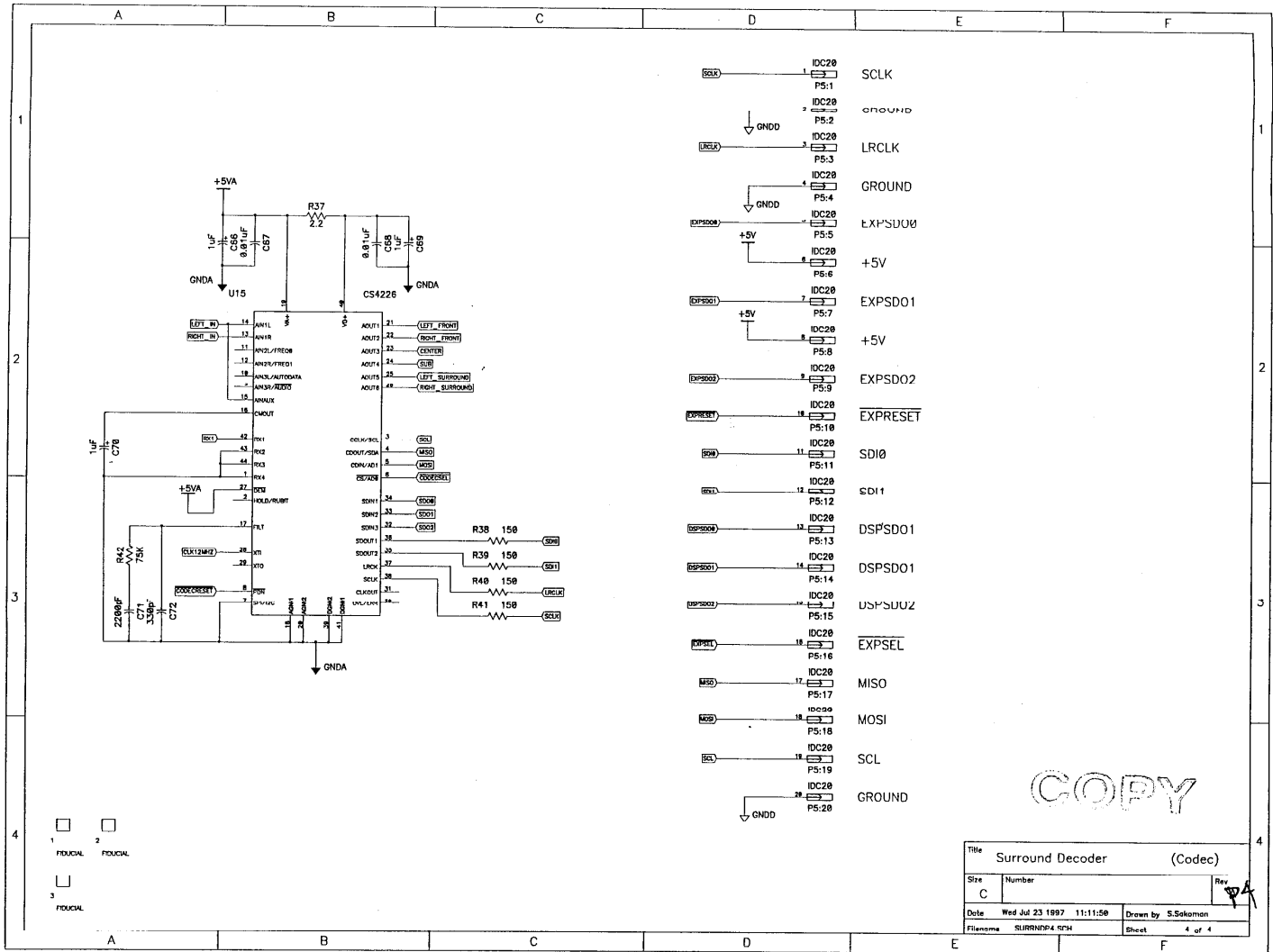

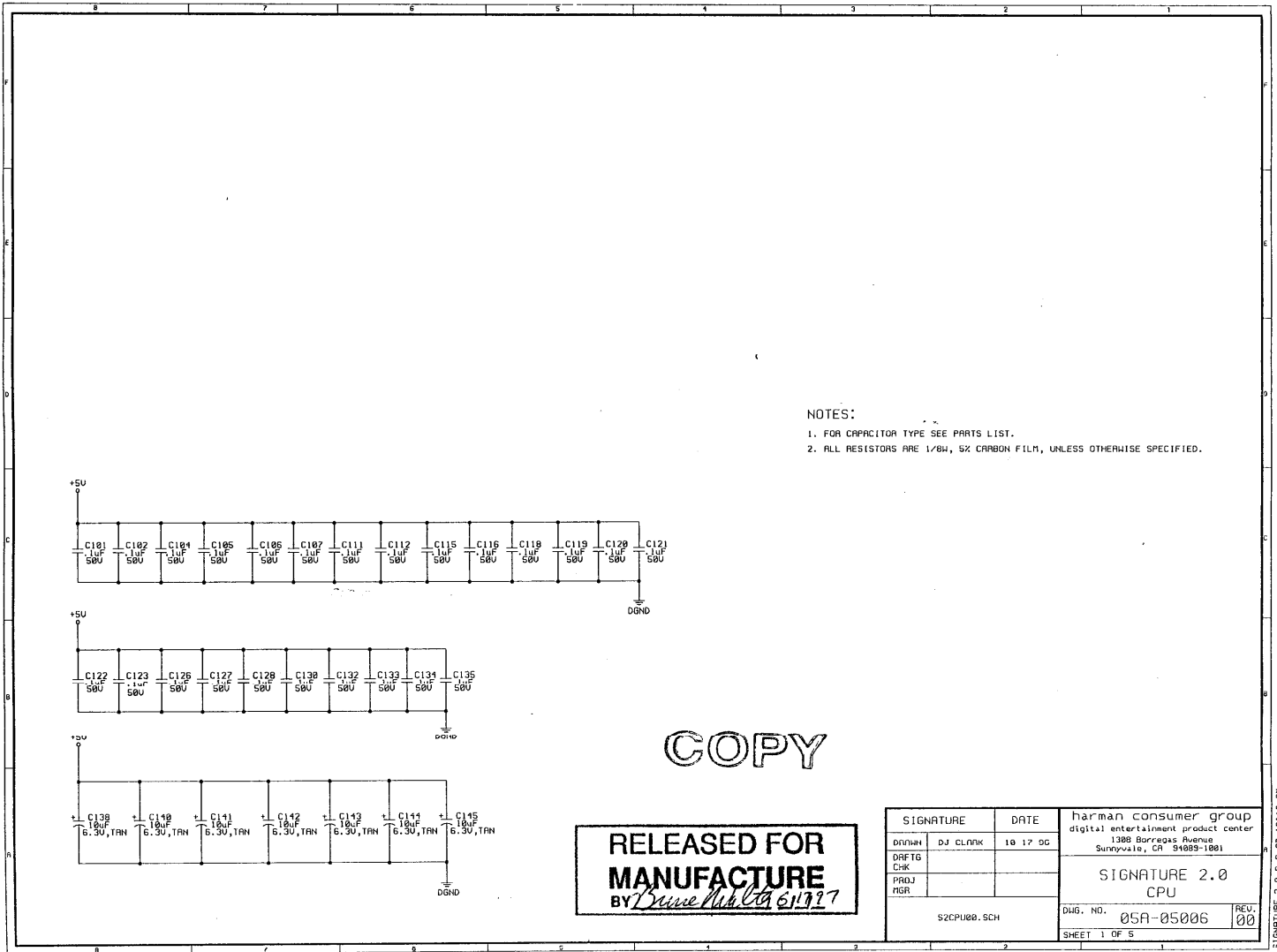

NOTES:

- 1. FOR CAPACITOR TYPE SEE PARTS LIST.
- 2. ALL RESISTORS ARE 1/8W, 5% CARBON FILM, UNLESS OTHERWISE SPECIFIED.

COPY

RELEASED FOR MANUFACTURE
 BY *Burne Inc. 6/17/77*

SIGNATURE		DATE	harman consumer group digital entertainment product center 1388 Borregas Avenue Sunnyvale, CA 94089-1001	
DRAWN	DJ CLARK	10 17 80	SIGNATURE 2.0 CPU	
DRAFTG				
CHK				
PROJ			Dwg. NO. 05A-05006	
AGR			REV. 00	
S2CPU00.SCH			SHEET 1 OF 5	

SIGNATURE 2.0 6-9-80 10:18 AM

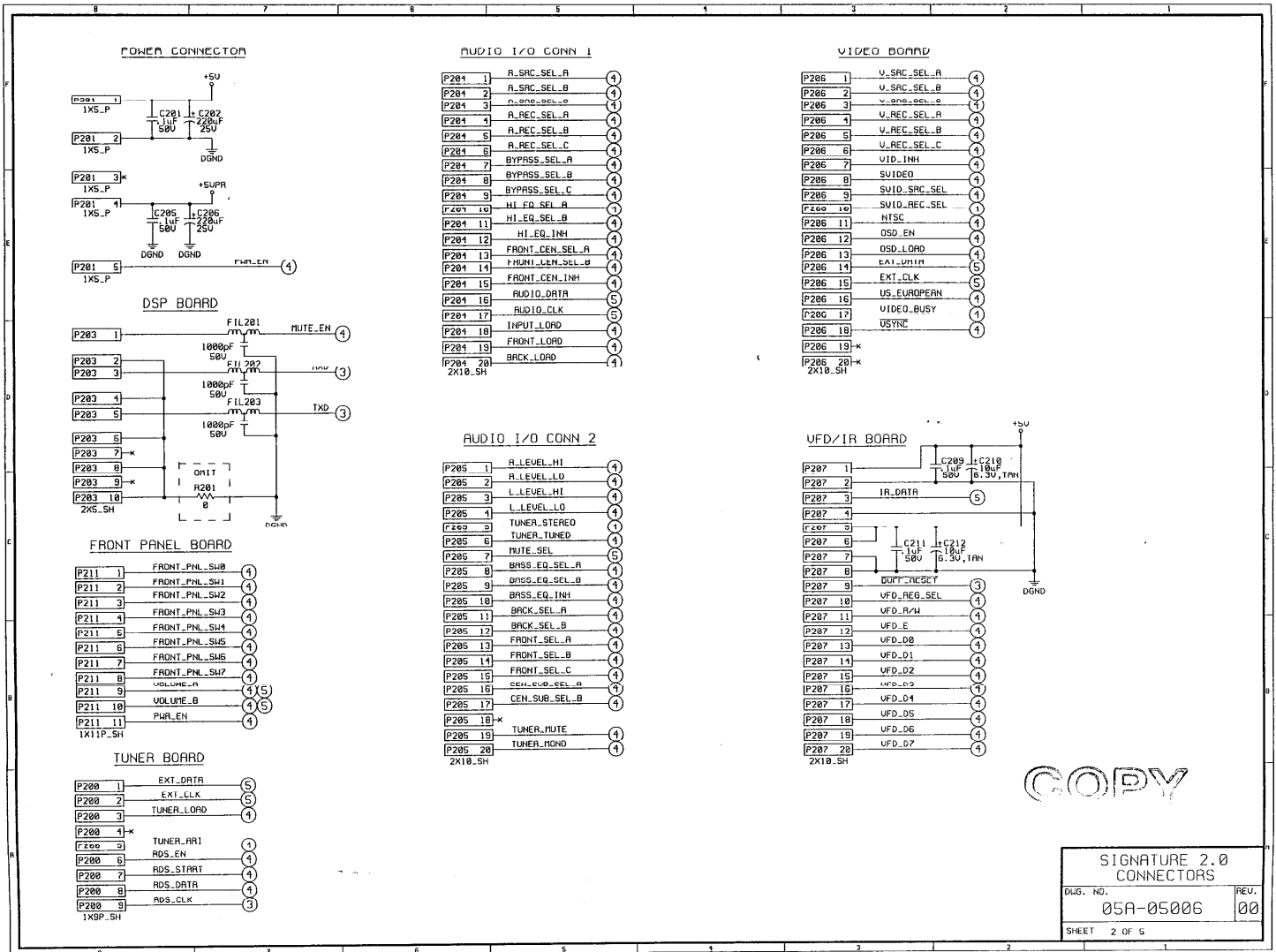

COPY

SIGNATURE 2.0
 CONNCTORS
 DWG. NO. 05A-05006
 REV. 00
 SHEET 2 OF 5

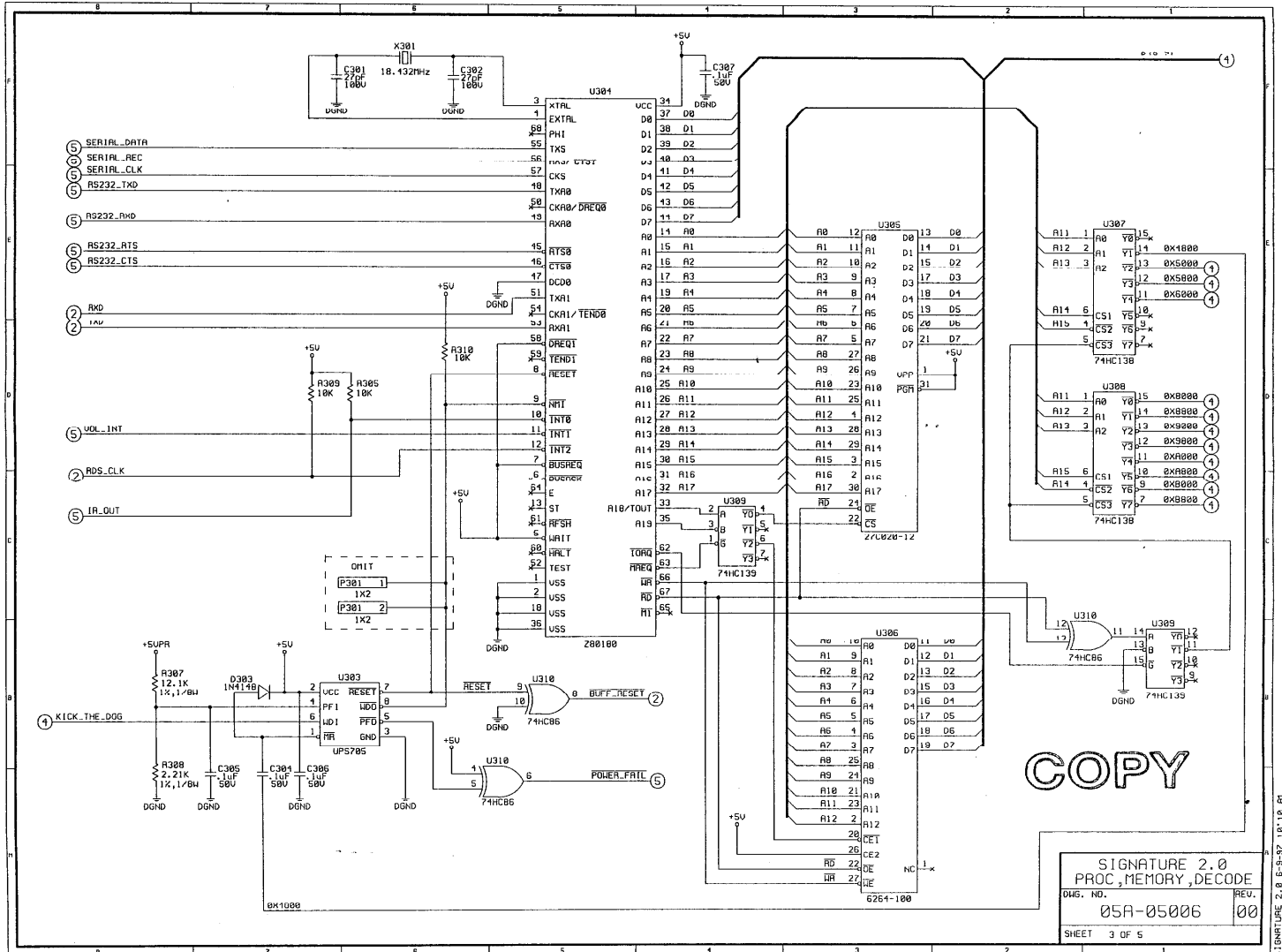

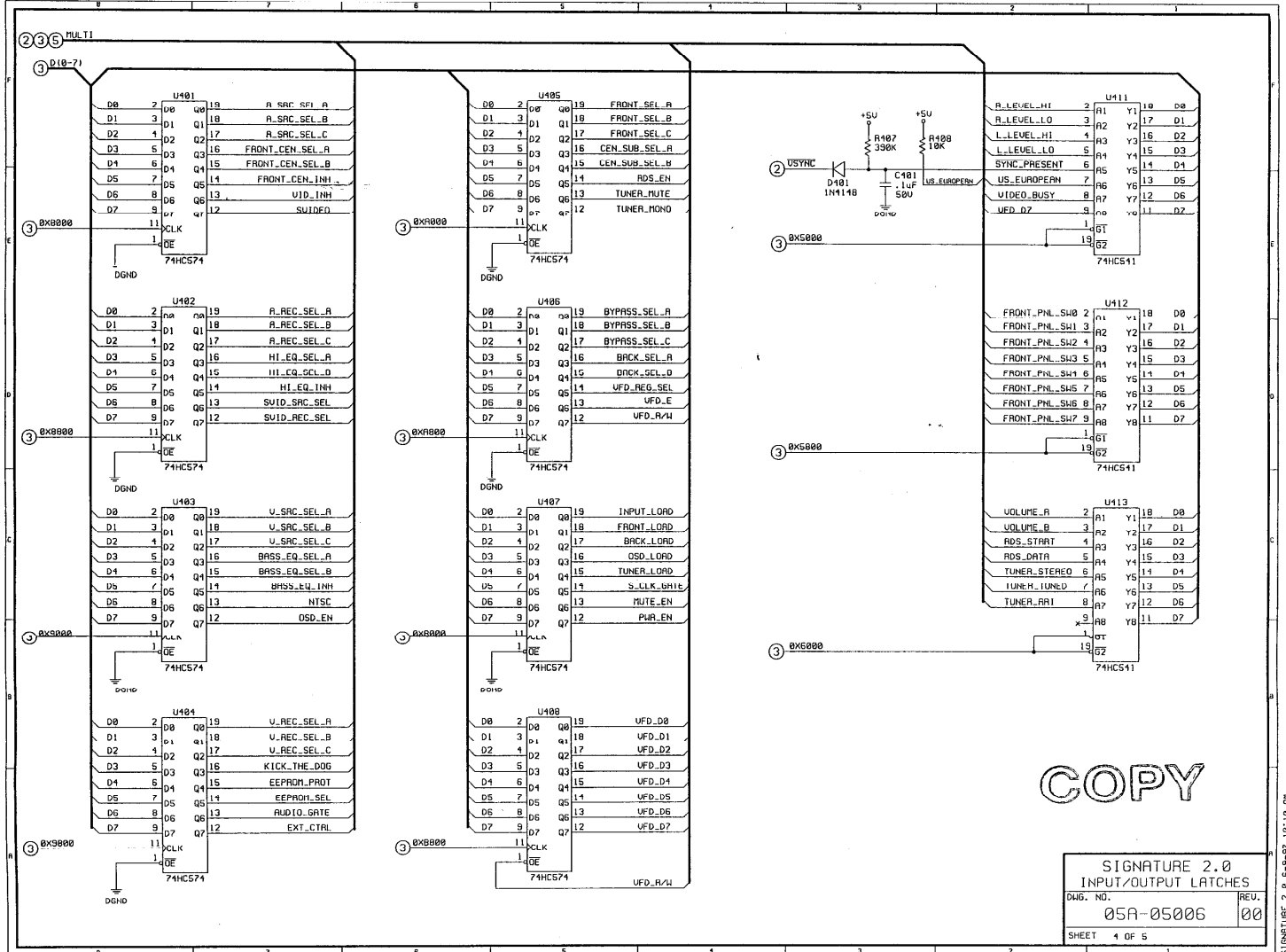

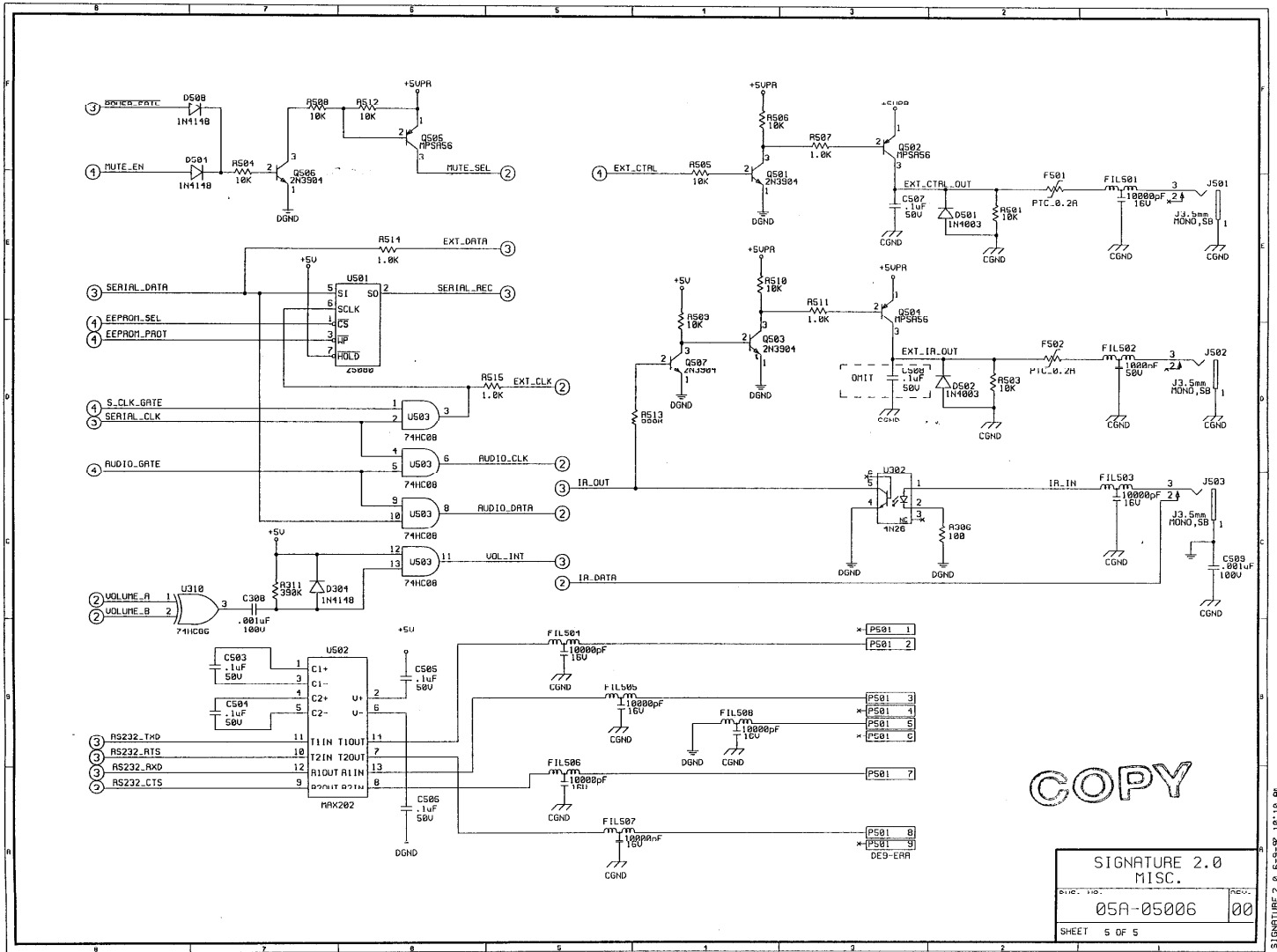

COPY

SIGNATURE 2.0
MISC.
05A-05006
SHEET 5 OF 5

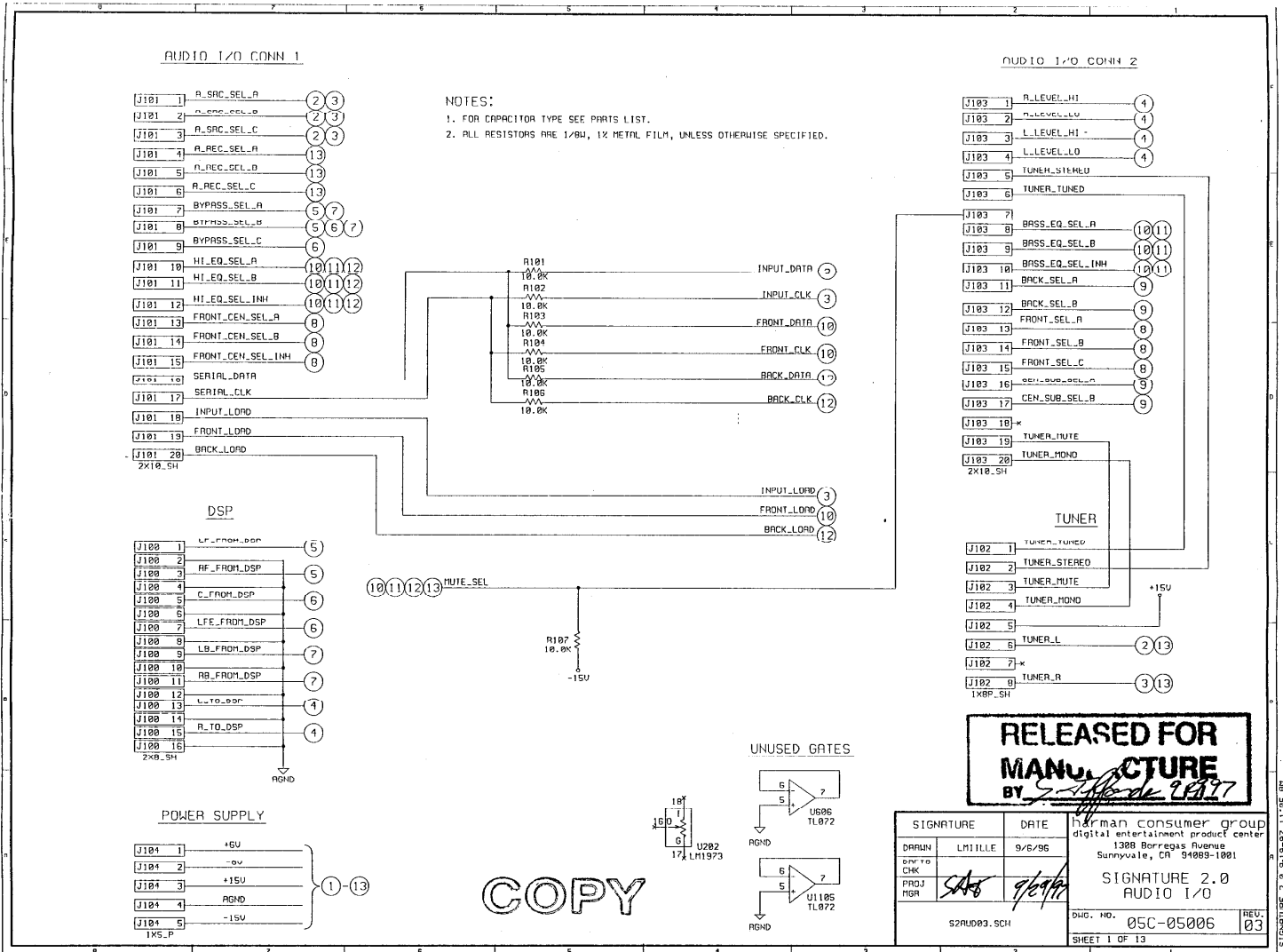

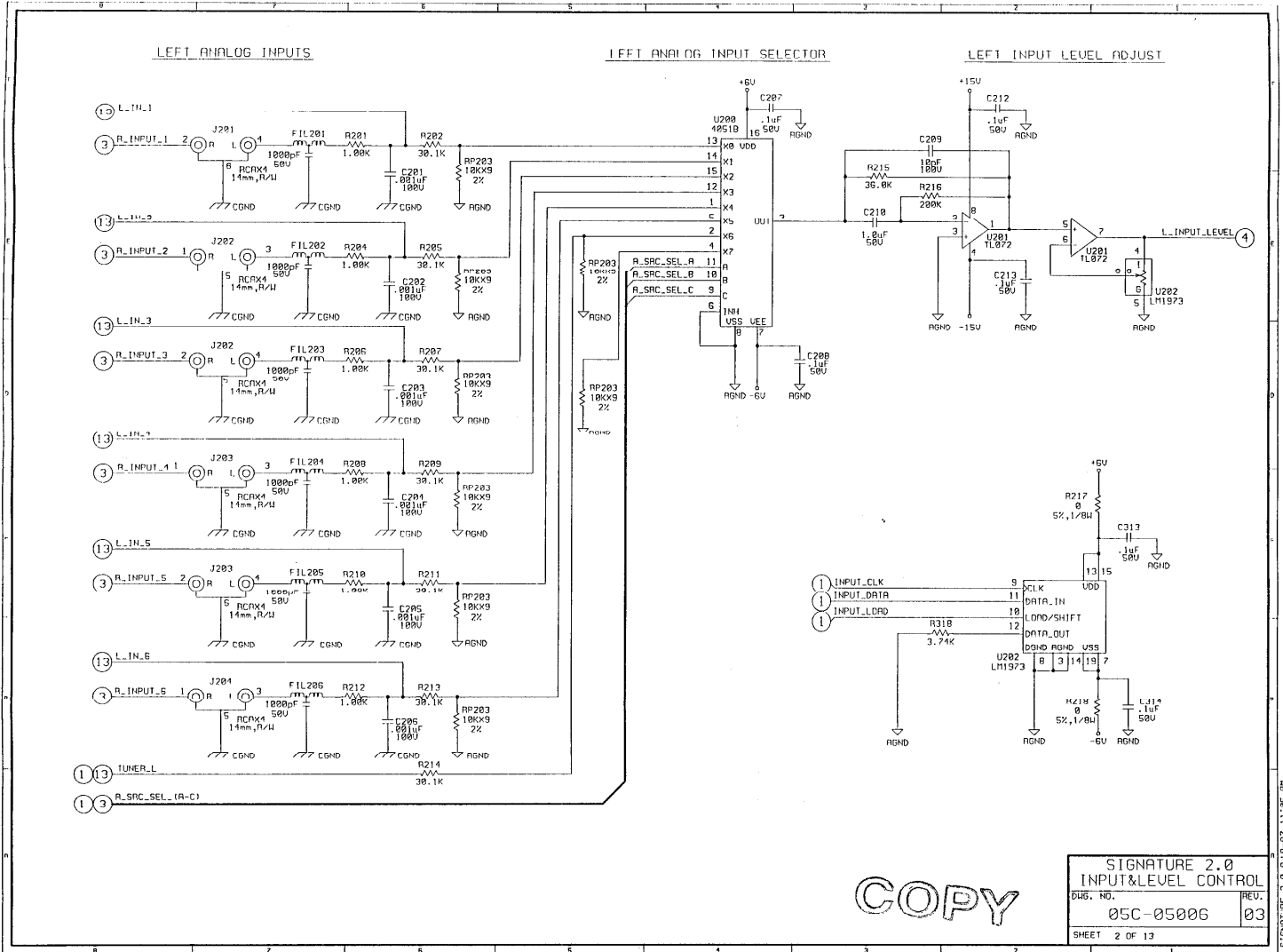

COPY

SIGNATURE 2.0	
INPUT & LEVEL CONTROL	
DWG. NO.	REV.
05C-05006	03
SHEET 2 OF 13	

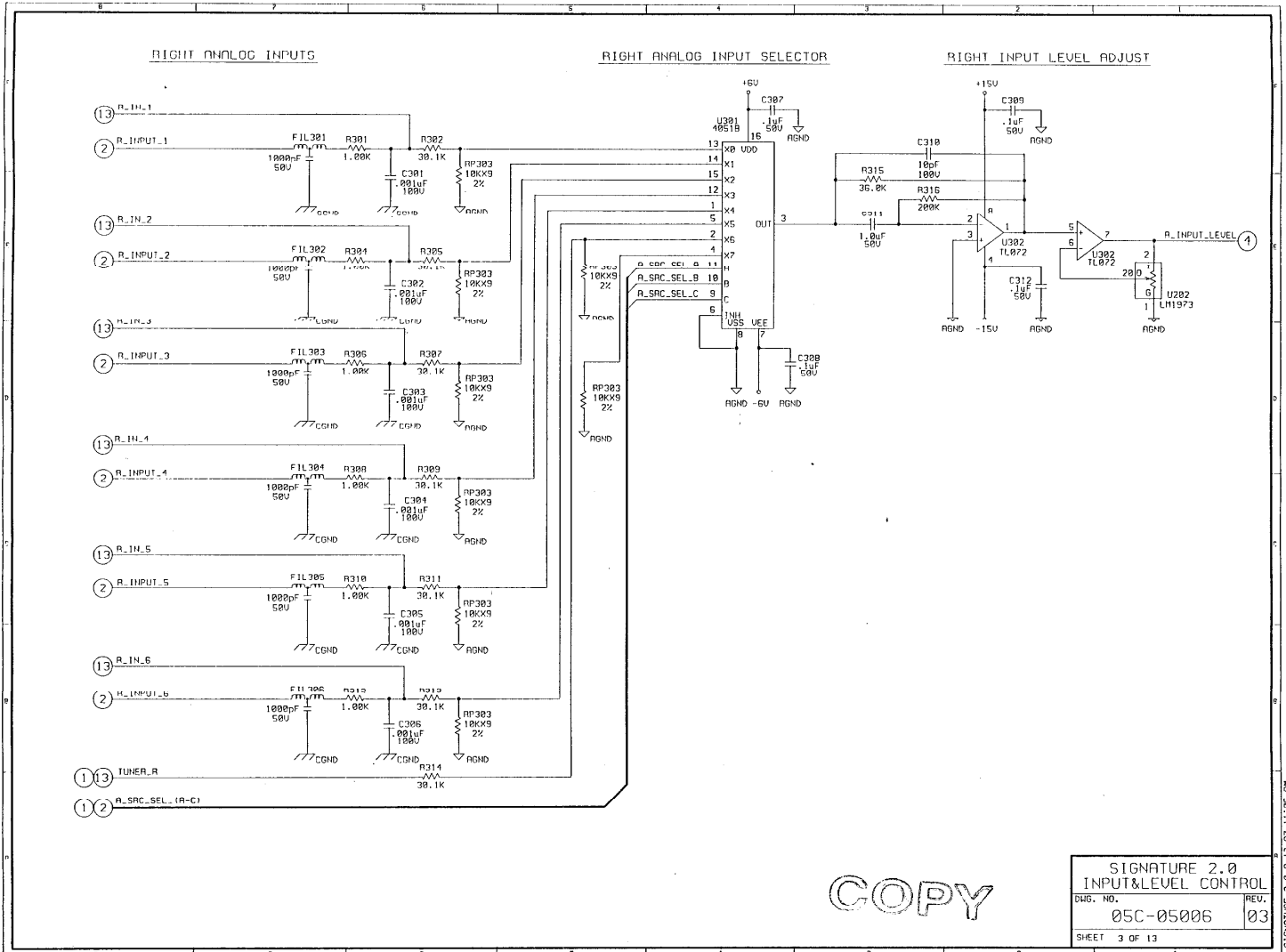

COPY

SIGNATURE 2.0	
INPUT & LEVEL CONTROL	
DRG. NO.	REV.
05C-05006	03
SHEET 3 OF 13	

SIGNATURE 2.0 9-13-97 11:06 AM

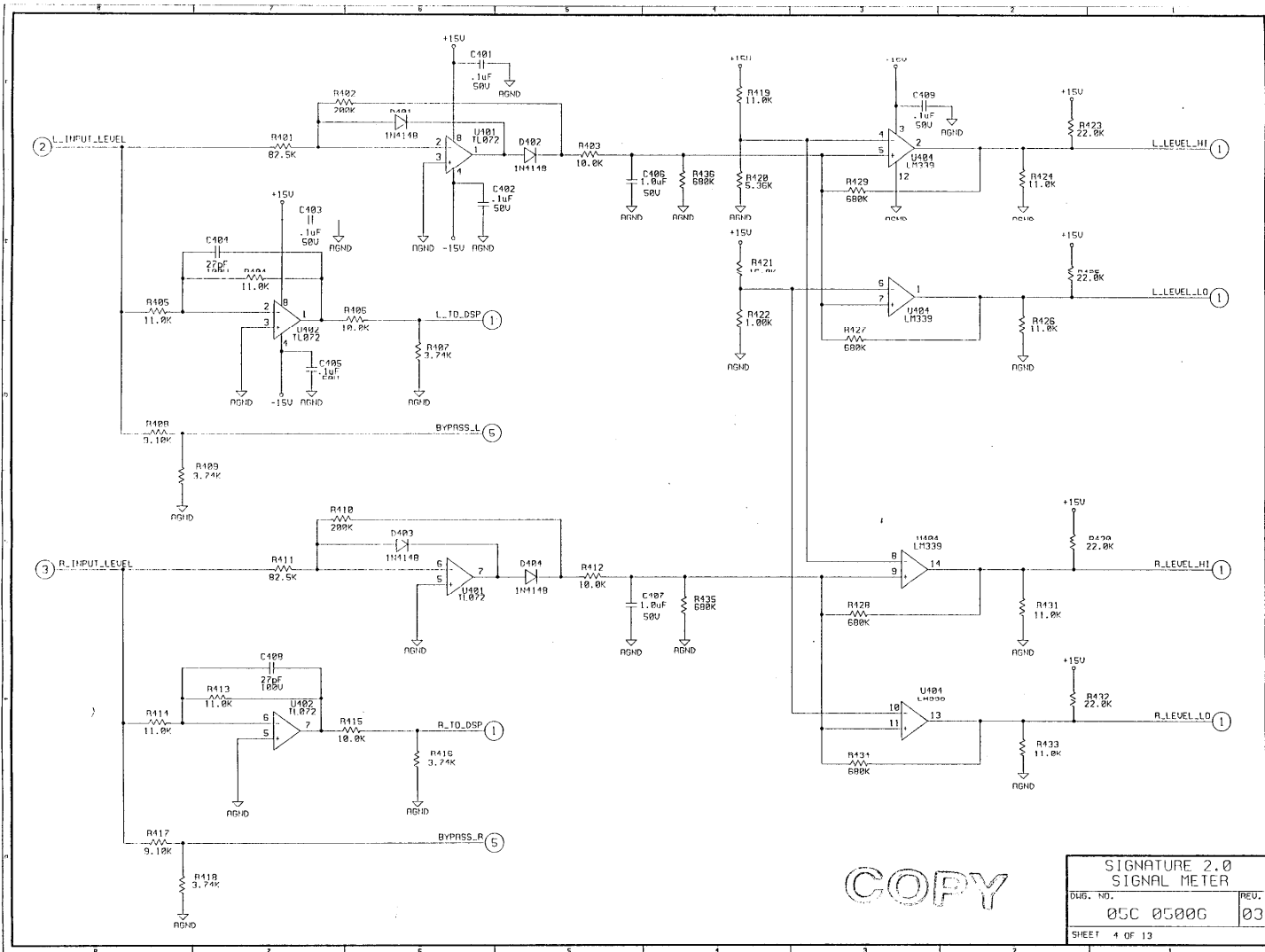

COPY

SIGNATURE 2.0 SIGNAL METER	
DES. NO.	REV.
05C 0500G	03
SHEET 4 OF 13	

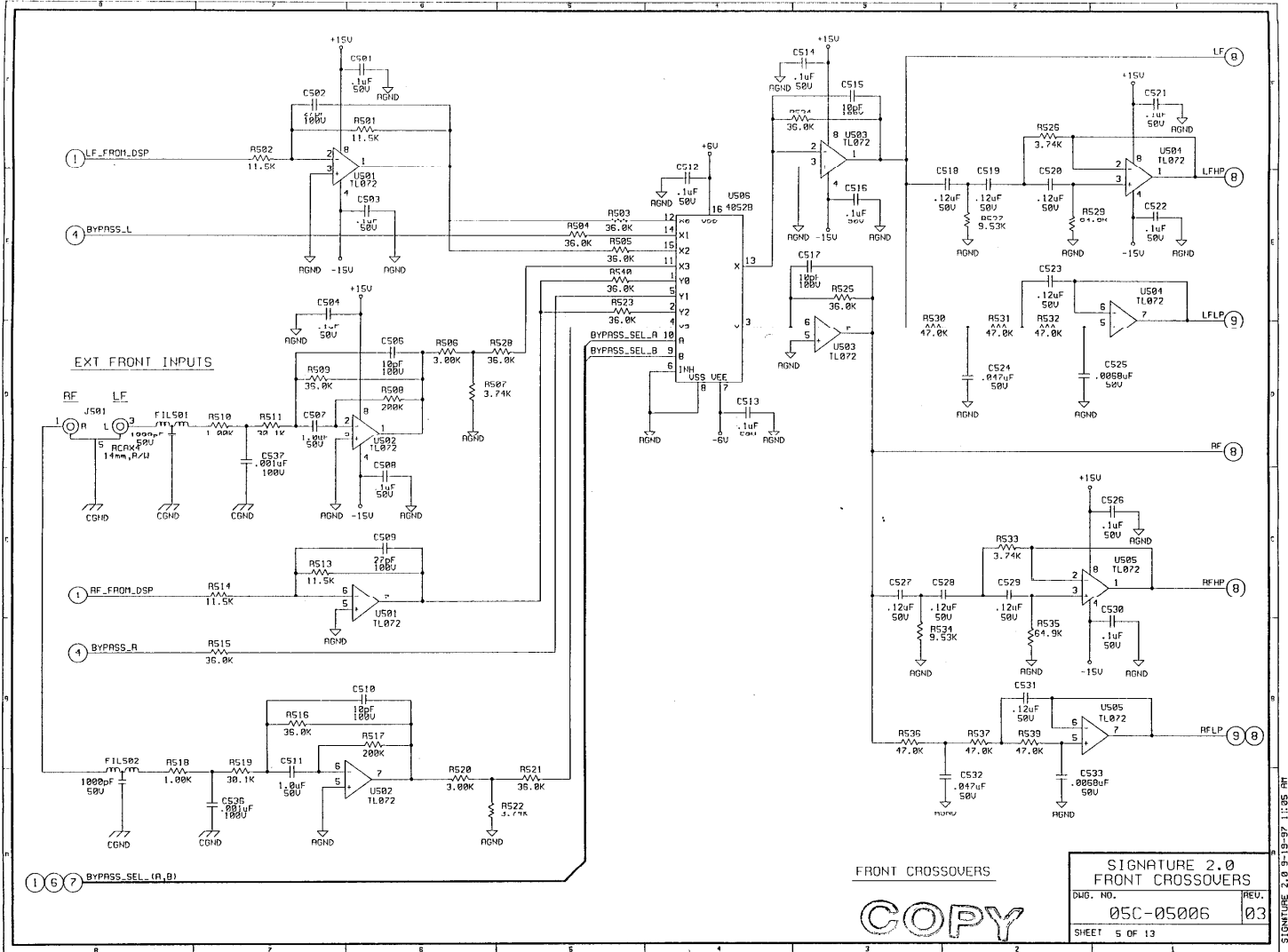

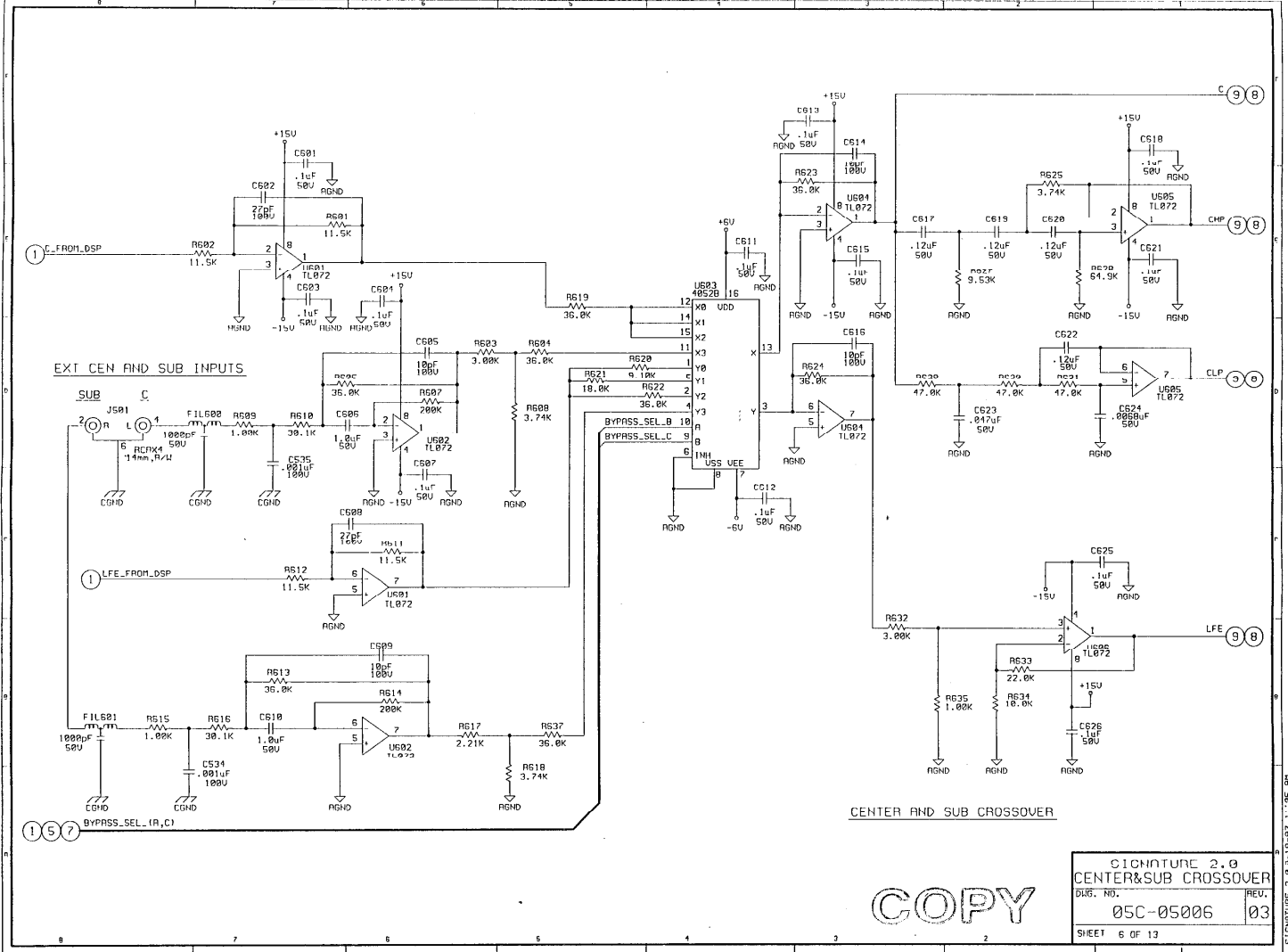

COPY

SIGNATURE 2.0	
CENTER & SUB CROSSOVER	
DRG. NO.	REV.
05C-05006	03
SHEET 6 OF 13	

SIGNATURE 2.0 3-19-97 1:05 PM

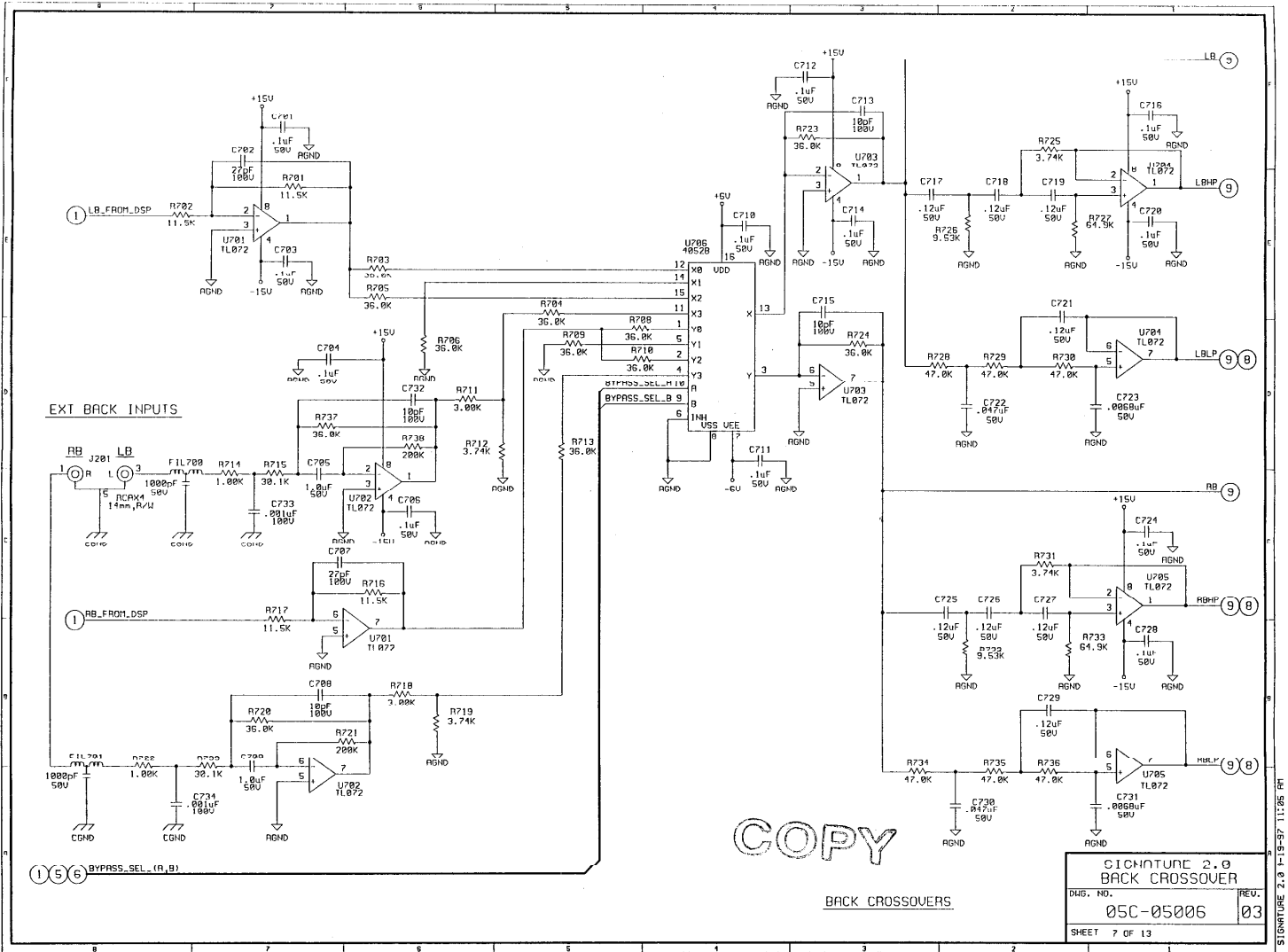

COPY

BACK CROSSOVERS

SIGNATURE 2.0		REV.
BACK CROSSOVER		
DWG. NO.	05C-05006	03
SHEET 7 OF 13		

SIGNATURE 2.0 1-19-87 11:25 AM

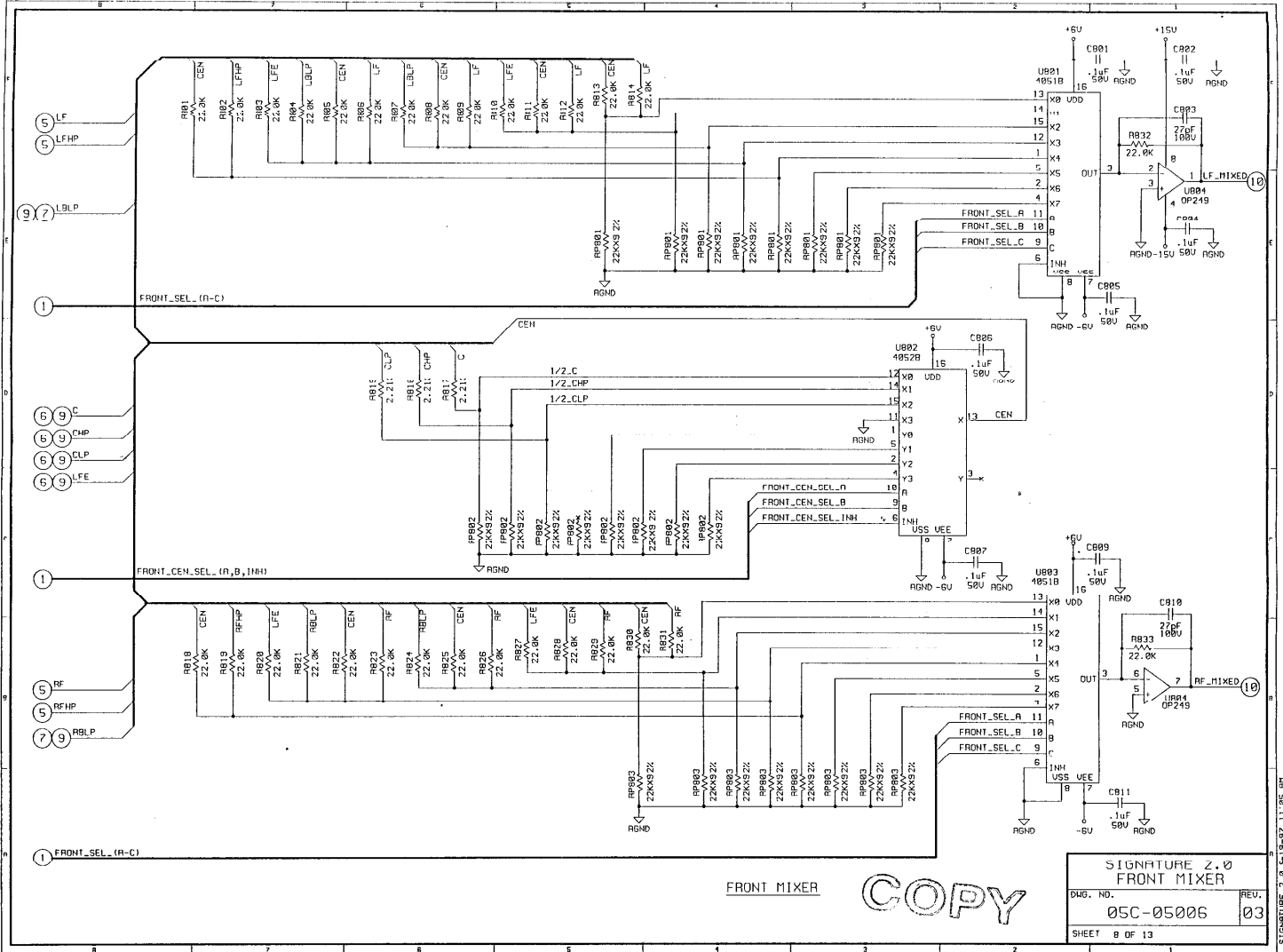

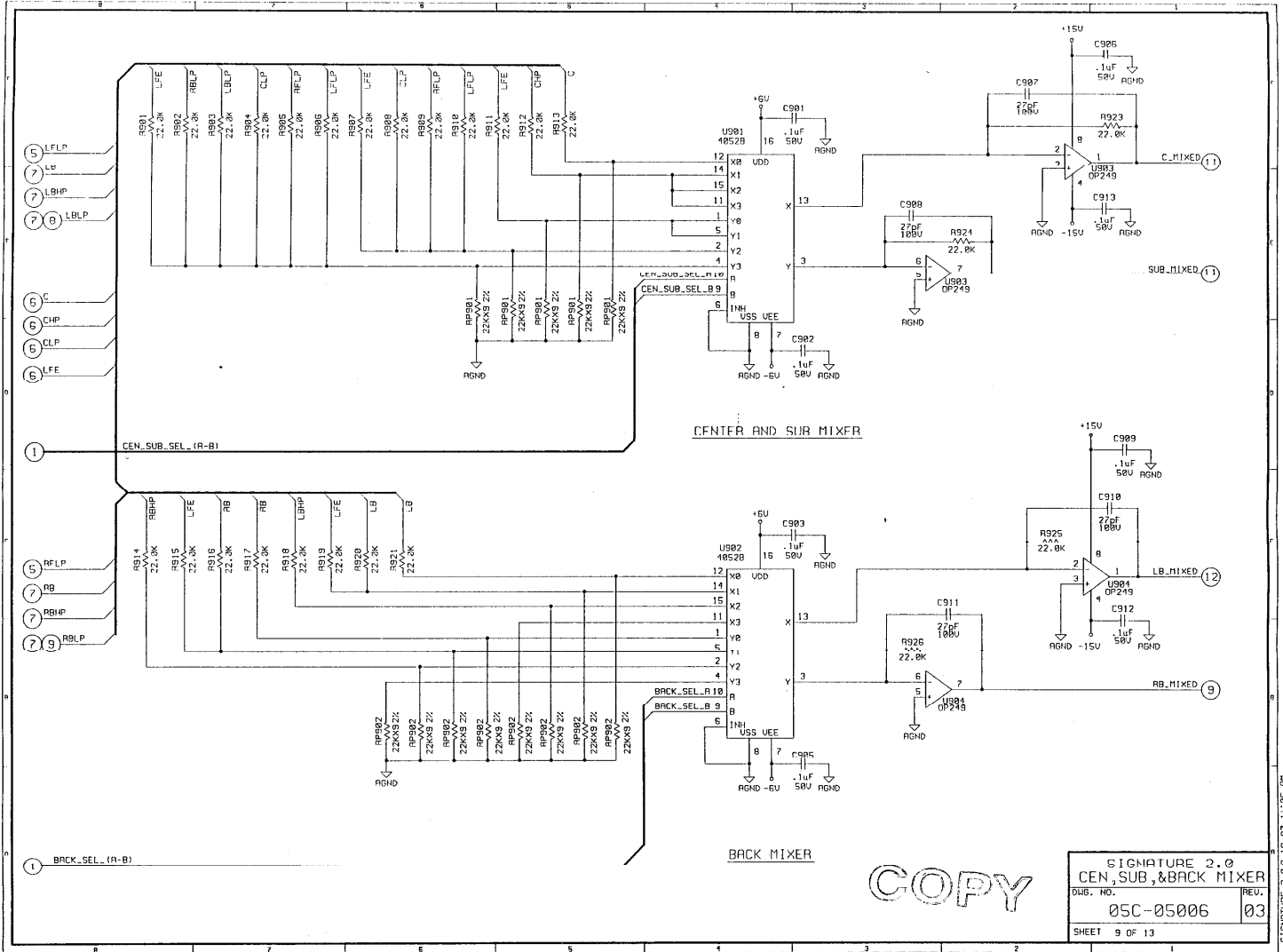

SIGNATURE 2.0	
CEN, SUB, & BACK MIXER	
DES. NO.	REV.
05C-05006	03
SHEET 9 OF 13	

SIGNATURE 2.0 9-19-97 11:05 AM

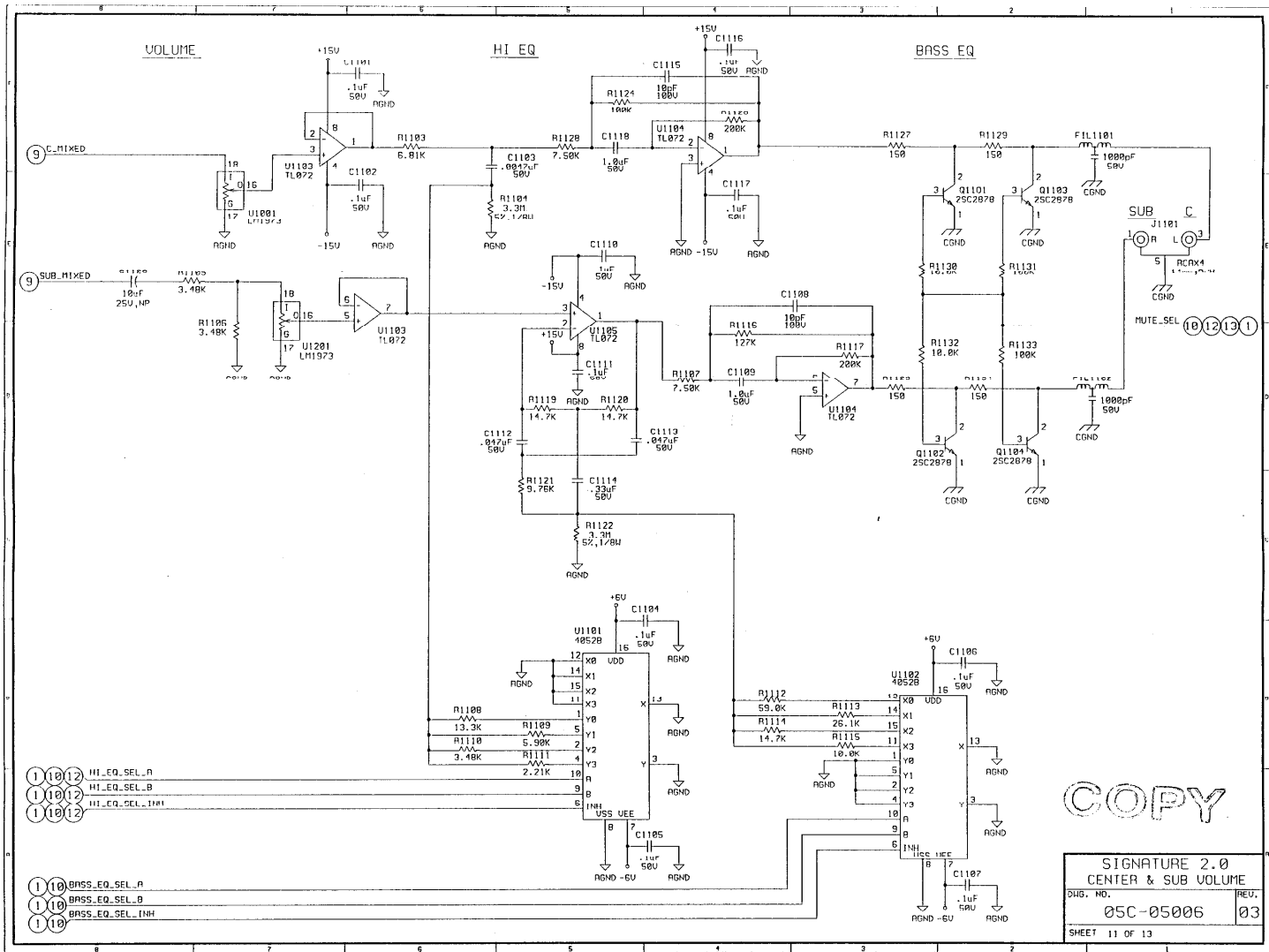

COPY

SIGNATURE 2.0
CENTER & SUB VOLUME
SHG. NO. 05C-05006 REV. 03
SHEET 11 OF 13

SIGNATURE 2.0 51-13-87 11:25 AM

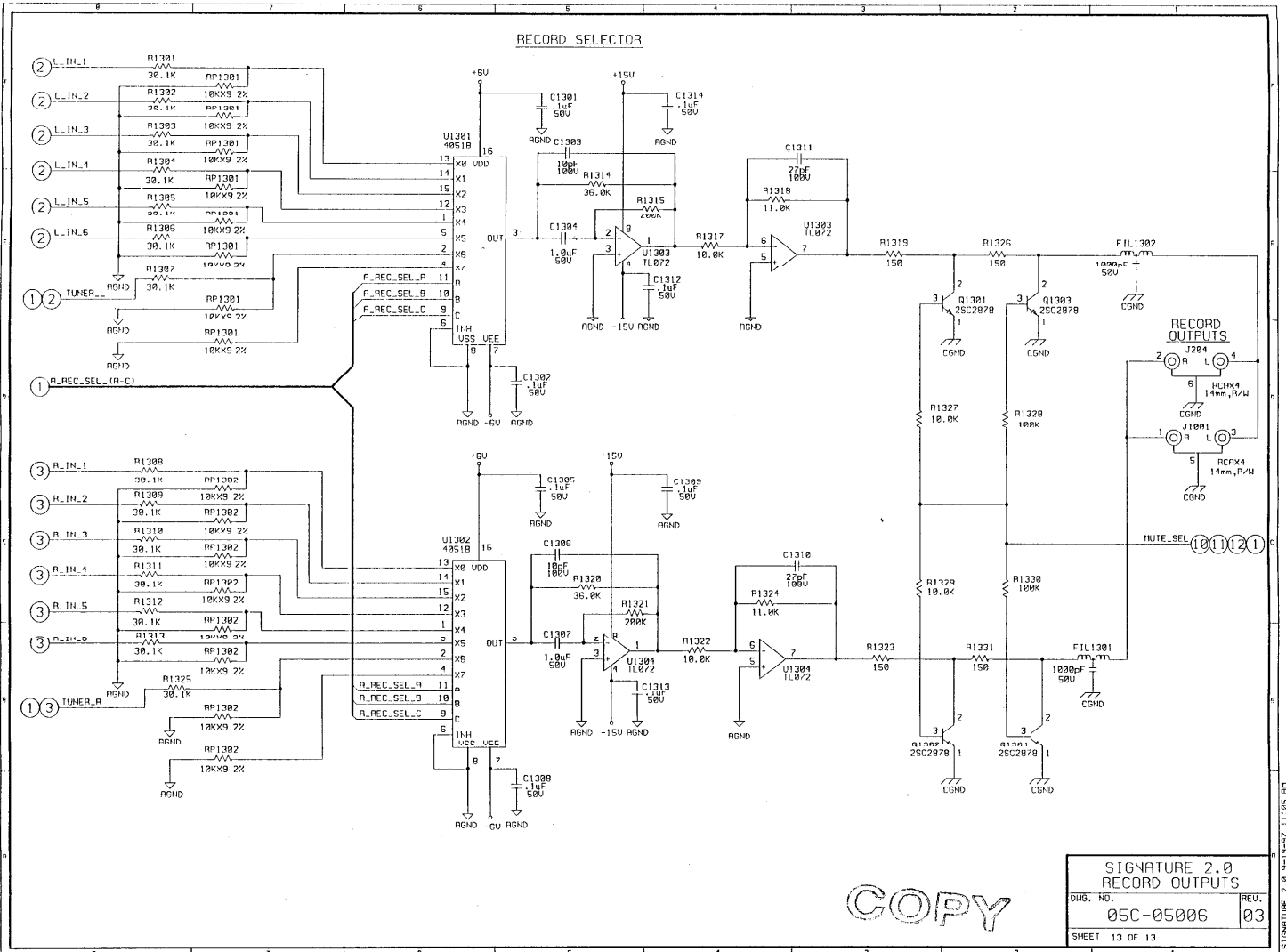

SIGNATURE 2.0 9-15-87 11:05 AM

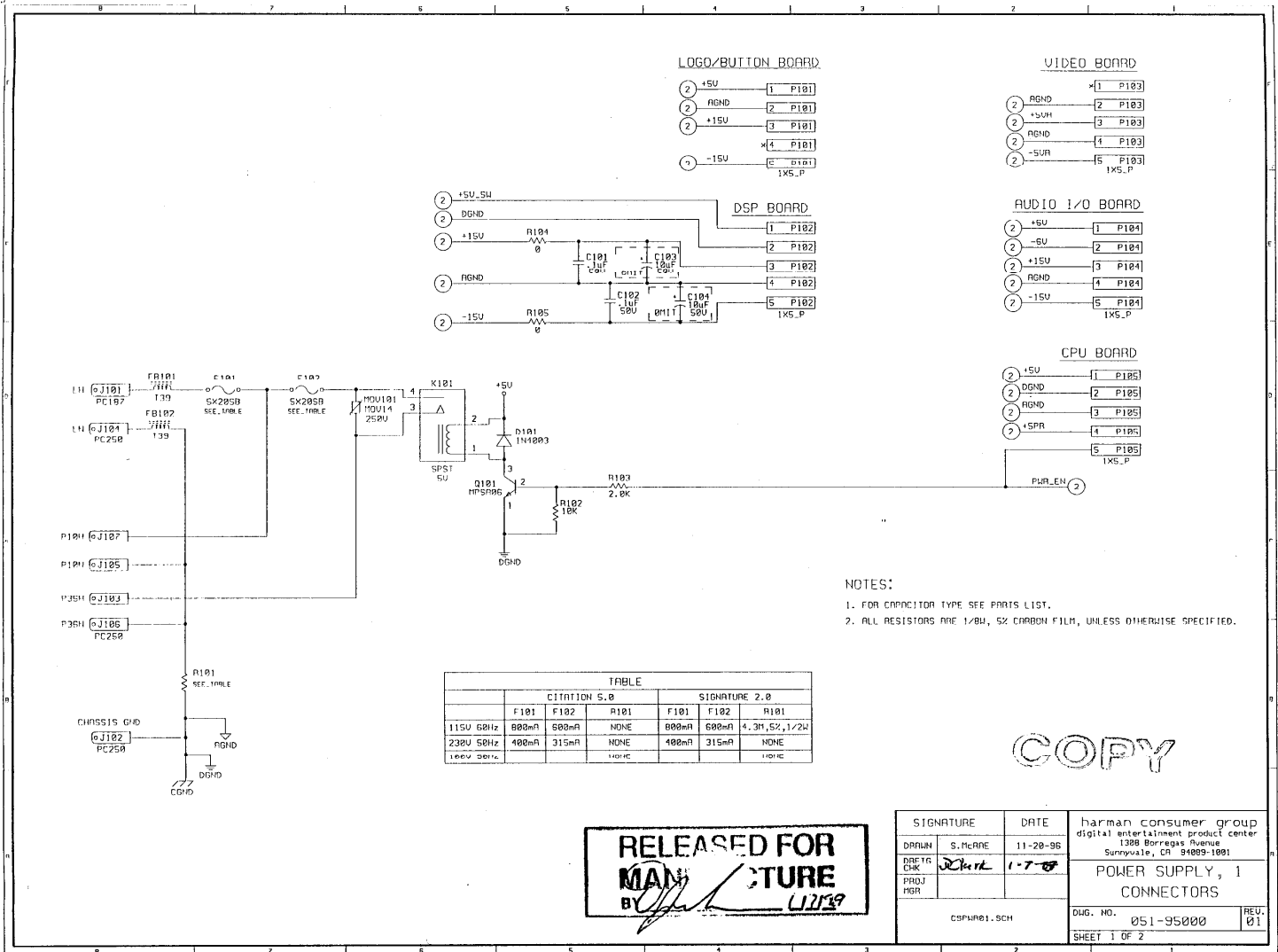

LOGO/BUTTON BOARD

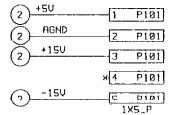

VIDEO BOARD

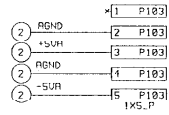

DSP BOARD

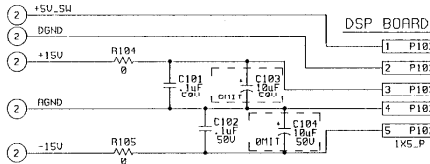

AUDIO I/O BOARD

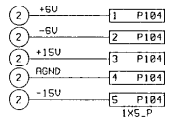

CPU BOARD

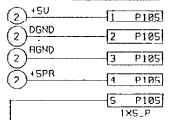

NOTES:

- 1. FOR CAPACITOR TYPE SEE PARTS LIST.
- 2. ALL RESISTORS ARE 1/8W, 5% CARBON FILM, UNLESS OTHERWISE SPECIFIED.

	CITATION S.0			SIGNATURE 2.0		
	F101	F102	R101	F101	F102	R101
115U 50Hz	800mA	500mA	NONE	800mA	500mA	4.3K, 5%, 1/2W
230U 50Hz	400mA	315mA	NONE	400mA	315mA	NONE
115U 250Hz			NONE			NONE

COPY

RELEASED FOR
 MANUFACTURE
 BY *[Signature]* 11/28/96

SIGNATURE		DATE	harman consumer group digital entertainment product center 1308 Borregas Avenue Sunnyvale, CA 94089-1001
DRAWN CHK	S. McARE	11-20-96	
PROJ MGR			POWER SUPPLY, 1 CONNECTORS
CSPH001.SCH			DWG. NO. 051-95000
			REV. 01
			SHEET 1 OF 2

CITATION S.0/SIGNATURE 2.0 1-6-96 1:00 PM

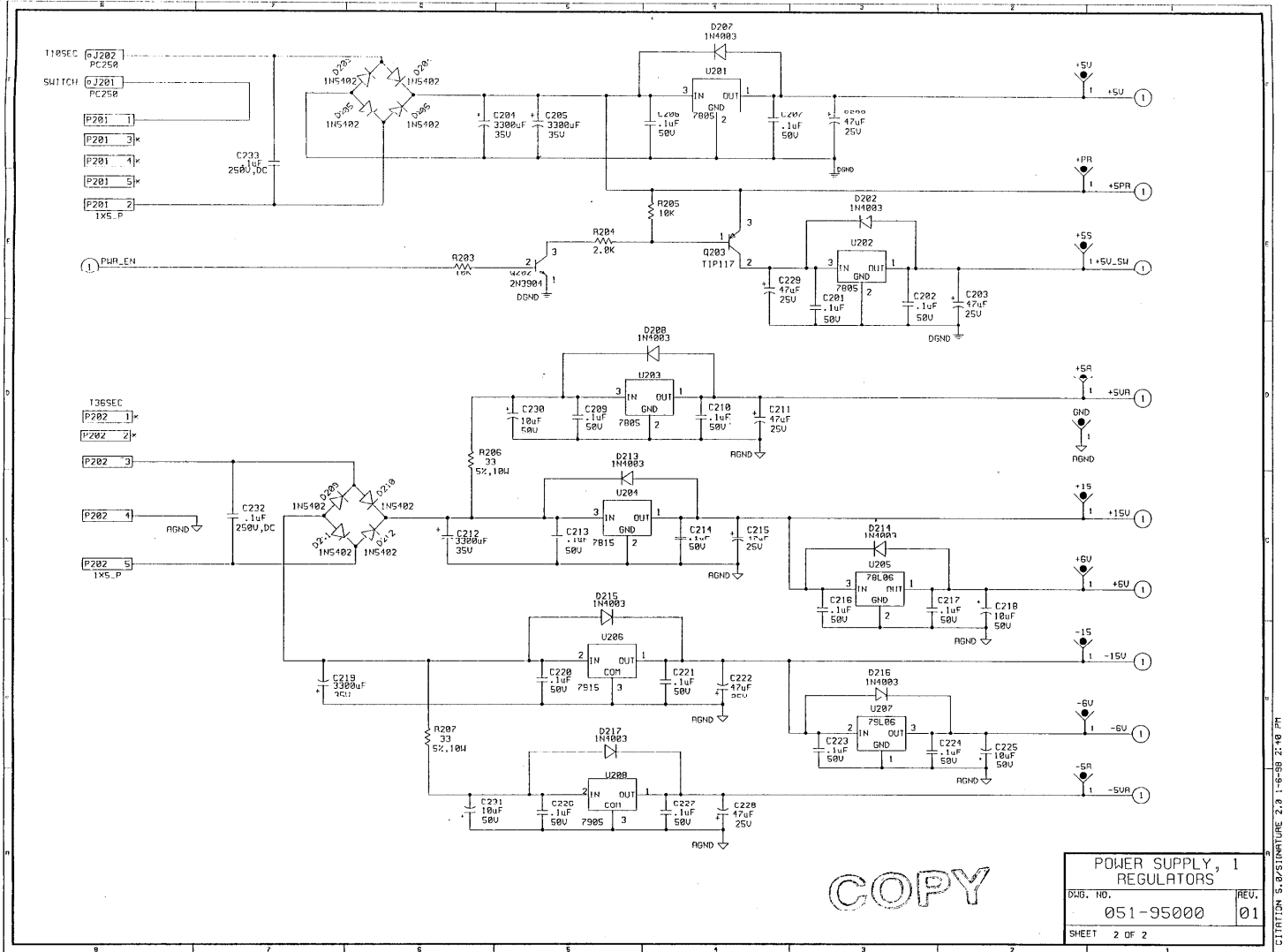

POWER SUPPLY, 1	
REGULATORS	
DWG. NO.	REV.
051-95000	01
SHEET	2 OF 2

CITATION 5: 051-95000 2: 46 PM

Signature 2.0 Processor/Tuner

harman/kardon

REVISIONS			
REV	DESCRIPTION OF CHANGE OR PREVIOUS STATE	DRAWN	DATE
00	ORIGINAL	DJC	3-19-97

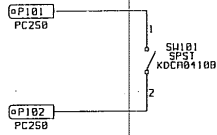

**RELEASED FOR
MANUFACTURE**
BY *S. J. [Signature]* 6/5/97

COPY

SIGNATURE		DATE	harman consumer group digital entertainment product center 1300 Borregas Avenue Sunnyvale, CA 94083-1801
DRAWN	DJ CLARK	3-18-97	
DRAFT	<i>[Signature]</i>	6/5/97	SIGNATURE 2.0 POWER SWITCH BD.
CHK	<i>[Signature]</i>		
PROJ	SAE	6/5/97	
TGR			
SZPS100.SCH			DWG. NO. 050-95006
			REV. 00
			SHEET 1 OF 1

Signature 2.0 Processor/Tuner

harman/kardon

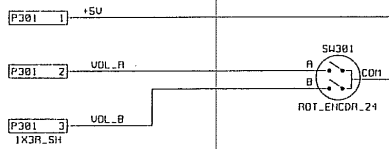

RELEASED FOR
MANUFACTURE
BY *S. J. Clark* 6/5/97

COPY

SIGNATURE		DATE	harman consumer group digital entertainment product center 1300 Borregas Avenue Sunnyvale, CA 94089-1001
DRAWN	DJ CLARK	12-9-96	
DRAFT	<i>S. J. Clark</i>	<i>6/5/97</i>	SIGNATURE 2.0 ROT ENC
CHK	<i>SAT</i>	<i>6/5/97</i>	
PROJ			REV: 00
NGR			
NOTE: 000. SCH			DWG. NO. 054-05006
			SHEET 1 OF 1

SIGNATURE 2.0 5-21-97 10:14 AM

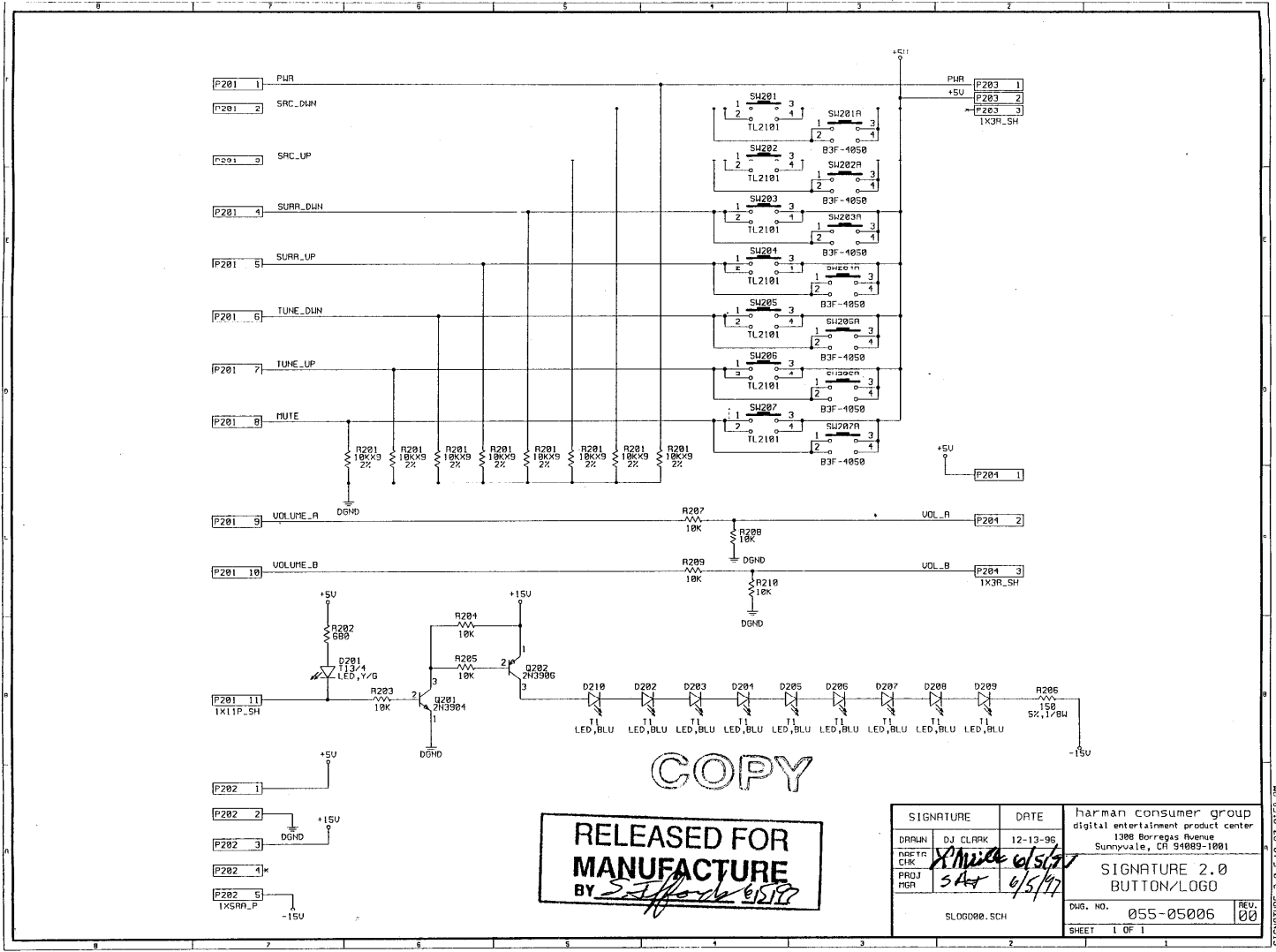

SIGNATURE 2.0 5-13-97 3:58 PM

B | C | D | E | F | G | H | I | J | K | L | M

HAITAI CAD TEAM	
DESIGN	
INSPECTION	
APPROVAL	
DATE	97.3.13

SCHEMATIC DIAGRAM

Signature 2.0 Processor/Tuner

harman/kardon

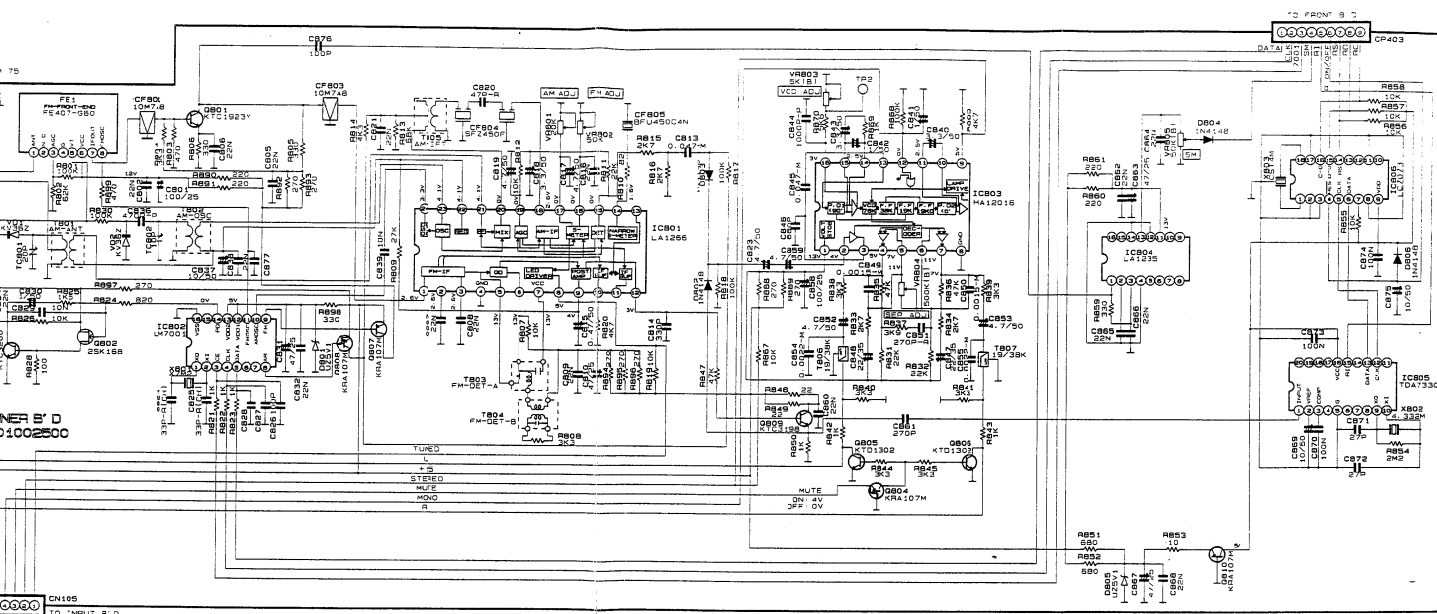

: "A" Version change

COPY

NOTES

1. Resistor values are indicated in ohms unless otherwise specified (K=1,000 M=1,000,000)
2. Capacitor values are indicated in microfarads unless otherwise specified (p=picofarads)

CAUTION
Safety precautions to be followed during servicing.

1. Since these parts marked with a triangle are critical parts for safety, use only the one described in the parts list.

2. Before returning the set to the customer, make appropriate leakage current or resistance measurements to determine the exposed parts are properly insulated from the AC supply.

REVISED	
NO.	DATE
1	5
2	7
3	8
4	9
5	10

EQUIPMENT	TUNER	MODEL	APR
DRAWN	CHECKED	APPROVED	DATE
			97.3.19

Signature 2.0 Processor/Tuner

harman/kardon

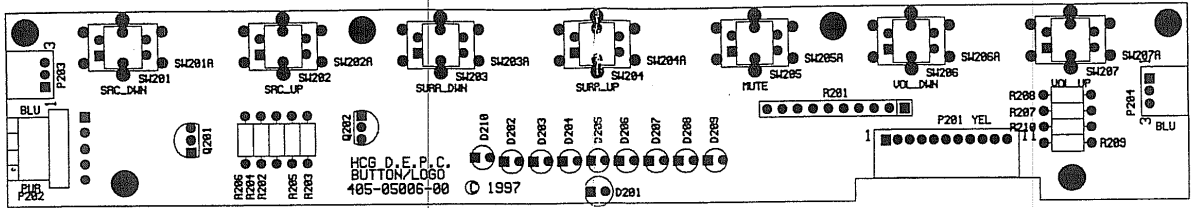

COPEY

RELEASED FOR
MANUFACTURE
 BY *S. J. Clark*

harman consumer group digital entertainment product center 1308 Borregas Avenue Sunnyvale, CA 94089-1001	LAYER: SILKSCREEN SOLDERMASK
PRINTED CIRCUIT BOARD ARTWORK SIGNATURE 2.0, BUTTON/LOGO	
405-05006-00	
DATE: JUNE 2, 1997	
DRAWN BY: D.J. CLARK	

HCG-DEPC
AC3/DSP BD © 1997
40B-05006-P4

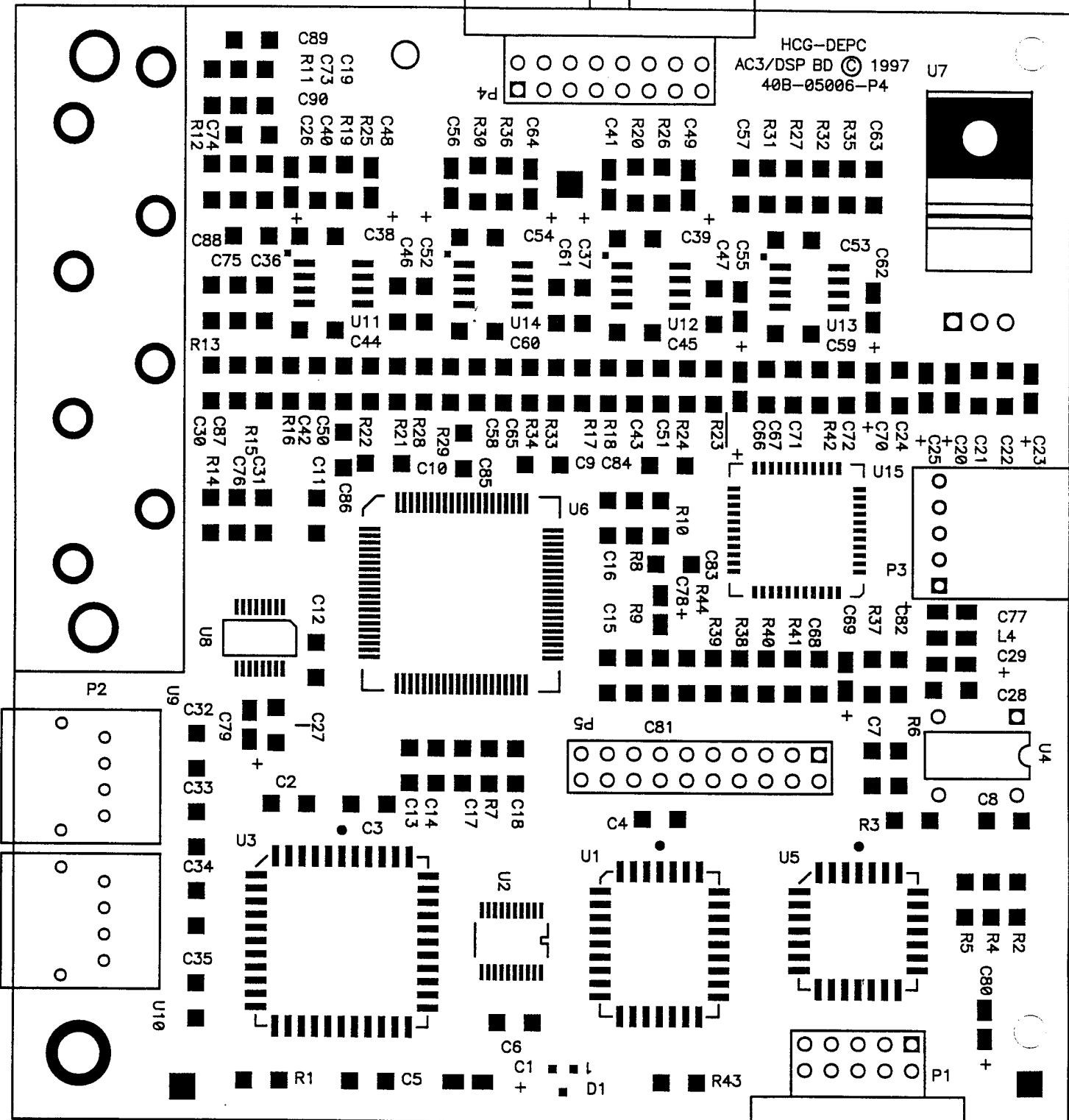

RELEASED FOR
MANUFACTURE
BY TT

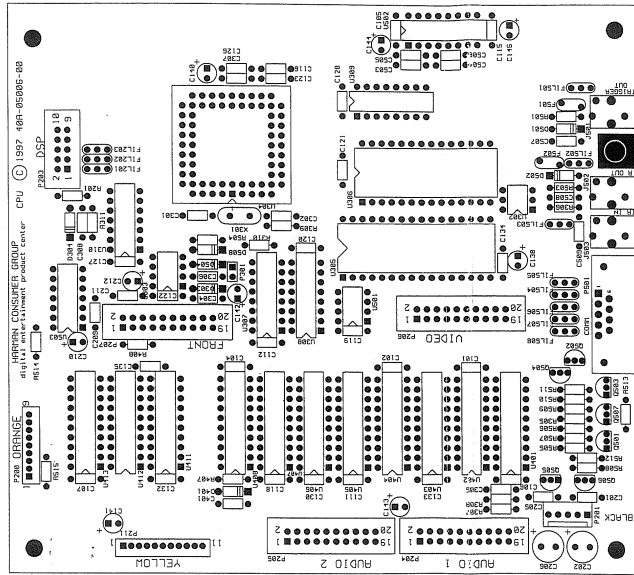

RELEASED FOR MANUFACTURE
BY *Daniel H. Smith* 5/11/7

COPY

LAYER:	
SILKSCREEN	
Harman Consumer Group Digital Entertainment Product Center 26046 EDEN HOLLOW RD. PLYMOUTH, OHIO 44135 (510) 253-0183	
PRINTED CIRCUIT BOARD ARTWORK SIGNATURE 2.0 CPU BOARD	
40A-05006-00	
DATE:	JUNE 16, 1987
DRAWN BY:	LAURIE MILLE

Signature 2.0 Processor/Tuner

harman/kardon

11 9 (FOR 230V ONLY)

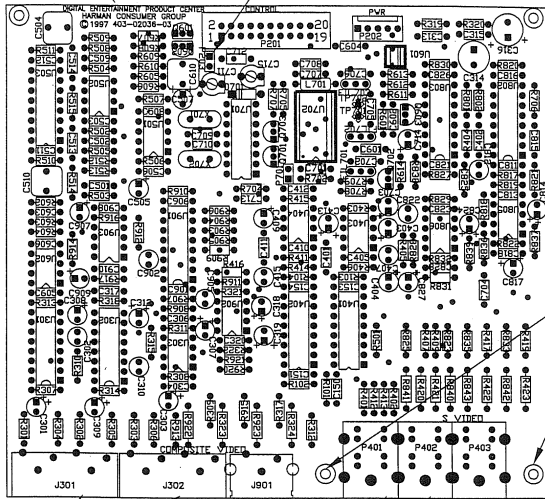

10 50 51
SEE DETAIL A

26 8

27 8

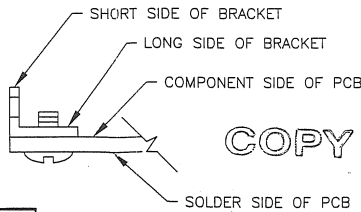

RELEASED FOR
MANUFACTURE
BY *[Signature]*

DETAIL A
NOT TO SCALE

73

REVISIONS

REV.	DESCRIPTION OF CHANGE OR PREVIOUS STATE	DRAWN	DATE
00	ORIGINAL	DJC	7/23/97
01	ADDED COMPONENTS AND TRACES	DJC	8/7/97
02	ADDED COMPONENTS AND TRACES	DJC	1/8/98

NOTES: UNLESS OTHERWISE SPECIFIED:

- SQUARE PADS ON THRU HOLE PARTS (ie: CONNECTORS, DIPS, SIPS, LEDS,) DENOTE PIN 1.
- ALL BOARDS REQUIRE A COMPLETE AND THOROUGH VISUAL INSPECTION.
- ALL BOARDS MUST BE BARE BOARD TESTED.
- (XX) CIRCLES REFER TO ITEM NUMBERS ON THE PARTS LIST.
- (XX) SQUARES REFER TO THE NOTES.
- ASSEMBLE AND SOLDER PER ANSI/IPC-A-610B. (THROUGH HOLE AND SURFACE MOUNT COMPONENTS.)

PRE WAVE:

- KEEP ALL MOUNTING HOLES, FREE AND CLEAR OF SOLDER.

POST WAVE:

- AFTER WAVE SOLDER; ALL COMPONENTS ARE TO BE FLUSH, AND PERPENDICULAR TO PCB. (ie: IC'S, JACKS, CONNECTORS) COMPONENTS AT THESE LOCATIONS: J301, J302, P401, P402, MAY BE INSTALLED PREWAVE WITH THE PROPER JIG, TO HOLD IN PLACE.
- INSTALL FOR EUROPEAN (230V) UNIT ONLY: ONE, SHORTING BLOCK, 2 PIN, ON P203.
- INSTALL TWO, BRACKET, L, 621 TYPE, TO COMPONENT SIDE OF PCB. SECURE IN PLACE WITH TWO 4-40 X 0.250" ZNC PH PN MCH SCREW FROM SOLDER SIDE OF PCB. (SEE DETAIL A)
- THIS ASSEMBLY DRAWING TO BE USED IN COMPLIANCE WITH BARE BOARD 403-02036-03, SIGNATURE 2.0 ONLY.

SIGNATURE		DATE	harman consumer group digital entertainment product center 1308 Borregas Ave., Sunnyvale, CA 94089-1001	
DRAWN	DJ CLARK	7/23/97	ASSY DRAWING, SIG. 2.0 VIDEO BD.	
DESIGN CHK				
PRQJ. MGR				
S2VIDA02.DWG			DWG. NUMBER 043-05006	REV. 02
			SCALE: NOT TO SCALE	SHEET: 1 OF 1

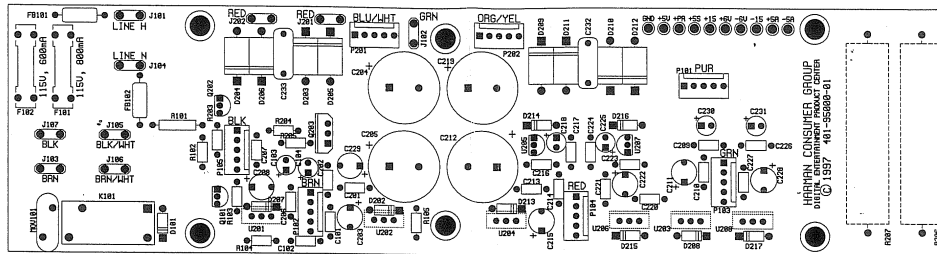

COPY

RELEASED FOR
MANUFACTURE
BY *Dennis Walters* 6/24/97

Harman Consumer Group Digital Entertainment Product Center 1300 Borregas Avenue Sunnyvale, CA 94089-1001 (408) 542-8800		LAYER: SILKSCREEN SOLDERMASK
PRINTED CIRCUIT BOARD ARTWORK CITATION/SIGNATURE POWER SUPPLY		
401-95000-01		
DATE:	JUNE 26, 1997	
DRAWN BY:	SYLVIA MCRAE	

ITEM	QTY	PART-NUMBER	REFERENCE-DESIGNATOR	DESCRIPTION
1	1	230-00139-00	U309	DECODER, DUAL, 2TO4, 74HC139
2	38	135-22410-00	C107, C101, C102, C104 C106, C135, C130, C132 C133, C134, C128, C122 C123, C126, C127, C121 C116, C118, C119, C120 C111, C112, C105, C115 C304, C305, C201, C205 C306, C307, C209, C211 C507, C506, C504, C503 C505, C401	CAP, AX, CER, 0.1uF, 50V, Z5U20%
3	2	135-30027-00	C301, C302	CAP, AX, CER, 27pF, 100V, COG5%
4	1	135-22410-00	C508	OMIT
5	2	135-31210-00	C509, C308	CAP, AX, CER, 0.001uF, 100V, X7R10%
6	2	230-00138-00	U308, U307	DECODER, 3TO8, 74HC138
7	1	320-52205-00	P201	HEADER, 1X5, POL, LOCKRAMP
8	13	101-13100-00	R503, R504, R509, R501 R510, R506, R305, R505 R310, R408, R512, R508 R309	RES, AXIAL, 10K, 5%, CF, 1/8W
9	4	101-12100-00	R507, R511, R514, R515	RES, AXIAL, 1.0K, 5%, CF, 1/8W
10	1	101-11100-00	R306	RES, AXIAL, 100, 5%, CF, 1/8W
11	3	101-14390-00	R513, R311, R407	RES, AXIAL, 390K, 5%, CF, 1/8W
12	1	100-11221-00	R308	RES, AXIAL, 2.21K, 1%, MF, 1/8W
13	1	100-12121-00	R307	RES, AXIAL, 12.1K, 1%, MF, 1/8W
14	9	142-11310-00	C141, C140, C142, C138 C143, C210, C212, C145 C144	CAP, RAD, TAN, 10uF, 6.3V, 10%

RELEASED FOR

MANUFACTURE

BY *Brown/Watkins 6/17/97*

1

COPY S2CPU00.XLS

SIGNATURE 2.0
CPU BD REV 00
06A-05006-00
6/17/97

15	3	211-00056-00	Q505, Q502, Q504	TRANS, PNP, MPSA56
16	4	210-03904-00	Q506, Q503, Q501, Q507	TRANS, NPN, 2N3904
17	4	320-55010-00	P206, P207, P205, P204	HEADER, 2X10, SHROUDED
18	1	262-02012-00	U305	EPROM, 256KX8, 120ns, 27C020-12
19	1	345-18432-00	X301	XTAL, HC49, 18.432MHz
20	4	190-50210-00	FIL502, FIL203, FIL202 FIL201	EMI, FILTER, RAD, 1000pF
21	7	190-50310-00	FIL501, FIL503, FIL508 FIL507, FIL506, FIL505 FIL504	EMI, FILTER, RAD, 10000pF
22	2	381-00020-00	F502, F501	PTC, 0.20amp
23	2	200-14003-00	D502, D501	DIODE, RECT, 1A, 1N4003
24	5	201-04148-00	D303, D508, D504, D304 D401	DIODE, SWITCHING, 500mW, 1N4148
25	3	321-20000-00	J502, J503, J501	PHONEJACK, 3.5MM, MONO, SB
26	1	254-10705-00	U303	uP, SUPERVISOR, 4.65V, UPS705
27	1	320-55005-00	P203	HEADER, 2X5, SHROUDED
28	1	230-00008-00	U503	NAND, GATE, QUAD, 2-IN, 74HC08
29	1	271-00426-00	U302	OPTOISOLATOR, 4N26
30	8	230-00574-00	U404, U407, U406, U405 U403, U408, U402, U401	D, FLIP, FLOP, OCT, 3STATE, 74HC574
31	3	230-00541-00	U411, U413, U412	BUFFER, OCTAL, TRISTATE, 74HC541
32	1	320-52002-00	P301	OMIT

32	3	190-50310-00	FIL701, FIL702, FIL703	EMI, FILTER, RAD, 10000pF
33	1	253-00075-00	U702	OSD, S-VIDEO, MB90075
34	1	321-01000-00	J901	OMIT
35	6	101-30000-00	R420, R922, R421, R323 R840, R841	RES, AXIAL, 0, 5%, CF, 1/4W
36	39	135-22410-00	C514, C513, C304, C306 C313, C315, C402, C405 C813, C818, C910, C401 C901, C811, C815, C906 C816, C908, C506, C509 C602, C606, C603, C604 C605, C702, C701, C713 C704, C705, C706, C150 C153, C154, C151, C508 C512, C511, C501	CAP, AX, CER, 0.1uF, 50V, Z5U20%
37	2	135-21310-00	C502, C503	CAP, AX, CER, 0.01uF, 50V, X7R10%
38	1	135-30110-00	C712	CAP, AX, CER, 100pF, 100V, COG5%
39	3	135-30027-00	C710, C709, C708	CAP, AX, CER, 27pF, 100V, COG5%
40	1	135-30147-00	C601	CAP, AX, CER, 470pF, 100V, COG5%
41	1	148-00010-00	C711	CAP, VAR, 10pF
42	1	148-00030-00	C715	CAP, VAR, 30pF
43	3	143-13510-00	C610, C510, C504	CAP, RAD, PEF, 1.0uF, 50V, 5%
44	5	210-03904-00	Q601, Q603, Q703, Q702 Q701	TRANS, NPN, 2N3904
45	1	211-03906-00	Q602	TRANS, PNP, 2N3906
46	1	226-14581-00	U601	VIDEO, SYNC, SEPARATOR, EL4581C
47	2	221-00072-00	U602, U502	OPAMP, DUAL, LN, JFET, TL072

14	1	100-13680-00	R602	RES, AXIAL, 680K, 1%, MF, 1/8W
15	1	100-11130-00	R604	RES, AXIAL, 1.30K, 1%, MF, 1/8W
16	2	100-11332-00	R603, R607	RES, AXIAL, 3.32K, 1%, MF, 1/8W
17	1	101-14100-00	R605	RES, AXIAL, 100K, 5%, CF, 1/8W
18	4	101-11470-00	R606, R707, R706, R705	RES, AXIAL, 470, 5%, CF, 1/8W
19	1	101-12270-00	R612	RES, AXIAL, 2.7K, 5%, CF, 1/8W
20	1	100-11680-00	R611	RES, AXIAL, 6.80K, 1%, MF, 1/8W
21	1	101-12200-00	R608	RES, AXIAL, 2.0K, 5%, CF, 1/8W
22	4	141-32310-00	C302, C902, C812, C407	CAP, RAD, AL, EL, NP, 10uF, 25V, 20%
23	5	221-04576-00	U303, U403, U501, U805 U903	OPAMP, DUAL, VIDEO, MC14576C
24	16	140-52310-00	C301, C714, C404, C307 C303, C403, C312, C309 C817, C814, C505, C907 C507, C703, C909, C308	CAP, RAD, AL, EL, 10uF, 50V, 20%
25	2	140-32422-00	C316, C314	CAP, RAD, AL, EL, 220uF, 25V, 20%
26	2	321-02000-00	J301, J302	RCA_JACK, 14mm, QUAD, YELLOW
27	2	322-00024-00	P402, P401	CONN, MINI, CIRC, SHLD, DUAL, VERT, 4PIN
28	2	320-52002-00	P701, P203	HEADER, 1X2
29	1	345-14318-00	X702	XTAL, HC49S, 14.31818MHz
30	1	345-17734-00	X701	XTAL, HC49S, 17.734475MHz
31	1	160-00333-00	L701	INDCTR, AX, HIQ, 33uH

ITEM	QTY	PART-NUMBER	REFERENCE-DESIGNATOR	DESCRIPTION
1	1	320-55010-00	P201	HEADER, 2X10, SHROUDED
2	1	320-52205-00	P202	HEADER, 1X5, POL, LOCKRAMP
3	2	230-04051-00	U301, U302	ANALOG, SWTCH, SNGL, 8TO1, HC4051
4	2	230-04052-00	U901, U802	ANALOG, SWITCH, DUAL, 4TO1, HC4052
5	16	101-10750-00	R301, R302, R303, R304 R305, R306, R309, R407 R409, R401, R402, R412 R913, R823, R825, R413	RES, AXIAL, 75, 5%, CF, 1/8W
6	15	100-12100-00	R310, R403, R503, R802 R405, R501, R508, R909 R801, R908, R818, R821 R702, R613, R609	RES, AXIAL, 10.0K, 1%, MF, 1/8W
7	6	101-10000-00	R312, R920, R836, R319 R320, R837	RES, AXIAL, 0, 5%, CF, 1/8W
8	14	101-10100-00	R308, R311, R404, R406 R506, R507, R502, R819 R504, R514, R917, R916 R822, R515	RES, AXIAL, 10, 5%, CF, 1/8W
9	15	101-11100-00	R313, R307, R318, R314 R907, R817, R510, R910 R820, R511, R704, R101 R104, R103, R102	RES, AXIAL, 100, 5%, CF, 1/8W
10	6	100-11100-00	R905, R906, R904, R903 R614, R610	RES, AXIAL, 1.00K, 1%, MF, 1/8W
11	4	100-11499-00	R505, R709, R708, R509	RES, AXIAL, 4.99K, 1%, MF, 1/8W
12	4	101-15330-00	R914, R912, R513, R512	RES, AXIAL, 3.3M, 5%, CF, 1/8W
13	1	101-11680-00	R601	RES, AXIAL, 680, 5%, CF, 1/8W

RELEASED FOR

MANUFACTURE

BY *[Signature]* 1/8/98

1

COPY

S2VID03.XLS

ITEM	QTY	PART-NUMBER	REFERENCE-DESIGNATOR	DESCRIPTION
1	49		C10, C11, C12 C13, C14, C15 C16, C17, C18 C19, C2, C21 C22, C24, C26 C27, C28, C3 C30, C31, C32 C33, C34, C35 C38, C39, C4 C44, C45, C53 C54, C59, C6 C60, C67, C68 C7, C8, C81, C82 C83, C84, C85 C86, C87, C88 C89, C9, C90	0.01uF, CAPSMD, CC1206
2	2		C57, C63	100PF
3	1		C71	2200pF
4	6		C42, C43, C50 C51, C58, C65	270pF
5	1		C5	27pF
6	5		C72, C73, C74 C75, C76	330pF
7	6		C36, C37, C46 C47, C52, C61	680pF
8	1		R44	0, RESSMD, CC1206
9	7		R16, R18, R22 R24, R29, R34 R43	13.7K
10	13		R1, R10, R2, R38 R39, R4, R40 R41, R5, R6, R7 R8, R9	150
11	1		R37	2.2

PROTOTYPE
ONLY

12	4	R27, R31, R32 R35	20K
13	6	R15, R17, R21 R23, R28, R33	5.62K
14	6	R19, R20, R25 R26, R30, R36	56.2K
15	5	R11, R12, R13 R14, R3	75
16	1	R42	75K
17	5	L5, L6, L7, L8 L9	SMDFERRITEB, CC1812
18	1	P1	IDC10M, IDC10RM
19	1	P4	IDC16M, IDC16RM
20	1	P2	ARL-4010-4, PAT-ARL-4010-4
21	1	U4	12.288Mhz, XTAL OSC, PAT-DIP8(4)
22	3	1, 2, 3	FIDUCIAL, PAT-FIDUCIAL
23	1	P5	IDC20, PAT-IDC20
24	1	P3	MOLEX5P, PAT-MOLEX5P
25	1	U8	QS3251, PAT-QSOP16
26	1	U2	74FCT2373, PAT-QSOP20
27	1	L4	SMDFERRITE, PAT-SMDFERRITE
28	2	U10, U9	TORX173, PAT-TOXX173

29	1	U15	CS4226, PAT-TQFP44
30	1	U5	PALCE20V8-PLCC, PLCC28
31	1	U1	27C256PLCC, PLCC32RJ
32	1	U3	80C251, PLCC44J
33	1	U6	DSP56009, QFP80
34	4	U11, U12, U13 U14	.01uF, MC33078, SO8
35	1	D1	<i>F2516LT1</i> DIODESMT, SOT-23
36	13	C23, C29, C40 C41, C48, C49 C55, C56, C62 C64, C78, C79 C80	10uF, PCAPSM, TC3216
37	5	C1, C66, C69 C70, C77	1uF
38	2	C20, C25	4.7uF
39	1	U7	7805, TO-220AB
<i>40</i>	<i>1</i>	<i>U1</i>	<i>socket, PLCC32RJ</i>

ITEM	QTY	PART-NUMBER	REFERENCE-DESIGNATOR	DESCRIPTION
1	18	135-31210-00	C306, C305, C201, C733 C734, C535, C534, C537 C304, C202, C203, C204 C205, C206, C303, C302 C536, C301	CAP, AX, CER, 0.001uF, 100V, X7R10%
2	22	135-30010-00	C209, C517, C715, C708 C732, C1108, C515, C1115 C614, C616, C713, C310 C1303, C506, C605, C609 C1306, C1214, C510, C1211 C1008, C1005	CAP, AX, CER, 10pF, 100V, NPO5%
3	105	135-22410-00	C409, C401, C402, C313 C714, C712, C706, C704 C615, C314, C501, C503 C513, C607, C530, C521 C526, C1302, C1313, C1308 C711, C618, C626, C724 C621, C625, C612, C611 C604, C603, C601, C720 C716, C710, C703, C701 C801, C809, C804, C902 C901, C802, C805, C912 C811, C806, C903, C1201 C1202, C1210, C1213 C1209, C1208, C1204 C1205, C1101, C1102 C1116, C1106, C1107 C1105, C1104, C913, C1117 C1012, C1009, C1004 C1013, C1014, C1036 C1035, C1007, C1016 C1015, C1002, C1001, C909 C905, C405, C1301, C403 C504, C512, C508, C613 C1110, C1111, C522, C728 C807, C1312, C1314, C1309 C1305, C516, C514, C906 C213, C307, C312, C308 C309, C207, C208, C212	CAP, AX, CER, 0.1uF, 50V, Z5U20%
4	16	135-30027-00	C502, C1311, C1310, C608 C602, C910, C803, C810 C702, C907, C911, C404 C408, C509, C908, C707	CAP, AX, CER, 27pF, 100V, COG5%
5	25	100-12100-00	R1228, R1130, R1132	RES, AXIAL, 10.0K, 1%, MF, 1/8W

RELEASED FOR
MANUFACTURE

R1047, R1049, R403, R634
R1317, R1322, R1230
R1115, R1039, R1043
R1329, R406, R412, R415
R101, R107, R102, R103
R104, R105, R106, R1327

6	16	100-10150-00	R1232, R1129, R1134 R1319, R1323, R1051 R1222, R1046, R1123 R1326, R1027, R1026 R1226, R1127, R1227 R1331	RES, AXIAL, 150, 1%, MF, 1/8W
7	13	100-13100-00	R1133, R1131, R1050 R1048, R1223, R1231 R1229, R1008, R1005 R1124, R1220, R1328 R1330	RES, AXIAL, 100K, 1%, MF, 1/8W
8	34	100-12301-00	R214, R213, R202, R511 R1306, R1313, R211, R205 R209, R1304, R1325, R1303 R616, R610, R739, R207 R715, R1302, R1312, R1301 R1309, R1308, R1310 R1311, R519, R1305, R302 R1307, R305, R307, R309 R311, R313, R314	RES, AXIAL, 30.1K, 1%, MF, 1/8W
9	8	101-15330-00	R1206, R1209, R1104 R1122, R1035, R1014 R1004, R1030	RES, AXIAL, 3.3M, 5%, CF, 1/8W
10	18	100-13200-00	R410, R216, R517, R1315 R1321, R721, R614, R738 R1117, R1009, R1006 R1224, R1126, R402, R607 R1221, R508, R316	RES, AXIAL, 200K, 1%, MF, 1/8W
11	2	100-12825-00	R411, R401	RES, AXIAL, 82.5K, 1%, MF, 1/8W
12	20	100-11100-00	R306, R310, R201, R308 R312, R510, R615, R609 R714, R722, R635, R422 R518, R204, R206, R208 R210, R212, R304, R301	RES, AXIAL, 1.00K, 1%, MF, 1/8W
13	36	100-12360-00	R525, R215, R524, R503 R504, R509, R515, R528	RES, AXIAL, 36.0K, 1%, MF, 1/8W

R505, R516, R1314, R1320
 R613, R724, R604, R622
 R720, R709, R706, R737
 R540, R637, R623, R624
 R723, R619, R605, R708
 R705, R704, R703, R713
 R710, R523, R315, R521

14	1	100-11536-00	R420	RES, AXIAL, 5.36K, 1%, MF, 1/8W
15	3	100-11910-00	R408, R620, R417	RES, AXIAL, 9.10K, 1%, MF, 1/8W
16	1	100-12150-00	R421	RES, AXIAL, 15.0K, 1%, MF, 1/8W
17	60	100-12220-00	R633, R905, R906, R907 R908, R813, R812, R811 R810, R809, R808, R807 R806, R805, R804, R803 R802, R801, R814, R909 R910, R912, R911, R831 R913, R830, R829, R828 R827, R826, R825, R824 R823, R822, R821, R820 R819, R818, R833, R832 R901, R921, R902, R904 R924, R926, R925, R919 R903, R923, R920, R918 R917, R916, R915, R914 R430, R425, R423, R432	RES, AXIAL, 22.0K, 1%, MF, 1/8W
18	11	100-12110-00	R413, R1324, R1318, R405 R404, R419, R426, R424 R433, R431, R414	RES, AXIAL, 11.0K, 1%, MF, 1/8W
19	18	100-11374-00	R318, R507, R522, R526 R533, R1205, R625, R618 R608, R725, R719, R1015 R407, R409, R416, R712 R731, R418	RES, AXIAL, 3.74K, 1%, MF, 1/8W
20	12	100-12115-00	R502, R501, R701, R611 R601, R717, R716, R702 R602, R612, R513, R514	RES, AXIAL, 11.5K, 1%, MF, 1/8W
21	15	100-12470-00	R539, R532, R530, R531 R536, R537, R736, R735 R630, R629, R631, R734 R728, R730, R729	RES, AXIAL, 47.0K, 1%, MF, 1/8W

22	6	100-11300-00	R520, R632, R603, R718 R711, R506	RES, AXIAL, 3.00K, 1%, MF, 1/8W
23	5	100-11953-00	R527, R534, R627, R732 R726	RES, AXIAL, 9.53K, 1%, MF, 1/8W
24	5	100-12649-00	R529, R535, R628, R733 R727	RES, AXIAL, 64.9K, 1%, MF, 1/8W
25	5	100-11590-00	R1215, R1211, R1109 R1017, R1021	RES, AXIAL, 5.90K, 1%, MF, 1/8W
26	9	100-11221-00	R815, R816, R1213, R817 R1217, R1111, R1023 R1019, R617	RES, AXIAL, 2.21K, 1%, MF, 1/8W
27	5	100-11681-00	R1207, R1208, R1103 R1003, R1012	RES, AXIAL, 6.81K, 1%, MF, 1/8W
28	7	100-11348-00	R1212, R1216, R1105 R1106, R1110, R1022 R1018	RES, AXIAL, 3.48K, 1%, MF, 1/8W
29	5	100-12133-00	R1210, R1214, R1108 R1020, R1016	RES, AXIAL, 13.3K, 1%, MF, 1/8W
30	6	100-11750-00	R1128, R1107, R1007 R1013, R1219, R1218	RES, AXIAL, 7.50K, 1%, MF, 1/8W
31	3	100-11976-00	R1121, R1034, R1031	RES, AXIAL, 9.76K, 1%, MF, 1/8W
32	9	100-12147-00	R1120, R1119, R1114 R1032, R1038, R1042 R1033, R1029, R1028	RES, AXIAL, 14.7K, 1%, MF, 1/8W
33	1	100-13127-00	R1116	RES, AXIAL, 127K, 1%, MF, 1/8W
34 f	3	100-12261-00	R1113, R1037, R1041	RES, AXIAL, 26.1K, 1%, MF, 1/8W
35	3	100-12590-00	R1112, R1036, R1040	RES, AXIAL, 59.0, 1%, MF, 1/8W
36	6	100-13680-00	R429, R427, R428, R434 R436, R435	RES, AXIAL, 680K, 1%, MF, 1/8W

37	1	100-12180-00	R621	RES, AXIAL, 18.0K, 1%, MF, 1/8W
38	4	101-10000-00	R1045, R217, R1044, R218	RES, AXIAL, 0, 5%, CF, 1/8W
39	16	210-02878-00	Q1203, Q1201, Q1204 Q1202, Q1104, Q1102 Q1103, Q1101, Q1303 Q1301, Q1304, Q1302 Q1004, Q1002, Q1001 Q1003	TRANS, NPN, MUTING, 2SC2878
40	26	190-50210-00	FIL201, FIL202, FIL203 FIL204, FIL205, FIL206 FIL501, FIL502, FIL1301 FIL1302, FIL601, FIL600 FIL700, FIL1101, FIL1102 FIL1202, FIL1002 FIL1001, FIL1201, FIL701 FIL306, FIL305, FIL304 FIL303, FIL302, FIL301	EMI, FILTER, RAD, 1000pF
41	6	232-04051-00	U200, U1301, U1302, U801 U803, U301	ANALOG, SWTCH, SNGL, 8TO1, 4051B
42	11	232-04052-00	U506, U603, U706, U802 U901, U1202, U1102, U1101 U1005, U1006, U902	ANALOG, SWITCH, DUAL, 4TO1, 4052B
43	7	321-02001-00	J1101, J1001, J501, J201 J204, J202, J203	RCA_JACK, 14mm, QUAD, R/W
44	4	110-06310-00	RP203, RP1301, RP1302 RP303	RES, NET, BUSS_SIP9, 10K
45	5	110-06322-00	RP801, RP901, RP802 RP803, RP902	RES, NET, BUSSED, SIP9, 22K, 2%
46	2	320-55010-00	J103, J101	HEADER, 2X10, SHROUDED
47	18	143-13510-00	C210, C511, C1304, C1307 C610, C606, C709, C705 C1109, C1011, C1006 C1215, C1118, C1212, C311 C507, C406, C407	CAP, RAD, PEF, 1.0uF, 50V, 5%
48	29	221-00072-00	U201, U401, U501, U502 U504, U505, U1303, U1304	OPAMP, DUAL, LN, JFET, TL072

ITEM	QTY	PART-NUMBER	REFERENCE-DESIGNATOR	DESCRIPTION
1	18	135-31210-00	C306, C305, C201, C733 C734, C535, C534, C537 C304, C202, C203, C204 C205, C206, C303, C302 C536, C301	CAP, AX, CER, 0.001uF, 100V, X7R10%
2	22	135-30010-00	C209, C517, C715, C708 C732, C1108, C515, C1115 C614, C616, C713, C310 C1303, C506, C605, C609 C1306, C1214, C510, C1211 C1008, C1005	CAP, AX, CER, 10pF, 100V, NPO5%
3	105	135-22410-00	C409, C401, C402, C313 C714, C712, C706, C704 C615, C314, C501, C503 C513, C607, C530, C521 C526, C1302, C1313, C1308 C711, C618, C626, C724 C621, C625, C612, C611 C604, C603, C601, C720 C716, C710, C703, C701 C801, C809, C804, C902 C901, C802, C805, C912 C811, C806, C903, C1201 C1202, C1210, C1213 C1209, C1208, C1204 C1205, C1101, C1102 C1116, C1106, C1107 C1105, C1104, C913, C1117 C1012, C1009, C1004 C1013, C1014, C1036 C1035, C1007, C1016 C1015, C1002, C1001, C909 C905, C405, C1301, C403 C504, C512, C508, C613 C1110, C1111, C522, C728 C807, C1312, C1314, C1309 C1305, C516, C514, C906 C213, C307, C312, C308 C309, C207, C208, C212	CAP, AX, CER, 0.1uF, 50V, Z5U20%
4	16	135-30027-00	C502, C1311, C1310, C608 C602, C910, C803, C810 C702, C907, C911, C404 C408, C509, C908, C707	CAP, AX, CER, 27pF, 100V, COG5%
5	25	100-12100-00	R1228, R1130, R1132 R1047, R1049, R403, R634 R1317, R1322, R1230	RES, AXIAL, 10.0K, 1%, MF, 1/8W

RELEASED FOR
MANUFACTURE
BY *[Signature]*

R1115, R1039, R1043
R1329, R406, R412, R415
R101, R107, R102, R103
R104, R105, R106, R1327

6	16	100-10150-00	R1232, R1129, R1134 R1319, R1323, R1051 R1222, R1046, R1123 R1326, R1027, R1026 R1226, R1127, R1227 R1331	RES, AXIAL, 150, 1%, MF, 1/8W
7	13	100-13100-00	R1133, R1131, R1050 R1048, R1223, R1231 R1229, R1008, R1005 R1124, R1220, R1328 R1330	RES, AXIAL, 100K, 1%, MF, 1/8W
8	34	100-12301-00	R214, R213, R202, R511 R1306, R1313, R211, R205 R209, R1304, R1325, R1303 R616, R610, R739, R207 R715, R1302, R1312, R1301 R1309, R1308, R1310 R1311, R519, R1305, R302 R1307, R305, R307, R309 R311, R313, R314	RES, AXIAL, 30.1K, 1%, MF, 1/8W
9	8	101-15330-00	R1206, R1209, R1104 R1122, R1035, R1014 R1004, R1030	RES, AXIAL, 3.3M, 5%, CF, 1/8W
10	18	100-13200-00	R410, R216, R517, R1315 R1321, R721, R614, R738 R1117, R1009, R1006 R1224, R1126, R402, R607 R1221, R508, R316	RES, AXIAL, 200K, 1%, MF, 1/8W
11	2	100-12825-00	R411, R401	RES, AXIAL, 82.5K, 1%, MF, 1/8W
12	20	100-11100-00	R306, R310, R201, R308 R312, R510, R615, R609 R714, R722, R635, R422 R518, R204, R206, R208 R210, R212, R304, R301	RES, AXIAL, 1.00K, 1%, MF, 1/8W
13	36	100-12360-00	R525, R215, R524, R503 R504, R509, R515, R528 R505, R516, R1314, R1320 R613, R724, R604, R622 R720, R709, R706, R737 R540, R637, R623, R624	RES, AXIAL, 36.0K, 1%, MF, 1/8W

R723, R619, R605, R708
 R705, R704, R703, R713
 R710, R523, R315, R521

14	1	100-11536-00	R420	RES, AXIAL, 5.36K, 1%, MF, 1/8W
15	3	100-11910-00	R408, R620, R417	RES, AXIAL, 9.10K, 1%, MF, 1/8W
16	1	100-12150-00	R421	RES, AXIAL, 15.0K, 1%, MF, 1/8W
17	60	100-12220-00	R633, R905, R906, R907 R908, R813, R812, R811 R810, R809, R808, R807 R806, R805, R804, R803 R802, R801, R814, R909 R910, R912, R911, R831 R913, R830, R829, R828 R827, R826, R825, R824 R823, R822, R821, R820 R819, R818, R833, R832 R901, R921, R902, R904 R924, R926, R925, R919 R903, R923, R920, R918 R917, R916, R915, R914 R430, R425, R423, R432	RES, AXIAL, 22.0K, 1%, MF, 1/8W
18	11	100-12110-00	R413, R1324, R1318, R405 R404, R419, R426, R424 R433, R431, R414	RES, AXIAL, 11.0K, 1%, MF, 1/8W
19	18	100-11374-00	R318, R507, R522, R526 R533, R1205, R625, R618 R608, R725, R719, R1015 R407, R409, R416, R712 R731, R418	RES, AXIAL, 3.74K, 1%, MF, 1/8W
20	12	100-12115-00	R502, R501, R701, R611 R601, R717, R716, R702 R602, R612, R513, R514	RES, AXIAL, 11.5K, 1%, MF, 1/8W
21	15	100-12470-00	R539, R532, R530, R531 R536, R537, R736, R735 R630, R629, R631, R734 R728, R730, R729	RES, AXIAL, 47.0K, 1%, MF, 1/8W
22	6	100-11300-00	R520, R632, R603, R718 R711, R506	RES, AXIAL, 3.00K, 1%, MF, 1/8W
23	5	100-11953-00	R527, R534, R627, R732 R726	RES, AXIAL, 9.53K, 1%, MF, 1/8W



24	5	100-12649-00	R529, R535, R628, R733 R727	RES, AXIAL, 64.9K, 1%, MF, 1/8W
25	5	100-11590-00	R1215, R1211, R1109 R1017, R1021	RES, AXIAL, 5.90K, 1%, MF, 1/8W
26	3	100-11200-00	R815, R816, R817	RES, AXIAL, 2.00K, 1%, MF, 1/8W
27	5	100-11681-00	R1207, R1208, R1103 R1003, R1012	RES, AXIAL, 6.81K, 1%, MF, 1/8W
28	7	100-11348-00	R1212, R1216, R1105 R1106, R1110, R1022 R1018	RES, AXIAL, 3.48K, 1%, MF, 1/8W
29	6	100-11221-00	R1213, R1217, R1111 R1023, R1019, R617	RES, AXIAL, 2.21K, 1%, MF, 1/8W
30	5	100-12133-00	R1210, R1214, R1108 R1020, R1016	RES, AXIAL, 13.3K, 1%, MF, 1/8W
31	6	100-11750-00	R1128, R1107, R1007 R1013, R1219, R1218	RES, AXIAL, 7.50K, 1%, MF, 1/8W
32	3	100-11976-00	R1121, R1034, R1031	RES, AXIAL, 9.76K, 1%, MF, 1/8W
33	9	100-12147-00	R1120, R1119, R1114 R1032, R1038, R1042 R1033, R1029, R1028	RES, AXIAL, 14.7K, 1%, MF, 1/8W
34	1	100-13127-00	R1116	RES, AXIAL, 127K, 1%, MF, 1/8W
35	3	100-12261-00	R1113, R1037, R1041	RES, AXIAL, 26.1K, 1%, MF, 1/8W
36	3	100-12590-00	R1112, R1036, R1040	RES, AXIAL, 59.0, 1%, MF, 1/8W
37	6	100-13680-00	R429, R427, R428, R434 R436, R435	RES, AXIAL, 680K, 1%, MF, 1/8W
38	1	100-12180-00	R621	RES, AXIAL, 18.0K, 1%, MF, 1/8W
39	4	101-10000-00	R1045, R217, R1044, R218	RES, AXIAL, 0, 5%, CF, 1/8W

40	16	210-02878-00	Q1201, Q1204, Q1202 Q1104, Q1102, Q1103 Q1101, Q1303, Q1301 Q1304, Q1302, Q1004 Q1002, Q1001, Q1003 Q1203	TRANS, NPN, MUTING, 2SC2878
41	26	190-50210-00	FIL201, FIL202, FIL203 FIL204, FIL205, FIL206 FIL501, FIL502, FIL1301 FIL1302, FIL601, FIL600 FIL700, FIL1101, FIL1102 FIL1202, FIL1002 FIL1001, FIL1201, FIL701 FIL306, FIL305, FIL304 FIL303, FIL302, FIL301	EMI, FILTER, RAD, 1000pF
42	6	232-04051-00	U200, U1301, U1302, U801 U803, U301	ANALOG, SWTCH, SNGL, 8TO1, 4051B
43	11	232-04052-00	U506, U603, U706, U802 U901, U1202, U1102, U1101 U1005, U1006, U902	ANALOG, SWITCH, DUAL, 4TO1, 4052B
44	7	321-02001-00	J1101, J1001, J501, J201 J204, J202, J203	RCA_JACK, 14mm, QUAD, R/W
45	4	110-06310-00	RP203, RP1301, RP1302 RP303	RES, NET, BUSS_SIP9, 10K
46	5	110-06247-00	RP801, RP901, RP802 RP803, RP902	RES, NET, BUSSED, SIP9, 4.7K, 2%
47	2	320-55010-00	J103, J101	HEADER, 2X10, SHROUDED
48	24	143-13510-00	C210, C511, C1304, C1307 C610, C606, C709, C705 C1109, C1011, C1006 C1215, C1118, C1212, C311 C507, C1217, C1038, C1216 C1037, C1121, C1122, C406 C407	CAP, RAD, PEF, 1.0uF, 50V, 5%
49	32	221-00072-00	U201, U401, U501, U502 U504, U505, U1303, U1304 U705, U702, U606, U605 U604, U602, U601, U704 U701, U1104, U1203, U1204 U1103, U1105, U1004 U1002, U1003, U402, U503	OPAMP, DUAL, LN, JFET, TL072

U703, U302, U903, U804
U904

	4	201-04148-00	D402, D401, D403, D404	DIODE, SWITCHING, 500mW, 1N4148
51	3	224-01973-00	U202, U1201, U1001	POT, DIG, CONT, TRI, AUD., LM1973
52	1	320-55008-00	J100	HEADER, 2X8, SHROUDED
53	1	320-56108-00	J102	HEADER, 1X8, POL, SHROUDED, 2mm
54	20	143-13412-00	C520, C519, C518, C531 C523, C527, C528, C529 C725, C622, C617, C620 C619, C729, C718, C719 C717, C721, C726, C727	CAP, RAD, PEF, 0.12uF, 50V, 5%
55	11	143-13347-00	C524, C532, C730, C623 C722, C1021, C1020, C1017 C1112, C1018, C1113	CAP, RAD, PEF, 0.047, 50V, 5%
56	5	143-13268-00	C525, C533, C624, C731 C723	CAP, RAD, PEF, 0.0068uF, 50V, 5%
57	5	143-13247-00	C1203, C1207, C1103 C1010, C1003	CAP, RAD, PEF, 0.0047uF, 50V, 5%
58	1	223-00339-00	U404	COMP, QUAD, LP, LO, LM339
59	3	143-13433-00	C1114, C1034, C1019	CAP, RAD, PEF, 0.33uF, 50V, 5%
60	1	320-52205-00	J104	HEADER, 1X5, POL, LOCKRAMP

ITEM	QTY	PART-NUMBER	REFERENCE-DESIGNATOR	DESCRIPTION
1	1	300-02101-00	SW201	SWITCH, PC, SPST, MOM, TL2101
2	1	320-56103-00	P201	HEADER, 1X3, RA, SHROUDED, 2mm
3	1	300-04050-00	SW202	OMIT

COPY

RELEASED FOR
MANUFACTURE
BY *[Signature]* 6/5/97

ITEM	QTY	PART-NUMBER	REFERENCE-DESIGNATOR	DESCRIPTION
1	2	324-01021-00	P101, P102	CONN, QC, PC, MALE, 0.250"
2	1	300-00410-00	SW101	SWITCH, PANEL, SPST, LATCH, KDC-A04-10-B, B2

RELEASED FOR

MANUFACTURE

BY *S. J. Kardon* 6/5/97

1

COPY

CSPWS00.XLS

ITEM	QTY	PART-NUMBER	REFERENCE-DESIGNATOR	DESCRIPTION
1	1	320-56103-00	P301	HEADER, 1X3, RA, SHROUDED, 2mm
2	1	305-04104-00	SW301	ROTARY, ENCODER, VPCMNT, 24POS

COPY

RELEASED FOR
MANUFACTURE
BY *S.T. Harde* 6/5/97

ITEM	QTY	PART-NUMBER	REFERENCE-DESIGNATOR	DESCRIPTION
1	2	320-56103-00	P203, P204	HEADER, 1X3, RA, SHROUDED, 2mm
2	7	300-02101-00	SW202, SW203, SW204 SW207, SW205, SW206 SW201	SWITCH, PC, SPST, MOM, TL2101
3	7	101-13100-00	R204, R205, R203, R210 R208, R207, R209	RES, AXIAL, 10K, 5%, CF, 1/8W
4	1	101-11680-00	R202	RES, AXIAL, 680, 5%, CF, 1/8W
5	1	101-11150-00	R206	RES, AXIAL, 150, 5%, CF, 1/8W
6	2	210-03904-00	Q202, Q201	TRANS, NPN, 2N3904
7	1	110-06310-00	R201	RES, NET, BUSS_SIP9, 10K
8	1	320-56111-00	P201	HEADER, 1X11, POL, SHROUDED, 2mm
9	1	204-10580-00	D201	LED, T1, 0.157", AMBER(580nm)
10	9	204-10470-00	D206, D207, D208, D209 D205, D204, D203, D202 D210	LED, T1, 0.157", BLUE(470nm)
11	1	320-52305-00	P202	HEADER, 1X5, RA, POL, LOCKRAMP
12	7	300-04050-00	SW207A, SW206A, SW205A SW204A, SW203A, SW202A SW201A	OMIT
13	10	640-00250-00	D206, D207, D208, D209 D205, D204, D203, D202 D210, D201	SPACER, NYLON RND, #4, 0.250"

COPY

RELEASED FOR
 MANUFACTURE
 BY *S. J. [Signature]* 7/21/97

20AUDIO

ASM: HA206-0015-3	SIG 2.0 AUDIO BOARD ASY,REV03	EA M
Gallien Part Number	Description	
001-1030-1	TL072CP, LOW NOISE JFET OPAMP 29.000000 EP 0 0 0.0 A REF: U 201,302,401,402,501,502,503, REF: 504,505,601,602,604,605,606,701 REF: 702,703,704,705,1002,1003,1004, REF: 1103,1104,105,1203,1204,1303, REF: 1304	EA B
001-1031-0	OP249,OPAMP DUAL PREC HS JFET 3.000000 EP 0 0 0.0 A REF: U 804,903,904	EA B
001-1195-0	LM339A,QUAD COMPARATOR 1.000000 EP 0 0 0.0 A REF: U 404	EA B
001-1973-0	LM1973N DIGITAL ATTENUATOR 3.000000 EP 0 0 0.0 A REF: U 202,1001,1201	EA B
002-0035-0	CD4052 EA B 11.000000 EP 0 0 0.0 A REF: U 506,603,706,802,901,902,1005, REF: 1006,1005,1101,1102,1202	
002-0051-0	CD4051 EA B 6.000000 EP 0 0 0.0 A REF: U 200,301,801,803,1301,1302	
010-0004-0	2SC2878B,TRANS,NPN,MUTING 16.000000 EP 0 0 0.0 A REF: Q 1001,1002,1003,1004,1101,1102, REF: 1103,1104,1201,1202,1203,1204, REF: 1301,1302,1303,1304	EA B
020-1000-0	1N4148 ,RECT-FAST,200MA,100V,4NS,DO-35 4.000000 EP 0 0 0.0 AI A REF: D 401,402,403,404	EA B
030-2104-0	CAP,CER,AX,104,10%,50V,X7R 105.000000 EP 0 0 0.0 AI A REF: C 207,208,212,213,307,308,309, REF: 312,313,314,401,402,403,405,409, REF: 501,503,504,508,512,513,514,516, REF: 521,526,530,601,603,604,607,611 REF: 612,613,615,618,621,625,626,701 REF: 703,704,706,710,711,712,714,716 REF: 720,724,728,801,802,804,805,806 REF: 807,809,811,901,902,903,905,906 REF: 909,912,913,1001,1002,1004,1007 REF: 1009,1012,1013,1014,1015,1016, REF: 1035,1036,1101,1102,1104,1105, REF: 1106,1107,1110,1111,1116,1117, REF: 1201,1202,1204,1205,1208,1209, REF: 1210,1213,1301,1302,1305,1308,	EA B
030-2104-0	CAP,CER,AX,104,10%,50V,X7R 105.000000 EP 0 0 0.0 AI A REF: 1309,1312,1313,1314,522	EA B

030-2270-0	CAP,CER AXIAL,27 PF,10%,50V,NPO	EA B
	16.000000 EP 0 0 0.0 AI A	
	REF: C 404,408,502,509,602,608,702,	
	REF: 707,803,810,907,908,910,911,1311	
	REF: 1310	
030-4100-0	CAP,CER AXIAL,10 PF,10%,100V	EA B
	22.000000 EP 0 0 0.0 A	
	REF: C 209,310,506,510,515,517,605,	
	REF: 609,614,616,708,713,715,732,1005	
	REF: 1008,1108,1115,1211,1214,1303,	
	REF: 1306	
030-4102-0	CAP,CER AXIAL,102,10%,100V,X7R	EA B
	18.000000 EP 0 0 0.0 A	
	REF: C 201,202,203,204,205,206,301,	
	REF: 302,303,304,305,306,534,535,536	
	REF: 537,733,734	
031-0106-1	CAP,ELEC,RAD,106,20%,25V,NP	EA B
	1.000000 EP 0 0 0.0 A	
	REF: C 1102	
036-2105-0	CAP,PE,RAD,105,5%,50V	EA B
	18.000000 EP 0 0 0.0 A	
	REF: C 210,311,406,407,507,511,606,	
	REF: 610,705,709,1006,1011,1109,1118	
	REF: 1212,1215,1304,1307	
036-2124-0	CAP,PE,RAD,124,5%,50V	EA B
	20.000000 EP 0 0 0.0 A	
	REF: C 518,519,520,523,527,528,529,	
	REF: 531,617,619,620,622,717,718,719	
	REF: 721,726,727,729	
036-2334-0	CAP,PE,RAD,334,5%,50V	EA B
	3.000000 EP 0 0 0.0 A	
	REF: C 1019,1034,1114	
036-2472-0	CAP,PE,RAD,472,5%,50V	EA B
	5.000000 EP 0 0 0.0 A	
	REF: C 1003,1010,1103,1203,1207	
036-2473-0	CAP,PE,RAD,473,5%,50V	EA B
	11.000000 EP 0 0 0.0 A	
	REF: C 524,532,623,722,730,1017,1020	
	REF: 1021,1112,1113,1118	
036-2682-0	CAP,PE,RAD,682,5%,50V	EA B
	5.000000 EP 0 0 0.0 A	
	REF: C 525,533,624,723,731	
050-0000-0	RES,METAL WIRE,0 OHM,1/8W	EA B
	4.000000 EP 0 0 0.0 AI A	
	REF: R 217,218,1044,1045	
050-3305-0	RES,CARBON FILM,3.3M OHM,1/8W,5%	EA B
	8.000000 EP 0 0 0.0 A	
	REF: R 1004,1014,1030,1035,1104,1122	
	REF: 1206,1209	
058-1003-0	RES,SIP 10K OHMS X 9	EA B
	4.000000 EP 0 0 0.0 A	
	REF: RP 203,303,1301,1302	
058-2203-0	RES,SIP,22K OHMS X9,2%	EA B

5.000000 EP 0 0 0.0 A
 REF: RP 801,802,803,901,902
 060-1002-0 RES,METAL FILM,1.00K,1/8W,1% EA B
 20.000000 EP 0 0 0.0 AI A
 REF: R 201,204,206,208,210,212,301
 REF: 304,306,308,310,312,422,510,518
 REF: 609,615,635,714,722
 060-1003-0 RES,METAL FILM,10.0K OHM,1/8W,1% EA B
 25.000000 EP 0 0 0.0 AI A
 REF: R 101,102,103,104,105,106,107,
 REF: 403,406,412,415,634,1039,1043,
 REF: 1047,1049,1115,1130,1132,1228,
 REF: 1230,1317,1322,1327,1329
 060-1004-0 RES,METAL FILM,100K,1/8W,1% EA B
 13.000000 EP 0 0 0.0 AI A
 REF: R 1005,1008,1048,1050,1124,1131,
 REF: 1133,1220,1223,1229,1231,1328,
 REF: 1330
 060-1103-0 RES,METAL FILM,11.0K,1/8W,1% EA B
 11.000000 EP 0 0 0.0 AI A
 REF: R 404,405,413,414,419,424,426,
 REF: 431,433,1318,1324
 060-1153-0 RES,METAL FIM,11.5 K OHM,1%,1/8W EA B
 12.000000 EP 0 0 0.0 A
 REF: R 501,502,513,514,601,602,611,
 REF: 612,701,702,716,717
 060-1274-0 RES,METAL FILM,127K,1/8W,1% EA B
 1.000000 EP 0 0 0.0 A
 REF: R 1116
 060-1333-0 RES,METAL FILM,13.3 K OHM,1%,1/8W EA B
 5.000000 EP 0 0 0.0 A
 REF: R 1016,1020,1108,1210,1214
 060-1473-0 RES,METAL FILM,14.7 K OHM,1%,1/8W EA B
 9.000000 EP 0 0 0.0 A
 REF: R 1028,1029,1032,1033,1038,1042
 REF: 1114,1119,1120
 060-1501-0 RES,METAL FILM,150 OHMS,1/8W,1% EA B
 16.000000 EP 0 0 0.0 A
 REF: R 1026,1027,1046,1051,1123,1127
 REF: 1129,1134,1222,1226,1227,1232,
 REF: 1319,1323,1326,1331
 060-1503-0 RES,METAL FILM,15.0 K OHM,1/8W,1% EA B
 1.000000 EP 0 0 0.0 A
 REF: R 421
 060-1803-0 RES,METAL FILM,18K OHM,1/8W,1% EA B
 1.000000 EP 0 0 0.0 A
 REF: R 621
 060-2004-0 RES,METAL FILM,200K OHM,1/8W,1% EA B
 18.000000 EP 0 0 0.0 A
 REF: R 216,316,402,410,508,517,607,
 REF: 614,721,738,1006,1009,1117,1126
 REF: 1221,1224,1315,1321
 060-2203-0 RES,METAL FILM,22K OHM,1/8W,1% EA B

	60.000000 EP 0 0 0.0 A	
	REF: R 423,425,430,432,633,801,802,	
	REF: 803,804,805,806,807,808,809,810,	
	REF: 811,812,813,814,818,819,820,821	
	REF: 822,823,824,825,826,827,828,829	
	REF: 830,831,832,833,901,902,903,904	
	REF: 905,906,907,908,909,910,911,912	
	REF: 913,914,915,916,917,918,919,920	
	REF: 921,923,924,925,926	
060-2212-0	RES,METAL FILM,2.21K OHM,1/8W,1%	EA B
	9.000000 EP 0 0 0.0 A	
	REF: R 617,815,816,817,1019,1023,1111	
	REF: 1213,1217	
060-2613-0	RES,METAL FILM,26.1 KOHM,1%,1/8W	EA B
	3.000000 EP 0 0 0.0 A	
	REF: R 1037,1041,1113	
060-3002-0	RES,METAL FILM,3 K OHM,1%,1/8 W	EA B
	6.000000 EP 0 0 0.0 A	
	REF: R 506,520,603,632,711,718	
060-3103-0	RES,METAL FILM,30.1K OHM,1/8W,1%	EA B
	34.000000 EP 0 0 0.0 A	
	REF: R 202,205,207,209,211,213,214,	
	REF: 302,305,307,309,311,313,314,511	
	REF: 519,610,616,715,739,1301,1302,	
	REF: 1303,1304,1305,1306,1307,1308	
	REF: 1309,1310,1311,1312,1313,1325	
060-3482-0	RES,METAL FILM,3.48K OHM,1/8W,1%	EA B
	7.000000 EP 0 0 0.0 A	
	REF: R 1018,1022,1105,1106,1110,1212,	
	REF: 1216	
060-3603-0	RES,METAL FILM,36K OHM,1/8W,1%	EA B
	36.000000 EP 0 0 0.0 A	
	REF: R 215,315,503,504,505,509,515,	
	REF: 516,521,523,524,525,528,540,604,	
	REF: 605,613,619,622,623,624,637,703,	
	REF: 704,705,706,708,709,710,713,720,	
	REF: 723,724,737,1314,1320	
060-3742-0	RES,METAL FILM,3.74K OHM,1/8W,1%	EA B
	18.000000 EP 0 0 0.0 A	
	REF: R 318,407,409,416,418,507,522,	
	REF: 526,533,608,618,625,712,719,725	
	REF: 731,1015,1205	
060-4703-0	RES,METAL FILM,47.0K OHM,1/8W,1%	EA B
	15.000000 EP 0 0 0.0 AI A	
	REF: R 530,531,532,536,537,539,629,	
	REF: 630,631,728,729,730,734,735,736	
060-5362-0	RES,METAL FILM,5.36K OHM,1%,1/8W	EA B
	1.000000 EP 0 0 0.0 A	
	REF: R 420	
060-5902-0	RES,METAL FILM,5.9K OHM,1/8W,1%	EA B
	5.000000 EP 0 0 0.0 A	
	REF: R 1017,1021,1109,1211,1215	
060-5903-0	RES,METAL FILM,59.0K OHM,1/8W,1%	EA B

	3.000000 EP 0 0 0.0	A
	REF: R 1036,1040,1112	
060-6493-0	RES,METAL FILM,64.9K,1/8W,1%	EA B
	5.000000 EP 0 0 0.0	A
	REF: R 529,535,628,727,733	
060-6804-0	RES,METAL FILM,680K OHM,1/8W,1%	EA B
	6.000000 EP 0 0 0.0	A
	REF: R 427,428,429,434,435,436	
060-6812-0	RES,METAL FILM,6.81K OHM,1/8W,1%	EA B
	5.000000 EP 0 0 0.0 AI	A
	REF: R 1003,1012,1103,1207,1208	
060-7502-0	RES,METAL FILM,7.5K OHM,1/8W,1%	EA B
	6.000000 EP 0 0 0.0	A
	REF: R 1007,1013,1107,1128,1218,1219	
060-8253-0	RES,METAL FILM,82.5 K OHM,1/8W,1%	EA B
	2.000000 EP 0 0 0.0	A
	REF: R 401,411	
060-9102-0	RES,METAL FILM,9.10K OHM,1/8W,1%	EA B
	3.000000 EP 0 0 0.0 AI	A
	REF: R 408,417,620	
060-9532-0	RES,METAL FILM,9.53K OHM,1/8W,1%	EA B
	5.000000 EP 0 0 0.0	A
	REF: R 527,534,627,726,732	
060-9762-0	RES,METAL FILM,9.76K OHM,1/8W,1%	EA B
	3.000000 EP 0 0 0.0	A
	REF: R 1031,1034,1121	
081-0102-0	EMI FILTER, RAD,1000PF	EA B
	26.000000 EP 0 0 0.0	A
	REF: FIL 201,202,203,204,205,206,301	
	REF: 302,303,304,305,306,501,502,600	
	REF: 601,700,701,1001,1002,1101,1102,	
	REF: 1201,1202,1301,1302	
092-0007-0	JACK,RCAX4,HORIZ,GOLD,RD/WT	EA B
	7.000000 EP 0 0 0.0	A
	REF: J 201,204,202,203,501,1001,1101	
093-0009-0	HDR,.1X5,VERT,MALE,LOCK	EA B
	1.000000 EP 0 0 0.0	A
	REF: J 104	
093-0019-0	HDR,.1X2X8,VERT,SHROUDED	EA B
	1.000000 EP 0 0 0.0	A
	REF: J 100	
093-2000-0	HDR,.1X2X10,VERT,MALE,SHROUDED	EA B
	2.000000 EP 0 0 0.0	A
	REF: J 101,103	
093-2003-0	HDR,2MMX8,VERT,SHROUDED	EA B
	1.000000 EP 0 0 0.0	A
	REF: J 102	
153-0105-0	LABEL,BLANK,.9"X.25"	EA B
	1.000000 EP 0 0 0.0	A
HA145-0015-3	SIG 2.0 AUDIO I/O RAW PCB	EA B
	1.000000 EP 0 0 0.0 03	A

63 COMPONENTS PRINTED

ASM: HA206-0012-0	SIG 2.0 CPU BOARD ASSY	EA M
Gallien Part Number	Description	
001-0004-0	4N26 OPTO-COUPLER SIX PIN 1.5KV	EA B
	1.000000 EP 0 0 0.0 A	
	REF: U 302	
002-0086-0	74HC86, EXCLUSIVE OR GATE, QUAD, 2 IN	EA B
	1.000000 EP 0 0 0.0 A	
	REF: U 310	
002-0202-0	MAX202, INTRFC XCVR RS232	EA B
	1.000000 EP 0 0 0.0 A	
	REF: U 502	
002-1008-0	74HC08	EA B
	1.000000 EP 0 0 0.0 A	
	REF: U 503	
002-1138-0	74HC138	EA B
	2.000000 EP 0 0 0.0 A	
	REF: U 307,308	
002-1139-0	74HC139N, DECODER, DUAL 2 TO 4	EA B
	1.000000 EP 0 0 0.0 A	
	REF: U 309	
002-1541-1	74HC541, BUFFER, OCTAL TRISTATE	EA B
	3.000000 EP 0 0 0.0 A	
	REF: U 411,412,413	
002-1574-0	74HC574N TRI-STATE OCTAL D FLIP FLOP	EA B
	8.000000 EP 0 0 0.0 A	
	REF: U 401,402,403,404,405,406,407,	
	REF: 408	
003-0020-4	EPROM, 128KX8, 120NS, 27C010-12	EA B
	1.000000 EP 0 0 0.0 2.4 A	
	REF: U 305	
003-0080-0	EPROM, SERIAL, 8K, 25080	EA B
	1.000000 EP 0 0 0.0 A	
	REF: U 501	
003-0264-0	SRAM, 8KX8, 28PIN, 600MIL, PLAST DIP	EA B
	1.000000 EP 0 0 0.0 A	
	REF: U 306	
003-1705-0	UP SUPERVISOR, 4.65V, UPS705	EA B
	1.000000 EP 0 0 0.0 A	
	REF: U 303	
003-2180-0	MICROPROCESSOR, Z80180, 10MHZ	EA B
	1.000000 EP 0 0 0.0 A	
	REF: U 304	
010-0002-0	2N3904 TRANS, NPN	EA B
	4.000000 EP 0 0 0.0 A	
	REF: Q 501,503,506,507	
010-1013-0	MPSA56 PNP 80V 500MA TO-92	EA B
	3.000000 EP 0 0 0.0 0 A	
	REF: Q 502,504,505	
020-1000-0	1N4148, RECT-FAST, 200MA, 100V, 4NS, DO-35	EA B
	6.000000 EP 0 0 0.0 AI A	
	REF: D 303,304,401,504,508 +	
	REF: ECO#972601	

020-2107-0	DIODE RECT 1A 1N4003	EA B
	2.000000 EP 0 0 0.0	A
	REF: D 501,502	
024-0005-0	CRYSTALL, 18.432 MHZ,HC49	EA B
	1.000000 EP 0 0 0.0	A
	REF: X 301	
030-2104-0	CAP,CER,AX,104,10%,50V,X7R	EA B
	38.000000 EP 0 0 0.0 AI	A
	REF: C 101,102,104,105,106,107,111,	
	REF: 112,115,116,119,120,121,122,123	
	REF: 126,127,128,130,132,133,134,135,	
	REF: 201,205,209,211,304,305,306,307,	
	REF: 401,503,504,505,506,507,118	
030-2270-0	CAP,CER AXIAL,27 PF,10%,50V,NPO	EA B
	2.000000 EP 0 0 0.0 AI	A
	REF: C 301,302	
030-4102-0	CAP,CER AXIAL,102,10%,100V,X7R	EA B
	2.000000 EP 0 0 0.0	A
	REF: C 308,509	
031-1227-0	CAP,ELEC,RAD,227,-10%+50%,25V	EA B
	2.000000 EP 0 0 0.0	A
	REF: C 202,206	
037-0106-0	CAP,TAN,RAD,106,10%,6.3V	EA B
	10.000000 EP 0 0 0.0	A
	REF: C 138,140,141,142,143,144,145,	
	REF: 210,212 + ECO# 972601	
050-1001-0	RES,CARBON FILM,100 OHM,1/8W,5%	EA B
	1.000000 EP 0 0 0.0 AI	A
	REF: R 306	
050-1002-0	RES,CARBON FILM,1K OHM,1/8W,5%	EA B
	4.000000 EP 0 0 0.0 AI	A
	REF: R 507,511,514,515	
050-1003-0	RES,CARBON FILM,10K OHM,1/8W,5%	EA B
	13.000000 EP 0 0 0.0 AI	A
	REF: R 305,309,310,408,501,503,504,	
	REF: 505,506,508,509,510,512	
050-3904-0	RES,CARBON FILM,390K OHM,1/8W,5%	EA B
	3.000000 EP 0 0 0.0 AI	A
	REF: R 311,407,513	
060-1213-0	RES,METAL FILM,12.1 K OHM,1/8W,1%	EA B
	1.000000 EP 0 0 0.0	A
	REF: R 307	
060-2212-0	RES,METAL FILM,2.21K OHM,1/8W,1%	EA B
	1.000000 EP 0 0 0.0	A
	REF: R 308	
081-0102-0	EMI FILTER, RAD,1000PF	EA B
	4.000000 EP 0 0 0.0	A
	REF: FIL 201,202,203,502	
081-0103-0	EMI FILTER, RAD, 103	EA B
	7.000000 EP 0 0 0.0	A
	REF: FIL 501,503,504,505,506,507,508	
091-1004-0	POLY SWITCH,2A	EA B
	2.000000 EP 0 0 0.0	A

092-0013-0	REF: F 501,502 CON,DSUB,9P,F,PC,HOR	EA B
	1.000000 EP 0 0 0.0	A
092-0021-0	REF: P 501 JACK,PHONE,3.5MM,MONO SB	EA B
	3.000000 EP 0 0 0.0	A
093-0009-0	REF: J 501,502,503 HDR,.1X5,VERT,MALE,LOCK	EA B
	1.000000 EP 0 0 0.0	A
093-0039-0	REF: P 201 HDR,.1X2X5,VERT,MALE,SHROUDED	EA B
	1.000000 EP 0 0 0.0	A
093-2000-0	REF: P 203 HDR,.1X2X10,VERT,MALE,SHROUDED	EA B
	4.000000 EP 0 0 0.0	A
093-2001-0	REF: P 204,205,206,207 HDR,2MMX11,POL,SHROUDED,	EA B
	1.000000 EP 0 0 0.0	A
093-2004-0	REF: P 211 HDR,2MMX9,VERT,SHROUDED	EA B
	1.000000 EP 0 0 0.0	A
094-0003-0	REF: P 200 SKT,DIP,.6X32,MPTST	EA B
	1.000000 EP 0 0 0.0	A
094-0005-0	REF: U 305 SKT,PLCC,TST,68PIN	EA B
	1.000000 EP 0 0 0.0	A
100-0104-0	REF: U 304 BRACKET,.25X.25,KEYSTONE,#621	EA B
	1.000000 EP 0 0 0.0	A
111-0041-0	BOLT,4-40,1/4,PHP,CAD	EA B
	1.000000 EP 0 0 0.0 0	A
153-0105-0	LABEL,BLANK,.9"X.25"	EA B
	1.000000 EP 0 0 0.0	A
HA145-0012-0	SIG-2.0 CPU RAW PCB	EA B
	1.000000 EP 0 0 0.0 00	A

45 COMPONENTS PRINTED

1 ASSEMBLIES PRINTED

ASM: HA206-0013-1 SIG 2.0 DSP BOARD ASSY REV 01 EA M

Gallien Part Number	Description	
001-1078-0	MC33078D DUAL LOW NOISE OP AMP	EA B
	4.000000 EP 0 0 0.0 A	
	REF: U 11,12,13,14	
001-3173-0	TORX173,FIBER OPTICS RECEIVING MODULE	EA B
	2.000000 EP 0 0 0.0 A	
	REF: U 9,10	
001-3251-0	QS3251Q,MUX/DEMUX QUICK SWITCH 8	EA B
	1.000000 EP 0 0 0.0 A	
	REF: U 8	
002-0237-0	QS74FCT2373TQ,LATCH 8BIT WITH OUTPUT RES	EA B
	1.000000 EP 0 0 0.0 A	
	REF: U 2	
003-2226-0	SURROUND SOUND 20 BIT CODEC	EA B
	1.000000 EP 0 0 0.0 A	
	REF: U 15	
003-2560-0	DSPF56009FJ81 DSP PROCESSOR	EA B
	1.000000 EP 0 0 0.0 A	
	REF: U 6	
003-2B16-0	MICROCONTROLLER,N80C251SB16	EA B
	1.000000 EP 0 0 0.0 A	
	REF: U 3	
003-3003-A	PAL	EA B
	1.000000 EP 0 0 0.0 A	
	REF: U 5	
003-4004-A	EPROM,256 KILOBIT CMOS OTP	EA B
	1.000000 EP 0 0 0.0 A	
	REF: U 1	
014-0071-0	LM7805CT 5V REG 1A TO-220	EA B
	1.000000 EP 0 0 0.0 A	
	REF: U 7	
024-0001-0	CLOCK OSCILLATOR (HALF SIZE) 12.288 MHZ	EA B
	1.000000 EP 0 0 0.0 A	
	REF: U 4	
031-0106-1	CAP,ELEC,RAD,106,20%,25V,NP	EA B
	1.000000 EP 0 0 0.0 A	
	REF: ECO # 972062	
031-0108-0	CAP,ELEC,RAD,108,-10%+50%,16V	EA B
	1.000000 EP 0 0 0.0 A	
	REF: ECO # 972062	
040-2101-0	CAP,CER,101,5%,50V,NPO,1206,SMT	EA B
	2.000000 EP 0 0 0.0 A	
	REF: C 57,63	
040-2103-0	CAP,CER,103,X7R,50V,1206	EA B
	49.000000 EP 0 0 0.0 A	
	REF: C 2,3,4,6,7,8,9,10,11,12,13,14	
	REF: 15,16,17,18,19,21,22,24,26,27,28	
	REF: 30,31,32,33,34,35,38,39,44,45,53	
040-2103-0	CAP,CER,103,X7R,50V,1206	EA B
	49.000000 EP 0 0 0.0 A	
	REF: 54,59,60,67,68,81,82,83,84,85,86	

	REF: 87,88,89,90	
040-2222-0	CAP,CER,222,10%,50V,X7R,1206,SMT	EA B
	1.000000 EP 0 0 0.0 A	
	REF: C 71	
040-2270-1	CAP,CER,27,20%,50V,X7R,1026,SMT	EA B
	1.000000 EP 0 0 0.0 A	
	REF: C 5	
040-2271-0	CAP CER,271,X7R,50V,1206	EA B
	6.000000 EP 0 0 0.0 A	
	REF: C 42,43,50,51,58,65	
040-2331-0	CAP,CER,331,X7R,50V,1206	EA B
	5.000000 EP 0 0 0.0 A	
	REF: C 72,73,74,75,76	
040-2681-0	CAP,CERAMIC,681,5%,50V,Z5U,1206,SMT	EA B
	6.000000 EP 0 0 0.0 A	
	REF: C 36,37,46,47,52,61	
047-0105-0	CAP,TANT,105,20%,16V,A CASE,SMT	EA B
	4.000000 EP 0 0 0.0 A	
	REF: C 1,66,70,77	
047-0106-1	CAP,TANT,106,20%,6.3V,C CASE,SMT	EA B
	14.000000 EP 0 0 0.0 A	
	REF: C 23,29,40,41,48,49,55,56,62,64,	
	REF: 69,78,79,80	
047-1105-0	CAP,TANT,105,20%,25V,A CASE,3216	EA B
	2.000000 EP 0 0 0.0 A	
	REF: C 20,25	
051-0200-0	RES,CARBON FILM,2 OHM,1/4W,5%	EA B
	1.000000 EP 0 0 0.0 A	
	REF: ECO # 972062	
062-0000-0	RES,CF,0 OHM,1/8W,5%,1206,SMT	EA B
	1.000000 EP 0 0 0.0 A	
	REF: R 44	
063-1372-0	RES,METAL FILM,13.7K OHM,1/8W,1%,1206	EA B
	7.000000 EP 0 0 0.0 A	
	REF: R 16,18,22,24,29,34,43	
063-1501-0	RES,METAL FILM,150 OHM,1/8W,1%,1206	EA B
	13.000000 EP 0 0 0.0 A	
	REF: R 1,2,4,5,6,7,8,9,10,38,39,40,41	
063-2003-0	RES,METAL FILM,20K OHM,1/8W,1%,1206	EA B
	2.000000 EP 0 0 0.0 A	
	REF: R 27,32	
063-5622-0	RES,METAL FILM,5.62K OHM,1/8W,1%,1206	EA B
	6.000000 EP 0 0 0.0 A	
	REF: R 15,17,21,23,28,33	
063-5623-0	RES,METAL FILM,56.2K OHM,1/8W,1%,1206	EA B
	6.000000 EP 0 0 0.0 A	
	REF: R 19,20,25,26,30,36	
063-7500-0	RES,METAL FILM,75 OHM,1/8W,1%,1206	EA B
	5.000000 EP 0 0 0.0 A	
	REF: R 3,11,12,13,14	
063-7503-0	RES,METAL FILM,75K OHM,1/8W,1%,1206	EA B
	1.000000 EP 0 0 0.0 A	
	REF: R 42	

081-0011-0	INDUCTOR,AX,HIQ,820UH	EA B
	1.000000 EP 0 0 0.0	A
	REF: ECO # 970262	
085-0106-0	FERRITE,SMT,3216	EA B
	1.000000 EP 0 0 0.0	A
	REF: L 4	
085-0106-1	FERRITE,SMT,4532	EA B
	5.000000 EP 0 0 0.0	A
	REF: L 5,6,7,8,9	
085-0336-0	INDUCTOR,SMT,33 UH,1206	EA B
	1.000000 EP 0 0 0.0	A
092-0020-0	JACK,RCA X4,H,PC,GOLD	EA B
	1.000000 EP 0 0 0.0	A
093-0010-0	HDR,.1X5,HORIZ,POL,LOCK RAMP	EA B
	1.000000 EP 0 0 0.0	A
	REF: P 3	
093-0019-0	HDR,.1X2X8,VERT,SHROUDED	EA B
	1.000000 EP 0 0 0.0	A
	REF: P 4	
093-0039-0	HDR,.1X2X5,VERT,MALE,SHROUDED	EA B
	1.000000 EP 0 0 0.0	A
	REF: P 1	
093-0041-0	HDR,.1X2X10,VERT,MALE	EA B
	1.000000 EP 0 0 0.0	A
	REF: P 5	
094-0073-0	SKT,PLCC,SMTX32,RECT	EA B
	1.000000 EP 0 0 0.0	A
	REF: U 1	
095-0500-0	WIRE,14GA,BLACK,600V	FT B
	0.167000 EP 0 0 0.0	A
100-0104-0	BRACKET,.25X.25,KEYSTONE,#621	EA B
	1.000000 EP 0 0 0.0	A
111-0041-0	BOLT,4-40,1/4,PHP,CAD	EA B
	1.000000 EP 0 0 0.0	A
153-0105-0	LABEL,BLANK,.9"X.25"	EA B
	1.000000 EP 0 0 0.0	A
HA145-0013-0	SIG 2.0 DSP RAW PCB,REV 01	EA B
	1.000000 EP 0 0 0.0	A

47 COMPONENTS PRINTED

1 ASSEMBLIES PRINTED

ASM: HA206-0016-0 SIG 2.0 BUTTON LOGO PANEL BOARD ASSY EA M

Gallien Part Number	Description	
010-0002-0	2N3904 TRANS,NPN	EA B
	1.000000 EP 0 0 0.0	A
	REF: Q 201	
010-1000-0	2N3906 PNP 40V 100MA TO-92	EA B
	2.000000 EP 0 0 0.0 0	A
	REF: Q 202,501	
025-0003-0	IR RECEIVER,38KHZ,W/CLIP,TFMT 5380	EA B
	1.000000 EP 0 0 0.0	A
	REF: U 501	
025-0024-0	LED,AMBER,T1,580NM	EA B
	1.000000 EP 0 0 0.0	A
	REF: D 201	
025-0030-0	LED,BLUE,T1,.190,470NM,SMALL	EA B
	9.000000 EP 0 0 0.0	A
	REF: D 202,203,204,205,206,207,208, REF: 209,210	
030-2104-0	CAP,CER,AX,104,10%,50V,X7R	EA B
	3.000000 EP 0 0 0.0 AI	A
	REF: C 502,504,506	
031-1476-0	CAP,ELEC,RAD,476,20%,25V	EA B
	2.000000 EP 0 0 0.0	A
	REF: C 501,503	
038-0336-0	CAP,ELEC,AXIAL TR,336,20%,25V	EA B
	1.000000 EP 0 0 0.0 AI	A
	REF: C 505	
050-1003-0	RES,CARBON FILM,10K OHM,1/8W,5%	EA B
	8.000000 EP 0 0 0.0 AI	A
	REF: R 501,203,204,205,207,208,209, REF: 210	
050-1501-0	RES,CARBON FILM,150 OHM,1/8W,5%	EA B
	1.000000 EP 0 0 0.0 AI	A
	REF: R 206	
050-3001-0	RES,CARBON FILM,300 OHM,1/8W,5%	EA B
	1.000000 EP 0 0 0.0	A
	REF: R 502	
050-6801-0	RES,CARBON FILM,680 OHM,1/8W,5%	EA B
	1.000000 EP 0 0 0.0 AI	A
	REF: R 202	
058-1003-0	RES,SIP 10K OHMS X 9	EA B
	1.000000 EP 0 0 0.0 0	A
	REF: R 201	
081-0004-0	INDUCTOR,100UH	EA B
	2.000000 EP 0 0 0.0	A
	REF: L 501,502	
090-0007-0	SWITCH,8A/128A,250V,PP,PCB	EA B
	1.000000 EP 0 0 0.0	A
	REF: SW 101	
090-0040-0	SWITCH PC SPST MOM TL2101	EA B
	8.000000 EP 0 0 0.0	A
	REF: SW 201,202,203,204,205,206,207	

	REF: SW 201 (STANDBY BOARD)	
090-1001-0	ENCODER,ROTARY,VPCMNT, 24 POS	EA B
	1.000000 EP 0 0 0.0 A	
	REF: SW 301	
092-0066-0	FASTON,M,PC,.250"	EA B
	2.000000 EP 0 0 0.0 A	
	REF: P 101,102	
093-0010-0	HDR,.1X5,HORIZ,POL,LOCK RAMP	EA B
	1.000000 EP 0 0 0.0 A	
	REF: P 202	
093-0044-0	HDR,2MMX3,HORIZ,MALE,LOCK	EA B
	4.000000 EP 0 0 0.0 A	
	REF: P 201,203,204,301	
093-2000-0	HDR,.1X2X10,VERT,MALE,SHROUDED	EA B
	1.000000 EP 0 0 0.0 A	
	REF: P 501	
093-2001-0	HDR,2MMX11,POL,SHROUDED,	EA B
	1.000000 EP 0 0 0.0 A	
	REF: P 201 (BUTTON LOGO BOARD)	
094-0002-0	SKT,STRIP,TST,2X7,HORIZ	EA B
	1.000000 EP 0 0 0.0 A	
	REF: P 502	
100-0121-0	SPACER,LED,NYLON,0.250"X0.187"	EA B
	10.000000 EP 0 0 0.0 A	
	REF: D 201,202,203,204,205,206,207,	
	REF: 208,209,210	
153-0105-0	LABEL,BLANK,.9"X.25"	EA B
	1.000000 EP 0 0 0.0 A	
HA145-0016-A	SIG 2.0 BUTTON LOGO PANEL RAW PCB	EA B
	1.000000 EP 0 0 0.0 00 A	
	REF: the panel consists of 5 boards:	
	REF: HA145-0005-0 Pwr switch board	
	REF: HA145-0007-0 VFD/IR board	
	REF: HA145-0008-0 Standby board	
	REF: HA145-0009-0 Button logo board	
	REF: HA145-0010-0 Rotary ecoder board	

26 COMPONENTS PRINTED

1 ASSEMBLIES PRINTED

ASM: HA302-1020-A

SIG 2.0 230V

Gallien Part Number	Description
014-0031-0	LM7815 +15V REG 1A TO-220 1.000000 EP 0 0 0.0 0 REF: U 204
014-0071-0	LM7805CT 5V REG 1A TO-220 3.000000 EP 0 0 0.0 0 REF: U 201,202,203
014-1001-0	VOLTAGE REGULATOR,TO-220 IN,-5V,7905 1.000000 EP 0 0 0.0 REF: U 208
014-1032-0	LM7915 -15V REG 1A TO-220 1.000000 EP 0 0 0.0 0 REF: U 206
025-1000-0	DISPLAY,VF 1.000000 EP 0 0 0.0
080-0032-2	TRANSFORMER SIG 2.0,10V@2.2A,230V 1.000000 EP 0 0 0.0 02
080-0033-2	TRANSFORMER SIG 2.0,36V@1.1A,230V 1.000000 EP 0 0 0.0 02
091-0032-0	FUSE,5MM,400MA,250V,SLB,SEMKO/VDE 1.000000 EP 0 0 0.0
091-0039-0	FUSE,5MM,315MA,250V,SLB,UL/CSA/SEMKO 1.000000 EP 0 0 0.0 REF: F 102
093-0003-1	HDR,.1X2X7,HORIZ,MALE 1.000000 EP 0 0 0.0 REF: VFD HEADER
093-0066-0	SHUNT .1",TIN,2 POS, 1.000000 EP 0 0 0.0 0
094-0019-0	LUG,#6,SOLDER 1.000000 EP 0 0 0.0 0
095-0007-0	CORD,2X.75MM,2.5A/250V,FLAT,8FT,EXP 1.000000 EP 0 0 0.0
095-0500-0	WIRE,14GA,BLACK,600V 0.700000 EP 0 0 0.0 0
096-0000-0	AAA ALKALINE BATTERY 2.000000 EP 0 0 0.0
100-0007-0	SIG 2.0, WINDOW 1.000000 EP 0 0 0.0
100-0011-0	STRAIN RELIEF,SPT-2,UL,CSA 1.000000 EP 0 0 0.0
100-0033-0	CABLE TIE - PLT 1M-M,SMALL 12.000000 EP 0 0 0.0 0
100-0121-0	SPACER,LED,NYLON,0.250"X0.187" 6.000000 EP 0 0 0.0
100-0126-0	HOLDER,CABLE TIE .75" SQUARE,ADHESIVE BK 2.000000 EP 0 0 0.0
101-0002-0	FOOT BLACK ANODIZED/RUBBER GASKET 4.000000 EP 0 0 0.0
102-0000-0	BUTTON, LARGE,CIT 7.0 1.000000 EP 0 0 0.0

102-0001-0	BUTTON, SMALL, CIT 7.0 7.000000 EP 0 0 0.0
102-0002-0	KNOB,2',ALUM CAP,BLACK,UNMARKED 1.000000 EP 0 0 0.0
102-0003-0	BUTTON CAP, LOUDNESS, H/K 1.000000 EP 0 0 0.0
105-0001-0	INSULATOR TAPE,1"X7MIL ADHESIVE BACK 0.500000 EP 0 0 0.0
111-0051-0	BOLT,4-40,5/16,PHP,CAD 2.000000 EP 0 0 0.0
111-0061-0	BOLT,4-40,3/8,PHP,CAD 1.000000 EP 0 0 0.0
111-1040-1	BOLT,4-40,1/4UFHP,BZ,UNDERCUT FLAT 3.000000 EP 0 0 0.0
111-2041-0	BOLT,4-40,1/4,PHP,INT STAR WSHR,ZINC 4.000000 EP 0 0 0.0
111-2080-0	BOLT,4-40,1/4,ZINC 2.000000 EP 0 0 0.0
111-3080-0	SCREW,4AB,1/2,PHP,B.Z. 13.000000 EP 0 0 0.0
111-6001-0	NUT,4-40,KEP SMALL 1.000000 EP 0 0 0.0
111-7011-0	WASHER,#4,SPLIT 2.000000 EP 0 0 0.0
111-8061-0	TR-BOLT,4-40,3/8,PHP,CAD 6.000000 EP 0 0 0.0
111-8101-0	TR-BOLT,4-40,5/8,PHP,CAD 6.000000 EP 0 0 0.0
112-0040-0	BOLT,6-32,1/4,PHP,ZINC 32.000000 EP 0 0 0.0
112-0081-0	BOLT,6-32,1/2,PHP,CAD 4.000000 EP 0 0 0.0
112-6001-0	NUT,6-32,KEP LARGE,CAD 6.000000 EP 0 0 0.0
112-6015-0	STANDOFF,6-32X22/16,NYLON 3.000000 EP 0 0 0.0
112-8040-0	TR-BOLT,6-32,1/4,PHP,B.Z. 24.000000 EP 0 0 0.0 PP
112-8041-0	TR-BOLT,6-32,1/4",PHP,ZINC 1.000000 EP 0 0 0.0
119-6000-0	NUT,M9X.75MM,PANEL ZNC 1.000000 EP 0 0 0.0
119-7000-0	WASHER,M9,ZNC,FLAT 1.000000 EP 0 0 0.0
150-0023-0	BAG,POLY 10 X 16 1 1/2 MILL 2.000000 EP 0 0 0.0
150-0099-0	BAG,POLY 24"X24"X2MIL ANTISTATIC 1.000000 EP 0 0 0.0
153-0000-0	TIE WRAP,BLACK 1.000000 EP 0 0 0.0
153-0100-2	SAFTEY LABEL(RISK OF FIRE),ENGL/FREN 1.000000 EP 0 0 0.0
153-0101-0	LABEL,SERIAL #,SIGNATURE 2.0

153-0103-0	1.000000 EP 0 0 0.0 LABEL,CE,PRODUCT
153-0104-0	1.000000 EP 0 0 0.0 LABEL,CE,OUTER PACKING
160-0005-0	1.000000 EP 0 0 0.0 GROUNDING SAFETY SHEET
HA080-0001-0	1.000000 EP 0 0 0.0 XFORMER,FM MATCHING,230V SIG 2.0
HA130-0000-0	1.000000 EP 0 0 0.0 OVERLAY,SIG 2.0 REMOTE CONTROL OVERLAY
HA132-0017-0	1.000000 EP 0 0 0.0 SIG 2.0,HEAT SINK
HA132-0018-3	1.000000 EP 0 0 0.0 00 SIG 2.0 CHASSIS
HA132-0019-0	1.000000 EP 0 0 0.0 03 SIG 2.0,TOP COVER
HA132-0020-A	1.000000 EP 0 0 0.0 00 SIG 2.0 FRONT PANEL
HA132-0021-A	1.000000 EP 0 0 0.0 04 LOGO,SIGNATURE SERIES,ACRYLIC
HA132-0022-6	1.000000 EP 0 0 0.0 SIG 2.0,SUBCHASSIS
HA132-0023-0	1.000000 EP 0 0 0.0 06 SIG 2.0,VOLUME MOUNTING BRACKET
HA132-0024-1	1.000000 EP 0 0 0.0 00 SIG 2.0 SHIELD TRANSFORMER
HA132-0025-0	1.000000 EP 0 0 0.0 01 SIG 2.0,HOUSING TRANSFORMER
HA150-0002-A	1.000000 EP 0 0 0.0 00 SIG 2.0 CARTON
HA151-0003-A	1.000000 EP 0 0 0.0 SIG 2.0 FOAM PACK
HA151-0005-0	1.000000 EP 0 0 0.0 SIG 2.0,PAD,LARGE
HA151-0006-0	2.000000 EP 0 0 0.0 SIG 2.0,PAD,SMALL
HA153-0100-0	2.000000 EP 0 0 0.0 LABEL,TRANSFORMER,SIG 2.0
HA153-0101-0	1.000000 EP 0 0 0.0 LABEL,REAR CHASSIS 230V,SIG 2.0
HA153-0103-0	2.000000 EP 0 0 0.0 LABEL,UPC,230V,SIG 2.0
HA153-0105-0	1.000000 EP 0 0 0.0 A LABEL,FUSE RATING,SIG 2.0,230V
HA160-0007-A	1.000000 EP 0 0 0.0 A SIG 2.0/230V OWNER'S MANUAL
HA202-0000-0	1.000000 EP 0 0 0.0 0 WIRE ASSY,26GA,YEL,17",11PIN
HA202-0001-0	2.000000 EP 0 0 0.0 00 WIRE ASSY,26GA,BLU,3",3PIN
HA202-0002-0	1.000000 EP 0 0 0.0 00 WIRE ASSY,26GA,ORG,17",9PIN

HA202-0100-0	WIRE ASSY,22GA,GRN,5",5PIN 1.000000 EP 0 0 0.0 00
HA202-0101-0	WIRE ASSY,22GA,BLK,12",5PIN 1.000000 EP 0 0 0.0 00
HA202-0102-0	WIRE ASSY,22GA,BRN,12",5PIN 1.000000 EP 0 0 0.0 00
HA202-0103-0	WIRE ASSY,22GA,RED,15",5PIN 1.000000 EP 0 0 0.0 00
HA202-0104-0	WIRE ASSY,22GA,PUR,18",5PIN 1.000000 EP 0 0 0.0 00
HA202-0105-0	WIRE ASSY,22GA,GRY,7",8PIN 1.000000 EP 0 0 0.0 00
HA202-0106-0	WIRE ASSY,18GA,BLK,6" 1.000000 EP 0 0 0.0 01
HA202-0107-0	WIRE ASSY,22GA,BLK,10,SPEAKER 1.000000 EP 0 0 0.0
HA202-0300-0	WIRE ASSY,14GA,GRN,6" 1.000000 EP 0 0 0.0 01
HA202-0301-0	WIRE ASSY,16GA,RED,8" 2.000000 EP 0 0 0.0 00
HA202-0500-0	RIBBON ASSY,28GA,F-F,8",10PIN 1.000000 EP 0 0 0.0 00
HA202-0501-0	RIBBON ASSY,28GA,F-F,9",16PIN 1.000000 EP 0 0 0.0 00
HA202-0502-0	RIBBON ASSY,28GA,F-F,11",20PIN 2.000000 EP 0 0 0.0 00
HA202-0503-0	RIBBON ASSY,28GA,F-F,5",20PIN 1.000000 EP 0 0 0.0 00
HA202-0504-0	RIBBON ASSY,28GA,F-F,15",20PIN 1.000000 EP 0 0 0.0 00
HA205-2000-0	SIG 2.0 AM ANTENNA LOOP 1.000000 EP 0 0 0.0
HA205-2001-0	SIG 2.0 FM DIPOLE ANTENNA 1.000000 EP 0 0 0.0
HA206-0006-1	SIG 2.0 POWER SUPPLY BOARD ASSY REV 01 1.000000 EP 0 0 0.0 01
HA206-0011-2	SIG 2.0 VIDEO BOARD ASSY REV02 1.000000 EP 0 0 0.0 02
HA206-0012-0	SIG 2.0 CPU BOARD ASSY 1.000000 EP 0 0 0.0 00
HA206-0013-1	SIG 2.0 DSP BOARD ASSY REV 01 1.000000 EP 0 0 0.0 01
HA206-0014-A	SIG 2.0 TUNER BOARD ASY EUR 1.000000 EP 0 0 0.0 A
HA206-0015-3	SIG 2.0 AUDIO BOARD ASY,REV03 1.000000 EP 0 0 0.0 03
HA206-0016-0	SIG 2.0 BUTTON LOGO PANEL BOARD ASSY 1.000000 EP 0 0 0.0 00 REF: the board consists of 5 parts REF: HA206-0005-0 Pwr Switch Assy REF: HA206-0007-0 VFD/IR Assy REF: HA206-0008-0 Standby Assy REF: HA206-0009-0 Button logo Assy

HA304-0000-0

REF: HA206-0010-0 Rotary Encoder
SIG 2.0 REMOTE CONTROL IR
1.000000 EP 0 0 0.0

100 COMPONENTS PRINTED

ASM: HA206-0006-1 SIG 2.0 POWER SUPPLY BOARD ASSY REV 01 EA M

Gallien Part Number	Description	EA	B
010-0002-0	2N3904 TRANS,NPN		
	1.000000 EP 0 0 0.0	A	
	REF: Q 202		
010-0012-0	MPSA06 NPN 80V 500MA TO-92		
	1.000000 EP 0 0 0.0	A	
	REF: Q 101		
011-1117-0	TIP117 PNP 100V 2A TO-220		
	1.000000 EP 0 0 0.0	A	
	REF: Q 203		
014-0003-0	78L06,VOLTAGE REGULATOR,+6V,TO-92		
	1.000000 EP 0 0 0.0	A	
	REF: U 205		
014-1002-0	79L06,VOLTAGE REGULATOR,TO-92,-6V		
	1.000000 EP 0 0 0.0	A	
	REF: U 207		
020-1121-0	DIODE RECT 3A 1N5402		
	8.000000 EP 0 0 0.0	A	
	REF: D 203,204,205,206,209,210,211,		
	REF: 212		
020-2107-0	DIODE RECT 1A 1N4003		
	9.000000 EP 0 0 0.0	A	
	REF: D 101,202,207,208,213,214,215,		
	REF: 216,217		
022-0070-0	MOV,RAD DISC,14MM,250V		
	1.000000 EP 0 0 0.0	A	
	REF: MOV 101		
030-2104-0	CAP,CER,AX,104,10%,50V,X7R		
	18.000000 EP 0 0 0.0 AI	A	
	REF: C 101,102,201,202,206,207,209		
	REF: 210,213,214,216,217,220,221,223		
	REF: 224,226,227		
031-1476-0	CAP,ELEC,RAD,476,20%,25V		
	7.000000 EP 0 0 0.0	A	
	REF: C 203,208,211,215,222,228,229		
031-2106-0	CAP,ELEC,RAD,106,-10%+50%,50V		
	4.000000 EP 0 0 0.0	A	
	REF: C 218,225,230,231		
031-2338-0	CAP,ELEC,RAD,338,20%,35V		
	4.000000 EP 0 0 0.0	A	
	REF: C 204,205,212,219		
032-7104-0	CAP,PE,104,20%,250V		
	2.000000 EP 0 0 0.0	A	
	REF: C 232,233		
050-0000-0	RES,METAL WIRE,0 OHM,1/8W		
	2.000000 EP 0 0 0.0 AI	A	
	REF: R 104,105		
050-1003-0	RES,CARBON FILM,10K OHM,1/8W,5%		
	3.000000 EP 0 0 0.0 AI	A	
	REF: R 102,203,205		
050-2002-0	RES,CARBON FILM,2K OHM,1/8W,5%		

	2.000000 EP 0 0 0.0	A
	REF: R 103,204	
053-8205-0	RES,CARBON FILM,8.2 M OHM,1/2W,5%	EA B
	1.000000 EP 0 0 0.0	A
	REF: R 101	
057-3300-0	RES,WIRE WOUND,33 OHM,10W,5%	EA B
	2.000000 EP 0 0 0.0	A
	REF: R 206,207	
081-0005-0	FERRITE BEAD,AX, TYPE39	EA B
	2.000000 EP 0 0 0.0	A
	REF: FB 101,102	
084-0003-0	RELAY, PC NPSS TYPE 1,5V	EA B
	1.000000 EP 0 0 0.0	A
	REF: K 101	
092-0024-0	FASTON,M,PC,.187"	EA B
	1.000000 EP 0 0 0.0	A
	REF: J 101	
092-0066-0	FASTON,M,PC,.250"	EA B
	8.000000 EP 0 0 0.0	A
	REF: J 102,103,104,105,106,107,201,	
	REF: 202	
093-0009-0	HDR,.1X5,VERT,MALE,LOCK	EA B
	7.000000 EP 0 0 0.0	A
	REF: P 101,102,103,104,105,201,202	
094-0004-1	FUSE CLIP, 5MM PC MNT,111-501	EA B
	4.000000 EP 0 0 0.0	A
153-0105-0	LABEL,BLANK,.9"X.25"	EA B
	1.000000 EP 0 0 0.0	A
HA145-0006-0	SIG 2.0 POWER SUPPLY BOARD,REV 01	EA B
	1.000000 EP 0 0 0.0 01	A

26 COMPONENTS PRINTED

1 ASSEMBLIES PRINTED

ASM: HA206-0011-2	SIG 2.0 VIDEO BOARD ASSY REV02	EA M
Gallien Part Number	Description	
001-1030-1	TL072CP, LOW NOISE JFET OPAMP 2.000000 EP 0 0 0.0 A REF: U 502,602	EA B
002-0053-0	HC4053, ANALOG SWITCH TRPL, 2 TO 1 4.000000 EP 0 0 0.0 A REF: U 401,402,503,701	EA B
002-0054-0	HC4052, ANALOG SWITCH DUAL 4 TO 1 2.000000 EP 0 0 0.0 A REF: U 802,901	EA B
002-0055-0	HC4051, ANALOG SWITCH SNGL 8 TO 1 2.000000 EP 0 0 0.0 A REF: U 301,302	EA B
003-0581-0	EL4581CS,VIDEO SYNC SEPARATOR 1.000000 EP 0 0 0.0 A REF: U 601	EA B
003-1075-0	MB90075,OSD,S-VIDEO 1.000000 EP 0 0 0.0 A REF: U 702	EA B
010-0002-0	2N3904 TRANS,NPN 5.000000 EP 0 0 0.0 A REF: Q 601,603,701,702,703	EA B
010-1000-0	2N3906 PNP 40V 100MA TO-92 1.000000 EP 0 0 0.0 A REF: Q 602	EA B
010-1004-0	OPAMP,DUAL VIDEO,MC14576 5.000000 EP 0 0 0.0 A REF: U 303,403,501,805,903	EA B
020-1000-0	1N4148 ,RECT-FAST,200MA,100V,4NS,DO-35 1.000000 EP 0 0 0.0 AI A REF: D 701	EA B
024-0002-0	CRYSTAL, 14.31818 MHZ, HC49S 1.000000 EP 0 0 0.0 A REF: X 702	EA B
024-0003-0	CRYSTAL, 17.734475 MHZ, HC49S 1.000000 EP 0 0 0.0 A REF: X 701	EA B
030-2103-0	CAP,CER,AX,103,10%,50V,X7R 2.000000 EP 0 0 0.0 AI A REF: C 502,503	EA B
030-2104-1	CAP,CER AX,104,50V,20%,Z5U 3 7.000000 EP 0 0 0.0 A REF: C 150,151,153,154,304,306,313, REF: 315,401,402,405,506,508,511,512 REF: 602,603,604,605,606,701,702,704 REF: 705,706,713,811,813,815,816,818 REF: 901,906,908,910,501,509	EA B
030-2270-0	CAP,CER AXIAL,27 PF,10%,50V,NPO 3.000000 EP 0 0 0.0 AI A REF: C 708,709,710	EA B
030-4101-0	CAP,CER AXIAL,101,5%,100 V,COG	EA B

	1.000000 EP	0	0	0.0	A	
	REF: C 712					
030-4471-0	CAP,CER AXIAL,471,5%,100V,X7R					EA B
	1.000000 EP	0	0	0.0	A	
	REF: C 601					
031-0106-1	CAP,ELEC,RAD,106,20%,25V,NP					EA B
	4.000000 EP	0	0	0.0	A	
	REF: C 302,407,812,902					
031-1227-0	CAP,ELEC,RAD,227,-10%+50%,25V					EA B
	2.000000 EP	0	0	0.0	A	
	REF: C 314,316					
031-2106-0	CAP,ELEC,RAD,106,-10%+50%,50V					EA B
	1 5.000000 EP	0	0	0.0	A	
	REF: C 301,303,307,308,309,312,403					
	REF: 404,505,507,703,814,817,907,909					
036-2105-0	CAP,PE,RAD,105,5%,50V					EA B
	3.000000 EP	0	0	0.0	A	
	REF: C 504,510,610					
050-0000-0	RES,METAL WIRE,0 OHM,1/8W					EA B
	4.000000 EP	0	0	0.0	AI	A
	REF: R 312,319,320,902					
050-0101-0	RES,CARBON FILM,10 OHM,1/8W,5%					EA B
	1 2.000000 EP	0	0	0.0	AI	A
	REF: R 308,311,404,406,502,504,506,					
	REF: 507,819,822,916,917					
050-1001-0	RES,CARBON FILM,100 OHM,1/8W,5%					EA B
	1 5.000000 EP	0	0	0.0	AI	A
	REF: R 101,102,103,104,307,313,314,					
	REF: 318,510,511,704,817,820,907,910					
050-2002-0	RES,CARBON FILM,2K OHM,1/8W,5%					EA B
	1.000000 EP	0	0	0.0	A	
	REF: R 608					
050-2702-0	RES,CARBON FILM,2.7K OHM,1/8W,5%					EA B
	1.000000 EP	0	0	0.0	AI	A
	REF: R 612					
050-3305-0	RES,CARBON FILM,3.3M OHM,1/8W,5%					EA B
	5.000000 EP	0	0	0.0	A	
	REF: R 512,513,836,837,918					
050-4701-0	RES,CARBON FILM,470 OHM,1/8W,5%					EA B
	4.000000 EP	0	0	0.0	AI	A
	REF: R 606,705,706,707					
050-6801-0	RES,CARBON FILM,680 OHM,1/8W,5%					EA B
	1.000000 EP	0	0	0.0	AI	A
	REF: R 601					
050-7500-0	RES,CARBON FILM,75 OHM,1/8W,5%					EA B
	1 6.000000 EP	0	0	0.0	A	
	REF: R 301,302,303,304,305,306,309,					
	REF: 401,402,407,409,412,413,823,825					
	REF: 913					
060-1002-0	RES,METAL FILM,1.00K,1/8W,1%					EA B
	6.000000 EP	0	0	0.0	AI	A
	REF: R 610,903,904,905,906					
	REF: + Harman ECO # 973232					

060-1003-0	RES,METAL FILM,10.0K OHM,1/8W,1%	EA B
	1 2.000000 EP 0 0 0.0 AI A	
	REF: R 310,403,405,501,503,508,609,	
	REF: 613,702,821,818,908	
060-1004-0	RES,METAL FILM,100K,1/8W,1%	EA B
	1.000000 EP 0 0 0.0 AI A	
	REF: R 605	
060-1302-0	RES,METAL FILM,1.3 KOHM,1/8W,1%	EA B
	1.000000 EP 0 0 0.0 A	
	REF: R 604	
060-3322-0	RES,METAL FILM, 3.32 K OHM,1/8W,1%	EA B
	2.000000 EP 0 0 0.0 A	
	REF: R 603,607	
060-4992-0	RES,METAL FILM,4.99K OHM,1/8W,1%	EA B
	2.000000 EP 0 0 0.0 AI A	
	REF: R 505,509	
060-6804-0	RES,METAL FILM,680K OHM,1/8W,1%	EA B
	1.000000 EP 0 0 0.0 A	
	REF: R 602	
060-6812-0	RES,METAL FILM,6.81K OHM,1/8W,1%	EA B
	1.000000 EP 0 0 0.0 AI A	
	REF: R 611	
071-0010-0	CAP,VAR,10PF	EA B
	1.000000 EP 0 0 0.0 A	
	REF: C 711	
071-0030-0	CAP,VAR,30PF	EA B
	1.000000 EP 0 0 0.0 A	
	REF: C 715	
081-0005-0	FERRITE BEAD,AX, TYPE39	EA B
	6.000000 EP 0 0 0.0 A	
	REF: FB 301,401,402,803,804,901	
081-0010-0	INDUCTOR,AX,HIQ,33UH	EA B
	1.000000 EP 0 0 0.0 A	
	REF: L 701	
081-0103-0	EMI FILTER, RAD, 103	EA B
	3.000000 EP 0 0 0.0 A	
	REF: FIL 701,702,703	
092-0006-0	CON,2XDINX5PIN,F,PC,H,SHIELD	EA B
	2.000000 EP 0 0 0.0 A	
	REF: P 401,402	
092-0007-2	JACK RCAX4 HORIZ GOLD YELLOW	EA B
	2.000000 EP 0 0 0.0 A	
	REF: J 301,302	
093-0009-0	HDR,.1X5,VERT,MALE,LOCK	EA B
	1.000000 EP 0 0 0.0 A	
	REF: P 202	
093-0022-0	HDR,.1X2,VERT,GOLD,N-LOCK	EA B
	2.000000 EP 0 0 0.0 A	
	REF: P 203,701	
093-2000-0	HDR,.1X2X10,VERT,MALE,SHROUDED	EA B
	1.000000 EP 0 0 0.0 A	
	REF: P 201	
100-0104-0	BRACKET,.25X.25,KEYSTONE,#621	EA B

	2.000000 EP	0	0	0.0	A
111-0041-0	BOLT,4-40,1/4,PHP,CAD				EA B
	2.000000 EP	0	0	0.0 0	A
HA145-0011-2	SIG 2.0 VIDEO BOARD				EA B
	1.000000 EP	0	0	0.0 02	A

51 COMPONENTS PRINTED

1 ASSEMBLIES PRINTED