

# The Harman Kardon Model T25

Manual No. 73A

## SEMI-AUTOMATIC TURNTABLE

# Technical Manual



## SPECIFICATIONS

Wow & Flutter (WRMS)	0.05%
Rumble (DIN-B WTD)	-65dB, DIN 45544 record reference
Pitch Adjustable Range	±3%
<b>Tonearm</b>	
Effective Tonearm Mass	11g (plus the mass of the cartridge used)
Stylus Overhang	18mm
Offset Angle	25.5°
Effective Length	216mm
Tracking Error	±2 degrees
Phono Capacitance	160pF
Tracking Force	0 ~ 3 grams

Acceptable Weight of Cartridge	4.5 ~ 7 g
Dimensions (W x H x D)	15-1/4" x 5-5/16" (386 x 134 x 3)
Weight	11 lbs. 11oz. (5.1 kg)
<b>Power Supply</b>	
U.S.A. and Canada models	AC120V, 60Hz
General model	AC110-120V/230V 50/60Hz
Power Consumption	3W

Specifications and components subject to change without notice. Overall performance will be maintained or improved.

## LEAKAGE TEST (FOR SERVICE ENGINEERS IN THE U.S.A.)

Before returning the unit to the user, perform the following safety checks:

1. Inspect all lead dress to make certain that leads are not pinched or that hardware is not lodged between the chassis and other metal parts in the unit.
2. Be sure that any protective devices such as nonmetallic control knobs, insulating fishpapers, cabinet backs, adjustment and compartment covers or shields, isolation resistor-capacity networks, mechanical insulators, etc. which were removed for servicing are properly reinstalled.
3. Be sure that no shock hazard exists; check for leakage current using Simpson Model 229 Leakage Tester, standard equipment item No. 21641, RCA Model WT540A or use alternate method as follows:

Plug the power cord directly into a 120-volt AC receptacle (do not use an Isolation Transformer for this test). Using two clip leads, connect a 1500 Ohm, 10-watt resistor paralleled by a 0.15μF capacitor, in series with all exposed metal cabinet parts and a known earth ground, such as a water pipe or conduit. Use a VTVM or VOM with 1000 Ohms per volt, or higher, sensitivity to measure the AC voltage drop across the resistor. (See Diagram.) Move the resistor connection to each exposed metal part having a return path to the chassis (antenna, metal, cabinet, screw heads, knobs and control shafts, escutcheon, etc.) and measure the AC voltage drop across the resistor. (This test should be performed with the power switch in both the On and Off positions.)

A reading of 0.35 volt RMS or more is excessive and indicates a potential shock hazard which must be corrected before returning the unit to the owner.

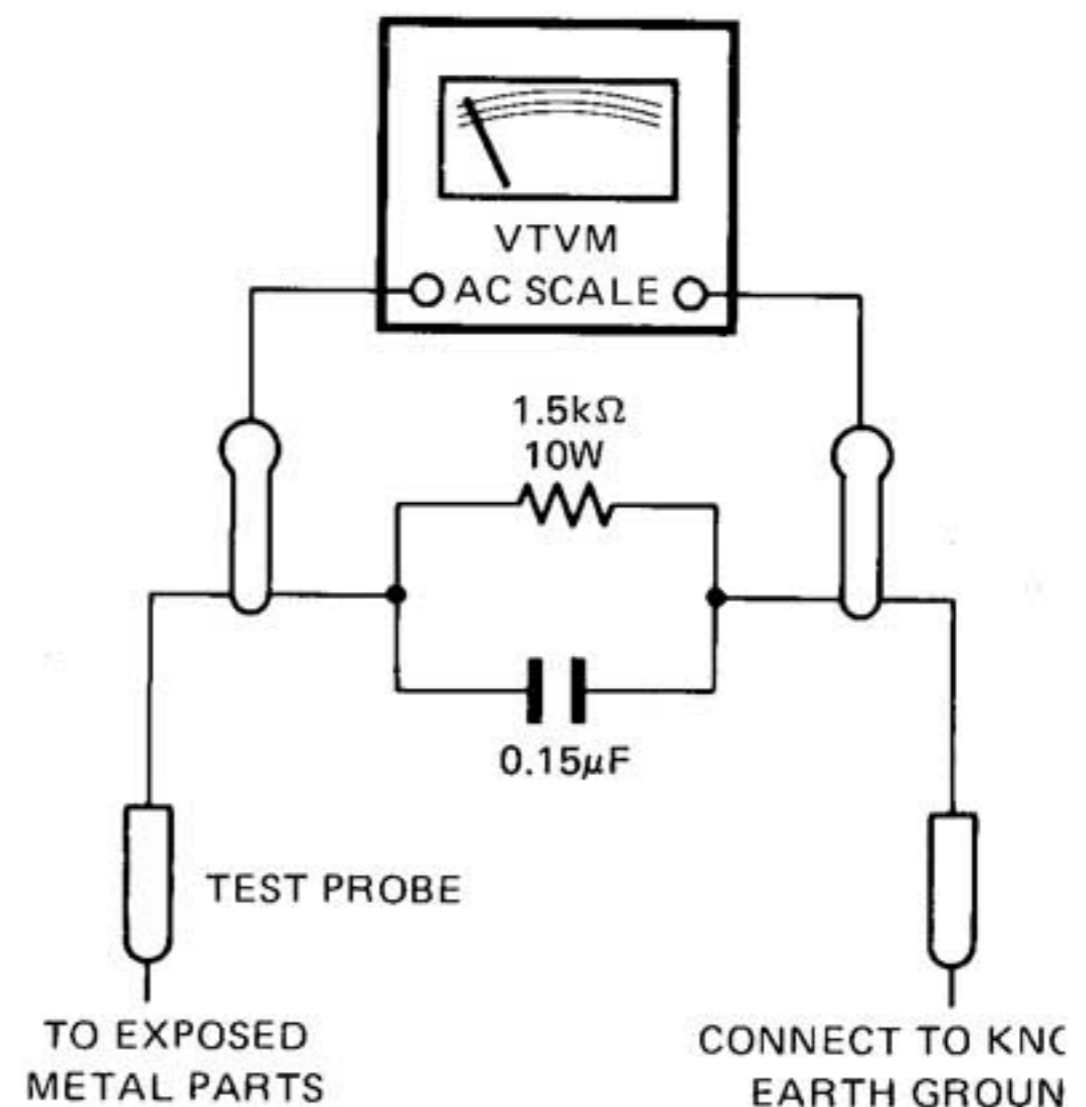
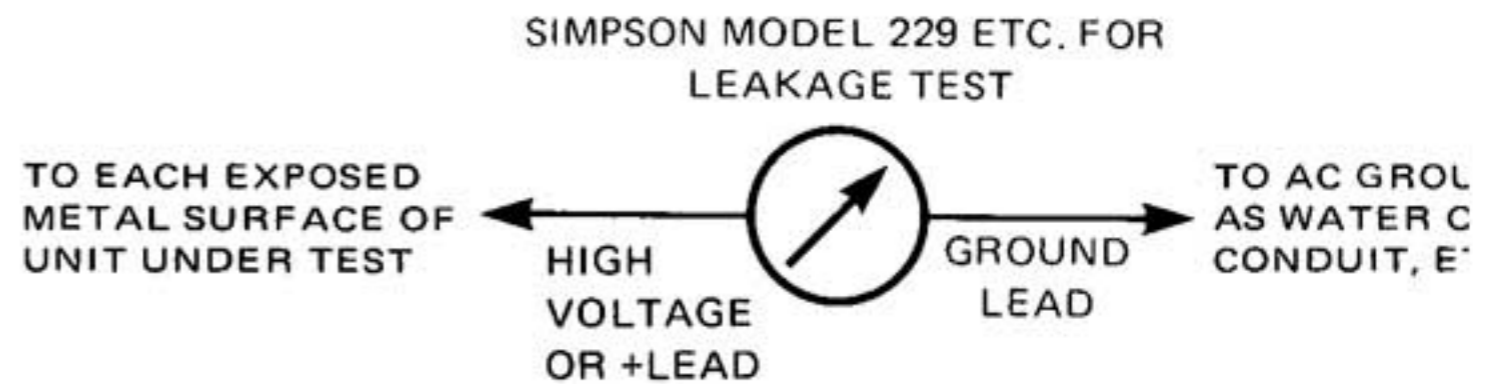

# CARTRIDGE REPLACEMENT INSTRUCTION

Only use cartridges in the headshell provided. Be sure to use a cartridge weighting 4.5 to 7 grams.

1. Release the tonearm clamp and lift the tonearm gently.
2. Loosen the headshell clamp and gently pull the headshell with cartridge. (See Fig. A.)
3. Disconnect the 4 leads from cartridge pins using a tweezers and then loosen the retaining screws so that the cartridge comes out.
4. Replace the leads onto the new cartridge. Refer to Fig. B for correct placement of leads.
5. When all leads are connected properly, install the cartridge to the headshell as shown in the Fig. B.
6. Temporarily tighten the retaining screw to hold the cartridge.
7. Insert the headshell with the cartridge fully into the tonearm and then tighten the headshell clamp.

When cartridge is replaced with a new one, it is necessary to adjust the Overhang and Tracking angle.

## ● Overhang Adjustment

1. Place the accessory tracking angle gauge on the center spindle and raise the flap.
2. Be sure to remove the stylus guard when adjusting the overhang.
3. Move the tonearm directly over the center spindle. Line up the raised flap on the gauge with the center spindle and the tonearm base. Gently move the cartridge backward or forward in the headshell so that the stylus tip lines up with the corner of the flap.

## ● Tracking Angle Adjustment

1. Check to be sure that the overhang adjustment has been completed.
2. Now move the tracking angle gauge until it is in the same position with respect to the tonearm as that shown in Fig. D. Place the stylus over the tracking angle setting point with stylus guard attached.
3. Without changing the stylus position, turn the cartridge so that its front edge is parallel with the lines on the gauge.
4. Now move it so that it is in the position shown in Fig. E and check that the cartridge is still parallel with the parallel lines as it was in step 3 above. If it is not parallel, then repeat steps 3 and 4 alternately until the cartridge is parallel in both cases.
5. When the above adjustment is completed, then tighten the screws that attach the cartridge to the headshell fully.

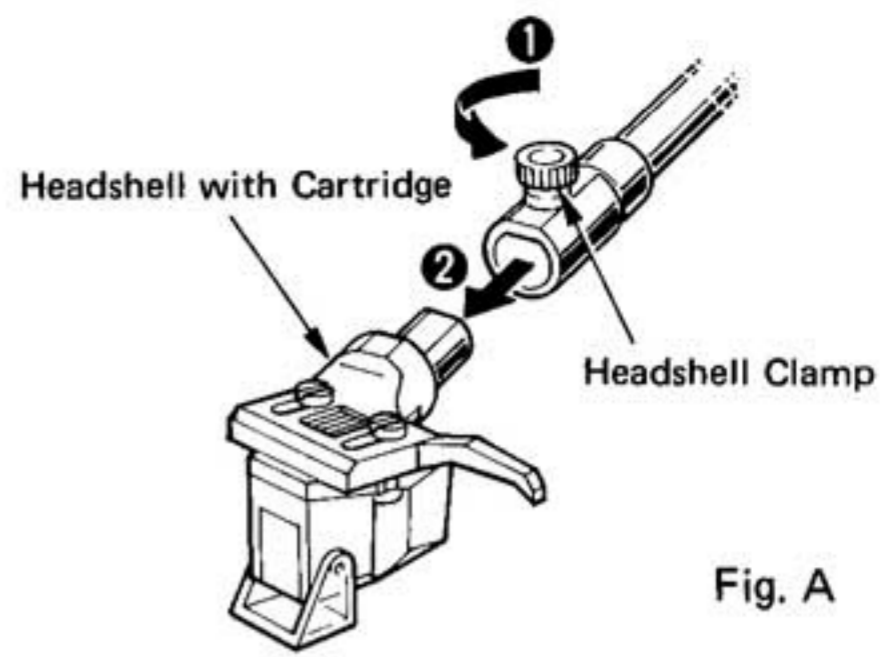

Fig. A

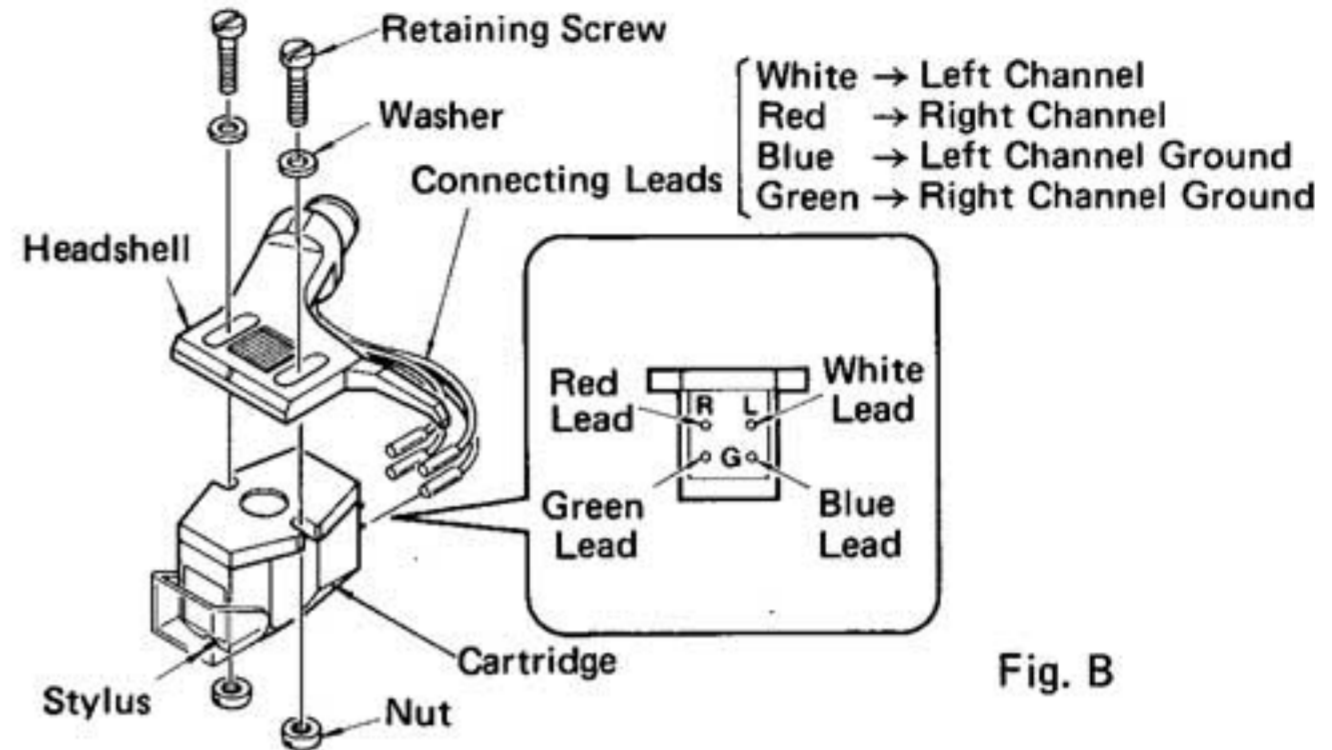

Fig. B

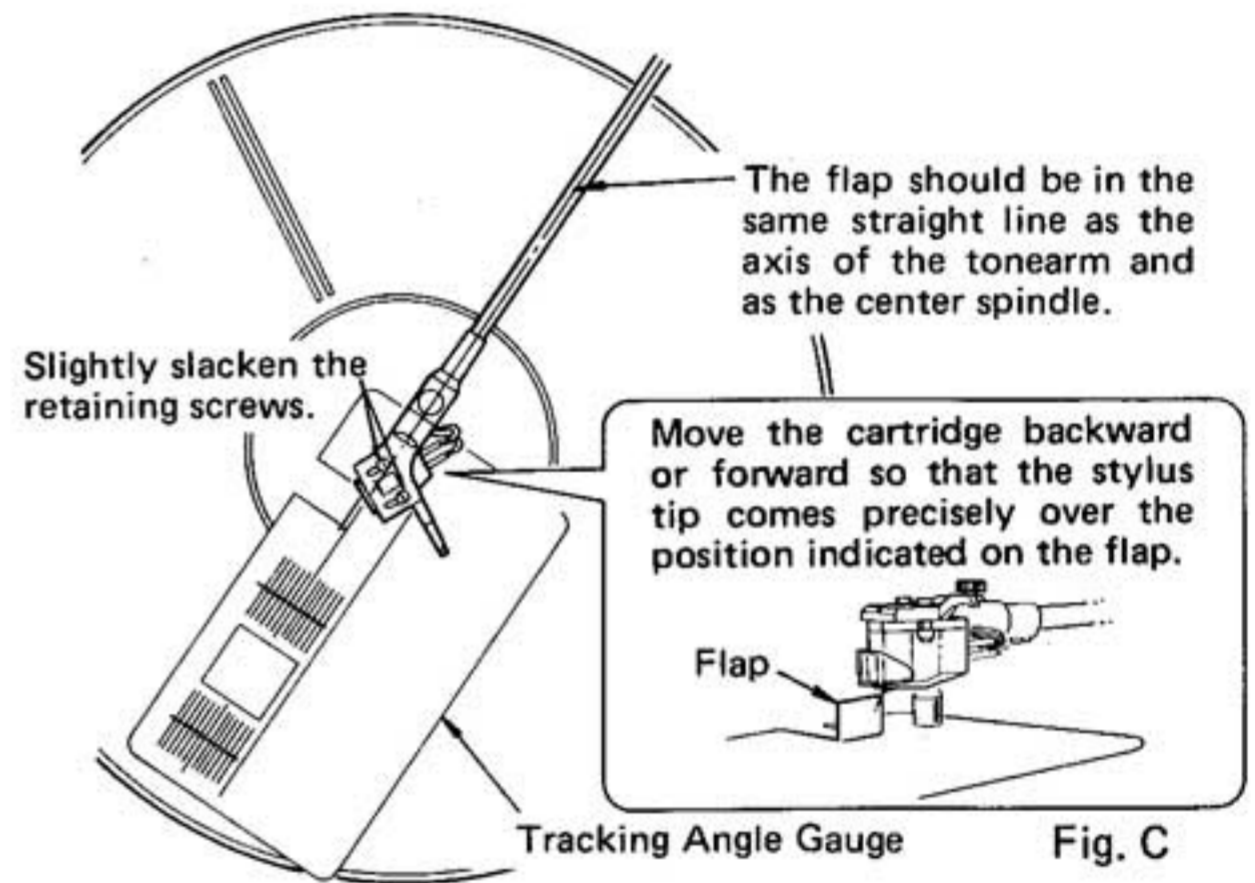

Fig. C

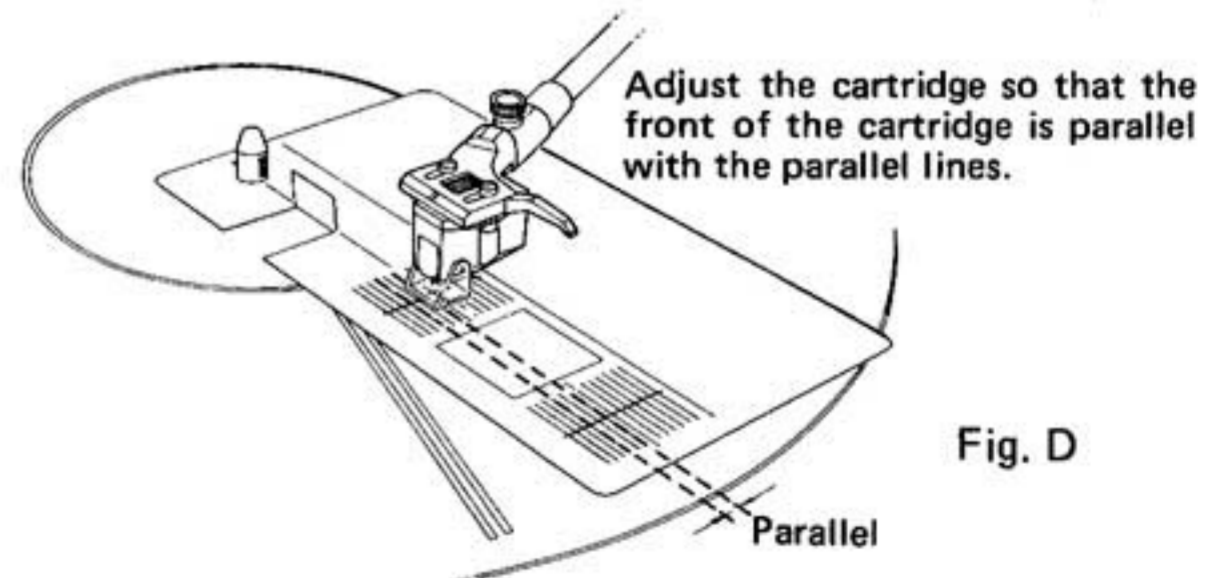

Fig. D

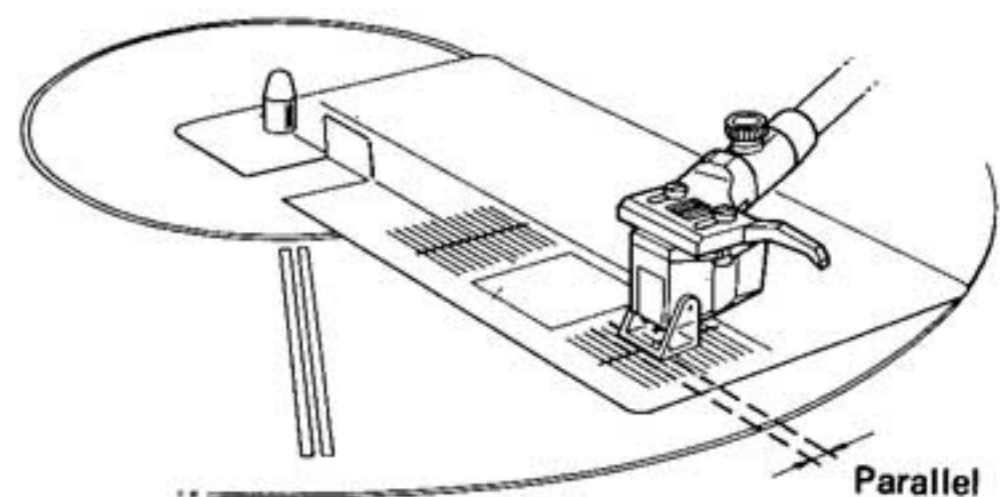

Fig. E

## ALIGNMENT PROCEDURES

### ■ AUTO-RETURN ADJUSTMENT

#### Conditions

- \* Be sure that the drive belt between platter and motor pulley is hung.
- \* Flip the cue lever forward to lift the tonearm up.

#### ● LP POSITION ADJUSTMENT

1. Set the speed selector to the 33 position.
2. Adjust the stylus pressure to the appropriate pressure.
3. Move tonearm horizontally as to be level with the platter, and rotate the platter.
4. Adjust the adjustment screw of forwarding arm assembly so that the tonearm automatically returns in the range of 111.94 mm ~ 107.2 mm from the center of center spindle on the operation plate assembly.

#### ● EP POSITION ADJUSTMENT

1. Set the speed selector to the 45 position.
2. Adjust the stylus pressure to the appropriate pressure.
3. Move tonearm horizontally as to be level with the platter, and rotate the platter.
4. Adjust the adjustment screw of forwarding arm assembly so that the tonearm automatically returns in the range of 102.74 mm ~ 98.4 mm from the center of center spindle on the operation plate assembly.

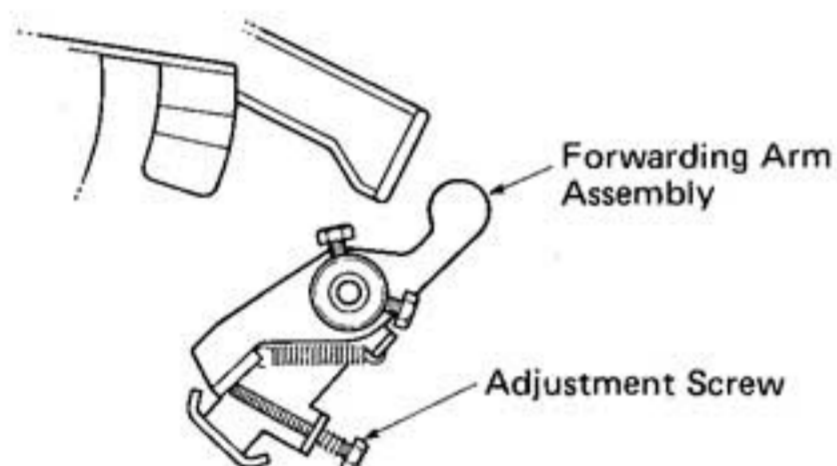

NOTE: If the auto-return motion is too fast, turn the adjustment screw clockwise to adjust. If the auto-return motion is too slow, turn the adjustment screw counter-clockwise to adjust.

### ■ POWER SWITCH CLEARANCE ADJUSTMENT

#### Instrument

Clearance Gauge

1. Fix the tonearm on the armrest.
2. After adjusting the clearance between the micro-switch and the forwarding arm assembly to 0.1 mm ~ 0.5 mm with a clearance gauge, tighten the mounting screws to fix it.

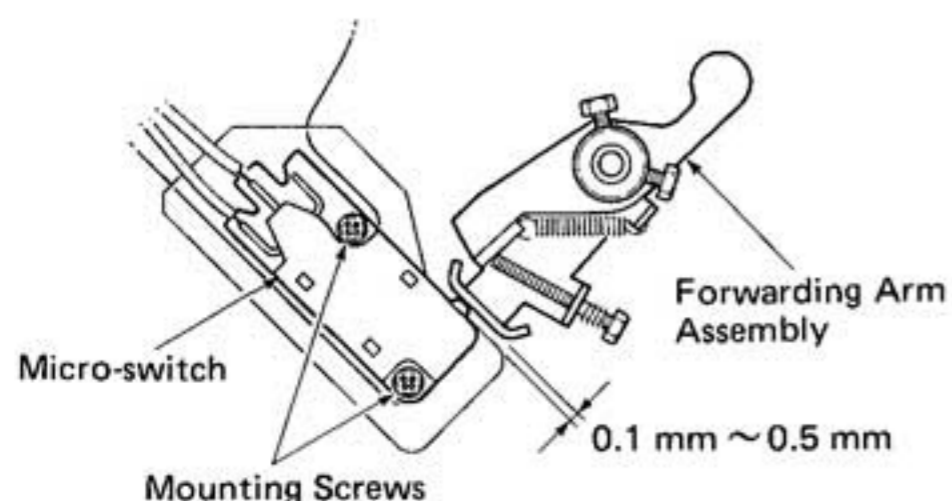

### ■ MOTOR R.P.M. ADJUSTMENT

#### Instrument

Low Range Tachometer

#### Conditions

- \* Be sure that the drive belt between platter and motor pulley is hung.
- \* Flip the cue lever forward to lift the tonearm up.

1. Set the speed selector to the 33 position and set the speed control knob to the center position.
2. Move tonearm horizontally as to be level with the platter, and rotate the platter.
3. With the platter turning, adjust VR102 so that the motor speed rating is within 33-1/3 r.p.m.
4. Set the speed selector to the 45 position.
5. With the platter turning, adjust VR103 so that the motor speed rating is within 45 r.p.m.

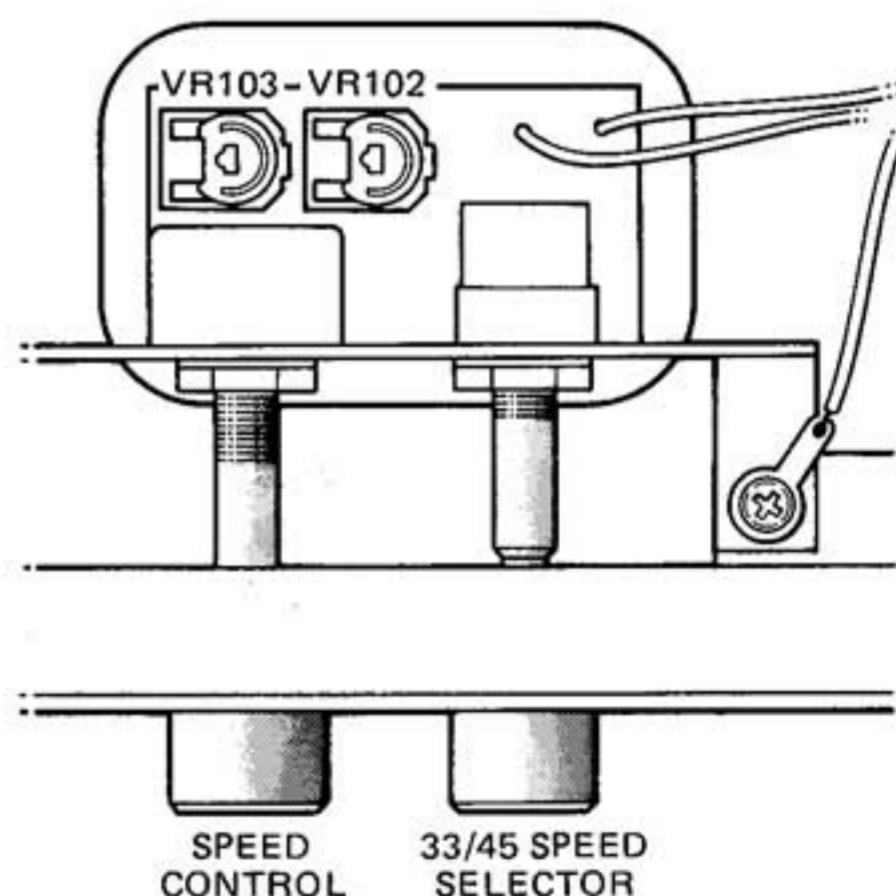
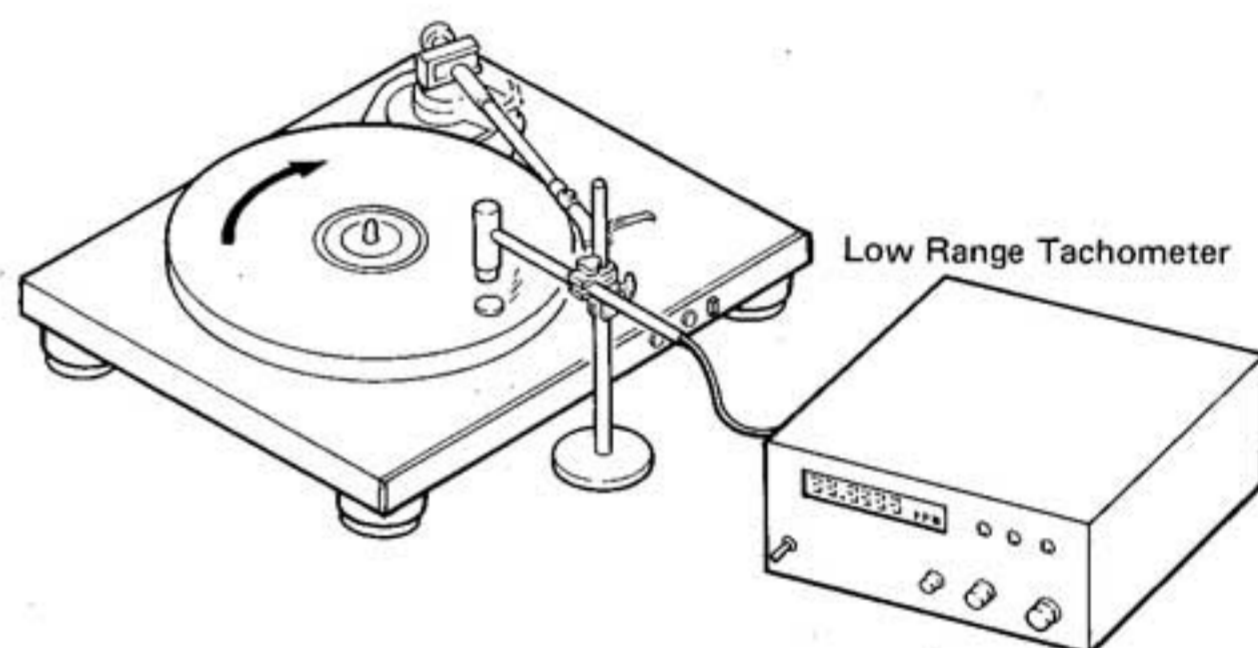

## DISASSEMBLY PROCEDURES (REFER TO PAGES 6 AND 10)

### 1 CABINET BOTTOM ASSEMBLY (2) REMOVAL

Remove 12 screws **A** and remove the Cabinet Bottom Assembly (2).

### 2 CONTROL P.C. BOARD (PCB-1) REMOVAL

1. Remove the Cabinet Bottom Assembly (2). (Refer to step 1.)
2. Remove the E-stop ring **B** and remove the Reject Lever (16) with Reject Spring (19).
3. Remove 2 screws **C** and remove the Control P.C. Board (PCB-1) with Chassis Assembly (12). If necessary, unsolder the lead wires.

### 3 FRONT PANEL ASSEMBLY (3) REMOVAL

1. Remove the Cabinet Bottom Assembly (2). (Refer to step 1.)
2. Remove 2 screws **D** and 3 screws **E**, and remove the Front Panel Assembly (3).

### 4 MOTOR ASSEMBLY (MO1) REMOVAL

1. Remove the Cabinet Bottom Assembly (2). (Refer to step 1.)
2. Remove 3 screws **F** and remove the Motor Assembly (MO1). If necessary, unsolder the lead wires.

### 5 POWER SUPPLY P.C. BOARD (PCB-2) REMOVAL

1. Remove the Cabinet Bottom Assembly (2). (Refer to step 1.)
2. Remove hexagon nut **G** and screw **H**, and remove the Power Supply P.C. Board (PCB-2) with the Power Transformer (T1). If necessary, unsolder the lead wires.

### 6 PICK-UP ASSEMBLY (4) REMOVAL

1. Remove the Cabinet Bottom Assembly (2). (Refer to step 1.)
2. Unsolder the pick-up leads from Terminal Strip (TE1).
3. Loosen 2 fixing screws **I** of the Forwarding Arm Assembly (11).
4. Remove screw **J** on the Pick-Up Base Assembly (5) and then pull out Pick-Up Assembly (4) upward from Pick-Up Base Assembly (5).

### 7 PICK-UP BASE ASSEMBLY (5) REMOVAL

1. Remove the Pick-Up Assembly (4). (Refer to step 6.)
2. Remove 4 screws **K** and remove the Pick-Up Base Assembly (5).

## POWER CORD REPLACEMENT (FOR SERVICE ENGINEERS OTHER THAN NORTH AMERICA)

In order to prevent fire or shock hazard when replacing the power cord, follow the procedure below to replace the parts with the standard supply parts.

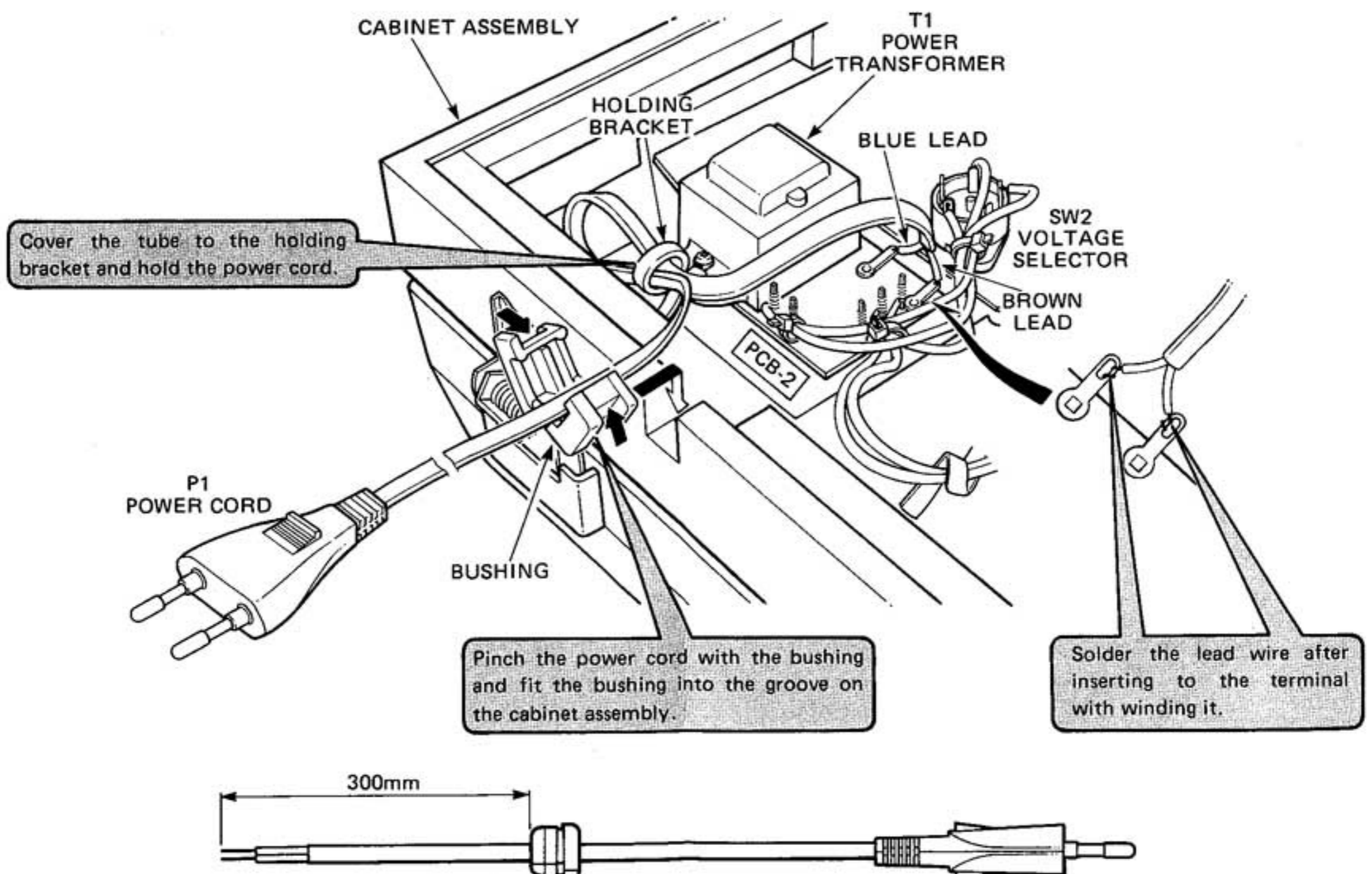

# GENERAL UNIT EXPLODED VIEW

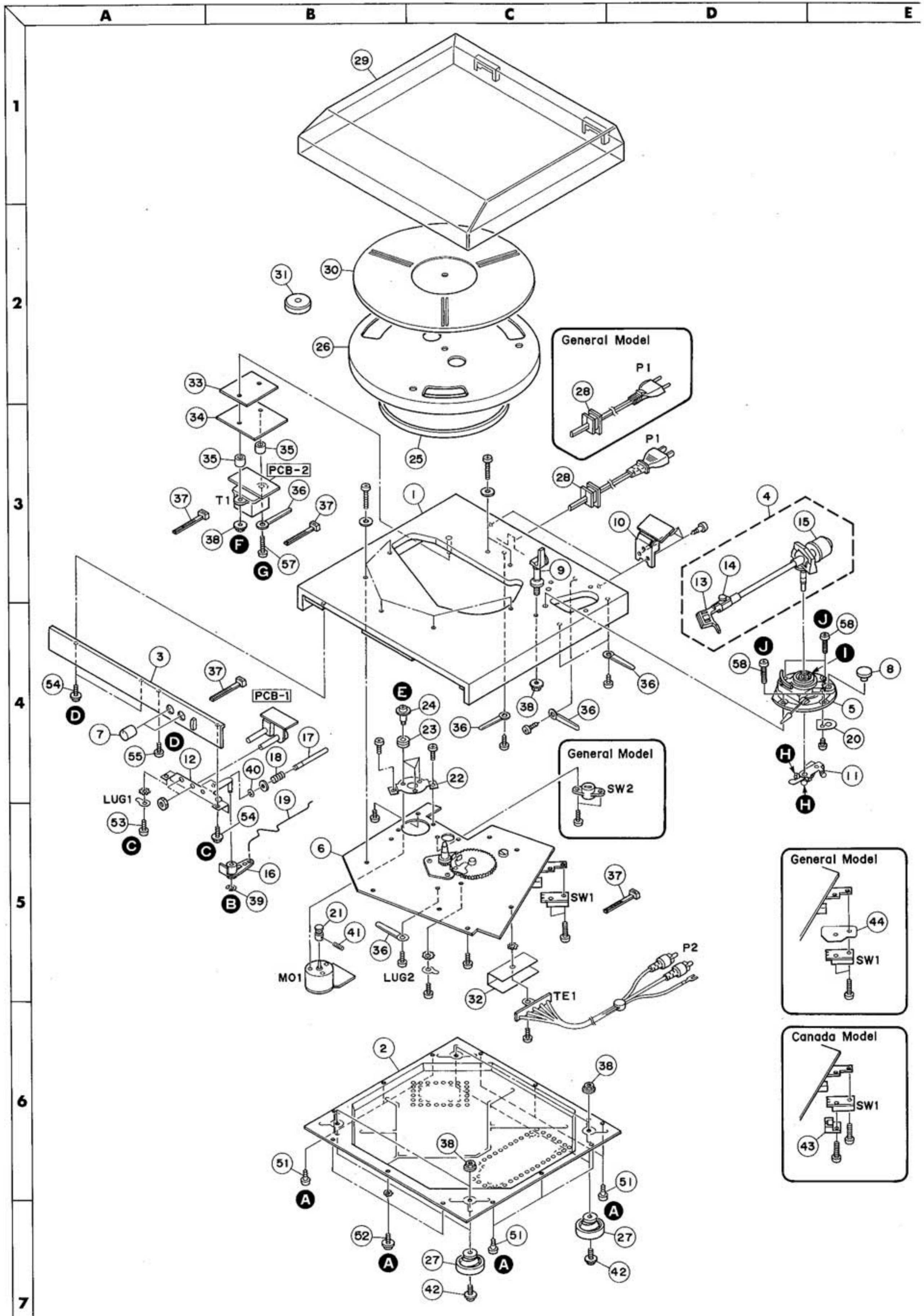

## GENERAL UNIT PARTS LIST

Ref. No.	Part No.	Description
1	A415-T25A	Cabinet Assembly (for U.S.A. and Canada models)
	A415-T25B	Cabinet Assembly (for General model)
2	A424-T25A	Cabinet Bottom Assembly (for U.S.A. and Canada models)
	A424-T25B	Cabinet Bottom Assembly (for General model)
3	A443-T25	Front Panel Assembly (includes: Cut Button)
4	A371-T25	Pick-Up Assembly (without Cartridge and Stylus)
5	A562-T25	Pick-Up Base Assembly
6	B211-T25A	Operation Plate Assembly (for U.S.A. and Canada models)
	B211-T25B	Operation Plate Assembly (for General model)
7	A634-T25A	Knob Assembly, 33/45 Speed Selector, Speed Control
8	A634-T25B	Anti-Skating Control Assembly
9	910742-2	Armrest Assembly
10	898532-1	Hinge Assembly
11	893583-3	Forwarding Arm Assembly
12	872982	Chassis Assembly
13	852366S	Headshell
14	852366A	Headshell Clamp
15	853255W	Counterweight
16	897574	Reject Lever
17	898534	Cut Shaft
18	832780-1	Elevation Spring
19	896722-4	Reject Spring
20	897596	Anti-Skating Cover
21	894021	Motor Pulley
22	893931	Motor Bracket
23	242020	Bushing
24	893057-7	Motor Mounting Screw
25	700515B	Drive Belt
26	620075-4	Platter
27	895773-9	Foot
28	871025	Bushing (for U.S.A. and Canada models)
	871026	Bushing (for General model)
29	852278	Dust Cover
30	2115-00102	Platter Mat
31	890876	45 RPM Adaptor
32	890959-1	Shield Plate
33	912451	Shield Plate
34	912439	Insulator
35	897342-1	Collar
36	890755	Holding Bracket
37	894408	Holder
38	Y22000302	Flange Nut (M3)
39	Y34000321	E-Stop Ring (3.2 $\phi$ )
40	Y34000201	E-Stop Ring (2 $\phi$ )
41	Y13200301	Screw (-) (2 x 3 mm)
42	Y01301004	Screw (+) (3 x 10 mm)
43	890335	Switch Cover (Canada model only)
44	893803	Shield Plate (General model only)
51	Y11311302	Screw (+) (3.1 x 13 mm)
52	Y01301004	Screw (+) (3 x 12 mm)
53	Y10300601	Screw (+) (3 x 6 mm)
54	Y09301201	Screw (+) (3 x 12 mm)
55	Y11311301	Screw (+) (3.1 x 13 mm)
57	Y08302501	Screw (+) (3 x 22 mm)
58	Y03301202	Screw (+) (3 x 12 mm)

## ELECTRICAL PARTS LIST

Ref. No.	Part No.	Description
<b>CHASSIS MISCELLANEOUS</b>		
△ P1	892435-1	Power Cord (for U.S.A. and Canada models)
	895617-2	Power Cord (for General model)
P2	871474	Output Cord
△ T1	872290	Power Transformer (for U.S.A. model)
	873105	Power Transformer (for Canada model)
	872292	Power Transformer (for General model)
△ SW1	870270	Micro-Switch, Power
△ SW2	898256-5	Rotary Switch, Voltage Selector (General model only)
MO1	705838	Motor Assembly
TE1	890979	Terminal Strip
LUG1, 2	Z42600701	Lug Terminal

Ref. No.	Part No.	Description
<b>PCB-1 CONTROL P.C. BOARD</b>		
<b>CONTROLS</b>		
VR101	910746	Variable Resistor, 5kΩB, Speed Control
VR102	704825-11	Semi-Variable Resistor, 50kΩB
VR103	704825-9	Semi-Variable Resistor, 20kΩB
<b>MISCELLANEOUS</b>		
SW101	910744	Rotary Switch, 33/45 Speed Selector
<b>PCB-2 POWER SUPPLY P.C. BOARD</b>		
<b>CAPACITORS</b>		
△C501	899299-3	4700pF, +100%—0%, 125V, Ceramic
C502	Z4080210H	330μF, ±20%, 16V, Electrolytic
<b>DIODES</b>		
△D501	Z4110061	Bridge Silicon, S1WB10

△ SAFETY RELATED COMPONENT. USE ONLY EXACT REPLACEMENT PART AS SPECIFIED.

**PACKAGE**

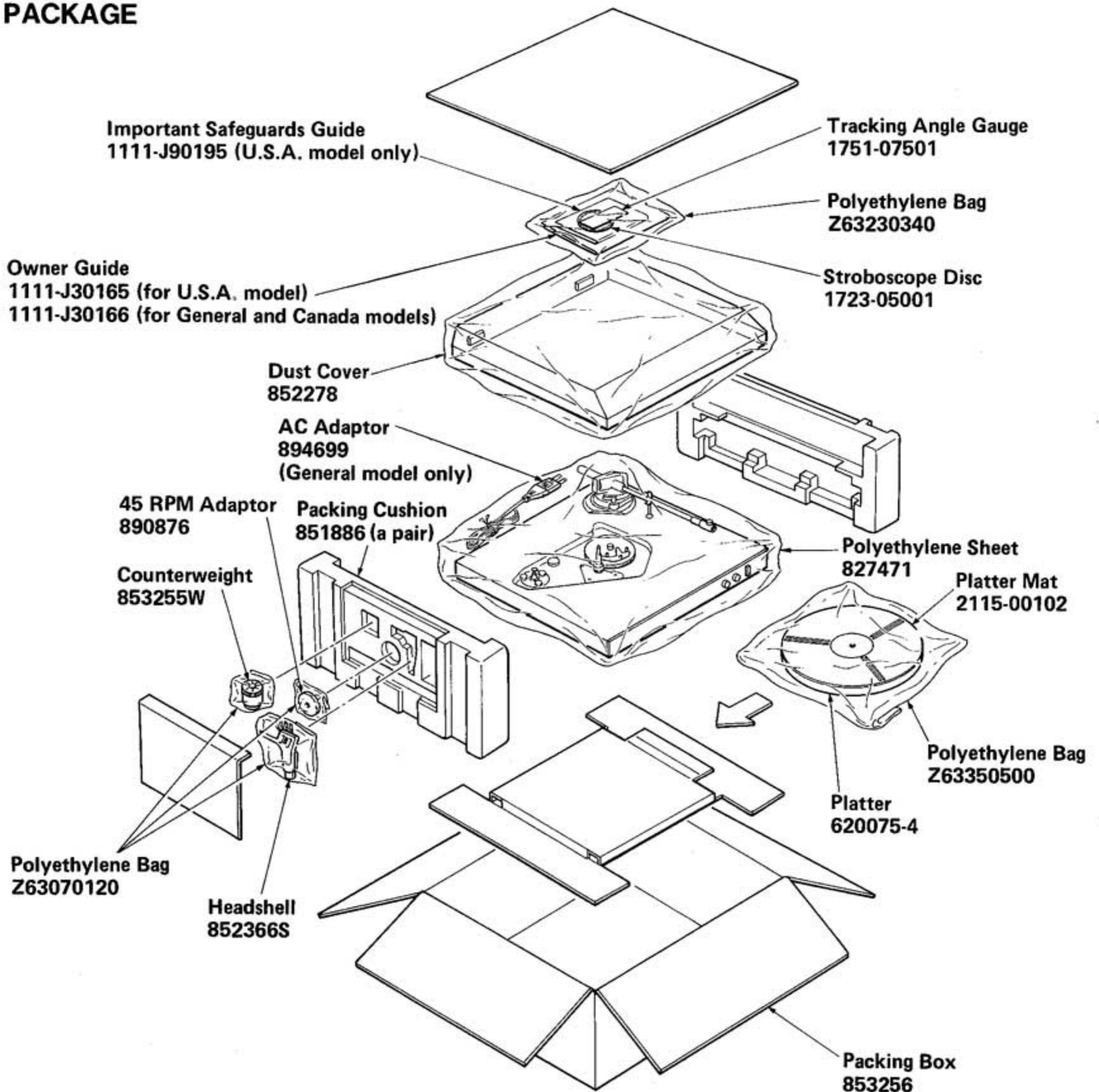



**SCHEMATIC DIAGRAM**

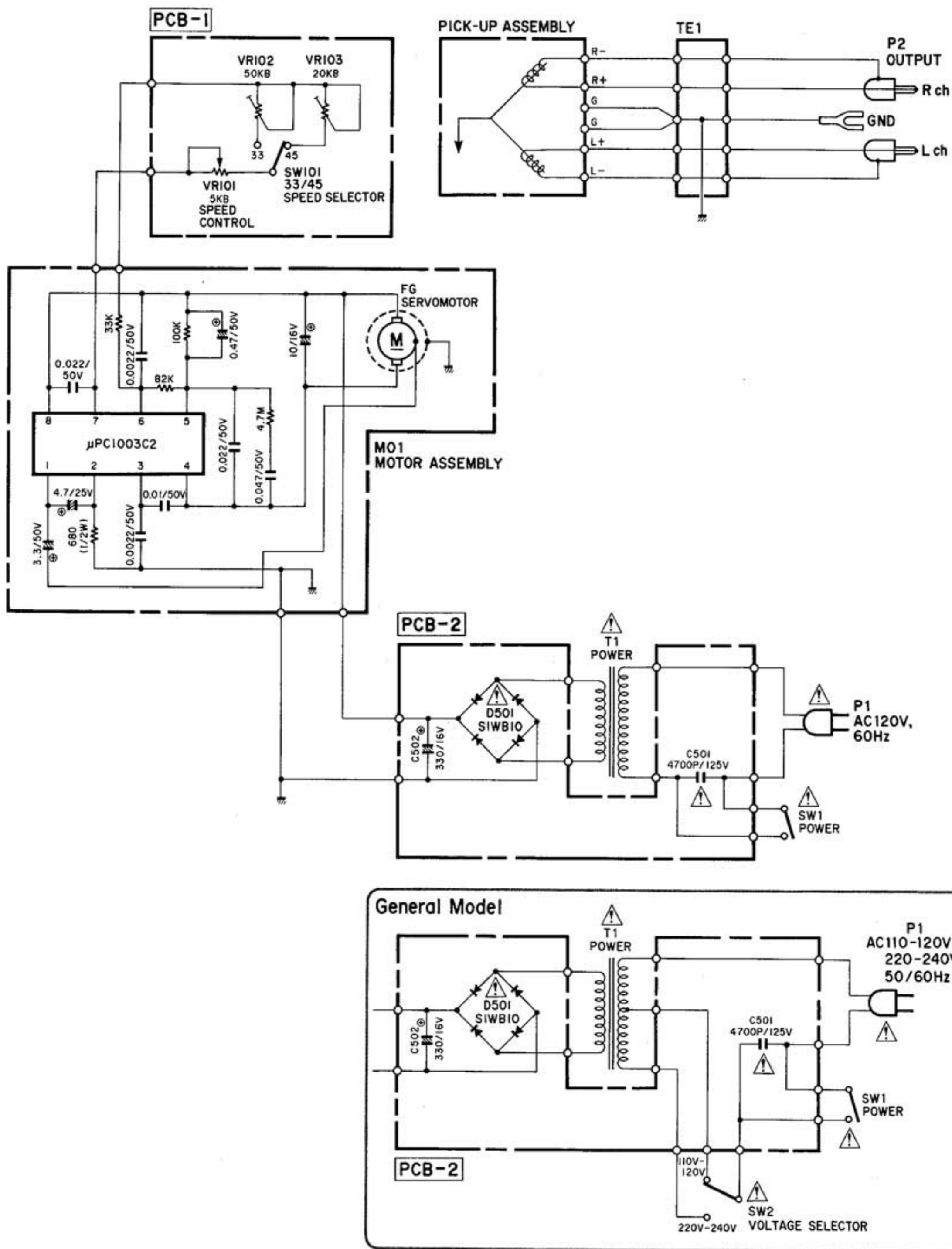

1. ALL RESISTANCES VALUES ARE IN  $\Omega$ .  
k $\Omega$  = 1000 $\Omega$ , M $\Omega$  = 1000k $\Omega$
2. THE WATTAGE OF RESISTORS IS 1/4W, UNLESS OTHERWISE NOTED.
3. ALL CAPACITANCES VALUES ARE IN  $\mu$ F UNLESS OTHERWISE NOTED. P =  $\mu$  $\mu$ F
4. SAFETY-REQUIREMENTS COMPONENTS IN ACCORDANCE WITH PRESENT SAFETY REGULATIONS, THESE COMPONENTS MUST ONLY BE REPLACED BY ORIGINAL PARTS.

WIRING DIAGRAM

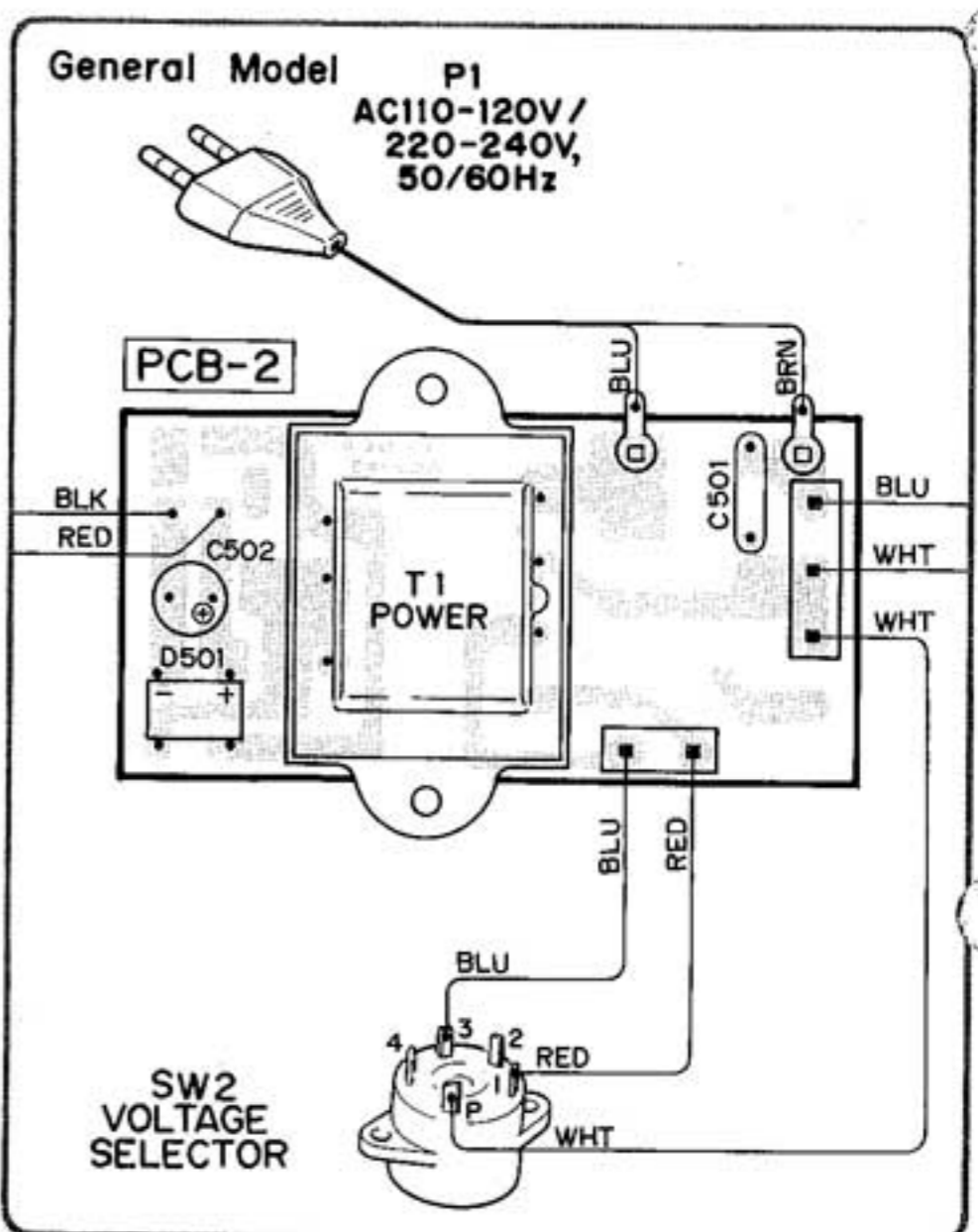
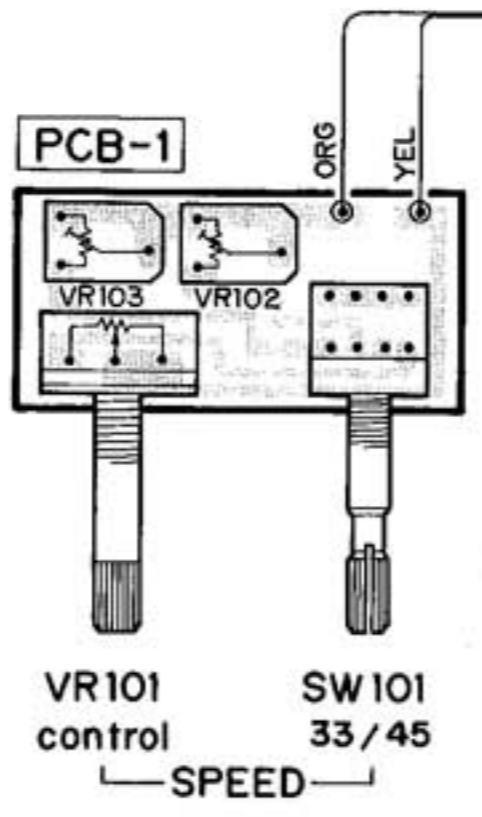
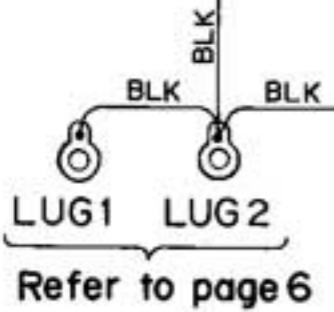
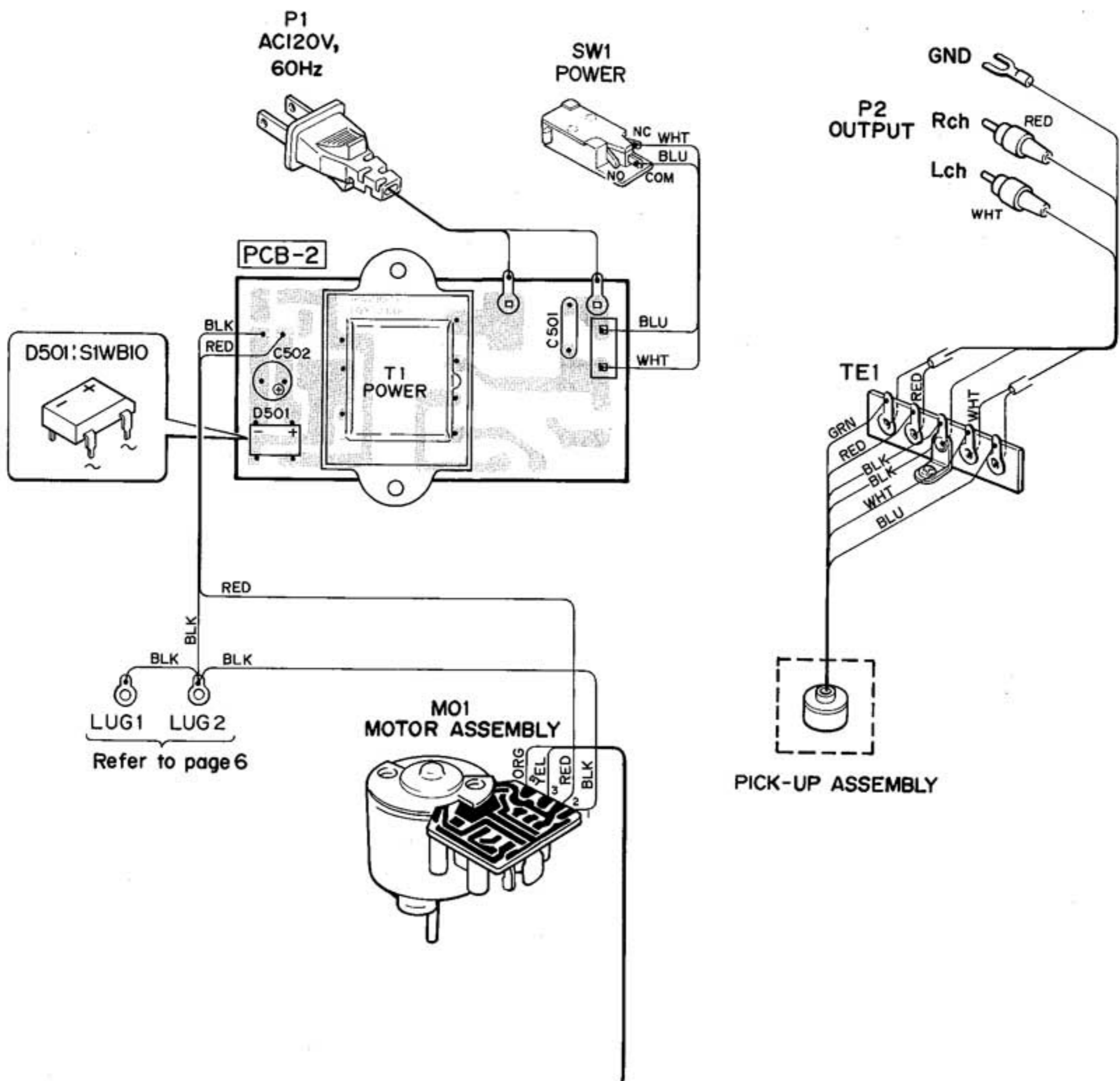

- WIRE COLOR ABBREVIATIONS
- RED : Red
  - ORG : Orange
  - BLU : Blue
  - WHT : White
  - GRN : Green
  - BLK : Black
  - YEL : Yellow
  - PUP : Purple
  - PIK : Pink